

DOCUMENT RESUME

ED 178 272

SE 028 465

AUTHOR Hathway, James A., Ed.
 TITLE Individualized Testing System: Performance Assessment Resources, ISCS Level I, Part 2.
 INSTITUTION Florida State Univ., Tallahassee. Curriculum Study Center.
 SPONS AGENCY National Science Foundation, Washington, D.C.
 PUB DATE 73
 NOTE 112p.; For related documents, see SE 028 460-488

EDRS PRICE MF01/PC05 Plus Postage.
 DESCRIPTORS Academic Achievement; Course Objectives; Elementary Secondary Education; *Evaluation; *Individualized Programs; Inservice Teacher Education; Junior High Schools; Performance Tests; *Resource Materials; *Science Course Improvement Project; Science Education; Science Materials; Science Tests; Student Evaluation; *Teaching Guides

IDENTIFIERS *Intermediate Science Curriculum Study; *National Science Foundation

ABSTRACT

This is part two of two performance assessment resources booklets for Level I of the Intermediate Science Curriculum Study (ISCS). The two booklets are considered one of four major subdivisions of a set of individualized evaluation materials for Level I of the ISCS developed as a part of the ISCS Individualized Teacher Preparation (ITP) program. Each booklet is a teacher's handbook to be used in identifying the appropriate performance checks with which to evaluate each student. Each also indicates how to set up testing situations, correct responses, and give remedial help. This manual (part 2) covers the last five units of Level I (6-10) in ten chapters. Each unit begins with a summary table that includes the objectives and performance checks of the unit. Immediately following each summary table comes the bulk of the resource material for each objective introduced in that unit. Suggestions of ways teachers can use the manual are also included. (HM)

 * Reproductions supplied by EDRS are the best that can be made *
 * from the original document. *



INTERMEDIATE
SCIENCE
CURRICULUM
STUDY

ED178272

INDIVIDUALIZED TESTING SYSTEM

U.S. DEPARTMENT OF HEALTH,
EDUCATION & WELFARE
NATIONAL INSTITUTE OF
EDUCATION

THIS DOCUMENT HAS BEEN REPRODUCED EXACTLY AS RECEIVED FROM THE PERSON OR ORGANIZATION ORIGINATING IT. POINTS OF VIEW OR OPINIONS STATED DO NOT NECESSARILY REPRESENT OFFICIAL NATIONAL INSTITUTE OF EDUCATION POSITION OR POLICY.

PERMISSION TO REPRODUCE THIS MATERIAL HAS BEEN GRANTED BY

Mary L. Charles
NSF

TO THE EDUCATIONAL RESOURCES
INFORMATION CENTER (ERIC).

Performance Assessment Resources ISCS LEVEL I PART 2



SILVER BURDETT
GENERAL LEARNING CORPORATION

Morristown, New Jersey • Park Ridge, Ill. • Palo Alto • Dallas • Atlanta

SE 028 465

INDIVIDUALIZED TESTING SYSTEM

- ALL LEVELS** **Individualizing Objective Testing (an ITP module)**
Evaluating and Reporting Progress (an ITP module)
- LEVEL I** **Performance Objectives, ISCS Level I**
Performance Checks, ISCS Level I, Forms A, B, and C
Performance Assessment Resources, ISCS Level I, Parts 1 and 2
- LEVEL II** **Performance Objectives, ISCS Level II**
Performance Checks, ISCS Level II, Forms A, B, and C
Performance Assessment Resources, ISCS Level II, Parts 1 and 2
- LEVEL III** **Performance Objectives, ISCS Level III**
Performance Checks, ISCS Level III, ES-WB, Forms A, B, and C
WYY-IV, Forms A, B, and C
IO-WU, Forms A, B, and C
WW-CP, Forms A, B, and C
Performance Assessment Resources, ISCS Level III, ES-WB
WYY-IV
IO-WU
WW-CP

ACKNOWLEDGMENTS

The work presented or reported herein was supported by funds provided by the National Science Foundation. However, the opinions expressed herein do not necessarily reflect the position or policy of the National Science Foundation, and no official endorsement by the agency should be inferred.

© 1973 THE FLORIDA STATE UNIVERSITY

All rights reserved. Printed in the United States of America. Published simultaneously in Canada. Copyright is claimed until 1978. Except for the rights to materials reserved by others, the Publishers and the copyright owner hereby grant permission to domestic persons of the United States and Canada for use of this work without charge in the English language in the United States and Canada after 1978 provided that the publications incorporating materials covered by the copyrights contain an acknowledgment of them and a statement that the publication is not endorsed by the copyright owner. For conditions of use and permission to use materials contained herein for foreign publications in other than the English language, apply to the copyright owner. This publication, or parts thereof, may not be reproduced in any form by photographic, electrostatic, mechanical, or any other method, for any use, including information storage and retrieval, without written permission from the publisher.

ILLUSTRATIONS: © 1973 GENERAL LEARNING CORPORATION
ALL RIGHTS RESERVED.

ISCS STAFF

David D. Redfield, Co-Director
William R. Snyder, Co-Director
Ernest Burkman, Steering Committee Chairman

Robert L. Cocanougher, Art Director
Stewart P. Darrow, Teacher Education
George O. Dawson, Teacher Education
Cheval Fagan, Artist
Ronald N. Giese, Evaluation
James A. Hathway, Editor
Adrian D. Lovell, Administration and Field Trial Coordinator
Janet Mauney, Artist
Lynn H. Rogers, Artist
Millicent Shargel, Grammarian
Stephen C. Smith, Artist
Lois S. Wilson, Assistant Editor

MATERIALS DEVELOPMENT CONTRIBUTORS

Betsy Conlon Balzano, State University of New York at Brockport
Thomas Boehm, State University of New York at Albany
Linda Dubaldi, F.S.U.
William H. Fletcher, F.S.U.
John R. Hassard, Georgia State University
H. Dale Luttrell, North Texas State University
Mildred MacMullen, Hudson, New York
E. Wesley McNair, F.S.U.
Luis A. Martinez-Perez, F.S.U.
Charles Mielcarski, Averill Park, New York
Lawrence E. Oliver, F.S.U.
Barney Parker, F.S.U.
Everett S. Stallings, F.S.U.
Paul H. Westmeyer, F.S.U.

FOREWORD

To implement an educational approach successfully, one must match the philosophy of evaluation with that of instruction. This is particularly true when individualization is the key element in the educational approach. Yet, as important as it is to achieve this match, the task is by no means simple for the teacher. In fact, without specific resource materials to help him, he is apt to find the task overwhelming. For this reason, ISCS has developed a set of individualized evaluation materials as part of its Individualized Teacher Preparation (ITP) program. These materials are designed to assist teachers in their transition to individualized instruction and to help them tailor their assessment of students' progress to the needs of all their students.

The two modules concerned with evaluation, *Individualizing Objective Testing and Evaluating and Reporting Progress*, can be used by small groups of teachers in in-service settings or by individual teachers in a local school environment. Hopefully, they will do more than give each teacher an overview of individualized evaluation. These ITP modules suggest key strategies for achieving both subjective and objective evaluation of each student's progress. And to make it easier for teachers to put such strategies into practice, ISCS has produced the associated booklets entitled *Performance Objectives*, *Performance Assessment Resources*, and *Performance Checks*. Using these materials, the teacher can objectively assess the student's mastery of the processes, skills, and subject matter of the ISCS program. And the teacher can obtain, at the moment when they are needed, specific suggestions for remedying the student's identified deficiencies.

If you are an ISCS teacher, selective use of these materials will guide you in developing an individualized evaluation program best suited to your own settings and thus further enhance the individualized character of your ISCS program.

The Co-Directors
Intermediate Science Curriculum Study
Rm 415, W.H. Johnston Building
415 North Monroe Street
Tallahassee, Florida 32301

THE ISCS INDIVIDUALIZED TESTING SYSTEM

The ISCS individualized testing system for each level of ISCS is composed of four major subdivisions:

1. The ITP modules *Evaluating and Reporting Progress* and *Individualizing Objective Testing*,
2. *Performance Objectives*,
3. *Performance Checks* in three alternate forms, and
4. *Performance Assessment Resources*.

Evaluating and Reporting Progress presents a comprehensive overview, with many refinements, for individualizing the grading and reporting of students' progress, based on both subjective and objective criteria. The module *Individualizing Objective Testing* describes more specifically those ISCS evaluation materials which have objective criteria – the performance objectives, checks, and resources – and it presents practical suggestions for their use. These two modules should be considered prerequisite to successful use of the other ISCS evaluation materials.

Each of the *Performance Objectives* booklets contains a composite list of selected measurable objectives considered important to a given level of the ISCS program. However, many of the long-range goals and aims that are at the heart of the ISCS program do not lend themselves to being expressed as measurable performance objectives. Thus, these booklets should not be construed as being all-inclusive anthologies of all the possible learning outcomes of ISCS.

Each of three *Performance Checks* booklets contains an equivalent but alternative set of performance checks which were developed to assess the students' achievement of the objectives stated in the *Performance Objectives* booklets.

The *Performance Assessment Resources* booklet is a teacher's handbook to be used in identifying the appropriate performance checks with which to evaluate each student. The booklet also indicates how to set up testing situations, correct responses, and give remedial help.

NOTES TO THE TEACHER

An overview of evaluation, including both objective and subjective criteria, is given in the module *Evaluating and Reporting Progress*. Many aspects of this booklet are described in more detail in Chapter 3 of the module *Individualizing Objective Testing*. These notes are meant to augment, not replace, Chapter 3 of that module. As you use this booklet, you will begin to see ways to modify its suggestions to meet your needs better. You are encouraged to enter your modifications at the points where they apply. Only by altering these materials will you evolve an evaluation system best suited to your own classroom environment. It is important to remember that only principles involved in objective criterion-referenced evaluation are applied in this booklet. Therefore, you will obviously want to incorporate subjective criteria also.

Units and Chapters

There are at least two *Performance Assessment Resources* booklets for each level of ISCS. These booklets are divided into units, thus breaking up a single level of the ISCS program into easily handled sections of correlative chapters. The relationship between the units and the chapters of *Probing the Natural World* are shown in Table 1.

LEVEL I

UNIT	CHAPTERS	EXCURSIONS
1	1 and 2	1 thru 3
2	3 and 4	4 thru 8
3	5 thru 7	9 thru 14
4	8 and 9	15 thru 19
5	10 and 11	20 thru 22
6	12 and 13	23 thru 27
7	14 and 15	29 thru 33
8	16 and 17	34 thru 39
9	18 and 19	40 thru 44
10	20 and 21	45 thru 48

Table 1

As you can see from Table 1, most units include the objectives and performance checks for two chapters and their related excursions. The individual objectives and performance checks for each unit are to be selected and used when the student has completed the entire unit. This delay should ensure that there is no premature assessment of the student's achievement of concepts and skills which may be introduced early in a unit, but which require development throughout the unit. Thus, subdividing units for assessment purposes should be done with great care. Keep this in mind if you decide to spot check students as they proceed through units, rather than conducting a formal evaluation at the end of the unit.

Summary Table

Each unit begins with a double-spread "Performance Check Summary Table." The left-hand page of the "Summary Table" serves as a table of contents for the unit. It provides a great deal of information about the objectives pertinent to the unit. Usually about twenty-five objectives for each unit are introduced for the first time in each "Summary Table." A maximum of ten relevant objectives from previous units are reintroduced.

On the left-hand side of the "Summary Table" is a list of code numbers, each of which is unique to one objective within the level. Two examples of code numbers and their meanings are illustrated in Figure 1 below.

<u>03</u> - <u>Core</u> - <u>17</u> . and <u>05</u> - <u>Exc</u> <u>19</u> - <u>2</u>					
unit	based on core material	unit	based on excursion material	excursion number	2nd objective for excursion

Figure 1

The core objectives first appear in an order that corresponds roughly to the text development. Exceptions to this ordering were made to place objectives based on related processes or content together. Objectives based on remedial excursions are numbered as core objectives because they involve skills essential to success in core activities. Next are listed the general or enrichment excursion objectives, and these are followed by objectives from prior units which are again considered important to the students' progress. These repeated objectives are easily spotted, as a capital R (for Repeated) appears after their identifying code number, giving a listing such as 03-Core-17R. The specific resource aids to be used with repeated objectives are given in the units designated by the code number (unit 3 in the just-cited example), and the information is not repeated each time within the textual material that follows the "Summary Table."

Each objective code number is followed by a short descriptive statement of that objective. These short statements were written, using the students' vocabulary. They should be helpful in communicating the objectives to the students should you desire to do so. Ways to involve your students in selecting the objectives are discussed in the module *Individualizing Objective Testing*.

The right side of the "Summary Table" is made up of eleven columns. Letters are used in the first five to designate the characteristics of the performance check. The letters and their meanings are as follows:

- M - Completing the check requires regular ISCS materials.
- O - An observer should view the student's performance as he does the check.
- P - Completing the check requires the use of specially prepared materials.
- Q - The answer to the check is of the quick-scoring variety.
- T - The check will require more than three minutes of the student's time.

Check marks in the next four columns help the teacher assign appropriate performance checks to individual students. The first of these columns is entitled "Basal." Achieving the objectives checked in this column is considered essential to most students' success with the total unit. These performance checks may be assigned to any student; however, better students will find that many of these offer little or no challenge.

Check marks in the columns headed "Math," "Reading," and "Concept" indicate performance checks which require a higher level of computational skills, a higher reading level, or a greater ability to think abstractly than the performance checks for most other objectives. Performance checks which have no marks in any of these four columns are considered to be more than basal, but the skills which they require are within the capability of most students.

A tenth column lists the action verb that identifies the theoretical mental process required of the student to complete the performance check for the objective. A precise definition of each of the verbs used to designate mental processes is given in the module *Individualizing Objective Testing*.

Finally, in the eleventh column, space is provided for notes. Although you will find an occasional comment printed here, this space is mainly for your notes. It's a good place to put any special instructions or preparations you have found helpful.

As mentioned earlier, some objectives are repeated objectives - ones that have appeared in previous units. When such an objective is listed again in the "Summary Table," its classification as basal or as presenting math, reading, or conceptual difficulties is likely to be different. This change most often derives from a change in purpose. The first time a concept or skill is introduced, the intent may be only to introduce students to it. When reintroduced in a later unit, the skill or concept is frequently developed and used extensively. Thus, in the "Summary Table" for the earlier unit, objectives related to a concept are likely to be classified as conceptually difficult for many students, whereas in the later units, the same objective might be reclassified as basal.

Organization of Resources

Immediately following each "Summary Table" comes the bulk of the resource material for each objective introduced in that unit. Once more, each objective is identified by its code number, but this time it appears in bold, black print in the outer margin directly beside the applicable resource. A pair of horizontal lines separates the resources for each objective from those for the previous and following objectives. When no horizontal line appears at the bottom of a page, the objective is continued on the next page.

The list immediately following delineates the functions of the various component resources provided for the objectives. Two of the components (Regular Supplies, Special Preparations) only appear when they are needed for a particular item. Many of the performance checks, for example, do not require any supplies, so supply headings are omitted. Observe the functional descriptions carefully — they are the keys to the types of resource materials provided in the *Performance Assessment Resources* booklet.

COMPONENTS	FUNCTION
Descriptive Statement	This statement duplicates the one that appears in the "Summary Table." If you misread a code number and find yourself looking at material for the wrong objective, this should stop you and send you back to the Table to check. More important, it should briefly indicate to you the basic purpose of the objective.
Objective	The underlined verb in this statement of the objective indicates the theoretical mental process that the student will perform. The phrase following it indicates the content or process skill which the student must perform. A complete description of the verbs and their meanings can be found in the ITP module <i>Individualizing Objective Testing</i> .
Regular Supplies	This section lists any ISCS equipment that the student will need — regular equipment that is being used in the unit on which the student is being evaluated or in previous units.
Special Preparations	Don't overlook this section. It lists and describes materials the teacher must collect or prepare in some way. Included are special solutions, special packaging, and labels required for materials for evaluation purposes. The section also specifies particular grids that the students will need for graphing.
Student Action	This is a general description of what the student should do in responding to any of the three performance checks based on the objective. If his expected response is to state a general principle, it is listed in this section. If the three performance checks require specific answers, they are provided below the general statement in the student action.
Performance Check A	Performance Check A is fully stated to allow for a quick review of the statement of the tasks as they are presented to the student. Performance Checks B and C generally present slightly different situations or wording but ask students to perform equivalent tasks.

Remediation

This final section outlines suggested action that can be taken if the student fails to achieve the objective. In some of the remediations, the listed steps are sequential; in others the steps represent options from which it is suggested that you select one or two. Some remediations suggest referring the student to review sections of the core, doing an excursion, or reviewing a self-evaluation question and its response.

How to Find It

Locating a particular objective whose number you know is easy. Just thumb through the pages watching for the unit number which appears in large black print above the word *core* or *excursion* in the margins. But suppose you wish to locate an objective pertinent to a given section or chapter of the text and you don't know the number. Here is a procedure to follow:

1. Determine the unit in which the chapter occurs, using Table 1.
2. Thumb through this booklet until you find that unit number as the beginning digits of any code number appearing in large black print in the outer margin.
3. Look for the "Summary Table" at the beginning of that unit.
4. Use the "Summary Table" to determine the number of the objective you seek.

Be Selective

The resource books for each level contain many more objectives and resources than any one teacher can use. If you add objectives and resources, and you probably will, your list will expand further. The most successful user of this catalog will be the teacher who picks and chooses selectively to meet the specific needs of his students. Therefore, once you are familiar with this book, it is imperative that you establish a system of selecting and assigning checks to the student. Suggestions on how to establish such a system are given in Chapter 3 of the module *Individualizing Objective Testing*.

Whatever selection and assignment system you develop, it must give due regard to individual student's differences. For example, if you administer too many recall performance checks to a high-ability student, he will not only be bored but you will also fail to assess his progress adequately. Too many difficult items administered to a low-ability student leads to frustration and reinforcement of the "I knew I couldn't do it" attitude. On the other hand, even the best students need their egos inflated by some questions that they can answer easily. And, the less able student needs to be appropriately challenged. Be careful, too, of placing too much emphasis on objectives. This may lead students to place undue emphasis on tests, thus slowing their progress to the extent that they lose interest in the story line.

Assigning Performance Checks

How many performance checks should be assigned to a student? This question has no fixed answer. The primary concern is that performance checks provide the needed feedback to both you and the student. If, in your judgment, evaluating a student on a particular unit is unnecessary, then don't do it. If you feel a student needs to be evaluated, then assign an appropriate selection of performance checks. *Individualizing Objective Testing* makes suggestions about how to do this. In no case should any student be assigned all the performance checks or even a random sampling of them. Such a practice would subject the student to tasks which would be either unduly difficult and time-consuming or perhaps too simple for him and therefore meaningless, time-wasting activities.

You may wish to specify the equivalent form (A, B, or C) of performance checks that the student should do when assigning the specific performance check numbers. There is, of course, no difference in their difficulty level. In any case, have the student record both the number and the letter of the specific performance check he does. These numbers and letters should appear on his answer sheet, as they will be needed to check his response. Since the numbers are unique within each ISCS level, there is no need to use a student's time copying the performance checks. Listing the number with the response is sufficient. It's a good idea to remind students frequently that their answers must go on separate paper — not in the *Performance Checks* books.

As you assign checks, keep the supply situation in mind. You won't want too much of some equipment tied up in Special Preparations at any one time. To avoid this, keep abreast of the range of your students' progress and prepare only those materials you anticipate needing, referring to the P's appearing in the third column on the right-hand page of the "Summary Table." Batteries, of course, will need replacement or recharging occasionally, and specially boxed supplies should be checked periodically for missing or nonfunctioning parts.

At the back of Part 2 of the *Performance Assessment Resources*, you will find grids identical to those the students must use in certain performance checks. The grids at the back are suitable for reproduction. You may make copies directly, using one of the well-known commercial copiers. For large quantities at low cost, make a master by the thermo process and use it to make duplicates. If you make copies in either of these ways, your students will not be wasting time drawing grids, and you will feel free to assign objectives that need grids.

06

Chapters 12 and 13

Performance Check

Excursions 23 thru 27

Summary Table

Objective Number	Objective Description
06-Core-1	Remembers when current will flow in a circuit
06-Core-2	Names the substance which causes the blue color in a solution
06-Core-3	Labels the reddish-brown solid on a carbon rod
06-Core-4	Selects the energy conversion within a charging battery
06-Core-5	Names the form of energy stored in a battery
06-Core-6	Describes the reaction within a battery during charging and discharging
06-Core-7	Indicates what makes an electrical circuit complete
06-Core-8	Constructs a series circuit
06-Core-9	Diagrams a series circuit
06-Core-10	Uses the effect of one appliance on another to classify the connection as series or parallel
06-Core-11	Diagrams a parallel circuit
06-Core-12	Constructs a parallel circuit
06-Core-13	Recognizes the effect of adding a resistor to a series circuit
06-Core-14	Indicates a way to reduce current flowing in a series circuit
06-Core-15	Labels circuit diagrams as series or parallel
06-Core-16	Gives the cause for temperature change in a current-carrying resistor
06-Core-17	Recognizes the effect of a magnet on a current-carrying wire

Materials	Observer	Special Preparations	Quick Score	3 + Minutes	Basal	Math	Reading	Concept	Action Verbs	Notes
					✓				applies	
		P	Q		✓				recalls	
		P	Q		✓				identifies	
			Q		✓				recalls	
			Q		✓				recalls	
									applies	
			Q		✓				recalls	
M	O			T	✓				applies	
			Q	T	✓				applies	
			Q	T					classifies	
				T	✓				applies	
M	O			T	✓				applies	
			Q		✓				applies	
								✓	applies	
			Q		✓				classifies	
					✓				applies	
					✓				applies	

06

Objective Number	Objective Description
06-Core-18	Recognizes the effect on the strength of an electromagnet of changing the number of loops of wire
06-Core-19	Selects characteristics of energy
06-Exc 23-1	Selects variables which affect the electrical output of a battery
06-Exc 24-1	Recognizes evidence of chemical changes in which energy is released
06-Exc 25-1	Recognizes errors in measurement
06-Exc 25-2	Draws a best-fit line between points on a grid
06-Exc 26-1	Selects a characteristic of parallel circuits
06-Exc 27-1	Indicates the direction compass needles point when electricity passes through a nearby wire
01-Core-8R	Selects simple electrical systems from among nonsystems
01-Core-14 thru 17R	(Arithmetic skills)
01-Core-18 thru 22R	(Student's responsibilities)
02-Core-13R	Explains magnetic attraction in terms of force
02-Core-16R	Remembers the question that operational definitions answer
05-Core-14R	Relates friction to temperature change
05-Core-16R	Selects relative amounts of potential and kinetic energy
05-Core-22R	Recognizes the characteristics of energy

Materials	Observer	Special Preparations	Quick Score	3 + Minutes	Basal	Math	Reading	Concept	Action Verbs	Notes
			Q		✓				applies	
			Q					✓	classifies	
			Q		✓				classifies	
			Q						applies	
									applies	
M		P		T	✓				applies	
			Q						applies	
				T					applies	
					✓				applies	
			Q		✓				applies	
M	O		Q		✓				chooses	
M				T	✓				applies	
					✓				recalls	
			Q		✓				applies	
			Q						applies	
			Q		✓				classifies	

O6 Core 1

Remembers when current will flow in a circuit.

The student applies the rule that current will not flow in an incomplete circuit.

Student Action: Responding to the effect that the component will not be activated because the circuit is not complete.

Performance Check A: Assume that the equipment shown in the diagram below is all in good working order.

1. Will the bulb light?
2. Why do you believe the bulb will or will not light?

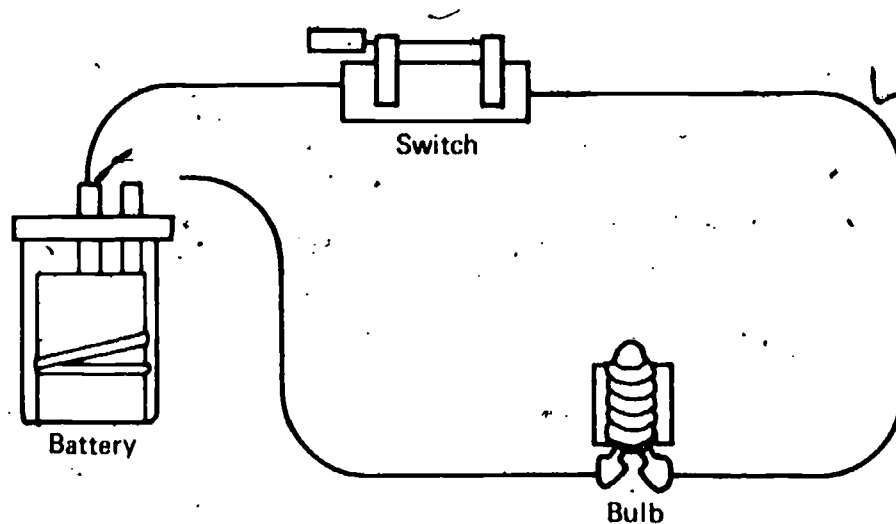

Remediation: (1) Suggest that the student review Chapter 1 in which the battery was involved in several different systems. Discuss the battery-motor-sinker system and the battery-bulb system. Is the pathway continuous in these systems? What would happen if a test lead were disconnected? Try it! (2) Refer the student to Self-Evaluation Check 13-1 on page 151.

O6 Core 2

Names the substance which causes the blue color in a solution.

The student recalls that the blue solution he used in connection with Chapter 12 contained copper.

Special Preparation: Prepare a bottle of copper sulfate solution labeled O6-Core-2.

Student Action: Selecting "copper."

A: b

B: a

C: c

Performance Check A: Get the bottle of blue solution labeled 06-Core-2. This is the same as the solution you used in Chapter 12. Which material in these solutions was responsible for the reddish-brown coating on the carbon rod?

- a. Water
- b. Copper
- c. Sulfate
- d. Oxygen

Remediation: (1) Discuss the copper plating experiment with the student. What happened to the carbon rod when it was placed in the blue liquid and electricity was allowed to flow through the circuit? What was the substance which was coated on the rod? Where did this substance come from? Check his response to question 12-15. (2) Suggest that the student read pages 145 and 146 if additional review is necessary.

Labels the reddish-brown solid on a carbon rod.

The student identifies copper as the reddish-brown solid on a carbon rod which was coated in the blue solution during the activities in Chapter 12.

Special Preparation: Put a copper-coated carbon rod in a box labeled 06-Core-3.

Student Action: Naming copper.

Performance Check A: The carbon rod in box 06-Core-3 was coated with a substance during the activities done in Chapter 12. Name the material that coats the carbon rod.

Remediation: (1) See the Remediation for 06-Core-2. (2) You may also wish to refer the student to Self-Evaluation Check 12-4, page 150.

Selects the energy conversion within a charging battery.

The student recalls that electrical energy is changed into chemical energy when a battery is charged.

Student Action: Selecting the statement "Electrical energy is changed into chemical energy."

- A: d
- B: a
- C: b

Performance Check A: A car battery is properly connected to an electric battery charger. Choose the letter of the sentence below which describes the energy conversion that takes place within the battery during charging.

- a. Electrical energy is changed into kinetic energy.
- b. Chemical energy is changed into electrical energy.
- c. Light energy is changed into heat energy.
- d. Electrical energy is changed into chemical energy.

06
Core
3

06
Core
4

Remediation: (1) Refer the student to Activity 12-13 in which he examined the lead strips of his charged battery. Ask him to describe the appearance of the lead in question 12-23. How were the strips different after charging from when he made the battery? What form of energy is stored in the strips? Where does his battery get its input energy? Therefore, what form of energy was put into it? (2) Have the student read page 150 for a good summary of energy conversion in a battery. (3) Refer him to Self-Evaluation Checks 12-1 and 12-2.

06 Core 5

Names the form of energy stored in a battery.

The student recalls that energy is stored in a battery as chemical energy.

Student Action: Stating that the form of energy is chemical.

Performance Check A: In what form is energy stored in a battery?

Remediation: See the Remediation for 06-Core-4.

06 Core 6

Describes the reaction within a battery during charging and discharging.

The student applies the concepts that charging a battery means storing energy in it by converting one substance into another and that during discharging, the reaction is reversed, releasing electrical energy.

Student Action: Responding to the effect that charging a battery stores electrical energy in it and discharging reverses the reaction and releases electrical energy.

Performance Check A:

1. What happens inside a rechargeable automobile battery when it is being charged?
2. When it discharges to the automobile, what happens inside the battery?

Remediation: (1) Refer the student to Activity 12-13 on page 149. What happened to the lead sheets inside your battery when it was charged? What do you think happens to this coating when your battery becomes discharged? (2) Have the student read page 150, which describes energy conversion in a battery. (3) Refer him to Self-Evaluation Check 12-1 and 12-5.

06 Core 7

Indicates what makes an electrical circuit complete.

The student recalls that a complete electrical circuit is one which has an unbroken conductive path through which electrical current may travel.

Student Action: Responding to the effect that he must make an unbroken conductive path.

Performance Check A: Luis has a battery, 2 bulbs, and 3 test leads. What must he do to make a complete electrical circuit? You may use a diagram as part of your answer.

Remediation: (1) Discuss Activity 13-1, page 154, with the student. In each arrangement you made with the given objects, how did you make the circuit complete? (How did you have to connect the objects so that electricity would flow?) (2) Check his response to question 13-1. Would electricity flow in a single wire which is not connected in a continuous pathway?

Constructs a series circuit.

The student applies the rule for constructing a series circuit in such a way that when any one of the bulbs is removed from the socket, the other bulbs go out.

Regular Supplies: 1 charged "D" size battery
2 No. 222 bulbs and sockets
3 test leads

Student Action: Connecting the two bulbs in a series circuit.

Teacher's Note: If properly connected, the two bulbs should glow dimly. You may test the circuit by removing one bulb; the other should then go out.

Performance Check A: Go get 1 charged flashlight battery, 2 bulbs and sockets, and 3 test leads. Using these materials, connect the two bulbs in a series circuit. Show your teacher what you have done.

Remediation: (1) Check the student's drawing of Figure 13-2 in his *Student Record Book*. If this drawing is correct, simply have him review the series circuit discussion on page 155. (2) If the drawing is incorrect, suggest that he do Excursion 26, which provides remediation on series and parallel circuits.

Diagrams a series circuit.

The student applies the rule that a series circuit is wired so that electricity follows a path from one battery terminal through the switch and each of the appliances in succession, terminating at the other battery terminal.

Student Action: Diagraming a series circuit which contains a battery and the other elements. No one terminal of any component should show more than one connection.

Performance Check A: Diagram a circuit that shows a switch, a battery, a motor, and two light bulbs connected in series.

06
Core
8

06
Core
9

Remediation: (1) Ask the student what a series circuit is. Refer him to page 155 and Figure 13-2. If he needs additional review of series circuits, suggest that he do Excursion 26. (2) Also refer the student to Self-Evaluation Check 13-2. (3) When you are sure that he has a clear understanding of a series circuit, ask him how he must connect the objects in the check he was given. Have him show you his diagram.

06 Core 10

Uses the effect of one appliance on another to classify the connection as series or parallel.

The student classifies the wiring (circuitry) as series when one device's ceasing to operate causes a second device to stop operating and as parallel when one device's ceasing to operate does not stop the second device.

Student Action: Naming the correct circuit type.

A: 1. series, 2. parallel, 3. series

B: 1. parallel, 2. series, 3. series

C: 1. series, 2. parallel, 3. parallel

Performance Check A: For each of the following statements, tell whether the electrical devices mentioned are wired in *parallel* or in *series* with each other. Write *series* or *parallel* on your answer sheet next to the number for each statement.

1. Suppose a fuse (circuit breaker) in a house is removed and that causes the television set in the living room to go off. How are the fuse (circuit breaker) and the television wired?
2. A toaster and a light are both plugged into the receptacles of a wall outlet. The toast pops up, and the toaster shuts off. But the light remains on. How are the toaster and the light wired?
3. Suppose you wish to roast meat in an electric oven. You set the electric timer on your oven for two hours. At the end of two hours, the timer rings and shuts off. The oven also shuts off. How are the timer and the oven wired?

Remediation: (1) Question the student to determine his understanding of series and parallel circuits. If he cannot define the two terms, have him do, or review, Excursion 26. (2) If the student needs only a brief review of series and parallel circuits, suggest that he read pages 429 and 430. If time permits, have him set up the two circuits with two bulbs in each and show you the effect of unscrewing a bulb in each circuit. Have him respond to questions 26-12 and 26-13 on page 430. (3) Reassess, using an alternate check.

06 Core

Diagrams a parallel circuit.

The student applies the rule that a parallel circuit is wired so that the electricity flows from one terminal of the battery through each of the appliances directly and from the opposite terminal of each of the appliances back to the other battery terminal.

Student Action: Diagraming a parallel circuit containing a battery and the other elements given. One terminal of each component should be connected to one battery terminal and the other battery terminal connected to each of the other component terminals.

Performance Check A: Diagram a circuit containing a battery, a motor, and two bulbs wired in parallel.

Remediation: (1) Check Figure 13-3 in the *Student Record Book*. If he has no idea what a parallel circuit is, suggest that he do the latter half of Excursion 26. (2) If the student needs only a brief review, refer him to Diagram 13-3, page 155, of the related discussion. Self-Evaluation Check 13-7 will also be helpful. (3) Reassess, using an alternate check.

Constructs a parallel circuit.

The student applies the rule for constructing a parallel circuit so that when one or two of three bulbs are removed from the sockets, such bulbs as remain stay lit.

Regular Supplies:

- 1 charged "D" size battery
- 3 No. 222 bulbs and sockets
- 6 test leads

Student Action: Connecting the three bulbs in a parallel circuit.

Teacher's Note: All three bulbs should light at full brilliance. If they are very dim, either the battery is weak or the circuit is improperly connected. You can check for the latter by unscrewing one bulb; if the remaining two bulbs stay lit, the circuit is correctly connected.

Performance Check A: Get the following: 1 charged "D" size battery, 3 bulbs and sockets, and 6 test leads. Using these materials, connect the three bulbs in a parallel circuit. Show your teacher what you have done.

Remediation: See the Remediation for O6-Core-11.

Recognizes the effect of adding a resistor to a series circuit.

The student applies the principle that each resistor added to a series circuit causes every other resistor in the circuit to receive less electrical energy.

Student Action: Responding to the effect that adding an element (resistor) to a series circuit reduces the amount of electrical energy received by each resistor within the circuit.

Teacher's Note: For purposes of this objective, bulbs and motors are treated as resistors.

11

O6
Core
12

O6
Core
13

Performance Check A: Look at the circuit diagramed below. Suppose one more bulb is added in series with the circuit. How would this affect the amount of electrical energy the motor and the other bulbs receive?

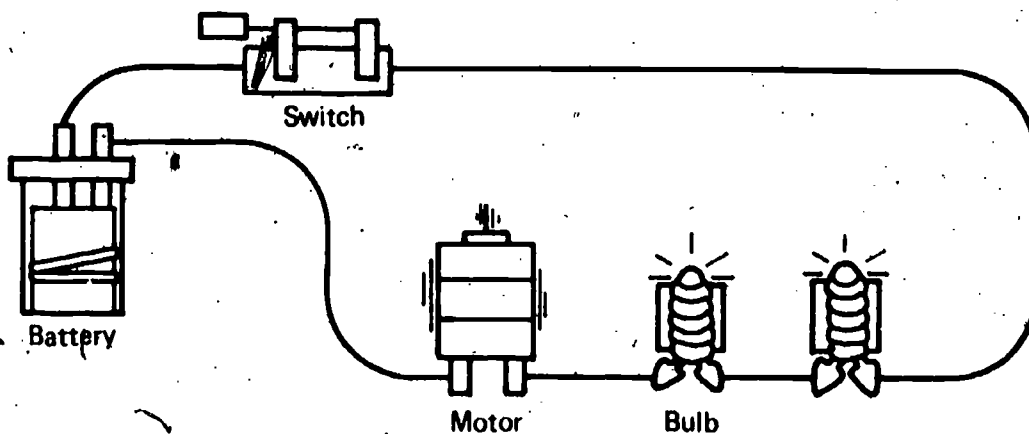

Remediation: Suggest that the student review pages 156 and 157. Figure 13-4 is also helpful. What happens to the amount of electrical energy each bulb receives when you add more bulbs in a series circuit?

O6 Core 14

Indicates a way to reduce current flowing in a series circuit.

The student applies the rule that increasing the resistance of a series circuit by adding resistors in the circuit decreases the current flow.

Student Action: Stating either that adding another resistor in series in the circuit or that substituting a resistor with higher resistance for one already in the circuit would decrease the flow of current.

Performance Check A: The amount of current flowing in the circuit diagramed below can be reduced in several ways. State one way in which the current can be reduced but not stopped.

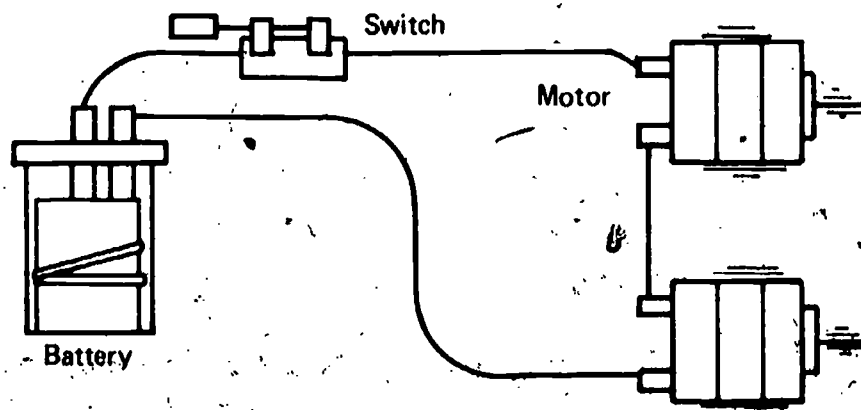

Remediation: (1) Suggest that the student review page 157 for the discussion of resistance. How does the brightness of the bulb in the series circuit which contains two bulbs compare with one which contains only one bulb? Is there a decrease in current flow in the two-bulb circuit? If the student has difficulty answering these two questions, have him do the activity. (2) The student can also be referred to Activity 13-8, in which a resistor is used. Check his response to questions 13-33 through 13-35. Have him compare the movements of the coil in Activities 13-6 and 13-8. Is there a decrease of current flow in 13-8? Why? (3) Refer the student to Self-Evaluation Check 13-5.

Labels circuit diagrams as series or parallel.

The student classifies each of four circuits as either parallel if the diagram shows more than one pathway from the battery to the resistors or series if the pathway for the electricity is shown going to each resistor consecutively.

Student Action: Indicating the correct circuit type in all four cases.

A: 1 and 3 – parallel; 2 and 4 – series.

B: 1 and 4 – parallel; 2 and 3 – series.

C: 1 and 3 – series; 2 and 4 – parallel.

Performance Check A: Each diagram below represents either a series or a parallel circuit. On your paper, beside the number of each diagram, name the type of circuit it shows.

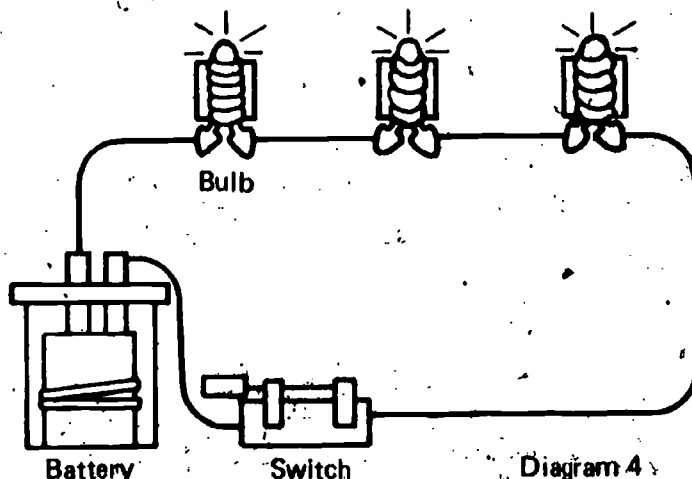
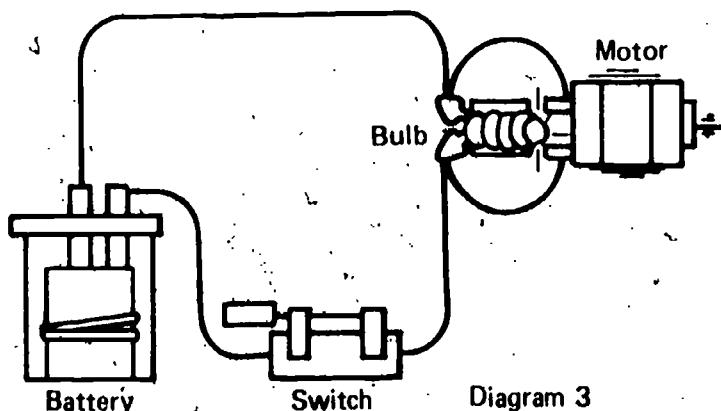
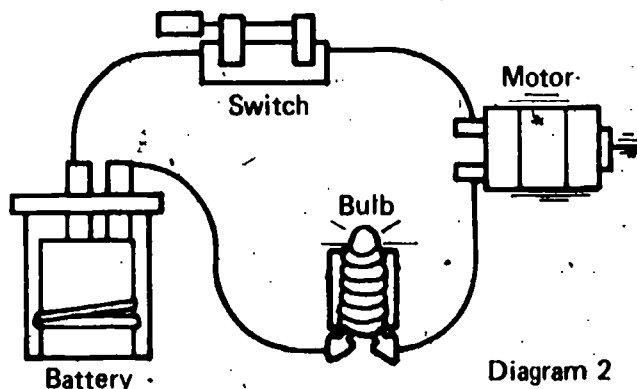
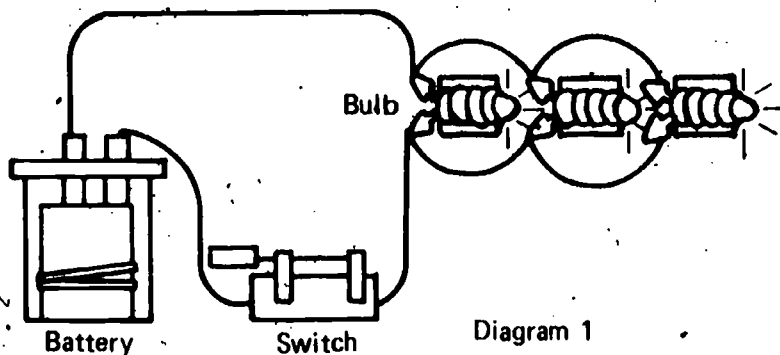

06
Core
15

Remediation: See the Remediation for 06-Core-14.

06 Core 16

Gives the cause for a temperature rise in a current-carrying resistor.

The student applies the concept that when electrical energy passes through a material, some of that electrical energy is changed into heat energy.

Student Action: Responding to the effect that when electrical energy passes through a resistor, some of that energy is changed into heat energy.

Performance Check A: When electricity is passed through a resistor, the temperature of the resistor rises. What causes this?

Remediation: (1) Refer the student to Activity 13-2, page 156. What happened to the nichrome wire when electricity passed through the circuit? What characteristic of the circuit is associated with this temperature change? (2) What form of energy conversion takes place? What form of energy is associated with nichrome wire?

06 Core 17

Recognizes the effect of a magnet on a current-carrying wire.

The student applies the concept that when a current-carrying wire and a magnet are brought near each other in a situation where only one is free to move, there will be a force between the two objects and the free object will move.

Student Action: Predicting that the free object will move in response to the force between the two objects.

Performance Check A: Suppose that a compass with its magnetic needle is placed under the wire of an electrical circuit, as shown below. What will happen when the switch is closed?

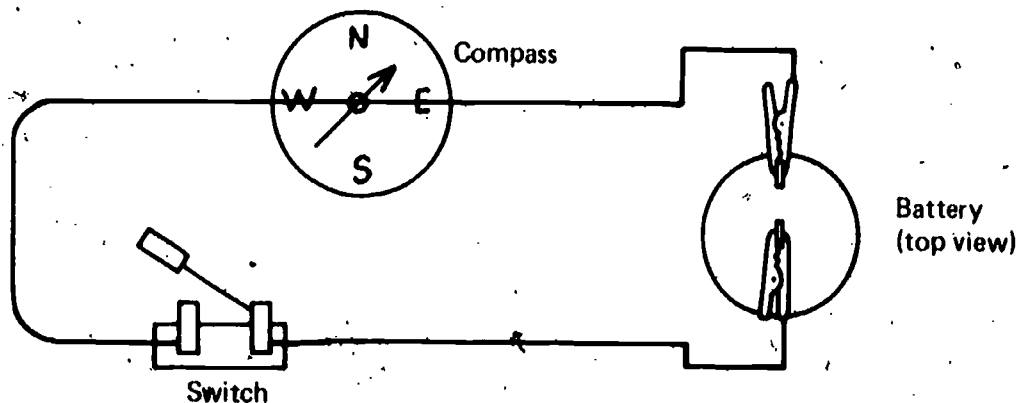

Remediation: (1) Suggest that the student review Activity 13-4. (2) Check his response to questions 13-17 through 13-20. (3) Suggest that he read page 160 which describes the concept of a magnet and a current-carrying wire exerting a force on each other. (4) Refer the student to Self-Evaluation Checks 13-4 and 13-8. (5) Suggest that the student do Excursion 27.

Recognizes the effect on the strength of an electromagnet of changing the number of loops of wire.

The student applies the concept that the strength of an electromagnet varies with the number of loops in the coil of wire.

Student Action: Stating that the strength of an electromagnet varies with the number of loops in a coil of wire.

Performance Check A: How does changing the number of loops in a coil of wire affect its magnetic strength?

Remediation: (1) Have the student compare the movement of the wire in Activity 13-4 to that in Activity 13-6, pages 159 and 162. (2) Check his response to questions 13-28 and 13-29. (3) How did the movement of the wire differ in the two activities? What caused this increase in the movement of the wire in Activity 13-6? How could you change the amount of wire so as to get even greater movement?

06
Core
18

Selects characteristics of energy.

The student classifies four statements which are offered as general characteristics of energy.

Student Action: Selecting "Energy can exist in more than one form" and "Energy can be transferred from one system to another" as characteristics of energy.

- A: c and d
- B: b and c
- C: a and b

Performance Check A: Record the letter of each statement below which identifies a characteristic of energy. Energy can

- a. be measured by speed multiplied by distance.
- b. be destroyed.
- c. exist in more than one form.
- d. be transferred from one system to another.

Remediation: The characteristics of energy are developed in the context of potential energy and kinetic energy in Chapters 8 and 9. (1) You may wish to refer the student to questions 9-19 through 9-21 and to the two paragraphs that follow. (2) In a broader context, you can refer to the first two paragraphs of Chapter 12 and discuss the answers to questions 12-1 and 12-2.

Selects variables which affect the electrical output of a battery.

The student classifies the type of metal in the strip and the type of solution as the variables affecting the amount of electrical energy given off by a battery.

06
Core
19

06

Exc 23 1

Student Action: Selecting the two variables "using strips made of different metals" and "using a different solution, such as copper sulfate."

- A: a and c
- B: a and d
- C: b and c

Performance Check A: This battery, as it is pictured, will not produce enough electricity to light a bulb. Write the letter of any change listed below which would let the battery produce more electrical energy.

- a. Using strips made of different metals
- b. Using a beaker rather than a battery jar
- c. Using a different solution, such as copper sulfate
- d. Using a cardboard divider

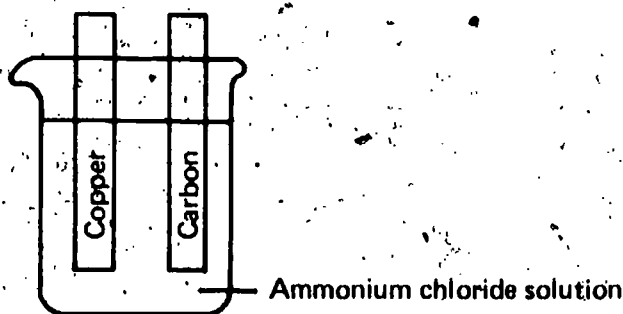

Remediation: (1) Have the student review Excursion 23 and his data in Tables 23-1 and 23-2. (2) Discuss the results with him. Which metal strips caused the bulb to light? Which caused the motor to run? Which solution worked best? (3) Check his response to questions 23-2 through 23-4. (4) Have the student do an alternate check.

O6 Exc 24 1

Recognizes evidence of chemical changes in which energy is released.

The student applies the concept that chemical changes in which chemical energy is given off can be identified by the production of light, heat, electricity, bubbles, or the physical scattering of reactants.

Student Action: Selecting the three entries containing such evidences.

- A, B, and C: a, b, c

Performance Check A: Chemical energy can be stored and then changed to other forms. Write the letters of any sentences below in which it is possible to say that the stored chemical energy is changing to other forms.

- a. The brown coating on the lead strip in your ISCS battery disappeared when electricity was produced.
- b. The zinc metal strip turned copper-colored when placed in copper sulfate solution and the solution got hot.
- c. The addition of glycerine to potassium permanganate produced light.
- d. None of those are correct.

Remediation: (1) Have the student review Excursion 24. (2) If the student failed to select letter *a*, refer him to Chapter 12, Activity 12-13, pages 149 through 151, for discussion. (3) If he failed to select letter *b*, refer him to page 416 where he did this activity. Check his response to question 24-11. (4) If he failed to select letter *c*, suggest that he review Activity 24-2 and questions 24-18 through 24-25.

Recognizes errors in measurements.

The student applies the concept that all measurements, no matter how precise, are approximations and that it is impossible to eliminate errors in measurement.

Student Action: Responding in disagreement with the proposition and to the effect that all measurements, no matter how precise, are approximations and that it is impossible to eliminate errors in measurement.

Performance Check A: Nick measures the weight of a beaker, using a balance like you use in your ICS course. He gets a weight of 25.0 g. Next he measures the same beaker using a more precise balance – a centigram, or *triple beam balance*, as it is sometimes called. He gets a weight of 24.98 g. Finally, he uses an electrical balance, which gives him a weight of 24.976 g. Nick says now he knows that the 25.0 g weight he recorded earlier is in error and that the weight of the beaker is exactly 24.976 g.

1. Do you agree or disagree with Nick?
2. Why?

Remediation: (1) Have the student review Excursion 25, especially Table 25-2. Discuss the data in this table with the student and the errors in measurement involved. Is it possible to eliminate these errors? Check his response to questions 25-7 through 25-11.

Draws a best-fit line between points on a grid.

The student applies the concept that a best-fit line is a smooth curve with as many points above as below the line.

Special Preparations: Grid paper must be available. You may wish to reproduce the grid below with axis labeled and points plotted, rather than have the students do the construction.

Student Action: Drawing a best-fit line on the grid.

Performance Check A: Luis plotted points for data he collected using a spinigig. The points were located as shown on the grid below. Get grid paper from your teacher. Label the axis, and plot the points as shown below. Then draw the best-fit line for the points.

O6
Exc
25
1

O6
Exc
25
2

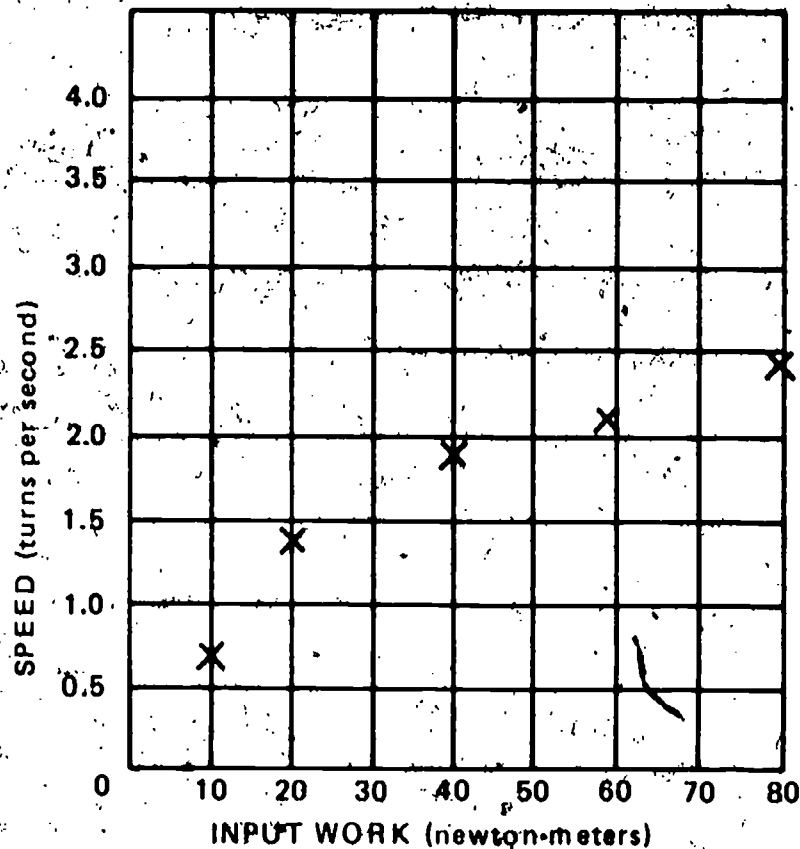

Remediation: (1) If the student can't draw a best-fit line, have him do or review Excursion 5, especially page 305. (2) Discuss Figure 5-2, page 305, with him. (3) Have him draw the best-fit line for the check he was given.

O6
EXC
26
1

Selects a characteristic of parallel circuits.

The student applies the principle that parallel circuits allow electricity to follow any one of several independent paths.

Student Action: Selecting only the response which indicates that electricity flows in several paths.

- A: d
- B: b
- C: c

Performance Check A: The electrical outlets in Iggy's house are wired in parallel. Write the letter of the sentence below that explains what that means.

- a. The circuit contains more light bulbs than if it had been wired in series.
- b. The TV, stove, and stereo will work whether or not they are switched on.
- c. If the TV is switched off, the fan also stops running.
- d. The electricity can flow through the circuits in any one of several paths.
- e. All of the above are correct.

Remediation: (1) Suggest that the student review pages 429 and 430 of Excursion 26, in which parallel circuits were introduced. (2) Check his response to questions 26-10 through 26-14.

Indicates the direction compass needles point when electricity passes through a nearby wire.

The student applies the concept that the magnetic field around a wire through which electricity is flowing is a series of concentric circles.

Student Action: Drawing compass needles pointing in directions tangential to imaginary circles centered on the wire and passing through their pivots.

Performance Check A: The following diagram shows a copper wire passing through a piece of cardboard on which several compasses have been placed. On your answer sheet, trace the cardboard and compasses. Then, use arrows to show the direction the compass needles will point when the switch is closed and electricity is passing through the wire.

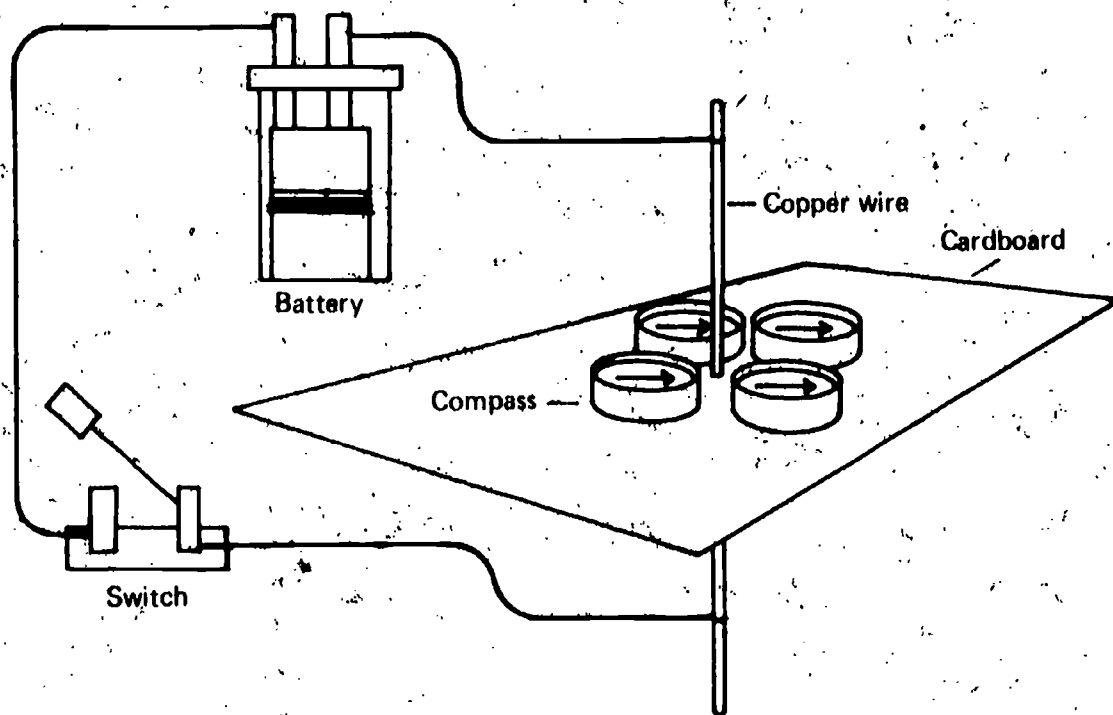

Remediation: (1) Suggest that the student review Excursion 27. (2) Check the student's results for Activity 27-13 and discuss Figure 27-2 with him.

O6
Exc
27
1

07

Chapters 14 and 15

Performance Check

Excursions 28 thru 33

Summary Table

Objective Number	Objective Description
07-Core-1	Selects a statement as not characteristic of a scientific model
07-Core-2	Selects the correct source of scientific models
07-Core-3	States two things done by a good scientific model
07-Core-4	Selects a characteristic of a scientific model
07-Core-5	Lists three characteristics assumed true of the ISCS electroparticle model
07-Core-6	Traces the path of electroparticles in charging a battery
07-Core-7	Decides the uniqueness and relevance of a model to a phenomenon
07-Core-8	Describes the process of charging a battery
07-Core-9	Uses the electroparticle model to explain how energy gets to components of an electric circuit
07-Core-10	Describes the function of the two poles of a battery
07-Core-11	States the effect which adding a resistor has on the current in a circuit
07-Core-12	Recognizes the effect of the amount of energy per electroparticle on the number of electroparticles flowing in a circuit
07-Core-13	Lists phenomena not explained by the electroparticle model
07-Core-14	States the reason for connecting an ammeter in series
07-Core-15	States a use of the ISCS electricity measurer in series with a circuit
07-Core-16	States how units of measurement come into being

Materials	Observer	Special Preparations	Quick Score	3 + Minutes	Basal	Math	Reading	Concept	Action Verbs	Notes
			Q		✓				recalls	
			Q		✓				recalls	
			Q		✓				recalls	
			Q					✓	classifies	
			Q		✓				recalls	
					✓				recalls	
								✓	recalls	
					✓				applies	
					✓				recalls	
					✓				recalls	
					✓				recalls	
					✓				recalls	
			Q		✓				applies	
					✓				recalls	
					✓				recalls	
					✓				classifies	
			Q						recalls	

07

Objective Number	Objective Description
07-Core-17	Describes the battery-charging process, using the electroparticle model
07-Core-18	States the name of the standard unit for measuring electrical current
07-Core-19	Names the unit used to measure electrical energy carried by an electroparticle
07-Core-20	Shows how to change an ammeter so that it will measure voltage
07-Core-21	Makes a voltmeter scale for an ISCS electricity measurer
07-Core-22	Shows the use of an ammeter in a constructed circuit
07-Core-23	States what reverses the direction of deflection of the pointer on an electricity measurer
07-Core-24	States the effect that adding one more series circuit element has on the energy received by each element in a circuit
07-Exc 28-1	States the direction of motion of surface water in waves
07-Exc 28-2	Explains the movement of waves, using a trough and cork
07-Exc 28-3	Explains what makes a good description a good model
07-Exc 29-1	Selects the reason that new models are accepted
07-Exc 29-2	Selects the reason for acceptance of a scientific model
07-Exc 29-3	Selects what is implied by acceptance of a model
07-Exc 30-1	Completes a drawn circuit showing wires attracting or repelling each other
07-Exc 31-1	Selects the best description of scientists
07-Exc 32-1	Decides whether batteries should be connected in series or in parallel

Materials	Observer	Special Preparations	Quick Score	3 + Minutes	Basal	Math	Reading	Concept	Action Verbs	Notes
					✓				generates	
			Q		✓				recalls	
			Q		✓				recalls	
M	O	P	Q	T	✓				manipulates	
M	O		Q	T	✓				manipulates	
M	O		Q	T	✓				applies	
			Q		✓				applies	
					✓				applies	
			Q						applies	
M				T					applies	
				T					applies	
			Q						applies	
			Q						applies	
			Q						applies	
			Q						applies	
			Q						applies	
				T					applies	

07

Objective Number	Objective Description
07-Exc 33-1	Explains the effect of change in simple parallel circuits, using the electroparticle model
07-Exc 33-2	States the results of adding more batteries to a series circuit
01-Core-18 thru 22R	(Student's responsibilities)
02-Core-16R	Remembers the questions that operational definitions answer
05-Core-22R	Recognizes the characteristics of energy
06-Core-7R	Indicates what makes an electrical circuit complete
06-Core-8R	Constructs a series circuit
06-Core-12R	Constructs a parallel circuit
06-Core-13R	Recognizes the effect of adding a resistor to a series circuit
06-Core-18R	Recognizes the effect on the strength of an electromagnet of changing the number of loops of wire
06-Core-19R	Selects characteristics of energy

Materials	Observer	Special Preparations	Quick Score	3 + Minutes	Basal	Math	Reading	Concept	Action Verbs	Notes
									applies	
					✓				applies	
M	⊖		Q		✓				chooses	
					✓				recalls	
			Q		✓				classifies	
			Q		✓				recalls	
M	O			T	✓				applies	
M	O			T	✓				applies	
			Q		✓				applies	
			Q		✓				applies	
			Q		✓				classifies	

07 Core 1

Selects a statement as not characteristic of a scientific model.

The student recalls that a model is an explanation which establishes a relationship within a set of observations, data, or generalizations by means of a mental or physical picture or a mathematical equation.

Student Action: Selecting the statement "It is an experimental observation" as not characteristic of a scientific model.

- A: b
- B: d
- C: a

Performance Check A: Select the answer which is not true of a scientific model.

- a. It explains observations.
- b. It is an experimental observation.
- c. It may in some cases be represented by a physical object or a sketch.
- d. It is useful.

Remediation: (1) Suggest that the student review Chapter 14, pages 171 and 172, where the characteristics of a good model are introduced, as well as his answer to Self-Evaluation Check 14-2. (2) Discuss these characteristics and the concept of a mental model with the student. In Chapter 14, we built a model for electricity called the *electroparticle* model. Can you see electroparticles passing from your charged battery to a bulb? Must you see these electroparticles in order for your model to be good, or can we say that you built a useful mental model based on your observations of electricity?

07 Core 2

Selects the correct source of scientific models.

The student recalls that scientific models are thought up by men.

Student Action: Selecting the entry to the effect that models are thought up in people's minds.

- A: d
- B: c
- C: b

Performance Check A: Select the best answer. Scientific models come into existence by being

- a. discovered in nature, using telescopes.
- b. found among data and pieced together.
- c. extracted from nature, using microscopes.
- d. thought up by men, using their observations.

Remediation: (1) Suggest that the student review pages 171 through 175 in Chapter 14. (2) Discuss building the electroparticle model with him (page 174). In building this model, one imagines that the battery contains millions of tiny electroparticles. Thus, electroparticles weren't discovered or found in nature – no one has seen them – but were created in the minds of people.

States two things done by a good scientific model.

The student recalls that a good scientific model (1) suggests questions, (2) explains observations, (3) suggests new experiments, and (4) predicts the nature of the results of the new experiments.

Student Action: Responding with two of the four characteristics above.

Performance Check A: State two things a good scientific model does.

Remediation: (1) Refer the student to Chapter 14, pages 171 through 173, where the characteristics of a good scientific model are developed. (2) Also refer him to Self-Evaluation Check 14-2.

Selects a characteristic of a scientific model.

The student classifies the concept that the models scientists use may be described as useful rather than as correct.

Student Action: Selecting the statement which describes the model as useful rather than as correct.

- A: c
- B: d
- C: a

Performance Check A: Select the statement below which best fits your understanding of the models that scientists use. A scientific model

- a. provides correct answers to all scientific questions.
- b. describes what actually happens in nature and therefore is correct.
- c. is not used because it is correct, but because it is useful in explaining observations and predicting other observations.
- d. cannot be shown to be incorrect.

Remediation: (1) Discuss the electroparticle model with the student. Why is this model useful? Is it useful because it helps to explain a set of observations and enables us to predict things? Or is it useful because we are certain that it is correct—we have seen electroparticles in test leads and they really do have hats and three legs. (2) Such a line of thought as that will eliminate the choices which indicate that the usefulness of a model lies in its correctness and will give strong evidence for the right choice. If a student suspects that “cannot be shown to be incorrect” is the right answer discuss the item with him. Would one throw out a floor-plan model of a school because a new room was added, or would one modify the existing floor-plan model?

07
Core
3

07
Core
4

07 Core 5

Lists three characteristics assumed true of the ISCS electroparticle model.

The student recalls that it is assumed that electroparticles (1) can be given energy, (2) can move from place to place, (3) can give up energy, (4) will move through conductors in a complete circuit, and (5) will lose all their energy in so doing.

Student Action: Responding with at least two of the notions above.

Performance Check A: The ISCS model for electricity uses the idea of the electroparticle. List three characteristics that are assumed to be true of the ISCS electroparticle.

Remediation: (1) Refer the student to page 174 of Chapter 14. (2) Here the ISCS model for electricity is built, and the characteristics of the model, which are assumed to be true, are listed. (3) If the student has difficulty in understanding or accepting these assumptions, a discussion may help him.

07 Core 6

Traces the path of electroparticles in charging a battery.

The student recalls that when an ISCS battery is being charged, low energy electroparticles move out of the low energy terminal of the battery, receive energy from the charger, and return to the battery through the high energy terminal.

Student Action: Describing the path of the electroparticles and explaining the charging of the battery as outlined above.

Performance Check A: The diagram below shows an ISCS battery charger and an ISCS battery. On your answer sheet, describe the path through the battery-charger circuit that we assume electroparticles follow. Tell what happens to the electroparticles at each step.

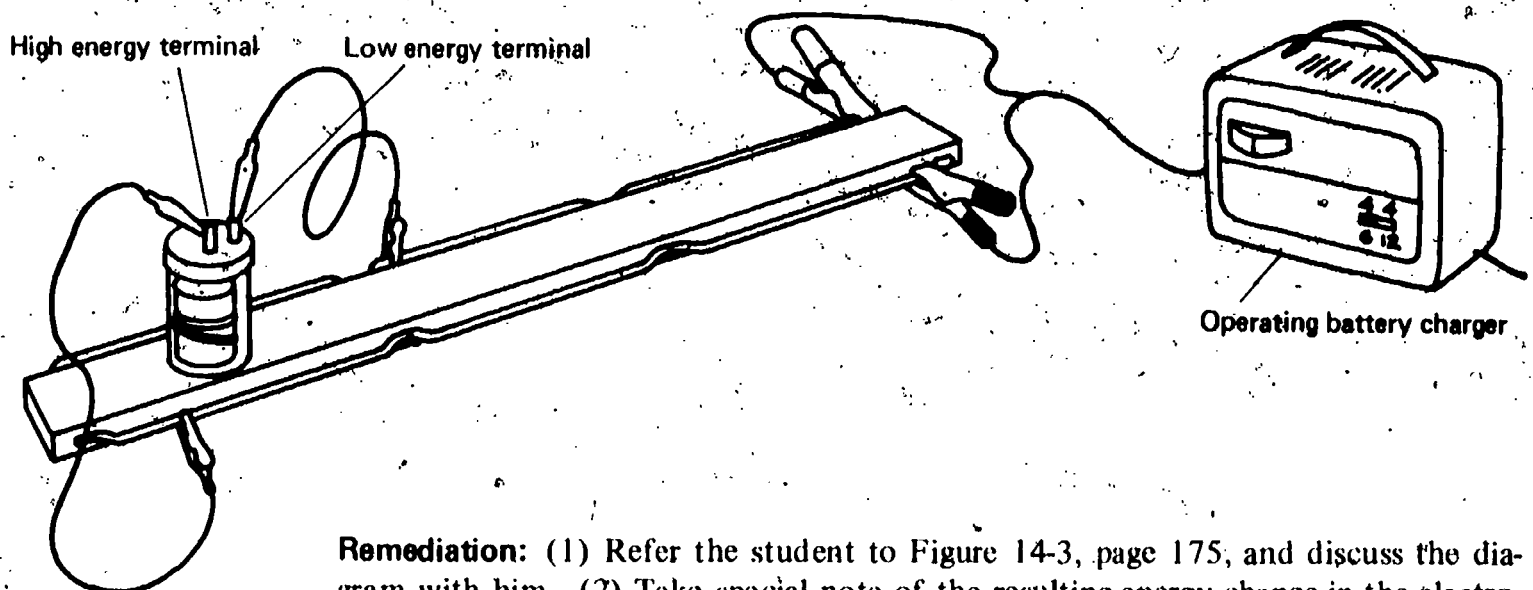

Remediation: (1) Refer the student to Figure 14-3, page 175, and discuss the diagram with him. (2) Take special note of the resulting energy change in the electroparticle and in the battery.

Decides the uniqueness and relevance of a model to a phenomenon.

The student recalls that more than one model can be invented to explain the same phenomena and that a scientist uses the model which best suits his ~~problem~~.

Student Action: Responding affirmatively and with the notion of the concept.

Performance Check A: Can scientists develop more than one model which can be used to explain light? If not, why not? If so, how would a scientist decide which model to use?

Remediation: (1) Discuss building a model with the student. How does one build a scientific model? What is this model based on? Could other models for electricity be developed, based on the same set of observations? (2) Refer the student to pages 171 through 173.

07
Core
7

Describes the process of charging a battery.

The student applies the assumptions of the electroparticle model to the process of charging a battery.

Student Action: Describing the battery charging process, using the notion that the charger gives energy to the electroparticles which then return to the battery and are stored there with their extra energy.

Performance Check A: Using the electroparticle model, describe the process of charging a battery.

Remediation: (1) See Remediation 07-Core-6. (2) Review the student's response to Self-Evaluation Check 14-4.

07
Core
8

Uses the electroparticle model to explain how energy gets to components of an electric circuit.

The student recalls that high energy electroparticles carry energy from the battery to a given component, give up their energy, and return to the battery as low energy electroparticles.

Student Action: Responding to the effect of the above.

Performance Check A: When a charged battery is connected to a light bulb and the circuit is complete, the bulb lights. Using the ISCS electroparticle model, explain how the energy travels through the circuit and how it makes the bulb light.

Remediation: (1) Refer the student to Figure 14-4. Discuss this diagram with the student. A light bulb or electric bell can be substituted for the motor. Give special consideration to the energy changes involved. (2) Review the student's response to Self-Evaluation Check 14-5.

07
Core
9

07 Core 10

Describes the function of the two poles of a battery.

The student recalls that outgoing high-energy electroparticles leave the battery from one pole and that returning low-energy electroparticles pass into the battery through the other pole.

Student Action: Responding to the effect of the above.

Performance Check A: Tell what happens at the poles (terminals) of a battery when there is a complete circuit to a motor. Explain your answer in terms of the ISCS electroparticle model.

Remediation: See the related Remediation for 07-Core-9.

07 Core 11

States the effect which adding a resistor has on the current in a circuit.

The student recalls that a resistor allows fewer electroparticles to flow through a circuit in a given period of time.

Student Action: Responding that a resistor allows fewer electroparticles to flow through a circuit in a given time period.

Performance Check A: Use the electroparticle model to explain what happens to the current flow in a circuit when a resistor is added.

Remediation: Refer the student to Figure 14-7 on page 179. Ask him to describe the difference between the two diagrams. What happened to the flow of energy when the resistor was added? How was the electroparticle different after the resistor was added; that is, what effect does the resistor have on the electroparticle?

07 Core 12

Recognizes the effect of the amount of energy per electroparticle on the number of electroparticles flowing in a circuit.

The student applies the feature of the electroparticle model which assumes that the number of electroparticles flowing through a resistor in a circuit in a given period of time is dependent upon the energy of each electroparticle.

Student Action: Selecting the entry which states to the effect that the number of electroparticles flowing depends upon the energy of each electroparticle.

A: d

B: c

C: b

Performance Check A: A circuit contains a charged battery, an electric motor, and a resistor. Which factor in the list below determines how many electroparticles will pass through the resistor in two minutes if the battery has a good charge?

- The charge of the battery
- The size of the electric motor
- The size of the electroparticles
- The energy of each electroparticle

Remediation: (1) Refer the student to Figure 14-8, page 180. Ask the student to describe this diagram to you. Why are there more electroparticles passing through the resistor in line 3 of the figure than in line 2? What causes this increase? What is different about the electroparticles in line 3 from those in line 2? (2) Ask what determines how many electroparticles will pass through a resistor per unit of time.

Lists phenomena not explained by the electroparticle model.

The student recalls at least two of the following phenomena not explained by the electroparticle model: (1) the capacity of electroparticles to pass through solid wire, (2) the capacity of electroparticles to cause a wire to act like a magnet, (3) the ability of electroparticles to carry energy, (4) the form of the energy carried by electroparticles, (5) the source of the energy that moves electroparticles, and (6) the release of differing amounts of energy to a given resistor depending on the number and type of resistors in the circuit.

Student Action: Listing the notion of at least two unexplained phenomena such as the above.

Performance Check A: List three things about the flow of electricity through a circuit that are not explained by the ISCS electroparticle model.

Remediation: (1) Refer the student to the list on page 181 of phenomena not explained by the electroparticle model. (2) If the student is not satisfied with this list, suggest that he do Excursion 29, which shows how the model is unable to explain all the characteristics about electricity. (3) Ask the student to check his own response to Self-Evaluation Check 14-6.

States the reason for connecting an ammeter in series.

The student recalls that only in a series circuit will all of the current flowing in the circuit flow through the meter.

Student Action: Responding to the effect of the above.

Performance Check A: When you use an ammeter to measure the current received by a circuit, you must connect it in series with the circuit. Why?

Remediation: (1) Suggest that the student review page 192 and Figure 15-5. (2) Check his responses to question 15-9 and to Self-Evaluation Check 15-3. (3) Discuss this figure with the student. Why can't an ammeter measure the current flowing through the bulb when it is hooked up in parallel?

07
Core
13

07
Core
14

07 Core 15

States a use of the ISCS electricity measurer in series with a circuit.

The student classifies an ISCS electricity measurer as an ammeter (or current flow meter) when its resistor is bypassed and it is in series with a circuit.

Student Action: Responding that the electricity measurer will measure current flow (amperes or electroparticles per second) passing through the circuit.

Performance Check A: Study the diagram below to determine how the electricity measurer is connected in the circuit. When it is connected in this manner, what does it measure?

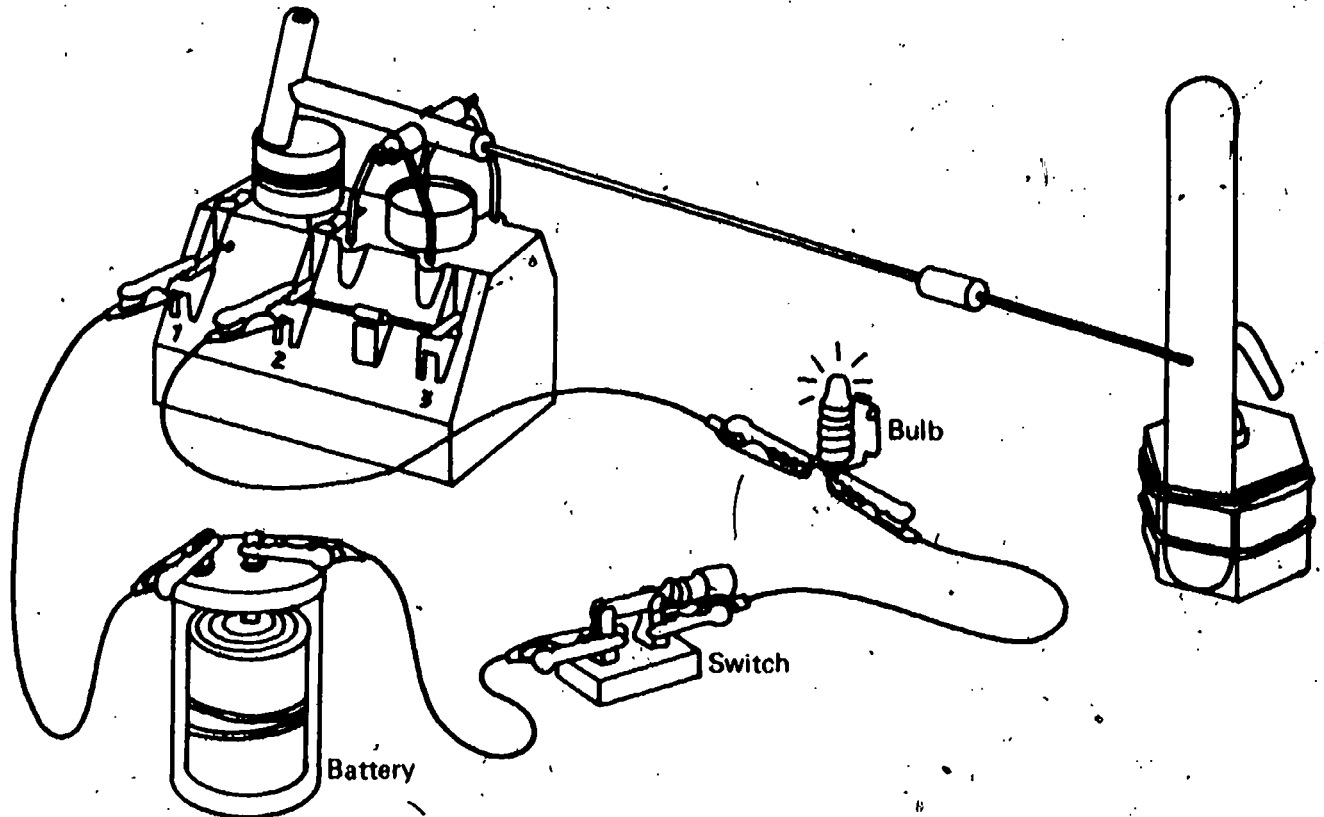

Remediation: (1) Suggest that the student review pages 184 through 186 in Chapter 15. (2) Check his response to questions 15-1 through 15-5. (3) If necessary, discuss these pages with him. It is there that the use of the electricity measurer as a counter of electroparticles is developed.

07 Core 16

States how units of measurement come into being.

The student recalls that a unit of measurement is a matter of definition.

Student Action: Selecting the entry to the effect that a unit of measurement is defined by man.

- A: b
- B: c
- C: d

Performance Check A: Select the best answer below. Accepted units of measurement come into existence when they are

- a. found by experience.
- b. defined by people.
- c. set by nature.
- d. experimentally discovered by scientists.

Remediation: (1) You may wish to have a short discussion on how accepted units of measurement came about. (2) Excursion 7, which may be used as a homework assignment, gives a background on the development of units for linear measurement and also emphasizes the importance of standard units. This excursion may prove beneficial here.

Describes the battery-charging process, using the electroparticle model.

The student generates an explanation for the charging of a battery in terms of the assumptions of the ISCS electroparticle model.

Student Action: Describing the charging of a battery and including the notion that the charger gives energy to the electroparticles which then return to the battery along a pathway which must be unbroken and are stored there with their extra energy.

Performance Check A: One way to describe electricity is to use the electroparticle model. Using this model, describe the process of charging a battery.

Remediation: (1) Ask the student to describe the electroparticle model for electricity. If he is unable to do this, have him review page 174, where the model is introduced. (2) Ask him what happens to the electroparticles when the battery gains a charge. See if he can represent this with a sketch. If not, refer him to Figure 14-3 on page 175. (3) Have him describe this figure to you. (4) Recommend that the student check his responses to Self-Evaluation Checks 14-4, 14-5, and 14-6.

States the name of the standard unit for measuring electrical current.

The student recalls that the ampere is the unit for measuring electrical current.

Student Action: Responding "ampere."

Performance Check A: Name the standard unit for measuring electrical current.

Remediation: (1) Suggest that the student review page 188 of the text, where *ampere* is first introduced. (2) Additional review can be provided by checking the answers to Self-Evaluation Check 15-4.

07
Core
17

07
Core
18

07 Core 19

Names the unit used to measure electrical energy carried by an electroparticle.

The student recalls the volt as the unit for measuring electrical energy carried by an electroparticle.

Student Action: Responding "volt."

Performance Check A: What is the standard unit for measuring electrical energy carried by an electroparticle?

Remediation: (1) Suggest that the student review pages 198 and 199 where *volt* is introduced. (2) Check his response to questions 15-16 and 15-17 and to Self-Evaluation Check 15-6a.

07 Core 20

Shows how to change an ammeter so that it will measure voltage.

The student manipulates an ISCS electricity measurer already set up as an ammeter so that it will measure voltage.

Regular Supplies:

- 1 electricity measurer with ammeter coil attached and 2 test leads properly connected to terminals 1 and 2
- 1 pointer assembly with magnet installed and balance rider attached
- 1 tongue depressor scale (blank) attached by 2 rubber bands to a $\frac{1}{2}$ kg mass
- 1 voltmeter coil

Special Preparations: Set up the equipment assembled as above in a box labeled 07-Core-20. Try to observe the student while he is manipulating the materials. Check his answer and then be sure to return the setup to the supply area assembled as specified above.

Student Action: Replacing the ammeter coil with the voltmeter coil and including the resistor by disconnecting the test lead from terminal 2 and connecting it to terminal 3.

Teacher's Note: As no written response is required, an observer must be available to assess performance on this objective.

Performance Check A: Carefully study the setup your teacher has assembled in box 07-Core-20. As it is set up, it is an ammeter. Change it into a voltmeter. Show your setup to your teacher.

Remediation: (1) Have the student review pages 197 and 198, Activities 15-3 and 15-4, in which the voltmeter setup was introduced to him. (2) You may promote discussion of why one must change to terminal 3 and use a many-turned coil to measure voltage. What does a voltmeter measure? How do we measure the amount of energy each electroparticle has? When we add this resistor, why is it also necessary to substitute the many-turned coil for the ammeter coil?

Makes a voltmeter scale for an ISCS electricity measurer.

The student manipulates an ISCS electricity measurer to construct a voltage scale.

Regular Supplies:

- 1 ISCS electricity measurer kit
- 4 D-cell batteries in holders
- 5 test leads
- 1 blank tongue depressor mounted on a $\frac{1}{2}$ kg mass with 2 rubber bands

Student Action: Assembling the equipment with the zero point marked on a tongue depressor when no cells are in the circuit, making additional points on the scale at the resting points when each additional cell is added in a series with the first cell, and then labeling the marked points above the zero as 1.5, 3.0, 4.5, and 6.0 volts in sequence.

Performance Check A: Get an ISCS electricity measurer kit, four D batteries in holders, five test leads, and a blank tongue depressor mounted on a $\frac{1}{2}$ kg mass with rubber bands. Using these materials, make a voltmeter scale for the electricity measurer.

Remediation: (1) If a student has difficulty with the voltmeter setup itself, see the Remediation for 07-Core-20. (2) Have him review Activities 15-15, 15-16, and 15-17 for the actual construction of the voltmeter scale. (3) Have the student reconstruct the scale for you. Watch for the correct test lead connections. (4) If his only problem was in labeling the scale, have him read the voltage printed on a battery to find the voltage of each cell.

Shows the use of an ammeter in a constructed circuit.

The student applies the rule that ammeters are connected in series with the current supply and the total resistance and the rule for measuring current flow.

- Regular Supplies:**
- 1 ISCS battery
 - 4 bulbs
 - 1 switch
 - 2 motors
 - 7 test leads
 - 1 ammeter complete with scale

Student Action: Connecting the ammeter correctly in each circuit and reporting both of the ampere readings within one of the smallest subdivisions on the scale. For circuit A, the ammeter can be inserted in series between any two interconnected components. For circuit B, the ammeter must be inserted between the battery terminal and the switch, between the battery and the first bulb or between the switch and the first bulb, but it cannot be connected between two bulb.

07
Core
21

07
Core
22

Performance Check A:

1. Construct circuit A. Close the switch and measure the current flow, and report your measurements. Show your ammeter hookup to your teacher.
2. Then hook up circuit B. Close the switch and measure and report the total current flowing in the circuit. Again show your hookup to your teacher.

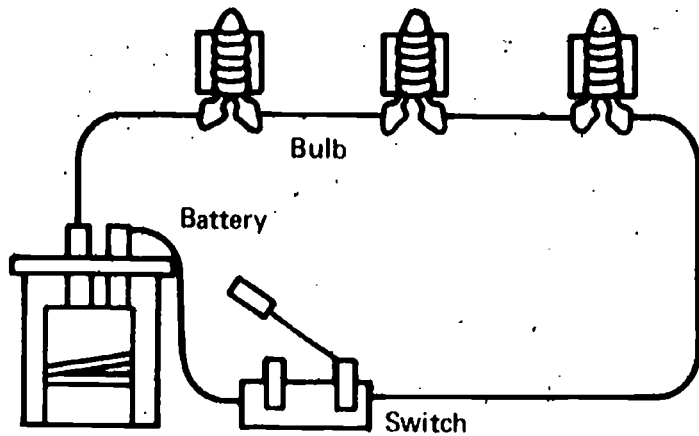

Circuit A

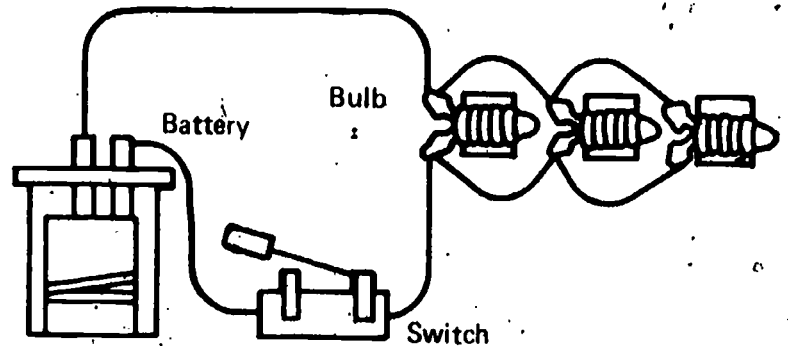

Circuit B

Remediation: (1) Does the student know how to set up an ammeter? If not, refer him to Activities 15-1 and 15-2, page 184. (2) Does he know how to measure the current flow in a circuit? If not, suggest that he review Activity 15-10 where he measured the current flowing through one bulb. Check his response to question 15-8. You may wish to discuss this activity with him. (3) Have the student redo the check. If difficulty still exists, trying in this performance check with Activity 15-10 may be helpful. Have him substitute three bulbs, in series or in parallel, in place of the single bulb in that activity, and then measure current flow.

**07
Core
23**

States what reverses the direction of deflection of the pointer on an electricity measurer.

The student applies the principle that the direction of deflection of a pointer can be reversed on a meter of that type by reversing the connections of the meter to the circuit.

Student Action: Responding to the effect that he would reverse the connections of the meter to the circuit.

Performance Check A: John connects an electricity measurer, closes the switch, and the pointer moves downward on the scale, as shown in the diagram below. What can he do to cause the pointer to deflect upward on the scale?

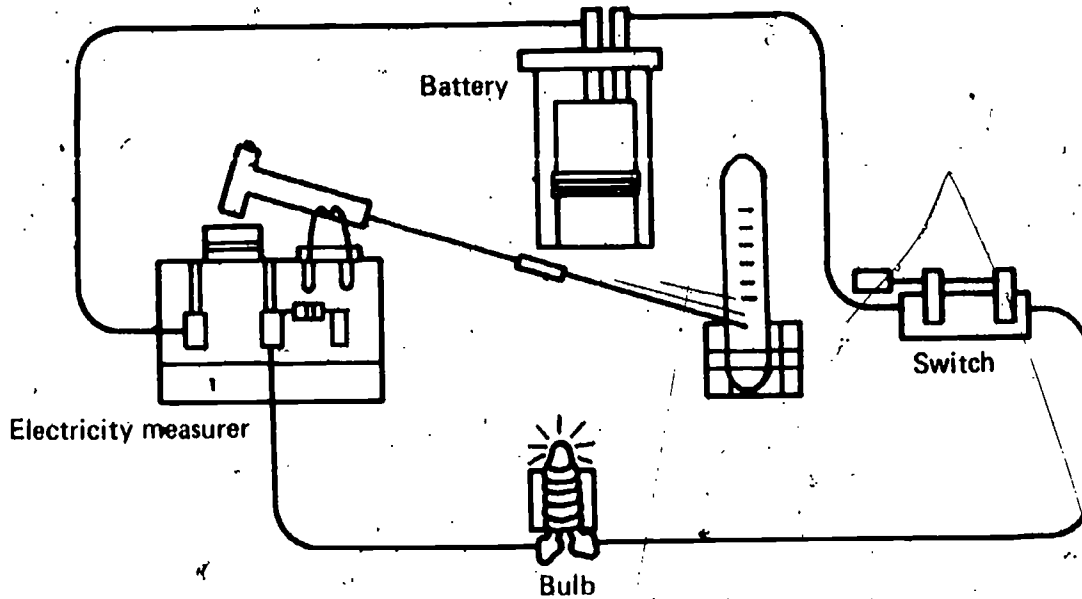

Remediation: (1) Have the student review Activity 15-2. (2) If he has never had the benefit of switching the leads to reverse a downward moving pointer, have him do this activity.

States the effect that adding one more series circuit element has on the energy received by each element in a circuit.

The student applies the principle that each resistor added to a series circuit causes every element in the circuit to receive less electrical energy.

Student Action: Stating in effect that less electrical energy is received by each element.

**07
Core
24**

Performance Check A:

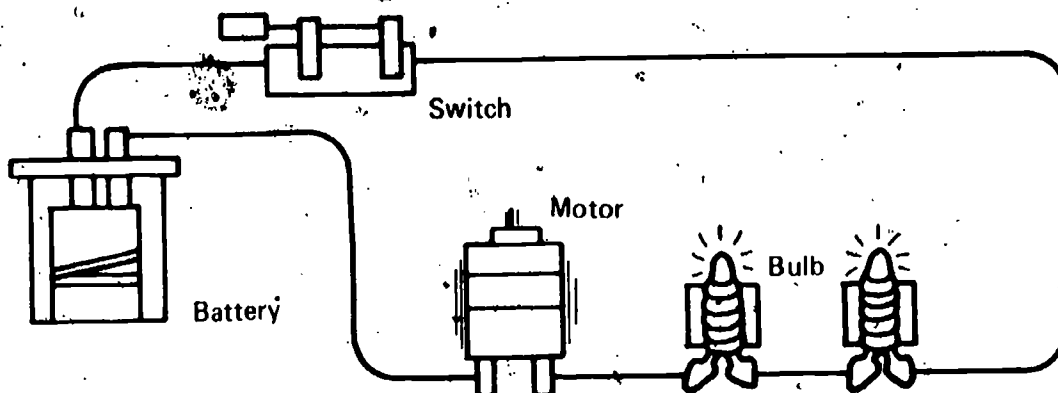

How will adding one more bulb in series in this circuit affect the amount of electrical energy each of the other bulbs receives?

Remediation: (1) Refer the student to Figure 13-4, page 157, and the accompanying text. (2) Refer the student to Figure 14-8, and the two statements above it. If adding a resistance to a circuit reduces the number of electroparticles that travel in a circuit and each electroparticle carries energy, what effect will the added resistor have on the amount of energy available to each circuit element?

O7
Exc
28
1

States the direction of motion of surface water in waves.

The student applies the principle that when waves pass through water, the surface water does not move horizontally but moves up and down.

Student Action: Selecting the statement indicating that the object moves up and down in the same general area.

A: c

B: a

C: b

Performance Check A: A stoppered bottle with a message inside has been thrown into a calm sea by a prisoner on a pirate ship. The captain sees the bottle and tries to shoot it with the ship's cannon. All he does is make waves with the cannon balls. The waves pass under the floating bottle. Which of the following statements best describes the motion of the bottle in the water?

a. Away from the ship

b. Towards the ship

c. Up and down in nearly the same spot

d. Impossible to answer unless you know if the waves are moving away from or toward the ship

Remediation: (1) Have the student review Excursion 28, especially page 445, Figure 28-2. Describe the motion of the man and the boat. Did the man move horizontally in either direction? (2) Suppose you tied a long rope to a post and then tied a handkerchief in the middle of the rope. When you cause waves to travel through the rope by moving it up and down, in which direction will the handkerchief move, up and down or back and forth from side to side?

O7
Exc
28

Explains the movement of waves, using a trough and cork.

The student applies the concept that it is energy which moves horizontally in a wave, and not the medium itself.

Regular Supplies: 1 trough or pan
1 cork

1 pencil
water

Student Action: Responding that there is no horizontal movement of the cork-water system and with the essence of the concept above.

Performance Check A: Place 2 inches of water in a water trough, and put a small cork in the middle of it. With a pencil, slowly tap the surface of the water at one end of the pan, creating a series of waves. Does the cork-water system move horizontally towards or away from the wave source, or doesn't the system move horizontally at all? What, if anything, travels across the water's surface?

Remediation: See the Remediation for 07-Exc 28-1.

Explains what makes a good description a good model.

The student applies the principle that any description is a good model if it explains the observations and can be used for the purpose intended.

Student Action: Responding negatively and stating the notion of the principle.

Performance Check A: Read the following story. Assume that both persons are stating correct facts. Zack Zap is training people to operate light shows. He explains the theory of series circuits, using the electroparticle model of electricity. This model is fairly simple and explains all the observations his students will make. One of his students brings in a new book which explains series circuits, using the new, but complicated, electron model for electricity. Would the student be right to say that because the electroparticle model is incomplete, it is wrong and should never be used? Explain your answer.

Remediation: (1) Review the characteristics of a good model on page 172. (2) Ask the student whether he can name any criteria for a good model which the electroparticle model fails to meet.

Selects the reason that new models are accepted.

The student applies the concept that new models and constructs are proposed as useful ways of thinking about phenomena.

Student Action: Selecting the response to the effect that models are accepted if they are useful ways of thinking about phenomena.

A: b

B: c

C: d

Performance Check A: Select the best answer below. The gravitron, a particle of gravity, is a model proposed to explain gravity. Most scientists will accept the gravitron model

- if forces other than gravity can also be explained in terms of gravitrons.
- if thinking about gravity as tiny particles is useful in explaining gravity.
- if a law is passed that gravity can only exist if it is in the tiny particles described in the model.
- only if gravitrons are seen in experiments.

2

07
Exc
28
3

07
Exc
29
1

Remediation: (1) Have the student review page 172, where the characteristics of a good model are presented. Discuss these characteristics with him to see if he can select the option which matches these characteristics. If he still selects a distractor option, see if he can defend his choice. This will lead to the selection of the correct response. (2) Ask the student to reevaluate his response to Self-Evaluation Check 14-1.

O7
Exc
29
2

Selects the reason for acceptance of a scientific model.

The student applies the concept that scientific acceptance of a model implies that it explains observations made to date but does not imply that scientists feel it to be an absolute truth or that no other model would work.

Student Action: Selecting the entry involving explanation of observations, but not those implying that the model represents an absolute truth.

- A: c
- B: b
- C: d

Performance Check A: Suppose that in 1970 nearly all scientists accepted the wave model for heat. This would mean that

- a. they had direct proof that heat traveled in waves.
- b. at least a few scientists had observed heat traveling as waves.
- c. thinking about heat as though it traveled in waves explained the observations made to that date.
- d. heat had the exact properties of a water wave.
- e. no other model could fit the observations made to date.

Remediation: (1) Discuss the ideas expressed in Excursion 29 with the student. What does this excursion tell him about his model for electricity? Do we have direct proof for electroparticles? Is this the only model which would explain our observations? (2) Review the student's response to Self-Evaluation Check 14-7.

O7
Exc
29
3

Selects what is implied by acceptance of a model.

The student applies the idea that a model needs to be modified to account for new observations.

Student Action: Selecting the entry that best states the idea given above.

- A: b
- B: c
- C: a

Performance Check A: Pretend that nearly all scientists accept the electroparticle model of electricity described in Excursion 29. Choose the entry below which best describes one of the things that acceptance implies.

- a. Scientists have seen electricity travelling as electroparticles.

- b. The model must be revised to incorporate any new observations that don't agree with it.
- c. No other model could fit the observations made to date.
- d. It answers all their questions about electricity.
- e. None of the above are correct.

Remediation: See the Remediation for 07-Exc 29-1.

Completes a drawn circuit showing wires attracting or repelling each other.

The student applies the concept that an attracting force exists between two parallel wires carrying electricity in the same direction and that a repelling force exists between two parallel wires carrying electricity in opposite directions.

Student Action: Indicating the battery polarities.

- A: 1. Terminal 4, 2. Terminal 3
- B: 1. Terminal 3, 2. Terminal 4
- C: 1. Terminal 4, 2. Terminal 3

Performance Check A: Two wires, A and B, are positioned as in Diagram 1 when the switches are open. Diagram 2 shows that when the switches are closed, wires A and B will attract each other. Suppose that in Diagram 2 in the circuit containing wire A the electroparticles come out of the battery through terminal 1 and reenter the battery through terminal 2.

1. Through which terminal in the circuit containing wire B do the electroparticles come out of the battery?
2. Through which terminal in the circuit containing wire B do the electroparticles go back into the battery?

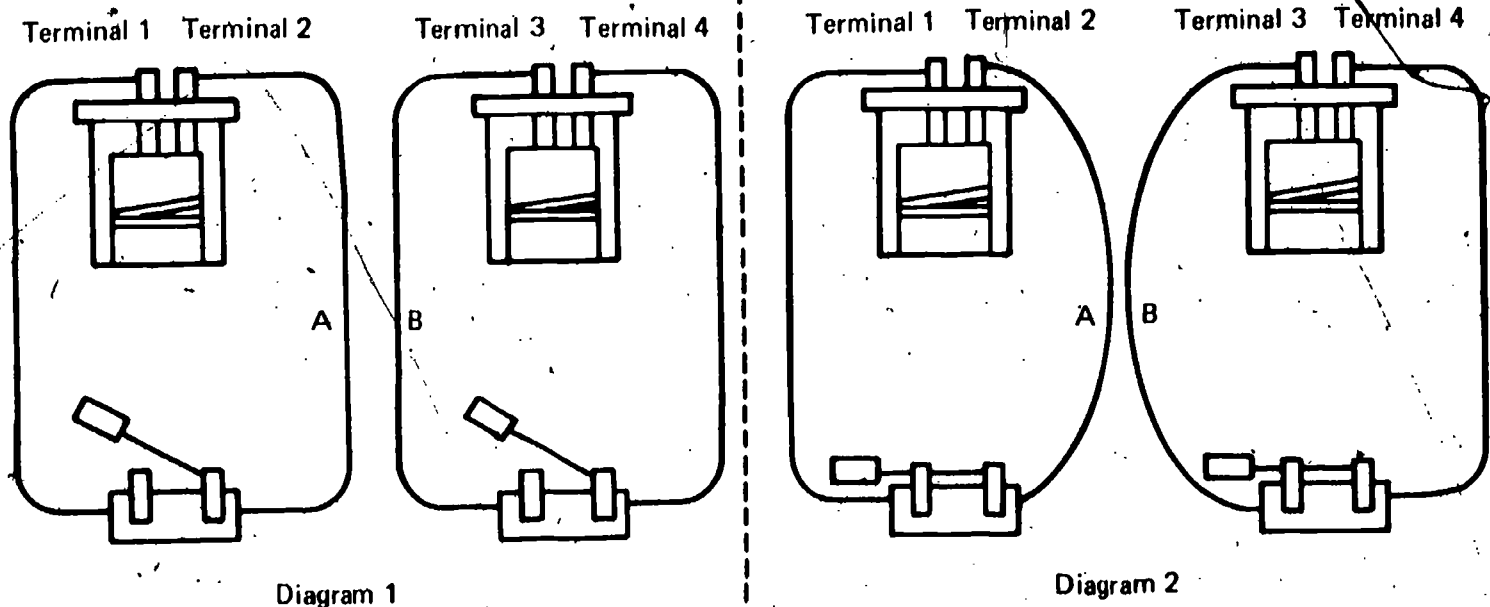

07
Exc
30
1

Remediation: (1) Refer back to Excursion 30, especially question 30-7 on page 456. Did the student answer this correctly? (2) Refer back to Excursion 27 for the magnetic field around a straight wire. Two adjacent wires would have fields like Diagram A below with the current flowing in the same direction, and like Diagram B below with current flowing in opposite directions. In magnetic fields with opposing lines of force, as in Diagram A, the wires attract (opposite magnetic fields attract), and in magnetic fields whose lines of force move in the same direction, as in Diagram B, the wires repel each other (as opposite poles repel each other). Diagram A is the situation existing in Checks A and C; Diagram B is that of Check B.

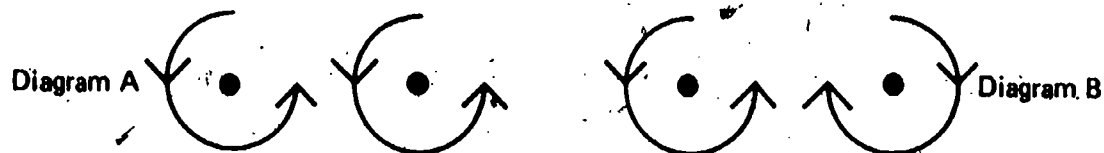

O7
Exc
31
1

Selects the best description of scientists.

The student applies the principle that scientists, like other human beings, exhibit a variety of behavior patterns.

Student Action: Selecting the statement to that effect.

- A: c
- B: d
- C: a

Performance Check A: Which of the following statements is the best description of scientists?

- a. Scientists all exhibit behavior patterns like Ampere's.
- b. Scientists are completely different from other people.
- c. Scientists' personalities vary like those of any other group of people.
- d. Scientists are a group of people who were geniuses even as children.
- e. Scientists are so involved with their work that they do not have time to be polite.

Remediation: (1) Discuss what is meant by *scientist*. Does the student know any scientists (his science teacher or others)? (2) Encourage additional reading on the lives of scientists.

O7
Exc
32

Decides whether batteries should be connected in series or in parallel.

The student applies the concepts that in a series circuit an electroparticle picks up energy from each battery through which it flows, thus enabling the toy to run faster but for less time than if it were in a parallel circuit, whereas in a parallel circuit electroparticles are furnished by each battery independently, causing the toy to run more slowly but for greater lengths of time than it would if wired in a series circuit.

Student Action: Responding with the notion of the concepts above.

Performance Check A: A toy manufacturer wants to make two battery-operated walking dolls which operate on two ordinary batteries. He advertises one doll as "Walking Wilma – she walks slowly, but she'll walk longer than any other doll you can buy." He advertises the other doll as "Running Rowena – she runs short races faster than any other doll made today."

For each doll, state whether the doll's batteries should be connected in series or in parallel. Explain your choices, using the electroparticle model.

Remediation: (1) Review the results of series and parallel connections on the propper in Excursion 32, especially the questions on page 465. (2) Suggest that the student read pages 466 and 467. (3) Retest with an alternate check.

Explains the effect of change in simple parallel circuits, using the electroparticle model.

The student applies the electroparticle model to determine that there is no change in the energy an electroparticle carries when the number of resistors or batteries in the parallel circuit is changed.

Student Action: Stating that with an increase in the number of batteries and resistors the voltmeter reading would remain the same because each cancels the effect of the other.

Performance Check A: Susie the Snoozing Doll operates on two batteries connected in parallel. The motor that operates her arms and the motor that operates her legs, as she stretches can be thought of as two similar resistors. The manufacturer plans a new, improved Susie who can move her head from side to side. This movement will require a third motor (resistor). In addition, the manufacturer plans to add a third battery in parallel. Will a voltmeter reading taken on the new improved Susie be more than, equal to, or less than a voltmeter reading taken on the older version of Susie? Explain your answer, using the electroparticle model.

Remediation: (1) Check the student's answers to questions 33-3, 33-7, and 33-8. (2) If the answers are not correct, have the student discuss Figure 33-1 with you.

States the results of adding more batteries to a series circuit.

The student applies the electroparticle model to explain what happens to an ammeter reading when an equal number of equivalent resistors are added to a series circuit.

Student Action: Responding that when an equal number of equivalent resistors and batteries are added to a series circuit, the ammeter reading should stay the same because if more of these batteries are connected in a series circuit the electroparticles are given more energy, resulting in more current through the resistors, and that an increase in the number of equivalent resistors connected in series decreases the current in the circuit and therefore the ammeter reading would not change.

1

O7
Exc
33
1

O7
Exc
33
2

Performance Check A: Wanda the Walking Doll operates on two batteries and motors connected in series. The motor that operates her arms and the motor that operates her legs can be thought of as two resistors. The manufacturer plans a new, improved Wanda, who can move her head. This movement will be a third motor the same as the other two. In addition to the motor, the manufacturer plans to add a third battery in series. Will an ammeter reading taken in the new, improved Wanda be more than, equal to, or less than an ammeter reading taken in the older version of Wanda? Explain your answer, using the electroparticle model.

Remediation: (1) Check the student's answers to questions 33-9, 33-10, and 33-11.
(2) Discuss Activities 33-4, 33-5, and 33-6 with the student.

08

Chapters 16 and 17

Performance Check

Excursions 34 thru 39

Summary Table

Objective Number	Objective Description
08-Core-1	Uses the electroparticle model to explain how an ammeter should be connected
08-Core-2	States the way a voltmeter should be connected in a circuit
08-Core-3	States the procedure for detecting and measuring voltage in a circuit
08-Core-4	Designates a meter's use as an ammeter or a voltmeter from its connection within a circuit
08-Core-5	Calculates electrical energy from given data
08-Core-6	Selects the formula for calculating electrical energy in a direct current circuit
08-Core-7	States variables needed to calculate electrical energy
08-Core-8	Measures appropriate quantities and calculates electrical energy
08-Core-9	States the advantages in recording observations as numbers
08-Core-10	Selects examples of electricity doing observable work
08-Core-11	Connects a voltmeter and measures voltage across both parallel and series circuits
08-Core-12	Explains why the total resistance of a series circuit is greater than that of a parallel circuit of identical resistors
08-Core-13	Selects characteristics of parallel and series circuits constructed from the same component
08-Core-14	Proposes an operational definition for the energy of a battery, using specified equipment
08-Exc 34-1	Selects simple analogies for <i>volt</i> , <i>ampere</i> , and <i>electroparticle</i>
08-Exc 35-1	Selects variables determining the electrical power received by a bulb
08-Exc 35-2	Measures voltage and amperage and calculates the power in a circuit

Materials	Observer	Special Preparations	Quick Score	3 + Minutes	Basal	Math	Reading	Concept	Action Verbs	Notes
					✓				applies	
			Q		✓				recalls	
					✓				applies	
			Q		✓				identifies	
			Q		✓				applies	
			Q		✓				classifies	
			Q		✓				recalls	
M	O	P	Q	T					applies	
									recalls	
			Q						classifies	
M	O			T	✓				applies	
								✓	applies	
			Q						classifies	
					✓				generates	
			Q					✓	classifies	
			Q						applies	
M	O	P		T				✓	applies	

08

Objective Number	Objective Description
08-Exc 36-1	Explains, using the electroparticle model, why resistance does not vary with voltage and
	current
08-Exc 37-1	Tells what happens if one magnet in a student motor is reversed
08-Exc 38-1	Describes an experiment to determine the work done
08-Exc 39-1	Recognizes factors making a scientific task easier
01-Core-14 thru 17R	(Arithmetic skills)
01-Core-18 thru 22R	(Student's responsibilities)
03-Core-5R	Measures work done
05-Core-13R	Compares amounts of input work with output work
05-Core-20R	Gives examples of electrical energy's being changed into kinetic energy
05-Core-22R	Recognizes the characteristics of energy
07-Core-9R	Uses the electroparticle model to explain how energy gets to components of an electrical
	circuit
07-Core-14R	States the reason for connecting an ammeter in series

Materials	Observer	Special Preparations	Quick Score	3 + Minutes	Basal	Math	Reading	Concept	Action Verbs	Notes
								✓	applies	
		P						✓	applies	Save a student's motor for this check.
			Q						applies	
M									identifies	
			Q		✓				applies	
M	O		Q		✓				chooses	
M		P	Q	T	✓				applies	
			Q		✓				applies	
					✓				applies	
			Q					✓	classifies	
					✓				recalls	
					✓				recalls	

08 Core 1

Uses the electroparticle model to explain how an ammeter should be connected.

The student applies the assumption of the electroparticle model that an ammeter counts all the electroparticles flowing through the circuit.

Student Action: Responding to the effect that only in a series connection will all the electroparticles pass through the ammeter.

Performance Check A: To measure the current flowing through a circuit, you must connect an ammeter in series with the circuit rather than parallel to it. Use the electroparticle model to explain why.

Remediation: (1) Refer to Remediation 07-Core-24 or suggest that the student review page 192 and Figure 15-5. (2) Check his response to question 15-9. (3) A discussion of Figure 15-5, which shows a bulb and an ammeter connected in parallel and connected in series, may be necessary. (4) Ask the student to recheck his answer to Self-Evaluation Check 15-3.

08 Core 2

States the way a voltmeter should be connected in a circuit.

The student recalls that a voltmeter should be connected in parallel with a component of a circuit to measure the voltage available to it.

Student Action: Responding that the voltmeter should be connected in parallel to the component.

Performance Check A: Suppose you need to measure the voltage available to a motor in a circuit. How should the voltmeter be connected into the circuit? If you wish, you may use a diagram as part of your answer.

Remediation: (1) Have the student review Activity 15-18, in which he measured the voltage of the bulb, and his response to Self-Evaluation Check 15-1. (2) Discuss Activity 16-4 with the student, and ask him for the reason this activity failed to give a correct reading on the meter scales. Also ask him how he would change the setup to get meter scale readings. (3) Check his response to questions 16-6 through 16-8. (4) Have the student review Figure 16-1 and discuss it with you.

08 Core 3

States the procedure for detecting and measuring voltage in a circuit.

The student applies the procedures to detect voltage (1) connects the terminals of an electricity measurer (voltmeter) to the two terminals of the device and (2) notes whether the meter pointer moves when current is flowing in the circuit, which is the sign that there is voltage and the procedure to measure voltage which simply involves reading the value on the voltmeter scale indicated after the upward swing of the pointer.

Student Action: Responding with the effect of the procedures above and indicating terminals B and C as the points to which the voltmeter should be connected.

Performance Check A: Study the circuit below. Describe how you could detect and measure voltage at the bulb when the switch is closed. Name any other piece of equipment you would need. Tell which letters on the diagram show the places where the equipment should be connected.

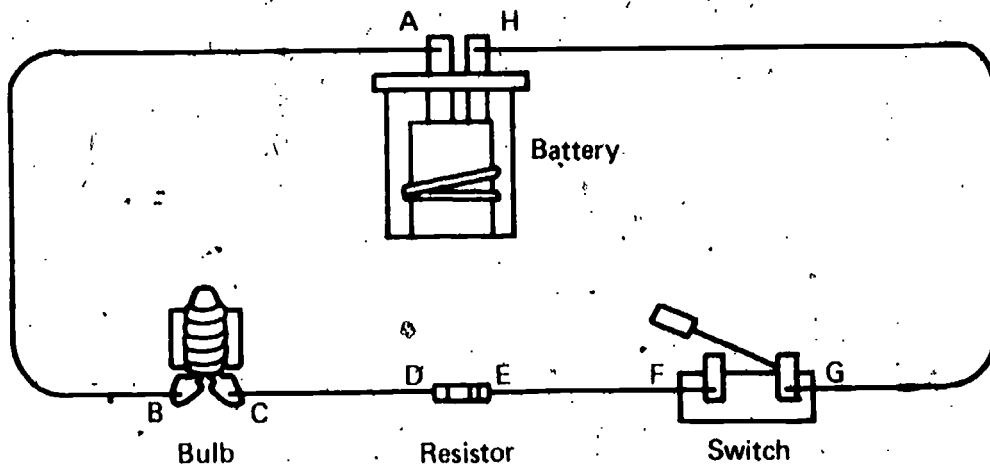

Remediation: (1) Discuss the item with the student. What piece of ISCS equipment is used to measure voltage? Which object in the circuit are you to measure the voltage across? Therefore, where must you place the voltmeter? How would you know if you were measuring any voltage at all? How would you measure the amount of voltage? How did you measure the amount of voltage in Chapter 15? (2) Suggest that the student review his response to Self-Evaluation Check 15-5b.

Designates a meter's use as an ammeter or a voltmeter from its connection within a circuit.

The student identifies from given circuit diagrams the electricity measurer (or meter) connected in series as an ammeter and the electricity measurer (or meter) connected in parallel as a voltmeter.

Student Action: Selecting the function of the meter and the type of circuitry with which they are connected to the main circuit.

- A: 1. parallel, voltmeter; 2. series, ammeter
- B: 1. series, ammeter; 2. parallel, voltmeter
- C: 1. series, ammeter; 2. parallel, voltmeter

08
Core
4

Performance Check A: In the diagram below, the meters are correctly connected to measure current and voltage. Decide for yourself how each meter is connected and whether it is an ammeter or a voltmeter. Then, record on your answer sheet the words in parentheses that best complete the statements below.

1. Meter X is connected in (series, parallel) with the light bulb. Therefore, Meter X is (an ammeter, a voltmeter).
2. Since Meter Y is connected in (series, parallel) with the light bulb, it is (an ammeter, a voltmeter).

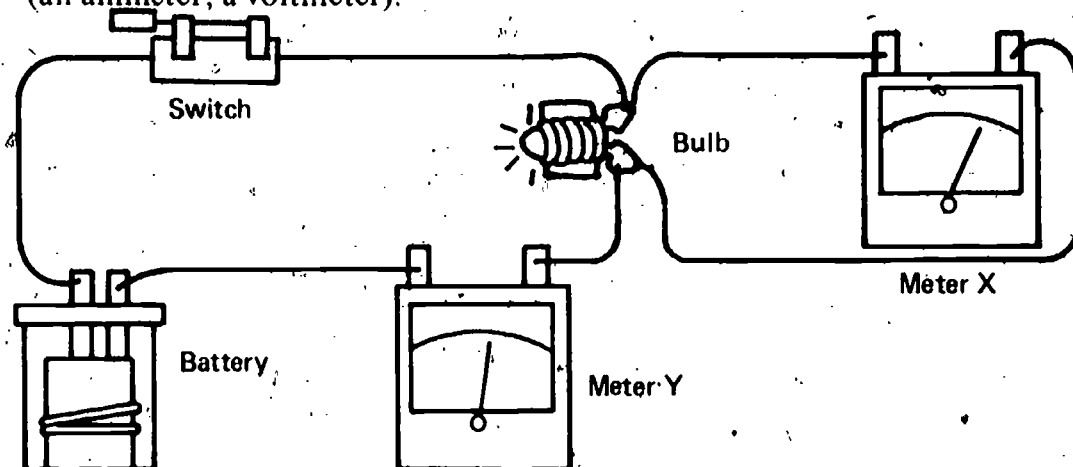

Remediation: (1) If the student does not recall the difference between series and parallel circuits, have him review page 155 in Chapter 13. (2) If the student does not recall that an ammeter must be connected in series, see the Remediation for 07-Core-24. (3) If the student does not realize that a voltmeter must be connected in parallel with a circuit, suggest that he review Activity 15-18. (4) You may also wish to discuss Activity 16-4 and ask the student why he failed to get both meters to move in this activity. (5) See the Remediation for 08-Core-2. (6) Ask the student to recheck his response to Self-Evaluation Check 15-1.

08 Core 5

Calculates electrical energy from given data.

The student applies the rules for calculating electrical energy – electrical energy equals voltage times amperage times time.

Student Action: Calculating the energy and expressing the answer in newton-meters.

- A: 12 newton-meters
- B: 50 newton-meters
- C: 52 newton-meters

Performance Check A: A light bulb receives 0.2 amperes and 6 volts for 10 seconds. Find the total electrical energy received by the bulb. Show your work, and use the correct units.

Remediation: (1) Refer the student to page 216 where the formula for electrical energy is introduced. (2) Check his responses to questions 16-16 and 16-17 and Tables 16-1 and 16-2. You may wish to discuss these tables with him. (3) Reassess, using an alternate check or ask the student to reassess himself with Self-Evaluation Checks 16-1a, 16-1b, and 17-4.

Selects the formula for calculating electrical energy in a direct current circuit.

The student classifies volts times amperes times time as the formula for calculating electrical energy.

Student Action: Selecting the entry "volts times amperes times time."

A: c

B: a

C: d

Performance Check A: Choose the correct answer below. What is the formula for calculating the total electrical energy supplied in a given circuit?

- a. Volts plus amperes divided by time
- b. Volts minus amperes plus time
- c. Volts times amperes times time
- d. Volts divided by amperes times time

Remediation: See the Remediation for 08-Core-10.

States variables needed to calculate electrical energy.

The student recalls the variables that must be measured to determine the total amount of electrical energy delivered to the components of the circuit.

Student Action: Stating the variables as current (or amperes), battery voltage (or volts), and time (or seconds).

Performance Check A: Below is a diagram of a complete circuit in which a bulb is lit. What three variables must you measure to determine the total amount of electrical energy that the bulb receives?

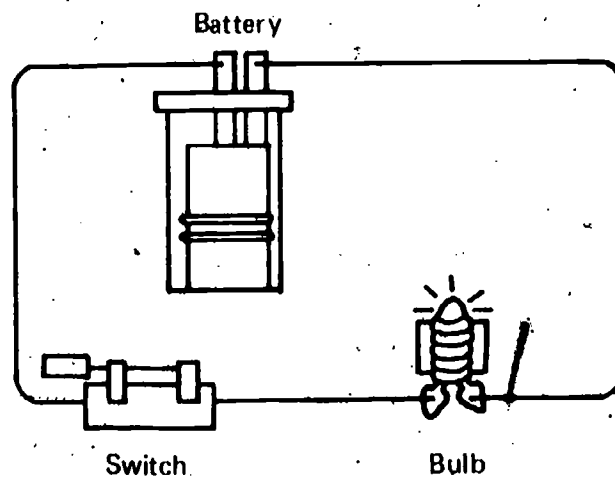

Remediation: See the Remediation for 08-Core-10.

08
Core
6

08
Core
7

08 Core 8

Measures appropriate quantities and calculates electrical energy.

The student applies the rules for connecting a voltmeter and an ammeter and for calculating the electrical energy supplied to one component in a parallel circuit using the formula voltage times amperes times time equals electrical energy.

Regular Supplies: 1 electricity measurer
1 ½ kg mass with voltmeter and ammeter scales attached
2 test leads
1 timer

Special Preparations: Construct three circuits, and store them in boxes labeled 08-Core-8A, 08-Core-8B, and 08-Core-8C. The circuit for 08-Core-8A is as illustrated below. For 08-Core-8B and 08-Core-8C, replace Bulb 2 with a motor.

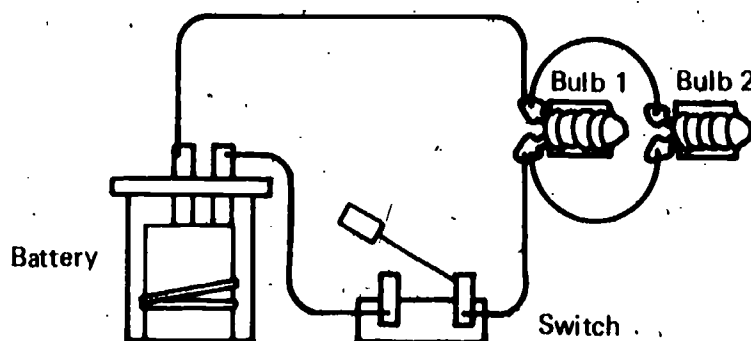

Student Action: Reporting the measurements and the calculations within the range of ± 1 newton-meter by using the electricity measurer and timer and measuring the voltage, amperage, and time.

Teacher's Note: Because the student's battery can become discharged quickly, you may wish to observe the student to be sure that he uses the correct procedures and that he reads his meter correctly the first time he attempts it.

Performance Check A: Get the assembled circuit in box 08-Core-8A, an electricity measurer, a timer, voltmeter and ammeter scales, and two test leads. Disconnect the battery, charge it, and replace it in the circuit. Measure how much electrical energy is supplied to one of the bulbs in the circuit in a fifteen-second period. Report your measurements and calculations.

Remediation: (1) Ask the student how he would measure electrical energy. What pieces of equipment will he need? How should he connect this equipment? If the student can answer these questions, ask him to construct the circuit asked for in the check and connect it both with the ammeter and the voltmeter. (2) If the student can't answer these questions, refer him to Activity 16-5 and discuss it with him. How did he measure electrical energy in this activity? What pieces of equipment did he use? How were they connected? (3) If the student has difficulty in calculating electrical energy, suggest that he review page 216. Check his response to questions 16-16 and 16-17 and to Tables 16-1 and 16-2. (4) You may wish to suggest that the student check his response to Self-Evaluation Checks 16-1a and 16-1b.

States the advantages in recording observations as numbers.

The student recalls that numerical information aids in precise, unambiguous communication and in data analysis.

Student Action: Responding to the effect of those two notions.

Performance Check A: Dr. Blades sent his students to the Everglades to collect data about birds. Jim and Pat were to collect data on species of birds. Their observations are shown in the chart below.

Student	No. of Birds	No. of Nests	Eggs per Nest	Food per Bird	No. of Birds in Flock
Jim	565	300	2 to 4	about 1 lb of insects per day	4 to 6
Pat	lots	lots	average	lots of insects	small

For what two reasons do scientists prefer the kinds of observations Jim made?

Remediation: (1) Discuss with the student the observations made in the chart. Ask him what the words *lots*, *many*, *small*, and *few* tell us. When we say *lots*, do we mean 90 out of 100 or 800 out of 1000? Therefore, why do scientists prefer to use numbers to communicate observations?

Selects examples of electricity doing observable work.

The student classifies situations in which electricity does observable work on the basis of evidence of a force being applied through a distance because of the application of electrical energy.

Student Action: Selecting those examples in which electricity does observable work.

- A: b, d, e
- B: b, c, e
- C: a, c, e

Performance Check A: Electricity is used to do many things. From the list below, select only those situations in which electrical energy does work which you can actually observe. Electrical energy

- a. heats a burner on an electric stove.
- b. operates a mixer.
- c. operates a radio.
- d. operates a fan.
- e. operates an electric lawn mower.

Remediation: (1) Ask the student what *observable work* is. If the student cannot answer this question, refer him to Chapter 5 and ask him to give an example of an

O8
Core
9

O8
Core
10

activity in which observable work is being done. (2) Stress the question, "How is observable work done in this activity?" (3) Suggest that the student redo the check after he has a good understanding of observable work. (4) Look at Self-Evaluation Checks 16-3a and 16-3b.

08 Core 11

Connects a voltmeter and measures voltage across both parallel and series circuits.

The student applies both the rule that a voltmeter should be connected in parallel with circuit element and the rule for measuring voltage across a circuit.

Regular Supplies:

12 test leads	6 bulbs and sockets
2 switches	4 motors
2 student batteries	1 electricity measurer (voltmeter)

Student Action: Installing the voltmeter in parallel to the circuits and reporting the voltage across each circuit correctly to within ± 1 volt.

Teacher's Note: You or someone you designate is needed to check that the student has constructed the circuits correctly, installed his meter correctly, charged his battery, and measured the voltage properly.

Performance Check A: The diagrams below are of two electrical circuits labeled Circuits A and B. Get a voltmeter and the materials to construct the circuits. After constructing the circuits as shown, measure the voltage across each entire circuit. Record the voltage, and show your setup to your teacher. Be sure your battery is charged before you make your measurements.

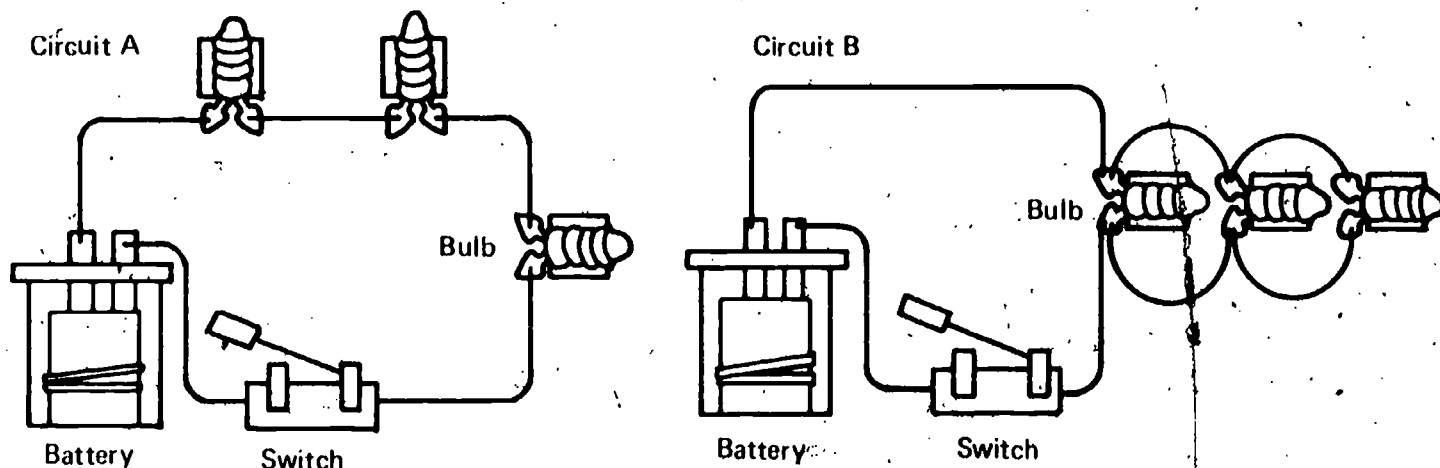

Remediation: (1) Does the student know how to connect a voltmeter into a circuit? If not, see the Remediation for 08-Core-2. (2) If the student knows that the voltmeter must be connected in parallel but does not know how to make the connection in the circuit, discuss Activity 15-18 with him. Then suggest that he substitute the two or three bulbs or motors as illustrated in the checks in place of the one bulb shown in the text. (3) Have him construct the circuits and measure his voltage.

Explains why the total resistance of a series circuit is greater than that of a parallel circuit of identical resistors.

The student applies the concepts that the current must flow through all the resistors in a series circuit, whereas parts of the current flow through each of several independent paths within a parallel circuit.

Student Action: Responding that the circuit with the resistors in series has more total resistance than the circuit with the resistors in parallel because in a series circuit the current must flow through all resistors, whereas parts of the current flow through each of several independent paths in the parallel circuit.

Performance Check A: Circuits A and B are shown below. Each contains one ISCS battery and four resistors connected by test leads. However, Circuit A has more total resistance to current flow than Circuit B. All of the resistors in both circuits are the same. Why does Circuit A have more total resistance than Circuit B?

Circuit A

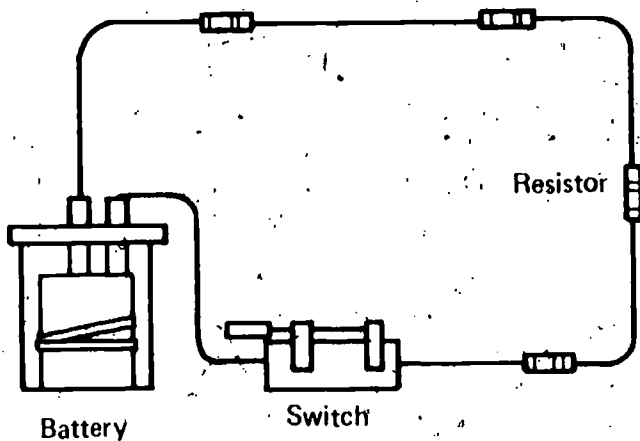

Circuit B

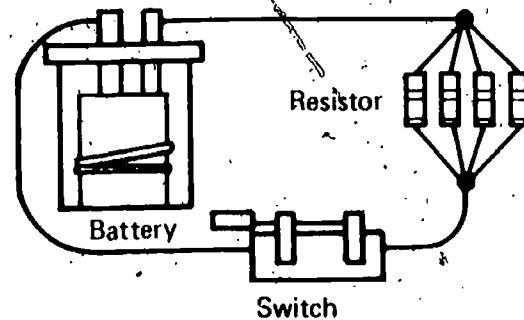

Remediation: (1) Does the student recall the difference between a series and a parallel circuit? If not, refer him to page 155, Figures 13-2 and 13-3, or to Excursion 26. (2) Suggest that the student review page 157 where the concept of resistance was introduced. (3) Discuss Figure 13-4 with the student. Ask him what happens to the brightness of the bulbs (to the resistance) when more bulbs are added in a series circuit. (4) Check his response to questions 13-9 and 13-10. (5) Why would the bulbs be of the same brightness in a parallel circuit? (6) At this point, the discussion can return to the check in question. How are the bulbs similar to the resistors in the checks? Why does Circuit A have more resistance to flow than Circuit B? (7) Suggest that the student check his responses to Self-Evaluation Checks 15-3 and 15-7 for review.

Selects characteristics of parallel and series circuits constructed from the same components.

The student classifies multiple-resistor circuits according to the flow of current through the resistors and the total resistance to current flow.

Core 13

Student Action: Selecting alternatives which indicate (1) that in the series circuit, the current flows through all resistors one after another and (2) that the total resistance to current flow is greater in the series circuit.

A, B, and C: 1. All resistors one after another, 2. Greater than

Performance Check A: Circuit A and Circuit B below both have identical components, but they are connected differently. Select the phrases in parentheses which best complete the sentences.

1. In Circuit A, the current flows through (each resistor by a separate path, all resistors one after another).
2. In Circuit A, the total resistance to current flow is (less than, greater than) the current flow in Circuit B.

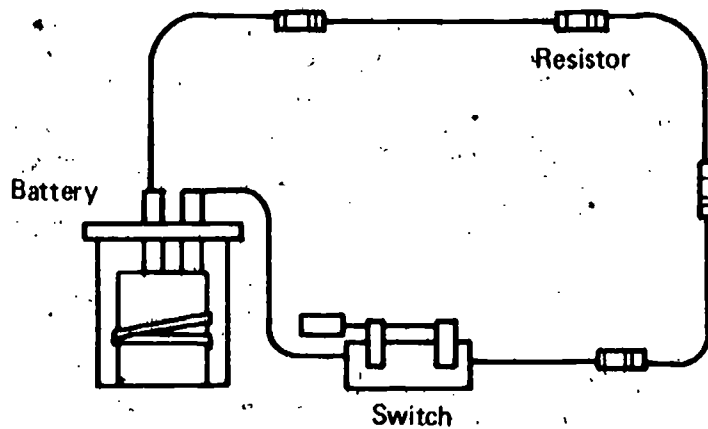

Circuit A

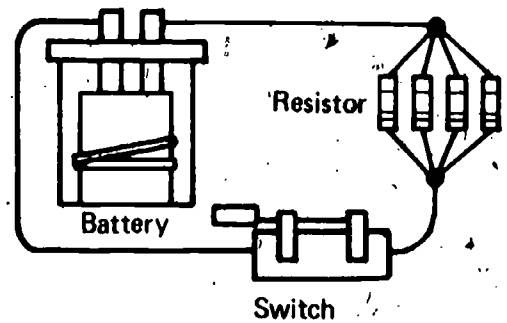

Circuit B

Remediation: See the related Remediation for 08-Core-12.

08 Core 14

Proposes an operational definition for the energy of a battery, using specified equipment.

The student generates a procedure for detecting the energy of a battery, based on an example of a battery-motor-sinker system.

Student Action: Stating an operational definition which includes the detection of energy by observing the work it does (or the movement of the sinkers) and measuring either (1) the total distance that the battery (motor) lifts a fixed number of sinkers before it stops lifting or (2) the number of sinkers the battery (motor) can lift a specified distance.

Performance Check A: Operationally define *battery energy*, using the equipment shown below. (Hint: Remember that an operational definition answers two questions.)

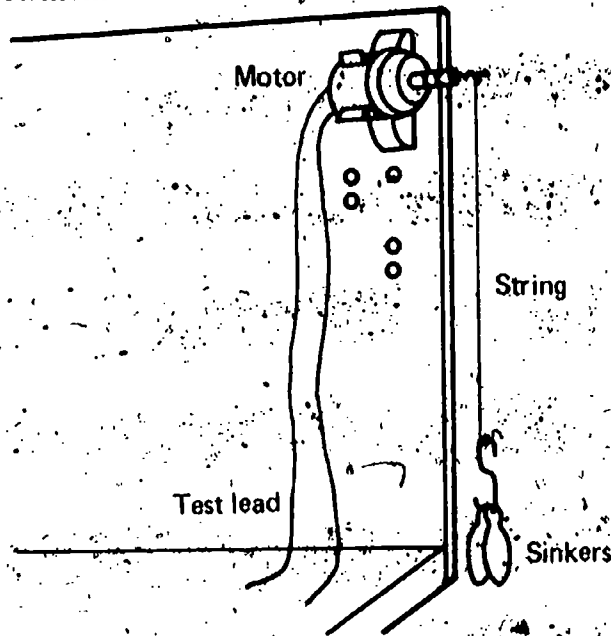

Remediation: (1) Does the student recall what an operational definition is? If not, suggest that he review the key questions to ask when building an operational definition, found on page 23. (2) When the student has a clear understanding of operational definitions, see if he can build one for the energy of the battery, using the two key questions. (3) If he still has difficulty, refer him to page 14 where the three operational definitions for the influence of the battery are presented. Ask him how each of these three operational definitions satisfies the two key questions one must ask when building an operational definition.

Selects simple analogies for *volt*, *ampere*, and *electroparticle*.

The student classifies a volt, an ampere, and an electroparticle in terms of a model which uses the transportation of canned goods.

Student Action: Matching the number of cans a person could carry with a volt, the number of cans being put down per time unit with an ampere, and the number of persons available to move the cans with an electroparticle.

A: 1. c, 2. b, 3. e

B: 1. b, 2. d, 3. a

C: 1. c, 2. d, 3. a

Performance Check A: In the following problem, let quart cans of oil stand for energy being supplied from one location to another. After the number of each question, write the letter of the statement below which answers it best.

Imagine that a large number of quart cans of Number 30 motor oil are to be removed from a warehouse and stacked in a truck outside the warehouse.

1. Which part of the operation is most like an electroparticle?
2. Which part of the operation is most like a volt?
3. Which part of the operation is most like an ampere?

08
Exc
34
1

- a. The length of time a person works
- b. The number of cans a person can carry at one time
- c. The number of persons available to move the cans
- d. The quality of the oil
- e. The number of cans put on the truck per hour

Remediation: (1) Check the student's answers to questions 34-8 and 34-9. (2) Suggest that he review page 188 where the term *ampere* is first introduced. (3) Suggest that he review page 199 where the term *volt* is introduced.

**Q8
EXC
35
1**

Selects variables determining the electrical power received by a bulb.

The student applies the principle that electrical power is a function of the voltage and the current.

Student Action: Selecting those items which include current or voltage or both.

- A: a, b
- B: c, e
- C: d, f

Performance Check A: There is a floor lamp next to Iggy's favorite reading chair. Record the letters of all of the variables in the list below, which affect the power received by the bulb when it is turned on.

- a. The voltage reading at the lamp is 120 volts.
- b. The current flowing through the lamp is one ampere.
- c. The bulb releases 20 calories of heat per minute.
- d. The bulb is a soft-white bulb.
- e. There are two other lighted 100-watt bulbs in the room.
- f. The bulb has just been turned off after burning for two hours.

Remediation: (1) Check the answer to question 35-8. (2) If the concept of power is not clear, check the answers to questions 35-3, 35-4, and 35-5.

**Q8
EXC
35
2**

Measures voltage and amperage and calculates the power in a circuit.

The student applies the rules that voltmeters are connected in parallel to the circuit, that ammeters are connected in series to the circuit, and that power is the product of voltage times amperage.

- Regular Supplies:**
- | | |
|---------------|-----------------------------------|
| 1 JCS battery | 2 motors |
| 7 test leads | 2 assembled electricity measurers |
| 3 bulbs | 1 switch |

Student Action: Measuring the voltage to within ± 1 volt and the amperage to within ± 0.2 amperes and calculating the power correctly from his measurements.

Teacher's Note: You, or a person designated by you, will need to check the student's setup and procedures for diagnostic purposes.

Performance Check A: Set up the circuit shown in the diagram. Be sure you use a freshly charged battery. Then connect one electricity measurer as an ammeter and the other as a voltmeter to measure the current flow and voltage of this circuit. Calculate the power of the circuit. Record your answer, and show it to your teacher before you dismantle your setup.

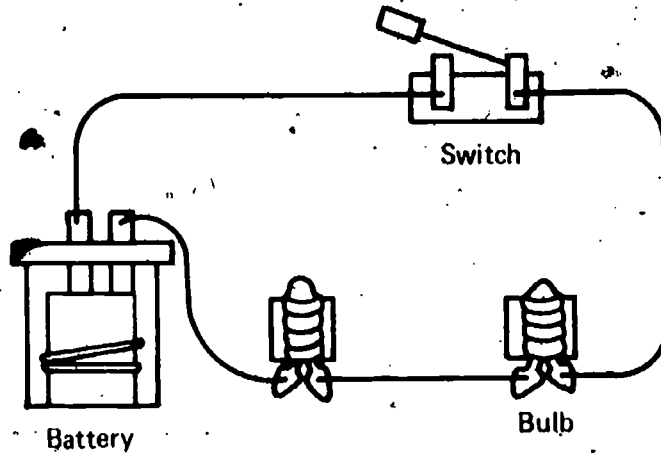

Remediation: (1) If the student hooked up the circuits correctly but did not know how to calculate power, see the Remediation for 08-Exc 35-1. (2) If he had difficulty connecting the electricity measurer, refer to the Remediation for 08-Core-4 and that for 08-Core-11.

Explains, using the electroparticle model, why resistance does not vary with voltage and current.

The student applies the electroparticle model to explain that the resistance of wires of the same kind, size, and length is the same when the voltage and the current both increase.

Student Action: Responding that the number of electroparticles passing through the wire increases and the energy of each electroparticle also increases, causing no change in the voltage-current ratio.

Performance Check A: The wires in Tessie the Tumbling Doll are all made of the same thickness of copper. The resistance of the wire is 3 ohms when the voltage is 9 volts and the current is 3 amps. A different model of Tessie is identical except that more batteries are required, thus producing more voltage and current. What would you expect the resistance of the wire to be in this version of Tessie. more than, equal to, or less than 3 ohms? Explain your answer, using the electroparticle model.

Remediation: (1) Check the student's answer to question 36-5. (2) If the concept is not clear to him, discuss Activity 36-1 with him.

08
Exc
36
1

O8
Exc
37
1

Tells what happens if one magnet in a student motor is reversed.

The student applies the concept that the N-pole of one magnet and the S-pole of the other (or one taped end and one untaped end) must be positioned near the coils to attract and repel the motor arm so that it is under constant magnetic force and revolves.

Special Preparation: Obtain one student-built motor and place it in a box labeled 08-Exc 37-1.

Student Action: Responding that the motor will not make a complete revolution because reversing one of the magnets will cause that magnet to repel the motor arm coming toward it and attract the motor arm moving away from it.

Performance Check A: Get the box labeled 08-Exc 37-1. What will happen if the taped magnet is turned so that its taped end is away from the coil? Explain your answer.

Remediation: Suggest that the student review questions 37-7 through 37-10 and the paragraph that follows on pages 492 and 493 of Excursion 37.

O8
Exc
38
1

Describes an experiment to determine the work done.

The student applies the principle that work is calculated by multiplying force times the distance the force is applied.

Student Action: Responding to the effect that he would make measurements of force and distance to calculate the work.

Performance Check A: Phyllis the Physical Fitness Doll has a motor inside her which causes her to move her arms up and down, lifting a weight. Describe what you would need to know in order to determine how much work the toy's motor can do in two minutes.

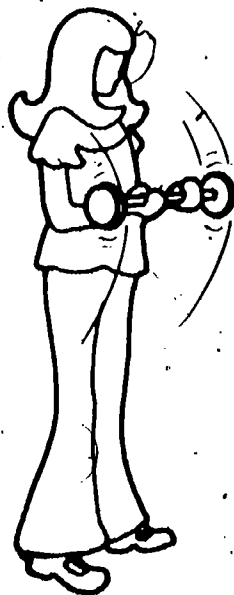

Remediation: (1) Determine if the student has considered using an instrument to measure force and an instrument to measure distance. (2) Discuss with the student the procedure he will follow in order to obtain his measurements.

Recognizes factors making a scientific task easier.

The student identifies those factors which make his scientific task easier than that of explorers.

Student Action: Stating the notion of at least one of the following factors - activities that have been pretested to be sure they are safe, safety tips, experimental designs written out for him, equipment that is available, models that have been suggested, and the accumulated body of scientific knowledge as factors which make his scientific task easier.

Performance Check A: In Excursion 39, you were told: "You have learned about electricity from activities like the ones in the textbook without too much trouble. It was the explorers who had a hard time." What helps have you had that the explorers did not have which makes your learning about electricity easier than theirs? You may refer to Excursion 39 to answer the question.

Remediation: Discuss one of the examples given in Excursion 39 to elicit the lack of or advantages of these factors in the work of the scientists.

O8
EXC
39
1

09

Chapters 18 and 19

Performance Check

Excursions 40 thru 44

Summary Table

Objective Number	Objective Description
09-Core-1	Fills an air piston with a specified amount of water
09-Core-2	Indicates the correct volume of liquid in an air piston
09-Core-3	Relates temperature increases to volume change
09-Core-4	Selects the material most sensitive to temperature change
09-Core-5	Explains why different standards for scales are possible
09-Core-6	Recognizes situations requiring standard units of measurement
09-Core-7	Names the standard unit used by scientists and in ISCS for measuring temperature
09-Core-8	States the significance of 0°C and 100°C
09-Core-9	Measures the temperature of a substance in Celsius units
09-Core-10	Describes how a liquid thermometer works
09-Core-11	Explains why heating a jar lid causes it to loosen
09-Core-12	Gives an operational definition for the change in the heat content of liquid water
09-Core-13	Calculates the calories required to change the temperature a given number of degrees Celsius
09-Core-14	Relates the amount of heating to the amount of water heated and to the temperature change
09-Core-15	States what a thermometer measures
09-Core-16	Selects the standard unit used in ISCS for measuring heat
09-Core-17	Lists properties of heat which support the heat-substance model

	Materials	Observer	Special Preparations	Quick Score	3 + Minutes	Basal	Math	Reading	Concept	Action Verbs	Notes
	M	O				✓				manipulates	
	M		P	Q		✓				manipulates	
				Q		✓				recalls	
				Q		✓				applies	
									✓	applies	
				Q		✓				applies	
				Q		✓				recalls	
				Q		✓				recalls	
	M	O	P	Q	T	✓				manipulates	
						✓				recalls	
										generates	
									✓	recalls	
				Q		✓				applies	
				Q			✓		✓	applies	
				Q		✓				recalls	
				Q		✓				recalls	
									✓	classifies	

09

Objective Number	Objective Description
09-Core-18	Selects characteristics of heat compatible with the heat-substance model
09-Core-19	Defeats an argument that cold, not heat, flows between objects
09-Core-20	Recognizes the reactions of metal to heat and cold
09-Exc 40-1	Selects properties which would not be desirable in a liquid to be used in a thermometer
09-Exc 41-1	Compares degrees Celsius to degrees Fahrenheit
09-Exc 42-1	Defines <i>calorie</i> in terms of water
09-Exc 43-1	Compares the calories the body needs in cold weather to those it needs in warm weather
09-Exc 44-1	Relates specific heat to temperature change
01-Core-14 thru 17R	(Arithmetic skills)
01-Core-18 thru 22R	(Student's responsibilities)
02-Core-2R	Explains the need for standard units for measurement
02-Core-20R	Recognizes that a part is missing on measuring instruments
02-Core-23R	Remembers characteristics of a standard for measurement
03-Core-21R	Predicts data from a graph
07-Core-1R	Selects a statement as not characteristic of a scientific model
07-Core-3R	States two things done by a good scientific model
08-Core-9R	States the advantages in recording observations as numbers

Materials	Observer	Special Preparations	Quick Score	3 + Minutes	Basal	Math	Reading	Concept	Action Verbs	Notes
			Q				✓	✓	classifies	
							✓	✓	generates	
			Q		✓				applies	
			Q						applies	
									applies	
			Q						recalls	
									applies	
			Q						classifies	
			Q		✓				applies	
M	O		Q		✓				chooses	
					✓				applies	
			Q		✓				applies	
			Q		✓				recalls	
M		P	Q	T	✓				applies	
			Q		✓				recalls	
			Q		✓				recalls	
					✓				recalls	

7

09 Core 1

Fills an air piston with a specified amount of water.

The student manipulates the air piston in such a way as to fill it with a specified amount of water.

Regular Supplies: 1 air piston
water

Student Action: Inserting the tip of the piston into the water and moving the plunger so that its front edge is on the specified mark (± 0.1 unit) and the chamber is completely filled with water and contains no air bubbles.

Teacher's Note: You or someone designated by you will need to be available to check each student's performance.

Performance Check A: Fill the air piston with water to the 2.0 cc mark. Then show the air piston to your teacher.

Remediation: Have the student practice using the air piston. Direct him to fill the air piston with water to different points you designate. Have him show you his procedure, and help him if difficulty arises.

09 Core 2

Indicates the correct volume of liquid in an air piston.

The student manipulates a partly-filled air piston to read its scale.

Special Preparations: Partly fill one 6.0 cc air piston with liquid, and put a cap over the end to prevent the liquid from accidentally being spilled. Place it in a box labeled 09-Core-2.

Student Action: Reporting the volume of liquid in the air piston accurately to within ± 0.1 cc.

Performance Check A: Box 09-Core-2 contains an air piston partly filled with a liquid. Look at the air piston, and record the volume of liquid in it.

Remediation: (1) If the student doesn't know how to use an air piston, see the Remediation for 09-Core-1. (2) If he doesn't know how to read the scale on the air piston to the nearest 0.1 cc, suggest that he do or review Excursion 6, from which he will get practice in reading scales.

09 Core

Relates temperature increases to volume change.

The student recalls that an increase in the volume of a substance is generally coincident with a temperature increase.

Student Action: Selecting the option which indicates that the volume increases.

A: a

B: b

C: d

Performance Check A: Which of the following will result from increasing the temperature of water?

- The volume of the water increases.
- The mass of the water changes.
- The water glows.
- The water changes to iodine.

Remediation: (1) Suggest that the student review page 236 where he proved that adding heat to water increased its volume. (2) Check Table 18-1 and his responses to questions 18-6 and 18-7. (3) If necessary, discuss this activity with him. What happened to the water inside the air piston when it was heated? Did this also happen when another liquid was substituted in Table 18-2?

Selects the material most sensitive to temperature change.

The student applies the concept that a gas has a greater increase in volume when heated than a solid or a liquid.

Student Action: Selecting the gas as the best-expanding substance.

A: a

B: c

C: d

Performance Check A: A company needs to design a device which will show very tiny changes in temperature and will have the temperature marks on the scale widely spaced. If you had to build such a device, what would you use for the expanding substance in it?

- Carbon dioxide
- Water
- Iron
- Plastic

Remediation: (1) Ask the student which substance shows the greatest expansion when heated - a solid, liquid, or gas. If the student can't answer this question, refer him to pages 236 and 237 and Tables 18-1 and 18-2. (2) Ask the student what is asked for. If he fails to see that what is wanted is the most expansive substance, discuss the item with him. Which substance would allow there to be wide spaces between each temperature mark to indicate small changes in temperature? If necessary, use the diagram below.

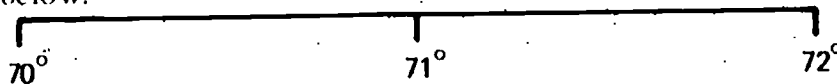

09 Core 5

Explains why different standards for scales are possible.

The student applies the concept that it is possible to have different scales based on different definitions to measure the same phenomenon.

Student Action: Responding to the effect that it is possible to measure the same phenomenon with different scales based on different definitions.

Performance-Check A: As shown below, a Fahrenheit and a Celsius thermometer scale have different numbers to indicate the freezing point of water. Explain why the freezing point can be represented by two different numbers.

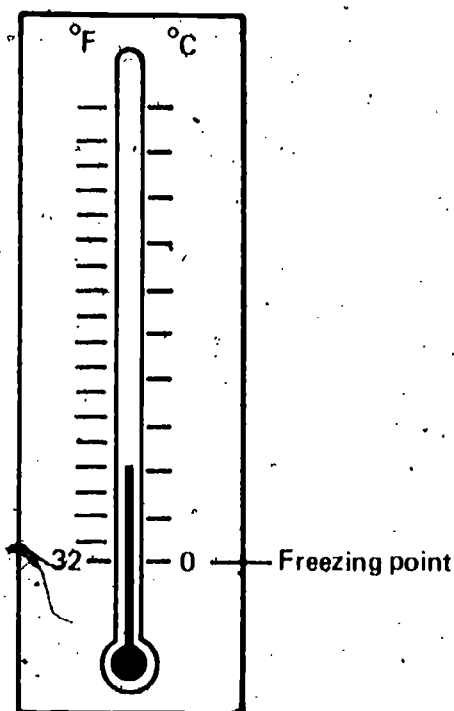

Remediation: (1) You may wish to discuss the characteristics of good standards of measurement with the student. These were introduced at the end of Chapter 3. (2) Do the Celsius and Fahrenheit scales both satisfy the characteristics of good standards of measurement? Have people agreed to use them? (3) Can he recall other differing scales which are used to measure phenomenon? You might discuss the centimeter-inch and gram-pound scales.

09 Core

Recognizes situations requiring standard units of measurement.

The student applies the rule that to be standard, the units of measurement must be agreed upon.

Student Action: Responding to the effect that a standard or an agreed-upon unit of measurement is necessary.

Performance Check A: Mrs. Collins went to the store to buy a piece of rope. She wanted 40 pinkies (40-little-finger lengths) of the rope. A young clerk measured the rope with her pinkie. When Mrs. Collins measured the rope, using her own pinkie, it measured only 38 pinkies. Feeling that she had been cheated by the clerk who measured the rope, she went to the manager of the store and complained. What is necessary to avoid such confusion in the future?

Remediation: (1) Is the body part a standard unit of measurement? What are the characteristics for a good standard of measurement? (If the student does not recall these, suggest that he review the end of Chapter 3, beginning at page 30.) Is the body part, therefore, a good unit of measurement? Why not? (2) What would have to be done to avoid the kind of confusion described in the check?

Names the standard unit used by scientists and in ISCS for measuring temperature.

The student recalls the degree Celsius as the standard unit used by scientists and in ISCS for measuring temperature.

Student Action: Naming "degree Celsius."

Performance Check A: What is the standard unit used by scientists and in ISCS for measuring temperature?

Remediation: Suggest that the student review page 241 where the degree Celsius unit is introduced.

States the significance of 0°C and 100°C .

The student recalls that at 0°C , water freezes and at 100°C , water boils.

Student Action: Stating that at 0°C , water freezes and at 100°C , water boils.

Teacher's Note: This objective assumes sea level pressure. In some locations, students will find that water boils at a lower temperature, as the boiling point of water decreases roughly at the rate of 1°C per 1000 feet of elevation. Thus at Denver, Colorado, water will boil at 95°C . The freezing point of water also varies with pressure changes, but the variation is too insignificant to affect the question. You may want to adjust this performance check to fit your location.

Performance Check A: What happens to water when its temperature registers 0°C and when its temperature registers 100°C on the thermometer shown below?

(Continued)

6

09
Core
7

09
Core
8

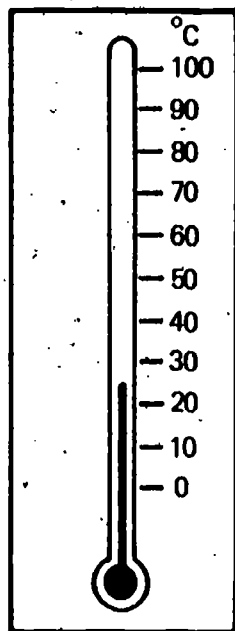

Remediation: (1) If the student cannot answer this question, suggest that he review page 241, where the Celsius scale is introduced. (2) You may also wish him to redo Activities 18-6 and 18-7, page 239, with the Celsius scale he has constructed, to prove to himself what the temperature registers on this scale at the boiling and freezing points of water.

09 Core 9

Measures the temperature of a substance in Celsius units.

The student manipulates the thermometer to find the temperature of a substance.

Regular Supplies: 1 Celsius thermometer
1 beaker
copper sulfate solution
water

Student Action: Reporting the temperature of the liquid to the teacher within an accuracy of ± 1.0 scale interval.

Teacher's Note: The correct temperature should be recorded at the time the student takes the thermometer reading. This means that you or someone you designate will need to be available when the student does this check.

Performance Check A: Get a beaker of water and measure its temperature. Report the temperature to your teacher.

Remediation: (1) Have the student redo the activity while you watch. Help him use the thermometer, if necessary. If he still has difficulty manipulating it, have him practice by taking different temperature readings you designate. (2) If the student has difficulty reading the scale to ± 1.0 scale interval, suggest that he do or review Excursion 6. (3) You may also refer him to Self-Evaluation Check 18-3 for review.

Describes how a liquid thermometer works.

The student recalls that the liquid in a thermometer expands as temperature increases and contracts as temperature decreases.

Student Action: Responding to the effect that the liquid in the thermometer expands as temperature increases and contracts as temperature decreases.

Performance Check A: You have used a thermometer which contains a liquid in a tube. Describe how it works.

Remediation: (1) Suggest that the student review Activity 18-5. Check his response to questions 18-8, 18-9, and 18-10. (2) If the student still has difficulty understanding how a thermometer works, discuss the principle with him. What happens to the liquid in the tube when the temperature is hotter? He can try using warm water to find out. What happens to the liquid when the temperature gets colder? He can try using ice or a refrigerator to find out. (3) Suggest that the student review Self-Evaluation Check 18-1.

09
Core
10

Explains why heating a jar lid causes it to loosen.

The student generates an explanation based on the concepts that most substances expand when heated and that different substances expand at different rates.

Student Action: Responding to the effect that the hot water heated the lid, and caused it to expand faster than the jar, and thus to loosen.

Performance Check A: Mrs. Pickens couldn't get the lid off a pickle jar. She turned the jar upside down and lowered the lid into a pan of hot water. Soon, she was able to twist the lid off easily. Why did heating the lid cause it to loosen?

Remediation: (1) Have the student review Activity 18-3 and Tables 8-1 and 8-2 on pages 236 and 237. (2) Discuss this activity with him. What happens to most substances when they are heated? What happened to the jar lid in the check? (3) Refer the student to Self-Evaluation Check 18-5.

09
Core
11

Gives an operational definition for the change in the heat content of liquid water.

The student recalls that an operational definition for the change in the heat content (energy) of liquid water includes multiplying the mass of the water in grams by the number of degrees Celsius that its temperature changes.

Student Action: Responding to the effect that the change in the heat content is obtained by multiplying the mass of the water in grams by the number of degrees Celsius that its temperature changes.

Performance Check A: Suppose that you have been given a sample of liquid water

09
Core
12

whose mass you know. You have taken its temperature before and after heating it. Write an operational definition for the change in its heat content.

Remediation: (1) Refer the student to page 254, where the operational definition for the change in the heat content of water is stated, and to Self-Evaluation Check 19-5, where he was questioned on the concept. (2) You may wish to discuss how this formula was derived in Chapter 19 using Table 19-2 and Figure 19-1 and the related questions.

09 Core 13

Calculates the calories required to change the temperature a given number of degrees Celsius.

The student applies the rule that the number of calories required to raise the temperature of a mass of water a given number of degrees Celsius is equal to the product of the mass of the water in grams times the number of degrees Celsius the temperature of the mass is raised.

Student Action: Reporting the product correctly in calories.
A: 250 calories
B: 350 calories
C: 1000 calories

Performance Check A: How many calories are required to raise 25 grams of water from 20°C to 30°C in three minutes?

Remediation: (1) Suggest that the student review page 254 where the calorie is introduced and the formula is stated. (2) Refer him to Self-Evaluation Check 19-3 for review. (3) Reassess using an alternate check.

09 Core 14

Relates the amount of heating to the amount of water heated and to the temperature change.

The student applies the concept that the temperature of water varies inversely with the amount of water being heated when a fixed amount of heat is supplied in a fixed amount of time.

Student Action: Selecting the response that represents the relationship stated above.
A: c
B: a
C: b

Performance Check A: A 100 g sample of water was heated for ten minutes. The temperature was 25°C higher after heating than before. What would the temperature change be if a 50 g sample of water were heated under the same conditions for ten minutes?

- a. 12.5°C
- b. 25°C
- c. 50°C
- d. 75°C

Remediation: (1) Suggest that the student review Table 19-2 and Figure 19-1 in which an inverse relationship was shown between the amount of water being heated and the resulting temperature change. (2) Check his responses to items 19-6, 19-9, and 19-10. (3) If necessary, discuss this activity with him. As you increased the amount of water, what does your graph (Figure 1) show will happen to the temperature change? If you decrease the amount of water, what does your graph show will happen to the temperature change? (4) For help in calculating a numerical answer, refer him to pages 253 and 254, where it is stated that when a fixed amount of heat is added to different quantities of water, the product of the mass and temperature changes should be equal. (5) Reassess, using an alternate check.

States what a thermometer measures.

The student recalls that a thermometer measures temperature.

Student Action: Responding "temperature."

Performance Check A: What does a thermometer measure?

Remediation: (1) Suggest that the student review page 252, especially the last paragraph. (2) Check his response to questions 19-6, 19-7, and 19-8. (3) You may wish to discuss Activity 19-3 with the student, especially page 252, where he discovered that his thermometer is a temperature measurer, but not a heat measurer.

Selects the standard unit used in ISCS for measuring heat.

The student recalls the calorie as a unit in which heat is measured.

Student Action: Selecting "calorie."

A: c

B: a

C: d

Performance Check A: Which of the following is a standard unit for measuring heat?

a. temperature

b. degree

c. calorie

d. Celsius

Remediation: (1) Suggest that the student review page 254, where the calorie was introduced. (2) If the student selected "degree," "Fahrenheit," or "Celsius," you should discuss with him the concept that a thermometer is a temperature measurer, not a heat measurer, and that "degrees Celsius" and "degrees Fahrenheit" are standard units for measuring temperature.

09
Core
15

09
Core
16

09 Core 17

Lists properties of heat which support the heat-substance model.

The student classifies as two observable properties of heat in agreement with the heat-substance model that heat can be transferred from one object to another and that matter expands when heated and contracts when cooled.

Student Action: Responding to the effect both that heat can be transferred from one object to another and that things expand when heated and contract when cooled.

Performance Check A: One model for heat assumes that heat is a substance which can flow between objects and whose quantity determines the temperature of objects. What are two observable properties of heat that support this heat-substance model?

Remediation: (1) Refer the student to pages 254 and 255, where the model for heat as a substance was developed. Check his response to questions 19-15 and 19-16. (2) What did you observe about objects when they are heated or cooled which could be accounted for by the addition or subtraction of the heat substance? (3) What was the first activity in which you observed what could be described as a heat substance flowing between objects? What happened to the temperature of the objects inside the air pistons when the pistons were placed into boiling water? Does this activity, therefore, support the heat-substance model is heat shown to be transferred from one substance to another? (4) Refer the student to Self-Evaluation Check 19-7, where he was questioned about these two properties.

09 Core 18

Selects characteristics of heat compatible with the heat-substance model.

The student classifies the characteristics of heat that are compatible with the heat-substance model.

Student Action: Selecting the entries which state that the substance must take up space, have mass, be made of tiny particles, and be able to move and no others.

A: b, c, f, h

B: a, c, d, h

C: a, b, c, e

Performance Check A: The diagram shows that the level of water in the test tube was at B before the test tube was heated in the beaker of water. After heating, the water in the tube rose to level A. The heat-substance model can explain this. From the following list, select the letters of the four statements which support the heat-substance explanation of how heat gets from the burner flame into the water in the test tube. The heat substance must

- | | |
|------------------------------------|----------------------------------|
| a. be composed of large particles. | f. have mass. |
| b. be able to move. | g. be able to reproduce. |
| c. take up space. | h. be made up of tiny particles. |
| d. be pushed. | |
| e. move as rapidly as light. | |

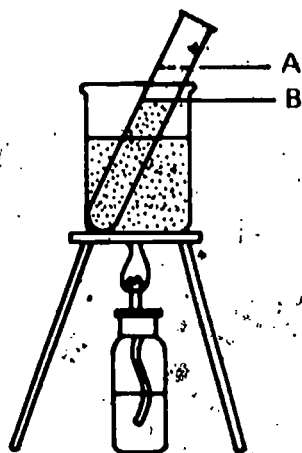

Remediation: (1) Have the student review pages 254 and 255, where the heat-substance model is built. (2) Discuss the correct options with the student. If heat is a substance, what characteristics must it have (take up space, have mass)? If heat is a substance, it should also be composed of particles -- small ones, since they are not visible to us. Can heat as a substance be transferred from one object to another? Therefore, can it move? (3) You should discuss with the student any incorrect choice he has selected. Do we have any evidence that heat moves "as rapidly as light" or that heat "can reproduce" or of a force causing heat to "be pushed"?

Defeats an argument that cold, not heat, flows between object.

The student generates the argument that it is heat substance, not cold substance, that flows between objects.

Student Action: Responding either (1) to the effect that if it were cold that was transferred, the object containing the cold substance would be expected to contract as the cold substance flowed out of it and the object got warm and the object receiving the cold substance would expand as it got cooler and the cold substance flowed into it or (2) to the effect that the object containing the cold substance would be expected to lose weight as it got warmer.

Performance Check A: Suppose someone said that cold objects have cold substance in them and that when a hot and a cold object are placed together, the cold substance flows into the hot object and the cold object gets warmer, not because it gains heat but because it loses cold substance. Use the activities you have done with heat and their results to show that it is heat, not cold, that is transferred.

Remediation: (1) Discuss the heat-substance model with the student. How can thinking of heat as a substance explain why things expand when heated? (See his answer to question 19-16.) Is more of the heat substance present in hot water than in cold water? (2) Now have him try to imagine a cold substance which flows between objects. When an object is heated, should it lose or gain cold substance? Should it contract or expand? Did the objects heated in the experiments contract or expand? Therefore, does a cold substance flow between objects?

09
Core
19

09 Core 20

Recognizes the reactions of metal to heat and cold.

The student applies the rule that metals usually expand when heated and contract when cooled.

Student Action: Selecting the entry which indicates that a heated metal cylinder will be larger than either a cooled cylinder or one at room temperature, and only that entry.

A: c

B: b

C: d

Performance Check A: The aluminum cans labeled A, B, and C are identical. Each has a mass of 40 grams. Assume that A is heated, B is cooled, and C is left at room temperature. Which of the following results can you expect?

- B will weigh more than either A or C.
- B will weigh less than either A or C.
- A will be larger than B or C.
- The size of B will not change.

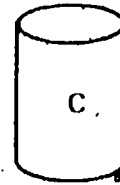
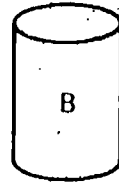
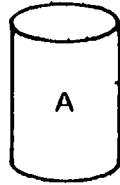

Remediation: (1) What happens to an object when it is heated? If the student can't answer, refer him to Activity 18-3. Check Tables 18-1 and 18-2 and questions 18-6 and 18-7. (2) Does the weight or the size of an object change when it is heated or cooled? If the student believes that the weight changes, have him weigh an object before and after it has been heated. This concept will be reassessed in Chapter 20.

Selects properties which would not be desirable in a liquid to be used in a thermometer.

The student applies the principle that the liquid used in a thermometer should not have a boiling or freezing point in the temperature range for which he wishes to make his measurements.

Student Action: Selecting "boiling temperature lower than water's" and a "freezing temperature higher than water's."

A: a, d

B: c, e

C: b, d

83

09 Exc 40 1

Performance Check A: Which of the following characteristics make a liquid a bad choice for a thermometer used to measure the temperature of water samples?

- a. A boiling temperature lower than water's
- b. A boiling temperature higher than water's
- c. A freezing temperature lower than water's
- d. A freezing temperature higher than water's
- e. None of the above

Remediation: (1) Refer the student to Excursion 40 and to Activities 40-1 and 40-2 in which he chose the liquid he would use in building a thermometer. Ask him why he chose the liquid he did. (2) Check his responses to questions 40-1, 40-2, and 40-3, and discuss these answers with him.

Compares degrees Celsius to degrees Fahrenheit.

The student applies the principle that there are more unit intervals between the freezing and the boiling temperatures of water on the Fahrenheit scale than on the Celsius scale.

Student Action: Responding to the effect (1) that there are more unit intervals between the freezing and the boiling temperatures of water on the Fahrenheit scale than on the Celsius scale and (2) that a drop of any given number of degrees on the Celsius scale is greater than a drop of the same number of degrees on the Fahrenheit scale.

Performance Check A: If you hear the TV weather girl say that the temperature will drop 10° tonight, does it make any difference whether she means a temperature drop of 10° Celsius or a temperature drop of 10° Fahrenheit? Explain your answer, using information from the diagram below.

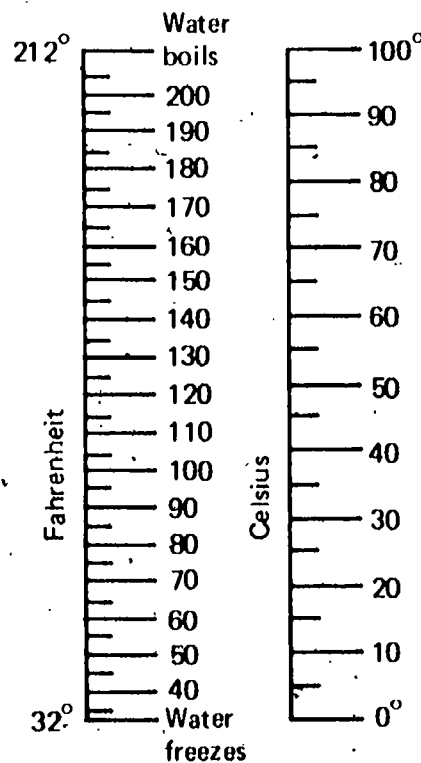

O9
EXC
41
1

Remediation: (1) Suggest that the student review Excursion 41, in which the temperature readings on the Fahrenheit and Celsius scales are compared. (2) Check his responses to questions 41-1, 41-2, and 41-3 and discuss the two scales with him if necessary.

O9
Exc
42
1

Defines *calorie* in terms of water.

The student recalls the definition that a calorie is the amount of heat it takes to raise the temperature of 1 gram of water 1° Celsius.

Student Action: Responding that a calorie is the amount of heat it takes to raise the temperature of 1 gram of water 1° Celsius.

Performance Check A: Calories are defined using water as a standard. Define *calorie* in terms of water.

Remediation: Refer the student to page 515 of Excursion 42 where *calorie* is defined.

O9
Exc
43
1

Compares the calories the body needs in cold weather to those it needs in warm weather.

The student applies the principle that the body needs to supply more calories to maintain normal body temperature when the temperature of the environment is lower.

Student Action: Responding to the effect that the body needs to supply more calories in winter or in cold climates to maintain normal body temperature.

Performance Check A: Suppose you go swimming with the Polar Bear Club in winter, and you go swimming at the beach in the summer. In which case does your body need to supply more calories? Explain your answer.

Remediation: (1) Suggest that the student review Excursion 43, especially the discussion on page 519. (2) If necessary, discuss this principle with him.

O9
Exc
44

Relates specific heat to temperature change.

The student classifies the substance having the lowest specific heat as undergoing the greatest temperature change.

Student Action: Selecting the substance with the lowest specific heat.

- A: d
- B: b
- C: a

Performance Check A: In each of the following cases, 700 calories were supplied to 1000 g of the substance named. Which of them would show the greatest temperature change?

- a. Hydrogen, whose specific heat is 3.41
- b. Helium, whose specific heat is 1.24
- c. Water, whose specific heat is 1.00
- d. Sulfur, whose specific heat is 0.175

Remediation: (1) Refer the student to Excursion 44, where he investigated specific heat. (2) Have him compare the temperature change of each substance in Table 44-1 with the specific heat of each substance in Table 44-2. Does the substance which undergoes the greatest temperature change have the highest or the lowest specific heat? (3) You may also wish to refer him to the formula on page 526.

10

Chapters 20 and 21

Performance Check

Excursions 45 thru 48

Summary Table

Objective Number	Objective Description
10-Core-1	Shows the direction of heat flow across materials of different temperatures
10-Core-2	Predicts the final temperature when materials of different temperature touch each other
10-Core-3	Selects the state of a substance that is the poorest conductor of heat
10-Core-4	Selects the material state that is the best conductor of heat
10-Core-5	Proposes ways to check for an increase in mass in a heated substance
10-Core-6	Predicts the effect of heating on the mass of an object
10-Core-7	Recognizes when a scientific model is suitable
10-Core-8	Recognizes the source of scientific models
10-Core-9	Selects the properties of models that apply to the heat-as-energy model
10-Core-10	Recognizes what accepting the heat-as-energy model means
10-Core-11	Selects the better of two models on the basis of the data they explain
10-Core-12	Uses the heat-substance model to explain why substances expand when heated
10-Core-13	Uses the heat-as-energy model to explain the expansion of heated substances
10-Core-14	Uses the heat-as-energy model to explain the heating of rubbed surfaces
10-Core-15	Ranks the three states of matter according to their relative amounts of internal energy
10-Core-16	Explains how a little hot water can contain less heat than a lot of cool water
10-Core-17	Uses the heat-as-energy model to explain how a thermometer works
10-Core-18	Explains the loss in usable output energy of a machine as its temperature increases

Materials	Observer	Special Preparations	Quick Score	3 + Minutes	Basal	Math	Reading	Concept	Action Verbs	Notes
			Q		✓				applies	
			Q			✓		✓	applies	
			Q		✓				recalls	
			Q		✓				applies	
M								✓	generates	
			Q		✓				applies	
				T			✓		applies	
			Q		✓				recalls	
			Q		✓				applies	
			Q		✓				applies	
			✓		✓				applies	
					✓				applies	
					✓				applies	
					✓				applies	
			Q				✓	✓	applies	
								✓	generates	
					✓				applies	
									generates	

10

Objective Number	Objective Description
10-Core-19	Uses the heat-as-energy model to explain the difference in input and useful output energy
10-Exc 45-1	Compares the volume per unit of mass of warm air to that of cool air
10-Exc 46-1	Selects a reason for discarding a scientific model
10-Exc 47-1	Describes temperature changes shown on a graph
10-Exc 47-2	Selects the graph which best represents a cooling curve
10-Exc 48-1	Relates the energy conversion of stored energy to the amount of output energy
01-Core-14 thru 17R	(Arithmetic skills)
01-Core-18 thru 22R	(Student's responsibilities)
03-Core-24R	Remembers the cause of the heating of sliding surfaces
04-Core-20R	Defines <i>mass</i>
05-Core-12R	Names the force which reduces useful output energy
05-Core-22R	Recognizes the characteristics of energy
06-Core-19R	Selects characteristics of energy
07-Core-4R	Selects a characteristic of a scientific model
09-Core-17R	Lists properties of heat which support the heat-substance model
09-Core-18R	Selects characteristics of heat compatible with the heat-substance model

Materials	Observer	Special Preparations	Quick Score	3 + Minutes	Basal	Math	Reading	Concept	Action Verbs	Notes
			Q					✓	applies	
								✓	applies	
			Q		✓				applies	
					✓				applies	
			Q		✓				applies	
								✓	applies	
			Q		✓				applies	
M	O		Q		✓				chooses	
			Q		✓				applies	
					✓				recalls	
			Q		✓				classifies	
			Q		✓				classifies	
			Q		✓				classifies	
			Q		✓				classifies	
			Q		✓				classifies	
			Q		✓				classifies	

10 Core 1

Shows the direction of heat flow across materials of different temperatures.

The student applies the rule that heat flows from hot to cold objects.

Student Action: Indicating that heat flows from the containers of relatively high temperature into adjacent containers of lower temperature.

- A: b
- B: a
- C: d

Performance Check A: Assume that four containers of water, A, B, C, and D, are placed in contact with each other as shown. Select the response below which indicates the directions of heat flow that occur as the containers touch each other. Ignore the heat lost to the air.

- a. B to A, B to C, and D to C
- b. A to B, C to B, and C to D
- c. A to B, B to C, and C to D
- d. B to A, C to B, and D to C

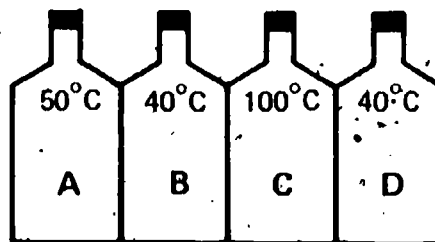

Remediation: (1) Refer the student to the last paragraph on page 260. (2) When your hand touches a hot object, which gets hotter, your hand or the object? (3) When you hold a cold drink in your warm hand, which gets warmer, the glass or your hand? Which gets cooler?

10 Core 2

Predicts the final temperature when materials of different temperature touch each other.

The student applies the rules that heat flows from hot to cold material until equilibrium is reached and that the equilibrium temperature of equal volumes of water at different temperatures may be calculated by adding the water temperatures of all and dividing by the number of volumes.

Student Action: Selecting the response that includes the equilibrium temperature.

- A: b
- B: d
- C: c

Performance Check A: The four containers, A, B, C, and D, each hold the same amount of water. They are placed in contact with each other inside a box which allows no heat to escape or enter. Approximately what will be the temperature of the water in container B after one hour?

- a. Between 60°C and 70°C
- b. Between 55°C and 60°C
- c. More than 70°C
- d. Less than 55°C

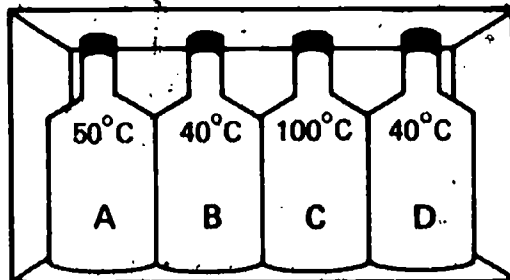

Remediation: (1) Refer the student to the bottom paragraph of page 260, and discuss the item with him. Will the 100°C container remain at that temperature? Will the 40°C container remain at 40°C ? How much will the temperature drop in the 100°C container and rise in the 40°C one? What determines the amount of change? (2) Refer the student to Excursion 13, page 357, on averaging temperatures if necessary.

Selects the state of a substance that is the poorest conductor of heat.

The student recalls that the gaseous state for a given substance is the poorest conductor of heat.

Student Action: Selecting "gas."

- A: a
- B: c
- C: b

Performance Check A: A new substance is formed that exists as a gas, a liquid, and a solid, depending on its temperature. In which state of matter would you expect it to be the poorest conductor of heat?

- a. Gas
- b. Liquid
- c. Solid
- d. Either b or c
- e. Texas

Remediation: (1) Refer the student to Activities 20-5 and 20-6 on page 261. (2) Check his response to questions 20-10, 20-11, 20-12, and 20-13. (3) If necessary, discuss these activities with him. (4) Suggest that he check his responses to Self-Evaluation Check 20-3.

10
Core
3

10 Core 4

Selects the material state that is the best conductor of heat.

The student applies the concept that, in general, metallic solids are better conductors of heat than the liquid or gaseous states of other materials.

Student Action: Selecting the beaker which contains the solid material and stating the essence of the concept above.

A, B, and C: 1. A

Performance Check A: Jerry lit burners under the three beakers (A, B, and C) at the same time. He also put thermometers into the beakers at equal distances from the heat source, as shown.

1. In which of the beakers will the thermometer begin to show changes in temperature first?
2. Why?

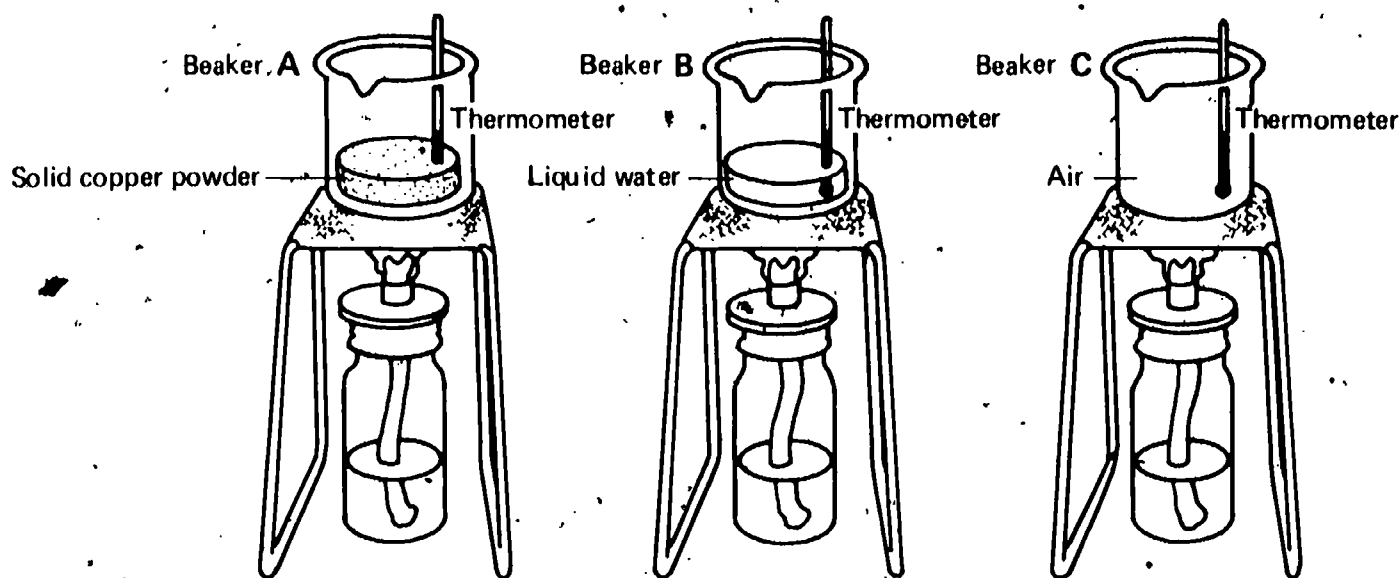

Remediation: See the Remediation for 10-Core-3.

10 Core 5

Proposes ways to check for an increase in mass in a heated substance.

The student generates a suggestion for an alternative to Activities 20-7 and 20-8 for detecting a possible increase in the mass of a heated material.

Student Action: Stating as an alternative to the effect (1) that a more sensitive balance be used or (2) that a larger mass be heated so that more of the postulated heat substance would be available, making it possible to detect an increase in mass more easily. An alternative of equal validity should also be accepted.

Performance Check A: A couple of students suggested to their teacher that Activities 20-7 and 20-8 did not provide good enough reasons to reject the heat-substance model. They said that the balance they used was too crude to detect any slight changes in the mass of the water. What change could you make in the activities which would make it possible to detect small changes in mass?

Remediation: (1) Have the student review Activities 20-7 and 20-8. (2) Ask him about an alternate way to detect a possible increase in mass. What piece of equipment could he use? If an increase in mass did occur, would the heating of a larger mass result in a greater increase in mass after heating? Would this be easier to test for? Which change in the experimental procedure would he suggest?

Predicts the effect of heating on the mass of an object.

The student applies the rule that heating does not change the mass of an object in a situation involving equal masses suspended from an equal-arm balance.

Student Action: Selecting the response which indicates that the position of the arm does not change as a result of heating the mass.

A: d

B: c

C: a

Performance Check A: Two $\frac{1}{2}$ kg masses are exactly balanced on the pegboard balance as shown. Suppose the left-hand mass is heated until it gets red hot. The right-hand mass would

- a. move down.
- b. move up slightly.
- c. move way up.
- d. not move at all.

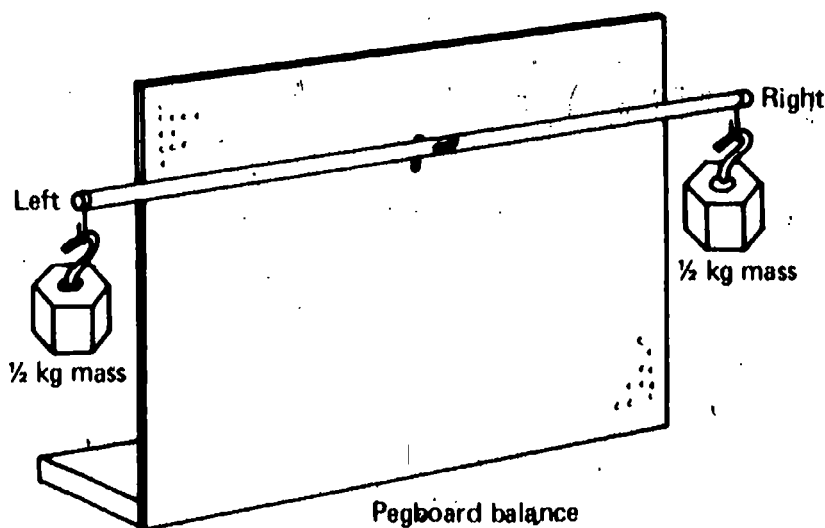

Remediation: (1) Refer the student to Activities 20-7 and 20-8 and check his responses to questions 20-16 through 20-19. If necessary, discuss his results. (2) Suggest that he review Self-Evaluation Check 20-2.

10
Core
6

10 Core 7

Recognizes when a scientific model is suitable.

The student applies the concept that a model is suitable to a specific situation if it explains the observations and can be used for the purpose intended.

Student Action: Responding negatively and stating the essence of the concept as his reason.

Performance Check A: In the following story, assume that both doctors' facts are correct. Dr. Bright is an eye doctor who writes prescriptions for glasses. The model he uses assumes that light travels in straight lines except when it goes from one substance to another; then, it bends. Dr. Hoberman, a physicist, uses a model which says that light is like a wave and does not travel in straight lines.

Dr. Hoberman says to Dr. Bright, "Your model and equations aren't used by scientists anymore. The model does not fit all the observations made, and it does not suggest further experiments."

Dr. Bright answers, "The model I use explains all the observations included in the optics of lens making. Furthermore, the arithmetic involved is fairly simple and quick. If I used the equations of your wave theory, my patients would be blind before I got their glasses ready."

1. Should Dr. Bright stop using the older model and use the newer, broader model which explains more phenomena of light?
2. Why did you give the answer you did?

Remediation: (1) Ask the student what makes a good model. Does the first doctor's model explain his observations? Can it be used for the purpose intended? Therefore, should the doctor continue to use his model?

10 Core 8

Recognizes the source of scientific models.

The student recalls that scientific models are mental creations.

Student Action: Selecting the phrase which reflects the notion of mental creation.

- A: d
- B: b
- C: c

Performance Check A: Select the best answer. Scientific models come into existence by being

- a. discovered in test tubes.
- b. found in nature by direct observation.
- c. produced as part of the data of an experiment.
- d. thought up by people.

Remediation: Ask the student what a scientific model is. Are they discovered? Must they be seen? (Can you see electroparticles?) How, then, do they come into existence?

Selects the properties of models that apply to the heat-as-energy model.

The student applies to the heat-as-energy model the concept that scientific models are best described as useful explanations and as the bases for predictions.

Student Action: Selecting the phrase to the effect of the concept above.

- A: c
- B: b
- C: d

Performance Check A: Select the letter of the phrase below which best completes this sentence. Scientists use the heat-as-energy model because it

- a. provides correct answers to all questions about heat.
- b. describes what heat actually is in nature and is therefore correct.
- c. helps to explain observations and to predict other observations.
- d. is the only true model for heat, and scientists found it.

Remediation: (1) Refer the student to Chapter 14, where the characteristics of a good model are stated, and to Self-Evaluation Check 14-2. (2) If necessary, discuss the other options with him.

Recognizes what accepting the heat-as-energy model means.

The student applies the concept that scientific acceptance of a model implies that it explains observations made to date, but does not imply that scientists feel either that this model is an exact representation of reality or that no other model would suffice.

Student Action: Selecting the interpretation involving explanation of observations, but not those implying that the model is absolute.

- A: c
- B: b
- C: d

Performance Check A: Scientists accept the heat-as-energy model for heat. This means that

- a. they have direct proof that heat is energy.
- b. at least a few scientists have seen heat as energy with their own eyes.
- c. thinking about heat as though it is energy explains most of the observations made to date.
- d. heat has the exact properties of a wave.
- e. no other model could fit the observations made to date.

Remediation: See the Remediation for 10-Core-9.

Selects the better of two models on the basis of the data they explain.

The student applies the rule that the better of two models is the one which explains more related phenomena.

10
Core
9

10
Core
10

10

Core 11

Student Action: Selecting the heat-as-energy model and stating the effect of the rule above.

Performance Check A: Heat-as-energy and heat-substance are two models used to explain heat. Study the chart below, and then answer the two questions that follow.

SITUATION	CAN BE EXPLAINED BY	
	Heat-as-Energy	Heat-Substance
Water doesn't increase weight when heated.	X	
Water increases volume when heated.	X	X
A metal rod gets longer when heated.	X	X
Spaghetti tastes better when hot than when cold.		

1. Based on the information in the chart, which is the better model?
2. Give a reason for your answer.

Remediation: Which model explains more situations which can be observed? Which, then, is the better model?

10 Core 12

Use the heat-substance model to explain why substances expand when heated.

The student applies the notion of the heat-substance model that heat substance itself takes up space and forces the particles of matter in the material being heated farther apart, thereby increasing the volume of the material.

Student Action: Stating the essence of the notion that the intrusion of the heat substance causes expansion.

Performance Check A: Arnold heated 60 ml of a liquid for five minutes. After heating it, he remeasured the liquid and found that it had a volume of 62 ml. Look at the diagram below. Using the heat-substance model, explain the 2 ml increase in volume.

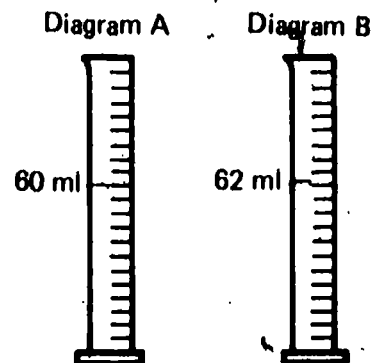

Remediation: (1) Refer the student to Figure 20-1, page 260. Have him describe this figure to you. (2) Check his responses to questions 20-4, 20-5, 20-6, and 20-7. (3) You may also wish to refer him to Self-Evaluation Check 20-4.

Uses the heat-as-energy model to explain the expansion of heated substances.

The student applies the notion of the heat-as-energy model that objects increase in volume when they are heated because the heat supplied to the particles of matter causes the particles to vibrate faster, thereby moving farther apart and consequently occupying more space.

Student Action: Stating the essence of the notion of the effects of increased particle vibration causing expansion.

Performance Check A: Ralph heated 40 ml of a liquid to 20°C. After it was heated, he remeasured the liquid and found that it had a volume of 45 ml. Using the heat-as-energy model, explain how the liquid could increase in volume.

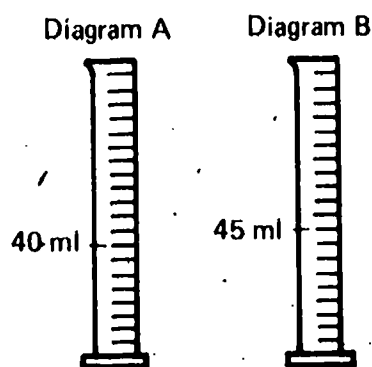

Remediation: (1) Refer the student to Figures 21-1, 21-2, 21-3, and 21-4 on pages 268 and 269. Have him explain those figures to you in terms of the heat-as-energy model. (2) Check his responses to questions 21-2 and 21-3. (3) You may wish to refer the student to Self-Evaluation Check 21-3.

Uses the heat-as-energy model to explain the heating of rubbed surfaces.

The student applies the heat-as-energy model to a situation in which heating results from rubbing objects together.

Student Action: Predicting that the objects will continue to heat up as long as they are rubbed together and stating that rubbing causes the particles in the objects to vibrate faster and that the faster vibrations will continue as long as the rubbing continues.

10
Core
13

10
Core

0.3

14

Performance Check A: Touch two palm size pieces of paper. Rub them together rapidly between your hands, noting any change that occurs.

1. If you keep rubbing them together, how long will they continue to produce the effect you observed?
2. Explain your answer in terms of the heat-as-energy model.

Remediation: (1) Have the student review the heat-as-energy model, especially the last paragraph on page 271, and check his responses to questions 21-11 and 21-13. (2) If necessary, discuss the model with him: What does rubbing cause the particles to do? For how long?

10 Core 15

Ranks the three states of matter according to their relative amounts of internal energy.

The student applies the concept that for a given substance, the gaseous state has more energy than the liquid state and the liquid state has more energy than the solid state.

Student Action: Indicating the relative energy levels of the three states of matter by placing on the scale an *S* nearest low energy, a *G* nearest high energy, and an *L* between the *S* and the *G*.

Performance Check A: Suppose that the energy within a substance called gunk could be measured and that the substance could exist as a solid, a liquid, or a gas, depending on the amount of energy it contained. Draw a line like the one shown below on your answer sheet to represent different amounts of energy. Mark the place on this line where you would expect to find each state of the gunk, using *S* for solid, *L* for liquid, and *G* for gas.

Low energy

High energy

Remediation: (1) Have the student review Table 18-1. (2) Find out if he understands that increasing the amount of energy causes materials to expand. (3) Find out if he understands that increasing the amount of energy causes the liquid in a thermometer to rise and that decreasing the amount of energy causes it to fall. When he understands those notions, have him put a thermometer into ice water, liquid water, and boiling water. Then, have him redo the Performance Check.

10

Explains how a little hot water can contain less heat than a lot of cool water.

The student generates an explanation using the heat-as-energy model for why there is more heat in a large quantity of cool water than there is in a small quantity of hot water.

Student Action: Responding to the effect that the amount of heat stored is the total amount of particle vibration and that in the large quantity of cool water so many particles vibrate that although they are vibrating more slowly than those in the small amount of hot water, the total amount of vibration —and therefore of heat — is greater.

Core
16

Performance Check A: Use the heat-as-energy model to explain why it is true that there is more heat in 2,000 ml of water at 30°C than in 50 ml of water at 90°C.

Remediation: Discuss the check with the student. In which quantity of water are the particles vibrating more slowly and in which are they vibrating faster? In which quantity of water are there many more vibrating particles? Do the faster vibrating particles in the small quantity of water produce more heat than the many slower vibrating particles in the larger volume of water?

Uses the heat-as-energy model to explain how a thermometer works.

The student applies the heat-as-energy model to explain the rising and falling of the liquid in a thermometer.

Student Action: Responding to the effect that when a thermometer is placed in hot materials, energy is absorbed causing the liquid particles of the thermometer to move faster and therefore farther apart, increasing the volume of the liquid, and when a thermometer is placed in cold materials, the particles in the thermometer liquid give up energy and vibrate less, becoming closer together and therefore occupying less space and reducing the volume of the liquid.

10
Core
17

Performance Check A: Using the heat-as-energy model, explain how a thermometer works to measure hot and cold materials.

Remediation: Refer the student to Figure 21-6 and have him describe to you what is happening there. Check his response to question 21-7. Have him review the top paragraph on page 271.

Explains the loss in usable output energy of a machine as its temperature increases.

The student generates an explanation for why the usable output energy of a machine which receives a constant amount of input energy is decreased as its temperature increases.

Student Action: Responding to the effect that the increase in temperature causes the decrease in usable output energy because the machine converts more input energy into heat energy and less into output energy as the temperature of the machine increases.

10
Core
18

Performance Check A: Look at the graph below. The amount of input energy supplied to the machine is a constant 100 units, represented by the dotted line on the

graph. The solid line on the graph represents the output energy plotted against the temperature change. Explain what happens to the input energy as the amount of usable output energy decreases.

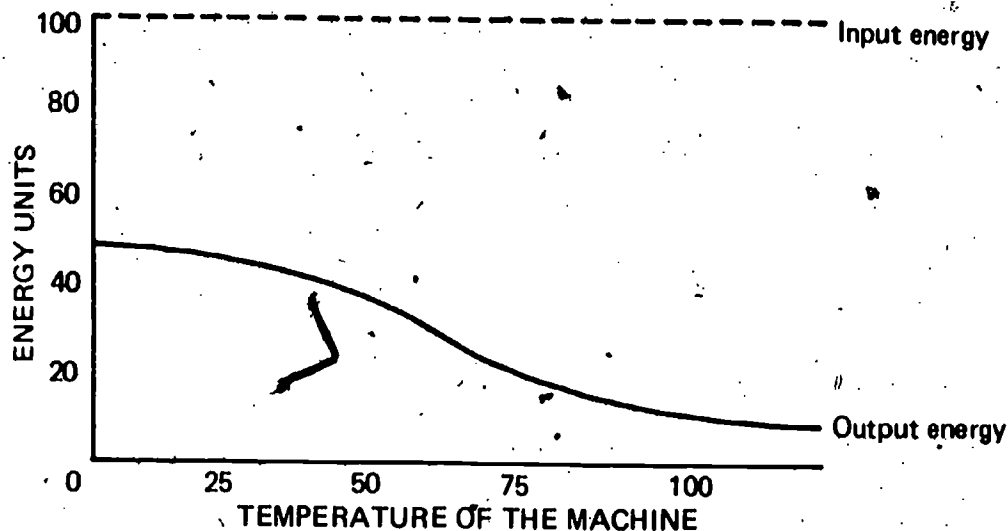

Remediation: (1) Refer the student to Figure 21-8 and discuss it with him. What accounts for the difference in input and output energy? (2) Therefore, what happens to some of the input energy in the Performance Check situation as the usable output energy decreases? Is it lost?

10 Core 19

Uses the heat-as-energy model to explain the difference in input and useful output energy.

The student applies the concept that the difference between input and useful output energy is energy that has been converted by friction into heat energy, or particle vibrations, in sliding surfaces.

Student Action: Stating in effect that the missing energy is converted by friction into heat energy, or particle vibrations, in sliding surfaces. (Ignore inertia.)

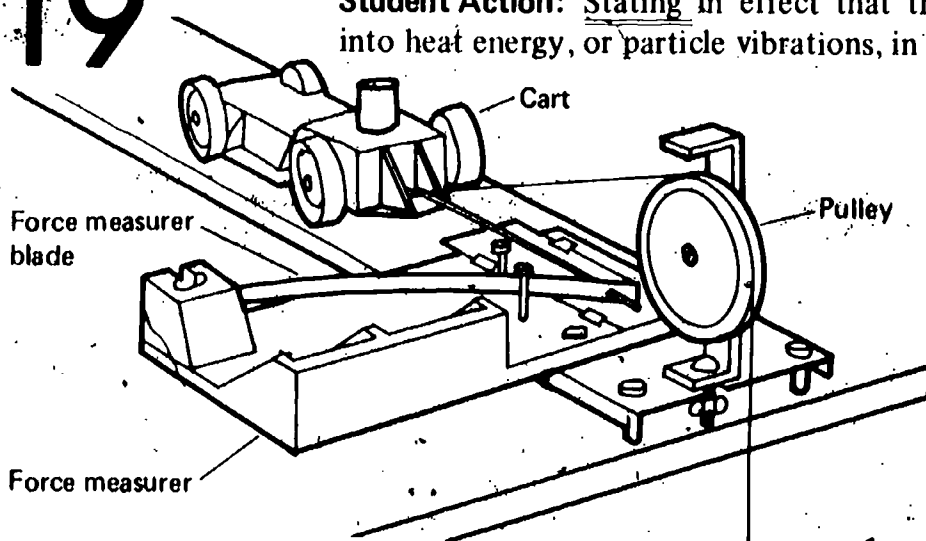

Performance Check A: In Activity 10-12, diagramed above, you converted the potential energy of the blade into the motion energy of the cart. You found that the kinetic energy of the cart was less than the potential energy of the blade. Use your heat-as-energy model to explain what appears to be a loss of usable energy.

Sinker

Remediation: See the Remediation for 10-Core-18.

Compares the volume per unit of mass of warm air to that of cool air.

The student applies the principle that warm air has more volume per unit of mass than a corresponding mass of cool air.

Student Action: Responding that he will be warmer in the top bunk and with the principle that the warm air has more volume per unit of mass and will rise, whereas the cooler air will sink.

Performance Check A: During the winter, Iggy visits a friend in the North who has bunk beds in his bedroom. Iggy is offered the upper bunk. The heating vent through which the bedroom is heated is on the wall near the floor. Will Iggy be warmer than, just as warm as, or cooler than his friend who is sleeping in the bottom bunk? Explain your answer.

Remediation: (1) Refer the student to Excursion 45, Activity 45-3. Discuss the results of this activity with him. (2) Suggest that he review pages 533 and 534 for the concluding discussion in the excursion and check his response to question 45-14.

10
EXC
45
1

Selects a reason for discarding a scientific model.

The student applies the principle that scientific models are discarded when new, well-tested observations are made that do not fit the model, that is, when the modification of the model begins to cause internal contradictions.

Student Action: Selecting the option which agrees with the statement above.

A: c

B: b.

C: a

Performance Check A: A scientific model is discarded when

- the developer of the model dies.
- a model which is less broad, but easier to understand, is developed.
- new observations produce contradictions within the model.
- a more complicated, mathematically-based model is developed.

Remediation: (1) Suggest that the student review Excursion 46, especially the historical section, pages 538 through 540, which describes how a model is discarded if you can't explain new observations with it.

10
EXC
46
1

Describes temperature changes shown on a graph.

The student applies the concepts that during cooling a curve has a negative slope or that during heating a curve has a positive slope and that during a phase change the temperature does not change.

10
EXC

47
1.

Student Action: Responding to the effect that during cooling the curve slopes downward to the right, that during heating the curve slopes upward to the right, and that when changing from one form to another the curve shows no change in temperature.

Performance Check A: Consider the cooling curve for sulfur shown in the graph below. Describe the processes that are taking place in sections A, B, and C.

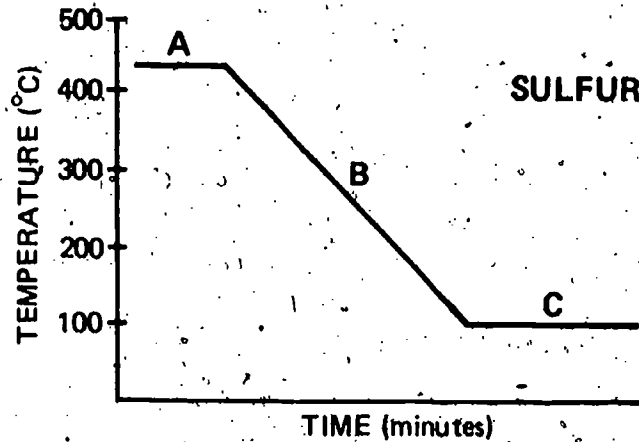

Remediation: (1) Refer the student to Excursion 47. Check his graph for the heating curve in Figure 47-1 and also his responses to questions 47-1, 47-2, and 47-3. (2) If necessary, discuss in which direction heating and cooling curves slope. Also, ask him what happens in the section where the temperature remains unchanged.

10
Exc
47
2

Selects the graph which best represents a cooling curve.

The student applies the principles that cooling curves have a negative slope and that during a phase change there is no change in the temperature of a pure substance.

Student Action: Selecting the curve which agrees with the principles governing a cooling situation.

- A: c
- B: b
- C: a

Performance Check A: Which of the following time-temperature graphs best describes the cooling behavior of water when it changes to ice?

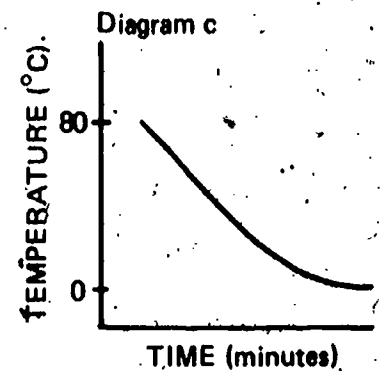
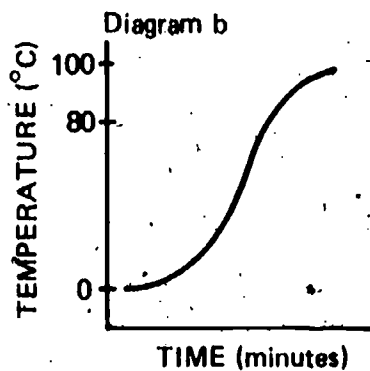
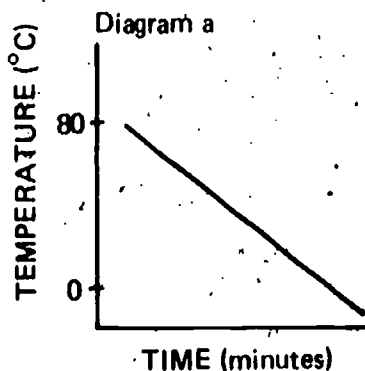

Remediation: (1) Discuss the check in question. In which direction does a cooling curve slope? Should the graph show level places? Why? (2) You may also wish to refer the student to Figure 47-1, which shows the opposite slope for a heating curve. Note that the term *slope* is not used in the checks because it has not been introduced formally within the ISCS Level I materials.

Relates the energy conversion of stored energy to the amount of output energy.

The student applies the rules that energy conversion always involves a loss of usable energy, that the total amount of energy is never altered, and that some of the input energy is converted to heat energy.

Student Action: Responding that the apparently lost energy has been converted into heat energy.

Performance Check A: Water is held in place behind a dam. It has potential energy. When the dam is opened, water spills out. The water now has kinetic energy (motion energy). As the water falls, it turns a large wheel, or turbine. The turbine generates electricity to produce power for the nearby city. Has all of the potential energy that was stored in the water behind the dam been converted to electrical energy? If not, where did the lost energy go or where did the gained energy come from?

Remediation: (1) Suggest that the student review the conclusions he made in Excursion 48, pages 551 and 552. Check his responses to questions 48-9 through 48-12 and, if necessary, discuss the Law of Conservation of Energy with him.

10
EXC
48
1

