

DOCUMENT RESUME

ED 173 159

SE 028 407

AUTHOR Tullock, Bruce, Ed.; And Others
TITLE Solar Energy Project, Activities: Junior High Science.
INSTITUTION Department of Energy, Washington, D.C.; New York State Education Dept., Albany. Bureau of Science Education.; State Univ. of New York, Albany. Atmospheric Science Research Center.
REPORT NO. DOE-CS-0062
PUB DATE Jan 79
NOTE 114p.; For related documents, see SE 028 406-413
AVAILABLE FROM Superintendent of Documents, U.S. Government Printing Office, Washington, D.C. 20402 (Stock Number 061-000-00228-6; \$2.75)

EDRS PRICE MF01/PC05 Plus Postage.
DESCRIPTORS Class Activities; *Energy; Environmental Education; Junior High Schools; *Lesson Plans; *Science Curriculum; *Science Education; Science Experiments; *Secondary Education; *Solar Radiation; Technological Advancement; Technology
IDENTIFIERS Energy Education; *Solar Energy

ABSTRACT

This guide contains lesson plans and outlines of science activities which present concepts of solar energy in the context of the junior high science curriculum. Each unit presents an introduction; objectives; skills and knowledge needed; materials; methods; questions; recommendations for further work; and a teacher information sheet. The teacher information sheet presents the target grade levels; the areas of science involved in the lesson; background information; hints on gathering materials; suggested time allotment; suggested approach; typical results; precautions; modifications; and evaluation. (PE)

 * Reproductions supplied by EDRS are the best that can be made *
 * from the original document. *

Activities

Junior High Science

January 1979

U.S. DEPARTMENT OF HEALTH,
EDUCATION & WELFARE
NATIONAL INSTITUTE OF
EDUCATION

THIS DOCUMENT HAS BEEN REPRODUCED EXACTLY AS RECEIVED FROM THE PERSON OR ORGANIZATION ORIGINATING IT. POINTS OF VIEW OR OPINIONS STATED DO NOT NECESSARILY REPRESENT OFFICIAL NATIONAL INSTITUTE OF EDUCATION POSITION OR POLICY.

ED173159

S

U.S. Department of Energy
Assistant Secretary for Conservation
and Solar Applications
Market Development and Training Program
Washington, D.C. 20545

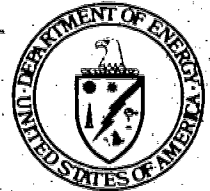

SOLAR ENERGY PROJECT

SE 028 407

For sale by the Superintendent of Documents, U.S. Government Printing Office
Washington, D.C. 20402
Stock Number 061-000-00228-6

A SOLAR DESALINIZER

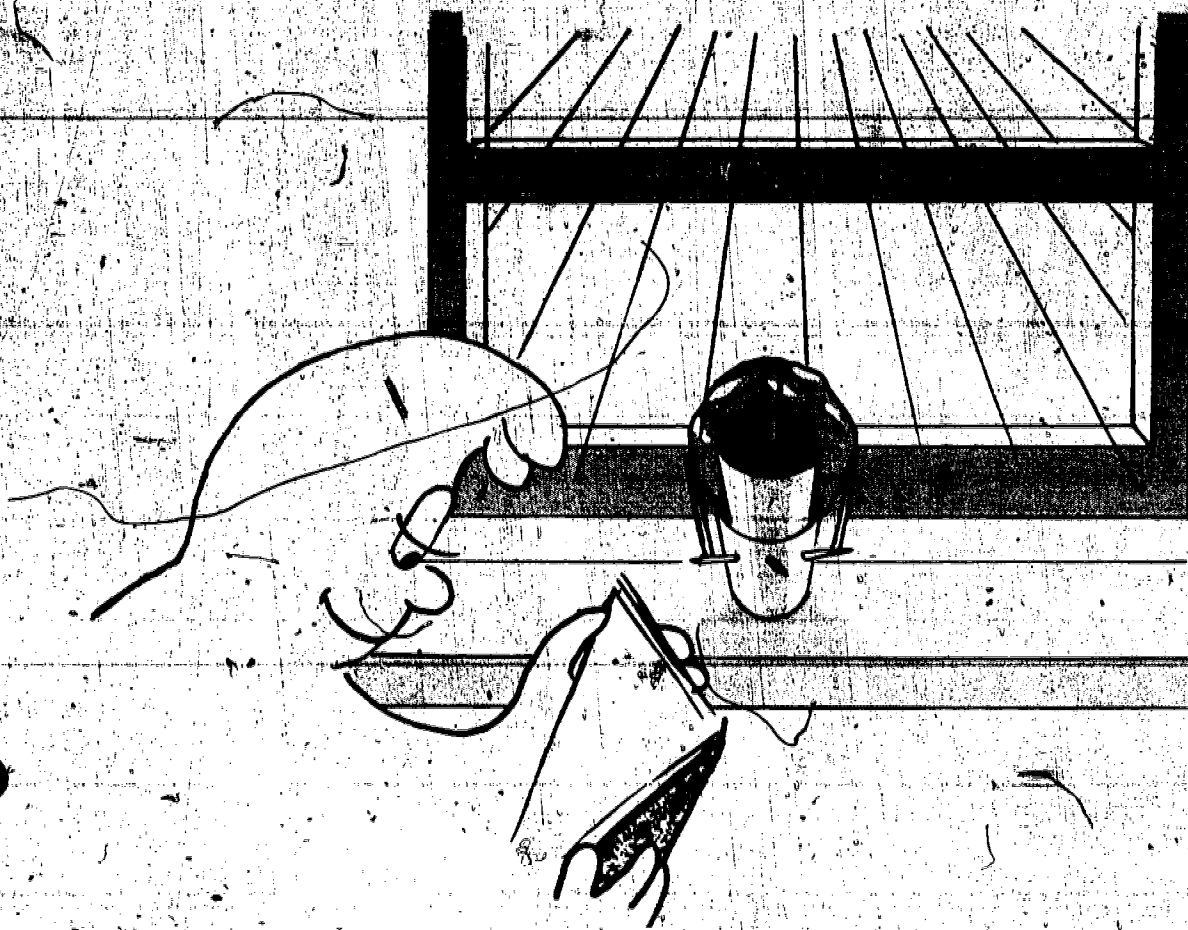

INTRODUCTION

Pure drinking water in the United States and other areas of the world is becoming scarce. Several alternative drinking water sources are possible, such as towing icebergs from Antarctica, seeding clouds, and chemically treating polluted surface water. But all of these methods are expensive and they use fossil fuels which are becoming less abundant. The chemical treatment of water has questionable health effects and often produces water which has an unpleasant taste. Fortunately it is possible to produce drinkable water from the ocean. Using the sun as an energy source, salt and other impurities can be removed by distillation.

OBJECTIVES

At the completion of this activity, you should be able to:

- o construct a small "still" that uses solar energy to make fresh water from salt water.
- o explain the process by which solar energy is used to remove impurities from salt water.

SKILLS AND KNOWLEDGE YOU NEED

- How to follow directions carefully.
- How to measure metric length and volume.
- How to collect and interpret data from an experiment.

MATERIALS

- 2 styrofoam cups.
- 3 flat toothpicks.
- 4 round toothpicks.
- 1 plastic sandwich bag.
- 1 7.5cm long section of $\frac{1}{2}$ " wooden dowel.
- 1 piece of modeling clay.
- 1 jar lid.
- A small amount of salt.
- 1 ruler (metric).
- 1 sheet of newspaper.
- Black enamel paint.
- White glue.
- Cellophane tape.
- 250ml graduated cylinder.

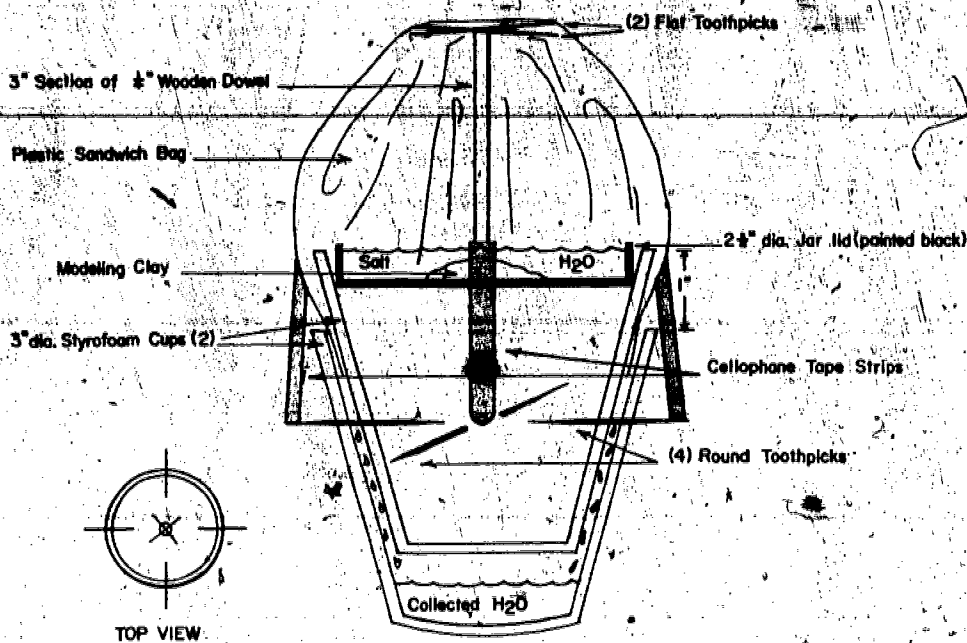

METHOD

1. Refer to the diagram and the teacher's model as you construct your own solar still. Do not place the plastic bag over the still until your teacher tells you to do so.
2. Pour 125ml of hot tap water into a clean container and add a small amount of table salt.
3. Use clean hands to carefully taste the solution by dipping your finger tip into it and placing it on your tongue. How does it taste?
4. Put enough salt water solution into the jar lid to almost fill it. Be careful not to spill any of the solution into the outer cup.
5. Without letting the plastic bag touch the salt water solution, place it over the two flat toothpicks. Carefully use another flat toothpick to tuck the sides of the bag between the two styrofoam cups.

6. To prevent the sandwich bag from collapsing, run four strips of cellophane tape from the sides of the bag to the four round toothpicks.
7. Place your still in direct sunlight for the school day.
8. After several hours, or when told to do so by your teacher, carefully remove the sandwich bag. What is in the jar lid? Taste it using the method already described and record your results.
9. Carefully remove the four toothpicks and separate the two cups. What is in the outer cup? If there is something there taste it. How does it taste? Use a graduated cylinder to determine the amount of liquid in the outer cup in milliliters and record your results.

LOOKING BACK

Commercial solar stills, also called solar desalinizers, are much larger, much more expensive, and more precise in design than your still. But they work on the same principle as yours. Nature, too, works in the same way to produce pure rainwater from the saltwater of the oceans.

QUESTIONS

1. a) What did the solution in the jar lid taste like before distillation? b) What did the solution in the jar taste like after distillation?
2. a) Was anything in the outer cup? b) If there was, what did it taste like? c) How many milliliters of liquid were in the outer cup?
3. How did the taste of the solution in the jar lid compare to the taste of the solution in the outer cup?
4. Energy was required to remove the salt from the saltwater solution. Where did the energy come from?
5. Explain as best you can how the still removed the salt from the saltwater.

GOING FURTHER

- Why was the jar lid painted black?
- Are there any regions of the world where this method of water purification would not be feasible? Why not?

- Can you think of uses other than water purification of an apparatus such as this? Explain your answer.

- Can you think of a method for desalinizing water which does not use solar energy? What are the advantages and disadvantages of such a method as compared to solar desalinization?

- List the advantages and disadvantages of each of the following methods of obtaining drinking water.

- a. Antarctic icebergs
- b. Cloud seeding
- c. Chemical treatment
- d. Solar desalinization

- How is the solar desalinizer you constructed similar to the water cycle in nature?

Teacher Information Sheet

A SOLAR DESALINIZER

Suggested Grade Level and Discipline

7-9 Science
Physical Science
Earth Science
Ecology

Background Information

The solar desalination of sea water is currently used in some coastal regions of the world located below 40° N latitude, where solar insolation is direct enough for desalination to be economically feasible. A solar desalinator utilizes two basic principles to produce freshwater for drinking. First, the solar insolation causes the sea water to evaporate causing the salt and other minerals to remain as residue in the evaporation vat. Secondly, the water vapor, which is now devoid of salt and other minerals, rises, cools, and condenses on a surface above the evaporation vat and is collected as freshwater. This process of separating mixtures by means of evaporation and condensation is called distillation.

Hints on Gathering Materials

All of the materials in this laboratory activity are readily accessible from the local grocery and hardware store at a minimal cost. The only item which cannot be purchased separately is the jar lid commonly used on jars containing instant coffee and other products. Consequently, have the students start bringing these into class two to three weeks prior to the activity to assure an adequate supply.

Suggested Time Allotment

- Approximately one class period is required to construct the desalinator.
- One school day (5 to 6 hours) is required for the apparatus to desalinate the salt water.
- One to two class periods are required for the collection, interpretation, and discussion of data.

Suggested Approach

Before the experiment, the teacher should build a solar still model for the students to examine. This will eliminate the need for lengthy instructions.

- Since the materials are inexpensive and a minimal amount of space is required, have the students work in groups of two or three.
- If possible, students who construct their apparatus in the morning should check it at the end of the school day. Those who set up their apparatus later in the day should check it the following morning.

It is important to make sure that the amount of insolation for each solar still is as uniform as possible. Therefore be careful of the location of the stills.

- As with most energy activities, career education can be introduced by contacting local power company representatives for a classroom or assembly presentation and for discussion of both the feasibility and availability of solar energy as a means to help meet the energy demands of today and the future.

- Below are listed steps for building a solar still.

1. Refer to the diagram as you make your desalinizer.
2. Glue two flat toothpicks together at right angles to each other forming an + , and then glue them to one end of a 7.6cm section of wooden dowel. Let this dry.
3. Place the jar lid inside up on a sheet of newspaper and paint all of its inside surface black. Let it dry.
4. Measure 2½cm from the top of one styrofoam cup and draw a pencil line completely around the outside of the cup.
5. Lower the marked cup inside the second styrofoam cup until the drawn line is level with the top of the outside cup. To fasten the two cups, put the four round toothpicks through both cups at 90° intervals.
6. To avoid being hurt by the sharp ends of the round toothpicks, put masking tape around their ends.
7. Mold modeling clay around the plain end of the wooden dowel. Place this clay, dowel, and toothpick assembly in the center of the jar lid. It should stand straight up.
8. Put the jar lid into the top of the inner styrofoam cup in a level position.

Typical Results

- Depending on the amount of insolation received, the amount of freshwater collected will vary from 1ml to 5ml.

Precautions

- Make sure that students pad the protruding ends of the round toothpicks with masking tape to prevent puncture wounds.

- Make sure that all of the styrofoam cups, water, and teaspoons used are clean, since students are to taste these solutions. Make sure that students clean their hands before tasting the solutions. Also, warn them that they should never taste any chemicals in a science classroom without a teacher's permission.

Modifications

- The jar lid can be left unpainted or the outer styrofoam cup can be painted black and the results compared to those of the standard apparatus.
- Use a 250 watt heat lamp at a distance of 1 meter above the apparatus if there is no effective sunlight.
- You may wish to make a stock solution of salt water rather than having students make their own.

Evaluation

- Check the students' ability to follow directions by noting the construction of their solar stills.
- Check the answers to the questions.

COLLECTING THE SUN'S ENERGY

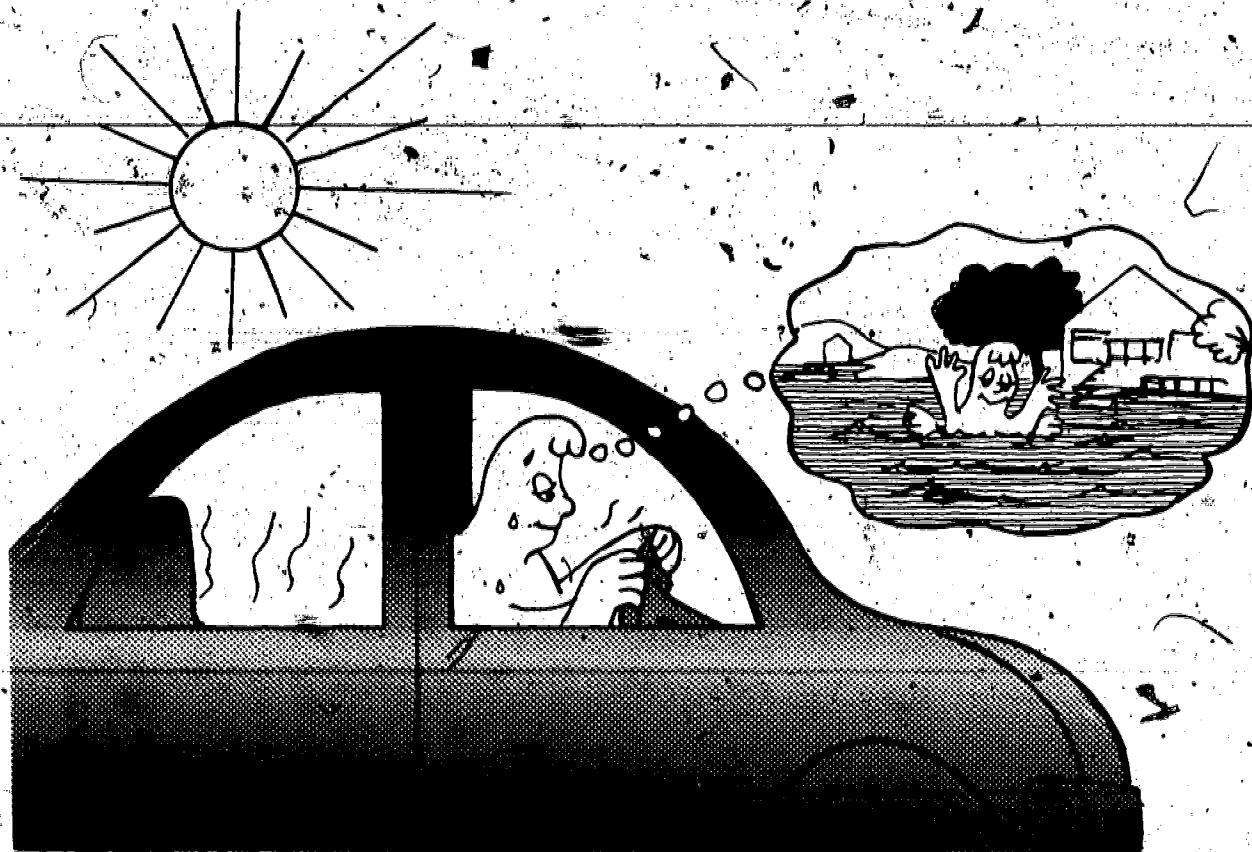

INTRODUCTION

Is the sun powerful enough to use as a source of energy? Sitting in a closed car on a sunny day seems to indicate it is. Think about all the solar energy that strikes the earth but is not used. If this energy-packed sunlight could be collected, it would provide a large source of clean, free, and much-needed energy. In this activity you will learn how a solar energy collector works and build a simple solar water heater.

OBJECTIVES

At the completion of this activity, you should be able to:

- o understand the basic parts of a solar energy collector.
- o construct a solar energy collector.
- o be aware of practical uses for solar energy.

SKILLS AND KNOWLEDGE YOU NEED

- How to read a thermometer.
- How to measure metric length, volume, and mass.
- Understand what a calorie is.
- How to graph data.

MATERIALS

- Quart size mayonnaise or canning jar; wide mouth with lid.
- 12 oz. aluminum beverage can.
- Thermometer; 12", 75mm immersible $0^{\circ}\text{C} - 100^{\circ}\text{C}$.
- 50ml or 100ml graduated cylinder.
- Flat black paint.
- Sandpaper.
- Paint brush.
- Modeling clay.
- Balloon or rubber membrane.
- Corrugated cardboard.
- Aluminum foil.
- Rubber bands.
- Scissors.
- Water.
- Clinometer (optional).

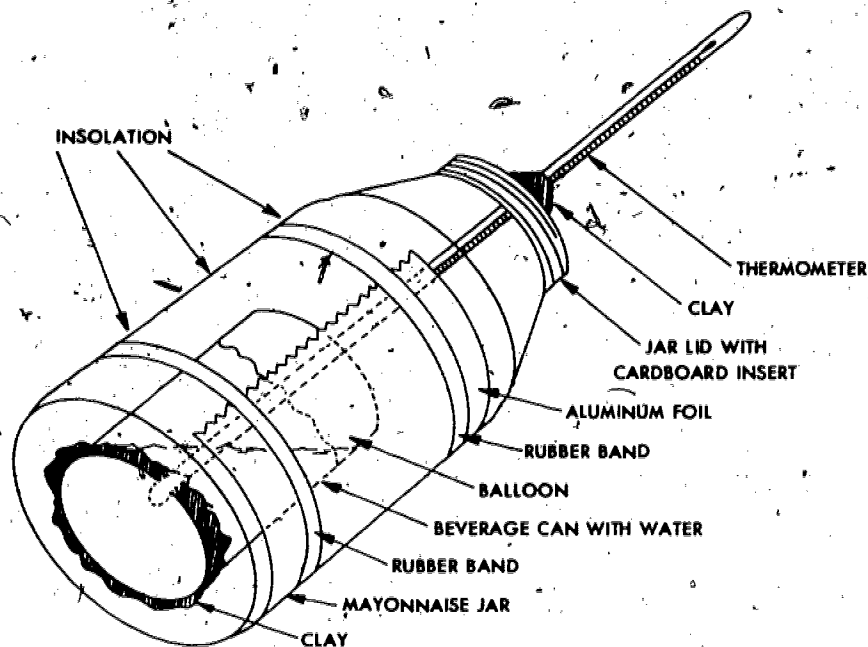

METHOD

1. Sand the outside of the beverage can so the paint will stick to it. Paint the outside of the can with flat, black paint.
2. Cut a circle of cardboard to fit inside the jar lid.
3. Punch or drill a hole in the center of the lid and cardboard so the thermometer will fit through.
4. Put 200ml of tap water into the beverage can.
5. Cut off the end of a balloon and fit it over the open end of the beverage can. Puncture the balloon to allow the thermometer to pass into the water in the can.
6. Position the beverage can in the center of the jar, anchoring it in position with a small ball of clay by pressing down on the can. Be careful not to spill the water.
7. Screw the lid on the jar.
8. Carefully fit the thermometer into the jar and can positioning it so you can read the water temperature. Do not force the thermometer in or turn the lid once the thermometer is in place. The thermometer breaks easily.

9. Pack a small amount of clay around the thermometer to plug the hole on the lid and make it air tight.
10. Wrap a piece of aluminum foil, shiny side in, around half of the jar. Secure the foil with rubber bands.
11. Enter all initial data on your data sheet. The sun's altitude can be determined with a clinometer or by asking your teacher: REMEMBER NEVER TO LOOK DIRECTLY AT THE SUN BECAUSE IT CAN CAUSE PERMANENT EYE DAMAGE.
12. Place your solar collector on an angle directly facing the sun with the foil side away from the sun. Begin making readings at 3 minute intervals for a total of 30 minutes. Record this information on your data sheet. In the "Notes" column list any changes, such as cloud cover or a movement of the collector, which might occur during the experiment.
13. Graph water temperature vs. time.

LOOKING BACK

Your solar collector should have increased the temperature of the water several degrees. This simple device made with everyday items works well and could have many practical uses if built on a larger scale. The glazing and collector box (glass jar) collector plate (blackened can), transfer medium (water) and insulation (cardboard) are all basic parts of any solar collector.

QUESTIONS

1. Interpret your graph. When did the temperature increase the most? Account for any dips or increases in the graph. If your graph leveled off, explain why.
2. List 5 different parts of the collector and explain their functions.
3. How many calories of heat energy were collected in the water? The number of calories = mass of water (in grams) x temperature change (in °C) x specific heat of water which is 1 cal./g °C.

GOING FURTHER

Do an experiment to see what air temperatures can be reached if no water was placed in the can. Does just warming air have any practical use?

- Determine what effect the slant of a collector has on the temperature attained. Try different angles of insolation.
- What effect do different outside air temperatures have on temperatures obtained? Is your collector just as effective in winter as in summer?
- Find out what effects wind and cloud cover have on your collector's performance.
- Experiment with changing the color of the beverage can. Does this affect the performance of the collector?
- Experiment with other liquids inside the beverage can. Does this affect your collector's performance?
- Experiment using a steel can for the collector plate. Does this change your results?
- Place the mayonnaise jar inside a larger glass jar. What effect does this have on your collector's performance?

COLLECTING THE SUN'S ENERGY

Suggested Grade Level and Discipline

7-9 Science
ISCS III - In Orbit
Earth Science
Physics

Background Information

A solar collector has five basic parts.

One major part of a collector is a covering material, called glazing, which transmits as much solar energy as possible. Its purpose is to trap the energy it transmits, inside the collector. The glazing should be able to withstand high temperatures without decomposing or melting and it must be able to withstand impact from objects that might fall on it.

Another part of any solar collector is the collector plate which absorbs the energy transmitted by the glazing. The collector plate is usually coated with a dark colored material that increases the absorptivity of the solar energy. The collector plate and its coating must be able to withstand high temperatures without vaporizing or otherwise breaking down. The collector plate is often made from copper or aluminum but other materials may be suitable. The collector plate (metal can) will absorb part of the energy collected but the effect on the change in temperature should be small so it is not absolutely necessary for students to calculate this.

A third part of a collector, the collector box, houses the various parts of the collector. It can be made from materials such as aluminum, wood, fiberglass or steel. It must be sturdy and able to withstand temperature extremes. In this activity the glazing is also the housing.

The fourth part of a collector is the insulation that surrounds five sides of the collector box. Conduction losses of trapped solar energy are substantial unless the collector box is well insulated. Fiberglass and various foams are commonly used for this purpose. A secondary glazing can be used as insulation. The cardboard in the lid provides insulation for heat lost through the metal top.

The fifth part of the collector is either air or a liquid. It is used to transfer the solar energy to a system for distribution throughout the space to be heated or to a substance to be heated. If water is used as the medium in cold climates, it is often mixed with an antifreeze.

A collector or a series of collectors can be used for space heating or to provide hot water for commercial or domestic uses.

The collector constructed in this activity is a water collector which will simulate the workings of a typical liquid collector.

Hints on Gathering Materials

- Several weeks before the activity is planned, have students start bringing in jars and cans. The jar openings must be wide enough to accommodate the cans. Students generally prefer to use their own equipment. Insist the jars be clean with all labels and glue removed.
- Any flat black paint will do as long as it is not water soluble when dry. Latex paint is preferred for clean up and for short drying time.
- 3/4 to 1 inch paint brushes may be borrowed from the art teacher. They are less messy than larger brushes.
- Corrugated cardboard may be pre-cut to fit into the jar lids to save time.

Suggested Time Allotment

- One period to construct the collectors.
- Two or three periods for collection and interpretation of data.

Suggested Approach

- Take data every three minutes.
- Have no more than two students to each collector.
- The collection should be done outside or through a direct sun-exposed window. Use a relatively sunny day to collect data. The results should be good on a partly cloudy or hazy day, but not dramatic enough during totally overcast weather. Variation in weather will create challenging variables in results to interpret.
- In the graph, temperature should be on the vertical axis and time will be on the horizontal axis.
- To infuse the concept of career education into the classroom, there are numerous sources of energy materials available. The Department of Energy and energy related industries and utilities will supply media resources upon request. Businesses, including solar heating system dealers, may be willing to come to your classroom or invite your group to their business to discuss their aspects of energy.
- Each student should be encouraged to explore his own home and determine where energy is wasted and how such wastes could be eliminated.

As a follow-up activity, students can be asked to design their house of the future that uses solar energy as a primary energy source and is energy efficient.

Typical Results

- Students should realize the effect weather conditions have on the degree of water temperature change.
- The angling of the collector to the sun will cause results to vary.
- The temperature change should level off if conditions are constant after 30 to 40 minutes.
- Different amounts of water should result in directly proportional changes in temperature.
- If a dry can is used (no water), the temperature increase is significantly higher, as compared to one which is water-filled.
- A second layer of glazing should increase the water temperature change.

Precautions

- *Holes should be pre-punched in the lids by someone other than the students.*
- *Thermometers must be placed in the collector after the jar lid is screwed on. Care should be taken that the holes in the lid and can are aligned. There should be no stress on the thermometer.*

Modifications

- See GOING FURTHER in student activity section.
- It may be advantageous to determine the mass of the metal can and include the heat energy absorbed by the can in the calculations.

Evaluation

- Observe your students' ability to follow instructions and work with other class members.
- Collect and review the data gathered by each student. Is it well organized? Is the analysis well-thought out? Are the graphs usable for data analysis?
- Check students' answers to the questions.

References

World's Most Advanced Solar Home, *Solar Energy Handbook*, 1978
(New York: Times Mirror Magazines.) 1978

Alternate Forms of Energy, Grey Feinmon. (New York: Kensington
Publishing Co) 1977

The Solar Home Book, Bruce Anderson. (Harrisville, New Hampshire:
Cheshire Books) 1976

DRAFT - ACTIVITY 3
ENERGY FROM THE SUN

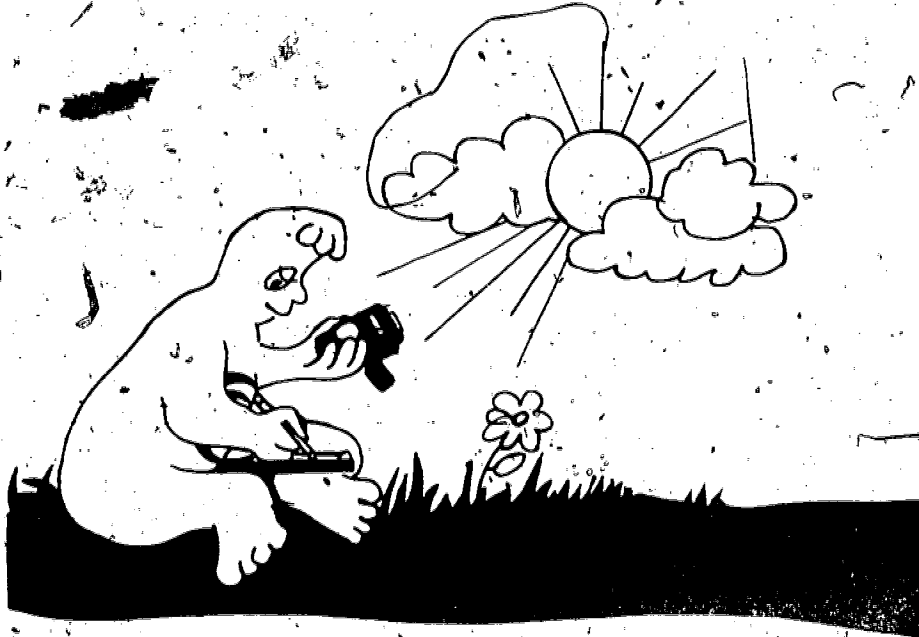

INTRODUCTION

Have you ever seen how a solar collector is placed to collect the sun's energy? Why do you think they are installed that way?

The amount of solar energy collected depends on the way the collector surface faces the sun. This activity will look at some factors involved in deciding how to place a solar collector to get the most solar energy.

OBJECTIVES

At the completion of this activity, you should be able to:

- o relate the energy received to the angle of the sun.
- o relate cloud cover to the energy received.
- o determine if all the light comes directly from the sun.
- o predict the best angle at which to set a solar collector.

SKILLS AND KNOWLEDGE YOU NEED

- How to use a solarimeter or light meter.
- How to use a clinometer (altitude measuring device).

MATERIALS

- Solarimeter or light meter (often available from a photography class).
- Clinometer (altitude measuring device).

METHOD

1. Record the presence or absence of clouds between you and the sun, as well as general cloud conditions.
2. If you do not know how to use the clinometer (altitude measuring device) or light meter, see your instructor for specific directions.
3. Take these two pieces of equipment outside to make your measurements; TAKE CARE NOT TO LOOK DIRECTLY AT THE SUN.
4. Record on the data sheet the solarimeter (or light meter) readings when aimed at angles of 0° , 15° , 30° , 45° , 60° , 75° , 90° , 105° , 120° , 135° , 150° , 165° , and 180° from the ground. See diagram A.

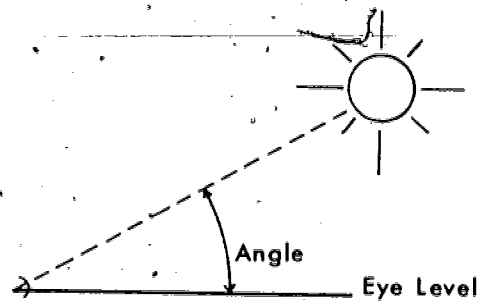
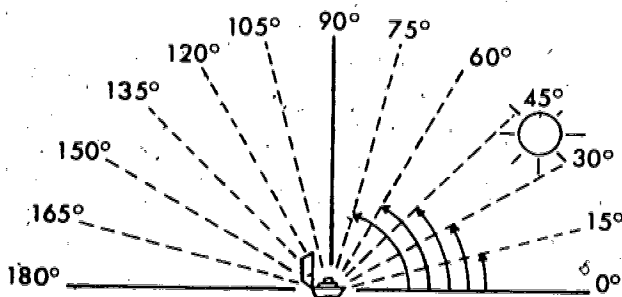

5. By aiming the solarimeter at varying angles determine the angle which will give a maximum solarimeter reading. Record the angle and maximum reading on the data sheet.
6. Using the clinometer measure the angle of the sun from the horizon or what is known as its altitude. BE CAREFUL YOU DO NOT LOOK AT THE SUN DIRECTLY. See diagram B. Measure the angle as accurately as possible by looking to the left or right of the sun.

7. Record the light meter reading at the angle determined in step 6. Add this to your chart.
8. Repeat the same measurements as in steps 3-7 on a different day when the clouds are not the same. Make sure the time of day remains the same on both days.
9. Plot the data, angle vs. amount of light on one graph using both sets of readings.

LOOKING BACK

You should understand how the intensity of the light received on a surface varies according to the position of the surface with relationship to the sun.

QUESTIONS

1. At what angle does the maximum amount of light arrive?
2. How does cloud cover affect the energy received? Explain your evidence for this.
3. Compare the angle which gives a maximum solarimeter reading with the clinometer reading. Explain these results.
4. Does your solarimeter reading ever reach zero? Explain.
5. Based on your data determine the best angle to position the receiving surface of a solar collector.

GOING FURTHER

- Point the solarimeter to obtain the maximum reading without changing the angle turn the solarimeter to the left and right while observing the readings. How do these observations compare with your earlier data?
- How will the time of day during which the experiment is conducted affect the results?
- How will the time of year during which the experiment is conducted affect the results?
- If you were installing a solar collector, what information must you consider in orienting its position?

DATA TABLE

ANGLES (°)	SOLARIMETER READINGS	
	DAY 1	DAY 2
0		
15		
30		
45		
60		
75		
90		
105		
120		
135		
150		
165		
180		

DAY 1 ANGLE OF MAXIMUM SOLARIMETER READING _____

MAXIMUM SOLARIMETER READING _____

ANGLE OF THE SUN AT THE TIME OF THE READING _____

SOLARIMETER READING AT THIS ANGLE _____

DAY 2 ANGLE OF MAXIMUM SOLARIMETER READING _____

MAXIMUM SOLARIMETER READING _____

ANGLE OF THE SUN AT THE TIME OF THE READING _____

SOLARIMETER READING AT THIS ANGLE _____

ENERGY FROM THE SUN

Suggested Grade Level and Discipline

7-9 General Science

Background Information

Sunlight arrives at the surface of the earth and is scattered and diffused by the atmosphere. It is these processes that provide the entire earth's surface with solar radiation. The radiation will be most intense when measured perpendicular to the sun.

Energy from the sun comes in the form of electromagnetic radiation. Only a small amount is in the visible range. About 28% of this radiation is scattered and reflected back into space. Another 25% is absorbed by ozone, CO₂, and clouds in the upper atmosphere. This leaves about 47% arriving at the surface.

Hints on Gathering Materials

- A durable and relatively inexpensive clinometer is available from many science supply companies. Plans for an inexpensive solarimeter and clinometer are provided in the hardware section of this solar energy document. Light meters are usually available from a photography class in the school. If not, students may have them.

Suggested Time Allotment

- 2-3 class periods.

Suggested Approach

- Start by explaining how to use the equipment. Demonstrate how angles can be approximated. Show how the light meter is read and recorded in (ev) exposure value or if you have a solarimeter, in millivolts or milliamps. In the post-activity discussion you can refer to the solar collectors that can be part of a later activity.

Typical Results

- On clear days the results will show clearly higher values the nearer to the altitude of the sun. On cloudy days the results will be somewhat ambiguous.

Precautions

Warn students *NOT* to look directly at the sun when sighting the clinometer.

Modifications

- Try this activity at different times of the day or year for variation.

Evaluation

Student evaluation should be based on the student's ability to collect, record and plot data, as well as his/her answers to the questions.

DRAFT - ACTIVITY 4
ENERGY STORAGE

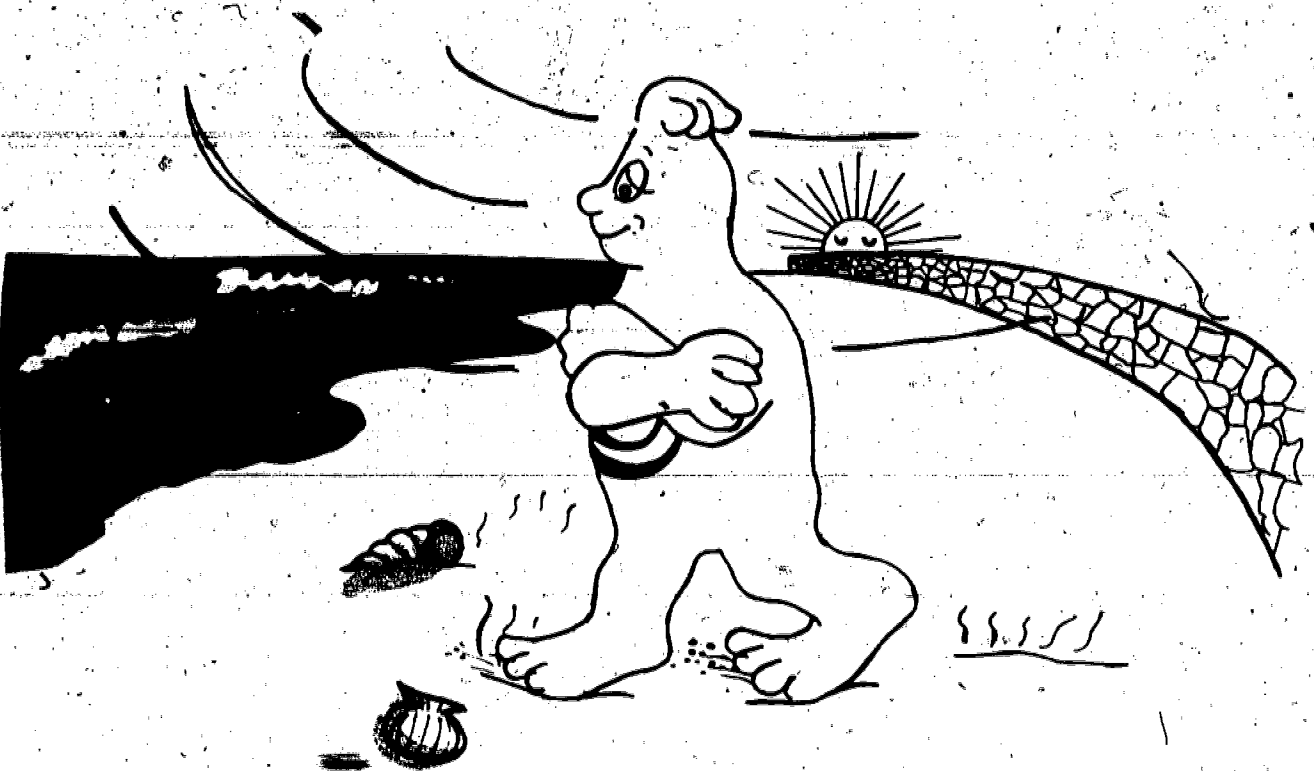

INTRODUCTION

Have you ever walked barefoot across a paved road on a hot summer day? If so, the experience showed you that the energy from the sun is trapped by the road surface.

Common materials, such as rock and water, can be used to capture and hold energy from the sun. If so, heat energy trapped by the rocks or water can be removed and used whenever it is needed, even when the sun is not shining.

In this activity, you will compare the ability of air and rock to capture and store heat energy.

OBJECTIVES

At the completion of this activity, you should be able to:

- o describe how rocks can be used to store heat energy.
- o determine which substance, rocks or air, absorbs heat the fastest and releases heat the fastest.

SKILLS AND KNOWLEDGE YOU NEED

- Ability to read a thermometer and stop watch or other timing device (school clock, wrist watch, etc.).
- Ability to construct and interpret a graph.

MATERIALS

- Gallon tin (ditto fluid can) with bottom removed and two holes for insertion of thermometer.
- Cardboard or wood, with a hole cut about 2" from one corner. Size of the hole may vary from about 2" to 4".
- Gravel enough to fill the gallon tin.
- Wire screen - 1/8" to 1/4" gauge.
- Thermometers 0°C to 100°C.
- Vacuum pump (vacuum cleaner).
- Hot plate.
- Funnels.
- Support (text books may be used as the major support with 2 strong pieces of wood to hold the gallon tin can.).

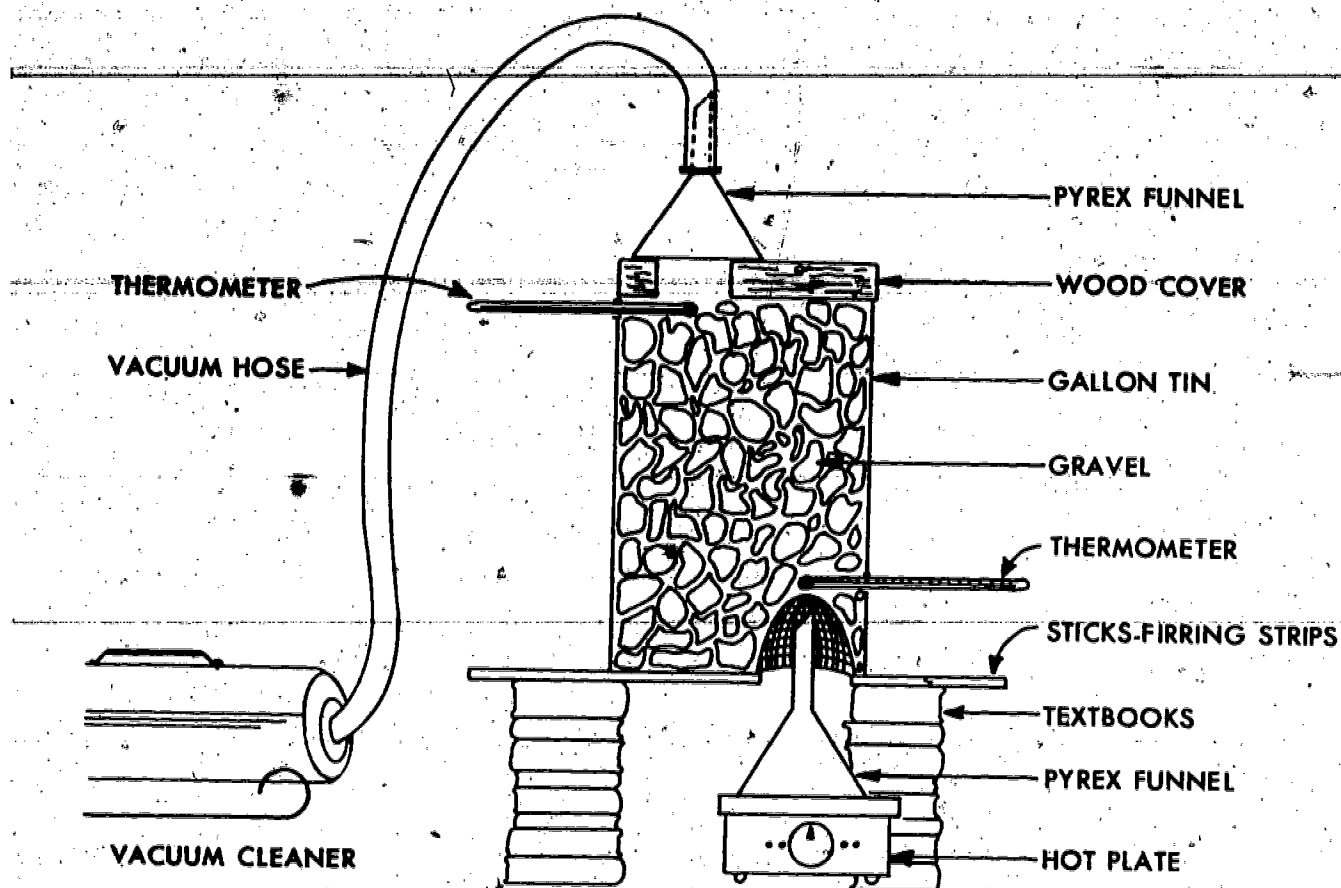

METHOD

1. First, set up the apparatus as shown without the gravel.
2. Prepare a data table to record the temperatures and times.
3. Turn on the hot plate and allow it to heat for about one minute.
4. Turn the vacuum cleaner on low.
5. Record on your data sheet, both thermometer temperatures each minute for 5 minutes.
6. After 5 minutes remove the hot plate. With the vacuum device still operating, continue recording temperatures for another 5 minutes.
7. Next, fill the gallon tin with gravel (be sure the screen is in place.).
8. Repeat steps -1 - 7.
9. Graph the data - temperature vs. time for each material, air and gravel. Prepare a graph for the heating phase and a second graph for the cooling phase.

LOOKING BACK

Heat storage using rocks is commonly used as part of a solar heating system. You now have data to show how well such a method works.

QUESTIONS

1. Referring to your graphs, which material, air or gravel heated most rapidly? Explain your answer.
2. Referring to your graphs, which material, air or gravel, cooled most rapidly? Explain your answer.
3. If you were designing a solar heating system, which material, air or gravel, would you choose to store the heat energy you gathered? Explain your choice.

GOING FURTHER

- Heat can be stored by melting a solid, such as paraffin (wax). Construct a box with thin sheets of paraffin in trays. You must select the paraffin with an appropriate melting point. See if you can store and extract heat from this type of storage.
- Is there any difference between storage in large rocks compared to small ones?
- How does insulating the storage container affect its heat storage properties?
- What other materials can be used to capture and hold heat energy?

Teacher Information Sheet

ENERGY STORAGE

Suggested Grade Level and Discipline

8th, 9th grade science

Background Information

The purpose of this activity is to demonstrate that heat can be stored for use at a later time. In this case, rocks are used, as they are the most common storage medium for a hot air solar system.

Storage can be done in several ways. If you are using a solar collector that circulates water, you can use a large tank of water to store the heat, generally 1 or 2 gallons per square foot of house. Insulation of the storage tank is very important to keep heat loss to a minimum.

If you are circulating air, there are several possibilities. One way is to store heat using the melting process. Such heat, called latent heat or heat of fusion, changes the state of a solid, such as paraffin, into a liquid with no change in temperature. When such substances turn back into solids they release their stored heat. Another way, used in this procedure, is to store hot air in solids without melting them, similar to that seen in water storage. The amount of heat energy that can be stored will be related to the amount of material, and the properties of the material itself.

Hints on Gathering Materials

- Gravel is available from hardware stores, lumber yards, and pet shops. Furring strips are readily available from lumber yards or school work shops (any wood strips of about 3/4" thickness and about 1" to 2" wide may be used). Thermometer holes are easily punched in the gallon tin before the bottom is removed. A large nail will easily puncture the walls of the tin can. Just give the nail a hard sharp tap with a hammer. Cardboard should be the corrugated type-two sheets which when taped together will provide added strength. The cardboard cover (or wood) should be large enough to completely cover the open can.

Suggested Time Allotment

- 1 to 2 class periods

Suggested Approach

- Depending on the abilities of the class, this activity could be introduced with a review or study of specific heat and latent heat. If students have had these concepts in earlier grades, their attention should be called to those experiences. The class could be divided into as many groups as there are boxes.

Typical Results

- During the heat storage phase, the bottom thermometer will remain rather steady, indicating a continued introduction of heat into the box. The thermometer at the top will show a gradual increase in temperature until the air or rocks have absorbed as much heat as they can. At this point, the temperature will stabilize. In this lesson, stabilization may not be attained since heating would have to continue for a much longer period of time. During the heat release phase, the upper thermometer will remain relatively stable and the lower thermometer will gradually rise to a higher temperature than the reading on the upper thermometer and then fall off as the heat is removed from the air or rocks and there is none left.

Precautions

- THE CAN FILLED WITH GRAVEL IS HEAVY. Be sure that the support is sturdy enough to hold it.

- Exercise caution when using the hot plate.

Modifications

- None suggested.

Evaluation

- Examine the graphs and the results of the questions. Are the conclusions reached in the questions, logical, and well developed?

EXPLORING BASIC PROPERTIES OF SOLAR ENERGY: ABSORPTION

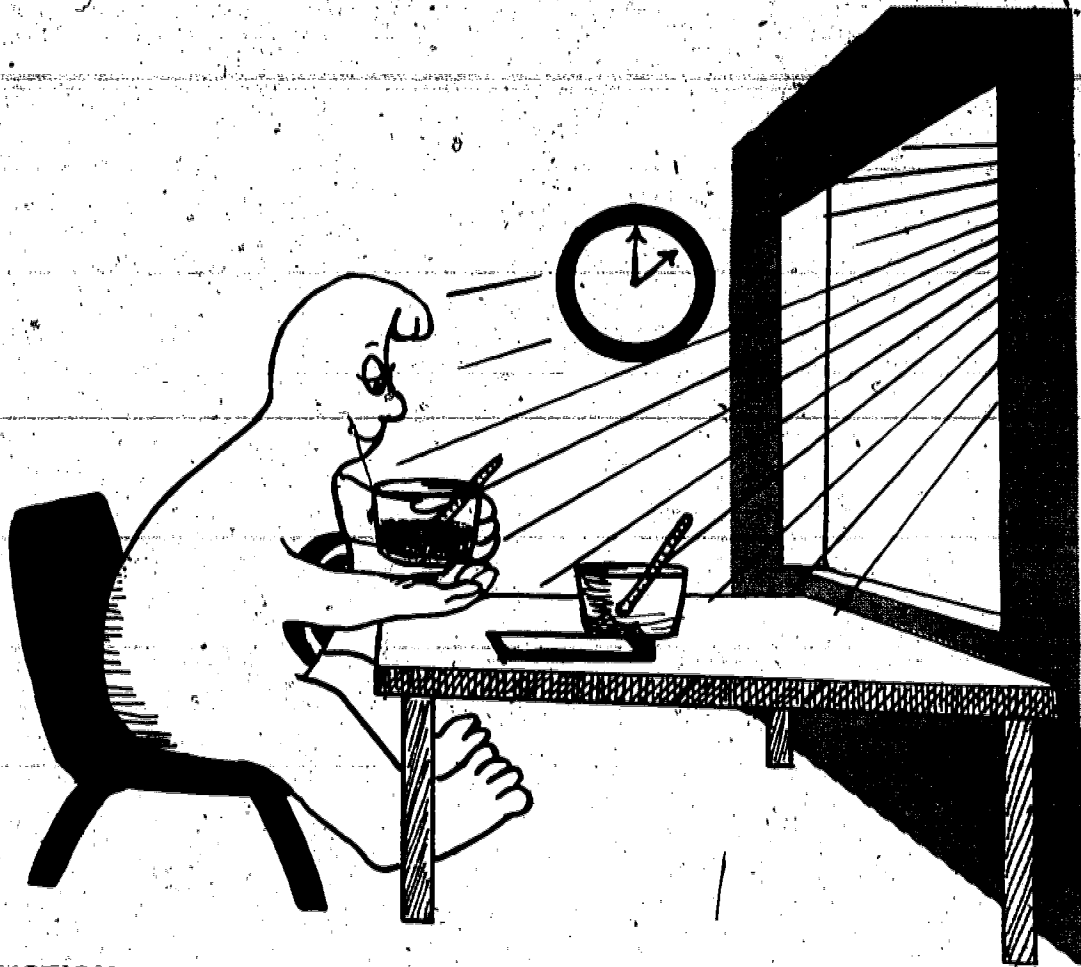

INTRODUCTION

Have you ever wondered why dark pavement gets very hot on a sunny day while lighter colored pavement seems to remain cooler? When the sun strikes an object, three things can happen. The solar energy can be transmitted through the object, it can be reflected from the object, or it can be absorbed by the object. In this activity you will examine what happens when solar energy is absorbed.

OBJECTIVES

At the completion of this activity, you should be able to:

- o demonstrate that solar energy can be absorbed by materials and changed into heat energy.
- o demonstrate that all materials do not absorb solar energy at the same rate.
- o identify and name the variables that might affect a simple investigation.

SKILLS AND KNOWLEDGE YOU NEED

- How to read a Celsius thermometer and a timing device (school clock, stop watch, etc.).
- How to construct a data table.
- How to graph data.

MATERIALS

- 3 glass or plastic dishes about 10cm in diameter and 5cm high.
- 3 thermometers, Celsius scale, range -10°C - 110°C .
- Dry, black soil to fill one dish.
- Dry, white sand to fill another dish.
- 200 watt incandescent lamp and reflector with clamp.
- Ringstand (The last two items are for those students who are unable to do this activity in sunlight.).
- A white surface for the experiment to be done on.

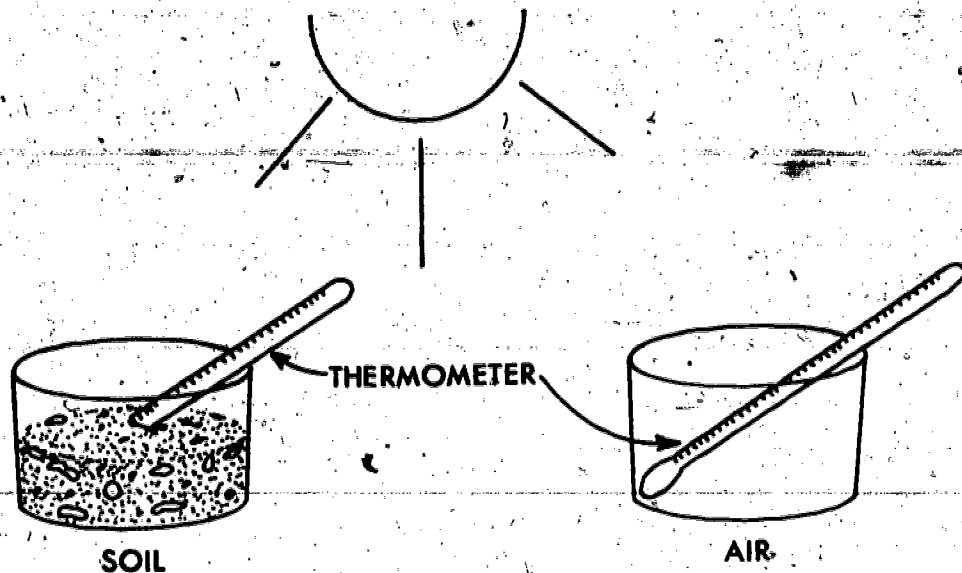

METHOD

1. Fill one dish to a depth of about 2.5cm with dry black soil. Fill the second dish to the same depth with dry white sand. Leave the third dish empty.
2. Place a thermometer in each dish. In the dish with the dry black soil, place the bulb of the thermometer just under the surface of the soil, making sure that the bulb is completely covered with the soil. Do the same for the sand.
3. Record the initial temperature of the soil, sand and air.
4. Place the 3 dishes on a table in direct sunlight. (If artificial light is used, place the dishes so that the light from the incandescent lamp shines equally on each dish.)
5. Take the temperatures of the soil, sand and air every 30 seconds for at least 25 minutes and record on the data table.
6. When the data taking is done lift the dish of dark soil from the table and place your hand under it. Observe whether any solar energy is transmitted through the dark soil. Do the same with both the dish containing the sand and the dish containing the air. Again observe whether any solar energy is transmitted.

7. Construct a graph using the data collected. Use different colors for plotting the changes in the temperature of the sand, soil and air.

LOOKING BACK

You have seen that when solar energy strikes an opaque material the temperature of the object rises. You have also seen that when solar energy strikes a transparent object the solar energy is transmitted through it and the temperature rises only slightly, if at all. When solar energy is absorbed by an object, the energy is changed to heat.

QUESTIONS

1. What happened to the temperature of each container as time passed?
2. What was the greatest difference in temperature between the three containers?
3. Was solar energy transmitted through the container of soil, sand, or air?
4. Was the temperature of the soil-filled or sand-filled containers higher than that of the air-filled container? Explain.
5. How do you explain the fact that the temperature curves on the graph did not continue to rise but flattened out?
6. On a sunny day, why do dark asphalt type roads get very hot, while concrete type, light colored pavements remain relatively cool?
7. Why were you told to use one container with only air in it?

GOING FURTHER

Repeat this activity but use black ink, red ink and clear water. Place the jars in direct sunlight or under the 200 watt incandescent lamp. Record the temperatures at 30 second intervals, as before, for 10 to 25 minutes. Graph the results of each jar. Compare this investigation with the ones in the original activity.

DATA TABLE

TIME	DARK SOIL °C	LIGHT SOIL °C	AIR °C
0.00			
0.30			
1.00			
1.30			
2.00			
2.30			
3.00			
3.30			
4.00			
4.30			
5.00			
5.30			
6.00			
6.30			
7.00			
7.30			
8.00			
8.30			
9.00			
9.30			
10.00			
10.30			
11.00			
11.30			
12.00			
12.30			

TIME	DARK SOIL °C	LIGHT SOIL °C	AIR °C
13.00			
13.30			
14.00			
14.30			
15.00			
15.30			
16.00			
16.30			
17.00			
17.30			
18.00			
18.30			
19.00			
19.30			
20.00			
20.30			
21.00			
21.30			
22.00			
22.30			
23.00			
23.30			
24.00			
24.30			
25.00			
25.30			

EXPLORING BASIC PROPERTIES OF SOLAR ENERGY: ABSORPTION

Suggested Grade Level and Discipline

7-9 Science
General Science
Earth Science

Background Information

This activity is intended to help students gain the knowledge and insights into the basic characteristics of solar energy. It should help them understand why solar collectors are designed with black collector plates and transparent glazings. This will enable them to select materials and designs for their own solar activity.

The phenomenon of absorption occurs every time light falls on a surface. The light energy is taken into the substance and is changed into heat energy, as is seen in the temperature rise of the soil and sand. This increased heat energy can be explained as an increase in the kinetic energy of the molecules in the substance; light energy in the form of infrared radiation strikes these molecules and causes their motion energy to increase. The color of a substance is also closely related to absorption. Certain wavelengths of light are absorbed, others are reflected. Those which are reflected produce the color of the substance.

Hints on Gathering Materials

- If it is impractical to use the sun as a source of solar energy or if the sun is not shining when you plan to do this activity, then a 200 watt incandescent lamp clamped to a ringstand will work just as effectively. Place the containers directly under the lamp so that each one receives an equal amount of light.

Suggested Time Allotment

- One to two class periods to perform the activity and answer the questions.
- One-half class period to discuss the activity.

Suggested Approach

- Discuss the way the activity will be carried out. Assign students to groups. If possible, use different soil types in the cans.

- Have the groups carry out the activity and collect their data. After the data is collected each student should prepare the graphs and answer the questions using the graphs.
- Discuss, as a class, the results. Were there any individual results that clearly stand out from the rest of the data? How are such results explained by the students?
- Can the students think of any practical application of their findings? Have them describe, in writing, things they think of.

Typical Results

- Typical results for absorption of solar energy by the dark soil, sandy soil, and the container of air are listed below:

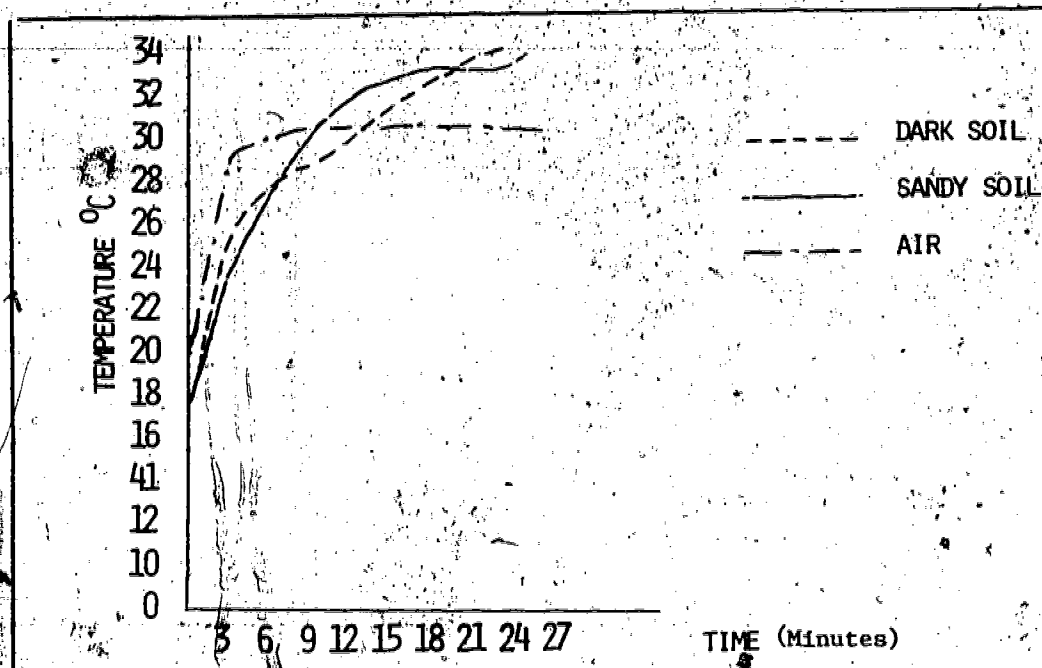

Evaluation

- Observe students' skills in setting up activity, making observations, recording data, plotting graphs, and interpreting data. Also observe their skills in identifying and controlling variables in an investigation.
- Check the quality of student answers to the questions and of hypotheses found to explain the data.

EXPLORING BASIC PROPERTIES OF SOLAR ENERGY : REFLECTION

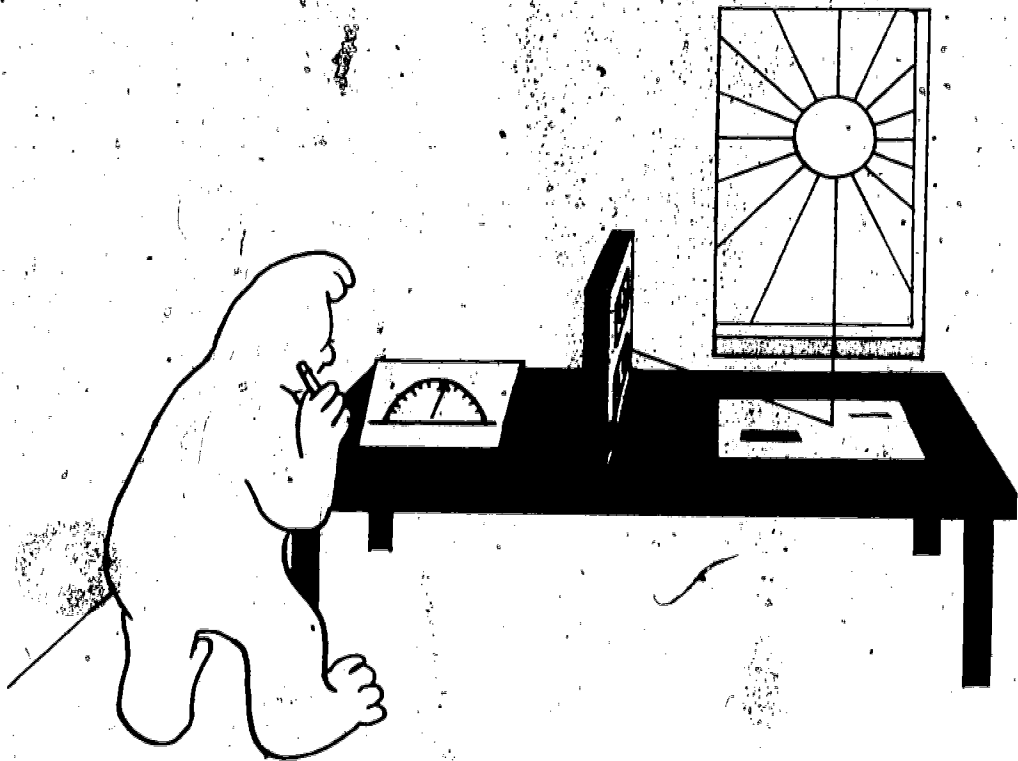

INTRODUCTION

What happens when solar energy strikes a mirror? How is that different from when it strikes a dark sheet of paper or a clear pane of glass? In this activity you will examine what happens when solar energy is reflected from an object. You will also determine what kinds of materials are good reflectors of solar energy and what kinds are poor reflectors. To do this you will use a solar cell connected to a sensitive electric meter.

OBJECTIVES

At the completion of this activity, you should be able to:

- o demonstrate that solar energy can be reflected.
- o construct a definition for reflection of solar energy.
- o compare the amounts of solar energy reflected by different materials of a given set.
- o name those materials of a given set which are the best and those which are the poorest reflectors of solar energy.
- o use a solar detecting device.

SKILLS AND KNOWLEDGE YOU NEED

- How to read an electric meter or pyranometer.
- How to record data.
- Understand the definition of a pyranometer.

MATERIALS

- A pyranometer, or a solar cell connected to a galvanometer or milliammeter.
- Squares, 5 centimeters on a side, of flat glass mirror, flat metal mirror, aluminum foil, flat glass, black construction paper, various colored construction paper, white typing paper, pans of water, dark dry soil, sand, concrete pavement, grass, a large green leaf.
- 200 watt incandescent lamp and reflector, with clamp.
- Ring stand (The last two items are for those students who are unable to do this activity in sunlight.)

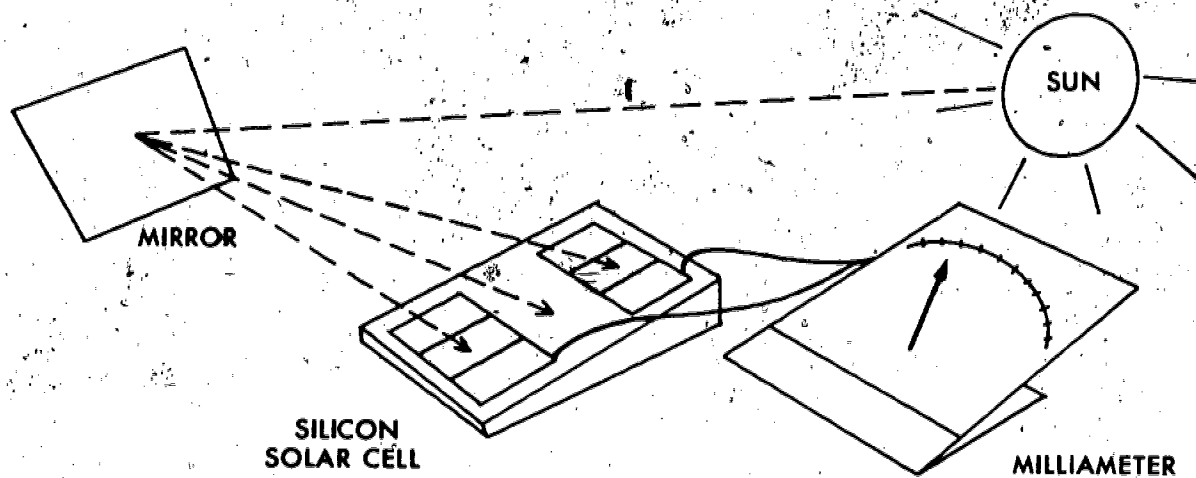

METHOD

1. Place the first material to be tested flat on a table top in the sun. Place the pyranometer close to this material, on the opposite side from the sun, and in such a position that the solar cell is receiving the reflection from this material. Position the pyranometer so that it shows almost a full-scale deflection or so that it receives as much reflected light from the test material as possible. (An artificial light may be substituted for the sun if necessary.)
2. Leave the pyranometer in this same position for the rest of the activity.
3. Remove the test sample and replace it in turn with each one of the test materials.
4. Record the reading for each material in the data table.
5. Arrange these materials in order from the best reflectors to the poorest and place on data table.
6. Arrange construction paper colors from the best reflectors to the poorest and compare the results.

DATA TABLE

<u>MATERIAL</u>	<u>READING</u>	<u>MATERIAL</u>	<u>READING</u>
FLAT GLASS MIRROR	_____	WHITE TYPING PAPER	_____
FLAT METAL MIRROR	_____	PAN OF WATER	_____
ALUMINUM FOIL	_____	DARK DRY SOIL	_____
FLAT WINDOW GLASS	_____	SAND	_____
CONSTRUCTION PAPER	_____	CONCRETE PAVEMENT	_____
BLACK	_____	GRASS	_____
RED	_____	LARGE GREEN LEAF	_____
GREEN	_____		
BLUE	_____		
YELLOW	_____		

LOOKING BACK

You have discovered that one basic property of solar energy is its ability to be reflected. Different materials reflect different amounts of solar energy, just as other materials transmit or absorb different amounts. You have also discovered what kinds of materials are good reflectors and what kinds are poor reflectors.

QUESTIONS

1. Of the materials tested, name the three best reflectors.
2. Of the materials tested, name the three poorest reflectors.
3. Of the materials tested, were there any that did not reflect at least some solar energy?
4. What probably happened to the solar energy which was not reflected?
5. How could you use what you've learned about the reflection of solar energy to get maximum heating of your house from solar energy?

GOING FURTHER

- Try some other materials to see whether or not they reflect solar energy and whether they are good or poor reflectors.
- How would you design a house that uses solar energy for heat in the winter and that keeps out solar energy for coolness in the summer? (Answer in detail.)

Teacher Information Sheet

EXPLORING BASIC PROPERTIES OF SOLAR ENERGY: REFLECTION

Suggested Grade Level and Discipline

7-9 Science
General Science
Earth Science

Background Information

This activity is intended to help students gain the knowledge and insight into the basic characteristics of solar energy that will enable them to understand solar design. It should help them understand why such items as solar collectors are designed as they are, and it should also enable them to select materials and designs for their own solar activities. This activity examines reflection of solar energy; two others will examine the properties of absorption and transmission.

A solar cell pyranometer can easily be made by connecting a solar cell to a milliammeter or to a galvanometer. Since the main purpose of this activity is to compare relative amounts of energy reflected and not to measure these amounts, there is no need to calibrate such a "home-made" instrument. (Perhaps it would be better named a solar cell comparometer.) Since the same meter is used to take all of the readings, and since the readings are used only to compare the solar energy reflected by different samples, the numbers alone are enough to tell the story. The higher the reading on the pyranometer, the greater the amount of solar energy reflected and the lower the reading, the smaller the amount.

Hints on Gathering Materials

If your school does not have a pyranometer, one can easily be made.

- a. A solar cell, 1cm x 1cm, delivering 22 ma at .45V. This will probably have to be ordered, so allow time for delivery.
- b. A milliammeter, range 0-15 milliamperes, D.C. or a galvanometer. These items are probably available from the supply cabinet.

To construct this "solar cell pyranometer", simply connect the leads from the solar cell to the terminals of the milliammeter or the galvanometer. You may want to secure the cell to the side of the meter with masking tape, since the wires attached to the solar cells can easily be separated from the cells.

A thermometer whose bulb is covered with copper plate painted with flat black paint can also be used.

Suggested Time Allotment

- One class period to perform the activity and answer questions.
- One-half class period to discuss the investigation.

Suggested Approach

- If enough pyranometers are available then it is suggested that students work in small groups (3 or 4 students) to perform the investigation.
- Another possibility is to do this activity in conjunction with the two others in this group, "Exploring Basic Properties", and to set up a few stations within the room for each activity. This would help to reduce equipment demand. Given adequate time to perform the activities at one station, each group could then move on to another station.
- When the activity is completed, the class as a whole can compile lists of materials which reflect or do not reflect solar energy, and place the materials in order from best to poorest reflectors. At this time any discrepancies between individual and class data can be discussed, as can the questions at the end of the activity.

Typical Results

- The values for the reflection of solar energy will vary from group to group. Discuss the possibility that some solar energy (or light) should shine directly onto the solar cell without being reflected. Consequently, the pyranometer would record not only reflected light but some direct light as well.
- The variation in group data should provide a good opportunity to introduce and discuss the identification and control of variables in an investigation. An important uncontrolled variable in this activity is the lack of calibrated scales, which may be a major cause of the variations.

Precautions

- *The solar cells are delicate, especially the attachment of the leads to the cell proper. Re-soldering the leads can be tricky if they are broken off. It is suggested that the solar cells and the leads be taped on to another object (perhaps the meter or a flat board) before use.*

Modifications

- Due to weather uncertainties, this investigation is designed to be carried out in artificial light if necessary. A 200 watt incandescent lamp with a reflector will perform just as effectively as sunlight.

- To prevent or reduce the possibility of any direct light striking the solar cell of the pyranometer, mount a 20cm x 20cm piece of black construction paper as a curtain between the energy source and the solar cell. At the same time, black construction paper can also be placed in the area around the pyranometer and the test materials to reduce to a minimum any unwanted reflection.

Evaluation

- Observe students' skills in operating the equipment, in making observations, in recording, classifying, and interpreting data, and in identifying and controlling variables.
- Check the quality of the answers to the questions and of hypotheses formed to explain the data.

EXPLORING BASIC PROPERTIES OF SOLAR ENERGY: TRANSMISSION

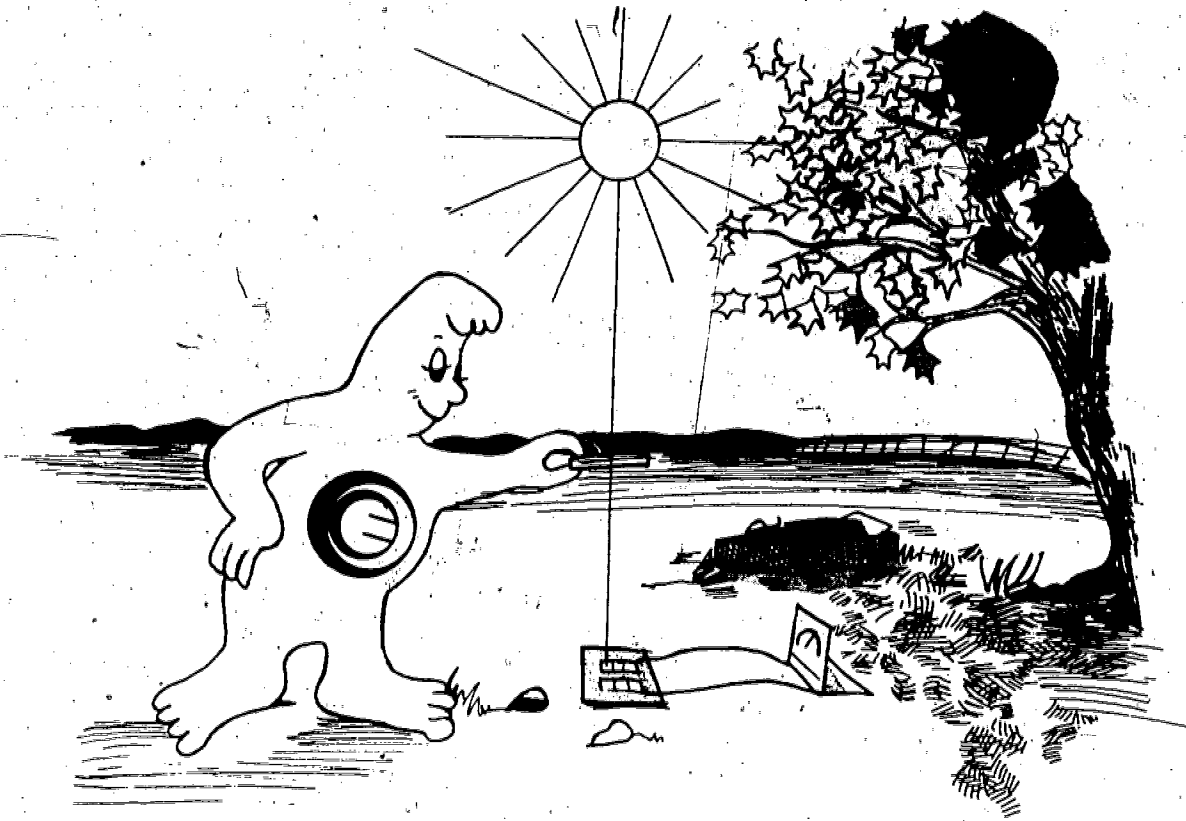

INTRODUCTION

What happens when solar energy strikes an object? There are three possibilities: 1) The solar energy may be transmitted through the object, 2) it may be absorbed by the object, or 3) it may be reflected by the object. In this activity you will examine materials to determine whether or not they allow solar energy to pass through them. You will also determine what kinds of materials are good transmitters and what kinds of materials are poor transmitters. To do this, you will use a solar cell connected to a sensitive electric meter.

OBJECTIVES

At the completion of this activity, you should be able to:

- o identify and name those materials of a given set which will transmit solar energy and those which will not.
- o demonstrate that solar energy passes through some materials but not through others.
- o compare the transmission of solar energy through different materials by using a solar cell and a sensitive electric meter.
- o construct a hypothesis explaining how some materials are able to transmit solar energy and others are not.

SKILLS AND KNOWLEDGE YOU NEED

- How to read an electric meter or pyranometer.
- How to record data.

MATERIALS

- Pyranometer, or a solar cell connected to a galvanometer or milliammeter.
- Squares, 5 centimeters on a side, of window glass, plastic sheets (clear, red, blue, yellow and green), waxed paper, frosted glass, tissue paper, composition paper, cardboard, wood, aluminum foil, copper sheeting, a mirror, a leaf; containers of dark soil and of water, a pair of eye glasses, and a pair of sunglasses.
- 200 watt incandescent lamp and reflector with clamp.
- Ringstand (The last two items are for those pupils who are unable to do this activity in sunlight.)

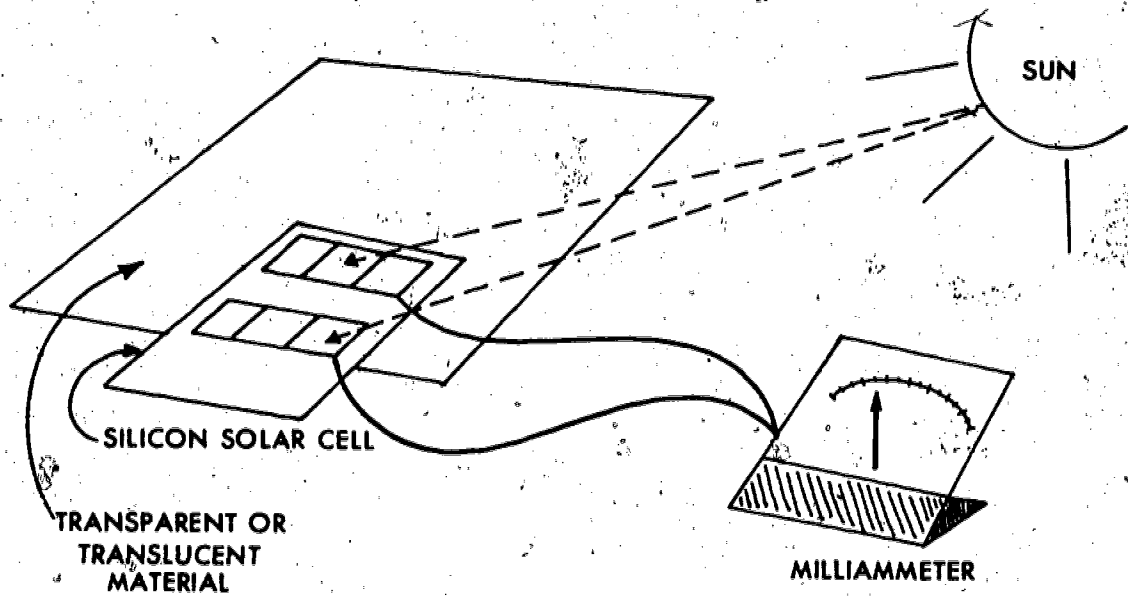

METHOD

1. Position the solar cell of the pyranometer facing the sun (or the incandescent lamp) so that the meter shows almost a full scale deflection (maximum reading).
2. Record this reading as the initial or beginning reading in the data table.
3. Leave the pyranometer in this same position for each reading of the set of materials being investigated.
4. Hold each piece of material in turn over the solar cell of the pyranometer.
5. Record the reading for each material in the data table.
6. Group the materials into two groups:
 - a. Those materials which allow at least some solar energy to pass through according to the meter. Arrange these materials in order from the best transmitter to the poorest.
 - b. Those materials which allow no solar energy to pass through according to the meter.
7. Identify those variables (factors which may influence an experiment) which you think might have affected the reading of the meter. Make plans to control these variables and repeat the investigation. Compare the results.

DATA TABLE

INITIAL READING _____

<u>MATERIAL</u>	<u>READING</u>	<u>MATERIAL</u>	<u>READING</u>
WINDOW GLASS	_____	CARDBOARD	_____
PLASTIC SHEETS:		WOOD	_____
CLEAR	_____	ALUMINUM FOIL	_____
RED	_____	COPPER SHEETING	_____
BLUE	_____	MIRROR	_____
YELLOW	_____	LEAF	_____
GREEN	_____	CONTAINER OF:	
WAXED PAPER	_____	DARK SOIL	_____
FROSTED GLASS	_____	WATER	_____
TISSUE PAPER	_____	EYE GLASSES	_____
COMPOSITION PAPER	_____	SUNGLASSES	_____

LOOKING BACK

You have discovered that one property of solar energy is that it can be transmitted through some materials, but not through others. Knowledge of which materials are transparent, translucent, or opaque to solar energy can be useful when discussing solar energy and its applications. For example, in the winter you would want the south-facing windows in your home to be transparent so that solar energy would be transmitted through them into your home; but in the hot summer months you would want your windows covered with an opaque material to keep the solar energy out. In the winter, this transmission of solar energy would warm your house; in the summer the absence of solar energy would keep it cool.

QUESTIONS

1. Why was the pyranometer left in the same position for all the readings in the investigation?
2. According to your results, which materials are good transmitters of solar energy? Which are poor transmitters?
3. Name those materials tested which do not transmit solar energy.
4. Construct a definition for the word "transmit" as it applies to solar energy.
5. Define the words "transparent", "translucent", and "opaque".
6. Name several materials which are transparent, several which are translucent, and several which are opaque to solar energy.
7. In building a house, where are materials used which transmit solar energy? Explain.
8. In building a house, where are materials used which are opaque to solar energy? Explain.

GOING FURTHER

Repeat the investigation using materials other than those given or try using combinations of materials in the set given. For example, you might try combinations of the colored plastic sheets - red and blue, red and yellow, blue and yellow, etc. Compare this data with your original data.

Construct an experiment to determine if reducing the glass area of a car parked in the sun on a warm day has any effect on the temperature inside the closed car.

Teacher Information Sheet

EXPLORING BASIC PROPERTIES OF SOLAR ENERGY: TRANSMISSION.

Suggested Grade Level and Discipline

7-9 Science
General Science
Earth Science

Background Information

This activity is intended to help students gain the knowledge and insight into one of the basic characteristics of solar energy that will enable them to understand solar design. It should help them understand why such items as solar collectors are designed as they are, and it should also enable them to select materials and designs for their own solar activities.

A solar cell pyranometer can easily be made by connecting a solar cell to a milliammeter or to a galvanometer. Since the main purpose of this activity is to compare relative amounts of energy transmitted and not to measure these amounts, there is no need to calibrate such a "home-made" instrument. (Perhaps it would be better named a solar cell comparometer.) Since the same meter is used to take all of the readings, and since the readings are used only to compare the solar energy transmitted by different samples, the numbers alone are enough to tell the story. The higher the reading on the pyranometer, the greater the amount of solar energy transmitted and the lower the reading, the smaller the amount that is transmitted.

Use of a galvanometer attached to a solar cell may create too sensitive an instrument when the solar cell is angled directly into the sun. This may cause more than a full scale reading on the galvanometer when using the best transmitting materials. If this occurs, the solar cell should be deflected from the sun just enough to give a full-scale reading with the best transmitters.

Solar cells are highly efficient silicon semi-conductor devices which convert light directly into electricity. When exposed to light, each cell produces approximately the same voltage between its two terminals. When a load is connected between the two terminals, the voltage difference causes a flow of current. This current is caused by the formation of "hole-electron pairs" by the absorbed light photons. Accordingly, the amount of current will depend on the amount of absorbed light, which, in turn, is dependent on the incident light intensity as well as the surface area of the solar cell. (Solar cells may be interconnected in series to provide higher voltage, in parallel to produce more current, or both.)

Hints on Gathering Materials

- If your school does not have a pyranometer, one can easily be made.

- a. A solar cell, 1cm x 1cm, delivering 22 ma at .45V. This will probably have to be ordered, so allow time for delivery.
- b. A milliammeter, range 0-15 milliamperes, D.C. or a galvanometer. These items are probably available from the supply cabinet or ask the physics teacher.

To construct this "solar cell pyranometer", simply connect the leads from the solar cell to the terminals of the milliammeter or the galvanometer. You may want to secure the cell to the side of the meter with masking tape, since the wires attached to the solar cells can easily be separated from the cells.

Suggested Time Allotment

- One class period to perform the activity and answer questions.
- One-half class period to discuss the investigation.

Suggested Approach

- If equipment is limited then this activity is best done as a teacher demonstration.
- If enough pyranometers are available, then it is suggested that students work in small groups (3 to 4 students) to perform the investigation.
- When the activity is completed, the class as a whole can compile lists of materials which transmit or are opaque to solar energy, and place the materials in order from best to poorest transmitters. At this time any discrepancies between individual and class data can be discussed, as can the questions at the end of the activity.

Typical Results

- The values for the transmission of solar energy will vary from group to group as a result of several variables, especially the lack of a calibrated scale. This should provide a good opportunity to introduce and discuss the identification and control of variables in an investigation.

Precautions

The solar cells, especially the attachment of the leads to the cell proper, are delicate. Re-soldering the leads can be tricky if they are broken off. It is suggested that the solar cells and the leads be taped to another object (perhaps the meter or a flat board) before use.

Modifications

Due to weather uncertainties, this investigation is designed to be carried out in artificial light if necessary. A 200 watt incandescent lamp with a reflector will perform just as effectively as sunlight.

Evaluation

- Observe students' skills in operating the equipment, in making observations, in recording, classifying, and interpreting data, and in identifying and controlling variables.
- Check the quality of the answers to the questions and of hypotheses formed to explain the data.

THE HEATING AND COOLING OF OBJECTS BY RADIATION

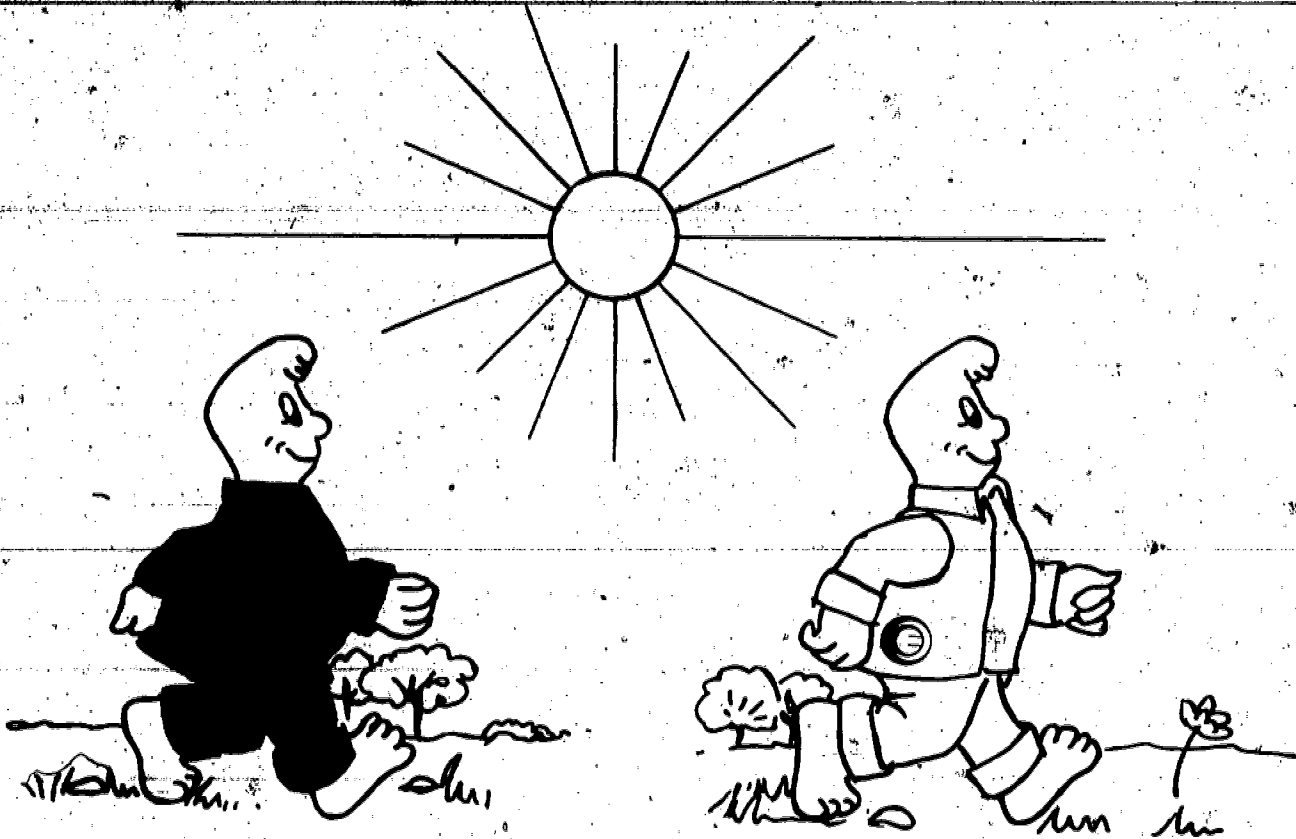

INTRODUCTION

Have you ever stood near a radiator and felt warm? How does the radiator cause you to be warm? The name, radiator, means that the heat energy reaches you by a process called radiation.

In this activity, you will investigate a form of radiant energy as it affects two objects. After you complete the activity, see if you can describe radiant energy.

OBJECTIVES

At the completion of this activity, you should be able to:

- o compare the rates at which two cans, one black and the other shiny, absorb and radiate heat energy.
- o select a color that would be best to use as a solar energy absorber in a solar collector.

SKILLS AND KNOWLEDGE YOU NEED

- How to read a thermometer.
- How to graph the time and temperature data on a simple line graph.

MATERIALS

- A source of radiant energy, such as a high wattage lamp.
- Two thermometers (-10°C to 110°C).
- Two cans of the same size and substance with some type of cover, one painted black and the other left shiny.
- Corrugated cardboard.
- A clock with a second hand.
- Water at room temperature.
- Hot water at least 50°C .

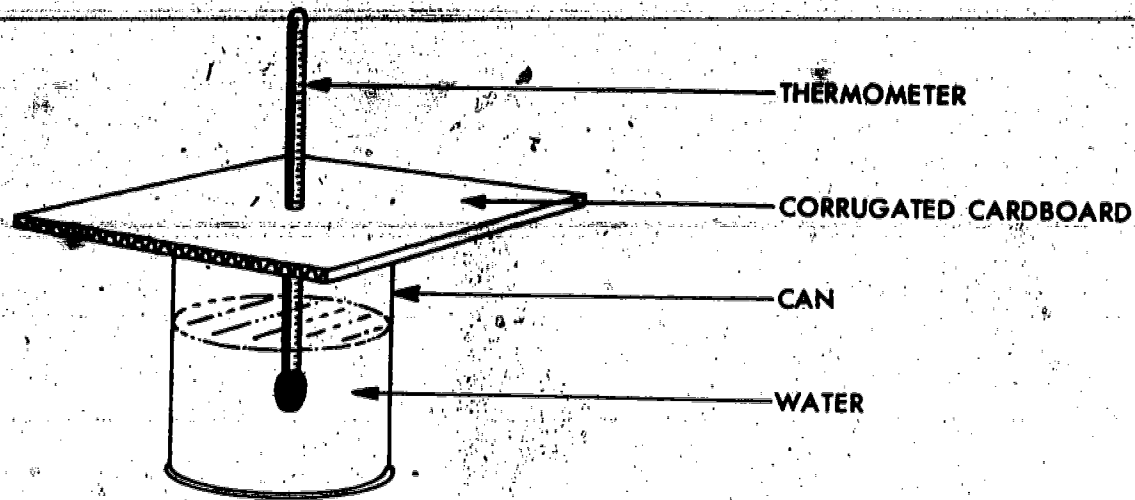

FIGURE 1

METHOD

1. Fill the two cans with equal amounts of water at room temperature.
2. Obtain a piece of corrugated cardboard cut slightly larger than the can top. Make a hole in the center of the cardboard with a pencil point slightly smaller than the diameter of the thermometer. Carefully insert the thermometer in the hole so that there is a snug fit. Repeat for the second thermometer.
3. Place the thermometer and cardboard lid arrangement on each can. Adjust the thermometer so that the bulb of the thermometer does not touch the sides or bottom of the can. See diagram 1.
4. Place each can 20cm from the heat source. See diagram 2.
5. Record in data table 1 the temperature of the water in each can.

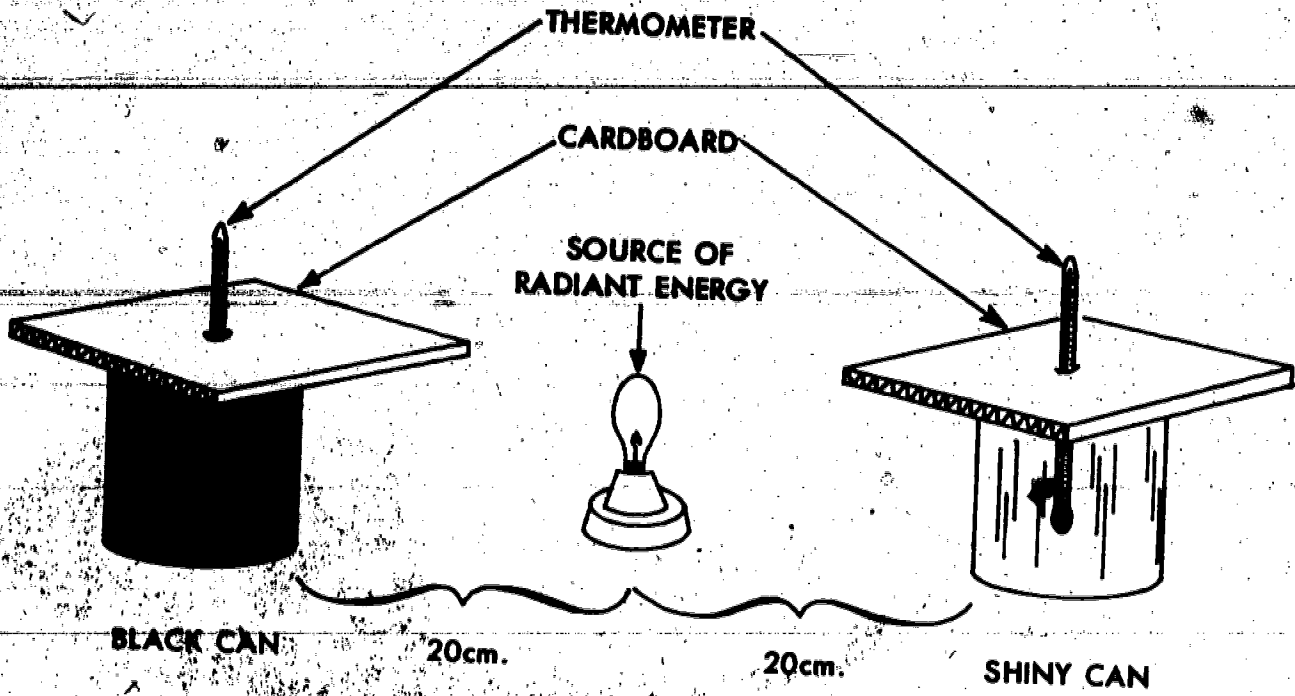

FIGURE 2.

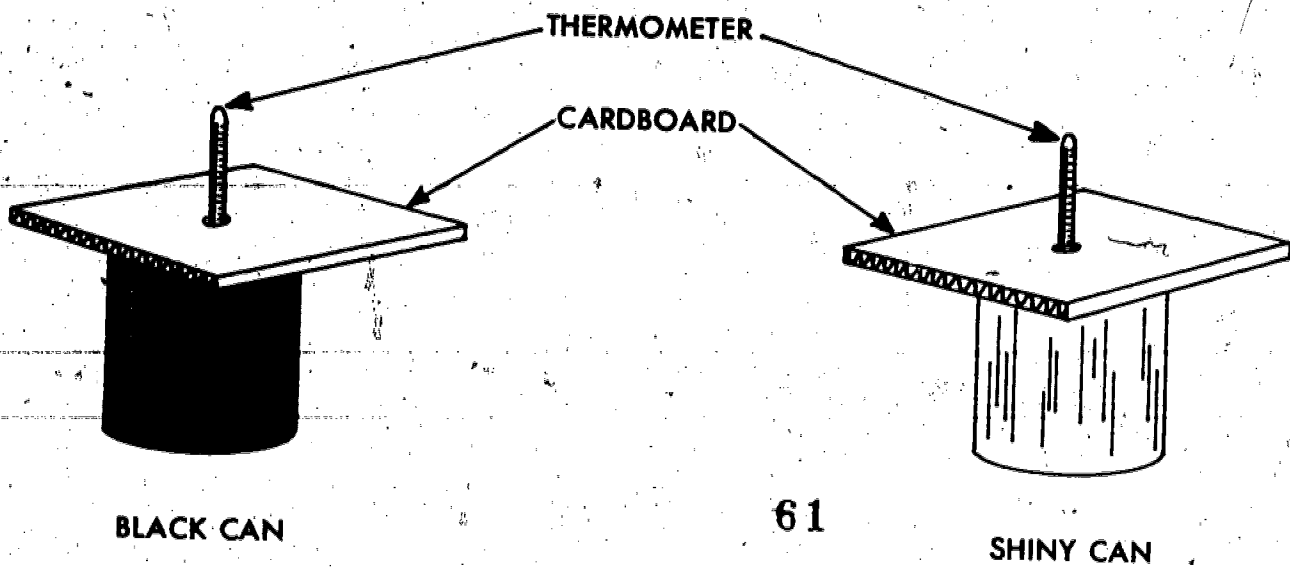

FIGURE 3

6. Turn on the heat source and record the temperature of the water in the cans every two minutes for about thirty minutes. Record this information in data table 1.

7. At the end of thirty minutes remove the heat source, and graph your results.
8. Next, empty both cans and then fill each of them with equal amounts of hot water.
9. Using the same thermometer arrangement as before, record the temperature of the water in each can every 2 minutes for 40 minutes as the water cools. See diagram 3.
10. Graph the results for the cooling of the water.

LOOKING BACK

Different colored substances absorb and radiate heat energy at different rates. Knowing which kinds of substances absorb heat energy the best and which kinds radiate it the best should help you in choosing which color of clothes to wear in cooler weather. It also explains why certain colors are used in the construction of solar panels.

QUESTIONS

1. Which of the cans absorbed the most heat energy? Explain.
2. Which of the cans radiated the most heat energy? Explain.
3. Why do you think that the parts of a solar collector panel that absorb heat energy are usually painted black?
4. Which colors would be better to wear in the summer, white or black? Explain your answer.

GOING FURTHER

Repeat the experiment using empty cans. Give reasons for any differences in results that you might observe.

- Repeat the experiment using different distances of the heat source for each trial. Explain the effect distance has on the amount of heat energy absorbed.
-
- Repeat the experiment using the sun as an energy source.

DATA TABLE 1

TIME (MIN.)	BLACK CAN TEMP. (°C)	SHINY CAN TEMP. (°C)
0		
2		
4		
6		
8		
10		
12		
14		
16		
18		
20		
22		
24		
26		
28		
30		

DATA TABLE 2

TIME (MIN.)	BLACK CAN TEMP. (°C)	SHINY CAN TEMP. (°C)
0		
2		
4		
6		
8		
10		
12		
14		
16		
18		
20		
22		
24		
26		
28		
30		
32		
34		
36		
38		
40		

Teacher Information Sheet

**THE HEATING AND COOLING OF
OBJECTS BY RADIATION**Suggested Grade Level and Discipline

7-9 Science
Physical Science

Background Information

Radiation is a method of heat transfer in which the heat travels in the form of electromagnetic waves. Heat can travel through a vacuum by radiation only. The light coming from the sun is an example of radiation. All warm objects radiate heat energy, and at the same time receive this energy from other objects in their surroundings. When an object absorbs energy its temperature rises, and when it emits energy its temperature drops.

Various substances radiate energy more rapidly than others. For example, if a silvered container were filled with hot water the heat would not escape very quickly because radiated heat is reflected by smooth surfaces such as shiny metals. In comparison, a black container would emit more heat since black substances do not reflect this energy as well.

Black is known as the super-absorber. This is because it absorbs light of all wavelengths. When it absorbs the light energy, the molecules composing the black material speed up. The increase in the speed of these molecules leads to a rise in temperature. Therefore, light energy absorbed by this black substance becomes heat energy. On the other hand, shiny or white substances reflect almost all colors of the electromagnetic spectrum, and therefore do not experience such a large temperature change.

This is the reason black is best worn in cold weather, since it takes in more light energy and changes it to heat, and white is best worn in hot weather, since it reflects light energy. This phenomenon also explains the use of black in the construction of solar collectors. The top is covered by a transparent plate of glass or plastic, which allows the solar radiation to pass through, and the back is blackened in order to absorb as much solar radiation as possible.

Hints on Gathering Materials

Several weeks before the activity is to be done, collect aluminum soda cans. Remove the paint from the ones which are to be shiny, and use flat black paint on the dark cans.

Suggested Time Allotment

- One class period (45 minutes) to do the first part of the activity on measuring the rate of absorption of radiant energy.

- One class period to do the second part of the experiment on measuring the rate of radiation of heat energy.
- One class period to discuss the results.

Suggested Approach

- Divide the class into groups of two or three. One student should be responsible for timing, while the other one or two are responsible for reading the temperatures and recording them.
- Unless the period is more than an hour long, it would be best to have students do the activity on absorption one day and the activity on radiation the next.
- If there is difficulty in obtaining an adequate number of heat sources, have half the class do the activity, measuring the rate of radiation, while the other half measures the rate of absorption. The next day the students should then do the opposite activity.
- A demonstration of the apparatus will facilitate the activity.

Typical Results

- In both of the activities, remind students that when the initial temperatures are different that it is the change in temperature that is important.
- More dramatic results are obtained using empty cans for absorption of heat energy.

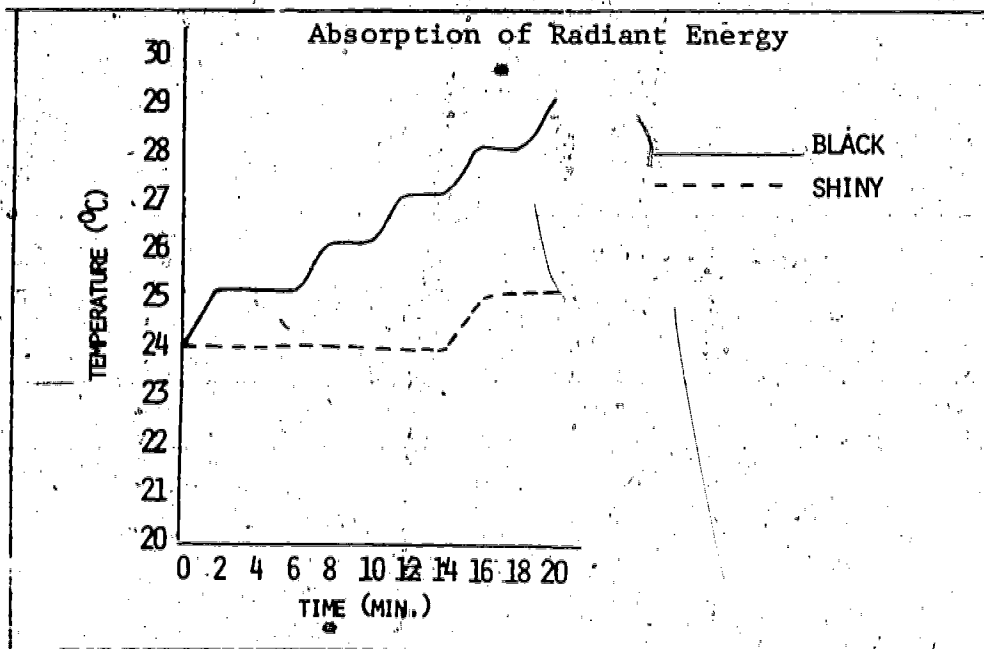

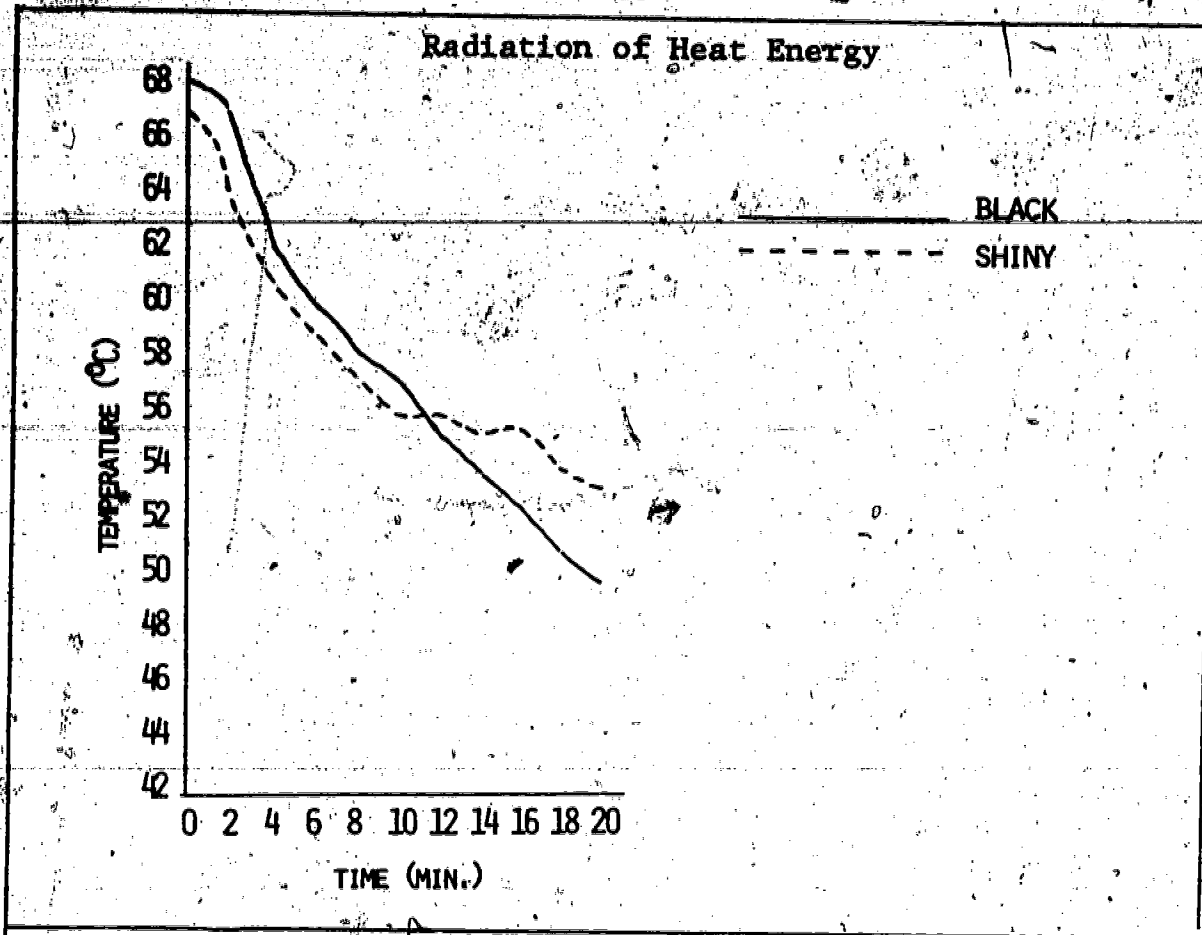

The graphs above are examples of actual student data.

Precautions

- Be careful pouring the hot water. A container with a spout should be used.
- Remind students not to touch the heat source.

Modifications

- This activity could be done using different substances in the cans or using different colored cans.

Evaluation

- Check the students' data, graphs, and answers to the questions.

INSULATION : CAN IT KEEP HEAT IN AND OUT



INTRODUCTION

With the rising cost of fuel, the conservation of energy has become very important. One method of conserving energy is to better insulate our buildings. Heat can enter or escape through walls and windows.

In this activity, you will be comparing various insulating materials as to their ability to keep heat in and out.

OBJECTIVES

At the completion of Part I of this experiment you should be able to:

- o compare insulating materials to keep heat out using temperature data collected.
- o use this information to determine the best insulating material to keep heat out.

At the completion of Part II of this experiment you should be able to:

- o compare insulating materials to keep heat in using temperature data collected.
- o use this information to determine the best material to insulate against heat loss.

SKILLS AND KNOWLEDGE YOU NEED

- How to read a thermometer.
- How to graph data.

MATERIALS

- Three soda cans of the same size and color.
- Three thermometers (-10°C to 110°C).
- A clock with a second hand.
- A source of radiant energy, such as the sun, an infrared lamp, or a heating coil.
- Hot water.
- Various insulating materials, such as fiber glass, wool, styrofoam, newspaper, or aluminum foil.

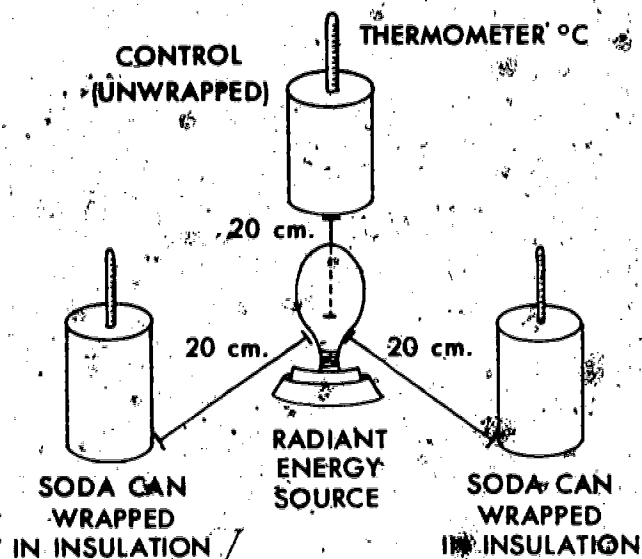

METHOD PART I

1. Obtain two types of insulating materials and cover one can entirely with one type of material and the second can with another material. (Make sure the top of each can is wrapped.)
2. Identify each can by the type of insulating material used.
3. The unwrapped can should be labeled CONTROL.
4. Place the three cans about 20 centimeters from the heat source.
5. Insert the thermometers through a small hole in the top of each can. Use a rubber band wrapped around the thermometer to keep the thermometer suspended so that it does not touch any part of the can.
6. Record the temperature of each can in Data Table 1.
7. Turn on the heat source or place the cans in the sun and record the temperature in the three cans every two minutes for twenty minutes.
8. At the end of twenty minutes remove the heat source and graph the results on Graph 1. Use different colors for the three different lines.
9. Save your cans for Part II.

DATA TABLE 1
INSULATION FROM ABSORPTION OF RADIANT ENERGY

TIME (MIN.)	TEMP. C	TEMP. C	CONTROL TEMP. C
0			
2			
4			
6			
8			
10			
12			
14			
16			
18			
20			

WRITE IN THE INSULATING MATERIAL THAT YOU USED.

DATA TABLE 2
INSULATING AGAINST HEAT LOSS

TIME (MIN.)	TEMP. C	TEMP. C	CONTROL TEMP. C
0			
2			
4			
6			
8			
10			
12			
14		71	
16			
18			
20			

WRITE IN THE INSULATING MATERIAL THAT YOU USED.

THERMOMETERS (°C)

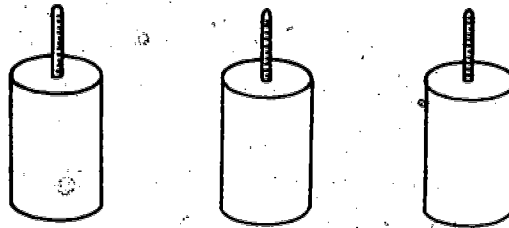

SODA CANS EACH WITH A
DIFFERENT KIND OF INSULATION

METHOD PART II

1. Fill the three cans used in Part I carefully with hot water to one centimeter from the top.
2. Insert the thermometer into each can of hot water once again being careful not to touch the sides of the can.
3. Record the temperature in Data Table 2.
4. Continue to record the temperature every two minutes for twenty minutes.
5. Graph your results on Graph 2 using different colors for each can.
6. If there is enough time and your teacher permits, repeat this activity using two or more types of insulating materials.

LOOKING BACK

It is extremely important to make sure that your house is properly insulated. If it is not, then large amounts of energy are going to be wasted. You have discovered that the choice of insulation material can be very important in preventing the loss of heat during the winter, and the absorption of heat during the summer.

QUESTIONS

1. What general conclusions can you draw from the graphs?
2. From the materials you tested which material was the best insulator against the absorption of energy?
3. From the materials you tested which material seemed to allow the least amount of heat loss?
4. Was the same material the best insulator in both cases?
5. Compare your results with the other members of your class. From the collective data, determine the best insulating material against both heat loss and heat gain.

GOING FURTHER

- Find out what type of insulation you have in your house. Does it seem effective?
- Go to the library and find out how insulation is rated as to effectiveness.
- Visit a lumber yard and gather information on insulation, cost, and R factor.
- What would be some methods to protect your house in the summer from the sun's radiant energy?
- Find out which types of insulating materials are used in building today. Which type seems to be the best insulator?
- Describe any hazards to using various types of insulators.
- Have a Cool Cube Contest. The project is to design a container to keep an ice cube cool. Students are given the problem of determining whose ice cube stays the longest in a container they built. (The problem, however, is that the best containers may hold the ice cube for 14 to 15 hours.)

INSULATION: CAN IT KEEP HEAT IN AND OUT?

Suggested Grade Level and Discipline

Middle School Science
9th Grade Science
Physical Science

Background Information

Insulators are materials used to reduce heat transfer. They prevent heat leakage through building walls and windows. It is estimated that a 20% savings could be realized by insulating attics. According to John Fowler,* "most homes built before 1965 had only 1½" of insulating materials in the ceiling, none in the walls and floors, and plain windows (only about half of all single family homes currently have storm windows). Current practices call for 2" - 3" of insulation in the walls, 4" - 6" in the ceiling. An EPA report estimated that complete retrofitting of one third of the existing homes would save 0.5×10^{15} BTU's". A BTU, British Thermal Unit, is an engineering unit for energy measurement. It is the amount of heat required to raise the temperature of one pound of water one Fahrenheit degree.

The proper choice of insulating materials is very important to the overall conservation of energy. Not all materials are effective insulators.

Hints on Gathering Materials

- Several weeks before this activity is to be done, begin collecting soda cans.
- Have students bring in various kinds of insulating materials. Check with a store that sells insulation to see if they will provide you with various samples of insulating materials.

Suggested Time Allotment

- Two class periods (45 minutes) to do the experiment.
- One class period to discuss the results.

Suggested Approach

- Divide the class into groups of three. One student should be responsible for the timing, and the others should be in charge of reading and recording the temperatures.

*Fowler, John M. "Energy Conservation Homes and Buildings," Factsheet #9, National Science Teachers Association. (Available from the United States Department of Energy, Technical Information Center, Box 62, Oak Ridge, Tennessee 37830)

- Have a variety of good and poor insulating materials available.
- Have a guest speaker come in to talk about home insulation. This could be a builder in the area.

Typical Results

The graphs below are examples of actual student data.

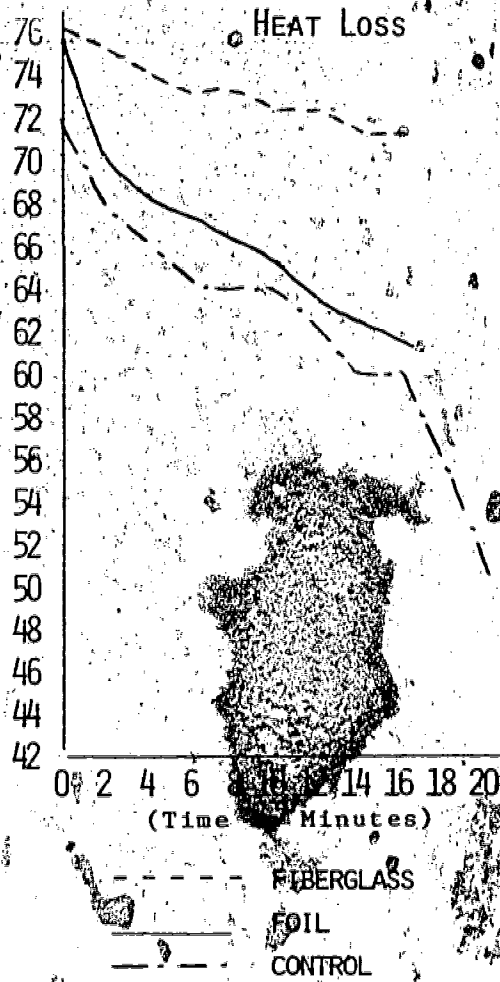
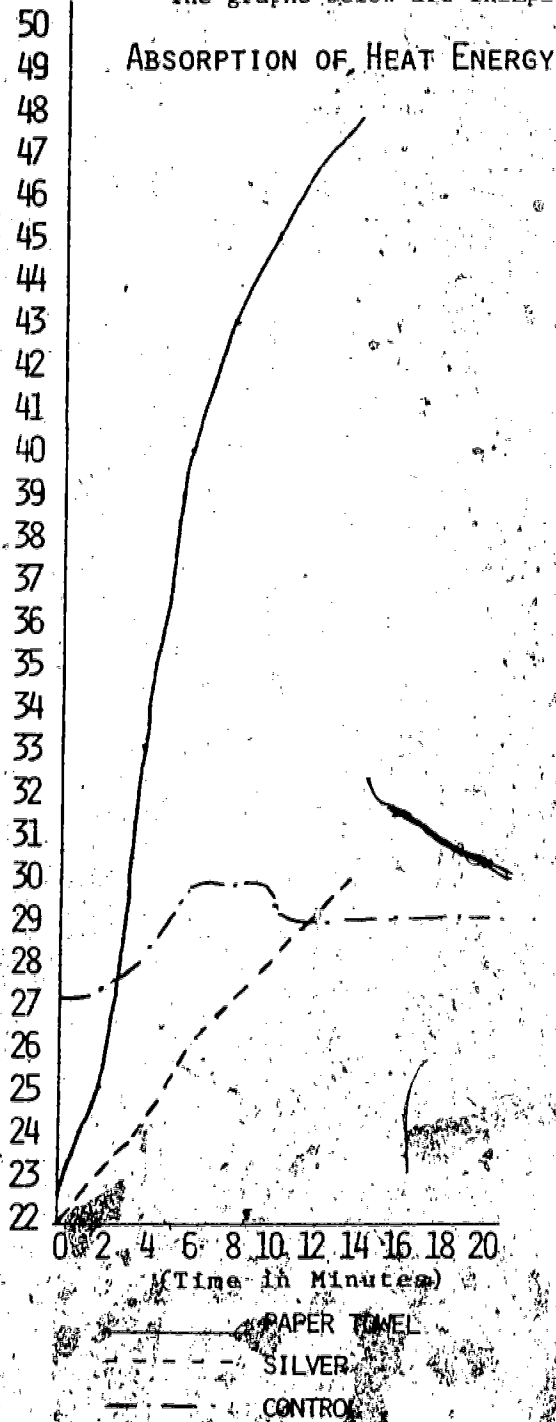

Precautions

- Be careful using any electrical source.
- Be careful when pouring hot water. A coffee percolator and a teapot are useful.
- Take the usual precautions in using the thermometers.

Modifications

- Students could test various heat sources, different cans, and different contents of the cans (air, water).
- A possible variation would be to study the heat loss or heat gain over a longer period of time. The first class could set up the experiment and the following classes could continue to record the data. Results could be presented and discussed the following day.

Evaluation

- Check the students' tables, graphs, and answers to the questions.
- Ask the students to describe a practical application based on the information they gathered. If the principles are described accurately the feasibility of the application is not important.

LET'S PUT SOLAR ENERGY TO WORK

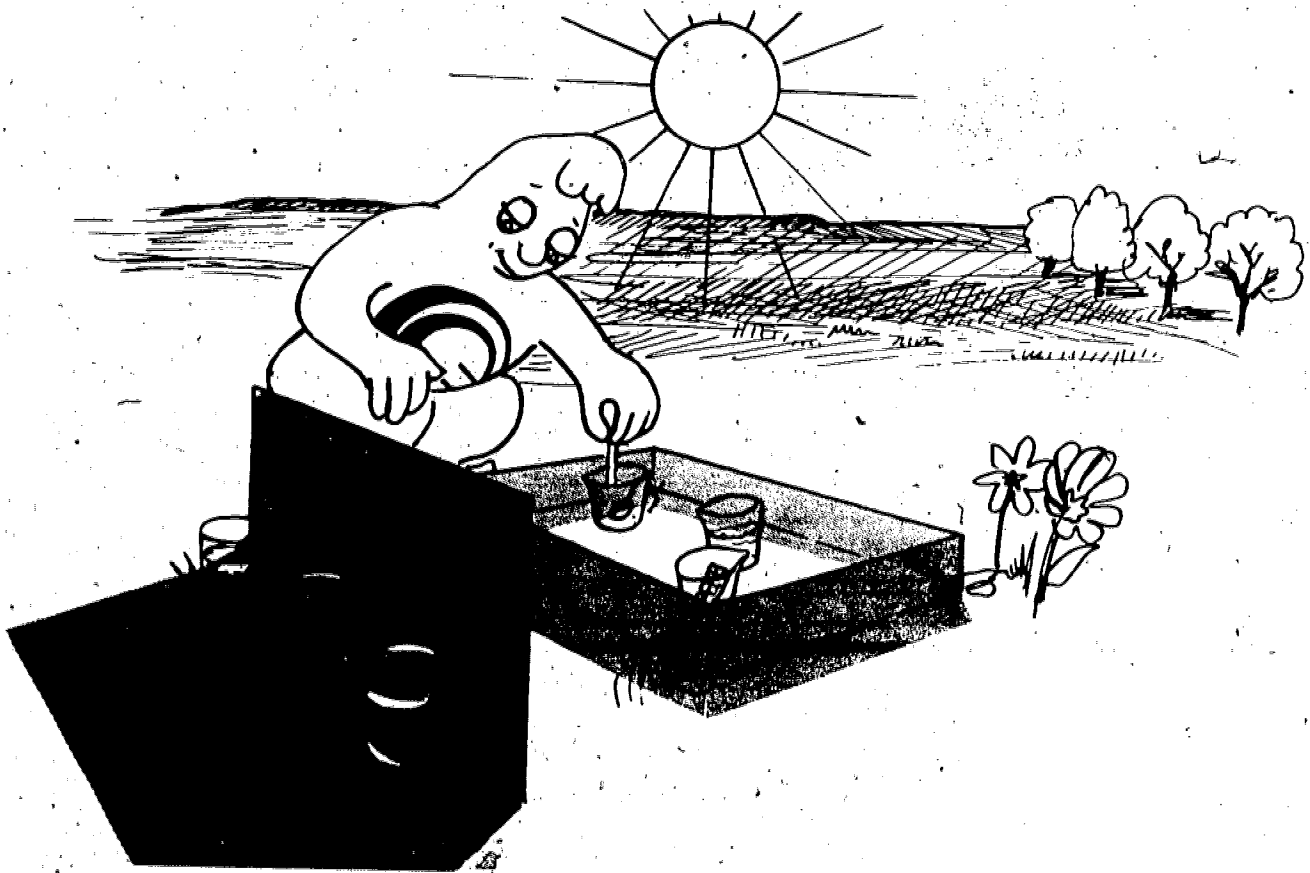

INTRODUCTION

The sun is a great source of energy. Most of you have probably experienced energy at work as you lie in the sun on a summer day. Just imagine what it would be like if you were able to capture that energy. Perhaps solar energy could be a solution to the energy crisis.

In this experiment you will try to collect solar energy and examine its effects on water, chocolate bars, and tea bags in water.

OBJECTIVES

At the completion of this activity, you should be able to:

- o use a flat plate solar collector.
- o determine if enough energy can be collected over a two hour period to change the physical properties of
 - a) water, b) chocolate bars, and c) tea bags in water.

SKILLS AND KNOWLEDGE YOU NEED

- How to set up a solar collector to effectively capture the sun's rays.
- How to graph data.
- How to perform a controlled experiment.

MATERIALS

FOR EACH GROUP COLLECT:

- 1 solar collector.
- 6 beakers.
- Water.
- 2 chocolate bars.
- 2 tea bags.
- 6 standard laboratory thermometers. (-10°C to 100°C)

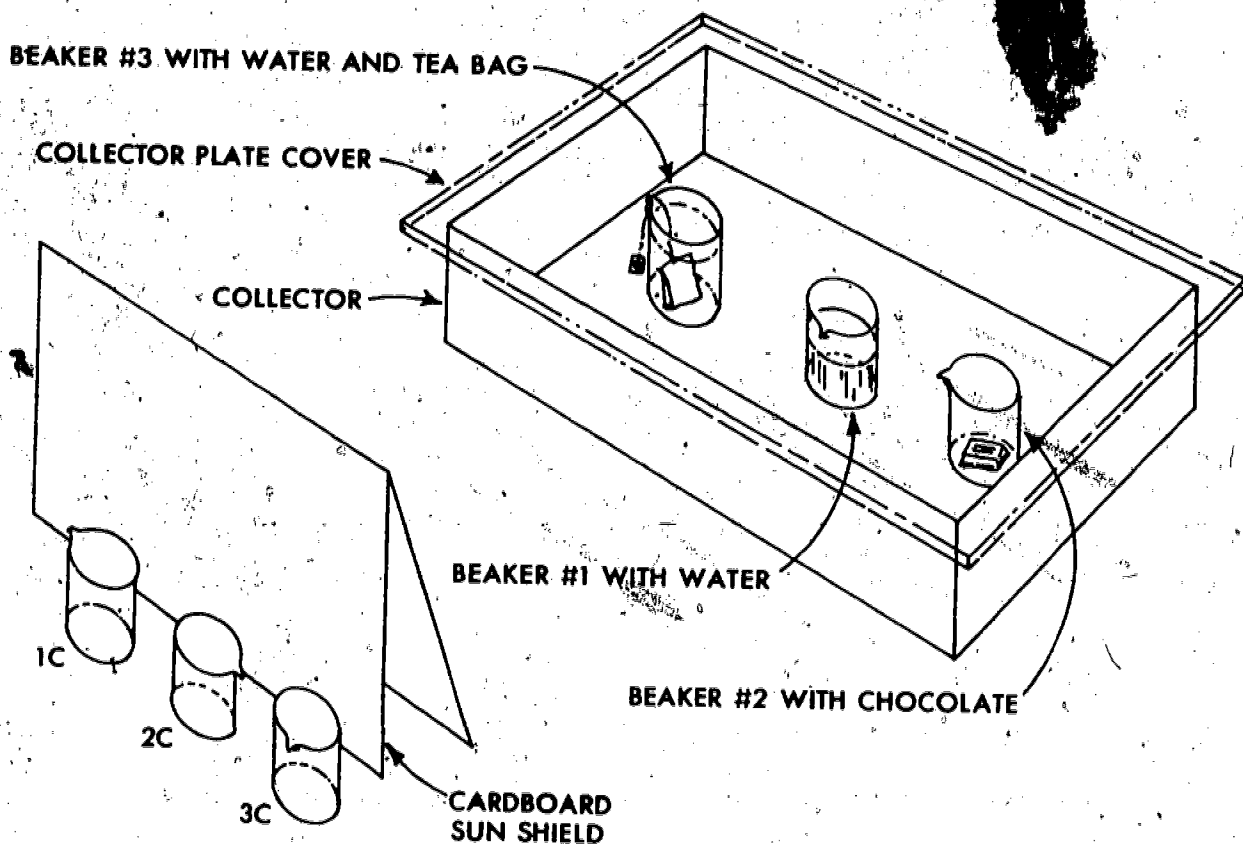

METHOD

1. Set up the solar collector so that it effectively catches the sun's rays.
2. Label 6 beakers as follows; 1, 1C; 2, 2C, 3, 3C. The beakers marked C will be our control.
3. Put a thermometer into each beaker.
4. Place the following substances in the following beakers.

1 & 1C	-	water
2 & 2C	-	chocolate bar
3 & 3C	-	water and tea bag
5. Place beakers 1C, 2C, and 3C in the shade. Place beakers 1, 2, and 3 in the collector.
6. Observe the physical appearance of each substance and record your observations in Data Table 1.

QUESTIONS

1. What conclusions can be drawn from the graphs?
2. Compare the final temperature and appearance of the water in beaker 1 and beaker 1C.
 - a. Was there any difference?
 - b. How do you account for any difference observed?
 - c. Do you see any way that you could use the information that you gained in this experiment in your home?
3. Compare the final temperature and appearance of the chocolate bar in beaker 2 and beaker 2C.
 - a. Was there any difference?
 - b. How do you account for any difference observed?
 - c. Do you see any way that you could use the information that you gained in this experiment in your home?
4. Compare the final temperature and appearance of the water and tea bag in beaker 3 and beaker 3C.
 - a. Was there any difference?
 - b. How do you account for any difference observed?
 - c. Do you see any way that you could use the information gained in this experiment in your home?

GOING FURTHER

- What effect would changing the place where the energy is collected (that is, indoors or outdoors) have on this exercise?
- What effect does time of day have on this experiment?
- If you used styrofoam cups instead of glass beakers, would you expect any change in the results? Why or why not? Ask your teacher if you can try this.
- If you used black styrofoam cups would you expect any change in the results? Why or why not? Ask your teacher if you can try this.

LET'S PUT SOLAR ENERGY TO WORK

Suggested Grade Level and Discipline

7-9 Science

Background Information

On the sun, hydrogen nuclei unite to form helium. During this process the sun gives off energy and transmits it to the earth at a rate of $1.94 \text{ cal/cm}^2/\text{min}$. As this energy is transmitted 15% is absorbed by the atmosphere, 42% is reflected by clouds, snow, water, or land and 43% is absorbed by the earth's surface. The total solar energy falling upon the earth is very much greater than current or projected demands for energy. (The energy the sun sends the earth each year is equivalent to 120 trillion tons of coal).

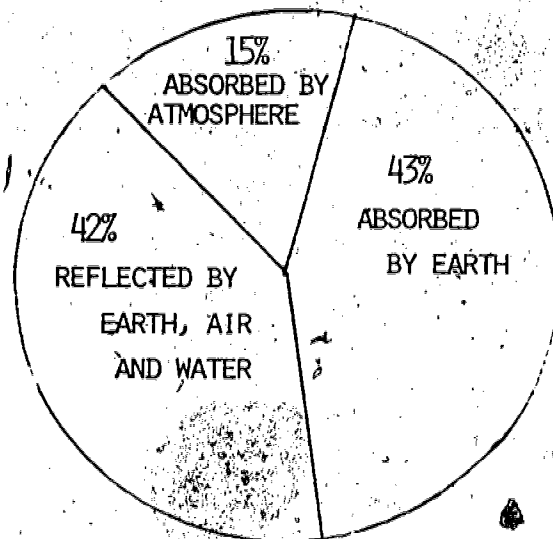

At the present time, the problem is how to effectively collect and store this energy at a reasonable cost. A solar collector itself is simple to operate and relatively easy to install.

In this experiment the students will see solar energy used to heat water, melt chocolate, and make tea. They should then be able to conclude that solar energy has many practical applications including heating their homes, producing hot water for their homes, and/or cooking in their homes.

The teacher might also point out that solar energy, striking photovoltaic cells called solar cells has produced electricity which has been used to power such items as radios, watches, spacecraft and remote electronic installations.

Typical Results

DATA TABLE 1

BEAKER	INITIAL OBSERVATION	FINAL OBSERVATION
1	clear water	water & bubbles
2	firm chocolate	melted chocolate
3	clear water, tea bag	water tea-colored
1C	clear water	no change
2C	firm chocolate	no change
3C	clear water, tea bag	slight diffusion of tea

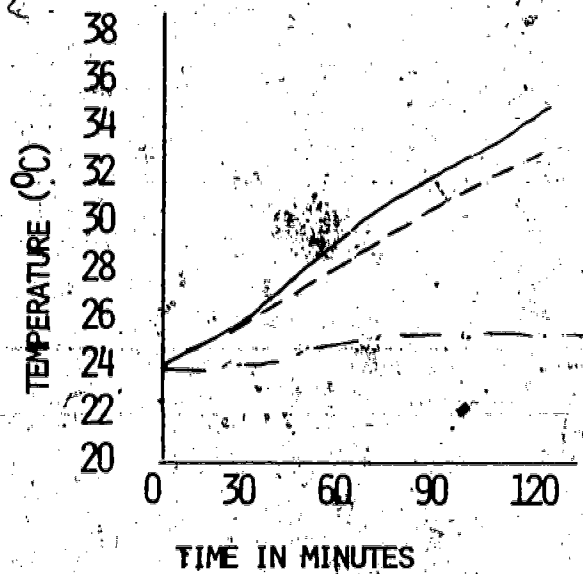

———— BEAKER 2

- - - - BEAKERS 1 AND 3

- · - · BEAKERS 1C, 2C, AND 3C

Hints on Gathering Materials

A flat plate collector can be made simply by painting a large wooden or cardboard box black both inside and out and covering it with a piece of glass or plastic wrap. Make sure that the flat plate collector you will use or construct is deep enough to accommodate 3 beakers.

If beakers are not available any glass container will suffice.

Suggested Time Allotment

One class period for the basic exercise. (Data would be collected during the school day.)

One to two class periods for initial and final discussions.

Suggested Approach

This lesson could be taught as part of a unit on energy with particular emphasis on the energy problem in the world today. Topics such as the sources, uses, and waste of energy would be covered. Alternate sources of energy could be introduced and then the class could focus on one viable alternative - solar energy.

The teacher could discuss how solar energy is created and how it reaches the earth. The construction and operation of a solar collector could be discussed, followed by the advantages and disadvantages of using solar energy. This experiment could then be tried, followed by a lecture-discussion class on the uses of solar energy with emphasis on its use to heat homes, heat hot water and cook food.

In carrying out this exercise you could divide the class into groups and have each group collect data. Alternatively, you could have the entire class set up the experiment one day in a suitable place and make initial observations. Then the class would be divided into groups and assigned a time to take temperature readings the next day before class. Each group would add its results to a class Data Table kept at the experiment. At the next class, the students would make final observations of physical appearances and complete their own data on temperature changes. During the remainder of the class period, completion of graphs and answering of questions could be accomplished.

The teacher might want the students to try #3 and #4 of **GOING FURTHER**. The procedure would be the same with the substitution of white styrofoam cups for beakers for 3 and, if 4 is chosen, white styrofoam cups painted black.

Precautions

- *Only the possibility of students eating the chocolate bars!*

Modifications

- Many alternatives for constructing flat plate collectors can be found in the literature. The teacher might wish to have the students construct their own collectors and then do the experiment.

- The data for this experiment was gathered indoors using the window as the covering for a flat plate collector. The teacher could vary the experiment by using different collectors indoors and outdoors.

- Additionally more quantitative experimental results will be obtained if temperature readings are taken at much shorter intervals e.g., (2 min.)

Evaluation

- Collect the data sheets from the students. Rate their ability to 1) make and interpret graphs, 2) transfer the experience of seeing water heated; or chocolate bars melted and tea formed, to the practical application of heating homes and water, and cooking.

Assign one of the following projects to the students.

1. Keep a notebook of clippings from magazines or newspapers on any articles on solar energy.
2. Visit an alternate energy store or a solar collector company and interview the manager concerning advantages, disadvantages and cost of solar energy equipment. Write a report or report to the class.
3. Visit an alternate energy store or solar collector company and interview the manager on career opportunities. Report to the class.

ROOF OVERHANG

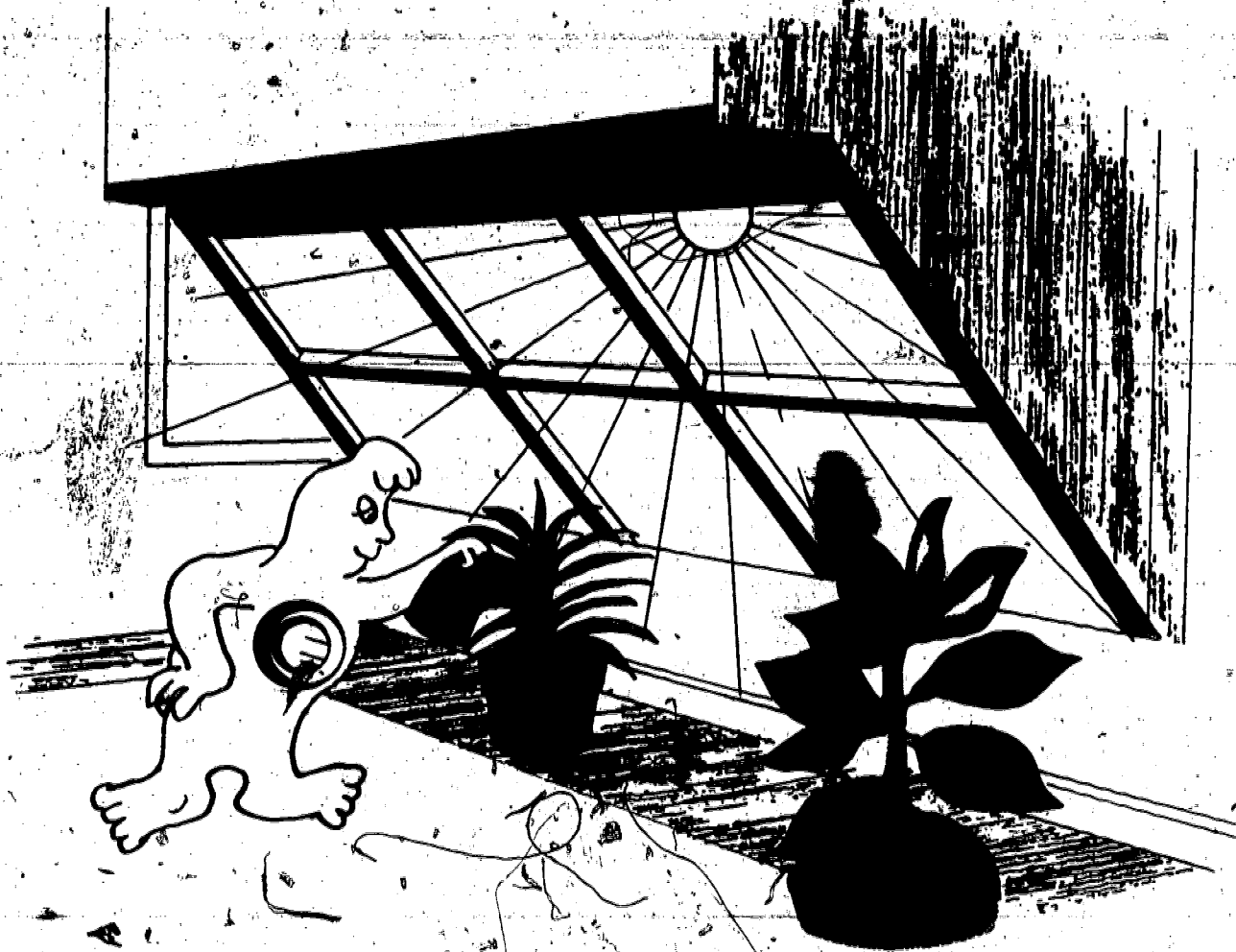

INTRODUCTION

Every house is a solar collector. Windows allow light in and the furnishings inside convert this into heat. The best collectors have windows that face south, are tilted on an angle toward the sun, and have dark colored interiors for efficient absorption. Houses differ greatly in effectiveness as collectors.

Like every solar collector, houses work best in the summer when the sun is most direct, and when we need the heat the least. Cooling is important at these times. During the winter, it would be important to have the collector working as well as possible.

There are many ways to increase collector effectiveness in the winter and decrease it in summer. One way can be as simple as changing the overhang of the roof.

OBJECTIVES

Upon completion of this activity you should be able to:

- o determine how a feature of your home, roof overhang, relates to solar heating of your home.

SKILLS AND KNOWLEDGE YOU NEED

- How to read a thermometer.
- How to read a stop watch or other timing device (school clock, wrist watch, etc.).
- How to graph data.

MATERIALS

- 1 insulated model house (per group).
- 1 laboratory thermometer (per group).
- (1 sun lamp, if done on a cloudy day).
- Timing device.

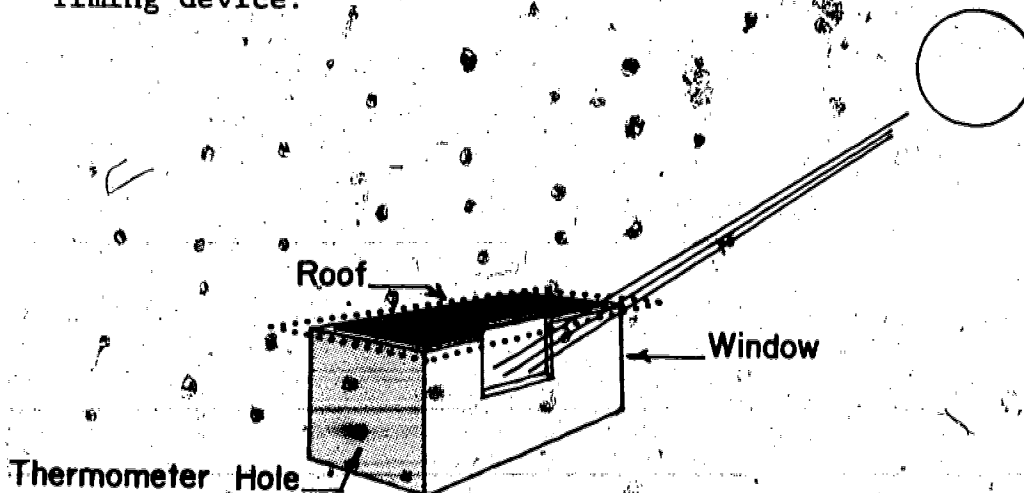

METHOD

1. Get an insulated model home from your teacher. **BE CAREFUL SINCE THE MODELS ARE SOMEWHAT FRAGILE AND SHOULD BE HANDLED WITH CARE.** It consists of a styrofoam box, painted black inside. It has one window in the side and another piece of styrofoam to form a flat roof. (See diagram).
2. Make a data sheet to record all information to be measured. A suggested form for recording data is shown on the next page.

Time	Temperature (°C)		
	Direct Sunlight	½ Shadow	Full Shadow

- Place a thermometer into the hole at the side of the house and record the temperature on your data sheet.
- Place the model in direct sunlight and adjust it so that the sun shines directly into the window without the roof overhang casting a shadow on it. If it is cloudy you can use a heat lamp in place of the sun.
- Record the temperature inside the model each minute for five minutes on your data sheet.
- Remove the roof from the house in order to allow the air inside the building to return to the same temperature as the surrounding air. Fanning with the roof will speed this.
- Plot the data, temperature vs. time, on a graph.
- Repeat steps 5, 6 and 7 using different amounts of shadow on the window. First, it should be done by adjusting the roof to cast a shadow which covers ½ the window, and then it should be repeated where the window is entirely in shadow. Plot all the information on the same graph.

LOOKING BACK

By looking at your graph, you will be able to determine which position of roof overhang would be best if you were interested in keeping your home cool in the summer or warmer in the winter. A good measurement of collector effectiveness is the change in air temperature that is achieved.

QUESTIONS

- If you were designing a home or remodeling one, what could you do with roof overhang to make the building cooler in the summer?
- In the summer the sun is higher in the sky than it would be in the winter. Explain how this might help or hinder the heating or cooling of your home with roof overhang.
- What are some other possible forms of heating and cooling that can be used in your home that would not require purchased energy, such as electricity and oil?

GOING FURTHER

Determine on the south side of your own home, the percentage of window area covered by shadows or roof overhangs.

- What effect would a home with no insulation have on the experiment?
- Using information about the angle of the sun at various times of the year at different latitudes, found in an earth science book, figure the best size overhang for the windows in your home.

Determine the effects of a double glazed window, roof cover, and different interior colors on the experiment.

Teacher Information Sheet

ROOF OVERHANG

Suggested Grade Level and Discipline

7-9 General Science

Background Information

The purpose of this activity is to demonstrate the value of properly placed roof overhangs in passive cooling and heating of a home.

When light passes into a house and strikes any surface, the visible radiation is absorbed and infrared is re-radiated. This longer wavelength radiation is associated with heat. The glass allows light in but doesn't allow the heat out. This is referred to as the "greenhouse effect". A darker surface absorbs better due to greater production of this infrared radiation.

During the summer where the sun is at a higher angle, the overhang should be far enough out so that the window is covered completely. In the winter with a smaller angle, the sun has a greater chance of entering the same window.

The optimum overhang for a house will vary with latitude, position of the window, etc.

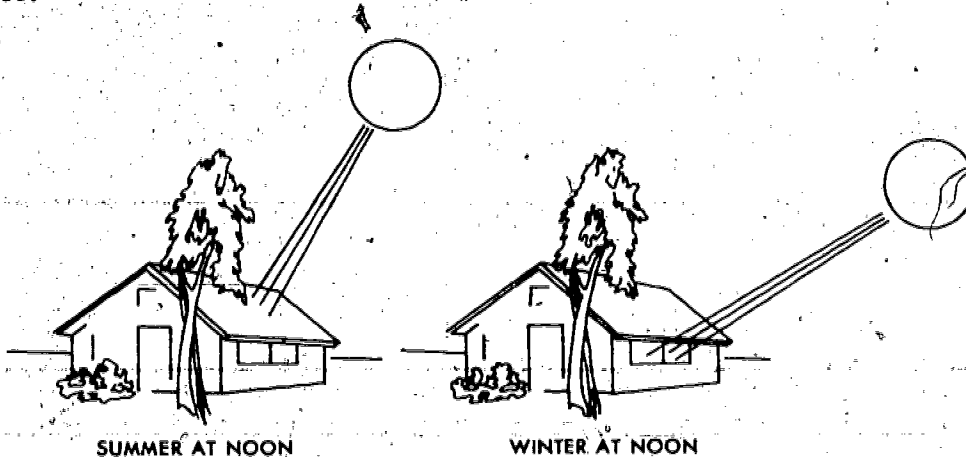
Hints on Gathering Information

The model homes can be constructed using styrofoam panels available as insulation in a lumber yard. They are, generally, approximately 2cm x 120cm. One model house is easily constructed out of a single panel this size ending up 20cm deep by 40cm wide by 30cm high. The styrofoam is easily cut with

a razor blade and glued together with a thick white glue. The white glue seals up openings in the seams as well as holds it together. Windows can be made of clear plastic glued to the inside of the model with the same glue. The use of styrofoam provides insulation as well as an easily handled construction material. The roof, also made of styrofoam, is 40cm x 30cm and made to fit on top and also overhang. The size of the window is approximately 10cm x 10cm. The location of the half-shadow can be marked on the house at the time of construction.

Suggested Time Allotment

- Two class periods. (One class period for collecting data, one class period for results and discussion.)

Suggested Approach

- This lab could be implemented in a heat or solar energy unit. The activity illustrates the absorption of radiation, the purpose of insulation and could be related to a solar collector.
- This lab could be introduced by having students measure the roof overhang on their homes facing south. They might discuss in post-activity whether their house has an optimum design.
- Divide the class into several groups and have each group collect data under the same conditions.

Typical Results

- The model house with no shadow on the window will generally go up 5 to 10°C in the time provided. With a ½ shadow, the increase is 3° to 5°C and with the full shadow, there is generally no increase.

Precautions

- *The models are somewhat fragile and should be handled with care.*

Modifications

- The model houses could be made of virtually any insulating material (wood, cardboard, newspaper, etc.). The window could be made of polyethylene or kitchen wrap type of plastic film. **GLASS SHOULD NOT BE USED BECAUSE OF ITS WEIGHT AND THE CHANCE OF BREAKAGE.**

Evaluation

- Students should be able to explain why roof overhangs are valuable.
- Comparison of data from different groups should coincide reasonably well.

SOLAR ENERGY IN A COFFEE CAN

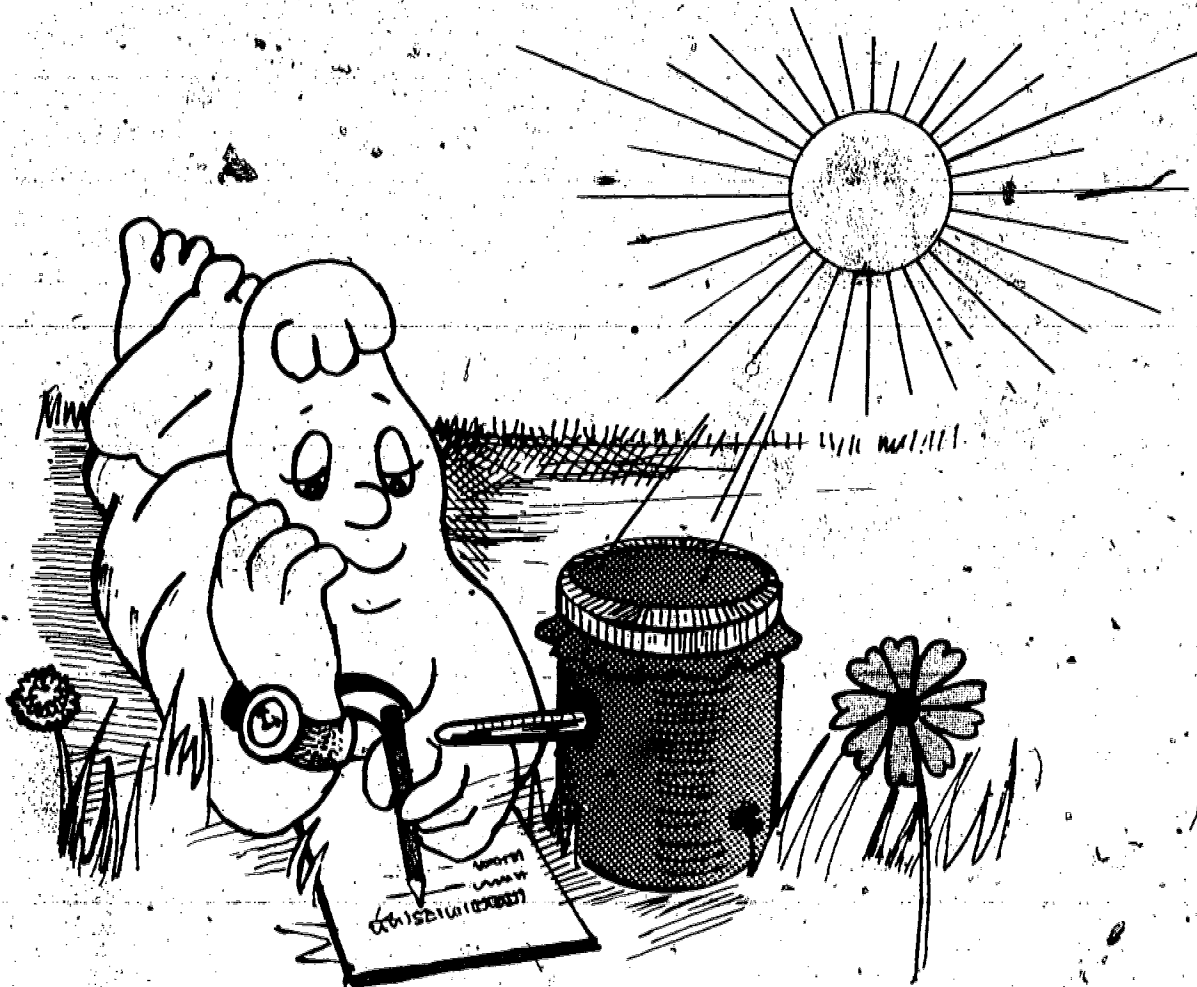

INTRODUCTION

This activity will give you basic information about the operation of a typical solar energy collector. Think about all the energy coming from the sun that strikes the earth but is not used. If this could be collected, we would have an abundant, clean, and free energy source.

As the sun shines it gives off tremendous amounts of energy which can be collected and used for heating purposes. Have you noticed any solar energy collectors in your neighborhood? Do you know how a solar energy collector can be used to heat a building?

In this activity you will construct a very simple solar collector that will help you understand how the sun's energy can be used for heating homes, office buildings, and factories.

OBJECTIVES

At the completion of this activity, you should be able to:

- o construct a solar collector from a can.
- o determine how the type of cover material (glazing) influences the performance of the collector.
- o determine how insulation influences the performance of the collector.

SKILLS AND KNOWLEDGE YOU NEED

- Reading a thermometer and a stop watch or other timing device (school clock, wrist watch, etc.).
- Graphing data.

MATERIALS

- A large can about 16cm to 20cm high and 10cm to 13cm wide (a 3 lb. coffee can, for example) with plastic cover.
- A smaller can about 10cm high and 7cm wide (a 1 lb. coffee can, for example) with plastic cover.
- A standard laboratory thermometer. (-10°C to 110°C)
- Several square pieces of transparent and translucent materials such as plastic wrap, polyethylene, waxed paper, etc. (Approximately 15cm square).
- Several types of insulation material such as shredded paper (cellulose), cotton, styrofoam, fiberglass, cork, sawdust.
- A watch or clock with a second hand.
- A can of flat black spray paint.

SOLAR ENERGY IN A COFFEE CAN

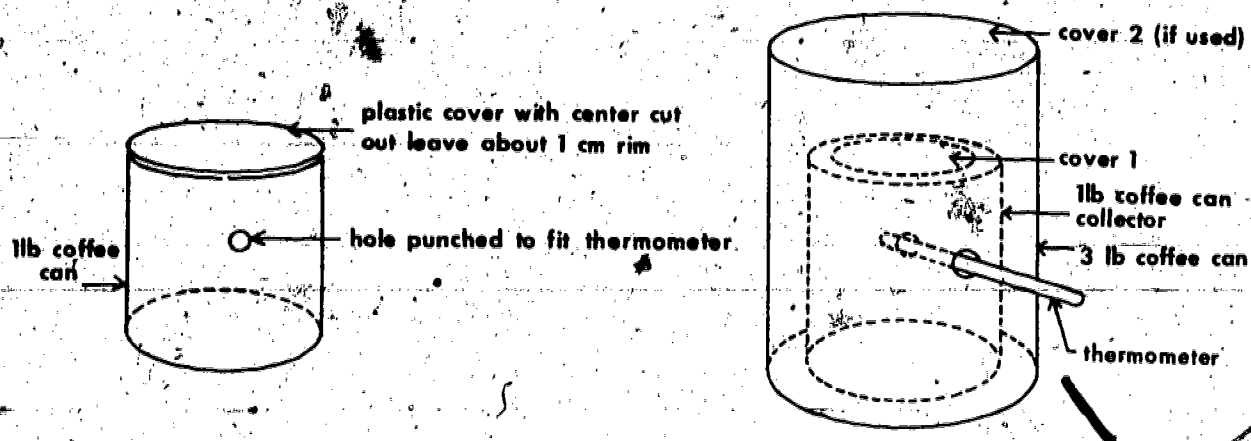

METHOD

1. Spray the inside of the smaller can with black paint.
2. Punch a hole in the side of the small can to fit the thermometer.
3. Punch a hole in the outer can so that the thermometer can pass through it. Allow for the insulation being placed in the outer can. Small can will rest on this, not on the bottom of the outer can.
4. Cut the center out of the small can's plastic lid, leaving a 1cm. rim. (See diagram above).
5. Choose one of the cover materials to stretch across the top of the smaller can. Hold the material secure by replacing the cut out plastic lid.
6. Put the small can inside the larger can.
7. Insert the thermometer through the hole in the large can and then fit it snugly into the smaller inside can.
8. Place your solar collector in the sun and record the temperature each minute for 15 minutes.
9. Plot the data, temperature vs. time, on a graph. Compare your results to the results of those students who used other cover materials.

10. Repeat procedures #7 and #8, but this time use an insulation material such as cotton. Make sure you put the insulating material in all the spaces between the two cans including the space underneath the center can. After you collect this data for cotton, try 3 or 4 other insulation materials.
11. Compare, on the same set of graph axes, the various types of insulation used. You may need to ask your teacher to help you with this graph.

LOOKING BACK

Solar collectors can be made from a variety of inexpensive, readily available materials. The goal of the design is to permit the solar energy to be trapped and converted into heat. One indication of collector performance is the change in air temperature achieved. Collector performance can be changed by altering the covering material through which the sun's rays pass and altering the insulation materials used.

QUESTIONS

1. According to your graphs, which type of cover material on the small can appeared to be most effective?
2. Why is it necessary to use insulation in a solar collector? Which type of insulation seemed to work best?
3. Of those materials you used, which combination of glazing and insulation material would you recommend for a solar collector?

GOING FURTHER

- What effect does the slant of a collector have on the temperature attained? Try different angles of orientation (slant toward the sun).
- What effect would sub-freezing temperatures outdoors have on temperatures attained? Would solar collectors be practical in colder climates?
- How do wind or cloud cover affect the collector's performance?
- How would adding an additional cover to the outside can affect performance?
- Would changing the color of the inside of the small can affect the energy collected?

Teacher Information Sheet

SOLAR ENERGY IN A COFFEE CAN

Suggested Grade Level and Discipline

7-9th Science
 Earth Science
 Physics

Background Information

A solar collector has five basic parts. Each will be investigated in this activity.

One major part of a collector is a covering material, called glazing, which transmits as much solar energy as possible. Its purpose is to trap the energy it transmits, inside the collector. The glazing should be able to withstand high temperatures without decomposing or melting, and it must be able to withstand impact from objects that might fall on it.

Another part of any solar collector is the collector plate which absorbs the energy transmitted by the glazing. The collector plate is usually coated with a dark colored material that increases the absorbance of the solar energy. The collector plate and its coating must be able to withstand high temperatures without vaporizing or otherwise breaking down. The collector plate is often made from copper or aluminum but other materials may be suitable.

A third part of a collector, the collector box, houses the various parts of the collector. It can be made from materials such as aluminum, wood, fiberglass or steel. It must be sturdy and able to withstand temperature extremes.

A fourth part of a collector is the insulation that surrounds five sides of the collector box. Conduction losses of trapped solar energy are substantial unless the collector box is well insulated. Fiberglass and various foams are commonly used for this purpose.

The fifth part of the collector is either air or a liquid. It is used to transfer the solar energy to a system for distribution throughout the space to be heated or to a substance to be heated. If water is used as the medium in cold climates, it is often mixed with an antifreeze.

A collector or a series of collectors can be used for space heating or to provide hot water for commercial or domestic uses.

The collector constructed in this activity is an integral part of typical hot air solar systems.

Hints on Gathering Materials

- Several weeks before the activity is planned, have students start bringing in one and three pound coffee cans with plastic lids.
- Have several extra coffee can covers (of both sizes) in case the students do not cut the lids properly.

Suggested Time Allotment

- One period to construct the collectors.
- Two or three days for collection and interpretation of data.

Suggested Approach

- Divide the class into several groups. Have each group use different combinations of glazing and insulating materials.
- Have each group collect their data under the same environmental conditions. This will help eliminate the number of variables. (Example: change in cloud cover conditions, etc.)
- In order to infuse the concept of career education into the classroom activity it is suggested that the teacher contact industrial, utility, and business representatives in the energy field. For example, a solar heating system dealer may be invited into the classroom to discuss the job of supplying materials necessary for considering and installing solar systems. Sample materials may be provided during the presentation as well as "hand-out" information. Beyond this activity, students may be asked to visit local firms and interview individuals associated with the energy industry. For example, the students could speak with a utility company representative, a gas station operator, a solar collector manufacturer, a county planner, a local newspaper representative, as well as plumbing and electrical contractors.

Typical Results

- The various combinations of insulation and glazing used will cause results to vary.
- The better the insulation and the greater the insolation, the higher the temperatures to be expected.
- A second layer of glazing with air space between it and the inside can should increase the temperature inside the smaller can.

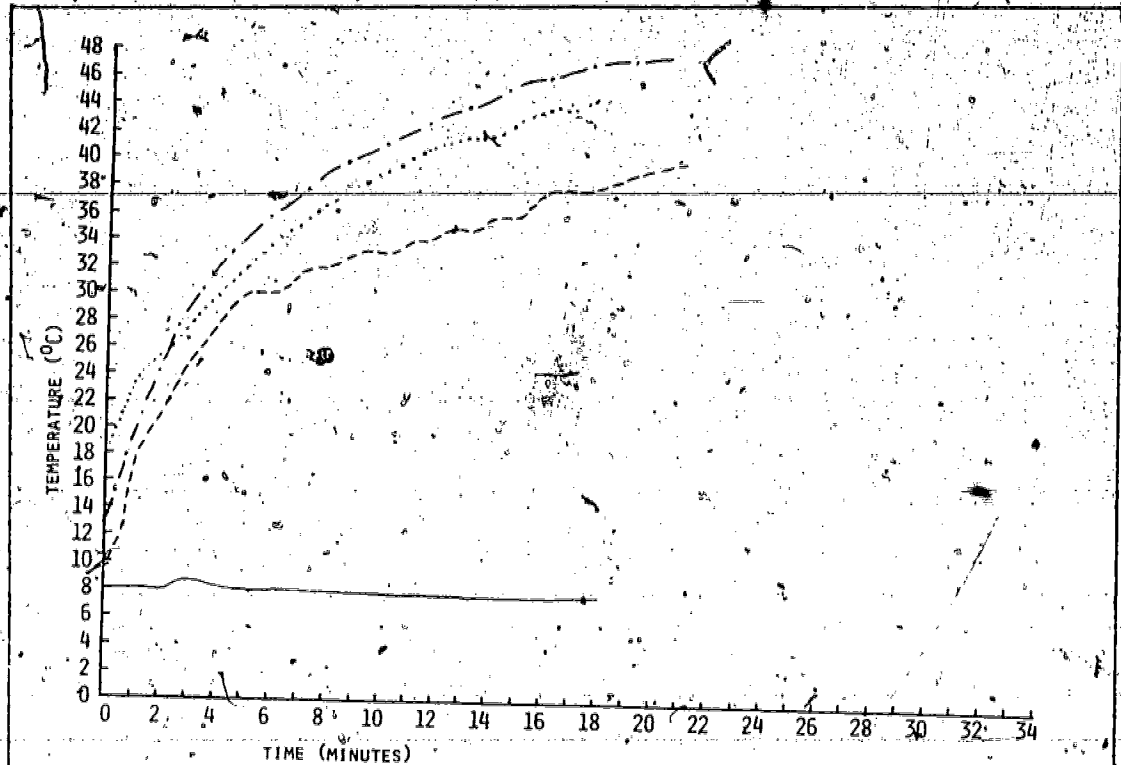

KEY

<u>Symbol</u>	<u>Absorber Color *</u>	<u>Insulation Type</u>	<u>Inner Cover</u>	<u>Outer Cover</u>
- · - · -	Lt. Blue	Styrofoam	Clear Plastic	Clear Plastic
- · - · -	Dk. Grey	Rock Wool	Clear Plastic	Clear Plastic
- - - - -	Black.	Fiberglass	Glass	None
—————	Air temperature			

**Note: In the activity described, the absorber color was black as accomplished by spraying the inside of the small can with black paint.*

Precautions

Holes could be pre-punched in the cans by someone other than the students. (Use a metal punch to form the holes with an appropriate backing to avoid bending the can.)

Modifications

- If cans are difficult to obtain, shoe boxes may be substituted.
- Paint the outside of the larger can (or shoe box) to observe if this affects results.
- If more background information is desired for the students, the teacher background information section could be duplicated for this purpose.

Evaluation

- Observe your students' ability to follow instructions and work with other class members.
- Collect and review the data gathered by each student. Is it well organized? Is the analysis well thought out? Are the graphs usable for data analysis?
- Check students' answers to the questions.

References

- *Kilowatts from the Sky*, Peter Britton, *The Lamp*, Summer, 1976, pp. 16-21.
- *Solar Energy*, William W. Eaton, (Department of Energy, Washington, D.C.) 1976.
- *Solar Energy Experiments*, Thomas Norton, (Emmaus, Pennsylvania: Rodale Press) 1977.

D-R-A-F-T - ACTIVITY 13
A SOLAR WATER HEATER

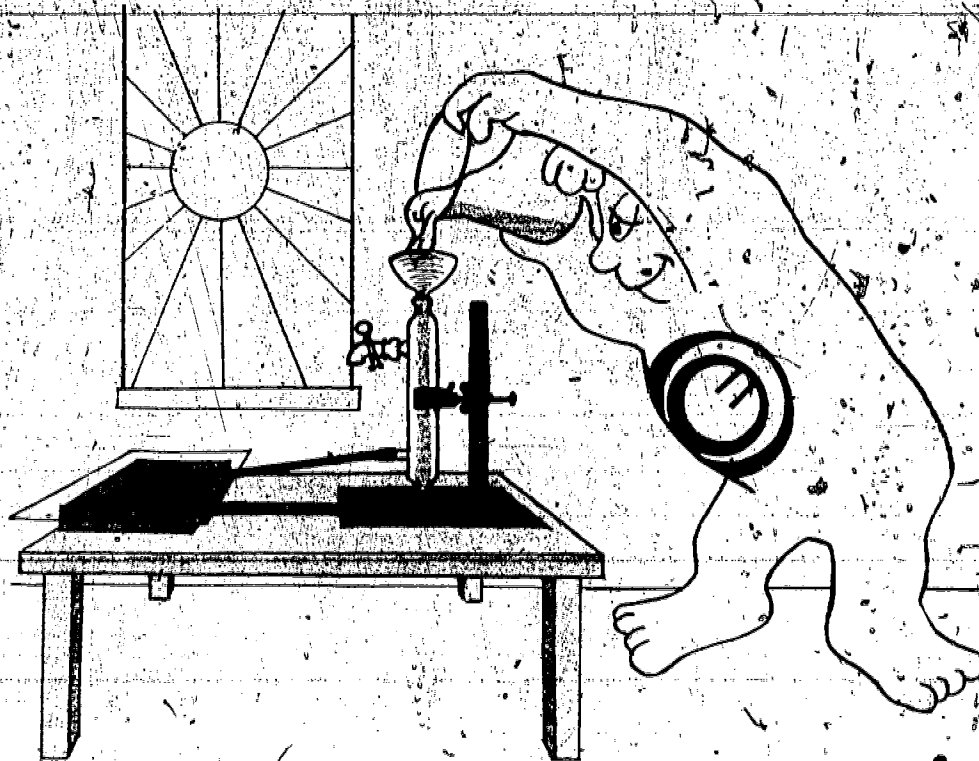

INTRODUCTION

The sun is our chief source of heat. We obtain heat from the sun directly when we are warmed by its rays. We make use of the sun's energy indirectly in several ways to provide heat. For example, energy from the sun can be captured in a solar collector and be used to warm our homes and heat our water.

In this activity you will learn about the operation of a simple solar water heater. Think about all the energy that is used each day to heat water using natural gas or electricity. Using energy from the sun to heat water would help conserve our rapidly dwindling fuel sources.

You will construct a simple solar water heater that consists of a solar energy collector, a storage tank and some very simple plumbing.

OBJECTIVES

At the completion of this activity, you should be able to:

- o construct a working model of a solar water heater.
- o understand the principles of solar energy collection.
- o determine how the efficiency of a solar collector can be increased.
- o design a solar water heating system that can be used in your home.

SKILLS AND KNOWLEDGE YOU NEED

- How to read a thermometer.
- How to graph data.
- Care in handling scientific apparatus.

MATERIALS

- 1 shallow cardboard box.
- 1 sheet of glass (large enough to cover the cardboard box).
- 20 feet of black rubber tubing.
- 1 ring stand.
- 1 large clamp.
- 1 condensation column.
- 1 pinch-cock.
- 1 Celsius thermometer.
- 1 50ml beaker.
- 1 one-hole stopper or cork.
- 1 funnel.
- 1 can of black paint and a paint brush.

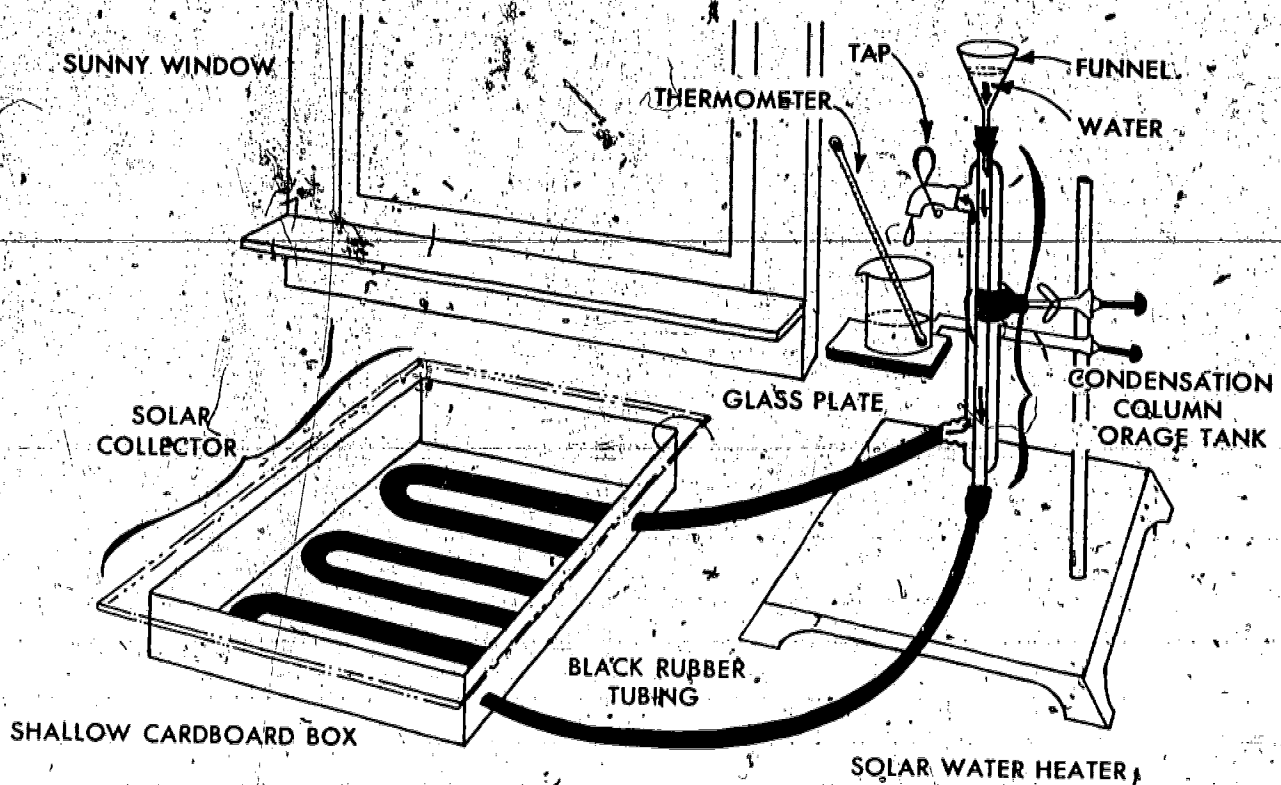

METHOD

1. Assemble the apparatus for your solar water heater according to the diagram provided.
2. Fill the entire unit with water. (Be sure that the tubing and condensation column are completely filled.)
3. Drain off 50ml of water from the tap and record the temperature on your data chart.
4. Pour the water back into the funnel.
5. Place the solar collector in the sun and record the temperature of the water each minute for 20 minutes or until a maximum temperature is reached. (Be sure to pour each sample back into the system.)
6. Graph your data on the grid provided.
7. Drain the entire system. Paint the cardboard box black and allow to dry, then repeat steps 2-5 of this activity.
8. Compare, on the same graph, the data received from the painted and unpainted collector boxes.

DATA CHART

UNPAINTED BOX: INITIAL WATER TEMPERATURE _____

MINUTE #	TEMP. READING	MINUTE #	TEMP. READING
1	_____	11	_____
2	_____	12	_____
3	_____	13	_____
4	_____	14	_____
5	_____	15	_____
6	_____	16	_____
7	_____	17	_____
8	_____	18	_____
9	_____	19	_____
10	_____	20	_____

PAINTED BOX: INITIAL WATER TEMPERATURE _____

MINUTE #	TEMP. READING	MINUTE #	TEMP. READING
1	_____	11	_____
2	_____	12	_____
3	_____	13	_____
4	_____	14	_____
5	_____	15	_____
6	_____	16	_____
7	_____	17	_____
8	_____	18	_____
9	_____	19	_____
10	_____	20	_____

LOOKING BACK

In this activity you have seen that solar energy can be captured and put to good use as in this model solar water heater. The performance of this design can be changed and made more efficient by painting the collector box black. On sunny days this model will produce small quantities of hot water if the tank is kept full. This simple system is basically the same design that would be used in an energy-saving home solar water heating unit.

QUESTIONS

1. Where does the energy to heat the water come from?
2. Why should a black rubber tube be used in this activity?
3. Would the water heat up if the tubing was not in a solar collector?
4. Under what weather conditions would a solar water heater work best?
5. How does changing the color of the collector box affect the temperature of the water?
6. Where would the collector box be placed in a practical home solar water heating system?
7. Examine the drawing of the apparatus for this activity. What part of the system would be the same as the cold water pipe in your home hot water unit?

GOING FURTHER

- After the collector has been in the sun for about 30 minutes add 15-20 drops of dark food coloring to the system through the funnel. Observe the currents that move the color through the system. Define the term convection.
- Experiment further by devising ways to make the system produce a higher temperature in less time. Suggestion: analyze such factors as the color of the collection box, insulation, the use of a pump, the use of mirrors & magnifying lenses, changing the angle of the collector to the incoming sun rays, different covers for the collector, colors and lengths of tubing, etc. Compare your results to the data collected in the original activity.