

DOCUMENT RESUME

ED 170 544

CE 020 696

AUTHOR Cordell, Curtis C.; And Others  
 TITLE The Design of a Shiphandling Training System. Final Report. June 1977 through January 1979.  
 INSTITUTION Naval Training Equipment Center, Orlando, Fla. Training Analysis and Evaluation Group.  
 REPORT NO TAEG-R-65  
 PUB DATE Jan 79  
 NOTE 157p.; For a related document see CE 020 697 ; Parts may not reproduce clearly due to light type

EDRS PRICE MF01/PC07 Plus Postage.  
 DESCRIPTORS Adult Education; Building Plans; \*Curriculum Development; Experiential Learning; \*Job Skills; Learning Modules; \*Military Training; Officer Personnel; Research Projects; \*Simulators; Skill Development; Staff Improvement; Systems Development; \*Training Techniques; Visual Perception  
 IDENTIFIERS \*Shiphandling; \*Small Craft; Surface Warfare Officers School

ABSTRACT

To improve shiphandlers' training in three surface warfare officers school courses, a study was designed to develop an integrated, career-structured program. Constructing the integrated system involved three tasks: (1) formulate a career-structured shiphandling training unit to enable preparation of curriculum, lesson guides, and measurement criteria; (2) develop a functional specification for a full-mission bridge simulator to be employed as an integral part of the training system; and (3) develop a concept design for a new small craft training device to prepare a preliminary design. Costs were estimated for the two training devices, and all tasks were accomplished. (Appendixes contain a glossary, shiphandling training unit lesson topic identification, functional specification for full mission shiphandling bridge simulator, and a concept design for the small craft training device.) (CSS)

\*\*\*\*\*  
 \* Reproductions supplied by EDRS are the best that can be made \*  
 \* from the original document. \*  
 \*\*\*\*\*

Training Analysis and Evaluation Group

January 1979

**BEST COPY AVAILABLE**

GOVERNMENT RIGHTS IN DATA STATEMENT

Reproduction of this publication in whole or in part is permitted for any purpose of the United States Government.

*Alfred F. Smode*

FRED F. SMODE, Ph.D., Director  
Training Analysis and Evaluation Group

*Worth Scanland*

WORTH SCANLAND, Ph.D.  
Assistant Chief of Staff for  
Research and Program Development  
Chief of Naval Education and Training

U.S. DEPARTMENT OF HEALTH,  
EDUCATION & WELFARE  
NATIONAL INSTITUTE OF  
EDUCATION

THIS DOCUMENT HAS BEEN REPRODUCED EXACTLY AS RECEIVED FROM THE PERSON OR ORGANIZATION ORIGINATING IT. POINTS OF VIEW OR OPINIONS STATED DO NOT NECESSARILY REPRESENT OFFICIAL NATIONAL INSTITUTE OF EDUCATION POSITION OR POLICY.

REPORT DOCUMENTATION PAGE		READ INSTRUCTIONS BEFORE COMPLETING FORM
1. REPORT NUMBER TAEG Report No. 65	2. GOVT ACCESSION NO.	3. RECIPIENT'S CATALOG NUMBER
4. TITLE (and Subtitle) THE DESIGN OF A SHIPHANDLING TRAINING SYSTEM		5. TYPE OF REPORT & PERIOD COVERED Final Report June 1977 - January 1979
7. AUTHOR(s) Curtis C. Cordell, Roger V. Nutter, and Edward A. Heidt		6. PERFORMING ORG. REPORT NUMBER
9. PERFORMING ORGANIZATION NAME AND ADDRESS Training Analysis and Evaluation Group Orlando, FL 32813		8. CONTRACT OR GRANT NUMBER(s)
11. CONTROLLING OFFICE NAME AND ADDRESS		10. PROGRAM ELEMENT, PROJECT, TASK AREA & WORK UNIT NUMBERS
14. MONITORING AGENCY NAME & ADDRESS (if different from Controlling Office)		12. REPORT DATE January 1979
		13. NUMBER OF PAGES 134
		15. SECURITY CLASS: (of this report) Unclassified
		15a. DECLASSIFICATION/DOWNGRADING SCHEDULE
16. DISTRIBUTION STATEMENT (of this Report) Approved for public release; distribution is unlimited.		
17. DISTRIBUTION STATEMENT (of the abstract entered in Block 20, if different from Report)		
18. SUPPLEMENTARY NOTES		
19. KEY WORDS (Continue on reverse side if necessary and identify by block number) Shiphandling Ship Dynamic Visual Simulation Shiphandling Training Devices Shiphandling Curriculum Personnel Training Training Craft Design		
20. ABSTRACT (Continue on reverse side if necessary and identify by block number) This is the second of two reports addressing the training of shiphandlers. The first, <u>Shiphandling and Shiphandling Training</u> , TAEG Report No. 41, December 1976, established the knowledge and skill elements required of competent shiphandlers. Based on these elements, a concept was proposed for a career-based training system for prospective shiphandlers. The system design included three courses of ashore training interspersed with operational tours at sea. Since Naval officers are expected to		

## 20. ABSTRACT (continued)

serve aboard vessels of widely divergent characteristics and to proceed from extended periods ashore to responsible positions aboard Naval vessels, two additional types of training were proposed for the system--refresher and transition training. In support of the training system, two needed training devices were identified--a full-mission bridge simulator and a small craft designed for use as a trainer.

In the current study, the initial concept is fully developed for a career-based training system for integration into the existing training curricula. A shiphandling unit is proposed for the three Surface Warfare Officers School (SWOS) courses. Only minor restructuring of the three curricula is needed. Course time remains essentially unchanged. It is proposed that underway time in a conning capacity on the small craft trainer be scheduled, without exception, in the Department Head Course and some additional conning time be made available to attendees of the PCO/PXO Course who have had little recent at-sea experience.

Content material for the transition and refresher training courses can be drawn from the appropriate SWOS courses.

The two full-mission training devices identified above are required to support the SWOS shiphandling units and the transition and refresher training courses. The present report examines these requirements in substantive detail with the intent to facilitate the development and eventual production of these two major trainers. To this end, a functional specification for the bridge simulator is presented. This specification defines the minimum acceptable operational performance limits necessary to be included in order that the training requirements may be met. In addition, a design concept for a small craft is also proposed. This training vessel is designed specifically as a replacement for existing craft used for training and will be capable of simulating the operating characteristics of most existing classes of Naval vessels.

PRECIS

This is the second of two reports addressing the training of shiphandlers. The first, Shiphandling and Shiphandling Training, TAEG Report No. 41, December 1976, established the knowledge and skill elements required of competent shiphandlers. Based on these elements, a concept was proposed for a career-based training system for prospective shiphandlers. The system design included three courses of ashore training interspersed with operational tours at sea. Since Naval officers are expected to serve aboard vessels of widely divergent characteristics and to proceed from extended periods ashore to responsible positions aboard Naval vessels, two additional types of training were proposed for the system--refresher and transition training. In support of the training system, two needed training devices were identified--a full-mission bridge simulator and a small craft designed for use as a trainer.

In the current study, the initial concept is fully developed for a career-based training system for integration into the existing training curricula. A shiphandling unit is proposed for the three Surface Warfare Officers School (SWOS) courses. Only minor restructuring of the three curricula is needed. Course time remains essentially unchanged. It is proposed that underway time in a conning capacity on the small craft trainer be scheduled, without exception, in the Department Head Course and some additional conning time be made available to attendees of the PCO/PXO Course who have had little recent at-sea experience.

Content material for the transition and refresher training courses can be drawn from the appropriate SWOS courses.

The two full-mission training devices identified above are required to support the SWOS shiphandling units and the transition and refresher training courses. The present report examines these requirements in substantive detail with the intent to facilitate the development and eventual production of these two major trainers. To this end, a functional specification for the bridge simulator is presented. This specification defines the minimum acceptable operational performance limits necessary to be included in order that the training requirements may be met. In addition, a design concept for a small craft is also proposed. This training vessel is designed specifically as a replacement for existing craft used for training and will be capable of simulating the operating characteristics of most existing classes of Naval vessels.

## TABLE OF CONTENTS

<u>Section</u>	<u>Page</u>
	PRECIS. . . . . 1
I	INTRODUCTION. . . . . 5
	Background. . . . . 7
	Purpose . . . . . 7
	Organization of the Report. . . . . 8
II	SHIPHANDLING TRAINING SYSTEM CONCEPT. . . . . 9
	Training System Concept . . . . . 10
	Shiphandling Training System Requirements. . . . . 10
	Shiphandling Training Unit Design. . . . . 12
	Instructional Modules . . . . . 12
	Subject Matter Prioritization . . . . . 14
	Other Instructional Components. . . . . 17
	Training Unit Support Equipment . . . . . 18
	Shiphandling Training Sequence . . . . . 19
	Course Entry Requirements . . . . . 20
III	FORMULATION OF THE SHIPHANDLING TRAINING UNIT . . . . . 23
	Basic Shiphandling Training . . . . . 23
	Intermediate Shiphandling Training. . . . . 24
	SWOS Department Head Course. . . . . 24
	SWOS Prospective Executive Officer Training. . . . . 28
	Advanced Shiphandling Training. . . . . 30
	Implementation of the Proposed Shiphandling Training Unit . . . . 30
IV	PROPOSED FULL-MISSION SHIPHANDLING BRIDGE SIMULATOR . . . . . 33
	Approach. . . . . 33
	Functional Specifications . . . . . 34
	Device Characteristics . . . . . 34
	Integrated Logistic Support (ILS) Considerations . . . . . 35
	Evaluation . . . . . 36
	Risk . . . . . 36
	Option Selection Rationale . . . . . 37
	Cost . . . . . 39

TABLE OF CONTENTS (continued)

<u>Section</u>	<u>Page</u>
Considerations . . . . .	44
Lead Time Estimate . . . . .	45
V    PROPOSED SMALL CRAFT TRAINING DE/ICE . . . . .	47
Background . . . . .	47
Concept Formulation . . . . .	48
Concept Design . . . . .	49
Training Device Craft Characteristics . . . . .	51
Training Device Craft Systems . . . . .	51
Personnel . . . . .	53
Support . . . . .	53
Alternate Propulsion Engine Configuration . . . . .	53
Cost . . . . .	54
Areas of Possible Savings . . . . .	55
Extended Cruise Alternative . . . . .	56
APPENDIX A Glossary of Definitions . . . . .	57
APPENDIX B Shiphandling Training Unit Lesson Topic Identification . . . . .	61
APPENDIX C Functional Specification for Full-Mission Shiphandling Bridge Simulator . . . . .	67
APPENDIX D Concept Design for Small Craft Training Device . . . . .	85

TAEG REPORT No. 65

LIST OF ILLUSTRATIONS

<u>Figure</u>		<u>Page</u>
1	Proposed Shiphandling Training System . . . . .	11
2	Career Progression to Command, Typical Surface Naval Officer . . . . .	13
3	Proposed Shiphandling Training System Module Concept. . . . .	15
4	Relative Frequency vs. Cost . . . . .	42
5	Probability vs. Cost. . . . .	43
6	Shiphandling Simulator Acquisition Milestones. . . . .	46
7	Artist Concept, Proposed Small Craft Training Device. . . . .	50
8	Groups of Major Ship Types. . . . .	52

LIST OF TABLES

<u>Table</u>		<u>Page</u>
1	Classification of Shiphandling Elements; Knowledge and Skill Requirements . . . . .	6
2	Prioritization of Learning Modules. . . . .	17
3	SWOS Basic Course . . . . .	25
4	SWOS Department Head Course . . . . .	27
5	SWOS PCO/PXO Course . . . . .	29
6	Projected Component Procurement Cost for Full-Mission Shiphandling Simulator (Two Bridge Configuration) . . . . .	40
B-1	Shiphandling Training Topics. . . . .	63



SECTION I

INTRODUCTION

"Proficiency in the art of shiphandling is a goal which each unrestricted line officer strives to attain."<sup>1</sup> In the past, most efforts to achieve this goal have been undertaken through on-the-job training aboard ships. However, recent reductions in ship availability and underway time have decreased the opportunity for such training. Other approaches to shiphandling training must be developed to insure officers receive sufficient training in critical skills related to shiphandling.

Shiphandling and shiphandling training are areas that have not been emphasized by the Navy in planning its operational capabilities for the post-1980s. Until recently, neither the identification of shiphandling training needs nor the application of current training technology to such training have been adequately pursued.

A previous Training Analysis and Evaluation Group (TAEG) study developed a concept for a career structured shiphandling training system (TAEG Report No. 41, Shiphandling and Shiphandling Training dated December 1976). The present study defines the specifics of that conceptual system and describes major training devices needed to support it.

Shiphandling is defined here as those situations wherein the conning officer is required to make immediate decisions with respect to the maneuvering of the ship and outside aids; e.g., Combat Information Center (CIC), ground tackle (including tugs), navigational aids, etc., are of relatively little value. However, a failure to use outside aids, the improper use of these aids, or the lack of preparation for a situation is considered to be poor shiphandling. The acceptance of this definition, which includes reference to both the situation itself and the actions of the conning officer in arriving in the situation, enables expert shiphandlers to identify 11 skill/knowledge elements crucial for proficiency in shiphandling. These elements are listed in table 1. Training to proficiency in these elements is the goal of the integrated training system defined in this report.

The prior investigation disclosed that the training aids and devices now used are not, in most cases, optimal for shiphandling training, more often because of the inadequacy of the device itself rather than because of any error in use. However, the specification of training system objectives in a logical and integrated framework would allow a clearer identification of training aid/device requirements. The results of this identification of need are specifically addressed in this report.

<sup>1</sup> CNET 1tr Code N-23 of 8 Apr 77.

TABLE 1. CLASSIFICATION OF SHIPHANDLING ELEMENTS;  
KNOWLEDGE AND SKILL REQUIREMENTS

1. Rules of the Road
2. Relative Motion
3. Navigation and Piloting
4. Internal and External Ship Forces
5. Ground Tackle
6. Ship Characteristics (own and other)
7. Tactical Publications and Thumb Rules
8. Meteorology and Oceanography
9. Planning Ahead
10. Ship Team
11. Trainer

A training analysis of shiphandling revealed the following:

- Shiphandling is not a completely procedural task, nor can it be reduced to that classification of task. Interviews and a review of pertinent published data led to the finding that the independent but related knowledge elements should be learned in a classroom setting, then practiced and reinforced in a trainer. The inter-relationship of each of the elements to the other elements could be emphatically demonstrated in a mission simulator. An effective shiphandling training system requires a transition from classroom to mission simulation and finally to operational craft.
- Three additional factors are relevant. First, there is a need to provide transition training for officers proceeding from one ship class to another of widely divergent characteristics. Second, officers proceeding to sea as qualified OOD(F)'s should have performed all of the evolutions required in the Personnel Qualifications Standard (PQS) to qualify as OOD(F). For many reasons this is not always accomplished, and some officers are qualified on waivers. Third, there are many shiphandling situations which cannot be duplicated for training purposes on board an operational unit. The reasons for this vary from safety to a lack of opportunity.

## BACKGROUND

The Chief of Naval Education and Training (CNET), by memorandum Code 00 of 15 April 1976, proposed the TAEG as the agency to study the broad question of shiphandling and shiphandling training. In May 1976, the TAEG was tasked to develop shiphandling training requirements and a training strategy. In June 1976, the Chief of Naval Operations (CNO) requested that the TAEG study address the "means for providing such training, at what points in the career pattern, a comprehensive prioritization of existing shiphandling training, including sailboating and YPs, and such matters as relate to meeting the training requirements."<sup>2</sup> This study (the aforementioned TAEG Report No. 41) was concluded in December 1976.

Based on this effort, the TAEG was requested to perform follow-on work in shiphandling and shiphandling training, focusing on development of the proposed career structured shiphandling training system. This follow-on effort was begun in July 1977 and completed in November 1978.

## PURPOSE

The purpose of the present study was to develop an integrated, career structured training program for shiphandling training based on the concept previously proposed by TAEG. Included in this development was the identification of requisite major training aids/devices and, for any such equipment not currently in the Navy's inventory, the formulation of a functional specification for its design.

Three tasks emerged as critical building blocks in the development of an integrated shiphandling training system:

Task 1. Formulate a career structured shiphandling training unit to the level of detail which will enable preparation of curriculum, lesson guides, and measurement criteria. Existing material should be used where appropriate and resource requirements identified.

Task 2. Develop a functional specification for a full-mission bridge simulator to be employed as an integral part of the training system. A cost and lead time estimate is to be included.

Task 3. Develop a concept design for a new small craft training device to the detail required to prepare a preliminary design. A cost estimate is to be included.

Each of these three tasks is presented in a separate section of this report. A description of the specific methodology used to accomplish each task is provided in the appropriate section.

<sup>2</sup> CNO ltr Serial 991C5/641826 dated 24 June 1976.

## ORGANIZATION OF THE REPORT

In addition to this introductory section, the report includes four sections and four appendices.

Section II presents the concept for the proposed shiphandling training unit. This is followed by section III which formulates the proposed shiphandling training unit extracted from current course offerings in accordance with the concept. Section IV presents a description of the full-mission shiphandling bridge training simulator, and section V describes the proposed small craft training device, both training devices to be used to support the training system.

The appendices provide, successively; a glossary of terms, shiphandling training unit lesson topics, and engineering data requirements for the full-mission bridge simulator and the small craft training device.

SECTION II

SHIPHANDLING TRAINING SYSTEM CONCEPT

There are four stages to the shore-based educational program taught in schools which address shiphandling training. The four programs are designed to provide a career continuum of training from basic to advanced and are furnished at predetermined stages of the officer's career. The four programs are:

- . The Naval Academy, NROTC programs, and Officer Candidate School acquisition programs
- . The Basic Surface Warfare Officer Course at the SWOS, Newport, RI, and Coronado, CA
- . The Department Head Course at the SWOS, Newport, RI
- . The Prospective Commanding Officer Course at the SWOS, Newport, RI.

These programs of instruction are supplemented by fleet courses conducted under the auspices of CINCLANTFLT and CINCPACFLT. Fleet courses are directed toward the correction of specific problems existing at the time and should not be considered as long-range or permanent courses required by all officers. However, in the event these courses do become permanent, or their material included as routine fleet training, some accommodation between them and the four educational programs must be made.

Technological advances, reduced manpower and underway time, specialization, increased administrative loading, and high officer turnover rates have dictated changes to the concept of a commanding officer's function. That position is approaching more a ship's manager than a performer or doer, except under extraordinary circumstances. The Navy has tacitly recognized this functional evolution with the development of courses to train Tactical Action Officers (TAO). Tactical Action Officers provide a coordinating function in that they review, evaluate, and advise commanding officers on the tactical situation as it evolves. Thus, programs designed to develop commanders of operating units, be they independent ships or groups of ships, must include provisions for both training technicians and for educating and training managers.

Examination of the current shiphandling training organization, and the related courses, revealed a separation of effort into three categories: basic, intermediate, and advanced. At the basic level, shiphandling training is still primarily conducted on-the-job by senior officers aboard operational ships. Preparation for on-the-job training is accomplished at one of several officer acquisition programs followed by training at the SWOS. Acquisition programs (i.e., Naval Academy, NROTC, OCS) devote very little time to preparatory training and, in addition, face the additional constraints of resources, weather, and training device availability for skill training. The SWO Basic Course faces similar limitations. Thus, the preparation (proficiency) levels of new officers reporting to sea and on-the-job shiphandling training vary considerably.

Intermediate and advanced shiphandling training at the SWOS is, by contrast, a form of shiphandling "refresher" training.<sup>3</sup> It presumes proficiency in shiphandling even though standardization of the criteria for proficiency (e.g., PQS) has not yet been fully achieved. Supplemental to the SWOS, specialized courses in various elements of shiphandling have been established and are managed by fleet training activities. There is apparently little coordination among schools. No provision for transition training in shiphandling now exists. All schools/courses face resource, weather, and training device constraints similar to those noted above.

The existing educational system recognizes four types of seagoing specialists: the engineer, the operations officer, TAO, and the weapons officer. A common denominator for all specializations among seagoing officers who aspire to command is the requirement to become certified as a qualified OOD(F). Critical to this certification is the ability to maneuver a ship, to avoid in-extremis situations, and to place the weapons system; i.e., the ship, where needed in a fully operable condition. It is obvious that shiphandling, including the knowledge and skills associated with it, becomes a core specialty upon which all other specialties have some degree of dependence.

In view of the criticality of shiphandling to the Navy mission and the costly results of shiphandling errors in terms of money, safety, and operational readiness, this phase of training within the continuum requires special emphasis. Two primary methods of emphasizing shiphandling's special character have been identified: (1) command attention, supported by an overt interest at all levels and (2) raising the professional status of qualified shiphandlers to the equal of technical specialists by formulating a specific unit of training within the education continuum.

The first method, command attention, is beyond the scope of this report and is not addressed. The second method, formulation of a distinct shiphandling training unit, is discussed in the following paragraphs.

#### TRAINING SYSTEM CONCEPT

The earlier TAEG effort (TAEG Report No. 41) developed the concept for an integrated shiphandling training system. A system model was proposed, general course objectives stated, and required training aids and devices identified. This integrated shiphandling training system concept is described in detail in the remainder of this section. The discussion centers on the following: system requirements, sequence of training, instructional unit design, and required student background. A graphic representation of the proposed system is illustrated in figure 1.

SHIPHANDLING TRAINING SYSTEM REQUIREMENTS. The knowledge and skill elements required of a shiphandler do not change with his level of proficiency. The difference in the proficiency levels lies in the depth of capability for handling

<sup>3</sup> A list of applicable terms and their definitions is found in appendix A.



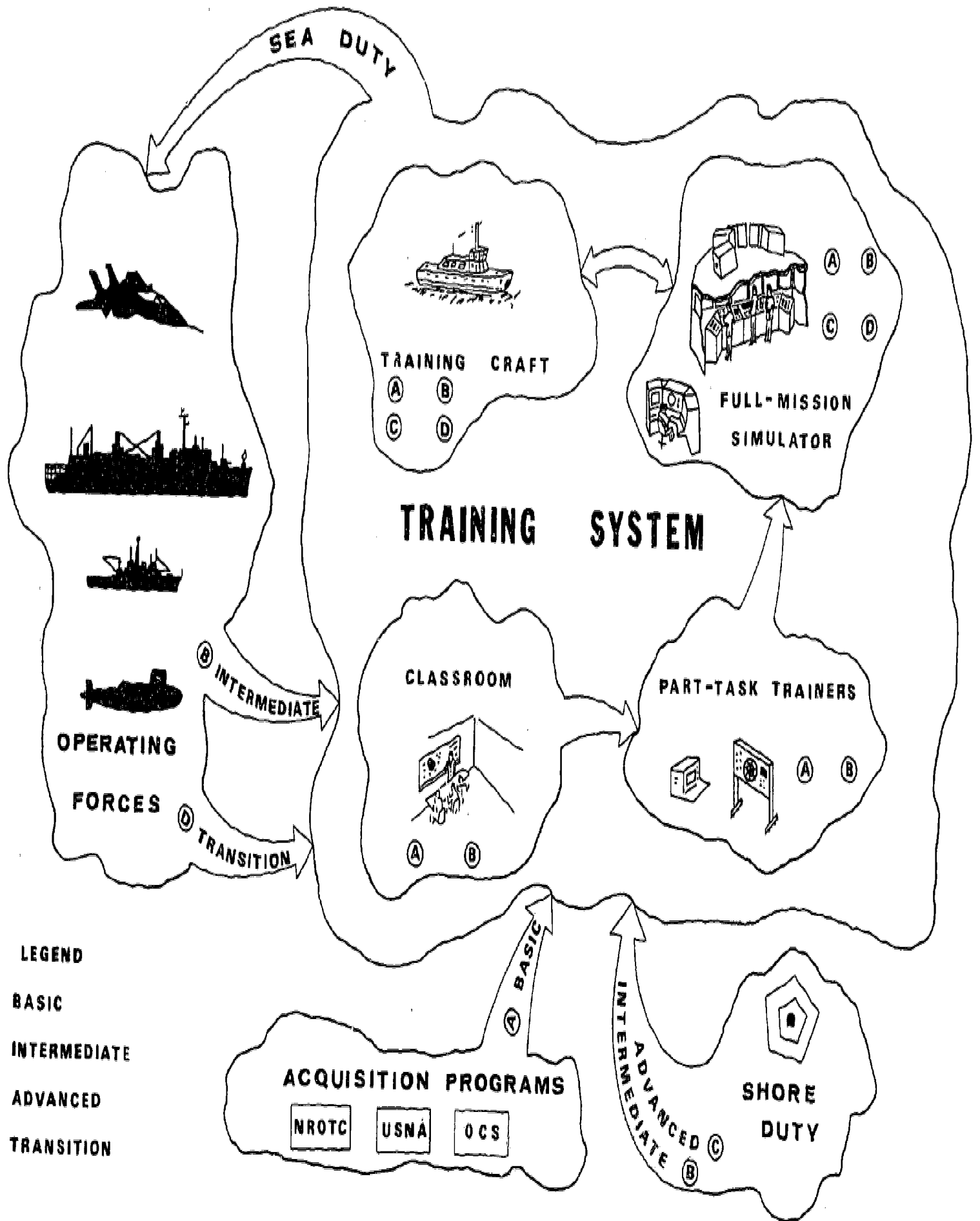

- LEGEND**
- (A) BASIC
  - (B) INTERMEDIATE
  - (C) ADVANCED
  - (D) TRANSITION

FIGURE 1. PROPOSED SHIP HANDLING TRAINING SYSTEM



a ship and in planning. The junior officer (JO) in a basic shiphandling role has a lesser required depth of capability than an officer in the intermediate category, and very few planning functions. He is, therefore, trained only to the level of proficiency necessary to prepare him for on-the-job training prior to proceeding to an operational unit where he will function as a JOOD. Junior officers attend only the Basic Course.

An intermediate category officer will have attained a high degree of competency for shiphandling in routine situations, but he will not have attained the planning and operational capabilities of an officer who has reached the advanced status. Officers in the intermediate category will attend two required shore-based courses to enhance their knowledge and skills. These are the Department Head Course and the PCO/PXO Course.

The PCO/PXO Course serves a dual function. For the prospective executive officer, it will provide advanced training which emphasizes planning as well as complex operations, while for the prospective commanding officer it will serve as a refresher course. Thus, both intermediate and advanced category officers may be in attendance at the course simultaneously. Figure 2 illustrates this shiphandling training progression within the anticipated career progression of an officer who aspires to command at sea.

Officers in the intermediate and advanced categories will have available two additional types of training: refresher and transition. Both are optional, to be made available at the discretion of the Type Commander.

The shiphandling training system must address the decisions and actions of the conning officer in the situation itself and those functions which, if ignored, may cause a conning officer to place a vessel in an in-extremis or dangerous situation. Thus, boundaries of the proposed training system extend to an in-extremis or dangerous situation and include those factors which may contribute to the arrival in that situation.

SHIPHANDLING TRAINING UNIT DESIGN. Required shiphandling training is divided into three distinct types: basic, intermediate, and advanced. Basic training is that which JO's receive prior to being certified as qualified OOD's. There is no facility ashore which can qualify an officer as an OOD. This, and certification, must be done by the officer's commanding officer aboard an operating ship. Therefore, proposed basic shiphandling training requires a resident ashore schooling phase and an operational phase. Intermediate training commences when the officer receives his OOD qualifying letter (certification) and continues through the individual officer's certification as qualified to command by the Command Qualification Board. Two ashore training periods are required during this intermediate phase, although there may be others which are made available on an "as needed" basis. Advanced training consists of refresher and/or transition training. No ashore advanced training school attendance is required.

Instructional Modules. The shiphandling training unit is composed of modules of instruction, each directed to a specific subject area. Every module consists of three submodules, each applicable to a specific required course. The first



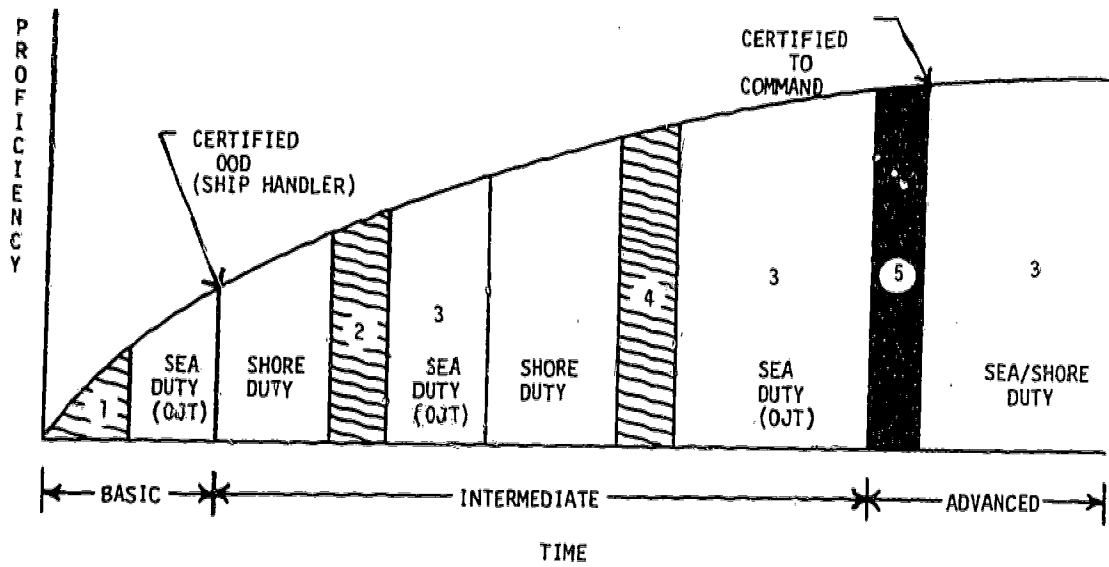

ENTRY LEVEL: OCS OR NROTC OR USNA

- ① Basic Training
- ② Department Head Training
- ③ Transition and/or Refresher Training as Required
- ④ PCO/PXO Training
- ⑤ Command Qualification Board

Figure 2. Career Progression to Command, Typical Surface Naval Officer

submodule will include only that information necessary for an officer in the basic category; the second will encompass all knowledge and skill elements required of a graduate of the Department Head Course; and the third will encompass the PCO/PXO Course. Figure 3 illustrates this concept.

Submodules are built on independent topics within the subject area. The sum of the topics includes all of the information needed by an officer in that subject area. The final breakdown, the bit, is defined as the smallest division of a learning module. It consists of discrete pieces of related information on a specific topic. Course developers should use the bit in the formulation of lesson plans.

In addition to providing training in the identified required knowledge elements, there is a need to integrate the acquired knowledges and skills and to insure each trainee understands the interaction between the individual knowledge elements. Thus, a practice module will be required to perform the function of integration.

As has been indicated in figure 2, there are three required shiphandling ashore schooling periods. Optional refresher and transition training requirements will be satisfied by drawing on the appropriate submodule and extracting specific units or bits of instruction as appropriate.

Course developers should construct each module independently but with an intent towards the future integration of modules. Information contained should be based solely on "need-to-know." No "nice-to-know" information (e.g., historical background) should be incorporated. Appropriate skill training must be an integral part of each topic and bit. After all submodules have been developed, an inspection of the skill training component must be made with the aim of combining those elements which lend themselves to being taught simultaneously. To illustrate, docking drills on a small craft can be used as skill training in several subject areas; e.g., external and internal forces, ground tackle, and navigation and piloting. When individual topics are integrated into a submodule for a given course, scheduling must coordinate this skill training for all modules, thereby reducing overall time necessary to complete the course.

Subject Matter Prioritization. An optimum shiphandling training unit would contain modules about each of the 11 identified learning areas plus a practice module. Time and resource constraints may compromise this optimum configuration. It is necessary to identify those learning areas which must not be allowed to be degraded. A system of priorities was developed which will permit the course developers to place emphasis where it is most needed.

The criteria for shiphandling module prioritization are based on four factors, each of which was assigned a numerical value, which were developed from discussions held with expert shiphandlers. These priority factors are defined as follows:

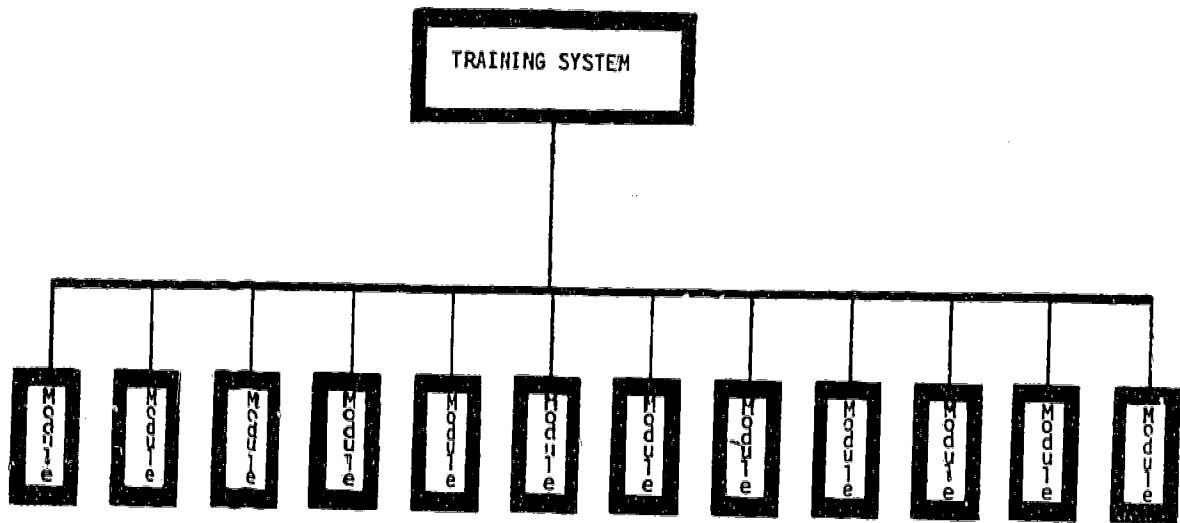

(a)

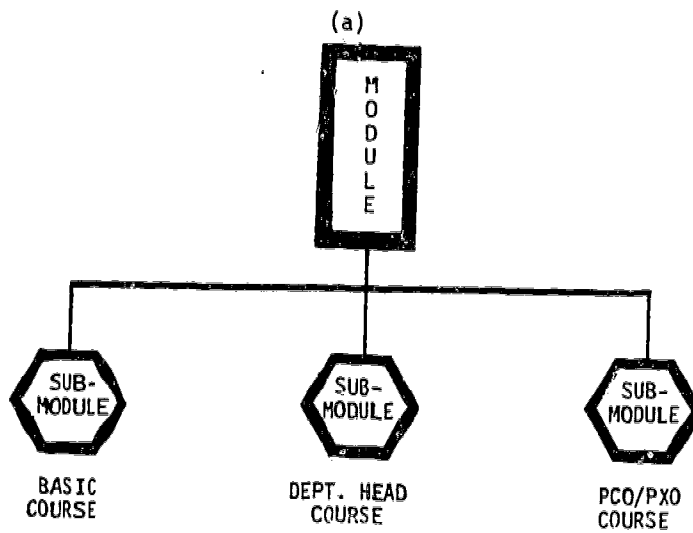

(a)

Figure 3. Proposed Ship Handling Training System Module Concept

- Priority factor 1 consists of those elements identified by over 50 percent of the respondents. A numerical value of 1 was assigned each of these elements. One additional point was added for each 10 percentage points over the base of 50 percent. Maximum point value for this factor is 6.
- Priority factor 2 consists of those elements which required grading on a "go/no-go" basis. Each of these elements was assigned a point value of 4.
- Priority factor 3 consists of those elements identified by all respondents who were senior officer shiphandlers and are now engaged in instructional duties. A point value of 3 was assigned to each of these elements.
- Priority factor 4 consists of those elements which should be directly reinforced in a synthetic setting. Two points were assigned each of these elements.

Table 2 depicts a matrix for prioritizing shiphandling learning modules. A maximum of 15 points is possible for any given module. Seven modules received a score of 7 or better, and these modules are considered to be the absolute minimum to be included in any shiphandling training unit. Each of these modules can be taught in the shore environment.

Unless a given learning module is covered completely, it should not be included in the curriculum at any level of schooling. No attempt should be made to include a module simply to introduce the subject, particularly if this is done at the expense of a higher priority subject. The modules not considered essential to the shiphandling training unit ashore are those which can be omitted with the least negative effects.

Five learning modules received a priority of 8 or less. These modules receive a reduced emphasis in the proposed training unit for two reasons:

1. Time is seriously constrained. A major increase in course time to teach these modules is neither practical nor economical; moreover, it is not prudent to reduce time spent in the classroom on higher priority modules for these subjects.

2. Four of the five modules (Tactical Publications and Thumb Rules, Plan Ahead, Own Ship Team, and Trainer) are exercised in a simulator/training craft by the trainee during normal training and do not require independently scheduled exercises. This exposure should be adequate. The fifth module, Meteorology and Oceanography, can be learned through correspondence courses available outside of the school.

TABLE 2. PRIORITIZATION OF LEARNING MODULES

Learning Module	Priority Factor					
	1	2	3	4	Total	Priority*
Rules of the Road	6	4	0	2	12	1
Relative Motion	5	4	0	2	11	2-3
Practice	6	0	3	2	11	2-3
Navigation and piloting	0	4	3	2	9	4
External and Internal Ship Forces	6	0	0	2	8	5
Ground Tackle	2	0	3	2	7	6-7
Own and Other Ship Characteristics	4	0	3	0	7	6-7
Tactical Publications and Thumb Rules	2	0	0	2	4	8-10
Meteorology and Oceanography	4	0	0	0	4	8-10
Plan Ahead	4	0	0	0	4	8-10
Own Ship Team	2	0	0	0	2	11
Trainer	0	0	0	0	0	12

\*Priority precedence is based on total numerical value. The higher the total value, the higher the priority.

Other Instructional Components. In addition to the courses discussed as required training, two additional, optional courses are included in the system.

1. Transition Training. The purpose of transition training is to provide the officer with explicit knowledge and skills required to perform his ship-handling duties aboard a ship with which he has had no recent experience. As such, it should be designed for administration by the Fleet Training Centers (FTC's). Transition training should require not more than 1 day in the classroom and 2 days in a simulator and/or on a small craft.

2. Refresher Training. There are two types of refresher training: that provided to officers in the intermediate category and that provided to the advanced category of officer. Intermediate category officers should have completed the Department Head Course prior to returning to sea duty for their second and subsequent tours. It is presumed that these officers have not been exposed to the conning situation in a responsible position during the shore

tour. Advanced category officers proceeding to sea from a shore billet may have spent up to 5 years in positions which did not permit them to have an exposure to the conning situation. Both categories of officers can be considered to be below the required level of proficiency in some areas; therefore, refresher training would be designed to raise their competence level in these areas. There is no need to expend resources to train in areas where these officers' capabilities are equal to, or above, a predetermined minimum level. For this reason, a refresher course should be designed to fill the knowledge and skill gaps rather than to present a fixed curriculum. Prior to commencing the schooling, officers proceeding to refresher training should be given a pretest on each of the learning modules in order that areas of weakness can be identified. Appropriate instructional bits can be extracted from each applicable learning module, and individual officers would proceed on a self-paced basis to complete the required study. The practice module would be required of all officers attending refresher training. Practice could be conducted either in a simulator or on a small craft. In the interest of economy, refresher courses should be co-located with the Department Head Course or the PCO/PXO Course.

The second type of refresher training is that provided to PCO's in attendance at the PCO/PXO Course. This course should be taken in its entirety since the advantages to be gained through association and discussion with peers will outweigh the small time saving which may accrue if the shiphandling portion of the course is abbreviated.

Training Unit Support Equipment. Four new devices are proposed. Two of these, a rules of the road and a ground tackle training device, are part-task trainers; the other two, a bridge simulator and new small craft, are full-mission trainers.

1. Rules of the Road Training Device. Rules of the road must be memorized and tested in the classroom. However, the application of the rules, in particular the recognition of situations, and other vessel aspect and lights, requires some additional reinforcement. The proposed rules of the road part-task trainer should be designed as a portable unit which could be used in a classroom or in an auditorium. Its purpose would be to insure that trainees recognize situations and can respond with an appropriate solution to the problem situation. A functional description of this device is contained in appendix I of TAEG Report No. 41.

2. Ground Tackle Training Device. Ground tackle, as used in this study, includes anchors, lines, tugs, and pilots. It is not economically feasible, in the Basic Course, to skill train in the use of ground tackle in operational craft or on the small craft trainer. In the Intermediate Courses, it is not economically feasible to conduct all evolutions with which a conning officer is required to be familiar on the small craft trainer. This proposed ground tackle part-task trainer would serve all required shiphandling courses.

The Ground Tackle Trainer would be designed to have the capability of demonstrating the location of ground tackle; the use of ground tackle in making various types of moors, to include a Mediterranean moor, flying moors, and moors to a buoy; the makeup of tugs; chain use and markings; nomenclature



and terminology; anchoring; and the use of an anchor to retract from the beach. A functional description of this device is contained in appendix I of TAEG Report No. 41.

3. Full-Mission Shiphandling Bridge Simulator. For safety and cost reasons, intermediate and senior categories of Officers cannot experience many of the environments or casualties which occur in an operational situation. There is no existing simulator capable of providing transition training between vessels of widely divergent characteristics.

There is a need to develop a full-mission bridge simulator which will fulfill the requirements for transition training and, at the same time, provide for a smooth, step-by-step capability enhancement for Naval officers as they bridge the gap between classroom and operational craft. The proposed training unit is designed to move from the classroom to part-task trainers to full-mission simulators and finally to operational craft.

4. Small Craft Training Device. The Small Craft Training Device will provide conning training from an actual bridge with a ship and team responding to the conning officer's orders. A small craft is necessary to teach the actual interaction between forces, the teamwork necessary, and to give a "feel" to the shiphandler. At the present time Yp's and utility boats are used. These craft are not satisfactory because of their lack of flexibility, high cost, and single operating mode. A new training device which consists of a less expensive, more effective class of small craft should be acquired. The replacement craft is designed expressly to fulfill the explicit training needs of prospective shiphandlers.

SHIPHANDLING TRAINING SEQUENCE. In every instance shore-based training situations are designed to impart knowledge, teach how the various knowledge elements are integrated, reinforce that which is learned to insure maximum retention, and prepare the student for career enhancing advancement examinations. At no stage of ashore training can the trainee be certified as qualified in any operational evolution, or for any specific ship. These certifications must occur at an operational command and be made by an operational commander.

Acquisition training gives the necessary indoctrination to the Naval service. For shiphandling, the trainee learns terminology, the purpose of the art, and the use of the basic tools. In shiphandling subjects, a foundation is laid for the SWO Basic Course.

During the Basic Course, each student learns the elements of knowledge required of an OOD(F). This is the educational phase of the school. Reinforcement, the interrelationships between the various knowledge elements, and teamwork are taught in a series of training devices commencing with part-task trainers, Rules of the Road devices, Maneuvering Tactical Trainers, and so on. Later, a full-mission simulator and a small craft are used. To insure that all elements are covered to the required depth, the PQS is used as a standard.

Subsequent to the Basic Course, JO's proceed to sea where they stand JOOD watches. The period between graduation and certification as a qualified OOD(F) is the on-the-job training period during which school acquired skills and knowledge are applied. Qualification is granted when the officer has:

- . completed all PQS items, including performance demonstrations
- . exhibited the requisite maturity and judgment required of an OOD(F)
- . demonstrated the capability of handling the ship under varying environmental situations
- . demonstrated a practical ability to perform all functions of an OOD(F) under operational conditions.

Newly qualified officers generally perform during other than routine situations only under the supervision of the commanding officer. It is the most highly qualified, experienced, and mature OOD who has the conn in potentially critical situations.

Intermediate training, that which prepares an officer for the Command Qualification Board, occurs during the Department Head and the PXO Courses. Primarily, the classroom phase deals with planning and technical training, while the shiphandling skill phase addresses more complex maneuvers and multiship operations and permits the student to perform in a training device representing various classes of vessels. The Department Head Course culminates with the officer proceeding to sea as a ship's department head and potential OOD. During this sea phase, the officer can anticipate serving in at least two types of ships with widely divergent operational characteristics. He becomes fully qualified and experienced in handling both high and low powered vessels. This intermediate period is concluded with the passing of the examination for command qualification.

Subsequent advanced schooling ashore is used to develop the managerial capabilities, to enhance skills, and to provide refresher or update training.

**COURSE ENTRY REQUIREMENTS.** In the Basic Course, the student is presumed to be at the level of graduation from the acquisition program. It must be assumed that the lowest entry proficiency level in shiphandling topics forms the base line for that topic in the Basic Course. Since OCS is the acquisition program with the least Naval shiphandling exposure (i.e., no cruises), this has been considered the starting point for shiphandling training for the SWO Basic Course. Most tactical evolutions performed by OCS students are indoctrinary; few real skills are acquired. In terms of knowledge elements, OCS students are introduced in the classroom to navigation, rules of the road, and tactical publications; however, skill training is minimal to nonexistent.

Students in the Department Head Course are certified as OOD(F) prior to assignment. They have received instruction in all of the knowledge elements and have had the opportunity to perform in an operational situation, at least under supervision. This means that in shiphandling they require only refresher



and specialized training. Much refresher training can be given in conjunction with tactical operations training. Consequently, with the exception of instruction in areas which require exceptionally high proficiency (e.g., rules of the road), classroom shiphandling training need not be scheduled. However, to provide specialized training, and to provide for individual ship and ship class differences, practice in a full-mission shiphandling trainer and/or a small craft is required.

Additionally, the Department Head Course provides knowledge element education and skill training needed for passage of the Command Qualification Board examinations. Since only general guidance about the examinations is given in official documents, heavy reliance must be placed on the expertise and experience of instructors. Because students have limited opportunity to practice the performance requirements of the examinations in the operating forces, simulator/small craft exercises in the school environment are necessary.

Prospective commanding officers in attendance at the SWOS are qualified to command. Their training cycle is essentially complete. The primary shiphandling areas for which they require additional training are those related to management of training, refreshing of dormant skills, and the opportunity to become acquainted with the characteristics of the vessel to which they have orders. Thus, as in the Department Head Course, heavy reliance is placed on the full-mission simulator and adaptable small craft.

### SECTION III

#### FORMULATION OF THE SHIPHANDLING TRAINING UNIT

The shiphandling training concept discussed in the preceding section forms the basis for formulation of the shiphandling training unit at the SWOS. The translation of the concept into an operable format is essentially a straightforward technical effort, hence only the course rearrangements and additions are addressed in the following paragraphs. Course content topical information is contained in appendix B.

Acquisition programs provide general orientation and foundation level information, and no change is recommended for the curriculum of any of these programs. Surface Warfare Officer courses, which include shiphandling training as a part of their curricula, were examined at the basic, intermediate, and advanced levels. Topics directly related to shiphandling at each course level were extracted and reorganized to form an integrated shiphandling instructional module that would respond to those shiphandling knowledge elements identified in table 1. Lesson topics which affect shiphandling only peripherally, or which require proficient shiphandling as a supportive feature, were not affected. Remaining course hours for each course can be adjusted to reflect the separation of shiphandling topics; total course hours for all courses remain essentially unchanged. Factors such as instructional priority, sequencing, and student prerequisites have been considered and incorporated into the design.

For each course, using the new instructional module as a base, instructional topics were identified to support the module. These topics are identified in appendix B and should be used in the derivation of individual bits. Development of lesson topics/instructor guides must be the responsibility of shiphandling experts in the field, but it is anticipated that most of the material already in existence will be applicable.

For the purpose of this report, each level and course of instruction is treated independently. It is emphasized that although current instructional material has been used as the basis for this development, the continuous process of review and revision of course curricula may necessitate changes to specific content areas as conditions change.

#### BASIC SHIPHANDLING TRAINING

Basic level shiphandling training begins in officer acquisition programs and terminates, insofar as resident training is concerned, with the first assignment to sea. Acquisition programs do not stress training in shiphandling. However, completion of such a program is a prerequisite to entry into the other basic level training program, the SWO Basic Course.

The current SWO Basic Course consists of 602.5 contact hours offered during 16 weeks (80 training days) at either Newport, Rhode Island, or Coronado, California. Students must be commissioned officers. The mission of this course is "to prepare newly commissioned line officers for junior officer

assignments in surface warfare units and provide a performance oriented foundation for attainment of qualification as surface warfare officers."<sup>4</sup> Initial training in shiphandling and shiphandling related subjects is an integral part of this preparation.

Review of the SWO Basic Course curriculum revealed that 8 of 26 units contained instruction in shiphandling and shiphandling related topics. Table 3 identifies these units, defines the hours and types of instruction (classroom or practice) involved, and depicts the shiphandling knowledge elements to which they apply.

Analysis of the information in table 3 shows that, with the exception of Unit 3, CIC Watch Officer, essentially all training contained in each of these units is applicable to shiphandling. For Unit 3, lesson topics dealing with Radar and Radar Systems are not considered applicable. Thus, the bulk of basic level required shiphandling training can be achieved by combining the units specified. To reformat Unit 3 involves either allowing the non-shiphandling material to stand alone or combining it with similar material in another unit. In this instance, its combination with other units dealing with electronic/electronic-related systems or equipments appears to be the better choice.

All shiphandling knowledge elements, except "trainer," are addressed in the present Basic Course. As the capability to train other officers/team members presumes knowledge and skill (experience) levels not yet acquired by the new officer, this deficiency is not considered sufficient to warrant additional material or the restructuring of existing topics.

Current practice hours included in the Basic Course for shiphandling training are adequate. This practice is accomplished in part-task trainers and small craft. The use of the proposed new simulator and small craft recommended in subsequent sections of this report will enhance the available practice but may require the inclusion of additional practice time. This decision must await the arrival at the school of the new devices.

Specific identification of instructional units to support each module of the basic program in shiphandling are included in appendix B.

#### INTERMEDIATE SHIPHANDLING TRAINING

The period of intermediate shiphandling training occurs between OOD(F) qualification and certification by the Command Qualification Board. Ashore training includes the Department Head Course and the Prospective Executive Officer Course, both offered only at the SWOS, Newport, RI.

SWOS DEPARTMENT HEAD COURSE. This course provides qualified junior officers with the basic skills and knowledge to function as a department head aboard

<sup>4</sup> Curriculum Outline for Surface Warfare Officer Basic Course, A-00-0118, 4 August 1976, p. ii.

TABLE 3 . SWOS BASIC COURSE

UNIT TITLE	CURRENT MODULE (HOURS)				NEW SHIPHANLING MODULE (HOURS)				KNOWLEDGE ELEMENTS AFFECTED											
	Classroom	Practical	Test	Total	Classroom	Practical	Test	Total	Rules of the Road	Relative Motion	Practice	Navigation & Piloting	Ext./Int. Forces	Ground Tackle	Ship's Characteristics	Tac. Pubs & Thumb Rules	Meteorology/Oceanog.	Planning	Own Ship's Team	Trainer
1. Maneuvering Board and Tactics	11.5	3.5	1.5	16.5	11.5	3.5	1.5	16.5		X	X					X		X		
2. JOOD/Special Evolutions	18.5	0	1.5	20.0	16.5	0	1.5	18.0		X		X	X	X	X	X			X	
3. CIC Watch Officer	17.5	2.0	1.5	21.0	4.0	2.0	0	6.0				X			X				X	
5. Rules of the Road	8.0	0	1.5	9.5	8.0	0	1.5	9.5	X											
6. Navigation	14.5	4.0	3.5	22.0	14.5	4.0	3.5	22.0			X	X			X				X	
24. Underway Training	1.0	36.0	4.0	41.0	1.0	36.0	4.0	41.0	X	X	X	X	X	X	X	X			X	
25. 20A61 Tactical Trainer	3.0	28.0	12.0	43.0	3.0	28.0	12.0	43.0	X	X	X	X			X		X		X	
26. Shiphandling Tank	0	4.0	0	4.0	0	4.0	0	4.0			X		X		X					
TOTALS	74.0	77.5	25.5	177.0	58.5	77.5	24.0	160.0												

TAEG Report No. 65

25



ship. Nine hundred and sixty-seven contact hours in a core curriculum, plus additional training in specialty areas, are provided during a 28-week period. Incoming students, selected through a screening process, must have completed 18 months of at-sea training and be SWO qualified, which includes OOD(F).

Satisfaction of these prerequisites presumes a basic knowledge of ship-handling elements and a reasonable skill level in their application. Accordingly, shiphandling topics are now subsumed under other areas of instruction in the Department Head Course. Table 4 identifies current units which include shiphandling topics by hours and indicates their application to the list of knowledge elements shown in table 1.

Analysis of the data contained in table 4 reveals the following:

- . Units 6 (Navigation) and 36 (Fleet Support Operations) can be applied to shiphandling in toto. Each of these units contains 4 hours of identified underway time. The shiphandling instructional package is built around these two existing units.
- . Unit 2 (Combat Information Center) includes 4 identified hours of underway training which, for the most part, can be applied to shiphandling. In classroom study, 2 hours of NC2/DRT work and 2 hours of maneuvering board practice are also applicable to shiphandling training. Remaining unit material can stand by itself, or be restructured and included with other units.
- . Unit 7 (Tactical Maneuvering and Screening) contains 2 hours of shiphandling model ship tank training time, which can be removed from this unit without difficulty.
- . Units 5 (Operational Reporting), 41 (Personnel Administration and Training), and 43 (Stability and Damage Assessment) contain 1 hour of shiphandling related topic material each. Lesson topics 5.5 (U.S. - U.S.S.R. Incidents-at-Sea Agreement), 41.12 (Shipboard Training), and 43.5 (Special Problems in Stability) can be removed from their respective units without measurably affecting the remaining material.

The relatively small amount of shiphandling specific training contained in this curriculum is not surprising. Classroom training at this level is, in essence, a review to refresh students' knowledge. Skill practice periods may also serve as refresher training or training to provide insight into relatively rare shiphandling evolutions. Moreover, other units, such as Unit 19 (Trainer, ASW), provide practice in shiphandling skills as an integral part of their instruction. However, because of emphasis on other areas of learning (in the case of Unit 19 such learning has to do with ASW tactics) and because of the entry prerequisites that imply skill possession to this level, it is not included as a part of the shiphandling training package.

The Department Head Course provides students with "underway" training time. By use of small craft, when available, and visits/deployments to operational units, students have an opportunity to practice skills and apply

TABLE 4. SWOS DEPARTMENT HEAD COURSE

UNIT TITLE	CURRENT MODULE (HOURS)				NEW SHIPHANDLING MODULE (HOURS)				KNOWLEDGE ELEMENTS AFFECTED											
	Classroom	Practical	Test	Total	Classroom	Practical	Test	Total	Rules of the Road	Relative Motion	Practice	Navigation & Piloting	Ext./Int. Forces	Ground Tackle	Ship's Characteristics	Tac. Pubs & Thumb Rules	Meteorology/Oceanog.	Planning	Dwn Ship's Team	Trainer
2. CIC	14.0	6.0	0	20.0	2.0	6.0	0	8.0		X	X	X			X		X	X		
5. Operational Reporting	24.0	20.0	0	44.0	1.0	0	0	1.0	X								X			
6. Navigation	4.0	44.0	0	48.0	4.0	44.0	0	48.0			X	X				X	X	X		
7. Tactical Maneuvering & Screening	6.0	4.0	0	10.0	0	2.0	0	2.0		X	X	X	X	X						
36. Fleet Support Operations	15.0	4.0	0	19.0	15.0	4.0	0	19.0		X		X	X	X	X		X	X		
41. Personnel Admin./ Training	18.0	0	0	18.0	1.0	0	0	1.0											X	
43. Stability/Damage Assessment	32.0	21.0	4.0	57.0	1.0	0	0	1.0				X	X	X						
TOTALS	113.0	99.0	4.0	216.0	24.0	56.0	0	80.0												



knowledge in an operational environment. From the shiphandling perspective, however, not all of these evolutions contain even indirect application to the shiphandling function; their primary focus is on other areas. Thus, although approximately 200 curriculum hours are specified as underway training, only 56 are associated with the technical specialty "shiphandling." The remainder are directly related to the other technical specialties.

As was previously stated, the total curriculum includes 967 core hours plus specialty training time. Eighty of these hours are allotted to shiphandling related topics. These are identified in table 4. Forty hours are devoted to a navigation practical exercise which is performed ashore. Of the remaining 40 hours, 24 are classroom. This leaves 16 hours; 2 are spent in the ship model tank and an additional 4 hours may be in the tank. The existing curriculum identifies the residual 10 hours as 6 to be spent in CIC and 4 in navigation-related positions. No time is firmly scheduled in the curriculum for the trainees to function as conning officers underway.

It is strongly recommended that underway conning time in the Department Head Course be firmly scheduled. The minimum hours per trainee will vary with the level of experience and demonstrated capability. This time could be spent in either a full-mission simulator or underway training craft or some combination thereof. Preferably, underway conning experiences would occur shortly before graduation; i.e., in the final 2 weeks of the course.

SWOS PROSPECTIVE EXECUTIVE OFFICER TRAINING. The second intermediate ashore training course occurs when prospective executive officers attend the 6-week PCO Course at Newport, RI. This course provides "an improved concept in controlling and evaluating the performance of (the) ship...directed toward the 'coordinated employment' of a ship's capabilities."<sup>5</sup> It is available to PXO's as intermediate training, and PCO's for refresher training. In addition to satisfying selection requirements via a screening process, students must have taken, or be scheduled to take, the Human Resources Management Course. Shiphandling prerequisites are assumed to have been completed. This is the final required course in the training continuum and concentrates less on procedures than on the integration and management of all factors that affect a ship's operation. Any shiphandling training is almost totally refresher, or specific training and practice needed to transition to a new (to the individual) type of vessel.

In specific terms, only Unit I (Navigation and Seamanship) involves direct shiphandling related topical material. Table 5 shows this instruction in hours and the applicability of this unit to the shiphandling elements previously defined.

All shiphandling elements are addressed during Unit I. However, only 8 hours of underway training are identified and this may be insufficient time for adequate conning practice, particularly if the officer is transitioning to a new (to him) class/type ship. Additional practice time would require the use of full-mission simulators and/or small craft.

<sup>5</sup> Curriculum Outline for Surface Warfare Officer Advanced Course - Command, A-00-0111, 15 January 1976, p. viii.

TABLE 5. SWS PCD/PXO COURSE

UNIT TITLE	CURRENT MODULE (HOURS)				NEW SHIPHANDLING MODULE (HOURS)				KNOWLEDGE ELEMENTS AFFECTED											
	Classroom	Practical	Test	Total	Classroom	Practical	Test	Total	Rules of the Road	Relative Motion	Practice	Navigation & Piloting	Ext./Int. Forces	Ground Tackle	Ship's Characteristics	Tac. Pubs & Thumb Rules	Meteorology/Oceanog.	Planning	Own Ship's Team	Trainer
	Unit 1 NAVIGATION & SEAMANSHIP																			
N-1 Navigation & Command	7.0	3.0	0	10.0	7.0	3.0	0	10.0	X	X	X	X			X			X	X	X
N-2 General Seamanship	5.0	8.0	0	13.0	5.0	8.0	0	13.0		X		X	X	X	X	X		X		
TOTALS	12.0	11.0	0	23.0	12.0	11.0	0	23.0												

The scheduled 8 hours underway time is probably adequate for officers who have extensive surface ship operating time, provided these officers have a full 8 hours each in a command position. Officers with little recent surface ship experience will probably require additional conning time in order that their confidence level and skill level can be raised to equate to their peer group of ship commanding officers. It is recommended that conning times range from 8 hours for officers with recent experience to as much as 24 hours of additional conning time for officers who have not served aboard a surface vessel in the past 5 years. Specific time requirements will vary with experience and capability.

The constraint of time for training is recognized. However, when one considers the responsibilities of commanding officers and the heavy reliance placed on them in terms of operational commitments, this additional time may be an essential investment. Lead times for reporting dates must be kept flexible; PCO's and PXO's need the full practice time to complete their underway training.

ADVANCED SHIPHANDLING TRAINING

In the proposed shiphandling training continuum, advanced training is refresher or transition. No new knowledge concerning shiphandling is provided. Additional practice is specifically directed to those areas in which the trainee feels he needs assistance, or has, through testing, demonstrated a weakness.

In terms of course development, no additional effort beyond the PCO Course is required. Completion of Command at Sea Qualifications implies expertise in shiphandling; however, assuming assignment to a new type ship, some transition training; i.e., practice in handling a ship with different characteristics from those previously maneuvered, is appropriate. This practice is accomplished utilizing a full-mission simulator or small craft.

Some sort of shiphandling "pretest" evaluation should be made a part of entry into the advanced courses, particularly for prospective commanding officers attending the PCO Course. It should not be necessary for a prospective commanding officer to repeat course subject matter previously learned during an earlier tour, as prospective executive officer attending the same course, if he has retained the material. This use of a pretest of subject matter could eliminate some classroom time thereby providing added time for practice in the conning capacity.

IMPLEMENTATION OF THE PROPOSED SHIPHANDLING TRAINING UNIT

To implement the proposed shiphandling training unit requires no major development effort. Some reorganization of current units and lesson topics is required in the Basic and Department Head Courses to separate and identify shiphandling as an independent module of study which equates to a technical specialty.



At the basic level, identified current topics should be grouped together into a single "Shiphandling" training package of 160 hours consisting of both classroom and practical training. Table 3 identifies the proposed module as containing 58.5 hours of classroom time, 77.5 hours of practice, and 24 hours devoted to testing. Using the identified lesson topics from table 3 as a guide, experts should review material for completeness and sequence topic presentations in the most convenient manner. The practical training identified as necessary must be formally described, using specific learning objectives which are to be acquired aboard small craft or through simulator training, and sequenced. This formal description will permit easier integration of practical training and classroom training objectives.

For the Department Head Course, similar minor reorganization is necessary. A relatively short shiphandling unit will result, but the identification of it as distinct training will support recognition of its importance. As can be seen in table 4, the new module will consist of 80 hours, 24 in the classroom and 56 practical application (40 of which are the take-home navigation practical). There is needed some scheduled, mandatory underway conning time in addition to the 56 hours practical application. Consideration should be given to the institution of night practice or off-hours training in a full-mission simulator or aboard a training craft.

No curriculum changes to Unit I of the PCO/PX0 Course are required; however, the addition of "Shiphandling" to the current unit title would emphasize the importance of the subject. Providing additional hours for practice/transition training should be considered. Initially additional hours would vary from 8 to 24 depending on the prior experience and proficiency of the student. For PCO's the provision of small craft or a full-mission simulator for training purposes on an individual basis, during off-hours, might be the solution to the proposed additional training hours.

The timing of the changes recommended at all levels should be at the discretion of the schools. Normal reorganization and/or revision of curricula take place at regular intervals, and it is logical to incorporate changes such as those proposed for shiphandling during those periods. However, the need for emphasis in shiphandling training will continue to be important, and implementation should not be postponed for a significant period of time.

Acquisition of the Full-Mission Bridge Simulator and new small craft training device should proceed in parallel with the proposed course reorganization. As these training devices become available, they should be incorporated in the curriculum. Until such time as they are available, the shiphandling training curriculum can incorporate existing devices. All recommended additional practice time should be scheduled on the existing small craft until such time as a full-mission simulator is acquired.

SECTION IV

PROPOSED FULL-MISSION SHIPHANDLING BRIDGE SIMULATOR

Existing simulation equipment is designed to provide training in the area of tactical operations with shiphandling being relegated to a secondary consideration. The reason for this is that existing simulators range from limited to no visual capability. They were designed with CIC, rather than the bridge, as the focus of training. They serve well as part-task shiphandling trainers.

This section addresses the full-mission shiphandling bridge simulator. The proposed small craft is discussed in section V of this report.

The proposed shiphandling training system, when incorporated in the SWOS training, and refresher training demand a scope of simulation of operational missions not now available. By definition, shiphandling evolutions primarily depend on information derived from the visual rather than the electronic scene. At the same time, effective training requires the conning officer to perform mission scenarios in a variety of environments and in craft with widely divergent operating characteristics. No such training capability currently exists. The simulator proposed in this section will provide that training capability.

An additional capability provided by this full-mission simulator is to reproduce incidents which developed into accidents or near accidents. Should the simulator be used for this purpose, on a "not-to-interfere-with-training" basis, the Navy will be able to identify and analyze incident cause with greater objectivity. Records of incident cause will produce trends and assist in the identification of training shortfalls. Training programs can be created and/or modified to correct the identified problem area.

APPROACH

Existing training was examined at the two SWOS's; Amphibious Base, Little Creek; FTC, San Diego; U.S. Coast Guard Officer Candidate School, Yorktown; Southampton School of Navigation, Warsash, U.K.; and Marine Safety International, Long Island. In addition, extended discussions were held with qualified Naval Surface Warfare Officers and merchant marine masters in order to establish how best to support the proposed shiphandling curriculum. The investigations revealed that no existing trainer was capable of providing the requisite training environments. Typical limitations included (1) a lack of daylight visual capability, (2) a lack of the necessary flexibility to provide a free-play mission, (3) the failure to coordinate visual with electronic simulations, (4) the inability to vary own ship operating characteristics, (5) a lack of visual resolution, particularly of objects close to own ship, and (6) the inability to perform many of the required operational missions.

The Computer Aided Operations Research Facility (CAORF), Kings Point, NY, was visited to study their ship bridge simulator in operation. The CAORF simulator incorporates many of the requisite environment features and has the

capability to include others. However, this device was designed as a research tool and has a number of features not required in a Naval shiphandling trainer.

As a result of these visits and discussions, the following minimum features were determined as required in a shiphandling training simulator:

- . two bridges which are capable of operating either independently or dependently
- . a limited CIC capability associated with each bridge
- . a coordinated visual-electronic capability which permits a comparison of visual bearings with electronic bearings
- . a changeable harbor and beach operating area capability in addition to open sea
- . multiple target ships (aircraft are not required)
- . the capability of approaching target vessels, docks, buoys, etc., to within 30 feet (goal)
- . variable environment to include light/dark, rain, fog, wind, sea, current, and bottom and bank effects
- . variable own ship operating characteristics
- . expansion capability for future design ships
- . real time simulation.

#### FUNCTIONAL SPECIFICATIONS

DEVICE CHARACTERISTICS. The minimum required capabilities were incorporated in a Functional Specification for a Full-Mission Shiphandling Bridge Simulator (see appendix C). The essential elements of the simulator complex are as follows:

- . two bridge mockups
- . one CIC and one chart house linked to each bridge
- . one problem control room
- . one computer complex
- . a visual system for and cylindrical screen surrounding each bridge
- . a small auditorium
- . space for two additional bridges with attendant CIC and chart house.

1. Bridge Mockups. No specific class bridge will be duplicated. Operating equipment on the bridge will be limited to those controls and displays associated with ship control, tactical maneuvering, and navigation functions. Repeaters, displays, and controls associated with other systems; i.e., sonar, weapons, etc., will be inoperative, stylized mockups. Motion is not required.
2. CIC and Chart House. Operative equipment in CIC will, as on the bridge, be limited to ship control, tactical maneuvering, and navigation functions. No equipment associated with other systems will be required. The chart house has the sole function of providing space for chart storage, electronic navigation, and piloting. No celestial navigation equipment is required.
3. Bridge Wings. The two bridge wings are to be identical. A conning and remote, plug-in, propulsion control capability will be operable.
4. Problem Control. There is to be an instructor's console for each bridge which has the capability of problem setup and control. In addition, the console will have the capability of activating diagnostic test programs and the built in test equipment (BITE). The two consoles will each have the capability of controlling both bridges when they are in a dependent mode, or operating independently.
5. Computer Complex. The computer complex is to be distinct from problem control and will be designed to serve the entire complex. It will contain the necessary computers, interface, signal conversion units, D/S and S/D converters, power supplies, and peripheral equipment.
6. Visual System. The visual system will require a minimum of  $270^{\circ}$  in the horizontal plane ( $360^{\circ}$  goal) and from  $-30^{\circ}$  to  $+15^{\circ}$  in the vertical plane. Color is required. Computer generated imagery is needed and oil film projectors are to be avoided if possible.
7. Auditorium. A space for approximately 25 persons is required for briefing/debriefing and for exercise observers. A projection of the gaming area is to be available.
8. Add-on Capability. The entire complex will be housed in a building designed for that purpose. In the design of the building space, capacity must be made available for the future addition of two additional bridges.

#### INTEGRATED LOGISTIC SUPPORT (ILS) CONSIDERATIONS.

1. Maintenance. Both organizational and intermediate maintenance will be performed onsite. Wherever possible, the device will be designed for modular replacement of elements, whether electrical, electronic, or mechanical. Modular repair will be accomplished as a part of intermediate maintenance. The device will be assigned Navy Material Cognizance Symbol 20 upon acceptance.

2. Personnel. It is proposed that Navy personnel be utilized as operators and Navy civilian personnel as maintainers of the device. In order that the simulator be available 16 hours per day for training and 8 hours for maintenance, the following numbers are proposed:

<u>POSITION</u>	<u>NUMBER</u>	<u>RANK/RATE</u>	<u>QUALIFICATIONS</u>
OIC, Simulator	1	LCDR/LT	SWO
Deputy OIC, Simulator	1	LT	SWO
Instructors	4	LT/LTJG	SWO
Operator Supervisor	3	LT	SWO
Operators	10	QM3/OS3	"A" School
Maintenance Supervisor	1	Senior Technician	TBD
Ass't Maint Supervisor	1	Senior Technician	TBD
Duty Technicians	6	Technicians	TBD
Clerk Typist	2	GS 3/4	TBD

3. Training. Simulator operators and course instructors require identical training on the device. Experience indicates that this training will consist of approximately 2 weeks onsite. The course will be prepared and presented by contractor personnel approximately 8 weeks prior to the Ready for Training (RFT) date.

Maintenance training will be two-phased, the first dealing with the computer and related peripheral equipment, programming, and diagnostic routines. Phase I maintenance training will be scheduled by the contractor and will probably occur at the computer manufacturer's facilities. The first 2 weeks of phase II training will be the operator's course and will be attended by all personnel assigned to the simulator. The subsequent 6 weeks portion of the course will be attended only by the maintenance personnel and/or the OIC and Deputy OIC of the simulator.

4. Documentation. Approved preliminary copies of all documents will be required at least 30 days prior to commencement of maintenance training.

EVALUATION. A Fleet Project Team will participate as advisors during the entire procurement cycle. An Operational Test and Evaluation (OTE) and Development Test and Evaluation (DTE) will be required.

RISK. With the exception of the visual system, there are no high or moderate technical risk areas. The proposed CGI, own ship simulation, environmental simulation, computer systems and interfaces are in existence in numerous flight simulators and at CAORF. All basic programs which will be required have been in use at CAORF. The dynamic coefficients of the majority of Naval



vessels to be simulated are available at David Taylor Naval Ship Research and Development Center (DTNSRDC).

The visual system is considered to be a moderate to high risk area for the following reasons:

- . A search of existing literature revealed that the goal of 30 feet visual distance between objects; i.e., own ship and dock or pier, may not be satisfactorily achieved with existing state-of-the-art equipment because of visual scene resolution limitations at this distance.
- . The oil film projectors in use at CAORF, the prime candidate for the simulator, may prove unsatisfactory in their present configuration. They are costly, very large and heavy, require sensitive alignment, generate large amounts of heat, and are very difficult to maintain.
- . The existing oil film projections may not have sufficient resolution close in, that is, within 100 feet.

The optimum approach for investigating resolution adequacy is to conduct engineering evaluations of existing equipment such as CAORF. Should an engineering evaluation not be possible, then a research study should be initiated to examine available projection systems for a substitute for the oil film projectors. Should another system not be readily available, alternative approaches are discussed under Option Selection Rationale.

OPTION SELECTION RATIONALE. Preliminary trade-off analyses were made in five areas. The recommended solution to four problems is incorporated in the Functional Specification for a Full-Mission Bridge Simulator (see appendix C). The fifth option requires engineering studies prior to resolution.

1. Visual System Projectors. Visual system projectors were considered a serious problem because of the risks associated with oil film projectors. No readily available substitutes could be located which satisfy all technical requirements. The trade-off was a research study. If this proved to be unproductive, then the oil film projector should be used on the initial version. Use of these projectors would probably preclude docking drills, but all other training evolutions, including underway replenishment and mooring to a buoy, could be performed. Docking drills could be held in the training craft as a substitute to the simulator.

2. Visual Scene Generation. Alternative methods of generating the visual scene were examined. No system, other than Computer Generated Imagery (CGI) offered an acceptable method of meeting the dynamic, free-play requirements of the simulator.

3. Software. Software is both expensive and time consuming to develop. In lieu of original development of programs for own ship, the software used



by CAORF, a U.S. Government Agency, could be acquired. The specific coefficients needed for various U.S. Navy type ships can be obtained from DTNSRDC.

4. Simulator Maintenance. Two primary options are available for long-term operation and maintenance of the simulator.

- . Option 1, utilize Navy personnel as both operators and maintainers.
- . Option 2, utilize Navy personnel as operators and Navy civilian field representatives as maintainers.

Option 2 is the recommended procedure for the following reasons:

- . Instructors and selected bridge enlisted personnel will operate the simulator thereby developing a group of highly qualified, trained shiphandling specialists within the Navy who are capable of representing the Navy's point of view.
- . With Naval officers, there is a higher degree of instructor acceptability by trainees, particularly senior officers.
- . Naval officer operators have a familiarity with the problems and situations faced by conning officers under operating conditions.
- . In the maintenance area, the use of Navy civilians offers a higher probability of continuity.
- . Specialization of maintenance personnel is practical. Navy personnel, for career reasons, must maintain a broad base of technical expertise, whereas civilian field representatives can concentrate in specific areas. The number of technical, highly complex interrelated systems; i.e., visual, electronic, computer, and mechanical, will require a wide diversity of Navy ratings and a continuous maintenance training program for reliefs. Individual field technicians can be trained across all systems and can provide relief training only when, and as, needed.
- . A fewer number of maintenance personnel will be required with civilian field representatives because of the anticipated continuity and specialization.

5. Computer Selection. The fifth option selection has been left for the performance specification developer. For reasons of flexibility, add-on capability, and continued training capability in the event of a casualty, a multiple computer configuration is planned. However, should the mean time between failure be high and the mean time to repair be low, it may be cost effective to design the simulator around a one computer complex. This analysis must consider the redundancy available in a multiple computer configuration.

COST. A substantial capital investment is contemplated with the proposed Bridge Simulator. A single, unqualified budget submission made to cover this outlay is fraught with risk. Because of the technical complexity of the simulator and the high variability of cost of material and labor, there is a good likelihood of underestimation with the consequence of having to request additional or supplemental funding at some future date. In order to account for these variables, the Acquisition Cost Estimating Using Simulation (ACES) technique was used to estimate the simulator cost (see TAFEG Technical Memorandum 75-4 dated September 1975).

1. Acquisition Cost Estimating Using Simulation Technique. The first step in the use of ACES is the identification of major subsystems and components. Upon completion of this task, the model user must determine the most efficient technical approach for each subsystem. Utilizing standard cost estimating methodology, estimates must be made for effort (in man-hours) and material cost (in dollars). Current rates (engineering and manufacturing labor, overhead, G&A, and profit) are entered into the model and are applied in the proper sequence to the labor and material estimates. The model has the flexibility of utilizing detailed cost components or composite "bottom line" costs. Probabilities are then assigned according to the likelihood of that cost actually occurring. Independently, subsystem costs are selected according to their probabilities of occurrence. An estimate for the total system is thus obtained for one possible configuration or set of approaches. This sequence is repeated and the results from each run are collected and aggregated. In this instance, the sequence cost calculations were repeated 10,000 times in order that an accurate picture of the possible range would be available. The outputs may be given in tabular, histogram, and/or curve formats.

2. Estimation Procedures. The most critical factor in performing estimations is the identification of major subsystems of the device and other cost modules which can be estimated independently. There are 14 engineering development subsystems, 1 engineering data cost module, and 5 cost modules in the ILS package. Thus, a total of 20 primary cost elements were identified for the simulator. Each module was estimated independently using a 4-point probability distribution for the various elements comprising the module.

Procurement component costs were grouped into five major cost categories, the first encompassed manufacturing, the second engineering, the third material, the fourth engineering data, and the fifth, ILS. For each major component cost category the mean cost and standard deviation were calculated. The results of these calculations are displayed in table 6. This table summarizes the major procurement component costs and identifies potential cost risk areas.<sup>6</sup>

<sup>6</sup> A detailed computer analysis using a 4-point estimation procedure and the assignment of likely probabilities was made. This resulted in an estimation of Engineering Labor, Manufacturing Labor, Material, and total submodule costs for each of the 20 primary cost elements. In addition, the cost range and range probability for each of the five procurement component costs depicted in table 6 were derived. The detailed cost computations for each of the 20 primary cost elements is available in TAFEG. It can be requested by authorized personnel through CNET.

TABLE 6. PROJECTED COMPONENT PROCUREMENT COST FOR FULL-MISSION SHIPHANDLING SIMULATOR (TWO BRIDGE CONFIGURATION)

ITEM						
COST DESCRIPTION	MANUFACTURING	ENGINEERING	MATERIAL	ENGINEERING DATA	INTEGRATED LOGISTICS SUPPORT	TOTAL COMPONENT COSTS
DOLLARS (000) (MEAN)	1000	2400	3900	200	1200	8700
STANDARD DEVIATION (000)	30	90	390	30	40	NA
COMPONENT COST RISK INDICATOR  (% STANDARD DEVIATION VARIES FROM MEAN)	3%	4%	10%	15%	3%	NA

NOTE: Figures have been rounded.

3. Cost Estimate.

a. Assumptions. The cost estimate is based on the following assumptions:

- The basic configuration and performance capabilities of the bridge simulator will be as set forth in the functional specification (appendix C).
- There will be a 360° field of view.
- There will be 2 man-years of field support over a 1-year period.
- The estimates are based on simulating the characteristics of eight ship classes for each bridge.
- The image display system will use oil film projectors.
- Building to house the device is not now in existence. It will be constructed on Navy-owned land and will include two bridges.
- The building will be adequately equipped with all facilities to support the simulator.
- November 1978 labor rates, costs, and overhead, as promulgated by the Procurement Contract Office, Naval Training Equipment Center, are valid. No escalation factors have been applied.

b. Simulator Cost. Using the numbers developed in computing the procurement component costs, an additional computer run was made to develop, independently, the composite mean and standard deviation for the simulator. This composite is shown in figure 4. This figure depicts the relative frequency with which the Navy can expect bids from potential contractors to fall within a predetermined cost range.

In addition to the histogram, a curve, figure 5, was produced which predicted the cumulative probability of any given cost occurring.

Based on the estimation procedures described, TAEG predicts the Bridge Simulator cost will range between \$8.3 million and \$9.1 million, with a mean cost of \$8.7 million. Maximum and minimum costs are based on a deviation from the mean of  $\pm 1$  standard deviation.

c. MILCON Costs. The building to house the two-bridge device will be new construction; therefore, MILCON funding is required. The Training Analysis and Evaluation Group estimates the building can be acquired for \$750,000 to \$850,000 with no escalation factors applied. Building costs include the shell, internal wiring, air conditioning and heating, and interior finish. This estimate was based on the criteria for operational trainer

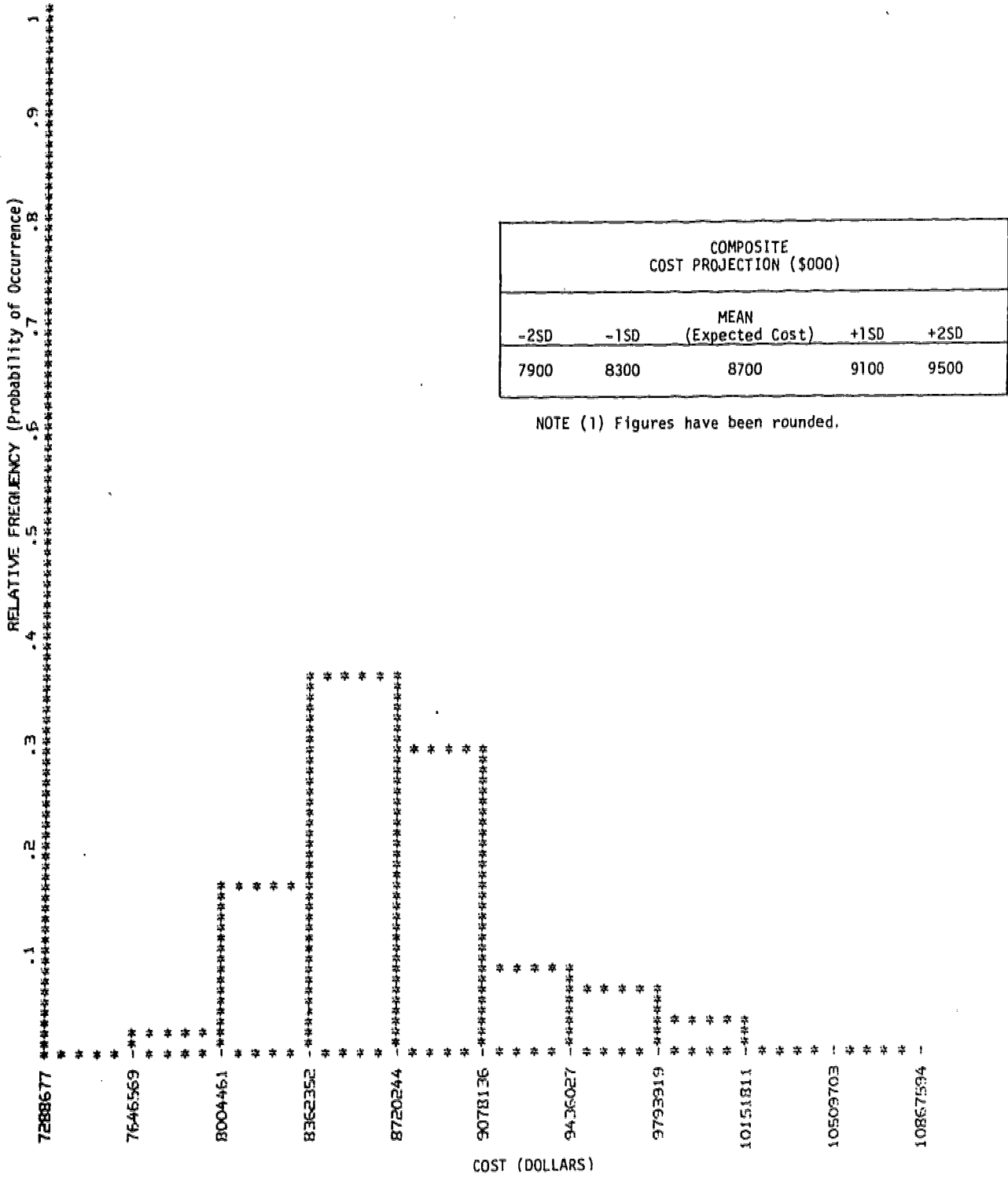

Figure 4. Relative Frequency vs. Cost

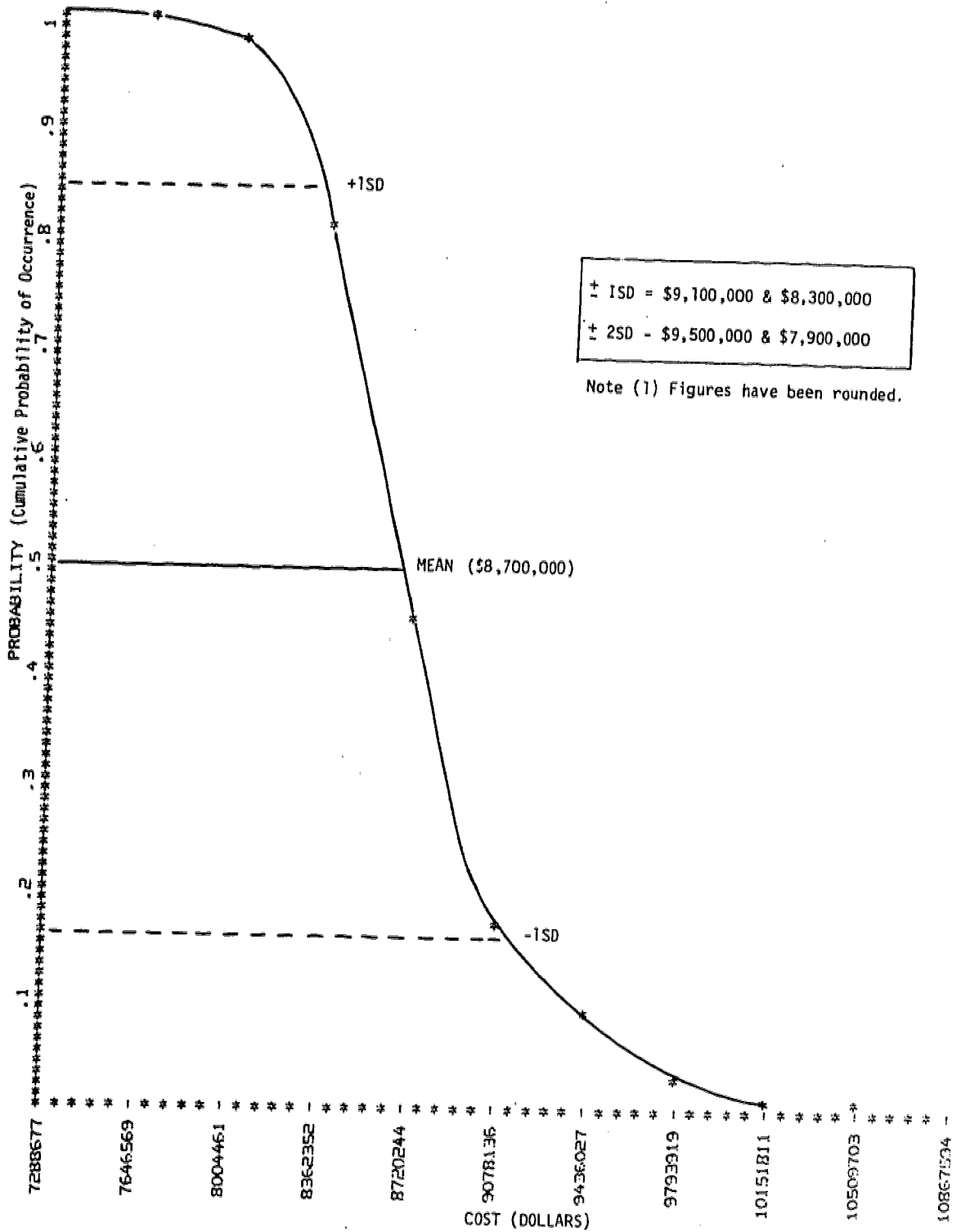

Figure 5. Probability vs. Cost



facilities, category Code 171-35, as specified in NAVFAC P-80, Facility Planning Factor Criteria For Navy and Marine Corps Shore Installations, Volumes I and II.

#### CONSIDERATIONS.

1. Cost of the initial simulator includes many one-time items. The following modules will not be required, or will be greatly reduced in cost for follow-on units.

- . liaison and data gathering
- . system engineering
- . operational test and evaluation
- . engineering data
- . maintainability
- . technical services
- . technical publications
- . provisioning
- . training course.

Based on this rationale, it is estimated that follow-on units of the device can be acquired for approximately \$5 million. MILCON funds will be needed.

2. In the event consideration is given to a single-bridge simulator, the cost would be approximately \$6.9 million. However, should the decision to construct a single-bridge simulator be made, the following disadvantages accrue:

- . Student load is such that the device will be overloaded at acceptance.
- . Many training evolutions which require intership cooperation will not be available.
- . Historically, the cost of an add-on greatly exceeds the cost if this capability is included in the initial buy.

3. Should it be considered that only one bridge is required in the simulator, MILCON funds in the amount of \$650,000 would be required.

It is, generally, more cost effective to construct the total building at once rather than to add to an existing building. Should a four-bridge configuration be considered, it would be less costly to contract for a building suitable

for the four bridges now rather than considering a building suitable for only two bridges now with the intent of increasing building size later. It is estimated that a building suitable for four bridges would cost \$1 million. The four bridge building calls for a 57 percent increase in floor space. This could be obtained for a cost increase of 34 percent over the two bridge building. Although no estimates for future year construction were made, historically this would be a major cost avoidance.

4. It is noteworthy that the module of greatest cost, Image Display Unit, is also the area of greatest risk. A brief preliminary investigation could uncover a more cost effective system than the oil film projector system costed in this estimate.

LEAD TIME ESTIMATE. Figure 6 depicts an estimated total time from contract award to the RFT date to be 28 months. This estimate is for the prototype device only. Follow-on units will probably require 18 months.

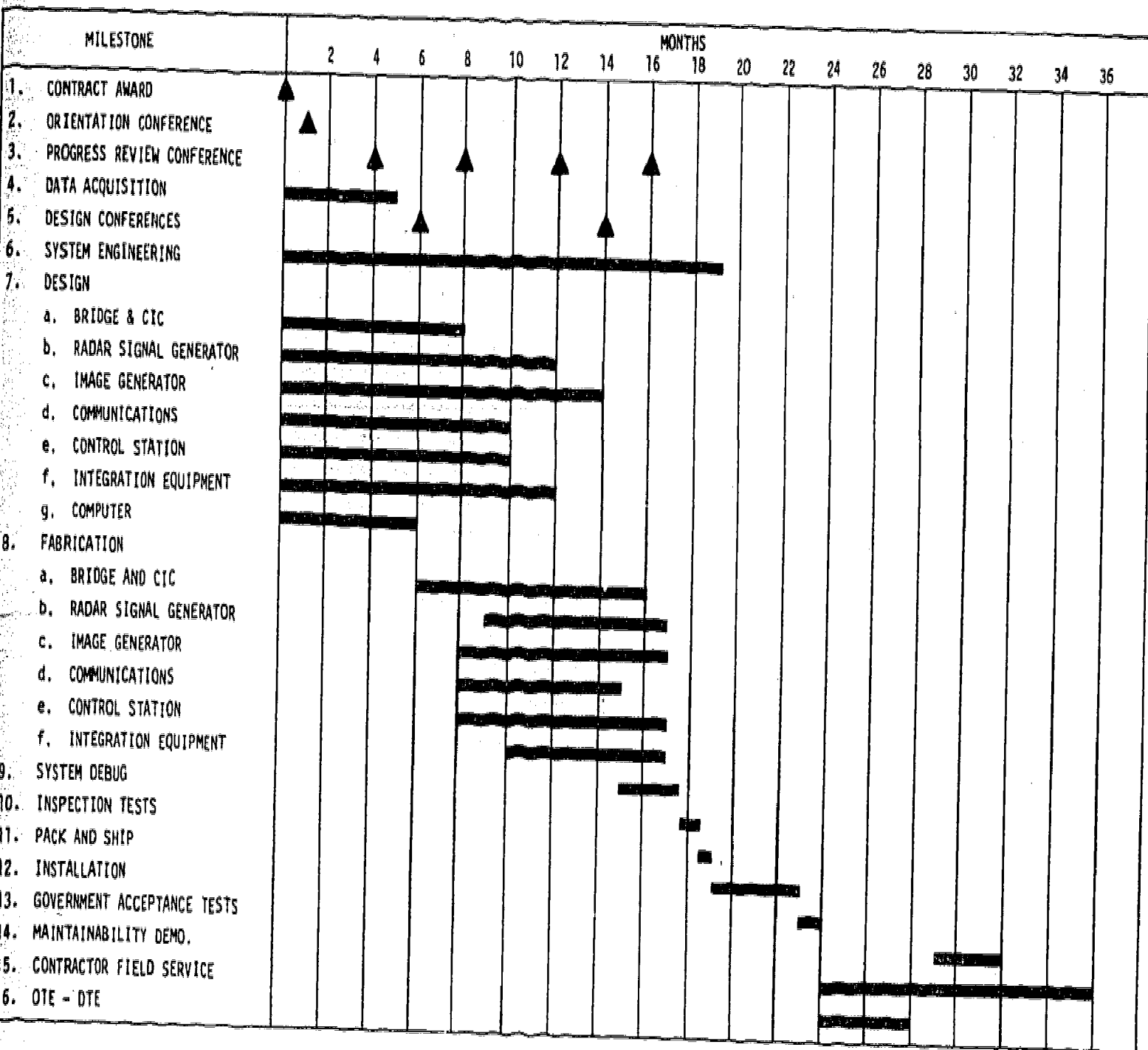

Figure 6. Shiphandling Simulator Acquisition Milestones

SECTION V

PROPOSED SMALL CRAFT TRAINING DEVICE

The small craft shiphandling training device discussed in this section has been designed to support the shiphandling curriculum previously described and is the logical intermediate step between the full-mission bridge simulator and actual operational craft. All critical shiphandling knowledge elements, the necessary team work, and the interrelationship between the various modules of instruction can be demonstrated and exercised utilizing this device. Successful conning of the small craft will lead to a degree of confidence and self-assurance that can only be acquired in a free-play environment wherein simulated operational missions are successfully performed. Although this device cannot, and must not, be considered as a substitute for operational experience on board fleet units, it can reduce the average time required by an officer to reach a fully-qualified status.

The intent of this device is to permit trainees to perform all functions of the shiphandling team on an operational craft. Exercise evaluations are constrained only by the elements of safety and the need to prevent material damage. All major evolutions required to be performed by operational ships can be performed in this device.

BACKGROUND

The basic problems in the design of the training craft were flexibility and economy. What was needed was a single craft which could simulate ships with widely divergent hull and power plant characteristics. The following operating characteristics were considered to be of major concern in the training of shiphandlers:

- . single screw and twin screw effects
- . variable acceleration/deceleration
- . variable turning rate
- . variable tactical diameter
- . variable advance/transfer
- . variable speed for given RPM
- . variable response delays to both the helm and throttle.

In addition to flexibility and economy, which were vital, course content dictated the need for skill training in areas such as teamwork, anchoring, underway replenishment, and piloting. This need placed an additional requirement on the training craft for the following:

## TAEG Report No. 65

- . a classroom for briefing/debriefing
- . CIC
- . visual and radio communication capabilities
- . Underway Replenishment (UNREP) capabilities (i.e, a kingpost).

It was considered highly desirable to provide a training capability in areas of shiphandling which are encountered only by a large percentage of conning officers. These specialized situations include mooring, beaching and retraction, towing, tug handling, and planning. To accomplish these objectives, the following additional features are needed on board the training craft.

- . a second CIC
- . three anchors, two forward and one aft
- . reinforced bow and fenders
- . skegs
- . towing capability.

### CONCEPT FORMULATION

The Training Analysis and Evaluation Group performed a concept formulation study for the small craft which considered, in addition to the factors previously established, three additional criteria: length, production cost per unit in quantities of 12 or more units, and the requirement for the craft to support the total shiphandling training unit. Length overall (o.a.) should be between 65 and 100 feet to provide adequate separation between bow and stern, yet not have the craft unwieldy. Production cost should not exceed \$1 million in 1978 dollars.

As mentioned earlier, the shiphandling training unit is composed of three levels of training and transition and refresher training. The Basic Course required the trainee to become familiar with relatively simple tactical maneuvers, docking and undocking, going alongside, and teamwork. The Department Head Course requires training in specialized missions, controlling of tactical maneuvers of a group of craft operating in concert, and the improvement of proficiency. The PCO Course, in addition to refreshing competency, must permit training in the planning and execution phases of all types of evolution. Transition training requires the craft to be capable of simulating a variety of ships with widely divergent operating characteristics.

It was determined that the development of a training device craft was feasible within the constraints previously stipulated provided a spartan approach to design was accepted. This meant the elimination of the following usual items on a craft of the anticipated size:

## TAEG Report No. 65

- Armament, small arms, and pyrotechnics. As a training craft planned to operate within sight of land and in a comparatively sheltered environment; i.e., within a harbor area, these are unnecessary.
- Galley and Galley Equipment. Training cruises are scheduled for less than 12 hours. Box lunches are used at the SWOS today, and have proved to be satisfactory. There is no anticipated need to change this procedure.
- Berthing Facilities. The brevity of training cruises precludes a necessity for berthing. However, in an emergency the classroom can be used for berthing.
- Shower Facilities. Short cruises preclude the need for on-board showers. No maintenance or repair, other than that of an emergency nature, will be performed underway.
- Refrigeration. No food preparation or food storage is anticipated; therefore, no refrigeration facilities are required. However, the drinking fountain will have the capability of cooling water.
- Infrared. Normal lighting and signal facilities are adequate for training purposes.
- Air Conditioning. Natural and forced air ventilation is adequate. Engine room will not be manned underway. However, should air conditioning be required for electronics equipment, single space air conditioning units will be provided.

Consideration was given to having an electronic capability (computer or programable calculator) to vary the operating characteristics of the training device. An examination of available systems was made. Because of the cost, increased maintenance requirements, and the additional logistic support and personnel such a system would require, it was rejected as an unnecessary "nice-to-have" feature.

It was expected that the initial allocation of these training devices would be to the two SWOS locations, with the possibility of subsequent assignment to various FTC's and the U.S. Naval Academy.

### CONCEPT DESIGN

The results of the concept formulation study were given the DTNSRDC. They, in conjunction with the Naval Ship Engineering Center, Norfolk Division (NAVSECNORDIV), performed a concept design for the proposed craft. (Details of this concept design are included as appendix D.) An artist's concept of the proposed small craft training device is illustrated in figure 7.

In order to determine the groupings of characteristics of Naval vessels in terms of displacement and speed, an examination of the tactical characteristics



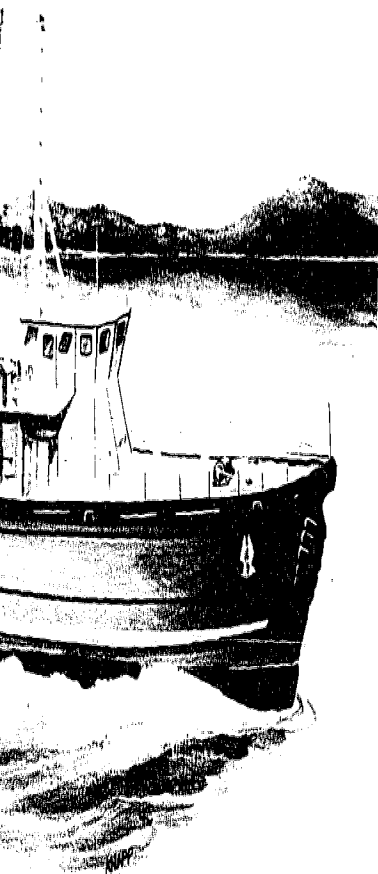

11 Craft Training Device

55

of 36 Naval vessels or classes of Naval vessels was conducted. Of this number, a plot of 33 was made of displacement vs. speed. The plot differentiated between single- and twin-screw vessels. Quadruple-screw vessels were not included. Figure 8 illustrates the plot. From this plot it was determined that there were five general groupings of ships. Within these groups individual characteristics varied as a function of underwater configuration, number of propellers, etc. Thus the required simulation was restricted to five general groupings of operating characteristics.

Within each of the major groups established, operational responses to orders differed as the number of screws, response rates, and tactical characteristics varied between classes and among individual vessels. These differences were incorporated in the concept design of the small craft by varying (1) the actual rudder angle with respect to the indicated rudder angle, varying the rate of response independently to both (2) rudder and (3) throttle, and (4) incorporating three propellers, each independently driven. In proper combination, these four variables permit the simulation of the operating characteristics of all classes of Naval ships except quadruple-screw ships.

Maximum speed of the craft does not approach the actual speed of combatants. However, shiphandling training is primarily concerned with evolutions which do not require high speeds. In the twin-screw configuration, flank speed will fall between 16 and 20 knots which is adequate for training.

**TRAINING DEVICE CRAFT CHARACTERISTICS.** The vessel hull is to be constructed of steel with an aluminum deck house. Other materials were considered but were rejected for reasons such as cost, maintainability, ease of damage caused by trainee judgmental errors, etc. Vessel dimensions are:

Length, o.a.	94 feet
Length, w.l.	90 feet
Beam	22.5 feet
Draft, hull	4.5 feet
Draft, navigation	7.5 feet

**TRAINING DEVICE CRAFT SYSTEMS.** Major systems of this proposed vessel are:

1. Propulsion - three, 1200 hp diesel engines connected to three fixed pitch propellers.
2. Fuel/lube oil - 9,000 gallons diesel. Spare lubricating oil will be stored aboard in five gallon cans.
3. Fresh water - 500 gallons storage taken aboard at dockside. Twenty gallon, quick recovery hot water heater.

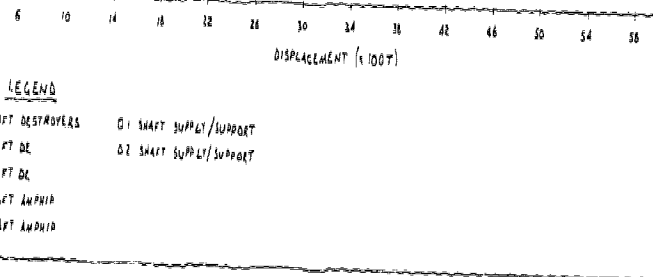

Figure 8. Groups of Major Ship Types

57

8. Bilge drain - an oily water separator with holding tank.

PERSONNEL. The training craft will have total propulsion control at the ship control console installed in the pilothouse. Therefore, the engine room need not be manned when underway. It is planned that all operational stations be manned by trainees. Based on these criteria, it is anticipated that only two enlisted personnel are required as permanent crew for each craft.

When underway on a training mission, one is needed in the pilothouse, each CIC, and one in charge of the exercise.

A maximum of 40 trainees can be embarked in addition to instructors and boat operating personnel.

The craft has been designed to accommodate a maximum of 46 persons. Therefore, the mix of instructors and students can be varied to suit the needs of each individual training cruise.

SUPPORT. The training craft is designed to be supported and maintained from shore facilities. No spare parts are planned to be carried aboard. It is envisioned that a central pool of maintenance, operations, and support personnel will be established ashore at each training location, and individual units will be serviced and supported from this pool.

ALTERNATE PROPULSION ENGINE CONFIGURATION. Late in the concept design phase, personnel at the DTNSRDC and NAVSECNAVRIV conceived a new approach to simulating a single-screw vessel. The only difference between a single- and twin-screw vessel, as observed by the shiphandlers (conning officers), is the lateral thrust caused by uncompensated torque of the single-screw. Because of this, it is possible to calculate the thrust on any given hull for any given speed, forward or reverse. The operative portion of this thrust, with respect to maneuvering a vessel, is that which occurs in a plane parallel to the shaft and perpendicular to the shaft at its juncture with the propeller.

The training craft is planned to have a twin-screw mode of operation which uses counter rotating propellers to offset the lateral thrust. It is possible to simulate the effect of single-screw torque with twin-screws by injecting a centerline thrust to either port or starboard using a thruster. This configuration would eliminate the planned third engine, shafting, and propeller.

53

58

The advantages to the use of the thruster are:

- . elimination of one 1200 hp diesel, shafting, and propeller. This is replaced by a 65 hp engine and a much smaller propeller.
- . reduction in required fuel storage
- . reduction in draft and weight
- . probable reduction in length
- . economy of operation
- . reduced maintenance and logistic support.

The possible disadvantages to the use of the thruster are:

- . need to develop an automatic control system such that the correct thrust in the proper direction is present at all times
- . need to develop an interlock with the throttle and main propulsion engines.

The concept of using a stern thruster to simulate the lateral forces generated by a single-screw craft is promising and gives every indication of success. In addition, it gives promise of additional simulation capabilities at low cost. For example, if the stern thruster concept proves feasible and is satisfactory in the operational environment, then a bow thruster can be installed for the purpose of simulating loading, wind, and current effects. Thus, a complete range of training situations can be simulated in one comparatively inexpensive craft.

It is strongly recommended that the concept of a stern thruster be investigated during the preliminary design phase of the small craft training device.

**COSTS.** Estimation procedures for the cost of the proposed small craft training device differed from the ACES technique used to estimate the simulator costs. A single, point estimate was produced. Such an estimate is practical for a small craft for the following reasons:

- . Labor and material are more predictable.
- . There is a larger, tested data base upon which to draw.
- . The small craft is not as technically complex as the simulator. All areas are well within the state-of-the-art and have been used in prior fabrications.
- . The basic estimate was produced by a Naval component which has extensive experience in small craft design.

Cost estimates for this craft are class D. The individual costs for the hull and major equipment are listed in appendix D. Additional money will be required for design, equipment (which includes, but is not limited to, furnishings, signal flags, control console, etc.), installation, and cabling. An estimate of the cost of the first unit follows:

Hull	\$ 118,500
Major Equipment (appendix D)	538,940
30 kw Diesel Generator	10,000
Intercom System	700
Radio, to include remotes, antenna, and coupling	13,360
Design, equipment, installation, documentation, cabling, and T&E	818,500
	<hr/>
Total	\$ 1,500,000

Subsequent units constructed to the original design, which do not require test and evaluation (T&E) and which take advantage of bulk buying, are estimated to cost no more than \$1 million each.

#### AREAS OF POSSIBLE SAVINGS.

1. The estimates presented above presume all equipment and equipment is purchased new from vendors. However, if advantage is taken of available equipment and equipment already owned by the Navy but not being used, certain major savings could be made. For example, the two DRT/DRA units are estimated to cost \$204,000. If these units could be obtained from ships in the inactive fleet, only overhaul and shipping charges would be required, and these charges would be far less than the cost of new units.

2. Previously an alternate engine configuration was discussed. One propulsion engine, shafting, and one propeller could be eliminated if a keel mounted thruster were to be substituted. This action could generate an initial cost saving of up to \$70,000 per craft. In addition, because of the fuel reduction, decreased craft weight, and draft reduction inherent in this change, there is the possibility that overall vessel length can be reduced with attendant estimated savings of approximately \$1,260 per foot. Because of the additional design and testing which would be required in the development of this concept, such savings would probably only be realized on follow-on units, not the original unit.

An added incentive to the use of a thruster in lieu of the third propulsion unit is the life cycle cost avoidances which could be generated. Both operating

and maintenance costs should be reduced by a significant amount. Additional study would be required to develop a valid estimate of these savings.

EXTENDED CRUISE ALTERNATIVE. The proposed design is based on the premise that training cruises are 12 hours or less. In terms of the curriculum at the SWOS and possible FTC training, this premise is valid. However, the U.S. Naval Academy conducts training cruises of extended duration; i.e., 1 to 2 weeks. As configured, the proposed craft does not have adequate facilities for these types of cruises.

In order to provide the berthing and food preparation space necessary for extended cruises, the interior layout can be redesigned at a very small additional cost. By eliminating the forward storage space on the platform deck and moving the CIC forward so that the forward bulkhead of the CIC is the after bulkhead of the Boatswain's Store Room, space is provided for a small galley and refrigerated store room on the port side and mess space on the starboard side. On the Main Deck, elimination of the classroom would provide space for a commanding officer's cabin, bunk space for trainees, and two additional water closets. A centerline bulkhead extending the length of the existing classroom would provide the necessary privacy for male and female trainees when both are embarked.

TAFG Report No. 65

APPENDIX A  
GLOSSARY OF DEFINITIONS

57

62



GLOSSARY OF DEFINITIONS

Accident	The overall description of a series of events, decisions, and situations which culminate in injury or damage.
Bit	The smallest subdivision of a module of instruction. Discrete pieces of related information on a specific topic.
Cause	In terms of an incident, cause is used to identify the primary and secondary reasons an accident occurred.
Certification	A statement, in writing, by competent authority that an officer has completed a given objective. A certification is part of an official record.
Class D Estimate	Feasibility Estimate. Estimate based on technical feasibility studies and/or extrapolated from higher quality estimates of similar items. (Reference: OPNAVINST 7000.17A of 15 September 1976.)
Conning Officer	The person who is in charge of the ship maneuvering and ground tackle team and who makes the decisions with respect to the maneuvering of the ship and use of ground tackle. He is the environment-team interface.
Education	Instruction and individual study for the purpose of intellectual development and the acquisition of knowledge. Education implies the acquisition rather than the application of knowledge.
Elements of a Shiphandler	Those specific skills and the knowledge which a qualified shiphandler must become proficient in prior to being certified.
Environment	The environment is limited to the physical characteristics extant at a given time.
Existing Training	That training, whether in a classroom, on a device, or in an operational setting, which is available at the time of this report. It is defined in terms of lesson plans for a schoolhouse setting and PQS for the operational or on-the-job training.
Expert Shiphandler	A Naval officer who has qualified as a SWO, or who is training other unrestricted line officers in shiphandling. An element of this definition is that seagoing officers must be, or have been, at least senior underway watch officers.
Ground Tackle	Any aid which is used to hold a ship in place, or move, or cause the ship to move through the use of forces applied external to the ship.

Incident	A dangerous or in-extremis situation wherein no damage to either vessel, or injury to personnel, necessarily occurred.
Junior Officer	In terms of shiphandling, junior officer refers to any officer who has not been certified by his CO as a qualified OOD(F). Generally, it is the Ensign and Lieutenant (junior grade) striving to obtain this qualification, although it could be any rank.
Module of Instruction	Knowledge and skill elements in a given subject matter area.
Qualified Shiphandler	An officer who has completed all prerequisites to and has demonstrated a capability for controlling a ship in an operational environment.
Refresher Training	Training given a certified Naval officer upon return to sea duty from extended periods ashore to insure he is in all respects prepared to assume the duties of a conning officer.
Senior Officer	In terms of shiphandling, senior officer refers to any officer who has been certified qualified as a SWO and is, or has been, charged with the training of junior officers in the conning situation. A senior officer will generally have filled more than one billet at sea which required him to act in a conning or conning supervisory capacity.
Shiphandling	Those situations wherein the conning officer is required to make immediate decisions with respect to the maneuvering of the ship, and outside aids; i.e., CIC, ground tackle (including tugs), navigational aids, etc., are of relatively little value. However, a failure to use outside aids, the improper use of these aids, or the lack of preparation for a situation is poor shiphandling.
Shiphandling Training System	A career-oriented system of training designed to prepare officers to qualify and maintain their proficiency as conning officers.
Submodule of Instruction	Knowledge and skill elements in a given subject matter area at a specific proficiency level.
Topic of Instruction	An independent topic within a given subject area.
Training	The application of knowledge in specific skill areas. Training generally is job-oriented or applies to a particular military specialty.

Transition  
Training

Training provided to personnel who are qualified conning officers in one or more ship classes to prepare them for the assumption of conning duties in another ship class of different characteristics.

TAEG Report No. 65

APPENDIX B

SHIPHANDLING TRAINING UNIT  
LESSON TOPIC IDENTIFICATION

## SHIPHANDLING TRAINING UNIT LESSON TOPIC IDENTIFICATION

Twelve instructional modules for shiphandling training were identified as needed. Eleven encompassed the required knowledge elements and the twelfth was the practice and integration module. Section II of this report gives the module concept; that is, the breakdown into its submodules, topics, and bits. Section III discusses the module content and relates this content to instructional hours and practice hours based on the existing curriculum for each of the three SWOS required courses.

During the process of developing a concept, a priority scheme evolved which identified the rank order of the modules with respect to the needs of a potential shiphandler. It was determined that modules 8 through 12 could, if time precluded their inclusion in the total shiphandling courses, be omitted. Should circumstances dictate the exclusion of all or any of these modules from the courses, then the course developer must attempt to incorporate the contents of these modules to some degree in other instructional modules, particularly the practice module. In the event a decision is made to include any or all of modules 8 through 12, it is incumbent on the course developer to insure that higher priority modules do not suffer through either abbreviation or omission.

Table B-1 subdivides each of the 12 modules into the training level (submodule) and the suggested topics of instruction applicable to each level. These topics are to be used by the subject matter experts in identifying the bits of instruction. These experts, in conjunction with course developers, will use the bits to develop lesson plans, instructor guides, and other classroom aids.

Particular attention must be given to the practice module. This module incorporates the knowledge elements acquired in the classroom and should demonstrate their interdependence as well as giving the student actual conning experience. As a consequence, the incorporation of the various elements into one or a series of practice sessions must be the final step. Only then can performance criteria be established which instructors can use.

The existing schools do not have a full-mission simulator. The small craft now being used lack many of the capabilities planned to be incorporated in the proposed small craft training device discussed in section V. Until the new devices are acquired, all practice sessions should be scheduled, insofar as is practical, in the existing small craft. Present schedules of underway training terminate in the early afternoon, approximately 1500. It is proposed that a two shift approach to the use of existing small craft be considered in order that the additional underway time proposed can be included. In this manner, additional practice sessions can be accommodated without an extension of time at the school.

TABLE B-1. SHIPHANDLING TRAINING TOPICS

MODULE TITLE & PRIORITY	SUBMODULES (COURSE LEVEL)	TOPICS
1. Rules of the Road	Basic (Basic Course)	<ul style="list-style-type: none"> <li>A. Definitions, Principles, &amp; Laws</li> <li>B. Steering &amp; Sailing Rules</li> <li>C. Special Circumstances</li> <li>D. Fog Signals</li> <li>E. Lights</li> <li>F. Day Shapes</li> </ul>
	Intermediate (Department Head)	<ul style="list-style-type: none"> <li>A. Review</li> <li>B. USA-USSR Incident Reporting</li> <li>C. Practice</li> </ul>
	Intermediate (PCO/PXO Course)	<ul style="list-style-type: none"> <li>A. Review</li> <li>B. Case Study</li> </ul>
2. Relative Motion	Basic (Basic Course)	<ul style="list-style-type: none"> <li>A. Maneuvering Board</li> <li>B. Formations &amp; Maneuvering</li> <li>C. Tactical Maneuvering</li> <li>D. Special Situations</li> <li>E. Practice</li> </ul>
	Intermediate (Department Head)	<ul style="list-style-type: none"> <li>A. Review</li> <li>B. Screening and Barrier Theory</li> <li>C. Practice</li> </ul>
	Intermediate (PCO/PXO Course)	<ul style="list-style-type: none"> <li>A. Review</li> <li>B. Practice</li> </ul>
3. Practice	Not Independent. Practice module topics are identified separately for individual modules.	
4. Navigation & Piloting	Basic (Basic Course)	<ul style="list-style-type: none"> <li>A. Navigation               <ul style="list-style-type: none"> <li>1. Publications</li> <li>2. Logs &amp; Charts</li> <li>3. Plotting Procedures &amp; Displays</li> <li>4. DR Navigation</li> <li>5. Electronic Navigation</li> <li>6. Navigation Aids</li> <li>7. Tides &amp; Currents</li> <li>8. Compass/Gyrocompass</li> <li>9. Celestial Navigation</li> </ul> </li> </ul>
		<ul style="list-style-type: none"> <li>B. Piloting               <ul style="list-style-type: none"> <li>1. U/W OOD Watch Standing</li> <li>2. Standard Commands</li> <li>3. Equipment</li> <li>4. S/H Evolutions</li> </ul> </li> </ul>



TABLE B-1. SHIPHANDLING TRAINING TOPICS (continued)

MODULE TITLE & PRIORITY	SUBMODULES (COURSE LEVEL)	TOPICS
	Intermediate (Department Head)	5. Emergency Bills & Procedures 6. Underway Replenishment 7. Aviation OPS 8. Special OPS 9. Piloting Team  C. Practice
	Intermediate (PCO/PXO Course)	A. Review B. Severe Weather & Reporting Requirements C. Towing D. Amphibious OPS E. Special Cases F. Practice  A. Review B. Case Study C. Practice
5. Internal/External Ship Forces	Basic (Basic Course)	A. Internal Forces 1. Propeller 2. Rudder 3. Other/Ship Characteristics
	Intermediate (Department Head)	B. External Forces 1. Wind 2. Current/Tides 3. Heavy Weather 4. Sail Area 5. Shallow Water 6. Waves (Pressure)  C. Practice
	Intermediate (PCO/PXO Course)	A. Review B. Applications C. Practice  A. Review B. Practice
6. Ground Tackle	Basic (Basic Course)	A. Mooring Rigs B. Anchoring Rigs C. Safety Precautions D. UNDER RIGS

TABLE B-1. SHIPHANDLING TRAINING TOPICS (continued)

MODULE TITLE & PRIORITY	SUBMODULES (COURSE LEVEL)	TOPICS
		F. Towing Rigs G. Practice
	Intermediate (Department Head)	A. Review B. Salvage/Rescue C. First LT Responsibilities D. Davits E. Wildcat & Capstans F. Practice
	Intermediate (PCO/PXO Course)	A. Review B. Non-U.S. Navy UNREP Rigs C. UNREP Planning D. Practice
7. Own/Other Ship Characteristics	Basic (Basic Course)	A. S/H Characteristics B. UNREP Characteristics C. Special Evolution Handling D. Stability Characteristics E. Practice
	Intermediate (Department Head)	A. Review B. Planning & Ship Characteristics C. Towing Characteristics D. Maneuvering Characteris- tics E. Practice
	Intermediate (PCO/PXO Course)	A. Review B. Practice
8. Tactical Publications & Thumb Rules	Basic (Basic Course)	A. Navigation B. Formations/Screens C. Maneuvering D. Tactics E. UNREP F. Communications
	Intermediate (Department Head)	A. Review B. Planning C. Practice
	Intermediate (PCO/PXO Course)	A. Review B. Practice
9. Meteorology &	Basic	

TABLE B-1. SHIPHANDLING TRAINING TOPICS (continued)

MODULE TITLE & PRIORITY	SUBMODULES ( COURSE LEVEL)	TOPICS
	Intermediate (Department Head)	A. Review B. Reporting Procedures
	Intermediate (PCO/PXO Course)	A. Review B. Identification & Effects C. Evasion
10. Plan Ahead	Not Independent. Planning topics are separately identified for appropriate individual modules.	
11. Own Ship's Team	Basic (Basic Course)	A. Shiphandling Team B. Navigation Team C. CIC Team D. UNREP Team
	Intermediate (Department Head)	A. Review
	Intermediate (PCO/PXO Course)	A. Review
12. Training	Basic (Basic Course)	Not Applicable
	Intermediate (Department Head)	A. How to Train B. Records/Reporting
	Intermediate (PCO/PXO Course)	A. Review B. Training Requirements C. Training Systems

TAEG Report No. 65

APPENDIX C  
FUNCTIONAL SPECIFICATION FOR  
FULL-MISSION SHIPHANDLING BRIDGE SIMULATOR

## FUNCTIONAL SPECIFICATION FOR FULL-MISSION SHIPHANDLING BRIDGE SIMULATOR

### BACKGROUND

TAEG Report No. 41, Shiphandling and Shiphandling Training, December 1976, outlined the concept for a shiphandling training system and proposed a series of training devices to support the system. One device was a ship bridge simulator designed to provide shiphandling and conning training over a wide range of conditions.

By letter (TAEG:AFS of 29 March 1977), a POA&M was submitted which proposed alternative approaches to the development of the simulator. The alternate was selected which produced a functional specification for the simulator but without design option testing.

### TRAINING SITUATION

1. A training analysis of shiphandling and shiphandling training was performed in TAEG Report No. 41. A summary of the findings follows:

a. Shiphandling has not come under scrutiny consistent with foreseeable needs, nor has the training of shiphandlers taken advantage of available technology. The term shiphandling itself, in the operational context, is used loosely to describe evolutions of all types. To date, training has been primarily on-the-job and dependent upon operational steaming during which shiphandling evolutions were performed. Recent underway experience by junior officers (JO's) has been drastically reduced due to the lack of underway time, very short availability of operational readiness training underway time, and the infrequency of the performance of many evolutions.

b. It has been determined that shiphandling is not a completely procedural task, nor can it be reduced to that classification of task. Based on this, a series of interviews were held with recognized experts and a review was made of pertinent published data. It was found that a series of independent but related knowledge elements should be learned in a classroom setting, then emphasized and reinforced in a trainer. The interrelationship of each of the elements to the other elements would be graphically demonstrated in the same trainer. A shiphandling training system should be designed to move from a classroom to trainers and finally to operational craft.

c. Three additional factors became apparent during the training analysis. First, there is a need to provide transition training for officers proceeding from one ship class to another of widely divergent characteristics. Second, officers proceeding to sea should have performed all of the evolutions specified as required to qualify as OOD(F) in the PQS. For many reasons this is not always accomplished, and some officers are qualified on waivers. Third, there are many shiphandling situations which cannot be duplicated for training purposes on board an operational unit. The reasons for this vary from safety through a lack of opportunity.

d. It is obvious that a training device is required to bridge the gap which exists between the classroom and part-task trainers and the operational environment. Two types of training devices have been identified as candidates. The first is a full scale, full-mission bridge simulator, and the other is a small craft designated as a training device. For maximum training effectiveness and efficiency both are needed. A small craft is constrained by the numbers of trainees per unit time, by the types of evolutions which can be performed, and by weather. Yet, there is no substitute for actual conning experience. A simulator is constrained only by the imagination of the programmer.

2. The operational system being simulated by this proposed device consists of those ship subsystems which are involved in the control and maneuvering of the vessel. Certain systems will be totally simulated, others will be partially simulated, and still others will not be simulated at all. However, insofar as the trainee is concerned, all systems are to be fully operational. A general description of the subsystems and their degree of simulation follows:

a. Own ship control subsystem. This subsystem consists of the steering system and the propulsion system. Those portions of these systems which are located on the bridge, or bridge wings, and function under control of the conning officer will function as if they were fully operational. Ship responses to the bridge orders will be fully simulated.

b. Navigation subsystem. Position locating equipment will be simulated. In addition, CIC and bridge repeaters (such as fathometer, radar, anemometer, gyro repeaters, etc.) used for navigational purposes will be duplicates of actual equipment and will function.

c. Weapons sensor and control subsystem. Repeater from this subsystem will be stylized mockups and will not function.

d. Ground tackle subsystem. The effects of this subsystem will affect own ship's operational capabilities, but the equipment itself will not be required.

e. Communications subsystem. Bridge and CIC transmitters and receivers for all methods of communication (radio, telephone, MC, pneumatic) will function.

3. The initial procurement of this simulator is to support three existing courses at the SWOS, Newport, RI, and to provide the capability of being used in transition training for a to-be-developed course. A discussion of the courses follows:

a. Course A-00-0118, Surface Warfare Officer Basic Course. This course is designed to provide newly acquired officers with the basic information



Many of these elements are reinforced in a model shiphandling tank using scaled models, in the Tactical Trainer (Device 20A61) during the execution of drills primarily related to the use of weapons, or in a simulator or underway training craft.

From a training aspect, this course suffers from the following shortcomings.

- Shiphandling is not a distinct unit; therefore, many of the knowledge elements are taught and tested under criteria not necessarily shiphandling related.
- The simulators were not designed to be used as shiphandling instructional tools. Some elements of shiphandling are overlooked, others are addressed only tangentially.
- Many shiphandling evolutions cannot be properly executed due to the lack of a coordinated visual/electronic presentation.
- For safety and maintenance reasons, many restrictions must be placed on the underway training craft. In addition, these craft are not representative of any existing operational ships classes, are overly maneuverable, and are all twin-screw configuration.

The proposed simulator, when integrated into the basic course, will provide training in all aspects of shiphandling as well as exposing the student to the interrelationship and mutual dependency of the knowledge element. It will, therefore, enhance the status of shiphandling, reduce the time required at sea to become familiar with own ship operating characteristics, and aid in the production of a more nearly qualified JOOD graduate.

b. Course A-00-0107, Surface Warfare Officer Department Head Course. The curriculum for this course has undergone a revision, primarily in the technical areas, which has not impacted the shiphandling aspects of the course. No existing unit of instruction directly addresses any of the problems associated with shiphandling. However, the objectives of some lesson topics do incorporate shiphandling knowledge elements. The emphasis in this course is managerial, both from a technical and a human resource point of view. Shiphandling training is incidental and, therefore, of secondary importance.

Graduates of course A-00-0107 proceed directly to operating ships as department heads. As such they are expected to be proficient in all phases of their duties, not the least of which is the underway OOD responsibility. Thus they can expect to be exposed to situations wherein shiphandling is primary. As a practical measure to insure the proficiency gained prior to entry into the school is maintained, and to prepare the graduate for the Command Qualification Board, emphasis should be placed on the performance aspects of shiphandling and the planning of evolutions which, if not properly executed, could lead to an in-extremis situation. In addition...

Actual craft, including training craft, cannot be used for all situations. A full-mission simulator with integrated optical and electronic capabilities can simulate any given set of conditions, either in a single or multiple ship environment. Errors in judgment in a simulator are not costly; therefore, students can be permitted to place their vessel in situations which cannot be allowed with actual craft. Thus the proposed full-mission simulator, when integrated into this course, will fulfill a needed training function.

c. Course A-00-0111, Surface Warfare Officer Advanced Course - Command. One module of this course addresses the evolutions and situations which encompass shiphandling. The only skill training is in the Shiphandling Trainer, a group of radio controlled models.

Since the officers attending this course are relatively senior and proceeding to either a surface ship command or executive officer billet and may not have served on a surface ship in the recent past, it would be to their and the Navy's advantage to insure they receive some skill training on a vessel with the same or the approximate characteristics of the ship to which ordered. The only cost effective method of having available ships with the operating characteristics of all existing and prospective vessels is through a simulator. Thus prospective commanding officers/executive officers can learn not only the normal responses in all environments, but also how the ship responds during emergency maneuvers and under casualty conditions.

d. Transition training. Graduates of the Surface Warfare Officer Department Head Course and a proportion of other officers in the middle grades serve split tours. That is, they proceed from relatively high powered, maneuverable craft to cumbersome, frequently underpowered service or amphibious craft. In addition, some senior naval officers command auxiliary vessels and proceed from these to high powered combatants. The ships' handling characteristics are at the two extremes.

Extreme differences in ship characteristics present problems which closely parallel those encountered by aviators when transitioning from one type of aircraft to another wherein functional and handling characteristics differ widely. Experience, practice, and "luck" may enable an officer to transition from ship to ship and even aircraft to aircraft. However, it is not prudent to base qualification on chance. Transition without training is neither warranted nor justified when one weighs the cost of a few days transition training against the costs incurred by one major accident and the possible loss of life. The sole economic method of exposing personnel to single- and multi-screw vessels with a complete range of shiphandling characteristics is in a simulator.

#### TRAINING DEVICE OBJECTIVES

It is a given that no officer can be qualified as an OOP/FA

transition training, can reduce the time required. For students of the Advanced Course - Command, the simulator will permit the acquisition of a "feel" for their prospective command thereby giving a confidence and understanding which otherwise could only be acquired by having served in a similar type. This would be of the greatest importance to officers who had not spent a major proportion of their time as ship's company.

#### SIMULATOR DESCRIPTION

1. General. The simulator complex will consist of:

- a. Two bridge mockups
- b. One CIC and one chart house linked with each bridge
- c. One port and one starboard wing to each bridge
- d. One problem control room
- e. One computer complex
- f. A visual system for and cylindrical screen surrounding each bridge
- g. A small auditorium capable of seating approximately 25 people
- h. Space for the addition of two additional bridges with attendant CICs and chart houses
- i. Restrooms, workshop, and other necessary support spaces.

2. Bridge Mockups. No specific class bridge will be duplicated in the mockup. Since each bridge will be used to simulate either single- or twin-screw combatant or auxiliary vessels and is to be designed to be used exclusively for shiphandling training, sonar repeaters, weapons control panels, and other repeaters/displays not directly associated with shiphandling are not required, or may be stylized nonoperative mockups. No motion will be required of the mockup. Bridge width, including wings, should not exceed 35 feet; depth should not exceed 25 feet.

The following are the minimum equipments required on the bridge. Equipment location should generally follow the layout of the DD-963 class ship bridge.

- a. A ship control indicator panel located on the forward bulkhead, amidships, above the windows. The panel shall contain a rudder angle indicator

TAEK Report No. 65

- b. A ship's course indicator located at the forward end of the pilothouse, deck mounted, on the centerline. This instrument will be a gyro repeater and capable of accepting an alidade. A duplicate of the ship's course indicator will be located on each bridge wing as far outboard and forward as possible.
- c. A captain's chair on the port side, forward.
- d. A plotting table on the starboard side, forward. This table will be fitted with a goosenecked lamp for night use.
- e. Available to the Officer of the Deck (OOD) on the forward bulkhead will be two radio telephone handsets, the 21 MC unit, an anemometer read out, a fathometer read out, a whistle and a siren actuator, and one voice tube connecting the bridge, CIC, and instructor's console.
- f. A navigation light switchboard will be located on the after bulkhead of the pilothouse. All combinations of lights required by the current edition of the Nautical Rules of the Road will be available. No actual lights are required to light, with the exception of port and starboard running lights; however, an indication on the instructor's console will show which navigation lights are on.
- g. The quartermaster of the watch log desk will be on the after bulkhead. This desk will be fitted with a gooseneck lamp. Above or adjacent thereto is to be the one MC primary station.
- h. One plotting board and one status board, each approximately 3 feet square is to be mounted vertically on the after bulkhead.
- i. Sound powered outlets will be located on the after bulkhead for the following circuits: JA, 1JV, 2JV, JX, and an instructor's circuit which can also be used for maintenance. These outlets will be duplicated on both the port and starboard wings. Outlets on the wings may be through a hand switch with one receptacle.
- j. The SCC will be located on the centerline sufficiently aft of the forward bulkhead so the OOD has unimpeded walk space from side to side of the pilothouse. There will also be space aft of the SCC for unimpeded passage thwartship. All ship control instrumentation, alarms, and controls are congregated on the SCC. It will be modeled after the console designed for the DD-963 class.

The SCC will contain the following minimum components:

- (1) The helm which is directly connected to the engine room

indicator. (4) Course to steer indicator to the left of the ship course

(5) Auto pilot panel.

(6) Steering pumps control panel which permits the shifting of pumps as well as shifting the steering control station.

(7) Steering alarm panel.

(8) To the right of the helm is the propulsion section of the SCC. The first panel to the right of the rudder angle indicator is the propulsion panel. It contains a speed calibration chart which, for the bridge mockup, must be changeable to conform to the class of vessel being simulated. The remainder of this panel is devoted to the throttle control station selectors, plant mode, and engine order telegraph.

(9) To the right of the propulsion panel is the throttle. The throttle must be capable of being changed to simulate either a single-screw (single throttle) or a twin-screw (two throttles) vessel configuration.

(10) Above the propulsion panel is the propulsion alarm panel and shaft performance indicator. The shaft performance indicator must be capable of representing both single and twin shaft configurations.

(11) The final panel is above the throttle and contains the dummy log and speed light controls.

In all instances where the difference between a single- and twin-screw vessel is depicted, only the class ship being simulated will be apparent on the SCC. When a two shaft, two screw vessel is being simulated, each shaft will be capable of being controlled independently. Read outs and indicators will react to the appropriate shaft. An outlet for the 1JV sound powered circuit is required on SCC.

k. To port of the SCC, but situated so that there is freedom to move around all installed equipment, is to be a chart table which contains drawers for chart storage. The top is to be equipped for performing piloting and inshore navigation during all light conditions. Immediately abutting the chart table is a remote radar display unit (PPI). This PPI will have a switching unit so that any radar being simulated can have the output displayed thereon. A digital display is not required, but a true or relative bearing capability is required. A single outlet controlled by a barrel switch for the JX, 1JV, and JA sound powered circuits is required on or adjacent to the chart table.

one in the port and one in the starboard bulkhead. These two doors will lead to their respective bridge wings. No other entrance to the bridge or wings is required.

3. Each bridge will be linked to a CIC. Equipment in the CIC will be limited to ship control and navigation equipment. No weapons control panels, sonar repeaters, or other repeater/displays not directly associated with shiphandling are required. The minimum specific hardware required is:

- a. A surface search radar display on a PPI.
- b. An air search radar display on a second PPI. Air control equipment is not required.
- c. One VHF and one UHF transceiver. Each of these transceivers will have the capability of transmitting/receiving on a maximum of four channels. The remote handsets on the bridge will be slaves of these transceivers.
- d. One NTDS console (UYA-4).
- e. One DRT or NC-2 (both are not required).
- f. Four vertical status boards approximately 3 feet square.
- g. One vertical plotting board.
- h. One HF/DF repeater.
- i. The following repeaters are to be available to the CICWO and visible from his primary station.
  - (1) Ship's heading indicator (gyro repeater)
  - (2) Fathometer repeater
  - (3) Rudder angle indicator
  - (4) Ship's speed indicator
  - (5) Anemometer indicator.
- j. Sound powered telephone outlets will be available for the JA, 1JV, JX, and the instructor's circuit. In addition, there shall be a handset for the use of the CICWO on a barrel switch which will permit him to monitor



4. The chart house shall be an independent space adjacent to the bridge. Its function is to provide the capability of performing electronic navigation and piloting. No celestial navigation equipment is required. This space will require a chart table which contains drawers for chart stowage. The top shall be equipped with standard navigation plotting equipment and a gooseneck light. Equipment shall include:

- a. An omega receiver
- b. A satellite navigation receiver
- c. An outlet for the JA and JX sound powered circuits.

5. The port and starboard wings shall be identical in layout. All equipment, except as noted, will be located forward of the access door on the forward or outboard bulkhead. The wings are to have a bulkhead approximately 4 feet high surrounding all exposed sides. Port and starboard running lights are to be installed outboard of the wings on the forward edge. The following equipment is required.

- a. A ship's course indicator (gyro repeater) capable of accepting an alidade. This instrument will be stand mounted, outboard, and well forward. It is to be identical to the instrument on the bridge.
- b. An engine order repeater.
- c. A rudder angle indicator.
- d. A connector box for a remote propulsion and steering control unit. Only one remote unit is required since there can be but one control station. Control stations are either wing, the bridge, or the engine room/steering aft.
- e. A voice tube adjacent to and aft of the ship course indicator connected to CIC and the instructor's console.

6. Total problem control will be vested in the problem control room. This room will contain two instructor consoles, one for each bridge, two status boards per instructor console, and one voice tube per console. It is required that total problem set-up and control, to include the visual scene, be from the instructor's console. In addition, the console will have the capability of activating test programs and the built in test equipment (BITE). Computers and peripheral equipment will be located in the computer complex which shall be distinct from the problem control room.



operating independently is also required, although this can be an add-on feature to be incorporated when additional bridges are added. Space must be available for the addition of two additional instructor consoles.

Each console will contain the following features:

a. A wrap around type of construction is desired. Two operators are normally to be employed, one for own ship, the other for the environment to include all contacts. Instructors are to sit side-by-side. In an emergency one instructor should be capable of performing all operations. Instructor chairs shall not be permanently attached to either the console or the floor.

b. In the center of the vertical surface there is to be an area display which duplicates the gaming area. This is to be a PPI type presentation on a CRT of approximately 16 inch diameter. The range scale on this display will be variable from 5 to 55 miles in 10-mile steps. All vessels, including own ship, aids to navigation, landmass, and other items which can be seen by the OOD are to be displayed. A special symbol shall be used for own ship and the other bridge when operating in a dependent mode. Other contacts will appear as they do on a natural PPI presentation.

c. The left portion of the console shall be devoted to own ship. There will be, on the vertical panel, the following displays and controls.

(1) A 12-inch PPI presentation with own ship centered. This presentation will use symbols in lieu of a natural presentation. Presentation will be relative with own ship always heading up. A true bearing circle will surround the relative picture. Three choices of scales will be available to the instructor--5 miles, 7.5 miles, and 10 miles. All contacts within the chosen range will be depicted with moving targets giving an indication of course, speed, CPA, and time of CPA on a demand basis. Each moving contact will be given a letter designation which will be visible at all times.

(2) A continuous display of own ship course, speed, and rudder angle.

(3) An on demand display of all other ship control functions and environmental factors as are available to the OOD. In addition, this display will show, on demand, the characteristics of own ship.

(4) An alarm panel to display instructor inserted malfunctions, out of tolerance factors, any approaching object which will strike or pass own ship within a given instructor determined range, and grounding of own

d. The left panel on the horizontal surface will contain:

(1) A writing surface.

(2) A keyboard to be used for all control functions to include initial set-up, demand calls, scale changes, malfunction insertion, and system test.

(3) A tape recorder which can be used, on instructor demand, to record bridge and bridge wing orders, CIC conversation and orders, or the talk on any designated radio or sound powered circuit. In addition to the recording capability, the selected input will be available on a monitor speaker at the console.

(4) Two handsets, one for use on a selected sound powered circuit, the other for use on a selected radio circuit. In addition, there will be a plug for earphones and microphones for both the sound powered and radio circuits.

(5) A speaker for the IMC.

(6) A 2IMC unit.

e. The right portion of the console shall be devoted to the various contacts which are within the gaming area. It shall contain the following displays on the vertical panel.

(1) A 12-inch CRT which will be used to print information called for by the instructor.

(2) An alarm panel which will alert the instructor to internal malfunctions, instances where ships, other than own ship, are approaching an in-extremis situation, and the insertion of any command which cannot be accomplished by the class of ship being simulated.

f. The right horizontal panel will contain:

(1) A keyboard for use in inserting all control functions relative to environmental change, target change, and any other change not related to own ship.

(2) A writing surface.

(3) Two handsets, one for use on a selected sound powered circuit, the other for use on a selected radio circuit.

(4) Facilities for selection of a dependent or independent operational mode.

g. A status board approximately 3 feet X 3 feet will be installed

h. The voice tube will be centered on or over the console. This is the tube from the bridge.

7. The computer complex will be designed to serve the entire simulator complex. It will contain necessary computers, interface, converters, power supplies, and peripheral equipment. There shall be a keyboard and display which will have the identical capabilities of the keyboards and display CRTs on the instructors' console. One 21MC unit and plug-in receptacles, with handsets, for all sound powered and R/T circuits are required. In addition, this room will be used for maintenance and repair of the simulator. The following minimum equipment is required.

- a. One workbench at least 6 feet long with continuous outlets for 120V/60HZ power along the entire length
- b. A vice
- c. Stowage for test equipment
- d. Spare parts stowage
- e. A dolly or hand truck for moving parts or subassemblies
- f. A desk.

8. The visual system will require a projection of at least  $270^{\circ}$  in the horizontal plane and from  $-30^{\circ}$  to  $+15^{\circ}$  in the vertical plane. If feasible a  $360^{\circ}$  horizontal projection is desired; however, should it be restricted to  $270^{\circ}$ , then the visual scene must be capable of rotating  $\pm 90^{\circ}$ . This is so the OOD can have visual perception from broad on bow through directly ahead to astern. This will be required during docking operations. A direct television type of projection is desired. Oil film projectors are to be avoided. Color is required.

Images, shading, shadow, perspective, depth, and color are to be computer generated. Output will be transmitted to the projectors which will throw the coordinated picture on the cylindrical screen surrounding the bridge. The visual horizon is to be variable in 1-mile steps from 5 miles to 10 miles. However, objects over the visual horizon will be visible if, in fact, they would be visible to the OOD. The radar horizon need not exceed 30 miles.

Piloting bearings will be taken from the bridge wing peloruses and transmitted by sound powered telephone to plotters. OOD will conduct docking and getting underway operations, and underway replenishment exercises from the bridge wings. Tactical operations will require the OOD to step onto the bridge wing to verify that his vessel can turn safely in the performance of maneuvers. Therefore, it is desirable that there be two optimum points of visual perception of the visual presentation, one for the starboard side at the bridge wing pelorus on the starboard wing, one for the portside at the

9. An auditorium seating approximately 25 people is required in the simulator complex. This space will be used for briefing/debriefing and for exercise observers. A projection of the gaming area is required in the front of the auditorium. The screen should be at least 6 feet high and proportional in width. All ships, navigational aids, landmass, and any other object which the OOD can see or detect by radar are to be visible. This projection is to be as if the observer was in the center of the gaming area looking down from infinity. Symbology will be used only for own ship. Moving targets will have their course and speed adjacent to their ship. The picture is to be north oriented toward the ceiling. Two scales are required, a 10-mile and a 30-mile scale.

10. The entire simulator will be housed in a building designed for that purpose. In the design of the basic building, space and capacity must be kept available for the future addition of two additional bridges. This could be a building add-on.

All spaces require air conditioning. A service elevator will be required for the movement of parts between levels. Halls, passageways, and doors must have at least 36 inches clearance. Entrances to simulated ship spaces are excluded from this dimension stipulation, and will use standard size ship watertight doors.

Electromagnetic interference shielding is not required for security reasons.

Male and female lavatories are required. Shower facilities are not required.

#### LOGISTIC SUPPORT

1. Maintenance Concept. In order that a high level of maintainability can be achieved, the device will be designed for modular replacement of all elements wherever possible, whether they be electrical, mechanical, or electronic. Computer diagnostic routines and test programs to detect and isolate faults to the replaceable module level will be developed. Removed modules will be capable of being repaired by intermediate maintenance level personnel. The device contractor will be responsible for developing routines and a Planned Maintenance System (PMS) covering test and maintenance at both the organizational and intermediate level. Organizational and intermediate maintenance will be performed at the device site. The Navy will provide support and test equipment for the simulator. When fully accepted, the device will be assigned Navy Material Cognizance Symbol 20.

The contractor will be required to prepare and to conform to a reliability program generated in accordance with MIL-STD-785. System reliability will be stated as a goal Mean Time Between Failures (MTBF) and a minimum acceptable MTBF. In addition, a maximum Mean Time To Repair (MTTR) of 30 minutes, exclusive of fault isolation and acquisition of spares, will be considered

2. Repair Parts. Initial repair parts for the simulator will be provided for a period of 180 days by the contractor. Subsequent repair parts will be in the Navy supply system. The contractor will provide the parts required to maintain the simulator during the period of contractor field engineering service. Approximately 6 months prior to delivery of the simulator to the installation site, a provisioning conference will be convened. A list of minimum items to be included in the procurement of the simulator to insure proper support follows:

- . Interim Repair Parts List
- . Support Equipment List
- . Provisioning Parts List
- . Drawings and Vendor Data
- . EAM Provisioning Cards
- . EAM Screening Cards
- . Common Bulk Items List
- . Inventory/Utilization Data Report
- . Interim Repair Parts
- . Support Equipment
- . Initial System Stock
- . Trouble Shooting Guide
- . Recommended PMS
- . List of Non-Standard Parts.

3. Training in the Simulator for Operators and Maintenance. Two primary options are available for long term operation and maintenance of the simulator.

- . Option 1, utilize Navy personnel as both operators and maintainers.
- . Option 2, utilize Navy personnel as operators and Navy civilian field representatives as maintainers.

Option 2 is the recommended procedure for the following reasons:

- . Instructors and selected bridge enlisted personnel will operate the simulator thereby developing a group of highly qualified, trained shiphandling specialists within the Navy who are capable of representing the Navy's point of view.
- . A higher degree of instructor acceptability by trainees, particularly senior officers.

TAEG Report No. 65

- . In the maintenance area, a higher probability of continuity.
- . Specialization of maintenance personnel is practical. Navy personnel, for career reasons, must maintain a broad base of technical expertise, whereas civilian field representatives can concentrate in specific areas.
- . A fewer number of maintenance personnel will be required with civilian field representatives because of the anticipated continuity and specialization.
- . The number of technical, highly complex interrelated systems; i.e., optical, electronic, computer, and mechanical, will require a wide diversity of Navy ratings or a continuous maintenance training program for reliefs. Individual field technicians can be trained across all systems and can provide relief training when and as needed.

Recommended numbers of instructors, operators, and simulator maintenance personnel are based on the proposed option 2. A manning requirements conference will be held within 60 days of design freeze of the simulator to adjust these recommendations as required. Simulator instructors, operators, and maintainers will be given formal initial training prior to the device being used for instructional purposes.

For the simulator to be most cost effective, it is necessary that it be utilized 16 hours per day and be available to maintenance personnel 8 hours per day. In addition, it is planned that the device computer will be energized continuously to preclude the problems which arise during shut-down/energize cycles. To provide for leave, personal emergencies, reliefs during extended periods of operation, and administrative burdens, the following initial manning is proposed.

<u>POSITION</u>	<u>NUMBER</u>	<u>RANK/RATE</u>	<u>QUALIFICATIONS</u>
OIC, Simulator	1	LCDR/LT	SWO
Deputy OIC, Simulator	1	LT	SWO
Instructors	4	LT/LTJG	SWO
Operator Supervisor	3	LT	SWO
Operators	10	QM3/OS3	"A" School
Maintenance Supervisor	1	Senior Technician	TBD
Ass't Maint. Supervisor	1	Senior Technician	TRN



T.A.E.G. Report No. 65

Operator and instructor training will be identical. This training will consist of approximately 2 weeks onsite. The course will be prepared and presented by contractor personnel approximately 8 weeks prior to the Ready For Training (RFT) date. A preliminary curriculum to include aids and devices will be submitted 60 days prior to course convening date for approval. Approval and/or proposed changes will be returned to the contractor 30 days prior to course convening date.

Maintenance training will be two phased, the first dealing with the computer and related peripheral equipment, programming, and diagnostic routines. Phase one need not be onsite, but must include hands-on experience with the simulation computer(s). Phase two of the maintenance training will be approximately 8 weeks in length and conducted onsite. The first 2 weeks of phase two training will be the operator's course and will be attended by all personnel assigned to the simulator. The subsequent 6 weeks portion of the course will be attended only by the maintenance personnel and/or the OIC and Deputy OIC of the simulator.

Initial training courses will be prepared in accordance with MIL-STD-1379 (effective edition).

4. Documentation. To insure complete information is available, the following data and information will be provided prior to commencement of maintenance training. Approved preliminary copies of these documents will be satisfactory.

- . Maintenance Handbook with Parts List
- . Instructor's Guide
- . PMS Publications
- . Complete Computer Documentation
- . Programming Manual
- . Training Device Inventory Records
- . Operator's Handbook

All publications data items will be prepared in accordance with the requirements of MIL-STD-1643 (Navy), Integrated Logistic Support Requirements For Training Devices (upon approval).

5. Service Acceptance/Evaluation Plan

a. The device project team shall monitor the device progress from contract award to device RFT. On a continuing basis, the project team shall



TAEG Report No. 65

b. When identified by appropriate authority, the user of the device shall be requested to designate a Fleet Project Team which will participate as advisors during the procurement cycle of the device. The Fleet Project Team members shall be invited to participate in all pertinent meetings, make recommendations, and have available experienced personnel to assist during device checkout at contractor's plant and on-site acceptance. The Fleet Project Team shall be expected to evaluate the device onsite and report satisfactory or unsatisfactory performance with recommendations for the needed corrections.

c. Operational Test and Evaluation (OTE) and Development Test and Evaluation (DTE) will be required subsequent to on-site acceptance.

6. Installation. To accommodate this device a new building will have to be constructed. A proposed MILCON schedule will be required 5 years prior to RFT.

7. Contractor Technical Services. The device contractor will provide maintenance assistance for a 12-month period. The assistance includes maintenance, on-the-job training, and repair of replaceable items.

a. Maintainability. A maintainability program will be a requirement of the contractor during design and fabrication and will be submitted by the device contractor for approval. It will describe how he is to develop and implement the program. The contractor will be required to demonstrate the achievement of quantitative maintainability specifications. The demonstrations will be performed in accordance with MIL-STD-471, Maintainability Demonstration.

b. Reliability. A contractor developed Reliability Program Plan in accordance with MIL-STD-785 will be specified for this trainer. The program will include provisions for appropriate reliability engineering tasks and reliability testing during development, manufacture, and interim support periods.

TAEG Report No. 65

APPENDIX D  
CONCEPT DESIGN FOR  
SMALL CRAFT TRAINING DEVICE

The material presented in this  
appendix was prepared by:

Gordon Hatchell  
Robert Hamilton  
Scotty Fulk

of

The Naval Ship Engineering Center, Norfolk Division  
Norfolk, Virginia

THE FEASIBILITY  
OF A  
TRAINING DEVICE  
FOR  
SIMULATING  
SHIP HANDLING CHARACTERISTICS

BY  
GORDON HATCHELL,  
ROBERT HAMILTON  
AND  
SCOTTY FULK

APPROVED FOR PUBLIC RELEASE  
DISTRIBUTION UNLIMITED

NAVAL SHIP ENGINEERING CENTER  
NORFOLK DIVISION  
COMBATANT CRAFT ENGINEERING DEPARTMENT  
NORFOLK, VA

## INTRODUCTION

The Center of Naval Analysis' (CNA) studies and the Training Analysis Evaluation Group's (TAEG) Report No. 41 (December 1976) indicate that inadequate training facilities and lack of opportunity exist to train and qualify surface warfare line officers in ship handling and seamanship. The Chief of Naval Education and Training (CNET) has tasked TAEG to develop training requirements and strategy. A craft capable of simulating the operating characteristics of a variety of Naval Ships is a part of the training facilities proposed by TAEG. The study reported herein is in support of the TAEG effort of investigating the feasibility of such a craft.

In order to determine the magnitude of the simulation problem, the tactical characteristics of a number of ship types were reviewed (see Appendix I). The results of this review led to the ship grouping of figure 1. The findings of this study indicate that it is feasible to simulate the mean operating characteristics of the five major groups of Naval Ships in figure 1, both single and twin screw, with a craft of approximately 94 feet overall length.

## APPROACH

This study was concerned with the development of a craft which would serve as a training device for simulating the handling characteristics of naval surface ships. This craft will serve the purpose of reinforcing, illustrating, and practicing the theories of ship handling and seamanship in realistic situations.

Ship handling is defined as "Those situations wherein the conning officer is required to make immediate decisions with respect to the maneuvering of the ship, and outside aids; i.e., CIC, ground tackle (including tugs), navigational aids, etc., are of relatively little value. However, a failure to use outside aids, the improper use of these aids, or the lack of preparation for a situation is poor ship handling" (TAEG Report No. 41). The training craft, as described herein, will provide for the practical application of knowledge of rules of the road, tactical situations (replenishment, station keeping, etc.), mooring and anchoring, with and without tugs (which can be simulated with landing craft), beaching, and evolutions which may lead to a "ship handling" situation.

The operating characteristics of major concern in ship handling (TAEG Report No. 41) are:

- Acceleration/Deceleration
- Advance/Transfer
- Tactical Diameter
- Turning Rate
- Single Screw Effect
- Shaft RPM versus Speed
- Various Response Delays

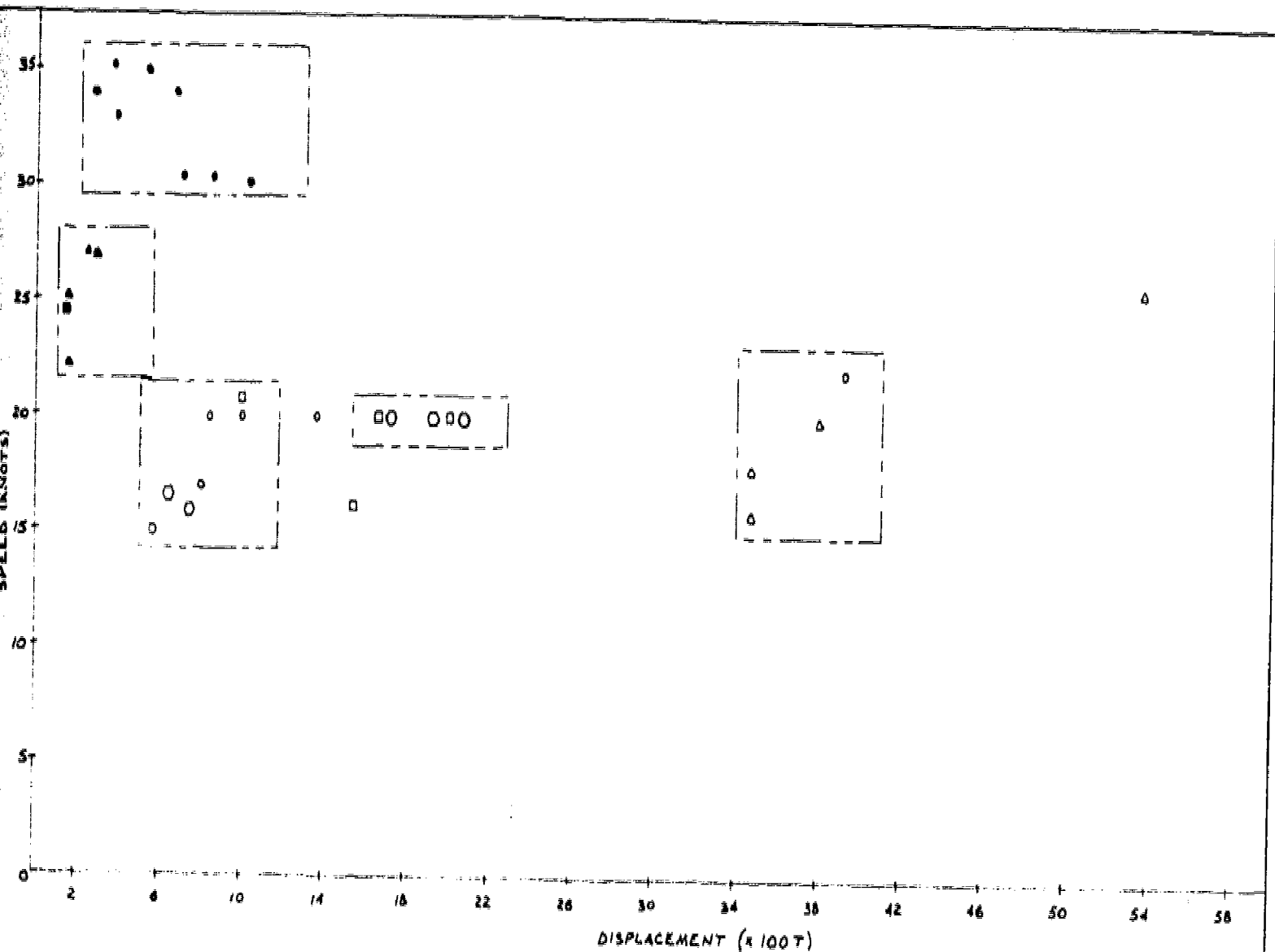

LEGEND

- 2 SHAFB DESTROYERS
- ▲ 1 SHAFB DE
- 2 SHAFB DE
- 1 SHAFB AMPHIP
- 2 SHAFB AMPHIP
- 1 SHAFB SUPPLY/SUPPORT
- ◇ 2 SHAFB SUPPLY/SUPPORT

GROUP OF MAJOR SHIP TYPES

SKETCH No.	FIG
6660-78-0028	1

The desire to provide a training device that can be easily transported to any location at which it is needed, to provide prospective deck officers with realistic ship handling situations, and the ability to operate within the "real world" environment led to the conclusion that a full speed, real time training device will offer the best training with the least requirements for additional and auxiliary support.

It is not meant to imply by "full speed" that this craft will have a maximum speed equal to the flank speed of a destroyer. The purpose of this device is to provide a vehicle for ship handling (seamanship) training. Maneuvers such as underway replenishment, mooring and docking are conducted at speeds below 20 knots. For this reason, and the high cost of additional power, "full speed" as mentioned herein refers to real time speed of various seamanship maneuvers.

Once the decision to provide full speed/real time ship responses in the training device had been made, a check of the possibility of scaling any one response, or group of responses, was investigated to assess the impact on cost and effectiveness of the device. Once again the conclusion was that any scaling of the training device will require a corresponding scaling of its operating environment and, therefore, severely limit the ability to utilize the training device at any location other than one expressly designed to accommodate the scaled response.

The added cost to provide full speed/real time response in the training device is associated with the propulsive power required and, in support of that power, the fuel required to be carried on board and consumed. Since the initial cost of the propulsion plant constitutes less than 15% of the total cost of the craft; the advantages realized in deployability, elimination of the necessity to scale the operating environment, and realistic training are considered cost effective and beneficial to the extent that the design of the training craft incorporates full speed/real time ship responses.

The next step in the development of the preliminary design of the training device was to determine the craft size. The facilities required on the craft include provisions for practical training in the areas of navigation and maneuvering, anchor handling and line handling as well as space for instruction and training critiques. These training requirements necessitated the installation of a pilot house with bridge wings, anchors and a windlass, signal halyards and lights, a CIC complex and a classroom. A second CIC is desirable in order to provide competitive training in course plotting and other navigation tasks.

The main deck envelope (overall length beam) was sized to accommodate the following:

- Classroom
- Forward Anchor Handling
- Aft Anchor Handling
- CIC
- Access to Torpedo Area

### Below Main Deck

- Boatswain Storeroom
- General Stores Storeroom
- CIC
- Two Watercloset Spaces
- Office
- Engineroom
- Auxiliary Machinery Area
- Underway Replenishment Gear Storeroom
- Lazarette (Emergency Steering)

### Above Main Deck

- Pilot House
- Bridge Wings
- Signal Bridge
- Underway Replenishment Station

The challenge in determining feasibility is incorporating the desired features in a minimum cost safe system configuration. A range of hull sizes (length and beam) were studied to determine the internal volume and deck area available for the training function. For a number of arrangements vertical centers of weight were established so that transverse stability could be calculated and requirements could be satisfied by adjusting the beam of the hull.

After the craft was configured, the overall stability of the craft was considered. Weight and stability calculations confirm that the craft is stable as presently configured. Rails and stanchions are being utilized over most of the deck house top and all around the pilot house top to reduce the sail area. Significantly increasing the sail area or vertical center of gravity may lead to an undesirable reduction in stability; therefore, issuing or allowing the use of decorative canvas on the rails and stanchions of this craft could be detrimental.

The following systems or equipment are not required as part of this training device:

- Armament, small arms, or pyrotechnics
- Galley or galley equipment
- Berthing facilities
- Shower facilities
- Refrigeration
- Infrared

### PROPOSED METHODS FOR VARYING MANEUVERING ACCELERATION RESPONSES



same manner and in the same time frame as a designated group of ships. As an example; twenty degrees of rudder causes a destroyer to turn in a tight circle and to begin the turn almost instantaneously. The same rudder angle applied to a fleet oiler produces a turn of much larger diameter and the turn begins much longer after the rudder angle is applied.

In order to produce all of these different reactions from one training craft the following mechanical adaptations are proposed:

.The rudder angle indicated at the helm will be controlled by the wheel.

.The angle that the rudder actually moves, in response to the wheel, will be varied by shortening or lengthening the tiller length (see figure 2).

.The response of the engine will be similarly adapted to simulate ship response to throttle movement (see figures 3 and 4).

The adaptation of rudder response to wheel command and engine response to throttle command will permit the training craft to simulate real time ship response.

In order to simulate both twin screw and single screw ships the following propulsion plant arrangement will be used:

Three engines, two outboard and one centerline will be installed. The engines will be of sufficient horsepower so that the utilization of two engines will deliver full craft speed.

When simulating twin screw ships, the two outboard engines, with counter rotating propellers, will be used. The centerline engine will not be used and will be allowed to windmill.

When simulating a single screw ship the centerline engine will be used at full power and, in order to provide the necessary total propulsive power, the two outboard engines will be run at approximately half power each. This will provide the side force or "kick" of a single screw ship.

## CRAFT CHARACTERISTICS

### Principal Description

The 94 Ft. training craft is a triple screw, semi-displacement craft providing a training capability for naval officers in ship handling and seamanship. This craft will provide more realistic situations in ship handling situations than the boats currently in use.

### Material

Craft construction will be in accordance with ABS specifications with

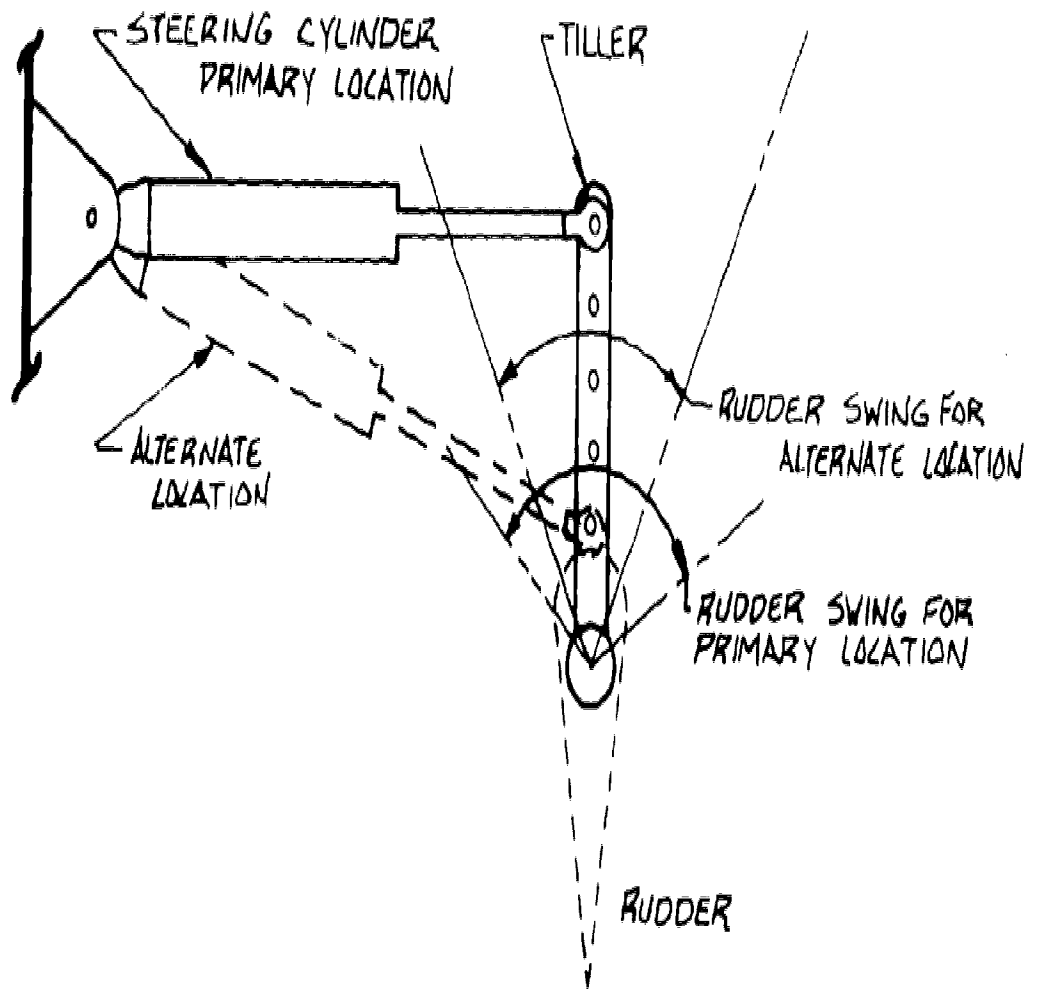

## METHOD OF VARYING RUDDER ANGLE

97

SKETCH NO.	FIG.
6660-78-0029	2

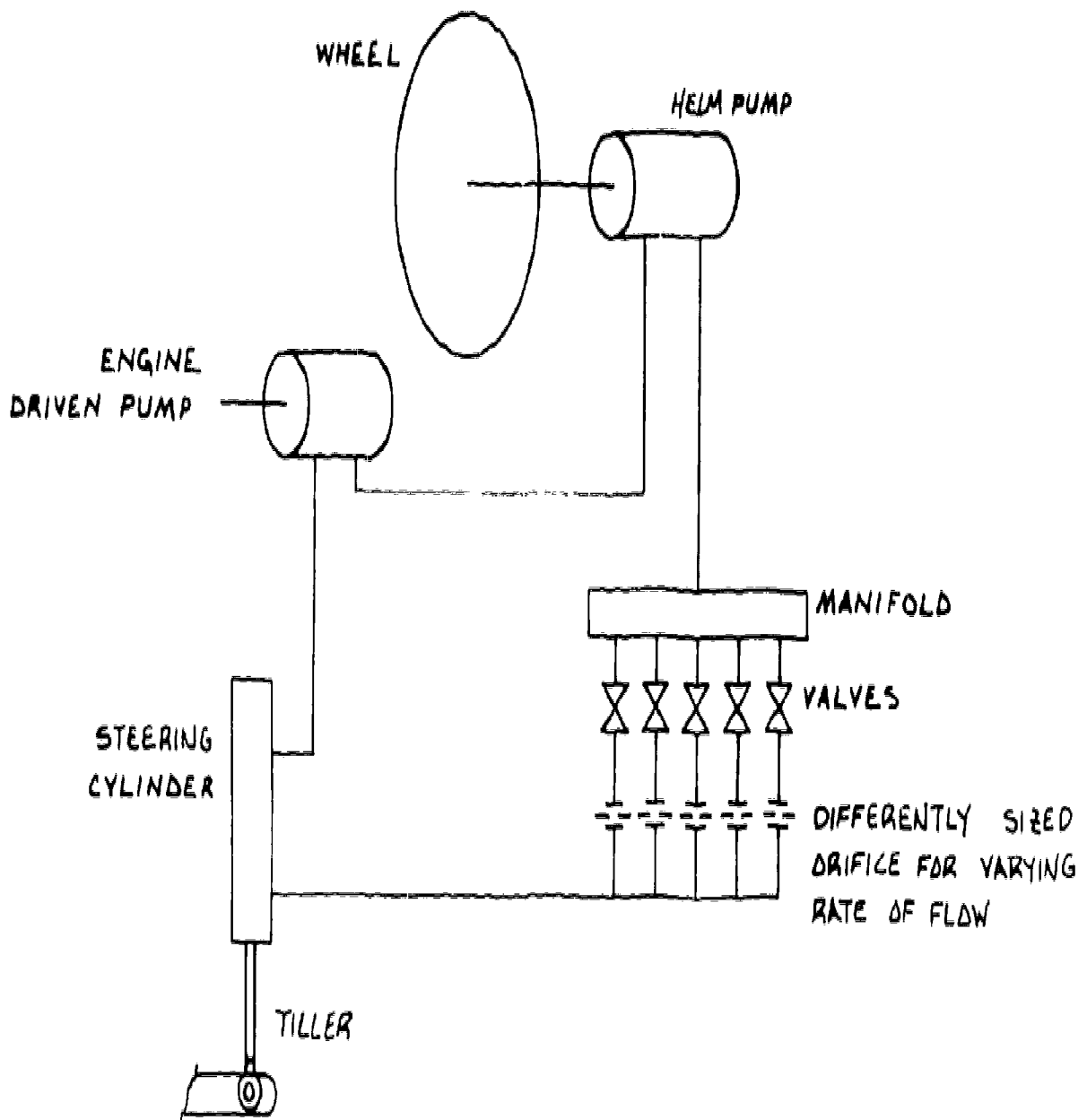

## METHOD OF VARYING RUDDER RATE

ONE SIDE OF SYSTEM  
SHOWN

SKETCH NO.	FIG
6660-78-0030	3

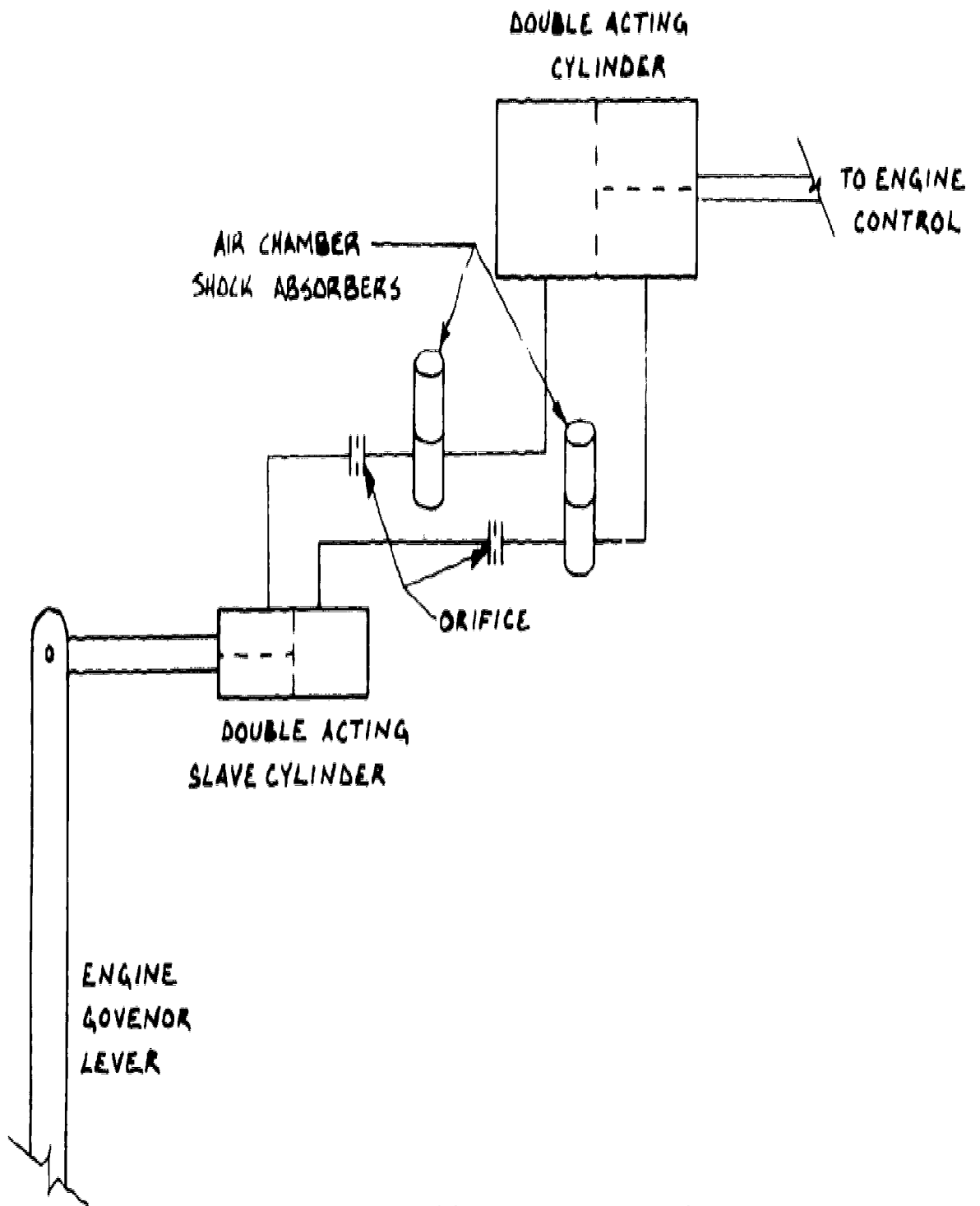

**SPEED CHANGE DELAY**

SKETCH No.	FIG.
6660-78-0031	4

## SPECIAL FEATURES

Engine control for simulation purposes  
Rudder control for simulation purposes  
Classroom for onboard instruction/critique  
Two (2) CIC's for competitive charting and course keeping  
Helm Control Console similar to new naval ships  
Underway Replenishment Kingpost  
Signal Bridge  
Interior Communication System  
Two (2) forward anchors in hawse pipe,  
One (1) stern anchor in hawse pipe

## Personnel

Total of 46, as follows:  
4 instructors (officers)  
2 crew (enlisted personnel)  
40 trainees

## SYSTEMS

Propulsion - Three (3) diesel engines (1200 hp each); Three (3) propellers, fixed pitch.

Fuel - 9000 gallons diesel fuel.

Fresh Water - 500 gallons fresh water; 20 gallon hot water heater, quick recovery type.

Electrical - Diesel driven ship service generator (30 KW or larger); 24 volt batteries; 24 VDC Alternator.

Steering - Hydraulic steering will be from the pilot house with emergency steering from the lazarette.

Environmental Pollution Control - Sanitary drainage system delivers macerated waste to holding tank for dockside discharge.

Plumbing Drainage - Two segregated systems: One serves lavatories, drinking fountains, deck drains, etc. and the second serves the sanitary system.

Heating, Air Conditioning, and Ventilation - Individual forced air electric heaters; Unit coolers (if required due to operating location); Natural ventilation inlets and exhaust blowers in each manned space; Window defogger system.

Fire Protection - Halon system in engine room; CO<sub>2</sub> and Purple K - portable extinguishers throughout.

Bilge - An oily-water separator and pump will be installed.

NOTE: See Appendix 2 for alternative to triple screw propulsion system.

## EQUIPMENT

The following is a listing of the major equipment required for the training craft. The cost listed is in 1978 dollars. The cost does not include installation labor, cabeling, piping or associated hookups.

<u>Equipment</u>	<u>Qty</u>	<u>Source</u>	<u>Cost Per Unit</u>	<u>Comments</u>
1. Engines	3	Stewart & Stevenson	\$85,000	16V-92MT1 (See Appendix 2)
2. Radar	1	Raytheon	10,300	AN/SPS46
3. Video Amp & Remote Radar Scopes	2	Raytheon	6,210	For AN/SPS46
4. Fathometer/Alarm	1	Raytheon	1,425	Digital Readout
5. Aux. Fathometer Readouts	2	Raytheon	345	For Fathometer
6. Gyro Compass	1	Sperry	12,000	MK27 MOD1
7. Gyro Signal Amplifier	1	Sperry	4,050	For Gyro Remotes
8. Gyro Repeater with Pelorus	3	Sperry	2,800	
9. Gyro Repeater	2	Sperry	1,500	
10. Intercom System	1			
11. Anemometer	1	Kenyon	350	WS200
12. Anemometer Aux. Readout	2	Kenyon	240	For Anemometer
13. Speed Log	1	Sperry	15,000	
14. Aux. Log Readout		Sperry	800	
15. DRT	2		25,500	
16. DRA	2		76,500	
17. HF/UHF-VHF Radio Transceiver	3			
18. Mufflers	3	Burgess Industries	3,407	

Based on FY 78 bid prices of \$49,000 material costs and \$77,000 labor costs for hull construction on a 100' Steel Torpedo Weapon Retriever; the estimated FY 78 hull construction becomes  $94/100 \times \$126,000 = \$118,500$ .

## GENERAL ARRANGEMENTS

The training craft will have 4 deck levels: a platform deck, main deck, deck house top and the pilot house top. Arrangement drawings are as shown in Appendix 3, figures 14-18.

### Platform Deck

The Platform Deck is divided into 8 watertight compartments. The usable compartments in order from the bow are the: Boatswain Storeroom, CIC, Vestibule with watercloset and office area, Engineroom, Storeroom, and Lazarette.

The void area and first bulkhead provide flooding protection for damaged stability in the bow area. The port and starboard chain lockers, as described in the Anchor Handling, Mooring, and Towing Section, are installed in the Boatswain's Storeroom. The remainder of this space will be outfitted with shelves with portable battens, pipe jack rods, and hooks for blocks and tackles. Access will be from the main deck.

The General Storeroom will be used for stowage of supplies. Built in shelves with battens on the shell and lockers and bins for general stowage will be provided. Exact types, quantities and size of stowages will be determined during the final design and may dictate smaller storeroom areas. Access to this storeroom will be from the CIC.

Two CIC's (non-combatant) are required for plotting and charting courses in competition. One of the two required CIC's will be installed aft of the General Storeroom. The second CIC will be located on the main deck in the forward portion of the deck house. The primary function of the CIC's will be to train the ship handling team in evolutions involving maneuvering in company, harbor operations, and rules of the road. The major emphasis is the support of the CIC to the CO. Each CIC will require the following major equipment:

- Dead Reckoning Tracer (DRT)
- Dead Reckoning Analyzer (DRA)
- Radar Repeater
- Gyro Repeater
- Anemometer Repeater
- Fathometer Repeater
- Speed Indicator
- Rudder Angle Indicator
- Clock
- Plotting Board
- Edge Lighted Status Board
- HF/UHF and VHF Radio Transceivers/Remotes
- Intercom Stations
- Sound Powered Communication Stations
- Voice Tube to Pilot House

A curtain will be installed around the door to provide a light trap to prevent white light from spilling into the CIC.

The next watertight compartment contains 2 waterclosets, an office and serves as a passage for access from above to the engineroom, CIC, waterclosets and office.

In each of the 2 waterclosets, a control volume-flush toilet (with flush valve, timing relay and transfer pump), a lavatory with hot and cold water self closing faucets, a mirror and a shelf will be installed. A bulkhead



will be installed between the toilet and lavatory with an opening as shown on the drawings. A curtain will be added across this opening. A soap dish, grab rods and paper holder will also be installed.

The office will be an onboard space for general office duties and file area for boat related manuals and maintenance records. There will be one desk and chair, 3 file cabinets, one safe/locker, and one bookrack. The access will be secured with an accordion type folding door.

In the passage there will be a drinking fountain (salt tablet dispenser over), a bulletin board, and a cleaning gear locker.

Aft of the vestibule area is the main engine and generator room. This compartment will contain the main propulsion units, generator, hot water heater and miscellaneous support equipment. Exhaust from the engines will be piped aft, out the transom. A workbench for minor repairs, with stowage under for needed tools, will be provided. Access will be from the vestibule with emergency exits to the main deck.

An aft boatswain and underway replenishment storeroom will form the next watertight compartment. Access will be from the main deck. In this storeroom reel stowage will be provided for UIREP lines, in addition pipe jack rods, hooks for blocks and tackles, and shelves and bins for stowage of repair parts and other miscellaneous items will be provided. Exact types, quantities, and sizes of stowages will have to be determined during the final design phase.

The Lazarette, with access from the main deck, will be the remote emergency steering station. A hawser reel for the towing rope and bridle will be located here. A sound powered communication station will also be installed.

Below the platform deck will be the fresh water, fuel and sewage holding tanks. The fresh water and fuel tanks are to hold enough water/fuel to provide for about a 3-day operation (minimum). Pierside fillup will be on an as-need basis.

The location of the fuel and fresh water tanks will be as close to the longitudinal center of gravity as possible to prevent major changes in trim as fuel/water are consumed. Necessary manholes will be provided in the platform deck for access below. In the engine room, a grating will be installed wherever possible to provide maximum walking access.

### Main Deck

The deck house containing the CIC, cross ships passage and instructional space will be located on the main deck. On the outside perimeter of the deck house will be a pipe handrail. Also two lockers, one port and one starboard, for life jacket stowage will be provided. (Life jackets of the vinyl encapsulated foam, similar to Gentex Corporation, Model DS 807-7 are recommended.) Two life ring buoys with attached lights and lines will be installed on the after portion of the deck house and one on the forward bulwark adjacent to the jackstaff.

In the forecandle area, in the proximity of the anchor windlass, a sound powered telephone station will be installed on the bulwark.

Exterior to the deck house aft will be a deck stowage/damage control and a life jacket locker. In the vicinity of the stern towing pad, at the fantail, a sound powered communication station will be provided.

Inside the forward portion of the deck house will be the second CIC. This CIC will contain the same equipment as the CIC located on the platform deck and will be arranged in the same manner to permit easy interchangeability

of trainees and instructors without having to learn new arrangements. A light proof, louvered vent will be installed to provide natural ventilation when weather permits.

A cross ships passage, with hatch for access below deck, will be installed aft of the CIC. In addition, a dresser to be utilized as a coffee mess will be installed. This dresser will have a sink, hot/cold water supply, coffee urn, and the option of a small refrigerator under.

An instructional space for teaching and reviewing exercises is located in the aft portion of the deck house. This classroom will have tables and chairs for 20 trainees. In addition a chart table and stool will be provided for the instructor. A blackboard and clock will be mounted behind the instructor on the forward bulkhead.

### Deck House Top

The Pilot House, Bridge Wings, Signal Bridge and Underway Replenishment Station are located on the deck house top.

The Pilot House will serve as the primary control station for the craft. An integrated console, similar to that being used on newer ships (see figure 5), will be installed to house the helm, direct engine controls, navigation and exterior lights switchboard, siren and navigation horn actuators, engine RPM indicators, master gyro compass, magnetic compass and rudder angle indicator. There will be direct speed control from the helm station to the engines (secondary controls in the engineroom will be provided for emergency and maintenance operations).

A fathometer, anemometer, rudder angle indicator, engine RPM indicator, and speed indicator will be overhead mounted for OOD, helmsman, and instructor observations. A gyro repeater and radar display unit will be on the forward bulkhead.

Other equipment required will be a HF/UHF and VHF transceiver, sound powered communication circuits, intercom stations, voice tubes to the CIC's and clock. A plotting board and quartermaster's desk will be installed in the aft portion of the Pilot House. Adjacent to the quartermaster's desk will be the remote set of diesel operation gauges and alarms. A remote Halon release/alarm will also be located here. List and trim clinometers will be installed on appropriate bulkheads.

Fixed windows forward, with heated windshield and wipers, and sliding windows port and starboard, will allow 180 degree viewing from inside the Pilot House.

Doors, port and starboard, from the Pilot House lead to the Bridge Wings. Bulwark mounted gyro compass repeaters and a sound powered communication station will be provided on both Bridge Wings. On the aft portion of each Bridge Wing there will be mounted a 7 inch signal light.

Behind the Pilot House is the Signal Bridge. The Signal Bridge will be a 36 inch raised platform to afford 360 degree viewing for the signalman. A weatherized log desk and binocular container will be installed on the aft railings of the Signal Bridge. A sound powered communication station and intercom station will be installed. A life jacket locker will be installed under the platform.

One double-banked flag board for a 3 signal halyard operation (P&S) will be installed aft of the Signal Bridge.

A kingpost for underway transfer of light loads (not to exceed 50 pounds) will be permanently installed aft, as shown on drawings, with associated fair-leads and deck attachments. The craft will have port or starboard delivery and receiving capability.

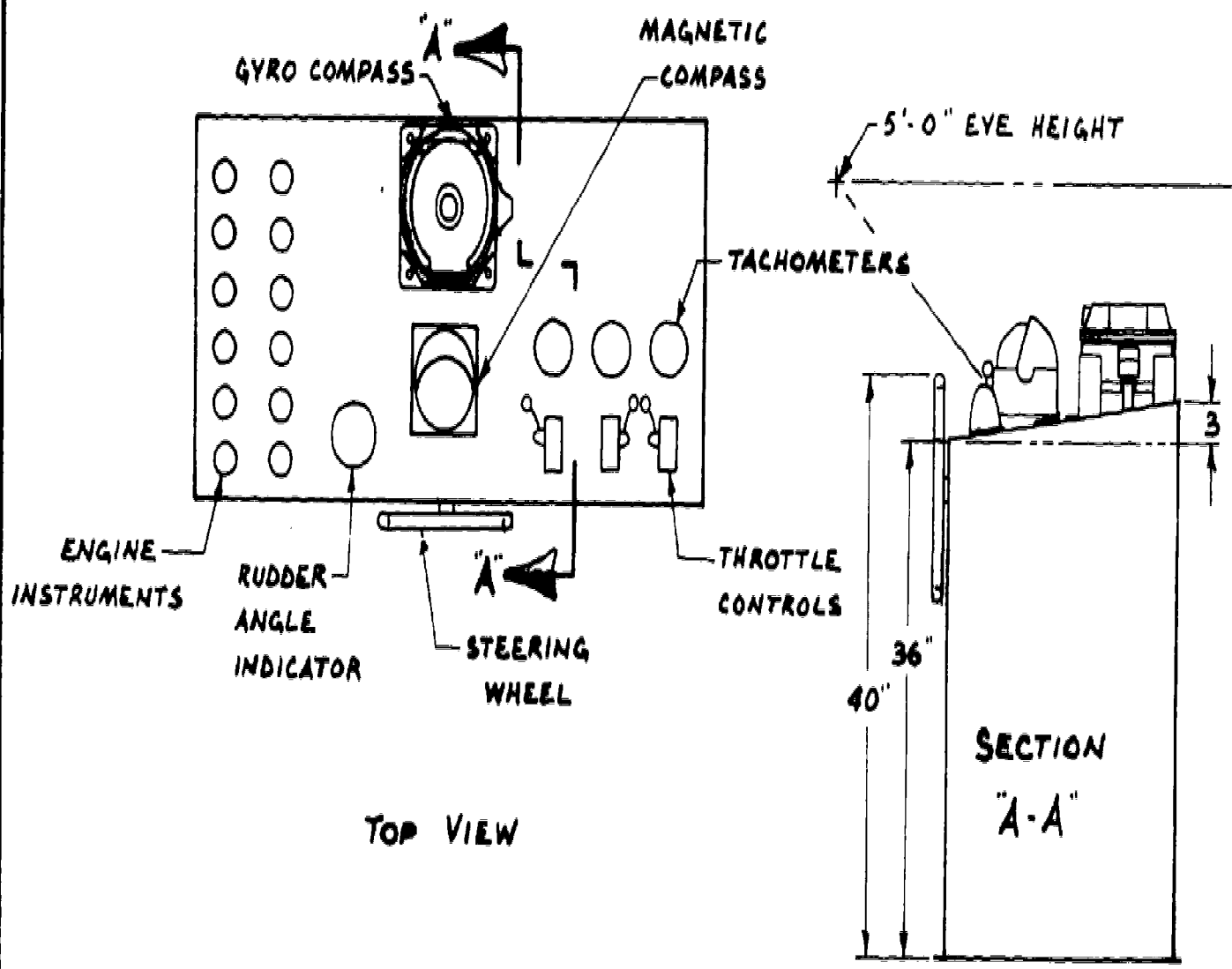

TOP VIEW

SECTION "A-A"

CONTROL CONSOLE

SKETCH NO.	FIG.
6660-78-0032	5

## Pilot House Top

The Pilot House Top, though not intended to be a manned area for stability reasons, will have fixed rails all around with vertical ladder access from the Signal Bridge. However, a sound powered communication station will be installed so that an OOD (or instructor) may take a higher vantage point during critical maneuvers. It is not meant to be an observation point for other trainees.

## Mast

A mast, which will serve for mounting antennas, navigation lights, the radar antenna, and yard arm signalling halyards, will be installed on top of the Pilot House (foundation to extend below). The mast will be fitted with ladder rungs for access to the top. The Signal Yardarm will provide accommodations for three hoists, port and starboard. The gaff will be provided with one hoist for the national ensign, command pennants, or personal flags.

## Miscellaneous

Rubber upper and lower guards (fenders) and a bow fender will be installed as shown on the drawings. These will provide basic hull protection during training exercises.

For semi-displacement hulls at higher speeds, roll instability can induce directional instability. Therefore, spray rails are installed port and starboard to improve the directional stability of the craft. A bilge keel, port and starboard, is installed to improve overall roll stability.

There will be a port, starboard, and centerline propeller (propeller shaft angle not to exceed 12 degrees from the baseline). A centerline skeg will be installed for protection for the propellers and the centerline rudder.

Shipping accesses for major equipment will be provided. Exact location and size will have to be determined during the final design process.

Two 25 man inflatable rafts will be installed on the bridge wings (one port and one starboard). Oxygen Breathing Apparatus (OBA) and damage control lockers will be installed as required.

## SYSTEMS

The following present a brief overview of the key systems installed on this craft for the purpose of better evaluating the overall capabilities and cost of this training craft.

### Navigation and Tracking System

A navigation horn and ships bell will be installed on the Pilot House structure (Top) with navigation horn control button located on the helmsman console. The horn shall be capable of 360 degree sounding for a minimum range of 2 miles.

One sealed beam searchlight, controlled from the pilot house, will be installed as a navigation searchlight.

A master gyro compass (MK 27, MOD 1) and 5 remote units will be installed. The master gyro compass and one remote will be in the Pilot House; the master located on centerline in the helmsman control console and the remote bulkhead mounted on the forward bulkhead at centerline. Two remotes will be bulwark

mounted on the bridge wings - one each port and starboard. The remaining two remotes will be installed in the CIC's - one in each CIC (bulkhead or deck mounted). The gyro compass will feed input to the plotting and dead reckoning equipment.

One magnetic compass will be installed in the helmsman's console for both OOD and helmsman viewing.

Navigation lights will be installed in accordance with the requirements of "Regulations for Preventing Collisions at Sea" (Title 33, United States Code, Sec 1051-1094). Control of all navigation lights will be from the helmsman's console in the Pilot House.

A rudder angle indicator with 3 remotes and a fathometer with 2 remotes will be installed. The Pilot House and each CIC will have one of each installed for easy viewing. In addition, one remote rudder angle indicator will be installed in the helmsman's console.

An underwater speed log will provide a means of measuring the speed of the craft through the water and for transmitting this data as speed in knots to remote indicators and to other systems equipments.

The radar unit with antenna, master, and two remote display units, featuring variable range marker and true bearing, will be installed. One unit will be installed in the Pilot House (adjacent to the forward bulkhead) and one in each CIC.

### Underway Replenishment

Ships of the United States Navy receive logistic support by means of Underway Replenishment (UNREP). This enables the ships to operate at sea for prolonged periods. The primary aim is the safe delivery of the maximum amount of cargo in a minimum of time.

The tending of both the highline and distance line plus compensating for the interactive forces between two craft, calls for a high degree of seamanship and experience. In addition the approach, station keeping, and breakaway requires the execution of theory learned in the classroom. It is with this in mind that facilities will be installed to execute an underway highline transfer of a light load (not to exceed 50 lbs.) between craft.

One centerline kingpost will be permanently installed on the Deck House Top to provide capability to deliver or receive a highline transfer to either port or starboard (but not simultaneously) (see figures 7 and 8).

Lines will be led through fairleads from the kingpost to the deck with crew handling of the lines and load on the same level. The life lines will be portable to facilitate removal during UNREP exercises.

The kingpost will have an open chock on top to allow pendant fittings to pass. Necessary fittings required will be similar to those shown in figure 6. To provide open access on the deck when UNREP exercises are not being accomplished, Baxter Bolts, similar to figure 9, will be utilized. When not in use the Baxter Bolts can be unscrewed from their sockets, turned over, and reinserted in the socket with the padeye down.

Sound powered circuit outlets will be located in the vicinity of the UNREP kingpost.

### Anchor Handling, Mooring, and Towing

The anchor handling system will be similar to that found on larger Naval Surface Ships. By stowing the port and starboard anchors in hawse pipes, it will be easy to practice both anchoring and weighing anchor using all the tackle that would be required for the larger ship. An example of

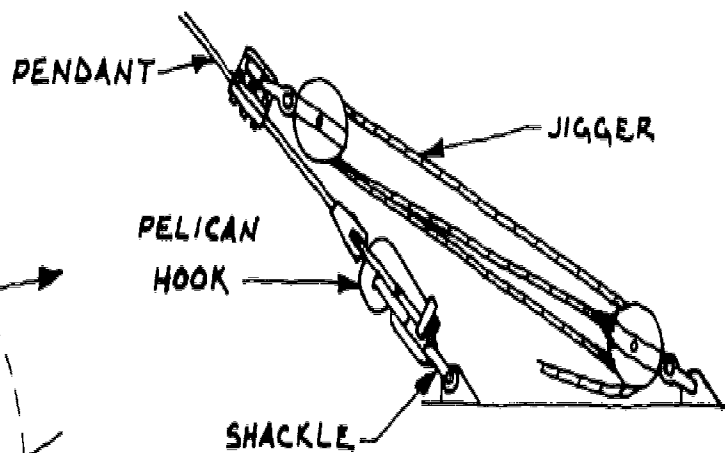
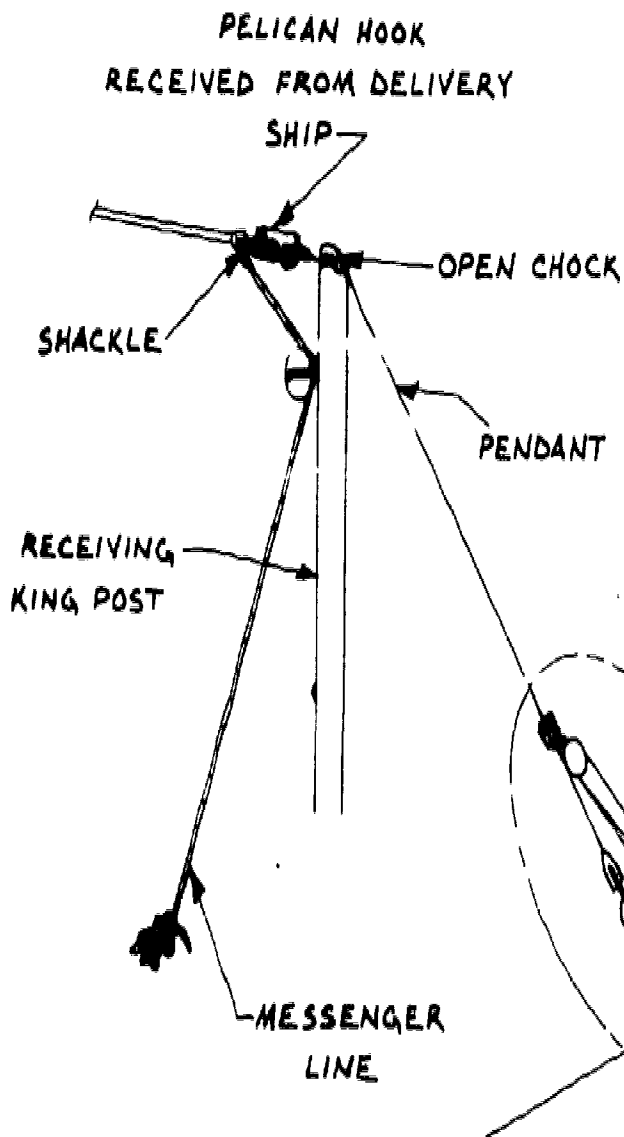
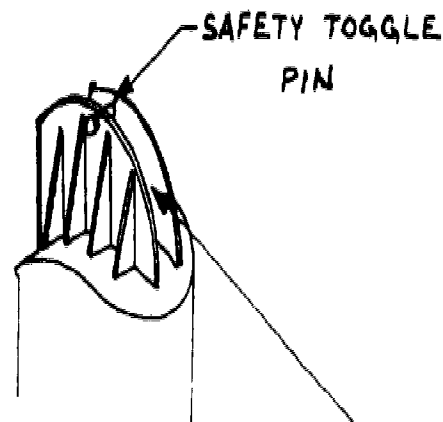
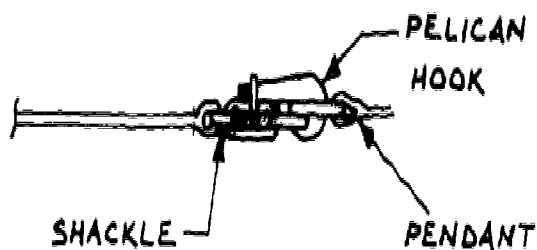

SECURING THE UNDERWAY TRANSFER RIG

112

SKETCH No.	FIG
6660-78-0033	6

113

103



RECEIVING SHIP----- (STBD SIDE OPERATION)

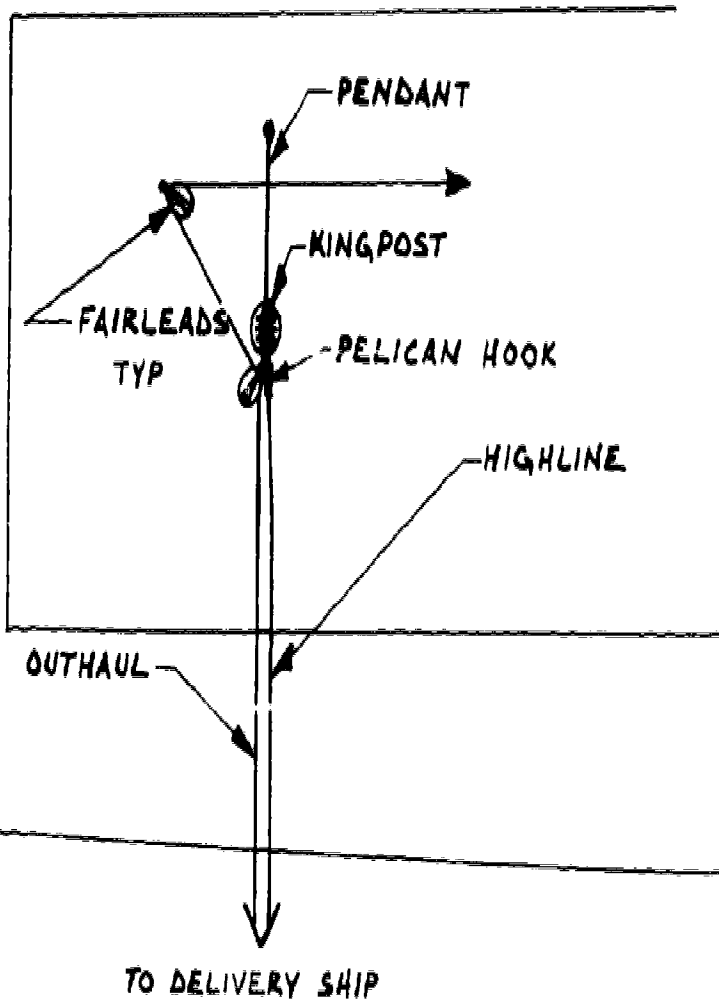

104

115

114

SKETCH	FIG
6660-78-0034	7



TO RECEIVING SHIP

INHAUL  
LINE

HIGHLINE

FAIRLEADS TYP

KINGPOST



DELIVERY SHIP ----- (PORT SIDE OPERATION)

116

SKETCH No.	FIG
6660-78-0035	8

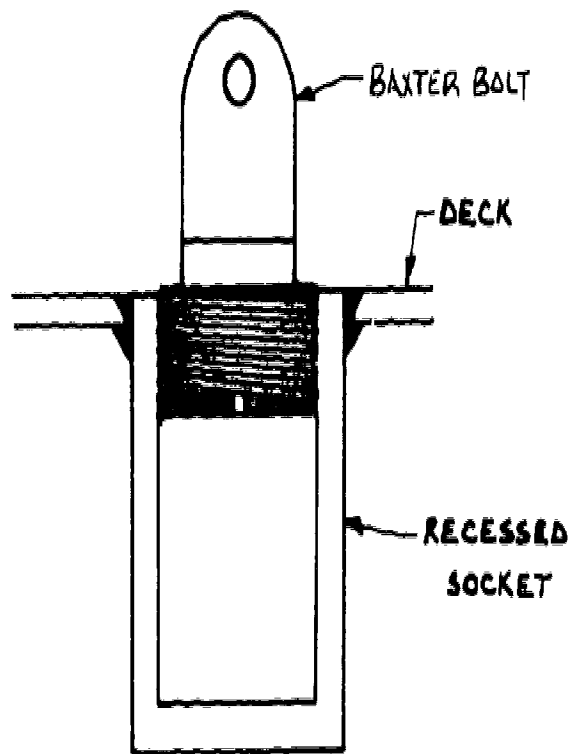

WORKING POSITION.

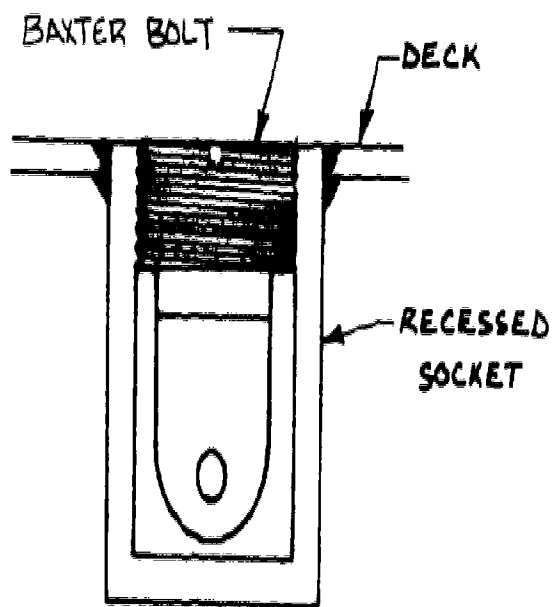

STOWED POSITION

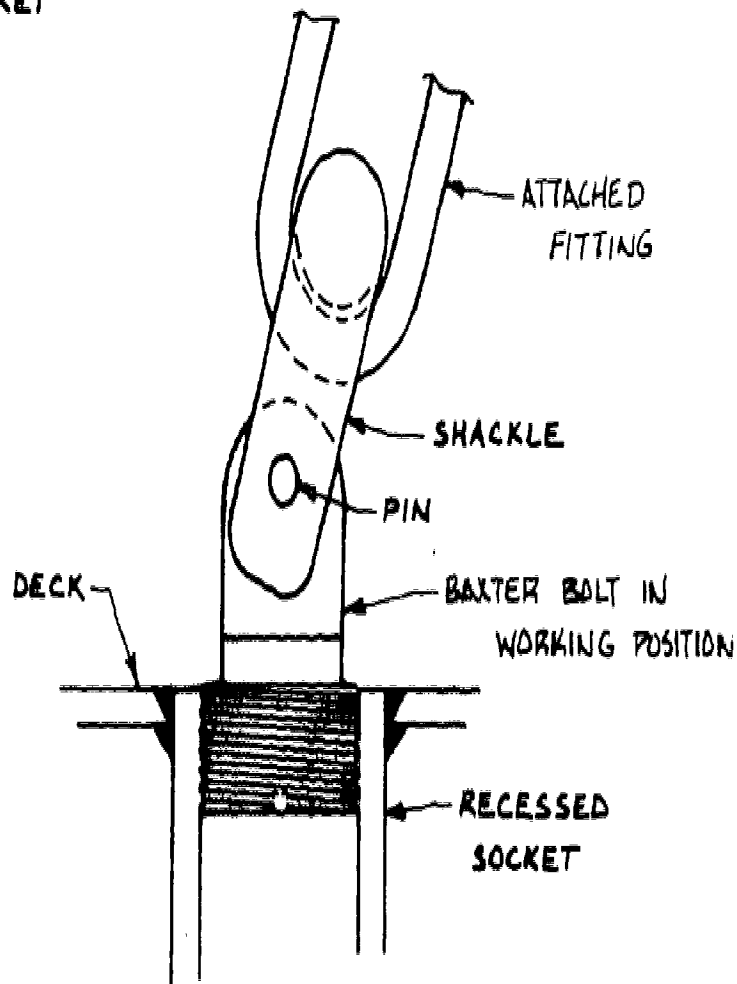

BAXTER BOLT FAIRLEAD

SKETCH No.	FIG
8660-78-0036	9

training would be weighing anchor. When heaving in, the windlass and chain can be relieved of considerable strain by judicious use of engines and rudder. To accomplish this, the forecastle detail must keep the bridge fully informed as to how the chain tends and when the anchor has broken loose. If the chain were to cross the bow, it could be cleared by stopping the windlass and going astern.

Using the anchor for open water mooring is done very frequently. This craft's anchor handling will be designed for use in various moorings similar to the "Eldridge" or "O'Neil Method".

The proper execution of the mooring depends on training, knowledge of the system and a close working relationship with the navigator, OOD, and the officer in charge at the forecastle.

Utilizing this craft's pier mooring capability will enhance the knowledge gained by the potential OOD on use and purpose of the various mooring lines. Current and wind are major factors to be encountered in docking and undocking, but when properly utilized these variables can benefit the procedure.

### Anchor Handling Equipment

Forward - There will be one anchor windlass of the double wildcat type. Two Danforth type anchors will be installed with approximately 50 fathoms of chain for each anchor. Anchor chain will be divided into two 25 fathom shots connected by a detachable link and fitted with a large link, shackle, and swivel at each end. The port and starboard hawse pipe will have a compatible chain stopper arrangement installed and be of sufficient size to allow passage of a mooring swivel.

Two separate, port and starboard, chain lockers will be provided for self-tiering stowage of the required length of chain. The locker will not only provide ample volume for the chain but will also have sufficient headroom above the chain pile to facilitate paying out chain. Chain pipes will extend from the chain locker to the main deck. Chain stoppers and deck pads will be installed.

Aft - One Danforth type anchor will be installed aft for use in beach approach and retraction exercises. The anchor will be installed on a short length of chain attached to 150 feet of wire rope. The wire rope will be attached to a hydraulic winch for release and hauling in. The anchor will stow on the transom of the craft for use in LST beaching simulation though the craft is not intended or designed to be completely beached.

### Mooring Equipment

A Bull Nose, 5 starboard chocks, 5 port chocks, and a centerline stern chock are provided for the basic seven-line pier moor. Towing bits forward, mooring bits port and starboard, and a stern centerline mounted bollard will be installed for securing the mooring lines.

Nylon mooring lines will be approximately 15 fathoms long with a 36 inch eye on one end and whipped on the other end.

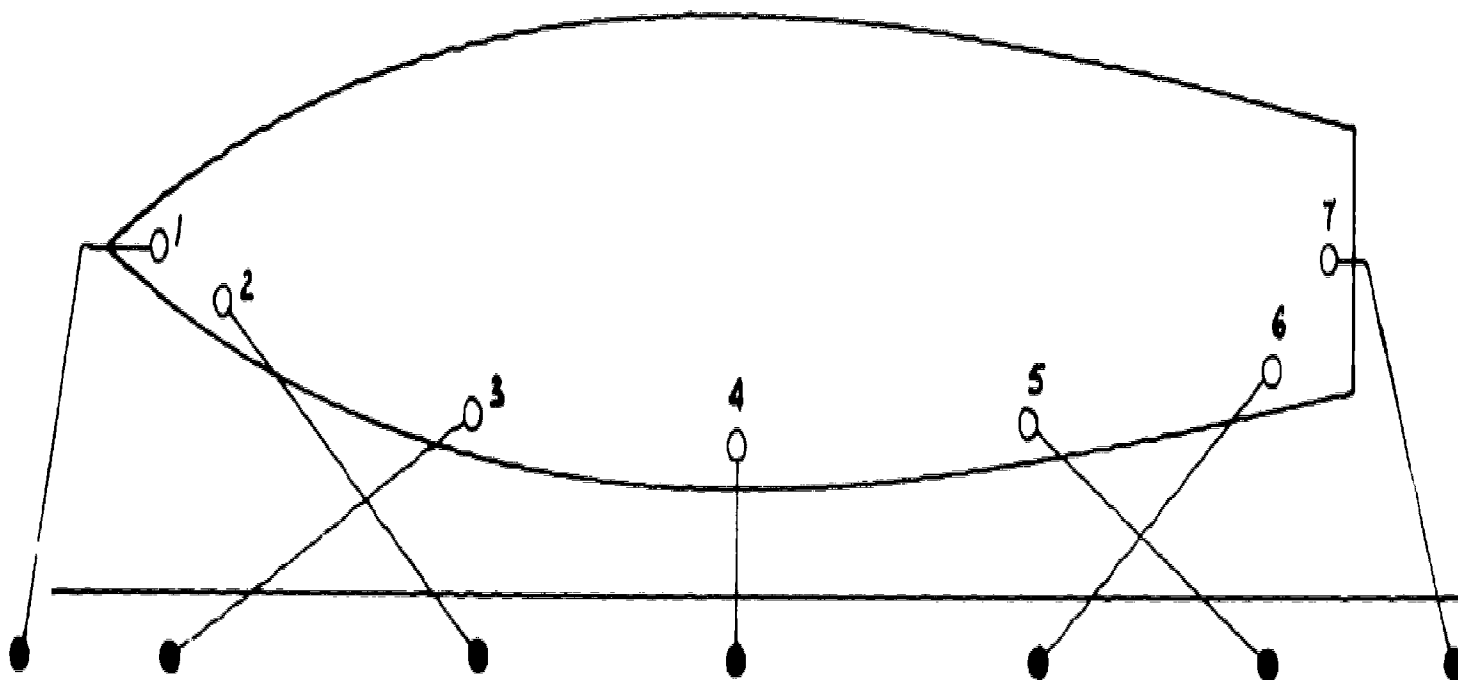

## MOORING LINE ARRANGEMENT

- 1) BOW LINE
- 2) AFTER BOW SPRING
- 3) FORWARD BOW SPRING
- 4) WAIST BREAST
- 5) AFTER QUARTER SPRING
- 6) FORWARD QUARTER SPRING
- 7) STERN LINE

SKETCH No.	FIG.
6660 - 78 - 0037	10

### Towing Equipment

A towline with a towing bridle will enable this training craft to be towed by another boat (or training craft). A stern mounted towing pad will enable this craft to tow another boat. A typical towing configuration will be similar to that shown in figure 11.

### Interior Communication System

A sound powered communication system will be provided. The location and circuits required are listed below. The system will have a circuit E - call system to provide a means of signalling between the sound powered stations. The system will consist of a jackbox with head/chest set or hand set (as appropriate to location) and bell/buzzer for the call signal device.

The following circuits will be installed:

- Circuit 1: To simulate the maneuvering, docking and UNREP circuit.  
Stations: Pilot House Top, Pilot House, Bridge Wings (port and starboard), Forecastle, Fantail, CIC's, Lazarette, Signal Bridge and Underway Replenishment.
- Circuit 2: To simulate Engineer's circuit.  
Stations: Pilot House, Engineroom, Lazarette.
- Circuit 3: To simulate Anchoring circuit.  
Stations: Pilot House, Bridge Wings (port and starboard), Forecastle, Fantail.
- Circuit 4: To simulate CIC information circuit.  
Stations: Pilot House, Bridge Wings (port and starboard), CIC's, Signal Bridge.

An intercom system with outlets in the Pilot House, Classroom, CIC's, Office and in the vicinity of the Signal Bridge, Fantail and Forecastle will be installed. The CIC's will be able to talk back over this system.

A voice tube system will be installed between the Pilot House and each CIC.

In addition, for pierside usage only, boat connections will be made for a dial telephone to be located in the Pilot House and Office.

An alarm system for all lubricating and circulating systems will be installed in the engineroom with remote alarms/gauges installed over the quartermaster's desk in the Pilot House.

### Power and Lighting

Pierside electric power for 110 volt service will be provided by a ship to shore power connection with underway power provided by a diesel-driven generator. A 24 volt DC system will be supplied from a 24 volt battery with battery charging provided by engine driven alternators or a rectifier. Complete power distribution circuits, with associated panels and breakers will be installed to feed all electric equipment and machinery, IC components and, lighting fixtures and receptacles.

Lighting fixtures will be installed in compartments and spaces to provide general illumination. Quantity and type will vary with compartment use. In addition special interior lighting will be provided for the Pilot House and CIC's for darkened ship operations.

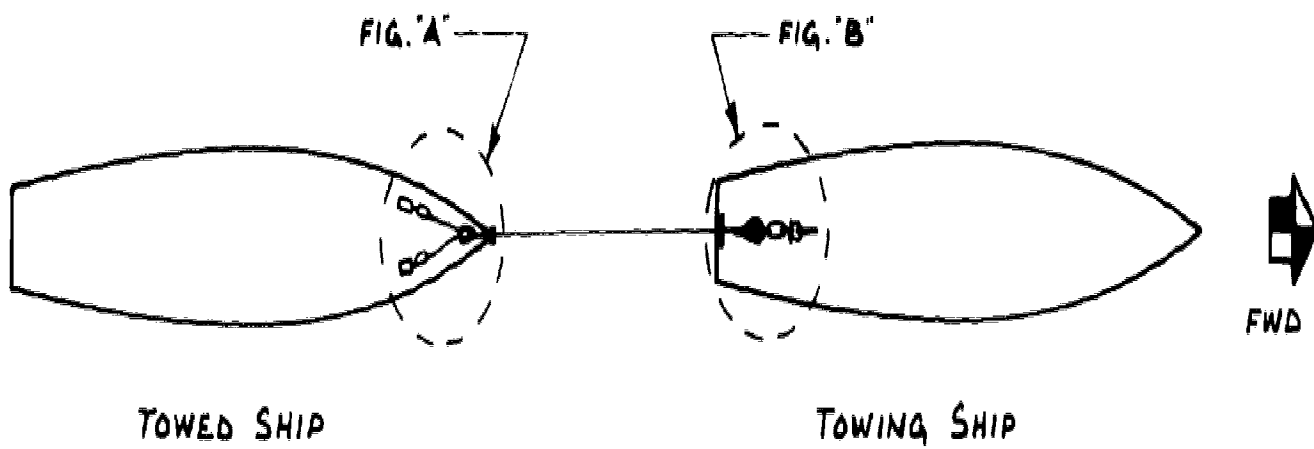

TOWING ARRANGEMENT

121

SKETCH NO.	FIG.
6660-78-0038	11

125

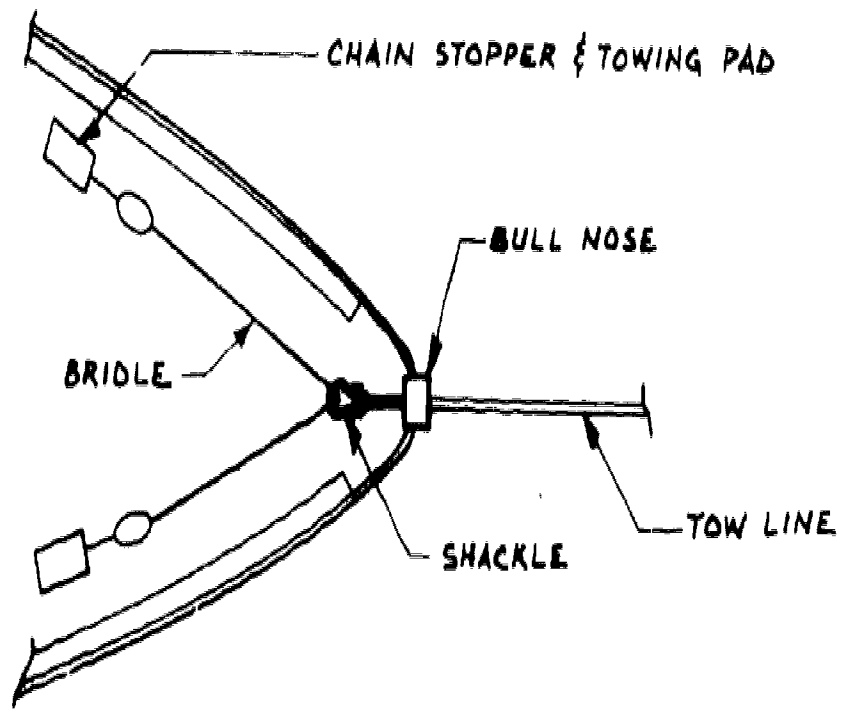

**BOW OF TOWED SHIP**  
**FIGURE 'A'**

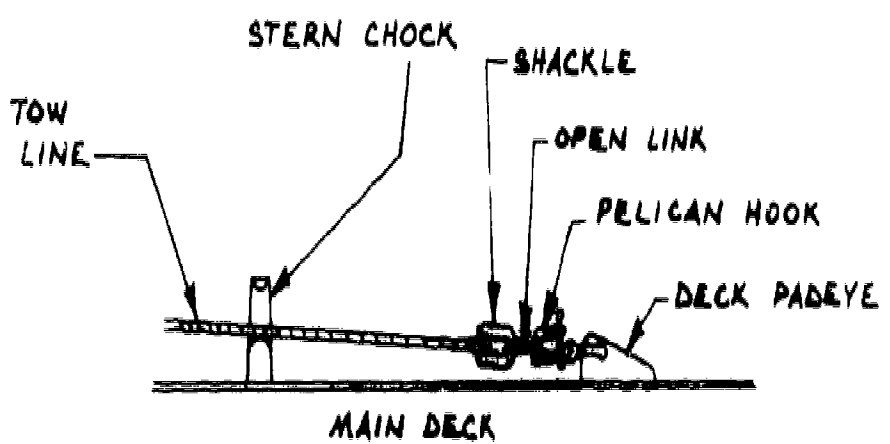

**TOWING PAD AT STERN OF TOWING SHIP**  
**FIGURE 'B'**

SKETCH No.	FIG
0660-78-0039	12



Weather deck lighting fixtures (water tight) will be installed forward, aft, and over each deck house access to the weather. Lights will also be provided for installation around the exterior ladders. Night lighting for underway replenishment consisting of wake, contour, truck, station marker, and low level lights will be installed.

Hand lanterns will be provided throughout the craft to provide limited illumination when other light sources fail. Hand lanterns with relays will be installed to mark escape routes, permit restoration of power, and to permit performance of ship control functions. Hand lanterns without relays will be installed to supplement relay hand lanterns.

### Fire Extinguishing System

Portable carbon dioxide fire extinguishers will be bulkhead mounted in the following locations: one each in the Pilot House, each CIC, and platform and main deck passageway; and two in the classroom.

Three portable dry chemical (purple K) extinguishers will be bulkhead mounted, two in the Engine Room and one in the Lazarette.

A fixed Halon system will be provided in the Engine Room. The system will utilize optical sensors for detection. An electrical control circuit will provide for automatic or manual release and a system test capability. Audible alarms will be located at the control panel in the Engine Room, and at the quartermaster's desk in the Pilot House so that discharge of Halon into the space will actuate the alarm.

### Heating, Ventilation, Air Conditioning, and Insulation

The CIC's, Classroom, Engine Room, Office, Waterclosets, and Passageways will be ventilated by a natural supply and mechanical exhaust system designed to deliver appropriate volume for the particular space. The Pilot House will have natural ventilation through the windows only (an oscillating fan will be provided). A window defogger system will be installed in the Pilot House. It will consist of a heater blower that intakes Pilot House Air and discharges it through slotted ducts onto the Pilot House windows. In addition the Engine Room will be fitted with louvers to provide engine combustion air.

For proposed craft operating in continually hot climates, unit coolers (air conditioning) may be added for protection of equipment in the two CIC's.

The heating system will consist of thermostatically controlled electric unit heaters. Each unit will be sized and located to suit the individual space. Spaces to be heated include the Pilot House, both CIC's, Classroom, Passageways, Waterclosets, Office, Engine Room, and Lazarette.

Two inch insulation will be installed on plane surfaces and one inch on webs and flanges of hull structure exposed to the weather.

One inch insulation will be installed on plane surfaces and webs and flanges of hull structure over remaining areas.

APPENDIX 1

113 129

## TACTICAL CHARACTERISTICS

The following tactical characteristics were considered in the development of this craft.

### TURNING CIRCLE

The path described by the ship when turning. A full 360 degrees with constant rudder angle and speed. The turning circle will vary with amounts of rudder and with speeds used.

### PIVOT POINT

The point of rotation within the ship as she makes a turn. This point is generally about one-third the length of the ship from the bow and fairly close to the bridge (when going ahead). It is also the point of the ship that scribes the turning circle.

### ADVANCE

For any turn, the advance is the distance gained in the direction of the original course from the time the rudder is put over until the ship is on the new course.

### TRANSFER

For any turn, the transfer is the distance gained in a direction perpendicular to that of the original course from the time the rudder is put over until on the new course.

### TACTICAL DIAMETER

For any amount of constant rudder angle, the tactical diameter is the distance made good in a direction perpendicular to that of the original course line from the time the rudder is put over until the ship is on a reverse heading. It is the transfer for a turn of 180 degrees.

### FINAL DIAMETER

Diameter of a circle ultimately scribed by a ship that continues to circle with a constant rudder angle.

### DRIFT ANGLE

Angle at any point on a turning circle between intersection of the tangent at that point and a ship's keel line.

### KICK

- (1) Swirl of water toward the inside of a turn when rudder is put over.
- (2) The momentary movement of the ship toward the side opposite the direction of turn.
- (3) Propeller side force.

## ACCELERATION AND DECELERATION RATES

Acceleration and deceleration rates are the rates at which a ship picks up or loses headway after a change of speed.

### REACH

Distance covered while ship is accelerating or decelerating.

These characteristics will have to be simulated by the training craft for a variety of Naval Ship types and classes in lieu of a specific ship. Consequently considerable effort was expended in collecting appropriate data (David W. Taylor Naval Ship Research and Development Center Trial Reports) and organizing it in a manner which would reduce substantially the number of variations.

In an effort to study the feasibility of characteristic simulation, NAVSECNORDIV conducted operational trials of a 100 foot (length overall) boat that would be similar in hull design to that of the craft training device. This data in addition to that obtained from trial reports for Naval Ships at David W. Taylor Naval Ship Research and Development Center, form the basis for our ship handling relationship.

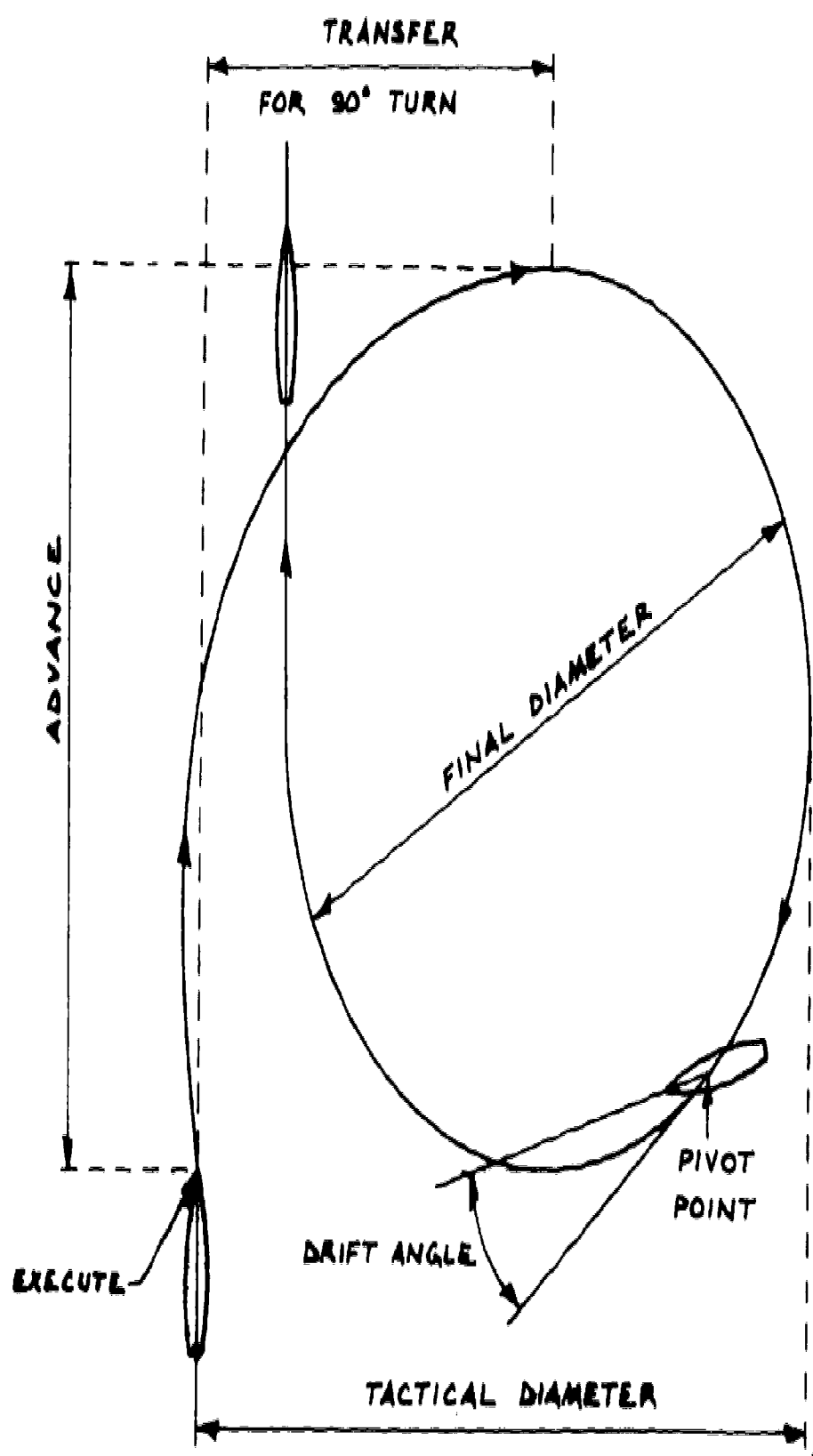

SKETCH NO.	FIG
0660-78-0040	13

## REFERENCES

1. David W. Taylor Naval Ship Research and Development Center Ship Trial Reports
  - a) CG-16 Class Reports #C1700 - Tactical Trials  
C1936 - Tactical & Maneuvering Trials  
C1719 - Standardization
  - b) DLGN-26 Class Reports #C2226 - Tactical Trials  
C2234 - Tactical & Maneuvering Trials  
C2207 - Standardization
  - c) CGN-9 Class Reports #C1442 - Tactical & Maneuvering  
C1430 - Standardization
  - d) CGN-25 Class Reports #C1893 - Maneuvering  
C1706 - Standardization
  - e) CGN-35 Class Reports #C3284 - Tactical & Maneuvering  
C3154 - Standardization
  - f) CGN-36 Class Reports #C4800 - Tactical & Maneuvering  
C4757 - Standardization
  - g) CGN-38 Class Report #C-77-0060 - Tactical & Maneuvering
  - h) DDG-2 Class Reports #C1484 - Tactical & Maneuvering  
C1529 - Standardization  
C2235 - Standardization
  - i) DDG-35 Class Reports #C954 - Tactical  
C1022 - Special Performance
  - j) DDG-37 Class Reports #C1451 - Tactical  
C1384 - Standardization
  - k) DD-931 Class Reports #C1096 - Tactical  
C994 - Tactical  
C560 - Maneuvering  
C1097 - Standardization  
C1046 - Special Performance
  - l) FF1034 Class Reports #C1154 - Tactical & Maneuvering  
C1138 - Standardization
  - m) FF1037 Class Reports #C1892 - Tactical  
C1934 - Maneuvering  
C1745 - Standardization
  - n) FF1040 Class Reports #C2614 - Tactical  
C2613 - Maneuvering  
C2401 - Standardization

- o) FF1052 Class Reports #C4523 - Tactical  
C3679 - Tactical & Maneuvering  
C4470 - Tactical & Maneuvering  
C3520 - Standardization  
C4133 - Standardization  
C512-H-01 - Standardization  
C4522 - Standardization
- p) LCC-19 Reports #C3981 - Tactical & Maneuvering  
C3839 - Standardization
- q) LHA-1 Report #77-0008 - Standardization
- r) LKA-113 Reports #C3542 - Tactical  
C3441 - Maneuvering
- s) LPD-4 Class Reports #C2408 - Tactical  
C2399 - Maneuvering  
C2322 - Standardization
- t) LPH-2 Class Reports #C1606 - Tactical  
C1603 - Maneuvering  
C1601 - Standardization
- u) LSD-28 Class Reports #C778 - Tactical  
C1164 - Maneuvering  
C755 - Standardization
- v) LST-1179 Class Reports #C3642 - Tactical  
C3523 - Standardization
- w) LST-1175 Class Reports #C1199 - Tactical  
C1149 - Standardization
- x) AD-26 Class Reports #C592 - Standardization
- y) AE-21 Class Reports #C-992 - Tactical  
C-1206 - Maneuvering  
C909 - Standardization  
C1010 - Standardization
- z) AE 26 Class Reports #C3512 - Standardization  
C4301 - Standardization
- aa) AF 58 Class Reports #C810 - Tactical  
C1044 - Maneuvering  
C774 - Standardization  
C1203 - Backing
- bb) AFS-1 Class Reports #C1978 - Tactical  
C1986 - Maneuvering  
C1975 - Standardization
- cc) AO 22 Class Reports #R-105 - Tactical  
R 149 - Maneuvering





APPENDIX 2

121

137

## ALTERNATE ENGINE CONFIGURATION

The three engine configuration shown on the study drawings is required to simulate single screw ship operation. The two outboard engines will be operated at less than maximum horsepower and the centerline engine will be operated at maximum horsepower to produce the propeller side force which effects a single screw ship, especially during the early stages of acceleration from low initial speeds.

When simulating a twin screw ship, only the two outboard engines will be used and the centerline propeller will be allowed to "windmill".

As an alternative to this arrangement, a two engine plus keel mounted, reversible, stern thruster will produce the low speed side kick simulation of a single screw ship.

The advantages of the thruster are savings in initial cost, craft weight, operating costs, and maintenance costs. In this arrangement the centerline propulsion engine can be replaced with a keel-mounted thruster, thus saving approximately \$70,000.00. The fuel required for the intermittent operation of the thruster will equal approximately 25% of that required for the centerline engine thereby reducing craft weight and fuel costs. The engine and drive mechanism will be smaller and lighter than the centerline engine, propeller shafting, and propeller, thereby further reducing weight. The smaller thrust engine will be easier and less expensive to maintain during the life of the craft. A reduction of draft due to the elimination of the centerline propeller is an additional benefit.

The side thruster will only be effective up to a craft speed of approximately four knots but this is considered sufficient to produce realistic craft response during mooring, and anchoring maneuvers. Side force effect on a full scale ship at higher speeds is minimal and is compensated for by carrying a slight rudder angle; an uncontinuous reaction on the part of a helmsman when steering an ordered course.

The only area in which the thruster arrangement is seen as less advantageous than the centerline engine is that of control. The thruster must be interlocked with the engine controls or engines such that thrust of the desired force and direction will produce the proper stern side motion during low speed, rapid acceleration. The interlocking can be accomplished by mechanical and electrical sensors and electrical controls and is not envisioned as a major problem. The direction of thrust, port or starboard, can be linked to respond to the forward/reverse engine order and the thrust force can be linked to the engine or shaft RPM.

The magnitude of thrust required can be calculated as approximately 600 pounds. This magnitude of thrust is comparable to that produced by a 65 HP outboard engine.

This alternate engine configuration, which was conceived late in the feasibility study (after the arrangement drawings were complete) should be given strong consideration for incorporation into further design efforts.

APPENDIX 3

123/12<sup>A</sup> 139

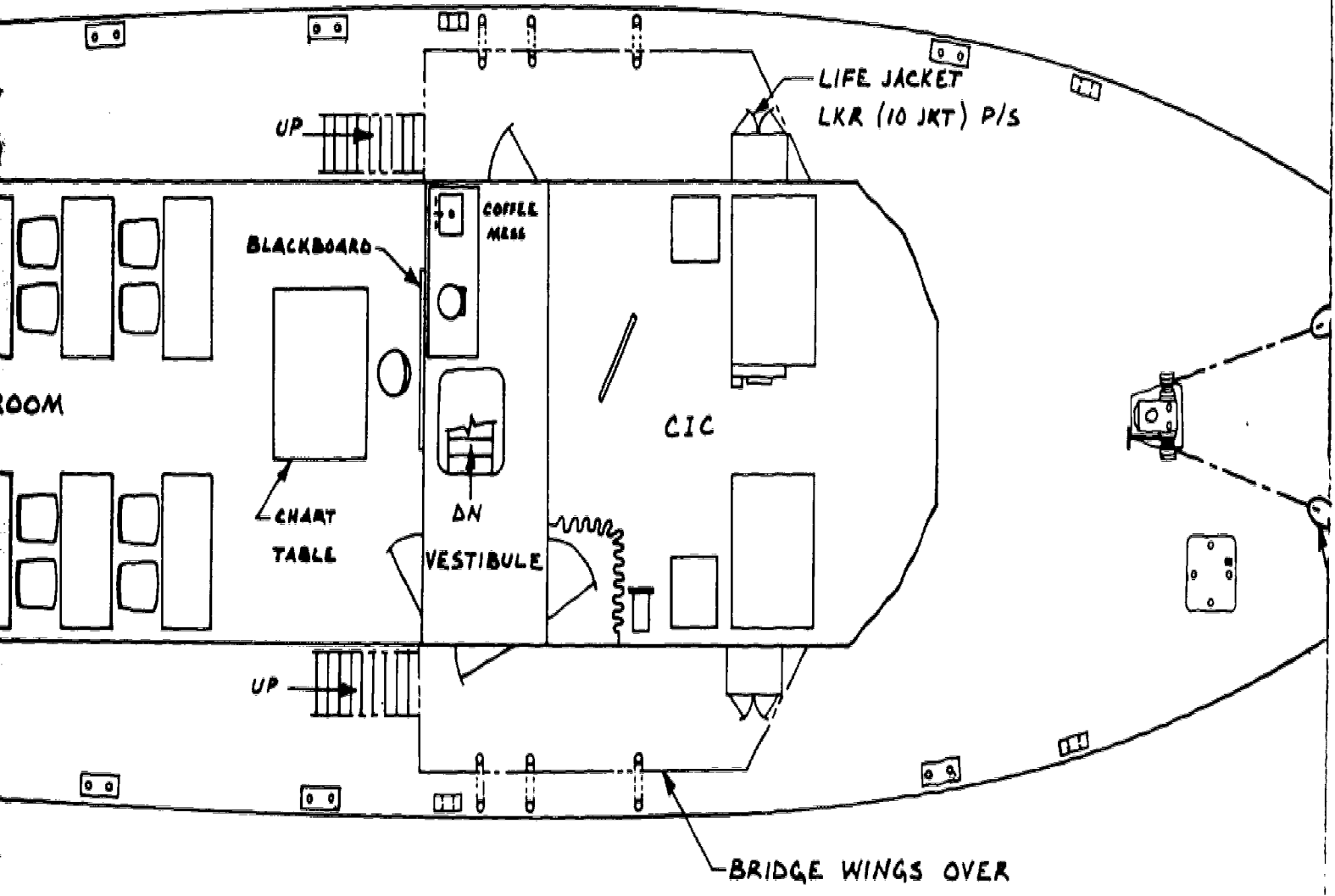

MAIN DECK

140F

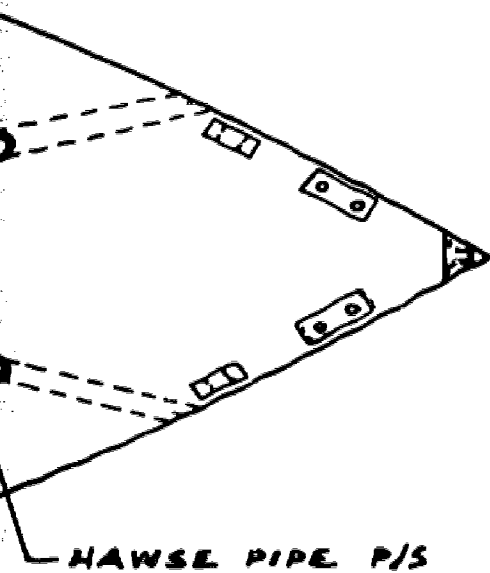

<b>NAVAL SHIP ENGINEERING CENTER NORFOLK DIVISION</b>	
<b>COMBATANT CRAFT ENGINEERING DEPT.</b>	
<b>SKETCH N<sup>o</sup> 6660-78-0041</b>	<b>FIG 14</b>

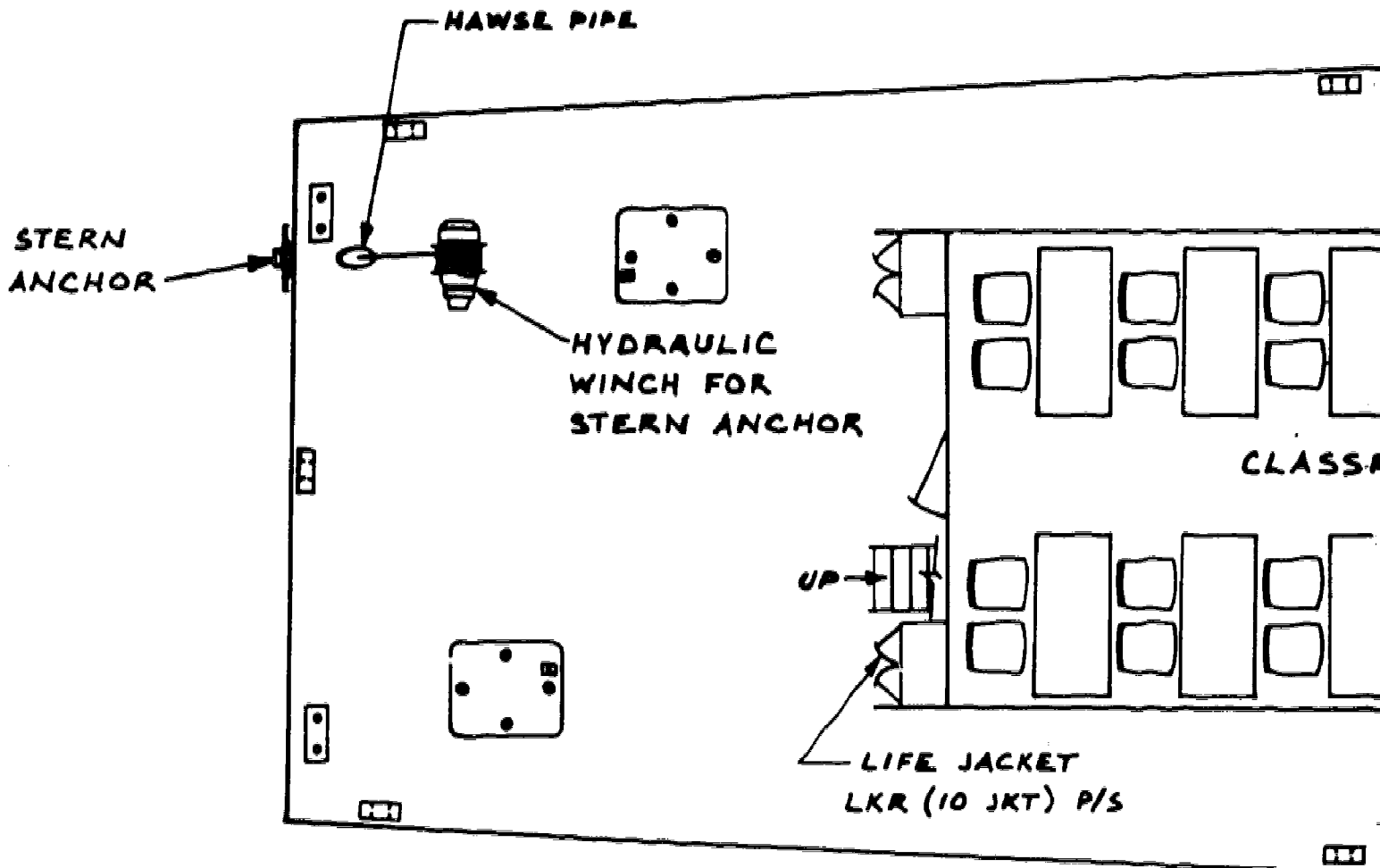



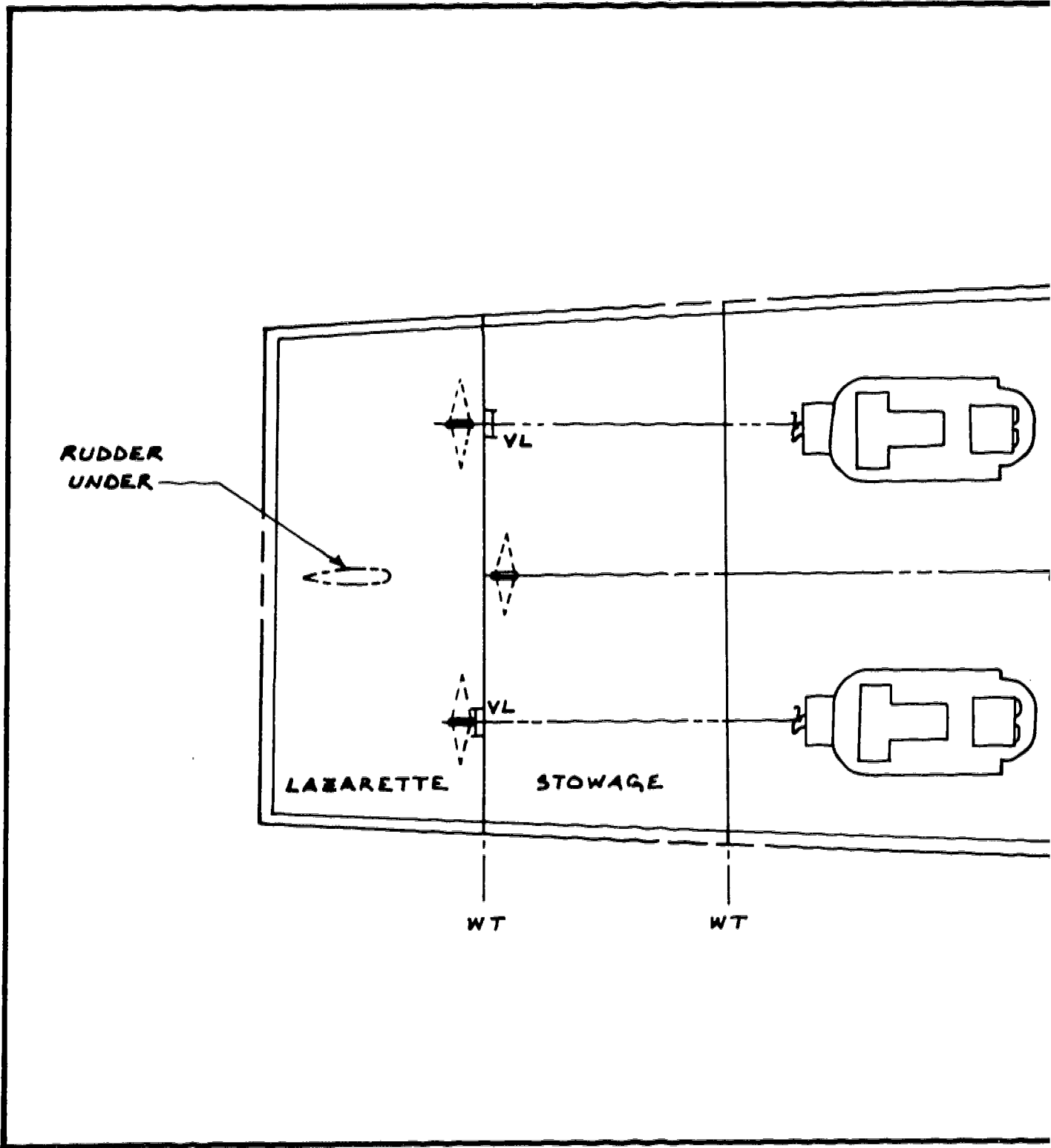

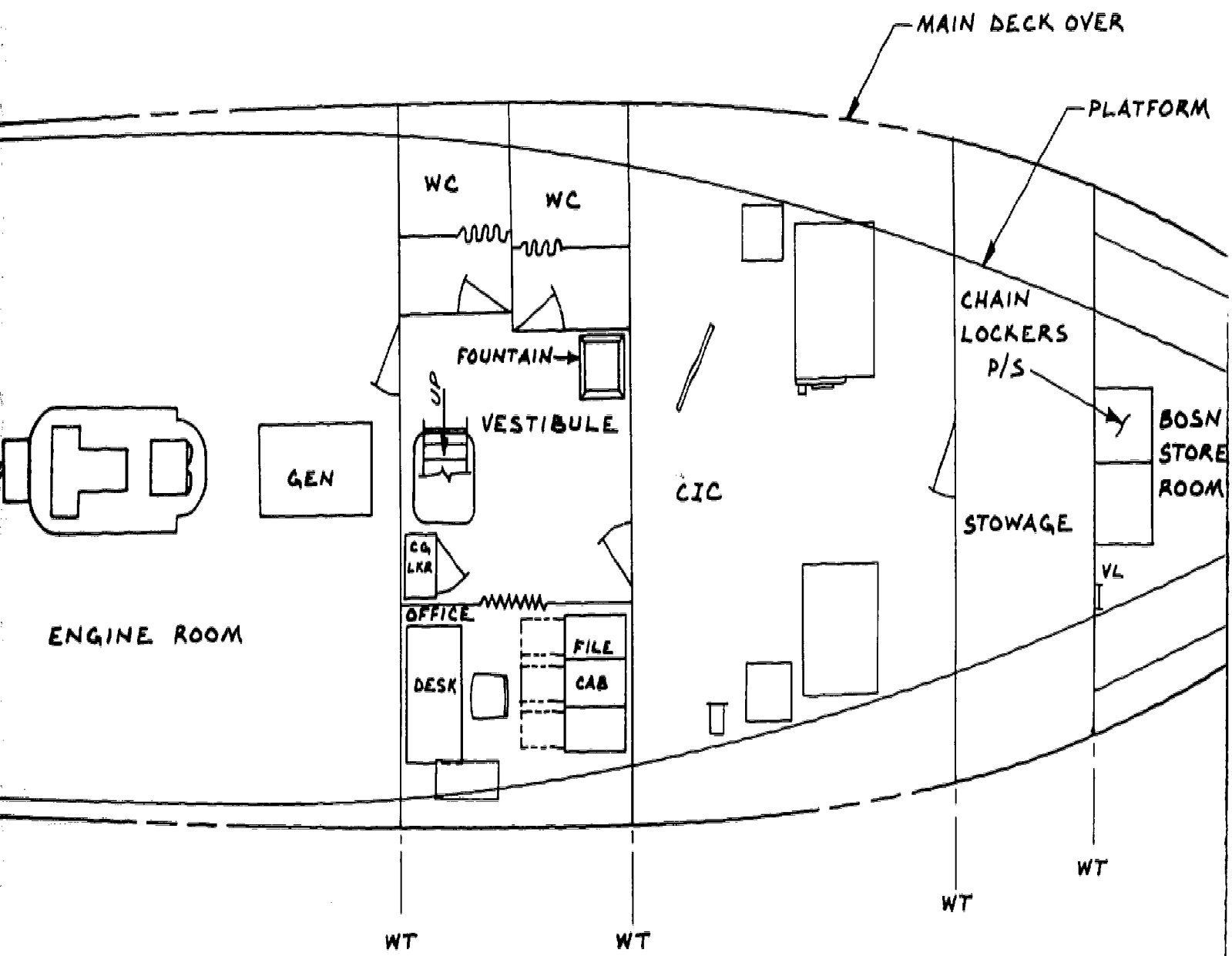

PLATFORM DECK

144A

SK

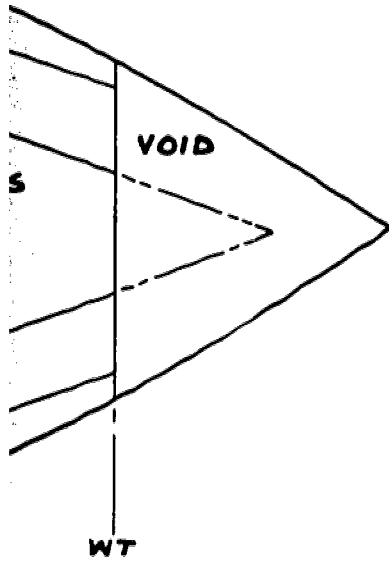

NAVAL SHIP ENGINEERING CENTER NORFOLK DIVISION	
COMBATANT CRAFT ENGINEERING DEPT.	
SKETCH N <sup>o</sup> 6680-78-0042	FIG. 15

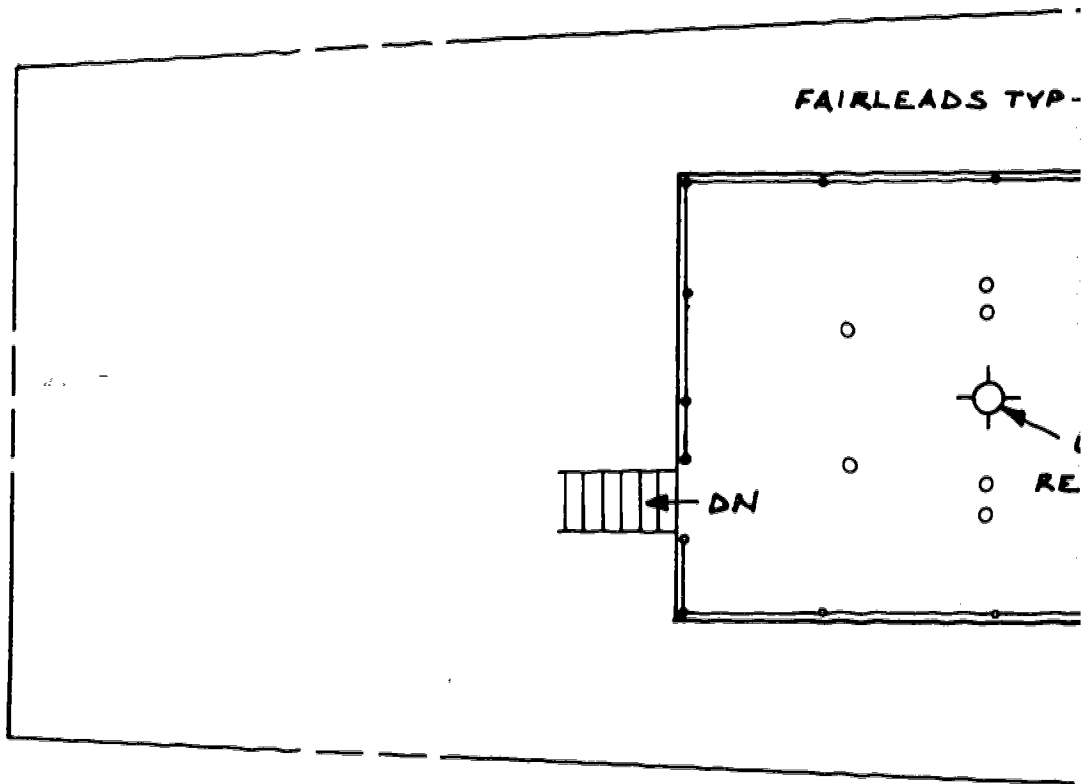

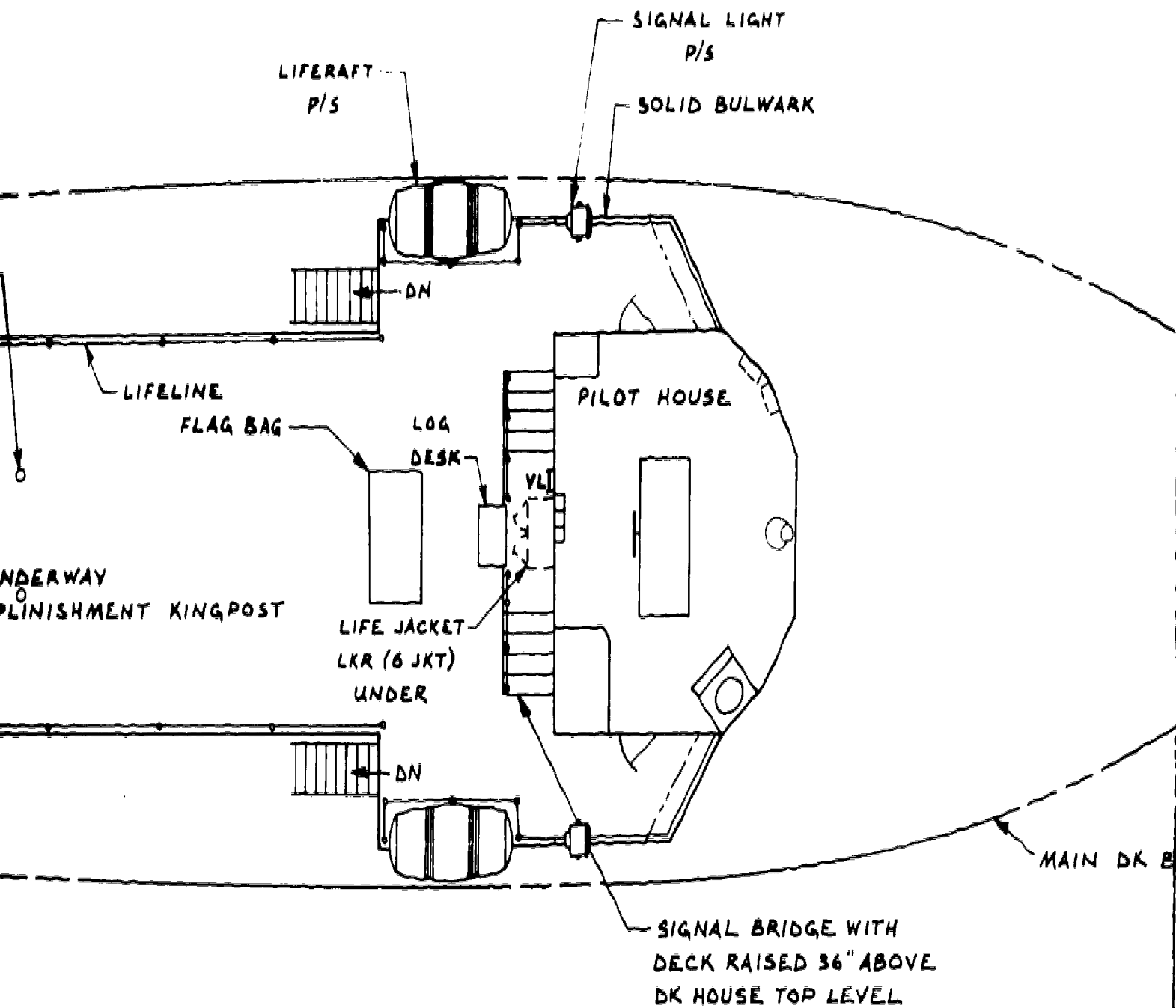

DECK HOUSE TOP

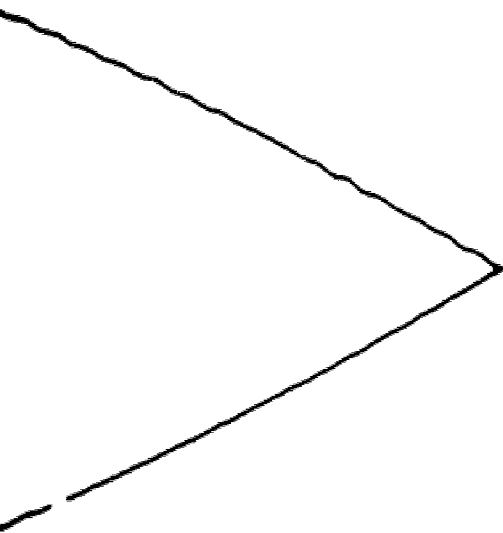

ELOW

NAVAL SHIP ENGINEERING CENTER NORFOLK DIVISION	
COMBATANT CRAFT ENGINEERING DEPT.	
SKETCH № 6660-78-0043	FIG 16

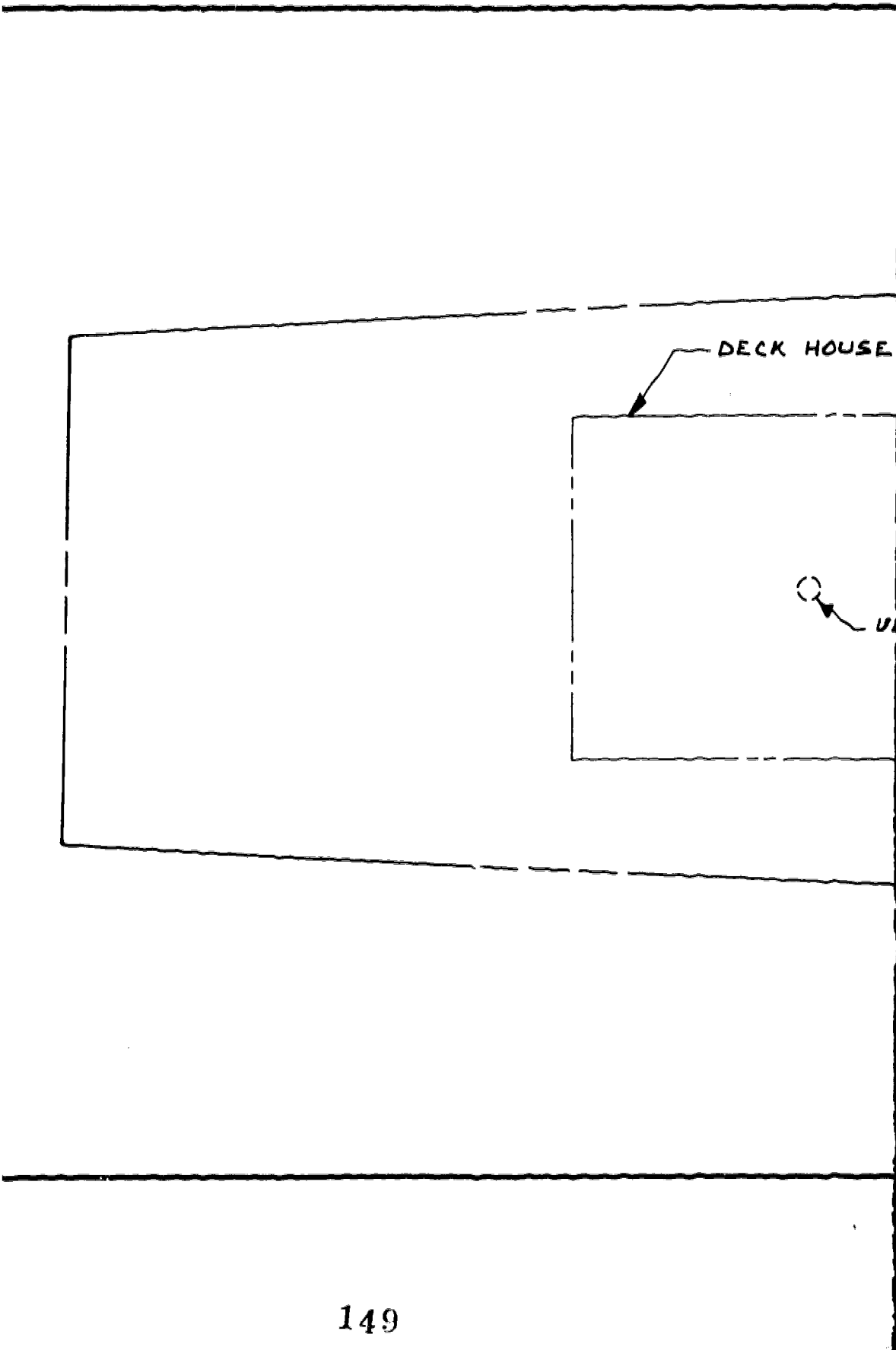



TOP BELOW

UNDERWAY REPLINISHMENT  
KINGPOST

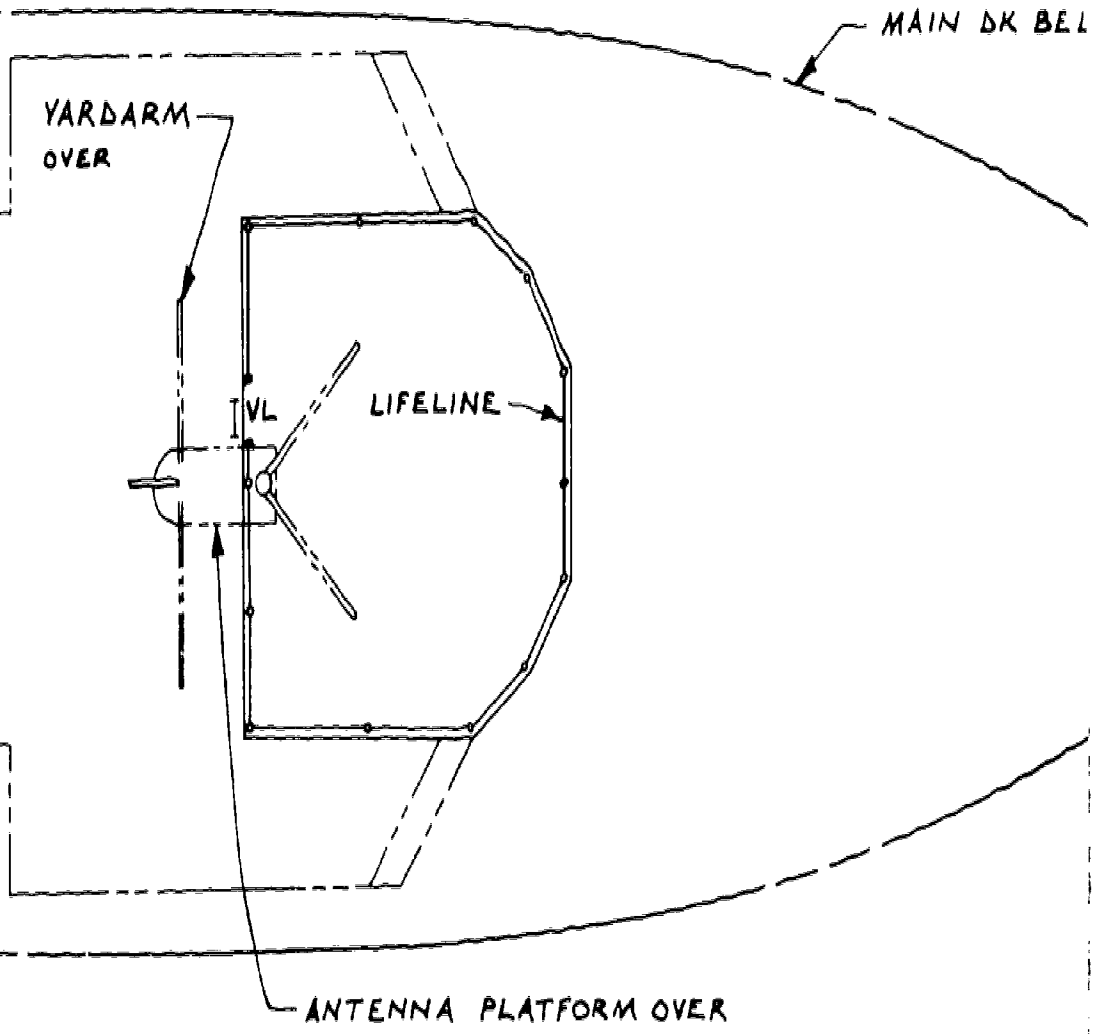

PILOT HOUSE TOP

150A

OW

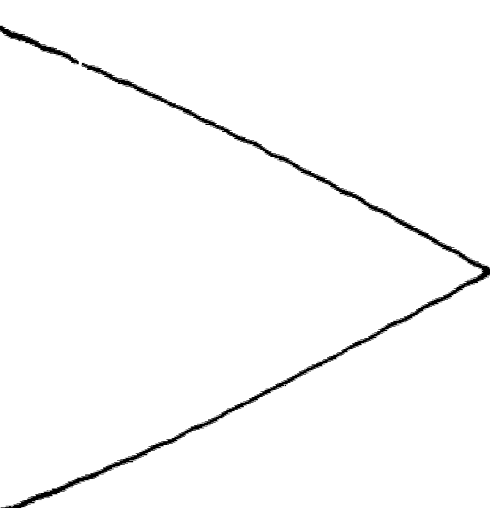

NAVAL SHIP ENGINEERING CENTER NORFOLK DIVISION	
COMBATANT CRAFT ENGINEERING DEPT.	
SKETCH NO 6660-78-0044	FIG 17

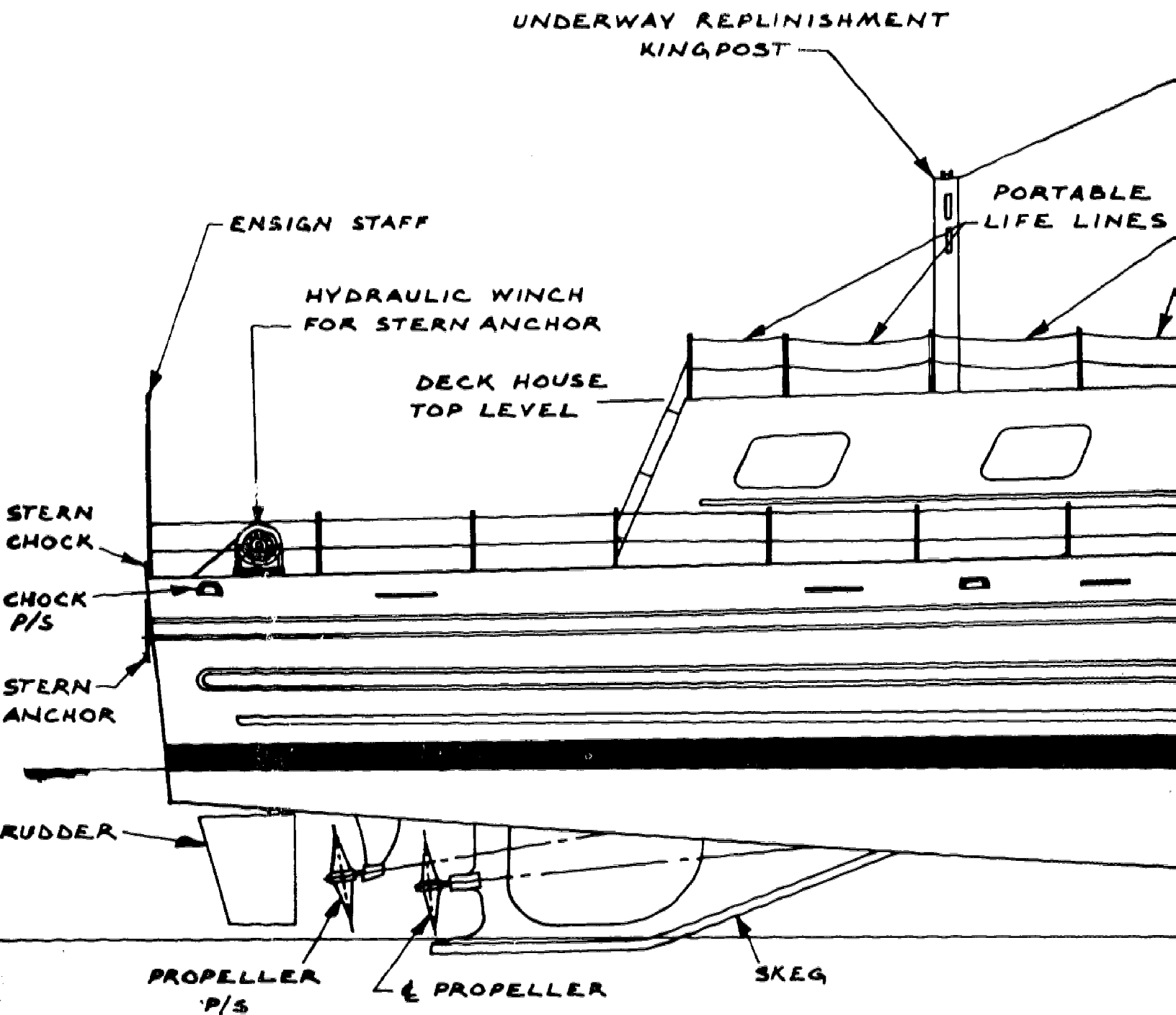

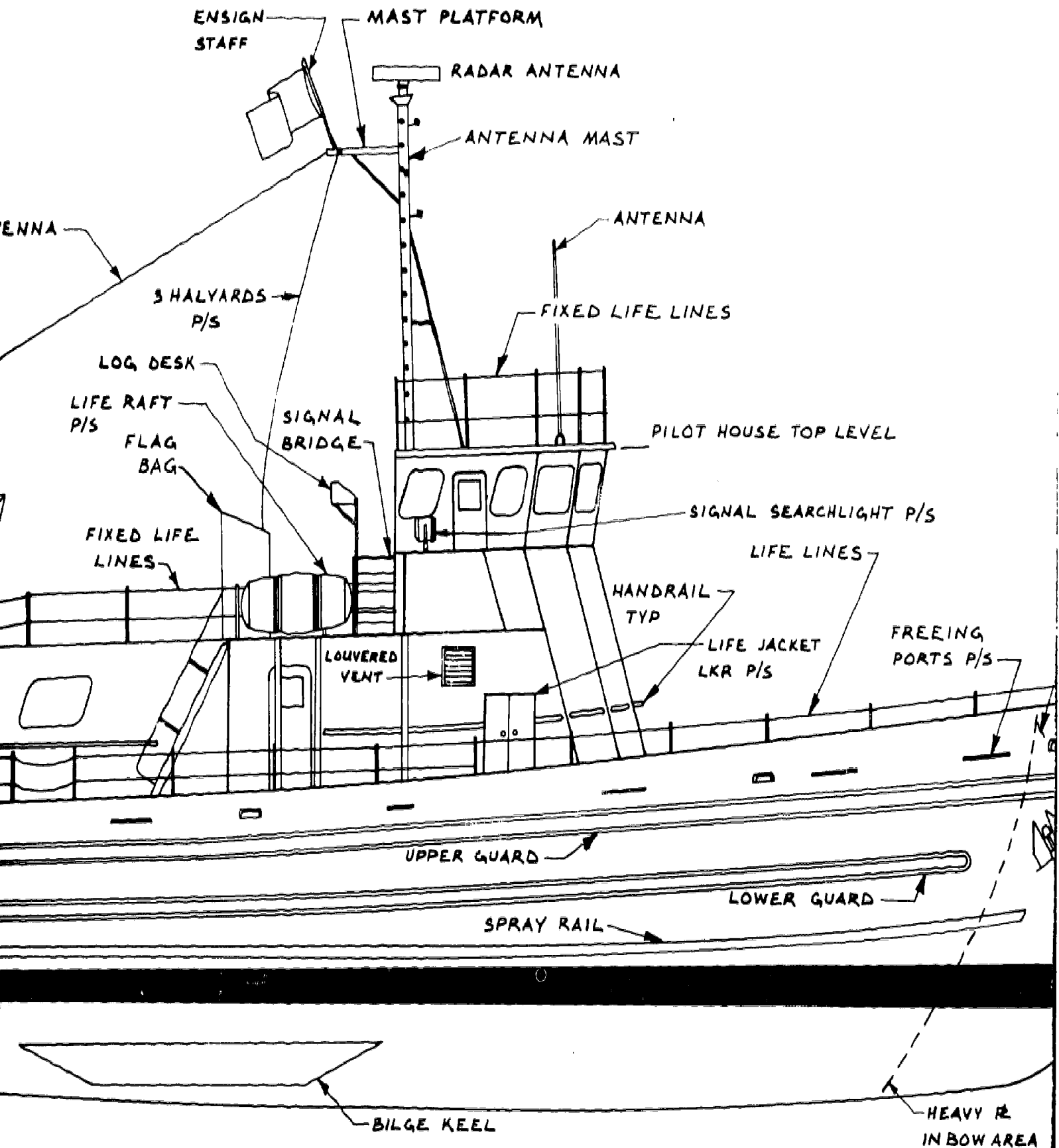

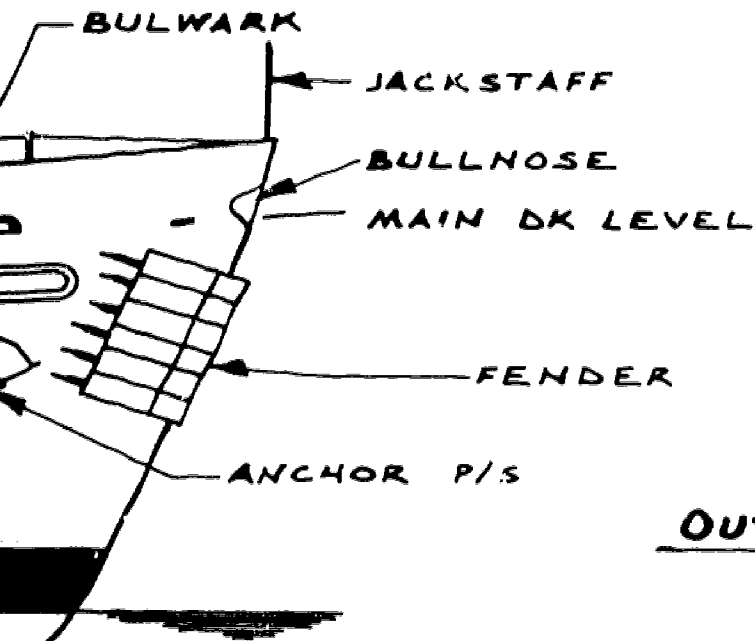

OUTBOARD PROFILE

NAVAL SHIP ENGINEERING CENTER NORFOLK DIVISION	
COMBATANT CRAFT ENGINEERING DEPT.	
SKETCH № 6660-78-0045	FIG 18

DISTRIBUTION LIST

Air Force

Headquarters, Air Training Command  
Air Force Office of Scientific Research (Dr. A. R. Fregly)

Army

Commandant TRADOC (Technical Library)

Coast Guard

Headquarters, Commandant, U.S. Coast Guard  
Headquarters, Commandant, U.S. Coast Guard (G-P-1/62; G-DSAT)

Marine Corps

CG MCDEC (Mr. Greenup)  
Director, Marine Corps Institute

Navy

Assistant Secretary of the Navy (R&D), Dr. S. Koslov (MRA&L), Dr. B. D. Rostker  
CNO (OP-102X, M. Malehorn; OP-987P10, Dr. R. Smith; OP-987, H. Stone; OP-03;  
OP-03B; OP-39; OP-099)

COMNAVELEX (Code 03)

COMNAVSEASYSKOM (Code 03, 047C1, 047C12)

COMNAVAIRSYSKOM (Code 03)

CO NAVMEDRSCHDEVCOM (CAPT H. J. Connery)

CNM (MAT-08T2, Mr. A. L. Rubinstein)

COMNAVAIRSYSKOM (Code 340F)

ONR (Code 458, 455, 438)

ONRBO Boston (J. Lester)

ONRBO Chicago

ONRBO Pasadena (E. E. Gloye)

CNET (01, 00A, N-5 (5 copies), N-2 (2 copies))

CO NAVEDTRAPRODEVCOM (AH3)

CNET SUPPORT (00, 01A)

CNTECHTRA (00 (2 copies); 0161, Dr. Kerr (5 copies))

CNATRA (F. Schufletowski)

CNAVRES (Code 02)

COMTRALANT

COMTRALANT (Educational Advisor)

COMTRAP/C

CO NAVETTRASUPPCEN NORVA

CO NAVETTRASUPPCENPAC

DISTRIBUTION LIST (continued)

CO NAVPERSRANDCEN (Library (4 copies))  
NAVPERSRANDCEN Liaison (Code 01H)  
NAMRL (Chief Aviation Psych. Div.)  
CO NAVSUB Base NLOW (Psychology Section)  
U.S. Naval Institute (CDR Bowler)  
NAVPGSCOL (Code 2124)  
U.S. Naval Academy (Chairman, Behavioral Science Dept.; Seamanship and  
Navigation Dept.)  
CO NAVTRAEQUIPCEN (N-71 (Mr. Sharkey), N-424 (2 copies), N-231, N-001, N-002,  
N-02, N-21)  
CO FLICOMDIRSYSTRACENPAC  
Center for Naval Analyses (2 copies)  
CO NAMTRAGRU  
Naval Safety Center, Ship Safety Programs  
CINCLANTFLT  
CINCPACFLT  
COMSURFLANT  
COMSURFPAC  
COMNAVAIRLANT  
COMNAVAIRPAC  
FTC, Mayport, FL  
Surface Warfare Officers School, NPT, RI  
Surface Warfare Officers School, San Diego Detachment  
OCS, NPT  
U.S. Naval Amphibious School, Coronado, CA  
U.S. Naval Amphibious School, Little Creek, VA  
David W. Taylor NSRDC (Code 117)  
NAVSEC NORDIV (Code 6660)

Other DOD

Military Assistant for Human Resources, OAD (E&LS), Room 3D129, Pentagon  
(CDR Paul Chatelier)  
OASD (MRA&L) (LTCOL Grosse)  
Director, Human Resources Office, ARPA (Dr. Dexter Fletcher)  
U.S. Department of Commerce, Maritime Administration (Mr. Marvin Pitkin),  
(Mr. Virgil Rinehart)

Non-Military

National Maritime Research Center  
Sperry Systems Management, NMRC, Great Neck, L.I. (Mr. T. Hanley)  
Grumman Data Systems Corporation, National Maritime Research Center  
Marine Safety International, LaGuardia Airport, Flushing, NY  
Eclectech Associates, Inc. (Mr. Allan Pesch)  
Performance Measurement Associates, Inc. (Mr. Edward Connally)

DISTRIBUTION LIST (continued)

Applied Digital Communications (Mr. Drexel Hanne)  
U.S. Salvage Association, Inc. (Mr. William Roettgen)  
International Organization of Masters, Mates, and Pilots  
Mr. Ben Ostlund, Naval Architect  
Farrell Shipping Lines (CAPT Frank Riley)  
Southampton School of Navigation

Information Exchanges

DDC (12 copies)  
DLSIE (James Dowling)  
Executive Editor, Psychological Abstracts, American Psychological Association  
ERIC Processing and Reference Facility, Bethesda, MD (2 copies)