

DOCUMENT RESUME

ED 167 814

CE 020 287

TITLE Training Program for Operation of Emergency Vehicles. Trainee Study Guide.

INSTITUTION INNOVATRIX, Inc., Ingomar, Pa.

SPONS AGENCY National Highway Traffic Safety Administration (DOT), Washington, D. C.

REPORT NO. DOT-HS-802-565

PUB DATE Oct-78

CONTRACT DOT-HS-6-01336

NOTE 471p.; For related documents see CE 020 285-286

AVAILABLE FROM Superintendent of Documents, U.S. Government Printing Office, Washington, D.C. 20402 (Stock Number 050-003-00331-0)

EDRS PRICE MF01/PC19 Plus Postage.

DESCRIPTORS Behavioral Objectives; Course Objectives; *Driver Education; *Emergency Squad Personnel; Traffic Safety; Training

ABSTRACT

A two-part trainee study guide for use in the classroom phase of the Emergency Vehicle Operation (EVO) training program is provided. Part 1, to be taken by all trainees, contains seven units organized into various subunits and includes the following: (1) introduction to the course; (2) some legal aspects of emergency vehicle operation (state statutes on EVO, interpreting the law); (3) selecting routes and reporting emergency vehicle operations; (4) before you drive (vehicle inspection, maintenance, preparing to drive); (5) important physical forces and EVO (major physical forces, weight transfer); (6) operation (use of lights and sirens, basic control tasks, urban driving, negotiating intersections, turning around to reverse direction, following another vehicle, expressway operation, and driving at high speed); and (7) handling unusual situations (driving in adverse conditions, handling contingency situations, pulling off the road). Part 2 contains three units, one of which is to be taken by each trainee, and includes the following: (1) operation of ambulances (route planning, inspection and maintenance, and operation); (2) operation of law enforcement vehicles (communications, pursuit driving, making a traffic stop, and emergency escort of another vehicle); and (3) operation of fire apparatus (selecting routes, inspection and maintenance, operating systems, and basic control tasks.) Each unit in the two parts of the guide contain student behavioral objectives, a basic content outline, questions to be answered about the content, and unit review exercises. (JH)

 * Reproductions supplied by EDRS are the best that can be made *
 * from the original document. *

Training Program for Operation of Emergency Vehicles

TRAINEE STUDY GUIDE

U.S. DEPARTMENT OF HEALTH,
EDUCATION & WELFARE
NATIONAL INSTITUTE OF
EDUCATION

THIS DOCUMENT HAS BEEN REPRODUCED EXACTLY AS RECEIVED FROM THE PERSON OR ORGANIZATION ORIGINATING IT. POINTS OF VIEW OR OPINIONS STATED DO NOT NECESSARILY REPRESENT OFFICIAL NATIONAL INSTITUTE OF EDUCATION POSITION OR POLICY.

U.S. DEPARTMENT OF TRANSPORTATION
NATIONAL HIGHWAY TRAFFIC SAFETY ADMINISTRATION

Training Program for Operation of Emergency Vehicles

PART I: Basic Units

TRAINEE STUDY GUIDE

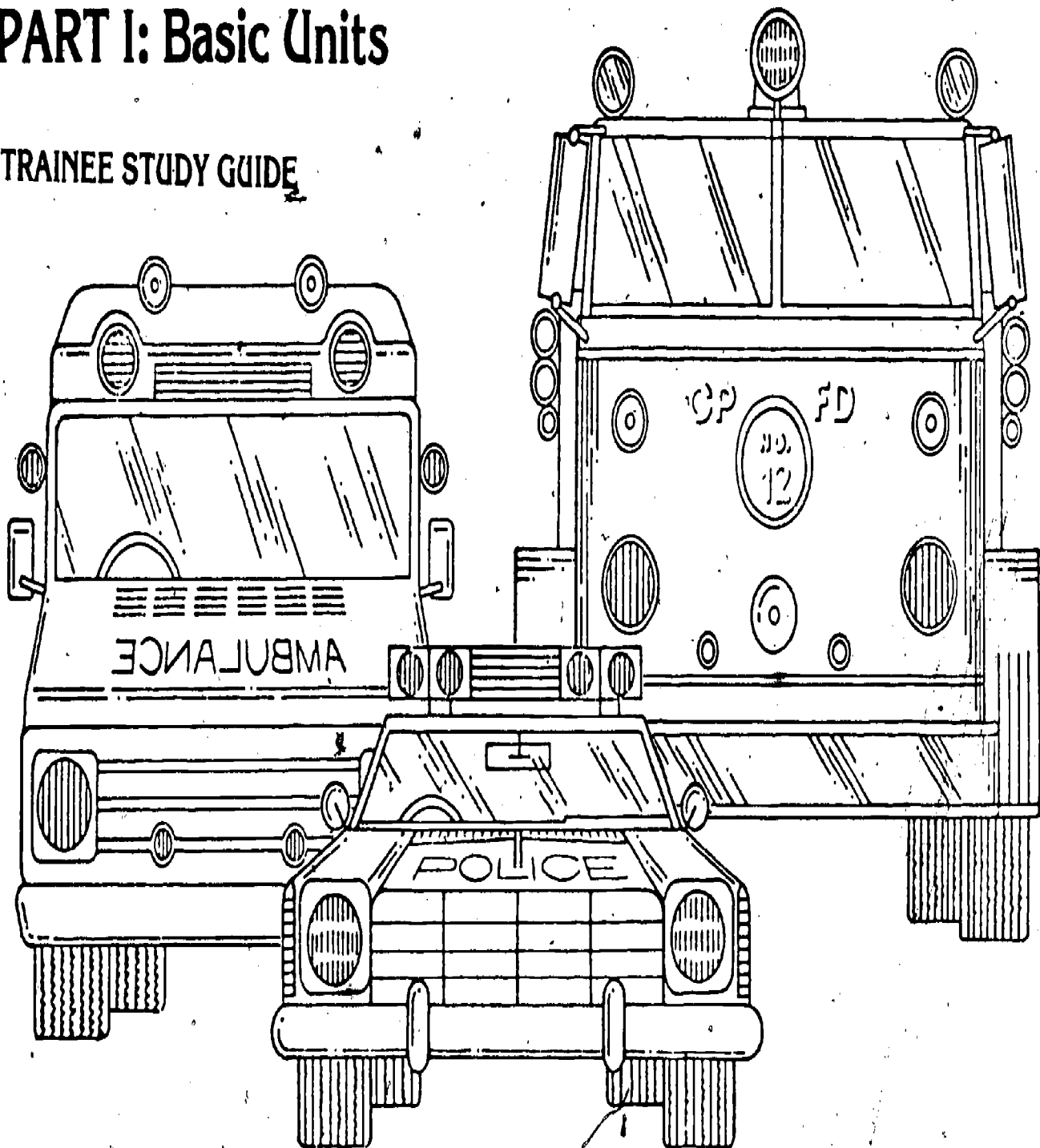

FOREWORD

This document is one of three in the Emergency Vehicle Operation (EVO) Curriculum; they are:

1. Course Guide--Training Program for Operation of Emergency Vehicles.
2. Instructor Lesson Plans--Training Program for Operation of Emergency Vehicles.
3. Trainee Study Guide--Training Program for Operation of Emergency Vehicles.

These documents were prepared for the U.S. Department of Transportation, National Highway Traffic Safety Administration (NHTSA), under contract No. DOT-HS-6-01636 by INNOVATRIX Inc., Ingomar, PA.

The NHTSA Contract Technical Manager was Dr. C. Harding Veigel and, in the final months of the development effort, Mrs. Dorothy McKinney. Other NHTSA personnel who made significant contributions to the development of this curriculum were John Anderson, Richard Frederick, and Robert Motley. The assistance of all of these individuals is gratefully acknowledged.

Some of the others who contributed their time and expertise were Dr. Aaron Adams, Cecil Arnold, and Dr. George Palmer of NHTSA; Norman Darwick, International Association of Chiefs of Police; Donald Flinn, International Association of Fire Chiefs; Richard Tippy and James Grisham of the National Safety Council; and Harold Rice, Pennsylvania State Police Academy. For those whom we have failed to mention: our appreciation and apologies.

And, our special thanks to the following people:

Chief Patrick McCabe, McCandless Township Police Department, who contributed his time and allowed the INNOVATRIX staff to interview and observe his officers while they operated their patrol and ambulance vehicles.

Fire Chief Kennelly, who assisted us in setting up observations and interviews with several stations of the City of Pittsburgh Fire Department.

Ron Kane, our primary Pilot Test classroom instructor. Ron helped develop the police materials, taught them at the Pilot Test, and presented the entire basic program very effectively.

Anthony Bizjak, who ably presented the fire service materials at the Pilot Test. Tony's knowledge of fire service vehicles and policies greatly assisted us in developing the fire service material.

John Kinzer, who presented the ambulance materials at the Pilot Test and loaned his company's vehicles for the range exercises.

Officer Mitchell, Spc. Ownby, and Spc. Butler, the Huntsville Police Academy driving instructors who pilot-tested the new program and provided excellent in-vehicle instruction. They guided our fire and ambulance range instructors and kept a fine sense of humor through the pressure of the Pilot Test (an accomplishment in Alabama in July).

Finally we would like to extend our special thanks and gratitude to:

The City of Huntsville--which may have some of the finest people in the world and certainly has the most cooperative administrators this staff has ever worked with.

Our Pilot Test trainees--who pitched in, learned a lot, and offered innumerable insights and suggestions which led to the improvement of the program.

Officer Danny Barnes, Director of the Huntsville Police Academy and head of the fine Evasive Driving Program at Huntsville, Alabama. Officer Barnes was the take-charge man who smoothed administrative matters so much that most of them were never noticed by the staff. He not only made the Pilot Test fun, but also became a true and lasting friend.

TABLE OF CONTENTS

UNIT A - INTRODUCTION

Introduction	I-A-1
Your Trainee Study Guide	I-A-2
Organization of the Course	I-A-3
Definitions	I-A-4
Schedule	I-A-5

UNIT B - SOME LEGAL ASPECTS OF EMERGENCY VEHICLE OPERATION

Trainees' Knowledge Objectives	I-B-1
Introduction	I-B-2
State Statutes on Emergency Vehicle Operation	I-B-3
Interpreting the Law	I-B-4
Summary	I-B-10
Review Exercises	I-B-12

UNIT C - SELECTING ROUTES AND REPORTING EMERGENCY VEHICLE OPERATIONS

Trainees' Knowledge Objectives	I-C-1
Selecting Routes	I-C-2
Reporting Emergency Vehicle Operations	I-C-5
Review Exercises	I-C-9

UNIT D - BEFORE YOU DRIVE

Trainees' Knowledge Objectives	I-D-1
Vehicle Inspection--The Operator's Responsibility	I-D-3
Maintenance of the Emergency Vehicle	I-D-10

Preparing to Drive	I-D-13
Practice in Inspection, Maintenance, and Pre-Start Procedures	I-D-18
Review Exercises	I-D-19
UNIT E - IMPORTANT PHYSICAL FORCES AND EMERGENCY VEHICLE CONTROL	
Trainees' Knowledge Objectives	I-E-1
Introduction	I-E-2
Major Physical Forces	I-E-3
Weight Transfer	I-E-9
Review Exercises	I-E-12
UNIT F - OPERATION	
Trainees' Knowledge Objectives	I-F-1
Content/Structure of This Unit	I-F-5
Use of Lights and Siren	I-F-6
Basic Control Tasks	I-F-9
Urban Driving	I-F-14
Negotiating Intersections	I-F-16
Turning Around to Reverse Direction	I-F-24
Following Another Vehicle	I-F-31
Passing Another Vehicle	I-F-37
Expressway Operation	I-F-42
Driving at High Speed	I-F-50
Review Exercises	I-F-58
UNIT G - HANDLING UNUSUAL SITUATIONS	
Trainees Knowledge Objectives	I-G-1

Introduction	I-G-3
Driving in Adverse Conditions	I-G-4
Handling Contingency Situations	I-G-10
If You Must Pull Off the Road	I-G-29
Review Exercises	I-G-35

LIST OF FIGURES

Figure
No.

I-1 Passenger in Police Vehicle Wins Negligence Case I-B-6

I-2 Property Tax Increase Periling Midwest Town I-B-9

I-3 Official List of Ten-Codes I-C-6

I-4 Inspection Checklist I-D-8

I-5 Engine Components I-D-9

I-6 Key Indicator Chart I-D-11

I-7 Parallel Parking I-F-13

I-8 Stopping Distances at Various Highway Speeds I-F-33

I-9 Entering and Exiting Freeways I-F-45



CONTENT

NOTES

INTRODUCTION

* * * BEGIN MODULE 1 * * *'

General Procedures

The following general procedures will be followed in each training day:

- A. Attendance.
- B. Announcements.

Trainee Prerequisites

- A. You are a licensed driver.
- B. You are qualified to operate the general class of vehicle (e.g., sedan, van, truck) you will be operating for your emergency service.
- C. You have completed the National Safety Council Defensive Driver Training Course.

CONTENT

NOTES

YOUR TRAINEE STUDY GUIDE

- A. Your Trainee Study Guide (TSG) should always be brought to class.
- B. Each unit is preceded by Knowledge Objectives. These tell you what you will be expected to know by the end of the unit.

Format

- A. Left Column: The left column of the TSG contains the text and illustrations.
- B. Right Column: The right column has two purposes:
 1. It provides space to answer the questions printed there. Whenever a plus sign (+) appears, it means that notetaking is required.
 2. It provides space to take additional notes on the basis of your instructor's presentation.
- C. Review Exercises: The Review Exercises at the end of each unit are meant to determine how much you know (or have learned) about the topics in that unit.

CONTENT

NOTES

ORGANIZATION OF THE COURSE

Part I - Basic

The units in Part I are general in nature; they are relevant to members of all emergency services, whether police, fire, ambulance, or rescue. They apply no matter what vehicle will be operated on the job.

Part II - Specialized

The Part II unit covers specific service - and mission-related knowledge you will need to know how to operate your vehicle.

Part III - In-Vehicle (Practical)

This third part of the course is devoted to practical, in-vehicle exercises for developing your skill in operating an EV.

+How will the groups for this part of the course be formed?

CONTENT

NOTES

DEFINITIONS

Whenever one of these terms appears in the training, it should be understood to mean the following:

A. Emergency Mode: When an authorized emergency vehicle, operating with emergency warning devices (lights and sirens) activated, is on a mission involving a (possible) life-threatening situation.

B. Emergency Vehicle (EV): Any vehicle which is legally authorized to operate in the emergency mode. The vehicle is an emergency vehicle whether or not it is operating in the emergency mode.

C. Emergency Vehicle Operator: A person who is authorized to drive an emergency vehicle in the emergency mode.

D. Emergency Service: Police and volunteer or salaried fire, rescue, and ambulance personnel.

E. Illustrations: In the text, illustrations of

1. An EV look like this:



2. An ordinary car look like this:



3. A large vehicle or truck look like this:



SCHEDULE

Example Schedule for Emergency Vehicle Operation Training

	8am	9	10	11	12pm	1	2	3	4	5	
Day 1	Unit A	Unit B		Unit C	L U N C H	Unit C	Unit D		Unit E		
Day 2	Unit E	Unit F (Modules 1-5)				Unit F (Modules 6-9)					
Day 3	Unit G		Part II Specialized			Part II Specialized	Part III Classroom				
Day 4	Part III Range					Part III Range					
Day 5	Part III Range					Part III Range					

Trainees' Knowledge ObjectivesModule 1

By the end of this module:

1. Given a list of topical areas covered by state statutes, you will be able to write a brief description of the statute as it relates to emergency vehicle operation.
2. Given descriptions of several situations, you will be able to identify those situations that represent a true emergency and explain why.

Module 2

By the end of this module:

1. Given descriptions of several situations, you will be able to identify those situations that illustrate due regard for the safety of others and those that do not.

CONTENT

NOTES

INTRODUCTION

- A. As an EV operator, you will have three types of regulations to follow: (1) motor vehicle and traffic laws enacted by the state government, (2) local ordinances (e.g., local speed limits), and (3) departmental policy about what you as an EV operator may and may not do.
- B. It is important that you understand the following three basic principles of EV operation before considering the specific statutes which apply in your state.
1. The operators of all EVs are subject to all traffic regulations unless a specific exemption is made in the state or local statutes. Your instructor will explain exactly what is meant by a "specific exemption."
 2. The specific exemptions made in the statutes refer to an EV only when it is operated in the emergency mode.
 3. Even when a specific exemption is made under the relevant statute, you can be held criminally and/or civilly liable for your actions should you become involved in an accident where property damage, injury, or loss of life occur.

* * * BEGIN MODULE 1 * * *

+What is meant by "specific exemption"?

CONTENT

NOTES

STATE STATUTES ON EMERGENCY VEHICLE OPERATION

- A. All states have statutes governing operation of emergency vehicles. It is very important that you understand what each of these statutes mean in relation to your operation of the vehicle.
- B. Your instructor will provide you with a listing of highlights of the statutes for your state. In addition to the statutes, your instructor will provide you with local ordinances and departmental policy, if this information is available. If your instructor does not provide you with this information, you should do this yourself once on the job. Do not hesitate to ask questions and take notes as required.

CONTENT

NOTES

INTERPRETING THE LAW

If you are involved in an accident where property damage, injury, or loss of life occurs, your actions will be evaluated and judged by your superiors. In some cases, your actions may be judged in a court of law. A court will judge your actions from at least these two aspects:

- A. Was the situation a true emergency?
- B. Did you exercise due regard for the safety of others?

What is a True Emergency?

A true emergency allows the EV operator to exercise those exemptions to the traffic laws granted under relevant statutes. Unfortunately, the definition of a true emergency is not always clear-cut.

- A. In some situations, you will not have to decide whether or not a given situation is a true emergency. Your instructor will tell you about the kinds of situations that will make the nature of the emergency clear.
- B. In other situations, you alone will be in a position to evaluate the situation and decide whether or not to exercise the exemptions granted under the relevant statutes. In such cases, you should consider the following definition of an emergency, which has been accepted in several courts:

A situation in which there is a high probability of death or serious injury to an individual or significant property loss, and action by an EV operator may reduce the seriousness of the situation.

+When will you not have to decide if a situation is a "true emergency"?

CONTENT

NOTES

Case History

Read over the court decision (Figure I-1) which appears on the next page. As you read, try to figure out what it was, specifically, that influenced the court's decision. Discussion will follow.

CONTENT

NOTES

In the case of Wood v. Morris* a police officer was transporting a young girl with an injured arm to the hospital when he collided with another vehicle. The collision caused additional injury to the child. Although the police vehicle's siren and red light were in operation at the time of the collision, the court found him negligent, and an appellate court affirmed that finding as follows:

"The evidence showed that the defendant approached the intersection, which he knew to be one of the main traffic arteries of the city, at a speed of 45-50 mph; that he knew the speed limit at that place was 25 mph; that the street was wet with rain and was of asphalt construction, which he knew makes it even more slick; that he did not apply the brakes as he approached the intersection and only slowed the vehicle perhaps 5 mph before entering the intersection; that he was operating the vehicle with his left hand, while holding the siren with his right hand, being right-handed; that the plaintiff's injuries were not of a critically serious nature, being confined primarily to her arm, so that she was able to get into the automobile and talk. The above evidence was sufficient to authorize a finding of ordinary negligence on the part of the defendant policeman. . ."

Figure I-1. Passenger in police vehicle wins negligence case.**

*109 Ga. App. 148, 135 S.E. 2nd 484, 487 (1964).

**7

+What was it that influenced the court's decision?

* * END OF MODULE 1 * *

CONTENT

NOTES

What is Due Regard for the Safety of Others?

Deciding whether an EV operator has exercised "due regard for the safety of others" is always based on a specific set of circumstances. Certain principles, however, should act as guidelines for your actions:

- A. You must give enough notice of your vehicle's approach to allow other motorists and pedestrians to clear a path and protect themselves. If you do not give notice of the EV's approach until a collision is inevitable, you have probably not satisfied the principle of due regard for the safety of others.
- B. In determining whether or not an EV operator was exercising due regard in the use of signaling equipment, the courts will consider the following (at least):
1. Whether it was reasonably necessary to use signaling equipment, under all of the circumstances.
 2. Whether the signaling equipment was in fact used.
 3. Whether the signal given was audible and/or visible to the other motorists or pedestrians.
- C. Proper use of signaling equipment does not relieve you of the duty to otherwise exercise caution--you must never travel at a speed that does not permit complete control of your vehicle.
- D. Even though each situation must be judged separately, an accepted definition of an act performed with "due regard" is:

A reasonably careful man, performing similar duties and under similar circumstances, would act in the same manner.

* * * BEGIN MODULE 2 * * *

+How do you "give notice" of your vehicle's approach?

CONTENT

NOTES

A Second Case History

Read over the newspaper article (Figure I-2) on the next page. When you are finished, your instructor will discuss this article. Be prepared to answer these two questions:

1. Does the situation appear to be a true emergency?
2. Did the EV operator exercise due regard for the safety of others?

+True emergency?

+Due regard?

Pittsburgh Press, Mon., Jan. 17, 1977

1,073% Property Tax Increase Periling Midwest Town

By JAMES J. FISHER

SALIX, Iowa - This town of 387 souls, 17 miles south of Sioux City, amid the rich bottomlands of the Missouri river, could be any of a thousand small towns in Middle America: a post office, a few stores, a feed mill, three bars, two schools and, of course, the tree-lined streets where residents—53 per cent retired and on fixed incomes, live in scrubbed houses.

But Salix isn't one of those towns. It's unique, for today it sits on a precipice - one from which it will almost surely fall come March 15, when the new city budget is certified and the 137 real property taxpayers find their bills increased by an average of 1,073 per cent to pay off a six-year-old lawsuit against the town.

For **ROGER HUOT**, a corn farmer, that means his bill will go from \$400 to \$3,500; for Mrs. Edna Peppin, whose husband has been in poor health for eight years, the jump will be from \$300 to \$1,500, and for Rupert Thorpe, the postmaster, the bill will go from \$300 to nearly \$5,000.

Talk of money pervades this town. Not greedy talk, but talk of relief from the burden that most know is coming.

There have been fanciful suggestions to burn the town to the ground, to move it to another township, or for the city council of six members to resign in protest.

And some talk isn't so fanciful. "We could solve all our problems if we'd take every judge, lawyer and insurance agent in the county out and line them up and shoot them," says one farmer. He is dead serious.

Salix's problems began on the afternoon of Oct. 29, 1970, when the Salix volunteer ambulance, transporting a dying 80-year-old man to a Sioux City hospital, collided with a car in Sioux City.

The ambulance entered the intersection against the stoplight, with sirens and red light on. The car, driven by Grant Wetz, an attorney who specialized in insurance, had the green. Wetz was injured fatally in the accident.

Subsequently, his widow, Mrs. Frances Wetz, filed a \$300,000 suit against the town of Salix. Although it was a volunteer ambulance squad, court decisions concerning workman's

compensation have declared that even volunteers are employees of a city.

Salix had insurance - \$100,000 - with Western Casualty and Surety of Fort Scott, Kan.

"Western was convinced that the town didn't have a thing to worry about," says William Shuminsky, Salix attorney. "They wanted to go to court. In April 1972, the attorneys for Mrs. Wetz offered to settle for \$85,000. I wrote Western's attorneys and demanded that they come to terms. But no, they went to court."

JUDGE JAMES P. KELLEY heard the suit in mid-1973 without a jury. He ruled in July 1972, awarding the Wetz estate \$188,663, plus interest from the day of the accident. The decision was later affirmed by the Iowa Supreme Court. Western paid out its \$100,000, plus about \$18,000 in interest. That left Salix holding the bag for the remainder. With interest, that came to \$118,561.03.

The Iowa legislature responded to Salix's plight last year by passing a law allowing the town to pay the debt off in 10 yearly installments. That law was struck down as unconstitutional by the

Iowa courts on the grounds that it infringed on a judicial decision.

Thus, this year, Salix was ordered by the courts to budget the settlement into its city appropriations, meaning the town will spend \$129,000. The town budget is usually about \$11,000.

Shuminsky has filed suit against Western in the amount of \$118,561.03, charging that the company acted in bad faith. There is little hope the suit can come to trial before the city budget is certified.

Postmaster Rupert Thorpe, who was driving the ambulance the day the accident occurred (but who never was charged with violation of any traffic laws), said the rescue squad still operates.

"We could have just quit, but that would have meant a lot of people would have died out on the interstate, in the towns around here or out on the farms," he says. "But people depend on us. That's why we go on."

And how much insurance does the rescue squad have?

"A million bucks," says Thorpe.

Wannan's News Service

Figure I-2. Property Tax Increase Periling Midwest Town.

CONTENT

NOTES

SUMMARY

You will greatly reduce the chances of being found guilty of negligence if you follow these guidelines:

- A. Be reasonably certain that a situation represents a true emergency before exercising the exemptions granted in your state statutes. You should be able to answer "yes" to the following questions:
1. Is there a high probability that this situation could cause death or serious injury to an individual?
 2. Is there significant property imperiled?
 3. Could action on my part reduce the seriousness of the situation?
- B. Once you have made the decision to treat a situation as a true emergency, remember that under all circumstances you must exercise due regard for the safety of others.

CONTENT

NOTES

Practice

Your instructor will describe some situations to you. Take notes as he describes all of the situations. You will want to try to determine for each situation whether or not it is a true emergency and whether or not it represents due regard.

Situation 1:
True emergency?
Due regard?

Situation 2:
True emergency?
Due regard?

Situation 3:
True emergency?
Due regard?

Review Exercises

1. For each of the topical areas listed below, write a brief description of the relevant points of your state statute.
 - a. Proceeding past red lights and stop signals:
 - b. Violating traffic flow and turn regulations:
 - c. Parking at the scene of an emergency:

2. From the information available, which of the following situations should be treated as a true emergency by an EV operator? Explain why.
 - a. Three-car collision, injuries (severity unknown). No other EVs at the scene.

True emergency (yes or no)? _____

Why? _____

- b. The dispatcher reports that a dog, possibly rabid, is threatening children in a nearby neighborhood.

True emergency (yes or no)? _____

Why?

- c. The dispatcher reports that a man phoned, requesting aid. He thinks his son may have broken his ankle; there is some pain and swelling.

True emergency (yes or no)? _____

Why?

3. From the information available, which of the following situations seem to represent "due regard for the safety of others" and which do not? Why?

- a. An EV operator, enroute to a true emergency, traveling 70 mph on an asphalt road in the rain (posted limit is 45 mph).

Due regard (yes or no)? _____

Why?

b. Proceeding through a red light, after slowing to 10 mph when returning to the station at the end of a run.

Due regard (yes or no)? _____

Why?

c. Traveling the wrong way down a one-way street, while enroute to a fire at a large apartment complex, using all signaling equipment.

Due regard (yes or no)? _____

Why?

Trainees' Knowledge ObjectivesModule 1

By the end of this module:

1. You will be able to state two advantages of careful route preselection.
2. You will be able to list three examples of the kinds of facilities whose location could be essential to route planning.

Module 2

By the end of this module:

1. Given a list of several statements relating to communications techniques and procedures, you will be able to identify which are correct.
2. You will be able to state the three items of information that must be obtained from the dispatcher before responding to an emergency call.

CONTENT

NOTES

SELECTING ROUTES

* * * BEGIN MODULE 1 * * *

Advantages of Preselecting Routes

- A. Travel time can be cut to a minimum, and this can mean savings in life, injury, and property damage.
- B. Effective route selection can minimize the amount of "accident exposure" by minimizing the likelihood of being in accident-likely areas at accident-likely times (e.g., busy intersections at rush hour).
- C. Effective route preselection will allow you to devote more of your attention to the actual driving tasks once the vehicle is underway.

Factors to Be Considered

Before you can select a route to travel you must consider four important factors:

- A. Location of Facilities (and their entrances and exits). Many emergency runs will be made to facilities that house large numbers of people. Being familiar with the exact location of such facilities and their entrances and exits will help save time. Try to think of some of the kinds of facilities that could be important to your route planning/selection.
- B. Events Affecting Traffic Flow. Traffic conditions can have considerable impact on the length of time it takes to respond to an emergency call or the length of time it takes to transport a patient to an emergency care facility. Try to think of some of the kinds of events that are likely to tie-up (or slow down) traffic.

+Kinds of facilities:

+Events that could tie-up traffic:

CONTENT

NOTES

C. Characteristics of Local Roads and Streets. Once you have been on the job for a while, you will begin to develop a "mental map" of your territory. Since some conditions constantly change, however, it is important to have up-to-date maps both at the base and in the vehicle. These maps can then be referred to when there is a need. Even the most experienced EV operator cannot remember everything all of the time. What kinds of information that is necessary for route selection can be found on detailed maps?

+Kinds of information on maps:

+What can be added to maps to make them more useful?

D. Road Conditions. This kind of information is likely to change from month to month, in some cases, almost day to day. This is another area where you want to make a special effort to keep yourself informed; some of this information can be noted on your maps. What are some of the kinds of road conditions that can have an impact on route selection?

+Kinds of road conditions that can have an impact on route selection:

CONTENT

NOTES

Summary

- A. Effective route selection can reduce the time required to arrive at the scene of an emergency or to transport a patient to a medical facility.
- B. Effective route selection can minimize "accident exposure" by minimizing the likelihood of being in accident-likely areas at accident-likely times.
- C. Effective route selection will allow you to devote your attention to the actual driving tasks once the vehicle is underway.

Practice

Your instructor will provide you with a copy of a local map and a list of conditions that could have an effect on your route selection. Read the conditions and look over the map carefully. Be prepared to present your route selection to the class, if called on. On the basis of the class discussion, can you make some conclusions about route selection?

+Conclusions about route selection:

* * END OF MODULE 1 * *

CONTENT

NOTES

REPORTING EMERGENCY VEHICLE OPERATIONS

* * * BEGIN MODULE 2 * * *

Introduction

As an EV operator, you will make both routine and mission-related communications.

A. To do this, you will use the in-vehicle communications equipment to communicate with the station or dispatcher.

B. There are standard, recognized codes (such as 10-codes) and communications techniques that facilitate emergency communications. Turn to the next page to see an example of 10-codes (Figure I-3).

C. General techniques for communications:

+What is the primary goal of good communications techniques?

1. Be brief and concise--don't tie up the air-waves with needlessly wordy messages.

+Are codes used locally?

2. If codes are used in your locale--use them!

+What kind?

3. Weigh the urgency of communications against the difficulty of the driving requirement. For example, when driving on unfamiliar roads which are in poor condition, it would be unwise to take a hand off the steering wheel to hold a microphone.

4. Drop mike into lap to avoid tangling the cord in the steering wheel.

5. Have your partner conduct communications whenever possible.

6. Finish communications before starting run (when possible).

10-1	Signal Weak	10-21	Call (_____) by Phone
10-2	Signal Good	10-22	Disregard
10-3	Stop Transmitting	10-23	Arrived at Scene
10-4	Affirmative (OK)	10-24	Assignment Completed
10-5	Relay (To)	10- 25	Report to (meet)
10-6	Busy	10-26	Estimated Arrival Time
10-7	Out of Service	10-27	License/Permit Information
10-8	In Service	10-28	Ownership Information
10-9	Say Again (Repeat)	10-29	Records Check
10-10	Negative	10-30	Danger/Caution
10-11	___ On Duty	10-31	Pick-Up
10-12	Stand By (Stop)	10-32	___ Units Needed (Specify)
10-13	Existing Conditions	10-33	Help Me Quick (Emergency)
10-14	Message/Information	10-34	Time
10-15	Message Delivered	10-35	-Reserved-
10-16	Reply to Message	10-36	-Reserved-
10-17	Enroute	10-37	-Reserved-
10-18	Urgent (Quickly)	10-38	-Reserved-
10-19	(In) Contact	10-39	-Reserved-
10-20	Location		

Figure I-3. Official List of Ten-Codes.*

CONTENT

NOTES

Routine Communications

- A. You should always inform the dispatcher whenever you will be leaving the vehicle. The only exception to this rule is if you have a partner and he will remain in the vehicle. Some reasons for this rule:
1. It could save your life (if you become involved in a dangerous situation, the dispatcher can send aid--if he knows where you are).
 2. It could save time, which could be critical to another emergency situation. If the dispatcher knows you are not in the vehicle, he will not waste time trying to contact you.
- B. You should report your arrival at a destination to the dispatcher or station. This gives you an opportunity to:
1. Ask the dispatcher to alert any other organizations whose services may be needed (e.g., hospital, highway maintenance department, other EVs).
 2. Receive information that might cause you to alter your next destination or route.
 3. Notify the dispatcher that you will be away from the vehicle and may not be available for communications.
- C. You should inform the dispatcher of any major condition which is likely to cause a disruption in emergency service, or ones that other EVs are not likely to know about.

CONTENT

NOTES

Practice

Your instructor will describe several conditions or situations. Try to determine whether or not that condition should be reported to the dispatcher, and the reason why.

+Condition 1:

+Condition 2:

+Condition 3:

+Condition 4:

Mission-Related Communications

A. There are three items of information that must be obtained for every call:

1. Description of emergency.
2. Address (location) and other identifiers.
3. Indication of priority.

B. Other information that might be obtained (depending on the type of call):

1. Is the roadway blocked?
2. Are there any other EVs on the way or on the scene?
3. Are any hazardous materials involved (e.g., gasoline spillage)?

+Why might these items of information be important?

Practice

Your instructor will "transmit" (read) some radio messages to you. Listen carefully to determine if you have been given all of the information you need to begin an emergency run. If you have not been given all of the necessary information, note what is missing.

+Message 1:

+Message 2:

+Message 3:

* * END OF MODULE 2 * *

Review Exercises

1. List two advantages of careful route planning.

2. List three examples of the kinds of facilities whose location could be essential to route planning.

3. Indicate which of the following statements are true and which are false:

a. All communications with the dispatcher should be conducted using 10-codes.

T F

b. Communications should be completed before starting a run, if possible.

c. The EV operator should always inform the dispatcher if he will be leaving the vehicle.

d. If a second crew member is present, he should conduct communications.

T

F

e. The microphone should always be placed on its clamp by the receiver as soon as communications are ended.

4. List three items of information that must be obtained from the dispatcher before responding to any emergency call.

Trainees' Knowledge ObjectivesModule 1

By the end of this module:

1. Given a list of several statements relating to vehicle inspection and maintenance, you will be able to identify those statements that are correct.
2. Given a list of vehicle components, you will be able to list two indicators (symptoms) of problem/malfunction for each.

Module 2

By the end of this module:

1. You will know the criteria for proper adjustment of:
 - a. Seat position.
 - b. Head restraint.
 - c. Lap belt.
 - d. Shoulder harness.
 - e. All mirrors.

Trainees' Knowledge Objectives (Continued)Module 3

By the end of this module:

1. Given a copy of the Inspection Checklist, you will be able to perform a thorough inspection of a motor vehicle, and correctly identify any symptoms of malfunctions or items requiring repair.
2. You will be able to perform minor maintenance tasks if they are required on your job.
3. You will be able to demonstrate proper adjustment of:
 - a. Seat position.
 - b. Head restraint.
 - c. Lap belt.
 - d. Shoulder harness.
 - e. All mirrors.

CONTENT

NOTES

VEHICLE INSPECTION--THE OPERATOR'S RESPONSIBILITY

Introduction

- A. Many accidents are caused by vehicle malfunction. Most, if not all, of these accidents could be prevented by a five-minute, routine physical and visual inspection of the EV at the beginning of every shift.
- B. In the final analysis, responsibility for the mechanical safety of the vehicle will rest with you, the operator. You must protect yourself, and the motoring public from the hazard of an unsafe vehicle. One way to do this is to routinely perform a thorough inspection at the start of your shift.

* * * BEGIN MODULE 1 * * *

+What are your four major in-
spection responsibilities?

1.

2.

3.

4.

Major Components of a Vehicle

A basic understanding of how vehicle components work will help you make a thorough inspection of your EV. Look at the Vehicle Components Chart beginning on the next page. Follow along as your instructor explains the components.

Vehicle Components Chart Note:

Vehicle ComponentsBraking System

Drum Brakes

Pressure on brake pedal causes fluid or air to flow into brake cylinder. Cylinder moves brake shoe outward against brake drum (inner surface of metal wheel). This pressure of shoe against drum causes wheel to slow and stop.

Disc Brakes

A disc brake consists of a rotor and caliper assembly. The rotor is the disc. It is attached to the wheel axle. When the brake pedal is depressed, a hydraulic piston in the caliper causes the caliper to squeeze together, bringing a pair of brake shoes into contact with the rotor. The friction of the opposing brake pads as they squeeze the rotor slows the rotor rotation and causes the wheel to slow and stop.

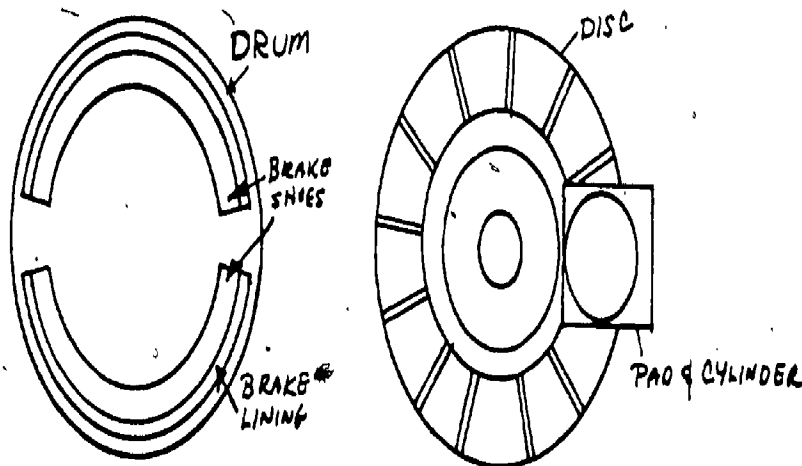

Vehicle Components (Continued)Engine (gasoline)

Carburetor

Combustion Chambers

Pistons

Crankshaft

Camshaft

Takes fuel in gas tank, mixes it with air in carburetor. Mixture is fed into combustion chamber where it is ignited by spark plugs. The exploding mixture causes pistons to move. The motion of the pistons causes the crankshaft to turn. The rotating crankshaft connects the final power from the engine to the transmission. The power is then carried to the driveshaft, the differential, the rear axles, and the rear wheels.

Engine (diesel)

Combustion Chambers

Pistons

Crankshaft

High compression of air charge in cylinder creates great heat. Fuel charge is injected into cylinder and is ignited by hot air. The exploding mixture causes pistons to move. The motion of the pistons causes crankshaft to turn.

Transmission and Drive-
shaft

A system of gears which allows you to change the ratio of number of engine revolutions to number of wheel revolutions. For example, in low gear, the engine might turn 100 times for one wheel turn. In a higher gear, the engine might turn ten times for one wheel turn. The driveshaft connects the transmission to the rear wheels, making them turn.

Clutch Pedal

When depressed, disconnects engine from transmission so you can change transmission gears.

Steering Assembly

Steering wheel and column connects to gears and linkage mechanism which changes direction of front wheels.

Electrical System

Generator

Alternator

Supplies power for primary and auxiliary functions.

Vehicle Components (Continued)Primary
Functions:

Power generation and storage (battery, generator/alternator, and voltage regulator).

Power distribution (engine wiring).

Timing (distributor).

Spark generation (spark plugs and coil).

Auxiliary
Functions:

Inside/outside lighting (headlights, amber/red/blue signal or warning lights, turn signals, instrument panel lights, etc.).

Air/heat circulation (heater, defroster, blowers).

Horn, siren, PA system.

Suspension

Springs, shock absorbers, wheels, and tires which enable the driver to handle the vehicle properly on rough terrain and sharp curves, etc.

CONTENT

NOTES

The Physical and Visual Inspection

A: The inspection procedure presented in this unit makes use of a checklist. Generally, it will take only a few minutes to perform this inspection. Two things to remember about making a vehicle inspection are:

1. You should inspect the vehicle when the engine is cold.
2. You should inspect the vehicle at a time when interruptions are unlikely, preferably at the beginning of your shift.

B. The checklist is divided into five parts. These five parts represent five separate "events" to be accomplished during the inspection. Each section is important and deserves consideration. Your instructor will explain the five "events" and their purpose in more detail.

+Why?

Event #1:
Purpose:

Event #2:
Purpose:

Event #3:
Purpose:

Event #4:
Purpose:

Event #5:
Purpose:

EMERGENCY VEHICLE INSPECTION CHECKLIST

Name: _____ Date: _____ Time: _____

Vehicle Identification No.: _____ Location: _____

		OK	FIX		OK	FIX
APPROACH VEHICLE	Vehicle Attitude	<input type="checkbox"/>	<input type="checkbox"/>	Body Damage	<input type="checkbox"/>	<input type="checkbox"/>
	Remarks: _____					

CIRCLE VEHICLE	Headlights	<input type="checkbox"/>	<input type="checkbox"/>	Beacon	<input type="checkbox"/>	<input type="checkbox"/>
	Running Lights	<input type="checkbox"/>	<input type="checkbox"/>	Flood	<input type="checkbox"/>	<input type="checkbox"/>
	Brake Lights	<input type="checkbox"/>	<input type="checkbox"/>	Body	<input type="checkbox"/>	<input type="checkbox"/>
	*Four-Way Flasher	<input type="checkbox"/>	<input type="checkbox"/>	Wheels	<input type="checkbox"/>	<input type="checkbox"/>
	Tires	<input type="checkbox"/>	<input type="checkbox"/>	Windshield	<input type="checkbox"/>	<input type="checkbox"/>
	Doors	<input type="checkbox"/>	<input type="checkbox"/>			
	Remarks: _____					

UNDER HOOD	Hoses	<input type="checkbox"/>	<input type="checkbox"/>	Belts	<input type="checkbox"/>	<input type="checkbox"/>
	Fluids: *Radiator	<input type="checkbox"/>	<input type="checkbox"/>	Oil	<input type="checkbox"/>	<input type="checkbox"/>
	Windshield	<input type="checkbox"/>	<input type="checkbox"/>	Hydraulic	<input type="checkbox"/>	<input type="checkbox"/>
	Battery	<input type="checkbox"/>	<input type="checkbox"/>	Steering/Brake	<input type="checkbox"/>	<input type="checkbox"/>
	Remarks: _____					

ENTER VEHICLE	Cleanliness	<input type="checkbox"/>	<input type="checkbox"/>	Interior Lights	<input type="checkbox"/>	<input type="checkbox"/>
	Gas Gauge	<input type="checkbox"/>	<input type="checkbox"/>	Seat Belt	<input type="checkbox"/>	<input type="checkbox"/>
	Alternator	<input type="checkbox"/>	<input type="checkbox"/>	Brake Indicator	<input type="checkbox"/>	<input type="checkbox"/>
	Temperature	<input type="checkbox"/>	<input type="checkbox"/>	Air Pressure	<input type="checkbox"/>	<input type="checkbox"/>
	Windshield Wipers	<input type="checkbox"/>	<input type="checkbox"/>	Turn Signals	<input type="checkbox"/>	<input type="checkbox"/>
	Inner Mirrors	<input type="checkbox"/>	<input type="checkbox"/>	Communications	<input type="checkbox"/>	<input type="checkbox"/>
	Outer Mirrors	<input type="checkbox"/>	<input type="checkbox"/>	Siren/Audibles	<input type="checkbox"/>	<input type="checkbox"/>
	Oil Pressure	<input type="checkbox"/>	<input type="checkbox"/>	PA System	<input type="checkbox"/>	<input type="checkbox"/>
	Seat Adjustment	<input type="checkbox"/>	<input type="checkbox"/>			
	Remarks: _____					

VEHICLE IN MOTION	Steering/Smoothness	<input type="checkbox"/>	<input type="checkbox"/>	Brakes	<input type="checkbox"/>	<input type="checkbox"/>
	Unusual Noises	<input type="checkbox"/>	<input type="checkbox"/>	Suspension	<input type="checkbox"/>	<input type="checkbox"/>
	Remarks: _____					

*Radiator must be cool to avoid injury and to make accurate inspection.

Figure I-4. Inspection Checklist.

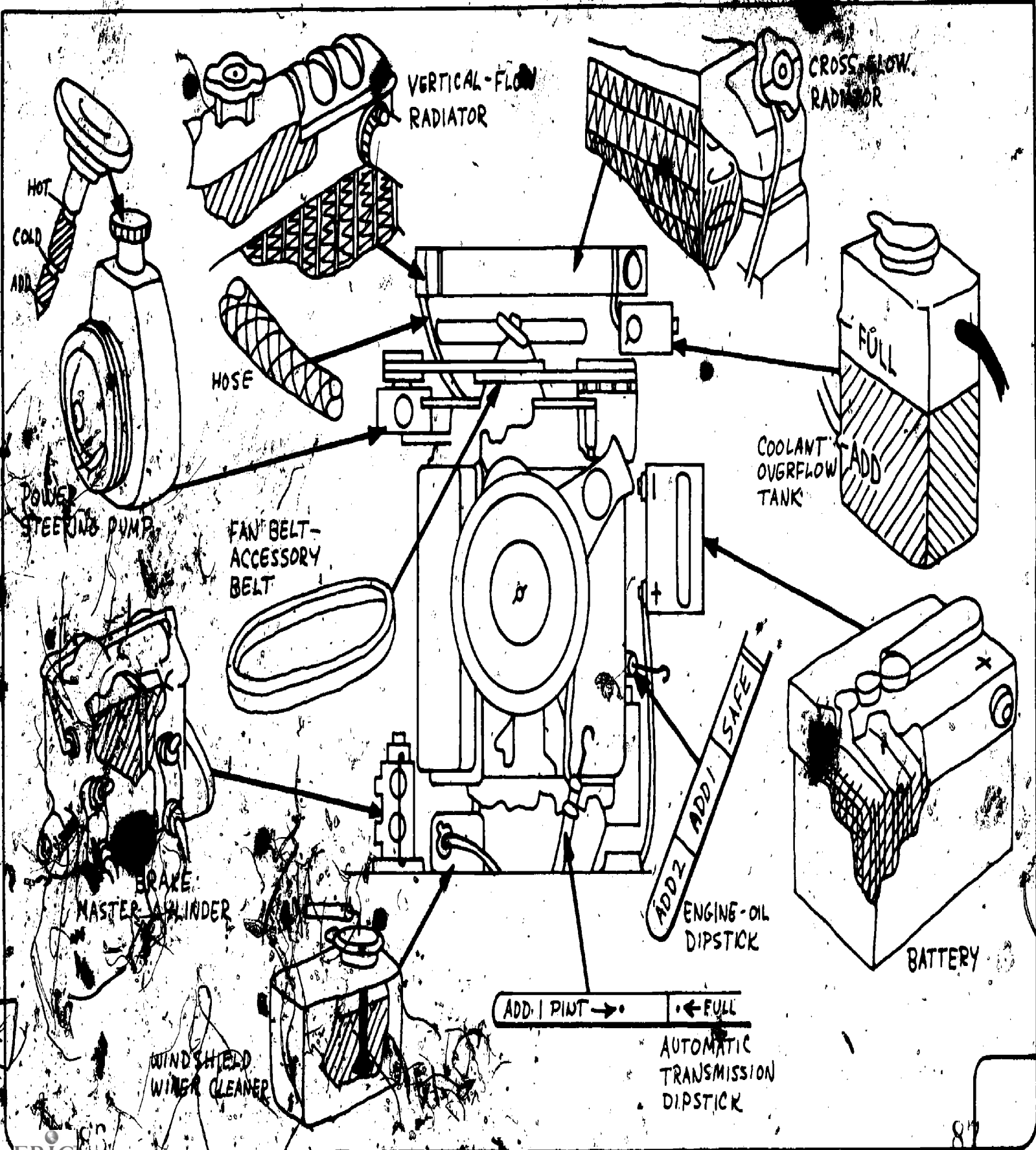

Figure I-5. Engine Components.

CONTENT

NOTES

MAINTENANCE OF THE EMERGENCY VEHICLE

A. Obviously, your safety is dependent on the condition of your EV. A vehicle in excellent condition will have fewer malfunctions, and in many cases will be easier to control. Part of your job is to:

1. Perform any minor maintenance/repair you are required (and competent) to perform. Your instructor will tell you, specifically, what kinds of things you are expected to adjust or repair.
2. Schedule maintenance, or notify those responsible for scheduling maintenance that maintenance is required.
3. Recheck the vehicle after corrective maintenance/repair has been performed to ensure the problem has been corrected.

B. Regardless of the departmental structure that has been set up for having maintenance/repair performed, it is your responsibility to see that it is performed.

Key Indicator Chart

The Key Indicator Chart on the following page I-D-11. Your instructor will explain what the four column headings mean. You should be able to recognize all of the key indicators--in many cases they mean the difference between a safe vehicle and an unsafe one.

+What kinds of maintenance are you required to perform?

+Whom should you notify about maintenance or repair?

+What is a "key indicator"?

KEY INDICATOR CHART

ITEM	KEY INDICATOR	UNSAFE FOR EMERGENCY OPERATION	OPERATOR MAINTENANCE
<p>APPROACH VEHICLE</p> <p><u>Attitude</u> -Springs, torsion bars, tires</p> <p><u>Body</u></p>	<p>Vehicle lists, sags to one side, slants.</p> <p>Dents or other damage. Oil on quarter panel.</p>	<p><input type="checkbox"/></p> <p><input type="checkbox"/></p> <p><input type="checkbox"/></p>	<p><input type="checkbox"/></p> <p><input type="checkbox"/></p> <p><input type="checkbox"/></p>
<p>CIRCLE VEHICLE</p> <p><u>Lights</u> -Emergency lights -Head, parking, brake, back</p> <p><u>Tires</u> -Tread -Sidewalls -Pressure</p> <p><u>Wheels</u></p> <p><u>Doors</u></p>	<p>Light does not go on; dirty lenses; cracked lenses; lights noticeably dim.</p> <p>Tread-wear indicator visible, uneven tread wear. Breaks, cracks, bubbles. Does not meet <u>vehicle manufacturer's specifications.</u></p> <p>Cracked, bent rim, loose lug nuts.</p> <p>Do not close squarely or totally.</p>	<p><input type="checkbox"/></p> <p><input type="checkbox"/></p> <p><input type="checkbox"/></p> <p><input type="checkbox"/></p> <p><input type="checkbox"/></p> <p><input type="checkbox"/></p>	<p><input type="checkbox"/></p> <p><input type="checkbox"/></p> <p><input type="checkbox"/></p> <p><input type="checkbox"/></p> <p><input type="checkbox"/></p> <p><input type="checkbox"/></p>
<p>UNDER HOOD</p> <p><u>Fluid Levels</u> -Radiator -Oil -Windshield washer -Hydraulic -Battery -Power Steering -Automatic Transmission</p> <p><u>Engine Block</u></p> <p><u>Hoses</u></p> <p><u>Belts</u></p>	<p>Fluid not visible in radiator. More than one quart low. Less than half full. Below add mark.</p> <p>Water not visible in cells. Below add mark. Below add mark.</p> <p>Check for evidence of oil or other fluid leak.</p> <p>Cracked, loose connections.</p> <p>Cracked; loose: depresses more than one inch at center; tight: glazed surface.</p>	<p><input type="checkbox"/></p> <p><input type="checkbox"/></p> <p><input type="checkbox"/></p> <p><input type="checkbox"/></p> <p><input type="checkbox"/></p> <p><input type="checkbox"/></p> <p><input type="checkbox"/></p> <p><input type="checkbox"/></p>	<p><input type="checkbox"/></p> <p><input type="checkbox"/></p> <p><input type="checkbox"/></p> <p><input type="checkbox"/></p> <p><input type="checkbox"/></p> <p><input type="checkbox"/></p> <p><input type="checkbox"/></p> <p><input type="checkbox"/></p>

Figure I-6. Key Indicator Chart

ITEM	KEY INDICATOR	UNSAFE FOR EMERGENCY OPERATION	OPERATOR MAINTENANCE
ENTER VEHICLE			
<u>Cleanliness</u>	Dirt or loose objects.	<input type="checkbox"/>	<input type="checkbox"/>
<u>Seat Belt</u>	Not bolted to floor; badly frayed; will not adjust properly or pull out fully.	<input type="checkbox"/>	<input type="checkbox"/>
<u>Gauge and Display Indicators</u>			
-Gas	Low (below 3/4).	<input type="checkbox"/>	<input type="checkbox"/>
-Oil Pressure	Low indication.	<input type="checkbox"/>	<input type="checkbox"/>
-Alternator/ammeter	Charging excessively; discharging; light on.	<input type="checkbox"/>	<input type="checkbox"/>
-Brake	Warning light on; skid control unit malfunction.	<input type="checkbox"/>	<input type="checkbox"/>
-Temperature	Warning light on; rises into danger zone.	<input type="checkbox"/>	<input type="checkbox"/>
-Air Pressure	Does not indicate proper pressure.	<input type="checkbox"/>	<input type="checkbox"/>
<u>Turn Signals</u>	Fast blinker; no blinker.	<input type="checkbox"/>	<input type="checkbox"/>
<u>Windshield Wipers</u>	Do not make contact with windshield; do not clear windshield properly.	<input type="checkbox"/>	<input type="checkbox"/>
<u>Windshield Washers</u>	Fluid does not come out; fluid does not come out with sufficient pressure; improperly aimed.	<input type="checkbox"/>	<input type="checkbox"/>
<u>Communications Equipment</u>	Cannot send or receive; channel drifts out.	<input type="checkbox"/>	<input type="checkbox"/>
<u>Mirrors</u>	Missing; will not hold adjustment.	<input type="checkbox"/>	<input type="checkbox"/>
<u>Siren</u>	Not audible.	<input type="checkbox"/>	<input type="checkbox"/>
<u>Seat Adjustment</u>	Will not lock into place.	<input type="checkbox"/>	<input type="checkbox"/>
<u>PA System</u>	Does not work; distorts.	<input type="checkbox"/>	<input type="checkbox"/>
<u>Interior Lights</u>	Do not light.	<input type="checkbox"/>	<input type="checkbox"/>
<u>Cleanliness of Windows</u>			
<u>Engine</u>	Will not start; stalls.	<input type="checkbox"/>	<input type="checkbox"/>
VEHICLE IN MOTION			
<u>Steering</u>	Wheel turns more than 1/8 turn without response; vehicle wanders; unusual noise; jerky on turn.	<input type="checkbox"/>	<input type="checkbox"/>
<u>Brakes</u>	Grab; pull to left or right; spongy; squealing.	<input type="checkbox"/>	<input type="checkbox"/>
<u>Suspension</u>	Unusual noise; too bouncy, not stable; noticeable vibration.	<input type="checkbox"/>	<input type="checkbox"/>
<u>Acceleration</u>	Rough, uneven, hesitates; cuts out.	<input type="checkbox"/>	<input type="checkbox"/>

Figure I-6. Key Indicator Chart (Continued)

CONTENT

NOTES

PREPARING TO DRIVE

* * * BEGIN MODULE 2 * * *

General Procedures to Increase Driving Use and Safety

- A. Check and adjust (if necessary) all safety equipment.
- B. Start the vehicle appropriately.
- C. Exercise precautions before moving.

Making Safety Checks and Adjustments

- A. Safety belts and shoulder harnesses.
 1. Why wear them?
 - a. Passenger restraints reduce the likelihood of serious injury or death in a collision.
 - b. Restraints improve your ability to control your EV.
 2. The proper adjustment for passenger restraints are:
 - a. Lap belt should be snug across the lower pelvis, not across the stomach.
 - b. Shoulder harness should be loose enough that your fist can fit between harness and chest.
- B. Head restraints.
 1. Why use them?
 - a. Head restraints help prevent neck and spinal injuries.

+How can restraints improve vehicle control?

CONTENT

NOTES

b. Head restraints can help you stay in position in a collision.

2. Proper adjustment for head restraints is with the center of the restraint positioned at the back of the skull--NOT at the base of the neck.

+Why is proper positioning so important?

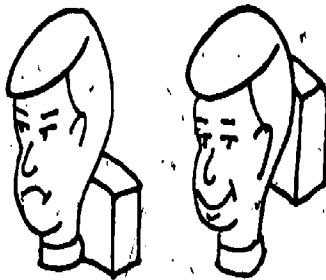

C. Seat position adjustment:

1. You should be able to apply the brake and accelerator without fully extending your legs.
2. You should be able to hold the steering wheel with only a slight bend at the elbows.
3. Seat must be locked into position.

D. Mirrors. The drawings on the next page illustrate the following points:

1. Proper mirror adjustment:

- a. Inside, rear-view mirror:

- 1) The entire rear window should be visible when your head is in a normal driving position.

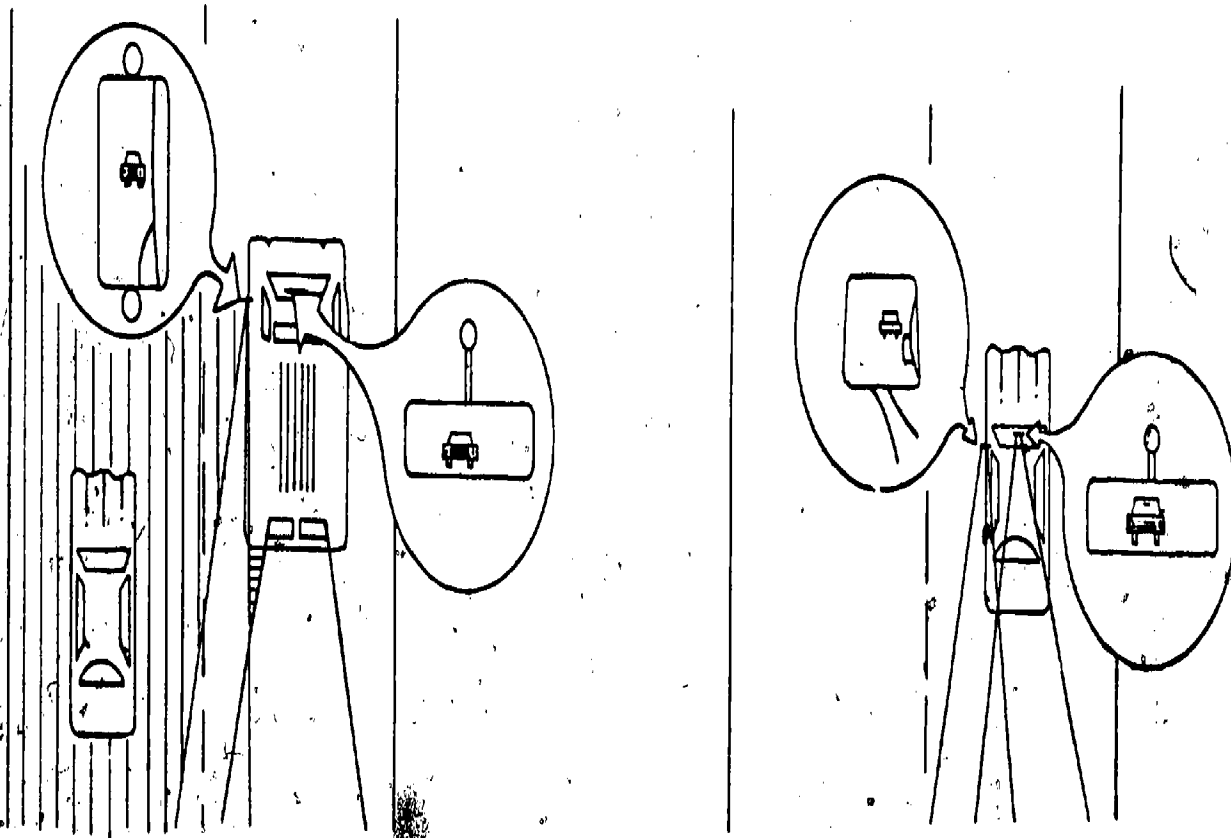
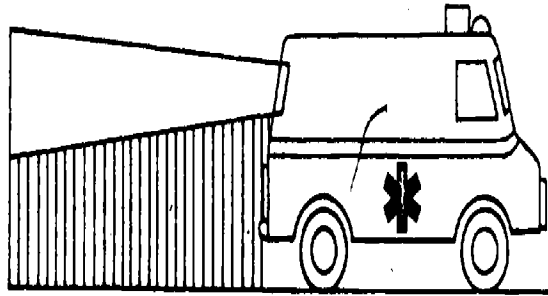

 Blind Spot

CONTENT

NOTES

2) A vehicle directly behind the EV should be centered (approximately) in the mirror.

b. Outside, side-view mirrors:

1) The edge of your vehicle's rear fender and side lanes should be visible.

2) Ideally, before a passing vehicle's image leaves the rear-view mirror, it would be visible in the side-view mirror.

2. Blind spots.

+Where are the most dangerous blind spots for all vehicles?

+Large vehicles have an additional blind spot. Where?

Start-up Procedures

A. Before starting the transmission vehicle should be in "neutral" on manual transmissions or in "park" on automatic transmissions.

B. If your vehicle has a manual transmission, depress the clutch.

C. Use the manufacturer's recommendations for setting the choke or using starting aids on hot or cold engine.

D. If engine sputters, or won't start right away, avoid reengaging starter until engine is completely stopped.

+Why?

CONTENT

NOTES

- E. Once engine is started, you will need to make a routine check of the dash panel.
- F. Remember to release the parking brake before attempting to move the vehicle.

Precautions Before Moving

- It is a good idea to pre-arrange a standard, audible signal with other crewmembers. In this way, you can always be sure that all crewmembers are aboard.
- B. No more than one other person should be in the front seat or control cab with you.
 - C. Check to be sure the station doors are open, and that no obstacles are in the vehicle's path.

+What items should you check on the dash panel?

+What about "timers" on the station doors?

** END OF MODULE 2 **

CONTENT

NOTES

PRACTICE IN INSPECTION, MAINTENANCE, AND PRE-START PROCEDURES

- A. Instructor demonstration of inspection procedures.
- B. Trainee performance of inspection procedures.
- C. Instructor demonstration of maintenance/repair procedures (if relevant).
- D. Trainee performance of maintenance/repair procedures (if relevant).
- E. Instructor demonstration of pre-start procedures.
- F. Trainee performance of pre-start procedures.

* * * BEGIN MODULE 3 * * *

* * END OF MODULE 3 * *

Review Exercises

Answer the following true/false questions:

- | | T | F |
|--|-------|-------|
| 1. You should inspect your vehicle once a week, at the end of a shift. | _____ | _____ |
| 2. Loose objects, such as paper cups, newspapers, flashlights, etc. should be removed from the passenger compartment or secured. | _____ | _____ |
| 3. Springs and shock absorbers are part of the suspension system. | _____ | _____ |
| 4. If the gas gauge indicates below 3/4 full, it is a good idea to have the tank filled. | _____ | _____ |
| 5. If you are working a daylight shift, it is not necessary to have a vehicle with a burned-out headlamp serviced. | _____ | _____ |
| 6. When a vehicle tends to wander due to steering problems, it is safe for emergency operation. | _____ | _____ |
| 7. A tire with a bubble by the rim does not have to be replaced as long as the tread-wear indicator is not showing. | _____ | _____ |
| 8. If your lights are dim, the vehicle is safe for emergency operation. | _____ | _____ |
| 9. If the vehicle swerves when you apply the brakes, it could mean that the wheels are not braking evenly. | _____ | _____ |

10. List two key indicators of problem/malfunction for each of the following items:

a. Tires

b. Steering

c. Belts

d. Seat belt

e. Brakes

Trainees' Knowledge ObjectivesModule 1

By the end of this module:

1. You will be able to write a brief description of the following terms:
 - a. Velocity
 - b. Centrifugal force
 - c. Inertia
 - d. Friction
2. You will be able to indicate on a drawing the effects of acceleration, deceleration, and turning on a vehicle's weight distribution.
3. You will be able to state the primary cause of brake fade.

CONTENT

NOTES

INTRODUCTION

A. While driving, you can control only the velocity and direction of the vehicle.

1. Velocity control is control of the vehicle's rate of motion or speed.

2. Directional control is the control of the direction the EV will travel.

B. Several physical forces influence the amount of control you have. If the limits created by the physical force are not exceeded, you can fully control the vehicle's velocity and direction. If these forces are exceeded, control will be lost.

C. The key is for you to know the conditions under which these limits are reached and, thus, when your ability to control the vehicle will be lost.

* * * BEGIN MODULE 1 * * *

+What actions do you perform that influence the vehicle's speed?

+What actions do you perform that influence the vehicle's direction?

+Think of some examples where you could exceed the limits and lose control.

CONTENT

NOTES

MAJOR PHYSICAL FORCES

The most important physical forces for EV control are friction, momentum and inertia, and centrifugal force.

Friction

A. What is friction?

1. Friction is the resistance to slipping.
2. Friction occurs whenever two surfaces "rub" together.

B. Friction occurs throughout the EV.

C. For vehicle control, the most important areas of friction are:

1. Between the tires and the road.
2. Between the brakes and the wheels.

D. Friction between the tires and the road.

1. If there were no friction between the tires and the road, the vehicle would slide all over the place. Vehicle control would be impossible.
2. The amount of friction between the tires and the road depends on many things, some of which you can control.
 - a. Tire size, tread; type, inflation, etc.

+What are some examples of friction throughout the EV?

+How do you know which size, type, etc. is best?

CONTENT

NOTES

b. Amount of rolling the tires do. Friction is:

- 1) Greatest--when the wheels and the vehicle are stationary.
- 2) Very good--when the wheel is rolling on a dry, smooth road surface.
- 3) Least--when the wheel is locked or spinning.

E. Friction at the brakes.

1. The shoes pressing on the drums (or pads clamping the disc) create friction and slow the wheel.
2. The friction at the brake surfaces generates heat.
3. As heat increases, braking ability goes down.
4. Brake fade is one of the worst consequences of heat due to excessive, hard braking.
 - a. When sustained (hard) braking heats up the brakes sufficiently, the pedal-force requirements go up dramatically. In extreme cases during hard application of the brakes, the brakes may suddenly "disappear." The vehicle will continue forward as if no brakes were being applied. At best it's a scary situation, at worst it's deadly.
 - b. Brake fade can occur in a variety of ways. In all cases, however, the cause is excessive heat.

+Specifically, what effect does the heat have?

CONTENT

NOTES

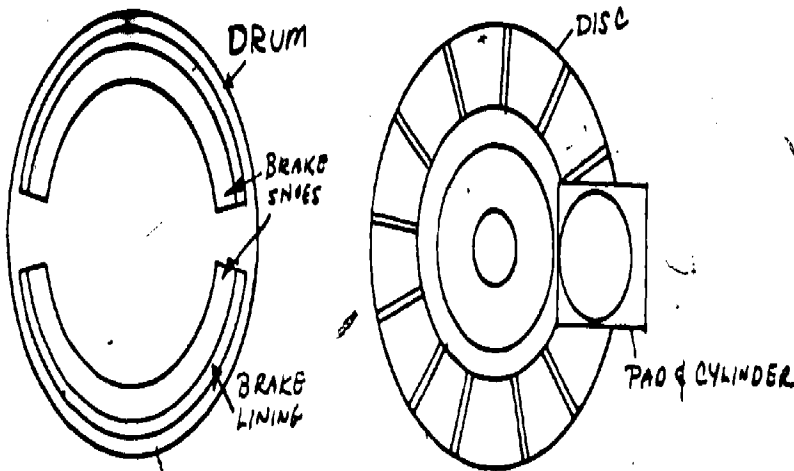

- 1) Drum brakes--almost 90 percent of the total drum surface is in contact with the brake shoe at one time. Thus, only about 10 percent of the surface can be cooling off at any one time. The brake drums can heat up and expand to the point where it is impossible for the shoes to make good contact with the drums.
- 2) Disc brakes--since the pad makes contact with only 15 percent of the disc surface, about 85 percent of the disc surface is cooling at any time. Obviously, disc brake design permits more cooling than drum brake design. Even if the disc were to get hot, it usually expands and makes better contact with the disc pads.

+Specifically, how does brake fade occur with disc brakes?

F. Velocity control and friction.

1. Accelerating.

- a. Spinning the wheels reduces friction. Acceleration is slowed.

CONTENT

NOTES

- b. Spinning the wheels smooths the tires. Friction between the tires and the road surface will be less in the future.

2. Braking.

- a. The shortest stopping distance is achieved by braking so that the wheels do not lock up and skid.

+How can you do this?

- b. Locking the wheels. One of the reasons locked wheels have less friction than rolling wheels is illustrated below.

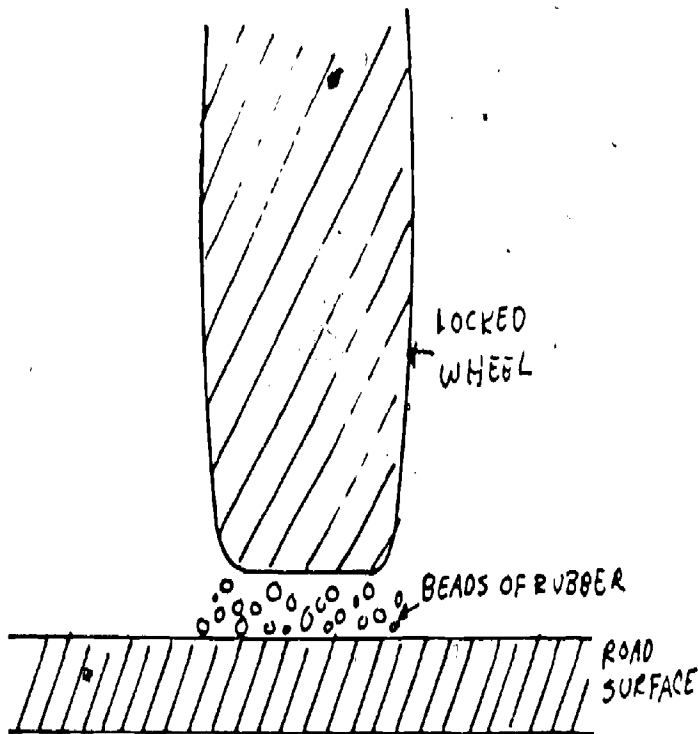

Little beads of rubber come off the locked, skidding tires and act as ball bearings for the vehicle to slide on.

CONTENT

NOTES

G. Changing direction and friction.

1. Friction between the tires and the road surface is required if you are to control the EV's direction.

2. Tires must be rolling to change the EV's direction.

Momentum and Inertia

A. Momentum is the product of a vehicle's mass (weight) times its velocity (speed).

B. Inertia is the force that makes a moving vehicle tend to stay in motion in the same direction.

C. As momentum increases, it is harder to overcome the effects of inertia.

D. Momentum and inertia affect velocity control.

E. Momentum and inertia affect directional control.

+What does this tell you about larger vehicles?

+In what ways do momentum and inertia affect velocity control?

+In what ways do momentum and inertia affect directional control?

CONTENT

NOTES

Centrifugal Force

- A. Centrifugal force is the force that tends to push a vehicle that is traveling around a curve away from the center of the turning radius.

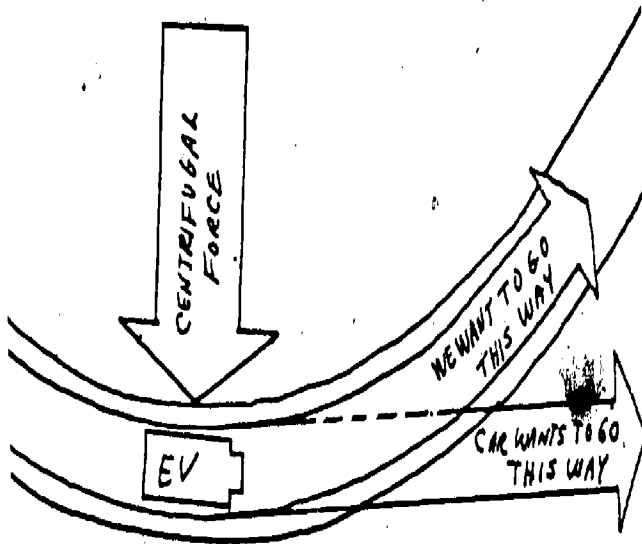

- B. Centrifugal force is influenced by both speed and the radius of the curve.
1. The higher the speed, the greater the centrifugal force.
 2. The tighter the curve, (smaller the radius), the greater the effects of centrifugal force.

+What is the other physical force that makes the vehicle tend to go straight?

+Does centrifugal force increase proportionately as speed increases?

+What can you do on tight curves to compensate for this increased centrifugal force?

+Which physical force helps overcome centrifugal force?

CONTENT

NOTES

WEIGHT TRANSFER

Definition

- A. Every time you accelerate, decelerate, or change the EV's direction, the weight distribution of the vehicle shifts.
- B. This shift of weight is called weight transfer.
- C. Effective use of weight transfer is critical for safe handling of an EV.

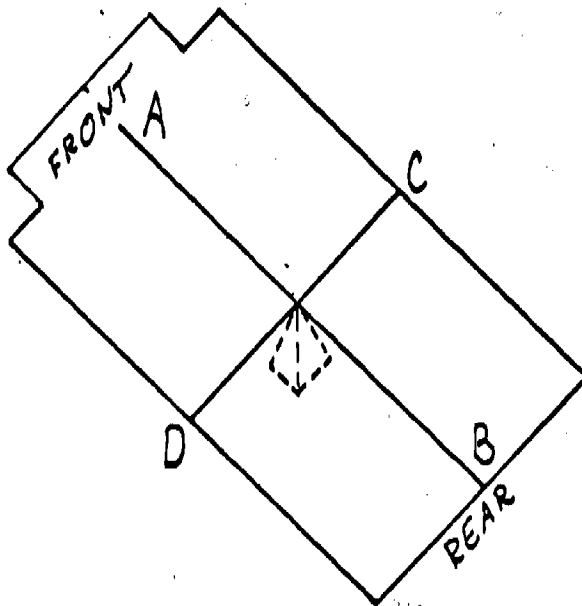
Effects of Changing Velocity on Weight Transfer

Imagine a fulcrum under the vehicle's center of gravity.

CONTENT

NOTES

A. If you accelerate the vehicle, it will cause a transfer of weight.

+If you accelerate, where will the downward force be greatest?

B. If you decelerate or brake, it will cause a transfer of weight.

+If you brake, where will the downward force be greatest?

Effects of Changing Direction on Weight Transfer

A. We are all familiar with the way a vehicle leans in a curve. This lean is because of increased downward force on one side of the vehicle.

B. If you make a right-hand turn it will cause a transfer of weight.

+If you make a right-hand turn, where will the downward force be greatest?

C. If you make a left-hand turn it will cause a transfer of weight.

+If you make a left-hand turn, where will the downward force be greatest?

+What are the names of these forces that cause a vehicle to lean to one side in a turn?

+What happens in a high-speed sharp right-hand turn if you suddenly apply the brakes?

CONTENT

NOTES

Suspension and Weight Transfer

- A. The EV's suspension works to balance the forces (during a change in direction or velocity). +What does the suspension do to help balance the forces?
- B. When changing vehicle direction, work with the suspension, not against it. +What can you do to work with the suspension?

Review Exercises

1. Write a brief description of each of the following terms:

a. Velocity:

b. Centrifugal force:

c. Inertia:

d. Friction:

2. On the drawing below:

- a. Put an "X" on the place that the downward force would be greatest if you were accelerating through a right turn.
- b. Put an "O" on the place that the downward force would be greatest if you were braking.

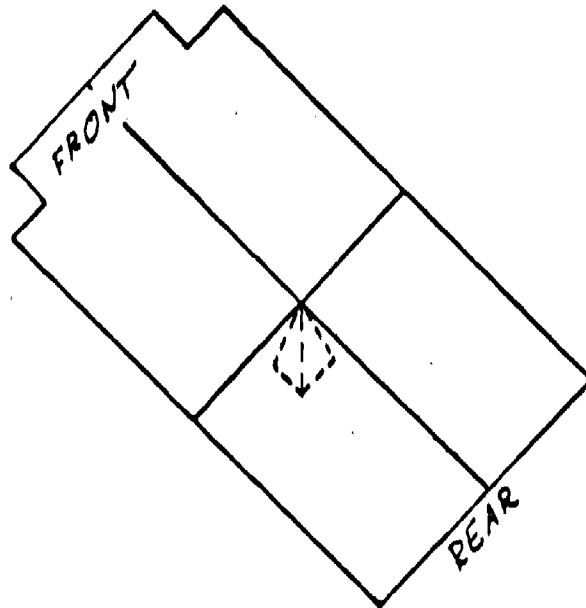

3. State the primary cause of brake fade.

Trainees' Knowledge ObjectivesModule 1

By the end of this module,

1. You will be able to state the purpose of emergency signaling equipment.
2. Given a list of statements relating to use of emergency signaling equipment, you will be able to identify those statements that are correct.

Module 2

By the end of this module,

1. You will be able to state the correct wheel position for a vehicle that is parked on a slope.
2. Given a description of a backing mishap, you will be able to describe actions that might have been taken to avoid the accident.

Module 3

By the end of this module,

1. You will be able to describe the provisions of your state's statute that deals with motorists' responsibilities for clearing a path for emergency vehicles.
2. You will be able to select the appropriate siren-use technique for negotiating through heavy or blocked traffic.

Trainees' Knowledge Objectives (Continued)Module 4

By the end of this module,

1. You will be able to identify the correct percentage of emergency vehicle accidents that occur at intersections.
2. You will be able to select the appropriate method for checking traffic before attempting to cross an intersection.
3. You will be able to state the kind of turn (left or right) which requires a larger gap in cross-traffic and explain why.

Module 5

By the end of this module,

1. You will be able to name the safest type of turnabout.
2. Given three illustrations, you will be able to illustrate the correct path for a vehicle making a U-turn.
3. Given an illustration of each, you will be able to illustrate the correct path for a vehicle making a left and a right side-road turnabout.

Trainees' Knowledge Objectives (Continued)Module 6

By the end of this module,

1. You will be able to describe two methods of estimating following distance.
2. Given a list of several conditions, you will be able to select those that indicate following distance should be increased.
3. Given a list of several statements relating to following distance, you will be able to identify those that are correct.

Module 7

By the end of this module,

1. You will be able to state two types of road configuration that indicate it is unsafe to pass.
2. Given a list of several conditions, you will be able to select those that would indicate it is unsafe to pass.

Module 8

By the end of this module,

1. You will be able to give an accurate explanation of what a "Yield" sign means.
2. You will be able to select the correct siren-use technique for entering/exiting expressways.

Trainees' Knowledge Objectives (Continued)Module 9

By the end of this module,

1. Given two drawings, you will be able to select the one that illustrates a properly banked road.
2. Given a listing of several incomplete sentences relating to driving curved roads, you will be able to insert the word that best completes the sentence.
3. Given an illustration of two vehicles' path of travel through a curve, you will be able to select the vehicle that has chosen the safest path.

UNIT
TITLE

OPERATION

UNIT
PAGE

I-F-5

CONTENT

NOTES

CONTENT/STRUCTURE OF THIS UNIT

This unit, Operation, is the longest unit in the course. It covers all aspects of the actual operation of Emergency Vehicles. It is structured in terms of operating tasks.

* * * BEGIN MODULE 1 * * *

CONTENT

NOTES

USE OF LIGHTS AND SIREN

Legal Aspects

- A. Lights and sirens are used to inform traffic of an EV's presence and thus, to aid in clearing a path for the EV.
- B. Most state laws require the EV to use emergency signaling equipment whenever any of the exemptions are exercised.
- C. Use of signaling equipment doesn't guarantee operator safety, nor does it free him from the possibility of civil or criminal liability if a mishap does occur.

+Exactly what do the laws in this state say?

Lights

- A. The particular type and configuration of emergency lights is set by law and local policy.
- B. Operating procedures are dependent on the type of equipment.
- C. Some limitations to be aware of when using emergency lights:
 1. Low sun or glare can greatly reduce effectiveness.
 2. At night red beacons can be confused with traffic lights and neons.
 3. Lights on high EVs may pass over motorists if EV is close to the rear of the vehicle ahead.

+What kinds of lights will your vehicle be equipped with?

+What are the operating procedures?

UNIT TITLE	OPERATION	UNIT PAGE	I-F-7
CONTENT		NOTES	
<p><u>Siren</u></p> <p>A. The particular type and siren options are set by law and local policy.</p> <p>B. Operating procedures are dependent on the type of equipment used.</p> <p>C. Limitations on siren usage.</p> <ol style="list-style-type: none"> 1. Usually the siren sound travels forward from the vehicle in a cone shape. <ol style="list-style-type: none"> a. The higher the frequency, the narrower the cone. b. The higher the frequency, the greater the distance the siren can be heard. c. The physical parameters that establish the effectiveness of sirens are: sound level and spectral content, directivity, propagation losses, vehicle insertion loss, and vehicle background noise. 2. Sirens do not travel around buildings or corners very well. 3. At high speeds it is possible to "out run" the siren. 4. Even at fairly close range, the siren may not be heard by a motorist with windows up, radio and air conditioner on. 		<p>+What kind of siren (or other audibles) will your vehicle be equipped with?</p> <p>+What are the operating procedures?</p> <p>+What do these terms mean?</p> <p>+What does "out run" mean?</p>	
<p><u>General Guidelines for Using Lights and Siren</u></p> <p>A. Ride with driver's window partly open at all times.</p>		<p>+Why should you have the window open?</p>	

143

143

CONTENT

NOTES

- B. In general, when activating the siren, let up slightly on the accelerator.
- C. Turn the siren off in high noise environments, e.g. railroad crossings and intersections.
- D. Vary siren to avoid hypnotic effects.
1. "Hypnotized" EV operators sometimes become vague, and inattentive.
 2. "Hypnotized" EV operators tend to take unnecessary risks.
- E. Do not use the siren when it is unlikely to be effective.

+Why should you let up on the accelerator?

+How can you preclude hypnosis?

* * END OF MODULE 1 * *

UNIT TITLE	OPERATION	UNIT PAGE	I-F-9
CONTENT		NOTES	
<p>BASIC CONTROL TASKS</p> <p>A. Directional and velocity control are accomplished by steering, accelerating, and braking.</p> <p>B. These basic control tasks are all present in two slow-speed activities--backing and parking.</p> <ol style="list-style-type: none"> 1. Relatively simple tasks. 2. Good performance requires practice. <p><u>Backing Up</u></p> <p>Backing mishaps account for a large proportion of all EV accidents. The techniques that will help minimize backing accidents are common sense techniques that require a few extra seconds--they are well worth the time.</p> <p>A. Park so that backing is minimized or eliminated. You must plan ahead to do this.</p> <p>B. When you <u>must</u> back the vehicle:</p> <ol style="list-style-type: none"> 1. Station a crewmember outside the vehicle to direct, if possible. 2. Check (before moving) for pedestrians and obstacles. 3. Back SLOWLY (as if you expected to hit something). 		<p>*** BEGIN MODULE 2 ***</p> <p>+What are some of the consequences of these relatively minor accidents?</p> <p>+What kind of planning can you do that will minimize or eliminate backing?</p> <p>+Where should the crewmember be positioned?</p>	

CONTENT

NOTES

4. Constantly check mirrors for changes in the traffic situation or obstacles in your path.
5. When backing out of an alley, hidden driveway, etc., sound the horn or "back-up alarm" for warning.
6. When turning while backing, check the front fender to avoid a front collision.

Parking

There are three basic types of parking maneuvers: angle, perpendicular, and parallel.

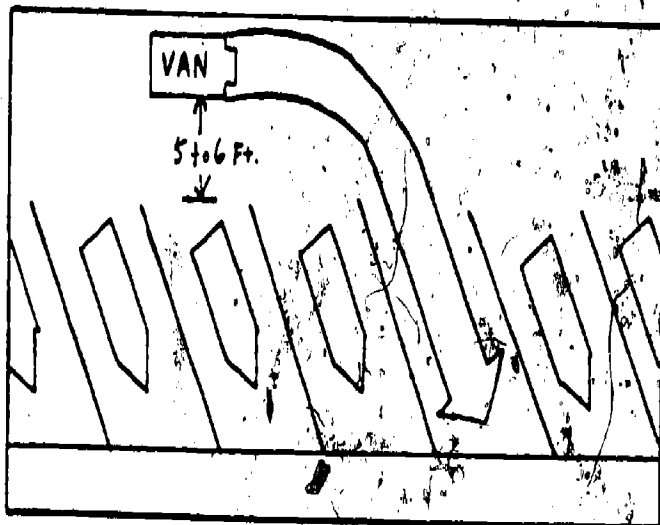
A. Angle Parking

+What is the procedure for angle parking?

CONTENT

NOTES

B. Perpendicular Parking

1. Sedans and vans.

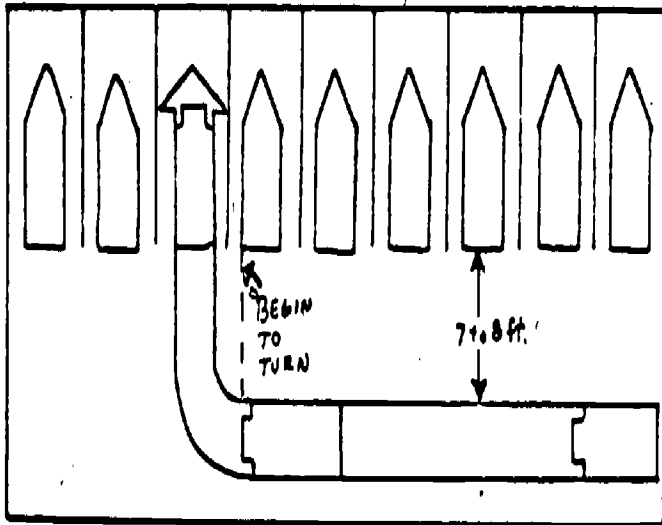

+What is the procedure for perpendicular parking in a sedan or van?

2. Long-wheel based vehicles

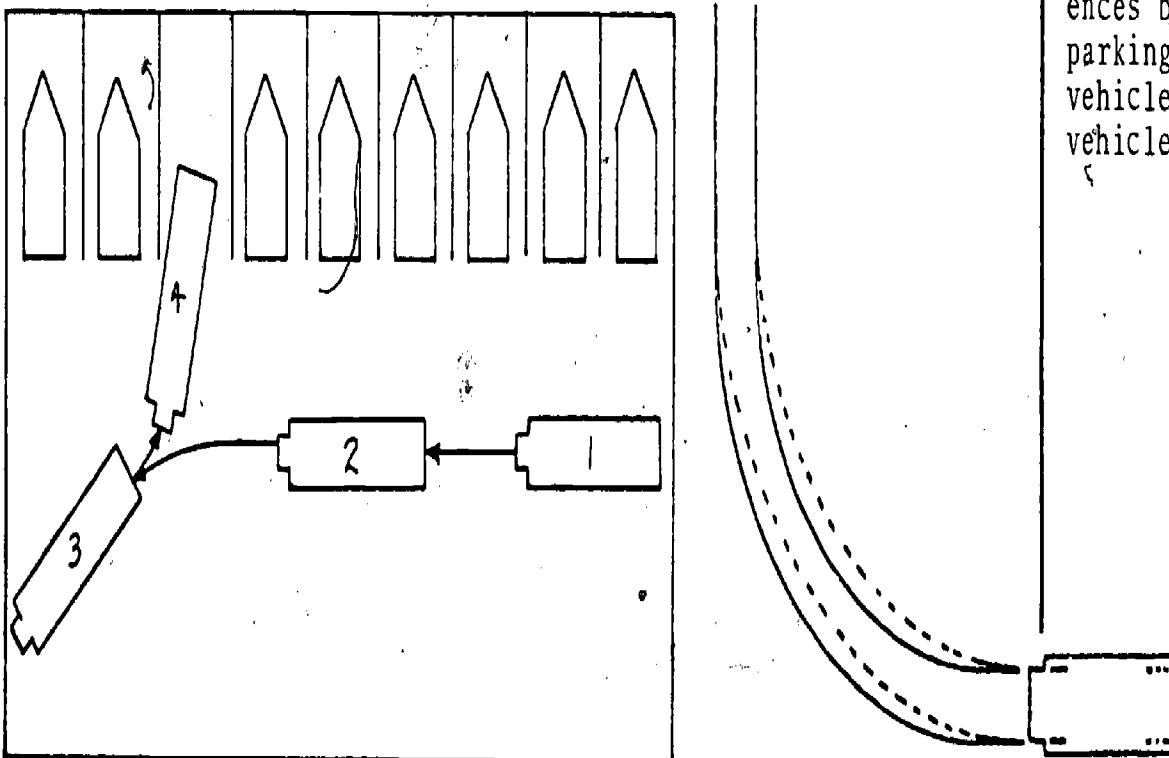

+What are the primary differences between perpendicular parking in a standard-sized vehicle and a long wheel-base vehicle?

CONTENT

NOTES

C. Parallel Parking. Parallel parking requires a space at least 25 percent longer than the vehicle. The important thing is knowing when to turn the wheels. (See illustration next page.)

D. Parallel Parking on Slopes (Special Considerations).

1. Set the parking brake.
2. If the vehicle has a manual transmission, leave it in gear.
3. If the EV is large or heavy, place chocks.
4. Always position the front wheels so that if the vehicle starts to roll:
 - a. Wheels will hit the curb (and prevent rolling).
 - b. Vehicle cannot roll through lanes of traffic.

Considerations: Backing and Parking in the Emergency Mode.

- A. Backing and parking when in the emergency mode must be performed quickly.
- B. It requires skill to be able to do it fast, without accident.

** END OF MODULE 2 **

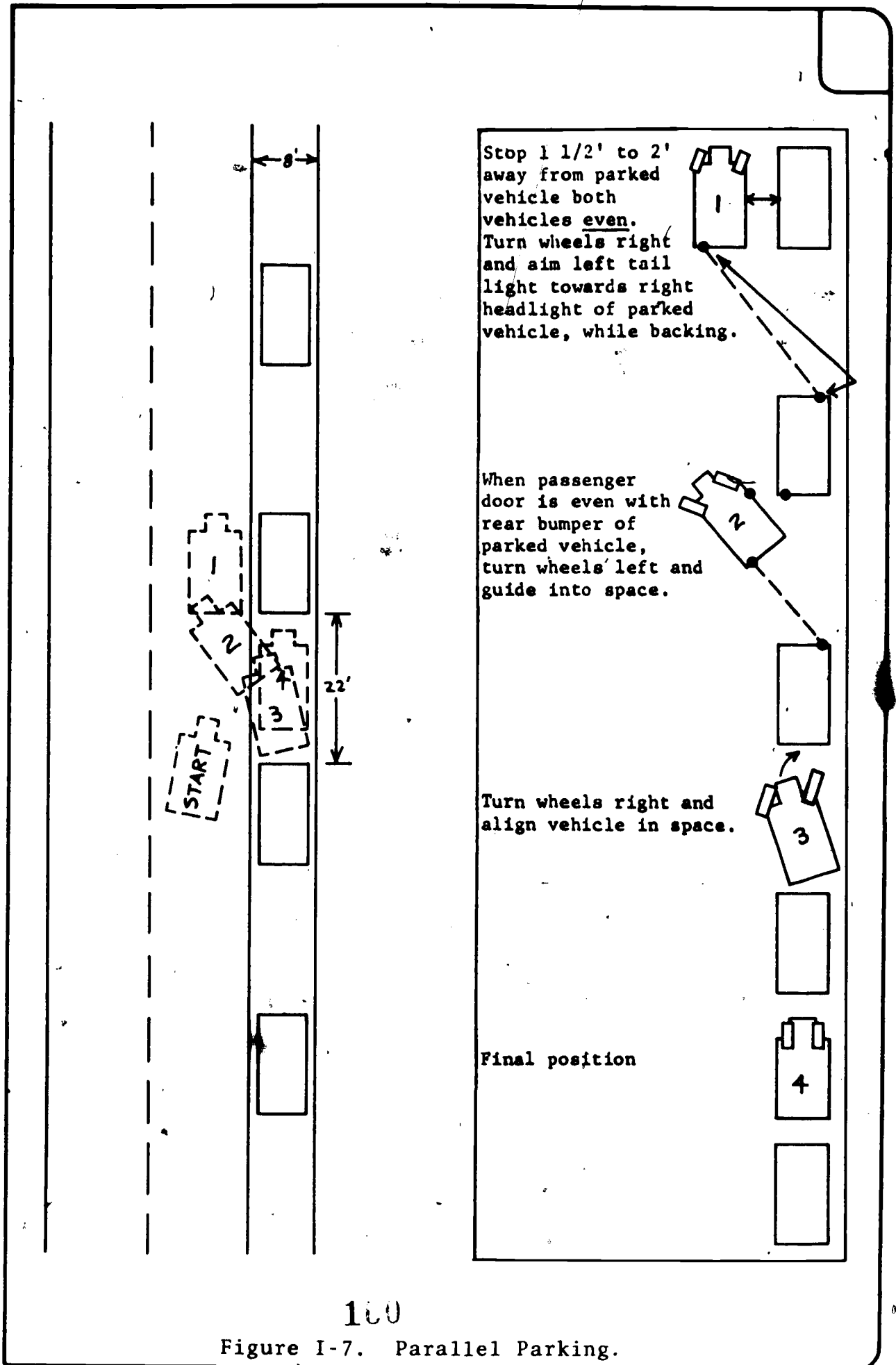

Stop 1 1/2' to 2' away from parked vehicle both vehicles even. Turn wheels right and aim left tail light towards right headlight of parked vehicle, while backing.

When passenger door is even with rear bumper of parked vehicle, turn wheels left and guide into space.

Turn wheels right and align vehicle in space.

Final position

Figure I-7. Parallel Parking.

CONTENT

NOTES

URBAN DRIVING

Introduction

- A. Even in normal, non-emergency conditions, operating an EV in urban area requires a high degree of skill.
- B. Keys to successful urban driving:
1. Keep alert.
 2. Don't anticipate other motorists' actions.
 - a. Motorists sometimes signal turns or lane changes when they don't mean to.
 - b. Motorists may enter or cross traffic without allowing a sufficient gap.
 - c. Motorists may try to beat a light, going through as it changes.

Considerations: Urban Driving in the Emergency Mode

- A. Speeds in excess of the limit are rarely justified--only in the most extreme emergency.
- B. Urban driving in the emergency mode requires effective use of lights and sirens to:
1. Warn motorists and pedestrians of the approaching EV.
 2. Clear traffic and/or help you negotiate through heavy or blocked traffic.

*** BEGIN MODULE 3 ***

+Why is it important to develop a high degree of skill?

+What kinds of things should you be alert for?

CONTENT

NOTES

C. Typical motorists' reactions to lights and sirens in urban areas:

1. Generally motorists will try to pull to the right and slow down or stop when they detect the EV.

Some motorists, however, will do senseless, unexpected things. A good EV operator is always aware of these possibilities.

a. Some motorists are just plain confused by the EV.

b. Some motorists may be totally unaware of EV's presence, even though signaling equipment is in use.

+What are some of the kinds of things motorists do?

+What is the best way to deal with confused motorists?

+What can you do to get the attention of unaware motorists?

D. If traffic is blocked:

1. Slow down before reaching the blockage.

2. Use siren intermittently.

3. Keep your patience.

4. Don't travel in opposing traffic lanes unless you know traffic is cleared for at least one block.

+Why should you slow before the blockage?

CONTENT

NOTES

NEGOTIATING INTERSECTIONS

Introduction

Intersections are the most accident-likely areas.

Techniques for Negotiating Intersections

- A. Before attempting to cross an intersection, you must make sure there is an adequate gap in traffic flow.
1. From a full stop, you need about four seconds to cross an intersection 30 feet wide (approximately 2 lanes).
 2. Cars approaching from either direction should be about six seconds away from the intersection, to allow an adequate gap.

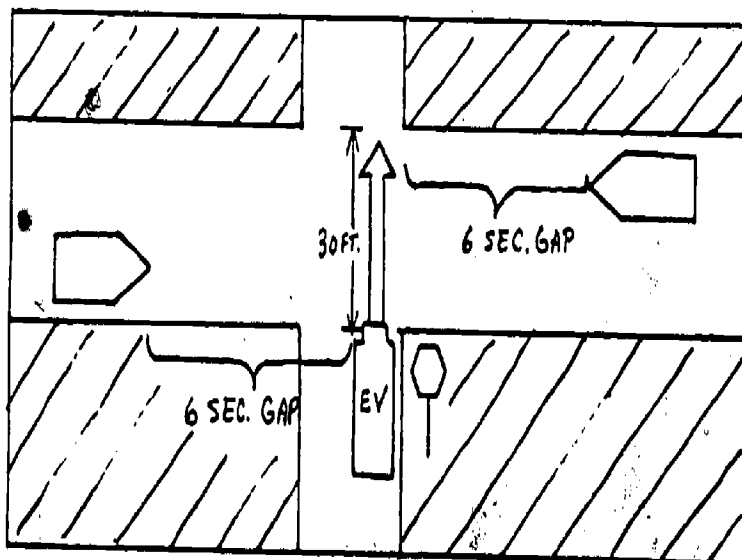

*** BEGIN MODULE 4 ***

+What percentage of emergency vehicle accidents occur at intersections?

+Why are intersections such accident-likely areas?

CONTENT

NOTES

B. Right turns at an intersection:

1. From a stop it takes about six seconds to turn right and accelerate to 30 mph.
2. When you begin to turn, any vehicle approaching the intersection from the left should be at least seven to eight seconds away from the intersection.
3. In faster cross traffic, a larger gap is required for safety.

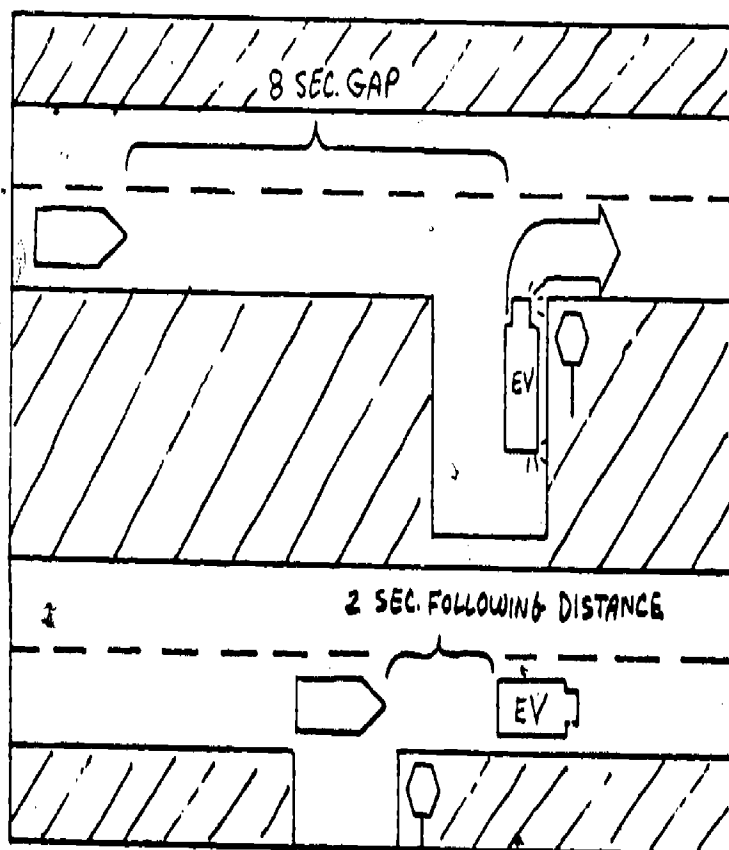

CONTENT

NOTES

C. Left turns at intersections.

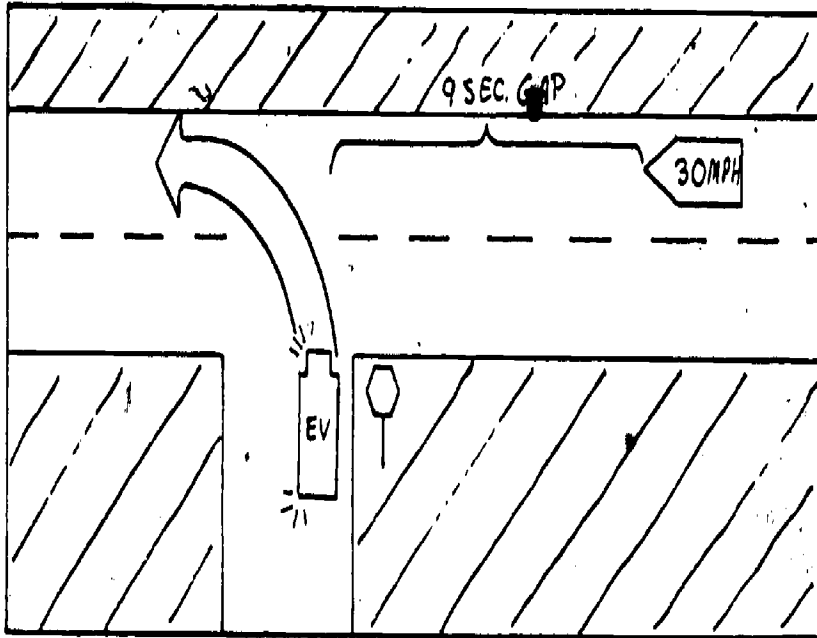

+Why do you need a larger gap to make a left turn than you do for a right turn?

D. Gaps needed for turning at various cross-traffic speeds.

<u>Speed of Cross Traffic</u>	<u>Sedan</u>		<u>Van</u>		<u>Large Truck</u>	
	<u>L</u>	<u>R</u>	<u>L</u>	<u>R</u>	<u>L</u>	<u>R</u>
30	9	8	10	9	11	10
40	10	9	11	10	12	11
50	12	11	13	12	14	13
55	13	12	14	13	15	14

Considerations: Negotiating Intersections in the Emergency Mode

A. Siren should be turned off for a short period just before entering an intersection. This will:

CONTENT

NOTES

1. Allow operator to hear other EVs.
 2. Lessen the chances of a "panic" reaction by motorists at the intersection.
- B. Provide as much information as possible to other motorists.
1. Use all means of signaling, including:
 - a. Lights.
 - b. Siren.
 - c. Turn signals.
 - d. Lane position.
 - e. Eye contact or hand signals.
 2. Signal intent at least 100 feet in advance of an urban intersection (200 feet in the country).
- C. Check for traffic control indicators in advance of every intersection.
- D. Check for hazards well in advance of intersections.
1. Make sure driver's window is partly open--this will enable detection of other EVs, if in the vicinity.
 2. Stay especially alert--search for:
 - a. Actual hazards.
 - b. Potential hazards.
- E. Practice--you decide.

+Why are lights and siren alone not sufficient warning for motorists?

+What should you look for?

+What are some actual hazards?

+What are some potential hazards?

CONTENT

NOTES

1. What are the hazards in the following illustration?

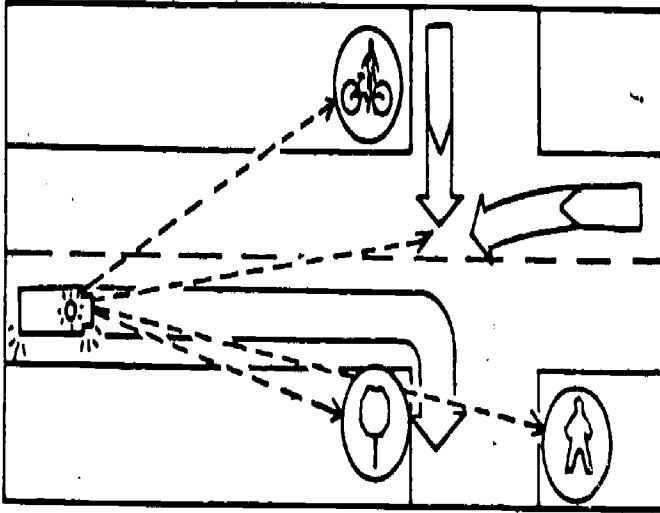

+Hazards:

2. What are the effects of following too closely when approaching an intersection?

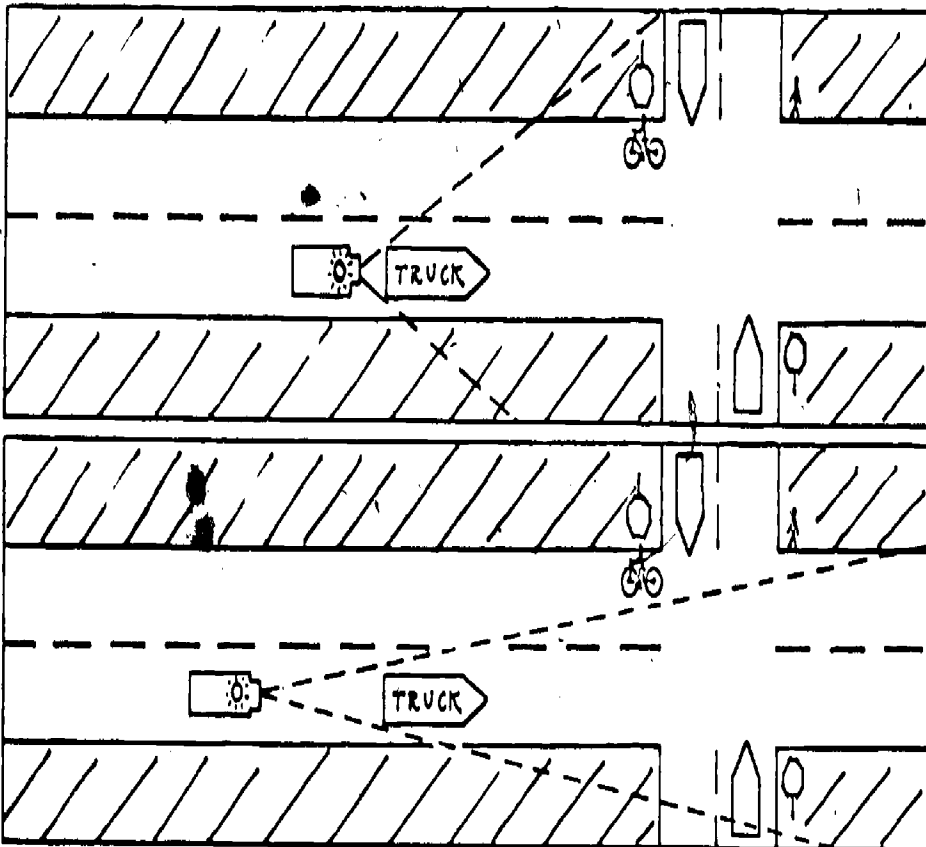

+Effects of following too closely:

CONTENT

NOTES

3. Vehicle "A" is a large truck. Why is this EV operator in trouble? What problems does the building create?

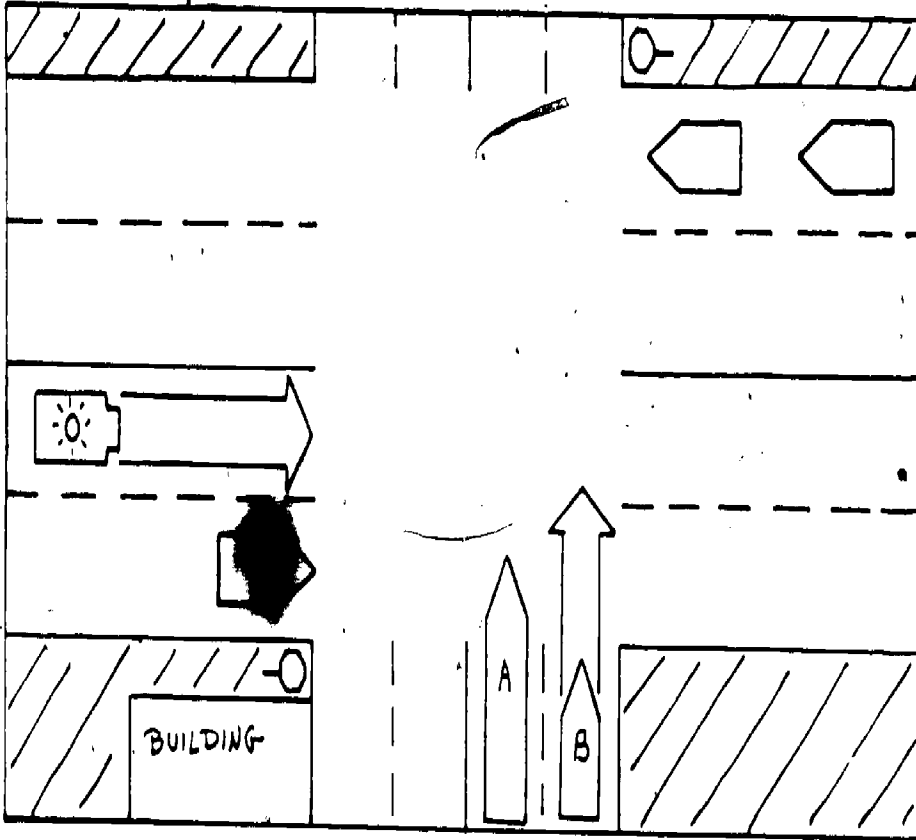

CONTENT

NOTES

4. Driver "A" looks left before turning right. He doesn't expect any oncoming traffic from the right. How can the EV operator avoid such problems?

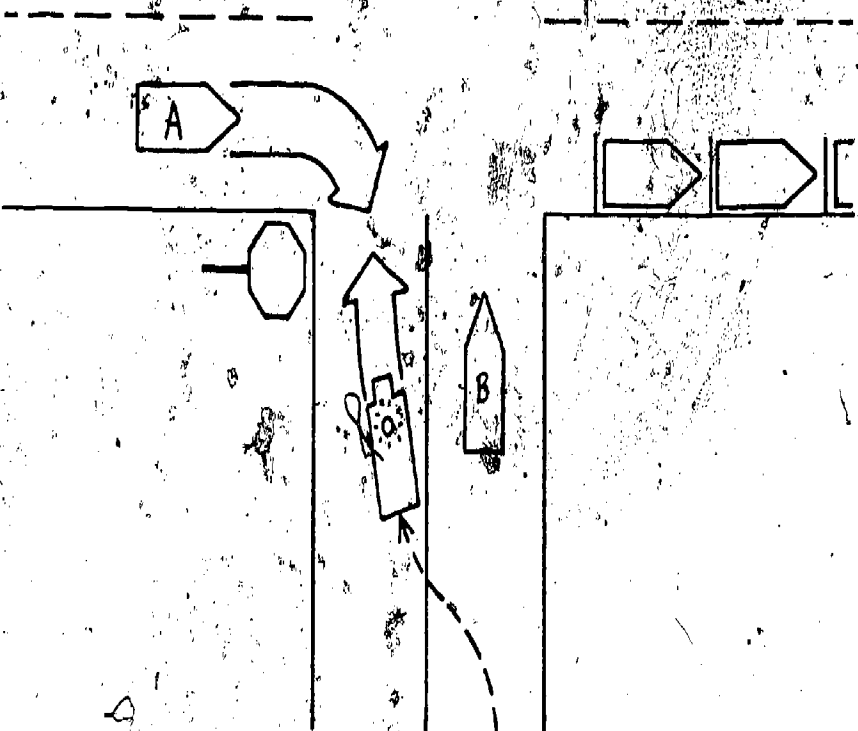
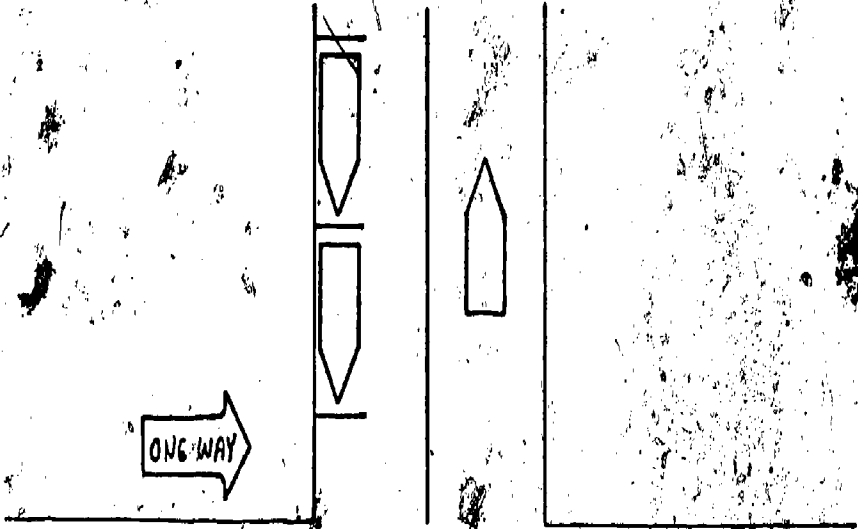

CONTENT

NOTES

5. How would you handle this situation--discussion.

Situation:

It can be hazardous when one EV operator follows another EV through an intersection. A motorist who has waited at the intersection and yielded to the first EV will, in many cases, proceed to drive through the intersection when the first EV has passed, not expecting the second EV to be so close behind, or perhaps not expecting it to be there at all. WHAT SHOULD AN EV OPERATOR, WHO IS FOLLOWING ANOTHER EV, DO?

** END OF MODULE 4 **

CONCEPT

NOTES

TURNING AROUND TO REVERSE DIRECTION

* * * BEGIN MODULE 5 * * *

Turnabouts.

A turnabout is the fastest way for you to turn around to reverse direction.

- A. Any kind of turnabout can create a hazardous situation when performed on a street.
- B. Choosing a safe location for a turnabout is important; choose an area with good visibility. You should have a clear view of the entire path of travel and all traffic lanes.
- C. Types of turnabouts (in order of increased hazard potential):
 1. U-turns.
 2. Two-point turns.
 3. Three-point turns.

+What should you avoid?

U-turns

- A. The U-turn is the least hazardous type of turnabout.
- B. The U-turn is the easiest to perform, but requires a wide roadway and good visibility.
- C. The U-turn is illegal in many areas. Remember, EVs are not exempt from the law unless they are in the emergency mode.

+When driving the kind of vehicle you will drive on the job, how many traffic lanes (12') would you need to make a U-turn?

CONTENT

NOTES

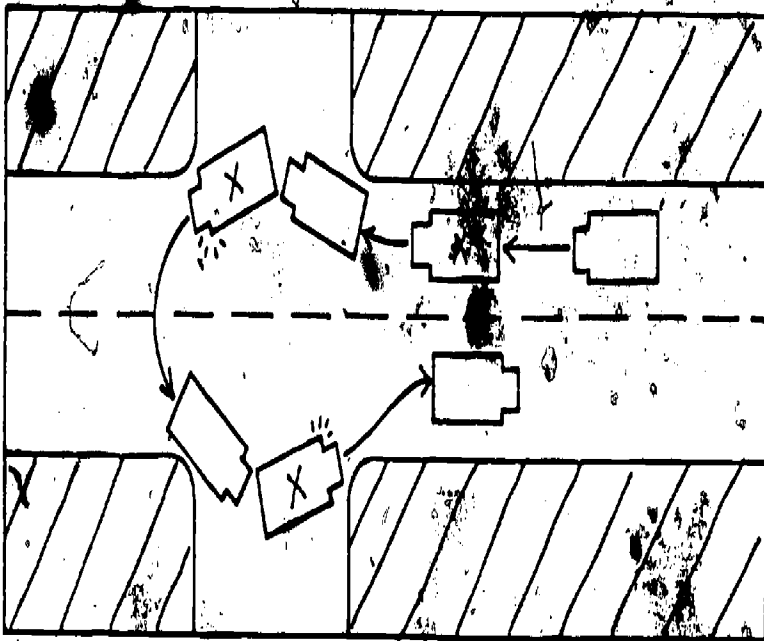
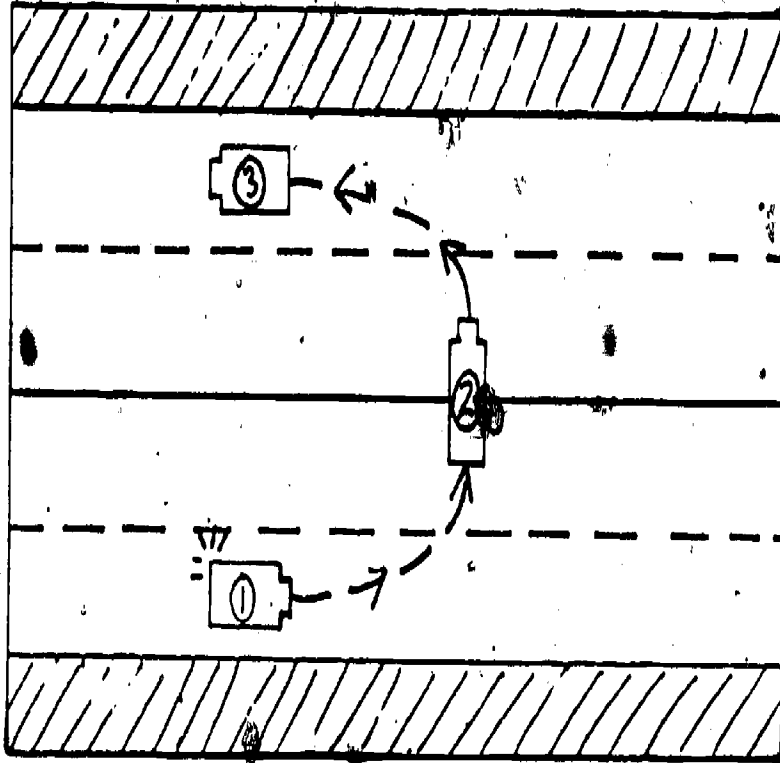

U-TURN
USING
INTERSECTION

CHECK
TRAFFIC
AT X

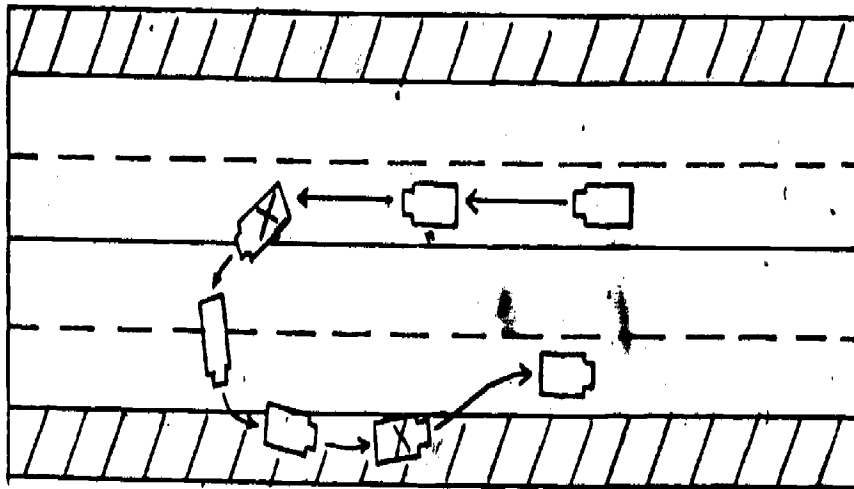

CHECK TRAFFIC AT X.

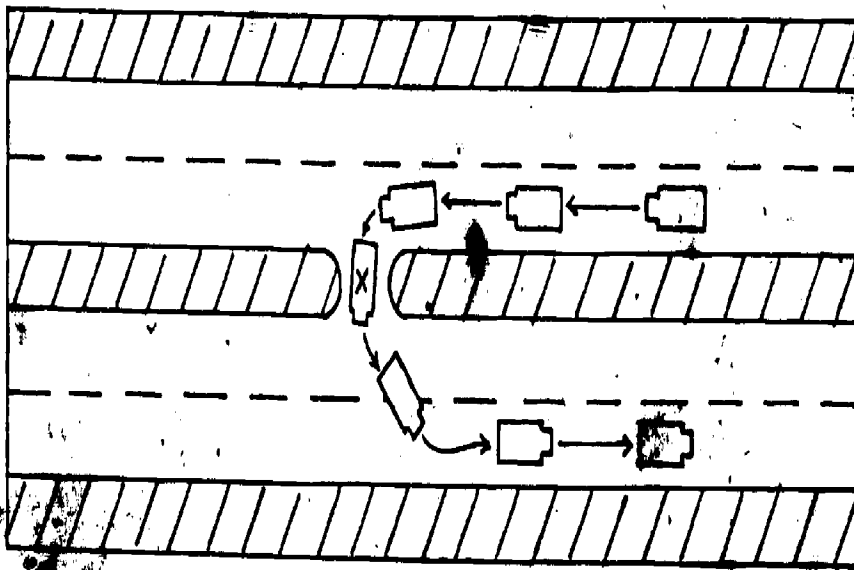

10' MEDIAN -
 CHECK TRAFFIC AT X.
 (Vehicles with a long wheel base may need to execute this turn from the outer lane.)

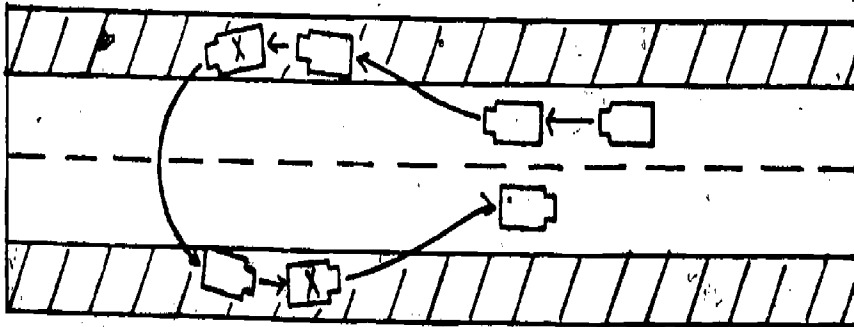

CHECK TRAFFIC AT X.

HEAVY EV'S - WATCH OUT FOR SOFT SHOULDER!

CONTENT

NOTES

Two-Point Turnabouts

A. These turns are made when the road is too narrow, or restricted visibility won't permit a U-turn.

B. The right side-road turnabout:

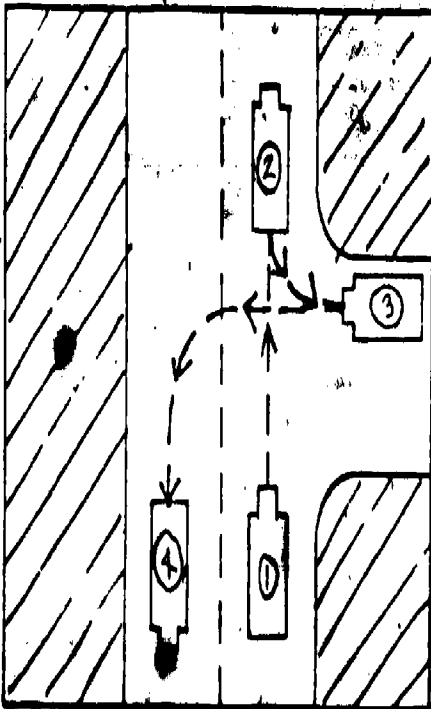

Good

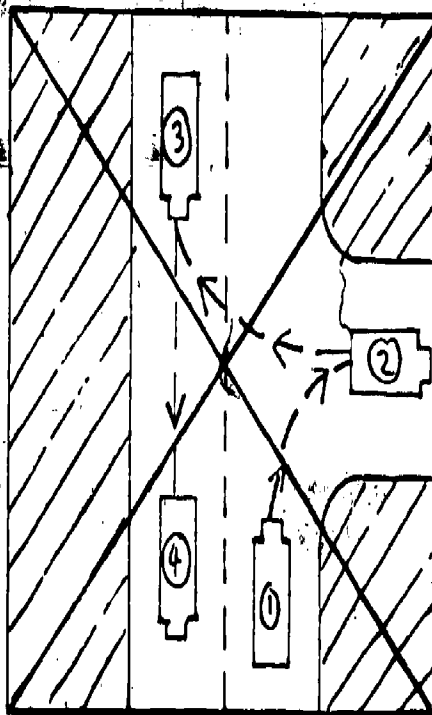

Not Good

Right side-road turnabout.

CONTENT

NOTES

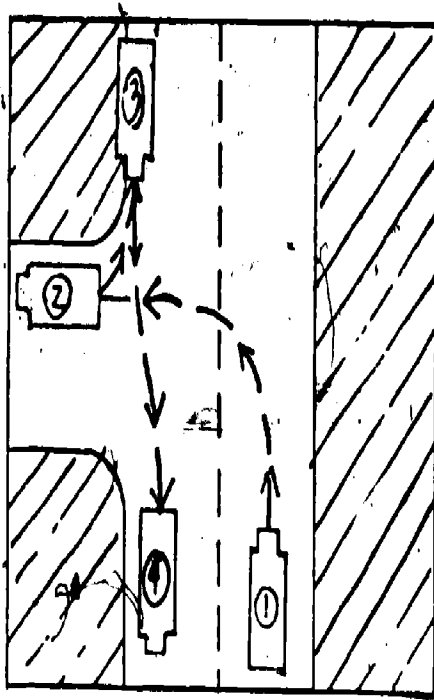
C. The left side-road turnabout:

Left side-road turnabout.

Three-Point Turnabouts

- A. Three-point turnabouts are the most hazardous turnabouts.
- B. These turnabouts should be used only when:
1. The road is too narrow for a U-turn.
 2. There are no alleys or side roads on either side.
 3. Traffic is light.

CONTENT

NOTES

- C. Y-turnabout. The front and rear of the EV will extend over the curb during this maneuver (see illustration).

+What is the big disadvantage of this turnabout?

Y-turnabout.

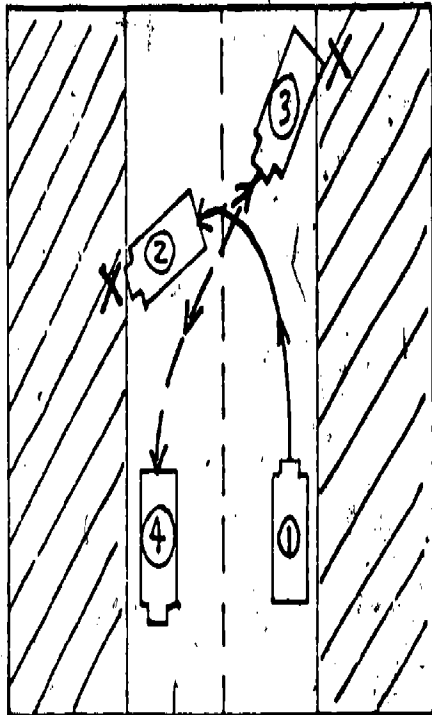

- D. Bootleg turnabout. This is faster than the Y-turnabout, but harder to perform well.

Bootleg turnabout.

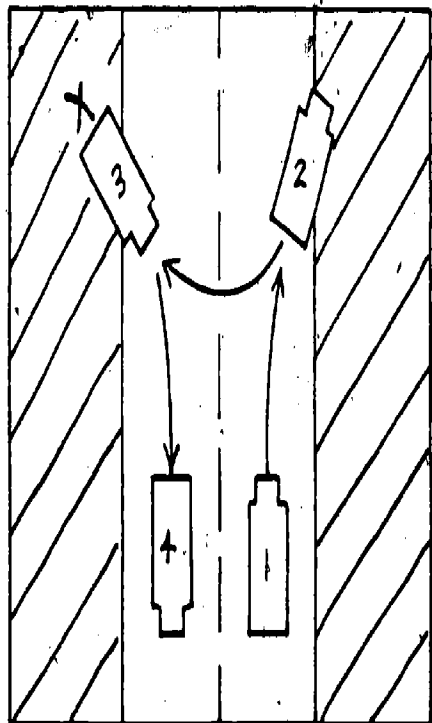

CONTENT

NOTES

Considerations: Turnabouts in the Emergency Mode

- A. In the emergency mode, if any exemptions to the state statutes are being exercised (e.g., U-turn where illegal) emergency signaling equipment must be activated.
- B. Emergency mode may dictate performing the more hazardous types of turns (depending on the relative seriousness of the emergency).

* * END OF MODULE 5 * *

CONTENT

NOTES

FOLLOWING ANOTHER VEHICLE

In 1974, approximately 150,000 disabling injuries and 500 deaths resulted from accidents caused by vehicles that were following too closely.* Three things you learn, to be able to follow at a safe, appropriate distance:

- A. What is a safe following distance?
- B. Techniques to help you judge or estimate following distance.
- C. When to increase following distance.

What is a Safe Following Distance?

You are following at a safe distance if you can:

- A. Stop without mishap if the vehicle in front comes to a sudden stop, or
- B. Take evasive action (steer around) to avoid mishap if the vehicle in front comes to a sudden stop.

Estimating Following Distance

A. What is stopping distance?

1. Reaction distance is the distance a vehicle travels from the time the driver recognizes the need to stop until brake pedal movement begins.

- a. Average drivers need about 3/4 second to react.

* * * BEGIN MODULE 6 * * *

+What information do you need to be able to estimate following distances?

CONTENT

NOTES

b. Distance traveled in $\frac{3}{4}$ second will be greater as vehicle speed is increased.

2. Braking distance is the distance traveled from the first brake pedal movement until the vehicle comes to a full stop.

3. Stopping distances for various types of vehicles at various speeds are shown in the chart on the next page.

a. All stopping distances on the chart assume driver uses $\frac{3}{4}$ second to react.

b. All stopping distances on the chart are based on "hard, dry surfaces."

B. How to tell when you are far enough behind.

1. Following at the full stopping distance (as shown on the chart) is not only unnecessary, it is also impossible!

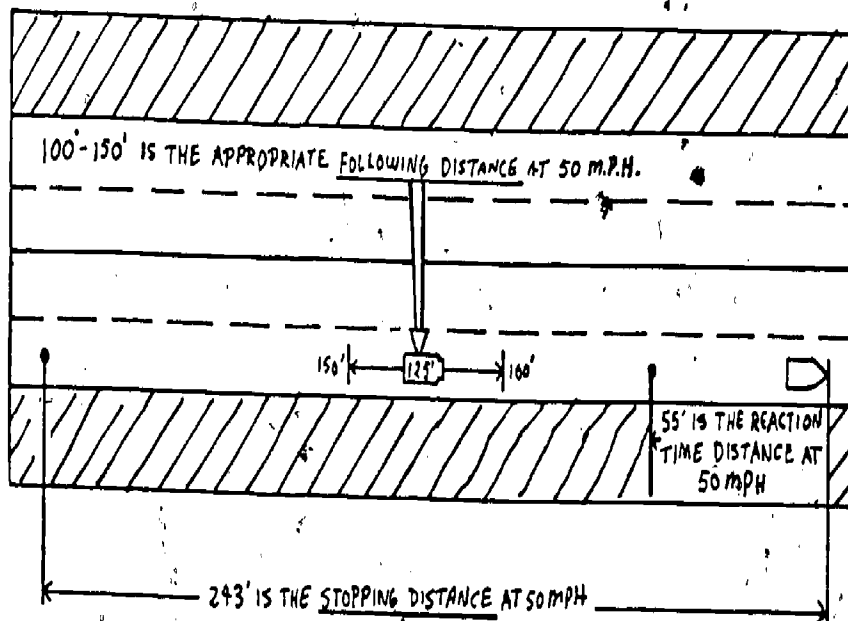

+What are some of the factors influencing reaction time?

+What are some of the factors that influence braking distance?

+Why is it impossible?

STOPPING DISTANCES AT VARIOUS HIGHWAY SPEEDS

Total Stopping Distances are Shown by the Numbers Below Each Bar

All Distances Are Based on Hard Dry Surfaces

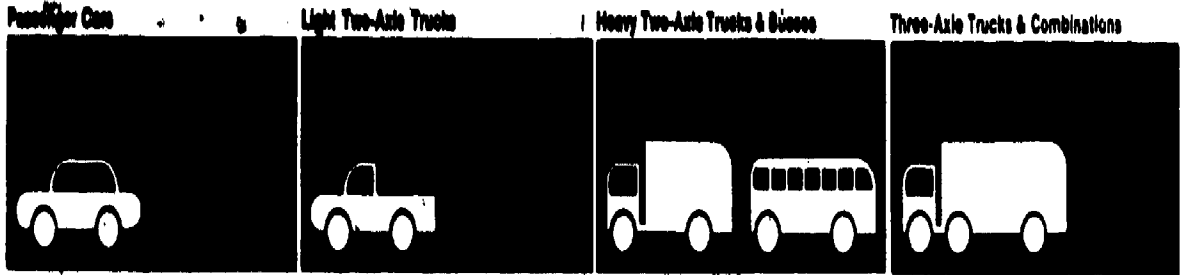

Feet Per Sec.	15	20	44	50	73	88	15	20	44	50	73	88	15	20	44	50	73	88	15	20	44	50	73	88
Miles Per Hr.	10	20	30	40	50	60	10	20	30	40	50	60	10	20	30	40	50	60	10	20	30	40	50	60

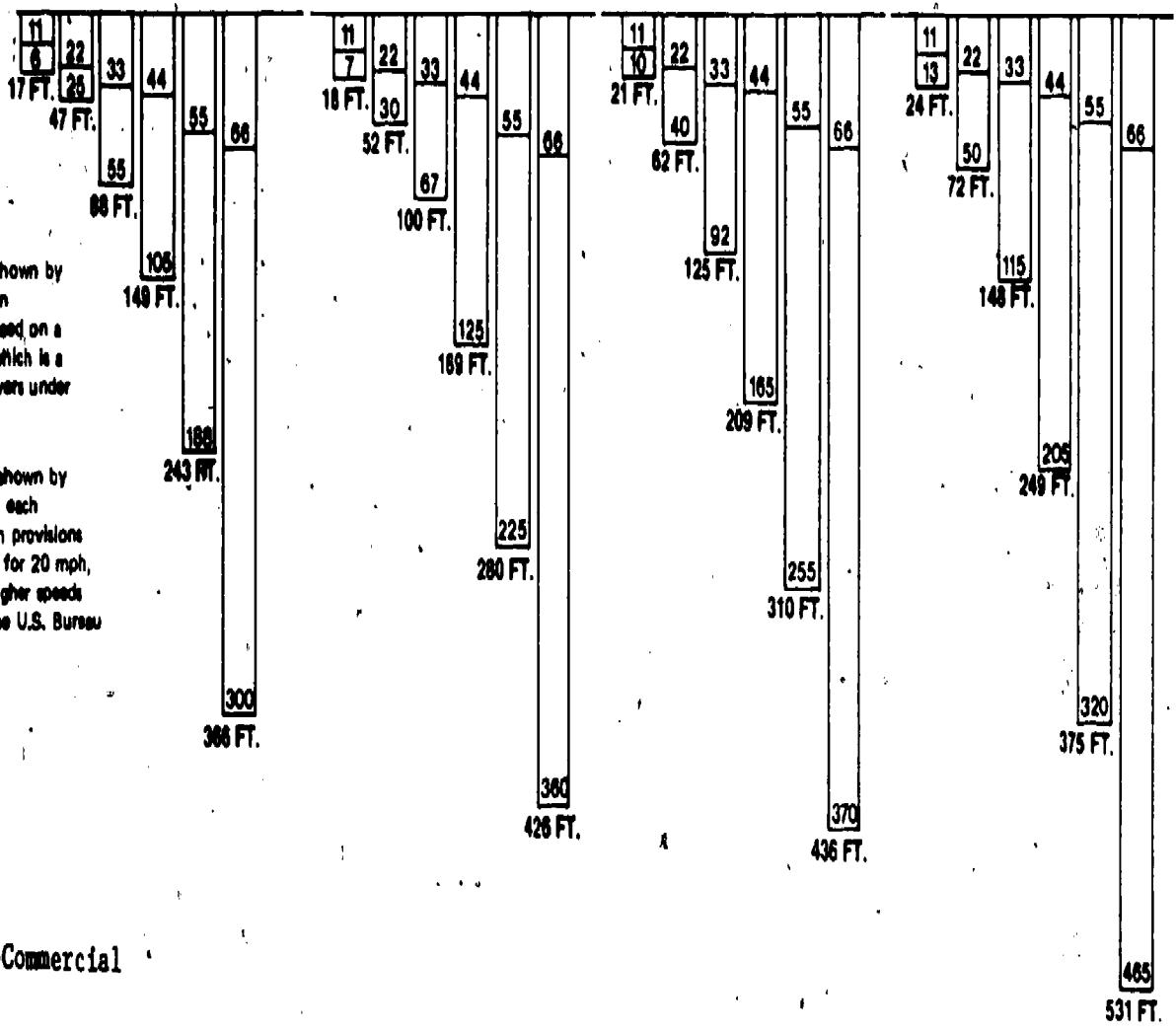

Driver Reaction Distance is shown by the number above the line on each bar. This distance is based on a reaction time of 1/4 second, which is a typical reaction for most drivers under most traffic conditions.

Vehicle Stopping Distance is shown by the number below the line in each bar. This distance is based on provisions of the Uniform Vehicle Code for 20 mph, adjusted when necessary at higher speeds to conform with studies of the U.S. Bureau of Public Roads.

Adapted from Employers-Commercial Union Companies

Figure I-8. Stopping Distances at Various Highway Speeds.

CONTENT

NOTES

2. An appropriate following distance will allow enough time to come to a complete stop if the lead vehicle panic stops (stops as fast as possible by braking).

+A safe following distance is:

3. Two ways to judge following distance:

+What is a rule for calculating following distances?

a. Estimate car lengths--one car length for every 10 mph. A full-sized car is approximately 20 feet long--estimating car lengths provides minimum following distance.

b. Two-second rule--keep a separation of at least two seconds between the EV and the vehicle being followed.

Start Count



Fixed Object (C)

"One-Thousand-One"

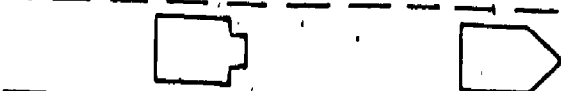

(C)

"One-Thousand-Two"



(C)

CONTENT

NOTES

When Should Following Distance Be Increased?

- A. Increase following distance by 50 percent: if the vehicle ahead is unusual, if your vehicle is large and/or heavy, or if your vehicle is not adequately maintained.
- B. Double following distance: if road surface is loose or slippery (wet, dirt, gravel) vision is obscured (rain, fog, dust, smog) or if you are not fully alert.
- C. Triple following distance: if road surface is packed snow or icy.

Practice

- A. A police officer is driving to the station at the end of a shift. He is very tired and the road is covered with hard snow.
- B. A large fire apparatus (elevated platform) is being driven on a high-speed expressway. The operator is taking the apparatus to the city's garage for service; some difficulties in the vehicle's braking system have been observed.

+By how much should he increase his following distance?

+By how much should the operator increase the following distance?

CONTENT

NOTES

Considerations: Following Distance in the Emergency Mode

A. In spite of the stress and urgency of an emergency run, the laws of physics do not change. It still takes 243 feet to stop a sedan from 50 mph, and longer for larger vehicles!

B. Should following distance be decreased when traveling in the emergency mode?

+Why might you decrease following distance when traveling in the emergency mode?

** END OF MODULE 6 **

CONTENT

NOTES

PASSING ANOTHER VEHICLE

How Long Does it Take to Pass?

- A. At highway speeds (40 to 60 mph) in a sedan, a safe pass can be completed in 10 seconds.
1. This assumes the starting speed is approximately the same as that of the vehicle to be passed.
 2. These figures allow a complete pass (including smooth return to the right lane).
- B. In terms of distance, a 10-second pass requires 1/6 mile at 60 mph. Due to the possibility of an oncoming vehicle, you must allow a full 1/3 mile of visible roadway before initiating a pass.

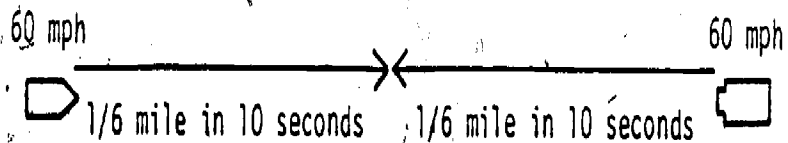

total distance used in 10 seconds by vehicles approaching each other at 60 mph

<u>Starting Speed</u>	<u>Passing Distance</u>	<u>Visible Roadway</u>
30 mph	450 ft.	900 ft.
35 mph	525 ft.	1,050 ft. (1/5 mile)
45 mph	675 ft.	1,350 ft.
55 mph	825 ft.	1,650 ft.
60 mph	900 ft.	1,800 ft. (1/3 mile)

*** BEGIN MODULE 7 ***

How does passing time vary according to vehicle capability?

CONTENT

NOTES

Considerations Before Passing

A. Vehicle Characteristics: You should be familiar with your specific vehicle. If you drive different vehicles daily, check out and familiarize yourself with the specific handling characteristics of every vehicle.

1. Accelerative capacity?

2. Steering precision?

3. Braking capability?

B. Road Information: Critical to successful passing. Look for

1. Informational signs: "No Passing," etc.

2. Road markings: solid center-line, broken center-line, etc.

3. Road configuration: hills, blind curves in intended passing area, intersecting roads, etc.

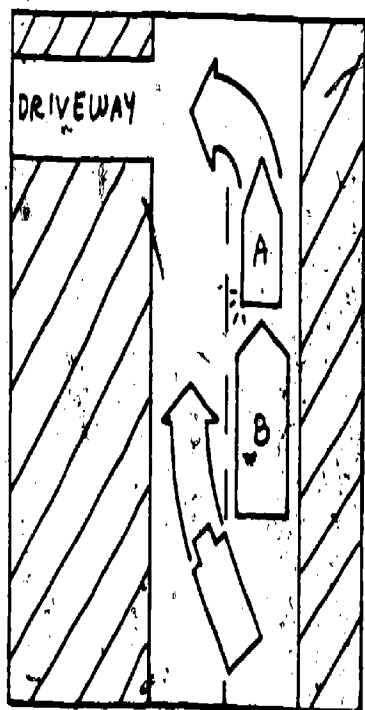

CONTENT

NOTES

C. Traffic situation:

1. Speed of traffic flow.

- a. Passing a vehicle that is traveling at the maximum posted limit is ILLEGAL unless you are in the emergency mode.
- b. On two- and three-lane roads, when traffic flow is heavy but moving at a constant speed, there is little to gain by passing.

2. Distance of oncoming traffic. How much of the oncoming lane of traffic is visible?

+What are the kinds of things that will limit visibility?

Executing a Passing Maneuver.

This maneuver assumes starting from a safe following distance.

- A. Check traffic--mirrors, blind spot.
- B. Signal before lane change.
- C. Accelerate while changing lanes.
- D. Signal before returning to right lane.
- E. Return to right lane when all of the passed vehicle is visible in your rear-view mirror.

CONTENT

NOTES

F. Cancel directional signal, resume cruising speed.

Being Passed

EVs are passed less often than other vehicles. When being passed certain courtesies should be extended:

- A. Do not change speed while being passed.
- B. If the passing driver gets into a dangerous situation, try to assist.

+What can you do to assist a passing driver who is in trouble?

Tips for Avoiding Mishaps When Passing

- A. If the decision has been made to pass, and conditions are okay, DON'T HESITATE--conditions could worsen.
- B. Stay in the passing lane for the shortest possible time.
- C. Constantly scan the roadway for unmarked, intersecting roads.
- D. Be prepared to abort if conditions worsen.

Considerations: Passing in the Emergency Mode

- A. Since motorists will attempt to pull over, the need to pass may be reduced.
- B. Evaluation of risk vs. gain.

CONTENT

NOTES

1. Many passing situations are potentially hazardous, involving some risk. In the emergency mode, the gain (e.g., save a life) may justify increased risk.

2. When conditions are ideal there is very little risk.

3. When one or more conditions are questionable, risk increases.

a. How important is saving time?

b. How much time will really be saved by passing?

c. If passing is delayed for a few moments, might conditions improve?

C. It may be necessary to execute a "running pass."

+What are ideal conditions?

+How might conditions improve?

+What is a "running pass"?

+How do you perform it?

+What are the disadvantages of the "running pass"?

* * END OF MODULE 7 * *

CONTENT

NOTES

EXPRESSWAY OPERATION

- A. The term expressway as used here includes interstates, free-ways, turnpikes, or any other type of limited-access multi-lane highway.
- B. Much of expressway operation is routine, requiring little or no decision making.
- C. Entering and exiting expressways are maneuvers that place a big demand on you to make fast, accurate decisions in rapid succession.
- D. Driving at the speed limit requires constant awareness of the road and traffic environment.

Entering and Exiting Expressways

- A. Cloverleaf intersections can be one of the biggest problems when entering or exiting expressways (see illustration on the next page).

* * * BEGIN MODULE 8 * * *

CONTENT

NOTES

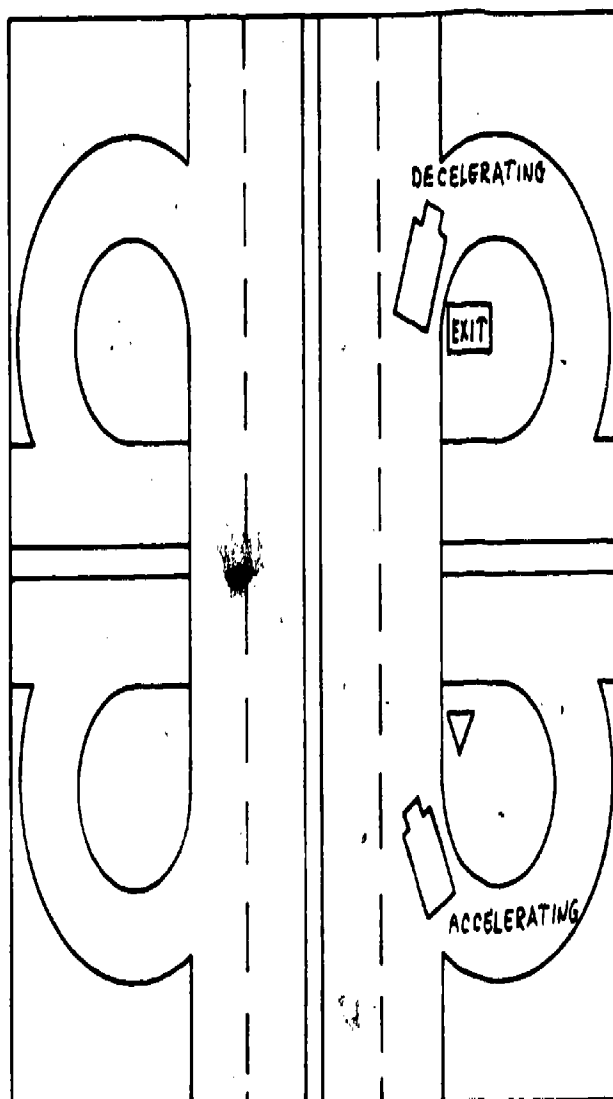
B. Entering an Expressway.

1. When on the entry ramp, stay well behind the vehicle ahead. Be prepared to stop should the vehicle in front come to a sudden stop due to traffic conditions.
2. While on the ramp, activate left-turn signal.
3. Before entering traffic, watch the traffic for a gap that is large enough to permit entry.

CONTENT

NOTES

4. Adjust speed for merging into the selected gap.

5. Yield signs.

+What does a "Yield" sign mean?

+What does a "Yield" sign at an expressway entrance indicate?

C. Exiting an expressway. It is important to position the EV in the correct lane well in advance of the exit.

1. If you must change lanes to position the EV for the exit ramp, move over one lane at a time, making sure to signal each time.

2. If the same traffic lane is used for both deceleration and acceleration, you may have to slow or accelerate quickly to get through and onto the exit ramp.

3. Once in the deceleration lane or exit lane, signal intention to exit.

4. Begin decelerating.

5. Once on the ramp, make sure speed does not exceed the recommended speed.

D. Review of entry/exit considerations.

ENTERING AND EXITING FREEWAYS

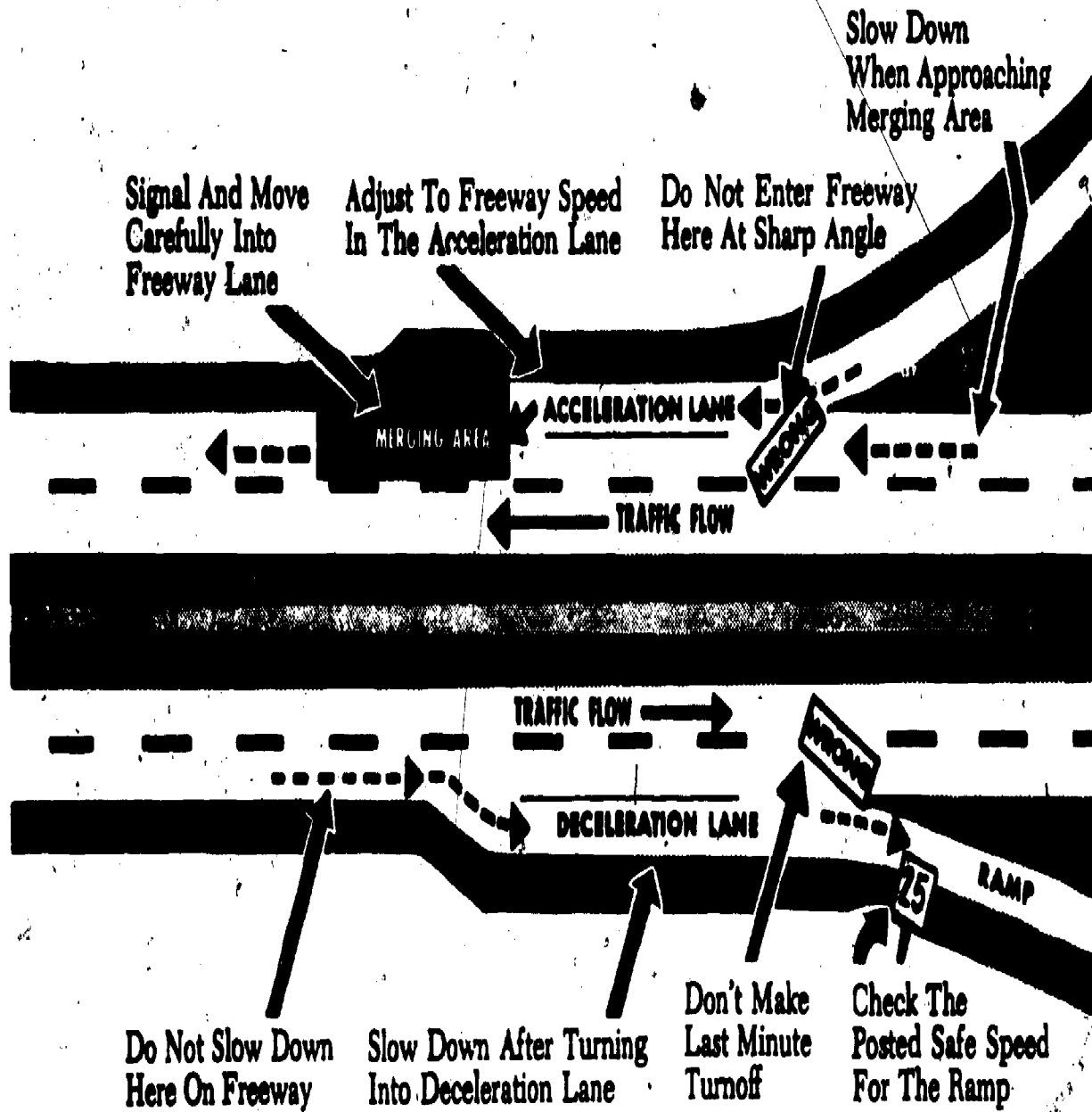
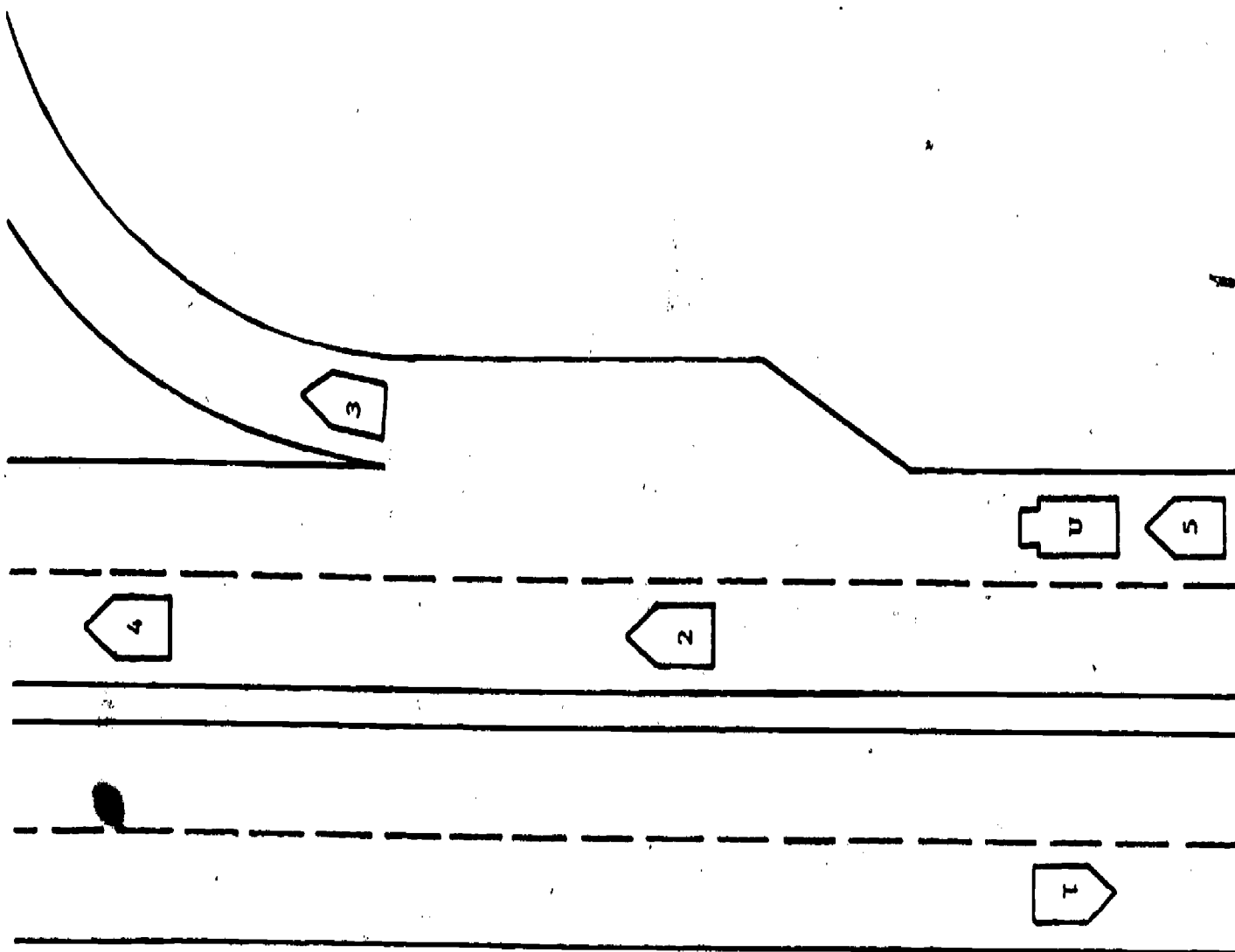

Figure I-9. Entering and Exiting Freeways.

DISCUSSION QUESTIONS

You are driving the EV marked "U." You want to leave the expressway at this exit.

- Circle the main things you should be observing.
- How would you communicate that you want to leave the expressway?



CONTENT

NOTES

Driving at the Limit on Expressways

Many of the high-speed roads in America have been so well designed and built that it is safer to travel at high speed on these roads, than at low speed on less modern roads. Some hints for safer driving:

A. Look far ahead. Keep in mind that stopping distance at 55 mph is over 300 feet (for sedans).

1. You should learn to spot potential trouble as early as possible.
2. Look beyond the car in front.
3. Watch for brake lights or a puff of dust or any other sign of trouble ahead.
4. The earlier you can begin to react to trouble, the more likely it is that trouble can be avoided.

B. Match your speed to the cars around you. Don't go over the limit, but don't go too slow either. Both can be dangerous.

C. Get away from the "pack." When a cluster of cars goes down the highway together, each driver depends on all of the others to drive carefully. Defensive driving means assuming the worst about the others on the road, and being ready for anything. If a cluster of cars is ahead, stay behind until it breaks up. If a cluster of cars comes up from behind, slow down enough to let them go by.

D. Use mirrors every few seconds. You need to be aware of all the vehicles surrounding yours.

CONTENT

NOTES

E. Signal lane changes well in advance. Change lanes only when you are sure the other lane is clear. Remember, turn signals do not grant the right to move over. Some drivers act as if they did.

Considerations: Expressway Operation in the Emergency Mode

A. Use of lights and siren.

1. Avoid using emergency signaling equipment on entrance ramps.

a. Make a normal entry.

b. Assess traffic flow conditions and choose lane for emergency run or high-speed operation before activating lights and siren.

2. Avoid weaving from lane to lane with lights and siren on.

3. Motorists may be unaware that EV is in the emergency mode if:

a. You are traveling fast (you may be driving "ahead of siren").

b. There is low sun or glare (may obliterate lights).

B. Beltway: A continuous-loop freeway or expressway, generally surrounding a large, metropolitan area.

1. Determine the proper entrance to use.

+Why?

+What does "driving ahead of siren" mean?

CONTENT

NOTES

2. Determine if your destination is East or West (North or South) of a given exit.

3. If you are on the way to an accident determine if it is in the East or Westbound (North or Southbound) traffic flow.

C. Local expressways.

+What are some of the things about local expressways that could be confusing?

CONTENT

NOTES

DRIVING AT HIGH SPEED

The coverage in this, the final module in the Operation Unit, is keyed to operation of the EV in the emergency mode at speeds in excess of the limit. The techniques presented are useful at any speed, however. In fact, they can (and should) be practiced at slower speeds (during low-traffic times) as part of an on-going program for developing the necessary skill for applying them at high speed.

Introduction

- A. Some emergencies may require high-speed operation.
- B. This module provides knowledge and techniques needed for:
 - 1. Driving on curved and winding roads at the highest possible safe speed.
 - 2. Slowing down from high speed.
- C. The primary rules are:
 - 1. Don't try to negotiate a curve faster than you know you can. Observe posted speed limits and allow for conditions which will make lower speeds necessary, i.e. wet pavement, ice, etc.
 - 2. Avoid brake fade.

Curves and Limits Imposed by the Laws of Physics

- A. In turns, centrifugal force quadruples as speed doubles. When the centrifugal force is high enough (0.8g) your vehicle cannot follow the curve on the intended track.

* * * BEGIN MODULE 9 * * *

CONTENT

NOTES

- B. For any curve, there is a maximum speed for traveling through the curve successfully.

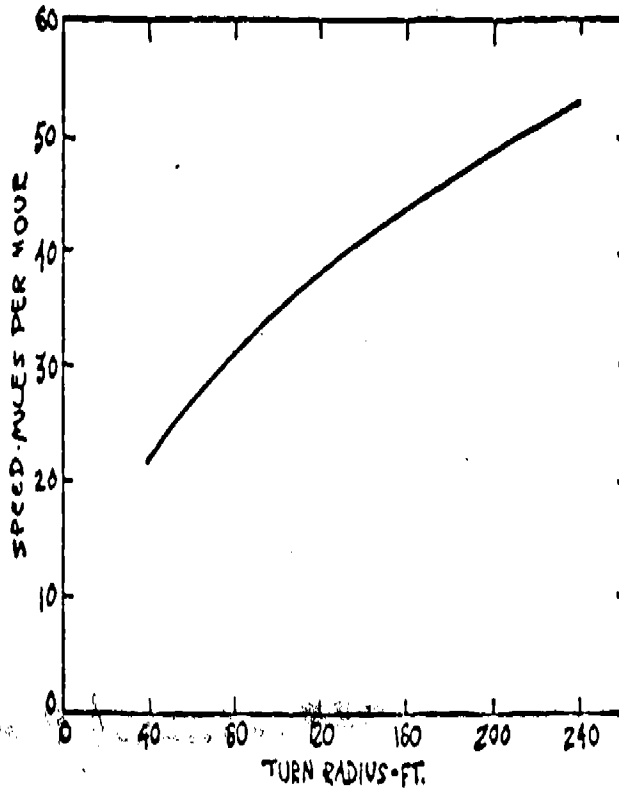

- C. The tighter the curve, the slower the EV must go.
- D. It is your job to control speed. If speed in a curve is too great, physics will win!

Curves in the Local Area

- A. Gain familiarity with all road conditions and layouts in the area. You should look for:
1. Bank of the curve.

CONTENT

NOTES

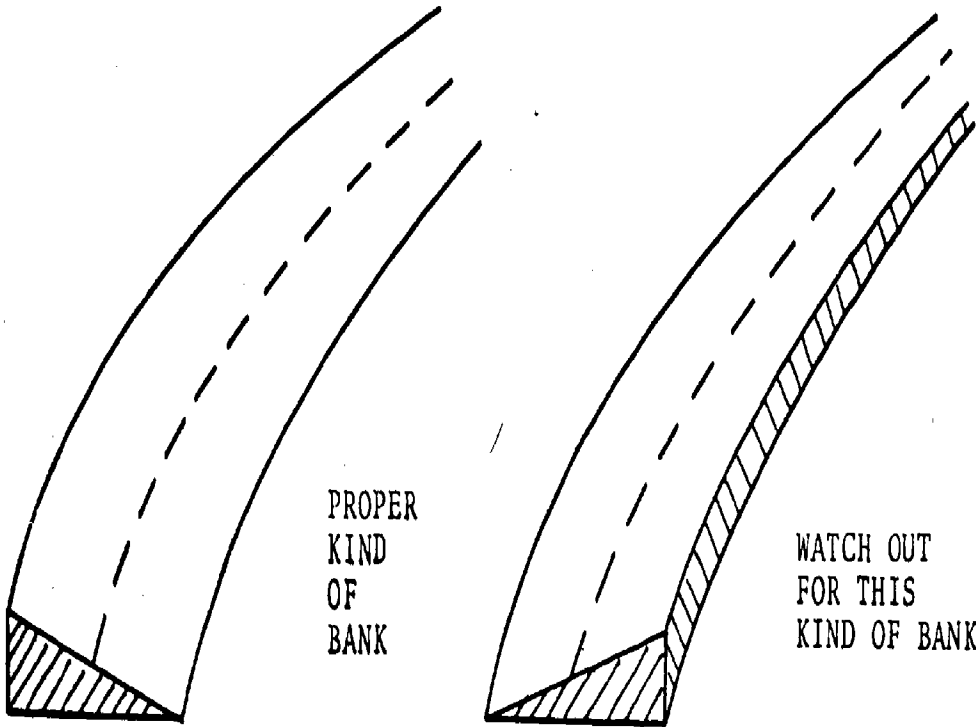

2. Type and condition of road surface.

3. Curves leading to potentially dangerous situations.

4. Curves having a decreasing radius.

+How should the road be banked?

+What is a high-crowned road?

+What kind of things should you look for?

+What are some of these dangerous situations?

+What does decreasing radius mean?

CONTENT

NOTES

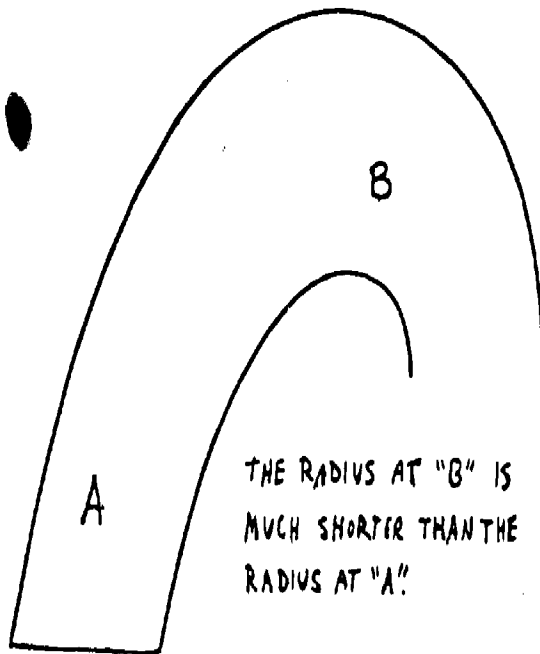

- a. On decreasing-radius curves, the maximum entry speed is too fast for the later (tighter) portion of the curve.
- b. When approaching a decreasing-radius curve, you should select an appropriate entry speed for the entire curve.

B. You must know about the road, in advance if you hope to be able to negotiate a curve at the highest possible safe speed.

Techniques for Negotiating Curves at High Speed

The entire curve must be considered. Following are the three points which are critical when negotiating curves:

1. Proper speed and vehicle position for entry to curve.
2. Maintaining speed in curve.
3. Proper speed and vehicle position for exit from the curve.

+What will happen if you enter a decreasing-radius curve at too high a speed?

CONTENT

NOTES

A. Entry.

1. Brake or decelerate to the proper entry speed before entering the curve.
2. Enter the curve as far to the outside as possible.
3. Begin turn as early as possible.
4. Establish an apex (when beginning the turn) at the last part of the inside road edge (or center-line) that can be seen from the entry point.

+Why should you enter on the outside?

+What is an "apex"?

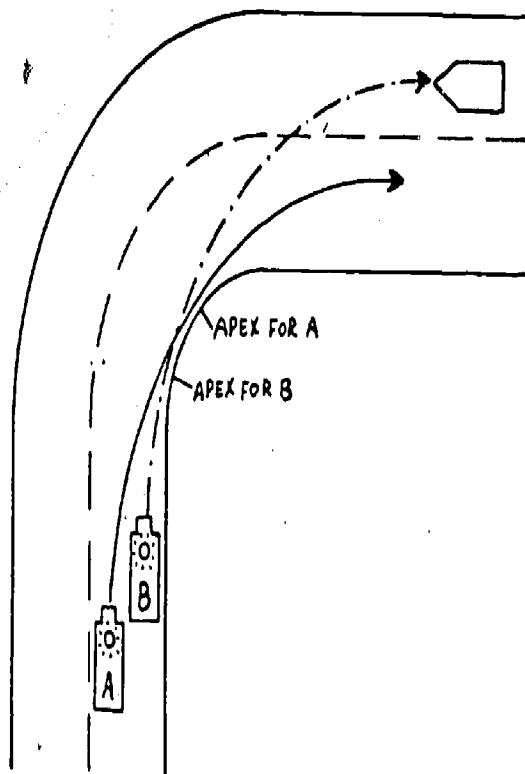

CONTENT

NOTES

B. In the curve.

1. If the maximum safe speed for a curve has been attained, the EV will feel "comfortable." Experienced drivers say such vehicles are "in the groove." This feeling can only be learned by experience. You will begin to develop this feeling in Part III of the course.

2. You should be in the groove by the time the apex is reached.

+How will you know if you are going too fast or if you have missed the groove?

+What do you do if you miss the groove?

3. Apply slight power in a curve to maintain speed.

4. Never try to gain speed beyond the established maximum safe speed for the curve.

C. Exit.

1. To another curve.

a. Keep it slow and steady.

b. Drift to farthest (outside) portion of the lane.

c. Adjust speed for next curve.

d. Establish an apex for the next curve.

2. To a straight.

CONTENT

NOTES

- a. Establish the widest (outside) position and the latest possible apex.
- b. Accelerate out of the curve after the apex has been reached.

Slowing from High Speed

- A. Braking distance increases dramatically with increased speed. When speed is doubled, braking distance more than quadruples.

Stopping Distance at High Speed

Speed in mph	Distance in feet (Good brakes, dry concrete, <u>sedan</u>)
40	149
50	243
60	366
70	497
80	708

- B. Techniques for stopping from high speed.
 1. Proper high-speed braking technique depends on the kind of brakes your vehicle has. For either disc or drum brakes, it is not advisable to lock up the wheels.

CONTENT

NOTES

2. Use the right foot for braking. When a stop is imminent, "cover" the brake with the right foot. Don't risk brake fade by riding the brake.
3. If the EV has disc brakes, to stop as fast as possible:
 - a. Always use a smooth braking motion.
 - b. Apply maximum pressure short of locking the wheels.
 - c. Keep the pressure on until you have slowed to the desired speed.
4. If EV has drum brakes, to stop as fast as possible:
 - a. Smooth braking action.
 - b. Pumping the brakes is mandatory. The goal is to allow the brakes time to cool.
 - c. Smooth, rapid pumping to the point just before the wheels lock is the best bet.
 - d. The pumping action should be of sufficient duration and force to transfer the vehicle weight to the front wheels without locking up the wheels.

+What are the dangers of left foot braking?

+What do you do if brakes fade?

Review Exercises

1. Write a brief description of the purpose of emergency signaling equipment.

2. Circle the letter in front of the statements that are correct:

- a. YOU are required to use emergency signaling equipment whenever any of the exemptions to the state law are exercised.
- b. An ambulance with a patient aboard should use emergency signaling equipment at all times.
- c. At high speeds, it is possible to "out-run" the siren sound.
- d. When siren is on, it is a good idea to leave driver's window partly open.
- e. It is especially important to turn the siren on at railroad crossings.
- f. It is especially important to turn the siren on at intersections.

3. When parallel parking on a slope, how should the vehicle's wheels be positioned?

4. Sam (the operator) and Joe are in the control cab on a van ambulance. As Sam is backing out of a parking stall, a sudden jolt and a tinkling sound tell them they have hit something. Sam was monitoring the left outside mirror as well as the center rear-view mirror and Joe was monitoring the right outside mirror. What more might have been done to avoid this accident?
-
-

5. Briefly describe the provisions of the state statute that deals with motorists' responsibilities for clearing a path for emergency vehicles.
-
-

6. Circle the letter in front of the statement which describes the best siren-use technique for negotiating through heavy or blocked traffic:

a. Low-pitch (growl) constant siren.

b. No siren.

c. High-pitch constant siren.

d. Intermittent siren.

7. Circle the number that represents the percentage of emergency vehicle accidents that occur at intersections.

35 percent

50 percent

65 percent

8. Circle the letter in front of the method appropriate for checking traffic before crossing an intersection.

a. Look right, then left, then right again.

b. Look left, then right, then left again.

c. Look left, then right.

d. Look right, then left.

9. State which type of turn, a right or left, requires a larger gap in cross traffic. Explain your answer.

10. What is the safest type of turnabout?

11. On the illustrations below, draw the correct path for a vehicle making U-turns.

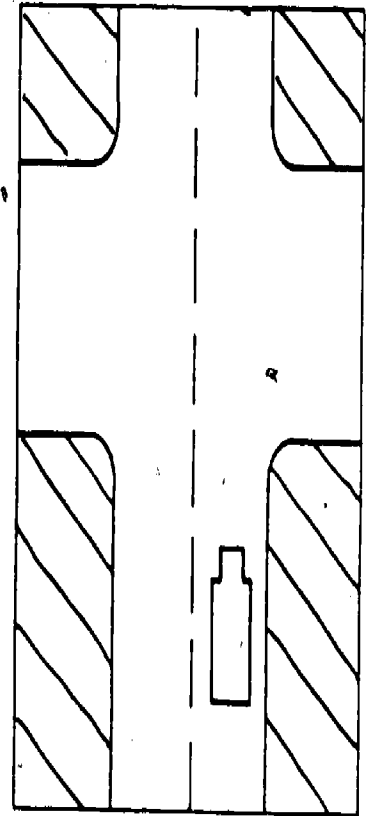
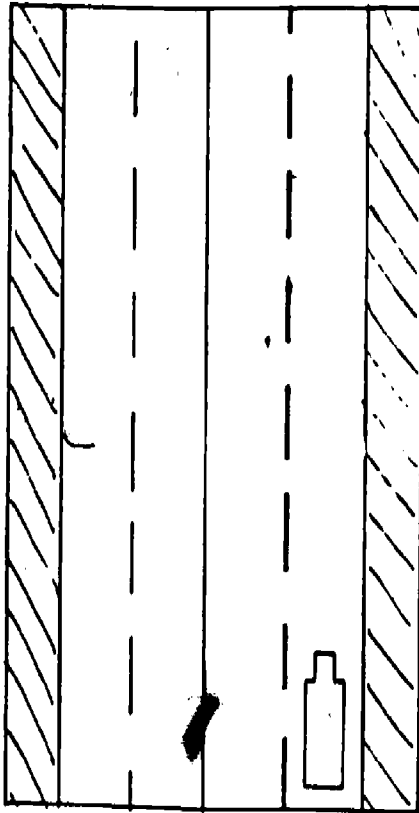
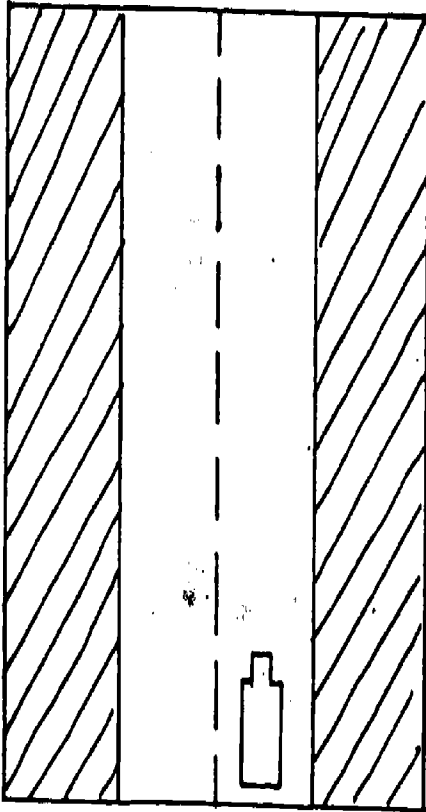

12. On the illustrations below, draw the correct path for a vehicle making a left and a right side-road turnabout.

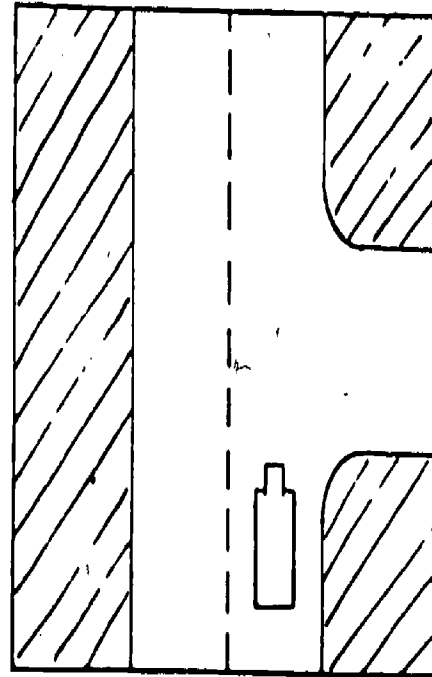
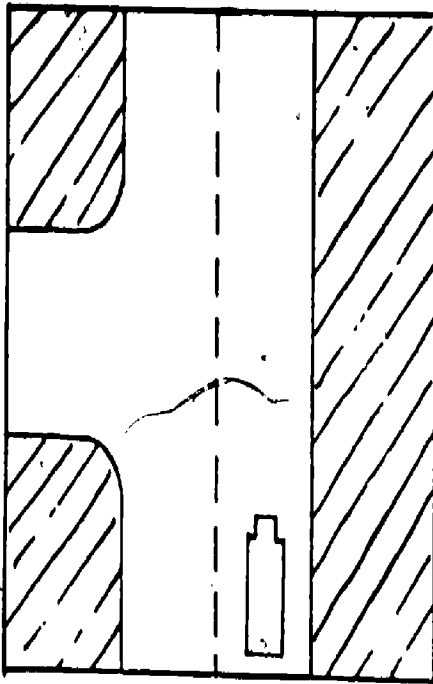

13. Write a brief description of the two methods of estimating following distance.

14. Of the items that appear below, some are cues to increase following distance. Circle the letter in front of those items.
- a. When following a vehicle that is being driven erratically.
 - b. When operating in the emergency mode.
 - c. When weather conditions are poor.
 - d. When following a late-model sports car.
 - e. When traveling on damaged road surfaces.
 - f. When traveling during rush hour.
 - g. When following another EV.
15. Below are several statements relating to following distance. Circle the letter in front of those that are correct.
- a. Following at the full stopping distance is unnecessary.
 - b. Not all vehicles have the same stopping distance for a given speed.
 - c. Vehicle condition can have an effect on stopping distance.
 - d. In general, large, heavy vehicles require less distance to stop.
 - e. Following distance should be decreased when traveling in the emergency mode.

Name two types of road configuration (not lane markings or signs) that indicate it is unsafe to pass.

In a 45 mph zone, the EV is traveling 45 mph. Circle the letter in front of any of the following statements that indicate it is unsafe for the EV to pass.

- a. Four-lane divided highway, heavy traffic in all lanes.
- b. Vehicle to be passed is traveling at the posted limit.
- c. Two-lane road, broken center line, hillcrest approximately 1/4 mile ahead.
- d. Straight two-lane road, broken center line, small driveway intersecting to the left approximately one block ahead.

Write a brief definition of the meaning of a "Yield" sign.

19. Select the siren-use technique most appropriate for entering and exiting expressways. Circle the letter in front of that item.

- a. Intermittent siren.
- b. Low-pitch (growl) siren.
- c. No siren.
- d. High-pitch siren.

20. Circle the drawing below that illustrates a properly banked road.

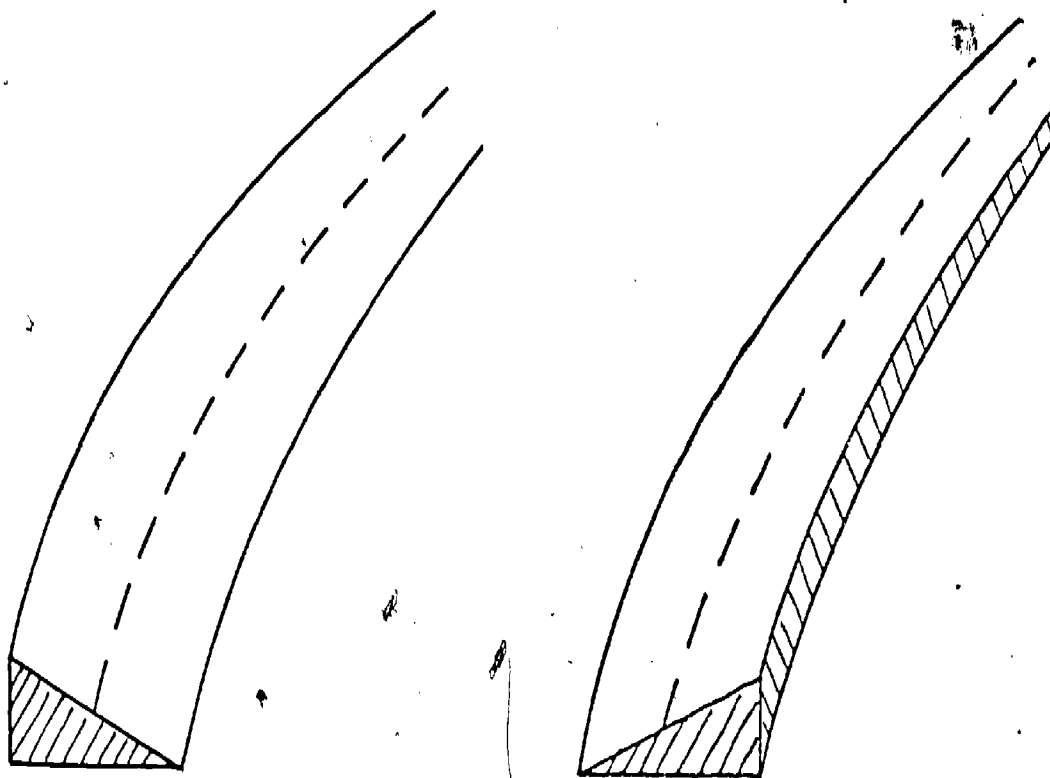

21. For each of the sentences relating to driving curved roads at high speed, insert the word(s) that best completes that sentence.
- On a decreasing radius curve the maximum possible entry speed is too _____ for the later (tighter) portion of the curve.
 - The _____ the curve, the slower the EV must go.
 - Brake or decelerate to the proper entry speed _____ entering a curve.
 - Entry speed for any curve can be increased somewhat by entering the curve on the _____ side.
 - On a decreasing radius curve, if the speed is too high for the tighter portion of the curve, vehicle control will be _____.
22. On the drawing below, the two vehicles are just beginning their turn. Circle the vehicle that has chosen the correct entry position for the curve. Give reasons why the position of the vehicle you chose is correct.

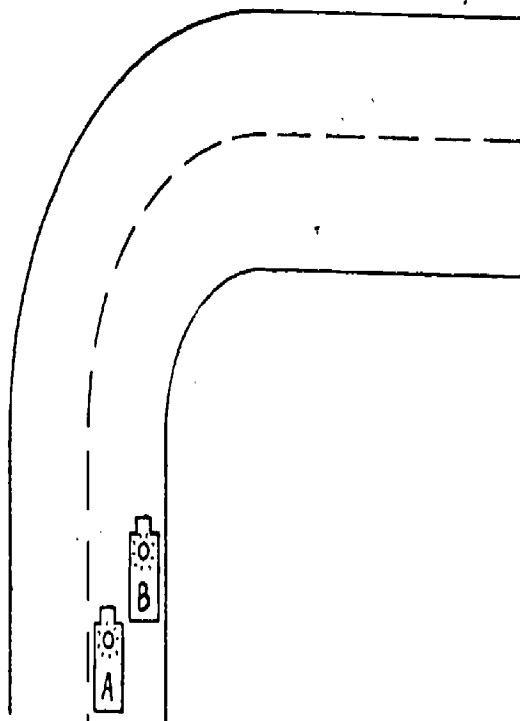

Trainees' Knowledge ObjectivesModule 1

By the end of this module:

1. Given a list of statements relating to driving under adverse conditions, you will be able to identify those that are correct.

Module 2

By the end of this module:

1. Given a list of several items, you will be able to determine which of the items are impact-absorbing (if struck with a moving vehicle) and which are not.
2. You will be able to state the three primary steps that should be taken in controlling any type of skid.
3. Given several statements relating to off-road recovery, you will be able to distinguish those that are correct from those that are not.
4. Given a list of vehicle malfunctions, you will be able to describe the appropriate driver response(s) for handling the malfunction.

Trainees' Knowledge Objectives' (Continued)Module 3

By the end of this module:

1. Given a list of several emergency vehicle light arrangements that could be used to warn other motorists, you will be able to rate them in order of effectiveness.
2. Given two drawings of a disabled vehicle (off-road and on-road), you will be able to indicate proper placement of warning devices (e.g., flares, reflectors).

CONTENT

NOTES

INTRODUCTION

This unit is divided into three modules, Driving in Adverse Conditions, Handling Contingency Situations, and If You Must Pull Off the Road.

* * * BEGIN MODULE 1 * * *

+What adverse conditions do you think might be covered in this module?

+What do you think the word "contingency" as used in this module means?

+What kind of information might you find in the section titled "If You Must Pull Off the Road?"

CONTENT

NOTES

DRIVING IN ADVERSE CONDITIONS

Driving techniques must be adjusted for all adverse conditions.

A. Slow down.

B. Increase following distance.

Night Driving

A. Causes of accidents (more likely to occur at night):

1. Obviously, at night there is less light to see by. Vision is somewhat restricted. Some facts you should remember:

a. Night vision varies considerably among persons.

b. Older people's night vision is not usually as good as younger people's night vision.

c. Eye-straining activities (during the day) can reduce night-vision.

d. Sunglasses reduce eye-strain in bright sun, but they should NEVER be worn after sunset.

e. Bright flashes of light (lightning, high-beam glare) can cause momentary blindness.

CONTENT

NOTES

2. There are many more drunk drivers on the road at night than there are during the day. Take these precautions:
 - a. Search for indications of drunk drivers.
 - b. Keep especially alert between 11 PM and 3 AM.
 3. For obvious reasons, many of the drivers on the road at night will be tired. Take these precautions:
 - a. Allow extra space and time for other drivers to react.
 - b. Don't be a tired driver--begin shift well rested.
- B. Using headlights and high beams:
1. Headlights:
 - a. Headlights should be used at all times between the first signs of dusk and full daylight.
 - b. Keep your headlights clean and properly aimed.
 - c. Make sure you have burned-out lights replaced immediately.
 2. High beams:
 - a. Dim your high beams whenever you are within 500 feet of approaching vehicles.
 - b. Dim your high beams whenever you are within 300 feet of overtaking or following other vehicles.

What are some indications?

CONTENT

NOTES

c. Avoid high beams on right curves--they will tend to blind the oncoming driver.

d. Don't start directly into high beams. Guide your vehicle by using the right edge of the road.

C. Tips to improve visibility at night:

1. Keep the windshield clean, both inside and outside.
2. Keep the instrument panel lights dim.
3. Slow the vehicle considerably on curves or when turning.
4. Keep your eyes moving.

Adverse Weather Conditions

The chart on the following page provides an indication of relative stopping distances at different speeds and in different weather conditions.

A. Wet or rainy weather:

1. Approximately six times more people are killed on wet roads than on snowy and icy roads combined*.
2. When it first begins to rain roads are likely to be especially slippery.
3. In rainy weather avoid (if at all possible) making sudden moves with the steering wheel, brakes, or accelerator.

Why should you slow on curves or when turning?

+Why?

+Why?

CONTENT

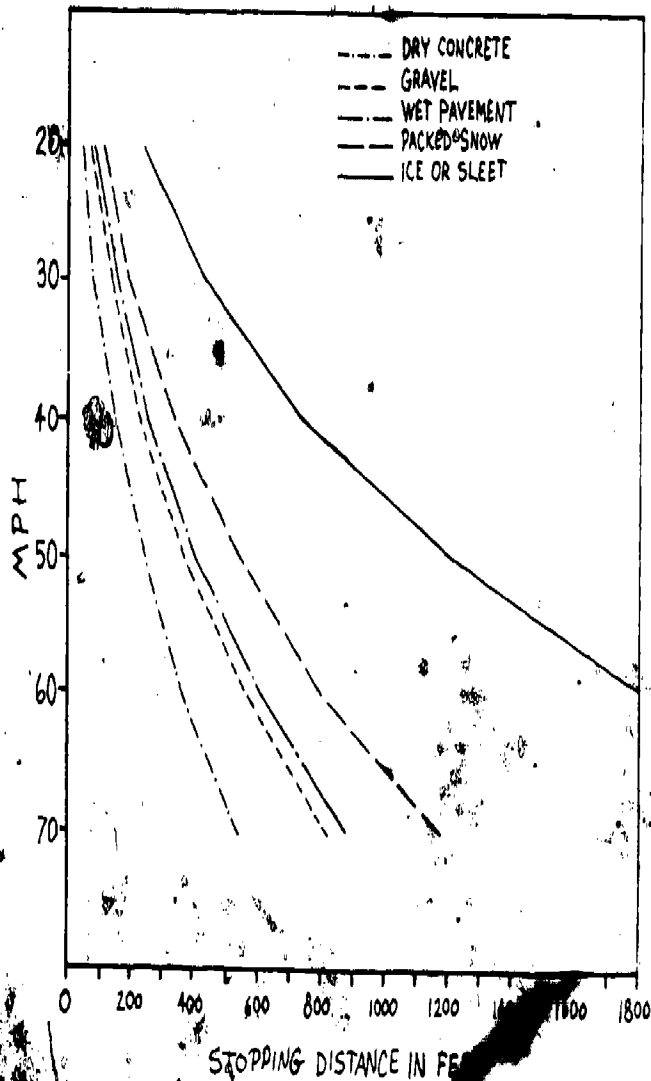

NOTES

+How much more distance does it take to stop on wet pavement than on dry pavement?

+How much more distance does it take to stop on ice or sleet, than on dry pavement?

+What conclusions can you draw from the facts presented in the chart?

+What can you do if brakes are grabbing or pulling?

4. Driving through large areas of water can affect brake performance, and the vehicle's electrical system. Following are some precautions you can take:

- Slow down before hitting water.
- Turn wipers on before hitting water.
- Tap brakes as you exit to see if brakes are grabbing or pulling.

CONTENT

NOTES

5. Double-check mirrors; rain on the rear window or outside mirrors can distort or obliterate images.
- B. Winter driving (including sleet, freezing rain, packed snow, and ice).
1. Prepare in advance whenever there is a chance of encountering winter driving conditions:
 - a. Engine should be in tune.
 - b. Heater/defroster should be in good working order.
 - c. Battery should be fully charged.
 - d. Emergency weather equipment should be stowed in the vehicle.
 - e. Snow tires and/or chains should be ON the vehicle.
 - f. Brakes should be properly adjusted.
 2. Tips for driving on ice and snow:
 - a. Keep informed of the temperature. "Wet" ice and freezing rain create the most treacherous of all driving conditions.
 - b. Don't make any sudden moves with the steering wheel, brakes, or accelerator unless absolutely necessary.
- C. Poor visibility (including fog, mist, smog, etc.).
1. Drive slowly, but keep moving.

+What kind of emergency weather equipment?

+Why is proper brake adjustment especially important in winter weather?

+What is "wet" ice?

CONTENT

NOTES

2. Turn lights (low beams) and wipers on.
3. Use four-way flashers if traveling 15 mph or more below the speed limit.
4. Stay alert for cars that are moving very slowly.
5. Check the rear-view mirror often.
6. Avoid decelerating suddenly.
7. If you must pull off the road, turn on the four-way flashers.
8. Do not pass.
9. Use the defroster to minimize fogging on the inside of the window.

CONTENT

NOTES

HANDLING CONTINGENCY SITUATIONS

- A. Contingency situations can arise at any time. When they arise, normal traffic flow may be suddenly interrupted, and the safety of all persons in the general area is diminished.
- B. It is a good policy to be familiar with the contingency situations that occur most often, and to understand the actions that can be taken to minimize the likelihood of death or injury.
- C. In general terms, there are four primary causes of contingency situations.

*** BEGIN MODULE 2 ***

+Can you think of what the four primary causes of contingency situations might be?

CONTENT

NOTES

Precautions to Help Prevent Contingencies

This section addresses precautions the operator can take to minimize the chances of a contingency occurring.

A. Vehicle malfunction or failure:

1. A thorough inspection of your vehicle at the beginning of every shift will minimize the chances of an unexpected vehicle malfunction or breakdown.
2. Prompt correction or repair of any malfunctions (even minor ones) you detect will prevent a sudden worsening of the malfunction.
3. You should constantly monitor to detect the following kinds of things:
 - a. Noises.
 - b. New (or changed) vibrations.
 - c. Odors.
 - d. Changes in handling characteristics.

- +What is meant by "noises"?
- +What might vibrations indicate?
- +What might odors indicate?
- +What are some examples of changes in handling characteristics?

B. A sudden change or deterioration in the road (due to weather, damage, construction, etc.). Precautions:

1. Remain alert, don't be caught off guard.
2. Scan the roadway well ahead to enable you to pick out possible problems well in advance.

CONTENT

NOTES

3. Look for cues indicating possibly dangerous situations.
 4. Know the area!
- C. The appearance of an obstacle in the roadway (including pedestrians, other vehicles, etc.). Precautions:
1. Always maintain a safe speed; one which allows maximum vehicle control.
 2. Search for obvious cues that might indicate obstacles are likely.
 3. Learn to spot very subtle cues that might indicate obstacles are likely.
- D. Driver error. Precautions:
1. Begin your shift well-rested, with no unusual physical impairment.
 2. Remain alert.
 3. Avoid unnecessary risks.
 4. When faced with a contingency situation, don't panic.

General Techniques for Handling Contingencies

Hundreds of "possible" contingencies could arise. Since you spend many hours driving (and travel many thousands of miles), it is probable that sooner or later a contingency will occur. Following are general techniques that can be applied to deal with many of the possible situations.

+What kind of things about the area would it be helpful to know?

+What kind of obvious cues?

+What kind of subtle cues?

CONTENT

NOTES

A. Evasive steering means a sudden or extreme change in the vehicle's direction. This maneuver is often used to avoid pedestrians, vehicles or other obstacles. Usually, this action is taken because it is too late to brake to a stop.

+What about animals in the roadway?

1. Scan the roadway and nearby areas for escape routes.
Consider:

a. Can the vehicle be safely steered off the right side of the road?

b. Can the vehicle be safely steered off the left side of the road?

+Which is usually safer?

c. Are there any obstacles on the roadside?

+What are some exceptions?

d. Are there any oncoming vehicles?

e. How stable is the road surface (e.g., gravel vs. concrete); is it likely to contribute to loss of control?

2. Scan especially carefully when approaching the crest of a hill, rounding a curve, and when approaching intersections.

+Why do you need to scan especially carefully in these situations?

3. Execute the evasive steering maneuver in the following way.

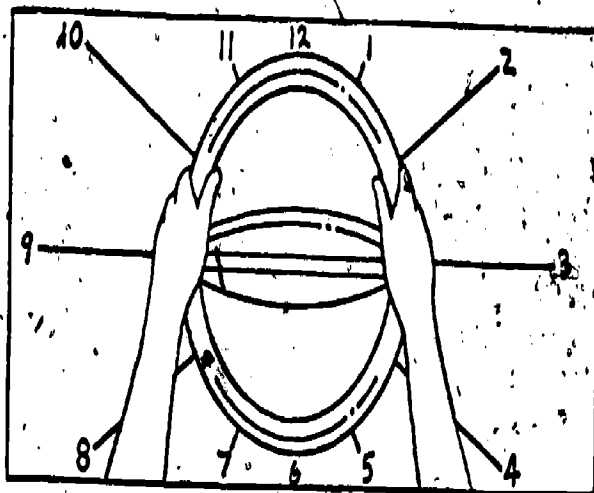

CONTENT

NOTES

- a. Hands should be at 3 and 9 o'clock on the steering wheel--this will allow the largest possible turn without moving the hands.
 - b. Turn the steering wheel sharply in the direction you have chosen for an escape route.
 - c. Countersteer as soon as your vehicle is clear of the obstacle.
 - d. Although it may be necessary to brake somewhat, hard braking should be avoided.
 - e. Slow down and maintain vehicle control.
- B. Emergency braking. If there is enough room to stop, or if no escape route is available, emergency braking may be one way to avoid a collision or minimize its consequences. The goal of emergency braking is to produce the shortest possible stopping distance without locking wheels or losing control. The best method for accomplishing this is:
1. Hard pressure to brake pedal without locking wheels:
 - a. Quick, firm jobs.
 - b. Short, steady pressure; release, repeat.
 2. If wheels lock, RELEASE BRAKE PEDAL. Then reapply with less pressure.
 3. Bear in mind that rapid deceleration could cause a rear-end collision.
- C. Evasive acceleration simply means a quick burst of speed. This maneuver can be used to avoid a collision with side-approaching or merging vehicles.

+Why should hard braking be avoided?

CONTENT

NOTES

D. Unavoidable collisions. When you are sure that a collision is unavoidable, choose an object to collide with. Take the following into consideration:

1. Always choose the course least likely to cause death or injury, or the course that will cause the fewest injuries.

2. Head-on collisions are the most damaging in terms of both life and property. Instead:

a. Steer so that your vehicle sideswipes or hits the other object at an angle.

b. Avoid hitting large, immobile objects in favor of "impact-absorbing" objects.

+What are some examples of impact-absorbing objects?

+Some examples of nonimpact-absorbing objects?

CONTENT

NOTES

What Would You Do?--Practice

- A. Each of the drawings in this practice section illustrates a potential accident.
- B. The things that could be done to avoid an accident include:
1. Emergency braking.
 2. Evasive steering.
 3. Evasive acceleration.
 4. No action.

The EV is traveling on a four-lane road with no median. Gravel berms are on both sides of the road. The only other vehicle in the immediate vicinity is the car that appears to be out of control--it is crossing the center line and headed for the EV.

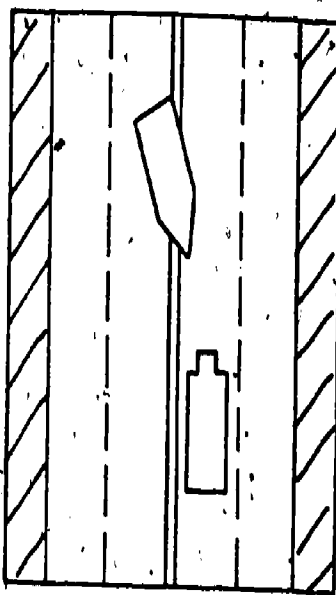

+What would be the appropriate response for this situation?

CONTENT

The EV is traveling at about 25 mph down a narrow, one-way alley. On either side of the alley are buildings set very close to the street. A large truck begins to back out of an intersecting alley to the left.

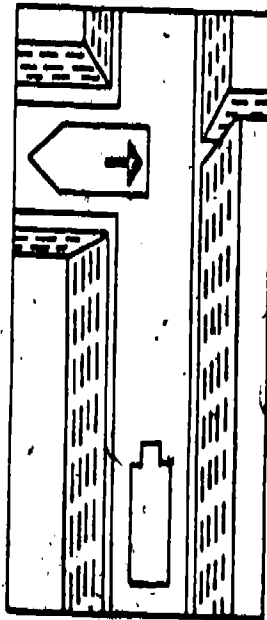

NOTES

+What would be the appropriate response for this situation?

The EV is traveling at about 30 mph on a busy, urban street. A car is behind the EV, following closely. Another car is approaching in the opposing lane of traffic. Parked cars are in the lane immediately to the EV's right. A small dog runs out into the roadway.

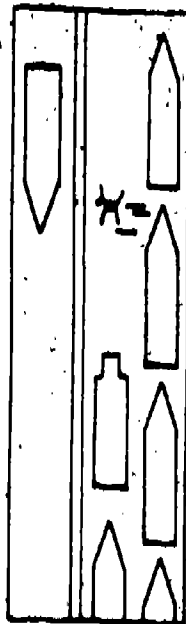

+What would be the appropriate response for this situation?

CONTENT

The EV is traveling 55 mph in the right-most lane of a four lane divided expressway. Two cars are in the left lane beside the EV. A car is about to enter the expressway from the entrance ramp; it is traveling approximately 45 mph.

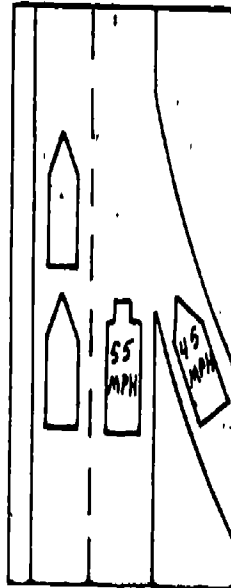

The EV is traveling on a two lane rural road. There is a car in the opposing lane. On both sides of the road is a heavy growth of low bushes and shrubs. A small child runs out into the road.



NOTES

+What would be the appropriate response for this situation?

•What would be the appropriate response for this situation?

CONTENT

NOTES

Handling Skids

In general terms, skidding means loss of steering and braking control.

- A. All skids are caused by two primary factors:
1. A too-sudden change of speed or direction.
 2. Any change of speed or direction under conditions of poor traction.
- B. No matter what kind of skid is occurring, the following will help you regain control:
1. Stay OFF the brake.
 2. Stay OFF the accelerator.
 3. Countersteer; steer in the direction to which the rear end of the vehicle is skidding. Two points to remember about countersteering:
 - a. You do not have to turn the steering wheel violently to correct a skid.
 - b. Once the wheel has been turned to countersteer, it may be necessary to immediately countersteer in the other direction.

+What can happen?

READ FROM BOTTOM



1. The vehicle is going straight.
2. The back end of the vehicle skids around to the left (the vehicle is still moving forward at an angle).
3. You'd steer left, in the direction you want the vehicle to go relative to the way it's facing.
4. The vehicle is back on course.
5. The back end fishtails to the right.
6. To control fishtailing in the opposite direction, you'd countersteer right to help you get back on course.
7. Steering control is reestablished.

CONTENT

NOTES

C. Specific skids:

1. Braking skid. This kind of skid occurs when, due to sudden, hard brake pressure, one or more of the vehicle's wheels lock. If brakes are evenly adjusted, all wheels will lock at the same time.

a. If all wheels lock evenly, or if just the front wheels lock, the vehicle will move straight ahead, unless influenced by some other force (e.g., a dip in the road).

b. If just the rear wheels lock, their reduced traction will cause them to move forward faster than the front wheels.

c. Actions to take if a braking skid occurs:

1) Release brakes IMMEDIATELY: it should then be possible to steer.

2) If braking is still necessary (to reduce speed or avoid an obstacle), apply with less pressure so that wheels don't lock again.

2. Power skid. This kind of skid occurs due to sudden, hard acceleration.

a. The back end of the vehicle may skid to one side, trying to overtake the front end.

b. The vehicle may spin all the way around.

c. Actions to take if a power skid occurs.

1) Ease off the accelerator.

+What can happen?

+Can you think of some examples of situations where braking skids could occur?

CONTENT

NOTES

- 2) Countersteer in the direction towards which the rear end of the vehicle is skidding.
3. Cornering skid. This skid occurs when speed is too great or traction is reduced (due to poor road/weather conditions) such that the vehicle cannot stay on an intended track around a curve.
- a. The vehicle may continue to travel straight ahead--not in the intended path of travel around the turn.
 - b. The rear end of the vehicle may try to overtake the front end, if just the rear wheels lost traction.
 - c. Actions to take if a cornering skid occurs:
 - 1) Ease up on the accelerator.
 - 2) If the vehicle is spinning out, countersteer as space permits.
4. Hydroplane skid. Hydroplaning occurs when the tire is moving too fast for the water on the road to escape (to flow around it or through the tread). A small wedge of water builds up in front of the tire and lifts it off the surface of the road.

Can you think of some examples of situations where power skids could occur?

+What is this called?

+What is this called?

CONTENT

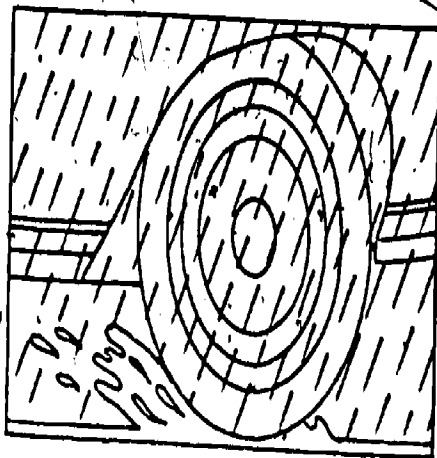

- a. The results of a hydroplane skid are difficult to predict:
 - 1) As with all skids, there is loss of braking and/or steering control.
 - 2) Unless the operator attempts to brake or steer (other than straight ahead) he may not know he is hydroplaning.
- b. Actions to take if a hydroplane skid occurs:
 - 1) Ease off brake or accelerator.
 - 2) Allow the vehicle to decelerate.

Handling Other Specific Contingencies

The occurrences and conditions listed in this part of the unit should be handled according to the procedures outlined:

- A. Blowout. Front tire blowouts are the most dangerous, the vehicle will pull to the side of the blown-out tire.

What are some ways to prevent hydroplane skids?

CONTENT

NOTES

1. Remove foot from accelerator, allowing vehicle to slow.
2. Hold steering wheel firmly; anticipate steering difficulty.
3. When steering is controlled, brake gradually; avoid locking wheels.

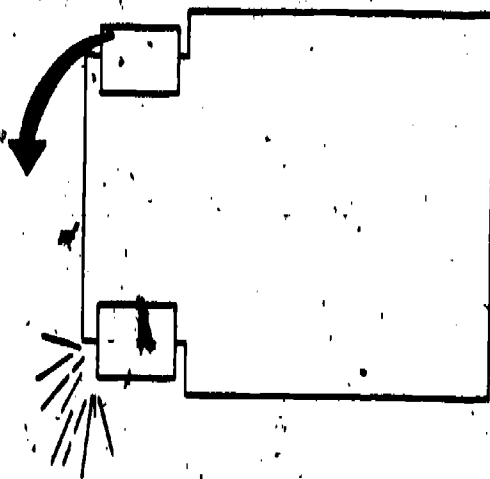
B. Brake failure.

1. Shift to lowest gear, if possible.
2. Apply parking brake in either of the following ways:
 - a. In a pumping manner--steady pressure, release, etc.
 - b. As hard as possible, without locking the wheels.
3. Pump brake pedal rapidly.
4. If these actions do not slow the vehicle, sound the horn to alert traffic; activate four-way flashers and/or emergency signaling devices; and choose an impact-absorbing object to collide with.

+What is the danger of this procedure?

+Why?

CONTENT

NOTES

- a. Avoid head-on collisions.
 - b. Try to sideswipe parked cars, shrubs, even a dirt hill-side--always at an angle.
5. If vehicle has been slowed sufficiently, select an off-road stopping place.
- a. If there is an upgrade within the assured clear distance ahead, stay on the road and allow the upgrade to further slow the vehicle, then select a path for leaving the roadway.
 - b. If no upgrade is within clear distance ahead, select the path for leaving the roadway that will minimize injuries and property damage.
- C. Transmission Failure.
1. Select a safe off-road stopping place.
 2. Brake gradually to a stop.
- D. Steering failure. Steering failure is most likely to occur when a vehicle with power steering stalls. This will make steering difficult, but not impossible.
1. Power steering stall (steering failure):
 - a. Anticipate steering difficulty; grasp wheel firmly.
 - b. Find safe spot and pull off the road.
 2. Total steering failure:
 - a. Keep trying to steer.

CONTENT

NOTES

- b. Stay OFF the brake.
- c. If the vehicle does not coast to a stop, shift to a lower gear and pump the parking brake (same procedure as brake failure).

+Why is it important to stay off the brake?

E. Accelerator sticks

- 1. If the accelerator sticks and there are no vehicles ahead of the EV, you should attempt to release the pedal by slipping the tip of your shoe under it and lifting.
- 2. If this method is unsuccessful:
 - a. Put the vehicle in "neutral" gear. In vehicles without power steering and power brakes, turn engine off.
 - b. If the vehicle has power-assisted brakes, do not pump them. Instead, apply steady pressure.
 - c. Select a safe off-road stopping place and pull off.
 - d. Turn engine off if still running.

+Why shouldn't you pump power brakes?

F. Visibility impaired (hood flies up, wiper or defroster failure.)

- 1. If hood flies up, look for a gap at the bottom of the windshield.
- 2. If forward visibility is completely blocked, put your head out the side window to see forward.
- 3. Apply brakes moderately.
- 4. Continue to brake gradually and select an off-road stopping place.
- 5. Pull off the roadway and activate the four-way flashers.

CONTENT

NOTES

G. Wheel(s) off the road (off-road recovery): If at some time the vehicle's wheel(s) leave the road surface (intentionally or unintentionally), you will have to perform an off-road recovery. This can be a dangerous maneuver unless performed properly. Following is the correct procedure:

1. Hold steering wheel firmly; steering may be difficult.

2. Check for traffic ahead and to the rear.

3. Reduce speed by easing off the accelerator.

4. If brakes must be applied to reduce speed, brake VERY gradually.

5. Center vehicle over the road edge.

6. Activate appropriate turn signal.

7. If you must avoid an obstacle, steer sharply toward the road, turning steering wheel about 90° while accelerating slightly.

8. If you do not have to avoid an obstacle, scan the road edge to find the point at which there is the least distance between the road edge and berm then turn the wheel gradually and steer on at that point.

9. As soon as the vehicle's front right wheel touches the road edge, countersteer to control lane position.

Danger signals from gauges and indicators on the instrument panel.

1. Fuel gauge low:

a. Continue to site if within range.

+Why is it necessary to brake very gradually?

+What is the danger with this procedure?

CONTENT

NOTES

- b. Consider the amount of fuel necessary for the return trip.
2. Charging system fails (battery not charging):
 - a. Turn off any equipment that will drain the battery.
 - b. If you stop the engine, it is unlikely it will restart.
3. Brake warning light comes on:
 - a. Stop immediately.
 - b. Do not drive the vehicle until maintenance has been performed.
4. Oil pressure drops:
 - a. Stop immediately.
 - b. Do not drive vehicle until maintenance has been performed.
5. Engine temperature rises into danger zone (and remains there):
 - a. Stop immediately.
 - b. Do not drive the vehicle until maintenance has been performed.

* * END QF MODULE 2 * *

CONTENT

NOTES

IF YOU MUST PULL OFF THE ROAD

Due to adverse weather conditions or a contingency situation, you may find that you must pull off the road. In the worst case, you will be unable to get the vehicle entirely off the road (and out of the path of surrounding traffic). Whenever this situation arises, both you and the vehicle must be protected. The goal of "protecting the scene" is to provide visible, early warning to surrounding traffic, and thus avoid a collision (or avoid causing a collision). Remember these principles:

- A. The position of your vehicle is critical. The more likely a hazard it represents, the more critical the need for rapid, effective placement of warning devices.
- B. You should select the method or combination of methods, most likely to provide visible, early warning to surrounding traffic. Some possible methods include:
 1. MOST EFFECTIVE: Emergency warning devices such as triangular reflectors, flares, fusees, etc.
 2. OKAY: Overhead beacon, four-way flashers, cab lights.
 3. POOR: Headlights, parking lights, nothing.
- C. During daylight:
 1. If the vehicle is well off the road, activating four-way flashers is usually sufficient to protect the scene.
 2. If the vehicle is not well off the road, you should take additional precautions.

* * * BEING MODULE 3 * * *

+What kind of warning devices are best and why?

+Why are parking lights poor?

+What additional precautions should you take?

CONTENT

NOTES

D. In darkness:

1. If the vehicle is on or near the road, warning devices should be positioned whenever the vehicle will be stopped for more than a few moments.
2. If the length of time the vehicle will be stopped is long or indefinite, warning devices should be positioned (whether the vehicle is on or off the road).

Placing Flares or Other Emergency Warning Devices

The obvious purpose of warning devices is to alert traffic to the stopped vehicle's presence, but another real goal is to cause as little interference as possible with the flow of traffic.

A. Placing warning devices on one-way roads (or divided highways).

1. Start the four-way flashers before leaving the vehicle-- leave the cab light ON.
2. Place a warning device just beside the vehicle on the traffic side.
3. Place a second warning device 100 to 200 feet to the rear of the vehicle, on the edge of the road. If the vehicle is actually ON the roadway, the device should be placed in the middle of the lane.
4. Place a third device approximately 300 feet to the rear of the vehicle, on the road edge (or in the lane if the vehicle is ON the road).

+How can you judge these distances, approximately?

CONTENT

NOTES

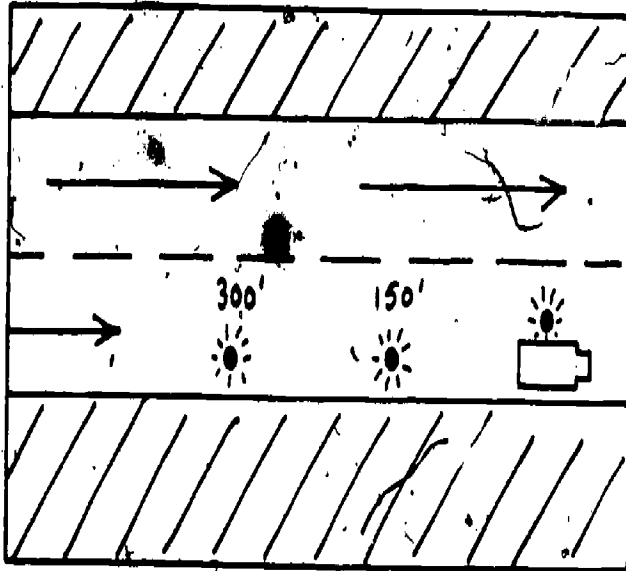

One-way flow of traffic.
Disabled vehicle off roadway.

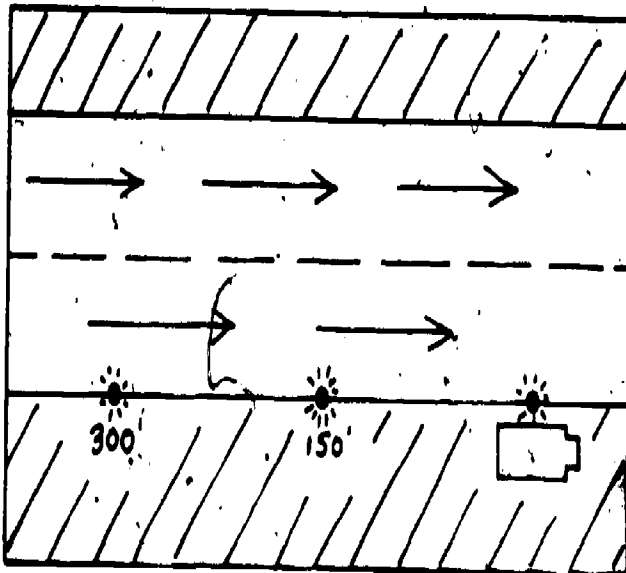

One-way flow of traffic.
Disabled vehicle on roadway.

CONTENT

NOTES

B. Placing warning devices on two-way roads:

1. Start four-way flashers before leaving vehicle--leave cab lights ON.
2. Place a warning device just beside the EV, on the road side.
3. Place a second device 100 to 200 feet to the rear of the vehicle, on the road edge. (Again, if the vehicle is ON the road, the device should be placed in the middle of the lane.)
4. Place a third device 100 to 200 feet to the front of the vehicle, on the road edge.

+Why is the positioning different for two-way roads?

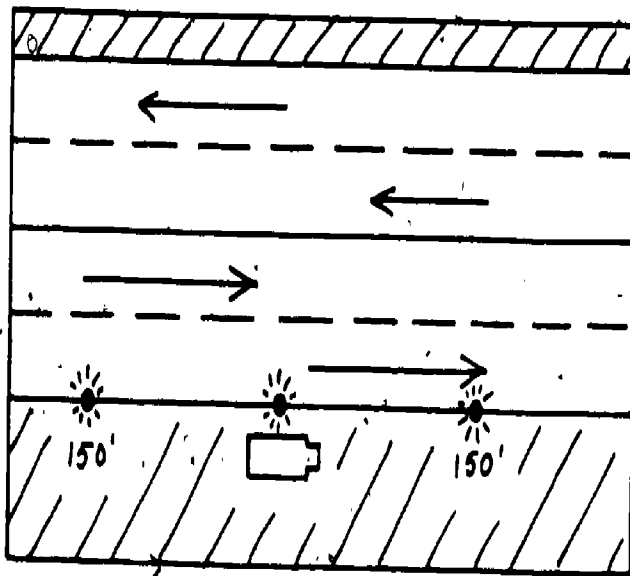

Two-way flow of traffic.
Disabled vehicle off roadway.

CONTENT

NOTES

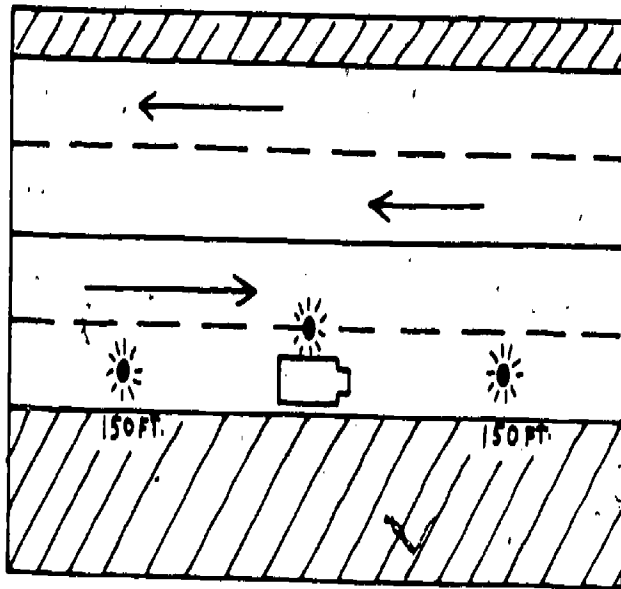

Two-way flow of traffic.
Disabled vehicle on roadway.

C. Use of flares or fuses:

1. Be sure to read all directions accompanying warning devices.
2. The following points can serve as general guidelines if no directions are present:
 - a. Do not light a warning device until you are ready to put it down.
 - b. Pull the tab near the top of the device, to free the cap.
 - c. Strike the matchlike head of the flare against the strike surface on the inside of the cap; point the flare or fusee away from your body as you do this.

CONTENT

NOTES

- d. If you are using flares with spiked ends and they must be placed on the roadway:
- 1) Push them between slabs of concrete.
 - 2) Simply lay them on the road.
3. Flares or fusees should NOT be used if there is evidence of the following:
- a. Odor of gasoline.
 - b. Any fluid leakage.
 - c. Any possibility of fire.
4. Replace any warning devices that have been used, as soon as the EV returns to quarters.

+What kind of warning devices can be used under these dangerous circumstances?

Review Exercises

1. Indicate which of the following statements are true and which are false.
- | | T | F |
|---|-------|-------|
| a. More than half of all fatal accidents occur at night. | _____ | _____ |
| b. Generally, older people's eyes function just as well as younger people's eyes when it comes to night driving. | _____ | _____ |
| c. It is a good idea to have instrument panel lights as bright as possible at night. | _____ | _____ |
| d. The roadway is usually most slippery when it has just begun to rain. | _____ | _____ |
| e. It is a good idea to go through large areas of water as quickly as possible, so that the vehicle is exposed to its effects for the shortest possible time. | _____ | _____ |
| f. The farther below freezing the temperature drops, the more hazardous the ice or snow on the road will be. | _____ | _____ |
| g. When driving in fog avoid the use of high beams. | _____ | _____ |
2. Some of the items listed below are less likely than the others to cause personal injury and property damage if struck in a collision because they are impact-absorbing. Circle the letters beside the items that are impact-absorbing.
- Road sign (speed limit, stop sign)
 - Telephone pole
 - Low bushes and shrubs

- d. Parked cars
 - e. Concrete bridge abutment
 - f. Chain-link fence
 - g. Full-size oak tree
3. What are the three primary steps that can be taken to help control a skid?
4. Indicate which of the following statements relating to off-road recovery are true, and which are false.
- | | T | F |
|--|---|---|
| a. If your wheels go off the road edge while traveling at high speed, pump-braking is a good way to reduce speed. | | |
| b. If possible, it is a good idea to reduce speed to about 15 mph before attempting to steer back onto the roadway. | | |
| c. If you do not have time to decelerate (because of an obstacle ahead) you can steer the vehicle sharply toward the road edge (about 90°) to effect an off-road recovery. | | |
| d. You should attempt to steer onto the road at the place where there is the least difference between road edge and berm. | | |
| e. As soon as all four wheels are back on the roadway, you should countersteer to control your lane position. | | |

5. Describe, for any five (5) of the following malfunctions, the appropriate procedure for handling the malfunction.

a. Brake failure: _____

b. Accelerator sticks: _____

c. Engine temperature rises into danger zone: _____

d. Transmission failure: _____

e. ~~Blowout:~~ _____

f. Hood flies up. _____

6. When the EV is at the side of the road, EV operators could use any one or a combination of the following to warn/alert motorists. On the list below, mark the most effective way with the letter "M" and mark the least effective way with the letter "L".

- Headlights
- Four-way flashers
- Triangles
- Overhead beacon
- Parking lights

7. On the two drawings below, indicate with Xs the correct placement of warning devices (e.g., reflectors, flares).

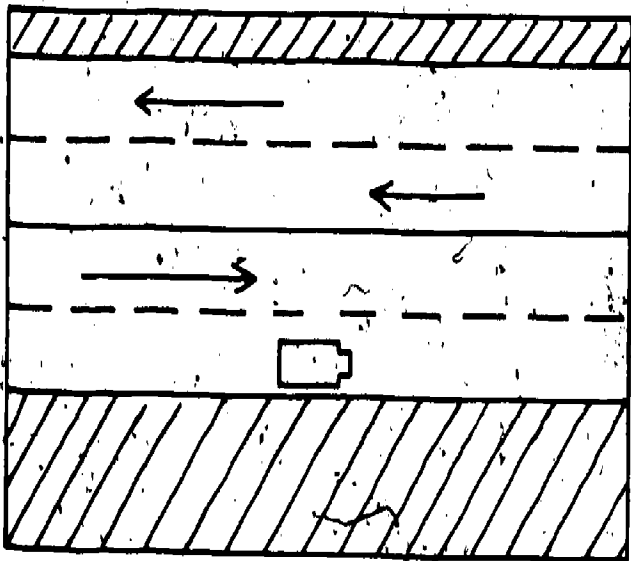

On-road, two-way traffic flow.

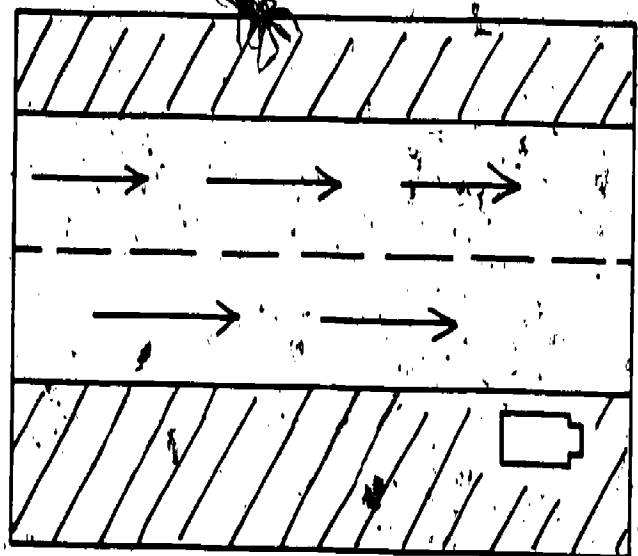

Off-road, divided highway.

Training Program for Operation of Emergency Vehicles

PART II: Specialized Unit Operation of EMT/Ambulances

TRAINEE/STUDY GUIDE

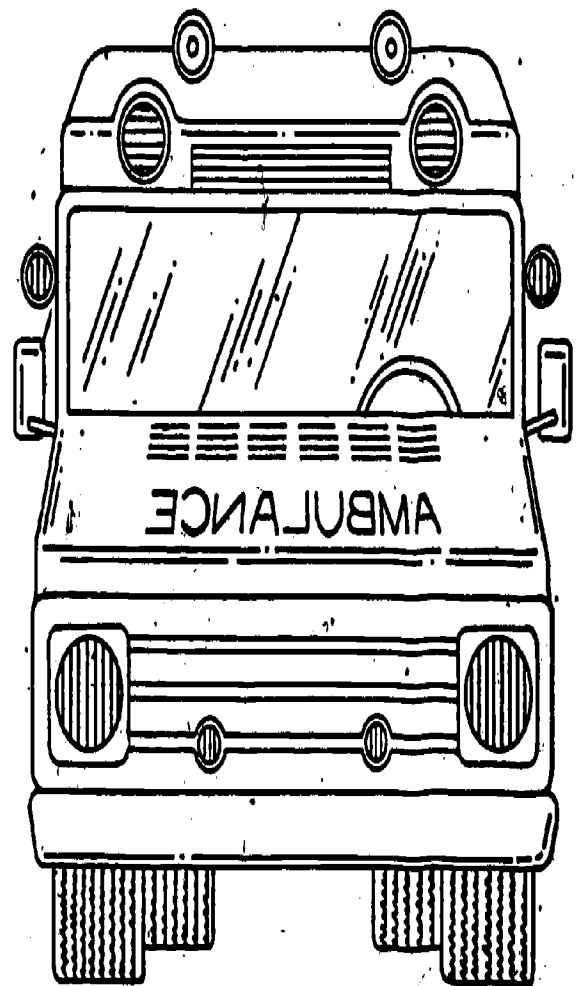

TABLE OF CONTENTS

OPERATION OF AMBULANCES

Trainees' Knowledge Objectives	II-A-1
Introduction	II-A-2
Route Planning	II-A-3
Inspection and Maintenance	II-A-4
Operation of Ambulance	II-A-6
Review Exercises	II-A-10



Trainees' Knowledge ObjectivesModule 1

By the end of this module:

1. Given a list of statements relating to driving to a victim, you will be able to identify those that are correct.
2. You will be able to list two reasons why it is not advisable to drive in the emergency mode with a patient aboard.
3. You will be able to name two medical conditions that indicate especially smooth, low-speed transport is required.
4. You will be able to name two conditions that indicate emergency mode transport is required.

CONTENT

NOTES

INTRODUCTION

- A. An ambulance operator's primary responsibility is the safe transport of the sick and injured. Safe means:
1. Not risking an accident.
 2. Smooth driving.
 - a. Driving that does not stress or traumatize the patient.
 - b. Driving in a manner that will permit the crew to provide medical care to the patient.
- B. No medical emergency, however severe, justifies driving in a manner that risks loss of control of the vehicle or that relies on the operators of other vehicles or pedestrians to react ideally.
- C. The topics that will be covered in the remainder of this unit include:
1. Route planning.
 2. Inspection and maintenance.
 3. Operation of the ambulance.
 - a. Driving to the victim.
 - b. Responsibilities at the scene.
 - c. Driving with a patient aboard.

CONTENT

NOTES

ROUTE PLANNING

- A. For ambulances operating from a fixed base, it is particularly important to plan in advance the various routes the ambulance is likely to travel. Advance planning usually takes the form of a "Routing Plan."
1. Divide the area into sections.
 2. Be based on test runs over selected routes at various times of day and night.
 3. Be updated at regular intervals.
- B. Drivers should always inform the dispatcher of any new conditions about the area (e.g., detours). This information can also be put in a trip report.

+What is the purpose of test runs?

UNIT
TITLE

OPERATION OF AMBULANCES

UNIT
PAGE

II-A-4

CONTENT

NOTES

INSPECTION AND MAINTENANCE

- A. The vehicle inspection and maintenance activities presented in Part I of the course apply directly to ambulances.
- B. Additionally, the driver or an attendant should inspect the vehicle's medical supplies and life-support equipment daily.

+What is the need for the daily inspection?

AMB

BY: [] DATE: []

OK LOW (REPLACE)

Medical

- Pillows
- Blanks & Sheets
- Portable suction apparatus
- Bag-mask ventilation unit
 - a. Adult mask
 - b. Child mask
 - c. Infant mask
- Oropharyngeal airways
 - a. Adult
 - b. Child
 - c. Infant
- Mouth to mouth airways
 - a. Adult
 - b. Child
- Oxygen equipment, tubing & masks
 - a. Adult
 - b. Child
 - c. Infant
- Mouth gags and tongue blades
- Universal dressings
- Sterile gauze pads

- Soft roll roll bandaging tape
- Aluminum foil, sterile & unsterile
- Adhesive tape
- Rice sheets
- Traction splint, limb-support sling, ankle hitch and traction strap
- Inflatable splints
- Spine boards with accessories
 - a. Short
 - b. Long
- Triangular bandages
- Large-size safety pins
- Shears for bandages
- Sterile obstetrical kit
- Poison kit
- Blood pressure manometer, cuff, and stethoscope
- Compartmentalized pneumatic trousers with inflation equipment

Other

- Fire extinguishing equipment
- Two-way radio for direct hospital communication
- Warning devices
- triangular reflectors
- battery operated flares
- Telenentry equipment
- Extrication equipment
- Wrench
- Screwdriver
- Screwdriver - Phillips
- Hacksaw (carbide) blades
- Pliers
- Hammer

- Fire Axe
- Wrecking bar
- Crowbar
- Bolt cutter
- Power jack & spreader tool
- Shovel
- Tin snip
- Two 50' manila ropes
- 3/4" diameter
- Hard hat
- Safety goggles
- 15' Rated chain, with hook & running hook

Remarks:

Driver:

Supervisor:

Date:

Date:

AMB

CONTENT

NOTES

OPERATION OF THE AMBULANCE

Driving to the Patient

- A. When an ambulance operator receives a call, he must obtain all relevant information.
- B. The operator should drive to the scene with all due speed consistent with safe arrival.
- C. All ambulances should come to a full stop at red lights, stop signs, and railroad crossings, regardless of the nature of the emergency.
- D. Generally, the basic and emergency mode operation techniques presented in Part I apply to ambulances. There is, however, an additional consideration, vehicle dynamics. Ambulances are larger than sedans (heavier, higher). Therefore, due to vehicle dynamics:
1. Be particularly aware of (and careful on) decreasing radius curves.
 2. Following distance should be increased.

At the SceneA. Parking Considerations.

1. Ambulance should be positioned for most convenient access to victim or patient.
2. Ambulance should be positioned to minimize disruption to any traffic.

+What about routine emergencies?

CONTENT

NOTES

Special care should be exercised when parking on hills.

4. If more than one ambulance is at the scene, they should be parked in the head-and-tailight position (ladder), if possible.

B. Directing traffic. If police have not arrived at the scene, the operator may need to direct traffic or assign someone at the scene to do so.

C. Ambulance should not leave the scene until:

1. Patient is secured.

2. All doors are closed and locked.

3. Crew gives an audible "okay" (indicating all are present and prepared).

Driving With a Patient Aboard

A. A high-speed transport, with its associated sudden starts and stops, can:

1. Frighten the patient.

2. Put a stabilized patient into shock.

3. Disrupt ongoing medical treatment.

4. Aggravate certain medical conditions sufficiently to cause DEATH OR PERMANENT DISABILITY TO THE PATIENT.

+What are some medical conditions that demand extra smooth, controlled driving?

CONTENT

NOTES

B. In almost all cases, the transport should be conducted:

At speeds below the legal limit.

With headlights on.

3 With emergency lights on.

4. With siren OFF.

5. Obeying all stop signals and red lights.

6. Coming to a FULL STOP at all railroad crossings.

C. There are certain medical conditions that may require "emergency mode" transport.

D. These conditions include:

1. Uncontrolled hemorrhage

2. Uncontrolled cardiovascular or respiratory impairment.

3. Complicated impending childbirth.

A TRAGIC CASE OF TOO MUCH SPEED*

About 4 am Indian Rocks Beach Fire Department emergency medical technicians were sent to the Frank Utnage residence to treat a possible heart attack. Two firefighters, David Crane and Lt. James Terry, were the initial respondents to the call. Michael Signorelli, an off-duty firefighter, also responded because he lived two blocks from the Utnage residence.

The two men started cardio pulmonary resuscitation on Utnage and prepared him for transport to a nearby hospital. The ambulance arrived and Signorelli volunteered to go to the hospital with the ambulance crew.

Leaving for the hospital at a high rate of speed, the ambulance was followed by Utnage's wife and son-in-law, Bob LaDisa. To keep up with the ambulance, LaDisa had to maintain speeds in excess of 70 mph. Traveling at this speed, LaDisa fell behind.

About 4:30 am Drs. Robert and Janet Pettyjohn were awakened by the sound of a crash in their front yard--the ambulance had failed to take a curve (posted 35 mph limit) and had wrapped around the tree in front of the Pettyjohn residence. The Pettyjohns ran out to the macabre scene, just as Bob LaDisa and Mrs. Utnage pulled up. Mrs. Pettyjohn kept Mrs. Utnage from the scene. She was later taken to University General Hospital and treated for shock.

Five people died: The ambulance driver, Charles Kozmar, 28, married and the father of two children; ambulance attendant Robert Lovett, 25, married and father of three children; Candy DeMarco, 20, an EMT trainee, married and mother of one child (investigators were not sure why she was with the ambulance); firefighter Michael Signorelli, 23; and Frank Utnage, 64, the heart attack victim.

The impact of the H&H Ambulance Service vehicle, leaving Indian Rocks Road and sliding into the tree, tore the vehicle apart. The fiberglass top was torn off the 1973 Chevrolet van, the driver's side and floor were buckled and the equipment scattered down the road. Police estimated the speed of the ambulance at the time of impact was 55 mph.

People were scattered all over Pettyjohn's yard. Dr. Pettyjohn, chief of emergency medicine at the hospital since 1973 said the accident was the worst he had ever seen. The doctor said everyone except Mrs. DeMarco appeared to have been killed on impact. The girl had a faint pulse, but by the time she was removed from the vehicle she was dead.

Director of the Division of Environmental Control of the Pinellas County Health Department, George McCall, said ambulances should not exceed posted speed limits. "There is never any reason for an ambulance to drive faster than speed limits allow. There is little to be gained and much to be lost in that kind of performance and this is a perfect example.

"There is no excuse at all for that kind of driving. Whatever the (medical) problem was, it wasn't good enough reason to be driving like that. Instead of one alive at the hospital, there are five dead."

There are no large city ordinances or Florida state statutes governing the speed of emergency vehicles. It would be difficult to nationalize emergency vehicle speed limits. What is needed is an emergency vehicle driving course to instruct drivers in safe driving and handling of the vehicles in various situations. This should reduce the number of emergency vehicles involved in accidents.

*Emergency Vehicle Driving Course

Review Exercises

1. Below are several statements relating to the operation of an ambulance. Circle the letter in front of those statements that are correct.
 - a. Advance route planning can save time in an emergency.
 - b. You should use a checklist to inspect the vehicle's medical supplies and life-support equipment once a week.
 - c. Routine transports are not considered medical emergencies.
 - d. Ambulances generally require longer stopping distances than ordinary passenger cars.
 - e. You should not leave the scene until a patient is stabilized.

2. List two reasons why it is not advisable to drive in the emergency mode with a patient aboard.

3/ Name two conditions that indicate especially smooth, low-speed transport is desirable.

4. Name two conditions that indicate emergency mode transport is required.

Training Program for Operation of Emergency Vehicles

PART II: Specialized Unit Operation of Law Enforcement Vehicles

TRAINEE STUDY GUIDE

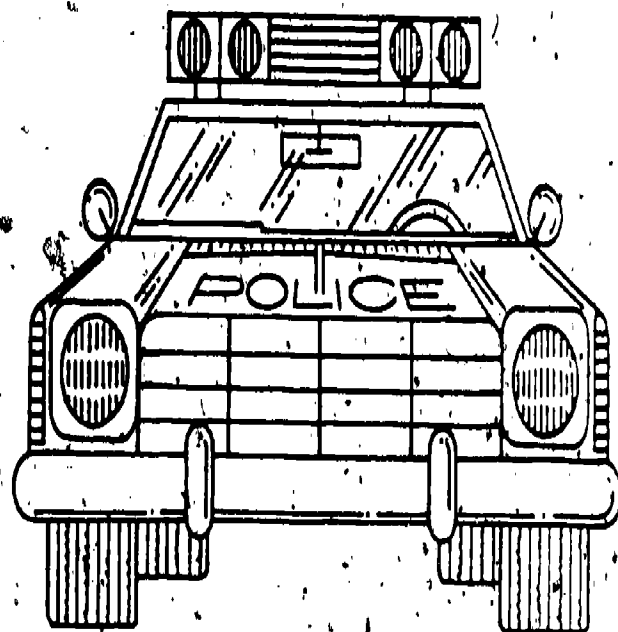

TABLE OF CONTENTS

OPERATION OF LAW ENFORCEMENT VEHICLES

Trainees' Knowledge Objectives	II-P-1
Introduction	II-P-2
Communications	II-P-3
Pursuit Driving	II-P-4
Pursuit Driving Techniques	II-P-9
Making a Traffic Stop	II-P-10
Emergency Escort of Another Vehicle	II-P-12
Review Exercises	II-P-14

370

Trainees' Knowledge ObjectivesModule 1

By the end of this module:

1. You will be able to list three items of identifying data that should be transmitted to the dispatcher whenever a suspect or violator is spotted.
2. You will be able to write a brief description of the effects of "tunnel vision" and "adrenalin kick."
3. Given a listing of several types of offenders, you will be able to identify which fall into the hazardous violator group.
4. You will be able to state two reasons why a pursuit might be abandoned.

Module 2

By the end of this module:

1. Given a list of several statements about pursuit driving, you will be able to select those which are correct.
2. Given a drawing illustrating several police vehicles and a violator's vehicle, you will be able to select the police vehicle that is in the correct position for making a routine traffic stop.
3. You will be able to state whether or not emergency escort of another vehicle is permitted in the department in which you will be working. If escort is permitted, you will state under what circumstances it is permitted.
4. Given a description of two situations, you will be able to indicate whether or not it would be appropriate to provide escort, and explain why.

CONTENT

NOTES

INTRODUCTION

- A. Most law enforcement officers spend approximately two-thirds of their on-duty time behind the wheel of a vehicle. It is therefore, critical that they have enough knowledge about the vehicle, and practice behind the wheel of a vehicle, to be able to make quick, accurate decisions when the need arises.
- B. The public depends on law enforcement officers to set an example. It is important that law enforcement officers, especially in times of stress, maintain control of themselves, their vehicles, and the situation.
- C. In this unit, material will be presented on topics that are of special importance to law enforcement officers. The topics include:
1. Communications.
 2. Pursuit driving.
 3. Making a traffic stop.
 4. Emergency escort of another vehicle.

* * * BEGIN MODULE 1 * * *

CONTENT

NOTES

COMMUNICATIONS

To a large extent, the safety of the general public, as well as the safety of the law enforcement officer, rests upon effective communications. Every officer should know the communications principles listed below and follow them without fail--they could save a life.

- A. Communications should be as brief as possible, without sacrificing accuracy.
- B. Whenever a suspect or violator is spotted, identifying data should be transmitted to the dispatcher or communications center at once.
- C. Whenever an officer becomes engaged in a high-speed chase (pursuit) he should notify the dispatcher of his position, and keep the dispatcher abreast of his position as it changes.

+What is meant by identifying data?

CONTENT

NOTES

PURSUIT DRIVING

Almost all police departments have established policies or guidelines that deal with pursuit driving and the apprehension of suspects or violators. Sometimes these policies are not formally written down. A law enforcement officer who is new to his job must find out what the local or departmental policies are in effect.

The Risks of Pursuit Driving

Pursuit driving, at best, is a risky business. Law enforcement officers should be aware of the factors that increase the risk.

A. Speed represents the single greatest contributor to risk during pursuit driving. The greater the speed:

1. The less time the driver has to identify hazards and take appropriate action.
2. The longer the stopping distance.
3. The greater the chance of skidding or rolling over on a turn.
4. The greater the danger in the event of a vehicle malfunction.
5. The greater the probability of personal injury and property damage in a collision.
6. The greater the force of impact in a collision.

B. The Violator, attempting to flee from a police officer, regardless of the violation or suspected violation, is committing a

CONTENT

NOTES

crime. People who are fleeing from police act in unpredictable. (and unsafe) ways:

1. A fleeing violator often has no concern for his own safety.
 2. He will perform dangerous maneuvers if he thinks they will enhance his chances of escape.
- C. Other Motorists often react unpredictably to the sound of sirens or to confusion in general.
- D. Heavy Traffic and congested roads increase the risk of mishap. The more vehicles the officer must pass from the beginning to the end of the pursuit, the greater the chance that the pursuit will end in a collision.
- E. Poor Environmental Conditions greatly increase the chance of mishap.
- F. The Pursuing Officer's Condition can influence the amount of risk involved in a pursuit. Every officer should recognize that the following conditions increase the risk of mishap:
1. Fatigue.
 2. Impaired vision (for any reason).
 3. Drug side-effects (prescription or nonprescription).
 4. Mental or emotional condition. Being upset about personal problems or "shaken" due to a recent emergency can impair judgment.
 5. Undesirable physical effects can be brought about by the act of pursuit. Some include:

+What kinds of dangerous maneuvers might a fleeing violator try?

+What are some poor environmental conditions?

+What are some frequent drug side-effects?

CONTENT

NOTES

- a. Tunnel vision. As speed is increased, the visual field narrows. Consequently, high speed limits peripheral vision.
- b. Adrenalin kick. The excitement and danger of high speed driving often causes an excessive amount of adrenalin to flow into the blood. This excess adrenalin can have two effects:
- 1) An expansion of the time-speed sense. Events are slowed down, in the driver's mind.
 - 2) An extreme sense of confidence. The adrenalin's effect often causes an officer to become overconfident in his driving ability or his vehicle's maneuverability. Officers should be alert for this kind of feeling.

Types of PursuitA. Hazardous Violator.

1. Pursuit of such violators introduces a high degree of risk.
2. This type of violator will have little (if any) concern for the safety of others.
3. Pursuit of this type of violator requires skill, good judgment, discretion, and persistence.

B. Nonhazardous Violator.

1. The actions of this type of violator are often made more hazardous by the act of pursuit.

+What is "peripheral vision?"

+Which offenders are included in this group?

+Which offenders are included in this group?

CONTENT

NOTES

2. Pursuit of violators who have not committed a hazardous violation does not merit excessive speed in chase, and the associated risk to the pursuing officer and the motoring public.

+What can you do?

Using Lights and Siren in Pursuit

The use of emergency signaling equipment when traveling over the speed limit is MANDATORY. Additionally, the use of signaling equipment provides the officer with some degree of protection from a legal viewpoint, should he become involved in a collision. Using signaling equipment, however, does NOT relieve an officer from the duty to exercise due regard for the safety of all persons.

- A. To be maximally effective, the siren should be turned off for very brief periods to vary the pitch.
- B. The warning effect of the siren will decrease rapidly as vehicle speed increases.
- C. At night, high beams should be used every moment legally possible.

+What is the most audible siren sound?

When Should Pursuit Be Abandoned?

- A. It is impossible to present exact guidelines indicating when to abandon pursuit. To a large extent, the decision of whether or not to begin or abandon pursuit must be based on each individual case. "To some police officers abandoning pursuit is unthinkable and often mistakenly thought to be cowardly. But the well-trained, well-disciplined police officer is aware that the decision to abandon pursuit is, under certain circumstances, the most intelligent course of action."*

CONTENT

NOTES

Don't ignore the cues. The following are good reasons to abandon pursuit:

1. If an officer begins to suspect that he is nervous, shaky, or frightened.
2. If an officer begins to suspect the vehicle has a malfunction.
3. When traffic conditions are such that the risk to the public is great (violation of due regard).
4. If an officer believes the actions of the violator are being made more hazardous by the act of pursuit.

** END OF MODULE 1 **

POL

CONTENT

NOTES

PURSUIT DRIVING TECHNIQUES

- A. Learn the territory.
- B. Keep the dispatcher informed of position and progress.
- C. Keep well away from pavement edges.
- D. Don't brake heavily and attempt to change the direction of the vehicle at the same time.
- E. Do not follow the violator too closely; move up only when ready to apprehend.
- F. If the pursuing officer must go through red lights and stop signals, he MUST slow enough to ensure that no motorist or pedestrian will be endangered.
- G. The pursuing officer should not travel at high speed in opposing lanes of traffic.
- H. Don't join a pursuit that already has two or more pursuing vehicles, unless specifically ordered to do so by a superior.
- I. Never attempt to ram or "nudge" the violator's vehicle with the emergency vehicle.
- J. Avoid pulling directly beside or in front of the violator's vehicle.
- K. Select a safe stopping place.

*** BEGIN MODULE 2 ***

+What kinds of things, specifically, should you look for?

+What would happen?

+Why should you avoid following closely?

+What is a "safe" stopping place?

CONTENT

NOTES

MAKING A TRAFFIC STOP

The procedures presented in this module are those for making a routine traffic stop. Procedures for stopping hazardous violators should be made according to departmental policy.

- A. Avoid stopping motorists on high-speed highways, unless both vehicles can be entirely removed from the roadway.
- B. Position the EV to the rear of the violator's vehicle, in the same lane of traffic.
- C. Shorten the gap between the EV and the violator and signal the motorist to stop.
- D. Choose the location for the stop. Be sure contact with the violator is made far enough in advance for him to reach it.
- E. Once ascertaining that the motorist is aware and intends to stop, signal for right turn, and assist violator in moving over lane by lane.
- F. Pull completely off the road; park approximately six feet to the rear and three feet to the left of the violator's vehicle.

+How can you signal the violator to stop?

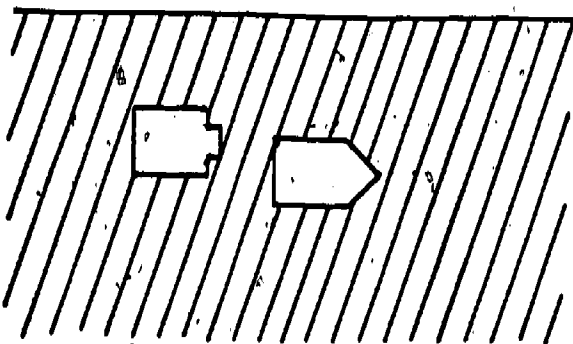

CONTENT

NOTES

If the EV Overshoots the Violator's Vehicle

Occasionally, due to traffic conditions or faulty maneuvering, the EV operator will be forced to pull in front of a violator. If this occurs, the officer should:

- A. Signal the motorist to pull his vehicle up, in front of the EV, if at all possible.
- B. If there is not sufficient room for the violator to pull in front of the EV, the officer should motion the violator to meet him at the rear of the EV, provided that neither the officer or the violator will compromise their safety by doing so.

+What are the dangers here?

391

392

POL

CONTENT

NOTES

EMERGENCY ESCORT OF ANOTHER VEHICLE

A. Emergency escort represents a dangerous situation. Some of the reasons are:

1. The EV operator does not know the other vehicle's handling characteristics or what the other driver's capabilities are.

2. In general, when traveling through intersections, the motoring public assumes the EV is alone.

B. An EV operator should not escort another vehicle unless it is a life-threatening emergency, or unless specifically instructed to do so by a superior.

C. There are several good alternatives to providing escort.

How to Escort

If, based on the guidelines listed above, the EV operator determines the best course of action is to provide escort, these procedures should be followed:

A. Establish a procedure with the other driver.

B. The EV should lead the other vehicle.

C. Use emergency signaling equipment as required by state or local law.

D. NEVER travel the wrong way down a one-way street or in opposing lanes of traffic with another vehicle following.

+What can you do to avoid intersection accidents?

+What are some good alternatives to providing escort?

+What points should be established?

+Why should the EV lead?

UNIT
TITLE

OPERATION OF LAW ENFORCEMENT VEHICLES

UNIT
PAGE

II-P-13

CONTENT

NOTES

- E. Avoid traveling at speeds in excess of the limit.
- F. Radio ahead to the destination so they will be prepared for arrival.

395

396

* * END OF MODULE 2 * *

POL

Review Exercises

1. There are several items of identifying data that should be transmitted to the dispatcher whenever a suspect or violator is spotted. List three of those items below.

2. Write a brief description of the following conditions:

Tunnel vision: _____

Adrenalin kick: _____

3. Several of the offenders in the list below are considered hazardous violators; circle the letter in front of those that would be considered hazardous violators.

a. A driver who has gone through a stop sign, without coming to a full stop.

b. A driver going 60 mph in a 45 mph zone.

- c. A driver who is operating the vehicle in a reckless manner.
- d. A driver whose vehicle has a burned-out headlight.
- e. A violator who has just pulled out of a parking space beside a fire hydrant.
4. There are many reasons why a pursuit might be abandoned. List two of them below.
-
-
5. Below are several statements about pursuit driving. Circle the letter in front of those statements that are correct.
- a. If traffic is light, you do not need to use the siren during pursuit.
- b. When pursuing a violator, you should follow him closely to avoid having him escape.
- c. About 50 percent of all pursuits end in a collision.
- d. The single greatest risk in pursuit driving is the unpredictable behavior of other motorists.
- e. A pursuing officer should not travel in opposing lanes of traffic at high speed.
- f. A law enforcement officer who is pursuing a dangerous, known felon should always pursue until the violator is apprehended.
- g. You should not join a pursuit that already has two or more pursuing vehicles.

6. The lettered vehicles below represent possible parking positions for making a traffic stop. Circle the letter that represents the vehicle that is parked in the correct (safest) position;

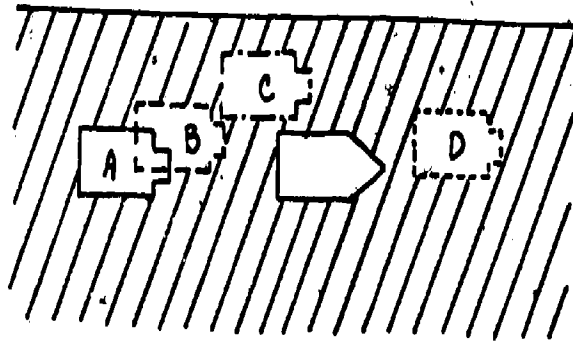

7. If emergency escort of another vehicle is permitted in your department, write a brief description of the conditions under which it is permitted. If escort is not permitted, write nothing.

8. For each of the situations listed below, indicate whether or not it would be appropriate to provide escort, and explain your answer.

a. You have just pulled over a car that has run through a red light. The driver, a woman, explains that she must get to the hospital quickly because her young son, who is in the back seat, has apparently broken his wrist.

b. You have just stopped to check a vehicle that was pulled off the expressway. The driver, an elderly man, explains his wife seems to have had a heart attack, she is unconscious.



Training Program for Operation of Emergency Vehicles

PART II: Specialized Unit Operation of Fire Apparatus

TRAINEE STUDY GUIDE

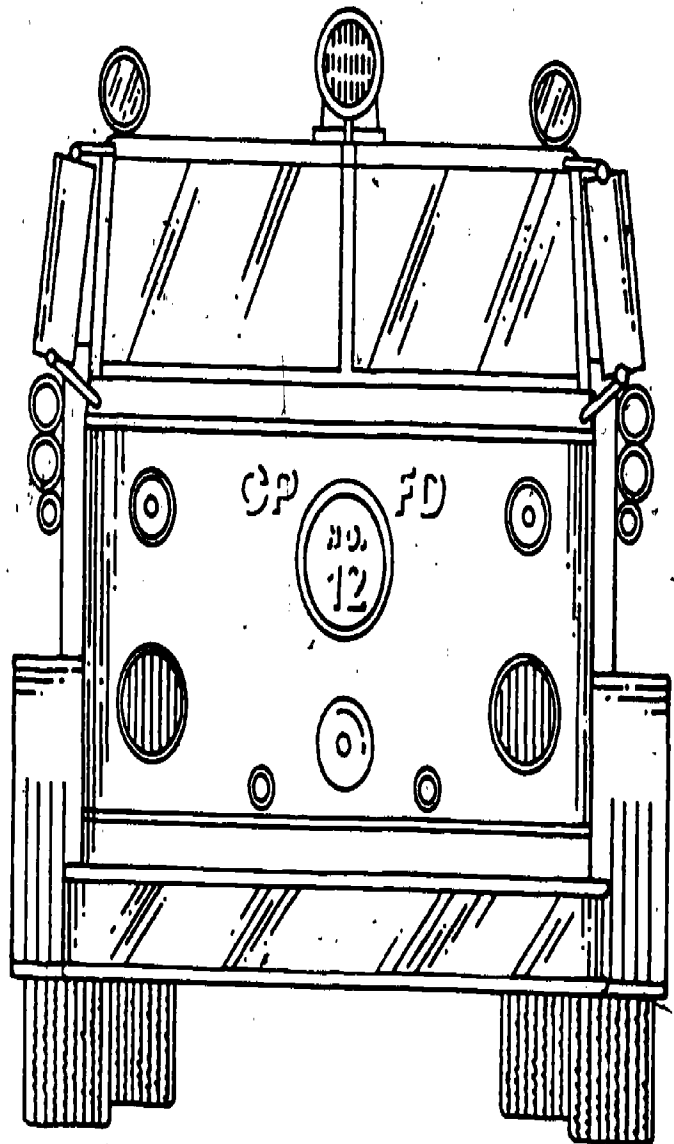

TABLE OF CONTENTS

OPERATION OF FIRE APPARATUS

Trainees' Knowledge Objectives	II-F-1
Inspection and Maintenance	II-F-3
Selecting Routes	II-F-13
Operating Systems	II-F-15
Special Operating Consideration	II-F-18
Basic Control Tasks	II-F-21
Review Exercises	II-F-30

Trainees' Knowledge ObjectivesModule 1

By the end of this module,

1. You will be able to demonstrate, on a large fire apparatus, the daily inspection procedure.
2. You will be able to identify on a large fire apparatus, certain inspection items that do not meet manufacturers recommended specifications.

Module 2

By the end of this module,

1. You will be able to state two guidelines which should be followed when more than one vehicle is dispatched from the same station.
2. You will be able to name the two basic categories of engines found on large fire apparatus.
3. You will be able to name the two types of transmissions found on large fire apparatus.
4. You will be able to state the primary difference between synchromesh and nonsynchromesh transmissions.
5. You will be able to state the normal operating pressure for air brakes.
6. You will be able to state the normal hydrovac gauge reading.
7. You will be able to state the two basic rules which relate to safe speeds for fire apparatus.

Trainees' Knowledge Objectives (Continued)Module 3

By the end of this module,

1. Given several statements relating to braking techniques, you will be able to identify those that are correct.
2. Given a listing of several different types of emergency vehicles, you will be able to rank them according to the priorities at a working fire.
3. You will be able to list three techniques that can minimize the possibility of intersection collisions.

CONTENT

NOTES

INSPECTION AND MAINTENANCE

Regular inspection of fire apparatus is necessary because the vehicles tend to be complex. Also, fire apparatus carry mission-related equipment which is constantly used, and supplies which are continually depleted. In many communities, fire apparatus operators are expected to participate in both daily and periodic maintenance. A recommended daily routine includes the following:

A. Underhood. Check:

1. Engine oil - within manufacturer's recommendations.
2. Coolant level - within manufacturer's recommendations.

B. External. Check:

1. Water tank level, dry chemical, light water, rapid water, wet water levels.
2. All glass.
3. Compartments:
 - a. Items inside properly secured.
 - b. Doors securely latched.
4. Hose load properly secured and aerial, snorkel, telescopic boom latched in bed.
5. Tires and wheels:
 - a. Tires up (thump test).
 - b. Tires undamaged.

*** BEGIN MODULE 1 ***

Local procedures:

Local procedures:

CONTENT

NOTES

c. Wheel lugs show no signs of slippage.

6. All externally mounted equipment secured.

7. Primer tank level.

8. All pump control and aerial control in proper position.

C. Undercarriage. Check for:

1. Excess oil, water, and hydraulic fluid leaks.

2. Apparatus attitude (not leaning excessively, etc.).

3. No obvious loose or dangling parts.

D. In cab with motor off. Check that:

1. Engine shutdown systems operate properly.

2. Master switches operate properly.

3. Seat is adjusted to assigned driver.

4. Mirrors are properly adjusted for assigned driver.

5. Proper clutch free play.

E. In cab with motor running. Check that:

1. Instruments show proper readings (per manufacturer).

2. All lights work.

3. Wipers work.

4. Brake warning system works.

Local procedures:

Local procedures:

Local procedures:

FIRE-

CONTENT

NOTES

5. Engine turns over at usual speed during start.
6. All switches in proper position.
7. Engine develops proper vacuum or air pressure for brakes.

Periodic Maintenance

Periodic maintenance can often be best carried out by the systems approach. Many of the most important areas to check are as follows:

A. Power train inspections must include an undercarriage inspection for leaks and looseness. The power train should occasionally be degreased to assist checking for leaks and cracks.

*Who is responsible for performing these checks?

1. Engine - check mounts.
 - a. Lubrication system.
 - 1) Change oil filters per manufacturer.
 - 2) Check for oil contamination.
 - 3) Check for gasket leaks.
 - 4) Analyze oil, if necessary.
 - b. Cooling system.
 - 1) Check level of coolant.
 - 2) Check coolant for contamination.
 - 3) Check radiator for external blockage (bugs, etc.).

CONTENT

NOTES

- 4) Check operation of shutters.
 - 5) Check hoses of water pump.
 - 6) Check belts to manufacturer's recommended tightness.
- c. Fuel system.
- 1) Check for leaks (lines, pump, etc.).
 - 2) Check filters, drain water and change filters per manufacturer's recommendations.
 - 3) Accelerator and choke cables free.
 - 4) Diesel shutdown and emergency shutdown working properly.
- d. Electrical system.
- 1) Check battery terminals for cleanliness and tightness.
 - 2) Check hold downs.
 - 3) Check level and specific gravity of battery water.
 - 4) Charge as required.
 - 5) Connections and all wiring clean and tight.
 - 6) Belts tight per manufacturer's specifications.

CONTENT

NOTES

- e. Air system.
 - 1) Air intake unrestricted.
 - 2) Service air cleaner and filter per manufacturer's specifications.
- f. Exhaust system.
 - 1) All connections tight.
 - 2) No obvious leaks or holes.
- 2. Clutch and manual transmission.
 - a. Proper free play in the pedal per manufacturer's specifications.
 - b. Clutch operates smoothly, with no slippage.
 - c. Transmission oil clean and at the proper level per manufacturer's specifications.
 - d. Transmission case shows no leaks.
 - e. Transmission not excessively noisy.
 - f. Transmission shifts smoothly and stays in gear.
 - g. Breather clean, if so equipped.
- 3. Automatic transmission.
 - a. Stays within manufacturer's specified operating temperature range.

CONTENT

NOTES

- b. Develops proper pressure and shifts smoothly.
 - c. Fluid checked following manufacturer's recommended procedure.
 - d. Fluid changed at proper intervals.
 - e. Breather clear if so equipped.
4. Driveshafts.
- a. No excessive slop (gear lash).
 - b. U-joints properly lubricated.
 - c. Hanger bearings properly lubricated.
 - d. No signs of twisting or bending.
5. Differential.
- a. Proper fluid level (change per manufacturer's specification).
 - b. No obvious leaks, especially at seals.
 - c. Axle bolts tight and to manufacturer's specifications.
 - d. Differential in proper alignment to chassis.
6. Chassis and suspension.
- a. Proper lubrication.
 - b. No cracks in frame.
 - c. No bends or apparent misalignment.

CONTENT

NOTES

- d. Axles properly secured to suspension.
 - e. Springs and suspension properly secured to frame.
 - f. No cracked leaves in springs.
 - g. U-bolts tight and properly aligned.
 - h. Body and cab bolts tight with no signs of chafing.
 - i. Front-end alignment checked.
 - j. Shocks properly attached. ✓
7. Tires and wheels.
- a. Tire inflation per manufacturer's recommendations.
 - b. Cast spoke lugs checked for tightness and slippage or excessive wobble.
 - c. Budd-type wheels checked for lug tightness and cracks.
 - d. Tires inspected for cuts, tread depth, and sidewall damage.
8. Steering.
- a. Steering free play per manufacturer's limits.
 - b. Inspect linkages and tie rods for acceptable amount of play.
 - c. Power steering--proper fluid level.

CONTENT

NOTES

9. Brakes (air and hydrovac).
- a. Brakes properly adjusted per manufacturer's specifications. (A rule of thumb for air brakes--take less than 10 p.s.i. for full application.)
 - b. All air lines or hydraulic lines tight.
 - c. Hydraulic fluid at correct level.
 - d. Vacuum connections tight.
 - e. Air system bled of water as required.
 - f. Air compressor develops proper pressure (governor operating properly).
 - g. Slack adjusters properly lubricated.
 - h. Maxi or spring brakes properly adjusted.
 - i. Correct lining and sufficient lining.
 - j. Parking brake controls operating properly.
 - k. Air or vacuum gauge working properly.
 - l. Low air warning signal working.
 - m. Computer (121) brakes working properly.
10. Brakes (driveline).
- a. Properly adjusted.
 - b. Sufficient lining.

CONTENT

NOTES

✓ Linkage properly lubricated.

11. Pump.

a. Check pump activation system.

1) Pump disengages easily.

2) Pump engages smoothly.

3) Pump noisy when engaged.

4) Pump throttle working properly.

b. Check pump transmission oil level and for contamination.

c. Check priming system for proper operation.

d. All valves operate smoothly.

12. Aerial ladder/aerialscope/articulating boom.

✓ a. P.T.O.

1) Engages/disengages easily.

2) Develops proper pressure.

b. Automatic throttle operates properly.

c. All U-joints properly lubricated.

d. Hydraulic fluid at proper level.

e. All controls functioning properly.

UNIT
TITLE

OPERATION OF FIRE APPARATUS

UNIT
PAGE

II-F-12

CONTENT

NOTES

- f. Locks for bed of aerial/boom working properly.
- g. Stabilizers and outriggers working properly.
- 13. Miscellaneous equipment.
 - a. Rescue squad winch P.T.O. works properly.
 - b. Generators remote start functioning properly.
 - c. All power tools working properly.

* * END OF MODULE 1 * *

FIRE

CONTENT

NOTES

SELECTING ROUTES

The operator of fire apparatus needs to be especially careful in selecting routes because of the length and weight of the vehicle.

A. Characteristics of roadways are very significant in the selection of a route for large fire apparatus.

1. Narrow alleys are more difficult to negotiate. They must be sufficiently wide to permit the fire apparatus to pass through without damaging property along the sides. Negotiating sharp curves of 90° turns may be impossible in narrow alleys.
2. Support capability of the roadway is critical. Some small bridges and wet dirt roads cannot support fire apparatus.
3. Be alert for sufficient overhead clearance.

B. Access to building entries must be considered in the selection of an approach route. Some fire departments perform periodic access inspections:

1. In many urban locations, block inspections are regularly conducted. Once a week, an inspection of some block in the station's district is scheduled. By inspecting a different square block each week, the firemen can update their information (and maps) on roads, buildings, and hydrants in the district.

2. In many suburban and rural locations, a number of buildings are selected for weekly inspections.

C. Multiple vehicle responses are common in the fire service, and they affect the selection of routes.

1. If several vehicles are dispatched from the same station, two guidelines apply:

+What signs of information should be gathered on block inspections?

+What sorts of buildings should be selected for weekly inspection?

CONTENT

NOTES

- a. The first vehicle must completely clear the driveway before the second vehicle pulls out.
 - b. Two or more vehicles traveling in the same direction should maintain a five-hundred-foot distance between vehicles.
2. If several emergency vehicles are approaching the scene of an emergency from different directions, they CAN COLLIDE AT AN INTERSECTION.

+Is this a legal requirement in this state?

CONTENT

NOTES

OPERATING SYSTEMS

Drivers must be aware of the systems that move and control the fire vehicle and how they operate. Understanding how the systems work and their interactions is necessary for efficient operation, routine maintenance, and troubleshooting.

Power Train

- A. The power train consists of the engine, transmissions, drive-shaft, and differential. The engine provides the motive (turning) power and has subsystems which perform other functions.
- B. Many different engines are in use today, but all fit in two basic categories:
1. Gasoline--air/fuel mix ignited by a spark electrically produced.
 2. Diesel--air compressed to provide heat; fuel injected; auto ignition. Diesels are further distinguished by power output:
 - a. The regular diesel has limited operating range in comparison with gas engines; power climbs to a peak and then drops.
 - b. The high-torque/constant torque diesel has a wide operating range with power almost constant throughout the range.
- C. The transmission modifies the power that the engine produces, to accomplish various tasks such as higher speed; better pulling power, etc.

+What are some of the power train's subsystems?

CONTENT

NOTES

1. There are two types of transmissions in common use by the fire service.
2. Manual transmissions can be disconnected from the engine by the clutch. The clutch is comprised of discs which are lined with a high-friction material.
3. Manual transmissions are either synchromesh or non-synchromesh. Synchromesh transmissions can be shifted without double-clutching and nonsynchromesh transmissions require double-clutching to make engine speed and gear speed match.
 - a. The most common manual transmissions for fire service use are four- and five-speeds.
 - b. Automatics most common to fire service are two, four, five, and six speeds.
- D. The differential transfers power between the driveshaft and the rear axles and then, in turn, to the rear wheels. Some departments utilize a two-speed differential to make better use of available engine power.

Braking System

Two different braking systems prevail in modern apparatus: air and hydrovac. Both systems operate on the principle of multiplying force by applying a small amount of force over a large pistonlike area.

- A. Air brakes. Air pressure is developed by a compressor driven by the vehicle's motor and stored in air tanks or reservoirs. For parking, air brake-equipped apparatus utilizes one or both of two methods:

+What is "double-clutching"?

CONTENT

NOTES

1. A driveline brake (actual disc or drum attached to drive-shaft activated by lever and cables).
 2. A spring-activated brake atop the service brake chamber which automatically applies brakes when air pressure drops below preset pressure.
- B. Hydrovac brakes utilize a vacuum from the engine. Since diesel engines do not produce a vacuum as the gas engine does, hydrovacs are found only on gasoline driven vehicles. Most hydrovac-equipped vehicles utilize driveline brakes or a lock-type device which is applied by moving a lever and stepping on the brake.

+What is normal operating pressure?

Mission-Related Systems

Mission-related systems include the fire pump (either power take-off [P.T.O.] or transmission driven) and the hydraulic system (also P.T.O.) which powers most aerial apparatus.

- A. The operator must be familiar with the procedure for engaging any and all such equipment.
- B. The operator must be totally familiar with the safe operation of pumps and aerial equipment to efficiently utilize any fire vehicle.

CONTENT

NOTES

SPECIAL OPERATING CONSIDERATIONS

Vehicle Dynamics

Vehicle dynamics are an important consideration for the operators of fire apparatus. A high center of gravity exaggerates side-to-side weight problems.

- A. Winding roads, sharp curves, soft shoulders, crowned roads and improperly banked roads can cause the fire apparatus to roll over as a result of weight shift.
- B. A half-full water tank can cause fire apparatus to skid out of control, as weight shift exceeds the ability of the tires to hold the road during a cornering maneuver. Policy usually requires that the pumper travel either completely full or completely empty. Baffles can make this problem much less serious.

+What are the local requirements re: water loads for pumpers?

Size and Weight

- A. The length of the apparatus makes it harder to drive.
 1. A larger gap in cross traffic is required for fire apparatus to cross an intersection.
 2. A large gap in traffic is required when fire apparatus is entering an expressway from a ramp.
 3. A number of lanes in both directions must be used to maneuver fire apparatus through a U-turn.
 4. Sufficient clearance is required forward and to the back of the apparatus when parking at curbside.
 5. Corners must be taken wider to allow for apparatus' length.

CONTENT

NOTES

- B. The weight of the apparatus can cause unexpected problems.
1. The weight of the apparatus produces greater momentum than might be expected. Slowing and stopping must be begun well in advance of the stopping point. Forgetting this fact can be especially hazardous at intersections. The only defense against this hazard is:
 - a. Scan well ahead of the vehicle.
 - b. Travel at speeds which allow control of the vehicle.
 - c. Begin to stop well in advance of the intended stopping point.
 2. The power-to-weight ratio of the apparatus generally makes the apparatus hard to accelerate from a stop and hard to accelerate to perform an accident avoidance maneuver.
 3. The weight support capability of the roadway must be accounted for by the fire apparatus operator.

Rules About Speed

Because of the unique characteristics of fire apparatus, two rules dictate the speed at which it is safe for fire apparatus to travel.

- A. FIRE APPARATUS SHOULD NOT EXCEED POSTED SPEED LIMITS. While this may seem extreme, it should be remembered that a heavy fire apparatus can easily go out of control. Its lights and siren will help clear a path through traffic.

*In what kinds of situations can the weight support capability of the roadway be critical?

CONTENT

NOTES

B. FIRE APPARATUS SHOULD NOT EXCEED CAUTIONARY SPEEDS. Cautionary limits are displayed as warnings on expressway ramps and at sharp curves. It is often difficult to control a passenger car at any speed above that posted. Since fire apparatus are far more difficult to control, they should never be driven above cautionary speeds. Speed should be reduced to cautionary limits by braking and gearing down.

* * END OF MODULE 2 * *

FIRE

CONTENT

NOTES

BASIC CONTROL TASKS

- A. Since you spend more time behind the wheel of your car than behind the wheel of an engine or truck, you must constantly remind yourself of the performance differences.
- B. You must also develop an awareness of the safety of the crew on board.
1. Standard start out procedures should be established if none exist, i.e., standard signals from the tailboard crew which indicate stop, go, and okay to back up.
 2. Crew should ride in the cab or in enclosed areas wherever possible.
 3. Turnout gear should be on and seat belts used.
 4. Pay attention to station door activation system. Is the door fully open? Will timer cause it to close on you on the way out?
- C. Safe, smooth responses demand coordination of steering, braking, shifting, and the perception of hazards, tempered with good working knowledge of the vehicle's dynamics.

Steering

- A. You should be thoroughly familiar with the steering "feel" of each vehicle you are assigned to drive. No two vehicles have the same "feel," you should get to know it to prevent problems before they occur.
- B. To eliminate unnecessary strain, avoid turning power assisted steering when the vehicle is stationary.

CONTENT

NOTES

- C. If the vehicle has air-assisted steering, constant maneuvering may reduce air pressure to a point where spring brakes will apply.
- D. Be familiar with the "track" the vehicle makes and the amount of room required for turns, etc.
- E. If the vehicle has an extreme overhang, as some do, you must learn the clearances.
- F. Use the 10 o'clock and 2 o'clock positions on the steering wheel for straight-ahead driving.
- G. Do not wrap your thumbs around the steering wheel, as the spokes may catch and break a thumb as the wheel spins.
- H. Do not allow your hands to cross on the wheel. Do not "palm" power steering.
- I. For off-road operations, keep a light touch on the wheel. If you hit an obstacle, the wheel can whip.
- J. To climb curbs, steps, etc., stop before the curb (one or two feet away) and let the vehicle inch toward the curb without power. Keep a light touch on the wheel and apply power only after the wheels have gently touched the curb. Do not "scrub" radial tires against the curb.
- K. Knowledge of vehicle dynamics should be used to "set up" the vehicle for turns. You must, however, be extremely familiar with the vehicle's "feel" to apply these principles.

CONTENT

NOTES

Braking

- A. Normal air operating pressure is 60-120 p.s.i. Normal hydrovac gauge reading is 20-25 inches mercury.
- B. Feel is important here also; be aware of the differences.
1. Hydrovacs often require extra "pump" to stiffen them.
 2. Hard constant pressure on air brakes often causes "nose-dive" prior to a stop. You should ease off prior to the stop to smooth out the stop.
- C. In normal use, you should not pump or fan the air brakes.
- D. Constant pressure on brakes causes tremendous heat build-up and brake fade. On steep grades use brakes intermittently to allow cooling and utilize engine compression to help slow the vehicle.
- E. Locking up the brakes actually reduces stopping efficiency and shortens tire life.
- F. Learn the procedures to follow for the vehicles you drive in the event of air or vacuum loss.
- G. Use parking brakes as recommended by the manufacturer. Use secondary means if available (driveline brake, chocks, etc.).
- H. Remember, with computerized brakes, if the computer fails, the system returns to normal air operation and you must gain control.
- I. Many trucks are equipped with "dry road/slippery road" or "front wheel limiting valves" for the driver's use.

+Why shouldn't you pump or fan air brakes?

CONTENT

NOTES

Shifting

- A. Shifting entails proper gear selection to accomplish the driver's objective for the power the engine produces; i.e., speed up, slow down, pull ahead. The transmission is the driver's tool; he must be able to utilize it properly.
- B. Manual shifting do's. A good driver:
1. Knows shift patterns of every piece of apparatus he drives.
 2. Knows just where the clutch begins to catch.
 3. Shifts before or after turns so as to keep both hands on the wheel during turns.
 4. Takes his foot off the clutch immediately after completing shifts.
 5. Places transmission in neutral and lets clutch out if vehicle will be parked idling for an extended period.
 6. Knows that heat and shock loading are major causes of premature driveline failure.
 7. Is capable of determining when clutch needs adjustment.
 8. Can double-clutch properly on upshifts and downshifts.
 9. Knows the speed ranges of each gear.
 10. Knows how to "flare out" shifts to get load off transmission to make shifting easier.
 11. Chooses proper gear to get vehicle moving on different terrain.

What are some indicators of an out-of-adjustment clutch?

CONTENT

NOTES

12. Is aware of special equipment on his vehicle, i.e., clutch brake, retarder.
- C. Manual shifting don'ts. A good driver doesn't:
1. Force transmission into gear.
 2. Hold vehicle on hill with the clutch.
 3. "Pop" clutch, especially on diesel.
 4. "Ride" the clutch.
- D. Manual shifting hints.
1. It is not necessary to upshift just because the engine is at governed speed. If you are in a congested area, you may achieve better performance by not shifting; you'll have good engine braking as well as power to accelerate. Remember, the transmission is a tool.
 2. If the transmission is hard to get out of gear on upshifts try "flaring out" shifts. Run the engine up to desired speed and hold it there a few seconds before attempting to shift. This lessens the shock on the driveline components.
 3. Many drivers experience difficulty with synchromesh transmissions because they don't move the shift lever from gear to gear fast enough.
 4. Some departments that use both synchromesh and nonsynchromesh transmissions require drivers to double clutch all vehicles. This keeps drivers in practice and eliminates the need for knowing which vehicles have which transmissions.

CONTENT

NOTES

5. Know what the manufacturers recommend for engine operating range, and use the transmission to keep the engine within it.

E. Automatic shifting do's. A good driver:

1. Learns what manufacturer's recommendations are for automatic upshifting and downshifting.
2. Learns what extra features transmission may have and how to use them properly.
3. Attempts to learn how to manipulate the transmission with the accelerator to make it work smoothly. Learns speed ranges in each gear.

F. Automatic shifting don'ts. A good driver doesn't:

1. Overheat transmission.
2. Try to force downshifts at speeds above those recommended by the manufacturer.

Backing

Because of the size of fire apparatus, your visibility is limited when attempting to back the vehicle. As a result, BACKING SHOULD BE AVOIDED whenever possible. If backing must be performed, several techniques will improve safety of the operation:

- A. Signal with horn and lights to warn other emergency personnel, motorists, and pedestrians.
- B. Monitor rear and side-view mirrors.

CONTENT

NOTES

C. Assign crew members to assist in backing.

Parking

The procedures and techniques for parking large fire apparatus were covered in the first part of the course and in the Backing section of this unit. In this part of the unit, special considerations for parking fire apparatus will be addressed.

A. At the scene of a working fire, the parking positions of fire equipment must facilitate, and not interfere with, performance of the mission.

1. Suppression apparatus have the first priority in choosing a parking position.

a. Aerial apparatus must be parked at the appropriate distance from access points to the building; clear access free of overhead obstructions is critical; space must be available for putting down the outriggers or jacks; outriggers need to be on pavement or firm ground.

b. Pumpers must not obstruct aerial ladder movements or block access to ground ladders.

c. Pumper apparatus must be parked at the proper distance from hydrant, standpipe, sprinkler connection or water source; space must be available for laying hose or setting up an auxiliary canvas tank in rural operations.

2. Support vehicles have second priority in choosing a parking position.

a. Ambulances must be upwind of a fire and must be reasonably near the victim.

+What can crew members do to assist the backing operation?

CONTENT

NOTES

b. Police cars are parked to allow other emergency vehicles easy access to the scene; they may also be parked to facilitate crowd control.

B. The vehicle must be protected at the scene of a fire:

1. Ground support capability, for both the apparatus and its outriggers, must be evaluated.
2. Chocks should be placed squarely, not at an angle, in front of the rear wheels. Chocks should be placed behind the rear wheels if vehicle is facing uphill.
3. You remain with your vehicle, monitoring instruments and gauges; you must be prepared to move the vehicle efficiently if so ordered by an officer.

Negotiating Intersections.

Preventing intersection collisions is a special concern for fire apparatus because they require extremely long stopping distances.

A. The best procedures for preventing intersection collisions are the following:

1. Travel with windows down, to hear other sirens.

2. Slow down to 10 mph on approaching an intersection.

3. Vary the sound of the siren to attract attention.

4. Turn the siren off for brief intervals to permit detection of other emergency vehicles.

5. Look left - straight - right - left before proceeding through an intersection.

FIRE

CONTENT

NOTES

- B. Some additional knowledge could help avoid a collision.
1. What other units have been dispatched?
 2. From which direction will the other units approach the scene?
 3. Knowing their direction of approach, you should anticipate potential points of conflict (intersections) and be especially cautious when approaching them.

+Do you know the standard procedures for straight, split, and reverse lays when operating with other companies?

Review Exercises

1. List two guidelines which should be followed whenever more than one vehicle is dispatched for a given fire station.

2. What are the two basic types of engines in use on fire apparatus?

3. What are the two types of transmissions in general use on large fire apparatus?

4. What is the primary difference between synchromesh and nonsynchromesh transmissions?

5. What is the normal operating pressure for air brakes?

6. What is the normal hydrovac gauge reading?

7. List the two basic rules which relate to safe speeds for fire apparatus.

8. Below are several statements relating to braking techniques. Circle the letter in front of those that are correct.

a. In normal use, you should not pump or fan air brakes.

b. Locking the brakes will reduce stopping efficiency.

c. If computerized brakes fail, the apparatus will have no braking capability.

9. Below is a listing of several different types of emergency vehicles. Rank them according to parking priorities at a working fire by placing a "1" beside the vehicle with the first priority, a "2" beside the vehicle with second priority, etc.

____ Pumper

____ Police vehicle

____ Ambulance

10. List three techniques that can minimize the possibility of an intersection collision.

FIRE