

DOCUMENT RESUME

ED 161 725

SE 025 189

AUTHOR Page, Lou Williams; Page, Thornton  
 TITLE Apollo-Soyuz Pamphlet No. 9: General Science.  
 Apollo-Soyuz Experiments in Space.  
 INSTITUTION National Aeronautics and Space Administration,  
 Washington, D.C.  
 REPORT NO NASA-EP-141  
 PUB DATE Oct 77  
 NOTE 87p.; For related documents, see SE 025 181-188;  
 Photographs may not reproduce well  
 AVAILABLE FROM Superintendent of Documents, U.S. Government Printing  
 Office, Washington, D.C. 20402 (Stock No.  
 033-800-00688-8; Available in sets only - \$10.00).

EDRS PRICE MF-\$0.83 HC-\$4.67 Plus Postage.  
 DESCRIPTORS Aerospace Education; College Science; Earth Science;  
 \*General Science; Higher Education; \*Instructional  
 Materials; \*Learning Activities; \*Science Education;  
 Secondary Education; Secondary School Science; Space  
 Sciences; \*Supplementary Textbooks  
 IDENTIFIERS National Aeronautics and Space Administration

ABSTRACT

This is the last pamphlet in a series of nine discussing the Apollo-Soyuz mission and experiments. This set is designed as a curriculum supplement for secondary and college teachers, supervisors, curriculum specialists, textbook writers, and the general public. These booklets provide sources of ideas, examples of the scientific method, references to standard textbooks, and descriptions of space experiments. There are numerous illustrations, as well as questions for discussion (with answers) and a glossary of terms. This last booklet describes the Apollo-Soyuz Mission, the spacecraft, astronomy experiments, geoscience experiments, biology experiments, and materials experiments performed on the mission.

(MA)

\*\*\*\*\*  
 \* Reproductions supplied by EDRS are the best that can be made \*  
 \* from the original document. \*  
 \*\*\*\*\*

# Apollo-Soyuz Pamphlet No. 9:

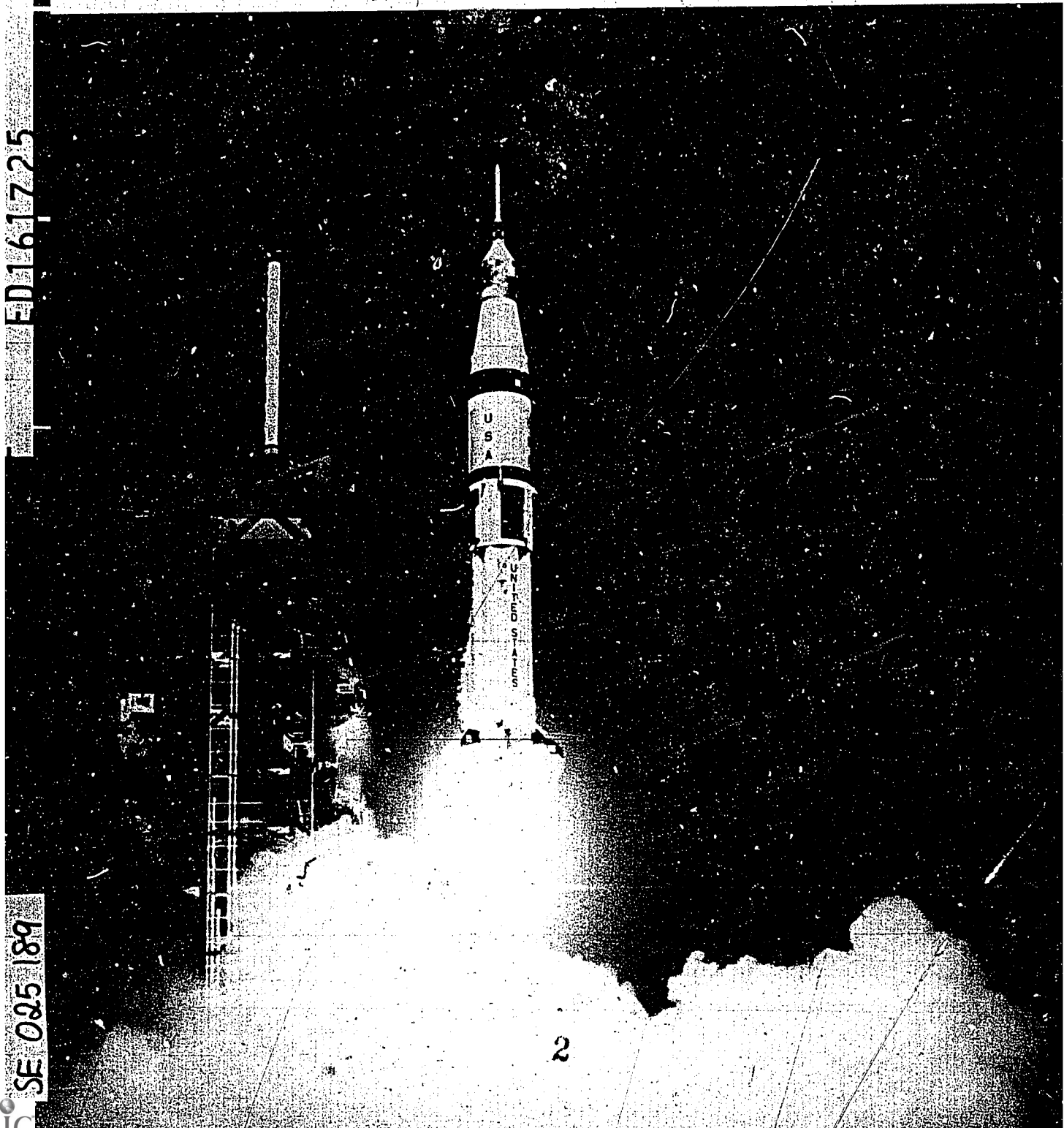
# General Science

U.S. DEPARTMENT OF HEALTH,  
EDUCATION & WELFARE  
NATIONAL INSTITUTE OF  
EDUCATION

THIS DOCUMENT HAS BEEN REPRODUCED EXACTLY AS RECEIVED FROM THE PERSON OR ORGANIZATION ORIGINATING IT. POINTS OF VIEW OR OPINIONS STATED DO NOT NECESSARILY REPRESENT OFFICIAL NATIONAL INSTITUTE OF EDUCATION POSITION OR POLICY

ED161725

SE 025 189



**Apollo-  
Soyuz  
Experiments  
In  
Space**

This is one of a series of nine  
curriculum-related pamphlets  
for Teachers and Students  
of Space Science

Titles in this series of  
pamphlets include:

- EP 133 Apollo-Soyuz Pamphlet No. 1 The Light
- EP 134 Apollo-Soyuz Pamphlet No. 2 X-Rays-Gamma Rays
- EP 135 Apollo-Soyuz Pamphlet No. 3 Sun Stars In Between
- EP 136 Apollo-Soyuz Pamphlet No. 4 Gravitational Field
- EP 137 Apollo-Soyuz Pamphlet No. 5 The Earth from Orbit
- EP 138 Apollo-Soyuz Pamphlet No. 6 Cosmic Ray Dosage
- EP 139 Apollo-Soyuz Pamphlet No. 7 Biology in Zero-G
- EP 140 Apollo-Soyuz Pamphlet No. 8 Zero-G Technology
- EP 141 Apollo-Soyuz Pamphlet No. 9 General Science

On The Cover

Launch of the Apollo Spacecraft from the  
NASA John F. Kennedy Space Center  
on July 15, 1975

Apollo-Soyuz  
Pamphlet No. 9:

# General Science

---

Prepared by Lou Williams Page and Thornton Page From  
Investigators' Reports of Experimental Results and With  
the Help of Advising Teachers

**NASA**

National Aeronautics and  
Space Administration

Washington, D.C. 20546

October 1977

For sale by the Superintendent of Documents,  
U.S. Government Printing Office, Washington, D.C. 20402  
(9-Part Set; Sold in Sets Only)  
Stock Number 033-800-00688-8

# Preface

The Apollo-Soyuz Test Project (ASTP), which flew in July 1975, aroused considerable public interest; first, because the space rivals of the late 1950's and 1960's were working together in a joint endeavor, and second, because their mutual efforts included developing a space rescue system. The ASTP also included significant scientific experiments, the results of which can be used in teaching biology, physics, and mathematics in schools and colleges.

This series of pamphlets discussing the Apollo-Soyuz mission and experiments is a set of curriculum supplements designed for teachers, supervisors, curriculum specialists, and textbook writers as well as for the general public. Neither textbooks nor courses of study, these pamphlets are intended to provide a rich source of ideas, examples of the scientific method, pertinent references to standard textbooks, and clear descriptions of space experiments. In a sense, they may be regarded as a pioneering form of teaching aid. Seldom has there been such a forthright effort to provide, directly to teachers, curriculum-relevant reports of current scientific research. High school teachers who reviewed the texts suggested that advanced students who are interested might be assigned to study one pamphlet and report on it to the rest of the class. After class discussions, students might be assigned (without access to the pamphlet) one or more of the "Questions for Discussion" for formal or informal answers, thus stressing the application of what was previously covered in the pamphlets.

The authors of these pamphlets are Dr. Lou Williams Page, a geologist, and Dr. Thornton Page, an astronomer. Both have taught science at several universities and have published 14 books on science for schools, colleges, and the general reader, including a recent one on space science.

Technical assistance to the Pages was provided by the Apollo-Soyuz Program Scientist, Dr. R. Thomas Giuli, and by Richard R. Baldwin, W. Wilson Lauderdale, and Susan N. Montgomery, members of the group at the NASA Lyndon B. Johnson Space Center in Houston which organized the scientists' participation in the ASTP and published their reports of experimental results.

Selected teachers from high schools and universities throughout the United States reviewed the pamphlets in draft form. They suggested changes in wording, the addition of a glossary of terms unfamiliar to students, and improvements in diagrams. A list of the teachers and of the scientific investigators who reviewed the texts for accuracy follows this Preface.

This set of Apollo-Soyuz pamphlets was initiated and coordinated by Dr. Frederick B. Tuttle, Director of Educational Programs, and was supported by the NASA Apollo-Soyuz Program Office, by Leland J. Casey, Aerospace Engineer for ASTP, and by William D. Nixon, Educational Programs Officer, all of NASA Headquarters in Washington, D.C.

Appreciation is expressed to the scientific investigators and teachers who reviewed the draft copies; to the NASA specialists who provided diagrams and photographs; and to J. K. Holcomb, Headquarters Director of ASTP operations, and Chester M. Lee, ASTP Program Director at Headquarters, whose interest in this educational endeavor made this publication possible.



## Teachers And Scientific Investigators Who Reviewed the Text

Hzrold L. Adair, Oak Ridge National Laboratory, Oak Ridge, Tenn.  
Lynette Aey, Norwich Free Academy, Norwich, Conn.  
J. Vernon Bailey, NASA Lyndon B. Johnson Space Center, Houston, Tex.  
Stuart Bowyer, University of California at Berkeley, Berkeley, Calif.  
Bill Wesley-Brown, California State University at Chico, Chico, Calif.  
Ronald J. Bruno, Creighton Preparatory School, Omaha, Nebr.  
T. F. Budinger, University of California at Berkeley, Berkeley, Calif.  
Robert F. Collins, Western States Chiropractic College, Portland, Oreg.  
B. Sue Criswell, Baylor College of Medicine, Houston, Tex.  
T. M. Donahue, University of Michigan, Ann Arbor, Mich.  
David W. Eckert, Greater Latrobe Senior High School, Latrobe, Pa.  
Lyle N. Edge, Blanco High School, Blanco, Tex.  
Victor B. Eichler, Wichita State University, Wichita, Kans.  
Farouk El-Baz, Smithsonian Institution, Washington, D.C.  
D. Jerome Fisher, Emeritus, University of Chicago, Phoenix, Ariz.  
R. T. Giuli, NASA Lyndon B. Johnson Space Center, Houston, Tex.  
M. D. Grossi, Smithsonian Astrophysical Observatory, Cambridge, Mass.  
Wendy Hindin, North Shore Hebrew Academy, Great Neck, N.Y.  
Tim C. Ingoldsby, Westside High School, Omaha, Nebr.  
Robert H. Johns, Academy of the New Church, Bryn Athyn, Pa.  
D. J. Larson, Jr., Grumman Aerospace, Bethpage, N.Y.  
M. D. Lind, Rockwell International Science Center, Thousand Oaks, Calif.  
R. N. Little, University of Texas, Austin, Tex.  
Sarah Manly, Wade Hampton High School, Greenville, S.C.  
Katherine Mays, Bay City Independent School District, Bay City, Tex.  
Jane M. Oppenheimer, Bryn Mawr College, Bryn Mawr, Pa.  
T. J. Pepin, University of Wyoming, Laramie, Wyo.  
H. W. Scheld, NASA Lyndon B. Johnson Space Center, Houston, Tex.  
Seth Shulman, Naval Research Laboratory, Washington, D.C.  
James W. Skehan, Boston College, Weston, Mass.  
B. T. Slater, Jr., Texas Education Agency, Austin, Tex.  
Robert S. Snyder, NASA George C. Marshall Space Flight Center, Huntsville, Ala.  
Jacqueline D. Spears, Port Jefferson High School, Port Jefferson Station, N.Y.  
Robert L. Stewart, Monticello High School, Monticello, N.Y.  
Aletha Stone, Fulmore Junior High School, Austin, Tex.  
G. R. Taylor, NASA Lyndon B. Johnson Space Center, Houston, Tex.  
Jacob I. Trombka, NASA Robert H. Goddard Space Flight Center, Greenbelt, Md.  
F. O. Vonbun, NASA Robert H. Goddard Space Flight Center, Greenbelt, Md.  
Douglas Winkler, Wade Hampton High School, Greenville, S.C.



# Contents

<b>Section 1</b>	Introduction: The Apollo-Soyuz Mission .....	1
	A. Astronauts and Cosmonauts .....	1
	B. International Cooperation .....	3
<b>Section 2</b>	The Spacecraft .....	5
	A. The Docking Module .....	5
	B. Launch and Booster .....	8
	C. Orbit .....	12
	D. Weightlessness .....	13
	E. Questions for Discussion (Time Zones, Docking Module, Launch, Zero-g) .....	14
<b>Section 3</b>	Astronomy Experiments .....	15
	A. Experiment Proposals and Organization for Apollo-Soyuz .....	15
	B. X-Ray Pulsar .....	22
	C. Artificial Solar Eclipse .....	23
	D. Questions for Discussion (X-Rays, Solar Eclipse) .....	26
<b>Section 4</b>	Geoscience Experiments .....	27
	A. Aerosols .....	27
	B. Clouds, Water Currents, and Landforms .....	29
	C. Questions for Discussion (Sunset, Refraction, Aerosols, Geometry) .....	38
<b>Section 5</b>	Biology Experiments .....	39
	A. Light Flashes in Astronauts' Eyes .....	40
	B. Biostack III .....	43
	C. "Up" and "Down" for Fish in Zero-g .....	45
	D. Questions for Discussion (Light Flashes, Cosmic Rays, Zero-g) .....	48
<b>Section 6</b>	Materials Experiments .....	49
	A. Wetting, Wicks, and Foam in Zero-g .....	49
	B. Multipurpose Electric Furnace .....	50
	C. Eutectics Formed in Zero-g .....	53
	D. Crystals Formed in Zero-g .....	55
	E. Questions for Discussion (Wetting, Foams, Furnace, Crystals) .....	59
<b>Appendix A</b>	Discussion Topics (Answers to Questions) .....	61
<b>Appendix B</b>	SI Units and Powers of 10 .....	66

---

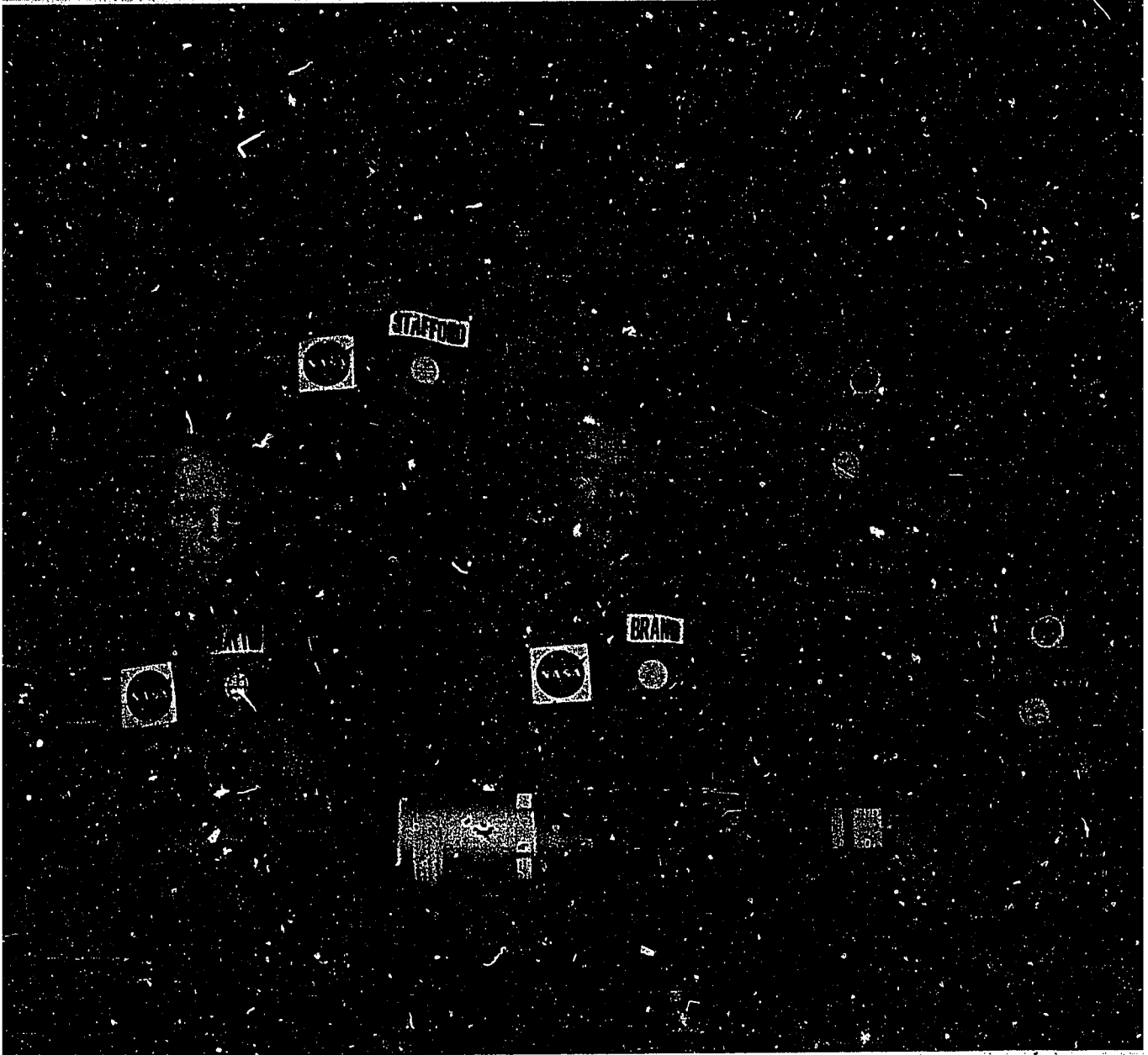
<b>Appendix C</b>	Glossary .....	69
<b>Appendix D</b>	Further Reading .....	75

---

## Table and Figures

<b>Table 3.1</b>	Apollo-Soyuz Experiments and Tests .....	16
<b>Figure 1.1</b>	The Apollo-Soyuz Crewmen .....	x
<b>Figure 2.1</b>	Apollo and Soyuz Spacecraft and the Docking Module .....	6
<b>2.2</b>	Apollo and Soyuz Launch Configurations .....	9
<b>2.3</b>	Diagram of a Multistage Launch .....	11
<b>2.4</b>	Satellite Orbit Around the Earth .....	12
<b>Figure 3.1</b>	Organization Diagram for NASA Space Science Experiments .....	21
<b>3.2</b>	Explanation of the SMC X-1 X-Ray Pulsar .....	23
<b>3.3</b>	Orbit and Separation of Apollo and Soyuz for the Artificial Solar Eclipse .....	24
<b>3.4</b>	Diagram of the Inner Corona, the Outer Corona, and the Zodiacal Light .....	25
<b>Figure 4.1</b>	Diagram of MA-007 Sunset Observations .....	28
<b>4.2</b>	Storm Clouds Over the South Atlantic Ocean .....	30
<b>4.3</b>	Sunlight Reflected From the Paraná River in Peru and Brazil .....	31
<b>4.4</b>	View Across Spain Into the Mediterranean Sea .....	32
<b>4.5</b>	Internal Waves in the Atlantic Ocean West of Spain .....	33
<b>4.6</b>	The Nile River Delta .....	35
<b>4.7</b>	The Simpson Desert in Australia .....	36
<b>4.8</b>	The Levantine Rift in Israel .....	37
<b>Figure 5.1</b>	Shapes and Sizes of Reported Light Flashes .....	41
<b>5.2</b>	Orbit Track, Location, and Type of Light Flashes .....	42
<b>5.3</b>	Diagram of Biostack III With a Cosmic-Ray Track .....	44
<b>5.4</b>	MA-161 Bags of Fish and Eggs in Water .....	46
<b>5.5</b>	Orientation of Fish in a Rotating Drum .....	47
<b>Figure 6.1</b>	Multipurpose Electric Furnace and Controls .....	51
<b>6.2</b>	Furnace Cartridge for the MA-070 Experiment .....	52
<b>6.3</b>	Lithium-Fluoride Fibers in Eutectic From Experiment MA-131 .....	54
<b>6.4</b>	Fibers in Magnetic Eutectic From Experiment MA-070 .....	55
<b>6.5</b>	Growth Lines in the Germanium Crystal From Experiment MA-060 .....	57
<b>6.6</b>	Diagram of the MA-028 Reactor .....	58
<b>6.7</b>	The MA-028 Crystals Grown in Zero-g .....	59
<b>Figure A.1</b>	Height of a Cloud Determined From a Pair of Apollo Photographs .....	63
<b>A.2</b>	Distance to the Horizon From Apollo-Soyuz .....	63

Figure 1.1 Apollo-Soyuz crewmen Donald K. Slayton, Thomas P. Stafford, Vance D. Brand, Aleksey A. Leonov, and Valeriy N. Kubasov.



# 1 Introduction

## The Apollo-Soyuz Mission

In July 1975, for the first time, manned spacecraft were launched by two nations and docked (sealed together). The spacecraft were in orbit 222 kilometers above the Earth's surface. The two-man Soyuz vehicle was launched first, at 2:20 p.m. Moscow time on July 15 from the giant Baykonur Cosmodrome near Tyuratam in central Russia. Seven and one-half hours later at 2:50 p.m. eastern daylight time, the three-man Apollo vehicle was launched from the NASA John F. Kennedy Space Center at Cape Canaveral in Florida. After making some careful changes in their orbit, the Apollo astronauts maneuvered close to Soyuz and the two spacecraft docked at 16:09 Greenwich mean time on July 17. This was 4:09 p.m. in Greenwich, near London, England. Greenwich mean time (GMT) was used to avoid confusion between Moscow time, eastern daylight time, and the central daylight time used in Houston, Texas, where the Apollo Mission Control Center was located. Moscow time is 2 hours ahead of GMT, and central daylight time is 5 hours behind GMT. So 16:09 GMT was 6:09 p.m. in Moscow and 11:09 a.m. in Houston.

After 2 days of joint operations in orbit 222 kilometers above the Earth's surface, Apollo and Soyuz undocked at 16:00 GMT on July 19, and Soyuz landed in the U.S.S.R. at 10:51 GMT on July 21. Apollo remained in orbit 3 days longer in order to complete 28 experiments, then splashed down in the Pacific Ocean south of Hawaii at 21:18 GMT on July 24. There was one "glitch" just before splashdown, when toxic gases were sucked into the Apollo spacecraft and painfully burned the eyes, skin, and lungs of the astronauts. However, the 23 American experiments and the five joint American-Russian experiments went well. Several Russian experiments were also conducted during the mission. Apollo and Soyuz brought back (or radioed back) much important scientific data, and the mission was a great success.

## A Astronauts and Cosmonauts

The three Apollo crewmembers and the two Soyuz crewmembers who visited each other in space are shown in Figure 1.1. They had worked together in the United States and the U.S.S.R. for more than a year before the flight and had learned to speak each other's language. (In orbit, each man spoke the language of his listeners.) They also learned all about the two spacecraft. The cosmonauts visited the NASA Lyndon B. Johnson Space Center in Houston, Texas, to examine a full-scale model of the Apollo spacecraft. The astronauts visited the Soviet Space Center near Moscow and saw full-scale models of the Soyuz vehicle, and engineers constructed a similar model in Houston.



The Apollo Commander, Tom Stafford, is a Major General in the U.S. Air Force. Before Apollo-Soyuz, he had flown on three NASA missions—Gemini VI, Gemini IX, and Apollo 10. The Soyuz Commander was Col. Aleksey Leonov. On March 18, 1965, during the Voskhod 2 mission, he had taken man's first walk in space. After Apollo-Soyuz, he was promoted to the rank of General.

For 13 years, D. K. (Deke) Slayton, the Apollo Docking Module Pilot, had been Director of Flight Operations at the Johnson Space Center. He had previously been excluded from spaceflight because of a heart problem, which cleared up by 1972. Apollo-Soyuz was also the first space mission for Vance Brand, the Apollo Command Module Pilot. Valeriy Kubasov, the Soyuz Flight Engineer, had flown on one previous Soviet mission, Soyuz 6.

In addition to the general training for the entire mission, each astronaut had to become a specialist. For instance, before the flight, Deke Slayton learned every design detail of the Docking Module and was ready to repair or service it.

During the flight, each crewman had specific jobs to do in at least 10 experiments. In addition, all of them had scheduled duties in operating the spacecraft. These tasks occupied almost every minute of the flight except for meals and rest periods. The schedule was arranged in advance by mission planners, and the crewmen practiced every part of it, over and over again. Although they knew it almost by heart, they took a printed schedule with them that showed just what was to be done and when to do it.

Beginning 45 days before launch, frequent medical tests were made on each crewman to check his health and to measure the bacteria in and on his body. He was weighed; his blood, saliva, urine, and excrement were analyzed; his eyes were examined; and his pulse and blood pressure were measured. The bacteria counts were checked once during the flight, and the medical tests were resumed after the flight for another 45 days. These tests allowed biologists to check the effects of spaceflight on the human body. Very little effect was recorded on the 9-day Apollo-Soyuz mission. Some loss of body weight and loss of calcium in the bones had been recorded on previous flights, especially on the longer Skylab flights which lasted as long as 84 days.

Both before and after the flight, the astronauts and cosmonauts conferred with the scientists who had designed the experiments. One scientist, the Principal Investigator for Experiment MA-136, Earth Observations and Photography, lectured the astronauts about what to look for on several continents and what kinds of photographs to take. He even took them on high-altitude airplane flights to help them learn to identify important landforms, water currents, and cloud types.



## B International Cooperation

Ever since Sputnik was launched by the Russians in 1957 to circle the Earth at an altitude of 600 kilometers, the United States and the U.S.S.R. have been in a space race. The goal of the Apollo-Soyuz mission was to show that two major powers, while still competing in space, could benefit by a cooperative mission. For the first time, the Russian people saw U.S. astronauts on live television and Americans were able to view a Soviet launch and landing. Specialists in both countries recognized the value of a common docking system for possible rescue missions in space. People in the rest of the world, seeing the cooperation between two rival major powers, may now have more interest in space science and technology.

The joint space project was first discussed between the National Aeronautics and Space Administration (NASA) and the Soviet Academy of Sciences in October 1970. Almost 2 years later on May 24, 1972, the mission concept was finalized in Moscow. During the next 3 years, detailed plans for the flight, the scientific experiments, and the press coverage were negotiated like treaties. The astronauts and cosmonauts exchanged visits, learned each other's language, and subsequently shared meals while in orbit 222 kilometers above the Earth. They are now respected friends.

In these and in many other ways, the Apollo-Soyuz mission improved international relations.

## 2 The Spacecraft

Both the Apollo and the Soyuz vehicles had been used on many earlier flights. Apollo was designed to carry three men to the Moon, together with the Lunar Module which was used to land two of them there. The first Apollo spacecraft was launched in 1966, and several test flights were flown before the first men were landed on the Moon in July 1969 by Apollo 11. Six more Apollo spacecraft flew to the Moon, and five Lunar Modules landed. (On Apollo 13, an oxygen tank exploded and the spacecraft had to return to Earth without a lunar landing.) Three more Apollo spacecraft carried three astronauts each (but no Lunar Module) up to Skylab in 1973. Each of these spacecraft docked with the orbiting Skylab 444 kilometers above the Earth and carried experimental equipment to use in the large Skylab workshop. The last Skylab crew worked there for 84 days. The Apollo spacecraft got its onboard electric power from a special kind of battery called a fuel cell, which uses hydrogen and oxygen.

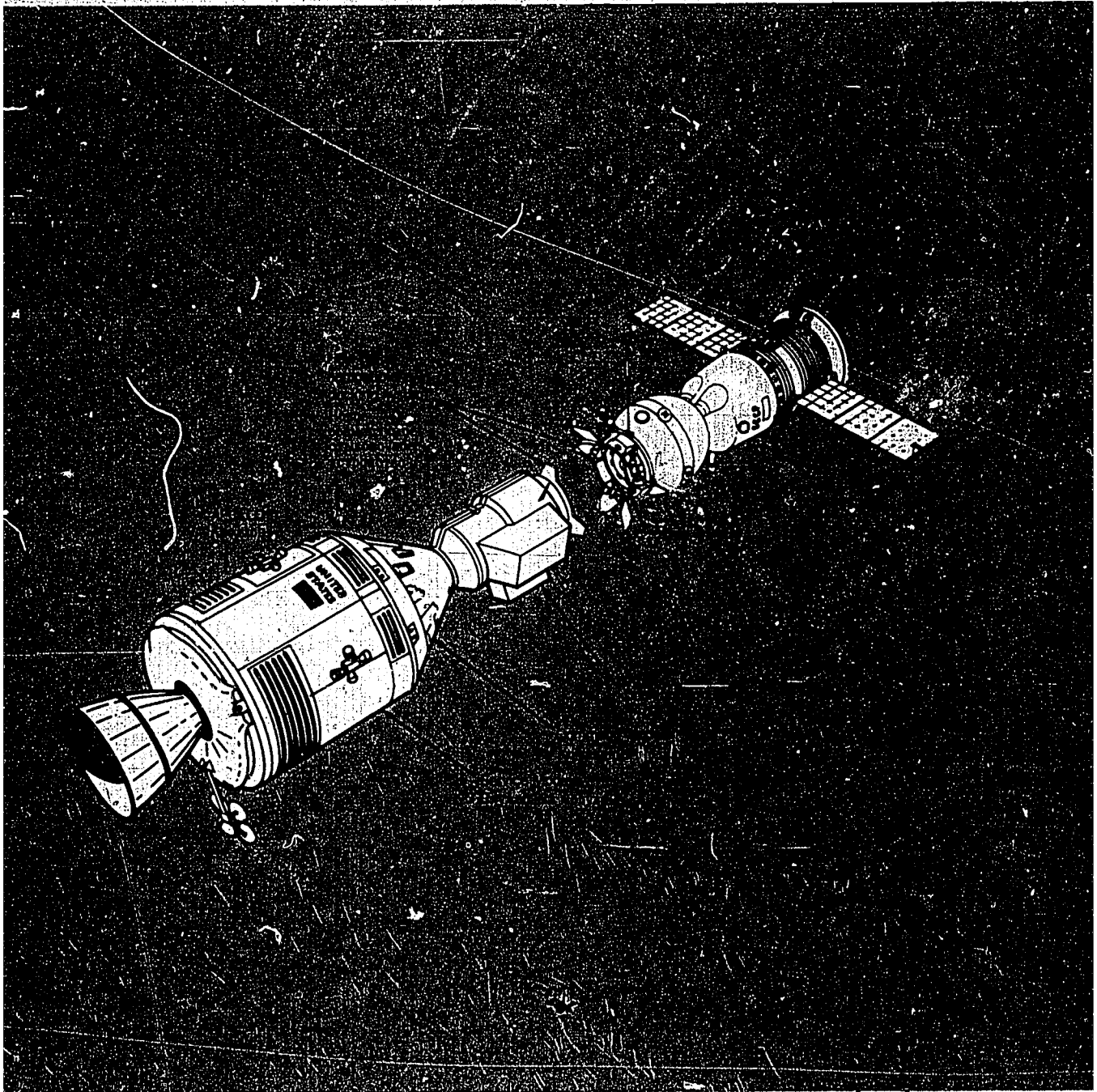
Soyuz was designed in 1966 and has been used in many Soviet missions in orbit around the Earth. The Russians have also built a space workshop that is similar to the American Skylab, although it is smaller. It is called Salyut, and Soyuz spacecraft have carried up several crews, each of two or three men, to dock with Salyut workshops in orbits about 260 kilometers in altitude. The Soyuz spacecraft uses solar panels for converting sunlight to electric power.

### A The Docking Module

Although an Apollo spacecraft had docked with Skylab and a Soyuz vehicle had docked with Salyut, Apollo and Soyuz could not dock with each other directly because their seals and latches were different. Also, the cabin atmosphere in Apollo was pure oxygen at low pressure, whereas Soyuz had ordinary air at sea-level pressure. (Of course, this cabin air had to be continuously reconditioned—oxygen added and carbon dioxide removed—as the cosmonauts lived and worked in Soyuz.) The first important job for the Apollo-Soyuz mission was the construction of a Docking Module that would fit both Apollo and Soyuz seals and latches. The Docking Module also had to have tanks of compressed oxygen and nitrogen to use in filling it to match either the pure-oxygen atmosphere in Apollo or the air in Soyuz.

The Apollo spacecraft with the Docking Module attached to its front end, facing Soyuz, is shown in Figure 2.1. The Apollo vehicle, including the Docking Module, was longer (about 12 meters, or 39 feet) and more massive (about 14 900 kilograms, or 15 tons) than Soyuz. The spacecraft consisted of two parts or "modules": the conical Command Module, where the astronauts worked, and the cylindrical Service Module, which contained the instruments, fuel tanks, and water tanks. The main thruster was located at the back

**Figure 2.1** Apollo and Soyuz spacecraft and the Docking Module. The labels are in English and Russian for the original publication in both countries. The cylindrical Service Module (left part of Apollo) has four sets of four jets each around its middle for moving in to dock with Soyuz.



of the Service Module. Just before reentering the Earth's atmosphere at the end of the mission, the Command Module was separated from the Service Module, and the astronauts rode in the Command Module, with its flat, wide end forward, through the atmosphere to splashdown.

The Soyuz spacecraft (Fig. 2.1) was smaller and lighter than the Apollo—about 6 meters (20 feet) in length and 6750 kilograms (7 tons) in weight. It consisted of three parts: the spherical Orbital Module, where the two cosmonauts worked; the Descent Vehicle, which corresponds to the Apollo Command Module; and the Instrument Assembly Module, which carries the solar panels and corresponds to the Apollo Service Module.

As Figure 2.1 shows, the guide plates, hooks, latches, and sealing rings on the Soyuz Orbital Module fit the guide plates, latches, hooks, and sealing rings on the Apollo Docking Module. These components form the "Compatible Docking System." The parts must fit exactly so that when the sealing rings are pressed tightly together, no air will leak from the cabin to the vacuum of space, even though the pressure inside is much higher than the pressure outside. Of course, there were sealed hatches (doors) inside the sealing rings on the Orbital Module and the Docking Module, and also between the Apollo Docking Module and Command Module and between the Soyuz Orbital Module and Descent Vehicle.

After Apollo and Soyuz maneuvered to "rendezvous" (to meet at the same place on the same orbit), the two crews lined up the two spacecraft as shown in Figure 2.1. Apollo approached Soyuz cautiously; no one wanted a collision in space! The astronauts used the small jets on the sides of the Service Module to roll and turn Apollo exactly to the right position; then they moved in slowly. The latches caught the hooks and pulled the sealing rings into contact. This rendezvous and docking is described in more detail in Pamphlet I.

When the seals had been tested, the astronauts filled the Docking Module with oxygen at one-third sea-level air pressure and opened the hatch between the Command Module and the Docking Module. Apollo Commander Stafford and Docking Module Pilot Slayton moved into the Docking Module, closed the hatch behind them, and slowly changed the Docking Module atmosphere to a higher pressure mixture of nitrogen and oxygen. At the same time, the cosmonauts reduced the pressure in Soyuz to match the Docking Module pressure. Then the two hatches between the Soyuz Orbital Module and the Docking Module were opened, and Soyuz Commander Leonov entered the Docking Module for the first international handshake in space, an event carried live by television in both the United States and the U.S.S.R.

The astronauts and cosmonauts worked for a while in the Docking Module. Stafford and Slayton looked around inside Soyuz. Going back, the astronauts had to close the hatches between Soyuz and the Docking Module, slowly change the Docking Module atmosphere to pure oxygen at one-third sea-level pressure, and then open the hatch into Apollo's Command Module.

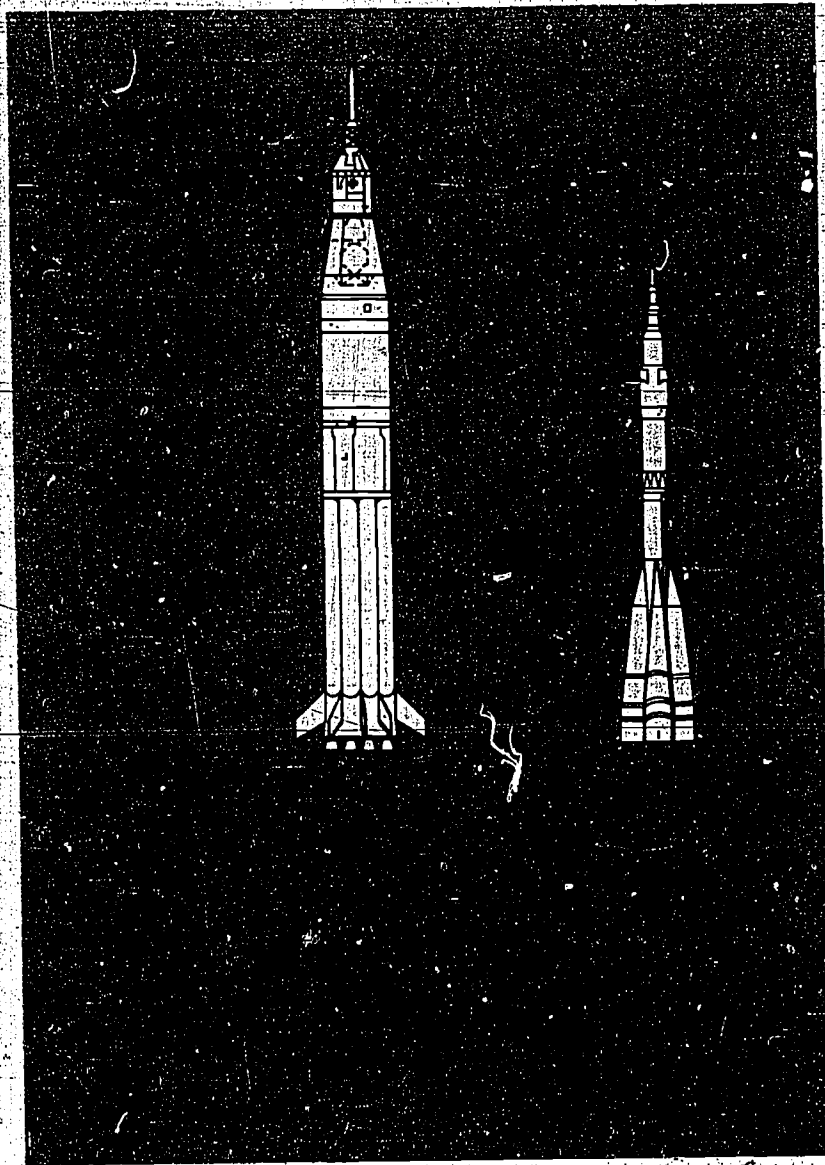


This complicated procedure, using the Docking Module to convert from the Soyuz atmosphere to the Apollo atmosphere (and vice versa), was followed several times during the 44 hours that the two spacecraft were sealed together. Each crewman visited the other spacecraft for a meal, and astronaut-cosmonaut pairs worked together in the Docking Module. They used the electric furnace described in Section 6, photographed several experiments, and exchanged parts of other experiments. Then all the hatches were sealed, and the two spacecraft undocked for the Artificial Solar Eclipse Experiment, in which Apollo moved between Soyuz and the Sun (see Sec. 3). Apollo then docked with Soyuz again, to try out the Compatible-Docking System in a different way. After 4 more hours, Apollo undocked and moved around Soyuz at three different distances to measure the amount of oxygen and nitrogen in the Earth's outer atmosphere (see Pamphlet V). Apollo then departed from Soyuz for the last time.

## B Launch and Booster

The launch of a spacecraft is a spectacular sight, as shown by the color photograph on the cover of this pamphlet. In this photograph, the huge Saturn IB booster is lifting about 588 000 kilograms (580 tons) off the launch pad at the Kennedy Space Center in Florida. Most of this weight is the fuel for the two rocket motors in the two boosters that put Apollo in orbit around the Earth. The rocket motor gets its thrust by ejecting hot gases produced by burning kerosene with liquid oxygen. It is a *reaction motor* and is described more fully in Pamphlet I.

The complete Apollo and Soyuz "launch configurations"—the combinations of boosters and spacecraft on the launch pad—are shown in Figure 2.2. Apollo, on the left, is much larger than Soyuz because it was designed to go to the Moon. The Docking Module was carried in a special "adapter" below the Service Module. The Lunar Module was carried in this adapter on the lunar missions. (Later, Apollo had to detach itself from the adapter, move away from it, turn around, and move in to dock with the Docking Module.) Below the spacecraft modules were the two stages of the Saturn IB booster rocket. As shown at the bottom of the figure, the first stage fired for 2 minutes and 30 seconds. Then the empty tanks, pumps, combustion chamber, and nozzles of the Saturn IB first stage were unlatched and discarded. (They fell back to Earth.) In the meantime, the Launch Escape System (which would have rescued the astronauts if the launch had gone wrong) was also unlatched and discarded. It fell into the ocean south of Florida, together with the empty booster.



Apollo and Soyuz launch configurations. The information beneath the drawing describes each spacecraft in terms of mass, booster thrust, total launch weight, and booster firing time.

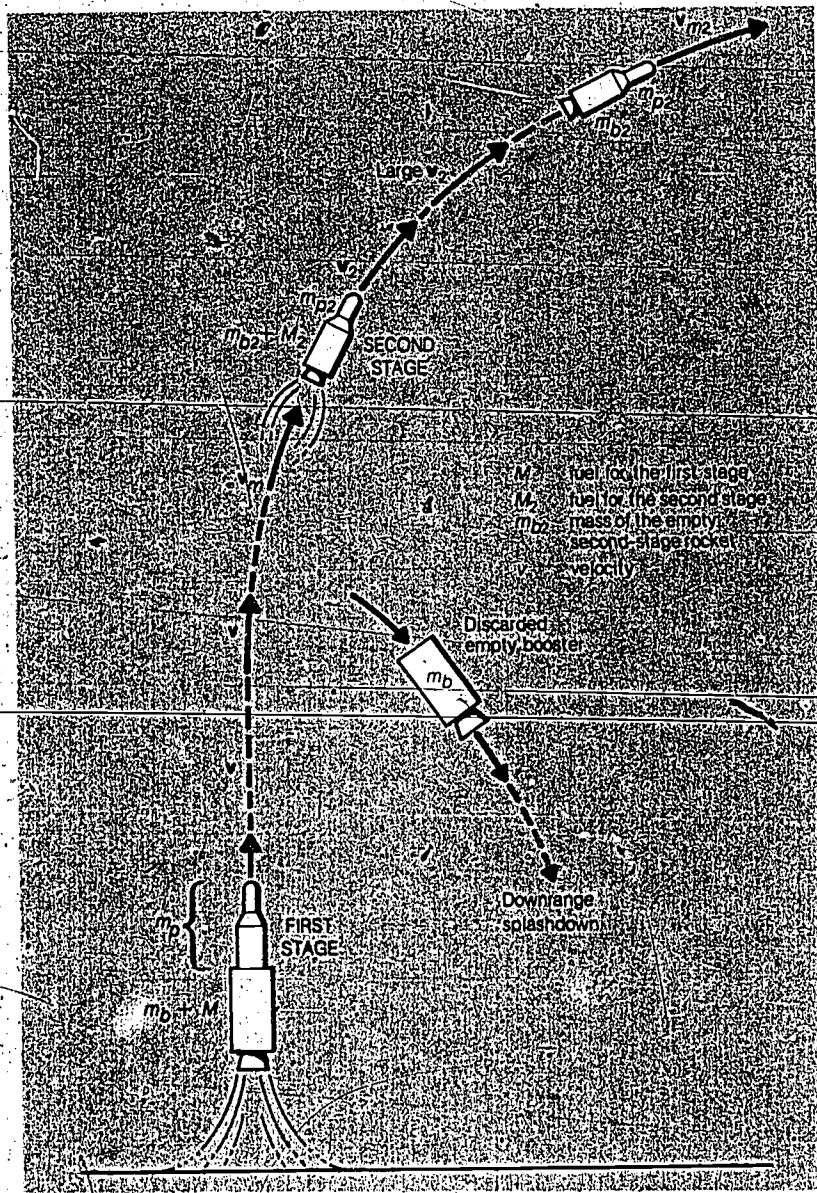
Figure 2.2

020



After the Saturn IB booster was discarded, the "second-stage" Saturn IVB booster fired for 7 minutes and 25 seconds. This booster accelerated Apollo from a speed of 4 km/sec (8750 mph) to a speed of almost 8 km/sec (17 500 mph) and changed the direction of the spacecraft from vertical toward horizontal. The second-stage Saturn IVB was then turned off. As shown schematically in Figure 2.3, the Apollo lift-off was a multistage launch (see Pamphlet I). It put Apollo into a nearly circular orbit about 165 kilometers above the Earth's surface.

The smaller Soyuz spacecraft had only one booster, with tanks that could be discarded when they were empty, and no launch escape system. Its dimensions and booster characteristics are shown at the right in Figure 2.2. The 20-engine booster lifted the 300 000-kilogram (300-ton) configuration off the launch pad, turned the spacecraft to the horizontal, and put Soyuz in an orbit about 220 kilometers above the Earth's surface. Along the way, it dropped four of the tubular booster engines after their fuel was used up.



Schematic diagram of a multistage launch. The total launch mass is the sum of the mass of the payload  $m_p$ , the mass of the booster tanks  $m_b$ , and the mass of the fuel  $M$ :  $m_p + m_b + M$ . After the first stage, the empty tank  $m_b$  is discarded and the remaining mass is speeded up to a higher velocity  $v_{m2}$ .

Figure 2.3

## C Orbit

After the boosters were turned off, Apollo was moving horizontally at 7.8 km/sec in orbit around the Earth. The orbit of a satellite around the Earth, shown in Figure 2.4, is similar to the much larger orbit of the Moon. The spacecraft, now a satellite, is being pulled toward the center of the Earth by gravity, but it is moving *horizontally* so fast that it never reaches the Earth's surface. The arrow labeled  $v_p$  shows the horizontal motion in 5 minutes, and the smaller arrow  $\Delta r$  shows how far the satellite falls in 5 minutes. Starting from the end of  $\Delta r$ , we can follow the next 5 minutes of horizontal motion and falling, and so on, all the way around the Earth. If the speed  $v_p$  is just right, the orbit will be a circle; otherwise, it will be an ellipse, as in Figure 2.4.

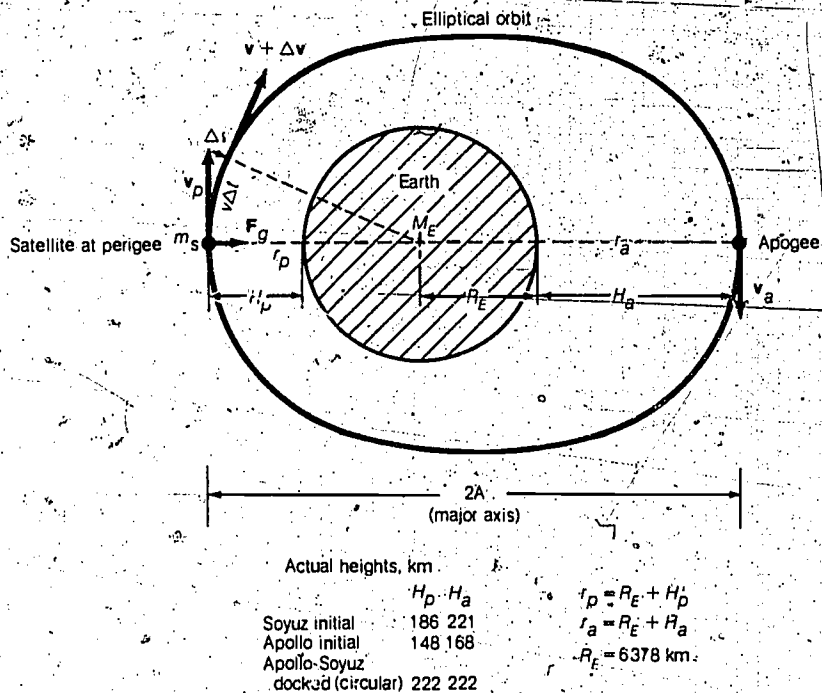


Figure 2.4 The orbit of a satellite around the Earth. The orbit size is exaggerated for clarity. The actual heights for Apollo and Soyuz are given at the bottom. The arrow  $F_g$  represents the force of gravity pulling the satellite mass  $m_s$  toward the large Earth mass  $M_E$ .



An ellipse looks like an oval. At one end of the ellipse, the satellite (spacecraft) is closest to the Earth. This point (left side of Fig. 2-4) is called *perigee*. At the other end of the oval, the satellite is farthest from the Earth, and this point is called *apogee*. The perigee height  $H_p$  and the apogee height  $H_a$  describe the *shape* of an orbit. When Apollo started in orbit, it had an  $H_p$  of 148 kilometers and an  $H_a$  of 168 kilometers. Space engineers call this a "148-by-168-kilometer orbit." The time needed to go around the Earth once is called the *period*  $T$ . This period becomes larger as the height  $H$  increases. For the first Soyuz orbit, which was 186 by 221 kilometers, the period was 92.5 minutes. For the smaller orbit of Apollo, the period was 91.7 minutes.

Several other numbers are needed to describe an orbit fully. The most important is the *inclination*  $i$ . The inclination is the angle between the orbital plane and the Equator of the Earth. If a satellite moves along the Equator,  $i$  is  $0^\circ$ . For Apollo and Soyuz,  $i$  was  $51.8^\circ$ , which means that they crossed the Equator going north, moved up to  $51.8^\circ$  N latitude, crossed the Equator going south and moved down to  $51.8^\circ$  S latitude.

Several changes in orbit were made by using the thrusters on Apollo and Soyuz to increase their speed at apogee. These changes put Apollo in a 205-by-205-kilometer circular orbit and Soyuz in an accurate 222-by-222-kilometer circular orbit. At just the right time, Apollo increased its speed to reach the 222-kilometer height near Soyuz for rendezvous and docking. Pamphlet I gives a more detailed description of these orbits and how they were changed.

## D Weightlessness

When you sit in a chair, you feel the force of gravity pulling you down because the chair pushes back up with an equal but opposite force (Newton's Third Law). On Earth, every mass  $m$  must be supported by a force  $F$  equal to its weight:  $F = mg$ , where  $g$  is the acceleration of gravity, a  $9.8\text{-m/sec}$  increase in speed during every second of fall. When Apollo or Soyuz, or any other spacecraft, is in orbit with the thrusters off, the spacecraft is falling toward Earth, and nothing inside needs to be supported. When an elevator starts to go down, you can feel a lessening of your weight, the force between your feet and the elevator floor. If the elevator cable broke so that the elevator fell down the shaft, the force on your feet would be zero. There is nothing to push you up because you and the elevator are falling together at the same speed and same acceleration. This applies equally to other people and objects in the falling elevator. In this "free fall," everything is *weightless*;  $F = 0$  and  $g = 0$ . This weightless condition is called *zero-g*.

Zero-g is one of the most significant factors affecting biological and materials experiments in space. It also produces surprising effects on the daily

lives of astronauts and cosmonauts. For instance, the astronaut cannot just put something on a table; it would float away. There is no "down" in the cabin. To stay in place without floating, the astronaut must anchor himself to something fixed on the cabin wall. (In Skylab, each astronaut had special cleats on his shoes that fit into a grating on the floor.) Liquids in zero-g won't stay in cups, so drinks are squeezed from plastic bags into the mouth. Water or fuel doesn't stay at the "bottom" of a partly filled tank. There are no convection currents in the cabin air; hot air doesn't rise. The astronauts needed 2 or 3 days to get used to zero-g. It made some of them seasick at first and shifted blood from their legs to the upper parts of their bodies. Other effects are described in Pamphlet VII.

## **E** Questions for Discussion

(Time Zones, Docking Module, Launch, Zero-g)

1. The cosmonauts ate supper in Soyuz at 10:55 p.m. Moscow standard time. What was the time then in London, England (GMT)? What was the time in your home town?
2. Why was there never an open passageway between Apollo and Soyuz while they were docked?
3. How much fuel (kerosene and liquid oxygen) was needed to put each kilogram of Apollo into orbit? How much for Soyuz?
4. An astronaut in zero-g wants to push a cabinet door shut. What would happen if he did so without anchoring himself?

# 3 Astronomy Experiments

Astronomers using data obtained outside the Earth's atmosphere have two major advantages over astronomers observing from Earth. The more important advantage is that their data come from outside the Earth's atmosphere, which blocks x-rays, ultraviolet, and most of the infrared light coming from space. Even with large telescopes like the 508-centimeter (200-inch) one at the Palomar Observatory in California, ground-based astronomers can photograph or detect only visible light (violet, blue, green, yellow, red) and a small portion of ultraviolet and infrared. Pamphlet II describes this in greater detail. Because the atmosphere blurs the photographs taken with large telescopes, very faint stars are missed and larger objects (gas clouds and galaxies) are not shown sharply. Observations obtained outside the atmosphere thus have a second advantage.

A telescope was carried to the Moon on Apollo 16, and other telescopes have been used above the atmosphere in Skylab and in unmanned satellites. A special x-ray detector was used on Apollo-Soyuz, and photographs were taken of the solar corona, a gas cloud around the Sun with a temperature of about 1 000 000 K.

## A Experiment Proposals and Organization for Apollo-Soyuz

In 1972, NASA invited scientists from all over the world to propose experiments for the Apollo-Soyuz mission. In all, 161 proposals were submitted to NASA Headquarters in Washington, D.C. Each proposed experiment was assigned a number: MA-001 to MA-161. Of these, 135 came from scientists in the United States; eight from West Germany; seven from France; four from India; three from the U.S.S.R.; and one each from Ireland, Scotland, Sweden, and Switzerland. Each proposal specified a scientific objective, described the equipment necessary, and estimated the amount of astronaut or cosmonaut time required in flight. Finally, the cost of building the equipment and analyzing the experiment results was estimated. For U.S. investigations, NASA supplied the necessary funds; foreign investigators were financed by their governments.

The U.S. National Academy of Sciences reviewed most of the proposals and rated them according to scientific value. Then, on the basis of weight, cost, operating time, and complexity of spacecraft maneuvers required, the NASA Manned Space Flight Experiments Board (MSFEB) selected 28 experiments. These experiments are listed in Table 3.1. Five of them required joint astronaut-cosmonaut activities, and the Soviet Space Science Board added six more for the cosmonauts only. There was a Principal Investigator for each experiment; he was held responsible by NASA for analyzing the results and



**Table 3.1 Apollo-Soyuz Experiments and Tests**

<i>Experiment Number</i>	<i>Experiment Name</i>	<i>Objective</i>	<i>Principal Investigator's organization</i>	<i>Reference</i>
MA-048	Solar X-Ray Observation	Survey the sky for soft x-ray sources and background	U.S. Naval Research Laboratory	Pamphlet II, Sec. 3
MA-151	Crystal Activation	Measure the radioactive isotopes created by cosmic rays in crystals used for gamma-ray detectors	NASA/Robert H. Goddard Space Flight Center (GSFC)	Pamphlet II, Sec. 4
MA-148	Artificial Solar Eclipse (joint)	Photograph the solar corona from Soyuz while Apollo blocks out the Sun	Soviet Academy of Sciences, Moscow, and NASA/ISG	Pamphlet III, Sec. 2
MA-033	Extreme Ultraviolet Survey	Survey of the sky for extreme-ultraviolet sources and background	University of California at Berkeley	Pamphlet III, Sec. 3
MA-088	Interstellar Helium Glow	Detect interstellar helium entering the solar system and measure its density and motion	University of California at Berkeley	Pamphlet III, Sec. 4
MA-089	Doppler Tracking	Measure large-scale (300-km) gravity anomalies on the Earth's surface by detecting minute changes in the 300-km separation between Apollo and the Docking Module	Smithsonian Astrophysical Observatory and Harvard University	Pamphlet IV, Sec. 4
MA-173	Geodynamics	Measure large-scale gravity anomalies by detecting small accelerations of Apollo in the 222-km orbit using Doppler tracking from the ATS-6 geosynchronous satellite	NASA/GSFC	Pamphlet IV, Sec. 5
MA-136	Earth Observations and Photography	Detect, photograph and measure peculiar surface features (mfts, deserts, long waves in the sea)	Smithsonian Institution	Pamphlet IV, Sec. 2



Table 3.1 Continued

Experiment number	Experiment name	Objective	Principal Investigator's organization	Reference
MA-007	Stratospheric Aerosol Measurement	Measure infrared sunlight intensity at spacecraft sunrise and sunset to determine the amount of aerosols from 30 to 150 km altitude and test this technique for continuous monitoring of the atmosphere	University of Wyoming and NASA Langley Research Center	Pamphlet V, Sec. 3
MA-059	Ultraviolet Absorption (joint)	Measure the density of atomic oxygen and nitrogen at the 222-km altitude by detecting absorption of 1304 and 1200 Å (130.4 and 120.0 nm) light from a beam reflected from Soyuz back to Apollo	University of Michigan and NASA JSC	Pamphlet V, Sec. 4
MA-106	Light Flashes	Count the flashes seen by blindfolded astronauts and measure high-energy cosmic-ray intensity in the CM cabin	University of California at Berkeley	Pamphlet VI, Sec. 2
MA-107	Biostack III	Expose to cosmic rays spores, seeds, and eggs in stacks between layers of plastic and photographic film to measure high-energy cosmic-ray tracks	University of Frankfurt (West Germany)	Pamphlet VI, Sec. 3
MA-147	Zone-Forming Fungi (joint)	Photograph cultures of funguslike cells and their spores before, during, and after exposure to zero-g and cosmic rays and measure the cosmic-ray intensity	Soviet Academy of Science, Moscow, and NASA JSC	Pamphlet VII, Sec. 2
MA-021	Electrophoresis Technology	Operate and photograph eight static electrophoresis columns in zero-g to separate live blood cells and live kidney cells for postflight examination	NASA George C. Marshall Space Flight Center (MSFC)	Pamphlet VII, Sec. 4



Table 3.1 Continued

Serial Number	Experiment Name	Objective	Principal Investigator's Organization	Reference
24	Electrophoresis	Test in zero-g the operation of a free-flow electrophoresis tube with electric field across the flow	Max Planck Institute of Biochemistry, Munich, West Germany	Pamphlet VII, Sec. 4
22	Microbial Exchange (joint)	Obtain skin-swab samples from astronauts and cosmonauts before, during, and after flight, and saliva and blood samples before and after flight for postflight analysis	NASA JSC and Institute of Biological Problems, Soviet Ministry of Health, Moscow	Pamphlet VII, Sec. 5
31	Cellular Immune Response	Collect astronaut blood samples before and after flight for analysis of lymphocyte response	Baylor College of Medicine, Houston, Texas	Pamphlet VII, Sec. 6
32	The Effects of Space Flight on Leukocyte Response	Collect astronaut blood samples before and after flight for analysis of leukocyte (white blood cell) response	Baylor College of Medicine, Houston, Texas	Pamphlet VII, Sec. 6
61	Killifish Hatching and Orientation	Observe and photograph baby fish and fish hatched from eggs in zero-g	Baylor College of Medicine, Houston, Texas	Pamphlet VII, Sec. 2
	Liquid Demonstrations	Operate and photograph demonstrations of chemical foams, liquid spreading, and wick action in zero-g	NASA MSFC	Pamphlet VIII, Sec. 2
10	Multipurpose Electric Furnace	Design, test, and operate in zero-g an electric furnace providing temperatures up to 1423 K (1150° C, 1200° F)	Westinghouse Research Laboratories, Pittsburgh, Pa., and NASA MSFC	Pamphlet VIII, Sec. 3
44	Monotectic and Syntectic Alloys	Heat to 1423 K (1150° C) and cool three small samples of aluminum-antimony and three of lead-zinc in zero-g	NASA MSFC	Pamphlet VIII, Sec. 3



Table 3.1 Concluded

Experiment number	Experiment name	Objective	Principal Investigator's organization	Reference
MA-150	Multiple Material Melting (joint)	Heat to 1423 K (1150° C) and cool small samples of aluminum-tungsten, germanium-silicon and aluminum in zero-g	Institute for Metallurgy, Moscow and NASA MSFC	Pamphlet VIII, Sec. 5
MA-070	Zero-g Processing of Magnets	Heat to 1348 K (1075° C) and cool small samples of bismuth-manganese and copper-cobalt-cerium alloys in zero-g	Grumman Aerospace Corporation, Bethpage, N.Y.	Pamphlet VIII, Sec. 3
MA-041	Surface-Tension-Induced Convection	Heat to 923 K (650° C) and cool three small samples of lead and lead-gold alloy in zero-g; heat three others to 723 K (450° C)	Oak Ridge National Laboratory, Oak Ridge, Tenn.	Pamphlet VIII, Sec. 3
MA-131	Hande Eutectic Growth	Heat to 1153 K (880° C) and cool a small sample of sodium chloride-lithium fluoride in zero-g	University of California at Los Angeles	Pamphlet VIII, Sec. 3
MA-060	Interface Markings in Crystals	Heat to melting, then cool in zero-g with thermal pulses every 4 seconds, three small samples of germanium doped with gallium and antimony	Massachusetts Institute of Technology, Cambridge, Mass.	Pamphlet VIII, Sec. 4
MA-085	Crystal Growth From the Vapor Phase	Heat to 877 K (604° C) three small samples of germanium compounds and alloys in zero-g, allowing crystal growth at the cool end of the ampoule	Rensselaer Polytechnic Institute, Troy, N.Y.	Pamphlet VIII, Sec. 4
MA-028	Crystal Growth	Photograph crystal growth in six tubes with reactants producing lead sulfide, calcium tartrate, and calcium carbonate as large crystals in zero-g	Rockwell International Science Center, Thousand Oaks, Calif.	Pamphlet VIII, Sec. 4

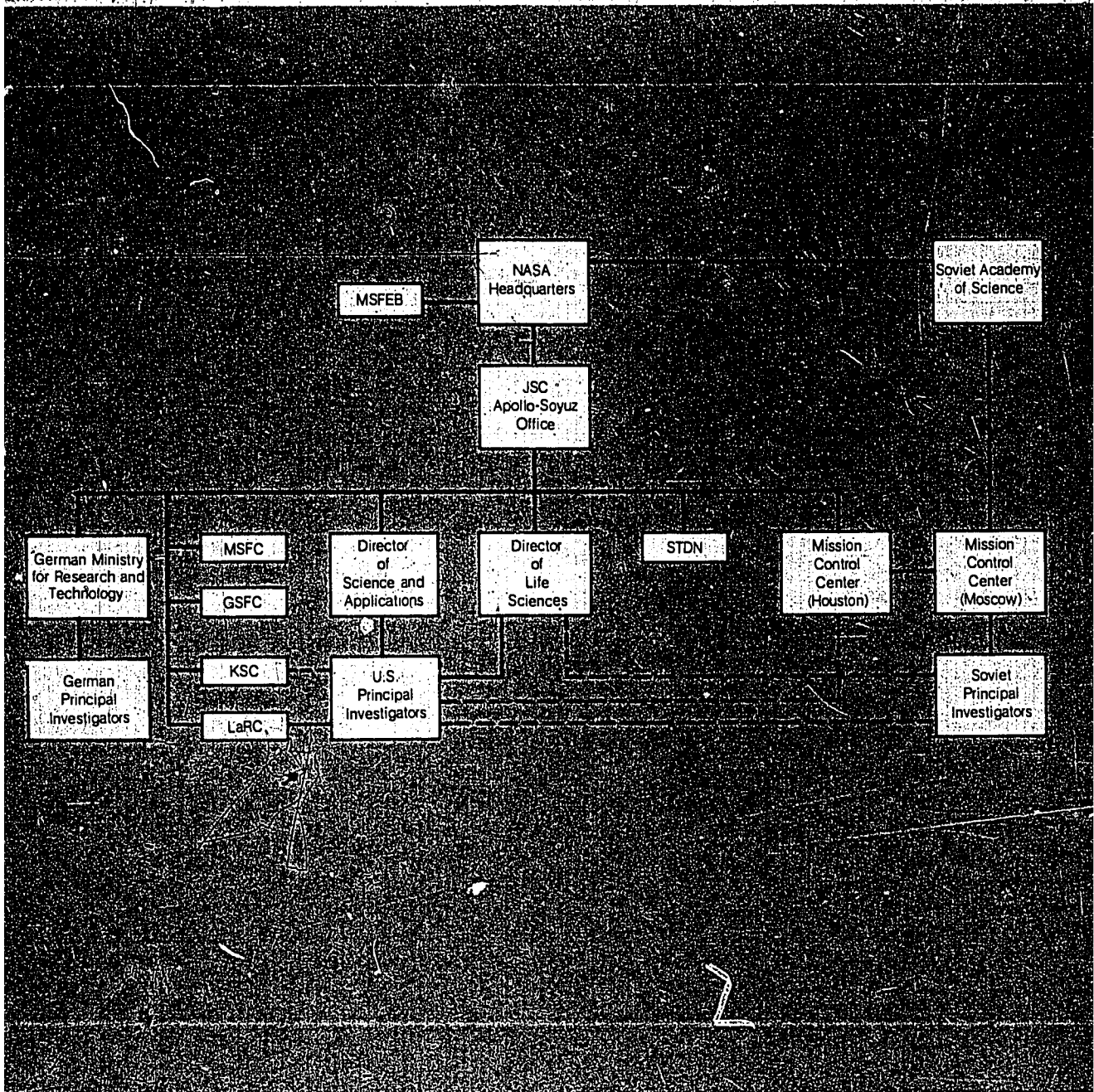
writing a final report. West Germany developed and financed two experiments, but their Principal Investigators had to make reports in English to NASA. The Russian scientists who worked on joint experiments also submitted reports to NASA.

The complicated organization for the experiments is shown in Figure 3.1. Arrangements for the U.S.-U.S.S.R. joint experiments were made between NASA and the Soviet Academy of Sciences, and arrangements for the West German experiments were made between NASA and the German Ministry for Research and Technology. The NASA John F. Kennedy Space Center (KSC), Lyndon B. Johnson Space Center (JSC), George C. Marshall Space Flight Center (MSFC), Robert H. Goddard Space Flight Center (GSFC), Langley Research Center (LaRC), and Spacecraft Tracking and Data Network (STDN) were all involved in ensuring that the experiments fitted into the Apollo-Soyuz schedule. The dashed lines in Figure 3.1 show informal communications that were used in preparing for flight and in writing the final published reports.



Organization diagram for NASA space science experiments. The Principal Investigators (bottom boxes) proposed the experiments and are responsible for reporting the results.

Figure 3.1

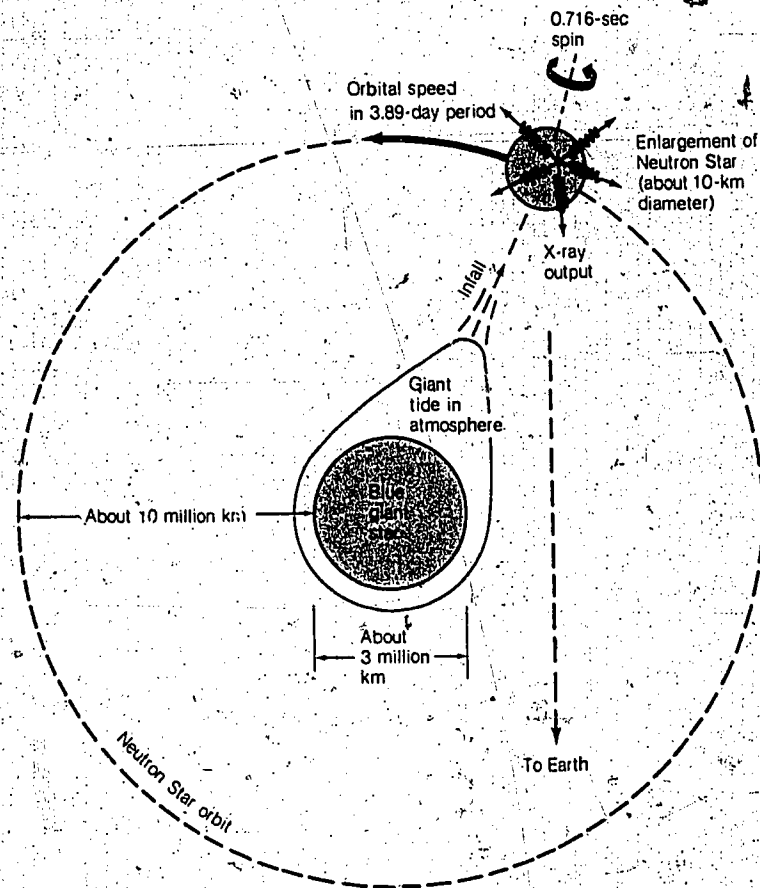




## B X-Ray-Pulsar

One of the interesting results of the astronomy experiments comes from x-ray measurements made in the MA-048 Experiment. The Principal Investigator was Herbert Friedman of the U.S. Naval Research Laboratory in Washington, D.C. As explained in Pamphlet II, this experiment measured x-rays coming from various directions. In one direction, x-rays were detected coming from a star 200 000 light-years away in the Small Magellanic Cloud, a galaxy outside our own Milky Way Galaxy. These x-rays came in pulses about 0.7 second apart, which is shorter than the periods of 10 other known x-ray pulsars. The best explanation is that a high-density Neutron Star (an old collapsed star) about 5 kilometers in radius is rotating once every 0.7 second. This is illustrated in Figure 3.2. The Neutron Star is in a 3.89-day orbit around a blue (very hot) giant star, which is distorted by the gravity of the Neutron Star. Gas is pulled off from this giant tide, falls at high speed into the Neutron Star, and produces x-rays.

Neutron Stars have collapsed because of large gravity forces. If gravity pulls a star to an even smaller radius, the star becomes an invisible Black Hole, a collapsed mass of extremely high density. Neutron Stars and Black Holes are described in Pamphlet II.



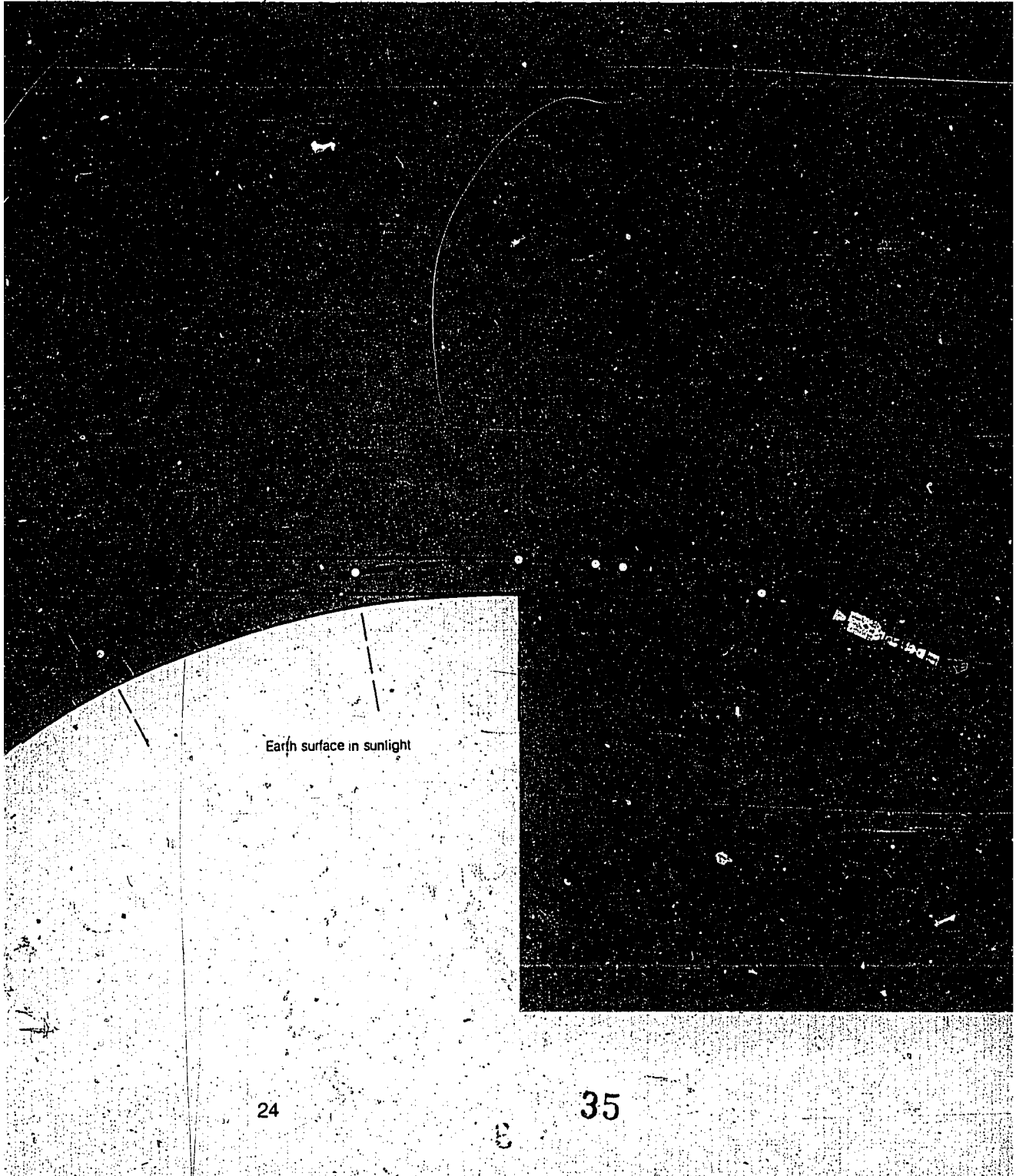
Explanation of the SMC X-1 x-ray pulsar. The small Neutron Star is spinning rapidly as it circles the huge blue giant star. The Neutron Star has a "hotspot" on it from which most of the x-rays come. They are detected when the hotspot faces the Earth.

Figure 3.2

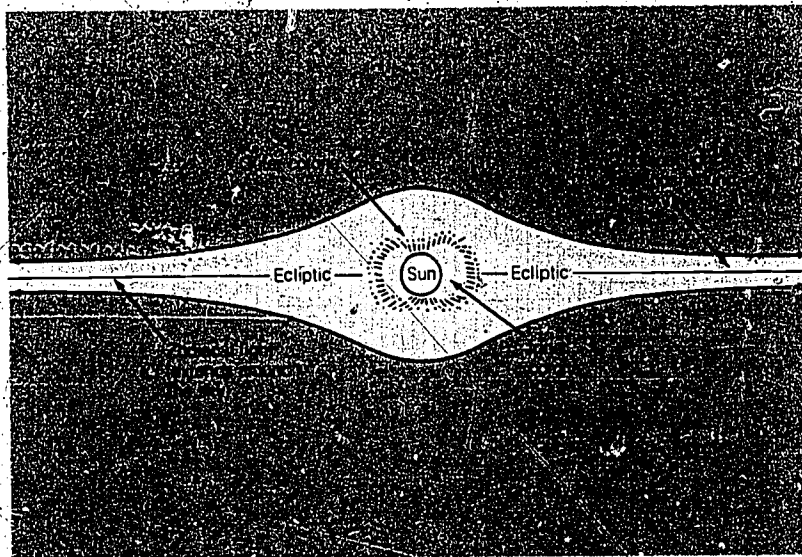
## C Artificial Solar Eclipse

In one of the joint experiments (MA-148), Apollo was undocked from Soyuz and moved about 200 meters ahead, along a line toward the Sun. At this distance, Apollo looked twice as large as the Sun, as seen from Soyuz. During the separation, Apollo occulted the Sun from Soyuz' view (Apollo's shadow covered Soyuz). Figure 3.3 shows the lineup, with Apollo between Soyuz and the Sun just before spacecraft sunrise.

**Figure 3.3** Orbit and separation of Apollo and Soyuz for the Artificial Solar Eclipse, Experiment MA-148. The lower arc is the surface of the Earth; the Apollo-Soyuz orbit (dashed line) is shown 222 kilometers above it. Six positions are shown, from sunrise (at the right) to redocking (at the left). The two horizontal lines show the direction of sunlight from which Apollo shadowed Soyuz.



The cosmonauts had a camera mounted at the window in the forward hatch of the Soyuz Orbital Module where the Docking Module had been docked. This camera was automatic; it repeatedly took six exposures of 1/6 second to 11 seconds on special high-speed Kodak film. (No one was sure of the proper exposure for the solar corona—the faint cloud of gases surrounding the Sun.) The Soviet scientists wanted to measure the brightness of the corona out to 3 million kilometers from the surface of the Sun. The corona fades into zodiacal light, as shown in Figure 3.4. The cosmonauts took several good photographs and a number of poor ones. When Apollo fired its jets to keep in the proper orientation, the jet gases were illuminated by the strong sunlight and showed up on the photographs, covering the solar corona. The best photographs, taken when the Apollo jets were off, were measured to get the brightness of the corona and the zodiacal light. These brightnesses were three times brighter than similar measurements made from airplanes during a solar eclipse by the Moon. In the airplane view, some corona light was absorbed. Also, light was scattered by the Earth's atmosphere—the sky background was not totally black for the airplane view. It is also possible that the corona was three times brighter in 1975 than it was in 1954 when the airplane measurements were made.



Schematic diagram of the inner corona, the outer corona, and the zodiacal light. Except for the edge of the Sun, there are no sharp edges to any of these regions.

Figure 3.4

## D Questions for Discussion

(X-Rays, Solar Eclipse)

5. X-rays are made by machines in the dentist's office or in the hospital. In these x-ray machines, high-speed electrons are fired at a target, using 20 000 or 30 000 volts to speed them up in a vacuum tube. How is this similar to what occurs in an x-ray pulsar?

6. Why couldn't the Russian scientists photograph an artificial solar eclipse from the ground by using a tall chimney to block out the Sun?



# 4 Geoscience Experiments

Two experiments (MA-089 and MA-128) were designed to measure small deviations in the Earth's gravity due to regions of the crust where the density is higher or lower than average. Accurate measurements were made by radar of the distance between two orbiting spacecraft as they passed over such a region. The changes in this distance indirectly measured the changing force of gravity (see Pamphlet IV). Another experiment (MA-059) measured the density of oxygen and nitrogen in the Earth's atmosphere at an altitude of 222 kilometers by observing their effects on a beam of light reflected back and forth between the spacecraft (see Pamphlet V). Two other experiments are described here.

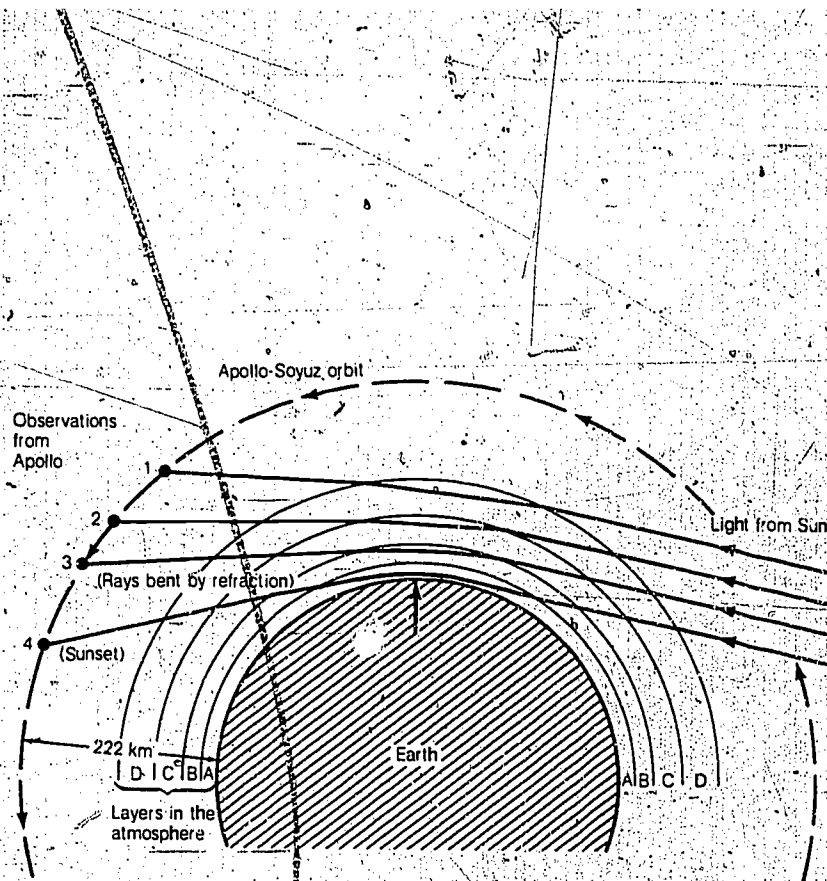
## A Aerosols

T. J. Pepin of the University of Wyoming was the Principal Investigator for MA-007, an experiment to measure how much sunlight is absorbed by the Earth's atmosphere just after spacecraft sunrise or just before spacecraft sunset. From these measurements, the amount of aerosols in the atmosphere could be estimated. The measurements from Apollo were compared with those made from the ground. (These measurements are given in Pamphlet VI.)

Aerosols are very small particles of dust or droplets of liquid like those from an aerosol spray can. The droplets from these spray cans do not pollute the upper atmosphere. It is the *Freon gas* in the cans that rises high into the atmosphere and reduces the amount of ozone ( $O_3$ ) by chemical reactions. Reduction of this ozone allows more ultraviolet sunlight, which causes sunburn and skin cancer, to come through the atmosphere.

The path of sunlight through the atmosphere to Apollo just before sunset is shown in Figure 4.1. The light reaching Apollo at point 4 passed through air in "layer A," very close to the surface, and was affected by aerosols at low altitude. Earlier, light passed through higher altitude air to reach point 3. The MA-007 Experiment used measurements of the Sun's brightness for 1.5 minutes before sunset to estimate the amounts of aerosols in layers A, B, C, D, and so on. Of course, the sunlight received at point 4 passed through layers B, C, and D as well as layer A, so the calculation is complicated.

Sunset from Apollo-Soyuz was much quicker than we see on the ground because the spacecraft had a "day" of only 93 minutes instead of our 24 hours. The Sun's changing brightness was measured with an instrument called a photometer, aimed at the Sun through a window in the Apollo Command Module. The photometer brightness readings for 1.5 minutes before sunset were recorded and later converted to curves of aerosol density versus altitude. These curves fitted measurements made from the ground and extended them up into the stratosphere, 20 to 30 kilometers above the Earth's surface.



**Figure 4.1** Schematic diagram of MA-007 sunset observations. The layers in the atmosphere and the Apollo-Soyuz orbit are exaggerated for clarity. The Sun's rays passing close to the Earth's surface are bent downward by refraction due to the higher density in the lower layers of the atmosphere.

The aerosol liquid droplets in the Earth's atmosphere seem to be sulfuric acid ( $H_2SO_4$ ) and water, which probably come from volcanoes on the surface. The volcanoes spew out hydrogen sulfide ( $H_2S$ ) and sulfur dioxide ( $SO_2$ ) gases that rise high in the atmosphere. As they rise, they react with each other under the influence of sunlight to form sulfuric acid. The MA-007 Experiment showed that there were more aerosols in the Northern Hemisphere than in the Southern Hemisphere on July 22, 1975. This was probably due to a volcano in Guatemala (south of Mexico) that erupted in October 1974.

The results of the MA-007 Experiment on Stratospheric Aerosols show that this technique of measuring sunlight at spacecraft sunrise and sunset can be used to determine the amount of dust and droplets high in the Earth's atmosphere. Such aerosols can affect the weather, so measurements of this kind are important for all of us on Earth.

## B Clouds, Water Currents, and Landforms

A large number of downward photographs were taken from Apollo-Soyuz. Such photographs from previous spacecraft had been found very useful. The spacecraft are much higher than airplanes, so the photographs can give a broader view (several hundred kilometers across). On such photographs, scientists can recognize the cloud patterns of an entire storm front and follow warm currents of seawater like the Gulf Stream along the U.S. Atlantic coast. On photographs of large land areas that are not obscured by clouds, geologists can trace mountain chains, river valleys, and breaks in the Earth's crust called rifts. They can spot old volcanoes and craters formed where large meteors hit the Earth long ago. Biologists use such photographs to see how green the forests are, how crops are growing, and where deserts are drying up the land.

The photographs and the astronauts' descriptions of the views they saw were organized in Experiment MA-136 by Farouk El-Baz of the Smithsonian Institution in Washington, D.C. The astronauts were provided with several cameras, two of them automatic. A camera was firmly mounted on a special window in the Apollo Command Module, and its exposures were automatically timed so that each photograph overlapped the one before and the one after. A 60-percent overlap was used to ensure that every point along the groundtrack was photographed at least twice. Pairs of photographs could be measured to determine mountain heights and cloud heights. About 1500 photographs were taken. Seven of the most interesting color photographs are shown in Figures 4.2 to 4.8.

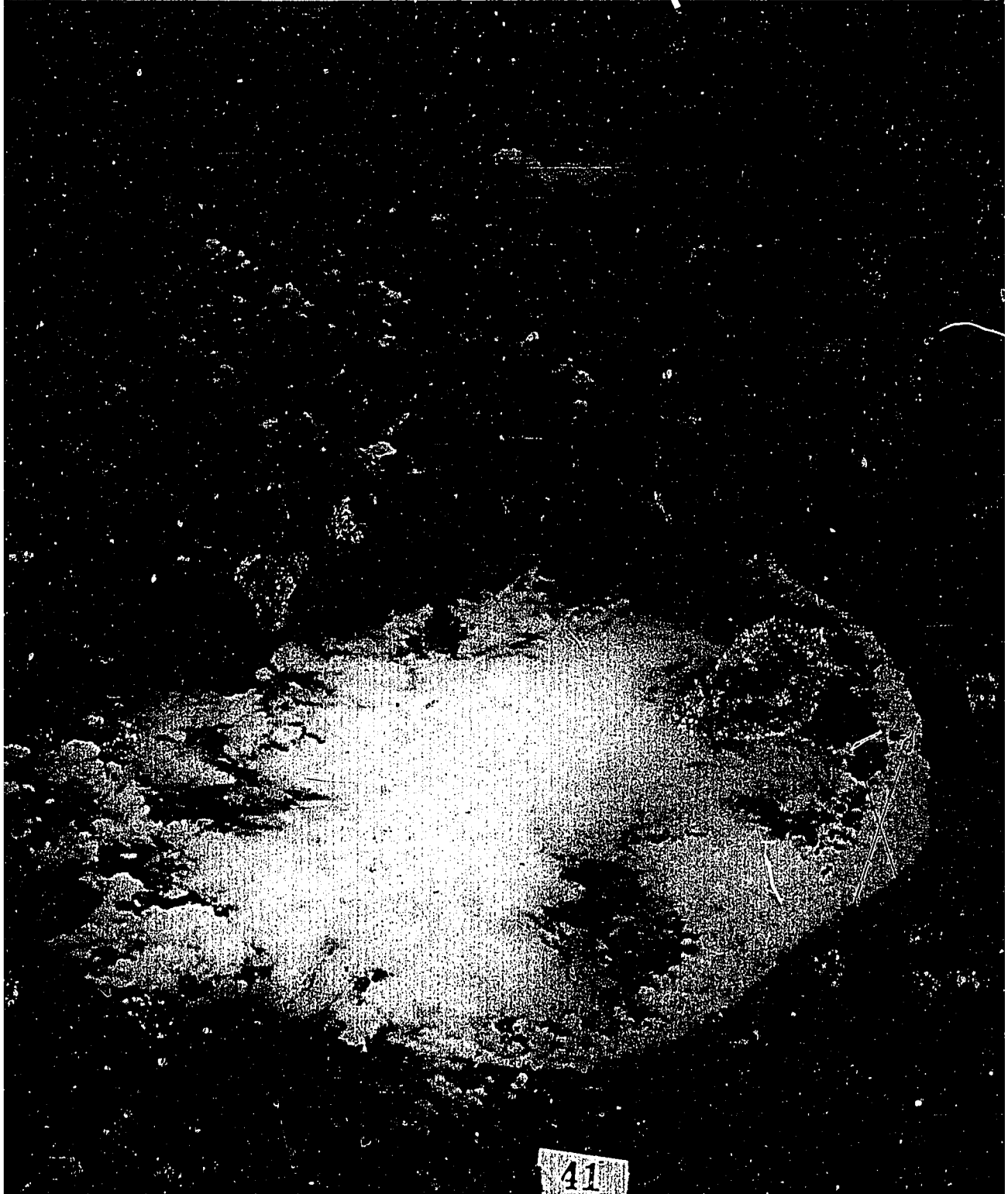
From their preflight training, the astronauts knew which areas were of most scientific interest. They tape-recorded descriptions in words, using a "color wheel" to specify the colors they saw. The color wheel was a paper disk with 54 reddish-brown colors and 54 bluish-green colors on it, each color with a number. The astronaut chose the color nearest the desert sand or seawater he was looking at and reported its number. He often caught glimpses of underwater features that did not appear on the photographs and also pointed out features that should be studied on the photographs later on (see Pamphlet V).

Ground crews made measurements at some of the 18 areas selected for MA-136 observations at the same time that Apollo-Soyuz passed overhead. For instance, several groups of ships measured salinity (amount of salt in the seawater), water color, red tides (poisonous plankton in the water), water currents, and types of clouds overhead. Other ground crews mapped part of the Western Desert in Egypt and measured the sand color in several places. The MA-136 photographs and astronauts reports agreed with these "ground-truth" measurements and extended them over much wider areas.

A storm over the South Atlantic Ocean is shown in Figure 4.2. Winds blowing clockwise around a low-pressure area form a spiral of clouds. Similar

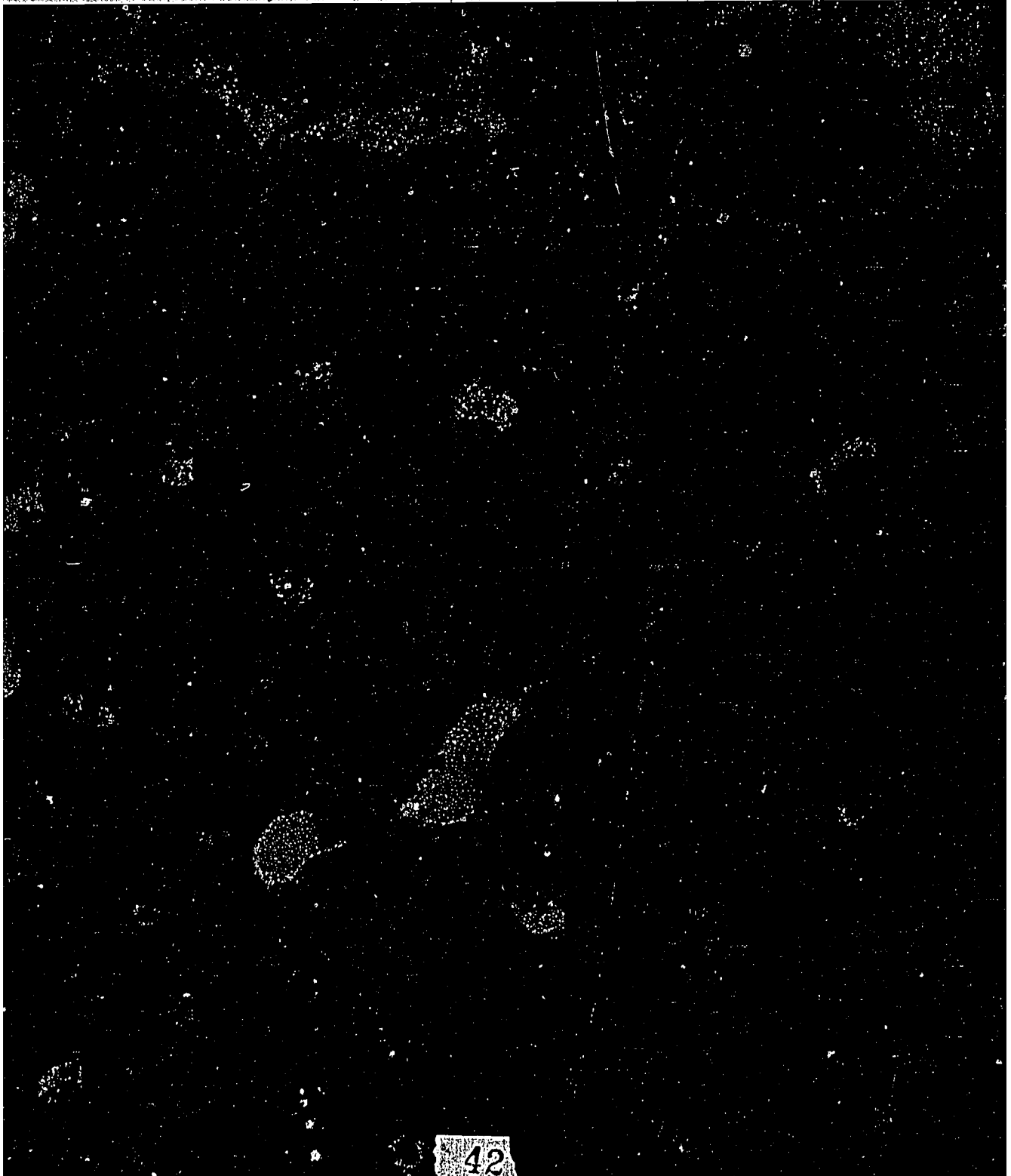


**Figure 4.2** Storm clouds over the South Atlantic Ocean. Note the spiral pattern caused by winds blowing in toward a low-pressure area.



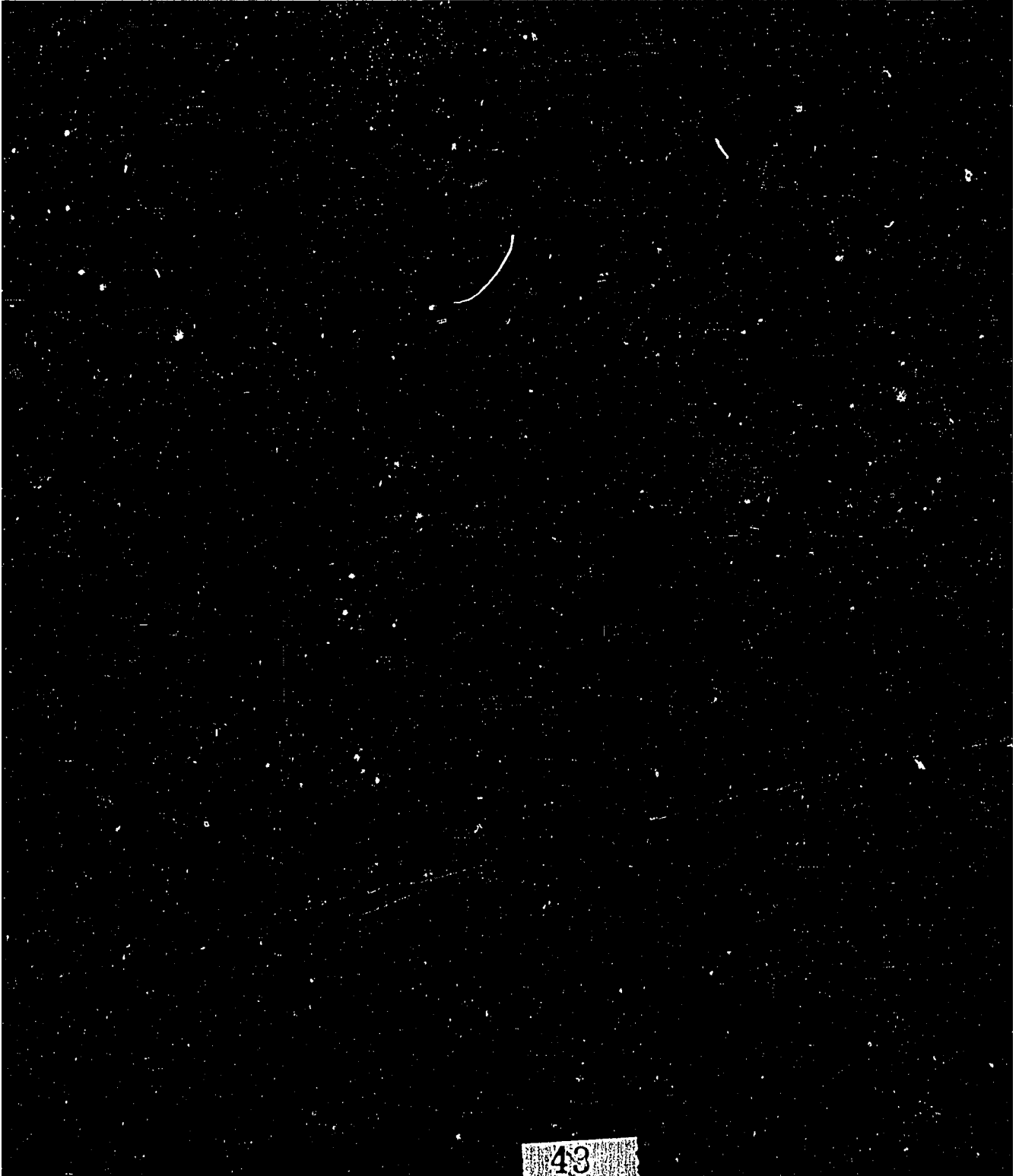
41

Sunlight reflected from the Paraná River in Peru and Brazil. The zig-zags built up over thousands of years as the river wore away its banks.



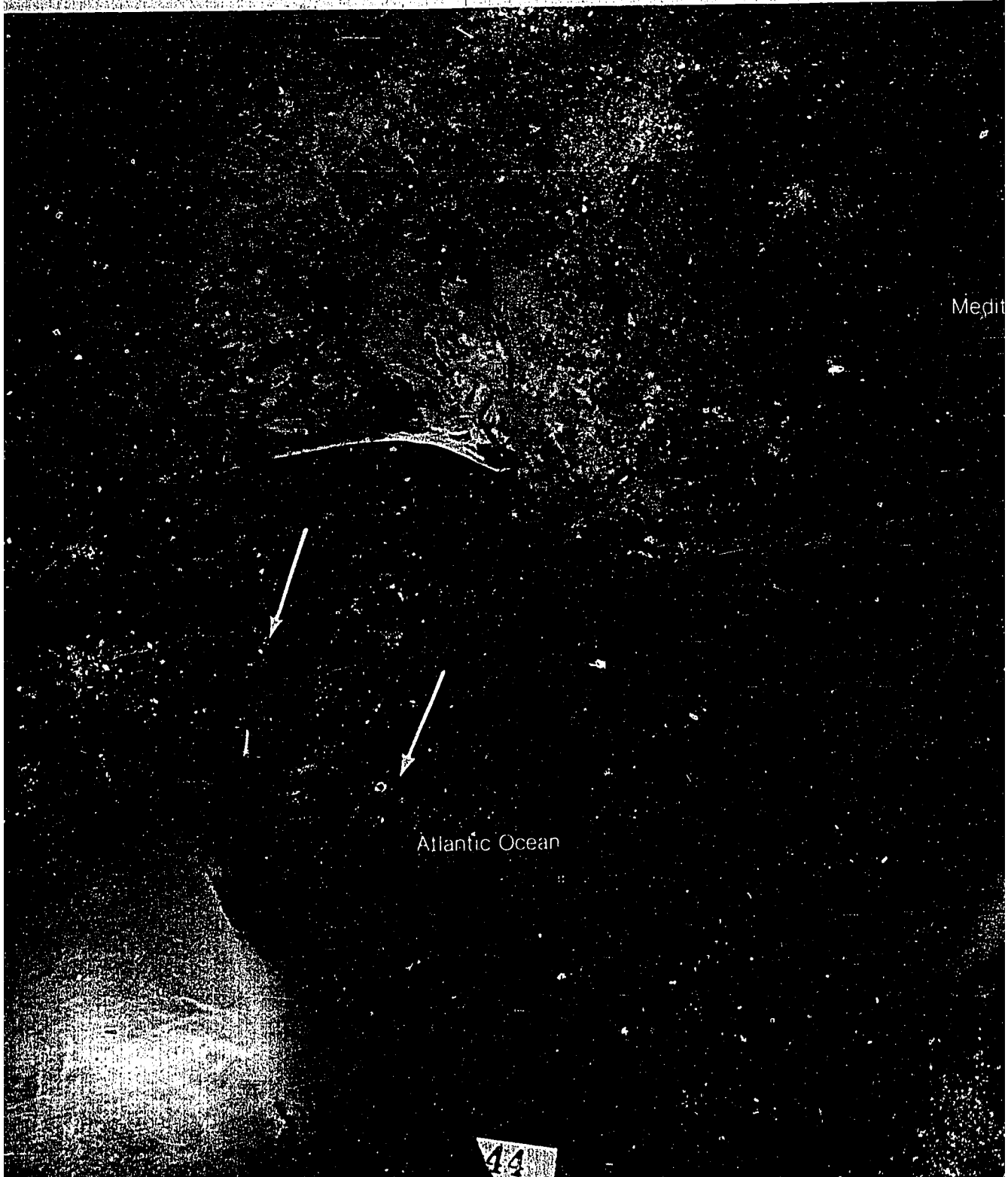


**Figure 4.4** View across Spain into the Mediterranean Sea. The Strait of Gibraltar is in the foreground, and the curved horizon (top) shows the atmosphere's airglow as a hazy blue band.



Internal waves in the Atlantic Ocean west of Spain. In this vertical view, sunlight is reflected from the ocean surface at the lower left. Just to the right of that, you can see faint blue stripes caused by the internal waves.

Figure 4.5



photographs at a smaller scale are provided by television in unmanned weather satellites for use by weather forecasters.

In Figure 4.3, sunlight is reflected from three rivers in Brazil and shows the zig-zag pattern of an old meandering river. The silt carried by the slowly flowing river is deposited in natural levees—banks along the river's zig-zags. These levees are not fixed but move slowly as the river wears them away and drops more silt. Figure 4.3 and other photographs show that these levees dam up ponds and swamps on either side of the river. Most of the valley is thus unsuitable for agriculture or highways or other development being studied by Brazilian and U.S. geographers.

As Apollo-Soyuz passed over the Strait of Gibraltar, the astronauts took a photograph that shows the curved horizon far across the Mediterranean Sea (Fig. 4.4). A little later, they took a downward view of the Atlantic Ocean west of Spain (Fig. 4.5). Sunlight is reflected off the ocean surface in the lower left corner of the photograph. To the right of that reflection, you can see long, dark-blue stripes, which indicate the presence of salinity deep in the water. Some of these stripes are more than 50 kilometers long. The internal waves in the sea are probably caused by the more salty Mediterranean water flowing out through the Strait of Gibraltar and can only be seen (or photographed) when the lighting is just right.

A vertical view of the Nile River Delta is shown in Figure 4.6. Sunlight is reflected off the Mediterranean Sea just north of the Egyptian coast. Around the edges of the Sun's reflection, you can see patches of white, which may be the freshwater of the Nile River mixing with the saltwater of the sea. The Suez Canal is off the photograph to the top right.

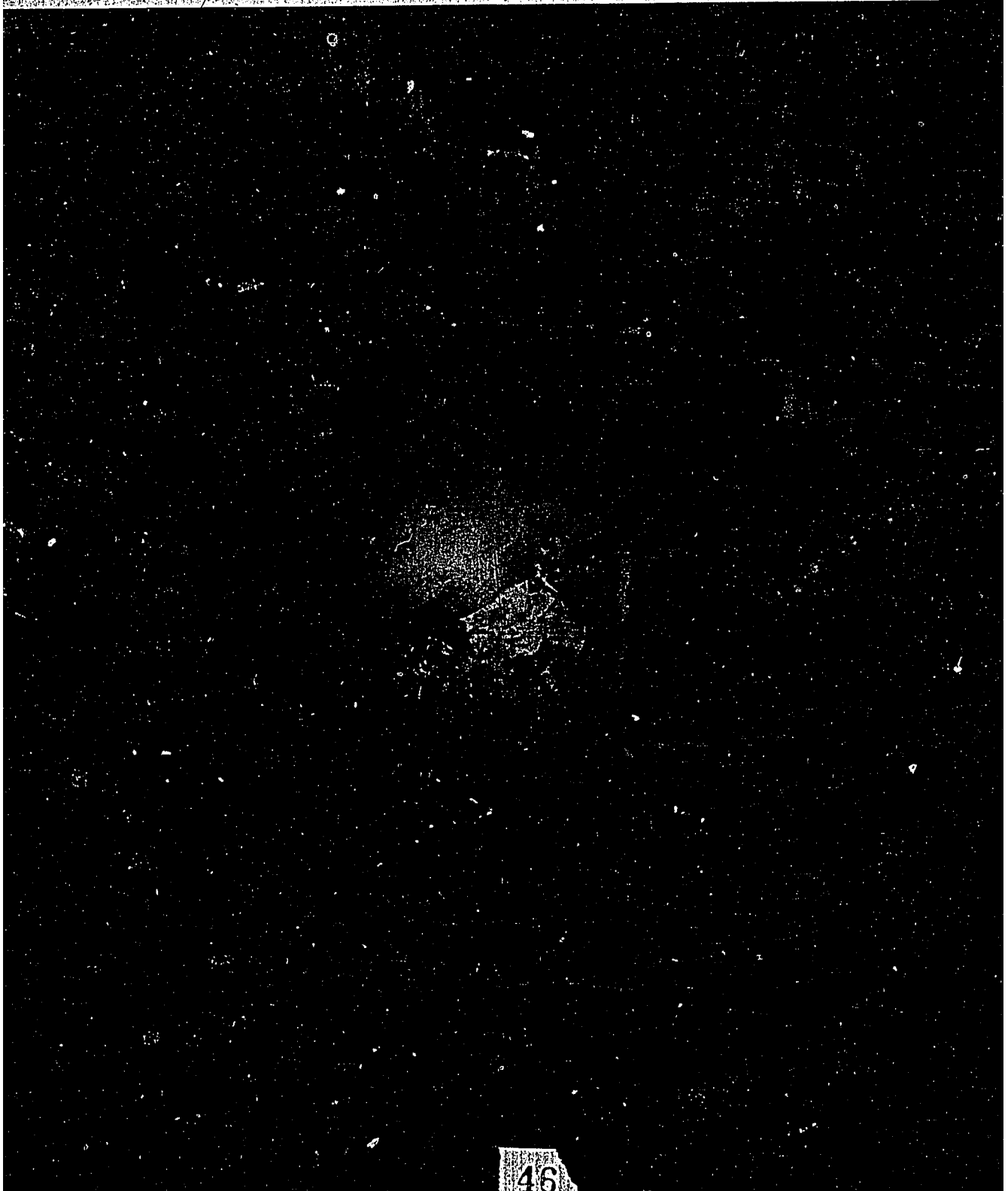
Differences in sand color are shown in Figure 4.7, a vertical view of a desert in Australia where new (yellow) sand is advancing over older (dark red) sand. This difference in color was confirmed by ground-truth teams.

Figure 4.8 shows the Levantine Rift, a crack in the Earth's crust that runs through the Dead Sea northward along the Jordan River through the Sea of Galilee in Israel. It was described by the astronauts as splitting into three rifts north of the Sea of Galilee. The westernmost of these three cracks is partly covered by clouds.

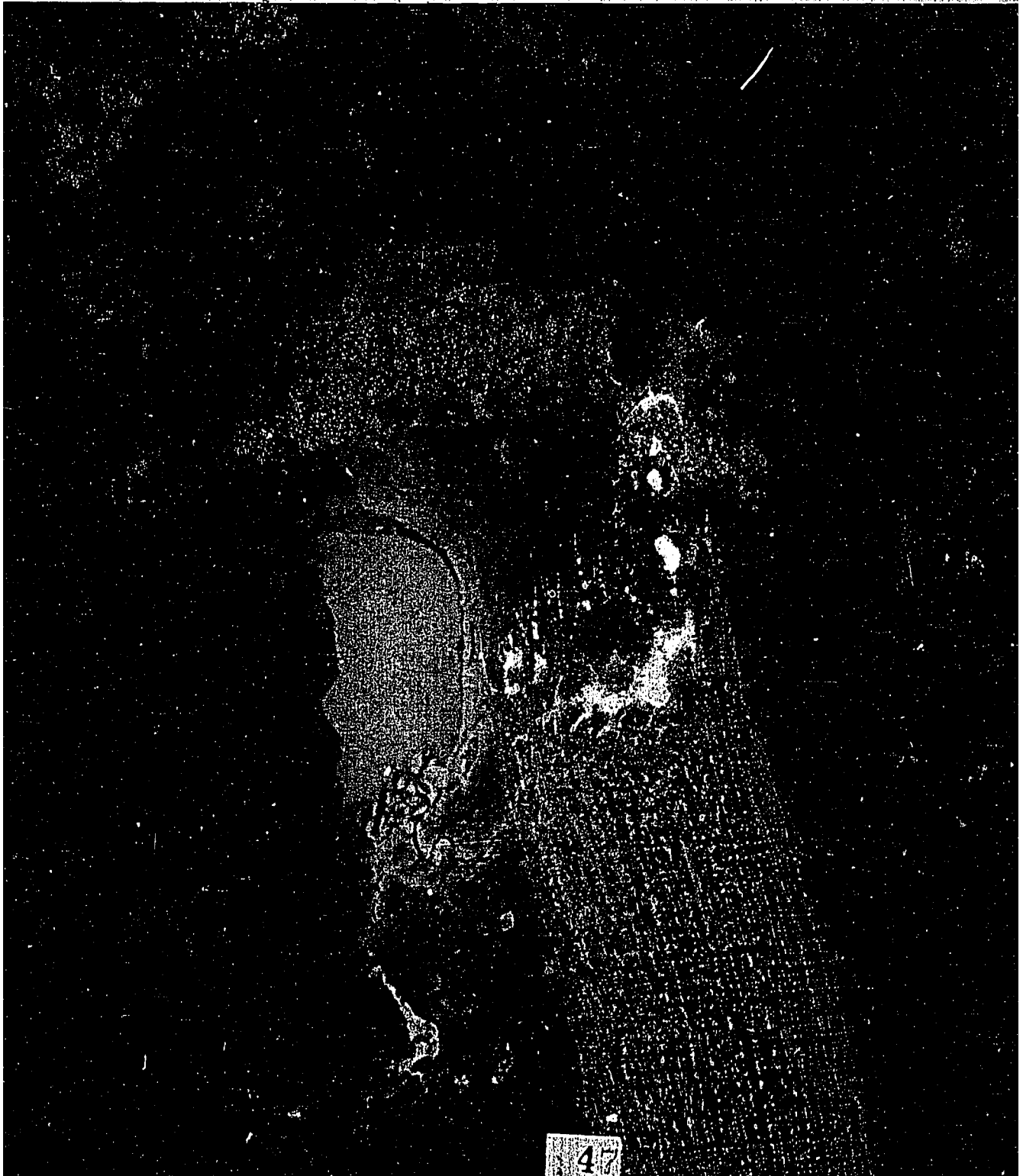
These and many other MA-136 photographs and descriptions are being studied by scientists who are interested in slow movements of the Earth's crust. They believe that North America drifted away from Europe and South America drifted away from Africa during the last 250 million years. The Levantine Rift shows that the Arabian Peninsula is now twisting away from Egypt and Africa. The scientists have traced slow continental drifts like this and made maps of what the land areas of the world looked like 500 million years ago. At that time, there was one big continent, now called Pangaea. It later split up into North and South America, Europe, Africa, Asia, and Australia.

The Nile River Delta. The bright patch is sunlight reflected from the sea surface. The delta or triangle of land at the river mouth is made of soil washed down from the mountains of Africa over many millions of years.

Figure 4.6



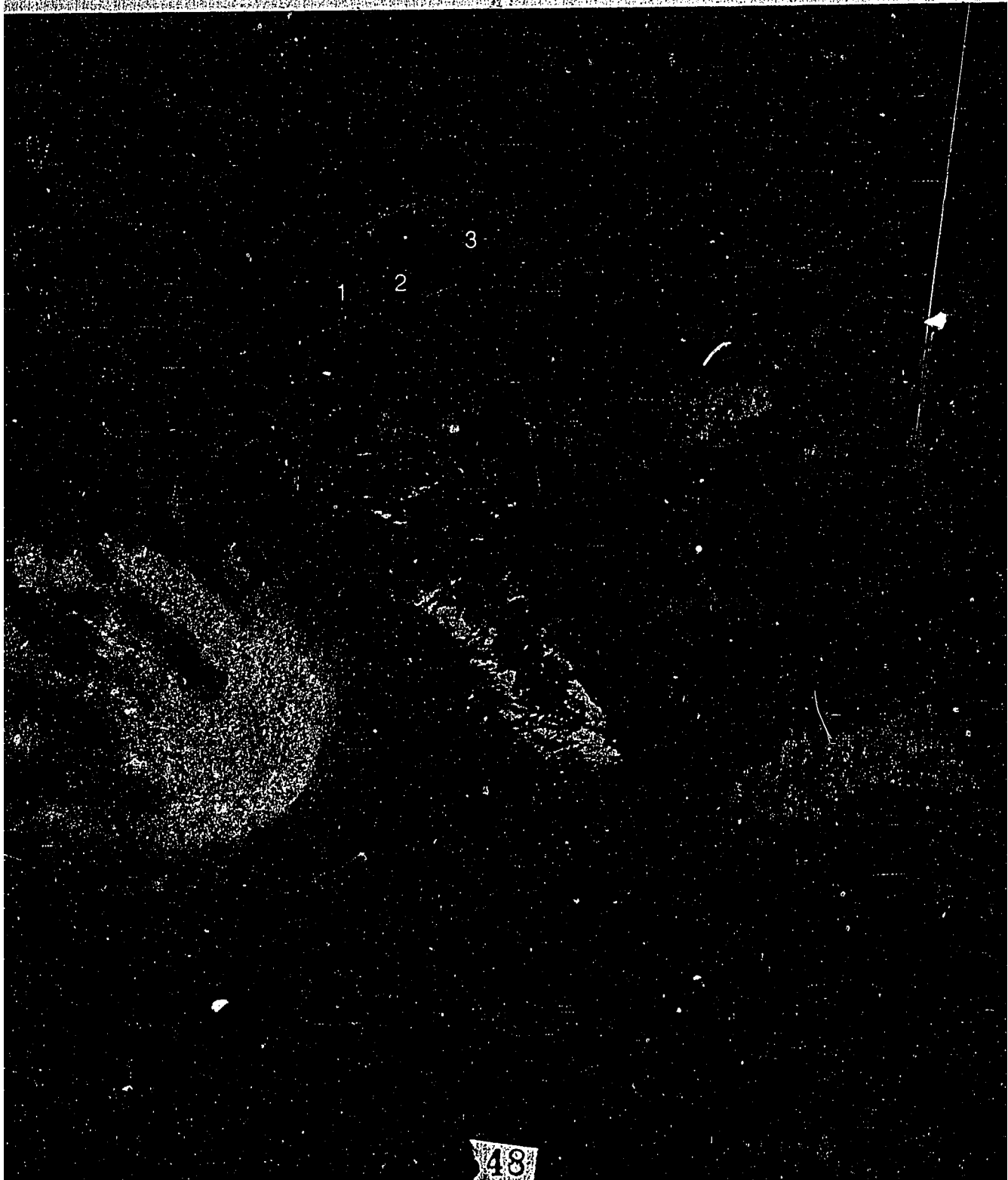
**Figure 4.7** The Simpson Desert in Australia. Note the color differences between old (red) sand and new (yellow) sand and the linear sand dunes that looked like "hundreds of parallel road tracks" to the astronauts.





The Levantine Rift in Israel. This crack in the Earth's crust extends from the Gulf of Aqaba at the northern end of the Red Sea through the Dead Sea (lower right) to the Sea of Galilee. It was probably caused by a twisting of the Arabian Peninsula away from Africa in the general continental drift.

Figure 4.8



## C Questions for Discussion

(Sunset, Refraction, Aerosols, Geometry)

7. On a very clear evening, you might see the Sun first touch the horizon at 6 p.m. About 2 minutes later, the top of the Sun would disappear below the horizon. How long did this sunset take as seen from Apollo-Soyuz?

8. Why are the rays of light bent downward in Figure 4.1?

9. Why do scientists think that the aerosols measured in the MA-007 Experiment came from volcanoes rather than from factory chimneys?

10. Show by drawing a diagram how two photographs of a cloud taken from two places in Apollo's orbit 60 kilometers apart and at a height of 222 kilometers can be used to measure the height of the cloud.

11. Show by drawing a diagram how far away the horizon is from the spacecraft in Figure 4.4, taken from 222 kilometers altitude.

12. If you were an astronaut describing the view shown in Figure 4.8, what aspects would you report?

# 5 Biology Experiments

For biologists, Apollo-Soyuz offered two conditions that cannot be matched in ground-based laboratories: (1) everything in the spacecraft was *weightless* and (2) everything was bombarded by many more high-energy *cosmic rays* than on the Earth's surface. In addition, the astronauts and cosmonauts were sealed in a fairly small space together with bacteria and other microbes. These conditions were used in nine biological experiments as well as for many medical tests made on the astronauts and cosmonauts before and after the flight. Many of these experiments and tests were continuations of space-medicine measurements made on previous NASA and Soviet flights. Ever since the beginning of the Space Age, people have wondered how the conditions in a spacecraft would affect humans, and the early flights were carefully controlled so that astronauts would not suffer or get sick. On Skylab, three astronauts stayed in orbit for a record 84 days without serious effect, which shows that the human body can adapt to spaceflight conditions.

The high intensity of cosmic rays in a spacecraft probably will set the time limit for humans in space. The effects of cosmic rays have been studied on small living organisms such as spores, seeds, and eggs. So much variability exists that many organisms must be studied to get results that are valid on the average. The cosmic rays themselves are not simple. They are a mix of nuclei from different kinds of atoms moving at speeds close to the velocity of light. The dangerous ones have high mass and high charge (compared to a proton) and very high speed (high energy); they come from all directions and are called galactic cosmic rays (see Pamphlet II). Other cosmic rays of lower energy come from the Sun. Biological effects are also produced by high-speed (low-mass) protons that oscillate between the Earth's magnetic poles in the Van Allen belt (see Pamphlet VI). Many of these particles produce additional ("secondary") particles and rays when they hit the metal in the spacecraft; that is, when a high-speed proton hits the nucleus of an aluminum atom, it can "knock out" a neutron or create an x-ray. Astronauts, seeds, and spores in Apollo-Soyuz were thus bombarded by galactic cosmic rays, solar cosmic rays, Van Allen-belt protons, and secondaries in varying proportions during each orbit around the Earth.

The effects of weightlessness or zero-g are less complicated. Animals and humans are confused by the absence of familiar gravity, and their body fluids, such as blood, tend to rise to the upper parts of the body because there is no gravity to pull the blood "down" into the legs. Astronauts who have spent several weeks in zero-g have lost body weight and have also lost calcium from their bones. These effects are well established, although biologists cannot yet explain the loss of calcium from bones.



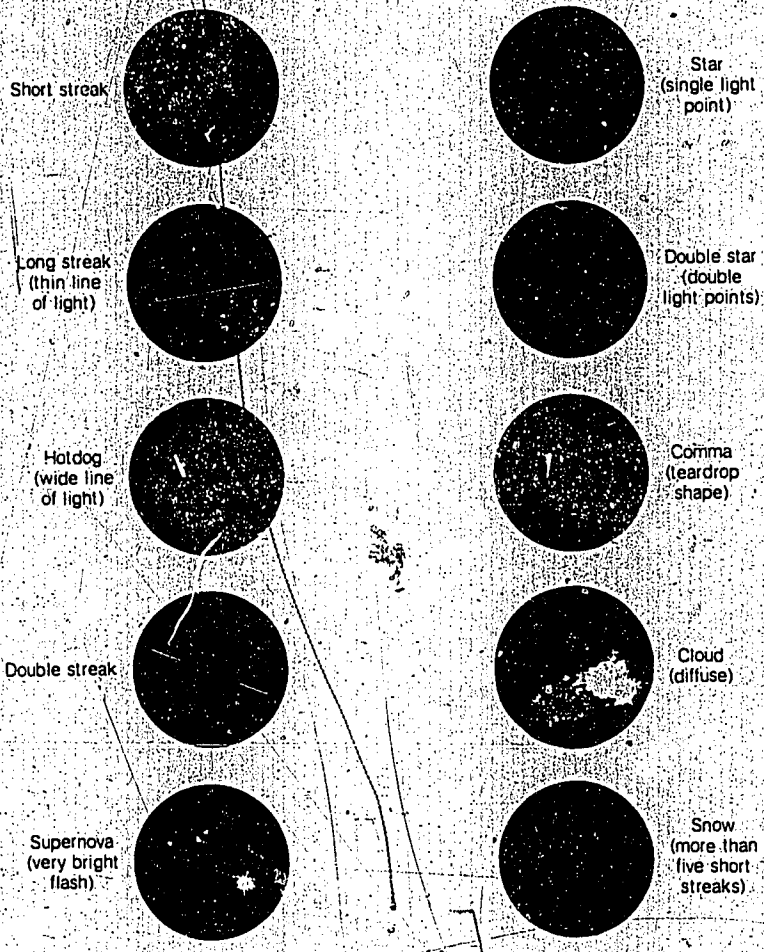
## A Light Flashes in Astronauts' Eyes

An unexpected effect of cosmic rays on humans was first noted on the Apollo 11 mission to the Moon in 1969. Astronaut Edwin "Buzz" Aldrin reported that he kept seeing flashes of light while his eyes were closed. On later flights, astronauts counted these flashes, and Bill Pogue (on Skylab in 1973) saw eight flashes per minute. T. F. Budinger, the Principal Investigator for Experiment MA-106, collected descriptions of these flashes and did some experiments with high-energy ions shot out of a cyclotron in his laboratory. He knew exactly what kind of particles were in the cyclotron beam and what energy they had as they entered the heads of the volunteers. If Budinger aimed the beam through the brain, the volunteer did not see a flash. It was only when the high-energy ions passed through the eye that flashes were seen.

The many different shapes and sizes of flashes reported by the astronauts in space and by the volunteers at the cyclotron are shown in Figure 5.1. These different shapes and sizes complicate the explanation of how the flashes are produced. The simplest idea is that a cosmic ray causes a flash when it passes through the eye's "detector," the retina. The retina is a region at the back of the eyeball where nerve endings are sensitive to the light focused there by the lens at the front of the eye. The cosmic ray ionizes a few atoms or molecules, which produces a signal in the optic nerve. This signal is interpreted by the brain as a "single star" (upper right in Fig. 5.1), or perhaps a "comma." The "diffuse cloud" flashes seem to be something different.

The "long streak" might be caused by a cosmic ray that crosses along the retina surface. Double stars and double streaks are most probably caused by a cosmic ray that hits two parts of one eye or perhaps passes through both eyes (since no one can tell which eye sees any flash). The "diffuse cloud" could be caused by galactic cosmic rays with very high energy, high mass, and high atomic number  $Z$ . Because they are moving so fast, these "HZE particles" (for High- $Z$ , High-Energy) might produce a flash of light like a shock wave as they enter the eyeball (see Pamphlet VI). This idea has not yet been checked in the laboratory.





Shapes and sizes of reported light flashes. These 10 pictures were sketched to illustrate flashes reported by astronauts and by volunteers in the cyclotron laboratory.

Figure 5.1

The MA-106 Experiment on Apollo-Soyuz involved two astronauts. They were blindfolded 15 minutes before the experiment started so that their eyes would be adapted to the darkness. When either one saw a flash, he pressed a button and described the flash into a tape recorder. For one complete orbit (93 minutes), the two men recorded the flashes that they saw in different parts of the orbit. Cosmic-ray detectors were located near their heads to record the physical nature of the particles (see Pamphlet VI). The number of flashes counted per minute matched the measured intensity of cosmic rays, which changed with the latitude of Apollo-Soyuz. (The intensity of cosmic rays is higher near the North and South Poles than near the Equator—an effect of the Earth's magnetic field.)

A map of the Earth with the Apollo-Soyuz groundtrack on it and the times (GMT) when the spacecraft passed over is shown in Figure 5.2. The light-flash experiment started at 15:00 GMT when Apollo-Soyuz was just south of Alaska at the top left of Figure 5.2; it ended at 16:35 GMT at the top right.

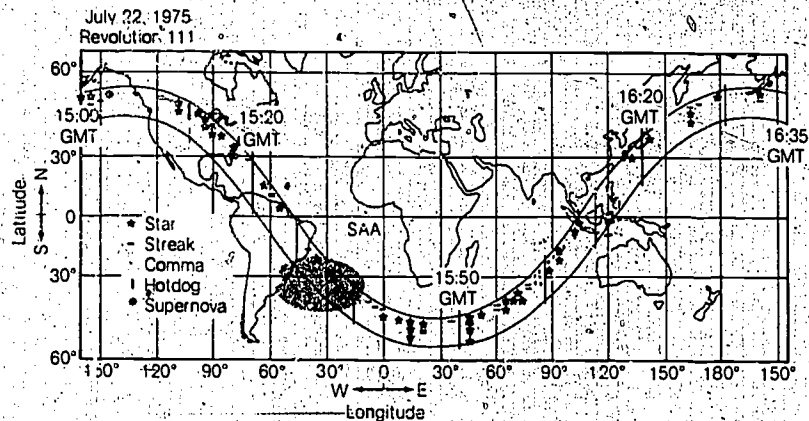


Figure 5.2 Orbit track, location, and type of light flashes. The six symbols are defined at the left as types of flashes pictured in Figure 5.1.

Along the groundtrack are shown the flashes that were reported: one "supernova" and two "hotdogs" (upper left) and many stars, streaks, and commas. Note that most of the flashes were seen at latitudes larger than 30° N or S, except for a group near 90° E longitude and a few near 60° W longitude. At 30° W longitude, "SAA" refers to the South Atlantic Anomaly, a place where the radiation in the Van Allen belt is very intense. Many high-energy protons (see Pamphlet VI) were expected at the South Atlantic Anomaly because they had been detected there by instruments on Skylab at a 440-kilometer altitude. The intensity of these protons at the 222-kilometer altitude of Apollo-Soyuz was 23 times less than in Skylab, partly because the thicker walls of Apollo were a better shield than the thin walls on Skylab. However, many protons still got through to the astronauts' eyes in Apollo-Soyuz, and Budinger explains the three or four flashes seen near the South Atlantic Anomaly as nuclear reactions between high-speed protons and atoms in the retina (carbon, nitrogen, and oxygen). When a proton collides with one of these atoms, the atom explodes and shoots out a high-speed alpha particle (helium nucleus). This alpha particle can ionize other atoms in the retina and cause a star or streak (Fig. 5.1) even though the original high-speed proton could not itself produce a flash.

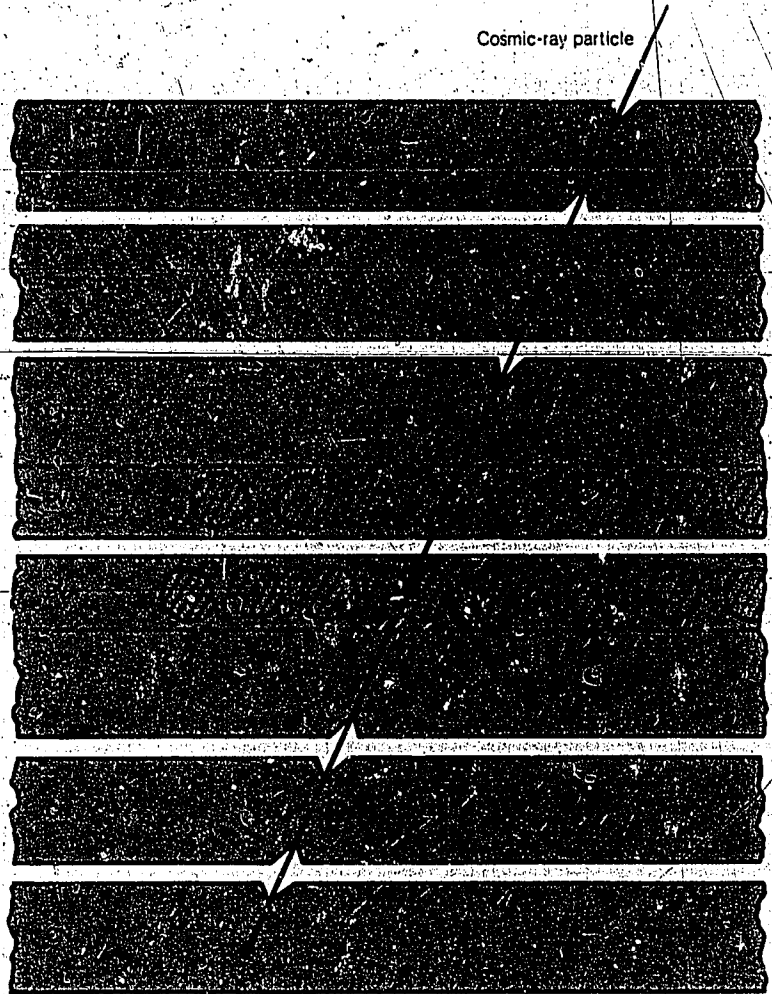
The MA-106 Experiment shows that high-energy cosmic rays cause the light flashes in astronauts' eyes, but more work must be done to explain the various shapes and sizes of the flashes and to discover whether cosmic rays will damage the retina or brain cells in people on long spaceflights in the future.

## B Biostack III

In the Biostack III Experiment, large numbers of living organisms— $5 \times 10^9$  spores, 23 000 seeds, and 30 000 eggs—were stacked with interleaved sheets of plastic that record the passage of cosmic rays. Biostack III was a German experiment (MA-107) and was supervised by Horst Bucker of the University of Frankfurt, assisted by 32 Co-Investigators from West Germany, France, and the United States. Figure 5.3 shows the basic idea; to track the passage of each cosmic-ray particle through the stack from its effect on the plastic sheets (cellulose nitrate and Lexan) and from the blackening of special photographic film that is sensitive to particle tracks. These sensitive layers show which spore, seed, or egg the cosmic ray passed through. The spores, seeds, and eggs that were penetrated were later watched as they grew or hatched to see what effect the cosmic ray had.

After the Biostack was returned to Frankfurt, the photographic film was developed and the plastic sheets were "etched" with sodium hydroxide





**Figure 5.3** Diagram of Biostack III with a cosmic-ray track. This sketch shows a small part of the stack, greatly enlarged. Each sheet of cellulose nitrate (CN) and Lexan plastic is about 0.1 millimeter thick. PVA stands for polyvinylalcohol, a kind of glue used to stick the small spores, seeds, or shrimp eggs to the CN sheets. The cosmic-ray track was located from its effect on each CN and Lexan layer.



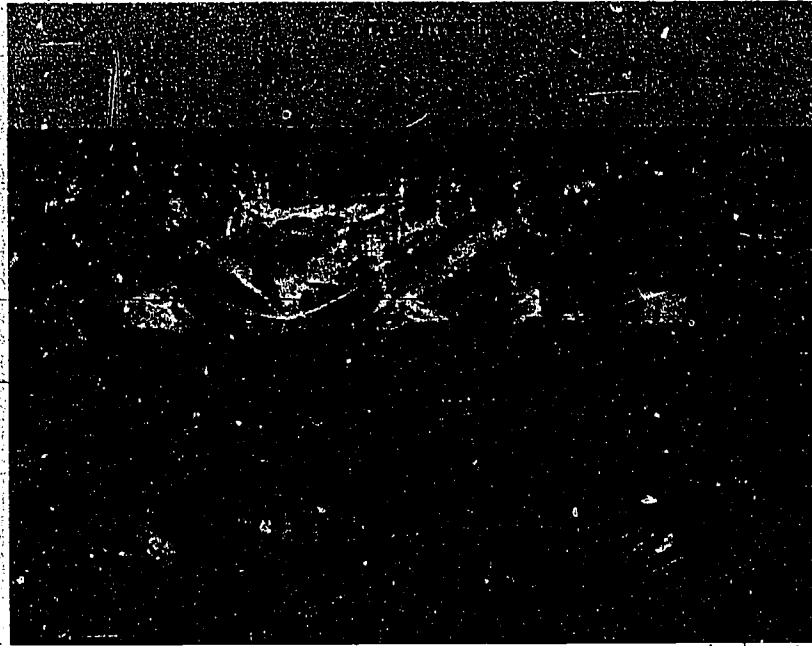
(NaOH), which dissolved the plastic where HZE particles had passed through. This etching left small tubes through the plastic that could be examined under a microscope to see which spore, seed, or egg had been "hit" (see Pamphlet VI). These spores, seeds, and eggs were lifted off the plastic with a special micromanipulator. Groups of spores, seeds, and eggs that were not near any cosmic-ray track were also gathered to be used as control samples. In these control groups, 90 percent of the spores formed bacterial colonies in a culture—a warm jelly that stimulates the growth of bacteria. Only 65 percent of the spores that were hit by cosmic rays formed colonies. The seeds that were hit sprouted, but some of their plants had smaller leaves than the plants of the control group. About 90 percent of the eggs that were hit hatched, but many of the shrimp larvae were deformed.

These Biostack results show that HZE cosmic rays generally damage small living organisms. The photographic film showed that many other high-energy particles produced "star tracks" where a cosmic ray exploded. If such an explosion occurred in a spore, seed, or egg, it would cause further damage. Further study of these results and similar experiments on future spaceflights should show how cosmic rays affect living cells, including those in humans on long spaceflights.

## C "Up" and "Down" for Fish in Zero-g

Like humans, fish know which direction is down on Earth. They swim with their bellies down. Like humans, they get this sense of up-down from the vestibular organ in the ear, which "feels" which way is down (along the force of gravity) and is responsible for a sense of balance. Like humans (astronauts), the fish are confused when put in a zero-g environment. The Killifish Hatching and Orientation Experiment (MA-161) was designed to measure the degree of confusion and to learn whether minnows hatched in zero-g would have less difficulty with up-down. The main parts of the vestibular organs are small calcium granules, called otoliths. It was expected that the development of the otoliths might be retarded in zero-g by the same kind of calcium loss that is observed in astronauts after several weeks in zero-g.

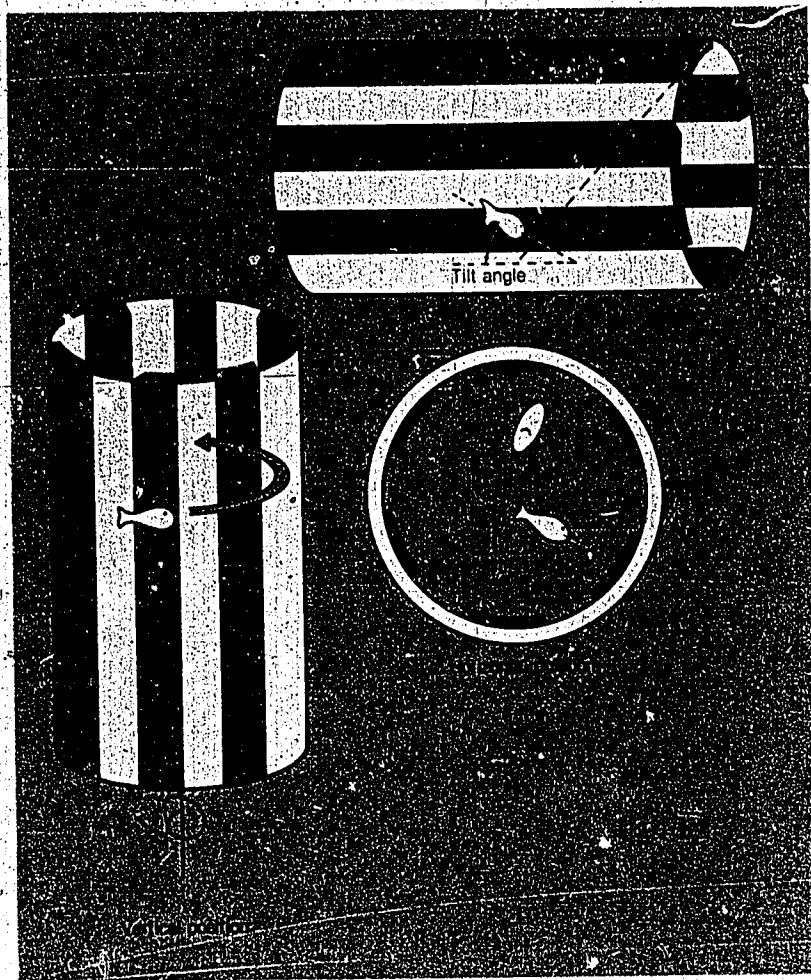
To verify this, the MA-161 Experiment had 10 plastic bags of seawater containing eggs and minnows on Apollo-Soyuz (Fig. 5.4): There were five bags of eggs of different ages, including one group that was almost ready to hatch and others that would hatch on Earth after return. The other five bags contained minnows about 21 days old at the time of the Apollo launch. The minnows in these bags had been "preconditioned"; that is, they had always lived in tanks that had stripes on the sides, or no stripes, or black overhead. This was to test whether the fish used their eyes to tell which way is up. In water on Earth, the bright sky is up.



**Figure 5.4** MA-161 bags of fish and eggs in water. Each of the five bags in the top row contained 100 eggs of one age group. Each bag in the lower row contained six minnows. The first bag had a gray background, the next two striped, and the next black. The fish in the fifth bag (lower right) were blinded.

Experiments had been made with minnows in one-g on Earth using striped cylinders that rotated slowly in the tank (Fig. 5.5). When a vertical cylinder with vertical stripes was rotated, the minnow picked one stripe and swam alongside it as the cylinder rotated. In a horizontal cylinder with horizontal stripes, the minnow would lean or dip in the direction of rotation. Rotating cylinders could not be carried on Apollo-Soyuz, but the minnows were tested before and after flight to determine whether zero-g had changed their behavior. It had not! During flight, in zero-g, the astronauts reported that all the minnows were confused at first. They swam in loops and circles, not knowing which way was down. After 2 or 3 days, the minnows decided that the dark side was "down" and swam with their bellies toward the wall of the Docking Module where the bags were attached. The fish in one bag had been blinded before launch, and they continued to swim in loops and circles, not knowing which way was down.

Ten of the eggs hatched in zero-g. The young hatchlings also decided that



**Orientation of fish in a rotating drum. When the drum was vertical, the minnow swam around following one stripe. When the drum was horizontal, the minnow would roll or tilt in the direction of rotation.**

**Figure 5.5**

the dark side of their water-filled bag was down. The other eggs hatched after Apollo splashdown, and these fish showed no effects of their time in zero-g. Several were dissected, and their vestibular organs and otoliths were found to be normal (there was no calcium loss). Many other tests were made on the minnows and hatchlings, but none of them showed any effects of the 9 days in

zero-g. It was concluded by the MA-161 scientists that fish eggs are unaffected and that 25-day-old minnows adapt to zero-g about as quickly as humans.

## **D Questions for Discussion**

(Light Flashes, Cosmic Rays, Zero-g)

13. If the astronauts had started counting flashes without waiting for their eyes to become adapted to the darkness, what errors might have been made in their reports?

14. The two astronauts reported 82 flashes in 93 minutes. If the rate had been much higher, what kind of error might have been made in the reports?

15. If flashes were counted on the way to the Moon, far from Earth, how would you expect the rate of flashes to differ from that of the MA-106 Experiment on Apollo-Soyuz?

16. At any one moment, did cosmic rays come in toward Apollo-Soyuz equally from all sides?

17. If cosmic rays damage and kill living cells, is it practical to build space colonies far from Earth where people would live all their lives?

18. In Skylab, where there was much more room than in Apollo and Soyuz, the crew quarters had a floor, a table, lockers and refrigerators on the walls, and overhead lights. In what way did the MA-161 Experiment create the same effect for the minnows' bags on Apollo-Soyuz?

19. At home, on Earth, someone can tell you that your supper is "on the top shelf of the refrigerator." How would you tell an astronaut in zero-g where his food was in a cabinet or refrigerator?



# 6 Materials Experiments

In zero-g, liquids behave differently than they do in one-g on the Earth's surface. When there is no downward force of gravity, other forces become important. Two of these forces in liquids are called *cohesion* and *adhesion*. Cohesive force tends to keep a liquid pulled together in droplets. Adhesive force tends to attract a liquid along the surface of a solid, wetting the surface as oil wets a metallic surface. Unless the cohesive forces are strong, two liquids mix better in zero-g because there is no gravity pulling the heavier liquid down. A liquid can even be mixed with a gas to give a long-lasting *foam* of small bubbles. When the liquids are molten metals, they can be cooled to form uniform *alloys*.

As described in Pamphlet VIII, several new technologies are developing for zero-g. One is concerned with handling liquids and gases aboard spacecraft—a matter of *housekeeping* in zero-g. Others are concerned with *manufacturing* and *processing* in zero-g. These include *biological* processes such as separating different kinds of cells (electrophoresis in Pamphlet VII), *chemical* processes such as producing fast reactions in foams and growing nearly perfect crystals, and *metallurgical* processes such as forming uniform alloys and making long, thin fibers.

## A Wetting, Wicks, and Foam in Zero-g

The strengths of cohesive and adhesive forces depend on the liquid and the solid surface. If cohesion is stronger than adhesion, as with water on a greasy surface, the liquid forms small drops and does not wet the surface. If adhesion is stronger than cohesion, as with oil on a steel surface, the liquid wets the surface smoothly. All this is familiar in one-g; however, the strong force of gravity complicates the measurement of cohesive and adhesive forces for various liquids and solids. Robert S. Snyder of the NASA George C. Marshall Space Flight Center therefore arranged three demonstrations for the Apollo-Soyuz mission. In the first demonstration, blue-colored oil was squirted into a cubical plastic cup. The oil quickly spread over the bottom and up the sides of the cup. The adhesive force between the oil and the plastic is stronger than the cohesive force of the oil. However, the cohesive force in zero-g could be determined by measuring the small amounts of oil that collected in the corners of the cubical cup. The cohesive force was able to resist the adhesive force in each corner because the adhesive force along each face of the cube terminated at the corners.

The second demonstration on Apollo-Soyuz showed how well wicks work in zero-g, where the fluid being "sucked up" has no weight. Wick action is due to the strong adhesive force between the liquid and the solid fibers of the wick. For instance, the wick of a candle sucks molten wax up about 5

millimeters, where it burns easily in the candle flame. A towel acts as a wick when it lifts water off a surface to dry it. In zero-g, wicks can be used instead of pumps to transport liquids from tanks to wherever they are needed in a spacecraft.

The wick demonstration used four different wicks, each 10 centimeters long and 1 centimeter wide. Three of the wicks were made of stainless-steel wire interwoven in different ways. The fourth was made of nylon. Each wick was held in a frame so that it dipped into a plastic cup at one end. Blue-colored soapy water and blue-colored silicone oil were squirted into the cups, and the motion of the fluids up the wicks was timed. Both the oil and the water moved up the wicks much faster than expected, and the oil moved up faster than the water. Timing showed that the stainless-steel wick with a Plain Dutch weave was the most efficient.

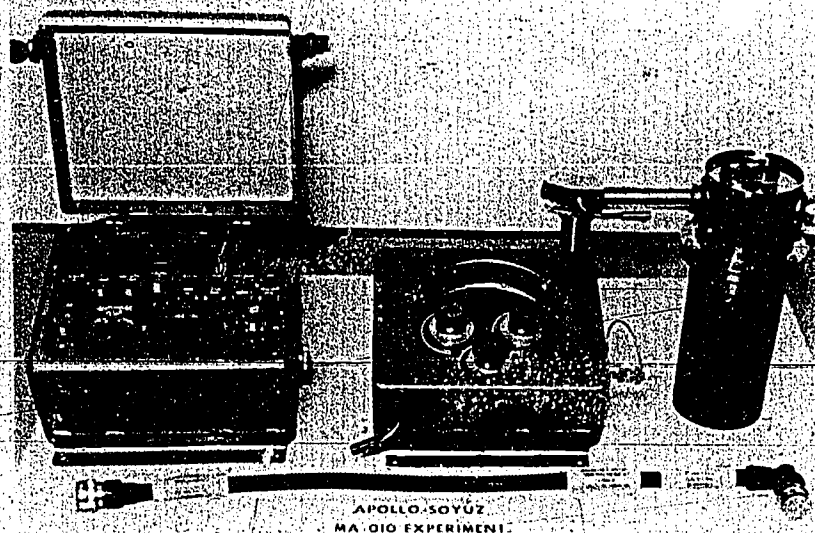
Some chemical reactions between liquids and gases take a long time to complete because the reactions can occur only at the boundary between the gas and the liquid. The speed of the reaction can be increased by making a foam in which the gas-liquid surface area is vastly increased. In one-g, however, the foam soon collapses because gravity pulls the liquid down the sides of the bubbles and the bubbles get so thin that they break.

The chemical-foam demonstration on Apollo-Soyuz used four different chemicals that slowly react with water and oxygen to change from clear to pink. After they were mixed in a small plastic bottle and shaken to make a foam, the reaction turned the foam pink in only 20 seconds. In addition to this demonstrated speedup of a chemical reaction, the long-lasting foams in zero-g may be useful in manufacturing lightweight plastics and foam rubber.

## B Multipurpose Electric Furnace

An electric furnace to be used in working with molten (liquid) metals was designed and built by Westinghouse for the Apollo-Soyuz mission. The design of the furnace was based on an earlier model used in Skylab. The major requirement was flexibility so that the furnace could be used for seven different experiments to melt materials as different as lead, aluminum, and salt.

The small furnace and its control boxes are shown in Figure 6.1. The materials for each experiment were enclosed in standard-sized cartridges (Fig. 6.2), each 2.1 centimeters in diameter and 20.5 centimeters long. Three such cartridges could be fitted into the furnace, which was then sealed and evacuated through a pipe leading through the Docking Module wall to the vacuum of space outside the spacecraft. Electric coils heated the bottom ends of the cartridges to a controlled temperature at high as 1423 K (1150°C) in 3

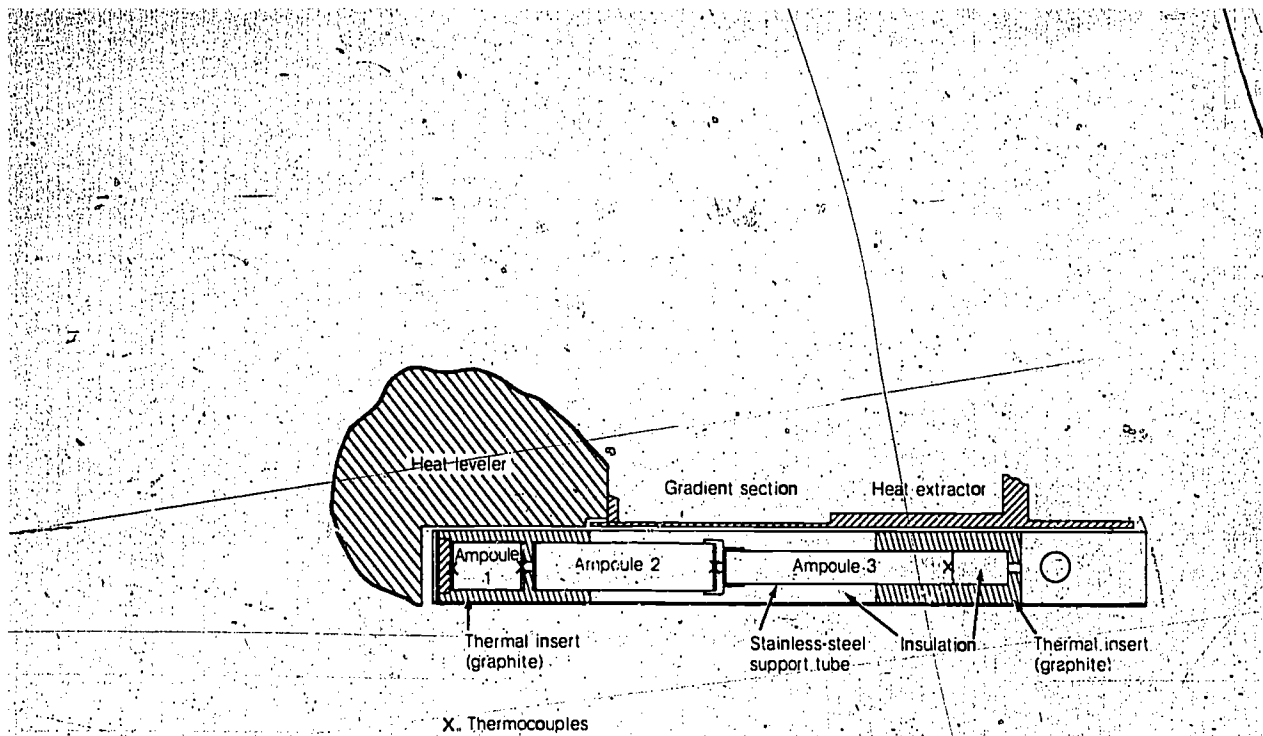


MA-010 multipurpose electric furnace and controls. The furnace is the cylinder at the right and is about 23 centimeters (9 inches) high and 8 centimeters (3 inches) in diameter. The three cartridges are inserted through holes in the top. The hot ends of the cartridges, which get as high as 1423 K (1150° C or 2100° F), are at the bottom of the furnace.

Figure 6.1

hours or less. The top ends were kept near room temperature (293 K, about 68° F). During heatup, the furnace used 205 watts of electric power. At constant temperature, it used only 10 watts.

After heatup, the materials were "soaked"; that is, they were kept at a high temperature for an hour or more to homogenize the mixture of elements. Then they were cooled, first at a slow rate by just turning off the electricity and then at a faster rate by injecting some helium gas into the furnace. (The helium gas conducted heat away from the hot cartridge.) All these processes were controlled automatically by the control boxes (Fig. 6.1). The astronaut merely set the switches and dials for the temperature, soak period, and cooling rate needed for the experiment. The time required for the various experiments ranged from 7 to 23 hours. After the experiment was completed, the astronaut removed the cartridges for return to the Principal Investigator on Earth and put in the next set of cartridges.



**Figure 6.2** Furnace cartridge for the MA-070 Experiment. The heat leveler at the left is at the hot (bottom) end of the furnace, and the heat extractor at the right is at the cool (top) end. The three ampoules contained different mixes for heating and cooling. The manganese bismuth mix in Ampoule 3 cooled to form a strong magnetic eutectic. The graphite "inserts" and the insulation controlled the temperature gradient in Ampoules 2 and 3.

As Figure 6.2 shows, the cartridges were designed to give different temperatures in "ampoules" at different places. The highest temperature was always in the furnace "heat leveler" (left side of Fig. 6.2, bottom of the furnace in Fig. 6.1). In the middle ampoules, there could be a uniform lower temperature or a change from the hot end to the cool end (a thermal gradient), depending on which insulators or heat conductors were used around the ampoule. Two thermocouples (electric thermometers), one at each end of the furnace, recorded the two end temperatures versus time. From these magnetic-tape records of temperature and time, the Principal Investigator knew exactly how his materials were heated, soaked, and cooled.

In one experiment (MA-044) that lasted 11 hours, an alloy of aluminum and antimony was produced. This alloy made in zero-g was found to be much more uniform than any made in one-g on Earth. This alloy can be used to make more efficient solar cells for converting sunlight to electricity. In two other experiments (MA-150 and MA-041) of about the same duration, several different metals were melted together to see how they mixed. Details of these three experiments and of the MA-010 furnace are given in Pamphlet VIII.

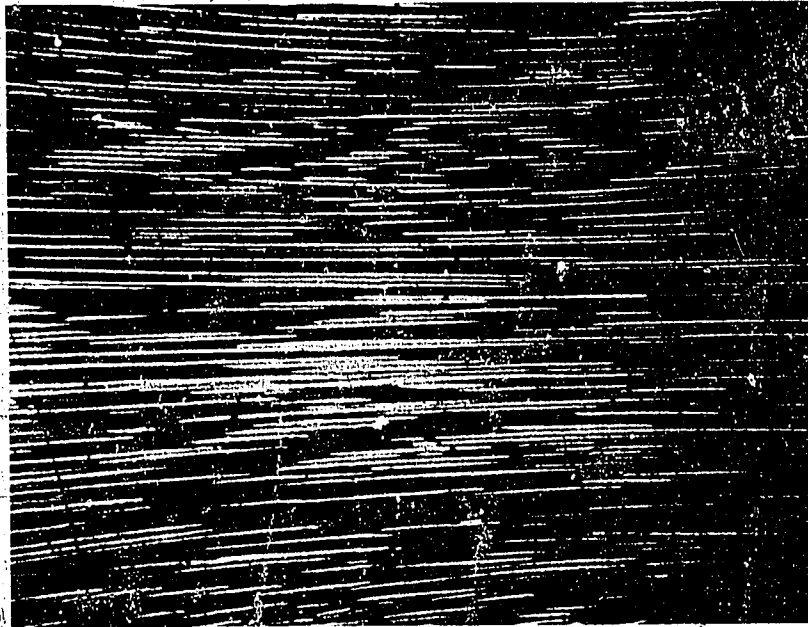


## C Eutectics Formed in Zero-g

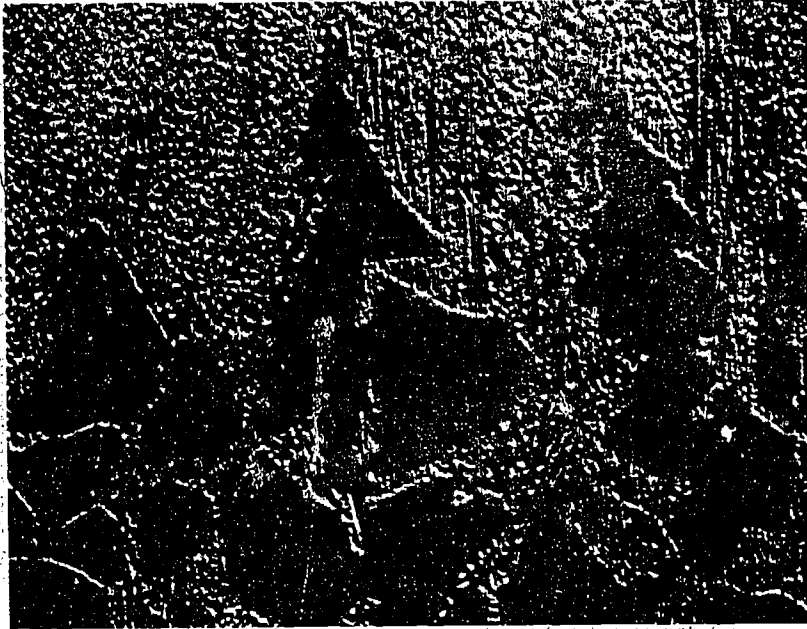
Many eutectics are very strong combinations of two materials in which one material forms long, thin, parallel fibers through the other. They can be made by "directional cooling" of a molten mix; that is, the mix is cooled from one end to the other. This type of cooling gives a bar with parallel fibers running through it from one end toward the other. In one experiment (MA-131), the idea was to make long, clear fibers of lithium fluoride for use as "light pipes" in fiber optics. Light travels efficiently through a thin fiber because it is totally reflected every time it hits the fiber surface. A bundle of fibers can be used to carry a picture from one place to another, even around corners. Each small fiber carries one picture element (the brightness of the picture at one point). By using special equipment to convert sound waves into pulsating light intensity, optical fibers can carry telephone conversations more efficiently than electric wires can.

In the MA-131 Experiment, a mixture of ordinary salt (sodium chloride) and lithium fluoride was heated to 1293 K (1020° C) at one end; the temperature at the other end was below 1073 K (800° C), which is the melting point of salt. The cartridge was cooled from the cool end as uniformly as possible during the next 20 hours. The long, thin fibers of lithium fluoride in the cooled bar (cut in half for measurements) are shown in Figure 6.3. The Principal Investigator, A. S. Yue of the University of California at Los Angeles, notes that the fibers are remarkably uniform, about 4 micrometers (0.00016 inch) in diameter and more than 1 millimeter long. Their length is more than 250 times their width. These fibers, and the eutectic, will be useful in work with infrared light.

Another eutectic was grown in Experiment MA-070 to make strong magnets. For this purpose, the fibers did not need to be very long, but they did need to be parallel and uniformly spaced in the bismuth metal. The bismuth was cooled from right to left in Ampoule 3 (Fig. 6.2). The fibers are the fine lines near the top of Figure 6.4, which is an enlarged photograph of a slice of the bar near the cool (unmelted) end. Measurements made by the Principal Investigator, D. J. Larson, Jr., of the Grumman Aerospace Corporation, showed that this eutectic would make magnets twice as strong as those made from the material cooled in one-g. More details on these two experiments are given in Pamphlet VIII.



**Figure 6.3** Lithium fluoride fibers in eutectic from the MA-131 Experiment. The cut-through bar of salt (enlarged 56 times) shows parallel fibers lined up by directional cooling from the molten state in zero-g.



Fibers in magnetic eutectic from Experiment MA-070. No fibers were formed in the large "chunks." The thin white lines at the top are fibers in the mottled gray bismuth.

Figure 6.4

## D Crystals Formed in Zero-g

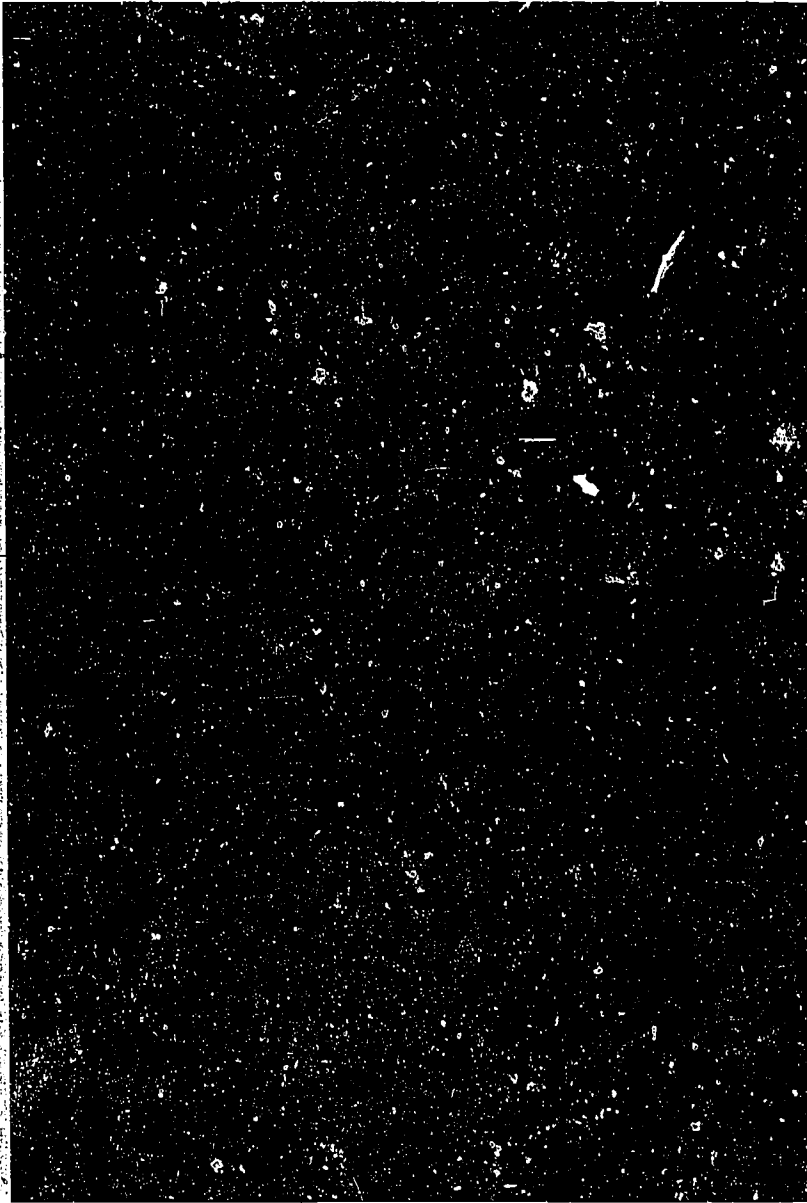
Crystals are solids in which the atoms are arranged in a regular pattern or lattice like a stack of bricks. As a crystal grows, interatomic forces ideally add another layer of "bricks" precisely placed on the ones already in place. Crystals can be grown by combining substances in a solution, by freezing a liquid, or by condensing a vapor on a solid. For instance, you can see salt crystals form in saltwater as it dries or ice crystals form in water as it freezes. Large, nearly perfect crystals seldom form naturally. The solution, or melt, or vapor is usually stirred, or is not uniform, or is moving irregularly, so that a growing crystal becomes uneven and a jumble of small crystals results. Even as a crystal grows, it generally develops imperfections in its layers when a suitable ion is not deposited (resulting in a "hole") or when some other kind of atom is deposited—like one oversize brick in a stack of bricks. Then the regular layers of bricks get out of step with the layers beneath, and there is a "structural defect" in the crystal.

Crystals have become important in modern technology. The hardness of diamonds (carbon crystals) makes them valuable for use in drill bits, and many other crystals are used for electronic components in radios, television, and computers. Scientists and engineers have made great progress in growing large crystals under carefully controlled conditions, but convection currents in one-g often prevent uniform growth and cause structural defects. For this reason, three experiments on crystal growth in zero-g were scheduled on Apollo-Soyuz, two of them in the MA-010 furnace.

The MA-060 Experiment produced almost perfect crystals of germanium 6.5 centimeters long and marked them in such a way that the rate of crystal growth could be measured. This marking was done by using pulses of electricity every 4 seconds while the germanium cooled from 1393 K (1120° C) at the hot end. The cool end was unmelted at 1231 K (958° C). After being returned to the Principal Investigator, H. C. Gatos of the Massachusetts Institute of Technology, the crystal was sliced lengthwise and etched with strong acid. Figure 6.5 shows the 4-second growth lines, starting at the edge of the unmelted germanium (top). The growth started slowly, increased (where the lines get farther apart), and leveled off at about 10 micrometers per second. The 4-second layers, which are 0.04 millimeter thick, are remarkably uniform. Another experiment (MA-085; see Pamphlet VIII) grew smaller crystals from chemical reactions in hot gases.

Crystals can also be grown from chemical reactions in solution at room temperature. In one-g, when insoluble materials form in a chemical reaction, they fall to the bottom as a sediment. In zero-g, the materials don't fall, and a crystal grows in the solution. If all conditions are very steady and the chemicals are very pure, large crystals can be grown, as demonstrated in Experiment MA-028 on Apollo-Soyuz.





Growth lines in the germanium crystal from the MA-060 Experiment. Each line shows where the crystal surface was (in 4-second intervals) as it grew from top to bottom. Figure 6.5

The MA-028 reactor, a sealed plastic container with three compartments, is shown in Figure 6.6. Compartment A was filled with pure water and was separated from Compartments B and C by two closed valves. (In Figure 6.6, the valve to Compartment B at left is open; the other valve is closed.) Compartments B and C were filled with the two chemicals that react in water to yield crystals. Several of these reactors were bolted to the wall of the Command Module. When all was quiet (when no thrusters were on and Apollo's direction was fixed in space), the valves were opened by twisting the end knobs, and the two chemicals spread through the water to mix in Compartment A. The astronauts watched and photographed the crystals as they formed. Later, when the reactors were returned to the Principal Investigator, M.D. Lind of the Rockwell International Science Center, he photographed the crystals shown in Figure 6.7. This first attempt at growing perfect crystals from solution in zero-g produced 5-millimeter crystals of calcium tartrate and 0.5-millimeter crystals of calcium carbonate. The photographs taken in Apollo show how the reactors may be improved to grow larger crystals on the next try.

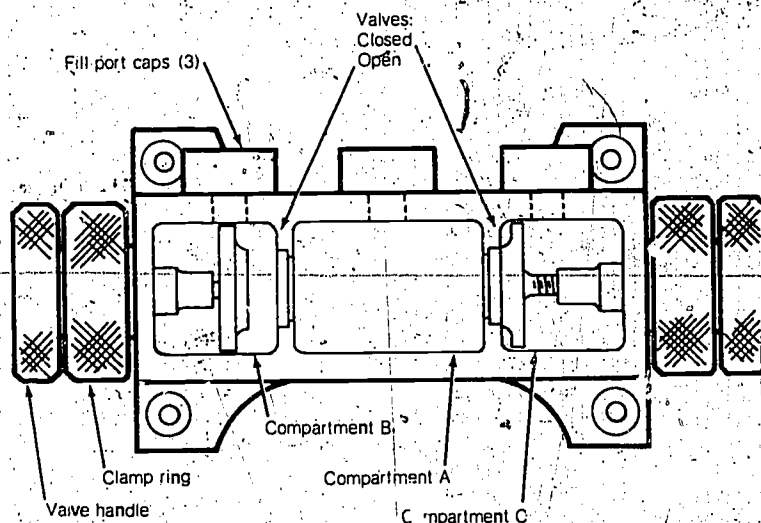
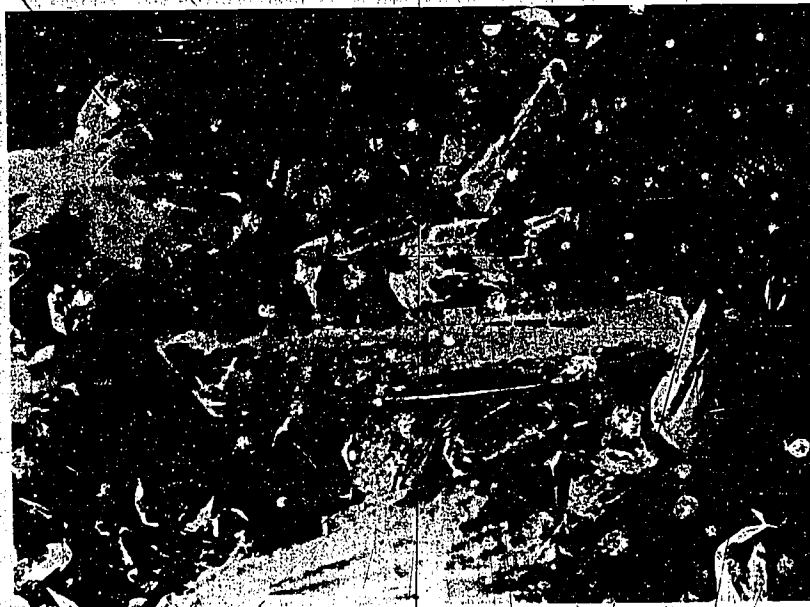


Figure 6.6 Diagram of the MA-028 reactor. The three compartments were filled before launch through the "fill ports" on the top. The crystals formed in Compartment A.



The MA-028 crystals grown in zero-g. These crystals of calcium tartrate are as long as 5 millimeters. Figure 6.7

## E Questions for Discussion

(Wetting, Foam, Furnace, Crystals)

20. Oil was squirted into a plastic cup in zero-g and started wetting up the inside. What happened when it got to the top of the cup?
21. Oil moved up the wick faster than water in zero-g. What forces account for this?
22. Gravity pulls the liquid down the side of a bubble in one-g until the bubble bursts. In zero-g, this doesn't happen. How might a bubble in zero-g burst?
23. Which would heat faster in the electric furnace: 50 grams of aluminum or 100 grams of lead and gold? Which would cool faster?
24. Why was there a vacuum in the MA-010 furnace casing during its use?

25. Crystals of many minerals split along "cleavage planes," which are flat or offset parallel surfaces that run straight through the crystal parallel to the layers of atoms. In the stack of bricks used as an analogy in Section 6D, how would the cleavage planes run?

26. Why were *very pure* chemicals used for growing crystals in Experiment MA-028?



# Appendix A

## Discussion Topics (Answers to Questions)

1. (Sec. 2E) Moscow is at 38° E longitude. The Earth rotates *eastward* 15°/hr; therefore, a clock in Moscow reads 2 hours *later* than GMT (the standard time in London at 0° longitude). The cosmonaut supper at 10:55 p.m. Moscow time was at 8:55 p.m. London time. If you live in the eastern standard time zone—for example, in New York at 74° W longitude—the supper started at 3:55 p.m. eastern standard time, which is 5 hours *earlier* than GMT. Farther west, it was 2:55 p.m. central standard time, 1:55 p.m. mountain standard time, and 12:55 p.m. Pacific standard time. Because the Apollo-Soyuz flight was in July, all these standard times were replaced by *daylight* time, which is 1 hour later than standard time. So the supper began at 4:55 p.m. eastern-daylight time, 3:55 p.m. central daylight time, 2:55 p.m. mountain daylight time, or 1:55 p.m. Pacific daylight time.

2. (Sec. 2E) It was necessary to keep the Soyuz oxygen-nitrogen cabin atmosphere at two-thirds normal Earth-surface (atmospheric) pressure and to keep the Apollo pure-oxygen cabin atmosphere at one-third atmospheric pressure. The Docking Module atmosphere alternated between the two. If there had been an open passageway, neither Soyuz nor Apollo could have maintained the proper pressure and oxygen content for astronauts and cosmonauts to breathe naturally. Actually, higher pressure would have opened leaks in the Apollo Command Module, and higher oxygen content would have been a serious fire hazard in Soyuz.

3. (Sec. 2E) The Apollo spacecraft weighed 14 900 kilograms, and the total launch configuration (Fig. 2.2) weighed 588 000 kilograms. The difference, 573 100 kilograms, was mostly fuel for the launch. Without considering the weight of the booster tanks, the adapter, and the launch escape system, it took about 38 kilograms of fuel ( $573\ 100 / 14\ 900 = 38$ ) to put each kilogram of the Apollo spacecraft into orbit. The same calculation for Soyuz is  $(300\ 000\ \text{kilograms} - 6750\ \text{kilograms}) / 6750\ \text{kilograms} = 293\ 250 / 6750 = 43$  kilograms of fuel for each kilogram of the Soyuz spacecraft.

4. (Sec. 2E) If an unanchored astronaut in zero-g pushes on a cabinet door (or anything else), he pushes himself away from it and goes backward across the cabin to bang against the opposite wall.

5. (Sec. 3D) The strong gravity of a Neutron Star pulls (accelerates) gas atoms—mostly hydrogen atoms—that break up (ionize) into electrons and protons. When they hit the surface of the Neutron Star, they emit x-rays just as the high-speed electrons in a dentist's x-ray machine do.

6. (Sec. 3D) The Earth's atmosphere scatters sunlight so that the sky is blue rather than black, as it is in space. This "sky background" is many times brighter than the Sun's corona. Therefore, even though the chimney would block out the direct sunlight, the sky background would outshine the corona.

7. (Sec. 4C) The Earth rotates  $360^\circ$  each 24 hours or  $15^\circ$  every 4 minutes. The Sun is  $0.5^\circ$  in angular diameter as seen from Earth, so it takes 2 minutes for the Sun to sink below the horizon. Apollo-Soyuz moved  $360^\circ$  around the Earth in 93 minutes, or  $3.9^\circ$  each minute. As seen from Apollo-Soyuz, therefore, it would take the Sun  $0.5/3.9 = 0.128$  minutes or 7.7 seconds to disappear beneath the horizon.

8. (Sec. 4C) The increase of atmospheric density toward the Earth's surface in Figure 4.1 causes the atmosphere to act like a prism of glass (thicker at the bottom) and bend the light rays by refraction. It bends blue and green rays more than red rays; thus, the view of the Sun from point 4 would be colored like a short rainbow, mostly red.

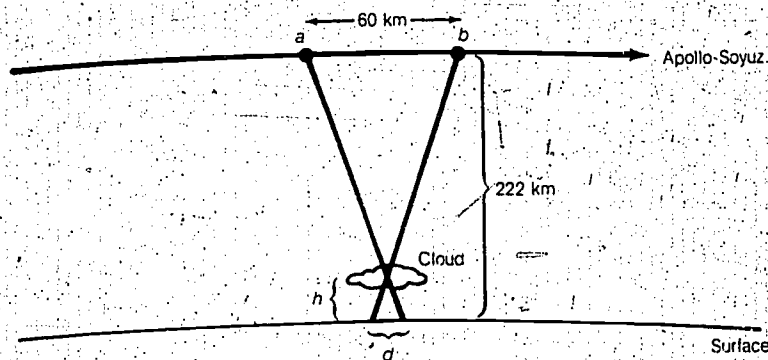
9. (Sec. 4C) Smoke from factory chimneys is warm and rises slowly by convection. After a short distance (a few hundred meters), it cools and is dispersed by winds. Gases from a volcano are much hotter and shoot upward at such a high speed that they reach the stratosphere (35-kilometer altitude). Chimney gases seldom get that high.

10. (Sec. 4C) In Figure A.1,  $h$  is the height of the cloud. The view from Apollo-Soyuz at  $a$  projects the cloud at a different place on the Earth's surface than does the view from  $b$ . The distance  $d$  between these two places on the surface can be measured on the photographs. Then  $h/222 \text{ kilometers} = d/60 \text{ kilometers}$ , approximately.

11. (Sec. 4C) The line of sight from Apollo-Soyuz is tangent to the sea surface at the horizon  $h$ , which is  $r = 6378$  kilometers from the center of the Earth  $C$ . In the right triangle  $CAh$  in Figure A.2,  $CA = 6378 \text{ kilometers} + 222 \text{ kilometers}$ ,  $Ch = 6378 \text{ kilometers}$ , and the distance  $Ah = d$  can be calculated from the formula  $CA^2 = d^2 + r^2$ , or  $d = \sqrt{6600^2 - 6378^2} = 1700 \text{ kilometers}$ .

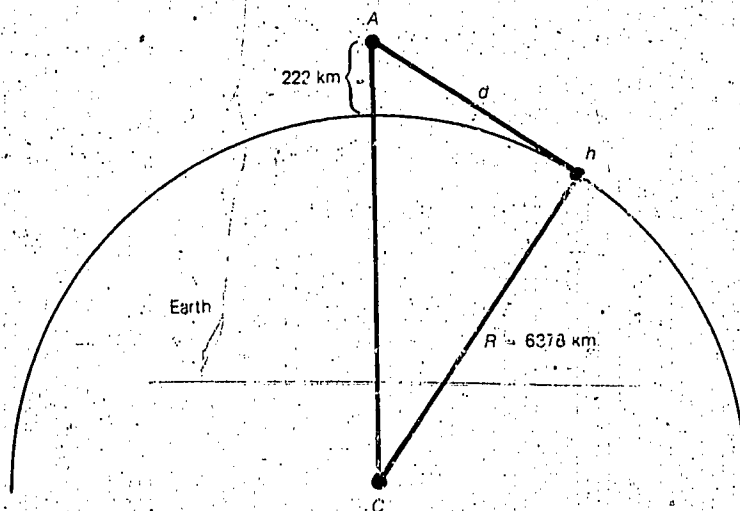
12. (Sec. 4C) "The one thing I noticed was that . . . line on the left up near the end . . . makes a bend to the left and follows a new tectonic line or fault which goes along parallel to the Turkish coast. In other words, the one on the left, number 1, goes up . . . and then makes a left turn and parallels the Turkish coast. [Number] two seems to be obscured and it just ends in a lot of jumbled country . . . and it seems to end right in this jumbled area. [Number] three, I could trace clear up to a river which—I'll have to see a map later. But I could trace the faults out, going rather eastward. You could see them through the valley silt, clear up to a river which must be inland in either Syria or Turkey.

So the overall pattern of these is a fan; [number] three going almost eastward, and [number] one bending finally to the north, and [number] two going to the northeast." (Verbal comments made during the mission by Astronaut Vance D. Brand.) Other reports referred to colors on the color wheel.



Height of a cloud determined from a pair of Apollo photographs. Two similar triangles are formed by the distance  $ab$  along the Apollo-Soyuz orbit and the distance  $d$  on the ground.

Figure A.1



Distance to the horizon from Apollo-Soyuz. Because the line  $Ah$  is tangent to the Earth's surface at  $h$ ,  $AhC$  is a  $90^\circ$  angle.

Figure A.2

13. (Sec. 5D) If the astronauts had counted flashes before their eyes had adapted to darkness, they might have missed some of the smaller, fainter flashes at the beginning of the experiment. The Principal Investigator wanted the same eye sensitivity to flashes throughout the experiment.

14. (Sec. 5D) If the flash rate were much higher, an astronaut might see two or three flashes almost at once and think that he saw only one. Then he would report fewer than the actual number of flashes.

15. (Sec. 5D) Far from Earth, cosmic rays can come from all sides. There is no Earth nearby to shield one side as there was for Apollo-Soyuz. Also, there would be no magnetic field to concentrate cosmic rays at high latitudes as there was in the MA-106 Experiment. You would therefore expect about twice the average rate of flashes reported in the MA-106 Experiment or two to three flashes per minute (as observed on Apollo flights to the Moon).

16. (Sec. 5D) The Earth is an effective shield; therefore, there were never any cosmic rays coming up from Earth toward Apollo-Soyuz.

17. (Sec. 5D) Each of the space colonies planned by Gerard O'Neill of Princeton University and engineers in the L-5 Society, which is promoting space colonies (1620 North Park Avenue, Tucson, Arizona 85719), would be protected from cosmic rays by a shield of lunar rocks. Their plan is to have rocks from the Moon thrown up to the space colony by a "launcher" that would be operated by a few hundred men carried to the Moon by spacecraft.

18. (Sec. 5D) The floor, table, walls, and light from the ceiling in the Skylab crew quarters gave a visual impression of "up" and "down." A similar visual impression was given to some of the fish in the MA-161 Experiment by painting stripes on their water-filled bags.

19. (Sec. 5D) In zero-g, there is no "up" or "down," no "top" or "bottom." The location of something in a cabinet must be described by using coordinates such as  $x$  and  $y$  marked on the side of the cabinet. This difficulty has been noted by several astronauts.

20. (Sec. 6E) Oil wetting the cup in zero-g will go right over the top edge and down the outside of the cup until it covers the entire surface.

21. (Sec. 6E) The adhesive force between oil and the wick fibers is stronger than the adhesive force between water and the wick fibers.

22. (Sec. 6E) Bubbles in a foam last much longer in zero-g than in one-g, but they eventually burst because of thermal motions of the molecules and evaporation of the thin liquid films.



23. (Sec. 6E) The more massive cartridges would require about twice as much heat energy. The power (heat input per second) is limited to 205 watts; therefore, the heatup time would be about twice as long. The same reasoning applies to the cooldown, where heat loss per second is proportional to the difference in temperature between the cartridges and their surroundings.

24. (Sec. 6E) The vacuum around the three cartridges in the MA-010 furnace casing prevented heat loss by conduction and convection. Loss by radiation was prevented by silvering the sides of the vacuum chamber. The remaining (10 watts) heat was lost through the insulated support of the heater and cartridges at the top of the case in Figure 6.1.

25. (Sec. 6E) If bricks are stacked one on top of another, there are three cleavage planes: up-down lengthwise, up-down sidewise, and horizontal. They are perpendicular to each other and can form a cube of bricks. The cleavage planes of the sodium chloride crystal (salt) are similar, and this type of crystal is called cubic.

26. (Sec. 6E) If the chemicals used in the MA-028 Experiment were contaminated with other compounds, odd atoms might be deposited in the crystal layer and cause structural defects.

# Appendix B

## SI Units Powers of 10

### International System (SI) Units

Names, symbols, and conversion factors of SI units used in these pamphlets:

Quantity	Name of unit	Symbol	Conversion factor
Distance	meter	m	1 km = 0.621 mile 1 m = 3.28 ft 1 cm = 0.394 in. 1 mm = 0.039 in. 1 $\mu$ m = $3.9 \times 10^{-5}$ in. = $10^4$ Å 1 nm = $10^9$ Å
Mass	kilogram	kg	1 tonne = 1.102 tons 1 kg = 2.20 lb 1 gm = 0.0022 lb = 0.035 oz 1 mg = $2.20 \times 10^{-6}$ lb = $3.5 \times 10^{-5}$ oz
Time	second	sec	1 yr = $3.156 \times 10^7$ sec 1 day = $8.64 \times 10^4$ sec 1 hr = 3600 sec
Temperature	kelvin	K	273 K = 0° C = 32° F 373 K = 100° C = 212° F
Area	square meter	m <sup>2</sup>	1 m <sup>2</sup> = 10 <sup>4</sup> cm <sup>2</sup> = 10.8 ft <sup>2</sup>
Volume	cubic meter	m <sup>3</sup>	1 m <sup>3</sup> = 10 <sup>6</sup> cm <sup>3</sup> = 35 ft <sup>3</sup>
Frequency	hertz	Hz	1 Hz = 1 cycle/sec 1 kHz = 1000 cycles/sec 1-MHz = 10 <sup>6</sup> cycles/sec
Density	kilogram per cubic meter	kg/m <sup>3</sup>	1 kg/m <sup>3</sup> = 0.001 gm/cm <sup>3</sup> 1 gm/cm <sup>3</sup> = density of water
Speed, velocity	meter per second	m/sec	1 m/sec = 3.28 ft/sec 1 km/sec = 2240 mi/hr
Force	newton	N	1 N = 10 <sup>5</sup> dynes = 0.224 lbf

Quantity	Name of unit	Symbol	Conversion factor
Pressure	newton per square meter	N/m <sup>2</sup>	1 N/m <sup>2</sup> = 1.45 × 10 <sup>-4</sup> lb/in <sup>2</sup>
Energy	joule	J	1 J = 0.239 calorie
Photon energy	electronvolt	eV	1 eV = 1.60 × 10 <sup>-19</sup> J; 1 J = 10 <sup>7</sup> erg
Power	watt	W	1 W = 1 J/sec
Atomic mass	atomic mass unit	amu	1 amu = 1.66 × 10 <sup>-27</sup> kg

#### Customary Units Used With the SI Units

Quantity	Name of unit	Symbol	Conversion factor
Wavelength of light	angstrom	Å	1 Å = 0.1 nm = 10 <sup>-10</sup> m
Acceleration of gravity	g	g	1 g = 9.8 m/sec <sup>2</sup>

## Unit Prefixes

Prefix	Abbreviation	Factor by which unit is multiplied
tera	T	$10^{12}$
giga	G	$10^9$
mega	M	$10^6$
kilo	k	$10^3$
hecto	h	$10^2$
centi	c	$10^{-2}$
milli	m	$10^{-3}$
micro	$\mu$	$10^{-6}$
nano	n	$10^{-9}$
pico	p	$10^{-12}$

## Powers of 10

### Increasing

$$10^2 = 100$$

$$10^3 = 1\ 000$$

$$10^4 = 10\ 000, \text{ etc.}$$

Examples:

$$2 \times 10^6 = 2\ 000\ 000$$

$$2 \times 10^{30} = 2 \text{ followed by 30 zeros}$$

### Decreasing

$$10^{-2} = 1/100 = 0.01$$

$$10^{-3} = 1/1000 = 0.001$$

$$10^{-4} = 1/10\ 000 = 0.000\ 1, \text{ etc.}$$

Example:

$$5.67 \times 10^{-5} = 0.000\ 056\ 7$$



# Appendix C

## Glossary

References to sections, Appendix A (answers to questions), figures, and Table 3.1 are included in the entries. Those in *italic type* are the most helpful.

**adhesive force** an attraction between two different substances at the boundary between them. (Secs. 6, 6A; App. A, no. 21)

**alloy** a uniform mix of two or more metals that have been melted together. (Secs. 6, 6B; Table 3.1)

**ampoule** a small container in the larger cartridge heated in the MA-010 furnace. Each ampoule contained a sample to be heated, then cooled and returned to Earth. (Secs. 6B, 6C; Fig. 6.2)

**apogee** the point farthest from Earth in an elliptical orbit around the Earth. To enlarge or circularize the orbit, a spacecraft's thruster is turned on at apogee to give it increased speed. (Sec. 2C; Fig. 2.4)

**Apollo spacecraft** a three-man spacecraft, originally designed for trips to the Moon. It consisted of a Command Module attached to a Service Module. For the Apollo-Soyuz mission, a Docking Module was attached to the Command Module. (Secs. 1, 1A, 2 to 2C, 3C, 5A; App. A, nos. 2, 3; Figs. 2.1, 2.2, 2.4)

**atmosphere** gases around an object. The Earth's atmosphere is approximately 80-percent nitrogen and 20-percent oxygen. The density and pressure decrease with increasing altitude and are barely detectable at 200 kilometers. (Secs. 3, 3C, 4, 4A; App. A, nos. 6, 8; Figs. 4.1, 4.4) *Cabin atmosphere* inside the Apollo spacecraft differed from that in Soyuz, which was the same as on Earth at sea level. (Secs. 2A, 2D; App. A, no. 2)

**bismuth (Bi)** a metallic element, atomic weight 209, atomic number 83, valence 3 or 5, melting point 544 K (271° C), density 9.8 gm/cm<sup>3</sup>. (Sec. 6C; Figs. 6.2, 6.4; Table 3.1)

**booster rocket** the large reaction motor used to launch a spacecraft. (Secs. 2B, 2C; Figs. 2.2, 2.3)

**calcium** a chemical element needed to make bones in animals and fish. (Secs. 1A, 5, 5C)

**cartridge** a cylinder containing one or more ampoules filled with material to be heated in the MA-010 furnace. Three cartridges fit into the furnace together. (Secs. 6B, 6C; App. A, nos. 23, 24; Figs. 6.1, 6.2)

**cohesive force** the force at the boundary of a liquid that pulls the liquid together (Secs. 6, 6A)

**Command Module** the part of the Apollo spacecraft in which the astronauts lived and worked; attached to the Service Module until reentry into the Earth's atmosphere. (Secs. 2A, 6D; App. A, no. 2; Figs. 2.1, 2.2)

**convection** material motions in a fluid. In one-g, it is the up-and-down drafts in a liquid or gas heated from below. (Secs. 2D, 6D; App. A, nos. 9, 24; Table 3.1)

**corona** a vast, low-density cloud of gases surrounding the Sun. Its brightness is about one-millionth of the Sun's brightness. (Secs. 3, 3C; App. A, no. 6; Fig. 3.4; Table 3.1)

**cosmic ray** an extremely high speed ion. Solar cosmic rays are blown out of the Sun; galactic cosmic rays arrive from all directions. (Secs. 5 to 5B; App. A, nos. 15 to 17; Fig. 5.3; Table 3.1)

**crystal** a solid composed of atoms or ions or molecules arranged in a regular repetitive pattern. The shape of the crystal is related to this pattern. (Secs. 6, 6D, 6E; App. A, nos. 25, 26; Figs. 6.5 to 6.7; Table 3.1)

**cyclotron** a machine that speeds up ions to very high kinetic energy by timed pulses of electric voltage. (Sec. 5A; Fig. 5.1)

**delta** a triangular-shaped area of sediment deposited by a river where it flows into a sea. (Sec. 4B; Fig. 4.6)

**dock** to seal two spacecraft together in orbit so that cabin atmosphere will not leak out and crewmen can move from one spacecraft to the other. (Secs. 1, 1B, 2A to 2C, 2E, 3C; Figs. 2.1, 3.3)

**Docking Module** a special component added to the Apollo spacecraft so that it could be joined with Soyuz. (Secs. 2A, 2B, 3C; App. A, no. 2; Figs. 2.1, 2.2) See Pamphlet I.

**Earth** third planet from the Sun, 149 600 000 kilometers from the Sun, very nearly a sphere of 6378-kilometer radius,  $6 \times 10^{24}$ -kilogram mass. The Earth is accompanied by the Moon, about one-fourth its size. The Earth-Moon distance is 384 405 kilometers. (App. A, nos. 7, 15, 16)

**eclipse** covering a bright object with a dark one. In a normal solar eclipse, the Sun is covered by the Moon. Apollo covered the Sun for Soyuz. (Secs. 2A, 3C; Fig. 3.3; Table 3.1)

**ecliptic** the line in the sky along which the Sun appears to move eastward  $360^\circ$  in a year. This line represents the plane of the Earth's orbit. (Fig. 3.4)

**ellipse** a smooth, oval curve accurately fitted by the orbit of a satellite around a much larger mass. (Sec. 2C; Fig. 2.4)

**energy** the capability of doing work. High-speed cosmic rays have high kinetic energy ( $1/2mv^2$ ) which is released by impacts when a cosmic ray passes through any dense material. (Secs. 5 to 5B; App. A, no. 23)

**eutectic** a mix of two materials that has a lower melting point than either material alone. When the molten mix solidifies, one material freezes in a regular pattern throughout the other. (Sec. 6C; Figs. 6.2 to 6.4; Table 3.1)

**fibers** long threads of one substance running through another substance. Fibers can be formed by directional cooling of a molten mix. (Secs. 6, 6C; Figs. 6.3, 6.4)

**foam** many small bubbles of gas in a liquid that has low cohesive force. (Secs. 6, 6A; App. A, no. 22; Table 3.1)

**galaxy** a vast assemblage of billions of stars with interstellar gas and dust. (Secs. 3, 3B)

**germanium (Ge)** a metallic element, atomic weight 72.60, atomic number 32, valence 4, melting point 1211 K (938° C), density 5.4 gm/cm<sup>3</sup>. It is a semiconductor and forms crystals that are used in electronics. (Sec. 6D; Fig. 6.5; Table 3.1)

**gravity** the downward force on a mass near the Earth. On the Earth's surface, it is one-g. (Secs. 2C, 2D, 3B, 4, 5, 5C, 6, 6A, 6E; App. A, no. 5; Fig. 2.4; Table 3.1)

**Greenwich mean time (GMT)** the time of an event, from 0 at midnight to 12 hours at noon to 24 hours at midnight, as measured at 0° longitude (Greenwich, near London, England); used on space missions to avoid confusion with other time zones. (Secs. 1, 5A; App. A, no. 1; Fig. 5.2) See Pamphlet I.

**heat leveler** a block of graphite heated in the MA-010 furnace; it kept the lower 5 centimeters of each cartridge at a uniform temperature. (Sec. 6B; Fig. 6.2)

**HZE particles** cosmic rays with high atomic number  $Z$  and high kinetic energy  $E$ ; atomic nuclei of atomic number  $Z$  greater than 6 and energy  $E$  greater than 100 megaelectronvolts. (Secs. 5A, 5B)

**infrared** invisible radiation of wavelength longer than visible red light. (Secs. 3, 6C; Table 3.1)

**ions** atoms with one or more electrons removed or, more rarely, added. Cosmic-ray ions have all electrons removed and ionize other atoms as they pass them at high speed. (Secs. 5A, 6D; App. A, no. 5)

**JSC** the NASA Lyndon B. Johnson Space Center in Houston, Texas, and its Mission Control Center for Apollo-Soyuz. (Sec. 3A; Fig. 3.1)

**KSC** the NASA John F. Kennedy Space Center at Cape Canaveral, Florida, where Apollo was launched on July 15, 1975. (Sec. 3A; Fig. 3.1)

**launch configuration** the combination of boosters, spacecraft, and launch escape system that must be lifted off the ground at launch. (Sec. 2B; App. A, no. 3; Fig. 2.2)

**light flash** a momentary flash seen with the eyes closed when a high-speed ion passes through the eye. (Sec. 5A; App. A, nos. 13 to 15; Figs. 5.1, 5.2; Table 3.1)

**light-year** the distance that light travels (at  $3 \times 10^8$  m/sec) in 1 year ( $3.15 \times 10^7$  seconds). One light-year =  $9.46 \times 10^{12}$  kilometers; about 63 000 times the distance from Sun to Earth. (Sec. 3B)

**lithium fluoride** a substance whose clear crystals transmit both ultraviolet and infrared light. (Sec. 6C; Fig. 6.3; Table 3.1)

**MA-XXX** the number assigned to the experiments on Apollo-Soyuz. See Table 3.1.

**magnet** a substance that has the property of attracting certain other substances. Some metals can be magnetized to attract other magnetic metals. (Sec. 6C; Figs. 6.2, 6.4; Table 3.1) Such a magnet has a *magnetic field*, a region around it where there are forces on other magnets. The Earth has a magnetic field. (Secs. 5, 5A; App. A, no. 15)

**Milky Way Galaxy** a disk-shaped group of more than 100 billion stars, including the Sun. There are other galaxies, far outside the Milky Way Galaxy. (Sec. 3B)

**Mission Control Center** the operational headquarters of a space mission. For Apollo-Soyuz, there were two, one in Houston and one in Moscow. (Fig. 3.1)

**MSFC** the NASA George C. Marshall Space Flight Center at Huntsville, Alabama. (Sec. 3A; Fig. 3.1)

**MSFEB** the NASA Manned Space Flight Experiment Board that decided which of the proposed experiments would go on Apollo-Soyuz. (Sec. 3A; Fig. 3.1)

**multistage launch** the launching of a space vehicle that involves two or more stages. After the first-stage booster uses its fuel, it is discarded and the second-stage booster is fired. When the second-stage fuel is gone, that booster is discarded, and so on. Such multistage launching gives very high velocities. (Sec. 2B; Fig. 2.3)

**Neutron Star** a collapsed star of very high density, formed almost entirely of neutrons (protons combined with electrons). (Sec. 3B; App. A, no. 5; Fig. 3.2)

**one-g** the downward acceleration of gravity at the Earth's surface,  $9.8 \text{ m/sec}^2$ . In an orbiting spacecraft, everything is weightless at zero-g. (Secs. 5C, 6 to 6E; App. A, no. 22)

**orbit** the path followed by a satellite around an astronomical body, such as the Earth or the Moon. (Secs. 1, 2 to 2B, 2C, 2D, 3B, 5A; App. A, no. 7; Figs. 2.4, 3.2, 3.3, 4.1, 5.2, A.1)

**perigee** the point closest to Earth on an elliptical orbit around the Earth. (Sec. 2C; Fig. 2.4)

**Principal Investigator** the individual responsible for a space experiment and for reporting the results. (Sec. 3A; Fig. 3.1)

**proton** a positively charged atomic particle, the nucleus of the hydrogen atom. (Secs. 5, 5A; App. A, no. 5)

**pulsar** a pulsating condensed star of a type first detected by regular 1-second pulses of radio waves; now thought to be a rapidly rotating Neutron Star with a "hotspot" on one side. (Secs. 3B, 3D; Fig. 3.2)

**radiation** a term used loosely to include cosmic-ray particles and high-energy protons, as well as penetrating electromagnetic waves (x-rays and gamma rays). (Sec. 5A; App. A, no. 24)



**reaction, chemical** a chemical change that occurs when two or more substances are mixed, usually in solution. (Secs. 4A, 6A, 6D)

**reaction, physical** a force defined by Newton's Third Law. Reaction motors—boosters (Sec. 2B) and jets (Secs. 2A, 3C; Fig. 2.1)—produce thrust by reaction force.

**reactor** a transparent container for chemical reactants, photographed as the reactants produced crystals for the MA-028 Experiment. (Sec. 6D; Fig. 6.6)

**refraction** the bending of a ray of light where the material that it is passing through changes in density or composition. (App. A, no. 8; Fig. 4.1)

**rendezvous** the close approach of two spacecraft in the same orbit so that docking can take place. (Secs. 2A, 2C)

**rift** a crack or "fault" in the Earth's crust, where one side has slipped along the other, or toward or away from the other. (Sec. 4B; Fig. 4.8; Table 3.1)

**salinity** the percentage content of salt in seawater. (Sec. 4B; Fig. 4.5)

**sealing rings** mechanical devices designed to fit tightly when two spacecraft are docked together so that cabin atmosphere will not leak out. (Sec. 2A; Fig. 2.1)

**Service Module** the large part of the Apollo spacecraft, attached to the Command Module until just before the Command Module reenters the Earth's atmosphere. (Sec. 2A; Figs. 2.1, 2.2)

**Skylab** a very large space workshop that NASA put into orbit on May 14, 1973. It was visited by three astronaut crews who worked on scientific experiments in space for a total of 172 days, the last crew for 84 days. (Secs. 1A, 2, 2A, 2D, 3, 5, 5A, 5D, 6B; App. A, no. 18)

**solar panel** a winglike set of cells that convert sunlight to electric power. (Secs. 2, 6B; Fig. 2.1)

**Soyuz** the Soviet two-man spacecraft. (Secs. 1, 1A, 2 to 2C, 3C; App. A, nos. 2, 3; Figs. 2.1, 2.2, 2.4)

**spore** a small seed-germ that can grow into a microbe or a plant such as a fern. (Secs. 5, 5B; Fig. 5.3; Table 3.1)

**star** a very hot ball of gas with an energy source near the center. Normal stars are like the Sun, about  $10^6$  kilometers in diameter. Blue stars are much hotter than the Sun. Giant stars are 200 times larger and White Dwarf stars 100 times smaller than the Sun. Neutron Stars and Black Holes are smaller still. (Secs. 3, 3B; Fig. 3.2)

**STDN** the NASA Spacecraft Tracking and Data Network of radio stations all around the world for communicating with spacecraft. (Sec. 3A; Fig. 3.1)

**stratosphere** a layer in the Earth's atmosphere from 15 to 50 kilometers above the surface where the temperature is very low. (Sec. 4A; App. A, no.

**temperature gradient** the change of temperature per centimeter along a cartridge or a sample inside it. (Sec. 6B; Fig. 6.2)

**thrust** the forward force provided by a reaction motor. (Secs. 2A to 2C, 6D; Fig. 2.2)

**ultraviolet** invisible light of wavelengths shorter than violet light. (Secs. 3, 4A; Table 3.1)

**Van Allen belt** a doughnut-shaped region around the Earth from about 320 to 32 400 kilometers (200 to 20 000 miles) above the magnetic equator, where high-speed protons and electrons oscillate north-south in the Earth's magnetic field. (Secs. 5, 5A)

**weightlessness** the condition in orbit or free fall when objects in a spacecraft need no support. See *zero-g*. (Secs. 2D, 5)

**wetting** the spread of a liquid over a solid surface when adhesive force is larger than cohesive force. (Secs. 6, 6A, 6E; App. A, no. 20)

**wick** a group or braid of thin fibers which "sucks up" a liquid if the adhesive force between the fiber and the liquid is greater than the liquid's cohesive force. (Secs. 6A, 6E; App. A, no. 21; Table 3.1)

**x-rays** electromagnetic radiation of very short wavelength and high photon energy. (Secs. 3, 3B, 3D, 5; App. A, no. 5; Fig. 3.2; Table 3.1)

**Z** atomic number, or the number of electrons in an atom. Cosmic rays are atoms with all electrons removed; that is, ions of charge Z.

**zero-g** the condition in an orbiting spacecraft where there are no forces to keep objects in place; the condition of free fall or weightlessness. (Secs. 2D, 5, 5C, 6 to 6E; App. A, nos. 4, 19, 20, 22; Figs. 6.3, 6.7; Table 3.1)

**zodiacal light** a faint band of light around the sky along the ecliptic. It is sunlight reflected by small chunks of rock in orbit around the Sun farther out than the Earth. (Sec. 3C; Fig. 3.4)

# Appendix D

## Further Reading

- ABC's of Space* by Isaac Asimov, Walker and Co. (New York), 1969—an illustrated glossary of spaceflight terms.
- Apollo Expeditions to the Moon*, Edgar Cortright, ed., NASA SP-350 (Available from the U.S. Government Printing Office, Washington, D.C. 20402), 1976—well-illustrated descriptions of the Saturn boosters, the Apollo spacecraft, mission control, and astronaut training.
- Astronauts and Cosmonauts: Biographical and Statistical Data* (Available from the U.S. Government Printing Office, Washington, D.C. 20402), 1976—describes the men who have gone on space missions.
- Astronomy Made Simple* by Meir H. Degani, Doubleday & Co., Inc. (New York), 1963—an easy-to-read description of astronomical objects.
- Astronomy One* by J. Allen Hynek and Necia H. Apfel, W. A. Benjamin, Inc. (Menlo Park, Calif.), 1972—a pleasant introduction to the architecture of the universe; for the serious student.
- Atoms and Astronomy* by Paul Blanchard (Available from the U.S. Government Printing Office, Washington, D.C. 20402), 1976—atomic spectra explained in simple terms and used to explain the spectra of stars.
- The Birth and Death of the Sun* by George Gamow, Viking Press, Inc. (New York), 1952—an explanation in simple terms of how stars shine and where they come from, by the master of science writing.
- Continental Drift: The Evolution of a Concept* by Ursula B. Marvin, Smithsonian Institution Press (Washington, D.C.), 1973—a clear and easily understood account of this newest branch of geology.
- Extragalactic Astronomy: The Universe Beyond Our Galaxy* by Kenneth Charles Jacobs (Available from the U.S. Government Printing Office, Washington, D.C. 20402), 1976—includes a simple description of our own Milky Way Galaxy and discussions of other galaxies, Doppler shift, radio galaxies, quasars, and cosmology.
- Ideas From Astronomy* by Lou Williams Page, Addison-Wesley Publishing Co. (Menlo Park, Calif.), 1973—written especially for junior high school students. (A Teachers' Guide by Nicholas Rosa and Alexander Joseph is also available.)
- Learning About Space*, British Department of Education and Science, 1970—excellent explanations of spaceflight.
- Living in Space* (Available from the U.S. Government Printing Office, Washington, D.C. 20402), 1976—an easily understood account of astronaut living conditions.
- Matter, Earth, and Sky* by George Gamow, Prentice-Hall, Inc. (New York), 1965—a well-illustrated survey of matter and radiation in space.

*Modern Earth Science* by W. Ramsey & Burckley, Holt, Rinehart and Winston (New York), 1973—contains well-illustrated chapters on astronomy and space travel.

*New Frontiers in Astronomy* (Readings from *Scientific American* with an introduction by Owen Gingerich), W. H. Freeman & Co., Inc. (San Francisco), 1975—contains articles on x-ray stars and searches for Black Holes.

*Physica! Science, A Modern Approach* by Charles L. Bickel, Norman Regenfeld, and John C. Hogg, American Book Co., 1970—contains an excellent chapter on rockets, g-forces, and weightlessness.

*Rendezvous in Space: Apollo-Soyuz* by F. Dennis Williams (Available out charge from NASA Educational Programs Division/FE, Washington, D.C. 20546), 1975—a popular account of the Apollo-Soyuz Test Project including the U.S.-U.S.S.R. agreements.

*Science From Your Airplane Window* by Elizabeth A. Wood, Dover Publications (New York), 1975—discusses locating and observing geologic features from the air.

*The Supernova: A Stellar Spectacle* by W. C. Straka (Available from the U.S. Government Printing Office, Washington, D.C. 20402), 1976—a well-illustrated and dramatic account of how some stars blow up, leaving a halo of gaseous remnants in the space around them.