

DOCUMENT RESUME

ED 160 551

SP 012 851

TITLE Planning and Design of Outdoor Sports Facilities.
 INSTITUTION Department of the Air Force, Washington, D.C.;
 Department of the Army, Washington, D.C.; Department
 of the Navy, Washington, D.C.
 REPORT NO AFR-88-33; NAVFAC-P-457; TM-5-803-10
 PUB DATE Oct 75
 NOTE 233p.
 AVAILABLE FROM Superintendent of Document, U.S. Government Printing
 Office, Washington, D.C. 20402 (Stock No.
 008-020-00588-6; \$2.35)

EDRS PRICE MF-\$0.83 Plus Postage. HC Not Available from EDRS.
 DESCRIPTORS *Construction (Process); *Facility Planning;
 *Guidelines; *Manuals; *Recreational Facilities

ABSTRACT

Information required for the planning and design of outdoor sports facilities is provided in the format of an outline text and design criteria placed opposite an accompanying page of definitive drawings. Scope of the manual covers those outdoor sports and games most commonly played for competition and/or recreation by military and civilian personnel. The document is divided into the following sections: general introduction; sports courts and fields; recreational shooting ranges; and construction details. Layouts and construction details are based on the latest available rules as indicated by the date after the name of each sports organization or other source of rules. (MJB)

 * Reproductions supplied by EDRS are the best that can be made *
 * from the original document. *

U.S. DEPARTMENT OF HEALTH,
EDUCATION & WELFARE
NATIONAL INSTITUTE OF
EDUCATION

TM 5-803-10
NAVFAC P-457
AFR 88-33

THIS DOCUMENT HAS BEEN REPRODUCED EXACTLY AS RECEIVED FROM THE PERSON OR ORGANIZATION ORIGINATING IT. POINTS OF VIEW OR OPINIONS STATED DO NOT NECESSARILY REPRESENT OFFICIAL NATIONAL INSTITUTE OF EDUCATION POSITION OR POLICY.

Planning and Design of **OUTDOOR SPORTS FACILITIES**

DEPARTMENTS OF THE ARMY, NAVY AND AIR FORCE

October 1975

TECHNICAL MANUAL 5-803-10
 NAVFAC P-457
 AIR FORCE REGULATION 88-33

DEPARTMENTS OF THE ARMY
 NAVY AND AIR FORCE
 Washington, D.C. October 1975

PLANNING AND DESIGN OF OUTDOOR SPORTS FACILITIES

TABLE OF CONTENTS

| Section | INTRODUCTION | Page | | Page |
|-----------|--|------|--|------|
| 1-1 | Purpose and Scope | 1-1 | | |
| 1-2 | Application | 1-1 | | |
| 1-3 | References | 1-1 | | |
| 1-4 | Cooperating Organizations | 1-1 | | |
| 1-5 | General Introductory Information | 1-1 | | |
| 1-6 | Proponent and User Comments | 1-3 | | |
| | | | | |
| Section 2 | SPORTS COURTS AND FIELDS | | | |
| 2-1 | Sports Courts | | | |
| | Badminton - Figure 1 | 2-2 | | |
| | Basketball (AAU) - Figure 2 | 2-4 | | |
| | Basketball (NCAA) - Figure 3 | 2-6 | | |
| | Basketball, Bidy - Figure 4 | 2-8 | | |
| | Basketball, Goal-Hi - Figure 5 | 2-10 | | |
| | Boccie Ball - Figure 6 | 2-12 | | |
| | Croquet - Figure 7 | 2-14 | | |
| | Handball, One-Wall - Figure 8 | 2-16 | | |
| | Handball, Three and Four Wall - Figure 9 | 2-18 | | |
| | Hopscotch - Figure 10 | 2-20 | | |
| | Horseshoes - Figure 11 | 2-22 | | |
| | Ice Hockey - Figure 12 | 2-24 | | |
| | Lawn Bowling - Figure 13 | 2-26 | | |
| | Roque - Figure 14 | 2-28 | | |
| | Shuffleboard - Figure 15 | 2-30 | | |
| | Tennis, Deck - Figure 16 | 2-32 | | |
| | Tennis, Paddle - Figure 17 | 2-34 | | |
| | Tennis, Platform - Figure 18 | 2-36 | | |
| | Tennis - Figure 19 | 2-38 | | |
| | Tetherball - Figure 20 | 2-40 | | |
| | Volleyball - Figure 21 | 2-42 | | |
| 2-2 | Sports Fields | | | |
| | Baseball - Official, Babe Ruth, Senior League - Figure 22 | 2-46 | | |
| | Baseball, Bronco League - Figure 23 | 2-48 | | |
| | Baseball, Pony League - Figure 24 | 2-50 | | |
| | Baseball, Colt League - Figure 25 | 2-52 | | |
| | Baseball, Little League - Figure 26 | 2-54 | | |
| | Field Hockey - Figure 27 | 2-56 | | |
| | Flickerball - Figure 28 | 2-58 | | |
| | Football, 11 Man, NCAA, Pop Warner Junior League - Figure 29 | 2-60 | | |
| | Football, Touch and Flag - Figure 30 | 2-62 | | |
| | Golf Driving Range - Figure 31 | 2-64 | | |
| | Lacrosse (Men's) - Figure 32 | 2-66 | | |
| | Lacrosse (Women's) - Figure 33 | 2-68 | | |
| | Soccer (Men's and Boys') - Figure 34 | 2-70 | | |
| | Soccer (Women's and Girls') - Figure 35 | 2-72 | | |
| | Softball, 12" - Figure 36 | 2-74 | | |
| | Softball, 16" - Figure 37 | 2-76 | | |
| | Speedball - Figure 38 | 2-78 | | |
| | Team Handball - Figure 39 | 2-80 | | |

| | Page |
|---|-------|
| 2-3 Track and Field | |
| 1/4 Mile Running Layout - Figure 40 | 2-84 |
| Marking Details-1 - Figure 41 | 2-86 |
| Marking Details-2 - Figure 42 | 2-87 |
| Marking Details-3 - Figure 43 | 2-88 |
| Marking Details-4 - Figure 44 | 2-89 |
| Shot Put - Figure 45 | 2-90 |
| Hammer Throw - Figure 46 | 2-92 |
| Discuss Throw - Figure 47 | 2-94 |
| Javelin Throw - Figure 48 | 2-96 |
| Long Jump and Triple Jump - Figure 49 | 2-98 |
| Pole Vault - Figure 50 | 2-100 |
| High Jump - Figure 51 | 2-102 |
| 2-4 Multiple Sports | |
| Combination Basketball-Volleyball Courts Figure 52 | 2-106 |
| Tennis, Volleyball, Basketball, Badminton Court - Figure 53 | 2-108 |
| Multiple Recreation Court - Figure 54 | 2-110 |
| Multiple Recreation Court Details - Figure 55 | 2-113 |
| Combination Baseball, Football, Softball Fields - Figure 56 | 2-114 |
| Athletic Ballfield within 1/4 Mile Running Track - Figure 57 | 2-116 |

Section 3 RECREATION SHOOTING RANGES

| | |
|--|-----|
| Archery Target Range - Figure 58 | 3-2 |
| International Shooting Union Automatic Trap - Figure 59 | 3-4 |

| | Page |
|---|------------|
| Skeet Field - Figure 60 | 3-6 |
| Trap Field - Figure 61 | 3-8 |
| Combination Skeet and Trap Field - Figure 62 | 3-10 |
| Section 4 CONSTRUCTION DETAILS | |
| Typical Court Fencing Details - Figure 63 | 4-2 |
| Fixed Net Posts - Figure 64 | 4-4 |
| Removable Net Posts - Figure 65 | 4-6 |
| Football Goal Posts and Basketball Standards - Figure 66 | 4-8 |
| One Wall Handball Walls - Figure 67 | 4-10 |
| Three and Four Wall Handball Walls - Figure 68 | 4-12 |
| Typical Grading and Drainage Details - Figure 69 | 4-14 |
| Typical Playing Surfaces - Figure 70 | 4-16 |
| Backstops - Figure 71 | 4-18 |
| Appendix A List of Sports Organizations | A-1 |
| Appendix B Metric Conversion Tables | B-1 |



SECTION 1. INTRODUCTION**1-1 PURPOSE AND SCOPE.**

This manual provides a comprehensive reference source for outdoor sports facilities that contains information required for the planning and design of these facilities. Information is provided for site adaptation in an outline text of planning and design criteria opposite an accompanying page of definitive drawings. The scope of this manual covers those outdoor sports and games most commonly played for competition and/or recreation by military and civilian personnel.

1-2 APPLICATION.

Layouts and construction details in this manual will serve as guidance material. They are based on the latest available rules as indicated by the date after the name of each sports organization or other source of rules. Actual construction drawings should be prepared by design professionals through selection of the appropriate layouts and details and their site adaptation with proper grading and drainage to fit local conditions. Changes in playing rules may affect the dimensions and shapes of outdoor sports facilities. Therefore, the latest official rules of the governing body for each sport should be checked and the project drawings prepared in conformance with those rules.

1-3 REFERENCES.

Following is a list of Government Regulations, Manuals and Guide Specifications which are applicable, in addition to the official rules of governing sports organizations, to the design and construction of outdoor sports facilities.

- a. DOD 4270.1-M, Department of Defense Construction Criteria Manual.
- b. AR 28-1, Army Recreation Services.
- c. AFM 215-2, Air Force Sports Manual.
- d. AFM 86-2, Standard Facility Requirements.
- e. AFM 88-15, Standard Outline Specifications for Air Force Facilities.

f. BUPERSINST 1710.11, Navy Special Services Manual.

g. OCE Guide Specification, CE-1000, Playing Surfaces for Outdoor Sports Facilities.

h. Military Construction Guide Specification, MCGS 02711, Fence, Chain-link.

i. Illuminating Engineering Society Lighting Handbook, Illuminating Engineering Society, 345 East 47th Street, New York, N. Y. 10017.

1-4 COOPERATING ORGANIZATIONS.

The initial impetus for the manual came from meetings held in the spring of 1973 in which representatives of the U.S. Departments of Army, Navy, Air Force, Agriculture, and the National Recreation and Park Association discussed the revision and updating of the Folio of Standard Drawings for Outdoor Sports Facilities for the Office of the Chief of Engineers, Department of the Army. Matching funds were obtained from the Departments of the Navy and Air Force along with additional funds from the Department of the Army, to finance this joint publication on Planning and Design of Outdoor Sports Facilities. The Department of Agriculture, through its Extension Service and its Soil Conservation Service, and the National Recreation and Park Association, expressed interest in a manual of this type and participated in the organization and review of the project.

1-5 GENERAL INTRODUCTORY INFORMATION.

For the purposes of the manual, an outline text of planning and design criteria applicable to all the sports contained herein was developed. The typical criteria categories are: Name of Sports Organization, Recommended Area, Size and Dimension, Orientation, Surface and Drainage, and Special Considerations. Additional considerations in the design and planning of some sports facilities are discussed below.

a. Lighting Requirements.

If it is desirable to provide lighting to extend the usable playing time of a sports facility and justifiable in view of the Government Energy Reduction Program, the current edition of the Recommended

Lighting Practices for Sports Lighting, published by the Illuminating Engineering Society, should be consulted. Illumination levels are provided for various classes of sports.

b. Suggested Support Facilities.

Another factor which may influence the planning and design of sports facilities is the availability of various support facilities.

(1)
Toilet facilities for participants must be available in some form. These may be provided by individual dwelling units for facilities that serve housing areas or by self-contained structures. Public toilets and a drinking fountain should be available at general recreation areas. Shower and locker facilities should be provided near sports facilities used for competitive events. Additional public toilets would be required for spectators at such events.

(2)
Walks should be provided for access to each sport facility. The size and pavement surface would be dependent on the nature of the activity and the anticipated volume of pedestrian traffic.

(3)
Parking should be provided for the participants and, in some cases, the spectators for certain sports. The quantity of parking is subject to space allowances in DOD 4270.1-M, and is also dependent on the number of players for the sport, the anticipated spectator attendance and the location of the facility. The parking area should include provision for bicycles, motorcycles and automobiles.

(4)
A grandstand, bleachers or other form of observation structure may also be required to provide properly for some spectator sports. The number of seats and location will be dependent on the particular sport. The structure may be portable in nature.

(5)
Storage facilities for the safe keeping of implements, supplies and other equipment required for the support of a sport activity should

be provided near the playing area. This unit may also house pertinent maintenance equipment required for a particular sport.

(6)
Design of all facilities should consider the needs of the handicapped, especially where spectators are involved.

(7)
Refreshment concession facilities should be considered for outdoor sport complexes and where there are large numbers of spectators. The size of the concession facility may vary from a vending machine concept to a hot service area, depending on the anticipated need or use.

c. Soil Considerations.

The existing soils of a given area may affect the planning, design and maintenance of sports facilities for that area. Removal, replacement or alteration of the existing material may be required.

(1)
For sports played on natural turf surfaces, special consideration must be given to the nutrient qualities of the topsoil, as well as to the drainage characteristics of the subsoils, in order to obtain the best possible playing surface.

(2)
For sports requiring a paved surface of concrete, bituminous or other hard material, the sub-base for the paving type required should be of inorganic material and well drained to prevent frost heave.

(3)
For any structure, such as the One, Three and Four Wall Handball Walls, the bearing capacity of the soils must be determined and the design modified or the facility moved if the bearing capacity is less than the design criteria.

(4)
Soils information is available from local representatives of the Soil

Conservation Service, U.S. Department of Agriculture. Mapping is generally done on a county basis and the soils are rated for usability as to structures and recreational land uses.

d. Metric Conversions.

Many sports contained in the manual are dimensioned in both metric and English measures. Metric measure is used when the sport originated in a European country and when the governing sports organization recognizes the international rules. In these sports the playing area is governed by the metric measurement, and the English equivalent is shown as a convenience in laying out the area. Although the metric system will eventually replace the English system of measurements, many sports organizations do not yet recognize the metric system in their official playing rules and regulations. Therefore, their playing areas are dimensioned only in the English system of measurement. Appendix B contains tables for conversion from English measure to metric and vice versa.

1-6 PROPONENT AND USER COMMENTS.

The proponent agency of this manual is the Office of the Chief of Engineers, Department of the Army. Users are invited to send comments and suggested improvements, indicating referenced page, paragraph, line, figure, detail and specific recommendations, to HQDA (DAEN-MCE-P) WASH DC 20314.

SECTION 2 SPORTS COURTS AND FIELDS

2-1

2-1

SPORTS COURTS

BADMINTON

NAME OF SPORTS ORGANIZATION

American Badminton Association (ABA) 1972-73.

RECOMMENDED AREA

Ground space is 1620 square feet minimum to edge of pavement.

SIZE AND DIMENSION

Singles court is 17' x 44', doubles court is 20' x 44' with a 5'-0" minimum unobstructed area on all sides.

ORIENTATION

Preferred orientation is for the long axis to be north-south.

SURFACE AND DRAINAGE

Surface is to be concrete or bituminous material with optional protective colorcoating for permanent installation.

Drainage is to be end to end, side to side or corner to corner diagonally at a minimum slope of 1" in 10'.

Badminton may be played on a turf court, for general recreation use with surface drainage as described above at a minimum slope of 2% and adequate underdrainage.

NOTES:

All measurements for court markings are to the outside of lines except for those involving the center service line which is equally divided between right and left service courts.

All court markings to be 1 1/2" wide and preferably white or yellow in color.

Minimum distance between sides of parallel courts to be 5'-0".

For net post details see figure 64 or 66.

For surfacing details see figure 70.

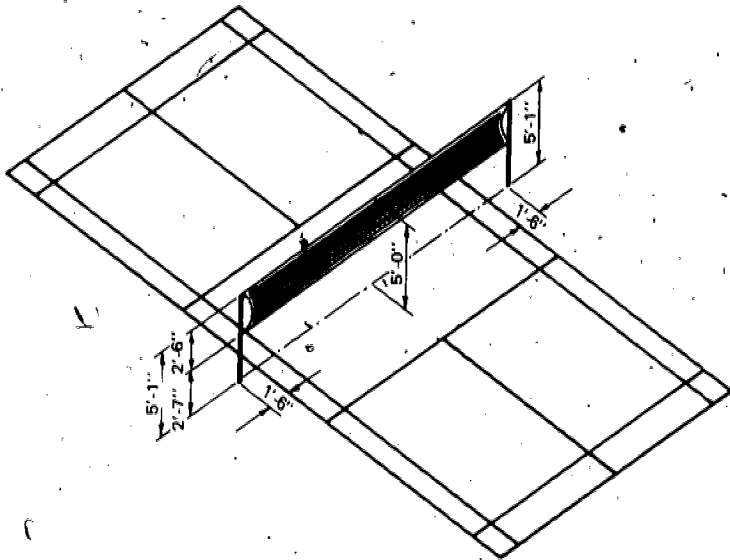

ISOMETRIC SHOWING NET

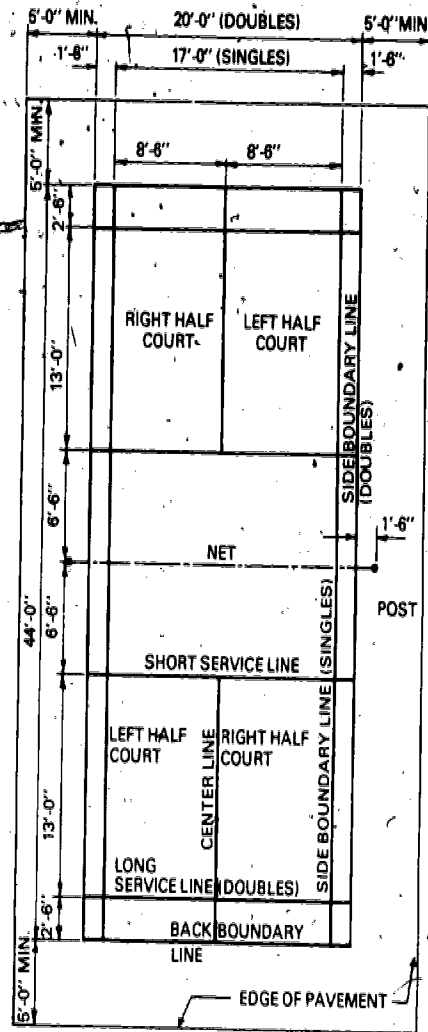

COURT LAYOUT

BADMINTON

FIGURE 1

BASKETBALL (AAU)

NAME OF SPORTS ORGANIZATION

Amateur Athletic Union, (AAU), 1974* (International Competition).

RECOMMENDED AREA

Ground space is 448 square metres minimum to 540 square metres recommended, including clear space.

SIZE AND DIMENSION

Playing court is 14 metres x 26 metres with an unobstructed space of 1 metre minimum to 2 metres recommended on all sides.

ORIENTATION

Preferred orientation is for the long axis to be north-south.

SURFACE AND DRAINAGE

Surface is to be concrete or bituminous material with optional protective colorcoating. Drainage is to be end to end, side to side or corner to corner diagonally at a minimum slope of .02 metres in 3.05 metres (1" in 10').

SPECIAL CONSIDERATIONS

Safety — Backboard is to be 1.65 metres from support post. Post may be padded.

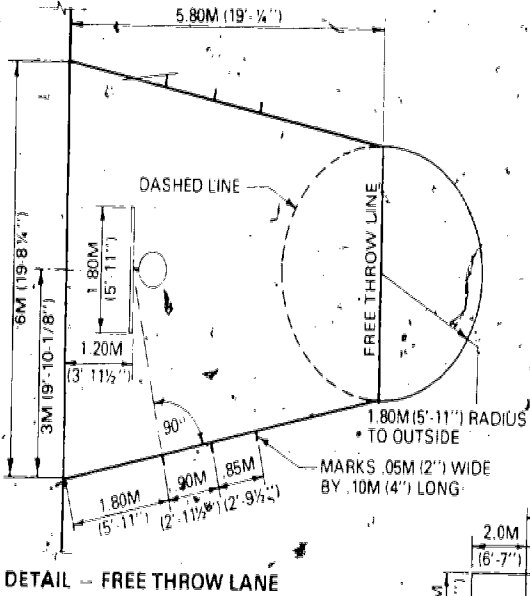

NOTES:

Backboard shall be of any rigid weather-resistant material.

The front shall be flat and painted white unless it is transparent.

If the backboard is transparent, it shall be marked with a .05M wide white line around the border and a .45 x .59M target area bounded with a .05M wide white line.

For details of backboard standards see Figure 66.

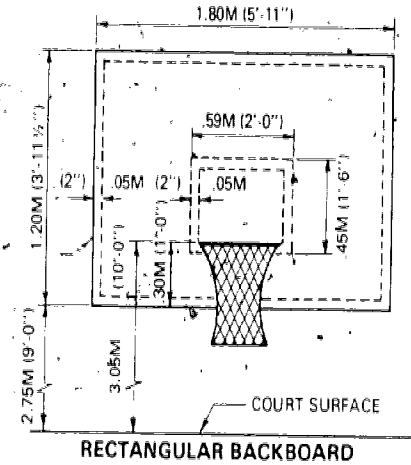

DETAIL - FREE THROW LANE

RECTANGULAR BACKBOARD

NOTES:

All dimensions are to inside edge of lines except as noted.

All lines to be .05M (2") wide.

For surfacing details see Figure 69.

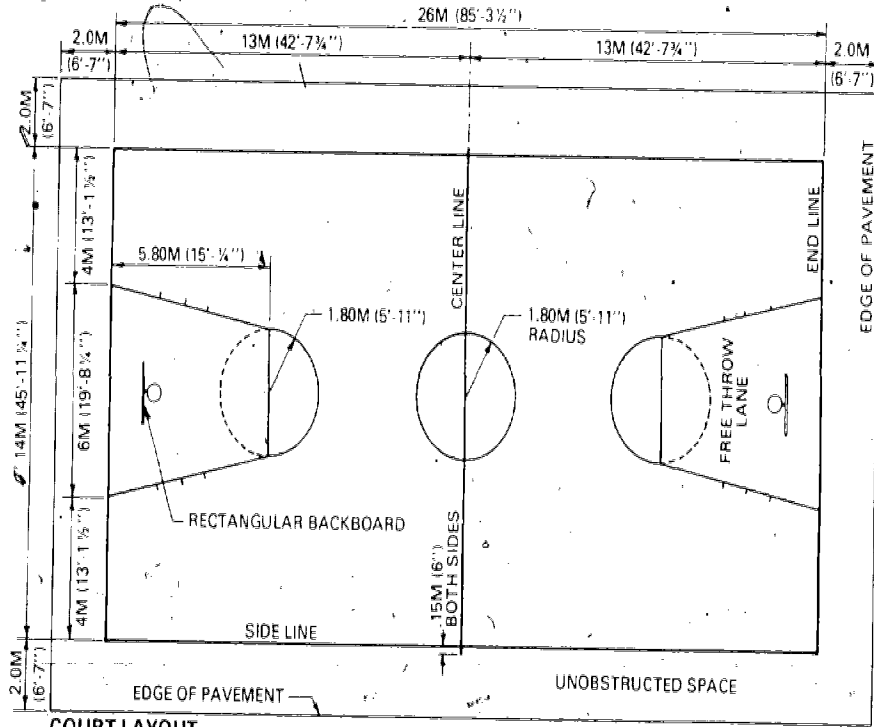

COURT LAYOUT

BASKETBALL (AAU)

FIGURE 2

BASKETBALL (NCAA)

NAME OF SPORTS ORGANIZATION

National Collegiate Athletic Association, (NCAA), 1974.

RECOMMENDED AREA

High School - ground space is 5040 square feet minimum to 7280 square feet maximum.

Collegiate - ground space is 5600 square feet minimum to 7980 square feet maximum.

SIZE AND DIMENSION

High School recommended court is 84' x 50' with a 10' unobstructed space on all sides (3' minimum).

Collegiate recommended court is 94' x 50' with a 10' unobstructed space on all sides (3' minimum).

ORIENTATION

Preferred orientation is for the long axis to be north-south.

SURFACE AND DRAINAGE

Surface is to be concrete or bituminous material with optional protective colorcoating.

Drainage is to be end to end, side to side or corner to corner diagonally at a minimum slope of 1" in 10'.

SPECIAL CONSIDERATIONS

Safety - Backboard and goal support should have a minimum 32" overhang and post may be padded if desired.

Bottom edge and lower sides of rectangular backboard must be padded.

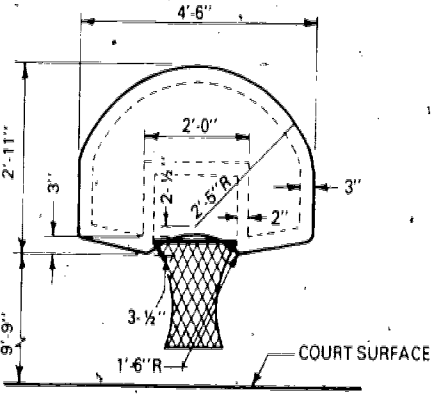

FAN SHAPED BACKBOARD

NOTES:

Backboard shall be of any rigid weather-resistant material.

The front surface shall be flat and painted white unless it is transparent.

If the backboard is transparent, it shall be marked with a 3" wide white line around the border and an 18"x24" target area.

If the backboard is transparent, it shall be marked with a 3" wide white line around the border and an 18"x24" target area bounded with a 2" wide white line.

For backboard standard details see figure 66.

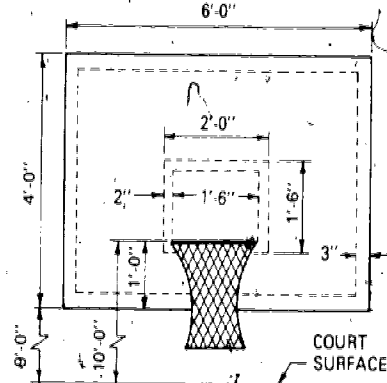

RECTANGULAR BACKBOARD

NOTES:

The color of the lane space marks and neutral-zone marks shall contrast with the color of the bounding lines.

The midcourt marks shall be the same color as the bounding lines.

All lines shall be 2" wide. (neutral zone excluded).

All dimensions are to inside edge of lines except as noted.

For surfacing details see figure 70.

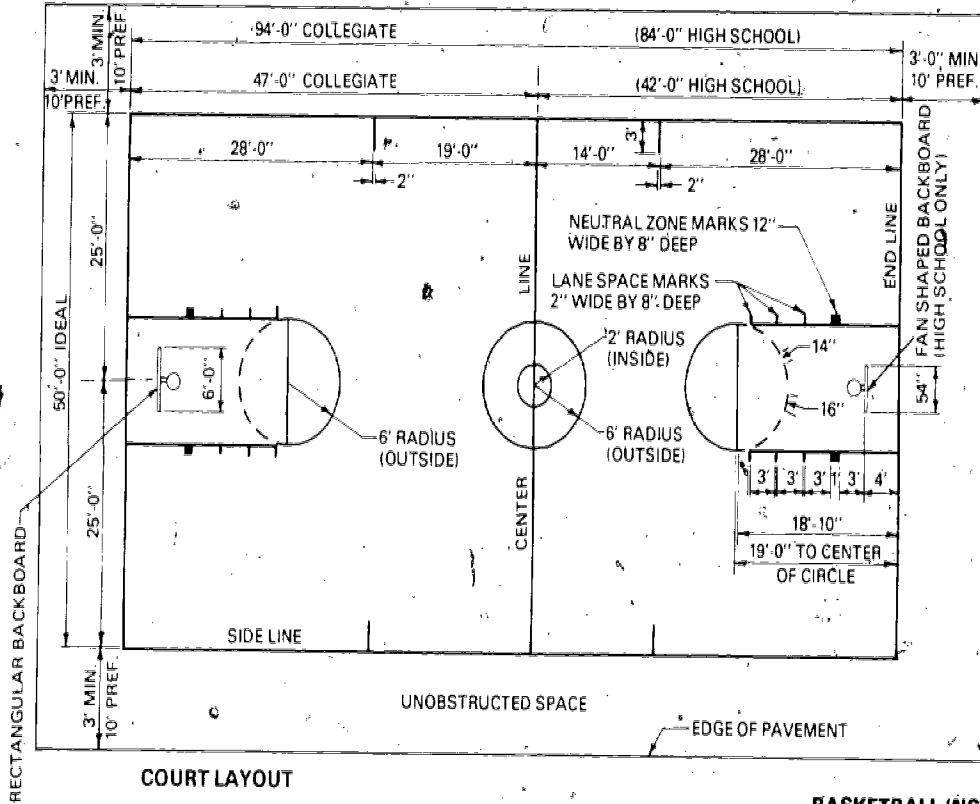

COURT LAYOUT

BASKETBALL (NCAA)

BIDDY BASKETBALL

NAME OF SPORTS ORGANIZATION

Biddy Basketball Association, Inc.

RECOMMENDED AREA

Ground space is 2,400 square feet to 3,036 square feet, including clear space.

SIZE AND DIMENSION

Playing court is 46'-0" to 50'-0" wide and 84'-0" long with an unobstructed space of at least 3 feet recommended on all sides.

ORIENTATION

Preferred orientation is for the long axis to be north-south.

SURFACE AND DRAINAGE

Surface is to be concrete or bituminous material with optional protective colorcoating.

Drainage is to be end to end, side to side or corner to corner diagonally at a minimum slope of 1" in 10'.

SPECIAL CONSIDERATIONS

Safety - Backboard support standard is to be a minimum of 2 feet, preferably 4 feet, outside of the court area. Post may be padded.

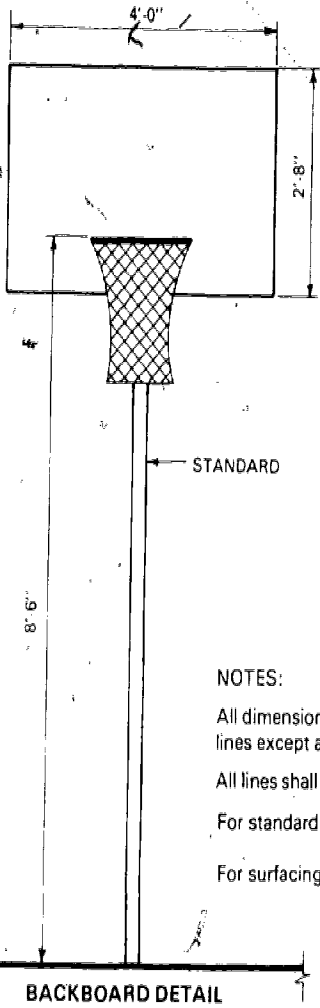

NOTES:
 All dimensions are to inside edge of lines except as noted.
 All lines shall be 2" wide.
 For standard details see figure 66.
 For surfacing details see figure 70.

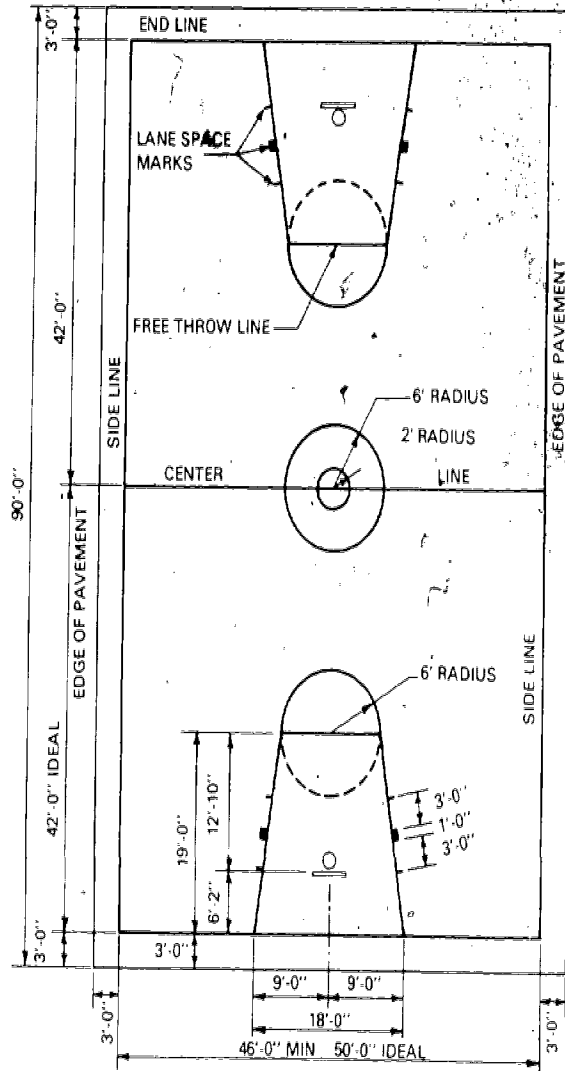

COURT LAYOUT

BIDDY BASKETBALL
 FIGURE 4

GOAL-HI BASKETBALL

NAME OF SPORTS ORGANIZATION

AMF Voit Corporation, 1974.

RECOMMENDED AREA

Ground space minimum is 1256 square feet; maximum is 2827 square feet.

SIZE AND DIMENSION

Playing court is to be an Outer Court circle with a minimum radius of 20'-0" and a maximum radius of 30'-0", surrounding an Inner Court circle with a minimum radius of 10'-0" and a maximum radius of 15'-0".

ORIENTATION

Optional.

SURFACE AND DRAINAGE

Concrete or bituminous surface may be used for minimum maintenance, but a resilient synthetic surface is preferred for safety and comfort. Minimum slope is 1" in 10' for drainage in any direction.

NOTES:

All court markings to be 2" wide.

For surfacing details see figure 69.

Goal Hi standard may be permanently mounted, removable flush mounted or portable as shown.

For fixed or removable post details see figures 64 or 65.

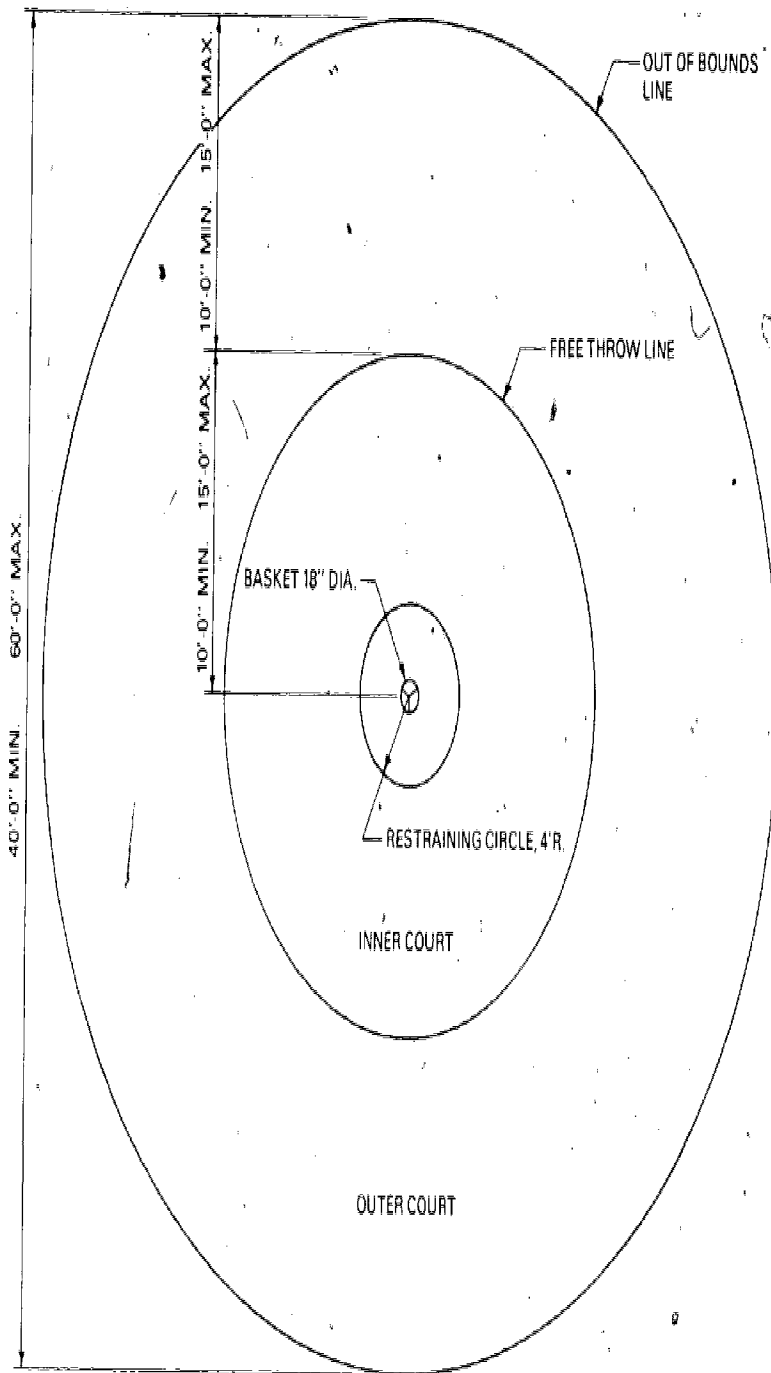
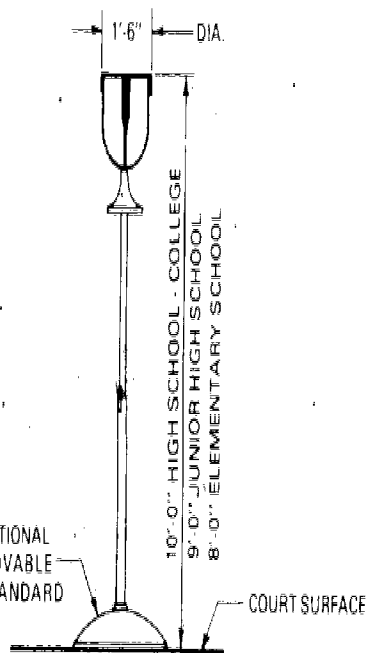

SECTION OF GOAL HI STANDARD

COURT LAYOUT

GOAL HI BASKETBALL

FIGURE 5

BOCCIE BALL

NAME OF SPORTS ORGANIZATION

General Sportcraft Company, Ltd., 1974.

RECOMMENDED AREA

Ground space is 1824 square feet to 2816 square feet.

SIZE AND DIMENSION

Overall court dimensions are 13'-0" to 19'-6" wide by 78'-0" to 92'-0" long. Additional space of at least 3'-0" on each side and 9'-0" on each end is recommended.

ORIENTATION

Preferred orientation is for the long axis to be north-south although it is of minor importance.

SURFACE AND DRAINAGE

Surface is to be preferably turf, although a mixture of sand and clay may be used.

Drainage may be in any direction at a recommended slope of 1% for turf and level for sand-clay with underdrainage.

SPECIAL CONSIDERATIONS

Optional low wooden barrier should be provided at each end and/or side of court.

NOTES:

Court markings to be 2" wide linen tape held in place with metal pins.

For surfacing details see figure 70.

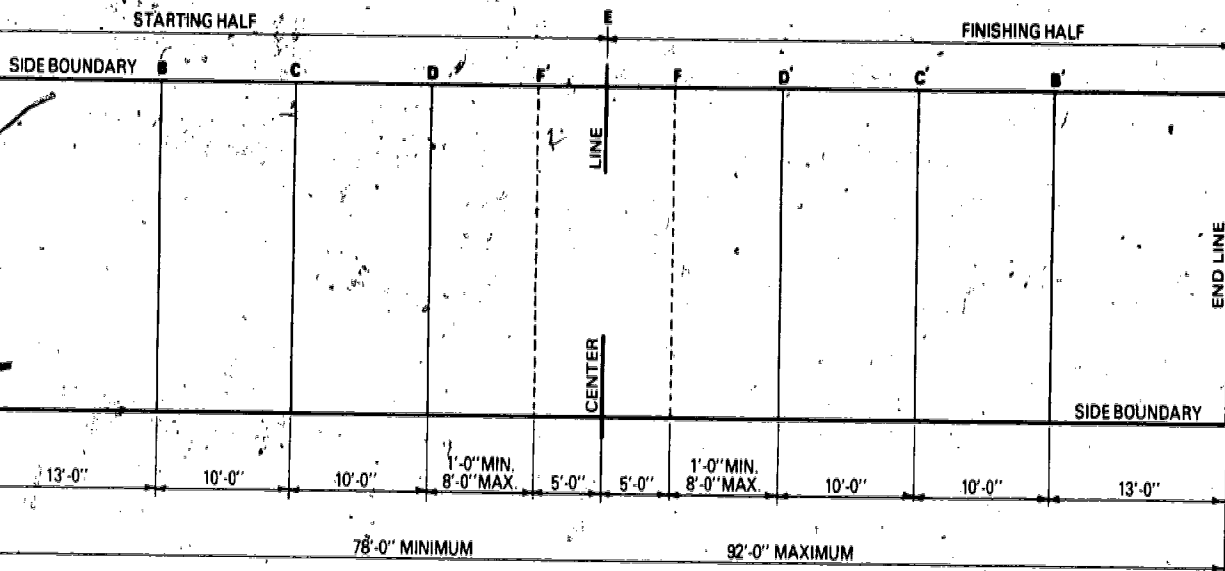

COURT LAYOUT

2-13

**BOCCIE
FIGURE 6**

27

CROQUET

NAME OF SPORTS ORGANIZATION

National Croquet Association, Inc. (NCA), 1963

RECOMMENDED AREA

Ground space is 3,000 square feet.

SIZE AND DIMENSION

Playing area is 35' x 70', plus minimum 2'-6" on each end and side.

ORIENTATION

Orientation is not critical and may be adjusted to suit local topographic conditions.

SURFACE AND DRAINAGE

Playing surface is to be turf closely cropped and rolled with a maximum 2% slope (preferably level) and adequate underdrainage.

NOTES:

Arches are 1/2" dia. steel rod- 3-3/8" wide and 9" above the ground when in place.

Stakes shall be made of steel and shall be firmly anchored. They shall be 11" high and set 1 1/2" outside the playing line half way between the end corners.

Boundary lines are marked with strong cotton twine held by corner staples.

Playing lines may be either imaginary, marked with white chalk or with smaller twine wired close to the ground.

For surfacing details see figure 70.

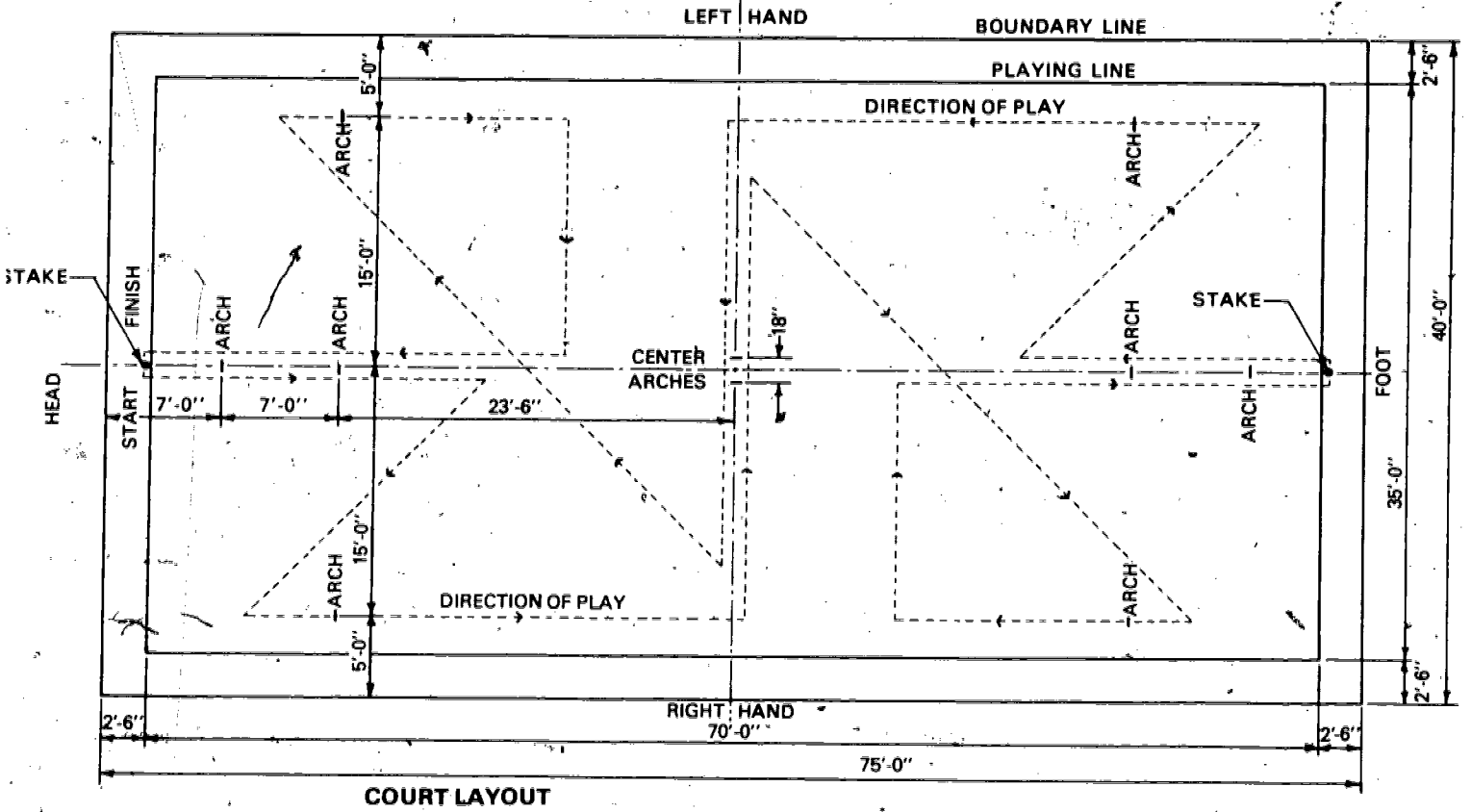

ONE WALL HANDBALL

NAME OF SPORTS ORGANIZATION

United States Handball Association, (USHA), 1974.

RECOMMENDED AREA

Ground space is 1665 square feet plus walls and footings.

SIZE AND DIMENSION

Playing court is 20'-0" wide by 34'-0" long plus a required 11'-0" minimum width of surfaced area to the rear and a recommended 8'-6" minimum width on each side. Courts in battery are to be a minimum of 6'-0" between courts.

ORIENTATION

Preferred orientation is for the long axis to be north-south with the wall at the north end.

SURFACE AND DRAINAGE

Surface is to be smooth concrete with a minimum slope of 1" in 10' from the wall to the rear of the court.

SPECIAL CONSIDERATIONS

Fencing - Court area preferably should be fenced with a 10' high chain link fence.

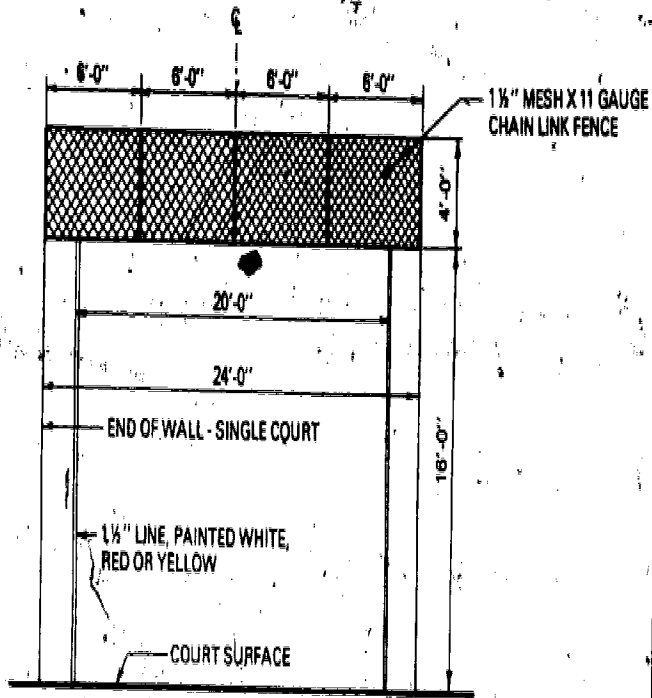

ELEVATION

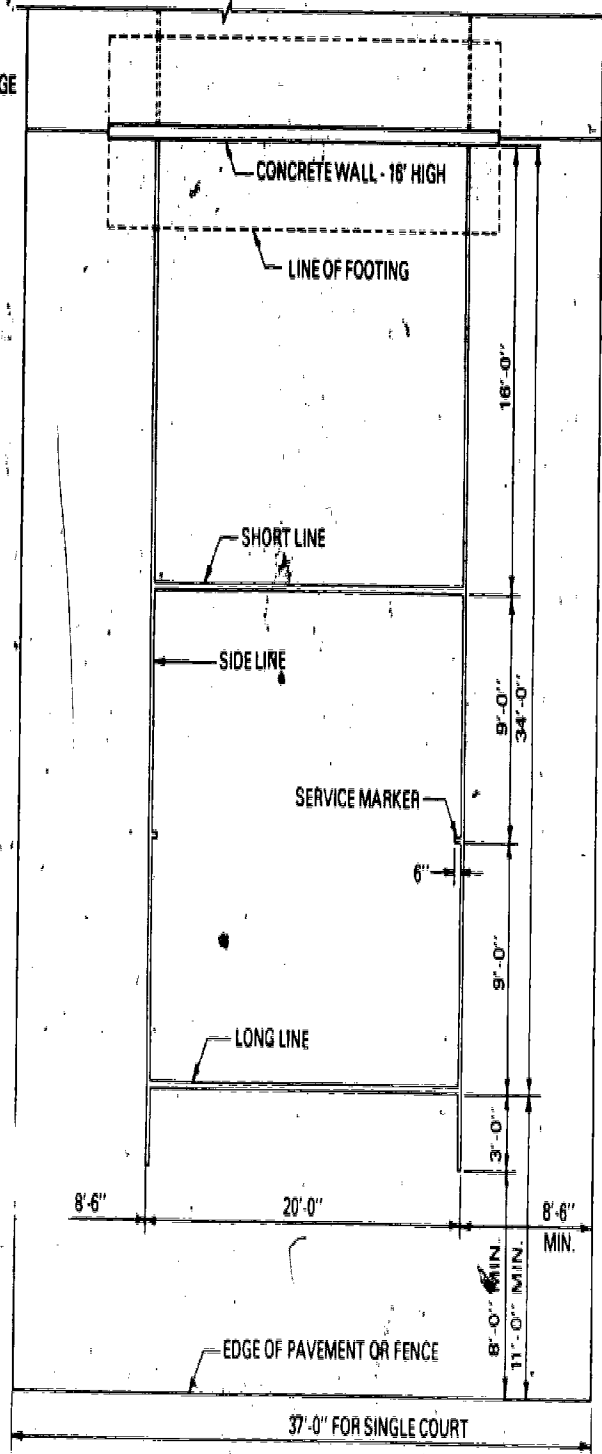

COURT LAYOUT

NOTES:

Court markings 1 1/2" wide lines painted white, red or yellow.

For surfacing details see figure 70.

For wall construction details see figure 67.

For fence details see figure 63.

ONE-WALL HANDBALL

FIGURE 8

THREE AND FOUR WALL HANDBALL

NAME OF SPORTS ORGANIZATION

United States Handball Association, (USHA), 1974.

RECOMMENDED AREA

Ground space for four wall handball is 800 square feet, plus walls and footing.
Allow an additional 200 square feet for three wall handball.

SIZE AND DIMENSION

Playing court is 20'-0" wide by 40'-0" long plus a minimum 10'-0" to the rear of the three wall court. Overhead clearance required is 20'-0" minimum.

ORIENTATION

Preferred orientation is for the long axis to be north-south with the front wall at north end.

SURFACE AND DRAINAGE

Surface is to be smooth concrete preferably with a minimum slope of 1" in 10' from front to rear of the court.

SPECIAL CONSIDERATIONS

Alternate Four Wall Court - Layout is the same as for three wall with the exception of a minimum 12'-0" high back wall at the rear of the court (long line) and necessary wall footings.

Special provisions for drainage must be made and access provided through the back wall for four wall courts.

Fencing - An optional 10' high chain link fence may be provided at the rear of the pavement for three wall courts.

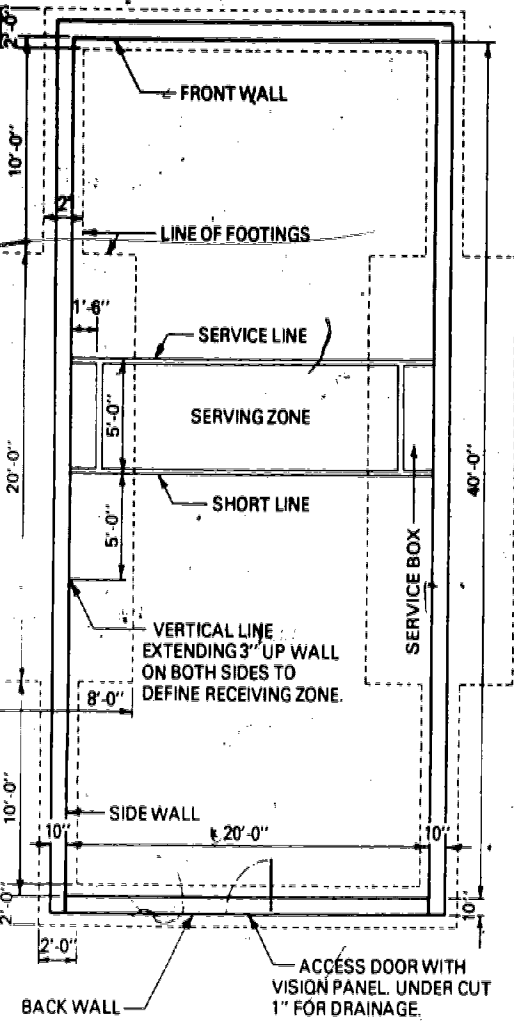

COURT LAYOUT - 4-WALL

NOTES:
 All court markings to be 1 1/2" wide and painted white, red or yellow.
 For surfacing details see figure 69.
 For wall construction details see figure 68.

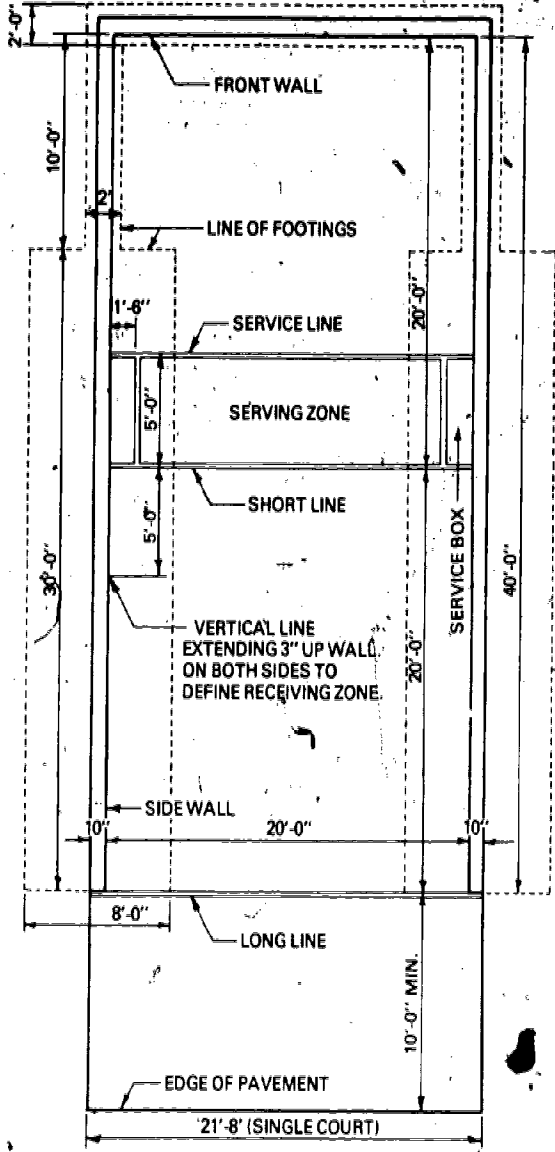

COURT LAYOUT - 3-WALL

THREE AND FOUR WALL HANDBALL

FIGURE 9

HOPSCOTCH

NAME OF SPORTS ORGANIZATION
AMF Volo Corporation, 1974.

RECOMMENDED AREA
Ground space is 62.5 square feet.

SIZE AND DIMENSION
Playing court is 5'-0" wide by 12'-6" long.

ORIENTATION
Optional.

SURFACE AND DRAINAGE
Surface is to be concrete or bituminous material with a lateral slope of 1" in 10' and a longitudinal slope of 1" in 10' minimum.

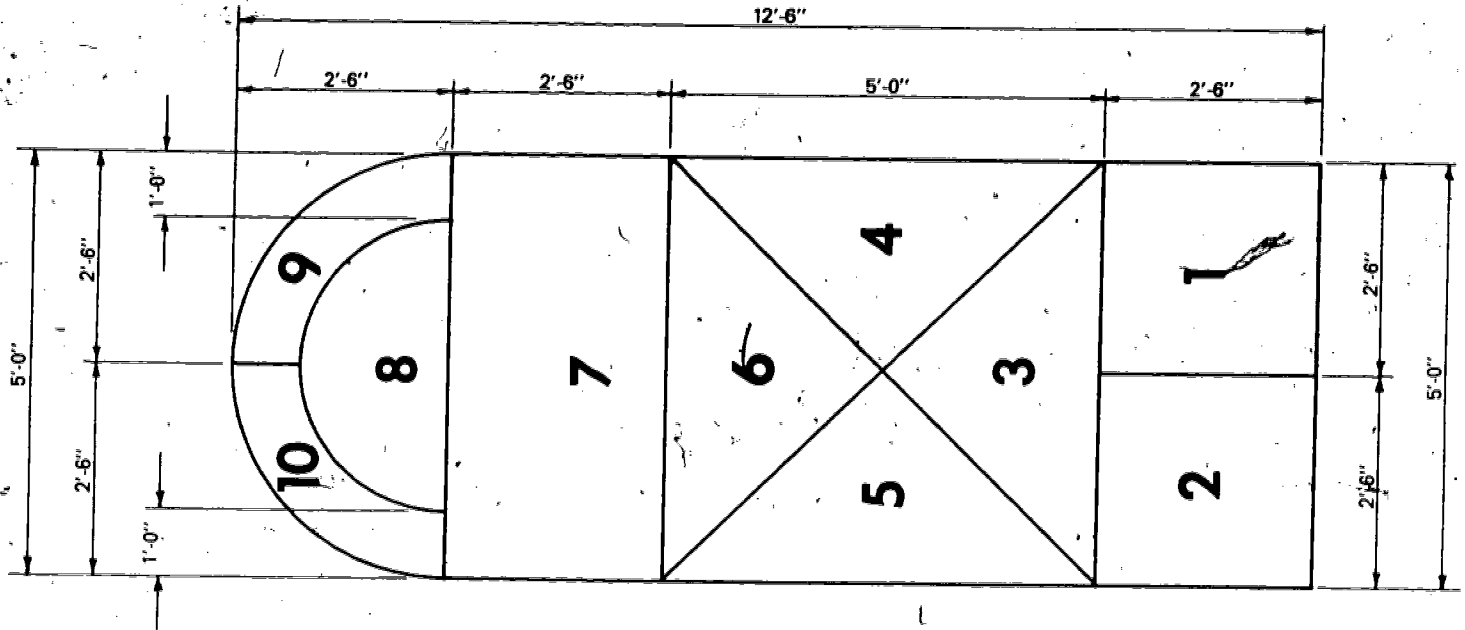

COURT LAYOUT

NOTES:

All lines to be 1 1/2" wide painted with white or black acrylic paint to contrast with court surface.

For surfacing details see figure 70.

HORSESHOES

NAME OF SPORTS ORGANIZATION

National Horseshoe Pitchers' Association of America, (NHPAA), 1974.

RECOMMENDED AREA

Ground space is 1400 square feet, including clear space.

SIZE AND DIMENSION

Playing court is 10'-0" x 50'-0" plus a recommended 10' minimum unobstructed area on each end and a 5' minimum wide zone on each side.

ORIENTATION

Recommended orientation is for the long axis to be north-south.

SURFACE AND DRAINAGE

Surface of playing area, except for boxes and optional concrete walkways, should be turf. Area should be pitched to the side at a maximum slope of 2%. Elevation and slant of steel pegs should be between 2" and 3" and equal.

SPECIAL CONSIDERATIONS

Boxes are to be filled with gummy potter's or blue clay.

Safety: A 2'-0" high backstop should be constructed at the end of the box to intercept overthrown or bounding shoes.

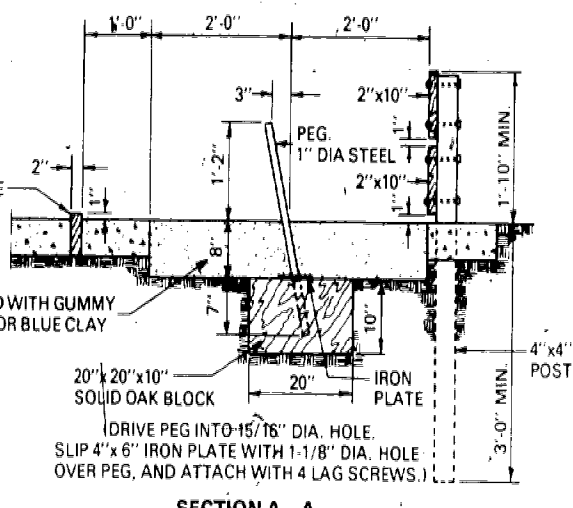
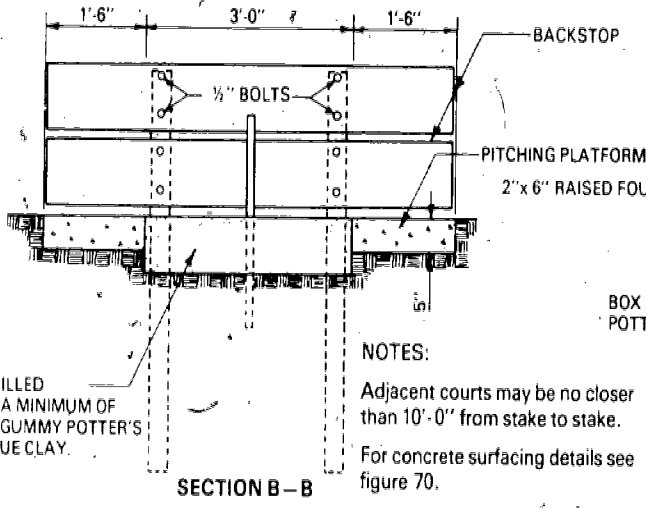

NOTES:
 Adjacent courts may be no closer than 10'-0" from stake to stake.
 For concrete surfacing details see figure 70.
 All wood members to be pressure treated with a paintable oil-borne preservative.

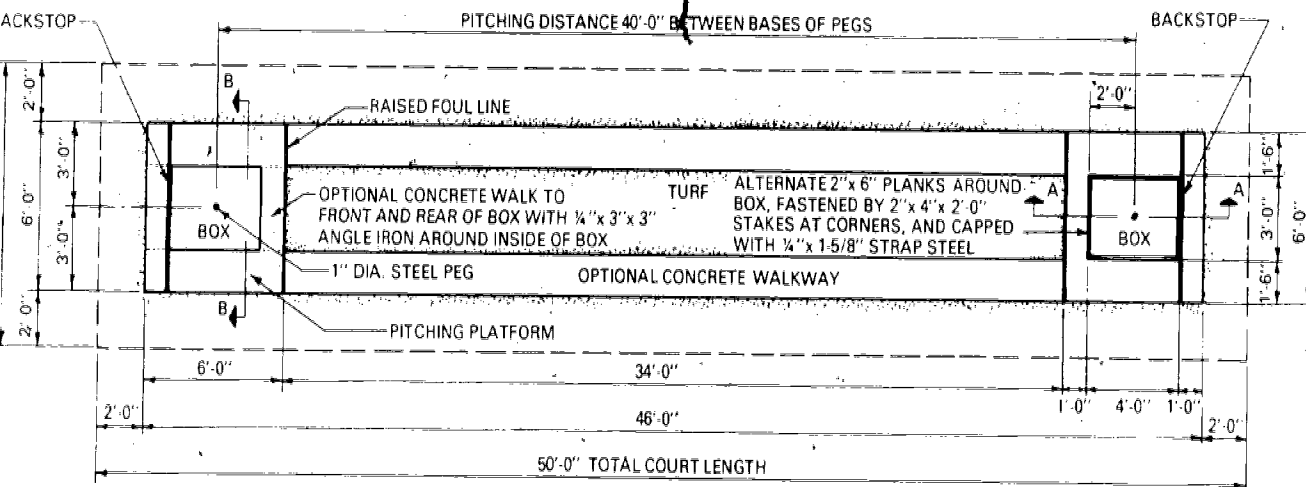
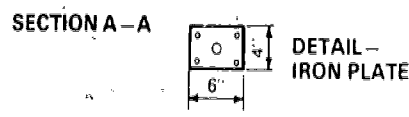

COURT LAYOUT

HORSESHOES
 FIGURE 11

ICE HOCKEY

NAME OF SPORTS ORGANIZATION

Amateur Hockey Association of the United States, (AHA), 1974.

RECOMMENDED AREA

Ground space is 22,000 square feet, including support area.

SIZE AND DIMENSION

Playing rink is 85'-0" wide by 200'-0" long, plus an additional 5,000 square feet of support area.

ORIENTATION

Preferred orientation is for the long axis to be north-south.

SURFACE AND DRAINAGE

The ice surface should be level over either sand-clay or bituminous surface. Provisions for drainage should be made on the surface beneath the ice and around the rink.

SPECIAL CONSIDERATIONS

Ice: Unless situated in northern climates, provisions for artificial ice will be required.

NOTES: The rink must be at least 185'x85', ideal 200'x85'.

The rink shall be surrounded by a wooden wall or fence known as the "BOARDS" which shall extend not less than 40" nor more than 48" above the level of the ice surface. Ideal 42".

The surface of the boards facing the ice shall be smooth and free from obstructions. All access doors to the playing surface must swing away from the ice surface.

A protective screening of heavy gauge wire or safety glass is recommended above the boards, except for the bench areas, for the protection of spectators around the rink.

The center line and the two blue lines shall extend across the rink and vertically to the top of the boards.

Surface to be flooded may be sand-clay or bituminous material, (see figure 70).

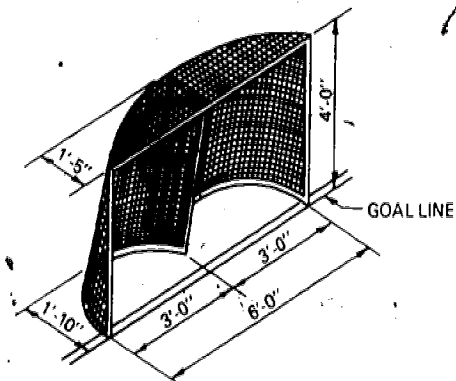

ISOMETRIC OF GOAL

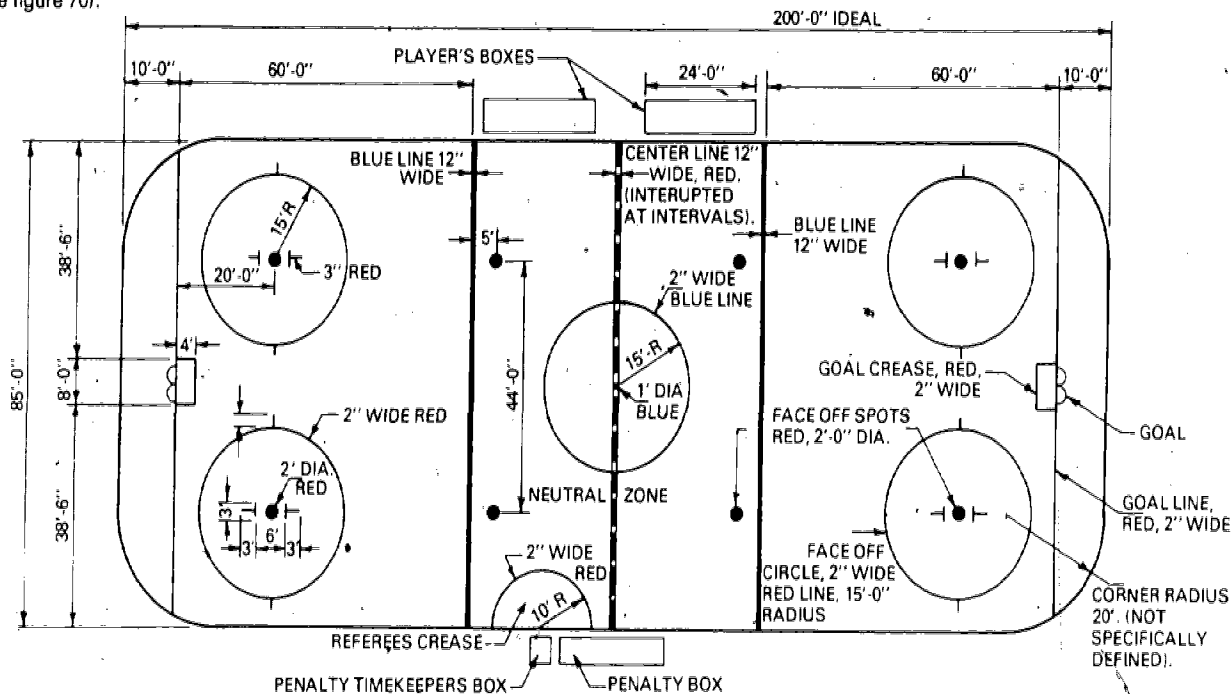

RINK LAYOUT

ICE HOCKEY RINK

FIGURE 12

LAWN BOWLING

NAME OF SPORTS ORGANIZATION

American Lawn Bowls Association, (ALBA), 1973-1974.

RECOMMENDED AREA

Square green with six rinks is 12,996 square feet minimum to 17,424 square feet maximum.

SIZE AND DIMENSION

Square green is 110' minimum and 125' maximum on each side. Additional width of 2'-0" minimum to 3'-6" maximum is required on front, rear and sides for ditch and backslope. Rink width minimum is 14'-0", maximum 19'-0". Rink length minimum is 110'-0", maximum 125'-0".

ORIENTATION

Optional.

SURFACE AND DRAINAGE

Surface should be of closely cropped bent grass or sand-clay.

Entire green should be level, with adequate underdrainage.

SPECIAL CONSIDERATIONS

Ditch - Depth minimum 2", maximum 8" below surface of green. Width minimum 8", maximum 15".

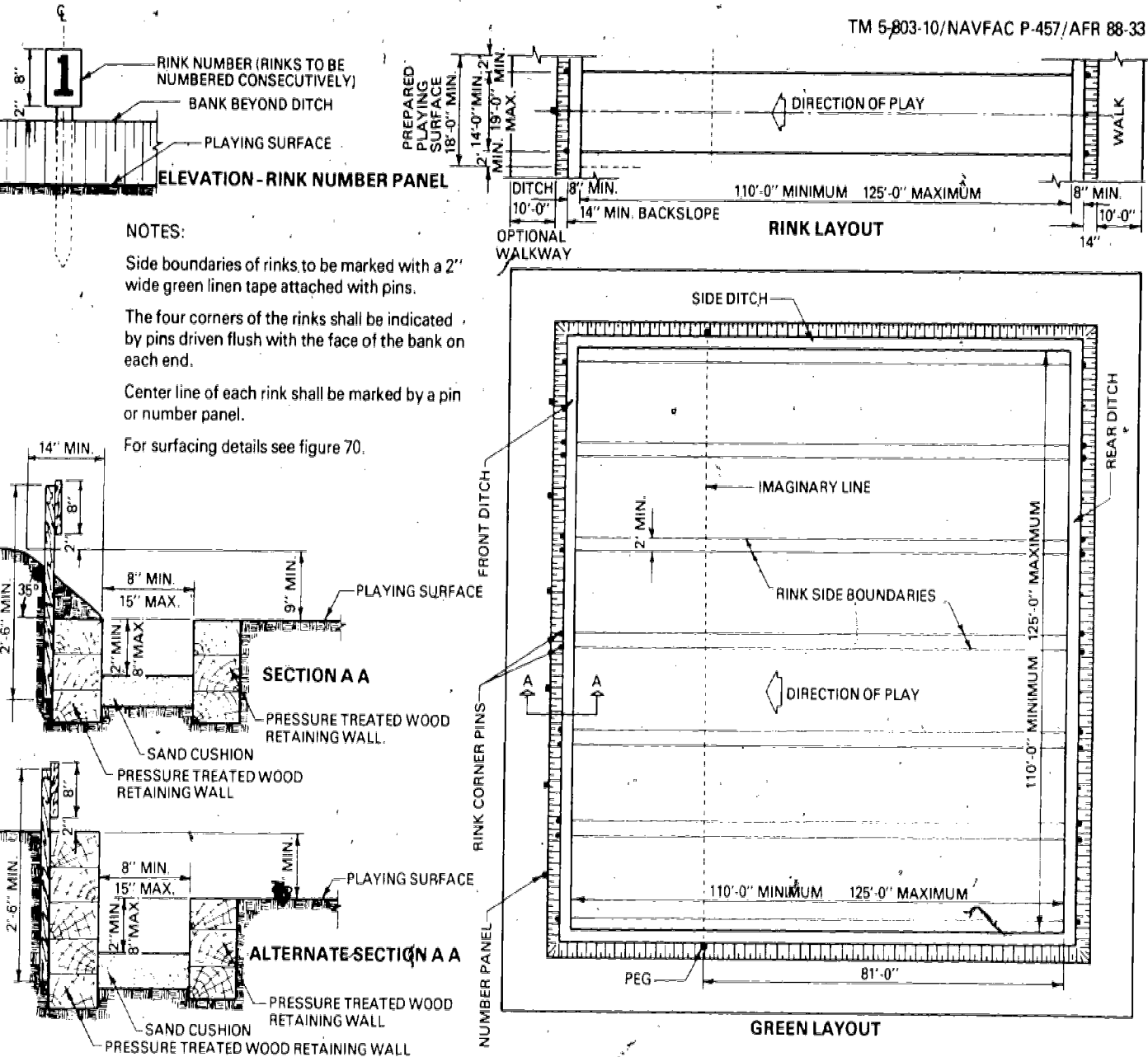

LAWN BOWLING

FIGURE 13

ROQUE

NAME OF SPORTS ORGANIZATION

The American Roque League Incorporated (ARL), 1959.

RECOMMENDED AREA

Ground space is 1800 square feet minimum, plus curb.

SIZE AND DIMENSION

Playing court is 30'-0" wide by 60'-0" long.

ORIENTATION

Preferred orientation is for the long axis to be north-south.

SURFACE AND DRAINAGE

Surface is to be level and sand-clay mixture.

Drainage is to be through perimeter system and/or through underdrains.

SPECIAL CONSIDERATIONS

Concrete curb is to be provided on all sides.

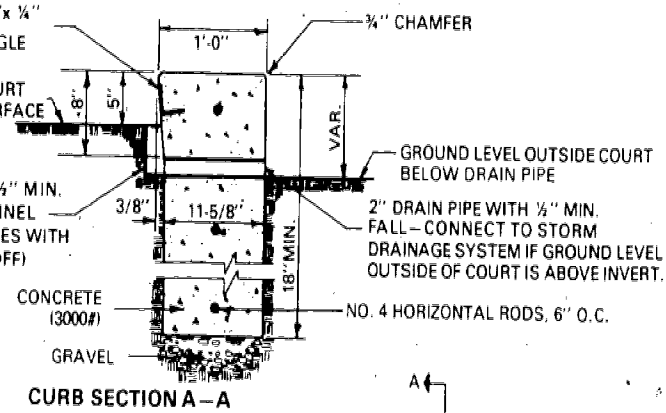

NOTES:

Boundary lines are marked by a light depression in playing surface without raising adjacent soil.

Arches are 5/8" dia. steel rod, 3-3/8" wide and 8" above the surface and set in 8"x15"x6" concrete anchors.

Stakes are 3/4" dia. steel, set rigidly in the ground and extending 2" above the surface.

Playing surface should be hard, smooth and level sand-clay, (see figure 70.)

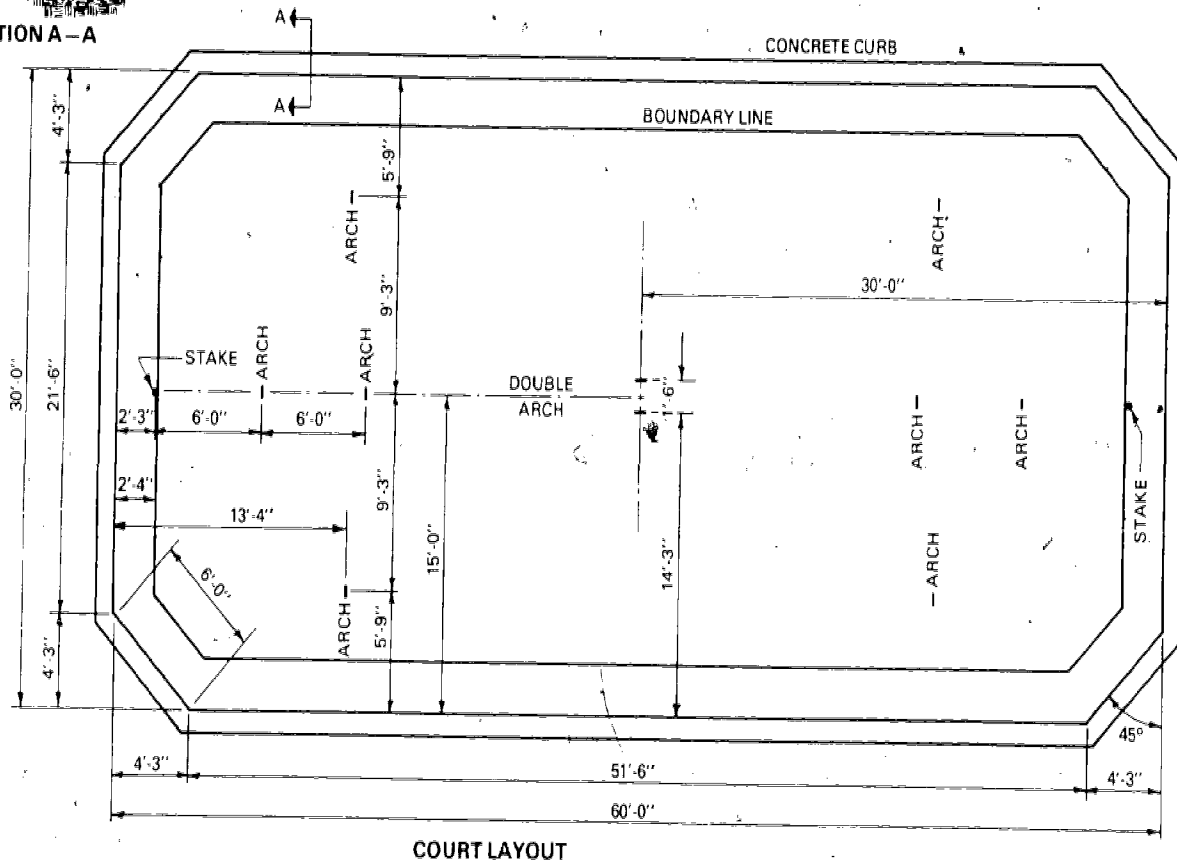

COURT LAYOUT

ROQUE

FIGURE 14

SHUFFLEBOARD

NAME OF SPORTS ORGANIZATION

National Shuffleboard Association, (NSA), 1974.

RECOMMENDED AREA

Ground space is 312 square feet minimum.

SIZE AND DIMENSION

Playing court is 6'-0" x 52'-0" plus a recommended minimum of 2'-0" on each side or 4'-0" between courts in battery.

ORIENTATION

Recommended orientation is for the long axis to be north-south.

SURFACE AND DRAINAGE

Surface is to be concrete with a burnished finish.

Court surface is to be level with drainage away from the playing surface on all sides.

SPECIAL CONSIDERATIONS

Secure covered storage for playing equipment should be provided near the court area.

NOTES:
 All dimensions are to centers of lines and to edge of court.
 Maximum line width 1 1/2", minimum 3/4".
 Lines and Figures "10", "8", "7" & "10 OFF" should be marked with black shoe dye or black acrylic paint.
 Court to be constructed of concrete without expansion joints.
 A depressed alley at least 24" wide and not less than 4" deep at midcourt, should be constructed between courts and on the inside of end courts.
 The alley should slope 1" in the first 6' of the length of the court from each base line, then slope to a minimum depth of 4" at midcourt where a suitable water drain should be provided.

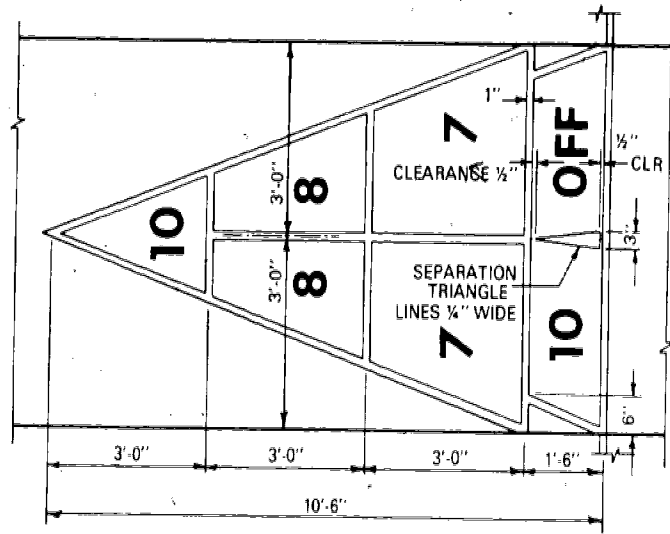

COURT MARKING DETAIL

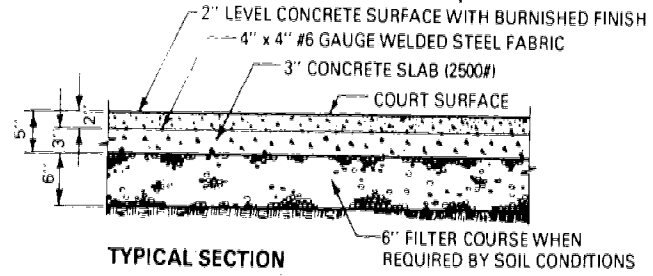

TYPICAL SECTION

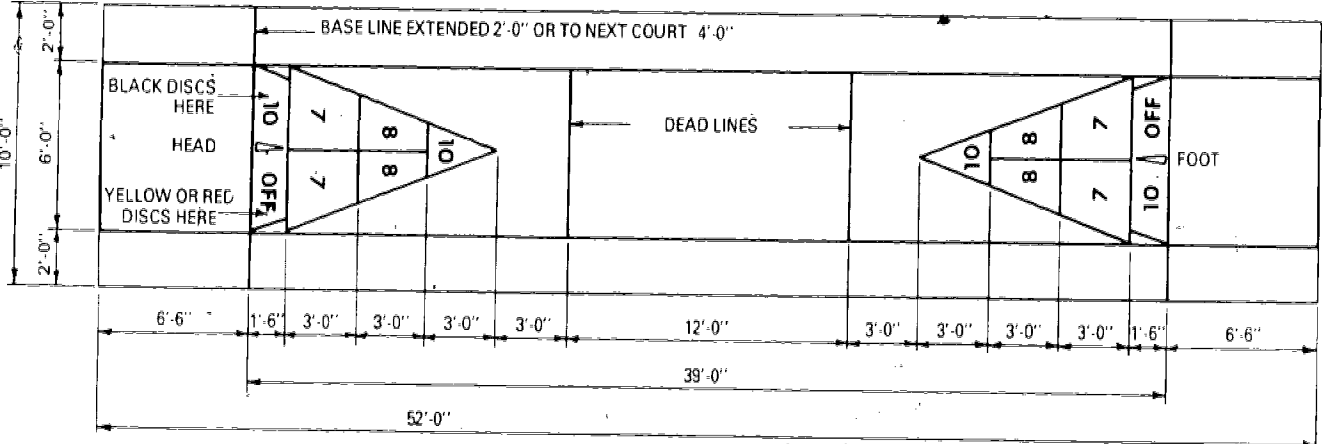

COURT LAYOUT

SHUFFLEBOARD

FIGURE 15

DECK TENNIS

NAME OF SPORTS ORGANIZATION

General Sportcraft Company, Ltd., 1974.

RECOMMENDED AREA

Ground space is 1300 square feet including clear space.

SIZE AND DIMENSION

Singles court is 12'-0" by 40'-0". Doubles court is 18'-0" by 40'-0".
Additional paved area at least 4'-0" on sides and 5'-0" on ends is recommended.

ORIENTATION

Preferred orientation is for the long axis to be north-south.

SURFACE AND DRAINAGE

Surface is to be concrete or bituminous material with optional protective colorcoating.

Drainage is to be end to end, side to side, or corner to corner diagonally at a minimum slope of 1" in 10'.

SPECIAL CONSIDERATIONS

Fencing - 10' high chain link fence is recommended on all sides of the court.

NOTES:
 All measurements for court markings are to the outside of lines except for those involving the center service line, which is usually divided between right and left service court.

All court markings to be 1 1/2" wide.

Fence enclosure, if provided, should be 1 1/2" mesh, 11 gauge chain link. For fence details see figure 63.

For net post details see figure 64 or 65.

For surfacing details see figure 70.

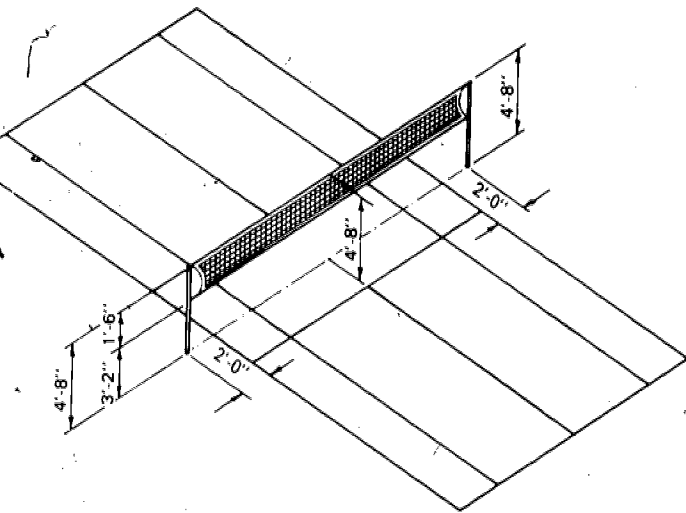

ISOMETRIC SHOWING NET

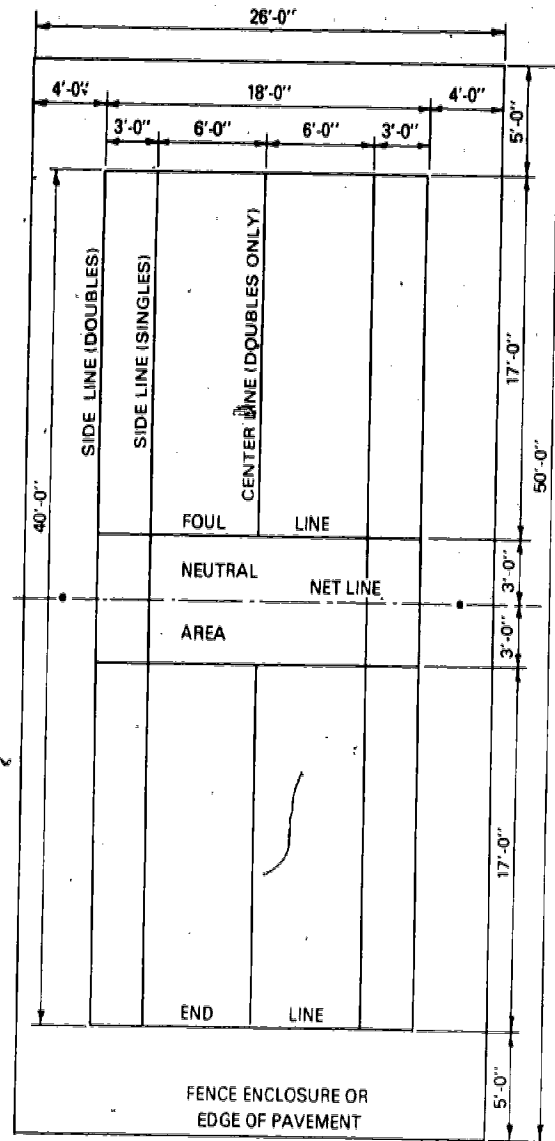

COURT LAYOUT

DECK TENNIS

FIGURE 16

PADDLE TENNIS

NAME OF SPORTS ORGANIZATION

United States Paddle Tennis Association, (USPTA), 1974.

RECOMMENDED AREA

Ground space is 3200 square feet minimum to edge of pavement.

SIZE AND DIMENSION

Playing court is 20'-0" x 50'-0" plus a 15' minimum space on each end and a 10' minimum space on each side or between courts in battery.

ORIENTATION

Preferred orientation is for the long axis to be north-south.

SURFACE AND DRAINAGE

Surface is to be concrete or bituminous material with optional protective colorcoating.

Drainage is to be end to end, side to side or corner to corner diagonally at a minimum slope of 1" in 10'.

SPECIAL CONSIDERATIONS

Fencing - 10' high chain link fence is recommended on all sides of the court.

NOTES:

All measurements for court markings are to the outside of lines except for those involving the center service line, which is equally divided between right and left service court.

All court markings to be 1 1/2" wide.

Fence enclosure, if provided, should be 1 1/2" mesh, 11 gauge chain link. For fence details see figure 63.

For net post details see figure 64 or 65.

For surfacing details see figure 70.

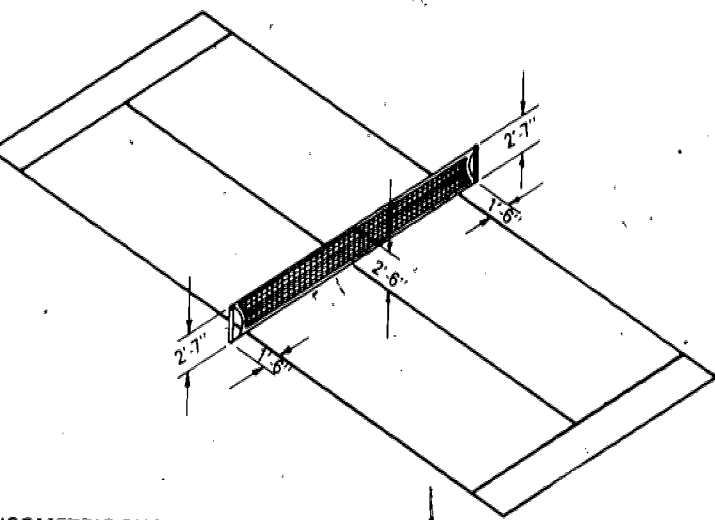

ISOMETRIC SHOWING NET

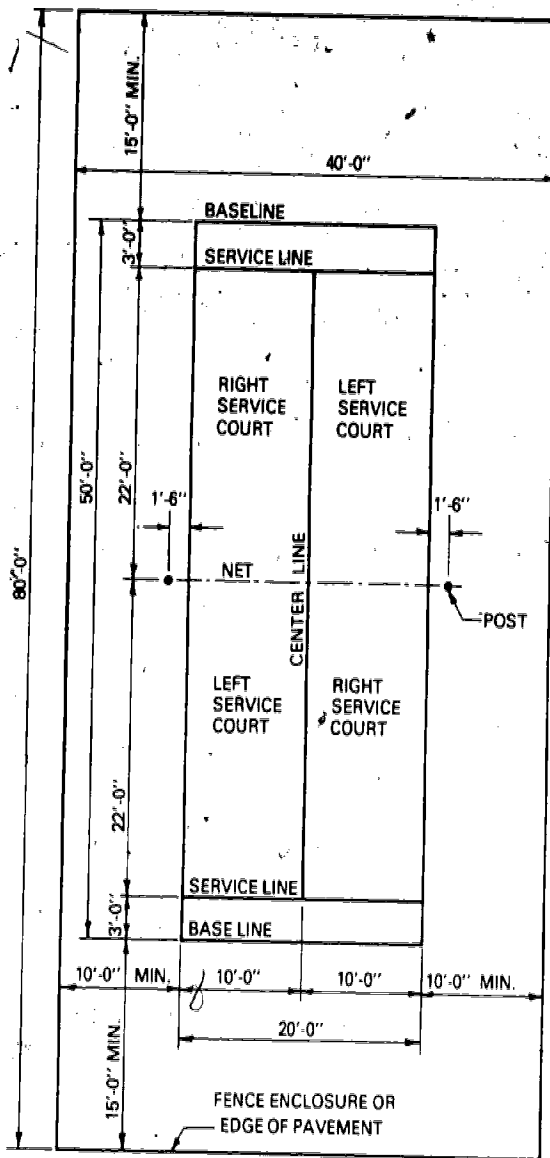

COURT LAYOUT

PADDLE TENNIS

FIGURE 17

PLATFORM TENNIS

/NAME OF SPORTS ORGANIZATION

American Platform Tennis Association, (APTA), 1963-73.

RECOMMENDED AREA

Ground space is 1800 square feet to the playable perimeter fence.

SIZE AND DIMENSION

Playing court is 20'-0" x 44'-0" plus an 8'-0" space on each end and a 5'-0" space on each side.

ORIENTATION

Preferred orientation is for the long axis to be north-south.

SURFACE AND DRAINAGE

Raised level platform is normally constructed of treated wood or aluminum superstructure with carriage set on concrete piers to permit construction on slopes.

Drainage is provided by ¼" space between 6" deck planks or channels. Snow removal is facilitated by hinged panels (snow gates) between posts around bottom of perimeter fence.

SPECIAL CONSIDERATIONS

Tension fencing - 12' high, 16 gauge, hexagonal, galvanized, 1" flat wire mesh fabric must be provided on all sides of the court. Lights should be provided, since this game is played at night throughout the year. Heating units with fans under the platform are used in cold climates. Pre-fabricated courts are available from several manufacturers.

ES:
 measurements for court markings are to the outside of lines
 pt for those involving the center service line, which is
 ally divided between right and left service court.

court markings to be 2" wide.

ing required - 12'-0" high with 16-gauge
 gonal, galvanized 1" flat wire mesh fabric.

et post details see manufacturers' literature.

eight to be 3'-1" at posts and 2'-10" at
 or court.

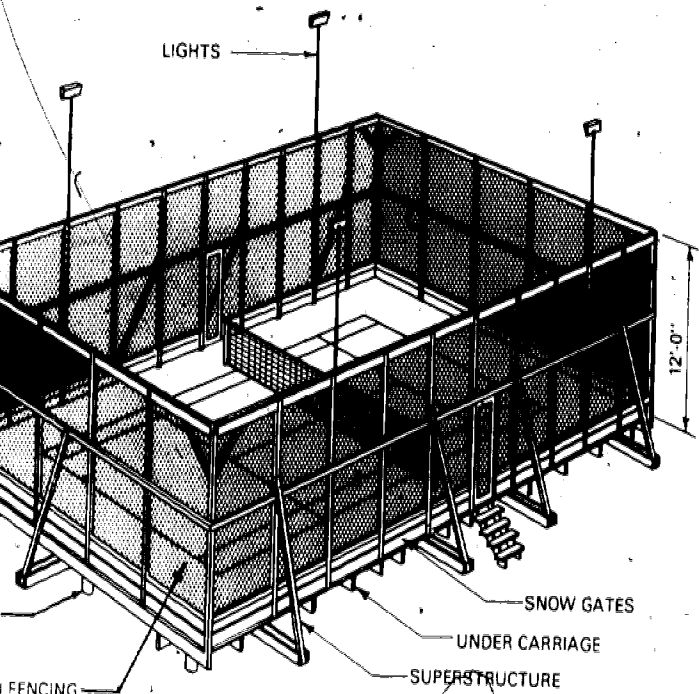

METRIC SHOWING FENCE (TYPICAL WOOD CONSTRUCTION)

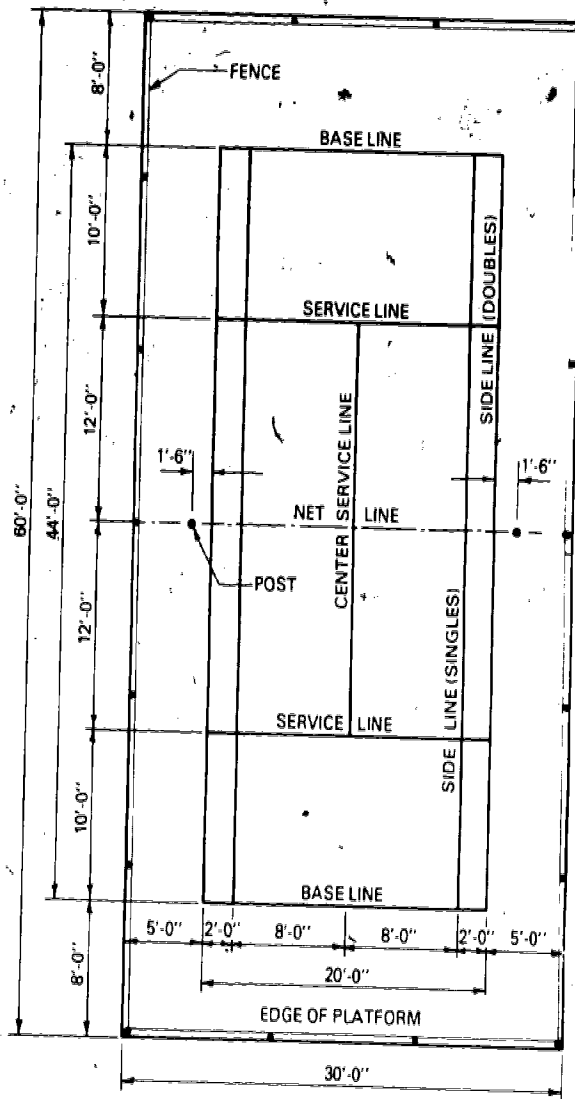

COURT LAYOUT

PLATFORM TENNIS

FIGURE 18

TENNIS

NAME OF SPORTS ORGANIZATION

United States Lawn Tennis Association, (USLTA), 1974.

RECOMMENDED AREA

Ground space is 7200 square feet minimum.

SIZE AND DIMENSION

Playing court is 36' x 78' plus at least 12' clearance on both sides or between courts in battery and 21' clearance on each end.

ORIENTATION

Orientation of long axis is to be north-south.

SURFACE AND DRAINAGE

Surface may be concrete, or bituminous material with specialized protective colorcoating, or sand-clay.

Drainage may be from end to end, side to side, or corner to corner diagonally at a minimum slope of 1" in 10' for pavement and level for sand-clay with underdrainage.

SPECIAL CONSIDERATIONS

Fencing - Recommended 10' high chainlink fence on all sides.

NOTES:

Measurements for court markings are to the outside of lines except for those involving the center service line which is usually divided between the right and left service courts.

Court markings to be 2" wide.

Fence enclosure, if provided, should be 10' high, 11 gauge, 2" mesh chain link. For fence details see figure 63.

Minimum distance between sides of parallel courts to be 12'-0".

Net post details see figure 64 or 65.

Surfacing details see figure 70.

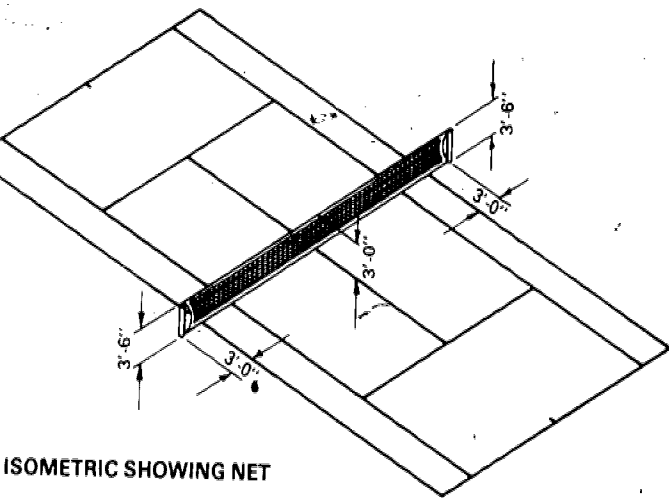

TM 5-803-10/NAVFAC P-457/AFR 88-33

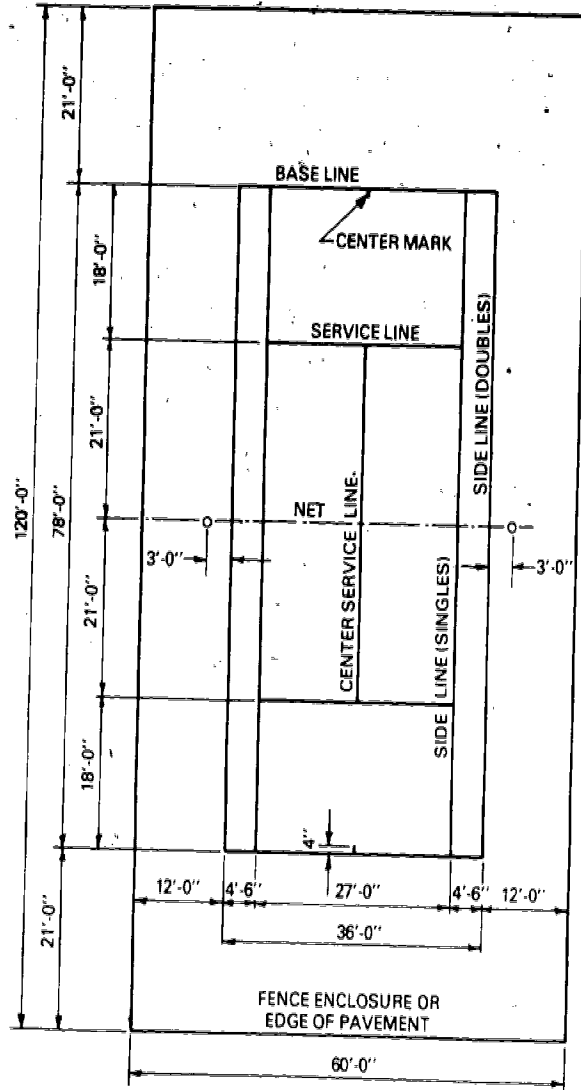

COURT LAYOUT

TENNIS
FIGURE 19

TETHER BALL

NAME OF SPORTS ORGANIZATION

General Sportcraft Company, Ltd., 1974.

RECOMMENDED AREA

Ground space is 314 square feet minimum to circumference of outer circle.

SIZE AND DIMENSION

- Playing court is a circle 20'-0" in diameter. Pole height is 10'.

ORIENTATION

Recommended axis through playing zone is north-south.

SURFACE AND DRAINAGE

Concrete or bituminous surface may be used for minimum maintenance, but a resilient synthetic surface or wood chips with adequate underdrainage is preferred for safety and comfort. Minimum slope is 1" in 10' for drainage in any direction.

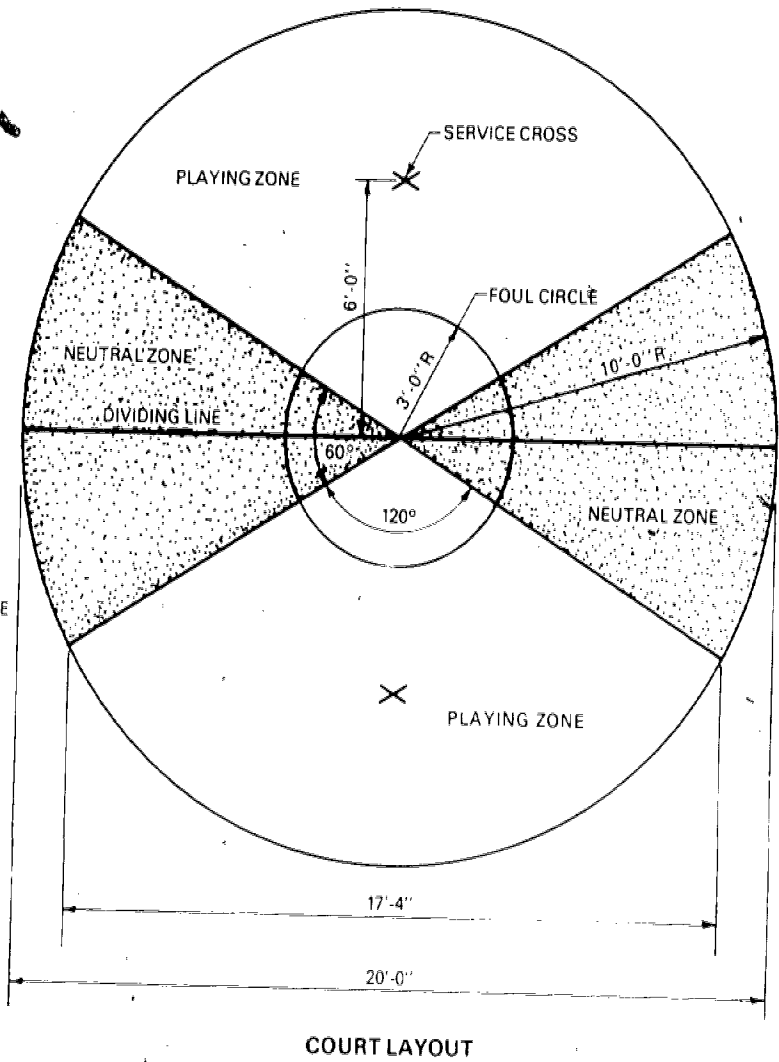
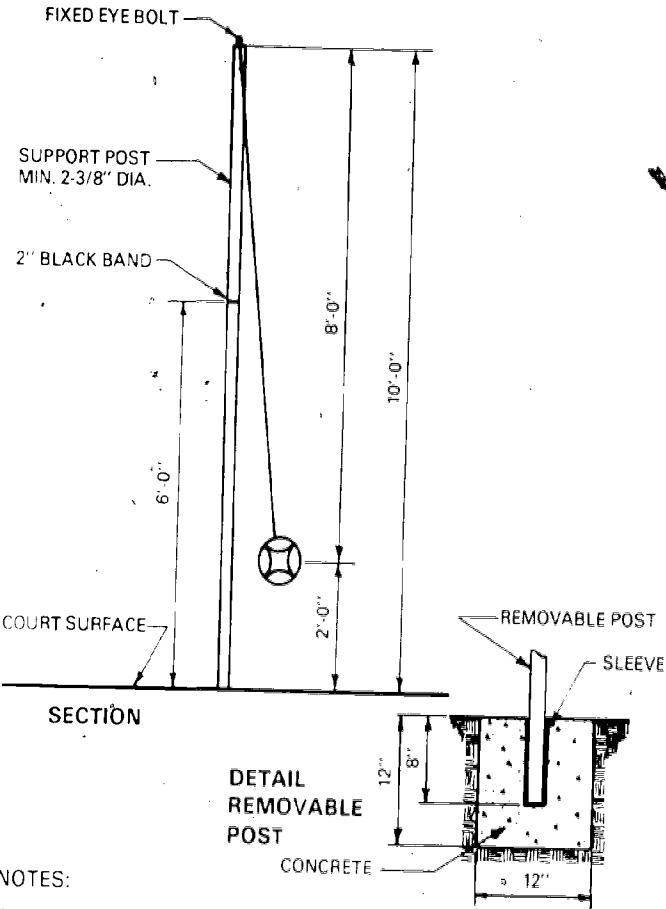

NOTES:

All measurements for court markings are to center of lines.

All court markings to be 2" wide.

If colorcoating is used, the neutral zones and the playing zones should be of contrasting colors.

For surfacing details see figure 70.



VOLLEYBALL

NAME OF SPORTS ORGANIZATION

United States Volleyball Association, (USVA), 1974.

RECOMMENDED AREA

Ground space is 4000 square feet.

SIZE AND DIMENSION

Playing court is 30' x 60' plus 6' minimum, 10' preferred, unobstructed space on all sides.

ORIENTATION

Preferred orientation is for the long axis to be north-south.

SURFACE AND DRAINAGE

Recommended surface for intensive use is to be bituminous material or concrete, but sand-clay or turf may be used for informal play. Drainage is to be end to end, side to side or corner to corner at a minimum slope of 1" in 10'.

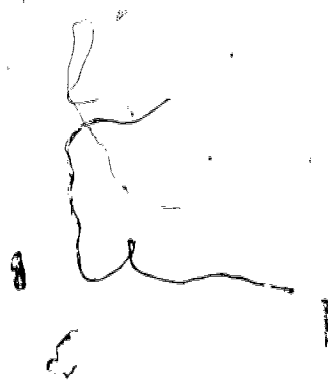

NOTES:

All measurements for court markings are to the outside of lines except for the center line.

All court markings to be 2" wide except as noted.

For surfacing details see figure 70.

Net height at center to be: men 8'-0", women 7'-4 1/4", high school 7'-0", elementary school 6'-6".

For net and post details see figure 64 or 65.

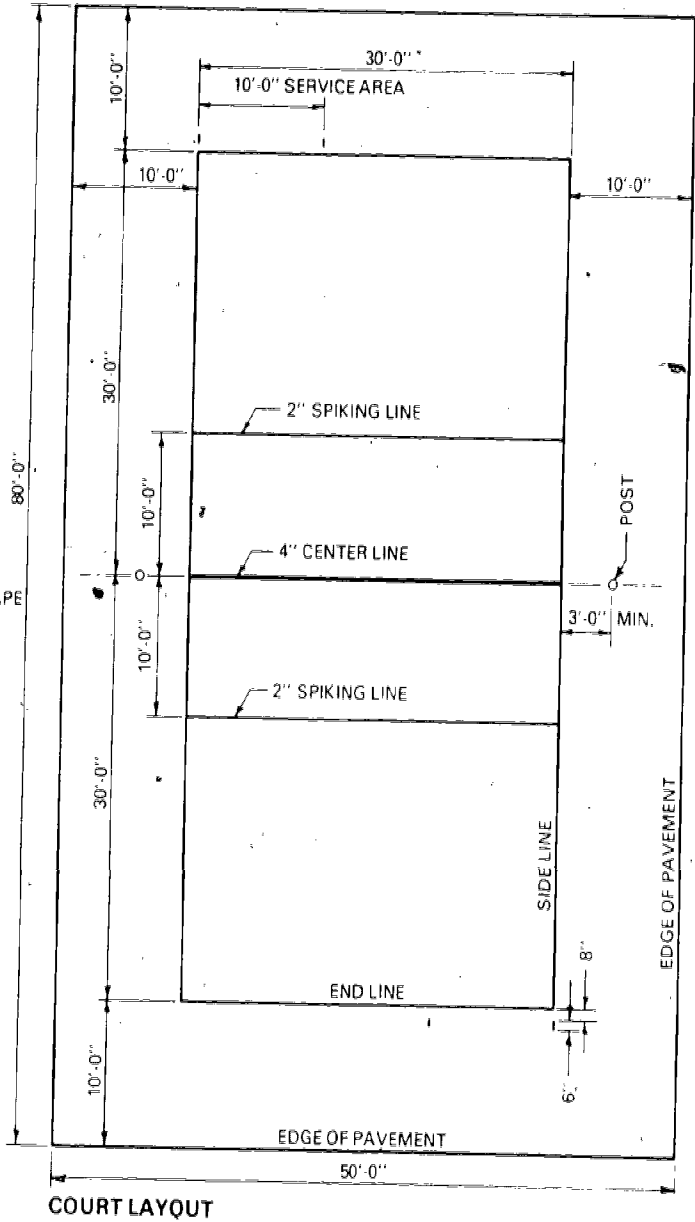

COURT LAYOUT

VOLLEYBALL

FIGURE 21

70

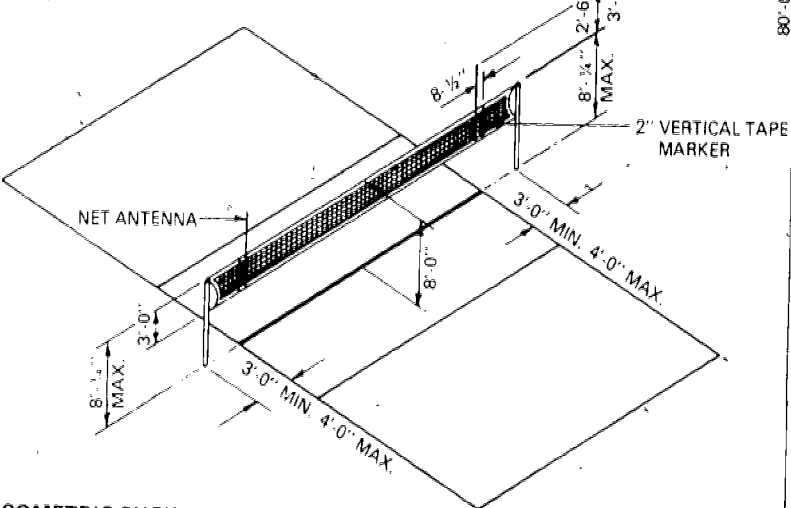

ISOMETRIC SHOWING NET

2 - 2

2 - 45

SPORTS FIELDS

OFFICIAL BASEBALL
BABE RUTH BASEBALL (13-15 yrs. and 16-18 yrs.)
SENIOR LEAGUE BASEBALL (13-15 yrs.)

NAME OF SPORTS ORGANIZATION

The Official Playing Rules Committee, 1974. Babe Ruth Baseball, 1974.
Senior League, Little League Baseball, Inc., 1974.

RECOMMENDED AREA

Ground space is 3.0 to 3.85 acres minimum.

SIZE AND DIMENSION

Baselines are 90'-0". Pitching distance is 60'-6". Pitcher's plate is 10" above the level of home plate. Distance down foul lines is 320' minimum, 350' preferred. Outfield distance to center field is 400' +. For Senior League Baseball, recommended distance from home plate to outfield fence at all points is 300' +.

ORIENTATION

Optimum orientation is to locate home plate so that the pitcher is throwing across the sun and the batter is not facing it. The line from home plate through the pitcher's mound and second base should run east-northeast.

SURFACE AND DRAINAGE

Surface is to be turf. Infield may be skinned, and shall be graded so that the base lines and home plate are level.

SPECIAL CONSIDERATIONS

Backstop is to be provided at a minimum distance of 40' or preferably 60' behind home plate.

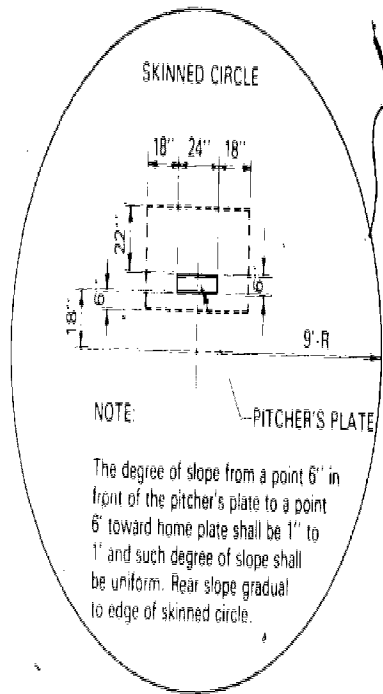

LAYOUT AT PITCHER'S PLATE

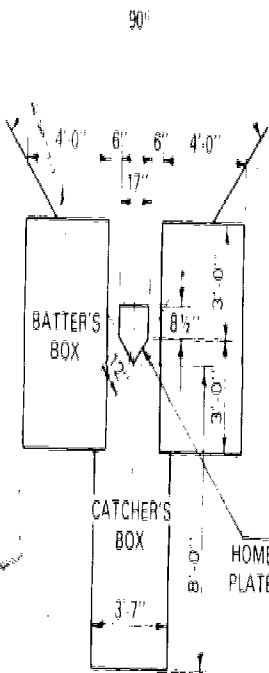

LAYOUT AT HOME PLATE

NOTES:

Foul lines, catcher's, batter's and coach's boxes, next batter's circles and 3' line shall be 2" to 3" wide and marked with chalk or other white material. Caustic lime must not be used.

Infield may be skinned.

For grading and drainage details see figure 69.

For surfacing details see figure 70.

For backstop details see figure 71.

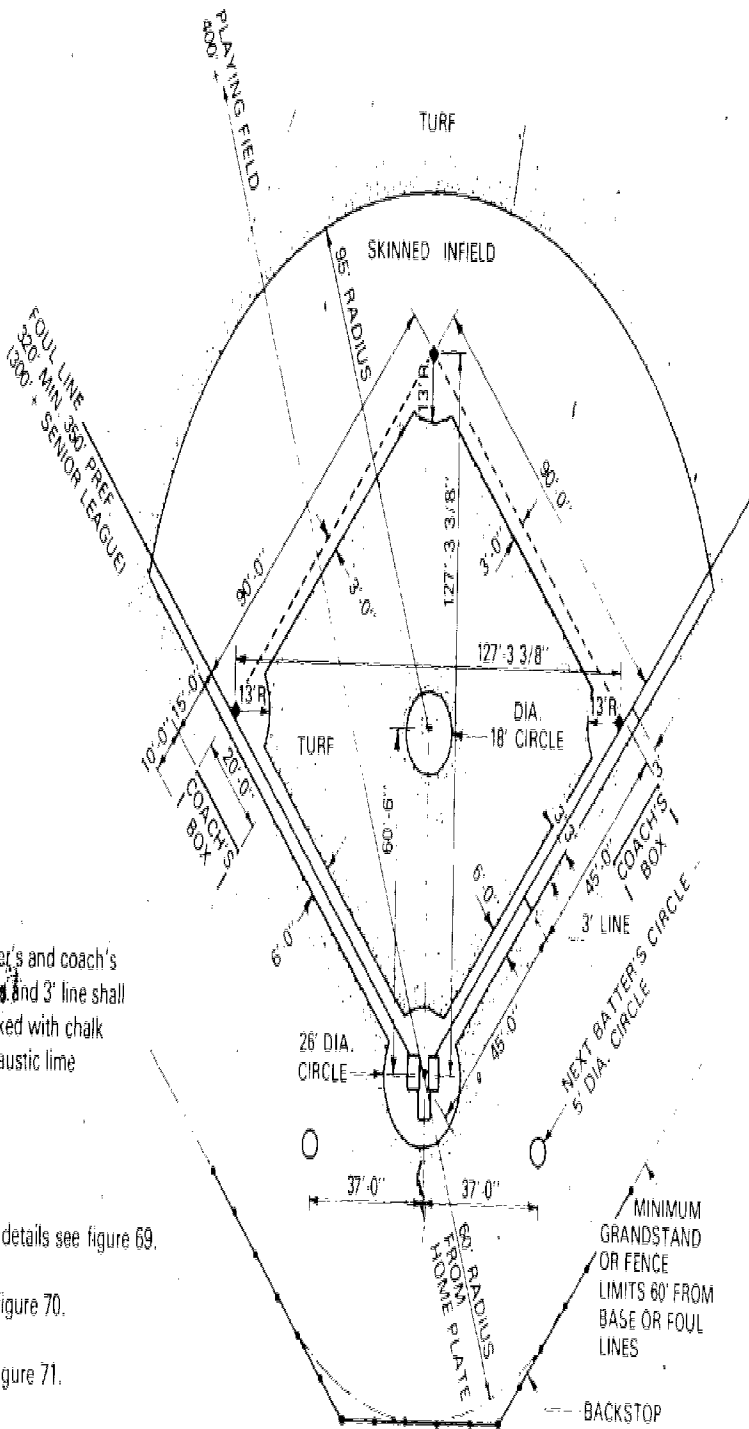

DIAMOND LAYOUT

BASEBALL

FIGURE 22

BASEBALL, BRONCO LEAGUE (9-12 yrs.)

NAME OF SPORTS ORGANIZATION

Bronco League, Boy's Baseball, Inc. 1974.

RECOMMENDED AREA

Ground space is 1.0 acre minimum.

SIZE AND DIMENSION

Baselines are 70'-0". Pitching distance is 48'-0". Pitcher's plate is 6" above the level of home plate. Distance down foul line is 175'. Outfield distance to pocket in center field is 225'.

ORIENTATION

Optimum orientation is to locate home plate so that the pitcher is throwing across the sun and the batter is not facing it. The line from home plate through the pitcher's mound and second base should run east-northeast.

SURFACE AND DRAINAGE

Surface is to be turf. Infield may be skinned, and shall be graded so that the base lines and home plate are level.

SPECIAL CONSIDERATIONS

Backstop is to be provided at a recommended distance of 20' behind home plate.

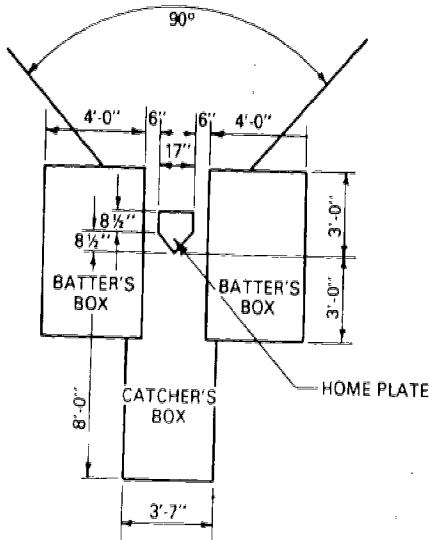

OPTIONAL LAYOUT AT HOME PLATE

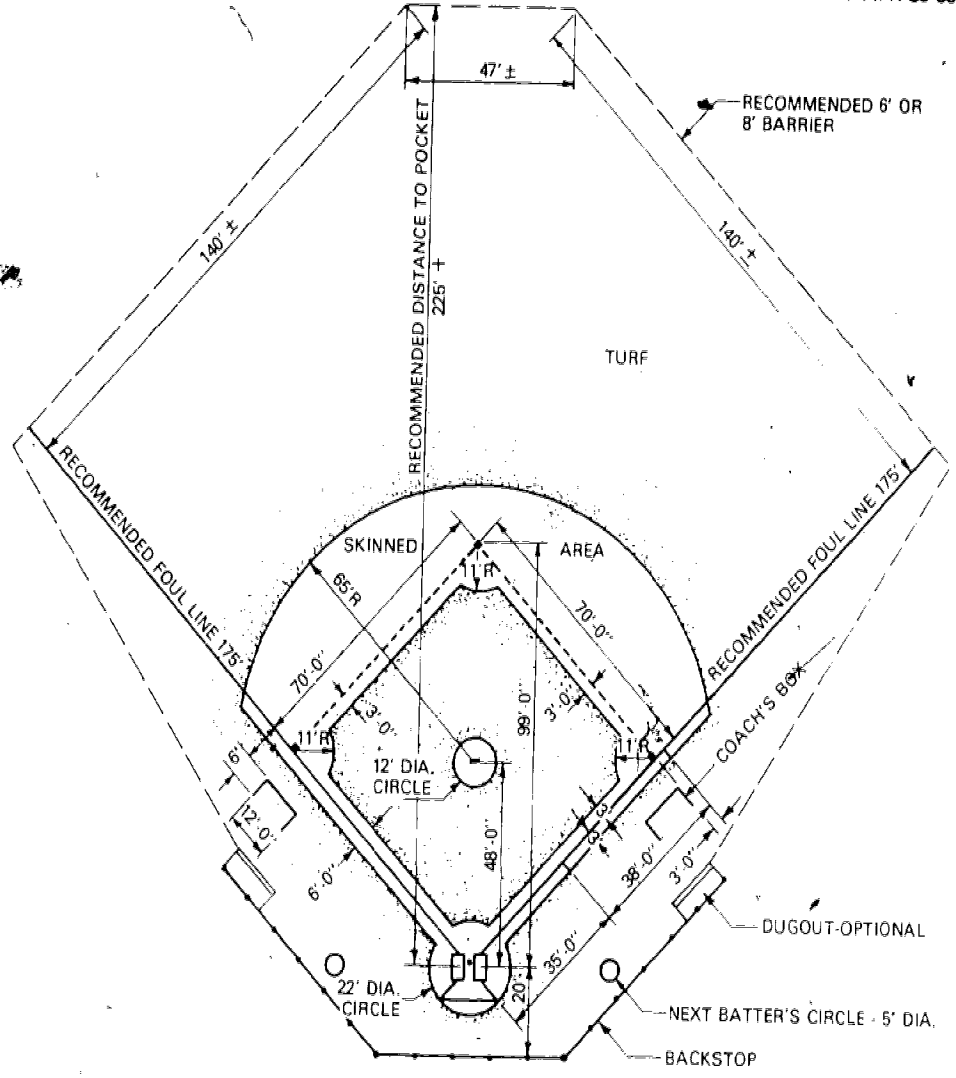

PLAYING FIELD LAYOUT

NOTES:

Foul lines, catcher's, batter's and coach's boxes, next batter's circles and 3' restraining lines shall be 2" wide and marked with white chalk or other white material. Caustic lime must not be used.

Infield may be skinned.

For grading and drainage details see figure 69.

For surfacing details see figure 70.

For backstop details see figure 71.

BRONCO LEAGUE BASEBALL

FIGURE 23

BASEBALL, PONY LEAGUE (13-14 yrs.)

NAME OF SPORTS ORGANIZATION

Pony League, Boy's Baseball, Inc., 1974.

RECOMMENDED AREA

Ground space is 2.0 acres minimum.

SIZE AND DIMENSION

Baselines are 80'-0". Pitching distance is 54'-0". Pitcher's plate is 8' above the level of home plate. Distance down foul line is 250'. Outfield distance to pocket in center field is 300'.

ORIENTATION

Optimum orientation is to locate home plate so that the pitcher is throwing across the sun and the batter is not facing it. The line from home plate through the pitcher's mound and second base should run east-northeast.

SURFACE AND DRAINAGE

Surface is to be turf. Infield may be skinned, and shall be graded so that the base lines and home plate are level.

SPECIAL CONSIDERATIONS

Backstop is to be provided at a recommended distance of 40' behind home plate.

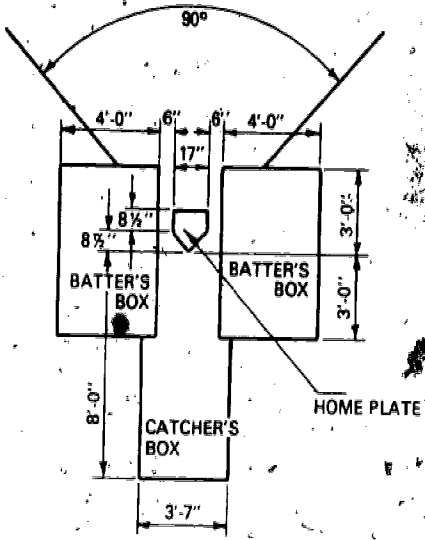

OPTIONAL LAYOUT AT HOME PLATE

NOTES:
 Foul lines, catcher's, batter's and coach's boxes, next batter's circles and 3' restraining lines shall be 6" wide and marked with white chalk or other white material. Caustic lime must not be used.

Field may be skinned.
 For grading and drainage details see figure 69.
 For surfacing details see figure 70.
 For backstop details see figure 71.

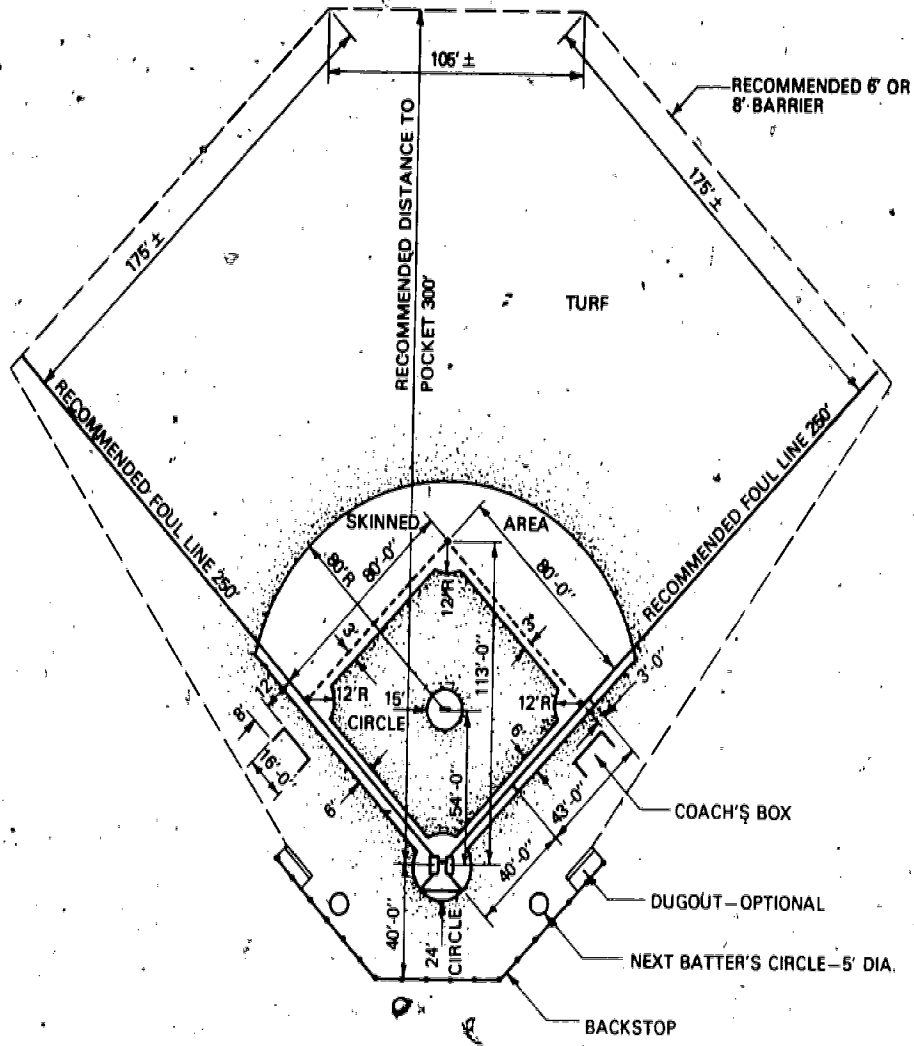

PLAYING FIELD LAYOUT

PONY LEAGUE BASEBALL
 FIGURE 24

BASEBALL, COLT LEAGUE (15-16 yrs.)

NAME OF SPORTS ORGANIZATION

Colt League, Boy's Baseball, Inc., 1974.

RECOMMENDED AREA

Ground space is 3.0 acres minimum.

SIZE AND DIMENSION

Baselines are 90'-0". Pitching distance is 60'-6". Pitcher's plate is 10" above the level of home plate. Distance down foul line is 300'. Outfield distance to pocket in center field is 350'.

ORIENTATION

Optimum orientation is to locate home plate so that the pitcher is throwing across the sun and the batter is not facing it. The line from home plate through the pitcher's mound and second base should run east-northeast.

SURFACE AND DRAINAGE

Surface is to be turf. Infield may be skinned, and shall be graded so that the base lines and home plate are level.

SPECIAL CONSIDERATIONS

Backstop is to be provided at a recommended distance of 60' behind home plate.

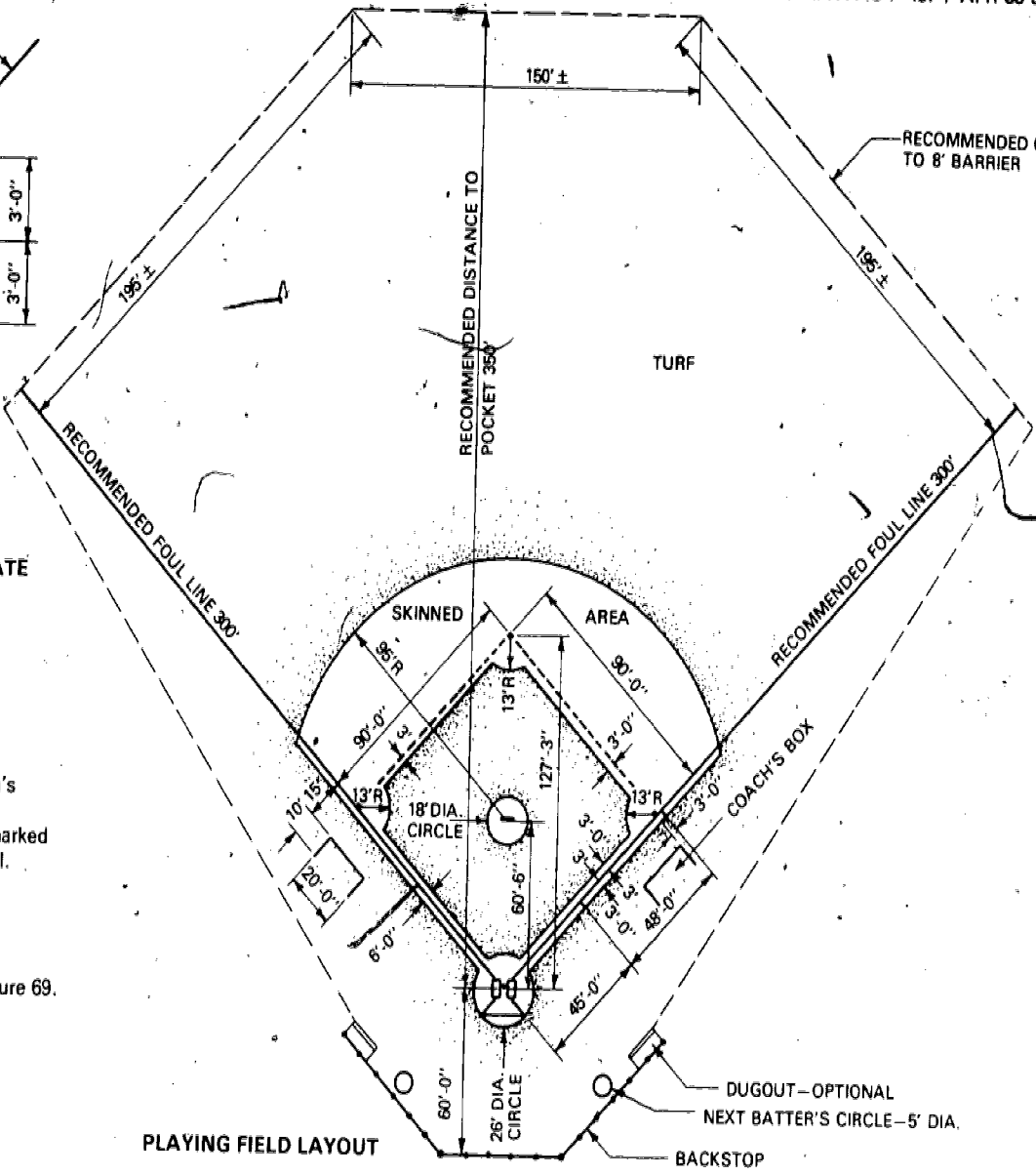
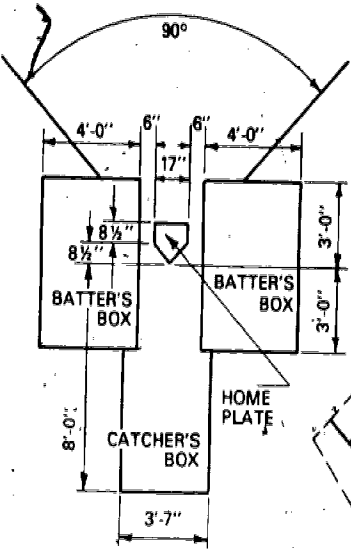

OPTIONAL LAYOUT AT HOME PLATE

- NOTES:
- 1. Foul lines, catcher's, batters and coach's boxes, next batter's circles and 3' training lines shall be 2" wide and marked with white chalk or other white material. Rustic lime must not be used.
 - 2. Field may be skinned.
 - 3. Grading and drainage details see figure 69.
 - 4. Surfacing details see figure 70.
 - 5. Backstop details see figure 71.

PLAYING FIELD LAYOUT

DUGOUT—OPTIONAL
NEXT BATTER'S CIRCLE—5' DIA.
BACKSTOP



BASEBALL, LITTLE LEAGUE (9-12 yrs.)

NAME OF SPORTS ORGANIZATION

Little League Baseball, Inc., 1974.

RECOMMENDED AREA

Ground space is 1.2 acres minimum.

SIZE AND DIMENSION

Baselines are 60'-0". Pitching distance is 46'-0". Pitcher's plate is 6" above the level of home plate. Distance down foul line is 200'. Outfield distance to pocket in center field is 200' to 250' optional.

ORIENTATION

Optimum orientation is to locate home plate so that the pitcher is throwing across the sun and the batter is not facing it. The line from home plate through the pitcher's mound and second base should run east-northeast.

SURFACE AND DRAINAGE

Surface is to be turf. Infield may be skinned, and shall be graded so that the base lines and home plate are level.

SPECIAL CONSIDERATIONS

Backstop is to be provided at a recommended minimum distance of 25' behind home plate.

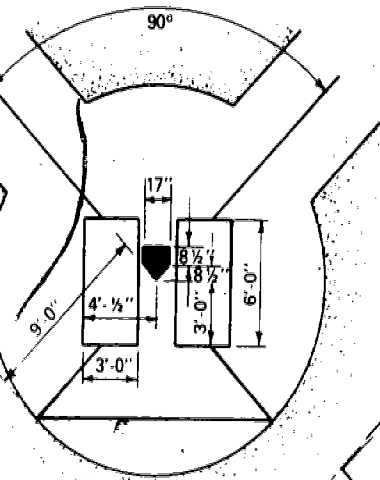

LAYOUT AT HOME PLATE

NOTES:

Foul lines, catcher's, batter's and coach's boxes, next batter's circles and 3' restraining lines shall be 2" wide and marked with white chalk or other white material. Caustic lime must not be used.

Field may be skinned.

For grading and drainage details see figure 69.

For surfacing details see figure 70.

For backstop details see figure 71.

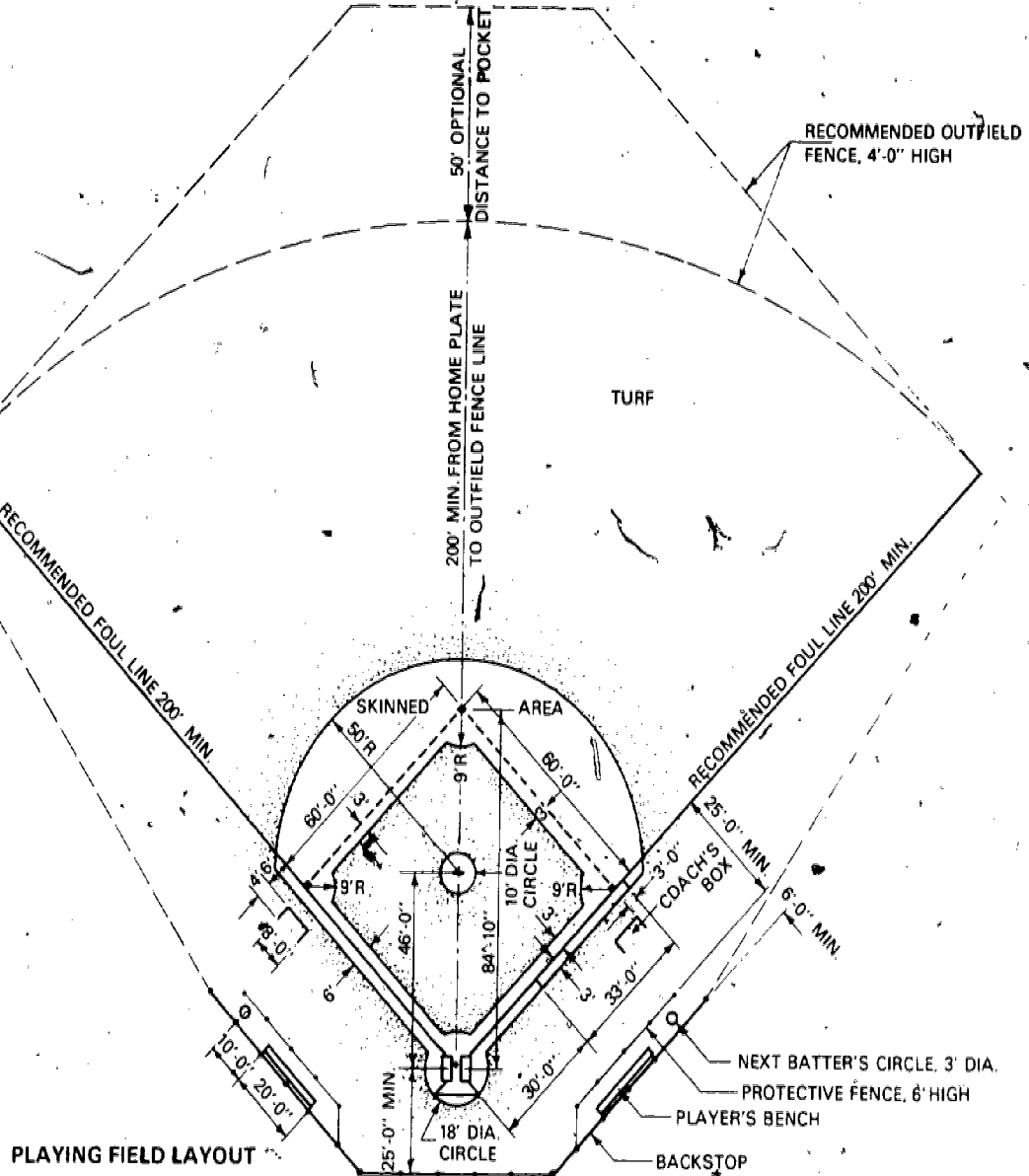

PLAYING FIELD LAYOUT

LITTLE LEAGUE BASEBALL

FIGURE 26

FIELD HOCKEY

NAME OF SPORTS ORGANIZATION

United States Field Hockey Association, (USFHA), 1974.

RECOMMENDED AREA

Ground space is 64,000 square feet (1.5 acres) minimum.

SIZE AND DIMENSION

Playing field width is 180'-0". Length is 300'-0". Additional area recommended is 10'-0" minimum unobstructed space on all sides.

ORIENTATION

Preferred orientation is for the long axis to be northwest-southeast to suit the angle of the sun in the fall playing season, or north-south for longer periods.

SURFACE AND DRAINAGE

Surface it to be turf. Preferred grading is a longitudinal crown with a 1% slope from center to each side and adequate underdrainage. Grading may be from side to side or corner to corner diagonally if conditions do not permit the preferred grading.

SPECIAL CONSIDERATIONS

Goal is to be provided at each end of the playing field.

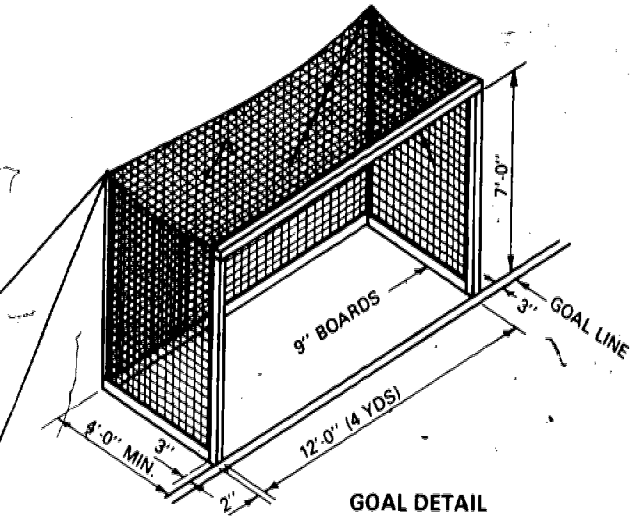

NOTES:

All measurements shall be made from the inside edge of lines marking boundaries.

Solid and broken lines shall be white, 3" wide and marked with a non-toxic material which is not injurious to the eyes or skin.

For grading and drainage details see figure 69.

For surfacing details see figure 70.

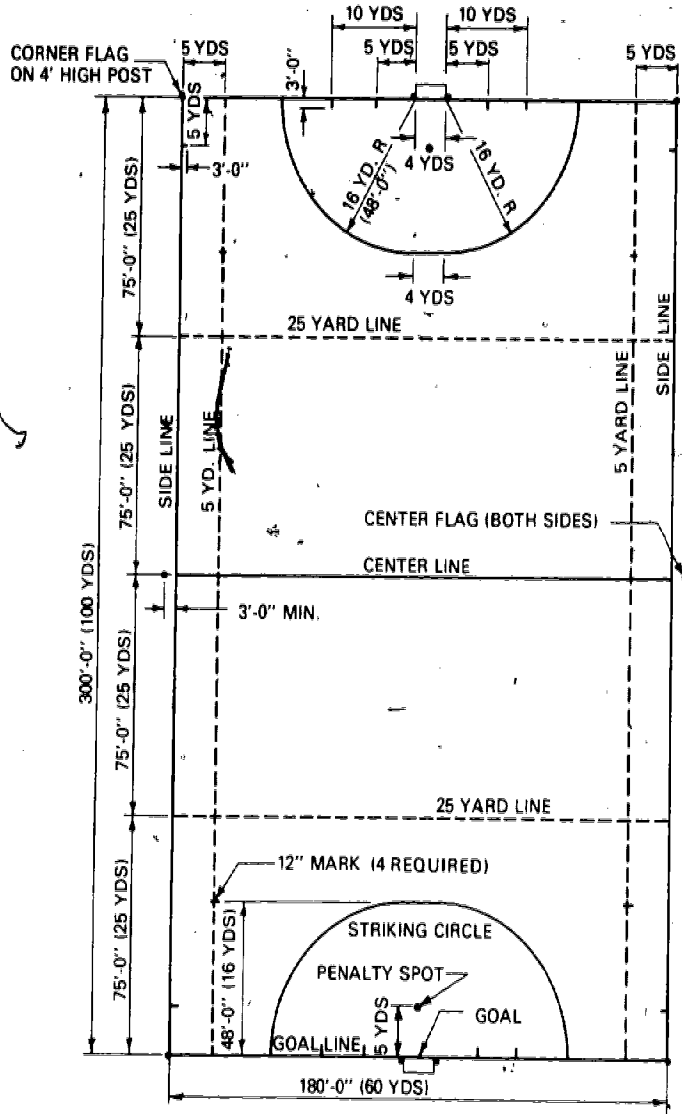

FIELD HOCKEY

FIGURE 27

FLICKERBALL

NAME OF SPORTS ORGANIZATION

Rules furnished by United States Air Force.

RECOMMENDED AREA

Ground space is 17,600 square feet (.4 acre) minimum.

SIZE AND DIMENSION

Playing field width is 90'-0". Length is 160'-0". Goals are 15'-0" beyond each end line. Additional area recommended is 6'-0" minimum unobstructed space on all sides.

ORIENTATION

Preferred orientation is for the long axis to be northwest-southeast to suit the angle of the sun in the fall playing season, or north-south for longer periods.

SURFACE AND DRAINAGE

Surface is to be turf. Preferred grading is a longitudinal crown with a 1% slope from center to each side and adequate underdrainage. Grading may be from side to side or corner to corner diagonally if conditions do not permit the preferred grading.

SPECIAL CONSIDERATIONS

Goal is to be provided 15'-0" behind each end line.

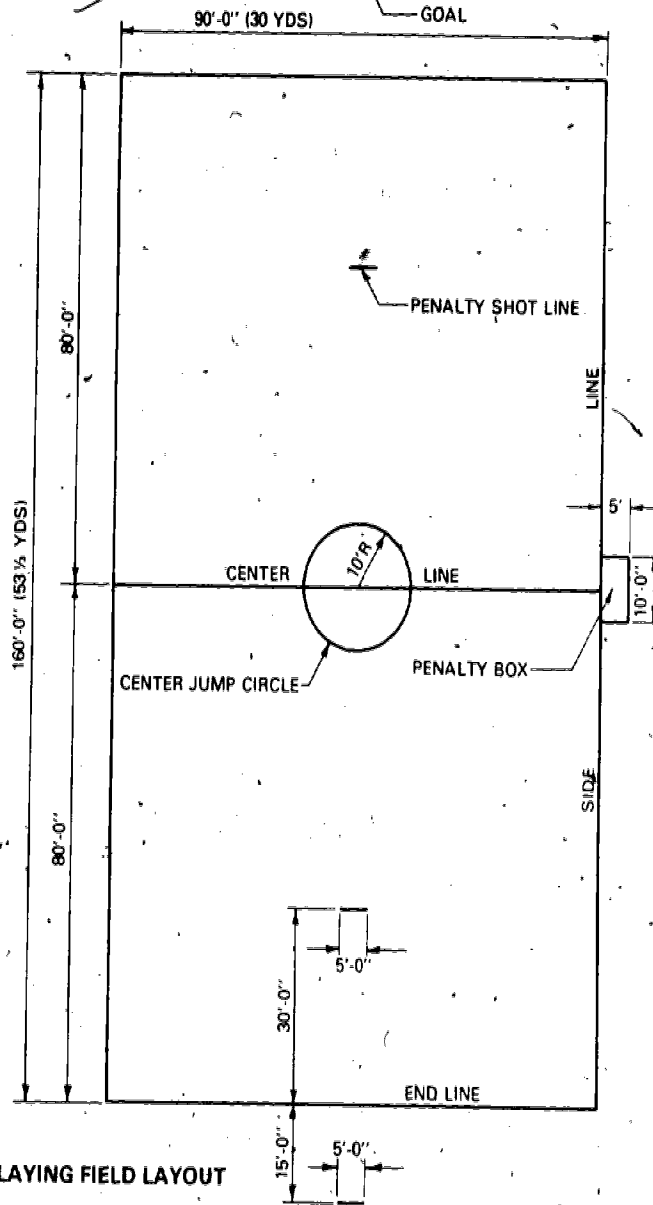
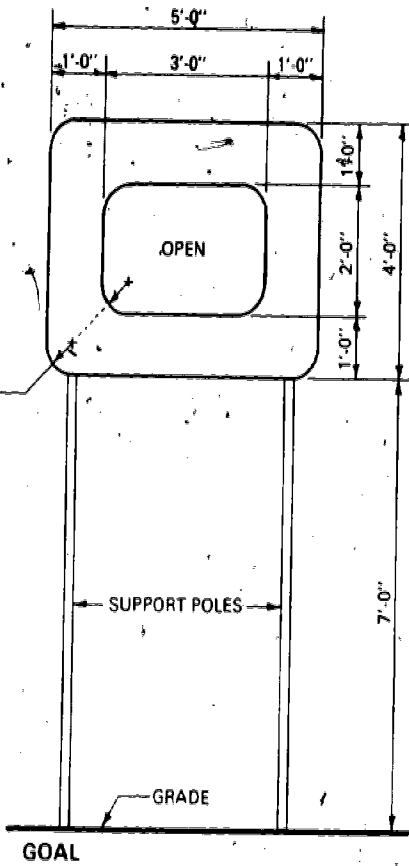

PLAYING FIELD LAYOUT

FLICKER BALL

FIGURE 28

FOOTBALL, (NCAA) Pop Warner Junior League Football

NAME OF SPORTS ORGANIZATION

National Collegiate Athletic Association, (NCAA), 1974. Pop Warner Junior League Football, 1974.

RECOMMENDED AREA

Ground space is 64,000 square feet (1.5 acres) minimum.

SIZE AND DIMENSION

Playing field width is 160'-0". Length is 360'-0". Additional area required is 6'-0" minimum unobstructed space on all sides.

ORIENTATION

Preferred orientation is for the long axis to be northwest-southeast to suit the angle of the sun in the fall playing season, or north-south for longer periods.

SURFACE AND DRAINAGE

Surface is to be turf.

Preferred grading is a longitudinal crown with a 1% slope from center to each side and adequate underdrainage.

Grading may be from side to side or corner to corner diagonally if conditions do not permit the preferred grading.

SPECIAL CONSIDERATIONS

Goal posts are to be provided at each end of the playing field. Pylons are to be provided as required by rules.

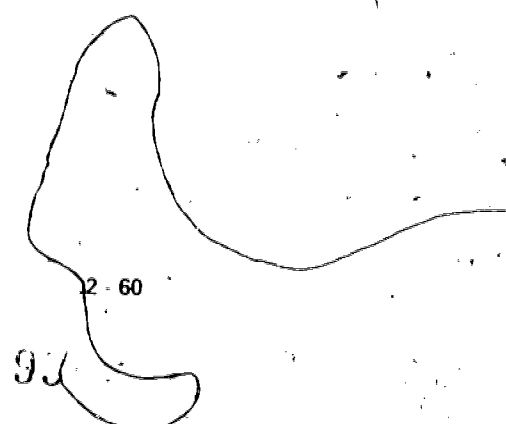

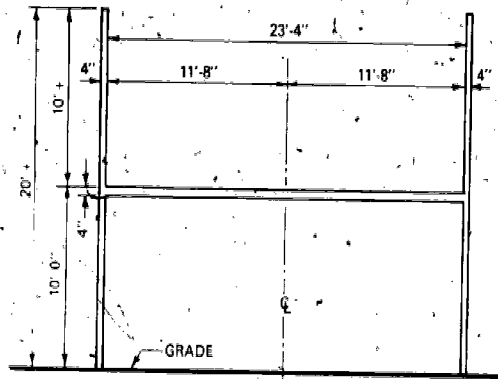

GOAL POSTS

NOTES:

Optional goal post may be used in the form of a single metal post set behind the end zone with a cantilevered horizontal crossbar and two uprights of the same height and spacing as for dual posts.

For goal post construction details see figure 65.

Pylon to be constructed of soft flexible material, red or orange in color.

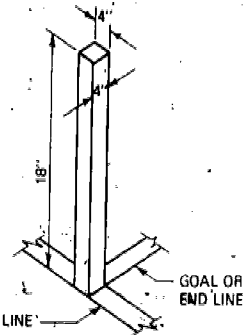

PYLON DETAIL

NOTES:

All measurements should be made from the inside edge of lines marking boundaries.

All field dimension lines shown must be marked 4" in width with a white, non-toxic material which is not injurious to the eyes or skin.

If cross hatching in end zone is white, it shall be no closer than two feet to the boundary lines.

For grading and drainage details see figure 69.

For surfacing details see figure 70.

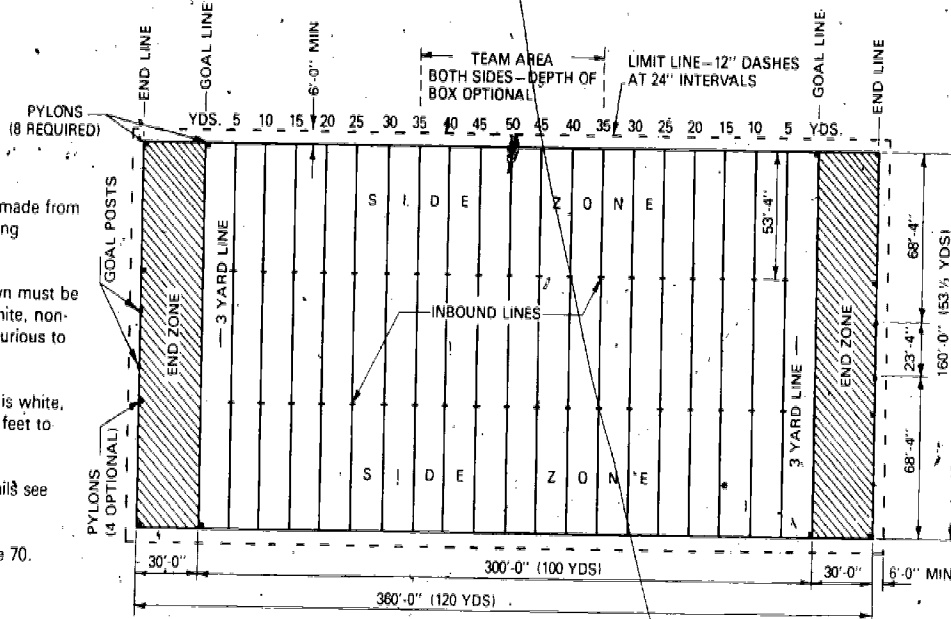

PLAYING FIELD LAYOUT

11-MAN FOOTBALL

FIGURE 29

TOUCH AND FLAG FOOTBALL

NAME OF SPORTS ORGANIZATION

National Touch and Flag Football Rules, The Athletic Institute, 1971.

RECOMMENDED AREA

Ground space is 41,200 square feet (.94 acre) minimum.

SIZE AND DIMENSION

Playing field width is 120'-0". Length is 300'-0". Additional area recommended is 6'-0" minimum unobstructed space on all sides.

ORIENTATION

Preferred orientation is for the long axis to be northwest-southeast to suit the angle of the sun in the fall playing season, or north-south for longer periods.

SURFACE AND DRAINAGE

Surface is to be turf.

Preferred grading is a longitudinal crown with a 1% slope from center to each side and adequate underdrainage.

Grading may be from side to side or corner to corner diagonally if conditions do not permit the preferred grading.

SPECIAL CONSIDERATIONS

Goal posts are to be provided at each end of the playing field. Pylons are to be provided as required by rules.

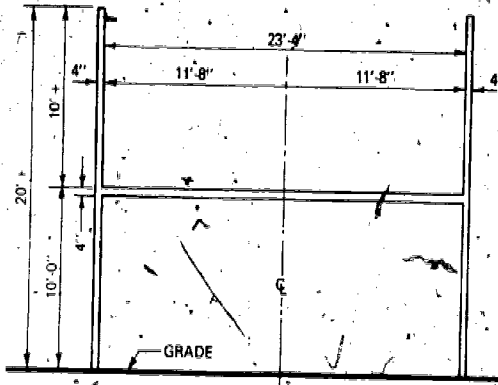

GOAL POSTS

NOTES:

Optional goal post may be used in the form of a single metal post set behind the end zone with a cantilevered horizontal crossbar and two uprights of the same height and spacing as for dual posts.

For goal post construction details see figure 65.

Pylon to be constructed of soft flexible material, red or orange in color.

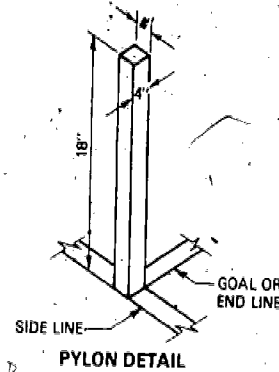

PYLON DETAIL

NOTES:

All measurements should be made from the inside edge of lines marking boundaries.

All field dimension lines shown must be marked 4" in width with a white, non-toxic material which is not injurious to the eyes or skin.

If cross hatching in end zone is white, it shall be no closer than two feet to the boundary lines.

When teams are composed of 9 or 11 players, a field 360'-0" (120 YDS) long with five 60'-0" (20 YD) zones and two 30'-0" (10 YD) end zones is recommended.

For grading and drainage details see figure 69.

For surfacing details see figure 70.

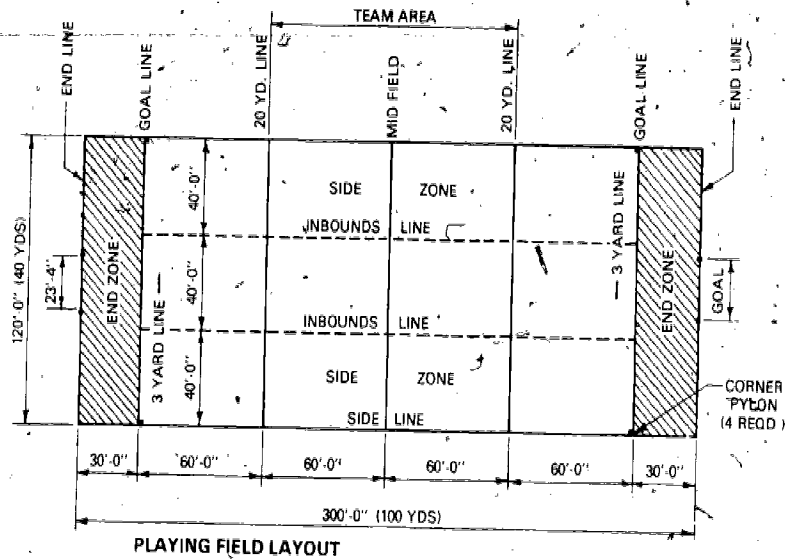

PLAYING FIELD LAYOUT

TOUCH AND FLAG FOOTBALL

FIGURE 30

GOLF DRIVING RANGE

NAME OF SPORTS ORGANIZATION

National Golf Foundation, Inc., 1974

RECOMMENDED AREA

Ground space for minimum of 25 tees is 13.5 acres.

SIZE AND DIMENSION

Minimum length is 900' (300 yards). Minimum width, including buffer area on each side, is 690' (230 yards). Add 12' width per additional tee.

ORIENTATION

Preferred orientation is for the long axis to run southwest to northeast with the golfer driving toward the northeast.

SURFACE AND DRAINAGE

Surface is to be turf closely mowed in center for ball collection. Side buffer areas are to be rough cut.

Drainage is to be away from raised tee area and preferably across the axis of play. Side buffer areas may rise to help contain stray drives.

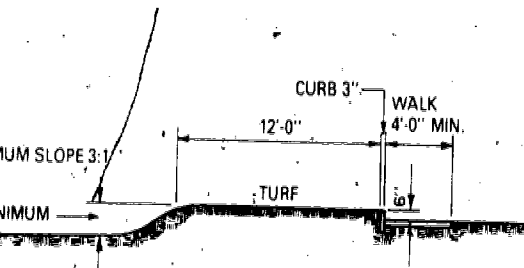

SECTION OF TEES

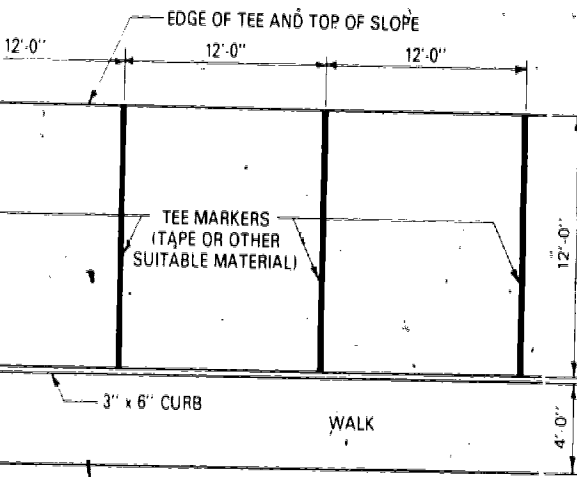

PLAN OF TEES

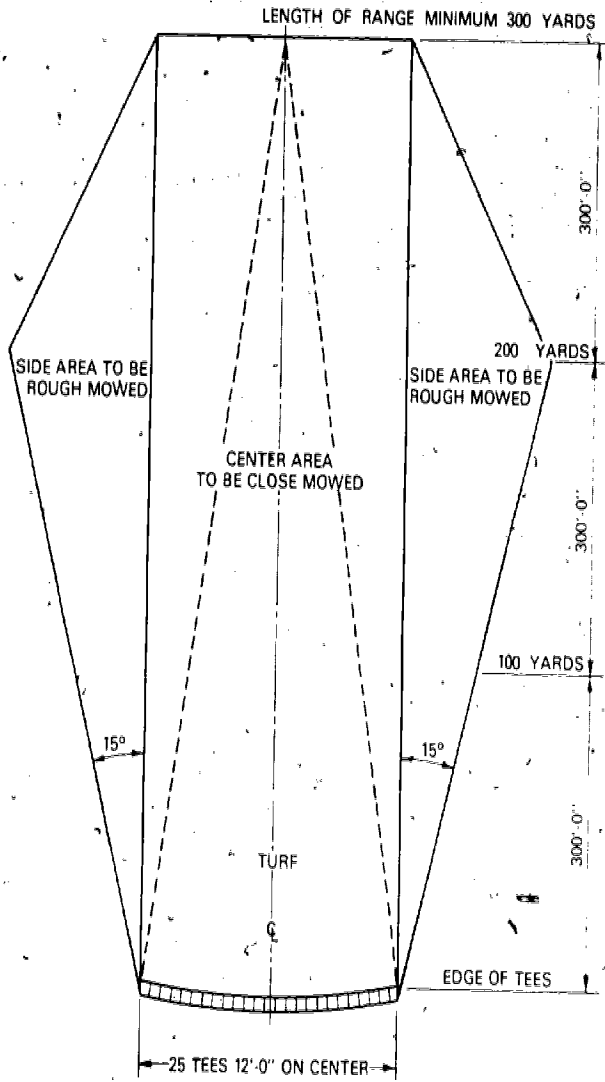

RANGE LAYOUT

GOLF DRIVING RANGE

FIGURE 31

LACROSSE (Men's)

NAME OF SPORTS ORGANIZATION

National Collegiate Athletic Association (NCAA), 1974.

RECOMMENDED AREA

Ground space is 62,650 square feet (1.4 acres) to 70,000 square feet (1.6 acres).

SIZE AND DIMENSION

Playing field width is 159'-0" to 180'-0". Length is 330'-0". Additional area recommended is 10'-0" minimum unobstructed space around entire perimeter of field with barrier fence, or 20'-0" without fence.

ORIENTATION

Preferred orientation is for the long axis to be northwest-southeast to suit the angle of the sun in the fall playing season, or north-south for longer periods.

SURFACE AND DRAINAGE

Surface is to be turf.

Preferred grading is a longitudinal crown with a 1% slope from center to each side and adequate underdrainage.

Grading may be from side to side or corner to corner diagonally if conditions do not permit the preferred grading.

SPECIAL CONSIDERATIONS

Goal is to be provided 45'-0" in front of each end line.

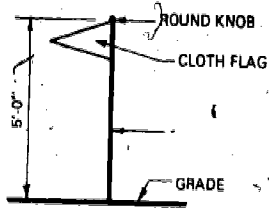

FLAG DETAIL

NOTES:

Goal net should be cord netting with openings of not more than 1 1/2".

Bottom of net must be held close to the ground with pegs or staples.

Posts to be 1 1/2" nominal pipe painted orange and secured to the ground.

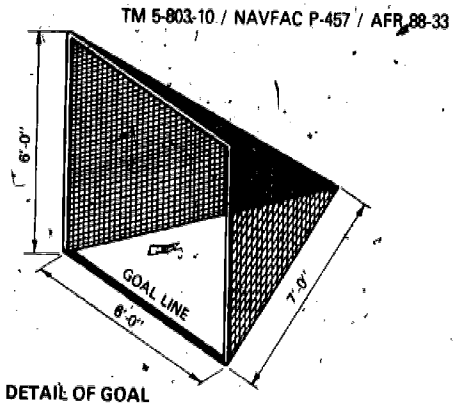

DETAIL OF GOAL

NOTES:

Lines must be marked with a white non-toxic material which is not injurious to the eyes or skin.

All lines shall be 2" wide except the center or offside line which should be 4" wide.

All dimensions are to inside of lines except at center line.

Barrier fence, 5' or 6' high, should be 10'-0" min. from end and side lines. If not used allow 20' space on all sides.

Flexible flag markers shall be placed at the four corners of the field and at each end of the center line.

For grading and drainage details see figure 69.

For surfacing details see figure 70.

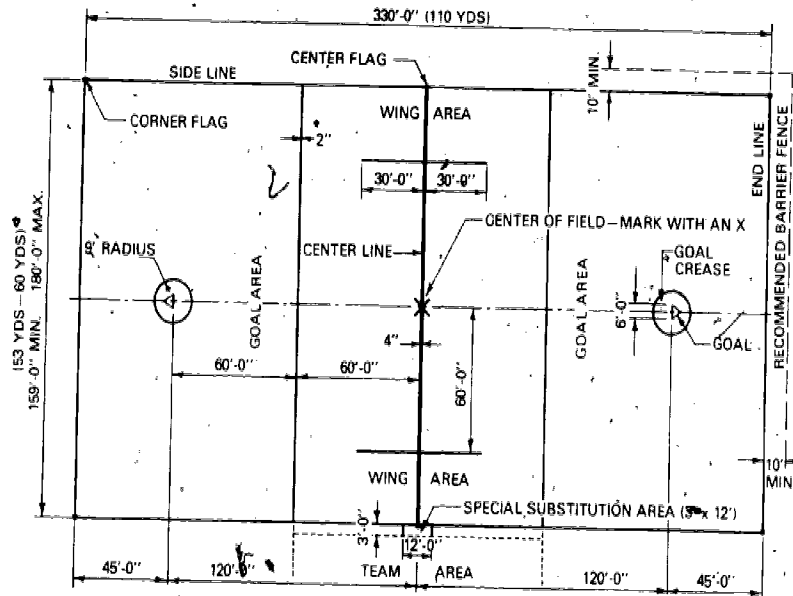

PLAYING FIELD LAYOUT

LACROSSE (MEN'S)

FIGURE 32

LACROSSE (Women's)

NAME OF SPORTS ORGANIZATION

National Association for Girls and Women in Sport (NAGWS), 1974-76.

RECOMMENDED AREA

Ground space is optional 54,000 square feet (1.2 acres) to 61,500 square feet (1.4 acres).

SIZE AND DIMENSION

Playing field minimum width is 150'-0". Optional length is 360'-0" to 410'-0". As in the original Indian game, there are no definite boundaries or shape for the field of play, but before a match the officials decide on the boundaries and declare specified obstructions out of bounds.

ORIENTATION

Preferred orientation is for the long axis to be northwest-southeast to suit the angle of the sun in the fall playing season, or north-south for longer periods.

SURFACE AND DRAINAGE

Surface is to be turf.

Preferred grading is a longitudinal crown with a 1% slope from center to each side with adequate underdrainage.

Grading may be from side to side or corner to corner diagonally if conditions do not permit the preferred grading.

SPECIAL CONSIDERATIONS

Goal is to be provided 45'-0' in front of each end line.

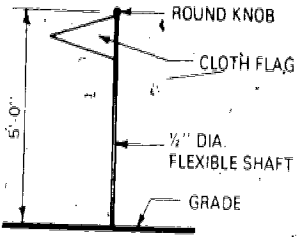

OPTIONAL FLAG DETAIL

NOTES:

Goal net should be cord netting with openings of not more than 1-1/2".

Bottom of net must be held close to the ground with pegs or staples.

Posts and crossbar shall be of wood; 2' x 2" and shall be painted white.

Goals made of pipe and painted white are considered legal but wooden 2" x 2" are preferred.

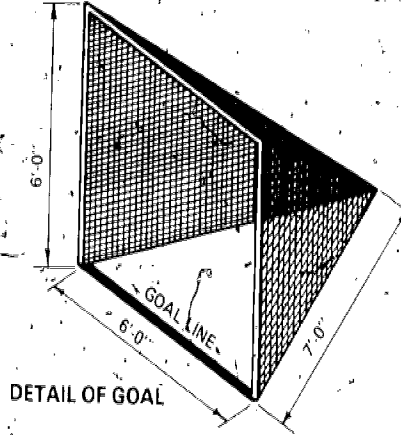

DETAIL OF GOAL

...ing lines shall be 2" wide and with a white non-toxic material not injurious to the eyes or skin.

...y lines are optional but should be marked.

... flag may be placed at the four or selected boundary points.

...ing and drainage details see

...ing details see figure 70.

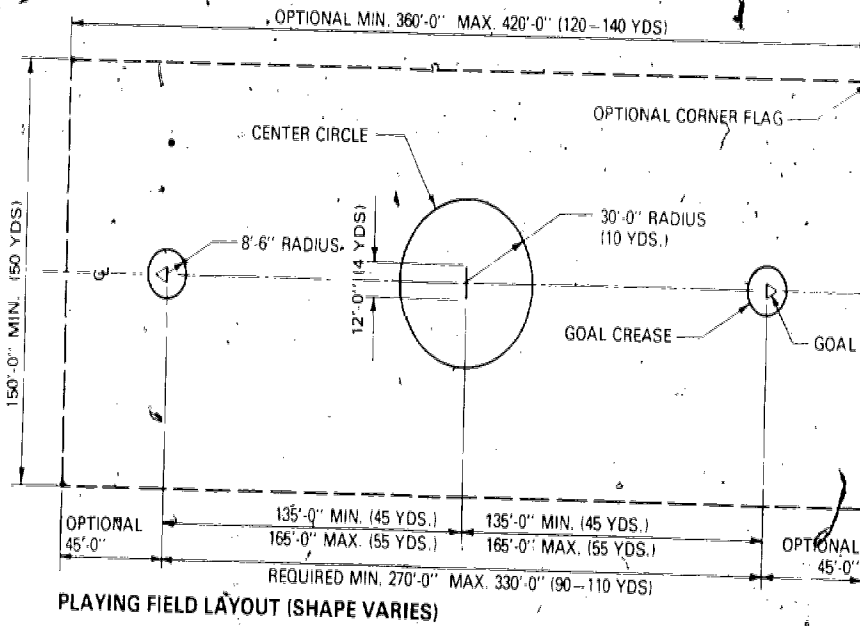

PLAYING FIELD LAYOUT (SHAPE VARIES)

LACROSSE (WOMEN'S)

FIGURE 33

SOCCER (Men's and Boys')

NAME OF SPORTS ORGANIZATION

National Collegiate Athletic Association, (NCAA), 1974.

RECOMMENDED AREA

Ground space is 75,250 square feet (1.7 acres) to 93,100 square feet (2.1 acres).

SIZE AND DIMENSION

Playing field width is 195'-0" to 225'-0". Length is 330'-0" to 360'-0".
Additional area recommended is 10'-0" minimum unobstructed space on all sides.

ORIENTATION

Preferred orientation is for the long axis to be northwest-southeast to suit the angle of the sun in the fall playing season, or north-south for longer periods.

SURFACE AND DRAINAGE

Surface is to be turf.

Preferred grading is a longitudinal crown with a 1% slope from center to each side and adequate underdrainage. Grading may be from side to side or corner to corner diagonally if conditions do not permit the preferred grading.

SPECIAL CONSIDERATIONS

Goal posts are to be provided at each end of the playing field.

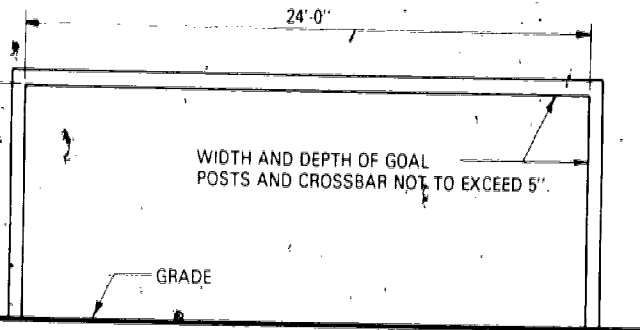

GOAL POSTS

NOTES:

Goal posts to be pressure treated with paintable, oil-borne preservative and painted above ground with three coats of white lead and oil.

The goalposts and crossbar shall present a flat surface to the playing field, not less than four inches nor more than five inches in width.

Nets shall be attached to the posts, crossbar and ground behind the goal.

The top of the net must extend backward 2'-0" level with the crossbar.

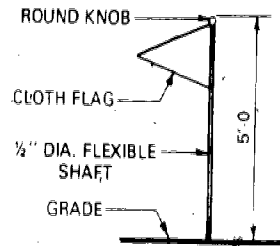

FLAG DETAIL

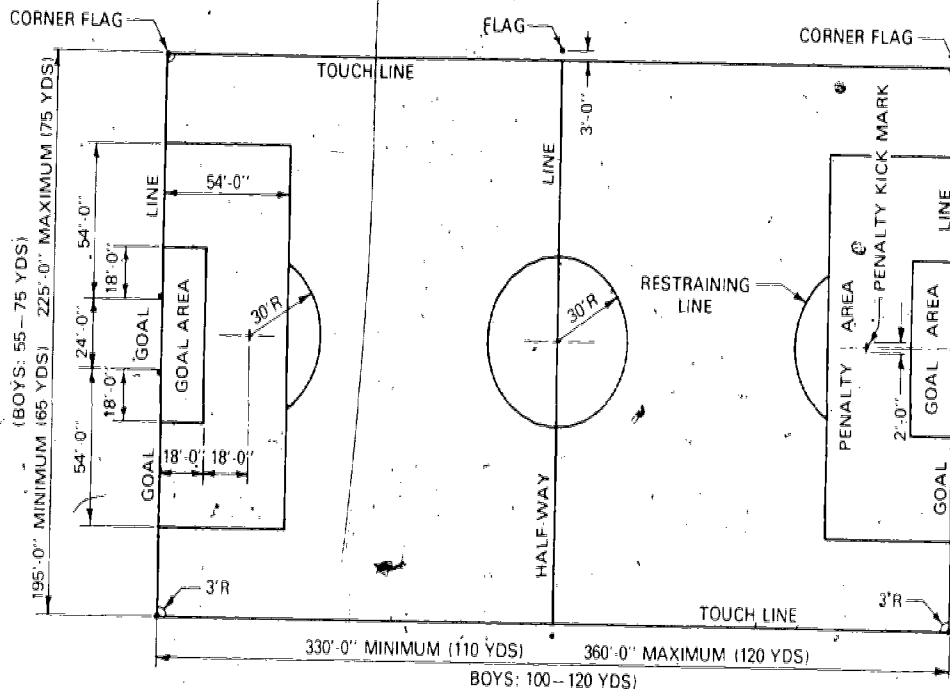

PLAYING FIELD LAYOUT

SOCCER (MEN'S AND BOYS')

FIGURE 34

SOCCER (Women's and Girls')

NAME OF SPORTS ORGANIZATION

National Association for Girls and Women in Sport (NAGWS), 1974-76.

RECOMMENDED AREA

Ground space is 36,400 square feet (.8 acre) to 64,000 square feet (1.4 acres).

SIZE AND DIMENSION

Playing field width is 120'-0" to 180'-0". Length is 240'-0" to 300'-0". Additional area recommended is 10'-0" minimum unobstructed space on all sides.

ORIENTATION

Preferred orientation is for the long axis to be northwest-southeast to suit the angle of the sun in the fall playing season, or north-south for longer periods.

SURFACE AND DRAINAGE

Surface is to be turf.

Preferred grading is a longitudinal crown with a 1% slope from center to each side and adequate underdrainage.

Grading may be from side to side or corner to corner diagonally if conditions do not permit the preferred grading.

SPECIAL CONSIDERATIONS

Goal posts are to be provided at each end of the playing field.

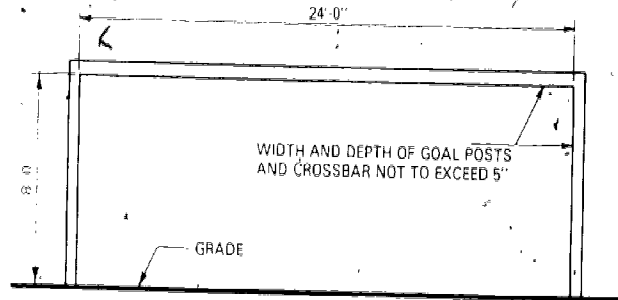

GOAL POSTS

NOTES:

Goal posts to be pressure treated with painted, oil-borne preservative and painted above ground with three coats of white lead and oil.

The goal posts and crossbar shall present a flat surface to the playing field, not less than 4" nor more than 5" in width.

Nets shall be attached to the posts, crossbar and ground behind the goal.

The top of the net must extend backward 2'-0" level with the crossbar.

NOTES:

All dimensions are to the inside edge of lines.

All lines shall be 2" wide and marked with a white, non-toxic material which is not injurious to the eyes or skin.

For grading and drainage details see figure 69.

For surfacing details see figure 70.

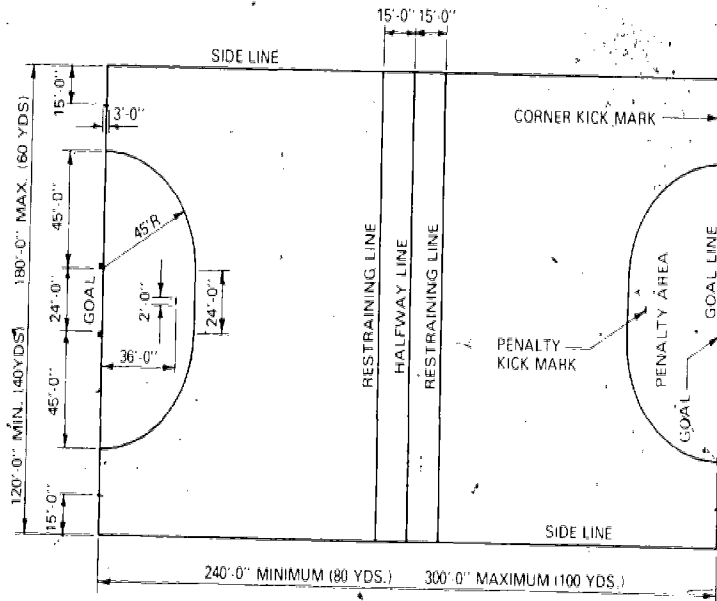

PLAYING FIELD LAYOUT

SOCCER (WOMEN'S AND GIRLS')

FIGURE 35

SOFTBALL 12" (Fast and Slow Pitch)

NAME OF SPORTS ORGANIZATION

Amateur Softball Association of America, (ASA), 1974.

RECOMMENDED AREA

Ground space is 62,500 square feet (1.5 acres) to 90,000 square feet (2.0 acres).

SIZE AND DIMENSION

Baselines are 60'-0" for men and women, 45'-0" for juniors. Pitching distances are 46'-0" for men, 40'-0" for women; 35'-0" for juniors. Fast pitch playing field is 225' radius from home plate between foul lines for men and women. Slow pitch is 275' radius for men, 250' radius for women.

ORIENTATION

Optimum orientation is to locate home plate so that the pitcher is throwing across the sun and the batter is not facing it.

SURFACE AND DRAINAGE

Surface is to be turf. Infield may be skinned. The infield shall be graded so that the base lines and home plate are level.

SPECIAL CONSIDERATIONS

Backstop is to be located at a minimum distance of 25' behind home plate.

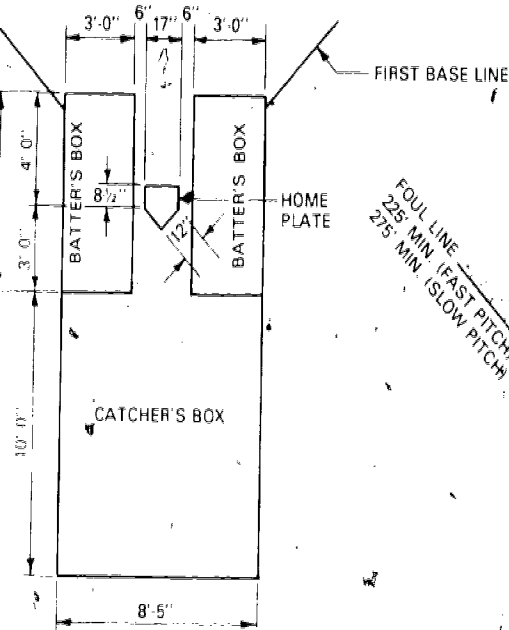

LAYOUT AT HOME PLATE

- NOTES:
- 1. Foul lines, catcher's, batter's and coach's boxes, and pitcher's plate are 2" to 3" chalk lines.
 - 2. Pitching distance for women's softball to be 40'-0".
 - 3. For junior player (9-12 years) 45' distance between bases, 35' pitching distance.

- 4. Grading and drainage details see figure 69.
- 5. Surfacing details see figure 70.
- 6. Backstop details see figure 71.

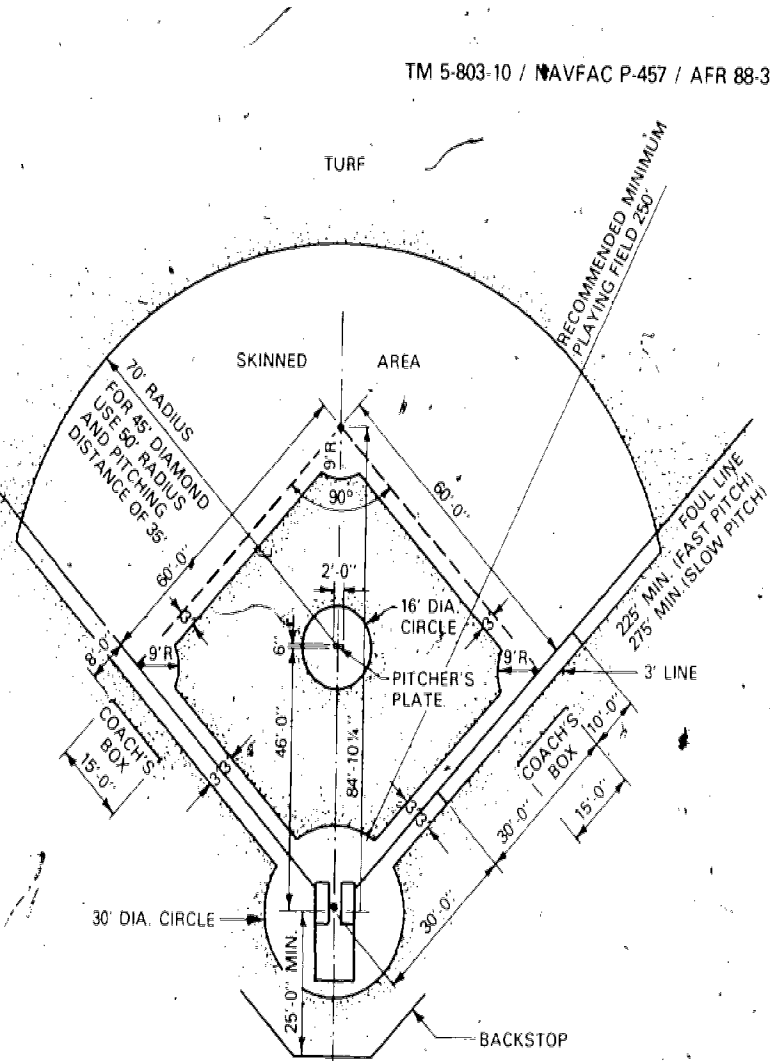

DIAMOND LAYOUT

SOFTBALL 12"

FIGURE 36

SOFTBALL 16" (Slow Pitch)

NAME OF SPORTS ORGANIZATION

Amateur Softball Association of America, (ASA); 1974.

RECOMMENDED AREA

Ground space is 50,625 square feet (1.2 acres) to 75,625 square feet (1.7 acres).

SIZE AND DIMENSION

Baselines are 55'-0" for men, 50'-0" for women. Pitching distance is 38'-0" for men and women. Playing field radius from home plate between foul lines is 250' for men, 200' for women.

ORIENTATION

Optimum orientation is to locate home plate so that the pitcher is throwing across the sun and the batter is not facing it.

SURFACE AND DRAINAGE

Surface is to be turf. Infield may be skinned. The infield shall be graded so that the baselines and home plate are level.

SPECIAL CONSIDERATIONS

Backstop is to be located at a minimum distance of 25' behind home plate.

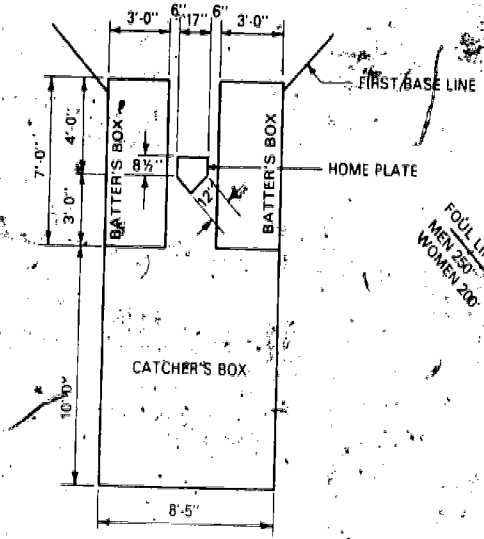

LAYOUT AT HOME PLATE

NOTES:

Foul lines, catcher's, batter's and coach's boxes and 3' lines are 2" to 3" chalk lines.

Baselines for women to be 50'-0". Pitching distance does not change.

For grading and drainage details see figure 69.

For surfacing details see figure 70.

For backstop details see figure 71.

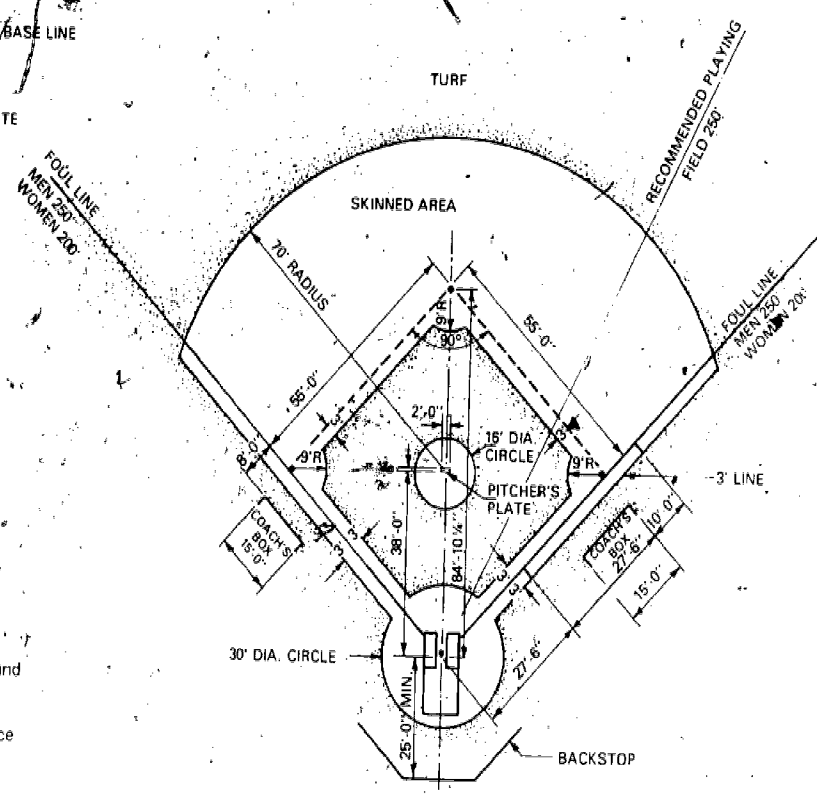

DIAMOND LAYOUT

SOFTBALL (16")

FIGURE 37

2-77

113

113

SPEEDBALL

NAME OF SPORTS ORGANIZATION

- ▷ National Association for Girls and Women in Sport (NAGWS), 1974-76.

RECOMMENDED AREA

Ground space is 36,400 square feet (.85 acre) (high school) to 76,000 square feet (1.7 acres).

SIZE AND DIMENSION

Playing field width is 180'-0". Length is 300'-0". An additional 30' x 180' out of bounds touchdown area is recommended on each end and unobstructed space of 10'-0" on all sides. High school field may be 120' wide by 240' long.

ORIENTATION

Preferred orientation is for the long axis to be northwest-southeast to suit the angle of the sun in the fall playing season, or north-south for longer periods.

SURFACE AND DRAINAGE

Surface is to be turf. Preferred grading is a longitudinal crown with a 1% slope from center to each side and adequate underdrainage.

Grading may be from side to side or corner to corner diagonally if conditions do not permit the preferred grading.

SPECIAL CONSIDERATIONS

Goal posts are to be provided at each end of the playing field.

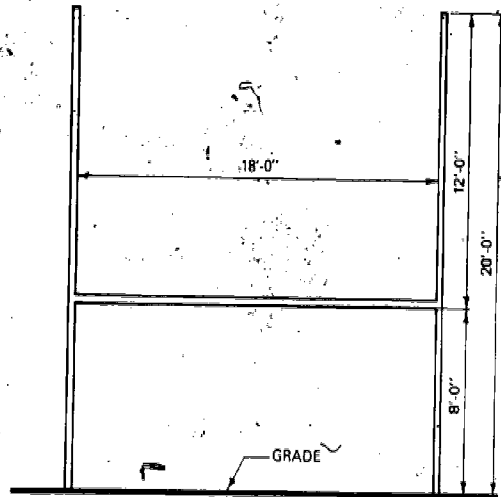

GOAL POSTS

NOTES:

All dimensions are to inside edge of lines.

All field markings to be 2" wide and marked with a white non-toxic material which is not injurious to the eyes or skin.

For grading and drainage details see figure 69.

For surfacing details see figure 70.

For goal post details see figure 66.

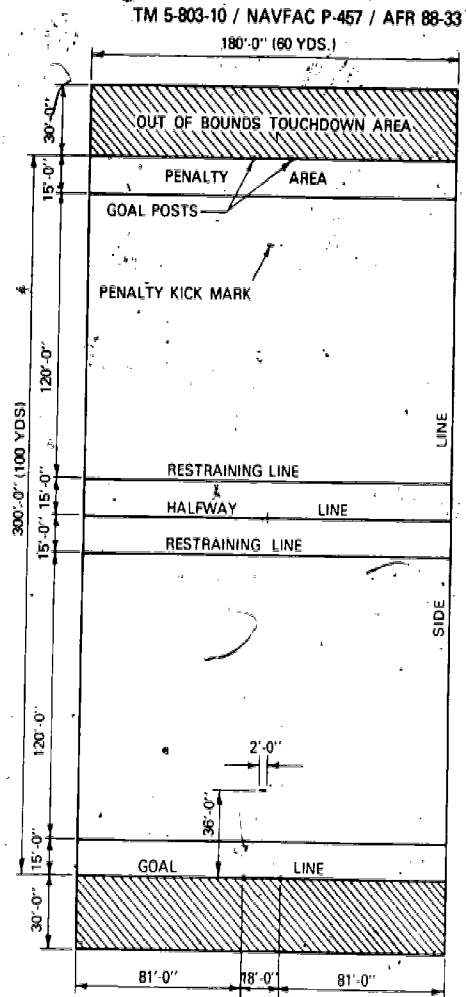

PLAYING FIELD LAYOUT

**SPEEDBALL
FIGURE 38**

TEAM HANDBALL

NAME OF SPORTS ORGANIZATION

United States Team Handball Federation, (USTHF), 1973.

RECOMMENDED AREA

Ground space is 11,230 square feet (.25 acre) (1066 square metres).

SIZE AND DIMENSION

Playing field width is 65'-8" (20M). Length is 111'-4" (40M). Additional area recommended is 6'-0" minimum unobstructed space on all sides.

ORIENTATION

Preferred orientation is for the long axis to be northwest-southeast to suit the angle of the sun in the fall playing season, or north-south for longer periods.

SURFACE AND DRAINAGE

Surface is to be turf.

Preferred grading is a longitudinal crown with a 1% slope from center to each side and adequate underdrainage.

Grading may be from side to side or corner to corner diagonally if conditions do not permit the preferred grading.

SPECIAL CONSIDERATIONS

Goal posts and crossbar are to be provided at each end of the playing field.

NOTES:

Team handball goal posts and crossbar are metal or wood and painted on all sides in two contrasting colors. Goals will be firmly fixed to the ground with hooked stakes.

The goal line between the goal posts is the same width as the posts.

All field markings are 2" (5cm) wide and form part of the area they enclose.

Lines shall be marked with a white, non-toxic material which is not injurious to eyes or skin.

For grading and drainage details see figure 69.

For surfacing details see figure 70.

TM 5-803-10 / NAVFAC P-457 / AFR 88-33

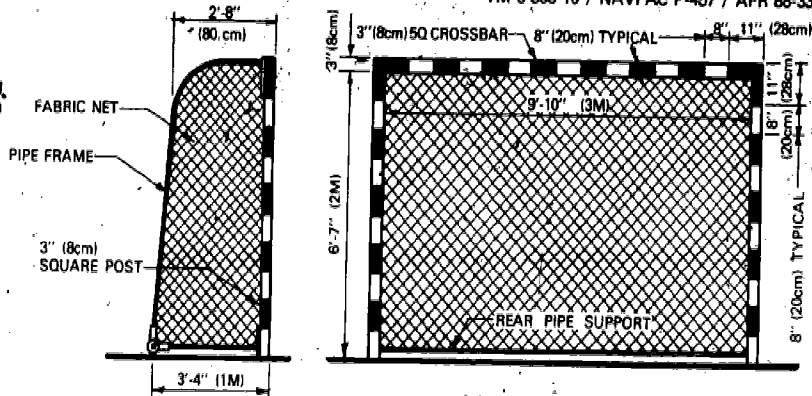

GOAL POSTS AND CROSSBAR

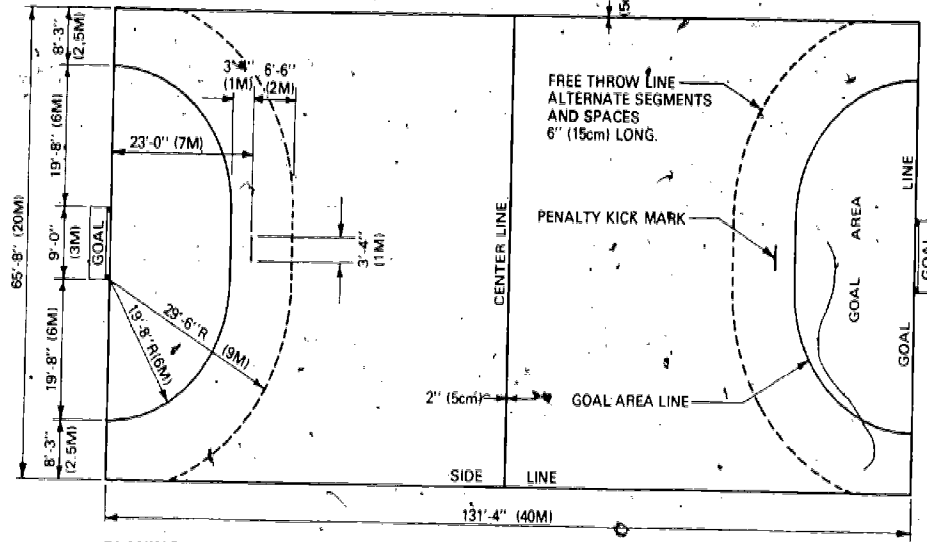

PLAYING FIELD LAYOUT

TEAM HANDBALL

FIGURE 39

2 - 81 (next page is 2 - 83)

134

135

TM 5-803-10 / NAVFAC P-457 / AFR 88-33

2-3

2-83

TRACK AND FIELD

123

¼ MILE RUNNING TRACK

NAME OF SPORTS ORGANIZATION

National Collegiate Athletic Association, (NCAA), 1974.

RECOMMENDED AREA

Ground space is approximately 4.3 acres.

SIZE AND DIMENSION

Inside radius to face of curb is 106'-0". Track width is 32'-0" for eight 4-foot-wide lanes. Overall width is 276'-0". Overall length is 600.02'.

ORIENTATION

The track should be oriented so that the long axis falls in a sector from north-south to northwest-southeast with the finish line at the northerly end.

SURFACE AND DRAINAGE

Track surface is to be preferably bituminous material with a hot plant cushion course mix and optional protective colorcoating.

Maximum slopes for the running track are two percent (1:50) inward in the center of curves, one percent (1:100) inward in the straightway, and one tenth on one percent (1:1000) in the running direction.

SPECIAL CONSIDERATIONS

Drainage must be provided for the track surface and optional football field, but will be dependent upon site grading.

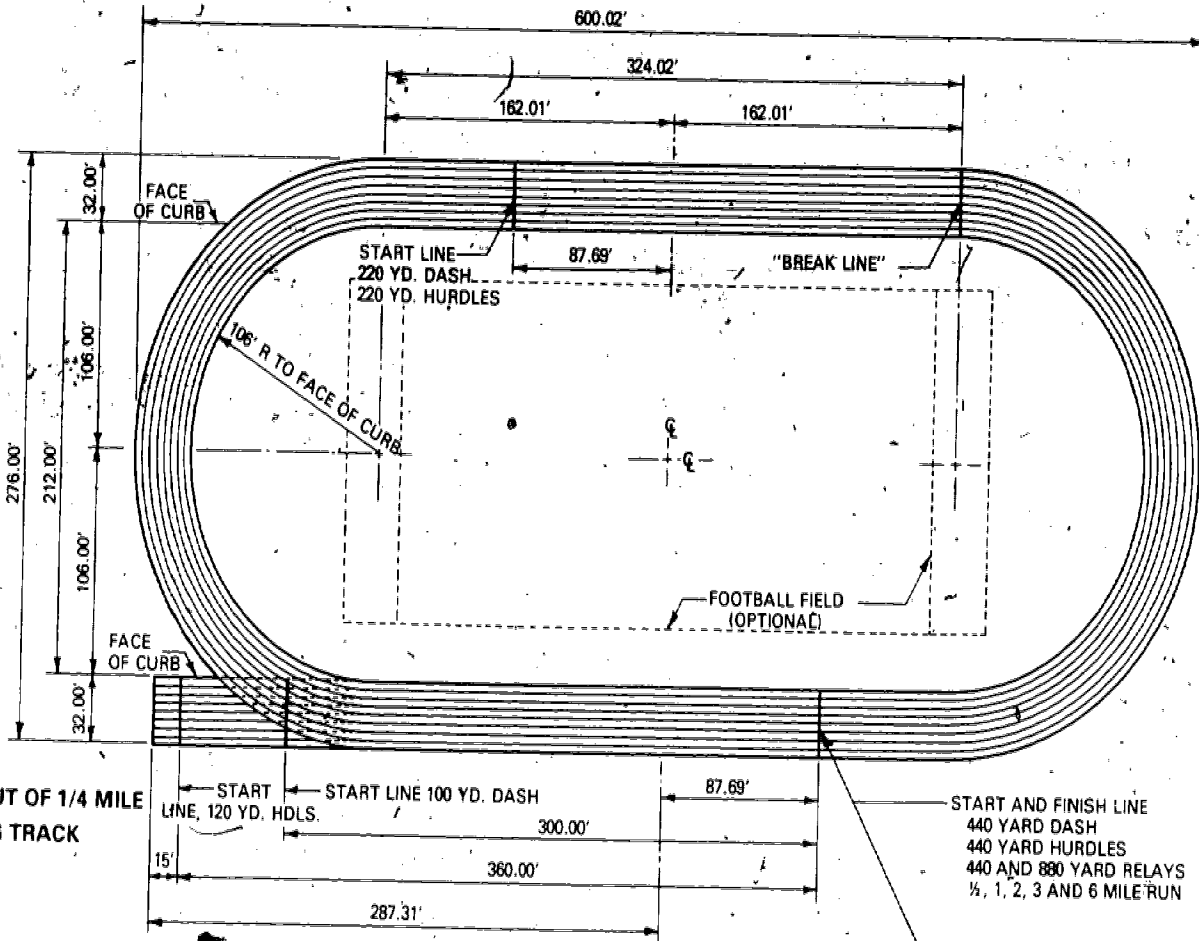

LAYOUT OF 1/4 MILE RUNNING TRACK

NOTES:

Distances in lane one shall be measured upon a line 12" outward from the inner edge of the track.

For events run in lanes around a turn, all lanes except the inner lane shall be measured upon a line 8" outward from the inner line of the lane.

For lane marking details and typical section of running track see figure 41.

- START LINE 120 YD. HDLS.
- START LINE 100 YD. DASH
- 300.00'
- 360.00'
- 287.31'
- 87.69'
- START AND FINISH LINE
- 440 YARD DASH
- 440 YARD HURDLES
- 440 AND 880 YARD RELAYS
- 1/4, 1, 2, 3 AND 6 MILE RUN
- FINISH LINE
- 100 YARD DASH
- 120 YARD HURDLES
- 220 YARD DASH
- 220 YARD HURDLES

1/4 MILE RUNNING TRACK
FIGURE 40

123

123

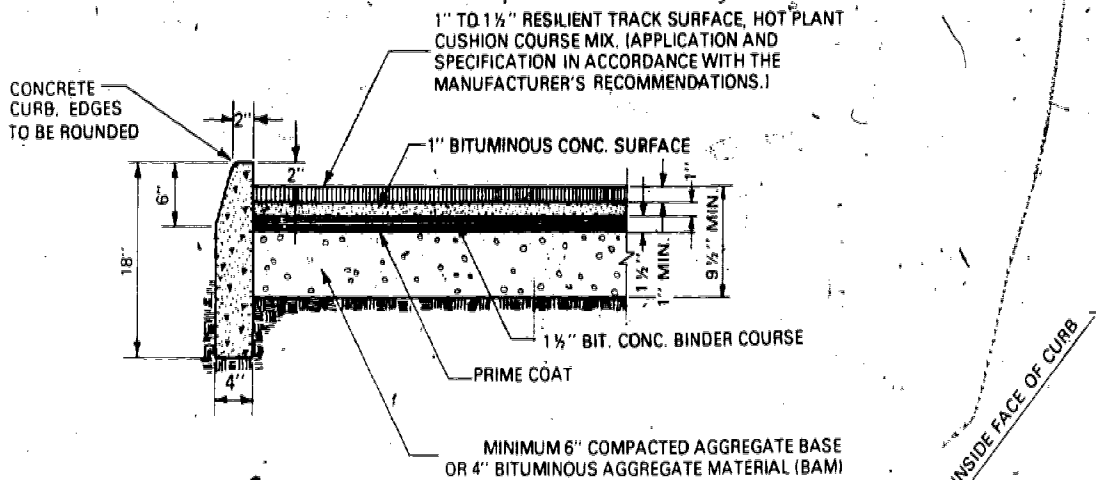

TYPICAL SECTION - RUNNING TRACK

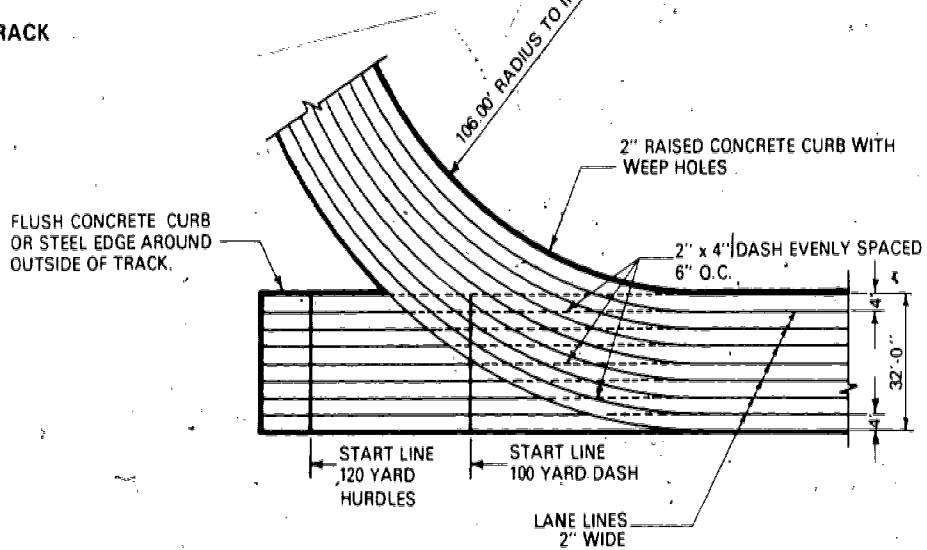

LANE MARKING DETAILS

1/4 MILE RUNNING TRACK (MARKING DETAILS - 1)

FIGURE 41

2 - 86

NOTES:

All distances in lane one shall be measured upon a line 12" outward from the inner edge of the track.

For events run in lanes around a turn, all lanes except lane one shall be measured upon a line 8" outward from the inner line of the lane.

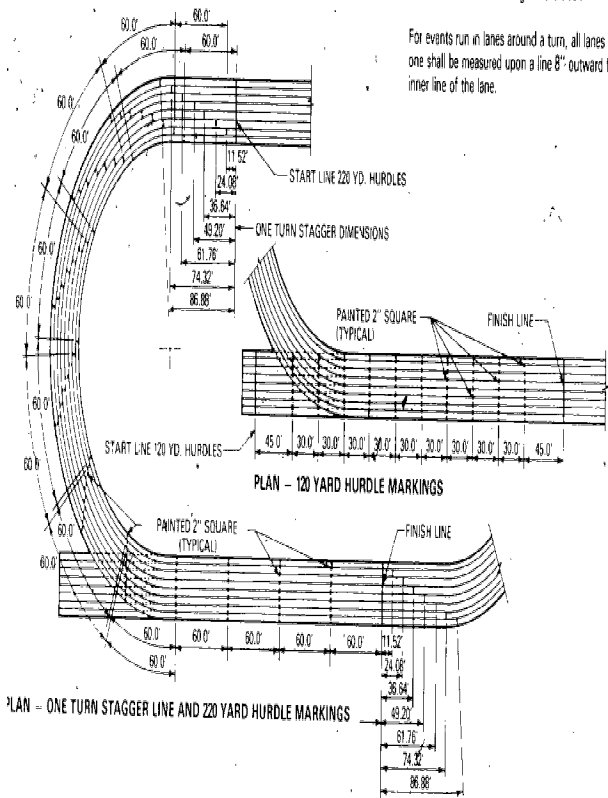

1/4 MILE RUNNING TRACK
(MARKING DETAILS-2)

FIGURE 42

2-87

13

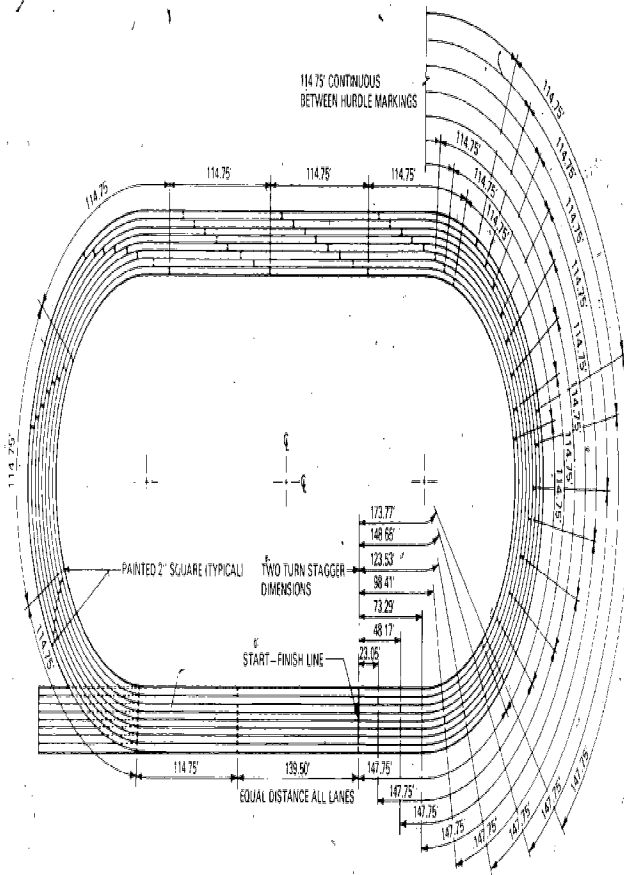

1/4 MILE RUNNING TRACK
(MARKING DETAILS-3)

1/4 MILE RUNNING TRACK
(MARKING DETAILS-3)

FIGURE 3

2-88

13

13

NOTES:

All distances in lane one shall be measured upon a line 12" outward from the inner edge of the track.

For events run in lanes around a turn, all lanes except lane one shall be measured upon a line 8" outward from the inner line of the lane.



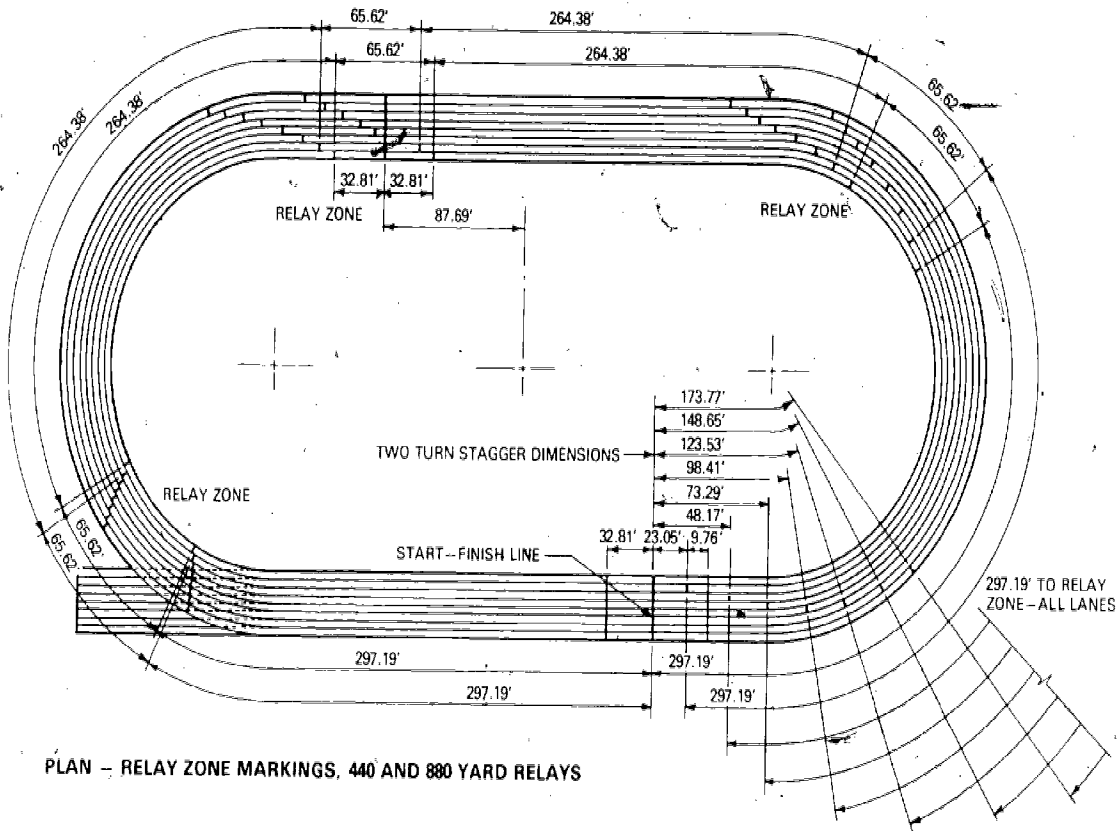

PLAN - RELAY ZONE MARKINGS, 440 AND 880 YARD RELAYS

NOTES:

All distances in lane one shall be measured upon a line 12" outward from the inner edge of the track.

For events run in lanes around a turn, all lanes except lane one shall be measured upon a line 8" outward from the inner line of the lane.

1/4 MILE RUNNING TRACK
(MARKING DETAILS-4)

FIGURE 44

130

130

SHOT PUT

NAME OF SPORTS ORGANIZATION

National Collegiate Athletic Association, (NCAA); 1974.

RECOMMENDED AREA

Ground space is 2100 square feet minimum.

SIZE AND DIMENSION

Shot put circle is 7'-0" (2.134M) in diameter. Throwing sector is 45° angle and 70' (21.33M) minimum radius.

ORIENTATION

Preferred orientation is for the throwing direction to be toward the northeast quadrant.

SURFACE AND DRAINAGE

Surface of inner circle is to be concrete or similar material.

Throwing sector is to be turf at the same level as the top of the metal ring.

SPECIAL CONSIDERATIONS

Stopboard must be firmly fixed so that its inner edge coincides with the inner edge of the shot put circle.

Sector flags are required to mark end of landing zone at distance required by the competition.

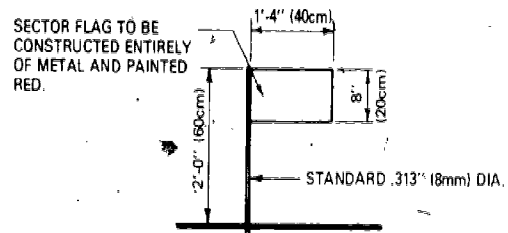

DETAIL - SECTOR FLAG

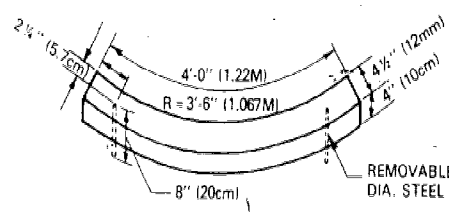
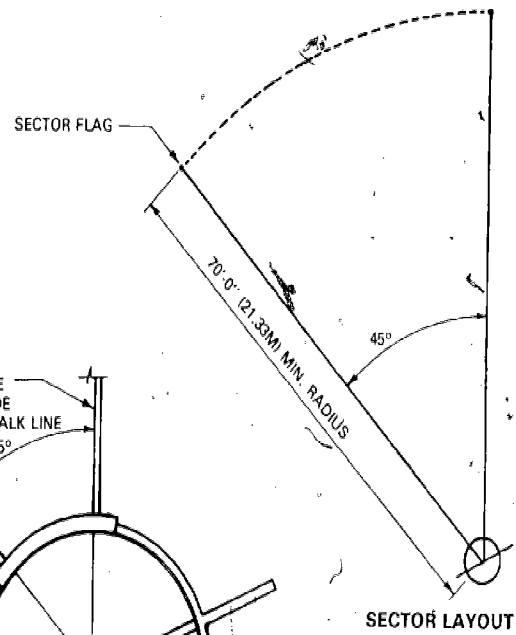

DETAIL - SHOT PUT STOP BOARD

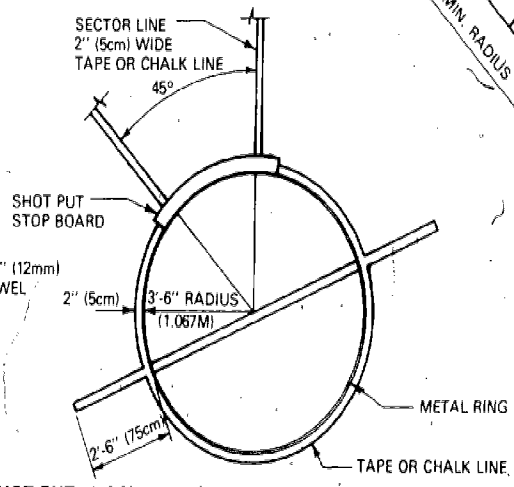

SHOT PUT THROW CIRCLE

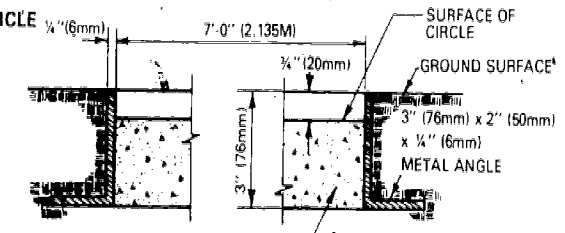

SECTION - SHOT PUT CIRCLE

SHOT PUT
FIGURE 45

NOTES:

Throwing circles to be formed of band iron or steel angle 3" (76mm) x 2" (50mm) x 1/4" (6mm) sunk flush with the ground outside.

The surface within the circle to be 1/4" (2cm) lower than the outside level and surfaced with concrete or similar material.

Sector lines to be white and marked with cloth tape held in place with metal pins or chalk.

Shot put stop board to be made of wood and painted white.

HAMMER THROW

NAME OF SPORTS ORGANIZATION

National Collegiate Athletic Association, (NCAA), 1974.

RECOMMENDED AREA

Ground space is 33,500 square feet minimum.

SIZE AND DIMENSION

Hammer throw circle is 7'-0" (2.134M) in diameter. Throwing sector is 60° angle and 250' (76.20M) minimum radius.

ORIENTATION

Preferred orientation is for the throwing direction to be toward the northeast quadrant.

SURFACE AND DRAINAGE

Surface of inner circle is to be concrete or similar material.

Throwing sector is to be turf at the same level as the top of the metal ring.

SPECIAL CONSIDERATIONS

For safety all throws must be made from within an approved enclosure or cage.

Sector flags are required to mark end of landing zone at distance required by the competition.

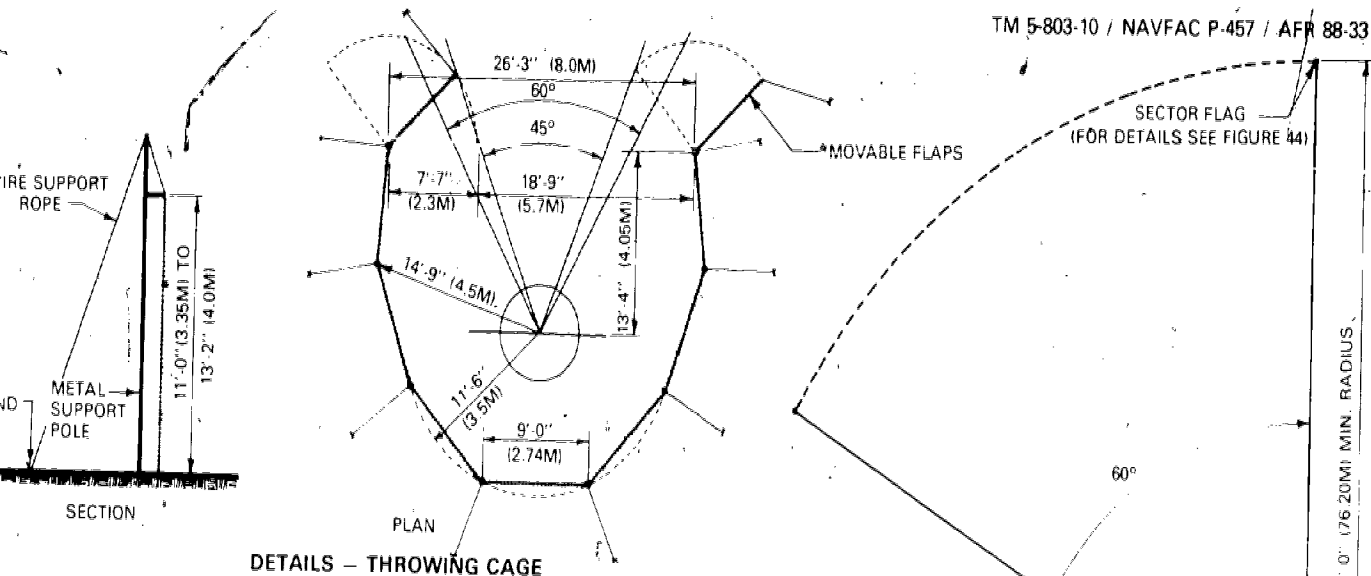

NOTES:
 All discus and hammer throws must be made from an enclosure or cage to insure the safety of spectators.

The cage should be C shaped in plan, the diameter being 29'-6" (9.0M) with the opening through which the throw is made 26'-3" (8.0M) wide. The height should not be less than 11 feet, but preferably 13'-2" (4.0M).

A wire cable, or series of metal struts, is suspended at a height of not less than 11 feet above the ground in the shape of a letter C. The cable or series of struts, is supported in a horizontal plane by 8 metal supports made in the shape of gallows, so that the C shape is formed by 7 straight panels, each 9'-0" (2.74M) wide. Two movable flaps 7'-7" (2.3M) are provided at the end of the C shape to afford adjustment for different throwing sectors.

The 8 metal supports are set into the ground with spikes or permanent sockets sunk to a depth of approximately 1 foot (30cm) and held in position with wire ropes.

The struts are 78'-2" (23.78M) long and 1 foot (0.3M) wider than the height of the struts, made of cord .5 inch (12.5mm) in circumference with 2 inch (50mm) meshes is suspended from the wire or metal strut framework with the lower edge resting on the ground and turned inward. The inner edge should be weighted at intervals with sand bags.

Throwing circles to be formed of continuous band iron or steel angle (76mm) x 2" (50mm) x 1/4" (6mm) sunk flush with the ground outside.

The surface within the circle to be 3/4" (2cm) lower than the outside and surfaced with concrete or similar material.

Color lines to be white and marked with cloth tape held in place with metal pins or chalk.

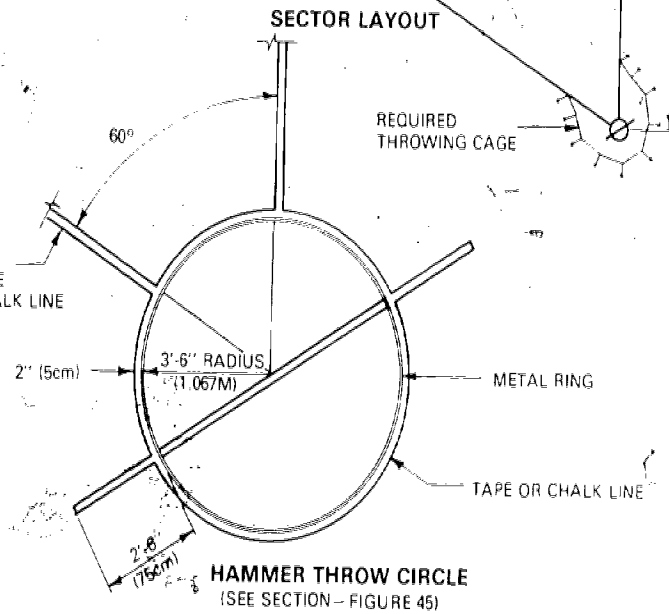

HAMMER THROW CIRCLE
 (SEE SECTION - FIGURE 45)

HAMMER THROW

FIGURE 46

DISCUS THROW

NAME OF SPORTS ORGANIZATION

National Collegiate Athletic Association, (NCAA), 1974.

RECOMMENDED AREA

Ground space is 25,500 square feet minimum.

SIZE AND DIMENSION

Discus throwing circle is 8'-2 1/2" (2.05M) in diameter. Throwing sector is 60° angle and 220' (67.06M) minimum radius.

ORIENTATION

Preferred orientation is for the throwing direction to be toward the northeast quadrant.

SURFACE AND DRAINAGE

Surface of inner circle is to be concrete or similar material.

Throwing sector is to be turf at the same level as the top of the metal ring.

SPECIAL CONSIDERATIONS

For safety all throws must be made from within an approved enclosure or cage.

Sector flags are required to mark end of landing zone at distance required by the competition.

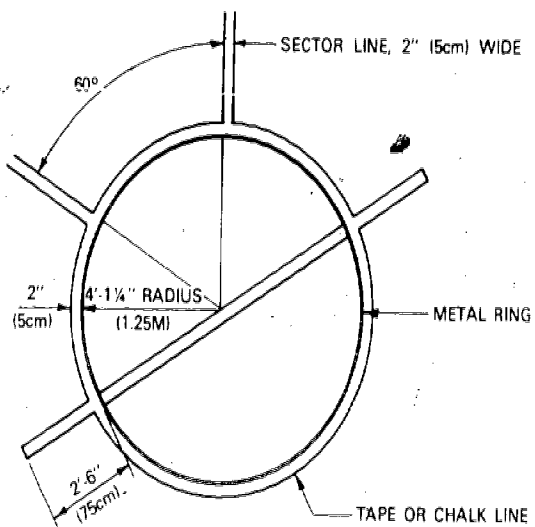

DISCUS THROW CIRCLE

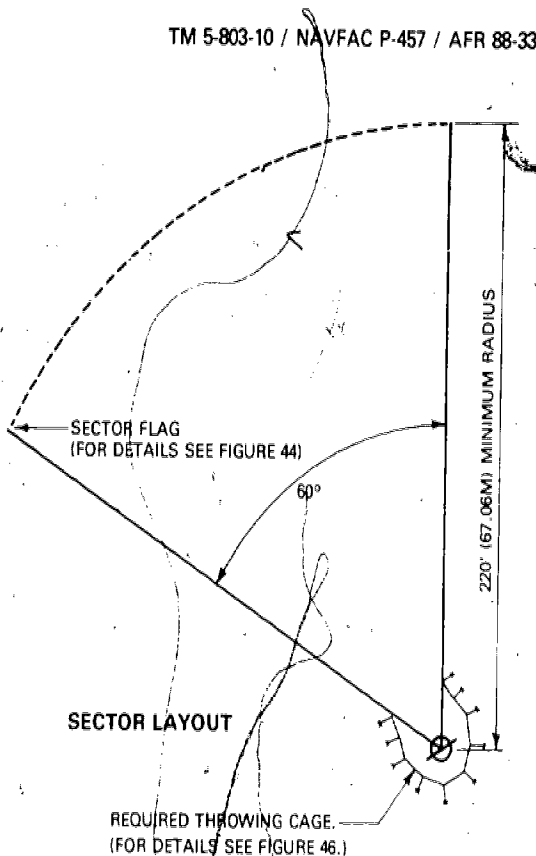

SECTOR LAYOUT

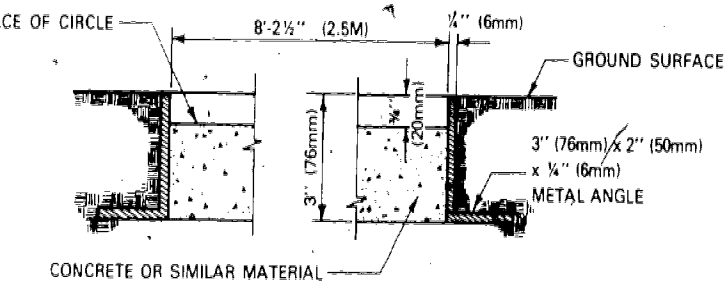

CROSS SECTION - DISCUS THROW CIRCLE

NOTES:

Throwing circles to be formed of continuous band iron or steel angle 3" (76mm) x 2" (50mm) x 1/4" (6mm) sunk flush with the ground outside.

The surface within the circle to be 3/4" (2cm) lower than the outside level and surfaced with concrete or similar material.

Sector lines to be white and marked with cloth tape held in place with metal pins or chalk.

DISCUS THROW

FIGURE 47

JAVELIN THROW

NAME OF SPORTS ORGANIZATION

National Collegiate Athletic Association, (NCAA), 1974.

RECOMMENDED AREA

Ground space is 24,000 square feet minimum.

SIZE AND DIMENSION

Runway length is minimum 120'-0" (36.5M). Runway width is 13'-1 1/2" (4.0M). Throwing sector is 30° angle and 300'-3" (91.5M) minimum radius.

ORIENTATION

Preferred orientation is for the throwing direction to be toward the northeast quadrant.

SURFACE AND DRAINAGE

Runway may be turf or specialized bituminous surfacing with a maximum slope of one percent (1:100) laterally and one tenth of one percent (1:1000) in the running direction.

Throwing sector is to be turf at the same level as the runway behind the throwing arc.

SPECIAL CONSIDERATIONS

Foul board is to be provided at end of runway.

Sector flags are required to mark end of landing zone at distance required by the competition.

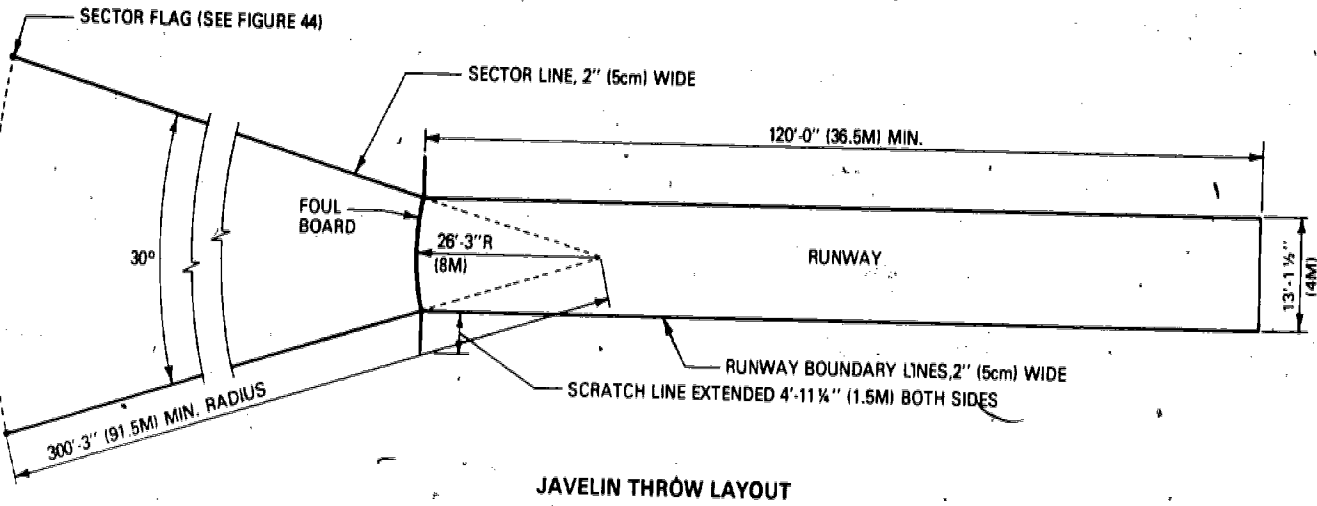

JAVELIN THROW LAYOUT

lines to be white, 2" (5cm) wide and marked with tape held in place with metal pins or chalk.

may be either turf or bituminous material.

way surfacing details see figure 41.

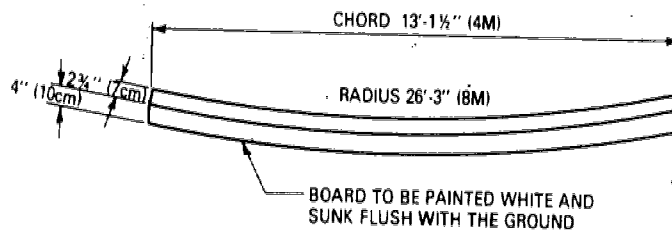

DETAIL - JAVELIN THROW FOUL BOARD

JAVELIN THROW

FIGURE 48

LONG JUMP AND TRIPLE JUMP

NAME OF SPORTS ORGANIZATION

National Collegiate Athletic Association, (NCAA), 1974.

RECOMMENDED AREA

Ground space is 1500 square feet minimum.

SIZE AND DIMENSION

Runway length is 130'-0" (39.62M) minimum. Runway width is 4'-0" (1.22M) minimum. Landing pit width is 9'-0" (2.75M) minimum. Landing pit length is 32'-0" (10M) minimum.

ORIENTATION

Preferred orientation is for the running direction to be toward the north or northeast.

SURFACE AND DRAINAGE

Runway preferably is to be bituminous material with a hot plant cushion course mix and optional protective colorcoating.

Maximum slope is to be one percent (1:100) laterally and one tenth of one percent (1:1000) in the running direction.

Landing pit is to be sand at the same elevation as the take off board.

SPECIAL CONSIDERATIONS

Take off board is to be of wood and must be fixed immovable in the runway.

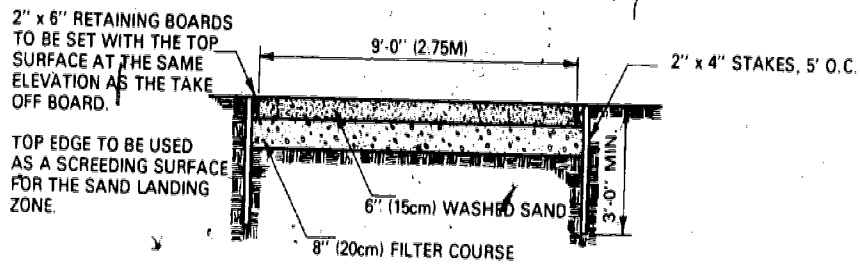
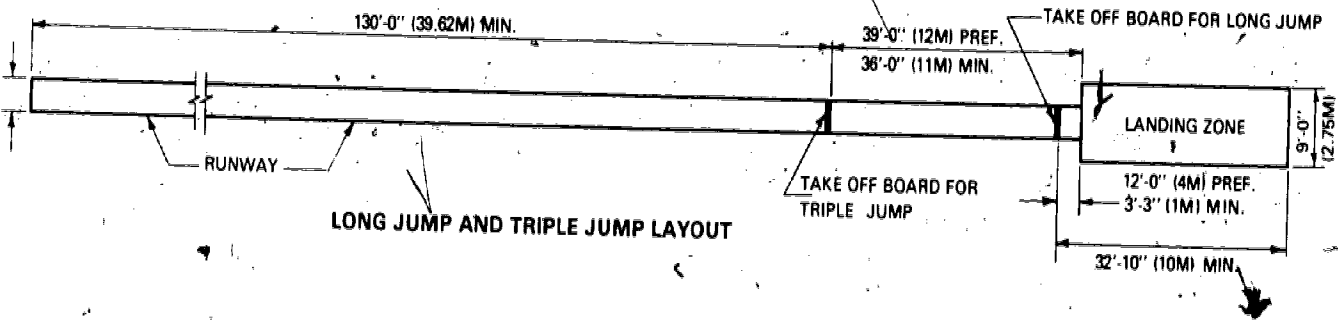

SECTION - LANDING ZONE

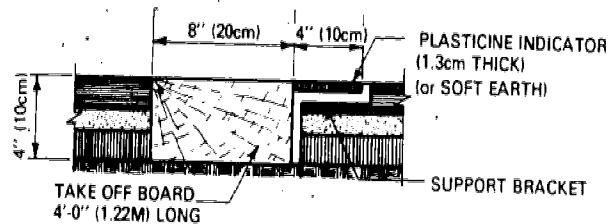

SECTION - TAKE OFF BOARD FOR LONG JUMP AND TRIPLE JUMP

NOTES:
The edge of the takeoff board nearest the landing shall be the scratch, or foul line.

The construction and material of the runway shall be extended beyond the takeoff board to the outer edge of the landing pit.

Runway surfacing details see figure 41.

LONG JUMP AND TRIPLE JUMP

FIGURE 49

POLE VAULT

NAME OF SPORTS ORGANIZATION

National Collegiate Athletic Association, (NCAA), 1974.

RECOMMENDED AREA

Ground space is 1500 square feet minimum.

SIZE AND DIMENSION

Runway length is 125'-0" (38.10M) minimum. Runway width is 4'-0" (1.22M) minimum. Vault pit width is 16'-0" (5M) minimum and depth is 12'-0" (3.66M) minimum to 16'-0" (5M) preferred. Height of material in jumping pit is 18" (0.46M) minimum to 36" (0.92M) preferred, with a connecting apron of the same material and decreasing height around the vaulting box.

ORIENTATION

Preferred orientation is for the running direction to be toward the north to east-northeast.

SURFACE AND DRAINAGE

Runway preferably is to be bituminous material with a hot plant cushion course mix and optional protective colorcoating.

Maximum slope is to be one percent (1:100) laterally and one tenth of one percent (1:1000) in the running direction.

SPECIAL CONSIDERATIONS

Pole vault box must be immovably fixed in the ground with its entire front edge flush with the front edge of the jumping pit.

Jumping pit is to be filled with a resilient sponge-like rubber or other synthetic material.

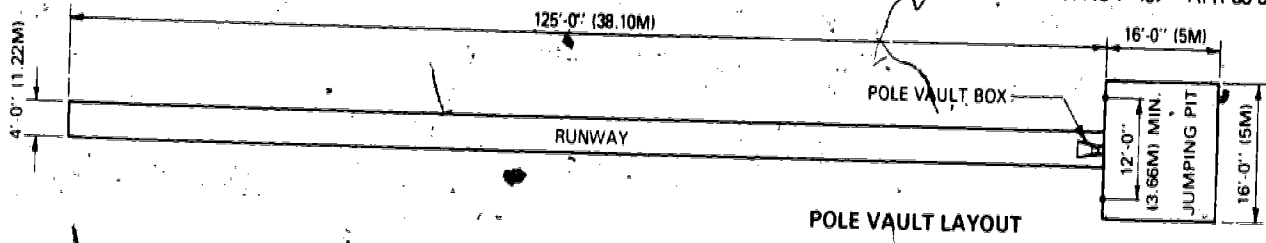

TO BE FILLED WITH FOAM RUBBER PADS, SHAVINGS OR SIMILAR MATERIAL, WITH FILTER CASE IF NEEDED FOR DRAINAGE

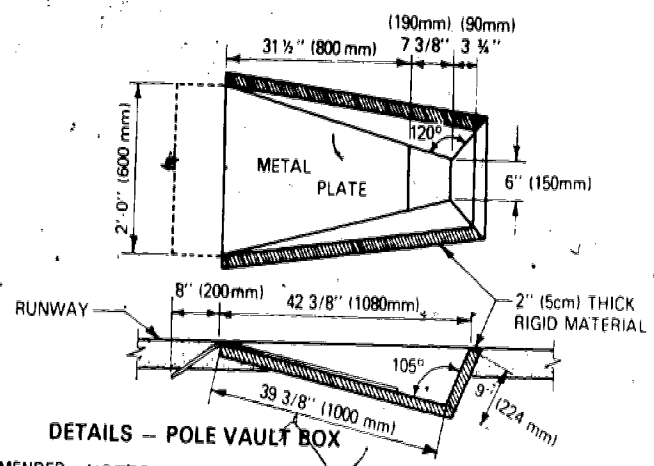
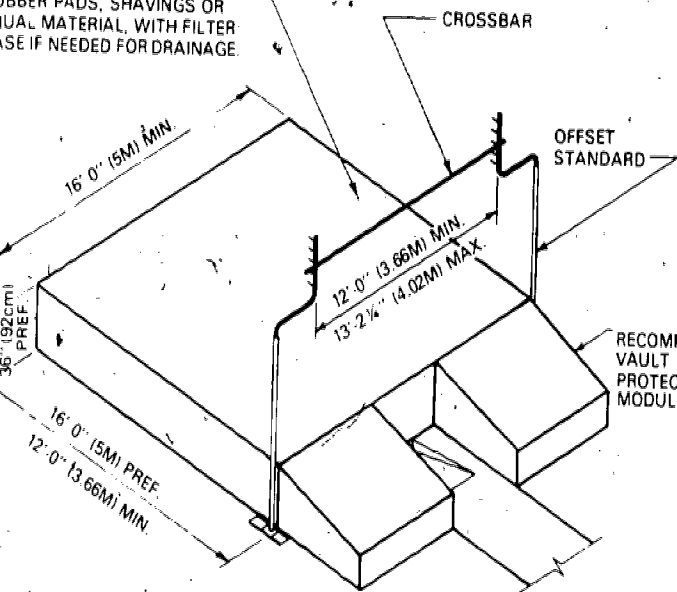

DETAILS - POLE VAULT BOX

NOTES:

Any style of uprights or standards may be used, provided they are rigid and supported by a base not to exceed 4" in height above the ground.

The crossbar shall rest on round pins which project not more than 3" (75mm) at right angles from the uprights and have a max. dia. of 1/2" (12mm).

The crossbar shall be of wood or metal and triangular or circular in section with flat ends.

Each side of the triangular bar shall measure 1.181 in. (30mm) and the diameter of the circular bar shall be .984 in. (25mm) MIN., 1.181 in. (30mm) MAX. Length shall be 12'-8" (3.8cm) MIN., 14'-10" (4.52M) MAX.

For runway surfacing details see figure 41.

ISOMETRIC SHOWING JUMPING PIT, STANDARDS AND CROSSBAR

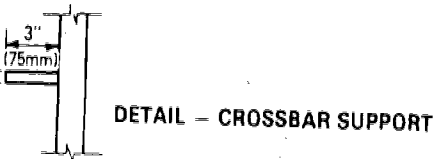

HIGH JUMP

NAME OF SPORTS ORGANIZATION

National Collegiate Athletic Association, (NCAA), 1974.

RECOMMENDED AREA

Ground space is 4000 square feet minimum.

SIZE AND DIMENSION

High jump runway is 50' (15.24M) radius semi-circle. High jump pit width is 16' (5M) by 8' (2.5M) depth minimum. Height of material in jumping pit is 12" (0.30M) minimum. Take-off area is 10'-0" (3M) radius semi-circle with centerpoint directly under center of crossbar, and no point within this area may be higher than point of measurement.

ORIENTATION

Preferred orientation is for the direction of jumping to be toward the north to east-northeast.

SURFACE AND DRAINAGE

Runway preferably is to be constructed of bituminous material with an optional synthetic surface.

Surface should be level and unvarying within its arc of 180°.

SPECIAL CONSIDERATIONS

Jumping pit is to be filled with a resilient sponge-like rubber or other synthetic material.

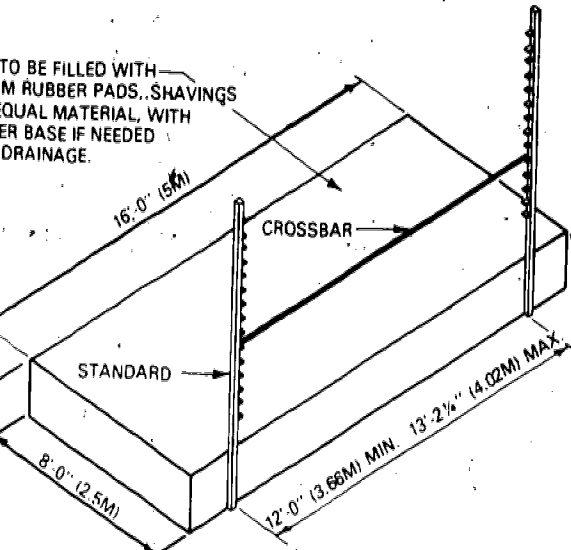

METRIC SHOWING JUMPING PIT, STANDARDS AND CROSSBAR

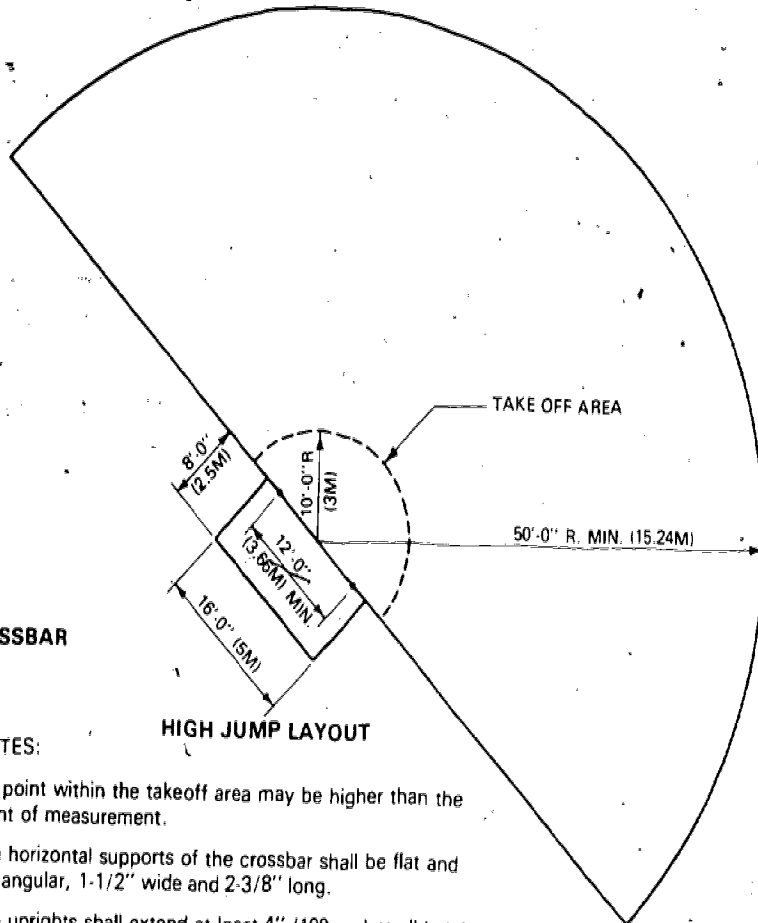

HIGH JUMP LAYOUT

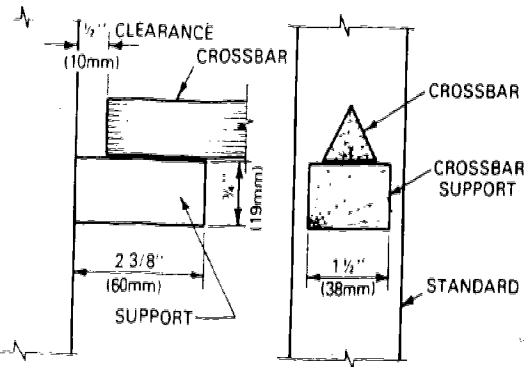

CROSSBAR SUPPORT DETAILS

NOTES:

No point within the takeoff area may be higher than the point of measurement.

The horizontal supports of the crossbar shall be flat and rectangular, 1-1/2" wide and 2-3/8" long.

The uprights shall extend at least 4" (100mm) at all heights above the crossbar.

The crossbar shall be of wood or metal and triangular or circular in section with flat ends.

Each side of the triangular bar shall measure 1.181 inches (30mm) and the diameter of the circular bar shall be .984-.984 in. (25mm) MIN. or 1.181 in. (30mm) MAX.

For surfacing details see figure 41.

TM 5-803-10 / NAVFAC P-457 / AFR 88-33

2-4

2-105

MULTIPLE SPORTS

153

COMBINATION BASKETBALL-VOLLEYBALL COURTS

NAME OF SPORTS ORGANIZATION

Basketball-National Collegiate Athletic Association, (NCAA), 1974.
Volleyball-United States Volleyball Association, (USVA), 1974.

RECOMMENDED AREA

Ground space is 9,120 square feet for one basketball and two volleyball courts.

SIZE AND DIMENSION

Overall length is 114'-0". Overall width is 80'-0".

ORIENTATION

Preferred orientation is for the long axis of the court(s), which is (are) expected to have primary use, to be north-south.

SURFACE AND DRAINAGE

Surface is to be preferably bituminous material with optional protective colorcoating.

Drainage is to be end to end, side to side or corner to corner diagonally at a minimum slope of 1" in 10'.

SPECIAL CONSIDERATIONS

Removable post with flush mounted deck plate must be used for the center volleyball net post to allow unobstructed use of the basketball court.

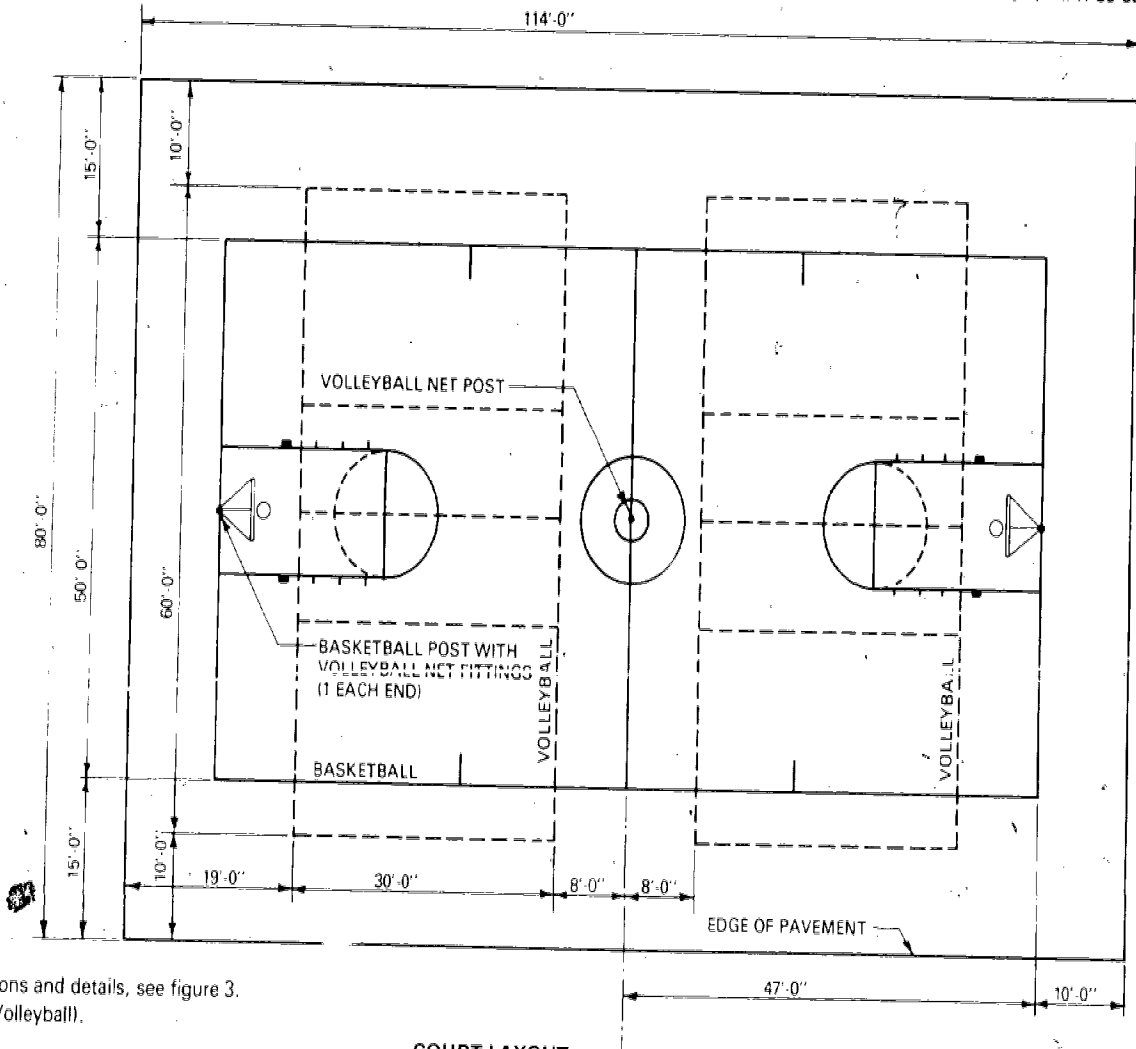

NOTES:

For individual court dimensions and details, see figure 3. (Basketball) and figure 21 (Volleyball).

For surfacing details see figure 70.

For removable volleyball net post details see figure 65.

COURT LAYOUT

ONE BASKETBALL AND TWO VOLLEYBALL COURTS

FIGURE 52

15

TENNIS, VOLLEYBALL, BASKETBALL, BADMINTON COURTS

NAME OF SPORTS ORGANIZATION

Basketball-National Collegiate Athletic Association, (NCAA), 1974. Volleyball-United States Volleyball Association, (USVA), 1974. Badminton-American Badminton Association (ABA), 1972-73. Tennis-United States Lawn Tennis Association, (USLTA), 1974.

RECOMMENDED AREA

Ground space is 21,720 square feet for four tennis courts with one basketball, one volleyball and one badminton court superimposed thereon.

SIZE AND DIMENSION

Overall length is 206'-0". Overall width is 120'-0".

ORIENTATION

Preferred orientation is for the long axis of all courts to be north-south.

SURFACE AND DRAINAGE

Surface is to be bituminous material with optional protective colorcoating.

Drainage is to be end to end, side to side or corner to corner diagonally at a minimum slope of 1" in 10'.

SPECIAL CONSIDERATIONS

Special provisions must be made to allow the various net posts to be erected for different court games.

Fencing should be provided 10'-0" high on all sides.

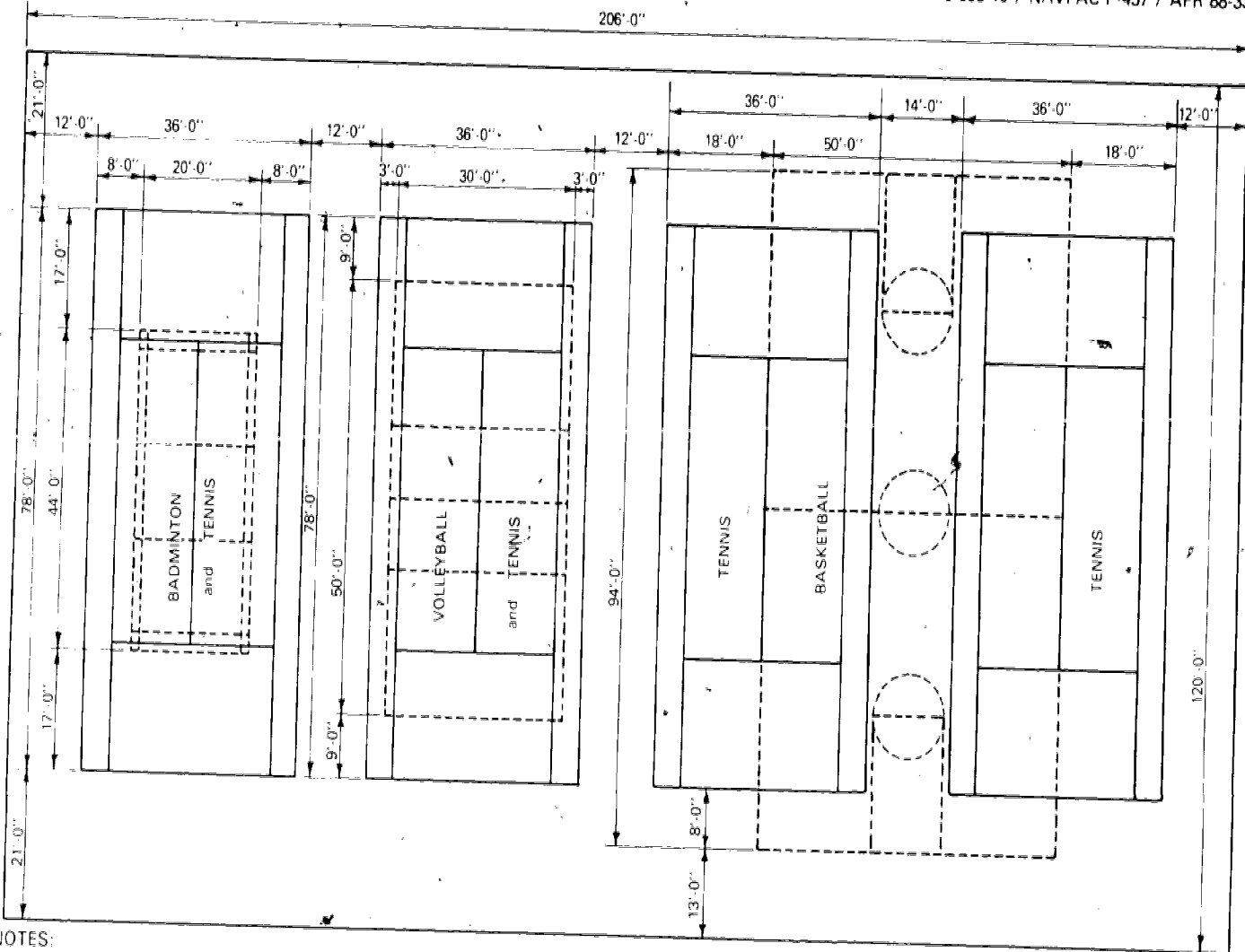

COURT LAYOUT

NOTES:
 For individual court dimensions and details see figure 1 (Badminton), figure 3 (Basketball), figure 19 (Tennis) and figure 21 (Volleyball); for fence details see figure 63.

For surfacing details see figure 70.

**FOUR TENNIS COURTS WITH ONE BASKETBALL
 ONE BADMINTON AND ONE VOLLEYBALL COURT**

13

13

MULTIPLE RECREATION COURT

NAME OF SPORTS ORGANIZATION

Basketball-National Collegiate Athletic Association, (NCAA), 1974. Volleyball-United States Volleyball Association, (USVA), 1974. Tennis-United States Lawn Tennis Association, (USLTA), 1974. Shuffleboard-National Shuffleboard Association, (NSA), 1974.

RECOMMENDED AREA

Ground space is 9,840 square feet.

SIZE AND DIMENSION

Overall length is 120'-0". Overall width is 82'-0".

ORIENTATION

Preferred orientation is for the long axis of the court(s), which is(are) expected to have primary use, to be north-south.

SURFACE AND DRAINAGE

Surface is to be bituminous material with optional protective colorcoating or Portland Cement concrete (PCC), except that shuffleboard courts must be concrete.

Preferred drainage is from end to end at a slope of 1" in 10' with the 12'-0" areas on each end to be level for the shuffleboard courts.

SPECIAL CONSIDERATIONS

Removable posts with flush mounted deck plates must be used for tennis and volleyball to allow unobstructed use of other courts.

Fencing should be provided 10'-0" high on all sides.

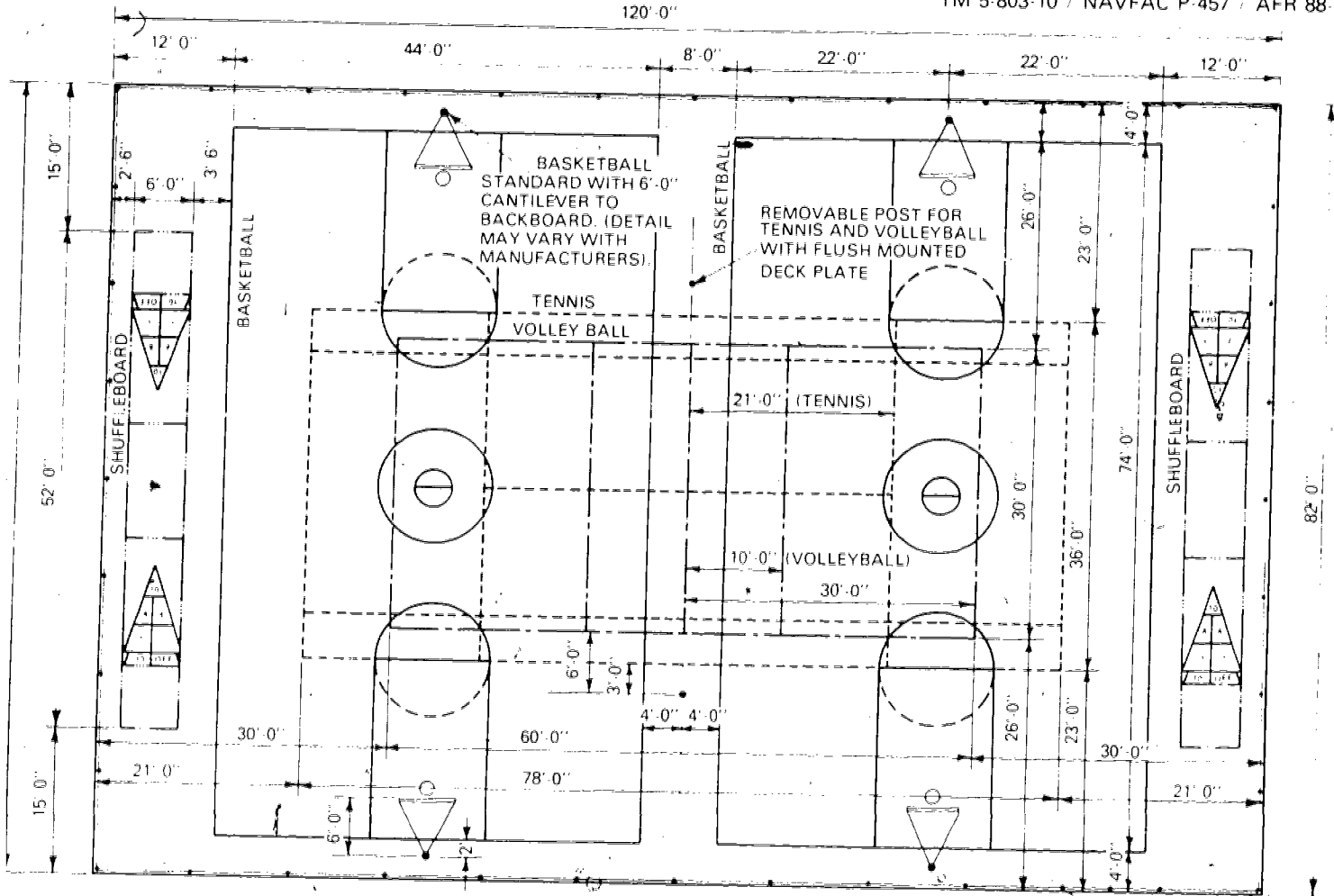

NOTES: COURT LAYOUT

For individual court dimensions and details see figure 3 (Basketball), figure 18 (Shuffleboard), figure 19 (Tennis) and figure 21 (Volleyball); for fence details see figure 63. For drainage details see figure 55; for surfacing details see figure 70. For removable net post details see figure 65.

TYPICAL GATE SECTION (LOCATION OPTIONAL DEPENDING ON SITE CONDITIONS).

MULTIPLE RECREATION COURT

FIGURE 54

2 - 111 (next page is 2 - 113)

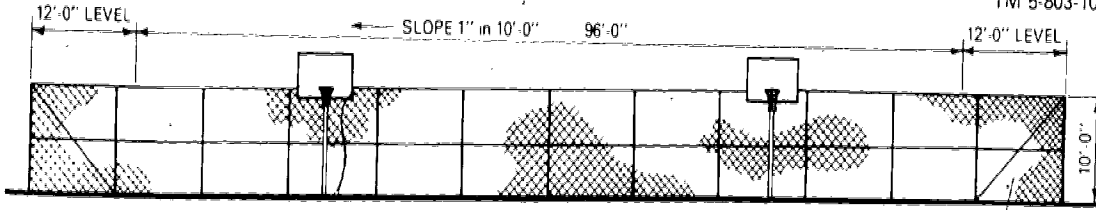

LONGITUDINAL SECTION - ELEVATION (END TO END MODIFIED DRAINAGE)

NOTE (see figure 54):

- Color key for painted court lines
- Basketball Light Green
 - Tennis White
 - Volleyball Yellow
 - Shuffleboard Black

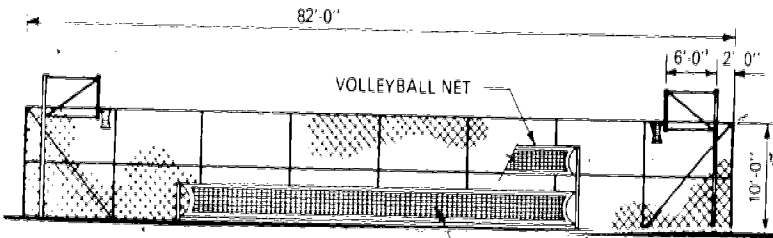

CROSS SECTION - ELEVATION

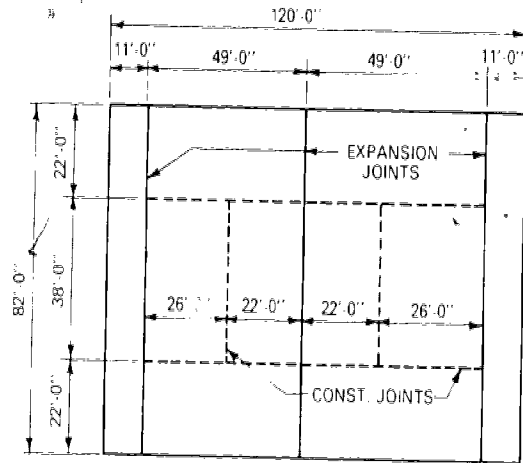

JOINT LAYOUT FOR CONCRETE CONSTRUCTION

NOTES:

- For layout details see figure 54.
- The area in which shuffleboard courts are located must be paved as an overrun for the tennis court whether or not the shuffleboard courts are installed; end to end modified drainage scheme must be used if they are installed.

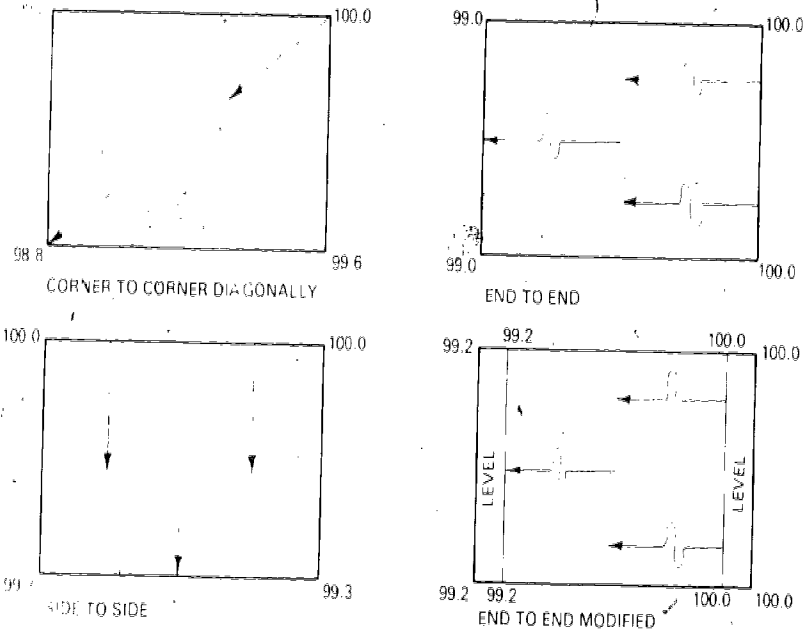

DRAINAGE DIAGRAMS

COMBINATION BASEBALL, FOOTBALL, SOFTBALL FIELDS

NAME OF SPORTS ORGANIZATION

Baseball-The Official Playing Rules Committee, Official Baseball Rules, 1974.

Softball-Amateur Softball Association of America (ASA). Touch and Flag

Football-National Touch and Flag Football Rules-The Athletic Institute.

Football, 11 man-National Collegiate Athletic Association (NCAA).

RECOMMENDED AREA

Varies with number of fields and configuration.

SIZE AND DIMENSION

Varies with number of fields and configuration.

ORIENTATION

Preferred orientation varies when combinations are used. Selection for priority should be based on anticipated use, time of play, and local site conditions.

SURFACE AND DRAINAGE

Surface is to be turf.

Drainage is to be provided following guidelines for individual sports.

SPECIAL CONSIDERATIONS

Safety aspects of each sport or field must not be compromised when multi-use concepts are employed.

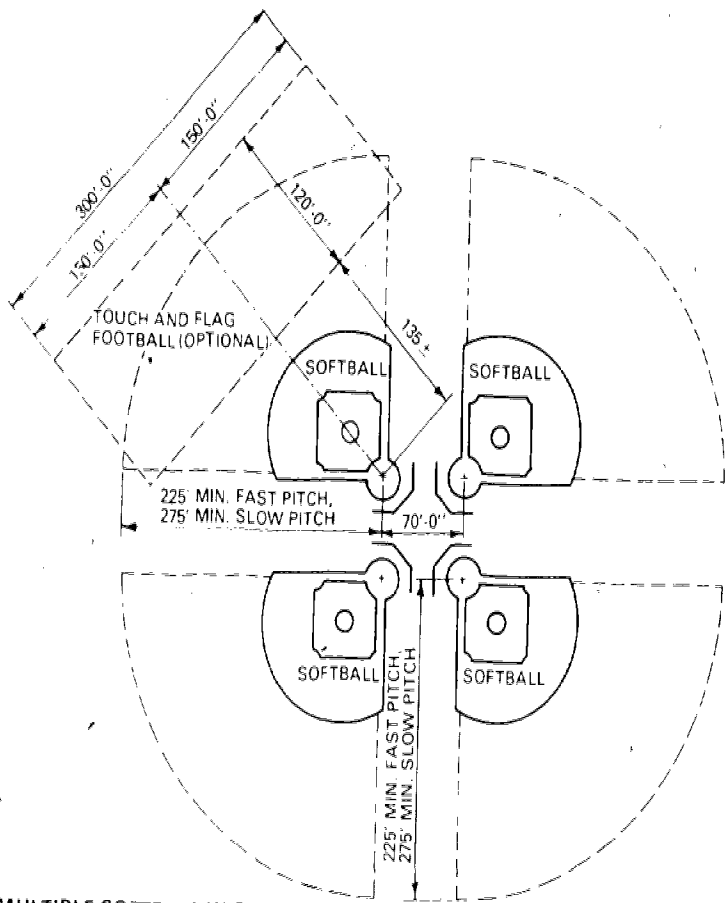

MULTIPLE SOFTBALL WITH OPTIONAL TOUCH AND FLAG FOOTBALL

NOTES:

For individual field dimensions and details see figure 22 (Baseball), figure 29 (Football), figure 30 (Touch and Flag Football) and figure 36 (Softball).

For grading and drainage details see figure 69.

For surfacing details see figure 70.

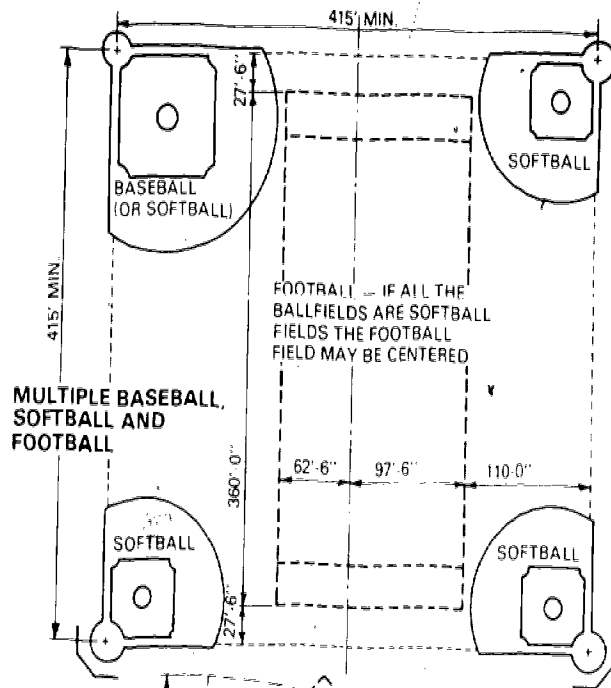

MULTIPLE BASEBALL, SOFTBALL AND FOOTBALL

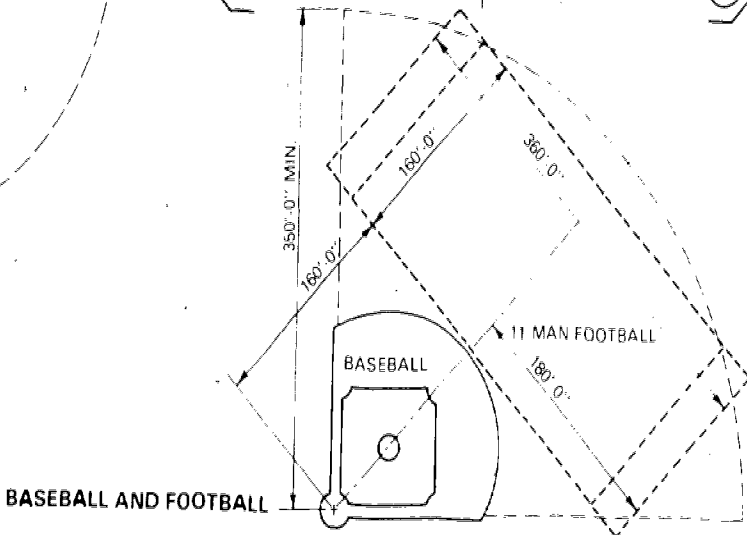

BASEBALL AND FOOTBALL

COMBINATION BALLFIELDS

FIGURE 56

ATHLETIC BALLFIELDS WITHIN ¼ MILE RUNNING TRACK

NAME OF SPORTS ORGANIZATION

¼ Mile Running Track-National Collegiate Athletic Association (NCAA).
Football-National Collegiate Athletic Association (NCAA). Soccer-National
Collegiate Athletic Association (NCAA).

RECOMMENDED AREA

Ground space is 4.0 acres.

SIZE AND DIMENSION

Overall length is 600.02'. Overall width is 276.00'.

ORIENTATION

The long axis of the complex should be so oriented that it runs north-south
to northwest-southeast.

SURFACE AND DRAINAGE

Track surface is to be preferably bituminous with optional synthetic surface.

Ballfields are to be turf.

Ballfields should be crowned for drainage.

Track should pitch inward at one percent (1:100) maximum slope.

SPECIAL CONSIDERATIONS

A system of underdrains and/or storm water sewers must be provided to
accommodate surface runoff.

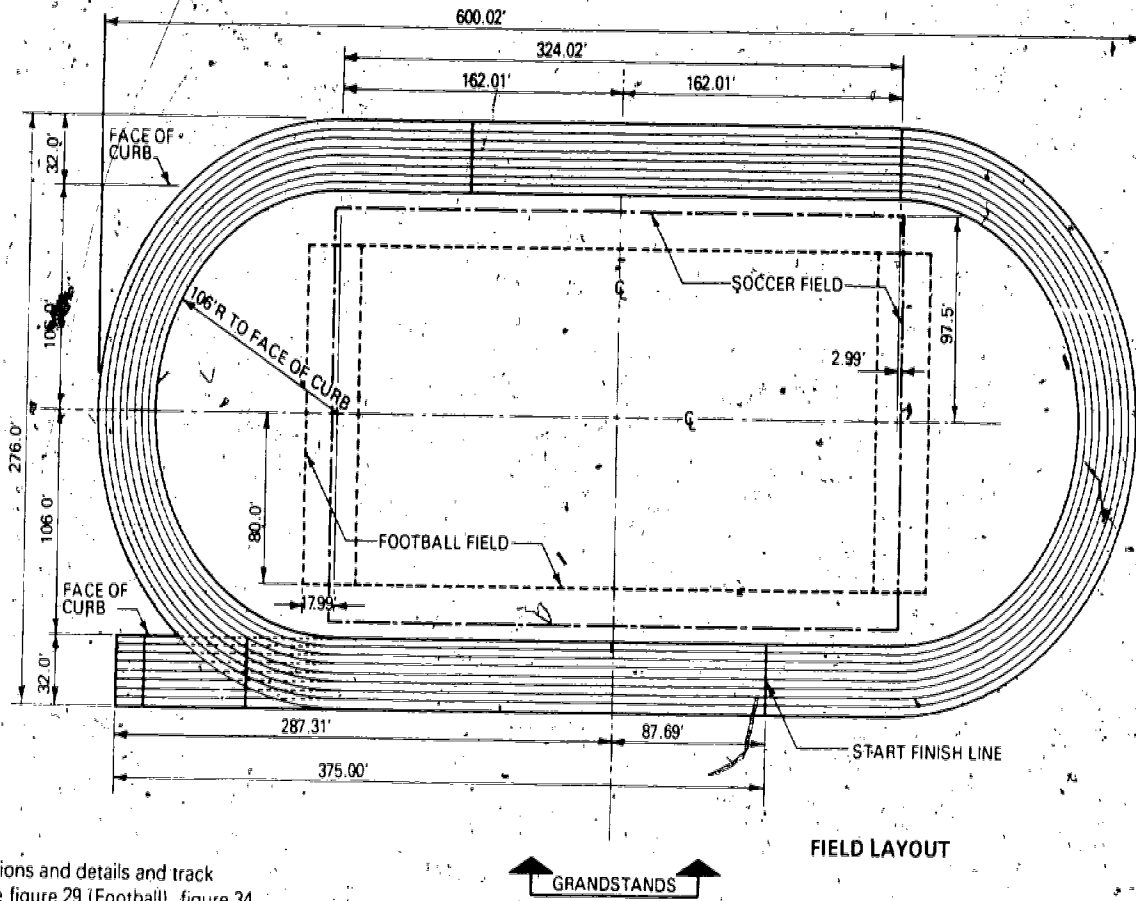

NOTES:

For individual field dimensions and details and track dimensions and details see figure 29 (Football), figure 34 (Soccer) and figures 40, 41, 42, 43 and 44 (1/4 Mile Running Track Layout).

For grading and drainage details see figure 69.

For surfacing details see figure 70.

BALLFIELDS WITHIN RUNNING TRACK

FIGURE 57

173

174

SECTION 3 RECREATION SHOOTING RANGES

3-1

173

ARCHERY, TARGET RANGE

NAME OF SPORTS ORGANIZATION

National Archery Association, (NAA), 1974.

RECOMMENDED AREA

Ground space is 28,600 square feet minimum (.65 acre).

SIZE AND DIMENSION

Shooting range is 300'-0" long by 10'-0" wide minimum, 15'-0" desirable, between targets. Roped clear space on each side of range is 30'-0" minimum. Roped clear space behind targets should be at least 90'-0" (45'-0" with bunker).

ORIENTATION

Range should be located so that the archer is facing north $\pm 45^\circ$.

SURFACE AND DRAINAGE

Surface is to be turf and free from obstructions or hard objects.

Drainage is to be preferably from side to side to maintain a constant, relatively level, elevation between the target and the archer at the various shooting distances.

SPECIAL CONSIDERATIONS

Target is to be provided as prescribed for official competition.

Conspicuous signs should be provided to the side and rear to warn people of the range.

NOTES:

Space behind and to either side of the range to be clear and free from hard objects.

Background behind targets to be preferably dense trees, natural or manmade hills or protective shields.

Range to be sited on fairly level land, free from obstructions, preferably sheltered from high winds and oriented to north $\pm 45^\circ$.

Standard rounds for adults, 30 - 100 yards.

Standard rounds for juniors, 20 - 50 yards.

Target may be mounted on a round butt of spirally sewn straw or rush supported by a portable soft wood target stand. Colors may be painted on an oilcloth cover.

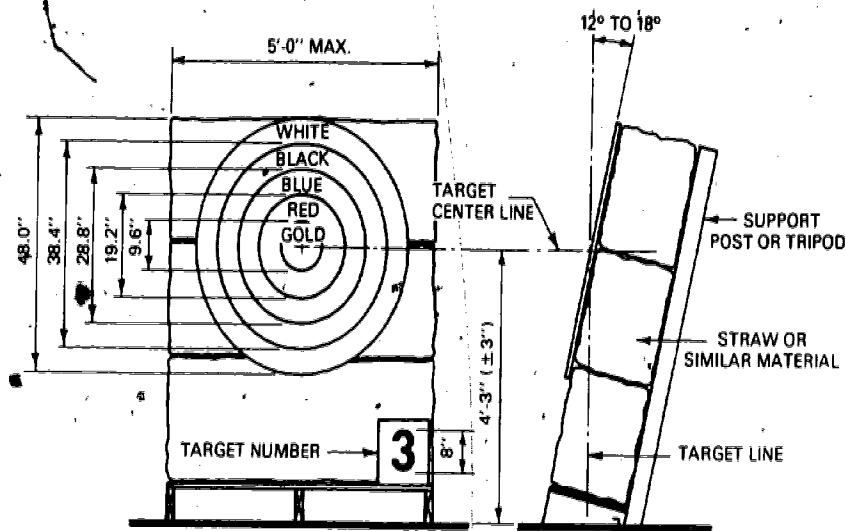

TARGET DETAILS

ROPED CLEAR SPACE BEHIND TARGETS

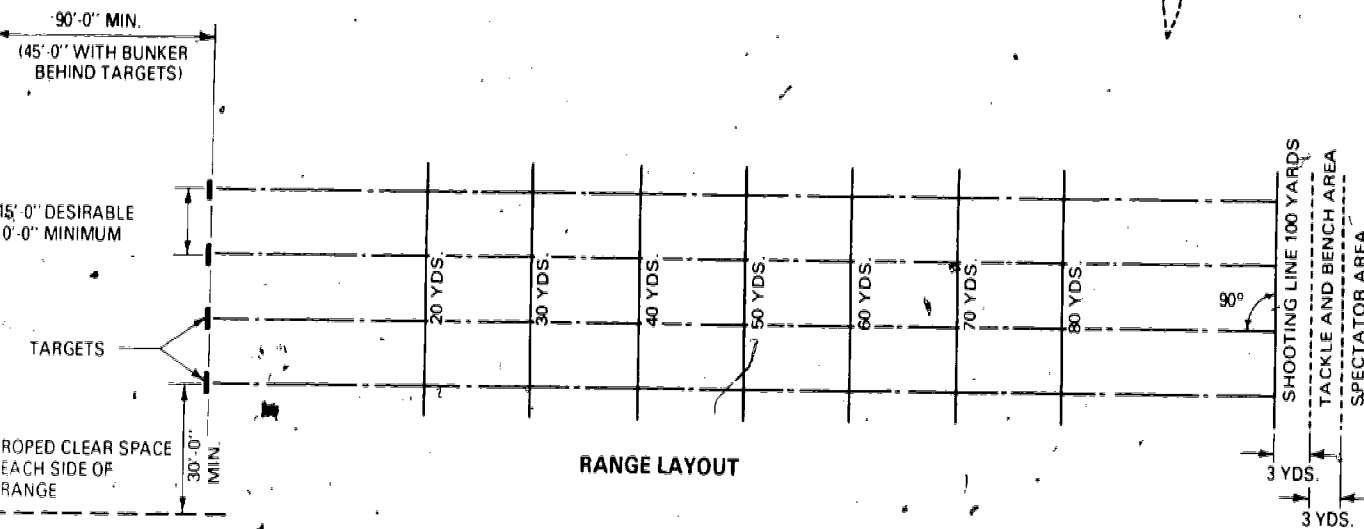

RANGE LAYOUT

ARCHERY, TARGET RANGE

FIGURE 58

INTERNATIONAL SHOOTING UNION AUTOMATIC TRAP

NAME OF SPORTS ORGANIZATION

National Rifle Association, (NRA).

RECOMMENDED AREA

Allow 15 acres for a single field.

SIZE AND DIMENSION

Walks and structure occupy an overall area approximately 60' deep by 45' wide.

Shooting stations may be 36" to 40" square.

ORIENTATION

Preferred orientation is for the center line through shooting station #3 to run northeast-southwest with the shooter facing northeast.

SURFACE AND DRAINAGE

Shooting stations are to be Portland cement concrete (PCC). Walkways may or may not be paved. Shooting area and 75 to 82 yard radius minimum cleared area are to be turf. The 300 yard radius shotfall danger zone outside of the cleared area may be turf, water or left in natural condition, and the entire field should be located in a relatively flat area with an open background.

SPECIAL CONSIDERATIONS

If shooting is entirely over land there should be safety provisions for fencing, posting of warning signs and clearing away of concealing brush.

If shooting is over water, warnings posted on buoys or other signs are required and the trap house should be back far enough from the water's edge to permit recovery of unbroken targets. The trap house roof must be on the same level as the shooting stations.

Contact the National Rifle Association for information on trap house construction and trap machines.

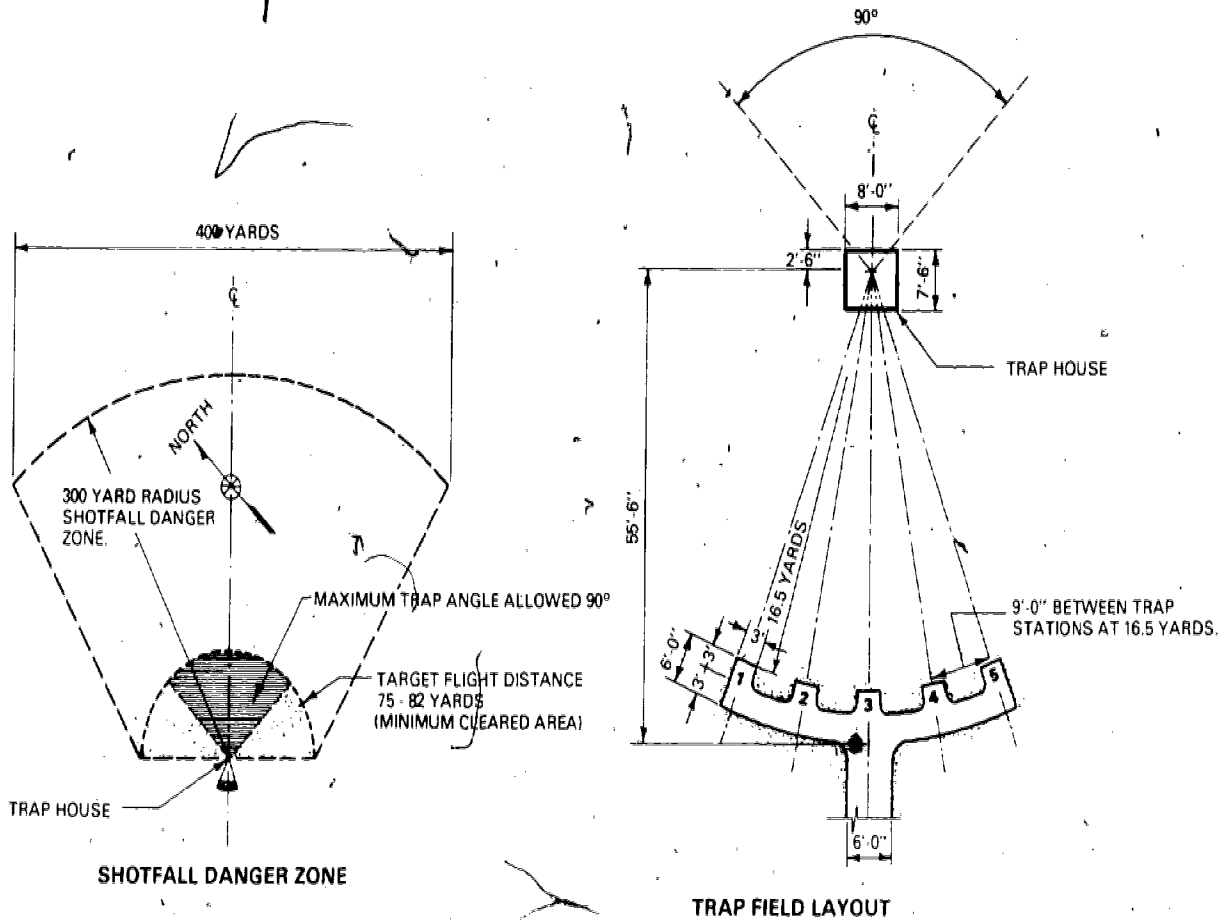

3-5

I.S.U. AUTOMATIC TRAP

FIGURE 59

180

181

SKEET FIELD

NAME OF SPORTS ORGANIZATION

National Skeet Shooting Association, (NSSA), 1974.

RECOMMENDED AREA

Allow 29 acres for a single field. Shotfall danger zones of adjacent fields partially overlap and require only 2 acres additional land.

SIZE AND DIMENSION

Walks and structures occupy an area approximately 130' wide by 80' deep. Minimum cleared area is a semi-circle with a radius of 100 yards (3.25 acres). Shotfall danger zone is a semi-circle with a radius of 300 yards (29 acres).

ORIENTATION

Preferred orientation is for the center line from station #4 through station #8 to run northeast-southwest with the shooter facing northeast.

SURFACE AND DRAINAGE

Shooting stations are to be Portland cement concrete (PCC). Walkways may or may not be paved. Shooting area and 100 yard radius minimum cleared area are to be turf. The 300 yard radius shotfall danger zone may be turf, water or left in natural condition, and the entire field should be located in a relatively flat area with an open background.

SPECIAL CONSIDERATIONS

If shooting is entirely over land, there should be safety provisions for fencing, posting of warning signs and clearing away of concealing brush.

If shooting is over water, warnings posted on buoys or other signs are required, and skeet houses should be back far enough from the water's edge to permit recovery of unbroken targets.

Contact the National Rifle Association for information on skeet house construction and trap machines.

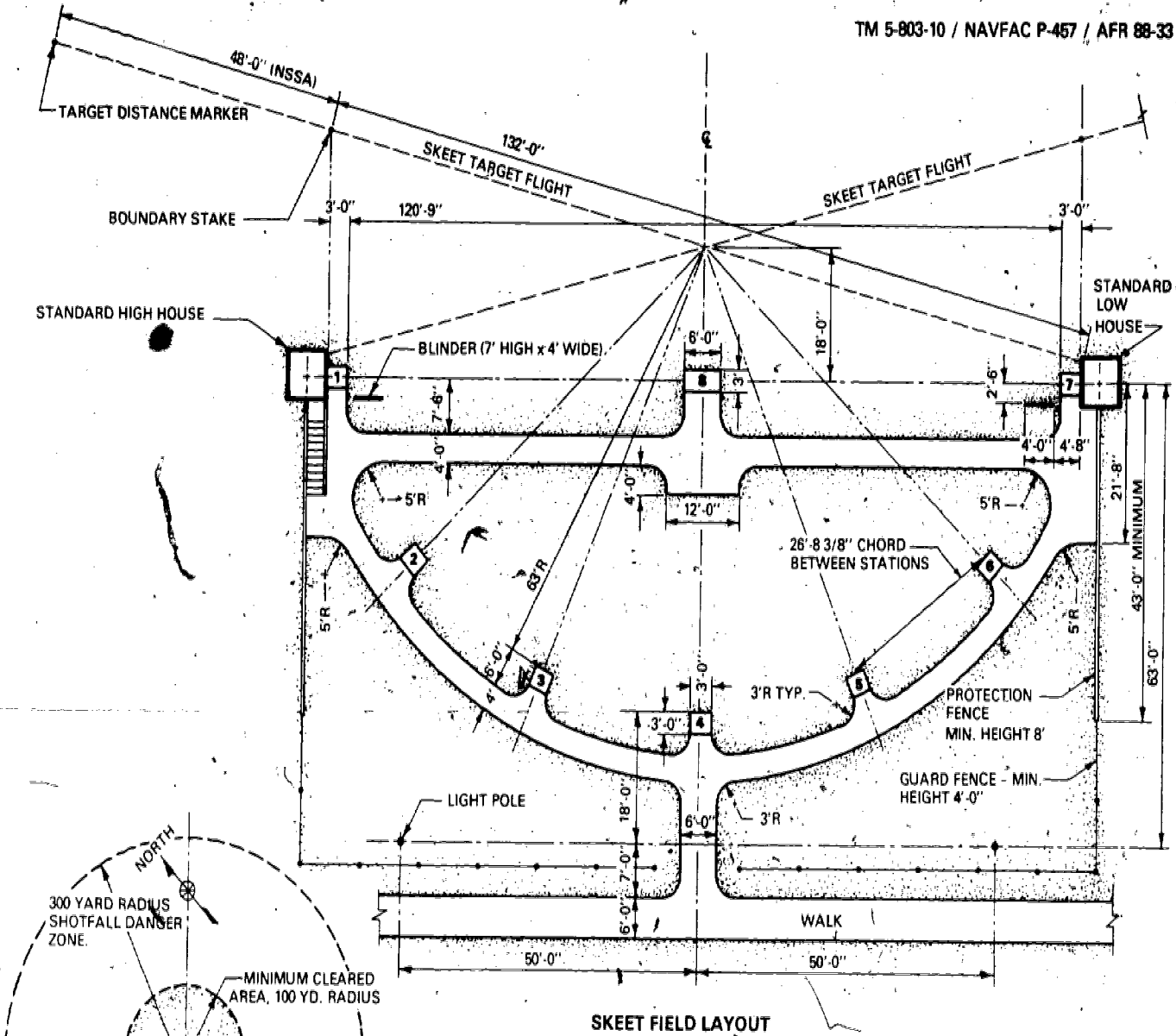

SKEET FIELD LAYOUT

SKEET FIELD
FIGURE 60

TRAP FIELD

NAME OF SPORTS ORGANIZATION

Amateur Trapshooting Association, (ATA), 1974.

RECOMMENDED AREA

Allow 16 acres for a single field. Shotfall danger zones of adjacent fields partially overlap and require only 3 acres additional land.

SIZE AND DIMENSION

Walks and structures occupy an overall area approximately 100' deep by 65' wide. Minimum cleared area is a section with a radius of 100 yards (1.7 acres). Shotfall danger zone is a section with a radius of 300 yards (14.8 acres).

ORIENTATION

Preferred orientation is for the center line through shooting station #3 to run northeast-southwest with the shooter facing northeast.

SURFACE AND DRAINAGE

Shooting stations are to be Portland cement concrete (PCC). Walkways may or may not be paved. Shooting area and 100 yard radius minimum cleared area are to be turf. The 300 yard radius shotfall danger zone may be turf, water or left in natural condition, and the entire field should be located in a relatively flat area with an open background.

SPECIAL CONSIDERATIONS

If shooting is entirely over land there should be safety provisions for fencing, posting of warning signs and clearing away of concealing brush.

If shooting is over water, warnings posted on buoys or other signs are required, and the trap house should be back far enough from the water's edge to permit recovery of unbroken targets.

Contact the National Rifle Association for information on trap house construction and trap machines.

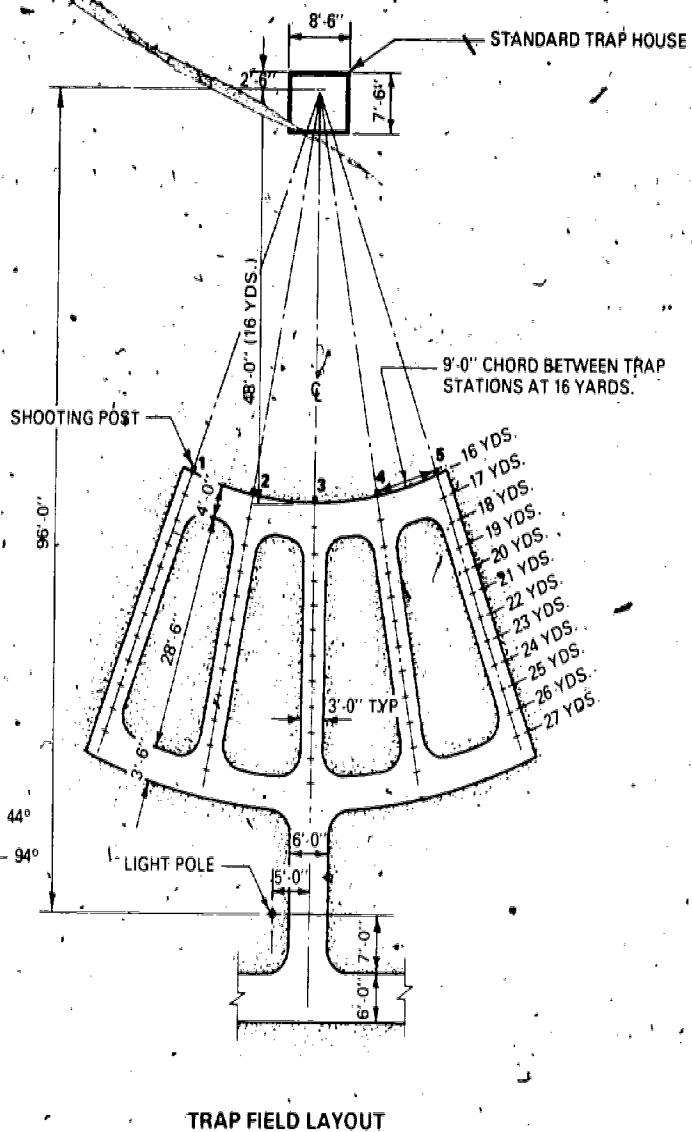
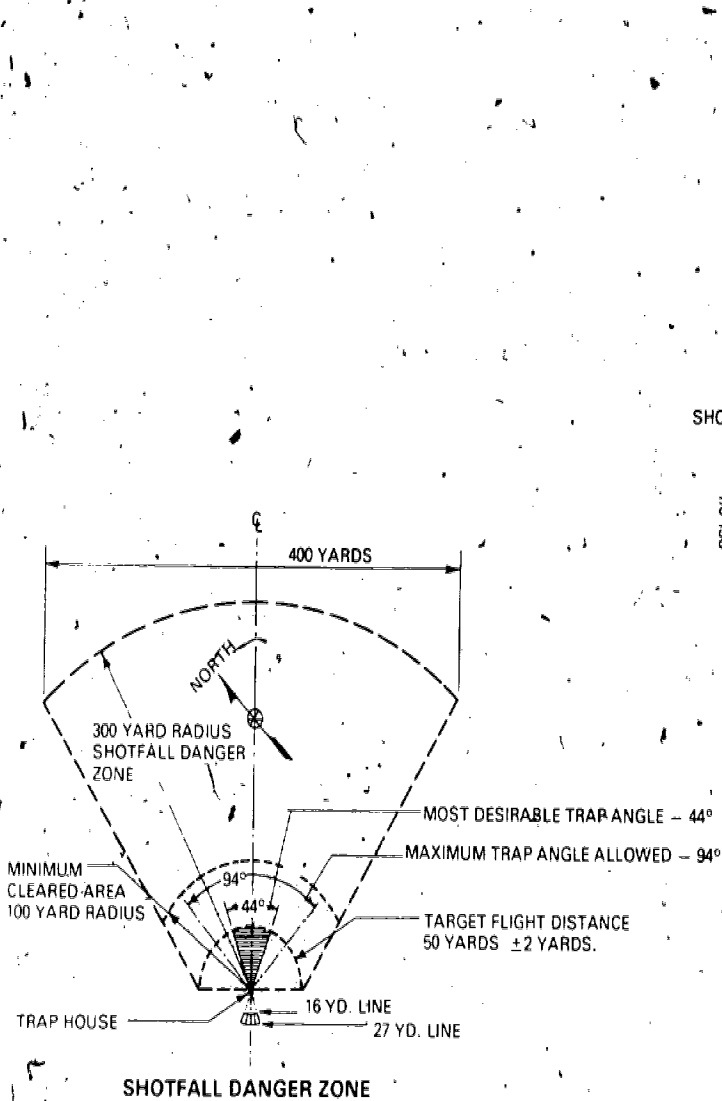

183

187

COMBINATION SKEET AND TRAP FIELDS

NAME OF SPORTS ORGANIZATION

Skeet-National Skeet Shooting Association (NSSA). Trap-Amateur Trap-shooting Association (ATA).

RECOMMENDED AREA

Allow 30 acres for a combination field.

SIZE AND DIMENSION

All walks and structures occur within an area approximately 130' wide by 115' deep. Minimum cleared area is contained within two superimposed segments with 100 yard radii (4 acres). Shotfall danger zone is contained within two superimposed segments with 300 yard radii (36 acres).

ORIENTATION

Preferred orientation is for the center line from skeet station #4 through trap station #3 to skeet station #8 to run northeast-southwest with the shooter facing northeast.

SURFACE AND DRAINAGE

Shooting stations are to be Portland cement concrete (PCC). Walkways may or may not be paved. Shooting area and minimum cleared area are to be turf. Shotfall danger zone may be turf, water, or left in natural condition and the entire field should be located in a relatively flat area with an open background.

SPECIAL CONSIDERATION

If shooting is entirely over land there should be safety provisions for fencing, posting of warning signs and clearing away of concealing brush.

If shooting is over water, warnings posted on buoys or other signs are required, and the trap house should be back far enough from the water's edge to permit recovery of unbroken targets.

Contact the National Rifle Association for information on skeet and trap house construction and trap machines.

NOTES:

For layout dimensions and details see figure 60 (Skeet) and figure 61 (Trap).

If paved, walks should be 4" concrete reinforced with 6" x 6", No. 6 gauge welded wire fabric or bituminous. (see figure 70).

STANDARD HIGH HOUSE

STANDARD LOW HOUSE

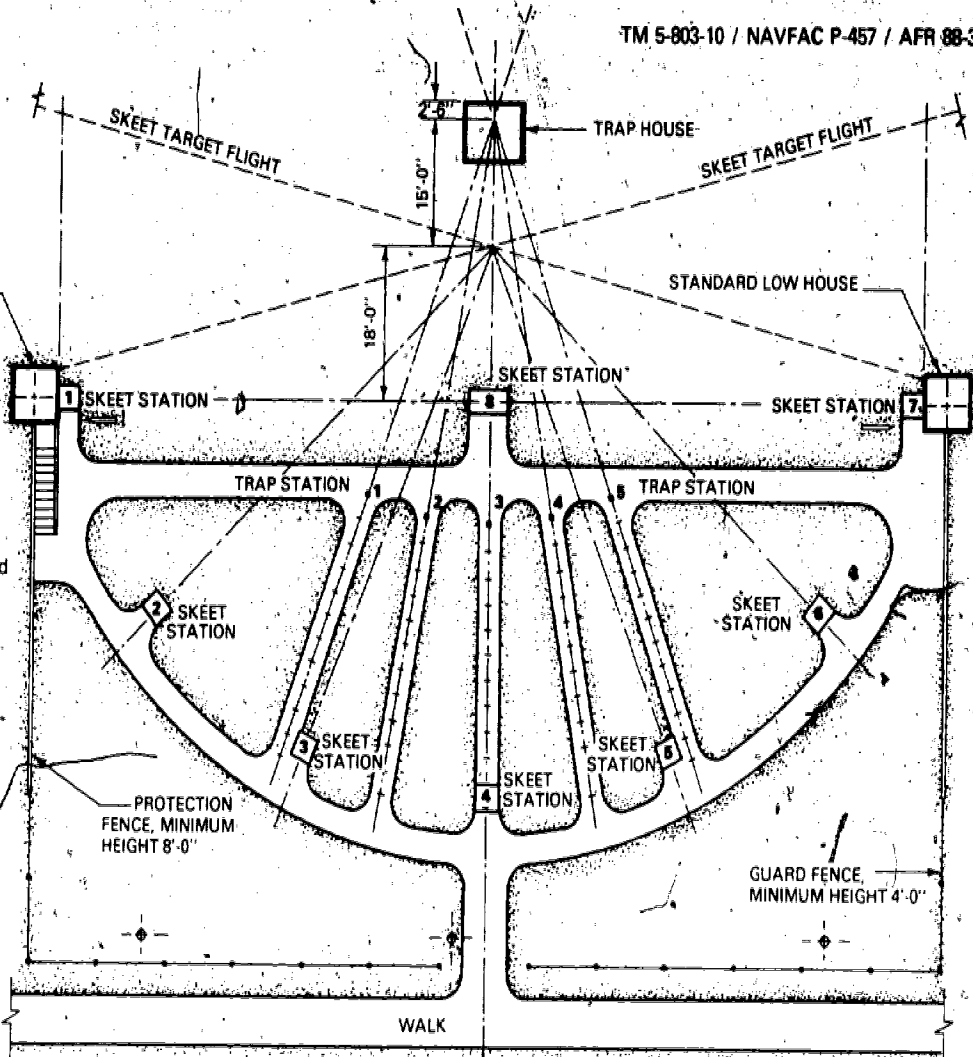

COMBINATION SKEET & TRAP FIELD LAYOUT

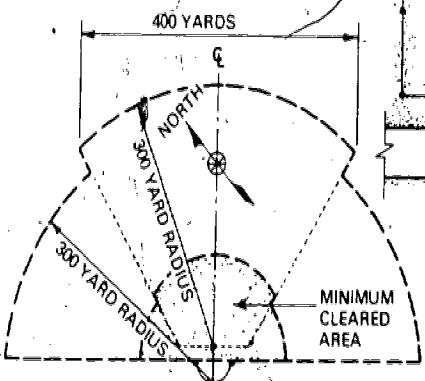

SHOTFALL DANGER ZONE

COMBINATION SKEET AND TRAP FIELDS

SECTION 4 CONSTRUCTION DETAILS

4-1

191

FENCE ENCLOSURES

Fence posts shall be a minimum of schedule 40 weight regardless of cross sectional configuration.

Fabric shall be chain link with galvanized coating per ASTM A392 or aluminized per ASTM A491, (optional polyvinyl chloride coated steel).

Reinforcing tension wire is to have a minimum tensile strength of 80,000 P.S.I.

Hog rings of .110" diameter aluminum wire shall be used to attach fabric to reinforcing tension wire 2'-0" O.C.

Tie wire of .144" diameter aluminum alloy shall be used to attach fabric to top rail and intermediate posts 14" O.C.

Tension bars of 1/4" x 3/4" or 3/16" x 3/4" galvanized steel woven through the fabric are to be fastened to terminal and gate posts with 11 gauge x 1" wide galvanized steel bands 14" O.C.

Selvage top and bottom is to be knuckled.

All ferrous metal parts are to be hot dipped galvanized or aluminized after fabrication.

Gates are to have offset hinges and a latching device that allows access to a padlocking device from both sides.

Concrete footings shall be minimum 9" diameter. Concrete shall conform to ASTM C94, maximum 3/4" aggregate, minimum 3,000 P.S.I. compressive strength (f'c) at 28 days.

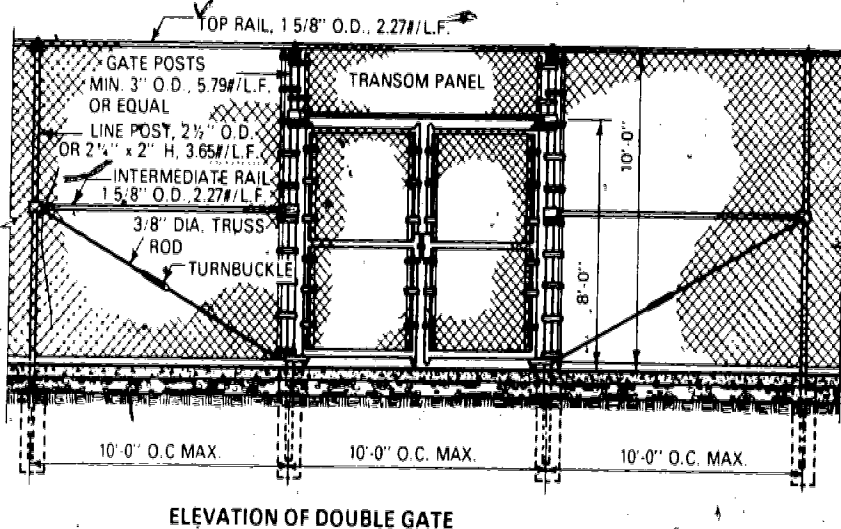
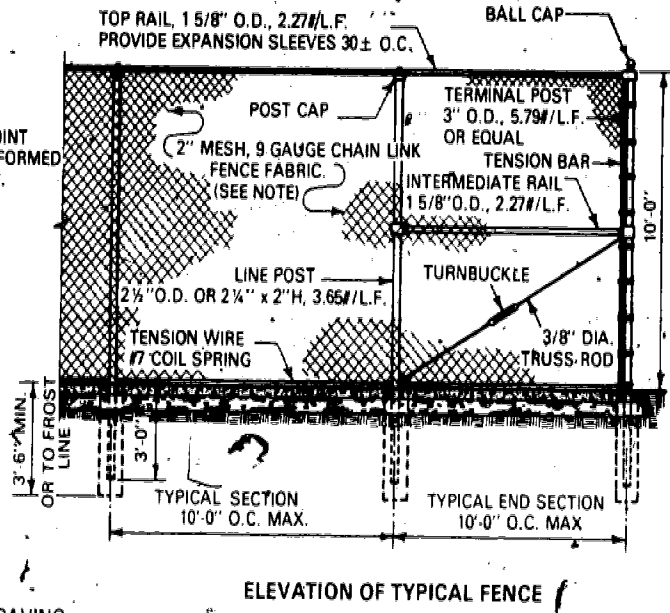
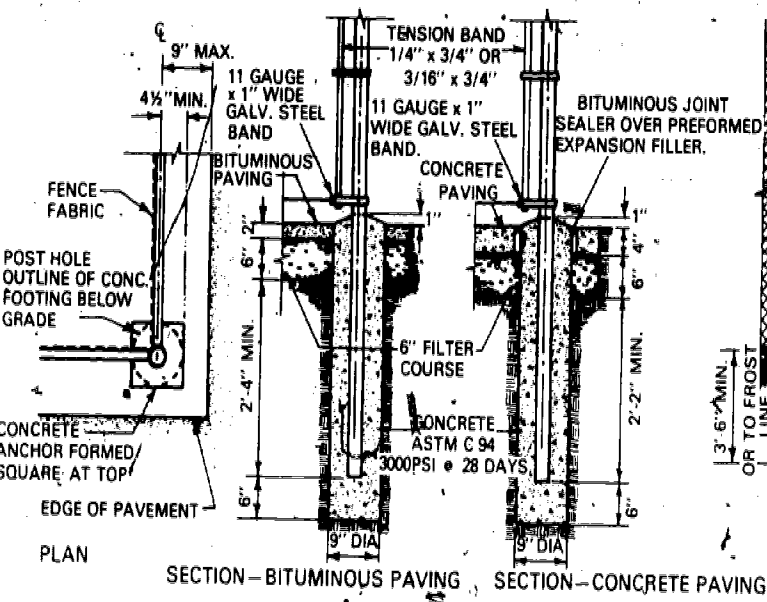

NOTES:

Layouts and details on this drawing are recommendations based on analysis of current construction techniques and manufacturers' equipment lines and should be utilized as a guideline in obtaining the appropriate product from local suppliers and manufacturers.

Double gate layout shown is for information as to type and designation.

In so far as possible, gate details shall be of the manufacturer's standard design. A single pedestrian gate may be used.

Different mesh and gauge sizes of chain link fabric are shown in notes on layout drawings for each sport.

FENCE ENCLOSURES
 FIGURE 63

193

FIXED NET POSTS

POST PIPE SIZES

Badminton, Paddle Tennis, Platform Tennis and Tennis - minimum 2.469" I.D., 2.875" O.D.

Volleyball - minimum 3.068" I.D., 3.500" O.D.

FOOTINGS

Concrete - 1'-4" minimum diameter for end posts, 8" minimum diameter for tennis anchor footing, and 4'-0" or to frost line depth. Top of concrete to slope away from post. Concrete minimum 2500#.

PIPE AND FITTINGS

All ferrous metal parts are to be hot dip galvanized or aluminized after fabrication.

PAINTING

If posts are to be painted, they should be etched with acid, primed and painted with a good exterior enamel.

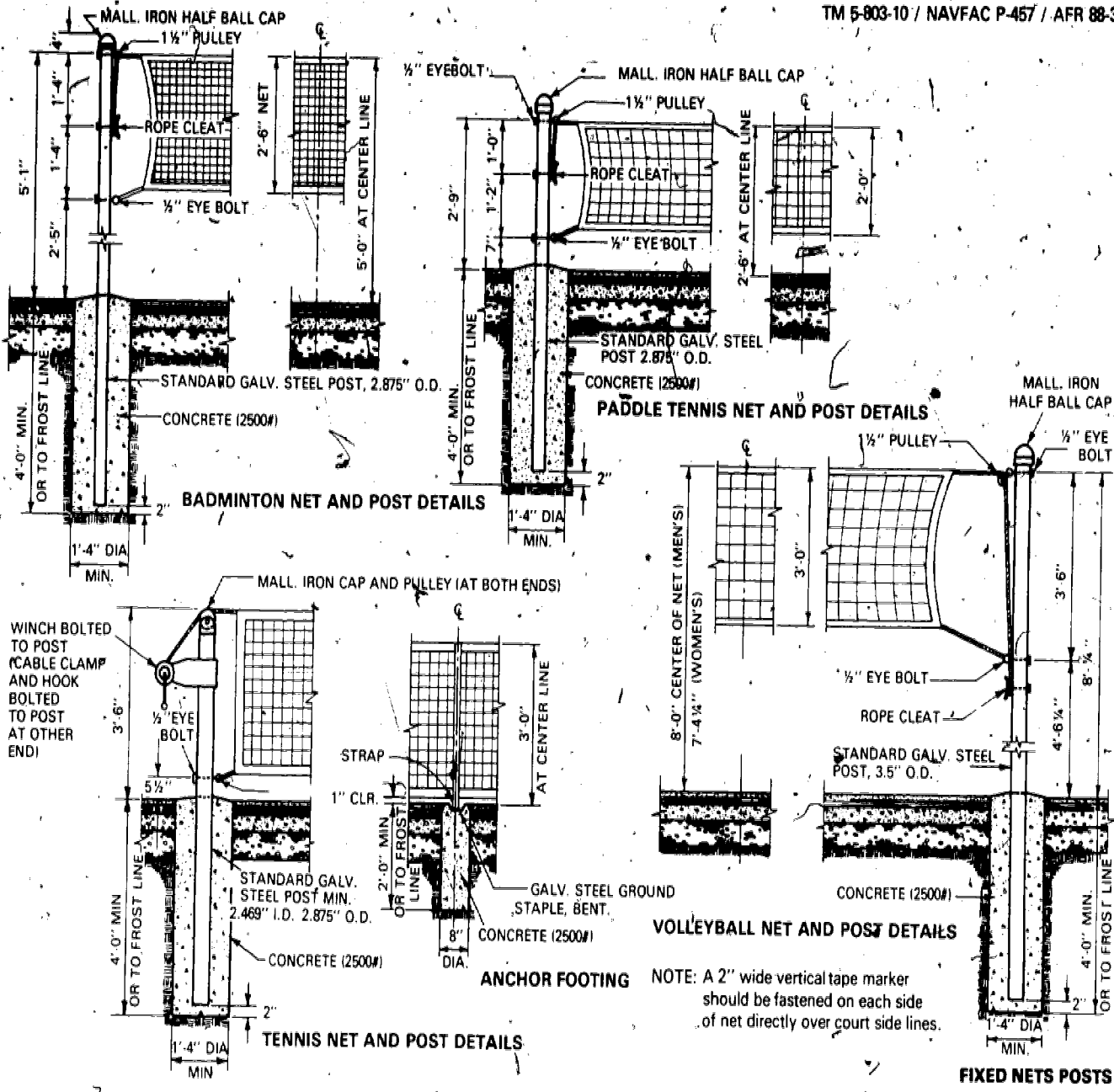

FIXED NETS POSTS

FIGURE 64

195

107

REMOVABLE NET POSTS

POST PIPE SIZES

Badminton, Paddle Tennis, Platform Tennis and Tennis - minimum 2.469" I.D., 2.875" O.D. Volleyball - minimum 3.068" I.D., 3.500" O.D.

SLEEVES

May be a commercially available product or fabricated per details on facing sheet.

FOOTINGS

Concrete - 1'-4" minimum diameter, and 4'-0" or to frost line depth. Top of concrete to slope away from post. Concrete minimum 2500#.

PIPE AND FITTINGS

All ferrous metal parts are to be hot dip galvanized or aluminized after fabrication.

PAINTING

If posts are to be painted, they should be etched with acid, primed and painted with a good exterior enamel.

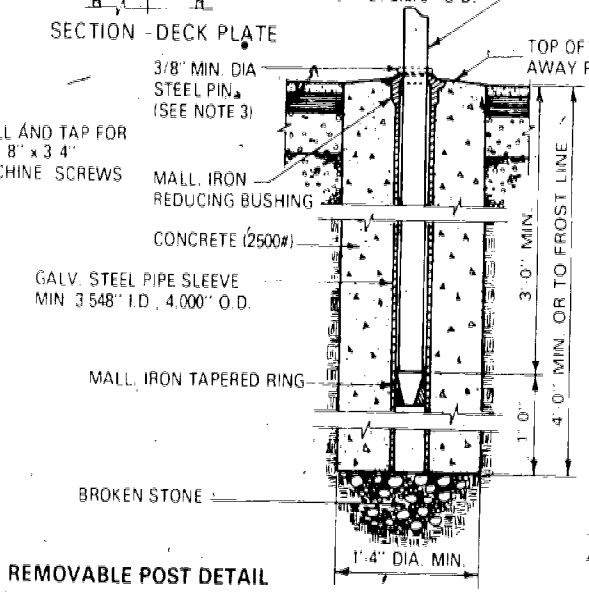
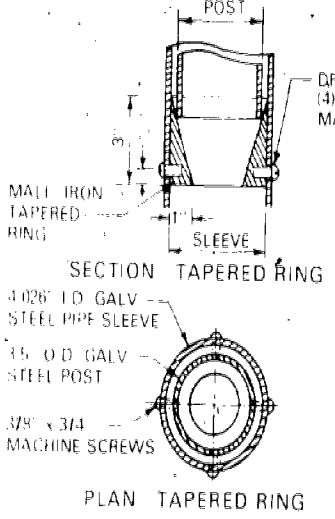
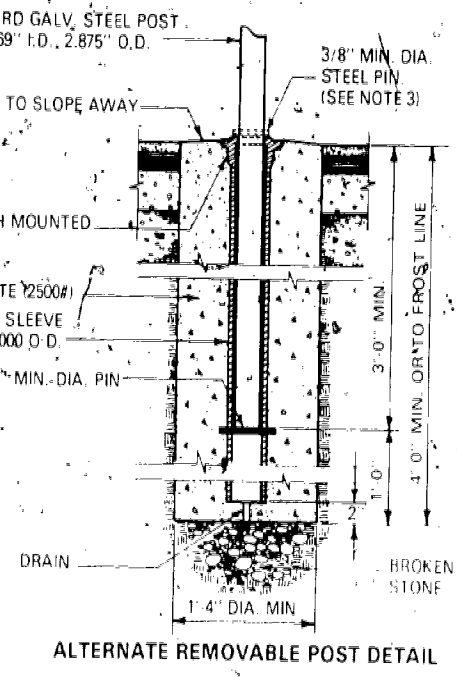
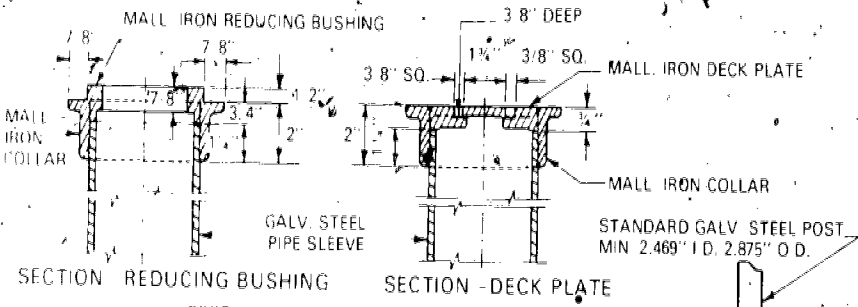
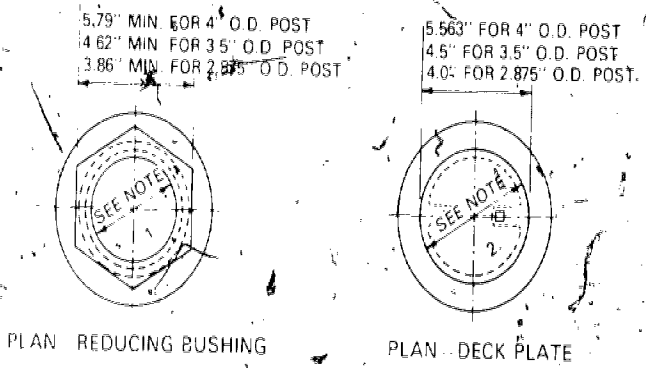

- NOTES:
1. I.D. of reducing bushing to be such that post is held firm when in place and removable without binding.
 2. Opening in pipe sleeve to be closed with deck plate when post is removed.
 3. The 3/8" minimum diameter steel pin is optional method of installing removable post (instead of by tapered ring or 5/8" pin through the sleeve), so that it can be reset at required height after resurfacing of paved court.

REMOVABLE NET POSTS

FIGURE 65

FOOTBALL GOAL POSTS AND BASKETBALL STANDARDS

FOOTBALL GOAL POSTS

Posts and crossbar are preferably made of 3.548" I.D., 4.000" O.D., 9.10#/L.F. galvanized steel pipe. For removable posts of this size, use 5.047" I.D., 5.563" O.D. minimum galvanized steel pipe sleeves.

All pipe joints should be welded.

All pipe should be etched with acid before painting and then primed before applying a good exterior enamel.

Optional goal post may be used in the form of a single metal post set behind the end zone in a 30" diameter by 4'-0" minimum concrete base with a cantilevered horizontal crossbar and two uprights of the same height and spacing as for dual posts.

BASKETBALL STANDARDS

Backboard support shall have a minimum overhang of 4'-0" for NCAA with a minimum post diameter of 4 1/2" O.D.

Regulation AAU, 5'-5" (1.65M) overhang and optional NCAA 4'-0" - 6'-0" overhang also require a minimum post diameter of 4 1/2" O.D.

Footing is to be concrete with a minimum 2'-0" diameter and 4'-0" depth.

Method of bracing and backboard support varies with manufacturer.

NOTES:

Posts and crossbar are preferably made of 3.548" I.D., 4.000" O.D. galv. steel pipe. For removable posts use 5.047" I.D., 5.563" O.D. min. galv. steel pipe sleeves.

All pipe joints should be welded.

All pipe should be etched with acid before painting and then primed before applying a good exterior enamel.

Optional goal post may be used in the form of a single metal post set behind the end zone in a 30" DIA 4'-0" min. concrete base with a cantilevered horizontal crossbar and two uprights of the same height and spacing as for dual posts.

PLUG END

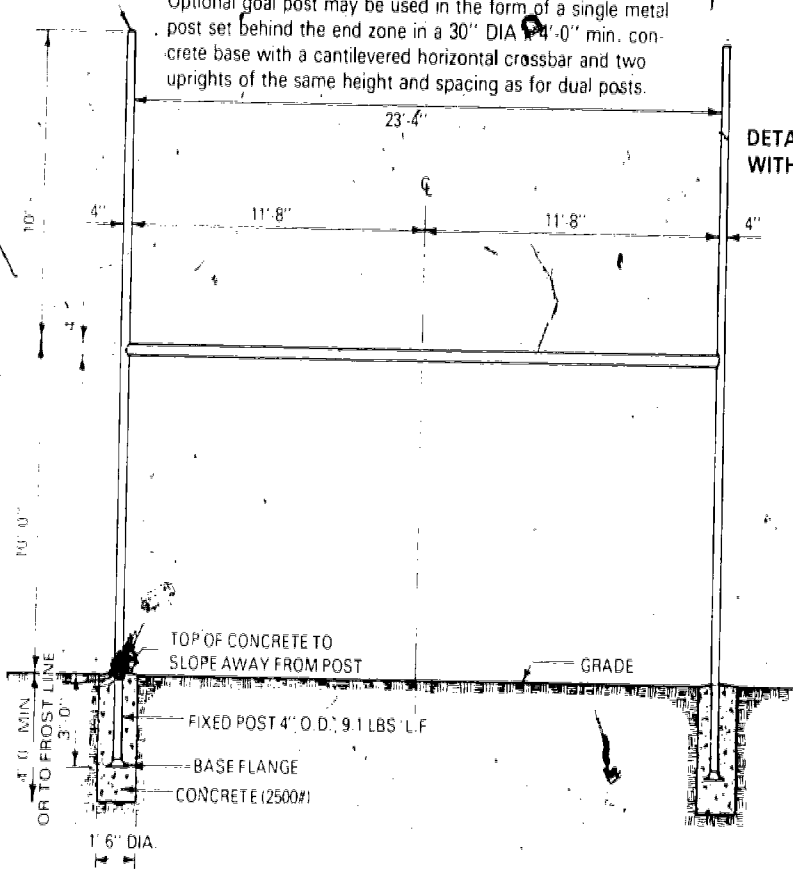

11 MAN & TOUCH AND FLAG FOOTBALL GOAL POSTS

TM 5-803-10 / NAVFAC P-457 / AFR 88-33

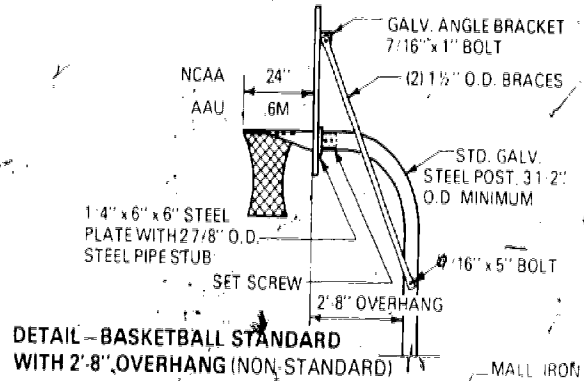

DETAIL - BASKETBALL STANDARD WITH 2'-8" OVERHANG (NON-STANDARD)

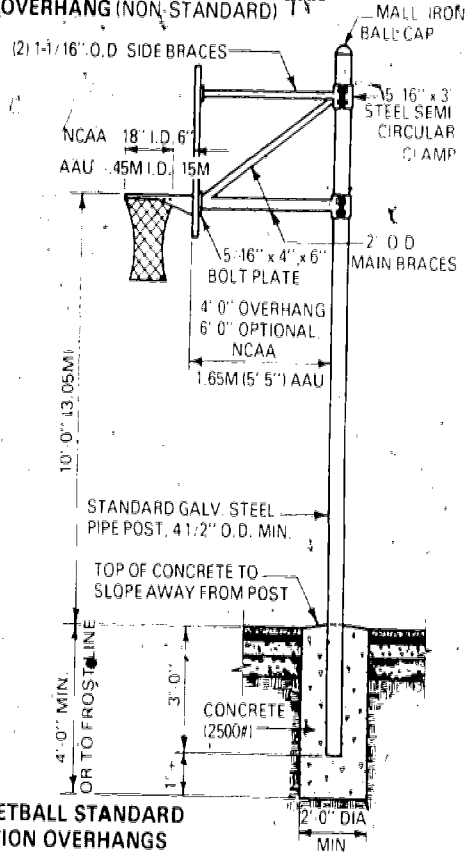

DETAIL - BASKETBALL STANDARD WITH REGULATION OVERHANGS

GOAL POSTS AND STANDARDS

FIGURE 66

ONE WALL HANDBALL WALL DETAILS

SIZE AND DIMENSION

Wall height - 16'-0" to top of concrete, 4'-0" chain link fence - top of wall.
Width - 24'-0" for single court (may be continuous with construction joint between courts in battery).

DESIGN CRITERIA

Design wind pressure for wall - 100 MPH.

Minimum soil bearing pressure required 2000 P.S.F.

Design concrete strength (f'c) at 28 days = 3000 P.S.I. (normal weight), maximum 3/4" aggregate, maximum w/c ratio - 0.50, 6% air entrainment.

Reinforcing steel - ASTM A615 Grade 60.

Weight of soil is assumed to be 100 pounds per cubic foot.

Water level is assumed to be below footings.

Vertical playing surfaces are to be plumb and true to within 1/8" in any 10'-0" dimension and to within 1/2" overall.

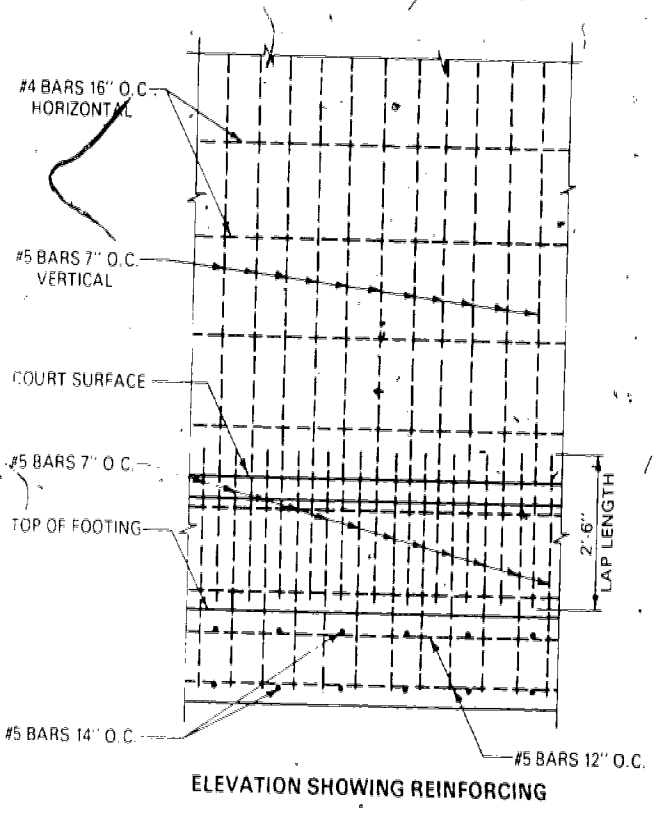

ELEVATION SHOWING REINFORCING

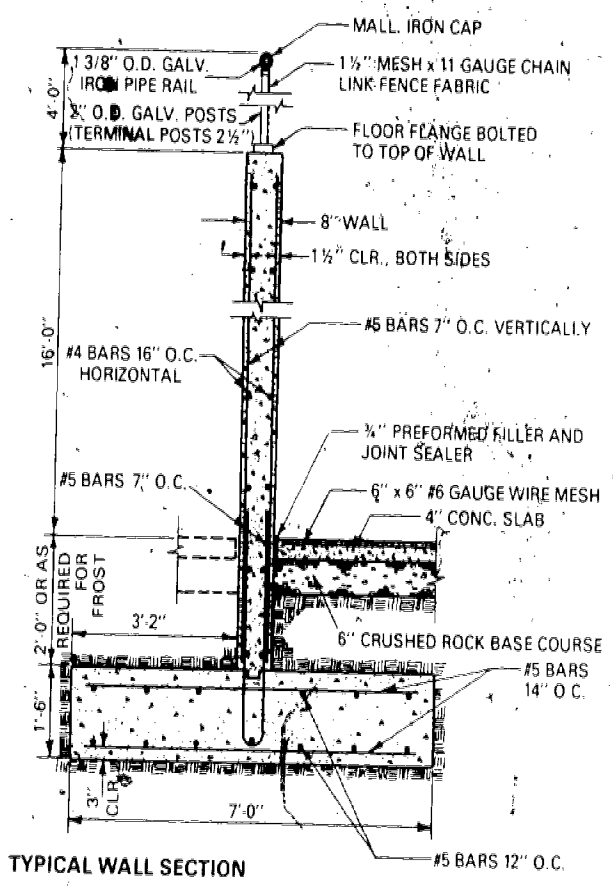

TYPICAL WALL SECTION

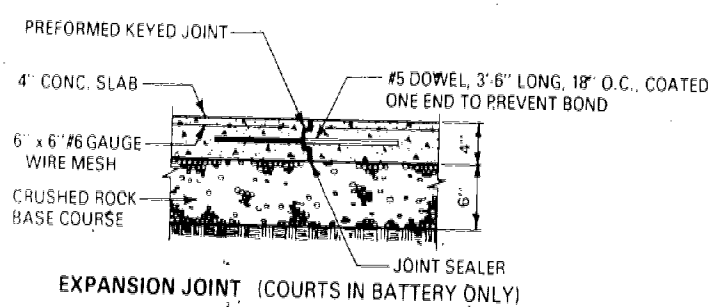

EXPANSION JOINT (COURTS IN BATTERY ONLY)

ONE WALL HAND BALL DETAILS

FIGURE 67

200

200

THREE AND FOUR WALL HANDBALL WALL DETAILS

SIZE AND DIMENSION

Front walls, 20'-0" high by 20'-0" wide. Side walls, 20'-0" high by 40'-0" long. Rear walls (four wall only) 12'-0" high minimum by 20'-0" wide.

DESIGN CRITERIA

Design wind pressure for walls - 100 MPH.

Minimum soil bearing pressure required - 2000 P.S.F.

Design concrete strength (f'c) at 28 days = 3000 P.S.F (normal weight), maximum 3/4" aggregate, maximum w/c ratio - 0.50, 6% air entrainment.

Reinforcing steel - ASTM A615 Grade 60.

Weight of soil is assumed to be 100 pounds per cubic foot.

Water level is assumed to be below footings.

Vertical playing surfaces are to be plumb and true to within 1/8" in any 10'-0" dimension and to within 1/2" overall.

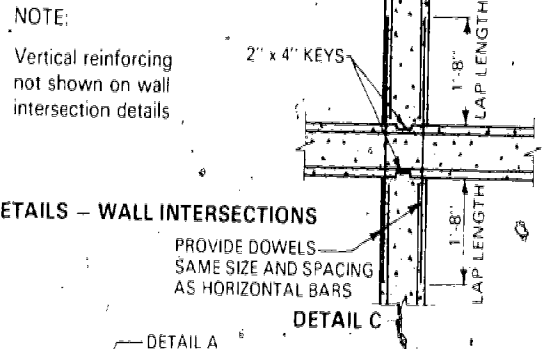
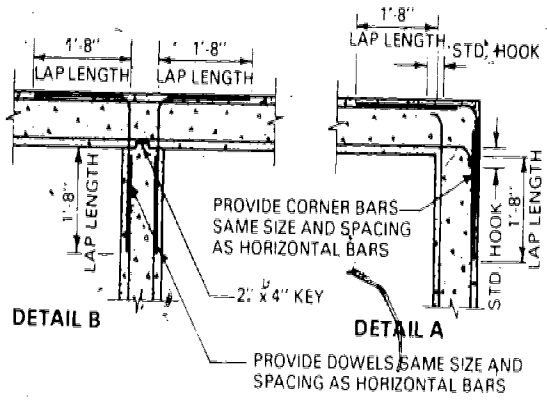
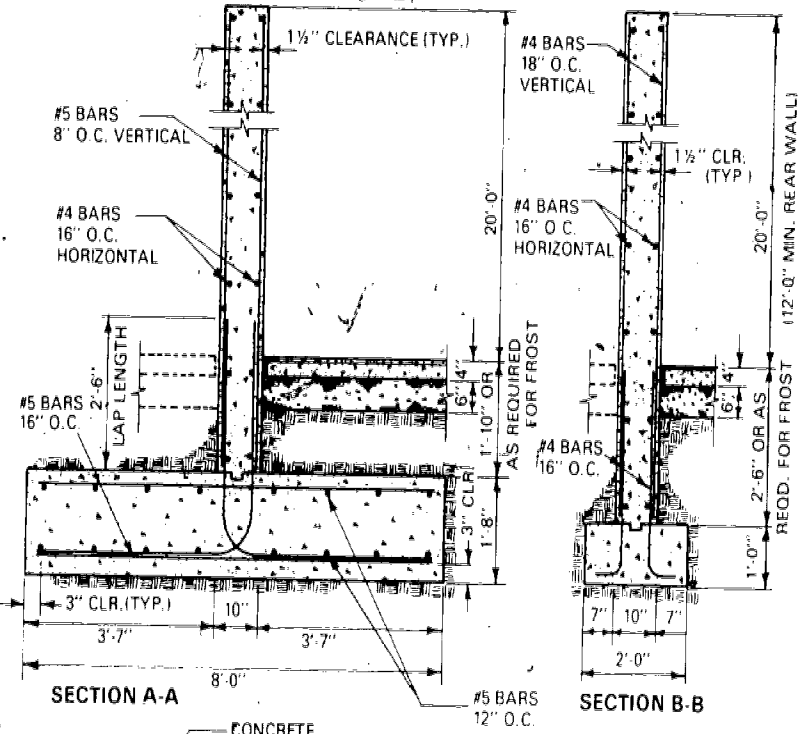

DETAILS - WALL INTERSECTIONS

NOTE:
Vertical reinforcing not shown on wall intersection details

PROVIDE CORNER BARS SAME SIZE AND SPACING AS HORIZONTAL BARS

PROVIDE DOWELS SAME SIZE AND SPACING AS HORIZONTAL BARS

PROVIDE DOWELS SAME SIZE AND SPACING AS HORIZONTAL BARS

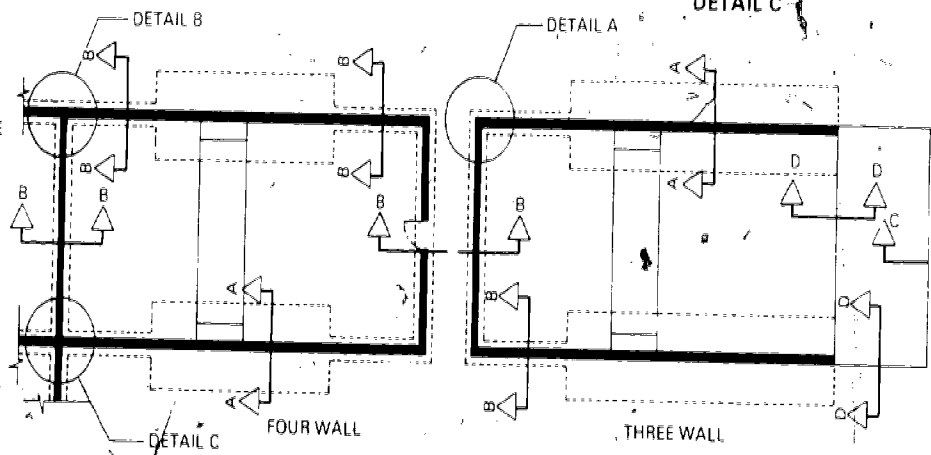
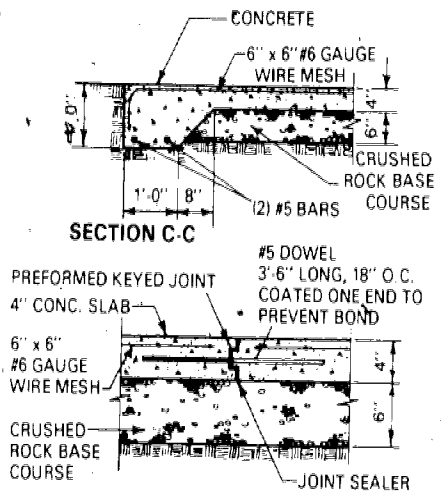

KEY PLANS

THREE AND FOUR WALL HANDBALL

TYPICAL GRADING AND DRAINAGE DETAILS

COURT SURFACES

Paved playing surfaces should be in one plane and pitched from side to side, end to end, or corner to corner diagonally, instead of in two planes pitched to or from the net. Minimum slope should be 1" in 10'-0". Subgrade should slope in the same direction as the surface. Perimeter drains may be provided for paved areas. Underdrains are not recommended beneath paved areas.

PLAYING FIELDS

Preferred grading for rectangular field is a longitudinal crown with 1% slope from center to each side.

Grading may be from side to side or corner to corner diagonally if conditions do not permit the preferred grading.

Subsoil drainage is to slope in the same direction as the surface. Subdrains and filter course are to be used only when subsoil conditions require. Where subsoil drainage is necessary, the spacing of subdrains is dependent on local soil conditions and rainfall.

Subdrains are to have a minimum gradient of 0.15 percent.

Baseball and softball fields should be graded so that the bases are level.

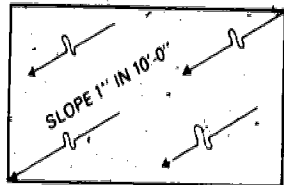

CORNER TO CORNER DIAGONALLY

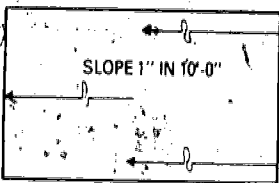

END TO END

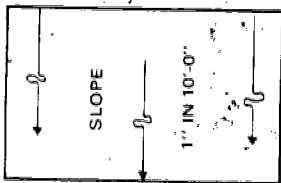

SIDE TO SIDE

DRAINAGE DIAGRAMS - SPORTS COURTS

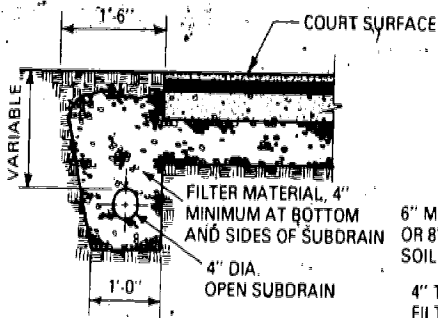

SECTION - PERIMETER DRAIN (SPORTS COURTS)

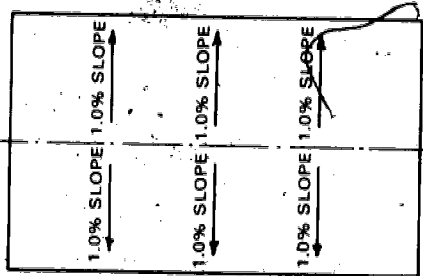

PREFERRED GRADING (RECTANGULAR SPORTS FIELDS)

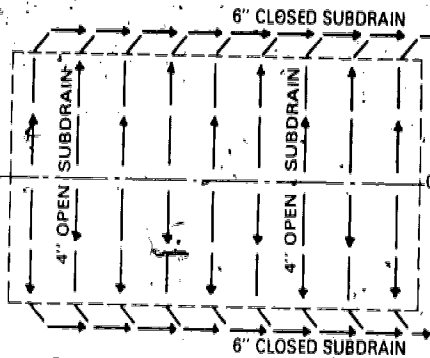

SUBSOIL DRAINAGE (RECTANGULAR SPORTS FIELDS)

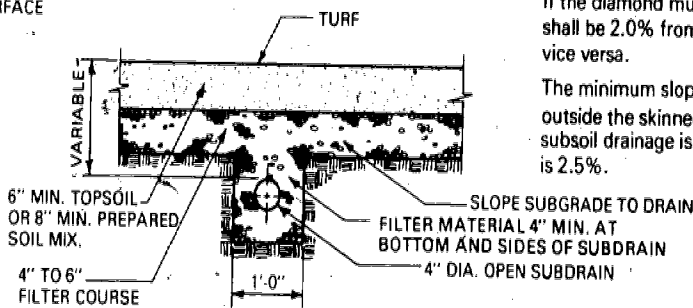

SECTION - SUBSOIL DRAIN

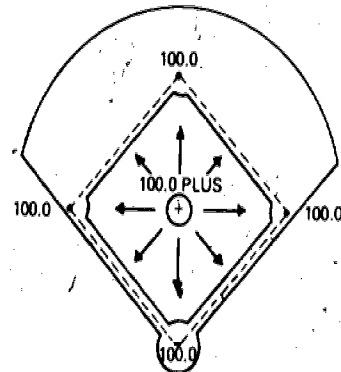

PREFERABLE GRADING (BASEBALL AND SOFTBALL DIAMONDS)

NOTES:

See figure on individual sports for height of pitcher's plate above home plate.

It is preferable that the base lines be level. If the diamond must pitch, the average slope shall be 2.0% from first base to third base or vice versa.

The minimum slope for drainage on turf areas outside the skinned area is 1.0% when adequate subsoil drainage is provided. The maximum is 2.5%.

TYPICAL GRADING AND DRAINAGE DETAILS

FIGURE 69

TYPICAL PLAYING SURFACES

CONCRETE

Minimum compressive strength - 2500#.

Reinforcing - 6" x 6" #6 gauge welded wire fabric.

Minimum thickness 4".

Expansion joints are to be provided as required and doweled 2'-0" O.C. with 3/4" diameter x 2'-0" long dowel coated on one end to prevent bonding. Joint is to be filled with a 3/4" foam or preformed bituminous filler and sealed with polysulfide joint sealant.

Sand filter course - minimum 6" deep required.

BITUMINOUS MATERIAL

Base - 4" minimum stabilized aggregate base course over minimum 6" filter course.

Surface - minimum 2-1/2" in two lifts: 1-1/2" leveling course of bituminous concrete and 1" surface course of bituminous concrete.

Sealcoat - on smooth asphalt surface apply protective colorcoating at the manufacturer's recommended rate.

SAND-CLAY

Filter course, 4" to 6", may be omitted if local soil conditions are suitable.

Base course - minimum 3" of 1-1/2" crushed stone choked with 1/4" to 1/2" of crushed fines.

Surface course - minimum 4" in two lifts: 3" clay screened through 1" mesh with a 1" surface lift of 1/3 sharp sand and 2/3 clay-silt screened through 1/4" mesh.

NATURAL TURF

Subgrade to pitch in the same direction as the surface and slope to underdrains.

Filter course, 4" to 6", is to be used only when subsoil conditions require.

Topsoil 6" minimum, or prepared soil mix 8" minimum.

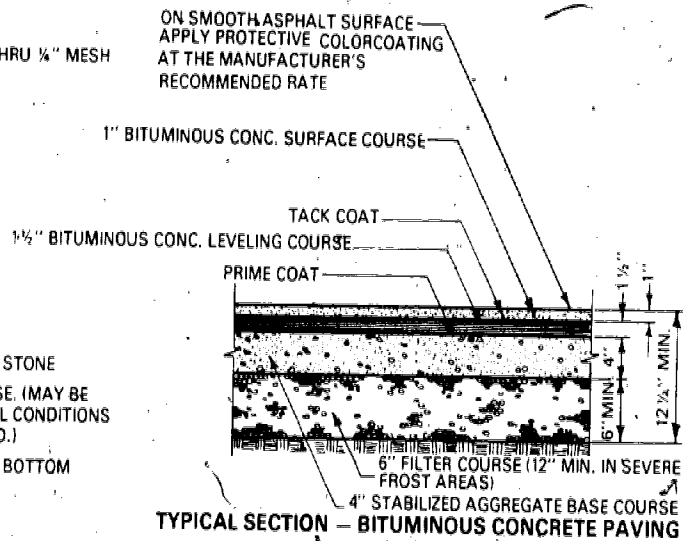
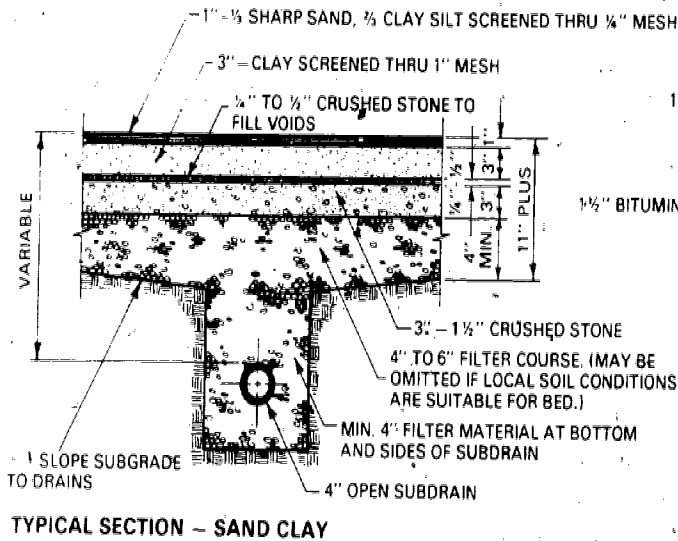
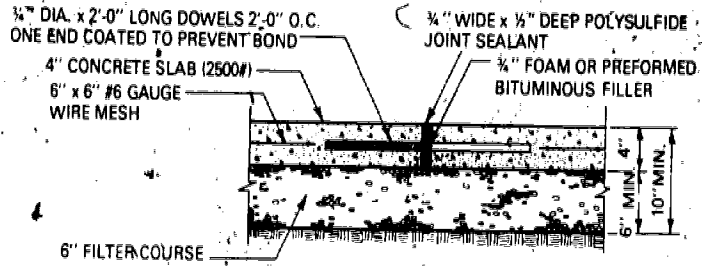
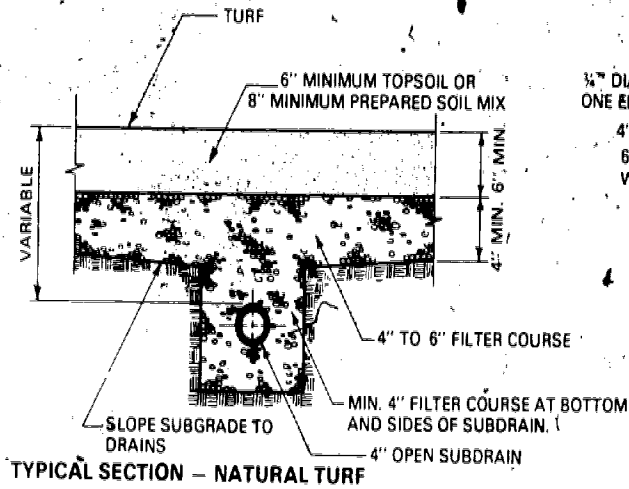

TYPICAL PLAYING SURFACES

FIGURE 70

BACKSTOPS

SIZE AND DIMENSION

Height and width of softball backstops are to be determined by sport and local condition requirements.

Consult backstop framing diagrams for layout of softball backstops.

PIPE SIZES

Posts for backstop heights up to 16'-0", use 3" O.D. - 5.75#/L.F.

Posts for backstop heights 18' to 24', use 4" O.D. - 9.10#/L.F.

Top, intermediate, and bottom rails, 1-5/8" O.D., 2.27#/L.F. minimum.

FABRIC

Fabric shall be chain link with galvanized coating per ASTM A392 or aluminized per ASTM A491 (optional polyvinyl chloride coated steel).

All ferrous metal parts are to be hot dip galvanized after fabrication.

CONCRETE FOOTINGS

Footings shall be minimum 12" diameter. Concrete shall conform to ASTM C94, maximum 3/4" aggregate, minimum 3000 p.s.i. compressive strength (f'c) at 28 days.

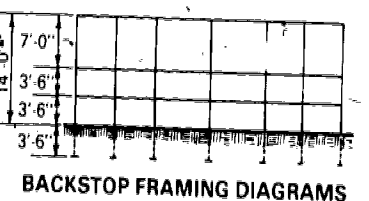
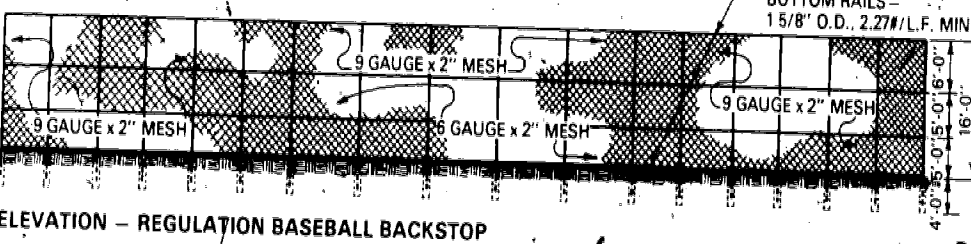
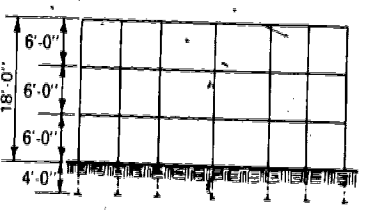
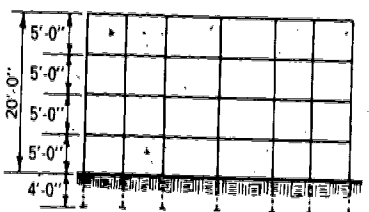
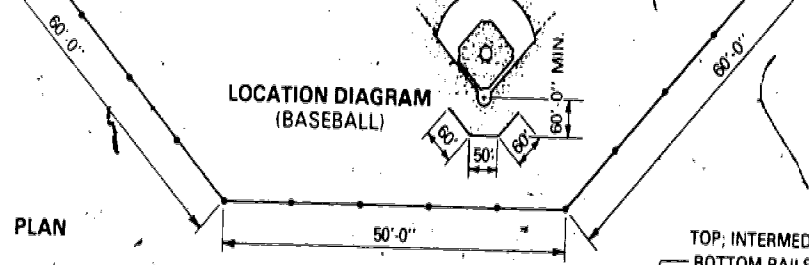
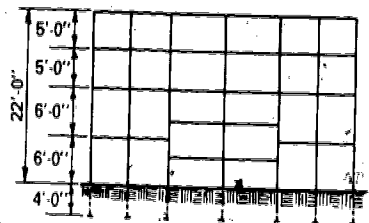
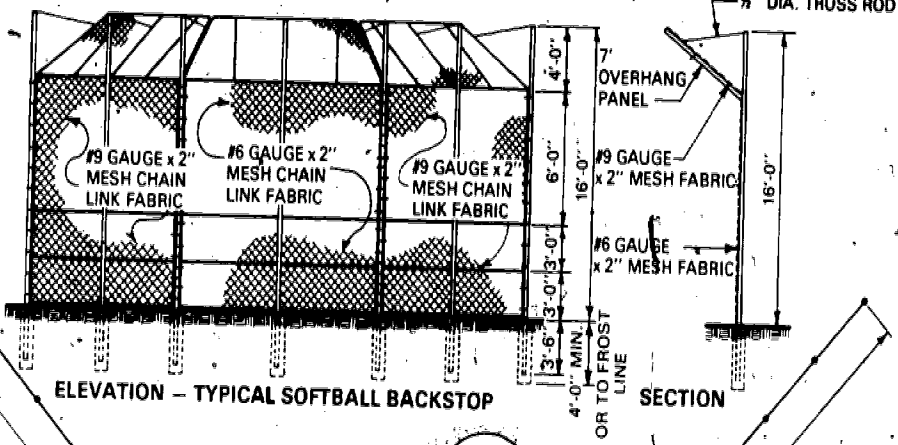
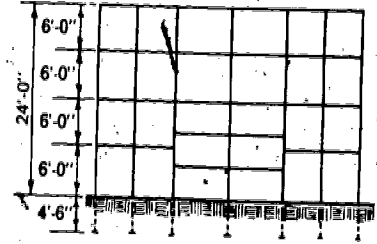
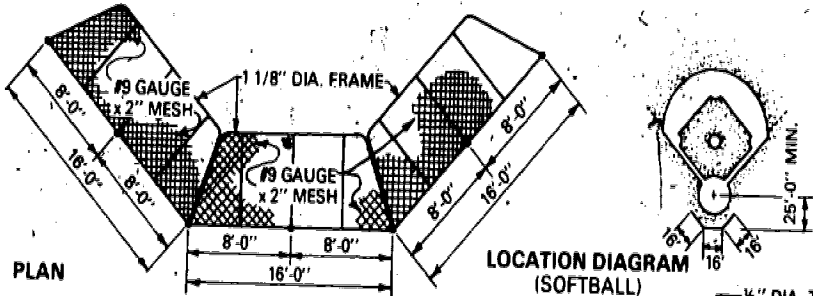

BASEBALL AND SOFTBALL BACKSTOPS
 FIGURE 71

217

218

APPENDIX A - LIST OF SPORTS ORGANIZATIONS

Rules and Regulations of the following organizations were used in the development of layout diagrams and construction details in this manual:

Amateur Athletic Union of the United States
 30 West 86th Street
 Indianapolis, Indiana 46268 (Basketball)

Amateur Hockey Association of the United States
 11 Cedar Avenue South
 Brimington, Minnesota 55420

Amateur Softball Association of America
 11 N.E. 50th
 Oklahoma City, Oklahoma 73111

Amateur Trapshooting Association of America
 West National Road
 Wadalia, Ohio 45377

AVF Corporation
 1 South Harbor Boulevard
 Santa Ana, California 92704 (Goal-Hi Basketball, Hopscotch)

American Badminton Association, Inc.
 10 Alexandria Drive
 San Diego, California 92107

American Lawn Bowls Association
 37 Cheryl Drive
 Phoenix City, Arizona 85351

American Platform Tennis Association
 Fox Meadow Tennis Club
 Riverside Lane
 Rosedale, New York 10583

American Roque League, Inc.
 Briar Creek Lane
 Dallas, Texas 75214

Babe Ruth Baseball, Inc.
 1770 Brunswick Avenue
 P.O. Box 5000
 Trenton, New Jersey 08638

Biddy Basketball Association, Inc.
 4711 Bancroft Drive
 New Orleans, Louisiana 70122

Boy's Baseball, Inc.
 P.O. Box 225
 Washington, Pennsylvania 15301

General Sportcraft Company, Ltd.
 140 Woodbine Street
 Bergenfield, New Jersey 07621
 (Boccie, Deck Tennis, Tether Ball)

International Shooting Union
 Wiesbaden - Klarenthal, West Germany
 (Rules may be obtained from:
 The National Rifle Association
 1600 Rhode Island Avenue N. W.
 Washington, D.C. 20036)

Little League Baseball, Inc.
 P.O. Box 1127
 Williamsport, Pennsylvania 17701

National Archery Association of the United States
 1951 Geraldson Drive
 Lancaster, Pennsylvania 17601

National Collegiate Athletic Association
 P.O. Box 1906
 Shawnee Mission, Kansas 66222
 (Football, Soccer, Basketball, Lacrosse, Track and Field)

National Croquet Association, Inc.
 c/o American Roque League, Inc.
 4205 Briar Creek Lane
 Dallas, Texas 75214

TM 5-803-10 / NAVFAC P-457 / AFR 88-33

National Golf Foundation, Inc.
707 Merchandise Mart
Chicago, Illinois 60654

National Horseshoe Pitchers'
Association of America
P.O. Box 3150
Eureka, California 95501

National Shuffleboard Association
10418 Northeast Second Avenue
Miami, Florida 33138

National Skeet Shooting Association
P.O. Box 28188
San Antonio, Texas 78228

National Touch and Flag Football Rules
The Athletic Institute
Merchandise Mart, Room 705
Chicago, Illinois 60654

National Association for Girls and Women in Sports
(Sports Library for Girls and Women)
c/o American Alliance for Health, Physical
Education and Recreation
1201 Sixteenth Street, N.W.
Washington, D.C. 20036 (Lacrosse, Soccer, Speedball)

The Official Playing Rules Committee
Official Baseball Rules
c/o The Sporting News
1212 North Lindbergh Boulevard
St. Louis, Missouri 63132

Pop Warner Junior League Football
International Headquarters
Suite 606, 1515 Walnut Street Building
Philadelphia, Pennsylvania 19107

United States Air Force
c/o Director of Student Operations
Squadron Officer School
Maxwell Air Force Base, Alabama 36112
(Flicker Ball)

United States Field Hockey Association
107 School House Lane
Philadelphia, Pennsylvania 19144

United States Handball Association
4101 Dempster Street
Skokie, Illinois 60076

United States Lawn Tennis Association
51 East 42nd Street
New York, New York 10017

United States Paddle Tennis Association
189 Seeler Street
Brooklyn, New York 11218

United States Team Handball Federation
10 Nottingham Road
Short Hills, New Jersey 07078

United States Volleyball Association
557 Fourth Street
San Francisco, California 94107

A-2

200

APPENDIX B - METRIC CONVERSION TABLES

How To Use The Tables

To find the metric equivalent of 9 feet, 6 1/4 inches, simply follow down the column headed 9 at the top until level with the 6 1/4 inches (shown in both left and right hand columns), and the point where the two measurements meet will give the answer, 2.90 metres.

To find the English equivalent of 2.90 metres, first locate the figure in the table. Then by reading vertically, establish the 9 feet and, by reading horizontally either right or left, establish the 6 1/4 inches, to give the answer, 9 feet, 6 1/4 inches.

Metric and English Measurements

Metric measurements can be converted to English measurements by using the following equivalents:

- 1 millimetre (mm) = .03937 inch
- 1 centimetre (cm) = .3937 inch
- 1 metre (M) = 39.37 inches
- 1 kilometre = .62137 miles

English measurements can be converted to metric measurements by using the following equivalents:

- 1 inch = 2.54 centimetres (cm)
- 1 foot = 30.48 centimetres (cm)
- 1 yard = .914401 metres
- 1 mile = 1.609347 kilometres

Reprinted by permission from "Metric Conversion Tables (Standard Edition)". Copyright ©1969 by ARENA PUBLICATIONS LTD., 325 Streatham High Road, London, S.W. 16 England. Compiled by Bob Sparks, B.Sc. (Statistics) and Charles Elliott.

Tables officially approved by the International Amateur Athletic Federation (Stockholm, 1970).

FEET & INCHES TO METRES
(0-99ft. 1 1/2 inches in quarter inches)

| feet | inches | | | | | | | | | | |
|-------|--------|------|------|------|------|------|-------|------|------|-------|-------|
| 0 | 1 | 2 | 3 | 4 | 5 | 6 | 7 | 8 | | | |
| 0 | 0-00 | 0-30 | 0-61 | 0-91 | 1-22 | 1-52 | 1-83 | 2-13 | 2-44 | 0 | |
| 0 1/4 | -00 | -31 | -61 | -92 | -22 | -53 | -83 | -14 | -44 | 0 1/4 | |
| 0 1/2 | -01 | -32 | -62 | -93 | -23 | -53 | -84 | -14 | -45 | 0 1/2 | |
| 0 3/4 | -02 | -32 | -63 | -93 | -24 | -54 | -85 | -15 | -46 | 0 3/4 | |
| 1 | 0-02 | 0-33 | 0-63 | 0-94 | 1-24 | 1-55 | 1-85 | 2-16 | 2-46 | 1 | |
| 1 1/4 | -03 | -33 | -64 | -94 | -25 | -55 | -86 | -16 | -47 | 1 1/4 | |
| 1 1/2 | -04 | -34 | -65 | -95 | -26 | -56 | -87 | -17 | -47 | 1 1/2 | |
| 1 3/4 | -04 | -35 | -65 | -96 | -26 | -57 | -87 | -18 | -48 | 1 3/4 | |
| 2 | 0-05 | 0-35 | 0-66 | 0-96 | 1-27 | 1-57 | 1-88 | 2-18 | 2-49 | 2 | |
| 2 1/4 | -06 | -36 | -66 | -97 | -27 | -58 | -88 | -19 | -49 | 2 1/4 | |
| 2 1/2 | -06 | -37 | -67 | -98 | -28 | -59 | -89 | -20 | -50 | 2 1/2 | |
| 2 3/4 | -07 | -37 | -68 | -98 | -29 | -59 | -90 | -20 | -51 | 2 3/4 | |
| 3 | 0-07 | 0-38 | 0-68 | 0-99 | 1-29 | 1-60 | 1-90 | 2-21 | 2-51 | 3 | |
| 3 1/4 | -08 | -39 | -69 | 1-00 | -30 | -60 | -91 | -21 | -52 | 3 1/4 | |
| 3 1/2 | -09 | -39 | -70 | -00 | -31 | -61 | -92 | -22 | -53 | 3 1/2 | |
| 3 3/4 | -09 | -40 | -70 | -01 | -31 | -62 | -92 | -23 | -53 | 3 3/4 | |
| 4 | 0-10 | 0-40 | 0-71 | 1-01 | 1-32 | 1-62 | 1-93 | 2-23 | 2-54 | 4 | |
| 4 1/4 | -11 | -41 | -72 | -02 | -33 | -63 | -93 | -24 | -54 | 4 1/4 | |
| 4 1/2 | -11 | -42 | -72 | -03 | -33 | -64 | -94 | -25 | -55 | 4 1/2 | |
| 4 3/4 | -12 | -42 | -73 | -03 | -34 | -64 | -95 | -25 | -56 | 4 3/4 | |
| 5 | 0-13 | 0-43 | 0-73 | 1-04 | 1-34 | 1-65 | 1-95 | 2-26 | 2-56 | 5 | |
| 5 1/4 | -13 | -44 | -74 | -05 | -35 | -66 | -96 | -27 | -57 | 5 1/4 | |
| 5 1/2 | -14 | -44 | -75 | -05 | -36 | -66 | -97 | -27 | -58 | 5 1/2 | |
| 5 3/4 | -14 | -45 | -75 | -06 | -36 | -67 | -97 | -28 | -58 | 5 3/4 | |
| 6 | 0-15 | 0-46 | 0-76 | 1-06 | 1-37 | 1-67 | 1-98 | 2-28 | 2-59 | 6 | |
| 6 1/4 | -16 | -46 | -77 | -07 | -38 | -68 | -99 | -29 | -60 | 6 1/4 | |
| 6 1/2 | -16 | -47 | -77 | -08 | -38 | -69 | -99 | -30 | -60 | 6 1/2 | |
| 6 3/4 | -17 | -47 | -78 | -08 | -39 | -69 | -2-00 | -30 | -61 | 6 3/4 | |
| 7 | 0-18 | 0-48 | 0-79 | 1-09 | 1-40 | 1-70 | 2-00 | 2-31 | 2-61 | 7 | |
| 7 1/4 | -19 | -49 | -80 | -10 | -41 | -71 | -02 | -32 | -63 | 7 1/4 | |
| 7 1/2 | -20 | -50 | -80 | -11 | -41 | -72 | -02 | -33 | -63 | 7 1/2 | |
| 8 | 0-20 | 0-51 | 0-81 | 1-12 | 1-42 | 1-73 | 2-03 | 2-33 | 2-64 | 2-94 | 8 |
| 8 1/4 | -21 | -51 | -82 | -12 | -43 | -73 | -04 | -34 | -65 | -95 | 8 1/4 |
| 8 1/2 | -21 | -52 | -82 | -13 | -43 | -74 | -04 | -35 | -65 | -96 | 8 1/2 |
| 8 3/4 | -22 | -53 | -83 | -13 | -44 | -74 | -05 | -35 | -66 | -96 | 8 3/4 |
| 9 | 0-23 | 0-53 | 0-84 | 1-14 | 1-45 | 1-75 | 2-06 | 2-36 | 2-67 | 2-97 | 9 |
| 9 1/4 | -23 | -54 | -84 | -15 | -45 | -76 | -06 | -37 | -67 | -98 | 9 1/4 |
| 9 1/2 | -24 | -54 | -85 | -15 | -46 | -76 | -07 | -37 | -68 | -98 | 9 1/2 |

TM 5-803-10/NAVFAC P-457/AFR 88-33

FEET & INCHES TO METRES
(0-99ft. 11½ inches in quarter inches)

| feet | inches | | | | | | | | | |
|------|--------|------|------|------|------|------|------|------|------|------|
| | 0 | 1 | 2 | 3 | 4 | 5 | 6 | 7 | 8 | 9 |
| 0 | 0-00 | 0-30 | 0-61 | 0-91 | 1-22 | 1-52 | 1-83 | 2-13 | 2-44 | 2-74 |
| 0¼ | -00 | -31 | -61 | -92 | 1-22 | 1-53 | 1-83 | 2-14 | 2-44 | 2-75 |
| 0½ | -01 | -32 | -62 | -93 | 2-23 | 2-53 | 2-84 | 3-14 | 3-45 | 3-75 |
| 0¾ | -02 | -32 | -63 | -93 | 2-24 | 2-54 | 2-85 | 3-15 | 3-46 | 3-76 |
| 1 | 0-02 | 0-33 | 0-63 | 0-94 | 1-24 | 1-55 | 1-85 | 2-16 | 2-46 | 2-77 |
| 1¼ | -03 | -33 | -64 | -94 | 2-25 | 2-55 | 2-86 | 3-16 | 3-47 | 3-77 |
| 1½ | -04 | -34 | -65 | -95 | 2-26 | 2-56 | 2-87 | 3-17 | 3-47 | 3-78 |
| 1¾ | -04 | -35 | -65 | -96 | 2-26 | 2-57 | 2-87 | 3-18 | 3-48 | 3-79 |
| 2 | 0-05 | 0-35 | 0-66 | 0-96 | 1-27 | 1-57 | 1-88 | 2-18 | 2-49 | 2-79 |
| 2¼ | -06 | -36 | -66 | -97 | 2-27 | 2-58 | 2-88 | 3-19 | 3-49 | 3-80 |
| 2½ | -06 | -37 | -67 | -98 | 2-28 | 2-59 | 2-89 | 3-20 | 3-50 | 3-80 |
| 2¾ | -07 | -37 | -68 | -98 | 2-29 | 2-59 | 2-90 | 3-20 | 3-51 | 3-81 |
| 3 | 0-07 | 0-38 | 0-68 | 0-99 | 1-29 | 1-60 | 1-90 | 2-21 | 2-51 | 2-82 |
| 3¼ | -08 | -39 | -69 | 1-00 | 3-30 | 3-60 | 3-91 | 4-21 | 4-52 | 4-82 |
| 3½ | -09 | -39 | -70 | 0-01 | 3-31 | 3-61 | 3-92 | 4-22 | 4-53 | 4-83 |
| 3¾ | -09 | -40 | -70 | 0-01 | 3-31 | 3-62 | 3-92 | 4-23 | 4-53 | 4-84 |
| 4 | 0-10 | 0-40 | 0-71 | 1-01 | 1-32 | 1-62 | 1-93 | 2-23 | 2-54 | 2-84 |
| 4¼ | -11 | -41 | -72 | 0-02 | 3-33 | 3-63 | 3-93 | 4-24 | 4-54 | 4-85 |
| 4½ | -11 | -42 | -72 | 0-03 | 3-33 | 3-64 | 3-94 | 4-25 | 4-55 | 4-86 |
| 4¾ | -12 | -42 | -73 | 0-03 | 3-34 | 3-64 | 3-95 | 4-25 | 4-56 | 4-86 |
| 5 | 0-13 | 0-43 | 0-73 | 1-04 | 1-34 | 1-65 | 1-95 | 2-26 | 2-56 | 2-87 |
| 5¼ | -13 | -44 | -74 | 0-05 | 3-35 | 3-66 | 3-96 | 4-27 | 4-57 | 4-87 |
| 5½ | -14 | -44 | -75 | 0-05 | 3-36 | 3-66 | 3-97 | 4-27 | 4-58 | 4-88 |
| 5¾ | -14 | -45 | -75 | 0-06 | 3-36 | 3-67 | 3-97 | 4-28 | 4-58 | 4-89 |
| 6 | 0-15 | 0-46 | 0-76 | 1-06 | 1-37 | 1-67 | 1-98 | 2-28 | 2-59 | 2-89 |
| 6¼ | -16 | -46 | -77 | 0-07 | 3-38 | 3-68 | 3-99 | 4-29 | 4-60 | 4-90 |
| 6½ | -16 | -47 | -77 | 0-08 | 3-38 | 3-69 | 3-99 | 4-30 | 4-60 | 4-91 |
| 6¾ | -17 | -47 | -78 | 0-08 | 3-39 | 3-69 | 4-00 | 4-30 | 4-61 | 4-91 |
| 7 | 0-18 | 0-48 | 0-79 | 1-09 | 1-40 | 1-70 | 2-00 | 2-31 | 2-61 | 2-92 |
| 7¼ | -18 | -49 | -79 | 1-10 | 4-40 | 4-71 | 4-01 | 5-32 | 5-62 | 5-93 |
| 7½ | -19 | -49 | -80 | 1-10 | 4-41 | 4-71 | 4-02 | 5-32 | 5-63 | 5-93 |
| 7¾ | -20 | -50 | -80 | 1-11 | 4-41 | 4-72 | 4-02 | 5-33 | 5-63 | 5-94 |
| 8 | 0-20 | 0-51 | 0-81 | 1-12 | 1-42 | 1-73 | 2-03 | 2-33 | 2-64 | 2-94 |
| 8¼ | -21 | -51 | -82 | 1-12 | 4-43 | 4-73 | 4-04 | 5-34 | 5-65 | 5-95 |
| 8½ | -21 | -52 | -82 | 1-13 | 4-43 | 4-74 | 4-04 | 5-35 | 5-65 | 5-96 |
| 8¾ | -22 | -53 | -83 | 1-13 | 4-44 | 4-74 | 4-05 | 5-35 | 5-66 | 5-96 |
| 9 | 0-23 | 0-53 | 0-84 | 1-14 | 1-45 | 1-75 | 2-06 | 2-36 | 2-67 | 2-97 |
| 9¼ | -23 | -54 | -84 | 1-15 | 4-45 | 4-76 | 4-06 | 5-37 | 5-67 | 5-98 |
| 9½ | -24 | -54 | -85 | 1-15 | 4-46 | 4-76 | 4-07 | 5-37 | 5-68 | 5-98 |
| 9¾ | -25 | -55 | -86 | 1-16 | 4-47 | 4-77 | 4-07 | 5-38 | 5-68 | 5-99 |
| 10 | 0-25 | 0-56 | 0-86 | 1-17 | 1-47 | 1-78 | 2-08 | 2-39 | 2-69 | 3-00 |
| 10¼ | -26 | -56 | -87 | 1-17 | 4-48 | 4-78 | 4-09 | 5-39 | 5-70 | 6-00 |
| 10½ | -26 | -57 | -87 | 1-18 | 4-48 | 4-79 | 4-09 | 5-40 | 5-70 | 6-01 |
| 10¾ | -27 | -58 | -88 | 1-19 | 4-49 | 4-80 | 4-10 | 5-40 | 5-71 | 6-01 |
| 11 | 0-28 | 0-58 | 0-89 | 1-19 | 1-50 | 1-80 | 2-11 | 2-41 | 2-72 | 3-02 |
| 11¼ | -28 | -59 | -89 | 2-20 | 5-81 | 5-11 | 6-42 | 7-72 | 8-03 | 8-33 |
| 11½ | -29 | -60 | -90 | 2-20 | 5-81 | 5-12 | 6-42 | 7-73 | 8-03 | 8-34 |
| 11¾ | -30 | -60 | -91 | 2-21 | 5-82 | 5-13 | 6-43 | 7-74 | 8-04 | 8-34 |

| | 10 | 11 | 12 | 13 | 14 | 15 | 16 | 17 | 18 | 19 |
|-----|------|------|------|------|------|------|------|------|------|------|
| 0 | 3-05 | 3-35 | 3-66 | 3-96 | 4-27 | 4-57 | 4-87 | 5-18 | 5-48 | 5-79 |
| 0¼ | -05 | -36 | -66 | -97 | -27 | -58 | -88 | -19 | -49 | -80 |
| 0½ | -06 | -36 | -67 | -97 | -28 | -58 | -89 | -19 | -50 | -80 |
| 0¾ | -07 | -37 | -67 | -98 | -28 | -59 | -89 | -20 | -50 | -81 |
| 1 | 3-07 | 3-38 | 3-68 | 3-99 | 4-29 | 4-60 | 4-90 | 5-21 | 5-51 | 5-81 |
| 1¼ | -08 | -38 | -69 | -99 | -30 | -60 | -91 | -21 | -52 | -82 |
| 1½ | -08 | -39 | -69 | 4-00 | -30 | -61 | -91 | -22 | -52 | -83 |
| 1¾ | -09 | -40 | -70 | 0-01 | -31 | -61 | -92 | -22 | -53 | -83 |
| 2 | 3-10 | 3-40 | 3-71 | 4-01 | 4-32 | 4-62 | 4-93 | 5-23 | 5-54 | 5-84 |
| 2¼ | -10 | -41 | -71 | 0-02 | -32 | -63 | -93 | -24 | -54 | -85 |
| 2½ | -11 | -41 | -72 | 0-02 | -33 | -63 | -94 | -24 | -55 | -85 |
| 2¾ | -12 | -42 | -73 | 0-03 | -34 | -64 | -94 | -25 | -55 | -86 |
| 3 | 3-12 | 3-43 | 3-73 | 4-04 | 4-34 | 4-65 | 4-95 | 5-26 | 5-56 | 5-87 |
| 3¼ | -13 | -43 | -74 | 0-04 | -35 | -65 | -96 | -26 | -57 | -87 |
| 3½ | -14 | -44 | -74 | 0-05 | -35 | -66 | -96 | -27 | -57 | -88 |
| 3¾ | -14 | -45 | -75 | 0-06 | -36 | -67 | -97 | -28 | -58 | -88 |
| 4 | 3-15 | 3-45 | 3-76 | 4-06 | 4-37 | 4-67 | 4-98 | 5-28 | 5-59 | 5-89 |
| 4¼ | -15 | -46 | -76 | 0-07 | -37 | -68 | -98 | -29 | -59 | -90 |
| 4½ | -16 | -47 | -77 | 0-07 | -38 | -68 | -99 | -29 | -60 | -90 |
| 4¾ | -17 | -47 | -78 | 0-08 | -39 | -69 | 5-00 | -30 | -61 | -91 |
| 5 | 3-17 | 3-48 | 3-78 | 4-09 | 4-39 | 4-70 | 5-00 | 5-31 | 5-61 | 5-92 |
| 5¼ | -18 | -48 | -79 | 0-09 | -40 | -70 | 0-01 | -32 | -62 | -92 |
| 5½ | -19 | -49 | -80 | 0-10 | -41 | -71 | 0-01 | -32 | -62 | -93 |
| 5¾ | -19 | -50 | -80 | 0-11 | -41 | -72 | 0-02 | -33 | -63 | -94 |
| 6 | 3-20 | 3-50 | 3-81 | 4-11 | 4-42 | 4-72 | 5-03 | 5-33 | 5-64 | 5-94 |
| 6¼ | -21 | -51 | -81 | 0-12 | -42 | -73 | 0-03 | -34 | -64 | -95 |
| 6½ | -21 | -52 | -82 | 0-13 | -43 | -74 | 0-04 | -34 | -65 | -95 |
| 6¾ | -22 | -52 | -83 | 0-13 | -44 | -74 | 0-05 | -35 | -66 | -96 |
| 7 | 3-22 | 3-53 | 3-83 | 4-14 | 4-44 | 4-75 | 5-05 | 5-36 | 5-66 | 5-97 |
| 7¼ | -23 | -54 | -84 | 0-14 | -45 | -75 | 0-06 | -36 | -67 | -97 |
| 7½ | -24 | -54 | -85 | 0-15 | -46 | -76 | 0-07 | -37 | -68 | -98 |
| 7¾ | -24 | -55 | -85 | 0-16 | -46 | -77 | 0-07 | -38 | -68 | -99 |
| 8 | 3-25 | 3-55 | 3-86 | 4-16 | 4-47 | 4-77 | 5-08 | 5-38 | 5-69 | 5-99 |
| 8¼ | -26 | -56 | -87 | 0-17 | -47 | -78 | 0-08 | -39 | -69 | 6-00 |
| 8½ | -26 | -57 | -87 | 0-18 | -48 | -79 | 0-09 | -40 | -70 | 0-01 |
| 8¾ | -27 | -57 | -88 | 0-18 | -49 | -79 | 0-10 | -40 | -71 | 0-01 |
| 9 | 3-27 | 3-58 | 3-88 | 4-19 | 4-49 | 4-80 | 5-10 | 5-41 | 5-71 | 6-02 |
| 9¼ | -28 | -59 | -89 | 0-20 | -50 | -81 | 0-11 | -41 | -72 | 0-02 |
| 9½ | -29 | -59 | -90 | 0-20 | -51 | -81 | 0-12 | -42 | -73 | 0-03 |
| 9¾ | -29 | -60 | -90 | 0-21 | -51 | -82 | 0-12 | -43 | -73 | 0-04 |
| 10 | 3-30 | 3-60 | 3-91 | 4-21 | 4-52 | 4-82 | 5-13 | 5-43 | 5-74 | 6-04 |
| 10¼ | -31 | -61 | -92 | 0-22 | -53 | -83 | 0-14 | -44 | -74 | 0-05 |
| 10½ | -31 | -62 | -92 | 0-23 | -53 | -84 | 0-14 | -45 | -75 | 0-06 |
| 10¾ | -32 | -62 | -93 | 0-23 | -54 | -84 | 0-15 | -45 | -76 | 0-06 |
| 11 | 3-33 | 3-63 | 3-94 | 4-24 | 4-54 | 4-85 | 5-16 | 5-46 | 5-76 | 6-07 |
| 11¼ | -33 | -64 | -94 | 0-25 | -55 | -86 | 0-16 | -47 | -77 | 0-08 |
| 11½ | -34 | -64 | -95 | 0-25 | -56 | -86 | 0-17 | -47 | -78 | 0-08 |
| 11¾ | -34 | -65 | -95 | 0-26 | -56 | -87 | 0-17 | -48 | -78 | 0-09 |



| | 20 | 21 | 22 | 23 | 24 | 25 | 26 | 27 | 28 | 29 | |
|--------|------|------|------|------|------|------|------|------|------|------|--------|
| 0 | 6:09 | 6:40 | 6:70 | 7:01 | 7:31 | 7:62 | 7:92 | 8:23 | 8:53 | 8:84 | 0 |
| 0 1/4 | 10 | 41 | 71 | 01 | 32 | 62 | 93 | 23 | 54 | 84 | 0 1/4 |
| 0 1/2 | 11 | 41 | 72 | 02 | 33 | 63 | 94 | 24 | 55 | 85 | 0 1/2 |
| 0 3/4 | 11 | 42 | 72 | 03 | 33 | 64 | 94 | 25 | 55 | 86 | 0 3/4 |
| 1 | 6:12 | 6:42 | 6:73 | 7:03 | 7:34 | 7:64 | 7:95 | 8:25 | 8:56 | 8:86 | 1 |
| 1 1/4 | 13 | 43 | 74 | 04 | 35 | 65 | 95 | 26 | 56 | 87 | 1 1/4 |
| 1 1/2 | 13 | 44 | 74 | 05 | 35 | 66 | 96 | 27 | 57 | 88 | 1 1/2 |
| 1 3/4 | 14 | 44 | 75 | 05 | 36 | 66 | 97 | 27 | 58 | 88 | 1 3/4 |
| 2 | 6:14 | 6:45 | 6:75 | 7:06 | 7:36 | 7:67 | 7:97 | 8:28 | 8:58 | 8:89 | 2 |
| 2 1/4 | 15 | 46 | 76 | 07 | 37 | 68 | 98 | 28 | 59 | 89 | 2 1/4 |
| 2 1/2 | 16 | 46 | 77 | 07 | 38 | 68 | 99 | 29 | 60 | 90 | 2 1/2 |
| 2 3/4 | 16 | 47 | 77 | 08 | 38 | 69 | 99 | 30 | 60 | 91 | 2 3/4 |
| 3 | 6:17 | 6:48 | 6:78 | 7:08 | 7:39 | 7:69 | 8:00 | 8:30 | 8:61 | 8:91 | 3 |
| 3 1/4 | 18 | 48 | 79 | 09 | 40 | 70 | 01 | 31 | 62 | 92 | 3 1/4 |
| 3 1/2 | 18 | 49 | 79 | 10 | 40 | 71 | 01 | 32 | 62 | 93 | 3 1/2 |
| 3 3/4 | 19 | 49 | 80 | 10 | 41 | 71 | 02 | 32 | 63 | 93 | 3 3/4 |
| 4 | 6:20 | 6:50 | 6:81 | 7:11 | 7:41 | 7:72 | 8:02 | 8:33 | 8:63 | 8:94 | 4 |
| 4 1/4 | 20 | 51 | 81 | 12 | 42 | 73 | 03 | 34 | 64 | 95 | 4 1/4 |
| 4 1/2 | 21 | 51 | 82 | 12 | 43 | 73 | 04 | 34 | 65 | 95 | 4 1/2 |
| 4 3/4 | 21 | 52 | 82 | 13 | 43 | 74 | 04 | 35 | 65 | 96 | 4 3/4 |
| 5 | 6:22 | 6:53 | 6:83 | 7:14 | 7:44 | 7:75 | 8:05 | 8:35 | 8:66 | 8:96 | 5 |
| 5 1/4 | 23 | 53 | 84 | 14 | 45 | 75 | 06 | 36 | 67 | 97 | 5 1/4 |
| 5 1/2 | 23 | 54 | 84 | 15 | 45 | 76 | 06 | 37 | 67 | 98 | 5 1/2 |
| 5 3/4 | 24 | 55 | 85 | 15 | 46 | 76 | 07 | 37 | 68 | 98 | 5 3/4 |
| 6 | 6:25 | 6:55 | 6:86 | 7:16 | 7:47 | 7:77 | 8:08 | 8:38 | 8:68 | 8:99 | 6 |
| 6 1/4 | 25 | 56 | 86 | 17 | 47 | 78 | 08 | 39 | 69 | 90 | 6 1/4 |
| 6 1/2 | 26 | 56 | 87 | 17 | 48 | 78 | 09 | 39 | 70 | 90 | 6 1/2 |
| 6 3/4 | 27 | 57 | 88 | 18 | 48 | 79 | 09 | 40 | 70 | 91 | 6 3/4 |
| 7 | 6:27 | 6:58 | 6:88 | 7:19 | 7:49 | 7:80 | 8:10 | 8:41 | 8:71 | 9:02 | 7 |
| 7 1/4 | 28 | 58 | 89 | 19 | 50 | 80 | 11 | 41 | 72 | 02 | 7 1/4 |
| 7 1/2 | 28 | 59 | 89 | 20 | 50 | 81 | 11 | 42 | 72 | 03 | 7 1/2 |
| 7 3/4 | 29 | 60 | 90 | 21 | 51 | 82 | 12 | 42 | 73 | 03 | 7 3/4 |
| 8 | 6:30 | 6:60 | 6:91 | 7:21 | 7:52 | 7:82 | 8:13 | 8:43 | 8:74 | 9:04 | 8 |
| 8 1/4 | 30 | 61 | 91 | 22 | 52 | 83 | 13 | 44 | 74 | 05 | 8 1/4 |
| 8 1/2 | 31 | 61 | 92 | 22 | 53 | 83 | 14 | 44 | 75 | 05 | 8 1/2 |
| 8 3/4 | 32 | 62 | 93 | 23 | 54 | 84 | 15 | 45 | 75 | 06 | 8 3/4 |
| 9 | 6:32 | 6:63 | 6:93 | 7:24 | 7:54 | 7:85 | 8:15 | 8:46 | 8:76 | 9:07 | 9 |
| 9 1/4 | 33 | 63 | 94 | 24 | 55 | 85 | 16 | 46 | 77 | 07 | 9 1/4 |
| 9 1/2 | 34 | 64 | 95 | 25 | 55 | 86 | 16 | 47 | 77 | 08 | 9 1/2 |
| 9 3/4 | 34 | 65 | 95 | 26 | 56 | 87 | 17 | 48 | 78 | 09 | 9 3/4 |
| 10 | 6:35 | 6:65 | 6:96 | 7:26 | 7:57 | 7:87 | 8:18 | 8:48 | 8:79 | 9:09 | 10 |
| 10 1/4 | 35 | 66 | 96 | 27 | 57 | 88 | 18 | 49 | 79 | 10 | 10 1/4 |
| 10 1/2 | 36 | 67 | 97 | 28 | 58 | 88 | 19 | 49 | 80 | 10 | 10 1/2 |
| 10 3/4 | 37 | 67 | 98 | 28 | 59 | 89 | 20 | 50 | 81 | 11 | 10 3/4 |
| 11 | 6:37 | 6:68 | 6:98 | 7:29 | 7:59 | 7:90 | 8:20 | 8:51 | 8:81 | 9:12 | 11 |
| 11 1/4 | 38 | 68 | 99 | 29 | 60 | 90 | 21 | 51 | 82 | 12 | 11 1/4 |
| 11 1/2 | 39 | 69 | 90 | 30 | 61 | 91 | 22 | 52 | 82 | 13 | 11 1/2 |
| 11 3/4 | 39 | 70 | 00 | 31 | 61 | 92 | 22 | 53 | 83 | 14 | 11 3/4 |

| | 30 | 31 | 32 | 33 | 34 | 35 | 36 | 37 | 38 | 39 | |
|--------|------|------|-------|-------|-------|-------|-------|-------|-------|-------|--------|
| 0 | 9:14 | 9:45 | 9:75 | 10:06 | 10:36 | 10:67 | 10:97 | 11:28 | 11:58 | 11:89 | 0 |
| 0 1/4 | 15 | 46 | 76 | 06 | 37 | 67 | 98 | 28 | 59 | 89 | 0 1/4 |
| 0 1/2 | 15 | 46 | 76 | 07 | 37 | 68 | 98 | 29 | 59 | 90 | 0 1/2 |
| 0 3/4 | 16 | 47 | 77 | 08 | 38 | 69 | 99 | 29 | 60 | 90 | 0 3/4 |
| 1 | 9:17 | 9:47 | 9:78 | 10:08 | 10:39 | 10:69 | 11:00 | 11:30 | 11:61 | 11:91 | 1 |
| 1 1/4 | 17 | 48 | 78 | 09 | 39 | 70 | 00 | 31 | 61 | 92 | 1 1/4 |
| 1 1/2 | 18 | 49 | 79 | 09 | 40 | 70 | 01 | 31 | 62 | 92 | 1 1/2 |
| 1 3/4 | 19 | 49 | 80 | 10 | 41 | 71 | 02 | 32 | 63 | 93 | 1 3/4 |
| 2 | 9:19 | 9:50 | 9:80 | 10:11 | 10:41 | 10:72 | 11:02 | 11:33 | 11:63 | 11:94 | 2 |
| 2 1/4 | 20 | 50 | 81 | 11 | 42 | 72 | 03 | 33 | 64 | 94 | 2 1/4 |
| 2 1/2 | 21 | 51 | 82 | 12 | 42 | 73 | 03 | 34 | 64 | 95 | 2 1/2 |
| 2 3/4 | 21 | 52 | 82 | 13 | 43 | 74 | 04 | 35 | 65 | 96 | 2 3/4 |
| 3 | 9:22 | 9:52 | 9:83 | 10:13 | 10:44 | 10:74 | 11:05 | 11:35 | 11:66 | 11:96 | 3 |
| 3 1/4 | 22 | 53 | 83 | 14 | 44 | 75 | 05 | 36 | 66 | 97 | 3 1/4 |
| 3 1/2 | 23 | 54 | 84 | 15 | 45 | 76 | 06 | 36 | 67 | 97 | 3 1/2 |
| 3 3/4 | 24 | 54 | 85 | 15 | 46 | 76 | 07 | 37 | 68 | 98 | 3 3/4 |
| 4 | 9:24 | 9:55 | 9:85 | 10:16 | 10:46 | 10:77 | 11:07 | 11:38 | 11:68 | 11:99 | 4 |
| 4 1/4 | 25 | 55 | 86 | 16 | 47 | 77 | 08 | 38 | 69 | 99 | 4 1/4 |
| 4 1/2 | 26 | 56 | 87 | 17 | 48 | 78 | 09 | 39 | 69 | 12:00 | 4 1/2 |
| 4 3/4 | 26 | 57 | 87 | 18 | 48 | 79 | 09 | 40 | 70 | 01 | 4 3/4 |
| 5 | 9:27 | 9:57 | 9:88 | 10:18 | 10:49 | 10:79 | 11:10 | 11:40 | 11:71 | 12:01 | 5 |
| 5 1/4 | 28 | 58 | 89 | 19 | 49 | 80 | 10 | 41 | 71 | 02 | 5 1/4 |
| 5 1/2 | 28 | 59 | 89 | 20 | 50 | 81 | 11 | 42 | 72 | 03 | 5 1/2 |
| 5 3/4 | 29 | 59 | 90 | 20 | 51 | 81 | 12 | 42 | 73 | 03 | 5 3/4 |
| 6 | 9:29 | 9:60 | 9:90 | 10:21 | 10:51 | 10:82 | 11:12 | 11:43 | 11:73 | 12:04 | 6 |
| 6 1/4 | 30 | 61 | 91 | 22 | 52 | 82 | 13 | 43 | 74 | 04 | 6 1/4 |
| 6 1/2 | 31 | 61 | 92 | 22 | 53 | 83 | 14 | 44 | 75 | 05 | 6 1/2 |
| 6 3/4 | 31 | 62 | 92 | 23 | 53 | 84 | 14 | 45 | 75 | 06 | 6 3/4 |
| 7 | 9:32 | 9:62 | 9:93 | 10:23 | 10:54 | 10:84 | 11:15 | 11:45 | 11:76 | 12:06 | 7 |
| 7 1/4 | 33 | 63 | 94 | 24 | 55 | 85 | 16 | 46 | 76 | 07 | 7 1/4 |
| 7 1/2 | 33 | 64 | 94 | 25 | 55 | 86 | 16 | 47 | 77 | 08 | 7 1/2 |
| 7 3/4 | 34 | 64 | 95 | 25 | 56 | 86 | 17 | 47 | 78 | 08 | 7 3/4 |
| 8 | 9:35 | 9:65 | 9:95 | 10:26 | 10:56 | 10:87 | 11:17 | 11:48 | 11:78 | 12:09 | 8 |
| 8 1/4 | 35 | 66 | 96 | 27 | 57 | 88 | 18 | 49 | 79 | 09 | 8 1/4 |
| 8 1/2 | 36 | 66 | 97 | 27 | 58 | 88 | 19 | 49 | 80 | 10 | 8 1/2 |
| 8 3/4 | 36 | 67 | 97 | 28 | 58 | 89 | 19 | 50 | 80 | 11 | 8 3/4 |
| 9 | 9:37 | 9:68 | 9:98 | 10:29 | 10:59 | 10:89 | 11:20 | 11:50 | 11:81 | 12:11 | 9 |
| 9 1/4 | 38 | 68 | 99 | 29 | 60 | 90 | 21 | 51 | 82 | 12 | 9 1/4 |
| 9 1/2 | 38 | 69 | 99 | 30 | 60 | 91 | 21 | 52 | 82 | 13 | 9 1/2 |
| 9 3/4 | 39 | 69 | 10:00 | 30 | 61 | 91 | 22 | 52 | 83 | 13 | 9 3/4 |
| 10 | 9:40 | 9:70 | 10:01 | 10:31 | 10:62 | 10:92 | 11:22 | 11:53 | 11:83 | 12:14 | 10 |
| 10 1/4 | 40 | 71 | 01 | 32 | 62 | 93 | 23 | 54 | 84 | 15 | 10 1/4 |
| 10 1/2 | 41 | 71 | 02 | 32 | 63 | 93 | 24 | 55 | 85 | 15 | 10 1/2 |
| 10 3/4 | 42 | 72 | 02 | 33 | 63 | 94 | 24 | 55 | 85 | 16 | 10 3/4 |
| 11 | 9:42 | 9:73 | 10:03 | 10:34 | 10:64 | 10:95 | 11:25 | 11:56 | 11:86 | 12:16 | 11 |
| 11 1/4 | 43 | 73 | 04 | 34 | 65 | 95 | 26 | 56 | 87 | 17 | 11 1/4 |
| 11 1/2 | 43 | 74 | 04 | 35 | 65 | 96 | 27 | 57 | 87 | 18 | 11 1/2 |
| 11 3/4 | 44 | 75 | 05 | 36 | 66 | 96 | 27 | 57 | 88 | 18 | 11 3/4 |

| | 40 | 41 | 42 | 43 | 44 | 45 | 46 | 47 | 48 | 49 | |
|-----|-------|-------|-------|-------|-------|-------|-------|-------|-------|-------|-----|
| 0 | 12-19 | 12-49 | 12-80 | 13-10 | 13-41 | 13-71 | 14-02 | 14-32 | 14-63 | 14-93 | 0 |
| 0½ | -20 | -50 | -81 | -11 | -42 | -72 | -03 | -33 | -64 | -94 | 0½ |
| 0¾ | -20 | -51 | -81 | -12 | -42 | -73 | -03 | -34 | -64 | -95 | 0¾ |
| 0¼ | -21 | -51 | -82 | -12 | -43 | -73 | -04 | -34 | -65 | -95 | 0¼ |
| 1 | 12-22 | 12-52 | 12-83 | 13-13 | 13-43 | 13-74 | 14-04 | 14-35 | 14-65 | 14-96 | 1 |
| 1½ | -22 | -53 | -83 | -14 | -44 | -75 | -05 | -36 | -66 | -97 | 1½ |
| 1¾ | -23 | -53 | -84 | -14 | -45 | -75 | -06 | -36 | -67 | -97 | 1¾ |
| 1¼ | -23 | -54 | -84 | -15 | -45 | -76 | -06 | -37 | -67 | -98 | 1¼ |
| 2 | 12-24 | 12-55 | 12-85 | 13-16 | 13-46 | 13-76 | 14-07 | 14-37 | 14-68 | 14-98 | 2 |
| 2½ | -25 | -55 | -86 | -16 | -47 | -77 | -08 | -38 | -69 | -99 | 2½ |
| 2¾ | -25 | -56 | -86 | -17 | -47 | -78 | -08 | -39 | -69 | -100 | 2¾ |
| 2¼ | -26 | -56 | -87 | -17 | -48 | -78 | -09 | -39 | -70 | -100 | 2¼ |
| 3 | 12-27 | 12-57 | 12-88 | 13-18 | 13-49 | 13-79 | 14-10 | 14-40 | 14-70 | 15-01 | 3 |
| 3½ | -27 | -58 | -88 | -19 | -49 | -80 | -10 | -41 | -71 | -02 | 3½ |
| 3¾ | -28 | -58 | -89 | -19 | -50 | -80 | -11 | -41 | -72 | -02 | 3¾ |
| 3¼ | -29 | -59 | -90 | -20 | -50 | -81 | -11 | -42 | -72 | -03 | 3¼ |
| 4 | 12-29 | 12-60 | 12-90 | 13-21 | 13-51 | 13-82 | 14-12 | 14-43 | 14-73 | 15-03 | 4 |
| 4½ | -30 | -60 | -91 | -21 | -52 | -82 | -13 | -43 | -74 | -04 | 4½ |
| 4¾ | -30 | -61 | -91 | -22 | -52 | -83 | -13 | -44 | -74 | -05 | 4¾ |
| 4¼ | -31 | -62 | -92 | -23 | -53 | -83 | -14 | -44 | -75 | -05 | 4¼ |
| 5 | 12-32 | 12-62 | 12-93 | 13-23 | 13-54 | 13-84 | 14-15 | 14-45 | 14-76 | 15-06 | 5 |
| 5½ | -32 | -63 | -93 | -24 | -54 | -85 | -15 | -46 | -76 | -07 | 5½ |
| 5¾ | -33 | -63 | -94 | -24 | -55 | -85 | -16 | -46 | -77 | -07 | 5¾ |
| 5¼ | -34 | -64 | -95 | -25 | -56 | -86 | -17 | -47 | -77 | -08 | 5¼ |
| 6 | 12-34 | 12-65 | 12-95 | 13-26 | 13-56 | 13-87 | 14-17 | 14-48 | 14-78 | 15-09 | 6 |
| 6½ | -35 | -65 | -96 | -26 | -57 | -87 | -18 | -48 | -79 | -09 | 6½ |
| 6¾ | -36 | -66 | -96 | -27 | -57 | -88 | -18 | -49 | -79 | -10 | 6¾ |
| 6¼ | -36 | -67 | -97 | -28 | -58 | -89 | -19 | -50 | -80 | -10 | 6¼ |
| 7 | 12-37 | 12-67 | 12-98 | 13-28 | 13-59 | 13-89 | 14-20 | 14-50 | 14-81 | 15-11 | 7 |
| 7½ | -37 | -68 | -98 | -29 | -59 | -90 | -21 | -51 | -81 | -12 | 7½ |
| 7¾ | -38 | -69 | -99 | -30 | -60 | -90 | -21 | -51 | -82 | -12 | 7¾ |
| 7¼ | -39 | -69 | 13-00 | -30 | -61 | -91 | -22 | -52 | -83 | -13 | 7¼ |
| 8 | 12-39 | 12-70 | 13-00 | 13-31 | 13-61 | 13-92 | 14-22 | 14-53 | 14-83 | 15-14 | 8 |
| 8½ | -40 | -70 | -01 | -31 | -62 | -92 | -23 | -53 | -84 | -14 | 8½ |
| 8¾ | -41 | -71 | -02 | -32 | -63 | -93 | -23 | -54 | -84 | -15 | 8¾ |
| 8¼ | -41 | -72 | -02 | -33 | -63 | -94 | -24 | -55 | -85 | -16 | 8¼ |
| 9 | 12-42 | 12-72 | 13-03 | 13-33 | 13-64 | 13-94 | 14-25 | 14-55 | 14-86 | 15-16 | 9 |
| 9½ | -43 | -73 | -03 | -34 | -64 | -95 | -26 | -56 | -86 | -17 | 9½ |
| 9¾ | -43 | -74 | -04 | -35 | -65 | -96 | -26 | -57 | -87 | -17 | 9¾ |
| 9¼ | -44 | -74 | -05 | -35 | -66 | -96 | -27 | -57 | -88 | -18 | 9¼ |
| 10 | 12-44 | 12-75 | 13-05 | 13-36 | 13-66 | 13-97 | 14-27 | 14-58 | 14-88 | 15-19 | 10 |
| 10½ | -45 | -76 | -06 | -36 | -67 | -97 | -29 | -58 | -89 | -19 | 10½ |
| 10¾ | -46 | -76 | -07 | -37 | -68 | -98 | -29 | -59 | -90 | -20 | 10¾ |
| 10¼ | -46 | -77 | -07 | -38 | -68 | -99 | -29 | -60 | -90 | -21 | 10¼ |
| 11 | 12-47 | 12-77 | 13-08 | 13-38 | 13-69 | 13-99 | 14-30 | 14-60 | 14-91 | 15-21 | 11 |
| 11½ | -48 | -78 | -09 | -39 | -70 | -100 | -31 | -61 | -91 | -22 | 11½ |
| 11¾ | -48 | -79 | -09 | -40 | -70 | -01 | -31 | -62 | -92 | -23 | 11¾ |
| 11¼ | -49 | -79 | -10 | -40 | -71 | -01 | -32 | -62 | -93 | -23 | 11¼ |

| | 50 | 51 | 52 | 53 | 54 | 55 | 56 | 57 | 58 | 59 | |
|-----|-------|-------|-------|-------|-------|-------|-------|-------|-------|-------|-----|
| 0 | 15-24 | 15-54 | 15-85 | 16-15 | 16-46 | 16-76 | 17-07 | 17-37 | 17-68 | 17-98 | 0 |
| 0½ | -24 | -55 | -85 | -16 | -46 | -77 | -07 | -38 | -68 | -99 | 0½ |
| 0¾ | -25 | -56 | -86 | -17 | -47 | -77 | -08 | -38 | -69 | -99 | 0¾ |
| 0¼ | -26 | -56 | -87 | -17 | -48 | -78 | -09 | -39 | -70 | -100 | 0¼ |
| 1 | 15-26 | 15-57 | 15-87 | 16-18 | 16-48 | 16-79 | 17-09 | 17-40 | 17-70 | 18-01 | 1 |
| 1½ | -27 | -57 | -88 | -18 | -49 | -79 | -10 | -40 | -71 | -01 | 1½ |
| 1¾ | -28 | -58 | -89 | -19 | -50 | -80 | -11 | -41 | -71 | -02 | 1¾ |
| 1¼ | -28 | -59 | -89 | -20 | -50 | -81 | -11 | -42 | -72 | -03 | 1¼ |
| 2 | 15-29 | 15-59 | 15-90 | 16-20 | 16-51 | 16-81 | 17-12 | 17-42 | 17-73 | 18-03 | 2 |
| 2½ | -30 | -60 | -90 | -21 | -51 | -82 | -12 | -43 | -73 | -04 | 2½ |
| 2¾ | -30 | -61 | -91 | -22 | -52 | -83 | -13 | -44 | -74 | -04 | 2¾ |
| 2¼ | -31 | -61 | -92 | -22 | -53 | -83 | -14 | -44 | -75 | -05 | 2¼ |
| 3 | 15-31 | 15-62 | 15-92 | 16-23 | 16-53 | 16-84 | 17-14 | 17-45 | 17-75 | 18-06 | 3 |
| 3½ | -32 | -63 | -93 | -24 | -54 | -84 | -15 | -45 | -76 | -06 | 3½ |
| 3¾ | -33 | -63 | -94 | -24 | -55 | -85 | -16 | -46 | -77 | -07 | 3¾ |
| 3¼ | -33 | -64 | -94 | -25 | -55 | -86 | -16 | -47 | -77 | -08 | 3¼ |
| 4 | 15-34 | 15-64 | 15-95 | 16-25 | 16-56 | 16-86 | 17-17 | 17-47 | 17-78 | 18-08 | 4 |
| 4½ | -35 | -65 | -96 | -26 | -57 | -87 | -17 | -48 | -78 | -09 | 4½ |
| 4¾ | -35 | -66 | -96 | -27 | -57 | -88 | -18 | -49 | -79 | -10 | 4¾ |
| 4¼ | -36 | -66 | -97 | -27 | -58 | -88 | -19 | -49 | -80 | -10 | 4¼ |
| 5 | 15-37 | 15-67 | 15-97 | 16-28 | 16-58 | 16-89 | 17-19 | 17-50 | 17-80 | 18-11 | 5 |
| 5½ | -37 | -68 | -98 | -29 | -59 | -90 | -20 | -51 | -81 | -11 | 5½ |
| 5¾ | -38 | -68 | -99 | -29 | -60 | -90 | -21 | -51 | -82 | -12 | 5¾ |
| 5¼ | -38 | -69 | -99 | -30 | -60 | -91 | -21 | -52 | -82 | -13 | 5¼ |
| 6 | 15-39 | 15-70 | 16-00 | 16-30 | 16-61 | 16-91 | 17-22 | 17-52 | 17-83 | 18-13 | 6 |
| 6½ | -40 | -70 | -01 | -31 | -62 | -92 | -23 | -53 | -84 | -14 | 6½ |
| 6¾ | -40 | -71 | -01 | -32 | -62 | -93 | -23 | -54 | -84 | -15 | 6¾ |
| 6¼ | -41 | -71 | -02 | -32 | -63 | -93 | -24 | -54 | -85 | -15 | 6¼ |
| 7 | 15-42 | 15-72 | 16-03 | 16-33 | 16-64 | 16-94 | 17-24 | 17-55 | 17-85 | 18-16 | 7 |
| 7½ | -42 | -73 | -03 | -34 | -64 | -95 | -25 | -56 | -86 | -17 | 7½ |
| 7¾ | -43 | -73 | -04 | -34 | -65 | -95 | -26 | -56 | -87 | -17 | 7¾ |
| 7¼ | -44 | -74 | -04 | -35 | -65 | -96 | -26 | -57 | -87 | -18 | 7¼ |
| 8 | 15-44 | 15-75 | 16-05 | 16-36 | 16-66 | 16-97 | 17-27 | 17-57 | 17-88 | 18-18 | 8 |
| 8½ | -45 | -75 | -06 | -36 | -67 | -97 | -28 | -58 | -89 | -19 | 8½ |
| 8¾ | -45 | -76 | -06 | -37 | -67 | -98 | -29 | -59 | -89 | -20 | 8¾ |
| 8¼ | -46 | -77 | -07 | -37 | -68 | -99 | -29 | -59 | -90 | -20 | 8¼ |
| 9 | 15-47 | 15-77 | 16-08 | 16-38 | 16-69 | 16-99 | 17-30 | 17-60 | 17-91 | 18-21 | 9 |
| 9½ | -47 | -78 | -08 | -39 | -69 | 17-00 | -30 | -61 | -91 | -22 | 9½ |
| 9¾ | -48 | -78 | -09 | -39 | -70 | -00 | -31 | -61 | -92 | -22 | 9¾ |
| 9¼ | -49 | -79 | -10 | -40 | -71 | -01 | -31 | -62 | -92 | -23 | 9¼ |
| 10 | 15-49 | 15-80 | 16-10 | 16-41 | 16-71 | 17-02 | 17-32 | 17-63 | 17-93 | 18-24 | 10 |
| 10½ | -50 | -80 | -11 | -41 | -72 | -02 | -33 | -63 | -94 | -24 | 10½ |
| 10¾ | -50 | -81 | -11 | -42 | -72 | -03 | -33 | -64 | -94 | -25 | 10¾ |
| 10¼ | -51 | -82 | -12 | -43 | -73 | -04 | -34 | -64 | -95 | -25 | 10¼ |
| 11 | 15-52 | 15-82 | 16-13 | 16-43 | 16-74 | 17-04 | 17-35 | 17-65 | 17-96 | 18-26 | 11 |
| 11½ | -52 | -83 | -13 | -44 | -74 | -05 | -35 | -66 | -96 | -27 | 11½ |
| 11¾ | -53 | -84 | -14 | -44 | -75 | -06 | -36 | -66 | -97 | -27 | 11¾ |
| 11¼ | -54 | -84 | -15 | -45 | -76 | -06 | -37 | -67 | -98 | -28 | 11¼ |

| | 60 | 61 | 62 | 63 | 64 | 65 | 66 | 67 | 68 | 69 | |
|--------|-------|-------|-------|-------|-------|-------|-------|-------|-------|-------|--------|
| 0 | 18-29 | 18-59 | 18-90 | 19-20 | 19-51 | 19-81 | 20-11 | 20-42 | 20-72 | 21-03 | 0 |
| 0 1/2 | -29 | -60 | -90 | -21 | -51 | -82 | -12 | -43 | -73 | -04 | 0 1/2 |
| 0 1/2 | -30 | -60 | -91 | -21 | -52 | -83 | -13 | -43 | -74 | -04 | 0 1/2 |
| 0 1/2 | -31 | -61 | -91 | -22 | -52 | -83 | -13 | -44 | -74 | -05 | 0 1/2 |
| 1 | 18-31 | 18-62 | 18-92 | 19-23 | 19-53 | 19-84 | 20-14 | 20-44 | 20-75 | 21-05 | 1 |
| 1 1/2 | -32 | -62 | -93 | -23 | -54 | -84 | -15 | -45 | -76 | -06 | 1 1/2 |
| 1 1/2 | -32 | -63 | -93 | -24 | -54 | -85 | -15 | -46 | -76 | -07 | 1 1/2 |
| 1 1/2 | -33 | -64 | -94 | -25 | -55 | -85 | -16 | -46 | -77 | -07 | 1 1/2 |
| 2 | 18-34 | 18-64 | 18-95 | 19-25 | 19-56 | 19-86 | 20-17 | 20-47 | 20-78 | 21-08 | 2 |
| 2 1/2 | -34 | -65 | -95 | -26 | -56 | -87 | -17 | -48 | -78 | -09 | 2 1/2 |
| 2 1/2 | -35 | -65 | -96 | -26 | -57 | -87 | -18 | -48 | -79 | -09 | 2 1/2 |
| 2 1/2 | -36 | -66 | -97 | -27 | -58 | -88 | -18 | -49 | -79 | -10 | 2 1/2 |
| 3 | 18-36 | 18-67 | 18-97 | 19-28 | 19-58 | 19-89 | 20-19 | 20-50 | 20-80 | 21-11 | 3 |
| 3 1/2 | -37 | -67 | -98 | -28 | -59 | -89 | -20 | -50 | -81 | -11 | 3 1/2 |
| 3 1/2 | -38 | -68 | -98 | -29 | -59 | -90 | -20 | -51 | -81 | -12 | 3 1/2 |
| 3 1/2 | -38 | -69 | -99 | -30 | -60 | -91 | -21 | -52 | -82 | -12 | 3 1/2 |
| 4 | 18-39 | 18-69 | 19-00 | 19-30 | 19-61 | 19-91 | 20-22 | 20-53 | 20-83 | 21-13 | 4 |
| 4 1/2 | -39 | -70 | -00 | -31 | -61 | -92 | -22 | -53 | -83 | -14 | 4 1/2 |
| 4 1/2 | -40 | -71 | -01 | -31 | -62 | -92 | -23 | -53 | -84 | -14 | 4 1/2 |
| 4 1/2 | -41 | -71 | -02 | -32 | -63 | -93 | -24 | -54 | -85 | -15 | 4 1/2 |
| 5 | 18-41 | 18-72 | 19-02 | 19-33 | 19-63 | 19-94 | 20-24 | 20-55 | 20-85 | 21-16 | 5 |
| 5 1/2 | -42 | -72 | -03 | -33 | -64 | -94 | -25 | -55 | -86 | -16 | 5 1/2 |
| 5 1/2 | -43 | -73 | -04 | -34 | -65 | -95 | -25 | -56 | -86 | -17 | 5 1/2 |
| 5 1/2 | -43 | -74 | -04 | -35 | -65 | -96 | -26 | -57 | -87 | -18 | 5 1/2 |
| 6 | 18-44 | 18-74 | 19-05 | 19-35 | 19-66 | 19-96 | 20-27 | 20-57 | 20-88 | 21-18 | 6 |
| 6 1/2 | -44 | -75 | -05 | -36 | -66 | -97 | -27 | -58 | -88 | -19 | 6 1/2 |
| 6 1/2 | -45 | -76 | -06 | -37 | -67 | -98 | -28 | -58 | -89 | -19 | 6 1/2 |
| 6 1/2 | -46 | -76 | -07 | -37 | -68 | -98 | -29 | -59 | -90 | -20 | 6 1/2 |
| 7 | 18-46 | 18-77 | 19-07 | 19-38 | 19-68 | 19-99 | 20-29 | 20-60 | 20-90 | 21-21 | 7 |
| 7 1/2 | -47 | -78 | -08 | -38 | -69 | -99 | -30 | -60 | -91 | -21 | 7 1/2 |
| 7 1/2 | -48 | -78 | -09 | -39 | -70 | 00 | -31 | -61 | -92 | -22 | 7 1/2 |
| 7 1/2 | -48 | -79 | -09 | -40 | -70 | -01 | -31 | -62 | -92 | -23 | 7 1/2 |
| 8 | 18-49 | 18-79 | 19-10 | 19-40 | 19-71 | 20-01 | 20-32 | 20-62 | 20-93 | 21-23 | 8 |
| 8 1/2 | -50 | -80 | -11 | -41 | -71 | -02 | -32 | -63 | -93 | -24 | 8 1/2 |
| 8 1/2 | -50 | -81 | -11 | -42 | -72 | -03 | -33 | -64 | -94 | -25 | 8 1/2 |
| 8 1/2 | -51 | -81 | -12 | -42 | -73 | -03 | -34 | -64 | -95 | -25 | 8 1/2 |
| 9 | 18-51 | 18-82 | 19-12 | 19-43 | 19-73 | 20-04 | 20-34 | 20-65 | 20-95 | 21-26 | 9 |
| 9 1/2 | -52 | -83 | -13 | -44 | -74 | -05 | -35 | -65 | -96 | -26 | 9 1/2 |
| 9 1/2 | -53 | -83 | -14 | -44 | -75 | -05 | -36 | -66 | -97 | -27 | 9 1/2 |
| 9 1/2 | -53 | -84 | -14 | -45 | -75 | -06 | -36 | -67 | -97 | -28 | 9 1/2 |
| 10 | 18-54 | 18-84 | 19-15 | 19-45 | 19-76 | 20-06 | 20-37 | 20-67 | 20-98 | 21-28 | 10 |
| 10 1/2 | -55 | -85 | -16 | -46 | -77 | -07 | -38 | -68 | -99 | -29 | 10 1/2 |
| 10 1/2 | -55 | -86 | -16 | -47 | -77 | -08 | -38 | -69 | -99 | -30 | 10 1/2 |
| 10 1/2 | -56 | -86 | -17 | -47 | -78 | -08 | -39 | -69 | -100 | -30 | 10 1/2 |
| 11 | 18-57 | 18-87 | 19-18 | 19-48 | 19-78 | 20-09 | 20-39 | 20-70 | 21-00 | 21-31 | 11 |
| 11 1/2 | -57 | -88 | -18 | -49 | -79 | -10 | -40 | -71 | -01 | -32 | 11 1/2 |
| 11 1/2 | -58 | -88 | -19 | -49 | -80 | -10 | -41 | -71 | -02 | -32 | 11 1/2 |
| 11 1/2 | -58 | -89 | -19 | -50 | -80 | -11 | -41 | -72 | -02 | -33 | 11 1/2 |

| | 70 | 71 | 72 | 73 | 74 | 75 | 76 | 77 | 78 | 79 | |
|--------|-------|-------|-------|-------|-------|-------|-------|-------|-------|-------|--------|
| 0 | 21-33 | 21-64 | 21-94 | 22-25 | 22-55 | 22-86 | 23-16 | 23-47 | 23-77 | 24-08 | 0 |
| 0 1/2 | -34 | -65 | -95 | -25 | -56 | -86 | -17 | -47 | -78 | -08 | 0 1/2 |
| 0 1/2 | -35 | -65 | -96 | -26 | -57 | -87 | -18 | -48 | -79 | -09 | 0 1/2 |
| 0 1/2 | -35 | -66 | -96 | -27 | -57 | -88 | -18 | -49 | -79 | -10 | 0 1/2 |
| 1 | 21-36 | 21-66 | 21-97 | 22-27 | 22-58 | 22-88 | 23-19 | 23-49 | 23-80 | 24-10 | 1 |
| 1 1/2 | -37 | -67 | -98 | -28 | -59 | -89 | -19 | -50 | -80 | -11 | 1 1/2 |
| 1 1/2 | -37 | -68 | -98 | -29 | -59 | -90 | -20 | -51 | -81 | -12 | 1 1/2 |
| 1 1/2 | -38 | -68 | -99 | -29 | -60 | -90 | -21 | -51 | -82 | -12 | 1 1/2 |
| 2 | 21-38 | 21-69 | 21-99 | 22-30 | 22-60 | 22-91 | 23-21 | 23-52 | 23-82 | 24-13 | 2 |
| 2 1/2 | -39 | -70 | -100 | -31 | -61 | -92 | -22 | -52 | -83 | -13 | 2 1/2 |
| 2 1/2 | -40 | -70 | -01 | -31 | -62 | -92 | -23 | -53 | -84 | -14 | 2 1/2 |
| 2 1/2 | -40 | -71 | -01 | -32 | -62 | -93 | -23 | -54 | -84 | -15 | 2 1/2 |
| 3 | 21-41 | 21-72 | 22-02 | 22-32 | 22-63 | 22-93 | 23-24 | 23-54 | 23-85 | 24-15 | 3 |
| 3 1/2 | -42 | -72 | -03 | -33 | -64 | -94 | -25 | -55 | -86 | -16 | 3 1/2 |
| 3 1/2 | -42 | -73 | -03 | -34 | -64 | -95 | -25 | -56 | -86 | -17 | 3 1/2 |
| 3 1/2 | -43 | -73 | -04 | -34 | -65 | -95 | -26 | -56 | -87 | -17 | 3 1/2 |
| 4 | 21-44 | 21-74 | 22-05 | 22-35 | 22-65 | 22-96 | 23-26 | 23-57 | 23-87 | 24-18 | 4 |
| 4 1/2 | -44 | -75 | -05 | -36 | -66 | -97 | -27 | -58 | -88 | -19 | 4 1/2 |
| 4 1/2 | -45 | -75 | -06 | -36 | -67 | -97 | -28 | -58 | -89 | -19 | 4 1/2 |
| 4 1/2 | -45 | -76 | -06 | -37 | -67 | -98 | -28 | -59 | -89 | -20 | 4 1/2 |
| 5 | 21-46 | 21-77 | 22-07 | 22-38 | 22-68 | 22-99 | 23-29 | 23-59 | 23-90 | 24-20 | 5 |
| 5 1/2 | -47 | -77 | -08 | -38 | -69 | -99 | -30 | -60 | -91 | -21 | 5 1/2 |
| 5 1/2 | -47 | -78 | -08 | -39 | -69 | 00 | -31 | -61 | -91 | -22 | 5 1/2 |
| 5 1/2 | -48 | -79 | -09 | -39 | -70 | -00 | -31 | -61 | -92 | -22 | 5 1/2 |
| 6 | 21-49 | 21-79 | 22-10 | 22-40 | 22-71 | 23-01 | 23-32 | 23-63 | 23-92 | 24-23 | 6 |
| 6 1/2 | -49 | -80 | -10 | -41 | -71 | -02 | -32 | -63 | -93 | -24 | 6 1/2 |
| 6 1/2 | -50 | -80 | -11 | -41 | -72 | -02 | -33 | -64 | -94 | -24 | 6 1/2 |
| 6 1/2 | -51 | -81 | -12 | -42 | -72 | -03 | -33 | -64 | -94 | -25 | 6 1/2 |
| 7 | 21-51 | 21-82 | 22-12 | 22-43 | 22-73 | 23-04 | 23-34 | 23-65 | 23-95 | 24-26 | 7 |
| 7 1/2 | -52 | -82 | -13 | -43 | -73 | -04 | -35 | -65 | -96 | -26 | 7 1/2 |
| 7 1/2 | -52 | -83 | -13 | -44 | -74 | -05 | -35 | -66 | -96 | -27 | 7 1/2 |
| 7 1/2 | -53 | -84 | -14 | -45 | -75 | -06 | -36 | -66 | -97 | -27 | 7 1/2 |
| 8 | 21-54 | 21-84 | 22-15 | 22-45 | 22-76 | 23-06 | 23-37 | 23-67 | 23-98 | 24-28 | 8 |
| 8 1/2 | -54 | -85 | -15 | -46 | -76 | -07 | -37 | -68 | -98 | -29 | 8 1/2 |
| 8 1/2 | -55 | -85 | -16 | -46 | -77 | -07 | -38 | -68 | -99 | -29 | 8 1/2 |
| 8 1/2 | -56 | -86 | -17 | -47 | -78 | -08 | -39 | -69 | -99 | -30 | 8 1/2 |
| 9 | 21-56 | 21-87 | 22-17 | 22-48 | 22-78 | 23-09 | 23-39 | 23-70 | 24-00 | 24-31 | 9 |
| 9 1/2 | -57 | -87 | -18 | -48 | -79 | -09 | -40 | -70 | -01 | -31 | 9 1/2 |
| 9 1/2 | -58 | -88 | -19 | -49 | -79 | -10 | -40 | -71 | -01 | -32 | 9 1/2 |
| 9 1/2 | -58 | -89 | -19 | -50 | -80 | -11 | -41 | -72 | -02 | -33 | 9 1/2 |
| 10 | 21-59 | 21-89 | 22-20 | 22-50 | 22-81 | 23-11 | 23-42 | 23-72 | 24-03 | 24-33 | 10 |
| 10 1/2 | -59 | -90 | -20 | -51 | -81 | -12 | -42 | -73 | -03 | -34 | 10 1/2 |
| 10 1/2 | -60 | -91 | -21 | -52 | -82 | -12 | -43 | -74 | -04 | -34 | 10 1/2 |
| 10 1/2 | -61 | -91 | -22 | -52 | -83 | -13 | -44 | -74 | -05 | -35 | 10 1/2 |
| 11 | 21-61 | 21-92 | 22-22 | 22-53 | 22-83 | 23-14 | 23-44 | 23-75 | 24-05 | 24-36 | 11 |
| 11 1/2 | -62 | -92 | -23 | -53 | -84 | -14 | -45 | -75 | -06 | -36 | 11 1/2 |
| 11 1/2 | -63 | -93 | -24 | -54 | -85 | -15 | -46 | -76 | -06 | -37 | 11 1/2 |
| 11 1/2 | -63 | -94 | -24 | -55 | -85 | -16 | -46 | -77 | -07 | -38 | 11 1/2 |

22



| | 80 | 81 | 82 | 83 | 84 | 85 | 86 | 87 | 88 | 89 | |
|-----|-------|-------|-------|-------|-------|-------|-------|-------|-------|-------|-----|
| 0 | 24.38 | 24.69 | 24.99 | 25.30 | 25.60 | 25.91 | 26.21 | 26.52 | 26.82 | 27.13 | 0 |
| 0½ | .39 | .60 | .25 | .00 | -.30 | -.61 | -.91 | -.22 | -.52 | -.83 | 0½ |
| 0¼ | .39 | .70 | .00 | -.31 | -.61 | -.92 | -.22 | -.53 | -.83 | -.14 | 0¼ |
| 0⅓ | .40 | .71 | -.01 | -.32 | -.62 | -.93 | -.23 | -.53 | -.84 | -.14 | 0⅓ |
| 1 | 24.41 | 24.71 | 25.02 | 25.32 | 25.63 | 25.93 | 26.24 | 26.54 | 26.85 | 27.15 | 1 |
| 1½ | .41 | .72 | .02 | -.33 | -.63 | -.94 | -.24 | -.55 | -.85 | -.16 | 1½ |
| 1¼ | .42 | .77 | .03 | -.33 | -.64 | -.94 | -.25 | -.55 | -.86 | -.16 | 1¼ |
| 1⅓ | .43 | .73 | .04 | -.34 | -.65 | -.95 | -.26 | -.56 | -.87 | -.17 | 1⅓ |
| 2 | 24.43 | 24.73 | 25.04 | 25.35 | 25.65 | 25.96 | 26.26 | 26.57 | 26.87 | 27.18 | 2 |
| 2½ | .44 | .74 | .05 | -.35 | -.66 | -.96 | -.27 | -.57 | -.88 | -.18 | 2½ |
| 2¼ | .45 | .75 | .06 | -.36 | -.66 | -.97 | -.28 | -.58 | -.88 | -.19 | 2¼ |
| 2⅓ | .45 | .76 | .06 | -.37 | -.67 | -.98 | -.28 | -.59 | -.89 | -.20 | 2⅓ |
| 3 | 24.46 | 24.76 | 25.07 | 25.37 | 25.68 | 25.98 | 26.29 | 26.59 | 26.90 | 27.20 | 3 |
| 3½ | .46 | .77 | .07 | -.38 | -.68 | -.99 | -.29 | -.60 | -.90 | -.21 | 3½ |
| 3¼ | .47 | .78 | .08 | -.39 | -.69 | -1.00 | -.30 | -.60 | -.91 | -.21 | 3¼ |
| 3⅓ | .48 | .78 | .09 | -.39 | -.70 | -.00 | -.31 | -.61 | -.92 | -.22 | 3⅓ |
| 4 | 24.48 | 24.79 | 25.09 | 25.40 | 25.70 | 26.01 | 26.31 | 26.62 | 26.92 | 27.23 | 4 |
| 4½ | .49 | .79 | .10 | -.40 | -.71 | -.01 | -.32 | -.62 | -.93 | -.23 | 4½ |
| 4¼ | .50 | .80 | .11 | -.41 | -.72 | -.02 | -.33 | -.63 | -.93 | -.24 | 4¼ |
| 4⅓ | .50 | .81 | .11 | -.42 | -.72 | -.03 | -.33 | -.64 | -.94 | -.25 | 4⅓ |
| 5 | 24.51 | 24.81 | 25.12 | 25.42 | 25.73 | 26.03 | 26.34 | 26.64 | 26.95 | 27.25 | 5 |
| 5½ | .52 | .82 | .13 | -.43 | -.73 | -.04 | -.34 | -.65 | -.95 | -.26 | 5½ |
| 5¼ | .52 | .83 | .13 | -.44 | -.74 | -.05 | -.35 | -.66 | -.96 | -.27 | 5¼ |
| 5⅓ | .53 | .83 | .14 | -.44 | -.75 | -.05 | -.36 | -.66 | -.97 | -.27 | 5⅓ |
| 6 | 24.53 | 24.84 | 25.14 | 25.45 | 25.75 | 26.06 | 26.36 | 26.67 | 26.97 | 27.28 | 6 |
| 6½ | .54 | .85 | .15 | -.46 | -.76 | -.06 | -.37 | -.67 | -.98 | -.28 | 6½ |
| 6¼ | .55 | .85 | .16 | -.46 | -.77 | -.07 | -.38 | -.68 | -.99 | -.29 | 6¼ |
| 6⅓ | .55 | .86 | .18 | -.47 | -.77 | -.08 | -.38 | -.69 | -.99 | -.30 | 6⅓ |
| 7 | 24.56 | 24.86 | 25.17 | 25.47 | 25.78 | 26.08 | 26.39 | 26.69 | 27.00 | 27.30 | 7 |
| 7½ | .57 | .87 | .18 | -.48 | -.79 | -.09 | -.40 | -.70 | -.00 | -.31 | 7½ |
| 7¼ | .57 | .88 | .18 | -.49 | -.79 | -.10 | -.40 | -.71 | -.01 | -.32 | 7¼ |
| 7⅓ | .58 | .88 | .19 | -.49 | -.80 | -.10 | -.41 | -.71 | -.02 | -.32 | 7⅓ |
| 8 | 24.59 | 24.89 | 25.19 | 25.50 | 25.80 | 26.11 | 26.41 | 26.72 | 27.02 | 27.33 | 8 |
| 8½ | .59 | .90 | .20 | -.51 | -.81 | -.12 | -.42 | -.73 | -.03 | -.33 | 8½ |
| 8¼ | .60 | .90 | .21 | -.51 | -.82 | -.12 | -.43 | -.73 | -.04 | -.34 | 8¼ |
| 8⅓ | .60 | .91 | .21 | -.52 | -.82 | -.13 | -.43 | -.74 | -.04 | -.35 | 8⅓ |
| 9 | 24.61 | 24.92 | 25.22 | 25.53 | 25.83 | 26.13 | 26.44 | 26.74 | 27.05 | 27.35 | 9 |
| 9½ | .62 | .92 | .23 | -.53 | -.84 | -.14 | -.45 | -.75 | -.06 | -.36 | 9½ |
| 9¼ | .62 | .93 | .23 | -.54 | -.84 | -.15 | -.45 | -.76 | -.06 | -.37 | 9¼ |
| 9⅓ | .63 | .93 | .24 | -.54 | -.85 | -.15 | -.46 | -.76 | -.07 | -.37 | 9⅓ |
| 10 | 24.64 | 24.94 | 25.25 | 25.55 | 25.86 | 26.16 | 26.47 | 26.77 | 27.08 | 27.38 | 10 |
| 10½ | .64 | .95 | .25 | -.56 | -.86 | -.17 | -.47 | -.78 | -.08 | -.39 | 10½ |
| 10¼ | .65 | .95 | .26 | -.56 | -.87 | -.17 | -.48 | -.78 | -.09 | -.39 | 10¼ |
| 10⅓ | .66 | .96 | .26 | -.57 | -.87 | -.18 | -.48 | -.79 | -.09 | -.40 | 10⅓ |
| 11 | 24.66 | 24.97 | 25.27 | 25.58 | 25.88 | 26.19 | 26.49 | 26.80 | 27.10 | 27.40 | 11 |
| 11½ | .67 | .97 | .28 | -.58 | -.89 | -.19 | -.50 | -.80 | -.11 | -.41 | 11½ |
| 11¼ | .67 | .98 | .28 | -.59 | -.89 | -.20 | -.50 | -.81 | -.11 | -.42 | 11¼ |
| 11⅓ | .68 | .99 | .29 | -.60 | -.90 | -.20 | -.51 | -.81 | -.12 | -.42 | 11⅓ |

FEET AND INCHES TO METRES.
(70 ft. - 349 ft. 11 inches in inches)

| | Feet | 70 | 71 | 72 | 73 | 74 | 75 | 76 | 77 | 78 | 79 | |
|--------|-------|-------|-------|-------|-------|-------|-------|-------|-------|-------|----|--|
| Inches | | | | | | | | | | | | |
| 0 | 21.34 | 21.64 | 21.94 | 22.26 | 22.56 | 22.86 | 23.16 | 23.48 | 23.78 | 24.08 | 0 | |
| 1 | .36 | .66 | .98 | .28 | .58 | .88 | .20 | .50 | .80 | .10 | 1 | |
| 2 | .38 | .70 | 1.00 | .30 | .60 | .92 | .22 | .52 | .82 | .14 | 2 | |
| 3 | .42 | .72 | .02 | .32 | .64 | .94 | .24 | .54 | .86 | .16 | 3 | |
| 4 | .44 | .74 | .04 | .36 | .66 | .96 | .26 | .58 | .88 | .18 | 4 | |
| 5 | .46 | .78 | .08 | .38 | .68 | .98 | .30 | .60 | .90 | .20 | 5 | |
| 6 | .50 | .80 | .10 | .40 | .72 | 1.02 | .32 | .62 | .92 | .24 | 6 | |
| 7 | .52 | .82 | .12 | .44 | .74 | .04 | .34 | .66 | .96 | .26 | 7 | |
| 8 | .54 | .84 | .16 | .46 | .76 | .06 | .38 | .68 | .98 | .28 | 8 | |
| 9 | .56 | .88 | .18 | .48 | .78 | .10 | .40 | .70 | 1.00 | .32 | 9 | |
| 10 | .60 | .90 | .20 | .50 | .82 | .12 | .42 | .72 | .04 | .34 | 10 | |
| 11 | .62 | .92 | .22 | .54 | .84 | .14 | .44 | .76 | .06 | .36 | 11 | |
| | 80 | 81 | 82 | 83 | 84 | 85 | 86 | 87 | 88 | 89 | | |
| 0 | 24.38 | 24.70 | 25.00 | 25.30 | 25.60 | 25.92 | 26.22 | 26.52 | 26.82 | 27.12 | 0 | |
| 1 | .42 | .72 | .02 | .32 | .64 | .94 | .24 | .54 | .86 | .16 | 1 | |
| 2 | .44 | .74 | .04 | .36 | .66 | .96 | .26 | .58 | .88 | .18 | 2 | |
| 3 | .46 | .76 | .08 | .38 | .68 | .98 | .30 | .60 | .90 | .20 | 3 | |
| 4 | .48 | .80 | .10 | .40 | .70 | 1.02 | .32 | .62 | .92 | .24 | 4 | |
| 5 | .52 | .82 | .12 | .42 | .74 | .04 | .34 | .64 | .96 | .26 | 5 | |
| 6 | .54 | .84 | .14 | .46 | .76 | .06 | .36 | .68 | .98 | .28 | 6 | |
| 7 | .56 | .86 | .18 | .48 | .78 | .10 | .40 | .70 | 1.00 | .30 | 7 | |
| 8 | .58 | .90 | .20 | .50 | .80 | .12 | .42 | .72 | .02 | .34 | 8 | |
| 9 | .62 | .92 | .22 | .52 | .84 | .14 | .44 | .74 | .06 | .36 | 9 | |
| 10 | .64 | .94 | .26 | .56 | .86 | .16 | .46 | .78 | .08 | .38 | 10 | |
| 11 | .66 | .98 | .28 | .58 | .88 | .20 | .50 | .80 | .10 | .40 | 11 | |
| | 90 | 91 | 92 | 93 | 94 | 95 | 96 | 97 | 98 | 99 | | |
| 0 | 27.44 | 27.74 | 28.04 | 28.34 | 28.66 | 28.96 | 29.26 | 29.56 | 29.88 | 30.18 | 0 | |
| 1 | .46 | .76 | .06 | .38 | .68 | .98 | .28 | .60 | .90 | .20 | 1 | |
| 2 | .48 | .80 | .10 | .40 | .70 | 1.00 | .32 | .62 | .92 | .22 | 2 | |
| 3 | .52 | .82 | .12 | .42 | .74 | .04 | .34 | .64 | .94 | .26 | 3 | |
| 4 | .54 | .84 | .14 | .46 | .76 | .06 | .36 | .66 | .98 | .28 | 4 | |
| 5 | .56 | .86 | .18 | .48 | .78 | .10 | .40 | .70 | 1.00 | .30 | 5 | |
| 6 | .58 | .90 | .20 | .50 | .80 | .12 | .42 | .72 | .02 | .34 | 6 | |
| 7 | .62 | .92 | .22 | .52 | .84 | .14 | .44 | .74 | .06 | .36 | 7 | |
| 8 | .64 | .94 | .24 | .56 | .86 | .16 | .46 | .78 | .08 | .38 | 8 | |
| 9 | .66 | .96 | .28 | .58 | .88 | .18 | .50 | .80 | .10 | .40 | 9 | |
| 10 | .68 | 1.00 | .30 | .60 | .90 | .22 | .52 | .82 | .12 | .44 | 10 | |
| 11 | .72 | .02 | .32 | .64 | .94 | .24 | .54 | .84 | .16 | .46 | 11 | |
| | 100 | 101 | 102 | 103 | 104 | 105 | 106 | 107 | 108 | 109 | | |
| 0 | 30.48 | 30.78 | 31.10 | 31.40 | 31.70 | 32.00 | 32.32 | 32.62 | 32.92 | 33.22 | 0 | |
| 1 | .50 | .82 | .12 | .42 | .72 | .04 | .34 | .64 | .94 | .26 | 1 | |
| 2 | .54 | .84 | .14 | .44 | .76 | .06 | .36 | .66 | .98 | .28 | 2 | |
| 3 | .56 | .86 | .16 | .48 | .78 | .08 | .38 | .70 | 1.00 | .30 | 3 | |
| 4 | .58 | .88 | .20 | .50 | .80 | .10 | .42 | .72 | .02 | .32 | 4 | |
| 5 | .60 | .92 | .22 | .52 | .82 | .14 | .44 | .74 | .04 | .36 | 5 | |
| 6 | .64 | .94 | .24 | .54 | .86 | .16 | .46 | .76 | .08 | .38 | 6 | |
| 7 | .66 | .96 | .28 | .58 | .88 | .18 | .48 | .80 | .10 | .40 | 7 | |
| 8 | .68 | 1.00 | .30 | .60 | .90 | .20 | .52 | .82 | .12 | .42 | 8 | |
| 9 | .72 | .02 | .32 | .62 | .94 | .24 | .54 | .84 | .14 | .46 | 9 | |
| 10 | .74 | .04 | .34 | .66 | .96 | .26 | .56 | .88 | .18 | .48 | 10 | |
| 11 | .76 | .06 | .38 | .68 | .98 | .28 | .60 | .90 | .20 | .50 | 11 | |

| | 110 | 111 | 112 | 113 | 114 | 115 | 116 | 117 | 118 | 119 | |
|----|-------|-------|-------|-------|-------|-------|-------|-------|-------|-------|----|
| 0 | 33.54 | 33.84 | 34.14 | 34.44 | 34.74 | 35.06 | 35.36 | 35.66 | 35.96 | 36.28 | 0 |
| 1 | .56 | .86 | .16 | .48 | .78 | .08 | .38 | .68 | 36.00 | 30 | 1 |
| 2 | .58 | .88 | .20 | .50 | .80 | .10 | .42 | .72 | .02 | .32 | 2 |
| 3 | .60 | .92 | .22 | .52 | .82 | .14 | .44 | .74 | .04 | .36 | 3 |
| 4 | .64 | .94 | .24 | .54 | .86 | .16 | .46 | .76 | .08 | .38 | 4 |
| 5 | .66 | .96 | .26 | .58 | .88 | .18 | .48 | .80 | .10 | .40 | 5 |
| 6 | .68 | .98 | .30 | .60 | .90 | .20 | .52 | .82 | .12 | .42 | 6 |
| 7 | .70 | 34.02 | .32 | .62 | .92 | .24 | .54 | .84 | .14 | .46 | 7 |
| 8 | .74 | .04 | .34 | .64 | .96 | .26 | .56 | .86 | .18 | .48 | 8 |
| 9 | .76 | .06 | .36 | .68 | .98 | .28 | .58 | .90 | .20 | .50 | 9 |
| 10 | .78 | .08 | .40 | .70 | 35.00 | .30 | .62 | .92 | .22 | .52 | 10 |
| 11 | .82 | .12 | .42 | .72 | .02 | .34 | .64 | .94 | .24 | .56 | 11 |

| | 120 | 121 | 122 | 123 | 124 | 125 | 126 | 127 | 128 | 129 | |
|----|-------|-------|-------|-------|-------|-------|-------|-------|-------|-------|----|
| 0 | 36.58 | 36.88 | 37.18 | 37.50 | 37.80 | 38.10 | 38.40 | 38.72 | 39.02 | 39.32 | 0 |
| 1 | .60 | .90 | .22 | .52 | .82 | .12 | .44 | .74 | .04 | .34 | 1 |
| 2 | .62 | .94 | .24 | .54 | .84 | .16 | .46 | .76 | .06 | .38 | 2 |
| 3 | .66 | .96 | .26 | .56 | .88 | .18 | .48 | .78 | .10 | .40 | 3 |
| 4 | .68 | .98 | .28 | .60 | .90 | .20 | .50 | .82 | .12 | .42 | 4 |
| 5 | .70 | 37.02 | .32 | .62 | .92 | .22 | .54 | .84 | .14 | .44 | 5 |
| 6 | .74 | .04 | .34 | .64 | .96 | .26 | .56 | .86 | .16 | .48 | 6 |
| 7 | .76 | .06 | .36 | .68 | .98 | .28 | .58 | .90 | .20 | .50 | 7 |
| 8 | .78 | .08 | .40 | .70 | 38.00 | .30 | .62 | .92 | .22 | .52 | 8 |
| 9 | .80 | .12 | .42 | .72 | .02 | .34 | .64 | .94 | .24 | .56 | 9 |
| 10 | .84 | .14 | .44 | .74 | .06 | .36 | .66 | .96 | .28 | .58 | 10 |
| 11 | .86 | .16 | .46 | .78 | .08 | .38 | .68 | 39.00 | .30 | .60 | 11 |

| | 130 | 131 | 132 | 133 | 134 | 135 | 136 | 137 | 138 | 139 | |
|----|-------|-------|-------|-------|-------|-------|-------|-------|-------|-------|----|
| 0 | 39.62 | 39.94 | 40.24 | 40.54 | 40.84 | 41.16 | 41.46 | 41.76 | 42.06 | 42.36 | 0 |
| 1 | .66 | .96 | .26 | .56 | .88 | .18 | .48 | .78 | .10 | .40 | 1 |
| 2 | .68 | .98 | .28 | .60 | .90 | .20 | .50 | .82 | .12 | .42 | 2 |
| 3 | .70 | 40.00 | .32 | .62 | .92 | .22 | .54 | .84 | .14 | .44 | 3 |
| 4 | .72 | .04 | .34 | .64 | .94 | .26 | .56 | .86 | .16 | .48 | 4 |
| 5 | .76 | .06 | .36 | .66 | .98 | .28 | .58 | .88 | .20 | .50 | 5 |
| 6 | .78 | .08 | .38 | .70 | 41.00 | .30 | .60 | .92 | .22 | .52 | 6 |
| 7 | .80 | .10 | .42 | .72 | .02 | .32 | .64 | .94 | .24 | .54 | 7 |
| 8 | .82 | .14 | .44 | .74 | .04 | .36 | .66 | .96 | .26 | .58 | 8 |
| 9 | .86 | .16 | .46 | .76 | .08 | .38 | .68 | .98 | .30 | .60 | 9 |
| 10 | .88 | .18 | .50 | .80 | .10 | .40 | .70 | 42.02 | .32 | .62 | 10 |
| 11 | .90 | .22 | .52 | .82 | .12 | .44 | .74 | .04 | .34 | .64 | 11 |

| | 140 | 141 | 142 | 143 | 144 | 145 | 146 | 147 | 148 | 149 | |
|----|-------|-------|-------|-------|-------|-------|-------|-------|-------|-------|----|
| 0 | 42.68 | 42.98 | 43.28 | 43.58 | 43.90 | 44.20 | 44.50 | 44.80 | 45.12 | 45.42 | 0 |
| 1 | .70 | 43.00 | .30 | .62 | .92 | .22 | .52 | .84 | .14 | .44 | 1 |
| 2 | .72 | .04 | .34 | .64 | .94 | .24 | .56 | .86 | .16 | .46 | 2 |
| 3 | .76 | .06 | .36 | .66 | .98 | .28 | .58 | .88 | .18 | .50 | 3 |
| 4 | .78 | .08 | .38 | .70 | 44.00 | .30 | .60 | .90 | .22 | .52 | 4 |
| 5 | .80 | .10 | .42 | .72 | .02 | .32 | .64 | .94 | .24 | .54 | 5 |
| 6 | .82 | .14 | .44 | .74 | .04 | .36 | .66 | .96 | .26 | .58 | 6 |
| 7 | .86 | .16 | .46 | .76 | .08 | .38 | .68 | .98 | .30 | .60 | 7 |
| 8 | .88 | .18 | .48 | .80 | .10 | .40 | .70 | 45.02 | .32 | .62 | 8 |
| 9 | .90 | .20 | .52 | .82 | .12 | .42 | .74 | .04 | .34 | .64 | 9 |
| 10 | .92 | .24 | .54 | .84 | .14 | .46 | .76 | .06 | .36 | .68 | 10 |
| 11 | .96 | .26 | .56 | .88 | .18 | .48 | .78 | .08 | .40 | .70 | 11 |

| | 150 | 151 | 152 | 153 | 154 | 155 | 156 | 157 | 158 | 159 | |
|----|-------|-------|-------|-------|-------|-------|-------|-------|-------|-------|----|
| 0 | 45.72 | 46.02 | 46.34 | 46.64 | 46.94 | 47.24 | 47.56 | 47.86 | 48.16 | 48.46 | 0 |
| 1 | .74 | .06 | .36 | .66 | .96 | .28 | .58 | .88 | .18 | .50 | 1 |
| 2 | .78 | .08 | .38 | .68 | 47.00 | .30 | .60 | .90 | .22 | .52 | 2 |
| 3 | .80 | .10 | .40 | .72 | .02 | .32 | .62 | .94 | .24 | .54 | 3 |
| 4 | .82 | .12 | .44 | .74 | .04 | .34 | .66 | .96 | .26 | .56 | 4 |
| 5 | .84 | .16 | .46 | .76 | .06 | .38 | .68 | .98 | .28 | .60 | 5 |
| 6 | .88 | .18 | .48 | .78 | .10 | .40 | .70 | 48.00 | .32 | .62 | 6 |
| 7 | .90 | .20 | .52 | .82 | .12 | .42 | .72 | .04 | .34 | .64 | 7 |
| 8 | .92 | .24 | .54 | .84 | .14 | .44 | .76 | .06 | .36 | .66 | 8 |
| 9 | .96 | .26 | .56 | .86 | .18 | .48 | .78 | .08 | .38 | .70 | 9 |
| 10 | .98 | .28 | .58 | .90 | .20 | .50 | .80 | .12 | .42 | .72 | 10 |
| 11 | 46.00 | .30 | .62 | .92 | .22 | .52 | .84 | .14 | .44 | .74 | 11 |

| | 160 | 161 | 162 | 163 | 164 | 165 | 166 | 167 | 168 | 169 | |
|----|-------|-------|-------|-------|-------|-------|-------|-------|-------|-------|----|
| 0 | 48.78 | 49.08 | 49.38 | 49.68 | 49.98 | 50.30 | 50.60 | 50.90 | 51.20 | 51.52 | 0 |
| 1 | .80 | .10 | .40 | .72 | 50.02 | .32 | .62 | .92 | .24 | .54 | 1 |
| 2 | .82 | .12 | .44 | .74 | .04 | .34 | .64 | .96 | .26 | .56 | 2 |
| 3 | .84 | .16 | .46 | .76 | .06 | .38 | .68 | .98 | .28 | .60 | 3 |
| 4 | .88 | .18 | .48 | .78 | .10 | .40 | .70 | 51.00 | .32 | .62 | 4 |
| 5 | .90 | .20 | .50 | .82 | .12 | .42 | .72 | .04 | .34 | .64 | 5 |
| 6 | .92 | .22 | .54 | .84 | .14 | .44 | .76 | .06 | .36 | .66 | 6 |
| 7 | .94 | .26 | .56 | .86 | .16 | .48 | .78 | .08 | .38 | .70 | 7 |
| 8 | .98 | .28 | .58 | .88 | .20 | .50 | .80 | .10 | .42 | .72 | 8 |
| 9 | 49.00 | .30 | .60 | .92 | .22 | .52 | .82 | .14 | .44 | .74 | 9 |
| 10 | .02 | .32 | .64 | .94 | .24 | .54 | .86 | .16 | .46 | .76 | 10 |
| 11 | .06 | .36 | .66 | .96 | .26 | .58 | .88 | .18 | .48 | .80 | 11 |

| | 170 | 171 | 172 | 173 | 174 | 175 | 176 | 177 | 178 | 179 | |
|----|-------|-------|-------|-------|-------|-------|-------|-------|-------|-------|----|
| 0 | 51.82 | 52.12 | 52.42 | 52.74 | 53.04 | 53.34 | 53.64 | 53.96 | 54.26 | 54.56 | 0 |
| 1 | .84 | .14 | .46 | .76 | .06 | .36 | .68 | .98 | .28 | .58 | 1 |
| 2 | .86 | .18 | .48 | .78 | .08 | .40 | .70 | 54.00 | .30 | .62 | 2 |
| 3 | .90 | .20 | .50 | .80 | .12 | .42 | .72 | .02 | .34 | .64 | 3 |
| 4 | .92 | .22 | .52 | .84 | .14 | .44 | .74 | .06 | .36 | .66 | 4 |
| 5 | .94 | .26 | .56 | .86 | .16 | .46 | .78 | .08 | .38 | .68 | 5 |
| 6 | .98 | .28 | .58 | .88 | .20 | .50 | .80 | .10 | .40 | .72 | 6 |
| 7 | 52.00 | .30 | .60 | .92 | .22 | .52 | .82 | .14 | .44 | .74 | 7 |
| 8 | .02 | .32 | .64 | .94 | .24 | .54 | .86 | .16 | .46 | .76 | 8 |
| 9 | .04 | .36 | .66 | .96 | .26 | .58 | .88 | .18 | .48 | .80 | 9 |
| 10 | .08 | .38 | .68 | .98 | .30 | .60 | .90 | .20 | .52 | .82 | 10 |
| 11 | .10 | .40 | .70 | 53.02 | .32 | .62 | .92 | .24 | .54 | .84 | 11 |

| | 180 | 181 | 182 | 183 | 184 | 185 | 186 | 187 | 188 | 189 | |
|----|-------|-------|-------|-------|-------|-------|-------|-------|-------|-------|----|
| 0 | 54.86 | 55.18 | 55.48 | 55.78 | 56.08 | 56.40 | 56.70 | 57.00 | 57.30 | 57.60 | 0 |
| 1 | .90 | .20 | .50 | .80 | .12 | .42 | .72 | .02 | .34 | .64 | 1 |
| 2 | .92 | .22 | .52 | .84 | .14 | .44 | .74 | .06 | .36 | .66 | 2 |
| 3 | .94 | .24 | .56 | .86 | .16 | .46 | .78 | .08 | .38 | .68 | 3 |
| 4 | .96 | .28 | .58 | .88 | .18 | .50 | .80 | .10 | .40 | .72 | 4 |
| 5 | 55.00 | .30 | .60 | .90 | .22 | .52 | .82 | .12 | .44 | .74 | 5 |
| 6 | .02 | .32 | .62 | .94 | .24 | .54 | .84 | .16 | .46 | .76 | 6 |
| 7 | .04 | .34 | .66 | .96 | .26 | .56 | .88 | .18 | .48 | .78 | 7 |
| 8 | .06 | .38 | .68 | .98 | .28 | .60 | .90 | .20 | .50 | .82 | 8 |
| 9 | .10 | .40 | .70 | 56.00 | .32 | .62 | .92 | .22 | .54 | .84 | 9 |
| 10 | .12 | .42 | .74 | .04 | .34 | .64 | .94 | .26 | .56 | .86 | 10 |
| 11 | .14 | .46 | .76 | .06 | .36 | .68 | .98 | .28 | .58 | .88 | 11 |

TM 5-803-10/NAVFAC P-457/AFR 88-33

| | 190 | 191 | 192 | 193 | 194 | 195 | 196 | 197 | 198 | 199 | |
|----|-------|-------|-------|-------|-------|-------|-------|-------|-------|-------|----|
| 0 | 57-92 | 58-22 | 58-52 | 58-82 | 59-14 | 59-44 | 59-74 | 60-04 | 60-36 | 60-66 | 0 |
| 1 | 94 | -24 | -54 | -86 | -16 | -46 | -76 | -08 | -38 | -68 | 1 |
| 2 | 96 | -28 | -58 | -88 | -18 | -48 | -80 | -10 | -40 | -70 | 2 |
| 3 | 58-00 | -30 | -60 | -90 | -22 | -52 | -82 | -12 | -42 | -74 | 3 |
| 4 | -02 | -32 | -62 | -94 | -24 | -54 | -84 | -14 | -46 | -76 | 4 |
| 5 | -04 | -34 | -66 | -96 | -26 | -56 | -88 | -18 | -48 | -78 | 5 |
| 6 | -06 | -38 | -68 | -98 | -28 | -60 | -90 | -20 | -50 | -82 | 6 |
| 7 | -10 | -40 | -70 | 59-00 | -32 | -62 | -92 | -22 | -54 | -84 | 7 |
| 8 | -12 | -42 | -72 | -04 | -34 | -64 | -94 | -26 | -56 | -86 | 8 |
| 9 | -14 | -44 | -76 | -06 | -36 | -66 | -98 | -28 | -58 | -88 | 9 |
| 10 | -16 | -48 | -78 | -08 | -38 | -70 | 60-00 | -30 | -60 | -92 | 10 |
| 11 | -20 | -50 | -80 | -10 | -42 | -72 | -02 | -32 | -64 | -94 | 11 |

| | 200 | 201 | 202 | 203 | 204 | 205 | 206 | 207 | 208 | 209 | |
|----|-------|-------|-------|-------|-------|-------|-------|-------|-------|-------|----|
| 0 | 60-96 | 61-26 | 61-58 | 61-88 | 62-18 | 62-48 | 62-80 | 63-10 | 63-40 | 63-70 | 0 |
| 1 | 98 | -30 | -60 | -90 | -20 | -52 | -82 | -12 | -42 | -74 | 1 |
| 2 | 61-02 | -32 | -62 | -92 | -24 | -54 | -84 | -14 | -46 | -76 | 2 |
| 3 | -04 | -34 | -64 | -96 | -26 | -56 | -86 | -18 | -48 | -78 | 3 |
| 4 | -06 | -36 | -68 | -98 | -28 | -58 | -90 | -20 | -50 | -80 | 4 |
| 5 | -08 | -40 | -70 | 62-00 | -30 | -62 | -92 | -22 | -52 | -84 | 5 |
| 6 | -12 | -42 | -72 | -02 | -34 | -64 | -94 | -24 | -56 | -86 | 6 |
| 7 | -14 | -44 | -76 | -06 | -36 | -66 | -96 | -28 | -58 | -88 | 7 |
| 8 | -16 | -48 | -78 | -08 | -38 | -68 | 63-00 | -30 | -60 | -90 | 8 |
| 9 | -20 | -50 | -80 | -10 | -42 | -72 | -02 | -32 | -62 | -94 | 9 |
| 10 | -22 | -52 | -82 | -14 | -44 | -74 | -04 | -36 | -66 | -96 | 10 |
| 11 | -24 | -54 | -86 | -16 | -46 | -76 | -08 | -38 | -68 | -98 | 11 |

| | 210 | 211 | 212 | 213 | 214 | 215 | 216 | 217 | 218 | 219 | |
|----|-------|-------|-------|-------|-------|-------|-------|-------|-------|-------|----|
| 0 | 64-02 | 64-32 | 64-62 | 64-92 | 65-22 | 65-54 | 65-84 | 66-14 | 66-44 | 66-76 | 0 |
| 1 | -04 | -34 | -64 | -96 | -26 | -56 | -86 | -16 | -48 | -78 | 1 |
| 2 | -06 | -36 | -68 | -98 | -28 | -58 | -90 | -20 | -50 | -80 | 2 |
| 3 | -08 | -40 | -70 | 65-00 | -30 | -62 | -92 | -22 | -52 | -84 | 3 |
| 4 | -12 | -42 | -72 | -02 | -34 | -64 | -94 | -24 | -56 | -86 | 4 |
| 5 | -14 | -44 | -74 | -06 | -36 | -66 | -96 | -28 | -58 | -88 | 5 |
| 6 | -16 | -46 | -78 | -08 | -38 | -68 | 66-00 | -30 | -60 | -90 | 6 |
| 7 | -18 | -50 | -80 | -10 | -40 | -72 | -02 | -32 | -62 | -94 | 7 |
| 8 | -22 | -52 | -82 | -12 | -44 | -74 | -04 | -34 | -66 | -96 | 8 |
| 9 | -24 | -54 | -84 | -16 | -46 | -76 | -06 | -38 | -68 | -98 | 9 |
| 10 | -26 | -56 | -88 | -18 | -48 | -78 | -10 | -40 | -70 | 67-00 | 10 |
| 11 | -30 | -60 | -90 | -20 | -50 | -82 | -12 | -42 | -72 | -04 | 11 |

| | 220 | 221 | 222 | 223 | 224 | 225 | 226 | 227 | 228 | 229 | |
|----|-------|-------|-------|-------|-------|-------|-------|-------|-------|-------|----|
| 0 | 67-06 | 67-36 | 67-66 | 67-98 | 68-28 | 68-58 | 68-88 | 69-20 | 69-50 | 69-80 | 0 |
| 1 | -08 | -38 | -70 | 68-00 | -30 | -60 | -92 | -22 | -52 | -82 | 1 |
| 2 | -10 | -42 | -72 | -02 | -32 | -64 | -94 | -24 | -54 | -86 | 2 |
| 3 | -14 | -44 | -74 | -04 | -36 | -66 | -96 | -26 | -58 | -88 | 3 |
| 4 | -16 | -46 | -76 | -08 | -38 | -68 | -98 | -30 | -60 | -90 | 4 |
| 5 | -18 | -50 | -80 | -10 | -40 | -70 | 69-02 | -32 | -62 | -94 | 5 |
| 6 | -22 | -52 | -82 | -12 | -44 | -74 | -04 | -34 | -64 | -96 | 6 |
| 7 | -24 | -54 | -84 | -16 | -46 | -76 | -06 | -38 | -68 | -98 | 7 |
| 8 | -26 | -56 | -88 | -18 | -48 | -78 | -10 | -40 | -70 | 70-00 | 8 |
| 9 | -28 | -60 | -90 | -20 | -50 | -82 | -12 | -42 | -72 | -04 | 9 |
| 10 | -32 | -62 | -92 | -22 | -54 | -84 | -14 | -44 | -76 | -06 | 10 |
| 11 | -34 | -64 | -94 | -26 | -56 | -86 | -16 | -48 | -78 | -08 | 11 |

| | 230 | 231 | 232 | 233 | 234 | 235 | 236 | 237 | 238 | 239 | |
|----|-------|-------|-------|-------|-------|-------|-------|-------|-------|-------|----|
| 0 | 70-10 | 70-42 | 70-72 | 71-02 | 71-32 | 71-64 | 71-94 | 72-24 | 72-54 | 72-84 | 0 |
| 1 | -14 | -44 | -74 | -04 | -36 | -66 | -96 | -26 | -58 | -88 | 1 |
| 2 | -16 | -46 | -76 | -08 | -38 | -68 | -98 | -30 | -60 | -90 | 2 |
| 3 | -18 | -48 | -80 | -10 | -40 | -70 | 72-02 | -32 | -62 | -92 | 3 |
| 4 | -20 | -52 | -82 | -12 | -42 | -74 | -04 | -34 | -64 | -96 | 4 |
| 5 | -24 | -54 | -84 | -14 | -46 | -76 | -06 | -36 | -68 | -98 | 5 |
| 6 | -26 | -56 | -86 | -18 | -48 | -78 | -08 | -40 | -70 | 73-00 | 6 |
| 7 | -28 | -58 | -90 | -20 | -50 | -80 | -12 | -42 | -72 | -02 | 7 |
| 8 | -30 | -62 | -92 | -22 | -52 | -84 | -14 | -44 | -74 | -06 | 8 |
| 9 | -34 | -64 | -94 | -24 | -56 | -86 | -16 | -46 | -78 | -08 | 9 |
| 10 | -36 | -66 | -98 | -28 | -58 | -88 | -18 | -50 | -80 | -10 | 10 |
| 11 | -38 | -70 | 71-00 | -30 | -60 | -92 | -22 | -52 | -82 | -12 | 11 |

| | 240 | 241 | 242 | 243 | 244 | 245 | 246 | 247 | 248 | 249 | |
|----|-------|-------|-------|-------|-------|-------|-------|-------|-------|-------|----|
| 0 | 73-16 | 73-46 | 73-76 | 74-06 | 74-38 | 74-68 | 74-98 | 75-28 | 75-60 | 75-90 | 0 |
| 1 | -18 | -48 | -78 | -10 | -40 | -70 | 75-00 | -32 | -62 | -92 | 1 |
| 2 | -20 | -52 | -82 | -12 | -42 | -72 | -04 | -34 | -64 | -94 | 2 |
| 3 | -24 | -54 | -84 | -14 | -46 | -76 | -06 | -36 | -66 | -98 | 3 |
| 4 | -26 | -56 | -86 | -18 | -48 | -78 | -08 | -38 | -70 | 76-00 | 4 |
| 5 | -28 | -58 | -90 | -20 | -50 | -80 | -12 | -42 | -72 | -02 | 5 |
| 6 | -30 | -62 | -92 | -22 | -52 | -84 | -14 | -44 | -74 | -06 | 6 |
| 7 | -34 | -64 | -94 | -24 | -56 | -86 | -16 | -46 | -78 | -08 | 7 |
| 8 | -36 | -66 | -96 | -28 | -58 | -88 | -18 | -50 | -80 | -10 | 8 |
| 9 | -38 | -68 | 74-00 | -30 | -60 | -90 | -22 | -52 | -82 | -12 | 9 |
| 10 | -40 | -72 | -02 | -32 | -62 | -94 | -24 | -54 | -84 | -16 | 10 |
| 11 | -44 | -74 | -04 | -34 | -66 | -96 | -26 | -56 | -88 | -18 | 11 |

| | 250 | 251 | 252 | 253 | 254 | 255 | 256 | 257 | 258 | 259 | |
|----|-------|-------|-------|-------|-------|-------|-------|-------|-------|-------|----|
| 0 | 76-20 | 76-50 | 76-82 | 77-12 | 77-42 | 77-72 | 78-04 | 78-34 | 78-64 | 78-94 | 0 |
| 1 | -22 | -54 | -84 | -14 | -44 | -76 | -06 | -36 | -66 | -98 | 1 |
| 2 | -26 | -56 | -86 | -16 | -48 | -78 | -08 | -38 | -70 | 79-00 | 2 |
| 3 | -28 | -58 | -88 | -20 | -50 | -80 | -10 | -42 | -72 | -02 | 3 |
| 4 | -30 | -60 | -92 | -22 | -52 | -82 | -14 | -44 | -74 | -04 | 4 |
| 5 | -32 | -64 | -94 | -24 | -54 | -86 | -16 | -46 | -76 | -08 | 5 |
| 6 | -36 | -66 | -96 | -26 | -58 | -88 | -18 | -48 | -80 | -10 | 6 |
| 7 | -38 | -68 | 77-00 | -30 | -60 | -90 | -20 | -52 | -82 | -12 | 7 |
| 8 | -40 | -72 | -02 | -32 | -62 | -92 | -24 | -54 | -84 | -14 | 8 |
| 9 | -44 | -74 | -04 | -34 | -66 | -96 | -26 | -56 | -86 | -18 | 9 |
| 10 | -46 | -76 | -06 | -38 | -68 | -98 | -28 | -60 | -90 | -20 | 10 |
| 11 | -48 | -78 | -10 | -40 | -70 | 78-00 | -32 | -62 | -92 | -22 | 11 |

| | 260 | 261 | 262 | 263 | 264 | 265 | 266 | 267 | 268 | 269 | |
|----|-------|-------|-------|-------|-------|-------|-------|-------|-------|-------|----|
| 0 | 79-26 | 79-56 | 79-86 | 80-16 | 80-46 | 80-78 | 81-08 | 81-38 | 81-68 | 82-00 | 0 |
| 1 | -28 | -58 | -88 | -20 | -50 | -80 | -10 | -40 | -72 | -02 | 1 |
| 2 | -30 | -60 | -92 | -22 | -52 | -82 | -14 | -44 | -74 | -04 | 2 |
| 3 | -32 | -64 | -94 | -24 | -54 | -86 | -16 | -46 | -76 | -08 | 3 |
| 4 | -36 | -66 | -96 | -26 | -58 | -88 | -18 | -48 | -80 | -10 | 4 |
| 5 | -38 | -68 | -98 | -30 | -60 | -90 | -20 | -52 | -82 | -12 | 5 |
| 6 | -40 | -70 | 80-02 | -32 | -62 | -92 | -24 | -54 | -84 | -14 | 6 |
| 7 | -42 | -74 | -04 | -34 | -64 | -96 | -26 | -56 | -86 | -18 | 7 |
| 8 | -46 | -76 | -06 | -36 | -66 | -98 | -28 | -58 | -90 | -20 | 8 |
| 9 | -48 | -78 | -08 | -40 | -70 | 81-00 | -30 | -62 | -92 | -22 | 9 |
| 10 | -50 | -80 | -12 | -42 | -72 | -02 | -34 | -64 | -94 | -24 | 10 |
| 11 | -54 | -84 | -14 | -44 | -74 | -06 | -36 | -66 | -96 | -28 | 11 |

2

| | 270 | 271 | 272 | 273 | 274 | 275 | 276 | 277 | 278 | 279 | |
|----|-------|-------|-------|-------|-------|-------|-------|-------|-------|-------|----|
| 0 | 82:30 | 82:60 | 82:90 | 83:22 | 83:52 | 83:82 | 84:12 | 84:44 | 84:74 | 85:04 | 0 |
| 1 | 32 | 62 | 94 | 24 | 54 | 84 | 16 | 46 | 76 | 06 | 1 |
| 2 | 34 | 66 | 96 | 26 | 56 | 88 | 18 | 48 | 78 | 10 | 2 |
| 3 | 38 | 68 | 98 | 28 | 60 | 90 | 20 | 50 | 82 | 12 | 3 |
| 4 | 40 | 70 | 83:00 | 32 | 62 | 92 | 22 | 54 | 84 | 14 | 4 |
| 5 | 42 | 74 | 04 | 34 | 64 | 94 | 26 | 56 | 86 | 16 | 5 |
| 6 | 46 | 76 | 06 | 36 | 68 | 98 | 28 | 58 | 88 | 20 | 6 |
| 7 | 48 | 78 | 08 | 40 | 70 | 84:00 | 30 | 62 | 92 | 22 | 7 |
| 8 | 50 | 80 | 12 | 42 | 72 | 02 | 34 | 64 | 94 | 24 | 8 |
| 9 | 52 | 84 | 14 | 44 | 74 | 06 | 36 | 66 | 96 | 28 | 9 |
| 10 | 56 | 86 | 16 | 46 | 78 | 08 | 38 | 68 | 85:00 | 30 | 10 |
| 11 | 58 | 88 | 18 | 50 | 80 | 10 | 40 | 72 | 02 | 32 | 11 |

| | 280 | 281 | 282 | 283 | 284 | 285 | 286 | 287 | 288 | 289 | |
|----|-------|-------|-------|-------|-------|-------|-------|-------|-------|-------|----|
| 0 | 85:34 | 85:66 | 85:96 | 86:26 | 86:56 | 86:88 | 87:18 | 87:48 | 87:78 | 88:08 | 0 |
| 1 | 38 | 68 | 98 | 30 | 60 | 90 | 20 | 50 | 82 | 12 | 1 |
| 2 | 40 | 70 | 86:00 | 32 | 62 | 92 | 22 | 54 | 84 | 14 | 2 |
| 3 | 42 | 72 | 04 | 34 | 64 | 94 | 26 | 56 | 86 | 16 | 3 |
| 4 | 44 | 76 | 06 | 36 | 66 | 98 | 28 | 58 | 88 | 20 | 4 |
| 5 | 48 | 78 | 08 | 38 | 70 | 87:00 | 30 | 60 | 92 | 22 | 5 |
| 6 | 50 | 80 | 10 | 42 | 72 | 02 | 32 | 64 | 94 | 24 | 6 |
| 7 | 52 | 82 | 14 | 44 | 74 | 04 | 36 | 66 | 96 | 26 | 7 |
| 8 | 54 | 86 | 16 | 46 | 76 | 08 | 38 | 68 | 98 | 30 | 8 |
| 9 | 58 | 88 | 18 | 48 | 80 | 10 | 40 | 70 | 88:02 | 32 | 9 |
| 10 | 60 | 90 | 22 | 52 | 82 | 12 | 42 | 74 | 04 | 34 | 10 |
| 11 | 62 | 94 | 24 | 54 | 84 | 16 | 46 | 76 | 06 | 36 | 11 |

| | 290 | 291 | 292 | 293 | 294 | 295 | 296 | 297 | 298 | 299 | |
|----|-------|-------|-------|-------|-------|-------|-------|-------|-------|-------|----|
| 0 | 88:40 | 88:70 | 89:00 | 89:30 | 89:62 | 89:92 | 90:22 | 90:52 | 90:84 | 91:14 | 0 |
| 1 | 42 | 72 | 02 | 34 | 64 | 94 | 24 | 56 | 86 | 16 | 1 |
| 2 | 44 | 76 | 06 | 36 | 66 | 96 | 28 | 58 | 88 | 18 | 2 |
| 3 | 48 | 78 | 08 | 38 | 70 | 90:00 | 30 | 60 | 90 | 22 | 3 |
| 4 | 50 | 80 | 10 | 42 | 72 | 02 | 32 | 62 | 94 | 24 | 4 |
| 5 | 52 | 82 | 14 | 44 | 74 | 04 | 36 | 66 | 96 | 26 | 5 |
| 6 | 54 | 86 | 16 | 46 | 76 | 08 | 38 | 68 | 98 | 30 | 6 |
| 7 | 58 | 88 | 18 | 48 | 80 | 10 | 40 | 70 | 91:02 | 32 | 7 |
| 8 | 60 | 90 | 20 | 52 | 82 | 12 | 42 | 74 | 04 | 34 | 8 |
| 9 | 62 | 92 | 24 | 54 | 84 | 14 | 46 | 76 | 06 | 36 | 9 |
| 10 | 64 | 96 | 26 | 56 | 86 | 18 | 48 | 78 | 08 | 40 | 10 |
| 11 | 68 | 98 | 28 | 58 | 90 | 20 | 50 | 80 | 12 | 42 | 11 |

| | 300 | 301 | 302 | 303 | 304 | 305 | 306 | 307 | 308 | 309 | |
|----|-------|-------|-------|-------|-------|-------|-------|-------|-------|-------|----|
| 0 | 91:44 | 91:74 | 92:06 | 92:36 | 92:66 | 92:96 | 93:28 | 93:58 | 93:88 | 94:18 | 0 |
| 1 | 46 | 78 | 08 | 38 | 68 | 93:00 | 30 | 60 | 90 | 22 | 1 |
| 2 | 50 | 80 | 10 | 40 | 72 | 02 | 32 | 62 | 94 | 24 | 2 |
| 3 | 52 | 82 | 12 | 44 | 74 | 04 | 34 | 66 | 96 | 26 | 3 |
| 4 | 54 | 84 | 16 | 46 | 76 | 06 | 38 | 68 | 98 | 28 | 4 |
| 5 | 56 | 88 | 18 | 48 | 78 | 10 | 40 | 70 | 94:00 | 32 | 5 |
| 6 | 60 | 90 | 20 | 50 | 82 | 12 | 42 | 72 | 04 | 34 | 6 |
| 7 | 62 | 92 | 24 | 54 | 84 | 14 | 44 | 76 | 06 | 36 | 7 |
| 8 | 64 | 96 | 26 | 56 | 86 | 16 | 48 | 78 | 08 | 38 | 8 |
| 9 | 68 | 98 | 28 | 58 | 90 | 20 | 50 | 80 | 10 | 42 | 9 |
| 10 | 70 | 92:00 | 30 | 62 | 92 | 22 | 52 | 84 | 14 | 44 | 10 |
| 11 | 72 | 02 | 34 | 64 | 94 | 24 | 56 | 86 | 16 | 46 | 11 |

| | 310 | 311 | 312 | 313 | 314 | 315 | 316 | 317 | 318 | 319 | |
|----|-------|-------|-------|-------|-------|-------|-------|-------|-------|-------|----|
| 0 | 94:50 | 94:80 | 95:10 | 95:40 | 95:70 | 96:02 | 96:32 | 96:62 | 96:92 | 97:24 | 0 |
| 1 | 52 | 82 | 12 | 44 | 74 | 04 | 34 | 64 | 96 | 26 | 1 |
| 2 | 54 | 84 | 16 | 46 | 76 | 06 | 38 | 68 | 98 | 28 | 2 |
| 3 | 56 | 88 | 18 | 48 | 78 | 10 | 40 | 70 | 97:00 | 32 | 3 |
| 4 | 60 | 90 | 20 | 50 | 82 | 12 | 42 | 72 | 04 | 34 | 4 |
| 5 | 62 | 92 | 22 | 54 | 84 | 14 | 44 | 76 | 06 | 36 | 5 |
| 6 | 64 | 94 | 26 | 56 | 86 | 16 | 48 | 78 | 08 | 38 | 6 |
| 7 | 66 | 98 | 28 | 58 | 88 | 20 | 50 | 80 | 10 | 42 | 7 |
| 8 | 70 | 95:00 | 30 | 60 | 92 | 22 | 52 | 82 | 14 | 44 | 8 |
| 9 | 72 | 02 | 32 | 64 | 94 | 24 | 54 | 86 | 16 | 46 | 9 |
| 10 | 74 | 04 | 36 | 66 | 96 | 26 | 58 | 88 | 18 | 48 | 10 |
| 11 | 78 | 08 | 38 | 68 | 98 | 30 | 60 | 90 | 20 | 52 | 11 |

| | 320 | 321 | 322 | 323 | 324 | 325 | 326 | 327 | 328 | 329 | |
|----|-------|-------|-------|-------|-------|-------|-------|-------|--------|--------|----|
| 0 | 97:54 | 97:84 | 98:14 | 98:46 | 98:76 | 99:06 | 99:36 | 99:68 | 99:98 | 100:28 | 0 |
| 1 | 56 | 86 | 18 | 48 | 78 | 08 | 40 | 70 | 100:00 | 32 | 1 |
| 2 | 58 | 90 | 20 | 50 | 80 | 12 | 42 | 72 | 02 | 34 | 2 |
| 3 | 62 | 92 | 22 | 54 | 84 | 14 | 44 | 74 | 06 | 36 | 3 |
| 4 | 64 | 94 | 24 | 56 | 86 | 16 | 46 | 78 | 08 | 38 | 4 |
| 5 | 66 | 98 | 28 | 58 | 88 | 18 | 50 | 80 | 10 | 40 | 5 |
| 6 | 70 | 98:00 | 30 | 60 | 92 | 22 | 52 | 82 | 12 | 44 | 6 |
| 7 | 72 | 02 | 32 | 64 | 94 | 24 | 54 | 86 | 16 | 46 | 7 |
| 8 | 74 | 04 | 36 | 66 | 96 | 26 | 58 | 88 | 18 | 48 | 8 |
| 9 | 76 | 08 | 38 | 68 | 98 | 30 | 60 | 90 | 20 | 52 | 9 |
| 10 | 80 | 10 | 40 | 70 | 99:02 | 32 | 62 | 92 | 24 | 54 | 10 |
| 11 | 82 | 12 | 42 | 74 | 04 | 34 | 64 | 96 | 26 | 56 | 11 |

| | 330 | 331 | 332 | 333 | 334 | 335 | 336 | 337 | 338 | 339 | |
|----|--------|--------|--------|--------|--------|--------|--------|--------|--------|--------|----|
| 0 | 100:58 | 100:90 | 101:20 | 101:50 | 101:80 | 102:12 | 102:42 | 102:72 | 103:02 | 103:32 | 0 |
| 1 | 62 | 92 | 22 | 52 | 84 | 14 | 44 | 74 | 06 | 36 | 1 |
| 2 | 64 | 94 | 24 | 56 | 86 | 16 | 46 | 78 | 08 | 38 | 2 |
| 3 | 66 | 96 | 28 | 58 | 88 | 18 | 50 | 80 | 10 | 40 | 3 |
| 4 | 68 | 101:00 | 30 | 60 | 90 | 22 | 52 | 82 | 12 | 44 | 4 |
| 5 | 72 | 02 | 32 | 62 | 94 | 24 | 54 | 84 | 16 | 46 | 5 |
| 6 | 74 | 04 | 34 | 66 | 96 | 26 | 56 | 88 | 18 | 48 | 6 |
| 7 | 76 | 06 | 38 | 68 | 98 | 28 | 60 | 90 | 20 | 50 | 7 |
| 8 | 78 | 10 | 40 | 70 | 102:00 | 32 | 62 | 92 | 22 | 54 | 8 |
| 9 | 82 | 12 | 42 | 72 | 04 | 34 | 64 | 94 | 26 | 56 | 9 |
| 10 | 84 | 14 | 46 | 76 | 06 | 36 | 66 | 98 | 28 | 58 | 10 |
| 11 | 86 | 18 | 48 | 78 | 08 | 40 | 70 | 103:00 | 30 | 60 | 11 |

| | 340 | 341 | 342 | 343 | 344 | 345 | 346 | 347 | 348 | 349 | |
|----|--------|--------|--------|--------|--------|--------|--------|--------|--------|--------|----|
| 0 | 103:64 | 103:94 | 104:24 | 104:54 | 104:86 | 105:16 | 105:46 | 105:76 | 106:08 | 106:38 | 0 |
| 1 | 66 | 96 | 26 | 58 | 88 | 18 | 48 | 80 | 10 | 40 | 1 |
| 2 | 68 | 104:00 | 30 | 60 | 90 | 20 | 52 | 82 | 12 | 42 | 2 |
| 3 | 72 | 02 | 32 | 62 | 94 | 24 | 54 | 84 | 14 | 46 | 3 |
| 4 | 74 | 04 | 34 | 66 | 96 | 26 | 56 | 86 | 18 | 48 | 4 |
| 5 | 76 | 06 | 38 | 68 | 98 | 28 | 60 | 90 | 20 | 50 | 5 |
| 6 | 78 | 10 | 40 | 70 | 105:00 | 32 | 62 | 92 | 22 | 54 | 6 |
| 7 | 82 | 12 | 42 | 72 | 04 | 34 | 64 | 94 | 26 | 56 | 7 |
| 8 | 84 | 14 | 44 | 76 | 06 | 36 | 66 | 98 | 28 | 58 | 8 |
| 9 | 86 | 16 | 48 | 78 | 08 | 38 | 70 | 106:00 | 30 | 60 | 9 |
| 10 | 88 | 20 | 50 | 80 | 10 | 42 | 72 | 02 | 32 | 64 | 10 |
| 11 | 92 | 22 | 52 | 82 | 14 | 44 | 74 | 04 | 36 | 66 | 11 |

Order of the Secretary of the Army:

al:

JUL T. SMITH
Major General, United States Army
Adjutant General

FRED C. WEYAND
General, United States Army
Chief of Staff

A. R. MARSCHALL
Rear Admiral, CEC, United States Army
Commander, Naval Facilities Command

DAVID C. JONES
General, United States Air Force
Chief of Staff

al:

ES J. SHEPARD
Colonel, United States Air Force
Director of Administration

ution:

ive Army:

To be distributed in accordance with DA Form 12-34B, (qty rqr block no. 93) requirements for TM 5-800: Engineering and Design for Realty Facilities.

Force: F

U.S. GOVERNMENT PRINTING OFFICE : 1978 O-256-323

Distribution: (1 copy unless otherwise specified)

| | | |
|--|---|---|
| ANTARCTICA only) | FE4 (Edzell, Galeta Island, Homestead, Winter Harbor, Sabana Seca, Sonoma, Todendorf only) | FKN1 (5 copies each) |
| AIN only) | FF1 (Washington only) | FKN2 |
| | FF4 | FKN3 |
| | FF6 | FKN5 |
| olis, Port Hueneme only) | FF19 (Brooklyn, Canal Zone, Long Beach, New Orleans, Seattle only) | FKN10 |
| gton only) | FG2 (Adak, Balboa, Cheltenham, Diego Gracia, Norfolk, Harold Holt, Londonderry, Morocco, Nea Makri, Stockton, Ponce, Wahiwawa only) | FKP1A |
| a, Brunswick, Cecil Field, Key Jacksonville, Virginia Beach only) | FG5 (East Machias only) | FKP1B |
| a, Guantanamo, Keflavik, Mayport, West Roads only) | FG11 | FKP1E |
| na, Barbados, Brawdy, Buxton, Thera, Lewes, Nantucket, Turks and Caicos only) | FH3 (Beaufort only) | FKPIJ |
| na, Barbars Point, Fallon, Lemoore, Harbor, Miramar, North Island, Cecil Field only) | FH25 (Philadelphia, Portsmouth, Virginia, Camp Lejeune, Oakland, Newport, Great Lakes, Long Beach only) | FKP4C |
| Midway, San Francisco only) | FH6 (Bethesda only) | FKR1A |
| wa, Sasebo only) | FH8 (Cairo only) | FKR3G |
| r, Coos Head, Ferndale, Pacific Grove, San Francisco only) | FKA6A1 | FKR3A |
| only) | FKA6A2 | FKR3H |
| only) | FKA6A3A | FKR4B |
| only) | FKA6A3B | FR3 |
| only) | FKA6A9 | FR4 |
| only) | FB31 (Oahu only) | FT6 |
| only) | FKA6A10 | FT19 (San Diego only) |
| only) | FKA6A11 | FT22 (Virginia Beach only) |
| only) | FKA6A15 | FT31 (Bainbridge, Orlando, San Diego only) |
| only) | FKP7 | FT37 |
| only) | FKP12 | FT55 |
| only) | FKM8 | FT69 |
| only) | FKM9 (Oakland only) | FT73 |
| only) | FKM13 | FKR5 |
| only) | FKM15 | FT28 |
| | | V16 (MCB Camp Lejeune, Camp Pendleton, Twentynine Palms, Smedley Butler only) |
| | | V5 (MCAS Cherry Point, Beaufort, El Toro, Yuma, Kaneohe Bay, Iwakuni only) |
| | | V8 (MCRD Parris Island only) |
| | | V9 (MCSC Albany, Barstow only) |
| | | V12 (MCDEC Quantico only) |
| | | BUPERS 7211 (300 copies under separate cover) |

Additional copies may be obtained from US Naval Publications and Forms Center
801 Tabor Avenue (300 copies)
Philadelphia, PA 19120

232

233