

DOCUMENT RESUME

ED 159 079

SE 024 960

AUTHOR Haag, V. H.; And Others
 TITLE Introduction to Secondary School Mathematics, Volume 2, Student's Text, Part I, Unit 40. Revised Edition.
 INSTITUTION Stanford Univ., Calif. School Mathematics Study Group.
 SPONS AGENCY National Science Foundation, Washington, D.C.
 PUB DATE 65
 NOTE 251p.; For related documents, see SE 024 957-962; Contains occasional light type

EDRS PRICE MF-\$0.83 HC-\$14.05 Plus Postage.
 DESCRIPTORS Curriculum; Geometric Concepts; *Grade 8; *Instructional Materials; Junior High Schools; Mathematics Education; Measurement; Number Concepts; Secondary Education; *Secondary School Mathematics; Statistics; *Textbooks
 IDENTIFIERS *School Mathematics Study Group

ABSTRACT

This is part one of a two-part SMSG text for grade eight students whose mathematical talents are underdeveloped. The reading level of this text has been adjusted downward, chapters shortened, and additional concrete examples included. Nevertheless, the authors warn that the text may not be appropriate for the very slow non-college-bound student. Chapter topics include: linear measurement, area and volume, angles and parallels, polygons and prisms, circles, and statistics and graphs. (MN)

 * Reproductions supplied by EDRS are the best that can be made *
 * from the original document. *

Introduction to Secondary School Mathematics, Volume 2

Student's Text, Part I

REVISED EDITION

Prepared under the supervision of
a Panel consisting of:

V. H. Haag	Franklin and Marshall College
Mildred Keiffer	Cincinnati Board of Education
Oscar Schaaf	South Eugene High School, Eugene, Oregon
M. A. Sobel	Montclair State College, Upper Montclair, New Jersey
Marie Wilcox	Thomas Carr Howe High School, Indianapolis, Indiana
A. B. Willcox	Amherst College

Stanford, California

Distributed for the School Mathematics Study Group

by A. C. Vroman, Inc., 367 Pasadena Avenue, Pasadena, California

Financial support for School Mathematics Study Group has been provided by the National Science Foundation.

Permission to make verbatim use of material in this book must be secured from the Director of SMSG. Such permission will be granted except in unusual circumstances. Publications incorporating SMSG materials must include both an acknowledgment of the SMSG copyright (Yale University or Stanford University, as the case may be) and a disclaimer of SMSG endorsement. Exclusive license will not be granted save in exceptional circumstances, and then only by specific action of the Advisory Board of SMSG.

© 1965 by The Board of Trustees
of the Leland Stanford Junior University.
All rights reserved.
Printed in the United States of America.

FOREWORD

The increasing contribution of mathematics to the culture of the modern world, as well as its importance as a vital part of scientific and humanistic education, has made it essential that the mathematics in our schools be both well selected and well taught.

With this in mind, the various mathematical organizations in the United States cooperated in the formation of the School Mathematics Study Group (SMSG). SMSG includes college and university mathematicians, teachers of mathematics at all levels, experts in education, and representatives of science and technology. The general objective of SMSG is the improvement of the teaching of mathematics in the schools of this country. The National Science Foundation has provided substantial funds for the support of this endeavor.

One of the prerequisites for the improvement of the teaching of mathematics in our schools is an improved curriculum--one which takes account of the increasing use of mathematics in science and technology and in other areas of knowledge and at the same time one which reflects recent advances in mathematics itself. One of the first projects undertaken by SMSG was to enlist a group of outstanding mathematicians and mathematics teachers to prepare a series of textbooks which would illustrate such an improved curriculum.

The professional mathematicians in SMSG believe that the mathematics presented in this text is valuable for all well-educated citizens in our society to know and that it is important for the precollege student to learn in preparation for advanced work in the field. At the same time, teachers in SMSG believe that it is presented in such a form that it can be readily grasped by students.

In most instances the material will have a familiar note, but the presentation and the point of view will be different. Some material will be entirely new to the traditional curriculum. This is as it should be, for mathematics is a living and an ever-growing subject, and not a dead and frozen product of antiquity. This healthy fusion of the old and the new should lead students to a better understanding of the basic concepts and structure of mathematics and provide a firmer foundation for understanding and use of mathematics in a scientific society.

It is not intended that this book be regarded as the only definitive way of presenting good mathematics to students at this level. Instead, it should be thought of as a sample of the kind of improved curriculum that we need and as a source of suggestions for the authors of commercial textbooks. It is sincerely hoped that these texts will lead the way toward inspiring a more meaningful teaching of Mathematics, the Queen and Servant of the Sciences.

CONTENTS

Chapter

11.	LINEAR MEASUREMENT	1
	11-1. The Ruler	1
	11-2. Standard Units of Length.	7
	11-3. Precision and Error	17
	11-4. Perimeter and Rectangles.	21
	11-5. Metric Units of Length.	25
	11-6. Summary	28
	11-7. Chapter Review.	29
	11-8. Cumulative Review	31
12.	AREA AND VOLUME.	33
	12-1. Meaning of Area	33
	12-2. Cutting Units of Area	36
	12-3. Area of a Rectangle	38
	12-4. Approximation	47
	12-5. Rectangular Prism	49
	12-6. Area of a Prism	51
	12-7. Meaning of Volume	53
	12-8. Volume of a Rectangular Solid	56
	12-9. Dimension	64
	12-10. Other Units of Volume	66
	12-11. Summary	68
	12-12. Chapter Review.	70
	12-13. Cumulative Review	71
	Tables for Reference.	73
13.	ANGLES AND PARALLELS	75
	13-1. Measurement of Angles	75
	13-2. Two Lines in a Plane.	80
	13-3. Adjacent Angles	81
	13-4. Vertical Angles	83
	13-5. Supplementary Angles.	84
	13-6. More About Vertical Angles.	87
	13-7. Right Angles.	90
	13-8. Three Lines in a Plane.	94
	13-9. Corresponding Angles.	95
	13-10. Parallel Lines and Corresponding Angles	99
	13-11. Summary	102
	13-12. Chapter Review.	104
	13-13. Cumulative Review	106
14.	POLYGONS AND PRISMS.	107
	14-1. Kinds of Triangles.	107
	14-2. Converse of a Statement	111
	14-3. Angles of a Triangle.	117
	14-4. Polygons.	123
	14-5. Parallelograms.	125
	14-6. Distance to a Line.	131
	14-7. Proof	135
	14-8. Area of a Parallelogram	139

14-9.	Area of a Triangle	145
14-10.	Right Prisms	148
14-11.	Summary	157
14-12.	Chapter Review	160
14-13.	Cumulative Review	162
15.	CIRCLES	165
15-1.	Circles and the Compass	165
15-2.	Interiors and Intersections	169
15-3.	Diameters	175
15-4.	Tangents	177
15-5.	Arcs	179
15-6.	Central Angles	180
15-7.	Length of a Circle	181
15-8.	Area of a Circle	187
15-9.	Volume of a Cylindrical Solid	192
15-10.	Surface Area of a Cylindrical Solid	198
15-11.	Summary	200
15-12.	Chapter Review	201
15-13.	Cumulative Review	203
16.	STATISTICS AND GRAPHS	205
16-1.	Gathering Data	205
16-2.	Bar Graphs	208
16-3.	Broken-Line Graphs	215
16-4.	Other Kinds of Graphs	219
16-5.	Averages	223
16-6.	Grouping Data	229
16-7.	Summary	232
16-8.	Chapter Review	234
16-9.	Cumulative Review	236
	Index	following page 237

PREFACE

To The Student:

This book will be your second adventure in secondary school mathematics. During this year you will develop a better understanding of what mathematics really is. We hope that you will enjoy this adventure.

Some of the big ideas in introductory high school mathematics are the following:

1. The numbers of arithmetic form a number system.

You have studied whole numbers and fractions. You will see that these numbers are part of a larger system of numbers. You will also learn new ways to think about whole numbers and fractions.

2. Arithmetic leads to algebra.

You will see how the ideas of algebra grow out of your knowledge of arithmetic.

3. Geometry helps us to understand the world in which we live.

Ideas of points, lines, planes, and space are the alphabet of geometry. You will learn how these ideas form the basis for exploring the world of geometry.

This book was written for you. We hope that you will find it pleasant reading. There may be places where you will need the help of your teacher. As you read be sure to have a pencil and paper handy so that you can make computations and sketch diagrams.

The exercises are planned to give you practice in using the ideas in the text. Before trying to work an exercise, read it carefully, more than once, if necessary. In each problem, be sure that you understand what you have to work with and what is required. Some exercises are marked with stars. These are harder than the others. Don't get discouraged if you cannot handle them immediately. The exercises marked "Brainbusters" are different from the others. Most of them are slightly "off beat" but they will give you a chance to use your imagination.

We hope that as you continue your study of mathematics this year you will strengthen and extend the ideas you learned last year. We also hope that you will understand still more clearly what mathematics is, and that you will establish a sound foundation for future study in this field.

Good reading!

Chapter 11

LINEAR MEASUREMENT

11-1. The Ruler.

Measuring is a way of using numbers to indicate the size of things. For the crudest kind of measuring we need only whole numbers. For more precise measuring we need the rational numbers. Suppose that you need to find the quantity of water a car radiator holds. Here is how you can do it. After making sure that the radiator is empty, you can get an empty tin can from the kitchen. Then you can fill the can with water and pour it into the radiator. You can keep doing this over and over again until the radiator overflows. If the 16th can of water overflows, then you may say that the radiator holds more than 15 cans and less than 16 cans. Suppose that nearly all of the 16th can goes into the radiator before it overflows. Then you can say that the volume of the radiator is just about 16 cans. Here you are using this can as your unit of volume. If you tell your father that the radiator holds 16 cans, he will have no idea of the volume of the radiator until he knows the size of the can. If you show him the can, or describe it in such a way that he can find another can just like it, then he will know how much the radiator holds.

Suppose you are asked to find out whether the segments \overline{AB} and \overline{CD} shown below have the same length.

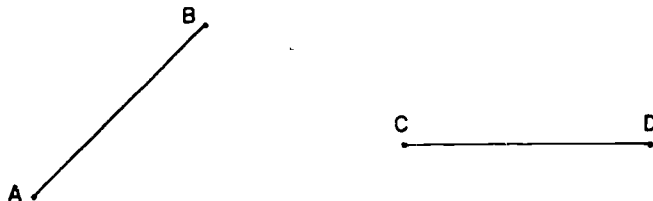

How will you do it? You will probably lay the edge of a sheet of paper along \overline{AB} and make marks exactly where A and B come on the paper.

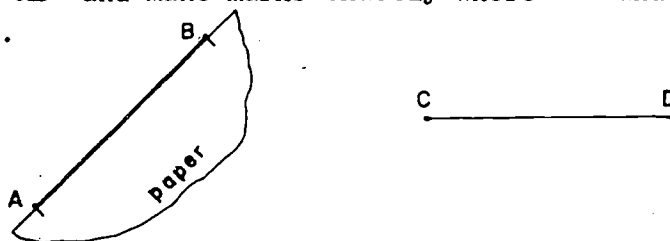

11-1

If the paper can then be laid along the segment \overline{CD} so that the marks come at C and D, we will say that \overline{AB} and \overline{CD} have the same length.



This is just what we will mean by saying that \overline{AB} and \overline{CD} have the same length. We will also use the expression \overline{AB} and \overline{CD} are congruent as another way of saying that they have the same length.

You can see that we can use this process to construct a segment congruent to \overline{AB} starting at any point on a given line.

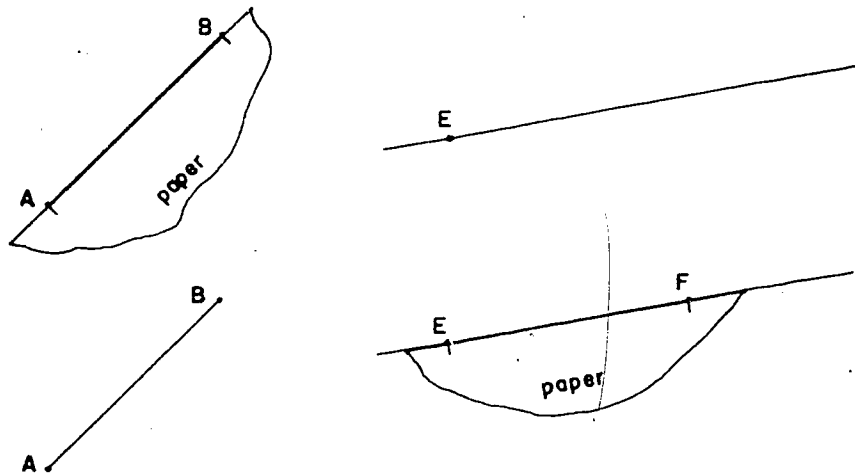

Thus, in the two figures above we have constructed point F so that \overline{EF} is congruent to \overline{AB} . This process is fundamental in measuring lengths.

Now we will see how lengths are measured. We will see that this process is very similar to the method used in finding the volume of the radiator at the beginning of this chapter.

First we must select a segment on our unit of length. Any segment may be chosen. For this example we will select the segment \overline{GH} below.

\overline{GH}

We shall need a name for this unit in the following discussion and we shall call this unit a "bar." This unit plays the same role as the can of water in the radiator example.

Now if we wish to measure a segment \overline{JK} we "fill" the segment \overline{JK} , until it "overflows," with segments congruent to \overline{GH} . Below we show segments congruent to \overline{GH} marked off along the ray \overline{JK} .

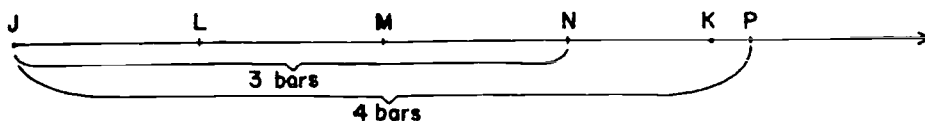

Now \overline{JN} is 3 bars in length while \overline{JP} is 4 bars in length. Segment \overline{JK} is longer than \overline{JN} and shorter than \overline{JP} . Thus, we say that \overline{JK} has length between 3 and 4 bars. We would say the same of any segment which contains \overline{JN} while being contained in \overline{JP} .

We see that this method is the same as is often used in kindergarten. Here the children are given a number of rods all of the same length which they use to measure segments as shown.

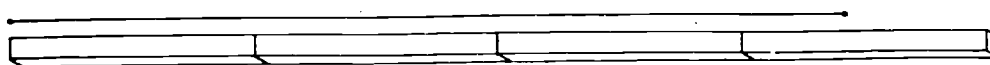

The method is also the same as you would use to measure the lengths of the wall of your classroom with a yardstick. Here you "lay off" the yardstick along the edge of the wall over and over again.

The method is also the same as that used in an earlier chapter in forming a number line. A very useful tool for measuring lengths is a portable number line called a ruler.

Here is the way to construct a ruler.

First of all, choose a line segment for the unit of length. Any segment you like could be chosen but in this example use the segment \overline{GH} which we called the "bar" in the above discussion.

11-1

G  H Figure 11-1a

This unit is used to construct a number line by repeatedly laying off the unit on a line.



Figure 11-1b

Now make a copy of this number line by laying the edge of a sheet of paper along the line with a corner at 0. Transfer the marked points and the numbers to the edge of the sheet of paper, as shown below.

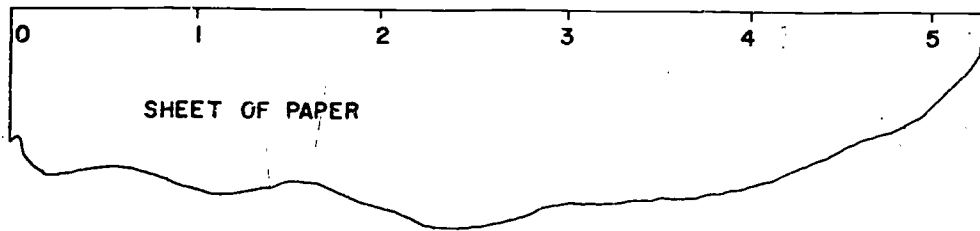

Figure 11-1c

When you have followed these instructions you will have constructed the simplest kind of ruler. You may now use this ruler to measure the lengths of segments. Consider the segment \overline{LM} .



To measure this segment place your ruler along \overline{LM} with zero at L. Find the point where M falls on the ruler.

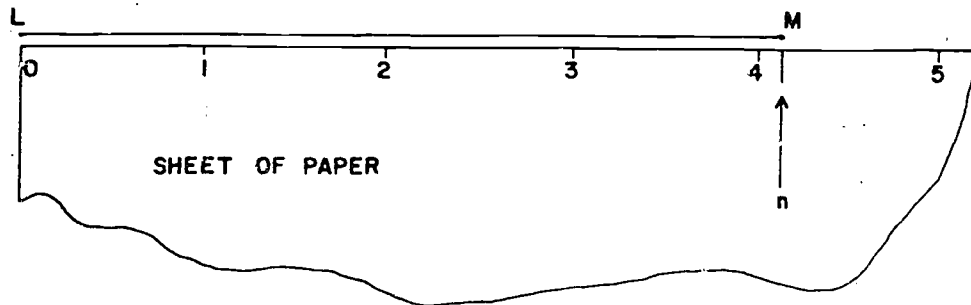

Figure 11-1d

The number n corresponding to this point is called the measure of \overline{LM} with our particular choice of unit. We say that the length of \overline{LM} is n bars. We shall use the symbol \overline{LM} (with no line above it) to mean the length of \overline{LM} . We may say then that \overline{LM} is n bars. Notice how our terms are used.

n is the measure
"bar" is the unit
 n bars is the length.

Let us take another look at Figure 11-1d. We cannot tell from this figure exactly what the number n is. But we can see that

$$4 < n < 5.$$

Therefore, the measure of \overline{LM} is between 4 and 5 or \overline{LM} is between 4 bars and 5 bars. We can also see that the number n is closer to 4 than to 5. We can express this fact by saying that the measure of \overline{LM} , to the nearest whole number, is 4. Or we may write

$$\overline{LM} \approx 4 \text{ bars.}$$

The symbol " \approx " means "is approximately."

Now use your ruler constructed as in Figure 11-1c to find the measures of the five segments below to the nearest whole number.

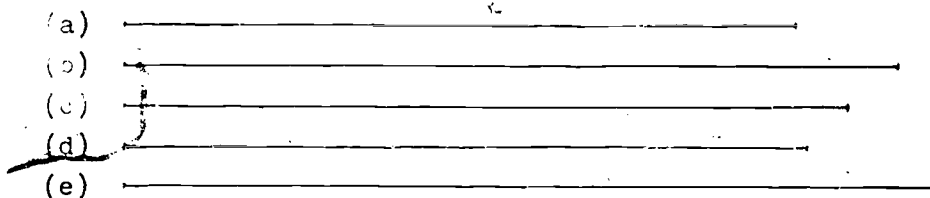

Figure 11-1e

You should have found that each of these segments is four units in length to the nearest whole number of units. When we say that a segment is 4 units in length to the nearest whole number of units, we mean that it is between $3\frac{1}{2}$ and $4\frac{1}{2}$ units in length. Thus, each of the segments in the figure below is 4 units in length to the nearest whole number of units.

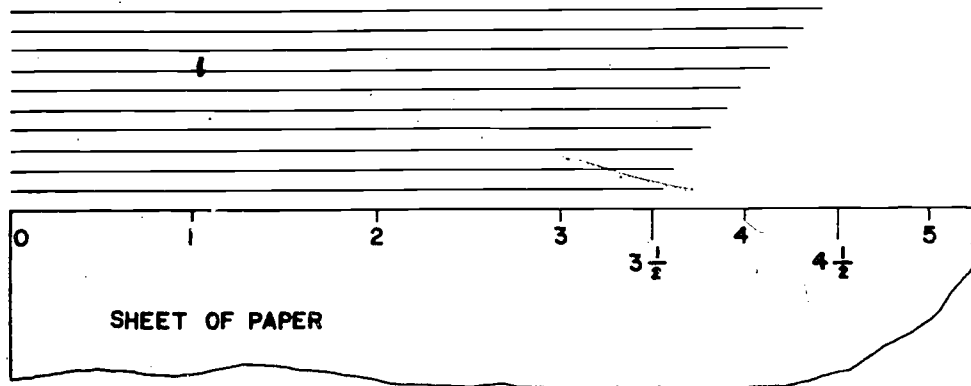

Figure 11-1f

We can obtain more accurate measurements of the lengths of segments by indicating more points on our number line. Here is the same ruler that we have been using with the multiples of $\frac{1}{4}$ shown.

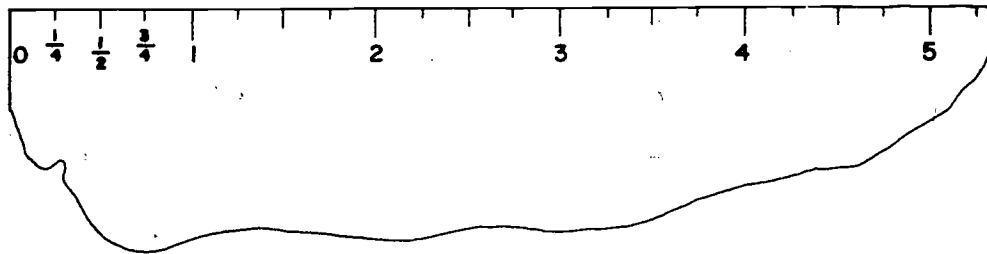

Figure 11-1g

Exercises 11-1
(Class Discussion)

1. Transfer the marks in Figure 11-1g to your sheet-of-paper ruler.
2. Use this ruler to measure the five segments shown in Figure 11-1e to the nearest quarter of a unit.
3. Use your paper ruler to find the lengths of the three sides of the triangle in Figure 11-1h to the nearest quarter of a unit.

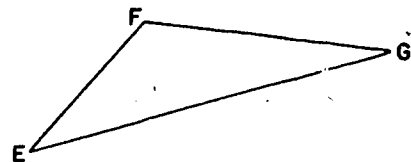
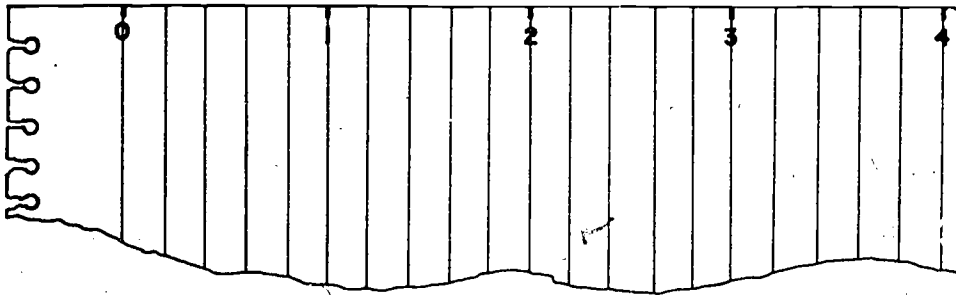

Figure 11-1h

11-2

4. What is the sum of the length of the sides of the triangle in Figure 11-1h?
5. On the paper ruler constructed in Problem 1, locate the points corresponding to eighths as closely as you can by estimating.
6. Use the ruler of Problem 5 to measure the segments in Figure 11-1e to the nearest eighth of a unit.
7. Are any of the segments of Figure 11-1e congruent? Explain. (Recall that when two segments have exactly the same length they are said to be congruent.)
8. Tear a sheet of lined paper from your notebook and make a number line along one edge as shown.



Using this ruler, measure the segments in Figure 11-1e to the nearest whole number of units.

9. Using the ruler of Problem 8, measure the segments in Figure 11-1e to the nearest $\frac{1}{5}$ of a unit.

11-2. Standard Units of Length.

Suppose you used a can to fill a radiator and found that the radiator held 16 cans of water. If you told your dad that the radiator held 16 cans, he wouldn't know the size of the radiator until you showed him the can. If you wanted to mention the volume of the radiator in a letter to a friend, you couldn't very well send him a can in an envelope. But perhaps you could find some way of describing the can so that your friend could find one like it. If you found that you had been using a No. $2\frac{1}{2}$ size can,

then that would solve the problem. This size of can is in very common use in this country and your friend would have no trouble finding an empty can of this size. Using this can as a unit, he could duplicate the volume of water, 16 cans, that you had described to him.

The same thing applies in measuring length. A statement that a certain segment is 5 units in length gives no information until the size of the unit is given. If the unit were chosen arbitrarily, the size of the unit would have to be expressed by providing a copy of it. It would not be possible to convey this information in speech.

These examples point out the need for units of measure that everyone knows and can easily find accurate copies of.

Usually the laws of a country state the units of measure to be used. When a unit of measure is established so that it is always the same size, it is called a standard unit. When you buy a ruler, the marks on it represent line segments that are units of measure of length. Your friend's ruler has units of the same size. This is so simple that it may seem strange that it took a long, long time and much hard work to secure agreements on these units.

People of caveman times had little need for a measuring unit that was the same as everyone else's. Without machinery or buildings, man had little need to measure. The few things he owned could be traded with little concern for size. As civilization developed there were more and more goods to be traded, buildings to be built, and finally machines to be made. These new activities made sizes of goods and sizes of parts very important. People now are obliged to measure with units that are the same size for everybody.

The first units used for length were parts of the body like the foot or hand. A man's foot is about as long as the unit foot. The distance from the tip of the nose to the end of the fingers when the arm is held straight out is about as long as a yard. Horses are still measured by a unit called a hand. A hand is the width of the average hand and is about the same as 4 inches. When boys play marbles, they sometimes measure with a unit called the span.

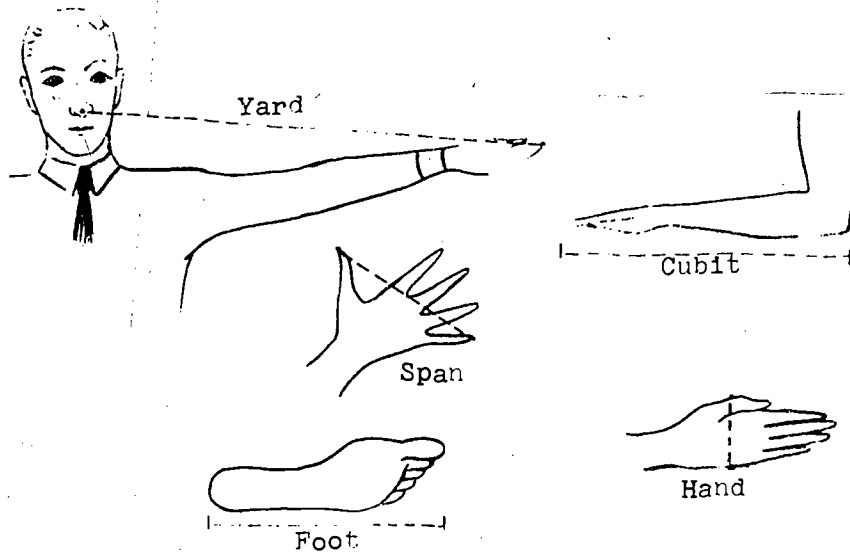

Figure 11-2a

A span is the distance between the tips of the thumb and little finger when they are spread apart as far as possible. When Noah built the ark, it was supposed to be 300 cubits long, 50 cubits wide and 30 cubits high. The length of a cubit is about 18 inches. Sailors measure water depth in fathoms. A fathom is 6 feet. When the Roman soldiers marched, they counted their paces. The Roman pace, however, was a double step. The Latin words for "a thousand paces" are "milia passuum". Our "mile" comes from "milia" which means 1000. What is the length of your pace?

Units of measure like the pace or hand are not all the same. Different people have hands of different size. When people began to trade and travel, it became important to have units of measure that are always the same. Gradually the sizes of the "foot", "yard", and other units, were described more precisely. Thus they became "standardized." Finally a group of scientists developed an orderly, complete system of measurement called the metric system. The meter is the basic unit of length in this system. One meter is a little longer than a yard. The length of a meter was chosen to be one-ten millionth ($\frac{1}{10,000,000}$) of the distance from the North Pole to the Equator.

The National Bureau of Standards in Washington has an accurate copy of the meter. This bar is made of platinum and iridium, a metal which changes very little in length when temperature and air pressure change. Congress has passed a law that tells the fraction of this bar which is the official yard in the United States. This bar is the standard unit of length with which all standard units of measurement in this country are compared. The bar is considered so important that it is locked up very securely. Recently the meter has been defined more precisely in terms of the length of light waves.

Measuring line segments is like comparing the line segment with a number line. The 12-inch ruler you use is a part of a number line in which the unit is an inch. The part shown on the ruler starts at zero and goes to 12. It is marked to show counting numbers and some of the other rational numbers. When you measure a segment, you compare the length of the segment with the number line marked on the ruler.

Exercises 11-2a
(Class Discussion)

Let's stop and take a careful look at the construction of a ruler.

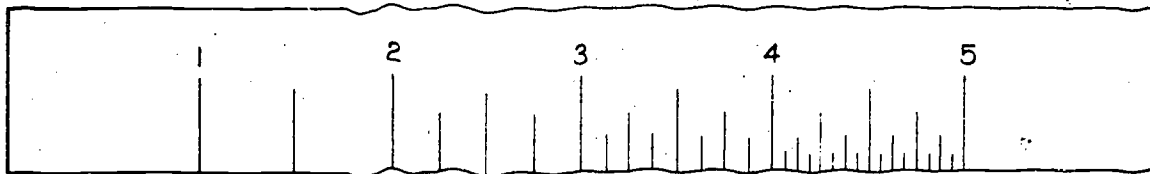

Figure 11-2b

The foot ruler is divided into 12 equal units that everyone knows as inches. The space at each end of the picture on this page is an inch long.

1. Why is it necessary to divide the units?
2. How is the inch between 1 and 2 divided?
3. How are the other inches divided?

4. When divisions smaller than those shown are needed, how are they obtained?
5. How many divisions are there in the third inch? The fourth inch? The fifth inch?
6. How many divisions is it possible to place between any two of the smallest divisions on your ruler?

One way to use a ruler to measure the length of \overline{AB} is shown in the figure below.

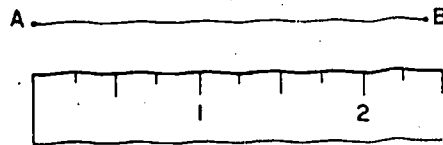

Figure 11-2c

Place the zero point of the ruler at the left end of the segment. The length of the segment is the number of the point on the ruler that matches the right end of the segment. What is the length of \overline{AB} ?

Exercises 11-2b

1. Use a piece of tagboard or cardboard with a straight edge and make a 6-inch ruler. Mark one edge with 1-inch segments and the opposite edge with $\frac{1}{2}$ -inch segments.
2. Make two more 6-inch rulers, one marked with $\frac{1}{4}$ -inch intervals and the other with $\frac{1}{8}$ -inch spaces.
3. Measure each of these lines to the nearest half inch using the ruler that you made in Problem 1. Use the symbol " \approx " in your answers to Problems 3-7 to show that your measurements are approximate.

- a. _____
- b. _____
- c. _____
- d. _____
- e. _____

11-2

4. Measure each of the above segments to the nearest $\frac{1}{4}$ inch, using your $\frac{1}{4}$ - inch ruler.
5. Measure each of the above segments to the nearest $\frac{1}{8}$ inch, using your $\frac{1}{8}$ - inch ruler.
6. Measure each of the above segments using the middle section of your third finger.
7. Which measuring unit gave you the most satisfactory results? Why?

Suppose your ruler were broken near the 2-inch mark. Can you still use it to measure segments? The diagram below shows a broken ruler placed to measure segment \overline{CD} .

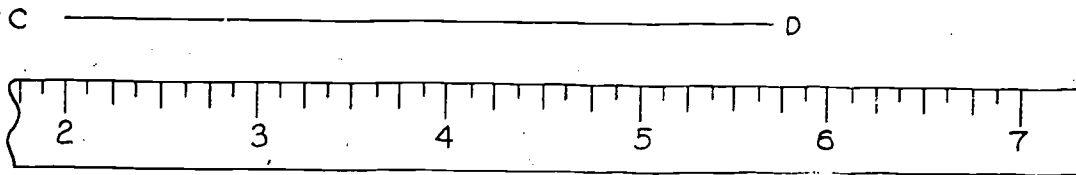
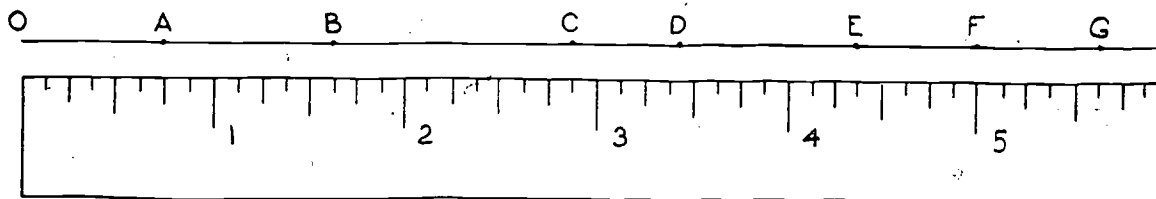

Figure 11-2d

How long is \overline{CD} , to the nearest $\frac{1}{8}$ inch? Is it $5\frac{3}{4}$ inches?

When you place a ruler so that the end of a segment lies on some other mark than zero, you must be careful to make a correction in the length that is read on the ruler. In the diagram on the preceding page the length of the segment is $5\frac{3}{4}$ in. - 2 in., or $3\frac{3}{4}$ in. It is sometimes easier to measure a segment accurately if this method is used, but you must remember to make the necessary correction.

Exercises 11-2c



What point on the ruler is directly below each of the points, A through G, on the line segment?

2. How long is:
 a. \overline{AB} ? b. \overline{AC} ? c. \overline{CD} ? d. \overline{DF} ? e. \overline{FG} ?
3. a. Draw a segment 5 inches long and divide it into sections each $\frac{5}{8}$ inch long.
 b. Divide 5 by $\frac{5}{8}$.
 c. Is there any relation between parts (a) and (b) of this problem?
4. a. Draw a line segment across your paper and mark these segments on it so that the left end of one starts where the right end of the preceding segment falls:
 $2\frac{1}{2}$ "; $1\frac{1}{4}$ "; $\frac{5}{8}$ "; $\frac{5}{16}$ ".
 b. What is the total length of these segments? Read this answer on your ruler.
 c. Check your answer by addition of fractions.
5. Measure with your ruler the segments marked on the line below as indicated:

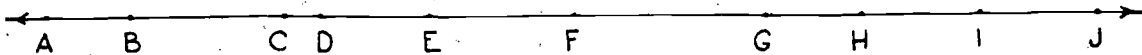

- | | |
|--------------------|--------------------|
| a. \overline{AB} | e. \overline{EF} |
| b. \overline{BE} | f. \overline{EJ} |
| c. \overline{AJ} | g. \overline{GH} |
| d. \overline{CG} | h. \overline{IJ} |
6. a. On the preceding line, measure each of the following segments if you have not already done so: \overline{AB} , \overline{BC} , \overline{CD} , \overline{DE} , \overline{EF} , \overline{FG} , \overline{GH} , \overline{HI} , and \overline{IJ} .
 b. Add all of these measures and check with the answer in 5(c).
- *7. Write the fractions $\frac{1}{4}$, $\frac{1}{2}$, $\frac{1}{8}$, and $\frac{1}{16}$ as common fractions in base two numerals.
- *8. Is there any relation between the divisions on a ruler and base 2?

There are many standard units of length such as the inch, yard, foot, mile. It is often necessary to be able to convert from one to the other. For example, if we are told that a segment is 175 inches in length, we may wish to be able to find the length of this segment in feet. Here is how we proceed. We know that if the measure of a segment in feet is 1, then the measure of this segment in inches is 12. Consider the ratio

$$\frac{\text{measure in inches}}{\text{measure in feet}} = \frac{12}{1}$$

This ratio is the same for any segment. For example, if the measure of a segment in inches is 36, then its measure in feet is 3. Thus

$$\frac{\text{measure in inches}}{\text{measure in feet}} = \frac{36}{3} = \frac{12}{1}$$

This principle holds true whatever the units may be. For example:

$$\frac{\text{measure of } \overline{AB} \text{ in bars}}{\text{measure of } \overline{AB} \text{ in rods}} = \frac{\text{measure of } \overline{CD} \text{ in bars}}{\text{measure of } \overline{CD} \text{ in rods}}$$

Let us answer the question raised above: "What is the measure in feet of a segment whose measure in inches is 175?" Let x denote the measure of this segment in feet. Then set up two ratios for:

$$\frac{\text{measure in feet}}{\text{measure in inches}}$$

Then

$$\begin{array}{ccc} \text{measure of this segment} & & \text{measure of 1 foot} \\ \text{in feet} & \searrow & \text{in feet} \\ & \frac{x}{175} = \frac{1}{12} & \\ & \swarrow & \text{measure of 1 foot} \\ \text{measure of this segment} & & \text{in inches} \\ \text{in inches} & & \end{array}$$

From our work on ratios we know that

$$12 \cdot x = 1 \cdot 175$$

$$x = \frac{175}{12}$$

The measure in feet of the segment is $14\frac{7}{12}$.

Here is a slightly harder problem. A segment whose measure in centimeters is 100, has measure in inches of approximately 39.37. What is the measure in centimeters of a 5-inch segment? Let n be the measure in centimeters of the 5-inch segment.

$$\begin{array}{ccc} \text{measure in centimeters} & & \text{measure in centimeters} \\ & \searrow & \swarrow \\ & \frac{n}{5} \approx \frac{100}{39.37} & \\ & \swarrow & \searrow \\ \text{measure in inches} & & \text{measure in inches} \end{array}$$

Then

$$(39.37)n \approx (5)(100)$$

$$n \approx 5 \cdot \frac{100}{39.37}$$

or

$$n \approx 12.70$$

Exercises 11-2d

- Use the method described above to change the following lengths to different units.

a. 4 ft. = _____ in.	f. 72 in. = _____ ft.
b. 27 ft. = _____ yd.	g. 4 mi. = _____ ft.
c. 27 yd. = _____ ft.	h. 54 in. = _____ ft.
d. 100 yd. = _____ ft.	i. 60 in. = _____ yd.
e. 120 ft. = _____ yd.	j. 27 in. = _____ yd.
- How many yards are there in one mile?
- Walk naturally for ten steps. Measure the distance from the first toe mark to the last toe mark. Divide by ten to find the length of your pace. Express this length in two ways:

a. in feet,	b. in inches.
-------------	---------------
- Use your pace to measure the length and width of your classroom. Change your answer to feet.
 - Measure the length and width of your classroom with a yardstick. Measure to the nearest foot and check with your answer to part (a).

5. Find the total length of each of the following simple closed curves by measuring each segment and adding all the measures. Use a ruler marked in 16ths of an inch.

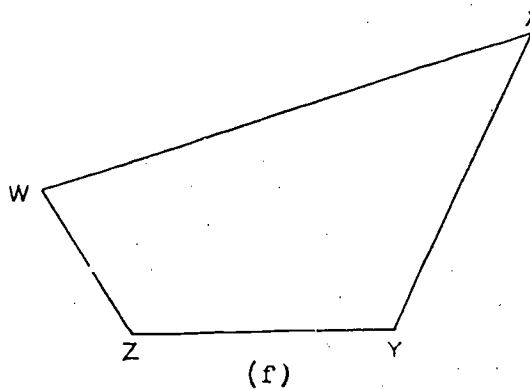
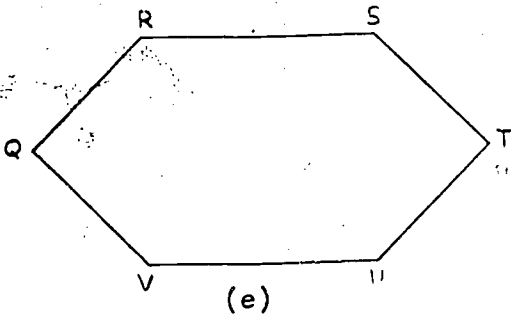
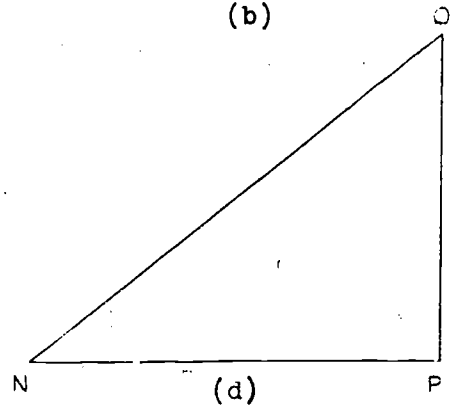
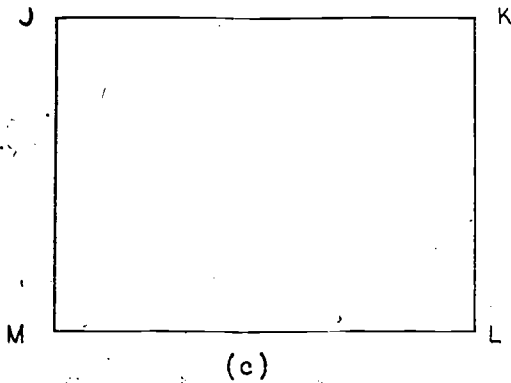
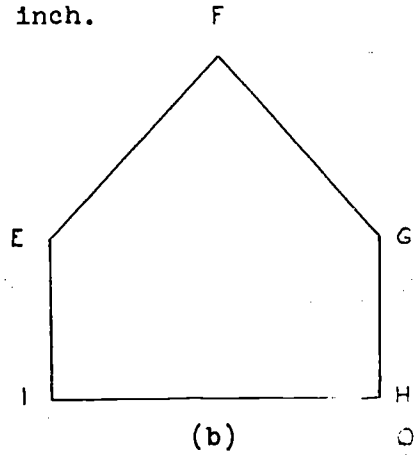
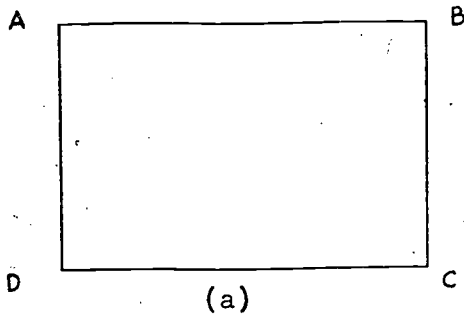

6. a. Use 18 inches as the length of a cubit and find the dimensions (length, width, and height) of Noah's Ark. You can find the dimensions in cubits near the beginning of Section 11-2.
 b. Give the dimensions of the Ark in feet and also in yards.

11-3

11-3. Precision and Error.

The true measure of a geometrical segment is an exact number, but we cannot make exact measurements with a ruler. The best that we can do with a ruler is to make measurements to the closest division marked on the ruler. If the ruler is marked only in whole numbers of inches, then we can measure with this ruler to the nearest whole number of inches. Such measurements are said to have 1-inch precision.

Thus, from the figure below:

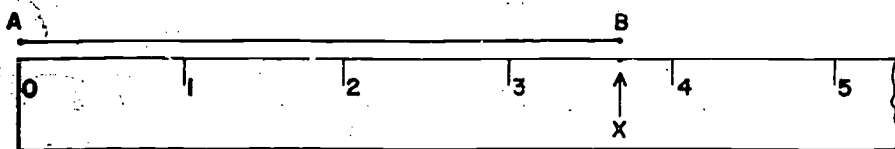

we may say that

$AB \approx 4$ inches with 1-inch precision.

This statement conveys the information that the length of \overline{AB} is closer to 4 inches than to any other whole number of inches. It tells us only that the true length of \overline{AB} is between $3\frac{1}{2}$ and $4\frac{1}{2}$ inches. It is clear that the statement does not convey all the information that is contained in the picture.

To say that a measurement has 1-inch precision means that this measurement was made with a ruler having only the whole numbers of inches marked. (Such a measurement could have been made by ignoring all the marks on the ruler except those indicating whole numbers of inches.)

Similarly, to say that a measurement has $\frac{1}{2}$ inch precision, means that the measurement was made with a ruler marked only with multiples of $\frac{1}{2}$ inch (0, $\frac{1}{2}$, 1, $1\frac{1}{2}$, 2, etc.). (Again, such a measurement could have been made by ignoring all the marks in the ruler except those indicating multiples of $\frac{1}{2}$ inch.)

Exercises 11-3a
(Class Discussion)

From the figure below:

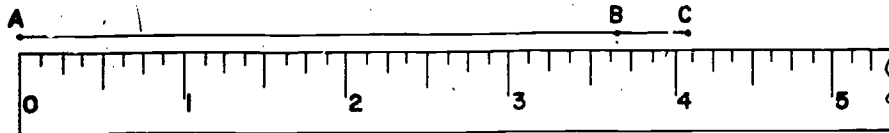

fill in the blanks in the following:

1. $AB \approx$ _____ inches with 1-inch precision.
2. $AB \approx$ _____ inches with $\frac{1}{2}$ -inch precision.
3. $AB \approx$ _____ inches with $\frac{1}{4}$ -inch precision.
4. $AB \approx$ _____ inches with $\frac{1}{8}$ -inch precision.
5. $AC \approx$ _____ inches with 1 - inch precision.
6. $AC \approx$ _____ inches with $\frac{1}{2}$ -inch precision.
7. $AC \approx$ _____ inches with $\frac{1}{4}$ -inch precision.
8. $AC \approx$ _____ inches with $\frac{1}{8}$ -inch precision.

A more convenient way of expressing the precision of measurements is to write measures as mixed numbers with the denominator denoting the precision. For example, we shall use the statement:

$$EF \approx 4\frac{6}{8} \text{ inches,}$$

to mean

$$EF \approx 4\frac{6}{8} \text{ inches with } \frac{1}{8}\text{-inch precision,}$$

while

$$EF \approx 4\frac{3}{4} \text{ inches,}$$

will mean

$$EF \approx 4\frac{3}{4} \text{ inches with } \frac{1}{4}\text{-inch precision.}$$

Of course, the numbers $4\frac{6}{8}$ and $4\frac{3}{4}$ are equal, but the numerals " $4\frac{6}{8}$ " and " $4\frac{3}{4}$ " are different. In statements involving measurements we choose the numeral which expresses the

precision of the measurement. You may wonder how we would shorten the statement

$$GH \approx 5 \text{ inches with } \frac{1}{4} \text{ - inch precision.}$$

The answer is very simple. We write

$$GH \approx 5\frac{0}{4} \text{ inches.}$$

An idea closely related to precision is greatest possible error. To understand what this means consider the following example:

Suppose we are told that:

$$GH \approx 3 \text{ inches with } \frac{1}{2} \text{ - inch precision;}$$

or, in other words,

$$GH \approx 3\frac{0}{2} \text{ inches.}$$

What do we know about the true length of \overline{GH} ? We know that 3 inches is the length of \overline{GH} to the nearest half inch so if \overline{GH} is measured by a ruler with G at 0, then H must fall somewhere in the segment \overline{WZ} along the edge of the ruler.

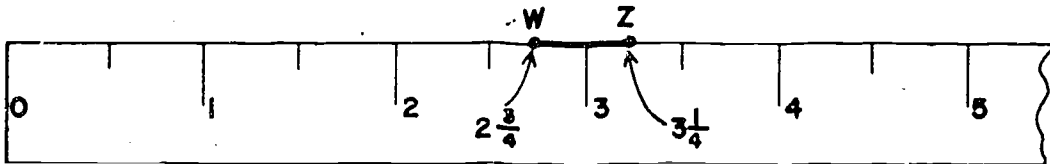

The true length of \overline{GH} must be between $2\frac{3}{4}$ inches and $3\frac{1}{4}$ inches.

What is the error in using 3 inches as if it were the true length of \overline{GH} ? The answer to this question depends on just where the point H falls in the segment \overline{WZ} . If H falls at point X then this error is $\frac{1}{8}$ inch.

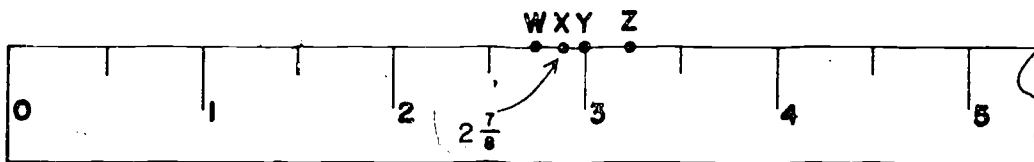

If H falls at point Y, then this error is 0 inches. If H falls at W or Z, this error is $\frac{1}{4}$ inch. But in no case can this error exceed $\frac{1}{4}$ inch. We say, therefore, that $\frac{1}{4}$ inch is

the greatest possible error that can result from using 3 inches as the true length of \overline{GH} . You should see that the greatest possible error is always half of the precision.

Exercises 11-3b

1. Draw the longest possible segment that would be measured as 3 inches if you were measuring to the nearest inch. Draw the shortest possible segment.
2. What could be the true length of the longest segment? the shortest?
3. What is the greatest possible difference between the true lengths of the two segments and 3 inches?
4. Draw the longest and the shortest segments that you would measure as $2\frac{1}{2}$ inches, if you were using only half-inch subdivisions.
5. What could be the true length of your longest segment? the shortest.
6. What could be the greatest possible difference between the true lengths of the segments described in Problem 4, and $2\frac{1}{2}$ inches?
7. Draw a segment 2 inches long and divide it so that it can be used to show a precision of $\frac{1}{8}$ inch.
8. Draw a segment 2 inches long and divide it so it can be used to show a greatest possible error of $\frac{1}{8}$ inch.

9. Measure the length and width of each of these figures to
(1) the nearest $\frac{1}{2}$ inch; (2) the nearest $\frac{1}{8}$ inch; and
(3) the nearest $\frac{1}{16}$ inch. In each case give the greatest possible error.

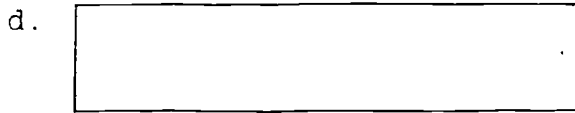
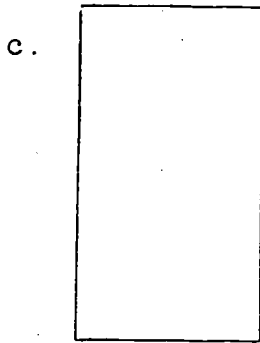
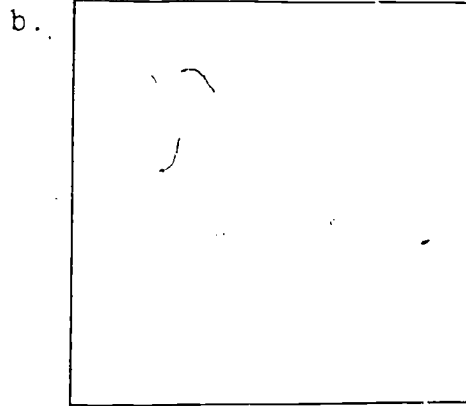
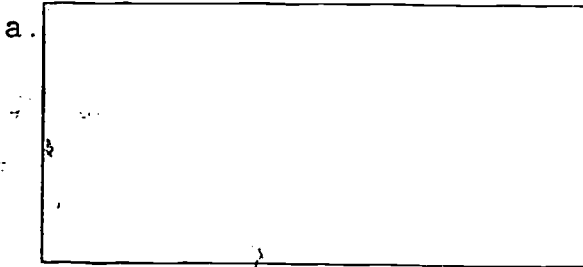

11-4. Perimeter and Rectangles.

The total length of a simple closed curve is called the perimeter of the curve. If the simple closed curve is made up of line segments, then the curve is called a polygon. The segments of which a polygon is made up are called the sides of the polygon. The perimeter of a polygon is therefore the sum of the lengths of its sides. You have already worked several problems in which you measured the perimeters of polygons.

A rectangle is a special kind of polygon; it has 4 sides and all of its corners are "square". Sides of a rectangle which do not intersect are called opposite sides. Sides which do intersect are called adjacent sides.

Exercises 11-4a
(Class Discussion)

1. For each of the following figures name the vertex at each "square" corner.

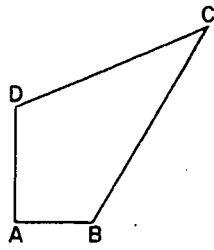

(a)

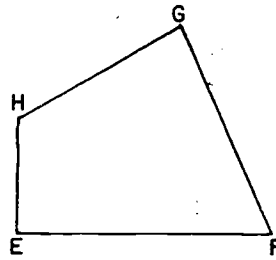

(b)

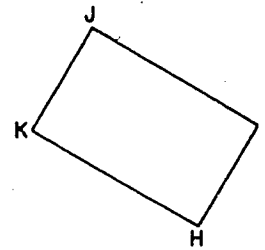

(c)

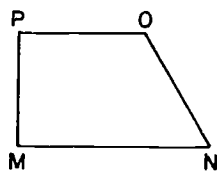

(d)

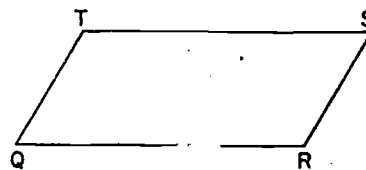

(e)

2. Which of the figures in Problem 1 are rectangles?
3. Find the perimeters of each of the figures in Problem 1, making your measurements with $\frac{1}{8}$ -inch precision.
4. In figure (c) of Problem 1, which side of the rectangle is opposite \overline{HK} ? Measure the sides of this rectangle again. How do the lengths of the opposite sides compare?
5. The cover of this book is rectangular in shape. Measure the lengths of its sides. How do the measures of the opposite sides compare?
6. What do you think is probably true about the opposite sides of a rectangle?

In Problem 6 you probably came to the conclusion that opposite sides of a rectangle have equal lengths. (At least this is the conclusion you were supposed to reach.) This is always true. This makes it possible to find the perimeter of a rectangle by measuring only two sides. That is, if two adjacent sides of a rectangle have measures l and w ,

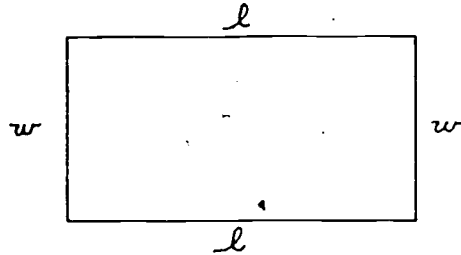

then the measure of the perimeter is $l + w + l + w$ or $2 \cdot l + 2 \cdot w$. If p is the measure of the perimeter, then

$$p = 2 \cdot l + 2 \cdot w.$$

or

$$p = 2 \cdot (l + w)$$

Exercises 11-4b

1. A school playground is in the shape of a rectangle 400 ft. long and 200 ft. wide. Make a drawing to represent the playground. What is the total length of the fence around it?
2. If fencing cost \$5 a yard, how much did the fence of Problem 1 cost?
3. A carpenter is nailing picture molding around a room which has a length of 15 ft. and a width of 10 ft. How much molding does he need? Express the answer in feet, and then in yards.
4. The carpenter of Problem 3 is also installing a baseboard around the room. He notices that the room has four doorways, and that each doorway is 3 ft. wide. Since he does not put baseboard across the doorways, how many feet of baseboard does he need? (Does it matter where the doorways are located?)

5. A boy has 24 feet of wire fence to make a rectangular pen for his pet rabbit. He plans to use all the fence in making the pen.
- Can he make a pen 12 ft. long and 12 ft. wide? Why or why not?
 - Can he make a pen 8 ft. long and 3 ft. wide?
 - How about 8 ft. long and 4 ft. wide?
 - Give five examples of lengths and widths he can use for his pen. (Use only whole numbers for lengths and widths.)
6. A girl is decorating for a party. She has 5 tables, each 28 inches wide and 42 inches long, and she wants to put a strip of crepe paper around the edge of each table.
- How many inches of crepe paper are needed?
 - How many yards of crepe paper are needed?
7. A Fourth of July parade is to follow the route shown by the arrows, starting at S. The squares represent city blocks.

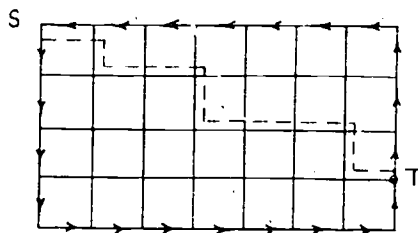

- In this city each block is $\frac{1}{8}$ mile on a side.
- What is the total length of the parade route?
 - If the decorations along the parade route cost about \$250 a mile, what was the approximate total cost of the decorations?
 - In the parade one man got tired, and from point T, he sneaked back to S by the route shown by the dotted lines. How far did he travel?
How much distance did he save?
8. A farmer found that it took 240 feet of fence to go around his rectangular farmyard. He noticed that one of the sides was 40 feet long. Find the length of each of the other sides.

11-5. Metric Units of Length.

The metric system is the measuring system used in most of the countries of the world. It is not the common system of the United States and other countries where English is the principal language, but even in these countries use of the metric system is increasing. Let us see how measurement with metric units is done.

The meter is the principal metric unit of length. It is a little longer than a yard (39.37 inches). It is a very convenient unit for measuring the lengths which we usually express in yards. In all track and field meets where athletes from several countries take part, distances are measured in meters.

When short lengths are measured, or when a more precise measurement is required, a unit smaller than the meter is needed. The most convenient unit is found by dividing a meter into 100 equal segments. Each of these units is called a centimeter (abbreviated cm). Most of the rulers that you buy have centimeters marked along one edge. You should have one of these rulers to use.

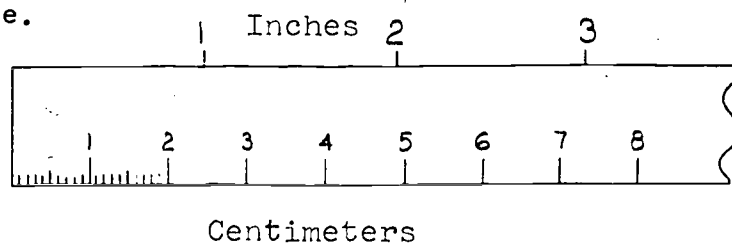

If you examine such a ruler you will see that a centimeter is a little less than half an inch. You will also find that each centimeter is divided into ten parts, rather than 4, 8, or 16, as is done with inches. Parts of a centimeter can therefore be named by numerals with a decimal point as well as by common fractions.

Measure \overline{RX} below to the nearest centimeter and to the nearest .1 cm. You should find that the length of $\overline{RX} \approx 9$ cm., or $\overline{RX} \approx 9.3$ cm.

R _____ X

Exercises 11-5a

1. Draw segments of the following lengths, making your drawings as precise as the marks on your ruler permit:
 - a. 4 cm.
 - b. 6 cm.
 - c. 2 cm.
 - d. 7 cm.
2. Measure the length and the width of the cover of your book. Measure each to the nearest centimeter and to the nearest .1 cm.
3. Measure the boundary line of each of the figures below. Measure each segment to the nearest centimeter and to the nearest .1 cm. When you record your measurements, remember that the symbol " \approx " should be used to show that these measurements are approximate.

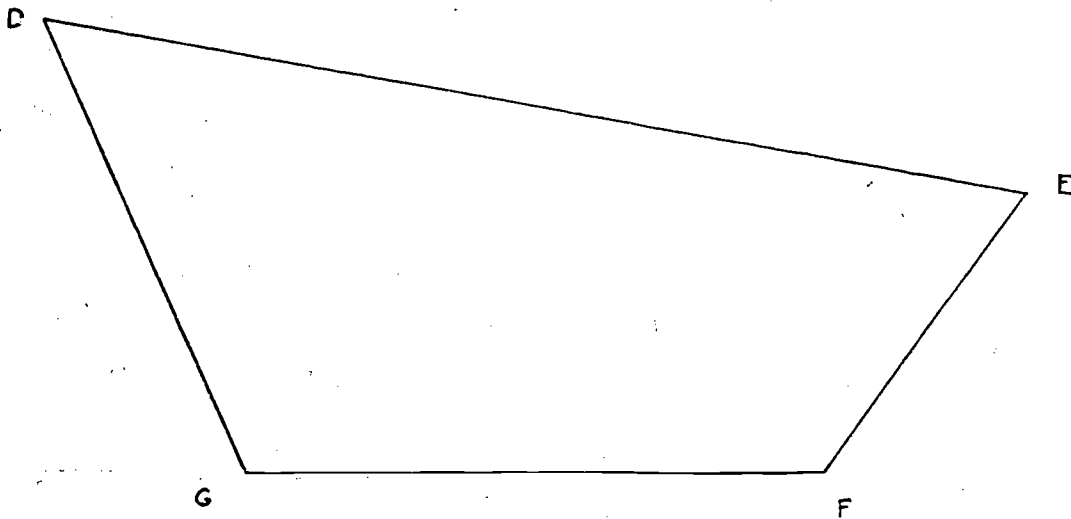
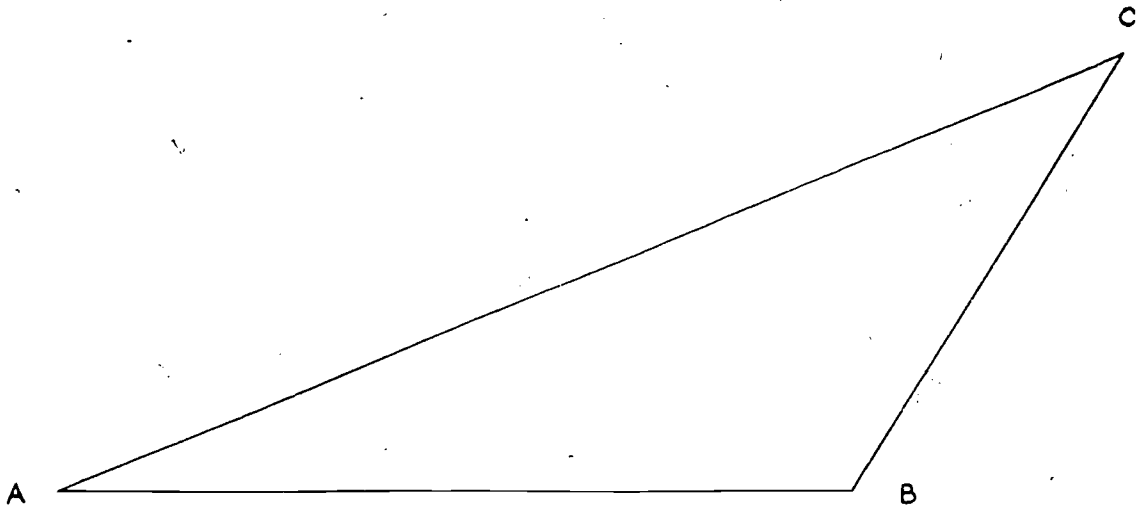

4. Express the following as a number of centimeters, using the basic fact that 1 meter = 100 cm.:

- | | |
|---------------|----------------|
| a. 2 meters | e. .6 meters |
| b. 7 meters | f. .05 meters |
| c. 6.5 meters | g. .32 meters |
| d. 1.2 meters | h. 1.28 meters |

5. How many meters are in a segment of each of these lengths?

- | | |
|------------|------------|
| a. 300 cm. | e. 50 cm. |
| b. 700 cm. | f. 450 cm. |
| c. 256 cm. | g. 75 cm. |
| d. 185 cm. | h. 8 cm. |

In Problem 2, above, you measured segments with a precision of .1 cm. The name of this very small unit is a "millimeter". A millimeter is $\frac{1}{10}$ of a centimeter, which is $\frac{1}{100}$ of a meter. Therefore, a millimeter is $\frac{1}{10}$ of $\frac{1}{100}$, or $\frac{1}{1000}$ of a meter. "Millimeter" is abbreviated "mm" and "meter" is abbreviated "M". The facts you now know about metric units are in the table below.

1 cm. = $\frac{1}{100}$ M.	or	1 meter = 100 cm.
1 mm. = $\frac{1}{10}$ cm.	or	1 cm. = 10 mm.
1 mm. = $\frac{1}{1000}$ M.	or	1 meter = 1000 mm.

The fractions above can be expressed in decimal form if that is preferred.

We often use millimeters in describing precise measurements. You may be familiar with a camera that uses 16 mm. or 35 mm. film. Airplane rockets and other artillery weapons are measured in millimeters.

Exercises 11-5b
(Class Discussion)

1. Draw segments of the lengths below. You will need to have a very sharp pencil and to mark very accurately in using such small units.

a. 20 mm.	e. 81 mm.
b. 50 mm.	f. 105 mm.
c. 70 mm.	g. 16 mm.
d. 35 mm.	h. 58 mm.
2. Exchange papers with a classmate and check the segments of Problem 1.

Exercises 11-5c

1. Measure in millimeters each segment of the figures in Problem 3, Exercises 11-5a.
2. Express these lengths in millimeters:

a. 3 cm.	e. 115 cm.
b. 12 cm.	f. 17.4 cm.
c. 2.8 cm.	g. 1 meter
d. 6.3 cm.	h. 3.5 meters
3. Express these lengths in the units called for:

a. 40 mm. = _____ cm.	e. 156 mm. = _____ cm.
b. 100 mm. = _____ cm.	f. 2000 mm. = _____ cm.
c. 100 mm. = _____ M.	g. 2000 mm. = _____ M.
d. 32 mm. = _____ cm.	h. 204 mm. = _____ cm.

11-6. Summary.

1. Segments having the same length are said to be congruent.
2. Measurement of length may be thought of as a process of "filling" a segment with unit segments.
3. When a unit segment is chosen we may use it to construct a number line called a ruler which we compare with other segments to determine their lengths.

4. The choice of a unit of length is entirely arbitrary, but in practice it is necessary to have standard units which are familiar to large groups of people.
5. The official standard units of length in America and England are the English units; inch, foot, yard, mile. The official standard units in most of the rest of the world are metric units; millimeter, centimeter, meter, kilometer.
6. Measurement is approximate, not exact; and when possible, the precision or greatest possible error in a measurement should be shown.
7. The symbol " \approx " means "approximately equal to".
8. A polygon is a simple closed curve which is a union of segments.
9. The perimeter of a polygon is the sum of the lengths of the sides.
10. A rectangle is a polygon having four sides and all corners "square".
11. If l and w are the measures of the lengths of two sides of a rectangle which meet at a corner, then the measure of the length of the perimeter, p , is given by:

$$p = 2 \cdot l + 2 \cdot w.$$

11-7. Chapter Review.

Exercises 11-7

1. Name six units of linear measure.
2. Name four standard units that are not linear units of measure.
3. Complete: If the length of a segment is correctly stated to be $8\frac{3}{4}$ inches, its actual length might be as short as _____ or as long as _____.

11-7

4. What is the perimeter of the following simple closed curves?

a.

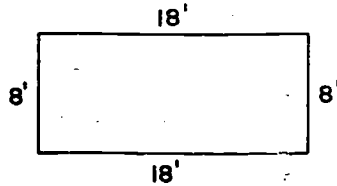

b.

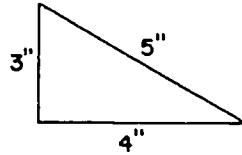

c.

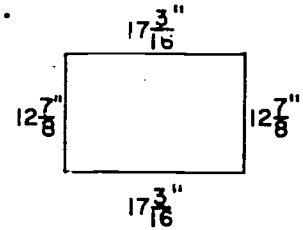

5. When you measure to the nearest $\frac{1}{4}$ inch, what is the greatest possible error?

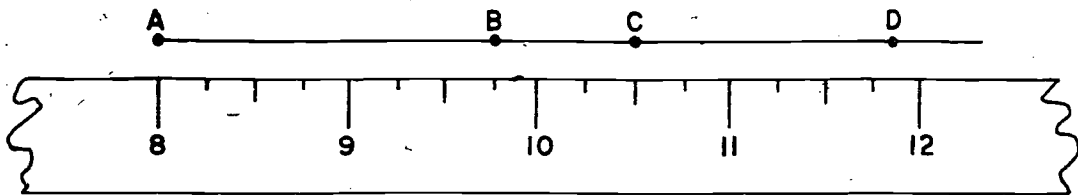

6. The ruler above measures to the nearest ? of a unit.

7. How many units are contained in \overline{AB} ?

8. How many units are contained in \overline{BC} ?

9. How many units are contained in \overline{CD} ?

10.

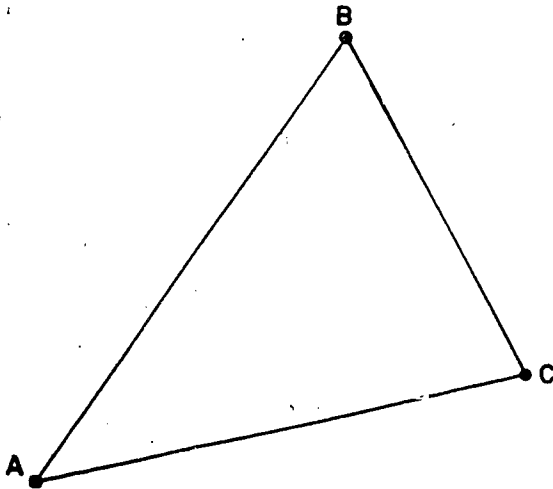

Find the perimeter of $\triangle ABC$ using

- a ruler which measures to $\frac{1}{16}$ of an inch.
- a ruler which measures to $\frac{1}{10}$ of a centimeter.

11-8. Cumulative Review.

Exercises 11-8

1. Use the distributive property to rewrite each of the following.

a. $9 \cdot (3 + 2)$

b. $(7 + 11) \cdot 6$

2. Are the following sets closed under addition?

a. $\{2, 4, 6, 8, 10, \dots\}$

b. $\{7, 14, 21, 28, 35\}$

3. Copy and replace the ? by < or > whichever is correct.

a. $6 ? 8$

d. $\frac{13}{15} ? \frac{5}{6}$

b. $\frac{1}{2} ? \frac{9}{17}$

e. $\frac{3}{4} ? \frac{25}{40}$

c. $\frac{9}{14} ? \frac{20}{31}$

f. $\frac{15}{18} ? \frac{28}{32}$

4. In which base is $203152_?$ written?

a. Base five

b. Base ten

c. Could be any base less than 5.

d. Could be any base greater than 5.

5. Which numeral represents the largest number?

a. 28_{ten}

c. 10000_{two}

b. 23_{twelve}

d. 37_{eight}

6. In the diagram on the right

a. How many planes contain point D? Name them.

b. How many planes contain \overline{AC} ? Name them.

c. What is $\overline{AC} \cap \overline{AB}$?

d. Are \overline{CA} and \overline{AD} in the same plane? State the property that says this.

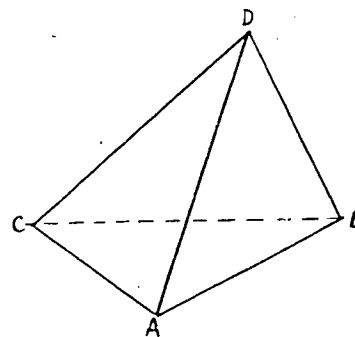

11-8

7.

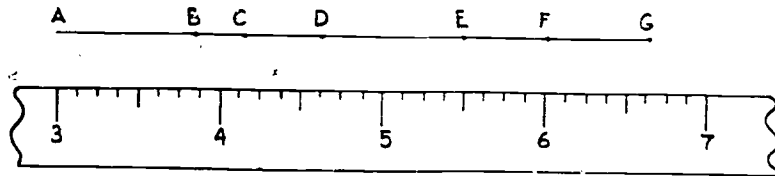

How long is each segment? Measure to the nearest $\frac{1}{16}$ inch.

- | | |
|--------------------|--------------------|
| a. \overline{AB} | d. \overline{AE} |
| b. \overline{AC} | e. \overline{AF} |
| c. \overline{ED} | f. \overline{EG} |

8. Perform the indicated operations and simplify.

- | | |
|--|--------------------------------------|
| a. $5\frac{2}{5} + 4\frac{4}{5}$ | d. $3\frac{7}{8} - 1\frac{3}{8}$ |
| b. $1\frac{1}{4} + 2\frac{2}{3}$ | e. $5\frac{1}{6} - 2\frac{5}{6}$ |
| c. $2\frac{1}{4} + \frac{3}{8} + 1\frac{1}{6}$ | f. $1\frac{1}{3} \times \frac{3}{4}$ |

9. Write a complete factorization of 66.

10. Which of the statements below is not true?

- If a number is divisible by 3 and 5 then it is also divisible by 15.
- A multiple of 6 must be an even number.
- The number 47 is a composite number.

11. If a TV antenna tower has a shadow 275 feet long when a 6-foot man's shadow is 15 feet long, find the height of the tower.

12. Joan reduced her weight during the summer from 150 pounds to 120 pounds. What was the percent of decrease?

Chapter 12
AREA AND VOLUME

12-1. Meaning of Area.

In Chapter 11 you learned how to measure the length of a segment. In this chapter you will learn how to measure a closed region. You recall that the interior of a simple closed curve together with its boundary is called a closed region. Consider the closed regions shown below.

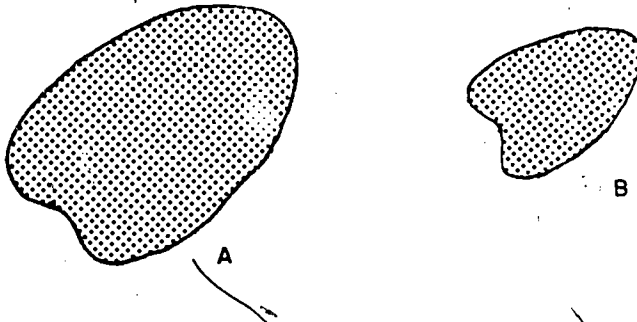

We may compare the size of the closed region B with the size of the closed region A by cutting out a copy of closed region B and placing it on a copy of closed region A. It is clear that closed region B would fit into closed region A with something to spare. We say that the area of A is larger than the area of B.

Exercises 12-1

1. In connection with the closed regions shown below, complete the following sentences using one of the symbols $>$, or $<$.

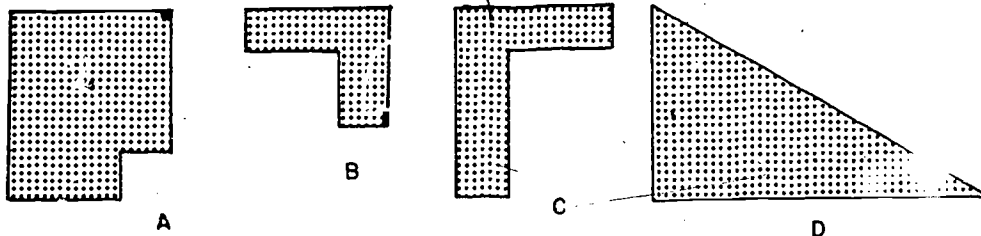

- a. area of closed region A \approx area of closed region B.
 b. area of closed region B \approx area of closed region D.
 c. area of closed region C \approx area of closed region B.
 d. area of closed region D \approx area of closed region A.
 e. area of closed region C \approx area of closed region A.

2. Make several cardboard copies of figure A and use them to compare the areas of the other five closed regions. Do this by finding the approximate number of copies of figure A which are necessary to cover each of the other figures. List them in order of size, beginning with the largest area.

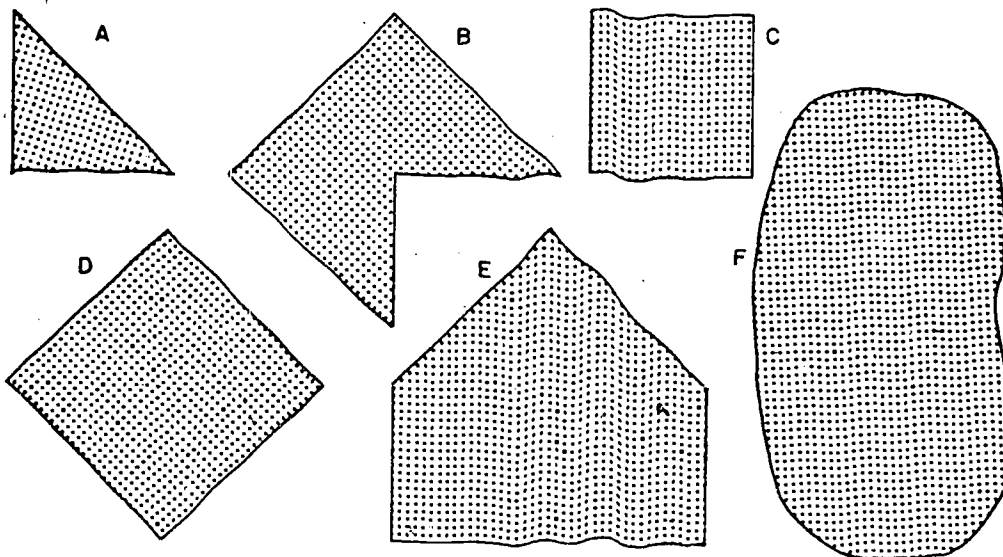

In Problem 2 you have seen that you can compare the areas of closed regions by finding how many times the closed region A is contained in the other closed regions. Thus, we may use a single closed region to make our comparisons. This simple closed region, A, may be considered our unit of area.

3. The measure of the area of figure R below is 1 unit. Make a copy of figure R and use it to measure the areas of the other four figures approximately.

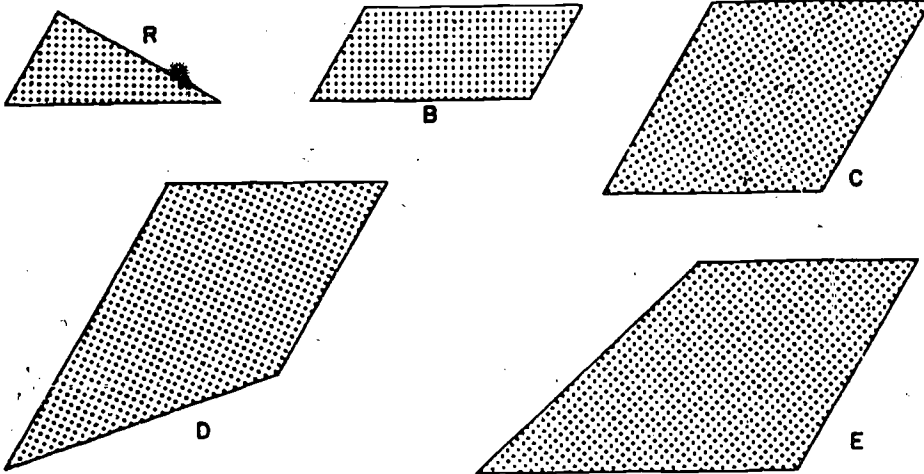

4. The closed region R represents the floor of a room. We wish to measure the area of this floor. Which of the following closed regions may be conveniently used as a unit of area, in your opinion? Give a reason for your answer.

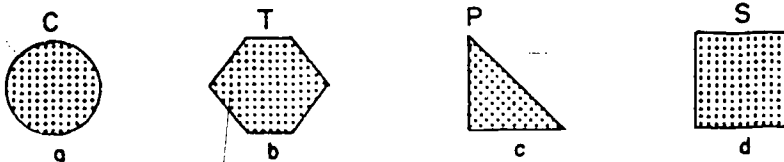
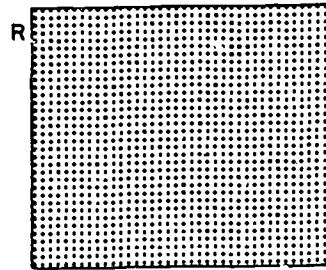

If you were to make a selection of one of these units, which one would you prefer? Why?

5. Draw a triangle ABC . On each side of the triangle locate a point which divides the side into two congruent segments. Name these points D , E , and F , as shown in the diagram below. Draw \overline{DE} , \overline{EF} , and \overline{DF} .

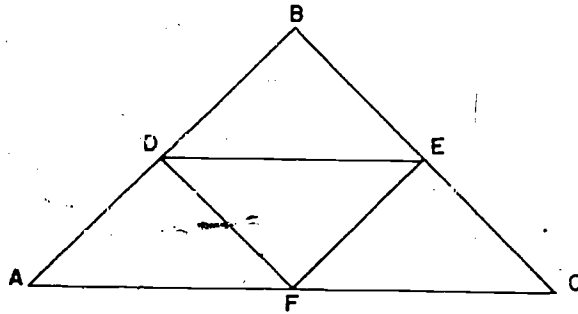

- Make a cardboard model of the triangular closed region ADF . Use your model of triangle ADF as a unit of area and find the areas of the following closed regions. DEF , ABC , $DECF$, and $ADEC$.
- Make a cardboard model of the closed region $AFED$. Use your model of the closed region $AFED$ to find other closed regions which have the same area as the closed region $AFED$.

12-2. Cutting Units of Area.

You have seen that the size of a segment may be found by measuring. In measuring segments, you used another segment as a unit of measure. Similarly, in measuring the area of a closed region you used another closed region as a unit. When you measure the area of a closed region, the unit that you use may not fit into the area of the closed region a whole number of times. Some of this region may remain uncovered around the edges of the measuring units. The part left over may not be shaped so that you can fit any more whole units on it.

12-2

In measuring the area of the shaded region below using the unshaded rectangular region as unit,

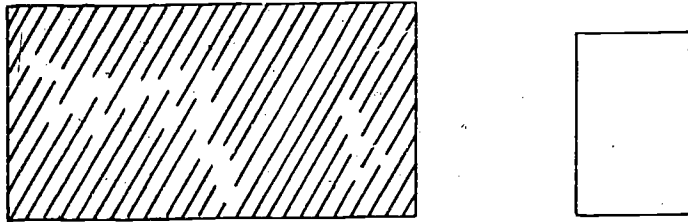

you can place units on the shaded region and find that part of the shaded region is not covered.

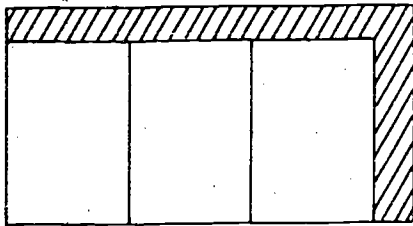

We can deal with this situation by cutting one of our units along the indicated lines and placing these pieces on the border as shown.

A		
B		
C		
D	E	
F	G	H

A	B	C	D
			F
			G
			H



One of the parts (the one labeled E) was left over. The area of the shaded region is therefore a little less than 4 units.

In doing this patchwork you must be careful to cut only one unit at a time. Be sure to use all the pieces of one unit before you cut the next one. Can you explain why?

Exercises 12-2

1. Using your notebook sheets as units, find the area of the top of your desk. Your unit may not fit into the top of your desk a whole number of times. In this case, cut up additional units and find the approximate area.
2. Find the approximate area of the closed region on the left by using the area of the closed region on the right as a unit. Make several cardboard models of the unit closed region so that you can cut up your area units to cover the area of the closed region on the left completely.

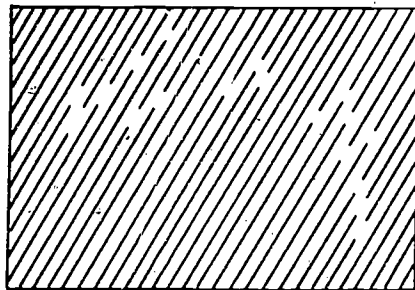

12-3. Area of a Rectangle.

In Chapter 11 you learned that a rectangle is a simple closed curve made up of four line segments with all corners "square." A rectangular region is a region consisting of a rectangle and its interior. In speaking of areas of rectangular regions we shall say "area of the rectangle" for short.

In previous sections you have used a number of different closed regions as units of area. The most convenient choice for a unit of area is a square closed region whose side is one unit of length. The reason that this choice is so convenient is that our unit of area is thus related to our unit of length.

If we are using the inch as a unit of length, then the corresponding unit of area is the square region shown below.

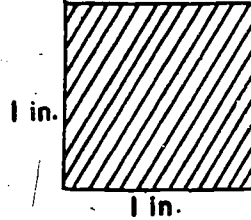

The name of this unit is the square inch. You should be able to see what is meant by a square foot, square yard, square centimeter, square mile, or in fact, square unit for any unit of length.

If a rectangle is 6 units long and 3 units wide, then the rectangular region can be covered by square units as shown. The measure of the area of the rectangle is then the number of square units used in the covering.

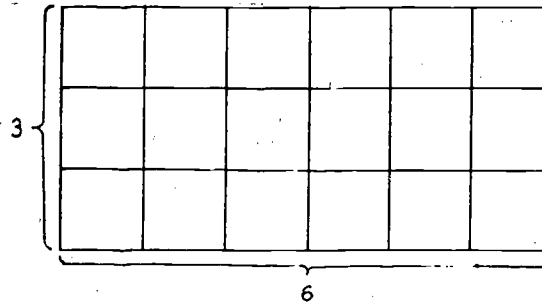

Is there an easier way to get the number of squares than by counting them? How can you do it?

If you counted by noting that each row has six squares and that there are three rows, you obtained the number of square units A in the area by writing

$$A = 3 \times 6$$

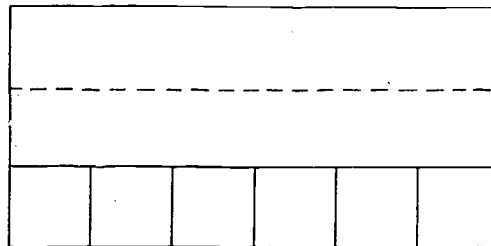

If you counted by saying that there are three squares in each column and six columns, you obtained:

$$A = 6 \times 3$$

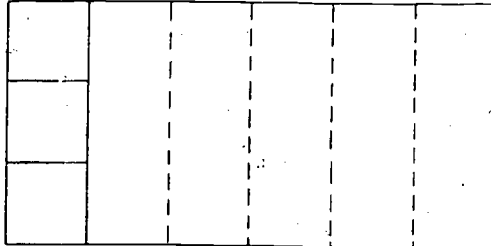

Of course, these numbers are the same. What property of multiplication is illustrated by $3 \cdot 6 = 6 \cdot 3$?

We see now why the square unit is so convenient in measuring area. If the lengths of the sides of a rectangle are whole numbers of units, then the measure of the area of the rectangle in the corresponding square units is simply the product of the measures of the sides.

In practice it is very likely that the lengths of the sides of many rectangles will not be whole numbers of units. Suppose, for instance, that the length is 3 inches and the width is $2\frac{1}{2}$ inches. You can easily fit in six of the square inch units but you are left with a border, as shown in the shaded area below.

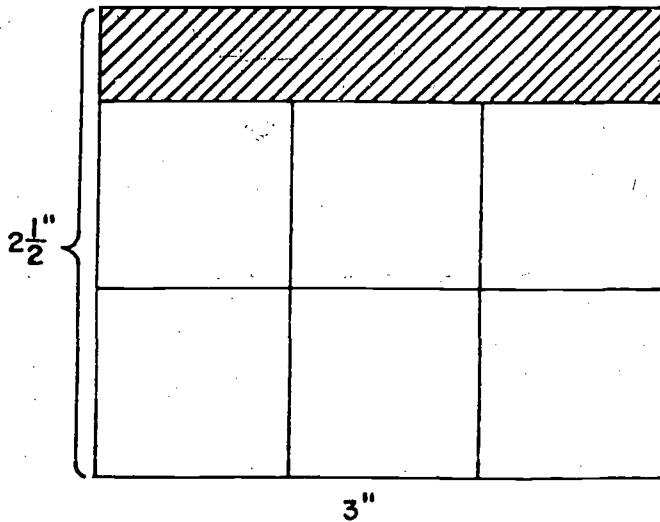

In order to fill the border, take a unit square and divide it into smaller squares as shown:

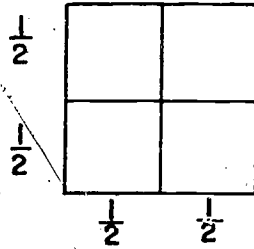

How many of the small squares are needed to cover the area of the large square? Do you agree that each small square ($\frac{1}{2}$ " by $\frac{1}{2}$ ") is $\frac{1}{4}$ of a square inch?

Now, consider the border alone. How many of these small squares are needed to fill the border?

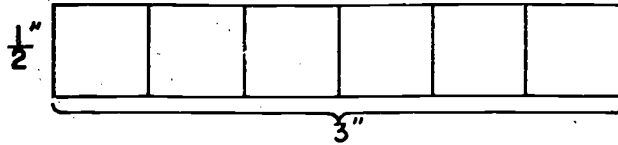

Do you see that you need six of these small squares to fill the border?

Thus, the area of the rectangle is

$$6 + (6)\left(\frac{1}{4}\right)$$

$$= 6 + 1\frac{1}{2} = 7\frac{1}{2}$$

The area of the rectangle is $7\frac{1}{2}$ square inches.

You may obtain the same result by dividing the entire figure into small squares ($\frac{1}{2}$ " by $\frac{1}{2}$ ") as shown below.

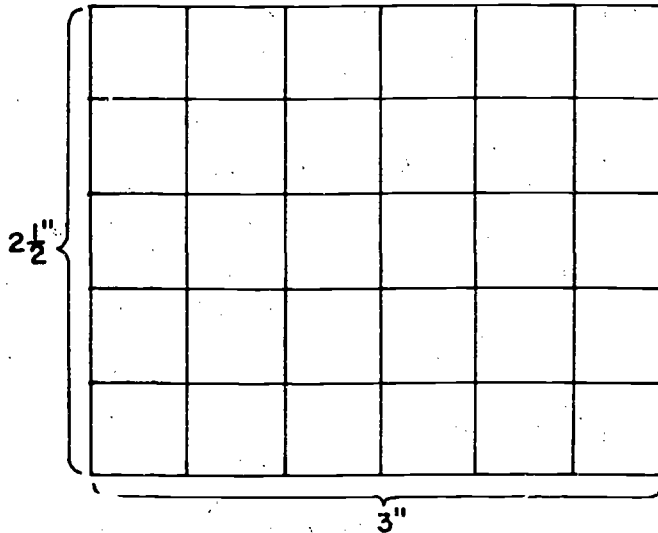

Since you have 6 columns with 5 small squares in each column you have 6×5 , or 30 small squares. This is equivalent to $(30)(\frac{1}{4})$, or $7\frac{1}{2}$ square inches. Can you obtain the area of this rectangle without using the diagram? Explain how this can be done.

Exercises 12-3a

1. Find the area of a rectangle $4\frac{1}{2}$ inches long and $3\frac{1}{2}$ inches wide, as follows:
 - a. Draw the rectangle on your paper.
 - b. Fit in as many whole square inch units as you can. How many did you fit in?
 - c. What are the dimensions of the squares that you will need to use in filling in the border? Make a drawing of this square.
 - d. How many of these smaller squares will you need in order to fill the border? How many square inches are there in the border?
 - e. What is the total area of the rectangle?
 - f. Find the area of the rectangle by dividing it into the smaller squares that you used in finding the area of the border.
 - g. You know how to find by computation the area of a rectangle in which the measures of the sides are whole numbers. Show that the same method applies for this rectangle where the measures are not whole numbers.
2. Find the area of a rectangle $3\frac{1}{2}$ inches long and $2\frac{1}{4}$ inches wide. Use the same procedure as you followed in Problem 1.
- *3. Using the method you used in Problem 2, find the area of a rectangle whose length and width are $5\frac{1}{2}$ inches and $4\frac{2}{3}$ inches. In this case, you may find it easier to cut the unit square inch into rectangles instead of squares by making two divisions horizontally and three vertically as shown.

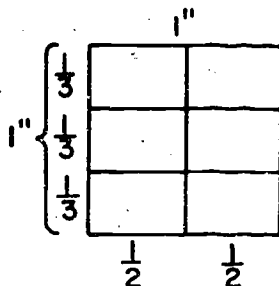

If the area of each small rectangle is y square inches, you know that $6 \cdot y = 1$. What is the area of each small rectangle?

When you wish to find the area of a rectangle, the lengths of whose sides are not whole number units, it is inconvenient to use the diagrammatic method of the last few examples. Let us examine the results obtained above and look for a simpler method.

<u>LENGTH</u>	<u>WIDTH</u>	<u>AREA</u>
6"	3"	18 square inches
3"	$2\frac{1}{2}$ "	$7\frac{1}{2}$ square inches
$4\frac{1}{2}$ "	$3\frac{1}{2}$ "	$15\frac{3}{4}$ square inches
$3\frac{1}{2}$ "	$2\frac{1}{4}$ "	$7\frac{7}{8}$ square inches
$5\frac{1}{2}$ "	$4\frac{2}{3}$ "	$25\frac{2}{3}$ square inches

In each case above, multiply the number of units in the length by the number of units in the width. Do you find that the product corresponds to the area, as shown in the third column?

We can now state the following conclusion:

If A is the number of square units in the area of a rectangle, and l and w stand for the number of linear units in the length and width of the rectangle, then $A = l \cdot w$.

In the exercises below you will use standard units and their relations. A list of some of the relations which you studied in Chapter 11 may be helpful.

$$12 \text{ inches} = 1 \text{ foot}$$

$$3 \text{ feet} = 1 \text{ yard}$$

$$36 \text{ inches} = 1 \text{ yard}$$

Exercises 12-3b

1.
 - a. On wrapping paper draw a sketch representing a square 1 foot long and 1 foot wide.
 - b. Along one side mark off distances representing 1 inch.
 - c. Along the other side mark off distances representing 1 inch.
 - d. Use your sketch to find the number of square inches in one square foot.
2. Use a procedure similar to the procedure in Problem 1 to determine the number of square feet in a square yard.
3.
 - a. Draw a square 3 inches on a side.
 - b. Draw a rectangle whose area is 3 square inches.
 - c. Which is larger? By how many square inches?
4.
 - a. Draw a rectangle which is 2 inches long and which has an area of 1 square inch.
 - b. Draw a rectangle which is 4 inches long and which has an area of 1 square inch.
 - c. How many different rectangles of area 1 square inch can you draw?
5. A living room rug is 12 feet long and 9 feet wide.
 - a. Find the area of the rug in square feet.
 - b. Find the area of the rug in square yards.
6. A baseball diamond is a square, 90 feet on a side. Find the area of this diamond both in square feet and in square yards.
7. The diamond used in softball is a square 60 feet on a side. Is this area more than or less than half the area of a baseball diamond? (See Problem 6.)

8. Use the sentence $A = l \cdot w$ to find A if

a. $l = 9$ inches, $w = 7$ inches

b. $l = 11\frac{1}{2}$ inches, $w = 6$ inches

c. $l = 5\frac{1}{2}$ inches, $w = 4\frac{1}{2}$ inches

d. $l = 7\frac{3}{4}$ inches, $w = 6\frac{1}{2}$ inches

e. $l = 9\frac{1}{4}$ inches, $w = 3\frac{3}{4}$ inches

9. A square is 10 millimeters on a side.

a. Find the area of the square in square millimeters.

b. Express your answer in square centimeters.

10. Measure in centimeters the length and width of the rectangle below.

a. The length is _____ cm.

b. The width is _____ cm.

c. The area is _____ square cm.

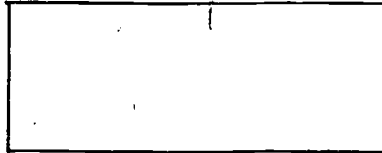

11. Repeat Problem 10, but measure the length and width in millimeters.

a. The length is _____ mm.

b. The width is _____ mm.

c. The area is _____ square mm.

12. Two rectangles are placed together as shown, to form a larger rectangle. The number of linear units in the sides is indicated.

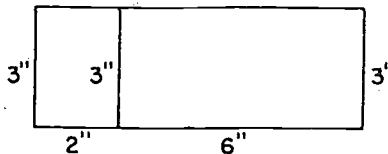

- a. Find the area of the small rectangle on the left.
 - b. Find the area of the small rectangle on the right.
 - c. Find the area of the large rectangle.
 - d. Is the area of the large rectangle equal to the sum of the areas of the two smaller rectangles?
 - e. Show how this equality illustrates the distributive property.
13. A rectangle is 3 units long and 2 units wide.
- a. If another rectangle is twice as long but has the same width, how do the areas of the two rectangles compare?
 - b. Draw a figure illustrating your answer.
 - c. Do the same if the new rectangle has the same length as the original but has twice the width.
14. Do the conclusions reached in Problem 13 depend upon the particular measures 3 and 2?
- a. Write a statement telling the effect on the area of any rectangle if you double the length.
 - b. Write a statement telling the effect on the area of any rectangle if you double the width.
15. If a rectangle has a length of 3 units and a width of 2 units, what is the effect on the area of doubling both length and width?
- a. Draw a figure to illustrate your conclusion.
 - b. Write a statement telling the effect on the area of doubling both the length and the width of any rectangle.
16. In the rectangles of Problem 15, what is the ratio of the larger perimeter to the smaller perimeter?
- *17. The outside length of a picture frame is 20 inches and the outside width of the frame is 12 inches. If the dimensions of the picture are 14" by 8", find the area of the frame.

12-4. Approximation.

In your work so far you have assumed that measurements of the sides of rectangles are exact. Actually, this is almost never the case because no measurement can be made exactly. If you measure a rectangle and find measurements of $3\frac{3}{4}$ inches and $2\frac{1}{4}$ inches, you should use the "approximately equal" symbol and write $l \approx 3\frac{3}{4}$, $w \approx 2\frac{1}{4}$ and therefore:

$$A = lw$$

$$A \approx (3\frac{3}{4})(2\frac{1}{4})$$

$$A \approx (\frac{15}{4})(\frac{9}{4})$$

$$A \approx \frac{135}{16}$$

$$A \approx 8\frac{7}{16}$$

Since A is the number of square inches, we find that the area is approximately $8\frac{7}{16}$ square inches.

A statement concerning a measured quantity should indicate that it is only approximate, and not an exact measure.

Exercises 12-4

Use the \approx sign in connection with numbers representing measured quantities.

1. Measure the length and width of the top of your desk to the nearest half inch.
 - a. Find the number of square inches in the area.
 - b. What is the perimeter?
2. A section of chalkboard is about 5 feet long and $3\frac{1}{2}$ feet wide.
 - a. Find the area. Express the answer in square feet and square yards.
 - b. Find the perimeter and express it in feet, and yards.
3. If a garage floor is measured to be 18 feet by 22 feet
 - a. Find the area of the garage floor.
 - b. Find the cost of laying a concrete floor at 60 cents a square foot.

4. A rectangular field is located at the intersection of two perpendicular roads. The length and width are measured as approximately $\frac{3}{10}$ mile and $\frac{4}{10}$ mile. Find the area of the field. Express the result in square miles.

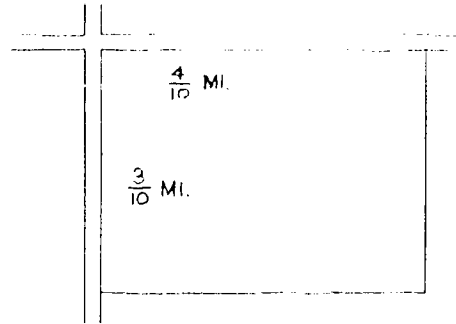

5. A rectangular lawn is found to be 84 feet by 50 feet. The lawn is to be seeded with grass. The directions on the box of grass seed say that one pound of seed is enough for 300 square feet. How many pounds of grass seed are necessary?
6. A bathroom floor is tiled with small tiles which are one inch squares. The floor contains 3240 of these tiles.
- What is the area of the floor in square inches?
 - What is the area of the floor in square feet?
7. A boy's room is in the shape of a rectangle. The length and width are measured as 15 feet and 12 feet. There is a closet 3 feet long and 3 feet wide built in one corner, as shown in the floor plan. What is the floor area of the room (not counting the closet)?

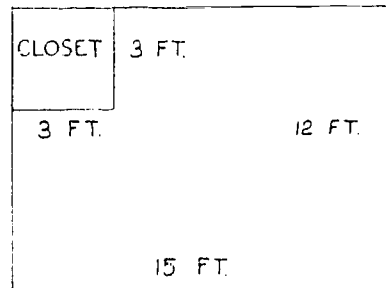

8. An attic is in the shape of a rectangle with measurements of 30 feet by 20 feet. There is an opening in the floor as shown where the stairway comes up.
- Find the floor area of the attic.
 - Does it matter in figuring area, where the opening for the stairs is placed?

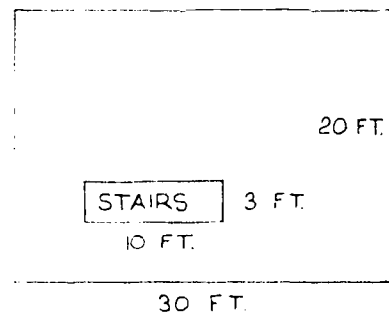

- *9. A rectangular sheet of metal is measured to be 10" by 8" with 1" precision.
- What is the smallest possible measure of the true width?
 - What is the smallest possible measure of the true length?
 - What is the largest possible measure of the true width?
 - What is the largest possible measure of the true length?
 - What is the smallest possible measure of the true area?
 - What is the largest possible measure of the true area?

12-5. Rectangular Prism.

We call a figure like a chalk box a rectangular prism. The rectangular prism is a familiar figure and you can find many examples. Your classroom is probably one example. Name as many examples as you can.

When you walk across the classroom floor you are moving in the interior of the rectangular prism of your classroom, if your room has this shape. Let us examine such a prism. Note that the prism has a certain number of surfaces. These are called its faces. How many faces does a rectangular prism have? What kind of figure is represented by each of the faces? Notice that each of the faces lies in a plane. For each face of the prism there is just one other face that does not meet it. Such a pair of faces are called opposite faces. Opposite faces actually lie in parallel planes. How many pairs of opposite faces are there? Identify the pairs of opposite faces in your classroom. What can you say about the shape of two opposite faces? How do you know? Faces which intersect are called adjacent faces. What is the intersection of two adjacent faces? What is the intersection of three faces?

Exercises 12-5

1. Name two opposite faces of the rectangular prism.
2. Name two adjacent faces of the rectangular prism.
3. Two faces which are not opposite intersect in points that lie on a line. These segments are called edges of the prism.
 - a. Name three edges of the prism.
 - b. How many edges does a rectangular prism have?
4. Name a set of equal edges.
5. There are certain points on the prism where three faces intersect. These points are called vertices of the prism.
 - a. Name three vertices of the prism.
 - b. How many vertices does a rectangular prism have?
6. The parallel edges of a rectangular prism have the same length. There can be at most three different lengths for the edges of a rectangular prism. In the figure, the number of units in the lengths of three edges have been marked. Tell the number of units in the length of each of the other nine edges.
7. Use paper or light cardboard to make a model of a rectangular prism. Use the pattern below. The dotted lines show where to make the folds. The flaps are needed to permit you to paste the model together.

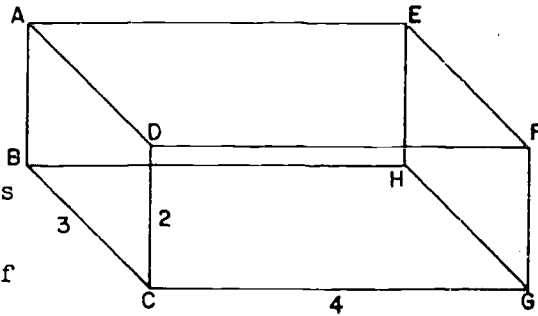

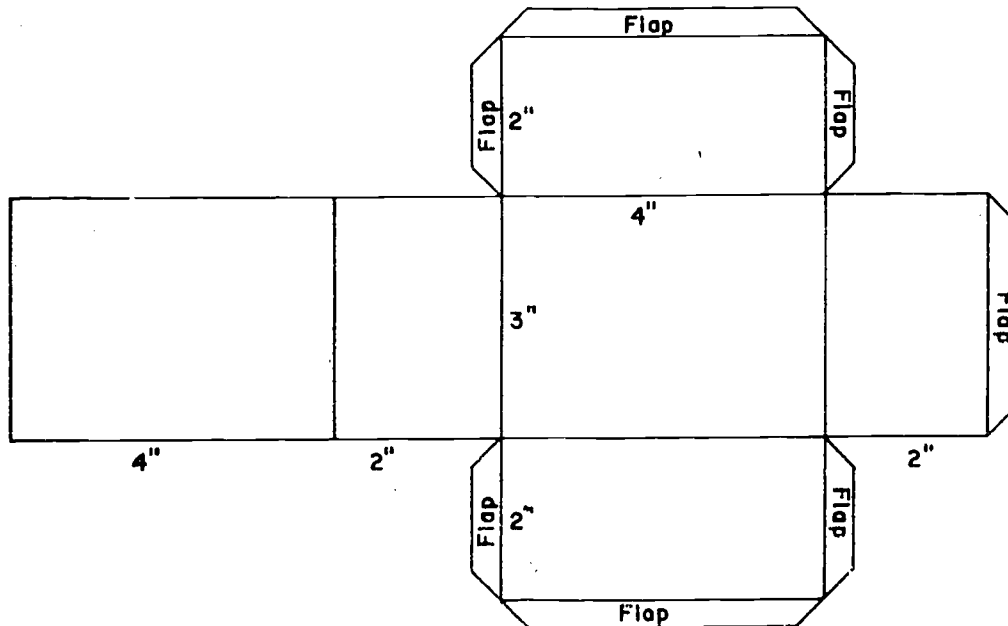

12-6. Area of a Prism.

The lengths of the edges in the three possible directions are often called the length, width, and height of the prism. How do the opposite faces compare in area? Since all the faces are rectangular regions, it is easy to find the areas of the faces. The sum of the areas of all the faces is called the surface area of the rectangular prism.

Using the number of units marked as lengths on the three edges, find the surface area of the rectangular prism shown in the figure above.

If A is the number of square units in the surface area of a rectangular prism, l the number of linear units in the length, w the number of linear units in the width, and h the number of linear units in the height; then

$$A = 2 \cdot l \cdot w + 2 \cdot l \cdot h + 2 \cdot w \cdot h .$$

Exercises 12-6

1. Find the surface area of the rectangular prism for which the length is 7 inches, the width is 5 inches, and the height is 4 inches.
2. A housewife has a cake tin in the shape of a rectangular prism (without a top). The tin is 10 inches long, 8 inches wide, and 2 inches deep. When she bakes a cake, she lines the pan with wax paper. About how many square inches of wax paper are needed to cover the inside of the tin?
3. A classroom wall is 30 feet by 10 feet. On this wall is a chalkboard 20 feet long and $3\frac{1}{2}$ feet high. The wall, except for the chalkboard, is to be painted. What is the approximate area to be painted? Express the answer in square feet, then in square yards.
4. An incubator for hatching eggs is in the shape of a rectangular prism 20 inches long, 10 inches wide, and 15 inches high. The top is made of glass (indicated by the shading).

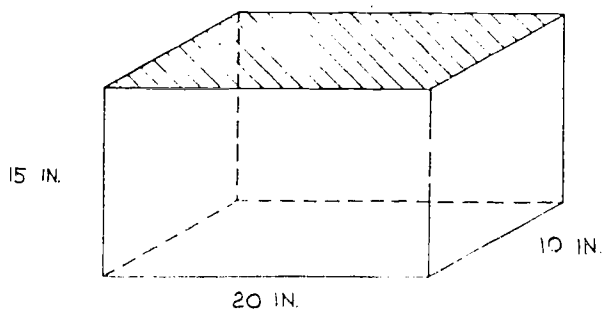

The sides and bottom are made of wood. What is the area of the piece of glass used? What is the area of the outside of the wooden box? Express your answers both in square inches and in square feet.

5. A room is 15 feet long, 12 feet wide, and 9 feet high.
 - a. How many squares of tile, each 12 inches by 12 inches, will be needed to tile the floor?
 - b. How many tiles will be needed if each is 6 inches by 6 inches?

6. In the room of Problem 5 there are five windows in the walls, each 3 feet wide and 6 feet high. How much wall surface is there, not counting the windows? (Does it matter where the windows are placed?)
7. In Problem 6 how many quarts of paint are necessary to paint these walls? A quart of paint will cover 132 square feet.
8. A trunk is 3 feet long, 18 inches wide, and 2 feet high. The edges are bound with strips of brass. How much brass stripping is necessary? Express the answer in inches, in feet, and in yards.
9. A cube is a rectangular prism all the edges of which are equal in length.
 - a. What is the shape of each face of a cube?
 - b. How many square inches of wood are needed to make a cubical box, including lid, with edges of 18 inches each?
 - c. Express your answer in square feet.
- *10. Let l , w , h stand for the numbers of units in the length, width, and height of an aquarium in the form of a rectangular prism. Write a number sentence telling how to find the number S of square units in the surface area if the aquarium is open at the top.

12-7. Meaning of Volume.

The term rectangular solid will be used to refer to the set of points consisting of a rectangular prism and its interior.

Do you recall that you were able to find the area of a rectangle just by working with its length and width? Do you agree, then, that it would also be useful if you had a way of finding the volume of a rectangular solid by working with its length, width, and height? First, it is necessary to agree on a unit of volume. The usual choice for a unit of volume is a cube. A cube is a rectangular prism for which all the edges have the same length. Would this have been your choice, or

12-7

would you have chosen something else? What size cube would you suggest? (Remember that we chose a 1-inch square as our unit of area.)

The usual choice is a cube, each edge of which is a unit of length. In this case what can be said about the size of the faces? It is the neat relationship between the units of volume, area, and length which makes it easy for us to compute volume. If we choose to measure lengths in inches, then the unit of volume is a cube, each edge of which is 1 inch. The unit of measure of this cube is called a cubic inch.

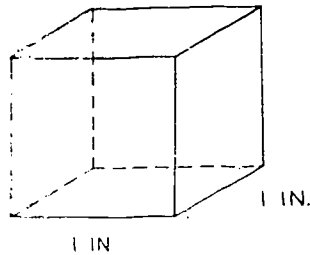

Exercises 12-7

1. Describe and name at least two other units of volume.
2. Make a model out of paper or light cardboard of a one-inch cube using the pattern below. The dotted lines show where to make your folds. The flaps are needed to paste the model together.

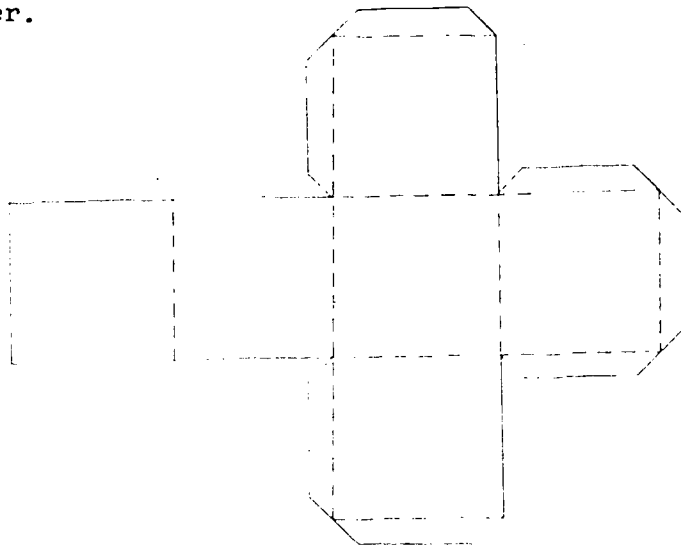

3. Obtain some small cubic blocks and think of the edge as a unit of length. Put these cubes together to form a rectangular solid 4 units by 3 units by 2 units. How many blocks did it take? (You and your classmates may put your model cubic inches together for this.)
4.
 - a. Use small cubic blocks to make a solid 3 units by 2 units by 2 units.
 - b. Make a rectangular solid with the length twice as long as in part (a) but the height and width the same. (6 by 2 by 2)
 - c. Make a solid with the width twice as long as the original but the other measures the same. (3 by 4 by 2)
 - d. Make a solid with the height twice as long as the original but the other measures the same. (3 by 2 by 4)
 - e. Compare the number of cubes in parts (b), (c), and (d) with the number of cubes in part (a).
5.
 - a. Write a statement telling what happens to the volume of a rectangular solid if one of the measurements is doubled.
 - b. What is the ratio of the larger volume to the smaller?
6.
 - a. Build a solid 6 units by 4 units by 2 units. Notice that both the length and the width of the prism in 4(a) are doubled.
 - b. Find the ratio of the number of cubes in the new solid to the number of cubes in the original.
 - c. Would you get the same ratio if you doubled a different pair of measurements?
7. Write a statement telling what happens to the volume of a rectangular solid if two of the measurements are doubled.
8.
 - a. Double each measurement of the solid in Problem 4(a) and construct a rectangular prism. (6 units by 4 units by 4 units.)
 - b. Compare the number of cubes in this solid to the number in the original solid.

12-8

9. a. Write a statement telling what happens to the volume of a rectangular solid if all three measurements are doubled.
b. State the ratio of the larger volume to the smaller volume.

12-8. Volume of a Rectangular Solid.

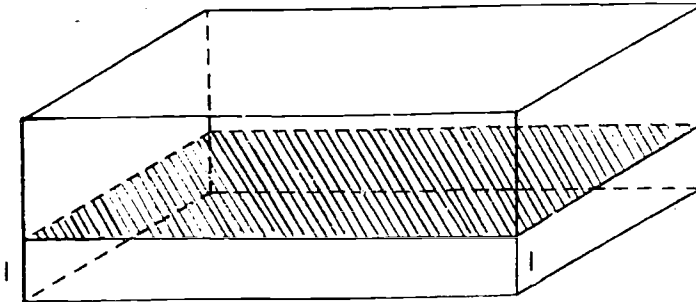

We know how to find the area of any face of a rectangular prism. Let us imagine we have found the area of the face on which the solid is shown to be resting. Suppose the area of this bottom face (often called the base) is 12 square units. If the base consists of 12 unit squares, let us place a unit cube on each of these squares. These unit cubes fill up a layer one unit thick covering the bottom of the solid. Since there are 12 such cubes, the volume of the layer is 12 cubic units. You saw examples of such layers in the problems in the last section. Since the top of the layer is just like the bottom, a second layer can be placed on the first. A third layer can also be placed on the second. Suppose the height of the solid is 3 units. Then it will be exactly filled by 3 layers. The total number of cubes may be found by multiplying 12 by 3 since there are 3 layers with 12 cubes in each layer. We need 36 cubes to fill this solid. Since each cube measures 1 cubic unit, the volume of this solid is 36 cubic units. Let us write this statement in symbols. Suppose we let the letter V represent the number of units of volume, then

$$V = 3 \times 12$$

$$V = 36.$$

The volume is 36 cubic units.

If the height is not a counting number, such as $2\frac{1}{2}$ units, then two layers will not fill the solid, but three layers will be too many. We can slice the third layer horizontally and use only half of this layer. The volume of the solid, then, is $(2\frac{1}{2})(12)$. In symbols we have

$$V = (2\frac{1}{2})(12)$$

$$V = 30$$

The volume is 30 cubic units.

Since our measurements of length, width, and height are always approximate, we should actually use the "approximately equal" sign, \approx , in writing statements about measurements.

Exercises 12-8a

In the exercises below use the \approx sign where it is appropriate.

1. Find the volume of a closet $8\frac{1}{2}$ feet high if the area of the floor is 10 square feet.
2. The base of a child's sandbox is a rectangle, and the area is 24 square feet. If the box is 10 inches deep, find its volume.
3. a. Write a statement in words telling how to find the number of cubic units in a rectangular solid if you know the number of square units in the base and the number of units in the height.
 b. Suppose we let the letter B represent the number of square units in the base, h represent the number of units in the height, and V represent the number of units in the volume. Write the statement in part (a) in symbols.
4. How deep should the sandbox of Problem 2 be made if the box is to hold 48 cubic feet?
5. A man is making a wooden box to hold 260 cubic feet of sand. In order to fit into a certain space the box must be 13 feet long. How many square feet of area must be at the end of the box?

6. Health regulations in a certain school district say that the school rooms must contain 50 cubic feet of air for each child. If a room has a floor area of 160 square feet and is 10 feet high, can the principal legally put 30 children in it? What is the greatest number of children who may be legally assigned to this room?

Look at the work of the last problems. Do you know in any of the problems the exact shape of the base? Is it necessary to know it? What must you know in order to find the volume of a rectangular solid? This procedure of finding the volume of a solid from the area of the base and height, without needing to know the exact shape of the base, will be used again when you consider other prisms and cylinders.

If you know all the edges of a rectangular solid, you know how to find the area of the base. Then you can find the volume.

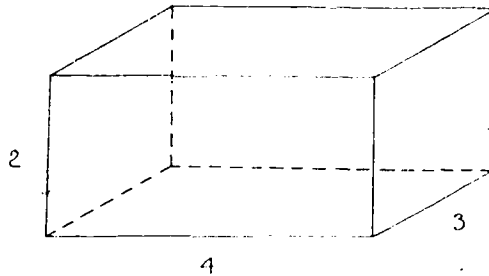

In a rectangular solid 4 units by 3 units by 2 units, you probably think of the largest face as the base. The area of this face is 4×3 square units so the volume, by Problem 3 above, is $2 \times (4 \times 3)$ cubic units. Notice that the number 4×3 which is enclosed in parentheses is the number of square units of area in the base. If you stand the solid on end, you can think of another face as being the base.

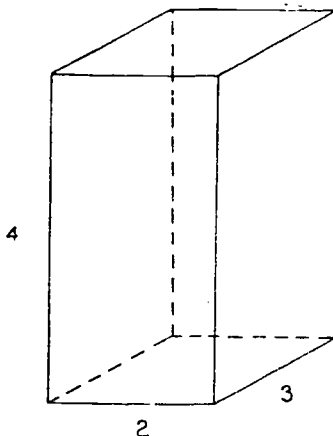

You now find that the area of the base is 2×3 square units and the volume is $4 \times (2 \times 3)$ cubic units. Resting the prism on its third face, you find that the volume is $3 \times (2 \times 4)$ cubic units. Thus, the numbers $2 \times (4 \times 3)$, $4 \times (2 \times 3)$, and $3 \times (2 \times 4)$ express the volume of the same rectangular solid. Therefore, the numbers $2 \times (4 \times 3)$, $4 \times (2 \times 3)$, and $3 \times (2 \times 4)$ are equal.

Exercises 12-8b

1. The inside of a freezer measures 4 feet long, 3 feet wide, and 2 feet deep. Find the volume of the freezer.
2. Find the number of cubic inches in a tool chest which is 14 inches long, 10 inches wide, and 9 inches deep.
3. The bottom of a desk drawer can be covered with two pieces of typewriter paper laid end to end. (Typewriter paper is $8\frac{1}{2}$ by 11 inches.) The drawer is 4 inches deep.
 - a. Find the area of the bottom of the drawer.
 - b. Find the volume of the drawer.
4. A woman has some blankets to store. The blankets just fit into a trunk 3 feet long, $1\frac{1}{2}$ feet wide, and 2 feet high. How many cubic feet of space are in the trunk?

5. A man plans to make a sidewalk 81 feet long, 4 feet wide and 3 inches thick.
 - a. How many cubic feet of concrete does he need?
 - b. Express your answer in cubic yards.
6. Write a statement in words telling how to find the number of cubic units in the volume of a rectangular solid if the number of units in the length, width, and height are known.
7. Let l , w , h stand for the number of units in the length, width and height of a rectangular solid. Let V represent the number of cubic units in the volume. Write a statement in symbols telling how to find the volume of this solid.
8.
 - a. How many cubic inches are there in a cubic foot?
 - b. How many cubic feet are in a cubic yard?
9.
 - a. What is the volume of a 3-inch cube (a cube each edge of which is 3 inches) ?
 - b. Is this volume larger or smaller than 3 cubic inches? Be very careful not to confuse the volume of a 3-inch cube with a volume of 3 cubic inches.
10. A rectangular solid is 2 inches long and 1 inch wide. The volume is 1 cubic inch.
 - a. Make a sketch of this solid.
 - b. What is the height of the solid?
11. A classroom is shaped like a rectangular prism. The length is 30 feet, the width is 28 feet, and the height is 12 feet.
 - a. Make a sketch of the classroom.
 - b. Find the volume.
12. A chalk box is 6 inches long, 4 inches wide, and 5 inches high.
 - a. Make a sketch of the chalk box.
 - b. Find the volume.
 - c. Suppose the length, width, and height were each doubled. Find the ratio of the volume of this box to the volume of the original box.

13. a. Find the volume of a cube each edge of which is $1\frac{1}{2}$ inches.
 b. Find the area of one face of this cube.
 c. Find the total area of the cube.
 d. Make a sketch of this cube.
14. A swimming pool in the form of a rectangular solid is 32 feet long and 20 feet wide. The pool is filled with water to a depth of $5\frac{1}{2}$ feet. How many cubic feet of water does the pool contain?

Exercises 12-8c

1. A stone block in the shape of a rectangular solid has a volume of $2\frac{1}{2}$ cubic yards. It weighs about 2400 lbs. per cubic yard. What is its total weight?
2. An apartment house is built in the shape of a rectangular prism 210 feet long, 30 feet wide, and 30 feet high.
 a. How many cubic feet of space are in the building?
 b. Express the volume in cubic yards.
3. A pirate's treasure chest was dug up and found to be filled with gold. The chest was a rectangular prism 2 feet 6 inches long, 18 inches wide, and 1 foot deep. A cubic foot of gold weighs 600 lbs. Could five men, each of whom can lift 400 lbs., lift the chest out of the hole?
4. Ed has a fish tank 24 inches long, 12 inches wide, and 14 inches high. He fills the tank to a height of 10 inches.
 a. How many cubic inches of water are in the tank?
 b. There are 231 cubic inches of water in one gallon.
 How many gallons of water are in the tank?
5. A steel bar is shaped like a rectangular prism. The bar is 18 inches long, two-thirds inches wide and two-thirds inches high. How many cubic inches of steel are in the bar?
6. An aquarium has the shape of a rectangular prism. The length is 40 inches, the width is 30 inches, and the height is 9 inches. The tank is filled with water. One cubic foot of water weighs about 62.5 lbs. How many pounds of water does the tank hold?

7. An electric fan is advertised as moving 3375 cubic feet of air per minute. How long will it take the fan to move the air in a room 27 ft. by 25 ft. by 10 ft.?
8. The bricks which are used in many buildings are 8 inches by 4 inches by 2 inches. How many cubic inches of space does a brick contain?
9. The length, width, and height of a rectangular prism are measured as $10\frac{1}{2}$ inches, $5\frac{0}{2}$ inches, and $3\frac{1}{2}$ inches. Find the volume from these measurements.
- *10. A sandbox with a base 10 feet long and 9 feet wide is built in a park. A dump truck carrying 135 cubic feet of sand is emptied into the box. If the sand is leveled off, what is the depth?

Probably the simplest possible solid is the rectangular prism. Of course, we shall learn later of other solids such as other prisms, cones, cylinders, and spheres.

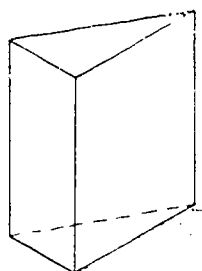

Triangular Prism

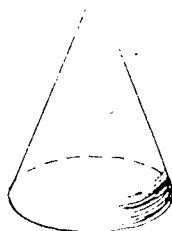

Cone

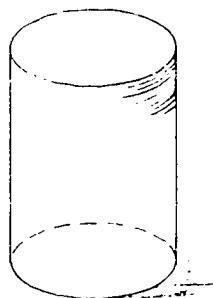

Cylinder

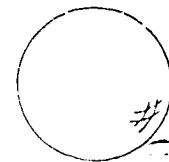

Sphere

It is clearly a losing battle to try to consider all possible shapes. We can often obtain the results by adding or subtracting volumes we already know about. For example, suppose that in a room 15 feet long, 12 feet wide, and 8 feet high, a man builds a closet in one corner. The closet runs to the ceiling

12-8

and has a base 3 feet on a side, so that the floor plan looks like this:

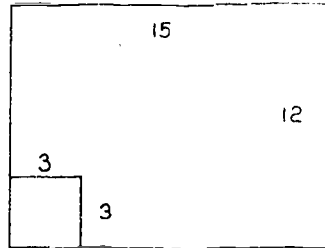

How can we find the volume of the remaining space in the room?
Let us try to devise a method.

1. Find the volume of the room before the closet was built.
2. Find the volume of the closet.
3. Now think of a way to find the remaining space after the closet was built.
4. Find the volume of this space.

Suppose we check our answers. The volume of the entire room should be 1440 cubic feet. The volume of the closet should be 72 cubic feet. To find the volume of the remaining space we simply subtract these two volumes. Therefore

$$1440 - 72 = 1368$$

The volume of the remaining space is 1368 cubic feet.

Exercises 12-8d

1. The floor plan of a room is as shown below.

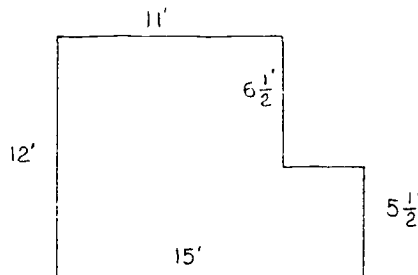

12-9

How many square feet of wall-to-wall carpeting are necessary for the floor? What is the volume of the room if it is 9 feet high?

2. A pantry, the floor of which is 6 ft. by 10 ft., is 9 ft. high. It contains a deep freeze which is 2 ft. by 3 ft. by 7 ft. How many cubic feet of space are left in the room? Express the answer also in cubic yards.
3. BRAINBUSTER. Two boys were much interested in making flying models of airplanes. They made one model which flew very well, and decided that they wanted a ~~larger~~ model just like it. They proceeded to build one by doubling all the dimensions (that is, twice the wingspread, twice the length, twice the height, etc.) and put in a motor with twice the power. To their disappointment, they found it would not fly at all. What was the trouble?

12-9. Dimension.

Consider two flies sitting side by side at a point A by the baseboard of a room. One of them is trying to direct the other to a lump of sugar which is also by the baseboard. What directions does he need to give?

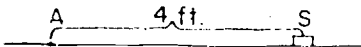

All he needs to say is, "Follow the baseboard this way for four feet--you can't miss it!" The complete description of where the sugar is located by the baseboard can be given by one number. For this reason the edge of the room is called one-dimensional. Of course, the section of baseboard followed may be a single segment, or may turn one or more corners, so any segment or simple closed curve is one-dimensional.

If the lump of sugar S is somewhere out in the middle of the floor, this presents more of a problem to the fly. His friend cannot get there at all by following the baseboard. How can he give directions? One of the ways is given below.

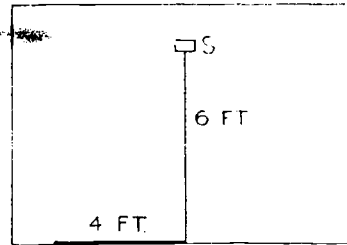

"Follow the baseboard for four feet. Then turn to the left so that you are headed perpendicular to the baseboard, and crawl for six feet." In this case when the lump of sugar is in the interior of the rectangle, it is convenient to use two numbers to describe its location. For this reason the set interior to a rectangle (or any simple closed curve) is called two-dimensional.

If the lump of sugar is not on the floor at all but is somewhere else in the room (for example, suspended from the ceiling by a string), the problem of direction is harder still.

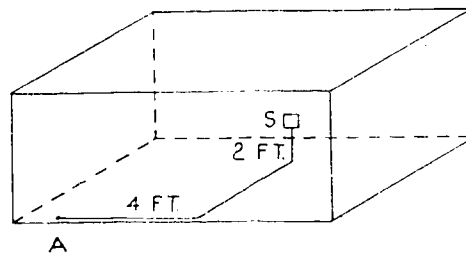

The directions then might go like this, "Crawl along the baseboard for four feet, then along the floor perpendicular to the baseboard for six feet. You will then be directly under the sugar. To get to the sugar fly directly up for two feet." This time three numbers are needed to describe how to get to the point S , so the interior of the room (that is, the interior of a rectangular solid) is called three-dimensional.

On the basis of the above discussion, what dimension should you give to a point?

The dimension of the set where the fly is shows how much freedom of motion he has. If he must stay in the one-dimensional set consisting of the floor's edge, he can move only along this edge. If he may go anywhere in the two-dimensional set inside the rectangular edge, he can crawl all over the floor. If he is merely confined to the three-dimensional set interior to the room, he can fly anywhere in the room.

The term dimension is also used in connection with more complicated sets. We do not try to give an exact definition, since it is usually clear whether a set is similar to a line, or to a region of the plane, or to the interior of a solid.

Exercises 12-9

Indicate for each of the following sets whether it is one-dimensional, two-dimensional, or three-dimensional:

- | | |
|---------------------------|------------------------------------|
| a. triangle | i. exterior of an angle |
| b. interior of a triangle | j. rectangular prism |
| c. circle | k. interior of a rectangular prism |
| d. interior of a circle | l. exterior of a rectangular prism |
| e. sphere | m. surface of a desk |
| f. interior of a sphere | n. interior of a desk drawer |
| g. angle | |
| h. interior of an angle | |

12-10. Other Units of Volume.

In our discussion so far we have used the units of volume which are related to linear measure, such as the cubic inch, cubic yard, or cubic mile. In practice we often use other units of volume. If you go to the grocery, you ask for milk, cream, or vinegar in quarts or pints rather than in cubic feet or cubic inches. Similarly you may ask for a bushel of peaches. There are definite relationships between these various measures and the cubic foot or cubic inch.

There would be a great advantage in doing away with most of these extra units of volume. Since these units are in everyday use, you should know their relationships, or at least where to find them. Unfortunately, in our English system we even use different units for measuring liquid and dry quantities. The quart measure most people use is actually the liquid quart, but there is a dry quart which is somewhat larger. For convenient reference a section with information about the various units and their relationships is placed at the end of this chapter.

Exercises 12-10

1. Milk often comes in quart containers that measure 7 in. by 3 in. by $2\frac{3}{4}$ in.
 - a. How many cubic inches are in the carton?
 - b. Is this $\frac{1}{4}$ of a gallon?
 - c. What is sometimes done to this container to make it look larger?
2. A quart milk carton has these measures: $2\frac{3}{4}$ " \times $2\frac{3}{4}$ " \times $7\frac{1}{4}$ ".
If the carton were filled, would you have more than a quart or less than a quart in it?
3. There is an old saying, "A pint's a pound, the world around". Give a reason why this is not necessarily true.
4. Berries are often sold in boxes that are labeled pints and quarts. A "quart" box measures $4\frac{3}{4}$ in. by $4\frac{3}{4}$ in. by $2\frac{7}{8}$ in.
 - a. How many cubic inches does it contain?
 - b. If a "dry" quart is $1\frac{1}{6}$ times the size of a liquid quart and a liquid quart contains $57\frac{3}{4}$ cu. in., how many cubic inches are there in a dry quart?
 - c. Does the "quart" box of Problem 4 hold one dry quart?
5. A pint berry box measures $3\frac{3}{4}$ \times $3\frac{3}{4}$ \times $2\frac{1}{2}$ inches.
 - a. How many cubic inches does this box contain?
 - b. How many cubic inches are in a standard dry pint?
 - c. How much larger or smaller is the box than it should be?
6. Is there any reason why a "dry" quart should be larger than a liquid quart?

7. A bushel of apples is priced at \$3.25. Apples can also be bought for 9¢ per pound. If a bushel holds 48 pounds of apples, how much do you save by buying a bushel?
 8. A bushel of potatoes weighs 60 pounds. Which is cheaper, a bushel that costs \$3.50 or 60 lbs. bought at 4 lbs. for 25¢?
 9. Half-gallon milk cartons have a base of $3\frac{1}{2}$ in. \times $3\frac{1}{2}$ in. How tall should the carton be? If h stands for the number of inches in the height, write a number sentence for this problem.
 - *10. The lengths of the edges of a certain rectangular prism all involve counting numbers greater than 1. If the interior of the prism has a volume of one gallon, what are the measurements of the prism?
-

12-11. Summary.

1. The area of a rectangle means the area of the closed region determined by the rectangle.
2. The standard unit for measuring area is a square inch. A square inch is the area of a square the sides of which are 1 inch.
3. The number of square units of area of a rectangle is the product of the number of linear units in the length and width. This may be written as the number sentence

$$A = l \cdot w$$

where A represents the number of square units of area and l and w represent the number of linear units in the length and the width.

4. A rectangular prism is a figure like a chalk box, your textbook, or a cigar box.

Every rectangular prism has six rectangular sides which are called faces. The line segments determined by

two intersecting faces is called an edge of the prism. Every rectangular prism has 12 edges. A point where three faces intersect is called a vertex. Every rectangular prism has 8 vertices.

5. The sum of the areas of all the faces of a rectangular prism is called the surface area of the prism.
6. A rectangular solid is a set of points consisting of a rectangular prism and its interior.
7. The standard unit for measuring volume is a cubic inch. A cubic inch is the volume of a cube each side of which is 1 inch.
8. The number of cubic units of volume of a rectangular solid is the product of the number of square units in the area of the base and the number of linear units in the height. This may be written as the number sentence

$$V = B \cdot h$$

where V represents the number of cubic units in the volume; B represents the number of square units in the area of the base; and h represents the number of linear units in the height. Since the base is a rectangle, this sentence may also be written

$$V = l \cdot w \cdot h$$

12-12. Chapter Review.

Exercises 12-12

1. Use the sentence $A = l \cdot w$ to find A if
 - a. $l = 18$ feet, $w = 6\frac{1}{2}$ feet
 - b. $l = 7\frac{1}{2}$ feet, $w = 5\frac{1}{4}$ feet.
2. Use the sentence $V = l \cdot w \cdot h$ to find V if
 - a. $l = 14$ inches, $w = 8\frac{1}{2}$ inches, $h = 7$ inches
 - b. $l = 17$ feet, $w = 3\frac{1}{2}$ feet, $h = 2\frac{3}{4}$ feet.

3. Mr. Stone's garden is 75 feet in length and 50 feet in width. In one corner of the garden he has a storage shed 14 feet long and 6 feet wide. The rest of the garden is lawn.
- What is the area of the entire garden?
 - What is the area of the storage shed?
 - What is the area of the lawn?
4. a. Find the volume of a $2\frac{1}{2}$ -inch cube.
b. Find the surface area of this cube.
5. a. A cube has ? faces.
b. A cube has ? vertices.
c. A cube has ? edges.
6. A tile floor is rectangular in shape. Each tile is a 6-inch square. Find the area of the floor if 1344 tiles are needed to cover the entire floor.
7. A room measures 11 feet by 14 feet. A rectangular rug is placed on the floor. The rug is 12 feet long and 9 feet wide. If the rug costs \$6.75 per square foot, find the total cost of the rug.
8. A storage box in the form of a rectangular prism is 10 feet long, $3\frac{1}{2}$ feet wide, and 4 feet high.
- Find the number of square feet of wood needed to build the box.
 - Find the volume of the box.
9. Indicate for each of the following sets whether it is one-dimensional, two-dimensional, or three-dimensional.
- the interior of a rectangle.
 - a segment
 - the interior of a closet
 - a football field
 - a foul line in baseball
 - the surface of a dollar bill
 - the interior of a TV set
10. A gas tank is 5 feet long, $3\frac{1}{2}$ feet wide, and 2 feet high. How many gallons does this tank hold if 1 gallon is equal to 231 cu. in. ?
-

12-13. Cumulative Review.Exercises 12-13

1. List the elements of the set of all days of the week whose names begin with R.
2. Write three multiples of 24.
3. Answer true or false.
 - a. Zero is a number which is both even and odd.
 - b. Twenty-four is a multiple of 3.
 - c. The first prime number is 1.
4. Write the set of factors of 50.
5. Write the Roman numerals.
 - a. 23
 - b. 19
6. List the common factors of 20 and 28.
7. On a motor trip, Mr. Tobin averages 42.5 miles per hour. At this rate how far does Mr. Tobin travel in 8.5 hours?
8. Write in symbols.
 - a. 3 is greater than 0.
 - b. 15 is between 13 and 17.
9. A workman was paid \$270 for a job which required 50 hours of his time. At this rate, what should be paid for a 40 hour job?
10. State which of the following ratios are equal.
 - a. $\frac{34}{51}$, $\frac{2}{3}$
 - b. $\frac{10}{8}$, $\frac{95}{76}$
 - c. $\frac{6}{14}$, $\frac{45}{105}$
11. A cigar box is 10 inches long, 5 inches wide, and 3 inches deep.
 - a. Find the surface area of the box.
 - b. Find the volume of the box.

12-13

12. The length and width of a rectangle have been measured as $3\frac{1}{2}$ inches and $2\frac{3}{4}$ inches so that $l \approx 3\frac{1}{4}$ and $w \approx 2\frac{3}{4}$.
- Draw a rectangle with these dimensions.
 - Find the approximate area.
13. In each case, describe the union of the two sets below.
- The set of prime numbers greater than 0 and less than 10 and the set of odd numbers greater than 0 and less than 10.
 - The set of children in a family and the set of parents in the same family.

14. In the diagram on the right:

- What is $\overleftrightarrow{AG} \cap \overleftrightarrow{BF}$?
- What is $\overline{BF} \cup \overline{CD}$?
- What is $\overline{BD} \cap \overline{CF}$?
- What is $\overleftrightarrow{BD} \cup \overleftrightarrow{CF}$?
- What is $\overrightarrow{DE} \cap \overrightarrow{CB}$?

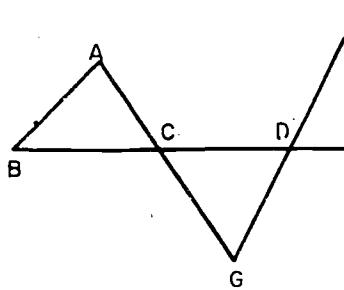

15. A segment appears to be $8\frac{1}{2}$ inches in length. Write the length of the segment to show precision of:
- $\frac{1}{2}$ inch.
 - $\frac{1}{8}$ inch
 - $\frac{1}{16}$ inch.

TABLES FOR REFERENCE

English Units

Metric Units

Measures of Length

12 in. = 1 ft.	10 millimeter (mm.) = 1 centimeter (cm.)
3 ft. = 1 yd.	100 cm. = 1 meter (M.)
$16\frac{1}{2}$ ft. = 1 rd.	1,000 mm. = 1 meter
320 rd. = 1 mi.	1,000 M. = 1 kilometer (km.)
5280 ft. = 1 mi.	

Measures of Surface

144 sq. in. = 1 sq. ft.	100 sq. mm. = 1 sq. cm.
9 sq. ft. = 1 sq. yd.	10,000 sq. cm. = 1 sq. M.
160 sq. rd. = 1 acre	1,000,000 sq. M. = 1 sq. km.
43,560 sq. ft. = 1 acre	
640 acres = 1 sq. mi.	

Measures of Volume

1728 cu. in. = 1 cu. ft.	1,000 cu. mm. = 1 cc.
27 cu. ft. = 1 cu. yd.	1,000,000 cc. = 1 cu. M.

Measures of Weight

16 oz. = 1 lb.	1,000 gram (g.) = 1 kilogram (kg.)
2000 lb. = 1 T.	1,000 kilogram = 1 metric ton

Liquid Measure

16 fluid oz. = 1 pt.	1,000 cc. = 1 liter (L.)
2 pt. = 1 qt.	
4 qt. = 1 gal.	

Dry Measures

2 pt. = 1 qt.	Volumes are used for this.
8 qt. = 1 peck (pk.)	
4 pk. = 1 bu.	

Miscellaneous Measures

1 gal. = 231 cu. in.
1 cu. ft. \approx $7\frac{1}{2}$ gal.
1 bu. \approx 2150 cu. in.
1 dry qt. \approx $1\frac{1}{6}$ liquid qt.

Metric and English Equivalents

1 in. = 2.54 cm.	1 cm. \approx 0.4 in.
1 yd. \approx 0.9 M.	1 M. \approx 1.1 yd.
1 mi. \approx 1.6 km.	1 km. \approx 0.62 mi.
1 lb. \approx 0.45 kg.	1 M. \approx 39.37 in.
1 qt. \approx 0.95 L.	1 kg. \approx 2.2 lb.
	1 L. \approx 1.05 qt.

Chapter 13
 ANGLES AND PARALLELS

13-1. Measurement of Angles.

You have been studying ways of measuring line segments and surfaces. Now let us see how angles are measured. First let us briefly review the meaning of an angle.

An angle is a set of points consisting of two rays with an endpoint in common and not both on the same line.

Exercises 13-1a
 (Class Discussion)

1. Name the angle in the figure in at least two different ways.
2. Name the rays which are the sides of the angle.
3. What is the point A called?
4. Name a point in the interior of the angle.
5. Name a point in the exterior of the angle.
6. Name a point on the angle.

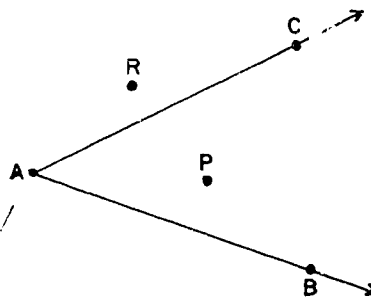

As you know, to measure anything you must use a unit of the same nature as the thing measured. Therefore, to measure angles we choose an angle as the unit of measure. Suppose we wish to measure $\angle CEF$ using the unit angle shown in the drawing.

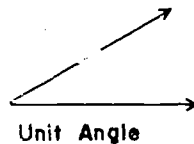
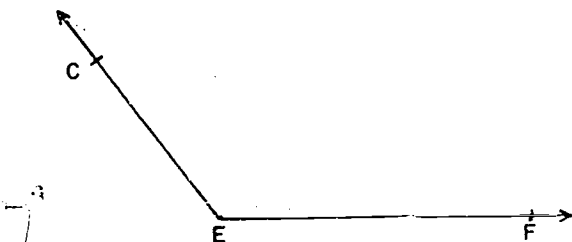

First we trace a supply of these unit angles.

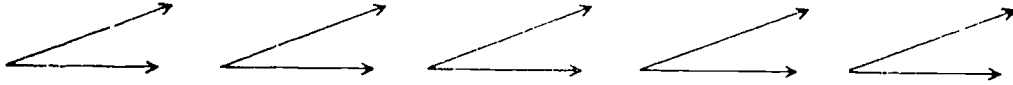

Next we subdivide the interior of $\angle CEF$, using these unit angles.

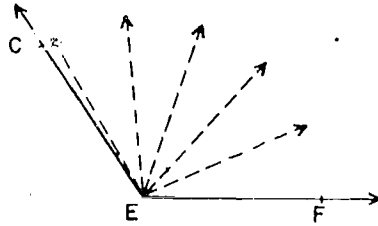

The size of $\angle CEF$ seems to be about 5 times the size of the unit angle. However, we selected our own unit angle. Just as there are standard units for measuring a line segment, so are there standard units for measuring an angle.

Angles are usually measured with an instrument called a protractor. Look at the following drawing of a protractor. Think of a set of rays from point P which subdivides the half-plane determined by the line \overleftrightarrow{AB} into 180 angles of the same size. One of these 180 angles is selected as the standard unit. The measurement of this angle is one degree. (This is written as 1° , where "°" is the symbol for "degree.") The measure of this unit angle, in degrees, is 1. Angles with the same measure are called congruent angles. The rays of the protractor determine 180 congruent angles.

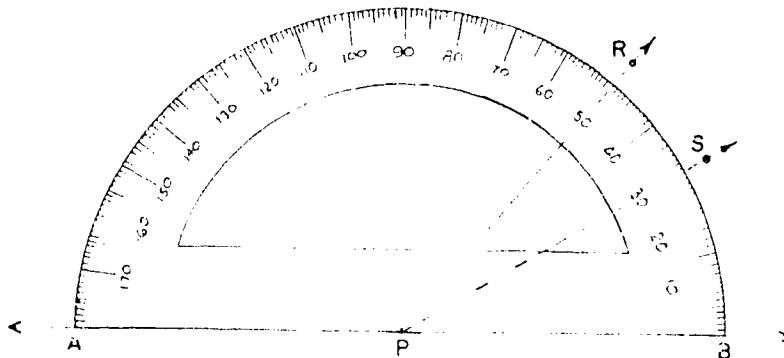

In the drawing, segments of the rays are shown on the curved part of the protractor. These rays correspond to the numbers from 0 to 180, forming a scale. Only the rays named by a multiple of 10 are labeled. Two of these rays, corresponding to 30° and 50° , are shown by dotted lines. The number of degrees in an angle is called its measure. Thus we may say:

The measure of $\angle RPB$ is 50; the size of $\angle RPB = 50^\circ$.

The measure of $\angle SPB$ is 30; the size of $\angle SPB = 30^\circ$.

Can you think of a way to find the measure of $\angle RPS$? By subtracting you find that the size of $\angle RPS = 20^\circ$.

Exercises 13-1b
(Class Discussion)

In the drawing below is shown a protractor placed on a figure with several rays drawn from point P. Find the measure, in degrees, of each of the following angles:

- | | | | |
|-----------------|-----------------|-----------------|------------------|
| 1. $\angle BPK$ | 4. $\angle BPH$ | 7. $\angle GPE$ | 10. $\angle CPG$ |
| 2. $\angle BPC$ | 5. $\angle BPE$ | 8. $\angle MPC$ | 11. $\angle KPF$ |
| 3. $\angle BPD$ | 6. $\angle MPF$ | 9. $\angle DPE$ | 12. $\angle HPF$ |

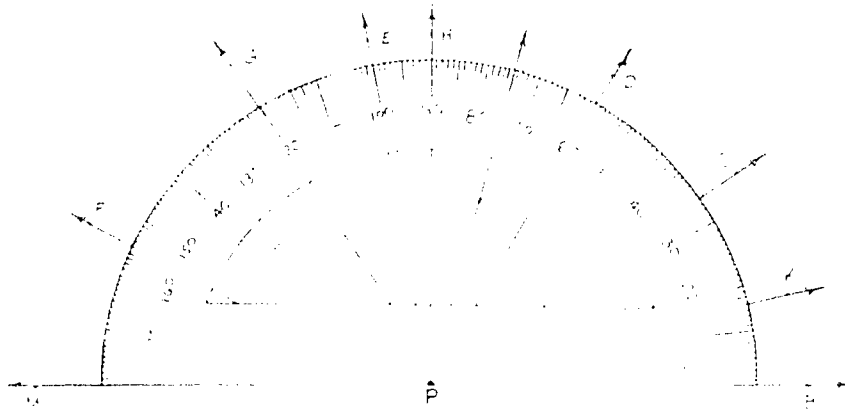

To measure an angle with a protractor, do the following:

1. Place the protractor on the angle so that point P is on the vertex of the angle.
2. Be sure that the ray which corresponds to zero on the protractor lies on one side of the angle.

3. Now locate, on the protractor, the mark which lies on the other side of the angle.
4. The number that corresponds to this ray is the measure, in degrees, of the angle.

You may find that your protractor has two scales. One scale starts with zero at the right and runs to 180 at the left. The other scale starts with zero at the left and runs to 180 at the right. The zero may not be marked on your protractor, but you will be able to see where it is supposed to be. When you read the measure of an angle, you must be sure to read the same scale that shows zero for one side of the angle.

Exercises 13-1c

1. Use a protractor to measure the angles below. If the parts of the rays shown are not long enough to show the intersection of the side of the angle with the protractor, lay the edge of a piece of paper along the side of the angle.

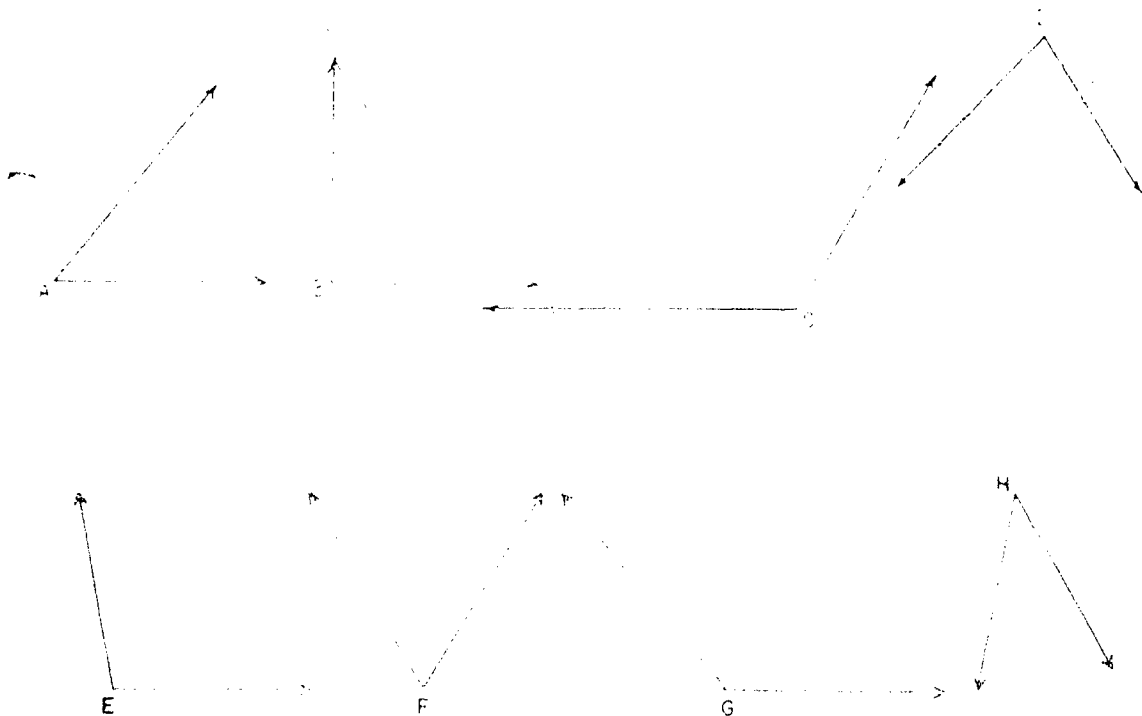

2. Draw a ray \vec{AB} with endpoint A . Place your protractor with point P on A and the zero line of the protractor on \vec{AB} . Then mark the point at 35° on the protractor scale, and name it point C . Remove your protractor and draw ray \vec{AC} . (This is shown as a dotted line in the figure.) You should now have angle BAC . What is its measure?

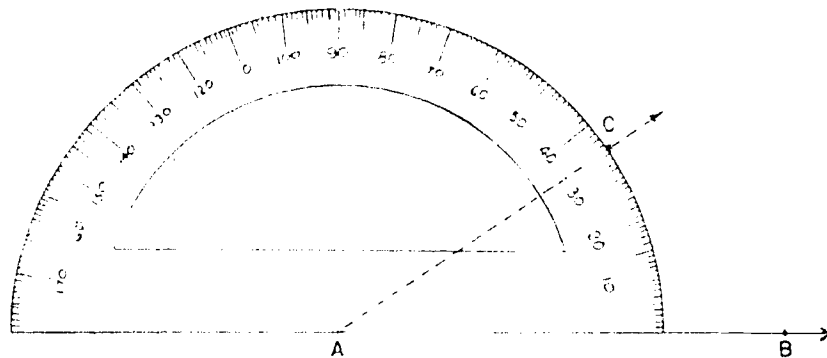

3. Use the method described in Problem 2 to draw angles of these sizes:
- | | |
|---------------|----------------|
| a. 20° | d. 90° |
| b. 45° | e. 150° |
| c. 61° | f. 175° |
4. In the drawing below, ray \vec{AB} and ray \vec{AC} are opposite rays; that is, they are on the same line, they have the same endpoint, and their intersection set is the endpoint A .



If the protractor is placed so that P is on A and the zero ray of one number is on ray \vec{AB} , what number corresponds to the protractor ray on ray \vec{AC} ?

13-2. Two Lines in a Plane.

Early man was very much interested in the ideas of geometry. Clay tablets, thousands of years old, show that the ancient Babylonians knew how to find the area of a rectangle. This idea and other geometric ideas found their way to Egypt. The Egyptians added them to their own ideas and used their new knowledge to build great temples and pyramids 5000 years ago. As new ideas quickly grew out of the old ideas, it became important that they be put in order. Students could study them better that way. Later the Greeks collected the scattered ideas and rules of geometry, wrote them down, and put them in order. To these collected ideas the Greeks added many new ones just as modern mathematicians are doing today.



Just as the Greeks did long ago, you will begin with a few of the simplest ideas of geometry and use these as stepping-stones to even more powerful ideas. Your study of geometry will give you some understanding of how the first parts of geometry grow out of the simplest beginnings.

For a simple beginning, suppose you think about two lines in space. What positions can they take in space? Can they be parallel? Can they be skew? Can they intersect? Suppose they intersect. In the figure below, ℓ_1 and ℓ_2 intersect in point A, and thus lie in a plane. Why?

Perhaps the lines of the figure have drawn your attention to the angles in the figure. The angles are determined by the lines l_1 and l_2 . How many angles are determined by l_1 and l_2 ? Two angles determined by the lines are angle BAD and angle EAC. Can you name two more angles determined by line l_1 and line l_2 ?

13-3. Adjacent Angles.

In the discussions about angles you will sometimes choose two angles of the four determined by lines l_1 and l_2 and use these two angles to show the truth of some geometric idea. It will be helpful to name certain pairs of angles which are used most often. One very important pair of angles is angle CAD and angle DAB. If these two angles meet the following requirements, they are called adjacent angles:

1. Their interiors have no point in common.
2. They use the same point for a vertex.
3. They have a common side (ray).

Suppose you check these requirements for angles CAD and DAB in the preceding figure. What is the name of the one point that both use for a vertex? Is \vec{AD} a common side? Can any point on the C side of l_1 be a point on the B side of l_2 ? The answers to these questions indicate that angle CAD and angle DAB are adjacent angles.

Exercises 13-3

1. Name four angles determined by l_1 and l_2 in each figure:
(Remember, the vertex letter is the middle letter.)

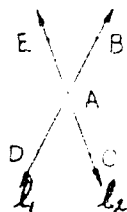

Figure 1

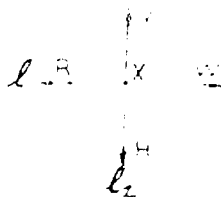
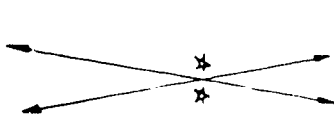
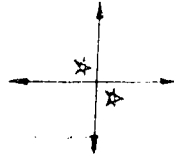

Figure 2

2. In which figure is a pair of adjacent angles marked with a star?



(a)



(b)

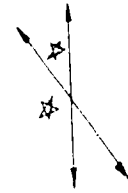

(c)

3. Which of these pairs of angles are not adjacent angles? Give requirement that is not met by these pairs.

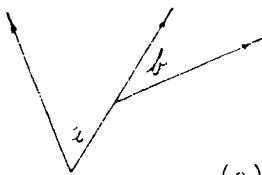

(a)

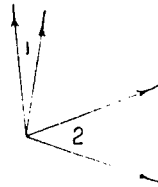

(b)

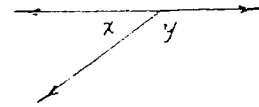

(c)

4. a. List six pairs of adjacent angles in the figure at the right.

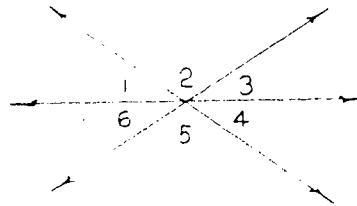

- b. Draw two adjacent angles which have equal measures.

5. a. Draw two adjacent angles which have measures adding up to 180.
- b. Use only two lines to draw four different pairs of adjacent angles.
- c. Label points in the drawing for part (b) and name the pairs of adjacent angles. (Remember that the vertex letter of an angle is between the other two.)

13-4. Vertical Angles.

Perhaps the following figures look like a display of men's bow ties. Actually, they are to call to your attention pairs of vertical angles determined by two intersecting lines.

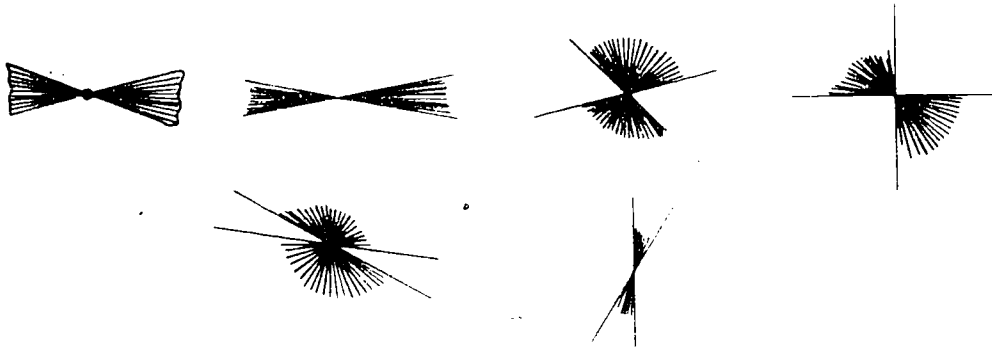

Notice that the above angle pairs meet the following requirements:

1. The same two lines determine each angle in a pair.
2. They are not adjacent angles. (They are non-adjacent angles.)

In the figure at the right, you will notice that when two lines intersect, two different "bow ties" or pairs of vertical angles are determined. One bow tie has a polka dot pattern and the other has a striped pattern. Name one pair of vertical angles in the drawing and then name the second pair of vertical angles. Look at the figures at the top of this page. Can you see the second pair of vertical angles in each figure?

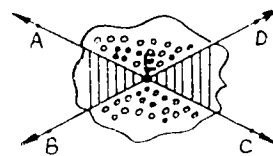

Exercises 13-4

1. One of the pairs of angles in these figures that are marked with stars is a pair of vertical angles. In which figure is a pair of vertical angles marked?

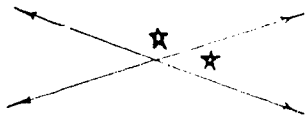

(a)



(b)

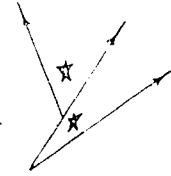

(c)

2. Is it possible for vertical angles also to be adjacent angles? Why?
3. Name three pairs of vertical angles in this figure?

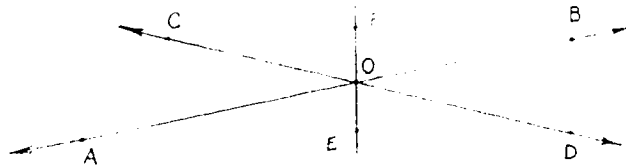

4. Name three more pairs of vertical angles in the figure for Problem 3. (Hint--combine two angles to get a third.)
5. Draw two intersecting lines so that they determine vertical angles all of which have the same measure.

13-5. Supplementary Angles

Earlier in this chapter we learned how to measure angles. The idea of angle measure is one on which many geometric ideas depend. Angle measure will be used so often that it will be helpful to agree on symbols to express it. For the word "measure" the letter "m" is used. For "angle" we use this symbol: \angle . With these symbols the words "measure of angle A" become simply: $m\angle A$.

13-5

Any angle can be used as a unit of measure but the degree is the one we selected as our standard unit of measure. In the future, unless some other unit of measure is named, $m\angle A = 40$ means that angle A is a forty-degree angle.

The drawing below shows a protractor placed in position to measure an angle.

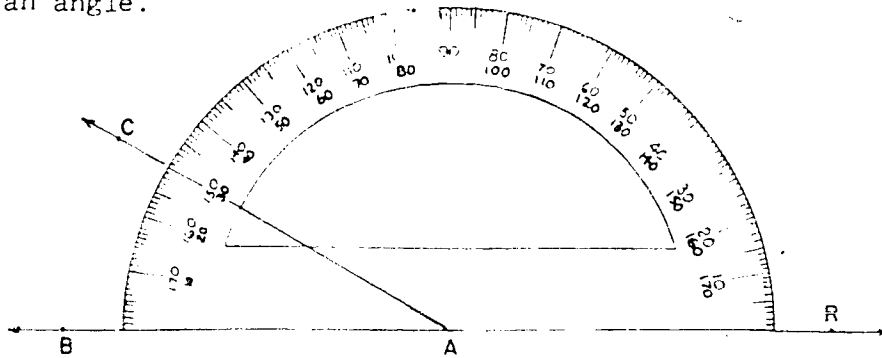

In the drawing there are two angles, $\angle BAC$ and $\angle CAR$, which have measures that total 180. The measure of angle BAC is 30 and the measure of angle CAR is 150. The sum of 30 and 150 is 180. If the sum of the measures of two angles is 180, the angles are called supplementary angles. Thus, $\angle BAC$ and $\angle CAR$ are supplementary angles. We also say " $\angle BAC$ is a supplement of $\angle CAR$."

Exercises 13-5

1. Measure these angles:

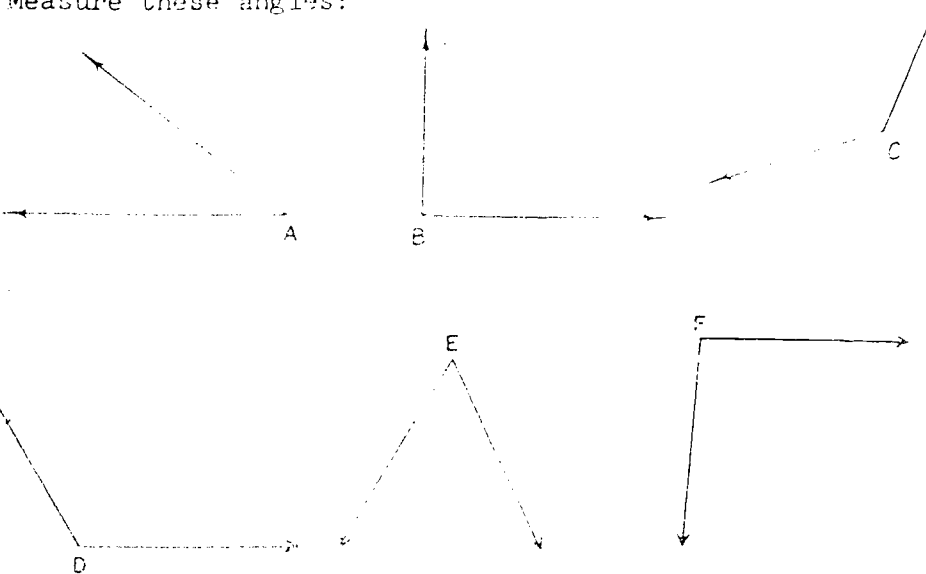

2. In the figure at the right, how many unit angles of one degree are in $\angle a$ and $\angle b$ together? Are $\angle a$ and $\angle b$ supplementary? Is it always necessary to measure angles to find out if the angles are supplementary? Complete the following statement: If the union of the interiors of two adjacent angles and their common half-line is a half-plane, then the angles are ? angles.

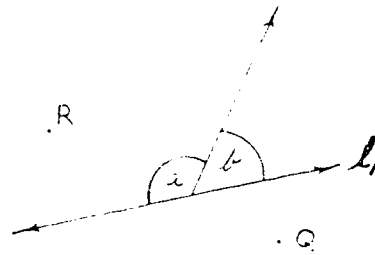

3. In which of these figures can you be quite sure that $\angle a$ and $\angle b$ are supplementary without actually measuring them? Why?

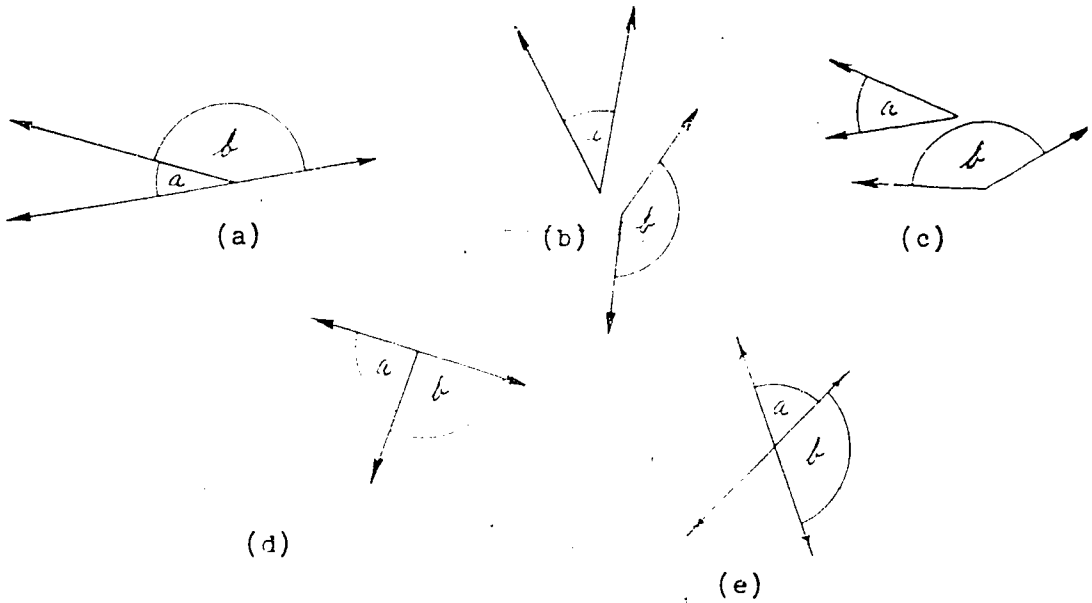

4. Name four pairs of supplementary angles in this figure:

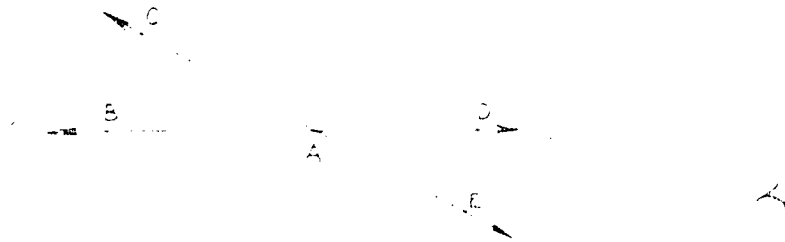

13-6

5. Draw a pair of non-adjacent supplementary angles.
6. Draw a pair of supplementary angles which have equal measures.
7. How many pairs of supplementary angles can you count in this figure?

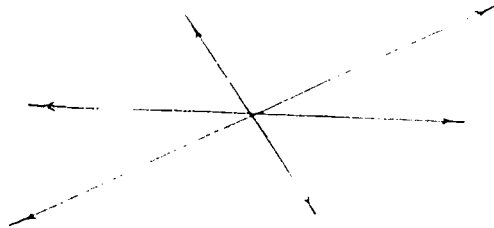

13-6. More About Vertical Angles.

In the rest of this chapter, as well as in the next chapter, there are a number of experiments. These experiments will help you discover new geometric ideas for yourself. In some ways, the plan of an experiment is like a map of a strange country. The plan gives you directions to follow. The map gives you roads to follow. But neither the map nor the plan warn you of many surprising things that lie ahead. These you must discover for yourself. Good hunting!

Experiment One

Discovering an Interesting Fact about Vertical Angles.

What is needed: Protractor, pencil, paper

What to do: 1. Draw two intersecting lines as in the following figure.



2. By placing a protractor as shown below, measure $\angle a$.

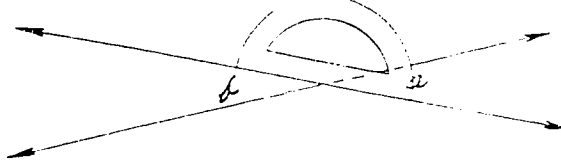

3. By placing a protractor as shown below, measure $\angle b$.

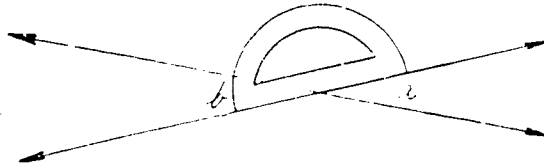

4. Do this experiment two more times for different pairs of intersecting lines.

5. Record your results in a table:

$m\angle a$	$m\angle b$

What seems to be true about the measures of two angles which form a pair of vertical angles? Check your answer by finding the measures of the other pair of vertical angles in each of your drawings.

This seems to be true:

If two lines intersect, the two angles in each pair of ? angles formed by the lines have ? measure.

Exercises 13-6

Do not use a protractor to find the answers for these exercises.

1. In which figure are $\angle x$ and $\angle y$ equal in measure? Give reason why you chose this figure. ("They look equal" is not a good reason as you will see in a later section.)

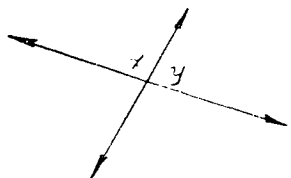

(a)

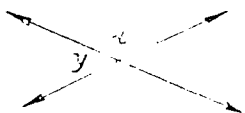

(b)

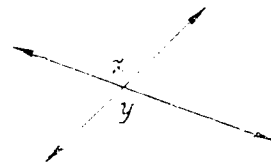

(c)

2. The figure below is followed by some statements which are to be completed.

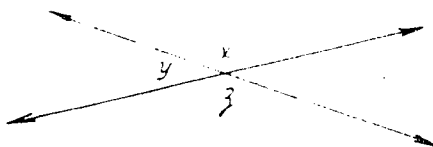

- a. $m\angle x + m\angle y = \underline{\quad ? \quad}$
- b. $m\angle z + m\angle y = \underline{\quad ? \quad}$
- c. If $m\angle y$ is known, how can you find $m\angle x$? How can you find $m\angle z$?
- d. Using your answers to part (c) fill in these blanks:
 $m\angle x = \underline{\quad ? \quad} - \underline{\quad ? \quad}$
 $m\angle z = \underline{\quad ? \quad} - \underline{\quad ? \quad}$
- e. Notice that the expression on the right side of each equation represents the same number. Since this is true, what can you say about the measure of $\angle x$ and the measure of $\angle z$? Note that this is another way to arrive at our conclusion about vertical angles without experimentation.

13-7

13-7. Right Angles.

The following discussion is based on the figure below.

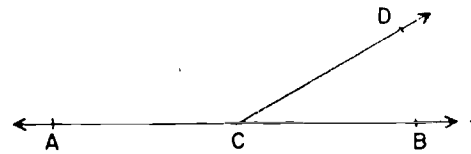

Exercises 13-7a
(Class Discussion)

1. $\angle ACD$ and $\angle DCB$ are adjacent angles. Why?
2. Is there another way to describe the relationship between these two angles?
3. Are all adjacent angles supplementary?
4. Are all supplementary angles adjacent?

Now let us consider another pair of supplementary adjacent angles. When two lines, such as \overleftrightarrow{AB} and \overleftrightarrow{CD} , meet and form a pair of congruent adjacent angles, the lines are said to be perpendicular. The symbol for perpendicular is " \perp ". Thus, we may write $\overleftrightarrow{AB} \perp \overleftrightarrow{CD}$.

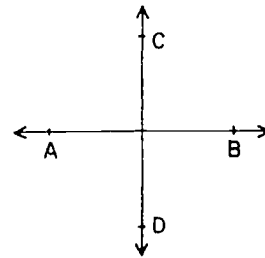

Line segments and rays are said to be perpendicular if the lines on which they lie are perpendicular, as shown in the following drawings.

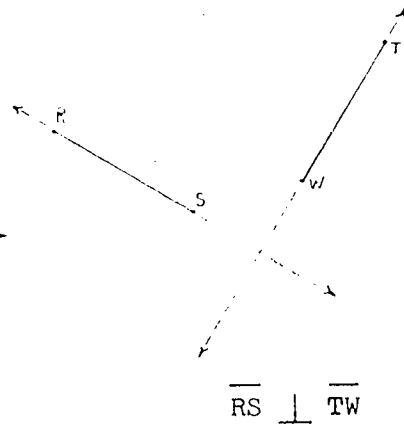
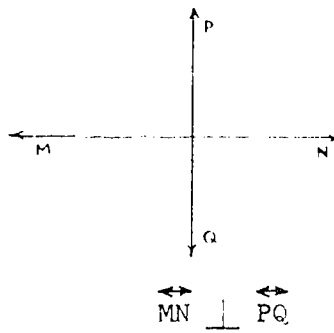
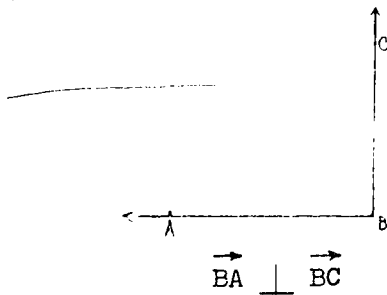

We may also say a line is perpendicular to a ray, or a line segment is perpendicular to a ray or a line.

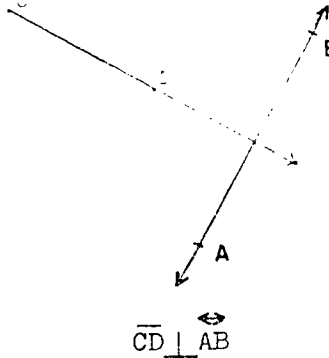
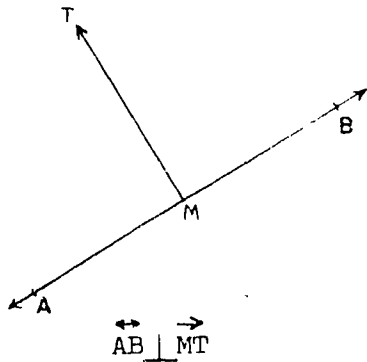

Exercises 13-7b
(Class Discussion)

1. Which of the drawings below represent
 - a. Perpendicular lines?
 - b. Perpendicular rays?
 - c. Perpendicular line segments?
 - d. A line perpendicular to a ray?
 - e. A ray perpendicular to a line segment?
 - f. A line segment perpendicular to a line?

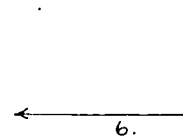
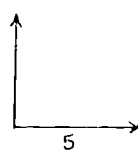
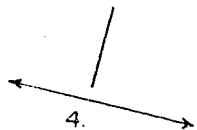
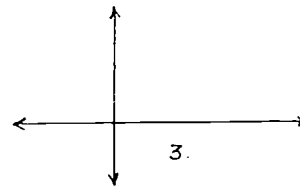
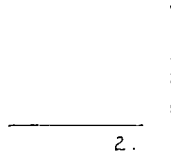
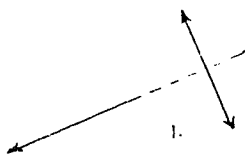

2. In the figure $\overleftrightarrow{AB} \perp \overleftrightarrow{CD}$. (This is often denoted by the symbol "⊥" marked at the point P.)

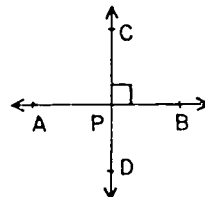

- The sum of the measures of $\angle APC$ and $\angle CPB$ is ?.
Why?
- The measure of $\angle APC$? the measure of $\angle CPB$. Why?
- Therefore, the measure, in degrees, of each of the angles APC and CPB is ?.
- Angle CPB and angle DPA are ? angles.
Angle APC and angle BPD are ? angles.
- Therefore, the measure of each of the angles DPA and BPD is ?. Why?

From the preceding exercise you should have noted that two perpendicular lines form four angles, each of which is a 90° angle. An angle of 90° is called a right angle.

When two lines intersect and are not perpendicular, they form angles whose measures are not 90 .

An angle whose measure is less than 90 , such as $\angle DPB$, is called an acute angle. An angle whose measure is more than 90 but less than 180 , such as $\angle APD$, is called an obtuse angle.

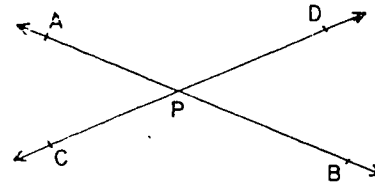

To summarize, angles may be classified according to their measures as follows:

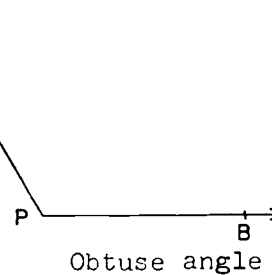
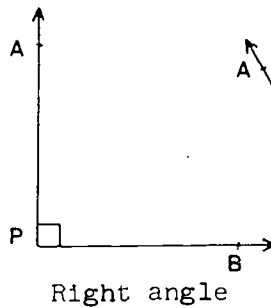
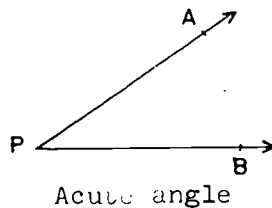

Exercises 13-7c

1. Without measuring, tell which of the angles below appear to be:
 - a. right angles;
 - b. acute angles;
 - c. obtuse angles.

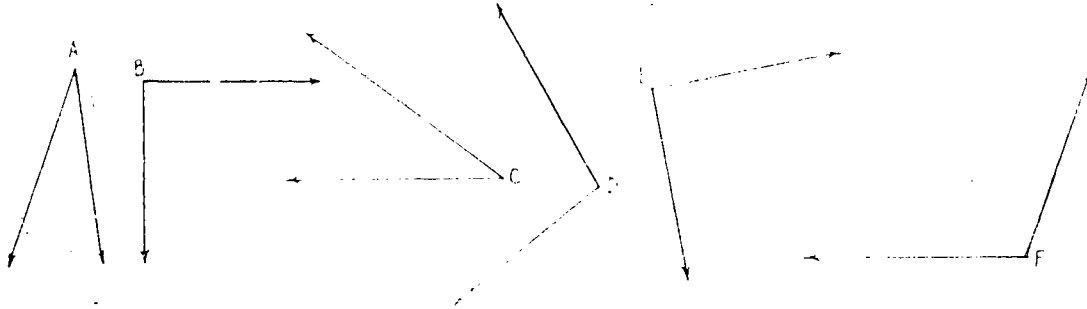

2. Use a protractor to measure each of the angles above.
3. a. The measure of an acute angle is greater than ? and less than ?.
 b. The measure of an obtuse angle is greater than ? and less than ?.

4. a. In the figure, name all the obtuse angles which have ray \vec{AB} as one side; all such acute angles; all such right angles.

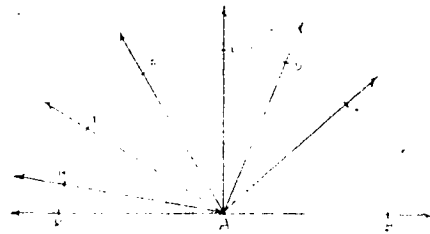

- b. Name all the acute angles that have ray \vec{AE} as one side; all such obtuse angles; all such right angles.
- c. Name all the right angles that have ray \vec{AK} as one side; all such obtuse angles; all such acute angles.

5. a. Without measuring, tell whether each angle below is an acute, right, or obtuse angle.
- b. Without measuring, estimate the number of degrees of each angle. (A good way to do this is to think how it compares with a right angle.)

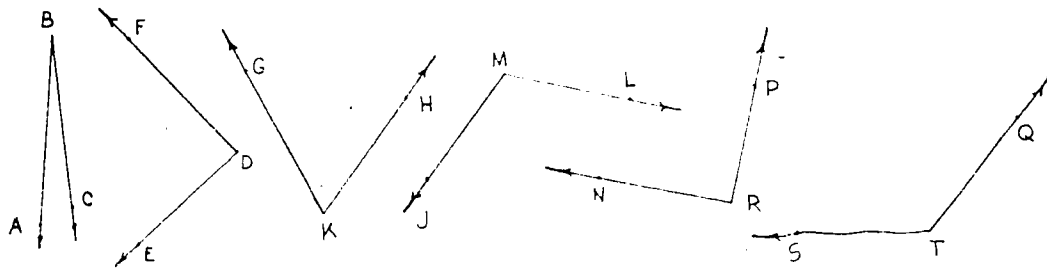

- c. Measure each angle in Problem 5b. How well did you estimate their sizes?

13-8. Three Lines in a Plane.

The property of vertical angles which you have just found was known long ago. Thales, a Greek mathematician and teacher of about 600 B.C., is given credit for the idea. He traveled widely in Egypt and other countries of the ancient world and gathered together many of the geometric ideas known at that time. He and his students used these ideas to create and build new ideas as you are doing in this chapter.

Now that you know about two intersecting lines, the next step is to study three intersecting lines. Let three pencils represent three lines. Suppose they are tossed into the air and allowed to fall on a flat surface. No matter how many times this is done, the final positions in which the pencils come to rest may be described by the phrases below.

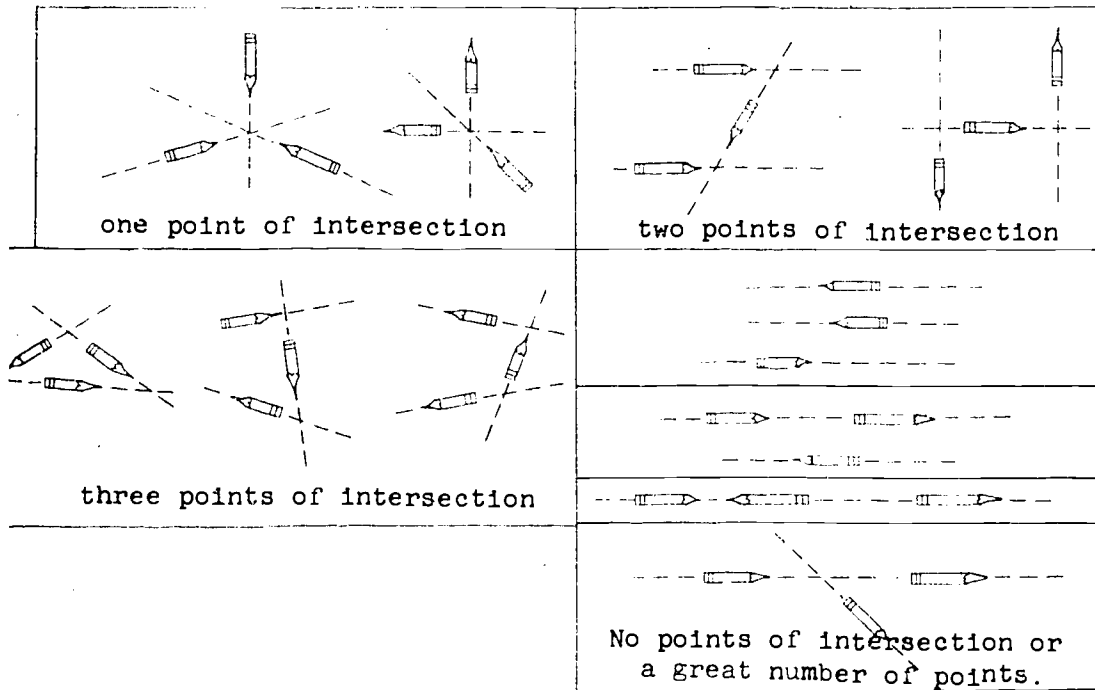

Which of these groups describe the most likely position in which three pencils would fall? Perhaps you could make up an experiment to test the answer to this question.

The group we shall examine first in our study of three lines in a plane is that which has three points of intersection.

Our next experiment will be about three lines belonging to the group that has three points of intersection. To get ready for this, we need a name for a certain pair of angles which are determined by lines in this group. The drawings below show four views of the same figure.

13-9. Corresponding Angles.

In each drawing the angles whose interiors contain the dot make up a pair for which a name is needed.

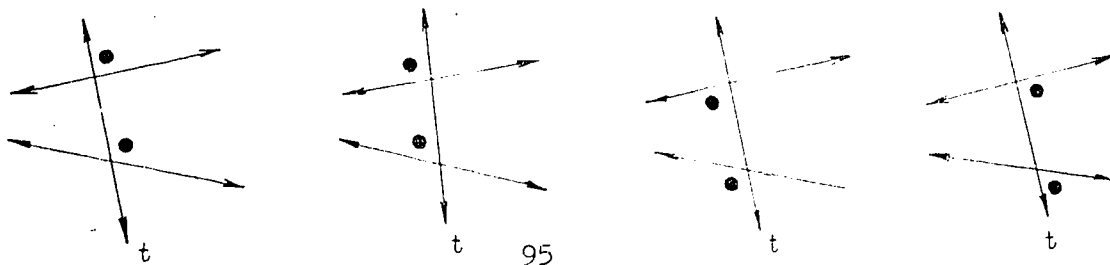

Two angles formed this way are called corresponding angles. In the drawing at the right there are four pairs of corresponding angles. The angles which have their interiors marked in the same way form a pair of corresponding angles.

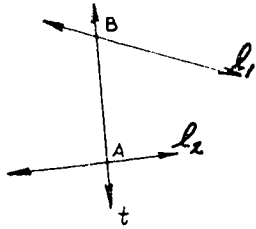
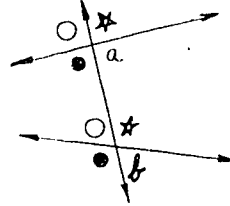

In the drawing at the left, the line t intersects two lines in separate points A and B . Line t is called a transversal of l_1 and l_2 .

To remove any doubt as to whether a certain pair of angles are corresponding angles we shall list two requirements:

1. The interiors of the angles are on the same side of the transversal.
2. The intersection of the (two) angles contains a ray on the transversal.

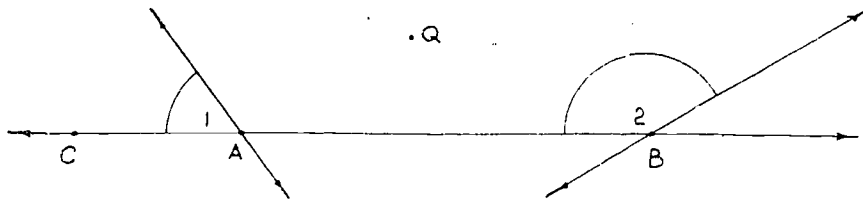

In the figure above, the intersection of $\angle 1$ and $\angle 2$ is \vec{AC} , which is contained in the transversal t . Notice also that the interiors of $\angle 1$ and $\angle 2$ are both on the Q side of the transversal t . The requirements for corresponding angles are met by $\angle 1$ and $\angle 2$. Therefore $\angle 1$ and $\angle 2$ are corresponding angles.

Exercises 13-9

1. In which of these figures is a pair of corresponding angles marked?

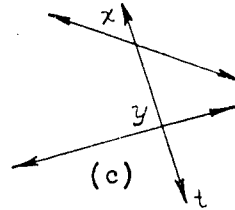
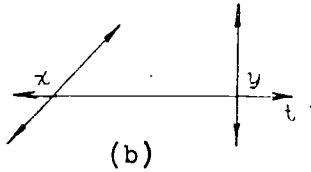
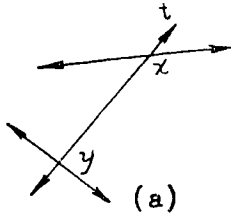

2. Name four pairs of corresponding angles in this figure:

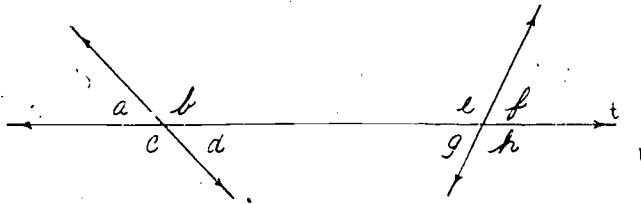

3. The angles marked in these figures are not corresponding angles. Which requirement is not met in each pair?

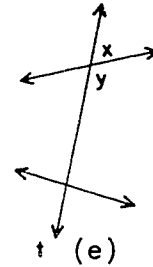
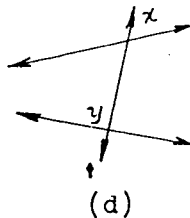
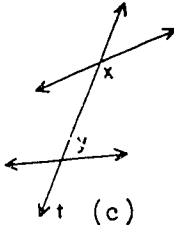
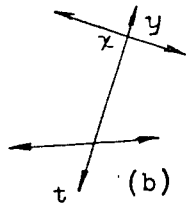
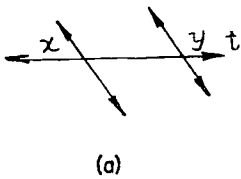

4. a. Can corresponding angles ever be adjacent angles as well? Why?
 b. Can corresponding angles ever be supplementary angles as well? Make a drawing that shows your answer is correct.
5. a. If $m\angle a = 80$ in the figure below, is it possible to tell what the $m\angle b$ is without measuring? How?
 b. Is it possible to find the measures of the other angles marked in the figure without using a protractor? How?

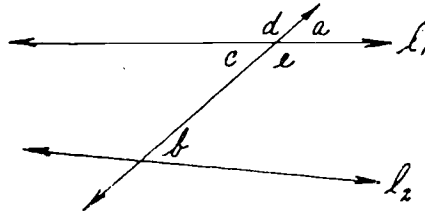

6. Look again at the figure for Problem 5. If you know that $m\angle b = m\angle c$, would you therefore know that $m\angle a = m\angle b$? Why?

7. In the figure at the right:

- Is l_1 a transversal? Why?
- Is l_2 a transversal? Why?
- Is l_3 a transversal? Why?

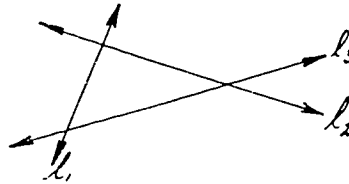

- How many pairs of vertical angles are there? How many pairs of adjacent angles? Supplementary angles? Corresponding angles?

13-10. Parallel Lines and Corresponding Angles.

Below is a section map of a large city where tall buildings hide one street from another. At point A, a policeman tells you that the street you are looking for is one block further at point B and is parallel to the street on which you are standing. On arriving at point B, however, you find two streets. It is impossible to see down the street where you met the policeman and see down the streets at B at the same time. The tall buildings block your view. How then, can you compare streets, to see which ones are parallel? Luckily, you recall the size of angle A. Recalling this fact makes it possible for you to decide which street at B is parallel to the street at A. How is this done? What kind of angle pair is suggested by the angles marked at A and at B?

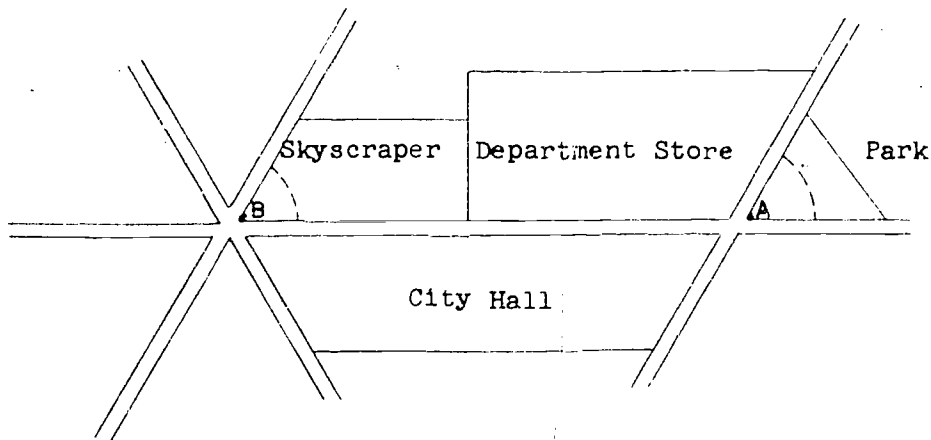
Experiment Two

Discovering Some Properties of Corresponding Angles

What is needed: protractor, pencil, paper.

What to do: 1. Draw and label two intersecting lines as in the figure below.

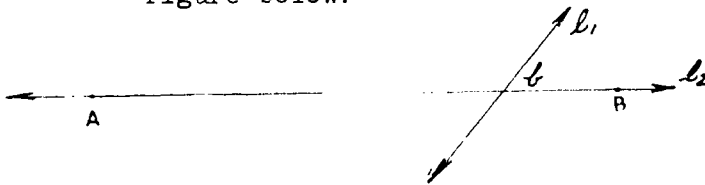

13-10

2. Measure $\angle b$. This drawing shows the protractor in place.

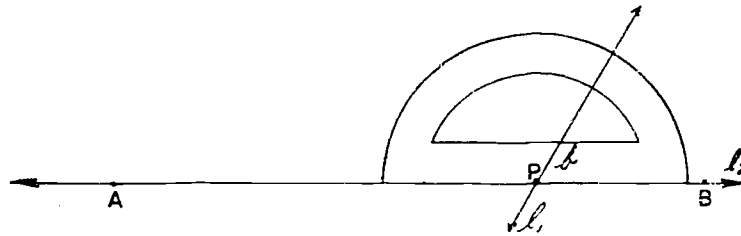

3. Place the center-point of the protractor on point A.

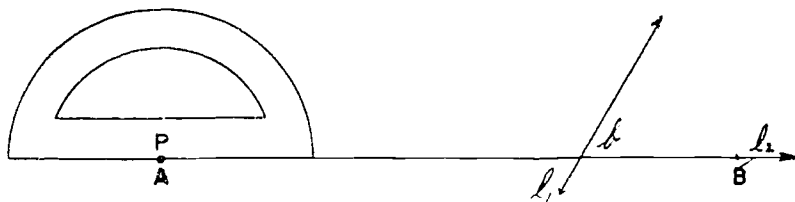

4. Locate point F so that $\angle FAB$ has a measure greater than that of $\angle b$. Draw line \overleftrightarrow{AF} .

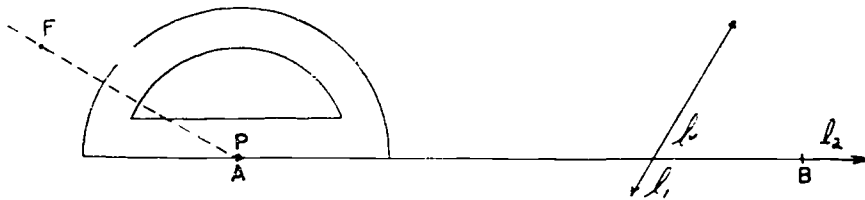

5. Repeat the experiment two more times. The first time make the measure of $\angle FAB$ less than $m\angle b$. The second time make the measure of $\angle FAB$ equal to the measure of $\angle b$.
6. Record the angle measures in a table as follows. In the third column answer "yes" or "no."

$m\angle b$	$m\angle FAB$	Does \overleftrightarrow{AF} seem to intersect l_1 ?

- Questions:
- Are angle FAB and angle b corresponding angles? How can you tell?
 - Did line \overleftrightarrow{AF} ever intersect l_1 ? What were the measures of the corresponding angles when this happened?
 - Will a pair of parallel lines result in all cases where two lines and a transversal form corresponding angles of the same measure?
 - Is this idea helpful in finding the answer to the "parallel street" problem?

This seems to be true:

If a transversal intersects two lines in such a way that a pair of corresponding angles have different ?, then the lines ?

If a transversal intersects two lines in such a way that a pair of corresponding angles have equal measures, then the lines are ?

Exercises 13-10

1. If the angles in the figures below have exactly the measures shown, in which of these figures do you think l_1 and l_2 will not meet? State a property as reason for your belief.

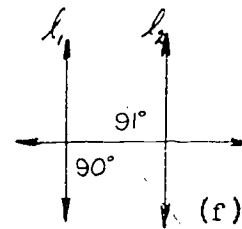
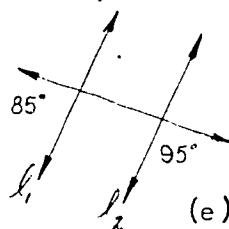
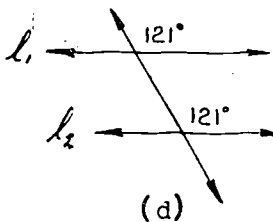
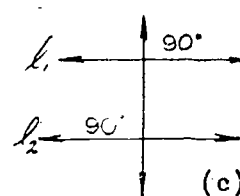
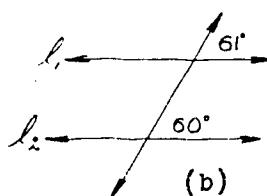
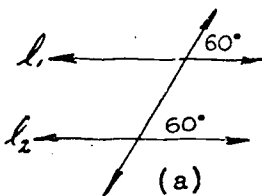

13-11

2. In which of the figures in Problem 1 will l_1 and l_2 intersect?
3. a. If the measures of angle 1 and angle 2 are equal in the figure below, do you have reason to think that $m\angle 3$ also equals the $m\angle 1$? Why are these measures equal?
- b. How many pairs of corresponding angles are in this figure?

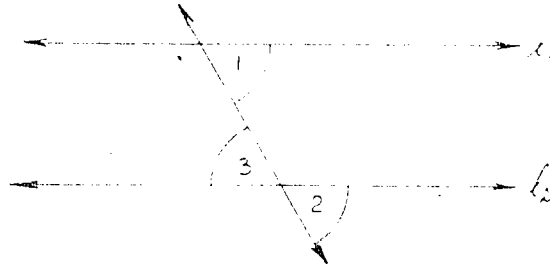

4. In the figure below will l_1 , l_2 , and l_3 determine a triangle? Why or why not?

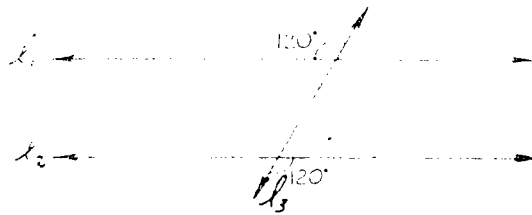

13-11. Summary.

In Chapter 13 you learned how to use a protractor to measure angles. Angles are measured in degrees and may be classified according to their measure. An angle of 90° is a right angle; an angle of less than 90° is an acute angle; an angle of more than 90° but less than 180° is an obtuse angle.

Lines, segments, or rays that form a right angle at their point of intersection are said to be perpendicular.

Important angle pairs studied in this chapter were:

1. Adjacent angles.

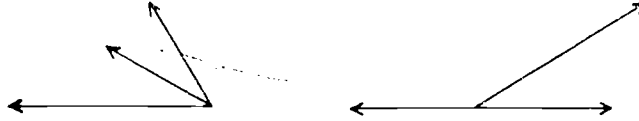

2. Vertical angles.

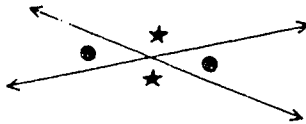

3. Supplementary angles.

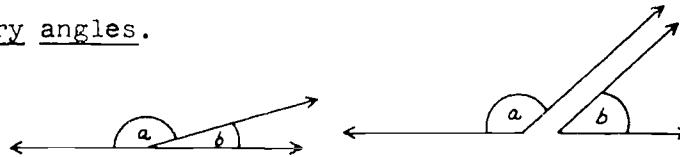

You discovered this property of vertical angles:

If two lines intersect, the two angles in each pair of vertical angles formed have equal measures.

This property helped you work with exercises about three lines intersecting a plane. In talking about these lines you found it helpful to know about:

Corresponding angles.

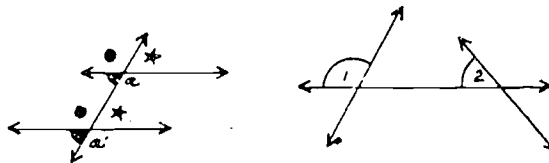

You discovered the following important properties:

If a transversal intersects two lines in such a way that a pair of corresponding angles have different measures then the lines intersect

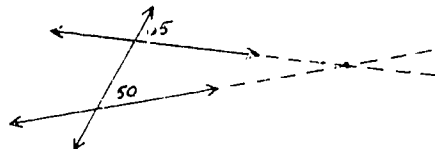

13-12

If a transversal intersects two lines in such a way that a pair of corresponding angles have equal measures, then the lines are parallel.

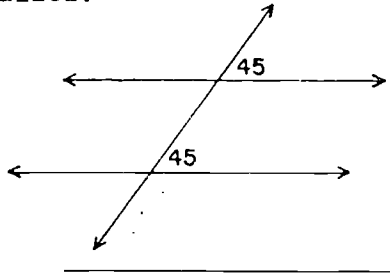

13-12. Chapter Review.

Exercises 13-12

1. Use a protractor to measure each of the following angles:

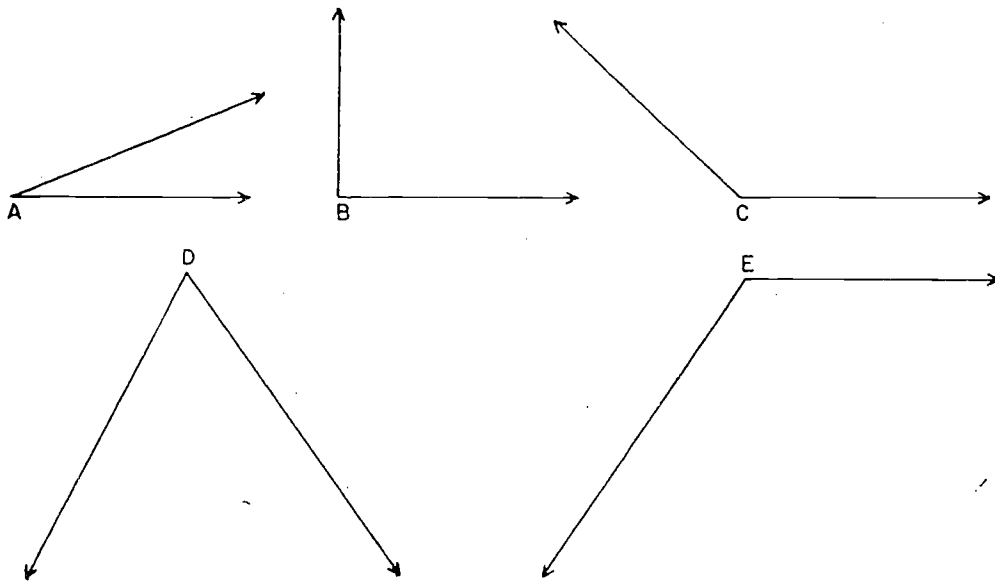

2. Classify each of the angles of Problem 1 as an acute, right, or obtuse angle.

3. Complete the following statements:

- a. Two angles which have the same measure are said to be ? angles.
- b. The rays of a protractor determine ? congruent angles.
- c. The number of degrees in an angle is called its ? .
- d. The standard unit of measurement for an angle is one ? .
- e. When two lines intersect so as to form right angles, we say the lines are ? .

4. Use the figure at the right and name three pairs of:

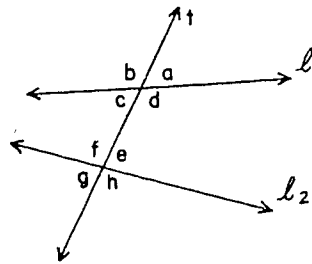

- a. vertical angles.
- b. adjacent angles.
- c. corresponding angles.
- d. supplementary angles.

5. Classify angles x and y in the following figures as vertical, adjacent, supplementary.

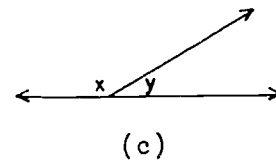
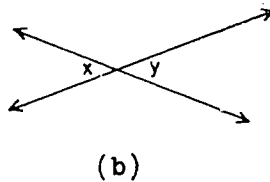
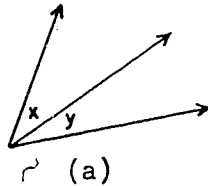

6. A pair of adjacent supplementary angles have the same measure. What is the size of each?

7. In the figure at the right, line l_1 is parallel to line l_2 . The measure of $\angle a$ is 70° . Find the measure of each of the other angles.

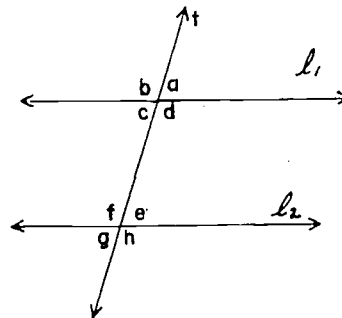

13-13

13-13. Cumulative Review.

Exercises 13-13

- List all the numbers between 100 and 131 which are multiples of 6.
- What is the difference between 6% of 75 and 5% of 54?
- Express each of the following as a fraction in simplest form:
 - $\frac{2}{3} + \frac{0}{3}$
 - $\frac{2}{3} \cdot \frac{0}{3}$
 - $\frac{2}{3} + \frac{2}{2}$
 - $\frac{2}{3} \cdot \frac{2}{2}$
- A rectangle has length $1\frac{2}{5}$ feet and width $\frac{5}{7}$ feet.
 - Find its area.
 - Find its perimeter.
- Draw a picture of a simple closed curve and a line whose intersection is
 - one point
 - two points
 - three points
 - four points
- Use one of the symbols $<$, $=$, or $>$ and make a true statement about each of the following pairs of numbers.
 - $\frac{9}{17}$, $\frac{8}{16}$
 - $\frac{11}{3}$, $\frac{33}{9}$
 - $\frac{0.3}{0.4}$, $\frac{0.06}{0.08}$
- Round the following to the nearest tenth:
 - 0.751
 - 5.98
 - $\frac{2}{3}$
 - $\frac{1}{7}$
- How long is a box if its volume is 1001 cu.ft. and its width is 13 ft. and its height is 7 ft.?
- What is the difference in length between a 1500 meter race and a half mile race?
- In the figure at the right:
 - What is $\overleftrightarrow{BD} \cap \overleftrightarrow{AE}$?
 - What is $\overline{BC} \cup \overline{CD}$?
 - What is $\overline{AB} \cap \overline{DE}$?
 - What is $\overrightarrow{CD} \cup \overrightarrow{CE}$?
 - What kind of angles are $\angle ACB$ and $\angle DCE$?

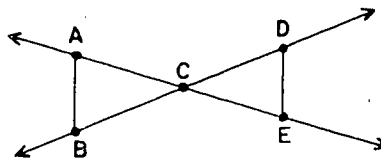

Chapter 14
POLYGONS AND PRISMS

14-1. Kinds of Triangles.

In the figure below there are three points not on the same line. Three segments join the points in pairs.

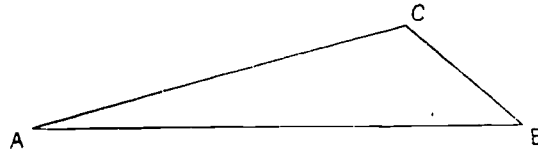

As you know from an earlier chapter, this figure is called a triangle. This triangle is the union of the segments \overline{AB} , \overline{BC} , and \overline{CA} . The vertices of the triangle are the points A, B, and C.

If at least two sides of a triangle have the same length, the triangle is an isosceles triangle. Does a triangle having three sides equal in length meet the requirement of having at least two sides of the same length? Such a triangle, then, is also isosceles. All of the triangles below are isosceles triangles:

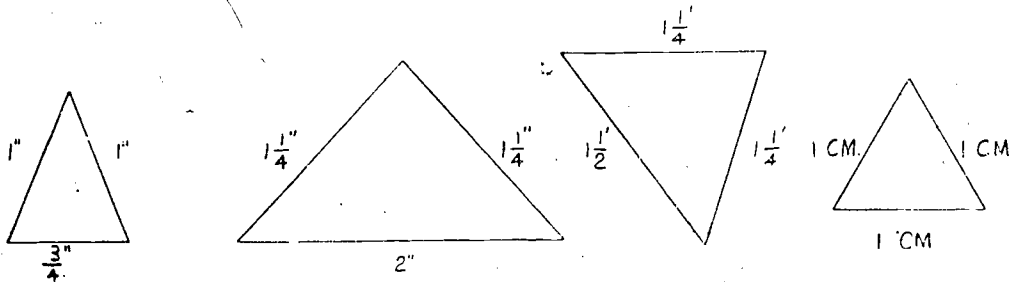

In the group below are all of the triangles isosceles triangles?

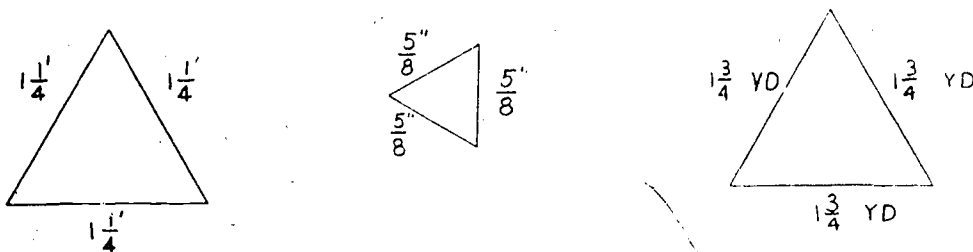

You may have noticed that each of the triangles in the last group is an example of an isosceles triangle of a special kind. This special kind of isosceles triangle is called an equilateral triangle. All three sides of an equilateral triangle have the same length.

A triangle is a scalene triangle if no two of its sides have the same length. Each of the following is a scalene triangle:

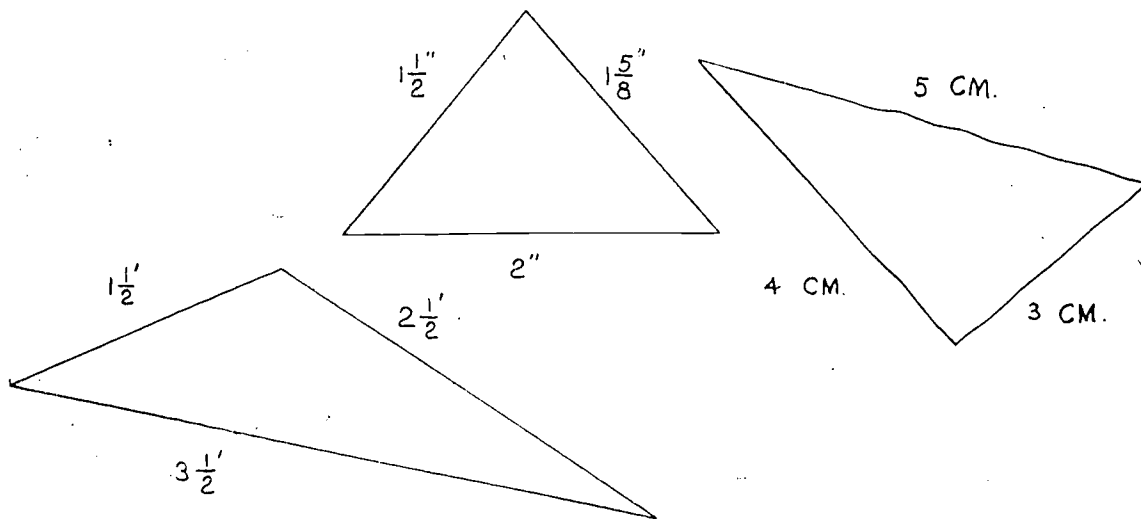

Exercises 14-1a

1. Draw a triangle in which each of two sides is one and one-half inches in length. What kind of triangle have you drawn?
2. Draw an isosceles triangle that has an angle of 90° .
3. One side of a triangle is two inches long, another is three inches long, and the third is one and one-half inches long. What kind of triangle is it? Why?
4. a. What kind of triangle is shown at the right?
b. If \overline{AB} were made the same length as \overline{AC} , what kind of triangle would be formed? Why?

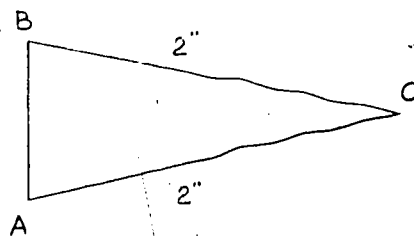

5. a. What kind of triangle is shown at the right?
 b. If \overline{XY} were shortened by half an inch and triangle XYZ were redrawn, what kind of triangle would it be? Why?

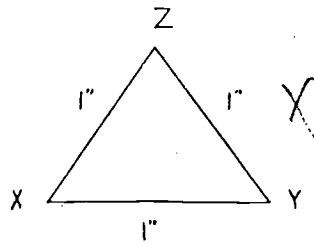

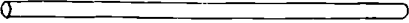
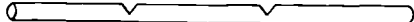
6. Here is a drawing of a soda straw: 
 Here it is creased at two points, 
 ready to be folded so that the ends come together like this:

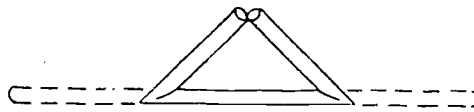

What kinds of triangles can be represented in this way by folding the following straws at the points indicated:

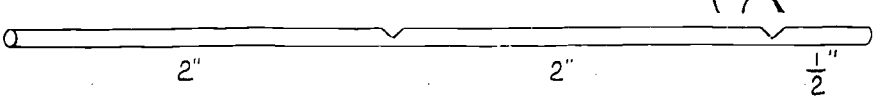
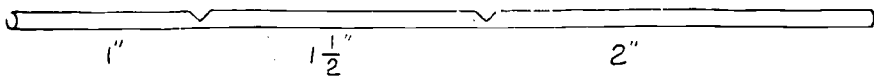
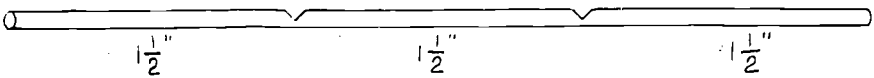
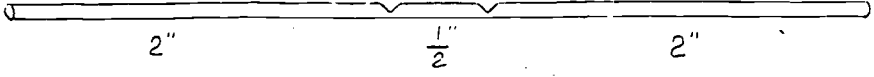
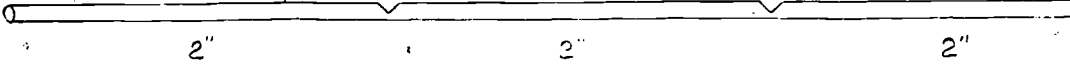
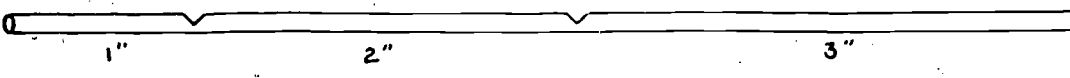
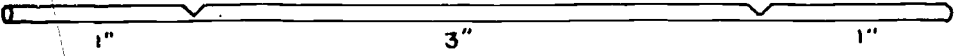
- a. 
- b. 
- c. 
- d. 
- e. 
- f. 
- g. 

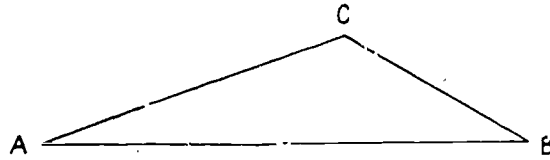

The point A is on two of the segments of the triangle ABC and not on the third segment (namely, \overline{BC}). We say that the segment \overline{BC} is the side opposite the vertex A . We also say that \overline{BC} is the side opposite the angle A .

Experiment One

An Important Fact About Angles in an Isosceles Triangle

What is needed: Ruler, pencil, drawing paper, tracing paper.

- What to do:
1. Draw three isosceles triangles of different sizes.
 2. In each triangle find the intersection of the sides which have the same length. Label this point A .
 3. Label the other vertices of the triangle with the letters B and C .
 4. In one of the triangles make a tracing of $\angle B$ and then see if the tracing will fit $\angle C$. Do this again for each of the other triangles.

- Questions:
1. In each triangle name the sides that are equal in length.
 2. What angle is opposite side \overline{AB} ?
 3. What angle is opposite side \overline{AC} ?
 4. What do you notice about the measures of angles opposite equal sides in a triangle?

This seems to be true:

If two sides of a triangle are ? in length, then the angles ? these sides are ? in measure.

Exercises 14-1b

1. Name a pair of angles with equal measures in each of these figures:

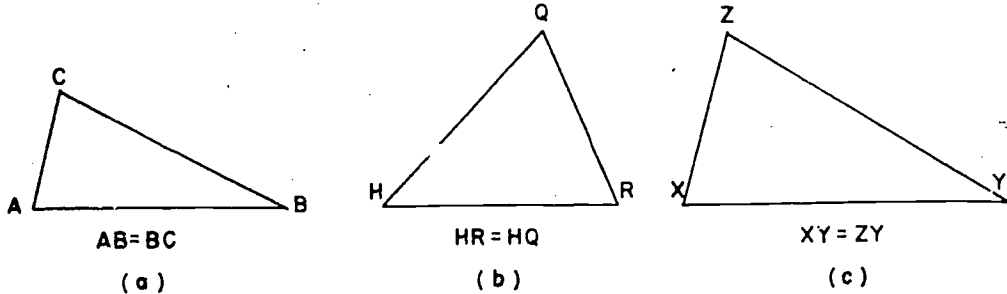

2. In the figures above, what angle is opposite side \overline{BC} ? What side is opposite $\angle R$? What angle is opposite side \overline{ZY} ? What side is opposite $\angle X$?
3. Are all equilateral triangles also isosceles? Are all isosceles triangles also equilateral? Explain your answers.

14-2. Converse of a Statement.

One of the many ways to get new ideas is to write a statement about an old idea and then change the words around according to the following plan:

First statement: If today is Monday then tomorrow is Tuesday.

Second statement: If tomorrow is Tuesday then today is Monday.

Suppose we call the words underlined once the "if" clause and the words underlined twice the "then" clause. As the arrows show, the "if" clause and the "then" clause of the first statement have been exchanged to produce the second statement.

Interchanging the "if" clause and the "then" clause of a statement gives a new statement. This new statement is called the converse of the first statement. In the above example, the

second statement is the converse of the first statement. Also, the first statement is the converse of the second. Note that if the first statement in the example given is true, then the converse is also true. Do you think that the converse of a true statement will always be true? Study the next pair of statements:

First statement: If Mary and Sue are sisters, then Mary and Sue are girls.

Second statement: If Mary and Sue are girls, then Mary and Sue are sisters.

The first statement is true. Is the second statement true?

Consider another pair of converse statements:

First statement: If $\angle a$ and $\angle b$ are vertical angles then $\angle a$ and $\angle b$ have the same measure.

Second statement: If $\angle a$ and $\angle b$ have the same measure then $\angle a$ and $\angle b$ are vertical angles.

We know that the first statement is true, but that its converse is not necessarily true. Thus, in the figure below, $\angle a$ and $\angle b$ have the same measure but are not vertical angles.

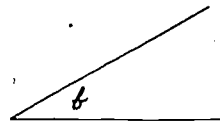
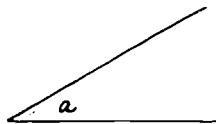

We can see from these examples, that if a statement is true, a second statement obtained from it and called its converse may or may not be true.

Could a false statement have a true converse? We can see that the answer is "yes" by referring to the last pair of statements again and interchanging them:

First statement: If $\angle a$ and $\angle b$ have the same measure then $\angle a$ and $\angle b$ are vertical angles. (False)

Second statement: If $\angle a$ and $\angle b$ are vertical angles then $\angle a$ and $\angle b$ have the same measure. (True)

Will the converse of a false statement always be true?
Consider the next pair of statements:

First statement: If today is Monday then tomorrow is
Wednesday. (False)

Second statement: If tomorrow is Wednesday then today is
Monday. (False)

To summarize: The converse of a true statement may be true or false and the converse of a false statement may be true or false. Thus, we see that knowing the truth or falsity of a statement tells us nothing about the truth or falsity of its converse.

Exercises 14-2a

1. Consider the statement, "If $\angle a$ and $\angle b$ are right angles, then $\angle a$ and $\angle b$ have the same measure." Write the converse of the statement and make a drawing to show that the converse is false.
2. For each of the following statements write "true" if the statement is always true; "false" if the statement is ever false.
 - a. If Blackie is a dog, then Blackie is a cocker spaniel.
 - b. If it is night, then we cannot see the sun.
 - c. If it is July 4th, then it is a holiday in the United States.
 - d. If Robert is the tallest boy in his school, Robert is the tallest boy in his class.
 - e. If an animal is a horse, the animal has four legs.
 - f. If an animal is a bear, the animal has thick fur.
3. Write the converse of each statement in Problem 2 and tell whether the converse is true or false.
4. Read the following statements. Write "true" if the statement is always true; "false" if the statement is sometimes false.
 - a. If a figure is a circle, then the figure is a simple closed curve.

- b. If a figure is a simple closed curve composed of three line segments, then the figure is a triangle.
 - c. If two angles have equal measures, then they are right angles.
 - d. If two lines are parallel, then the lines have no point in common.
 - e. If two angles are supplementary, then they are adjacent.
 - f. If two adjacent angles are both right angles, they are supplementary.
5. Write the converse of each statement in Problem 4 and tell whether the converse is true or false.
- *6. Write the converse of the fact discovered in Experiment One in this chapter. Do you think the converse is true?

The converse of a geometric statement often suggests another geometric idea worth studying. Earlier in this chapter you discovered the fact that if two sides of a triangle are equal in measure, then the angles opposite these sides are equal in measure. In the next experiment we shall see whether or not the converse of this statement is true.

Experiment Two

Another Important Fact About Angles in an Isosceles Triangle

What is needed: Protractor, ruler, pencil, drawing paper.

What to do: 1. Draw a segment \overline{BC} about five inches long. With vertex B draw an angle of 40° .

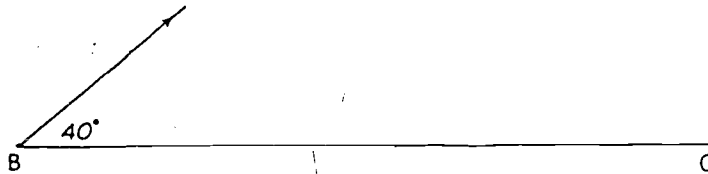

2. Place the center point of the protractor on point C and draw another 40° angle as shown;



3. Extend the rays until they intersect. Label the point of intersection F.

Questions:

1. In drawing triangle CBF did you use sides of the same measure or angles of the same measure? Name the parts measured.
2. Which side of the triangle is opposite angle B? Opposite angle C?
3. What fact about \overline{FC} and \overline{FB} must be true for triangle FCB to be an isosceles triangle? Measure \overline{FC} and \overline{FB} to see if triangle FCB is isosceles.

This seems to be true:

If two angles of a triangle are ? in measure, then the sides ? these angles are ? in length.

Exercises 14-2b
(Class Discussion)

Let us study another example of an important geometric fact which is obtained by taking the converse of a statement.

1. Write the converse of the following statement which you studied in Chapter 13.

If a transversal intersects two lines in such a way that a pair of corresponding angles have equal measures, then the lines are parallel.

2. To test the possible truth of the converse, draw lines m_1 and m_2 , and transversal t as in the figure. Are corresponding angles a and b congruent? Now draw any other transversal of m_1 and m_2 . Call it t_1 . Measure the angles in each pair of corresponding angles along t_1 . Are they congruent?

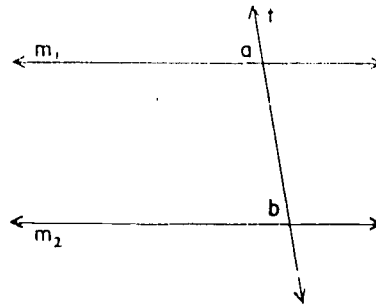

Compare your results with those of your classmates.

3. On the basis of this work, do you think the converse of the statement in Problem 1 is true or false?
4. Write the converse for the following statement.

If a transversal intersects two lines in such a way that a pair of corresponding angles have different measures, then the lines are not parallel.

Does the statement you have written seem to be true, or false? You can test your answer by making drawings as in Problem 2.

Exercises 14-2c

1. Name two segments of equal length in each of the following figures: (Do not measure the segments.)

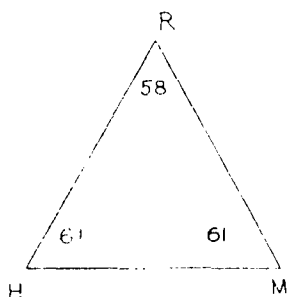

(a)

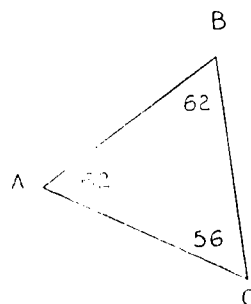

(b)

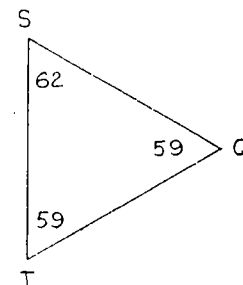

(c)

2. Draw a triangle which has two angles whose measures are equal. What kind of triangle have you drawn? Name the equal sides.

3. In the figure at the right these two facts are known:

1. \overleftrightarrow{AB} and \overleftrightarrow{DE} are parallel.
2. $DC = CE$.

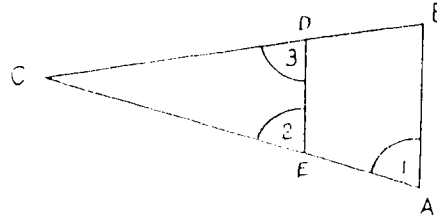

- a. Why does $m\angle 1 = m\angle 2$?
- b. Why does $m\angle 3 = m\angle 2$?
- c. Make a true statement about the measures of $\angle 1$ and $\angle 3$.

4. If the angles of the following figure have the measures shown, what kind of triangle is triangle ABC? Why?

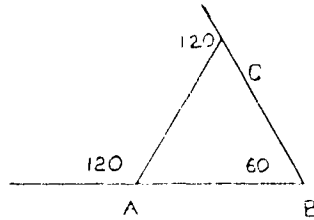

5. How can the property discovered in Experiment Two be used to show that a triangle having three angles of the same measure must be an equilateral triangle?
6. Define the three kinds of triangles (scalene, isosceles, equilateral) by using angle measures rather than side measures.

14-3. Angles of a Triangle.

In the preceding sections you studied special properties of certain triangles. In this section you will learn about a property which holds true for all triangles.

Experiment Three

The Sum of the Measures of the Angles of a Triangle

What is needed: Scissors, paper, pencil, protractor.

What to do: 1. Draw a triangle on a piece of paper. Cut out the triangular region by cutting along the sides of the triangle.

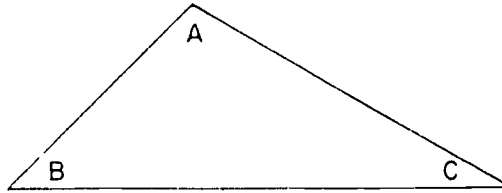

2. Cut the corners off the triangle and place them to form adjacent angles as in the drawing. The common vertex is marked V.

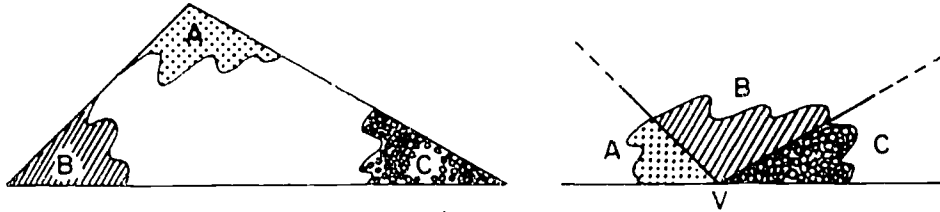

3. Use your protractor to find the sum of the measures of the three angles with vertices at V.

Questions: 1. What is the sum of the measures of the three angles of triangle ABC ?

2. Did your classmates find the same result?

This seems to be true:

The sum of the measures in degrees of the angles of a triangle is ____?

Exercises 14-3

Do not use a protractor for the following exercises.

1. Find the measure of $\angle x$.

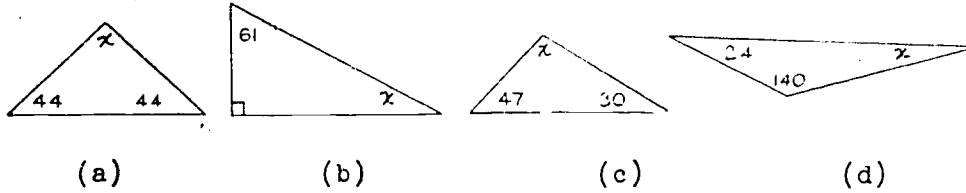

2. Find the measures of $\angle x$ and $\angle y$. Triangles (a) and (e) are isosceles.

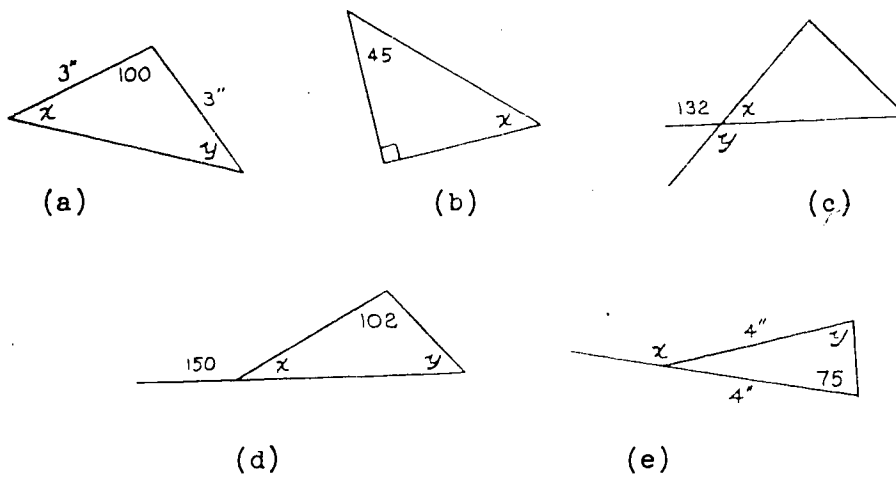

3. What is the measure of each angle of an equilateral triangle?
4. Suppose one angle of an isosceles triangle has a measure of 50.
- a. Find the measures of the other two angles.
 - b. Is there more than one solution to Problem 4a ?

14-3

5. Find the measures of $\angle x$, $\angle y$, and $\angle z$. \overleftrightarrow{RS} is parallel to \overleftrightarrow{AB} .

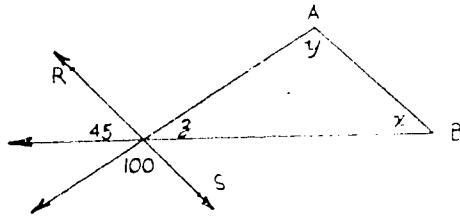

(a)

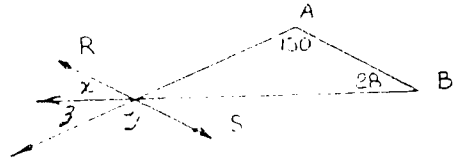

(b)

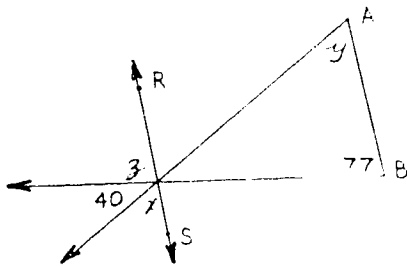

(c)

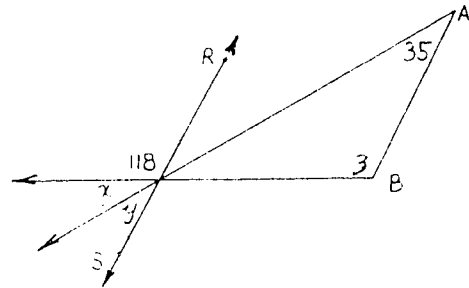

(d)

6. Find the measures of $\angle x$, $\angle y$, $\angle z$.

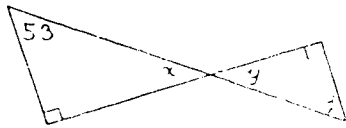

(a)

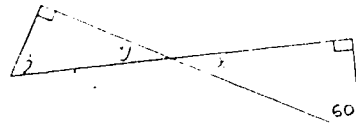

(b)

7. Find the measures of $\angle a$, $\angle b$, $\angle c$.

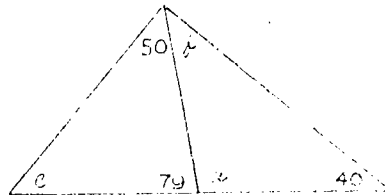

8. Find the measures of all labeled angles. (The two triangles in the figure are equilateral.)

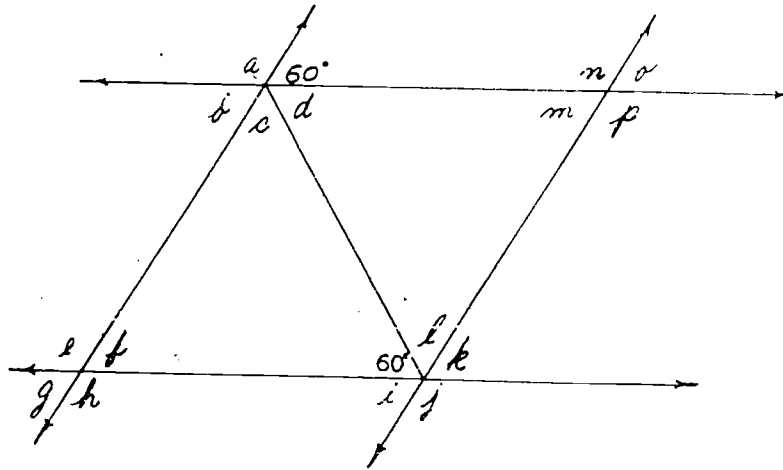

9. Draw a triangle, making each side from two to three inches in length. Cut out this triangular region. Tear off the corners and mount the whole figure on cardboard or a sheet of paper. As shown on the right, place corners B and C around the vertex A. What do you observe about angle 1, angle 2, and angle BAC in this new arrangement?

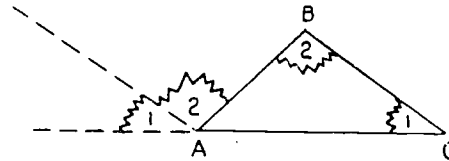

10. a. Draw a triangle making the largest side about 4 inches long, one of the remaining two sides about 3 inches long, and the third side about 2 inches long. Cut out this triangular region.

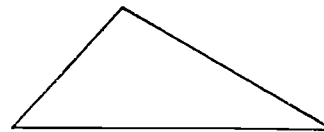

- b. Label the vertices A , B , and C in the interior as shown in the drawing at the right. Mark off the midpoint of \overline{AB} . Label the midpoint D . (The midpoint is halfway from one endpoint of a line segment to the other endpoint.) Find the midpoint of \overline{BC} . Label the midpoint E . \overline{AD} and \overline{DE} will have the same length. \overline{BE} and \overline{EC} will have the same length.

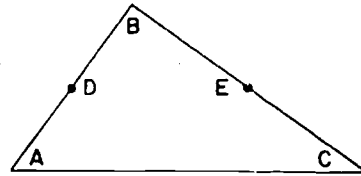

- c. Draw a line segment joining D and E . Fold downward the portion of the triangle containing the vertex B along the line segment \overline{DE} so that the vertex B falls on \overline{AC} . Label the point where B falls on \overline{AC} as G . The fold is along the segment \overline{DE} .

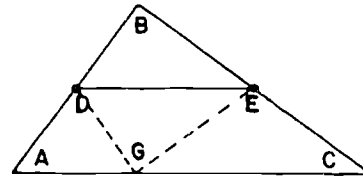

- d. Fold the portion containing A to the right so that the vertex A falls on the point C to the left so that the vertex C also falls on point G . The resulting figure will be a rectangle.

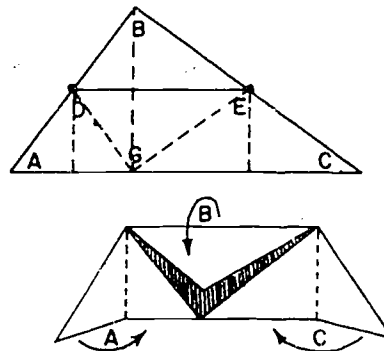

- e. Explain how this exercise seems to show that the conclusion obtained in Experiment Three is correct.

14-4. Polygons.

In Chapter 7 you discussed the following requirements for simple closed curves:

- a. The drawing starts and stops at the same point.
- b. No other point is touched twice by the pencil mark.

Are these figures simple closed curves?

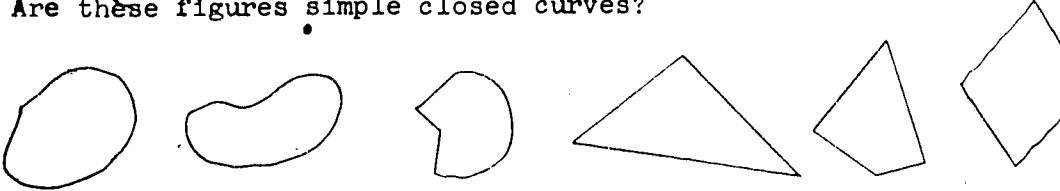

Notice these things about the last three figures at the right:

- a. They are simple closed curves.
- b. Each is the union of several segments.

A simple closed curve which is a union of segments is called a polygon.

Perhaps you have noticed that the triangle is a certain kind of polygon. The name for a polygon depends on the number of sides which form the figure. A polygon with four sides is called a quadrilateral, a polygon with five sides is called a pentagon, and a polygon with six sides is called a hexagon.

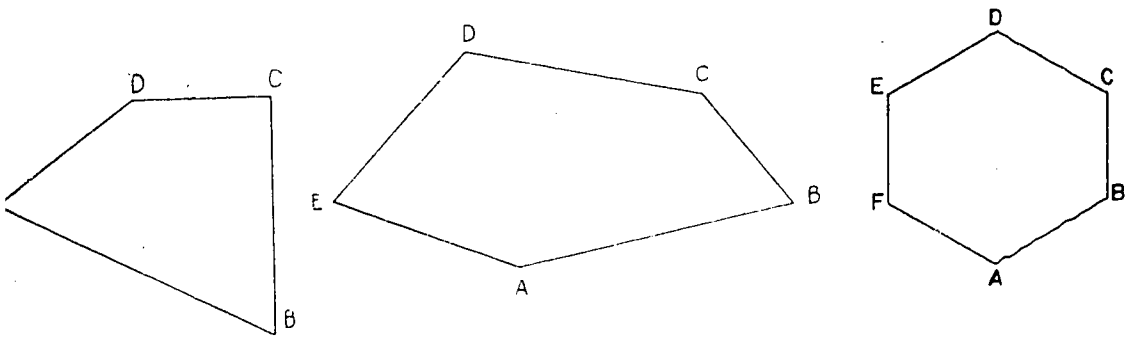

Quadrilateral

Pentagon

Hexagon

In a quadrilateral, two sides (segments) which do not intersect are called opposite sides. In the quadrilateral ABCD, \overline{AB} and \overline{DC} are opposite sides, as are \overline{AD} and \overline{BC} .

Exercises 14-4

1. Which one of these three figures is a simple closed curve?



(a)



(b)

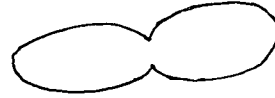

(c)

2. Which one of these three figures is not a simple closed curve?

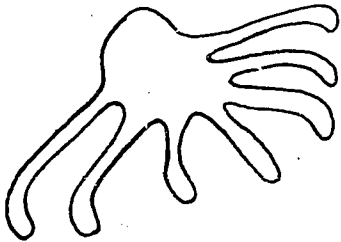

(a)

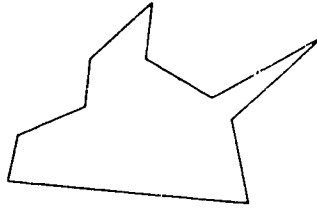

(b)

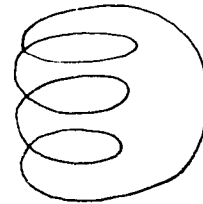

(c)

3. Which of these figures are polygons? Which one is not? Which requirement for a polygon does it fail to meet?



(a)

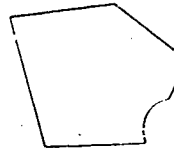

(b)

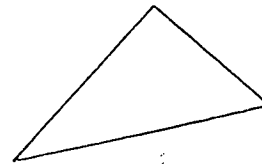

(c)

4. Name each of the following polygons.

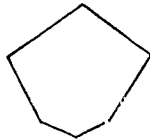

(a)

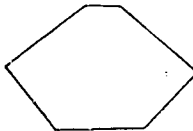

(b)

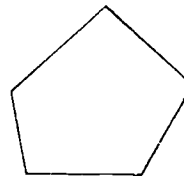

(c)

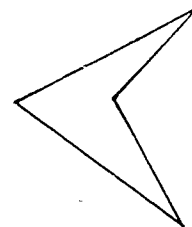

(d)

5. Name three quadrilaterals in this figure:

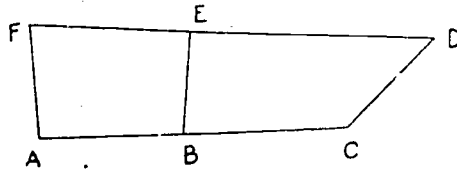

6. In the figure at the right:

- Name a pair of opposite sides.
- Name a different pair of opposite sides.
- Name two sides that do not intersect.
- Name two other sides that do not intersect.

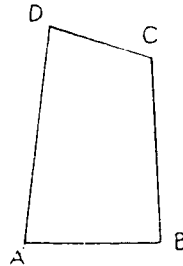

14-5. Parallelograms.

A parallelogram is a quadrilateral whose opposite sides lie on parallel lines. The figure ABCD below represents a parallelogram. Name two pairs of opposite sides.

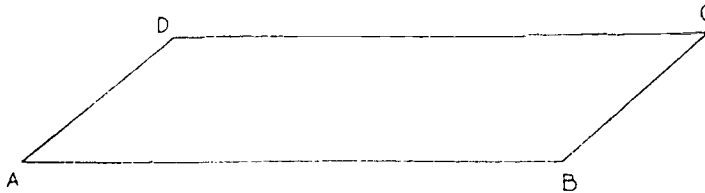

In the future, if two segments lie on parallel lines we shall speak of the segments as parallel. Thus we can say that the opposite sides of a parallelogram are parallel.

Exercises 14-5a
(Class Discussion)

1. Which of the following figures are parallelograms, assuming that segments which appear to be parallel are parallel?

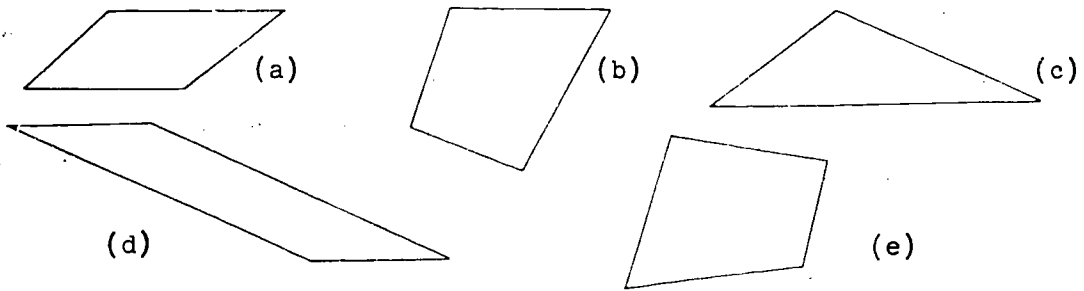

2. Name three parallelograms in this figure:

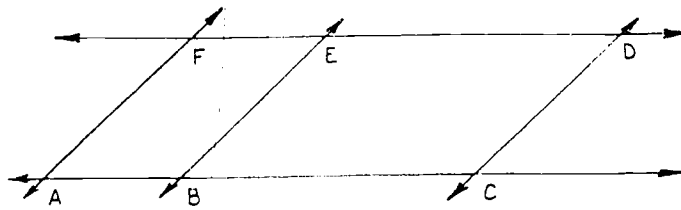

3. Name nine parallelograms in this figure:

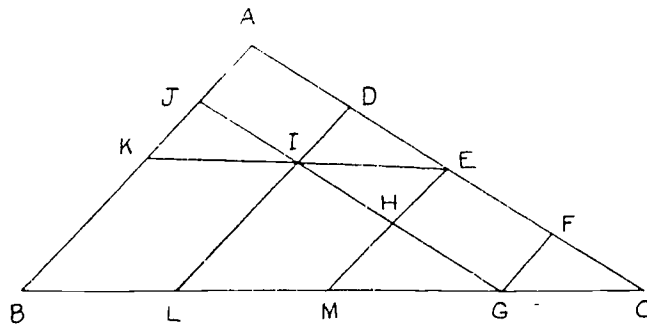

Exercises 14-5b

1. The figure at the right represents a rectangular sheet of paper. (Notice that a rectangle is a special kind of parallelogram.) Fold the paper as shown and cut or tear it along the line of the fold. By laying one piece on the other, show that the areas of triangle ABD and triangle BCD are equal. Is the area of one of the triangles equal to one-half the area of the rectangle? Why?

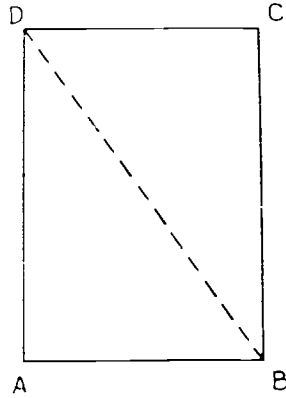

2. Draw a parallelogram ABCD and cut carefully along its sides. Draw \overline{BD} , a diagonal (a line joining opposite vertices). Cut along this diagonal to form two triangular pieces. Lay one of these pieces on the other. What do you conclude about these triangular pieces?

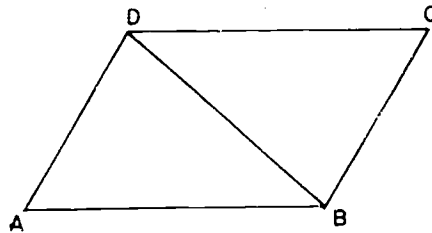

3. Repeat Problem 2 using diagonal \overline{AC} .

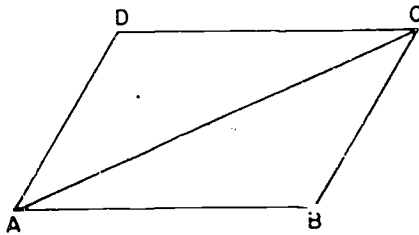

4. Write a statement that appears to be true concerning the two triangular pieces formed by a diagonal of a parallelogram.

Experiment Four

A Property of the Opposite Sides of a Parallelogram

What is needed: Ruler, pencil, paper.

What to do: 1. Find a pair of opposite sides in the parallelograms drawn below. Find the length of each side in the pair.

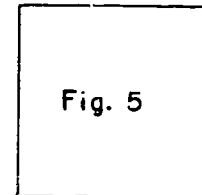
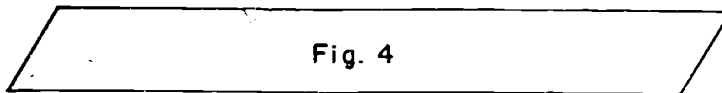
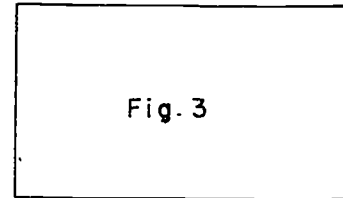
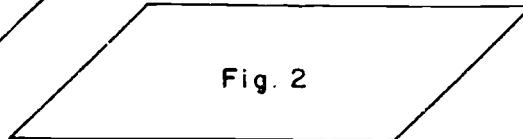
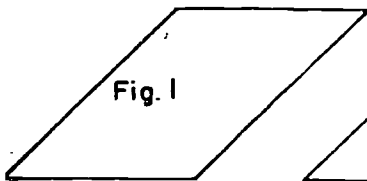

2. Make a copy of the table below. Record the lengths of the sides.

Number of the figure	Lengths of opposite sides:	
	First Side	Second side
1	1"	1"
	$1\frac{1}{4}$ "	$1\frac{1}{4}$ "
2	2"	2"

- Questions:
1. What have you discovered about the lengths of opposite sides of a parallelogram?
 2. What requirement have you found that a quadrilateral must meet in order to be called a parallelogram?

This seems to be true:

The opposite sides of a parallelogram are equal in length.

For the next set of exercises you will need a quick way to draw parallelograms of different shapes and sizes. Here are two ways to do this. Follow the steps carefully with your compass and decide which of the two ways you like better. Be sure to answer the questions following the last step in each method.

Method I

Step One. Draw two intersecting lines.

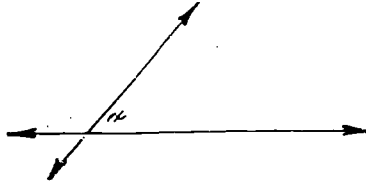

Step Two. Measure angle x . A short distance to the right mark a point A . Slide the protractor to the right and make angle x' the same size as angle x .

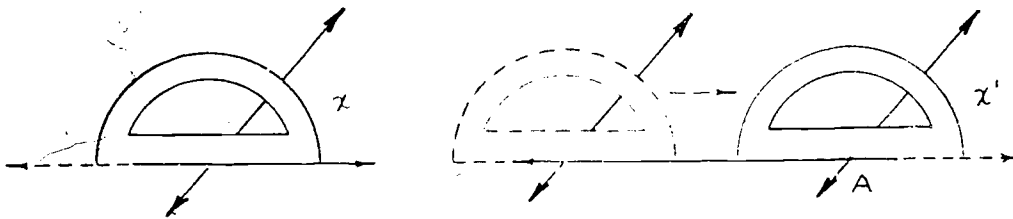

Step Three. Measure angle y . Mark a point B . Slide the protractor so that you can make angle y' have the same measure as angle y .

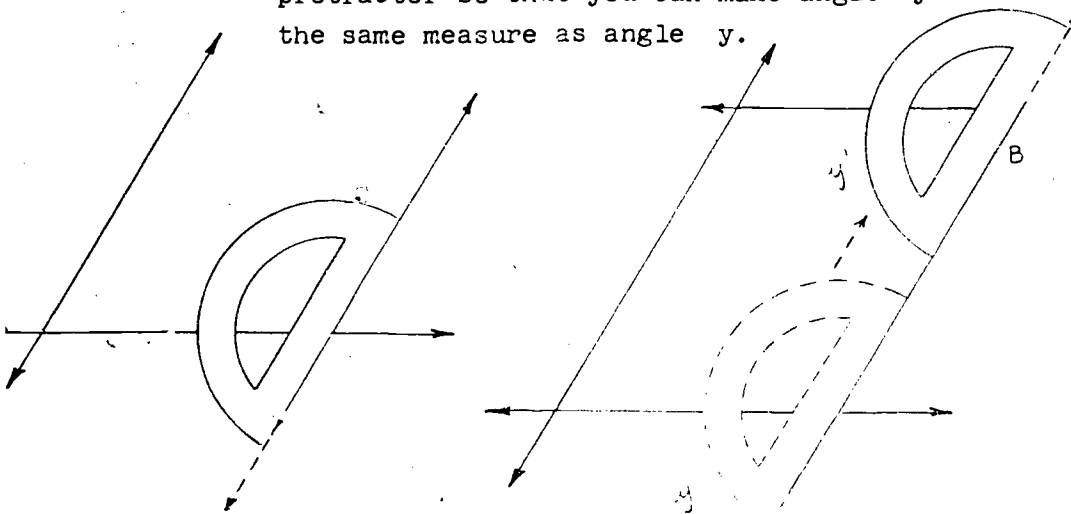

Questions:

1. In step two, what kind of angle pair did you measure and mark? Are these angles equal in measure?
2. Do you have two parallel lines after this step? What property says so?
3. After step three, do you have another pair of parallel lines? How do you know?
4. Is the resulting quadrilateral a parallelogram? Why?

Method II

Step One. Draw a line and mark two points on it. Call these points A and B. Open your compass a little and make two curves as shown.

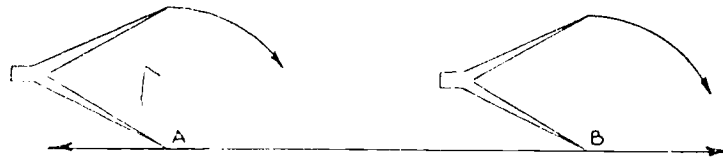

Step Two. Mark point C on one of the curves, as shown. Open your compass the distance AB.

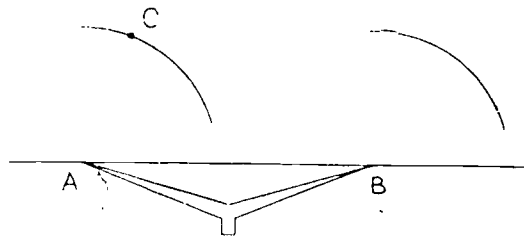

Step Three. Placing compass point at C make a curve as shown. Draw the segments indicated.

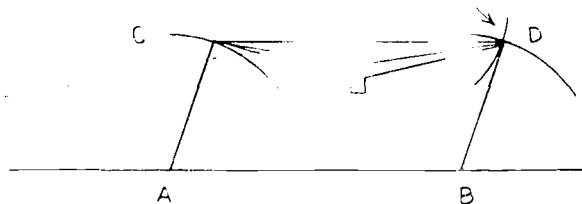

Questions:

1. Are the opposite sides of quadrilateral ABDC equal in length? How do you know?
2. What special kind of quadrilateral does figure ABDC seem to be?
3. Complete this statement: If the opposite sides of a quadrilateral are equal in length then the quadrilateral is a ? .
4. How many examples will you need to show that this statement is true?

Exercises 14-5c

1. Draw two parallelograms different in shape and size.
2. If your parallelograms are drawn carefully, can you expect the opposite sides to be equal in measure? Why?
3. In the parallelogram at the right, $\angle a$, $\angle b$, $\angle c$, and $\angle d$ are called angles of the parallelogram. Are the angles actually part of the parallelogram or are they determined by the parallelogram? Why?
4. Label and measure the angles of the parallelograms you drew for Problem 1. What interesting fact can you discover about a certain pair of these angles? List the pairs that show this property and give their measures.

14-6. Distance to a Line.

Suppose you are in a leaky rowboat not far from a long dock. You must get to the dock quickly before the boat sinks! Which of the paths marked in the picture should you take?

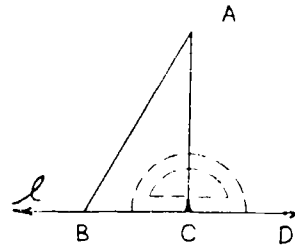
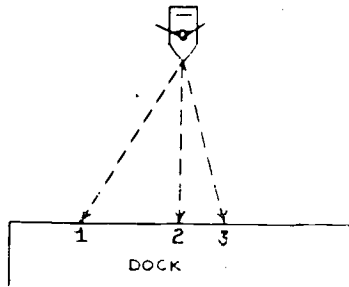

Do you think segment \overline{AC} in the diagram at the right is the shortest path from point A to line BC ? Place your protractor as shown and measure angle ACB . Measure angle ACD . Do you agree that segment \overline{AC} is not only the shortest path from point A to line BC but also forms two right angles with line BC ?

In the future, the distance from a point A to a line l will mean the length of the segment which:

1. forms right angles with the line,
2. has the given point A as one of its endpoints,
3. has its other endpoint on the given line.

Below is a picture of a street in town:

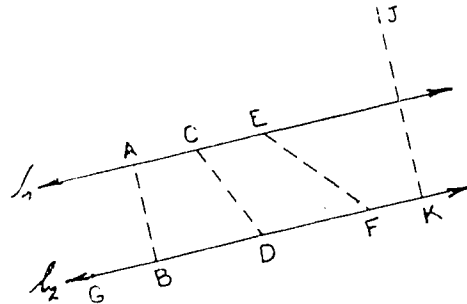
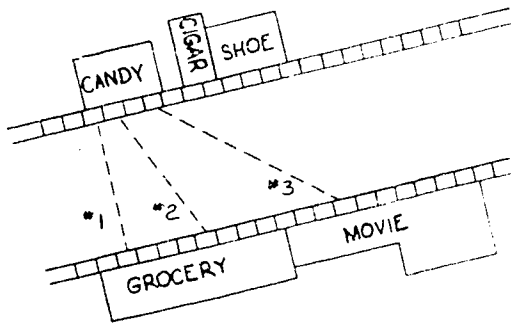

What is the number label of the shortest path from the candy store to the grocery store? In the drawing at the right, which segment must be measured to determine the shortest distance between the parallel lines l_1 and l_2 ? What is the measure of angle ABG ? of angle BAC ? In the future, the distance between two parallel lines will be the length of a special segment. This segment, like \overline{AB} , must meet the following requirements:

1. It must lie in a line that makes right angles with each of the parallel lines.
2. It must have an endpoint on each of the parallel lines.

Which of the above requirements is not met by \overline{EF} ? By \overline{JK} ?

There are several ways in which we can find the distance from a point A to a line ℓ . We can slide a transparent protractor along the line until the point A lies on the 90° ray. Then draw a line through point A perpendicular to ℓ at a point B . Finally, measure the segment \overline{AB} .

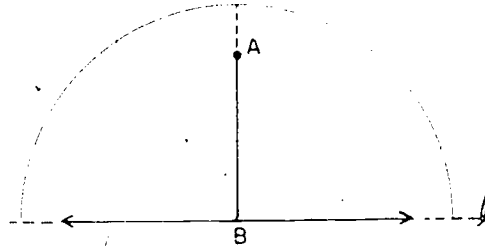

We could also use a rectangular sheet of notebook paper and slide this along ℓ until one edge passes through A . At this point draw \overline{AB} , as in the figure, and find the length of \overline{AB} .

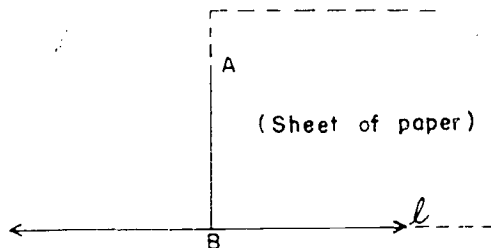

To find the distance between two parallel lines ℓ and m , select any point A on line ℓ . At this point use your protractor to construct a line perpendicular to ℓ which meets m at a point B . Measure the segment \overline{AB} .

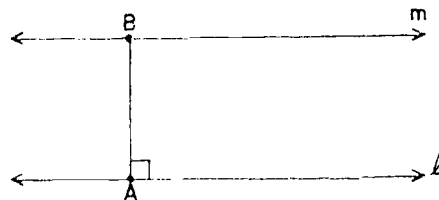

Exercises 14-6

1. For each of these figures, find the distance from the point Q to the line containing segment \overline{AB} .

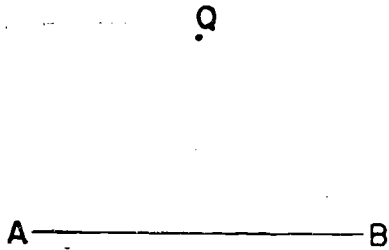

(a)

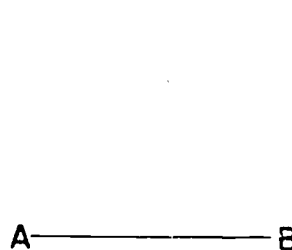

(b)

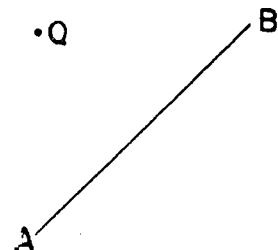

(c)

2. In each triangle, find the distance from vertex A to the line containing the side opposite angle A.

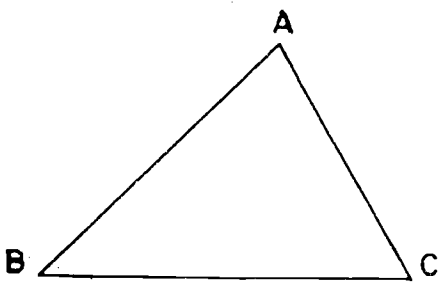

(a)

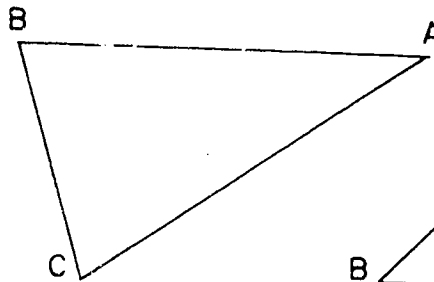

(b)

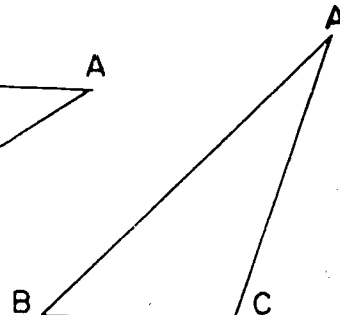

(c)

3. In the following parallelograms, find the distance from point A to side \overline{BC} .

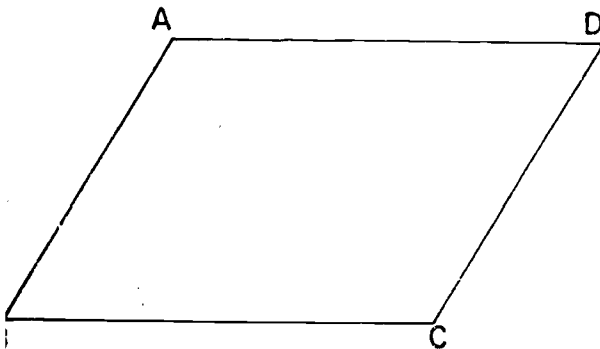

(a)

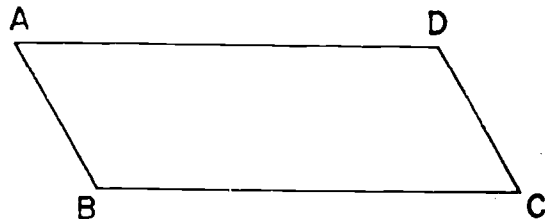

(b)

14-7

4. Find the distance between the following pairs of parallel lines, l and m .

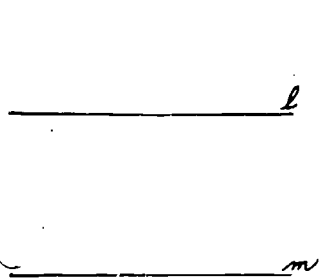

(a)

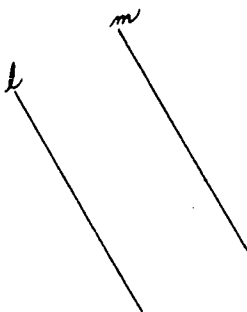

(b)

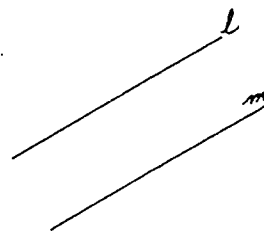

(c)

14-7. Proof.

In the drawing of two parallel lines below, several segments are labeled. Is the length of one of these segments the distance between the parallel lines?

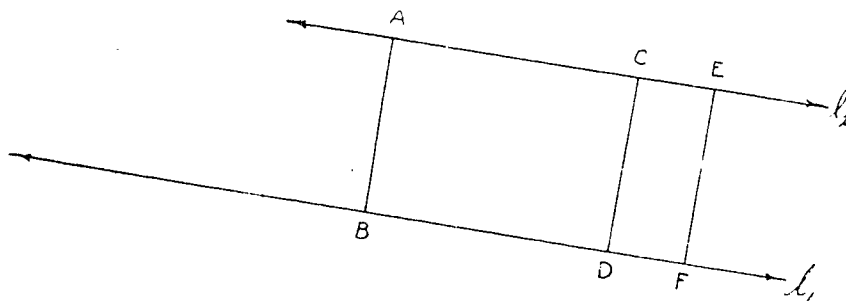

Measure segments \overline{AB} , \overline{CD} , and \overline{EF} . Do these segments have the same measure?

You may have decided that these segments have a common measure. Then you can say that the distance between the parallel lines is the same for each segment. Suppose many more segments are drawn with their endpoints in l_1 and l_2 so that each segment lies in a line forming right angles with l_1 and l_2 .

Will these segments have the measure common to \overline{AB} , \overline{CD} , and \overline{EF} ?
 If so, you can say, "It seems to be true that the distance between two parallel lines does not change."

We can't be sure that the last statement is true, but it does seem to be true. We can't be sure because the reasons for believing that the statement is true are not good reasons. The reasons are:

1. The distances look the same.
2. We tested the idea with many correctly drawn segments and found the distance unchanged in every case.

Consider reason number one. To show that this is a poor reason for belief, look at the figures below:

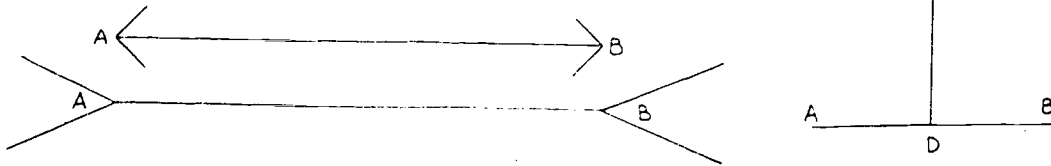

Without measuring, name the longer segment in each figure. Now measure the segments. Are you as certain now about the lengths as you were before? Can you be sure about the lengths of segments by simply looking at them?

Now consider reason number two. If testing many times is a way to make sure of a statement, let's test this number statement many times:

If you:

1. multiply a counting number by the next smaller counting number,
2. and add 41 to the product,

then the final result will always be a prime number.

The same idea may be stated this way: For a counting number n the expression $n(n - 1) + 41$ always represents a prime number. Do you think the statement true? How many tests are needed to show that the statement is true?

Here are forty tests of the above number statement:

After checking the table on the right are you sure that the statement is true? It is very likely that you have tested the number statement many more times than you did our geometric statement.

Now try just one more test. Try the counting number 41. Is the result a prime? Try dividing the result by 41. Does the expression $n(n - 1) + 41$ represent a prime number for every counting number n ?

Number	Expression	Result
1	$1(0) + 41$	41
2	$2(1) + 41$	43
3	$3(2) + 41$	47
4	$4(5) + 41$	61
5	$5(6) + 41$	71
Complete this table through the number 39		
40	$40(39) + 41$	1601
41	$41(40) + 41$?

To make sure of a certain property, mathematicians follow a kind of plan called a proof. Many of the conclusions you reached in your experiments will be proved in future work in geometry. You will not be expected to do any proofs of your own this year but an example is included so that you may see how a proof is developed.

One of the main parts of a proof lists certain rules or agreements that must be made before continuing the discussion. This part will be called "Facts Already Agreed Upon".

Why must there be such a section? Suppose your team has just scored a goal. "The score doesn't count!", shouts a player on the other team. "I just made up a rule that all scores must be made while running backwards!" Can you give some reasons why certain agreements should be made before starting a game? For many of the same reasons there must be a list of "Facts Already Agreed Upon".

The following proof is planned to show that the measure of angle CAD is equal to the measure of angle B added to the measure of angle C.

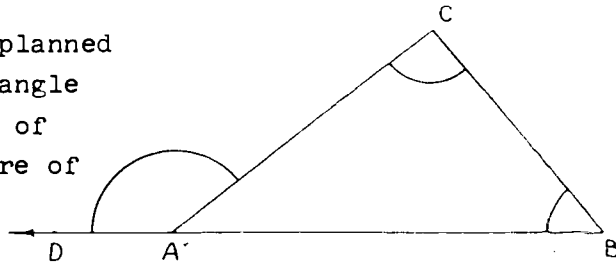

Proof

The Measure of $\angle CAD$ Is Equal To
the Measure of $\angle B$ Added To the Measure of $\angle C$

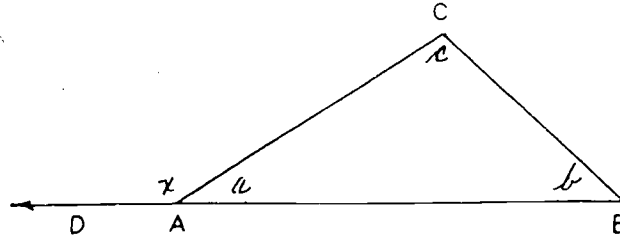
**Facts Already Agreed Upon:**

1. The requirements for supplementary angles.
2. The sum of the measures of the angles in a triangle is 180.
3. The letters a , b , c , represent the measures of the angles of the triangle. The letter x represents the measure of $\angle CAD$.
4. $180 - a$ is that number which added to a gives 180.

Statements	Why the Statement is True
1. $x + a = 180$	1. Angle CAD and angle CAB meet the requirements for supplementary angles.
2. $180 - a = x$	2. Item 4 in the "agreed upon" section.
3. $(b + c) + a = 180$	3. The sum of the measures of the angles in a triangle is 180.
4. $180 - a = (b + c)$	4. Item 4 in the "agreed upon" section.
5. $x = b + c$	5. Steps 2 and 4 show that x and $(b + c)$ are two names for the same number, $180 - a$.

14-8. Area of a Parallelogram.

A parallelogram, as you have learned, is a special type of quadrilateral. The opposite sides lie on parallel lines. A rectangle is a quadrilateral. Is a rectangle a parallelogram?

As you have already discovered, the opposite sides of a parallelogram have the same length. Which pairs of sides in the figure below have the same lengths?

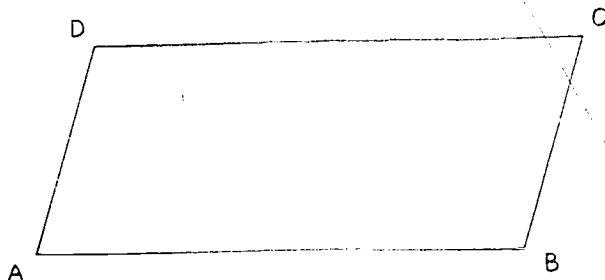

In the figure below, segment \overline{DE} is called an altitude of the parallelogram.

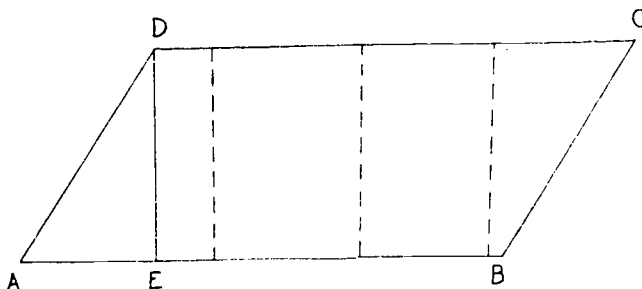

A parallelogram has many altitudes. The dotted segments represent altitudes of the same parallelogram but they are in different positions. When we wish to speak of the length of an altitude, we refer to the length as the altitude. You may have noticed that \overline{DE} is also called the distance between the parallel lines \overline{AB} and \overline{DC} . The altitude of a parallelogram is the distance between a pair of parallel lines of the parallelogram.

The sides between which the altitudes are drawn are called bases of the parallelogram. In the figure below, we say that altitude \overline{RT} is drawn between the bases \overline{AB} and \overline{CD} . Sometimes we say that \overline{AB} is the base to which the altitude is drawn or that \overline{CD} is the base to which the altitude is drawn.

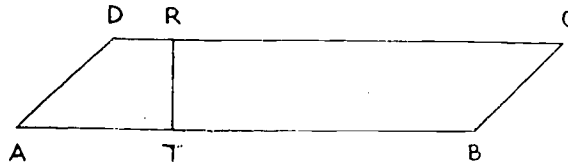

Exercises 14-8a

1. Polygon ABCD is a parallelogram.
 - a. Name the vertices.
 - b. Name the sides.
 - c. Name a pair of opposite sides.
 - d. Is the distance between opposite sides the same whether measured between \overline{AB} and \overline{CD} or between \overline{AD} and \overline{BC} ?

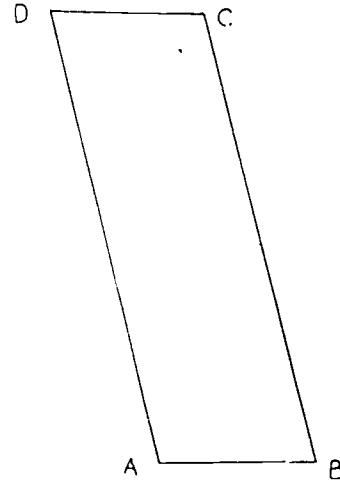

2. Name one base for each altitude in the following parallelograms.

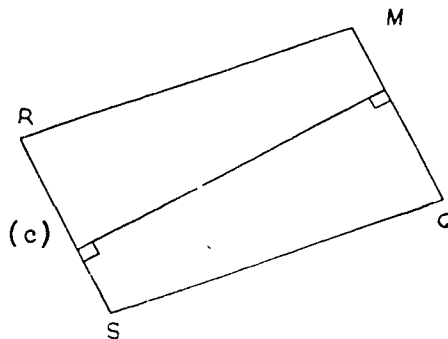
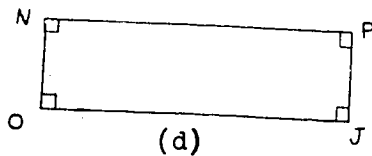
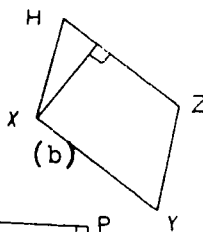
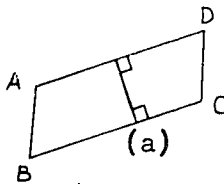

3.

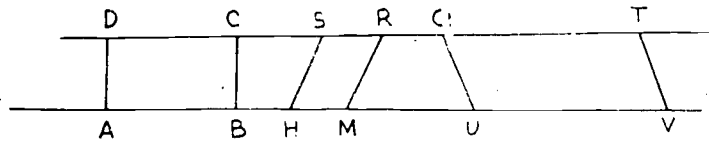

- a. Name three parallelograms in the figure above.
 - b. Is the measure of an altitude in one of these the same as the measure of an altitude in one of the others? Why?
4. In the figure at the right:

- a. Name two parallelograms.
- b. Name two segments either of which is an altitude for both parallelograms.

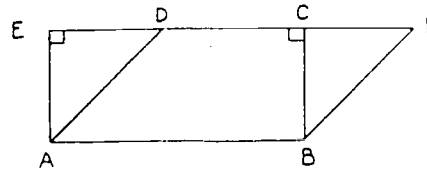

Experiment Five

Finding the Area of a Parallelogram

What is needed: Scissors, pencil, paper, straightedge.

What to do: 1. Draw a parallelogram. Cut out the region determined by this parallelogram.



2. Draw an altitude as shown. Cut on the dotted segment.

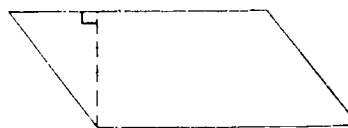

3. Without lifting either piece from your desk, slide the triangular region to the right and place it in the position shown.

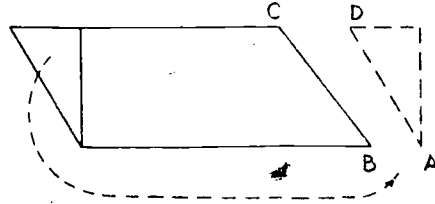

4. Slide the two pieces together so that point D falls on point C and point A falls on point B.

Questions:

1. What special polygon is suggested by the two pieces in their final positions?
2. Is the area of this polygon the same as the area of the parallelogram with which you began this experiment? Why?
3. Is the measure of the width of the rectangle the same as the measure of an altitude in the parallelogram?
4. Is the length of the rectangle the same as the measure of the base of the parallelogram to which the altitude is drawn?
5. In order to find the area of a parallelogram will you always have to cut it up as we have done? Why?

This seems to be true:

The number of square units of area in a parallelogram is the ? of the number of linear units in the ? and the number of linear units in the ? to this base.

If we let A represent the number of square units of area in a parallelogram, b the number of linear units in the base, and h the number of linear units in the altitude to this base, we may summarize our conclusion by the following number sentence:

$$A = b \cdot h$$

Exercises 14-8b

1. Find the areas of the following parallelograms:

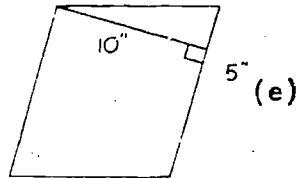
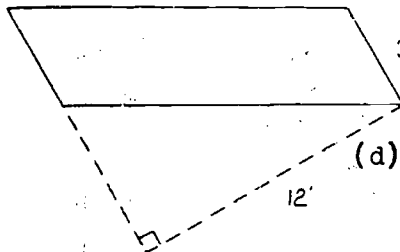
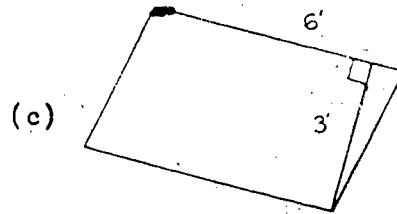
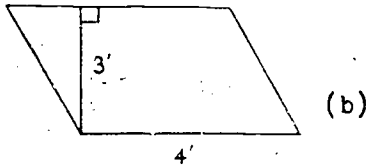
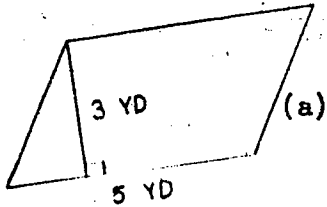

2. Measure the bases and altitudes of the parallelogram below and use them to find the area in two ways. How well do your results agree? Since measurement is approximate, they may not be exactly the same, but should be close.

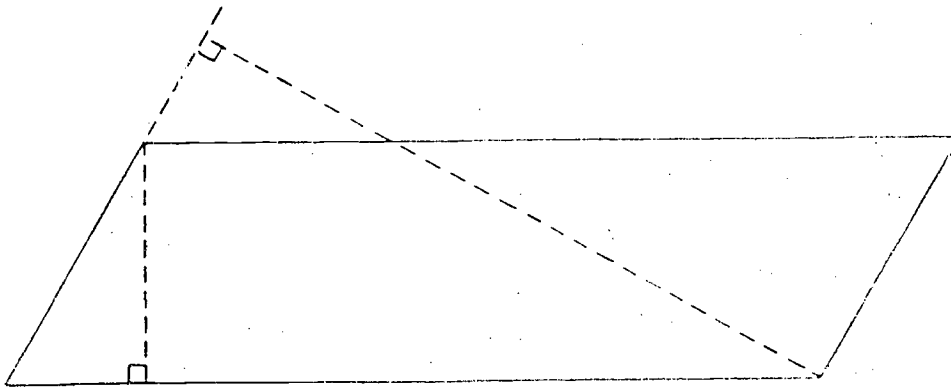

14-8

3. Find the area of parallelogram ABCD.

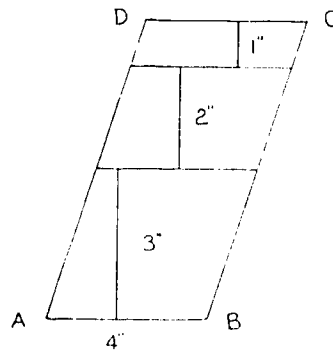

4. Find the area of parallelogram ABCD.

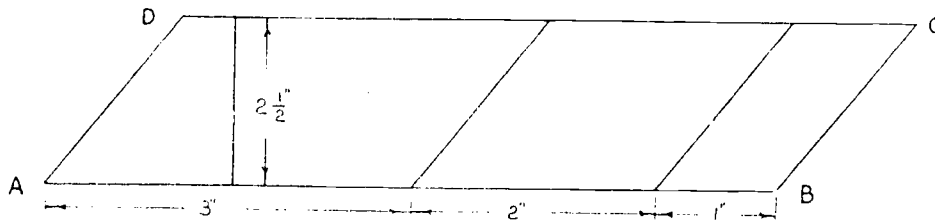

5. Show that these parallelograms have the same area:

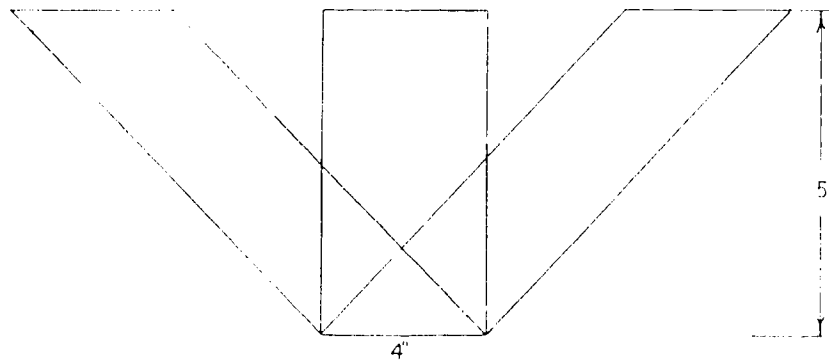

144

171

- *6. Look at the parallelogram and rectangle below which have bases of equal length and altitudes of equal length.

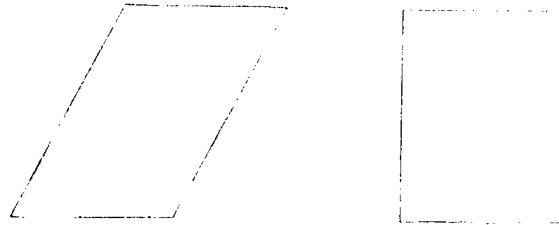

Make a copy of the parallelogram and cut it into pieces that can be reassembled to form the closed rectangular region.

14-9. Area of a Triangle.

Consider any triangle ABC as shown below. We wish to discover a way of finding the area of this triangle. Through C draw a line parallel to \overline{AB} .

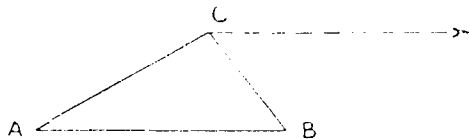

Through B draw a line parallel to \overline{AC} .

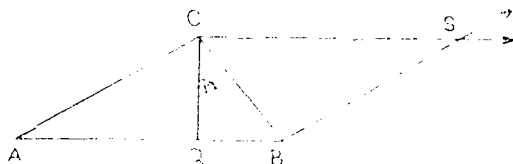

Label the point of intersection of the lines you have drawn with the letter S .

The figure $ABSC$ is therefore a parallelogram. How do we know this? The segment \overline{CQ} through C perpendicular to line \overline{AB} is called the altitude of the triangle to the base \overline{AB} . The length of altitude \overline{CQ} is the distance from C to line \overleftrightarrow{AB} .

What do you know about the triangular regions ABC and SCB ? Since the interior of the parallelogram is made up of the two triangular regions, it follows that the area of

triangle ABC is one-half the area of parallelogram ABSC. Copy and complete the following statement:

"The number of square units of area in a triangle is ? the ? of the number of linear units in the ? and the number of linear units in the ? to this base".

If we let A represent the number of square units in the area of a triangle, b the number of linear units in the base, and h the number of linear units in the altitude to this base, we may summarize our conclusion by the following number sentence:

$$A = \frac{1}{2} \cdot b \cdot h$$

Any side of a triangle may be considered a base. This is illustrated in the following figures. The same triangle is shown in three positions, using each of its sides as a base.

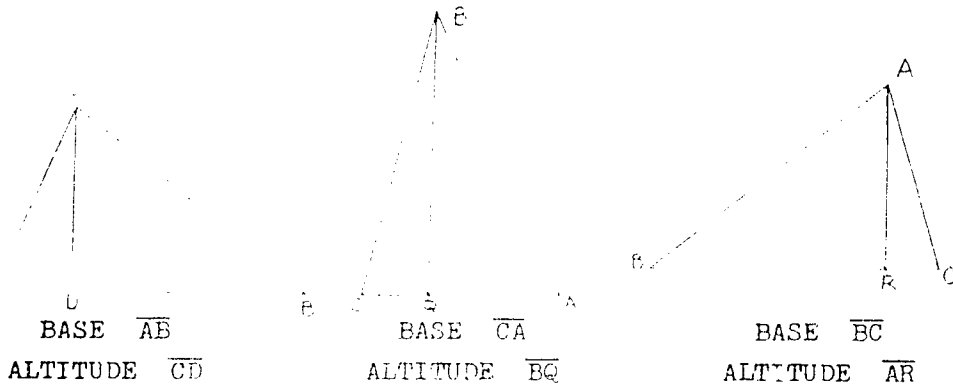

In the three figures above the base was shown as horizontal in each case. The base does not always lie in a horizontal position. The following figures show this:

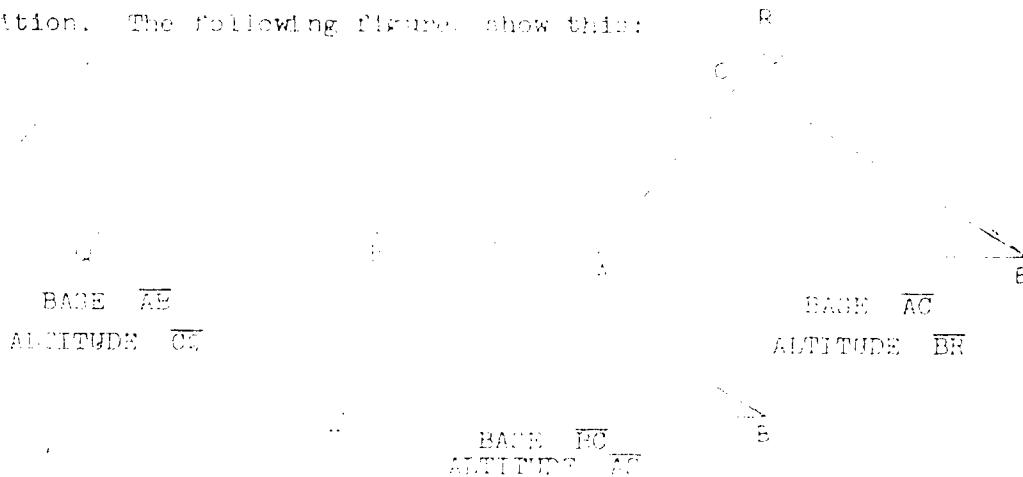

Exercises 14-9

1. Find the areas of the triangles shown, using the measures given:

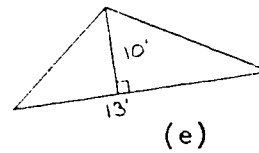
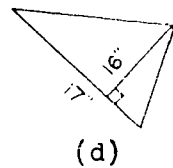
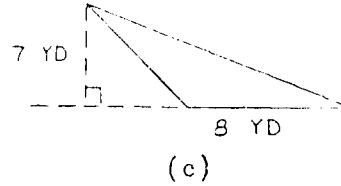
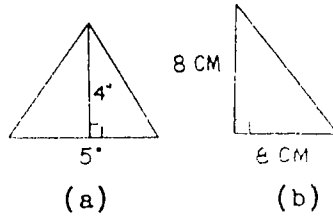

2. A right triangle has sides of 5 yards and 12 yards as shown. Find the number of square yards in its area.

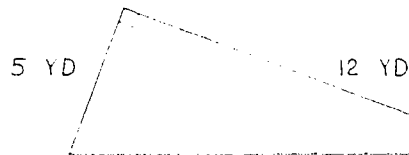

3. A certain house attic must have openings near the roof which have a total area of 12 square feet. This is needed for good cooling of the attic. The house has two openings like that in the drawing. Is this attic well ventilated?

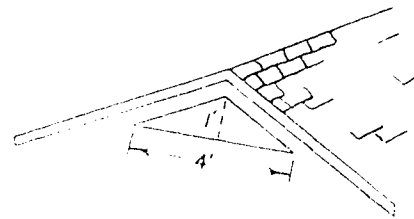

4. A stained-glass window in a church is in the shape of a triangle. If its measurements are as shown, what is the total cost of the window if the cost per square foot is \$50 ?

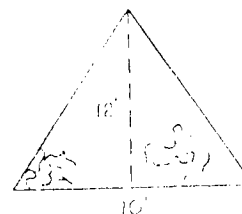

14-10

5. A man owned a rectangular lot 150 ft. by 100 ft. From one corner A, there was a path to the point M in the center of the longer opposite side. Find the area of the two pieces of the lot.

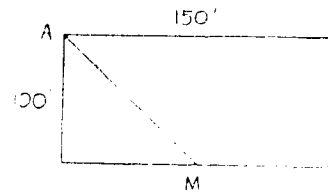

6. Measure the bases and altitudes in the triangle ABC and thus find the area of this triangle in three different ways. How well do your results agree? They may not be exactly the same but they should be fairly close.

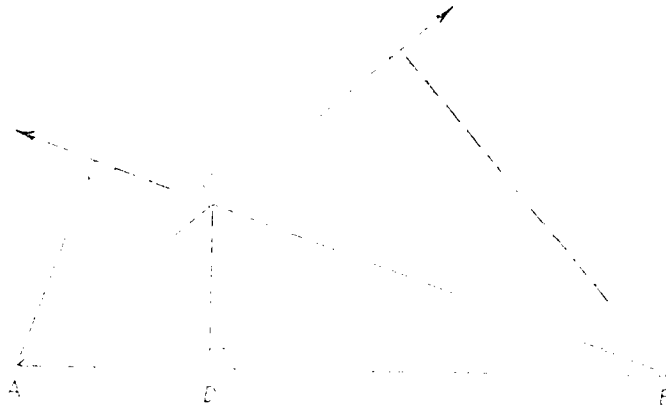

14-10. Right Prisms.

In Chapter 12 you studied rectangular prisms. In this chapter you will study other kinds of prisms.

Imagine holding in one hand a model of a table with a triangular top and holding in the other hand a triangular piece of cardboard as in Figure 1. The cardboard and the table top are exactly the same size and shape.

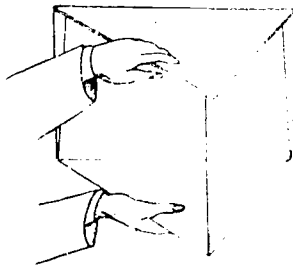

Figure 1

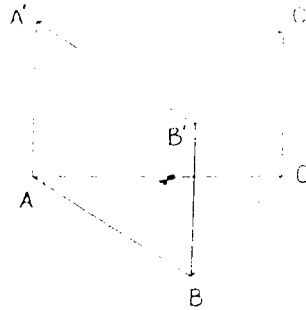

Figure 2

Figure 2 represents segments which are suggested by the table legs, the edges of the top, and the edges of the cardboard. Which segments are suggested by the edges of the table top? What are the names of the segments suggested by the table legs? By the edges of the cardboard?

Not only segments, but several planes are suggested by the "table and cardboard" picture. The table top suggests a plane that is parallel to the plane of the cardboard. If the plane determined by points A' , B' , and C' is parallel to the plane determined by A , B , and C , then the labeled geometric figure needs to meet just one more requirement in order to be called a triangular right prism. The requirement is that the quadrilaterals determined by $ABB'A'$, $BCC'B'$, and $ACC'A'$ must be rectangles.

The closed rectangular regions which are determined by:

1. the edges of the table top
2. the edges of the cardboard and
3. the edges which the legs suggest

are called faces. The triangular regions are faces too, but they are called bases as they are used in this particular discussion. Points A , B , C , A' , B' , and C' are called the vertices of the triangular right prism.

If, in place of using triangular regions for bases, we use the regions bounded by other polygons, the resulting figures are other kinds of prisms. Can you describe a pentagonal right prism?

Exercises 14-10a

For each of these right prisms do the following:

1. Write the name in words.
2. Name the vertices.
3. Name the rectangular faces.
4. Name both bases, with letters of their vertices.

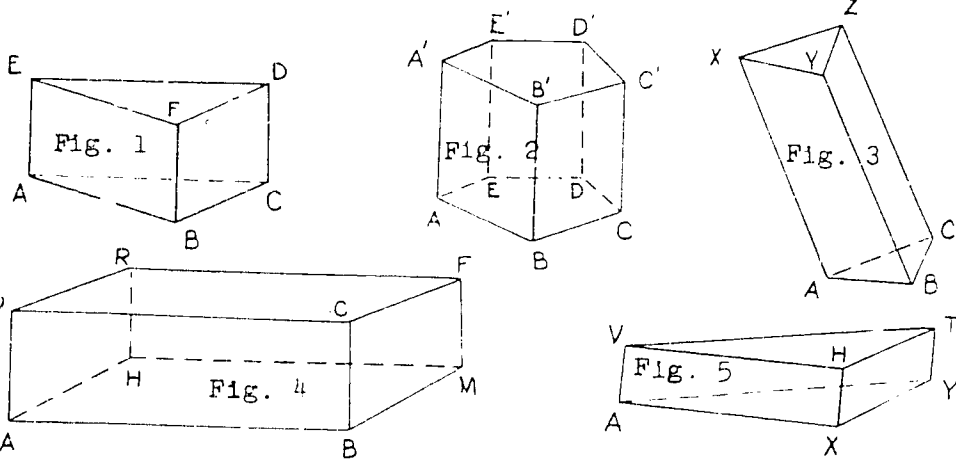

It may seem from the drawing of the table that the bases of a right prism must lie in horizontal planes. The drawings below are intended to show that the bases of a right prism may lie in planes that are not horizontal.

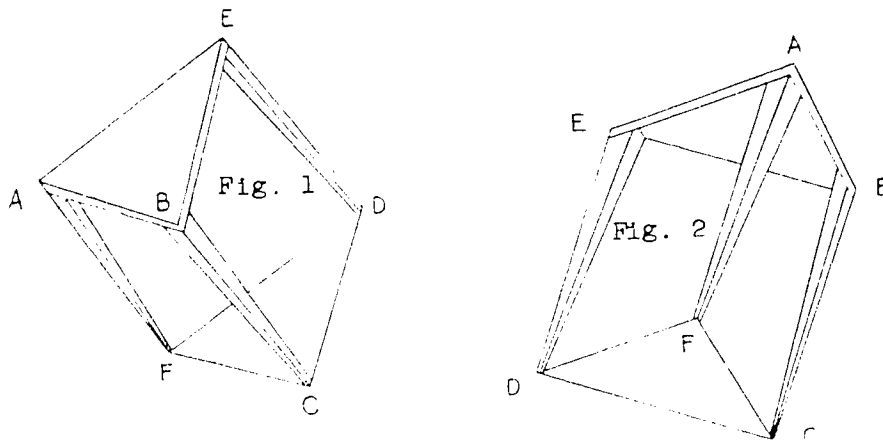

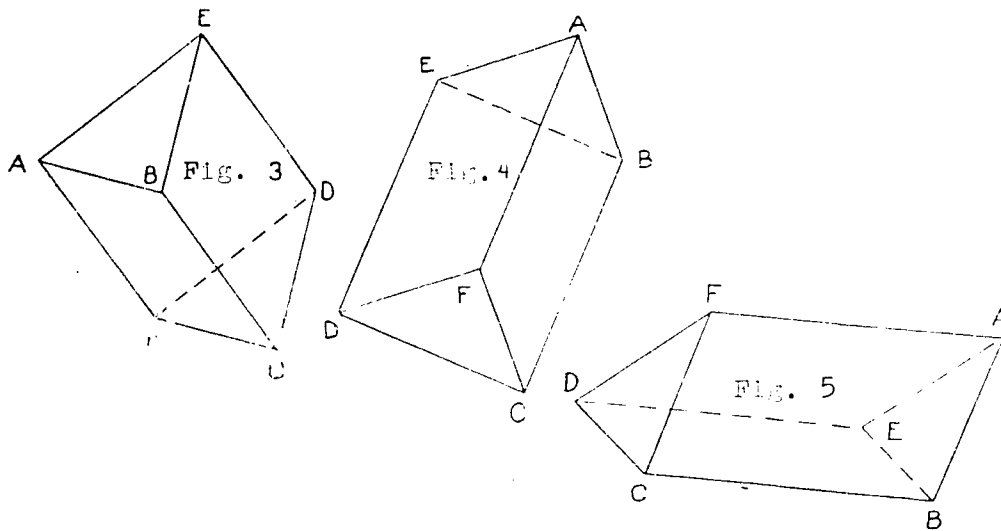

In the drawing at the right, the sides of the window frame are parallel planes marked M_1 and M_2 . The curtain rod is described as fitting exactly between the parallel planes.

The length of the rod represents the distance between the two parallel planes M_1 and M_2 .

The rod will fit exactly between the planes M_1 and M_2 in many other positions than that shown. This suggests that the distance between parallel planes, like the distance between parallel lines, is always the same.

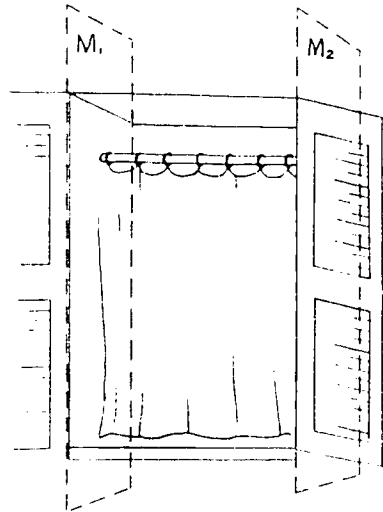

In a prism the distance between the parallel planes which contain the bases is called the height of the prism. In a right prism the measurement of an edge suggested by one of the table legs may be used as the height of the prism.

Just as we have been using "area of a rectangle" to mean the area of the closed region determined by the rectangles, we shall use "volume of a prism" to mean the volume of the solid consisting of the points of the prism and the points in the interior of the prism.

One way to discover new ideas is to take a certain example for which measures are given and use these measures to obtain at least one test of the new idea. For example, in the figure below there are two pieces of cake with measures as given:

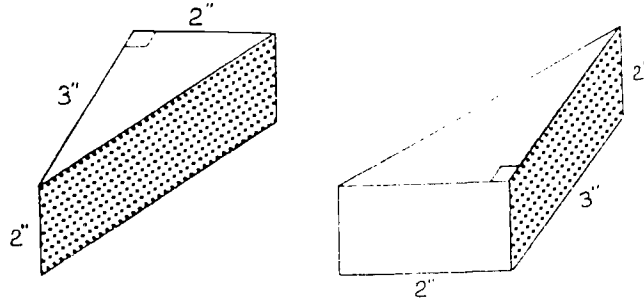

Notice that these pieces are triangular prisms of the same shape and size. By placing them together in the following way another kind of prism is formed:

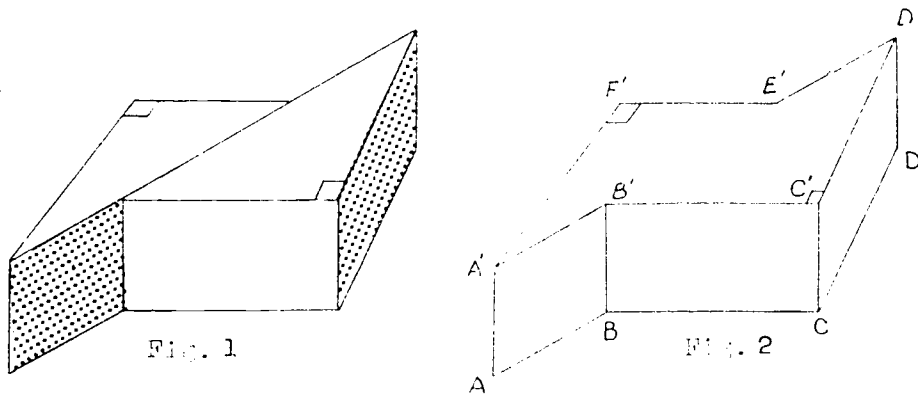

What reasons are there for thinking Figure 2 is a prism? It is not likely that you know the name of this prism but if we slide the pieces of cake along a little further, we get a prism that you should be able to name.

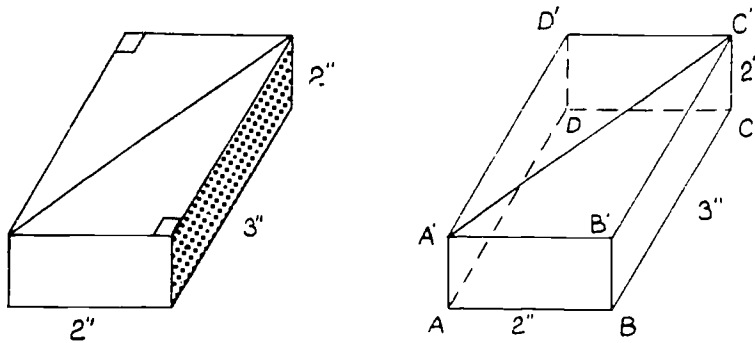

Find the volume of the rectangular prism. Is the volume 12 cubic inches? Since two of the triangular prisms make up the rectangular prism, what is the volume of one triangular prism?

There is another way of finding the volume of one of the triangular prisms without using a rectangular prism at all. Try multiplying the height of the triangular prism by the area of its base. Do you get the same result as before?

While you have tested the following statement only once, you will find in future study of geometry that the statement is true for all prisms:

The number of cubic units of volume in a prism is the product of the number of square units of area in the base and the number of linear units in the height.

If we let V represent the number of cubic units in the volume of a prism, B the number of square units of area in the base, and h the number of linear units in the height, we may summarize our conclusion by the following number sentence:

$$V = B \cdot h$$

Exercises 14-10b

1.

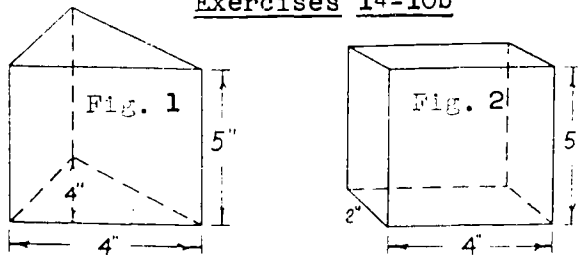

- a. Find the area of the base in Figure 1.
- b. Find the area of the base in Figure 2.
- c. What is the height of each right prism?
- d. What is the volume of each prism?

2. Find the number of cubic units of volume of each of the right prisms shown below:

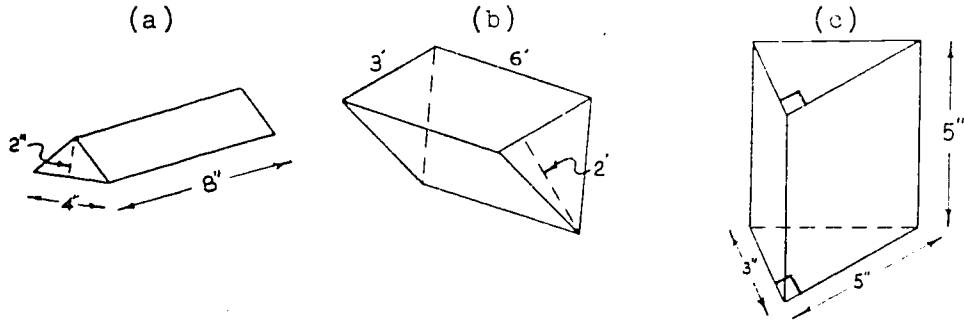

3. Find the volume of each right prism below:

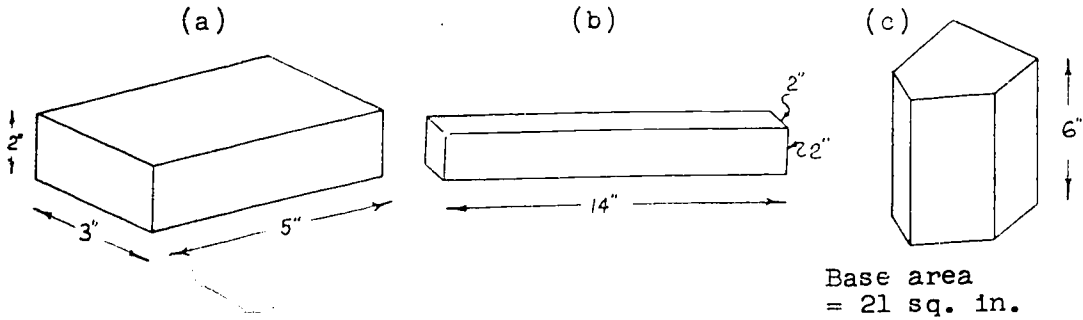

4. A fish tank must have at least 12 cubic inches of water for each fish of a certain kind.
- What is the volume of the fish tank?
 - What is the greatest number of fish allowed in the tank?

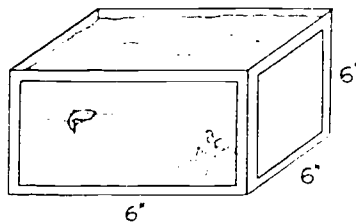

14-10

5. At the zoo some animals in a certain cage drink a total of at least fifty cubic feet of water a day. Can the tank below hold a day's supply of water for these animals?

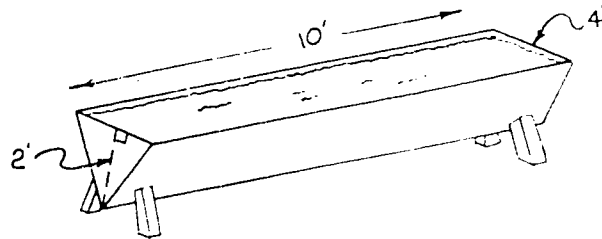

6. Make a copy of the following pattern. The copy must be drawn on stiff paper. The letters show which parts are to be pasted. The dotted lines show where the folds are to be made.

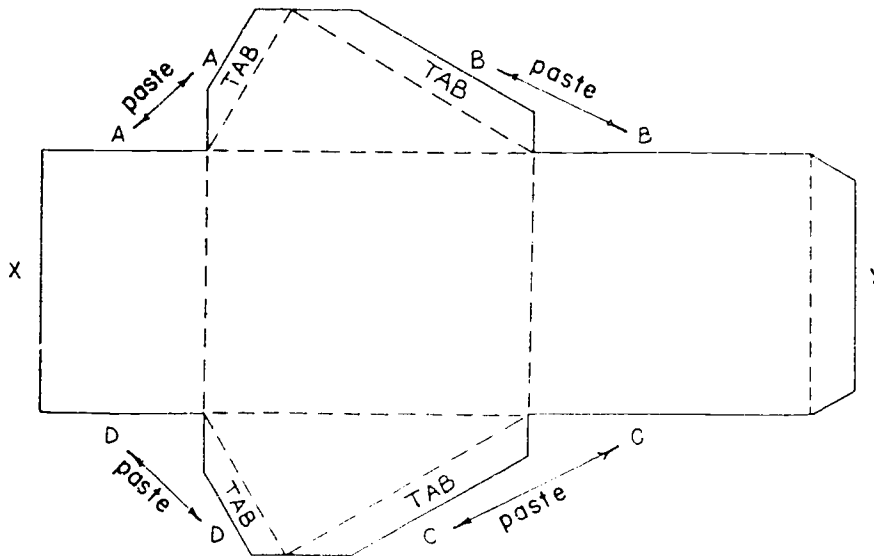

What geometric figure is represented by this model?

14-10

7. Fold and paste a copy of this pattern. What kind of geometric figure is represented by this model?

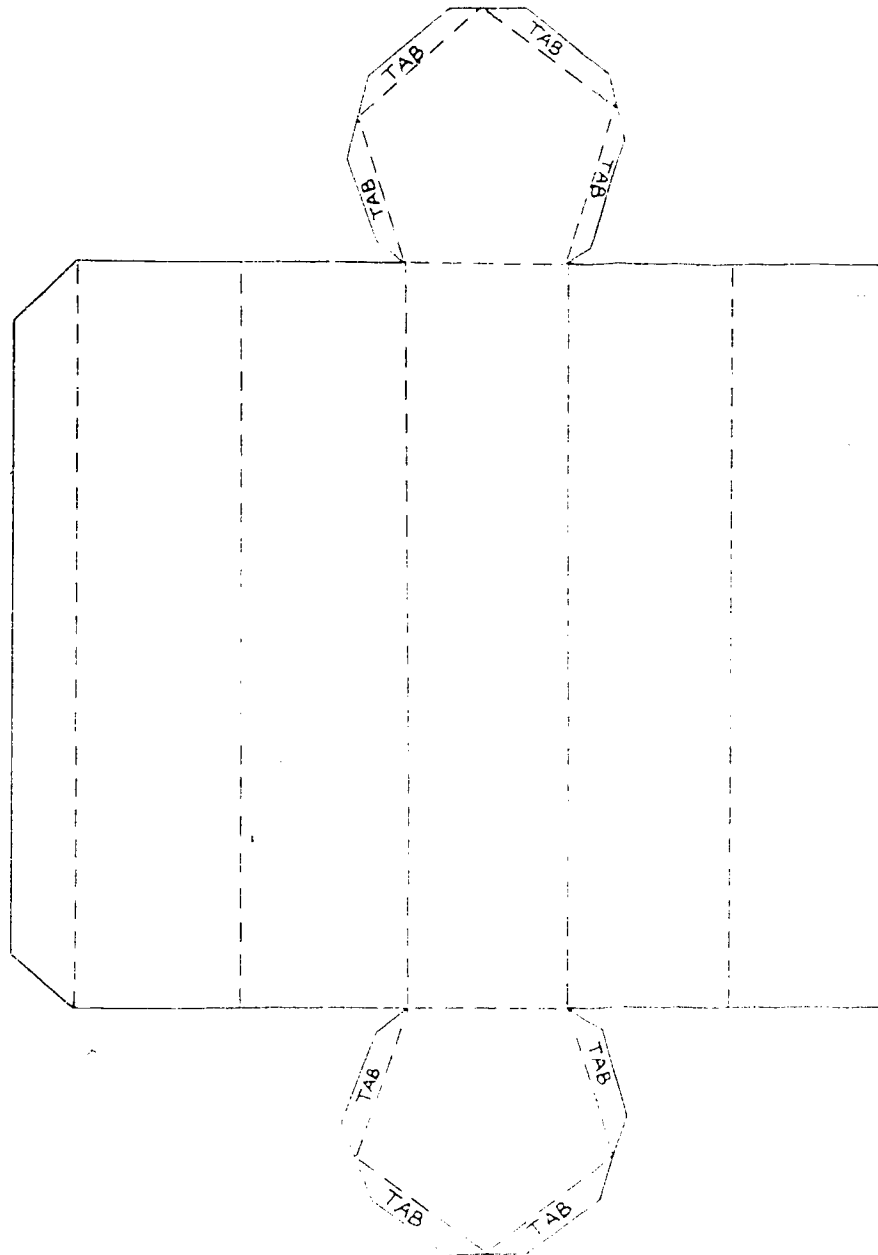

156

100

14-11. Summary.

In this chapter you studied many types of polygons. Polygons are simple closed curves which are the union of segments.

Triangles were classified as equilateral (three equal sides), isosceles (at least two equal sides), or scalene (no equal sides).

You learned of a new way to think up ideas with which to experiment. The plan is to interchange the "if clause" and the "then clause" of a statement to get a new idea or statement called a converse. Sometimes the converse of a statement is true and sometimes it is false.

<u>Statement</u>	<u>Converse</u>
If $\angle a$ and $\angle b$ are vertical angles then $\angle a$ and $\angle b$ have equal measures.	If $\angle a$ and $\angle b$ have equal measures then $\angle a$ and $\angle b$ are vertical angles.

By experimentation you found each of the following statements to be true.

Statement:

If two sides of a triangle have the same length, then the angles opposite these sides have equal measure.

Converse:

If two angles of a triangle have equal measure, then the sides opposite these angles have the same length.

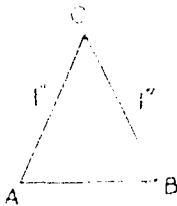

If $m \overline{AC} = m \overline{BC}$
Then $m \angle A = m \angle B$

If $m \angle A = m \angle B$
Then $m \overline{AC} = m \overline{BC}$

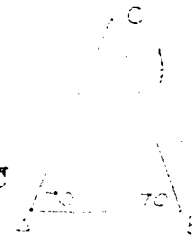

An important property you studied in this chapter was that the sum of the measures of the angles of a triangle is 180.

In your study of polygons, you gave special attention to the parallelogram. Some important facts to remember about a parallelogram are:

1. It is a quadrilateral.
That is, it has four sides.

2. The opposite sides are parallel.

l_1 is parallel to l_4
 l_2 is parallel to l_3

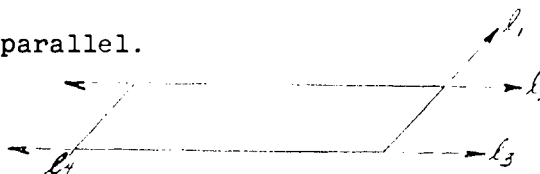

3. The opposite sides of a parallelogram are equal in length.

$$AD = BC$$

$$DC = AB$$

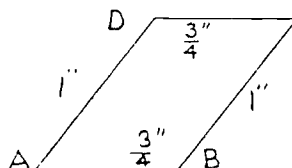

You also learned in this chapter that the shortest segment from a point to a line is the one which is drawn perpendicular to the line and that two parallel lines are always the same distance apart. Then you found that, while your experiments helped you to discover important ideas and test them, a certain plan called a proof is used in making sure that a particular idea is true for all possible cases.

The distance between a point A and a line l is the length of the segment \overline{AB} , where $\overline{AB} \perp l$.

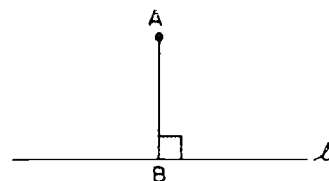

The distance between two parallel lines l and m is the length of the segment \overline{AB} where $\overline{AB} \perp l$, and $\overline{AB} \perp m$.

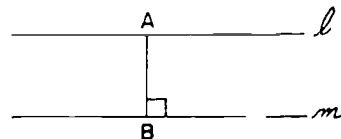

An altitude of a parallelogram is the distance between a pair of parallel lines of the parallelogram. An altitude of a triangle is the distance between a vertex of the triangle and the opposite side.



1. In a triangle three different altitudes may be drawn.
2. In a parallelogram there are many altitudes but only two possible measures for them according to the pair of opposite sides between which they are drawn.
3. Any side of a triangle or parallelogram may be used as the base for an altitude.

You learned how to find the area of a parallelogram and the area of a triangle:

- a. The number of square units of area in a parallelogram is the product of the number of linear units in the base and the number of linear units in the altitude to this base.
- b. The number of square units of area in a triangle is one-half the product of the number of linear units in the base and the number of linear units in the altitude to this base.

Finally, in Section 14-1, you learned that in previous sections were used to study prisms. The following facts to remember about a prism are:

1. Its bases must lie in parallel planes.

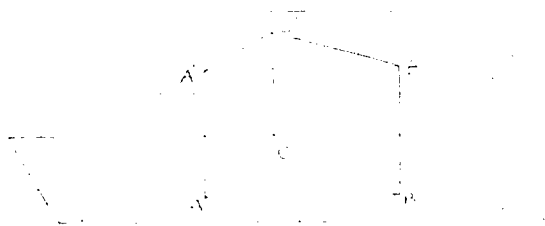

2. Its bases must be exactly alike in size and shape.
3. All faces, except the bases, must be rectangles. The bases in a rectangular prism are also rectangles.

14-12

4. The name of a particular right prism depends on the number of sides of a base.

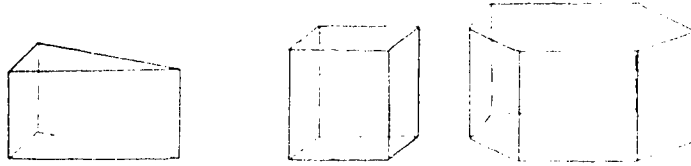

5. The number of cubic units of volume in a prism is the product of the number of square units of area in the base and the number of linear units in the height.

14-12. Chapter Review.

Exercises 14-12

1. Classify each of the following triangles as equilateral, isosceles, or scalene:

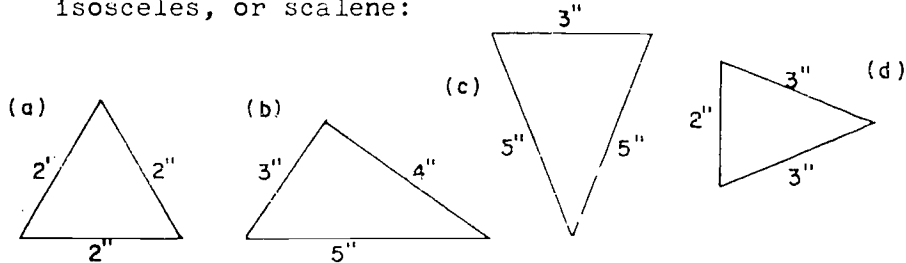

2. Write the converse for each of the following statements and tell whether the converse is true or false.
- If a figure is a triangle, then the figure is a simple closed curve.
 - If $\angle a$ and $\angle b$ are equal in measure, then $\angle a$ and $\angle b$ are corresponding angles.
3. Find the measure of $\angle x$. Do not use your protractor.

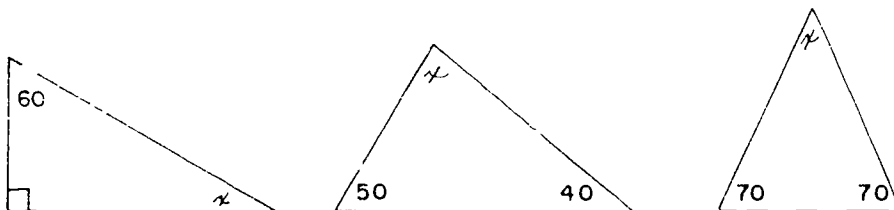

4. In each of the following tell which segment must be measured to find the distance from point A to line l .

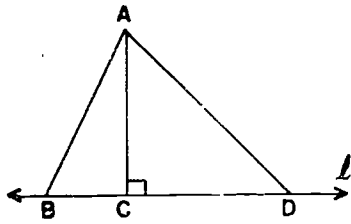

(a)

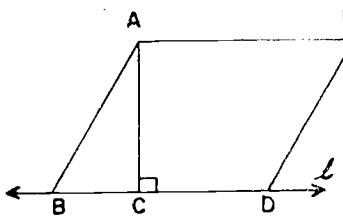

(b)

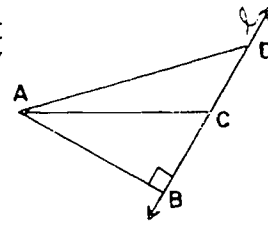

(c)

5. Find the area of each of the following parallelograms:

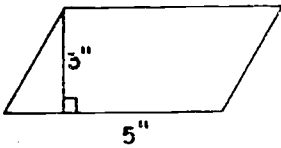

(a)

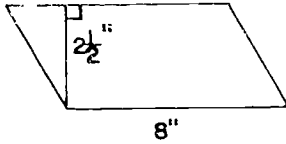

(b)

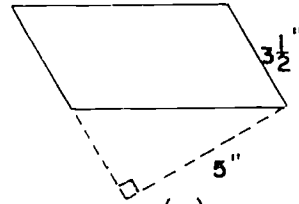

(c)

6. Find the area of each of the following triangles:

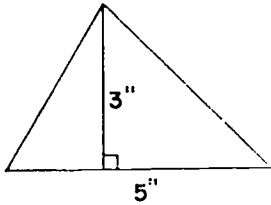

(a)

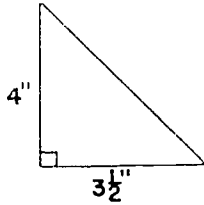

(b)

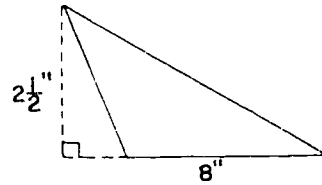

(c)

7. Find the volume of each of the following right prisms:

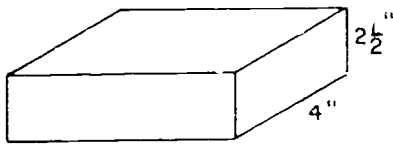

(a)

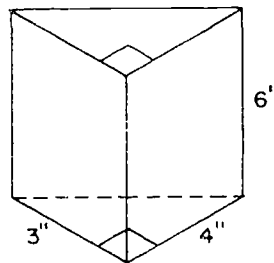

(b)

14-13

8. A container in the shape of a prism is 11 inches high and holds one gallon. How many square inches are there in the base? A gallon contains 231 cu. in. (Do you know the shape of the base?)
- _____

14-13. Cumulative Review.

Exercises 14-13

1. Write the set of factors of 49.
2. Suppose I multiply two numbers together and get an answer of 0. What can you say about the numbers I multiplied?
3. Write DCXL in decimal numerals.
4. Mark true or false:
 - a. The number 23 is a prime number.
 - b. The greatest common factor for any two even numbers is at least 2.
5. Write decimal fractions for each of the following. Place a horizontal bar over repeating digits.
 - a. $\frac{7}{18}$
 - b. $\frac{1}{14}$

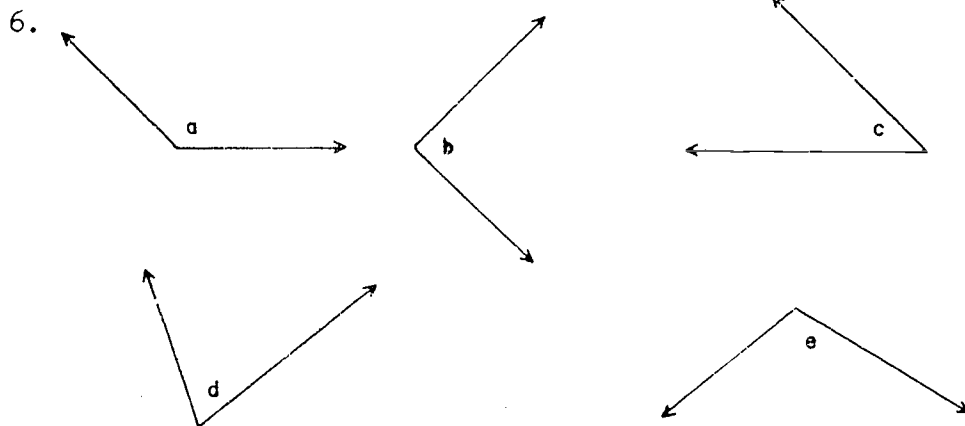

Classify each of the above angles as acute, right, or obtuse. Then find the measure of each with your protractor.

7. In the diagram at the right explain how each of the following acts as a separation:

- a. Plane GFH
- b. Point F
- c. \overleftrightarrow{EF}

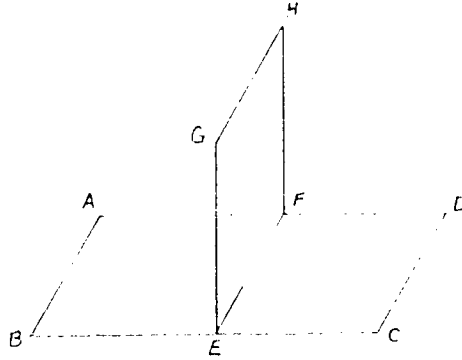

8. By drawing lines through Point R (as shown) show how to set up a one-to-one correspondence between the set of points on \overline{ST} and the set of points on \overline{VW} .

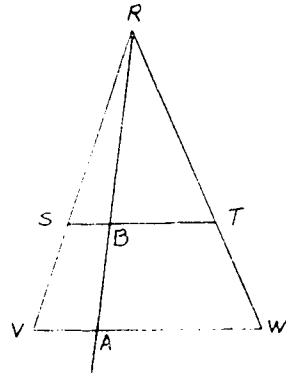

9. Find the number of cubic inches in a box that is 1 foot long, 7 inches wide, and 4 inches high.
10. Complete: The measure of an angle formed by two perpendicular rays is _____.
11. State which of the following ratios are equal:
 - a. $\frac{68}{17}$, $\frac{760}{19}$
 - b. $\frac{12}{13}$, $\frac{8}{9}$
 - c. $\frac{19}{8}$, $\frac{37}{17}$
12. Perform the following divisions:
 - a. $.0081 \div 30$
 - b. $1.4048 \div .08$
13. List the set of numbers which are less than 100 and also multiples of both 3 and 7.
14. According to the budget in the newspaper, the Mills family should not spend more than 27% of its monthly income on housing. The monthly income of the family is \$390. What is the limit they must set on housing cost per month?

14-13

15. A trunk is shaped like a rectangular solid. Find the surface area if the length is $5\frac{1}{4}$ ft., the width is $2\frac{3}{4}$ ft., and the height is $2\frac{2}{3}$ ft.
16. Find the area of the polygon ABCD shown below.

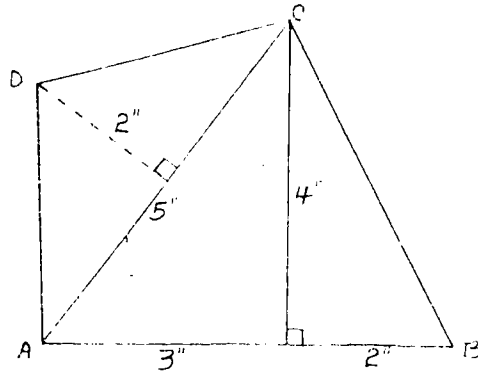

17. How does the area of a triangle ABC compare with the area of a parallelogram ABDE?

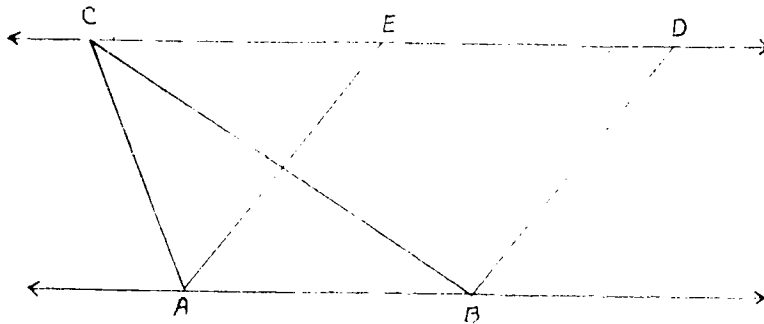

164

171

Chapter 15

CIRCLES

15-1. Circles and the Compass.

You have already studied simple closed curves, such as parallelograms, rectangles, and triangles. You have discovered some properties of these special curves. Another simple closed curve is a circle. Now you will discover some properties of circles. Have paper, pencil, ruler, and compass ready to use as you read this chapter.

Choose a point near the middle of your notebook paper and label it **P**. Now use your ruler to make ten points, each at a distance of 3 inches from **P** and each in a different direction. Do these points suggest any geometric figure? They should suggest a circle. Where are all the points on your paper that are 3 inches from **P**? How many of these points are there? Can you locate them all with your ruler?

There is a better way to draw a circle. Use a compass.

Open the arms of your compass so that the distance between the sharp point and the pencil tip is more than 3 inches. Place the point on one of the inch marks of your ruler and slowly close the pencil arm until the pencil point is 3 inches away.

Place the sharp point of the compass on point **P**.

Hold the compass by the hinged top so that it leans slightly in the direction in which you are going to draw.

Let the compass swing around the sharp point so that the pencil traces a complete circle in a single continuous sweep.

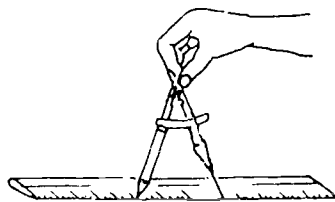

Point P is the center of the circle you have drawn. This circle may be called "circle P ", as in Figure 1. Another way to name the circle is shown in Figure 2, where the circle is called "circle C ". C represents the set of all the points of the circle, not just a single point.

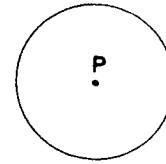

Figure 1

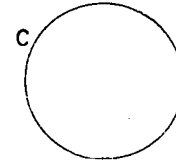

Figure 2

Choose one of the points of the circle. Label it point S . Draw segment \overline{PS} . How long is this segment?

Segment \overline{PS} is called a radius of the circle. A radius is any line segment which joins the center and a point on the circle. Draw another radius.

Call it \overline{PT} . When we talk about more than one radius, we say "radii".

\overline{PS} and \overline{PT} are radii of circle P .

How many radii can a circle have? Do all radii of a circle have the same length?

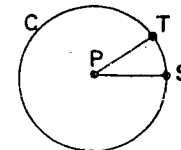
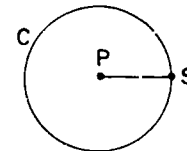

The word "radius" is also used to mean the length of a radius. There is only one length which is "the" radius of a circle, but "a" radius may be any line segment having the center and a point of the circle as its endpoints.

A circle is a set of points. All points of the circle are at the same distance from a certain point called the center. The center does not belong to the set of points that belong to the circle.

Exercises 15-1a

1.
 - a. Draw a circle with center at O and radius $2\frac{1}{2}$ inches.
 - b. Choose a point of the circle. Label it K . Draw radius \overline{OK} .
 - c. How long is \overline{OK} ?
 - d. How long is each radius of circle O ?
 - e. Choose any point on your paper. Label it Q . Draw \overline{OQ} .
 - f. On \overline{OQ} locate a point $2\frac{1}{2}$ inches from O . Label this point T .
 - g. Is T a point on circle O ?
 - h. Is \overline{OT} a radius of circle O ?
2. Draw four circles, each with center at point X but with radii 1 inch, 2 inches, $2\frac{1}{2}$ inches, and $2\frac{3}{4}$ inches.
3. Many designs are made with circles. Three are given here. Copy them and then make up some of your own.

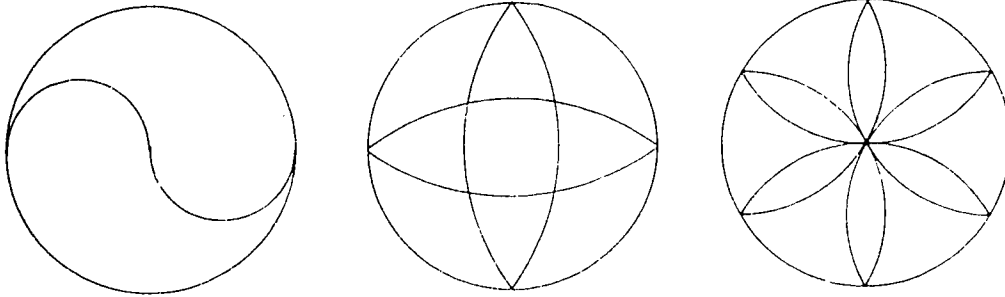

The compass has another use in addition to drawing circles. It is used for measuring and copying distances. Draw a line segment about 3 inches long. Label the endpoints M and N . Now look at segment \overline{AB} drawn at the right.

Open your compass arms until the sharp point and the pencil tip touch the endpoints A and B .

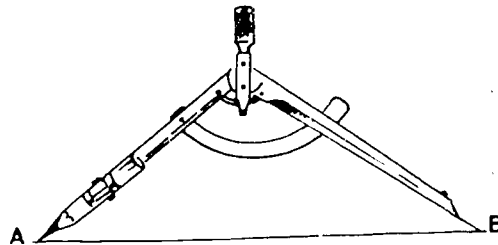

15-1

Without changing the distance between the compass arms, place the sharp point on point M and draw a small part of the circle cutting \overline{MN} . Call the point of intersection point Q .



Since the length of \overline{MQ} is the same as the length of \overline{AB} , we can write $MQ = AB$.

Exercises 15-1b

The problems below will give you practice in using your compass to draw circles and to transfer distances. Read the directions carefully, and label each point, circle or line segment before you go on to the next direction.

- Draw a circle with center X and radius 2 inches. Call it circle G .
 - Choose a point on circle G . Label it Q . Draw a circle with center Q and radius 1 inch.
 - Draw a circle with center X and radius 1 inch.
 - What is the intersection set of the two small circles?
- In this problem you are to copy some distances from the figure below.

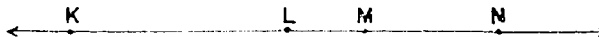

- Draw a horizontal line on your paper, and label a point P on the line near the right arrowhead.
- Use your compass to locate point Q to the left of P on the line, so that $PQ = KL$.
- Locate point R to the left of P on the line, so that $PR = KM$.
- Locate point S to the left of P on the line, so that $PS = KN$.
- With Q as center and QS as radius, draw a circle.
- If your drawing is accurate, there will be two labeled points on the circle. Name the points.

3. a. Draw two intersecting lines which are not perpendicular. Call the lines ℓ and m .
- b. Label the point of intersection of the two lines point E.
- c. Draw a circle, with E as center and radius 1 inch.
- d. What is the intersection set of the circle and line ℓ ? Label these points F and G.
- e. What is the intersection set of the circle and line m ? Label these points H and K.
- f. Draw \overline{HF} , \overline{FK} , \overline{KG} , and \overline{GH} .
- g. What kind of figure does HFKG seem to be?
- *4. Draw a line ℓ and label points X and Y one inch apart on ℓ .
- a. Draw a circle A which has its center at X and passes through Y.
- b. Draw a circle B which has its center at Y and passes through X.
- c. Label Z as the other intersection of circle B and line ℓ .
- d. Draw a circle C which has its center at Z and passes through X.
- e. What is the intersection set of circle A and circle C?
- f. What is the intersection set of circle B and circle C?
-

15-2. Interiors and Intersections.

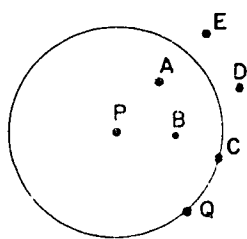

All simple closed curves have an inside and an outside, or an interior and an exterior. To the left is a circle with center at point P and radius one inch. You have three sets of points on your paper.

1. Points whose distance from P is one inch:
They are on the circle. Name two points on this circle.

2. Points whose distance from P is less than one inch.
They are in the interior of the circle. Name two points in the interior of this circle.
3. Points whose distance from P is greater than one inch.
They are in the exterior of the circle. Name two points in the exterior of this circle.

Exercises 15-2a

(Class Discussion)

Complete each sentence by choosing the best response.

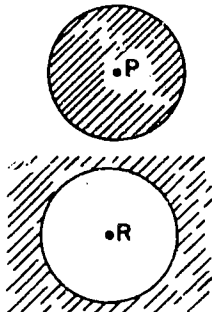

1. The set of points of the shaded region belong to _____.
(circle P, interior of circle P, exterior of circle P.)
2. The set of points of the shaded region belong to _____.
(circle R, interior of circle R, exterior of circle R.)
3. The center of a circle belongs to the set of points called _____. (the circle, the interior of the circle, the exterior of the circle.)
4. A point is in the interior of a circle if its distance from the center is _____ the radius. (less than, equal to, greater than.)
5. A point is on the circle if its distance from the center is _____ the radius. (less than, equal to, greater than.)
6. A point is in the exterior of a circle if its distance from the center is _____ the radius. (less than, equal to, greater than.)

You have worked with the ideas of intersection and union of two sets. A circle is an example of a set of points, so we may ask questions about intersections and unions of circles.

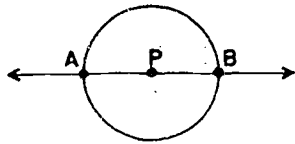

What is the intersection of line \overleftrightarrow{AB} and circle P? Remember that the intersection of two sets of points is the set of all points common to the two given sets.

Points A and B are the only points common to the line and the circle. We say $\overleftrightarrow{AB} \cap (\text{circle } P) = \{A, B\}$.

The union of two sets is the set of all points which belong to either of the two given sets. The union of \overleftrightarrow{AB} and circle P is every point of the circle and the line and there is no easier way to name all these points except to say $\overleftrightarrow{AB} \cup (\text{circle } P)$.

Exercises 15-2b

(Class Discussion)

1.

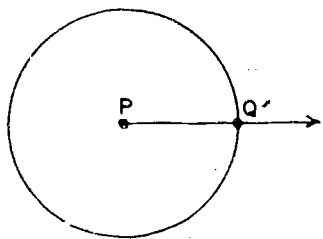

Draw a circle with center at P. Choose a point of the circle. Label it Q. Draw ray \overrightarrow{PQ} .

- Are any points of the circle also on the ray \overrightarrow{PQ} ?
- What is $\overrightarrow{PQ} \cap (\text{circle } P)$?

2.

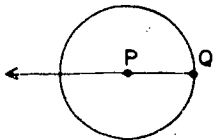

Draw a circle with center at P. Choose a point on the circle. Label it Q. Draw ray \overrightarrow{QP} . How many points belong to the intersection of circle P and ray \overrightarrow{QP} ?

- Draw a circle with center at P. Let S be any other point in the same plane. (Draw the picture. Is it the same as the pictures drawn by your classmates?)
 - How many points belong to the intersection of the circle P and the ray \overrightarrow{PS} ?
 - How many points belong to the set $(\text{circle } P) \cap \overleftrightarrow{PS}$?
 - Do your answers to parts (a) and (b) depend upon where you located the point S?
 - How many points belong to the set $(\text{circle } P) \cap \overleftrightarrow{PS}$? Does your answer depend on the location of S? Explain.

4. Draw a circle with center at K .
 Shade the interior of circle K ,
 with vertical line segments.
 Shade the exterior of circle K
 with horizontal line segments.

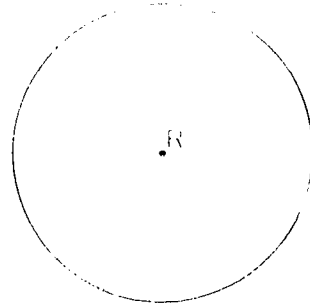

- a. Are there any points common to
 the interior and exterior of
 circle K ?
- b. What is the intersection of the interior of circle K
 and the exterior of circle K ?
- c. Are there any points on the circle which are also in the
 interior?
- d. What is the intersection of circle K and its interior?
- e. What is the union of circle K and its interior?

5. Choose two points about one inch apart on your paper.
 Label them P and Q .

- a. Draw two circles with center at P so that one is in
 the exterior of one circle and in the interior of the
 other.
- b. Label the smaller circle A and the larger circle B .
- c. Shade the interior of circle A with horizontal line
 segments.
- d. Shade the exterior of circle B with vertical line
 segments.
- e. How do you find the union of the interior of circle A and
 the exterior of circle B on your paper?

Example 2

Circle A and circle B

In the figure at the right, the
 lines are perpendicular, and their point
 of intersection is P , the center of the
 circles. The diameters AB and CD
 are on the circles. Draw circle A
 on your paper. Then draw circle B so
 that P is the center of circle B . Draw
 the diameter AB of circle B so that P
 is the midpoint of AB .



G

15-2

1. In your drawing, shade the half-plane with center O and whose boundary is the line \overleftrightarrow{AB} . Call this half-plane H .
2. a. What is the intersection of the half-plane H and the circle?
b. Does A belong to this intersection? Does B ? Does P ?
c. How many points belong to this intersection?
3. a. Choose two points of the intersection which will belong to the interior of the angle $\angle APB$. Label these points M and N .
b. Choose a point K which lies on the straight line that is the interior of the angle $\angle APB$.
c. Draw the angle $\angle MKN$. What is the intersection of the circle and the angle $\angle MKN$?
d. What is the intersection of the interior of the circle and the interior of the angle $\angle MKN$?
- *4. Shade the part of \overleftrightarrow{BG} which contains A . Call this half-plane J .
 - a. What is the set $H \cap J$?
 - b. What is the intersection of the interior of the angle $\angle APB$ and H and the circle?
 - c. Draw the interior of the angle $\angle APB$ and the interior of the angle $\angle MKN$ and shade the intersection of the interior of the angle $\angle APB$ and the interior of the angle $\angle MKN$.
 - d. Draw the interior of the angle $\angle APB$ and the interior of the angle $\angle MKN$ and shade the intersection of the interior of the angle $\angle APB$ and the interior of the angle $\angle MKN$ and the interior of the circle.

4. Draw a line segment \overline{AB} . Locate a point P on \overline{AB} .
 With A as center and \overline{AP} as radius draw circle a .
 With B as center and \overline{BP} as radius, draw circle b .
 What is the intersection of the two circles?
5. Locate two different points P and Q . Draw the circle with center at P and with segment \overline{PQ} as a radius. Then draw the circle with center at Q and with P on the circle.
 - a. What is the intersection of these two circles? Label other points if necessary.
 - b. Draw a line which passes through every point of the intersection of the two circles. Can you draw more than one such line. Why?
 - c. In your picture shade the intersection of the interiors of the two circles.
 - d. Shade the intersection of the interiors of the circle with center P and the exterior of the circle with center Q . Use a different type of shading from that in (c) above.
 - e. Make another model of the two circles. Call the interior of the first circle A and the exterior of the second circle B .

6. In the figure at the right, the two circles are tangent at point T . The line AB is a secant line and CD is a tangent line. AC and BD are drawn. AC and BD are drawn. AC and BD are drawn.

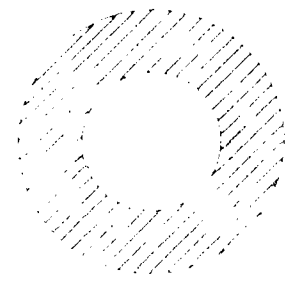

7. In the figure at the right, the two circles are tangent at point T . The line AB is a secant line and CD is a tangent line. AC and BD are drawn. AC and BD are drawn. AC and BD are drawn.

15-3. Diameters.

A diameter of a circle is a line segment which contains the center of the circle and whose endpoints lie on the circle. In the figure, three diameters are shown; \overline{AB} , \overline{MN} , and \overline{VW} . How many diameters can a circle have?

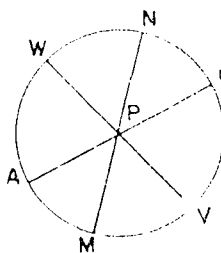

The diameter of a circle is closely associated with the radius of a circle. A radius is a line segment with one endpoint on the circle and the other endpoint at the center. How many radii are shown in the figure?

We use the word diameter in two ways just as we use the word radius. Sometimes we say "diameter" to mean a particular segment and sometimes we say "diameter" to mean the length of a segment. For example, consider the circle above. We say \overline{AB} is a diameter of the circle. We also say the diameter of the circle is 2 inches. We can usually tell from the problem which meaning to give to the words "radius" and "diameter."

A diameter is a set of points. It may be described in another way. A diameter of a circle is the union of two different radii which are segments of the same line. In the figure above, the diameter \overline{AB} is the union of the two radii \overline{AP} and \overline{PB} . Describe the diameter \overline{MN} as the union of two radii. How does the length of a diameter compare with the length of a radius in the same circle?

If we divide any unit of length and if we set r to be the measure of the radius and d the measure of the diameter (of the same circle), then we have the important relationship:

$$d = 2r \quad \text{or} \quad r = \frac{1}{2}d$$

EXERCISES

1. In a circle, if the radius is 3 inches, what is the diameter of the circle?
2. In a circle, if the diameter is 10 inches, what is the radius of the circle?

3. Use the relationship above and give the missing information in each case:
- If $r = 3$, then $d = \underline{\quad ? \quad}$.
 - If $d = 10$, then $r = \underline{\quad ? \quad}$.
 - If $r = 4\frac{1}{2}$, then $d = \underline{\quad ? \quad}$.
 - If $d = 3$, then $r = \underline{\quad ? \quad}$.
4. Draw a circle. Locate a point on the circle. Call the point R.
- How many radii of the circle contain the given point R?
 - How many diameters of the circle contain the given point R?
5. The diameter of a circle is 18 inches. How many inches from the center of the circle is a point on the circle?
6. Draw a circle C with center at the point P. Draw three diameters of C. Draw a circle with center at P whose radius is equal to the diameter of C.
7. (Use your compass very carefully in this problem.)
- Mark a point O, near the middle of your paper.
 - Draw a circle with center at O and radius about 2 inches. Do not change the opening of your compass until the end of the problem.
 - Mark a point U on the circle.
 - With the compass, draw a point V on the circle such that \overline{OU} and \overline{OV} are congruent.
 - With the compass, draw a third point W on the circle such that \overline{OU} and \overline{OW} have the same length.
 - Without opening the compass, locate a point X, Y, Z on the circle such that the length of each segment \overline{OX} , \overline{OY} , \overline{OZ} is the same as the length of \overline{OU} .
 - Draw the length of \overline{OU} with the pencil on the circle.
 - Draw the segments \overline{OU} , \overline{OV} , \overline{OW} , \overline{OX} , \overline{OY} , \overline{OZ} . They are radii of the circle. Call them the radii of the circle.
 - Draw the segments \overline{UV} , \overline{UW} , \overline{VW} , \overline{UX} , \overline{UY} , \overline{UZ} , \overline{VX} , \overline{VY} , \overline{VZ} , \overline{WX} , \overline{WY} , \overline{WZ} , \overline{XZ} , \overline{YZ} , \overline{XY} .

15-4. Tangents.

The line and the circle in the figure remind us of a train wheel resting on a track. How many points on the circle are also on the line? There is only one point. Name it. We say that the line is tangent to the circle, if their intersection is a single point. This intersection is called the point of tangency.

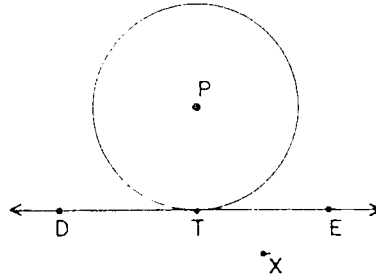

Exercises 15-1

1. Draw a circle and line in the same plane so that their intersection is:
 - a. the empty set.
 - b. one point.
 - c. two points.
 - d. four points.
2. In which part of Problem 1 are the circle and the line tangent?

3. In the figure to the right:
 - a. How many lines are shown?
 - b. How many lines are not tangent to the circle?
 - c. Name each tangent and its point of tangency.

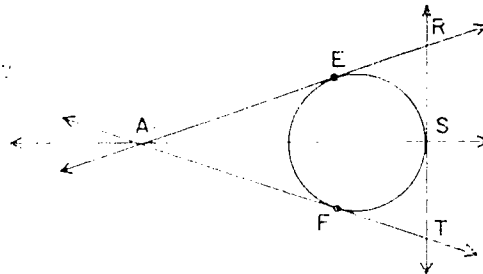

4. How many tangents do you find in each of the following?
 - a.
 - b.
 - c.

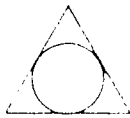

5. In the figure, Q is the center of the circle and the center of the square PQRS.
 - a. What is the intersection of the circle and the square?
 - b. What is the intersection of line \overleftrightarrow{HT} and the circle?

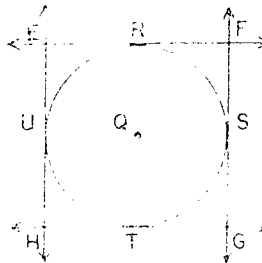



- c. Name all the lines which are tangent to the circle.
 d. Name all the points of tangency.
6. On your paper make a sketch of the figure in Problem 5. (A careful drawing is not needed.) Draw the quadrilateral RSTU.
 a. How many sides of RSTU are segments of lines tangent to the circle?
 b. What is the intersection of the interior of the circle and the exterior of the square EFGH?
 c. What is the intersection of the exterior of the circle and the interior of the square EFGH?
 d. What is the intersection of the interior of the circle and the exterior of RSTU? Shade this portion of your figure.
7. Below are several circles and tangent lines. The centers and points of tangency are marked.

a.

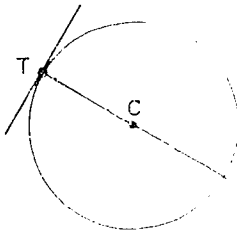

b.

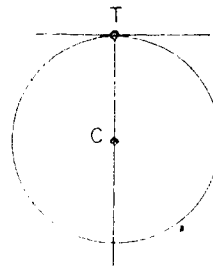

c.

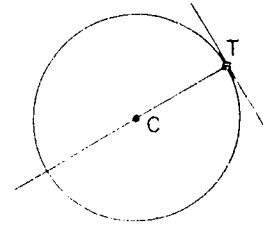

The line joining the center of each circle and the point of tangency is drawn. Use your protractor and measure in each case one of the angles formed by these lines. What relationship do you suspect always exists between the tangent line and the line containing the point of tangency and the center of the circle?

8. All radii of a circle have the same length. How do you know that all diameters of a circle have the same length?

15-5. Arcs.

You learned that a single point on a line separates the line into two half-lines. This idea of separation led you to see that on a line a single point determines two half-lines.

In the figure, does the single point Q separate circle P into two parts? How many points do you need to separate a circle into two parts?

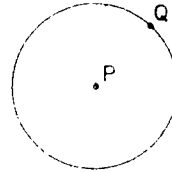

The points M and N separate the circle into two parts. One part contains point A and the other contains point E. It takes two distinct points to separate a circle into two different parts.

Each part of a circle together with its endpoints is called an arc. We use the symbol " \frown " to represent the word "arc." We use the endpoints and another point on the arc to name it. \widehat{MAN} is the arc with endpoints M and N which contains point A.

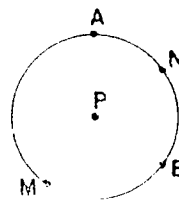

- Which points belong to \widehat{MEN} ?
- Can we use \widehat{MEN} in place of \widehat{SEM} ?
- What other symbol represents the same points as \widehat{MAN} ?
- What are the endpoints of \widehat{AMB} ?

Exercises

1. In the drawing of circle P, points A, B, C, and D are on the circle. Name the arcs:
 - a. with endpoints A and B which contains point C.
 - b. with endpoints A and B which contains point D.
 - c. which contains point A but not point B.
 - d. which contains point A but not point C.



15-0

2. Using the drawing at the right name a point or points which are on each of the following arcs. State which are endpoints.

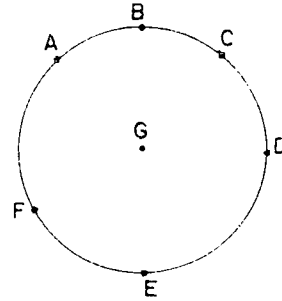

- a. \widehat{ABC} d. \widehat{FCE}
 b. \widehat{ACE} e. \widehat{FE}
 c. \widehat{ADE}

3. In the drawing to the right, the pair of points A and B separate the points X and Y. Which of the marked points, if any, do the pairs of points below separate?

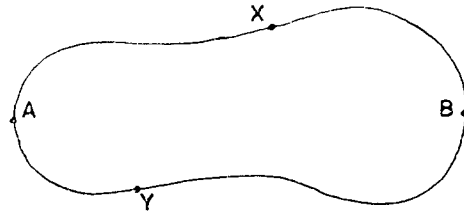

- a. A, Y e. B, X
 b. X, Y d. B, Y

4. Draw a circle. Draw a diameter of the circle and label its endpoints A and B.

- a. Into how many parts do points A and B separate the circle?
 b. Describe these areas in relation to the circle.
 c. Label a point P on one of these areas.
 d. Does P separate \widehat{APB} into two areas?
 e. Does P separate the circle into two areas?
 f. What is the intersection of \widehat{APB} and \widehat{AB} ?

15-0. Central Angles.

Whenever the endpoints of an arc are also endpoints of a diameter, the two arcs are called semicircles.

Draw a circle, label the center K. Choose any two points on the circle that are not endpoints of a diameter. Label these points P and Q. Draw the rays \vec{KP} and \vec{KQ} . Notice $\angle PKQ$. The vertex of the angle is the intersection of the rays \vec{KP} and \vec{KQ} . Since the vertex of this angle is at the center of the circle, $\angle PKQ$ is called a central angle.

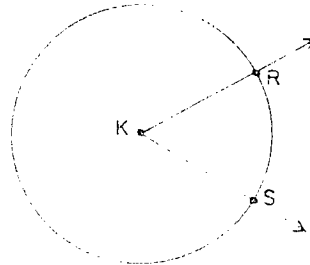

Exercise 15-4

1. In the drawing the center of the circle is point P.
 - a. Name two segments which are radii.
 - b. Name two segments which are diameters.
 - c. Name four arcs which are semicircles.
 - d. Name four angles which are central angles.

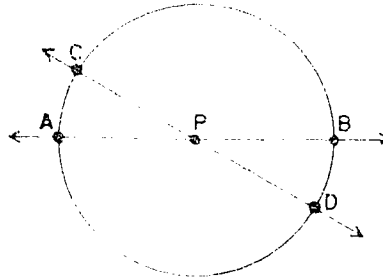

2. Look at the drawing of \widehat{ABP} and determine the following:

- | | |
|---------------------------------------|--|
| a. $\widehat{ABP} \cap \widehat{CDF}$ | e. $\widehat{ABC} \cup \widehat{CDE}$ |
| b. $\widehat{ACF} \cap \widehat{BDE}$ | f. $\widehat{APC} \cup \widehat{CPD}$ |
| c. $\widehat{ABC} \cap \widehat{DEF}$ | g. $\widehat{BDF} \cap \widehat{CDE}$ |
| d. $\widehat{ABC} \cap \widehat{CDE}$ | *h. $\widehat{ABC} \cup \widehat{DEF}$ |

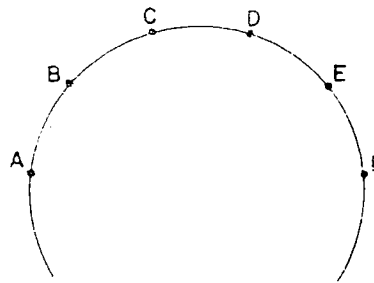

3. Draw a circle with radius one inch. Call its center T. Choose a point X on the circle. Use your compass and locate a point Y so that the length of \overline{XY} is the same as the radius. Draw $\triangle XYT$.

- a. How long is each side of $\triangle XYT$?
- b. What kind of triangle is $\triangle XYT$?
- c. Which angle of $\triangle XYT$ is a central angle?
- d. What is the measure of this central angle?
- e. Label a point W which is a point on the arc in the interior of this central angle.
- f. Which is longer, \overline{XY} or \widehat{XYW} ?

15-11. Length of a Circle.

When you studied polygons you learned that the perimeter of a triangle, and that of any polygon, could be found by adding the lengths of all the sides. You can find the length of a circle by measuring the length of the circumference. The circumference is made up of line segments. In order to find the length of a circle, measuring the total length of these segments is necessary.

The length of a circle is much harder to measure. It is the distance an ant would travel if he started at a point on the circle and crawled on the circle in the same direction until he returned to his starting point. The length of a circle is called its circumference.

One way of measuring the length of a circle is to take a tape measure or steel tape and bend it into the shape of your circle.

Another way is to mark a point A on your circle and place A at the zero point of your ruler. Let the circle roll along the ruler until point A again touches the ruler. The distance between these two marks on the ruler is the same as the circumference of the circle.

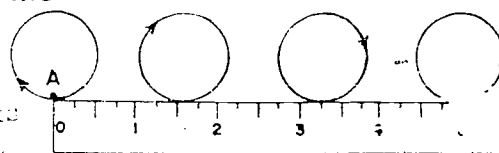

Neither of these methods is as easy as measuring a line segment. Fortunately, there is a line segment connected with the circle whose length is related to the circumference in a very simple way. It is the diameter. You will try two experiments to see if you can discover this relationship for yourself.

Experiment 1

Do this very carefully at home and bring your results to class.

1. Choose three circular objects of different size in your home. Use a tape measure to find the length of each circle. (If you do not have a tape measure, use a piece of string and then measure the string.)
2. Measure the diameter of the same three circular objects. It may be hard to find the center of your circle, so measure the diameter several times to get a fair measure.

- c. Make a table like the one below and write the results of your experiment in the table.

Name of object	c circumference	d diameter	c - d	$\frac{c}{d}$
1. water glass				
2.				
3.				

- d. One way to compare two numbers is to find their difference. Find the difference between the circumference and the diameter of each of your circular objects. Write the results in the column headed "c - d."
- e. Another way to compare two numbers is to find their ratio. Find the ratio of the circumference to the diameter. Express this ratio as a decimal rounded to the nearest tenth. Write your results in the column headed " $\frac{c}{d}$."
- f. Compare column "c - d" with your classmates. Do the differences appear to be the same?
- g. Compare column " $\frac{c}{d}$ " with your classmates. Do the ratios appear to be the same? This suggests that the circumference of each circle is about how many times as long as its diameter?

Experiment 2

Do part (a) at home. The rest is a class exercise.

- On stiff paper or cardboard draw a circle with a diameter between $\frac{1}{2}$ and $1\frac{1}{2}$ inches. Put a pin in the circle.
- Draw a line about 10 inches long. Label a point A near the left end of the line. Now locate point B to the right on the line so that \overline{AB} is a diameter of the circle of your circle.
- Make a number line on the line \overline{AB} with A at 0 and B at 1. Continue the line to the right of B.

d. Mark a point C on your circle. Place the circle on the line so that it is tangent to your number line with C as the point of tangency.

e. Carefully roll the circle to the right along the line. Each point of the circle will touch a point of the line. Continue until C again touches the line. Label this point on the line D.

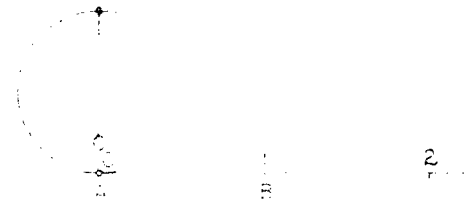

f. Point D is between what consecutive whole numbers? What decimal (nearest tenth) is your thinking corresponding to the distance CD? Did your classmate verify the same result?

g. What segment of the line did the circle travel along during one rotation of the circle?

h. How does the length of the segment of the line compare with the diameter of the circle?

The result of these two experiments is stated in the following statement.

1. For any circle, the ratio of the length of the line segment of the line that the circle travels along during one rotation to the diameter of the circle is a little more than 3.
2. This number is called pi and is denoted by the Greek letter π .
3. If the diameter of a circle is d units, then the length of the line segment that the circle travels along during one rotation is πd units.

If we use generalized terms, we can state the above result. A special way to refer to the number π is the ratio of the length of the line segment that the circle travels along during one rotation to the diameter of the circle. The number π is written as π . It is a number that is not a simple fraction or decimal.

Another way to refer to the number π is the ratio of the

circumference of a circle to its diameter. The number π is written as π . It is a number that is not a simple fraction or decimal.

The diameter of a circle is related to its radius. If the circumference of a circle is also related to the radius. You know

$$C = 2\pi r \quad \text{and} \quad d = 2r$$

then by substitution

$$c = \pi \cdot (2 \cdot r)$$

then $c = (\pi \cdot 2) \cdot r$ by the associative property

then $c = (2 \cdot \pi) \cdot r$ by the commutative property

or $c = 2\pi r$ by the associative property

The Number π

The number represented by the symbol " π " is a new kind of number. It is not a whole number. It is not a rational number. It can be written as a decimal which never ends and never repeats. Computers have found $\pi \approx 3.1415926535897932384626433832795$. We round to a decimal to get an approximate value for π .

Exercises 1-7

(Class Discussion)

1. Find a decimal representation of $\frac{2}{3}$. Carry the division to the nearest thousandth.
2. Find the decimal representation of $\frac{1}{4}$ to the nearest thousandth.
3. Compare the results of Problems 1 and 2. Are they the same?
4. Round the decimal representation of $\frac{2}{3}$ to the nearest hundredth.
5. Round $\frac{1}{4}$ to the nearest hundredth.
6. Compare the results of Problems 4 and 5. Are they the same?
7. It is the same as $\frac{1}{4}$.

For example in the numerator we could convert $\frac{1}{4}$ to a decimal. The result is 0.25. $\frac{1}{4} = 0.25$.

15-7

8. What is the circumference (approximately) of a circular table whose diameter is 7 feet?
9. About how much fencing is needed to enclose a circular flower garden if the radius is 15 feet?
10. A wheel moves a distance of 12 feet along a track when the wheel turns once. What is the approximate diameter of the wheel?
11. Use the relationship $c = \pi d$. Copy and complete the following statements about c , π , and d .
- a. $\pi = \frac{?}{?}$ b. $? = \pi \cdot ?$ c. $\frac{?}{\pi} = ?$
- *12. Use the relationship $c = 2\pi r$. Copy and complete the following statements about c , π , and r .
- a. $\frac{c}{r} = ?$ b. $r = \frac{?}{?}$ c. $\frac{c}{2r} = ?$

Exercises 15-7b

1. Find the missing information about the circles described in the table. (Use $\pi \approx 3.14$.)

	Circle	Radius	Diameter	Circumference
a.	A		10 in.	
b.	B	4.2		
c.	C			25 ft.
d.	D		12.5 in.	

2. Using $\pi \approx \frac{22}{7}$, find the following.
- a. The length of a circle whose diameter is 14 inches.
- b. The length of a circle with radius 21 feet.
- c. The diameter of a circle with circumference 132 inches.
- d. The radius of a circle with circumference 44 feet.
- e. The circumference of a circle with radius $10\frac{1}{2}$ inches.
3. The diameter of a circular tablecloth is 35 inches. What is the circumference of the tablecloth?
4. A circular lampshade 12 inches in diameter needs new binding around the bottom. How long a strip of binding is needed?

5. The circular track at Central High School has a radius of 110 feet. What is its approximate circumference?
6. A strip of metal 62 inches long is to be made into a circular hoop. What will its diameter be?
7. A merry-go-round in a playground has a 15 foot radius. If you sit on the edge, about how far do you ride in one complete turn?
8. A circle with a diameter of 20 inches is separated by points into 8 arcs of equal length.
 - a. What is the length of the whole circle?
 - b. What is the length of each arc?

9. In the figure, A and B are the endpoints of the diameter of circle G. If the diameter of circle G is 8 inches, then what is the length of each semicircle?

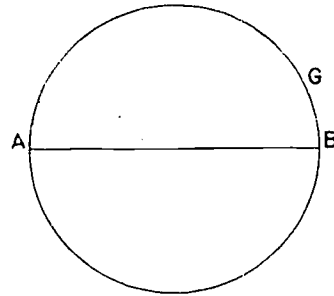

10. In the figure, circle C and circle D have the same center P. The radius of circle C is 7 inches and the radius of circle D is 5 inches.

- a. Find the length of each circle.
- b. \widehat{QYR} is one-fifth of circle C and arc \widehat{SXT} is one-fifth of circle D. Find the length of \widehat{QYR} and \widehat{SXT} .

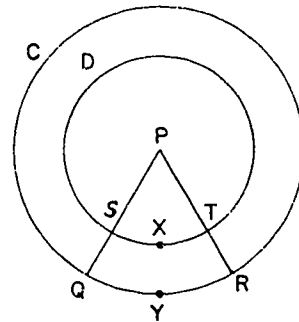

15-8. Area of a Circle.

Do you have a circular frying pan in your kitchen? Perhaps it is a "nine-inch skillet." The boundary of the frying surface represents a circle. The "nine-inch" tells the diameter of the circle. Have you seen electric frying pans that are square shaped? You may have both kinds of pans in your home. When you look at these two pans, you may ask which is bigger. In

this case bigger means more frying surface. To answer the question you must compare the area enclosed by the circle with the area enclosed by the square. (For convenience you may shorten the "area of the region enclosed by the circle" to the "area of the circle.")

The area of a square is related to the measure of a side. If the square has 8-inch sides, what is its area? If the side of a square has measure s , what is its area? We can write this as s^2 where s^2 means $s \times s$.

Do you think that the area of a circle is related to the circumference or radius of a circle? It is. You can discover the relationship yourself.

Exercises 15-8a
(Class Discussion)

1. a. If P is the center of the circle, what is \overline{AB} ?
- b. The endpoints of diameter \overline{AB} divide the circle into two semicircles. How does \overline{AB} divide the area of the circle?

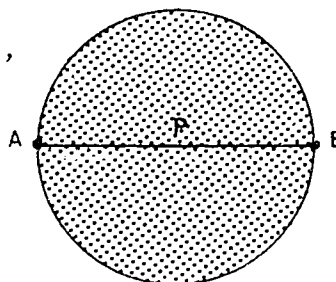

2. Each semicircle is now divided into arcs of equal length by rays of central angles which have the same measure. (You can do this with a protractor.)

- a. Into how many arcs is each semicircle divided?
- *b. What is the measure of each central angle?
- c. How is \overline{PO} or \overline{PB} related to the circle?
- d. If the radius of the circle is r , how long is \widehat{AOB} ?

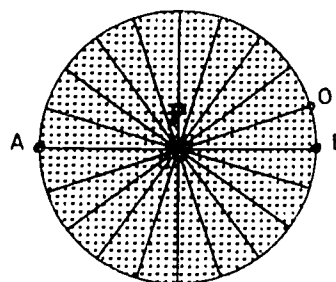

3. Each semicircular region is now cut into pie-shaped pieces. These are arranged so that they look like saw-teeth.

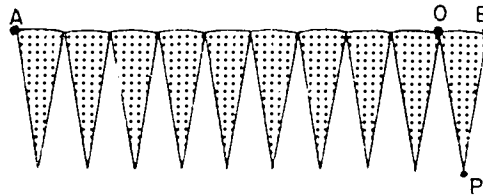

4. With both semicircular regions cut in a tooth fashion, the pieces are fitted together.

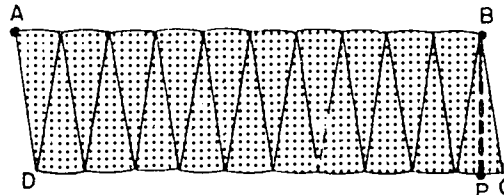

- a. Is the shaded area the same as the area of the circle?
- b. The boundary along the top and bottom of this region is scalloped. If the scalloped curves were straight, the shaded area would be like the interior of what simple closed curve?
- c. How long is the scalloped curve from A to B?
- d. How long is \overline{BP} ?
5. a. How do you find the area of a parallelogram?
- b. If ABCD is a parallelogram and $AB = \pi r$ and $BP = r$, what is its area?

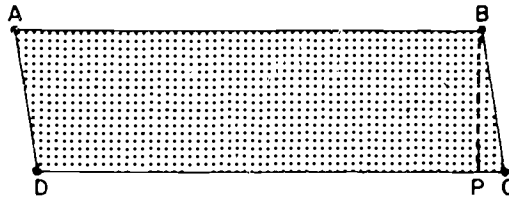

6. If ABCD in Problem 4 is a parallelogram, and the radius of the circle r , complete the following:
- a. Its base AB is _____.
- b. Its altitude BP is _____.
- c. Its area is _____ times _____.
- d. Its area is _____.
7. How do you think the area of a circle is related to its radius?

The exercises above suggest that the area A of a circle is related to the radius of the circle and the number π . This statement can be written in symbols as

$$A = \pi r^2.$$

It can be proved that this is the correct relationship.

Now you can answer the problem about the frying pans. The nine-inch frying pan has a diameter of 9 inches. Its radius is $\frac{9}{2}$ inches. The number of square inches in its area is $\pi\left(\frac{9}{2}\right)^2$. This is the same as $\frac{81}{4}\pi$ square inches, which is nearly 63.6 square inches. The area of the interior of the nine-inch circular skillet is nearly 63.6 square inches.

Remember that the area of the interior of the square frying pan was 64 square inches. Is there enough difference between the two pans to make a problem for the cook?

Exercise 15-8

1. A circular wading pool has a radius of 7 feet. What is its approximate area?
2. What is the area of a circle that is 12 feet in diameter?
3. Find the missing information about the circles described in the table. (Use $\pi \approx 3.14$.)

Circle	Radius	Diameter	Circumference	Area
A	20			
B		8		
C			0.093	
D	12			

4. Which has the greater frying surface--an eight-inch circular skillet or a seven-inch square frying pan?
5. A circular drum-head is twelve inches in diameter. What is the area of the drum-head?
6.
 - a. Find the area of a circle that has a radius of 3 inches.
 - b. Find the area of a circle that has a radius of 6 inches.
 - c. Complete the statement: The area of a circle that has a radius of 6 inches is about _____ times as large as the area of a circle that has a radius of 3 inches.
 - d. How does the area of a circle change if the radius of the circle is doubled?
 - e. How does the area of a circle change if the diameter of the circle is doubled?

7. What is the approximate floor area of a circular tent that has a 14 foot diameter?
8. What is the approximate area of a circular mirror whose diameter is $3\frac{1}{2}$ feet?
9. What is the area of the region enclosed by a semicircle and the diameter of a circle if the diameter is 56 inches?
10. a. What is the approximate area of the largest circle that can be drawn within a 14 foot square?
 b. The area of the circle is about $\frac{?}{\pi}$ of the area of the square?

- *11. A rectangular plot of land, 40 feet by 30 feet, is mostly lawn. The circular flowerbed has a radius of 7 feet. What is the area of the portion of plot that is planted in grass?

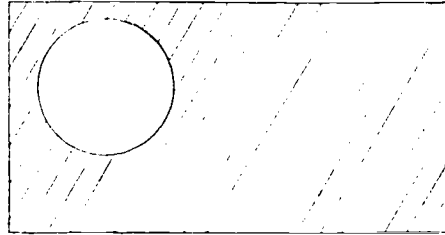

- *12. The figure represents a simple closed curve composed of an arc of a circle and a diameter of the circle. The area of the region enclosed by this simple closed curve, measured in square inches, is 8π . Do not use an approximation for π in this problem. Keep the symbol π .
- a. What is the area of the entire circle?
 b. How long is a radius of the circle?
 c. How long is the straight portion of the closed curve represented in the figure?
 d. What is the circumference of the (entire) circle?
 e. How long is the arc represented in the figure?
 f. What is the total length of the simple closed curve?



- *13. The center of the longer circle lies on the shorter circle. The intersection of the two circles is a single point. This point and the centers of the two circles lie on one line. If the interior of the shorter circle is chosen as a unit of measure, what is the measure of the region inside the longer circle and outside the shorter circle?

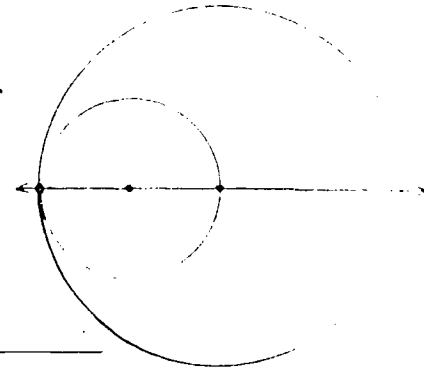

15-9. Volume of a Cylindrical Solid.

You have studied prisms, and the solids made up of the prisms and their interiors. You learned about their volume and surface area.

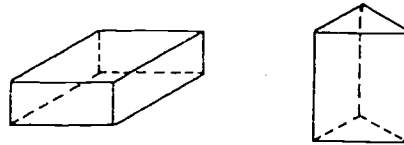

Now you will learn about another set of points called a cylinder, and about a cylindrical solid made up of a cylinder and its interior. Instead of having a rectangular region as a base, like a box, cylinders have circular regions as bases. Tin cans, pipes, tanks, silos, and some drinking glasses, are examples of cylindrical shapes.

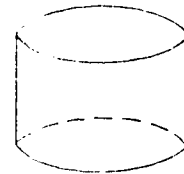

Figure 1

Figures 1 and 2 represent right cylinders. Figure 3 represents a slanted cylinder. Slanted cylinders are seldom used in ordinary life. You will study only right cylinders.

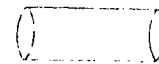

Figure 2

You can find some of the properties of right cylinders by studying a model of one.



Figure 3

Exercises 15-9a
(Class Discussion)

You need a tin can or some other three-dimensional model of a cylinder to help you answer the following questions.

1. How many bases does a cylinder have?
2. What is the shape of each base?
3. Do the bases seem to have the same area?
4. Each base is in a plane. Describe the position of these planes.
5. If the bases are horizontal, describe the position of the bases.

6. A right cylinder with its bases horizontal is pictured. Notice that \overline{AB} is a line segment joining a point on the edge of the upper base to a point directly below it on the lower base.



- a. Will the intersection set of \overline{AB} and the cylinder contain all the points of \overline{AB} ?
- b. Will this line segment \overline{AB} always be the same length for a particular cylinder?
- c. If C is a point of the edge of the lower base but not directly below A , what is $\overline{AC} \cap \text{cylinder}$?

(Try this with a ruler and a tin can, or other model of a cylinder, before you answer the question.)

A cylinder can be described by means of two lengths. These are the radius of the base of the cylinder and the altitude (or height) of the cylinder. The altitude can be thought of as the length of one of the segments lying in the lateral or side surface and joining the two bases of the cylinder.

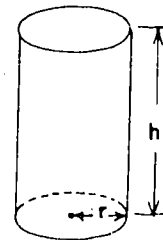

How could you find the volume of a cylindrical solid? If the solid is like a tin can and will hold water (or sand), you can fill it up and then pour the contents into a standard container. For some cylinders, especially large ones, this method is not practical.

How did you find the volume of a box or rectangular solid? First you considered a prism one unit high. The number of cubic units in this solid is the same as the number of square units in the area of the base. You saw that the measure of the volume is the measure of the area of the base times one. Suppose the prism has an altitude of two units. Then the measure of the volume is twice as much as the measure of the area of the base. The measure of the volume is 2 times the measure of the area of the base.

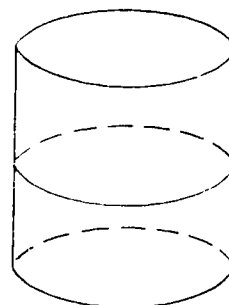
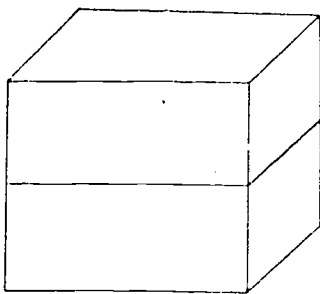

In general, if the area of the base is B square units and the altitude of the prism is h units, then the volume of the prism is $B \cdot h$ cubic units.

This method is also used to find the volume of a cylindrical solid. The measure of the volume is the measure of the area of the base times the measure of the altitude. Since the base of a cylinder represents a circle, its area is πr^2 square units. Therefore, the volume is $\pi r^2 \cdot h$ cubic units. Notice the kind of unit necessary to measure volume. It is a cubic unit.

There is one basic principle which applies to rectangular prisms, to other prisms, and to cylinders. The measure of the volume is the measure of the area of the base times the measure of the altitude.

To compute the volume of a cylindrical solid, you multiply the measure of the area of the base by the measure of the altitude. This statement can be written in symbols as

$$V = \pi r^2 h$$

πr^2 represents the area of the base which is a circular region, h represents the altitude (or height). The radius and altitude are measured with the same kind of unit.

For most of you it is probably better not to memorize the formula as such. You should learn how to compute the volume of a cylindrical solid. First you think of the geometrical figure and what it is you want to find. Then most problems of this type are easy.

Exercises 15-9b
(Class Discussion)

1. a. What is the area of the base of cylinder A ?
b. What is the volume of cylinder A ?
c. Is the number of square inches in the area of the base of cylinder A the same as the number of cubic inches in the volume? Why?
2. What is volume of cylinder B?
3. What is volume of cylinder C?
4. Complete the following statements.
 - a. The volume of cylinder B is _____ as large as the volume of cylinder A.
 - b. The volume of cylinder C is _____ times as large as the volume of cylinder A.

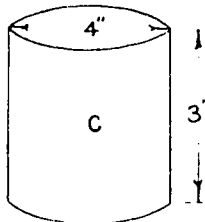
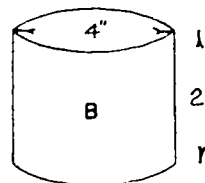
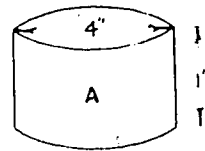

15-9

5. A cylinder is 8 feet high. The diameter of its base is 6 feet. Approximately how many cubic feet are in the volume?
6. Find the volume of a cylindrical can that is 5 feet high and has a diameter of 4 feet.

A note to save some work time. When you have problems using π , it may be easier to use a decimal approximation for π only at the last step of arithmetic. In this way lengthy decimals are avoided as long as possible. In the last problem you found

$$V = \pi \cdot 2^2 \cdot 5$$

$$V = \pi \cdot 4 \cdot 5$$

$$V = \pi \cdot 20 \text{ or } 20\pi \text{ (This is volume in terms of } \pi \text{ .}$$

Sometimes this form is preferred.)

$$V \approx (3.14)(20)$$

$$V \approx 62.8$$

Exercises 15-9c

1. A silo (with a flat top) is 30 feet high and the inside radius is 6 feet. Approximately how many cubic feet of green feed can it hold? (What is its volume?) Use $\pi \approx 3.14$.
2. The diameter of a tin can is 6 inches and its height 7 inches. What is its approximate volume? Use $\pi \approx \frac{22}{7}$.
3. Information is given for four cylinders. The letters r , d , h , and V are the measures of the radius, the diameter, the altitude, and the volume, respectively. Find the missing information. Leave your answers in terms of π . Example - 15π .

r	d	h	V
	10	12	
	2	20	
$4\frac{1}{2}$		$5\frac{1}{2}$	
	$2\frac{1}{2}$	16	

4. Harry has two cans of juice. One can is 4 inches high and 3 inches in diameter, the other is 3 inches high and 4 inches in diameter. Which can holds more juice?

5. A cylindrical water tank is 8 feet high. The diameter of its base is 1 foot.
- Find the volume (in cubic feet) of water which it can hold.
 - There are about $7\frac{1}{2}$ gallons in a cubic foot of water. About how many gallons will the tank of the problem above hold?
6. a. Find the volume of a cylindrical solid whose altitude is 10 centimeters and the radius of whose base is 3 centimeters. Leave your answer in terms of π .
- What would the volume be if the altitude were doubled and the radius of the base were left unchanged? Find the ratio of the larger volume to the smaller.
 - What would be the volume if the radius were doubled and the altitude were left unchanged? Find the ratio of the larger volume to the smaller.
 - What would be the volume if the altitude were doubled and the radius of the base were also doubled? Find the ratio of the larger volume to the smaller.
- *e. Use your results to help you complete the following statements.
- When the altitude of a cylinder is doubled, the volume is _____.
 - When the radius of the base of a cylinder is doubled, the volume is _____.
 - When both the altitude and the radius of the base of a cylinder are doubled, the volume is _____.
- *7. A cylindrical tank has a 5 foot diameter. It is filled with water to a height of 20 inches. What is the approximate volume of the water in cubic inches?
- *8. Find the amount of water (volume in cubic inches) which a 100 foot length of pipe will hold if the inside radius of a cross section is 1 inch. Use $\pi r \approx 3.14$. (A cross section is shaped like the base. A cross section is the intersection of the solid and of a plane parallel to the planes of the bases.)
-

15-10. Surface Area of a Cylindrical Solid.

There are two questions you might ask about the surface area of a cylindrical solid.

1. What is the surface area of the curved part (the lateral area)?
2. What is the total surface area?

The total area is the lateral area plus the area of the top base plus the area of the bottom base. The areas of the top and bottom bases are the same. The measure of the area of each base is πr^2 where r is the measure of the radius of the base. If you know how to find the lateral surface area, you also know how to find the total area. The following experiment should help you to find the lateral area of a cylinder.

Experiment 5

For this experiment you will need a tin can and its paper label. The label on the can covers the lateral surface of the cylinder.

- a. Cut the label along its full height. Lay the label out flat (as shown in the diagrams below).



Complete the following statements.

- b. The label is made and printed in the shape of a _____.
- c. The height of the rectangle is the _____ of the cylinder.
- d. The length of the rectangle is the _____ of the base circle of the cylinder.
- e. The length of the rectangle is the same as _____ times the diameter of the cylinder.

- f. The area of the rectangle, using the symbols π , d , and h , is _____.
- g. The area of the rectangle, using the symbols π , $2 \cdot r$, and h is _____.
- h. Is this a true statement? "The lateral area of a cylinder is the area of a rectangle which will just cover it."

Did you notice these facts as a result of your experiment?

1. The lateral area of a cylinder is the area of a certain rectangle.
2. The altitude of the rectangle and the altitude of the cylinder are the same.
3. The length of the base of the rectangle and the length of the base circle of the cylinder are the same.

Now you know that the measure of the lateral surface area of the cylinder is the product of the measure of the circumference of the base circle and the measure of the height. We could write that the measure is

$$2\pi r \cdot h \quad \text{or} \quad \pi \cdot d \cdot h .$$

Why are these the same?

Not all curved surfaces can be treated in such a simple way. Think of the surface of a ball. Rectangular regions, or other flat surfaces, just do not wrap nicely around balls. The areas of such surfaces can be found in other ways, but we shall not learn about them this year.

Exercises 15-10

(Use $\pi \approx 3.14$)

1. a. What is the lateral area of a cylindrical water tank that is 20 feet in diameter and 20 feet high?
b. Find the total surface area of the cylinder.
2. a. Find the lateral surface area of a cylinder whose altitude is 8 centimeters and the radius of whose base is $1\frac{1}{2}$ centimeters.

15-11

- b. Find the total surface area of the cylinder.
3. Find the total area of a cylinder whose altitude is 7 inches and the radius of whose base is 5 inches.
- *4. A small town has a large cylindrical water tank that needs painting. A gallon of paint covers about 400 square feet. How much paint is needed to cover the whole tank if the radius of the base is 8 feet and the height of the tank is 20 feet? Give your answer to the nearest tenth of a gallon.
5. If r is the measure of the radius of a right cylinder and h is the measure of the altitude, then complete the following statements in terms of π , r , and h .
- The area of one base is _____.
 - The area of both bases is _____.
 - The lateral area is _____.
 - The total area is _____ + _____.

15-11. Summary.

The circle is a simple closed curve in a plane. Each point of the circle is the same distance from a certain point called the center. The center is not in the set of points that make up the circle, but it is in the same plane.

The compass may be used to draw circles and to transfer distances.

A radius of a circle is one of the segments joining a point of the circle and the center.

A diameter of a circle is a line segment which contains the center of the circle and whose endpoints are points of the circle.

The words "radius" and "diameter" are used to mean either the segment, or the length of the segment described above.

A circle has many radii and many diameters.

If r is the measure of the radius of a circle and d is the measure of the diameter of the same circle, then $d = 2r$ or $r = \frac{1}{2}d$.

If the intersection of a line and a circle is a single point, then the line is tangent to the circle. The single point of their intersection is called the point of tangency.

An arc is a portion of a circle. Two different points are necessary to separate a circle into arcs.

An arc is a semicircle if the endpoints of the arc are also endpoints of a diameter of the circle.

An angle whose vertex is at the center of a circle is called a central angle.

The length of a circle is called its circumference.

The measure of circumference is $2\pi r$ or πd .

3.14 or $\frac{22}{7}$ can be used as approximations for the number π .

The area of a circle is π times the area of a square whose side is the length of the radius of the circle. This statement can be written in symbols as $A = \pi r^2$.

The measure of volume of a cylindrical solid is the measure of the area of the base (πr^2) times the measure of the height or altitude (h). In symbols $V = \pi r^2 h$.

The total surface area of a cylindrical solid is found by thinking of the surface that a cylinder represents when it is flattened out. The lateral area is the same as the area of a rectangular region and each base area is the same as the area of a circular region.

15-12. Chapter Review.

Exercises 15-12

1. Complete the following statements.
 - a. A circle is a _____ curve.
 - b. Any line segment through the center of a circle with its endpoints on the circle is a _____ of the circle.
 - c. The diameter of a circle is _____ as long as the radius of the same circle.
 - d. A part of a circle is called a(n) _____.
 - e. The length of a circle is called its _____.
 - f. A circle whose diameter is 5 inches has a radius that is _____ inches.

- g. A line that intersects a circle in exactly one point is called a _____.
- Draw three concentric circles in which the diameter of the smallest circle is 2 inches.
 - Find the missing information. Use $\pi \approx 3.1$.

r	d	c	A
14			
	14		
		51	
17.5			
10			310

- What is the circumference of a circle with a radius of $24\frac{1}{2}$ inches?
- A circular flower garden has a radius of 12 feet. What is its diameter?
- A wheel on Harry's wagon has a diameter of 15 inches. What is the circumference of the wheel?
- A circular fish pond has a diameter of $9\frac{1}{2}$ feet. How far is it from the center of the fish pond to the edge of the pond?
- What radius should be used to draw a circle that will have a circumference of 22 inches?
- What is the area of a circle whose radius is 20 feet?
 - What is the area of a circle whose radius is 10 feet?
 - Compare the areas of the two circles.
- A circular table top is 27 inches in diameter. What is the approximate area of the table top?
- What is the approximate area of a circular mirror that is 21 inches in diameter?
- The center-jump circle on a basketball court has an inside diameter of 4 feet. What is the approximate area of the circle?

15-13

13. Find the approximate volume of a cylindrical can that is 5 inches high and has a diameter of 4 inches.
- *14. Round concrete pillars 14 inches in diameter and 18 feet high are used as supports for a boat landing. About how many cubic feet of concrete will there be in one of these pillars?
-

15-13. Cumulative Review.

Exercises 15-13

1. Which of the following statements is not true?
 - a. The difference between any two prime numbers greater than 5 is always an even number.
 - b. A multiple of a prime number is also a prime number.
 - c. Zero is a multiple of all counting numbers.
2. Write the set of factors of 77.
3. Express 26 as the sum of 2 prime numbers.
4. What is the least common multiple of 3, 6, and 12?
5. The value of 1^{30} is _____.
6. Round each of the following as indicated.
 - a. 0.04753 (nearest thousandth)
 - b. 628.3849 (nearest hundredth)
7. Perform the following operations.
 - a. 16.532×100
 - b. $349.1 + 1000$
8. Find the rate of interest if the interest on \$2500 for one year is \$112.50.
9. What is the cost of 15 candy bars at 3 for 25¢?

15-13

10. In the figure at the right, what is

- a. $\overrightarrow{BA} \cup \overrightarrow{BF}$?
- b. $\overleftrightarrow{BF} \cup \overleftrightarrow{EC}$?
- c. $\overleftrightarrow{ED} \cap \overleftrightarrow{AB}$?
- d. $\overleftrightarrow{AG} \cap \overleftrightarrow{DE}$?
- e. $\overleftrightarrow{DE} \cap \overleftrightarrow{FC}$?
- f. $\overleftrightarrow{DE} \cap \triangle ABC$?

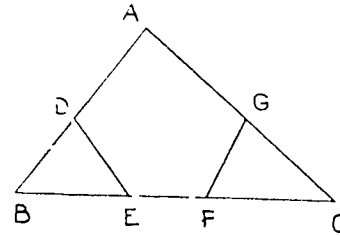

11. In the figure at the right C_1 and C_2 are two simple closed curves.

- a. Make a copy of this figure.
- b. Shade the exterior of C_2 with horizontal lines.
- c. Shade the interior of C_1 with vertical lines.
- d. Using the word "intersection" describe in words the region that is doubly shaded.

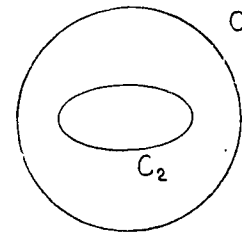

12. Complete:

- a. 7.2 M. = _____ cm.
- b. 47 mm. = _____ cm.
- c. 246 in. = _____ ft.
- d. $4\frac{1}{4}$ mi. = _____ ft.

13. a _____
 b _____
 c _____

Which of the above segments is nearest the length of one centimeter?

14. How many pairs of angles in the drawing are

- a. adjacent angles
- b. supplementary angles
- c. corresponding angles
- d. vertical angles

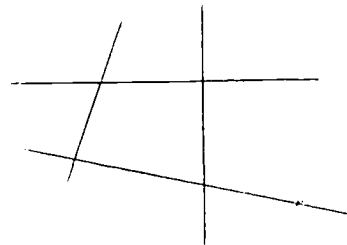

15. The distance from the center of a wheel to its circumference is 33 inches. What is the circumference of the wheel? (Give answer to the nearest inch.)

Chapter 16
STATISTICS AND GRAPHS

16-1. Gathering Data.

"I always thought I was the shortest boy in my class," Harry informed his father one evening. "But tomorrow I'll know. We're going to be measured and collect information about heights of students in our class."

The next day the students were measured and Harry was surprised to find that his height of 58 inches was the same as one other student and more than the height of two others in the class. The students found the heights in inches of the fifteen boys in the class to be 59, 65, 63, 56, 65, 58, 65, 67, 57, 68, 61, 58, 59, 69, 64. They agreed that it would be difficult to work with these numbers unless they were arranged in some way. They listed them as in the following table:

Heights of Fifteen Boys	
Boys	Heights in Inches
A	69
B	68
C	67
D	65
E	65
F	65
G	64
H	63
I	61
J	59
K	59
L	58
M	58
N	57
O	56

Table 16-1a

When such information is arranged in a table it is easy to answer questions such as those in the following exercise.

Exercises 16-1a
(Class Discussion)

1. Which boy is the shortest?

2. What is the height of the shortest boy?
3. What is the height of the tallest boy?
4. How many boys are 55 inches tall?
5. What do you notice about the number of boys that are 59 inches tall and the number of boys that are 58 inches tall?
6. How many boys are more than 64 inches tall?
7. How many boys are less than 64 inches tall?
8. How many boys are more than 63 inches tall?
9. How many boys are less than 63 inches tall?

The pupils collected facts to answer questions that they had in mind. They were gathering data. The word "data" is the plural of the Latin word "datum" which means "fact." Then "data" means "facts."

Gathering data is one of the jobs of statisticians. They prepare tables and charts of numbers which represent the data. The tables and charts usually make it easier to understand the information which is contained in the data that have been gathered.

A new junior high school opened in 1955 with 500 students. In 1956 the enrollment was 625; in 1957 it was 1000; in 1958 it rose to 1125; by 1959 the school had 1250 students; in 1960, 1300; in 1961, 1390; and in 1962, the enrollment was 1500.

A table of such information adds to the ease of reading and of comparing quantities.

Western Junior High School Enrollment

Year (Sept.)	Number of students
1955	500
1956	625
1957	1000
1958	1125
1959	1250
1960	1300
1961	1390
1962	1500

Table 16-lb

Exercises 16-1b
(Class Discussion)

1. What seems to be the general trend in the enrollment of Western Junior High School?
2. Find the increase from each September to the next.
3. In which year was the increase (a) the greatest? (b) the smallest?

Often it is not possible to get certain information every year. There may be intervals of 2 years, 5 years, 10 years, or even 50 or 100 years, depending on the kind of information. For example, the United States census is taken every 10 years. The following table shows the population of Arizona every ten years in the period 1890 - 1960.

Growth of Arizona

Year	Official Population	Population in number of ten thousands	Increase (in ten thousands)	% of Increase (Whole %)
1890	88,243	9		
1900	122,931	12	3	33%
1910	204,354			
1920	334,162			
1930	435,573			
1940	499,261			
1950	749,587			
1960	1,302,161			

Table 16-1c

Exercises 16-1c

1. Copy and complete the following table from the facts given above.

Year	Official Population	Population in number of ten thousands	Increase (in ten thousands)	% of Increase (Whole %)
1890	88,243	9		
1900	122,931	12	3	33%
...

16-2

2. In which period was the increase the largest?
3. In which period was the percent of increase the largest?
4. In which period was the second largest increase?
5. Was this the period in which the next largest percent of increase occurred? Explain.

Use an almanac or other reference to find the information for the problems that follow.

- *6. a. Find the population of your city or state for the years 1920, 1930, 1940, 1950, and 1960.
b. Do you observe a trend of any kind?
- *7. a. Find the enrollment of your school in the last ten years.
b. Is there a trend of any kind?

16-2. Bar Graphs.

It is easier to understand a "picture" of a set of data than it is to understand a list of numbers. For instance, compare the following ways, first by a table, and then by a graph, of telling about the size of the six largest states in the United States.

1. Table

State	Area in Square Miles	Ten Thousands of Square Miles
Alaska	586,400	59
Arizona	113,909	11
California	158,693	16
Montana	147,138	15
New Mexico	121,666	12
Texas	267,339	27

Table 16-2

You may not be sure how the last column was obtained. Recall that a number such as 7000 may be thought of as 7000

ones, 700 tens, 70 hundreds, or 7 thousands. Similarly, a number such as 586,400 may be thought of as:

586,400	ones
58,640	tens
5,864	hundreds
586.4	thousands
58.64	ten thousands
5.864	hundred thousands

In ten thousands of square miles, the area of Alaska is 58.64. Rounded to the nearest whole ten thousand, the number is 59.

In drawing graphs, you will need to express large numbers in a similar way.

16-2

2. Bar Graph.

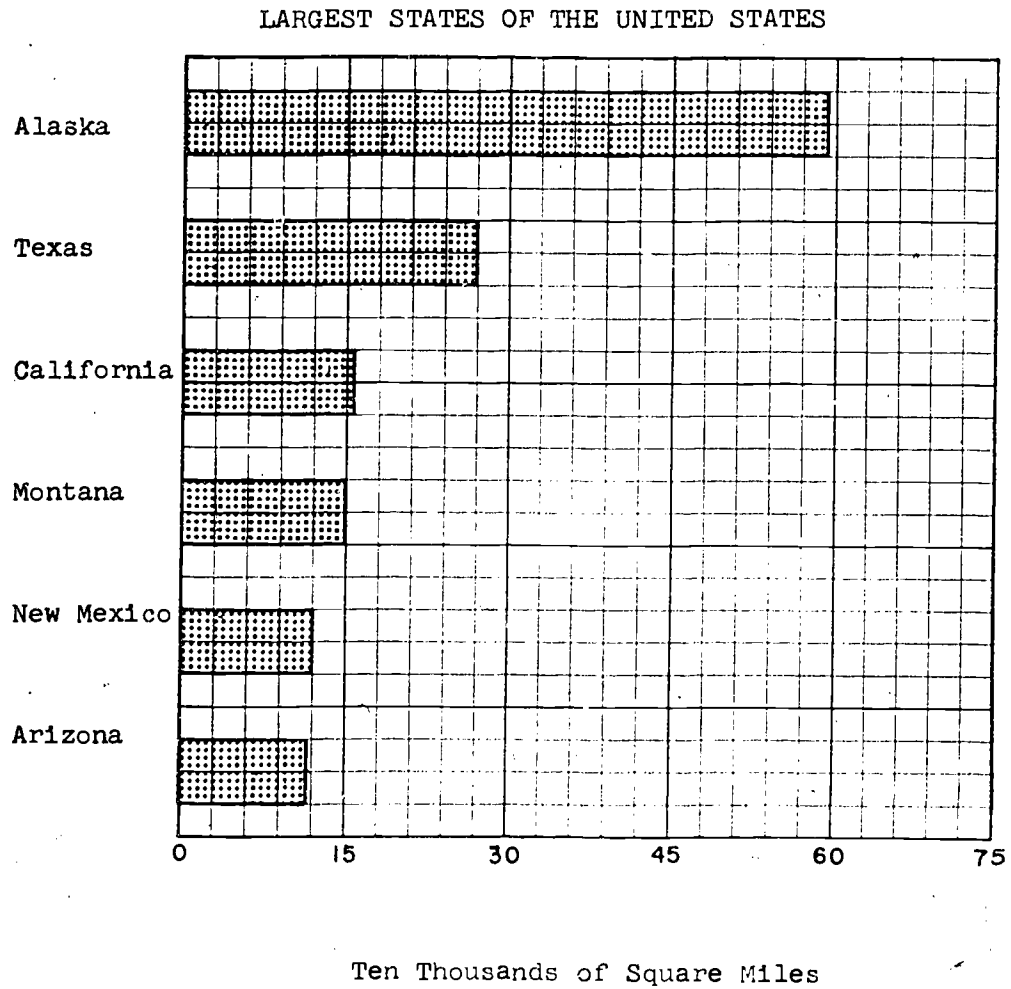

Source: THE WORLD ALMANAC, 1962.

Figure 16-2

Exercises 16-2a
(Class Discussion)

Look at the length of the bars in the graph to tell:

1. Which is the largest state?
2. How does its area compare with the area of each of the other states represented?
3. How does the area of Texas compare with the area of New Mexico?
4. What other facts can you read from the graph?

Bar graphs use lengths of bars to represent numbers. They make it possible for the reader to compare quantities at a quick glance. He can gain information about several numbers much faster than he usually can from a table. How does the graph do this? The following questions will guide you to the answer.

Exercises 16-2b
(Class Discussion)

Examine the graph in Figure 16-2 to answer the following questions.

1. What tells you what the graph is about?
2. What do the numerals at the bottom of the vertical lines mean?
3. With what number does the base line begin?
4. What number does the "30" represent? The "60"?
5. What tells you the size of each state?
6. How wide are the bars?
7. How wide is the space between the bars?
8. a. Are the state names arranged alphabetically?
b. How are they arranged?

Notice that:

1. A graph tells a story.
2. A clear title tells what the story is about. Room is provided for the title.
3. Squared paper or graph paper is used.
4. All units are labeled. Room is provided for all labels.
5. The units are equally spaced.
6. The names of the units are written to the left of the vertical line and below the base line.
7. The scale that is selected depends on the largest number to be represented.
8. If the graph is a bar graph, each bar must be labeled.
9. Bar graphs usually look the best when spaces between the bars are the same width as the bars.
10. The bars are arranged in order of size.
11. The source of the information is indicated.

Exercises 16-2c

1. The following table shows the number of states admitted to the United States in 50-year periods of our history.

50-year Period	Number of states admitted
1751-1800	16
1801-1850	15
1851-1900	14
1901-1950	3
Since 1951	2

Make a bar graph of this information by the following steps:

- a. Select a sheet of graph paper and decide how much space you will use.
- b. Notice that there are five periods in the table and thus five bars will be needed. Plan to have space between bars and above and below them.

- c. Examine the information to find which is the largest number to be represented.
- d. Count the number of units in the space you have selected.

Sometimes you will have as many spaces as the largest number to be graphed. Then your job is easy. If the number to be graphed is larger than the number of units, the following example will help you decide on the scale. Suppose you have 30 spaces, and the largest number to be represented is 511.

$$\frac{511}{30} = 17\frac{1}{30}$$

If each unit represents $17\frac{1}{30}$, the bar will just fill the 30 spaces.

If the unit is less than $17\frac{1}{30}$, the bar will extend beyond the available space.

The sensible thing to do is to round off the $17\frac{1}{30}$ to the next larger convenient number. In this case, rounding to the nearest ten ($17\frac{1}{30} \rightarrow 20$) is probably best. Let each unit represent 20.

2. Prepare a bar graph to illustrate the enrollments in Hoover Junior High School. There are 350 students in the seventh grade, 300 in the eighth grade and 290 in the ninth grade.
3. Following are the heights of some of the tallest structures in the United States. Prepare a vertical bar graph which will compare their heights.

Space Needle, Seattle World's Fair	660 ft.
Washington Monument, Washington, D. C.	555 ft.
Statue of Liberty, New York	305 ft.
San Jacinto Monument, Houston, Tex.	570 ft.
Empire State Building, New York	1250 ft.
Prudential Building, Chicago	601 ft.
City Hall, Philadelphia	548 ft.
Terminal Tower, Cleveland	708 ft.

4. Prepare a bar graph to illustrate the comparison of the sizes of the world's largest cities:

City	Population
Tokyo	9,311,774
London	8,171,902
New York	7,781,984
Shanghai	7,100,000
Moscow	5,032,000
Bombay	4,146,491
Peiping	4,140,000
Sao Paulo	3,850,000

16-3. Broken-Line Graphs.

A class kept a record of the temperature at 2 p.m. during their class period each afternoon for a week. They pictured their results as follows:

TEMPERATURES DURING THE WEEK OF FEBRUARY 10 AT 2 p.m.

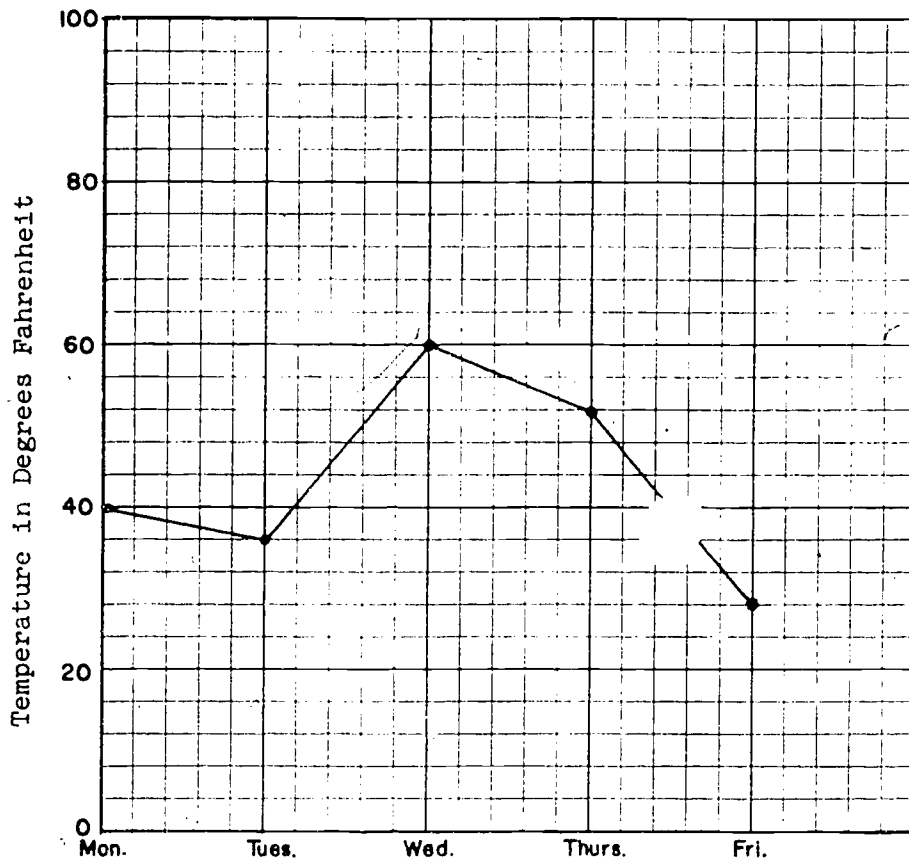

Figure 16-3

In the above graph one vertical line and one horizontal line are used in such a way that they resemble number lines. In this graph the horizontal line is used to tell the days of the week. Notice that the lines for days are equally spaced.

The vertical line shows the temperature in degrees. How many degrees does each vertical unit represent? We say that the scale is one space for 4 degrees.

Each dot on the graph represents the temperature for the day written directly below it. The temperature for each is then read by following the horizontal line to the left to find where it crosses the vertical scale.

After the dots are located on the graph, they can be connected by line segments. Then the graph is called a broken-line graph.

Exercises 16-3a
(Class Discussion)

1. From the graph tell the temperature at 2 p.m. each school day during the week.
2. On which day was the lowest temperature recorded?
3. On which day was the highest temperature recorded?
4. Between which two days did the temperature rise the most?
5. Between which two days did the biggest drop in temperature occur?
6. Could a temperature of 37° be recorded exactly on this graph? Could its location be estimated?

Exercises 16-3b

1. Prepare a broken-line graph to show the following information.

Growth of Schools in Madison County

Year	Number of Schools
1920	4
1930	6
1940	10
1950	17
1960	25

Source: Board of Education of Madison County.

2. Prepare a line graph to show Babe Ruth's home run record as shown in the following chart. Source: THE WORLD ALMANAC, 1962.

Year	Number of Home Runs	Year	Number of Home Runs
1914	1	1925	25
1915	4	1926	47
1916	3	1927	60
1917	2	1928	54
1918	11	1929	46
1919	29	1930	49
1920	54	1931	46
1921	59	1932	41
1922	35	1933	34
1923	41	1934	22
1924	46	1935	6

3. Make a broken-line graph to represent the data in this table. Draw a broken line in blue for one party and a red line for the other.

Popular Vote in Millions Cast
for Presidential Candidates
1928 - 1960

Year	Republican Party	Democratic Party
1928	21	15
1932	16	23
1936	17	28
1940	22	27
1944	22	26
1948	22	24
1952	34	27
1956	36	26
1960	34	34

Source: THE WORLD ALMANAC, 1962.

4. Complete the following table and prepare a broken-line graph to represent the data.

Population of the United States

Census Years	Population	Population in Millions
1900	75,994,575	76
1910	91,972,266	
1920	105,710,620	
1930	122,775,046	
1940	131,669,275	
1950	150,697,361	
1960	179,323,175	

Source: Bureau of the Census.

16-4. Other Kinds of Graphs.

There are many kinds of graphs. Several kinds will be shown, with help in interpreting them.

Exercises 16-4

1. Circle Graphs are used to show comparison among parts of a whole and between the whole and its parts. The area of the circle represents the whole amount.

How One Family Spends Its Money

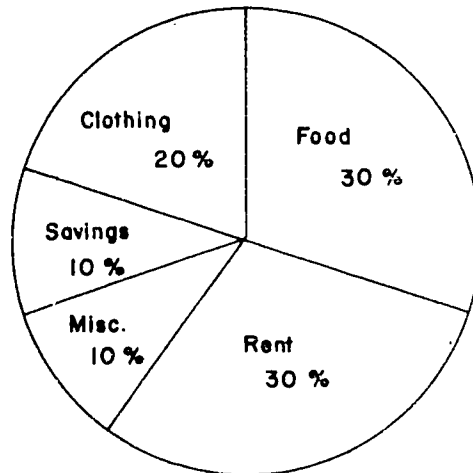

Examine the graph to find the answers to the following questions:

- a. How does the amount that the family spends on rent compare with what is spent for food?
- b. How does the amount spent for rent compare with the amount saved?
- c. If the family income is \$6400, how much is spent for each item mentioned in the graph?

2. The following circle graph shows how one city budgets its spending.

Central City Budget

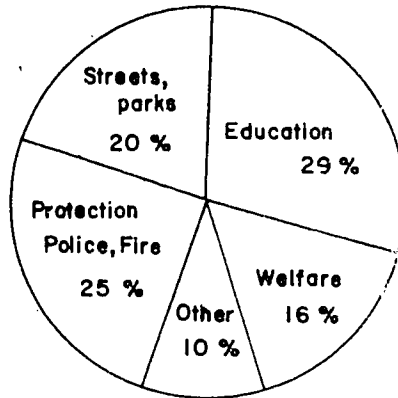

- a. If 360° represents the total number of angle degrees around a point, how large is each angle in the graph?
- b. Compare:
- (1) The amount spent for streets with the amount spent on welfare.
 - (2) The amount spent for education with the amount for police and fire protection.
- c. The total income of the city in 1961 was \$3,194,000. How much was budgeted for each item?
3. A rectangular bar graph, sometimes called 100% bar graph, is useful to indicate how a total is distributed.

Marks in a Class

A	B	C	D	F
15 %	25 %	40 %	15 %	5 %

- a. 15% of the class received a mark of A, etc. If there were 40 pupils in the class, find how many received each mark.

- b. Compare:
- (1) The number of A's with the number of F's.
 - (2) The number of C's with the number of B's.
 - (3) The number of D's with the number of A's.
- c. Name two advantages of this kind of graph.
4. Pictographs are an interesting type of bar graph. Symbols or pictures are used to represent a given number of units, as in the following pictograph:

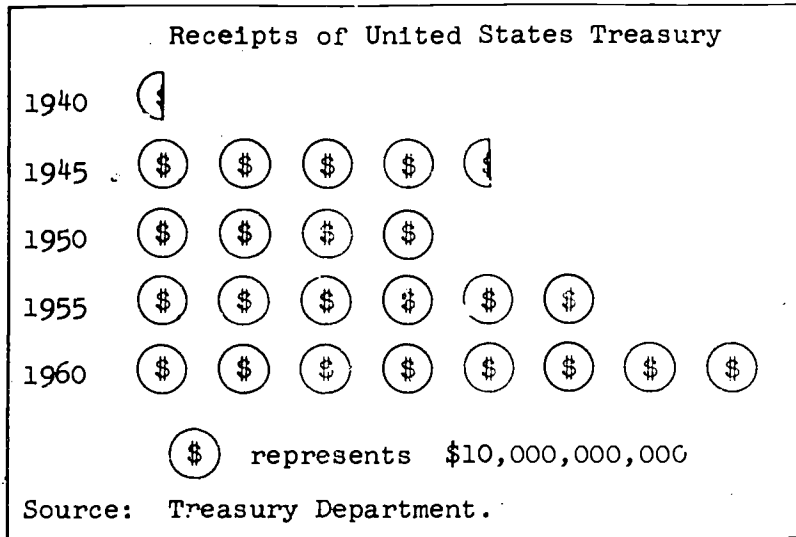

- a. What amount is represented by  ?
 - b. What were the receipts each year?
 - c. How did the receipts in 1960 compare with those in 1950? in 1940?
5. Graphs can mislead you!
Study carefully the following two graphs which were prepared in order to show the same facts. The second graph is made from the first by using only the top half of it.

Percent of Total Tax Spent on
Highways in States A, B, C, and D

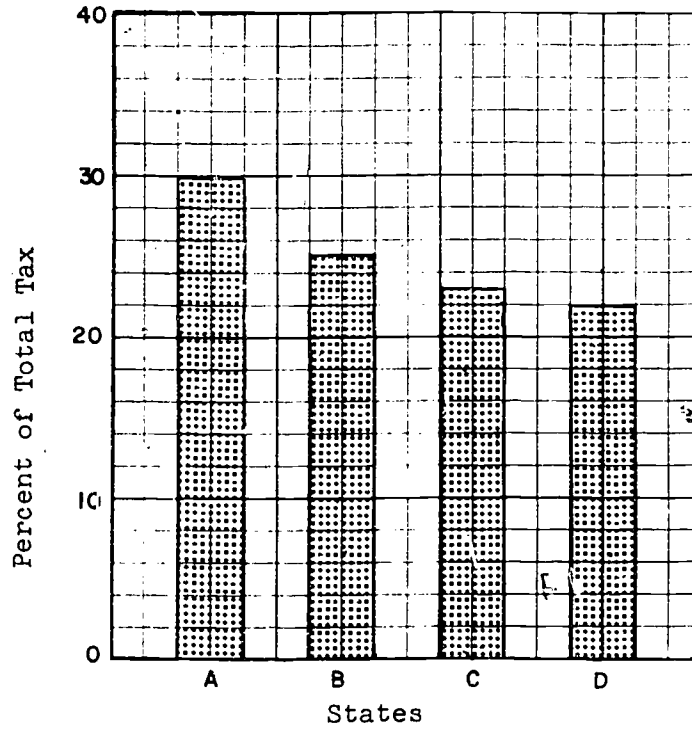

Figure 1

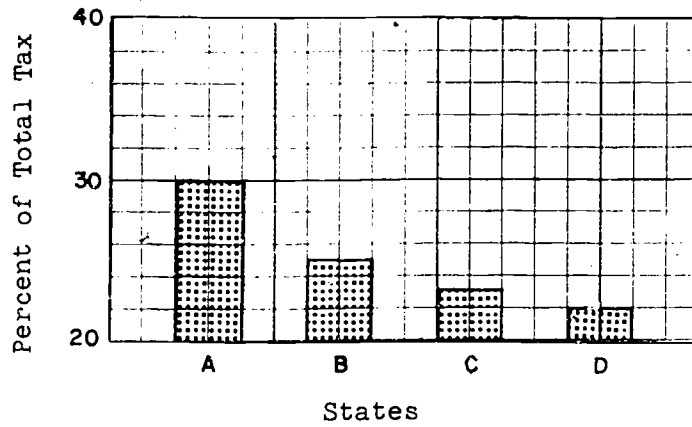

Figure 2

- a. Where does the vertical scale start in
 - (1) Figure 1?
 - (2) Figure 2?
 - b. In Figure 1, what is the ratio of the length of Bar A to Bar D?
 - c. In Figure 2, what is the ratio of the length of Bar A to Bar D?
 - d. What incorrect conclusions could you draw from glancing at Figure 2 and not examining the scale?
-

16-5. Averages.

If you received grades of 95, 90, and 40 on the three mathematics tests in a certain marking period, you surely would not want the teacher to use just one of them--especially the lowest! The usual way to describe a set of data with one number is to find an average. You may be familiar with one kind of average, but there are several kinds which are useful for different purposes.

Arithmetic Mean

When you find the average of a group of numerical grades by adding the grades and dividing by the number of grades, you accept a single number to represent the whole group of grades. This useful average with which you are already familiar is called the arithmetic mean or the mean. (When the word "mean" is used in this chapter it always refers to the arithmetic mean.) For example, to find the mean of the three grades mentioned above, you add them and divide by 3. The arithmetic mean is $\frac{95 + 90 + 40}{3} = \frac{225}{3}$ or 75.

Now let us look once more at the heights recorded in Table 16-1a. This table gives the heights of 15 boys arranged in order from the tallest to the shortest.

One number which describes these data is the average called the arithmetic mean. In this table the average height or arithmetic mean is the sum of the heights, 934, divided by

16-5

the number of boys.

$$\frac{934}{15} \approx 62$$

This average can be computed without arranging the data in any special way. It is a commonly used measure.

Here is another way of looking at the arithmetic mean. Think of it as the single score you might have received in every test, if the total were equal to the total of the scores you did receive. For instance if you received marks of 80, 70, 95, 60, 75, and 100, what is the average? Would six marks at the average give you the same total?

You might picture the marks in another way.

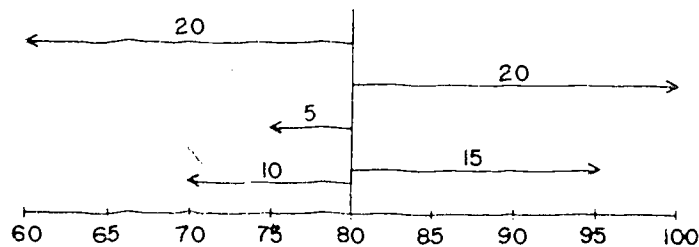

Figure 16-5a

If the marks are pictured as distances from the mean, a chart such as Figure 16-5a shows how each score differs from the mean. The sum of the distances on the left should equal the sum of the distances on the right. Does it?

Exercises 16-5a

- Find the arithmetic mean of each of the following sets of numbers:
 - 84, 78, 67, 59, 74, 75, 81, 74
 - 2116, 1827, 2143, 1865, 1974, 2045
- One week a bus driver collected the following number of fares: 208, 186, 180, 211, and 195. What was the average number of fares that he collected?
- Jim bowled once a week. His scores for six consecutive weeks were: 161, 148, 155, 172, 150, 167. What was his average score for the six-week period?

4. A real estate development contains five lots in one block. The areas of the lots are as follows: 17,317 sq. ft., 18,740 sq. ft., 16,236 sq. ft., 19,052 sq. ft., and 15,976 sq. ft. What is the average size of the lots to the nearest whole number of square feet?

Median

Another way of describing a set of data is by using, if possible, one number such that half of the numbers in the group are greater and half of them are less than the number found. This number is called the median.

To find the median of a set of numbers, we must first arrange them in order of size. Suppose the five boys in a certain class received grades of 100, 92, 85, 83, and 30.

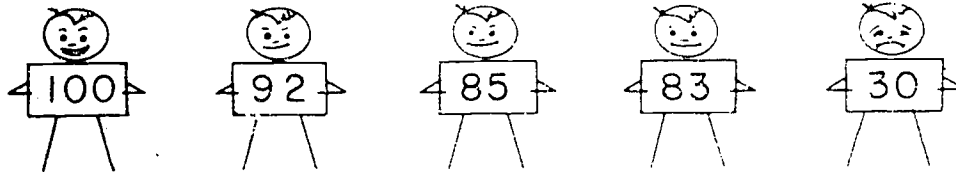

Figure 16-5b

Two grades are greater than 85; two are less than 85. The median of the set then is 85, the score of the middle pupil.

In the set of heights given in Table 16-1a the middle number is 63. This is the median of the set. Half of the numbers are greater than 63 and half are less than 63.

Does the size of the numbers at either end affect the median? No. This is in contrast to the arithmetic mean where all the numbers are added to find the total.

Boys	Heights in Inches	
A	69	} 7 boys are taller than 63 in.
B	68	
C	67	
D	65	
E	65	
F	65	
G	64	
H	63	— MEDIAN
I	61	} 7 boys are shorter than 63 in.
J	59	
K	59	
L	58	
M	58	
N	57	
O	56	

Table 16-5b

The median of a collection of numbers is not always a number in the collection. If there is an even number of items in the collection, the median is taken as the average of the two middle numbers. For example, consider these eight numbers 8, 10, 11, 12, 14, 16, 17, 19.

8	
10	
11	
12	
14	→ The average or mean of these two "middle" numbers is 13. The median for the whole set is then, 13.
16	
17	
19	

Consider another set of numbers this time with 6 members in it: 12, 13, 15, 15, 17, 20.

12	
13	
15	
15	→ The average or mean of these two "middle" numbers (since they are both the same) is 15. The median of this set is 15.
17	
20	

Mode

Which height occurs more than any other in Table 16-1a? How many pupils have this height? This height is called the mode.

In sets which you have studied such as the set of natural numbers, $\{1, 2, 3, 4, 5, \dots\}$, no number occurred in the set more than once. But in a set of data some number or numbers may occur more than once. If one number occurs in the set of data more often than any other number it is called the mode. (We might say it is the most fashionable.) However, there may be several modes. In Table 16-1a there was just one. The number 65 occurs three times. But in the set of scores 19, 20, 21, 21, 21, 24, 26, 26, 26, 29, 30 there are two modes, 21 and 26. (These are equally fashionable.) If there had been another 21 in this set of scores, what would the mode have been? In Table 16-1a if the pupil L were 59 inches tall how would this affect the mode?

Manufacturers of clothing are interested in knowing the mode of a set of numbers of articles of different sizes sold, namely, what size most people are buying. To them, this is a more important "average" (a single number to represent all of the data) than the mean or median.

Range

Sometimes it is useful to know the range, or the difference between the largest and smallest numbers in a collection. For instance, Jim's scores on three tests were 78, 80, and 82 and Joe's scores were 60, 80, and 100. The median of each set is 80 and the mean of each set is 80. But the range is quite different.

The range of Jim's scores was $82 - 78$ or 4.

The range of Joe's scores was $100 - 60$ or 40!

Which boy appears to be the most consistent worker?

Let us now take two lists of test scores and find the arithmetic mean, the median, the mode, and the range.

16-5

<u>Scores</u>	
98	Range: $98 - 66 = 32$
95	
90	
80	Median: $\frac{90 + 80}{2} = \frac{170}{2} = 85$
75	Mode: There is no mode.
<u>66</u>	
Total 504	Mean: $\frac{504}{6} = 84$

<u>Scores</u>	
100	Range: $100 - 60 = 40$
100	
99	
97	
84	Median: 84
75	
75	Mode: 75
75	
<u>60</u>	Mean: $\frac{765}{9} = 85$
Total 765	

Table 16-5c

Exercises 16-5b

1. Following is a list of test scores: 79, 94, 85, 81, 74, 85, 91, 87, 69, 85, 83.
 - a. Arrange these scores in a table starting with the highest and ending with the lowest.
 - b. Find the mode.
 - c. Find the median.
 - d. Find the range.
 - e. Find the mean.

2. The following annual salaries were received by a group of ten employees: \$4,000, \$6,000, \$12,500, \$5,000, \$7,000, \$5,500, \$4,500, \$5,000, \$6,500, \$5,000.
- Find the mean of the data.
 - How many salaries are greater than the mean?
 - How many salaries are less than the mean?
 - Does the mean seem to be a fair way to describe the "average" of the data?
 - Find the median of the set of data.
 - Does the median seem to be a fair way to describe the "average" of the data?
 - If one of the employees received \$70,000 instead of \$7000, would this change affect:
 - the mode?
 - the mean?
 - the median?
 - Do you see that the median may be useful in some cases because one very large or very small number does not affect it?
3. Following are the temperatures in degrees Fahrenheit at 6 p.m. for a two-week period in Kansas City.
47, 68, 58, 80, 42, 43, 68, 74, 43, 46, 48, 76, 48, 50
Find the (a) mean, (b) median, (c) range.

*16-6. Grouping Data.

If numerical facts are listed for very many students it is often inconvenient to list each one separately. For instance, the Physical Education Department of George Washington High School measured the heights of all pupils in the school. The heights of the members of the eighth grade class, measured in inches, were as follows: 59, 65, 59, 60, 63, 58, 62, 62, 59, 61, 62, 64, 59, 58, 61, 61, 62, 59, 59, 60, 62, 64, 58, 60, 61, 62, 64, 65, 64, 62, 62, 63, 64.

In order to get a clearer picture of these data, we can arrange them in a frequency distribution.

Heights (in inches)	Tallies	Frequency
58		3
59	 	6
60		3
61		4
62	 	8
63		2
64	 	5
65		2
Totals	33	33

Table 16-6a

Exercises 16-6a
(Class Discussion)

1. What is the range in heights of the pupils in this class?
2. The median is the score of the middle pupil.
 - a. If there are 33 pupils in the class, which pupil is the middle pupil?
 - b. If you count down to him from the top of the table or up to him from the bottom, in which height group do you find that he is located? This is then the median height for this class.
3. Which height is the mode for this class?

If you are listing numerical facts about very many students, it is often inconvenient to list each one separately. It is simpler to group the figures in some such way as this:

Height in Inches	Number of Pupils
67 - 69	12
64 - 66	17
61 - 63	42
58 - 60	57
55 - 57	33
52 - 54	14

Table 16-6b

In order to find the median, first find the total number of pupils and divide by 2. The sum of 12, 17, 42, 57, 33, and 14 is 175. $\frac{175}{2} = 87\frac{1}{2}$. The middle person will be the 88th person counting from the top or bottom. If we count down from the top, $12 + 17 + 42 = 71$. We need 17 more to reach 88. Counting down 17 more in the group of 57 brings us to the median. Since the 88th person is within that group, we say that the median height of the whole group of pupils is between 58 and 60 inches. Since the 88th person comes before we reach the middle of that group as we count down, we might say that the median height is likely to be nearer 60 than 58.

Let's check our work and count up from the bottom to the 88th person. $14 + 33 = 47$. We need 41 more than 47 to make 88. We count 41 more and that takes us into the upper part of the group of 57, just as we found when we counted down from the top. Again you find the 88th person in the group of 57 whose height is between 58 and 60. Thus the median height of the group is between 58 and 60 inches.

Exercises 16-6b

1. Give an example in which the principal of your school might choose to group data rather than list all the individual items.

16-7

2. a. Find the median of the following age groups.
b. What is the median age?

Ages in Years	Number in Group
27 - 29	35
24 - 26	48
21 - 23	68
18 - 20	18
15 - 17	94
12 - 14	53
9 - 11	73
6 - 8	26

3. The following set of figures gives the maximum daily temperature for a month in Central City:

62, 74, 53, 91, 68, 84, 75, 76, 80, 77, 68, 72, 71, 86,
82, 74, 55, 72, 50, 63, 51, 52, 61, 67, 58, 53, 64, 69,
71, 59, 84.

Find the median by grouping, using intervals of 5, namely:
59 - 54, 55 - 59, etc., to 90 - 94.

16-7. Summary.

The subject matter of statistics deals, in part, with collecting data, putting the data in table form, and representing the data by graphs. The tabulating and graphing of the data should be done in such ways that the story told by the data can be easily understood. The broken-line graphs, bar graphs, and circle graphs are just a few of the kinds of graphs that may be used.

The next time you see graphs or tables in magazines, newspapers, or your social studies book, look them over carefully. If averages are mentioned, be sure to note which average is used. Whenever the kind of average used is not stated, you have a right to question whether the average used gives the best representation of all the data.

To help you recall the new terms you have used in working with statistics, they are listed for you:

Range--difference between largest and smallest number in a list.

Arithmetic mean or mean--the sum of all the numbers in a list divided by the number of items in the list.

Median--the middle number when data are ordered either from smallest to largest or largest to smallest. When there is no one middle number, the average of the two middle numbers is the median.

Mode--the number occurring most in the list of data. There may be several modes.

Frequency distribution--a method of arranging data in order to tell how often a single number or a particular group of numbers appears.

16-8

16-8. Chapter Review.

Exercises 16-8

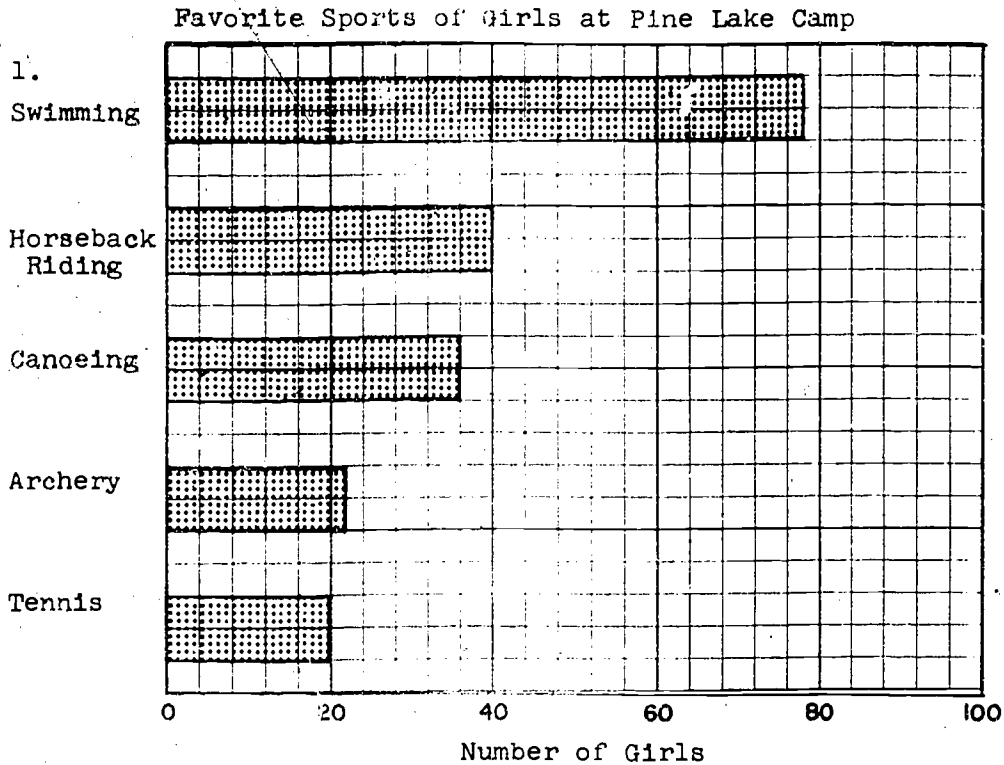

- a. What general story does the graph tell?
 - b. What unit is used on the horizontal scale?
 - c. How many girls indicated each sport as their favorites?
 - d. Which sport is most popular?
 - e. Compare the popularity of:
 - (1) Swimming to canoeing.
 - (2) Swimming to archery.
 - (3) Horseback riding to canoeing.
2. Draw a line graph to represent Jim's monthly earnings during his school year as shown by the table:
- | Month: | Sept. | Oct. | Nov. | Dec. | Jan. | Feb. | Mar. | Apr. | May |
|-----------|---------|---------|--------|---------|---------|---------|---------|--------|--------|
| Earnings: | \$10.50 | \$15.00 | \$4.50 | \$11.00 | \$12.00 | \$18.00 | \$14.50 | \$5.00 | \$3.00 |

3. Round off these numbers to the nearest thousand.
- a. 5429
 - b. 14,857
 - c. 3099
 - d. 154,828
4. Draw a bar graph to illustrate the comparative enrollment in the six grades of Roosevelt High School:

Grade	Enrollment
7	413
8	401
9	628
10	576
11	549
12	455

5. The following marks were earned by the students in a mathematics class:
- 81, 72, 94, 90, 86, 85, 92, 70, 83, 71, 89, 95, 85, 97, 62.
- a. Arrange the numbers in order. What is the range?
 - b. What is the mode?
 - c. Find the arithmetic mean.
 - d. What is the median?
 - e. If the mark of 62 had been 22, would that have affected the median? the mean?
- *6. Draw either a bar graph or a line graph to illustrate the production of ice cream in the United States in the given years:

Year	Millions of Gallons
1945	477
1947	631
1949	558
1951	569
1953	602

16-9

16-9. Cumulative Review.

Exercises 16-9

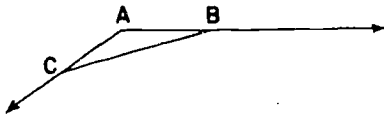
1. Find the greatest common factor of 8, 12, and 30.
2. The base two numeral for the number twelve has how many digits?
3. What is the intersection of the set of whole numbers between 1 and 11 and the set of even numbers between 5 and 15?
4. Find the simplest numeral for $\frac{16}{25}$ divided by $\frac{8}{5}$.
5. What is the largest number of rays indicated in this diagram?

6. What is the reciprocal of $\frac{2}{9}$?
7. Explain one way of determining if $\frac{a}{b} = \frac{c}{d}$ is a true statement.
8. If the length of a line segment is measured to the nearest $\frac{1}{2}$ inch, what is the greatest possible error?
9. Find 75% of 14.
10. Write another name for $\frac{7}{8} \cdot \frac{7}{8} \cdot \frac{7}{8} \cdot \frac{7}{8} \cdot \frac{7}{8} \cdot \frac{7}{8}$ using an exponent.
11. If two angles of an isosceles triangle measure 64 and 58, what is the measure of the third angle?
12. Which of the following averages will always be one of the original data? Mean, Median, Mode.
13. Lenore has a picture negative 4 inches wide and 6 inches high. She wants an enlargement that will be 10 inches wide. How high will the enlarged print be?
14. Find b so that the statement is true:
a. $\frac{18}{14} = \frac{b}{35}$ b. $\frac{b}{100} = \frac{24}{60}$
15. A passenger ship can travel at an average rate of 23.8 knots (23.8 nautical miles per hour). How long does it take this ship to travel between two ports that are 345.1 nautical miles apart?

16-9

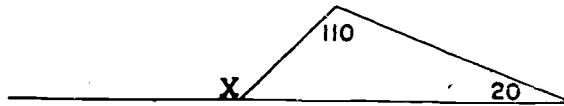
16. What is the measure of $\angle X$ in this figure.



17. Write each of the following in decimal form:

- a. Seven and sixteen thousandths
- b. Four hundred five and seven hundredths

18. Round each of the following, as indicated.

- a. 57,539 (to the nearest hundred)
- b. 685,750 (to the nearest thousand)
- c. 15.0365 (to the nearest hundredth)
- d. 0.0951 (to the nearest tenth)

INDEX

- acute angle, 92
- addition
 - of negative numbers, 247-249, 252-254
 - of rational numbers on the number line, 247-249, 252-254
- additive inverse, 254, 273, 373, 374
- adjacent angles, 81
- altitude of a cylinder, 193
- angle, 75
 - acute, 92
 - adjacent, 81
 - congruent, 76
 - corresponding, 96
 - measure of, 75, 77
 - non-adjacent, 83
 - obtuse, 92
 - right, 92
 - supplementary, 85
 - vertical, 83, 87
- "approximately equal to", 380
- approximation, 47
- arc of circle, 179, 201
- area, 33
 - of a circle, 189, 201
 - of a closed region, 33
 - cutting units of, 36
 - meaning of, 33
 - of a parallelogram, 139
 - of a prism, 51
 - of a rectangle, 36, 43, 68
 - of a triangle, 145
 - unit of, 34
- arithmetic mean, 223
- associative property
 - of addition, 273, 373, 374
 - of multiplication, 267, 273, 373, 374
- averages, 223
 - arithmetic mean, 223
 - median, 225
 - mode, 227
- axes, 307
- axis, 307
- bar graphs, 208
- broken-line graphs, 215
- centimeter, 404, 405
- central angle, 180, 201

- circle
 - arc of, 179
 - area of, 187
 - central angle of, 180
 - circumference of, 182, 184
 - concentric, 174
 - definition of, 166, 169
 - diameter, 175
 - exterior of, 170
 - interior of, 170
 - point of tangency, 177
 - radius, 166
 - tangent to, 177
- circle graphs, 219
- circumference, 182, 184, 201
- closure, 273, 373, 374
- commutative property
 - of addition, 2 3, 3.3, 374
 - of multiplication, 262, 267, 3.3, 3 3, 3 4
- compass, use of, 165, 167
- completeness, 374, 375
- concentric circles, 174
- cone, 62
- congruent, 2
- congruent angles, 76
- converse, 111
- coordinate geometry, 316
- coordinate pair, 350
- coordinates in the plane, 301, 306
- corresponding angles, 96
- counting numbers, 245, 374
- cube, 53
- cubic inch, 54, 69
- cubit, 9
- cylinder, 62, 192, 201
 - altitude, 193
 - lateral area, 198, 208
 - right, 192
 - surface area, 198, 199
 - volume, 195
- cylindrical solids, 192
- data, 205
 - grouping, 229
- decimal approximations for square roots, 394-395
- decimal system, 403
- decimals
 - use of exponents in multiplying and dividing, 399-401
- decimeter, 404, 405
- degree, 76
- dekameter, 404, 405
- Descartes, René, 316
- diameter
 - definition 175, 200
 - relation to circumference, 182
- dimension, 64
 - one-dimensional, 64
 - two-dimensional, 65
 - three-dimensional, 65

distance, 131
 between two parallel lines, 132
 between two points, 330-334, 343-347
 to a line, 131
 distributive property, 267, 273, 373, 374
 division
 by powers of ten, 386
 of negative numbers, 268-270
 of rational numbers, 268-270
 English system of measurement, 403
 conversion to metric units, 407-408
 equation, 279, 284, 296, 318
 equilateral triangle, 108
 error, greatest possible, 19
 exponent, 380, 387, 388, 390-391, 394, 397, 399-401
 negative exponents, 388
 exterior of circle, 170
 fathom, 9
 foot, 8
 formulas, 287-288, 297
 frequency distribution, 229
 graphs, 208, 292, 297, 318
 bar, 208
 broken-line, 215
 circle, 219
 graphing solution sets of sentences, 292-294
 graphs in the plane, 316-320
 greater than, 243
 half-line, 245
 negative, 245
 positive, 245
 half-plane, 311
 left half-plane, 311
 lower half-plane, 311
 right half-plane, 311
 upper half-plane, 311
 hand, 8
 hectometer, 404, 405
 hexagon, 123
 regular, 176
 hypotenuse, 336
 identity element
 for addition, 273, 373, 374
 for multiplication, 267, 273, 373, 374
 inequality, 284, 296
 infinite decimals, 366-370, 374, 376
 integers, 245, 374
 negative, 245
 non-negative, 245
 positive, 245
 set of, 245
 interior of circle, 170
 intersection of circles, 171
 inverse
 additive, 254, 273, 373, 374
 multiplicative, 271, 273, 373, 374
 irrational numbers, 362-365, 366-370, 376
 and infinite decimals, 366-370

- isosceles triangle, 107
 - angles in, 114
- kilometer, 404, 405
- lateral surface of a cylinder, 190, 280
- left half-plane, 311
- length, 5
 - of a circle, 181
 - same length, 2
 - standard units of, 8
 - unit of, 2
- less than, 243
- light year, 403
- line
 - distance between two points on a line, 330-332
 - through the origin, 318, 323-327
- lines in a plane, 80, 94
 - intersecting, 80, 94
 - parallel, 80, 99, 101
 - skew, 80
- lower half-plane, 311
- mean, 223
- measure, 5
- measure of an angle, 75, 77
- median, 225
- mega, 406
- megacycle, 406
- meter, 9, 403, 404, 405
- metric system, 403-408
 - conversion to English units, 407-408
- micro, 406
- micron, 406
- millimeter, 404, 405
- mode, 227
- multiplication
 - by powers of ten, 383-384
 - of negative numbers, 251-267
 - of rational numbers, 260-267
 - of rational numbers on the number line, 260-262
- multiplication property of 0, 267, 373, 374
- multiplicative inverse, 271, 273, 313, 374
- negative
 - exponents, 388
 - half-line, 245
 - integers, 245
 - numbers, 244
 - rational numbers, 239, 245
- non-negative integers, 245
- non-negative rationals, 374
- number, π , 185
- number line, 242-262, 357-359, 360-361, 374, 376
 - addition on the, 247-249, 252-254
 - multiplication on the, 260-262
 - subtraction on the, 255-258

- numbers
 - irrational, 362-365, 366-370, 371
 - negative, 244
 - positive, 243, 245
 - rational, 245, 272, 358, 366, 373, 374
 - real, 357-359, 365, 374, 376
- obtuse angle, 92
- opposite, 245, 254
- order property, 373
- origin, 242, 306, 307
- pace, 9
- parallel lines, 80, 99, 101
- parallelogram, 125
 - altitude of, 139
 - angles of, 131
 - area of, 139
 - bases of, 140
 - opposite sides of, 128
- pentagon, 123
- perimeter, 21
- perpendicular, 90
- phrases, 279, 280, 296
- π (π), 185
 - approximations of, 185
- point of tangency, 177
- polygons, 21, 123
 - hexagon, 123
 - pentagon, 123
 - quadrilateral, 123
- positive, 243
 - half-line, 243
 - integers, 245
 - number, 243, 245
 - rational number, 245
- powers of ten
 - dividing by, 386
 - multiplying by, 383-384
- precision, 17
- prism, 148
 - bases, of, 149
 - edge of, 69
 - faces of, 49, 68, 149
 - height of, 151
 - pentagonal, 149
 - rectangular, 49, 68, 149
 - surface area, 69
 - triangular, 62, 149
 - vertices of, 50, 69, 149
 - volume of, 152
- product of two negative numbers, 337
- proof, 135, 138
- properties of number systems, 337
- protractor, 76
- Pythagoras, 337
- Pythagorean Property, 337
 - proof of, 338-342
- quadrants, 312

quadrilateral, 123
 radius, 166, 175, 200
 definition, 166
 relation to circumference, 185
 relation to diameter, 175
 range, 227
 rational numbers, 245, 272, 358, 366, 373, 374
 addition of, 247-249, 252-254
 division of, 268-270
 multiplication of, 260-267
 negative, 239, 245
 non-negative, 374
 positive, 245
 properties of, 273, 313, 374
 set of, 245
 subtraction of, 254-258
 real numbers, 357-359, 365, 374, 376
 reciprocal, 271
 rectangle, 21
 rectangular region, 38
 rectangular solid, 69
 repeating decimals, 366, 370, 376
 right angle, 92
 right half-plane, 311
 right prisms, 148
 right triangle, 337, 338
 ruler, 3
 scalene triangle, 108
 scientific notation, 379, 382, 390, 391
 definition, 382
 division, 396-397
 multiplication, 393-395
 semi-circle, 180, 201
 sentences, 279, 283-286, 292, 296
 separation, on a circle, 179
 set
 of integers, 245
 of rational numbers, 245
 solution set, 286, 292-294, 296
 solutions
 of equations, 279, 281
 of sentences, 279, 281
 sphere, 62
 square
 centimeter, 39
 foot, 39
 inch, 39, 68
 region, 39
 yard, 39
 square root, ($\sqrt{\quad}$), 345
 table of, 354-355
 subtraction
 of negative numbers, 255-258
 of rational numbers on the number line, 254-258
 supplementary angles, 85
 surface area of a cylindrical solid, 108

symbols
 $>$ (greater than), 243, 284
 $<$ (less than), 243, 284
 $=$ (equal to), 284
 \approx (approximately equal to), 380
 π (pi), 185
 $\sqrt{\quad}$ (square root), 345
 table--squares and square roots of numbers, 354-355
 tables for reference, 73
 tangent lines, 171, 201
 transversal, 96, 101
 triangle, 107
 altitude of, 145
 area of, 145
 base of, 146
 equilateral, 108
 isosceles, 107
 right, 337, 338
 scalene, 108
 sum of the measures of the angles of, 118
 vertices of, 107
 union of circles, 171
 upper half-plane, 311
 "verbs", 284
 $=$, 284
 $>$, 284
 $<$, 284
 vertical angles, 83, 87
 vertices of a triangle, 107
 volume
 meaning of, 53
 of cylindrical solid, 195
 of prism, 152
 of rectangular solid, 56
 whole numbers, 245, 374
 X-axis, 307
 X-coordinate, 308, 310
 negative, 311
 positive, 311
 Y-axis, 307
 Y-coordinate, 308, 310
 negative, 311
 positive, 311
 yard, 8
 zero, 245
 zero property of multiplication, 267, 303, 374