

DOCUMENT RESUME

ED 159 028

SE 024 838

**AUTHOR** Weber, Cornelius I., Ed.  
**TITLE** Biological Field and Laboratory Methods for Measuring the Quality of Surface Waters and Effluents. Program Element 1BA027.  
**INSTITUTION** Environmental Protection Agency, Cincinnati, Ohio.  
**REPORT NO** EPA-670/4-73-001  
**PUB DATE** Jul 73  
**NOTE** 196p.; Contains occasional small, light and broken type; Pages 3-8 of Units of Weight and Measure missing from document prior to being shipped to EDRS

**EDRS PRICE** MF-\$0.83 HC-\$10.03 Plus Postage.  
**DESCRIPTORS** Biological Sciences; \*Biology; Environmental Technicians; Field Studies; \*Laboratory Techniques; \*Sampling; \*Statistical Analysis; \*Water Pollution Control; Zoology

**IDENTIFIERS** Environmental Protection Agency

**ABSTRACT**

This Environmental Protection Agency manual was developed to provide pollution biologists with the most recent methods for measuring the effects of environmental contaminants on freshwater and marine organisms. The sections of this manual include: (1) Biometrics; (2) Plankton; (3) Periphyton; (4) Macrophyton; (5) Macroinvertebrates; (6) Fish; and (7) Bioassay. Each of these sections is divided up into chapters. The Biometrics section deals primarily with introductory statistics. The section discussing Plankton covers sample collection, preservation, preparation, analysis and biomass determination. Sample collection, preservation, analysis, and preparation for Periphyton and Macrophyton are covered in those respective sections. In the section on Macroinvertebrates, selection of sampling sites, sampling methods, and data evaluation are described. Also in this section, a taxonomic bibliography for the Microinvertebrate groups is included. In the Fish section, sample collection, preservation and analysis is discussed among other things. In the final section, bioassay techniques for Phytoplankton, Periphyton, Macroinvertebrates, and Fish are described and the Flathead Minnow and Brook Trout Chronic Tests are included. References are given in all of the above sections. (MR)

\*\*\*\*\*  
 \* Reproductions supplied by EDRS are the best that can be made \*  
 \* from the original document. \*  
 \*\*\*\*\*

U.S. DEPARTMENT OF HEALTH,  
EDUCATION & WELFARE  
NATIONAL INSTITUTE OF  
EDUCATION

EPA-670/4-73-001

July 1973

THIS DOCUMENT HAS BEEN REPRODUCED EXACTLY AS RECEIVED FROM THE PERSON OR ORGANIZATION ORIGINATING IT. POINTS OF VIEW OR OPINIONS STATED DO NOT NECESSARILY REPRESENT OFFICIAL NATIONAL INSTITUTE OF EDUCATION POSITION OR POLICY.

ED159028

# BIOLOGICAL FIELD AND LABORATORY METHODS FOR MEASURING THE QUALITY OF SURFACE WATERS AND EFFLUENTS

Edited by

Cornelius I. Weber, Ph.D.  
Chief, Biological Methods  
Analytical Quality Control Laboratory  
National Environmental Research Center-Cincinnati

Program Element 1BA027

BEST COPY AVAILABLE

NATIONAL ENVIRONMENTAL RESEARCH CENTER  
OFFICE OF RESEARCH AND DEVELOPMENT  
U.S. ENVIRONMENTAL PROTECTION AGENCY  
CINCINNATI, OHIO 45268

SE 024 838

**\*Review Notice**

This report has been reviewed by the National Environmental Research Center, Cincinnati, and approved for publication. Mention of trade names or commercial products does not constitute endorsement or recommendation for use.

## FOREWORD

Man and his environment must be protected from the adverse effects of pesticides, radiation, noise and other forms of pollution, and the unwise management of solid waste. Efforts to protect the environment require a focus that recognizes the interplay between the components of our physical environment – air, water, and land. The National Environmental Research Centers provide this multidisciplinary focus through programs engaged in

- studies on the effects of environmental contaminants on man and the biosphere, and
- a search for ways to prevent contamination and to recycle valuable resources.

This manual was developed within the National Environmental Research Center – Cincinnati to provide pollution biologists with the most recent methods for measuring the effects of environmental contaminants on freshwater and marine organisms in field and laboratory studies which are carried out to establish water quality criteria for the recognized beneficial uses of water and to monitor surface water quality.

Andrew W. Breidenbach, Ph.D.  
Director  
National Environmental  
Research Center, Cincinnati, Ohio

## PREFACE

This manual was published under Research Objective Achievement Plan IBA027-05AEF, "Methods for Determining Biological Parameters of all Waters," as part of the National Analytical Methods Development Research Program. The manual was prepared largely by a standing committee of senior Agency biologists organized in 1970 to assist the Biological Methods Branch in the selection of methods for use in routine field and laboratory work in fresh and marine waters arising during short-term enforcement studies, water quality trend monitoring, effluent testing and research projects.

The methods contained in this manual are considered by the Committee to be the best available at this time. The manual will be revised and new methods will be recommended as the need arises.

The Committee attempted to avoid duplicating field and laboratory methods already adequately described for Agency use in *Standard Methods for the Examination of Water and Wastewater*, 13th edition, and frequent reference is made to this source throughout the manual.

Questions and comments regarding the contents of this manual should be directed to:

Cornelius I. Weber, Ph.D.  
Chief, Biological Methods Branch  
Analytical Quality Control Laboratory  
National Environmental Research Center  
U.S. Environmental Protection Agency  
Cincinnati, Ohio 45268

# BIOLOGICAL ADVISORY COMMITTEE

January 1, 1973

CHAIRMAN: Cornelius I. Weber, Ph. D.

| Name                    | Program   | Name                  | Program   |
|-------------------------|---|-----------------------|---|
| Anderson, Max           | Indiana Office, Region V, Evansville, IN                | Maloney, Thomas       | Natl. Eutrophication Research Program, Corvallis, OR    |
| Arthur, John W.         | Natl. Water Quality Lab, Duluth, MN                     | Mathews, John         | Region VI, Dallas, TX                                   |
| Bugbee, Stephen L.      | Region VII, Kansas City, MO                             | Murray, Thomas        | Office of Air & Water Programs, Washington, DC          |
| DeBen, Wally            | Natl. Coastal Pollution Research Program, Corvallis, OR | Nadeau, Dr. Royal     | Oil Spill Research Program, Edison, NJ                  |
| Duffer, Dr. William R.  | Natl. Water Quality Control Research Program, Ada, OK   | Nebecker, Dr. Alan V. | Western Fish Toxicology Lab, Corvallis, OR              |
| Gakstatter, Dr. Jack H. | Natl. Eutrophication Survey Program, Corvallis, OR      | Oldaker, Warren       | Region I, Needham Heights, MA                           |
| Harkins, Dr. Ralph      | Region VI, Ada, OK                                      | Parrish, Loys         | Region VIII, Denver, CO                                 |
| Horning, William        | Newtown Fish Toxicology Lab, Newtown, OH                | Phelps, Dr. Donald K. | Natl. Marine Water Quality Laboratory, Narragansett, RI |
| Ischinger, Lee          | Natl. Field Investigations Center, Cincinnati, OH       | Prager, Dr. Jan C.    | Natl. Marine Water Quality Laboratory, Narragansett, RI |
| Jackson, Dr. Herbert W. | Natl. Training Center, Cincinnati, OH                   | Preston, Ronald       | Wheeling Office, Region III, Wheeling, WV               |
| Karvelis, Ernest        | Natl. Field Investigations Center, Cincinnati, OH       | Sainsbury, John       | Region X, Seattle, WA                                   |
| Kerr, Pat               | Natl. Fate of Pollutants Research Program, Athens, GA   | Tebo, Lee             | Region IV, Athens, GA                                   |
| Keup, Lowell E.         | Office of Air & Water Programs, Washington, DC          | Thomas, Nelson A.     | Large Lakes Research Program, Grosse Ile, MI            |
| Kleveno, Conrad         | Region V, Chicago, IL                                   | Tunz, Dr. Milton      | Region IX, Alameda, CA                                  |
| LaBuy, James            | Region III, Charlottesville, VA                         | Wagner, Richard A.    | Region X, Seattle, WA                                   |
| Lassiter, Dr. Ray       | Region IV, Southeast Water Lab, Athens, GA              | Warner, Richard W.    | Natl. Field Investigations Center, Denver, CO           |

Other personnel who were former members of the Advisory Committee or assisted in the preparation of the manual:

|                    |   |                       |   |
|--------------------|---|-----------------------|---|
| Austin, R. Ted     | Natl. Eutrophication Survey, Corvallis, OR            | McKim, Dr. James      | Natl. Water Quality Lab, Duluth, MN                   |
| Boyd, Claude E.    | Savannah River Ecology Lab, Aiken, SC                 | Mackenthun, Kenneth   | Office of Air and Water Programs, EPA, Washington, DC |
| Collins, Dr. Gary  | Analytical Quality Control Lab, Cincinnati, OH        | Mason, William T. Jr. | Analytical Quality Control Lab, Cincinnati, OH        |
| Garton, Dr. Ronald | Western Fish Toxicology Lab, Corvallis, OR            | Lewis, Philip         | Analytical Quality Control Lab, Cincinnati, OH        |
| Hegre, Dr. Stanley | Natl. Marine Water Quality Lab, Narragansett, RI      | Schneider, Robert     | Natl. Field Investigations Center, Denver, CO         |
| Katko, Albert      | Natl. Eutrophication Survey, Corvallis, OR            | Seeley, Charles       | Region IX, San Francisco, CA                          |
| McFarland, Ben     | Analytical Quality Control Laboratory, Cincinnati, OH | Sinclair, Ralph       | Natl. Training Center, Cincinnati, OH                 |
|                    |   | Stephan, Charles      | Newtown Fish Toxicology Lab, Newtown, OH              |

# PERSONNEL CONTRIBUTING TO THE BIOLOGICAL METHODS MANUAL

## SUBCOMMITTEES:

### Biometrics

Lassiter, Dr. Ray – Chairman  
Harkins, Dr. Ralph  
Tebo, Lee

### Plankton

Maloney, Thomas – Chairman  
Collins, Dr. Gary  
DeBen, Wally  
Duffer, Dr. William  
Katko, Albert  
Kerr, Pat  
McFarland, Ben  
Prager, Dr. Jan  
Seeley, Charles –  
Warner, Richard

### Periphyton-Macrophyton

Anderson, Max – Chairman  
Boyd, Dr. Claude E.  
Bugbee, Stephen L.  
Keup, Lowell  
Kleveno, Conrad

### Macroinvertebrates

Tebo, Lee – Chairman  
Garton, Dr. Ronald  
Lewis, Philip A.  
Mackenthun, Kenneth  
Mason, William T., Jr.  
Nadeau, Dr. Royal  
Phelps, Dr. Donald  
Schneider, Robert  
Sinclair, Ralph

### Fish

LaBuy, James – Chairman  
Karvelis, Ernest  
Preston, Ronald  
Wagner, Richard

### Bioassay

Arthur, John – Chairman  
Hegre, Dr. Stanley  
Ischinger, Lee  
Jackson, Dr. Herbert  
Maloney, Thomas  
McKim, Dr. James  
Nebeker, Dr. Allan  
Stephan, Charles  
Thomas, Nelson

## INTRODUCTION

The role of aquatic biology in the water pollution control program of the U. S. Environmental Protection Agency includes field and laboratory studies carried out to establish water quality criteria for the recognized beneficial uses of water resources and to monitor water quality.

Field studies are employed to: measure the toxicity of specific pollutants or effluents to individual species or communities of aquatic organisms under natural conditions; detect violations of water quality standards; evaluate the trophic status of waters; and determine long-term trends in water quality.

Laboratory studies are employed to: measure the effects of known or potentially deleterious substances on aquatic organisms to estimate "safe" concentrations; and determine environmental requirements (such as temperature, pH, dissolved oxygen, etc.) of the more important and sensitive species of aquatic organisms. Field surveys and water quality monitoring are conducted principally by the regional surveillance and analysis and national enforcement programs. Laboratory studies of water quality requirements, toxicity testing, and methods development are conducted principally by the national research programs.

The effects of pollutants are reflected in the population, density, species composition and diversity, physiological condition and metabolic rates of natural aquatic communities. Methods for field surveys and long-term water quality monitoring described in this manual, therefore, are directed primarily toward sample collection and processing, organism identification, and the measurement of biomass and metabolic rates. Guidelines are also provided for data evaluation and interpretation.

There are three basic types of biological field studies; reconnaissance surveys, synoptic surveys, and comparative evaluations. Although there is a considerable amount of overlap, each of the above types has specific requirements in terms of study design.

*Reconnaissance* surveys may range from a brief perusal of the study area by boat, plane, or

car, to an actual field-study in which samples are collected for the purpose of characterizing the physical boundaries of the various habitat types (substrate, current, depth, etc.) and obtaining cursory information on the flora and fauna. Although they may be an end in themselves, reconnaissance surveys are generally conducted with a view to obtaining information adequate to design more comprehensive studies. They may be quantitative or qualitative in approach. As discussed in the biometrics section, quantitative reconnaissance samples are very useful for evaluating the amount of sampling effort required to obtain the desired level of precision in more detailed studies.

*Synoptic* surveys generally involve an attempt to determine the kinds and relative abundance of organisms present in the environment being studied. This type of study may be expanded to include quantitative estimates of standing crop or production of biomass, but is generally more qualitative in approach. Systematic sampling, in which a deliberate attempt is made to collect specimens from all recognizable habitats, is generally utilized in synoptic surveys. Synoptic surveys provide useful background data, are valuable for evaluating seasonal changes in species present, and provide useful information for long-term surveillance programs.

The more usual type of field studies involve *comparative evaluations*, which may take various forms including: comparisons of the flora and fauna in different areas of the same body of water, such as conventional "upstream-downstream" studies; comparisons of the flora and fauna at a given location in a body of water over time, such as is the case in trend monitoring; and comparisons of the flora and fauna in different bodies of water.

Comparative studies frequently involve both quantitative and qualitative approaches. However, as previously pointed out, the choice is often dependent upon such factors as available resources, time limitations, and characteristics of the habitat to be studied. The latter factor may be quite important because the habitat to be studied may not be amenable to the use of quan-



titative sampling devices.

A special field method that warrants a brief notation is scuba (Self Contained Underwater Breathing Apparatus). Scuba enables the biologist to observe, first hand, conditions that otherwise could be described only from sediment, chemical, physical, and biological samples taken with various surface-operated equipment. Equipment modified from standard sampling equipment or prefabricated, installed, and/or operated by scuba divers has proven very valuable in assessing the environmental conditions where surface sampling gear was inadequate. Underwater photography presents visual evidence of existing conditions and permits the monitoring of long-term changes in an aquatic environment.\*

By utilizing such underwater habitats as Tektite and Sublimnos, biologists can observe, collect, and analyze samples without leaving the aquatic environment. Scuba is a very effective tool available to the aquatic biologist, and methods incorporating scuba should be considered for use in situations where equipment operated at the surface does not provide sufficient information.

\*Braidech, T.E., P.E. Gehring, and C.O. Kleveno. Biological studies related to oxygen depletion and nutrient regeneration processes in the Lake Erie Basin. Project Hypo-Canada Centre for Inland Waters, Paper No. 6, U. S. Environmental Protection Agency Technical Report TS05-71-208-24, February 1972.

## SAFETY

The hazards associated with work on or near water require special consideration. Personnel should not be assigned to duty alone in boats, and should be competent in the use of boating equipment (courses are offered by the U. S. Coast Guard). Field training should also include instructions on the proper rigging and handling of biological sampling gear.

Life preservers (jacket type work vests) should be worn at all times when on or near deep water. Boats should have air-tight or foam-filled compartments for flotation and be equipped with fire extinguishers, running lights, oars, and anchor. The use of inflatable plastic or rubber boats is discouraged.

All boat trailers should have two rear running and stop lights and turn signals and a license plate illuminator. Trailers 80 inches (wheel to wheel) or more wide should be equipped with amber marker lights on the front and rear of the frame on both sides.

Laboratories should be provided with fire extinguishers, fume hoods, and eye fountains. Safety glasses should be worn when mixing dangerous chemicals and preservatives.

A copy of the *EPA Safety Manual* is available from the Office of Administration, Washington, D.C.

## CONTENTS

FOREWORD

PRÉFACE

BIOLOGICAL ADVISORY COMMITTEE

PERSONNEL CONTRIBUTING TO THE  
BIOLOGICAL METHODS MANUAL

INTRODUCTION

BIOMETRICS

PLANKTON

PERIPHYTON

MACROPHYTON

MACROINVERTEBRATES

FISH

BIOASSAY

APPENDIX

# BIOMETRICS

11 4

# BIOMETRICS

|   | Page |
|---|------|
| 1.0 INTRODUCTION                                    | 1    |
| 1.1 Terminology                                     | 1    |
| 2.0 STUDY DESIGN                                    | 2    |
| 2.1 Randomization                                   | 2    |
| 2.2 Sample Size                                     | 4    |
| 2.3 Subsampling                                     | 6    |
| 3.0 GRAPHIC EXAMINATION OF DATA                     | 6    |
| 3.1 Raw Data  | 6    |
| 3.2 Frequency Histograms                            | 6    |
| 3.3 Frequency Polygon                               | 7    |
| 3.4 Cumulative Frequency                            | 7    |
| 3.5 Two-dimensional Graphs                          | 8    |
| 4.0 SAMPLE MEAN AND VARIANCE                        | 9    |
| 4.1 General Application                             | 9    |
| 4.2 Statistics for Stratified Random Samples        | 10   |
| 4.3 Statistics for Subsamples                       | 10   |
| 4.4 Rounding  | 10   |
| 5.0 TESTS OF HYPOTHESES                             | 11   |
| 5.1 T-test  | 11   |
| 5.2 Chi Square Test                                 | 13   |
| 5.3 F-test  | 15   |
| 5.4 Analysis of Variance                            | 15   |
| 6.0 CONFIDENCE INTERVALS FOR MEANS<br>AND VARIANCES | 18   |
| 7.0 LINEAR REGRESSION AND CORRELATION               | 19   |
| 7.1 Basic Concepts                                  | 19   |
| 7.2 Basic Computations                              | 20   |
| 7.3 Tests of Hypotheses                             | 24   |
| 7.4 Regression for Bivariate Data                   | 26   |
| 7.5 Linear Correlation                              | 27   |
| 8.0 BIBLIOGRAPHY                                    | 27   |

# BIOMETRICS

## 1.0 INTRODUCTION

Field and laboratory studies should be well-planned in advance to assure the collection of unbiased and precise data which are technically defensible and amenable to statistical evaluation. The purpose of this chapter is to present some of the basic concepts and techniques of sampling design and data evaluation that can be easily applied by biologists.

An attempt has been made to present the material in a format comfortable to the non-statistician, and examples are used to illustrate most of the techniques.

### 1.1 Terminology

To avoid ambiguity in the following discussions, the basic terms must be defined. Most of the terms are widely used in everyday language, but in biometry may be used in a very restricted sense.

#### 1.1.1 Experiment

An experiment is often considered to be a rigidly controlled laboratory investigation, but in this chapter the terms experiment, study, and field study are used interchangeably as the context seems to require. A general definition which will usually fit either of these terms is "any scientific endeavor where observations or measurements are made in order to draw inferences about the real world."

#### 1.1.2 Observation

This term is used here in much the same manner as it is in everyday language. Often the context will suggest using the term "measurement" in place of "observation." This will imply a quantified observation. For statistical purposes, an observation is a record representing some property or characteristic of a real-world object.

This may be a numeric value representing the weight of a fish, a check mark indicating the presence of some species in a bottom quadrat — in short, any type of observation.

#### 1.1.3 Characteristics of interest

In any experiment or sampling study, many types of observations or measurements could be made. Usually, however, there are few types of measurements that are related to the purpose of the study. The measurement of chlorophyll or ATP in a plankton haul may be of interest, whereas the cell count or detritus content may not be of interest. Thus, the characteristic of interest is the characteristic to be observed or measured, the measurements recorded, analyzed and interpreted in order to draw an inference about the real world.

#### 1.1.4 Universe and experimental unit

The experimental unit is the object upon which an observation is made. The characteristic of interest to the study is observed and recorded for each unit. The experimental unit may be referred to in some cases as the sampling unit. For example, a fish, an entire catch, a liter of pond water, or a square meter of bottom may each be an experimental unit. The experimental unit must be clearly defined so as to restrict measurements to only those units of interest to the study. The set of all experimental units of interest to the study is termed the "universe."

#### 1.1.5 Population and sample

In biology, a population is considered to be a group of individuals of the same species. The statistical use of the term *population*, however, refers to the set of values for the characteristic of interest for the entire group of experimental units about which the inferences are to be made (universe).

When studies are made, observations are not usually taken for all possible experimental units. Only a sample is taken. A sample is a *set of observations*, usually only a small fraction of the total number of observations that conceivably could be taken, and is a subset of the population. The term *sample* is often used in everyday language to mean a portion of the real world which has been selected for measurement, such as a water

## BIOLOGICAL METHODS

sample or a plankton haul. However, in this section the term "sample" will be used to denote "a set of observations" — the written records themselves.

### 1.1.6 Parameter and statistic

When we attempt to characterize a population, we realize that we can never obtain a perfect answer, so we settle for whatever accuracy and precision that is required. We try to take an adequately-sized sample and compute a number from our sample that is representative of the population. For example, if we are interested in the population mean, we take a sample and compute the sample mean. The sample mean is referred to as a statistic, whereas the population mean is referred to as a parameter. In general, the statistic is related to the parameter in much the same way as the sample is related to the population. Hence, we speak of population parameters and sample statistics.

Obviously many samples may be selected from most populations. If there is variability in the population, a statistic computed from one sample will differ somewhat from the same statistic computed from another sample. Hence, whereas a parameter such as the population mean is fixed, the statistic or sample mean is a variable, and there is uncertainty associated with it as an estimator of the population parameter which derives from the variation among samples.

## 2.0 STUDY DESIGN

### 2.1 Randomization

In biological studies, the experimental units (sampling units or sampling points) must be selected with known probability. Usually, random selection is the only feasible means of satisfying the "known probability" criterion. The question of why known probability is required is a valid one. The answer is that only by knowing the probability of selection of a sample can we extrapolate from the sample to the population in an objective way. The probability allows us to place a weight upon an observation in making our extrapolation to the population. There is no other quantifiable measure of "how well" the selected sample represents the population.

Thus our efforts to select a "good" sample should include an appropriate effort to define the problem in such a way as to allow us to estimate the parameter of interest using a sample of known probability; i.e., a random sample.

The preceding discussion should leave little doubt that there is a fundamental distinction between a "haphazardly-selected" sample and a "randomly-selected" sample. The distinction is that a haphazardly-selected sample is one where there is *no conscious bias*, whereas a randomly-selected sample is one where there is *consciously no bias*. There is consciously no bias because the randomization is planned, and therefore bias is planned out of the study. This is usually accomplished with the aid of a table of random numbers. A sample selected according to a plan that includes random selection of experimental units is the only sample validly called a random sample.

Reference to the definition of the term, sample, at the beginning of the chapter will remind us that a sample consists of a set of observations, each made upon an experimental or sampling unit. To sample randomly, the entire set of sampling units (population) must be identifiable and enumerated. Sometimes the task of enumeration may be considerable, but often it may be minimized by such conveniences as maps, that allow easier access to adequate representation of the entity to be sampled.

The comment has frequently been made that random sampling causes effort to be put into drawing samples of little meaning or utility to the study. This need not be the case. Sampling units should be defined by the investigator so as to eliminate those units which are potentially of no interest. Stratification can be used to place less emphasis on those units which are of less interest.

Much of the work done in biological field studies is aimed at explaining spatial distributions of population densities or of some parameter related to population densities and the measurement of rates of change which permit prediction of some future course of a biologically-related parameter. In these cases the sampling unit is a unit of space (volume, area). Even in cases where the sampling unit is not a unit of space, the problem may often be stated

in such a manner that a unit of space may be used, so that random sampling may be more easily carried out.

For example, suppose the problem is to estimate the chlorophyll content of algae in a pond at a particular time of year. The measurement is upon algae, yet the sample consists of a volume of water. We could use our knowledge of the way the algae are spatially distributed or make some reasonable assumptions, then construct a random sampling scheme based upon a unit of volume (liter) as the basic sampling unit.

It is not always a simple or straightforward matter to define sampling units, because of the dynamic nature of living populations. Many aquatic organisms are mobile, and even rooted or sessile forms change with time, so that changes occurring during the study often make data interpretation difficult. Thus the benefit to be derived from any attempt to consider such factors in the planning stage will be considerable.

Random sample selection is a subject apart from the selection of the study site. It is of use only after the study objectives have been defined, the type of measurements have been selected, and the sampling units have been defined. At this point, random sampling provides an objective means of obtaining information to achieve the objectives of the study.

One satisfactory method of random sample selection is described. First, number the universe or entire set of sampling units from which the sample will be selected. This number is  $N$ . Then from a table of random numbers select as many random numbers,  $n$ , as there will be sampling units selected for the sample. Random number tables are available in most applied statistics texts or books of mathematical tables. Select a starting point in the table and read the numbers consecutively in any direction (across, diagonal, down, up). The number of observations,  $n$  (sample size), must be determined prior to sampling. For example, if  $n$  is a two-digit number, select two-digit numbers ignoring any number greater than  $n$  or any number that has already been selected. These numbers will be the numbers of the sampling units to be selected.

To obtain reliable data, information about the

statistical population is needed in advance of the full scale study. This information may be obtained from prior related studies, gained by pre-study reconnaissance, or if no direct information is available, professional opinion about the characteristics of the population may be relied upon.

### 2.1.1 Simple random sampling

Simple (or unrestricted) random sampling is used when there is no reason to subdivide the population from which the sample is drawn. The sample is drawn such that every unit of the population has an equal chance of being selected. This may be accomplished by using the random selection scheme already described.

### 2.1.2 Stratified random sampling

If any knowledge of the expected size or variation of the observations is available, it can often be used as a guide in subdividing the population into subpopulations (strata) with a resulting increase in efficiency of estimation. Perhaps the most profitable means of obtaining information for stratification is through a pre-study reconnaissance (a pilot study). The pilot study planning should be done carefully, perhaps stratifying based upon suspected variability. The results of the pilot study may be used to obtain estimates of variances needed to establish sample size. Other advantages of the pilot study are that it accomplishes a detailed reconnaissance, and it provides the opportunity to obtain experience in the actual field situation where the final study will be made. Information obtained and difficulties encountered may often be used to set up a more realistic study and avoid costly and needless expenditures. To maximize precision, strata should be constructed such that the observations are most alike within strata and most different among strata, i.e., minimum variance within strata and maximum variance among strata. In practice, the information used to form strata will usually be from previously obtained data, or information about characteristics correlated with the characteristic of interest. In aquatic field situations, stratification may be based upon depth, bottom type, isotherms, and numerous other variables suspected of being correlated with the character-



## BIOLOGICAL METHODS

istic of interest. Stratification is often done on other bases such as convenience or administrative imperative, but except where these correspond with criteria which minimize the variation within strata, no gain in precision may be expected.

### *Number of Strata*

In aquatic biological field studies, the use of knowledge of biological cause-and-effect may help define reasonable strata (e.g., thermoclines, sediment types, etc., may markedly affect the organisms so that the environmental feature may be the obvious choice for the strata divisions). Where a gradient is suspected and where stratification is based on a factor correlated to an unknown degree with the characteristic of interest, the answer to the question of how many strata to form and where to locate their boundaries is not clear. Usually as many strata are selected as may be handled in the study. In practice, gains in efficiency due to stratification usually become negligible after only a few divisions unless the characteristic used as the basis of stratification is very highly correlated with the characteristic of interest.

### *2.1.3 Systematic random sampling*

In field studies, the biologist frequently wishes to use some sort of transect, perhaps to be assured of including an adequate cross section while maintaining relative ease of sampling. The use of transects is an example of systematic sampling. However, a random starting point is chosen along the transect to introduce the randomness needed to guarantee freedom from bias and allow statistical inference.

The method of placement of the transect should be given a great deal of thought. Often transects are set up arbitrarily, but they should not be. To avoid arbitrariness, randomization should be employed in transect placement.

## 2.2 Sample Size

### *2.2.1 Simple random sampling*

In any study, one important early question is that of the size of the sample. The question is important because if, on the one hand, a sample is too large, the effort is wasteful, and if, on the

other hand, a sample is too small, the question of importance to the study may not be properly answered.

### *Case 1 – Estimation of a Binomial Proportion*

An estimate of the proportion of occurrence of the two categories must be available. If the categories are presence and absence, let the probability of observing a presence be  $P$  ( $0 < P < 1$ ) and the probability of observing an absence be  $Q$  ( $0 < Q < 1$ ,  $P + Q = 1$ ). The second type of information which is needed is an acceptable magnitude of error,  $d$ , in estimating  $P$  (and hence  $Q$ ). With this information, together with the size,  $n$ , of the population, the formula for  $n$  as an initial approximation ( $n_0$ ), is:

$$n_0 = \frac{t^2 PQ}{d^2} \quad (1)$$

The value for  $t$  is obtained from tables of "Student's  $t$ " distribution, but for the initial computation the value 2 may be used to obtain a sample size,  $n_0$ , that will ensure with a .95 probability, that  $P$  is within  $d$  of its true value. If  $n_0$  is less than 30, use a second calculation where  $t$  is obtained from a table of "Student's  $t$ " with  $n_0 - 1$  degrees of freedom. If the calculation results in an  $n_0$ , where  $\frac{n_0}{N} < .05$ , no further calculation is warranted. Use  $n_0$  as the sample size. If  $\frac{n_0}{N} > .05$ , make the following computation:

$$n = \frac{n_0}{1 + \frac{n_0 - 1}{N}} \quad (2)$$

### *Case 2 – Estimation of a Population Mean for Measurement Data*

In this case an estimate of the variance,  $s^2$ , must be obtained from some source, and a statement of the margin of error,  $d$ , must be expressed in the same units as are the sample observations. To calculate an initial sample size:

$$n_0 = \frac{t^2 s^2}{d^2} \quad (3)$$



If  $n_0 < 30$ , recalculate using  $t$  from the tables, and if  $\frac{n_0}{N} > .05$ , a further calculation is in order:

$$n = \frac{n_0}{1 + \frac{n_0}{N}} \quad (4)$$

After a sample of size,  $n$ , is obtained from the population, the basic sample statistics may be calculated. The calculations are the same as for equations (11) through (15) unless the sample size,  $n$ , is greater than 5 percent of the population  $N$ . If  $\frac{n}{N} > .05$ , a correction factor is used so that the calculation for the sample variance is:

$$s^2 = \left(\frac{N-n}{N}\right) \frac{\sum X_i^2 - \frac{(\sum X_i)^2}{n}}{n-1} \quad (5)$$

The other calculations make use of,  $s^2$ , as calculated above, wherever  $s^2$  appears in the formulas.

### 2.2.2 Stratified random sampling

To compute the sample size required to obtain an estimate of the mean within a specified acceptable error, computations can be made similar to those for simple random sampling: a probability level must be specified; an estimate of the variance within each stratum must be available; and the number of sampling units in each stratum must be known. Although this involves a good deal of work, it illustrates the need for a pilot study and indicates that we must know something about the phenomena we are studying if we are to plan an effective sampling program.

If the pilot study or other sources of information have resulted in what are considered to be reliable estimates of the variance within strata, the sampling can be optimally allocated to strata. Otherwise proportional allocation should be used. Optimal allocation, properly used, will result in more precise estimates for a given sample size.

For proportional allocation the calculation for sample size is:

$$n = \frac{t^2 \sum N_k s_k^2}{N d^2 + \sum N_k s_k^2} \quad (6)$$

where  $t$  = the entry for the desired probability level from a table of "Student's  $t$ " (use 2 for a rough estimate);  $N_k$  = the number of sampling units in stratum  $k$ ;  $s_k^2$  = the variance of stratum  $k$ ;  $N$  = the total number of sampling units in all strata; and  $d$  = the acceptable error expressed in the same units as the observations.

For optimal allocation, the calculation is:

$$n = \frac{t^2 (\sum N_k s_k)^2}{N^2 d^2 + t^2 \sum N_k s_k^2} \quad (7)$$

where the symbols are the same as above and where  $s_k = \sqrt{s_k^2}$ , the standard deviation of stratum  $k$  [see Equations (16) to (19)].

Having established sample size, it remains to determine the portion of the sample to be allocated to each stratum.

For proportional allocation:

$$n_k = \frac{n N_k}{N} \quad (8)$$

where  $n_k$  = the number of observations to be made in stratum  $k$ .

For optimal allocation:

$$n_k = \frac{n N_k s_k}{\sum N_k s_k} \quad (9)$$

Sample selection within each stratum is performed in the same manner as for simple random sampling.

### 2.2.3 Systematic random sampling

After the location of a transect line is selected, the number of experimental units (the number of possible sampling points) along this line must be determined. This may be done in many ways depending upon the particular situation. Possible examples are the number of square meter plots of bottom centered along a 100-meter transect ( $N = 100$ ); or the meters of distance along a 400-meter transect as points of departure for making a plankton haul of some predetermined duration perpendicular to the transect. (In the second example, a question of subsampling or some assumption about local, homogeneous distribution might arise since the plankton net has a radius less than one meter). The interval of sampling,  $C$ , determines sample

## BIOLOGICAL METHODS

size:  $n = N/C$ . The mean is estimated as usual; the variance as for a simple random sample if there are no trends, periodicities, or other non-random effects.

### 2.3 Subsampling

Situations often arise where it is natural or imperative that the sampling units are defined in a two-step manner. For example: colonies of benthic organisms might be the first step, and the measurement of some characteristic on the individuals within the colony might be the second step; or streams might be the first (primary) step, and reaches, riffles or pools as the second step (or element) within the unit. When a sample of primary units is selected, and then for each primary unit a sample is selected by observing some element of the primary unit, the sampling scheme is known as subsampling or two-stage sampling. The computations are straight forward, but somewhat more involved.

The method of selection of the primary units must be established. It may be a simple random sample (equal probabilities), a stratified random sample (equal probabilities within strata), or other scheme such as probability proportional to size (or estimated size) of primary unit. In any case, let us call the probability of selection of the  $i^{\text{th}}$  primary unit,  $Z_i$ . For simple random sampling,  $Z_i = \frac{1}{N}$ , where  $N$  is the number of primary units in the universe. For stratified random sampling,  $Z_{ki} = \frac{1}{N_k}$ , where  $k$  signifies the  $k^{\text{th}}$  stratum. For selection in which the primary units are selected with probability proportional to their size, the probability of selection of the  $j^{\text{th}}$  primary unit is

$$Z_j = \frac{L_j}{\sum_{i=1}^n L_i} \quad (10)$$

where  $L$  equals the number of elements in the primary unit indicated by its subscript. If stratification is used with the latter scheme, merely apply the rule to each stratum. Other methods of assigning probability of selection may be used. The important thing is to establish the probability of selection for each primary unit.

## 3.0 GRAPHIC EXAMINATION OF DATA

Often the most elementary techniques are of the greatest use in data interpretation. Visual examination of data can point the way for more discriminatory analyses, or on the other hand, interpretations may become so obvious that further analysis is superfluous. In either case, graphical examination of data is often the most effortless way to obtain an initial examination of data and affords the chance to organize the data. Therefore, it is often done as a first step. Some commonly used techniques are presented below. Cell counts (algal cells per milliliter) will serve as the numeric example (Table 1).

### 3.1 Raw Data

As brought out in other chapters of this manual, it is of utmost importance that raw data be recorded in a careful, logical, interpretable manner together with appropriate, but not superfluous, annotations. Note that although some annotations may be considered superfluous to the immediate intent of the data, they may not be so for other purposes. Any note that might aid in determining whether the data are comparable to other similar data, etc., should be recorded if possible.

### 3.2 Frequency Histograms

To construct a frequency histogram from the data of Table 1, examine the raw data to determine the range, then establish intervals. Choose the intervals with care so they will be optimally integrative and differentiative. If the intervals are too wide, too many observations will be integrated into one interval and the picture will be hidden; if too narrow, too few will fall into one interval and a confusing overdifferentiation or overspreading of the data will result. It is often enlightening if the same data are plotted with the use of several interval sizes. Construct the intervals so that no doubt exist as to which interval an observation belongs, i.e., the end of one interval must not be the same number as the beginning of the next.

The algal count data in Tables 2 and 3 were grouped by two interval sizes (10,000 cells/ml and 20,000 cells/ml). It is easy to see that the data are grouped largely in the range 0 to  $6 \times 10^4$  cells/ml and that the frequency of occurrence is

TABLE 1. RAW DATA ON PLANKTON COUNTS

| Date   | Count   | Date    | Count   | Date    | Count  |
|--------|---------|---------|---------|---------|--------|
| June 8 | 23,077  | June 25 | 7,692   | July 11 | 44,231 |
|        | 36,538  | 26      | 23,077  | 12      | 50,000 |
|        | 26,923  | 27      | 134,615 | 13      | 26,923 |
| 11     | 23,077  | 28      | 32,692  | 14      | 44,231 |
| 12     | 13,462  | 29      | 25,000  | 15      | 46,154 |
| 13     | 19,231  | 30      | 146,154 | 16      | 55,768 |
| 14     | 21,154  | July 1  | 107,692 | 17      | 9,615  |
| 15     | 61,538  | 2       | 13,462  | 18      | 13,462 |
| 16     | 96,154  | 3       | 9,615   | 19      | 3,846  |
| 17     | 23,077  | 4       | 148,077 | 20      | 3,846  |
| 18     | 46,154  | 5       | 53,846  | 21      | 11,538 |
| 19     | 48,077  | 6       | 103,846 | 22      | 7,692  |
| 20     | 51,923  | 7       | 78,846  | 23      | 13,462 |
| 21     | 50,000  | 8       | 132,692 | 24      | 21,154 |
| 22     | 292,308 | 9       | 228,846 | 25      | 17,308 |
| 23     | 165,385 | 10      | 307,692 |         |        |
| 24     | 42,308  |         |         |         |        |

lesser, the larger the value. Closer inspection will reveal that with the finer interval width (Table 2), the frequency of occurrence does not increase monotonically as cell count decreases. Rather, the frequency peak is found in the interval 20,000 to 30,000 cells/ml. This observation was not possible using the coarser interval width; the frequencies were "overintegrated" and did not reveal this part of the pattern. Finer interval widths could further change the picture presented by each of these groupings.

Although a frequency table contains all the information that a comparable histogram contains, the graphical value of a histogram is usually worth the small effort required for its construction. Figures 1 and 2 are frequency histograms corresponding to Tables 2 and 3, respectively. It can be seen that the histograms are more immediately interpretable. The height of each bar is the frequency of the interval; the width is the interval width.

3.3 Frequency Polygon

Another way to present essentially the same information as that in a frequency histogram is the use of a frequency polygon. Plot points at the height of the frequency and at the midpoint of the interval, and connect the points with straight lines. The data of Table 3 are used to

TABLE 2. FREQUENCY TABLE FOR DATA IN TABLE 1 GROUPED AT AN INTERVAL WIDTH OF 10,000 CELLS/ML

| Interval  | Frequency | Interval  | Frequency |
|-----------|-----------|-----------|-----------|
| 0 - 10    | 6         | 200 - 210 | 0         |
| 10 - 20   | 7         | 210 - 220 | 0         |
| 20 - 30   | 9         | 220 - 230 | 1         |
| 30 - 40   | 2         | 230 - 240 | 0         |
| 40 - 50   | 6         | 240 - 250 | 0         |
| 50 - 60   | 5         | 250 - 260 | 0         |
| 60 - 70   | 1         | 260 - 270 | 0         |
| 70 - 80   | 1         | 270 - 280 | 0         |
| 80 - 90   | 0         | 280 - 290 | 0         |
| 90 - 100  | 1         | 290 - 300 | 1         |
| 100 - 110 | 2         | 300 - 310 | 1         |
| 110 - 120 | 0         | 310 - 320 | 0         |
| 120 - 130 | 0         | 320 - 330 | 0         |
| 130 - 140 | 2         | 330 - 340 | 0         |
| 140 - 150 | 2         | 340 - 350 | 0         |
| 150 - 160 | 0         | 350 - 360 | 0         |
| 160 - 170 | 1         | 360 - 370 | 0         |
| 170 - 180 | 0         | 370 - 380 | 0         |
| 180 - 190 | 0         | 380 - 390 | 0         |
| 190 - 200 | 0         | 390 - 400 | 0         |

illustrate the frequency polygon in Figure 3.

3.4 Cumulative Frequency

Cumulative frequency plots are often useful in data interpretation. As an example, a cumulative frequency histogram (Figure 4) was constructed using the frequency table (Table 2 or 3). The height of a bar (frequency) is the sum of all frequencies up to and including the one being plotted. Thus, the first bar will be the same as the frequency histogram, the second bar equals the sum of the first and second bars of the frequency histogram, etc., and the last bar is the sum of all frequencies.

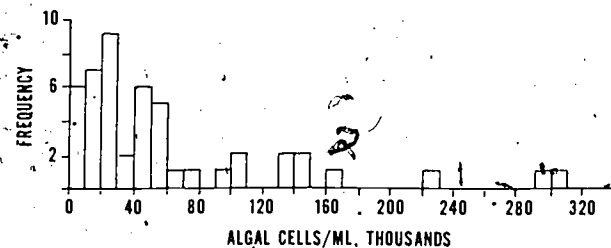

Figure 1. Frequency histogram; interval width is 10,000 cells/ml.

## BIOLOGICAL METHODS

TABLE 3. FREQUENCY TABLE FOR DATA IN TABLE 1 GROUPED AT AN INTERVAL WIDTH OF 20,000 CELLS/ML.

| Interval  | Frequency | Interval  | Frequency |
|-----------|-----------|-----------|-----------|
| 0 - 20    | 13        | 200 - 220 | 0         |
| 20 - 40   | 11        | 220 - 240 | 1         |
| 40 - 60   | 11        | 240 - 260 | 0         |
| 60 - 80   | 2         | 260 - 280 | 0         |
| 80 - 100  | 1         | 280 - 300 | 1         |
| 100 - 120 | 2         | 300 - 320 | 1         |
| 120 - 140 | 2         | 320 - 340 | 0         |
| 140 - 160 | 2         | 340 - 360 | 0         |
| 160 - 180 | 1         | 360 - 380 | 0         |
| 180 - 200 | 0         | 380 - 400 | 0         |

Closely related to the cumulative frequency histogram is the cumulative frequency distribution graph, a graph of relative frequencies. To obtain the cumulative graph, merely change the scale of the frequency axis on the cumulative frequency histogram. The scale change is made by dividing all values on the scale by the highest value on the scale (in this case the number of observations or 48).

The value of the cumulative frequency distribution graph is to allow relative frequency to be read, i.e., the fraction of observations less than or equal to some chosen value. Exercise caution in extrapolating from a cumulative frequency distribution to other situations. Always bear in mind that in spite of a planned lack of bias, each sample, or restricted set of samples, is subject to influences not accounted for and is therefore unique. This caution is all the more pertinent for cumulative frequency plots because they tend to

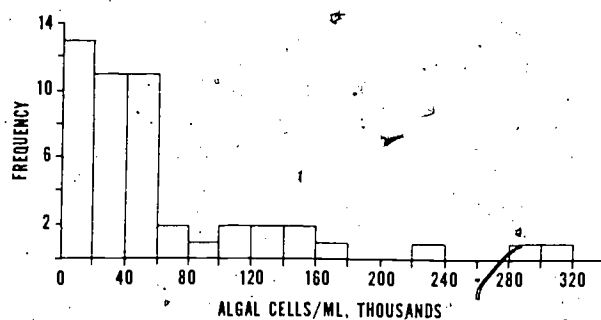

Figure 2. Frequency histogram; interval width is 20,000 cells/ml.

smooth out some of the variation noticed in the frequency histogram. In addition, the phrase "fraction of observations less than or equal to some chosen value" can easily be read "fraction of time the observation is less than or equal to some chosen value." It is tempting to generalize from this reading and extend these results beyond their range of applicability.

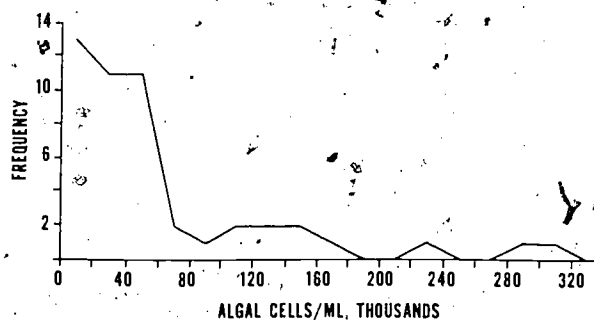

Figure 3. Frequency polygon; interval width is 20,000 cells/ml.

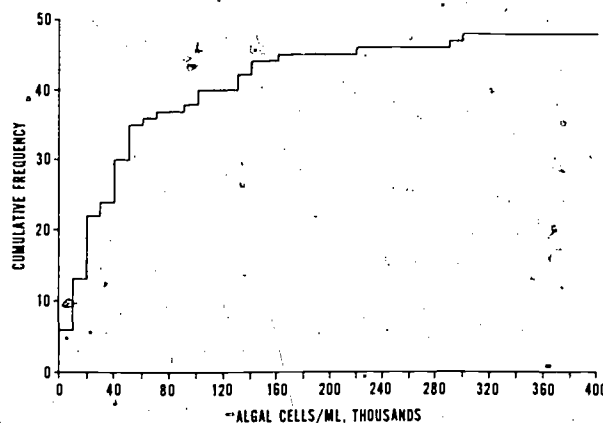

Figure 4. Cumulative frequency histogram; interval width is 10,000 cells/ml.

### 3.5 Two-dimensional Graphs

Often data are taken where the observations are recorded as a pair (cell count and time), (biomass and nutrient concentration). Here a quick plot of the set of pairs will usually be of value. Figure 5 is such a graph of data taken from Table 1. Each point is plotted at a height

corresponding to cell count and at a distance from the ordinate axis corresponding to the number of days since the beginning observation. The peaks and troughs, their frequency, together with intimate knowledge of the conditions of the study, might suggest something of biological interest, further statistical analysis, or further field or laboratory work.

In summary, carefully prepared tables and graphs may be important and informative steps in data analysis. The added effort is usually small, whereas gains in interpretive insight may be large. Therefore, graphic examination of data is a recommended procedure in the course of most investigations.

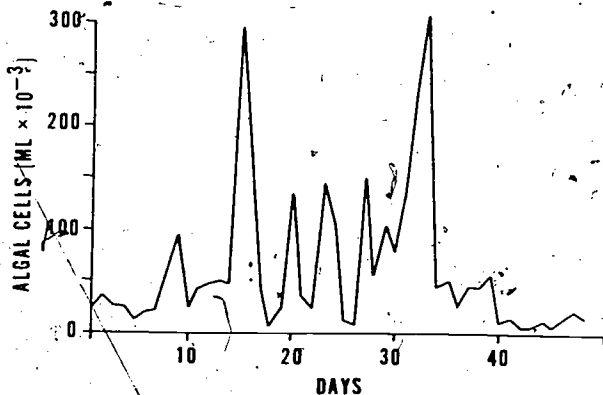

Figure 5. An example of a two-dimensional graph plotted from algal-count data in Table 1.

## 4.0 SAMPLE MEAN AND VARIANCE

### 4.1 General Application

Knowledge of certain computations and computational notations is essential to the use of statistical techniques. Some of the more basic of these will be briefly reviewed here.

To illustrate the computations, let us assume we have a set of data, i.e., a list of numeric values written down. Each of these values can be labeled by a set of numerals beginning with 1. Thus, the *first* of these values can be called  $X_1$ , the *second*  $X_2$ , etc., and the *last* one we call  $X_n$ .

The data values are labeled with consecutive numbers (recall from the definitions that these numeric values are observations), and there are  $n$  values in the set of data. A typical observation is  $X_i$ , where  $i$  may take any value between 1 and  $n$ , inclusive, and the subscript indicates which  $X$  is being referenced.

The sum of the numbers in a data set, such as our sample, is indicated in statistical computations by capital-sigma,  $\Sigma$ . Associated with  $\Sigma$  are an operand (here,  $X_i$ ), a subscript (here,  $i = 1$ ),

and a superscript (here,  $n$ ),  $\sum_{i=1}^n X_i$ . The subscript  $i = 1$  indicates that the value of the operand  $X$  is to be the number labeled  $X_1$  in our data set and that this is to be the first observation of the sum. The superscript  $n$  indicates that the last number of the summation is to be the value of  $X_n$ , the last  $X$  in our data set.

Computations for the mean, variance, standard deviation, variance of the mean, and standard deviation of the mean (standard error) are presented below. Note that these are computations for a sample of  $n$  observations, i.e., they are statistics.

Mean ( $\bar{X}$ ):

$$\bar{X} = \frac{\sum_{i=1}^n X_i}{n} \quad (11)$$

Variance ( $s^2$ ):

$$s^2 = \frac{\sum_{i=1}^n X_i^2 - \frac{(\sum_{i=1}^n X_i)^2}{n}}{n-1} \quad (12)$$

Note: The  $X_i$ 's are squared, then the summation is performed in the first term of the numerator; in the second term, the sum of the  $X_i$ 's is first formed, then the sum is squared, as indicated by the parentheses.

Standard deviation ( $s$ ):

$$s = \sqrt{s^2} \quad (13)$$

Variance of the mean ( $s_{\bar{X}}^2$ ):

$$s_{\bar{X}}^2 = \frac{s^2}{n} \quad (14)$$

## BIOLOGICAL METHODS

Standard deviation of the mean or standard error ( $s_{\bar{X}}$ ):

$$s_{\bar{X}} = \sqrt{\frac{s^2}{n}} = \frac{s}{\sqrt{n}} \quad (15)$$

### 4.2 Statistics for Stratified Random Sampling

The calculations of the sample statistics for stratified random sampling are as follows (see 2.2.2 Stratified random samples):

For the mean of stratum k:

$$\bar{y}_k = \frac{\sum_{i=1}^{n_k} y_{ki}}{n_k} \quad (16)$$

i.e., simply compute an arithmetic average for the measurements of stratum k.

For the variance of stratum k:

$$s^2 = \frac{\sum_{i=1}^{n_k} y_{ki}^2 - \left( \frac{\sum_{i=1}^{n_k} y_{ki}}{n_k} \right)^2}{n_k - 1} \quad (17)$$

i.e., simply Equation 12 applied to the data of the k<sup>th</sup> stratum.

For the mean of the stratified sample:

$$\bar{y}_{st} = \frac{\sum_{k=1}^m N_k \bar{y}_k}{N} \quad (18)$$

for either type allocation or alternatively for proportional allocation:

$$\bar{y}_{st} = \frac{\sum_{k=1}^m n_k \bar{y}_k}{n} \quad (19)$$

Note that Equations (18) and (19) are identical only for proportional allocation.

### 4.3 Statistics for Subsamples

If simple random sampling is used to select a subsample, the following formulas are used to calculate the sample statistics (see 2.3 Sub-

sampling):

For the sample mean:

$$\bar{y} = \frac{1}{n} \sum_{i=1}^n \left( \frac{L_i \bar{y}_i}{Z_i} \right) \quad (20)$$

where  $\bar{y}$  is the average, computed over subsamples as well as for the sample

$$\bar{y}_i = \frac{\sum_{j=1}^{L_i} y_{ij}}{L_i} \quad (21)$$

where  $y_{ij}$  equals the observation for the j<sup>th</sup> element in the i<sup>th</sup> primary unit, and  $L_i$  is the number of observations upon elements for primary unit i.

For the variance of the sample mean:

$$s^2(\bar{y}) = \frac{1}{n(n-1)} \sum_{i=1}^n \left( \frac{L_i}{Z_i} \right)^2 (Y_i - \hat{Y}_n)^2 \quad (22)$$

where  $\hat{Y}_i$  is computed as

$$\hat{Y}_i = \frac{L_i \bar{y}_i}{Z_i} \quad (23)$$

where  $\hat{Y}_n$  is computed as

$$\hat{Y}_n = \frac{1}{n} \sum_{i=1}^n \hat{Y}_i = \bar{y} \sum_{i=1}^n L_i \quad (24)$$

or alternatively

$$s^2(\bar{y}) = \frac{1}{n(n-1)} \sum_{i=1}^n \left( \frac{L_i}{Z_i} \right)^2 \left( \frac{\sum_{j=1}^{L_i} y_{ij}^2}{L_i} - \bar{y}_i^2 \right) \quad (25)$$

### 4.4 Rounding

The questions of rounding and the number of digits to carry through the calculations always arise in making statistical computations. Measurement data are approximations, since they are rounded when the measurements were taken; count data and binomial data are not subject to this type of approximation.

Observe the following rules when working with measurement or continuous data.

- When rounding numbers to some number of decimal places, first look at the digit to the



right of the last place to be retained. If this number is greater than 5, the last place to be retained is rounded up by 1; if it is less than 5; do not change the last place - merely drop the extra places. To round to 2 decimal places:

| Unrounded | Rounded |
|-----------|---------|
| 1.239     | 1.24    |
| 28.5849   | 28.58   |

• If the digit to the right of the last place to be retained is 5, then look at the second digit to the right of the last place to be kept, provided that the unrounded number is recorded with that digit as a significant digit. If the second digit to the right is greater than 0, then round the number up by 1 in the last place to be kept; if the second digit is 0, then look at the third digit, etc. To round to 1 place:

| Unrounded | Rounded |
|-----------|---------|
| 13.251    | 13.3    |
| 13.25001  | 13.3    |

• If the number is recorded to only one place to the right of the last place to be kept, and that digit is 0, or if the significant digits two or more places beyond the last place to be kept are all 0, a special rule (odd-even rule) is followed to ensure that upward rounding occurs as frequently as downward rounding. The rule is: if the digit to the right of the last place to be kept is 5, and is the last digit of significance, or if all following significant digits are 0, round up when the last digit to be retained is *odd* and drop the 5 when the last digit to be retained is *even*. To round to 1 place:

| Unrounded | Rounded |
|-----------|---------|
| 13.2500   | 13.2    |
| 13.3500   | 13.4    |

Caution: all rounding must be made in 1 step to avoid introducing bias. For example the number 5.451 rounded to a whole number is clearly 5, but if the rounding were done in two steps it would first be rounded to 5.5 then to 6.

*Retaining Significant Figures*

Retention of significant figures in statistical computations can be summarized in three rules:

- Never use more significance for a raw data value than is warranted.
- During intermediate computations keep all significant figures for each data value, and carry the computations out in full.
- Round the final result to the accuracy set by the least accurate data value.

5.0 TESTS OF HYPOTHESES

Often in biological field studies some aspect of the study is directed to answering a hypothetical question about a population. If the hypothesis is quantifiable, such as: "At the time of sampling, the standing crop of plankton biomass per liter in lake A was the same as the standing crop per liter in lake B," then the hypothesis can be tested statistically. The question of drawing a sample in such a way that there is freedom from bias, so that such a test may be made, was discussed in the section on sampling (2.0).

Three standard types of tests of hypotheses will be described: the "t-test," the "χ<sup>2</sup>-test," and the "F-test."

5.1 T-test

The t-test is used to compare a sample statistic (such as the mean) with some value for the purpose of making a judgment about the population as indicated by the sample. The comparison value may be the mean of another sample (in which case we are using the two samples to judge whether the two populations are the same). The form of the t-statistic is

$$t = \frac{\theta - \Theta}{S_{\theta}} \quad (26)$$

where  $\theta$  = some sample statistic;  $S_{\theta}$  = the standard deviation of the sample statistic; and  $\Theta$  = the value to which the sample statistic is compared (the value of the null hypothesis).

The use of the t-test requires the use of t-tables. The t-table is a two-way table usually arranged with the column headings being the probability,  $\alpha$ , of rejecting the null hypothesis when it is true, and the row headings being the degrees of freedom. Entry of the table at the

## BIOLOGICAL METHODS

correct probability level requires a discussion of two types of hypotheses testable using the t-statistic.

The null hypothesis is a hypothesis of no difference between a population parameter and another value. Suppose the hypothesis to be tested is that the mean,  $\mu$ , of some population equals 10. Then we would write the null hypothesis (symbolized  $H_0$ ) as

$$H_0: \mu = 10$$

Here 10 is the value of  $\Theta$  in the general form for the t-statistic. An alternative to the null hypothesis is now required. The investigator, viewing the experimental situation, determines the way in which this is stated. If the investigator merely wants to answer whether the sample indicates that  $\mu = 10$  or not, then the alternate hypothesis,  $H_a$ , is

$$H_a: \mu \neq 10$$

If it is known, for example, that  $\mu$  cannot be less than 10, then  $H_a$  is

$$H_a: \mu > 10$$

and by similar reasoning the other possible  $H_a$  is

$$H_a: \mu < 10$$

Hence, there are two types of alternate hypotheses: one where the alternative is simply that the null hypothesis is false ( $H_a: \mu \neq 10$ ); the other, that the null hypothesis is false and, in addition, that the population parameter lies to one side or the other of the hypothesized value [ $H_a: \mu (> \text{or } <) 10$ ]. In the case of  $H_a: \mu \neq 10$ , the test is called a two-tailed test; in the case of either of the second types of alternate hypotheses, the t-test is called a one-tailed test.

To use a t-table, it must be determined whether the column headings (probability of a larger value, or percentage points, or other means of expressing  $\alpha$ ) are set for one-tailed or two-tailed tests. Some tables are presented with both headings, and the terms "sign ignored" and "sign considered" are used. "Sign ignored" implies a two-tailed test, and "sign considered" implies a one-tailed test. Where tables are given for one-tailed tests, the column for any probability (or percentage) is the column appropriate to twice the probability for a two-tailed test. Hence, if a column heading is .025

and the table is for one-tailed tests, use this same column for .05 in a two-tailed test (double any one-tailed test heading to get the proper two-tailed test heading; or conversely, halve the two-tailed test heading to obtain proper headings for one-tailed tests).

Testing  $H_0: \mu = M$  (the population mean equals some value M):

$$t = \frac{\bar{X} - M}{s_{\bar{X}}} \quad (27)$$

where  $\bar{X}$  is given by equation (11) or other appropriate equation;  $M$  = the hypothesized population mean; and  $s_{\bar{X}}$  is given by equation (15). The t-table is entered at the chosen probability level (often .05) and  $n-1$  degrees of freedom, where  $n$  is the number of observations in the sample.

When the computed t-statistic exceeds the tabular value there is said to be a  $1 - \alpha$  probability that  $H_0$  is false.

Testing  $H_0: \mu_1 = \mu_2$  (the mean of the population from which sample 1 was taken equals the mean of the population from which sample 2 was taken):

$$t = \frac{\bar{X}_1 - \bar{X}_2}{s_{\bar{X}_1 - \bar{X}_2}} \quad (28)$$

where  $s_{\bar{X}_1 - \bar{X}_2}$  = the pooled standard error obtained by adding the corrected sums of squares for sample 1 to the corrected sums of squares for sample 2, and dividing by the sum of the degrees of freedom for each times the sum of the numbers of observations, i.e.,

$$s_{\bar{X}_1 - \bar{X}_2} = \sqrt{\frac{\sum X_1^2 - \frac{(\sum X_1)^2}{n_1} + \sum X_2^2 - \frac{(\sum X_2)^2}{n_2}}{(n_1 + n_2) [(n_1 - 1) + (n_2 - 1)]}} \quad (29)^*$$

An alternative and frequently useful form is

$$s_{\bar{X}_1 - \bar{X}_2} = \sqrt{\frac{(n_1 - 1)s_1^2 + (n_2 - 1)s_2^2}{(n_1 + n_2)(n_1 + n_2 - 2)}} \quad (30)$$

where  $s_1^2$  and  $s_2^2$  are each computed according to equation (12).

For all conditions to be met where the t-test is applicable, the sample should have been selected

\* $\Sigma$  sign, when unsubscripted, will indicate summation for all observations, hence  $\Sigma X_1$  means sum of all observations in sample 1.



from a population distributed as a normal distribution. Even if the population is not distributed normally, however, as sample size increases, the t-test approaches to applicability. If it is suspected that the population deviates too drastically from the normal, exercise care in the use of the t-test. One method of checking whether the data are normally distributed is to plot the observations on normal probability graph paper. If the plot approximates a straight line, using the t-test is acceptable.

The t-test is used in certain cases where it is known that the parent distribution is not normal. One case commonly encountered in field studies is the binomial. The binomial may describe presence or absence, dead or alive, male or female, etc.

Testing  $H_0: P = K$  (the population proportion equals some value  $K$ ):

$$t = \frac{P - K}{\sqrt{\frac{pq}{n}}} \quad (31)$$

where  $P$  = the symbol for the population proportion (e.g., proportion of males in the population);  $K$  = a constant positive fraction as the hypothesized proportion;  $p$  = the proportion observed in the sample;  $q$  = the complementary proportion (e.g., the proportion of females in the sample or  $1 - p$ ); and  $n$  = the number of observations in the sample. Note that since  $p$  is computed as (number of males in the sample) / (total number of individuals in the sample), it will always be a positive number less than one, and hence, so will  $q$ . Again  $\alpha$  must be chosen;  $H_a$  can be any of the types previously discussed; and the degrees of freedom are  $n - 1$ .

Count data, where the objects counted are distributed randomly, follow a Poisson distribution. If the Poisson can be used as an adequate description of the distribution of the population, an approximate  $t$  may be computed.

Testing  $H_0: \mu = M$  for the Poisson (the mean of the population distributed as a Poisson equals some hypothesized value  $M$ ):

$$t = \frac{X - M}{\sqrt{\frac{X}{n}}} \quad (32)$$

Note that  $\bar{X} = \sigma^2$  for the Poisson, thus  $\sqrt{\frac{\bar{X}}{n}}$  is the standard deviation of the mean,  $s_{\bar{X}}$ .

### 5.2 Chi Square Test ( $\chi^2$ -test)

Like  $t$ ,  $\chi^2$  values may be found in mathematical and statistical tables tabulated in a two-way arrangement. Usually, as with  $t$ , the column headings are probabilities of obtaining a larger  $\chi^2$  value when  $H_0$  is true; and the row headings are degrees of freedom. If the calculated  $\chi^2$  exceeds the tabular value, then the null hypothesis is rejected. The chi square test is often used with the assumption of approximate normality in the population.

Chi square appears in two forms that differ not only in appearance, but that provide formats for different applications.

- One form:

$$\chi^2 = \frac{(n-1)s^2}{\sigma^2} \quad (33)$$

is useful in tests regarding hypotheses about  $\sigma^2$ .

- The other form:

$$\chi^2 = \sum \frac{(O - E)^2}{E} \quad (34)$$

where  $O$  = an observed value, and  $E$  = an expected (hypothesized) value, is especially useful in sampling from binomial and multinomial distribution, i.e., where the data may be classified into two or more categories.

Consider first a binomial situation. Suppose the data from fish collections from three lakes are to be pooled and the hypothesis of an equal sex ratio tested (Table 4).

TABLE 4. POOLED FISH SEX DATA FROM 3 LAKES

| No. males   | No. females | Total |
|-------------|-------------|-------|
| 892* (919)† | 946 (919)   | 1838  |

\*Observed values.

†Expected, or hypothesized, values.

To compute the hypothesized values (919 above), it is necessary to have formulated a null hypothesis. In this case, it was

$$H_0: \text{No. males} = \text{No. females} = (.5) (\text{total})$$

## BIOLOGICAL METHODS

Expected values are always computed based upon the null hypothesis. The computation for  $\chi^2$  is

$$\chi^2 = \frac{(892 - 919)^2 + (946 - 919)^2}{919} = 1.59 \text{ n.s.}^*$$

\*n.s. = not significant

There is one degree of freedom for this test. Since computed  $\chi^2$  is not greater than tabulated  $\chi^2$  (3.84), the null hypothesis is not rejected. This test, of course, applies equally well to data that has not been pooled, i.e., where the values are from two unpooled categories.

The information contained in each of the collections is partially obliterated by pooling. If the identity of the collections is maintained, two types of test may be made: a test of the null hypothesis for each collection separately; and a test of interaction, i.e., whether the ratio depends upon the lake from which the sample was obtained (Table 5).

TABLE 5. FISH SEX DATA FROM 3 LAKES

| Lake  | No Males    | No Females | Total | $\chi^2$  |
|-------|-------------|------------|-------|-----------|
| 1     | 346* (354)† | 362 (354)  | 708   | .36 n.s.  |
| 2     | 302 (288)   | 274 (288)  | 576   | 1.30 n.s. |
| 3     | 244 (277)   | 310 (277)  | 554   | 7.88      |
| Total | 892 (919)   | 946 (919)  | 1838  | 1.59 n.s. |

\*Observed values.

†Expected, or hypothesized values.

With the use of the same null hypothesis, the following results are obtained.

The individual  $\chi^2$ 's were computed in the same manner as equation (34), in separate tests of the hypothesis for each lake. Note that the first two are not significant whereas the third is significant. This points to probable ecological differences among lakes, a possibility that would not have been discerned by pooling the data.

The test for interaction (dependence) is made by summing the individual  $\chi^2$ 's and subtracting the  $\chi^2$  obtained using totals, i.e.,

$$\chi^2 (\text{interactions}) = \sum \chi^2 (\text{individuals}) - \chi^2 (\text{total}) \\ = .36 + 1.30 + 7.88 - 1.59 = 7.95$$

The degrees of freedom for the interaction  $\chi^2$  are the number of individual  $\chi^2$ 's minus one; in this case, two. This interaction  $\chi^2$  is significant ( $P > .025$ ), which indicates that the sex ratio is indeed dependent upon the lake.

Another  $\chi^2$  test may be illustrated by the following example. Suppose that comparable techniques were used to collect from four streams. With the use of three species common to all streams, it is desired to test the hypothesis that the three species occur in the same ratio regardless of stream, i.e., that their ratio is independent of stream (Table 6).

TABLE 6. OCCURRENCE OF THREE SPECIES OF FISH

| Stream         | Number of organisms |           |           | Frequency |
|----------------|---------------------|-----------|-----------|-----------|
|                | Species 1           | Species 2 | Species 3 |           |
| 1              | 24* (21.7)†         | 12 (12.5) | 30 (31.7) | 66        |
| 2              | 15 (18.5)           | 14 (10.6) | 27 (26.9) | 56        |
| 3              | 28 (27.4)           | 15 (15.7) | 40 (39.9) | 83        |
| 4              | 20 (19.4)           | 9 (11.2)  | 30 (28.4) | 59        |
| Total          | 87                  | 50        | 127       | 264       |
| Expected ratio | 87/264              | 50/264    | 127/264   |           |

\*Observed values.

†Expected, or hypothesized

To discuss the table above,  $O_{ij}$  = the observation for the  $i^{\text{th}}$  stream and the  $j^{\text{th}}$  species. Hence,  $O_{23}$  is the observation for stream two and species three, or 27. A similar indexing scheme applies to the expected values,  $E_{ij}$ . For the totals, a subscript replaced by a dot (.) symbolizes that summation has occurred for the observations indicated by that subscript. Hence,  $O_{.2}$  is the total for species two (50);  $O_{.3}$  is the total for stream three (83); and  $O_{..}$  is the grand total (264).

Computations of expected values make use of the null hypothesis that the ratios are the same regardless of stream. The best estimate of this ratio for any species is  $\frac{O_{.j}}{O_{..}}$ , the ratio of the sum for species  $j$  to the total of all species. This ratio multiplied by the total for stream  $i$  gives the expected number of organisms of species  $j$  in stream  $i$ :

$$E_{ij} = \left( \frac{O_{.j}}{O_{..}} \right) (O_{i.}) \quad (35)$$

For example,

$$E_{12} = \left( \frac{O_{.2}}{O_{..}} \right) (O_{1.}) \\ = \frac{50}{264} (66) \\ = 12.5$$

$\chi^2$  is computed as

$$\chi^2 = \sum_{ij} \frac{(O_{ij} - E_{ij})^2}{E_{ij}} = 2.69 \text{ (n.s.)}$$

For this type of hypothesis, there are (rows - 1) (columns - 1) degrees of freedom, in this case

$$(3)(2) = 6$$

In the example,  $\chi^2$  is nonsignificant. Thus, there is no evidence that the ratios among the organisms are different for different streams.

Tests of two types of hypotheses by  $\chi^2$  have been illustrated. The first type of hypothesis was one where there was a theoretical ratio, i.e., the ratio of males to females is 1:1. The second type of hypothesis was one where equal ratios were hypothesized, but the values of the ratios themselves were computed from the data. To draw the proper inference, it is important to make a distinction between these two types of hypotheses. Because the ratios are derived from the data in the later case, a better fit to these ratios (smaller  $\chi^2$ ) is expected. This is compensated for by loss of degrees of freedom. Thus, smaller computed  $\chi^2$ 's may be judged significant than would be in the case where the ratios are hypothesized independently of the data.

### 5.3 F-test

The F distribution is used for testing equality of variance. Values of F are found in books of mathematical and statistical tables as well as in most statistics texts. Computation of the F statistic involves the ratio of two variances, each with associated degrees of freedom. Both of these are used to enter the table. At any entry of the F tables for  $(n_1 - 1)$  and  $(n_2 - 1)$  degrees of freedom, there are usually two or more entries. These entries are for various levels of probability of rejection of the null hypothesis when in fact it is true.

The simplest F may be computed by forming the ratio of two variances. The null hypothesis is  $H_0: \sigma_1^2 = \sigma_2^2$ . The F statistic is

$$F = \frac{s_1^2}{s_2^2} \quad (36)$$

where  $s_1^2$  is computed from  $n_1$  observations and  $s_2^2$  from  $n_2$ . For simple variances, the degrees of freedom,  $f$ , will be  $f_1 = n_1 - 1$  and

$f_2 = n_2 - 1$ . The table is entered at the chosen probability level,  $\alpha$ , and if F exceeds the tabulated value, it is said that there is a  $1 - \alpha$  probability that  $\sigma_1^2$  exceeds  $\sigma_2^2$ .

### 5.4 Analysis of Variance

Two simple but potentially useful examples of the analysis of variance are presented to illustrate the use of this technique. The analysis of variance is a powerful and general technique applicable to data from virtually any experimental or field study. There are restrictions, however, in the use of the technique. Experimental errors are assumed to be normally (or approximately normally) distributed about a mean of zero and have a common variance; they are also assumed to be independent (i.e., there should be no correlations among responses that are unaccounted for by the identifiable factors of the study or by the model). The effects tested must be assumed to be linearly additive. In practice these assumptions are rarely completely fulfilled, but the analysis of variance can be used unless significant departures from normality, or correlations among adjacent observations, or other types of measurement bias are suspected. It would be prudent, however, to check with a statistician regarding any uncertainties about the applicability of the test before issuing final reports or publications.

#### 5.4.1 Randomized design

The analysis of variance for completely randomized designs provides a technique often useful in field studies. This test is commonly used for data derived from highly-controlled laboratory or field experiments where treatments are applied randomly to all experimental units, and the interest lies in whether or not the treatments significantly affected the response of the experimental units. This case may be of use in water quality studies, but in these studies the treatments are the conditions found, or are classifications based upon ecological criteria. Here the desire is to detect any differences in some type of measurement that might exist in conjunction with the field situation or the classifications or criteria.

For example, suppose it is desired to test whether the biomass of organisms attaching to

BIOLOGICAL METHODS

slides suspended in streams varies from stream to stream. A simple analysis such as this could precede a more in-depth biological study of the comparative productivity of the streams. Data from such a study are presented in Table 7.

TABLE 7. PERIPHYTON PRODUCTIVITY DATA

| Stream | Slide | Biomass (mg dry wt.) |
|--------|-------|----------------------|
| 1      | 1     | 26                   |
|        | 2     | 20                   |
|        | 3     | 14                   |
|        | 4     | 25                   |
| 2      | 1     | 34                   |
|        | 2     | 28                   |
|        | 3     | Lost                 |
|        | 4     | 23                   |
| 3      | 1     | 31                   |
|        | 2     | 35                   |
|        | 3     | 40                   |
|        | 4     | 28                   |

In testing with the analysis of variance, as with other methods, a null hypothesis should be formulated. In this case the null hypothesis could be:

$H_0$ : There are no differences in the biomass of organisms attached to the slides that may be attributed to differences among streams.

In utilizing the analysis of variance, the test for whether there are differences among streams is made by comparing two types of variances; most often called "mean squares" in this context. Two mean squares are computed: one based upon the means for streams; and one that is free of the effect of the means. In our example, a *mean square for streams* is computed with the use of the averages (or totals) from the streams. The magnitude of this mean square is affected both by differences among the means and by differences among slides of the same stream. The *mean square for slides* is computed that has no contribution due to stream differences. If the null hypothesis is true, then differences among streams do not exist and, therefore, they make no contribution to the *mean square for streams*. Thus, both mean squares (for streams and for slides) are estimates of the same variance, and with repeated sampling, they would be expected to average to the same value.

If the null hypothesis ( $H_0$ ) is true, the ratio of these values is expected to equal one. If  $H_0$  is not true, i.e., if there are real differences due to the effect of streams, then the mean square for streams is affected by these differences and is expected to be the larger. The ratio in the second case is expected to be greater than one. The ratio of these two variances forms an F-test.

The analysis of variance is presented in Table 8.

The computations are:

$$C = \frac{(85 + 85 + 134)^2}{11} = 8401.45$$

$$\sum_{ij} X_{ij}^2 = 26^2 + 20^2 + \dots + 40^2 + 28^2 = 8936$$

$$\text{Total SS} = 8936 - 8401.45 = 534.55$$

$$\sum_i \left( \frac{X_i^2}{r_i} \right) = \frac{85^2}{4} + \frac{85^2}{3} + \frac{134^2}{4} = 8703.58$$

$$\text{Streams SS} = 8703.58 - 8401.45 = 302.13$$

$$\begin{aligned} \text{Slides w/i streams SS} &= \text{Total SS} - \text{Streams SS} \\ &= 534.55 - 302.13 \\ &= 232.42 \end{aligned}$$

The mean squares (MS column) are computed by dividing the sums of squares (SS column) by its corresponding degrees of freedom (df column). (Nothing is usually learned in this context by computing a total MS.) The F-test is

TABLE 8. F-TEST USING PERIPHYTON DATA

| Source             | df                 | SS  | MS | F |
|--------------------|--------------------|---|----|---|
| Total              | N-1*               | $\sum_{ij} X_{ij}^2 - C$                      |    |   |
| Streams            | t-1                | $\sum_i \left( \frac{X_i^2}{r_i} \right) - C$ |    |   |
| Slides w/i streams | $\sum_i (r_i - 1)$ | Total SS - Stream SS                          |    |   |

\*The symbols are defined as: N = total number of observations (slides); t = number of streams;  $r_i$  = number of slides in stream i;  $X_{ij}$  = an observation (biomass of a slide);  $X_i$  = sum of the observations for stream i; and C = correction for mean =  $\frac{(\sum_{ij} X_{ij})^2}{N}$

| Source             | df | SS     | MS      | F     |
|--------------------|----|--------|---------|-------|
| Total              | 10 | 534.55 |         |       |
| Streams            | 2  | 302.13 | 151.065 | 5.20* |
| Slides w/i streams | 8  | 232.42 | 29.053  |       |

\*Significant at the 0.05 probability level.

performed by computing the ratio, (mean square for streams)/(mean square for slides), in this case,  $\frac{151.065}{29.055} = 5.20$ .

When the calculated F value (5.20) is compared with the F values in the table (tabular F values) where  $df = 2$  for the numerator and  $df = 8$  for the denominator, we find that the calculated F exceeds the value of the tabular F for probability .05. Thus, the experiment indicates a high probability (greater than 0.95) of there being a difference in biomass attached to the slides, a difference attributable to differences in streams.

Note that this analysis presumes good biological procedure and obviously cannot discriminate differences in streams from differences arising, for example, from the slides having been placed in a riffle in one stream and a pool in the next. In general, the form of any analysis of variance derives from a model describing an observation in the experiment. In the example, the model, although not stated explicitly, assumed only two factors affecting a biomass measurement – streams and slides within streams. If the model had included other factors, a more complicated analysis of variance would have resulted.

5.4.2 Factorial design

Another application of a simple analysis of variance may be made where the factors are arranged factorially. Suppose a field study where the effect of a suspected toxic effluent upon the fish fauna of a river was in question (Tables 9 and 10). Five samples were taken about one-quarter mile upstream and five, one-quarter mile downstream in August of the summer before the plant began operation, and the sampling scheme was repeated in August of the summer after operations began.

Standard statistical terminology refers to each of the combinations  $P_1T_1$ ,  $P_2T_1$ ,  $P_1T_2$ , and  $P_2T_2$  as treatments or treatment combinations. Of use in the analysis is a table of treatment totals.

In planning for this field study, a null and alternate hypothesis should have been formed. In fact, whether stated explicitly or not, the null hypothesis was:

$H_0$ : The toxic effluent has no effect upon the weight of fish caught

This hypothesis is not stated in statistical terms and, therefore, only implicitly tells us what test to make. Let us look further at the analysis before attempting to state a null hypothesis in statistical terms.

In this study two factors are identifiable: times and positions. A study could have been done on each of the two factors separately, i.e., an attempt could have been made to distinguish whether there was a difference associated with times, assuming all other factors insignificant, and likewise with the positions. The example, used here, however, includes both factors simultaneously. Data are given for times and for positions but with the complication that we cannot assume that one is insignificant when studying the other. For the purpose of this study, whether there is a significant difference with times or on the other hand with positions, are questions that are of little interest. Of interest to this study is whether the upstream-downstream difference varies with times. This type of contrast is termed a positions-times interaction. Thus, our null hypothesis is, in statistical

TABLE 9. POUNDS OF FISH CAUGHT PER 10 HOURS OVERNIGHT SET OF A 125-FOOT, 1½-INCH-MESH GILL NET

| Times                       | Positions                  |                              |
|-----------------------------|----------------------------|------------------------------|
|                             | Upstream (P <sub>1</sub> ) | Downstream (P <sub>2</sub> ) |
| Before<br>(T <sub>1</sub> ) | 28.3                       | 29.0                         |
|                             | 33.7                       | 28.9                         |
|                             | 38.2                       | 20.3                         |
|                             | 41.1                       | 36.5                         |
|                             | 17.6                       | 29.4                         |
| After<br>(T <sub>2</sub> )  | 15.9                       | 19.2                         |
|                             | 29.5                       | 22.8                         |
|                             | 22.1                       | 24.4                         |
|                             | 37.6                       | 16.7                         |
|                             | 26.7                       | 11.3                         |

TABLE 10. TREATMENT TOTALS FOR THE DATA OF TABLE 9

| Total            | Positions |            | Times totals      |
|------------------|-----------|------------|-------------------|
|                  | Upstream  | Downstream |                   |
| Before           | 158.9     | 144.1      | 303.0             |
| After            | 131.8     | 94.4       | 226.2             |
| Positions totals | 290.7     | 238.5      | Grand total 529.2 |



## BIOLOGICAL METHODS

terminology:

$H_0$ : There is no significant interaction effect

Computations for testing this hypothesis with the use of an analysis of variance table are presented below.

Symbolically, an observation must have three indices specified to be completely identified: position, time, and sample number. Thus there are three subscripts:  $X_{ijk}$  is an observation at position  $i$ , time  $j$ , and from sample  $k$ . A value of 1 for  $i$  is upstream; 2, downstream; 1 for  $j$  is before; 2, after. A particular example is  $X_{123}$ , the third sample upstream after the plant began operation, or 22.1 pounds. A total (Table 10) is specified by using the dot notation. For the value of  $X_{i..}$ , then the individually sampled values for position  $i$ , time  $j$  are totaled. It is a total for a treatment combination. For example, the value of  $X_{11.}$  is 158.9, and the value of  $X_{1..}$ , where samplings and times are both totaled to give the total for upstream, is 290.7.

For a slight advantage in generality, let the following additional symbols apply:  $t$  = number of times of sampling (in this case  $t = 2$ );  $p$  = number of positions samples (in this case  $p = 2$ );  $s$  = number of samples per treatment combination; and  $n$  = the total number of observations:

The computations are:

Correction for mean (CT):

$$\frac{(\sum X_{ijk})^2}{n} = \frac{(529.2)^2}{20} = 14002.63$$

Treatment Sum of Squares (SSTMT):

$$\frac{(\sum X_{i.j.})^2}{s} - CT = \frac{(158.9)^2}{5} + \frac{(131.8)^2}{5} + \frac{(144.1)^2}{5} + \frac{(94.4)^2}{5} - 14002.63 = 456.69$$

(Note that the divisor (5) may be factored out here, if desired, but where a different number of samples is taken for each treatment combination it should be left as above.)

Positions Sum of Squares (SSP):

$$\frac{\sum X_{i..}^2}{st} - CT = \frac{(250.7)^2}{10} + \frac{(238.5)^2}{10} - 14002.63 = 136.24$$

Times Sum of Squares (SST):

$$\frac{\sum X_{.j.}^2}{sp} - CT = \frac{(303.0)^2}{10} + \frac{(226.2)^2}{10} - 14002.63 = 294.91$$

Interaction of Positions and Times Sum of Squares (SSPT):

$$SSTMT - SSP - SST = 456.69 - 136.24 - 294.91 = 25.54$$

Error Sums of Squares:

$$\sum X_{ijk}^2 - SSTMT - CT = 15308.24 - 456.69 - 14002.63 = 848.92$$

Although not important to this example, the main effects, positions and times, are tested for significance. The F table is entered with  $df = 1$  for effect tested, and  $df = 16$  for error. The positions effect is not significant at any probability usually employed. The times effect is significant with probability greater than .95. The interaction effect is not significant, and we, therefore, conclude that no effect of the suspected toxic effluent can be distinguished in this data. Had the F value for interaction been large enough, we would have rejected the null hypothesis, and concluded that the effluent had a significant effect (Table 11).

TABLE 11. ANALYSIS OF VARIANCE  
TABLE FOR FIELD STUDY DATA  
OF TABLE 9

| Source            | df | SS     | MS     | F     |
|-------------------|----|--------|--------|-------|
| Treatments        | 3  | 456.69 |        |       |
| Positions         | 1  | 136.24 | 136.24 | 2.56  |
| Times             | 1  | 294.91 | 294.91 | 5.55* |
| Positions X times | 1  | 25.54  | 25.54  | <1    |
| Error             | 16 | 848.92 | 53.05  |       |

## 6.0 CONFIDENCE INTERVALS FOR MEANS AND VARIANCES.

When means are computed in field studies, the desire often is to report them as intervals rather than as fixed numbers. This is entirely reasonable because computed means are virtually always derived from samples and are subject to the same uncertainty that is associated with the sample.

The correct computation of confidence intervals requires that the distribution of the observations be known. But very often approximations are close enough to correctness to be of use, and often are, or may be made to be, conservative. For computation of confidence intervals for the mean, the normal distribution is usually assumed to apply for several reasons: the central limit theorem assures us that with large samples the mean is likely to be approximately normally distributed; the required computations are well known and are easily applied; and when the normal distribution is known not to apply, suitable transformation of the data often is available to allow a valid application.

The confidence interval for a mean is an interval within which the true mean is said to have some stated probability of being found. If the probability of the mean *not* being in the interval is  $\alpha$  ( $\alpha$  could equal .1, .05, .01 or any probability value), then the statement may be written

$$P(CL_1 < \mu < CL_2) = 1 - \alpha$$

This is read, "The probability that the lower confidence limit ( $CL_1$ ) is less than the true mean ( $\mu$ ) and that the upper confidence limit ( $CL_2$ ) is greater than the true mean, equals  $1 - \alpha$ ." However, we never know whether or not the true mean is actually included in the interval. So the confidence interval statement is really a statement about our procedure rather than about  $\mu$ . It says that if we follow the procedure for repeated experiments, a proportion of those experiments equal to  $\alpha$  will, by chance alone, fail to include the true mean between our limits. For example, if  $\alpha = .05$ , we can expect 5 of 100 confidence intervals to fail to include the true mean.

To compute the limits, the sample mean,  $\bar{X}$ ; the standard error,  $s_{\bar{X}}$ ; and the degrees of freedom,  $n-1$ , must be known. A  $t_{\alpha, n-1}$  value from tables of Student's  $t$  is obtained corresponding to  $n-1$  degrees of freedom and probability  $\alpha$ . The computation is

$$CL_1 = \bar{X} - (t_{\alpha}) (s_{\bar{X}})$$

$$CL_2 = \bar{X} + (t_{\alpha}) (s_{\bar{X}})$$

Other confidence limits may be computed, and one additional confidence limit is given in

this section - the confidence limits for the true variance,  $\sigma^2$ . The information needed here is similar to that needed for the mean, namely, the estimated variance,  $s^2$ ; the degrees of freedom,  $n-1$ ; and values from  $\chi^2$  tables. The values from  $\chi^2$  depend upon the degrees of freedom and upon the probability level,  $\alpha$ . The confidence interval is

$$P \left[ \frac{(n-1)s^2}{\chi^2_{\frac{\alpha}{2}}} \leq \sigma^2 \leq \frac{(n-1)s^2}{\chi^2_{1-\frac{\alpha}{2}}} \right] = 1 - \alpha$$

This will be illustrated for  $\alpha = .05$ ;  $(n-1) = 30$ ; and  $s^2 = 5$ . Since  $\alpha = .05$ ;  $1 - \frac{\alpha}{2} = 0.975$ ; the associated  $\chi^2_{.975} = 16.8$ , and the  $\chi^2_{0.025} = 47.25$ . Thus, the probability statement for the variance in this case is

$$P [3.19 \leq \sigma^2 \leq 8.93] = .95$$

## 7.0 LINEAR REGRESSION AND CORRELATION

### 7.1 Basic Concepts

It is often desired to investigate relationships between variables, i.e., rate of change of biomass and concentration of some nutrient; mortality per unit of time and concentration of some toxic substance; chlorophyll and biomass; or growth rate and temperature. As biologists, we appreciate the incredible complexity of the real-world relationships between such variables, but, simultaneously, we may wish to investigate the desirability of approximating these relationships with a straight line. Such an approximation may prove invaluable if used judiciously within the limits of the conditions where the relation holds. It is important to recognize that no matter how well the straight line describes the data, a causal relationship between the variables is never implied. Causality is much more difficult to establish than mere description by a statistical relation.

When studying the relationship between two variables, the data may be taken in one of two ways. One way is to measure two variables, e.g., measure dry weight biomass and an associated chlorophyll measurement. Where two variables

## BIOLOGICAL METHODS

are measured, the data are termed bivariate. The other way is to choose the level of one variable and measure the associated magnitude of the other variable.

Straight line equations may be obtained for each of these situations by the technique of *linear regression* analysis, and if the object is to predict one variable from the other, it is desirable to obtain such a relation. When the degree of (linear) association is to be examined, no straight line need be derived — only a measure of the strength of the relationship. This measure is the *correlation coefficient*, and the analysis is termed correlation analysis.

Thus, linear regression analysis and linear correlation analysis are two ways in which linear relationships between two variables may be examined.

### 7.2 Basic Computations

#### 7.2.1 Regression equation

The regression equation is the equation for a straight line,

$$Y = a + bx$$

A graphic representation of this function is a straight line plotted on a two-axis graph. The line intercepts the y-axis a distance, *a*, away from the origin and has a slope whose value is *b*. Both *a* and *b* can be negative, zero, or positive. Figure 6 illustrates various possible graphs of a regression equation.

The regression equation is obtained by "least-squares," a technique ensuring that a "best" line will be objectively obtained. The application of least-squares to the simple case of a straight line relation between two variables is extremely simple.

In Table 12 is a set of data that are used to illustrate the use of regression analysis. Figure 7 is a plot of these data along with fitted line and confidence bands.

In fitting the regression equation, it is convenient to compute at least the following quantities:

- (1)  $n$  = the number of pairs of observation of  $X$  and  $Y$ ,
- (2)  $\Sigma X$  = the total for  $X$ ,
- (3)  $\Sigma Y$  = the total for  $Y$ ,

TABLE 12. PERCENT SURVIVAL TO FRY STAGE OF EGGS OF GOGGLE-EYED WYKE VERSUS CONCENTRATION OF SUPERCHLOROKILL IN PARENTS' AQUARIUM WATER

| Percent survival (Y) | Concentration, ppb (X) |
|----------------------|------------------------|
| 74.                  | 1.                     |
| 82.                  | 1.                     |
| 68.                  | 1.                     |
| 65.                  | 2.                     |
| 60.                  | 2.                     |
| 72.                  | 2.                     |
| 64.                  | 3.                     |
| 60.                  | 3.                     |
| 57.                  | 3.                     |
| 51.                  | 4.                     |
| 50.                  | 4.                     |
| 55.                  | 4.                     |
| 24.                  | 6.                     |
| 28.                  | 6.                     |
| 36.                  | 6.                     |
| 0.                   | 10.                    |
| 10.                  | 10.                    |
| 4.                   | 10.                    |

- (4)  $\Sigma X^2$  = the total of the squared  $X$ 's,
- (5)  $\Sigma Y^2$  = the total of the squared  $Y$ 's,
- (6)  $\Sigma XY$  = the total of the products of the  $X, Y$  pairs,
- (7)  $(\Sigma X)^2$  = the square of quantity (2),
- (8)  $(\Sigma Y)^2$  = the square of quantity (3),
- (9)  $(\Sigma X)(\Sigma Y)$  = the product of quantities (2) and (3),
- (10)  $CT_x$  = quantity (7) divided by quantity (1),
- (11)  $CT_y$  = quantity (8) divided by quantity (1),
- (12)  $CT_{xy}$  = quantity (9) divided by quantity (1).

With the calculation of these quantities, most of the work associated with using linear regression is complete. Often calculating machine characteristics may be so utilized that when one quantity is calculated the calculation of another is partly accomplished. Modern calculators and computers greatly simplify this task.

In Table 13 are the computed values of quantities (1) through (12) for the data of Table 12.

The estimated value for the slope of the line,  $b$ , is computed using

$$b = \frac{\Sigma XY - CT_{xy}}{\Sigma X^2 - CT_x} = \frac{(6) - (12)}{(4) - (10)} \quad (37)$$



For the example, this is

$$b = \frac{2453 - 3726.67}{498 - 338} = -8$$

rounded to the nearest whole number.

Computation of the estimated intercept, a, is as follows:

$$a = \bar{y} - b\bar{x} \tag{38}$$

$$= \frac{\sum Y}{n} - b \frac{\sum X}{n}$$

$$= \frac{(3)}{(1)} - b \frac{(2)}{(1)}$$

which for the example

$$= \frac{860}{18} - (-8) \frac{78}{18} = 82$$

rounded to the nearest whole number.

Thus, the regression equation for this data is

$$\hat{Y} = 82 - 8X$$

where  $\hat{Y}$  = the percent survival, and  $X$  = concentration of pesticide.

Figure 7 shows the regression line, plotted along with the data points. Note that this line appears to be a good fit but that an eye fit might have been slightly different and still appear to be a "good fit." This indicates that some uncertainty is associated with the line. If a value for  $y$  is obtained with the use of the regression equation with a given  $x$ , another experiment, however well controlled, could easily produce a different value. The predicted values for  $y$  are

TABLE 13. COMPUTED VALUES OF QUANTITIES (1) THROUGH (12) FOR THE DATA OF TABLE 12

| Quantity               | Value     |
|------------------------|-----------|
| (1) n                  | 18        |
| (2) $\sum X$           | 78        |
| (3) $\sum Y$           | 860       |
| (4) $\sum X^2$         | 498       |
| (5) $\sum Y^2$         | 51,676    |
| (6) $\sum XY$          | 2,453     |
| (7) $(\sum X)^2$       | 6,084     |
| (8) $(\sum Y)^2$       | 739,600   |
| (9) $(\sum X)(\sum Y)$ | 67,080    |
| (10) $CT_x$            | 338       |
| (11) $CT_y$            | 41,088.89 |
| (12) $CT_{xy}$         | -3,726.67 |

subject to some uncertainty, and a statement of that uncertainty should invariably accompany the use of the predicted  $y$ .

7.2.2 Confidence intervals

The proper statement of the uncertainty is an interval estimate, the same type as those previously discussed for means and variances. The probability statement for a predicted  $y$  depends upon the type of prediction being made. The regression equation is perhaps most often used to predict the mean  $y$  to be expected when  $x$  is some value, but it may also be used to predict the value of a particular observation of  $y$  when  $x$  is some value. These two types of predictions differ only in the width of the confidence intervals. A confidence interval for a predicted observation will be the wider of the two types because of uncertainty associated with variations among observations of  $y$  for a given  $x$ .

To compute the confidence intervals, first compute a variance estimate. This is the variance due to deviations of the observed values from the regression line. This computation is:

$$s^2_{y,x} = \frac{\sum Y^2 - CT_y - \frac{(\sum XY - CT_{xy})^2}{(\sum X^2 - CT_x)}}{n-2} \tag{39}$$

For this example:

$$s^2_{y,x} = \frac{51,676 - 41,089 - \frac{(2,453 - 3,727)^2}{(498 - 338)}}{18-2} = 28$$

This statistic is useful in other computations as will become apparent.

For the confidence interval, the square root of the above statistic, or the standard error of deviations from regression is required, i.e.,

$$s_{y,x} = \sqrt{s^2_{y,x}} = 5 \tag{40}$$

The confidence limits are computed as follows for a predicted mean:

$$CL(\hat{Y}) = a + bX_p \pm (t_\alpha) (s_{y,x}) \sqrt{\frac{1}{n} + \frac{(X_p - \bar{X})^2}{(\sum X^2 - CT_x)}} \tag{41}$$

where  $t_\alpha$  is chosen from a table of  $t$  values using  $n-2$  degrees of freedom and probability level  $\alpha$ ;  $\hat{Y}$  = the computed  $Y$  for which the confidence interval is sought, a mean  $\hat{Y}$  predicted to be

BIOLOGICAL METHODS

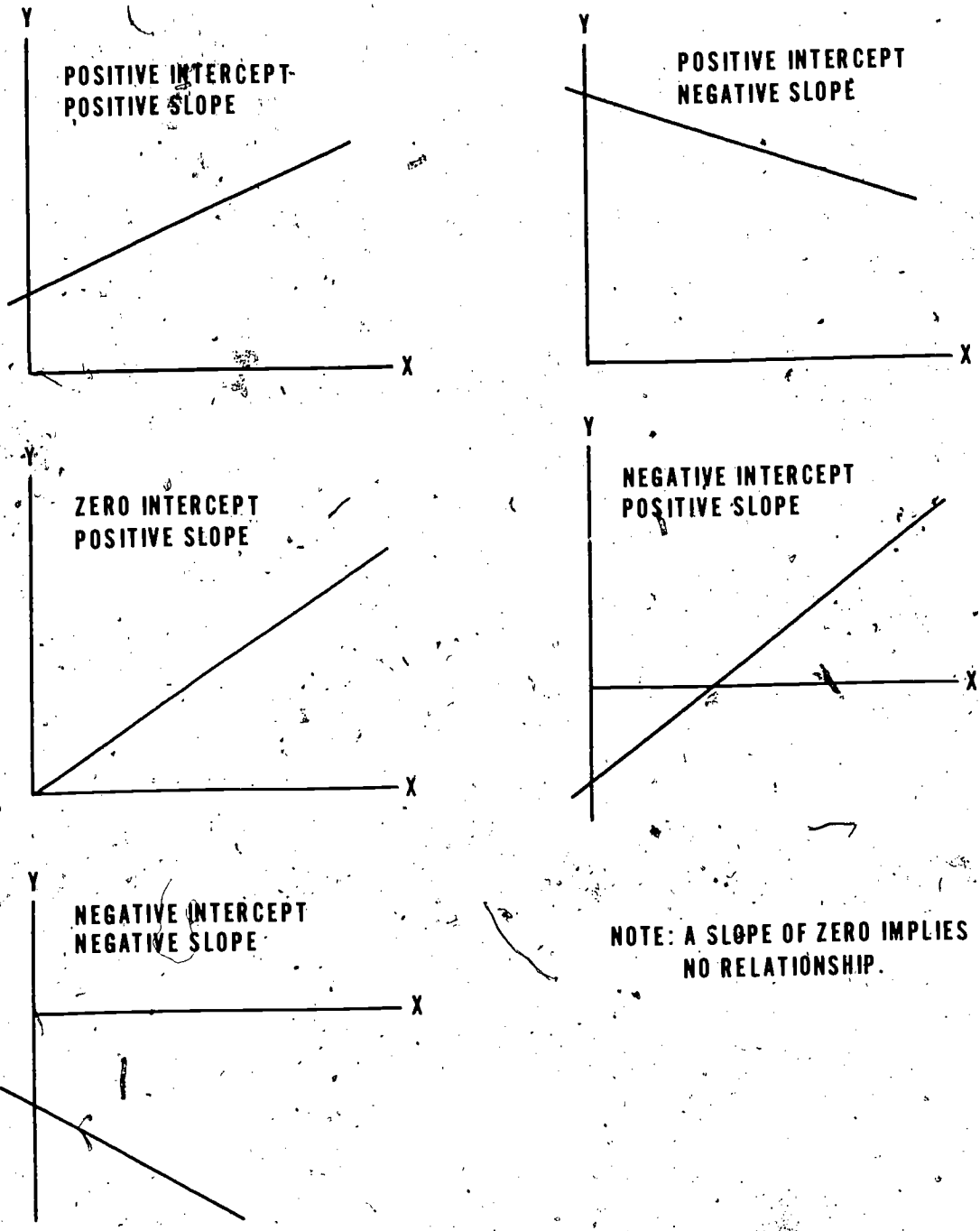

Figure 6. Examples of straight-line graphs illustrating regression equations.

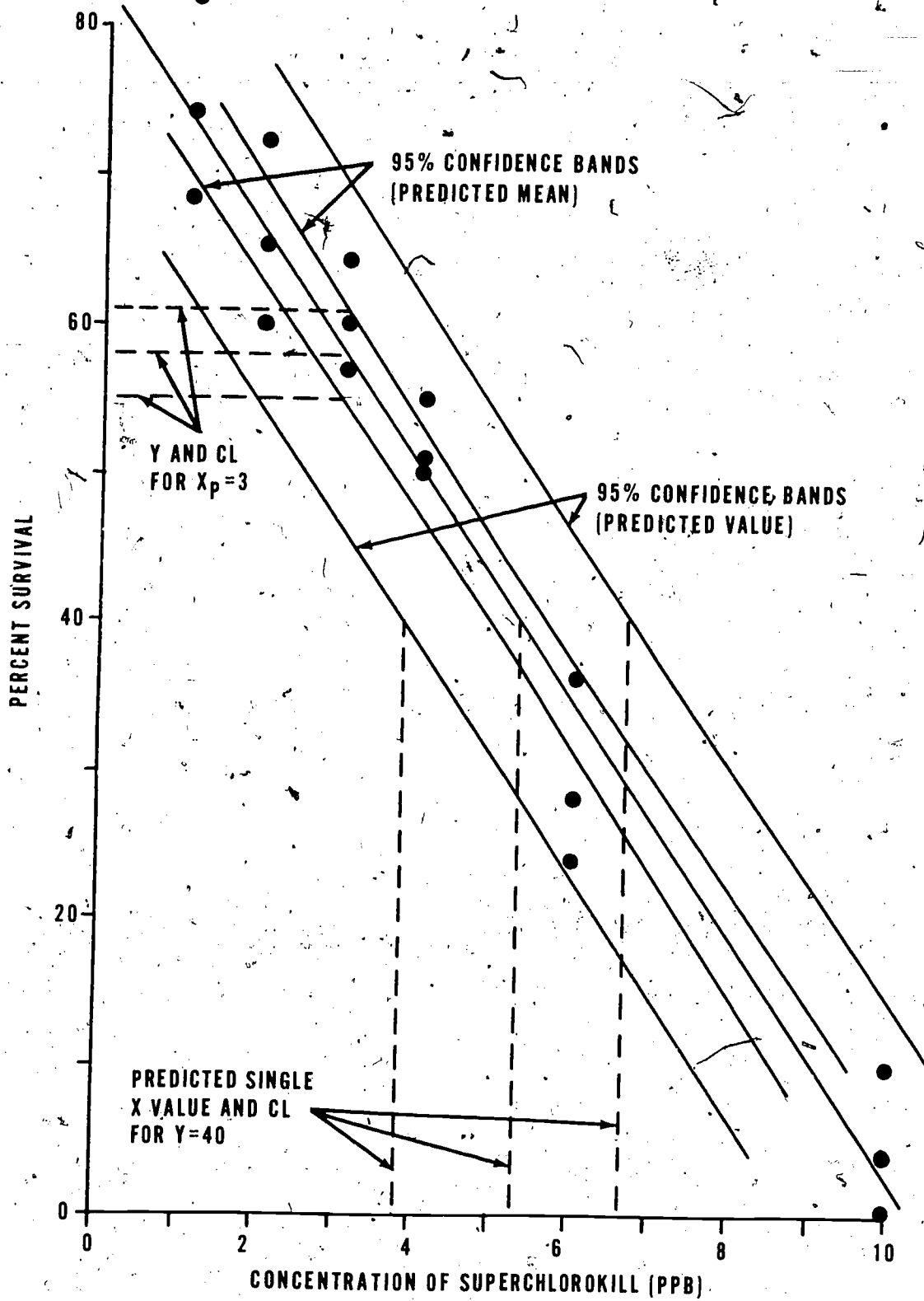

Figure 7. Regression analysis of data in Table 12.

## BIOLOGICAL METHODS

observed on the average when the X value is  $X_p$ ;  $X_p$  = the particular X value used to compute  $\hat{Y}$ ;  $\bar{X}$  = the mean of the X's used in these computations;  $\frac{\sum X}{n} = \frac{(2)}{(1)}$ ;  $\sum X^2$  = relation (4) in the computations; and  $CT_x$  = relation (10) in the computations. Note that in using Equation (41) where the signs ( $\pm$ ) are shown, the minus (-) sign is used when computing the lower confidence limit and the plus (+) for the upper.

If a confidence interval for a particular Y (given a particular X, i.e.,  $\hat{Y}$ ) is desired, the confidence limits are computed using

$$CL(\hat{Y}) = a + bX_p \pm (t_{\alpha}) (s_{y,x}) \sqrt{1 + \frac{1}{n} + \frac{(X_p - \bar{X})^2}{(\sum X^2 - CT_x)}} \quad (42)$$

Note that Equation (42) differs from Equation (41) only by the addition of 1 under the radical. All the symbols are the same as for Equation (41). Again these confidence intervals will be wider than those for  $\hat{Y}$ .

If a graphical representation of the confidence interval for  $\hat{Y}$  or  $\hat{Y}$  over a range of X is desired, merely compute the confidence interval for several (usually about 5) values of X, plot them on the same graph as the regression line, and draw a smooth curve through them. The intervals at the extremes of the data will be wider than the intervals near the mean values. This is because the uncertainty in the estimated slope is greater for the extreme values than for the central ones.

With such a plot, the predicted value of Y and its associated confidence interval for a given X can be read (see Figure 7, vertical line corresponding to X = 3 and notation).

### 7.2.3 Calibration curve

Often with data such as that given in Table 12, a calibration curve is needed from which to predict X when Y is given. That is, the linear relation is established from the data where values of X (say pesticide) are fixed and then Y (survival of eggs) is observed, where this relation predicts Y given X; then unknown concentrations of the pesticide are used, egg survival measured, and the relation is worked backwards

to obtain pesticide concentration from egg survival. This may be done graphically from a plot such as that illustrated in Figure 7. Predicted X's and associated confidence intervals may be read from the plot (see horizontal line corresponding to  $y = 40$  and notation).

Calibration curves and confidence intervals may also be worked algebraically. Where the problem has fixed X's, as in the example, the equation for X should be obtained algebraically, i.e.,

$$X = \frac{(Y-a)}{b} \quad (43)$$

for a predicted X ( $\hat{X}$ ) given a mean value  $\bar{Y}_m$  from a sample of m observations, the confidence limits may be computed as follows:

compute the quantity

$$A = b^2 - \frac{t_{\alpha}^2 s_{y,x}^2}{(\sum X^2 - CT_x)}$$

compute the confidence limits as (44)

$$CL(\hat{X}) = \bar{X} + \frac{b(\bar{Y}_m - \bar{Y})}{A} \pm \frac{t_{\alpha} s_{y,x}}{A} \sqrt{A \left( \frac{1}{m} + \frac{1}{n} \right) + \frac{(\bar{Y}_m - \bar{Y})^2}{(\sum X^2 - CT_x)}}$$

where  $\bar{Y}_m$  = the average of m newly observed Y values;  $\bar{X}$ , b,  $\bar{Y}$ ,  $s_{y,x}$ ,  $\sum X^2$ ,  $CT_x$ , and n = values obtained from the original set of data and whose meanings are unchanged. Note that m may equal one, and  $\bar{Y}_m$  would therefore be a single observation.

### 7.3 Tests of Hypotheses

If it is not clear that a relationship exists between Y and X, a test should be made to determine whether the slope differs from zero. The test is a t-test with n-2 degrees of freedom. The t value is computed as

$$t = \frac{b - \beta_0}{s_b} \quad (45)$$

where

$$s_b = \frac{s_{y,x}}{\sqrt{\sum X^2 - CT_x}}$$

Since the null hypothesis is

$$H_0: \beta_0 = 0$$

set  $\beta_0 = 0$  in the t-test and it becomes

$$t = \frac{b}{s_b}$$

If the computed  $t$  exceeds the tabular  $t$ , then the null hypothesis is rejected and the estimated slope,  $b$ , is tentatively accepted. Other values of  $\beta_0$  may be tested in the null hypothesis and in the  $t$ -test statistic.

With data such as those in Table 12, another hypothesis may be tested - that of lack of fit of the model to the data, or bias. This idea must be distinguished from random deviations from the straight line. Lack of fit implies a nonlinear trend as the true model, whereas random deviations from the model imply that the model adequately represents the trend. If more than one  $Y$  observation is available for each  $X$  (3 in the example Table 12), random fluctuations can be separated from deviations from the model; i.e., a random error may be computed at each point so that deviations from regression may be partitioned into random error and lack of fit.

The test is in the form of an analysis of variance and is illustrated in brief form symbolically in Table 14. Here, the  $F$  ratio  $MSL/MSE$  tests linearity, i.e., whether a linear model is sufficient; the ratio  $MSR/MSD$  tests whether the slope is significantly different from zero.

TABLE 14. ILLUSTRATION OF ANALYSIS OF VARIANCE TESTING LINEARITY OF REGRESSION AND SIGNIFICANCE OF REGRESSION

| Source                     | df  | MS  | F       |
|----------------------------|-----|-----|---------|
| Total                      | n-1 |     |         |
| Regression                 | 1   | MSR | MSR/MSD |
| Deviations from regression | n-2 | MSD |         |
| Lack of fit                | m-2 | MSL | MSL/MSE |
| Error                      | n-m | MSE |         |

To use this analysis, one set of computations must be made in addition to those of Table 13. The computation is the same as that for treatment sums of squares in the analysis of variance previously discussed; in this case, levels of  $X$  are comparable to treatments. First compute the sum of the  $Y$ 's,  $T_i$ , for each level of  $X$ . For  $X = 1$ ,  $T_1 = 224$ , etc. Then compute:

$$\sum \frac{T_i^2}{k_i}$$

where  $k_i$  = the number of observations for the

level of  $X$ ; in this case always 3. For the example,

$$\sum \frac{T_i^2}{k_i} = 51341$$

With this, the analysis of variance table (Table 15) may be constructed. In the first part of Table 15, the sums of squares and degrees of freedom are given symbolically to relate to the computations of Table 13 and to the above computations. The mean squares (MS) are always obtained by dividing SS by df.

When the data for Table 12 are analyzed (second part of Table 15), there is a very unusual coincidence in the values of MS for deviations from regression, lack of fit, and error. Note that this is coincidence and they must always be computed separately.

As already known from the graph,  $t$ -test, etc., the regression is highly significant. A negative result from the test for nonlinearity (lack of fit) was also suspected from the visually-satisfactory fit of Figure 7. Therefore, for this range of data, we can conclude that a linear (straight line) rela-

TABLE 15. ANALYSIS OF VARIANCE OF THE DATA OF TABLE 12; TESTS FOR LINEARITY AND SIGNIFICANCE OF REGRESSION\*

| Source                     | df  | SS  |
|----------------------------|-----|---|
| Total                      | n-1 | $\sum Y^2 - CT_y$                                 |
| Regression                 | 1   | $\frac{(\sum XY - CT_{xy})^2}{(\sum X^2 - CT_x)}$ |
| Deviations from regression | n-2 | Total SS - Regression SS                          |
| Lack of fit                | m-2 | Deviation SS - Error SS                           |
| Error                      | n-m | $\sum Y^2 - \frac{\sum T_i^2}{k_i}$               |

\*Symbols refer to quantities of Table 13 or to symbols defined in the text immediately preceding this table.

For the data of Table 12:

| Source                     | df | SS     | MS     | F      |
|----------------------------|----|--------|--------|--------|
| Total                      | 17 | 10,587 |        |        |
| Regression                 | 1  | 10,139 | 10,139 | 362**  |
| Deviations from regression | 16 | 448    | 28     |        |
| Lack of fit                | 4  | 113    | 28     | 1 n.s. |
| Error                      | 12 | 335    | 28     |        |

\*\*Significant at the 0.01 probability level.

## BIOLOGICAL METHODS

relationship exists, with estimated slope and intercept as computed.

### 7.4 Regression for Bivariate Data

As mentioned, where two associated measurements are taken without restrictions on either, the data are called bivariate. Linear regression is sometimes used to predict one of the variables by using a value from the other. Because no attempt is usually made to test bivariate data for lack of fit, a test for deviation from regression is as far as an analysis of variance table is taken. Linearity is assumed. Large deviations from linearity will appear in deviations from regression and cause the *F* values that are used to test for the significance of regression to appear to be nonsignificant.

Computations for the bivariate case exactly follow those for the univariate case [quantities (1) to (12) and as illustrated for the univariate case, Table 13]. The major operating difference is that, for bivariate data, the dependent variable is chosen as the variable to be predicted, whereas for univariate data, the dependent variable is fixed in advance. For example, if the bivariate data are pairs of observations on algal biomass and chlorophyll, either could be considered the dependent variable. If biomass is being predicted, then it is dependent. For the univariate case, such as for the data of Table 12, percent survival is the dependent variable by virtue of the nature of the experiment.

In the preceding section, it was seen that *X* and its confidence interval could be predicted from *Y* for univariate data (Equations 43, 44, and 45). But note that Equation (43) is merely

TABLE 16. TYPES OF COMPUTATIONS ACCORDING TO VARIABLE PREDICTED AND DATA TYPE\*

| Predicted variable | Bivariate data | Univariate data (fixed X's) |
|--------------------|----------------|-----------------------------|
| Y                  | $y = R_1(X)$   | $y = R_1(X)$                |
| X                  | $x = R_2(Y)$   | $X = R_1^{-1}(y)$           |

\* $R_1$  symbolizes the regression using *Y* as dependent variable,  $R_2$  a regression computed using *X* as dependent variable,  $R_1^{-1}$  is an algebraic rearrangement solving for *X* when the regression was  $R_1$ .

an algebraic rearrangement of the regression of *Y* on *X*. For the bivariate case, this approach is not appropriate. If a regression of *Y* on *X* is fitted for bivariate data, and subsequently a prediction of *X* rather than *Y* is desired, a new regression must be computed. This is a simple task, and all the basic quantities are contained in a set of computations similar to computations in Table 13. A summary of the types of computations for univariate and bivariate data is given in Table 16.

Since the computations for the bivariate regression of *Y* on *X* are the same as those for the univariate case, they will not be repeated. Where *X* is to be predicted, all computations proceed simply by interchanging *X* and *Y* in the notation. The computations for *b* and *a* are:

for the slope:

$$b_{x,y} = \frac{\Sigma XY - CT_{xy}}{\Sigma Y^2 - CT_y} \quad (46)$$

$$= \frac{(6) - (12)}{(5) - (11)}$$

for the intercept:

$$a_{x,y} = \frac{(\Sigma X)}{n} - b_{x,y} \frac{(\Sigma Y)}{n} \quad (47)$$

$$= \frac{(2)}{(1)} - b_{x,y} \frac{(3)}{(1)}$$

### 7.5 Linear Correlation

If a linear relationship is known to exist or can be assumed, the degree of association of two variables can be examined by linear correlation analysis. The data must be bivariate.

The correlation coefficient, *r*, is computed by the following:

$$r = \frac{\Sigma XY - CT_{xy}}{\sqrt{(\Sigma X^2 - CT_x)(\Sigma Y^2 - CT_y)}} \quad (48)$$

A perfect correlation (all points falling on a straight line with a nonzero slope) is indicated by a correlation coefficient of,  $r = 1$ , or  $r = -1$ . The negative value implies a decrease in one of the variables with an increase in the other. Correlation coefficients of  $r = 0$  implies no linear relationship between the variables. Any real data will result in correlation coefficients between the extremes.

If a correlation coefficient is computed and is of low magnitude, test it to determine whether it is significantly different from zero. The test, a t-test, is computed as follows:

$$t = \frac{r}{\sqrt{\frac{(1-r^2)}{(n-2)}}} \quad (49)$$

The computed t is compared with the tabular t with  $n-2$  degrees of freedom and chosen probability level. If the computed t exceeds the tabular t, the null hypothesis that the true correlation coefficient equals zero is rejected, and the computed r may be used.

## 8.0 BIBLIOGRAPHY

- Cochran, W. G. 1959. Sampling techniques. John Wiley and Sons, New York. 330 pp.
- Li, J. C. R. 1957. Introduction to statistical inference. Edward Brothers, Inc., Ann Arbor. 353 pp.
- Natrella, M. G. 1963. Experimental statistics. National Bureau of Standards Handbook No-91, U.S. Govt. Printing Office.
- Snedecor, G. W., and W. G. Cochran. 1967. Statistical methods, 6th edition. Iowa State Univ. Press, Ames.
- Southwood, R. T. E. 1966. Ecological methods with particular reference to the study of insect populations. Chapman and Hall, Ltd., London. 391 pp.
- Steele, R. G. D., and J. H. Torrie. 1960. Principles and procedures of statistics with special reference to the biological sciences. McGraw Hill, New York. 481 pp.
- Stuart, A. 1962. Basic ideas of scientific sampling. Halper, New York. 99 pp.

# PLANKTON



# PLANKTON

|  | Page |
|--|------|
| 1.0 INTRODUCTION                             | 1    |
| 2.0 SAMPLE COLLECTION AND PRESERVATION       | 1    |
| 2.1 General Considerations                   | 1    |
| 2.1.1 Influential factors                    | 1    |
| 2.1.2 Sampling frequency                     | 2    |
| 2.1.3 Sampling locations                     | 2    |
| 2.1.4 Sampling depth                         | 2    |
| 2.1.5 Field notes                            | 3    |
| 2.1.6 Sample labelling                       | 3    |
| 2.2 Phytoplankton                            | 3    |
| 2.2.1 Sampling equipment                     | 3    |
| 2.2.2 Sample volume                          | 4    |
| 2.2.3 Sample preservation                    | 4    |
| 2.3 Zooplankton                              | 4    |
| 2.3.1 Sampling equipment                     | 4    |
| 2.3.2 Sample volume                          | 5    |
| 2.3.3 Sample preservation                    | 5    |
| 3.0 SAMPLE PREPARATION                       | 5    |
| 3.1 Phytoplankton                            | 5    |
| 3.1.1 Sedimentation                          | 6    |
| 3.1.2 Centrifugation                         | 6    |
| 3.1.3 Filtration                             | 6    |
| 3.2 Zooplankton                              | 6    |
| 4.0 SAMPLE ANALYSIS                          | 6    |
| 4.1 Phytoplankton                            | 6    |
| 4.1.1 Qualitative analysis of phytoplankton  | 6    |
| 4.1.2 Quantitative analysis of phytoplankton | 8    |
| 4.2 Zooplankton                              | 12   |
| 4.2.1 Qualitative analysis of zooplankton    | 12   |
| 4.2.2 Quantitative analysis of zooplankton   | 12   |
| 5.0 BIOMASS DETERMINATION                    | 13   |
| 5.1 Dry and Ash-Free Weight                  | 13   |
| 5.1.1 Dry weight                             | 14   |
| 5.1.2 Ash-free weight                        | 14   |
| 5.2 Chlorophyll                              | 14   |
| 5.2.1 <i>In vitro</i> measurements           | 14   |
| 5.2.2 <i>In vivo</i> measurement             | 15   |
| 5.2.3 Pheophytin correction                  | 15   |
| 5.3 Cell Volume                              | 16   |
| 5.3.1 Microscopic (algae and bacteria)       | 16   |
| 5.3.2 Displacement (zooplankton)             | 16   |
| 5.4 Cell Surface Area of Phytoplankton       | 16   |
| 6.0 PHYTOPLANKTON PRODUCTIVITY               | 16   |
| 6.1 Oxygen Method                            | 16   |
| 6.2 Carbon-14 Method                         | 17   |
| 7.0 REFERENCES                               | 17   |

# PLANKTON

## 1.0 INTRODUCTION

Plankton are defined here as organisms suspended in a body of water and because of their physical characteristics or size, are incapable of sustained mobility in directions counter to the water currents. Most of the plankton are microscopic and of essentially neutral buoyancy. All of them drift with the currents.

Plankton consists of both plants (phytoplankton) and animals (zooplankton), and complex interrelationships exist among the various components of these groups. Chlorophyll-bearing plants such as algae usually constitute the greatest portion of the biomass of the plankton. Phytoplankton use the energy of sunlight to metabolize inorganic nutrients and convert them to complex organic materials. Zooplankton and other herbivores graze upon the phytoplankton and, in turn, are preyed upon by other organisms, thus passing the stored energy along to larger and usually more complex organisms. In this manner nutrients become available to large organisms such as macroinvertebrates and fish.

Organic materials excreted by plankton, and products of plankton decomposition, provide nutrients for heterotrophic microorganisms (many of which are also members of the plankton assemblage). The heterotrophs break down organic matter and release inorganic nutrients which become available again for use by the "primary producers." In waters severely polluted by organic matter, such as sewage, heterotrophs may be extremely abundant, sometimes having a mass exceeding that of the algae. As a result of heterotrophic metabolism, high concentrations of inorganic nutrients become available and massive algal blooms may develop.

Plankton may form the base of the food pyramid and drift with the pollutants; therefore, data concerning them may be particularly significant to the pollution biologist. Plankton blooms often cause extreme fluctuations of the dissolved oxygen content of the water, may be one of the causes of tastes and odors in the water and, if present in large numbers, are aesthetically objectionable. In some cases, plankton may be of limited value as indicator organisms because

the plankton move with the water currents; thus, the origin of the plankton may be obscure and the duration of exposure to pollutants may be unknown.

The quantity of phytoplankton occurring at a particular station depends upon many factors including sampling depth, time of day, season of year, nutrient content of water, and the presence of toxic materials.

## 2.0 SAMPLE COLLECTION AND PRESERVATION

### 2.1 General Considerations

Before plankton samples are collected, a study design must be formulated. The objectives must be clearly defined, and the scope of the study must remain within the limitations of available manpower, time, and money. Historical, biological, chemical, and physical (especially hydrological) data should be examined when planning a study. Examination of biological and chemical data often reveals areas that warrant intensive sampling and other areas where periodic or seasonal sampling will suffice.

Physical data are extremely useful in the design of plankton studies; of particular importance are data concerning volume of flow, currents, prevailing wind direction, temperature, turbidity (light penetration), depths of reservoir penstock releases, and estuarine salinity "wedges."

After historical data have been examined, the study site should be visited for reconnaissance and preliminary sampling. Based on the results of this reconnaissance and on the preliminary plankton data, the survey plan can be modified to better fulfill study objectives and to facilitate efficient sampling.

#### 2.1.1 Influential factors

In planning and conducting a plankton survey, a number of factors influence decisions and often alter collection routines. Since water currents determine the directions of plankton movements, knowing the directions, intensity, and complexity of currents in the sampling area is important. Some factors that influence cur-

## BIOLOGICAL METHODS

rents are winds, flow, solar heating, and tides.

Sunlight influences both the movements of plankton and primary production. Daily vertical plankton migrations are common in many waters. Cloud cover, turbidity, and shading (e.g., from ice cover and dense growths of vegetation) influence the amount of light available to plankton.

Chemical factors, such as salinity, nutrients, and toxic agents, can profoundly affect plankton production and survival.

The nutrients most frequently mentioned in the literature as stimulators of algal growth are nitrogen and phosphorus; however, a paucity of any vital nutrient can limit algal production. The third category of chemical factors, toxic agents, is almost limitless in its components and combinations of effects. Toxic compounds may be synergistic or antagonistic to one another and may either kill planktonic organisms or alter their life cycles. Many chemicals discharged in industrial effluents are toxic to plankton.

### 2.1.2 Sampling frequency

The objectives of the study and time and manpower limitations dictate the frequency at which plankton samples are taken. If it is necessary to know the year-round plankton population in a body of water, it is necessary to sample weekly through spring and summer and monthly through fall and winter. However, more frequent sampling is often necessary. Because numerous plankton samples are usually needed to characterize the plankton, take daily samples whenever possible. Ideally, collections include one or two subsurface samples per day at each river sampling station and additional samples at various depths in lakes, estuaries, and oceans.

### 2.1.3 Sampling locations

In long-term programs, such as ambient trend monitoring, sampling should be sufficiently frequent and widespread to define the nature and quantity of all plankton in the body of water being studied. In short-term studies designed to show the effects of specific pollution sources on the plankton, sampling station locations and sampling depths may be more restricted because

of limitations in time and manpower.

The physical nature of the water greatly influences the selection of sampling sites. On small streams, a great deal of planning is not usually required; here, locate the stations upstream from a suspected pollution source and as far downstream as pollutional effects are expected. Take great care, however, in interpreting plankton data from small streams, where much of the "plankton" may be derived from the scouring of periphyton from the stream bed. These attached organisms may have been exposed to pollution at fixed points for unknown time periods. On rivers, locate sampling stations, both upstream and downstream from pollution sources and, because lateral mixing often does not occur for great distances downstream, sample on both sides of the river. In both rivers and streams, care should be taken to account for confusing interferences such as contributions of plankton from lakes, reservoirs, and backwater areas. Plankton sampling stations in lakes, reservoirs, estuaries, and the oceans are generally located in grid networks or along longitudinal transects.

The location, magnitude, and temperature of pollutional discharges affect their dispersal, dilution, and effects on the plankton. Pollutants discharged from various sources may be antagonistic, synergistic, or additive in their effects on plankton. If possible, locate sampling stations in such a manner as to separate these effects.

In choosing sampling station locations, include areas from which plankton have been collected in the past. Contemporary plankton data can then be compared with historical data, thus documenting long-term pollutional effects.

### 2.1.4 Sampling depth

The waters of streams and rivers are generally well mixed, and subsurface sampling is sufficient. Sample in the main channel and avoid backwater areas. In lakes and reservoirs where plankton composition and density may vary with depth, take samples from several depths. The depth at the station and the depth of the thermocline (or sometimes the euphotic zone) generally determines sampling depths. In shallow areas (2 to 3 meters; 5 to 10 feet), subsurface

sampling is usually sufficient. In deeper areas, take samples at regular intervals with depth. If only phytoplankton are to be examined, samples may be taken at three depths, evenly spaced from the surface to the thermocline. When collecting zooplankton, however, sample at 1-meter intervals from the surface to the lake bottom.

Because many factors influence the nature and distribution of plankton in estuaries, intensive sampling is necessary. Here, marine and freshwater plankton may be found along with brackish-water organisms that are neither strictly marine nor strictly freshwater inhabitants. In addition to the influences of the thermocline and light penetration on plankton depth distribution, the layering of waters of different salinities may inhibit the complete mixing of freshwater plankton with marine forms. In estuaries with extreme tides, the dimensions of these layers may change considerably during the course of the tidal cycle. However, the natural buoyancy of the plankton generally facilitates the mixing of forms. Estuarine plankton should be sampled at regular intervals from the surface to the bottom three or four times during one or more tidal cycles.

In deep marine waters or lakes, collect plankton samples at 3- to 6-meter intervals throughout the euphotic zone (it is neither practical nor profitable to sample the entire water column in very deep waters). The limits of sampling depth in these waters may be an arbitrary depth below the thermocline or the euphotic zone, or both. Perform tow or net sampling at 90° to the wind direction.

### 2.1.5 Field notes

Keep a record book containing all information written on the sample label, plus pertinent additional notes. These additional notes may include, but need not be restricted to:

- Weather information — especially direction and intensity of wind
- Cloud cover
- Water surface condition — smooth? Is plankton clumping at surface?
- Water color and turbidity

- Total depth at station
- A list of all types of samples taken at station.
- General descriptive information (e.g., direction, distance, and description of effluents in the vicinity). Sampling stations should be plotted on a map.

### 2.1.6 Sample labelling

Both labels and marker should be water proof (a soft-lead pencil is recommended). Insert the labels into sample containers immediately as plankton samples are collected. Record the following information on all labels:

- Location  
name of river, lake, etc.  
distance and direction to nearest city  
state and county  
river mile, latitude, and longitude, or other description
- Date and time
- Depth
- Type of sample (e.g., grab, vertical plankton net haul, etc.)
- Sample volume, tow length
- Preservatives used and concentration
- Name of collector

## 2.2 Phytoplankton

### 2.2.1 Sampling equipment

The type of sampling equipment used is highly dependent upon where and how the sample is being taken (i.e., from a small lake, large deep lake, small stream, large stream, from the shore, from a bridge, from a small boat, or from a large boat) and how it is to be used.

The cylindrical type of sampler with stoppers that leave the ends open to allow free passage of water through the cylinder while it's being lowered is recommended. A messenger is released at the desired depth to close the stoppers in the ends. The Kemmerer, Juday, and Van Dorn samplers have such a design and can be obtained in a variety of sizes and materials. Use only nonmetallic samplers when metal analysis, algal assays, or primary productivity measurements are being performed. In shallow waters and when surface samples are desired, the

## BIOLOGICAL METHODS

sampler can be held in a horizontal position and operated manually. For sampling in deep waters, the Nansen reversing water bottle is often used and a boat equipped with a winch is desirable. Take caution when sampling from bridges with a Kemmerer type water bottle; if the messenger is dropped from the height of a bridge, it can batter and destroy the triggering device. To avoid this, support a messenger a few feet above the sampler by an attached string and drop it when the sampler is in place.

Net collection of phytoplankton is not recommended for quantitative work. Nannoplankton and even larger algae, such as some pennate diatoms, are thin enough to pass through the meshes of the net if oriented properly. Using a pump also presents problems: when the water is stratified, the tubing must be flushed between samplings and delicate algae may be harmed.

### 2.2.2 Sample volume

No fixed rule can be followed concerning the volume of sample to be taken — sampling personnel must use their own judgment. The volume of the sample needed depends on the numbers and kinds of analyses to be carried out, e.g., cell counts, chlorophyll, dry weight. When phytoplankton densities are less than 500 per ml, approximately 6 liters of sample are required for Sedgwick-Rafter and diatom species proportional counts. In most cases, a 1- to 2-liter sample will suffice for more productive waters.

### 2.2.3 Sample preservation

Biologists use a variety of preservatives, and each has advantages. If samples are to be stored for more than 1 year, the preferred preservative is formalin (40 percent formaldehyde = 100 percent formalin), which has been neutralized with sodium tetraborate (pH 7.0 to 7.3). Five milliliters of the neutralized formalin are added for each 100 ml of sample. This preservative will cause many flagellated forms to lose flagella. Adding saturated cupric sulfate solution to the preserved samples maintains the green color of phytoplankton samples and aids in distinguishing phytoplankton from detritus. One milliliter of the saturated solution per liter of sample is adequate. Adding detergent solution prevents

clumping of settled organisms. One part of surgical detergent to five parts of water makes a convenient stock solution. Add 5 ml of stock solution per liter of sample. Do not use detergent when diatom slides are to be made.

Merthiolate is less desirable as a preservative, but offers the advantage of staining cell parts and simplifying identification. It also causes some of the algae, such as blue-greens, to lose gas from their vacuoles and, therefore, enhances settling. Samples preserved with merthiolate are not sterile, and should not be stored for more than 1 year. After that time formalin should be used. Merthiolate solution is prepared by dissolving the following in 1 liter of distilled water.

- 1.0 gram of merthiolate (sodium ethylmercury thiosalicylate).
- 1.0 ml of aqueous saturated iodine-potassium iodide solution prepared by dissolving 40 grams of iodine and 60 grams of potassium iodide in 1 liter of distilled water.
- 1.5 gram of Borax (sodium borate)

Dissolve each of the components separately in approximately 300 ml of distilled water, combine, and make up to 1 liter with distilled water. Add the resulting stock solution to samples to give a final concentration (V/V) of 36 mg/liter (i.e., 37.3 ml added to 1 liter of sample).

## 2.3 Zooplankton

### 2.3.1 Sampling equipment

Zooplankton analyses require larger samples than those needed for phytoplankton analyses. Collect quantitative samples with a messenger-operated water bottle, plankton trap, or metered plankton net. Obtain semi-quantitative samples by filtering surface water samples through nylon netting or by towing an unmetred plankton net through the water. In moderately and highly productive waters, a 6-liter water sample is usually sufficient. In oligotrophic, estuarine and coastal waters, remove zooplankters from several hundred liters of the waters being sampled with the use of towed nets. Take duplicate samples if chemical analyses are desired.



Several sampling methods can be used.

### Towing

An outboard motor boat fitted with a small davit, meter wheel, wire-angle indicator, and hand-operated winch is desirable. A 3- to 5-kg weight attached to the line is used to sink the net. Maintain speed to ensure a wire angle near  $60^\circ$  for easy calculation of the actual sampling depth of the net. The actual sampling depth equals the amount of wire extended times the cosine of the wire angle.

**Oblique tow**—Make an 8-minute tow at four levels in the water column (2 minutes at each level: just above the bottom, 1/3 total depth, 2/3 total depth, and just below the surface) to estimate zooplankton abundance.

**Horizontal tow**—Take samples for estimating zooplankton distribution and abundance within a particular layer of water with a messenger-operated net equipped with a flow-through measuring vane (such as the Clarke-Bumpus sampler). Each tow lasts from 5 to 8 minutes.

**Vertical tow**—Lower a weighted net to the desired depth, record the amount of line extended, and retrieve at a rate of 0.5 to 1.0 meters per second. The volume of water strained can be estimated. Duplicate vertical tows are suggested at each station.

To sample most sizes of zooplankters, two nets of different mesh size can be attached a short distance apart on the same line.

### Net casting

Zooplankton can also be sampled from shore by casting a weighted net as far as possible, allowing the net to reach depth, and hauling to shore at the rate of 0.5 to 1.0 meters per second. Take several samples to obtain a qualitative estimate of relative abundance and species present.

Suggested net sizes are: No. 6 (0.239 mm aperture) for adult copepods in estuarine and coastal waters; No. 10 (0.158 mm) for copepodites in saline water or microcrustacea in fresh water; and No. 20 (0.076 mm) for rotifers and nauplii. The No. 20 net clogs easily with phytoplankton because of its small aperture size.

Rinse messenger-operated samplers with clean

water, allow to dry, and lubricate all moving parts with light machine oil. Clean nylon netting material thoroughly, rinse with clean water, and allow to dry (out of direct sunlight) before storing.

### 2.3.2 *Sample volume*

The sample volume varies with the specific purpose of the study. Twenty-liter surface samples obtained by bucket and filtered through No. 20 net are large enough to obtain an estimate of zooplankton present in flowing streams and ponds. In lakes, large rivers, estuaries and coastal waters, filter  $1.5 \text{ m}^3$  (horizontal tow) to  $5 \text{ m}^3$  (oblique tow) of water through nets for adequate representation of species present.

### 2.3.3 *Sample preservation*

For identification and enumeration, preserve grab samples in a final concentration of 5 percent neutral (add sodium tetraborate to obtain a pH of 7.0 to 7.3) formalin. Adding either 70 percent ethanol or 3 percent neutral formalin, each with 5 percent glycerol (glycerol) added, to preserve the concentrated net samples. Formalin is usually used for preserving samples obtained from coastal waters. In detritus-laden samples, add 0.04 percent Rose Bengal stain to help differentiate zooplankters from plant material.

For chemical analysis (taken, in part, from Recommended Procedures for Measuring the Productivity of Plankton Standing Stock and Related Oceanic Properties, National Academy of Sciences, Washington, D.C. 1960), the concentrated sample is placed in a fine-meshed (bolting silk or nylon) bag, drained of excess water, placed in a plastic bag, and frozen for laboratory processing. If the sample is taken from an estuarine or coastal station, the nylon bag is dipped several times in distilled water to remove the chloride from interstitial seawater which can interfere with carbon analysis.

## 3.0 SAMPLE PREPARATION

### 3.1 Phytoplankton

As the phytoplankton density decreases, the amount of concentration must be increased and, accordingly, larger sample volumes are required.



## BIOLOGICAL METHODS

As a rule of thumb, concentrate samples when phytoplankton densities are below 500 per ml; approximately 6 liters of sample are required at that cell concentration. Generally, 1 liter is an adequate routine sample volume.

The following three methods may be used for concentrating preserved phytoplankton, but sedimentation is preferred.

### 3.1.1 Sedimentation

Preserved phytoplankton samples can often be settled in the original storage containers. Settling time is directly related to the depth of the sample in the bottle or settling tube. On the average, allow 4 hours per 10 mm of depth. After settling, siphon off the supernatant (Figure 1) or decant through a side drain. The use of a detergent aids in settling. Exercise caution because of the different sedimentation rates of the diverse sizes and shapes of phytoplankton.

### 3.1.2 Centrifugation

During centrifugation, some of the more fragile forms may be destroyed or flagella may become detached. In using plankton centrifuges, many of the cells may be lost; modern continuous-flow centrifuges avoid this.

### 3.1.3 Filtration

To concentrate samples by filtration, pass through a membrane filter. A special filter apparatus and a vacuum source are required. Samples containing large amounts of suspended material (other than phytoplankton) are difficult to enumerate by this method, because the suspended matter tends to crush the phytoplankters or obscure them from view. The vacuum should not exceed 0.5 atmospheres. Concentration by filtration is particularly useful for samples low in plankton and silt content.

### 3.2 Zooplankton

The zooplankton in grab samples are concentrated prior to counting by allowing them to settle for 24 hours in laboratory cylinders of appropriate size or in specially constructed settling tubes (Figure 1).

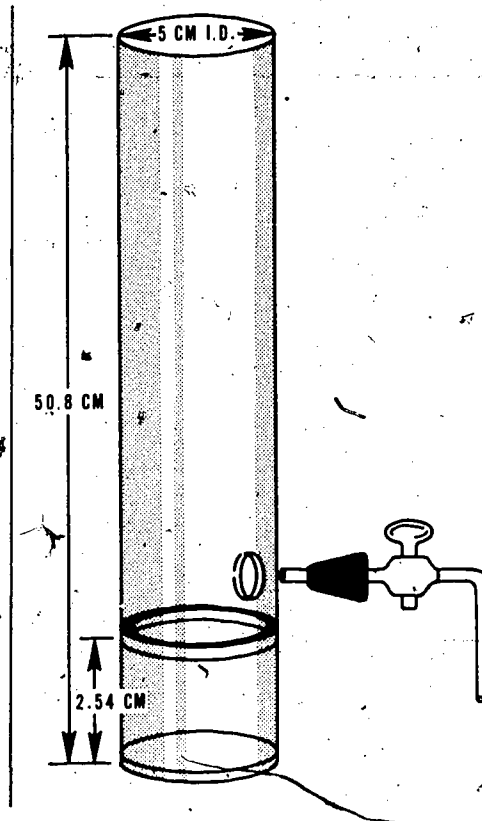

Figure 1. Plexiglas plankton settling tube with side drain and detachable cup. Not drawn to scale.

Take care to recover organisms (especially the Cladocera) that cling to the surface of the water in the settling tube.

## 4.0 SAMPLE ANALYSIS

### 4.1 Phytoplankton

#### 4.1.1 Qualitative analysis of phytoplankton

The optical equipment needed includes a good quality compound binocular microscope with a mechanical stage. For high magnification, a sub-stage condenser is required. The ocular lens should be 8X to 12X. Binocular eyepieces are generally preferred over a monocular eyepiece because of reduced fatigue. Four turret-mounted objective lenses should be provided with magnifications of approximately 10, 20, 45, and

100X. When combined with the oculars, the following characteristics are approximately correct.

| Objective lens | Ocular lens | Subject magnification | Maximum working distance between objective and cover slip, mm | Depth of focus, $\mu$ |
|----------------|-------------|-----------------------|---|-----------------------|
| 10X            | 10X         | 100X                  | 7   | 8                     |
| 20X            | 10X         | 200X                  | 1.3   | 2                     |
| 45X            | 10X         | 450X                  | 0.5-0.7   | 1                     |
| 100X           | 10X         | 1000X                 | 0.2   | 0.4                   |

An initial examination is needed because most phytoplankton samples will contain a diverse assemblage of organisms. Carry out the identification to species whenever possible. Because the size range of the individual organisms may extend over several orders of magnitude, no single magnification is completely satisfactory for identification. For the initial examination, place one or two drops of a concentrate on a glass slide and cover with a No. 1 or No. 1-1/2 cover slip. Use the 10X objective to examine the entire area under the cover slip and record all identifiable organisms. Then examine with the 20 and 45X objectives. Some very small organisms may require the use of the 100X objective (oil immersion) for identification. The initial examination helps to obtain an estimate of population density and may indicate the need for subsequent dilution or concentration of the sample, to recognize characteristics of small forms not obvious during the routine counting procedure, and to decide if more than one type of counting procedure must be used.

When identifying phytoplankton, it is useful to examine fresh, unpreserved samples. Preservation may cause some forms to become distorted, lose flagella, or be lost together. These can be determined by a comparison between fresh and preserved samples.

As the sample is examined under the microscope, identify the phytoplankton and tally under the following categories: coccoid blue-green, filamentous blue-green, coccoid green, filamentous green, green flagellates, other pigmented flagellates, centric diatoms, and pennate diatoms. In tallying diatoms, distinguish be-

tween "live" cells, i.e., those that contain any part of a protoplast, and empty frustules or shells.

The availability of taxonomic bench references and the skill of the biologist will govern the sophistication of identification efforts. No single reference is completely adequate for all phytoplankton. Some general references that should be available are listed below. Those marked with an asterisk are considered essential.

American Public Health Association, 1971. Standard methods for the examination of water and wastewater. 13th edition. Washington, D.C.

Bourrelly, P. 1966-1968. Les algues d'eau douce. 1966. Tome I-III, Boubee & Cie, Paris.

Fott, B. 1959. Algenkunde. Gustav Fischer, Jena. (2nd revised edition, 1970.)

Prescott, G. W. 1954. How to know the fresh-water algae. W. C. Brown Company, Dubuque. (2nd edition, 1964.)

\*Prescott, G. W. 1962. Algae of the Western Great Lakes Area. (2nd edition), W. C. Brown, Dubuque.

\*Smith, G. M. 1950. The freshwater algae of the United States. (2nd edition), McGraw-Hill Book Co., New York.

Ward, H. B., and G. C. Whipple. 1965. Fresh-water biology. 2nd edition edited by W. T. Edmonson. John Wiley and Sons, New York.

\*Weber, C. I. 1966. A guide to the common diatoms at water pollution surveillance system stations. USDI, FWPCA, Cincinnati.

West, G. S., and F. E. Fritsch. 1927. A treatise on the British freshwater algae. Cambridge Univ. Press. (Reprinted 1967; J. Cramer, Lehre; Wheldon & Wesley, Ltd.; and Stecherthafner, Inc., New York.)

Specialized references that may be required for exact identification within certain taxonomic groups include:

Brant, K., and C. Apstein. 1964. Nordisches Plankton. A. Asher & Co., Amsterdam. (Reprint of the 1908 publication published by Verlag von Lipsius & Tischer, Kiel and Leipzig.)

Cleve-Euler, A. 1968. Die diatomeen von Schweden und Finnland, I-V. Bibliotheca Phycologica, Band 5, J. Cramer, Lehre, Germany.

Cupp, E. 1943. Marine plankton diatoms of the west coast of North America. Bull. Scripps Inst. Oceanogr., Univ. Calif., 5:1-238.

Curl, H. 1959. The phytoplankton of Apalachee Bay and the Northwestern Gulf of Mexico. Univ. Texas Inst. Marine Sci., Vol. 6, 277-320.

\*Drouet, F. 1968. Revision of the classification of the Oscillatoriaceae. Acad. Natural Sci., Philadelphia.

\*Drouet, F., and W. A. Daily. 1956. Revision of the coccoid Myxophyceae. Butler Univ. Bot. Stud. XII., Indianapolis.

Fott, B. 1969. Studies in phycology. E. Schweizerbart'sche Verlagsbuchhandlung (Nagele u. Obermiller), Stuttgart, Germany.

## BIOLOGICAL METHODS

- \*Fritsch, F. E. 1956. The structure and reproduction of the algae. Volumes I and II. Cambridge University Press.
- Güttler, L. 1932. Cyanophyceae. In: Rabenhorst's Kryptogamen-Flora, 14:1-1096. Akademische Verlagsgesellschaft m.b.H., Leipzig. (Available from Johnson Reprint Corp., New York.)
- Glezer, Z. I. 1966. Cryptogamic plants of the U.S.S.R., volume VII: Silioflagellatophyceae. Moscow. (English Transl. Jerusalem, 1970) (Available from A. Asher & Co., Amsterdam.)
- Gran, H. H., and E. C. Angst. 1930. Plankton diatoms of Puget Sound. Univ. Washington, Seattle.
- Hendey, N. I. 1964. An introductory account of the smaller algae of British coastal waters. Part V: Bacillariophyceae (Diatoms). Fisheries Invest. (London), Series IV.
- Huber-Pestalozzi, G., and F. Hustedt. 1942. Die Kieselalgen. In: A. Thienemann (ed.), Das Phytoplankton des Süßwassers, Die Binnengewässer. Band XVI; Teil II, Hälfte II. E. Schweizerbart'sche Verlagsbuch-handlung, Stuttgart. (Stechert, New York, reprinted 1962.)
- \*Hustedt, F. 1930. Die Kieselalgen. In: L. Rabenhorst (ed.), Kryptogamen-Flora von Deutschland, Österreich, und der Schweiz. Band VII. Akademische Verlagsgesellschaft m.b.H., Leipzig. (Johnson Reprint Co., New York.)
- \*Hustedt, F. 1930. Bacillariophyta. In: A. Pascher (ed.); Die Süßwasser-Flora Mitteleuropas, Heft 10. Gustav Fischer, Jena. (University Microfilms, Ann Arbor, Xerox.)
- Hustedt, F. 1955. Marine littoral diatoms of Beaufort, North Carolina. Duke Univ. Mar. Sta. Bull. No. 6. Duke Univ. Press, Durham, N. C., 67 pp.
- Irene-Marie, F. 1938. Flore Desmidiace de la région de Montréal. Laprairie, Canada.
- \*Patrick, R., and C. W. Reimer. 1966. The diatoms of the United States. Vol. I. Academy of Natural Sciences, Philadelphia.
- Tiffany, L. H., and M. E. Britton. 1952. The algae of Illinois. Reprinted in 1971 by Hafner Publishing Co., New York.
- Tilden, J. 1910. Minnesota algae, Vol. I. The Myxophyceae of North America and adjacent regions including Central America, Greenland, Bermuda, the West Indies and Hawaii. Univ. Minnesota. (First and unique volume) (Reprinted, 1969, in Bibliotheca Phycologica, 4, J. Cramer, Lehre, Germany.)

### 4.1.2 Quantitative analysis of phytoplankton

To calibrate the microscope, the ocular must be equipped with a Whipple grid-type micrometer. The exact magnification with any set of oculars varies, and therefore, each combination of oculars and objectives must be calibrated by matching the ocular micrometer against a stage micrometer. Details of the procedure are given in Standard Methods, 13th Edition.

When counting and identifying phytoplankton, analysts will find that samples from most natural waters seldom need dilution or concentration and that they can be enumerated

directly. In those samples where algal concentrations are extreme, or where silt or detritus may interfere, carefully dilute a 10-ml portion of the sample 5 to 10 times with distilled water. In samples with very low populations, it may be necessary to concentrate organisms to minimize statistical counting errors. The analyst should recognize, however, that manipulations involved in dilution and concentration may introduce error.

Among the various taxa are forms that live as solitary cells, as components of natural groups or aggregates (colonies), or as both. Although every cell, whether solitary or in a group, can be individually tallied, this procedure is difficult, time consuming, and seldom worth the effort. The unit or clump count is easier and faster and is the system used commonly within this Agency. In this procedure, all unicellular or colonial (multi-cellular) organisms are tallied as single units and have equal numerical weight on the bench sheet.

The apparatus and techniques used in counting phytoplankton are described here.

### Sedgwick-Rafter (S-R) Counting Chamber

The S-R cell is 50 mm long by 20 mm wide by 1 mm deep; thus, the total area of the bottom of the cell is 1000 mm<sup>2</sup> and the total volume is 1000 mm<sup>3</sup> or one ml. Check the volume of each counting chamber with a vernier caliper and micrometer. Because the depth of the chamber normally precludes the use of the 45X or 100X objectives, the 20X objective is generally used. However, special long-working-distance, higher-power objectives can be obtained.

For the procedure, see Standard Methods, 13th Edition. Place a 24 by 60 mm, No. 1 cover-glass diagonally across the cell, and with a large-bore pipet or eyedropper, quickly transfer a 1-ml aliquot of well-mixed sample into the open corner of the chamber. The sample should be directed diagonally across the bottom of the cell. Usually, the cover slip will rotate into place as the cell is filled. Allow the S-R cell to stand for at least 15 minutes to permit settling. Because some organisms, notably blue-green algae, may

float, examine the underside of the cover slip and add these organisms to the total count. Lower the objective lens carefully into position with the coarse focus adjustment to ensure that the cover slip will not be broken. Fine focus should always be up from the cover slip.

When making the strip count, examine two to four "strips" the length of the cell, depending upon the density of organisms. Enumerate all forms that are totally or partially covered by the image of the Whipple grid.

When making the field count, examine a minimum of 10 random Whipple fields in at least two identically prepared S-R cells. Be sure to adopt a consistent system of counting organisms that lie only partially within the grid or that touch one of the edges.

To calculate the concentration of organisms with the S-R cell, for the strip count:

$$\text{No. per ml} = \frac{C \times 1000 \text{ mm}^3}{L \times D \times W \times S}$$

where:

- C = number of organisms counted (tally)
- L = length of each strip (S-R cell length), mm
- D = depth of a strip (S-R cell depth), mm
- W = width of a strip (Whipple grid image width), mm
- S = number of strips counted

To calculate the concentration of organisms with the field count:

$$\text{No. per ml} = \frac{C \times 1000 \text{ mm}^3}{A \times D \times F}$$

where:

- C = actual count of organisms (tally)
- A = area of a field (Whipple grid image area), mm<sup>2</sup>
- D = depth of a field (S-R cell depth), mm
- F = number of fields counted

Multiply or divide the number of cells per milliliter by a correction factor for dilution (including that resulting from the preservative) or for concentration.

### Palmer-Maloney (P-M) Nannoplankton Cell

The P-M cell was especially designed for enumerating nannoplankton with a high-dry objective (45X). It has a circular chamber 17.9 mm in diameter and 0.4 mm deep, with a volume of 0.1 ml. Although useful for examining samples containing a high percentage of nannoplankton, more counts may be required to obtain a valid estimate of the larger, but less numerous, organisms present. Do not use this cell for routine counting unless the samples have high counts.

Pipet an aliquot of well-mixed sample into one of the 2 X 5 mm channels on either side of the circular chamber with the cover slip in place. After 10 minutes, examine the sample under the high-dry objective and count at least 20 Whipple fields.

To calculate the concentration of organisms:

$$\text{No. per ml} = \frac{C \times 1000 \text{ mm}^3}{A \times D \times F}$$

where:

- C = number of organisms counted (tally)
- A = area of a field (Whipple grid image), mm<sup>2</sup>
- D = depth of a field (P-M cell depth), mm
- F = number of fields counted

### Bacterial Counting Cells and Hemocytometers

The counting cells in this group are precisely-machined glass slides with a finely ruled grid on a counting plate and specially-fitted ground cover slip. The counting plate proper is separated from the cover slip mounts by parallel trenches on opposite sides. The grid is ruled such that squares as small as 1/20 mm (50 μ) to a side are formed within a larger 1-mm square. With the cover slip in place, the depth in a Petroff-Hausser cell is 1/50 mm (20 μ) and in the hemocytometer 1/10 mm (100 μ). An optical micrometer is not used.

With a pipet or medicine dropper, introduce a sample to the cell and at high magnification identify and count all the forms that fall within the gridded area of the cell.

To calculate the number of organisms per milliliter, multiply all the organisms found in the gridded area of the cell by the appropriate factor. For example, the multiplication factor

## BIOLOGICAL METHODS

for the Petroff-Hausser bacterial counting cell is based on the volume over the entire grid. The dimensions are 1 mm X 1 mm X 1/50 mm, which gives a volume of 1/50 mm<sup>3</sup> and a factor of 50,000.

Carefully follow the manufacturer's instructions that come with the chamber when purchased. Do not attempt routine counts until experienced in its use and the statistical validity of the results are satisfactory. The primary disadvantage of this type of counting cell is the extremely limited capacity, which results in a large multiplication factor. Densities as high as 50,000 cells/ml are seldom found in natural waters except during blooms. Such populations may be found in sewage stabilization ponds or in laboratory cultures.

For statistical purposes, a normal sample must be either concentrated or a large number of mounts per sample should be examined.

### Membrane Filter

A special filtration apparatus and vacuum source are required, and a 1-inch, 0.45 $\mu$  membrane filter is used.

Pass a known volume of the water sample through the membrane filter under a vacuum of 0.5 atmospheres. (Note: in coastal and marine waters, rinse with distilled water to remove salt.) Allow the filter to dry at room temperature for 5 minutes, and place it on top of two drops of immersion oil on a microscope slide. Place two drops of oil on top of the filter and allow it to dry clear (approximately 48 hours) at room temperature, cover with a cover slip, and enumerate the organisms. The occurrence of each species in 30 random fields is recorded.

Experience is required to determine the proper amount of water to be filtered. Significant amounts of suspended matter may obscure or crush the organisms.

Calculate the original concentration in the sample as a function of a conversion factor obtained from a prepared table, the number of quadrates or fields per filter, the amount of sample filtered, and the dilution factor. (See Standard Methods, 13th Edition.)

### Inverted Microscope

This instrument differs from the conventional microscope in that the objectives are mounted below the stage and the illumination comes from above. This design allows cylindrical counting chambers (which may also be sedimentation tubes) with thin clear glass bottoms to be placed on the stage and sedimented plankton to be examined from below, and it permits the use of short focus, high-magnification objectives including oil immersion. A wide range of concentrations is automatically obtained by merely altering the height of the chamber. Chambers can be easily and inexpensively made: use tubular Plexiglas for large capacity chambers, and flat, plastic plates of various thicknesses, which have been carefully bored out to the desired dimension, for smaller chambers; then cement a No. 1 or No. 1-1/2 cover slip to form the cell bottom. Precision-made, all-glass counting chambers in a wide variety of dimensions are also available. The counting technique differs little from the S-R procedure, and either the strip or separate field counts can be used. The Whipple eyepiece micrometer is also used.

Transfer a sample into the desired counting chamber (pour with the large chambers, or pipet with 2-ml or smaller chambers), fill to the point of overflow, and apply a glass cover slip. Set the chamber aside and keep at room temperature until sedimentation is complete. On the average, allow 4 hours per 10 mm of height. After a suitable period of settling, place the chamber on the microscope stage and examine with the use of the 20X, 45X, or 100X oil immersion lens. Count at least two strips perpendicular to each other over the bottom of the chamber and average the values. Alternatively, random field counts can be made; the number depends on the density of organisms found. As a general rule, count a minimum of 100 of the most abundant species. At higher magnification, count more fields than under lower power.

When a 25.2 mm diameter counting chamber is used (the most convenient size), the conversion



of counts to numbers per ml is quite simple:

$$\text{No. per ml (strip count)} = \frac{C \times 1000 \text{ mm}^3}{L \times W \times D \times S}$$

where:

- C = number of organisms counted (tally)
- L = length of a strip, mm
- W = width of a strip (Whipple grid image width), mm
- D = depth of chamber, mm
- S = number of strips counted

$$\text{No. per ml (field count)} = \frac{C \times 1000 \text{ mm}^3}{A \times D \times F}$$

where:

- C = number of organisms counted (tally)
- A = area of a field (Whipple grid image area), mm<sup>2</sup>
- D = depth of chamber, mm
- F = number of fields counted

#### Diatom Analysis

Study objectives often require specific identification of diatoms and information about the relative abundance of each species. Since the taxonomy of this group is based on frustule characteristics, low-power magnification is seldom sufficient, and permanent diatom mounts are prepared and examined under oil immersion.

To concentrate the diatoms, centrifuge 100 ml of thoroughly mixed sample for 20 minutes at 1000 X g and decant the supernatant with a suction tube. Pour the concentrated sample into a disposable vial, and allow to stand at least 24 hours before further processing. Remove the supernatant water from the vial with a suction tube. If the water contains more than 1 gm of dissolved solids per liter (as in the case of brackish water or marine samples), salt crystals form when the sample dries and obscure the diatoms on the finished slides. In this case, reduce the concentration of salts by refilling the vial with distilled water, resuspending the plankton, and allowing the vial to stand 24 hours before removing the supernatant liquid. Repeat the dilution several times if necessary.

If the plankton counts are less than 1000 per ml, concentrate the diatoms from a larger volume of sample (1 to 5 liters) by allowing them to settle out. Exercise caution in using this

method, however, to ensure quantitative removal of cells smaller than 10 microns in diameter.

Thoroughly mix the plankton concentrate in a vial with a disposable pipet, and deliver several drops to a No. 1, circular 18-mm coverglass. Dry the samples on a hotplate at 95°C. (Caution: overheating may cause splattering and cross-contamination of samples.) When dry, examine the coverglasses to determine if there is sufficient material for a diatom count. If not, repeat the previous steps one or two more times, depending upon the density of the sedimented sample. Then heat the samples on a heavy-duty hotplate 30 minutes at approximately 570°C to drive off all organic matter. Remove grains of sand or other large objects on the cover glass with a dissection needle. The oil immersion objective has a very small working distance, and the slide may be unusable if this is not done.

Label the frosted end of a 25- X 75-mm microscope slide with the sample identification. Place the labelled slide on a moderately warm hotplate (157°C), put a drop of Hyrax or Araldor 5442 (melt and use at about 138°C) mounting medium (Index of Refraction 1.66-1.82) at the center, and heat the slide until the solvent (xylene or toluene) has evaporated (the solvent is gone when the Hyrax becomes hard and brittle upon cooling).

While the coverglass and slide are still hot, grasp the coverglass with a tweezer, invert, and place on the drop of Hyrax on a slide. It may be necessary to add Hyrax at the margin of the coverglass. Some additional bubbles of solvent vapor may appear under the coverglass when it is placed on the slide. When the bubbling ceases, remove the slide from the hotplate and place on a firm, flat surface. Immediately apply slight pressure to the coverglass with a pencil eraser (or similar object), and maintain until the Hyrax cools and hardens (about 5 seconds). Spray a protective coating of clear lacquer on the frosted end of the slide, and scrape the excess Hyrax from around the coverglass.

Identify and count the diatoms at high magnification under oil. Examine random lateral strips the width of the Whipple grid, and identify and count all diatoms within the borders of the grid until 250 cells (500 halves) are tallied.



## BIOLOGICAL METHODS

Ignore small cell fragments. If the slide has very few diatoms, limit the analysis to the number of cells encountered in 45 minutes of scanning.

When the count is completed, total the tallies and calculate the percentages of the individual species.

### 4.2 Zooplankton

#### 4.2.1 Qualitative analysis of zooplankton

In the initial examination, remove excess preservative from the sample with the use of an aspirator bulb attached to a small piece of glass tubing whose orifice is covered with a piece of No. 20 mesh netting. Swirl the sample, and with a large-bore pipet, remove a portion of the suspension and place 2 ml into each section of a four-compartment glass culture dish (100 × 15 mm). Examine a total of 8 ml for adult Copepoda, Cladocera, and other large forms with the use of a binocular dissecting microscope at a magnification of 20 to 40X. Count and identify rotifers at a higher magnification (100X). All animals should be identified to species if possible. For qualitative analysis of relative frequency, the following classification is suggested:

| Species in fields, % | Relative frequency |
|----------------------|--------------------|
| 60 - 100             | abundant           |
| 30 - 60              | very common        |
| 5 - 30               | common             |
| 1 - 5                | occasional         |
| <1                   | rare               |

The following taxonomic bench references are recommended:

Calman, W. T. 1912. The Crustacea of the order Cumacea in the collection of the United States National Museum. No. 1876-Proc. U. S. Natl. Mus. 41: 603-676.

Chien, S. M. 1970. *Alonella fitzpatricki* sp. n. and *A. leeii* sp. n.: new Cladocera from Mississippi. Trans. Amer. Microsc. Soc. 89(4): 532-538.

Conseil Permanent International Pour L'Exploration De La Mer. 1970. Fiches D'identification du Zooplankton. Sheets No. 1-133.

Davis, C. 1949. The pelagic Copepoda of the northeastern Pacific Ocean. Univ. Wash. Publ. in Biol. 14:1-188. Univ. Wash. Press, Seattle.

Davis, C. 1955. The marine and freshwater Plankton, Mich. State Univ. Press, East Lansing.

Edmondson, W. T. (ed.). Ward, H. B. and G. C. Whipple. 1959. Fresh-water biology. John Wiley and Sons, New York, 1248 pp.

Faber, D. J. and E. J. Jermolajev. 1966. A new copepod genus in the plankton of the Great Lakes. Limnol. Oceanogr. 11(2): 301-303.

Ferguson, E., Jr. 1967. New ostracods from the Playa lakes of eastern New Mexico and western Texas. Trans. Amer. Microsc. Soc. 86(3):244-250.

Hyman, L. H. 1951. The Invertebrates: Acanthocephala, Aschelminthes, and Ectoprocta. The pseudocoelomate Bilateria. Vol. III. McGraw-Hill, New York, 572 pp.

Light, S. F. 1938. New subgenera and species of diaptomid copepods from the inland waters of California and Nevada. Univ. Calif. Publ. in Zool. 43(3): 67-78. Univ. Calif. Press, Berkeley.

Marsh, C. C. 1933. Synopsis of the calanoid crustaceans, exclusive of the Diaptomidae, found in fresh and brackish waters, chiefly of North America. No. 2959, Proc. U. S. Nat. Mus. 82 (Art. 18): 1-58.

Pennak, R. W. 1953. Fresh-water invertebrates of the United States. The Roland Press Co., New York. 369 pp.

Ruber, E. 1968. Description of a salt marsh copepod cyclops (*Apocyclops spartinus* n. sp. and a comparison with closely related species. Trans. Amer. Microsc. Soc. 87(3):368-375.

Wilson, M. S. 1956. North American Harpacticoid copepods. 1. Comments on the known fresh water species of the Canthocamptidae.

2. *Canthocamptus oregonensis* n. sp. from Oregon and California. Trans. Amer. Microsc. Soc. 75 (3): 290-307.

Wilson, M. S. 1958. The copepod genus *Halicyclops* in North America, with a description of a new species from Lake Pontchartrain, Louisiana, and the Texas coast. Tulane Studies Zool. 6(4): 176-189.

Zimmer, C. 1936. California Crustacea of the order Cumacea. No. 2992. Proc. U. S. Natl. Mus. 83:423-439.

#### 4.2.2 Quantitative analysis of zooplankton

##### Pipet Method

Remove excess liquid using a screened (No. 20 mesh net) suction device until a 125- to 250-ml sample volume remains. Pour the sample into a conical container graduated in milliliters, and allow the zooplankton to settle for 5 minutes. Read the settled volume of zooplankton; multiply the settled volume by a factor of five to obtain the total diluted volume; and add enough water to obtain this volume. Insert a 1-ml Stempel pipet into the water-plankton mixture, and stir rapidly with the pipet. While the mixture is still agitated, withdraw a 1-ml subsample from the center of the water mass. Transfer the subsample to a gridded culture dish (110 × 15mm) with 5-mm squares. Rinse the

pipet with distilled water into a culture dish to remove any adherent organisms. Enumerate (about 200 zooplankters) and identify under a dissecting microscope.

To calculate the number of plankton with an unmetred collecting device:

$$\text{Total no.} = \frac{DV}{SV} \times TN$$

To calculate the number of plankton with a metered collecting device:

$$\text{No. per m}^3 \text{ of water} = \frac{TN \times DV}{SV \times Q}$$

where:

- DV = total diluted volume, ml
- SV = total subsample volume, ml
- TN = total no. zooplankters in sample
- Q = quantity of water strained, m<sup>3</sup>

#### Counting Chamber

Bring the entire concentrate (or an appropriate aliquot) to a volume of 8 ml, mix well, and transfer to a counting chamber 80 × 50 × 2 mm (8-ml capacity). To fill, use the technique previously described for the Sedgwick-Rafter cell. The proper degree of sample concentration can be determined only by experience.

Using a compound microscope equipped with an ocular Whipple grid, enumerate and identify the rotifers (to species if possible) in 10 strips scanned at a magnification of 100X (one-fifth of the chamber volume). Enumerate the nauplii also during the rotifer count. Count the adult microcrustacea under a binocular dissecting microscope at a magnification of 20 to 40X by scanning the entire chamber. Species identification of rotifers and microcrustacea often require dissection and examination under a compound microscope (see Pennak, 1953).

When calculating the number of plankton, determine the volume of the counting chamber from its inside dimensions. Convert the tallies to organisms per liter with the use of the following relationships:

$$\text{Rotifers per liter} = \frac{T \times C}{P \times V}$$

$$\text{Microcrustacea per liter} = \frac{T \times G}{S \times V}$$

where:

- T = total tally
- C = total volume of sample concentrate, ml
- P = volume of 10 strips in the counting chamber, ml
- V = volume of netted or grab sample, liters
- S = volume of counting chamber, ml

## 5.0 BIOMASS DETERMINATION

Because natural plankton populations are composed of many types of organisms (i.e., plant, animal, and bacterial), it is difficult to obtain quantitative values for each of the component populations. Currently-used indices include dry and ash-free weight, cell volume, cell surface area, total carbon, total nitrogen, and chlorophyll content. The dry and ash-free weight methods yield data that include the particulate inorganic materials as well as the plankton. Cell volume and cell surface area determinations can be made on individual components of the population and thus yield data on the plant, the animal, or the bacterial volume, or surface area, or both. Chlorophyll determinations yield data on the phytoplankton.

### 5.1 Dry and Ash-Free Weight

To reduce the amount of contamination by dissolved solids, wash the sample with several volumes of distilled water by centrifugation or settling. After washing, concentrate the sample by centrifugation or settling. If possible, take sufficient sample to provide several aliquots each having at least 10 mg dry weight. Process at least two replicate aliquots for each sample. (Generally, 10 mg dry weight is equivalent to 100 mg wet weight.)

## BIOLOGICAL METHODS

### 5.1.1 Dry weight

Place the aliquot of concentrated sample in a tared porcelain crucible, and dry to a constant weight at 105°C (24 hours is usually sufficient). Subtract the weight of crucible to obtain the dry weight.

### 5.1.2 Ash-free weight

After the dry weight is determined, place the crucible in a muffle furnace at 500°C for 1 hour. Cool, rewet the ash with distilled water, and bring to constant weight at 105°C. The ash is wetted to reintroduce the water of hydration of the clay and other minerals that, though not driven off at 105°C, is lost at 500°C. This water loss often amounts to 10 percent of the weight lost during ignition and, if not corrected for, will be interpreted as organic matter. Subtract the weight of crucible and ash from the dry weight to obtain ash-free weight.

## 5.2 Chlorophyll

All algae contain chlorophyll *a*, and measuring this pigment can yield some insight into the relative amount of algal standing crop. Certain algae also contain chlorophyll *b* and *c*. Since the chlorophyll concentration varies with species and with environmental and nutritional factors that do not necessarily affect the standing crop, biomass estimates based on chlorophyll measurements are relatively imprecise. Chlorophyll can be measured *in vivo* fluorometrically or in acetone extracts (*in vitro*) by fluorometry or spectrophotometry.

### 5.2.1 *In vitro* measurement

The algae differ considerably in the ease of pigment extraction. The diatoms extract easily, whereas the coccoid greens extract with difficulty. Complete extraction of pigments from all taxonomic groups, therefore, requires disruption of the cells with a tissue grinder or blender, or by freezing or drying. Generally, pigment is more difficult to extract from old cells than from young cells.

Concentrate the algae with a laboratory centrifuge, or collect on a membrane filter (0.45- $\mu$  porosity) or a glass fiber filter (0.45- $\mu$  effective pore size). If the analysis will be delayed, dry

the concentrate and store frozen in a desiccator. Keep the stored samples in the dark to avoid photochemical breakdown of the chlorophyll.

Place the sample in a tissue grinder, cover with 2 to 3 milliliters of 90 percent aqueous acetone (use reagent grade acetone), add a small amount (0.2 ml) of saturated aqueous solution of magnesium carbonate and macerate.

Transfer the sample to a screw-capped centrifuge tube, add sufficient 90 percent aqueous acetone to bring the volume to 5 ml, and steep at 4°C for 24 hours in the dark. Use the solvent sparingly, avoiding unnecessary pigment dilution. Agitate midway during the extraction period and again before clarifying.

To clarify the extract, centrifuge 20 minutes at 500 g. Decant the supernatant into a clean, calibrated vessel (15-ml, screw-capped, calibrated centrifuge tube) and determine the volume. Minimize evaporation by keeping the tube capped.

Three procedures for analysis and concentration calculations are described.

### Trichromatic Method

Determine the optical density (OD) of the extract at 750, 663, 645, and 630 nanometers (nm) using a 90 percent aqueous acetone blank. Dilute the extract or shorten the light path if necessary, to bring the OD<sub>663</sub> between 0.20 and 0.50. The 750 nm reading is used to correct for turbidity. Spectrophotometers having a resolution of 1 nm or less are preferred. Stopper the cuvettes to minimize evaporation during the time the readings are being made.

The chlorophyll concentrations in the extract are determined by inserting the corrected 1-cm OD's in the following equations. (UNESCO 1966).

$$C_a = 11.64D_{663} - 2.16D_{645} + 0.10D_{630}$$

$$C_b = -3.94D_{663} + 20.97D_{645} - 3.66D_{630}$$

$$C_c = -5.53D_{663} - 14.81D_{645} + 54.22D_{630}$$

where  $C_a$ ,  $C_b$ ,  $C_c$  are the concentrations, in milligrams per liter, of chlorophyll *a*, *b*, and *c*, respectively, in the extract; and  $D_{663}$ ,  $D_{645}$ , and  $D_{630}$  are the 1-cm OD's at the respective wavelengths, after subtracting the 750-nm blank.

The concentration of pigment in the phytoplankton grab sample is expressed as mg/m<sup>3</sup> or µg/m<sup>3</sup> or µg/liter and is calculated as follows:

$$\text{mg chlorophyll } a/\text{m}^3 = \frac{C_a \times \text{volume of extract (liters)}}{\text{volume of grab sample (m}^3\text{)}}$$

#### Fluorometric (for chlorophyll *a*)

The fluorometric method is much more sensitive than the photometric method and permits accurate determination of much lower concentrations of pigment and the use of smaller sample volumes. Optimum sensitivity is obtained at excitation and emission wavelengths of 430 and 663 nm, respectively, using a R-136 photomultiplier tube. Fluorometers employing filters should be equipped with Corning CS-5-60 excitation and CS-2-64 emission filters, or their equivalents. Calibrate the fluorometer with a chlorophyll solution of known concentration.

Prepare a chlorophyll extract and determine the concentration of chlorophyll *a* by the spectrophotometric method as previously described.

Prepare serial dilutions of the extract to provide concentrations of approximately 0.002, 0.006, 0.02 and 0.06 mg chlorophyll *a* per liter of extract, so that a minimum of two readings are obtained in each sensitivity range of the fluorometer (1/3 and 2/3 of full scale). With the use of these values, derive factors to convert the fluorometer readings in each sensitivity range to milligrams of chlorophyll *a* per liter of extract.

$$F_s = \frac{\text{Conc. chlorophyll } a \text{ (mg/l)}}{\text{fluorometer reading}}$$

where  $F_s$  is the fluorometric conversion factor and  $s$  is the sensitivity range (door).

#### 5.2.2 *In vivo* measurement

Using fluorescence to determine chlorophyll *a* *in vivo* is much less cumbersome than methods involving extraction; however, it is reportedly considerably less efficient than the extraction method and yields about one-tenth as much fluorescence per unit weight as the same amount in solution. The fluorometer should be calibrated with a chlorophyll extract that has been analyzed with a spectrofluorometer.

To determine the chlorophyll *a*, zero the fluorometer with a distilled water blank before taking the first sample reading at each sensitivity level.

Mix the phytoplankton sample thoroughly to ensure a homogenous suspension of algal cells. Pour an aliquot of the well-mixed sample into a cuvette, and read the fluorescence. If the reading (scale deflection) is over 90 units, use a lower sensitivity setting, e.g., 30X > 10X > 3X > 1X. Conversely, if the reading is less than 15 units, increase the sensitivity setting. If the samples fail to fall in range, dilute accordingly. Record the fluorescent units based on a common sensitivity factor, e.g., a reading 50 at 1X equals 1500 at 30X.

#### 5.2.3 *Pheophytin* Correction

Pheophytin is a natural degradation product of chlorophyll and often occurs in significant quantities in phytoplankton. Pheophytin *a*, although physiologically inactive, has an absorption peak in the same region of the visible spectrum as chlorophyll *a* and can be a source of error in chlorophyll determinations. In nature, chlorophyll is converted to pheophytin upon the loss of magnesium from the porphyrin ring. This conversion can be accomplished in the laboratory by adding acid to the pigment extract. The amount of pheophytin *a* in the extract can be determined by reading the OD<sub>663</sub> before and after acidification. Acidification of a solution of pure chlorophyll *a* results in a 40 percent reduction in the OD<sub>663</sub>, yielding a "before:after" OD ratio (663<sub>b</sub>/663<sub>a</sub>) of 1.70. Samples with 663<sub>b</sub>/663<sub>a</sub> ratios of 1.70 are considered free of pheophytin *a*, and contain algal populations consisting mostly of intact, nondecaying organisms.

Conversely, samples containing pheophytin *a* but not chlorophyll *a* show no reduction in OD<sub>663</sub> upon acidification, and have a 663<sub>b</sub>/663<sub>a</sub> ratio of 1.0. Samples containing both pigments will have ratios between 1.0 and 1.7.

To determine the concentration of pheophytin *a*, prepare the extract as previously described and determine the OD<sub>663</sub>. Add one drop of 1 N HCl to the cuvette, mix well, and reread the OD<sub>750</sub> and OD<sub>663</sub> after 30 seconds.

## BIOLOGICAL METHODS

Calculate the chlorophyll *a* and pheophytin *a* as follows:

$$\text{Chlorophyll } a \text{ (mg/m}^3\text{)} = \frac{26.7 (663_b + 663_a) \times E}{V \times L}$$

$$\text{Pheophytin } a \text{ (mg/m}^3\text{)} = \frac{26.7 (1.7 \times 663_a - 663_b) \times E}{V \times L}$$

where  $663_b$  is the 1-cm corrected  $OD_{663}$  before acidification;  $663_a$  is the  $OD_{663}$  after acidification;  $E$  the volume of acetone used for the extraction (ml);  $V$  the volume of water filtered (liters); and  $L$  the path length of the cuvette (cm).

### 5.3 Cell Volume

#### 5.3.1 Microscopic (algae and bacteria)

Concentrate an aliquot of sample by settling or centrifugation, and examine wet at a 1000X magnification with a microscope equipped with a calibrated ocular micrometer. Higher magnification may be necessary for small algae and the bacteria. Make optical measurements and determine the volume of 20 representative individuals of each major species. Determine the average volume (cubic microns), and multiply by number of organisms per milliliter.

#### 5.3.2 Displacement (zooplankton)

Separate sample from preservative by pouring through a piece of No. 20 mesh nylon bolting cloth placed in the bottom of a small glass funnel. To hasten evaporation, wash sample with a small amount of 50 percent ethanol to remove excess interstitial fluid and place on a piece of filter or blotting paper. Place the drained plankton in a 25-, 50-, or 100-ml (depending on sample size) graduated cylinder, and add a known volume of water from a burette. Read the water level in the graduated cylinder. The difference between the volume of the zooplankton plus the added water and the volume of the water alone is the displacement volume and, therefore, the volume of the total amount of zooplankton in the sample.

### 5.4 Cell Surface Area of Phytoplankton

Measure the dimensions of several representative individuals of each major species with a

microscope. Assume the cells to be spherical, cylindrical, rectangular, etc., and from the linear dimensions, compute the average surface area ( $\mu^2$ ) per species. Multiply by the number of organisms per milliliter (Welch, 1948, lists mathematical formulas for computing surface area).

## 6.0 PHYTOPLANKTON PRODUCTIVITY

Phytoplankton productivity measurements indicate the rate of uptake of inorganic carbon by phytoplankton during photosynthesis and are useful in determining the effects of pollutants and nutrients on the aquatic community.

Several different methods have been used to measure phytoplankton productivity. Diurnal curve techniques, involving pH and dissolved oxygen measurements, have been used in natural aquatic communities by a number of investigators. Westlake, Owens, and Talling (1969) present an excellent discussion concerning the limitations, advantages, and disadvantages of diurnal curve techniques as applied to non-isolated natural communities. The oxygen method of Gaarder and Gran (1927) and the carbon-14 method of Steeman-Neilson (1952) are techniques for measuring *in situ* phytoplankton productivity. Talling and Fogg (1959) discussed the relationship between the oxygen and carbon-14 methods, and the limitations of both methods. A number of physiological factors must be considered in the interpretation of the carbon-14 method for measurement of phytoplankton productivity. Specialized applications of the carbon-14 method include bioassay of nutrient limiting factors and measurement of the potential for algal growth.

The carbon-14 method and the oxygen method have the widest use, and the following procedures are presented for the *in situ* field measurement of inorganic carbon uptake by these methods.

### 6.1 Oxygen Method

General directions for the oxygen method are found in: Standard Methods for the Examination of Water and Wastewater, 13th Edition, pp. 738-739 and 750-751.



Specific modifications and additions for apparatus, procedures, and calculations are:

Apparatus - Rinse the acid-cleaned sample bottles with the water being tested prior to use.

Procedure - Obtain a profile of the input of solar radiation for the photoperiod with a pyrhelimeter. Incubate the samples at least 2 hours, but never longer than to that point where oxygen-gas bubbles are formed in the clear bottles or dissolved oxygen is depleted in the dark bottles.

Calculations - Using solar radiation profile and photosynthetic rate during the incubation period, adjust the data to represent phytoplankton productivity for the entire photoperiod.

## 6.2 Carbon-14 Method

General directions for the carbon-14 method are found in Standard Methods for the Examination of Water and Wastewater, 13th Edition, pp. 739-741 and 751-752.

Specific modifications and additions for apparatus, procedures, and calculations are listed below:

Apparatus - A fuming chamber is not required. Use the methods of Strickland and Parsons (1968) to prepare ampoules containing a carbonate solution of the activity desired.

Procedure - The carbon-14 concentration in the filtered sample should yield the number of counts required for statistical significance; Strickland and Parsons suggest a minimum of 1,000 counts per minute. Obtain a profile of the input of solar radiation for the photoperiod with a pyrhelimeter. Incubate up to 4 hours; if measurements are required for the entire photoperiod, overlap 4-hour periods from dawn until dusk (e.g.; 0600-1000, 0800-1200, . . . . ., 1400-1800, 1600-2000). A 4-hour incubation period may be sufficient, however, provided energy input is used as the basis for integrating the incubation period into the entire photoperiod. To dry and store the filters, place the membranes in a desiccator for 12 hours following filtration. Fuming with HCl is not required, and dried filters may be stored indefinitely.

Calculations - Using solar radiation profile and photosynthetic rates during the incubation period, adjust data to represent phytoplankton productivity for the entire photoperiod.

## 7.0 REFERENCES

### 7.1 Sample Collection and Preservation

#### 7.1.1 General considerations

- Hutchinson, G. E. 1957. A treatise on limnology, Vol. 1. Geography, Physics, and Chemistry. John Wiley and Sons, Inc., New York.
- Hutchinson, G. E. 1967. A treatise on limnology, Vol. 2, Introduction to lake biology and the limnoplankton. John Wiley and Sons, Inc., New York.
- Reid, G. K. 1961. Ecology of inland waters and estuaries. Reinhold Publishing Co., New York.
- Ruttner, F. 1953. Fundamentals of limnology (transl. by D. G. Frey and F. E. J. Fry), University of Toronto Press, Toronto, Canada.

#### 7.1.2 Phytoplankton

- Ingram, W. M., and C. M. Palmer. 1952. Simplified procedures for collecting, examining, and recording plankton. JAWWA. 44:617.
- Lackey, J. B. 1938. The manipulation and counting of river plankton and changes in some organisms due to formalin preservation. Pub. Health Rep. 53:2080.
- Weber, C. I. 1968. The preservation of phytoplankton grab samples. Trans. Amer. Microscop. Soc. 87:70.
- Welch, P. S. 1948. Limnological methods. Blakiston Co., Philadelphia.

#### 7.1.3 Zooplankton

- Arnon, W., et al. 1965. Towing characteristics of plankton sampling gear. Limnol. Oceanogr. 10(3):333-340.
- Barlow, J.-P. 1955. Physical and biological processes determining the distribution of zooplankton in a tidal estuary. Biological Bull. 109(2):211-225.
- Barnes, H., and D. J. Tränter. 1964. A statistical examination of the catches, numbers, and biomass taken by three commonly used plankton nets. Aust. J. Mar. Freshwater Res. 16(3):293-306.



## BIOLOGICAL METHODS

- Bayly, I. A. E. 1962. Ecological studies on New Zealand lacustrine zooplankton with special reference to *Boeckella propinqua* Sars (Copepoda: Calanoida). Aust. J. Mar. Freshwater Res. 13(2):143-197.
- Brooks, J. L. 1957. The systematics of North America *Daphnia*. Yale Univ. Press, New Haven.
- Culver, D. A., and G. J. Brunskill. 1969. Fayetteville Green Lake, New York. V. Studies of primary production and zooplankton in a meromictic marl lake. Limnol. Oceanogr. 14(6):862-873.
- Curl, H., Jr. 1962. Analysis of carbon in marine plankton organisms. J. Mar. Res. 20(3):181-188.
- Dovel, W. L. 1964. An approach to sampling estuarine macroplankton. Chesapeake Sci. 5(1-2): 77-90.
- Faber, K. J. 1966. Free-swimming copepod nauplii of Narragansett Bay with a key to their identification. J. Fish. Res. Bd. Canada, 23(2):189-205.
- Faber, K. J. 1966. Seasonal occurrence and abundance of free-swimming copepod nauplii in Narragansett Bay. J. Fish. Res. Bd. Canada, 23(3):415-422.
- Frolander, H. F. 1957. A plankton volume indicator. J. Cons. Perm. int. explor. Mer. 22(3):278-283.
- Frolander, H. F. 1968. Statistical variation in zooplankton numbers from subsampling with a Stempel pipette. JWPCF, 40(2), Pt. 2: R 82-R 88.
- Galbraith, M. G., Jr. 1967. Size-selective predation on *Daphnia* by rainbow trout and yellow perch. Trans. Amer. Fish. Soc. 96(1):1-10.
- Hall, D. J. 1964. An experimental approach to the dynamics of a natural population of *Daphnia galeata mendotae*. Ecology, 45(1):94-112.
- Hazelwood, D. H., and R. A. Parker. 1961. Population dynamics of some freshwater zooplankton. Ecology, 42(2):266-274.
- Herman, S. S., J. A. Mihursky, and A. J. McErlean. 1968. Zooplankton and environmental characteristics of the Patuxent River Estuary. Chesapeake Sci. 9(2):67-82.
- Johnson, W. E. 1964. Quantitative aspects of the pelagic entomostracan zooplankton of a multibasin lake system over a 6-year period. Verh. Internat. Verein. Limnol. 15:727-734.
- Jossi, J. W. 1970. Annotated bibliography of zooplankton sampling devices. U. S. Fish. Wildl. Serv., Special Scientific Report. Fisheries. No. 609.
- Likens, G. E., and J. J. Gilbert. 1970. Notes on quantitative sampling of natural populations of planktonic rotifers. Limnol. Oceanogr. 15(5):816-820.
- McGowan, J. A., and V. J. Fraundorf. 1966. The relationship between size of net used and estimates of zooplankton diversity. Limnol. Oceanogr. 11(4):456-469.
- National Academy of Sci. 1969. Recommended procedures for measuring the productivity of plankton standing stock and related oceanic properties. Washington, D. C., 59 pp.
- Paquette, R. G., and H. F. Frolander. 1967. Improvements in the Clarke-Bumpus plankton sampler. J. Cons. Perm. int. explor. Mer. 22(3):284-288.
- Paquette, R. G., E. L. Scott, and P. N. Sund. 1961. An enlarged Clarke-Bumpus sampler. Limnol. Oceanogr. 6(2):230-233.
- Pennak, R. W. 1957. Species composition of limnetic zooplankton communities. Limnol. Oceanogr. 2(3):222-232.
- Smith, M. W. 1961. A limnological reconnaissance of a Nova Scotian brown-water lake. J. Fish. Res. Bd. Canada, 18(3):463-478.
- Smith, P. E., R. C. Counts, and R. I. Clutter. 1968. Changes in filtering efficiency of plankton nets due to clogging under tow. J. Cons. Perm. int. explor. Mer. 32(2):242-249.
- Smyly, W. J. P. 1968. Some observations on the effect of sampling technique under different conditions on numbers of some fresh-water planktonic Entomostraca and Rotifera caught by a water-bottle. J. Nat. Hist. 2:569-575.
- Stross, R. G., J. C. Neess, and A. D. Hasler. 1961. Turnover time and production of planktonic crustacea in limed and reference portion of a bog lake. Ecology, 42(2):237-245.
- Tranter, D. J., J. D. Kerr, and A. C. Heron. 1968. Effects of hauling speed on zooplankton catches. Aust. J. Mar. Freshwater Res. 19(1):65-75.
- Ward, J. 1955. A description of a new zooplankton counter. Quart. J. Microscopical Sci. 96:371-373.
- Yentsch, C. S., and A. C. Duxbury. 1956. Some factors affecting the calibration number of the Clarke-Bumpus quantitative plankton sampler. Limnol. Oceanogr. 1(4):268-273.
- Yentsch, C. S., and F. J. Hebard. 1957. A gauge for determining plankton volume by the mercury immersion method. J. Cons. Perm. int. explor. Mer. 32(2):184-190.

### 7.2 Sample preparation and analysis

#### 7.2.1 Sample analysis - phytoplankton

- Hasle, G. R., and G. A. Fryxell. 1970. Diatoms: cleaning and mounting for light and electron microscopy. Trans. Amer. Microscop. Soc., 89(4):469-474.

- Holmes, R. W. 1962. The preparation of marine phytoplankton for microscopic examination and enumeration on molecular filters. U. S. Fish and Wildlife Serv., Special Scientific Report. Fisheries No. 433, 1-6.
- Jackson, H. W., and L. G. Williams. 1962. Calibration and use of certain plankton counting equipment. *Trans. Amer. Microscop. Soc.* 81:96.
- Lackey, J. B. 1938. The manipulation and counting of river plankton and changes in some organisms due to formalin preservation. *Publ. Health Repts.* 53(47):2080-93.
- Levinson, S. A., R. P. MacFate. 1956. *Clinical laboratory diagnosis.* Lea and Febiger, Philadelphia.
- Lund, J. W. G., C. Kipling, and E. D. LeCren. 1958. The inverted microscope method of estimating algae numbers and the statistical basis of estimations by counting. *Hydrobiologia*, 11(2): 143-70.
- McCrone, W. C., R. G. Draftz, and J. G. Delly. 1967. *The particle atlas.* Ann Arbor Science Publishers, Inc., Ann Arbor.
- McNabb, C. D. 1960. Enumeration of freshwater phytoplankton concentrated on the membrane filter. *Limnol. Oceanogr.* 5:57-61.
- National Academy of Sciences. 1969. Recommended procedures for measuring the productivity of plankton standing stock and related oceanographic properties. NAS, Washington, D. C. 59 pp.
- Palmer, C. M., and T. E. Maloney. 1954. A new counting slide for nanoplankton. *Amer. Soc. Limnol. Oceanog. Spec. Publ. No. 21,* pp. 1-6.
- Prescott, G. W. 1951. The ecology of Panama Canal algae. *Trans. Amer. Microscop. Soc.* 70:1-24.
- Schwoerbel, J. 1970. *Methods of hydrobiology (freshwater biology).* Pergamon Press, Hungary, 200 pp.
- Utermohl, H. 1958. Zur Vervollkommnung der quantitativen Phytoplankton-Methode. *Mitl. Intern. Ver. Limnol.* 9:1-38.

### 7.2.2 Biomass determination

#### Chlorophyll

- Lorenzen, C. J. 1966. A method for the continuous measurement of *in vivo* chlorophyll concentration. *Deep Sea Res.* 13:223-227.
- Lorenzen, C. J. 1967. Determination of chlorophyll and pheopigments: spectrophotometric equations. *Limnol. Oceanogr.* 12(2):343-346.
- Moss, B. 1967. A spectrophotometric method for the estimation of percentage degradation of chlorophylls to pheo-pigments in extracts of algae. *Limnol. Oceanogr.* 12(2):335-340.
- Strickland, J. D. H., and T. R. Parsons. 1968. *A practical handbook of seawater analysis.* Fisheries Res. Board of Canada, Bulletin No. 167, 311 pp.
- United Nations Educational, Scientific, and Cultural Organization. 1966. *Monographs on oceanographic methodology. 1. Determination of photosynthetic pigments in sea water.* UNESCO, Paris. 69 pp.
- Yentsch, C. S., and D. W. Menzel. 1963. A method for the determination of phytoplankton chlorophyll and phaeophytin by fluorescence. *Deep Sea Res.* 10:221-231.

#### Cell Surface Area

- Mackenthun, K. M. 1969. *The practice of water pollution biology.* U.S. Dept. Interior, FWPCA. 281 pp.
- Mullin, M. M., P. R. Sloan, and R. W. Eppley. 1966. Relationship between carbon content, cell volume, and area in phytoplankton. *Limnol. Oceanogr.* 11(2):307-311.
- Welch, P. S. 1948. *Limnological methods.* Blakiston Co., Philadelphia. 344 pp.

### 7.3 Phytoplankton productivity

- American Public Health Association. 1970. *Standard Methods for the Examination of Water and Wastewater*, 13th Edition, APHA, Washington, D. C.
- Beyers, R. J., J. L. Larimer, H. T. Odum, R. A. Parker, and N. E. Armstrong. 1963. Directions for the determination of changes in carbon dioxide concentration from changes in pH. *Publ. Inst. Mar. Sci., Univ. Texas*, 9:454-489.
- Beyers, R. J., and H. T. Odum. 1959. The use of carbon dioxide to construct pH curves for the measurement of productivity. *Limnol. Oceanogr.* 4(4):499-502.
- Bransome, Edwin D., Jr. (ed.) 1970. *The current status of liquid scintillation counting.* Grune and Stratton, Inc., New York. 394 pp.
- Chase, G. D., and J. L. Rabinowitz. 1967. *Principles of radioisotope methodology.* 3rd edition. Burgess Publ. Co., Minneapolis. 633 pp.
- Edwards, R. W., and M. Owens. 1962. The effects of plants on river conditions IV. The oxygen balance of a chalk stream. *J. Ecol.* 50:207-220.
- Fee, E. J. 1969. Numerical model for the estimation of photosynthetic production, integrated over time and depth in natural waters. *Limnol. Oceanogr.* 14(6):906-911.
- Gaarder, T., and H. H. Gran. 1927. Investigations of the production of plankton in the Oslo Fjord. *Rapp. et Proc. Verb., Cons. Internat. Explor. Mer.* 42:1-48.

## BIOLOGICAL METHODS

- Goldman, C. R., and R. C. Carter. 1965. An investigation by rapid Carbon-14 bioassay of factors affecting the cultural eutrophication of Lake Tahoe, California-Nevada. *J. WPCF*, 37(7):1044-1059.
- Goldman, C. R. 1969. Measurements (*in situ*) on isolated samples of natural communities, bioassay technique for nutrient limiting factors. In: A manual on methods for measuring primary production in aquatic environments (R. A. Vollenweider, ed.) IBP Handbook, No. 12. F. A. Davis, Philadelphia. pp. 79-81.
- Goldman, C. R. 1963. Measurement of primary productivity and limiting factors in freshwater with C-14. In: Proc. conf. on primary productivity measurement, marine and freshwater (M. S. Doty, ed.) Univ. of Hawaii, Aug.-Sept. 1961. U. S. Atomic Energy Commission, Div. Tech. Inf. T.I.D. 7633, 103-113.
- Goldman, C. R. 1968. The use of absolute activity for eliminating serious errors in the measurement of primary productivity with C-14. *J. Cons. Int. Explor. Mer.* 32:172-179.
- Jenkins, D. 1965. Determination of primary productivity of turbid waters with carbon-14. *J. WPCF*, 37:1281-1288.
- Jitts, H. R., and B. D. Scott. 1961. The determination of zero-thickness activity in geiger counting of C<sup>14</sup> solutions used in marine productivity studies. *Limnol. Oceanogr.* 6:116-123.
- Jitts, H. R. 1963. The standardization and comparison of measurements of primary production by the carbon-14 technique. In: Proc. Conf. on Primary Productivity Measurement, Marine and Freshwater (M. S. Doty, ed.) Univ. of Hawaii, Aug.-Sept. 1961. U. S. Atomic Energy Commission, Div. Tech. Inf. T.I.D. 7633, 103-113.
- Joint Industry/Government Task Force of Eutrophication. 1969. Provisional algal assay procedure. pp.16-29.
- McAllister, C. D. 1961. Decontamination of filters in the C<sup>14</sup> method of measuring marine photosynthesis. *Limnol. Oceanogr.* 6(3):447-450.
- Odum, H. T. 1956. Primary production in flowing water. *Limnol. Oceanogr.* 1(2):102-117.
- Odum, H. T. 1957. Primary production measurements in eleven Florida springs and a marine turtle grass community. *Limnol. Oceanogr.* 2(2):85-97.
- Odum, H. T., and C. M. Hoskin, 1958. Comparative studies on the metabolism of marine waters. *Publ. Inst. Mar. Sci., Univ. of Texas*, 5:16-46.
- Owens, M., and R. W. Edwards. 1963. Some oxygen studies in the River Lark. *Proc. Soc. for Water Treatment and Examination*, 12:126-145.
- Park, K., D. W. Hood, and H. T. Odum. 1958. Diurnal pH variation in Texas bays and its application to primary production estimation. *Publ. Inst. Mar. Sci., Univ. Texas*, 5:47-64.
- Rodhe, W., R. A. Vollenweider, and A. Nauwerck. 1958. The primary production and standing crop of phytoplankton. In: *Perspectives in Marine Biology* (A. A. Buzzati-Traverso, ed.), Univ. of California Press. pp. 299-322.
- Saijo, Y., and S. Ichimura. 1963. A review of recent development of techniques measuring primary production. In: Proc. conf. on primary productivity measurement, marine and freshwater (S. Doty, ed.) Univ. Hawaii, Aug.-Sept. 1961. U. S. Atomic Energy Commission; Div. Tech. Inf. T.I.D. 7633, 91-96.
- Steeman-Neilson, E. 1952. The use of radioactive carbon (C-14) for measuring organic production in the sea. *J. Cons. Int. Explor. Mer.* 18:117-140.
- Strickland, J. D. H., and T. R. Parsons. 1968. A practical handbook of seawater analysis. *Fish. Res. Bd. Canada, Bull. No. 167*, 311 pp.
- Talling, J. F., and G. E. Fogg. 1959. Measurements (*in situ*) on isolated samples on natural communities, possible limitations and artificial modifications. In: A manual of methods for measuring primary production in aquatic environments (R. A. Vollenweider, ed.) IBP Handbook, No. 12. F. A. Davis, Philadelphia. pp. 73-78.
- Thomas, W. H. 1963. Physiological factors affecting the interpretation of phytoplankton production measurements. In: Proc. conf. on primary productivity measurement, marine and freshwater (M. S. Doty, ed.) Univ. Hawaii, Aug.-Sept. 1961. U. S. Atomic Energy Commission, Div. Tech. Inf. T.I.D. 7633, 147-162.
- Verduin, J. 1952. Photosynthesis and growth rates of two diatom communities in western Lake Erie. *Ecology*, 33(2):163-168.
- Westlake, D. F., M. Owens, and J. F. Talling. 1969. Measurements on non-isolated natural communities. In: A manual on methods for measuring primary production in aquatic environments (R. A. Vollenweider, ed.) IBP Handbook, No. 12. F. A. Davis, Philadelphia. pp. 90-100.

# PERIPHYTON

62

# PERIPHYTON

|  | Page |
|--|------|
| 1.0 INTRODUCTION                       | 1    |
| 2.0 SAMPLE COLLECTION AND PRESERVATION | 2    |
| 2.1 Qualitative Sampling               | 2    |
| 2.2 Quantitative Sampling              | 2    |
| 3.0 SAMPLE PREPARATION AND ANALYSIS    | 3    |
| 3.1 Sample Preparation                 | 3    |
| 3.2 Sample Analysis                    | 3    |
| 4.0 BIBLIOGRAPHY                       | 5    |

# PERIPHYTON

## 1.0 INTRODUCTION

Periphyton is an assemblage of a wide variety of organisms that grow on underwater substrates and includes but is not limited to, bacteria, yeasts and molds, algae, protozoa, and forms that may develop large colonies such as sponges and corals. All organisms within the community are not necessarily attached but some may burrow or live within the community structure of the attached forms.

Literally translated, periphyton means "around plants," such as organisms overgrowing pond weeds, but through widespread usage, the term has become associated with communities of microorganisms growing on substrates of any nature. *Aufwuchs* (Seligo, 1905), the German noun for this community, does not have an equivalent English translation, but essentially means growing on and around things. Other terms that are essentially synonymous with periphyton or describe important or predominant components of the periphytic community are: *neriden*, *bewuchs*, *laison*, *belag*, *besatz*, attached, sessile, sessile-attached, sedentary, seeded-on, attached materials, slimes, slime growths, and coatings. Some of these terms are rarely encountered in the literature. Terminology based on the nature of the substrate is as follows:

| <u>Substrate</u> | <u>Adjective</u>                |
|------------------|---------------------------------|
| various          | epiholitic, nereiditic, sessile |
| plants           | epiphytic                       |
| animals          | epizooic                        |
| wood             | epidendritic, epixylonic        |
| rock             | epilithic                       |

Most above-listed Latin-root adjectives are derivatives of nouns such as *epihola*, *epiphyton*, *epizoa*, etc. (After Srameck-Husek, 1946 and Sladeckova, 1962).

Periphyton was recognized as an important component of aquatic communities before the beginning of the 20th century, and the study of periphyton was initiated in Europe in the early 1900's. Kolkwitz and Marsson in two articles

(1908 and 1909) made wide use of components in this community in the development of the saprobic system of water quality classification. This system has been continued and developed in Middle and Eastern Europe (Srameck-Husek, 1946; Butcher, 1932, 1940, 1946; Sladeckova, 1962; Sladeczek and Sladeckova, 1964; Fjerdingstad, 1950, 1964, 1965).

The study of periphyton was introduced in the United States in the 1920's and expanded in the 1930's. The use of the community has grown steadily and rapidly in water quality investigations (Blum, 1956; Cooke, 1956; Patrick, 1957; Cairns, et al., 1968).

The periphyton and plankton are the principal primary producers in waterways — they convert nutrients to organic living materials and store light energy through the processes of photosynthesis. In extensive deep waters, the plankton are probably the predominant primary producers. In shallow lakes, ponds, and rivers, the periphyton are the predominant primary producers.

Periphyton is the basis of the trickling filter system form of secondary sewage treatment. It is the film of growths covering the substrate in the filter that consumes nutrients, micro-solids, and bacteria from the primary treated sewage passing through the filter. As these growths accumulate, they eventually slough from the substrate, pass through the filter, and are captured in the final clarifier; thus, they change chemical and biological materials to a solid that can be removed with the physical process of settling. Excellent studies and reports on this process have been published by Wisniewski (1948), Cooke (1959), and Holtje (1943).

The periphyton community is an excellent indicator of water quality. Changes may range from subtle alteration of species composition to extremely dramatic results, such as when the addition of organic wastes to waters supporting a community of predominately diatom growths result in their replacement by extensive slime colonies composed predominately of bacteria such as *Sphaerotilus* or *Leptomitus* and vorticellid protozoans.



## BIOLOGICAL METHODS

Excessive growth stimulated by increased nutrients can result in large, filamentous streamers that are esthetically displeasing and interfere with such water uses as swimming, wading, fishing, and boating, and can also affect the quality of the overlying water. Photosynthesis and respiration can affect alkalinity (U. S. FWPCA, 1967) and dissolved oxygen concentrations (O'Connell and Thomas, 1965) of lakes and streams. Metabolic byproducts released to the overlying water may impart tastes and odors to drinking waters drawn from the stream or lake, a widespread problem throughout the United States (Lackey, 1950; Silvey, 1966; Safferman, et al., 1967). Large clumps of growth may break from the site of attachment and eventually settle to form accumulations of decomposing, organic, sludge-like materials.

Periphyton have proven useful in reconnaissance surveys, water quality monitoring studies, short-term investigations, research and development, and enforcement studies. The investigation objectives dictate the nature, approach, and methodology of sampling the periphyton community. Factors to be considered are the time and duration of the study and the characteristics of the waterway.

Sladeckova (1962) published an extensive review of methodology used in investigating this community.

### 2.0 SAMPLE COLLECTION AND PRESERVATION

#### 2.1 Qualitative Sampling

Time limitations often prohibit the use of artificial substrate samplers for quantitative collection, and thus necessitate qualitative sampling from natural substrates. Periphyton usually appear as brown, brownish-green, or green growths on the substrate. In standing or flowing water, periphyton may be qualitatively collected by scraping the surfaces of several different rocks and logs with a pocket knife or some other sharp object. This manner of collecting may also be used as a quantitative method if accurate measurements are made of the sampled areas. When sampling this way, limit collections to

littoral areas in lakes and shallow or riffle areas in flowing water where the greatest number and variety of organisms are found. Combine the scrapings to a volume of 5 to 10 ml for a sufficient sample. In lakes and streams where long strands of filamentous algae occur, weigh the sample.

After scraping has been completed, store the material in bottles containing 5 percent formalin. If the material is for chlorophyll analysis, do not preserve. Store at 4°C in the dark in 100 ml of 90 percent aqueous acetone. Use bottle caps with a cone-shaped polyethylene seal to prevent evaporation.

#### 2.2 Quantitative Sampling

The standard (plain, 25 X 75 mm) glass microscope slide is the most suitable artificial substrate for quantitative sampling. If less fragile material is preferred, strips of Plexiglas may be used in place of glass slides.

Devices for exposing the substrates can be modified to suit a particular situation, keeping in mind that the depth of exposure must be consistent for all sampling sites. In large rivers or lakes, a floating sampler (APHA, 1971) is advantageous when turbidities are high and the substrates must be exposed near the surface. In small, shallow streams or littoral areas of lakes where turbidity is not a critical factor, substrates may be exposed in several ways. Two possible methods are: (a) attach the substrates with PLASTIC TAK adhesive to bricks or flat rocks in the stream bed, or (b) anchor Plexiglas racks to the bottom to hold the substrates. In areas where siltation is a problem, hold the substrates in a vertical position to avoid a covering of silt. If desired, another set of horizontally-exposed substrates could be used to demonstrate the effects of siltation on the periphyton community.

The number of substrates to be exposed at each sampling site depends on the type and number of analyses to be performed. Because of unexpected fluctuations in water levels, currents, wave action, and the threat of vandalism, duplicate samplers should be used. A minimum of four replicate substrates should be taken for each type of analysis.

The length of exposure depends upon many factors, including the survey time schedule, growth patterns, which are seasonal, and prevailing hydrologic conditions. On the assumption that periphyton growth rate on clean substrates proceeds exponentially for 1 or 2 weeks and then gradually declines, the optimum exposure period is 2 to 4 weeks.

### 3.0 SAMPLE PREPARATION AND ANALYSIS

#### 3.1 Sample Preparation.

Sample preparation varies according to the method of analysis; see the 13th edition of Standard Methods, Section 602-3 (APHA, 1971).

#### 3.2 Sample Analysis

##### 3.2.1 Identification

In addition to the taxonomic references listed in the Plankton Section, the following bench references are essential for day-to-day periphyton identification.

##### Algae

- Desikachary, T. W. 1956. Cyanophyta. Indian Council. Agric. Res., New Delhi.
- Fairdi, M. 1964. A monograph of the fresh water species of *Cladophora* and *Rhizoclonium*. Ph.D. Thesis, Univ. Kansas (available in Xerox from University Microfilms, Ann Arbor).
- Islan, A. K., and M. Nurul. 1963. Revision of the genus *Stigeoclonium*. Nova Hedwigia, Suppl. 10. J. Cramer, Weinheim, Germany.
- Rananathan, K. R. 1964. Ulotrichales. Indian Council. Agric. Res., New Delhi.
- Randhawa, M. S. 1959. Zygnemaceae. Indian Council. Agric. Res., New Delhi.
- Tiffany, L. H. 1937. Oedogoniales, Oedogoniaceae. In: North American Flora, 11(1):1-102. N. Y. Bot. Garden, Hafner Publ. New York.

##### Fungi

Cooke, W. Bridge. 1963. A laboratory guide to fungi in polluted waters, sewage, and sewage treatment systems. US DHEW, USPHS, DWSPC, Cincinnati.

##### Protozoa

- Bick, H. 1967-69. An illustrated guide to ciliated protozoa (used as biological indicators in freshwater ecology). Parts 1-9. World Hlth. Organ., Geneva, Switzerland.
- Kudo, R. R. 1963. Protozoology. Charles Thomas, Publ., Springfield, Ill.

##### Rotifers

- Donner, J. 1966. Rotifers. Butler and Tanner, Ltd., London.
- Edmondson, W. T. 1959. Freshwater biology. John Wiley and Sons, New York.
- Pennak, R. W. 1953. Freshwater invertebrates of the United States. Ronald Press, New York.

##### Microcrustacea

- Edmondson, W. T. (see above).
- Pennak, R. W. (see above).

#### 3.2.2 Counts and enumeration

##### Sedgwick-Rafter Method

Shake vigorously to mix the sample, transfer 1 ml to a Sedgwick-Rafter cell, and make strip counts, as described in the Plankton Section, except that a *cell count* is made of *all* organisms. If the material is too concentrated for a direct count, dilute a 1-ml aliquot with 4 ml of distilled water; further dilution may be necessary. Even after vigorous shaking, the scrapings may contain large clumps of cells. These clumps can result in an uneven distribution of material in the counting chamber that could seriously affect the accuracy of the count. Should this condition occur, stir 50 ml of the sample (or a proper dilution) in a blender for 1 minute and reexamine. Repeat if necessary. *Caution:* Some colonial organisms cannot be identified in a fragmented condition. Therefore, the sample must be examined before being blended.

The quantitative determination of organisms on a substrate can then be expressed as:

$$\text{No. cells/mm}^2 = \frac{C \times 1000 \text{ mm}^3 \times V \times DF}{L \times W \times D \times S \times A}$$

where:

- C = number of cells counted (tally)
- V = sample volume, ml
- DF = dilution factor
- L = length of a strip, mm
- W = width of a strip (Whipple grid image-width), mm
- D = depth of a strip (S-R cell depth), mm
- S = number of strips counted
- A = area of substrate scraped, mm<sup>2</sup>

## BIOLOGICAL METHODS

### Diatom Species Proportional Count

Before preparing the diatom slides, use an oxidizing agent to digest the gelatinous stalks and other extracellular organic materials causing cell clumping. Before the oxidant is added, however, centrifuge or settle the sample to remove the formalin.

If centrifugation is preferred, transfer the sample to a conical tube and centrifuge 10 minutes at 1000 X G. Decant the formalin, re-suspend the sample in 10 ml of distilled water, and recentrifuge. Decant, take up the sample in 8 ml of 5 percent potassium (or ammonium) persulfate, and transfer back to the (rinsed) sample vial.

If the settling method is preferred, follow the instructions given in the Plankton Section for removing salt from the diatom concentrate, but add persulfate or hydrogen peroxide instead of distilled water. After the formalin is replaced by the oxidant, heat the sample to 95°C for 30 minutes (do not boil). Cool, remove the oxidant by centrifugation or settling, and take up the diatoms in 2 to 3 ml of distilled water. Proceed with the preparation of the permanent diatom mount as described in the Plankton Section. Label the slide with the station location and inclusive sample dates. Carry out the diatom strip count as described in the Plankton Section, except that separated, individual valves (half cell walls) are tallied as such, and the tally is divided by two to obtain cell numbers.

### 3.2.3 Biomass

#### Cell Volume

See the Plankton Section.

#### Dry and Ash-free Weight

See the Plankton Section.

#### Centrifugation, Sedimentation and Displacement

**Centrifugation.** Place sample in graduated centrifuge tube and centrifuge for 20 minutes at 1000 X G. Relate the volume in milliliters to the area sampled.

**Sedimentation.** Place sample in graduated cylinder and allow sample to settle at least 24 hours. Relate the volume in milliliters to the area sampled.

**Displacement.** Use displacement for large growths of periphyton when excess water can be readily removed. Once the excess water is removed, proceed as per Plankton Section; however, do not pour sample through a No. 20 mesh, nylon bolting cloth.

### Chlorophyll

The chlorophyll content of the periphyton is used to estimate the algal biomass and as an indicator of the nutrient content (or trophic status) or toxicity of the water and the taxonomic composition of the community. Periphyton growing in surface water relatively free of organic pollution consists largely of algae, which contain approximately 1 to 2 percent chlorophyll *a* by dry weight. If dissolved or particulate organic matter is present in high concentrations, large populations of filamentous bacteria, stalked protozoa, and other nonchlorophyll bearing microorganisms develop and the percentage of chlorophyll *a* is then reduced. If the biomass-chlorophyll *a* relationship is expressed as a ratio (the autotrophic index), values greater than 100 may result from organic pollution (Weber and McFarland, 1969; Weber, 1973).

$$\text{Autotrophic Index} = \frac{\text{Ash-free Wgt (mg/m}^2\text{)}}{\text{Chlorophyll } a \text{ (mg/m}^2\text{)}}$$

To obtain information on the physiological condition (or health) of the algal periphyton, measure the amount of pheophytin *a*, a physiologically inactive degradation product of chlorophyll *a*. This degradation product has an absorption peak at nearly the same wavelength as chlorophyll *a* and, under severe environmental conditions, may be responsible for most if not all of the OD<sub>663</sub> in the acetone extract. The presence of relatively large amounts of pheophytin *a* is an abnormal condition indicating water quality degradation. (See the Plankton Section.)

To extract chlorophyll, grind and steep the periphyton in 90 percent aqueous acetone (see Plankton Section). Because of the normal seasonal succession of the algae, the taxonomic composition and the efficiency of extraction by steeping change continually during the year. Although mechanical or other cell disruption may not increase the recovery of pigment from

every sample, routine grinding will significantly increase (10 percent or more) the average recovery of chlorophyll from samples collected over a period of several months. Where glass slides are used as substrates, place the individual slides bearing the periphyton directly in separate small bottles (containing 100 ml) of acetone when removed from the sampler. Similarly, place periphyton removed from other artificial or natural substrates in the field immediately in 90 percent aqueous acetone. (Samples should be macerated, however, when returned to the lab.)

For the chlorophyll analysis, see the Plankton Section.

Acetone solutions of chlorophyll are ex-

#### 4.0 BIBLIOGRAPHY

- American Public Health Association. 1971. Standard methods for the examination of water and wastewater, 13th ed., APHA, New York.
- Blum, J. L. 1956. The ecology of river algae. *Bot. Rev.* 22(5):291.
- Butcher, R. W. 1932. Studies in the ecology of rivers. II. The microflora of rivers with special reference to the algae on the river bed. *Ann. Bot.* 46:813-861.
- Butcher, R. W. 1940. Studies in the ecology of rivers. IV. Observations on the growth and distribution of sessile algae in the River Hull, Yorkshire. *J. Ecology*, 28:210-223.
- Butcher, R. W. 1946. Studies in the ecology of rivers. VII. The algae of organically enriched waters. *J. Ecology*, 35:186-191.
- Butcher, R. W. 1959. Biological assessment of river pollution. *Proceedings Linnean Society*, 170:159-165. Abstract in: *J. Sci. Food Agri.* 10:(11):104.
- Cairns, J., Jr., D. W. Alrough, F. Busey, and M. D. Chanay. 1968. The sequential comparison index: A simplified method for nonbiologists to estimate relative differences in biological diversity in stream pollution studies. *JWPCF*, 40(9):1607-1613.
- Cooke, W. B. 1956. Colonization of artificial bare areas by microorganisms. *Bot. Rev.* 22(9):613-638.
- Cooke, W. B. 1959. Fungi in polluted water and sewage. IV. The occurrence of fungi in a trickling filter-type sewage treatment plant. In: *Proceeding, 13th Industrial Waste Conference, Purdue University, Series No. 96*, 43(3):26-45.
- Cummins, K. W., C. A. Tyron, Jr., and R. T. Hartman (Editors). 1966. *Organism-substrate relationships in streams*. Spec. Publ. No. 4, Pymatuning Lab. of Ecol., Univ. Pittsburgh, 145 pp.
- Fjordingstad, E. 1950. The microflora of the River Molleaa with special reference to the relation of the benthic algae to pollution. *Folia Limnol. Scand.* No. 5, Kobenhaven, 123 pp.
- Fjordingstad, E. 1964. Pollution of stream estimated by benthic phytomicroorganisms. I. A saprobic system based on communities organisms and ecological factors. *Hydrobiol.* 49(1):63-131.
- Fjordingstad, E. 1965. Taxonomy and saprobic valency of benthic phytomicroorganisms. *Hydrobiol.* 50(4):475-604.
- Hawkes, H. A. 1963. Effects of domestic and industrial discharge on the ecology of riffles in midland streams. *Intern. J. Air Water Poll.* 7(6/7):565-586.
- Holtje, R. H. 1943. The biology of sewage sprinkling filters. *Sewage Works J.* 15(1):14-29.
- Keup, L. E. 1966. Stream biology for assessing sewage treatment plant efficiency. *Water and Sewage Works*, 113:11-411.
- Kolkwitz, R., and M. Marsson. 1908. Oekologie der pflanzlichen Saprobien. *Berichte Deutschen Botanischen Gesellschaft*, 26a:505-519.
- Kolkwitz, R., and M. Marsson. 1909. Oekologie der Tierischen Saprobien. *Internationale Revue Gesamten Hydrobiologie Hydrographie*, 2:126-152.
- Lackey, J. B. 1950. Aquatic biology and the water works engineer. *Public Works*, 81:30-41, 64.
- Mackenthun, K. M. 1969. *The practice of water pollution biology*. U. S. FWPCA, Washington, D.C. 281 pp.
- Mackenthun, K. M., and L. E. Keup. 1970. Biological problems encountered in water supplies. *JAWWA*, 62(8):520-526.
- O'Connell, J. M., and N. A. Thomas. 1965. Effect of benthic algae on stream dissolved oxygen. *Proc. ASCE, Sanit. Eng. Div.* 91:1-16.
- Odum, H. T. 1957. Trophic structure and productivity of Silver Springs, Florida. *Ecol. Monogr.* 27:55-112.
- Parrish, J. P., and A. M. Lucas. 1970. The effects of waste waters on periphyton growths in the Missouri River. (Manuscript). U. S. FWPCA Nat'l Field Investigations Center, Cincinnati.

## BIOLOGICAL METHODS

- Patrick, R. 1957. Diatoms as indicators of changes in environmental conditions. In: *Biological Problems in Water Pollution—Transactions of the 1956 Seminar*, Robert A. Taft Sanitary Engineering Center, U. S. Public Health Service, Cincinnati, Ohio. pp. 71-83. W57-36.
- Rohlich, G. A., and W. B. Sarles. 1949. Chemical composition of algae and its relationship to taste and odor. *Taste Odor Control J.* 18:1-6.
- Safferman, R. S., A. A. Rosen, C. I. Mashni, and M. E. Morris. 1967. Earthy - smelling substance from a blue-green alga. *Environ. Sci. Technol.* 1:429-430.
- Seligo, A. 1905. *Über den Ursprung der Fischnahrung.* *Mitt.d. Westpr. Fisch.* 17(4):52.
- Silvey, J. K. G. 1966. Taste and odors - Joint discussion effects of organisms. *JAWWA*, 58(6):706-715.
- Sladeczek, V., and A. Sladeczkova. 1964. Determination of the periphyton production by means of the glass slide method. *Hydrobiol.* 23:125-158.
- Sladeczkova, A. 1962. Limnological investigation methods for the periphyton ("Aufwuchs") community. *Bot. Rev.* 28:286-350.
- Srameck-Husek. 1946. (On the uniform classification of animal and plant communities in our waters) *Sbornik MAP*, 20(3):213 Orig. in Czech.
- Strickland, J. D. H. 1960. Measuring the production of marine phytoplankton. *Bull. No. 122. Fish. Res. Bd. Canada, Ottawa*, 172 pp. (Review of methods of primary production measurement, many applicable to periphyton analyses.)
- Thomas, N. A. 1968. Methods for slide attachment in periphyton studies. (Manuscript). U. S. FWPCA, Nat'l. Field Investigations Center, Cincinnati.
- U. S. Federal Water Pollution Control Administration. 1967. Effects of pollution on aquatic life resources of the South Platte River in Colorado. Vol. 2. Technical Appendix. USFWPCA. Cincinnati. 85 pp.
- Warner, R. W., R. K. Ballentine, and L. E. Keup. 1969. Black-water impoundment investigations. U. S. FWQA, Cincinnati, Ohio. 95 pp.
- Weber, C. 1973. Recent developments in the measurement of the response of plankton and periphyton to changes in their environment. In: *Bioassay Techniques and Environmental Chemistry*. G. Glass, ed. Ann Arbor Science Publishers, Inc., p 119-138.
- Weber, C. I., and B. McFarland. 1969. Periphyton biomass-chlorophyll ratio as an index of water quality. Presented at the 17th Annual Meeting, Midwest Benthological Society, Gilbertsville, Ky., April, 1969.
- Weber, C. I., and R. L. Raschke. 1966. Use of a floating periphyton sample for water pollution surveillance. U. S. FWPCA, Cincinnati, Ohio.
- Weston, R. S., and C. E. Turner. 1917. Studies on the digestion of a sewage filter effluent by a small and otherwise unpolluted stream. *Mass. Inst. Technol., Sanit. Res. Lab. Sewage Exper. Sta.* 10:1-43.
- Wisniewski, T. F. 1948. The chemistry and biology of milk waste disposal. *J. Milk Food Technol.* 11:293-300.
- Young, O. W. 1945. A limnological investigation of periphyton in Douglas Lake, Michigan. *Trans. Amer. Microscop. Soc.* 64:1

# MACROPHYTON



# MACROPHYTON

|                                    | Page |
|------------------------------------|------|
| 1.0 INTRODUCTION                   | 1    |
| 2.0 SAMPLE COLLECTION AND ANALYSIS | 1    |
| 2.1 Qualitative Sampling           | 2    |
| 2.2 Quantitative Sampling          | 2    |
| 3.0 REFERENCES                     | 3    |

# MACROPHYTON

## 1.0 INTRODUCTION

Macrophytes are all aquatic plants possessing a multi-cellular structure with cells differentiated into specialized tissues. Included are the mosses, liverworts, and flowering plants. Their sizes range from the near microscopic watermeal to massive cypress trees. The most commonly dealt with forms are the herbaceous water plants.

Macrophyton may be conveniently divided into three major growth types:

*Floating.* These plants have true leaves and roots and float on the water surface (duckweed, watermeal, water hyacinth).

*Submerged.* These plants are anchored to the substratum by roots and may be entirely submerged or have floating leaves and aerial reproductive structures (water milfoil, eel grass, pondweeds, bladderwort).

*Emersed.* These plants are rooted in shallow water and some species occur along moist shore lines. The two major groups are:

Floating leaved plants (water lilies and water shields).

Plants with upright shoots (cattails, sedges, woody shrubs, rice and trees).

The use of macrophytes in water quality investigations has been sorely neglected. Kolkwitz and Marsson (1908) used some species in their saprobic system of water quality classification, but they are rarely mentioned in most literature. A number of pollutants have dramatic effects on macrophyte growth:

*Turbidity* restricting light penetration can prevent the growth of submerged weeds.

*Nutrients* can stimulate overproduction of macrophytes in numbers sufficient to create nuisances or can stimulate excessive plankton growths that effect an increase in turbidities, thus eliminating macrophyte growths.

*Herbicidal compounds*, if present at sublethal concentrations, can stimulate excessive growths or they can, at higher concentrations, destroy plant growths.

Organic or inorganic nutrients, or both, can support periphytic *algal* and *slime* growths sufficient to smother and thus destroy submerged forms.

*Sludge deposits*, especially those undergoing rapid decomposition, usually are too unstable or toxic to permit the growth of rooted plants.

The rampant growth of some macrophytes has caused concern over recent years (Holm et al. 1969). Millions of dollars are spent each year in controlling macrophytes that interfere with irrigation operation, navigation, and related recreational uses. Mechanical cutting, application of herbicides, and habitat alteration are the primary control methods. Mackenthun and Ingram (1967) and Mackenthun (1969) have reviewed and summarized control techniques.

Yount and Crossman (1970) and Boyd (1970) discussed schemes for using macrophytes to remove nutrients from effluents and natural waters.

Aquatic macrophytes are a natural component of most aquatic ecosystems, and are present in those areas suitable for macrophyte growth, unless the habitat is altered. Furthermore, the proper proportions of macrophytes are ecologically desirable (Wilson, 1939; Hotchkiss, 1941; Penfound, 1956; Boyd, 1971). Boyd (1970, 1971) introduced concepts of macrophyte management opposed to the current idea of eradicating aquatic macrophytes from many aquatic ecosystems. Much additional research is needed on the role of macrophytes in aquatic ecosystems.

The objective of an investigation dictates the nature and methodology of sampling macrophytes. Critical factors are the time available, how critical the information is, expertise available, duration of the study, and characteristics of the waterway.

Techniques are few, and the investigator's best asset is his capability for innovating sound procedures.

## 2.0 SAMPLE COLLECTION AND ANALYSIS

Collecting representative genera from the macrophyton community is generally not difficult because of their large size and littoral habitats. Macrophytes may be readily identified to genera and some to species in the field, or they may be dried in a plant press and mounted for

## BIOLOGICAL METHODS

further identification. Small, delicate species may be preserved in buffered 4 percent formalin solution. Some of the more useful taxonomic works for identification are Muenscher (1944), Eyles and Robertson (1944), Fassett (1960) and Winterringer and Lopinot (1966).

### 2.1 Qualitative Sampling

Qualitative sampling includes visual observation and collection of representative types from the study area. Report the extent of growth as *dense* when coverage is continuous, *moderate* when growths are common, and *sparse* when the growth is rarely encountered. The crop of plants may be comprised of just one genus or may be a mixture; if a mixture, estimate the percentage of individual types.

Sampling gear is varied and the choice of tools usually depends on water depth. In shallow water, a garden rake or similar device is very effective for collecting macrophytes. In deeper water, employ grabs, such as the Ekman, to collect submersed types. In recent years, scuba diving has gained popularity with many investigators in extensive plant surveys. Phillips (1959) provides detailed information on qualitative sampling.

### 2.2 Quantitative Sampling

Quantitative sampling for macrophytes is usually to determine the extent or rate of growth or weight of growth per unit of area. The study objectives determine whether measurements will involve a single species or several.

Before beginning a quantitative investigation, develop a statistical design to assist in determining the best sampling procedure, sampling area size, and number of samples. Often proce-

dures adapted from terrestrial plant surveys are applicable in the aquatic environment. The following references will be helpful in adopting a suitable technique: Penfound, 1956; Westlake, 1966; Boyd, 1969; Forsberg, 1959, 1960; Edwards and Owens, 1960; Jervis, 1969; Blackburn, et al., 1968.

*Standing crop.* Sampling should be limited to small, defined subareas (quadrates) with conspicuous borders. Use a square framework with the poles anchored on the bottom and floating line for the sides. Collect the plants from within the frame by hand or by using a long-handled garden rake. Forsberg (1959) has described other methods such as laying out long, narrow transects.

Obtain the wet weight of material after the plants have drained for a standard period of time, determined by the investigator. Dry the samples (or subsamples for large species) for 24 hours at 105°C and reweigh. Calculate the dry weight of vegetation per unit area.

Planimeter accurate maps to determine the total area of investigation. If additional boat or air reconnaissance (using photographs) is done to determine type and extent of coverage, data collected from the subareas can then be expanded for the total study area. Boyd (1969) describes a technique for obtaining surface coverage by macrophytes in a small body of water.

*Productivity.* Estimate standing crops at predetermined intervals to relate growth rates to pollution, such as nutrient stimulation, retardation, or toxicity from heavy metals and thermal effects. Wetzel (1964) and Davies (1970) describe a more accurate method with the use of a carbon-14 procedure to estimate daily productivity rates of macrophytes.

## 3.0 REFERENCES

- Blackburn, R. D., P. F. White, and L. W. Weldon. 1968. Ecology of submersed aquatic weeds in south Florida canals. *Weed Sci.* 16:261-266.
- Boyd, C. E. 1969. Production, mineral nutrient absorption, and biochemical assimilation by *Justicia americana* and *Alternanthera philoxeroides*. *Archiv. Hydrobiol.* 66:139-160.
- Boyd, C. E. 1970. Vascular aquatic plants for mineral nutrient removal from polluted waters. *Econ. Bot.* 24:95-103.
- Boyd, C. E. 1971. The limnological role of aquatic macrophytes and their relationship to reservoir management. In: *Reservoir Fisheries and Limnology*, G. E. Hall (ed.), Spec. Publ. No. 8. Amer. Fish. Soc., Washington, D.C. pp. 153-166.
- Davies, G. S. 1970. Productivity of macrophytes in Marion Lake, British Columbia. *J. Fish. Res. Bd. Canada*, 27:71-81.
- Edwards, R. W., and M. Owens. 1960. The effects of plants on river conditions. I. Summer crops and estimates of net productivity of macrophytes in a chalk stream. *J. Ecol.* 48:151-160.
- Eyles, D. E., and J. L. Robertson, Jr. 1944. A guide and key to the aquatic plants of the southeastern United States. Public Health Bull. No. 286. U. S. Gov. Printing Office, Washington, D.C. 151 pp.
- Fassett, N. C. 1960. A manual of aquatic plants. Univ. Wisconsin Press, Madison. 405 pp.
- Forsberg, C. 1959. Quantitative sampling of subaquatic vegetation. *Oikos*, 10:233-240.
- Forsberg, C. 1960. Subaquatic macrovegetation in Osbyssjon, Djurholm. *Oikos*, 11:183-199.
- Holm, L. G., L. W. Weldon, and R. D. Blackburn. 1969. Aquatic weeds. *Science*, 166:699-709.
- Hotchkiss, N. 1941. The limnological role of the higher plants. In: A symposium of hydrobiology, Univ. Wisconsin Press, Madison. pp. 152-162.
- Jervis, R. A. 1969. Primary production in the freshwater marsh ecosystems of Troy Meadows, New Jersey. *Bull. Torrey Bot. Club*, 96:209-231.
- Kolkwitz, R., and M. Marsson. 1908. Oekologie der pflanzlichen Saprobien. *Berichte deutschen botanischen Gesellschaft*, 26a:505-519.
- Mackenthun, K. M. 1969. The practice of water pollution biology. U. S. FWPCA, Cincinnati. 281 pp.
- Mackenthun, K. M., and W. M. Ingram. 1967. Biological associated problems in freshwater environments. U. S. FWPCA, Cincinnati. 287 pp.
- Muenschler, W. C. 1944. Aquatic plants of the United States. Comstock Pub. Co., Ithaca. 374 pp.
- Penfound, W. T. 1956. An outline for ecological life histories of herbaceous vascular hydrophytes. *Ecology*, 33:123-128.
- Phillips, E. A. 1959. Methods of vegetation study. Henry Holt & Co., New York, 107 pp.
- Westlake, D. F. 1966. The biomass and productivity of *Glyceria maxima*. I. Seasonal changes in biomass. *J. Ecol.* 54:745-753.
- Wetzel, R. G. 1964. A comparative study of the primary productivity of higher aquatic plants, periphyton, and phytoplankton in a large shallow lake. *Int. Rev. ges. Hydrobiol.* 49:1-61.
- Wilson, L. R. 1939. Rooted aquatic plants and their relation to the limnology of fresh-water lakes. In: *Problems of Lake Biology*. Publ. No. 10, Amer. Assoc. Adv. Sci. pp. 107-122.
- Winterringer, G. S., and A. C. Lopinot. 1966. Aquatic plants of Illinois. Ill. State Museum Popular Ser. V51, VI, Ill. State Museum Division. 142 pp.
- Yount, J. L., and R. A. Crossman, Jr. 1970. Eutrophication control by plant harvesting. *JWPCF*, 42:173-183.

# MACROINVERTEBRATES

# MACROINVERTEBRATES

|   | Page |
|---|------|
| 1.0 INTRODUCTION                              | 1    |
| 2.0 SELECTION OF SAMPLE SITES                 | 2    |
| 2.1 Systematic Sampling                       | 2    |
| 2.2 Random Sampling                           | 2    |
| 2.3 Measurement of Abiotic Factors            | 2    |
| 2.3.1 Substrate                               | 2    |
| 2.3.2 Depth                                   | 4    |
| 2.3.3 Current Velocity                        | 4    |
| 2.3.4 Salinity                                | 4    |
| 3.0 SAMPLING METHODS                          | 5    |
| 3.1 Quantitative                              | 5    |
| 3.1.1 Definitions and Purpose                 | 5    |
| 3.1.2 Requirements                            | 5    |
| 3.1.3 Advantages                              | 5    |
| 3.1.4 Limitations                             | 6    |
| 3.2 Qualitative                               | 6    |
| 3.2.1 Definitions and Purpose                 | 6    |
| 3.2.2 Requirements                            | 6    |
| 3.2.3 Advantages                              | 6    |
| 3.2.4 Limitations                             | 6    |
| 3.3 Devices                                   | 7    |
| 3.3.1 Grabs                                   | 7    |
| 3.3.2 Sieving Devices                         | 9    |
| 3.3.3 Coring Devices                          | 9    |
| 3.3.4 Artificial Substrates                   | 10   |
| 3.3.5 Drift Nets                              | 11   |
| 3.3.6 Photography                             | 12   |
| 3.3.7 Qualitative Devices                     | 12   |
| 4.0 SAMPLE PROCESSING                         | 12   |
| 4.1 Sieving                                   | 12   |
| 4.2 Preservation                              | 13   |
| 4.3 Labelling                                 | 13   |
| 4.4 Sorting and Subsampling                   | 13   |
| 4.5 Identification                            | 14   |
| 4.6 Biomass                                   | 15   |
| 5.0 DATA EVALUATION                           | 15   |
| 5.1 Quantitative Data                         | 15   |
| 5.1.1 Reporting Units                         | 15   |
| 5.1.2 Standing Crop and Taxonomic Composition | 15   |
| 5.1.3 Diversity                               | 16   |
| 5.2 Qualitative Data                          | 18   |
| 5.2.1 Indicator Organism Schemes              | 18   |
| 5.2.2 Reference Station Methods               | 18   |
| 6.0 LITERATURE CITED                          | 32   |
| 7.0 TAXONOMIC BIBLIOGRAPHY                    | 33   |
| 7.1 Coleoptera                                | 33   |



|                   | Page |
|-------------------|------|
| 7.2 Crustacea     | 34   |
| 7.3 Diptera       | 34   |
| 7.4 Ephemeroptera | 35   |
| 7.5 Hemiptera     | 36   |
| 7.6 Hirudinea     | 36   |
| 7.7 Hydracarina   | 36   |
| 7.8 Lepidoptera   | 36   |
| 7.9 Megaloptera   | 36   |
| 7.10 Mollusca     | 36   |
| 7.11 Odonata      | 37   |
| 7.12 Oligochaeta  | 37   |
| 7.13 Plecoptera   | 37   |
| 7.14 Trichoptera  | 37   |
| 7.15 Marine       | 38   |

# MACROINVERTEBRATES

## 1.0 INTRODUCTION

The aquatic macroinvertebrates, as discussed in this section, are animals that are large enough to be seen by the unaided eye and can be retained by a U. S. Standard No. 30 sieve (28 meshes per inch, 0.595-mm openings) and live at least part of their life cycles within or upon available substrates in a body of water or water transport system.

Any available substrate may provide suitable habitat including bottom sediments, submerged logs, debris, pilings, pipes, conduits, vascular aquatic plants, filamentous algae, etc.

The major taxonomic groups included in fresh water are the insects, annelids, molluscs, flatworms, roundworms, and crustaceans. The major groups in salt water are the molluscs, annelids, crustaceans, coelenterates, porifera, and bryozoans.

Benthic macroinvertebrates can be defined by location and size but not by position in the trophic structure since they occupy virtually all levels. They may be omnivores, carnivores, or herbivores; and in a well-balanced system, all three types will likely be present. They include deposit and detritus feeders, parasites, scavengers, grazers, and predators.

Species present, distribution, and abundance of aquatic macroinvertebrates may be subject to wide seasonal variations. Thus, when conducting comparative studies, the investigator must be quite careful to avoid the confounding effects of these seasonal changes. Seasonal variations are particularly important in fresh-water habitats dominated by aquatic insects having several life stages, not all of which are aquatic.

The macroinvertebrates are important members of the food web, and their well-being is reflected in the well-being of the higher forms such as fish. Many invertebrates, such as the marine and fresh-water shellfish, are important commercial and recreational species. Some, such as mosquitos, black flies, biting midges, and Asiatic clams, are of considerable public health significance or are simple pests; and many forms are important for digesting organic material and recycling nutrients.

A community of macroinvertebrates in an aquatic ecosystem is very sensitive to stress, and thus its characteristics serve as a useful tool for detecting environmental perturbations resulting from introduced contaminants. Because of the limited mobility of benthic organisms and their relatively long life span, their characteristics are a function of conditions during the recent past, including reactions to infrequently discharged wastes that would be difficult to detect by periodic chemical sampling.

Also, because of the phenomenon of "biological magnification" and relatively long-term retention of contaminants by benthic organisms, contaminants such as pesticides, radioactive materials, and metals, which are only periodically discharged or which are present at undetectable levels in the water, may be detected by chemical analyses of selected components of the macroinvertebrate fauna.

In pollution-oriented studies of macroinvertebrate communities, there are basically two approaches—quantitative and qualitative—that may be utilized singly or in combination. Because of the basic nature of this decision, the section of this manual relating to sampling methods and data evaluation of macroinvertebrates is arranged on the basis of whether a quantitative or qualitative approach is used.

Ideally, the design of macroinvertebrate studies should be based upon study goals or objectives; however, the ideal must frequently be tempered by the realities of available resources, time limitations imposed on the study, and the characteristics of the habitat to be studied. To aid in selecting the most advantageous sampling method, sample sites, and data evaluation, the reader of this section should be familiar with the material in the "Introduction" of this manual, particularly those portions outlining and discussing requirements of the various types of field studies in which an investigator may become involved.

To supplement the material contained in this manual, a number of basic references should be available to investigators of the benthic community, particularly to those engaged in water

## BIOLOGICAL METHODS

pollution studies. These include Standard Methods (2), Welch (57), Mackenthun (37), Kittrell (29), Hynes (26), and Buchanan and Sommers (9).

### 2.0 SELECTION OF SAMPLE SITES

As discussed and defined more fully in the section on biometrics, sample sites may be selected systematically or by various randomization procedures.

#### 2.1 Systematic Sampling

Unless the data are to be utilized for quantitative evaluations, some type of systematic sampling is generally employed for synoptic surveys and reconnaissance studies. Line transects established at discrete intervals across a river or stream and sampled at quarter points or more frequent intervals are a form of systematic sampling and serve as an excellent means of delimiting and mapping the habitat types. In lakes, reservoirs, and estuaries, transects may be established along the short or long axis or may radiate out from a pollution source. If a random start point is used for selecting sampling sites along the transects, the data may be amenable to quantitative evaluation (see Biometrics Section). As will be discussed, however, the confounding effects of changes in physical characteristics of the environment along the transect must be fully recognized and accounted for.

In another form of systematic sampling, the investigator, using a variety of gear, consciously selects and intensively samples all recognizable habitat types. As previously mentioned, this form of sample site selection is useful for synoptic surveys and for comparative studies where qualitative comparisons are being made.

#### 2.2 Random Sampling

For conducting quantitative studies, where a measure of precision must be obtained, some type of randomization procedure must be employed in selecting sampling sites. This selection may be carried out on the whole of the area under study (simple random sampling), or the randomization procedure may be conducted independently on selected strata (stratified random sampling). Because the characteristics of

macroinvertebrate communities are so closely related to physical factors such as substrate type, current velocity, depth, and salinity, a design using simple random sampling is seldom meaningful. Therefore, the investigator should stratify the habitat on the basis of known physical habitat differences and collect samples by the random grid technique within each habitat type.

As alluded to above, and regardless of the method of sample site selection, the biologist must consider and account for those natural environmental variations that may affect the distribution of organisms. Among the more important natural environmental variables in fresh-water habitats are substrate type, current velocity, and depth. In estuaries, the salinity gradient is an additional variable that must be accounted for.

### 2.3 Measurement of Abiotic Factors

#### 2.3.1 Substrate

Substrate is one of the most important factors controlling the characteristics of the community of aquatic macroinvertebrates found at a given location in a body of water (49). Over a period of time, the natural substrates may be greatly altered by the discharge of particulate mineral or organic matter and the location and expanse of various substrate types (silt, sand, gravel, etc.) may change because of normal variations in hydrologic factors such as current velocity and stream flow. The biologist, therefore, must be cognizant of changes in the nature and properties of the substrate which may provide clues on the quality and quantity of pollutants and consider factors which affect the normal distribution of the benthic fauna.

Where the pollutant has a direct effect on the characteristics of the substrate, the effects of changes in water quality may be inseparable from the effects of changes in the substrate. In cases where substrate deterioration has occurred, faunal effects may be so obvious that extensive sampling may not be required, and special attention should be given to the physical and/or chemical characterization of the deposits.

In conducting synoptic surveys or other types of qualitative studies and taking into account

## MACROINVERTEBRATE SAMPLING

the limitations of available sampling devices, sampling sites should be selected to include all available substrates. If these qualitative samples are to be used for determining the effects of pollutants where the pollutant does not have a direct affect on the substrate, the investigator must bear in mind that only the fauna from sites having similar substrates (in terms of organic content, particle size, vegetative cover, and detritus) will provide valid data for comparison.

For quantitative studies, it is sometimes necessary in the interest of economy and efficiency and within the limitations of the available gear, to sample primarily at sites having substrates which normally support the most abundant and varied fauna, and devote a minimum effort to those substrates supporting little or no life. For instance, in many large, swiftly-flowing rivers of the Midwest and Southeast, the areas of "scour" with a substrate of shifting sand or hardpan may be almost devoid of macroinvertebrates; sampling effort may be reduced there in

favor of the more productive areas of "deposition" on the inside of bends or in the vicinity of obstructions. Just the opposite situation may occur in many of the swiftly-flowing upland streams, where most of the effort may be devoted to sampling the productive rubble and gravel riffle areas instead of the pools.

Because of the importance of substrate (in terms of both organic content and particle size) in macroinvertebrate studies, it is suggested that sufficient samples be collected to conduct the following minimal analyses and evaluations:

- In the field, classify and record, on suitable forms, the mineral and organic matter content of the stream, lake, or estuary bottom at each sample site on a percentage basis with the use of the categories shown in Table 1. Although the categories given in Table 1 may not apply universally, they should be applicable to most situations with only slight modification.

TABLE 1. CATEGORIES FOR FIELD EVALUATION OF SOIL CHARACTERISTICS\*

| Type                        | Size or characteristic  |
|-----------------------------|---|
| <b>Inorganic Components</b> |   |
| Bed rock or solid rock      |   |
| Boulders                    | >256 mm (10 in.) in diameter  |
| Rubble                      | 64 to 256 mm (2½ to 10 in.) in diameter   |
| Gravel                      | 2 to 64 mm (1/12 to 2½ in.) in diameter   |
| Sand                        | 0.06 to 2.0 mm in diameter; gritty texture when rubbed between fingers.   |
| Silt                        | 0.004 to 0.06 mm in diameter  |
| Clay                        | <0.004 mm in diameter; smooth, slick feeling when rubbed between fingers  |
| Marl                        | Calcium carbonate; usually gray; often contains fragments of mollusc shells or <i>Chara</i> ; effervesces freely with hydrochloric acid                           |
| <b>Organic Components</b>   |   |
| Detritus                    | Accumulated wood, sticks, and other undecayed coarse plant materials  |
| Fibrous peat                | Partially decomposed plant remains; parts of plants readily distinguishable   |
| Pulpy peat                  | Very finely divided plant remains; parts of plants not distinguishable; varies in color from green to brown; varies greatly in consistence—often being semi-fluid |
| Muck                        | Black, finely divided organic matter; completely decomposed   |

\*Modified from Roelofs, E. W. 1944. Water soils in relation to lake productivity. Tech. Bull. 190. Agr. Exp. Sta., State College, Lansing, Mich.

## BIOLOGICAL METHODS

- In the laboratory, evaluate the inorganic components by conducting a wet and dry particle size analysis on one or more samples and preferably on replicate samples from each sampling site with the use of standard sieves and following the modified Wentworth classification shown in Table 2. Detailed procedures for sediment analysis are found in IBP handbook No. 16.\*

TABLE 2. SOIL PARTICLE SIZE CLASSIFICATION\*

| Name           | Particle size (mm) | U.S. standard sieve series #  |
|----------------|--------------------|-------------------------------|
| Boulder        | >256               |                               |
| Rubble         | 64-256             |                               |
| Coarse gravel  | 32-64              |                               |
| Medium gravel  | 8-32               | †                             |
| Fine gravel    | 2-8                | 10                            |
| Coarse sand    | 0.5-2              | 35                            |
| Medium sand    | 0.25-0.5           | 120                           |
| Fine sand      | 0.125-0.25         | 230                           |
| Very fine sand | 0.0625-0.125       |                               |
| Silt           | 0.0039-0.0625      | Centrifuge (750 rpm, 3 min) ‡ |
| Clay           | <0.0039            | Evaporate and weigh residue   |

\*Modified from Wentworth (58); see Cummins, K. A. 1962. An evaluation of some techniques for the collection and analysis of benthic samples with special emphasis on lotic waters. Amer. Midl. Nat. 67:477-504.

†Standard sieves with 8-mm diameter openings are commonly available.

‡Jackson, M. L. 1956. Soil chemical analysis. Univ. Wisconsin Press, Madison.

- Determine the organic content by drying and ashing a representative sample of the sediments; use the methods outlined in the Plankton Section.

### 2.3.2 Depth

Depth indirectly affects the distribution of aquatic macroinvertebrates as a result of its influence on the availability of light for plant growth, on water temperature, on the zonation of bottom deposits, on the water chemistry (particularly oxygen), and phototactic responses of organisms. In regard to the selection of

\*Holme, N. A., and A. D. MacIntyre. 1971. Methods for the study of marine benthos. International Biological Program, Davis Company, Philadelphia. 346 pp.

sampling sites for both qualitative and quantitative studies, depth must be measured and included as an independent variable in the study design.

### 2.3.3 Current velocity

Current velocity affects the distribution of organisms in lotic environments and along the windswept shores of lentic environments, both directly (because of differing species requirements) and indirectly (sorting of bottom sediments). Therefore, it is of critical importance that velocity be considered when sampling sites are selected, and when data are analyzed. Only sites with comparable velocity should be compared. At the actual time of sampling, determine velocity at each sample site by using a suitable current measuring device. The TSK flow meter listed in the appendix is suitable if modified by the addition of a stabilizing fin and propeller lock.

- At depths greater than 3 feet, use the two-point method (1); take readings at 0.2 and 0.8 of the depth below the surface. The average of these two observations is taken as the mean velocity.
- At depths less than 3 feet, the 0.6-depth method (1) is used; take readings at 0.6 of the depth below the surface.
- Where artificial substrate samplers are being utilized, take the reading directly upstream of the sampler and at the same depth.

### 2.3.4 Salinity

Salinity is an important factor in marine and estuarine environments. The salinity of sea water is approximately 35 parts per thousand; salinity of fresh water is generally a few parts per million. In estuaries, where sea water and fresh water meet, there may be wide fluctuations of salinity with tides and river discharge. This area may be inhabited to some extent by both fresh- and salt-water forms, but the number of species is usually less than that that occurs under more stable conditions of salinity (35). Since movement, as well as general location of many species, is governed by tides and salinity, these must be taken into account in determining sampling time and location.



Because of the extreme spatial and temporal fluctuations of salinity in estuaries, simple, rapid instrumental methods of measurement are more desirable than slower, more precise chemical methods (38):

Wide-range, temperature-compensated conductivity salinometers are recommended for determining both horizontal and vertical salinity profiles at high-slack and low-slack tide levels in the area of estuary or reach of river being studied.

### 3.0. SAMPLING METHODS

#### 3.1. QUANTITATIVE

##### 3.1.1. Definitions and purpose

Although the data may be evaluated in various ways, a quantitative method essentially involves an estimation of the numbers or biomass (standing crop) of the various components of the macroinvertebrate community per unit area in all or a portion of the available habitats (including artificially introduced habitats) in the ecosystem being studied, and provides information on the species composition, richness of species and distribution of individuals among the species.

##### 3.1.2. Requirements

Obtain quantitative estimates by using devices that sample a unit area or volume of habitat, such as a Surber square-foot sampler, which in use presumably collects all organisms enclosed within the frame of the sampler, or an artificial substrate sampler having a fixed volume or exposing a fixed amount of surface.

In the study of macroinvertebrate populations, the sampling precision is affected by a number of factors, including size, weight, and construction of the sampling device, the type of substrate, and the distribution of organisms in and on the substrate. For example, it is expected that the estimates of standing crop drawn from a series of samples will be more precise (have a lower coefficient of variation) when the community consists of a few species represented

by a large number of individuals, evenly distributed in the substrate. Conversely, a large coefficient of variation would be expected if the fauna consists of a large number of species with a patchy distribution of individuals. To obtain the same level of precision at a given level of probability, a larger number of replicates would be required in the latter case than in the former. In general, the smaller the surface area encompassed by a sampling device, the larger the number of samples required to obtain a desired level of precision. Thus, precision can be increased by collecting larger samples, or by increasing the numbers of samples collected.

An objective, quantitative approach necessitates that a measure of the precision of the estimates be obtained — thus, replicate sampling in each habitat or stratum selected for study is an absolute requirement. For measurement of precision, three replicates are an absolute minimum. (A series of single samples taken at discrete points along a transect do not represent replicate samples of benthic organisms unless it can be demonstrated that the physical characteristics of the habitat do not change along the transect.)

It is preferable, if data are available (or can be obtained by reconnaissance or exploratory studies), to determine the number of replicates on the basis of the desired level of precision as discussed in the Biometrics Section.

##### 3.1.3. Advantages

In addition to providing the same data obtained from a qualitative study, the standing crop data generated by a quantitative study provide a means of comparing the productivity of different environments, and if a measure of turnover is available, the actual production can be computed.

The use of quantitative sampling devices in carefully chosen habitats is recommended because they reduce sampling bias resulting from differences in expertise of the sample collector.

The data from properly designed quantitative studies are amenable to the use of simple but



## BIOLOGICAL METHODS

powerful statistical tools that aid in maintaining the objectivity of the data evaluation process. The measures of precision and probability statements that can be attached to quantitative data reduce the possibilities of bias in the data evaluation process and make the results of different investigators more readily comparable.

The advantages, then, of quantitative methods are:

- They provide a measure of productivity.
- The investigator can measure precision of estimates and attach probability statements, thus providing objective comparisons.
- The data of different investigators may be compared.

### 3.1.4 Limitations

Presently, no sampling devices are adequate to sample all types of habitat; so when quantitative devices are used, only selected portions of the environment may be sampled.

Sampling precision is frequently so low that prohibitive numbers of replicate samples may be required to obtain meaningful estimates. Sample processing and analysis are slow and time-consuming. In some cases, therefore, time limitations placed on a study may prohibit the use of quantitative techniques.

## 3.2 Qualitative

### 3.2.1 Definitions and purpose

The objective of qualitative studies is to determine the presence or absence of forms having varying degrees of tolerance to contaminants and to obtain information on "richness of species." Samples are obtained with the use of a wide variety of collecting methods and gear, many of which are not amenable to quantitation on a unit-area basis. When conducting qualitative studies, an attempt is usually made to collect all species present by exhaustive sampling in all available habitat types.

### 3.2.2 Requirements

Recognizing and locating various types of habitats where qualitative samples can be collected and selecting suitable collecting

techniques require experience and a high level of expertise.

When conducting comparative studies of the macrobenthos, a major pitfall is the confounding effect of the differences in physical habitat among the different stations being studied. This danger is particularly inherent in qualitative studies when an attempt is made to systematically collect representative specimens of all species present at the sampling stations or reaches of river being compared. Unfortunately, differences in habitat unrelated to the effects of introduced contaminants may render such comparisons meaningless. Minimize this pitfall by carefully recording, in the field, the habitats from which specimens are collected and then basing comparisons only on stations with like habitats in which the same amount of collecting effort has been expended.

### 3.2.3 Advantages

Because of wide latitude in collecting techniques, the types of habitat that can be sampled are relatively unrestricted. Assuming taxonomic expertise is available, the processing of qualitative samples is often considerably faster than that required for quantitative samples.

### 3.2.4 Limitations

Collecting techniques are subjective and depend on the skill and experience of the individual who makes the field collections. Therefore, results of one investigator are difficult to compare with those of another.

As discussed elsewhere, the drift of organisms into the sample area may bias the evaluation of qualitative data and render comparisons meaningless.

No information on standing crop or production can be generated from a qualitative study.

## 3.3 Devices

### 3.3.1 Grabs

Grabs are devices designed to penetrate the substrate by virtue of their own weight and leverage, and have spring- or gravity-activated closing mechanisms. In shallow waters, some of these devices may be rigged on poles or rods and physically pushed into the substrate to a

predetermined depth. Grabs with spring-activated closing devices include the Ekman, Shipek, and Smith-McIntyre; gravity-closing grabs include the Petersen,\* Ponar, and Orange Peel. Excellent descriptions of these devices are given in Standard Methods (2) and Welch (57). Grabs are useful for sampling at all depths in lakes, estuaries, and rivers in substrates ranging from soft muds through gravel.

In addition to the previously discussed problems related to the patchy distribution of organisms in nature, the number and kinds of organisms collected by a particular grab may be affected by:

- depth of penetration
- angle of closure
- completeness of closure of the jaws and loss of sample material during retrieval
- creation of a "shock" wave and consequent "wash-out" of near-surface organisms
- stability of sampler at the high-flow velocities often encountered in rivers.

Depth of penetration is a very serious problem and depends on the weight of sampler as opposed to the particle size and degree of compaction of the bottom sediments. The Ekman grab is light in weight and most useful for sampling soft, finely divided substrates composed of varying proportions of fine sand, clay, silt, pulpy peat, and muck. For clay hardpan and coarse substrates, such as coarse sands and gravels, the heavier grabs such as the orange peel or clam shell types (Ponar, Petersen, Smith-McIntyre) are more satisfactory. Auxiliary weights may be added to aid penetration of the substrate and to add stability in heavy currents and rough waters.

Because of differences in the depth of penetration and the angle of "bite" upon closure, data from the different grabs are not comparable. The Ekman essentially encloses a square, which is equal in area from the surface to

\*Forest Modification of the Petersen grab described in Welch (57).

maximum depth of penetration before closure. In soft substrates, for which this grab is best suited, the penetration is quite deep and the angular closure of the spring-loaded jaws has very little effect on the volume of sample collected. In essence this means that if the depth of penetration is 15 cm, the organisms lying at that depth have the same opportunity to be sampled as those lying near the surface.

In clam-shell type grabs, such as the Petersen, Ponar, Shipek, and Smith-McIntyre, the original penetration is often quite shallow: because of the sharp angle of "bite" upon closure, the area enclosed by the jaws decreases at increasing depths of substrate penetration. Therefore, within the enclosed area, organisms found at greater depths do not have an equal opportunity to be sampled as in the case of the Ekman grab and other sampling methods described in the next section. This problem is particularly true of the Shipek sampler — the jaws do not penetrate the substrate before closure and, in profile, the sample is essentially one-half of a cylinder.

Probably one of the most frustrating aspects of sampling macroinvertebrates with various types of grabs relates to the problem of incomplete closure of the jaws. Any object — such as clumps of vegetation, woody debris, and gravel — that cannot be sheared by the closing action of the jaws often prevents complete closure. In the order of their decreasing ability to shear obstructing materials, the common grabs may be ranked: Shipek, Smith-McIntyre, Orange Peel, Ponar, Petersen, and Ekman. If the Ekman is filled to within more than 5 cm of the top, there may be loss of substrate material on retrieval (16). An advantage of the Ekman grab is that the surface of the sediment can be examined upon retrieval, and only those samples in which the sediment surface is undisturbed should be retained.

All grabs and corers produce a "shock" wave as they descend. This disturbance can affect the efficiency of a sampler by causing an outward wash (blow-out) of flocculent materials near the mud-water interface that may result in

## BIOLOGICAL METHODS

inadequate sampling of near-surface organisms such as phantom midge larvae, and some chironomid midges. The shock wave of the Ekman grab is minimized by the use of hinged, freely-opening top flaps. The Ponar grab is a modified Petersen with side curtains and a screen on the top. The screen allows water to pass and undoubtedly reduces the shock wave; however, divers have observed blow-out with this device (16).

Grab-collected samples provide a very imprecise estimate of the numbers of individuals and numbers of taxa of aquatic macroinvertebrates. A summary of data from various sources shows that the mean coefficient of variation (C) for numbers of individuals collected by Ponar, Petersen, and Ekman grabs was 46, 48, and 50 percent, respectively (Table 3). In most of the studies on which the calculations in Table 3 are based, the level of replication ranged from three to six samples. Estimations of number of taxa are more precise; for Ponar, Petersen, and Ekman grabs, the mean calculated C was 28, 36, and 46 percent respectively (Table 3).

On the basis of the calculations in Table 4, there appear to be no consistent differences in the precision of estimates collected by Ekman, Ponar, and Petersen grabs in mud or sand substrates. The poor closure ability of the Ekman in coarse substrates such as gravel is demonstrated by the large C values for the Ekman as compared with values for the Petersen and Ponar in gravel substrates.

Another way of demonstrating the reliability of grab sample estimates of macrobenthos standing crop is to calculate, at a given probability level, the range of values around the sample mean in which the true mean should lie if a given number of replicate samples were collected. From the data shown in Table 3 for the Petersen, Ponar, and Ekman grabs in various types of substrate, coefficients of variation near 50 percent for numbers of individuals and 35 percent for numbers of taxa should be expected with 3 to 6 replicates. With the use of these expected values, the true mean for numbers of individuals and number of taxa of macroinvertebrates should lie within plus or minus 36 percent

TABLE 3. MEAN AND MODAL VALUES FOR COEFFICIENTS OF VARIATION\* (EXPRESSED AS PERCENTAGE) FOR NUMBERS OF INDIVIDUALS AND NUMBERS OF TAXA OF MACROINVERTEBRATES COLLECTED BY VARIOUS DEVICES

| Sampling device             | Individuals |       | Taxa |       | Remarks   |
|-----------------------------|-------------|-------|------|-------|---|
|                             | Mean        | Mode† | Mean | Mode‡ |   |
| Rock-filled barbecue basket | 32          | 21-30 | 20   | 11-20 | 22 sets of samples with 4-6 reps. per set (52) and 2 sets of samples having 15 and 16 reps. (13). |
| Ponar                       | 46          | 41-50 | 28   | 11-20 | 12 sets of samples with 3-12 reps. per set (16, 31).  |
| Petersen                    | 48          | 51-60 | 36   | 21-30 | 21 sets of samples with 3-6 reps. per set (31, 52, 54).   |
| Ekman                       | 50          | 41-50 | 46   | 31-40 | 27 sets of samples with 3-12 reps. per set (8, 16, 31, 45, 53).                                   |
| Surber                      | 50          | 41-50 |      |       | 60 sets of samples having 6 reps. per set (20).   |
| Corenet                     | 50          |       |      |       | 7 sets of samples having 10 reps. per set (8).  |
| Stovepipe                   | 56          | 31-40 | 38   | 21-30 | 32 sets of samples having 3-4 reps. per set (53).   |

\*Coefficient of variation = (standard deviation x 100)/mean.

†Frequency distribution based on 10% increments.

‡Oligochaetes only.

## MACROINVERTEBRATE SIEVING AND CORING DEVICES

and 25 percent, respectively, of the sample mean at a 95 percent probability level, if 10 replicates were collected. (See Biometrics Section.)

Precision would, of course, be increased if additional samples were collected, or if the sampling method were more precise.

Since the assumptions necessary for the statistical calculations shown in Tables 3 and 4 are not likely met in the data of different investigators collected from different habitats, the above calculations only provide a gross approximation of the precision to be expected. They do, however, serve to emphasize the very imprecise nature of grab sample data and the resultant need for careful stratification of the type of the habitat sampled and sample replication.

TABLE 4. MEAN COEFFICIENTS OF VARIATION (EXPRESSED AS PERCENTAGE) FOR NUMBERS OF INDIVIDUALS AND NUMBERS OF TAXA OF MACROINVERTEBRATES COLLECTED IN DIFFERENT SUBSTRATES BY GRAB-TYPE DEVICES AND A CORER DEVICE\*

| Sampling device | Substrate |      |      |      |        |      |
|-----------------|-----------|------|------|------|--------|------|
|                 | Mud       |      | Sand |      | Gravel |      |
|                 | Ind.      | Taxa | Ind. | Taxa | Ind.   | Taxa |
| Ekman           | 49        | 40   | 41   | 21   | 106    | 74   |
| Petersen        | 41        | 29   | 50   | 41   | 49     | 20   |
| Ponar           | 46        | 25   | 38   | 33   | 48     | 19   |
| Corer†          | 50        |      |      |      |        |      |

\*Calculated from data in references (8, 16, 31, 45, 53, 54).  
†Oligochaetes only.

### 3.3.2 Sieving devices

For quantitative sampling, the well-known Surber square-foot sampler (2, 57) is the most commonly used sieving device. This device can be used only in flowing water having depths not greater than 18 inches and preferably less than 12 inches. It is commonly used for sampling the rubble and gravel riffles of small streams and may be used in pools where the water depth is not too great.

When using a sieving-type device for quantitative estimates, reliability may be affected by:

- adequacy of seating of the frame on the substrate
- backwash resulting from resistance of the net to water flow – at high velocity of flow this may be significant
- care used in recovering the organisms from the substrate materials
- depth to which the substrate is worked
- drift of organisms from areas upstream of the sample site

To reduce the possibility of bias resulting from upstream disturbance of the substrate, always stand on the downstream side of a sieving device and take replicates in an upstream or lateral direction. Never start in the upstream portion of a pool or riffle and work in a downstream direction.

The precision of estimates of standing crops of macrobenthos obtained with Surber-type sieving devices varies widely and depends on a number of factors including the uniformity of substrate and distribution of organisms therein, the care used in collecting samples, and level of sample replication.

For a large series of Surber samples from southeastern U. S. trout streams, the coefficient of variation (C) ranged from 11 percent to greater than 100 percent (Table 3). The mean value of C was near 50 percent, and more than one-half of the C values fell between 30 and 50 percent. These values are similar to the 20 to 50 percent reported by Allen (1) and for those discussed above for grab sample data.

### 3.3.3 Coring devices

Included in this category are single- and multiple-head coring devices, tubular inverting devices, and open-ended stowpipe-type devices.

Coring devices are described in Standard Methods (2) and Welch (57). Corers can be used at various depths in any substrate that is sufficiently compacted so that the sample is retained; however, they are best suited for sampling the relatively homogeneous soft sediments of the deeper portions of lakes.



## BIOLOGICAL METHODS

Because of the small area sampled, data from coring devices are likely to provide very imprecise estimates of the standing crop of macrobenthos. As the data in Table 3 illustrate, the variability in numbers of oligochaetes (a dominant component of the fauna studied) collected in corers is similar to that for grab-type devices; however, the corer data were calculated from two to three times as many replicate samples and were collected from a relatively homogeneous substrate.

Such additional replication with corers is feasible because of the small amount of material per sample that must be handled in the laboratory. Multiple-head corers have been used in an attempt to reduce the field sampling effort that must be expended to collect large series of core samples (19).

The Dandy inverting sampler (57) is a highly efficient coring-type device used for sampling at depths to 2 or 3 meters in nonvegetated substrates ranging from soft muds through coarse sand. Because of the small surface area sampled, data obtained by this sampler suffer from the same lack of precision (51) as the coring devices described above. Since the per-sample processing time is reduced, as with the corers, large series of replicates can be collected. The Dandy sampler is highly recommended for use in habitats for which it is suitable.

Stovepipe-type devices include the Wilding sampler (2, 57) and any tubular material such as 60 to 75 cm sections of standard 17-cm-diameter stovepipe (51) or 75 cm sections of 30-cm-diameter aluminum irrigation pipe fitted with handles. In use, the irrigation pipe or commercial stovepipe is manually forced into the substrate, after which the contained vegetation and coarse substrate materials are removed by hand. The remaining materials are repeatedly stirred into suspension, removed with a long-handled dipper, and poured through a wooden-framed floating sieve. Because of the laborious and repetitive process of stirring, dipping, and sieving large volumes of material, the collection of a sample often requires 20 to 30 minutes.

The use of stovepipe samplers is limited to standing or slowly moving waters having a maximum depth of less than 60 cm. Since

problems relating to depth of sediment penetration, changes in cross-sectional area with depth of penetration, and escapement of organisms are circumvented by stovepipe samplers, they are recommended for quantitative sampling in all shallow water benthic habitats. They probably represent the only quantitative device suitable for sampling shallow-water habitats containing stands of rooted vascular plants and will collect organisms inhabiting the vegetative substrates as well as those living in sediments. The coefficients of variation for the stovepipe samples in Table 3 are comparable to the coefficients for grab samples, although the stovepipe samples were collected in heavily vegetated and consequently highly variable habitats.

### 3.3.4 Artificial substrates

The basic multiple-plate sampler (23) and rock-filled basket sampler (21) have been modified by numerous workers (17, 40) and are widely used for investigating the macroinvertebrate community. Both samplers may be suspended from a surface float or may be modified for use in shallow streams by placing them on a rod that is driven into the stream bottom or anchored in a piece of concrete (24).

A multiple-plate sampler similar to that described by Fullner (17), except with circular plates and spacers, is recommended for use by EPA biologists. This sampler is constructed of 0.3-cm tempered hardboard cut into 7.5-cm diameter circular plates and 2.5-cm circular spacers. A total of 14 plates and 24 spacers are required for each sampler. The hardboard plates and spacers are placed on a 1/4-inch (0.625 cm) eyebolt so that there are eight single spaces, one double space, two triple spaces, and two quadruple spaces between the plates. This sampler has an effective surface area (excluding the bolt) of 0.13 square meter and conveniently fits into a wide-mouth glass or plastic jar for shipment and storage. Caution should be exercised in the reuse of samplers that may have been subjected to contamination by toxicants, oils, etc.

The rock basket sampler is a highly effective device for studying the macroinvertebrate community. A cylindrical, chromeplated basket

## MACROINVERTEBRATE ARTIFICIAL SUBSTRATES AND DRIFT NETS

(2) or comparable enclosure filled with 30, 5 to 8-cm-diameter rocks or rock-like material is recommended for use by EPA biologists.

To reduce the number of organisms that escape when the samplers are retrieved, the multiple-plate-sampler and the rock-filled basket sampler should be enclosed by a dip net constructed of 30-mesh or finer grit bolting cloth.

Artificial substrate samplers, to a great extent, depend on chance colonization by drifting or swimming organisms; and, thus, the time of exposure may be critical to the development of a relatively abundant and diverse community of organisms. Adequate data are currently unavailable to determine the optimum exposure period, which is likely to differ in different bodies of water and at different times of the year. Until more data become available, adoption of a 6-week exposure period (2) is provisionally recommended as standard. If study time limitations reduce this period, the data must be evaluated with caution and, in no case, should data be compared from samplers exposed for different time periods (43).

In deeper waters, artificial substrate samplers should be suspended from floats and should be well up in the photic zone so that periphytic growths can develop and provide food for grazing forms of macroinvertebrates. Unless the water is exceptionally turbid, a 1.2-meter (4-foot) depth is recommended as standard. If the water is less than 2.5 meters deep, the sampler should be suspended from a float halfway between the water surface and the stream bed.

In some situations, artificial substrate methods are the best means of conducting quantitative studies of the ability of an aquatic environment to support a diverse assemblage of macroinvertebrate organisms. Advantages of the method are:

- The confounding effects of substrate differences are reduced.
- A higher level of precision is obtained than with other sampling devices (Table 3).
- Quantitatively comparable data can be obtained in environments from which it is virtually impossible to obtain samples with conventional devices.

- Samples usually contain negligible amounts of extraneous material, permitting quick laboratory processing.

Limitations of artificial substrate samplers are:

- The need for a long exposure period makes the samplers unsuited for short-term survey studies.
- Samplers and floats are sometimes difficult to anchor in place and may present a navigation hazard.
- Samplers are vulnerable to vandalism and are often lost.
- Samplers provide no measure of the condition of the natural substrate at a station or of the effect of pollution on that substrate, including settled solids.
- Samplers only record the community that develops during the sampling period, thus reducing the value of the collected fauna as indicators of prior conditions.

Two other objections often made to the use of artificial substrate samplers are that they are selective to certain types of fauna and the data obtained do not provide a valid measure of the productivity of a particular environment. The validity of the latter objection depends on study objectives and may be of minor consequence in many pollution-oriented studies. The selectivity of artificial substrate samplers is a trival objection, since all currently available devices are selective. The selectivity of conventional sampling devices other than artificial substrates is directed toward those organisms that inhabit the types of substrate or substrates for which a particular type of sampler is designed.

### 3.3.5 Drift nets

Nets having a 1.5 by 30-cm upstream opening and a bag length of 1.3 m (No. 40 mesh netting) are recommended for small, swift streams. In large, deep rivers with a current of approximately 0.03 meters per second (mps), nets having an area of 0.093 m<sup>2</sup> are recommended (2). Anchor the nets in flowing water (current not less than 0.015 mps) for from 1 to 24 hours, depending on the density of bottom



## BIOLOGICAL METHODS

fauna and hydrologic conditions. Place the top of the nets just below the surface of the water to permit calculation of the flow through the nets and to lessen the chance for collection of floating terrestrial insects. Do not permit the nets to touch bottom. In large rivers, maximum catches are obtained 0.3 to 0.6 meter above the bottom in the shoreline zone at depths not exceeding 3 meters.

Drift nets are useful for collecting macro-invertebrates that migrate or are dislodged from the substrate; they are particularly well-suited for synoptic surveys because they are lightweight and easily transported. Thousands of organisms — including larvae of stoneflies, mayflies, caddisflies, and midges and other Diptera, may be collected in a sampling period of only a few hours. Maximum drift intensity occurs between sunset and midnight (55). Elliot (14) presents an excellent synopsis of drift net methodology.

### 3.3.6 Photography

The use of photography is mainly limited to environments that have suitably clear water and are inhabited by sessile animals and rooted plants. Many estuarine habitats, such as those containing corals, sponges, and attached algal forms, fall in this category and can be photographed before, during, and after the introduction of stress. The technique has been used with success in south Florida to evaluate changes brought about by the introduction of heated effluents.

The technique for horizontal underwater photos using scuba gear involves placing a photographically identifiable marker in the habitat to be photographed and an additional nearby marker on which the camera is placed, each time a photograph is taken. By this means, identical areas can be photographed repeatedly over a period of time to evaluate on-site changes in sessile forms at both affected and control stations. Vertical, overhead photos may also be taken under suitable conditions.

### 3.3.7 Qualitative devices

The investigator has an unlimited choice of gear for collecting qualitative samples. Any of

the quantitative devices discussed previously, plus hand-held screens, dip nets, rakes, tongs, post hole diggers, bare hands, and forceps can be used. For deep-water collecting, some of the conventional grabs described earlier are normally required. In water less than 2 meters deep, a variety of gear may be used for sampling the sediments including long-handled dip nets and post-hole diggers. Collections from vascular plants and filamentous algae may be made with a dip net, common garden rake, potato fork, or oyster tongs. Collections from floating debris and rocks may be made by hand, using forceps to catch the smaller organisms.

In shallow streams, short sections of common window screen may be fastened between two poles and held in place at right angles to the water flow to collect organisms dislodged from upstream materials that have been agitated.

## 4.0 SAMPLE PROCESSING

### 4.1 Sieving

Samples collected with grabs, tubular devices, and artificial substrates contain varying amounts of finely divided materials such as completely decomposed organic material, silts, clays, and fine sand. To reduce sample volume and expedite sample processing in the laboratory, these fines should be removed by passing the sample through a U. S. Standard No. 30 sieve. Sieves may range from commercially constructed models to homemade sieves framed with wood or metal. Floating sieves with wooden frames reduce the danger of accidental loss of both sieve and sample when working over the side of a boat in deeper waters. A good sieve contains no cracks or crevices in which small organisms can become lodged.

If at all possible, sieving should be done in the field immediately after sample collection and while the captured organisms are alive. Once preserved, many organisms become quite fragile and if subjected to sieving will be broken up and lost or rendered unidentifiable.

Sieving may be accomplished by one of several techniques depending upon the preference of the individual biologist. In one technique, the sample is placed directly into a sieve and the

sieve is then partially submerged in water and agitated until all fine materials have passed through. The sieve is agitated preferably in a tub of water.

A variation of this technique is to place the original sample in a bucket or tub, add screened water, stir, and pour the slurry through a U. S. Standard No. 30 sieve. Only a moderate amount of agitation is then required to completely clean the sample. Since this method requires considerably less effort, most biologists probably prefer it.

In both of the above methods, remove all the larger pieces of debris and rocks from samples collected, clean carefully, and discard before the sample is stirred or agitated.

The artificial substrate samplers are placed in a bucket or tub of screened water and are dismantled. Each individual piece of substrate material is shaken and then cleaned gently under water with a soft brush (a soft grade of toothbrush is excellent), examined visually, and laid aside. The water in the bucket or tub is then poured through a U. S. Standard No. 30 sieve to remove the fines.

#### 4.2 Preservation

Fill sample containers no more than one-half full of sample material (exclusive of the preservative). Supplemental sample containers are used for samples with large volumes of material. Obtain ample numbers and kinds of sample containers before the collection trip: allow two or three 1-liter containers per grab sample, a 1-liter container for most artificial substrate samples, and 16-dram screw-cap vials for miscellaneous collections.

Preserve the sample in 70 percent ethanol. A 70 percent ethanol solution is approximated by filling the one-half-full bottle, containing the sample and a small amount of rinse water, with 95 percent ethanol. Do not use formalin.

#### 4.3 Labelling

Make sample labels of water-resistant paper and place inside the sample container. Write all information on the label with a soft-lead pencil. Where the volume of sample is so great that several containers are needed, additional

external labels with the log number and notations such as 1 of 2, 2 of 2, are helpful for identifying sample containers in the laboratory.

Minimum information required on the sample label is a sample identification (log) number. The log number identifies the sample in a bound ledger where the name of water body, station number, date, sampling device used, name of sample collector, substrate characteristics, depth, and other environmental information are placed.

#### 4.4 Sorting and Subsampling

For quantitative studies, sort and pick all samples by hand in the laboratory using a low-power scanning lens. To pick organisms efficiently and accurately, add only very small amounts of detritus (no more than a heaping tablespoon full) to standard-sized (25 X 40 X 5 cm), white enamel pans filled approximately one-third full of water. Small insects and worms will float free of most debris when ethanol-preserved samples are transferred to the water-filled pan.

Analysis time for samples containing excessively large numbers of organisms can be substantially reduced if the samples are subdivided before sorting. The sample is thoroughly mixed and distributed evenly over the bottom of a shallow tray. A divider, delineating one-quarter sections, is placed in a tray, and two opposite quarters are sorted. The two remaining quarters are combined and stored for future reference or discarded (57). The aliquot to be sorted must be no smaller than one-quarter of the original sample; otherwise considerable error may result in estimating the total numbers of oligochaetes or other organisms that tend to clump. The same procedure may be followed for individual taxonomic groups, such as midges and worms, that may be present in large numbers.

Numerous techniques other than hand-picking have been proposed to recover organisms from the sample, including sugar solutions, salt solutions, stains, electricity for unpreserved samples in the field, bubbling air through sample in a tube, etc. The efficacy of these techniques is affected both by the characteristics of the substrate material and the types of organisms. No

## BIOLOGICAL METHODS

technique, or combination of techniques, will completely sort out or make more readily discernible all types of organisms from all types of substrate material. In the end, the total sample must be examined. If technicians are routinely conducting the picking operation, these techniques may lead to overconfidence and careless examination of the remainder of the sample. If used with proper care, such aids are not objectionable; however, they are not recommended as standard techniques.

As organisms are picked from the debris, they should be sorted into major categories (i.e., insect orders, molluscs, worms, etc.) and placed into vials containing 70 percent ethanol. All vials from a sample should be labeled internally with the picker's name and the lot number and kept as a unit in a suitable container until the organisms are identified and enumerated, and the data are recorded on the bench sheets. A typical laboratory bench sheet for fresh-water samples is shown in the Appendix.

### 4.5 Identification

The taxonomic level to which animals are identified depends on the needs, experience, and available resources. However, the taxonomic level to which identifications are carried in each major group should be constant throughout a given study. The accuracy of identification will depend greatly on the availability of taxonomic literature. A laboratory library of basic taxonomic references is essential. Many of the basic references that should be available in a benthos laboratory are listed at the end of the chapter.

For comparative purposes and quality control checks, store identified specimens in a reference collection. Most identifications to order and family can be made under a stereoscopic microscope (up to 50X magnification). Identification to genus and species often requires a compound microscope, preferably equipped with phase contrast (10, 40 and 100X objectives) of Nomarski (interference phase) optics.

To make species identifications, it is often necessary to mount the entire organism or parts

thereof on glass slides for examination at high magnification. Small whole insects or parts thereof may be slide-mounted directly from water or 70-percent ethanol preservative if CMC mounting media is used. Label the slides immediately with the sample log number and the name of the structure mounted. Euparal mounting medium may be preferable to CMC for mounts to be kept in a reference collection. Place specimens to be mounted in Euparal in 95 percent ethanol before mounting.

To clear opaque tissue, heat (do not boil) in a small crucible (5-ml capacity) containing 5 to 10 percent KOH solution (by weight) until it becomes transparent. The tissue can be checked periodically under a stereoscopic microscope to determine if it is sufficiently cleared. Then transfer the tissue stepwise to distilled water and 95 percent ethanol for 1 minute each and mount with CMC or Euparal. Several different structures can be heated simultaneously, but do not reuse the KOH solution.

The above methods work well for clearing and mounting midges, parts of caddisflies, mayflies, stoneflies, other insects, crustaceans, and molluscs; however, worms, leeches, and turbellarians require more specialized treatment before mounting (10, 47).

Larval insects often compose the majority of macroinvertebrates collected in artificial substrate samplers and bottom samples. In certain cases, identifications are facilitated if exuviae, pupae, and adults are available. Collect exuviae of insects with drift nets or by skimming the water's surface with a small dip net near the shore. Obtain adults with sweep nets and tent traps in the field or rear larvae to maturity in the laboratory.

The life history stages of an insect can be positively associated only if specimens are reared individually. Rear small larvae individually in 6- to 12-dram vials half filled with stream water and aerated with the use of a fine-drawn glass tubing. Mass rearing can be carried out by placing the larvae with sticks and rocks in an aerated aquarium. Use a magnetic stirrer inside of the aquarium (41) to provide a current.

## MACROINVERTEBRATE DATA EVALUATION

### 4.6 Biomass

Macroinvertebrate biomass (weight of organisms per unit area) is a useful quantitative estimation of standing crop. To determine wet weights, soak the organisms in distilled water for 30 minutes, centrifuge for 1 minute at 140 g in wire mesh cones, and weigh to the nearest 0.1 mg. Wet weight, however, is not recommended as a useful parameter unless, by a determination of suitable conversion factors, it can be equated to dry weight.

To obtain dry weight, oven dry the organisms to a constant weight at 105°C for 4 hours or vacuum dry at 105°C for 15 to 30 minutes at 1/2 atmosphere. Cool to room temperature in a desiccator and weigh. Freeze drying (-55°C, 10 to 30 microns pressure) has advantages over oven drying because the organisms remain intact for further identification and reference, preservatives are not needed, and cooling the material in desiccators after drying is not required. The main disadvantage of freeze drying is the length of time (usually 24 hours) required for drying to a constant weight.

To completely incinerate the organic material, ash at 550°C for 1 hour. Cool the ash to ambient temperature in a desiccator and weigh. Express the biomass as ash-free dry weight.

## 5.0 DATA EVALUATION

### 5.1 Quantitative Data

#### 5.1.1 Reporting units

Data from quantitative samples may be used to obtain:

- total standing crop of individuals, or biomass, or both per unit area or unit volume or sample unit, and
- numbers or biomass, or both, of individual taxa per unit area or unit volume or sample unit.

Data from quantitative samples may also be evaluated in the same manner as discussed for qualitative samples in part 5.2.

For purposes of comparison and to provide data useful for determining production, a

uniform convention must be established for the units of data reported. For this purpose, EPA biologists should adhere to the following units:

- Data from devices sampling a unit area of bottom will be reported in grams dry weight or ash-free dry weight per square meter ( $gm/m^2$ ), or numbers of individuals per square meter, or both.
- Data from multiplate samplers will be reported in terms of the total surface area of the plates in grams dry weight or ash-free dry weight or numbers of individuals per square meter, or both.
- Data from rock-filled basket samplers will be reported as grams dry weight or numbers of individuals per sampler, or both.

#### 5.1.2 Standing crop and taxonomic composition

Standing crop and numbers of taxa in a community are highly sensitive to environmental perturbations resulting from the introduction of contaminants. These parameters, particularly standing crop, may vary considerably in unpolluted habitats, where they may range from the typically high standing crop of littoral zones of glacial lakes to the sparse fauna of torrential soft-water streams. Thus, it is important that comparisons are made only between truly comparable environments. Typical responses of standing crop or taxa to various types of stress are:

| Stress                                | Standing crop (numbers or biomass) | Number of taxa                        |
|---------------------------------------|------------------------------------|---------------------------------------|
| Toxic substance                       | Reduce                             | Reduce                                |
| Severe temperature alterations        | Variable                           | Reduce                                |
| Silt                                  | Reduce                             | Reduce                                |
| Inorganic nutrients                   | Increase                           | Variable - often no detectable change |
| Organic nutrients (high $O_2$ demand) | Increase                           | Reduce                                |
| Sludge deposits (non-toxic)           | Increase                           | Reduce                                |



## BIOLOGICAL METHODS

Organic nutrients and sludge deposits are frequently associated. The responses shown are by no means simple or fixed and may vary depending on a number of factors including:

- a combination of stresses acting together or in opposition,
- indirect effects, such as for example the destruction of highly productive vegetative substrate by temperature alterations, sludge deposits, turbidity, chemical weed control,
- the physical characteristics of the stressed environment, particularly in relation to substrate and current velocity.

Data on standing crop and numbers of taxa may be presented in simple tabular form or pictorially with bar and line graphs, pie diagrams, and histograms. Whatever the method of presentation, the number of replicates and the sampling variability must be shown in the tables or graphs. Sampling variability may be shown as a range of values or as a calculated standard deviation, as discussed in the Biometrics Section of this manual.

Data on standing crop and number of taxa are amenable to simple but powerful statistical techniques of evaluation. Under grossly stressed situations, such analyses may be unnecessary; however, in some cases, the effects of environmental perturbations may be so subtle in comparison with sampling variation that statistical comparisons are a helpful and necessary tool for the evaluative process. For this purpose, biologists engaged in studies of macroinvertebrates should familiarize themselves with the simple statistical tools discussed in the Biometrics Section of this manual.

### 5.1.3 Diversity

Diversity indices are an additional tool for measuring the quality of the environment and the effect of induced stress on the structure of a community of macroinvertebrates. Their use is based on the generally observed phenomenon that relatively undisturbed environments support communities having large numbers of species with no individual species present in overwhelming abundance. If the species in such a community are ranked on the basis of their

numerical abundance, there will be relatively few species with large numbers of individuals and large numbers of species represented by only a few individuals. Many forms of stress tend to reduce diversity by making the environment unsuitable for some species or by giving other species a competitive advantage.

The investigator must be aware that there are naturally occurring extreme environments in which the diversity of macroinvertebrate communities may be low, as for example the profundal fauna of a deep lake or the black fly-dominated communities of the high gradient, bed rock section of a torrential stream. Furthermore, because colonization is by chance, diversity may be highly variable in a successional community; for this reason, diversity indices calculated from the fauna of artificial substrate samplers must be evaluated with caution. These confounding factors can be reduced by comparing diversity in similar habitats and by exposing artificial substrate samplers long enough for a relatively stable, climax community to develop.

Indices, such as  $\frac{S}{N}$ ,  $\frac{S}{\log N}$  and  $\frac{S-1}{\log N}$ , where  $S$  = number of taxa and  $N$  = total number of individuals, are merely additional means of summarizing data on total numbers and total taxa in a single numerical form for evaluation and summarization. They add no new dimension to the methods of data presentation and analyses discussed above and, in addition, are highly influenced by sample size. Sample size in this context relates to the total number of organisms collected (an uncontrollable variable in most macroinvertebrate sampling), not to the area or volume of habitat sampled. Do not use such indices for summarizing and evaluating data on aquatic macroinvertebrate communities.

There are two components of species diversity:

- richness of species
- distribution of individuals among the species.

It is immediately obvious that the second component adds a new dimension that was not considered in the methods for evaluating data

MACROINVERTEBRATE SPECIES DIVERSITY

discussed above. The distribution of individuals among the species may be readily presented in frequency distribution tables or graphs; but for any appreciable number of samples, such methods of presentation are so voluminous that they are virtually impossible to compare and interpret.

Indices of diversity based on information theory, as originally proposed by Margalef (39) and subsequently utilized by numerous workers, include both components of species diversity as enumerated above. Additionally, a measure of the component of diversity due to the distribution of individuals among the species can readily be extracted from the overall index. For purposes of uniformity, the Shannon-Weaver function is provisionally recommended for calculating mean diversity  $\bar{d}$ .

The machine formula presented by Lloyd, Zar, and Karr (34) is:

$$\bar{d} = \frac{C}{N} (N \log_{10} N - \sum n_j \log_{10} n_j)$$

where  $C = 3.321928$  (converts base 10 log to base 2 [bits]);  $N =$  total number of individuals; and  $n_j =$  total number of individuals in the  $j$ th species. When their tables (reproduced in Table 5) are used, the calculations are simple and straightforward, as shown by the following example:

| Number of individuals in each taxa ( $n_j$ 's) | $n_j \log_{10} n_j$ (from Table 5) |
|--|------------------------------------|
| 41   | 66.1241                            |
| 5  | 3.4949                             |
| 18   | 22.5949                            |
| 3  | 1.4314                             |
| 1  | .0000                              |
| 22   | 29.5333                            |
| 1  | .0000                              |
| 2  | .6021                              |
| 12   | 12.9502                            |
| 4  | 2.4082                             |
| Total 109                                      | 139.1391                           |

Total number of taxa,  $s = 10$

Total number of individuals,  $N = 109$

$$\begin{aligned} N \log_{10} N &= 222.0795 \text{ (from Table 5)} \\ \sum n_j \log_{10} n_j &= 139.1391 \\ &= \frac{3.321928}{109} (222.0795 - 139.1391) \\ &= 0.030476 \times 82.9404 \\ &= 2.5 \end{aligned}$$

Mean diversity,  $\bar{d}$ , as calculated above is affected both by richness of species and by the distribution of individuals among the species and may range from zero to  $3.321928 \log N$ .

To evaluate the component of diversity due to the distribution of individuals among the species, compare the calculated  $\bar{d}$  with a hypothetical maximum  $\bar{d}$  based on an arbitrarily selected distribution. The measure of redundancy proposed by Margalef (39) is based on the ratio between  $\bar{d}$  and a hypothetical maximum computed as though all species were equally abundant. In nature, equality of species is quite unlikely, so Lloyd and Ghelardi (33) proposed the term "equitability" and compared  $\bar{d}$  with a maximum based on the distribution obtained from MacArthur's (36) broken stick model. The MacArthur model results in a distribution quite frequently observed in nature - one with a few relatively abundant species and increasing numbers of species represented by only a few individuals. Sample data are not expected to conform to the MacArthur model, since it is only being used as a yardstick against which the distribution of abundances is being compared. Lloyd and Ghelardi (33) devised a table for determining equitability by comparing the number of species ( $s$ ) in the sample with the number of species expected ( $s'$ ) from a community that conforms to the MacArthur model. In the table (reproduced as Table 6 of this Section), the proposed measure of equitability is:

$$e = \frac{s'}{s}$$

where  $s =$  number of taxa in the sample and  $s' =$  the tabulated value. For the example given above (without interpolation in the table):

$$e = \frac{s'}{s} = \frac{8}{10} = 0.8$$



## BIOLOGICAL METHODS

Equitability "e," as calculated, may range from 0 to 1 except in the unusual situation where the distribution in the sample is more equitable than the distribution resulting from the MacArthur model. Such an eventuality will result in values of  $e$  greater than 1; and this occasionally occurs in samples containing only a few specimens with several taxa represented. The estimate of  $\bar{d}$  and  $e$  improves with increased sample size, and samples containing less than 100 specimens should be evaluated with caution, if at all.

When Wilhm (59) evaluated values calculated from data that numerous authors had collected from a variety of polluted and unpolluted waters, he found that in unpolluted waters  $\bar{d}$  was generally between 3 and 4; whereas in polluted water,  $\bar{d}$  was generally less than 1. However, collected data from southeastern U. S. waters by ERA biologists has shown that where degradation is at slight to moderate levels,  $\bar{d}$  lacks the sensitivity to demonstrate differences. Equitability, the contrary, has been found to be very sensitive to even slight levels of degradation. Equitability levels below 0.5 have not been encountered in southeastern streams known to be unaffected by oxygen-demanding wastes, and in such streams,  $e$  generally ranges between 0.6 and 0.8. Even slight levels of degradation have been found to reduce equitability below 0.5 and generally to a range of 0.0 to 0.3.

Agency biologists are encouraged to calculate both mean diversity  $\bar{d}$  and equitability  $e$  for samples collected in the course of macroinvertebrate studies. (If the mean and range of values found by different sampling methods and under varying levels and types of pollution are reported to the Biological Methods Branch, these data will be included in tabular form in future revisions of this Section.)

### 5.2 Qualitative Data

As previously defined, qualitative data result from samples collected in a manner that no estimate of numerical abundance or biomass can be calculated. The output consists of a list of taxa collected in the various habitats of the environment being studied. The numerous

schemes advanced for the analysis of qualitative data may be grouped in two categories:

#### 5.2.1 Indicator-organism scheme

For this technique, individual taxa are classified on the basis of their tolerance or intolerance to various levels of putrescible wastes (4, 5, 30, 42, 48). Taxa are classified according to their presence or absence in different environments as determined by field studies. Beck (6) reduced data based on the presence or absence of indicator organisms to a simple numerical form for ease in presentation.

#### 5.2.2 Reference station methods

Comparative or control station methods compare the qualitative characteristics of the fauna in clean water habitats with those of fauna in habitats subject to stress. Patrick (46) compared stations on the basis of richness of species and Wurtz (8) used indicator organisms in comparing stations.

If adequate background data are available to an experienced investigator, both of these techniques can prove quite useful—particularly for the purpose of demonstrating the effects of gross to moderate organic contamination on the macroinvertebrate community. To detect more subtle changes in the macroinvertebrate community, collect quantitative data on numbers or biomass of organisms. Data on the presence of tolerant and intolerant taxa and richness of species may be effectively summarized for evaluation and presentation by means of line graphs, bar graphs, pie diagrams, histograms, or pictorial diagrams (27).

The classification by various authors of representative macroinvertebrates according to their tolerance of organic wastes is presented in Table 7. In most cases, the taxonomic nomenclature used in the table is that of the original authors. The pollutional classifications of the authors were arbitrarily placed in three categories—tolerant, facultative, and intolerant—defined as follows:

- Tolerant; Organisms frequently associated with gross organic contamination and are generally capable of thriving under anaerobic conditions.

## MACROINVERTEBRATE INDICATOR ORGANISMS

- Facultative: Organisms having a wide range of tolerance and frequently are associated with moderate levels of organic contamination.
- Intolerant: Organisms that are not found associated with even moderate levels of organic contaminants and are generally intolerant of even moderate reductions in dissolved oxygen.

When evaluating qualitative data in terms of material such as that contained in Table 7, the investigator should keep in mind the pitfalls mentioned earlier, as well as the following:

- Since tolerant species may be found in both clean and degraded habitats, a simple record of their presence or absence is of no significance. Therefore, the indicator-organism technique can provide positive evidence of only one condition—clean water—and this only if taxa classified as intolerant are collected. An exception to this rule would occur where sensitive species may be totally

absent because of the discharge of toxic substances or waste heat.

- Because evaluations are based on the mere presence or absence of organisms, a single specimen has as much weight as a large population. Therefore, data for the original classification and from field studies may be biased by the drift of organisms into the study area.
- The presence or absence of a particular taxa may depend more on characteristics of the environment, such as velocity and substrate, than on the level of degradation by organic wastes. This affects both the original placement of the taxa in the classificatory scheme and its presence in study samples.
- Technique is totally subjective and quite dependent upon the skill and experience of the individual who makes the field collections. Therefore, results of one investigator are difficult to compare with those of another, particularly where data are summarized in an index such as that proposed by Beck (6).

TABLE 5. FUNCTIONS FOR CALCULATING SPECIES DIVERSITY AND (FOR PERFECTLY RANDOM SAMPLING) ITS STANDARD ERROR LOGARITHMS ARE TO BASE 10. TABLE VALUES ARE ACCURATE TO WITHIN  $\pm 1$  IN THE EIGHTH SIGNIFICANT FIGURE. (REPRODUCED WITH PERMISSION FROM LLOYD, ZAR, AND KARR, 1968.)

| n  | log n!   | n log n  | n log <sup>2</sup> n | n   | log n!   | n log n  | n log <sup>2</sup> n |
|----|----------|----------|----------------------|-----|----------|----------|----------------------|
| 27 | 28.0370  | 38.6468  | 53.3177              | 84  | 126.3204 | 161.6393 | 311.0393             |
| 28 | 29.4841  | 40.3204  | 58.6393              | 85  | 128.4498 | 164.0006 | 316.4289             |
| 29 | 30.9463  | 42.4095  | 62.0196              | 86  | 130.3843 | 166.3669 | 321.4364             |
| 30 | 32.4237  | 44.3136  | 63.4566              | 87  | 132.3238 | 168.7382 | 327.2709             |
| 31 | 33.9150  | 46.2322  | 68.9490              | 88  | 134.2683 | 171.1145 | 332.7291             |
| 32 | 35.4202  | 48.1648  | 72.4932              | 89  | 136.2177 | 173.4937 | 338.2100             |
| 33 | 36.9387  | 50.1110  | 76.0942              | 90  | 138.1719 | 175.8818 | 343.7157             |
| 34 | 38.4702  | 52.0703  | 79.7445              | 91  | 140.1310 | 178.2728 | 349.2437             |
| 35 | 40.0142  | 54.0424  | 83.4431              | 92  | 142.0948 | 180.6683 | 354.7946             |
| 36 | 41.5703  | 56.0269  | 87.1948              | 93  | 144.0632 | 183.0689 | 360.3680             |
| 37 | 43.1387  | 58.0235  | 90.9923              | 94  | 146.0364 | 185.4740 | 365.9640             |
| 38 | 44.7183  | 60.0318  | 94.8372              | 95  | 148.0141 | 187.8837 | 371.5821             |
| 39 | 46.3096  | 62.0513  | 98.7280              | 96  | 149.9964 | 190.2980 | 377.2223             |
| 40 | 47.9116  | 64.0824  | 102.6638             | 97  | 151.9831 | 192.7169 | 382.8844             |
| 41 | 49.5244  | 66.1241  | 106.6439             | 98  | 153.9744 | 195.1402 | 388.5682             |
| 42 | 51.1477  | 68.1763  | 110.6674             | 99  | 155.9700 | 197.5679 | 394.2734             |
| 43 | 52.7811  | 70.2391  | 114.7334             | 100 | 157.9700 | 200.0000 | 400.0000             |
| 44 | 54.4246  | 72.3119  | 118.8412             | 101 | 159.9743 | 202.4363 | 405.7477             |
| 45 | 56.0778  | 74.3946  | 122.9900             | 102 | 161.9829 | 204.8772 | 411.5164             |
| 46 | 57.7406  | 76.4869  | 127.1791             | 103 | 163.9938 | 207.3222 | 417.3039             |
| 47 | 59.4127  | 78.5886  | 131.4078             | 104 | 166.0128 | 209.7713 | 423.1160             |
| 48 | 61.0939  | 80.6996  | 135.6733             | 105 | 168.0340 | 212.2249 | 428.9466             |
| 49 | 62.7841  | 82.8196  | 139.9814             | 106 | 170.0593 | 214.6824 | 434.7976             |
| 50 | 64.4831  | 84.9483  | 144.3230             | 107 | 172.0887 | 217.1441 | 440.6686             |
| 51 | 66.1906  | 87.0861  | 148.7056             | 108 | 174.1221 | 219.6098 | 446.5597             |
| 52 | 67.9066  | 89.2322  | 153.1227             | 109 | 176.1593 | 222.0795 | 452.4706             |
| 53 | 69.6309  | 91.3866  | 157.5757             | 110 | 178.2009 | 224.5532 | 458.4013             |
| 54 | 71.3633  | 93.5493  | 162.0642             | 111 | 180.2462 | 227.0309 | 464.3514             |
| 55 | 73.1037  | 95.7199  | 166.5874             | 112 | 182.2953 | 229.5124 | 470.3210             |
| 56 | 74.8519  | 97.8983  | 171.1430             | 113 | 184.3483 | 231.9979 | 476.3098             |
| 57 | 76.6077  | 100.0849 | 175.7363             | 114 | 186.4034 | 234.4872 | 482.3178             |
| 58 | 78.3712  | 102.2788 | 180.3613             | 115 | 188.4611 | 236.9803 | 488.3447             |
| 59 | 80.1420  | 104.4803 | 185.0191             | 116 | 190.5206 | 239.4771 | 494.3905             |
| 60 | 81.9202  | 106.6891 | 189.7093             | 117 | 192.5828 | 241.9777 | 500.4530             |
| 61 | 83.7035  | 108.9051 | 194.4316             | 118 | 194.6470 | 244.4821 | 506.5380             |
| 62 | 85.4919  | 111.1283 | 199.1854             | 119 | 196.7142 | 246.9901 | 512.6393             |
| 63 | 87.2872  | 113.3585 | 203.9705             | 120 | 198.7824 | 249.5017 | 518.7594             |
| 64 | 89.1034  | 115.5953 | 208.7863             | 121 | 200.8528 | 252.0170 | 524.8974             |
| 65 | 90.9163  | 117.8394 | 213.6326             | 122 | 202.9244 | 254.5359 | 531.0533             |
| 66 | 92.7339  | 120.0899 | 218.5088             | 123 | 205.0044 | 257.0583 | 537.2273             |
| 67 | 94.5619  | 122.3470 | 223.4148             | 124 | 207.0919 | 259.5843 | 543.4194             |
| 68 | 96.3945  | 124.6106 | 228.3500             | 125 | 209.1848 | 262.1138 | 549.6290             |
| 69 | 98.2333  | 126.8806 | 233.3143             | 126 | 211.2831 | 264.6467 | 555.8561             |
| 70 | 100.0784 | 129.1569 | 238.3071             | 127 | 213.3870 | 267.1831 | 562.1007             |
| 71 | 101.9297 | 131.4393 | 243.3282             | 128 | 215.4962 | 269.7229 | 568.3627             |
| 72 | 103.7870 | 133.7279 | 248.3772             | 129 | 217.6097 | 272.2661 | 574.6420             |
| 73 | 105.6503 | 136.0226 | 253.4540             | 130 | 219.7280 | 274.8126 | 580.9383             |
| 74 | 107.5196 | 138.3231 | 258.5580             | 131 | 221.8518 | 277.3623 | 587.2517             |
| 75 | 109.3946 | 140.6296 | 263.6891             | 132 | 224.0048 | 279.9158 | 593.5821             |
| 76 | 111.2754 | 142.9418 | 268.8469             | 133 | 226.1674 | 282.4723 | 599.9292             |
| 77 | 113.1619 | 145.2598 | 274.0312             | 134 | 228.3393 | 285.0320 | 606.2930             |
| 78 | 115.0540 | 147.5834 | 279.2417             | 135 | 230.4298 | 287.5951 | 612.6733             |
| 79 | 116.9516 | 149.9123 | 284.4781             | 136 | 232.5264 | 290.1613 | 619.0704             |
| 80 | 118.8547 | 152.2472 | 289.7401             | 137 | 234.6300 | 292.7307 | 625.4837             |
| 81 | 120.7632 | 154.5873 | 295.0273             | 138 | 236.7400 | 295.3033 | 631.9134             |
| 82 | 122.6770 | 156.9327 | 300.3400             | 139 | 238.8563 | 297.8791 | 638.3592             |
| 83 | 124.5961 | 159.2833 | 305.6774             | 140 | 241.1291 | 300.4579 | 644.8211             |

| n  | log n! | n log n | n log <sup>2</sup> n | n  | log n!  | n log n | n log <sup>2</sup> n |
|----|--------|---------|----------------------|----|---------|---------|----------------------|
| 1  | .0000  | .0000   | .0000                | 14 | 10.9404 | 16.0458 | 18.3905              |
| 2  | .3010  | .6021   | .1812                | 15 | 12.1163 | 17.6414 | 20.7479              |
| 3  | .7782  | 1.4314  | .6829                | 16 | 13.3206 | 19.2659 | 23.1985              |
| 4  | 1.3802 | 2.4082  | 1.4499               | 17 | 14.5511 | 20.9176 | 25.7381              |
| 5  | 2.0792 | 3.4949  | 2.4428               | 18 | 15.8063 | 22.5949 | 28.3628              |
| 6  | 2.8373 | 4.6689  | 3.6331               | 19 | 17.0851 | 24.2963 | 31.0690              |
| 7  | 3.7024 | 5.9137  | 4.9993               | 20 | 18.3861 | 26.0206 | 33.8536              |
| 8  | 4.6033 | 7.2247  | 6.5246               | 21 | 19.7083 | 27.7666 | 36.7133              |
| 9  | 5.5398 | 8.5882  | 8.1952               | 22 | 21.0508 | 29.5333 | 39.6462              |
| 10 | 6.5198 | 10.0000 | 10.0000              | 23 | 22.4123 | 31.3197 | 42.6490              |
| 11 | 7.6012 | 11.4553 | 11.9295              | 24 | 23.7927 | 33.1251 | 45.7196              |
| 12 | 8.6803 | 12.9502 | 13.9756              | 25 | 25.1906 | 34.9485 | 48.8559              |
| 13 | 9.7943 | 14.4813 | 16.1313              | 26 | 26.6056 | 36.7893 | 52.0539              |

TABLE 5. (Continued)

| n   | log n!   | n log n  | n log <sup>2</sup> n | n   | log n!   | n log n  | n log <sup>2</sup> n | n   | log n!   | n log n  | n log <sup>2</sup> n | n   | log n!   | n log n  | n log <sup>2</sup> n |
|-----|----------|----------|----------------------|-----|----------|----------|----------------------|-----|----------|----------|----------------------|-----|----------|----------|----------------------|
| 141 | 243.2783 | 303.0399 | 631.2991             | 198 | 370.2970 | 434.7397 | 1044.3849            | 233 | 504.3232 | 613.6677 | 1476.8161            | 312 | 644.3226 | 778.1762 | 1940.8918            |
| 142 | 243.4306 | 303.6249 | 637.7930             | 199 | 372.5959 | 437.4718 | 1051.6604            | 236 | 506.9334 | 616.5094 | 1484.7026            | 313 | 646.8182 | 781.1034 | 1949.2831            |
| 143 | 247.3860 | 308.2131 | 664.3027             | 200 | 374.8969 | 460.2060 | 1058.9478            | 237 | 509.3433 | 619.3528 | 1492.5988            | 314 | 649.3151 | 784.0359 | 1957.6825            |
| 144 | 249.7443 | 310.8042 | 670.8281             | 201 | 377.2001 | 462.9424 | 1066.2471            | 238 | 511.7549 | 622.1979 | 1500.3047            | 315 | 651.8134 | 786.9678 | 1966.0900            |
| 145 | 251.9057 | 313.3984 | 677.3692             | 202 | 379.5054 | 465.6810 | 1073.5583            | 239 | 514.1682 | 625.0446 | 1508.4201            | 316 | 654.3131 | 789.9011 | 1974.5056            |
| 146 | 254.0700 | 313.9935 | 683.9258             | 203 | 381.8129 | 468.4217 | 1080.8812            | 260 | 516.5832 | 627.8931 | 1516.3450            | 317 | 656.8142 | 792.8358 | 1982.9293            |
| 147 | 256.2374 | 318.5936 | 690.4979             | 204 | 384.1226 | 471.1646 | 1088.2159            | 261 | 518.9999 | 630.7432 | 1524.2795            | 318 | 659.3166 | 795.7718 | 1991.3610            |
| 148 | 258.4076 | 321.1987 | 697.0833             | 205 | 386.4343 | 473.9095 | 1095.5622            | 262 | 521.4182 | 633.5949 | 1532.2234            | 319 | 661.8204 | 798.7092 | 1999.8007            |
| 149 | 260.5808 | 323.8048 | 703.6880             | 206 | 388.7482 | 476.6566 | 1102.9202            | 263 | 523.8381 | 636.4484 | 1540.1769            | 320 | 664.3253 | 801.6480 | 2008.2484            |
| 150 | 262.7569 | 326.4137 | 710.3060             | 207 | 391.0642 | 479.4039 | 1110.2897            | 264 | 526.2597 | 639.3034 | 1548.1397            | 321 | 666.8320 | 804.5881 | 2016.7041            |
| 151 | 264.9339 | 329.0255 | 716.9390             | 208 | 393.3822 | 482.1572 | 1117.6709            | 265 | 528.6830 | 642.1602 | 1556.1119            | 322 | 669.3399 | 807.5296 | 2025.1678            |
| 152 | 267.1177 | 331.6402 | 723.5871             | 209 | 395.7024 | 484.9106 | 1125.0635            | 266 | 531.1078 | 645.0185 | 1564.0936            | 323 | 671.8491 | 810.4724 | 2033.6394            |
| 153 | 269.3024 | 334.2578 | 730.2501             | 210 | 398.0246 | 487.6661 | 1132.4679            | 267 | 533.5344 | 647.8785 | 1572.0845            | 324 | 674.3596 | 813.4166 | 2042.1189            |
| 154 | 271.4899 | 336.8782 | 736.9280             | 211 | 400.3489 | 490.4236 | 1139.8829            | 268 | 535.9625 | 650.7401 | 1580.0847            | 325 | 676.8715 | 816.3621 | 2050.6064            |
| 155 | 273.6803 | 339.5014 | 743.6207             | 212 | 402.6752 | 493.1832 | 1147.3098            | 269 | 538.3922 | 653.6034 | 1588.0943            | 326 | 679.3847 | 819.3089 | 2059.1016            |
| 156 | 275.8734 | 342.1274 | 750.3281             | 213 | 405.0036 | 495.9449 | 1154.7479            | 270 | 540.8236 | 656.4682 | 1596.1130            | 327 | 681.8993 | 822.2571 | 2067.6048            |
| 157 | 278.0699 | 344.7562 | 757.0501             | 214 | 407.3340 | 498.7083 | 1162.1873            | 271 | 543.2566 | 659.3347 | 1604.1410            | 328 | 684.4152 | 825.2066 | 2076.1157            |
| 158 | 280.2679 | 347.3878 | 763.7867             | 215 | 409.6664 | 501.4743 | 1169.6379            | 272 | 545.6912 | 662.2027 | 1612.1782            | 329 | 686.9324 | 828.1573 | 2084.6345            |
| 159 | 282.4693 | 350.0221 | 770.3377             | 216 | 412.0009 | 504.2420 | 1177.1896            | 273 | 548.1273 | 665.0724 | 1620.2245            | 330 | 689.4509 | 831.1096 | 2093.1611            |
| 160 | 284.6733 | 352.6592 | 777.3032             | 217 | 414.3373 | 507.0118 | 1184.6126            | 274 | 550.5651 | 667.9437 | 1628.2800            | 331 | 691.9707 | 834.0631 | 2101.6934            |
| 161 | 286.8803 | 355.2990 | 784.0830             | 218 | 416.6758 | 509.7835 | 1192.1066            | 275 | 553.0044 | 670.8163 | 1636.3446            | 332 | 694.4918 | 837.0178 | 2110.2375            |
| 162 | 289.0898 | 357.9414 | 790.8770             | 219 | 419.0162 | 512.5573 | 1199.6116            | 276 | 555.4453 | 673.6909 | 1644.4182            | 333 | 697.0143 | 839.9739 | 2118.7874            |
| 163 | 291.3020 | 360.5866 | 797.6852             | 220 | 421.3587 | 515.3330 | 1207.1277            | 277 | 557.8878 | 676.5669 | 1652.5009            | 334 | 699.5380 | 842.9313 | 2127.3449            |
| 164 | 293.5168 | 363.2344 | 804.5075             | 221 | 423.7031 | 518.1107 | 1214.6547            | 278 | 560.3318 | 679.4443 | 1660.5927            | 335 | 702.0631 | 845.8900 | 2135.9102            |
| 165 | 295.7343 | 365.8849 | 811.3438             | 222 | 426.0494 | 520.8904 | 1222.1926            | 279 | 562.7774 | 682.3236 | 1668.6934            | 336 | 704.5894 | 848.8500 | 2144.4831            |
| 166 | 297.9544 | 368.5379 | 818.1941             | 223 | 428.3977 | 523.6720 | 1229.7415            | 280 | 565.2246 | 685.2042 | 1676.8031            | 337 | 707.1170 | 851.8113 | 2153.0636            |
| 167 | 300.1771 | 371.1936 | 825.0582             | 224 | 430.7480 | 526.4556 | 1237.3011            | 281 | 567.6733 | 688.0865 | 1684.9217            | 338 | 709.6460 | 854.7738 | 2161.6518            |
| 168 | 302.4024 | 373.8520 | 831.9362             | 225 | 433.1002 | 529.2411 | 1244.8716            | 282 | 570.1235 | 690.9702 | 1693.0492            | 339 | 712.1762 | 857.7377 | 2170.2477            |
| 169 | 304.6303 | 376.5129 | 838.8280             | 226 | 435.4543 | 532.0285 | 1252.4528            | 283 | 572.5733 | 693.8556 | 1701.1856            | 340 | 714.7076 | 860.7028 | 2178.8510            |
| 170 | 306.8608 | 379.1763 | 845.7334             | 227 | 437.8103 | 534.8179 | 1260.0447            | 284 | 575.0287 | 696.7424 | 1709.3309            | 341 | 717.2404 | 863.6692 | 2187.4620            |
| 171 | 309.0938 | 381.8423 | 852.6524             | 228 | 440.1682 | 537.6091 | 1267.6473            | 285 | 577.4835 | 699.6306 | 1717.4850            | 342 | 719.7744 | 866.6369 | 2196.0806            |
| 172 | 311.3293 | 384.5109 | 859.5850             | 229 | 442.5281 | 540.4023 | 1275.2606            | 286 | 579.9399 | 702.5207 | 1725.6479            | 343 | 722.3097 | 869.6059 | 2204.7067            |
| 173 | 313.5674 | 387.1820 | 866.5311             | 230 | 444.8898 | 543.1974 | 1282.8844            | 287 | 582.3977 | 705.4121 | 1733.8196            | 344 | 724.8463 | 872.5761 | 2213.3403            |
| 174 | 315.8079 | 389.8556 | 873.4906             | 231 | 447.2534 | 545.9944 | 1290.5188            | 288 | 584.8571 | 708.3050 | 1742.0001            | 345 | 727.3841 | 875.5476 | 2221.9814            |
| 175 | 318.0509 | 392.5317 | 880.4634             | 232 | 449.6189 | 548.7932 | 1298.1637            | 289 | 587.3180 | 711.1995 | 1750.1893            | 346 | 729.9232 | 878.5203 | 2230.6299            |
| 176 | 320.2965 | 395.2102 | 887.4496             | 233 | 451.9862 | 551.5939 | 1305.8192            | 290 | 589.7804 | 714.0954 | 1758.3871            | 347 | 732.4633 | 881.4943 | 2239.2860            |
| 177 | 322.5444 | 397.8913 | 894.4489             | 234 | 454.3555 | 554.3965 | 1313.4850            | 291 | 592.2443 | 716.9929 | 1766.5937            | 348 | 735.0051 | 884.4696 | 2247.9495            |
| 178 | 324.7948 | 400.5748 | 901.4615             | 235 | 456.7263 | 557.2009 | 1321.1613            | 292 | 594.7097 | 719.8918 | 1774.8089            | 349 | 737.5479 | 887.4461 | 2256.6204            |
| 179 | 327.0477 | 403.2607 | 908.4871             | 236 | 459.0994 | 560.0072 | 1328.8479            | 293 | 597.1766 | 722.7922 | 1783.0327            | 350 | 740.0920 | 890.4238 | 2265.2988            |
| 180 | 329.3030 | 405.9491 | 915.5257             | 237 | 461.4742 | 562.8154 | 1336.5448            | 294 | 599.6449 | 725.6941 | 1791.2651            | 351 | 742.6373 | 893.4028 | 2273.9845            |
| 181 | 331.5606 | 408.6398 | 922.5774             | 238 | 463.8508 | 565.6253 | 1344.2521            | 295 | 602.1147 | 728.5975 | 1799.5061            | 352 | 745.1838 | 896.3830 | 2282.6776            |
| 182 | 333.8207 | 411.3330 | 929.6419             | 239 | 466.2292 | 568.4371 | 1351.9696            | 296 | 604.5860 | 731.5023 | 1807.7557            | 353 | 747.7316 | 899.3645 | 2291.3780            |
| 183 | 336.0832 | 414.0285 | 936.7193             | 240 | 468.6094 | 571.2507 | 1359.6973            | 297 | 607.0588 | 734.4087 | 1816.0138            | 354 | 750.2806 | 902.3471 | 2300.0858            |
| 184 | 338.3480 | 416.7265 | 943.8096             | 241 | 470.9914 | 574.0661 | 1367.4352            | 298 | 609.5330 | 737.3164 | 1824.2803            | 355 | 752.8308 | 905.3311 | 2308.8009            |
| 185 | 340.6152 | 419.4268 | 950.9123             | 242 | 473.3752 | 576.8833 | 1375.1833            | 299 | 612.0087 | 740.2257 | 1832.5554            | 356 | 755.3823 | 908.3162 | 2317.5233            |
| 186 | 342.8847 | 422.1294 | 958.0282             | 243 | 475.7608 | 579.7023 | 1382.9415            | 300 | 614.4858 | 743.1364 | 1840.8389            | 357 | 757.9349 | 911.3026 | 2326.2531            |
| 187 | 345.1565 | 424.8344 | 965.1564             | 244 | 478.1482 | 582.5231 | 1390.7098            | 301 | 616.9644 | 746.0485 | 1849.1308            | 358 | 760.4888 | 914.2901 | 2334.9900            |
| 188 | 347.4307 | 427.5417 | 972.2973             | 245 | 480.5374 | 585.3457 | 1398.4881            | 302 | 619.4444 | 748.9621 | 1857.4312            | 359 | 763.0439 | 917.2789 | 2343.7342            |
| 189 | 349.7071 | 430.2513 | 979.4506             | 246 | 482.9283 | 588.1700 | 1406.2764            | 303 | 621.9258 | 751.8771 | 1865.7399            | 360 | 765.6002 | 920.2689 | 2352.4857            |
| 190 | 351.9859 | 432.9632 | 986.6164             | 247 | 485.3210 | 590.9961 | 1414.0747            | 304 | 624.4087 | 754.7936 | 1874.0570            | 361 | 768.1577 | 923.2601 | 2361.2444            |
| 191 | 354.2669 | 435.6774 | 993.7946             | 248 | 487.7154 | 593.8240 | 1421.8829            | 305 | 626.8930 | 757.7115 | 1882.3824            | 362 | 770.7164 | 926.2525 | 2370.0102            |
| 192 | 356.5502 | 438.3939 | 1000.9852            | 249 | 490.1116 | 596.6536 | 1429.7010            | 306 | 629.3787 | 760.6308 | 1890.7162            | 363 | 773.2764 | 929.2461 | 2378.7832            |
| 193 | 358.8358 | 441.1126 | 1008.1880            | 250 | 492.5096 | 599.4850 | 1437.5291            | 307 | 631.8659 | 763.5515 | 1899.0582            | 364 | 775.8375 | 932.2409 | 2387.5634            |
| 194 | 361.1236 | 443.8335 | 1015.4031            | 251 | 494.9093 | 602.3181 | 1445.3669            | 308 | 634.3544 | 766.4736 | 1907.4085            | 365 | 778.3997 | 935.2369 | 2396.3508            |
| 195 | 363.4136 | 446.5567 | 1022.6304            | 252 | 497.3107 | 605.1529 | 1453.2146            | 309 | 636.8444 | 769.3972 | 1915.7670            | 366 | 780.9632 | 938.2341 | 2405.1453            |
| 196 | 365.7059 | 449.2822 | 1029.8698            | 253 | 499.7138 | 607.9895 | 1461.0720            | 310 | 639.3357 | 772.3221 | 1924.1337            | 367 | 783.5279 | 941.2324 | 2413.9469            |
| 197 | 368.0003 | 452.0098 | 1037.1213            | 254 | 502.1186 | 610.8278 | 1468.9392            | 311 | 641.8285 | 775.2485 | 1932.5087            | 368 | 786.0937 | 944.2320 | 2422.7556            |

MACROINVERTEBRATE SPECIES DIVERSITY



TABLE 5. (Continued)

BIOLOGICAL METHODS

| n   | log n!   | n log n   | n log <sup>2</sup> n | n   | log n!    | n log n   | n log <sup>2</sup> n | n   | log n!    | n log n   | n log <sup>2</sup> n | n   | log n!    | n log n   | n log <sup>2</sup> n |
|-----|----------|-----------|----------------------|-----|-----------|-----------|----------------------|-----|-----------|-----------|----------------------|-----|-----------|-----------|----------------------|
| 369 | 788.6608 | 947.2327  | 2431.5714            | 426 | 936.8329  | 1120.1285 | 2945.2766            | 483 | 1088.3234 | 1296.3463 | 3479.3253            | 540 | 1242.7390 | 1475.4926 | 4031.6268            |
| 370 | 791.2290 | 950.2346  | 2440.3942            | 427 | 939.4633  | 1123.1927 | 2954.4774            | 484 | 1091.0082 | 1299.4651 | 3488.8630            | 541 | 1245.4722 | 1478.6597 | 4041.4687            |
| 371 | 793.7983 | 953.2377  | 2449.2241            | 428 | 942.0948  | 1126.2579 | 2963.6844            | 485 | 1093.6940 | 1302.5847 | 3498.4062            | 542 | 1248.2061 | 1481.8276 | 4051.3156            |
| 372 | 796.3689 | 956.2420  | 2458.0610            | 429 | 944.7272  | 1129.3242 | 2972.8976            | 486 | 1096.3806 | 1305.7052 | 3507.9520            | 543 | 1250.9409 | 1484.9963 | 4061.1676            |
| 373 | 798.9406 | 959.2474  | 2466.9050            | 430 | 947.3607  | 1132.3914 | 2982.1171            | 487 | 1099.0681 | 1308.8266 | 3517.5094            | 544 | 1253.6765 | 1488.1658 | 4071.0247            |
| 374 | 801.5133 | 962.2540  | 2475.7559            | 431 | 949.9952  | 1135.4597 | 2991.3428            | 488 | 1101.7565 | 1311.9489 | 3527.0693            | 545 | 1256.4129 | 1491.3361 | 4080.8868            |
| 375 | 804.0875 | 965.2617  | 2484.6139            | 432 | 952.6307  | 1138.5290 | 3000.5746            | 489 | 1104.4458 | 1315.0720 | 3536.6349            | 546 | 1259.1501 | 1494.5072 | 4090.7541            |
| 376 | 806.6627 | 968.2706  | 2493.4787            | 433 | 955.2672  | 1141.5993 | 3009.8126            | 490 | 1107.1360 | 1318.1961 | 3546.2059            | 547 | 1261.8881 | 1497.6791 | 4100.6263            |
| 377 | 809.2390 | 971.2807  | 2502.3506            | 434 | 957.9047  | 1144.6705 | 3019.0568            | 491 | 1109.8271 | 1321.3210 | 3555.7825            | 548 | 1264.6269 | 1500.8517 | 4110.5035            |
| 378 | 811.8165 | 974.2919  | 2511.2294            | 435 | 960.5431  | 1147.7428 | 3028.3071            | 492 | 1112.5191 | 1324.4468 | 3565.3646            | 549 | 1267.3663 | 1504.0252 | 4120.3859            |
| 379 | 814.3952 | 977.3043  | 2520.1151            | 436 | 963.1826  | 1150.8161 | 3037.5636            | 493 | 1115.2119 | 1327.5735 | 3574.9523            | 550 | 1270.1068 | 1507.1995 | 4130.2732            |
| 380 | 816.9749 | 980.3178  | 2529.0077            | 437 | 965.8231  | 1153.8904 | 3046.8261            | 494 | 1117.9057 | 1330.7011 | 3584.5454            | 551 | 1272.8480 | 1510.3745 | 4140.1635            |
| 381 | 819.5559 | 983.3324  | 2537.9072            | 438 | 968.4646  | 1156.9657 | 3056.0948            | 495 | 1120.6003 | 1333.8296 | 3594.1441            | 552 | 1275.5899 | 1513.5504 | 4150.0629            |
| 382 | 822.1379 | 986.3482  | 2546.8133            | 439 | 971.1071  | 1160.0419 | 3065.3696            | 496 | 1123.2957 | 1336.9589 | 3603.7482            | 553 | 1278.3327 | 1516.7270 | 4159.9632            |
| 383 | 824.7211 | 989.3651  | 2555.7268            | 440 | 973.7505  | 1163.1192 | 3074.6505            | 497 | 1125.9921 | 1340.0891 | 3613.3578            | 554 | 1281.0762 | 1519.9044 | 4169.8726            |
| 384 | 827.3055 | 992.3832  | 2564.6469            | 441 | 976.3949  | 1166.1974 | 3083.9374            | 498 | 1128.6895 | 1343.2202 | 3622.9730            | 555 | 1283.8205 | 1523.0826 | 4179.7849            |
| 385 | 829.8909 | 995.4024  | 2573.5738            | 442 | 979.0404  | 1169.2766 | 3093.2303            | 499 | 1131.3874 | 1346.3522 | 3632.5935            | 556 | 1286.5655 | 1526.2616 | 4189.7021            |
| 386 | 832.4775 | 998.4227  | 2582.5075            | 443 | 981.6868  | 1172.3568 | 3102.5295            | 500 | 1134.0864 | 1349.4850 | 3642.2195            | 557 | 1289.3114 | 1529.4413 | 4199.6245            |
| 387 | 835.0632 | 1001.4441 | 2591.4480            | 444 | 984.3342  | 1175.4380 | 3111.8346            | 501 | 1136.7862 | 1352.6187 | 3651.8510            | 558 | 1292.0580 | 1532.6219 | 4209.5516            |
| 388 | 837.6540 | 1004.4667 | 2600.3953            | 445 | 986.9825  | 1178.5202 | 3121.1458            | 502 | 1139.4869 | 1355.7533 | 3661.4879            | 559 | 1294.8054 | 1535.8032 | 4219.4838            |
| 389 | 840.2440 | 1007.4904 | 2609.3493            | 446 | 989.6318  | 1181.6033 | 3130.4629            | 503 | 1142.1885 | 1358.8887 | 3671.1302            | 560 | 1297.5536 | 1538.9863 | 4229.4210            |
| 390 | 842.8351 | 1010.5152 | 2618.3102            | 447 | 992.2822  | 1184.6875 | 3139.7861            | 504 | 1144.8909 | 1362.0250 | 3680.7779            | 561 | 1300.3026 | 1542.1682 | 4239.3630            |
| 391 | 845.4272 | 1013.5411 | 2627.2777            | 448 | 994.9334  | 1187.7725 | 3149.1152            | 505 | 1147.5942 | 1365.1621 | 3690.4310            | 562 | 1303.0523 | 1545.3518 | 4249.3099            |
| 392 | 848.0205 | 1016.5681 | 2636.2520            | 449 | 997.5857  | 1190.8586 | 3158.4504            | 506 | 1150.2984 | 1368.3002 | 3700.0896            | 563 | 1305.8028 | 1548.5362 | 4259.2618            |
| 393 | 850.6149 | 1019.5963 | 2645.2330            | 450 | 1000.2389 | 1193.9456 | 3167.7915            | 507 | 1153.0034 | 1371.4390 | 3709.7535            | 564 | 1308.5541 | 1551.7214 | 4269.2187            |
| 394 | 853.2104 | 1022.6255 | 2654.2206            | 451 | 1002.8931 | 1197.0336 | 3177.1385            | 508 | 1155.7093 | 1374.5788 | 3719.4228            | 565 | 1311.3062 | 1554.9074 | 4279.1804            |
| 395 | 855.8070 | 1025.6558 | 2663.2150            | 452 | 1005.5482 | 1200.1226 | 3186.4915            | 509 | 1158.4160 | 1377.7193 | 3729.0974            | 566 | 1314.0590 | 1558.0941 | 4289.1470            |
| 396 | 858.4047 | 1028.6873 | 2672.2160            | 453 | 1008.2043 | 1203.2125 | 3195.8505            | 510 | 1161.1235 | 1380.8608 | 3738.7775            | 567 | 1316.8126 | 1561.2816 | 4299.1185            |
| 397 | 861.0035 | 1031.7198 | 2681.2237            | 454 | 1010.8614 | 1206.3033 | 3205.2154            | 511 | 1163.8320 | 1384.0031 | 3748.4629            | 568 | 1319.5669 | 1564.4698 | 4309.0949            |
| 398 | 863.6034 | 1034.7534 | 2690.2380            | 455 | 1013.5194 | 1209.3952 | 3214.5862            | 512 | 1166.5412 | 1387.1462 | 3758.1536            | 569 | 1322.3220 | 1567.6589 | 4319.0762            |
| 399 | 866.2044 | 1037.7882 | 2699.2589            | 456 | 1016.1783 | 1212.4880 | 3223.9629            | 513 | 1169.2514 | 1390.2902 | 3767.8496            | 570 | 1325.0779 | 1570.8487 | 4329.0623            |
| 400 | 868.8064 | 1040.8240 | 2708.2865            | 457 | 1018.8382 | 1215.5817 | 3233.3455            | 514 | 1171.9623 | 1393.4350 | 3777.5510            | 571 | 1327.8345 | 1574.0392 | 4339.0533            |
| 401 | 871.4096 | 1043.8609 | 2717.3206            | 458 | 1021.4991 | 1218.6764 | 3242.7339            | 515 | 1174.6741 | 1396.5807 | 3787.2577            | 572 | 1330.5919 | 1577.2305 | 4349.0492            |
| 402 | 874.0138 | 1046.8989 | 2726.3613            | 459 | 1024.1609 | 1221.7720 | 3252.1283            | 516 | 1177.3868 | 1399.7272 | 3796.9697            | 573 | 1333.3501 | 1580.4226 | 4359.0499            |
| 403 | 876.6191 | 1049.9379 | 2735.4086            | 460 | 1026.8237 | 1224.8686 | 3261.5284            | 517 | 1180.1003 | 1402.8746 | 3806.6870            | 574 | 1336.1090 | 1583.6154 | 4369.0554            |
| 404 | 879.2255 | 1052.9781 | 2744.4624            | 461 | 1029.4874 | 1227.9661 | 3270.9345            | 518 | 1182.8146 | 1406.0228 | 3816.4095            | 575 | 1338.8687 | 1586.8090 | 4379.0658            |
| 405 | 881.8329 | 1056.0193 | 2753.5228            | 462 | 1032.1520 | 1231.0646 | 3280.3464            | 519 | 1185.5298 | 1409.1718 | 3826.1374            | 576 | 1341.6291 | 1590.0033 | 4389.0810            |
| 406 | 884.4415 | 1059.0616 | 2762.5897            | 463 | 1034.8176 | 1234.1640 | 3289.7641            | 520 | 1188.2458 | 1412.3217 | 3835.8705            | 577 | 1344.3903 | 1593.1984 | 4399.1010            |
| 407 | 887.0510 | 1062.1049 | 2771.6631            | 464 | 1037.4841 | 1237.2643 | 3299.1876            | 521 | 1190.9626 | 1415.4724 | 3845.6089            | 578 | 1347.1522 | 1596.3943 | 4409.1258            |
| 408 | 889.6617 | 1065.1493 | 2780.7430            | 465 | 1040.1516 | 1240.3656 | 3308.6169            | 522 | 1193.6803 | 1418.6240 | 3855.3526            | 579 | 1349.9149 | 1599.5909 | 4419.1555            |
| 409 | 892.2734 | 1068.1948 | 2789.8293            | 466 | 1042.8200 | 1243.4678 | 3318.0521            | 523 | 1196.3988 | 1421.7764 | 3865.1015            | 580 | 1352.6783 | 1602.7882 | 4429.1898            |
| 410 | 894.8862 | 1071.2414 | 2798.9222            | 467 | 1045.4893 | 1246.5710 | 3327.4930            | 524 | 1199.1181 | 1424.9296 | 3874.8556            | 581 | 1355.4425 | 1605.9863 | 4439.2291            |
| 411 | 897.5001 | 1074.2890 | 2808.0215            | 468 | 1048.1595 | 1249.6750 | 3336.9396            | 525 | 1201.8383 | 1428.0836 | 3884.6150            | 582 | 1358.2074 | 1609.1852 | 4449.2731            |
| 412 | 900.1150 | 1077.3376 | 2817.1272            | 469 | 1050.8307 | 1252.7801 | 3346.3921            | 526 | 1204.5592 | 1431.2385 | 3894.3795            | 583 | 1360.9731 | 1612.3848 | 4459.3218            |
| 413 | 902.7309 | 1080.3874 | 2826.2394            | 470 | 1053.5028 | 1255.8860 | 3355.8503            | 527 | 1207.2811 | 1434.3942 | 3904.1493            | 584 | 1363.7395 | 1615.5851 | 4469.3754            |
| 414 | 905.3479 | 1083.4381 | 2835.3580            | 471 | 1056.1758 | 1258.9928 | 3365.3142            | 528 | 1210.0037 | 1437.5507 | 3913.9243            | 585 | 1366.5066 | 1618.7862 | 4479.4337            |
| 415 | 907.9660 | 1086.4900 | 2844.4830            | 472 | 1058.8498 | 1262.1006 | 3374.7838            | 529 | 1212.7271 | 1440.7080 | 3923.7045            | 586 | 1369.2745 | 1621.9880 | 4489.4967            |
| 416 | 910.5850 | 1089.5428 | 2853.6143            | 473 | 1061.5246 | 1265.2093 | 3384.2592            | 530 | 1215.4514 | 1443.8662 | 3933.4899            | 587 | 1372.0432 | 1625.1906 | 4499.5645            |
| 417 | 913.2052 | 1092.5967 | 2862.7521            | 474 | 1064.2004 | 1268.3189 | 3393.7403            | 531 | 1218.1765 | 1447.0252 | 3943.2804            | 588 | 1374.8125 | 1628.3939 | 4509.6370            |
| 418 | 915.8264 | 1095.6517 | 2871.8962            | 475 | 1066.8771 | 1271.4295 | 3403.2271            | 532 | 1220.9024 | 1450.1850 | 3953.0761            | 589 | 1377.5827 | 1631.5979 | 4519.7143            |
| 419 | 918.4486 | 1098.7077 | 2881.0467            | 476 | 1069.5547 | 1274.5409 | 3412.7196            | 533 | 1223.6292 | 1453.3456 | 3962.8770            | 590 | 1380.3535 | 1634.8027 | 4529.7963            |
| 420 | 921.0718 | 1101.7647 | 2890.2035            | 477 | 1072.2332 | 1277.6533 | 3422.2177            | 534 | 1226.3567 | 1456.5070 | 3972.6830            | 591 | 1383.1251 | 1638.0082 | 4539.8830            |
| 421 | 923.6961 | 1104.8228 | 2899.3666            | 478 | 1074.9126 | 1280.7665 | 3431.7216            | 535 | 1229.0851 | 1459.6693 | 3982.4942            | 592 | 1385.8974 | 1641.2144 | 4549.9744            |
| 422 | 926.3214 | 1107.8819 | 2908.5360            | 479 | 1077.5930 | 1283.8807 | 3441.2310            | 536 | 1231.8142 | 1462.8326 | 3992.3105            | 593 | 1388.6705 | 1644.4214 | 4560.0706            |
| 423 | 928.9478 | 1110.9420 | 2917.7117            | 480 | 1080.2742 | 1286.9958 | 3450.7462            | 537 | 1234.5442 | 1465.9962 | 4002.1319            | 594 | 1391.4443 | 1647.6291 | 4570.1714            |
| 424 | 931.5751 | 1114.0031 | 2926.8938            | 481 | 1082.9564 | 1290.1118 | 3460.2669            | 538 | 1237.2750 | 1469.1609 | 4011.9584            | 595 | 1394.2188 | 1650.8376 | 4580.2769            |
| 425 | 934.2035 | 1117.0653 | 2936.0820            | 482 | 1085.6394 | 1293.2287 | 3469.7933            | 539 | 1240.0066 | 1472.3263 | 4021.7901            | 596 | 1396.9940 | 1654.0468 | 4590.3871            |

TABLE 5. (Continued)

| n   | log n!    | n log n   | n log <sup>2</sup> n | n   | log n!    | n log n   | n log <sup>2</sup> n | n   | log n!    | n log n   | n log <sup>2</sup> n | n   | log n!    | n log n   | n log <sup>2</sup> n |
|-----|-----------|-----------|----------------------|-----|-----------|-----------|----------------------|-----|-----------|-----------|----------------------|-----|-----------|-----------|----------------------|
| 397 | 1399.7700 | 1637.2367 | 4600.3020            | 634 | 1359.1662 | 1841.3878 | 5184.5706            | 711 | 1720.7210 | 2027.6793 | 5782.6769            | 768 | 1884.2611 | 2215.9574 | 6393.8376            |
| 398 | 1402.5467 | 1660.4673 | 4610.6213            | 635 | 1361.9824 | 1844.6380 | 5194.9439            | 712 | 1723.5733 | 2030.9637 | 5793.2092            | 769 | 1887.1470 | 2219.2773 | 6404.6710            |
| 399 | 1403.3241 | 1663.6787 | 4620.7457            | 636 | 1364.7993 | 1847.8889 | 5205.3254            | 713 | 1726.4263 | 2034.2528 | 5803.9035            | 770 | 1890.0335 | 2222.5978 | 6415.3081            |
| 600 | 1408.1023 | 1666.8907 | 4630.8746            | 637 | 1367.6169 | 1851.1404 | 5215.7092            | 714 | 1729.2802 | 2037.5403 | 5814.5257            | 771 | 1892.9205 | 2225.9189 | 6426.3489            |
| 601 | 1410.8811 | 1670.1035 | 4641.0081            | 638 | 1370.4351 | 1854.3926 | 5226.0973            | 715 | 1732.1346 | 2040.8288 | 5825.1500            | 772 | 1895.8082 | 2229.2405 | 6437.1935            |
| 602 | 1413.6608 | 1673.3171 | 4651.1463            | 639 | 1373.2540 | 1857.6455 | 5236.4897            | 716 | 1734.9893 | 2044.1177 | 5835.7783            | 773 | 1898.6963 | 2232.5627 | 6448.0419            |
| 603 | 1416.4411 | 1676.5313 | 4661.2891            | 660 | 1376.0733 | 1860.8990 | 5246.8863            | 717 | 1737.8430 | 2047.4072 | 5846.4105            | 774 | 1901.5851 | 2235.8855 | 6458.8940            |
| 604 | 1419.2221 | 1679.7463 | 4671.4363            | 661 | 1378.8938 | 1864.1332 | 5257.2873            | 718 | 1740.7011 | 2050.6973 | 5857.0468            | 775 | 1904.4744 | 2239.2088 | 6469.7498            |
| 605 | 1422.0039 | 1682.9620 | 4681.5886            | 662 | 1381.7146 | 1867.4080 | 5267.6927            | 719 | 1743.5578 | 2053.9881 | 5867.6870            | 776 | 1907.3642 | 2242.5327 | 6480.6094            |
| 606 | 1424.7863 | 1686.1784 | 4691.7452            | 663 | 1384.5361 | 1870.6633 | 5278.1022            | 720 | 1746.4132 | 2057.2794 | 5878.3312            | 777 | 1910.2547 | 2245.8571 | 6491.4727            |
| 607 | 1427.5693 | 1689.3953 | 4701.9063            | 664 | 1387.3583 | 1873.9196 | 5288.5161            | 721 | 1749.2731 | 2060.5713 | 5888.9794            | 778 | 1913.1456 | 2249.1821 | 6502.3396            |
| 608 | 1430.3534 | 1692.6134 | 4712.0724            | 665 | 1390.1811 | 1877.1764 | 5298.9341            | 722 | 1752.1316 | 2063.8638 | 5899.6316            | 779 | 1916.0372 | 2252.5077 | 6513.2103            |
| 609 | 1433.1380 | 1695.8319 | 4722.2429            | 666 | 1393.0046 | 1880.4338 | 5309.3564            | 723 | 1754.9908 | 2067.1570 | 5910.2877            | 780 | 1918.9293 | 2255.8338 | 6524.0847            |
| 610 | 1435.9234 | 1699.0512 | 4732.4180            | 667 | 1395.8287 | 1883.6919 | 5319.7830            | 724 | 1757.8505 | 2070.4507 | 5920.9478            | 781 | 1921.8219 | 2259.1604 | 6534.9628            |
| 611 | 1438.7094 | 1702.2712 | 4742.5977            | 668 | 1398.6535 | 1886.9507 | 5330.2138            | 725 | 1760.7109 | 2073.7450 | 5931.6118            | 782 | 1924.7151 | 2262.4877 | 6545.8446            |
| 612 | 1441.4962 | 1705.4919 | 4752.7819            | 669 | 1401.4789 | 1890.2101 | 5340.6489            | 726 | 1763.5718 | 2077.0400 | 5942.2797            | 783 | 1927.6089 | 2265.8154 | 6556.7301            |
| 613 | 1444.2836 | 1708.7133 | 4762.9707            | 670 | 1404.3050 | 1893.4701 | 5351.0881            | 727 | 1766.4333 | 2080.3353 | 5952.9517            | 784 | 1930.5032 | 2269.1438 | 6567.6193            |
| 614 | 1447.0718 | 1711.9354 | 4773.1641            | 671 | 1407.1317 | 1896.7308 | 5361.5317            | 728 | 1769.2953 | 2083.6316 | 5963.6273            | 785 | 1933.3981 | 2272.4727 | 6578.5122            |
| 615 | 1449.8607 | 1715.1582 | 4783.3620            | 672 | 1409.9591 | 1899.9921 | 5371.9794            | 729 | 1772.1582 | 2086.9283 | 5974.3073            | 786 | 1936.2935 | 2275.8021 | 6589.4088            |
| 616 | 1452.6503 | 1718.3817 | 4793.5643            | 673 | 1412.7871 | 1903.2541 | 5382.4313            | 730 | 1775.0215 | 2090.2257 | 5984.9910            | 787 | 1939.1895 | 2279.1321 | 6600.3090            |
| 617 | 1455.4403 | 1721.6059 | 4803.7715            | 674 | 1415.6158 | 1906.5168 | 5392.8873            | 731 | 1777.8854 | 2093.5236 | 5995.6786            | 788 | 1942.0860 | 2282.4626 | 6611.2129            |
| 618 | 1458.2315 | 1724.8309 | 4813.9834            | 675 | 1418.4451 | 1909.7800 | 5403.3478            | 732 | 1780.7499 | 2096.8221 | 6006.3701            | 789 | 1944.9831 | 2285.7937 | 6622.1203            |
| 619 | 1461.0232 | 1728.0565 | 4824.1992            | 676 | 1421.2750 | 1913.0440 | 5413.8124            | 733 | 1783.6150 | 2100.1212 | 6017.0636            | 790 | 1947.8807 | 2289.1254 | 6633.0317            |
| 620 | 1463.8156 | 1731.2828 | 4834.4198            | 677 | 1424.1056 | 1916.3085 | 5424.2812            | 734 | 1786.4807 | 2103.4209 | 6027.7650            | 791 | 1950.7789 | 2292.4576 | 6643.9467            |
| 621 | 1466.6087 | 1734.5099 | 4844.6450            | 678 | 1426.9368 | 1919.5737 | 5434.7542            | 735 | 1789.3470 | 2106.7212 | 6038.4683            | 792 | 1953.6776 | 2295.7903 | 6654.8652            |
| 622 | 1469.4023 | 1737.7376 | 4854.8746            | 679 | 1429.7687 | 1922.8396 | 5445.2313            | 736 | 1792.2139 | 2110.0221 | 6049.1734            | 793 | 1956.5769 | 2299.1236 | 6665.7875            |
| 623 | 1472.1970 | 1740.9660 | 4865.1088            | 680 | 1432.6012 | 1926.1060 | 5455.7123            | 737 | 1795.0814 | 2113.3235 | 6059.8865            | 794 | 1959.4767 | 2302.4573 | 6676.7134            |
| 624 | 1474.9922 | 1744.1952 | 4875.3473            | 681 | 1435.4344 | 1929.3732 | 5466.1981            | 738 | 1797.9494 | 2116.6256 | 6070.6015            | 795 | 1962.3771 | 2305.7918 | 6687.6429            |
| 625 | 1477.7880 | 1747.4250 | 4885.5906            | 682 | 1438.2681 | 1932.6409 | 5476.6877            | 739 | 1800.8181 | 2119.9282 | 6081.3203            | 796 | 1965.2780 | 2309.1268 | 6698.5761            |
| 626 | 1480.5846 | 1750.6555 | 4895.8383            | 683 | 1441.1026 | 1935.9093 | 5487.1815            | 740 | 1803.6873 | 2123.2314 | 6092.0430            | 797 | 1968.1794 | 2312.4623 | 6709.5129            |
| 627 | 1483.3819 | 1753.8867 | 4906.0905            | 684 | 1443.9376 | 1939.1784 | 5497.6794            | 741 | 1806.5571 | 2126.5353 | 6102.7697            | 798 | 1971.0814 | 2315.7983 | 6720.4534            |
| 628 | 1486.1798 | 1757.1187 | 4916.3470            | 685 | 1446.7733 | 1942.4480 | 5508.1816            | 742 | 1809.4275 | 2129.8397 | 6113.5002            | 799 | 1973.9840 | 2319.1349 | 6731.3975            |
| 629 | 1488.9783 | 1760.3512 | 4926.6082            | 686 | 1449.6096 | 1945.7183 | 5518.6878            | 743 | 1812.2985 | 2133.1447 | 6124.2345            | 800 | 1976.8871 | 2322.4720 | 6742.3452            |
| 630 | 1491.7778 | 1763.5845 | 4936.8737            | 687 | 1452.4466 | 1948.9893 | 5529.1982            | 744 | 1815.1701 | 2136.4503 | 6134.9727            | 801 | 1979.7907 | 2325.8096 | 6753.2963            |
| 631 | 1494.5779 | 1766.8185 | 4947.1437            | 688 | 1455.2842 | 1952.2608 | 5539.7128            | 745 | 1818.0422 | 2139.7564 | 6145.7140            | 802 | 1982.6949 | 2329.1478 | 6764.2515            |
| 632 | 1497.3786 | 1770.0532 | 4957.4182            | 689 | 1458.1224 | 1955.5330 | 5550.2314            | 746 | 1820.9150 | 2143.0631 | 6156.4608            | 803 | 1985.5996 | 2332.4866 | 6775.2100            |
| 633 | 1500.1800 | 1773.2883 | 4967.6971            | 690 | 1460.9612 | 1958.8059 | 5560.7542            | 747 | 1823.7883 | 2146.3705 | 6167.2105            | 804 | 1988.5049 | 2335.8258 | 6786.1722            |
| 634 | 1502.9821 | 1776.5246 | 4977.9804            | 691 | 1463.8007 | 1962.0793 | 5571.2811            | 748 | 1826.6622 | 2149.6784 | 6177.9642            | 805 | 1991.4106 | 2339.1657 | 6797.1380            |
| 635 | 1505.7849 | 1779.7613 | 4988.2682            | 692 | 1466.6408 | 1965.3534 | 5581.8122            | 749 | 1829.5367 | 2152.9869 | 6188.7216            | 806 | 1994.3170 | 2342.5060 | 6808.1074            |
| 636 | 1508.5883 | 1782.9987 | 4998.5604            | 693 | 1469.4816 | 1968.6281 | 5592.3474            | 750 | 1832.4117 | 2156.2939 | 6199.4829            | 807 | 1997.2239 | 2345.8469 | 6819.0804            |
| 637 | 1511.3924 | 1786.2368 | 5008.8571            | 694 | 1472.3229 | 1971.9035 | 5602.8866            | 751 | 1835.2874 | 2159.6036 | 6210.2480            | 808 | 2000.1313 | 2349.1884 | 6830.0569            |
| 638 | 1514.1973 | 1789.4756 | 5019.1581            | 695 | 1475.1649 | 1975.1794 | 5613.4299            | 752 | 1838.1636 | 2162.9158 | 6221.0170            | 809 | 2003.0392 | 2352.5303 | 6841.0371            |
| 639 | 1517.0028 | 1792.7150 | 5029.4636            | 696 | 1478.0073 | 1978.4560 | 5623.9774            | 753 | 1841.0404 | 2166.2266 | 6231.7898            | 810 | 2005.9477 | 2355.8729 | 6852.0209            |
| 640 | 1519.8089 | 1795.9552 | 5039.7734            | 697 | 1480.8507 | 1981.7332 | 5634.5289            | 754 | 1843.9178 | 2169.5380 | 6242.5654            | 811 | 2008.8567 | 2359.2159 | 6863.0082            |
| 641 | 1522.6158 | 1799.1960 | 5050.0877            | 698 | 1483.6946 | 1985.0111 | 5645.0843            | 755 | 1846.7957 | 2172.8499 | 6253.3469            | 812 | 2011.7663 | 2362.5595 | 6873.9992            |
| 642 | 1525.4233 | 1802.4375 | 5060.4064            | 699 | 1486.5391 | 1988.2893 | 5655.6442            | 756 | 1849.6742 | 2176.1625 | 6264.1311            | 813 | 2014.6764 | 2365.9036 | 6884.9937            |
| 643 | 1528.2316 | 1805.6796 | 5070.7294            | 700 | 1489.3842 | 1991.5686 | 5666.2079            | 757 | 1852.5533 | 2179.4756 | 6274.9191            | 814 | 2017.5870 | 2369.2483 | 6895.9918            |
| 644 | 1531.0404 | 1808.9225 | 5081.0568            | 701 | 1492.2299 | 1994.8483 | 5676.7738            | 758 | 1855.4330 | 2182.7892 | 6285.7110            | 815 | 2020.4982 | 2372.5934 | 6906.9935            |
| 645 | 1533.8500 | 1812.1660 | 5091.3886            | 702 | 1495.0762 | 1998.1286 | 5687.3477            | 759 | 1858.3132 | 2186.1035 | 6296.5066            | 816 | 2023.4099 | 2375.9391 | 6917.9987            |
| 646 | 1536.6602 | 1815.4102 | 5101.7248            | 703 | 1497.9232 | 2001.4096 | 5697.9236            | 760 | 1861.1941 | 2189.4183 | 6307.3060            | 817 | 2026.3221 | 2379.2854 | 6928.9974            |
| 647 | 1539.4711 | 1818.6551 | 5112.0653            | 704 | 1500.7708 | 2004.6911 | 5708.5037            | 761 | 1864.0754 | 2192.7337 | 6318.1093            | 818 | 2029.2348 | 2382.6322 | 6940.0198            |
| 648 | 1542.2827 | 1821.9006 | 5122.4102            | 705 | 1503.6189 | 2007.9733 | 5719.0878            | 762 | 1866.9574 | 2196.0497 | 6328.9163            | 819 | 2032.1481 | 2385.9795 | 6951.0357            |
| 649 | 1545.0950 | 1825.1468 | 5132.7594            | 706 | 1506.4678 | 2011.2561 | 5729.6738            | 763 | 1869.8399 | 2199.3662 | 6339.7271            | 820 | 2035.0619 | 2389.3273 | 6962.0551            |
| 650 | 1547.9079 | 1828.3937 | 5143.1130            | 707 | 1509.3172 | 2014.5395 | 5740.2580            | 764 | 1872.7230 | 2202.6833 | 6350.5416            | 821 | 2037.9763 | 2392.6757 | 6973.0781            |
| 651 | 1550.7215 | 1831.6412 | 5153.4709            | 708 | 1512.1672 | 2017.8235 | 5750.8442            | 765 | 1875.6067 | 2206.0010 | 6361.3604            | 822 | 2040.8911 | 2396.0246 | 6984.1047            |
| 652 | 1553.5357 | 1834.8894 | 5163.8331            | 709 | 1515.0179 | 2021.1082 | 5761.4644            | 766 | 1878.4909 | 2209.3192 | 6372.1821            | 823 | 2043.8065 | 2399.3741 | 6995.1347            |
| 653 | 1556.3506 | 1838.1383 | 5174.1997            | 710 | 1517.8691 | 2024.3934 | 5772.0866            | 767 | 1881.3757 | 2212.6380 | 6383.0079            | 824 | 2046.7223 | 2402.7240 | 7006.1683            |

MACROINVERTEBRATE SPECIES DIVERSITY



TABLE 5. (Continued)

BIOLOGICAL METHODS

| n   | log n!    | n log n   | n log <sup>2</sup> n | n   | log n!    | n log n   | n log <sup>2</sup> n | n   | log n!    | n log n   | n log <sup>2</sup> n | n    | log n!    | n log n   | n log <sup>2</sup> n |
|-----|-----------|-----------|----------------------|-----|-----------|-----------|----------------------|-----|-----------|-----------|----------------------|------|-----------|-----------|----------------------|
| 825 | 2049.6389 | 2406.0745 | 7017.2054            | 882 | 2216.7274 | 2597.9033 | 7652.0425            | 939 | 2383.4159 | 2791.3330 | 8297.6995            | 995  | 2552.6090 | 2982.8340 | 8942.0084            |
| 826 | 2052.5559 | 2409.4235 | 7028.2462            | 883 | 2219.6734 | 2601.2833 | 7663.2784            | 940 | 2388.3800 | 2794.7402 | 8309.1199            | 996  | 2555.6072 | 2986.2663 | 8953.6007            |
| 827 | 2055.4734 | 2412.7770 | 7039.2903            | 884 | 2222.6198 | 2604.6638 | 7674.5173            | 941 | 2391.3626 | 2798.1478 | 8320.5433            | 997  | 2558.6059 | 2989.6991 | 8965.1960            |
| 828 | 2058.3914 | 2416.1291 | 7050.3380            | 885 | 2225.5668 | 2608.0448 | 7685.7600            | 942 | 2394.3367 | 2801.5559 | 8331.9700            | 998  | 2561.6051 | 2993.1323 | 8976.7944            |
| 829 | 2061.3100 | 2419.4817 | 7061.3893            | 886 | 2228.5142 | 2611.4263 | 7697.0059            | 943 | 2397.3112 | 2804.9645 | 8343.3998            | 999  | 2564.6046 | 2996.5659 | 8988.3956            |
| 830 | 2064.2291 | 2422.8348 | 7072.4440            | 887 | 2231.4621 | 2614.8082 | 7708.2549            | 944 | 2400.2862 | 2808.3735 | 8354.8326            | 1000 | 2567.6046 | 3000.0000 | 9000.0000            |
| 831 | 2067.1487 | 2426.1884 | 7083.5023            | 888 | 2234.4105 | 2618.1907 | 7719.5074            | 945 | 2403.2616 | 2811.7831 | 8366.2687            | 1001 | 2570.6051 | 3003.4345 | 9011.6072            |
| 832 | 2070.0688 | 2429.5426 | 7094.5640            | 889 | 2237.3594 | 2621.5736 | 7730.7632            | 946 | 2406.2375 | 2815.1930 | 8377.7079            | 1002 | 2573.6059 | 3006.8694 | 9023.2174            |
| 833 | 2072.9894 | 2432.8973 | 7105.6293            | 890 | 2240.3088 | 2624.9571 | 7742.0222            | 947 | 2409.2138 | 2818.6034 | 8389.1503            | 1003 | 2576.6072 | 3010.3049 | 9034.8307            |
| 834 | 2075.9106 | 2436.2525 | 7116.6980            | 891 | 2243.2587 | 2628.3410 | 7753.2846            | 948 | 2412.1906 | 2822.0143 | 8400.5957            | 1004 | 2579.6090 | 3013.7406 | 9046.4469            |
| 835 | 2078.8323 | 2439.6082 | 7127.7703            | 892 | 2246.2091 | 2631.7254 | 7764.5502            | 949 | 2415.1679 | 2825.4256 | 8412.0442            | 1005 | 2582.6111 | 3017.1769 | 9058.0660            |
| 836 | 2081.7545 | 2442.9644 | 7138.8460            | 893 | 2249.1599 | 2635.1104 | 7775.8192            | 950 | 2418.1456 | 2828.8374 | 8423.4960            | 1006 | 2585.6133 | 3020.6136 | 9069.6881            |
| 837 | 2084.6772 | 2446.3212 | 7149.9252            | 894 | 2252.1113 | 2638.4957 | 7787.0914            | 951 | 2421.1238 | 2832.2497 | 8434.9507            | 1007 | 2588.6160 | 3024.0507 | 9081.3132            |
| 838 | 2087.6005 | 2449.6785 | 7161.0079            | 895 | 2255.0631 | 2641.8816 | 7798.3670            | 952 | 2424.1024 | 2835.6624 | 8446.4087            | 1008 | 2591.6202 | 3027.4882 | 9092.9419            |
| 839 | 2090.5242 | 2453.0363 | 7172.0942            | 896 | 2258.0154 | 2645.2680 | 7809.6458            | 953 | 2427.0815 | 2839.0755 | 8457.8698            | 1009 | 2594.6241 | 3030.9262 | 9104.5724            |
| 840 | 2093.4485 | 2456.3946 | 7183.1838            | 897 | 2260.9682 | 2648.6548 | 7820.9279            | 954 | 2430.0611 | 2842.4891 | 8469.3339            | 1010 | 2597.6284 | 3034.3646 | 9116.2063            |
| 841 | 2096.3733 | 2459.7534 | 7194.2770            | 898 | 2263.9214 | 2652.0421 | 7832.2133            | 955 | 2433.0411 | 2845.9032 | 8480.8011            | 1011 | 2600.6332 | 3037.8034 | 9127.8433            |
| 842 | 2099.2986 | 2463.1128 | 7205.3736            | 899 | 2266.8752 | 2655.4300 | 7843.5020            | 956 | 2436.0216 | 2849.3177 | 8492.2715            | 1012 | 2603.6384 | 3041.2427 | 9139.4832            |
| 843 | 2102.2244 | 2466.4726 | 7216.4736            | 900 | 2269.8295 | 2658.8182 | 7854.7959            | 957 | 2439.0025 | 2852.7327 | 8503.7450            | 1013 | 2606.6440 | 3044.6823 | 9151.1260            |
| 844 | 2105.1508 | 2469.8330 | 7227.5772            | 901 | 2272.7842 | 2662.2070 | 7866.0891            | 958 | 2441.9838 | 2856.1481 | 8515.2216            | 1014 | 2609.6500 | 3048.1225 | 9162.7719            |
| 845 | 2108.0776 | 2473.1939 | 7238.6842            | 902 | 2275.7394 | 2665.5963 | 7877.3876            | 959 | 2444.9657 | 2859.5640 | 8526.7012            | 1015 | 2612.6565 | 3051.5630 | 9174.4205            |
| 846 | 2111.0030 | 2476.5553 | 7249.7946            | 903 | 2278.6961 | 2668.9860 | 7888.6893            | 960 | 2447.9479 | 2862.9804 | 8538.1840            | 1016 | 2615.6634 | 3055.0040 | 9186.0723            |
| 847 | 2113.9329 | 2479.9172 | 7260.9086            | 904 | 2281.6512 | 2672.3763 | 7899.9943            | 961 | 2450.9307 | 2866.3972 | 8549.6698            | 1017 | 2618.6707 | 3058.4454 | 9197.7269            |
| 848 | 2116.8613 | 2483.2797 | 7272.0270            | 905 | 2284.6078 | 2675.7669 | 7911.3026            | 962 | 2453.9138 | 2869.8144 | 8561.1588            | 1018 | 2621.6784 | 3061.8872 | 9209.3845            |
| 849 | 2119.7902 | 2486.6426 | 7283.1467            | 906 | 2287.5650 | 2679.1501 | 7922.6141            | 963 | 2456.8975 | 2873.2321 | 8572.6508            | 1019 | 2624.6866 | 3065.3295 | 9221.0450            |
| 850 | 2122.7196 | 2490.0061 | 7294.2709            | 907 | 2290.5226 | 2682.5498 | 7933.9288            | 964 | 2459.8815 | 2876.6502 | 8584.1459            | 1020 | 2627.6952 | 3068.7722 | 9232.7084            |
| 851 | 2125.6495 | 2493.3700 | 7305.3986            | 908 | 2293.4807 | 2685.9419 | 7945.2468            | 965 | 2462.8661 | 2880.0688 | 8595.6442            | 1021 | 2630.7043 | 3072.2158 | 9244.3749            |
| 852 | 2128.5800 | 2496.7345 | 7316.5297            | 909 | 2296.4393 | 2689.3346 | 7956.5681            | 966 | 2465.8510 | 2883.4879 | 8607.1454            | 1022 | 2633.7137 | 3075.6588 | 9256.0441            |
| 853 | 2131.5109 | 2500.0995 | 7327.6642            | 910 | 2299.3983 | 2692.7277 | 7967.8926            | 967 | 2468.8365 | 2886.9074 | 8618.6498            | 1023 | 2636.7236 | 3079.1028 | 9267.7163            |
| 854 | 2134.4424 | 2503.4650 | 7338.8022            | 911 | 2302.3578 | 2696.1212 | 7979.2203            | 968 | 2471.8223 | 2890.3273 | 8630.1571            | 1024 | 2639.7339 | 3082.5471 | 9279.3915            |
| 855 | 2137.3744 | 2506.8310 | 7349.9436            | 912 | 2305.3178 | 2699.5153 | 7990.5513            | 969 | 2474.8087 | 2893.7477 | 8641.6676            | 1025 | 2642.7446 | 3085.9919 | 9291.0696            |
| 856 | 2140.3068 | 2510.1975 | 7361.0884            | 913 | 2308.2783 | 2702.9098 | 8001.8855            | 970 | 2477.7954 | 2897.1686 | 8653.1812            | 1026 | 2645.7557 | 3089.4372 | 9302.7506            |
| 857 | 2143.2398 | 2513.5645 | 7372.2366            | 914 | 2311.2393 | 2706.3048 | 8013.2230            | 971 | 2480.7827 | 2900.5898 | 8664.6973            | 1027 | 2648.7673 | 3092.8828 | 9314.4346            |
| 858 | 2146.1733 | 2516.9321 | 7383.3882            | 915 | 2314.2007 | 2709.7003 | 8024.5636            | 972 | 2483.7703 | 2904.0116 | 8676.2174            | 1028 | 2651.7793 | 3096.3289 | 9326.1213            |
| 859 | 2149.1073 | 2520.3001 | 7394.5433            | 916 | 2317.1626 | 2713.0963 | 8035.9075            | 973 | 2486.7584 | 2907.4338 | 8687.7402            | 1029 | 2654.7917 | 3099.7754 | 9337.8110            |
| 860 | 2152.0418 | 2523.6686 | 7405.7018            | 917 | 2320.1249 | 2716.4927 | 8047.2546            | 974 | 2489.7470 | 2910.8564 | 8699.2660            | 1030 | 2657.8046 | 3103.2223 | 9349.5038            |
| 861 | 2154.9768 | 2527.0377 | 7416.8636            | 918 | 2323.0878 | 2719.8896 | 8058.6049            | 975 | 2492.7360 | 2914.2795 | 8710.7948            | 1031 | 2660.8178 | 3106.6697 | 9361.1993            |
| 862 | 2157.9123 | 2530.4073 | 7428.0289            | 919 | 2326.0511 | 2723.2869 | 8069.9584            | 976 | 2495.7254 | 2917.7030 | 8722.3267            | 1032 | 2663.8315 | 3110.1174 | 9372.8977            |
| 863 | 2160.8483 | 2533.7773 | 7439.1975            | 920 | 2329.0149 | 2726.6848 | 8081.3152            | 977 | 2498.7153 | 2921.1270 | 8733.8517            | 1033 | 2666.8456 | 3113.5656 | 9384.5991            |
| 864 | 2163.7848 | 2537.1479 | 7450.3696            | 921 | 2331.9792 | 2730.0831 | 8092.6752            | 978 | 2501.7057 | 2924.5514 | 8745.3997            | 1034 | 2669.8601 | 3117.0142 | 9396.3033            |
| 865 | 2166.7218 | 2540.5189 | 7461.5450            | 922 | 2334.9439 | 2733.4819 | 8104.0383            | 979 | 2504.6965 | 2927.9762 | 8756.9407            | 1035 | 2672.8751 | 3120.4633 | 9408.0105            |
| 866 | 2169.6594 | 2543.8905 | 7472.7238            | 923 | 2337.9091 | 2736.8812 | 8115.4047            | 980 | 2507.6877 | 2931.4016 | 8768.4847            | 1036 | 2675.8904 | 3123.9127 | 9419.7206            |
| 867 | 2172.5974 | 2547.2625 | 7483.9060            | 924 | 2340.8748 | 2740.2809 | 8126.7742            | 981 | 2510.6794 | 2934.8273 | 8780.0319            | 1037 | 2678.9062 | 3127.3623 | 9431.4336            |
| 868 | 2175.5359 | 2550.6351 | 7495.0916            | 925 | 2343.8409 | 2743.6811 | 8138.1470            | 982 | 2513.6715 | 2938.2535 | 8791.5819            | 1038 | 2681.9224 | 3130.8128 | 9443.1494            |
| 869 | 2178.4749 | 2554.0082 | 7506.2805            | 926 | 2346.8075 | 2747.0818 | 8149.5229            | 983 | 2516.6640 | 2941.6801 | 8803.1351            | 1039 | 2684.9390 | 3134.2635 | 9454.8682            |
| 870 | 2181.4144 | 2557.3817 | 7517.4728            | 927 | 2349.7746 | 2750.4829 | 8160.9021            | 984 | 2519.6570 | 2945.1071 | 8814.6913            | 1040 | 2687.9560 | 3137.7147 | 9466.5897            |
| 871 | 2184.3544 | 2560.7558 | 7528.6686            | 928 | 2352.7421 | 2753.8845 | 8172.2844            | 985 | 2522.6505 | 2948.5347 | 8826.2505            | 1041 | 2690.9735 | 3141.1662 | 9478.3142            |
| 872 | 2187.2950 | 2564.1304 | 7539.8676            | 929 | 2355.7101 | 2757.2866 | 8183.6699            | 986 | 2525.6443 | 2951.9626 | 8837.8127            | 1042 | 2693.9914 | 3144.6181 | 9490.0416            |
| 873 | 2190.2360 | 2567.5054 | 7551.0700            | 930 | 2358.6786 | 2760.6891 | 8195.0586            | 987 | 2528.6386 | 2955.3910 | 8849.3781            | 1043 | 2697.0096 | 3148.0705 | 9501.7719            |
| 874 | 2193.1775 | 2570.8810 | 7562.2758            | 931 | 2361.6476 | 2764.0921 | 8206.4504            | 988 | 2531.6334 | 2958.8199 | 8860.9463            | 1044 | 2700.0284 | 3151.5233 | 9513.5050            |
| 875 | 2196.1195 | 2574.2570 | 7573.4849            | 932 | 2364.6170 | 2767.4956 | 8217.8455            | 989 | 2534.6286 | 2962.2491 | 8872.5176            | 1045 | 2703.0475 | 3154.9765 | 9525.2410            |
| 876 | 2199.0620 | 2577.6336 | 7584.6974            | 933 | 2367.5869 | 2770.8996 | 8229.2438            | 990 | 2537.6242 | 2965.6788 | 8884.0918            | 1046 | 2706.0670 | 3158.4301 | 9536.9799            |
| 877 | 2202.0050 | 2581.0106 | 7595.9133            | 934 | 2370.5572 | 2774.3040 | 8240.6451            | 991 | 2540.6203 | 2969.1090 | 8895.6692            | 1047 | 2709.0869 | 3161.8842 | 9548.7216            |
| 878 | 2204.9485 | 2584.3882 | 7607.1324            | 935 | 2373.5280 | 2777.7088 | 8252.0497            | 992 | 2543.6168 | 2972.5396 | 8907.2495            | 1048 | 2712.1073 | 3165.3386 | 9560.4662            |
| 879 | 2207.8925 | 2587.7666 | 7618.3549            | 936 | 2376.4993 | 2781.1142 | 8263.4574            | 993 | 2546.6138 | 2975.9706 | 8918.8328            | 1049 | 2715.1281 | 3168.7935 | 9572.2136            |
| 880 | 2210.8370 | 2591.1447 | 7629.5808            | 937 | 2379.4710 | 2784.5200 | 8274.8683            | 994 | 2549.6111 | 2979.4020 | 8930.4191            | 1050 | 2718.1493 | 3172.2487 | 9583.9640            |
| 881 | 2213.7820 | 2594.5238 | 7640.8100            | 938 | 2382.4433 | 2787.9262 | 8286.2823            |     |           |           |                      |      |           |           |                      |

MACROINVERTEBRATE SPECIES EQUITABILITY

TABLE 6. THE DIVERSITY OF SPECIES,  $\bar{d}$ , CHARACTERISTIC OF MacARTHUR'S MODEL FOR VARIOUS NUMBERS OF HYPOTHETICAL SPECIES,  $s^*$ .

| $s^*$ | $\bar{d}$ | $s^*$ | $\bar{d}$ | $s^*$ | $\bar{d}$ | $s^*$ | $\bar{d}$ |
|-------|-----------|-------|-----------|-------|-----------|-------|-----------|
| 1     | 0.0000    | 51    | 5.0941    | 102   | 6.0792    | 205   | 7.0783    |
| 2     | 0.8113    | 52    | 5.1215    | 104   | 6.1069    | 210   | 7.1128    |
| 3     | 1.2997    | 53    | 5.1485    | 106   | 6.1341    | 215   | 7.1466    |
| 4     | 1.6556    | 54    | 5.1749    | 108   | 6.1608    | 220   | 7.1796    |
| 5     | 1.9374    | 55    | 5.2009    | 110   | 6.1870    | 225   | 7.2118    |
| 6     | 2.1712    | 56    | 5.2264    | 112   | 6.2128    | 230   | 7.2434    |
| 7     | 2.3714    | 57    | 5.2515    | 114   | 6.2380    | 235   | 7.2743    |
| 8     | 2.5465    | 58    | 5.2761    | 116   | 6.2629    | 240   | 7.3045    |
| 9     | 2.7022    | 59    | 5.3004    | 118   | 6.2873    | 245   | 7.3341    |
| 10    | 2.8425    | 60    | 5.3242    | 120   | 6.3113    | 250   | 7.3631    |
| 11    | 2.9701    | 61    | 5.3476    | 122   | 6.3350    | 255   | 7.3915    |
| 12    | 3.0872    | 62    | 5.3707    | 124   | 6.3582    | 260   | 7.4194    |
| 13    | 3.1954    | 63    | 5.3934    | 126   | 6.3811    | 265   | 7.4468    |
| 14    | 3.2960    | 64    | 5.4157    | 128   | 6.4036    | 270   | 7.4736    |
| 15    | 3.3899    | 65    | 5.4378    | 130   | 6.4258    | 275   | 7.5000    |
| 16    | 3.4780    | 66    | 5.4594    | 132   | 6.4476    | 280   | 7.5259    |
| 17    | 3.5611    | 67    | 5.4808    | 134   | 6.4691    | 285   | 7.5513    |
| 18    | 3.6395    | 68    | 5.5018    | 136   | 6.4903    | 290   | 7.5763    |
| 19    | 3.7139    | 69    | 5.5226    | 138   | 6.5112    | 295   | 7.6008    |
| 20    | 3.7846    | 70    | 5.5430    | 140   | 6.5318    | 300   | 7.6250    |
| 21    | 3.8520    | 71    | 5.5632    | 142   | 6.5521    | 310   | 7.6721    |
| 22    | 3.9163    | 72    | 5.5830    | 144   | 6.5721    | 320   | 7.7177    |
| 23    | 3.9779    | 73    | 5.6027    | 146   | 6.5919    | 330   | 7.7620    |
| 24    | 4.0369    | 74    | 5.6220    | 148   | 6.6114    | 340   | 7.8049    |
| 25    | 4.0937    | 75    | 5.6411    | 150   | 6.6306    | 350   | 7.8465    |
| 26    | 4.1482    | 76    | 5.6599    | 152   | 6.6495    | 360   | 7.8870    |
| 27    | 4.2008    | 77    | 5.6785    | 154   | 6.6683    | 370   | 7.9264    |
| 28    | 4.2515    | 78    | 5.6969    | 156   | 6.6867    | 380   | 7.9648    |
| 29    | 4.3004    | 79    | 5.7150    | 158   | 6.7050    | 390   | 8.0022    |
| 30    | 4.3478    | 80    | 5.7329    | 160   | 6.7230    | 400   | 8.0386    |
| 31    | 4.3936    | 81    | 5.7506    | 162   | 6.7408    | 410   | 8.0741    |
| 32    | 4.4381    | 82    | 5.7681    | 164   | 6.7584    | 420   | 8.1087    |
| 33    | 4.4812    | 83    | 5.7853    | 166   | 6.7757    | 430   | 8.1426    |
| 34    | 4.5230    | 84    | 5.8024    | 168   | 6.7929    | 440   | 8.1757    |
| 35    | 4.5637    | 85    | 5.8192    | 170   | 6.8099    | 450   | 8.2080    |
| 36    | 4.6032    | 86    | 5.8359    | 172   | 6.8266    | 460   | 8.2396    |
| 37    | 4.6417    | 87    | 5.8524    | 174   | 6.8432    | 470   | 8.2706    |
| 38    | 4.6792    | 88    | 5.8687    | 176   | 6.8596    | 480   | 8.3009    |
| 39    | 4.7157    | 89    | 5.8848    | 178   | 6.8758    | 490   | 8.3305    |
| 40    | 4.7513    | 90    | 5.9007    | 180   | 6.8918    | 500   | 8.3596    |
| 41    | 4.7861    | 91    | 5.9164    | 182   | 6.9076    | 550   | 8.4968    |
| 42    | 4.8200    | 92    | 5.9320    | 184   | 6.9233    | 600   | 8.6220    |
| 43    | 4.8532    | 93    | 5.9474    | 186   | 6.9388    | 650   | 8.7373    |
| 44    | 4.8856    | 94    | 5.9627    | 188   | 6.9541    | 700   | 8.8440    |
| 45    | 4.9173    | 95    | 5.9778    | 190   | 6.9693    | 750   | 8.9434    |
| 46    | 4.9483    | 96    | 5.9927    | 192   | 6.9843    | 800   | 9.0363    |
| 47    | 4.9787    | 97    | 6.0075    | 194   | 6.9992    | 850   | 9.1236    |
| 48    | 5.0084    | 98    | 6.0221    | 196   | 7.0139    | 900   | 9.2060    |
| 49    | 5.0375    | 99    | 6.0366    | 198   | 7.0284    | 950   | 9.2839    |
| 50    | 5.0661    | 100   | 6.0510    | 200   | 7.0429    | 1000  | 9.3578    |

\*The data in this table are reproduced, with permission, from Lloyd and Ghelardi, Reference 33.

BIOLOGICAL METHODS

TABLE 7. CLASSIFICATION, BY VARIOUS AUTHORS, OF THE TOLERANCE OF VARIOUS MACROINVERTEBRATE TAXA TO DECOMPOSABLE ORGANIC WASTES; TOLERANT (T), FACULTATIVE (F), AND INTOLERANT (I)

| Macroinvertebrate                         | T   | F        | I     | Macroinvertebrate               | T     | F    | I   |
|---|-----|----------|-------|---------------------------------|-------|------|-----|
| Porifera                                  |     |          |       | Prosopora                       |       |      |     |
| Demospongiae                              |     |          |       | Lumbriculidae                   | 60    |      |     |
| Monaxonida                                |     |          |       | Hirudinea                       |       |      |     |
| Spongillidae                              |     |          | 42*   | Rhynchobdellida                 |       |      |     |
| <i>Spongilla fragilis</i>                 |     | 48       |       | Glossiphoniidae                 |       |      |     |
| Bryozoa                                   |     |          |       | <i>Glossiphonia complanata</i>  | 48    |      |     |
| Ectoprocta                                |     |          |       | <i>Helobdella stagnalis</i>     | 48,42 |      |     |
| Phylactolaemata                           |     |          |       | <i>H. nepheloidea</i>           | 48    |      |     |
| Plumatellidae                             |     |          |       | <i>Placobdella montifera</i>    | 60    |      |     |
| <i>Plumatella repens</i>                  |     | 51       |       | <i>P. rugosa</i>                |       | 48   |     |
| <i>P. princeps</i> var. <i>mucosa</i>     | 48  |          |       | <i>Placobdella</i>              |       | 42   |     |
| <i>P. p.</i> var. <i>mucosa spongiosa</i> |     | 48       |       | Piscicolidae                    |       |      | 60  |
| <i>P. p.</i> var. <i>fruticosa</i>        | 48  |          |       | <i>Piscicola punctata</i>       |       |      |     |
| <i>P. polymorpha</i> var. <i>repens</i>   |     |          | 48    | Gnathobdellida                  |       |      |     |
| Cristatellidae                            |     |          |       | Hirudidae                       |       |      |     |
| <i>Cristatella mucedo</i>                 |     | 51       |       | <i>Macrobdella</i>              | 28    |      |     |
| Lophopodidae                              |     |          |       | Pharyngobdellida                |       |      |     |
| <i>Lophopodella carteri</i>               |     |          | 42    | Erpobdellidae                   |       |      |     |
| <i>Pectinatella magnifica</i>             |     |          | 48,42 | <i>Erpobdella punctata</i>      | 48    |      |     |
| Endoprocta                                |     |          |       | <i>Dina parva</i>               | 48    |      |     |
| Urnatellidae                              |     |          |       | <i>D. microstoma</i>            | 48    |      |     |
| <i>Urnatella gracilis</i>                 |     | 48,42    |       | <i>Dina</i>                     |       | 42   |     |
| Gymnolaemata                              |     |          |       | <i>Mooreobdella microstoma</i>  | 42    |      | 5   |
| Ctenostomata                              |     |          |       | Hydracarina                     |       |      |     |
| Paludicellidae                            |     |          |       | Arthropoda                      |       |      |     |
| <i>Paludicella ehrenbergi</i>             |     | 48       |       | Crustacea                       |       |      |     |
| Coelenterata                              |     |          |       | Isopoda                         |       |      |     |
| Hydrozoa                                  |     |          |       | Asellidae                       |       |      |     |
| Hydroida                                  |     |          |       | <i>Asellus intermedius</i>      |       | 48   |     |
| Hydriidae                                 |     |          |       | <i>Asellus</i>                  | 60    | 42   | 5,4 |
| <i>Hydra</i>                              |     | 42       |       | <i>Lirceus</i>                  |       | 42   |     |
| Clavidae                                  |     |          |       | Amphipoda                       |       | 4    |     |
| <i>Cordylophora lacustris</i>             |     | 42       |       | Talitridae                      |       |      |     |
| Platyhelminthes                           |     |          |       | <i>Tyalia azteca</i>            |       | 5,3, |     |
| Turbellaria                               |     |          | 42    |                                 | 4,42  |      |     |
| Tricladida                                |     |          |       | <i>H. knickerbockeri</i>        | 48    |      |     |
| Planariidae                               |     |          |       | Gammaridae                      |       |      |     |
| <i>Planaria</i>                           |     | 48       |       | <i>Gammarus</i>                 |       | 42   |     |
| Nematoda                                  |     | 42       |       | <i>Crangonyx pseudogracilis</i> |       | 42   |     |
| Nematomorpha                              |     |          |       | Decapoda                        |       |      |     |
| Gordiida                                  |     |          |       | Palaeomonidae                   |       |      |     |
| Gordiidae                                 |     |          | 48    | <i>Palaeomonetes paludosus</i>  |       | 5,3, |     |
| Annelida                                  |     |          |       |                                 |       | 4    |     |
| Oligochaeta                               | 5,4 |          | 48    | <i>P. exilipes</i>              | 48    |      |     |
| Plesiopora                                |     |          |       | Astacidae                       |       |      |     |
| Naididae                                  |     |          | 48    | <i>Cambarus striatus</i>        | 25    |      |     |
| <i>Nais</i>                               |     |          | 42    | <i>C. fodiens</i>               | 1     |      |     |
| <i>Dero</i>                               |     |          | 48    | <i>C. bartoni bartoni</i>       |       | 1    | 1   |
| <i>Ophidonais</i>                         | 60  |          |       | <i>C. b. cavatus</i>            |       | 1    |     |
| <i>Stylaria</i>                           |     | 42       |       | <i>C. tonasugaensis</i>         |       |      | 1   |
| Tubificidae                               |     |          |       | <i>C. asperimanus</i>           |       |      | 1   |
| <i>Tubifex tubifex</i>                    |     | 48,42    |       | <i>C. latimanus</i>             |       | 1    |     |
| <i>Tubifex</i>                            |     | 48,18,40 |       | <i>C. acuminatus</i>            |       |      | 1   |
| <i>Limnodrilus hoffmeisteri</i>           |     | 48,3,42  |       | <i>C. hiwassensis</i>           |       |      | 1   |
| <i>L. claparedianus</i>                   |     | 48       |       | <i>C. extraneus</i>             |       |      | 1   |
| <i>Limnodrilus</i>                        |     | 48,18,60 |       | <i>C. diogenes diogenes</i>     | 1     |      |     |
| <i>Branchiura sowerbyi</i>                |     | 42       |       | <i>C. cryptodytes</i>           |       |      | 1   |

\*Numbers refer to references enumerated in the "Literature" section immediately following this table.

†Albinistic

MACROINVERTEBRATE POLLUTION TOLERANCE

TABLE 7. (Continued)

| Macroinvertebrate               | T     | F     | I     | Macroinvertebrate                  | T     | F     | I     |
|---------------------------------|-------|-------|-------|------------------------------------|-------|-------|-------|
| <i>C. floridanus</i>            |       |       |       | <i>Psilotanytus bellus</i>         | 42    |       |       |
| <i>C. carolinus</i> ‡           | 1     |       |       | <i>Tanytus stellatus</i>           | 44,12 | 18,60 | 5     |
| <i>C. longulus longirostris</i> |       |       | 1     | <i>T. carinatus</i>                |       | 42    |       |
| <i>Procambarus raneyi</i>       |       |       | 1     | <i>T. punctipennis</i>             |       | 44,12 |       |
| <i>P. acutus acutus</i>         | 1     |       |       | <i>Tanytus</i>                     |       | 44,12 |       |
| <i>P. paeninsularis</i>         |       | 1     |       | <i>Psectrotanytus dyari</i>        | 44,12 | 48    |       |
| <i>P. spiculifer</i>            |       |       | 1     | <i>Psectrotanytus</i>              |       | 44    |       |
| <i>P. versutus</i>              |       |       | 1     | <i>Larsia lurida</i>               |       | 4     |       |
| <i>P. pubescens</i>             |       | 1     |       | <i>Clinotanytus caliginosus</i>    |       |       | 44,12 |
| <i>P. litosternum</i>           |       | 1     |       | <i>Clinotanytus</i>                |       | 4     |       |
| <i>P. enoplosternum</i>         |       | 1     |       | <i>Orthocladius obumbratus</i>     |       |       | 60    |
| <i>P. angustatus</i>            |       | 1     |       | <i>Orthocladius</i>                |       | 5,48  | 60,42 |
| <i>P. seminolae</i>             |       | 1     |       |                                    |       |       | 44,12 |
| <i>P. truculentus</i> ‡         | 1     |       |       | <i>Nanocladus</i>                  |       |       | 4,42  |
| <i>P. advena</i> ‡              | 1     |       |       | <i>Psectrocladius niger</i>        |       | 42    |       |
| <i>P. pygmaeus</i> ‡            | 1     |       |       | <i>P. julia</i>                    |       | 42    |       |
| <i>P. pubisichelae</i>          |       | 1     |       | <i>Psectrocladius</i>              |       |       | 4,44  |
| <i>P. barbatus</i>              |       | 1     |       | <i>Metriocnemus lundbecki</i>      |       |       | 4     |
| <i>P. howellae</i>              |       | 1     |       | <i>Cricotopus bicinctus</i>        |       |       | 3,4   |
| <i>P. troglodytes</i>           | 1     |       |       |                                    |       |       | 44,12 |
| <i>P. epicyrtus</i>             |       | 1     |       | <i>C. bicinctus</i> group          | 42    |       |       |
| <i>P. fallax</i>                | 1     |       |       | <i>C. exilis</i>                   |       | 44    | 12    |
| <i>P. chacei</i>                |       | 1     |       | <i>C. exilis</i> group             |       | 42    |       |
| <i>P. lunzi</i>                 |       | 1     |       | <i>C. trifasciatus</i>             |       | 44    | 12    |
| <i>Orconectes propinquus</i>    |       | 42    |       | <i>C. trifasciatus</i> group       |       | 42    |       |
| <i>O. rusticus</i>              |       | 42    |       | <i>C. politus</i>                  |       |       | 44,12 |
| <i>O. juvenilis</i>             |       |       | 1     | <i>C. tricinctus</i>               |       | 44    | 12    |
| <i>O. erichsonianus</i>         |       | 1     |       | <i>C. absurdus</i>                 |       |       | 18,44 |
| <i>Faxonella clypeata</i>       |       | 1     |       |                                    |       |       | 12    |
| <b>Insecta</b>                  |       |       |       | <i>Cricotopus</i>                  |       |       | 44    |
| <b>Diptera</b>                  |       |       |       | <i>Corynoneura taris</i>           |       |       | 4     |
| <b>Chironomidae</b>             |       |       |       | <i>C. scutellata</i>               |       |       | 44,12 |
| <i>Pentaneura inculta</i>       |       | 60    | 3,4   | <i>Corynoneura</i>                 |       |       | 5,42  |
| <i>P. carnea</i>                |       | 60,44 | 60,12 |                                    |       |       | 12    |
| <i>P. flavifrons</i>            | 5     |       |       | <i>Thienemanniella xena</i>        |       |       | 4,42  |
| <i>P. melanops</i>              | 44,12 |       |       | <i>Thienemanniella</i>             |       |       | 4,44  |
| <i>P. americana</i>             |       |       | 44,12 | <i>Trichocladius robacki</i>       |       |       | 3,4   |
| <i>Pentaneura</i>               |       |       | 42,44 | <i>Brillia par</i>                 |       |       | 4     |
| <i>Ablabesmyia jahta</i>        |       | 3,4   |       | <i>Diamesa nivoriunda</i>          |       |       | 18,42 |
|                                 |       | 42    |       |                                    |       |       | 44    |
| <i>A. americana</i>             |       | 48,60 | 5     | <i>Diamesa</i>                     |       |       | 60    |
| <i>A. illinoense</i>            | 12    | 44    |       | <i>Prodiamesa olivacea</i>         |       |       | 12    |
| <i>A. mallochii</i>             |       | 42    | 4     | <i>Chironomus attenuatus</i> group | 5,4   |       | 44    |
| <i>A. ornata</i>                |       |       | 4     |                                    | 42,12 |       |       |
| <i>A. aspera</i>                |       |       | 4     | <i>C. riparius</i>                 |       | 18,44 |       |
| <i>A. peleensis</i>             |       | 4     |       |                                    |       | 12    |       |
| <i>A. auriensis</i>             |       |       | 4     | <i>C. riparius</i> group           |       | 42    |       |
| <i>A. rhamnphie</i>             |       | 42    |       | <i>C. tentans</i>                  |       |       | 12    |
| <i>Ablabesmyia</i>              |       |       | 42    | <i>C. tentans-plumosus</i>         |       |       |       |
| <i>Procladius culiciformis</i>  | 60    | 44,12 |       | <i>C. plumosus</i>                 | . 60  |       |       |
| <i>P. denticulatus</i>          | . 42  |       |       |                                    | 48,18 |       | 48,12 |
| <i>Procladius</i>               | 12    | 4,44  |       |                                    | 60    |       |       |
|                                 |       | 12    |       | <i>C. plumosus</i> group           |       | 42    |       |
| <i>Labrundinia floridana</i>    |       |       | 4     | <i>C. carus</i>                    |       | 4     |       |
| <i>L. pilosella</i>             |       |       | 42    | <i>C. crassicaudatus</i>           |       | 4     |       |
| <i>L. virescens</i>             |       |       | 4     | <i>C. stigmaterus</i>              |       | 4     |       |
| <i>Guttipelopia</i>             |       | 42    |       | <i>C. flavus</i>                   |       |       | 60    |
| <i>Conchapelopia</i>            |       | 42    |       | <i>C. equisitus</i>                |       |       | 60    |
| <i>Coelotanytus scapularis</i>  |       | 42    |       | <i>C. fulvipilus</i>               |       | 4     |       |
| <i>C. concinnus</i>             | 42    | 48,60 | 44    | <i>C. anthracinus</i>              |       |       | 12    |
|                                 |       | 44,12 |       | <i>C. paganus</i>                  |       |       | 12    |
|                                 |       |       |       | <i>C. staegeri</i>                 |       | 12    |       |

‡Not usually inhabitant of open water; are burrowers.

TABLE 7. (Continued)

| Macroinvertebrate                     | T    | F     | I     | Macroinvertebrate                   | T     | F     | I     |
|---------------------------------------|------|-------|-------|-------------------------------------|-------|-------|-------|
| <i>Chironomus</i>                     | 5    | 60    |       | <i>Cladotanytarsus</i>              |       | 42    |       |
| <i>Kiefferullus dux</i>               | 4    |       | 44,12 | <i>Micropsectra dives</i>           |       | 60    | 12    |
| <i>Cryptochironomus fulvus</i>        | 3,4  |       | 44,12 | <i>M. deflecta</i>                  |       |       | 42    |
| <i>C. fulvus</i> group                |      | 42    |       | <i>M. nigripula</i>                 |       |       | 44,12 |
| <i>C. digitatus</i>                   |      | 48    | 12    | <i>Calopsectra gregarius</i>        | 5     |       |       |
| <i>C. sp. B (Joh.)</i>                |      |       | 5     | <i>Calopsectra</i>                  |       |       | 44,12 |
| <i>C. blarina</i>                     |      | 42    | 12    | <i>Stempellina johannseni</i>       |       | 44    | 12    |
| <i>C. psittacinus</i>                 |      |       | 60    | Culicidae                           |       |       |       |
| <i>C. nais</i>                        |      | 42    |       | <i>Culex pipiens</i>                | 18,44 |       |       |
| <i>Cryptochironomus</i>               | 5    |       |       | <i>Anopheles punctipennis</i>       |       |       | 44    |
| <i>Chaetolabis atroviridis</i>        |      |       | 12    | Chaoboridae                         |       |       |       |
| <i>C. ochreateus</i>                  |      |       | 12    | <i>Chaoborus punctipennis</i>       |       | 60,42 | 44    |
| <i>Endochironomus nigricans</i>       |      | 4,42  | 44,12 | Ceratopogonidae                     | 5,4   | 42    |       |
| <i>Stenochironomus macateei</i>       |      |       | 42,44 | <i>Palpomyia tibialis</i>           |       | 60    |       |
| <i>S. hilaris</i>                     |      |       | 3,4   | <i>Palpomyia</i>                    |       | 48,60 |       |
| <i>Stictochironomus devinctus</i>     |      |       | 4,12  | <i>Bezzia glabra</i>                | 44    |       |       |
| <i>S. varius</i>                      |      |       | 44    | <i>Stilbezia antenalis</i>          | 44    |       |       |
| <i>Xenochironomus xenolabis</i>       |      |       | 42    | Tipulidae                           | 4     | 42    |       |
| <i>X. rogersi</i>                     |      | 42    |       | <i>Tipula caloptera</i>             |       |       | 44    |
| <i>X. scopula</i>                     |      |       | 44,12 | <i>T. abdominalis</i>               |       |       | 44    |
| <i>Pseudochironomus richardson</i>    |      |       | 44,12 | <i>Pseudolimnophila luteipennis</i> |       |       | 44    |
| <i>Pseudochironomus</i>               |      |       | 12    | <i>Hexatoma</i>                     |       |       | 44    |
| <i>Parachironomus abortivus</i> group |      | 42    |       | <i>Eriocera</i>                     |       | 60    |       |
| <i>P. pectinatellae</i>               |      | 42    |       | Psychodidae                         | 4     |       |       |
| <i>Gryptotendipes emorsus</i>         |      | 42    |       | <i>Psychoda alternata</i>           | 44    |       |       |
| <i>Microtendipes pedellus</i>         |      |       | 44,12 | <i>P. schizura</i>                  | 44    |       |       |
| <i>Microtendipes</i>                  |      |       | 12    | <i>Psychoda</i>                     | 42    |       |       |
| <i>Paqatendipes albimanus</i>         |      |       | 44,12 | <i>Telmatoscopus albipunctatus</i>  | 60    |       |       |
| <i>Tribelos jucundus</i>              |      |       | 12    | <i>Telmatoscopus</i>                |       |       | 44    |
| <i>T. fuscicornis</i>                 |      |       | 42    | Simuliidae                          | 42    | 44    | 5,4   |
| <i>Harnischia collator</i>            |      | 42    |       | <i>Simulium vittatum</i>            |       | 18,44 |       |
| <i>H. tenuicaudata</i>                |      |       | 44    | <i>S. venustum</i>                  |       |       | 44    |
| <i>Phaenopsectra</i>                  |      |       | 42    | <i>Simulium</i>                     |       |       | 3     |
| <i>Dicrotendipes modestus</i>         |      | 42    |       | <i>Prosimulium johannseni</i>       |       |       | 44    |
| <i>D. neomodestus</i>                 |      | 44    | 42,12 | <i>Cnephia pecuarum</i>             |       |       | 44    |
| <i>D. nervosus</i>                    |      | 42    | 12    | Stratiomyiidae                      | 4     |       |       |
| <i>D. incurvus</i>                    | 42   |       |       | <i>Stratiomys discalis</i>          | 44    |       |       |
| <i>D. fumidus</i>                     |      |       | 42,12 | <i>S. meigeni</i>                   | 44    |       |       |
| <i>Glyptotendipes senilis</i>         |      |       | 42    | <i>Odontomyia cincta</i>            |       | 44    |       |
| <i>G. paripes</i>                     | 4    |       | 12    | Tabanidae                           | 4     |       |       |
| <i>G. meridionalis</i>                |      | 42    |       | <i>Tabanus atratus</i>              | 18    | 44    |       |
| <i>G. lobiferus</i>                   | 48,4 |       | 44,12 | <i>T. stygius</i>                   |       | 44    |       |
|                                       | 42   |       |       | <i>T. benedictus</i>                |       | 44    |       |
| <i>G. barbipes</i>                    | 42   |       |       | <i>T. giganteus</i>                 |       |       | 44    |
| <i>G. amplus</i>                      |      | 42    |       | <i>T. lineola</i>                   | 44    |       |       |
| <i>Glyptotendipes</i>                 | 12   |       |       | <i>T. variegatus</i>                |       |       | 44    |
| <i>Polypedilum halterale</i>          |      | 42    | 4,12  | <i>Tabanus</i>                      |       |       | 44    |
| <i>P. fallax</i>                      |      | 5,44  | 4     | Syrphidae                           | 4     |       |       |
|                                       |      | 12    |       | <i>Syrphus americanus</i>           | 44    |       |       |
| <i>P. scalanum</i>                    | 4    | 42    |       | <i>Eristalis bastardi</i>           | 18,44 |       |       |
| <i>P. illinoense</i>                  |      | 3,4   | 44,12 | <i>E. aënaus</i>                    |       | 44    |       |
|                                       |      | 42,44 |       | <i>E. brousi</i>                    |       | 44    |       |
| <i>P. tritum</i>                      |      | 42    |       | <i>Eristalis</i>                    | 44    |       |       |
| <i>P. simulans</i>                    |      | 42    | 12    | Empididae                           |       |       | 42    |
| <i>P. nubeculosum</i>                 |      |       | 12    | Ephydriidae                         |       |       |       |
| <i>P. vibex</i>                       |      |       | 44    | <i>Brachydeutera argentata</i>      | 44    |       |       |
| <i>Polypedilum</i>                    |      | 48,44 | 12    | Anthomyiidae                        |       |       | 42    |
| <i>Tanytarsus neoflavellus</i>        |      | 44,12 | 18    | Lepidoptera                         |       |       |       |
| <i>T. gracilentus</i>                 |      |       | 12    | Pyralididae                         |       |       | 5,4   |
| <i>T. dissimilis</i>                  |      |       | 42    | Trichoptera                         |       |       |       |
| <i>Rheotanytarsus exiguus</i>         | 5    |       | 3,4   | Hydropsychidae                      |       |       |       |
| <i>Rheotanytarsus</i>                 |      | 42    |       | <i>Hydropsyche orris</i>            |       | 42    |       |



MACROINVERTEBRATE POLLUTION TOLERANCE

TABLE 7. (Continued)

| Macroinvertebrate                 | T | F     | I     | Macroinvertebrate           | T  | F     | I     |
|-----------------------------------|---|-------|-------|-----------------------------|----|-------|-------|
| <i>H. bifida</i> group            |   | 42    |       | Caenidae                    |    |       |       |
| <i>H. simulans</i>                |   |       | 42    | <i>Caenis diminuta</i>      | 4  |       |       |
| <i>H. frisoni</i>                 |   |       | 42    | <i>Caenis</i>               |    | 42    | 48    |
| <i>H. incommoda</i>               |   | 48    | 5,3,4 | Tricorythidae               |    | 42    |       |
| <i>Hydropsyche</i>                |   |       | 5,4   | Siphonuridae                |    |       |       |
| <i>Cheumatopsyche</i>             |   | 5,18, |       | <i>Isonychia</i>            |    |       | 42    |
|                                   |   | 3,4,  |       | Plecoptera                  |    |       | 5,4   |
|                                   |   | 42    |       | Perlidae                    |    |       |       |
| <i>Macronemum carolina</i>        |   |       | 5,3,4 | <i>Perlesta placida</i>     |    | 18    | 3     |
| <i>Macronemum</i>                 |   |       | 42    | <i>Acroneuria abnormis</i>  |    | 42    |       |
| <i>Potamyia flava</i>             |   | 42    |       | <i>A. arida</i>             |    |       | 42    |
| Psychomyiidae                     |   |       |       | Nemouridae                  |    |       |       |
| <i>Psychomyia</i>                 |   |       | 42    | <i>Taeniopteryx nivalis</i> |    |       | 42    |
| <i>Neureclipsis crepuseularis</i> |   |       | 42    | <i>Allocapnia viviparia</i> |    | 18    |       |
| <i>Polycentropus</i>              |   | 42    | 5,48, | Perlodidae                  |    |       |       |
|                                   |   |       | 4     | <i>Isoperla bilineata</i>   |    |       | 42    |
| <i>Cyrnellus fraternus</i>        |   | 42    |       | Neuroptera                  |    |       |       |
| <i>Oxyethira</i>                  |   |       | 5,4   | Sisyridae                   |    |       |       |
| Rhyacophilidae                    |   |       |       | <i>Climacia areolaris</i>   |    |       | 42    |
| <i>Rhyacophila</i>                |   |       | 48    | Megaloptera                 |    |       |       |
| Hydroptilidae                     |   |       |       | Corydalidae                 |    |       |       |
| <i>Hydroptila waubesiana</i>      |   |       | 42    | <i>Corydalis cornutus</i>   |    | 42    | 5,3,4 |
| <i>Hydroptila</i>                 |   |       | 5,3,4 | Sialidae                    |    |       |       |
| <i>Ochrotrichia</i>               |   |       | 42    | <i>Sialis infumata</i>      |    |       | 48    |
| <i>Agraylea</i>                   |   |       | 42    | <i>Sialis</i>               |    | 42    |       |
| Leptoceridae                      |   |       | 48    | Odonata                     |    |       |       |
| <i>Leptocella</i>                 |   | 5,4   | 42    | Calopterygidae              |    |       |       |
| <i>Athripsodes</i>                |   |       | 42    | <i>Hetaerina titia</i>      |    |       | 4     |
| <i>Oecetis</i>                    |   | 5,4   |       | Agrionidae                  |    |       |       |
| Philopotamidae                    |   |       |       | <i>Argia apicalis</i>       |    | 42    |       |
| <i>Chimarra perigua</i>           |   |       | 3,4   | <i>A. translata</i>         |    | 42    |       |
| <i>Chimarra</i>                   |   |       | 5,4   | <i>Argia</i>                |    |       | 5,4   |
| Brachycentridae                   |   |       |       | <i>Ischnura verticalis</i>  | 48 | 42    |       |
| <i>Brachycentrus</i>              |   |       | 4     | <i>Enallagma antennatum</i> |    | 42    |       |
| Molannidae                        |   |       | 48    | <i>E. signatum</i>          |    | 42    | 48    |
| Ephemeroptera                     |   |       |       | Aeshnidae                   |    |       |       |
| Heptageniidae                     |   |       |       | <i>Anax junius</i>          |    |       | 48    |
| <i>Stenonema integrum</i>         |   | 32,42 |       | Gomphidae                   |    |       |       |
| <i>S. rubromaculatum</i>          |   |       | 32    | <i>Gomphus pallidus</i>     |    | 5,3,4 |       |
| <i>S. fuscum</i>                  |   |       | 32    | <i>G. plagiatus</i>         |    |       | 48    |
| <i>S. pulchellum</i>              |   | 32    |       | <i>G. externus</i>          |    |       | 48    |
| <i>S. ares</i>                    |   | 32    |       | <i>G. spiniceps</i>         |    | 42    |       |
| <i>S. scitulum</i>                |   | 42    |       | <i>G. vastus</i>            |    | 42    |       |
| <i>S. femoratum</i>               |   | 18,42 | 32    | <i>Gomphus</i>              |    | 5,4   |       |
| <i>S. terminatum</i>              |   |       | 42    | <i>Progomphus</i>           |    |       | 5,4   |
| <i>S. interpunctatum</i>          |   |       | 32,42 | <i>Dromogomphus</i>         |    | 42    |       |
| <i>S. i. ohioense</i>             |   |       | 32    | <i>Erpetogomphus</i>        |    | 42    |       |
| <i>S. i. canadense</i>            |   |       | 32    | Libellulidae                |    |       |       |
| <i>S. i. heterotarsale</i>        |   | 32    |       | <i>Libellula lydia</i>      |    | 18    |       |
| <i>S. exiguum</i>                 |   |       | 5,3,4 | <i>Neurocordulia moesta</i> |    | 42    |       |
| <i>S. smithae</i>                 |   |       | 5,3,4 | <i>Plathemis</i>            |    | 42    |       |
| <i>S. proximum</i>                |   |       | 3     | <i>Macromia</i>             |    | 5,42  | 4     |
| <i>S. tripunctatum</i>            |   |       | 32    | Hemiptera                   |    | 4     |       |
| <i>Stenonema</i>                  |   |       | 32    | Corixidae                   |    |       | 42    |
| Hexageniidae                      |   |       |       | <i>Corixa</i>               |    | 18    |       |
| <i>Hexagenia limbata</i>          |   |       | 42    | <i>Hesperocorixa</i>        |    | 18    |       |
| <i>H. bilineata</i>               |   | 60    | 48    | Gerridae                    |    |       |       |
| <i>Pentagenia vittgera</i>        |   |       | 42    | <i>Gerris</i>               |    | 18    |       |
| Baetidae                          |   |       |       | Belostomatidae              |    |       |       |
| <i>Baetis vagans</i>              |   |       | 42    | <i>Belostoma</i>            |    | 18,3  |       |
| <i>Callibaetis floridanus</i>     | 4 |       |       | Hydrometridae               |    |       |       |
| <i>Callibaetis</i>                |   | 18    |       | <i>Hydrometra martini</i>   |    | 3     |       |



BIOLOGICAL METHODS

TABLE 7. (Continued)

| Macroinvertebrate               | T     | F     | I     | Macroinvertebrate                  | T     | F     | I  |
|---------------------------------|-------|-------|-------|------------------------------------|-------|-------|----|
| Coleoptera                      | 4§    |       |       | <i>P. gyrina</i>                   |       | 28    |    |
| Elmidae                         |       |       |       | <i>P. acuta</i>                    |       | 28    | 28 |
| <i>Stenelmis crenata</i>        |       |       | 18,50 | <i>P. fontinalis</i>               |       | 28    | 28 |
| <i>S. sexlineata</i>            |       | 42,50 | 18    | <i>P. anatina</i>                  | 28    |       |    |
| <i>S. decorata</i>              | 50    |       |       | <i>P. halei</i>                    | 28    |       |    |
| <i>Dubiraphia</i>               |       | 42,50 |       | <i>P. cubensis</i>                 | 28    |       |    |
| <i>Promoresia</i>               |       |       | 50    | <i>P. pumilia</i>                  | 3     |       |    |
| <i>Optioservus</i>              |       | 50    |       | <i>Physa</i>                       | 5,4   |       |    |
| <i>Macronychus glabratus</i>    |       |       | 50    | <i>Aplexa hypnorum</i>             |       | 28    | 28 |
| <i>Anacyronyx variegatus</i>    |       |       | 50    | Lymnaeidae                         |       |       |    |
| <i>Microcylloepus pusillus</i>  |       |       | 50    | <i>Lymnaea ovata</i>               | 28    |       |    |
| <i>Gonielmis dietrichi</i>      |       | 50    |       | <i>L. peregra</i>                  |       | 28    |    |
| Hydrophilidae                   |       |       |       | <i>L. caperata</i>                 |       | 28    |    |
| <i>Berosus</i>                  | 42    |       |       | <i>L. humilis</i>                  |       | 28    |    |
| <i>Tropisternus natator</i>     | 18    |       |       | <i>L. obrussa</i>                  |       | 28    |    |
| <i>T. lateralis</i>             | 3     |       |       | <i>L. polustris</i>                |       | 28    | 28 |
| <i>T. dorsalis</i>              |       |       | 48    | <i>L. auricularia</i>              |       | 28    |    |
| Dytiscidae                      |       |       |       | <i>L. stagnalis</i>                |       | 28    | 28 |
| <i>Laccophilus maculosus</i>    | 18    |       |       | <i>L. s. appressa</i>              |       |       | 28 |
| Gyrinidae                       |       |       |       | <i>Lymnaea</i>                     | 4     | 42    |    |
| <i>Gyrinus floridanus</i>       | 3     |       |       | <i>Pseudosuccinea columella</i>    |       | 28    |    |
| <i>Dineutus americanus</i>      | 18    |       |       | <i>Galba catascopium</i>           | 28    |       |    |
| <i>Dineutus</i>                 |       | 42    |       | <i>Fossaria modicella</i>          | 28    |       |    |
| Mollusca                        |       |       |       | Planorbidae                        |       |       |    |
| Gastropoda                      |       |       |       | <i>Planorbis carinatus</i>         |       |       | 28 |
| Mesogastropoda                  |       |       |       | <i>P. trivolvis</i>                | 28    |       |    |
| Valvatidae                      |       |       |       | <i>P. panus</i>                    | 28    |       |    |
| <i>Valvata tricarinata</i>      |       | 28    | 48,28 | <i>P. corneus</i>                  |       | 28    | 28 |
| <i>V. piscinalis</i>            |       | 28    |       | <i>P. marginatus</i>               |       |       | 28 |
| <i>V. bicarinata</i>            |       |       | 48    | <i>Planorbis</i>                   |       | 28    |    |
| <i>V. b. var. normalis</i>      |       |       | 48    | <i>Segmentina armigera</i>         | 28    |       |    |
| Viviparidae                     |       |       |       | <i>Helisoma anceps</i>             |       | 28    |    |
| <i>Viviparus contectoides</i>   |       |       | 48    | <i>H. trivolvis</i>                |       | 28    |    |
| <i>V. subpurpurea</i>           |       |       | 48    | <i>Helisoma</i>                    | 3,4   |       |    |
| <i>Campeloma integrum</i>       |       | 28    |       | <i>Gyraulus arcticus</i>           |       | 28    |    |
| <i>C. rufum</i>                 |       | 28    |       | <i>Gyraulus</i>                    |       | 28    |    |
| <i>C. contectus</i>             |       | 28    |       | Ancylidae                          |       |       |    |
| <i>C. fasciatus</i>             |       | 28    |       | <i>Ancylus lacustris</i>           |       | 28    | 28 |
| <i>C. decusum</i>               |       |       | 28    | <i>A. fluviatilis</i>              |       | 28    | 28 |
| <i>C. subsolidum</i>            |       | 48,28 |       | <i>Ferrissia fusca</i>             |       | 28    |    |
| <i>Campeloma</i>                |       | 60    |       | <i>F. tarda</i>                    |       | 28    |    |
| <i>Lioplax subcarinatus</i>     |       |       | 48    | <i>F. rivularis</i>                |       |       | 28 |
| Pleuroceridae                   |       |       |       | <i>Ferrissia</i>                   | 5,3,4 | 42    |    |
| <i>Pleurocera acuta</i>         |       | 48,28 |       | Bivalvia                           |       |       |    |
| <i>P. elevatum</i>              |       | 28    |       | Eulamellibranchia                  |       |       |    |
| <i>P. e. lewisi</i>             |       | 28    |       | Margaritiferidae                   |       |       |    |
| <i>Pleurocera</i>               |       | 28    |       | <i>Margaritifera margaritifera</i> |       |       | 28 |
| <i>Goniobasis livescens</i>     |       | 48,28 |       | Unionidae                          |       |       |    |
| <i>G. virginica</i>             | 28    |       |       | <i>Unio complanata</i>             | 28    |       |    |
| <i>Goniobasis</i>               |       | 28    | 5,4   | <i>U. gibbosus</i>                 | 28    | 28    |    |
| <i>Anculosa</i>                 |       | 28    |       | <i>U. batavus</i>                  |       |       | 28 |
| Bulimidae                       |       |       |       | <i>U. pictorum</i>                 |       |       | 28 |
| <i>Bulimus tentaculatus</i>     |       | 28    |       | <i>U. tumidus</i>                  |       | 28    |    |
| <i>Amnicola emarginata</i>      |       |       | 48    | <i>Lampsilis luteola</i>           |       | 28    |    |
| <i>A. limosa</i>                |       |       | 48    | <i>L. alata</i>                    |       | 28    |    |
| <i>Somatogyryus subglobosus</i> |       |       | 48    | <i>L. anadontoides</i>             |       | 28    |    |
| Basommatophora                  |       |       |       | <i>L. gracilis</i>                 |       | 48    |    |
| Physidae                        |       |       |       | <i>L. parvus</i>                   |       |       | 48 |
| <i>Physa integra</i>            | 18,28 | 28    |       | <i>Lampsilis</i>                   |       | 48,42 |    |
| <i>P. heterostropha</i>         | 28    | 28    |       | <i>Quadrula pustulosa</i>          |       | 28,42 |    |

§ Except riffle beetles

MACROINVERTEBRATE POLLUTION TOLERANCE

TABLE 7. (Continued)

| Macroinvertebrate             | T   | F     | I  | Macroinvertebrate                 | T     | F     | I  |
|-------------------------------|-----|-------|----|-----------------------------------|-------|-------|----|
| <i>Q. undulata</i>            |     | 28    |    | <i>S. s. var. lilycashense</i>    |       | 48    |    |
| <i>Q. rubiginosa</i>          |     | 28    |    | <i>S. sulcatum</i>                |       | 28    |    |
| <i>Q. lachrymosa</i>          |     | 28    |    | <i>S. stamineum</i>               |       | 48,28 |    |
| <i>Q. plicata</i>             |     | 28    |    | <i>S. moenanum</i>                |       | 28    | 28 |
| <i>Truncilla donaciformis</i> |     |       | 48 | <i>S. vivicolum</i>               |       | 28    | 28 |
| <i>T. elegans</i>             |     |       | 48 | <i>S. solidulum</i>               |       |       | 28 |
| <i>Tritigonia tuberculata</i> |     | 28    |    | <i>Sphaerium</i>                  |       | 42    |    |
| <i>Symphynota costata</i>     |     | 28    |    | <i>Musculium securis</i>          |       | 28    |    |
| <i>Strophitus edentulus</i>   |     | 28    |    | <i>M. transversum</i>             | 48,28 | 28    |    |
| <i>Anodonta grandis</i>       |     | 28,42 |    | <i>M. truncatum</i>               | 48    | 28    |    |
| <i>A. imbecillis</i>          |     | 48,28 |    | <i>Musculium</i>                  |       | 60    |    |
| <i>A. mutabilis</i>           |     |       | 28 | <i>Pisidium abditum</i>           |       | 28    |    |
| <i>Alasmodonta costata</i>    |     | 28    |    | <i>P. fossarinum</i>              |       |       | 28 |
| <i>Proptera alata</i>         |     |       | 42 | <i>P. pauperculum crystalense</i> |       | 48,28 |    |
| <i>Leptodea fragilis</i>      |     |       | 42 | <i>P. amnicum</i>                 |       | 28    | 28 |
| <i>Amblema undulata</i>       |     | 28    |    | <i>P. caserianum</i>              |       |       |    |
| <i>Lasmigona complanata</i>   |     | 28    |    | <i>P. compressum</i>              | 48    | 28    |    |
| <i>Obliquaria reflexa</i>     |     |       | 60 | <i>P. fallax</i>                  |       | 28    |    |
| Heterodonta                   |     |       |    | <i>P. henslowianum</i>            |       | 28    |    |
| Corbiculidae                  |     |       |    | <i>P. idahoensis</i>              | 28    |       |    |
| <i>Corbicula manilensis</i>   |     |       | 42 | <i>P. complanatum</i>             | 48,28 | 48,28 |    |
| Sphaeriidae                   | 5,4 |       |    | <i>P. subtruncatum</i>            |       | 28    |    |
| <i>Sphaerium notatum</i>      | 28  |       |    | <i>Pisidium</i>                   |       | 48    |    |
| <i>S. corneum</i>             |     | 28    |    | Dresisensiidae                    |       |       |    |
| <i>S. rhomboideum</i>         |     | 28    |    | <i>Mytilopsis leucophaeatus</i>   |       | 28    |    |
| <i>S. striatinum</i>          |     | 28    |    | Mastridae                         |       |       |    |
| <i>S. s. var. corpulentum</i> |     | 48    |    | <i>Rangia cuneata</i>             |       | 28    |    |

## BIOLOGICAL METHODS

### 6.0 LITERATURE CITED

1. Allen, K. R. 1951. The Horokwi Stream - a study of a trout population. New Zealand Marine Dept. Fish Bull. #10. 231 pp.
2. American Public Health Association. 1971. Standard methods for the examination of water and wastewater, 13th edition. American Public Health Association, New York. 874 pp.
3. Beck, W. M., Jr. Biological parameters in streams. Florida State Board of Health, Gainesville. 13 pp. (Unpublished)
4. Beck, W. M., Jr. Indicator organism classification. Florida State Board of Health, Gainesville. Mimeo. Rept. 8 pp. (Unpublished)
5. Beck, W. M., Jr. 1954. Studies in stream pollution biology: 1. A simplified ecological classification of organisms. J. Fla. Acad. Sciences, 17(4):211-227.
6. Beck, W. J., Jr. 1955. Suggested method for reporting biotic data. Sewage Ind. Wastes, 27(10):1193-1197.
7. Brinkhurst, R. O. 1963. Taxonomical studies on the Tubificidae (Annelida, Oligochaeta). Internat. Rev. Hydrobiol., (Systematische Beihefte) 2: 1-89.
8. Brinkhurst, R. O., K. E. Chua, and E. Batoosingh. 1969. Modifications in sampling procedures as applied to studies on the bacteria and tubificid oligochaetes inhabiting aquatic sediments. J. Fish. Res. Bd. Canada, 26(10):2581-1593.
9. Buchanan, T. J., and W. P. Sommers. 1969. Techniques of water investigations of the United States. Geological Survey. Chapter 8A, Discharge Measurements at Gaging Stations, Book 3, Applications of Hydraulics.
10. Carpenter, J. H. 1969. A new killing and fixing technique for small animals. Trans. Amer. Microscop. Soc. 88:450-451.
11. Chutter, F. M. and R. G. Noble. 1966. The reliability of a method of sampling stream invertebrates. Arch. Hydrobiol., 62(1):95-103.
12. Curry, L. L. 1962. A survey of environmental requirements for the midge (Diptera: Tendipedidae). In: Biological Problems in Water Pollution, Transactions of Third Seminar, C. M. Tarzwell, ed., USDHEW, PHS, Robert A. Taft Sanitary Engineering Center, Cincinnati.
13. Dickson, K. L., J. Cairns, Jr., and J. C. Arnold. 1971. An evaluation of the use of a basket-type artificial substrate for sampling macroinvertebrate organisms. Trans. Am. Fish. Soc. 100(3):553-559.
14. Elliott, J. M. 1970. Methods of sampling invertebrate drift in running water. Ann. Limnol. 6(2):133-159.
15. Elliott, J. M. 1971. Some methods for the statistical analysis of samples of benthic invertebrates. Freshwater Biological Association, U.K. Ferry House, Ambleside, Westmorland, England. 144 pp.
16. Flannagan, J. F. 1970. Efficiencies of various grabs and corers in sampling freshwater benthos. J. Fish. Res. Bd. Canada, 27(10):1691-1700.
17. Fullner, R. W. 1971. A comparison of macroinvertebrates collected by basket and modified multiple-plate samplers. JWPCF, 43(3):494-499.
18. Gauvin, A. R., and C. M. Tarzwell. 1956. Aquatic macroinvertebrate communities as indicators of organic pollution in Lytle Creek. Sewage & Ind. Wastes, 28(7):906-924.
19. Hamilton, A. L., W. Burton, and J. Flannagan. 1970. A multiple corer for sampling profundal benthos. J. Fish Res. Bd. Canada, 27(10):1867-1869.
20. Hassler, W. W., and L. B. Tebo, Jr. 1958. Fish management investigations on trout streams. Fed. Aid Proj. F4-R Comp. Report. Fish. Div., N.C. Wildl. Resour. Comm., Raleigh, N.C.
21. Henson, E. B. 1965. A cage sampler for collecting aquatic fauna. Turtox News, 43(12):298-299.
22. Henson, E. B. 1958. Description of a bottom fauna concentrating bag. Turtox News, 36(1):34-36.
23. Hester, F. E., and J. S. Dendy. 1962. A multiple-plate sampler for aquatic macroinvertebrates. Trans. Amer. Fish. Soc. 91(4):420-421.
24. Hilsenhoff, W. L. 1969. An artificial substrate device for sampling benthic stream invertebrates. Limnol. Oceanogr. 14(3):465-471.
25. Hubbs, H. H., Jr. 1965. List of Georgia crayfishes with their probable reactions to wastes (lethal chemicals not taken into consideration). Mimeo. Rept. 1 p. (Unpublished)
26. Hynes, H. B. N. 1970. The ecology of running waters. Liverpool Univ. Press.
27. Ingram, W. M., and A. F. Bartsch. 1960. Graphic expression of biological data in water pollution reports. JWPCF, 32(3):297-310.
28. Ingram, W. M. 1957. Use and value of biological indicators of pollution: Fresh water clams and snails. In: Biological Problems in Water Pollution, C. M. Tarzwell, ed. USDHEW, PHS, R. A. Taft Sanitary Engineering Center, Cincinnati.
29. Kittrell, F. W. 1969. A practical guide to water quality studies of streams. USDI, FWPCA, Washington, D. C.
30. Kolkwitz, R., and M. Marsson, 1909. Ecology of animal saprobia. Int. Rev. of Hydrobiology and Hydrogeography, 2:126-152. Translation In: Biology of Water Pollution, USDI, FWPCA, Cincinnati. 1967.
31. Lewis, P. A., W. T. Mason, Jr., and C. I. Weber. A comparison of Petersen, Ekman, and Ponar grab samples from river substrates. U. S. Environmental Protection Agency, Cincinnati. In preparation.
32. Lewis, P. A. 1969. Mayflies of the genus *Stenonema* as indicators of water quality. Presented at Seventeenth Annual Meeting of the Mid. Benth. Soc., Kentucky Dam Village State Park, Gilbertsville, Ky. 10 pp.

## MACROINVERTEBRATE REFERENCES

33. Lloyd, M., and R. J. Ghelardi. 1964. A table for calculating the "equitability" component of species diversity. *J. Anim. Ecol.* 33:217-225.
34. Lloyd, M., J. H. Zar, and J. R. Karr. 1968. On the calculation of information - theoretical measures of diversity. *Am. Mid. Nat.* 79(2):257-272.
35. Macan, T. T. 1963. *Freshwater ecology*. Camelot Press Ltd., London and Southampton, England. 338 pp.
36. MacArthur, R. H. 1957. On the relative abundance of bird species. *Proc. Nat. Acad. Sci., Washington*, 43:293-295.
37. Mackenthun, K. M. 1969. *The practice of water pollution biology*. USDI, FWPCA, Washington, D. C.
38. Mangelsdorf, D. C. 1967. Salinity measurements in estuaries. *Estuaries. Publication #83, American Association for the Advancement of Science*. pp. 71-79.
39. Margalef, D. R. 1957. Information theory in ecology. *General systems* 3:36-71. (English translation by W. Hall.)
40. Mason, W. T., Jr., J. B. Anderson, and G. E. Morrison. 1967. A limestone-filled artificial substrate sampler-float unit for collecting macroinvertebrates from large streams. *Fish-Cult.* 29(2):74.
41. Mason, W. T., Jr. and P. A. Lewis. 1970. Rearing devices for stream insect larvae. *Prog. Fish-Cult.* 32(1):61-62.
42. Mason, W. T., Jr., P. A. Lewis, and J. B. Anderson. 1971. Macroinvertebrate collections and water quality monitoring in the Ohio River Basin, 1963-1967. Cooperative Report, Office Tech. Programs. Ohio Basin Region and Analytical Quality Control Laboratory, WQO, USEPA, NERC-Cincinnati.
43. Mason, W. T., Jr., C. I. Weber, P. A. Lewis, and E. C. Julian. 1973. Factors affecting the performance of basket and multiplate macroinvertebrate samplers. *Freshwater Biol. (U.K.)* 3: In press.
44. Paine, G. H., Jr. and A. R. Gauffin. 1956. Aquatic diptera as indicators of pollution in a midwestern stream. *Ohio J. Sci.* 56(5):291.
45. Paterson, C. G., and C. H. Fernando. 1971. A comparison of a simple corer and an Ekman grab for sampling shallow-water benthos. *J. Fish. Res. Bd. Canada*, 28(3):365-368.
46. Patrick, R. 1950. Biological measure of stream conditions. *Sewage Ind. Wastes*, 22(7):926-938.
47. Pennak, R. W. 1953. *Freshwater invertebrates of the United States*. Ronald Press Co., New York. 769 pp.
48. Richardson, R. E. 1928. The bottom fauna of the middle Illinois River, 1913-1925: Its distribution, abundance, valuation, and index value in the study of stream pollution. *Bull. Ill. Nat. Hist. Surv.* XVII(XII):387-475.
49. Scott, D. C. 1958. Biological balance in streams. *Sewage Ind. Wastes*, 30:1169-1173.
50. Sinclair, R. M. 1964. Water quality requirements of the family Elmidae (Coleoptera). *Tenn. Stream Poll. Cont. Bd., Dept. Public Health*. Nashville.
51. Tebo, L. B., Jr. 1955. Bottom fauna of a shallow eutrophic lake, Lizard Lake, Pocahontas County, Iowa. *Amer. Mid. Nat.* 54(1):89-103.
52. U.S. Environmental Protection Agency. Data collected from the Coosa, Chattahoochee, Escambia and Savannah Rivers by the Aquatic Biology Branch, Region IV, Surveillance and Analysis Division, Athens, Georgia. (Unpublished)
53. U.S. Environmental Protection Agency. Data collected from the vicinity of Big Cypress Swamp jetport, south Florida, by the Aquatic Biology Branch, Region IV, Surveillance and Analysis Division, Athens, Georgia. (Unpublished)
54. U.S. Public Health Service. 1963. Data collected from the Ohio, Wabash and Allegheny Rivers by the Biology Section, National Water Quality Network, Cincinnati, Ohio. (Unpublished)
55. Waters, T. F. 1962. Diurnal periodicity in the drift of stream invertebrates. *Ecology*, 43(2):316-320.
56. Waters, T. F. 1969. Invertebrate drift-ecology and significance to stream fishes. In: *Symposium Salmon and Trout in Streams*, T. G. Northcote, ed. H. R. MacMillan Lectures in Fisheries. Univ. British Columbia, Vancouver. pp. 121-134.
57. Welch, P. S. 1948. *Limnological methods*. The Blakiston Co., Philadelphia, Pa. 381 pp.
58. Wentworth, C. K. 1922. A scale of grade and class terms for clastic sediments. *J. Geology*, 30:377-392.
59. Wilhm, J. L. 1970. Range of diversity index in benthic macroinvertebrate populations. *JWPCF*, 42(5):R221-R224.
60. Wimmer, G. R., and E. W. Surber. 1952. Bottom fauna studies in pollution surveys and interpretation of the data. Presented at: Fourteenth Mid. Wildl. Conf., Des Moines, Iowa. 13 pp.
61. Wurtz, C. B. 1955. Stream biota and stream pollution. *Sewage Ind. Wastes*, 27(11):1270-1278.

## 7.0 TAXONOMIC BIBLIOGRAPHY

### 7.1 Coleoptera

- Brown, H. P. 1970. A key to the dryopoid genera of the new world (Coleoptera, Dryoidea). *Ent. News*, 81:171-175.
- Hinton, H. E. 1940. New genera and species of Elmidae (Coleoptera). *Trans. Royal Entomol. Soc.* 91(3):65-104.
- Leech, H. B. 1948. Contributions toward a knowledge of the insect fauna of Lower California. No. 11, Coleoptera: Haliplidae, Dytiscidae, Byrrinidae, Hydrophilidae, Limnebiidae. *Proc. Calif. Acad. Sci.* 24:375-484, 2 pl.

## BIOLOGICAL METHODS

- Sanderson, M. W. 1938. A monographic revision of the North American species of *Stenelmis* (Dryopidae: Coleoptera). Kansas Univ. Dept. Eng. 25(22):635-717.
- Sanderson, M. W. 1953. A revision of the nearctic genera of Elmidae (Coleoptera). J. Kansas Ent. Soc. 26(4):148-163.
- Sanderson, M. W. 1954. A revision of the nearctic genera of Elmidae (Coleoptera). J. Kansas Ent. Soc. 27(1):1-13.
- Sinclair, R. M. 1964. Water quality requirements of the family Elmidae (Coleoptera). Tenn. Stream Pollution Control Board, Nashville. 14 pp.
- Wilson, C. B. 1923. Water beetles in relation to pondfish culture, with life histories of those found in fishponds at Fairport, Iowa. Bull. U.S. Bur. Fish. XXXIX:231-345.
- Wooldrige, D. P. 1967. The aquatic Hydrophilidae of Illinois. Ill. State Acad. Sci. 60(4):42-51.
- Young, F. N. 1954. The water beetles of Florida. Univ. Fla. Press. Biol. Science Series, V(1):1-238.

### 7.2 Crustacea

- Bousfield, E. L. 1958. Fresh-water amphipod crustaceans of glaciated North America. Canad. Field Nat. 72:55-113.
- Crocker, D. W. 1957. The crayfishes of New York State. N.Y. State Mus. and Sci. Service Bull. 355. pp. 13-89.
- Hobbs, H. H., Jr. 1942. The crayfishes of Florida. Univ. Fla. Biol. Sci. Series, III(2):1-179.
- Hobbs, H. H., Jr. and C. W. Hart, Jr. 1959. The freshwater decapod crustaceans of the Appalachian drainage system in Florida, southern Alabama, and Georgia. Bull. Fla. State Mus., Biol. Sci. 4(5):145-191.
- Holsinger, J. R. 1967. Systematics, speciation, and distribution of the subterranean amphipod *Stygonectes*. US Nat. Mus. Bull. 32:1-827.
- Francois, D. D. 1959. The crayfishes of New Jersey. Ohio J. Sci. 59(2):108-127.
- Ortmann, A. E. 1931. Crayfishes of the Southern Appalachians and Cumberland Plateau. Ann. Carnegie Mus. 20:61-160.
- Rhoades, R. 1944. Crayfishes of Kentucky, with notes on variations, distributions, and descriptions of new species and subspecies. Amer. Midl. Nat. 31:111-149.
- Riegel, J. A. 1959. The systematics and distribution of crayfishes in California. Calif. Fish Game, 45(1):29-50.
- Stansbery, D. H. 1962. A revised checklist of the crayfish of Ohio (Decapoda: Astacidae). Ohio State Univ. Dept. Zool. Ent., Columbus. 5 pp.
- Turner, C. L. 1926. The crayfish of Ohio. Ohio Biol. Surv. Bull. No. 13, 3(3):145-195.
- Williams, A. B. 1954. Speciation and distribution of the crayfishes of the Ozark Plateau and Ouachita Provinces. Kans. Univ. Sci. Bull. 36(12):803-918.
- Williams, A. B. 1965. Marine decapod crustaceans of the Carolinas. USDI, Fish Wildl. Serv., Bur. Comm. Fish. 65(1):1-298.

### 7.3 Diptera

- Bath, J. L., and L. D. Anderson. 1969. Larvae of seventeen species of chironomid midges from southern California. J. Kans. Entomol. Soc. 42(2):154-176.
- Beck, E. C., and W. M. Beck, Jr. 1959. A checklist of the Chironomidae (Insecta) of Florida (Diptera: Chironomidae). Bull. Fla. State Mus. 4(3):85-96.
- Beck, E. C., and W. M. Beck, Jr. 1969. The Chironomidae of Florida. Fla. Ent. 52(1):1-11.
- Beck, W. M., Jr. and E. C. Beck. 1964. New Chironomidae from Florida. Fla. Ent. 47(3):201-207.
- Beck, W. M., Jr. and E. C. Beck. 1966. Chironomidae (Diptera) of Florida. Part I. Pentaneurini (Tanypodinae). Bull. Fla. State Mus. 10(8):305-379.
- Beck, W. M., Jr. and E. C. Beck. 1969. Chironomidae (Diptera) of Florida: Part III, The Harnischia complex. Bull. Fla. State Mus. 13(5):277-313.
- Cook, E. F. 1956. The nearctic Chaoborinae (Diptera: Culicidae). Minn. Agr. Exp. Sta. Tech. Bull. 218:1-102.
- Curran, H. C. 1965. The families and genera of North American Diptera. H. Tripp Co., Woodhaven, N.Y. 515 pp.
- Curry, L. L. 1958. Larvae and pupae of the species of *Cryptochironomus* (Diptera) in Michigan. ASLO, 3(4):427-442.
- Curry, L. L. 1962. A key for the larval forms of aquatic midges (Tendipedidae: Diptera) found in Michigan. NIH Rept. No. 2, Contract No. RG-6429. Dept. Biol. Central Mich. Univ., Mt. Pleasant. 149 pp.
- Darby, R. E. 1962. Midges associated with California rice fields, with special reference to their ecology (Diptera: Chironomidae). Hilgardia, 32(1):1-206.
- Dendy, J. S., and J. E. Sublette. 1959. The Chironomidae (=Tendipedidae: Diptera) of Alabama, with Descriptions of Six New Species. Ann. Ent. Soc. Amer. 52(5):506-519.
- Frommer, S. 1967. Review of the anatomy of adult Chironomidae. Calif. Mosquito Contr. Assoc., Tech. Series Bull. No. 1. 40 pp.
- Hamilton, A. L., O. A. Sather, and D. R. Oliver. 1969. A classification of the nearctic Chironomidae. Fish. Research Bd. Can., Tech. Rept. 129. 42 pp.



- Hauber, U. A. 1947. The Tendipedinae of Iowa. *Amer. Mid. Nat.* 38(2):456-465.
- \*Johannsen, O. A. 1934. Aquatic Diptera. Part I. Nematocera, exclusive of Chironomidae and Ceratopogonidae. *Mem. Cornell Univ. Agr. Exp. Sta.* 164:1-70.
- \*Johannsen, O. A. 1935. Aquatic Diptera. Part II. Orthorrhapha-Brachycera and Cyclorrhapha. *Mem. Cornell Univ. Agr. Exp. Sta.* 177:1-62.
- \*Johannsen, O. A. 1937. Aquatic Diptera. Part III. Chironomidae: subfamilies Tanypodinae, Diamesinae, and Orthocladiinae. *Mem. Cornell Univ. Agr. Exp. Sta.* 205:1-84.
- \*Johannsen, O. A. 1934-37. "Aquatic Diptera" may be purchased from Entomological Reprint Specialists, East Lansing, Mich. 48823.
- Johannsen, O. A. 1937a. Aquatic Diptera. Part IV. Chironomidae: subfamily Chironominae. *Mem. Cornell Univ. Agr. Exp. Sta.* 210:1-56.
- Johannsen, O. A. 1964. Revision of the North American species of the genus *Pentaneura* (Tendipedidae: Diptera). *J. New York Ent. Soc.* 54.
- Johannsen, O. A., H. K. Townes, F. R. Shaw, and E. Fisher. 1952. Guide to the insects of Connecticut. Part VI. The Diptera of true flies. *Bull. Conn. Geol. and Nat. Hist. Surv.* 80:1-255.
- Malloch, J. R. 1915. The Chironomidae or midges of Illinois, with particular reference to the species occurring in the Illinois River. *Bull. Ill. State Lab. Nat. Hist.* 10:273-343.
- Mason, W. T., Jr. 1968. An introduction to the identification of Chironomid larvae. Division of Pollution Surveillance, FWPCA, USDI, Cincinnati. 90 pp. (Revised 1973).
- Roback, S. S. 1953. Savannah River tendipedid larvae. *Acad. Nat. Sci., Philadelphia*, 105:91-132.
- Roback, S. S. 1957. The immature tendipedids of the Philadelphia area. *Acad. Nat. Sci., Philadelphia Mono. No. 9.* 148 pp.
- Roback, S. S. 1963. The genus *Xenochironomus* (Diptera: Tendipedidae) Kieffer, taxonomy and immature stages. *Trans. Amer. Ent. Soc.* 88:235-245.
- Roback, S. S. 1969. The immature stages of the genus *Tanytus* Meigen. *Trans. Amer. Ent. Soc.* 94:407-428.
- Saeter, O. A. 1970. Nearctic and palaearctic *Chaoborus* (Diptera: Chaoboridae). *Bull. Fish. Res. Bd. Can.*, No. 174. 57 pp.
- Stone, A., C. W. Sabrasky, W. W. Wirth, R. H. Foote, and J. R. Coulson, eds. A catalog of the Diptera of America north of Mexico. USDA Handbook No. 276.
- Stone, A., and E. R. Snoddy. 1969. The black flies of Alabama (Diptera: Simuliidae). *Auburn Univ. Agr. Exp. Sta. Bull. No. 390.* 93 pp.
- Sublette, J. E. 1960. Chironomid midges of California. Part I. Chironominae, exclusive of Tanytarsini (Calopsectrini). *Proc. U.S. Natl. Museum*, 112:197-226.
- Sublette, J. E. 1964. Chironomid midges of California. Part II. Tanypodinae, Podonominae, and Diamesinae. *Proc. U.S. Natl. Museum*, 115(3481):85-136.
- Sublette, J. E. 1964. Chironomidae (Diptera) of Louisiana. Part I. Systematics and immature stages of some lentic chironomids of west central Louisiana. *Tulane Studies Zool.* 11(4):109-150.
- Thomsen, L. C. 1937. Aquatic Diptera. Part V. Ceratopogonidae. *Mem. Cornell Univ. Ga. Exp. Sta.* 210:57-80.
- Townes, H. K. 1945. The nearctic species of Tendipedini. *Amer. Mid. Nat.* 34(1):1-206.
- Wood, D. M., B. L. Peterson, D. M. Davies, and H. Györhos. 1963. The black flies (Diptera: Simuliidae) of Ontario. Part II. Larval identification, with descriptions and illustrations. *Proc. Ent. Soc. Ontario*, 93:99-129.

## 7.4 Ephemeroptera

- Berner, L. 1950. The mayflies of Florida. *Univ. Fla. Press, Gainesville.* 267 pp.
- Berner, L. 1959. A tabular summary of the biology of North American mayfly nymphs (Ephemeroptera). *Bull. Fla. State Mus.* 4(1):1-58.
- Burks, B. D. 1953. The mayflies, or Ephemeroptera, of Illinois. *Bull. Ill. Nat. Hist. Surv.* 26:1-216.
- Edmunds, G. F., Jr., R. K. Allen, and W. L. Peters. 1963. An annotated key to the nymphs of the families and subfamilies of mayflies (Ephemeroptera). *Univ. Utah Biol. Series XII(1):*1-55.
- Leonard, J. W., and F. A. Leonard. 1962. Mayflies of Michigan trout streams. *Cranbrook Institute Sci., Michigan.* 139 pp.
- Needham, J. G., J. R. Traver, and Yin-Chi Hsu. 1935. The biology of mayflies. *Entomological Reprint Specialists, Inc., East Lansing, Mich.*
- Needham, J., and H. E. Murphy. 1924. Neotropical mayflies. *Bull. Lloyd Libr. No. 24, Entom. Series No. 4,* pp. 5-79, Cincinnati.
- Spith, H. T. 1947. Taxonomic studies on the Ephemeroptera: Part IV. The genus *Stenonema*. *Anni. Entomol. Soc. Am.* XL:1-162.

## BIOLOGICAL METHODS

### 7.5 Hemiptera

- Brooks, G. T. 1951. A revision of the genus *Anisops* (Notonectidae, Hemiptera). Univ. Kans. Sci. Bull. XXXIV(8):301-519.
- Cummings, C. 1933. The giant water bugs (Belostomatidae, Hemiptera). Univ. Kans. Sci. Bull. XXI(2):197-219.
- Hungerford, H. B. 1933. The genus *Notonecta* of the world. Univ. Kans. Sci. Bull. XXI(9):5-195.
- Hungerford, H. B. 1948. The Corixidae of the western hemisphere. Kans. Univ. Sci. Bull. 32:1-827.
- Hungerford, H. B., and R. Matsuda. 1960. Keys to subfamilies, tribes, genera, and subgenera of the Gerridae of the world. Univ. Kans. Sci. Bull. XLI(1):3-23.
- Schaefer, K. F., and W. A. Drew. 1968. The aquatic and semiaquatic Hemiptera of Oklahoma. Proc. Okla. Acad. Sci. 47:125-134.
- Schaefer, K. F., and W. A. Drew. 1969. The aquatic and semiaquatic Hemiptera (Belostomatidae and Saldidae) of Oklahoma. Proc. Okla. Acad. Sci. 48:79-83.

### 7.6 Hirudinea

- Meyer, M. C., and J. P. Moore. 1954. Notes on Canadian leeches (Hirudinea), with the description of a new species. Wasmann J. Biology, 12(1):63-95.
- Sawyer, R. T. 1967. The leeches of Louisiana, with notes on some North American species (Hirudinea, Annelida). Proc. La. Acad. Sci. XXX:32-38.

### 7.7 Hydracarina

- Crowell, R. M. 1960. The taxonomy, distribution, and developmental stages of Ohio water mites. Bull. Ohio Biol. Surv. 1(2):1-77.

### 7.8 Lepidoptera

- Lange, W. H. 1956. A generic revision of the aquatic moths of North America (Lepidoptera:Pyralidae Nymphulinae). Wasmann J. Biology, 14(1):59-114.

### 7.9 Megaloptera

- Baker, J. R., and H. H. Neunzig. 1968. The egg masses, eggs, and first instar larvae of eastern North American Corydalidae. Ann. Ent. Soc. Amer. 61(5):1181-1187.
- Davis, K. C. 1903. Aquatic insects in New York State. Part 7, Sialididae of North and South America. N. Y. State Mus. Bull. 68:442-486.
- Needham, J. G., and C. Betten. 1901. Aquatic insects in the Adirondacks. N. Y. State Mus. Bull. 47:383-612.
- Ross, H. H., and T. H. Frison. 1937. Studies of nearctic aquatic insects. Bull. Ill. Nat. Hist. Surv. 21:57-78.

### 7.10 Mollusca

- Amos, M. H. 1966. Commercial clams of the North American Pacific Coast. US Bur. Comm. Fish. Circular, 237:1-18.
- Baker, F. C. 1928. The fresh-water mollusca of Wisconsin. Wis. Acad. Sci. Bull. Part I. Gastropoda, 70:1-505. Part II. Pelecypoda, 70:1-495.
- Branson, B. A. (No date). Checklist and distribution of Kentucky aquatic gastropods. Ky. Dept. Fish and Wildl., Res. Fish. Bull. No. 54. pp. 1-20.
- Call, R. E. 1899. Mollusca of Indiana. Ind. Dept. Geol. Nat. Res., 24th Ann. Rept. pp. 337-535.
- Clarke, A. H., Jr. and C. O. Berg. 1959. The freshwater mussels of central New York with an illustrated key to the species of northeastern North America. Mem. Cornell Univ. Agr. Exp. Sta. 367:1-79.
- Clench, W. J., and R. D. Turner. 1956. Freshwater mollusks of Alabama, Georgia, and Florida from the Escambia to the Suwannee River. Fla. State Mus. Bull. 1(3):97-239.
- Goodrich, C. 1932. The Mollusca of Michigan. Univ. Mich. Handbook Series No. 5, pp. 1-120.
- Heard, W. H., and J. Burch. 1966. Key to the genera of freshwater pelecypods of Michigan. Mich. Mus. Zool., Univ. Mich., Circ. No. 4. Ann Arbor.
- Ingram, W. M. 1948. The larger freshwater clams of California, Oregon, and Washington. J. Ent. Zool. 40(4):72-92.
- Leonard, A. B. 1959. Gastropods in Kansas. Kans. Univ. Dept. Zool., State Biol. Surv. 224 pp.
- Murry, H. D., and A. B. Leonard. 1962. Unionid mussels in Kansas. Kans. Univ. Dept. Zool., State Biol. Surv. No. 28. 104 pp.
- Ortmann, A. E. 1919. A monograph of the naiades of Pennsylvania. Part III, Systematic account of the Genera and species. Carnegie Inst. Mus. 8(1):1-378.

- Robertson, I. C. S., and C. L. Blakeslee. 1948. The Mollusca of the Niagara frontier region. Bull. Buffalo Soc. Nat. Sci. 19(3):1-191.
- Sinclair, R. M., and B. G. Isom. 1963. Further studies on the introduced asiatic clam *Corbicula* in Tennessee. Tenn. Stream Poll. Control Bd., Tenn. Dept. Public Health. 75 pp.
- Stein, C. B. 1962. Key to the fresh-water mussels (family Unionidae) of western Lake Erie. Ohio State Univ., Stone Lab. 5 pp.
- Taft, C. 1961. The shell-bearing land snails of Ohio. Bull. Ohio Biol. Surv. 1(3):1-108.
- Thompson, F. G. 1968. The aquatic snails of the family Hydrobiidae of peninsular Florida. Univ. Fla. Press. 268 pp.

### 7.11 Odonata

- Byers, C. F. 1930. A contribution to the knowledge of Florida Odonata. Univ. Fla. Biol. Sci. Ser. 1(1):1-327.
- Gorman, P. 1927. Guide to the insects of Connecticut. Part V, The Odonata or dragonflies of Connecticut. Conn. Geol. Nat. Hist. Surv. 39:1-331.
- Kennedy, C. H. 1915. Notes on the life history and ecology of the dragonflies (Odonata) of Washington and Oregon. Proc. US Nat. Mus. 49:259-345.
- Kennedy, C. H. 1917. Notes on the life history and ecology of the dragonflies (Odonata) of central California and Nevada. Proc. US Nat. Mus. 52:483-635.
- Needham, J. G., and M. J. Westfall, Jr. 1954. Dragonflies of North America. Univ. Calif. Press, Berkeley and Los Angeles. 615 pp.
- Walker, E. M. 1958. The Odonata of Canada and Alaska. Vol. 1 and 2. Univ. Toronto Press, Toronto.
- Williamson, E. B. 1899. The dragonflies of Indiana. Ind. Dept. Geol. Nat. Res., 24th Annual Rept. pp. 229-333.
- Wright, M., and A. Peterson. 1944. A key to the genera of Anisopterous dragonfly nymphs of the United States and Canada (Odonata, suborder Anisoptera). Ohio J. Sci. 44:151-166.

### 7.12 Oligochaeta

- Brinkhurst, R. O. 1964. Studies on the North American aquatic Oligochaeta. Part I. Proc. Acad. Nat. Sci., Philadelphia, 116(3):195-230.
- Brinkhurst, R. O. 1965. Studies on the North American aquatic Oligochaeta. Part II. Proc. Acad. Sci., Philadelphia, 117(4):117-172.
- Brinkhurst, R. O. 1969. Oligochaeta. In: Keys to Water Quality Indicative Organisms (Southeast United States). FWPCA, Athens, Ga.
- Galloway, T. W. 1911. The common fresh-water Oligochaeta of the United States. Trans. Amer. Micros. Soc. 30:285-317.

### 7.13 Plecoptera

- Claassen, P. W. 1931. Plecoptera nymphs of America (north of Mexico). Published as Volume III of the Thomas Say Foundation, Ent. Soc. Amer. Charles C. Thomas, Springfield, Ill.
- Claassen, P. W. 1940. A catalogue of the Plecoptera of the world. Mem. Cornell Univ. Agr. Exp. Sta. 232:1-235.
- Frison, T. H. 1935. The stoneflies, or Plecoptera, of Illinois. Bull. Ill. Nat. Hist. Surv. 20:281-371.
- Frison, T. H. 1942. Studies of North American Plecoptera. Bull. Ill. Nat. Hist. Surv. 22:235-355.
- Gaufin, A. R., A. V. Nebeker, and J. Sessions. 1966. The stoneflies (Plecoptera) of Utah. Univ. Utah Biol. Series, 14(1):1-93.
- Harden, P. H., and C. E. Mickel. 1952. The stoneflies of Minnesota (Plecoptera). Univ. Minn. Agr. Exp. Sta. 201:1-84.
- Hilsenhoff, W. L. 1970. Key to genera of Wisconsin Plecoptera (stoneflies) nymphs, Ephemeroptera (mayfly) nymphs, Trichoptera (caddisfly) larvae. Res. Rept. No. 67, Wis. Dept. Nat. Res., Madison.
- Jewett, S. G., Jr. 1955. Notes and descriptions concerning western stoneflies (Plecoptera). Wasmann J. Biol. 91(1):1-543.
- Jewett, S. G., Jr. 1959. The stoneflies (Plecoptera) of the Pacific Northwest. Ore. State Coll. Press. 95 pp.
- Jewett, S. G., Jr. 1960. The stoneflies (Plecoptera) of California. Bull. Calif. Insect Surv. 6(6):125-177.
- Nebeker, A. V., and A. R. Gaufin. 1966. The *Capnia* *Columbiana* complex of North America (Capniidae:Plecoptera). Trans. Amer. Ent. Soc. 91:467-487.
- Needham, J. G., and P. W. Claassen. 1925. A monograph of the Plecoptera or stoneflies of America north of Mexico. Published as Volume II of the Thomas Say Foundation, Ent. Soc. Am. Charles C. Thomas, Springfield, Ill.
- Ricker, W. E., and H. H. Ross. 1968. North American species of *Taeniopteryx* (Plecoptera:Insecta). J. Fish. Res. Bd. Can. 25:1423-1439.

### 7.14 Trichoptera

- Betten, C. 1934. The caddisflies or Trichoptera of New York State. N. Y. State Mus. Bull. 292:1-576.
- Edwards, S. W. 1966. An annotated list of the Trichoptera of middle and west Tennessee. J. Tenn. Acad. Sci. 41:116-127.
- Flint, O. S. 1960. Taxonomy and biology of nearctic limnephelid larvae (Trichoptera), with special reference to species in eastern United States. Entomologica Americana, 40:1-120.

## BIOLOGICAL METHODS

- Flint, O. S. 1961. The immature stages of the Arctopsychinae occurring in eastern North America (Trichoptera:Hydropsychidae). Ann. Ent. Soc. Amer. 54(1):5-11.
- Flint, O. S. 1962. Larvae of the caddisfly Genus *Rhyacophila* in eastern North America (Trichoptera:Rhyacophilidae). Proc. US Natl. Mus. 113:465-493.
- Flint, O. S. 1963. Studies of neotropical caddisflies. Part I, Rhyacophilidae and Glossosomatidae (Trichoptera). Proc. US Natl. Mus. 114:453-478.
- Flint, O. S. 1964. The caddisflies (Trichoptera) of Puerto Rico. Univ. Puerto Rico Agr. Exp. Sta. Tech. Paper No. 40. 80 pp.
- Flint, O. S. 1964a. Notes on some nearctic Psychomyiidae with special reference to their larvae (Trichoptera). Proc. US Nat. Mus. Publ. No. 3491, 115:467-481.
- Hickin, N. E. 1968. Caddis larvae, larvae of the British Trichoptera. Associated Univ. Presses, Inc., Cranbury, N. J. pp. 1-480.
- Leonard, J. W., and F. A. Leonard. 1949. An annotated list of Michigan Trichoptera. Mich. Mus. Zool. Occ. Paper No. 522. pp. 1-35.
- Lloyd, J. T. 1921. North American caddisfly larvae. Bull. Lloyd Libr. No. 21, Entom. Series No. 1. pp. 16-119.
- Ross, H. H. 1941. Descriptions and records of North American Trichoptera. Trans. Amer. Entom. Soc. 67:35-129.
- Ross, H. H. 1944. The caddisflies, or Trichoptera, of Illinois. Bull. Ill. Nat. Hist. Surv. 23:1-326.
- Wiggins, G. B. 1960. A preliminary systematic study of the North American larvae of the caddisflies, family Phryganeidae (Trichoptera). Can. J. Zool. 38:1153-1170.
- Wiggins, G. B. 1962. A new subfamily of phryganeid caddisflies from western North America (Trichoptera:Phryganeidae). Can. J. Zool. 40:879-891.
- Wiggins, G. B. 1963. Larvae and pupae of two North American limnephilid caddisfly genera (Trichoptera:Limnephilidae). Bull. Brooklyn Ent. Soc. 57(4):103-112.
- Wiggins, G. B. 1965. Additions and revisions to the genera of North American caddisflies of the family Brachycentridae with special reference to the larval stages (Trichoptera). Can. Ent. 97:1089-1106.
- Wiggins, G. B., and N. H. Anderson. 1968. Contributions to the systematics of the caddisfly genera *Pseudostenophylax* and *Philocasca* with special reference to the immature stages (Trichoptera:Limnephilidae). Can. J. Zool. 46:61-75.
- Yamamoto, T., and G. B. Wiggins. 1964. A comparative study of the North American species in the caddisfly genus *Mystacides* (Trichoptera:Leptoceridae). Can. J. Zool. 42:1105-1126.

### 7.15 Marine

- Hartman, O. 1961. Polychaetous annelids from California. Allan Hancock Pacific Expeditions. 25:1-226.
- Hartman, O., and D. J. Reish. 1950. The marine annelids of Oregon. Ore. State Coll. Press, Corvallis, Ore.
- Miner, R. W. 1950. Field book of seashore life. G. P. Putnam's Sons, New York.
- Smith, R. I. 1964. Keys to the marine invertebrates of the Woods Hole region. Woods Hole Marine Biol. Lab., Cont. No. 11.
- Smith, R., F. A. Pitelka, D. P. Abbott, and F. M. Weesner. 1967. Intertidal invertebrates of the central California coast. Univ. Calif. Press. Berkeley.

# FISH

116



# FISH

|                                 | Page |
|---------------------------------|------|
| 1.0 INTRODUCTION                | 1    |
| 2.0 SAMPLE COLLECTION           | 1    |
| 2.1 General Considerations      | 1    |
| 2.2 Active Sampling Techniques  | 2    |
| 2.2.1 Seines                    | 2    |
| 2.2.2 Trawls                    | 3    |
| 2.2.3 Electrofishing            | 5    |
| 2.2.4 Chemical Fishing          | 5    |
| 2.2.5 Hoek and Line             | 6    |
| 2.3 Passive Sampling Techniques | 7    |
| 2.3.1 Entanglement Nets         | 7    |
| 2.3.2 Entrapment Devices        | 7    |
| 3.0 SAMPLE PRESERVATION         | 10   |
| 4.0 SAMPLE ANALYSIS             | 11   |
| 4.1 Data Recording              | 11   |
| 4.2 Identification              | 11   |
| 4.3 Age, Growth, and Condition  | 11   |
| 5.0 SPECIAL TECHNIQUES          | 11   |
| 5.1 Flesh Tairting              | 11   |
| 5.2 Fish Kill Investigations    | 12   |
| 6.0 REFERENCES                  | 13   |
| 7.0 BIBLIOGRAPHY                | 14   |
| 7.1 General References          | 14   |
| 7.2 Electrofishing              | 14   |
| 7.3 Chemical Fishing            | 15   |
| 7.4 Fish Identification         | 16   |
| 7.5 Fish Kills                  | 18   |

# FISH

## 1.0 INTRODUCTION

To the public, the condition of the fishery is the most meaningful index of water quality. Fish occupy the upper levels of the aquatic food web and are directly and indirectly affected by chemical and physical changes in the environment. Water quality conditions that significantly affect the lower levels of the food web will affect the abundance, species composition, and condition of the fish population. In some cases, however, the fish are more sensitive to the pollutant(s) than are the lower animals and plants; they may be adversely affected even when the lower levels of the food web are relatively unharmed.

Many species of fish have stringent dissolved oxygen and temperature requirements and are intolerant of chemical and physical contaminants resulting from agricultural, industrial, and mining operations. The discharge of moderate amounts of degradable organic wastes may increase the nutrient levels in the habitat and result in an increase in the standing crop of fish. This increase, however, usually occurs in only one or a few species and results in an imbalance in the population. The effects of toxic wastes may range from the elimination of all fish to a slight reduction in reproductive capacity, growth, or resistance to disease and parasitism.

Massive and complete fish kills are dramatic signs of abrupt, adverse changes in environmental conditions. Fish, however, can repopulate an area rapidly if the habitat is not destroyed, and the cause of the kill may be difficult to detect by examination of the fish community after it has recovered from the effects of the pollutant. Chronic pollution, on the other hand, is more selective in its effects and exerts its influence over a long period of time and causes recognizable changes in the species composition and relative abundance of the fish.

The principal characteristics of interest in field studies of fish populations include: (1) species present, (2) relative and absolute abundance of each species, (3) size distribution, (4) growth rate, (5) condition, (6) success of reproduction, (7) incidence of disease and parasitism,

and (8) palatability. Observations of fish behavior can also be valuable in detecting environmental problems; e.g. ventilation rates, position in the current, and erratic movement. Fish may also be collected for use in laboratory bioassays, for tissue analyses to measure the concentrations of metals and pesticides, and for histopathologic examination.

Fisheries data have some serious limitations. Even if the species composition of the fish in a specific area were known before and after the discharge of pollutants, the real significance of changes in the catch could not be properly interpreted unless the life histories of the affected species were understood, especially the spawning, seasonal migration, temperature gradient and stream-flow responses, diurnal movements, habitat preferences, and activity patterns. Without this knowledge, fish presence or absence cannot be correlated with water quality. Of course, any existing data on the water quality requirements of fish would be of great value in interpreting field data.

Fisheries data have been found useful in enforcement cases and in long-term water quality monitoring (Tébo, 1965). Fishery surveys are costly, however, and a careful and exhaustive search should be conducted for existing information on the fisheries of the area in question before initiating a field study. State and Federal fishery agencies and universities are potential sources of information which, if available, may save time and expense. Most states require a collecting permit, and the state fishery agency must usually be contacted before fish can be taken in a field study. If data are not available and a field study must be conducted, other Federal and State agencies will often join the survey and pool their resources because they have an interest in the data and have found that a joint effort is more economical and efficient.

## 2.0 SAMPLE COLLECTION

### 2.1 General Considerations

Fish can be collected actively or passively. Active sampling methods include the use of seines, trawls, electrofishing, chemicals, and

## BIOLOGICAL METHODS

hook and line. Passive methods involve entanglement (gill nets and trammel nets) and entrapment (hoop nets, traps, etc.) devices. The chief limitations in obtaining qualitative and quantitative data on a fish population are gear selectivity and the mobility and rapid recruitment of the fish. Gear selectivity refers to the greater success of a particular type of gear in collecting certain species, or sizes of fish, or both. All sampling gear is selective to some extent. Two factors that affect gear selectivity are: (1) the habitat or portion of habitat (niches) sampled and (2) the actual efficiency of the gear. A further problem is that the efficiency of gear for a particular species in one area does not necessarily apply to the same species in another area. Even if non-selective gear could be developed, the problem of adequately sampling an area is difficult because of the nonrandom distribution of fish populations.

Temporal changes in the relative abundance of a single species can be assessed under a given set of conditions if that species is readily taken with a particular kind of gear, but the data are not likely to reflect the true abundance of the species occurring in nature.

Passive collection methods are very selective and do not obtain representative samples of the total population. Active methods are less selective and more efficient, but usually require more equipment and manpower. Although the choice of method depends on the objectives of the particular fishery investigation, active methods are generally preferred.

### 2.2 Active Sampling Techniques

#### 2.2.1 Seines

A haul seine is essentially a strip of strong netting hung between a stout cork or float line at the top and a strong, heavily-weighted lead line at the bottom (Figure 1). The wings of the net are often of larger mesh than the middle portion, and the wings may taper so that they are shallower on the ends. The center portion of the net may be formed into a bag to aid in confining the fish. At the ends of the wings, the cork and lead lines are often fastened to a short stout pole or brail. The hauling lines are then attached to the top and bottom of the brail by a short bridle.



Figure 1. The common haul seine. (From Dumont and Sundstrom, 1961.)

Deepwater seining usually requires a boat. One end of one of the hauling lines is anchored on shore and the boat pays out the line until it reaches the end. The boat then changes direction and lays out the net parallel to the beach. When all of the net is in the water, the boat brings the end of the second hauling line ashore. The net is then beached rapidly.

The straight seines (without bags), such as the common-sense minnow seines, can usually be handled quite easily by two people. The method of paying out the seine and bringing it in is similar to the haul seine, except the straight seine is generally used in shallow water where one member of the party can wade offshore with lines.

Bag and straight seines vary considerably in dimensions and mesh size. The length varies from 3 to 70 meters, and mesh size and net width vary with the size of the fish and the depth of the water to be sampled.

Nylon seines are recommended because of the ease of maintenance. Cotton seines should be treated with a fungicide to prevent decay.

Seining is not effective in deep water because the fish can escape over the floats and under the lead line. Nor is it effective in areas that have snags and sunken debris. Although the results are expressed as number of fish captured per unit area seined, quantitative seining is very difficult. The method is more useful in determining the variety rather than the number of fish inhabiting the water.

### 2.2.2. Trawls

Trawls are specialized submarine seines used in large, open-water areas of reservoirs, lakes, large rivers, estuaries, and in the oceans. They may be of considerable size and are towed by boats at speeds sufficient to overtake and enclose the fish. Three basic types are: (1) the beam trawl used to capture bottom fish (Figure 2), (2) the otter trawl used to capture near-bottom and bottom fish (Figure 3), and (3) the mid-water trawl used to collect schooling fish at various depths.

The beam trawls have a rigid opening and are difficult to operate from a small boat. Otter trawls have vanes or "otter boards," which are

attached to the forward end of each wing and are used to keep the mouth of the net open while it is being towed. The otter boards are approximately rectangular and usually made of wood, with steel strapping. The lower edge is shod with a steel runner to protect the wood when the otter slides along the bottom. The leading edge of the otter is rounded near the bottom to aid in riding over obstructions.

The towing bridle or warp is attached to the board by four heavy chains or short heavy metal rods. The two forward rods are shorter so that, when towed, the board sheers to the outside and down. Thus, the two otters sheer in opposite directions and keep the mouth of the trawl open and on the bottom. Floats or corks along the headrope keep the net from sagging, and the weights on the lead-line keep the net on the bottom. The entrapped fish are funneled back into the bag of the trawl (cod end).

A popular small trawl consists of a 16- to 20-foot (5- to 6-m) headrope, semiballoon modified shrimp (otter) trawl with 3/4-inch (1.9 cm) bar mesh in the wings and cod end. A 1/4-inch (0.6 cm) bar mesh liner may be installed in the cod end if smaller fish are desired. This small trawl uses otter boards, the dimensions of which, in inches, are approximately 24 to 30 (61 to 76 cm) X 12 to 18 (30 to 46 cm) X 3/4 to 1-1/4 inches (0.9 to 3.2 cm), and the trawl can be operated out of a medium-sized boat.

The midwater trawl resembles an otter trawl with modified boards and vanes for controlling the trawling depth. Such trawls are cumbersome for freshwater and inshore areas.

Trawling data are usually expressed in weight of catch per unit of time.

The use of trawls requires experienced personnel. Boats deploying large trawls must be equipped with power winches and large motors. Also, trawls can not be used effectively if the bottom is irregular or harbors snags or other debris. Trawls are best used to gain information on a particular species of fish rather than to estimate the overall fish population. See Rounsefell and Everhart (1953), Massman, Ladd and McCutcheon (1952) and Trent (1967) for further information on trawls.

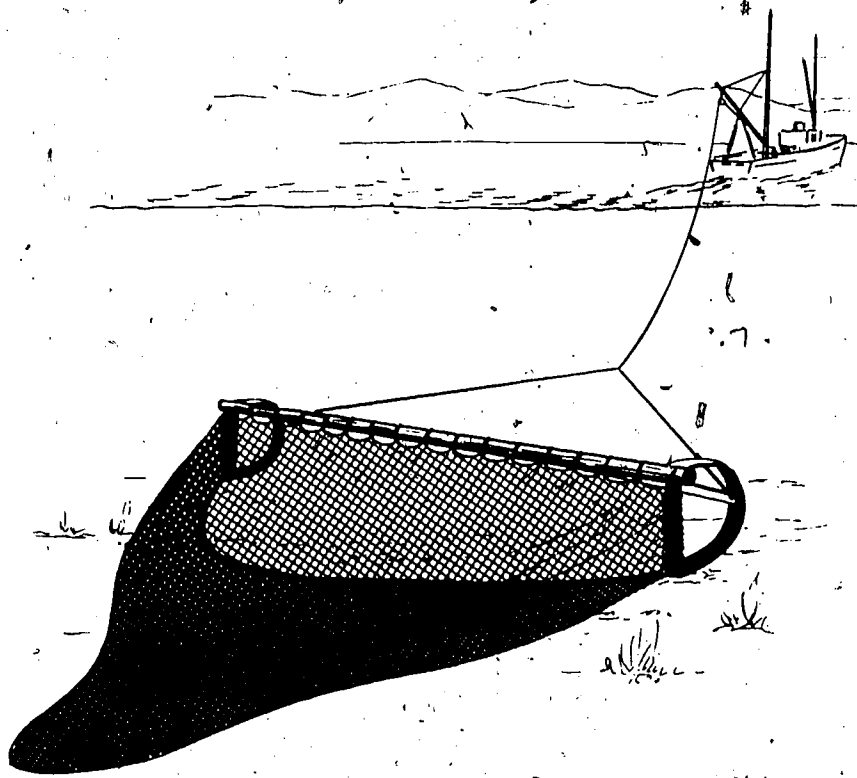

Figure 2. The beam trawl. (From Dumont and Sundstrom, 1961.)

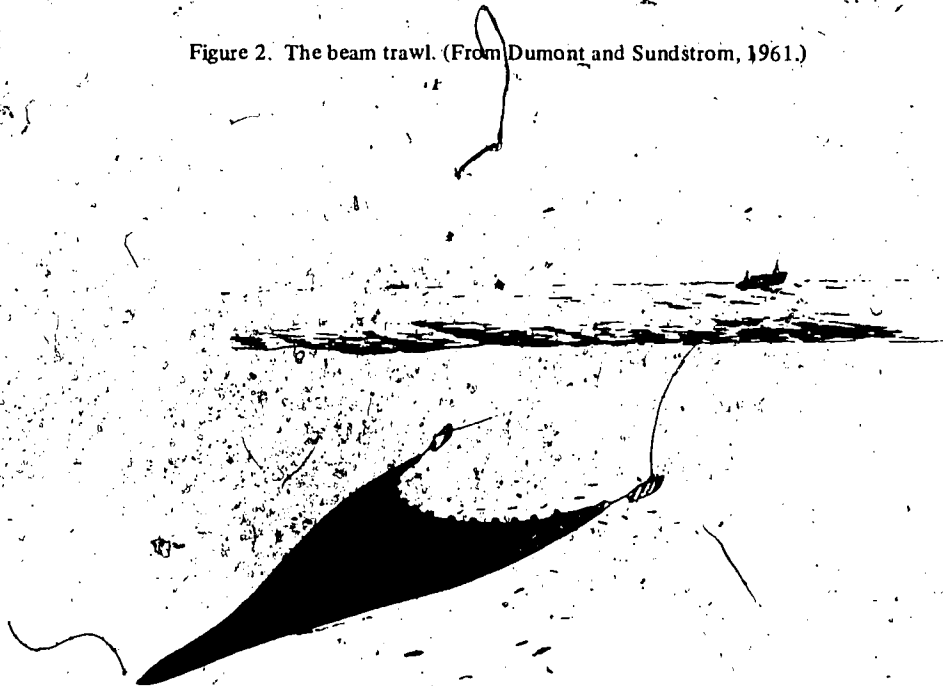

Figure 3. The otter trawl. (From Dumont and Sundstrom, 1961.)



### 2.2.3 Electrofishing

Electrofishing is a sampling method in which alternating (AC) or direct (DC) electrical current is applied to water that has a resistance different from that of fish. The difference in the resistance of the water and the fish to pulsating DC stimulates the swimming muscles for short periods of time, causing the fish to orient towards and be attracted to the positive electrode. An electrical field of sufficient potential to immobilize the fish is present near the positive electrode.

The electrofishing unit may consist of a 110-volt, 60-cycle, heavy-duty generator, an electrical control section consisting of a modified, commercially-sold, variable-voltage pulsator, and electrodes. The electrical control section permits the selection of any AC voltage between 50 to 700 and any DC voltage between 25 to 350 and permits control of the size of the electrical field required by various types of water. The alternating current serves as a standby for the direct current and is used in cases of extremely low water resistance.

Decisions on the use of AC, DC, pulsed DC, or alternate polarity forms of electricity and the selection of the electrode shape, electrode spacing, amount of voltage, and proper equipment depend on the resistance, temperature, and total dissolved solids of the water. Light-weight conductivity meters are recommended for field use. Lennon (1959) provides a comprehensive table and describes the system or combination of systems that worked best for him.

Rollefson (1958, 1961) thoroughly tested and evaluated AC, DC, and pulsating DC, and discussed basic electrofishing principles, wave forms, voltage - current relationships, electrode types and designs, and differences between AC and DC and their effects in hard and soft waters. He concluded that pulsating DC was best in terms of power economy and fishing ability when correctly used. Haskell and Adelman (1955) found that slowly pulsating DC worked best in leading fish to the anode. Pratt (1951) also found the DC shocker to be more effective than the AC shocker.

Fisher (1950) found that brackish water requires much more power (amps) than fresh-

water, even though the voltage drops may be identical. Seehorn (1968) recommended the use of an electrolyte (salt blocks) when sampling in some soft waters to produce a large enough field with the electric shocker. Frankenberger (1960), Larimore, Durlham and Bennett (1950) and Latta and Meyers (1961) have excellent papers on boat shockers. Frankenberger and Latta and Meyers used a DC shocker and Larimore et al. an AC shocker. Stubbs (1966) used DC or pulsed DC, and has his (aluminum) boat wired as the negative pole. In his paper, he also shows the design and gives safety precautions that emphasize the use of the treadle switch or "deadman switch" in case a worker falls overboard.

Backpack shockers that are quite useful for small, wadeable streams have been described by Blair (1958) and McCrimmon and Berst (1963), as has a backpack shocker for use by one man (Seehorn, 1968). Most of these papers give diagrams for wiring and parts needed.

There are descriptions of electric trawls (AC) (Haskell, Geduliz, and Snolk, 1955, and Loeg, 1955); electric seines (Funk, 1947; Holton, 1954; and Larimore, 1961); and a fly-rod electrofishing device employing alternating polarity current (Lennon, 1961).

The user must decide which design is most adaptable to his particular needs. Before deciding which design to use, the biologist should carefully review the literature. The crew should wear rubber boots and electrician's gloves and adhere strictly to safety precautions.

Night sampling was found to be much more effective than day sampling. Break sampling efforts into time units so that unit effort data are available for comparison purposes.

### 2.2.4 Chemical fishing

Chemicals used in fish sampling include rotenone, toxaphene, cresol, copper sulfate, and sodium cyanide. Rotenone has generally been the most acceptable because of its high degradability; freedom from such problems as precipitation (as with copper sulfate) and persistent toxicity (as with toxaphene); and relative safety for the user.

Rotenone, obtained from the derris root (*Deguelia elliptica*, East Indies) and cube root

## BIOLOGICAL METHODS

(*Lonchocarpus nicour*, South America), has been used extensively in fisheries work throughout the United States and Canada since 1934 (Krumholz, 1948). Although toxic to man and warm-blooded animals (132 mg/kg), rotenone has not been considered hazardous in the concentrations used for fish eradication (0.025 to 0.050 ppm active ingredient) (Hooper, 1960), and has been employed in waters used for bathing and in some instances in drinking water supplies (Cohen et al., 1960, 1961). Adding activated carbon not only effectively removes rotenone, but it also removes the solvents, odors, and emulsifiers present in all commercial rotenone formulations.

Rotenone obtained as an emulsion containing approximately 5 percent active ingredient, is recommended because of the ease of handling. It is a relatively fast-acting toxicant. In most cases, the fish will die within 1 to 2 hours after exposure. Rotenone decomposes rapidly in most lakes and ponds and is quickly dispersed in streams. At summer water temperatures, toxicity lasts 24 hours or less. Detoxification is brought about by five principal factors: dissolved oxygen, light, alkalinity, heat, and turbidity. Of these, light and oxygen are the most important factors.

Although the toxicity threshold for rotenone differs slightly among fish species, it has not been widely used as a selective toxicant. It has, however, been used at a concentration of 0.1 ppm of the 5 percent emulsion to control the gizzard shad (Bowers, 1955).

Chemical sampling is usually employed on a spot basis, e.g. a short reach of river or an embayment of a lake. A concentration of 0.5 ppm active ingredient will provide good recovery of most species of fish in acidic or slightly alkaline waters. If bullheads and carp are suspected of being present, however, a concentration of 0.7 ppm active ingredient is recommended. If the water is turbid and strongly alkaline, and resistant species (i.e., carp and bullheads) are present, use 1-2 ppm. To obtain a rapid kill, local concentrations of 2 ppm can be used; however, caution is advised because rotenone dispersed into peripheral water areas may kill fish as long as the concentration is above 0.1 ppm.

A very efficient method of applying emulsion products is to pump the emulsion from a drum mounted in the bottom of a boat. The emulsion is suctioned by a venturi pump (Amundson boat bailer) clamped on the outboard motor. The flow can be metered by a valve at the drum hose connection. This method gives good dispersion of the chemical and greater boat handling safety, since the heavy drum can be mounted in the bottom of a boat rather than above the gunwales, as required for gravity flow.

Spraying equipment needed to apply a rotenone emulsion efficiently varies according to the size of the job. For small areas of not more than a few acres, a portable hand pump ordinarily used for garden spraying or fire fighting is sufficient. The same size pump is also ideal for sampling the population of a small area.

A power-driven pump is recommended for a large-scale or long-term sampling program. A detailed description of spraying equipment can be found in Mackenthun and Ingram (1967). The capacity of the pump need not be greater than 200 liters per minute. Generally speaking, a 1-1/2 H.P. engine is adequate.

The power application of rotenone emulsives requires a pressure nozzle, or a spray boom, or both, and sufficient plumbing and hose to connect with the pump. The suction line of the pump should be split by a "Y" to attach two intake lines. One line is used to supply the toxicant from the drum, and the other line, to supply water from the lake or embayment. The valves are adjusted so the water and toxicant are drawn into the pumping system in the desired proportion and mixed.

In sampling a stream, select a 30- to 100-meter reach depending on the depth and width of the stream; measure the depth of the section selected, calculate the area, and determine the amount of chemical required. Block off the area upstream and downstream with seines. To detoxify the area downstream from the rotenone, use potassium permanganate. Care must be exercised, however, because potassium permanganate is toxic to fish at about 3 ppm.

### 2.2.5- Hook and line

Fish collection by hook and line can be as simple as using a hand-held rod or trolling baited

hooks or other lures, or it may take the form of long trot lines or set lines with many baited hooks. Generally speaking, the hook and line method is not acceptable for conducting a fishery survey, because it is too highly selective in the size and species captured and the catch per unit of effort is too low. Although it can only be used as a supporting technique, it may be the best method to obtain a few adult specimens for heavy metal analysis, etc., where sampling with other gear is impossible.

### 2.3 Passive Sampling Techniques

#### 2.3.1 Entanglement nets

Gill and trammel nets are used extensively to sample fish populations in estuaries, lakes, reservoirs, and larger rivers.

A gill net is usually set as an upright fence of netting and has a uniform mesh size. Fish attempt to swim through the net and are caught in the mesh (Figure 4). Because the size of the mesh determines the species and size of the fish to be caught, gill nets are considered selective. The most versatile type is an experimental gill net consisting of five different mesh size sections. Gill nets can be set at the surface, in mid-water, or at the bottom, and they can be operated as stationary or movable gear. Gill nets made of multifilament or monofilament nylon are recommended. Multifilament nets cost less and are easier to use, but monofilament nets generally capture more fish. The floats and leads usually supplied with the nets can cause net entanglement. To reduce this problem, replace the individual floats with a float line made with a core of expanded foam and use a lead-core leadline instead of individual lead weights.

The trammel net (Figure 5) has a layer of large mesh netting on each side of loosely-hung, smaller gill netting. Small fish are captured in the gill netting and large fish are captured in a "bag" of the gill netting that is formed as the smaller-mesh gill netting is pushed through an opening in the larger-mesh netting. Trammel nets are not used as extensively as are gill nets in sampling fish.

Results for both nets are expressed as the number or weight of fish taken per length of net per day.

Stationary gill and trammel nets are fished at right angles to suspected fish movements and at any depth from the surface to the bottom. They may be held in place by poles or anchors. The anchoring method must hold the net in position against any unexpected water movements such as, runoff, tides, or seiches.

Drifting gill or trammel nets are also set and fished the same as stationary gear, except that they are not held in place but are allowed to drift with the currents. This method requires constant surveillance when fishing. They are generally set for a short period of time, and if currents are too great, stationary gear is used.

The use of gill nets in the estuaries may present special problems, and consideration should be given to tidal currents, predation, and optimum fishing time, and to anchors, floats, and line.

The gunnels of any boat used in a net fishing operation should be free of rivets, cleats, etc., on which the net can catch.

#### 2.3.2 Entrapment devices

With entrapment devices, the fish enter an enclosed area (which may be baited) through a series of one or more funnels and cannot escape.

The hoop net and trap net are the most common types of entrapment devices used in fishery surveys. These traps are small enough to be deployed from a small open boat and are relatively simple to set. They are held in place with anchors or poles and are used in water deep enough to cover the nets, or to a depth up to 4 meters.

The hoop net (Figure 6) is constructed by covering hoops or frames with netting. It has one or more internal funnels and does not have wings or a lead. The first two sections can be made square to prevent the net from rolling in the currents.

The fyke net (Figure 7) is a hoop net with wings, or a lead, or both attached to the first frame. The second and third frames can each hold funnel throats, which prevent fish from escaping as they enter each section. The opposite (closed) end of the net may be tied with a slip cord to facilitate fish removal.

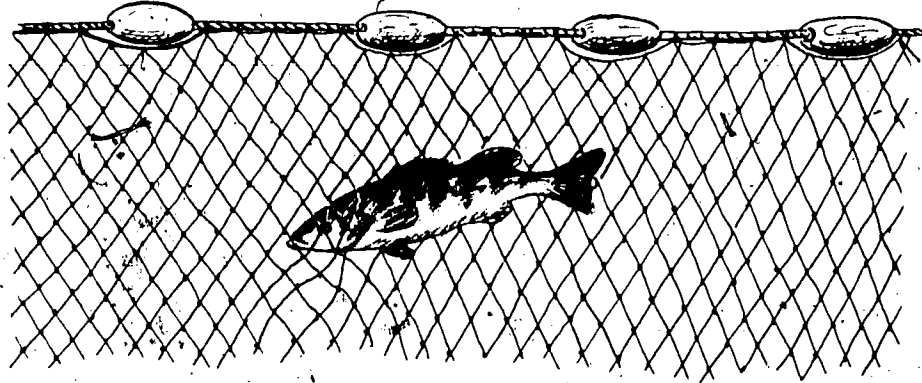

Figure 4. Gill net. (From Dumont and Sundstrom, 1961.)

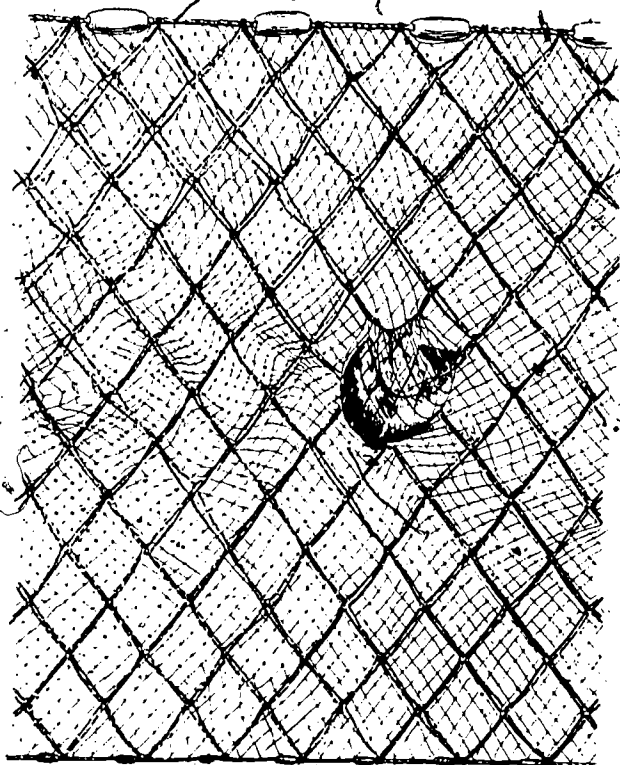

Figure 5. Trammel net. (From Dumont and Sundstrom, 1961.)

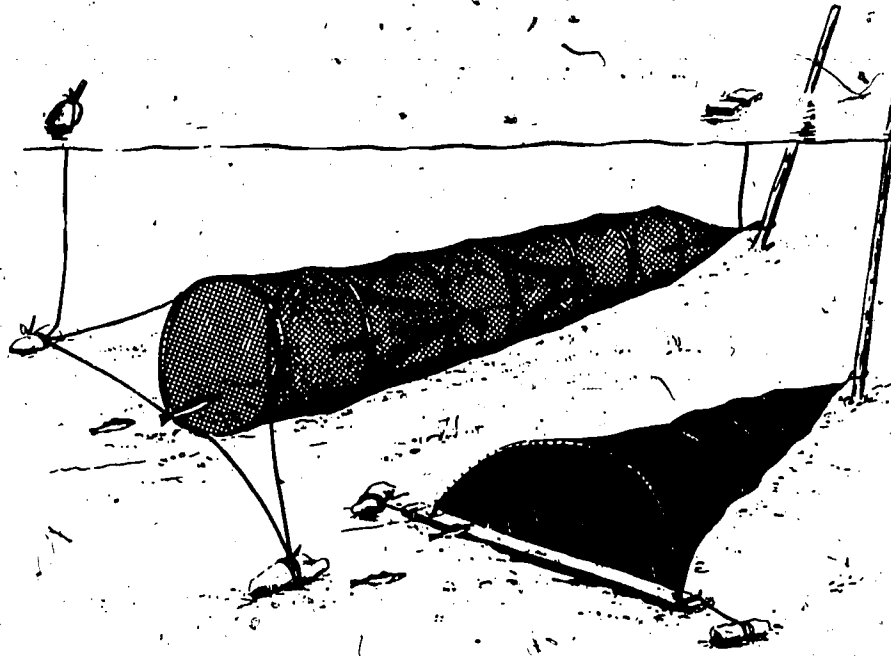

Figure 6. Hoop net. (From Dumont and Sundstrom, 1961.)

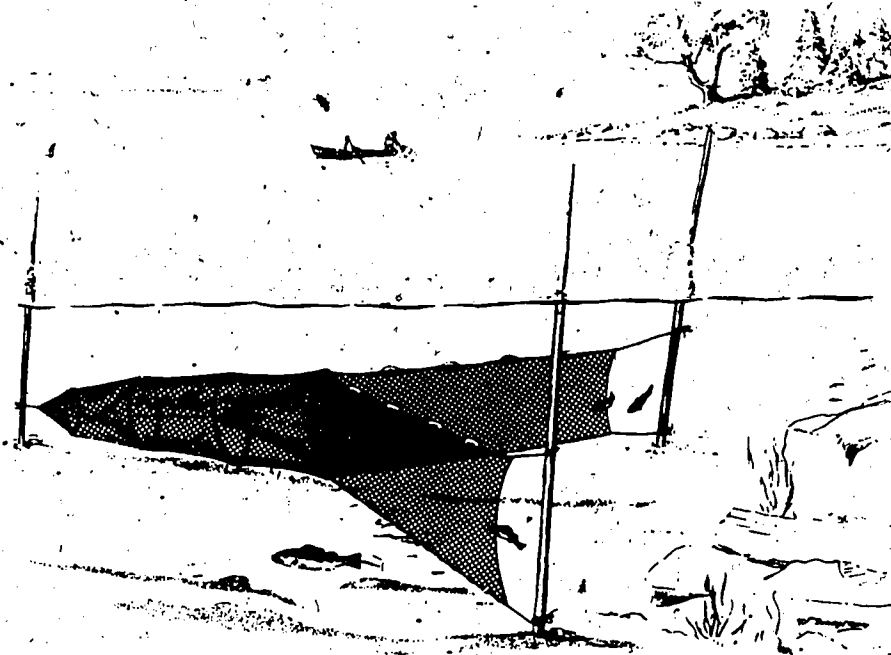

Figure 7. Fyke net. (From Dumont and Sundstrom, 1961.)



## BIOLOGICAL METHODS

Hoop nets are fished in rivers and other waters where fish move in predictable directions, whereas the fyke net is used when fish movement is more random such as in lakes, impoundments, and estuaries. Hoop and fyke nets can be obtained with hoops from 2 to 6 feet (0.6 to 1.8 meters) in diameter, but any net over 4 feet (1.2 meters) in diameter is too large to be used in a fishery survey.

Trap nets use the same principle as hoop nets for capturing fish, but their construction is more complex. Floats and weights instead of hoops give the net its shape. The devices are expensive, require considerable experience, and are fished in waters deep enough to cover them.

One of the most simple types is the minnow trap, usually made of wire mesh or glass, with a single inverted funnel. The bait is suspended in a porous bag. A modification of this type is the slat trap; this employs long wooden slats in a cylindrical trap, and when baited with cheese bait, cottonseed cake, etc., it is used very successfully in sampling catfish in large rivers (Figure 8).

Most fish can be sampled by setting trap and hoop nets of varying mesh sizes in a variety of

habitats. Hoop and trap nets are made of cotton or nylon, but nets made of nylon have a longer life and are lighter when wet. Protect cotton nets from decay by treatment. Catch is recorded as numbers or weight per unit of effort, usually fish per net day.

### 3.0 SAMPLE PRESERVATION

Preserve fish in the field in 10 percent formalin. Add 3 grams borax and 50 ml glycerin per liter of formalin. Specimens larger than 7.5 cm should be slit on the side at least one-third of the length of the body cavity to permit the preservative to bathe the internal organs. Slit the fish on the right side, because the left side is generally used for measurements, scale sampling, and photographic records.

Fixation may take from a few hours with small specimens to a week or more with large forms. After fixation, the fish may be washed in running water or by several changes of water for at least 24 hours and placed in 40 percent isopropyl alcohol. One change of alcohol is necessary to remove the last traces of formalin. Thereafter, they may be permanently preserved in the 40 percent isopropyl alcohol.

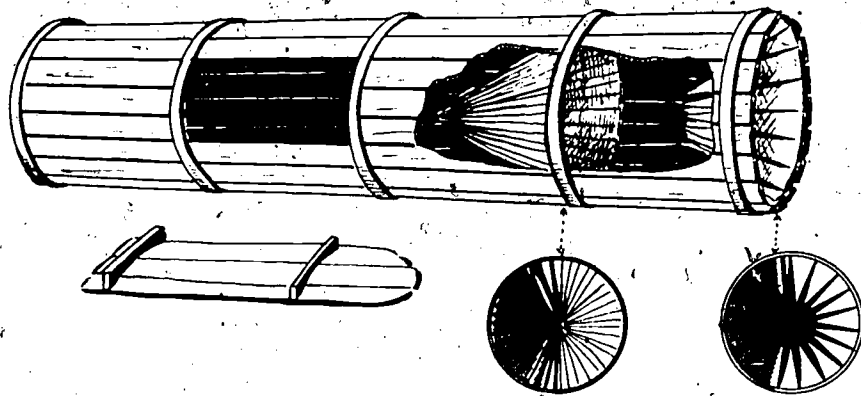

Figure 8. Slat trap. (From Dumont and Sundstrom, 1961.)



## 4.0 SAMPLE ANALYSIS

### 4.1 Data Recording

The sample records should include collection number, name of water body, date, locality, and other pertinent information associated with the sample. Make adequate field notes for each collection. Write with water-proof ink and paper to ensure a permanent record. Place the label inside the container with the specimens and have the label bear the same number or designation as the field notes, including the locality, date, and collector's name. Place a numbered tag on the outside of the container to make it easier to find a particular collection. Place any detailed observations about a collection on the field data sheet. Record fishery catch data in standard units such as number or weight per area or unit of effort. Use the metric system for length and weight measurements.

### 4.2 Identification

Proper identification of fishes to species is important in analysis of the data for water quality interpretation. A list of regional and national references for fish identification is located at the end of this chapter. Assistance in confirming questionable identification is available from State, Federal, and university fishery scientists.

### 4.3 Age, Growth, and Condition

Changes in water quality can be detected by studying the growth rate of fishes. Basic methods used to determine the age and growth of fish include:

- Study of fish length-frequencies, and
- Study of seasonal ring formations in hard bony parts such as scales and bones.

The length-frequency method of age determination depends on the fact that fish size varies with age. When the number of fish per length interval is plotted on graph paper, peaks generally appear for each age group. This method works best for young fish.

The seasonal ring-formation method depends on the fact that fish are cold-blooded animals and the rates of their body processes are affected

by the temperature of the water in which they live. Growth is rapid during the warm season and slows greatly or stops in winter. This seasonal change in growth rate of fishes is often reflected in zones or bands (annual rings) in hard bony structures, such as scales, otoliths (ear stone), and vertebrae. The scales of fish may indicate exposure to adverse conditions such as injury, poor food supply, disease, and possibly water quality.

Note the general well being of the fish — do they appear emaciated? diseased from fungus? have open sores, ulcers, or fin rot? parasitized? Check the gill condition, also. Healthy fish will be active when handled, reasonably plump, and not diseased. Dissect a few specimens and check the internal organs for disease or parasites. The stomachs can be checked at this time to determine if the fish are actively feeding.

## 5.0 SPECIAL TECHNIQUES

### 5.1 Flesh Tainting

Sublethal concentrations of chemicals, such as phenols, benzene, oil, and 2,4-D, are often responsible for imparting an unpleasant taste to fish flesh, even when present in very low concentrations. Flesh tainting is nearly as detrimental to the fisheries as a complete kill.

A method has been developed (Thomas, 1969) in which untainted fish are placed in cages upstream and downstream from suspected waste sources. This procedure will successfully relate the unacceptable flavor produced in native fish if exposed to a particular waste source.

To ensure uniform taste quality before exposure, all fish are held in pollution-free water for a 10-day period. After this period, a minimum of three fish are cleaned and frozen with dry ice as control fish. Test fish are then transferred to the test sites, and a minimum of three fish are placed in each portable cage. The cages are suspended at a depth of 0.6 meter for 48 to 96 hours.

After exposure, the fish are dressed, frozen on dry ice, and stored to 0°F until tested. The control and exposed samples are shipped to a fish-tasting panel, such as is available at the food science and technology departments in many of

## BIOLOGICAL METHODS

the major universities, and treated as follows: (a) The fish are washed, wrapped in aluminum foil, placed on slotted, broiler-type pans, and cooked in a gas oven at 400°F for 23 to 45 minutes depending on the size of the fish. (b) Each sample is boned and the flesh is flaked and mixed to ensure a uniform sample. (c) The samples are served in coded cups to judges. Known and coded references or control samples are included in each test. The judges score the flavor and desirability of each sample on a point scale. The tasting agency will establish a point on the scale designated as the acceptable and desirable level.

### 5.2 Fish Kill Investigations

Fish mortalities result from a variety of causes, some natural and some man-induced. Natural fish kills are caused by phenomena such as acute temperature change, storms, ice and snow cover, decomposition of natural organic materials, salinity changes, spawning mortalities, and bacterial, parasitic, and viral epidemics. Man-induced fish kills may be attributed to municipal or industrial wastes, agricultural activities, and water manipulations. Winter kills occur in northern areas where ice on shallow lakes and ponds becomes covered with snow, and the resulting opaqueness stops photosynthesis. The algae and vascular plants die because of insufficient light, and their decomposition results in oxygen depletion. Oxygen depletion and extreme pH variation can be caused also by the respiration or decay of algae and higher plants during summer months in very warm weather. Kills resulting from such causes are often associated with a series of cloudy days that follow a period of hot, dry, sunny days.

Occasionally fish may be killed by toxins released from certain species of living or decaying algae that reached high population densities because of the increased fertility resulting from organic pollution.

Temperature changes, either natural or the

result of a heated water discharge, will often result in fish kills. Long periods of very warm, dry weather may raise water temperatures above lethal levels for particular species. A wind-induced seiche may be hazardous to certain temperature-sensitive, deep-lake, cold-water fish, or fish of shallow coastal waters.

Disease, a dense infestation of parasites, or natural death of weakened fish at spawning time must always be suspected as contributory factors in fish mortalities.

Explosions, abrupt water level fluctuations, hurricanes, extreme turbidity or siltation, discharges of toxic chemicals, certain insecticides, algicides, and herbicides may each cause fish kills.

Recent investigations in Tennessee have shown that the leaking of small amounts of very toxic chemicals from spent pesticide-containing barrels used as floats for piers and diving rafts in lakes and reservoirs can produce extensive fish kills.

Fish die of old age, but the number so afflicted at any one time is usually small.

All possible speed must be exercised in conducting the initial phases of any fish kill investigation because fish disintegrate rapidly in hot weather and the cause of death may disappear or become unidentifiable within minutes. Success in solving a fish kill problem is usually related to the speed with which investigators can arrive at the scene after a fish kill begins. The speed of response in the initial investigation is enhanced through the training of qualified personnel who will report immediately the location of observed kills, the time that the kill was first observed, the general kinds of organisms affected, an estimate of the number of dead fish involved, and any unusual phenomena associated with the kill.

Because there is always the possibility of legal liability associated with a fish kill, lawyers, judges, and juries may scrutinize the investigation report. The investigation, therefore, must be made with great care.

## 6.0 REFERENCES

- Blair, A. A. 1958. Back-pack shocker. *Canad. Fish Cult.* No. 23, pp. 33-37.
- Bowers, C. C. 1955. Selective poisoning of gizzard shad with rotenone. *Prog. Fish-Cult.* 17(3):134-135.
- Cohen, J. M., Q. H. Pickering, R. L. Woodward, and W. Van Heruvelen. 1960. The effect of fish poisons on water supplies. *JAWWA*, 52(12):1551-1566.
- Cohen, J. M., Q. H. Pickering, R. L. Woodward, and W. Van Heruvelen. 1961. The effect of fish poisons on water supplies. *JAWWA*, 53(12)Pt. 2:49-62.
- Dumont, W. H., and G. T. Sundstrom. 1961. Commercial fishing gear of the United States. U.S. Fish and Wildlife Circular No. 109. U.S. Government Printing Office, Washington, D.C., 61 pp.
- Fisher, K. C. 1950. Physiological considerations involved in electrical methods of fishing. *Canad. Fish Cult.* No. 9, pp. 26-34.
- Frankenberger, L. 1960. Applications of a boat-rigged direct-current shocker on lakes and streams in west-central Wisconsin. *Prog. Fish-Cult.* 22(3):124-128.
- Funk, J. L. 1947. Wider application of electrical fishing method of collecting fish. *Trans. Amer. Fish. Soc.* 77:49-64.
- Haskell, D. C., and W. E. Adelman, Jr. 1955. Effects of rapid direct current pulsations on fish. *New York Fish Game J.* 2(1):95-105.
- Haskell, D. C., D. Geduldiz, and E. Snolk. 1955. An electric trawl. *New York Fish Game J.* 2(1):120-125.
- Holton, G. D. 1954. West Virginia's electrical fish collecting methods. *Prog. Fish-Cult.* 16(1):10-18.
- Hooper, F. 1960. Pollution control by chemicals and some resulting problems. *Trans. Second Seminar on Biol. Problems in Water Pollution*, April 20-24, USPHS, Robert A. Taft San. Engr. Ctr., Cincinnati, p241-246.
- Krumholz, L. A. 1948. The Use of Rotenone in Fisheries Research. *J. Wildl. Mgmt.* 12(3):305-317.
- Larimore, R. W. 1961. Fish population and electrofishing success in a warm water stream. *J. Wildl. Mgmt.* 25(1):1-12.
- Larimore, R. W., L. Durham, and G. W. Bennett. 1950. A modification of the electric fish shocker for Lake Work. *J. Wildl. Mgmt.* 14(3):320-323.
- Latta, W. C., and G. F. Meyers. 1961. Night use of a D.C electric shocker to collect trout in lakes. *Trans. Amer. Fish.Soc.* 90(1):81-83.
- Lennon, R. E. 1959. The electrical resistivity in fishing investigations. U.S. Fish Wildl. Serv., Spec. Sci. Rept. Fish. No. 287, pp. 1-13.
- Lennon, R. E. 1961. A fly-rod electrode system for electrofishing. *Prog. Fish-Cult.* 23(2):92-93.
- Loeb, H. A. 1955. An electrical surface device for crop control and fish collection in lakes. *New York Fish Game J.* 2(2):220-221.
- McCrannon, H. R., and A. H. Berst. 1963. A portable A C - D C backpack fish shocker designed for operation in Ontario streams. *Prog. Fish-Cult.* 25(3):159-162.
- Mackenthun, K. M. 1969. The practice of water pollution biology. USDI, FWPCA, 281 pp.
- Mackenthun, K. M., and W. M. Ingram. 1967. Biological associated problems in freshwater environments, their identification, investigation and control. USDI, FWPCA, 287 pp.
- Massman, W. H., E. C. Ladd, and H. N. McCutcheon. 1952. A surface trawl for sampling young fishes in tidal rivers. *Trans. North Amer. Wildl. Conf.* 17:386-392.
- Pratt, V. S. 1951. A measure of the efficiency of alternating and direct current fish shockers. *Trans. Amer. Fish.Soc.* 81(1):63-68.
- Rollefson, M. D. 1958. The development and evaluation of interrupted direct current electrofishing equipment. *Wyo. Game Fish Dept. Coop. Proj. No. 1.* pp. 1-123.
- Rollefson, M. D. 1961. The development of improved electrofishing equipment. In: *Proc. Forty-first Ann. Conf. West.Assoc. St. Game and Fish Comm.* pp.218-228.
- Rounsefell, G. A., W. H. Everhart. 1953. *Fishery science: Its methods and applications.* John Wiley and Sons, New York.
- Seehorn, M. E. 1968. An inexpensive backpack shocker for one man use. In: *Proc. 21st. Ann. Conf. Southeastern Assoc. Game and Fish Comm.* pp. 516-524.
- Stubbs, J. M. 1966. Electrofishing, using a boat as the negative. In: *Proc. 19th Ann. Conf. Southeastern Assoc. Game and Fish Comm.* pp. 236-245.
- Tebo, Jr., L. B. 1965. Fish population sampling studies at water pollution surveillance system stations on the Ohio, Tennessee, Clinch and Cumberland Rivers. Applications and development Report No. 15, Div. Water Supply and Pollution Control, USPHS. Cincinnati. 79 pp.
- Thomas, N. 1969. Flavor of Ohio River channel catfish (*Ictalurus punctatus* Raf.).USEPA. Cincinnati. 19 pp.
- Trent, W. E. 1967. Attachment of hydrofoils to otter boards for taking surface samples of juvenile fish and shrimp. *Ches. Sci.* 8(2):130-133.

## BIOLOGICAL METHODS

### 7.0 BIBLIOGRAPHY

#### 7.1 General References

- Allen, G. H., A. C. Delacy, and D. W. Gotshall. 1960. Quantitative sampling of marine fishes - A problem in fish behavior and fish gear. In: Waste Disposal in the Marine Environment. Pergamon Press. pp 448-511.
- American Public Health Association et al. 1971. Standard methods for the examination of water and wastewater. 13th ed. APHA, New York. pp. 771-779.
- Breder, C. M., and D. E. Rosen. Modes of reproduction in fishes. Amer. Mus. Natural History, Natural History Press, New York. 941 pp.
- Calhoun, A., ed. 1966. Inland fisheries management. Calif. Dept. Fish and Game, Sacramento. 546 pp.
- Carlander, K. D. 1969. Handbook of freshwater fishery; Life history data on freshwater of the U.S. and Canada, exclusive of the Perciformes, 3rd ed. Iowa State Univ. Press, Ames. 752 pp.
- Curtis, B. 1948. The Life Story of the Fish. Harcourt, Brace and Company, New York. 284 pp.
- Cushing, D. H. 1968. Fisheries biology. A study in population dynamics. Univ. Wis. Press, Madison. 200 pp.
- FAO. 1964. Modern fishing gear of the world: 2. Fishing News (Books) Ltd., London. 603 pp.
- Green, J. 1968. The biology of estuarine animals. Univ. Washington, Seattle. 401 pp.
- Hardy, A. 1965. The open sea. Houghton Mifflin Company, Boston. 657 pp.
- Hynes, H. B. N. 1960. The biology of polluted water. Liverpool Univ. Press, Liverpool. 202 pp.
- Hynes, H. B. N. 1970. The ecology of running waters. Univ. Toronto Press. 555 pp.
- Jones, J. R. E. 1964. Fish and river pollution. Butterworths, London. 203 pp.
- Klein, L. 1962. River pollution 2: causes and effects. Butterworths, London. 456 pp.
- Lagler, K. F. 1966. Freshwater fisheries biology. William C. Brown Co., Dubuque. 421 pp.
- Lagler, K. F., J. E. Bardach, and R. R. Miller, 1962. Ichthyology. The study of fishes. John Wiley and Sons Inc., New York and London. 545 pp.
- Macan, T. T. 1963. Freshwater ecology. John Wiley and Sons, New York. 338 pp.
- Marshall, N. B. 1966. Life of fishes. The World Publ. Co., Cleveland and New York. 402 pp.
- Moore, H. B. 1965. Marine ecology. John Wiley and Sons, Inc., New York. 493 pp.
- Reid, G. K. 1961. Ecology of inland waters and estuaries. Reinhold Publ. Corp., New York. 375 pp.
- Ricker, W. E. 1958. Handbook of computations for biological statistics of fish populations. Fish. Res. Bd. Can. Bull. 119. 300 pp.
- Ricker, W. E. 1968. Methods for the assessment of fish production in fresh water. International Biological Program Handbook No. 3. Blackwell Scientific Publications, Oxford and Edinburgh. 326 pp.
- Rounsefell, G. A., and W. H. Everhart. 1953. Fishery science, its methods and applications. John Wiley & Son, New York. 444 pp.
- Ruttner, F. 1953. Fundamentals of limnology. Univ. Toronto Press, Toronto. 242 pp.
- Warren, C. E. 1971. Biology and water pollution control. W. B. Saunders Co., Philadelphia. 434 pp.
- Welch, P. S. 1948. Limnological methods. McGraw-Hill, New York. 381 pp.

#### 7.2 Electrofishing

- Applegate, V. C. 1954. Selected bibliography on applications of electricity in fishery science. U.S. Fish and Wildl. Serv., Spec. Sci. Rept. Fish. No. 127. pp: 1-55.
- Bailey, J. E., et al. 1955. A direct current fish shocking technique. Prog. Fish-Cult. 17(2):75.
- Burnet, A. M. R. 1959. Electric fishing with pulsatory electric current. New Zeal. J. Sci. 2(1):48-56.
- Burnet, A. M. R. 1961. An electric fishing machine with pulsatory direct current. New Zeal. J. Sci. 4(1):151-161.
- Dale, H. B. 1959. Electronic fishing with underwater pulses. Electronics, 52(1):1-3.
- Elson, P. F. 1950. Usefulness of electrofishing methods. Canad. Fish Cult. No. 9, pp. 3-12.
- Halsband, E. 1955. Untersuchungen uber die Betaubungsgrenzimpulsheln vor schiedener suswasser Fische. Archiv. fur Fischereiwissenschaft, 6(1-2):45-53.
- Haskell, D. C. 1939. An electrical method of collecting fish. Trans. Amer. Fish. Soc. 69:210-215.
- Haskell, D. C. 1954. Electrical fields as applied to the operation of electric fish shockers. New York Fish Game J. 1(2):130-170.
- Haskell, D. C., and R. G. Zilliox. 1940. Further developments of the electrical methods of collecting fish. Trans. Amer. Fish. Soc. 70:404-409.

- Jones, R. A. 1959. Modifications of an alternate-polarity electrode. *Prog. Fish-Cult.* 21(1):39-42.
- Larkins, P. A. 1950. Use of electrical shocking devices. *Canad. Fish. Cult.*, No. 9, pp. 21-25.
- Lennon, R. E., and P. S. Parker. 1955. Electric shocker developments on southeastern trout waters. *Trans. Amer. Fish. Soc.* 85:234-240.
- Lennon, R. E., and P. S. Parker. 1957. Night collection of fish with electricity. *New York Fish Game J.* 4(1):109-118.
- Lennon, R. E., and P. S. Parker. 1958. Applications of salt in electrofishing. *Spec. Sci. Rept.*, U.S. Fish Wildl. Serv. No. 280.
- Ming, A. 1964a. Boom-type electrofishing device for sampling fish populations in Oklahoma waters. *Okla. Fish. Res. Lab., D-J Federal Aid Proj. FL-6, Semiann. Rept. (Jan-June, 1964).* pp. 22-23.
- Ming, A. 1964b. Contributions to a bibliography on the construction, development, use and effects of electrofishing devices. *Okla. Fish. Res. Lab., D-J Federal Aid Proj. FL-6, Semiann. Rept. (Jan-June, 1964).* pp. 33-46.
- Monan, G. E., and D. E. Engstrom. 1962. Development of a mathematical relationship between electric field parameters and the electrical characteristics of fish. *U.S. Fish Wildl. Serv., Fish. Bull.* 63(1):123-136.
- Murray, A. R. 1958. A direct current electrofishing apparatus using separate excitation. *Canad. Fish Cult.*, No. 23, pp. 27-32.
- Northrop, R. B. 1962. Design of a pulsed DC-AC shocker. *Conn. Bd. Fish and Game, D-J Federal Aid Proj. F-25-R, Job No. 1.*
- Omand, D. N. 1950. Electrical methods of fish collection. *Canad. Fish Cult.* No. 9, pp. 13-20.
- Petty, A. C. 1955. An alternate-polarity electrode. *New York Fish Game J.* 2(1):114-119.
- Ryhr, C. E. 1953. The electric shocker in Tennessee. *Tenn. Game Fish Comm.* (mimeo). 12 pp.
- Saunders, J. W., and M. W. Smith. 1954. The effective use of a direct current fish shocker in a Prince Edward Island stream. *Canad. Fish. Cult.*, No. 16, pp. 42-49.
- Schwartz, F. J. 1961. Effects of external forces on aquatic organisms. *Maryland Dept. Res. Edu., Chesapeake Biol. Lab., Contr.* No. 168, pp. 3-26.
- Smith, G. F. M., and P. F. Elson. 1950. A D.C. electrical fishing apparatus. *Canad. Fish Cult.*, No. 9, pp. 34-46.
- Sullivan, C. 1956. Importance of size grouping in population estimates employing electric shockers. *Prog. Fish-Cult.* 18(4):188-190.
- Taylor, G. N. 1957. Galvanotaxic response of fish to pulsating D.C. *J. Wildl. Mgmt.* 21(2):201-213.
- Thompson, R. B. 1959. The use of the transistorized pulsed direct current fish shocker in assessing populations of resident fishes. In: *Proc. Thirty-ninth Ann. Conf. West. Assoc. St. Fish and Game Comm.* pp. 291-294.
- Thompson, R. B. 1960. Capturing tagged red salmon with pulsed direct current. *U.S. Fish Wildl. Serv., Spec. Sci. Rept. - Fish*, No. 355, 10 pp.
- Vibert, R., ed. 1967. *Fishing with electricity - Its applications to biology and management.* European Inland Fish. Adv. Comm. FAO, United Nations, Fishing News (Books) Ltd. London, 276 pp.
- Webster, D. A., J. L. Forney, R. H. Gibbs, Jr., J. H. Severns, and W. F. Van Woert. 1955. A comparison of alternating and direct electric currents in fishery work. *New York Fish Game J.* 2(1):106-113.
- Whitney, L. V., and R. L. Pierce. 1957. Factors controlling the input of electrical energy into a fish in an electrical field. *Limnol. Oceanogr.* 2(2):55-61.

### 7.3 Chemical Fishing

- Hester, F. E. 1959. The tolerance of eight species of warm-water fishes to certain rotenone formulations. In: *Proc. 13th Ann. Conf. Southeastern Assoc. Game and Fish Comm.*
- Krumholz, L. A. 1950. Some practical considerations in the use of rotenone in fisheries research. *J. Wildl. Mgmt.*, vol. 14.
- Lawrence, J. M. 1956. Preliminary results on the use of potassium permanganate to counteract the effects of rotenone on fish. *Prog. Fish-Cult.* 18(1):15-21.
- McKee, J. E., and H. W. Wolf, eds. 1963. *Water quality criteria.* 2nd ed. Calif. Water Quality Control Board Publ. 3A.
- Ohio River Valley Water Sanitation Commission. 1962. *Aquatic life resources of the Ohio River.* pp. 72-84.
- Post, G. 1955. A simple chemical test for rotenone in water. *Prog. Fish-Cult.* 17(4):190-191.
- Post, G. 1958. Time vs. water temperature in rotenone dissipation. In: *Proc. 38th Ann. Conf. Game and Fish Comm.* pp. 279-284.
- Solman, V. E. F. 1949. *History and use of fish poisons in the United States.* Dominion Wildlife Service, Ottawa. 15 pp.
- Sowards, C. L. 1961. Safety as related to the use of chemicals and electricity in fishery management. *U.S. Fish and Wildl. Serv., Bur. Sport Fish and Wildl., Branch Fish Mgt., Spearfish, South Dakota.* 33 pp.
- Tanner, H. A., and M. L. Hayes. 1955. Evaluation of toxaphene as a fish poison. *Colo. Coop. Fish. Res. Unit, Quar. Rep.* 1(3-4):31-39.
- Turner, W. R. 1959. Effectiveness of various rotenone-containing preparations in eradicating farm pond fish populations. *Kentucky Dept. Fish and Wildl. Res., Fish. Bull. No. 25,* 22 pp.
- Wilkins, L. P. 1955. Observations on the field use of cresol as a stream-survey method. *Prog. Fish-Cult.* 17:85-86.



## BIOLOGICAL METHODS

### 7.4 Fish Identification

#### General:

- Bailey, R. M., et al. 1970. A list of common and scientific names of fishes from the United States and Canada. 3rd ed. Spec. Publ. Amer. Fish. Soc. No. 6. 149 pp.
- Blair, W. F., and G. A. Moore. 1968. Vertebrates of the United States. McGraw Hill, New York. pp. 22-165.
- Eddy, S. 1957. How to know the fresh-water fishes. Wm. C. Brown Co., Dubuque. 253 pp.
- Jordan, D. S., B. W. Evermann, and H. W. Clark. 1955. Check list of the fishes and fish like vertebrates of North and Middle America north of the northern boundary of Venezuela and Colombia. U.S. Fish Wildl. Ser., Washington, D.C. 670 pp.
- LaMonte, F. 1958. North American game fishes. Doubleday, Garden City, N.Y. 202 pp.
- Morita, C. M. 1953. Freshwater fishing in Hawaii. Div. Fish Game. Dept. Land Nat. Res., Honolulu. 22 pp.
- Perlmutter, A. 1961. Guide to marine fishes. New York Univ. Press, New York. 431 pp.
- Scott, W. B., and E. J. Crossman. 1969. Checklist of Canadian freshwater fishes with keys of identification. Misc. Publ. Life Sci. Div. Ontario Mus. 104 pp.
- Thompson, J. R., and S. Springer. 1961. Sharks, skates, rays, and chimaeras. Bur. Comm. Fish., Fish Wildl. USDI Circ. No. 119, 19 pp.

#### Marine: Coastal Pacific

- Baxter, J. L. 1966. Inshore fishes of California. 3rd rev. Calif. Dept. Fish Game, Sacramento. 80 pp.
- Clemens, W. A., and G. V. Wilby. 1961. Fishes of the Pacific coast of Canada. 2nd ed. Bull. Fish. Res. Bd. Can. No. 68. 443 pp.
- McAllister, D. E. 1960. List of the marine fishes of Canada. Bull. Nat. Mus. Canada No. 168; Biol. Ser. Nat. Mus. Can. No. 62. 76 pp.
- McHugh, J. L. and J. E. Fitch. 1951. Annotated list of the clupeoid fishes of the Pacific Coast from Alaska to Cape San Lucas, Baja, California. Calif. Fish Game. 37:491-95.
- Rass, T. S., ed. 1966. Fishes of the Pacific and Indian Oceans; Biology and distribution. (Translated from Russian). Israel Prog. for Sci. Translat., IPST Cat. 1411; TT65-50120; Trans Frud. Inst. Okeanal. 73. 266 pp.
- Roedel, P. M. 1948. Common marine fishes of California. Calif. Div. Fish Game Fish Bull. No. 68. 150 pp.
- Wolford, J. A. 1937. Marine game fishes of the Pacific Coast from Alaska to the Equator. Univ. Calif. Press, Berkeley. 205 pp.

#### Marine: Atlantic and Gulf of Mexico

- Ackerman, B. 1951. Handbook of fishes of the Atlantic seaboard. American Publ. Co., Washington, D.C.
- Bearden, C. M. 1961. Common marine fishes of South Carolina. Bears Bluff Lab. No. 34, Wadmalaw Island, South Carolina.
- Bigelow, H. B., and W. C. Schroeder. 1953. Fishes of the gulf of Maine. Fish. Bull. No. 74. Fish Wildl. Serv. 53:577 pp.
- Bigelow, H. B. and W. C. Schroeder. 1954. Deep water elasmobranchs and chimaeroids from the northwestern slope. Bull. Mus. Comp. Zool. Harvard College, 112:37-87.
- Bohlke, J. E., and C. G. Chaplin. 1968. Fishes of the Bahamas and adjacent tropical waters. Acad. Nat. Sci. Philadelphia. Livingston Publishing Co., Wynnewood, Pa.
- Breder, C. M., Jr. 1948. Field book of marine fishes of the Atlantic Coast from Labrador to Texas. G. P. Putnam and Sons, New York. 332 pp.
- Casey, J. G. 1964. Angler's guide to sharks of the northeastern United States, Maine to Chesapeake Bay. Bur. Sport Fish. Wildl. Cir. No. 179, Washington, D.C.
- Fishes of the western North Atlantic. 1, 1948—Mem. Sears Edn., Mar. Res. 1.
- Hildebrand, S. R., and W. C. Schroeder. 1928. Fishes of Chesapeake Bay. U.S. Bur. Fish. Bull. 43:1-366.
- Leim, A. H., and W. B. Scott. 1966. Fishes of the Atlantic Coast of Canada. Bull. Fish. Res. Bd. Canada. No. 155. 485 pp.
- McAllister, D. E. 1960. List of the marine fishes of Canada. Bull. Nat. Mus. Canada No. 168; Biol. Ser. Nat. Mus. Can. No. 62. 76 pp.
- Pew, P. 1954. Food and game fishes of the Texas Coast. Texas Game Fish Comm. Bull. 33. 68 pp.
- Randall, J. E. 1968. Caribbean reef fishes. T. F. H. Publications, Inc., Jersey City.
- Robins, C. R. 1958. Check list of the Florida game and commercial marine fishes, including those of the Gulf of Mexico and the West Indies, with approved common names. Fla. State Bd. Conserv. Educ. Ser. 12. 46 pp.
- Schwartz, F. J. 1970. Marine fishes common to North Carolina. North Car. Dept. Cons. Develop., Div. Comm. Sport Fish. 32 pp.
- Taylor, H. F. 1951. Survey of marine fisheries of North Carolina. Univ. North Car. Press, Chapel Hill.



*Freshwater: Northeast*

- Bailey, R. M. 1938. Key to the fresh-water fishes of New Hampshire. In: The fishes of the Merrimack Watershed. Biol. Surv. of the Merrimack Watershed. N. H. Fish Game Dept., Biol. Surv. Rept. 3. pp. 149-185.
- Bean, T. H. 1903. Catalogue of the fishes of New York. N. Y. State Mus. Bull. 60. 784 pp.
- Carpenter, R. G., and H. R. Siegler. 1947. Fishes of New Hampshire. N.H. Fish Game Dept. 87 pp.
- Elsner, H. J. 1950. The common fishes of Maryland - How to tell them apart. Publ. Maryland Dept. Res. Educ. No. 88. 45 pp.
- Everhart, W. H. 1950. Fishes of Maine. Me. Dept. Inland Fish Game. (ii). 53 pp.
- Greeley, J. R., et al. 1926-1940. (Various papers on the fishes of New York.) In: Biol. Surv. Repts, Suppl. Ann. Rept., N.Y. St. Cons. Dept.
- McCabe, B. C. 1945. Fishes. In: Fish. Sur. Rept. 1942. Mass. Dept. Cons., pp. 30-68.
- Van Meter, H. 1950. Identifying fifty prominent fishes of West Virginia. W. Va. Cons. Comm. Div. Fish Mgt. No. 3. 45 pp.
- Whitworth, W. R., R. L. Berri u, and W. T. Keller. 1968. Freshwater fishes of Connecticut. Conn. State Geol. Nat. Hist. Surv. Bull. No. 101. 134 pp.

*Freshwater: Southeast*

- Black, J. D. 1940. The distribution of the fishes of Arkansas. Univ. Mich. Ph.D. Thesis. 243 pp.
- Briggs, J. C. 1958. A list of Florida fishes and their distribution. Bull. Fla. State Mus. Biol. Sci. 2:224-318.
- Carr, A. F., Jr. 1937. A key to the freshwater fishes of Florida. Proc. Fla. Acad. Sci. (1936):72-86.
- Clay, W. M. 1962. A field manual of Kentucky fishes. Ky. Dept. Fish Wildl. Res., Frankfort, Ky. 147 pp.
- Fowler, H. W. 1945. A study of the fishes of the southern Piedmont and coastal plain. Acad. Nat. Sci., Philadelphia Monogr. No. 7. 408 pp.
- Gowanlock, J. N. 1933. Fishes and fishing in Louisiana. Bull. La. Dept. Cons. No. 23. 638 pp.
- Heemstra, P. C. 1965. A field key to the Florida sharks. Tech. Ser. No. 45. Fla. Bd. Cons., Div. Salt Water Fisheries.
- King, W. 1947. Important food and game fishes of North Carolina. N.C. Dept. Cons. and Dev. 54 pp.
- Kuhne, E. R. 1939. A guide to the fishes of Tennessee and the mid-South. Tenn. Dept. Cons., Knoxville. 124 pp.
- Smith, H. 1970. The fishes of North Carolina. N.C. Geol. Econ. Surv. 2:x1; 453 pp.
- Smith-Vaniz, W. F. 1968. Freshwater fishes of Alabama. Auburn Univ. Agr. Exper. Sta. Paragon Press, Montgomery, Ala. 211 pp.

*Freshwater: Midwest*

- Bailey, R. M., and M. O. Allum. 1962. Fishes of South Dakota. Misc. Publ. Mus. Zool. Univ. Mich. No. 119. 131 pp.
- Cross, F. B. 1967. Handbook of fishes of Kansas. Misc. Publ. Mus. Nat. Hist. Univ. Kansas No. 45. 357 pp.
- Eddy, S., and T. Surber. 1961. Northern fishes with special reference to the Upper Mississippi Valley. Univ. Minn. Press, Minneapolis. 276 pp.
- Evermann, B. W., and H. W. Clark. 1920. Lake Maxinkuckee, a physical and biological survey. Ind. St. Dept. Cons., 660 pp. (Fishes, pp. 238-451).
- Forbes, S. A., and R. E. Richardson. 1920. The fishes of Illinois. Ill. Nat. Hist. Surv. 3: CXXXI. 357 pp.
- Gerking, S. D. 1945. The distribution of the fishes of Indiana. Invest. Ind. Lakes and Streams, 3(1):1-137.
- Greene, C. W. 1935. The distribution of Wisconsin Fishes. Wis. Cons. Comm. 235 pp.
- Harlan, J. R., and E. B. Speaker. 1956. Iowa fishes and fishing. 3rd ed. Iowa State Cons. Comm., Des Moines, 337 pp.
- Hubbs, C. L., and G. P. Cooper. 1936. Minnows of Michigan. Cranbrook Inst. Sci., Bull 8: 95 pp.
- Hubbs, C. L., and K. F. Lagler. 1964. Fishes of the Great Lakes Region. Univ. Mich. Press, Ann Arbor. 213 pp.
- Johnson, R. E. 1942. The distribution of Nebraska fishes. Univ. Mich. (Ph.D. Thesis). 145 pp.
- Trautman, M. B. 1957. The fishes of Ohio. Ohio State Univ. Press. Columbus. 683 pp.
- Van Oosten, J. 1957. Great Lakes fauna, flora, and their environment. Great Lakes Comm., Ann Arbor, Mich. 86 pp.

*Freshwater: Southwest*

- Beckman, W. C. 1952. Guide to the fishes of Colorado. Univ. Colo. Mus. Leaflet 11. 110 pp.
- Burr, J. G. 1932. Fishes of Texas; Handbook of the more important game and commercial types. Bull. Tex. Game, Fish, and Oyster Comm. No. 5, 41 pp.
- Dill, W. A. 1944. The fishery of the Lower Colorado River. Calif. Fish Game, 30:109-211.
- LaRivers, I., and T. J. Trelease. 1952. An annotated check list of the fishes of Nevada. Calif. Fish Game, 38(1):113-123.

## BIOLOGICAL METHODS

- Miller, R. R. 1952. Bait fishes of the Lower Colorado River from Lake Mead, Nevada, to Yuma, Arizona, with a key for their identification. *Calif. Fish Game*. 38(1):7-42.
- Sigler, W. F., and R. R. Miller, 1963. Fishes of Utah. Utah St. Dept. Fish Game. Salt Lake City. 203 pp.
- Walford, L. A. 1931. Handbook of common commercial and game fishes of California. Calif. Div. Fish Game Fish Bull. No. 28. 181 pp.
- Ward, H. C. 1953. Know your Oklahoma fishes. Okla. Game Fish Dept, Oklahoma City. 40 pp.

### *Freshwater: Northwest*

- Baxter, G. T., and J. R. Simon. 1970. Wyoming fishes. Bull. Wyo. Game Fish Dept. No. 4. 168 pp.
- Bond, C. E. 1961. Keys to Oregon freshwater fishes. Tech. Bull. Ore. Agr. Exp. Sta. No. 58. 42 pp.
- Hankinson, T. L. 1929. Fishes of North Dakota. Pop. Mich. Acad. Sci. Arts, and Lett. 10(1928):439-460.
- McPhail, J. D., and C. C. Lindsey. 1970. Freshwater fishes of Northwestern Canada and Alaska. Fish. Res. Bd. Canada, Ottawa. Bull. No. 173. 381 pp.
- Schultz, L. P. 1936. Keys to the fishes of Washington, Oregon and closely adjoining regions. Univ. Wash. Publ. Biol. 2(4):103-228.
- Schultz, L. P. 1941. Fishes of Glacier National Park, Montana. USDI, Cons. Bull. No. 22. 42 pp.
- Willimovsky, N. J. 1954. List of the fishes of Alaska. Stanford Ichthyol. Bull. 4:279-294.

## 7.5 Fish Kills

- Alexander, W. B., B. A. Southgate, and R. Bassindale. 1935. Survey of the River Tees, Pt. II. The Estuary, Chemical and Biological. Tech. Pop. Wat. Pol. Res., London, No. 5.
- Anon., 1961. Effects of Pollution on Fish. Mechanism of the Toxic Action of Salts of Zinc, Lead and Copper. Water Pollution Research, 1960:83.
- Burdick, G. E. 1965. Some problems in the determination of the cause of fish kills. In: Biological Problems in Water Pollution. USPHS Pub. No. 999-WP-25.
- Carpenter, K. E. 1930. Further researches on the action of soluble metallic salts on fishes. J. Exp. Biol. 56:407-422.
- Easterday, R. L., and R. F. Miller. 1963. The acute toxicity of molybdenum to the bluegill. Va. J. Sci. 14(4):199-200. Abstr.
- Ellis, M. M. 1937. Detection and measurement of stream pollution. Bull. U.S. Bur. Fish. 48:365-437.
- Extrom, J. A., and D. S. Farner. 1943. Effect of sulfate mill wastes on fish life. Paper Trade J. 117(5):27-32.
- Fromm, P. O., and R. H. Schiffman. 1958. Toxic action of hexavalent chromium on largemouth bass. J. Wildlife Mgt. 22:40-44.
- Fujiya, M. 1961. Effects of kraft pulp mill wastes on fish. JWPCF, 33(9):968-977.
- Havelka, J., and M. Effenberger. 1957. Symptoms of phenol poisoning of fish. Ann. Czech. Acad. Agric. Sci., U. Serv. Animal Prod. 2(5):421.
- Henderson, C., Q. H. Pickering, and C. M. Tarzwell. 1959. Relative toxicity of ten chlorinated hydrocarbon insecticides to four species of fish. Trans. Amer. Fish. Soc. 88:23-32.
- Ingram, W., and G. W. Prescott. 1954. Toxic freshwater algae. Amer. Mid. Nat. 52:75.
- Jones, J. R. E. 1948. A further study of the reaction of fish to toxic solutions. J. Exp. Biol. 25:22-34.
- Kuhn, O., and H. W. Koecke. 1956. Histologische und cytologische Veränderungen der fishkierne nach Einwirkung im wasser enthaltener schädigender Substanzen. Ztschr. F. Zellforsch. 43:611-643. (Cited in Fromm and Schiffman, 1958.)
- Mathur, D. S. 1962a. Histopathological changes in the liver of certain fishes as induced by BHC and lindane. Proc. Natl. Acad. Sci. India, Sec. B, 32(4):429-434.
- Mathur, D. S. 1962b. Studies on the histopathological changes induced by DDT in the liver, kidney and intestine of certain fishes. Experientia, 18:506.
- Rounsefell, G. A., and W. R. Nelson. 1966. Red-tide research summarized to 1964, including an annotated bibliography. USDI Special Sci. Rept., Fisheries No. 535.
- Schmid, O. J., and H. Mann. 1961. Action of a detergent (dodecyl benzene sulfonate) on the gills of the trout. Nature, 192(4803):675.
- Shelford, U. E. 1917. An experimental study of the effects of gas wastes upon fishes, with special reference to stream pollution. Bull. Ill. Lab. Nat. Hist. 11:381-412.
- Skrapek, K. 1963. Toxicity of phenols and their detection in fish. Pub. Health Eng. Absts. XLIV(8) Abst. No. 1385.
- Smith, L. L., Jr. et al. 1956. Procedures for investigation of fish kills. A guide for field reconnaissance and data collection. Ohio River Valley Water Sanitation Comm., Cincinnati.
- Stansby, M. E. 1963. Industrial fishery technology. Reinhold Publ. Co., New York.
- Stundle, K. 1955. The effects of waste waters from the iron industry and mining on Styrian waters. Österreich Wasserw. (Austria). 7:75. Water Poll. Abs. 29:105. 1956.

## FISH REFERENCES

U.S. Department of the Interior. 1968a. Pollution caused fish kills 1967. FWPCA Publ. No. CWA-7.

U.S. Department of the Interior. 1968b. Report of the National Technical Advisory Commission. FWPCA, Washington, D.C.

U.S. Department of the Interior. 1970. Investigating fish mortalities. FWPCA Publ. No. CWT-5. Also available from USGPO as No. O-380-257.

Wallen, I. E. 1951. The direct effect of turbidity on fishes. Bull. Okla. Agr. Mech. Coll. 48(2):1-27.

Wood, E. M. 1960. Definitive diagnosis of fish mortalities. JWPCF, 32(9):994-999.

# BIOASSAY

137

# BIOASSAY

|                                      | Page |
|--------------------------------------|------|
| 1.0 GENERAL CONSIDERATIONS           | 1    |
| 2.0 PHYTOPLANKTON - ALGAL ASSAY      | 2    |
| 2.1 Principle                        | 2    |
| 2.2 Planning Algal Assays            | 2    |
| 2.3 Apparatus and Test Conditions    | 3    |
| 2.3.1 Glassware                      | 3    |
| 2.3.2 Illumination                   | 3    |
| 2.3.3 pH                             | 3    |
| 2.4 Sample Preparation               | 3    |
| 2.5 Inoculum                         | 3    |
| 2.6 Growth Response Measurements     | 3    |
| 2.7 Data Evaluation                  | 4    |
| 2.8 Additions, (Spikes)              | 5    |
| 2.9 Data Analysis and Interpretation | 5    |
| 2.10 Assays to Determine Toxicity    | 5    |
| 3.0 PERIPHYTON                       | 5    |
| 3.1 Static                           | 5    |
| 3.2 Continuous Flow                  | 6    |
| 4.0 MACROINVERTEBRATES               | 8    |
| 5.0 FISH                             | 8    |
| 6.0 REFERENCES                       | 8    |
| 6.1 General                          | 8    |
| 6.2 Phytoplankton - Algal Assay      | 9    |
| 6.3 Periphyton                       | 10   |
| 6.4 Macroinvertebrates               | 10   |
| 6.5 Fish                             | 11   |
| FATHEAD MINNOW CHRONIC TEST          | 15   |
| BROOK TROUT CHRONIC TEST             | 25   |



## BIOASSAY

### 1.0 GENERAL CONSIDERATIONS

The term BIOASSAY includes any test in which organisms are used to detect or measure the presence or effect of one or more substances or conditions. The organism responses measured in these tests include: mortality, growth rate, standing crop (biomass), reproduction, stimulation or inhibition of metabolic or enzyme systems, changes in behavior, histopathology, and flesh tainting (in shellfish and fish). The ultimate purpose of bioassays is to predict the response of native populations of aquatic organisms to specific changes within the natural environment. Whenever possible, therefore, tests should be carried out with species that are native (indigenous) to the receiving water used as the diluent for the bioassay. Bioassays are important because in most cases the success of a water pollution control program must be judged in terms of the effects of water quality on the condition of the indigenous communities of aquatic organisms. Also, in many cases, bioassays are more sensitive than chemical analyses.

Two general kinds of bioassays are recognized:

- laboratory tests conducted to determine the effects of a substance on a species; more or less arbitrary conditions are employed;
- in situ tests conducted to determine the effects of a specific natural environment; the test organisms are held in "containers" through which the water circulates freely.

The general principles and methods of conducting laboratory bioassays presented in Standard Methods for the Examination of Water and Waste Water, 13th edition (APHA, 1971) apply to most bioassays, and the described methods can be used with many types of aquatic organisms with only slight modification.

The following are suggested improvements to the methods given in Standard Methods, 13th edition (APHA, 1971).

- The 48- and 96-hour LC50 values are presently important for determining compliance with water quality standards as established by various pollution control authorities. Short-term threshold information can be derived by reporting LC50 values at 24-hour intervals to demonstrate the shape of the toxicity curve.
- Reports of LC50's should state the method of calculation used and the statistical confidence limits when possible.
- Rubber or plastic materials should be used in bioassay equipment only after consideration has been given to the possibility of the leaching of substances such as plasticizers or sorption of toxicants.
- Test materials should be administered in such a way that their physical and chemical behavior approximates that in natural systems.

Biological tests can be conducted in any kind of water with proper precautions, and although most tests have been conducted in freshwater, the same general principles apply to brackish and salt waters. The literature contains a great many formulations for artificial seawater. Of these, a modification of the Kester et al. (1967) formulation (LaRoche et al., 1970; Zarogian et al., 1969) seems to support the greatest variety of marine organisms. When metal-containing wastes are to be bioassayed, omitting EDTA and controlling trace metals, as described by Davey et al. (1970), is recommended.

Using a standard toxicant and a parallel series in a standard medium is recommended to help assess variations due to experimental technique and the condition of the organisms. Such tests are also useful in distinguishing effects due to an altered character of the effluent from changes in the sensitivity of the organism, or from changes in the quality of the receiving water.

## BIOLOGICAL METHODS

When making waste management decisions, it is important to consider and tentatively define the persistence of a pollutant. Materials that have half lives less than 48 hours can be termed as rapidly decaying compounds; those with half lives greater than 48 hours but less than 6 months, as slowly decaying; and those compounds in natural waters with half lives longer than 6 months, as long-lived persistent materials.

Bioassays can be conducted over almost any interval of time, but the test duration must be appropriate to the life stage or life cycle of the test organisms and the objectives of the investigation. The purpose of short-term tests, such as acute mortality tests, is to determine toxicant concentrations lethal to a given fraction (usually 50 percent) of the organisms during a short period of their life cycle. Acute mortality tests with fish generally last about 4 to 7 days. Most toxicants, however, cause adverse effects at levels below those that cause mortality. To meet this need, long-term (chronic) tests are designed to expose test organisms to the toxicant over their entire life cycle and measure the effects of the toxicant on survival, growth, and reproduction. Sometimes only a portion of the life cycle is tested, such as studies involving growth or emergence of aquatic insects. With fish, such tests usually last for 30, 60, or 90 days and are often termed subacute.

Laboratory bioassays may be conducted on a "static" or "continuous flow" basis. The specific needs of the investigator and available test facilities determine which technique should be used. The advantages and applications of each have been described in Standard Methods, (APHA, 1971) and by the National Technical Advisory Committee (1968). Generally, the continuous-flow technique should be used where possible. Apparatus advantageous for conducting flow-through tests includes diluters (Mount and Warner, 1965; Mount and Brungs, 1967), valve controlling systems (Jackson and Brungs, 1966) and chemical metering pumps (Symons, 1963).

The biological effects of many industrial wastes are best evaluated in the field; transporting large volumes of industrial wastes to a laboratory for bioassay purposes can be impractical. Testing facilities are best located at the site

of the waste discharge. A bioassay trailer (Zillich, 1969) has proven useful for this purpose. *In situ* bioassay procedures are also a good method for defining the impact to aquatic life below the source of industrial waste discharges (Basch, 1971).

Biomonitoring, a special application of biological tests, is the use of organisms to provide information about a surface water, effluent, or mixtures thereof on a periodic or continuing basis. For the best results, biomonitoring should maintain continuous surveillance with the use of indigenous species in a flow-through system under conditions that approximate the natural environment.

### 2.0 PHYTOPLANKTON -- ALGAL ASSAY

The Algal Assay Procedure: Bottle Test was published by the National Eutrophication Research Program (USEPA, 1971) after 2 years of intensive evaluation, during which excellent agreement of the data was obtained among the 8 participating laboratories. This test is the only algal bioassay that has undergone sufficient evaluation and refinement to be considered reliable. The following material represents only a brief outline of the test. For more explicit details, see the references.

#### 2.1 Principle

An algal assay is based on the principle that growth is limited by the nutrient that is present in shortest supply with respect to the needs of the organism. The test can be used to identify algal growth-limiting nutrients, to determine biologically the availability of algal growth-limiting nutrients, to quantify the biological response (algal growth response) to changes in concentrations of algal growth-limiting nutrients, and to determine whether or not various compounds or water samples are toxic or inhibitory to algae.

#### 2.2 Planning Algal Assays

The specific experimental design of each algal assay is dictated by the particular problem to be solved. All pertinent ecological factors must be considered in planning a given assay to ensure that valid results and conclusions are obtained.

Water quality may vary greatly with time and location in lakes, impoundments and streams. If meaningful data are to be obtained, therefore, the sampling program must take these variations into account.

## 2.3 Apparatus and Test Conditions

### 2.3.1 Glassware

Use good-quality borosilicate glassware. When studying trace nutrients, use special glassware such as Vycor or polycarbonate containers. Although container size is not critical, the surface to volume ratios are critical because of possible carbon limitation. The recommended sample volumes for use in Erlenmeyer flasks are: 40 ml in a 125 ml flask; 60 ml in a 250 ml flask; and 100 ml in a 500 ml flask. Use culture closures such as loose-fitting aluminum foil or inverted beakers to permit good gas exchange and prevent contamination.

### 2.3.2 Illumination

After inoculation, incubate the flasks at  $24 \pm 2^\circ\text{C}$  under cool-white fluorescent lighting: 200 ft-c (2152 lux)  $\pm 10$  percent for blue-green algae and diatom test species, and 400 ft-c (4304 lux)  $\pm 10$  percent for green algae test species. Measure the light intensity adjacent to the flask at the liquid level.

### 2.3.3 pH

To ensure the availability of carbon dioxide, maintain the pH of the incubating cultures below 8.5 by using the sample volumes mentioned above and shaking the cultures at 100 oscillations per minute. In samples containing high concentrations of nutrients, such as highly-productive surface waters or domestic waste effluents, it may be necessary to bubble air or an air/carbon dioxide mixture through the culture to maintain the pH below 8.5.

## 2.4 Sample Preparation

Two alternate methods of sample preparation are recommended, depending upon the type of information to be obtained from the sample:

- membrane filtration (0.45 pore diameter) – remove the indigenous algae by filtration if

you wish to determine the growth response to growth-limiting nutrients which have not been taken up by filterable organisms, or if you wish to predict the effect of adding nutrients to a test water at a specific time.

- autoclaving – autoclave samples if you wish to determine the amount of algal biomass that can be grown from *all* nutrients in the water, including those in the plankton. Autoclaving solubilizes the nutrients in the indigenous filterable organisms and releases them for use by the test organisms.

## 2.5 Inoculum

The algal test species may be one of those recommended in the Bottle Test or another that has been obtained in unialgal culture. Grow the test species in a culture medium that minimizes the intracellular carryover of nutrients in the test species when transferred from the stock culture to the test water (Table I.) When taken from the stock culture, centrifuge the test cells and discard the supernatant. Resuspend the sedimented cells in an appropriate volume of glass-distilled water containing 15 mg sodium bicarbonate per liter and recentrifuge. Decant the supernatant, resuspend the algae in fresh bicarbonate solution, and use as the inoculum. The amount of inoculum depends upon the algal test species used. The following initial cell concentrations are recommended:

| Test organism                    | Initial cell count/ml |
|----------------------------------|-----------------------|
| <i>Selenastrum capricornutum</i> | 1000/ml               |
| <i>Anabaena flos-aquae</i>       | 50000/ml              |
| <i>Microcystis aeruginosa</i>    | 50000/ml              |

Prepare test flasks in triplicate.

## 2.6 Growth Response Measurements

The method used to determine growth response during incubation depends on the equipment available. Cells may be counted with a microscope, using a hemacytometer or a Palmer-Maloney or Sedgwick-Rafter plankton counting chamber. The amount of algal biomass may be determined by measuring the optical density of the culture at 600–750 nm with a colorimeter or spectrophotometer. The amount of chlorophyll contained in the algae may be

## BIOLOGICAL METHODS

TABLE 1. STOCK CULTURE AND CONTROL NUTRIENT MEDIUM.

| MACROELEMENTS:                       |                            |                   |                              |
|--------------------------------------|----------------------------|-------------------|------------------------------|
| Compound                             | Final concentration (mg/l) | Element furnished | Element concentration (mg/l) |
| NaNO <sub>3</sub>                    | 25.500                     | N                 | 4.200                        |
| K <sub>2</sub> HPO <sub>4</sub>      | 1.044                      | P                 | 0.186                        |
|                                      |                            | K                 | 0.468                        |
| MgCl <sub>2</sub>                    | 5.700                      | Mg                | 1.956                        |
| MgSO <sub>4</sub> ·7H <sub>2</sub> O | 14.700                     | Mg                | 1.450                        |
|                                      |                            | S                 | 1.911                        |
| CaCl <sub>2</sub> ·2H <sub>2</sub> O | 4.410                      | Ca                | 1.203                        |
| NaHCO <sub>3</sub>                   | 15.000                     | Na                | 11.004                       |

(If the medium is to be filtered, add the following trace-element-iron-EDTA solution from a single combination stock solution after filtration. With no filtration, K<sub>2</sub>HPO<sub>4</sub> should be added last to avoid iron precipitation. Stock solutions of individual salts may be made up in 1000 x's final concentration or less.)

| MICROELEMENTS:                                      |        |    |        |
|---|--------|----|--------|
|   | (μg/l) |    | (μg/l) |
| H <sub>3</sub> BO <sub>3</sub>                      | 185.64 | B  | 33     |
| MnCl <sub>2</sub>                                   | 264.27 | Mn | 114    |
| ZnCl <sub>2</sub>                                   | 32.70  | Zn | 15     |
| CoCl <sub>2</sub>                                   | 0.78   | Co | 0.35   |
| CuCl <sub>2</sub>                                   | 0.009  | Cu | 0.003  |
| Na <sub>2</sub> MoO <sub>4</sub> ·2H <sub>2</sub> O | 7.26   | Mo | 2.88   |
| FeCl <sub>3</sub>                                   | 96     | Fe | 33     |
| Na <sub>2</sub> EDTA·2H <sub>2</sub> O              | 333    |    |        |

measured either directly (*in vivo*) by fluorometry or after extraction by fluorometry or spectrophotometry. If available, an electronic particle counter will provide an accurate and rapid count of the cells. All methods used for determining the algal biomass should be related to a dry weight measurement (mg/l) determined gravimetrically. (See the Plankton Section of the manual for analytical details.)

### 2.7 Data Evaluation

Two parameters are used to describe the growth of a test alga: maximum specific growth rate and maximum standing crop. The maximum specific growth rate ( $\mu_{max}$ ) for an individual flask is the largest specific growth rate ( $\mu$ ) occurring at any time during incubation. The  $\mu_{max}$  for a set of replicates is determined by

averaging the  $\mu_{max}$  of the individual flasks. The specific growth rate,  $\mu$ , is defined by:

$$\mu = \frac{\ln(X_2/X_1)}{t_2 - t_1}$$

where:

- ln = log to the base "e"
- X<sub>2</sub> = biomass concentration at the end of the selected time interval.
- X<sub>1</sub> = biomass concentration at the beginning of the selected time interval
- t<sub>2</sub> - t<sub>1</sub> = elapsed time (days) between selected determinations of biomass

Because the maximum specific growth rate ( $\mu_{max}$ ) occurs during the logarithmic phase of growth (usually between day 3 and day 5), the biomass must be measured at least daily during the first 5 days of incubation.

The maximum standing crop in any flask is defined as the maximum algal biomass achieved during incubation. For practical purposes, the maximum standing crop is assumed to have been achieved when the rate of increase in biomass has declined to less than 5 percent per day.

### 2.8 Additions (Spikes)

The quantity of cells produced in a given medium is limited by the nutrient present in the lowest relative quantity with respect to the needs of the organism. If a quantity of the limiting substance were added to the test flasks, cell production would increase until this additional supply was depleted or until some other substance became limiting to the organism. Adding substances other than the limiting substance would not increase algal growth. Nutrient additions may be made singly or in combination, and the growth response can be compared with that of unspiked controls to identify those substances that limit growth rate or cell production.

In all instances, the volume of a spike should be as small as possible. The concentration of spikes will vary and must be matched to the waters being tested. When selecting the spike concentration, keep in mind that (1) the concentration should be kept small to minimize alterations of the sample, but at the same time, be sufficiently large to yield a potentially measurable response; and (2) the concentration should be related to the fertility of the sample.

### 2.9 Data Analysis and Interpretation

Present the results of spiking assays together with the results from two types of reference samples: the assay reference medium and unspiked samples of the water under consideration. Preferably, the entire growth curves should be presented for each of the two types of reference samples. Present the results of individual assays in the form of the maximum specific growth rate (with time of occurrence) and maximum standing crop (with time at which it was reached), both with the confidence interval indicated.

Growth rate limiting nutrients can be determined by spiking a number of replicate flasks with single nutrients, determining the maximum

specific growth rate for each flask, and comparing the averages by a Students' t-test or other appropriate statistical tests.

Data analysis for multiple nutrient spiking can be performed by analysis of variance calculations. In multiple nutrient spiking, accounting for the possible interaction between different nutrients is important and can readily be done by factorial analysis. The same methods described above can be used to determine the nutrient limiting growth of the maximum standing crop.

### 2.10 Assays to Determine Toxicity

As previously pointed out, the assay may be used to determine whether or not various compounds or water samples are either toxic or inhibitory to algal growth. In this case the substance to be tested for toxicity is added to the standard algal culture medium in varying concentrations, the algal test species is added, and either the maximum standing crop or maximum specific growth rate (or both) determined. These are then compared to those obtained in the standard culture medium without the additions (controls). The LC50, or that concentration at which either 50% of the maximum standing crop or maximum specific growth rate is obtained, as compared with the controls, is then calculated.

## 3.0 PERIPHYTON

Uniform methods for conducting bioassays with periphyton have not been developed, and their environmental requirements and toxicology are still relatively unknown. Many of the common species have not been successfully cultured, and the bioassays that have been carried out with the algae and other microorganisms occurring in this community were conducted principally to screen potential algicides, fungicides, and other control agents. Two kinds of tests can be conducted with periphyton: static and continuous flow.

### 3.1 Static

Because the techniques currently employed in the Algal Assay Procedure: Bottle Test (USEPA, 1971) have been more rigorously tested than any procedure previously used for periphyton,



## BIOLOGICAL METHODS

this method is recommended for static bioassays with the periphyton.

### 3.2. Continuous Flow

Many periphyton grow well only in flowing water and can be studied only *in situ* or in artificial streams (Whitford, 1960; Whitford *et al.*, 1964). The following procedure, which is similar to the method described by McIntire *et al.* (1964), is tentatively recommended at this time.

- Test Chamber – Twin, inter-connected channels, each approximately 4" X 4" X 36", with two inches of water circulated by

a paddle wheel. Duplicate chambers should be provided for each condition tested (Figures 1 and 2).

- Current velocity – 30 cm/sec:
- Temperature – 20°C
- Light – 400 fc, cool-white (daylight) fluorescent lamps
- Culture medium – Optional
  - a. Algal Assay Medium (Table 1).
  - b. Natural surface water supply

Where direct flow-through is not provided, the water exchange rate should ensure a complete change at least six times daily.

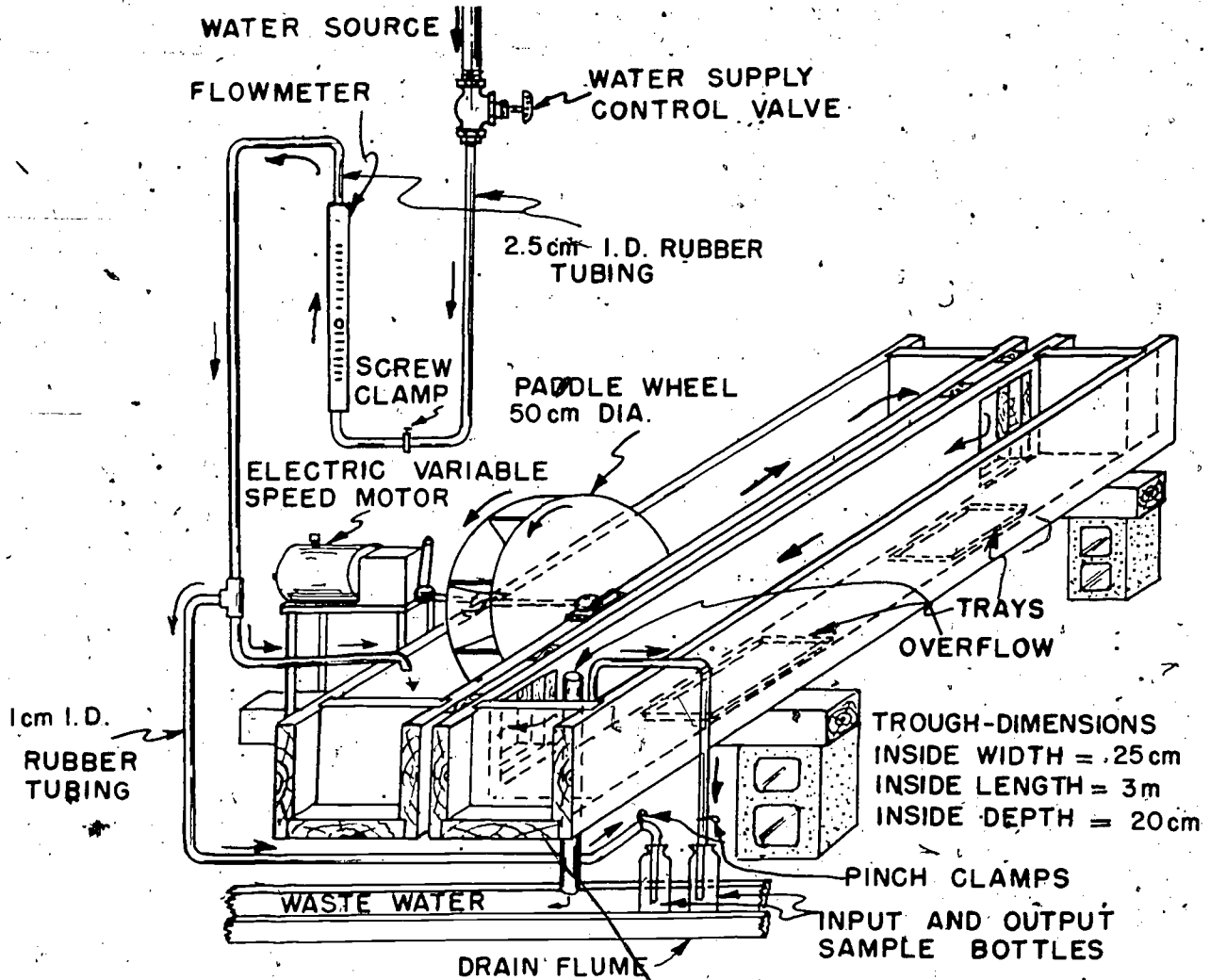

Figure 1. Diagram of laboratory stream, showing the paddle wheel for circulating the water between the two interconnected troughs and the exchange water system. (From McIntire *et al.*, 1964).



## PERIPHYTON BIOASSAY

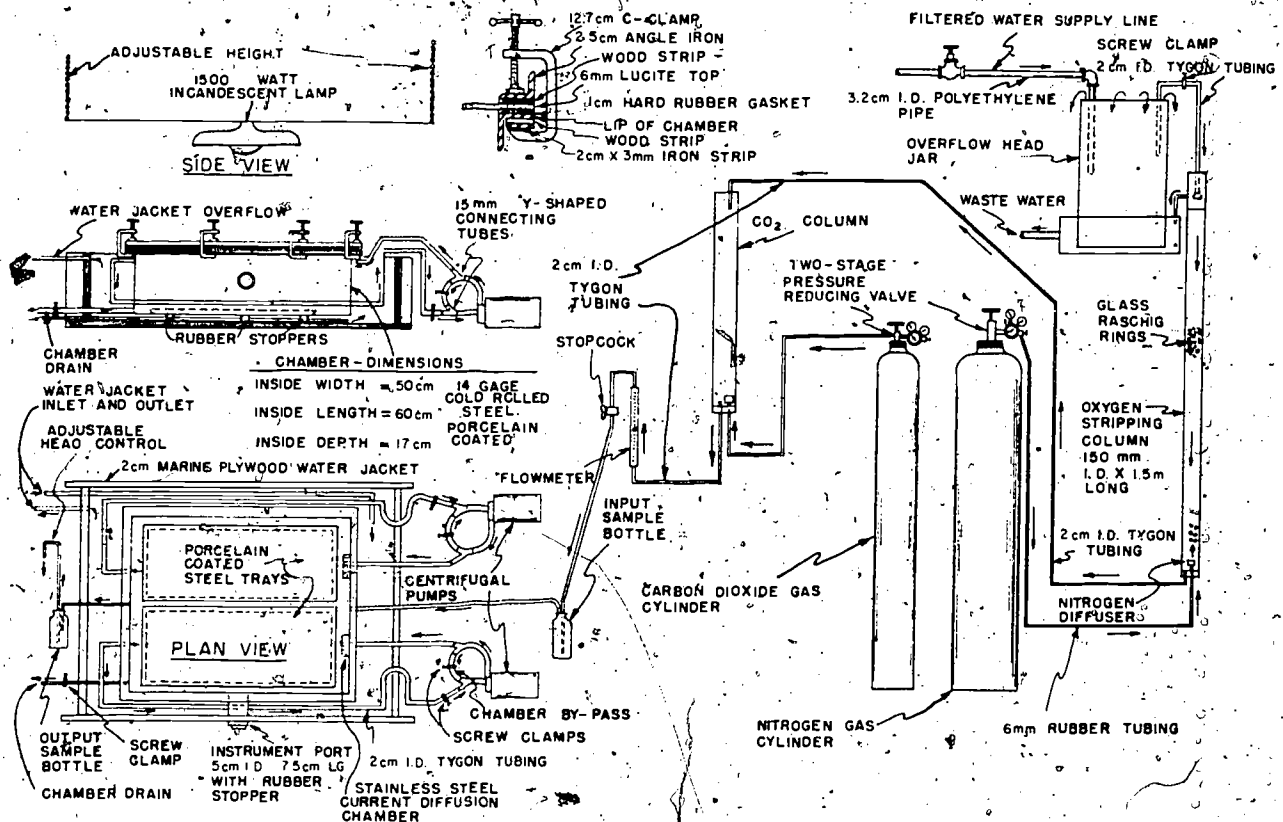

Figure 2. Diagram of photosynthesis-respiration chamber, showing the chamber with its circulating and exchange water systems, the water jacket for temperature control, the nutrient and gas concentration control system, and the light source.

- Test organism(s) – Optional; filamentous blue-green or green algae or diatoms.
  - a. Unialgal culture – No standard test organisms are available
  - b. Periphyton community – Use “seed” of periphyton from the water resource for which the data are being developed.
- Acclimatization period – The culture (or community) should be allowed to develop in the test chambers for a minimum of two weeks before introducing the test condition.
- Maintaining test conditions – Chemicals are added to the water supply prior to flow into the test chamber. Temperature control may be maintained by placing thermostatically controlled heating (or cooling) elements in the channel.
- Substrate – A minimum of eight 1" X 3" plain glass slides should be placed on the bottom of each channel.
- Test duration – Two weeks
- Evaluation – The effects of the test condition are evaluated at the end of the test period by comparing the biomass and community structure in the test chambers with that of the control chambers. (See Periphyton Section for methodology.)
  - a. Biomass – Use four of the eight slides; analyze individually.
    - (1) Chlorophyll *a* (mg/m<sup>2</sup>)
    - (2) Organic matter (Ash-free weight, g/m<sup>2</sup>)
  - b. Cell count and identification – Use four pooled slides.
    - (1) Cell density (cells/mm<sup>2</sup>)
    - (2) Species proportional count
    - (3) Community diversity (Diversity Index)
- Toxicity – The toxicity of a chemical or effluent is expressed as the LC50, which is

## BIOLOGICAL METHODS

the concentration of toxicant resulting in a 50% reduction in the biomass or cell count. Community diversity is not affected in the same manner as biomass and cell counts, and would yield a much different value.

### 4.0 MACROINVERTEBRATES

In general, most of the considerations covered by Standard Methods (APHA, 1971) apply equally well to macroinvertebrate tests in fresh and marine waters. Recent refinements in acute and chronic methodology for aquatic insects, amphipods, mussels, and *Daphnia* have been described by Gauvin (1971), Bell and Nebeker (1969), Arthur and Leonard (1970), Dimick and Bréese (1965), Woelke (1967), and Biesinger and Christensen (1971), respectively.

### 5.0 FISH

The general principles and methods for acute and chronic laboratory fish toxicity tests are presented in Standard Methods (APHA, 1971)

and in the report of the National Technical Advisory Committee (1968). Sprague (1969, 1970) has recently reviewed many of the problems and the terminology associated with fish toxicity tests.

Chronic tests are becoming increasingly important as sublethal adverse effects of more and more toxic agents are found to be significant. At present, a chronic fish bioassay test is a relatively sophisticated research procedure and entails large allocations of manpower, time, and expense. Important contributions in this area include those by Mount and Stephan (1969), Brungs (1969), Eaton (1970), and McKim, *et al.* (1971).

Two procedures for chronic toxicity tests using the fathead minnow, *Pimephales promelas* Rafinesque, and the brook trout, *Salvelinus fontinalis* (Mitchell), developed by the staff of the National Water Quality Laboratory, U.S. Environmental Protection Agency, Duluth, Minn., are presented following the references in this section.

## 6.0 REFERENCES

### 6.1 General

- American Public Health Association. 1971. Standard methods for the examination of water and wastewater. 13th ed. Amer. Public Health Assoc., New York. 874 pp.
- Basch, R. 1971. Chlorinated municipal waste toxicities of rainbow trout and fathead minnows. Mich. Bur. Water Mgmt., Dept. Nat. Res., Lansing, Mich. Final Report of Grant Number 18050 GZZ for the U.S. Environmental Protection Agency.
- Davey, E. W., J. H. Gentile, S. J. Erickson, and P. Betzer. 1970. Removal of trace metals from marine culture media. *Limnol. Oceanogr.* 15:486-488.
- Jackson, H. W., and W. A. Brungs. 1966. Biomonitoring of industrial effluents. Proc. 21st Ind. Waste Conf., Purdue Univ., Eng. Ext. Bull. No. 121. pp. 117.
- Kester, D. R., I. W. Duedall, D. N. Connors, and R. M. Pytkowicz. 1967. Preparation of artificial seawater. *Limnol. Oceanogr.* 12(1):176-179.
- LaRoche, G., R. Eisler, and C. M. Tarzwell. 1970. Bioassay procedures for oil and oil dispersant toxicity evaluation. *JWPCF*, 42:1982-1989.
- Mount, D. I., and R. E. Warner. 1965. A serial-diluter apparatus for continuous delivery of various concentrations in water. PHS Publ. No. 99-WP-23. 16 pp.
- Mount, D. I., and W. A. Brungs. 1967. A simplified dosing apparatus for fish toxicology studies. *Water Res.* 1:21-29.
- National Technical Advisory Committee. 1968. Water quality criteria. Report of the National Technical Advisory Committee on Water Quality Criteria to the Secretary of the Interior. USDI, FWPCA, Washington, D. C. 234 pp.
- Symons, J. M. 1963. Simple continuous flow, low and variable rate pump. *JWPCF*, 35:1480-1485.
- Zarogian, G. E., G. Pesch, and G. Morrison. 1969. Formulation of an artificial medium suitable for oyster larvae development. *Amer. Zool.* 9:1144.
- Zillich, J. 1969. The simultaneous use of continuous flow bioassays and automatic water quality monitoring equipment to evaluate the toxicity of waste water discharges. Presented at: 44th Annual Conf. of Mich. Water Poll. Cont. Assoc., Boyne Falls, Mich., June 16, 1969. 3 pp.

## 6.2 Phytoplankton – Algal Assay

- Berge, G. 1969. Predicted effects of fertilizers upon the algae production in Fern Lake. *FiskDiv. Skr. Ser. HavUnders.* 15:339-355.
- Davis, C. C. 1964. Evidence for the eutrophication of Lake Erie from phytoplankton records. *Limnol. Oceanogr.* 9:275-283.
- Edmondson, W. T., and G. C. Anderson. 1956. Artificial eutrophication of Lake Washington. *Limnol. Oceanogr.* 1(1):47-53.
- Francisco, D. E. and C. M. Weiss. 1973. Algal response to detergent phosphate levels. *JWPCF*, 45(3):480-489.
- Fruh, E. G., K. M. Stewart, G. F. Lee, and G. A. Rohlich. 1966. Measurements of Eutrophication and Trends. *JWPCF*, 38(8):1237-1258.
- Goldman, C. R., and R. C. Carter. 1965. An investigation by rapid  $C^{14}$  bioassay of factors affecting the cultural eutrophication of Lake Tahoe, California. *JWPCF*, 37:1044-1063.
- Hasler, A. D. 1947. Eutrophication of lakes by domestic drainage. *Ecology*, 28(4):383-395.
- Johnson, J. M., T. O. Odlaug, T. A. Olson and O. R. Ruschmeyer. 1970. The potential productivity of fresh water environments as determined by an algal bioassay technique. *Water Res. Res. Ctr., Univ. Minn. Bull. No. 20.* 77 pp.
- Joint Industry/Government Task Force on Eutrophication. 1969. Provisional Algal Assay Procedure. P. O. Box 3011, Grand Central Station, New York, N.Y., 10017. 62 pp.
- Lake Tahoe Area Council. 1970. Eutrophication of Surface Waters – Indian Creek Reservoir, First Progress Report, FWQA Grant No. 16010 DNY.
- Maloney, T. E., W. E. Miller, and T. Shiroyama. 1972. Algal Responses to Nutrient Additions in Natural Waters. I. Laboratory Assays. In: *Nutrients and Eutrophication, Special Symposia, Vol. I, Amer. Soc. Limnol. Oceanogr., Lawrence, Kansas*, p 134-140.
- Maloney, T. E., W. E. Miller, and N. L. Blind. 1973. Use of Algal Assay in Studying Eutrophication Problems. *Proc. Internat. Assoc. Water Poll. Res., Sixth Conference, Jerusalem, 1972.* Pergamon Press.
- Middlebrooks, E. J., E. A. Pearson, M. Tunzi, A. Adinarayana, P. H. McGauhey, and G. A. Rohlich. 1971. Eutrophication of surface water – Lake Tahoe. *JWPCF*, 43:242-251.
- Miller, W. E. and T. E. Maloney. 1971. Effects of Secondary and Tertiary Waste Effluents on Algal Growth in a Lake River System. *JWPCF*, 43(12):2361-2365.
- Murray, S., J. Schertig, and P. S. Dixon. 1971. Evaluation of algal assay procedures – PAAP batch test. *JWPCF*, 43(10):1991-2003.
- Oglesby, R. T., and W. T. Edmondson. 1966. Control of Eutrophication. *JWPCF*, 38(9):1452-1460.
- Potash, M. 1956. A biological test for determining the potential productivity of water. *Ecology*, 37(4):631-639.
- Rawson, D. S. 1956. Algal indicators of lake types. *Limnol. Oceanogr.* 1:18-25.
- Schreiber, W. 1927. Der Reinkultur von marinem Phytoplankton und deren Bedeutung fur die Erforschung der Produktionsfahigkeit des Meerwassers. *Wissensch. Meeresunters. N.F.*, 16:1-34.
- Shapiro, J. and R. Ribeiro. 1965. Algal growth and sewage effluent in the Potomac estuary. *JWPCF*, 37(7):1034-1043.
- Shelef, G., and R. Halperin. 1970. Wastewater nutrients and algae growth potential. In: H. I. Shoval, ed., *Developments in Water Quality Research, Proc. Jerusalem Internat'l. Conf. on Water Quality and Poll. Res., June, 1969.* Ann Arbor-Humphrey Science Publ. p. 211-228.
- Skulberg, O. M. 1964. Algal problems related to the eutrophication of European water supplies, and a bioassay method to assess fertilizing influences of pollution on inland waters. In: D. F. Jackson, ed., *Algae and Man*, Plenum Press, N.Y. p. 262-299.
- Skulberg, O. M. 1967. Algal cultures as a means to assess the fertilizing influence of pollution. In: *Advances in Water Pollution Research, Vol. 1*, Pergamon Press, Washington, D. C.
- Strom, K. M. 1933. Nutrition of algae. Experiments upon the feasibility of the Schreiber method in fresh waters; the relative importance of iron and manganese in the nutritive medium; the nutritive substance given off by lake bottom muds. *Arch. Hydrobiol.* 25:38-47.
- Toerien, D. F., C. H. Huang, J. Radimsky, E. A. Pearson, and J. Scherfig. 1971. Final report provisional algal assay procedures. Report No. 71-6, Sanit. Eng. Res. Lab., Coll. Eng. Sch. Pub. Hlth., Univ. Calif., Berkeley. 211 pp.
- U. S. Environmental Protection Agency. 1971. Algal assay procedure: bottle test. National Eutrophication Research Program, USEPA, Corvallis, Oregon.
- Wang, W., W. T. Sullivan, and R. L. Evans. 1973. A technique for evaluating algal growth potential in Illinois surface waters. Ill. St. Water Sur., Urbana, Rept. of Investigation 72, 16 pp.
- Weiss, C. M. and R. W. Helms. 1971. Interlaboratory precision test – An eight-laboratory evaluation of the Provisional Algal Assay Procedure: Bottle Test. National Eutrophication Research Program, U. S. Environmental Protection Agency, Corvallis, Oregon. 70 pp.

## BIOLOGICAL METHODS

### 6.3 Periphyton

- Burbank, W. D., and D. M. Spoon. 1967. The use of sessile ciliates collected in plastic petri dishes for rapid assessment of water pollution. *J. Protozool.* 14(4):739-744.
- Cairns, J., Jr. 1968. The effects of dieldrin on diatoms. *Mosq. News*, 28(2):177-179.
- Cairns, J., Jr. 1969. Rate of species diversity restoration following stress in freshwater protozoan communities. *Univ. Kansas, Sci. Bull.* 48:209-224.
- Cairns, J., Jr., and K. L. Dickson. 1970. Reduction and restoration of the number of fresh-water protozoan species following acute exposure to copper and zinc. *Trans. Kansas Acad. Sci.* 73(1):1-10.
- Cairns, J., Jr., A. Scheier, and N. E. Hess. 1964. The effects of alkyl benzene sulfonate on aquatic organisms. *Ind. Water Wastes*, 1(9):1-7.
- Fitzgerald, G. P. 1964. Factors in the testing and application of algicides. *Appl. Microbiol.* 12(3):247-253.
- Jackson, H. W., and W. A. Brungs. 1966. Biomonitoring industrial effluents. *Ind. Water Eng.* 45:14-18.
- McIntire, C. D., R. L. Garrison, H. K. Phinney, and C. E. Warren. 1964. Primary production in laboratory streams. *Limnol. Oceanogr.* 9(1):92-102.
- McIntire, C. D., and H. K. Phinney. 1965. Laboratory studies of periphyton production and community metabolism in lotic environments. *Ecol. Monogr.* 35:237-258.
- McIntire, C. D. 1966a. Some effects of current velocity on periphyton communities in laboratory streams. *Hydrobiol.* 27:559-570.
- McIntire, C. D. 1966b. Some factors affecting respiration of periphyton communities in lotic environments. *Ecology*, 47:918-930.
- McIntire, C. D. 1968a. Structural characteristics of benthic algal communities in laboratory streams. *Ecology*, 49(3):520-537.
- McIntire, C. D. 1968b. Physiological-ecological studies of benthic algae in laboratory streams. *JWPCF*, 40(11) Part 1:1940-1952.
- Otto, N. E. 1968. Algacidal evaluation methods using the filamentous green alga, *Cladophora*. Rep. No. WC-40, Div. Res., Bur. Reclam., USDI, Denver.
- Patrick, R. 1964. Tentative method of test for evaluating inhibitory toxicity of industrial waste waters. ASTM Standards, Part 23, pp. 517-525, American Society for Testing and Materials, Philadelphia, Pa.
- Patrick, R. 1966. The effect of varying amounts and ratios of nitrogen and phosphate on algae blooms. *Proc. Ind. Waste Conf. (Purdue)* 21:41-51.
- Patrick, R. 1968. The structure of diatom communities in similar ecological conditions. *Amer. Nat.* 102(924):173-183.
- Patrick, R., J. Cairns, Jr., and A. Scheier. 1968a. The relative sensitivity of diatoms, snails, and fish to twenty common constituents of industrial wastes. *Prog. Fish-Cult.* 30(3):137-140.
- Patrick, R., B. Crum, and J. Coles. 1969. Temperature and manganese as determining factors in the presence of diatom or blue-green algal floras in streams. *Proc. Nat. Acad. Sci. Phil.* 64(2):472-478.
- Patrick, R., N. A. Roberts, and B. Davis. 1968b. The effect of changes in pH on the structure of diatom communities. *Not. Natur.* 416:1-16.
- Phaup, J. D., and J. Gannon. 1967. Ecology of *Sphaerotilus* in an experimental outdoor channel. *Water Res.* 1:523-541.
- Phinney, H. K., and C. D. McIntire. 1965. Effect of temperature on metabolism of periphyton communities developed in laboratory streams. *Limnol. Oceanogr.* 10(3):341-344.
- Whitford, L. A. 1960. The current effect and growth of fresh-water algae. *Trans. Amer. Microsc. Soc.* 79(3):302-309.
- Whitford, L. A., G. E. Dillard, and F. J. Schumacher. 1964. An artificial stream apparatus for the study of lotic organisms. *Limnol. Oceanogr.* 9(4):598-600.
- Whitton, B. A. 1967. Studies on the growth of riverain *Cladophora* in culture. *Arch. Mikrobiol.* 58:21-29.
- Whitton, B. A. 1970. Toxicity of zinc, copper, and lead to Chlorophyta from flowing waters. *Arch. Mikrobiol.* 72:353-360.
- Williams, L. G., and D. I. Mount. 1965. Influence of zinc on periphytic communities. *Amer. J. Bot.* 52(1):26-34.
- Wuhrmann, K. 1964. River bacteriology and the role of bacteria in self-purification of rivers. In: *Principles and Applications in Aquatic Microbiology*. John Wiley, NY.
- Zimmermann, P. 1961. Experimentelle Untersuchungen über die ökologische Wirkung der Stromungsgeschwindigkeit auf die Lebensgemeinschaft des fließenden Wassers. *Schweiz. z. Hydrol.* 23:1-81.

### 6.4 Macroinvertebrates

- Arthur, J. W., and E. N. Leonard. 1970. Effects of copper on *Gammarus pseudolimnaeus*, *Physa integra*, and *Campeloma decisum* in soft water. *J. Fish. Res. Bd. Canada*, 27:1277-1283.
- Bell, H. L., and A. V. Nebeker. 1969. Preliminary studies on the tolerance of aquatic insects to low pH. *J. Kansas Entomol. Soc.* 42:230-236.
- Biesinger, K. E., and G. M. Christensen. 1971. Metal effects on survival, growth, and reproduction and metabolism of *Daphnia magna*. National Water Quality Laboratory, Duluth, Minnesota. 43 pp.

## BIOLOGICAL METHODS

- Dimick, R. E., and W. P. Breese. 1965. Bay mussel embryo bioassay. Proc. 12th Pacific Northwest Ind. Conf., College of Engineering, Univ. of Wash. pp. 165-175.
- Gaufin, A. R. 1971. Water quality requirements of aquatic insects. Department of Biology, University of Utah. Contract No. 14-12-438, USDI, FWPCA, National Water Quality Laboratory, Duluth. 65 pp.
- Wolke, C. E. 1967. Measurement of water quality with the Pacific oyster embryo bioassay. In: Water Quality Criteria, Amer. Soc. for Testing and Materials, Special Tech. Pub. No. 416. pp. 112-120.

### 6.5 Fish

- Brungs, W. A. 1969. Chronic toxicity of zinc of the fathead minnow, *Pimephales promelas* Rafinesque. Trans. Amer. Fish. Soc. 98:272-279.
- Eaton, J. G. 1970. Chronic malathion toxicity to the bluegill (*Lepomis macrochirus* Rafinesque). Water Res. 4:673-684.
- McKim, J. M., and D. A. Benoit. 1971. Effects of long-term exposures to copper on survival, growth, and reproduction of brook trout *Salvelinus fontinalis* (Mitchill). J. Fish. Res. Bd. Canada, 28:655-662.
- Mount, D. I., and C. E. Stephan. 1969. Chronic toxicity of copper to the fathead minnow (*Pimephales promelas*, Rafinesque) in soft water. J. Fish. Res. Bd. Canada, 26:2449-2457.
- Sprague, J. B. 1969. Measurement of pollutant toxicity to fish. I. Bioassay methods for acute toxicity. Water Res. 3:793-821.
- Sprague, J. B. 1970. Measurement of pollutant toxicity to fish. II. Utilizing and applying bioassay results. Water Res. 4:3-32.

11-149

**RECOMMENDED BIOASSAY PROCEDURES**  
**NATIONAL WATER QUALITY LABORATORY**  
**DULUTH, MINNESOTA**

Recommended Bioassay Procedures are established by the approval of both the Committee on Aquatic Bioassays and the Director of the National Water Quality Laboratory. The main reasons for establishing them are: (1) to permit direct comparison of test results, (2) to encourage the use of the best procedures available, and (3) to encourage uniformity. These procedures should be used by National Water Quality Laboratory personnel whenever possible, unless there is a good reason for using some other procedure.

Recommended Bioassay Procedures consider the basic elements that are believed to be important in obtaining reliable and reproducible results in

laboratory bioassays. An attempt has been made to adopt the best acceptable procedures based on current evidence and opinion, although it is recognized that alternative procedures may be adequate. Improvements in the procedures are being considered and tested, and revisions will be made when necessary. Comments and suggestions are encouraged.

Director, National Water Quality Lab (NWQL)

Committee on Aquatic Bioassays, NWQL

150

13



Fathead Minnow *Pimephales promelas*  
Rafinesque Chronic Tests  
April, 1971  
(Revised January, 1972)

## 1.0 PHYSICAL SYSTEM

### 1.1 Diluter

Proportional diluters (Mount and Brungs, 1967) should be employed for all long-term exposures. Check the operation of the diluter daily, either directly or through measurement of toxicant concentrations. A minimum of five toxicant concentrations and one control should be used for each test with a dilution factor of not less than 0.30. An automatically triggered emergency aeration and alarm system must be installed to alert staff in case of diluter, temperature control or water supply failure.

### 1.2 Toxicant Mixing

A container to promote mixing of toxicant-bearing and w-cell water should be used between diluter and tanks for each concentration. Separate delivery tubes should run from this container to each duplicate tank. Check at least once every month to see that the intended amounts of water are going to each duplicate tank or chamber.

### 1.3 Tank

Two arrangements of test tanks (glass, or stainless steel with glass ends) can be utilized:

- a. Duplicate spawning tanks measuring 1 X 1 X 3 ft. long with a one sq. ft. portion at one end screened off and divided in half for the progeny. Test water is to be delivered separately to the larval and spawning chambers of each tank, with about one-third the water volume going to the former chamber as to the latter.
- b. Duplicate spawning tanks measuring 1 X 1 X 2 ft. long with a separate duplicate progeny tank for each spawning tank. The larval tank for each spawning tank should be a minimum of 1 cu. ft. dimensionally

and divided to form two separate larval chambers with separate standpipes, or separate 1/2 sq. ft. tanks may be used. Test water is to be supplied by delivery tubes from the mixing cells described in Step 2 above.

Test water depth in tanks and chambers for both a and b above should be 6 inches.

### 1.4 Flow Rate

The flow rate to each chamber (larval or adult) should be equal to 6 to 10 tank volumes/24 hr.

### 1.5 Aeration

Total dissolved oxygen levels should never be allowed to drop below 60% of saturation, and flow rates must be increased if oxygen levels do drop below 60%. As a first alternative, flow rates can be increased above those specified in 1.4. Only aerate (with oil free air) if testing a non-volatile toxic agent, and then as a last resort to maintain dissolved oxygen at 60% of saturation.

### 1.6 Cleaning

All adult tanks, and larvae tanks and chambers after larvae swim-up, must be siphoned a minimum of 2 times weekly and brushed or scraped when algal or fungus growth becomes excessive.

### 1.7 Spawning Substrate

Use spawning substrates made from inverted cement and asbestos halved, 3-inch ID drain tile, or the equivalent, each of these being 3 inches long.

### 1.8 Egg Cup

Egg incubation cups are made from either 3-inch sections of 2-inch OD (1 1/2-inch ID) polyethylene water hose or 4-oz., 2-inch OD round glass jars with the bottoms cut off. One end of the jar or hose sections is covered with

## BIOLOGICAL METHODS

stainless steel or nylon screen (with a minimum of 40 meshes per inch). Cups are oscillated in the test water by means of a rocker arm apparatus driven by a 2 r.p.m. electric motor (Mount, 1968). The vertical-travel distance of the cups should be 1 to 1 1/2 inches.

### 1.9 Eight

The lights used should simulate sunlight as nearly as possible. A combination of Duro-Test (Optima FS)<sup>1,2</sup> and wide spectrum Grow-lux<sup>3</sup> fluorescent tubes has proved satisfactory at the NWQL.

### 1.10 Photoperiod

The photoperiods to be used (Appendix A) simulate the dawn to dusk times of Evansville, Indiana. Adjustments in day-length are to be made on the first and fifteenth day of every Evansville test month. The table is arranged so that adjustments need be made only in the dusk times. Regardless of the *actual* date that the experiment is started, the Evansville *test* photoperiod should be adjusted so that the mean or estimated hatching date of the fish used to start the experiment corresponds to the Evansville test day-length for December first. Also, the dawn and dusk times listed in the table need *not* correspond to the actual times where the experiment is being conducted. To illustrate these points, an experiment started with 5-day-old larvae in Duluth, Minnesota, on August 28 (actual date), would require use of a December 5 Evansville test photoperiod, and the lights could go on anytime on that day just so long as they remained on for 10 hours and 45 minutes. Ten days later (Sept. 7 actual date, Dec. 15 Evansville test date) the day-length would be changed to 10 hours and 30 minutes. Gradual changes in light intensity at dawn and dusk (Drummond and Dawson, 1970), if desired, should be included within the day-lengths shown, and should not last for more than 1/2 hour from full on to full off and vice versa.

<sup>1</sup> Mention of trade names does not constitute endorsement.

<sup>2</sup> Duro-Test, Inc., Hammond, Ind.

<sup>3</sup> Sylvania, Inc., New York, N. Y.

### 1.11 Temperature

Temperature should not deviate instantaneously from 25°C by more than 2°C and should not remain outside the range of 24 to 26°C for more than 48 hours at a time. Temperature should be recorded continuously.

### 1.12 Disturbance

Adults and larvae should be shielded from disturbances such as people continually walking past the chambers, or from extraneous lights that might alter the intended photoperiod.

### 1.13 Construction Materials

Construction materials which contact the diluent water should not contain leachable substances and should not sorb significant amounts of substances from the water. Stainless steel is probably the preferred construction material. Glass absorbs some trace organics significantly. Rubber should not be used. Plastic containing fillers, additives, stabilizers, plasticizers, etc., should not be used. Teflon, nylon, and their equivalents should not contain leachable materials and should not sorb significant amounts of most substances. Unplasticized polyethylene and polypropylene should not contain leachable substances, but may sorb very significant amounts of trace organic compounds.

### 1.14 Water

The water used should be from a well or spring if at all possible, or alternatively from a surface water source. Only as a last resort should water from a chlorinated municipal water supply be used. If it is thought that the water supply could be conceivably contaminated with fish pathogens, the water should be passed through an ultraviolet or similar sterilizer immediately before it enters the test system.

## 2.0 BIOLOGICAL SYSTEM

### 2.1 Test Animals

If possible, use stocks of fathead minnows from the National Water Quality Laboratory in Duluth, Minnesota or the Fish Toxicology

Laboratory in Newtown, Ohio. Groups of starting fish should contain a mixture of approximately equal number of eggs or larvae from at least three different females. Set aside enough eggs or larvae at the start of the test to supply an adequate number of fish for the acute mortality bioassays used in determining application factors.

## 2.2 Beginning Test

In beginning the test, distribute 40 to 50 eggs or 1- to 5-day-old larvae per duplicate tank using a stratified random assignment (see 4.3). All acute mortality tests should be conducted when the fish are 2 to 3 months old. If eggs or 1- to 5-day-old larvae are not available, fish up to 30 days of age may be used to start the test. If fish between 20 and 60 days old are used, the exposure should be designated a partial chronic test. Extra test animals may be added at the beginning so that fish can be removed periodically for special examinations (see 2.12.) or for residue analysis (see 3.4).

## 2.3 Food

Feed the fish a frozen trout food (e.g., Oregon Moist). A minimum of once daily, fish should be fed *ad libitum* the largest pellet they will take. Diets should be supplemented weekly with live or frozen-live food (e.g., *Daphnia*, chopped earthworms, fresh or frozen brine shrimp, etc.). Larvae should be fed a fine trout starter a minimum of 2 times daily, *ad libitum*; one feeding each day of live young zooplankton from mixed cultures of small copepods, rotifers, and protozoans is highly recommended. Live food is especially important when larvae are just beginning to feed, or about 8 to 10 days after egg deposition. Each batch of food should be checked for pesticides (including DDT, TDE, dieldrin, lindane, methoxychlor, endrin, aldrin, BHC, chlordane, toxaphene, 2,4-D, and PCBs), and the kinds and amounts should be reported to the project officer or recorded.

## 2.4 Disease

Handle disease outbreaks according to their nature, with all tanks receiving the same treatment whether there seems to be sick fish in all

of them or not. The frequency of treatment should be held to a minimum.

## 2.5 Measuring Fish

Measure total lengths of all starting fish at 30 and 60 days by the photographic method used by McKim and Benoit (1971). Larvae or juveniles are transferred to a glass box containing 1 inch of test water. Fish should be moved to and from this box in a water-filled container, rather than by netting them. The glass box is placed on a translucent millimeter grid over a fluorescent light platform to provide background illumination. Photos are then taken of the fish over the millimeter grid and are enlarged into 8 by 10 inch prints. The length of each fish is subsequently determined by comparing it to the grid. Keep lengths of discarded fish separate from those of fish that are to be kept.

## 2.6 Thinning

When the starting fish are sixty ( $\pm 1$  or 2) days old, impartially reduce the number of surviving fish in each tank to 15. Obviously injured or crippled individuals may be discarded before the selection so long as the number is not reduced below 15; be sure to record the number of deformed fish discarded from each tank. As a last resort in obtaining 15 fish per tank, 1 or 2 fish may be selected for transfer from one duplicate to the other. Place five spawning tiles in each duplicate tank, separated fairly widely to reduce interactions between male fish guarding them. One should also be able to look under tiles from the end of the tanks. During the spawning period, sexually maturing males must be removed at weekly intervals so there are no more than four per tank. An effort should be made *not* to remove those males having well established territories under tiles where recent spawnings have occurred.

## 2.7 Removing Eggs

Remove eggs from spawning tiles starting at 12:00 noon Evansville test time (Appendix A) each day. As indicated in Step 1.10, the test time need not correspond to the actual time where the test is being conducted. Eggs are loosened from the spawning tiles and at the

## BIOLOGICAL METHODS

same time separated from one another by lightly placing a finger on the egg mass and moving it in a circular pattern with increasing pressure until the eggs begin to roll. The groups of eggs should then be washed into separate, appropriately marked containers and subsequently handled (counted, selected for incubation, or discarded) as soon as possible after all eggs have been removed and the spawning tiles put back into the test tanks. All egg batches must be checked initially for different stages of development. If it is determined that there is more than one distinct stage of development present, then each stage must be considered as one spawning and handled separately as described in Step 2.8.

### 2.8 Egg Incubation and Larval Selection

Impartially select 50 unbroken eggs from spawnings of 50 eggs or more and place them in an egg incubator cup for determining viability and hatchability. Count the remaining eggs and discard them. Viability and hatchability determinations must be made on each spawning (>49 eggs) until the number of spawnings (>49 eggs) in each duplicate tank equals the number of females in that tank. Subsequently, only eggs from every third spawning (>49 eggs) and none of those obtained on weekends need be set up to determine hatchability; however, weekend spawns must still be removed from tiles and the eggs counted. If unforeseen problems are encountered in determining egg viability and hatchability, additional spawnings should be sampled before switching to the setting up of eggs from every third spawning. Every day, record the live and dead eggs in the incubator cups, remove the dead ones, and clean the cup screens. Total numbers of eggs accounted for should always add up to within two of 50 or the entire batch is to be discarded. When larvae begin to hatch, generally after 4 to 6 days, they should not be handled again or removed from the egg-cups until all have hatched. Then, if enough are still alive, 40 of these are eligible to be transferred immediately to a larval test chamber. Those individuals selected out to bring the number kept to 40 should be chosen impartially. Entire egg-cup-groups not used for survival and growth studies should be counted and discarded.

### 2.9 Progeny Transfer

Additional important information on hatchability and larval survival is to be gained by transferring control eggs immediately after spawning to concentrations where spawning is reduced or absent, or to where an effect is seen on survival of eggs or larvae, and by transferring eggs from these concentrations to the control tanks. One larval chamber in, or corresponding to, each adult tank should always be reserved for eggs produced in that tank.

### 2.10 Larval Exposure

From early spawnings in each duplicate tank, use the larvae hatched in the egg incubator cups (Step 2.8. above) for 30 or 60 day growth and survival exposures in the larval chambers. Plan ahead in setting up eggs for hatchability so that a new group of larvae is ready to be tested for 30 or 60 days as soon as possible after the previously tested group comes out of the larval chambers. Record mortalities, and measure total lengths of larvae at 30 and, if they are kept, 60 days posthatch. At the time the larval test is terminated they should also be weighed. No fish (larvae, juveniles, or adults) should be fed within 24 hr's. of when they are to be weighed.

### 2.11 Parental Termination

Parental fish testing should be terminated when, during the receding day-length photoperiod, a one week period passes in which no spawning occurs in any of the tanks. Measure total lengths and weights of parental fish; check sex, and condition of gonads. The gonads of most parental fish will have begun to regress from the spawning condition, and thus the differences between the sexes will be less distinct now than previously. Males and females that are readily distinguishable from one another because of their external characteristics should be selected initially for determining how to differentiate between testes and ovaries. One of the more obvious external characteristics of females that have spawned is an extended, transparent anal canal (urogenital papilla). The gonads of both sexes will be located just ventral to the kidneys. The ovaries of the females at this time will appear transparent, but perhaps con-

taining some yellow pigment, coarsely granular, and larger than testes. The testes of males will appear as slender, slightly milky, and very finely granular strands. Fish must not be frozen before making these examinations.

### 2.12 Special Examinations

Fish and eggs obtained from the test should be considered for physiological, biochemical, histological and other examinations which may indicate certain toxicant-related effects.

### 2.13 Necessary Data

Data that must be reported for each tank of a chronic test are:

- a. Number and individual total length of normal and deformed fish at 30 and 60 days; total length, weight and number of either sex, both normal and deformed, at end of test.
- b. Mortality during the test.
- c. Number of spawns and eggs.
- d. Hatchability.
- e. Fry survival, growth, and deformities.

## 3.0 CHEMICAL SYSTEM

### 3.1 Preparing a Stock Solution

If a toxicant cannot be introduced into the test water, as is, a stock solution should be prepared by dissolving the toxicant in water or an organic solvent. Acetone has been the most widely used solvent, but dimethylformamide (DMF) and triethylene glycol may be preferred in many cases. If none of these solvents are acceptable, other water-miscible solvents such as methanol, ethanol, isopropanol, acetonitrile, dimethylacetamide (DMAC), 2-ethoxyethanol, glyme (dimethylether of ethylene glycol, diglyme (dimethyl ether of diethylene glycol) and propylene glycol should be considered. However, dimethyl sulfoxide (DMSO) should not be used if at all possible because of its biological properties.

Problems of rate of solubilization or solubility limit should be solved by mechanical means if at all possible. Solvents, or as a last resort, surfactants, can be used for this purpose, only after

they have been proven to be necessary in the actual test system. The suggested surfactant is p-tert-octylphenoxynonaethoxy-ethanol (p-1, 1, 3, 3-tetramethylbutylphenoxynonaethoxy-ethanol, OPE<sub>10</sub>) (Triton X-100, a product of the Rohm and Haas Company, or equivalent).

The use of solvents, surfactants, or other additives should be avoided whenever possible. If an additive is necessary, reagent grade or better should be used. The amount of an additive used should be kept to a minimum, but the calculated concentration of a solvent to which any test organisms are exposed must never exceed one one-thousandth of the 96-hr. LC50 for test species under the test conditions and must never exceed one gram per liter of water. The calculated concentration of surfactant or other additive to which any test organisms are exposed must never exceed one-twentieth of the concentration of the toxicant and must never exceed one-tenth gram per liter of water. If any additive is used, two sets of controls must be used, one exposed to no additives and one exposed to the highest level of additives to which any other organisms in the test are exposed.

### 3.2 Measurement of Toxicant Concentration

As a minimum, the concentration of toxicant must be measured in one tank at each toxicant concentration every week for each set of duplicate tanks, alternating tanks at each concentration from week to week. Water samples should be taken about midway between the top and bottom and the sides of the tank and should not include any surface scum or material stirred up from the bottom or sides of the tank. Equivolume daily grab samples can be composited for a week if it has been shown that the results of the analysis are not affected by storage of the sample.

Enough grouped grab samples should be analyzed periodically throughout the test to determine whether or not the concentration of toxicant is reasonably constant from day to day in one tank and from one tank to its duplicate. If not, enough samples must be analyzed weekly throughout the test to show the variability of the toxicant concentration.



## BIOLOGICAL METHODS

### 3.3 Measurement of Other Variables

Temperature must be recorded continuously (see 1.11.).

Dissolved oxygen must be measured in the tanks daily, at least five days a week on an alternating basis, so that each tank is analyzed once each week. However, if the toxicant or an additive causes a depression in dissolved oxygen, the toxicant concentration with the lowest dissolved oxygen concentration must be analyzed daily in addition to the above requirement.

A control and one test concentration must be analyzed weekly for pH, alkalinity, hardness, acidity, and conductance, or more often, if necessary, to show the variability in the test water. However, if any of these characteristics are affected by the toxicant, the tanks must be analyzed for that characteristic daily, at least five days a week, on an alternating basis so that each tank is analyzed once every other week.

At a minimum, the test water must be analyzed at the beginning and near the middle of the test for calcium, magnesium, sodium, potassium, chloride, sulfate, total solids, and total dissolved solids.

### 3.4 Residue Analysis

When possible and deemed necessary, mature fish, and possibly eggs, larvae, and juveniles, obtained from the test, should be analyzed for toxicant residues. For fish, muscle should be analyzed, and gill, blood, brain, liver, bone, kidney, GI tract, gonad, and skin should be considered for analysis. Analyses of whole organisms may be done in addition to, but should not be done in place of, analyses of individual tissues, especially muscle.

### 3.5 Methods

When they will provide the desired information with acceptable precision and accuracy, methods described in Methods for Chemical Analysis of Water and Wastes (EPA, 1971) should be used unless there is another method which requires much less time and can provide the desired information with the same or better precision and accuracy. At a minimum, accuracy should be measured using the method of known additions for all analytical methods for tox-

icants. If available, reference samples should be analyzed periodically for each analytical method.

## 4.0 STATISTICS

### 4.1 Duplicates

Use true duplicates for each level of toxic agent, i.e., no water connections between duplicate tanks.

### 4.2 Distribution of Tanks

The tanks should be assigned to locations by stratified random assignment (random assignment of one tank for each level of toxic agent in a row followed by random assignment of the second tank for each level of toxic agent in another or an extension of the same row).

### 4.3 Distribution of Test Organisms

The test organisms should be assigned to tanks by stratified random assignment (random assignment of one test organism to each tank, random assignment of a second test organism to each tank, etc.).

## 5.0 MISCELLANEOUS

### 5.1 Additional Information

All routine bioassay flow-through methods not covered in this procedure (e.g., physical and chemical determinations, handling of fish) should be followed as described in Standard Methods for the Examination of Water and Wastewater, (American Public Health Association, 1971), or information requested from appropriate persons at Duluth or Newtown.

### 5.2 Acknowledgments

These procedures for the fathead minnow were compiled by John Eaton for the Committee on Aquatic Bioassays. The participating members of this committee are: Robert Andrew, John Arthur, Duane Benoit, Gerald Bouck, William Brungs, Gary Chapman, John Eaton, John Hale, Kenneth Hokanson, James McKim, Quentin Pickering, Wesley Smith, Charles Stephan, and James Tucker.



## 6.0 REFERENCES

For additional information concerning flow through bioassays with fathead minnows, the following references are listed:

- American Public Health Association. 1971. Standard methods for the examination of water and wastewater. 13th ed. APHA. New York.
- Brungs, William A. 1969. Chronic toxicity of zinc to the fathead minnow, *Pimephales promelas* Rafinesque. Trans. Amer. Fish. Soc. 98(2): 272-279.
- Brungs, William A. 1971. Chronic effects of low dissolved oxygen concentrations on the fathead minnow (*Pimephales promelas*). J. Fish. Res. Bd. Canada, 28(8): 1119-1123.
- Brungs, William A. 1971. Chronic effects of constant elevated temperature on the fathead minnow (*Pimephales promelas*). Trans. Amer. Fish. Soc. 100(4): 659-664.
- Carlson, Dale R. 1967. Fathead minnow, *Pimephales promelas* Rafinesque, in the Des Moines River, Boone County, Iowa, and the Skunk River drainage, Hamilton and Story Counties, Iowa. Iowa State J. Sci. 41(3): 363-374.
- Drummond, Robert A., and Walter F. Dawson. 1970. An inexpensive method for simulating Diel patterns of lighting in the laboratory. Trans. Amer. Fish. Soc. 99(2): 434-435.
- Isaak, Daniel. 1961. The ecological life history of the fathead minnow, *Pimephales promelas* (Rafinesque). Ph.D. Thesis, Library, Univ. of Minnesota.
- Markus, Henry C. 1934. Life history of the fathead minnow (*Pimephales promelas*). Copeia, (3): 116-122.
- McKim, J. M., and D. A. Benoit. 1971. Effect of long-term exposures to copper on survival, reproduction, and growth of brook trout *Salvelinus fontinalis* (Mitchill). J. Fish. Res. Bd. Canada, 28: 655-662.
- Mount, Donald I. 1968. Chronic toxicity of copper to fathead minnows (*Pimephales promelas*, Rafinesque). Water Res. 2: 215-223.
- Mount, Donald I., and William Brungs. 1967. A simplified dosing apparatus for fish toxicology studies. Water Res. 1: 21-29.
- Mount, Donald I., and Charles E. Stephan. 1967. A method for establishing acceptable toxicant limits for fish - malathion and the butoxyethanol ester of 2,4-D. Trans. Amer. Fish. Soc. 96(2): 185-193.
- Mount, Donald I., and Charles E. Stephan. 1969. Chronic toxicity of copper to the fathead minnow (*Pimephales promelas*) in soft water. J. Fish. Res. Bd. Canada, 26(9): 2449-2457.
- Mount, Donald I., and Richard E. Warner. 1965. A serial-dilution apparatus for continuous delivery of various concentrations of materials in water. PHS Publ. No. 999-WP-23. 16 pp.
- Pickering, Quentin H., and Thomas O. Thatcher. 1970. The chronic toxicity of linear alkylate sulfonate (LAS) to *Pimephales promelas* Rafinesque. JWPCF, 42(2): 243-254.
- Pickering, Quentin H., and William N. Vigor. 1965. The acute toxicity of zinc to eggs and fry of the fathead minnow. Progr. Fish-Cult. 27(3): 153-157.
- Verma, Prabha. 1969. Normal stages in the development of *Cyprinus carpio* var. communis L. Acta biol. Acad. Sci. Hung. 21(2): 207-218.

FATHEAD MINNOW BIOASSAY

Appendix A  
 Test (Evansville, Indiana) Photoperiod  
 For Fathead Minnow Chronic

| <u>Dawn to Dusk<br/>Time</u> | <u>Date</u> | <u>Day-length (hour and minute)</u> |                                       |
|------------------------------|-------------|-------------------------------------|---------------------------------------|
| 6:00 - 4:45)                 | DEC. 1      | 10:45)                              |                                       |
| 6:00 - 4:30)                 | 15          | 10:30)                              |                                       |
|                              |             | )                                   |                                       |
| 6:00 - 4:30)                 | JAN. 1      | 10:30)                              |                                       |
| 6:00 - 4:45)                 | 15          | 10:45)                              |                                       |
|                              |             | )                                   |                                       |
| 6:00 - 5:15)                 | FEB. 1      | 11:15)                              | 5-month pre-spawning<br>growth period |
| 6:00 - 5:45)                 | 15          | 11:45)                              |                                       |
|                              |             | )                                   |                                       |
| 6:00 - 6:15)                 | MAR. 1      | 12:15)                              |                                       |
| 6:00 - 7:00)                 | 15          | 13:00)                              |                                       |
|                              |             | )                                   |                                       |
| 6:00 - 7:30)                 | APR. 1      | 13:30)                              |                                       |
| 6:00 - 8:15)                 | 15          | 14:15)                              |                                       |
|                              |             | )                                   |                                       |
| 6:00 - 8:45)                 | MAY 1       | 14:45)                              |                                       |
| 6:00 - 9:15)                 | 15          | 15:15)                              |                                       |
|                              |             | )                                   |                                       |
| 6:00 - 9:30)                 | JUNE 1      | 15:30)                              | 4-month spawning<br>period            |
| 6:00 - 9:45)                 | 15          | 15:45)                              |                                       |
|                              |             | )                                   |                                       |
| 6:00 - 9:45)                 | JULY 1      | 15:45)                              |                                       |
| 6:00 - 9:30)                 | 15          | 15:30)                              |                                       |
|                              |             | )                                   |                                       |
| 6:00 - 9:00)                 | AUG. 1      | 15:00)                              |                                       |
| 6:00 - 8:30)                 | 15          | 14:30)                              |                                       |
|                              |             | )                                   |                                       |
| 6:00 - 8:00)                 | SEPT. 1     | 14:00)                              |                                       |
| 6:00 - 7:30)                 | 15          | 13:30)                              |                                       |
|                              |             | )                                   |                                       |
| 6:00 - 6:45)                 | OCT. 1      | 12:45)                              | post spawning period                  |
| 6:00 - 6:15)                 | 15          | 12:15)                              |                                       |
|                              |             | )                                   |                                       |
| 6:00 - 5:30)                 | NOV. 1      | 11:30)                              |                                       |
| 6:00 - 5:00)                 | 15          | 11:00)                              |                                       |

Brook Trout *Salvelinus fontinalis*  
(Mitchill) Partial Chronic Tests  
April, 1971  
(Revised January, 1972)

## 1.0 PHYSICAL SYSTEM

### 1.1 Diluter

Proportional diluters (Mount and Brungs, 1967) should be employed for all long-term exposures. Check the operation of the diluter daily, either directly or through the measurement of toxicant concentrations. A minimum of five toxicant concentrations and one control should be used for each test with a dilution factor of not less than 0.30. An automatically triggered emergency aeration and alarm system must be installed to alert staff in case of diluter, temperature control or water supply failure.

### 1.2 Toxicant Mixing

A container to promote mixing of toxicant-bearing and well water should be used between diluter and tanks for each concentration. Separate delivery tubes should run from this container to each duplicate tank. Check to see that the same amount of water goes to duplicate tanks and that the toxicant concentration is the same in both.

### 1.3 Tank

Each duplicate spawning tank (preferably stainless steel) should measure 1.3 X 3 X 1 ft. wide with a water depth of 1 foot and alevin-juvenile growth chambers (glass or stainless steel with glass bottom) 7 X 15 X 5 in. wide with a water depth of 5 inches. Growth chambers can be supplied test water by either separate delivery tubes from the mixing cells described in Step 2 above or from test water delivered from the mixing cell to each duplicate spawning tank. In the second choice, test water must always flow through growth chambers before entering the spawning tank. Each growth chamber should be designed so that the test water can be drained down to 1 inch and the chamber transferred over a fluorescent light box for photographing the fish (see 2.10).

### 1.4 Flow Rate

Flow rates for each duplicate spawning tank and growth chamber should be 6-10 tank volumes/24 hr.

### 1.5 Aeration

Brook trout tanks and growth chambers must be aerated with oil free air unless there are no flow limitations and 60% of saturation can be maintained. Total dissolved oxygen levels should never be allowed to drop below 60% of saturation.

### 1.6 Cleaning

All tanks and chambers must be siphoned daily and brushed at least once per week. When spawning commences, gravel baskets must be removed and cleaned daily.

### 1.7 Spawning Substrates

Use two spawning substrates per duplicate made of plastic or stainless steel which measure at least 6 X 10 X 12 in. with 2 inches of .25 to .50 inch stream gravel covering the bottom and 20 mesh stainless steel or nylon screen attached to the ends for circulation of water.

### 1.8 Egg Cup

Egg incubation cups are made from 4-oz. 2-inch OD round glass jars with the bottoms cut off and replaced with stainless steel or nylon screen (40 meshes per inch). Cups are oscillated in the test water by means of a rocker arm apparatus driven by a 2 r.p.m. electric motor (Mount, 1968).

### 1.9 Light

The lights used should simulate sunlight as nearly as possible. A combination of Duro-Test (Optima FS)<sup>1,2</sup> and wide spectrum Gro-lux<sup>3</sup> fluorescent tubes has proved satisfactory at the NWQL.

<sup>1</sup>Mention of trade names does not constitute endorsement.

<sup>2</sup>Duro-Test, Inc., Hammond, Ind.

<sup>3</sup>Sylvania, Inc., New York, N. Y.

## BIOLOGICAL METHODS

### 1.10 Photoperiod

The photoperiods to be used (Appendix A) simulate the dawn to dusk times of Evansville, Indiana. Evansville dates must correspond to actual dates in order to avoid putting natural reproductive cycles out of phase. Adjustments in photoperiod are to be made on the first and fifteenth of every Evansville test month. The table is arranged so that adjustments need be made only in the dusk times. The dawn and dusk times listed in the table (Evansville test time) need *not* correspond to the actual test times where the test is being conducted. To illustrate this point, a test started on March first would require the use of the photoperiod for Evansville test date March first, and the lights could go on any time on that day just so long as they remained on for twelve hours and fifteen minutes. Fifteen days later, the photoperiod would be changed to thirteen hours. Gradual changes in light intensity at dawn and dusk (Mannford and Dawson 1970) may be included within the photoperiods shown, and should not last for more than 1/2 hour from full on to full off and vice versa.

### 1.11 Temperature

Utilize the attached temperature regime (see Appendix B). Temperatures should not deviate instantaneously from the specified test temperature by more than 2°C and should not remain outside the specified temperature  $\pm 1^\circ\text{C}$  for more than 48 hours at a time.

### 1.12 Disturbance

Spawning tanks and growth chambers must be covered with a screen to confine the fish and concealed in such a way that the fish will not be disturbed by persons continually walking past the system. Tanks and chambers must also be shielded from extraneous light which can affect the intended photoperiod or damage light-sensitive eggs and alevins.

### 1.13 Construction Materials

Construction materials which contact the diluent water should not contain leachable substances and should not sorb significant amounts of substances from the water. Stainless steel is

probably the preferred construction material. Glass absorbs some trace organics significantly. Rubber should not be used. Plastic containing fillers, additives, stabilizers, plasticizers, etc., should not be used. Teflon, nylon, and their equivalents should not contain leachable materials and should not sorb significant amounts of most substances. Unplasticized polyethylene and polypropylene should not contain leachable substances, but may sorb very significant amounts of trace organic compounds.

### 1.14 Water

The water used should be from a well or spring if at all possible, or alternatively from a surface water source. Only as a last resort should water from a chlorinated municipal water supply be used. If it is thought that the water supply could be conceivably contaminated with fish pathogens, the water should be passed through an ultraviolet or similar sterilizer immediately before it enters the test system.

## 2.0 BIOLOGICAL SYSTEM

### 2.1 Test Animals

Yearling fish should be collected no later than March 1 and acclimated in the laboratory to test temperature and water quality for at least one month before the test is initiated. Suitability of fish for testing should be judged on the basis of acceptance of food, apparent lack of diseases, and 2% or less mortality during acclimation with no mortality two weeks prior to test. Set aside enough fish to supply an adequate number for short-term bioassay exposures used in determining application factors.

### 2.2 Beginning Test

Begin exposure no later than April 1 by distributing 12 acclimated yearling brook trout per duplicate using a stratified random assignment (see 4.3). This allows about a four-month exposure to the toxicant before the onset of secondary or rapid growth phase of the gonads.

Extra test animals may be added at the beginning so that fish can be removed periodically for special examinations (see 2.13), or for residue analysis (see 3.4).

### 2.3 Food

Use a good frozen trout food (e.g., Oregon Moist). Fish should be fed the largest pellet they will take a minimum of two times daily. The amount should be based on a reliable hatchery feeding schedule. Alevins and early juveniles should be fed trout starter a minimum of five times daily. Each batch of prepared food should be checked for pesticides (including DDT, TDE, dieldrin, endrin, aldrin, BHC, chlordane, toxaphene, 2,4-D, and PCBs), and the kinds and amounts should be reported to the project officer or recorded.

### 2.4 Disease

Handle disease outbreaks according to their nature, with all tanks receiving the same treatment whether there seems to be sick fish in all of them or not. The frequency of treatment should be held to a minimum.

### 2.5 Measuring Fish

Record mortalities daily, and measure fish directly at initiation of test, after three months and at thinning (see 2.6) (total length and weight). Fish should not be fed 24 hours before weighing and lightly anesthetized with MS-222 to facilitate measuring (100 mg MS-222/liter water).

### 2.6 Thinning

When secondary sexual characteristics are well developed (approximately two weeks prior to expected spawning), separate males, females and undeveloped fish in each duplicate and randomly reduce sexually mature fish (see 4.4) to the desired number of 2 males and 4 females, and discard undeveloped fish after examination. Place two spawning substrates (described earlier) in each duplicate. Record the number of mature, immature, deformed and injured males and females in each tank and the number from each category discarded. Measure total length and weight of all fish in each category before any are discarded and note which ones were discarded.

### 2.7 Removing Eggs

Remove eggs from the redds at a fixed time each day (preferably after 1:00 p.m. Evansville

time, so the fish are not disturbed during the morning).

### 2.8 Egg Incubation and Viability

Impartially select 50 eggs from the first eight spawnings of 50 eggs or more in each duplicate and place them in an egg incubator cup for hatch. The remaining eggs from the first eight spawnings (>50 eggs) and all subsequent eggs from spawnings should be counted and placed in separate egg incubator cups for determining viability (formation of neural keel after 11-12 days at 9°C). The number of dead eggs from each spawn removed from the nest should be recorded and discarded. Never place more than 250 eggs in one egg incubator cup. All eggs incubated for viability are discarded after 12 days. Discarded eggs can be used for residue analysis and physiological measurements of toxicant-related effects.

### 2.9 Progeny Transfer

Additional important information on hatchability and alevin survival can be gained by transferring control eggs immediately after spawning to concentrations where spawning is reduced or absent, or to where an affect is seen on survival of eggs or alevin, and by transferring eggs from these concentrations to the control tanks. Two growth chambers for each duplicate spawning tank should always be reserved for eggs produced in that tank.

### 2.10 Hatch and Alevin Thinning

Remove dead eggs daily from the hatchability cups described in Step 2.8 above. When hatching commences, record the number hatched daily in each cup. Upon completion of hatch in any cup, randomly (see 4.4) select 25 alevins from that cup. Dead or deformed alevins must not be included in the random selection but should be counted as being dead or deformed upon hatch. Measure total lengths of the 25 selected and discarded alevins. Total lengths are measured by the photographic method used by McKim and Benoit (1971). The fish are transferred to a glass box containing 1 inch of test water. They should be moved to and from this box in a water-filled container, rather than by netting them. The glass box is placed on a translucent millimeter grid

## BIOLOGICAL METHODS

over a fluorescent light box which provides background illumination. Photos are then taken of the fish over the millimeter grid and are enlarged into 8 X 10 inch prints. The length of each fish is subsequently determined by comparing it to the grid. Keep lengths of discarded alevins separate from those which are kept. Place the 25 selected alevins back into the incubator cup and preserve the discarded ones for initial weights.

### 2.11 Alevin-Juvenile Exposure

Randomly (see 4.4) select from the incubation cups two groups of 25 alevins each per duplicate for 90-day growth and survival exposures in the growth chambers. Hatching from one spawn may be spread out over a 3-to 6-day period; therefore, the median-hatch date should be used to establish the 90-day growth and survival period for each of the two groups of alevins. If it is determined that the median-hatch dates for the five groups per duplicate will be more than three weeks apart, then the two groups of 25 alevins must be selected from those which are less than three weeks old. The remaining groups in the duplicate which do not hatch during the three-week period are used only for hatchability results and then photographed for lengths and preserved for initial weights. In order to equalize the effects of the incubation cups on growth, all groups selected for the 90-day exposure must remain in the incubation cups three weeks before they are released into the growth chambers. Each of the two groups selected per duplicate must be kept separate during the 90-day period. Record mortalities daily, along with total lengths 30 and 60 days post-hatch, and total length and weight at 90 days post-hatch. Alevins and early juveniles should not be fed 24 hours before weighing. Total lengths are measured by transferring the growth chambers described earlier to a translucent millimeter grid over a fluorescent light box for photographing as described in Step 2.10 above. Survival and growth studies should be terminated after three months. Terminated fish can be used for tissue residue analysis and physiological measurements of toxicant-related effects.

### 2.12 Parental Termination

All parental fish should be terminated when a three-week period passes in which no spawning occurs in any of the spawning tanks. Record mortality and weigh and measure total length of parental fish, check sex and condition of gonads (e.g., reabsorption, degree of maturation, spent ovaries, etc.) (see 3.4).

### 2.13 Special Examinations

Fish and eggs obtained from the test should be considered for physiological, biochemical, and histological investigations which may indicate certain toxicant-related effects.

### 2.14 Necessary Data

Data that must be reported for each tank of a chronic test are:

- a. Number and individual weights and total lengths of normal, deformed, and injured mature and immature males and females at initiation of test, three months after test commences, at thinning and at the end of test.
- b. Mortality during the test.
- c. Number of spawns and eggs. A mean incubation time should be calculated using date of spawning and the median-hatch dates.
- d. Hatchability.
- e. Fry survival, growth and deformities.

## 3.0 CHEMICAL SYSTEM

### 3.1 Preparing a Stock Solution

If a toxicant cannot be introduced into the test water as is, a stock solution should be prepared by dissolving the toxicant in water or an organic solvent. Acetone has been the most widely used solvent, but dimethylformamide (DMF) and triethylene glycol may be preferred in many cases. If none of these solvents are acceptable, other water-miscible solvents such as methanol, ethanol, isopropanol, acetonitrile, dimethylacetamide (DMAC), 2-ethoxyethanol, glyme (dimethylether of ethylene glycol) diglyme (dimethyl ether of diethylene glycol)



and propylene glycol should be considered. However, dimethyl sulfoxide (DMSO) should not be used if at all possible because of its biological properties.

Problems of rate of solubilization or solubility limit should be solved by mechanical means if at all possible. Solvents, or as a last resort, surfactants, can be used for this purpose only after they have been proven to be necessary in the actual test system. The suggested surfactant is p-tert-octylphenoxynonaethoxyethanol (p-1, 1, 3, 3-tetramethylbutylphenoxynonaethoxyethanol, OPE<sub>10</sub>) (Triton X-100, a product of the Rohm and Haas Company, or equivalent).

The use of solvents, surfactants, or other additives should be avoided whenever possible. If an additive is necessary, reagent grade or better should be used. The amount of an additive used should be kept to a minimum, but the calculated concentration of a solvent to which any test organisms are exposed must never exceed one one-thousandth of the 96-hr. LC50 for test species under the test conditions, and must never exceed one gram per liter of water. The calculated concentration of surfactant or other additive to which any test organisms are exposed must never exceed one-twentieth of the concentration of the toxicant and must never exceed one-tenth gram per liter of water. If any additive is used, two sets of controls must be used, one exposed to no additives and one exposed to the highest level of additives to which any other organisms in the test are exposed.

### 3.2 Measurement of Toxicant Concentration

As a minimum, the concentration of toxicant must be measured in one tank at each toxicant concentration every week for each set of duplicate tanks, alternating tanks at each concentration from week to week. Water samples should be taken about midway between the top and bottom and the sides of the tank and should not include any surface scum or material stirred up from the bottom or sides of the tank. Equivolume daily grab samples can be composited for a week if it has been shown that the results of the analysis are not affected by storage of the sample.

Enough grouped grab samples should be analyzed periodically throughout the test to determine whether or not the concentration of toxicant is reasonably constant from day to day in one tank and from one tank to its duplicate. If not, enough samples must be analyzed weekly throughout the test to show the variability of the toxicant concentration.

### 3.3 Measurement of Other Variables

Temperature must be recorded continuously (see 1.11).

Dissolved oxygen must be measured in the tanks daily at least five days a week on an alternating basis, so that each tank is analyzed once each week. However, if the toxicant or an additive causes a depression in dissolved oxygen, the toxicant concentration with the lowest dissolved oxygen concentration must be analyzed daily in addition to the above requirement.

A control and one test concentration must be analyzed weekly for pH, alkalinity, hardness, acidity, and conductance, or more often, if necessary, to show the variability in the test water. However, if any of these characteristics are affected by the toxicant, the tanks must be analyzed for that characteristic daily, at least five days a week, on an alternating basis, so that each tank is analyzed once every other week.

At a minimum, the test water must be analyzed at the beginning and near the middle of the chronic test for calcium, magnesium, sodium, potassium, chloride, sulfate, conductance, total solid, and total dissolved solids.

### 3.4 Residue Analysis

When possible and deemed necessary, mature fish, and possibly eggs, larvae, and juveniles, obtained from the test, should be analyzed for toxicant residues. For fish, muscle should be analyzed, and gill, blood, brain, liver, bone, kidney, GI tract, gonad, and skin should be considered for analysis. Analyses of whole organisms may be done in addition to, but should not be done in place of, analyses of individual tissues, especially muscle.

## BIOLOGICAL METHODS

### 3.5 Methods

When they will provide the desired information with acceptable precision and accuracy, methods described in Methods for Chemical Analysis of Water and Wastes (EPA, 1971) should be used unless there is another method which requires much less time and can provide the desired information with the same or better precision and accuracy. At a minimum, accuracy should be measured using the method of known additions for all analytical methods for toxicants. If available, reference samples should be analyzed periodically for each analytical method.

### 4.0 STATISTICS

#### 4.1 Duplicates

Use true duplicates for each level of the toxic agent, i.e., no water connections between duplicate tanks.

#### 4.2 Distribution of Tanks

The tanks should be assigned to locations by stratified random assignment (random assignment of one tank for each level of the toxic agent in a row, followed by random assignment of the second tank for each level of the toxic agent in another or an extension of the same row).

### 6.0 REFERENCES

For additional information concerning flow-through bioassay tests with brook trout, the following references are listed:

- Allison, L. N. 1951. Delay of spawning in eastern brook trout by means of artificially prolonged light intervals. *Prog. Fish-Cult.* 13: 111-116.
- American Public Health Association. 1971. Standard methods for the examination of water and wastewater. 13th ed. APHA, New York.
- Carson, B. W. 1955. Four years progress in the use of artificially controlled light to induce early spawning of brook trout. *Prog. Fish-Cult.* 17: 99-102.
- Drummond, Robert A., and Walter F. Dawson. 1970. An inexpensive method for simulating Diel patterns of lighting in the laboratory. *Trans. Amer. Fish. Soc.* 99(2): 434-435.
- Fabricius, E. 1953. Aquarium observations on the spawning behavior of the char, *Salmo alpinus*. *Rep. Inst. Freshwater Res., Drottningholm*, 34: 14-48.
- Hale, J. G. 1963. Observations on brook trout, *Salvelinus fontinalis* spawning in 10-gallon aquaria. *Trans. Amer. Fish. Soc.* 92: 299-301.
- Henderson, N. E. 1962. The annual cycle in the testis of the eastern brook trout, *Salvelinus fontinalis* (Mitchill). *Can. J. Zool.* 40: 631-645.

### 4.3 Distribution of Test Organisms

The test organisms should be assigned to tanks by stratified random assignment (random assignment of one test organism to each tank, random assignment of a second test organism to each tank, etc.).

### 4.4 Selection and Thinning Test Organisms

At time of selection or thinning of test organisms the choice must be random (random, as defined statistically).

### 5.0 MISCELLANEOUS

#### 5.1 Additional Information

All routine bioassay flow-through methods not covered in this procedure (e.g., physical and chemical determinations, handling of fish) should be followed as described in Standard Methods for the Examination of Water and Wastewater (American Public Health Association, 1971).

#### 5.2 Acknowledgments

These procedures for the brook trout were compiled by J. M. McKim and D. A. Benoit for the Committee on Aquatic Bioassays. The participating members of this committee are: Robert Andrew, John Arthur, Duane Benoit, Gerald Bouck, William Brungs, Gary Chapman, John Eaton, John Hale, Kenneth Hokanson, James McKim, Quentin Pickering, Wesley Smith, Charles Stephan, and James Tucker.

## BROOK TROUT BIOASSAY

- Henderson, N. E. 1963. Influence of light and temperature on the reproductive cycle of the eastern brook trout *Salvelinus fontinalis* (Mitchill). J. Fish. Res. Bd. Canada, 20(4): 859-897.
- Hoover, E. E., and H. E. Hubbard, 1937. Modification of the sexual cycle in trout by control of light. Copeia, 4: 206-210.
- MacFadden, J. 1961. A population study of the brook trout *Salvelinus fontinalis* (Mitchill). Wildlife Soc. Pub. No. 7.
- McKim, J. M., and D. A. Benoit. 1971. Effect of long-term exposures to copper on survival, reproduction, and growth of brook trout *Salvelinus fontinalis* (Mitchill). J. Fish. Res. Bd. Canada, 28: 655-662.
- Mount, Donald I. 1968. Chronic toxicity of copper to fathead minnows (*Pimephales promelas*, Rafinesque). Water Res. 2: 215-223.
- Mount, Donald I., and William Brungs. 1967. A simplified dosing apparatus for fish toxicology studies. Water Res. 1: 21-29.
- Pyle, E. A. 1969. The effect of constant light or constant darkness on the growth and sexual maturity of brook trout. Fish. Res. Bull. No. 31. The nutrition of trout, Cortland Hatchery Report No. 36, p 13-19.
- U. S. Environmental Protection Agency. 1971. Methods for Chemical Analysis of Water and Wastes. Analytical Quality Control Laboratory, Cincinnati, Ohio.
- Wydoski, R. S., and E. L. Cooper. 1966. Maturation and fecundity of brook trout from infertile streams. J. Fish. Res. Bd. Canada, 23(5): 623-649.

BIOLOGICAL METHODS

Appendix A  
 Test (Evansville, Indiana) Photoperiod  
 For Brook Trout Partial Chronic

| <u>Dawn to Dusk<br/>Time</u> | <u>Date</u> | <u>Day-length (hour and minute)</u> |                             |
|------------------------------|-------------|-------------------------------------|-----------------------------|
| 6:00 - 6:15)                 | MAR. 1      | 12:15)                              |                             |
| 6:00 - 7:00)                 | 15          | 13:00)                              |                             |
| 6:00 - 7:30)                 | APR. 1      | 13:30)                              |                             |
| 6:00 - 8:15)                 | 15          | 14:15)                              |                             |
| 6:00 - 8:45)                 | MAY 1       | 14:45)                              |                             |
| 6:00 - 9:15)                 | 15          | 15:15)                              |                             |
| 6:00 - 9:30)                 | JUNE 1      | 15:30)                              | Juvenile-adult exposure     |
| 6:00 - 9:45)                 | 15          | 15:45)                              |                             |
| 6:00 - 9:45)                 | JULY 1      | 15:45)                              |                             |
| 6:00 - 9:30)                 | 15          | 15:30)                              |                             |
| 6:00 - 9:00)                 | AUG. 1      | 15:00)                              |                             |
| 6:00 - 8:30)                 | 15          | 14:30)                              |                             |
| 6:00 - 8:00)                 | SEPT. 1     | 14:00)                              |                             |
| 6:00 - 7:30)                 | 15          | 13:30)                              |                             |
| 6:00 - 6:45)                 | OCT. 1      | 12:45)                              |                             |
| 6:00 - 6:15)                 | 15          | 12:15)                              | Spawning and egg incubation |
| 6:00 - 5:30)                 | NOV. 1      | 11:30)                              |                             |
| 6:00 - 5:00)                 | 15          | 11:00)                              |                             |
| 6:00 - 4:45)                 | DEC. 1      | 10:45)                              |                             |
| 6:00 - 4:30)                 | 15          | 10:30)                              |                             |
| 6:00 - 4:30)                 | JAN. 1      | 10:30)                              | Alevin-juvenile exposure    |
| 6:00 - 4:45)                 | 15          | 10:45)                              |                             |
| 6:00 - 5:15)                 | FEB. 1      | 11:15)                              |                             |
| 6:00 - 5:45)                 | 15          | 11:45)                              |                             |

**Appendix B**  
**Temperature Regime for Brook Trout Partial Chronic**

| <u>Months</u> |                             | <u>Temperature ° C</u> |
|---------------|-----------------------------|------------------------|
| Mar.          |                             | 9                      |
| Apr.          |                             | 12                     |
| May           | Juvenile-adult exposure     | 14                     |
| June          |                             | 15                     |
| July          |                             | 15                     |
| Aug.          |                             | 15                     |
| Sept.         |                             | 12                     |
| Oct.          | Spawning and egg incubation | 9                      |
| Nov.          |                             | 9                      |
| Dec.          | Alevin-juvenile exposure    | 9                      |
| Jan.          |                             | 9                      |
| Feb.          |                             | 9                      |
| Mar.          |                             | 9                      |

A constant temperature must be established just prior to spawning and egg incubation, and maintained throughout the 3-month alevin-juvenile exposure.

# APPENDIX



# APPENDIX

|   | Page |
|---|------|
| 1.0 BENCH SHEETS                                | 1    |
| 1.1 Phytoplankton Sedgwick-Rafter Count         | 1    |
| 1.2 Zooplankton Count                           | 2    |
| 1.3 Plankton and Periphyton Diatom Analysis     | 3    |
| 1.4 Periphyton Sedgwick-Rafter Count            | 4    |
| 1.5 Plankton and Periphyton Pigment and Biomass | 5    |
| 1.6 Macroinvertebrates                          | 6    |
| 2.0 EQUIPMENT AND SUPPLIES                      | 7    |
| 2.1 Plankton and Periphyton                     | 7    |
| 2.2 Macroinvertebrates                          | 8    |
| 2.3 Fish  | 11   |
| 3.0 UNITS OF MEASUREMENT CONVERSION FACTORS     | 13   |









# 1.5 Plankton and Periphyton Pigment and Biomass

## PLANKTON AND PERIPHYTON CHLOROPHYLL AND BIOMASS DATA

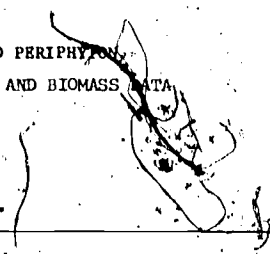

### I. IDENTIFYING INFORMATION:

A. Station: \_\_\_\_\_

B. Date: \_\_\_\_\_

C. Method of Sample Collection and Handling: \_\_\_\_\_

### II. SPECTROPHOTOMETER DATA:

#### A. OPTICAL DENSITY MEASUREMENTS:

| Rep. | Extract Volume | Dilution Factor | Optical Density Readings |       |     |            | 663 b/a |
|------|----------------|-----------------|--------------------------|-------|-----|------------|---------|
|      |                |                 | 550                      | 663b* | 645 | 630, 663a* |         |
| 1.   |                |                 |                          |       |     |            |         |
| 2.   |                |                 |                          |       |     |            |         |
| 3.   |                |                 |                          |       |     |            |         |
| 4.   |                |                 |                          |       |     |            |         |

\*(b = before acidification; a = after acidification)

#### B. CHLOROPHYLL CALCULATIONS:

| Rep. | Concentration of Chlorophyll in Extract (mg/l) |       |       | Sample area or volume (liters; m <sup>2</sup> ) | Chlorophyll content of sample (ug/l; mg/m <sup>2</sup> ) |       |       |
|------|--|-------|-------|---|--|-------|-------|
|      | Chl a  | Chl b | Chl c |   | Chl a  | Chl b | Chl c |
|      | 1.   |       |       |   |  |       |       |
| 2.   |  |       |       |   |  |       |       |
| 3.   |  |       |       |   |  |       |       |
| 4.   |  |       |       |   |  |       |       |

### III. FLUOROMETER DATA:

| Rep. | Dilution Factor | Reading Before (b) Acidification |                 | Reading After (a) Acidification |     |                                |
|------|-----------------|----------------------------------|-----------------|---------------------------------|-----|--------------------------------|
|      |                 | Reading                          | Sens. Level (S) | R <sub>a</sub>                  | (S) | R <sub>b</sub> /R <sub>a</sub> |
|      |                 | 1.                               |                 |                                 |     |                                |
| 2.   |                 |                                  |                 |                                 |     |                                |
| 3.   |                 |                                  |                 |                                 |     |                                |
| 4.   |                 |                                  |                 |                                 |     |                                |

### IV. ORGANIC MATTER (ASH-FREE WEIGHT)

| Rep. | Cruc. No. | Empty Crucible Weight | Weight with Dry Sample (B) | Weight After Firing (C) | Sample Dry Weight (B-A) | Ash Free Weight (B-C) | Organic Matter (gm/m <sup>2</sup> ) |
|------|-----------|-----------------------|----------------------------|-------------------------|-------------------------|-----------------------|-------------------------------------|
| 1.   |           |                       |                            |                         |                         |                       |                                     |
| 2.   |           |                       |                            |                         |                         |                       |                                     |
| 3.   |           |                       |                            |                         |                         |                       |                                     |
| 4.   |           |                       |                            |                         |                         |                       |                                     |

### V. REMARKS:

\_\_\_\_\_

\_\_\_\_\_

\_\_\_\_\_

50179





## 2.0 EQUIPMENT AND SUPPLIES

This section contains an abbreviated list of equipment and supplies used for the collection and analysis of biological samples. The companies and addresses are listed alphabetically at the end of the table. Mention of commercial sources or products in this section does not constitute endorsement by the U. S. Environmental Protection Agency.

| Item  | Source* | Cat. No. | Unit | Approx. Cost (1973) |
|---|---------|----------|------|---------------------|
| <b>2.1 Plankton and Periphyton</b>  |         |          |      |                     |
| <i>Sampling and field equipment</i>   |         |          |      |                     |
| Water sampler, alpha bottle, nonmetallic, transparent, 6 liter  | (30)    | 1160TT   |      | \$ 150.00           |
| Plankton sampler, Clarke-Bumpus, 12 inch, with No. 10' and No. 20 nets and buckets  | (30)    | 37       |      | 400.00              |
| Plankton towing net, No. 20 (173 mesh/inch)   | (30)    |          |      | 41.00               |
| Plankton net with bucket, Wisconsin style, No. 20 net (173 mesh/inch)   | (30)    |          |      | 92.00               |
| Submarine photometer, with deck cell  | (7)     |          |      | 500.00              |
| <i>Laboratory equipment</i>   |         |          |      |                     |
| Balance, analytical, 100 gm capacity, accuracy 0.1 mg.  |         |          |      | 1,000.00            |
| Balance, Harvard Trip, double beam, (to balance loaded centrifuge tubes)  |         |          |      | 50.00               |
| Centrifuge, clinical, Centricone, 8-place   |         |          |      | 100.00              |
| Centrifuge, IEC, model UV, Refrigerated   |         |          |      | 850.00              |
| Centrifuge head, 8-place, 100 ml  |         |          |      | 50.00               |
| Centrifuge shield, cups   |         |          | 8    | 30.00               |
| Centrifuge trunnion rings   |         |          | 8    | 20.00               |
| Centrifuge tubes, plain, round bottom, polypropylene, 100 ml  |         |          | 16   | 9.00                |
| Blood Cell Calculator (counter), 8-Key  | (24)    | 2944-B50 |      | 110.00              |
| Fluorometer, Turner 111 or equivalent, equipped with:<br>Red-sensitive photomultiplier tube No. R-136<br>Turner No. 110-883 blue lamp, T-5<br>Turner No. 110-856, lamp adaptor for T-5 lamp<br>Turner No. 110-005, Standard sample holder<br>Turner No. 110- High-Sensitivity sample holder<br>Turner No. 110-871, flow-through cuvette<br>Corning filter No. CS-5-60 (excitation)<br>Corning filter No. CS-2-64 (emission)<br>Disposable vials for fluorometer, 12 X 75 mm, 5 ml, Kahn type  | (25)    |          |      | 2,000.00            |
| Hot-plate, Thermolyne HP-A1915B, thermostatically controlled (to dry diatoms on cover glasses), 115 volts, 750 watts.   |         |          |      | 30.00               |
| Hot-plate, Chromalox, 230 volts, 2000 watt, AC, three heat (to incinerate diatom preparation on cover glasses).   |         |          |      | 30.00               |
| Microscope and accessories (Americal Optical, Series 10T Trinocular Microstar, or equivalent).<br>In-base illuminator and transformer.<br>Trinocular body.<br>Graduated mechanical stage.<br>Quadruple nose piece.<br>N.A. 1.25 condenser.<br>Condenser mount.<br>Objective, 4X, Achromatic.<br>Objective, 10X, Achromatic.<br>Objective, 20X, Achromatic, standard, must have working distance greater than .1 mm for Sedgwick-Rafter counts.<br>Objective, 45X, Achromatic.<br>Objective, 100X, Achromatic.<br>Wide field eyepieces, 10X. |         |          |      | 1,500.00            |

\*See list of suppliers at the end of this table.

| Item   | Source | Cat. No.    | Unit      | Approx. Cost (1973) |
|--|--------|-------------|-----------|---------------------|
| Light meter  | (29)   | Model 756   |           | 100.00              |
| Muffle furnace, 1635 Temco, Thermolyne, 240 volts  |        |             |           | 180.00              |
| Temperature control for muffle furnace, Amplitrol Proportioning Controller, 0-2400°F, for 240 volt furnace (recommended for use with Temco 1635)                                     |        |             |           | 230.00              |
| Oven, Thermozone, forced draft, double walled, three shelves, 230°C  |        |             |           | 350.00              |
| Pipetting machine, automatic, large, BBL. (for dispensing preservative)  | (24)   | 7750-M10    |           | 320.00              |
| *Spectrophotometer, double-beam, recording, resolution 2 nm or better at 663 nm; Coleman-124 or equivalent.  | (1)    |             |           |                     |
| Washer, mechanical, glassware, variable speed, Southern Cross, Model 300-B-2, Complete.  |        |             |           | 330.00              |
| <i>Supplies</i>  |        |             |           |                     |
| Cubitainer, 1 qt (approx 1 liter)  | (8)    |             | 1 doz.    | 7.00                |
| Cubitainer shipping carton, 1 qt   | (8)    |             | 1 doz.    | 4.00                |
| Bottles, pill, square, DURAGLAS, 3 ounce for periphyton samples. Do not use caps supplied with bottles.  |        | clear glass | ½ gross   | 8.00                |
|  |        | amber glass | ½ gross   | 15.00               |
| Caps, Polyscal, black, size 38, G. C.M.I. thread No. 400. Use on Duraglas bottles above.   | (16)   |             | ½ gross   | 11.00               |
| Crucibles, Coors, high form, porcelain, size 1, capacity 30 ml   | (24)   | 3319-B55    | Case (36) | 25.00               |
| Crucible covers for above, Size G  | (24)   | 3319-D47    | Case (72) | 20.00               |
| Desiccator, aluminum, with shelf   | (24)   | 3747-C10    |           | 22.00               |
| Merthiolate, powder No. 20, (Thimerosal, N.F.)   | (13)   |             | ¼ ounce   | 2.00                |
|  |        |             | 1 ounce   | 7.00                |
|  |        |             | 1 pound   | 95.00               |
| Metal plate, 5 X 10 X 1/8 inches, steel (to transfer cover glasses between hot-plates).  |        |             |           |                     |
| Micrometer, eye-piece, whipple   | (16)   |             |           | 18.00               |
| Micrometer, stage (American Optical)   | (16)   | 400         |           | 32.00               |
| Mounting medium, HYRAX   | (3)    |             | 1 ounce   | 10.00               |
| Pipettes, disposable, Pasteur type, 5-3/4 inches   | (23)   | P5205-2     | 2½ gross  | 8.00                |
| Sedgwick-Rafter Counting Chamber, as prescribed by "Standard Methods for the examination of Water and Wastes."   | (30)   | 1801        |           | 9.00                |
| Issue grinder, glass, Dual, complete   | (12)   | size C      |           | 10.00               |
| Vials, Opticlear, Owens-Illinois, 3 drams, snap caps, for diatom preparation.  | (21)   | SK-3        | Gross     | 11.00               |
| <b>2.2 Macroinvertebrates</b>  |        |             |           |                     |
| Boat, flat bottom, 14-16 feet, Arkansas Traveler or Boston Whaler with winch and davit, snatch-block meter wheel, and trailer, 18 hp Outboard motor, Life jackets, other accessories | (17)   |             |           | 3,000.00            |
| Cable fastening tools:   | (20)   |             |           |                     |
| Cable clamps, 1/8 inch   |        |             | 25        | 3.00                |
| Micro-press sleeves, 1/8 inch  |        |             | 100       | 6.00                |
| Micro-press tool, 1/8 inch   |        |             |           | 32.00               |
| Wire cutter, Felco   |        | 7           | 1         | 7.00                |
| Wire thimbles, 1/8 inch  |        |             | 25        | 2.00                |
| Cable, 1/8 inch, galvanized steel  |        |             | 1000 feet | 89.00               |
| Large capacity, metal wash tubs  |        |             | 1         | 3.00                |
| Core sampler, K. B., multiple, and gravity corers  | (30)   | 2400        | 1         | 225.00              |
| Hardboard multiplate sampler   | (30)   |             | 1         | 7.50                |
| Trawl net  | (30)   |             |           | 100.00              |
| Drift net, stream  | (30)   | 15          | 2         | 75.00               |
| Grabs  |        |             |           |                     |
| Ponar  | (30)   | 1725        | 1         | 200.00              |
| Ekman, 6 X 6 inch  | (30)   | 196B        | 1         | 78.00               |
| Petersen, 100 square inch  | (30)   | 1750        | 1         | 200.00              |
| Weights for Petersen   | (30)   | 1751        | 1 pair    | 25.00               |

| Item   | Source   | Cat. No.  | Unit     | Approx. Cost (1973) |
|--|----------|-----------|----------|---------------------|
| Basket, Bar-B-Q, (RB-75) Tumbler   | (22)     | 1         | 12       | 25.00               |
| Sieve, US standard No. 30 (0.595 mm opening) and others as needed  | (26)     | V 73250 L | 1 each   | 10.00               |
| Flow meter, TSK, (propeller type)  | (10)     | 313 T.S.  |          | 200.00              |
| Flow meter, electromagnetic, two-axis  | (15)     |           |          | 2,600.00            |
| Mounting media, CMC-9AF  | (6)      |           | 4 ounce  | 2.00                |
| Mounting media, CMC-S  | (6)      |           | 4 ounce  | 2.00                |
| Low-temp bath  | (31)     | 94370     | 1        | 500.00              |
| Water pump, epoxy-encapsulated, submersible and open air.  | (14)     | 1A-MD     | 2        | 50.00               |
| Sounding equipment and specialized gear  | (7,9,11) |           |          |                     |
| Large, constant temperature holding tanks with 1/3 hp water chiller, charcoal  | (5)      | MT-700    | 1        | 540.00              |
| Polyethylene bottles, dark bottles, tubing   | (18)     |           |          |                     |
| Cahn electrobalance  | (27)     | DTL       | 1        | 1,000.00            |
| Porcelain balls for baskets (2-inch diameter)  |          | unlapped  | 1 pound  | 0.30                |
| Porcelain multiplates  |          |           | 1        | 7.50                |
| Counter, differential, 9 unit, Clay-Adams  |          | B 4120-4  | 1        | 105.00              |
| Counter, hand tally  | (24)     | 3297-H10  | 2        | 11.00               |
| Magnifier, Dazor, 2X, floating, with illuminator and base.   | (6)      | 375 A 95  | 1        | 50.00               |
| Microscope, compound, trinocular, equipped for bright-field and phase microscopy with 10X and 15X wide-field oculars, 4.0 X, 10X, 20X, 45X, and 100X bright-field objectives, and 45X and 100X phase objectives. |          |           | 1        | 2,000.00            |
| Stereoscopic dissecting Microscope   | (32)     |           | 1        | 1,000.00            |
| Tessovar photomicrographic Zoom System   |          | 49-65-01  | 1        | 1,779.00            |
| Camera body, 35 mm Zeiss Contarex, for Tessovar  | (32)     | 10-2611   | 1        | 600.00              |
| Stirrer, magnetic  | (6)      | 375AA4514 | 1        | 42.50               |
| Aquaria (of various sizes)   | (6)      |           |          |                     |
| Aquatic dip nets   | (6)      |           |          |                     |
| Microscope Slides and Cover slips, Standard square, 15 mm  | (6)      | 320A 10   | 10 gross | 31.00               |
|  |          | 320A 210  | 1 ounce  | 3.50                |
| Vials, specimen, glass, 1 dram, 15 mm x 45 mm  | (6)      | 315A 57   | 10 gross | 78.00               |
| Petri dish, ruled grid, 150 mm x 15 mm   | (2)      | 315AA4094 | 12       | 24.00               |
| Freeze dryer with freezing shelf   | (28)     | 10-800    | 1        | 4,000.00            |
| Vacuum oven  | (19)     | 5831      | 1        | 300.00              |

1978

## Sources of equipment and supplies for plankton, periphyton, and macroinvertebrates

1. Coleman Instruments  
42 Madison St.  
Maywood, IL 60153
2. Corning Glass Works  
1470 Merchandise Mart  
Chicago, IL 60654
3. Custom Research and Development Company, Inc.  
Mt. Vernon Rd., Route 1, Box 1586  
Auburn, CA 95603
4. Ferro Corporation  
P. O. Box 20  
East Liverpool, OH 43920
5. Frigid Units, Inc.  
3214 Sylvania Ave.  
Toledo, OH 43613
6. General Biological Inc.  
8200 S. Hoynes Ave.  
Chicago, IL 60620
7. G-M Manufacturing & Instrument Company  
2417 Third Ave.  
New York, NY 10451
8. Hedwin Corporation  
1209 E. Lincolnway  
Laporte, IN 46350
9. Hydro Products  
11777 Sorrento Valley Rd.  
San Diego, CA 92121
10. Inter Ocean, Inc.  
3446 Kurtz St.  
San Diego, CA 92110
11. Kalm Scientific Instruments  
P. O. Box 1166  
El Cajon, CA 92022
12. Kontes Glass Company  
Vineland, NJ 08360
13. Eli-Lilly Company  
307 E. McCarty St.  
Indianapolis, IN 46206
14. March Manufacturing Company  
Glenview, IL 60025
15. Marsh-McBirney, Inc.  
2281 Lewis Ave.  
Rockville, MD 20851
16. Matheson Scientific  
1850 Greenleaf Ave.  
Elk Grove Village, IL 60007
17. MonArk Boat Company  
Monticello, AK 71655
18. Nalge Corporation  
Rochester, NY 14602
19. National Appliance Company  
P. O. Box 23008  
Portland, OR 97223
20. National Telephone Supply Company  
3100 Superior St.  
Cleveland, OH 44114
21. Owens-Illinois  
P. O. Box 1035  
Toledo, OH 43666
22. Paramount Wire, Inc.  
1035 Westminster Ave.  
Alhambra, CA 91803
23. Scientific Products  
1210 Leon Place  
Evanston, IL 60201
24. Arthur H. Thomas Company  
Vine Street at Third  
P. O. Box 779  
Philadelphia, PA 19105
25. G. K. Turner, Assoc.  
2524 Pulgas Ave.  
Palo Alto, CA 94303
26. W. S. Tyler Company  
Mentor, OH 44060
27. Ventron Instrument Corporation  
7500 Jefferson St.  
Paramont, CA 90723
28. Virtis Company  
Gardiner, NY 12525
29. Weston Instruments, Inc.  
614 Frelinghuysen Ave.  
Newark, NJ 07114
30. Wildlife Supply Company  
301 Cass St.  
Saginaw, MI 48602
31. Wilkens-Anderson Company  
4525 W. Division St.  
Chicago, IL 60651
32. Carl Zeiss, Inc.  
444 Fifth Ave.  
New York, NY 10018

## 2.3 Fish

### Sources of information on fishery sampling equipment.

American Association for the Advancement of Science. Annual guide to scientific instruments (Published in Science).

American Society of Limnology and Oceanography. 1964. Sources of limnological and oceanographic apparatus and supplies. Special Publ. No. 1. IX, xxxii.

Oceanology International Yearbook/Directory.

Sinha, E. Z., and C. L. Kuehne. 1963. Bibliography on oceanographic instruments. I. General. II. Waves, currents, and other geophysical parameters. Meteorol. Geostrophys. Abst. Amer. Meteorol. Soc. 14:1242-1298; 1589-1637.

U.S. Fish and Wildlife Service. 1959. Partial list of manufacturers of fishing gear and accessories and vessel equipment. Fishery Leaflet 195. 27 pp.

Water Pollution Control Federation Yearbook.

180

11



UNITED STATES  
DEPARTMENT OF  
COMMERCE  
PUBLICATION



# UNITS OF MEASUREMENT

*Conversion Factors and Special Tables*

October, 1972

**REPRINTED FROM**  
Units of Weight and Measure  
International (Metric) and U.S. Customary

NBS Miscellaneous Publication 286  
May, 1967

WITH THE COURTESY OF  
TECHNICAL INFORMATION OFFICE  
NATIONAL ENVIRONMENTAL RESEARCH CENTER, CINCINNATI  
U.S. ENVIRONMENTAL PROTECTION AGENCY

181

## CONTENTS

(Reprint includes only those items asterisked)

|   | Page |
|---|------|
| *INTRODUCTION.....  | 1    |
| THE INTERNATIONAL SYSTEM.....   | 1    |
| Prefixes.....   | 3    |
| HISTORICAL OUTLINE.....   |      |
| France.....   | 3    |
| The United States.....  | 5    |
| WEIGHTS AND MEASURES IN THE WORLD'S INDEPENDENT STATES.....                 |      |
| Metric.....   | 6    |
| Nonmetric.....  | 6    |
| IMPORTANT DATES IN U. S. METRIC HISTORY.....                                | 7    |
| SELECTED BIBLIOGRAPHY.....  | 8    |
| *DEFINITIONS.....   | 9    |
| *Definitions of Units.....  | 9    |
| *SPELLING AND SYMBOLS FOR UNITS.....  | 10   |
| *Some Units and Their Symbols.....  | 10   |
| *UNITS OF MEASUREMENT—CONVERSION FACTORS.....                               |      |
| *Length.....  | 11   |
| *Mass.....  | 12   |
| *Capacity, or Volume.....   | 13   |
| *Area.....  | 17   |
| *SPECIAL TABLES.....  |      |
| *Equivalents of Decimal and Binary Fractions of an Inch in Millimeters..... | 18   |
| *International Nautical Miles and Kilometers.....                           | 19   |
| UNITS OF MEASUREMENT—TABLES OF EQUIVALENTS.....                             |      |
| Length.....   | 21   |
| Mass.....   | 127  |
| Capacity, or Volume.....  | 161  |
| Area.....   | 219  |

Chisholm, L.J., Units of Weight and Measure. International (Metric) and U. S. Customary. (NBS Miscellaneous Publication 286). For sale by Superintendent of Documents, U. S. Government Printing Office, Washington, D. C. 20402. Price \$2.25.

# Units of Weight and Measure

## International (Metric) and U.S. Customary

L. J. Chisholm

The primary purpose of this publication is to make available the most often needed weights and measures conversion tables—conversions between the U. S. Customary System and International (Metric) System. A secondary purpose is to present a brief historical outline of the International (Metric) System—following it from its country of origin, France, through its progress in the United States.

Key Words: Conversion tables, International System (SI), Metric System, U. S. Customary System, weights and measures, weights and measures abbreviations, weights and measures systems, weights and measures units.

### Introduction

Two systems of weights and measures exist side by side in the United States today, with roughly equal but separate legislative sanction: the U. S. Customary System and the International (Metric) System. Throughout U. S. history, the Customary System (inherited from, but now different from, the British Imperial System) has been, as its name implies, customarily used; a plethora of Federal and State legislation has given, through implication, standing as our primary weights and measures system. However, the Metric System (incorporated in the scientists' new SI or *Système International d'Unités*) is the only system that has ever received specific legislative sanction by Congress. The "Law of 1866" reads:

It shall be lawful throughout the United States of America to employ the weights and measures of the metric system; and no contract or dealing, or pleading in any court, shall be deemed invalid or liable to objection because the weights or measures expressed or referred to therein are weights or measures of the metric system.

Over the last 100 years, the Metric System has seen slow, steadily increasing use in the United States and, today, is of importance nearly equal to the Customary System.

### The International System \*

\* For up-to-date information on the international metric system, see current edition of *The International System of Units (SI)*, Editors: Chester Page and Paul Vigoureux (NBS Special Publication 330). For sale by Superintendent of Documents, U.S. Government Printing Office, Washington, D.C. 20402. Price 90 cents. For NBS policy on the usage of SI, see NBS Technical News Bulletin Vol. 55 No. 1, pp. 18-20, January 1971.

<sup>1</sup> Act of 28 July 1866 (14 Stat. 339)—An Act to authorize the use of the Metric System of Weights and Measures.

Six units have been adopted to serve as the base for the International System: \*

|                           |          |
|---------------------------|----------|
| Length                    | meter    |
| Mass                      | kilogram |
| Time                      | second   |
| Electric current          | ampere   |
| Thermodynamic temperature | kelvin   |
| Light intensity           | candela  |

Some of the other more frequently used units of the SI and their symbols and, where applicable, their derivations are listed below.

### SUPPLEMENTARY UNITS

| Quantity    | Unit      | Symbol | Derivation |
|-------------|-----------|--------|------------|
| Plane angle | radian    | rad    |            |
| Solid angle | steradian | sr     |            |

### DERIVED UNITS

|  |                                |                      |                          |
|--|--------------------------------|----------------------|--------------------------|
| Area   | square meter                   | m <sup>2</sup>       |                          |
| Volume   | cubic meter                    | m <sup>3</sup>       |                          |
| Frequency  | hertz                          | Hz                   | (s <sup>-1</sup> )       |
| Density  | kilogram per cubic meter       | kg/m <sup>3</sup>    |                          |
| Velocity   | meter per second               | m/s                  |                          |
| Angular velocity                                   | radian per second              | rad/s                |                          |
| Acceleration                                       | meter per second squared       | m/s <sup>2</sup>     |                          |
| Angular acceleration                               | radian per second squared      | rad/s <sup>2</sup>   |                          |
| Force  | newton                         | N                    | (kg · m/s <sup>2</sup> ) |
| Pressure   | newton per square meter        | N/m <sup>2</sup>     |                          |
| Kinematic viscosity                                | square meter per second        | m <sup>2</sup> /s    |                          |
| Dynamic viscosity                                  | newton-second per square meter | N · s/m <sup>2</sup> |                          |
| Work, energy, quantity of heat                     | joule                          | J                    | (N · m)                  |
| Power  | watt                           | W                    | (J/s)                    |
| Electric charge                                    | coulomb                        | C                    | (A · s)                  |
| Voltage, potential difference, electromotive force | volt                           | V                    | (W/A)                    |
| Electric field strength                            | volt per meter                 | V/m                  |                          |
| Electric resistance                                | ohm                            | Ω                    | (V/A)                    |
| Electric capacitance                               | farad                          | F                    | (A · s/V)                |
| Magnetic flux                                      | weber                          | Wb                   | (V · s)                  |
| Inductance   | henry                          | H                    | (V · s/A)                |
| Magnetic flux density                              | tesla                          | T                    | (Wb/m <sup>2</sup> )     |
| Magnetic field strength                            | ampere per meter               | A/m                  |                          |
| Magnetomotive force                                | ampere                         | A                    |                          |
| Flux of light                                      | lumen                          | lm                   | (cd · sr)                |
| Luminance  | candela per square meter       | cd/m <sup>2</sup>    |                          |
| Illumination                                       | lux                            | lx                   | (lm/m <sup>2</sup> )     |

\* Recent (1971) addition of the mole as the unit for amount of substance brings the total to seven units. See asterisked footnote on page 1.

PAGES 3-8 MISSING FROM DOCUMENT PRIOR TO BEING  
SHIPPED TO EDRS FOR FILMING.

BEST COPY AVAILABLE

135

## Definitions

In its original conception, the meter was the fundamental unit of the Metric System, and all units of length and capacity were to be derived directly from the meter which was intended to be equal to one ten-millionth of the earth's quadrant. Furthermore, it was originally planned that the unit of mass, the kilogram, should be identical with the mass of a cubic decimeter of water at its maximum density. The units of length and mass are now defined independently of these conceptions.

In October 1960 the Eleventh General (International) Conference on Weights and Measures redefined the meter as equal to 1 650 763.73 wavelengths of the orange-red radiation in vacuum of krypton 86 corresponding to the unperturbed transition between the  $2p_{10}$  and  $5d_5$  levels.

The kilogram is independently defined as the mass of a particular platinum-iridium standard, the International Prototype Kilogram, which is kept at the International Bureau of Weights and Measures in Sèvres, France.

The liter has been defined, since October, 1964, as being equal to a cubic decimeter. The meter is thus a unit on which is based all metric standards and measurements of length, area, and volume.

## Definitions of Units

### Length

A *meter* is a unit of length equal to 1 650 763.73 wavelengths in a vacuum of the orange-red radiation of krypton 86.

A *yard* is a unit of length equal to 0.914 4 meter.

### Mass

A *kilogram* is a unit of mass equal to the mass of the International Prototype Kilogram.

An *avoirdupois pound* is a unit of mass equal to 0.453 592 37 kilogram.

### Capacity, or Volume

A *cubic meter* is a unit of volume equal to a cube the edges of which are 1 meter.

A *liter* is a unit of volume equal to a cubic decimeter.

A *cubic yard* is a unit of volume equal to a cube the edges of which are 1 yard.

A *gallon* is a unit of volume equal to 231 cubic inches. It is used for measuring liquids only.

A *bushel* is a unit of volume equal to 2 150.42 cubic inches. It is used for measuring dry commodities only.

### Area

A *square meter* is a unit of area equal to the area of a square the sides of which are 1 meter.

A *square yard* is a unit of area equal to the area of a square the sides of which are 1 yard.



## Spelling and Symbols for Units

The spelling of the names of units as adopted by the National Bureau of Standards is that given in the list below. The spelling of the metric units is in accordance with that given in the law of July 28, 1866, legalizing the Metric System in the United States.

Following the name of each unit in the list below is given the symbol that the Bureau has adopted. Attention is particularly called to the following principles:

1. No period is used with symbols for units. Whenever "in" for inch might be confused with the preposition "in," "inch" should be spelled out.

2. The exponents "2" and "3" are used to signify "square" and "cubic," respectively, instead of the symbols "sq" or "cu," which are, however, frequently used in technical literature for the U. S. Customary units.

3. The same symbol is used for both singular and plural.

### Some Units and Their Symbols

| Unit              | Symbol          | Unit                        | Symbol  | Unit               | Symbol           |
|-------------------|-----------------|-----------------------------|---------|--------------------|------------------|
| acre              | acre            | fathom                      | fath    | millimeter         | mm               |
| are               | a               | foot                        | ft      | minim              | minim            |
| barrel            | bbbl            | furlong                     | furlong | ounce              | oz               |
| board foot        | fbm             | gallon                      | gal     | ounce, avoirdupois | oz avdp          |
| bushel            | bu              | grain                       | grain   | ounce, liquid      | liq oz           |
| carat             | c               | gram                        | g       | ounce, troy        | oz tr            |
| Celsius degree    | °C              | hectare                     | ha      | peck               | peck             |
| centare           | ca              | hectogram                   | hg      | pennyweight        | dwt              |
| centigram         | cg              | hectoliter                  | hl      | pint, liquid       | liq pt           |
| centiliter        | cl              | hectometer                  | hm      | pound              | lb               |
| centimeter        | cm              | hogshead                    | hhd     | pound, avoirdupois | lb avdp          |
| chain             | ch              | hundredweight               | cwt     | pound, troy        | lb tr            |
| cubic centimeter  | cm <sup>3</sup> | inch                        | in      | quart, liquid      | liq qt           |
| cubic decimeter   | dm <sup>3</sup> | International Nautical Mile | INM     | rod                | rod              |
| cubic decimeter   | dm <sup>3</sup> | Kelvin                      | K       | second             | s                |
| cubic foot        | ft <sup>3</sup> | kilogram                    | kg      | square centimeter  | cm <sup>2</sup>  |
| cubic hectometer  | hm <sup>3</sup> | kiloliter                   | kl      | square decimeter   | dm <sup>2</sup>  |
| cubic inch        | in <sup>3</sup> | kilometer                   | km      | square dekameter   | dam <sup>2</sup> |
| cubic kilometer   | km <sup>3</sup> | link                        | link    | square foot        | ft <sup>2</sup>  |
| cubic meter       | m <sup>3</sup>  | liquid                      | liq     | square hectometer  | hm <sup>2</sup>  |
| cubic mile        | mi <sup>3</sup> | liter                       | liter   | square inch        | in <sup>2</sup>  |
| cubic millimeter  | mm <sup>3</sup> | meter                       | m       | square kilometer   | km <sup>2</sup>  |
| cubic yard        | yd <sup>3</sup> | microgram                   | μg      | square meter       | m <sup>2</sup>   |
| decigram          | dg              | microinch                   | μin     | square mile        | mi <sup>2</sup>  |
| deciliter         | dl              | microliter                  | μl      | square millimeter  | mm <sup>2</sup>  |
| decimeter         | dm              | mile                        | mi      | square yard        | yd <sup>2</sup>  |
| dekagram          | dag             | milligram                   | mg      | stere              | stere            |
| dekaliter         | dal             | milliliter                  | ml      | ton, long          | long ton         |
| dekameter         | dams            |                             |         | ton, metric        | t                |
| dram, avoirdupois | dr avdp         |                             |         | ton, short         | short tons       |
|                   |                 |                             |         | yard               | yd               |

# Units of Measurement—Conversion Factors

## Units of Length

| To          | To Convert from<br>Centimeters | Multiply by         |
|-------------|--------------------------------|---------------------|
| Inches..... |                                | <b>0.393 700 8</b>  |
| Feet.....   |                                | <b>0.032 808 40</b> |
| Yards.....  |                                | <b>0.010 936 13</b> |
| Meters..... |                                | <b>0.01</b>         |

| To               | To Convert from<br>Meters | Multiply by         |
|------------------|---------------------------|---------------------|
| Inches.....      |                           | <b>39.370 08</b>    |
| Feet.....        |                           | <b>3.280 840</b>    |
| Yards.....       |                           | <b>1.093 613</b>    |
| Miles.....       |                           | <b>0.000 621 37</b> |
| Millimeters..... |                           | <b>1 000</b>        |
| Centimeters..... |                           | <b>100</b>          |
| Kilometers.....  |                           | <b>0.001</b>        |

| To               | To Convert from<br>Inches | Multiply by         |
|------------------|---------------------------|---------------------|
| Feet.....        |                           | <b>0.083 333 33</b> |
| Yards.....       |                           | <b>0.027 777 78</b> |
| Centimeters..... |                           | <b>2.54</b>         |
| Meters.....      |                           | <b>0.025 4</b>      |

| To               | To Convert from<br>Feet | Multiply by         |
|------------------|-------------------------|---------------------|
| Inches.....      |                         | <b>12</b>           |
| Yards.....       |                         | <b>0.333 333 3</b>  |
| Miles.....       |                         | <b>0.000 189 39</b> |
| Centimeters..... |                         | <b>30.48</b>        |
| Meters.....      |                         | <b>0.304 8</b>      |
| Kilometers.....  |                         | <b>0.000 304 8</b>  |

\* All boldface figures are exact; the others generally are given to seven significant figures.

In using conversion factors, it is possible to perform division as well as the multiplication process shown here. Division may be particularly advantageous where more than the significant figures published here are required. Division may be performed in lieu of multiplication by using the reciprocal of any indicated multiplier as divisor. For example, to convert from centimeters to inches by division, refer to the table headed "To Convert from Inches" and use the factor listed at "centimeters" (**2.54**) as divisor.

| To               | To Convert from<br>Yards | Multiply by         |
|------------------|--------------------------|---------------------|
| Inches.....      |                          | <b>36</b>           |
| Feet.....        |                          | <b>3</b>            |
| Miles.....       |                          | <b>0.000 568 18</b> |
| Centimeters..... |                          | <b>91.44</b>        |
| Meters.....      |                          | <b>0.914 4</b>      |

| To               | To Convert from<br>Miles | Multiply by      |
|------------------|--------------------------|------------------|
| Inches.....      |                          | <b>63 360</b>    |
| Feet.....        |                          | <b>5 280</b>     |
| Yards.....       |                          | <b>1 760</b>     |
| Centimeters..... |                          | <b>160 934.4</b> |
| Meters.....      |                          | <b>1 609.344</b> |
| Kilometers.....  |                          | <b>1.609 344</b> |

## Units of Mass

| To Convert from<br>Grams |              |
|--------------------------|--------------|
| To                       | Multiply by  |
| Grains.....              | 15.432 36    |
| Avoirdupois Drams.....   | 0.564 383 4  |
| Avoirdupois Ounces.....  | 0.035 273 96 |
| Troy Ounces.....         | 0.032 150 75 |
| Troy Pounds.....         | 0.002 679 23 |
| Avoirdupois Pounds.....  | 0.002 204 62 |
| Milligrams.....          | 1 000        |
| Kilograms.....           | 0.001        |

| To Convert from<br>Kilograms |              |
|------------------------------|--------------|
| To                           | Multiply by  |
| Grains.....                  | 15 432.36    |
| Avoirdupois Drams.....       | 564.383 4    |
| Avoirdupois Ounces.....      | 35.273 96    |
| Troy Ounces.....             | 32.150 75    |
| Troy Pounds.....             | 2.679 229    |
| Avoirdupois Pounds.....      | 2.204 623    |
| Grams.....                   | 1 000        |
| Short Hundredweights.....    | 0.022 046 23 |
| Short Tons.....              | 0.001 102 31 |
| Long Tons.....               | 0.000 984 2  |
| Metric Tons.....             | 0.001        |

| To Convert from<br>Metric Tons |             |
|--------------------------------|-------------|
| To                             | Multiply by |
| Avoirdupois Pounds.....        | 2 204.623   |
| Short Hundredweights.....      | 22.046 23   |
| Short Tons.....                | 1.102 311 3 |
| Long Tons.....                 | 0.984 206 5 |
| Kilograms.....                 | 1 000       |

| To Convert from<br>Grains |                  |
|---------------------------|------------------|
| To                        | Multiply by      |
| Avoirdupois Drams.....    | 0.036 571 43     |
| Avoirdupois Ounces.....   | 0.002 285 71     |
| Troy Ounces.....          | 0.002 083 33     |
| Troy Pounds.....          | 0.000 173 61     |
| Avoirdupois Pounds.....   | 0.000 142 86     |
| Milligrams.....           | 64.798 91        |
| Grams.....                | 0.064 798 91     |
| Kilograms.....            | 0.000 064 798 91 |

| To Convert from<br>Avoirdupois Ounces |                   |
|---------------------------------------|-------------------|
| To                                    | Multiply by       |
| Grains.....                           | 437.5             |
| Avoirdupois Drams.....                | 16                |
| Troy Ounces.....                      | 0.911 458 3       |
| Troy Pounds.....                      | 0.075 654 86      |
| Avoirdupois Pounds.....               | 0.062 5           |
| Grams.....                            | 28.349 523 125    |
| Kilograms.....                        | 0.028 349 523 125 |

| To Convert from<br>Avoirdupois Pounds |                  |
|---------------------------------------|------------------|
| To                                    | Multiply by      |
| Grains.....                           | 7 000            |
| Avoirdupois Drams.....                | 256              |
| Avoirdupois Ounces.....               | 16               |
| Troy Ounces.....                      | 14.583 33        |
| Troy Pounds.....                      | 1.215 278        |
| Grams.....                            | 453.592 37       |
| Kilograms.....                        | 0.453 592 37     |
| Short Hundredweights.....             | 0.01             |
| Short Tons.....                       | 0.000 5          |
| Long Tons.....                        | 0.000 446 428 6  |
| Metric Tons.....                      | 0.000 453 592 37 |

| To Convert from<br>Short Hundredweights |               |
|---|---------------|
| To                                      | Multiply by   |
| Avoirdupois Pounds.....                 | 100           |
| Short Tons.....                         | 0.05          |
| Long Tons.....                          | 0.044 642 86  |
| Kilograms.....                          | 45.359 237    |
| Metric Tons.....                        | 0.045 359 237 |

| To Convert from<br>Short Tons |              |
|-------------------------------|--------------|
| To                            | Multiply by  |
| Avoirdupois Pounds.....       | 2 000        |
| Short Hundredweights.....     | 20           |
| Long Tons.....                | 0.892 857 1  |
| Kilograms.....                | 907.184 74   |
| Metric Tons.....              | 0.907 184 74 |

| To Convert from<br>Long Tons |                 |
|------------------------------|-----------------|
| To                           | Multiply by     |
| Avoirdupois Ounces.....      | 35 840          |
| Avoirdupois Pounds.....      | 2 240           |
| Short Hundredweights.....    | 22.4            |
| Short Tons.....              | 1.12            |
| Kilograms.....               | 1 016.046 908 8 |
| Metric Tons.....             | 1.016 046 908 8 |

| To Convert from<br>Troy Ounces |              |
|--------------------------------|--------------|
| To                             | Multiply by  |
| Grains.....                    | 480          |
| Avoirdupois Drams.....         | 17.554 29    |
| Avoirdupois Ounces.....        | 1.097 143    |
| Troy Pounds.....               | 0.083 333 3  |
| Avoirdupois Pounds.....        | 0.068 571 43 |
| Grams.....                     | 31.103 476 8 |

| To Convert from<br>Troy Pounds |               |
|--------------------------------|---------------|
| To                             | Multiply by   |
| Grains.....                    | 5 760         |
| Avoirdupois Drams.....         | 210.651 4     |
| Avoirdupois Ounces.....        | 13.165 71     |
| Troy Ounces.....               | 12            |
| Avoirdupois Pounds.....        | 0.822 857 1   |
| Grams.....                     | 373.241 721 6 |

### Units of Capacity, or Volume, Liquid Measure

| To Convert from<br>Milliliters |              |
|--------------------------------|--------------|
| To                             | Multiply by  |
| Minims.....                    | 16.230 73    |
| Liquid Ounces.....             | 0.033 814 02 |
| Gills.....                     | 0.008 453 5  |
| Liquid Pints.....              | 0.002 113 4  |
| Liquid Quarts.....             | 0.001 056 7  |
| Gallons.....                   | 0.000 264 17 |
| Cubic Inches.....              | 0.061 023 74 |
| Liters.....                    | 0.001        |

| To Convert from<br>Liters |              |
|---------------------------|--------------|
| To                        | Multiply by  |
| Liquid Ounces.....        | 33.814 02    |
| Gills.....                | 8.453 506    |
| Liquid Pints.....         | 2.113 376    |
| Liquid Quarts.....        | 1.056 688    |
| Gallons.....              | 0.264 172 05 |
| Cubic Inches.....         | 61.023 74    |
| Cubic Feet.....           | 0.035 314 67 |
| Milliliters.....          | 1 000        |
| Cubic Meters.....         | 0.001        |
| Cubic Yards.....          | 0.001 307 95 |

| To Convert from<br>Cubic Meters |             |
|---------------------------------|-------------|
| To                              | Multiply by |
| Gallons.....                    | 264.172 05  |
| Cubic Inches.....               | 61 023 74   |
| Cubic Feet.....                 | 35.314 67   |
| Liters.....                     | 1 000       |
| Cubic Yards.....                | 1.307 950 6 |

| To Convert from<br>Minims |              |
|---------------------------|--------------|
| To                        | Multiply by  |
| Liquid Ounces.....        | 0.002 083 33 |
| Gills.....                | 0.000 520 83 |
| Cubic Inches.....         | 0.003 759 77 |
| Milliliters.....          | 0.061 611 52 |

| To Convert from<br>Gills |                  |
|--------------------------|------------------|
| To                       | Multiply by      |
| Minims.....              | 1 920            |
| Liquid Ounces.....       | 4                |
| Liquid Pints.....        | 0.25             |
| Liquid Quarts.....       | 0.125            |
| Gallons.....             | 0.031 25         |
| Cubic Inches.....        | 7.218 75         |
| Cubic Feet.....          | 0.004 177 517    |
| Milliliters.....         | 118.294 118 25   |
| Liters.....              | 0.718 294 118 25 |

| To Convert from<br>Liquid Pints |               |
|---------------------------------|---------------|
| To                              | Multiply by   |
| Minims.....                     | 7 680         |
| Liquid Ounces.....              | 16            |
| Gills.....                      | 4             |
| Liquid Quarts.....              | 0.5           |
| Gallons.....                    | 0.125         |
| Cubic Inches.....               | 28.875        |
| Cubic Feet.....                 | 0.018 710 07  |
| Milliliters.....                | 473.176 473   |
| Liters.....                     | 0.473 176 473 |

| To Convert from<br>Liquid Ounces |              |
|----------------------------------|--------------|
| To                               | Multiply by  |
| Minims.....                      | 480          |
| Gills.....                       | 0.25         |
| Liquid Pints.....                | 0.062 5      |
| Liquid Quarts.....               | 0.031 25     |
| Gallons.....                     | 0.007 812 5  |
| Cubic Inches.....                | 1.804 687 5  |
| Cubic Feet.....                  | 0.001 044 38 |
| Milliliters.....                 | 29.573 53    |
| Liters.....                      | 0.029 573 53 |

| To Convert from<br>Cubic Feet |                   |
|-------------------------------|-------------------|
| To                            | Multiply by       |
| Liquid Ounces.....            | 957.506 5         |
| Gills.....                    | 239.376 6         |
| Liquid Pints.....             | 59.844 16         |
| Liquid Quarts.....            | 29.922 08         |
| Gallons.....                  | 7.480 519         |
| Cubic Inches.....             | 1 728             |
| Liters.....                   | 28.16 846 592     |
| Cubic Meters.....             | 0.028 316 846 592 |
| Cubic Yards.....              | 0.037 037 04      |

| To Convert from<br>Cubic Inches |                   |
|---------------------------------|-------------------|
| To                              | Multiply by       |
| Minims.....                     | 265.974 0         |
| Liquid Ounces.....              | 0.554 112 6       |
| Gills.....                      | 0.138 528 1       |
| Liquid Pints.....               | 0.034 632.03      |
| Liquid Quarts.....              | 0.017 316 02      |
| Gallons.....                    | 0.004 329 0       |
| Cubic Feet.....                 | 0.000 578 7       |
| Milliliters.....                | 16.387 064        |
| Liters.....                     | 0.016 387 064     |
| Cubic Meters.....               | 0.000 016 387 064 |
| Cubic Yards.....                | 0.000 021 43      |

| To Convert from<br>Cubic Yards |                   |
|--------------------------------|-------------------|
| To                             | Multiply by       |
| Gallons.....                   | 201.974 0         |
| Cubic Inches.....              | 46 656            |
| Cubic Feet.....                | 27                |
| Liters.....                    | 764.554 857 984   |
| Cubic Meters.....              | 0.764 554 857 984 |

| To                 | To Convert from<br>Liquid Quarts | Multiply by   |
|--------------------|----------------------------------|---------------|
| Minims.....        |                                  | 15 360        |
| Liquid Ounces..... |                                  | 32            |
| Gills.....         |                                  | 8             |
| Liquid Pints.....  |                                  | 2             |
| Gallons.....       |                                  | 0.25          |
| Cubic Inches.....  |                                  | 57.75         |
| Cubic Feet.....    |                                  | 0.033 420 14  |
| Milliliters.....   |                                  | 946.352 946   |
| Liters.....        |                                  | 0.946 352 946 |

| To                 | To Convert from<br>Gallons | Multiply by       |
|--------------------|----------------------------|-------------------|
| Minims.....        |                            | 61 440            |
| Liquid Ounces..... |                            | 128               |
| Gills.....         |                            | 32                |
| Liquid Pints.....  |                            | 8                 |
| Liquid Quarts..... |                            | 4                 |
| Cubic Inches.....  |                            | 231               |
| Cubic Feet.....    |                            | 0.033 680 6       |
| Milliliters.....   |                            | 3 785.411 784     |
| Liters.....        |                            | 3.785 411 784     |
| Cubic Meters.....  |                            | 0.003 785 411 784 |
| Cubic Yards.....   |                            | 0.004 981 13      |

### Units of Capacity, or Volume; Dry Measure

| To              | To Convert from<br>Liters | Multiply by  |
|-----------------|---------------------------|--------------|
| Dry Pints.....  |                           | 1.816 166    |
| Dry Quarts..... |                           | 0.908 082 98 |
| Pecks.....      |                           | 0.113 510 4  |
| Bushels.....    |                           | 0.028 377 59 |
| Dekaliters..... |                           | 0.1          |

| To                | To Convert from<br>Dekaliters | Multiply by |
|-------------------|-------------------------------|-------------|
| Dry Pints.....    |                               | 18.161 66   |
| Dry Quarts.....   |                               | 9.080 829 8 |
| Pecks.....        |                               | 1.135 104   |
| Bushels.....      |                               | 0.283 775 9 |
| Cubic Inches..... |                               | 610.237 4   |
| Cubic Feet.....   |                               | 0.353 146 7 |
| Liters.....       |                               | 10          |

| To           | To Convert from<br>Cubic Meters | Multiply by |
|--------------|---------------------------------|-------------|
| Pecks.....   |                                 | 113.510 4   |
| Bushels..... |                                 | 28.377 59   |

| To                | To Convert from<br>Dry Pints | Multiply by  |
|-------------------|------------------------------|--------------|
| Dry Quarts.....   |                              | 0.5          |
| Pecks.....        |                              | 0.062 5      |
| Bushels.....      |                              | 0.015 625    |
| Cubic Inches..... |                              | 33.600 312 5 |
| Cubic Feet.....   |                              | 0.019 444 63 |
| Liters.....       |                              | 0.550 810 47 |
| Dekaliters.....   |                              | 0.055 061 05 |



| To Convert from<br>Dry Quarts |              |
|-------------------------------|--------------|
| To                            | Multiply by  |
| Dry Pints.....                | 2            |
| Pecks.....                    | 0.125        |
| Bushels.....                  | 0.031 25     |
| Cubic Inches.....             | 67.200 625   |
| Cubic Feet.....               | 0.038 889 25 |
| Liters.....                   | 1.101 221    |
| Dekaliters.....               | 0.110 122 1  |

| To Convert from<br>Pecks |              |
|--------------------------|--------------|
| To                       | Multiply by  |
| Dry Pints.....           | 16           |
| Dry Quarts.....          | 8            |
| Bushels.....             | 0.25         |
| Cubic Inches.....        | 537.605      |
| Cubic Feet.....          | 0.311 114    |
| Liters.....              | 8.809 767 5  |
| Dekaliters.....          | 0.880 976 75 |
| Cubic Meters.....        | 0.008 809 77 |
| Cubic Yards.....         | 0.011 522 74 |

| To Convert from<br>Bushels |              |
|----------------------------|--------------|
| To                         | Multiply by  |
| Dry Pints.....             | 64           |
| Dry Quarts.....            | 32           |
| Pecks.....                 | 4            |
| Cubic Inches.....          | 2 150.42     |
| Cubic Feet.....            | 1.244 456    |
| Liters.....                | 35.239 07    |
| Dekaliters.....            | 3.523 907    |
| Cubic Meters.....          | 0.035 239 07 |
| Cubic Yards.....           | 0.046 090 96 |

| To Convert from<br>Cubic Inches |               |
|---------------------------------|---------------|
| To                              | Multiply by   |
| Dry Pints.....                  | 0.029 761 6   |
| Dry Quarts.....                 | 0.014 880 8   |
| Pecks.....                      | 0.001 860 10  |
| Bushels.....                    | 0.000 465 025 |

| To Convert from<br>Cubic Yards |             |
|--------------------------------|-------------|
| To                             | Multiply by |
| Pecks.....                     | 86.784 91   |
| Bushels.....                   | 21.696 227  |

| To Convert from<br>Cubic Feet |              |
|-------------------------------|--------------|
| To                            | Multiply by  |
| Dry Pints.....                | 51.428 09    |
| Dry Quarts.....               | 25.714 05    |
| Pecks.....                    | 3.214 256    |
| Bushels.....                  | 0.803 563 95 |

## Units of Area

| To Convert from<br>Square Centimeters |               |
|---------------------------------------|---------------|
| To                                    | Multiply by   |
| Square Inches.....                    | 0.155 000 3   |
| Square Feet.....                      | 0.001 076 39  |
| Square Yards.....                     | 0.000 119 599 |
| Square Meters.....                    | 0.000 1       |

| To Convert from<br>Square Meters |               |
|----------------------------------|---------------|
| To                               | Multiply by   |
| Square Inches.....               | 1,550.003     |
| Square Feet.....                 | 10.763 91     |
| Square Yards.....                | 1.195 990     |
| Acres.....                       | 0.000 247 105 |
| Square Centimeters.....          | 10 000        |
| Hectares.....                    | 0.000 1       |

| To Convert from<br>Hectares |              |
|-----------------------------|--------------|
| To                          | Multiply by  |
| Square Feet.....            | 107 639.1    |
| Square Yards.....           | 11 959.90    |
| Acres.....                  | 2,471 054    |
| Square Miles.....           | 0.003 861 02 |
| Square Meters.....          | 10 000       |

| To Convert from<br>Square Inches |               |
|----------------------------------|---------------|
| To                               | Multiply by   |
| Square Feet.....                 | 0.006 944 44  |
| Square Yards.....                | 0.000 771 605 |
| Square Centimeters.....          | 6.451 6       |
| Square Meters.....               | 0.000 645 16  |

| To Convert from<br>Square Feet |               |
|--------------------------------|---------------|
| To                             | Multiply by   |
| Square Inches.....             | 144           |
| Square Yards.....              | 0.111 111 1   |
| Acres.....                     | 0.000 022 957 |
| Square Centimeters.....        | 929.030 4     |
| Square Meters.....             | 0.092 903 04  |

| To Convert from<br>Square Yards |                     |
|---------------------------------|---------------------|
| To                              | Multiply by         |
| Square Inches.....              | 1 296               |
| Square Feet.....                | 9                   |
| Acres.....                      | 0.000 208 611 6     |
| Square Miles.....               | 0.000 000 322 830 6 |
| Square Centimeters.....         | 8 361.273 6         |
| Square Meters.....              | 0.836 127 36        |
| Hectares.....                   | 0.000 083 612 736   |

| To Convert from<br>Acres |                  |
|--------------------------|------------------|
| To                       | Multiply by      |
| Square Feet.....         | 43 560           |
| Square Yards.....        | 4 840            |
| Square Miles.....        | 0.001 562 5      |
| Square Meters.....       | 4 046.856 422 4  |
| Hectares.....            | 0.404 685 642 24 |

| To Convert from<br>Square Miles |                   |
|---------------------------------|-------------------|
| To                              | Multiply by       |
| Square Feet.....                | 27,878 400        |
| Square Yards.....               | 3 097 600         |
| Acres.....                      | 640               |
| Square Meters.....              | 2 589 988.110 336 |
| Hectares.....                   | 258.998 811 033 6 |

## Special Tables

### Length—Inches and Millimeters—Equivalents of Decimal and Binary Fractions of an Inch in Millimeters

From 1/64 to 1 Inch

| 1/4's | 8ths | 16ths | 32ds | 64ths | Milli-<br>meters | Decimals<br>of<br>an inch | Inch | 1/2's | 1/4's | 8ths | 16ths | 32ds | 64ths | Milli-<br>meters | Decimals<br>of<br>an inch |          |
|-------|------|-------|------|-------|------------------|---------------------------|------|-------|-------|------|-------|------|-------|------------------|---------------------------|----------|
|       |      |       |      | 1     | = 0.397          | 0.015625                  |      |       |       |      |       |      |       | 33               | = 13.097                  | 0.515625 |
|       |      |       | 1    | 2     | = .794           | .03125                    |      |       |       |      |       | 17   | 34    | = 13.494         | .53125                    |          |
|       |      |       |      | 3     | = 1.191          | .046875                   |      |       |       |      |       |      | 35    | = 13.891         | .546875                   |          |
|       |      | 1     | 2    | 4     | = 1.588          | .0625                     |      |       |       |      | 9     | 18   | 36    | = 14.288         | .5625                     |          |
|       |      |       |      | 5     | = 1.984          | .078125                   |      |       |       |      |       |      | 37    | = 14.684         | .578125                   |          |
|       |      |       | 3    | 6     | = 2.381          | .09375                    |      |       |       |      |       | 19   | 38    | = 15.081         | .59375                    |          |
|       |      |       |      | 7     | = 2.778          | .109375                   |      |       |       |      |       |      | 39    | = 15.478         | .609375                   |          |
|       | 1    | 2     | 4    | 8     | = 3.175          | .1250                     |      |       |       | 5    | 10    | 20   | 40    | = 15.875         | .625                      |          |
|       |      |       |      | 9     | = 3.572          | .140625                   |      |       |       |      |       |      | 41    | = 16.272         | .640625                   |          |
|       |      |       | 5    | 10    | = 3.969          | .15625                    |      |       |       |      |       | 21   | 42    | = 16.669         | .65625                    |          |
|       |      |       |      | 11    | = 4.366          | .171875                   |      |       |       |      |       |      | 43    | = 17.066         | .671875                   |          |
|       |      | 3     | 6    | 12    | = 4.762          | .1875                     |      |       |       |      | 11    | 22   | 44    | = 17.462         | .6875                     |          |
|       |      |       |      | 13    | = 5.159          | .203125                   |      |       |       |      |       |      | 45    | = 17.859         | .703125                   |          |
|       |      |       | 7    | 14    | = 5.556          | .21875                    |      |       |       |      |       | 23   | 46    | = 18.256         | .71875                    |          |
|       |      |       |      | 15    | = 5.953          | .234375                   |      |       |       |      |       |      | 47    | = 18.653         | .734375                   |          |
| 1     | 2    | 4     | 8    | 16    | = 6.350          | .2500                     |      |       | 3     | 6    | 12    | 24   | 48    | = 19.050         | .75                       |          |
|       |      |       |      | 17    | = 6.747          | .265625                   |      |       |       |      |       |      | 49    | = 19.447         | .765625                   |          |
|       |      |       | 9    | 18    | = 7.144          | .28125                    |      |       |       |      |       | 25   | 50    | = 19.844         | .78125                    |          |
|       |      |       |      | 19    | = 7.541          | .296875                   |      |       |       |      |       |      | 51    | = 20.241         | .796875                   |          |
|       |      | 5     | 10   | 20    | = 7.938          | .3125                     |      |       |       |      | 13    | 26   | 52    | = 20.638         | .8125                     |          |
|       |      |       |      | 21    | = 8.334          | .328125                   |      |       |       |      |       |      | 53    | = 21.034         | .828125                   |          |
|       |      |       | 11   | 22    | = 8.731          | .34375                    |      |       |       |      |       | 27   | 54    | = 21.431         | .84375                    |          |
|       |      |       |      | 23    | = 9.128          | .359375                   |      |       |       |      |       |      | 55    | = 21.828         | .859375                   |          |
|       | 3    | 6     | 12   | 24    | = 9.525          | .3750                     |      |       |       | 7    | 14    | 28   | 56    | = 22.225         | .875                      |          |
|       |      |       |      | 25    | = 9.922          | .390625                   |      |       |       |      |       |      | 57    | = 22.622         | .890625                   |          |
|       |      |       | 13   | 26    | = 10.319         | .40625                    |      |       |       |      |       | 29   | 58    | = 23.019         | .90625                    |          |
|       |      |       |      | 27    | = 10.716         | .421875                   |      |       |       |      |       |      | 59    | = 23.416         | .921875                   |          |
|       |      | 7     | 14   | 28    | = 11.112         | .4375                     |      |       |       |      | 15    | 30   | 60    | = 23.812         | .9375                     |          |
|       |      |       |      | 29    | = 11.509         | .453125                   |      |       |       |      |       |      | 61    | = 24.209         | .953125                   |          |
|       |      |       | 15   | 30    | = 11.906         | .46875                    |      |       |       |      |       | 31   | 62    | = 24.606         | .96875                    |          |
|       |      |       |      | 31    | = 12.303         | .484375                   |      |       |       |      |       |      | 63    | = 25.003         | .984375                   |          |
| 2     | 4    | 8     | 16   | 32    | = 12.700         | .5                        | 1    | 2     | 4     | 8    | 16    | 32   | 64    | = 25.400         | 1.000                     |          |

## Length—International Nautical Miles and Kilometers

Basic relation: International Nautical Mile = 1.852 kilometers.

| Int. nautical miles | Kilometers | Int. nautical miles | Kilometers | Kilometers | Int. nautical miles | Kilometers | Int. nautical miles |
|---------------------|------------|---------------------|------------|------------|---------------------|------------|---------------------|
| 0                   |            | 50                  | 92.600     | 0          |                     |            | 26.9978             |
| 1                   | 1.852      | 51                  | 94.452     | 1          | 0.5400              | 1          | 27.5378             |
| 2                   | 3.704      | 52                  | 96.304     | 2          | 1.0799              | 2          | 28.0778             |
| 3                   | 5.556      | 53                  | 98.156     | 3          | 1.6199              | 3          | 28.6177             |
| 4                   | 7.408      | 54                  | 100.008    | 4          | 2.1598              | 4          | 29.1577             |
| 5                   | 9.260      | 55                  | 101.860    | 5          | 2.6998              | 5          | 29.6976             |
| 6                   | 11.112     | 56                  | 103.712    | 6          | 3.2397              | 6          | 30.2376             |
| 7                   | 12.964     | 57                  | 105.564    | 7          | 3.7797              | 7          | 30.7775             |
| 8                   | 14.816     | 58                  | 107.416    | 8          | 4.3197              | 8          | 31.3175             |
| 9                   | 16.668     | 59                  | 109.268    | 9          | 4.8596              | 9          | 31.8575             |
| 10                  | 18.520     | 60                  | 111.120    | 10         | 5.3996              | 60         | 32.3974             |
| 1                   | 20.372     | 1                   | 112.972    | 1          | 5.9395              | 1          | 32.9374             |
| 2                   | 22.224     | 2                   | 114.824    | 2          | 6.4795              | 2          | 33.4773             |
| 3                   | 24.076     | 3                   | 116.676    | 3          | 7.0194              | 3          | 34.0173             |
| 4                   | 25.928     | 4                   | 118.528    | 4          | 7.5594              | 4          | 34.5572             |
| 5                   | 27.780     | 5                   | 120.380    | 5          | 8.0994              | 5          | 35.0972             |
| 6                   | 29.632     | 6                   | 122.232    | 6          | 8.6393              | 6          | 35.6371             |
| 7                   | 31.484     | 7                   | 124.084    | 7          | 9.1793              | 7          | 36.1771             |
| 8                   | 33.336     | 8                   | 125.936    | 8          | 9.7192              | 8          | 36.7171             |
| 9                   | 35.188     | 9                   | 127.788    | 9          | 10.2592             | 9          | 37.2570             |
| 20                  | 37.040     | 70                  | 129.640    | 20         | 10.7991             | 70         | 37.7970             |
| 1                   | 38.892     | 1                   | 131.492    | 1          | 11.3391             | 1          | 38.3369             |
| 2                   | 40.744     | 2                   | 133.344    | 2          | 11.8790             | 2          | 38.8769             |
| 3                   | 42.596     | 3                   | 135.196    | 3          | 12.4190             | 3          | 39.4168             |
| 4                   | 44.448     | 4                   | 137.048    | 4          | 12.9590             | 4          | 39.9568             |
| 5                   | 46.300     | 5                   | 138.900    | 5          | 13.4989             | 5          | 40.4968             |
| 6                   | 48.152     | 6                   | 140.752    | 6          | 14.0389             | 6          | 41.0367             |
| 7                   | 50.004     | 7                   | 142.604    | 7          | 14.5788             | 7          | 41.5767             |
| 8                   | 51.856     | 8                   | 144.456    | 8          | 15.1188             | 8          | 42.1166             |
| 9                   | 53.708     | 9                   | 146.308    | 9          | 15.6587             | 9          | 42.6566             |
| 30                  | 55.560     | 80                  | 148.160    | 30         | 16.1987             | 80         | 43.1965             |
| 1                   | 57.412     | 1                   | 150.012    | 1          | 16.7387             | 1          | 43.7365             |
| 2                   | 59.264     | 2                   | 151.864    | 2          | 17.2786             | 2          | 44.2765             |
| 3                   | 61.116     | 3                   | 153.716    | 3          | 17.8186             | 3          | 44.8164             |
| 4                   | 62.968     | 4                   | 155.568    | 4          | 18.3585             | 4          | 45.3564             |
| 5                   | 64.820     | 5                   | 157.420    | 5          | 18.8985             | 5          | 45.8963             |
| 6                   | 66.672     | 6                   | 159.272    | 6          | 19.4384             | 6          | 46.4363             |
| 7                   | 68.524     | 7                   | 161.124    | 7          | 19.9784             | 7          | 46.9762             |
| 8                   | 70.376     | 8                   | 162.976    | 8          | 20.5184             | 8          | 47.5162             |
| 9                   | 72.228     | 9                   | 164.828    | 9          | 21.0583             | 9          | 48.0562             |
| 40                  | 74.080     | 90                  | 166.680    | 40         | 21.5983             | 90         | 48.5961             |
| 1                   | 75.932     | 1                   | 168.532    | 1          | 22.1382             | 1          | 49.1361             |
| 2                   | 77.784     | 2                   | 170.384    | 2          | 22.6782             | 2          | 49.6760             |
| 3                   | 79.636     | 3                   | 172.236    | 3          | 23.2181             | 3          | 50.2160             |
| 4                   | 81.488     | 4                   | 174.088    | 4          | 23.7581             | 4          | 50.7559             |
| 5                   | 83.340     | 5                   | 175.940    | 5          | 24.2981             | 5          | 51.2959             |
| 6                   | 85.192     | 6                   | 177.792    | 6          | 24.8380             | 6          | 51.8359             |
| 7                   | 87.044     | 7                   | 179.644    | 7          | 25.3780             | 7          | 52.3758             |
| 8                   | 88.896     | 8                   | 181.496    | 8          | 25.9179             | 8          | 52.9158             |
| 9                   | 90.748     | 9                   | 183.348    | 9          | 26.4579             | 9          | 53.4557             |
|                     |            | 100                 | 185.200    |            |                     | 100        | 53.9957             |