

DOCUMENT RESUME

ED 153 843

SE 024 169

AUTHOR Childs, Barbara; And Others
TITLE Interdisciplinary Student/Teacher Materials in Energy, the Environment, and the Economy: 3, Energy, Engines, and the Industrial Revolution, Grades 8, 9.
INSTITUTION National Science Teachers Association, Washington, D.C.
SPONS. AGENCY Bureau of Intergovernmental and Institutional Relations (DCE), Washington, D.C. Office of Education, Business and Labor Affairs.
REPORT NO EDM-1032
PUB DATE Oct 77
CONTRACT NOTE EX-76-C-10-3841.
AVAILABLE FROM 80p.; For related documents, see SE Q24 167-172 and SE 024 218; Not available in hard copy due to marginal legibility of original document.
 U.S. Department of Energy, Technical Information Office, P.O. Box 62, Oak Ridge, Tennessee 37830 (no price quoted)
EDRS PRICE MF-\$0.83 Plus Postage. PC Not Available from EDRS.
DESCRIPTORS Economic Education; *Energy; History; Industrialization; *Instructional Materials; Integrated Curriculum; *Science Education; *Secondary Education; *Social Studies; *Teaching Guides

ABSTRACT
 This instructional unit for grades 8-9 combines science and social studies in a look at the broad social and economic upheavals that took place during the industrial revolution, giving special emphasis to the role of energy. The invention and development of the steam engine is highlighted in the lesson. Other lessons show how the industrial revolution affected the location and growth of cities around sites of energy sources, and give greater understanding of the effects of technology on the daily lives of people. There are five lessons in all, two relating to science and three to social studies. Complete teacher and student materials are included. (BB)

 * Reproductions supplied by EDRS are the best that can be made *
 * from the original document. *

EDM-1032

Prepared for Education Programs Branch, Office of Public Affairs, ERDA (now U.S. Department of Energy) under contract number EX-76C-10-3841 by National Science Teachers' Association October 1977

U.S.
Department
of
Energy

National
Science
Teachers
Association

ED153843



Interdisciplinary
Student/Teacher Materials
in Energy, the Environment,
and the Economy

U.S. DEPARTMENT OF HEALTH,
EDUCATION & WELFARE
NATIONAL INSTITUTE OF
EDUCATION

THIS DOCUMENT HAS BEEN REPRODUCED EXACTLY AS RECEIVED FROM THE PERSON OR ORGANIZATION ORIGINATING IT. POINTS OF VIEW OR OPINIONS STATED DO NOT NECESSARILY REPRESENT OFFICIAL NATIONAL INSTITUTE OF EDUCATION POSITION OR POLICY.

"PERMISSION TO REPRODUCE THIS MATERIAL HAS BEEN GRANTED BY

Elizabeth Larkin

TO THE EDUCATIONAL RESOURCES INFORMATION CENTER (ERIC) AND USERS OF THE ERIC SYSTEM "

3
Energy, Engines, and the
Industrial Revolution
Grades 8, 9

024 169



This material was produced by the National Science Teachers Association under contract with the U.S. Energy Research and Development Administration (now U.S. Department of Energy). The facts, statistics, and conclusions are those of the authors.

Copies of these materials may be obtained from:

U.S. Department of Energy
Technical Information Office
P.O. Box 62
Oak Ridge, TN 37830

U.S.
Department
of
Energy

EDM-1032

Prepared for Education Programs
Branch, Office of Public Affairs,
ERDA (now U.S. Department of
Energy) under contract number
EX-76C-10-3841 by National Sci-
ence Teachers Association
October 1977

3

Energy, Engines, and the Industrial Revolution

Grades 8, 9

National Science Teachers Association
1742 Connecticut Avenue, N.W.
Washington, D.C. 20009

This instructional unit was produced by NSTA's Project for an Energy-Enriched Curriculum under contract #EX-76C-10-3841 from the Education Programs Branch, Office of Public Affairs, the U.S. Energy Research and Development Administration (now U.S. Department of Energy). The NSTA project staff is as follows:

John M. Fowler, Project Director
King C. Kryger, Associate Project Director
Helen H. Carey, Editor-Coordinator

"Energy, Engines, and the Industrial Revolution" is the product of a writing session held at the University of Maryland during Summer 1976. The following teachers were the main contributors to this unit:

Barbara Childs Browne Junior High School Washington, D.C.	Bette Johnson Dunloggin Middle School Howard County, Maryland
---	---

Arthur Goldman Benjamin Banneker Junior High Montgomery County, Maryland	Leon Scipio Browne Junior High School Washington, D.C.
--	--

The PEEC staff also wishes to acknowledge the cooperation of the National Council for the Social Studies (NCSS) and its Executive Director, Brian Larkin. The NCSS has suggested teachers and consultants to us and has assisted in evaluation and review of the social studies aspects of this unit.

Finally, we wish to acknowledge the support and cooperation of Bart McGarry, Assistant Director for Public Services, Office of Public Affairs, Energy Research and Development Administration (ERDA), and especially of Donald Duggan, Chief, Education Programs Branch, Office of Public Affairs, ERDA, and Program Manager of the PEEC contract, who has actively and enthusiastically contributed advice and counsel on many phases of this materials development effort.

October 1977
John M. Fowler
Project Director

Energy, Engines, and the Industrial Revolution

Introduction

Since prehistoric times human beings have used tools to help them do work. It was not until the 18th century that tools, which merely extend the range of energy available through muscle power, began to give way to machines, which convert external sources of energy into mechanical energy, which is then used to do work. This change is one of the most important technical breakthroughs of that period we commonly call the Industrial Revolution.

This unit examines some of the broad social and economic upheavals that took place during this period. It calls special attention to the role of energy in this dramatic period of history which ushered in our own technological age. We have chosen to highlight the invention and development of the steam engine -- a machine that made possible much of the rapid growth of technology from the mid 18th century to 1860. The history of the steam engine demonstrates the close link between machinery and the abundant use of energy. It can also show how the pervasive use of fossil fuel energy which began in the Industrial Revolution was the forerunner of the present age of energy scarcity.

We have introduced the energy topic in several ways. In some of the lessons the social studies teacher can emphasize energy resources at appropriate times while approaching the Industrial Revolution in an historical manner. For example, there are lessons about inventors and inventions which cover traditional ground, but give special emphasis to the involvement of energy in the inventions. Other lessons, also primarily designed for use in social studies classes, show how the Industrial Revolution affected the location and growth of cities around sites of energy sources, and give greater understanding of the effects of technology on the daily

lives of people.

Teachers will notice that this unit contains lessons for both science and social studies classes. These lessons are meant to be mutually supportive. It is our hope that science teachers will give some attention to the social implications of the Industrial Revolution and that social studies teachers will try some of the experiments in their classes in order to demonstrate the technical principles which run beneath the surface of this great movement in history.

<u>Activity</u>	<u>Contents</u>	<u>Target Classes</u>
1	<u>Energy, Engines, and the Industrial Revolution</u> An Industrial Revolution student reader, 1700 - 1860 with focus on energy.	Social Studies
2	<u>Energy Converts to...What? And...Why?</u> Students describe the energy conversions that take place in an automobile.	Science
3	<u>The Great Joule Robbery</u> Consideration of the heat engine (gasoline, diesel, and steam turbine) upon which the Industrial Revolution was built.	Science
4	<u>Energy and The Industrial City</u> Students examine a series of maps and graphs that focus on the place industrialization holds in national and urban life.	Social Studies
5	<u>How to Succeed By Really Trying</u> The "knife and fork" part of history. Students describe the effects a major change such as the Industrial Revolution has on the daily lives of people.	Social Studies

Teachers' Manual

1. Energy, Engines, and the Giant Step of the Industrial Revolution

Overview

The term "revolution" can be applied to a period of history during which human beings' ways of living change drastically. To "revolutionize" means to make a complete change and to substitute something else that is accepted by a vast number of people. In this sense, the industrial change that took place in 18th Century England -- and later, in 19th Century America -- was a revolution. It was over this relatively short period of time that the production of goods changed from the hand to the machine and from the home to the factory. The purpose of this set of lessons is to focus on the development of these remarkable machines and the revolution in the sources of energy. Students should be reminded throughout the lesson that these machines depended on a primary source of energy (usually coal), and that they converted these sources into mechanical energy in order to do work:

Objectives

Students should be able to:

1. Explain in technological terms the progression of the first era in industrialization as a giant step forward in power, speed, energy, and adaptability.
2. List prominent inventors, and match them with their inventions and source of energy.
3. Explain the progression of machines that distinguished the times.
4. Explain how the repeated economic success of new inventions led to extraordinary changes in the every day lives of people.

Time Allotment

Two- three class periods.

Materials

Class copies of the Industrial Revolution text
Time-line -- The Industrial Revolution 1700-1860.

Teaching Strategies

Motivating the Lesson

Since the topic of the Industrial Revolution is important, it should be presented in a challenging and stimulating fashion. You may wish to begin with a discussion of the question, "Where would you look to find evidence of the beginnings of an Industrial Revolution in this country?" Is there evidence in your own region or community? Bring out the fact that the evidences are very scanty. Encourage students to mention things such as a fragment of stonework from the Erie Canal, a part of the brickwork from an old factory smoke-stack, etc.

You may prefer to introduce the topic with a discussion of this question. "What was life like before we learned to harness the energy resources necessary for developing these machines?" How would daily life have been different then? If students were suddenly transported back into pre-industrialized times, how would their "lifestyles" have to change? What would they have to give up? Would they be gaining anything?

Developing the Lesson

This lesson may develop in a variety of ways. There is no one best way to teach history or social studies. The most effective approach for your class will depend upon their interests, abilities, and background. You will be guided by the materials available, the time to be devoted to a particular topic, and the nature of the learning for which you are striving.

Have the class use the questions at the end of the reader as a guide to their reading and as a stimulation for discussion. As the class reading proceeds, you can move around the room, noting the rate of reading of the pupils and helping any student who is having difficulty with words or ideas. As soon as the class has completed the assigned reading, a discussion can be held in which the answers to the questions are brought out and explained. A variation of this kind of lesson would be to assign the reading for homework and then use the class time to deal with the questions. This procedure would provide time for you to help the students begin keeping notes.

Another approach is to have an interested student set up and demonstrate the experiments suggested in the text. These can be used to clarify the reading and to illustrate principles in later les-

sons.

In cases where the teacher plans to use only this lesson, we suggest using the other lessons as supplements to the reader. For example, students interested in the more technical aspects of the Industrial Revolution may wish to look at the materials in the lesson "Energy Converts to ... What? And ... Why?" or in the lesson "The Great Joule Robbery." Similarly, teachers will find that the readings in "How to Succeed by Really Trying" make an interesting supplement to a discussion of the factory system.

Note to the Social Studies Teacher: Your colleagues in the science department may have equipment useful in demonstrating the steam engine and the principles that govern its operation. Perhaps you can even borrow a science teacher along with the equipment, to explain the scientific parts of the lesson.

Note to the Science Teacher: Think about teaming up with a social studies teacher, or combining segments of social studies and science classes to explore questions of how the Industrial Revolution demonstrates the interdependence of science and society. This can be done by combining scientific experiments and demonstrations with group discussions.

Answers

To AFTER YOU HAVE FINISHED THE READER (Student Questions)

Understanding History Terms

You may wish to add other terms to those listed here. An ideal use of these terms in sentences would demonstrate not only that the student understands the term, but also its importance in the Industrial Revolution.

Time-line -- Inventors and Inventions (See completed Time-line)

Thinking About Historical Links

1. Students should mention how the steam engine created a need for stronger, more durable metals to stand up to the increased pressure from steam power. Iron was less durable than steel. To make steel, higher temperatures were needed. Charcoal gave way to coke. Other things that could be mentioned are the developments that came along to put

the power of the steam engine to use: stronger and better bridges to support the heavier locomotives, railroads replacing wagons and horses; steamboats replacing wind and sail, etc.

In textiles, the faster loom created a need for more thread. Entire industries became housed under one roof in the beginning factory system. The list of links is endless.

2. The first Industrial Revolution began in England with the first machines that increased production in the textile industries. Mechanization was well advanced in Europe long before America turned to manufacturing. After the Civil War, industrialism exploded in America. The conditions were right, the resources rich, and with government encouragement, expansion took place in every sector: social; political, and economic.

3. The relationship between the invention of a machine and new energy sources is a chicken and egg affair. The gasoline engine could not have been invented without the knowledge of gasoline. Its invention, on the other hand, so greatly increased the demand for oil that it established oil as a new and important energy source. In the same way, the steam engine greatly increased the demand for coal. We have not yet built an engine to run directly on nuclear energy, but if one is invented, that will hasten the turn to this energy source.

4. The purpose of this discussion question is to bring out the idea that the Industrial Revolution came about because a number of situations existed at just the right time.

5. This is also a discussion question. Its purpose is to show that inventions (and the ideas behind them) have an evolution. They don't just happen. And they are seldom the product of a single person working in isolation.

Completing
the Outline

Students should refer to the Student Reader in order to complete the outline.

THE INDUSTRIAL REVOLUTION 1700-1860

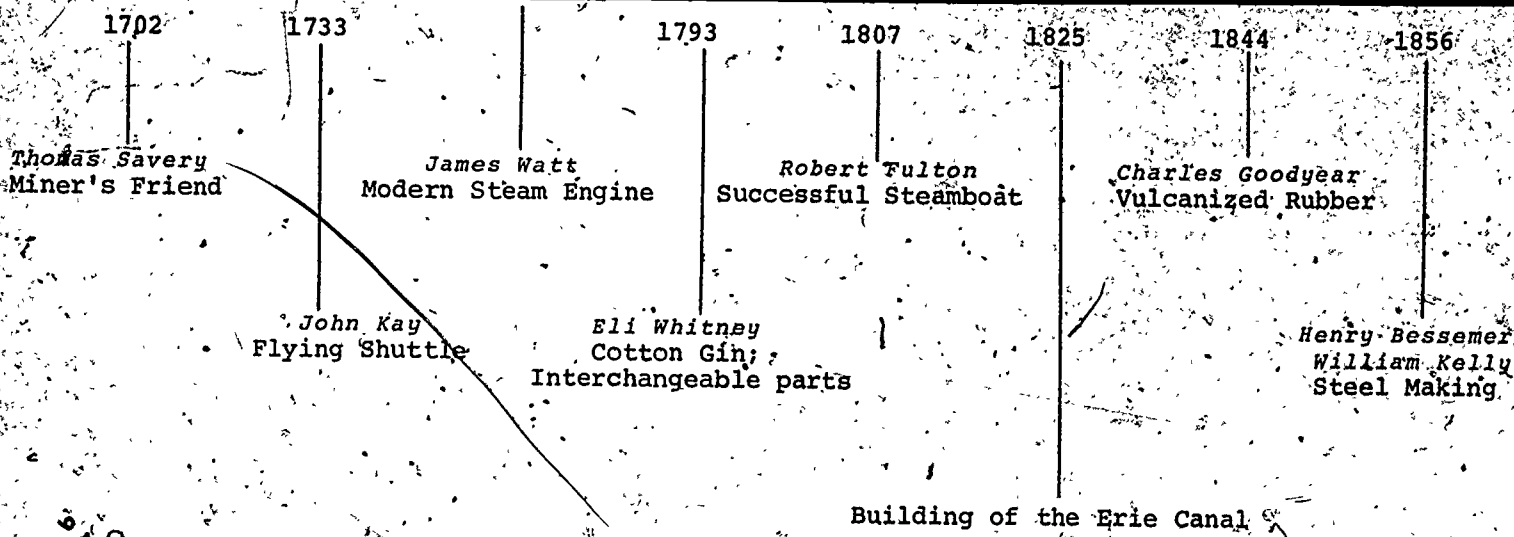
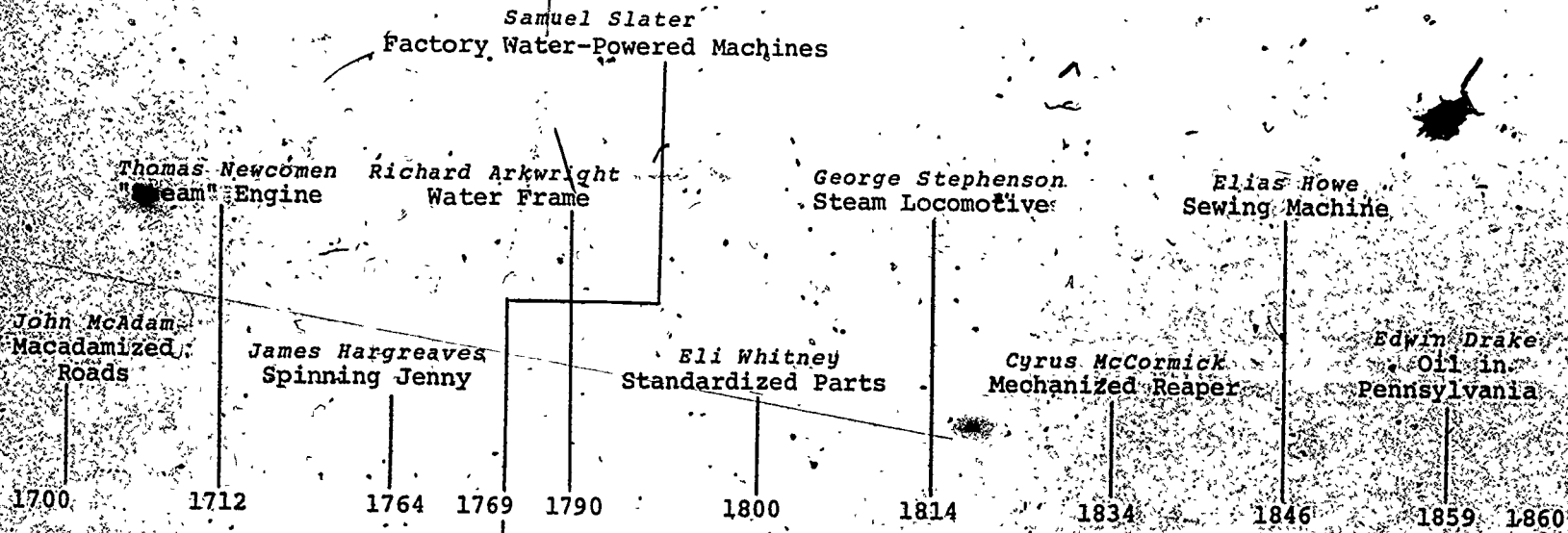

Building of the Erie Canal



2. Energy Converts to ... What? And ... Why?

Overview

One very important property of energy is that almost any form of energy can be converted into almost any other form. Changes in energy are most useful when controlled. Mastery of energy has been the key to technological progress; it is what made the Industrial Revolution possible. Unwise use of energy might be the key to humankind's destruction.

The automobile, being familiar to all, is a good example of a way in which changes in energy have been controlled and used.

Objectives

The student should be able to:

1. Describe the energy conversions that take place in an automobile.
2. Demonstrate how stored chemical energy can be converted to heat energy.
3. Demonstrate that heat energy can be converted into mechanical energy.
4. Give examples of energy conversions, using everyday things around them.

Time Allotment

Two - three class periods

Materials

Parts 3 and 4 of this lesson will need some special materials. A list can be found at the beginning of each of these parts.
Ditto copies of "Energy Conversion: A Fact Sheet."
Ditto copies of "Tracing the Energy Conversions in an Automobile."

Teaching Strategies

Ask students when they last used energy. Do they have any idea how energy is used? Is energy heat, light, electricity, magnetism? What is energy anyway? (*The ability to produce heat, light, or to do work.*) What has to happen before energy can be used to do work? (*It often has to be changed into another form.*)

About Converted Energy

Activity 1: After the brief introduction to the topic of energy, distribute the Fact Sheet to students and allow sufficient time for in-class reading of the material. The Fact Sheet might well be read aloud in class. Pause frequently to explain and bring out important functions of energy conversion.

Energy Tracing

Activity 2: Have students use the information found in the Fact Sheet to help trace light energy in the automobile back to its energy origin. Ditto class copies of the pictured auto and energy tracing blocks to be filled in. The blocks should read:

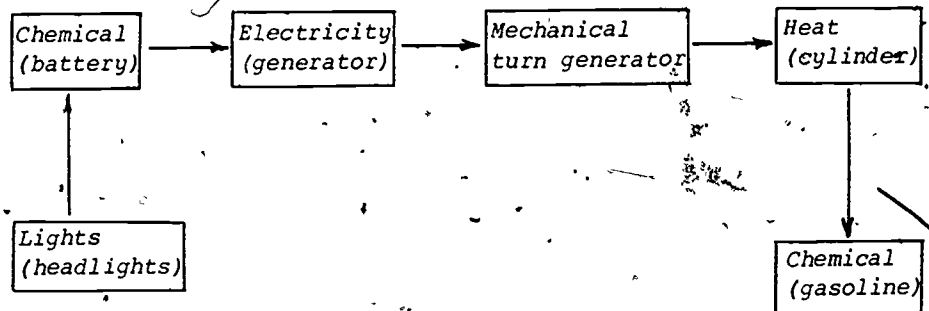

Student Activity 1 - Energy Conversion: A Fact Sheet

What is energy? The first step in trying to define energy is to set up two categories. Energy in the form of motion, heat, or light is called kinetic energy. Energy that is stored in food, gasoline, the nucleus of atoms and batteries is called potential energy. Kinetic energy is energy on the move. Potential energy is stored energy and it is in this form that we dig it from mines and pump it from wells. To use energy, it must be in kinetic form.

We use energy because we want to do something to matter; move it, illuminate it, or warm it. We usually store energy in the potential form but it is possible to store energy in the kinetic form, too. This form of storage, however, is quite dif-

ferent from potential storage, it is temporary; we trap or insulate kinetic energy. Examples of kinetic energy being stored are the flywheel of an engine and heat energy in a thermos bottle. Potential energy storage is more permanent. It is accomplished by changes in the structure of matter. A simple way to store energy is to lift something away from the earth (energy is stored when water is pumped to the top of a water tower, then converted to kinetic energy when it is allowed to run through pipes).

Energy constantly changes forms. It can be potential stored in coal. When coal burns at a power plant it changes to the kinetic form, the heat of steam. When the steam is allowed to strike the blades of a turbine, some of the heat energy becomes the kinetic energy of motion (mechanical) of the engine. The turbine turns an electric generator and some of the energy becomes electrical energy. Electric energy is also changed in form when it is used.

These changes of forms are governed by strict laws; the first of these is called the First Law of Thermodynamics, which states that energy can neither be created nor destroyed. The Second Law of Thermodynamics states that in any conversion of energy from one form to another some of it becomes unavailable for use. This is mainly because some of it becomes heat and it is not possible to convert all of a given amount of heat energy completely back to another form. This unusable heat energy leaks away. (It is important to realize that escaped heat caused by inefficient conversions is one of the major causes of energy waste in our society.)

It is possible to convert all of a certain amount of mechanical energy to heat by, for instance, putting on the brakes of a car. It is possible to convert all the chemical energy of coal into heat by burning it. These conversions cannot go to completion in the other direction, only a limited amount of heat energy is convertible back to other forms. There are many forms of energy but before most energy can be used to do work it first must be changed into mechanical energy.

You may sum up by having students use the terms from the lesson orally in filling the blanks of the auto story, which you may ditto for paper and pencil work, or read aloud, pausing at appropriate times to have students fill in the energy form.

Naming the Energy Form

When a fuel, such as gasoline is ignited, the chemical energy is converted to heat energy. This heat energy is converted to mechanical energy of the pistons in the engine, which causes the rotation of the flywheel. Some of the mechanical energy is then used to turn the generator to convert mechanical energy to electrical energy. Some of the electrical energy is converted to light energy for the headlights, and heat energy in the cigarette lighter.

An alternate summing up may be accomplished by having students identify energy by what it does. Prepare a series of statements similar to these, or have students invent statements of their own.

When you clap your hands, you change muscular energy to (motion) and to (sound).

When you are talking, you change (mechanical) energy to (sound).

When striking a match, you convert (chemical) energy to (heat) and to (light).

Making a Working Model of a Steam Turbine

Activity 3: The special feature of this lesson involves students making and turning a turbine wheel by steam. The experiment does a good job of explaining energy conversion under observable conditions. This lab activity demonstrates that mechanical energy can be changed into heat energy. It also shows that stored chemical energy can be converted into heat energy.

Suggest to the students that they read through the lab before attempting the construction of the model turbine and proceeding with the demonstration. Have students complete the lab, and at the end of the lesson, have the students complete the summing up by filling in the blank spaces on the evaluation sheets. You may want to go deeper into the conversion mechanism and get them to think about the water molecules striking the turbine blades.

Materials

Class copies of instructional sheets for making and operating a model steam turbine.

Class sets of evaluation sheets

Class lab materials:

medicine dropper tubes	2-3 thimbles
test tubes	2-3 scissors
bunsen burners	pencils with erasers
stoppers	manila circles
support rods	needles
rulers	2-3 compasses

Ask the students to tell how energy was converted to other forms. Ask how these conversions help people.

Where was energy stored? *(In the chemical energy of natural gas, alcohol, or water.)*

How was chemical energy converted? Into what? *(It was converted into heat.)*

What did the turbine convert the heat energy into? *(Mechanical energy.)*

The overall conclusion might go something like this: You have demonstrated how stored energy (chemical energy in natural gas) can be converted into heat and how this heat can be converted into mechanical energy. Ask: What use can a turbine be put to? *(A turbine is a heat engine. It changes heat energy into mechanical energy and can turn a generator which produces electrical energy.)*

Activity 4 (optional): After completing the set of activities 1-3, students may find their interest running high. This activity will enable them to find out how energy changes take place. The availability of materials may dictate whether you demonstrate this activity, or whether the students perform the experiment. Either way, the students should be able to make a written statement about energy conversion at the end. The statement can be used as an informal evaluation.

Energy Conversion

Materials

1 beaker	cardboard tube
1 lb BB's (lead shot)	masking tape
thermometer	

Procedure

Pour about 1 lb of lead shot into a beaker. Place a thermometer well into the lead shot and record the temperature. Pour the lead shot into a cardboard tube that is closed at one end by masking tape. Close the other end with your hand and shake the tube vigorously 30-50 times. Insert the thermometer again and record the temperature. Answer these questions:

1. Why did the temperature change?
2. What kind of energy change took place?

General conclusion: Shaking the tube caused the BB's to rub against each other. The resulting friction caused heat. Muscle energy (mechanical energy) converted to heat energy. Suggest that the students suggest other examples (rubbing sticks together, for instance).

Lesson Evaluation Activity

Distribute copies of the Evaluation matrix to the class. Have students fill in the blank space with examples of energy conversions. Use the responses as a form of evaluation. You may wish to set a time limit and invite more interest by making the task into a game. Challenge the students to fill in the blank blocks within a time limit, counting each correct answer 5 points. "Winners" would accumulate the highest number of points.

Evaluation Sheet

Directions: Write in each box examples of one form of energy being converted into another form. Begin with the vertical column on the left. Example: Heat is converted into light energy in a light bulb, so write "light bulb" in the box formed by the intersection of the two energy forms.

	HEAT	LIGHT	SOUND	MECHANICAL (Movement)	CHEMICAL	ELECTRIC	NUCLEAR
HEAT		light bulb, fire, electric arc	explosions	steam turbine	disassociation of water or other molecules	thermionic effects	nuclear reactions in stars
LIGHT	infra red absorption			light pressure, photoelectric effect	photosynthesis, other photo-chemical reactions	solar cell, other photo-voltaic effects	
SOUND	sound eventually dissipates as heat	sound converted to modification of laser beam		sound is a mechanical motion of molecules		microphones, telephones	
MECHANICAL (Movement)	rubbing hands, friction in general	non-electrical sparks	vocal cords, musical instruments			electric generator	cyclotrons & other high energy machines
CHEMICAL	gas furnaces, fuels in general	fuel burning, fire-fly phosphorescence	firecrackers, other explosives			fuel cell battery	
ELECTRIC	incandescent light, iron, cooking	fluorescent light, television	telephone speakers, radio, etc.	motor	charging storage battery		
NUCLEAR	nuclear reactor, fusion reaction	nuclear bomb	nuclear bomb	nuclear bomb		"nuclear batteries"	

3. The Great Joule Robbery

Overview This lesson is designed to provide students with some understanding of the "heat engines" - gasoline and diesel engines and steam turbines, for instance - upon which the Industrial Revolution was built. It focuses upon the basics of heat engines, the process by which heat energy is converted to mechanical energy, and the two limiting laws, the first and second laws of thermodynamics, which control this conversion.

There is particular emphasis on the second law of thermodynamics for it is that law that gives us the most trouble. It puts strict limits on the amount of heat energy which can be converted to work. It is from this law that we get the title of this activity. We cannot use all of the joules of energy (a joule is an energy unit) from the fuels we burn; the second law robs us of some.

Target Audiences

Physical and Social sciences

Objectives

The student should be able to:

1. Explain through drawings and models the different types of heat engines.
2. Demonstrate that chemical energy is changed into heat energy and finally into mechanical energy.
3. Identify the types of heat engines according to where the fuel is burned, and by the way heat is converted to mechanical energy.

Time Allotment

One - five class periods

Teaching Strategies

Day 1 - To open up a thoughtful consideration of what the steam engine does, you may ask, "What is an engine?" This will lead to a discussion of an engine as a machine. In the case of the steam engine it is a machine that changes heat energy into mechanical energy. Write this last part on the chalkboard. Then ask a series of questions similar to

these:

- How is heat obtained?
- How is energy changed into mechanical energy?
- Must you always have an energy source (or fuel)?
- Can all of the heat be turned into useful work?

(Refer to Fact Sheets for answers.)

Set up the experimental model of a steam engine as illustrated. You will need the following equipment:

- one-hole stopper
- Florence flask
- bunsen burner
- length of rubber tubing
- thin cardboard for blades
- support stand

There may be a short time delay for the fuel to heat. Review the terms external and internal. Explain that external means outside, internal, inside. Specifically, external combustion takes place when the working fluid (steam, for instance) is heated outside of the expansion chamber and brought under pressure. Internal combustion means that the fuel is burned inside the chamber in which the expansion is to take place. Ask: Which form of combustion do you think this experimental steam engine is? Proceed with the experiment. While they observe the operation, ask: "Where might the internal combustion engine be used? Where do you think an external combustion engine might be used?" Some examples of each are:

External combustion engine - reciprocating steam engine; steam turbine, and other stationary engines.

Internal combustion engine - rocket engine, automobile, airplane engines, and other mobile engines.

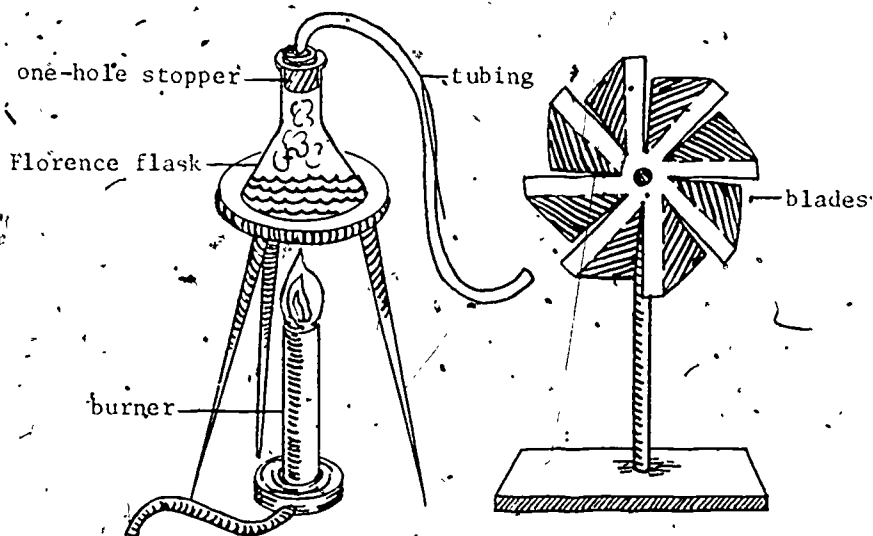

Sum up by asking: Is this model an external or internal combustion engine? Tell how you know. Complete the following sentence by supplying the best word:

In this engine, chemical energy in the fuel is converted to heat energy and then to mechanical energy.

Day 2 - You may encourage fuller understanding of the fact that all heat engines - no matter what their type is - convert heat energy to mechanical energy if you distribute the fact sheet about types of engines and what they do to fuel at this time. Have students complete the crossword combustion puzzle to culminate the lesson on heat engines.

You may prefer to provide a transition from the experiment to the summing-up part of the lesson by giving the students a drill exercise on the various engine terms. Distribute the word study list and allot sufficient time for the students to read it carefully. Then ask some questions such as the following:

1. What do we call a jet with no moving parts?
(Ramjet.)
2. What do we call a machine that changes another form of energy into mechanical energy?
(Engine.)
3. What kind of engine is it that burns fuel outside the engine.
(External combustion engine.)
4. What name is specifically given to an engine that converts heat energy into mechanical energy by the back and forth motion of a piston in a cylinder?
(Reciprocating engine.)

Extending
the Learning

Continue with the drill until interest wanes, and distribute the crossword puzzle. Have students complete it, working independently or in groups of two.

Have highly motivated students look up in a good encyclopedia the first and second laws of thermodynamics. Suggest that they use these laws to explain how the following statement is true.

All heat engines follow the universal rule that energy runs downhill, that is, from a hotter state to a cooler one. In doing so, energy is converted to work. (Remind the students that not all of the heat energy emerges as useful work, and suggest that they reason out why this is so.)

Background
Information
(Teacher use
only)

For years, men had built their heat engines without really knowing the theory behind their operations. It was not until 1828 that the scientific groundwork for an understanding of heat energy was established. This great beginning was a modest and little appreciated paper by Sadi Carnot. Carnot did not start from scratch, of course; few discoverers of great "new" ideas do. What he did was work out a basis for the laws of thermodynamics.

Carnot knew how the steam engine worked. It burned coal which heated the water and turned it into steam. The steam, expanding to some seventeen hundred times the volume of water, gave up its heat as mechanical energy to drive the piston. However, it did not convert all the heat into mechanical energy. Carnot was able to show that even the most perfect steam engine could not convert all the heat energy into mechanical energy. Some of the energy cannot do useful work.

In expanding, the steam drives the piston outward. To get the piston back, the intervening steam has to condense. To condense, the steam has to lose heat. As a result, some heat energy escapes and is lost in the atmosphere.

Carnot also showed that whether engines used steam, hot air, or explosives, they are all heat engines.

Day 3 - The heat engine cannot be understood without some knowledge of thermodynamics. Thermodynamics is a word combining two Greek words: therme, meaning heat, and dynamis, meaning power. This

lesson, a continuation of the preceding ones, introduces the students to the first and second laws of thermodynamics. It asks the students to read, recall, and use an efficiency formula to compute efficiency. It also requires students to construct a graph.

This lesson may be approached by showing a paddle wheel picture, and asking the students to explain why the paddle wheel works (turns). Eventually, they should suggest that a paddle wheel works because water flows naturally from a higher to a lower level.

Show a significant picture of a heat engine. Ask the students to explain the direction of heat transfer. Lead them to the natural flow of heat, which is from a hotter to a colder body.

Heat Engine - Efficient or Inefficient

The second law of thermodynamics sets limits on the amount of heat energy which can be converted into mechanical energy. You can get your students to think about the existence of some such limit and its application to engine efficiency by drawing on their knowledge of an automobile engine.

Ask them to think about the engine. Does it convert energy from one form to another? (Yes, it converts the chemical energy of gasoline to heat energy and the heat energy to mechanical energy.) Focus their attention on the second conversion, heat energy to mechanical energy. Is there any evidence that they know of which proves that this conversion is less than 100 percent efficient? (They can be led to remember that the exhaust gas is very hot, - the exhaust pipe will burn you if you touch it. Therefore, a lot of heat energy is being discharged to the surroundings. Since it came from the burning of gasoline, some of that available heat energy is not being converted into mechanical work. Thus, the efficient, output work/input energy, cannot be 100%.)

You can now lead the students to consider the relation between temperature and efficiency. Ask them "If you had two engines which burned gasoline at the same rate, how could you determine which one was more efficient?" (You could feel the exhaust gases and see which was cooler. The more efficient engine converts more of the input heat energy to

mechanical work and so has less of it to get rid of. Since the energy of a given volume of material such as gas is higher, the higher the temperature, less heat energy to get rid of means lower temperature exhaust gas.) You have now made an intuitive connection between temperature and efficiency. You can follow up this and lead to the efficiency equation in the following way:

Suppose you start with a certain amount of gasoline and oxygen in the cylinder and ignite it. It burns, reaches a high temperature T (hot), and expands, pushing the piston and doing work. What happens to the temperature of this gas? (It cools down.) It cools down and reaches a temperature of T (cold). Does it have less energy now? (Yes, some of the original heat energy was converted into work.) Since the amount of gas has not changed, the amount of heat energy converted into work must be related to the temperature difference T (hot) - T (cold). The heat energy converted to work is proportional to T (hot) - T (cold). "How about the total heat energy to start with, what does it depend on?" It does seem reasonable that the more heat energy you have, the higher T (hot) is. Now, however, we have to consider the scale we measure temperature in. Whether we measure in centigrade or Fahrenheit can't make a difference to the actual amount of energy - but the numbers are different. What we must do, if we want to take into account all of the heat energy, is to measure temperature from absolute zero, the lowest temperature that can be reached.

The efficiency of an engine is defined as:

$$E = \frac{\text{work out}}{\text{energy in}}$$

As we said earlier, the work cannot be larger than the heat energy that is missing, that we found proportional to T (hot) measured on the absolute or Kelvin scale. [T (cold) must of course also be measured on the same scale.] In terms of temperature, the highest possible efficiency of an engine operating with an input temperature of T (hot) and an exhaust temperature of T (cold) is:

$$\text{Efficiency} = \frac{T \text{ (hot)} - T \text{ (cold)}}{T \text{ (hot)}}$$

(with all temperatures in degrees Kelvin)

This is the highest possible efficiency. In fact, some of the heat energy leaks away, some work is lost to friction and the actual efficiency is always lower than this "ideal" efficiency.

Post the formula equation on the chalkboard. Give students the following hypothetical problem and help them work out the efficiency equation:

- Suppose we run a steam engine using steam at 120°C (or 393°K) and dump the waste heat at some normal temperature, such as 20°C (or 239°K). If the engine is ideal, what is its efficiency?

$$E = \frac{T(\text{hot}) - T(\text{cold})}{T(\text{hot})} = \frac{393^{\circ}\text{K} - 239^{\circ}\text{K}}{393^{\circ}\text{K}} = 0.39 \text{ or } 39\%$$

Have the students calculate the following problems dealing with efficiency. They may work the problems independently or in groups of two or three students.

1. What is the maximum efficiency of a steam turbine if steam enters the turbine at 400°K (127°C) and is exhausted in the condenser at 360°K (87°C)?
2. In some gasoline engines, the initial temperature of the gas mixture is about 2700°K and the exhaust is 1890°K , what is the maximum efficiency of these engines?
3. If steam enters a turbine at 600°K and the exhaust is 373°K , what is the efficiency of the engines?
4. What is the efficiency of a diesel engine if the initial temperature is 300°K and the exhaust temperature is 2000°K ?

The answers are:

- (1) .40 or 40% (2) .30 or 30% (3) .38 or 38%
(4) .33 or 33%

Have students make a bar graph to show the efficiency of some different types of heat engines. Use the following figures:

Diesel engine 38%

Gasoline turbine	36%
Automobile engine	25%
Wankel rotary engine	18%
Steam locomotive	10%
Jet and rocket engine	10%

Ask students to write a statement that gives the reason for the different efficiencies. Tell how you can improve the efficiency of a heat engine. (Increase the input temperature, decrease the output temperature, and of course, reduce heat leakage and friction.)

Engine Puzzle

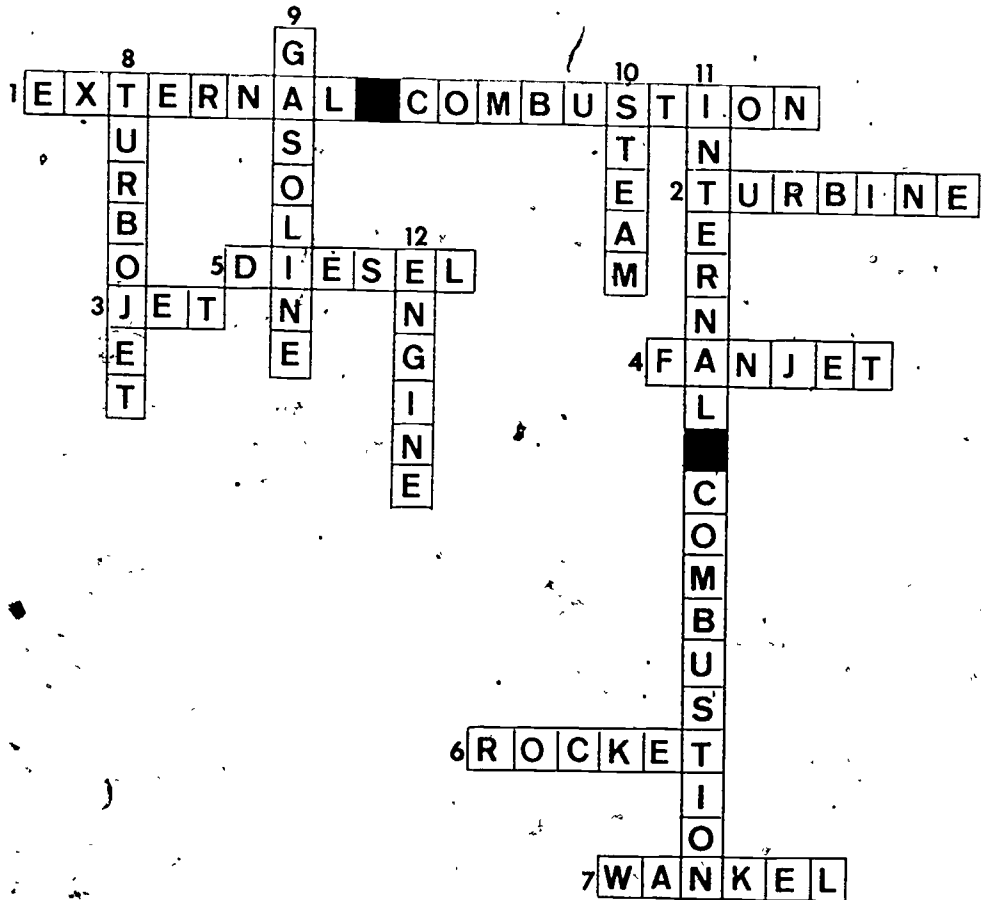

Across

1. The kind of engine in which fuel is burned outside the engine.
2. This engine is turned by the force of a gas or liquid acting against its vanes (blades).
3. The engine that gets thrust from high speed exhaust gases.
4. A jet in which some air by-passes the combustion chamber.
5. An internal combustion engine which requires no spark plug.
6. The only engine that will operate in a vacuum.
7. A small gasoline engine that does not use pistons.

Down

8. An engine with an air compressor used in most high speed aircraft.
9. A four-cycle internal combustion engine requiring spark plugs.
10. Non-reciprocating external combustion engine.
11. The kind of machine in which fuel is burned inside the engine.
12. A machine that changes another form of energy into mechanical energy.

4. Energy and the Industrial City

Overview

The purpose of this lesson is to show the influence of the Industrial Revolution on the number and growth of cities. Examples are offered through a series of map and graph readings. The lesson ends with a consideration of the place industrialization holds in national urban life.

Objectives

The student should be able to:

1. Explain the relationship between the location of cities and energy sources, using maps showing specific cities and time periods.
2. Read and interpret graphs to explain significant changes in urban growth.
3. Relate the role of energy in urbanization to their own environment.

Time Allotment

1 - 2 class periods

Materials

Three activity sheets included at the end of this packet, Energy and the Industrial Revolution:

Maps

Population Tables

Inquiry Exercises

Background Information (Teacher Use Only)

During the Industrial Revolution people flocked to the cities, mainly to find jobs. Older commercial-oriented cities branched out into mechanized production centers to compete with newer regional cities that developed and grew rapidly along new transportation routes or at sites near primary energy sources.

Teaching Strategies

Have students write a brief description of "My Ideal City" and have them read their efforts to the class. The descriptions should stress the features a good city should have. Their efforts should also bring out some definitions of what a city is. How do the students' "ideal" city differ from the one

they live in or near, or that they have visited?

Place the heading: "THE CITY: WHAT IS IT?" on the chalkboard. Have students list their ideas as to what a city is. You may anticipate students having some difficulty in pinning down a concrete definition. Trying to define a city may be difficult.

Introduce the topic of why cities grew in a particular location by placing the maps (Map 1 and Map 2) before them. Ask: What differences do you see in the two maps? (Map 2 shows many more cities.) What statement can you make about where the cities were located in 1790? (They were near coasts and on rivers.) What statement can you make about the location of cities on the 1850 map? (They have become more spread out; they seem less dependent on bodies of water.) Have students list some of the reasons for the new locations of cities in the years 1800 and 1850.

Have students examine Map 3 next. "What does this map show?" (Map 3 shows cities located near coal mines.) Ask students to put their findings into a general statement. (Cities at the time of the Industrial Revolution grew near the source of energy in use at the time.)

Have students compare Map 3 with Maps 1 and 2. What seems to determine the location of modern cities? Lead students to the discovery that many modern cities grow around new energy sources. You may wish to add that fully mechanized factory production with electricity as the new energy source has contributed to the new flexibility in the location of cities: The new production and transportation networks have created the giant industrial metropolis with its related multi-city manufacturing belts.

Distribute the ditto copies of Table 1. Have students complete the questions on the ditto. Use a wall map or atlas to verify their location. Have students look again at the maps and the table and ask them to prove this statement:

The factors that changed cities during the years 1700 - 1900 were science and invention.

Extending
the Learning

Simple projects may be assigned for students to look up in standard sources. For example: Pick any city in the United States having a population of 50,000 - 1,000,000+. How fast has it grown in 100 years? What industries are located in this city? What forms of transportation link this city to other cities? What are its important geographic features? How is this city a mixture of factories, commercial centers, transportation routes, and places for people to live?

Do your students live in or near a city? Use that city as an example of how energy resources have affected its growth. One way to do this is to ask how the city would have been different without these resources.

Ask students to think about parallels between the growth of cities during the Industrial Revolution and modern situations where rapid growth in energy development has changed American cities. (Some examples are modern energy "boomtowns" like Colstrip, and Gillette, Wyoming.)

5. How to Succeed by Really Trying

- Overview** This lesson uses two case studies about young people who lived before and during the Industrial Revolution. Students will be asked to describe the effects a major change can have on the lives of people by reading the two accounts and answering questions.
- Objectives** Students should be able to:
1. Make efficient use of case studies as an aid to social understanding.
 2. Contrast the great wealth and power the Industrial Revolution brought to us as a nation with the great social consequences it had on people.
 3. Explore the wide gulf that exists between human and mechanical energy.
- Time Allotment** One - three class periods
- Materials** Copies of Case Studies 1 and 2
- Teaching Strategies** This lesson emphasizes the place that the production of goods has in the everyday lives of people. It deals realistically with the need to adjust to the rapid changes that affect daily living in an increasingly complex society. Learning how young people over the years have responded to challenges can help your students discover the importance of learning to make adjustments now.
- One way to approach the lesson is to give the pre-test questions. Then discuss why so many people work in America. List the reasons on the chalkboard. Then you might ask: How does having a job affect your everyday life? How does a parents' job? A lively discussion can result in a consideration of the effects of the factory on people.

Another way in which to begin this lesson is to list several paired words on the chalkboard and tell the students that the words are related but different. Ask students to study them and try to explain the relationships and differences. Such an exercise will sharpen their understanding of the vocabulary.

Vocabulary: Related But Different

Factory	Industrial Revolution
Apprentice	Education
Machine	Energy Conversion
Job	Career

Points for discussion might be:

A factory is a place where people gather to work together in some form of production. The factory grew out of the Industrial Revolution which changed the production of goods from the home to the large factory; from hand to machine.

An apprentice serves a term as helper, moving up in his chosen career after an accepted period of work years. Part of education is preparation for a job, but most of it is preparation for life. The broad purpose of education is to develop the maximum potential of each individual.

It is a machine that changes heat and chemical energy into mechanical energy. Machines are useless unless energy is converted and put to work.

An example of a line of work such as Government Service would provide a good overview of what a career is. The publication, Careers in Government Service, lists many jobs that are open to young men and women.

Questions for Pre-test

1. How have recent technological advances changed the job outlook for you?
2. How many different kinds of jobs are there open to Americans - to you someday?
3. Is there something about factory work that you might not like?
4. How is factory work different today than it was 150 years ago? How is it the same?
5. How many of you think you would like to follow the occupation of your parents? Why?
6. What kind of work was open to most workers 100 years ago?
7. What do you think would be a good way to describe the effect of the Industrial Revolution on workers? On the everyday lives of people?
8. Do you think machines have made workers happier?
9. Do people work as hard today as they did, say 150 years ago?
10. What would young people your age be doing 150 years ago? In school? Working in a factory? On a farm?

Turn students' attention to the first case study: John Goederson. Have students read the story of his job and answer the following questions:

Case Study #1

1. What was the purpose of the contract?
(The contract set down the responsibilities of both the Apprentice and the Master Craftsman.)
2. According to the contract, what did the Master provide?
(Food, clothing, shelter, some schooling and to teach him the trade.)
3. Suppose I were to say that under this contract the Master and the Apprentice were exchanging energy for energy - would I be right? Explain.
(One example might be that the Master gave John food (food energy) and John turned the food energy into muscle power to do work.)
4. Do you think the contract gave John a fair deal? Why?
(After six years, John would have a marketable skill.)

Case Study #2

After students have finished Dreiser's story about Carrie, have them respond to the following questions:

1. How did Carrie's fellow workers cooperate in helping her when she was in need?
(They cooperated by slowing down their work so that too many shoes would not pile up in front of Carrie. One worker urged her to stand to ease her aching muscles.)
2. List several examples of the unappealing working conditions in the shoe factory.
(Long work day, unpleasant smells, dirt, noise, frantic speed to keep the line going, impersonal machines, etc.)
3. There was a very long sentence in the story that described the repetitive work of the assembly line quite well. Read aloud the cadence that makes the reader feel the ache that comes with performing a single mechanical movement over and over. Find the sentence and write it down. What does the sentence tell you about the gulf that exists between human energy and mechanical energy?
(The sentence describes the time before the lunch break. It reads: "Her hands began to ache at the wrists and then in the fingers, and towards the last she seemed one mass of dull, complaining

muscles, fixed in an eternal position and performing a single mechanical movement which became more and more distasteful, until at last it was absolutely nauseating." The sentence tries to help the reader sense the ceaseless movement of the machine in contrast to the weakening energy of the human being.

One senses the power of the created machine over its creator, the human.

4. The end of the story tells you something about Carrie's feelings about the job. Summarize her feelings in one sentence.

(She felt humiliated, worn out, and subdued.)

5. How is Carrie's work more of a job while John Goederson has a career to look forward to? What is the difference?

(Carrie works at one machine and is learning a skill which will probably not be very useful anywhere else. John, on the other hand, is learning his life's work.)

End the lesson with a discussion of the importance of citizens having the freedom to choose a job.

Student Guide

1. Energy, Engines, and the Giant Step of the Industrial Revolution: A Reader

The dramatic period in history that we call the Industrial Revolution had its beginnings in England in the 1760's. In only a few years this revolution changed the social and economic life of England, Eastern Europe, and the United States forever. What it brought about was a new and different type of human being - one who worked with machinery instead of hands, who lived in cities instead of villages, whose factories depended on vast supplies of power, money, and raw materials, and whose markets soon were far beyond the places where they lived.

But the Industrial Revolution would not have happened had it not been for the huge, untapped resources of coal and wood that were then available. The story of the Industrial Revolution is the story of how people found new and better ways of getting useful work out of these primary energy sources and getting it at a faster and faster rate.

We are now entering an era in which our energy resources are becoming more and more scarce. It is interesting to look back just a few generations ago, to a time when people were entering another new period - the era of energy abundance.

But in order to fully appreciate how new ways of using energy changed people's lives, we have to take a brief look at how things were just before the "giant step" of the Industrial Revolution.

THE GRASSROOTS BEGINNINGS OF THE FACTORY SYSTEM:
MUSCLES AND TOOLS

Before the Industrial Revolution, life was agricultural and the pace was slow. Most people lived in small cottages, villages, and farms that dotted the countryside and most of their energy requirements were met by manpower and horsepower aided by simple tools like the plow and the spinning wheel.

Then, at about the time when new colonies in America began sending raw materials in vast quantities to England and to Western Europe, life began to speed up. Craftsmen everywhere could not keep up with the demand for manufactured goods. This explosion in demand made it necessary to find new ways of making things faster. English businessmen, to meet these new needs, turned to farming families, called cottagers.

The English cottage system of manufacturing was the forerunner of what later was to become the factory system. In the cottage system, a businessman would bring raw materials to the cottages of workers who would then turn them into manufactured goods. Pay was usually based on the goods produced. To increase the amount of cash, everyone in the cottage worked--men, women, children, and servants. The hours were long, the tools simple, and the pay low.

By and by, some industrious cottage families began to increase the number of workers by hiring members of other cottage families to help get the job done and to increase the amount of cash. Some cottagers began to specialize--in the weaving of cloth, dyeing material, processing wool, or making shoes, to list only a few examples. At the same time they began to change the design of their homes to allow space for additional workers and their tools. Once-dark cottages became lighter with the building of larger windows. Soon passers-by could see the people inside working at wheels and looms, and sometimes they could hear the workers singing the rhythmical tunes they made up to help pass the weary hours and to help measure the beat so necessary in producing goods that were even and smooth--and which thereby, insured more contracts.

New inventions and new fuels to power these inventions would change life for millions of these workers.

As the demand for goods increased, so did the demand for sturdier metals, new machines and more and better fuel to run the machines. These demands in time began to cause migrations of populations and to create new ways of living. Cottagers left their farms for factory jobs or went into the mines.

The Factory System: A New Combination of Muscle and Tools

The factory system differed from the cottage system because in factories larger numbers of people worked together under one roof. The factory system began with a series of inventions, with each new invention bringing on a need for another.

In 1733, for example, Jay Kay invented a flying shuttle that made it possible for one worker instead of two to be able to weave cloth. But then, with workers weaving cloth much more quickly, more thread was needed. James Hargreaves invented a machine that spun thread eight times faster than the spinning wheel. He called his invention the spinning jenny. But both of these new materials required hand labor, so to keep up with the ever-increasing demand for manufactured goods, Edmund Cartwright invented and patented a power loom for weaving that was worked by a water wheel. Richard Arkwright and Samuel Compton also invented water-powered machines. Arkwright's was called a water frame. Compton's was the spinning mule, a machine which combined the water frame with the spinning jenny.

Disadvantages of Water Power

With the widespread use of water power, people had begun to tap sources of energy other than the muscle power of humans and animals. But water power, like all sources of energy, has its disadvantages.

Because it depended on water power, for instance, Compton's machine, like the other early machines, had to be located near fast flowing rivers and streams. For this reason, the factories were often built far away from the places where the workers lived. These sites were often great distances

from the necessary raw materials as well. There were other problems with machinery driven by waterwheels. For instance, water does not always flow at the same rate or at the same level. Spring floods and summer droughts from time to time made power unavailable. Cold spells often blocked the river with ice and froze the waterwheels for weeks at a time. Water power, then, worked well--when it worked. But obviously a new, more reliable source of power was needed.

THE CENTURY OF THE STEAM ENGINE

For all its limitations, water power played a much larger role in England's industrialization than most people realize. It should be pointed out that the first stages of the Industrial Revolution and the factory system were achieved largely through water power. For all that, a new source of power assumed command and remained important for a hundred years. This new power had mobility, flexibility, and an all-season reliability. Moreover, its primary source of energy, coal, was inexpensive and in plentiful supply. Its name was steam.

Inventors had tried for years to find an efficient and reliable engine that could allow people to build factories anywhere they wanted to. In 1769, James Watt perfected a steam engine.

The steam engine turned out to be a source of tremendous power. However, like most other important ideas, it did not appear all at once in final form-- it had an evolution. One forerunner of the steam engine was a vacuum pump invented by Thomas Newcomen in 1712.

Newcomen's pump included a piston, cylinder, steam, and the creation of a vacuum. It had all the necessary ingredients for the practical steam engine, except that it was terribly heavy and bulky. Newcomen's engine was used in the tin mines in England to pump water out and keep them dry enough to be worked. Thomas Savery, a business partner of Newcomen, made some improvements on the pump and advertised it for sale as The Miner's Friend. As it was, mines often went below the earth as far as 400 feet. At that level water poured in and the mines flooded. To save lives and get the tin and coal out, new lifting and pumping devices were indeed friends of the miners.

The Miner's Friend consisted of a boiler connected to an egg-shaped metal tank. A pipe went down from the tank into the water that was to be pumped out of the mine. Later the pump worked with two tanks, so that, while one was being emptied, the other could be filled. However, Savery's engine could not lift water more than a few feet above the engine. He needed steam at high pressure and no one knew the first thing about making boilers and pipes that could withstand high pressure. So his engine con-

stantly sprung leaks and experienced breakdowns.

The pumping devices of Newcomen and Savery were slow, and useful only at the mine site. However, and perhaps by chance, James Watt was sent a Newcomen engine to repair. He not only repaired it, but he used his engineering gifts to improve it to such a degree that he made it possible for a factory to be built anywhere because the steam engine that supplied its power could be built anywhere. James Watt's steam engine could turn wheels as well as pump water. Because of its tremendous power, his steam engine laid the foundation for the Industrial Revolution.

A picture of these two engines follows, along with a short description.

Newcomen's pump

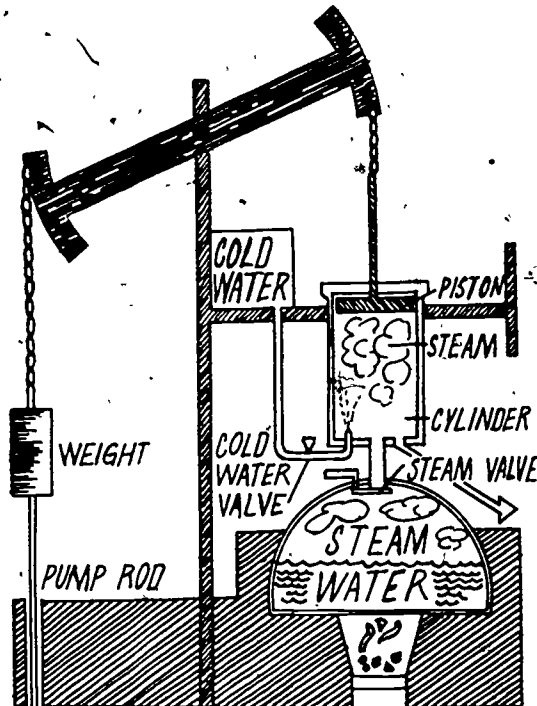

When the piston is at the bottom of the cylinder, the steam valve is opened. Low pressure steam flows into the cylinder and raises the piston. It is able to lift the piston because the piston's weight is almost exactly counter-balanced by the counterweight on the side of the beam.

The piston raises and when it reaches the top, the cylinder is full of steam. Now the steam valve is opened. The steam in the cylinder turns to liquid (meaning it condenses) creating a vacuum beneath the piston. At once the piston is forced down by the pressure of the atmosphere on the top of the piston. As it goes down, it gives a strong stroke to the water pump at the other end of the beam. When the piston reaches the bottom of the cylinder, the process begins all over.

THE "MINER'S FRIEND"

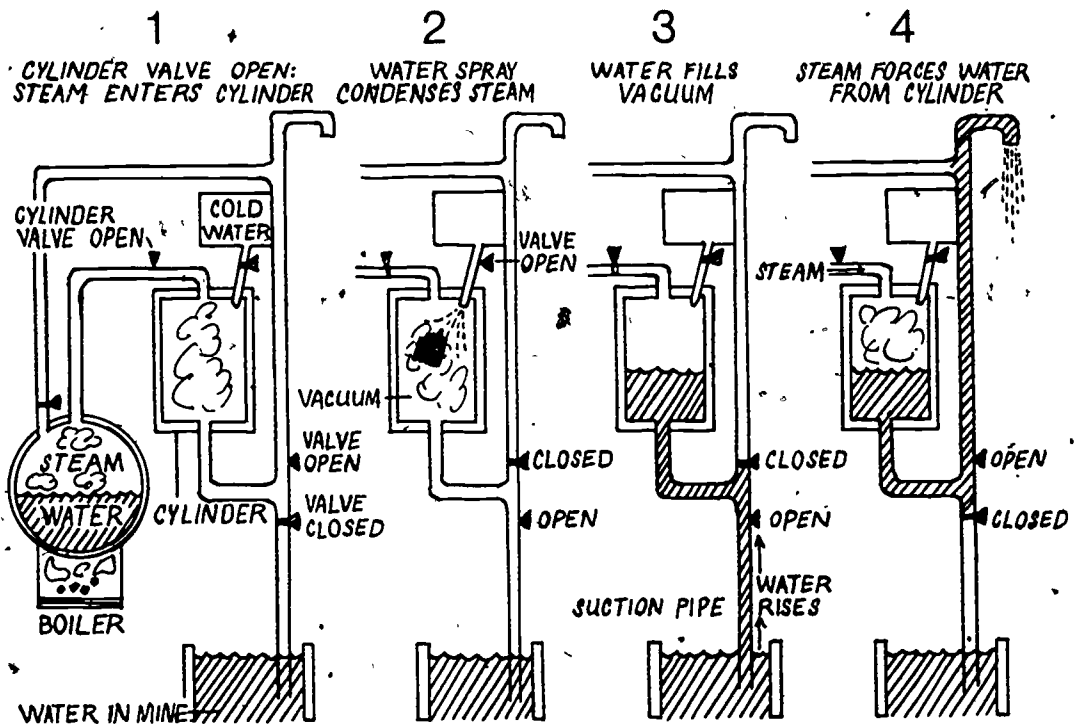

How this engine worked is diagramed in the picture. The egg-shaped tank was filled with steam and the air was forced out of it. When the steam was then cooled by a water spray, it condensed to a liquid, leaving a partial vacuum. The tank was now opened to the water which was to be pumped and it was forced up into the tank by the pressure of the atmosphere on the water. Water will only rise 32 feet with a perfect vacuum under these conditions and since the actual vacuum was much less than perfect, it could only be pumped 70 feet or so at a time. The final step in the process was to empty the tank with steam again, forcing the water on up the outlet pipe.

TRY IT. You can demonstrate the operational principle of Newcomen's engine by this experiment:

1. Put a small amount of water in a gasoline or duplicating fluid can (plastic bottle will do). Put a cap on loosely so the air can escape.
2. Heat the water until it boils, then tighten the cap.
3. Remove the can and immediately run a spray of cold water on the can. The steam will condense and create a partial vacuum inside the can, thus producing energy to do work (crushing the can).

James Watt's Steam engine had a separate chamber in which the steam was condensed. He realized that much energy was lost in the Newcomen engine because the cylinder was alternately cooled and heated. Most of the engine heat was wasted in warming up the cylinder walls. Watt was able to remedy this by using both a cylinder and a separate condensing chamber. This way, the cylinder could be kept hot all the time and the condenser could be kept cool all the time.

For each power stroke of the Watt engine, the steam valve opened and forced the piston up. When the piston neared the top of the cylinder, the steam valve closed and the condenser valve opened. Steam then left the cylinder and entered the condenser. The condenser was kept cool by water flowing over it so the steam condensed. As steam left the cylinder the pressure decreased. Atmospheric pressure (helped by the movement of the flywheel) pushed the piston down. When the piston reached the bottom of the cylinder, the condenser valve closed and the steam valve opened and the process repeated.

Watt's Steam Engine

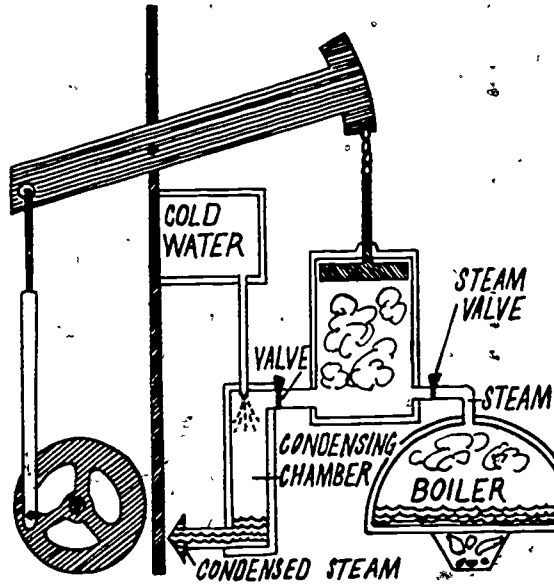

TRY IT. Make a bulletin board cut-out model of Watt's engine. Use your model to show the engineering principle of Watt's engine.

Think of five changes that have occurred in our own lives that have been the result of the steam engine.

Research the modern steam engine, which uses a high pressure system to produce power. Compare the high pressure systems with Newcomen's, Savery's, and Watt's atmospheric engines.

NEW SOURCES OF ENERGY: THE AGE OF FOSSIL FUELS
BEGINS

Great changes in the course of history seldom happen just because of one person, one event, or one invention. The steam engine was only one of several ingredients that went into the making of the Industrial Revolution. Certainly this "giant step" would never have been taken without the availability of great amounts of capital and labor, and an abundant and inexpensive source of energy. One of the most important reasons why the Industrial Revolution happened as it did was that England had plenty of coal. Steam engines are clever devices, but without something to make them go, they are worthless.

If the power that began the Industrial Revolution was steam, the fuel that produced it was coal. The spread of what can be called the "coal culture" stimulated the growth of mills and factories, created a new working class (and a new class of owners and managers), and even changed the land as the shapes and contours of valleys and hills were altered by the whim of men and machines. But even these changes were not the measure of the most remarkable change of all. What was truly remarkable was the rate of change. Each new invention - and there would be thousands of them - stimulated other inventions, other processes, and brought new changes in the lives of people.

Perhaps we should begin to think of the Industrial Revolution as several revolutions, each one of which leads to another. The first was based on the application of steam (with coal as the source of power) to the textile (clothing) industries, the iron industry, and to railroads. The second was based on steel; the third on electricity (with oil as the source of power). In our own times, there seems to be little doubt that this evolution from one source of energy to another is still taking place; with atomic, solar, geothermal, and other sources all being considered as supplements to our dwindling fossil fuel resources.

How did the Industrial Revolution cause so many changes? How did the new machines run with a sort of inward control all their own? Let's go back to the steam engine again to show the dazzling industrial growth in all directions.

Before the coming of the steam engine, wood was the primary fuel used to produce heat. Wood does very well to heat water in a boiler. But to run a factory, it is necessary to use a huge amount of wood. Such heavy use of wood tended to drive up the price and put a limit on its availability. As a result, manufacturers searched for a large supply of good, cheaper fuels. Coal, used mainly at that time in home fireplaces, suddenly became very important. One problem solved. Then another problem popped up. Pressure in the new steam engines made it necessary for machines to be made of stronger metal. Manufacturers turned to iron, which was found all over the world.

At the time of Watt's invention, iron-making was a slow process depending on charcoal to provide the heat. Charcoal, as you know from backyard barbecues, is made from wood. In fact, it is wood that has been heated to remove all but the carbon. Unfortunately, after years of making charcoal to smelt iron from ore, wood grew very scarce. Coal was tried, but coal left too many ashes. Then a way was found to bake coal to drive out most of the impurities and produce a scarce material, coke, which was almost pure carbon and similar to charcoal. Coke quickly came to be used instead of the new (and expensive) charcoal. Enormous quantities of iron could now be smelted by this efficient fuel and enormous new industries came into being.

Iron for Rails and Ships: Energy in Transportation

Perhaps the most spectacular development during the Industrial Revolution was the growth of the railroads. George Stephenson, a Scottish inventor, patented a steam locomotive that ran very effectively on straight, level railbeds. However, his locomotive could not be used on the curved or steeply-graded rails. Peter Cooper, an American, was the person who invented a locomotive that could travel on winding routes.

One of the major problems of steam locomotive was to obtain enough power for the engine to pull a string of cars as well as to move itself. One way was to shovel more coal into the fire that turned the water in the boiler into steam. Another way was to improve the efficiency of the steam engine. In those days the locomotives used a great amount of coal to drive the pistons, which, in turn, moved the wheels. Today's big diesels have more efficient engines which use oil for fuel.

The locomotives were made of iron, and so were the early tracks. These heavy engines soon required stronger rails and, where needed, stronger bridges to hold the enormous weight of long trains. What was soon needed was more durable metal. Steel was the answer but no one had yet discovered a way to introduce into the iron oven a blast of air that would raise the temperature high enough to get steel from iron. It is certain that no one knew how to do it cheaply. Henry Bessemer's blast furnace, developed in 1856, was the leap forward in steel-making. The Bessemer process lowered the cost of producing steel which soon became the basic material of industry. In the United States, because of Bessemer converters and open hearth plants the production of steel rose from about 20,000 tons in 1866 to over 600,000 tons in 1876.

Other Inventions

The Industrial Revolution spawned the transportation revolution. The movement of goods (and people, too) created at least two remarkable changes - one on land, the other revolutionized river and ocean travel. We have already mentioned the significance of the railroad, but we did not mention a new kind of road bed for carriages and other horse-drawn vehicles that quickened the rate of the delivery of goods and made travel for people more comfortable. More of an innovation than an invention was the process of improving roads developed by one John McAdam. He layered a roadbed with large stones, then covered these layers with smaller ones. Pressure from the weight of wagon wheels kept the McAdam roads in fair condition. We use a similar process today. Blacktop roads are the descendants of the old McAdam process, only today the stones are held together by asphalt. Highways and railroads linked the American continent by the end of the nineteenth century and both helped build our nation.

America's first successful steam boat was built by Robert Fulton, who called his boat the Clermont. It had its first successful run over a distance of 150 miles, traveling from New York City to Albany. It set no speed records, but it was able to do one thing very well: it could travel against the current, something that was not easily done before. Traveling on waterways in both directions would now become a reality. Not long afterwards, steam-powered ships replaced the tall sailing ships on the world's oceans.

With each new invention, it seemed that man was only a short step away from a new era in which the machine would give people all kinds of blessings, especially the blessings of wealth for the nations that had the new industrialism. It was to maintain this wealth that England tried to discourage manufacturing in the colonies in America. Much as England tried to keep manufacturing out, it did develop in the English colonies of North America. By 1790, the first factory was in operation in Rhode Island. The story of Samuel Slater's textile factory is an interesting one. He, like other workers in textile mills in England, was forbidden to leave the country, or to export any plans or drawings of the machines in the factory. Samuel Slater did what was considered nearly impossible to do - he memorized the plans for a machine-powered factory. He came to America disguised as a farm worker and built his first water-powered factory from memory.

In 1793, Eli Whitney invented the cotton gin, a machine (gin is a short work for engine) that revolutionized the cotton industry. Because of Whitney's machines, and an abundance of land suitable for growing it, cotton became the mainstay of Southern economy before the Civil War. Because of Whitney's cotton gin, textile mills spread throughout New England and in "Old" England. These mills became the forerunners of America's future industrial growth.

As it did in England, the growth of industry affected every part of American life. By 1860, America (and, indeed most of the world) had set a new course. Our new machines, and our use of enormous amounts of energy, had revolutionized farming, transportation, manufacturing, and technology itself. The direction in America was toward more efficient power and production. In the end, this new direction would change the face of the earth.

AFTER YOU HAVE FINISHED THE READER

Understanding History Terms

Review the meaning of each of the following terms. Use each term in a sentence that describes some aspect of the Industrial Revolution.

Bessemer Process	Manufacturing
Industrial Revolution	Fossil fuels
Cottage industries	Water power
Factory system	Steam engine

Energy Timeline

Use the timeline and a good encyclopedia to write in the name of the inventor who developed the invention or patented an important process. Lines have been provided for this purpose.

Thinking About Historical Links

1. Explain how the development of one new industry can help to create many new industries. Give as many examples as you can think of.
2. America owed some of its success in becoming the industrial power of the world to developments in England. What evidence can you see to support this statement?
3. Explain how the invention of a machine can open up a new energy source. Explain how the presence of an energy source can provide the incentive for the invention of new machines.
4. Coal was the primary source of energy in the Industrial Revolution, but coal had been available for thousands of years before this period. Why hadn't it been used before? (For example: Why didn't the Vikings, the American Indians or the Puritans develop a "coal culture"?)
5. List two items that have come into the world since the turn of the century (i.e., T.V. set, automobile). Opposite each item, list some of the inventions that had to take place before that item could come into being.

THE INDUSTRIAL REVOLUTION 1700 - 1860

56

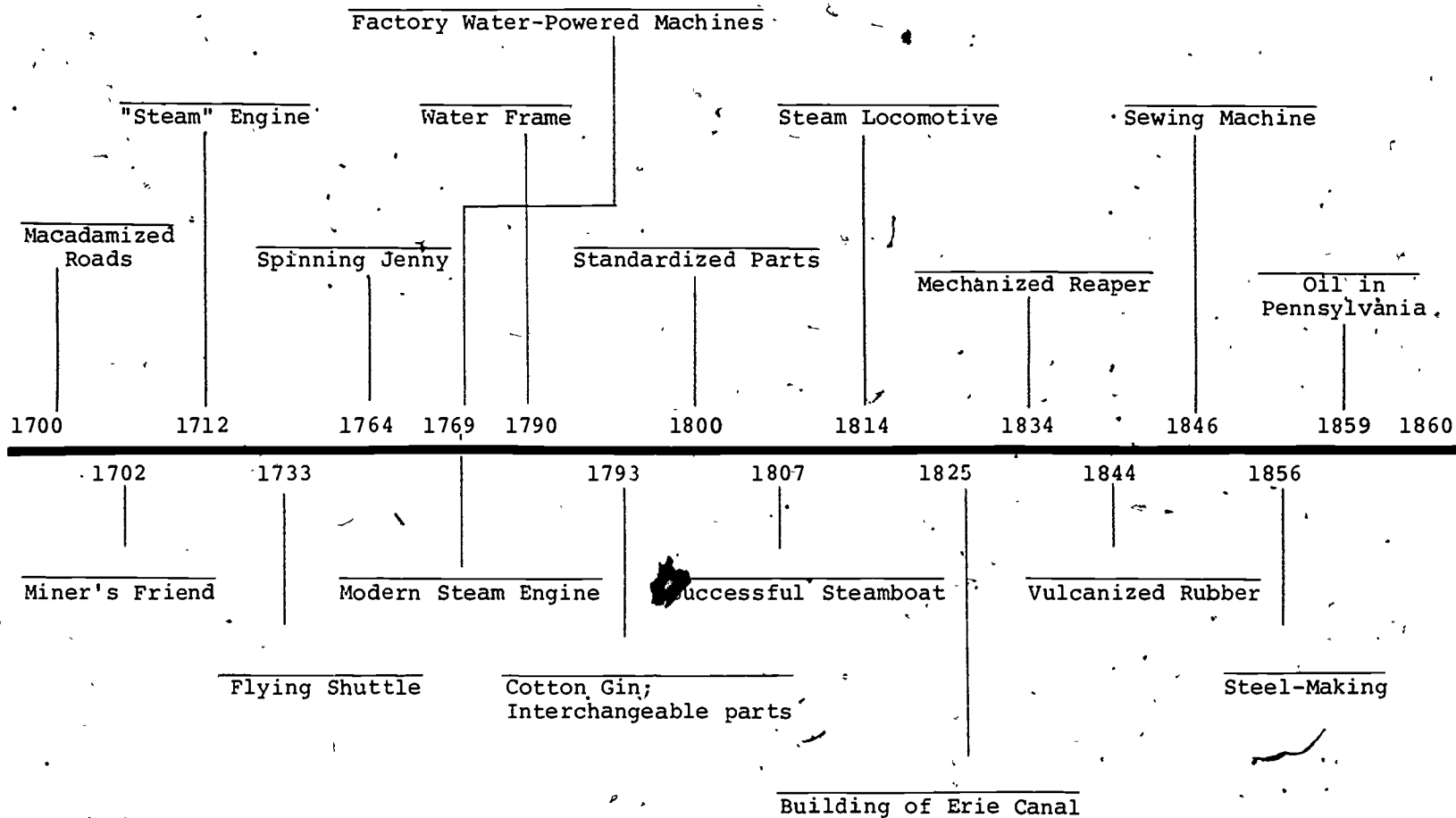

56

57

Summing-up Ideas and Skills

Complete this outline:

A. The Meaning of the Industrial Revolution

- 1.
- 2.

B. English Inventions Lead to the Beginnings of New Industries

- 1.
- 2.
- 3.
- 4.

C. Inventions Lead to New Processes and New Energy Sources

- 1.
- 2.
- 3.
- 4.

D. The Industrial Revolution Changed the Lives of People

- 1.
- 2.
- 3.

E. Energy Sources for the Continuing Industrial Revolution

- 1.
- 2.
- 3.

2. Energy Converts to ... What? And ... Why?

Student
Activity 1

Energy Conversion:
A Fact Sheet

What is energy? The first step in trying to define energy is to set up two categories. Energy in the form of motion, heat, or light is called kinetic energy. Energy that is stored in food, gasoline, the nucleus of atoms and batteries is called potential energy. Kinetic energy is energy on the move. Potential energy is stored energy and it is in this form that we dig it from mines and pump it from wells. To use energy, it must be in the kinetic form.

We use energy because we want to do something to matter; move it, illuminate it, or warm it. We usually store energy in the potential form but it is possible to store energy in the kinetic form, too. This form of storage, however, is quite different from potential storage, it is temporary; we trap or insulate kinetic energy. Examples of kinetic energy being stored are the flywheel of an engine and heat energy in a thermos bottle. Potential energy storage is more permanent. It is accomplished by changes in the structure of matter. A simple way to store energy is to lift something away from the earth (energy is stored when water is pumped to the top of a water tower, then converted to kinetic energy when it is allowed to run through pipes).

Energy constantly changes forms. It can be potential stored in coal and when the coal burns at a power plant it changes to the kinetic form, the heat of steam. When the steam is allowed to strike the blades of a turbine, some of the heat energy becomes the kinetic energy of motion (mechanical) of the engine. The turbine turns an electric generator and some of the energy becomes electric energy. Electric energy is also changed in form when it is used.

These changes of forms are governed by strict laws; the first of these is called the First Law of Thermodynamics, which states that energy can neither be created or destroyed. The Second Law of Thermodynamics states that in any conversion of energy from one form to another some of it becomes unavailable for use. This is mainly because some of it becomes heat and it is not possible to convert all of a given amount of heat energy completely back to another form. This unusable heat energy leaks away and gradually warms up the universe.

It is possible to convert all of a certain amount of mechanical energy to heat by, for instance, putting on the brakes of a car. It is possible to convert all the chemical energy of coal into heat by burning it. These conversions cannot go to completion in the other direction, only a limited amount of heat energy is convertible back to other forms. There are many forms of energy, but before most energy can be used to do work it first needs to be changed into mechanical energy.

Student Activity 2

Tracing Energy Conversion in an Automobile

Directions

Take an automobile trip backwards by tracing the light energy in an automobile back to its original source. Fill in each numbered block with the name of the appropriate energy form: heat, light, chemical, etc., and with what part of the car makes this conversion possible. The first space has been filled in to help you.

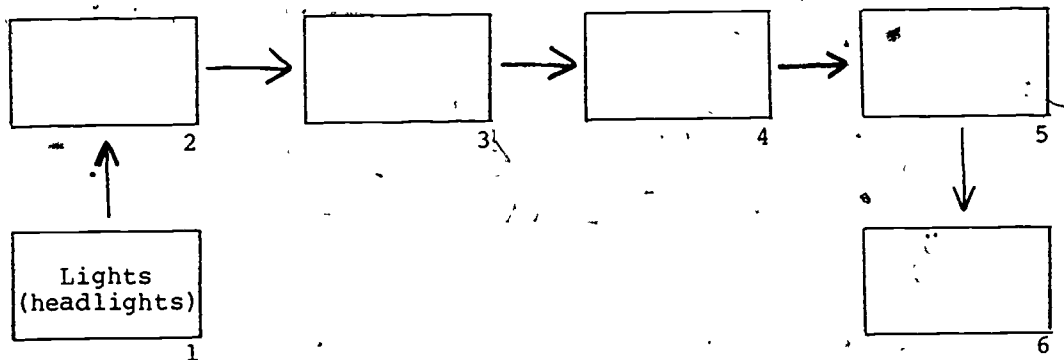
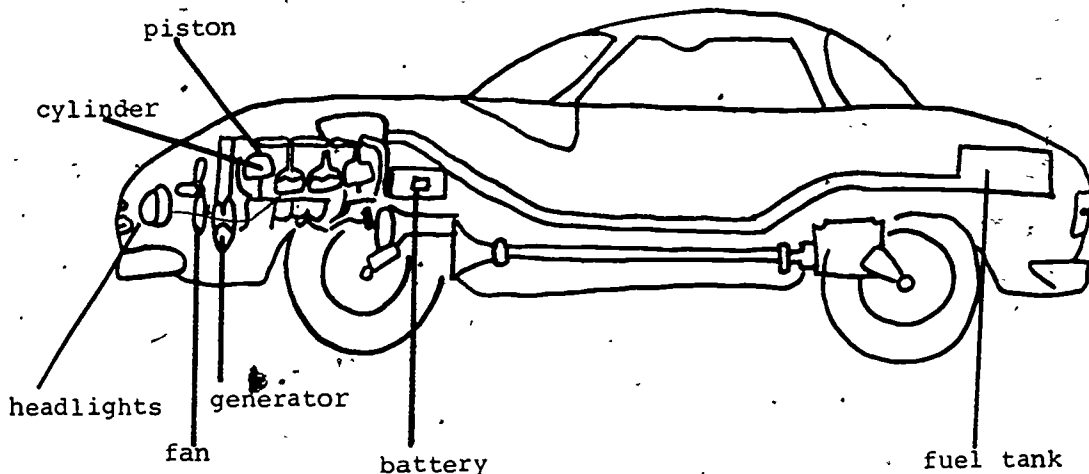

Student
Activity 3

Making a Working Model of a Steam Turbine

Object

The object of this activity is to demonstrate how a steam turbine converts heat energy into mechanical energy.

Equipment

medicine dropper	scissors
test tube (attached to support rod)	pencil with eraser
bunsen burner	manila circles
stopper (one-hole)	ruler
needle	compass
	thimble

Directions

Make the turbine wheel first. Use the compass to draw a circle five inches in diameter in the manila folder. Use the same center for the compass, and draw a 1-inch diameter circle inside the larger circle. Place the thimble open-end down on the center of the circle you have drawn, and draw a third circle around the thimble.

Use the scissors to cut along the inside of this small circle, and insert the thimble into the hole. Use the ruler to draw eight lines to the inner circle so that you have a large circle divided into eight equal parts.

Cut along the lines to the drawn inner circle. Next bend half of each section back along the dotted lines in the diagram (see below). The paper halves should show right angles.

Insert the needle into the rubber eraser of a pencil. Place the paper turbine wheel over the tip of the thimble and set the inside of the thimble on top of the needle.

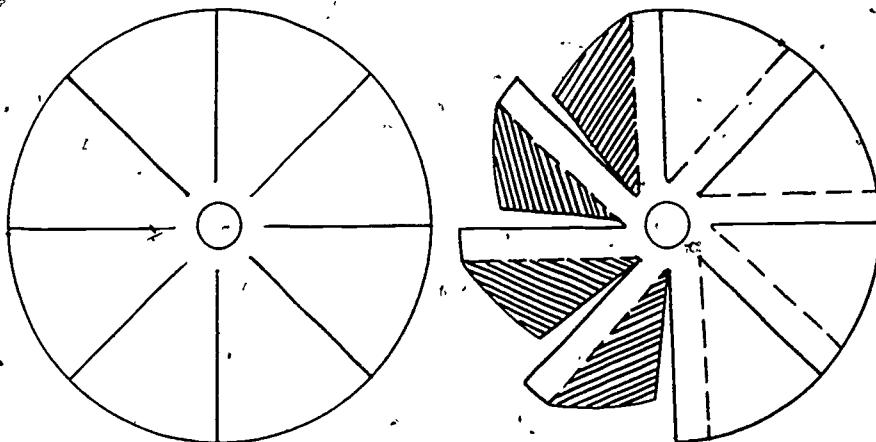

Operating the Turbine

Put about 1 inch of water in a test tube and assemble the equipment as shown in the diagram below.

Remove the rubber bulb from the medicine dropper. Moisten the outside of the medicine dropper and insert it carefully through the one-hole stopper. Insert the stopper into the open end of the test tube, but don't push it in too tightly. Light the bunsen burner and heat the water in the test tube. Answer these questions:

1. What changes do you see?
2. Is energy involved in these changes? How?

Hold the pencil with the thimble top of the turbine attached in such a way that it turns freely, and direct the path of the steam against the paper blades of the turbine.

1. What is happening to the blades?
2. Can you explain why this is happening?
3. Is work being done? How?

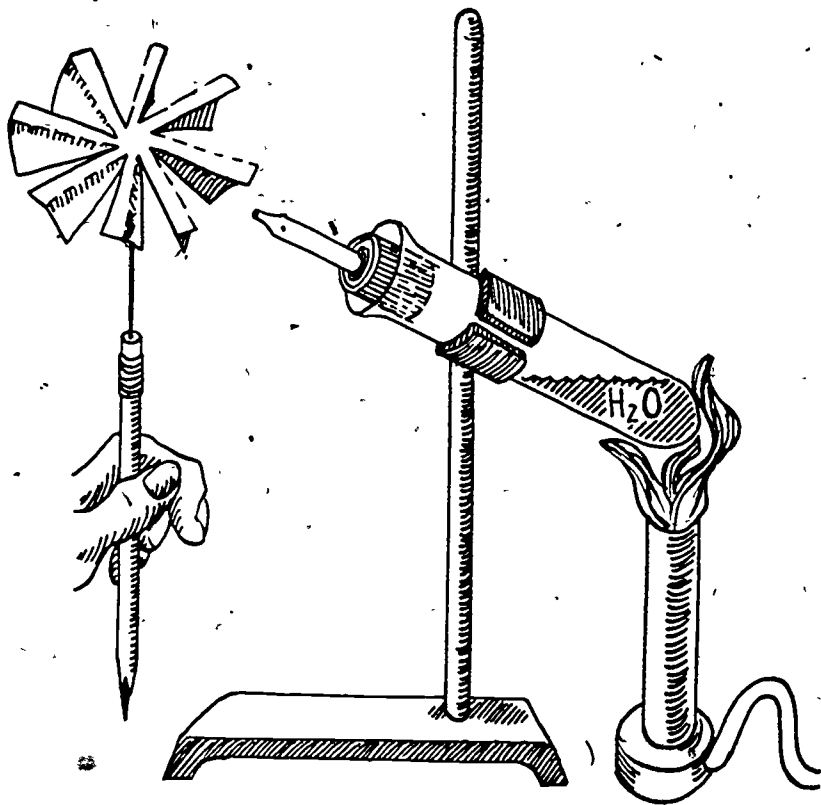

Student
Activity 4

Materials and
Equipment

Procedure

Energy Conversion

1 beaker
1 pound of BB's (lead shot)
thermometer
cardboard tube
masking tape

Pour about 1 pound of lead shot into a beaker. Place thermometer well into the lead shot and record the temperature. Pour lead shot into a cardboard tube that is closed at one end by masking tape. Close the other end with your hand and shake the tube vigorously 30-50 times. Insert the thermometer again and record the temperature. Answer these questions:

1. Why did the temperature change?
2. What kind of energy change took place?

Evaluation Sheet

Directions: Write in each box examples of one form of energy being converted into another form. Begin with the vertical column on the left. Example: Heat is converted into light energy in a light bulb, so write "light bulb" in the box formed by the intersection of the two energy forms.

	HEAT	LIGHT	SOUND	MECHANICAL (Movement)	CHEMICAL	ELECTRIC	NUCLEAR
HEAT							
LIGHT							
SOUND							
MECHANICAL (Movement)							
CHEMICAL							
ELECTRIC							
NUCLEAR							

3. The Great Joule Robbery

Student
Activity 5

The Heat Engine:
Fact Sheet

Heat engines are devices for converting heat energy into mechanical energy. In all heat engines a hot gas expands and cools, doing work. Heat engines may be classified according to where the fuel is burned. If the fuel is burned inside the chamber in which the expansion is to take place, we have an internal combustion engine. Examples of this type are rockets, automobile engines and airplane engines (piston or turbine type). If the gas is heated outside of the expansion chamber and brought under pressure, into the chamber where it expands, we have an external combustion engine. Examples are reciprocating steam engines and steam turbines.

Engines may also be classified according to the way in which the heat is converted to mechanical energy. Here there are three types:

1. Piston or reciprocating engine - a hot working gas expands against a piston in a cylinder. The back-and-forth motion of the piston operates shafts and gears that convert the energy to rotary motion and convey it to the place where it is used.

RECIPROCATING ENGINE (Pistons)

<u>Engine</u>	<u>How Heat is Obtained</u>	<u>How Heat is Converted to Mechanical Energy</u>
Gasoline	Gasoline is mixed with air on carburetor. Mixture enters cylinder and is compressed. Electric spark ignites the mixture.	Hot gases formed by combustion expand, pushing piston.
Diesel	Air enters cylinder and is highly compressed raising its temperature. Fuel oil is sprayed into cylinder, igniting spontaneously when it hits hot air.	Same as above.

Reciprocating
Steam Engine

Combustion of coal, oil
or other fuel in firebox
heats steam in boiler,
oxygen obtained from air.

Steam travels to cylinder
where it expands and
pushes piston. Valves
permit steam to enter the
cylinder first on one
side of the piston and
then on the other.

2. Turbine or rotary type - a hot working gas expands and pushes against blades attached to a central shaft. This is something like a child's pinwheel. The rotating shaft extends beyond the turbine and can be used to turn other machinery. It is commonly used to operate ship propellers and generators in power plants.

ROTARY ENGINES (Turbines)

Engine

How Heat is Obtained

How Heat is Converted
to Mechanical Energy

Steam

May use combustion of
coal, oil or gas. Some
use nuclear reactor to
heat water and produce
steam.

Steam expands and pushes
against blades of tur-
bines causing rotation.

Gas
Turbine

Compressed air is mixed
with fuel in combustion
chamber and ignited.

Expanding exhaust gases
turn turbine. Reaction
of exhaust may also be
a power source when this
engine is used.

3. Reaction engines - the expanding gas is ejected through an opening at one end of the engine and the reaction (Newton's third law) sends the engine and the vehicle in the opposite direction.

REACTION ENGINES.

Engine

How Heat is Obtained

How Heat is Converted
to Mechanical Energy

Jet

Air from atmosphere is
compressed and then
combines with fuel
(kerosene) in combustion
chamber. Spark cause
fuel to ignite.

Hot exhaust gases expand
and escape from rear at
high velocity. Reaction
sends engine forward.

REACTION ENGINES (continued)

Liquid-fuel
rocket

Carries tank of liquid propellant (kerosene, gasoline, aniline, alcohol) and tank of liquid oxygen or other oxidizer. These are injected into combustion chambers at same time and combustion is frequently spontaneous.

Same as above.

Solid-fuel
rocket

Combustion chamber is packed with a mixture of solid oxidizer and solid fuel (usually various organic resins). Igniter is required. Burning occurs at surface and rate is controlled by design of surface shape.

Same as above.

Student
Activity 6

Word Study List

1. Steam engine - reciprocating external combustion engine.
2. Steam turbine - non-reciprocating external combustion engine.
3. Gasoline engine - a four-cycle internal combustion engine requiring spark plugs.
4. Ramjet - a jet with no moving parts.
5. Turbojet - an engine with a turbine driven air compressor used in most high-speed aircraft.
6. Fanjet - a jet engine in which some air bypasses the combustion chamber.
7. Rocket engine - only engine that will operate in the vacuum of space.
8. Diesel engine - internal combustion engine which requires no spark plugs.
9. Turbine - an engine turned by the force of a gas or liquid acting against its vanes or blades.
10. Jet engine - engine that gets thrust from high speed exhaust gases.
11. Engine - a machine that changes another form of energy into mechanical energy.
12. Reciprocating engine - engine which converts heat energy to mechanical energy by the back and forth motion of a piston in a cylinder.
13. Wankel rotary engine - a small gasoline engine that does not use pistons.
14. External combustion engine - the kind of engine in which the fuel is burned outside the engine.
15. Internal combustion engine - the kind of engine in which the fuel is burned inside the engine.

Engine Puzzle

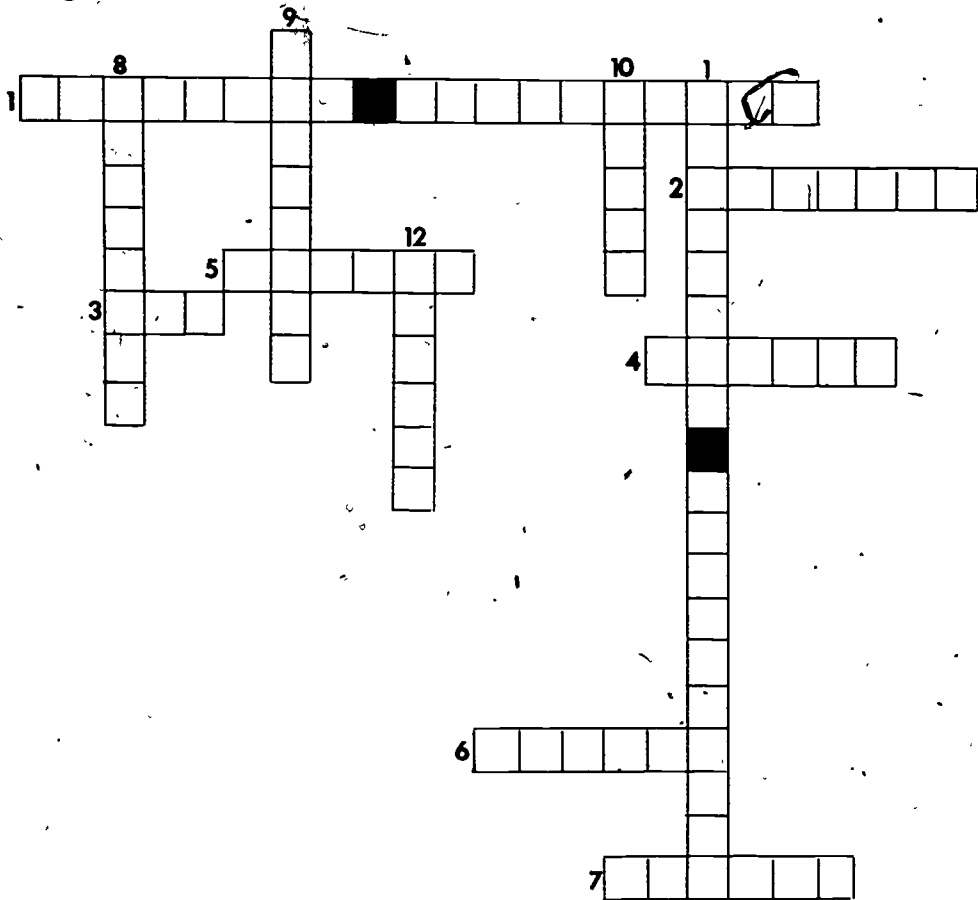

Across

1. The kind of engine in which fuel is burned outside the engine.
2. This engine is turned by the force of a gas or liquid acting against its vanes (blades).
3. The engine that gets thrust from high speed exhaust gases.
4. A jet in which some air by-passes the combustion chamber.
5. An internal combustion engine which requires no spark plug.
6. The only engine that will operate in a vacuum.
7. A small gasoline engine that does not use pistons.

Down

8. An engine with an air compressor used in most high speed aircraft.
9. A four-cycle internal combustion engine requiring spark plugs.
10. Non-reciprocating external combustion engine.
11. The kind of machine in which fuel is burned inside the engine.
12. A machine that changes another form of energy into mechanical energy.

4. Energy and the Industrial City

CITIES IN THE BRITISH ISLES IN MODERN HISTORY (Population in Thousands)

City	1800	1850	% chg.	1900	% chg.	1950	% chg.	Now	% chg.
Leeds	6	104	+1750	280	+ 270	292	+ 4	294	+ 1
Brighton	7	70	+1000	123	+ 76	156	+ 18	160	+ 2
Glasgow	77	329	+ 450	736	+ 120	1090	+ 48	897	- 18
Liverpool	78	376	+ 490	685	+ 82	789	+ 15	609	- 23
Manchester	70	303	+ 420	544	+ 80	703	+ 29	542	- 23
Sheffield	31	135	+ 430	381	+ 180	513	+ 35	520	+ 1

1. What was the population of Leeds in 1800? _____ In 1850? _____
2. What was the percentage increase for Leeds during the years 1800-1850? _____
3. During which time span did the population of Leeds increase by the largest percentage? 1800-1950; 1850-1900; 1900-1950; 1950-present? _____
4. What are some things that might have caused the population of Leeds to increase from year to year? _____

5. What was the population of Manchester in 1850? _____ In 1950? _____ Has Manchester (lost, gained) population in the last 50 years? _____ What are some things that might account for the difference in the last 50 years? _____

6. How do energy resources affect the growth of cities? (You may need to refer to Map 3 to help you answer this question.) _____

MAP AND TABLE STUDY

- Reexamine the three maps and two charts. Describe the relationship of industrial cities, population concentrations, and energy resources in the Midlands of England.

CITIES IN ENGLAND, SCOTLAND, WALES—1790

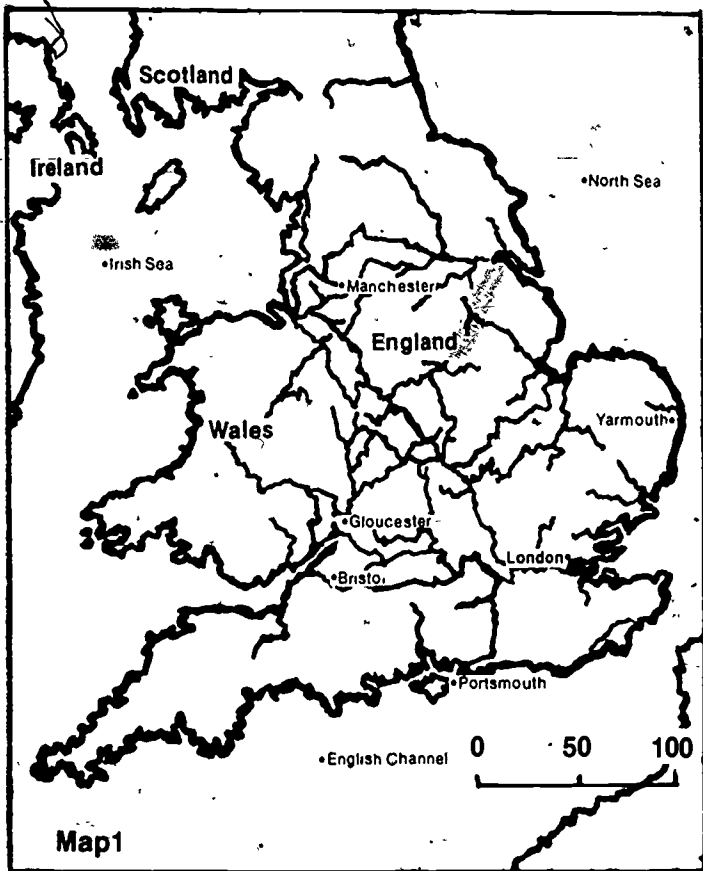

Have you ever thought about why your city is where it is? What could change it in 100 years? This activity encourages you to consider some important factors of change.

1. What factor determined where cities were located in 1790?

2. What changes have taken place by 1850?

CITIES IN ENGLAND, SCOTLAND, WALES—1850

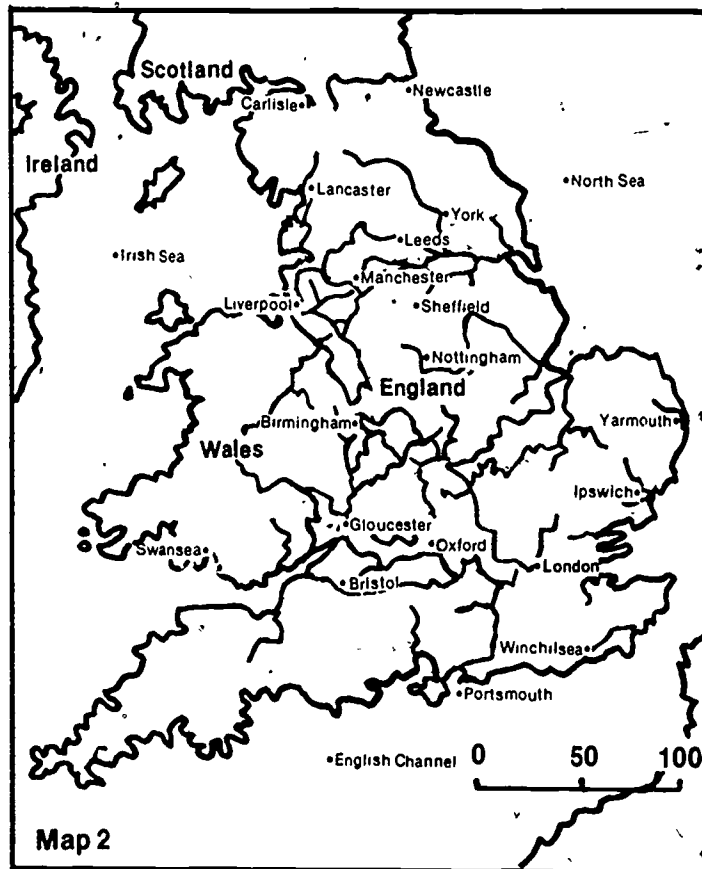

3. How were the sites of the cities in 1850 determined?

4. What factors have determined the degree of industrialization achieved by the cities and state in which you presently live?

INDUSTRIAL AREAS OF BRITISH ISLES—1800-1900

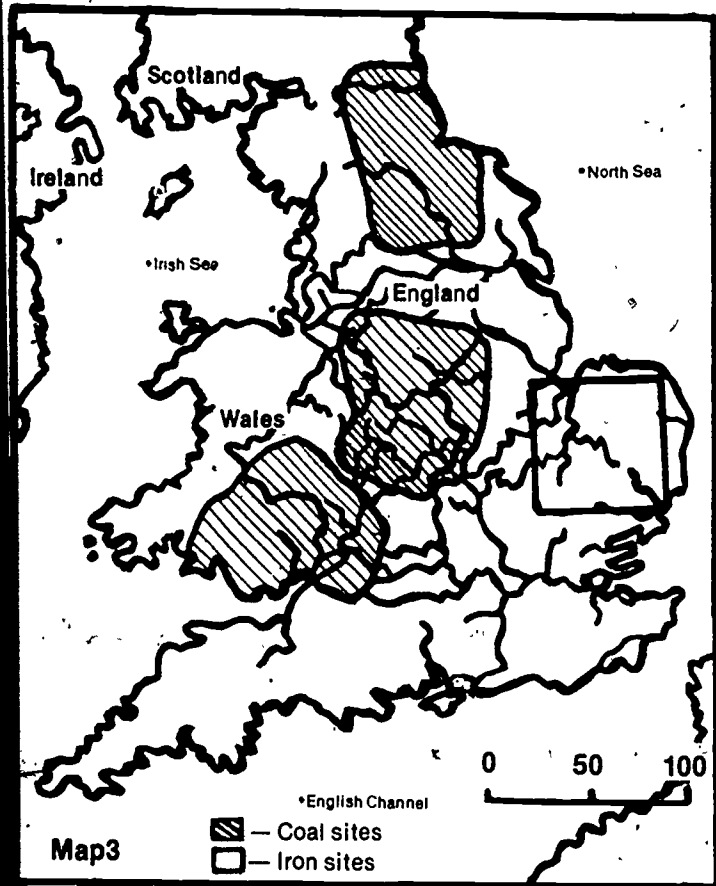

1. How does the map help explain why England became an industrial nation?

2. Refer to Maps 1 and 2 as well as this one. What distinctions can be drawn between natural sites for cities and artificial ones?

England and Wales Population Increase

1750	6,500,000
1801	8,890,000
1831	13,800,000
1851	17,900,000
1871	22,700,000
1901	32,500,000

Ireland and Scotland Population Increase

1801	7,000,000
1901	8,500,000

Percent of People in Cities and Rural Areas

1750	25% Urban, 75% Rural
1851	50% Urban, 50% Rural
1901	75% Urban, 25% Rural

3. The table shows two notable effects of the Industrial Revolution.

1. Dramatic increase in _____

2. Dramatic increase in _____

4. Why did the population of Ireland and Scotland increase by 1,500,000 between 1801 and 1901 while that of England and Wales increased more than 23,000,000 during that same period?

5. How to Succeed by Really Trying

Case Study #1

A Contract for Apprenticeship in Shoemaking Between a New York Shoemaker and John Goederson

The Contract

That John Goederson, now aged fourteen years, eight months, and twenty-seven days, by and with the consent of his stepfather, John Wright, and his mother, Mary Wright, hath...of his own free will and accord, put himself Apprentice to Frederick Seely of the city of New York, Cordwainer...to serve...until the full end and term of six years, three months and three days next ensuing during all of which time the said Apprentice where readily obeyed...He shall not contract matrimony within the said term; at Cards, Dice, or any other unlawful game shall he not play... He shall not absent himself, day or night, from his Master's service without leave, nor haunt ale-houses, taverns or playhouses; but in all things behave as a faithful apprentice ought to do...And the said Master shall use the utmost of his endeavors to teach, or cause to be taught or instructed the said Apprentice in the trade, or mystery, of a Cordwainer, and procure and provide for him sufficient meat, drink, washing, lodging and clothing fit for an Apprentice during the said term of service and four quarters of night schooling during the said term. In WITNESS WHEREOF the said parties have interchangeably set their hands and seals hereunto. Dated the sixth day of August, in the thirty-fifth year of the Independence of the United States of America, and in the year of our Lord eighteen hundred and eleven.

Frederick J. Allen, The Shoe Industry,
1916, pp. 31-32

1. What was the purpose of the contract?
2. According to the contract, what did the Master provide?
3. Suppose I were to say that under this contract the Master and the Apprentice were exchanging energy for energy - would I be right? - Explain.
4. Do you think the contract gave John a fair deal? Why?

Case Study #2.

THE JOB

After:

It was with weak knees and a slight 'catch' in her breathing that she came up to the great shoe company at Adams and Fifth Avenue and entered the elevator. When she stepped out on the fourth floor, there was no one at hand, only great aisles of boxes piled to the ceiling. She stood, very much frightened, awaiting someone.

Presently Mr. Brown came up. He did not seem to recognize her.

"What is it you want?" he inquired.

Carrie's heart sank. "You said I should come in this morning to see about work--"

"Oh," he interrupted. "Um - Yes. What is your name?"

"Carrie Meeber."

"Yes," he said. "You come with me."

He led the way through dark, box-lined aisles which had the smell of new shoes, until they came to an iron door which opened into the factory proper. There was a large low-ceilinged room, with clacking, rattling machines at which men in white shirt sleeves and blue gingham aprons were working. She followed him diffidently through the clattering automatons, keeping her eyes straight before her, and flushing slightly. They crossed to a far corner and took an elevator to the sixth floor. Out of the array of machines and benches, Mr. Brown signalled a foreman.

"This is the girl," he said, and turning to Carrie, "You go with him." He then returned, and Carrie followed her new superior to a little desk in a corner, which he used as a kind of official center.

"You've never worked at anything like this before, have you?" he questioned rather sternly.

"No, sir," she answered.

He seemed rather annoyed at having to bother with such help, but put down her name and then led her across where a line of girls occupied stools in front of clacking machines. On the shoulder of one of the girls who was punching eye holes in one piece of the upper, by the aid of the machine, he put his hand.

"You," he said, "show the girl how to do what you're doing. When you get through come to me."

The girl addressed rose promptly and gave Carrie her place.

"It isn't hard to do," she said, bending over. "You just take this like so, fasten it with this clamp, and start the machine."

She suited action to word, fastened the piece of leather, which was eventually to form the right half of the upper of a man's shoe, by little adjustable clamps, and pushed a small steel rod at the side of the machine. The machine jumped to the task of punching, with sharp snapping clicks, cutting circular bits of leather out of the upper, leaving the holes which were to hold the laces. After observing a few times, the girl let Carrie work it alone. Seeing that it was fairly well done, she went away.

The pieces of leather came from the girl at the machine to her right, and were passed on to the girl at her left. Carrie saw at once that an average speed was necessary or the work would pile up on her and all those below would be delayed. She had no time to look about, and bent anxiously to her task. The girls at her left and right realized her predicament and feelings; and, in a way, tried to aid her, as much as they dared, by working slower.

At this task she labored incessantly for sometime, finding relief from her own nervous fears and imaginings in the humdrum, mechanical movement of the machine. She felt, as the minutes passed, that the room was not very light. It had a thick odor of fresh leather, but that did not worry her. She felt the eyes of the other help upon her, and troubled lest she was not working fast enough.

Once, when she was fumbling at the little clamp, having made a slight error in setting in the leather, a great hand appeared before her eyes and fastened

the clamp for her. It was the foreman. Her heart thumped so that she could scarcely see to go on.

"Start your machine," he said, "start your machine. Don't keep the line waiting."

This recovered her sufficiently and she went excitedly on, hardly breathing until the shadow moved away from behind her. Then she heaved a great breath.

As the morning wore on the room became hotter. She felt the need of a breath of fresh air and a drink of water, but she did not venture to stir. The stool she sat on was without a back or footrest, and she began to feel uncomfortable. She found, after a time, that her back was beginning to ache. She twisted and turned from one position to another slightly different, but it did not ease her for long. She was beginning to weary.

"Stand up, why don't you?" said the girl at her right, without any form of introduction. "They won't care."

Carrie looked at her gratefully. "I guess I will," she said.

She stood up from her stool and worked that way for a while, but it was a more difficult position. Her neck and shoulders ached in bending over...

Carrie at last could scarcely sit still. Her legs began to tire and she wanted to get up and stretch. Would noon never come? It seemed as if she had worked an entire day.. She was not hungry at all, but weak, and her eyes were tired, straining at the one point where the eye-punch came down... The halves of the uppers came piling down steadily. Her hands began to ache at the wrists and then in the fingers, and towards the last she seemed one mass of dull, complaining muscles, fixed in an eternal position and performing a single mechanical movement which became more and more distasteful, until at last it was absolutely nauseating. When she was wondering whether the strain would ever cease, a dull-sounding bell clanged somewhere down an elevator shaft, and the end came.. In an instant there was a buzz of action and conversation. All the girls instantly left their stools and hurried away in an adjoining room. Men passed through, coming from some department that opened on the right.

The whirling wheels began to sing in a steadily modifying key, until at last they died away in a low buzz. There was an audible silence, in which the common voice sounded strange.

Carrie got up and sought her lunch box. She was stiff, a little dizzy, and very thirsty. On the way to the small space portioned off by wood, where all the wraps and lunches were kept, she encountered the foreman, who stared at her hard.

"Well," he said, "did you get along all right?"

"I think so," she replied very respectfully,

"Um," he replied, for want of something better, and walked on...

The place smelled of the oil of the machine and the new leather -- a combination which, added to the stale odors of the building, was not pleasant even in cold weather.

The floor, though regularly swept every evening, presented a littered surface. Not the slightest provision had been made for the comfort of the employees, the idea being that something was gained by giving them as little and making the work as hard and unremunerative as possible.... The washrooms were disagreeable, crude, if not foul places, and the whole atmosphere was sordid....

By three o'clock she was sure that it must be six, and by four it seemed that they had forgotten to note the hour and were letting all work overtime. The foreman became a true ogre, prowling constantly about, keeping her tied down to her miserable task... When six o'clock came, she hurried eagerly away, her arms aching and her limbs stiff from sitting in one position...

Carrie turned her face to the West with a subdued heart. As she turned the corner, she saw through the great shiny window the small desk at which she had applied. There were the crowds, hurrying with the same buzz and energy-yielding enthusiasm. She felt a slight relief, but it was only at her escape. She felt ashamed in the face of better dressed girls who went by. She felt as though she should better be served, and her heart revolted.

Theodore Dreiser, Sister Carrie

1. How did Carrie's fellow workers cooperate in helping her when she was in need?
2. List several examples of the unappealing working conditions in the shoe factory.
3. There was a very long sentence in the story that described the repetitive work of the assembly line quite well. Reading aloud the cadence makes the reader feel the ache that comes with performing a single mechanical movement. Find the sentence and write it down. What does the sentence tell you about the gulf that exists between human energy and mechanical energy?
4. The end of the story tells you something about Carrie's feelings about her job. Summarize her feelings in one sentence.
5. How is Carrie's work more of a job while John Goederson has a career to look forward to? What is the difference?