

DOCUMENT RESUME

ED 148 619

SE 023 745

TITLE COPES, Conceptually Oriented Program in Elementary Science: Teacher's Guide for Grade Five, Preliminary Edition.

INSTITUTION New York Univ., N.Y. Center for Field Research and School Services.

SPONS AGENCY National Science Foundation, Washington, D.C.; Office of Education (DHEW), Washington, D.C.

PUB DATE 73

NOTE 437p.; For related documents, see SE 023 743-744 and ED 054 939; Not available in hard copy due to copyright restrictions

AVAILABLE FROM Center for Educational Research, New York University, 51 Press Building, Washington Square, New York, N.Y. 10003 (\$8.40; over 10, less 2%, over 25, less 5%)

EDRS PRICE MF-\$0.83, Plus Postage. HC Not Available from EDRS.

DESCRIPTORS Curriculum; \*Curriculum Development; Curriculum Guides; Elementary Education; \*Elementary School Science; \*Grade 5; Science Curriculum; Science Education; \*Teaching Guides

IDENTIFIERS \*Conceptually Oriented Program Elementary Science

ABSTRACT

This document provides the teacher's guide for grade five for the Conceptually Oriented Program in Elementary Science (COPES) science curriculum project. The guide includes an introduction to COPES, instructions for using the guide, instructions for assessment of student's grade 4 mastery of science concepts, and five science units. Each unit includes from three to five activities and an assessment. Unit topics include: cells, work, heat, energy transformations, and investigating populations. Each activity includes a teaching sequence and commentary. (SL)

\*\*\*\*\*  
 \* Documents acquired by ERIC include many informal unpublished \*  
 \* materials not available from other sources. ERIC makes every effort \*  
 \* to obtain the best copy available. Nevertheless, items of marginal \*  
 \* reproducibility are often encountered and this affects the quality \*  
 \* of the microfiche and hardcopy reproductions ERIC makes available \*  
 \* via the ERIC Document Reproduction Service (EDRS). EDRS is not \*  
 \* responsible for the quality of the original document. Reproductions \*  
 \* supplied by EDRS are the best that can be made from the original. \*  
 \*\*\*\*\*

ED148619

PERMISSION TO REPRODUCE THIS  
MATERIAL IN MICROFICHE ONLY  
HAS BEEN GRANTED BY

Janice A. Cutler

TO THE EDUCATIONAL RESOURCES  
INFORMATION CENTER (ERIC) AND  
USERS OF THE ERIC SYSTEM

U.S. DEPARTMENT OF HEALTH,  
EDUCATION & WELFARE  
NATIONAL INSTITUTE OF  
EDUCATION

THIS DOCUMENT HAS BEEN REPRO-  
DUCED EXACTLY AS RECEIVED FROM  
THE PERSON OR ORGANIZATION ORIGIN-  
ATING IT. POINTS OF VIEW OR OPINIONS  
STATED DO NOT NECESSARILY REPRESENT  
OFFICIAL NATIONAL INSTITUTE OF  
EDUCATION POSITION OR POLICY

# COPES

Conceptually Oriented Program  
in Elementary Science

## Teacher's Guide for Grade Five

Preliminary Edition

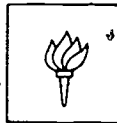

NEW YORK UNIVERSITY

Printed and Distributed by the Center for Field Research and School Services

083745

© Copyright 1973, New York University

This Teacher's Guide represents one of the products of the COPEP Project at New York University which is supported by funds from the Bureau of Research, U. S. Office of Education, and the National Science Foundation.

Copyright for these materials is claimed only during the period of development, test, and evaluation, unless authorization is granted by the U. S. Office of Education to claim copyright also on the final materials. For information on the status of the copyright claim, contact the copyright proprietor or the U. S. Office of Education.

ii

# COPES: Background and Acknowledgments

Recognition of the need for a highly structured, sequentially organized K-6 science program grew out of a three-day conference on elementary school science conducted by New York University scientists, psychologists, and educators in 1962. As a result of this conference, Morris H. Shamos, Professor of Physics, and J. Darrell Barnard, Professor of Science Education, developed a plan to produce a conceptually oriented program in elementary science (COPES). With the administrative support of Dean Daniel E. Griffiths, of the School of Education, and Dean George Winchester Stone, Jr., of the Graduate School of Arts and Science, the plan was accepted as an all-University project. The Advisory Committee and Consultants to the project include the following members:

## ADVISORY COMMITTEE

J. Myron Atkin, Dean, School of Education, University of Illinois, Urbana

Margaret B. Dordick, Principal, Kensington-Johnson School, Great Neck, New York

Glen Heathers, Professor of Educational Research, University of Pittsburgh

M.J. Kopac, Professor of Biology, New York University

Serge A. Korff, Professor of Physics, New York University

Roper F. Larsen, Superintendent of Schools, Bethpage, New York

Ernest Nagel, Professor Emeritus of Philosophy, Columbia University, New York

Charles G. Overberger, Professor of Chemistry, University of Michigan, Ann Arbor

Leo Schubert, Professor of Chemistry, American University, Washington, D.C.

Mark Zemansky, Professor Emeritus of Physics, City University of New York

#### CONSULTANTS

Robert Bernoff, Associate Professor of Chemistry, Pennsylvania State University at Ogonitz

Seymour S. Brody, Professor of Biology, New York University

William J. Crotty, Professor of Biology, New York University

Muriel Green, Supervisor of Science, District 29, New York City Public Schools

Alvin Hertzberg, Principal, Cherry Lane School, Great Neck, New York

Morris Kline, Professor of Mathematics, New York University

Alvin I. Kosak, Professor of Chemistry, New York University

Mary Budd Rowe, Associate Professor of Science Education, University of Florida at Gainesville

Malvin A. Ruderman, Adjunct Professor of Physics, New York University

Arnold A. Strassenburg, Professor of Physics, State University of New York at Stony Brook

Davis A. Young, Assistant Professor of Geology, New York University

A two-year pilot study to test the feasibility of a conceptual schemes approach was funded by the United States Office of Education. The success of the pilot study, dealing with one conceptual scheme--the conservation of energy--led to the production of an elementary school science program based upon the five conceptual schemes outlined in the Introduction to this Guide.

The COPES Staff is cited below, along with previous members who have contributed to the Grade 5 materials:

## THE COPES STAFF

Morris H. Shamos  
Director

J. Darrell Barnard  
Associate Director

Janice A. Cutler  
Assistant Director

Philip R. Merrifield  
Head, Evaluation Team

Lois Arnold  
Editor

Nancy L. Marcus  
Associate Editor

C. Theodora DeVries  
Administrative Assistant

Pauline Zahlout  
Technician

## PREVIOUS MEMBERS OF THE STAFF ASSOCIATED WITH THE DEVELOPMENT OF COPES GRADE 5 MATERIALS

Joan Alexander  
Teaching Assistant

Ronald Caruso  
Elementary School Teacher

Dean R. Casperson  
Science Educator

Vincent S. Darnowski  
Science Educator

Arnold H. Diamond  
Evaluation Specialist

Katherine E. Hill  
Evaluation and Elementary  
Science Specialist

Kit Irvine  
Elementary Science Specialist

Dorothy M. Lynch  
Administration Assistant

Joseph H. Rubinstein  
Biologist

Anne Saenger  
Elementary Science Consultant

Rashid Shah  
Evaluation Specialist

Stanley Simmons  
Science Teacher

Jane H. Steury  
Elementary School Teacher

Bobby J. Woodruff  
Science Educator

Many teachers and staff members have been actively involved in testing and teaching the COPES materials. A laboratory school at the University, as well as regular classrooms of cooperating teachers, tested the initial Grade 5 materials.

ELEMENTARY SCHOOL PRINCIPALS AND TEACHERS  
INVOLVED IN TRIALS OF THE GRADE 5 MATERIALS

Grade Church School  
New York, New York

Henry O. Milliken, Jr.  
Headmaster

Kensington-Johnson School  
Great Neck, New York

Margaret B. Dordick, Principal  
Edith Edwards, teacher

Parkville School  
Great Neck, New York

Edward F. Stone, Principal  
Miriam Chatinover, teacher

Theodore Roosevelt School  
Oyster Bay, New York

Daniel F. Stevens,  
Former Principal  
Warren Reichert,  
Science Consultant

Public School 41  
New York, New York

Irving Kreitzberg  
Principal

Oak Drive School  
Plainview, New York

Ered Karpman, Principal  
Daniel Rosenfeld, teacher  
Naomi Starobin, teacher

Joyce Road School  
Plainview, New York

Marvin Witte, Principal  
Leonard Storz, teacher  
Robert Krapp, teacher

Baldwin Drive School  
Plainedge, New York

Leonard DiGiovanni, Principal  
Stanley Nikodem, teacher

Several research studies have been conducted with the COPES materials. Leon Ukens conducted a research study in Towson, Maryland including Minisequence II of this grade as part of his doctoral studies at New York University.

Many other teachers, scientists, science educators, and school communities have contributed and still are contributing to the program. Acknowledgment must also be extended to those many children who have worked with COPES materials and who have provided us with immediate and invaluable critiques of the Activities.

Finally, we wish to acknowledge the assistance of the Publications Bureau of N.Y.U., who helped to prepare this Guide, and of David Prestone, Lawrence Trupiano, and James Ceribello of the Fat Cat Studio, who did the illustrations.

# Contents

COPEs: BACKGROUND AND ACKNOWLEDGMENTS . . . . .	iii
AN INTRODUCTION TO COPEs . . . . .	1
USING THE COPEs TEACHER'S GUIDE. . . . .	8
THE GRADE 5 ASSESSMENTS. . . . .	14
MINISEQUENCE I CELLS: UNITS OF STRUCTURE AND FUNCTION	
Activity 1 Introduction to the Microscope . . . . .	21
Activity 2 Plant and Animal Cells . . . . .	33
Activity 3 Changes Inside Banana Cells. . . . .	49
MINISEQUENCE I ASSESSMENTS . . . . .	57
MINISEQUENCE II DOING SOME WORK	
Activity 1 A Rolling Marble. . . . .	65
Activity 2 What Can A Rolling Marble Do . . . . .	77
Activity 3 What Is "Work"? . . . . .	84
Activity 4 Kinetic Energy . . . . .	95
Activity 5 Potential Energy . . . . .	106
MINISEQUENCE II ASSESSMENTS. . . . .	116
MINISEQUENCE III HEAT ENERGY AND LIQUEFYING SOLIDS	
Activity 1 Melting and Dissolving Solids. . . . .	127
Activity 2 The Disappearance of Heat Energy . . . . .	140
Activity 3 Some Properties of Salt-Water Solutions. . . . .	156
Activity 4 The Reappearance of Heat Energy. . . . .	171
MINISEQUENCE III ASSESSMENTS. . . . .	190
MINISEQUENCE IV ENERGY TRANSFORMATIONS	
Activity 1 Radiant Energy to Heat Energy. . . . .	204
Activity 2 Chemical Energy (Batteries) to Heat Energy . . . . .	220
Activity 3 Chemical Energy (Food) to Heat Energy. . . . .	233
Activity 4 Kinetic Energy to Heat Energy. . . . .	244



MINISEQUENCE IV ASSESSMENTS. . . . .	259
MINISEQUENCE V INVESTIGATING POPULATIONS	
Activity 1 Selecting Marbles. . . . .	269
Activity 2 Tossing Cubes. . . . .	277
Activity 3 How Do Thumbtacks Land?. . . . .	292
Activity 4 When Do Seeds Germinate? . . . . .	304
Activity 5 How Do Chemicals Affect Germination? . . . . .	321
MINISEQUENCE V ASSESSMENTS . . . . .	342
MATERIALS AND EQUIPMENT. . . . .	355
THE MICROSCOPE . . . . .	362
SCORING GUIDE FOR THE ASSESSMENTS. . . . .	366
WORKSHEET AND ASSESSMENT PAGES FOR DUPLICATION . . . . .	395

# An Introduction to COPES

COPES (Conceptually Oriented Program in Elementary Science) is a science curriculum centered on some of the major conceptual schemes in science. We accept the premise that general education in science is a necessary part of the educational structure, not so much for whatever practical values it may afford as for its pure intellectual stimulation. There is also a growing awareness among the general public of the increasing impact of science and technology on modern civilization. Yet, paradoxically, our society is very poorly informed in science. While many believe that science belongs with those disciplines that traditionally have been regarded as essential to man's cultural enrichment, the average person fails to see it in this light. Whatever the reason, clearly our educational system is at fault. It is probable that past efforts to minimize the intellectual challenge in science curricula have succeeded mainly in distorting the nature of the enterprise in the minds of most school children. By the time these children reach high school, their natural curiosity and interest in science appear to be greatly diminished. Of those that enter college, a great many are actually repelled by science.

Elementary school children, as a whole, are probably the most receptive, the most curious, the most imaginative, and the most cooperative "non-science" students one can find in our educational system. Today, it is apparent that much more can be accomplished at this level than was believed possible in the past. In these formative years, when minds are so receptive to new ideas and before children's patterns of thinking become too crystallized, we think it possible to develop a foundation in science that will remain a permanent part of their intellectual life.

What is the best way to help young children attain a level of understanding and appreciation of science that will serve them through their adult lives? Rather than fill their minds with unrelated facts and details, the COPES approach is to focus their attention on certain of the "big ideas" in science--the broad, inclusive, conceptual schemes in terms of which the scientific community seeks to account for the familiar facts of nature. These central ideas are stressed throughout the program; wherever possible, everything in the curriculum is related to these conceptual schemes. We believe that long after he or she has forgotten the facts of science, a child exposed to such a curriculum may retain some understanding of what is truly important. It should make it clear that science is more

than a collection of isolated facts and provide the child with a solid framework on which to construct a personal view of the world of nature. We also believe that having such definite objectives, in the form of conceptual schemes, adds to the pedagogical strength of the curriculum because it provides teachers and students with clearly defined goals, as well as a cohesive picture of science.

## THE CONCEPTUAL SCHEMES

Civilized man has always prized bold ideas, whether in art, literature, politics--or science. Throughout history, the great ideas stand out as focal points for new systems of philosophy, new religions, new modes of thought, even new societies. Their counterparts in the sciences play a similar role. The big ideas in science are man's response to the challenge of nature, his way of trying to account for familiar facts in terms of a relatively few basic schemes which help to unify broad ranges of experience. Thus science is not simply a matter of accurate and detailed descriptions of things and events, or of extending our senses by the use of instruments. These are merely steps to a much larger objective; the invention of models (theories) that form the bases for all explanation in science. Such unifying ideas as the kinetic-molecular theory, the statistical view of the universe, the conservation principles, the quantum theory, the gene theory of heredity, etc., are the kinds of fundamental schemes to which scientists instinctively turn when faced with new problems. They represent the pinnacle of explanation in science, the product of man's creative imagination--and should be classed among the greatest of his intellectual achievements.

While they may differ greatly in subject matter within the broad field of science, these conceptual schemes have in common that they are not susceptible to direct experimental verification. Thus, the assumption that matter is composed of small, discrete particles--atoms or molecules--which is basic to the kinetic-molecular theory, is obviously not subject to proof of the kind that might be considered "direct." The same is true of all major conceptual schemes; to scientists they are essentially "articles of faith." Our confidence in them rests upon the degree to which they help us to account for our experiences with nature in an intellectually satisfying fashion. And the wider their range of application, the stronger is our belief in their validity. This is not to say that conceptual schemes are infallible; they are, after all, subject to almost the same uncertainties as any other of man's ideas. But those that persist after being subjected to the test of time, including repeated challenges and refinements by competent critics, become the foundations of science.

Five such conceptual schemes form the nucleus of the COPES curriculum: 1. The Structural Units of the Universe; 2. Interaction and Change; 3. The Conservation of Energy; 4. The Degradation of Energy; 5. The Statistical View of Nature. These schemes were selected because they include most of what is fundamental in science and because they provide the basis for a logical, sequential development of skills and concepts through the elementary grades. It may be noted that the last three schemes are new to the elementary school. They have been taught, if at all, only in the secondary schools and colleges. Nevertheless, because of their great importance in contemporary science, and a conviction that even such seemingly sophisticated topics can be made meaningful to elementary school children, they are included in COPES.

Following are brief descriptions of each of the conceptual schemes from a scientific point of view. How COPES deals with them is described in greater detail in introductions to each grade level and sequence of Activities.

#### 1. The Structural Units of the Universe

The notion that the universe is made up of various kinds of discrete units of matter is central to the formal pursuit of science. Whether they be the smallest subnuclear particles or the largest stars, whether a single living cell or a complex organism, it is the discreteness of matter that makes it feasible to study nature--to classify its structural units and establish a hierarchy among them. Atoms, molecules, crystals, cells, organisms, plants, animals, planets, stars, etc.--these are the structural forms in which matter is found. The more complex forms, or higher levels of organization, exhibit properties that are generally more than the simple sum of their parts. The structural units with which students have any direct experience, that is, large-scale matter, are composed of smaller units, and these, in turn, of still smaller units. As for the fundamental "building blocks" of matter, for the purpose of the COPES program these are taken to be atoms or, as more commonly encountered in nature, molecules.

While the idea that matter is made up of discrete parts is obviously an important one, a corollary is perhaps equally important: This holds that nature is essentially simple--that in spite of the great diversity we observe, the number of truly different "building blocks" is reasonably small. The number of different molecules (compounds) is huge, but all are made of combinations of two or more atoms. There are only about one hundred different kinds of atoms (elements) found in nature, but even these exhibit certain similarities that permit grouping them into still fewer major categories (e.g., the eight different "families" of the Periodic Table). It is this simplicity that permits us to seek out the order in nature and

understand it. Think how impossible this task would be were it not for the fact that we are able to reduce our observations to relatively few totally different experiences. Corresponding order is found in the life sciences. The basic reason for classifying things--for seeking similarities among apparently diverse plants and animals--is to reduce the total number of different living things to manageable proportions. Think how difficult the life sciences would be if no two plants, or no two animals, had similar characteristics.

## 2. Interaction and Change

Taken as a whole, the universe is constantly changing. This is evident at most levels of organization: stars, planets, geological formations, living things, etc., all change with time in perceptible ways. Some changes are readily observable, which means that they occur in relatively short periods of time. Certain chemical and nuclear reactions are examples of rapid changes. Others, such as most evolutionary or geological changes involving very long periods of time, are not as evident and must be inferred from indirect evidence rather than from direct observation. Thus the rate at which a given change occurs is a critical factor in detecting this change and assessing its magnitude and import.

Changes occur because of interactions among the structural units of matter, with the result that either the properties or arrangement of the units may be altered. Interactions among units of matter take place through fields of force, of which several basically different types can be distinguished. Only two of these, gravity and electromagnetism (electric and magnetic forces), are normally experienced by the average individual. In fact, the electric force alone is sufficient to account for most of our experiences, including practically all chemical and biological changes. The weakest force (gravitational) and the strongest (nuclear) play particularly interesting roles in effecting changes in the universe. The former is significant only for the largest structural units--planets, stars, etc.--while the latter applies only to the smallest, subnuclear particles.

No change occurs without an interaction--either between units of matter or between matter and energy. Thus the concept of force as the "agent" of change plays a central role in science and in understanding the evolving universe.

## 3. The Conservation of Energy

As one contemplates the concept of a changing universe, it is comforting to find some properties of the universe that appear to be invariant. Such invariant properties are said to be

"conserved," and the statements describing them are generally referred to as "conservation laws."

The most fundamental of these laws are conservation of electric charge and conservation of energy. The latter is of special interest because it is so basic to all of science. In fact, the concept of energy itself, became central to all of science, largely because of the conservation idea. Conservation of matter, if thought of as conservation of mass, while a useful concept in ordinary, low-energy phenomena, is not valid for high-energy interactions. Instead, the principle of conservation of energy has been broadened to include mass as a form of energy, leading to the conservation of matter-energy.

The notion that the total amount of matter and energy in the universe remains constant is obviously a powerful conceptual idea, perhaps the most useful guiding principle in all of science. The more limited idea of conservation of energy alone, while not so inclusive, is found to hold so well for the low-energy interactions normally encountered by children (e.g., in energy conversions) as to constitute a highly significant conceptual scheme at the level to which the COPES program is addressed.

#### 4. The Degradation of Energy

One cannot fully develop the idea of energy conservation in a meaningful way without also calling attention to the direction of energy changes, as embodied in the corollary conceptual scheme, degradation of energy.

Natural events tend to have a unidirectional character. That is, changes occur in such a way as to bring the universe closer to a final state in which it will have lost the ability to do any useful work. Thus, in the conversion of energy from one form to another, while the principle of energy conservation applies, part of the energy appears in a form that cannot be fully harnessed to do mechanical work. This form is heat energy, by which is meant the kinetic energy of the assumed random motion of particles of matter.

The idea of particles moving at random is central to the kinetic-molecular theory, which has proved to be an effective model for understanding gases, as well as the concepts of heat, temperature, and the states of matter. In this sense degradation of energy means that every change in the universe occurs in such a way as to result in greater randomness—that is, matter tends to spread out or become less organized and energy tends to distribute itself more widely.

In more formal terms, the idea that changes occur in this fashion is expressed as the second law of thermodynamics.

Thus, heat flows from a warmer to a colder body, but the reverse is not observed unless energy is supplied from an external source. Similarly, it is easy to fill a large container with gas (molecules) by releasing a small amount of gas into it--the gas "spreads out" to fill the container. The reverse is not so easy. Compressing gas from a large container into a smaller one requires that external work be done on it. The same general idea applies to all changes that appear to result in higher states of organization, even to those in living systems. While the organism itself may become more ordered, it does so only at the expense of its environment, which becomes more disordered. The net result is an overall trend toward disorder, meaning that the total energy is degraded.

### 5. The Statistical View of Nature

The modern view is that natural events can be predicted only on a statistical basis. Most of our experiences with nature involve large numbers, with the result that, on the whole, nature appears regular and predictable. Even the smallest sample of matter with which one normally comes into contact contains huge numbers of atoms or molecules, so large that one can readily predict the average behavior of the sample. This is somewhat analogous to a game of chance where, given a large number of events, the overall outcome can be reliably predicted--even though the result of a single event cannot be forecast. In fact, the same mathematical laws of probability that apply to games of chance appear to be successful in helping one predict the statistical behavior of natural phenomena.

When one studies individual or small numbers of events, the random character of natural phenomena becomes evident. Radioactivity is one such phenomenon where behavior can be predicted only on a statistical basis. Another example is the transmission of genetic characteristics to successive generations of living things, as described by the Mendelian laws. Still another is the Brownian motion of small, microscopic particles, which have an erratic, unpredictable motion. Examples are limited because randomness is apparent only when dealing with small numbers, which one does not often encounter in nature.

Yet the idea that on a submicroscopic level all phenomena are random, and that nature is predictable only by the play of large numbers, is obviously a basic and important conceptual scheme. The challenge is to convince children that one can reasonably generalize to this conclusion from the few concrete examples that are available--to convince them, for instance, that while the motion of individual molecules of a gas is perfectly random, the overall behavior of a large collection of molecules, like that involved in the diffusion of cooking odors through a house, is entirely predictable.

## THE METHODOLOGY OF SCIENCE

Such are the "big ideas" with which COPES is concerned. There is more to them than appears here, of course, and elaborations of each of the schemes will be found at various points throughout the curriculum. There is also more to the "conduct" of science than may be apparent in this approach. What might be called the *methodology of science*, by which we mean both scientific procedure and the attitudes one must bring to it, is an essential part of scientific inquiry.

There is a popular misconception that in the practice of science one proceeds in an orderly, systematic, prescribed fashion. The term "scientific method" is often used to describe this, as though all that is needed for scientific discovery is to follow a particular set of rules. The term is unfortunate because it implies a fixed routine that one rarely, if ever, finds in practice. There is no one "scientific method." Instead, there are certain processes that one can identify as being common to all scientific inquiry. These include such steps as observation, measurement, experiment, formulation of laws, and the creation of theories.

Since one can hardly expect students to formulate basic laws and theories, science process takes on a somewhat different connotation in the classroom. Here, the emphasis is generally placed upon careful observation and measurement, the formulation of "hypotheses" by the students, and the design of experiments to test their hypotheses. The latter might be thought of as "student theories."

Learning to "observe," rather than merely to "see," to make careful measurements, and to report results accurately and concisely are skills that should stand one in good stead in all walks of life. So, too, should the habit of logical thought, the value of which is very evident in science and mathematics. As for experiment, asking the proper questions of nature is both an art and a skill--and, in the final analysis, is the only way of testing the validity of ideas about nature.

All these considerations, plus a fundamental belief that nature is orderly and that its behavior can be understood through scientific study, comprise the methodology of science.



# Using the COPES Teacher's Guide

COPES is a spirally constructed elementary science curriculum that proceeds from Kindergarten through Grade 6, by a progressively sophisticated series of learning experiences, to an understanding of the five major conceptual schemes outlined in the Introduction. In the COPES Teacher's Guides, the learning experiences to be developed are presented as sequences of teaching Activities.

## THE MINISEQUENCES

The pre-sequence of COPES Activities is designed for young children and is presented in two volumes--the Kindergarten, Grade One and Grade Two Teacher's Guides. The main sequence of teaching Activities for Grades 3 through 6 is divided into a series of shorter sequences, each of which is called a Minisequence. The teaching Activities in a Minisequence focus upon a set of closely related concepts supporting one or more of the conceptual schemes. Activities have been serially arranged, as have the Minisequences within each grade.

The titles of the Minisequences and teaching Activities for which this Teacher's Guide has been prepared are listed in the Contents on pages VIII and IX. In the Guide, each Minisequence is preceded by an introduction which summarizes its relevant features and conceptual development. You can obtain a good overview of the Activities in this Guide by reading the introductions to the various Minisequences.

Assessment materials are included after each Minisequence. These materials, which are more fully described in the section beginning on page 14, have been carefully prepared to assess the concepts presumed to be developed and to aid children in attaining mastery of them.

## THE ACTIVITIES

Within each Minisequence, Activities are arranged and numbered in the order in which they should be taught. Although the title of each Activity indicates something of its nature, the

introductory paragraph which follows states its objectives and describes briefly what it includes. Each introduction may also explain how the Activity is related to others in the Minisequence. As you will note, the introductory statement is followed by a list of materials and equipment, suggestions about how to prepare to teach the Activity, and an indication of the approximate amount of time that will be needed to complete the Activity.

Suggestions for step-by-step teaching procedures, including questions that might be raised with the children, are presented in the main body of the Activity in the left-hand columns entitled TEACHING SEQUENCE. Practical hints, explanations of the science content, and alternative teaching suggestions are included in the right-hand columns entitled COMMENTARY. The teaching suggestions are somewhat detailed. During your first time through the Activities, you may wish to follow the suggestions rather closely. After that you may prefer to modify the procedures in ways that are more in keeping with your own teaching style.

At the end of some Activities, there is a final section called EXTENDED EXPERIENCES. These sections suggest ways in which the children can obtain further practice with the skills or ideas in the Activity or ways in which their understanding of the underlying concepts can be enriched. The Extended Experiences are meant to provide opportunities for particular children to go beyond the specific activities outlined in the Teaching Sequence.

#### INVOLVEMENT OF CHILDREN

A fundamental commitment underlying the development of all COPES teaching materials is that the children must become intellectually involved in each learning activity. These materials will help you to encourage such involvement by creating learning situations that, from the child's point of view, are incomplete. You will then lead the child to produce an idea that tends to complete the situation. In psychological terms, you will be helping the child to create a meaningful entity, a *gestalt*, from the observations he or she makes during each Activity. To the extent that the child contributes to this creation, by finding necessary data or by evolving an explanatory idea, the *gestalt* becomes *his or her* concept to label, to remember, and to use in further explorations.

In a COPES Activity, there are objects and ideas about the objects. Both objects and ideas may be arranged in various ways. You and the child may evaluate the implications of different arrangements with regard to how complete each appears to be.

The children's interest in explaining their observations of different arrangements can be used to encourage them to arrange their knowledge systematically and to search for information that appears to be lacking.

The Activities presented in each Minisequence are examples of how specific parts of the environment can be arranged. The Activities lead the children to develop new concepts in order to explain what they observe. In the overall COPES program, the concepts evolving from the Minisequences at successive grade levels are gradually blended into more widely applicable concepts. That collection of concepts, in turn, is part of what is called "Science."

To be successful in teaching science, it is desirable to help children develop the point of view that science is a cooperative venture. You should attempt to use whatever techniques seem appropriate to get children directly involved and working together in planning each Activity, in assembling materials and equipment, in collecting, organizing, and interpreting data, and, finally, in arriving at whatever conclusions appear to be reasonable.

To assist the children in performing these tasks, Worksheets are included whenever appropriate. These must be duplicated in sufficient quantities for each child to have his or her own. Worksheets are used in recording data and in applying the mathematical skills required to interpret the data. Through experience, the children should see that putting information on paper makes it unnecessary for them to remember numbers when they want to compare one result with another and that the systematic arrangement of data makes explaining the results easier. In short, the Worksheets provide a place to store information and facilitate its interpretation.

The materials used by the children, for the most part, are familiar. Some equipment, such as test tubes, magnifiers, and thermometers, may be new to them. If so, allow the children time to play with such items before they begin to use them. If this is not done, their attention will be divided between their desire to explore the new equipment and becoming involved in using it in the Activity. You will notice that the materials and equipment to be used by the children in a particular Activity are not simply handed out at the beginning. Instead they are distributed when the children perceive a need for them, often as a result of discussions where problems or questions are raised requiring the equipment to investigate them.

From time to time, materials and equipment with which the children have been working may be left in a place where they can continue to work with them during their free time. This opportunity helps not only to sustain interest but to reinforce skills, wherever additional practice would be useful. Finally,

it is desirable to use materials at home and out-of-doors whenever possible. Children should not have their conception of science restricted to what happens during the "science period" in the classroom.

In order to get as many children as possible directly involved in each Activity, it is suggested that they work individually where distribution of materials and supervision are not too difficult. In those Activities where teamwork is not only feasible but desirable, it is suggested that they work in small groups of two to five children. In only very few Activities, where the techniques are too difficult and/or possibly dangerous for the children to manage, will the teacher demonstrate.

Suggestions are given for initiating each Activity. This is generally done by suggesting ways in which the new Activity builds upon the previous one(s). Regardless of how it is done, children should be helped to recognize the reasons for getting involved. You should not feel constrained to limit your approaches to those suggested--you know the children and the kinds of approaches that will have the greatest appeal to them.

#### PREPARATION OF MATERIALS AND EQUIPMENT

The teacher holds the key to the success of any science program, and COPES is no exception in this regard. If anything, the teacher must assume a more critical role than in many elementary science programs. There are no textbooks for the children. All learning Activities must be teacher-initiated and judiciously directed.

From a child's point of view, COPES is essentially a "do-it-yourself" science program. This means that the materials and equipment must be available, or there will be no science learning. If there is more than one teacher for each grade in your school, the task of collecting materials can be shared. This will considerably reduce the preparation time required by any one of you. Children and paraprofessionals may also assist you in bringing the materials together. (Whenever some advance preparation must be made, it is detailed for the teacher.) Getting organized for science teaching takes time; however, it is one of the imperatives of effective teaching in COPES.

One of the advantages of COPES is that it is not necessary to obtain complicated--and expensive--laboratory kits in order to teach the program. As you will observe from an examination of the lists in the Activities, and the cumulative listing at the end of this Guide, the materials and equipment required are relatively simple and, for the most part, are readily available locally. Some of the equipment, such as children's scis-

sors, may already be available in your school; a few items may have to be ordered from one of the scientific supply companies. Insofar as possible, the same materials and equipment are used repeatedly throughout each Guide and from grade to grade. This is done to reduce the need for a wide variety of materials and equipment. For convenience, the quantity of items indicated in the list with each Activity is based on the assumption that there are 30 students in the class. You will need to obtain only enough for the actual number of children in your group. Quantitative specifications of materials are given in both the English and Metric systems. However the Metric system is used with the children throughout the COPEs curriculum, whenever measurements are made.

Worksheets and assessment materials are bound into the Guide at places where they are to be used. In this condition they cannot be easily reproduced. Therefore a separate section containing duplicate copies of all Worksheets (and Assessments) is included at the end of the Guide. These single copies are to be torn out along the binding of the Guide, as needed, and used for reproducing multiple copies for the children. Thus it is essential that you have facilities for reproducing copies of these materials.

#### TEACHING TIME

The recommended number of hours that the children will need to complete the work is given for each Activity. The time to be allocated is given in hours, rather than class sessions, because the duration of the latter varies so much from school to school, and even from class to class. It is usually reported as a range of hours rather than a specific number. You may find that some Activities will be completed in less time than recommended, whereas others may take longer. Avoid rushing the children; on the other hand, avoid extending work beyond the time that is obviously suitable. You must be the judge regarding the optimum time to allocate for each Activity.

Most Activities take between half an hour and two hours. The children's attention span must be taken into account in determining how the longer Activities will be broken up. Logical breaking points are at the end of the numbered Sections in the TEACHING SEQUENCE for each Activity.

#### PRODUCTIVE DISCUSSIONS

Discussions of children's observations are frequently used in leading them to the idea or concept for which the observations

were planned. However, as you know, the best-intentioned discussions do not always turn out as planned. When this happens, teachers often resort to asking clue questions to help children guess the teacher--desired response. Such a technique, born out of desperation, usually results in a trial-and-error guessing game rather than in an intellectual experience.

In order to initiate and sustain effective discussions among the children, it is necessary to ask productive questions. Such questions stimulate the intellectual processes of children and assist them in using their observations to arrive at the conceptual goals. In the TEACHING SEQUENCE, questions are suggested that may help you direct discussions toward these ends. The children should be given adequate time to handle the questions. There is often as much silent time in an effective discussion as there is talking time.

#### REVIEW AND REUSE OF SKILLS AND CONCEPTS

It cannot be assumed that a concept or a skill is learned the first time it is introduced. For instance, the concept of magnetic force as the push or pull of one magnet on another is one that is learned by repeated observation of the behavior of magnets in a number of different situations. Skill in using a thermometer comes after repeated experiences in using thermometers to measure the temperature of a variety of substances. Concepts such as properties, and skills such as classifying, are introduced in the kindergarten teaching materials and re-introduced in practically every subsequent grade level. Throughout the CORES program there is constant review and reuse of important skills and concepts.

# The Grade 4 Assessments

The primary theme of the COPEs curriculum is that experience with the ideas underlying common phenomena can lead the child to conceptualize the fundamental and pervasive schemes of modern science. Accordingly, the primary objective of the Grade 4 Assessment materials is to ascertain whether the child has mastered the concepts underlying his experiences with the COPEs Activities. It is important that this goal of the Assessments be kept in mind, in contrast to such alternatives as finding out how well the child remembers specific details of what was done, or the degree to which he has acquired a useful skill. The emphasis on mastery of concepts is intentional: it is not that the alternatives are unimportant, but rather that the concept goals are more germane to COPEs. However, to a greater extent than in the Assessments for Grades K-3, the specific techniques and context of Activities developed at this level are reflected in the Assessments for Grade 4 and Grade 5. Written questions and multiple-choice answers are used as in Grade 4. Teachers are asked to read all written material aloud while children read it silently.

We have not made an issue of the distinction between concepts and skills; rather, we have tried to apply skills in the enhancement of concept learning, and to introduce concepts as the foci of skills. For example, the child learns the skill of grouping, or classification, concomitantly with the concept of a group as a set of objects having a common property. Also, the concept of a property can be abstracted from observations of objects in groups, while at the same time the skill of making abstractions begins to be learned. Thus an attempt to make a clear distinction between "grouping" as a skill, and "a group" as a concept-- or between "property" as a concept and "seeing properties" as a simple kind of abstracting skill--seems more likely to confuse the child than to help him at this stage of his cognitive development. The trained scientist abstracts as he recognizes properties in complex phenomena, and classifies those phenomena into larger groups in terms of perceived properties, without introspecting about whether, at any particular moment, he or she is practicing a skill or applying a concept.

Throughout the Activities, emphasis is placed on concepts and relationships rather than on the specific phenomena, or "facts," and so it is in the Assessments. However, what seems a simple relational idea for an older child may be quite difficult integrative task for the younger child. To assimilate a new explanatory idea into the body of previous ideas, the child may

need a great deal of help in what the psychologist, Jean Piaget, calls accommodation--the transformation of previous experience to facilitate the assimilation of new experience. There will also be individual differences in the ease with which children assimilate new ideas, and these differences may appear in different contexts--the same child may readily reach mastery of one concept, but have to struggle with another. For these reasons, the Assessments have been prepared at two levels: *Screening Assessments*, designed for group administration to ascertain which children have attained mastery of the concepts; and *Individual Assessments*, designed for administration to a single child or small group. The Group Assessments are included at the end of each Minisequence while the Individual Assessments are included in the Scoring Guide section at the end of the book. The Individual Assessments have been constructed to help the teacher focus instruction on those areas in which children need additional help.

The form of the Individual Assessment is a series of leading questions which take a specific problem from the Screening Assessments and break the problem down into a series of simple questions. There is an intentional similarity in the small-step approach to concept evaluation and the more successful aspects of programmed instruction. Some children need greater help in building up their confidence in their knowledge of the concepts and the small-step, guided inquiry strategy is intended for their benefit. (It is not inappropriate for any beginner, but some might find it tedious.) Using this method, the teacher should improvise and ask the same type of questions as in the example. The example questions are meant as a guide. The teacher should feel free to add, subtract, or adapt the questions in any way he or she feels will help the child.

In these Assessments, it might appear that the usual distinctions between achievement and aptitude are blurred. In a sense this is true, because at this stage of development the child's ability to learn new things is based to a significant degree on what he or she has previously learned. A few children may be able to perform well on these Assessments because their previous experience, interacting with their genetic endowment, permits them to "figure it out." However, for the majority, the experience of the COBES Activities should increase the likelihood that they will do well on the Assessments provided for each Minisequence.

#### ADMINISTERING AND SCORING THE ASSESSMENTS

Instructions for administering the Assessments are included with the Assessment pages at the end of each Minisequence. Of course, you will need to make copies of the Assessment pages beforehand. These copies can be made by tearing out the appropriate duplicate Assessment page(s) from the section at the back of this volume. Like the Worksheets, the Assessment pages appear twice--once in context for your reference and once at the back of the



Guide for use in duplication.

The Scoring Guide for the Assessments is also included in this volume. The preferred response for each task is given, together with a commentary. Incorrect alternatives on the multiple-choice questions are discussed when the reasons for their being incorrect are closely related to necessary limits on the concepts, e.g., when the incorrect choice reflects common misconceptions.

### QUANTIFYING THE RESPONSES

Discussions of mastery in learning seem inevitably to lead to the question of "percent passing," as a quantification of what mastery is presumed to be. The teacher is the major judge for mastery of school content; the assessment materials help him or her to make that judgement. Using these materials, the group average on the Screening Assessments should be 70% of the tasks successfully completed, as a minimum. For example, if there are ten tasks, a group of 20 children should have at least a total of 140 correctly done. We have no information as yet on the relative difficulty of the tasks, but they have been devised and arranged in a sequence that makes this percentage passing reasonable, given appropriate instructional use of the Activity material.

For an individual pupil, the level of mastery should be higher, say 80% of the tasks reasonably completed, considering that in some of the tasks the child may have guessed the preferred response. A child doing less well should have the benefit of a discussion of his or her responses with the teacher, and probably the Individual Assessment for the Minisequence. (He or she should be provided with an Individual Assessment and a guide--the teacher, or perhaps a paraprofessional, a parent or an older child.) Remember that the purpose of the Assessment is to assure both teacher and child that mastery of a concept has been achieved.

### USING THE RESULTS

It is our intent that the Assessments not be used to differentiate one child from another, e.g., as a basis for "grading." Two major uses of the Assessment responses are intended: First, the teacher may use quantification of the responses as evidence for a decision regarding the mastery of concepts by the group as a whole. The teacher, not the numbers we suggest above, must be the major decision-maker in this context. Should you decide that the group has not mastered the concepts presented in a Minisequence, re-examine your use of the teaching materials and the

readiness of the group to undertake the experiences. Second, the Assessments should be used as components in the essential feedback you provide the child as he or she strives for mastery of the concepts. Review of the child's performance on the Screening Assessments, and on the Individual Assessment if used, are very important in the child's development of his concept of himself as a learner.

It is the responsibility of the teacher to assess the children's progress, and to distinguish between his or her evaluation of a child's readiness for new learning and any evaluation of that child as an individual person. Comparisons of one child with another in terms of personal worth may well be traumatic, and frequently inhibit the child's participation in future learning situations. However, a realistic appraisal of the child's mastery of significant cognitive aspects of his or her environment should facilitate and motivate continuing intellectual development.

For some years it has been advocated that teachers emphasize their support of children in their attempts to learn. Typically, support has been most evidenced by verbalizations of positive tone--"fine," "good," "OK"--although occasional nonverbal positive reinforcement has been encouraged. The findings from some current research, looking at the distinction between the emotional and cognitive domains of behavior, imply that children trying, with mixed success, to acquire a desired cognitive behavior find a consistently positive tone from the teacher very confusing. The confusion arises because the teacher's behavior is inconsistent with the changes (or lack of them) which the child can observe in his own cognitive behavior. For example, if he or she continues to reach an inconsistent response (wrong answer) on several tries, but the teacher's only response is one of positive acceptance, the child is likely to wonder whether the teacher is attending to the difficulty. While most instances of the well-known "turn-off" arise from a combination of lack of success and negative attitude from the teacher, many children will turn away from a cognitive task when, having failed by their own evaluation, they decide that the teacher's response is irrelevant because it doesn't relate consistently to their cognitive problem.

The teacher's evaluation of a child's response should be consistent with the situation, as the child perceives it, on two levels: (1) rewarding for effort, as that motivates another try; (2) rewarding for realistic success at the task, but non-rewarding for lack of it. That kind of guidance provides much more relevant information, and thus engenders a greater effort on the part of the child to focus on the cognitive aspects of the task.

## PROVIDING FEEDBACK

We hope you will find the Assessments useful in helping the child to mobilize and focus his or her thinking skills on the COPES experiences. In order to determine their usefulness, we ask your assistance in providing feedback to us regarding the Assessments. Information on confusing instructions and the like are received with some regret, of course, but they are nevertheless welcome. Information on relative difficulty of tasks will be extremely valuable. Don't hesitate to request additional Assessment materials from us, and to suggest new formats that such Assessments might take. We shall be most interested in communicating with you.

# Minisequence I

## Cells: Units of Structure and Function

It was a little more than 300 years ago that Robert Hooke used a magnifying lens to observe thin sections of charcoal, cork, and other plant tissues. He observed that they were all made up of small cavities separated by walls. These cavities became known as cells. In 1665 Hooke wrote about cellular organization in plants. Shortly thereafter, Anton van Leeuwenhoek, using a microscope that he had made, discovered single-celled organisms in pond water. Neither of these great discoveries could have been made until lenses were perfected that brought into view a heretofore unseen world. But neither Hooke, nor Leeuwenhoek, nor the many others who for the next 170 years observed and wrote about cells in different plants and animals, understood the great significance of their discoveries. It was not until 1838 that two scientists, Schleiden and Schwann, put the evidence together and came to the conclusion that all living things are composed of cells. This idea is known as the cell theory. The cell is considered to be not only the unit of structure in living things, but the unit of function as well. Among modern biologists the cell is considered to be the minimum organization of matter that is capable of carrying on all of those processes we have become accustomed to calling "life."

In this Minisequence, children will have experiences somewhat comparable to the experiences of those men whose discoveries led to the conclusion that cells are the units of structure and function in living things. The outcomes of these experiences will be an introduction to the more sophisticated implications of the cell theory; they represent a beginning in the direction of one of the truly big ideas in biology.

Because of its importance in this Minisequence, a special section under Materials and Equipment (pages 362 to 364) is devoted to a discussion of the microscope. Six questions are dealt with in a manner that should help the teacher to use the microscope with greater confidence. The material also provides the necessary background for aiding the children in their initial efforts to use the microscope.

In the first Activity children are encouraged to make a transition from magnifying glasses, which they have been using for some time, to microscopes. This is done at both the conceptual and skill level. After some skill in using the microscope has been developed, it is applied in observing that the leaves of the water plant, *Elodea*, are made up of small parts, called cells. Furthermore, the children observe that the leaf cells

contain still smaller parts--green bodies called chloroplasts that contain the coloring material found in all green plants, chlorophyll. Subsequently, they will learn that chloroplasts make it possible for leaf cells to function as food makers.

The second Activity picks up a question raised at the conclusion of the first Activity: Are other parts of plants also made up of cells? The techniques learned in the first Activity are then applied to a microscopic examination of the leaf, stem, flower, and root of a Begonia plant. All its parts are found to be made of cells and, in addition, the flower petals are found to contain still smaller, colored bodies. Other investigations are made of the thin lining between the layers of an onion, the outer covering and interior of a carrot root, the coat of a bean seed, and different parts of the fruit of a tomato plant, to broaden the children's ability to generalize. In dealing with a question regarding the cellular composition of animals, scrapings from the tissue that lines the cheeks of children are examined. These, too, are found to be composed of cells. From these investigations the children obtain some evidence that plants and animals are composed of cells.

In the last Activity the children discover that the pulp cells of an unripe banana contain starch grains. Later, when the banana has ripened, noticeably fewer starch grains are found in the pulp cells. After comparing the taste of ripened and unripened banana, an hypothesis is proposed--that the starch has been changed to sugar. This firsthand observation introduces the idea that things are happening in the cells. Cells are something more than just static structural units; they carry on certain functions, such as changing starch to sugar. Thus, there are two major concepts in this sequence:

1. Living things are made up of structural units, called cells.
2. Some cells contain even smaller parts that over a period of time may change.

## Activity 1 Introduction to the Microscope

In this Activity, the children's previous experiences with magnifying glasses are reviewed and then used as an introduction to the microscope. The essential components of the microscope are demonstrated, along with the materials needed in using it, and the children are given practice in some of the elementary techniques of microscope investigation. By applying these techniques they discover that the *Elodea* leaf is made up of smaller units, called cells, and that the cells themselves contain smaller green bodies.

### MATERIALS AND EQUIPMENT:

For each child you will need:

- 1 magnifying glass (e.g., A.S. & E. hand magnifiers No. 2400 x 126)
- 1 cutout picture from a newspaper
- 1 microscope (40X), if available; otherwise; one for each group of two or three children. (Bausch and Lomb 40X Elementary Science microscopes are recommended if you are purchasing them. However, any available microscopes can be used.)
- 1 glass microscope slide
- 1 plastic coverslip
- 1 medicine dropper
- 1 plastic cup, of any convenient size, to be used as a water container for preparing wet mounts

In addition you will need:

- 5 camel's hair paint brushes
- 3 *Elodea* plants
- 10 plastic or glass dishes in which slides and coverslips can be washed and rinsed
- 1 oz of liquid detergent

- paper towels, 2 or 3 for each child
- 1 box of facial tissues
- 1 oz of granulated sugar
- 1 page of classified advertisements from a newspaper

#### PREPARATION FOR TEACHING:

*Elodea* plants can be purchased from a pet shop that sells live fish and aquarium supplies. The plants must be kept immersed in water.

The plastic dishes should be filled about two-thirds full of water. One pair of dishes should be arranged in each of five stations in the room. One half of a medicine dropperful of detergent should be put into one of the two dishes of water. This water will be used in washing slides and coverslips. The water in the second dish will be used in rinsing them. A supply of paper towels should be kept at each station for use in drying the slides and coverslips.

From a newspaper, cut out as many sections of classified ads as there are children. Each cutout should be about 1 in. by 3 in. and may have more than one ad on it. The print in the ads should be somewhat smaller than that in which the news is printed.

It is imperative that you try out each of the microscope experiences suggested in this Activity ahead of time in order to identify the kinds of problems the children may encounter. If you are not well acquainted with the microscope that your children will be using, practice using it with these materials until you feel reasonably competent. Begin by reading the section on the microscope (pages 362 - 364).

Check to be sure that there are adequate light sources for all microscope users. The overhead artificial lighting in your room may be adequate. If it is not, you may find that you can use outside natural light by arranging the microscopes near windows. If neither of these is adequate, then you may use flashlights or desk lamps.

[In Activity 2, the children will observe the cells in a lettuce seed coat. In order to obtain the seed coat, the seeds should be germinated ahead of time--the germination process causes the seed coat to separate from the seed so that it can be removed. To germinate the seeds, do the following: 3 or 4 days ahead of the time when the children will be doing Activity 2, place about twice as many seeds as will be needed on a few layers of moist paper toweling on a saucer or shallow pan. Enclose the saucer in a clear plastic bag and place it in a well-lighted location.

(It should not be placed in direct sunlight, however.)]

#### ALLOCATION OF TIME:

The children will need approximately 3 hours to complete this Activity.

#### TEACHING SEQUENCE

1. Distribute the newspaper cutout pictures so that the children can view them. Ask each group to identify the various parts of their pictures. Then ask them to concentrate on one part, such as a person, and identify its parts.

Ask if, in the picture, these parts are made up of still smaller parts.

Distribute the magnifying glasses to the children and ask them to use the magnifiers to examine the printed picture.

• What is the picture made up of?

Emphasize the fact that a magnifying glass was needed in order to see that each part of the picture was made up of dots.

2. Arrange the class into whatever number of groups will be necessary in order for each group to have a microscope. Give a microscope to each group

#### COMMENTARY

The parts might include people, animals, cars, buildings, and the like; the parts of a person would be the head, arms, legs, feet, body, etc.

Continue this kind of questioning to direct attention to the smaller and smaller parts of the picture.

If children have had the experiences included in Activity 1, Minisequence 1, in Grade 3, they will recall that a black and white newspaper picture is composed of small black dots.

If the recommended A.S. & E. magnifiers are used, have them examine the picture through each of the three lenses. They should note that the smallest lens magnifies most and that as magnification increases, the dots not only appear larger but there is more space between them.



## TEACHING SEQUENCE

## COMMENTARY

and appoint someone in the group to assume general responsibility for it.

Use the diagram of the microscope on page 363 of the Materials and Equipment section as your reference in directing children's attention to the different parts of their microscope.

As these parts are identified and their functions demonstrated, you may wish to write their names on the chalkboard:

arm--attaches to the base and supports the tube

base--the part which rests on the table

stage--the flat part upon which objects are placed when they are to be observed

tube--contains the lenses. The lens at the bottom is called the objective; the lens at the top is the eyepiece.

tube adjustor--the part that one turns in order to raise or lower the objective and bring the object into focus.

mirror--reflects light from its source into the lenses in the tube

mirror adjusting knob--used in adjusting the mirror to reflect the best intensity of light.

After the function of the mirror and its adjusting knob is discussed, have each child use

Emphasize the fact that the microscope is one complete instrument. However it is made up of parts, each of which has a special purpose or function.

The tube, containing the lenses, and the tube adjustor make up the magnifier system.

In the Bausch & Lomb microscope, the tube adjustor is part of the top of the tube.

The mirror and the knobs used in adjusting it are the principal parts of the illuminator system.

## TEACHING SEQUENCE

them to form a light circle that can be seen as he or she looks through the microscope. (Before looking through the microscope, have the child lower the objective until it is at its lowest position over the base.) Then check to make certain that each has adjusted the mirror properly. As this is being done, talk to the children about light being necessary before anything can be seen through the microscope. Also impress upon them the function of the mirror in reflecting the light from its source into the microscope. A diagram on the chalkboard would help to show that light coming to the mirror is reflected into the lens.

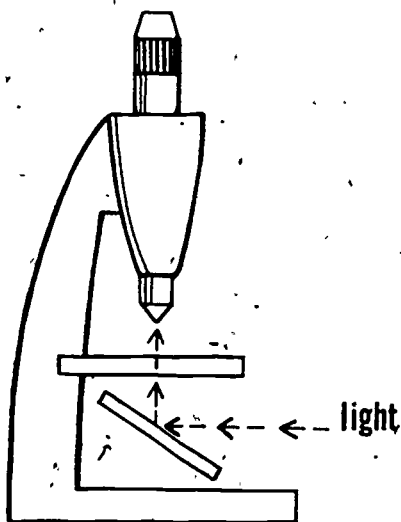

Now have them turn the adjustor again to lower the objective as far as it will go or until it is just above the stage, but not touching it.

## COMMENTARY

When children look through the eyepiece of their microscope, encourage them to keep both eyes open, but don't insist on it for those who find it difficult. There is less strain on eye muscles, if both eyes can be kept open.

If the mirror is properly adjusted they should see a rather bright circle, called the field, when they look through the eyepiece of the microscope. If the children do not see a relatively bright field they should adjust the angle at which the mirror is tipped until the field brightens.

A dirty mirror or dirty lenses may prevent a bright field from being obtained. If dust has collected on the lenses, they may be cleaned by using a camel's hair brush. In order to remove other kinds of dirt, the children may have to wipe gently with a wet tissue and then with a dry tissue.

When the objective in the B. & L. microscope is lowered, it will not touch the stage. Its lowest position will be about 1/4 inch above it. In some microscopes it is possible to lower the objective into the object under observation. When

## TEACHING SEQUENCE

Next, ask them to put the newspaper picture previously observed with the magnifying glasses onto the stage and observe it through the microscope.

As they look through the microscope, have them turn the tube adjuster very slowly to raise the objective. They should continue turning the adjuster until the dots making up the picture come clearly into view.

- How does the size of the dots compare with the size of those observed with the magnifying glasses?

When the children are able to use the microscope to observe their newspaper pictures, give them each a cutout from the classified advertising section of a newspaper.

Ask them to draw a circle around one of the small "e's" found in one of the words and observe it with their magnifying glasses.

Next ask them to observe the "e" with the microscope.

## COMMENTARY

this happens, the lens in the objective may be damaged. For this reason, caution should be exercised in lowering the objective in such microscopes.

When they look through the microscope, the field will be much dimmer than before. However, they should still be able to see it.

As this is done with the B. & L. microscope, one hand should be used to hold the base firmly on the table while fingers of the other hand rotate the tube counterclockwise. Since this may be their first experience in focusing a microscope, take the time necessary for every child to focus on the dots with one of the microscopes.

The dots appear considerably larger and the distance between them is greater. They will also be able to see the fibers that make up the newsprint with the microscope. These were not visible with the hand magnifiers.

When they put the cutout on the microscope stage, they should place the circled "e" in the center of the round hole in the stage. The hole will appear as

## TEACHING SEQUENCE

- How is the "e" under the microscope different from the "e" you observed with the magnifying glass?

After they have discovered that the "e" is upside down, tell them that the microscope has more than one lens in the tube. For this reason it is called a compound microscope. All objects appear upside down when observed through a compound microscope. Ask them to observe the "e" as they move the paper slightly back and forth.

3. Next, show the children a microscope slide and demonstrate how to hold it so that you do not get finger prints on it.

Explain that when objects are to be observed with a microscope they usually are put on a glass slide which is then placed on the stage. To be most useful, the slide should be clean--there should be no dust or finger prints on it.

## COMMENTARY

a lighted circle on the paper. Proper placement will result in the "e" being directly beneath the object so that only the tube adjustor has to be regulated to see the "e."

It will appear larger, as they probably expected. However, they should also observe that the "e" is upside down.

They should now discover that in viewing through the compound lenses the "e" appears to move in the opposite direction from that in which the paper is being moved. Everything under a compound microscope appears backward.

The slide should be held by its edges between the index finger and the thumb. When the slide is put on the desk, a part of one end should extend over the edge so that it can easily be picked up.

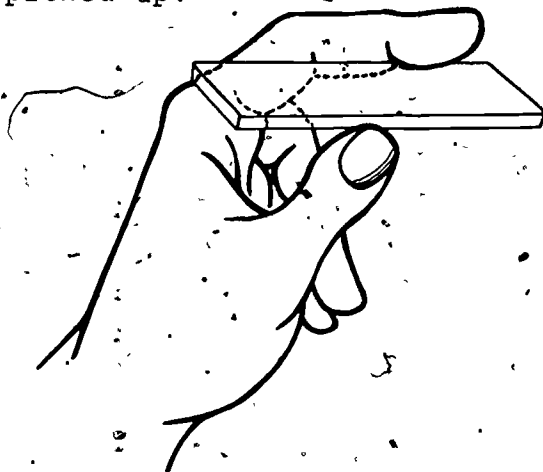

## TEACHING SEQUENCE

Give each child a microscope slide and ask them to practice picking it up, holding it, and placing it back on the table. Then demonstrate how slides are to be washed in the detergent water, rinsed in the clear water, and dried with a paper towel.

After each child has a clean, dry slide, he or she should put a few crystals of sugar on it and examine the crystals with the magnifying glass.

Next they should examine the crystals with their microscopes. Discuss the differences in appearance of the crystals when observed with the microscope, and when observed with the magnifying glass.

Now have them clean their slides by following the procedure outlined above.

4. By now the children should be ready to use the microscope

## COMMENTARY

As this is being done, ask them to hold the slide up to the light and examine it for dust or finger prints.

To wash a slide, one end and then the other should be swished back and forth in the detergent water; to rinse it, the same swishing process should be followed in the clear water. After this, one end and then the other should be dried with a paper towel. The slide should then be examined for finger prints by holding it up to the light. If it is not clean, repeat the process. In order to get finger prints off a slide, it may be necessary to rub it when it is in the detergent water. Do not rub when it is in the rinse water.

You might tell them that when an object is put on a slide it is called a mount. When no water is put on it, it is called a dry mount. The crystals are dry mounts.

Under the microscope the crystals of sugar appear to be much larger. One can also observe a distinguishable crystal shape. It is possible to adjust the mirror so that no light will be reflected from the crystal faces. However, the crystals may still be visible because of light coming from above them. Encourage children to experiment with this phenomenon. When light from the mirror comes through the crystals from below, they appear relatively dark against a light background, when light comes from above, the crystals appear brighter against a darker background.

Most of the children should recognize it as a green plant.

## TEACHING SEQUENCE

to view living things. Hold up one of the *Elodea* plants and ask them what it is and where they might have seen such an object before.

Ask each child to remove a leaf from the *Elodea* plant, put it on his or her microscope slide, gently hold it against the slide with the point of a pencil, and examine it with the magnifying glasses.

- What are some properties of the *Elodea* leaf?

Tell the children that because leaves of *Elodea* plants are so thin, they can be observed nicely with a microscope. Ask them to look at the *Elodea* leaf with the microscope.

- What do you see?

Tell them that these little parts of the leaf are called cells.

## COMMENTARY

Some may recall having seen plants like it in a fish tank.

After the children have removed leaves from the plant, put it back into the water. It should not be allowed to dry out.

They should recognize such properties as greenness and thinness. If they have difficulty in recognizing that the leaf is quite thin, have them hold their slide up to the light. The leaf appears to be a much lighter green, indicating that some light comes through it. If they place the slide on ruled tablet paper and then observe the leaf with the magnifier, they will be able to see the lines on the ruled paper through the leaf.

Most of the objects to be examined in this Minisequence must be thin enough for light to pass through them. Otherwise it will not be possible to see the cellular parts of which they are composed.

Allow time for all the children to get the leaf in focus. They should see what look like very tiny boxes.

## TEACHING SEQUENCE

## COMMENTARY

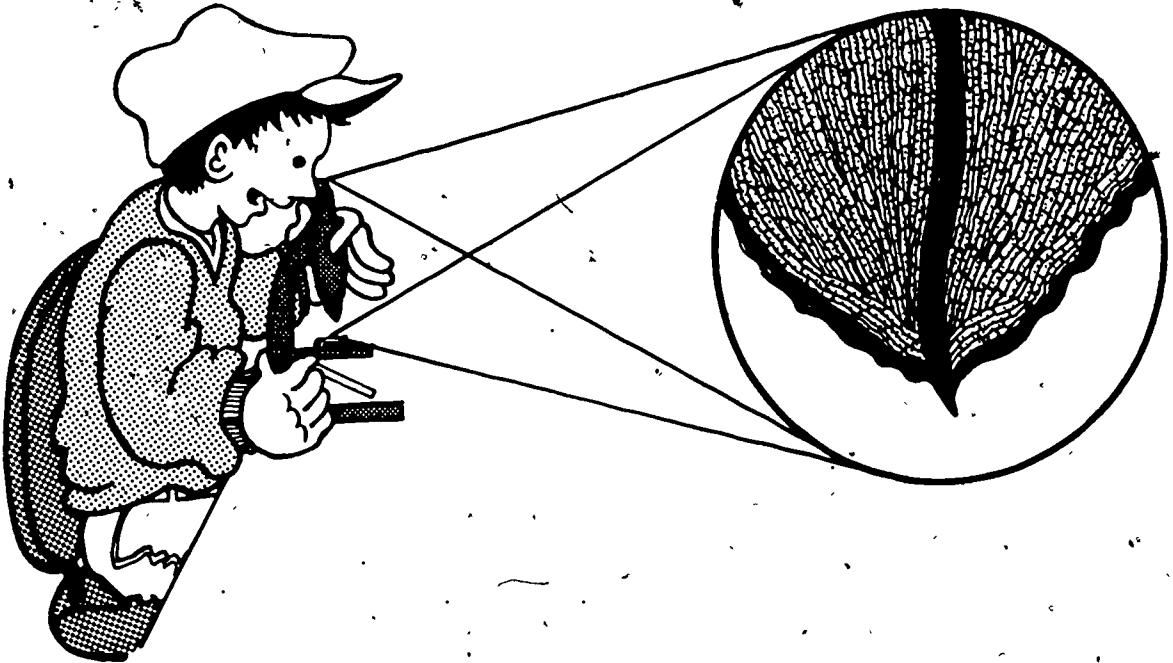

- What happens to the leaf cells as they are left exposed on the slide?

After a while ask them to remove the *Elodea* leaf and clean the slide. As children are cleaning their slides, arrange a plastic cup, 2/3 full of water, at every other seating position in the room. Distribute a medicine dropper to every seating position. When the slide is clean, have each of them place another *Elodea* leaf on it. However, this time ask them to put three or four drops of water on the leaf.

Next, show them a coverslip. Tell them that the thin coverslip is placed on top of the

As they continue this observation of the exposed leaf, it will dry out and the cells will no longer appear as distinct as they did when the leaf was moist.

As drops of water are put on the leaf, tell them that the water will keep the leaf fresh and make its cells more clearly visible. The leaf is now called a wet mount.

Hold the coverslip in the same manner as you did the slide. Coverslips should be examined

## TEACHING SEQUENCE

wet mount for two reasons: It keeps the viewing surface level, thus making it easier to focus on the leaf cells, and it reduces the loss of water by evaporation.

Demonstrate how the coverslip is placed on the slide.

After satisfactory wet mounts have been made of *Elodea* leaves, have the children examine the cells carefully. Ask questions such as these to direct their observation:

- Are all *Elodea* leaf cells the same?
- Is there only one layer of cells in an *Elodea* leaf?
- What can you see inside the

## COMMENTARY

to determine if they are dirty. If they are dirty they should be washed and dried in the same way that the slides were.

This should be done by holding one edge of the coverslip on the slide and the opposite edge about 1/2 inch above the slide. The coverslip is then moved toward the leaf until its touching edge makes contact with the water. The slip is then released to cover the mount. If there is not enough water on the mount, more can be supplied by using a medicine dropper. A drop of water on the tip of the dropper should be placed at the edge of the dry part of the mount. The water will move in under the coverslip. If there is too much water on the mount, the coverslip will float. When this happens, the edge of a facial tissue can be gently placed in or near the excess water to absorb it. It takes considerable practice to prepare good wet mounts.

Most of them are shaped like rectangles or elongated boxes. Some children may draw sketches to show the shape.

There are several layers, as demonstrated by the fact that one can see cells come in and out of focus as one turns the microscope adjuster ever so slightly.

If they have developed some rea-



## TEACHING SEQUENCE

cells?

- Are other parts of plants, (fruits, seeds, stems, roots) made up of cells?

## COMMENTARY

sonable skill in focusing the microscope, they can see little green dots inside the cells. These are called chloroplasts and contain chlorophyll, the green coloring material in plants. In other words, the *Elodea* leaf, which is itself a part of the *Elodea* plant, is also composed of parts--the cells, in turn, apparently contain even smaller parts!

Encourage speculation and then tell them that this question will be investigated in the following Activities.

## Activity 2 Plant and Animal Cells

This Activity is introduced with the question that was posed at the conclusion of Activity 1: Are other parts of plants, such as roots, stems, flowers, fruits, and seeds, also made up of cells? In order to find out, a microscopic study is made of the leaf, stem, root, and flower petals of a single plant, the Begonia.

In order to broaden their investigation to include other plants, the children look at tissues from an onion bulb, a carrot root, a lettuce seed, tomato peel, and tomato pulp under the microscope. The presence of cells in these materials is used as additional evidence that all parts of plants may be made up of cells. A question is then raised regarding the cellular composition of animals. Human cheek cells are examined as one example of animal cells. Thus children are provided with a number of experiences in which they directly observe cells as structural units of living things.

### MATERIALS AND EQUIPMENT:

For each child (or small group) you will need:

- 1 microscope (40X)
- 1 microscope slide
- 1 plastic coverslip
- 1 plastic cup, 1-oz, to be used as a container for iodine solution
- 1 medicine dropper
- 1 plastic cup to be used as a water container for preparing wet mounts
- 1 toothpick

In addition you will need:

- 1 garden trowel
- 1 water bucket, 2-gal

- 10 plastic dishes in which slides and coverslips can be washed and rinsed
- 1 oz of liquid detergent
- paper towels
- 1 box of facial tissues
- 1 oz tincture of iodine
- 1 bottle with cork or cap, 1-pt
- 1 razor blade, single edge
- 5 sharp paring knives
- 1 shallow saucer
- 1 potted Begonia plant with flowers on it
- 15-20 sheets of newspaper
- 1 onion, medium size
- 3 ripe tomatoes, medium size
- 30 lettuce seeds, germinated
- 3 carrots, medium size
- 1 roll of wax paper:

#### PREPARATION FOR TEACHING:

Begonias are a common plant that can usually be obtained wherever plants are sold.

The dishes of water, in which slides and coverslips are to be washed and rinsed, should be prepared as they were in Activity 1. Again, these should be arranged for children's use at five different stations. There should also be a supply of paper towels at each station.

Three other things should also be done in advance:

1. The 2-gal bucket should be filled about  $\frac{2}{3}$  full of water.
2. Prepare about  $\frac{1}{2}$  pint of iodine solution by mixing 1 ounce of tincture of iodine with  $\frac{1}{2}$  pint of water. The solution should be mixed in the 1-pt bottle. It should then be capped or corked and set aside until used. Whatever is left over can be saved for use in Activity 3.

3. Retrieve the germinating lettuce seeds (see the Preparation for Teaching in Activity 1).

Before children get started on this Activity, it is again important that you yourself examine each of the materials with the microscope beforehand.

#### ALLOCATION OF TIME:

The children will need approximately 4 hours to complete this Activity. (Less time will be necessary if they share some of the slide preparations.)

#### TEACHING SEQUENCE

1. Introduce this Activity by having children recall the question that was raised at the conclusion of the last Activity. Then suggest that they study the Begonia plant (show it to them) and see if it, too, is made up of cells.

Ask someone to name the different parts of the plant. They can examine these parts to get additional evidence to use in answering the question regarding the cellular make-up of plants.

Give each child a microscope slide, a coverslip and a medicine dropper. Place a plastic cup of water at each seating position. Unless you have enough for each child, form groups and distribute the microscopes as you did in the preceding Activity.

Each child should prepare a wet mount of a petal from one of the Begonia flowers and use the microscopes to see if

#### COMMENTARY

You might write the question on the chalkboard.

Begonias are particularly suitable for such an investigation since they can easily be cut or torn into pieces that can be readily examined with the microscope.

The different parts that many plants have: flowers, leaves, stems, and roots, were discussed in Topic I of Grade 2.

The cups of water can be shared, if you wish.

It should be noted that the flower petals are very thin. It will be quite easy for them to observe the circular shaped

## TEACHING SEQUENCE

it is made up of cells. Encourage them to draw sketches of the cells and label the sketches for later use.

Show them how to tear a Begonia leaf so that a thin strip of it is left at the torn edge.

Ask them to prepare a wet mount of the thin Begonia leaf strip and examine the torn edge under the microscope.

- How does the shape of these leaf cells compare with those of the *Elodea* leaf and the cells of the flower petal?

## COMMENTARY

cells of a begonia flower petal.

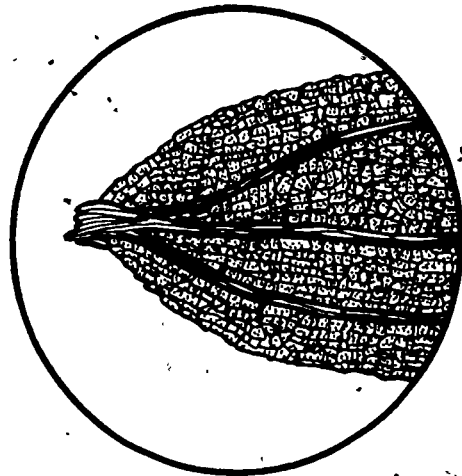

After the petal is examined, have the children clean their slides and coverslips in preparation for the next examination.

This is not difficult to accomplish if the leaf is torn on the bias rather than straight across.

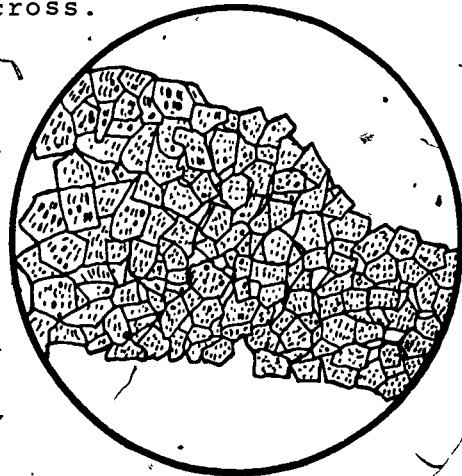

The flower-petal cells are much more regularly shaped than the leaf cells. Also, the leaf cells are mostly green, whereas the petal cells have other colored materials in them. (The leaves of a waxed Begonia are rust-colored and thus their

## TEACHING SEQUENCE

Next, show the children how to peel off the thin skin (outside covering) of the Begonia stem.

Have them obtain a section of skin, prepare a wet mount of it, and examine it with the microscope for evidence of cells.

Ask them to draw sketches of the cells and label them as the skin cells of a Begonia stem.

Now show the class how cross-sectional slices of the Begonia stem are prepared.

Give each child a toothpick and ask him or her to remove one of the slices of Begonia

## COMMENTARY

cells have reddish colored bodies in them.)

This is done by using a sharp paring knife to tear off the outer skin of the stem. It strips off quite easily. One strip may be long enough to supply several children with 1/2-inch sections.

These cells will appear to be tinted green and somewhat elongated in shape.

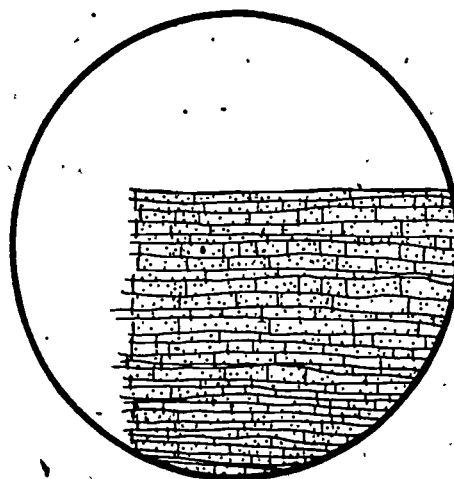

Since a razor blade is used in this operation, the teacher should probably perform it: Cut a section of stem at the tip of the plant and lay it on a piece of cardboard. With the razor blade, slice very thin pieces across the cut end of the stem. It may take a little practice to get the slices paper thin. Cut about 35 to 40 slices and put them in a shallow saucer of water. In this condition they will stay fresh for several hours.

## TEACHING SEQUENCE

stem from the saucer, prepare a wet mount of it, and then examine it with the microscope.

After they have established the fact that the inside of the stem is also made up of cells, have them draw sketches of the cells and label them.

- How does the cross-sectional view of the stem cells compare with the view of stem cells you saw in the skin?

Invite children to observe as you prepare sections of Begonia roots.

## COMMENTARY

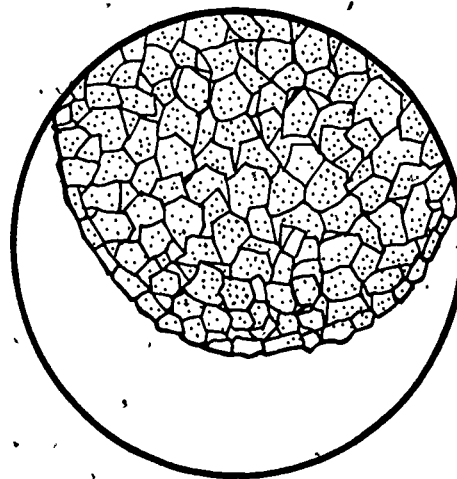

Most of the cells will appear to be shaped like the cells in a honeycomb. This is because what you actually see in this cross section is a top view of the cut ends of cells. Many of the stem cells are elongated, as they appeared to be in the skin that was peeled off the outside of the stem. In the skin you were getting a side view of stem cells.

Before you begin this operation, assure the children that what you are going to do will not kill the plant. Over newspapers spread on the floor, carefully remove the Begonia plant and the soil it is in from the pot. Loosen the soil with your fingers so that much of it will fall away from the roots. Now put the root end of the plant into the prepared bucket of water and slowly move it up and down while holding onto the stem. This slow churning action in the water should remove most of the remaining soil from the roots.

There will be literally hundreds of white hairlike roots

## TEACHING SEQUENCE

Have each of the children prepare a wet mount of Begonia root section and examine it to find out if it, too, is made up of cells.

Encourage them to sketch root cells and label their sketches.

Summarize this Section by discussing questions such as:

- What do all parts of the Begonia plant have in common?
- Are the cells in all parts the same?
- In what ways are the cells different?

2. Introduce this Section by showing the children the onion, the carrot, the germinated lettuce seeds, and the

## COMMENTARY

exposed when the soil is removed. Carefully detach a number of these and put them into the saucer of water. Use a sharp paring knife or razor blade to cut them into sections about 1/2 inch long. (The Begonia plant will not have been seriously damaged by this operation. It can be replanted in the pot and watered well. The soil should be kept moist for several days.)

They will find that each hair-like root is made up of clear, almost colorless, elongated cells.

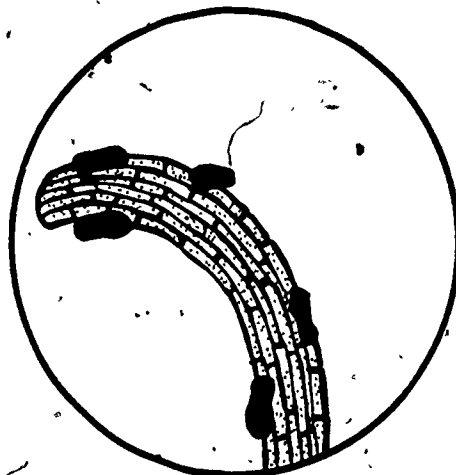

They are all made up of cells.

In discussing this question, have children compare their sketches of the different kinds of cells.

They may be different sizes, shapes, and colors.

They will probably have little difficulty in recognizing the carrot as a root and the lettuce seeds as seeds. However,



## TEACHING SEQUENCE

tomato. Ask them to tell what part of a plant each object represents and then discuss their responses.

After each object is properly identified, write the information on the chalkboard:

onion bulb - underground bud  
lettuce seed - seed  
carrot - root  
tomato - fruit

Suggest that they investigate the parts of these plants to find out if they, too, are made up of cells.

First, discard the outer layer of the onion which has a dried appearance. Cut out a small section of one of the moist scale leaves and demonstrate how the onion skin, which is nearly transparent, may be peeled off.

## COMMENTARY

They may have difficulty in accepting the tomato as fruit. If they do, cut a tomato in half and show them that it contains seeds just as other fruits do, such as apples, peaches, cherries, and oranges.

They will probably have greatest difficulty in identifying the onion as a bulb. Even when they are told it is a bulb, they may think of it as a root since it is obtained by digging it out of the soil. A bulb is a specialized form of underground plant bud containing, in an underdeveloped condition, the parts of a complete plant. To help them see this, cut the onion bulb in half by cutting through it from top to bottom. The overlapping fleshy shell like structures that we eat are "scale leaves." They contain stored food that will be used by the undeveloped parts of the onion plant when it begins to grow.

In this Section, you may want to have different groups of children prepare the onion, lettuce seed, carrot, and tomato for viewing. The observations and inferences would then be made concurrently and shared. All the children should have the experience of staining the onion skin cells, however.

A very thin layer of cells covers the overlapping scale leaves in the onion bulb. These may be referred to as onion skin cells (scientifically they are called onion epithelial cells).

## TEACHING SEQUENCE

Next, give each child a piece of scale leaf from the onion bulb and ask him or her to prepare wet mounts and examine the onion skin to find out if it is made up of cells.

Ask them to sketch the cells, label the sketches and compare their sketches with those of the other children. You might ask one of the children to reproduce his or her sketch on the chalkboard.

Give each group a 1-oz cup. Tell the class that you are going to put a weak solution of iodine into each cup. After the solution has been poured into each cup, ask the children to touch the iodine solution with the tip of a finger.

- What does the iodine solution do to the tips of your fingers?

Ask them if they think that, when iodine solution touches onion skin cells, it will stain them. They can find out by doing the following:

- Tear off a strip of paper towel about 1-in. wide.

## COMMENTARY

Use a knife or finger nail to loosen the thin skin at the cut end of the scale leaf and then peel it off in the same manner that the skin was peeled off the Begonia stem.

If the onion skin membrane is exposed to the air for very long, it will dry out and curl up. Therefore, the wet mounts should be prepared as quickly as possible for best results.

It may take a little time for all the children to locate the cells. However it is important that they do. Encourage the children to help others who need it.

The cells will be somewhat clear and elongated.

You should get the answer that it colors or stains their fingers.

One edge of the paper towel should be even.

## TEACHING SEQUENCE

- b. Take up a small amount of iodine solution into a medicine dropper.
  - c. Place one or two drops of iodine solution on the slide directly next to coverslip.
  - d. Place one edge of the paper towel on the opposite side of the coverslip so that it just touches the water under the coverslip.
  - e. Let the slide stand for about 10 minutes and then observe it with the microscope.
- How does the iodine stain help you to observe the onion skin cells?

## COMMENTARY

No more than 4 drops will be needed.

The drops of iodine solution should be touching the coverslip.

As the water is drawn out by the paper towel, the iodine solution will be drawn under the coverslip into contact with the onion skin cells.

The walls of the cells will be stained yellow and will become more distinct. A small body within each cell will also be stained yellow. This body is the nucleus of the cell.

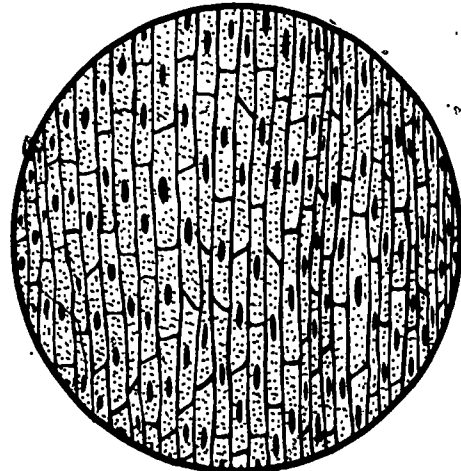

Iodine solutions is only one of several kinds of solutions that may be used to stain cells. At the end of this Activity, suggestions are made for those children who wish to have additional experiences investigating plant cells. Suggestions are also

## TEACHING SEQUENCE

Give each child a germinated lettuce seed. Ask him or her to remove the outer skinlike covering of the seed that has been loosened. They should then prepare a wet mount of this seed coat. As they examine it, have them draw a sketch of the cells.

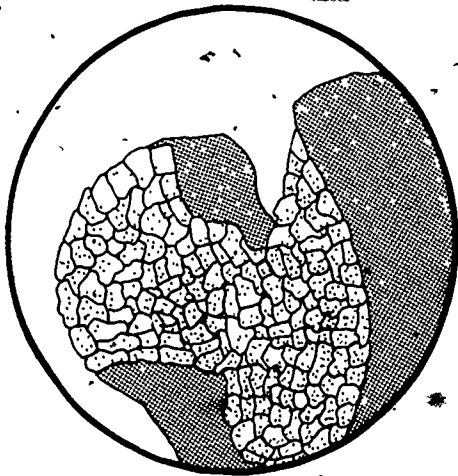

Ask if they can generalize from this evidence that all seeds are made up of cells.

Cut the carrots into several 1-in. sections and give each child one section.

Demonstrate how they are to prepare wet mounts of material taken from the surface of the carrot root. After the demonstration, have them prepare a wet mount and examine it with the microscope. Encourage them to sketch and label the cells, which will be similar in size and shape to those skinned off the stem of the Begonia plant.

## COMMENTARY

made for using other kinds of stains, such as food coloring.

All seeds have an outer coat. This serves to protect the stored food and the embryonic plant inside the seed. Seeds will not begin to grow until the seed coat is broken or loosened, thus admitting air and water. The lettuce seed coat can be obtained after the seed has germinated.

No--because they have examined only one part of one kind of seed. However, the evidence is building up that all parts of plants are made up of cells.

Save the small, more tender, tip end of each carrot root to use in making cross sections (see below). Since it is not possible to peel off the outer layer of cells on the large carrot tap root, a sample of the covering cells must be obtained by lightly scraping the carrot with a knife. The scrapings should then be put onto a slide and two or three drops of water added to them. A toothpick should be used to spread the scrapings before putting on the coverslip. When the slide is observed

## TEACHING SEQUENCE

Have each child make a wet mount of a cross-sectional slice of carrot root. All should observe their mounts, sketch a few cells, and label them.

Next, cut each tomato into 6 pie-shaped sections and give each group of children a tomato section on a piece of waxed paper. Suggest that they prepare wet mounts of tomato material from three different places: the skin, the pulpy material directly under the skin, and the gelatinous material beneath that.

After they have prepared each mount, they might sketch the cells and compare their sketches with those of other children.

## COMMENTARY

with a microscope, some parts of the scrapings will be leveled out so that cells can be seen.

Prepare cross-sectional slices of the carrot root by using the razor blade as was done when cross-sectional slices of the Begonia stem were prepared. The carrot is tougher and getting good thin slices will be a little more difficult. Store the slices into a saucer of water.

These cells will also look much like those in the Begonia stem. As in the Begonia stem, they will be arranged in symmetrical patterns around the center of the root.

To save time, they can work in groups of three, with each child making one mount.

By this time children should have learned the technique for removing a thin layer from the skin of the tomato. A mount of the softer material beneath the skin should be prepared by cutting a thin slice off it with a paring knife. The gelatinous material may be removed and put onto the slide with a medicine dropper.

## TEACHING SEQUENCE

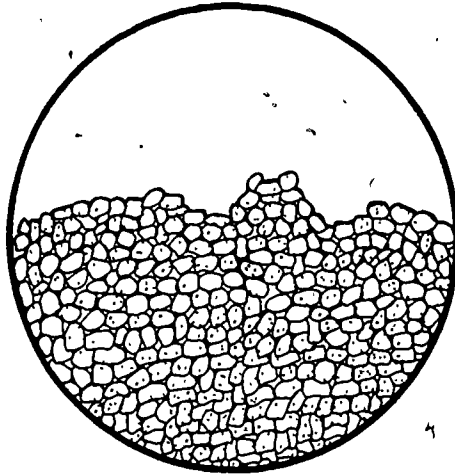

Summarize this Section by discussing questions such as:

- Did you find cells in the onion bulb, the lettuce seed, the carrot root, and the tomato fruit?
- Were the cells in these parts all alike?
- Can you now say that all plants, and all parts of plants, are made up of cells?

3. Ask the children if, from the evidence they have about plants, they would expect to find that animals are also made up of cells.

- Where might you get an animal to use in finding out if it is made up of cells?

## COMMENTARY

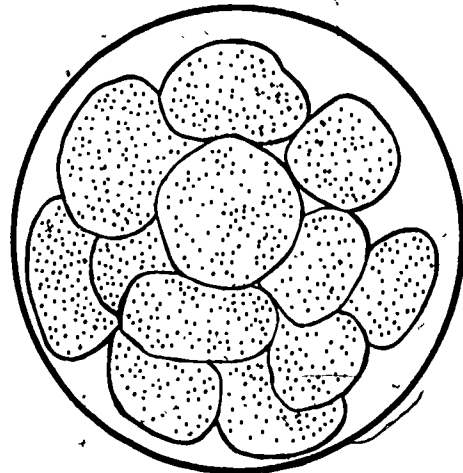
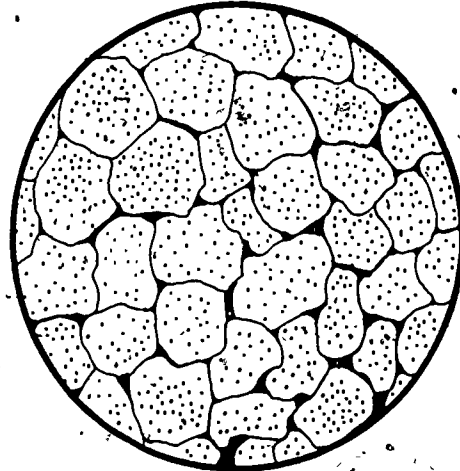

Although scientists believe this to be true, many more plants would have to be examined and their cells observed before the children could be sure. This is what scientists over the years have actually found. No one scientist has examined all plants but no plant has been found by any scientist that was not made up of cells. For those who say "yes," ask what evidence they have: Have they actually seen animal cells or has someone told them?

As various suggestions are made, someone will probably come up with the idea that they themselves might be a source of cells.

## TEACHING SEQUENCE

- From what part of your body could you take a sample to find out if it is made up of cells?

If hair, finger nails, and saliva are mentioned, encourage the children to examine them under the microscope.

Ask the children to feel the inside of their cheeks with their tongues. Tell them that their cheeks are lined with a thin layer of material that can be scraped off with a toothpick.

Demonstrate how this is done and how the scrapings can be transferred to a microscope slide.

Have the children prepare wet mounts of the material scraped off their cheeks and examine it with a microscope.

## COMMENTARY

The following will probably be included among their suggestions: hair, finger nails, saliva, and blood.

Explain that there would be danger of infection if they were to prick a finger for blood. Hair, finger nails, and saliva are all produced by cells of the body. However, they are not alive and when examined by the microscope will show no evidence of living cells. There will be air bubbles in the saliva and particles of material floating in the liquid but no cells.

The cheeks are lined with epithelial tissue, as are all cavities in the body. Thin layers of lining tissue in plants, such as in the onion, are also called epithelial tissues. Epithelial tissue is made up of epithelial cells.

The scraping should be done gently with the side of a toothpick. The toothpick should then be wiped on the flat surface of a slide. Drops of water and a cover slip should be used to make a wet mount, as usual.

It may take a while for them to locate the scattered cheek cells. They may be found singly or in small clumps of three or four. They are clear, somewhat irregular in shape, and the cell walls separating them are not as distinct as was seen in plant cells.

## TEACHING SEQUENCE

After they have located the cheek cells, have them stain the cells with iodine solution in the same manner that the onion skin cells were stained. Encourage them to prepare sketches of cheek cells and to compare their sketches.

- Would you expect to find other parts of the body made up of cells?

Conclude this Activity with a discussion of the following question:

- In what ways are all living things alike?

Encourage children to give examples such as the following to emphasize the idea of structural units:

- A brick building is made up of structural units called bricks.
- Grains of sand are the structural units of a sandy beach.

## COMMENTARY

After about 5 minutes, the cheek cells will be stained yellow and will become much more evident.

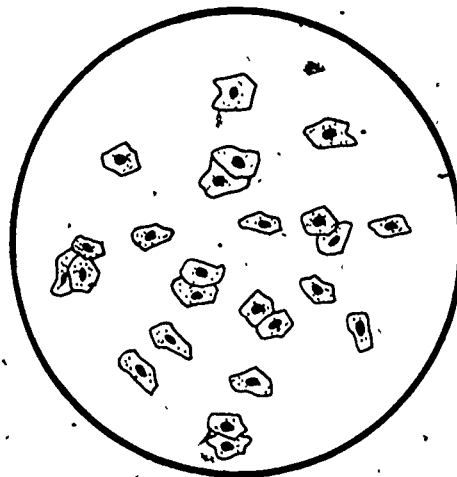

As the children may suspect, living parts of the animal body are made up of cells. These include skin, muscle, bone, blood, nerves, and tissues that hold various organs in place.

The central idea to be established here is that all living things are made up of cells. Cells are the structural units of living things.

There are many examples such as these that children can give which will help them to



## TEACHING SEQUENCE

- Letters are the structural units of a word.
- Words are the structural units of a sentence.
- Black dots are the structural units of a black and white printed picture.
- Cells are the structural units of living things.

## EXTENDED EXPERIENCES:

1. You may wish to encourage one or more of your children to continue their microscope investigations of the cellular structure of different parts of plants. The following are some that can be investigated satisfactorily with either 40X or 100X magnification:

apple - skin and pulp  
 plum - skin and pulp  
 cucumber - skin, peelings and pulp  
 blueberry - pulp  
 carnation stems - peeled skin  
 cherry - skin and pulp  
 geranium - leaves, flower petals, peeled skin of stem and hairlike roots.

2. Some children may be interested in experimenting with different food colors as stains to be used with such cells as onion skin and cheek epithelium. Green food color has been found to be quite a good stain.

## COMMENTARY

Establish the concept that cells are the structural units of living things.

### Activity 3 Changes Inside Banana Cells

In addition to verifying the hypothesis that the fruit of the banana plant is made up of cells, children discover that the pulp cells of unripened bananas contain starch. They also discover that the starch in banana cells is found in the form of small particles. These particles are called starch grains. However, when the cells of a ripened banana are examined, very few starch grains are found. This discrepancy leads to the question of what happened to the starch. After comparing the taste of a ripened and unripened banana, an hypothesis--that the starch has been changed to sugar--is proposed. Thus the idea is introduced that cells not only contain smaller particles but that the particles may change over a period of time. This idea is basic to the concept of cells as functional units of living things.

#### MATERIALS AND EQUIPMENT:

For each child (or small group) you will need:

- 1 microscope (40X)
- 1 bottle with cap or cork, 1-pt
- 1 microscope slide
- 1 plastic coverslip
- 1 plastic cup, 1 oz, to be used as a container for iodine solution
- 1 medicine dropper
- 1 plastic cup to be used as a water container in preparing wet mounts
- 2 toothpicks

In addition you will need:

- 1 box of corn starch (optional--see page 53)
- iodine solution from Activity 2 (make more if necessary)
- 10 plastic dishes in which slides and coverslips can be washed and rinsed

- 1 oz liquid detergent
- paper towels
- 1 box of facial tissue
- 5 sharp paring knives
- 1 roll of waxed paper
- 4 unripe bananas
- 2 ripe bananas
- 2 serving trays

#### PREPARATION FOR TEACHING:

As was recommended in Activities 1 and 2, it is imperative that the teacher work through the suggested experiences in this Activity before undertaking them with children. In assisting children there is no substitute for the "voice of experience."

When purchasing the 4 unripe bananas, select those whose skins are greenish yellow. If the skins are mostly green, so much the better. In selecting the 2 ripe bananas, select those that have yellow skins with a number of brown spots on them. Since each banana will eventually be cut into 15 1/2-inch slices, each should be approximately 7 inches long. After the bananas are purchased, they should not be stored in a refrigerator. Unripe bananas will not ripen in the cold and thus the starch will not be converted to sugar.

The dishes of water in which slides and coverslips are to be washed and rinsed should again be prepared and arranged in stations for children to use.

#### ALLOCATION OF TIME:

This Activity will take approximately 1-1/2 hours of total class time over a period of a few days, which are necessary for observation of the ripening banana.

#### TEACHING SEQUENCE

1. Show the children one of the unripe bananas. Ask them to identify it and describe its

#### COMMENTARY

It should not only be identified as a banana, but as the fruit of a banana plant. A

## TEACHING SEQUENCE

properties.

Now show them one of the ripe bananas. Ask them to describe its properties.

Ask them to compare the properties of the unripe and ripe bananas and to tell which banana they would prefer to eat.

Ask why they would prefer to eat the ripe banana.

Tell the children that you are going to give each of them a slice of unripe banana and a slice of ripe banana. Since a part of the skin will be left on each slice, they will be able to tell which is the unripe slice and which is the ripe slice. After each child has been served the two slices, he or she is to taste each one.

- What difference do you notice in their taste?

After the children have completed the taste test, dispose of the remains of the test and discuss possible reasons for the ripe banana tasting sweeter.

## COMMENTARY

number of properties, including its size and shape, may be given. However, the property of particular importance at this point is its green, or greenish yellow, color.

Again color is important to include in the list of properties.

It should be established that the greenish banana is unripe and the brownish-yellow banana is ripe and therefore to be preferred for eating.

They will probably say that it would taste better. If the suggestion that the ripe banana is probably sweeter does not come out, it will as a result of the comparative taste test which follows.

Two or more children could assist in making these preparations. Cut the slices of banana on a sheet of waxed paper covering a serving tray and use the serving tray to distribute the banana slices. Each child should be given a 4-in strip of waxed paper upon which the slices of banana can be placed. He or she should also be given a toothpick to use in removing pieces of the slices in order to taste them.

The children should generally agree that the ripe banana tastes sweeter.

Out of the discussion will probably come the idea that the ripe banana may contain more sugar. When this happens tell

## TEACHING SEQUENCE

2. Have the class recall what they discovered about plants in the previous Activity. Ask how they would expect the banana to be like other plants they have examined.

- What parts of the banana fruit would you expect to be made up of cells?

Distribute the microscopes, microscope slides, coverslips, and medicine droppers to each child. Give each pair of children a fresh 4-in. strip of waxed paper, a fresh slice of unripe banana, two toothpicks, and approximately 1/2 oz of iodine solution in a 1-oz. cup. Ask each child to prepare a wet mount of banana skins and examine it with the microscope.

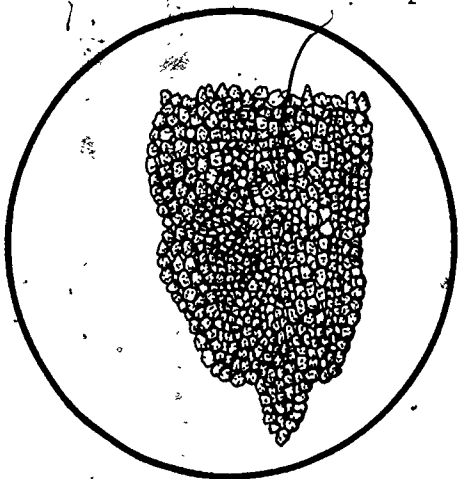

Now have them prepare wet mounts of the unripe banana pulp.

## COMMENTARY

the children that they should hold onto that idea as a good hypothesis.

The parts of plants they examined were made up of cells. They should expect the banana to be made up of cells.

Based upon previous experience they should expect both the skin and the pulp to be made up of cells.

If children in groups are to share a microscope, divide the class into groups and give each group a microscope.

One of the remaining unripe bananas should be cut into at least 15 slices. Each slice should be made up of both skin and pulp. One unripe banana should remain unsliced.

The banana skin should be scraped to remove small bunches of the thin layer of cells that cover it. Mounts of the banana skin scrapings should be prepared in the same manner as the mounts of carrot root skin scrapings were prepared.

If sketches of tomato skin cells were made, cells of the banana skin might be compared with them.

A toothpick should be used to remove a small bit of pulp. It should then be placed on a clean slide and spread out into a very thin smear. The smear should be so thin that it is hardly visible. Three or four drops of water should then be

## TEACHING SEQUENCE

Ask them to observe carefully the cells of the unripe banana pulp.

Be sure that all children have not only seen the pulp cells, but the oval bodies inside them.

- What do you think the oval bodies might be?

Have them recall how they stained onion skin cells and cheek cells with iodine solution in order to see them more clearly. Suggest that they use the technique learned in Activity 2 and add iodine solution to their wet mounts of banana pulp cells.

After the iodine solution has had time to get to the cells, ask the children how the appearance of the cells has changed.

- Have you ever seen something turn blue-black when iodine solution was added to it?

## COMMENTARY

put on the smear and a cover-slip added.

Cells taken from the outer edge of the pulp will be smaller and rounder than the elongated cells taken near the center of the pulp. Most of the cells will contain many oval particles.

If they find it difficult to come up with any ideas, don't push them into making a wild guesses.

Two changes will be noted: the cell walls will be more distinct and the oval particles will have changed from being relatively clear to being dark blue--almost black.

In Grade 3, Minisequence VI, Activity 1, children discovered that when an iodine solution is added to starch, the starch changes from white to a blue-black color. In subsequent COPES Activities this interaction is established as a standard test for starch. If your children have not had these experiences, put a pinch of corn starch on their strips of waxed paper and have them put a drop of iodine solution

## TEACHING SEQUENCE

After it has been established that the oval particles contain starch, tell the class that they are called starch grains. Ask them to sketch several banana pulp cells with stained starch grains inside of them.

3. Now call their attention to the one remaining unripe banana. Ask them to tell again how the ripe banana was different from the unripe banana.

- What would you have to do in order to get this unripe banana to ripen?

Put the banana in a bag and put it where mice or insects cannot get to it.

The class should observe the banana every day and describe how the color of its skin changes, and how it becomes softer as it ripens.

## COMMENTARY

on it. Make certain the children know that the white powder put on the waxed paper is starch. The color of the starch will change to that resembling the oval particles in the pulp cells.

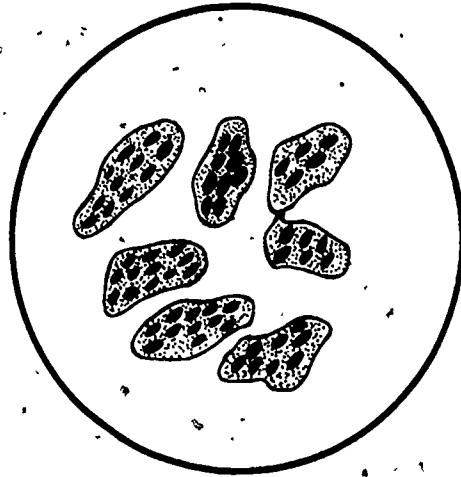

Be sure they include not only the change in color of the skin, but also the change in taste.

Most children will have observed bananas ripening at home and will know that all you have to do is to set them aside and wait a few days.

The banana should not be put into a refrigerator. It ripens best at room temperature.

It will take several days for the unripe banana to ripen. As you know, the skin of a ripening banana passes through color changes from green through yellow to dark brown. Observation of the same banana over the period of its ripening process can become a worthwhile experience in developing the

## TEACHING SEQUENCE

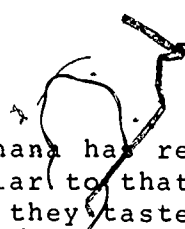

After the banana has reached a stage similar to that of the ripe bananas they tasted, have the children prepare wet mounts of ripe banana pulp cells, observe the cells, and describe the changes that have taken place.

Suggest that they stain the cells with iodine solution. They should observe some of the stained cells in the ripe pulp and sketch them. These sketches should be compared with the ones made earlier of unripe pulp cells.

- What do you think happened to the starch grains?

They should recall that the ripe banana pulp tasted sweeter than the unripe banana. Ask if there could possibly be any connection between the two changes: disappearance of starch grains and appearance of sweet tasting pulp.

Help the children to see that the idea of starch grains being changed to sugar is based only upon the observation that a ripe banana tastes sweeter than an unripe one. This evidence is not conclusive proof that this is what actually happened. Therefore, the idea must be considered an hypothesis.

- What else might be done to make more certain that the starch did change to sugar?

## COMMENTARY

idea that a living thing changes with time.

The cells should look much like they did in unripe pulp. However, the children should be impressed with the lack of starch grains in the cells.

When comparisons are made, the principal difference should be the lack of blue-black starch grains in the ripe pulp cells.

This discussion could, quite reasonably, lead to the hypothesis that the starch in the unripe banana was changed to sugar during the ripening process.

They may suggest that if tests, similar to the starch-iodine test, could be performed to determine if the ripe banana really did contain more sugar,



## TEACHING SEQUENCE

4. Summarize the ideas developed in this Minisequence by discussing questions such as:

- What was observed when the *Elodea* leaf was examined with the microscope?
- What other plant parts were found to be made up of cells?
- What parts of animals were found to be made up of cells?
- If you could examine all parts of plants and animals with a microscope; what would you expect to find?
- Do cells contain anything?
- Do the bodies which cells contain ever change?

## COMMENTARY

then you could be more certain. If they make such a suggestion, commend them for their good thinking.

By using such tests, scientists have actually demonstrated that during the ripening process the starch stored in the banana pulp cells is changed to sugar. The change is called digestion and is brought about by the interaction of an enzyme with starch within the banana cell. This is but one example of cells as functional units in living things.

The *Elodea* leaf was found to be made up of cells.

Flower petals, and the stems, roots, and fruit and seed coat of plants were found to be made up of cells.

Human cheek lining.

Cells

They saw green colored bodies in *Elodea* leaf cells, and starch grains in banana cells.

There was evidence that the starch grains in unripe banana cells change as the banana ripens.

# Minisequence I Assessments

## Screening Assessments

The concepts being tested in this Minisequence are:

- a. All plants and animals are made up of cells.
- b. There may be different kinds of cells within the same plant or animal.
- c. Cells contain different substances within them which perform various functions.

In this Assessment, there is only one Part, covering all three concepts. Distribute the two assessment pages to the children. Have them write their names in the appropriate place. This assessment will take about 5 minutes.

The assessment pages are in alphabetical order for an entire Minisequence. The letters, which appear in the upper right hand corner of each page, allow the children to identify the page they are to work on at any given time. The letters also permit you to maintain the correct order in collating the pages. The pages may be collated in groups, Part 1, Part 2, etc.--sometimes the children appreciate the change of pace afforded by collecting one set of papers and passing out the next. The pages may also be distributed as a complete set for the Minisequence.

In the assessments, suggested instructions to be read to the children appear in capital letters, as do the problems themselves. After distributing the assessment pages, read the instructions and then the problems, one by one, together with the possible responses. The children should read the problems along with you, silently, and then circle the letter of the best response. They should be encouraged to think out their responses and not to guess.

We have tried to use language at the level suggested in the Activities themselves. In some problems, however, a child may ask for the meaning of a particular word. If, in your judgment, your answer would provide the answer to the problem, you should decline, considering that he or she does not know the concept being assessed. If you can answer the child simply, without disclosing the answer to the problem itself, you may do so. As a general

rule, you should ask the child to respond stating what he or she thinks the word means.

Page A

Ask the children to turn to page A.

1. IF YOU EXAMINE A THIN SLICE OF AN APPLE AND THE LEAF OF AN APPLE TREE UNDER A MICROSCOPE, YOU WOULD FIND THAT THEY ARE BOTH MADE UP OF

- A. STARCH.
- B. CELLS.
- C. GREEN PARTICLES.

2. WHEN YOU STUDY THE CELLS FROM TWO DIFFERENT PARTS OF A PLANT, YOU WILL PROBABLY FIND THAT THE CELLS

- A. DIFFER IN SIZE AND SHAPE.
- B. HAVE THE SAME SIZE AND SHAPE.
- C. ARE NOT AT ALL ALIKE.

3. CELLS WITHIN THE SAME PART OF A LEAF

- A. ALWAYS LOOK EXACTLY THE SAME.
- B. HAVE MANY DIFFERENT SIZES AND SHAPES.
- C. USUALLY LOOK A LITTLE DIFFERENT FROM EACH OTHER.

4. CELLS ARE

- A. LARGER THAN MOLECULES.
- B. SMALLER THAN MOLECULES.
- C. THE SAME SIZE AS MOLECULES.

5. CELLS CAN BE FOUND

- A. ONLY AS PARTS OF PLANTS.
- B. ONLY AS PARTS OF ANIMALS.
- C. AS PARTS OF BOTH PLANTS AND ANIMALS.

Page B

NOW TURN TO PAGE B.

6. THE CELLS IN A LEAF

- A. ARE THE SMALLEST PARTICLES IN THE PLANT.
- B. MAY HAVE SMALLER PARTICLES WITHIN THEM.
- C. HAVE THE SAME SIZE AND SHAPE.

7. IF YOU LOOKED AT POTATO AND BANANA CELLS UNDER A MICROSCOPE, YOU WOULD FIND THAT

- A. THEY ARE EXACTLY THE SAME BECAUSE BOTH CONTAIN STARCH.
- B. THEY LOOK VERY DIFFERENT BECAUSE THEY COME FROM QUITE DIFFERENT PLANTS.
- C. THEY ARE ALIKE IN HAVING WALLS SEPARATING THEM AND MATERIAL INSIDE THEM.

8. PHILIP FOUND A LONG, VERY THIN THREADLIKE PIECE OF GREEN MATERIAL IN A SAMPLE OF WATER HE HAD TAKEN FROM A POND. SINCE IT WAS GREEN HE THOUGHT THAT IT MIGHT BE SOME KIND OF A PLANT. HIS FRIENDS SUGGESTED THE FOLLOWING AS THINGS HE MIGHT DO TO FIND OUT FOR SURE. WHICH ONE DO YOU CONSIDER TO BE THE BEST SUGGESTION?

- A. USE A MICROSCOPE TO FIND OUT IF IT HAS LEAVES THAT CAN BE USED TO MANUFACTURE THE FOOD IT NEEDS.
- B. USE A MICROSCOPE TO FIND OUT IF IT HAS ROOTS THAT CAN BE USED TO TAKE IN THE WATER IT NEEDS.
- C. USE A MICROSCOPE TO FIND OUT IF IT IS MADE UP OF CELLS CLEARLY SEPARATED BY CELL WALLS.

9. IN AN ANIMAL, CELLS ARE

- A. MANY DIFFERENT SHAPES AND SIZES.
- B. ALIKE IN THAT THEY HAVE A WALL AND MATERIAL INSIDE.
- C. BOTH A AND B ARE TRUE.

1. IF YOU EXAMINE A THIN SLICE OF AN APPLE AND THE LEAF OF AN APPLE TREE UNDER A MICROSCOPE, YOU WOULD FIND THAT THEY ARE BOTH MADE UP OF

- A. STARCH.
- B. CELLS.
- C. GREEN PARTICLES.

2. WHEN YOU STUDY THE CELLS FROM TWO DIFFERENT PARTS OF A PLANT, YOU WILL PROBABLY FIND THAT THE CELLS

- A. DIFFER IN SIZE AND SHAPE.
- B. HAVE THE SAME SIZE AND SHAPE.
- C. ARE NOT AT ALL ALIKE.

3. CELLS WITHIN THE SAME PART OF A LEAF

- A. ALWAYS LOOK EXACTLY THE SAME.
- B. HAVE MANY DIFFERENT SIZES AND SHAPES.
- C. USUALLY LOOK A LITTLE DIFFERENT FROM EACH OTHER.

4. CELLS ARE

- A. LARGER THAN MOLECULES.
- B. SMALLER THAN MOLECULES.
- C. THE SAME SIZE AS MOLECULES.

5. CELLS CAN BE FOUND

- A. ONLY AS PARTS OF PLANTS.
- B. ONLY AS PARTS OF ANIMALS.
- C. AS PARTS OF BOTH PLANTS AND ANIMALS.

6. THE CELLS IN A LEAF
- A. ARE THE SMALLEST PARTICLES IN THE PLANT.
  - B. MAY HAVE SMALLER PARTICLES WITHIN THEM.
  - C. HAVE THE SAME SIZE AND SHAPE.
7. IF YOU LOOKED AT POTATO AND BANANA CELLS UNDER A MICROSCOPE, YOU WOULD FIND THAT
- A. THEY ARE EXACTLY THE SAME BECAUSE BOTH CONTAIN STARCH.
  - B. THEY LOOK VERY DIFFERENT BECAUSE THEY COME FROM QUITE DIFFERENT PLANTS.
  - C. THEY ARE ALIKE IN HAVING WALLS SEPARATING THEM AND MATERIAL INSIDE THEM.
8. PHILIP FOUND A LONG, VERY THIN THREADLIKE PIECE OF GREEN MATERIAL IN A SAMPLE OF WATER HE HAD TAKEN FROM A POND. SINCE IT WAS GREEN HE THOUGHT THAT IT MIGHT BE SOME KIND OF A PLANT. HIS FRIENDS SUGGESTED THE FOLLOWING AS THINGS HE MIGHT DO TO FIND OUT FOR SURE. WHICH ONE DO YOU CONSIDER TO BE THE BEST SUGGESTION?
- A. USE A MICROSCOPE TO FIND OUT IF IT HAS LEAVES THAT CAN BE USED TO MANUFACTURE THE FOOD IT NEEDS.
  - B. USE A MICROSCOPE TO FIND OUT IF IT HAS ROOTS THAT CAN BE USED TO TAKE IN THE WATER IT NEEDS.
  - C. USE A MICROSCOPE TO FIND OUT IF IT IS MADE UP OF CELLS CLEARLY SEPARATED BY CELL WALLS.
9. IN AN ANIMAL, CELLS ARE
- A. MANY DIFFERENT SHAPES AND SIZES.
  - B. ALIKE IN THAT THEY HAVE A WALL AND MATERIAL INSIDE.
  - C. BOTH A AND B ARE TRUE.

## Minisequence II      Doing Some Work

The concept of energy was first developed Minisequence V in Grade 3 in the form of heat energy, and extended in Grade 4 (Minisequences II and III), where the idea of conservation of heat energy was introduced. The present Minisequence further extends the concept of energy to include another common form -- *mechanical energy* -- and develops another, related concept: *work*.

It may be helpful to consider the following example showing the relationship between work and energy in a practical situation. Consider a rubber ball, initially lying on the floor, that is lifted to a table top. Work must be done to lift the ball. A force equal to its weight must be applied to lift the ball, and this force acts through a distance equal to the height of the table. The actual amount of work done is the product of the force and the distance, and the ball is said to have an amount of energy when on the table -- *potential energy* -- equal to the work done to place it there. The ball is "potentially" able to do work, for example, by allowing it to fall to the floor while attached by a string to another object, causing the latter to move -- hence the term *potential energy*. The energy that the ball has in this case is sometimes called *gravitational potential energy* because the force causing it to fall to the floor is the gravitational pull of the Earth.

Suppose the ball is allowed to fall freely. As it falls it picks up speed; some of its potential energy, or energy of position, is converted to another form of mechanical energy -- *kinetic energy*, or energy of motion. These are the two forms of mechanical energy: potential and kinetic. Before the ball begins to fall it has only potential energy. At any point in its fall it has both potential and kinetic energy, and if we apply the conservation of energy principle, their sum must be equal to the original potential energy of the ball, provided no energy has escaped from the system in some other form. When the ball strikes the floor, all of its potential energy is converted to kinetic energy. A split second later, when it is momentarily motionless, its kinetic energy is zero. All the energy has now gone into doing some work, namely, compressing the ball. When compressed, the ball has elastic energy, similar to a stretched rubber band, which is converted back to kinetic and potential energy as it rebounds, and the entire process is then repeated.

If, at any time after the ball is dropped, an inventory is taken of its various forms of energy, i.e., potential, kinetic, and

elastic, these should add up to the original gravitational energy, assuming the conservation principle holds, and the ball should continue bouncing forever. But this does not happen, as we know. How do we account for the fact that a bouncing ball never returns to its original height and, in fact, eventually loses all its energy to come to rest on the floor? The answer is that we have neglected to take into account the heat energy that is produced. Each time the ball strikes the floor, part of its energy goes into heating the ball (and surroundings) because compressing it causes internal friction in the rubber. Unfortunately, this form of energy cannot be fully transformed back into the kinetic energy of the ball. Hence, the ball gradually loses all its energy in the form of heat and comes to rest. However, if the heat energy were included in the calculation we would find that the total energy of the system remains constant and equal to the initial gravitational energy. That is, the total energy is conserved. The question of energy conversions will be dealt with in Minisequence V.

The first Activity of this sequence has the children observing the speed of a marble, released from different heights on an incline, as it rolls off the bottom of the incline. The relative speeds associated with different heights are inferred from the distances that the marble rolls along the ground after leaving the incline. While energy is not discussed in the Activity its purpose is to lay the groundwork for subsequent Activities relating work and mechanical energy. The children also have an opportunity to observe variability in this Activity. They find that even when a marble is released from the same position on an incline it does not always roll the same distance. From their data they can see that repeating the same experiment still gives rise to an "error" of measurement. The reason, of course, is that it is impossible to precisely duplicate two measurements.

The second Activity extends the concept of a moving object (a marble) to include what it can do by virtue of its motion. Again, an incline is used, but as the marble leaves the ramp it is caught by an object (a small "sled"), to which it transfers its momentum, causing the sled to move. While again, no mention is made of energy, the children find that the distance the sled moves is related, at least qualitatively, to the speed of the marble.

Activity 3 introduces the notion of mechanical work, defining it as the product of force and distance. The children lift weights (books) to different heights, noting qualitatively that it is harder to lift several books than one, and harder to lift any object to a greater height than a lesser one. With these observations one readily concludes that work is related both to weight (force) and distance and that the relationship is the product of the two. The product is introduced in a graphical manner, similar to that used in developing the concept of a



heat energy unit (h.e.u.) in Grade 4. There, the variables were volume and temperature, rather than force and distance, but the graphical interpretation is the same. The children also find that an unbalanced force is needed to move an object, or to keep it moving on a surface because of frictional effects.

All the observations of the first three Activities are brought together in Activity 4, where the children find that the amount of work a moving marble can do, as measured by the distance it causes a sled to move, is related both to the speed and the weight (massiveness) of the marble. Thus the concept of kinetic energy (energy of motion) is introduced on a semiquantitative level. The children compare the work done by marbles of different size moving with different speeds.

The final Activity completes the cycle by introducing the concept of gravitational potential energy. The children first relate the potential energy (energy of position) of a marble at any point on the incline to the work required to lift it to that position. Then, as the marble rolls down the incline and this energy is converted first to kinetic, and finally to work done in moving the sled, the children realize the interconversion of work and mechanical energy. They also realize that the conversion is not complete -- that some of the energy probably is converted to heat as the marble rolls down the incline, and as the sled slides and finally comes to rest.

## Activity 1. A Rolling Marble

The first Activity introduces children to the characteristic behavior of a rolling marble. They observe that the faster a marble rolls down an incline, the farther it can move when it reaches the bottom. They also discover that the height of the incline determines the speed at which the marble rolls off the ramp.

In gathering their data on the distance the marble rolls, the children are introduced to the idea that variability not only occurs in measuring a property of a number of objects in a group, but is also exhibited when one repeats measurements of the same property. This variability inevitably enters into all such measurements and should be expected. It is caused by the fact that when making repeated measurements of the same event-- in this case, measurement of the distance rolled by a marble-- since one cannot reproduce exactly the conditions of the measurement, the children are led to understand that the average of several measurements of the property is the best value to report.

### MATERIALS AND EQUIPMENT:

For each team of two children you will need:

- 2 rulers, 30-cm, with groove, inflexible
- 4 equal-sized objects, about 2 cm high, such as paperbound books, match boxes, etc.
- 1 meter stick, or other long measuring device, with mm markings
- 2 marbles, 3/4-in. or 5/8-in. diameter, glass
- 2 towels, or strips of wool or felt cloth (if the floor is not carpeted)
- 1 Worksheet II-1.

### PREPARATION FOR TEACHING:

Be sure there is enough room on the floor for each pair of children to perform the experiment. If the floor is not carpeted,

a textured surface can be provided by giving each team a piece of wool or felt cloth, or a towel. Have the other materials available for each team to help itself. You may want to duplicate additional copies of Worksheet II-1, which will also be used in Activity 2.

#### ALLOCATION OF TIME:

The children will need about 1-1/2 hours for this Activity.

#### TEACHING SEQUENCE

1. Place a marble on a desk or table in full view of the children.

- How can the marble be made to roll?

A child may respond that you have to push it.

- What is a push, really?

Suggest that one of the children try different ways to get the marble to roll.

Now lift the marble and let it drop.

- Why does the marble move in this case?

#### COMMENTARY

In discussion, try to elicit the idea that a force (interaction) has to be applied to get the marble to move.

In Grade 3, the children were exposed to Activities involving objects subjected to balanced forces. When forces are balanced, or when there are no forces, the objects do not move.

He or she might flick, as one does in playing marbles. Relate the flick to applying a force.

A gravitational force is acting on it. The attraction between the Earth and the marble causes the marble to move towards the Earth. In Grade 3 of COPES, the children learned that what

## TEACHING SEQUENCE

What is this force called?

Now set up a ruler to serve as a ramp for the marble. Support one end of the ruler on a book, box, or other such object. Hold a marble near the top of the ruler-ramp and then release it.

- What happens?
- What causes the marble to move down the ramp?
- What factors do you think determine how far the marble can roll?

Have each child pick up the materials for a marble-roll set-up.

While the children investigate this set-up, ask how they would go about determining the effect of the ramp height (or inclination) on the distance a marble would roll.

## COMMENTARY

we mean by the *weight* of an object is the gravitational force acting on it.

The ruler should have a central groove running along its length to serve as a channel for the marble to run down. Many rulers have this feature.

The marble will roll down and continue to move across the carpet or cloth.

Be sure the children recognize that the gravitational force interacting with the marble causes it to move down the ramp.

Encourage them to consider different factors. One factor that might be suggested is the type of surface that the marble rolls onto. Some children may want to demonstrate this by letting the marble roll onto a smooth surface and then onto the carpeting. Another factor might be the position from which the marble is released. Both of these are pertinent factors--or variables.

Be sure the set-up includes a ruler, a marble, and two equal-sized supports such as paper-bound books, match boxes, etc. The size of the support should be such as to keep the upper end of the ruler at a height of about 2 cm.

## TEACHING SEQUENCE

Eventually, the children should suggest rolling two marbles down separate ramps supported at two different heights. Thus two separate sets of data would be collected on the distances the marbles rolled.

Suggest that two children share the equipment for this observation. They should set up the two ramps side by side. One ruler can be supported on the edge of one box (or book) and the second ruler on two or three boxes. The children will then be ready to release similar marbles from each ramp and observe their behavior. In order to compare the two, be sure they recognize that each ramp must be the same length and each marble must be released from the same spot.

The release of the marble can be conveniently controlled if they take a card (e.g., 3 x 5) hold it at a specific line of the ruler, and place the marble behind the card. When they raise the card quickly, the marble will roll down the ramp.

## COMMENTARY

Equally valid would be a suggestion that the same ramp set-up be supported first at one height and then at another. However, one of the purposes of this Activity is to provide children with the opportunity (later on) to compare the speeds of the marbles when released from two different heights. For such a comparison, two marbles must be released simultaneously on the two ramps.

The ramps should be situated close to one another.

Although each ruler is the same length, the teams may have them extending beyond the boxes to different degrees so that the ramps are of different lengths. To control this variable, the children should suggest supporting each ruler at the same position on its box, e.g., by using one of the inch or centimeter marks as a guide.

Have them practice this release. It allows them to release the marble from the same place and in the same way. An inadvertent push by the child is thus avoided.

## TEACHING SEQUENCE

The surface onto which the marble rolls should be textured cloth. Some classrooms are carpeted and this is ideal.

## COMMENTARY

If the floor is smooth tile, or linoleum, they will quickly see that the marble rolls for a considerable distance before stopping. If there is no carpeting, felt pads or pieces of wool cloth will substitute. Even a bath towel can be used, but be sure that creases do not interfere with the roll.

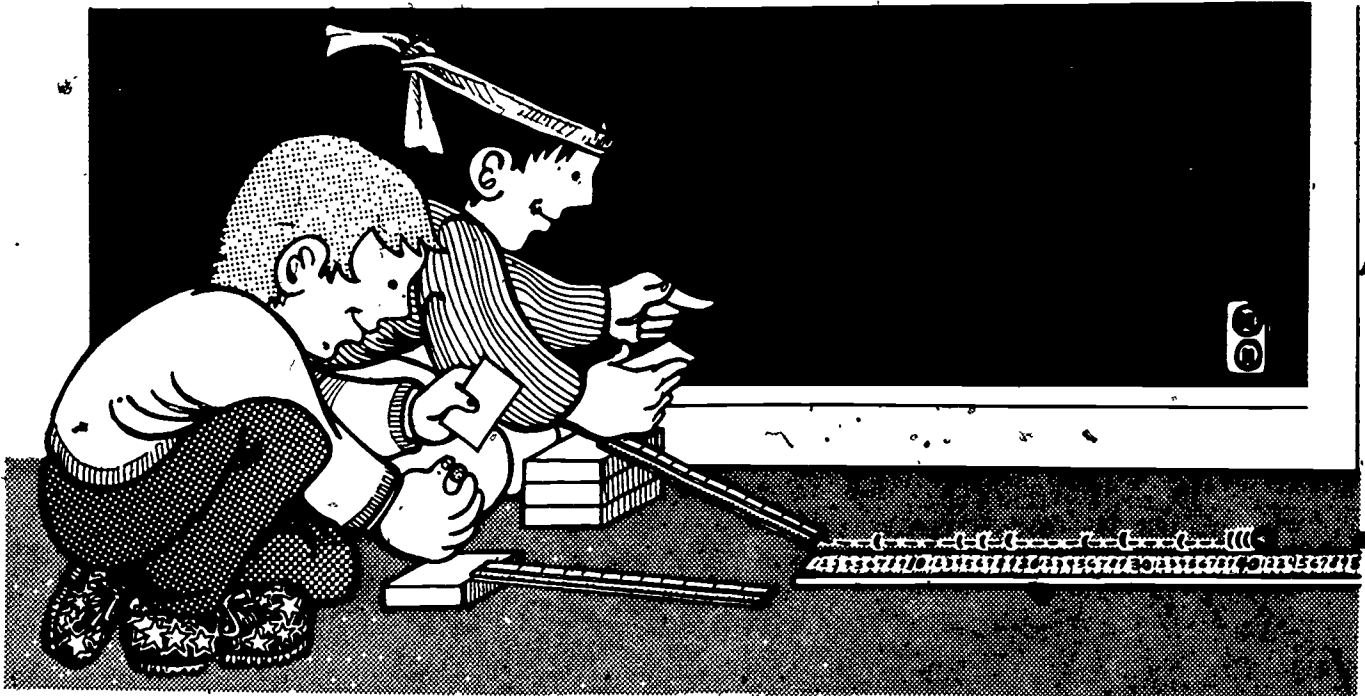

- How is the distance the marbles roll to be measured?

This question should be thoroughly discussed. If there are sufficient meter sticks, each team could place one between the ramps so that the end marked zero is on a line with the lower end of the ramps, but not interfering with the exiting marbles. If meter sticks are not available, the children could place a toothpick or pencil point to mark the position of the front of

## TEACHING SEQUENCE

Once the children have perfected their skill at releasing the marbles and measuring the distances rolled, have the teams collect data on the distance the marbles roll in millimeters. Each child can carefully release the marble on his or her ramp and mark where it lands. The distance the marble rolled for that height can then be measured. This should be repeated three times by each child and recorded on Worksheet II-1. (Both children in the team can record the data on the same Worksheet.)

After this initial set of data has been collected, ask the following questions:

- Is the height from which the marble is released a factor in determining how far the marble will roll?

## COMMENTARY

the marble when it comes to rest. (The diameter of the marbles may range from 16 mm to 25 mm, so an error may be introduced if care is not taken to measure from the same point of the resting marble each time.) The distance from the end of the ramp to the marker could then be measured, for instance, with several rulers touching end to end.

In Grade 4, children were introduced to measuring lengths in millimeters. If your children need practice, review the scale with them and have them measure several lengths. You may want to look at the Grade 4 Activity, "How Long is a Fourth Grader's Finger?"

On the Worksheet the height of the ramp could be recorded as 1, 2 or 3 book or box units.

As each marble is rolled, be sure the markers do not interfere, if they are being used. It is better to measure each roll immediately and then remove the marker.

There should be general agreement that the marbles released from a position at the top of two or three supports rolled





## TEACHING SEQUENCE

- Was there a difference in how fast each marble went down the ramp? Which one arrived at the ramp exit first?

Next, ask a child who worked with a ramp height of only one box whether the three rolls resulted in the same distance measurement. Then ask the same question of a child who released the marble from a higher position.

- What could account for differences in measurements of the same event?

## COMMENTARY

farther than the marbles released from a position at the top of only one support.

The marbles released from the ruler supported by more than one book or box came down much faster. However, some children may not have noticed the difference in speed and may be uncertain about which marble moved faster--especially if the marbles were not released simultaneously.

There will be considerable variation in measurements even for a given height. A marble does not repeat its behavior even under what appear to be the same experimental conditions. Starting in Grade 3 and extending into Grade 4, the COPES curriculum deals extensively with describing measurements which exhibit variability--but in connection with separate but similar objects. Here, for the first time, the variations are in repeated measurements of the same event.

Some children may think that the differences are due to a failure to release the marble from "exactly" the same position each time and to read the distance traveled from "exactly" the same position on the marble when it came to rest, and the like. They may want to repeat the experiment, being "more careful" as to how they release the marble and how they measure the distance. They may also want to make sure the set-up is the same in other

## TEACHING SEQUENCE

- What factors must you try to keep the same? Discuss these with the class and list them on the board.

2. At this point, if the children have not already done so, you might suggest that they roll the marbles in the paired ramp set-ups three more times to see if, for a given position, they can get the same measurement each time. The children should also look for any difference in the speed of the marbles as they roll down the ramps in the two set-ups. Thus, they should release the marbles simultaneously.

The children can now proceed to set up the equipment again and roll the marbles three more times. Again, the results can be recorded on Worksheet II-1.

- Was there a difference in how fast each marble went down the ramp? Which one arrived at the bottom of the ramp first?

At this point you might introduce the term speed, which refers to the rate of travel: a faster moving object is moving with greater speed. Speed

## COMMENTARY

respects each time.

These factors should include:

1. the elevation of the ruler-ramp;
2. the position from which the marble is released;
3. how it is released (no extra help by anything but gravitational attraction);
4. the surface on which the marble rolls.

Experience has shown that interested children will often devise elaborate procedures to ensure obtaining the same results the second time around.

This time the children should be sure that the marble released from the greater height went down the ramp faster.

The term speed should not be new to many children--speedometers in cars indicate if a car is moving slow or fast. However, this is the first real

## TEACHING SEQUENCE

can be determined by measuring the distance traveled in a unit of time.

- Did you obtain the same measurements for a given position this time?

Indicate to the children that variability inevitably enters into measurements of repeated events. It is to be expected and depends partly on the units used. It also depends on the set-up and on the manner of taking the reading. Sometimes with greater experience one can minimize the variations but there may be things about the marble, or ruler, or carpeting, that always cause at least slightly different results to be obtained.

## COMMENTARY

introduction the children have had to the concept of rate. Thus, you may have to help them to realize that if the time is shorter--for the marble arriving at the ramp exit first--that marble could actually have moved a greater distance in a unit of time as compared with the slower marble. If this seems too difficult for the children (that is, the concept of *dividing* distance by time), then merely refer to the marble which moves faster (gets down the ramp first) and that which moves slower.

Although the results may vary, somewhat less than they did previously--that is, the range may have narrowed--there will still be a noticeable variation in the measurements.

For instance, if the measurements had been made in centimeters, much less variation would have been apparent. Results appearing as 308, 321, and 315 in mm would have read 31, 32, and 32 in cm. In Grade 4, variations in finger lengths became apparent only when measured in mm, not in cm.

The details of complex events cannot be reproduced in successive repetitions. Encourage the children to accept such variations--with the idea that they should try to minimize them.

## TEACHING SEQUENCE

- Is there any one measurement of the three which is correct? Which one should you report for your findings?

If no child suggests taking an average of the three measurements, you may have to. They may use whatever technique is familiar, to them to find the average and record it in the fourth column on the Worksheet. (The fifth column will be used in a subsequent Activity.) Below is a set of data collected by one team of children the second time they did the marble roll.

1. RAMP POSITION	2. RELATIVE SPEED OF MARBLE	3. DISTANCE (mm)			4. AVERAGE DISTANCE (mm)
		TRIAL 1	TRIAL 2	TRIAL 3	
1 box	slower	523	529	541	531
2 box	faster	873	886	888	882

With each child reporting a single value--the average of their measurements--focus their attention again on a comparison of the distances the marbles traveled when released from different positions.

In this concluding discussion be sure that the children are aware of the direct relationship between the marble's

## COMMENTARY

No single measurement is the "correct" one. In previous Grades, children were introduced to the concept that when describing such measurements, an average value is a good estimate of the likely result of another trial. The same applies to the collection of measurements each team has made here.

In Grade 3 of COPEs, children were introduced to averaging by "evening off" a bar graph representing the data; in Grade 4, they found averages by "piling-in" squares on a frequency distribution histogram. If they are familiar with arithmetic averaging (adding the measurements and dividing by the number of them), this method may also be used.

In the sample data just given, a marble traveled an average of 531 mm from an elevation of one book; the same size marble traveled an average of 882 mm from an elevation of two books in the same kind of set-up. The marble released from the greater elevation again traveled farther.

## TEACHING SEQUENCE

speed as it leaves the ramp and the distance it travels along the floor. Help them to understand that the marble which leaves the ramp with the greatest speed travels the farthest.

## EXTENDED EXPERIENCE:

Some children may be interested in investigating other properties of these ramp-marble systems. Although different-size marbles are not called for in this Activity because they would not add to the concept development, some children may be curious to see how larger (or smaller) marbles behave. If they take two similar marbles (but of different size) and observe how long it takes each to travel down the ramp when released simultaneously, they will discover that the marbles arrive at the bottom at the same time! There is not much difference in how far the marbles travel either. This phenomenon will be touched on briefly in Activity 4.

## COMMENTARY

## Activity 2 What Can a Rolling Marble Do

In this Activity, an object is placed in the path of the rolling marble. The marble collides with, and is captured by, the object--a small cup-sled--which then moves along a comparatively smooth surface. Again, although the distances that this object can be moved are much smaller than those moved by the freely moving marble (as in Activity 1), the children find that the greater the speed of the marble when it leaves the ramp, the greater the distance the cup-sled can be moved. This Activity prepares them for the idea, which is introduced in Activity 4, that a property of a moving object called kinetic energy determines how far another object it collides with can be moved.

### MATERIALS AND EQUIPMENT:

For each team of two children you will need:

- 1 marble, 3/4-in. or 5/8-in. diameter, glass
- 1 ramp set-up from Activity 1, including books or boxes
- 2 rulers, 30-cm (12-in.). (with mm markings)
- 1 cup, 1-oz, waxed paper or plastic
- 1 piece of cardboard, slightly wider than the 1-oz cup and about 1/2 again as long
- 1 piece of plasticene or modeling clay, about the size of a marble
- supply of smooth tape, e.g., "Magic-mending"
- 1 Worksheet II-1

You will also need:

- an extra 1-oz. cup, piece of cardboard, and piece of plasticene

### PREPARATION FOR TEACHING:

A sample cup-sled should be made ahead of class time: First,

the cup must be modified: part of the rim should be trimmed so that the cup sits firmly near one end of the piece of cardboard, without rolling. Then attach the cup with pieces of tape which adhere to the upper surface of the cardboard. Press a piece of clay inside the cup near the opening. The clay should provide a small mound over which the entering marble will roll and which will then prevent it from rolling back out of the cup. The clay should be about 1/4 in. thick. The remainder of the clay can be pressed onto the bottom of the cup (on the inside), so as to cause the marble to stick there when it enters. (This will prevent energy losses resulting from the marble bouncing around in the cup.) Finally, put several strips of the "Magic-Mending" tape on the bottom surface of the cardboard. These pieces should be placed on the cardboard next to one another and should not overlap. The tape acts as a lubricant so that the sled can move very easily across a smooth surface. The sketch shows the completed assembly.

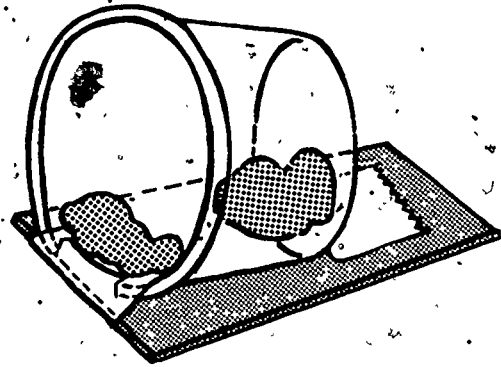

It is assumed that the teams will make their own cup sleds. If this is too time consuming for the class or is not feasible for other reasons, the cup-sleds will have to be prepared ahead of time. In that case, a sample sled is not needed.

Have the supply of materials readily available for the children to help themselves. Each team should pick up the ramp set-up it used in Activity 1, including several boxes. The cup-sled and ramp set-ups will also be used in subsequent Activities.

#### ALLOCATION OF TIME:

One hour, at most, will be needed for this Activity.

#### TEACHING SEQUENCE

1. Show the class your sample cup-sled.

- What would you have to do to the cup-sled in order to get it to move?

#### COMMENTARY

Just as with the marble, a push with the hand or a pull by a rubber band or string can

## TEACHING SEQUENCE

Tell the children that instead of letting the marble roll along the carpet (or cloth), as they did in the first Activity, you would like to try using this cup to "capture" it.

- If the rolling marble were captured by the cup-sled, what do you think would happen?
- What might happen if the marble were going at greater speed? How could you find out?

Have each team pick up the equipment to make a cup-sled. In addition, have them pick up two extra rulers and possibly a card to help in releasing the marble and in reading distances. Then have them set up a ramp. The ramp should be on a smooth surface this time--a work table, desk, or tile floor will be fine.

The two extra rulers should be placed on the table surface with the "zero" end right at the base of the ramp. Place the rulers far enough apart so that the sled is free to move between them, and tape them in position on the table. The two rulers serve to guide the sled and to measure distances.

## COMMENTARY

get it to move.

The children will probably respond that the cup would be moved along. Some might think that the cup-sled and marble will stop.

Hopefully, the suggestion will be made that the ramps be set up at different heights, and the marbles allowed to roll into the cups. The children have found that they can obtain greater speed of the marble by releasing it from a higher position.

Only one ramp is needed for each pair of children since the marbles need not be released simultaneously from the different positions.

The distances moved by the sled will depend on the sliding friction between its bottom surface and the table top. It



## TEACHING SEQUENCE

The children can begin by investigating the behavior of the marble as it collides with the cup-sled. Let them practice how to measure the distance the sled moves after each collision.

Each team should now release its marble--in a controlled fashion as they did in Activity 1--capture it in the sled which is placed at the bottom of the ramp and measure the distance that the sled with its captured marble slides.

Have them repeat the collision three times and enter the distances on a copy of Worksheet II-1.

- At this particular ramp position, does the sled move about the same distance when the released marble collides with it? Are the data "reproducible"?

## COMMENTARY

is unlikely that the distances will exceed 200 mm, so it will not be necessary to use meter sticks.

Since they are interested in measuring the distance moved by the sled and captured marble, they must decide to have a definite part of the cardboard at the zero position of the guide rulers before collision and then use that same part of the cardboard to measure its position after it stops sliding. The front edge of the sled is a good reference point since it is aligned with the end of the ramp before collision. Having the card perpendicular to the ruler will make measuring the distance (in mm) easier.

Again, the results of the three trials will not be exactly the same. However, they should fall within a reproducible range.

## TEACHING SEQUENCE

## COMMENTARY

The results of the three trials should be averaged, as before, in order to provide the best single value to report for their findings.

- Predict how far the sled will go if the marble has more speed?
- How can you give the marble more speed?

Each team should now stack two boxes and set the sled at the base of the ramp supported on these boxes. Be sure the two measuring-guide rulers are in line with the sled, as in the previous part of the experiment. Release the same marble again and capture it in the cup-sled.

Repeat the collision three times, entering each distance on the Worksheet. Calculate the average distance traveled.

Now support the ramp on three boxes and repeat the experiment.

- How does the resulting speed of the marble compare with that of the one released from a single box?

The children should enter the three distances on the Worksheet and again calculate the average distance. Some typical data are shown below.

If the children are skilled in arithmetic averaging, have them calculate the average by that method. If not, use either of the graphical methods referred to in Activity 1.

The children will probably predict that the sled and captured marble will move farther, but they probably will be unsure how much farther.

Raise the ramp. Do not encourage the children to give the marble a push by hand since this would be very difficult to repeat on successive trials.

The marble moves with much greater speed from a height of three boxes.

## TEACHING SEQUENCE

## COMMENTARY

1. RAMP POSITION	2. RELATIVE SPEED OF MARBLE	3. DISTANCE (mm)			4. AVERAGE DISTANCE (mm)
		TRIAL 1	TRIAL 2	TRIAL 3	
1 box unit	slowest	25	24	25	25
2 box units	faster	42	50	45	46
3 box units	fastest	61	65	62	63

- What inferences can be made from the data that you gathered? How is the speed of the marble related to the height of the ramp?

By the conclusion of this Activity, the children should realize that:

1) Releasing a marble from a higher position results in the marble having greater speed as it leaves the ramp than one released from a lower position.

2) A marble moving with more speed will roll freely a greater distance.

3) A marble moving with more speed will cause an object it strikes to move farther. The greater its speed, the greater the distance it can move the object.

As before, the actual value of the height is not important to this discussion--only that there are definite increments from which the marble was released--and that each new height corresponded to an increase in the distance the sled moved.

The Worksheets completed in this Activity should be saved for references in Activity 4.

## EXTENDED EXPERIENCES:

1. After the children have observed and recorded the effect of the interaction of the moving marble and the cup-sled, a coordinate graph of the collected data could be made. Have the children plot the variable which is being manipulated--that is, the ramp position--as units on the vertical axis and plot the average distance the cup sled moved on the horizontal axis. Then, as they did in Grade 4 Activities, have them draw the best trend line through the data points. This line will show visually that as the ramp position is made steeper, the distance moved increases. Such visual representations are always helpful in reinforcing the relationship between the variables.

2. Those children interested in collecting more data can stack additional boxes (or books) of the same size, thus making even higher ramps. They can then determine how much farther the weighted sled-cup will move as the marble comes down with even greater speeds.

### Activity 3 What Is "Work"?

It is in this Activity, as children try to analyze what is happening as the cup-sled and captured marble are moved along the table surface, that an operational definition of work is introduced. Although the term work is familiar to children, it is used colloquially in a very loose sense. The aim of this Activity is to help them develop an understanding of work as the product of a force acting through a distance.

The children observe that the cup-sled cannot move across the table without applying some force to it. The force needed to move the object is greater if it is made heavier or if it is placed on a rougher surface. They then proceed to analyze simple situations where forces are being applied against that of gravity in order to lift objects. They will be helped to realize that in lifting one book--which can be considered one "book force unit"--through two units of distance they will be doing twice as much work as in lifting the book through one distance unit. In addition, they will develop a "feel" for the idea that if two (or three) books are lifted, it takes twice (or three times) as much work to move them through the same distance as a single book. In other words, both force (F) and distance (D) determine the amount of work done. The product,  $F \times D$ , is introduced graphically in a manner similar to the product of volume and temperature in Grade 4; thus work units (w.u.) are introduced here just as heat energy units (h.e.u.) were introduced in Grade 4.

#### MATERIALS AND EQUIPMENT:

For each group of two or more children:

- the cup-sled from Activity 2, with marble
- 6 books, paperback, all similar, or boxes e.g., food boxes, match boxes, or similar magazines, erasers, etc., to provide unit increments of weight
- 1 scale, spring, 0-500 g capacity
- 3-4 uniform stackable cardboard boxes, blocks, a bookcase, steps, etc., to provide unit increments of height
- graph paper.

For the class:

supply of string or rubber bands

wastebasket and several heavy books

#### PREPARATION FOR TEACHING:

No preparation for teaching is necessary, other than assembling the materials.

#### ALLOCATION OF TIME:

This Activity will probably take about 1-1/2 hours, depending upon how much time must be spent on graphical product calculations.

#### TEACHING SEQUENCE

1. Have the children take out the cup-sleds, and place a marble inside the cup. They should then push the sleds parallel to the table top. Help them to recognize that a force must be applied constantly to keep this object moving. Unless they continue to push, the sled will not move.

- What do you think might be keeping the object from moving by itself?

The children should come up with the idea that the surfaces seem to have something to do with the force needed to push an object along. Let them try to push the sled (with its marble) along the table top and then along a

#### COMMENTARY

A resisting force must be overcome to get the sled to move. They might suggest that there is some interaction (an attraction) between the object and the surface it is on which prevents it from moving by itself.

In order to emphasize this point, some children might consider the effect on the cup-sled's ability to slide if the "magic-mending" tape were not on the bottom of the cardboard:

Use carpeting or cloth used in

## TEACHING SEQUENCE

rougher surface.

- How does the amount of force necessary to move the sled differ on rough and smooth surfaces?

- What else might affect the amount of force needed to move the sled?

Suggest that they load the sled with additional marbles and try pushing it.

- Is it easier or harder to move the sled now?

Now distribute the six equal-sized books they are to work with. Ask the children to push one book, then two books (one on top of the other), and then three books across the surface of the table.

- How does the force required to push one book compare with that required to push two books, or three books?
- Suppose you wanted to lift the books. What would you have to do?

## COMMENTARY

## Activity 1.

A greater force is needed to move the sled along the rougher surface because the amount of friction is greater. Although the word friction may be familiar to everyone, they may not think of it as a force. As described in Activity 2, help them to understand that it is friction between the sled and the underlying surface which produces a force on the cup-sled, and, in fact, it is this frictional force which must be overcome in order to keep the sled moving. That is what they felt as they pushed with their hands.

Someone may suggest that the weight of the sled might be a factor.

Probably the response will be that it appears harder to move it. It requires more of a push--that is, more force.

A greater force is required to push two books than to push one and still greater to push three books than to push two.

Again, a force would have to be applied--in this case, to overcome the gravitational force or weight.

## TEACHING SEQUENCE

Have them tie together two of the books and then three.

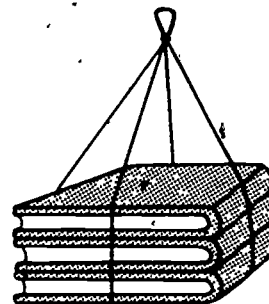
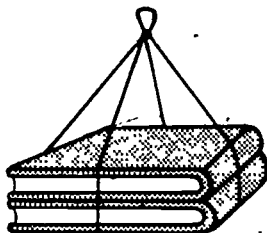
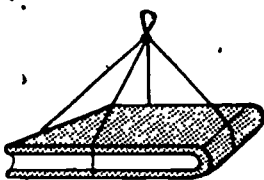

Have the children lift each set of books by the string. What sensations do they feel? Is there any difference among the three sets?

Referring now to the weight of each set of books, have the children suspend them from the spring scales one after the other.

- What is the difference in the amount of extension of the scale produced by each set?
- While each set is being lifted, does the amount of lifting force change?

## COMMENTARY

The illustration indicates how to tie across the books in two directions so the string doesn't slip and each set of books can be lifted as a unit. Two rubber bands can substitute for the string, one across the width, the other across the length.

They will feel a pulling against their fingers, with the set of three books exerting the greatest pull and the single book exerting the least.

At this point some children surely will mention the weight of the books. Review with them the concept, developed in Grade 3, that weight is a measure of the gravitational force on an object.

They may want to read off the weight in grams for each set of books.

If there appears to be any doubt that it does not, have them slowly lift the single book with the scale. As they lift, the reading on the scale



## TEACHING SEQUENCE

Now have the children remove the spring scale and suspend the single book from their hands by the string alone. Ask them how much force is now supporting the book. Suggest that this amount of force be considered one "book force unit". (Whatever the scale may have read, the lifting force could also be expressed in these units.)

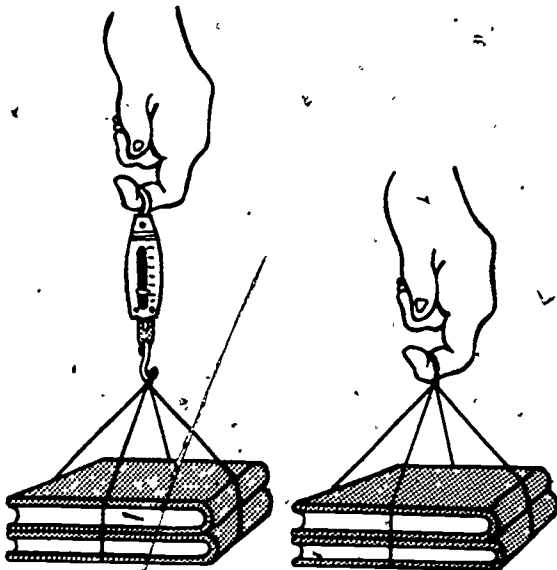

- If one book force unit is needed to lift one book, how many would be needed to lift the two books? How many would be needed to lift the three books?

## COMMENTARY

remains the same. If the pull down on the scale is the same, then the force necessary to overcome it must also continue to be the same. If they jerk the book up the reading will change, but not if they raise it slowly.

The children should realize that the value of the force required to lift the book is the same whether the scale is still equivalent to the weight of the book. For those who do not realize this, a chalkboard diagram like the one shown here may be helpful.

The "book force unit" is invented here to simplify later calculations. Expressing weight in this fashion, the children should readily see that two book force units would be needed to lift two of these similar size books and three

## TEACHING SEQUENCE

2. At this point, you might expand the focus of the discussion to include distance: Ask the children to lift the single book to a height of 2 or 3 cm. Then ask them to lift it way up, possibly twenty times as high.

- What difference do you feel?

If no one uses the term "work" in comparing the lifting of the book, introduce the term in the discussion.

Distribute whatever you are using to serve as increments of height. Have them lift the single book up to the level of, say, the top of one inverted cardboard box. Refer to this height as one distance unit and to the operation as "the work of lifting the book one distance unit." As they do this, emphasize that distance as well as force can be measured in arbitrary units.

Now have them lift the same book from the floor to the top of two stacked cardboard boxes. Ask them to compare

## COMMENTARY

book force units would be needed to lift three of them.

The children should notice that it is "harder" to lift the book to a greater height, even though the force required is the same. In other words, it takes more work to lift the same book higher.

To emphasize this idea, you may find it desirable to have one or two of the children also compare the sensation of lifting a wastebasket partly filled with heavy books through a relatively short distance, for instance, onto a chair, with that of lifting the same wastebasket up to the table top.

The children should be aware that it seems to take more work

## TEACHING SEQUENCE

the amounts of work done in lifting the book two distance units and in lifting it one distance unit:

- Although the force is the same in both cases, how much more work is done when the book is lifted two distance units?

The children should repeat the operation, lifting the book successively from the floor up to each distance interval available. Again, they can estimate the amount of work in each case.

Next, ask the children to compare the amounts of work done in lifting one book and two books through one distance unit:

- Although the distance is the same in both cases, which task takes more work?

- How much force is required to lift the two books?

- How does it compare with the amount of force necessary to lift one book?

- How much work does it take to lift the two books to the first level as compared with the one book?

- What if we lift it higher?

## COMMENTARY

to lift the book through the two distance units.

They may be able to guess that the work would be doubled. At least, they will find it convenient to think of work this way.

This activity and the discussion of it should help children to understand that more work is done in moving a heavier object a certain distance than to move another, lighter object through the same distance. To reach this understanding they will need to recognize, of course, that a larger force is needed to lift the heavier object than is needed to lift the lighter one.

A force equal to the weight of two books, or two book force units.

It takes twice as much force.

Since it takes twice the force, lifting it the same distance would take twice the work.

Help them to see that lifting this two-book unit will still require twice as much work as lifting a one-book unit through the same distance.

## TEACHING SEQUENCE

Do the same with the three-book unit.

3. To introduce Section 3, you might pose the following question: Suppose you lifted two books one unit of distance. How would the amount of work you did compare with the amount you would do if you lifted one book two distance units?

Suggest to the children that they might set up a graph to represent the force units and distance units. Perhaps they could determine how much work is done in each case.

Distribute the graph paper and have them draw two lines perpendicular to one another. Indicate that one variable, distance, can be represented by unit values on the vertical "axis." They should write "distance" on the left side of the graph and mark off unit distances at each line. Let each column going across from left to right stand for a unit of force and write "force" along this axis. They should

## COMMENTARY

The children should be helped to realize that the lifting force is now three book units and that three times as much work would be done in lifting them as is done in lifting one book through the same distance.

By examining one factor at a time, the children should have developed a "feeling" that the amount of work done in lifting an object is related both to the force exerted to lift it and to the distance through which it is lifted.

Some children may intuitively see that the amount of work would be the same. Others may be puzzled and unsure of how much work would be represented in each case.

At this point a graphical method is being introduced to reinforce the idea that work depends on the two factors, or variables, force and distance. If your children are facile in multiplication you can proceed quickly through this Section.

See COPES Grade 4 materials for experience in setting up graphs.

## TEACHING SEQUENCE

enter a numeral standing for one force unit, two force units, etc., at each line on the horizontal axis.

Now ask them how they would represent the case in which two books were lifted one distance unit:

- How would you represent case 2--one book being lifted two distance units?

The two graphs would appear as illustrated below:

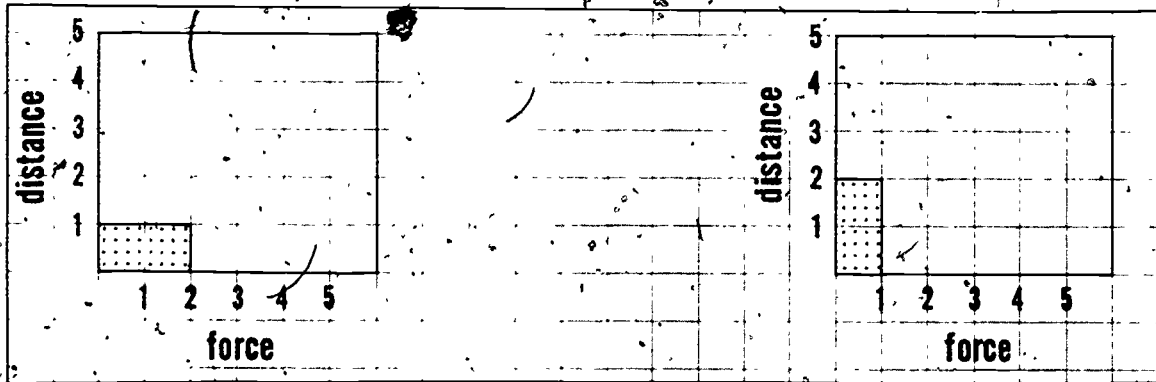

- What is the difference in the number of squares shaded in on the two graphs?
- In which case was more work done?

As soon as the graphing is completed, open a class discussion by asking children to make and compare the graphical representations of several other situations. In each case, a comparison of the number of squares in the graph should be made. For instance, they might graph some or all

## COMMENTARY

Since the distance is one unit, count up one space and put a mark there; since the force is two units, count over two spaces and put a mark there. Thus, in order to represent this first case, two squares should be shaded.

Here the representation would be 2 units high, but still only one unit wide since the force is only that of one book.

Both graphs have two squares shaded in.

The same amount of work was done in both cases.

## TEACHING SEQUENCE

of the following:

Force Units	Distance Units
2	2
2	3
2	4
3	1
3	2
3	3
3	4

Some of the children may notice the similarity between this type of graphical representation and that of the VT graphs they did in Grade 4. Most likely, they will want to name the blocks on their graphs as they did in the case of heat energy units. If they do not suggest the term, work unit, introduce it.

Now have them compare the count of these squares, or work units, for several of the graphs. For instance:

- In lifting 2 books through 2 distance units, how many squares are on the graph?  
(2) How many work units does this represent? (2 work units)
- In lifting 2 books through 3 distance units, how many squares are on the graph?  
(6) How many work units are represented? (6 work units)
- How does the work of lifting 2 books 3 distance units compare with the work of

## COMMENTARY

Children should understand that counting the blocks on a graph is a way of determining the amount of work done when a force moves an object. If they know how many units of force are needed to move an object and how many units of distance the force moved it, they can measure the number of work units in the same way that they found heat energy units.

At some point, the children will recognize that work units determined by the graphs may also be determined by an arithmetic multiplication of force units and distance units ( $F \times D$ ). At that point, they should be encouraged to use whichever technique for calculating work units they prefer.

The three books are, of course, heavier than two but the children should count 6 work units

## TEACHING SEQUENCE

lifting 3 books 2 distance units? Which is heavier to lift?

4. This Activity can be concluded with two simple demonstrations. First, bring out the wastebasket, this time filled with heavy books. Have a child attempt to lift it, but be certain that it is so heavy that it will be impossible. Ask the class if they think that the child is exerting a force.

Now ask the children to do a graphical calculation of the work done in trying to lift the object. They will find that there are no distance units to plot, and therefore, no work units can result.

A second demonstration can be used to help determine whether the children have grasped the meaning of work. Give a crumpled sheet of paper to a child and ask him or her to hold it at shoulder level. Have the child drop the paper from that height and ask the class if any work was done as the paper dropped.

The question of what did the work should be pursued. In this case, the work was done by the gravitational force pulling the paper toward the Earth. Thus, an inanimate agency performed the work.

94

## COMMENTARY

in each situation. Both took the same amount of work because the lighter load was lifted through a greater distance.

Of course a force is being exerted, but they should note that the basket does not move.

Use this observation as a basis for helping children to understand that a force must move an object through a distance for work to be done in the mechanical sense. One might say the child was applying a force in trying to do work but that no work could be accomplished, although he or she did expend "muscle energy", which would be tiring.

Gravitational force was exerted on the paper as it fell through a distance, thus meeting the criterion for work.

Children initially may tend to consider work only in terms of what they themselves do. They should be led to realize that some agency does work each time a force moves an object through a distance.

### Activity 4 Kinetic Energy

In this Activity, the children discover that the amount of work a rolling marble can do on a sled (as measured by the distance the sled moves) is related not only to the speed with which the marble left the ramp before collision but also to the massiveness of the marble! They see that two marbles of different sizes released from ramps at the same height move down and off the ramps at about the same speed. The children make comparative measurements of the relative amount of work these two different marbles can do on the same sled. (Again they apply the idea of repeated measurements, to obtain an average result which can then be used for calculations of work.) Although they discovered in working with a single marble that its speed determined how far the cup-sled could be moved, now they will find that the heavier marble although moving at the same speed can do more work. Thus the ability to move the sled appears to depend on two factors: the marble's speed and its mass (or in their terms, its weight). In this context, a new property of a moving object is introduced: its energy of motion or kinetic energy.

#### MATERIALS AND EQUIPMENT:

For each group of two or more children:

- 1 spring scale, 0-500 g capacity
- 1 set of books (1, 2, and 3 books) from the previous Activity
- 1 cup-sled
- 1 marble, 3/4 in. or 5/8-in. diameter
- 1 marble, 1-in. diameter
- 1 ramp set-up
- 2 rulers, 30-cm (12-in) (with mm markings)
- supply of modeling clay or plasticene
- supply of masking tape



For the class:

- 1 platform balance, e.g., Ohaus model 1200 (optional)

PREPARATION FOR TEACHING:

No advance preparation is necessary.

ALLOCATION OF TIME:

The children will need about 1-1/2 hours to complete this Activity.

TEACHING SEQUENCE

1. You might begin the Activity by asking the children what is being done when the cup-sled and captured marble are moved along the table top.

- How would you determine how much force is needed to move an object across the table top?

Distribute the spring scales and sets of books and suggest that they use the scales to determine the amount of force necessary to pull the books along the table.

- Does the amount of force needed to move a given set of books change as they are moved along?
- Could you measure the amount of force needed to move the cup-sled and marble along the table top?

Have them retrieve their cup-

COMMENTARY

By now the children should be aware that work is being done when the cup sled and marble move along the table. A force is acting through a distance.

Some children will probably suggest using the spring scale.

As before, the spring scales can be hooked onto the string and the amount of extension recorded in each case. The children should note that the force is much less than that required to lift the books. However, it still takes noticeably more force to pull two books than one and three books than two.

As before, the amount of extension remains constant.

## TEACHING SEQUENCE

sleds and marbles and push them along with their fingers.

- Could you invent a unit to express the amount of force necessary to move the cup-sled and marble?

- How could you determine the amount of work done on the sled as the marble collides with it?

## COMMENTARY

They should note that a very slight force is required. In fact it would be very difficult to measure it with the spring scales they have. Even if they attached a thin rubber band and measured its stretch as a measure of the force needed to push the sled along, the force is too slight to be readily observed. (See Grade 3, Minisequence II where the stretch of rubber bands was used as a measure of added force on an object.) However, some children may enjoy trying and they should be encouraged to do so.

It may be expected that as a result of their experiences with force units in Activity 3, they will suggest a unit which will be defined as the amount of force necessary to move this particular sled with this particular marble any distance along the table. (They have already established with the books that the necessary force is constant regardless of the distance.) This unit might be called a "sliding-force unit."

Allow time for careful discussion of this question. The work is equal to the force times the distance the sled moved. Since the force is constant as the sled slides along the table, the work will depend only on the distance traveled. In relative terms, the work done for a sled moving 20 mm, for example, will be twice that done when it is moved 10 mm.

In terms of the unit the children have just invented, the work done would be expressed as 1 sliding-force unit times the

TEACHING SEQUENCE

COMMENTARY

The children should now retrieve the data they collected on Worksheet II-1 in Activity 2. Have them examine the Worksheet and, in the empty fifth column, enter the amount of work done by the marble when it collided with the sled after being released from the different ramp heights:

distance in mm. Since the force has a numerical value of 1 in all cases, the work done will have the same numerical value as the distance.

If the children wish, a unit value can be given to the work done, just as they did in the case of the other units. However, this is not necessary since the focus will be on comparing the amount of work done.

1. RAMP POSITION	2. RELATIVE SPEED OF MARBLE	3. DISTANCE (mm)			4. AVERAGE DISTANCE (mm)	5. WORK DONE
		TRIAL 1	TRIAL 2	TRIAL 3		
1 box unit	slowest	25	24	25	25	25
2 box units	faster	42	50	45	46	46
3 box units	fastest	61	65	62	63	63

- In which case was the marble able to do the greatest amount of work?
  - Does the amount of work seem to be related to the speed of the marble as it left the ramp?
2. Now introduce the larger 1-inch marble. Distribute one to each group of children and ask them if they think it would be able to do more or less work in moving the sled than the smaller marble.
- You have found that the greater the speed, the greater the amount of work done. Which marble do you think

The marble was able to do the greatest amount of work when it was released from a position at the top of three box units.

Yes--the greater the speed, the greater the amount of work done. Be sure this relationship is brought out in discussion.

At least some children will probably predict that the larger marble will be able to do more work.

Those who did not investigate differently sized marbles as part of the Extended Experiences in Activity 1 may have varied re

## TEACHING SEQUENCE

would have the greatest speed at the bottom of the ramp?

- How could you find out?

Encourage them to set up the ramps, release the marbles at the same time, and see what happens.

After having made what may be a surprising observation to them, ask the children if they think the bigger marble will be able to do more work in moving the sled.

To find out, they should remove the second ramp and again set up the two rulers as measuring guides for the cup-sled, which should be replaced at the bottom of the ramp.

## COMMENTARY

sponses but some children will expect the larger marble to get to the bottom much faster.

The children should readily suggest setting up paired ramps as they did in Activity 1, but with both at the same height, and releasing the different sized marbles simultaneously.

Both should get to the bottom of the ramp at about the same time. Slight variations in speed may be observed but they are much less than any differences in the time of travel if the ramp were to be lifted higher. Some children may want to try elevating one or both ramps. Again they will find that the marble rolling down the ramp from the higher position will reach the table with the greater speed.

At this point, they may be unsure of their earlier prediction and will be anxious to try to find out which marble will move the cup-sled farther. Since both marbles are landing in the cup with the same speed, some children may now expect that the larger marble will move the sled about the same distance.

They should be sure the front

TEACHING SEQUENCE

COMMENTARY

Before they release the larger marble, they should have the data they collected with the smaller marble available for comparison. Then they should release the larger one and measure the distance the sled is moved. This distance will be much greater! Have them repeat the collision a few more times, enter the data on the Worksheet, and calculate the average distance moved by the sled.

- What will happen if you give this larger marble greater speed? Have them predict and then perform the experiment. Some sample data are given below:

edge, or whatever measuring criterion they selected in Activity 2 (e.g., a pencil mark on the cardboard), is lined up with the start of the measuring rulers.

They may have to check the clay in the cup sleds. If the speed of the marble is low and the clay is dry, the marble may not stick when it hits. If this occurs, simply moisten the clay and reshape the little mound in the middle of the cup to ensure capture without bouncing.

The increase in speed, of course, can be accomplished by releasing the marble from a higher position, as they did in Activity 2 with the smaller marble.

1. RAMP POSITION	2. RELATIVE SPEED OF MARBLE	3. DISTANCE (mm)			4. Average Distance (mm)
		TRIAL 1	TRIAL 2	TRIAL 3	
1 box unit	slowest	55	49	53	52
2 box units	faster	113	105	107	109
3 box units	fastest	143	145	145	145

- What about the work which this larger marble can do compared with the smaller one?
- Can the average distances be compared in order to compare the work done by the larger and the smaller marble?

Both could move the sled, but one more than the other.

Discuss how they could determine the answer to this question.

## TEACHING SEQUENCE

To help the children consider these questions, place two cup-sleds on a table top where they can easily see them. Place one of the larger marbles in one sled and one of the smaller ones in the other. Ask one of the children to push both.

In order to compare work by comparing distance, the force necessary to move the cup-sled and marble must be the same. Here the forces are not the same because the weights of the marbles are different. With the two cup-sleds containing their respective marbles still in front of the children, ask how the weights of the sleds could be made the same.

## COMMENTARY

The purpose of this little demonstration is to focus the children's attention on the fact that the sleds must require different amounts of force to move them because the marbles inside are of two different sizes and weights. If the children don't bring up this point, you may have to. Have several children check the weights of the small and large marbles. This can be done either on a standard platform-type balance or they can put some tape and then string around the marbles and suspend them one at a time from their spring scales. Let them figure out how to check the weights. A typical 5/8-in. marble was found to weigh 5.5 g. while a 1-in. marble weighed 21 g.

Encourage suggestions. Some children have an immediate insight that the weights could be made the same if a smaller marble were on the sled that the larger marble enters and a larger marble were on the sled that the smaller marble enters. That way both sleds would be carrying a weight of, say, 5.5 g plus 21 g, 27 grams. If no one comes up with this idea, point out the small extension of the cardboard at the back of the cup. Ask if another marble, not the one colliding with the sled, could be placed

## TEACHING SEQUENCE

Now, at the same ramp position, have them measure the distance the sled can slide when the smaller marble rolls into it (while the larger one is attached) and then the distance the sled moves when the larger marble rolls into the cup (while the smaller one is attached).

Before continuing to collect more data on other ramp positions, discuss the results obtained so far.

- Which marble could do more work?
- Which marble was going faster?

Remind them, if necessary, that when they increased speed, by lifting the ramp, the marble was able to do more work on the sled. But right now, the speeds are the same.

- What factor other than speed, then, seems to determine how much work the rolling marble can do?

Help the children to recognize from their data that the work each marble could do seems to be a property of that specific marble--that in one experiment its speed seemed to determine how far the sled could move, but now, of two marbles going at about the same speed, the

## COMMENTARY

there, and so on.

The other marble can be placed anywhere on the sled, but if it is put inside the cup, the rolling marble can not enter easily. Some children may put the second marble on top of the cup. It can go anywhere as long as it becomes part of the sled. They can use a small piece of clay to make it stick.

Keeping in mind that the force that must be overcome is now the same, the distances the sled moved indicate that the heavier marble could indeed do more work.

They saw that the speeds of the different size marbles were about the same.

The amount of matter in the marble. Here it was measured by both size and by weight--a measure of the gravitational force on the marble.

## TEACHING SEQUENCE

heavier one could do more work in pushing the sled.

3. Now that they have seen that the more massive marble moves the sled farther than the lighter one, will this also be true if the marbles hit the sled with more speed?

- How could you give the marbles more speed?
- What do you predict about the distance the sled will move if the different size marbles are moving faster? Will the sled move farther if hit by a faster, lighter marble or if moved by a slower, heavier marble?

Have them change the ramp position and repeat the experiment they just did, comparing what each released marble could do to the sled in different height positions. Some typical results are given below. One team's data might be placed on the chalkboard for purposes of subsequent discussion.

## COMMENTARY

Again, they can make the marbles move faster by raising the ramp, i.e., supporting it on more boxes (or books).

As before, be sure in this comparison that the control marble is always attached to the sled--so that the moving sled has two marbles on it, the one that rolled into it, and the one attached to it.

All the children should keep their data for reference in Activity 5.

RAMP POSITION	MARBLE ROLLED	MARBLE ATTACHED	RELATIVE SPEED	AVERAGE DISTANCE SLED MOVED (mm)	WORK DONE
1 box unit	5/8-in. (5.5g)	1-in.	Slowest	3	3
1 box unit	1-in. (21 g)	5/8-in.	Slowest	39	39
2 box units	5/8-in.	1-in.	Faster	9	9
2 box units	1-in.	5/8-in.	Faster	80	80
3 box units	5/8-in.	1-in.	Fastest	15	15
3 box units	1-in.	5/8-in.	Fastest	115	115



## TEACHING SEQUENCE

- What experimental conditions produced the most amount of work? What produced the least amount of work?
- What two factors seem to determine how much work a moving object like the marble can do?

Now introduce the term energy into the discussion. The ability of a moving object to do work is the result of its "energy of motion." The faster and heavier the moving object is, the more energy of motion it has and the more work it can do.

At this point, you might return to the data on the chalkboard and ask the children which marble had the most kinetic energy before colliding. Which had the least? This information might be added to the table.

## COMMENTARY

The larger, heavier marble released from the 3-box ramp position did the most work; the smaller, lighter marble released from the 1-box ramp position did the least work.

Both its speed and how massive an object is--a heavier object can do more work than a lighter one even when both are moving at the same speed.

For instance, you might say that the larger marble was able to do more work in moving the sled because it possessed more energy. The scientific term is kinetic energy--from a Greek word meaning motion. Use the term kinetic energy interchangeably with energy of motion in subsequent discussions.

In the case of the results shown on page 103, the heavier marble released from a height of 3 boxes had the most kinetic energy and the lighter marble released from 1 box had the least.

Some children might be interested in rank ordering the relative kinetic energies:

WORK DONE	RELATIVE KINETIC ENERGY
3	1 (least)
39	4
9	2
80	5
15	3
115	6 (greatest)

## TEACHING SEQUENCE

All these experiences should help the children come to an understanding that the kinetic energy of a moving object, that is, its ability to do work, increases with the massiveness of the object and with its speed.

## COMMENTARY

Note: There is an implication in this Activity that the kinetic energy, for which the children are developing an understanding, is equal to the work done on the cup-sled. This is not exactly true. Some of the kinetic energy of the rolling marble is lost as heat when it hits the clay in the cup.

## EXTENDED EXPERIENCES:

1. Some children may wish to investigate this behavior further by lifting the ramp to higher positions, thus giving the marbles greater exit speed. In addition, some may want to investigate the effect of changing the surfaces in contact with the sled as it moves. This can be done either by changing the bottom surface of the sled (removing the tape or improving lubrication with some graphite) or by letting the sled move on a surface other than the table top. If so, they should be alerted to the fact that the force needed to move the sled will now be different.

It will require a greater force to move the sled if there is greater frictional force between it and the surface. If two similar marbles with the same amount of kinetic energy collide with a sled, the same amount of work will be done. However, if one of the marbles collides with the higher frictioned sled, it will move a shorter distance. The work done is the same; the force applied was greater.

2. If other types of rolling spheres are available, some children may wish to extend the investigation still further. Steel balls or ball bearings could be used. They will be much denser than the glass marbles. Thus, although they may be of the same size, they will be much heavier and, at the same speed, will possess much greater kinetic energy.

3. Several hypothetical situations can be discussed with the children. For instance, suppose a hay wagon and a train, both moving at 10 miles per hour, collide with identical big boxes. Which will move the box farther? Which has more kinetic energy, the wagon or the train?

## Activity 5 Potential Energy

In Activity 4, the speed of the exiting marble (and thus its kinetic energy) has been related to the ramp position. Whether its speed depends on the angle of the ramp or simply on the height of the marble before release has not been investigated. Here the children will observe that even at a fixed ramp incline, if the marble is released from greater heights, it will possess more kinetic energy at the base and thus be able to do more work. It is at this point that a new concept is introduced-- that of stored or gravitational potential energy. The marble is not moving when it is held at the height from which it is to be released. Thus it has no kinetic energy. But it certainly has the potential of developing such energy if allowed to roll down the ramp. The gravitational potential energy of the marble at the top of the ramp is completely converted to the marble's kinetic energy at the base.

The children then relate the potential energy of a marble to the work required to lift it to a given height on the ramp. This work is calculated by the force (the marble's weight) multiplied by the distance to be lifted (the height before release). As a summary the children attempt to analyze the total situation in terms of (1) work needed to lift a marble into place (2) its potential energy as a result of its position (3) the kinetic energy derived from the potential energy as the marble rolls down and finally (4) the work done on the cup-sled when the marble collides with it.

### MATERIALS AND EQUIPMENT:

For each group of two or more children:

the ramp set-up and cup-sled from Activity 2.

2 extra rulers

1 Worksheet II-2

1 marble; 1-in. diameter

For the class:

1 piece of sand paper (optional)

1 block of wood (optional)

## PREPARATION FOR TEACHING:

None, except to have the materials available.

## ALLOCATION OF TIME:

This Activity should not take more than about one hour to complete.

## TEACHING SEQUENCE

1. You might introduce this Activity by setting up a ramp on one or two boxes or books in full view of the children. Then take a marble which had been sitting on the table and lift it to the top of the ramp.

Holding the marble at the top, ask about its energy there.

- Does it have kinetic energy?

- What happens if it is let go? What can be said about its energy then?

Encourage discussion of this question as you release the marble. Help the children to realize that once the marble is in motion it acquires kinetic energy. If a sled were at the base, the colliding marble would move the sled, thereby doing work on it.

Return the marble to the top of the ramp.

- Can the stationary marble in this position be said to have any energy?

## COMMENTARY

No, it isn't moving. The children found that kinetic energy depended partly on the speed of the marble. At zero speed, the marble has no kinetic energy.

Introduce the idea that the marble at the top of the ramp has the potential to do work once it gets to the bottom--

## TEACHING SEQUENCE

Next, ask the children to look at the data they recorded in Activity 4 (see page 103), and try to figure out what determined the amount of kinetic energy that a marble had when leaving the ramp. Later, a connection will be made between the kinetic energy at the bottom of the ramp and the potential energy at the top.

## COMMENTARY

that is, it has the potential to develop kinetic energy when released. Thus, when the marble is at the top of the ramp, it can be said to possess "potential energy."

The children found that an object's kinetic energy depends on its weight and on its speed. For a marble of a given size and weight, its speed seemed to be determined by the position from which it was released. For children who still have difficulty seeing this relationship, set up the data they obtained in Activity 4 on the chalkboard, listing it in order from the least to the greatest amount of kinetic energy:

RAMP POSITION	MARBLE ROLLED	RELATIVE KINETIC ENERGY
1 box unit	5/8-in. (5.5 g)	1 (least)
2 box units	5/8-in.	2
3 box units	5/8-in.	3
1 box unit	1-in. (21 g)	4
2 box units	1-in.	5
3 box units	1-in.	6 (greatest)

2. You might tell the children that you have been wondering what it is about the ramp position that determines the amount of kinetic energy the marble will develop.

- What about the incline of the ramp? Does this have

Discuss whether it is the angle of the ramp or the actual height of the marble which determines the kinetic energy of the marble. You may want to use the ramp set-up in front of them to illustrate the problem.

Some children may reply that the incline does matter. When

## TEACHING SEQUENCE

any effect on the final kinetic energy of the marble--and therefore on its potential energy at the top of the ramp? Or is it the height of the marble?

- How could you release the marble from different heights but still keep the angle of the ramp the same?

## COMMENTARY

they lifted the ramp to a new position, there was a new incline each time.

Encourage suggestions from the children: If it does not come from them, you may have to elicit the idea that a ramp could be kept at the same incline (support the end on a fixed number of boxes) but the marble could be placed at different points on the ramp, which would correspond to different heights. (See the illustration below.) In this way they could separate the effect of the marble's vertical position from the effect of the ramp incline.

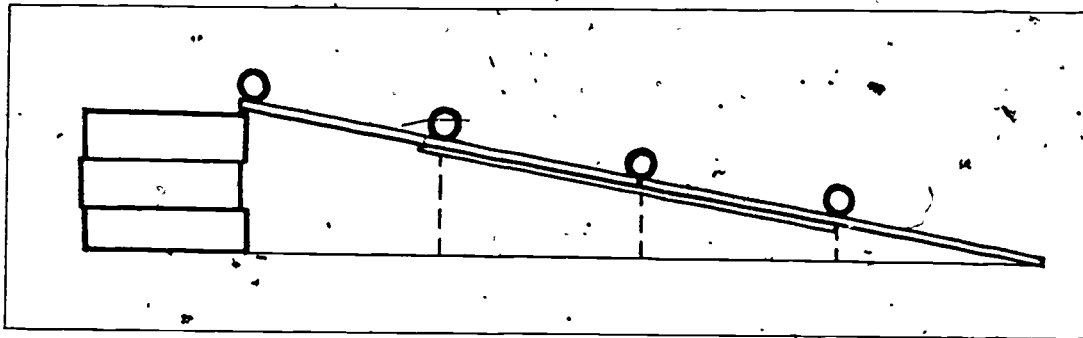

Have each team reassemble the materials for the ramp, the cup-sled, and the guide measuring rulers. The children should support the ramp so that the incline is as steep as practicable. (If a double-length ramp is being used, a high support would not be needed.) With a constant incline, they could position the marble about 1/4 of the way up the ramp and measure

A very convenient way to study the effect of height of release at constant incline is to attach two ruler ramps together--resulting in a ramp twice as long. The two can be attached if a third ruler is nested and taped behind the two rulers, as shown in the illustration. This requires two more rulers per team but it makes it much easier to study different drop heights at a constant incline.



17

completed the fifth grade and 195 boys who had just begun the sixth grade are presented and discussed.

Harris, M. L., Tabachnick, B. R., & Huysamen, G. An analysis of content and task dimensions of social studies items designed to measure level of concept attainment. Technical Report No. 194. 43 pp. November 1971. ED 068 410.

Content and task dimensions of social studies items were studied using factor analytic techniques. These items were developed to measure concept attainment using a completely crossed design with 30 concepts and 12 tasks. Conventional factor analyses were performed, separately for boys and girls, for concept scores and for task scores. Three-mode factor analyses were performed.

The main conclusions drawn from the results of the conventional factor analyses are that all 30 of the concepts are measures of a single functional relationship existing among the concepts, and that all 12 tasks are measures of a single underlying ability or latent trait. The three-mode results indicate that there are no important concept-task interactions for the idealized persons; thus it is reasonable to regard the concepts and the tasks as being two independent modes.

Harris, M. L., & Voelker, A. M. An analysis of content and task dimensions of science items designed to measure level of concept attainment. Technical Report No. 198. 29 pp. November 1971. ED 065 348.

Content and task dimensions of science items were studied using factor analytic techniques. These items were developed to measure concept attainment using a completely crossed design with 30 concepts and 12 task scores. Three-mode factor analyses were performed.

The main conclusions drawn from the results of the conventional factor analyses are that all 39 of the concepts are measures of a single functional relationship existing among the concepts, and that all 12 tasks are measures of a single underlying ability or latent trait. The three-mode results indicate that there are no important concept-task interactions for the idealized persons; thus it is reasonable to regard the concepts and the tasks as being two independent modes.

Haveman, J. E., & Farley, F. H. Arousal and retention in paired-associate, serial, and free learning. Technical Report No. 91. Out of print. 18 pp. July 1969. ED 035 959.

In an effort to investigate the relationships between arousal and long-term learning recall, arousal was manipulated by white noise during paired-associate, serial, and free learning in three experiments. The results suggested that the effects of arousal are dependent on the nature of the material to be processed and the intensity of arousal.

Hawkins, P. D. Hypostatization of selected environmental concepts in elementary school children. Technical Report No. 215. (Master's thesis) 61 pp. March 1972. ED 070 022.



## TEACHING SEQUENCE

The procedure can be repeated at a point  $1/2$  way up the ramp,  $3/4$  of the way up the ramp, and at the top. They can record the data on Worksheet II-2.

With the inclination of the ramp the same, the children should readily observe that the higher the marble is before it is released, the more work it can do on the sled. Thus the more kinetic energy it must have had at the bottom of the ramp and the more potential energy at the top.

Now ask the following questions:

- How did the marble get to each of the four positions on the ramp? How did it acquire the potential energy it has at those positions?
- What has to be done to lift the marble up?
- What force is required to lift the marble?
- What is the distance?

## COMMENTARY

Be sure that they measure the height of the marble above the table before it is released each time.

The new data should be recorded and rankings given for relative kinetic and potential energy.

In discussing their results help them to see that (1) the higher the marble is when released, the more potential energy it has before release; (2) the more potential energy it has when released, the more kinetic energy it develops as it rolls down the ramp; (3) the more kinetic energy the marble has when it hits the sled, the more work it does on the sled.

Someone lifted it up and put it there. Accompany these questions by lifting the marble to a particular height on the demonstration ramp.

There should be no difficulty in eliciting the idea that in the act of lifting, work is done--a force is applied through a distance. If necessary, refer to their earlier experiences with lifting books.

It is the force just equal and opposite to the weight of the marble. The marble is being pulled down by the gravitational force.

The distance will correspond to the four different heights to which the marble was raised.

## TEACHING SEQUENCE

- Suppose you called the force necessary to lift the marble one "marble-force unit." How would you calculate the work required to lift the marble into position?

Have them enter the amount of work done in lifting the marble to each of the four ramp positions in the last (empty) column on Worksheet II-2. A completed Worksheet is shown on page 113.

- What did you infer about the potential energy at each height?

Help them to recognize that as the marble is placed at each new height position, it has more potential energy--and to get the marble to this new height requires more work. Thus, if it took 15 units of work to get a marble to a particular position, we might say it possessed 15 units of potentially available work (or

## COMMENTARY

It would be the product of this marble-force unit and the distance. Since the force has a numerical value of 1, the amount of work done in lifting the marble would have the same numerical value as the height of the marble when released.

Some children may want to substitute the actual weight of the marble and use this figure to calculate the work done. In either case, the comparison will still depend on the distances lifted since the force is constant.

As the height increased, the potential energy increased. Note that the potential energy we calculated is the work put into lifting the marble up from a reference level--in this case, the table top. Thus its potential energy is with reference to this table top. If we wanted to know the potential energy with reference to, say, the floor below, we would calculate the work put into lifting the marble from that greater distance. Potential energy is always calculated from some reference position.

Note also that it is not possible to make valid comparisons of work done on the sled and work done in lifting the marble (for a given position). This is because the force units are not the same even though both distances are measured in millimeters. It might be added that, even if they could be compared, the work done would not be

Name: *Cindy*

RAMP INCLINE	HEIGHT OF MARBLE WHEN RELEASED (mm)	AVERAGE DISTANCE SLED MOVED (mm)	WORK DONE ON SLED	RELATIVE KINETIC ENERGY	RELATIVE POTENTIAL ENERGY	Work done in lifting the marble
<i>same</i>	<i>11</i>	<i>31</i>	<i>31</i>	<i>1</i>	<i>1</i>	<i>11</i>
<i>same</i>	<i>21</i>	<i>49</i>	<i>49</i>	<i>2</i>	<i>2</i>	<i>21</i>
<i>same</i>	<i>34</i>	<i>65</i>	<i>65</i>	<i>3</i>	<i>3</i>	<i>34</i>
<i>same</i>	<i>43</i>	<i>93</i>	<i>93</i>	<i>4</i>	<i>4</i>	<i>43</i>

Horvitz, J. M. Transfer in children's paired-associate learning as a function of levels of meaning. Technical Report No. 313. (Ph.D. dissertation) 5.1.10.30.08.01.03. 84 pp. January 1975. ED 105 445.

The study was designed to assess whether negative transfer in children's paired-associate learning could be reduced by changing the levels of meaning at which stimuli were encoded on the two lists. Stimuli and instructions were specifically designed to approximate three levels of meaning postulated by Paivio (representational, referential, and associative). It was hypothesized that changes in meaning levels, from first to second list would result in less interference than conditions where stimuli remained at constant levels of meaning over lists. Another facet of the study was designed to test the encoding variability hypothesis with children, which suggested that less meaningful stimuli would be subject to less interference.

Three separate experiments were conducted. The hypotheses were not confirmed by any of the three experiments. Results were discussed in terms of possible characteristics of the learners and the stimuli that may have contributed to the nonsignificant findings.

Houston, T. R., Jr. Comparable common factors in English homophone recognition. Technical Report No. 163. (Ph.D. dissertation) 168 pp. March 1971. ED 056 045.

A list of 7,300 English homophones was compiled and used to construct two tests. Scores were obtained on these and on reference tests for J. P. Guilford's factors CMU, CSU, DMU, DSU for 70 native speakers of midwestern American English from a university population. The homophone tests showed Hoyt reliabilities of .95 and .87 for these subjects.

Following Harris's procedure for determining Comparable Common Factors, a 15 x 15 matrix of intercorrelations was subjected to three factoring procedures, each yielding oblique and orthogonal solutions. Results were in close agreement for all analyses, yielding three common factors. Two corresponded to CMU and to DMU. The CSU and DSU tests loaded on the third factor, which had its largest loading on the homophone tests, and involved comparing verbal stimuli with formal elements of internally generated lists. These findings replicate Harris's failure to extract distinct CSU and DSU factors, and suggest that homophone recognition tasks can provide short but reliable reference tests for the symbolic factor, into which CSU and DSU coalesce.

Hubert, L. J., & Levin, J. R. A general statistical framework for assessing categorical clustering in free recall. Theoretical Paper No. 58. 5.1.10.30.09.01.07.01. 28 pp. October 1975. ED 116 162.

A graph-theoretic paradigm is used to generalize the common measures of categorical clustering in free recall based on the number of observed repetitions. Two graphs are defined: a graph G that characterizes the a priori structure of the item set defined by a researcher, and a graph R that characterizes a subject's protocol. Two indices of clustering, denoted by lambda and omega, are obtained by evaluating the sum of the

## TEACHING SEQUENCE

potential energy.)

As the children discuss the situation, start to analyze the system in terms of:

- a) Work done to lift the marble up.
- b) The potential energy of the marble at the top of the ramp (equivalent to the work done in lifting it there).
- c) As the marble rolls down, the potential energy is changing to kinetic energy.
- d) At the bottom of ramp, the potential energy of the marble is zero (since it has zero height) but it is moving at its maximum speed. All the energy is kinetic.
- e) When it collides with the sled, it does work in moving the sled, thus completing the cycle.

## COMMENTARY

exactly the same because of energy losses.

If we assume that mechanical energy is conserved, the kinetic energy of the marble at the bottom of the ramp should be equal to its potential energy at the top. In practice, this is impossible, since some of its energy must be transformed to heat energy due to frictional forces as the marble rolls down. Hence the kinetic energy at the bottom must always be somewhat less than the work done to lift the marble to a given point on the ramp (which is its potential energy).

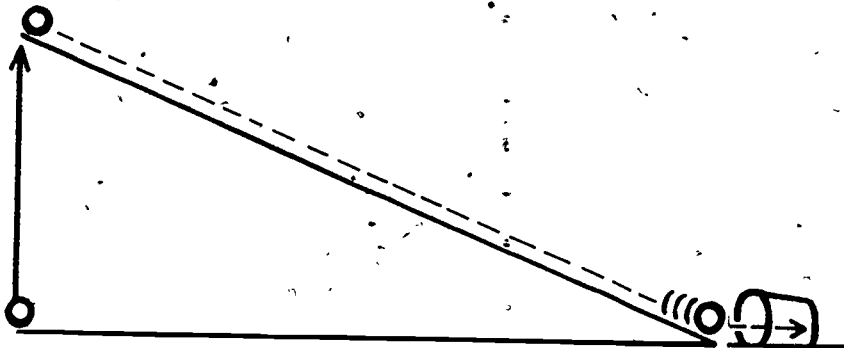

You may wish to use a schematic diagram such as the one shown above to summarize the idea that the stored potential

## TEACHING SEQUENCE

energy at a given height depends on the work required to lift the object up to that height [Force (weight) X distance]. As it moves down a ramp, the object's potential energy is converted to kinetic energy, which can do work.

Some children may wonder what happened to the kinetic energy after the rolling marble moved the sled and everything came to rest. Although this will be pursued in the final Mini-sequence on energy conversions, if children appear curious about it, ask what was happening as the sled moved on the table surface. What forces were being overcome?

Especially if children have been exposed to the conservation of thermal energy sequences in Grade 4, they will likely be concerned about accounting for the kinetic energy. If so, have them take a piece of wood and amplify the frictional rubbing action by sliding the wood over some sandpaper. After about ten strokes, they should pick up the wood and feel the surface. What does it sense? What do they think happened to the kinetic energy?

## EXTENDED EXPERIENCES:

As extensions you might pose some problems, such as:

There are two big hammers, A and B, which are to be used to crush some rocks. Each weighs 500 weight units and will be allowed to fall on the rocks. What is the difference in potential energy if A is lifted twice as high as B? (A has twice the potential energy.) Which required more work to lift it? Which has a better chance to crush the rocks?

## COMMENTARY

The frictional forces between the two surfaces.

It was converted to heat energy!

# Minisequence II Assessments

## Screening Assessments.

The concepts being tested in this Minisequence are:

### I. Mechanical Energy

The two forms of mechanical energy, kinetic and potential, may be transformed from one to the other.

- a. A moving object possesses an amount of kinetic energy that is related to its speed and to its mass (as measured by weight); that is, more energy for more speed; more energy for more mass at a given speed.
- b. The potential energy of a stationary object is related to how high it has been lifted against the earth's gravitational force.

### II. Work

Work is done when a force moves an object through a distance.

- a. The amount of work done, as measured in work units, is the product of the number of force units and the number of distance units.

### III. The relation between energy and work

- a. A moving object (possessing kinetic energy) has the capacity to do work.
- b. The potential energy of an object increases by the amount of work needed to lift the object to a given position.

Part 1 contains 5 problems to help assess mastery of the concepts of Mechanical Energy; Part 2 contains 5 problems to assess mastery of the concept of Work; and Part 3 contains 5 problems to assess mastery of the concepts of how mechanical energy and work are related. Each Part should take 7 to 10 minutes; children should be encouraged to think out their responses and not to guess.

PART 1

Page A

Have the children turn to page A.

READ THE QUESTIONS AND CHOICES SILENTLY AS I READ THEM ALOUD TO YOU. AFTER I READ ALL THE CHOICES, DRAW A CIRCLE AROUND THE LETTER OF THE BEST CHOICE.

THE PICTURE SHOWS TWO SKIERS AT THE BOTTOM OF TWO HILLS. BOTH SKIERS WEIGH THE SAME AMOUNT. BOTH HILLS HAVE THE SAME KIND OF SURFACE. BOTH SKIERS ARE EQUALLY GOOD.

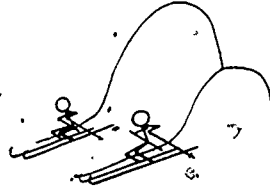

Peggy Jane

1. WHICH GIRL WILL HAVE MORE POTENTIAL ENERGY AT THE TOP OF HER HILL?

- A. JANE.
- B. PEGGY.
- C. VERY CLOSE TO THE SAME.

2. WHO WILL HAVE MORE KINETIC ENERGY AS THEY PAUSE JUST BEFORE THEY START DOWN?

- A. JANE.
- B. PEGGY.
- C. THE SAME.

3. AS EACH REACHES THE BOTTOM OF HER HILL, WHO WILL BE GOING FASTER?

- A. JANE.
- B. PEGGY.
- C. VERY CLOSE TO THE SAME.



4. WHICH GIRL WAS GOING FASTER AT THE BOTTOM OF HER HILL?

- A. THE ONE WHO INCREASED HER POTENTIAL ENERGY MORE GOING DOWN.
- B. THE ONE WHO HAD THE MORE KINETIC ENERGY AT THE BOTTOM.
- C. BOTH STATEMENTS A AND B ARE TRUE.

5. IN THE LOBBY OF THE SKI LODGE, WHO HAD THE MORE POTENTIAL ENERGY?

- A. JANE.
- B. PEGGY.
- C. VERY CLOSE TO THE SAME.

PART 2

Page B

1. MORRIS LIFTED A BOX WHICH WEIGHED 100 FORCE UNITS THROUGH A VERTICAL DISTANCE OF 5 UNITS.. HOW MANY UNITS OF WORK DID HE DO?

- A. 5 UNITS
- B. 100 UNITS
- C. 500 UNITS

2. DARRELL SAID HE DID AS MUCH WORK AS MORRIS BUT HE LIFTED HIS BOX 10 VERTICAL DISTANCE UNITS. HOW MUCH DID DARRELL'S BOX WEIGH?

- A. 5 UNITS
- B. 50 FORCE UNITS
- C. 100 FORCE UNITS

3. DEAN USED 100 FORCE UNITS TO PUSH A TABLE OVER A DISTANCE OF 3 DISTANCE UNITS. JOE USED 3 FORCE UNITS TO PUSH A DIFFERENT TABLE ON THE SAME FLOOR 100 DISTANCE UNITS. WHO DID MORE WORK?

- A. DEAN
- B. JOE
- C. THEY DID THE SAME AMOUNT OF WORK.

4. PHIL USED 1 FORCE UNIT TO MOVE A PIECE OF PAPER 1 DISTANCE UNIT. ARNOLD EXERTED 500 FORCE UNITS ON THE WALL OF HIS HOUSE BUT IT DIDN'T MOVE. WHO DID MORE WORK?

- A. PHIL
- B. ARNOLD
- C. THEY DID THE SAME AMOUNT OF WORK.

5. KANDY SAID SHE WORKED VERY HARD ALL DAY. KANDY WEIGHS 25 FORCE UNITS AND SHE SAT IN A CHAIR FOR 3 HOURS. HOW MUCH WORK DID KANDY DO?

- A. NO WORK.
- B. 25 WORK UNITS.
- C. 75 WORK UNITS.

PART 3

Page C

1. TWO BOYS LIVE IN AN APARTMENT BUILDING ON THE THIRD FLOOR. ONE AFTERNOON, BOB CLIMBED THE STAIRS AND JOE TOOK THE ELEVATOR. WHO DID MORE WORK?

- A. BOB.
- B. JOE.
- C. THEY DID THE SAME AMOUNT OF WORK.

2. IN QUESTION 1, WHICH BOY HAD MORE POTENTIAL ENERGY ON THE THIRD FLOOR?

- A. JOE.
- B. BOB.
- C. IT DEPENDS ON WHO IS HEAVIER.

3. BOB CARRIED HIS BALL DOWN STAIRS TO PLAY ON THE SIDEWALK. JOE DROPPED HIS BALL, WHICH WAS THE SAME KIND AS BOB'S, FROM THE THIRD FLOOR WINDOW TO WHERE BOB WAS STANDING. AT THE MOMENT BEFORE JOE'S BALL HIT THE SIDEWALK, WHOSE BALL HAD MORE KINETIC ENERGY?

- A. BOB'S.
- B. JOE'S.
- C. BOTH BALLS HAD THE SAME KINETIC ENERGY.

4. IN QUESTION 3, AT THE MOMENT WHEN BOB'S BALL WAS ON THE SIDEWALK AND JOE'S BALL HIT THE SIDEWALK, WHICH BALL HAD MORE POTENTIAL ENERGY?

- A. BOB'S.
- B. JOE'S.
- C. BOTH BALLS HAD THE SAME POTENTIAL ENERGY.

5. NEXT MORNING, JOE RAN UP THE STAIRS. IF HE HAD WALKED UP, HE WOULD HAVE DONE:

- A. MORE WORK
- B. THE SAME AMOUNT OF WORK
- C. LESS WORK

THE PICTURE SHOWS TWO SKIERS AT THE BOTTOM OF TWO HILLS. BOTH SKIERS WEIGH THE SAME AMOUNT. BOTH HILLS HAVE THE SAME KIND OF SURFACE. BOTH SKIERS ARE EQUALLY GOOD.

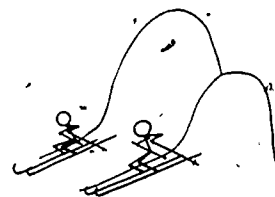

Peggy Jane

1. WHICH GIRL WILL HAVE MORE POTENTIAL ENERGY AT THE TOP OF HER HILL?
  - A. JANE.
  - B. PEGGY.
  - C. VERY CLOSE TO THE SAME.
2. WHO WILL HAVE MORE KINETIC ENERGY AS THEY PAUSE JUST BEFORE THEY START DOWN?
  - A. JANE.
  - B. PEGGY.
  - C. THE SAME.
3. AS EACH REACHES THE BOTTOM OF HER HILL, WHO WILL BE GOING FASTER?
  - A. JANE.
  - B. PEGGY.
  - C. VERY CLOSE TO THE SAME.
4. WHICH GIRL WAS GOING FASTER AT THE BOTTOM OF HER HILL?
  - A. THE ONE WHO INCREASED HER POTENTIAL ENERGY MORE GOING DOWN.
  - B. THE ONE WHO HAD THE MORE KINETIC ENERGY AT THE BOTTOM.
  - C. BOTH STATEMENTS A AND B ARE TRUE.
5. IN THE LOBBY OF THE SKI LODGE, WHO HAD THE MORE POTENTIAL ENERGY?
  - A. JANE.
  - B. PEGGY.
  - C. VERY CLOSE TO THE SAME.

1. MORRIS LIFTED A BOX WHICH WEIGHED 100 FORCE UNITS THROUGH A VERTICAL DISTANCE OF 5 UNITS. HOW MANY UNITS OF WORK DID HE DO?
  - A. 5 UNITS.
  - B. 100 UNITS.
  - C. 500 UNITS.
  
2. DARRELL SAID HE DID AS MUCH WORK AS MORRIS BUT HE LIFTED HIS BOX 10 VERTICAL DISTANCE UNITS. HOW MUCH DID DARRELL'S BOX WEIGH?
  - A. 5 FORCE UNITS.
  - B. 50 FORCE UNITS.
  - C. 100 FORCE UNITS.
  
3. DEAN USED 100 FORCE UNITS TO PUSH A TABLE OVER A DISTANCE OF 3 DISTANCE UNITS. JOE USED 3 FORCE UNITS TO PUSH A DIFFERENT TABLE ON THE SAME FLOOR 100 DISTANCE UNITS. WHO DID MORE WORK?
  - A. DEAN.
  - B. JOE.
  - C. THEY DID THE SAME AMOUNT OF WORK.
  
4. PHIL USED 1 FORCE UNIT TO MOVE A PIECE OF PAPER 1 DISTANCE UNIT. ARNOLD EXERTED 500 FORCE UNITS ON THE WALL OF HIS HOUSE BUT IT DIDN'T MOVE. WHO DID MORE WORK?
  - A. PHIL.
  - B. ARNOLD.
  - C. THEY DID THE SAME AMOUNT OF WORK.
  
5. KANDY SAID SHE WORKED VERY HARD ALL DAY. KANDY WEIGHS 25 FORCE UNITS AND SHE SAT IN A CHAIR FOR 3 HOURS. HOW MUCH WORK DID KANDY DO?
  - A. NO WORK.
  - B. 25 WORK UNITS.
  - C. 75 WORK UNITS.

1. TWO BOYS LIVE IN AN APARTMENT BUILDING ON THE THIRD FLOOR. ONE AFTERNOON, BOB CLIMBED THE STAIRS AND JOE TOOK THE ELEVATOR. WHO DID MORE WORK?

- A. BOB.
- B. JOE.
- C. THEY DID THE SAME AMOUNT OF WORK.

2. IN QUESTION 1, WHICH BOY HAD MORE POTENTIAL ENERGY ON THE THIRD FLOOR?

- A. JOE.
- B. BOB.
- C. IT DEPENDS ON WHO IS HEAVIER.

3. BOB CARRIED HIS BALL DOWN STAIRS TO PLAY ON THE SIDEWALK. JOE DROPPED HIS BALL, WHICH WAS THE SAME KIND AS BOB'S, FROM THE THIRD FLOOR WINDOW TO WHERE BOB WAS STANDING. AT THE MOMENT BEFORE JOE'S BALL HIT THE SIDEWALK, WHOSE BALL HAD MORE KINETIC ENERGY?

- A. BOB'S.
- B. JOE'S.
- C. BOTH BALLS HAD THE SAME KINETIC ENERGY.

4. IN QUESTION 3, AT THE MOMENT WHEN BOB'S BALL WAS ON THE SIDEWALK AND JOE'S BALL HIT THE SIDEWALK, WHICH BALL HAD MORE POTENTIAL ENERGY?

- A. BOB'S.
- B. JOE'S.
- C. BOTH BALLS HAD THE SAME POTENTIAL ENERGY.

5. NEXT MORNING, JOE RAN UP THE STAIRS. IF HE HAD WALKED UP, HE WOULD HAVE DONE:

- A. MORE WORK.
- B. THE SAME AMOUNT OF WORK.
- C. LESS WORK.

## Minisequence III

# Heat Energy and Liquefying Solids

In Grade 4, Minisequence V, the role of heat energy in changes of state was investigated. It was found that heat energy must be added to a solid in order to melt it--i.e., change it from the solid to the liquid state. And the same amount of heat energy must be removed from the liquid to change back to the solid state--i.e., freeze the liquid. A model was developed to account for the "disappearance" of heat energy during the melting of a solid. According to the model the heat energy was used to free the molecules from the (binding) forces holding them in the fixed positions characteristic of a solid structure. The free molecules in the liquid state were then considered to have more energy than in the solid state because of the thermal energy given to them during the change of state. The present Minisequence extends this idea to another very common process whereby certain solids can be changed to the liquid state, namely, dissolution--the process of dissolving or breaking up solids by placing them in suitable liquids, called solvents. In this process, as in melting, the molecules of the solid absorb heat energy as they are freed from their fixed positions and become part of the liquid along with the solvent. However, unlike melting, where the necessary heat energy is supplied from the outside, in dissolution the solid extracts heat energy from its immediate surroundings, i.e., from the solvent.

Consider a solid such as ordinary table salt (sodium chloride). It can be melted, as can most solids but its melting temperature is very high ( $801^{\circ}\text{C}$ ), much too high to achieve in the ordinary classroom--or even in the kitchen. However, it is easy to dissolve table salt in water, without having to heat it. How does water break the bonds that hold table salt in the crystalline (solid) state? It must first be understood that these binding forces are electrical in nature. In the case of melting a solid, one must provide enough thermal energy to its molecules so that their increased molecular vibrations, i.e., increased kinetic energy, are enough to overcome their electrical attraction and hence they break apart. An analogy might be a rubber ball attached to a paddle by a rubber band, of the sort that children often play with. The object is to keep the ball continually in motion by hitting it each time it returns to the paddle. If the ball is hit harder each time it returns, thereby acquiring more and more kinetic energy, it eventually stretches the rubber band to the breaking point and the "bond" is broken.

In a solvent, the bond is broken by weakening the electrical at-

traction between molecules of the solid to the point where the temperature of the solvent (usually room temperature) is great enough to break the bond. The electrical attraction is weakened by the electrical character of the solvent molecules. In the analogy given above, it would be as though the rubber band were weakened by partly cutting through it--such that a much smaller stretch would break it. Water is sometimes called the "universal solvent," because so many substances are soluble in it. This is one reason why it is so useful in washing. All salts are soluble in water, some more readily than others. Salt is a generic term used to indicate compounds which are formed when an acid and a base neutralize one another. For instance, when hydrochloric acid is neutralized by sodium hydroxide, sodium chloride is formed. Other examples of salts are sodium thiosulfate (hypo), magnesium sulfate (Epsom salts), and phenyl salicylate (salol).

One cannot dissolve an indefinite amount of a given salt in water. At some point the solution becomes saturated, which means that it is no longer capable of weakening the bonds between molecules of any additional solid. This can be thought of as meaning that a given number of solvent molecules can weaken the bonds of a fixed number of solid molecules to the point where room temperature can overcome the binding forces. More solid can be dissolved if the solvent temperature is increased. Thus, one can dissolve more salt in hot water than in cold.

Now, we have seen that even where the binding forces are weakened, the bonds are actually broken by thermal energy. Hence, when a solid salt dissolves in water, for example, it must absorb heat energy from the water, thereby lowering the temperature of the solution. If the process could then be reversed, i.e., if the solid could be precipitated back out of solution, then the heat absorbed during dissolution should be liberated, thereby conserving energy. Under proper circumstances, salts can be precipitated out of solution with the corresponding release of heat energy.

The first Activity reviews the process of melting for the children. They observe that different substances require different heat sources to melt them, i.e., they have different melting temperatures. They also find that one (table salt) cannot be melted by any heat source available to them, but can be "liquefied" by dissolving it in water.

In the next Activity the children study the temperature of water as they dissolve various salts in it. They find, as expected, that the temperature drops as the salts dissolve, but that the decrease varies with the different salts as does the amount of each salt that will dissolve in a given amount of water at a given temperature.

The third Activity carries forward the investigation of saturated solutions. The children find that for some salts, raising the temperature of the solvent (water) greatly increases the solubility; for others, such as table salt, the solubility changes



very little if at all with temperature. They also establish experimental criteria for determining when a solution is saturated. If the temperature of a saturated solution (free of excess salt) is carefully lowered, it may become supersaturated, which means that all the salt may remain in solution despite the fact that at the lower temperature it contains more than the saturation amount of salt. The excess salt can be made to precipitate out suddenly by various means. The children work with such solutions in the final Activity, observing the release of heat energy (the heat of solution) as their supersaturated solutions are allowed to precipitate.

## Activity 1 Melting and Dissolving Solids

Initially, in this first Activity, the children review the concept that heat energy is needed to overcome the binding forces within a solid to produce a melt. They discover that ice can be melted by a very mild heat source; salol must be placed in contact with hot water to melt; paraffin requires a hot plate; and ordinary table salt cannot be melted by any source of heat energy available to them. Thus the binding forces within solids apparently vary in strength from one substance to another and substances can be classified accordingly.

An alternative way of liquefying the "non-meltable" salt is then discovered--the salt (sodium chloride) dissolves in water to form a solution. The children consider the ability of water to accomplish what moderate heat energy could not and are led to infer that the water molecules may exert an attractive force on the salt molecules which is strong enough to overcome the solid's binding force. The similarities between melting and dissolving are emphasized in that each frees the molecules from the restrictions of the solid structure to become part of a freely moving liquid. Breakdown of the solid and its incorporation into a moving liquid is observed by the children through a microscope.

### MATERIALS AND EQUIPMENT:

For the class, you will need:

- 1 hot plate
- 1 cookie sheet
- table salt (sodium chloride), pure, e.g., "Kosher" salt (sold in many grocery stores), about 1/4 cup
- salol (phenyl salicylate) (sold in most drugstores), 1/4 cup
- paraffin shavings, 1/4 cup
- 1 paring knife
- alcohol, rubbing, or mineral oil, 1 oz (30 ml) (optional)
- table salt, 2 tablespoons

potassium permanganate (sold in drug and photographic supply stores), 2 teaspoons

- 3 wooden splints or popsicle sticks
- chips of ice in a double foam cup
- 3 (or more) wide-mouth containers, glass, waxed paper, or plastic (approximately 8-oz size)
- 5 set-ups for washing and rinsing slides (see Activity 1 of Minisequence I)
- microprojector (optional)

For each pair of children, you will need:

- 1 test tube (100 mm by 25 mm)
- 1 jar or cup for holding the test tube
- supply of hot water
- 2 cups, polyfoam, 6-oz to 8-oz (180-ml to 240-ml)
- 1 test tube clamp
- 2 magnifying glasses
- 3 aluminum foil muffin-cup liners, or 3 in. by 3 in. (7.5 cm by 7.5 cm) pieces of aluminum foil
- 1 microscope
- 2 glass microscope slides
- 1 medicine dropper (when filled, it should release 1/4 tsp of liquid)

\*There is at least one brand of table salt on the market in which the crystals have been crushed to make the salt dissolve more quickly on food. Check to be sure that the salt is in the form of readily identifiable cubic crystals--most brands are.

#### PREPARATION FOR TEACHING:

Have hot water available. (You may have to heat up some on the hot plate if there is none in a tap readily available.)

Locate the hot plate in a position where each child can view the heating surface. Adjust the thermostatic control to low heat. Invert the cookie sheet over it to increase the heating surface.

The paraffin scrapings can be made from a slab of paraffin or wax candles by scraping with a small paring knife, or kitchen grater. Place them in a wide-mouthed container. Put the other chemicals in similar containers at separate locations where the children can help themselves easily.

Place the wooden splints (or adequate substitute) next to each supply of chemicals. Draw a line across each splint about 1/2 inch from one end. The amount of chemicals which can be taken up on that 1/2 in. portion of the stick is considered a "unit measure" of solid. A spatula, a flattened end of a straw, or similar substitute can also be used.

#### ALLOCATION OF TIME:

The children will need about 1-1/2 hours to complete this Activity.

#### TEACHING SEQUENCE

1. Exhibit the pieces of ice to the class. Review with them what is required to liquefy (melt) it:

- What will happen to a piece of ice if it is left in the room?

Be sure the children realize that heat energy is involved in getting the solid water (ice) to melt. As the discussion proceeds, put the following on the chalkboard:

LIQUID  
 ↑ heat energy absorbed  
 SOLID

#### COMMENTARY

It will melt. Ice melts at 0°C and the temperature of the room is higher than 0°C.

Starting in Kindergarten, the COPE curriculum has dealt with the role of heat energy in the melting process. In particular, Grade 4, Minisequences II and V lead into this investigation. You may wish to review these Activities with the children. In Minisequence V, children found that energy was absorbed by a solid in order to break the binding forces holding the particles of the substance together in the rigid structure characteristic of a solid. They also learned that heat energy had to be absorbed by a liquid in order to change it into a gas. Thus they developed some understanding about the differences in energy between a

## TEACHING SEQUENCE

- Where does the ice get this heat energy from?

Show the children a polyfoam cup with hot water. Ask them to tell you something about its properties after one or two of them have tested it with their fingers.

Put some ice into one of the aluminum foil cups.

- Will the ice melt if the foil dish and ice are placed in contact with the hot water?

Holding the foil dish with a test tube clamp, lower it onto the surface of the hot water.

- Which can provide more heat energy, the room or the cup of hot water?

- How was the heat energy transferred?

2. Now show the class the other solids--sugar, sodium chloride, and the paraffin shavings.

- Can the bonds holding the molecules in the solid structure be broken--as they were in the ice?

## COMMENTARY

solid, its liquid, and its gas. They arrived at the following generalization: a solid is at the lowest energy level, the molecules of its liquid possess more energy, and its gas is at the highest energy level.

From the room.

They should be able to say that its temperature is higher than that of the room. They should also realize that it possesses heat energy.

See page 131 for a description of how to make these cups from aluminum foil, if you are not using muffin-cup liners.

The ice pieces will melt very rapidly and leave a pool of liquid water.

There should be general agreement that the cup of hot water will be able to transfer more heat energy.

You may want to sketch the path on the chalkboard:

Hot water → foil pan → ice

Reintroduce the term, *molecule*, to refer to the invisible ultimate particle of a particular substance. This term was first introduced in Grade 4.

## TEACHING SEQUENCE

- How could you find out?

This part of the Activity can be done by pairs of children. Have them take three measures of each solid from the various stations, place each in a foil dish and bring it back to their work areas.

The other child in the team can get about a 1/2-cup supply of the hot water in a double (nested) polyfoam cup. Then they should test each substance in turn on the hot water: Pick up each foil "boat" carefully with a clamp, and place it on the water. Do not let any water get into the boat.



## COMMENTARY

The children will probably suggest placing the solids in foil dishes and seeing if they will melt when placed on the hot water.

Note that a measure refers to as much solid as can be picked up within the line marked on the wooden dispenser. (See Preparation for Teaching.)

The children can prepare their own aluminum dishes if foil muffin cup liners are not used. Give each team 3 pieces of foil, at least 3 in. by 3 in. (7.5 cm by 7.5 cm). They can form a flat-bottomed dish by pressing the foil against the bottom of a small jar, e.g. a 4-oz baby food jar. There should be sufficient aluminum foil on the side walls so that the dish, when heated, can be picked up with a clamp.

## TEACHING SEQUENCE

- What substances melt in contact with hot water?
- What can you say at this point about the strength of the binding forces of the salol compared with salt and with paraffin? Compared with ice?

Now suggest that the children take the boats with the two substances which didn't melt to the warm hot plate. Do they think this might be more effective than the hot water? Let them try the two, placing the foil cups on the inverted cookie sheet.

Discuss their overall results:

- How do the relative temperatures of the heat sources compare?
- How would you rank the difficulty of melting the four substances?

Encourage the children to suggest possible explanations for the differences.

## COMMENTARY

They will find that the salol melts but not the paraffin or the salt.

The salol has weaker binding forces than salt and paraffin, but stronger than ice. (The ice can melt at room temperature but not the salol.)

They may remember that a hot plate was used to melt both the salol and paraffin in Grade 4. Now they are to test only the paraffin and salt since they found that salol was already melted by the hot water. They will find that the paraffin melts now but that the sodium chloride still does not.

The hot plate is at the highest temperature, next is the hot water, and the room is at the lowest temperature.

Sodium chloride is the hardest to melt, paraffin is next, then salol, and ice is the easiest to melt:

sodium chloride	4
paraffin	3
salol	2
ice	1

The forces binding the molecules in the sodium chloride must be much stronger than any of the others, which can be arranged in descending order. In other words, the four substances can be classified on the basis of their bond strengths.

## TEACHING SEQUENCE

3. Begin this Section by asking the children if they can think of a different way in which the salt could be changed from a solid to a liquid. Assuming that they will eventually come up with the idea of adding water to the salt (previous experiences in Grade 4 indicated that water dissolves many materials), suggest that they set up an experiment to try out their hypothesis.

Have each team get a supply of room temperature water in a cup. While one child does that, the other should go to the supply of salt and put about three measures of salt into a test tube.

When they return to their work areas, the children should add about 4 droppersful of water to each tube and swirl the contents as well as they can. After swirling for 15 or 20 seconds, they should examine the tubes and their contents. Most, if not all, of the solid pieces of sodium chloride will have disappeared.

- Where is the sodium chloride at this time and how has it changed?

## COMMENTARY

If the children suggest that the sodium chloride salt may be liquefied by adding a liquid, you could follow up their suggestion casually by a demonstration. Use either some alcohol or mineral oil as the liquid. Pour about one inch of the "liquid" into an empty test tube and add about three measures of the sodium chloride to the tube. Shake it vigorously for 10 to 15 seconds. After the tube is shaken, the children will observe that no salt dissolves in the liquid--the solid does not liquefy. Someone will surely suggest that something may be "the matter" with the liquid, or that the "proper" liquid was not used!

If the question comes up, you might set up a test tube containing 3 measures of the paraffin shavings and/or salol and add 4 droppersful of water. Although the paraffin chips could easily be melted by the hot plate, and salol by the hot water, water is ineffective in liquefying them.

In taking a dropperful of water, they should squeeze the bulb completely, insert the dropper in the water, release the bulb and let as much water come up as possible. The amount drawn up will be about 1/4 teaspoonful in the recommended normal size dropper and will probably fill about 1/2 the tube.

In swirling the contents of the test tube, they should be careful not to spill material out.

Help them to understand that the sodium chloride particles are now moving about in the



## TEACHING SEQUENCE

The salt particles are now somewhere in the water. This may be verified if the water is tasted. (Caution them, however, about tasting just any solution. Some may be harmful. Table salt in water, of course, is not.)

Help the children to search for a reasonable explanation of the breaking down of the solid salt when water is added to it. Start by drawing on information from past activities.

- What was present in the test tube that was not present in the foil boat?
- What is needed to overcome the strong binding forces so the particles can move out of the solid structures?

## COMMENTARY

water. We shall ignore, for purposes here, the fact that in solution, units of sodium and of chlorine do not stay together as a sodium chloride molecule, but are in the form of individual ions (electrically charged atoms) of sodium and of chlorine.

If some children suggest that perhaps the water contained some salt particles beforehand, this can be explored by repeating the activity and letting the children taste the water before the salt is put in the tube.

They should recognize that the systems in the test tubes contain a component, water, that was not present in the foil boats. Thus it is reasonable to assume that the water, the second component in the system, is interacting with the salt and causing it to liquefy.

If anyone suggests that heat energy in the water could supply the necessary force for separating the molecules from each other, pursue this by asking the class to compare the amount of heat energy they think is in the test tube of water with that supplied by the hot plate. Most of the children will quickly realize that more heat energy was supplied by the hot plate.

## TEACHING SEQUENCE

- Since the cold water was not able to transfer as much heat energy as the hot plate, how did it cause the solid salt to liquefy?

Suggest to the children that the molecules of water might exert a strong attractive force on the salt molecules in the solid. If so, how would the strength of the binding force between the salt molecules in the solid compare with the strength of the force between the water and the salt molecules? Are they equally strong? If not, which would seem to be stronger?

4. At this point, suggest that the children take a closer look at the process by which the solid salt liquefies in water. Have each child carry a microscope slide to the supply of table salt and place several crystals on the slide.

Have them view the salt with the magnifying glass at first. If it has three different power lenses, use all three.

- How would you describe the solid?

## COMMENTARY

Since the heat energy of the water cannot be used to explain the breakdown of the solid structure, it is reasonable to assume that some property of water might be responsible for the effect.

You may want to refer to the model of a solid developed in Activity 2, Minisequence V of Grade 4.

The children should be helped to see that the attractive forces between water and salt molecules must be considerably stronger than the binding forces within the solid itself. In Minisequence II of Grade 3, the children found that an object moves from rest when the forces on it are unbalanced. In this case, we can say the attraction between water and salt molecules is greater than the forces holding the molecules in their position in the solid, and thus they are pulled out of the solid.

The table salt need not be pure here, as no solutions will be formed. However it should be in the form of cubic crystals.

The children will undoubtedly notice the regular shape of the tiny pieces of salt. Introduce

## TEACHING SEQUENCE

- What kind of crystals does sodium chloride form?

Now have them place the slide on the stage of the microscope, being sure that the salt crystals are under the objective. Using the techniques developed in Minisequence I, they can get one of the crystals into the field of vision by slowly shifting the slide. The focus can then be adjusted.

- What do you see now?

## COMMENTARY

the term crystal here. Crystals are solid forms which have plane surfaces and distinct angles where the surfaces meet.

Sodium chloride forms cubic crystals; all the sides meet at right angles. (Some children call them little boxes.) They will also note that crystals reflect light from the flat faces. They may recall from earlier Activities, that different substances will have different crystal shapes.

The cubic shape of the salt will be very well defined. If some children are observing imperfect crystals, at least they will see some sharp edges at right angles. You may want to review what they learned about the effect of changing the lighting as they view crystals. If viewed with the light coming from below, the crystal appears dark against the light; however, if they shift the mirror, they can get light in from above and the crystals appear as light cubes against a dark background. When the focusing mechanism is moved up and down, some parts of the crystal go out of focus and others come in. The children should see the 3-dimensional quality of the crystal.

## TEACHING SEQUENCE

- What could account for the regular geometric shape of the salt crystals?

- What do you think will happen if you place a drop of water on the slide?

Suggest that the children get a small supply of water in the unit-measure cups and obtain a medicine dropper. As one child views the crystal in the scope, the other child should put one drop of water on or near the crystal so that the edge of the crystal is in the water. After the first child observes this action, the second can view his or her own slide while the first adds the water.

While they are at it, have the children observe the dissolving action on another type of crystal--one which is colored. After they wash off and dry the slide, give each child a few very tiny crystals of potassium permanganate.

Again have them view the dissolving action.

## COMMENTARY

The salt molecules making up the structure of the solid may be held together in a regular geometric pattern. (See Activity 2 of Minisequence V in Grade 4.)

Encourage answers and reasons for their answers. Based on their experiences, some children may say that the water will pull out the salt molecules from the crystal.

The children will observe that the sharp edges of the cubic crystals will start to be rounded off. Some swirling action of the water will be noticeable. The overall effect is that of activity in the system as the water interacts with the salt. The swirling motion is probably due to currents set up in the water as a result of dropping it on the slide, and to any temperature differences. Also, as the salt dissolves, differences in salt concentration will occur near the crystal and farther away. These differences will result in what appear to be streaks in the clear liquid.

Since the children might stain their fingers, it is advisable that you put the crystals on the slides for them.

Be sure the child is viewing a single tiny crystal. If the crystal is too large, when the water is added the color may be so intense as to mask the action. This crystal results in very dramatic scenes. A purple solution results--clear

## TEACHING SEQUENCE

As they observe the purple solution form, follow similar discussions as with the salt.

- What did you observe happen to each solid (potassium permanganate and salt) when water was added to it?

Through discussion, help the children to recognize the analogy between the dissolving and the melting process. A liquid in both cases formed from a solid by an interaction. In melting, it is an interaction of a single substance with heat energy; in making solutions it is an interaction between two substances--here a salt and water. See if the children can distinguish this difference between the two. In each case, however, the molecules in the solid are freed from the binding forces and become more mobile as a liquid.

- Which has more energy, the solid or its liquid melt?
- Which has more energy, a solid or its solution with water?

## COMMENTARY

but colored. Because of currents in the liquid, the color will be seen to spread out in a freely flowing manner--emphasizing the mobility of liquids.

In both cases, the pieces of solid gradually became smaller as they became part of the mobile liquid.

The liquid--heat energy is absorbed in the process of melting.

Let the children speculate about the answer to this. They will be arriving at some answers in the next Activities. But it is hoped that some may hypothesize that since a liquid solution moves more freely than the solid from which it was formed, the liquid here also will have more energy.

## EXTENDED EXPERIENCES:

1. For those children interested in observing more solids dissolve as viewed under the microscope, give them some crystals of salts which they will work with in the next Activities. Let them observe the epsom salt needlelike crystals, or the rhombic hypo crystals as they dissolve. Their interaction with water will be very similar to that of sodium chloride. If you have small crystals of copper sulfate, hydrated blue crystals, they are also very effective. Caution the children, however, that they must not touch this last chemical. Handle it as you did the potassium permanganate.

2. If you have enough slides so that the children can have one for each of the crystals, an interesting extension for them would be to let the water evaporate. Before you do so, when they discuss whether the salt molecules are really in solution, ask if they can be sure they are there. In the case of the potassium permanganate they can see the color, but not with the sodium chloride. On drying, they will obtain beautiful cubes of sodium chloride, even if they didn't have perfect ones to start with. With the potassium permanganate, it is even more dramatic. Beautiful needles form, and they can see the purple solution being sucked up into the rigid needles, which are dark and shiny. Eventually all the colored substance reappears in the needles. After drying, the children can follow the dissolving process again with the crystals they have made.

## Activity 2 The Disappearance of Heat Energy

Both melting and dissolving are changes in the state of matter. When solutions form, however, it is the result of an interaction between two substances--such as water and a salt. Thus, the liquid contains not one, but two components. In this Activity the children discover that in addition to the attractive force (interaction) between water and salts, heat energy also plays a role as the salt dissolves. When they investigate five different kinds of salts, they observe that the temperature of each salt-water system drops as the interaction with water takes place. The children find that the interaction of the five salts with water varies with respect to how much will dissolve (in the same amount of water), and how much the temperature is lowered. In all cases, however, heat energy seems to disappear--apparently it is absorbed during the process of dissolving. This absorption is related to the breaking of the bonds holding the salt molecules within the solid, as with the melting process. The children are led to the concept that the added heat energy is then present in the more energetic molecules of the liquid solutions. In Activity 3 they will investigate the properties of some of the solutions in greater detail, preparing them for the final Activity where they will observe the release of the absorbed heat energy.

### MATERIALS AND EQUIPMENT:

For the class:

2 containers, polyfoam, approximately 3-qt (3-liter) capacity

a supply of the following salts (about 1 cup of each)

sodium chloride, pure, or "kosher" salt\*

ammonium alum (sold in drugstores)\*

sodium thiosulfate, crystals, "hypo" (sold in photographic supply stores)\*

ammonium chloride, (Sal Ammoniac) (sold in drugstores or hardware stores)\*

magnesium sulfate crystals, "epsom salts" (sold in drugstores)\*

6 containers, wide-mouthed for the salts, e.g., short olive jars, cottage cheese containers, mugs, plastic bowls, etc.

5 set-ups for rinsing thermometers

supply of 1/2-tsp measuring spoons for each container. The commonly available plastic spoons sold in packages usually hold about 1/2 tsp.

supply of wooden splints or popsicle sticks near each container

magnifying glasses and microscopes (optional)

For each child:

paper towels

1 cup, 5-oz to 8-oz (150-ml to 240-ml) for water supply

6 or more cups, 1-oz (30-ml), waxed paper or plastic

1 medicine dropper (It should release 1/4 tsp of liquid)

1 thermometer, -20°C to +50°C

pieces of paper (optional)

1 Worksheet III-1

\*Each of the five salts can also be ordered from chemical supply houses, such as Cenco. (See Preparation for Teaching and the Materials and Equipment Section at the end of this Guide.)

#### PREPARATION FOR TEACHING:

For Part A, prepare a supply of water at a temperature close to that of room temperature, 20°C to 25°C, in the two large poly-foam containers. Children will take about 1/2 cup as a supply to be used at their work areas. Leave the supply of 1-oz cups, thermometers, medicine droppers, and water-supply cups in another location for the children to help themselves.

Obtain hypo from a photo supply store. This quality gives best results. Put the "hypo" out in several squat containers in different locations. Leave spoons and flat wooden sticks near it so children can help themselves to a level 1/2 tspful. No comparison in behavior between salts is made in Part A, but they can use the practice in measuring out standard level quantities. In Part B, it will be important that the same amount of salt be taken in each case.



If the plastic backing on the thermometers extends below the bulb, it may be desirable to cut it off so that the bulb can sit as far down in the 1-oz cup as possible. The bulb must be immersed in the material whose temperature is being read. Shortening the backing will also minimize the amount of salt to be used. You can use the same cut-off thermometers for the remaining activities--or for any activity. The extra backing merely protects the bulb. Grade 5 children should be able to exercise the caution necessary in working with these altered thermometers to prevent breakage.

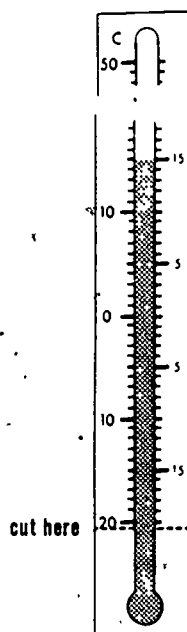

For Part B, set up four separate stations where a supply of one of each of the four salts is made available. Using different locations avoids any possibility of confusing one salt with another. Place each in one or two squat containers and label them with numbers 1 through 4, and, if you wish, with the name of the salt: sodium chloride, ammonium alum, ammonium chloride, and magnesium sulfate. Kosher-style sodium chloride is called for. It has no additive to make it "free flowing," which results in a cloudy mixture in water. The hydrated magnesium sulfate crystals, commonly called epsom salts, should not be dried out. Keep it covered when not in use to avoid its drying out in the room. Some varieties sold in drugstores may be dry; therefore, you may have to obtain the salt from a chemical supply house. (If you use partially dried material, instead of a decrease in temperature there will be a rise when it is added to water. This is due to the heat liberated as the salt rehydrates--a point which the children will investigate in Grade 6. This must be avoided at the present stage since it would interfere with the desired conceptual development.) All the salts recommended for investigation in this minisequence exhibit "negative" heats of solution. That is, they absorb heat energy when dissolving. For this reason, if you decide to have the children test some sodium acetate crystals also, be sure to use pure, hydrated crystals.

Provide 1/2 tsp dispenser spoons and wooden levelers next to each salt container. Again, have the supply of 1-oz cups, droppers and thermometers available. Provide a supply of rinse water for the thermometers. Since the children will be testing at least two systems, the thermometers must be rinsed clean between each test. The reason for the rinsing is to avoid contamination of one salt with another.

## ALLOCATION OF TIME:

The children will need about 1-1/2 hours to complete this Activity.

## PART A

## TEACHING SEQUENCE

1. You might briefly review the concepts discussed in Activity 1 by asking the following questions:

- What overcomes the binding forces between molecules during melting?
- If a solid becomes a liquid when mixed with water, what forces overcome the binding forces?
- Do you think that heat energy would be needed for such a process? If so, what do you think might happen to the temperature of water as a salt dissolves in it?

## COMMENTARY

If there is a long lapse between the finish of Activity 1 and the start of Activity 2, review these points with the class in greater detail.

Heat energy.

It has been suggested that the attractive forces between the water molecules and the molecules of the solid cause it to liquefy. Some children may suggest as an analogy the concept of work as defined in Minisequence II. They may see that the force between water and the molecules of salt in the solid may be acting through a distance ( $F \times D$ ) as the salt molecules go into solution, and thus work is being done. This is a reasonable analogy and should be accepted if children offer it; but you should not introduce it.

Encourage the children to express their ideas. Answers might range from "nothing" to "its going to get very hot." However, some children may reason that if bonds are being broken, energy is being used-- by applying the same reasoning they used in explaining the loss of heat energy units (h.e.u.) in Grade 4, Minisequence V. Since some children may not have

## TEACHING SEQUENCE

Suggest that they try to find out what happens to the temperature of the water. Have each child get a supply of water from the reservoir. He or she can use one of the 1-oz unit-measure cups. Each child will also need a thermometer, a medicine dropper and two additional small cups (or, 1 cup and a small piece of paper).

The children should then each get a sample of the white crystalline salt, called "hypo." They should measure out a level spoonful using either the 1/2-tsp measure or the small plastic teaspoons and place this measured amount of salt either in a small, dry, 1-oz cup or on a piece of paper and carry it back to their work areas.

- How does this salt compare in appearance with the sodium chloride?

Next, the children should put into an empty 1-oz cup, six droppersful of water from their supply. See if the children realize that the next step would be to measure and record the temperature of this sample of water before the salt is added.

Then, leaving the thermometer in place, have them allow the

## COMMENTARY

experiences this, or in any event did so many months ago, do not press for the "right" answer.

The hypo will usually be in the form of much larger crystals. Some children may even want to view them under their microscopes and repeat what they did in Activity 1 by adding a drop of water to a crystal of the salt.

They can measure out the droppersful of water as they did before.

## TEACHING SEQUENCE

hypo salt and water to interact. They should pour the sample of hypo into the water and use their thermometers to gently stir the mixture!

- What appears to be happening to the salt?

- What is happening to the temperature of the water?

- What was the temperature of the water before the salt was added?

- How much did the temperature of the system change once the salt was added?

## COMMENTARY

The cup, or the piece of paper, can very easily serve as a pouring aid for the salt. The mixture must be gently stirred to prevent breaking the thermometer.

Some or most of the salt is dissolving. With this ratio of water to salt, all will dissolve in time--particularly if the system warms up to room temperature on standing.

It is decreasing.

The water was at room temperature. Since everyone took the sample of water from the same reservoir, the readings will be very close. If there are slight variations, you might encourage suggestions as to why. Some variations may be attributed to the error of reproducibility--which has been discussed in Minisequence II. Errors may also be attributed to how the child read the thermometer or to the instrument (stem slipping, etc.) In reading the temperature, be sure 1) that the bulb is completely immersed, and 2) the child's eyes are on a level with the liquid level in the stem of the thermometer.

Have the children report their findings. Not all readings will be alike. In addition to errors in the measurement of temperature, the children may have put slightly different amounts of hypo into slightly different amounts of water, which would yield different final temperatures. Different

## TEACHING SEQUENCE

- Hold the cup in your hand. What do you feel?

Focus the discussion on the temperature of the system before and after the two components were added together.

- If the temperature dropped, what can we say about the heat energy of the solution?

## COMMENTARY

crystal sizes would also mean more or less hypo in the 1/2 teaspoon.

A typical result is: Using 25°C water, the temperature dropped to 11°C when 1/2 tsp of hypo was added to six droppersful.

The cup will feel quite cool. If some children are still not convinced that the temperature went down, or expect any water sample to feel as cool, they can put a fresh sample of water in another cup and feel it; if some think that the salt was cold to start with, have them check the supply with a dry thermometer.

You may want to record the temperature change found by a number of children on the chalkboard, and average them.

Heat energy was absorbed in the process of making the solution. Recall the concepts on heat energy which were extensively developed in Grade 4. They should recognize that heat energy depends not only on the temperature of a sample but also on the amount of the sample. In comparing equal-sized samples like the ones they used, the temperature alone would be a yardstick of the heat energy.

If they appear to have some difficulty with this question, ask them what they would have to do to bring the temperature back to that of the original hypo and water (e.g., 25°C). Their responses should include the statement that you would have to heat it, or, more precisely, place it in contact with a source of

## TEACHING SEQUENCE

Help the children to recognize that some heat energy seems to be "lost," as indicated by the fact that the temperature of the solution is much less.

- Where is the "lost" heat energy?

2. Now ask the children to recall what happens to the heat energy of a sample of water when a piece of ice is added.

## COMMENTARY

heat energy so that heat energy could be added.

Most children will recognize that this lost heat energy was being "used" as the salt was dissolving because that was when the temperature dropped. Some children may suggest that the heat energy was lost to the surrounding air. This is partially true but it is also true that the salt, which was originally at room temperature, added some of its own heat energy to the total making up the mixture!

This is a review of Activity 1 of Minisequence V, in Grade 4. The "loss" of heat energy as the salt dissolves is directly analogous to the "disappearance" of heat energy when ice melts in a sample of water. If the children have not had the Grade 4 COPES experiences, including Minisequence II of the Water Mix, they probably will not be prepared to make this analogy. In that case you may want to prepare them for doing so by the following Activity: Have them add 1 oz of iced water (at close to 0°C) to 1 oz of room temperature water, like they have been using, and record its temperature; then have them add 1 oz of crushed ice (at close to 0°C) to 1 oz of room temperature water and record the temperature again. In the latter case, the temperature will be much lower. Again, heat energy seems to be "missing"--it is

## TEACHING SEQUENCE

- What is the heat energy used for in melting ice?
- Is there any similarity between the melting of ice in water and the dissolving of hypo in water?

Compare the situation here in the salt and water with what happens when heat energy interacts with ice and transforms it into a liquid.

In summarizing, help the children to make the jump to the understanding that the "missing" heat energy was added to the energy of the more freely moving dissolved salt molecules, just as it was to the more freely moving molecules of water, or paraffin, or any other melts they observed.

## Part B

The children have now seen what happens to the temperature of water when a salt is added to it.

## COMMENTARY

absorbed in the process of liquefying the solid ice.

To break the bonds holding the water molecules in the solid structure.

In both instances, a mobile liquid was formed from a rigid solid. Help the children realize that when water was present with the salt, the attractive force between the two kinds of molecules pulls the salt molecules away from the mass of solid material. As a result, the salt particles, or molecules, have greater mobility; they move about much more freely among the liquid water molecules.

Again, as the molecules of water in the ice structure are freed from the bonds holding them, the water molecules then can move about much more freely. In fact, one might even say that solid ice "dissolves" in liquid water.

## TEACHING SEQUENCE

- Do you think it would make a difference in the temperature that the salt-water system comes to if the water were added to the salt, instead of vice versa?

For those who wish to do so, suggest that they try making another mixture of hypo and water, using the same amounts as they did before, but this time adding the water to the salt.

- On the basis of your results, would it be safe to say that the temperature of a salt-water system goes down as a result of the interaction of the two substances?

Tell them that they will now be able to see what happens to four other salts when each is allowed to interact with some water. Point out the different salt supplies.

The children can work in teams of two. Each team should obtain 4 small dry cups, 1 5-oz to 8-oz cup for a supply of

## COMMENTARY

At this time it will be difficult for the children to predict. They may suggest it makes no difference, since both the salt and the water are the same temperature.

The intent here is to lead up to to simplifying the procedure somewhat so that they can obtain supplies of salts and then add water to the salts. In Part A, it was important for them to focus attention on what was happening to the temperature of the water. Thus, they had to add salt to the water in their initial experience.

They should observe the same order of temperature decrease. (Be sure that the thermometers are rinsed before proceeding. Advise the children that they must always rinse before testing a new system, to avoid contamination.)

See if the children realize that they have no grounds for a generalization because they have tested only one "salt"-- hypo.

At this point, set out the 5-oz to 8-oz cups and the remaining salts, numbered 1 through 4, in their respective containers.



## TEACHING SEQUENCE

water, 2 medicine droppers, 2 thermometers, 2 paper towels, and Worksheet III-1.

Have the teams number the four dry cups to correspond to the salts they will be taking. Then each child in the team should take two of the cups and place a level  $\frac{1}{2}$  tsp of the labeled salt in the cup.

## COMMENTARY

They must be sure that cup labeled 1 has the No. 1 salt in it, 2 the No. 2 salt, etc.



When they have their salt supplies, they should bring the cups back to their work areas and place them on a piece of paper toweling. Before adding water to each salt, encourage the children to observe each one and describe its appearance.

SALT	TEMPERATURE OF THE SALT-WATER SYSTEM		CHANGE IN TEMPERATURE WITH TIME	OBSERVATIONS
	Start	Finish		
1				
2				
3				
4				

## TEACHING SEQUENCE

• Do the salts look alike?

As before, they should measure and record the temperature of the water supply (and dry salts, if they wish). Then, each child should add six droppersful of the water to one of his or her two salts, insert the thermometer, stir gently, and note the temperature on the Worksheet. When it no longer changes, he or she should read and record it again. After they have tested one salt, they should rinse off the thermometer and test the second salt. Be sure the teams share the data, so that each child will be aware of what happens in each of the four salt-water systems.

Some typical results are listed below:

SALT	TEMPERATURE OF THE SALT-WATER SYSTEM		CHANGE IN TEMPERATURE WITH TIME	OBSERVATIONS
	Start	Finish		
1 Sodium chloride (table salt)	25°	24°	1° cooler	a lot of salt left
2 Ammonium chloride	25°	9°	16° cooler	some salt left
3 Ammonium alum	25°	23°	2° cooler	a lot left
4 Magnesium sulfate (epsom salts)	25°	20°	5° cooler	very little left (eventually disappeared)

Encourage the children to discuss their results.

If sodium acetate was tested, they would have observed, in a typical test, that the temperature of the water dropped from

## COMMENTARY

They will all be white, some more powdery than others. At this point it might be appropriate to give them the common name for each.

## TEACHING SEQUENCE

- Did all the salts behave in the same manner? Did the systems all decrease in temperature by the same amount?
- What can we say about the heat energy needed to assist in dissolving the salts?

A schematic representation of the events, such as the one shown at the right, may be useful in the discussion. Emphasize that heat energy from the system is absorbed in the formation of the solution, and point out that the solution contains salt as well as water in the liquid state.

Did all the salt-water systems act in the same way in other respects than heat energy?

- What happened in the case of the hypo?
- Although there are differences, was heat energy absorbed as dissolving took place?

## COMMENTARY

25°C to 16°C with almost all the salt dissolving. Room has been left on the Worksheet for including this substance. The children could also add the results of their investigation of hypo to the Worksheet.

The children may respond that all the systems decreased in temperature, but some more than others.

Some systems used more heat energy than others.

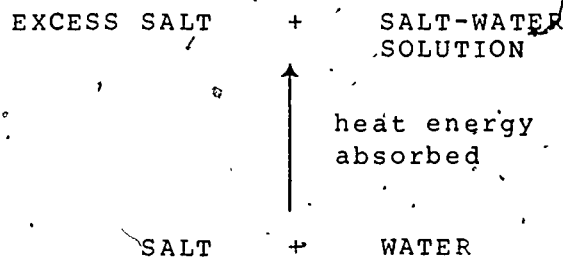

You might wish to display the above on oak tag, as this schematic can be used again, in Activity 4.

Some systems seemed to have dissolved more than others. For instance, in the case of the sodium chloride, there was a lot of salt left in the cup after the temperature stopped going down. The same was true of the alum. Very little epsom salt was left.

It all seemed to dissolve--or at least most of it.

Yes, in all cases investigated so far, heat energy appeared to be absorbed. (Some salts show a rise in temperature when dissolved. They will be investigated in Grade 6, Minisequence II.)

## TEACHING SEQUENCE

- Where is this absorbed heat energy?

## COMMENTARY

By now, the children should be able to infer that the absorbed heat energy is present in the freely moving molecules which make up the liquid solution.

Have them save the cup with the sodium chloride for Activity 3. It can be covered to retard evaporation. The other solutions can be discarded and the cups and thermometers rinsed for later use.

You may want to administer the first Part (9 items) of the Assessments after you have completed Activity 2. This will break up the work for the children and allow you to assess their progress so far.

## EXTENDED EXPERIENCES:

Some children may be interested in seeing crystals of the salts re-form from the solutions they have just made. Although they have performed some recrystallizations in earlier grades, it might be opportune to repeat this now. They can work with the solutions of sodium chloride, magnesium sulfate, and ammonium chloride, which will form cubic, rhombic and needlelike crystals respectively. (Do not have them recrystallize either the hypo or the sodium acetate since they may "supersaturate" and not reform crystals readily. This would interfere with what will be developed in subsequent Activities.) If there is too little solution to work with, they can make more solution, but use the same ratio of salt to water. For instance, the 1/2 tsp of salt plus six droppersful of water would correspond to about a tablespoon of salt to 1 oz (30 ml) of water. They can decant (pour off) the liquids and set them aside for crystals to form. (Note that in order to obtain reasonably large crystals, the children must allow only the clear solutions to "dry." The presence of extra undissolved solid may mean that only very tiny crystals will form.) Some crystals may appear within the hour if placed on a slide; some will do so overnight. "Drying" time is influenced by such factors as the temperature and relative humidity of the room.

A convenient way for them to evaporate the solutions is to invert a squat plastic cup sold as an "old fashioned" glass and put a drop or two of solution on it. The bottom of the cups

usually have a rim and retain the liquid. Since the cup is transparent, the resulting crystals will be readily viewable with the magnifying lenses. Some children may want to place them on a slide and view them with their microscopes.

### Activity 3 Some Properties of Salt-Water Solutions

In this Activity the children investigate the properties of a saturated solution--one which contains as much dissolved substance as the liquid can hold. Two criteria are established by which they judge saturation: 1) if excess solid salt is present in the liquid solution, then the solution is saturated and 2) if a crystal of the dissolved salt were placed in a sample of a saturated solution, it would not dissolve.

The children will discover that in some salt-water solutions the amount of salt which will saturate it varies with the temperature. Of the two salts investigated, sodium chloride does not appear to increase its solubility as the temperature of the system is increased, whereas sodium thiosulfate (hypo) exhibits a large increase in solubility. As the temperature rises, more solid goes into solution until, at any given temperature, a saturated solution is formed (as long as there is still undissolved solid present). This behavior is different from that of a melting solid: when heat energy is added to a solid as it melts, the temperature remains constant until all the solid is liquefied. However, the molecules making up the liquid, whether it is a melt or a solution, have more energy than the solid they came from. Thus, the concept is reinforced that the liquid state means a higher level of energy. The children make use of these concepts and criteria of saturation in the subsequent Activity, where they investigate a supersaturated solution.

#### MATERIALS AND EQUIPMENT:

For the class:

A supply of:

table salt, about 2 tablespoons

sodium chloride, pure, e.g., "Kosher" style, about 1 cup

sodium thiosulfate, hydrated crystals ("hypo"), about 1 cup

several wide-mouthed containers for the salts

supply of 1/2 tsp measuring spoons for each container

supply of wooden splints or popsicle sticks, near each container

chopped or crushed ice (optional)

5 set-ups for rinsing test-tubes and thermometers

paper towels

4 polyfoam containers, 3-qt capacity

1 microprojector (optional)

For each pair of children:

1 1-oz (30-ml) cup containing sodium chloride solution and excess salt, from Activity 2

1 microscope

1 microscope slide

2 medicine droppers

2 test tubes, 4-in. by 1-in. (100-mm by 25-mm), heat resistant

2 thermometers,  $-20^{\circ}\text{C}$  to  $+50^{\circ}\text{C}$

1 jar to serve as a test tube "rack"

2 magnifying lenses

1 Worksheet III-2

small cups, optional

#### PREPARATION FOR TEACHING:

For Part A, the children will need the microscopes, slides, the 1-oz cups of sodium chloride solution and excess salt from Activity 2, medicine droppers, table salt and a small amount of plain water. You might also want to use a microprojector, if one is available.

For Part B, the children will need the two salts--sodium chloride and sodium thiosulphate (hypo), the test tubes, jars, hot water, thermometers, foam cups, and Worksheet III-2.

Set up several supply stations where the children can get the required materials. Be sure that the two salts are in different locations to avoid accidental contamination. Number each container of salt--1 (sodium chloride) and 2 (hypo)--and place



spoons and leveling sticks next to each one.

The wide test tubes are being called for instead of the more common 18-mm ones so that the plastic backed inexpensive thermometers can fit in. If you have only 18-mm test tubes, the plastic on the thermometers will have to be trimmed so that the thermometer can fit all the way down to the bottom of the test tube.

Half fill 2 water containers with water at room temperature and the other 2 with water at about 50°C. This usually can be obtained from the hot water tap. If so, the children may go directly to the tap for their supply of hot water. If there is no such tap available, you may have to heat up a supply of water. Later, these same containers will have to be filled with cool water (about 15°C).

#### ALLOCATION OF TIME:

The children will need about 2 hours for this Activity. (Less time will be required if the children investigate the sodium chloride and hypo concurrently in Part B.)

#### Part A

##### TEACHING SEQUENCE

Review with the class the observations they made on the different salts in Activity 2.

- Did each salt dissolve completely? Which did?
- What salts did not completely dissolve?
- Why do you think all of the salts didn't dissolve?

##### COMMENTARY

Some children may want to refer to Worksheet III-1.

The hypo and the epsom salts dissolved completely when allowed to stand for a while.

The sodium chloride, ammonium chloride and alum did not dissolve completely. The alum left the most solid undissolved.

Some children may suggest, quite reasonably, that: (a) the attractive forces between some salts and water were small, or that the attraction became less as some salt dissolved or (b) that the water became so "crowded" with the dissolved salt that there was no room for more.

## TEACHING SEQUENCE

Have them again observe the cup with the sodium chloride and water prepared in Activity 2.

- Could any more salt dissolve in the water?

- How can you find out?

One way to find out would be to remove some of the liquid and test it with a solid crystal of sodium chloride to see if the liquid can dissolve it.

Each child should now take a glass slide, place a few (2 or 3) table salt crystals on it, place it on the microscope stage and get the crystal in focus, as they did in Activity 1.

Once the crystal is in focus, they should place a drop of solution on the crystal, being sure not to let any liquid touch parts of the microscope.

- How would you judge if the crystal were dissolving?

Ask them if they observe any changes around the crystal. When they indicate that they can see nothing happening to

## COMMENTARY

Encourage them to think about this. Apparently the liquid contains as much of the solid in dissolved form as it can hold.

Encourage suggestions. If some children suggest putting some more crystals in the cup, ask how they could tell the added ones from those already on the bottom.

Here again, if a microprojector is available, you might consider projecting what the children are asked to view with the microscopes.

If children seem to have difficulty managing it for themselves, a teammate can add the drop of solution.

Based on their experience in Activity 1, the crystal would eventually disappear, before which the edges of the cubes would start to round off.

The solid pieces of salt will appear unaffected. In the discussion help the children to see that once solution has been

## TEACHING SEQUENCE

the solid, introduce the term saturated solution. Refer to the observation under the microscope as a test confirming their idea that no more solid can dissolve in such a solution.

- Suppose some plain water were added to the saturated solution, would anything happen to the crystal?

Someone will eventually suggest that they put a drop of water onto the saturated solution on the slide, thus making it dilute, and observe the salt crystal.

- What happens to the crystal now?
- If you added more salt crystals, would they continue to dissolve indefinitely?
- If you had two clear liquids and were told that one was a saturated salt solution and one was not, how could you tell which was which?

## COMMENTARY

formed, and there is still extra solid in the container, as there was in the cup, they can feel confident that as much solid as possible has dissolved in that amount of liquid. Once extra solid is present, the liquid above it is considered saturated. We can say that there is an equilibrium between the extra solid and the solution.

If plain water were added, then the liquid portion would consist of a mixture of saturated solution and water. The added water could accommodate some salt and thus some dissolving could possibly take place. Such a solution would be diluted and is then called unsaturated.

The crystal now will show signs of dissolving--the edges will start to round off, and it may eventually disappear.

No--when the liquid again became saturated, that is, when it took in all the salt molecules it could accommodate, no more salt would dissolve.

See if the children suggest placing some of each on a salt crystal. The solution which did not dissolve any of the crystal would be the saturated one.

At this point, the microscopes

## TEACHING SEQUENCE

## Part B

1. Focus attention again on the 1-oz cups containing the salt solution and undissolved solid.

- How do you think we can get more salt to dissolve?

To those who suggest adding water, agree and ask what effect that would have on the heat energy of the system.

- How can heat energy be added to the salt-water system without increasing the amount of material?

Have each team of children take two clean test tubes. They should also obtain 2 thermometers, a jar to hold the tubes, 2 polyfoam cups, and a supply of room temperature water. Ask them to prepare 2 salt-water systems by putting 1/2 teaspoon of sodium chloride in each test tube and adding 3 droppersful of room-temperature water to each tube.

- How much salt do you predict

## COMMENTARY

and slides can be put away.

Some children may suggest adding more water. Their immediate experience would certainly suggest this.

The children may remember that heat energy depends on both temperature and amount and therefore realize that adding more material to a system also increases its heat energy. Some children may be able to hypothesize that since heat energy was absorbed as the solution was forming, adding heat energy may promote more dissolving.

Heat energy can be added by increasing the temperature of the system.

The children will observe the effect of raising temperature on one salt (sodium chloride) and then repeat the observations on a second salt (hypo). If you have sufficient test tubes and thermometers, you may consider having each team investigate both salts at one time.

The reason for taking less water is to ensure that there will be a saturated solution (containing excess solid) both before and after heating.

Of course, the answer to the

## TEACHING SEQUENCE

After they add the water, have them swirl the two test tubes and compare the liquid and solid levels once the contents settle down. The levels can be sketched in on Worksheet III-2. Then they can place the test tubes in the glass jar.

Now have each team prepare a double (nested) foam cup for their hot water bath. This double cup should be half filled with the hot water available in the reservoirs.

Now ask the children to insert a thermometer into one of the test tubes, read and record the temperature on Worksheet III-2. Do the same for the second test tube. Next, they are to take one of the test tubes, immerse it in the hot water bath they have just made and stir its contents gently with the thermometer. They should observe the temperature as they stir.

- What appears to be happening within the test tube?

Let the temperature rise to about 35°C. Once it reaches this level, the test tube should be removed from the hot water bath. Then the children should place it next to the unheated one and compare the contents. Again, the solid and liquid levels can be sketched in on the Worksheet.

## COMMENTARY

question is that there will be even more salt left over than before because less water is being added.

There will be equal amounts of solid and liquid in each tube. One will be used as a control, for purposes of comparison, and the other will be heated.

This can be done by dipping the inner cup in the reservoir and then replacing it in the cup.

For one thing, the temperature will be increasing.

They will find that the contents of both appear the same. There appears to be as much solid left on the bottom as before, even after adding heat energy!

Before Heating

TEMP. \_\_\_\_\_°C    TEMP. \_\_\_\_\_°C

After Heating

TEMP. \_\_\_\_\_°C    TEMP. \_\_\_\_\_°C

Salt  
1

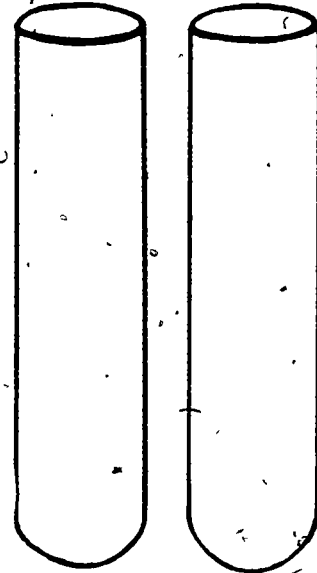
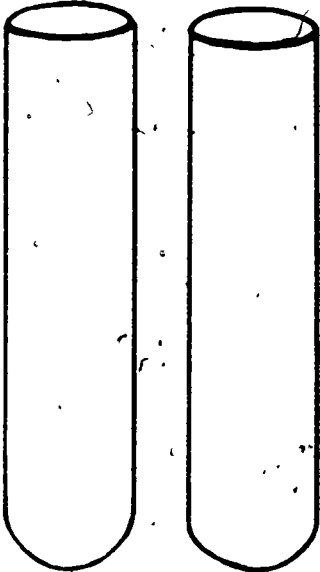

CONTROL

CONTROL

Before Heating

TEMP. \_\_\_\_\_°C    TEMP. \_\_\_\_\_°C

After Heating

TEMP. \_\_\_\_\_°C    TEMP. \_\_\_\_\_°C

Salt  
2

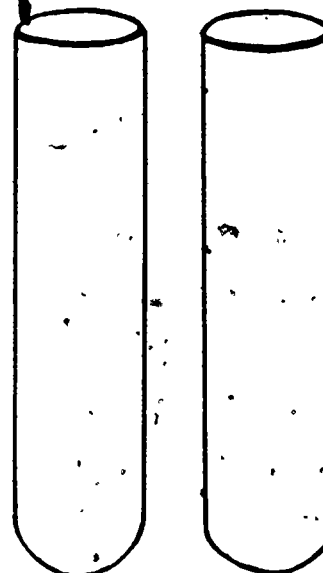
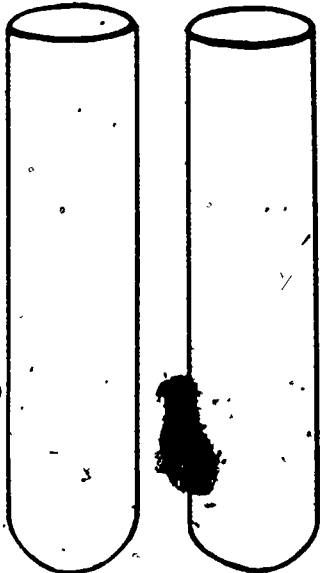

CONTROL

CONTROL

## TEACHING SEQUENCE

- How do you know that heat energy was really being added?

- Did the added heat energy cause any more sodium chloride to dissolve?
- On the basis of your results, could you draw conclusions about the other salts you have been investigating?

2. Suggest that they experiment in an identical way with one of the other salts--"hypo."

Discuss the previous observations they made with the hypo:

- How did its interaction with water compare with that of sodium chloride?

Each team should put 1/2 teaspoon of hypo into each of the two test tubes. But since they observed that the hypo was so much more soluble, they should put only one dropperful of room temperature water into the salt crystals. Then the contents should be swirled while both tubes are carefully observed.

- How do the contents of the tubes compare with one another?

## COMMENTARY

The temperature rose in the tube which was immersed in the hot water bath. Based on experiences in Grade 4, they discovered that heat energy was transferred between samples of liquid, separated by a glass wall, from the sample at the higher temperature to the one at the lower temperature.

Not to a noticeable extent.

Since they have investigated only a single substance, help them to see that it is invalid for them to make such inferences about other salt-water systems.

Have them discard the sodium chloride solutions and rinse the test tubes and thermometers.

They might recall that in the case of the hypo not only did a large amount of solid dissolve, but also there was a larger decrease in temperature.

They should sense again that the temperature decreases. There will be a small amount of liquid above the crystals.

After the solid settles down, there will appear to be about the same amount of solution and of extra solid in each tube.

## TEACHING SEQUENCE

The levels of solid and liquid should be sketched in on the lower left of Worksheet III-2.

- How do the contents compare with the sodium chloride water systems?
- What can you say about the liquid part? Is it saturated?

Now have them get a fresh supply of hot (50°C) water in their double foam cups. Insert a thermometer in one of the tubes, and place it in the hot water bath. Slowly stir the contents with the thermometer.

- What appears to be happening?

Once the thermometer registers about 35°C, the children should remove the tube and observe the contents.

Again, have the children place the unheated control tube next to the heated one. They should compare the two systems and sketch in the levels of solid and liquid on the Worksheet.

- Did adding heat energy have an effect on dissolving hypo?

As they observe both tubes, ask whether the solution in each tube is saturated.

## COMMENTARY

Since there was less water added, there is less liquid.

It is a hypo-water solution. Since the solution is above excess solid, they should be able to infer, from the criterion they have established, that the solution is a saturated one.

As before, the other thermometer should remain in the unheated "control" test tube standing in the jar.

The temperature will rise, just as it did with the sodium chloride.

There will now be a noticeable difference in the amount of excess solid salt. A large proportion of the hypo has dissolved.

A noticeable effect--The children should realize that the tube at the higher temperature was able to dissolve much more salt than the one at room temperature.

Since both solutions are in contact with some solid which did not dissolve, the liquid solu-



## TEACHING SEQUENCE

- Which solution contains more salt?

Compare the energy of the two systems--the solution at 35°C and that at room temperature.

- How does this hypo-water solution system compare with the one you investigated with the sodium chloride and water?

Now refocus attention on the hypo solutions. As they observe the two tubes, ask the children what they would expect to happen in the warmed tube if it were cooled back down to room temperature, i.e., to the temperature of the control tube, which was not heated at all.

## COMMENTARY

tion in both the heated and unheated systems are saturated. Each contains as much salt as it can hold. The heated system, however, can hold more dissolved hypo.

Obviously the one which was heated. Since there is so much less solid there we can surmise that the "missing" solid went into solution.

Since heat energy was added to the saturated solution at the higher temperature, it must contain that absorbed energy. Help the children to realize that the higher energy is not only due to its higher temperature, but also to all the salt molecules in it which were freed from the solid salt and are now part of the mobile liquid.

If the children have been experimenting with both systems at the same time, the difference in behavior of the two salts with the increase in temperature will be quite dramatic.

At this point the children may correctly suspect that at least a small additional amount of sodium chloride went into solution when the temperature was raised. Gross observation simply did not reveal it.

If they understand some of the concepts of reversibility, as developed in Grade 4, they may expect the extra salt which dissolved at the higher temperature to precipitate out when the system is cooled down--that is, when the extra heat energy is taken away.

## TEACHING SEQUENCE

- How could you lower the temperature of the warmed tube back to the temperature of the control tube?

At this point, have some reservoirs of cool water available. Either use water from the cold water tap or add several ice cubes to water at room temperature to ensure that it will be cool (about 15°C would be fine). Then have them pour out the hot water from the double foam cups and replace it with cool water. Next, they should insert the test tube containing the warm solution, and its thermometer, into the cool water bath. They should stir the solution gently and as soon as the temperature reaches that of the control tube, they should remove the tube from the bath and observe the contents.

Ask the children to report their observations.

- Did the system behave as expected?

## COMMENTARY

Surely one of the suggestions will include placing the tube in very cool water, because adding heat energy was accomplished by placing the tube in hot water.

By placing it in cool water, there will be a transfer of heat energy out of the hot tube and into the cooler water--reinforcing the idea of heat energy transfer from higher temperature to lower temperature.

Many crystals will have formed. However, their appearance may not be identical to those of the control--they may be much smaller. This happens when crystals form quickly. But there should be a large quantity of them and there will be only a small amount of solution, as was the case with the control.

Help the children recognize that as they reversed the situation and removed the added

## TEACHING SEQUENCE

- How do these observations compare with what happens to a liquid melt when heat energy is removed from it?
- What happens to the temperature of a melting system as heat energy is added?
- What happens to the temperature of a hypo-water system as heat energy is added?

## COMMENTARY

heat energy from the system, the original conditions were attained again--that is, a lot of undissolved salt and a little solution. All the extra dissolved salt "precipitated out"--it reformed solid hypo crystals when heat energy was removed.

Changes of state are also reversible. When heat energy is removed from a melt, it causes the solid to reform. (See Activity 4 of Minisequence V in Grade 4.)

For those children who have done Activity 3 of Minisequence V, in Grade 4, they observed that as ice was being melted with the addition of heat energy, the temperature of the ice and its melt (water) remained at or near 0°C until all the ice disappeared. (See below.)

The temperature rises steadily while solid is still present--although more and more solid goes into solution as the temperature continues to rise.

In order to help reinforce the distinction between these two solid-liquid processes, for children who have not had the Grade 4 experiences, you might have them take one of their test tubes (rinsed) and fill it with crushed or broken ice. Then have them add one dropperful of ice-water to the ice. (This will ensure that the bulb of the thermometer will be immersed in the mixture of ice and water.) Insert their thermometers, stir and note the temperature once the liquid level in the stem of the thermometer no longer changes. It

## TEACHING SEQUENCE

## COMMENTARY

• When a solid is melting, what happens if you add more solid to the mixture?

• When a solution is forming, what happens if you add more solid?

During a summarizing discussion, the following should be reinforced:

(1) A solution is considered saturated when it is in the presence of excess solid.

(2) In some cases, more salt can be dissolved if heat energy is added, by raising the temperature.

(3) A solution saturated with salt at one temperature, may be able to hold more salt at a higher temperature.

(4) Removing the heat energy-- lowering the temperature-- caused the extra dissolved salt to re-form solid and precipitate out.

should read close to  $0^{\circ}\text{C}$ .

The children can read and record the temperature of this system as it is being stirred. As indicated above, they will find that the temperature remains at about  $0^{\circ}\text{C}$  until all the ice has disappeared. Then the temperature rises.

As long as there is heat energy available, the solid will continue to liquefy (melt).

If the solution is saturated, the added solid just remains there--they found that once a solution was saturated, it could not dissolve any more salt; if it is not saturated, the solid gradually disappears as it becomes liquefied.

Of course more salt can be dissolved if more water is added.

## EXTENDED EXPERIENCES:

1. Some children may be interested in using the microscope to test other salt-water systems to see if their saturated solutions will dissolve more solid. If they do, be sure that the solutions are really saturated. Sometimes it takes considerable elapsed time to ensure this. For instance, magnesium sulfate (Epsom salts) may have to be left overnight to ensure saturation. Be sure that there are still extra crystals left at the bottom if children want to test the solution on a fresh crystal.
2. If they want to pursue the effect on solubility of an increase in temperature, they can investigate other salts, but do not let them use hypo because it will detract from the teaching strategy in the next Activity. Ammonium chloride does not exhibit much of a difference in solubility with increased temperature; magnesium sulfate does. But if the solutions are not completely saturated at room temperature, they will not observe reversibility on cooling. Again, let any solutions stand overnight before they investigate them.

### Activity 4 The Reappearance of Heat Energy

This final Activity provides the children with further evidence regarding the conservation of heat energy. They discover that the heat energy absorbed (lost) as a given amount of salt dissolves in water reappears (or is released) when that salt precipitates out. It is possible for the children to keep track of such "heats of solution" because of the unique property of certain salts to form supersaturated solutions in water. A supersaturated solution is a solution (not in the presence of excess solid) which contains much more salt dissolved in it than the liquid should hold at that temperature. When the children attempt to test the liquid, using one of the criteria they established for saturation, they find that all the excess salt of the supersaturate precipitates out and the heat energy absorbed when the solution was formed is liberated concurrently. Because the children can feel and measure this release of heat energy, they develop an even better appreciation that solutions are at a higher energy level than the solids which form them. Thus the disappearance of heat energy is accounted for--it reappears when the system reverts to its original state. Heat energy is conserved..

#### MATERIALS AND EQUIPMENT:

For the class:

2 containers, polyfoam, approx. 3-qt (3-liter) capacity

supply of:

sodium thiosulfate, hydrated crystals (hypo), about 1 cup

sodium acetate, hydrated crystals, about 1 cup (optional)

paper towels

1 box safety matches

several wide-mouthed containers for the hypo

supply of 1/2 tsp measuring spoons for each container

supply of wooden splints or popsicle sticks near each container

For each child (or team of children):

- 2 test tubes, 4-in. by 1-in. (100-mm by 25-mm), heat resistant
- 1 test tube clamp
- 1 medicine dropper
- 1 cup, polyfoam, 6-oz to 8-oz (80-ml to 240-ml) capacity
- 2 thermometers, plastic backed,  $-20^{\circ}\text{C}$  to  $+50^{\circ}\text{C}$
- 1 candle, preferably approx. 1 1/2-in. by 2-in. (4-cm wide at base, 5-cm high) (food-warmer type)
- 2 pieces of aluminum foil, approx. 4-in. (10-cm) square
- 1 jar to serve as a test tube rack
- 1 small piece of cloth, dampened
- 2 pieces of paper, 2-in. by 2-in. (5-cm by 5-cm) (optional)

#### PREPARATION FOR TEACHING:

It may be difficult for children to prepare the solutions required in this Activity unless the test tubes are thoroughly clean and free of severe internal scratches. Therefore, wash out and select the test tubes. Even new ones may contain sawdust.

To reduce traffic you may want to set up more than one supply of the hypodermic. As in the earlier Activities, place spoons and levelers next to each container. Have the rest of the equipment needed by the teams of children in an accessible place, except for the thermometers. These will be distributed later in the Activity.

Add sufficient water at 20 to  $25^{\circ}\text{C}$  to the polyfoam containers so that each team can have a cupful. When the children start to heat their test tubes over the candle flame, have dampened small pieces of cloth or toweling available so that if soot collects on the bottom of the test tube, it can easily be wiped off. The dampened cloth can also be used, if necessary, to snuff out the flame.

#### ALLOCATION OF TIME:

The children will need about 2 hours to complete this Activity.

## TEACHING SEQUENCE

1. Review Activity 3 by asking how heat energy affects the amount of salt which can dissolve in a specific amount of water. Be sure that the children are aware of the concept of a saturated solution as one which contains the maximum amount of salt at a particular temperature. We can be sure a solution is saturated if there is extra undissolved salt present in the system.

- What have you found out about the effect of raising the temperature of a saturated hypo solution?

Suggest that they continue to investigate the hypo-water system which they found showed an increase in solubility as the temperature was increased.

Have each child obtain a supply of materials and equipment.

This should include 2 test tubes, 1 test tube clamp, 1 jar to serve as a test tube rack, 1 medicine dropper, and a polyfoam cup. Then they should go to one of the supply stations and put a level spoonful (1/2 tsp) of hypo in each of the test tubes. As before, each child should also get about 1/2 cupful of the water from the reservoir in the polyfoam cup.

- What will happen when some water is added to the hypo?

Now have them add some water, but this time add only 5-7 drops to each test tube.

## COMMENTARY

From their limited experience, they found that raising the temperature increased considerably the amount of salt which could be held in solution.

In addition to predicting that some of the salt will dissolve in the added water, they should also expect that the temperature will decrease.

Note that they are adding drops, not droppersful! This lesser amount of water is required so that they will observe a more



## TEACHING SEQUENCE

After they add the water, have them hold the bottoms of the test tubes in the palms of their hands.



•How does the bottom of the test tube feel?

## COMMENTARY

dramatic effect when they "destroy" the supersaturated solution they will be preparing. Also, although this concept will not be developed with the children in this grade, the hypo contains a great deal of bound water which is freed as the system is warmed and which contributed to the amount of water available for solution.

It may be difficult for some children to observe that any of the salt has dissolved, since such a small amount of water was added to the system. However, there will be a small amount of liquid solution at the bottom of the tube.

It feels rather cool, which should suggest that the temperature has decreased.

## TEACHING SEQUENCE

As they are observing and reporting on what appears to be happening in the tubes, review with them how heat energy might be playing a role in this interaction.

- Since the temperature decreased, what can you say about what might be happening with respect to heat energy.
- Where is it getting the heat energy from?
- Is the solution formed saturated or unsaturated with hypo salt?

You might put this initial part of a schematic diagram of the energy changes, along with changes in appearance, on the chalkboard:

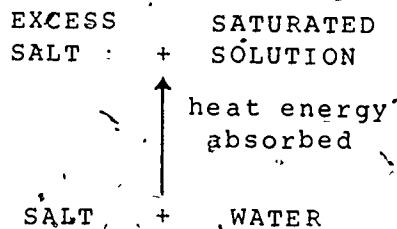

- How could you get more of the hypo to dissolve in the saturated solution?

Tell them that this time you wonder if they could get all the salt dissolved without adding water. How could this be done?

## COMMENTARY

As in Activity 2, heat energy seems to have "disappeared." It is being absorbed as some of the salt dissolves to a solution. Be sure the children realize that when a system becomes cooler (when its temperature decreases), it means that some interaction is occurring that is taking in heat energy.

From the surroundings: the tube, the room, the water itself.

Since there is excess salt present, the small amount of solution formed must be saturated.

If you made a display poster of the schematic earlier, you might bring it out again and modify it.

Such an experiment was performed in Activity 3, so undoubtedly they will suggest adding heat energy to it to raise its temperature.

Since they observed that in-

## TEACHING SEQUENCE

Show them the candles and tell the class that they can use these as a source of heat energy. Distribute one to each child, together with 2 pieces of aluminum foil. Have each child set up his or her own candle heat source.

## COMMENTARY

creasing the temperature increased the amount of hypo dissolved, they should suggest bringing the temperature up even higher than  $35^{\circ}\text{C}$ . Some suggestions may include "put it on a hot plate." All of these are valid.

One piece of aluminum foil is used under the candles to protect the work surfaces; the other can be wadded and used to snuff out the flame later. You may want to place an asbestos square under the foil. If the squat, food-warmer candles are not being used, the children may have to use some plasticene as a holder for the more slender candles. Have the children shape it into a ball, flatten one end so it sits firmly on the table and insert the candle into the plasticene.

The candle, which is familiar and readily available, has been chosen as the source of more intense heat energy. Water at about  $90^{\circ}\text{C}$  would also serve as well but you would have to have a pot of boiling water in the room and the children would have to renew their supply frequently since the hot water baths would cool off. Also, the visible flame is more of an alert to a child of the high temperature than a container of scalding hot water would be. Canned heat in the form of Sterno, which is also used as a food warmer, can substitute for the candles. However, its flame is at a higher temperature

## TEACHING SEQUENCE

Give each child a piece of dampened cloth. Tell them that they can use it to wipe off any soot if some collects on the bottom of the test tube as they heat it over the candle flame.

Now show them how to place the test tube clamp around one of the tubes.

To avoid inadvertently releasing the tube, the clamp should be held near the end as shown in the diagram.

After checking each site and child for safety, light the children's candles. Advise them to heat the tube gently over the flame while observing what happens inside. Ask them to remove the tube from the flame as soon as all the solid in it dissolves. One way of

## COMMENTARY

and not as visible as that of the wax candle. Whatever heat source is used, be sure that standard precautions are observed. In addition to whatever is directed by your school, the following should be emphasized:

- (1) Hair must be tied back, no loose strands.
- (2) No long or loose sleeves.
- (3) Do not stretch arms over the flame to get at an object.
- (4) The candle must be placed in an area clear of books, papers, etc.
- (5) When the contents are to be observed, the children must bring the tube away from the flame to avoid leaning over it.

The other test tube should remain in the jar. Its contents will serve as a control and should always be visible so that the children can see what the system looked like before heating.

Remind them to hold the open end of the tube away from themselves and from any other child working near them.

Optimally, the tube should be held just a little above the flame of the candle--this will minimize the formation of soot. Many children will tend to hold the tube within the flame.

In judging if all the solid has dissolved, be sure they look at

## TEACHING SEQUENCE

being sure all solid is dissolved ~~is~~ to look at the sides and down the tube to be sure that no crystals are adhering to the sides or bottom.

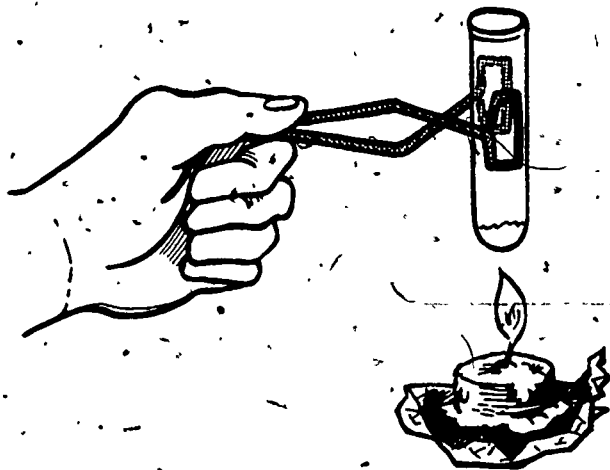

Once the solid is all dissolved have them place the tube with its liquid contents gently in the jar which serves as a test tube rack. Then tell them to snuff out their candles.

Now discuss what has been happening to this system, with particular emphasis on the role of heat energy. Such questions as the following may be used:

- What did the heating accomplish? What happened as a result of the system absorbing all that heat energy?

## COMMENTARY

the contents of the tube away from the flame.

Be sure they do not overheat the contents; otherwise, the solution will start to boil. Thermometers have not been used, as they were in the previous Activity, because the temperature will be much higher than their 50°C upper limit. The temperature will be above 65°C. If the children want to know the temperature, you can check it for them with a clean thermometer which has a greater range, e.g., to 100°C or 110°C.

It raised the temperature of the system. In addition, all the solid salt dissolved. Instead of any solid being present, everything is in the liquid state.

Based on their prior experiences, the children should be able to show their understanding that the added heat energy absorbed by this system was used in freeing the hypo molecules from the bonds holding them in the

## TEACHING SEQUENCE

- How do the contents of this tube compare with the one you warmed in Activity 3?
- How do the contents of this tube compare with the control tube?

At this point, add to the schematic diagram:

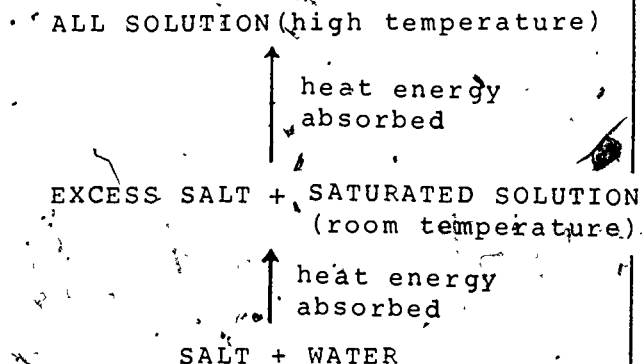

2. The children are now ready to prepare a different kind of solution. Ask them to carefully take the tube with the clear solution, which had been cooling off in the jar, and place it gently in the poly-foam cup which contains some cool water. The tube should cool in the water for 2 or 3 minutes.

## COMMENTARY

solid structure. This energy then became part of the greater energy of the freely moving hypo molecules in the liquid solution.

For one thing, it is at a higher temperature; for another, there is no undissolved solid hypo.

It should be apparent to the children that the system that was heated possesses more energy. The test tubes contain the same amounts of material (hypo and water) but their temperatures are, of course, different and the contents in one are in the liquid state. The control tube contains saturated solution and a lot of undissolved solid.

Before the children begin this Section, refill the large poly-foam containers with cool water slightly below room temperature—about 20°C.

The tube should be handled gently, disturbing the contents as little as possible. If the tube were placed in the cool water immediately after heating, the shock of the difference in

## TEACHING SEQUENCE

- What is happening with respect to heat energy when the tube is in the cool water?
- What do you predict will happen to the temperatures within the tube and in the surrounding water?
- What do you think will happen to the contents of the tube when they cool to room temperature?

After 2 or 3 minutes, or when the discussion is completed, have each child carefully remove the tube from the cooling water and gently place it in the jar next to the control tube. As they do so, have them feel the bottom of the tube.

- Is it still hot?
- What about your predictions about the appearance of the contents? Were they verified?
- Are their temperatures different?

## COMMENTARY

temperature would precipitate the solid prematurely.

The higher temperature tube and its contents will be transferring some heat energy to the cool water surrounding it.

The tube contents will cool down; the surrounding water will warm up.

Undoubtedly some children will expect that once the contents are cooled to room temperature, solid hypo will come out of solution and look like the contents of the control tube. As the children discuss their expectations, encourage them to use the expression "to precipitate" when they refer to the solid coming out of solution.

No, it will have cooled off. As it sits in the air, its temperature will approach that of the other tube. Both will be at room temperature.

The contents of the tube which had been heated are still all liquid. Most children will be extremely surprised and puzzled because in their prior experience cooling down precipitated the solid.

Apparently not. (They can gently touch the bottom of the





## TEACHING SEQUENCE

• Now that both tubes are at the same temperature, is there any difference?

• What was the difference in treatment of the two solutions?

• Do you think that one now contains more energy than the other?

• But where is the heat energy?

Now have each child remove the tube containing all liquid and hold the bottom in the palm of his or her hand. They should hold the tube at about eye level, so they can easily observe the contents.

## COMMENTARY

tubes to test.)

They are at the same temperature; they contain the same total amount of materials. Yet they are not alike. One (the control) contains solid plus solution; the other is all solution.

One had heat energy added to it--its temperature was raised until all the extra solid dissolved.

Encourage all responses. The fact that one is all liquid, although both are so similar in the respects noted above, should provide a clue for the children. As they discuss this question, refer to the schematic you have placed on the board. They should be able to recognize that the contents of the tube containing all liquid are at a higher energy state than those in the tube containing solid salt plus solution. If some children need additional help, refer to the differences in energy between a solid and its melt (its liquid). As developed in "Change of State" in Grade 4, and reviewed in Activity 1, there is a hierarchy of energy states from solid to liquid.

Let the children discuss this question before proceeding with the next step.

## TEACHING SEQUENCE

## COMMENTARY

As they look at the contents of the tube, ask whether the solution is saturated or not.

- What about the liquid in the other tube?

Have them recall the tests they did to tell if a solution were saturated or not.

- If you test this solution with a small crystal, what do you expect to happen?

Have each child place a few extra crystals of hypo on a piece of paper. Then encourage them to add a tiny test crystal of the hypo to the tube and see what happens.

The children may be uncertain as to whether the liquid is saturated. They may think that it is not because there is no excess solid present.

It is certainly saturated-- there is excess solid.

They added some solution to a small piece of the solid. If the solution was saturated, the crystal did not dissolve; if it was unsaturated, the crystal dissolved into the solution.

Encourage speculation. Some may possibly reason correctly that there is so much more solid in the solution compared with the control tube that the very reverse might take place-- solid will precipitate out. They will probably not be prepared for the large temperature increase. Don't alert them to this.

Each child should have a few extra crystals on the piece of paper used to get the original supply for the 2 tubes. It might be best to do this by having one child add the crystal to a partner's tube. Then after the observations they can reverse roles.

The response to what happens is likely to be immediate and dramatic. Two things will occur in rapid order: The excess salt in the supersaturated solution will precipitate, and the children will notice a sharp temperature rise at the bottom of the test tube. These events are likely to create considerable excitement.

## TEACHING SEQUENCE

## COMMENTARY



- Can you explain what happened? Where did all the solid come from?

Remind them of what they had talked about regarding the energy of the all liquid system compared with the control.

- In discussion, help the children to understand that the heat energy released when the solid hypo was reformed was present in the liquid in the form of the energy of the mobile hypo molecules. Introduce the term, supersaturated.

The tiny salt crystal acts as a nucleus around which the extra dissolved salt re-forms a solid structure. When that happens, the energy possessed by the mobile particles of the salt is released.

It had been dissolved and precipitated out of solution.

The extra energy which was present in the liquid came out of the system as heat energy.

## TEACHING SEQUENCE

Tell them that the liquid really had more solid salt dissolved in it than it normally should hold at room temperature. Help the children to recognize that adding a solid crystal to a saturated solution, an unsaturated solution, and a supersaturated solution all result in very different changes.

- Which is at a higher energy state--a supersaturated solution or a saturated one in contact with its solid?
- What evidence do you have?

The concept of reversibility should also be discussed at this point. Have them compare the two tubes now. After subjecting the contents of one tube to heating, cooling and then precipitation, the system, once it returns to its original state, has the same properties it started with.

Complete the schematic diagram as illustrated below and discuss the points raised. As you continue to develop the diagram, emphasize the role of heat energy and the changes

## COMMENTARY

The supersaturated one--even though both are at the same (room) temperature.

When the excess salt came out of the saturated solution, it released its extra energy. Everything got hot. In order to get this idea across, that heat energy is given up, this initial experience did not make use of thermometers. It was important that the children sense the system becoming hot and not associate the increase in temperature with a heat source outside the system. They might have thought that heat energy was being added to the system by an external agent.

They will observe that once the tube returns to room temperature, the contents look like those in the control tube: a little solution and a lot of solid.

The arrows indicate the absorption and release of heat energy and should reinforce the idea of reversibility with this type of interaction. Four steps are depicted:

TEACHING SEQUENCE

COMMENTARY

(1) The formation of the original saturated solution. This is not being remade. They are working with the salt, and saturated solution prepared earlier.

(2) represents the heating and preparation of the all-liquid system (solution) at a high temperature.

(3) represents the cooling down of the solution to room temperature but no precipitation occurs.

A supersaturated solution is now present in the tube.

(4) represents the addition of the seed crystal to the supersaturated solution accompanied by release of heat energy and the precipitation of the excess salt.

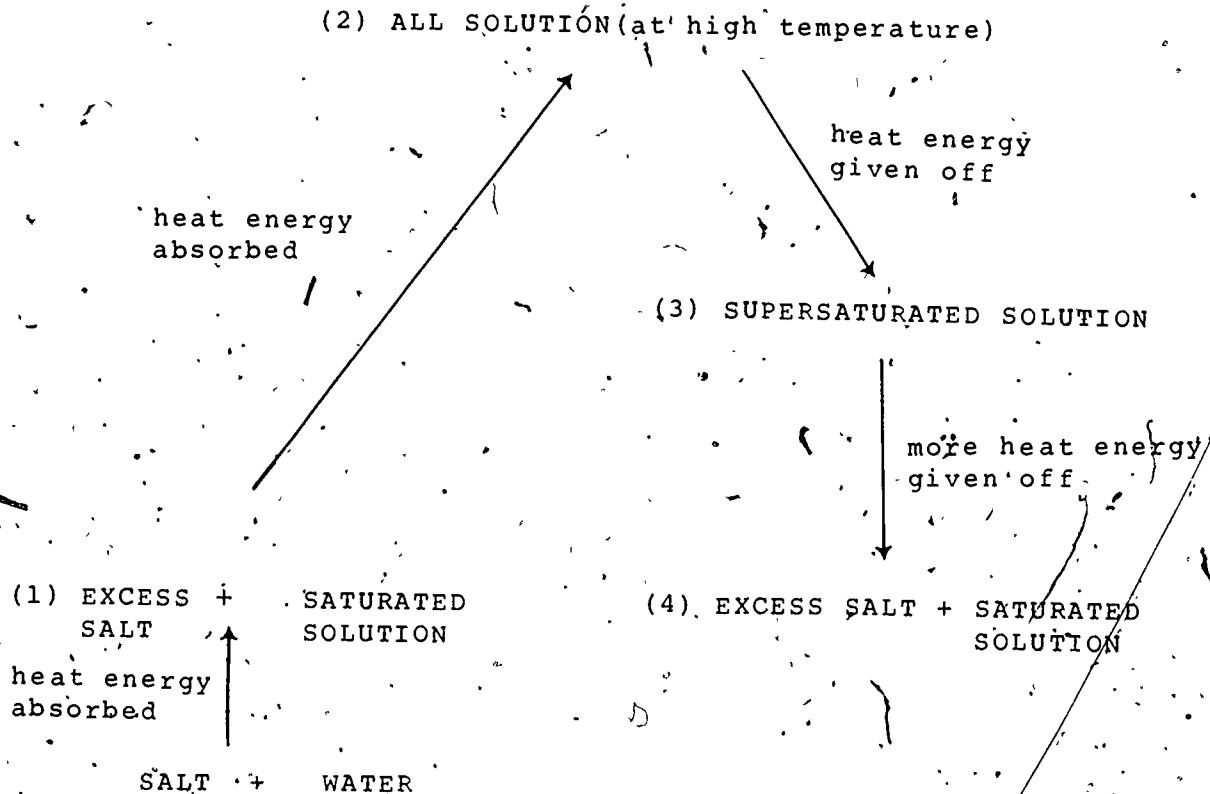

## TEACHING SEQUENCE

3. Relight the candles for the children, and, using the same two test tubes with the contents already inside, suggest that the children repeat the experiment, using a thermometer in the final step to measure the rise in temperature of the system as the hypo precipitates from the supersaturated solution.

Use the schematic diagram as a basis for discussion as to what is happening to the solid salt at each step and the role of heat energy as this step is taking place.

Once the children get to the stage of again having the all-liquid supersaturated solution (at room temperature), ask them to obtain a thermometer so they can follow what happens to the temperature within the system. Have them insert the thermometer, and then seed the supersaturated solution as they did before.

## COMMENTARY

In this part of the Activity, the children will repeat the preparation of the supersaturated solution and follow the absorption and liberation of heat energy, but with one difference--they will follow the release of heat energy from the system by inserting a thermometer into the supersaturated solution at room temperature and measure the temperature change after the seed crystal is added to the system. (Be sure they do not have the thermometer in the test tube while the all-liquid solution is being made because the temperature rises above the upper limit of the thermometer during heating.)

They are now at Step 4 of the schematic. As the precipitate forms, the temperature of the system will rise. A supersaturated solution at 25°C may, on precipitation, go up to 40°C or 45°C, depending on the ratio of salt to water.

If some children infer that heat energy is being added to the solution during this precipitation when they observe a temperature rise, ask them where the source of heat energy is to

## TEACHING SEQUENCE

The summarizing discussion should center about keeping track of heat energy as the salt dissolved and then as the original conditions were restored.

- In the preparation of the saturated solution (step 1), what was the role of heat energy? What happened to it?
- How was an all-liquid system formed?
- What was the role of the heat energy here?

Indicate on the schematic that now they have accounted for the absorption of heat energy in going from the salt and water, before any interaction, all the way up to the all-liquid system at the high temperature.

Next focus on the return or reverse "trip."

- What happens as the solution is cooled--as its temperature decreases back to room temperature?

## COMMENTARY

cause the temperature to rise. Help them to see that the heat energy must be coming from within the solution.

Use the schematic as a focus for these discussions.

It was absorbed by the system as some of the solid salt was freed from the solid structure. The absorbed heat energy was present in the freely moving, mobile molecules of hypo which became part of the liquid.

More heat energy was added by heating the system to a higher temperature in a candle flame.

In Step 2, heat energy was absorbed by the additional hypo molecules in the solid, which continued to go into solution. Heat energy was also absorbed as the temperature of the system increased.

You are now focusing on the downward arrows, representing the release of heat energy.

Heat energy is given off by the system in Step 3. The temperature is now back to that of the room but all the solid is still in solution.

## TEACHING SEQUENCE

- What is the energy state of this solution compared with the control, which wasn't heated at all?

Help the children to infer that this extra energy of the all-liquid supersaturated solution is in the greater energy of the freely moving hypo molecules, since they are all in the liquid state.

- What evidence do you have that the liquid molecules have more energy?

- Do you get the heat energy back?

In all the discussions help the children develop an understanding that the heat energy absorbed in dissolving the solid salts is present in the energy of the liquid salt molecules in the solution and is released (given back) when the solid re-forms. Not only is the process reversible, but heat energy is conserved--it can be accounted for at all stages.

## COMMENTARY

The all-liquid supersaturated solution has more energy in it.

Some children may leap to the idea that perhaps these invisible molecules, which are moving about so freely and thus have more energy, really have an energy of motion which they associate with the moving marbles in Minisequence II. That is, these liquid molecules possess kinetic energy. Such analogies are quite valid and such reasoning should be readily accepted. But whether or not the children are able to visualize what might be happening at the molecular level, the liquid state does possess more energy.

When these extra hypo molecules precipitate out as a solid, that extra amount of energy is given off by the system as it reverts to its starting condition.

Apparently in two stages. Yes, it seems to be accounted for.



## EXTENDED EXPERIENCES:

To broaden the children's experience to include another substance, the children can follow the same procedure with sodium acetate that they followed with hypo. They can use the same proportion of salt (1/2 tsp) to water (5 to 7 drops) in the test tubes. Of course, the tubes and thermometers must be carefully rinsed before proceeding. Very nice results are obtained with sodium acetate.

# Minisequence III Assessments

## Screening Assessments

The concepts being tested in this Minisequence are:

- a. In both melting and dissolving, a mobile liquid is formed from a rigid solid.
- b. When some solid salts form a solution with water, heat energy is absorbed from the water.
- c. The heat energy that is absorbed when a salt goes into solution appears as additional energy of the salt molecules in the solution.
- d. The mobile molecules of a melt or a solution possess more energy because they move about more freely than in their respective solids.
- e. Different salts have different solubility properties.
- f. A saturated salt-water solution contains as much salt as can possibly dissolve in that amount of water at that temperature.
- g. Increasing the temperature of certain salt solutions may increase the amount of salt which can be dissolved in a saturated solution.
- h. A supersaturated salt solution contains more dissolved particles than the same volume of a saturated solution of the same salt (at the same temperature).

There are two Parts to this assessment. Part 1 is aimed at the first four concepts in the list above and may be administered after Activity 2, if desired, or combined with Part 2 after Activity 4. Each Part takes about 8 minutes.

## PART 1.

Page A

Ask the children to turn to page A.

HERE ARE SOME QUESTIONS WITH THREE POSSIBLE ANSWERS EACH. READ EACH QUESTION AND ITS ANSWER SILENTLY WHILE I READ THEM ALOUD. AFTER I HAVE FINISHED YOU WILL HAVE A SHORT TIME TO SELECT YOUR CHOICE AND CIRCLE THE LETTER IN FRONT OF IT.

(Allow about 30 seconds for each choice. If you think it helpful to the children, read each question again as they select their choice.)

1. WHEN A SOLID CHANGES TO A LIQUID,
  - A. THE TEMPERATURE OF THE SUBSTANCE ALWAYS INCREASES.
  - B. THE MOLECULES OF THE SUBSTANCE MOVE MORE FREELY.
  - C. THE NUMBER OF MOLECULES INCREASES.
  
2. MELTING ALWAYS INVOLVES:
  - A. THE ADDITION OF HEAT ENERGY TO THE SYSTEM.
  - B. THE OVERCOMING OF SOME BINDING FORCES IN THE SOLID.
  - C. BOTH STATEMENTS A AND B ARE TRUE.
  
3. MANY SALTS GOING INTO SOLUTION INVOLVE:
  - A. THE ABSORPTION OF HEAT ENERGY FROM THE WATER.
  - B. THE OVERCOMING OF SOME BINDING FORCES IN THE SOLID.
  - C. BOTH STATEMENTS A AND B ARE TRUE.
  
4. WHEN SODIUM CHLORIDE (TABLE SALT) GOES INTO SOLUTION,
  - A. THERE IS AN ATTRACTION BETWEEN THE SALT MOLECULES AND WATER MOLECULES.
  - B. HEAT ENERGY IS GIVEN OFF.
  - C. HEAT ENERGY IN THE WATER MAKES THE SALT CRYSTAL SWELL AND BURST.

5. MORRIS ADDED A SALT TO WATER. THE TEMPERATURE OF THE LIQUID DECREASED. THE MOST LIKELY REASON FOR THIS OBSERVATION IS THAT:

- A. THE SALT WAS VERY COLD AND COOLED THE WATER WHEN IT MELTED.
- B. HEAT ENERGY WAS USED IN BREAKING APART THE MOLECULES OF SALT IN THE SOLID.
- C. THE SALT CAUSED SOME WATER TO EVAPORATE, THUS COOLING THE SYSTEM.

Page B

NOW TURN TO PAGE B.

6. SOMETIMES WE SEE ROCK OUTCROPPINGS WITH GREAT GASHES AND PITS IN THEM. IT IS MOST LIKELY THAT:

- A. LAYERS OF SOLUBLE SALTS WERE THERE WHEN THE ROCK WAS FIRST EXPOSED.
- B. EXPOSURE TO THE SUN EVAPORATED THE SALT.
- C. ANIMALS HAD USED UP ALL THE SALT AS A "SALT LICK".

7. WHEN DIFFERENT SALTS GO INTO SOLUTION IN WATER,

- A. ALL THE SOLUTIONS ARE SATURATED ONES.
- B. TEMPERATURE DECREASES ARE THE SAME FOR ALL SALTS.
- C. THE PARTICLES OF THE SALT MOVE MORE FREELY.

8. JANICE DISSOLVED SOME SALT IN WATER. THE TEMPERATURE DECREASES AS THE SALT GOES INTO SOLUTION, BUT SOME UNDISSOLVED SALT REMAINS IN THE CONTAINER. WHEN MORE OF THE SAME SALT IS ADDED, THE TEMPERATURE OF THE SYSTEM:

- A. CONTINUES TO DECREASE.
- B. STAYS THE SAME.
- C. INCREASES.

9. WHEN A SALT SOLUTION IS LEFT OPEN TO AIR,

- A. WATER MOLECULES TAKE UP HEAT ENERGY AND GO INTO A GAS.
- B. SALT MOLECULES RE-FORM INTO SOLID CRYSTALS AS THEY GIVE UP HEAT ENERGY.
- C. BOTH A AND B ARE TRUE.

## PART 2

Ask the children to turn to page C.

IN THIS PART THE QUESTIONS ON PAGES C AND D HAVE THREE POSSIBLE ANSWERS. READ EACH QUESTION AND ITS POSSIBLE ANSWER SILENTLY WHILE I READ THEM ALOUD. THEN INDICATE YOUR CHOICE FOR EACH QUESTION BY CIRCLING THE LETTER IN FRONT OF IT.

(Allow about 30 seconds for each choice. If you consider it desirable, repeat the question and the choices while the children are making their selections.)

## Page C

QUESTIONS 1, 2 AND 3 HAVE TO DO WITH DARRELL'S EXPERIMENT. DARRELL COMPLETELY DISSOLVED A SAMPLE OF HYPO CRYSTALS IN WATER AT ROOM TEMPERATURE AND THEN STORED IT IN A REFRIGERATOR.

1. THE TEMPERATURE OF THE SOLUTION WHEN HE REMOVED IT WAS 5°C. WHICH OF THE FOLLOWING WOULD HE MOST LIKELY OBSERVE?
  - A. A LOT OF HYPO CRYSTALS IN THE CONTAINER.
  - B. ICE IN THE CONTAINER.
  - C. NO CHANGE IN THE CONTENTS OF THE CONTAINER.
2. IF DARRELL WARMED THE SOLUTION UP TO ROOM TEMPERATURE AGAIN, THE FOLLOWING WOULD MOST LIKELY HAPPEN:
  - A. THE HEAT ENERGY IN THE SYSTEM WOULD BECOME GREATER THAN BEFORE HE STORED IT IN THE REFRIGERATOR.
  - B. THE HEAT ENERGY OF THE SYSTEM WOULD BECOME THE SAME AS BEFORE HE STORED IT IN THE REFRIGERATOR.
  - C. MORE HYPO CRYSTALS WOULD GO INTO SOLUTION AS HE WARMED IT.

3. IF HE HAD ADDED A LITTLE MORE HYPO BEFORE HE WARMED THE ABOVE SOLUTION, THE MOST LIKELY RESULT WOULD HAVE BEEN:

- A. NO CHANGE IN THE SOLUTION.
- B. FURTHER DECREASE IN TEMPERATURE OF THE SOLUTION.
- C. HYPO PRECIPITATING FROM THE SOLUTION.

Page D

NOW TURN TO PAGE D.

QUESTIONS 4, AND 5 HAVE TO DO WITH THIS SITUATION: PHIL HAS TWO CONTAINERS WITH THE SAME AMOUNT OF CLEAR LIQUID IN EACH. CONTAINER X HAS WATER IN IT, BUT HE DOES NOT KNOW WHAT IS IN CONTAINER Y.

4. HE DROPS THE SAME AMOUNT OF A SALT INTO EACH CONTAINER. THE TEMPERATURE IN CONTAINER X GOES DOWN. BUT THE TEMPERATURE IN CONTAINER Y GOES UP. WHICH OF THE FOLLOWING MOST LIKELY DESCRIBES WHAT HAPPENED?

- A. HEAT ENERGY WAS ABSORBED BY THE SALT GOING INTO SOLUTION IN CONTAINER X, THUS STRENGTHENING ITS MOLECULAR BONDS.
- B. THE TEMPERATURE IN X AND IN Y EQUALIZED SINCE THEY WERE DIFFERENT TO START WITH.
- C. THE LIQUID IN Y WAS SUPERSATURATED WITH THAT SALT AND IT PRECIPITATED.

5. AFTER OBSERVING THE ABOVE, PHIL MADE SURE THAT THE SOLUTIONS IN X AND Y WERE AT THE SAME TEMPERATURE BY WARMING UP THE COOLER SYSTEM. HE THEN ADDED MORE OF THE SAME SALT TO X UNTIL IT WAS SATURATED, AND ADDED THAT SAME AMOUNT OF THE SALT TO Y. WHICH OF THE FOLLOWING WOULD HE MOST LIKELY OBSERVE?

- A. THE TEMPERATURE OF THE SOLUTION IN X WOULD DECREASE.
- B. THE TEMPERATURES IN X AND Y WOULD REMAIN THE SAME.
- C. THE TEMPERATURE IN SOLUTION X WOULD INCREASE.

Page E

NOW TURN TO PAGE E.

THE NEXT FOUR QUESTIONS DEAL WITH THE CHART AT THE TOP OF THE PAGE. THE CHART SHOWS WHAT HAPPENS WHEN HEAT ENERGY INTERACTS WITH SALT-WATER SYSTEMS. ITEMS A THROUGH F BELOW THE CHART INDICATE WHAT MIGHT HAPPEN OR WHAT MIGHT BE PRODUCED. YOU CAN SEE THERE ARE SOME BLANK SPACES IN THE CHART. I WILL READ THROUGH THE CHART WITH YOU AND THEN READ THE SIX ITEMS. YOU ARE TO DECIDE WHICH ITEM BELONGS IN WHICH NUMBERED SPACE AND WRITE ITS LETTER ON THE BLANK LINE.

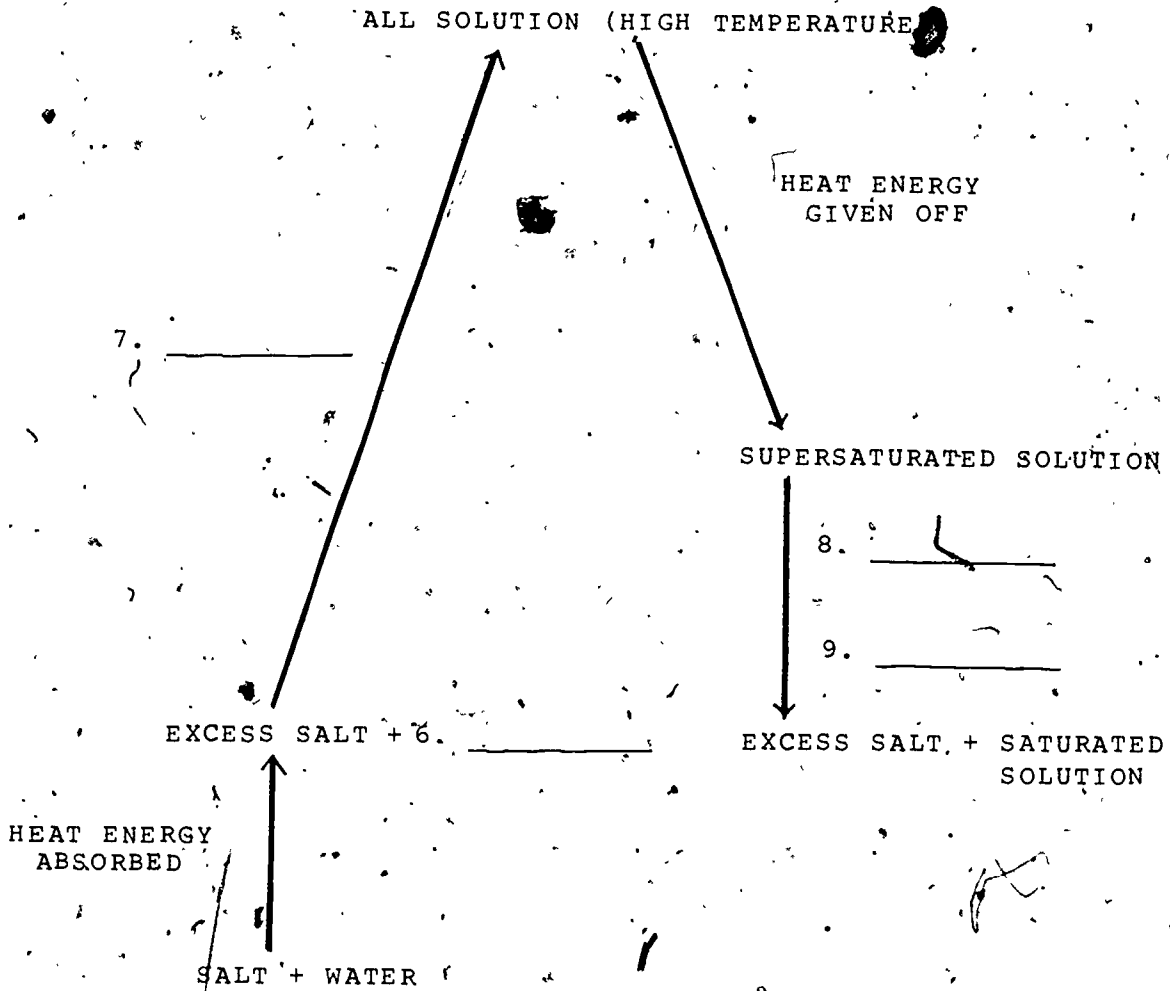

- A. EXCESS SALT
- B. HEAT ENERGY ABSORBED
- C. HEAT ENERGY GIVEN OFF
- D. SATURATED SOLUTION
- E. SEED CRYSTAL ADDED
- F. SUPERSATURATED SOLUTION

1. WHEN A SOLID CHANGES TO A LIQUID,
  - A. THE TEMPERATURE OF THE SUBSTANCE ALWAYS INCREASES.
  - B. THE MOLECULES OF THE SUBSTANCE MOVE MORE FREELY.
  - C. THE NUMBER OF MOLECULES INCREASES.
  
2. MELTING ALWAYS INVOLVES:
  - A. THE ADDITION OF HEAT ENERGY TO THE SYSTEM.
  - B. THE OVERCOMING OF SOME BINDING FORCES IN THE SOLID.
  - C. BOTH STATEMENTS A AND B ARE TRUE.
  
3. MANY SALTS GOING INTO SOLUTION INVOLVE:
  - A. THE ABSORPTION OF HEAT ENERGY FROM THE WATER.
  - B. THE OVERCOMING OF SOME BINDING FORCES IN THE SOLID.
  - C. BOTH STATEMENTS A AND B ARE TRUE.
  
4. WHEN SODIUM CHLORIDE (TABLE SALT) GOES INTO SOLUTION,
  - A. THERE IS AN ATTRACTION BETWEEN THE SALT MOLECULES AND WATER MOLECULES.
  - B. HEAT ENERGY IS GIVEN OFF.
  - C. HEAT ENERGY IN THE WATER MAKES THE SALT CRYSTAL SWELL AND BURST.
  
5. MORRIS ADDED A SALT TO WATER. THE TEMPERATURE OF THE LIQUID DECREASED. THE MOST LIKELY REASON FOR THIS OBSERVATION IS THAT:
  - A. THE SALT WAS VERY COLD AND COOLED THE WATER WHEN IT MELTED.
  - B. HEAT ENERGY WAS USED IN BREAKING APART THE MOLECULES OF SALT IN THE SOLID.
  - C. THE SALT CAUSED SOME WATER TO EVAPORATE, THUS COOLING THE SYSTEM.



6. SOMETIMES WE SEE ROCK OUTCROPPINGS WITH GREAT GASHES AND PITS IN THEM. IT IS MOST LIKELY THAT:

- A. LAYERS OF SOLUBLE SALTS WERE THERE WHEN THE ROCK WAS FIRST EXPOSED.
- B. EXPOSURE TO THE SUN EVAPORATED THE SALT.
- C. ANIMALS HAD USED UP ALL THE SALT AS A "SALT LICK".

7. WHEN DIFFERENT SALTS GO INTO SOLUTION IN WATER,

- A. ALL THE SOLUTIONS ARE SATURATED ONES.
- B. TEMPERATURE DECREASES ARE THE SAME FOR ALL SALTS.
- C. THE PARTICLES OF THE SALT MOVE MORE FREELY.

8. JANICE DISSOLVED SOME SALT IN WATER. THE TEMPERATURE DECREASES AS THE SALT GOES INTO SOLUTION, BUT SOME UNDISSOLVED SALT REMAINS IN THE CONTAINER. WHEN MORE OF THE SAME SALT IS ADDED, THE TEMPERATURE OF THE SYSTEM:

- A. CONTINUES TO DECREASE.
- B. STAYS THE SAME.
- C. INCREASES.

9. WHEN A SALT SOLUTION IS LEFT OPEN TO AIR,

- A. WATER MOLECULES TAKE UP HEAT ENERGY AND GO INTO A GAS.
- B. SALT MOLECULES RE-FORM INTO SOLID CRYSTALS AS THEY GIVE UP HEAT ENERGY.
- C. BOTH A AND B ARE TRUE.

QUESTIONS 1, 2, AND 3 HAVE TO DO WITH DARRELL'S EXPERIMENT. DARRELL COMPLETELY DISSOLVED A SAMPLE OF HYPO CRYSTALS IN WATER AT ROOM TEMPERATURE AND THEN STORED IT IN A REFRIGERATOR.

1. THE TEMPERATURE OF THE SOLUTION WHEN HE REMOVED IT WAS  $5^{\circ}\text{C}$ . WHICH OF THE FOLLOWING WOULD HE MOST LIKELY OBSERVE?

- A. A LOT OF HYPO CRYSTALS IN THE CONTAINER.
- B. ICE IN THE CONTAINER.
- C. NO CHANGE IN THE CONTENTS OF THE CONTAINER.

2. IF DARRELL WARMED THE SOLUTION UP TO ROOM TEMPERATURE AGAIN, THE FOLLOWING WOULD MOST LIKELY HAPPEN:

- A. THE HEAT ENERGY IN THE SYSTEM WOULD BECOME GREATER THAN BEFORE HE STORED IT IN THE REFRIGERATOR.
- B. THE HEAT ENERGY OF THE SYSTEM WOULD BECOME THE SAME AS BEFORE HE STORED IT IN THE REFRIGERATOR.
- C. MORE HYPO CRYSTALS WOULD GO INTO SOLUTION AS HE WARMED IT.

3. IF HE HAD ADDED A LITTLE MORE HYPO BEFORE HE WARMED THE ABOVE SOLUTION, THE MOST LIKELY RESULT WOULD HAVE BEEN:

- A. NO CHANGE IN THE SOLUTION.
- B. FURTHER DECREASE IN TEMPERATURE OF THE SOLUTION.
- C. HYPO PRECIPITATING FROM THE SOLUTION.

QUESTIONS 4 AND 5 HAVE TO DO WITH THIS SITUATION: PHIL HAS TWO CONTAINERS WITH THE SAME AMOUNT OF CLEAR LIQUID IN EACH. CONTAINER X HAS WATER IN IT, BUT HE DOES NOT KNOW WHAT IS IN CONTAINER Y:

4. HE DROPS THE SAME AMOUNT OF A SALT INTO EACH CONTAINER. THE TEMPERATURE IN CONTAINER X GOES DOWN. BUT THE TEMPERATURE IN CONTAINER Y GOES UP. WHICH OF THE FOLLOWING MOST LIKELY DESCRIBES WHAT HAPPENED?

- A. HEAT ENERGY WAS ABSORBED BY THE SALT GOING INTO SOLUTION IN CONTAINER X, THUS STRENGTHENING ITS MOLECULAR BONDS.
- B. THE TEMPERATURE IN X AND IN Y EQUALIZED SINCE THEY WERE DIFFERENT TO START WITH.
- C. THE LIQUID IN Y WAS SUPERSATURATED WITH THAT SALT AND IT PRECIPITATED.

5. AFTER OBSERVING THE ABOVE, PHIL MADE SURE THAT THE SOLUTIONS IN X AND Y WERE AT THE SAME TEMPERATURE BY WARMING UP THE COOLER SYSTEM. HE THEN ADDED MORE OF THE SAME SALT TO X UNTIL IT WAS SATURATED, AND ADDED THAT SAME AMOUNT OF THE SALT TO Y. WHICH OF THE FOLLOWING WOULD HE MOST LIKELY OBSERVE?

- A. THE TEMPERATURE OF THE SOLUTION IN X WOULD DECREASE.
- B. THE TEMPERATURES IN X AND Y WOULD REMAIN THE SAME.
- C. THE TEMPERATURE IN SOLUTION X WOULD INCREASE.

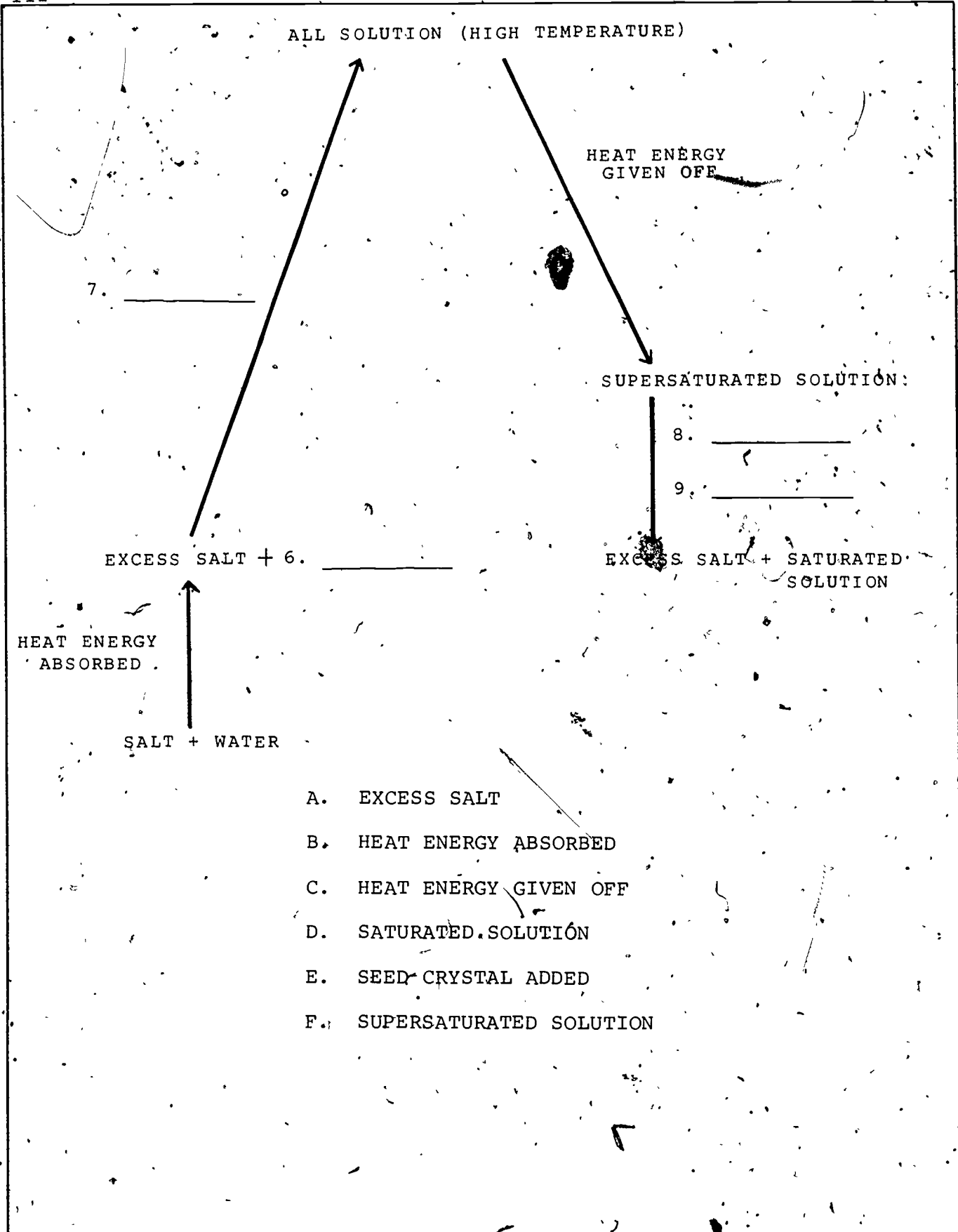

- A. EXCESS SALT
- B. HEAT ENERGY ABSORBED
- C. HEAT ENERGY GIVEN OFF
- D. SATURATED SOLUTION
- E. SEED CRYSTAL ADDED
- F. SUPERSATURATED SOLUTION

## Minisequence IV Energy Transformations

Up to this point the children have been exposed on several occasions and in different ways to the concept of energy and to the important idea of conservation of energy. The latter was introduced in Grade 4 in relation to thermal energy in the water mix experiments. It was extended earlier in the present grade to include mechanical energy (Minisequence II), and to thermal energy changes associated with dissolving salts in water and precipitating them out (Minisequence III). In both these cases it was not possible to demonstrate strict conservation of energy, but only to have the children infer from their experiments that if one had ideal conditions--or could accurately measure all the energy changes involved--conservation of energy probably would be demonstrated.

From their experience with mechanical energy the children know that one can change one form to the other--kinetic energy to potential energy, and vice versa. This is but one example of an energy transformation. One finds a number of different forms of energy in nature, and generally these can be transformed from one to another--either directly or in a two-stage process involving a third form of energy. This is not a contradiction of the principle of energy conservation, which requires only that the total energy in the universe remains constant, regardless of transformations that may occur among its various forms.

The present Minisequence focuses attention on a few of the different forms of energy, and on the transformations that occur among them. The activities are intended to prepare the children for a final detailed treatment of energy conservation in Grade 6. The pervading idea that should be kept uppermost in mind in this Minisequence is that whenever some energy seems to have disappeared, one should look for its reappearance in some other form (or forms). In other words, energy cannot be "lost", but only changed into other forms. An important corollary to this is the observation that some heat energy is invariably produced during these transformations, leading to an appreciation of another of the COPES conceptual schemes: The Degradation of Energy.

The first Activity is concerned with the interaction of light (radiant energy) with surfaces. Everyone has had some experience with the behavior of light as it strikes a surface. In some cases (light-colored surfaces) most of the light is reflected and little is lost. In the case of dark-colored surfaces, however, most of the light may be absorbed. If the light

"disappears" what happens to its energy? This cannot be lost, but must reappear in another form--in this case, heat energy. The children experiment with light falling upon various surfaces, observing qualitatively whether the surface is a good reflector or not, and correlating this observation with the amount that the surface is warmed by the light. At the conclusion of the Activity the children construct a device to detect radiant energy, with which they are able to compare various light sources as to the energy they emit. In the course of this Activity they find that just as thermal energy is invisible, some light (radiant energy) is also invisible, e.g., infra-red and ultra-violet radiation. In fact, thermal radiation and infra-red radiation are one and the same.

The second Activity carries on with the conversion of light energy to heat energy in an unusual manner. The children know that an incandescent lamp not only emits light but also gives off considerable heat energy. The latter is easily experienced by holding one's hand near a lighted bulb. In fact, only about 10% of the energy is given off as visible light, most of the remaining being in the form of infra-red radiation!! What would happen if a lamp bulb were prevented from emitting light, e.g., by coating it with a non-transparent material? The coating must absorb the light, transforming it to heat energy and thereby raising the temperature of the bulb. The children check this point by comparing the temperatures of coated and uncoated flashlight bulbs. This Activity also provides an opportunity to explore the question of the ultimate source of energy in a flashlight battery, which the children conclude is due to some form of chemical interaction.

Activity 3 deals with the conversion of chemical energy (in the form of food) into heat energy, a process that plays a vital role in living things. The children investigate this energy conversion by studying the interaction between live yeasts and apple juice (food), as evidenced by the production of heat. They can also observe the heat produced as seeds germinate. They are able to conclude that food is the source of energy for living things--some of its chemical energy going into growth and some into heat.

In the final Activity, the children investigate the conversion of kinetic energy into heat. In the first part of the Activity the children convert kinetic energy entirely to heat through friction. They then try to convert kinetic energy to (elastic) potential energy and find that now some of the energy is "lost", i.e., it is converted to heat rather than to potential energy. We know that in any real situation the conversion of energy from one form to another is always accompanied by the production of heat (Degradation of Energy). The amount of heat produced depends upon the efficiency of the conversion process, those that are less efficient producing proportionately more heat than others. Thus, there is one type of energy conversion that

can be fully efficient, namely, one in which the end form of energy is heat. Obviously, since the end form is heat energy, this does not contradict the concept of degradation of energy.

## Activity 1 • Radiant Energy to Heat Energy

A corollary of the idea of conservation of energy is that although energy is not destroyed it can be converted from one form to another. To get across the idea that when energy seems to have disappeared it can be accounted for in another form, the children must be introduced to the other forms as they are "created" in certain familiar interactions.

In Activity 1 the children observe the interaction of light, which is a form of energy called radiant energy, when it strikes surfaces of different colors. When light strikes a dark surface, most of it is "trapped"--that is, it is absorbed (not reflected) by the surface. Since the temperature of the surface rises as the light is trapped, the rise is used as evidence that heat energy is appearing in the place of the radiant energy. They find that the more radiant energy that is trapped, the more heat energy is produced. By means of a simple device which they construct, children will also discover that not all radiant energy is visible to the eye; some is invisible. Just as they were aware in previous Activities of "invisible" heat energy by the changes it produced such as melting, or a rise in temperature; so also they will sense the presence of invisible radiant energy by the changes it produces in their radiation detector.

### MATERIALS AND EQUIPMENT:

For the class you will need:

- 1 lb (450 g) modeling clay
- 1 jar poster paint, black
- newspaper, for catching spills of poster paint
- 1 roll aluminum foil (see also below).
- 15 sheets of paper, 8-1/2 in. by 11 in. (21.5 cm by 28 cm)
- several jars of Elmer's glue, with brushes, for glueing aluminum foil to paper
- 1 or more staplers
- 1 piece of corrugated cardboard, about 12-in. square. (30 cm by 30 cm)



1 electric iron

For each team of 2 children, you will need:

- \*1-2 pieces of aluminum foil, about 6-in. (15-cm) square
- 1-2 pieces of stiff white paper, e.g., white construction paper, about 6-in. (15-cm) square
- 1-2 pieces of transparent plastic (e.g., thin cellophane sheer), about 6-in. (15-cm) square. (This can be purchased in a roll from a "five and ten" cent store.)
- 1-2 pieces of stiff, flat, black paper, e.g., black construction paper, about 6-in. (15-cm) square
- 1-2 pieces of paper, gray or other color that is not very dark or very light, about 6-in. (15-cm) square
- 1-2 small mirrors, any kind, e.g., purse mirrors. (You might have each child bring a mirror from home.)
- 1-2 flashlights, any kind, in good working order
- 2 thermometers,  $-20^{\circ}\text{C}$  to  $+50^{\circ}\text{C}$

\*In each case, the smaller number is required if you decide not to have the children do the experimental part of this Activity at home.

#### PREPARATION FOR TEACHING:

You may want to ask the children to bring mirrors and flashlights from home before starting Section 1. Remove the glass lenses from the flashlights.

Two different kinds of thermometer-bulb covers will be made by the children in this Activity. The first kind is made and used in Sections 2 and 3. Make a few sample covers of this kind from the pieces of paper and aluminum foil, following the diagram shown on the next page. Do this by folding the paper in half (step 1), folding a little of two of the open edges under (step 2), folding back the corners on the remaining open edges (step 3), and then taping these folds (step 4). This should form a small cover with an opening just large enough to slip a thermometer into (step 5). After positioning a thermometer in a cover with its bulb near the center, you can use a bit of tape to keep it in place.

Before beginning Section 4, place the jar of black poster paint where it will be accessible to the children. Just before class, shake the jar thoroughly and then remove the lid. Since this

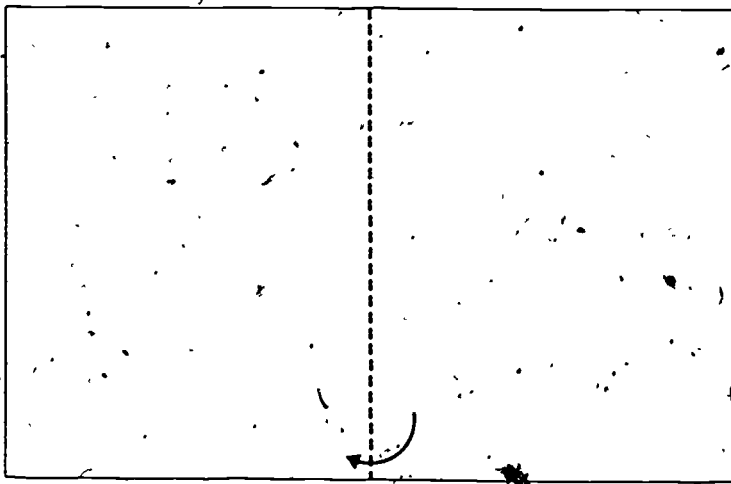

Step 1

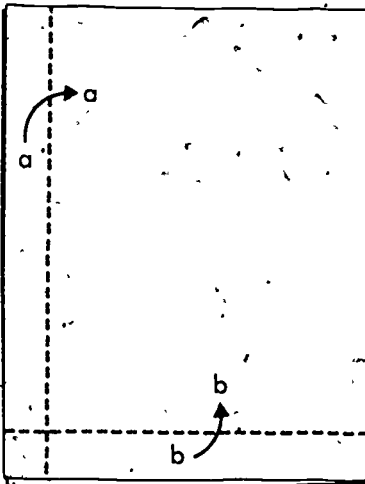

Step 2



Step 3

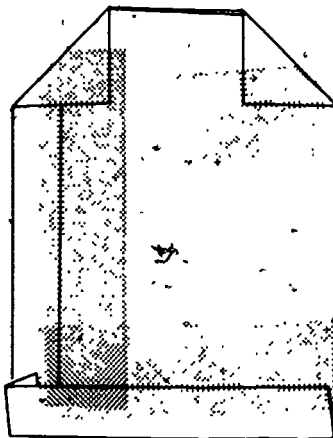

Step 4

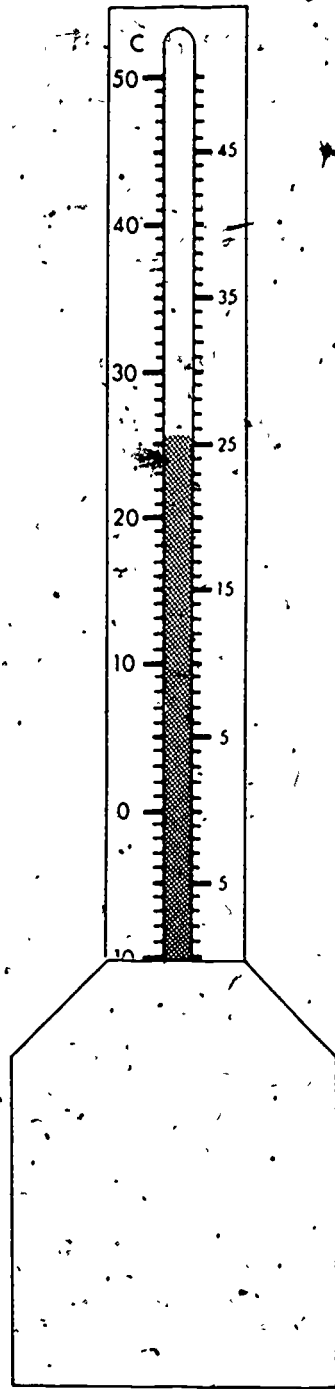

Step 5

black paint could be a little messy if spilled, you will want to have some paper towels or old newspapers around to catch drips. Also, plan for a place for the children to lay the thermometers with the bulb ends exposed after they dip them into the paint. The children could put the thermometers on a table with the bulbs projecting out over the edge to dry.

Before Section 5, fold and tear the sheets of 8-1/2 in. by 11 in. paper into halves 5-1/2 in. by 8-1/2 in. These will be used by the children in making cones.

For use in Section 6, glue a piece of aluminum foil about 12-in. square to a piece of corrugated cardboard the same size. The shiny side of the foil should be out and should be as smooth and mirror-like as possible.

You should try the different Sections of this Activity on your own before you begin working on it with the class. In this way you will be prepared for difficulties the children might have. You will also know what kind of results to expect with available radiant energy sources.

#### ALLOCATION OF TIME:

This Activity requires 20-minute segments of time on a number of different days. If done entirely in class, the Activity requires approximately 3 hours; however, some of the Activity can be done by the children at home.

Some Sections of the Activity *must* be done on a clear sunny day. For this reason, this Activity need not precede the rest of the Minisequence, but can be done concurrently with Activities 3, 4, and 5.

#### TEACHING SEQUENCE

1. Show the children a flashlight and ask them to describe what happens when you turn it on.

#### COMMENTARY

If the children do not realize that there are batteries in the flashlight, be sure to let them discover this. In addition to the beam of light which is produced, the children may also infer from previous experience that the batteries in the flashlight are changing and that their chemical energy is being used up. (See Grade 3, Minisequence IV, Activity 4.)

## TEACHING SEQUENCE

Give each team a piece of black paper, a piece of white paper, a piece of transparent plastic or cellophane, and a piece of aluminum foil. You may also want to give them a mirror or ask them to bring one from home.

- What happens when the beam from the flashlight is allowed to fall on the mirror, on the aluminum foil? cellophane? white paper? black paper?

Suggest that the children experiment in a darkened room and pay close attention to everything that they can find different about the interactions of the light with the various materials. They should write down what they find out for later use in class discussion.

After the children have had a chance to experiment with the materials, have the class as a whole discuss what they have found.

- What happened to the light in each case?

If the children do not notice that some of the light bounced back (reflected) from the white paper, suggest that they try experimenting again while paying attention to what happens to the rest of the room

## COMMENTARY

The children can work in pairs for this Activity. In addition to the recommended materials, you may, of course, suggest that the children try other materials of their own choosing.

If you decide to carry out this part of the Activity at home rather than in school, each child will need to have access to a flashlight and mirror.

The children should find, at least, that most of the light goes right through the clear plastic; that most of the light "just stops," or disappears, when it strikes the black paper; that the light bounces off the aluminum foil and the front side of the mirror; and that some of the light goes through the white paper and some of it bounces back.

## TEACHING SEQUENCE

when the light is turned on and off the various materials. This should help them find that the light bounces back from the white paper and lights up the room much more than it does when it hits the black paper.

- What happened to the light that you couldn't see any more--the light that was "trapped" by the black paper?

2. This Section can be done by teams of 3 to 4 students, or you may have individual students working on it at different times after the initial discussion.

- What happens to the temperature of objects when they are left in the sunlight?
- Does it make a difference whether the objects are light colored or dark colored?

Whatever they say, you may suggest that they check their ideas by using thermometers and pieces of different colored paper--black, grey, and white (or aluminum foil).

Ask the children to suggest possible ways of doing the experiment. The procedure on

## COMMENTARY

The evidence for its bouncing back is that they can still see the light. This is not true when light strikes black paper. It is important that children understand this difference, because, in the next Section, they will find that heat energy is produced when the black paper "traps" light, and very little heat energy is produced when light reflects from white paper or aluminum foil.

The children probably will not be able to answer this question yet and should not be pushed to do so. It is useful, however, to lead them into the next Section.

The children will probably respond by saying that the objects become warmer (their temperature increases).

Even if they happen to have heard that dark objects become warmer than light-colored objects, the children will probably not all be certain of this..

Discuss their ideas. The children should realize the importance of having every group

## TEACHING SEQUENCE

which they agree should be something like the following: One member of each team will keep track of the time with a sweep second hand watch, calling time at the end of each minute. Another child will record the temperatures which are called out by the remaining members of the team, who will be holding the thermometers (by the tops), facing the sun.

You may want to suggest the design described under Preparation for Teaching for the folding and taping of the thermometer covers. Give each group an example of a finished cover. Then have the children prepare their own sets of thermometer covers with thermometers. The children should also agree on how they are going to hold the thermometers, record the temperature, carry them into the sunlight and then record subsequent temperature changes.

This is an excellent time for the children to try making their own Worksheets. Pass out paper and suggest that they write in headings for the information needed.

3. This Section must be done on a bright, clear, sunny day, without much wind. Five minutes is generally enough

## COMMENTARY

use exactly the same techniques if the results are to be compared later.

Let the children try any other designs they may think of. It is a good opportunity to encourage innovation in experimental procedures.

Their Worksheet should be some variation of the following format:

Activity:

Name:

Reading	Time	Temperature
1		
2		
3		
4		
5		

If you wish, each child can make outdoor observations independently on the worksheet which the class has developed.

## TEACHING SEQUENCE

time to observe the thermometers in the sunlight, although the children may repeat the experiment after waiting inside or in the shade long enough for the temperatures registered by the thermometers to return to normal.

When the children have all had a chance to try the experiment, call them together to discuss what they have learned.

Ask the children to recall the results of Section 1.

- What happened to light when it struck a white or shiny surface? What happened when it struck a black surface.

The children should now be prepared to answer the question they were left with at the end of that Section.

- What happens to light when it is trapped by a black surface? Does it just disappear?

You may have the children mention some practical examples of the conversion of light to heat energy.

Point out that since light can be converted into heat energy, we consider that light is also a kind of energy. The name for this kind of energy is "radiant energy."

## COMMENTARY

The data obtained can then be discussed in class.

Caution the children not to lay the thermometers down on a surface because the temperature of that surface will affect their readings.

They should agree that the black covered thermometer showed the greatest rise in temperature; that the grey-covered thermometers showed less of a rise in temperature and that white paper or aluminum foil-covered thermometers showed the least rise in temperature.

The light bounced off the white or shiny surfaces. The light was stopped or "trapped" by a black surface.

No, light is converted to heat energy when it is trapped.

For example, they may know that black, asphalt roads become very hot on a sunny day or that dark clothing generally becomes hotter in the sun than does white clothing.

You may want to have the children speculate on whether or not all of the light energy became heat energy. Although they will not know for sure, they should be able to infer, from their experience in the

## TEACHING SEQUENCE

4. Now suggest to the children that, since black surfaces "trap" more radiant energy and become warmer in the sun than do lighter colored surfaces, a thermometer might be made into a good radiant energy "trap" by painting its bulb black.

Give each pair of children a thermometer. The children can take the thermometers to the black poster paint and dip the bulbs in just up to the edge of the plastic.

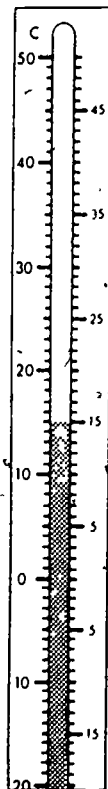

black paint

## COMMENTARY

preceding sequence among others, that no energy should be "lost."

It is assumed that the children will be using the same thermometers whose lower backing was cut off in Minisequence III. If they are not, the backing should first be cut off as described there in order to expose the bulb.

If the paint does not cover the glass bulb, but runs off, it may be necessary for the children to wash the bulbs clean with a little soap and water and then dry them with a paper towel before dipping them again into the paint. Because it will take some time for the thermometer bulbs to dry, you may wish to have the children prepare the thermometers early in the day and return to the Activity later on.



## TEACHING SEQUENCE

They should then set the thermometers to dry with the bulb end propped up so that it does not touch anything.

- What might happen if these thermometers with blackened bulbs were placed in the sunlight?

Now ask what would happen if the thermometers were placed in the shade and beams of light reflected onto them by using mirrors in the sunlight.

Let pairs of children try placing thermometers in the shade and shining beams of sunlight onto the blackened bulbs with mirrors. One child in each pair can hold and observe the thermometer while the other positions the mirror.

Some children may become curious about what might happen if several reflected beams of sunlight are allowed to strike one blackened thermometer bulb. They should be encouraged to work with other teams to try such an experiment.

5. In this Section the

## COMMENTARY

The children should be able to predict that the thermometers will show higher temperatures than usual because the blackened bulbs will trap radiant energy from the sun. (Unblackened bulbs would trap some radiant energy also, but would show a smaller temperature rise.)

If some of the children have learned to think of light as radiant energy, which can be converted into heat energy, they should be able to answer that they expect the temperatures registered by the thermometers to go up. If they have not as yet grasped this, the following experiences will reinforce this concept.

This part of the Activity must be done on a bright, clear, sunny day. Caution the children about the danger of looking directly at the sun or at its reflection in a mirror.

In some classrooms the child holding the thermometer could remain inside the room while the other child reflects a beam of sunlight in through the window.

If this question does not arise spontaneously, you might raise it and let the children test it. They will generally find that the more mirrors they aim at the blackened thermometer bulb, the higher the temperature rises.

## TEACHING SEQUENCE

children are shown how to make a kind of mirror that will reflect and concentrate a very large amount of light onto the blackened thermometer bulb. You might begin by asking the children if they have seen the reflectors that people sometimes use to shine sunlight on their faces to get a suntan. Suggest that they might use the same principle here to help the thermometer catch even more radiant energy.

Give each pair of children a piece of white paper, a piece of aluminum foil about the same size from the roll, a pair of scissors, and access to glue (this can be shared with other teams). They can begin by gluing the aluminum foil to the piece of paper with the shiny side showing and the dull side toward the paper. Then they can use the scissors to trim the excess foil from the edges. When everyone has their foil glued to paper and trimmed, they can roll it into a cone, like the one shown, with the shiny side in. The cones should come to a point on one end and be open 6 or 7 cm wide on the other. When the children have formed good cones, they should staple them, as shown, or use tape to hold them in shape. Then have the children cut just enough (about 1 cm) off the tips of their cones so that the thermometer bulb can just slip through. They can then insert the blackened thermometer bulbs to the point where the backing touches the cone. With a little modeling clay

## COMMENTARY

You might warn them that this is a very poor practice because the absorption of radiant energy from the sun, which includes invisible ultra-violet radiation as well as visible light and invisible infra-red (heat), can cause damage to the skin and to the eyes.

TEACHING SEQUENCE

they can fasten the thermometer and cone together. The bulb of the thermometer should be centered so that it does not touch the sides of the cone. The adjacent sketch shows the completed "radiant energy trap."

COMMENTARY

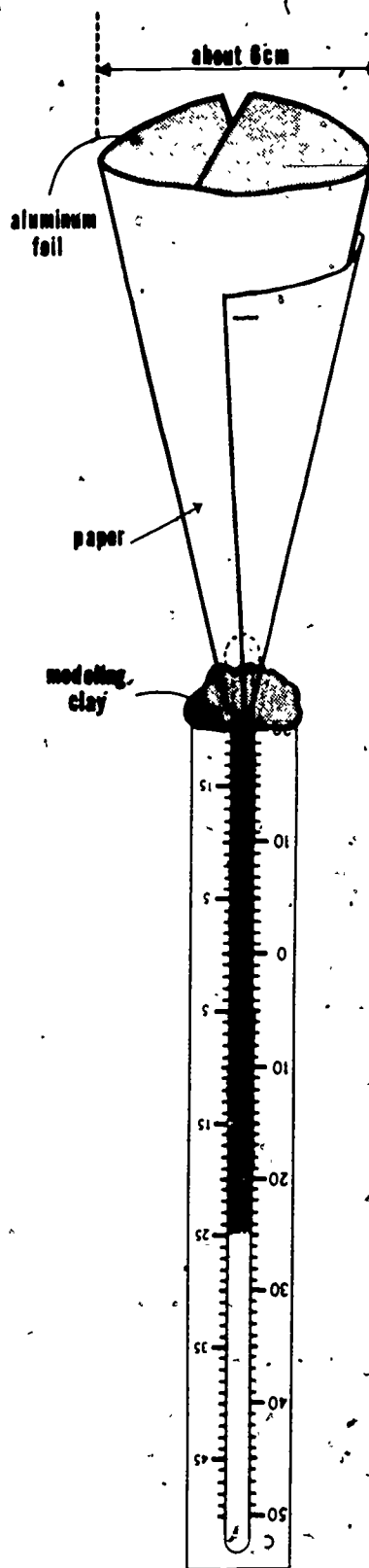

## TEACHING SEQUENCE

Let the children try out their radiant energy traps on light sources such as flashlight, incandescent lamps, and the sun. The trap is used by pointing the open end of the cone at the source. The children should record their findings on a worksheet of their own design.

When the children have had time to use their radiant energy traps with various light sources, have them share their findings. If questions come up which can be answered by experiment, groups of children can design and perform such experiments.

Next, ask what would happen if a mirror were used to reflect a beam of sunlight into the radiant energy trap. Have pairs of children try out their ideas. (Again, caution them not to look directly at

## COMMENTARY

This section should be kept fairly "open" for the children to try out the cone device on all sorts of light sources.

Caution the children not to let the thermometers go above  $50^{\circ}\text{C}$  as they may break. They will reach  $50^{\circ}\text{C}$  in about twenty seconds if the traps are aimed at the sun on a clear day; so care will be necessary.

For example, when the cone device is two feet from a 100 watt light bulb, some children may think that it shows an increased temperature because the air around it gets warm and not because it is catching radiant energy. They can test this idea by putting an ordinary thermometer near the device to measure the air temperature.

You might show the children a picture of "solar cookers" which work the same way as do their radiant energy thermometers. One such picture is on page 184 of the LIFE Science Library book, *Energy*. Such cookers are actually used in some parts of the world where there is a great deal of sunshine and the cost of fuel is high compared with the general economic level.

Unless the children have themselves thought of this experiment, you should suggest it. Its purpose is to strengthen the connection between radiant energy, which is converted to heat energy when absorbed, and

## TEACHING SEQUENCE

the sun or into the sun's reflection in a mirror.) One way to perform the experiment is to have one child stand in the shade against a wall holding the device pointed toward the other child, but without looking into the beam of reflected sunlight. This reflected beam is produced by the other child holding a mirror in the sunlight a few feet away, aimed at the open end of the cone.

6. Finally, set the electric iron where it can be seen by the class. Tilt it up in the usual way so that the hot side faces across a table and turn it to the highest setting, but don't plug it in. From a distance of about one and a half feet, aim one of the radiant energy traps at the flat surface of the iron. Also set an ordinary thermometer next to the trap equidistant from the iron to measure the air temperature.

Ask some children to look at the thermometers and report their readings to the class. Get the others to predict what the readings will be after the iron is plugged in. Then plug it in and let other children read the thermometers from time to time.

- How do the temperature readings compare?

- Why do you think the

## COMMENTARY

light, which reflects from mirrors, travels in a straight line, and goes through materials.

Having a wall in the background will help the second child to see how he or she is aiming the light beam.

The children should find that the temperature shown by the thermometer rises quickly, although not as quickly as when the cone is aimed directly at the sun.

This last Section of the Activity is done as a demonstration.

Within a few minutes the thermometer in the radiant energy trap will be showing a higher temperature than the ordinary thermometer.

Apparently there is energy

## TEACHING SEQUENCE

readings differ?

How does this energy travel? Next, set the radiant energy trap as shown in the illustration. Notice that radiation from the iron cannot get to it because of the screen, (which may be a book, etc.): Before putting the mirror (aluminum foil-covered cardboard) in place as shown, let some children read the temperature of the thermometer in the trap. Then place the aluminum foil mirror in position by sighting along the detector and turning the mirror until the electric iron can be seen in the mirror in line with the trap. Now let some other children read the thermometer.

Discuss the children's observations with them.

## COMMENTARY

coming from the iron which is registered as a temperature increase by the thermometer in the cone device but not by the other thermometer. (The latter measures only the air temperature.)

The temperature of the cone device should have returned nearly to room temperature before beginning this part of the demonstration.

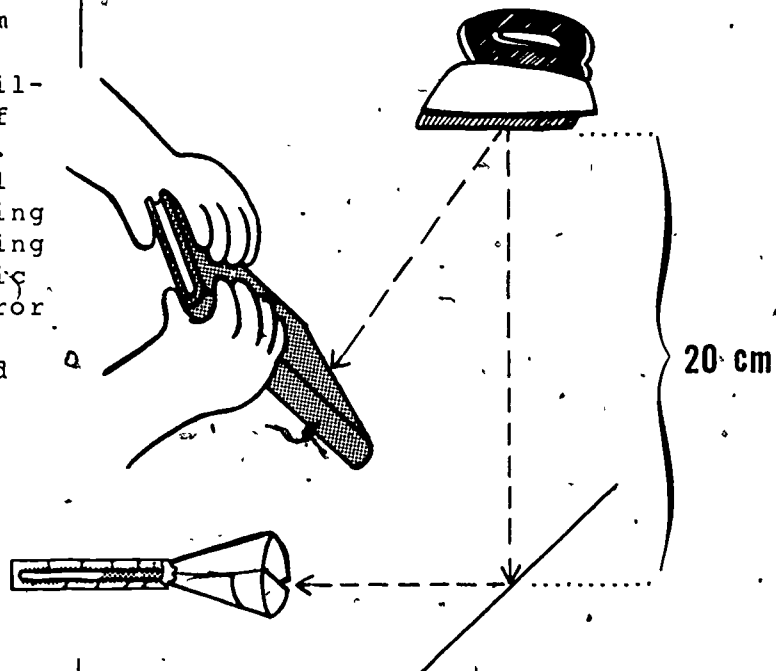

Within a few minutes the thermometer will again show an increased temperature.

Appropriate conclusions might be that:

1. The iron is a source of energy which can be trapped by the cone device;

## TEACHING SEQUENCE

You may suggest that what the iron is giving off can also be called "radiant energy" even though it can't be seen. It can, however, be detected by their cone device, which in this case could be called a radiant energy detector.

## COMMENTARY

2. This energy appears to travel in the same way that light does;

3. And it reflects from aluminum foil the way that visible light does.

If you wish, you can tell the children that this type of invisible radiation is called "infra-red radiation." It is just one of many types of invisible radiant energy. Ultra-violet radiation and radio waves are two others.

## Activity 2 Chemical Energy (Batteries) to Heat Energy

In this Activity the children will find that a battery and bulb, which they know can produce both light and heat energy when connected into a completed circuit (Grade 3, Minisequence IV), may be used to produce only heat energy. A bulb that has been painted black is used as the "heat machine."

In the previous Activity, the children used a blackened thermometer bulb to help them detect and measure heat energy being transferred. Here, by comparing a blackened and an unblackened flashlight bulb, the children find that a battery and bulb may be used to produce either heat energy only or to produce less heat energy and some light (radiant energy).

What is the ultimate source of the energy in a battery? How long will it last? The children investigate these points by drawing current from a flashlight battery to the end of its useful life. They find that part of the energy stored in the battery goes into heating the battery, the remainder presumably going into whatever circuit is connected to it. From their observation of a chemical leaking out of the battery at the end of its life, the children are led to strengthen the conclusion that the source of energy in a battery is chemical (electrochemical energy).

### MATERIALS AND EQUIPMENT:

For the class you will need:

- 1 jar poster paint, black
- 1 clock with a sweep second hand
- 1 roll masking tape
- aluminum foil (small amount)
- paper
- graph paper (about 4 squares/in.) (2/cm)
- several old newspapers or a roll of plastic wrap
- 1 No. 6, "Ignitor" dry cell. This is the large (6-1/2 cm diameter by 16 cm) dry cell with two screw terminals on



the top. (optional)

- 1 wire cutter (optional)
- 1 piece, about 20 cm long, of iron hair wire, No. 30C, available from Woolworth's and other department stores (optional)

For each team of 4 children, you will need:

- 2 flashlight bulbs, No. 14
- 2 sockets for the above (A.S.&E No. 006H002)
- 4 flashlight batteries in good condition ("D" cells, not alkaline batteries)
- 3 pieces of bare copper or aluminum wire, 12-in. (30-cm) long
- 1 thermometer

#### PREPARATION FOR TEACHING:

Half of the No. 14 bulbs are to be used as they are. The others should have the glass portion blackened. This can be done by dipping the bulb into black poster paint. If the paint does not adhere to the glass, first wash the bulbs in soap and water to remove any oil from the glass. The children prepared their mometers in this way for use in Activity 1, so you may want to have several volunteers prepare all the bulbs for the class.

Remove the cardboard outer covering from the lower two thirds of each of the flashlight batteries. This will expose most of the zinc can (negative end) of the battery.



#### ALLOCATION OF TIME:

Approximately 2 hours are needed for this Activity.

#### PART A

## TEACHING SEQUENCE

1. Divide the class into groups and give each group a regular No. 14 bulb, a socket, two flashlight batteries and two or three copper or aluminum wires to be used to make the circuit. They should also have access to aluminum foil and masking tape.

Ask the children to attempt to assemble the materials in such a way that the bulb lights.

- Can you get the bulb to light more brightly than it does with one battery?

See that each team knows how to do this with a circuit such as the one shown in the illustration below. You may want to draw such a circuit on the chalkboard.

Next ask the children to break their circuit at some point to turn the bulb off.

Then give each group a blackened bulb, another socket, two more flashlight batteries and two or three more wires. Ask them to connect this bulb in

## COMMENTARY

Groups of four children each would be good for this activity. If you wish to use less equipment, you might have groups work with the materials at different times in a corner of the room and discuss the results with the whole class at a later time.

Children who have worked with these materials before, (e.g., in COPEs Grade 3, Minisequence 4), will have no trouble lighting the bulb. Others should be given sufficient time to experiment with the materials. If the children need help in making connections to the battery, suggest that they double back about 1 cm at the ends of the wires and crimp a small piece of aluminum foil around one doubled wire. This will make ends that are easy to tape to the batteries. (See p. 185 of the Teacher's Guide for Grade 3.)

From Minisequence IV, Activity 3 of Grade 3, they should know that 2 batteries will make the bulb glow brighter than 1 battery.

Remind the children of what the symbols in the sketch mean.

It is probably a good idea to tell the children that the blackened bulb is a bulb just like the regular No. 14 bulb but with black paint on it.

## TEACHING SEQUENCE

a complete circuit with two batteries at the same time that they reconnect the circuit with the regular No. 14 bulb. Both circuits should be like the one shown in the illustration.

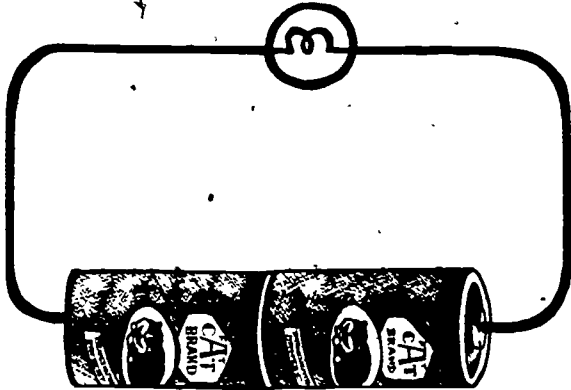

When the children have done this, ask them to state whether or not they have made complete circuits and what evidence they can give for their statements.

Eventually some of the children should remark on how hot the blackened bulb feels. When they do, let them discuss why the two bulbs (blackened and unblackened) feel different.

## COMMENTARY

In one case the lighted bulb is sufficient evidence of a complete circuit. If necessary, remind the children that batteries, bulbs, wires, etc., are said to make a complete circuit when they produce certain changes such as the production of light or heat, and the gradual wearing out of the batteries. In the case of the blackened bulb, the children may see light through small holes in the paint, or they may feel the heat produced.

If no one notices the heat energy, suggest that the children touch the bulbs to see how they feel. If a child says that one set of batteries may be stronger, and that this difference accounts for the heat energy, ask whether they think all of the children would

## TEACHING SEQUENCE

2. Ask the children which bulb, the blackened or the unblackened one, will use up the energy of the batteries first.

- What kind of a test could be set up to determine the answer to this question?

Have some of the children set up two circuits as before, one with a blackened bulb and one with a clear bulb. Use two, identical, new "D" batteries for each circuit. Connect both circuits at the same time and place them where they may be observed from time to time. If there are no holes at all in the black coating on the one bulb, use a metal object such as a paper clip to scrape a tiny hole so that the brightness of the light inside can be seen.

## COMMENTARY

have chosen the strongest batteries for the blackened bulb by chance.

There may be other plausible suggestions for the difference in temperature, for which you can let the children make up their own experimental tests. For example, they may suggest switching batteries to check whether one set of batteries is stronger than the other.

Since both bulbs are electricaly the same, (one is just as good a conductor as the other, etc.), the children may suggest that they will both use up the batteries' energy at about the same time, (if the batteries are about equally good to start with). On the other hand, they may feel that one or the other will use up the batteries sooner. In any case their ideas can be put to experimental test.

The batteries should be the same brand, purchased at the same time, etc. Be sure that the children make good electrical connections in the circuit.

The bulbs will dim and finally go out at about the same time. In order that this can be observed, it may be necessary to disconnect the circuits at the end of one school day and reconnect them on the next. (The batteries will recover some of their capacity to supply current during these "rest" periods, but eventually their electrochemical energy will be used up

## TEACHING SEQUENCE

3. Have the class as a whole summarize the similarities and differences between the circuits made with the two kinds of bulbs in a class discussion.

If the children don't raise the question, you should ask whether or not the ordinary bulb does give off some heat energy. If the children haven't noticed it before, they can feel this by comparing an unlit bulb with one that has been lighted for a while and then turned off just before being touched.

## PART B

1. So far the children have found that a battery and bulb can produce a larger amount of heat energy as well as light and a smaller amount of heat energy. Apparently some of the radiant energy coming from inside the blackened bulb was converted to heat energy. But what provides the energy

## COMMENTARY

and the bulbs will go out.)

Here are some of the similarities the children might list:

1. Same kind of batteries
2. Same kind of wires
3. Same kind of bulbs
4. Same kind of circuit
5. Batteries used up in about the same amount of time
6. Filaments in the bulbs equally bright.

Some of the differences the children may list:

1. Light given off by one bulb
2. More heat energy given off by the blackened bulb
3. Black paint on the bulb giving off heat energy.

The bulb that was lighted will feel a little warmer, showing that it did produce some heat energy while it was producing light.

TEACHING SEQUENCE

COMMENTARY

to light the bulbs? Is there an energy conversion there also?

Provide each team with a battery, a thermometer, a piece of bare copper wire and access to aluminum foil, masking tape, flashlight bulb and a socket.

At this point they should test their batteries by seeing if they will light a flashlight bulb as in the previous sections.

Divide each team in the following way. One child should be the timekeeper. He or she will be responsible for watching the clock and marking the time at the end of each minute. A second child will read the thermometer and state the temperature when the first says the time. Finally, a third will record both the time and the corresponding temperature as stated by the first two.

When they understand their various roles, explain that they will be observing any changes in, and recording the temperature of, a battery when a copper wire is connected between its two ends.

Show them how they should tape a thermometer with its bulb against the zinc can of the battery. Then show them how to connect the copper wire and begin taking data, recording the temperature once a minute.

After the test, the bulbs and sockets can be set aside.

By having a separate timekeeper for each team, it will be possible for them to work independently and to begin whenever they have their equipment ready.

The form in which they record the data should be something like the sample shown below. You may wish to put an example on the board.

TIME (min.)	TEMPERATURE (°C)

It is recommended that this work be done on old newspapers or plastic wrap to prevent damage from leaking chemicals.

In order to make a good connection, suggest that the children double back 1 cm of both ends of the wire and

## TEACHING SEQUENCE

## COMMENTARY

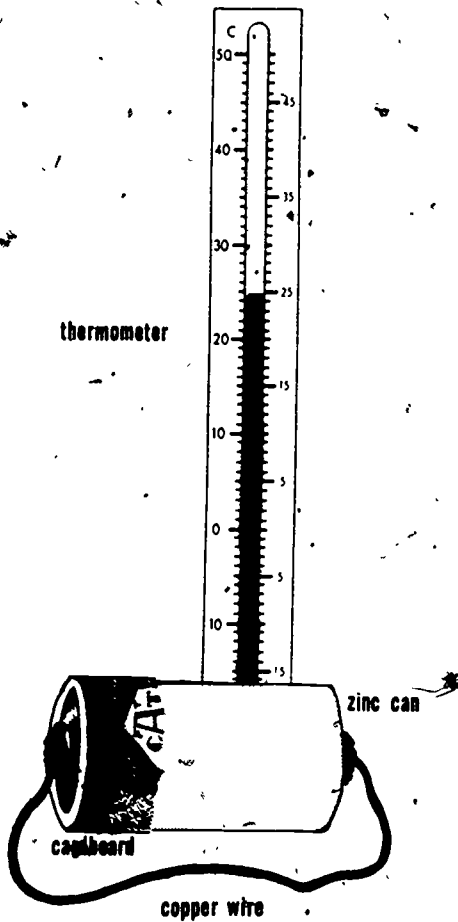

Answer any questions the children have and then let them begin. From time to time, while they are taking data, suggest that they briefly touch the zinc can of the battery to feel its temperature.

The children should continue taking data for a minimum of about 25 minutes. If their interest does not flag, they can continue for 40 minutes, or even longer. Otherwise, a few children may take a longer series of data to show the class later.

crimp a small wad of aluminum foil around each end before taping it to the battery, as described earlier.

Because some of the batteries may show signs of leakage, the children should wash their hands to remove any chemicals when they finish.

The thermometer will probably remain a few degrees above room temperature for nearly a day.

## TEACHING SEQUENCE

Have a few of the teams leave their batteries connected, and set them aside for observation on succeeding days.

The other teams can disconnect their batteries and check them again with flashlight bulbs. Discuss the changes that have occurred in the flashlight batteries as a result of the interaction.

Also, discuss the temperatures that were obtained:

- Did the temperature change more at the beginning or later?
- What was the highest temperature reached?
- Did the temperature go up faster or down faster?

Give each child a sheet of graph paper on which to make a graph of the temperatures that they recorded. A typical graph is shown on page 229.

3. Now, discuss the activity again with the children. You might ask whether or not the temperature of the battery changes more at the beginning or later.

## COMMENTARY

These should be left on plastic wrap or some other surface that will not be damaged by the chemicals that leak out.

The changes mentioned should include the production of heat energy, the loss of ability to light a flashlight bulb, and perhaps changes in the material of the battery.

You may wish to let them try a few unused batteries for comparison.

If the children seem to have trouble with these questions because they have no graph of the data, do not press the discussion. Instead, suggest that a graph might help to answer them.

Coordinate graphing was introduced in Grade 4 of COPEs. Some children may need help marking the axes and labeling them. This should be done as in the sample graph. It is important that the units ( $^{\circ}\text{C}$  and minutes) be specified, as well as the numbers on each axis.

The temperature should go up the most during the early minutes (except perhaps, for the first minute).



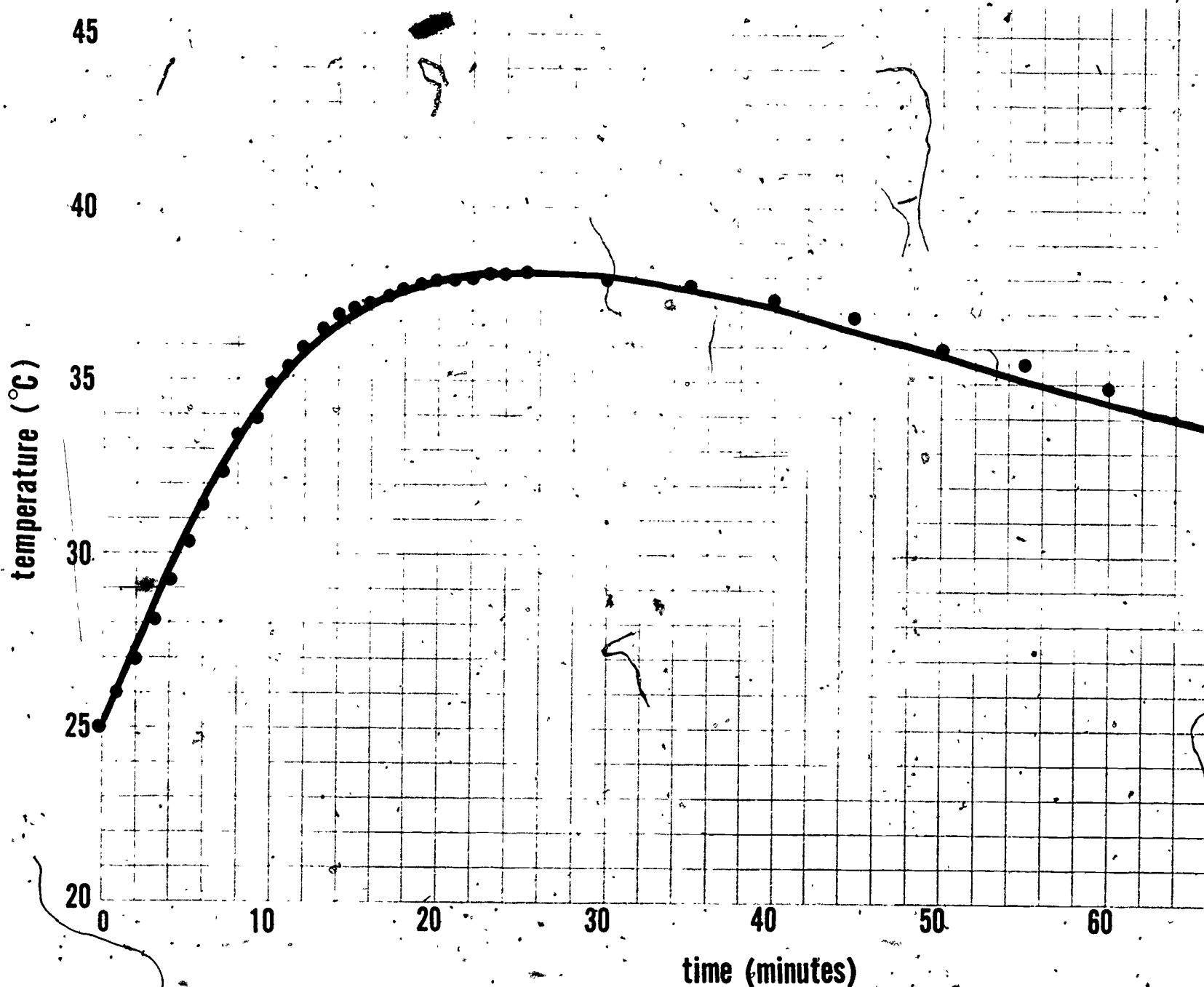

241

TASK AND TRAINING VARIABLES IN HUMAN PROBLEM SOLVING  
AND CREATIVE THINKING  
Project 103

Principal Investigator:

Gary A. Davis, Professor of Educational Psychology

TECHNICAL REPORTS, THEORETICAL PAPERS,  
PRACTICAL PAPERS, AND BOOKS

Davis, G. A. The current status of research and theory in human problem solving. Occasional Paper No. 2. Out of print. 23 pp. June 1966. ED 010 506.

Problem-solving theories in three areas are summarized: traditional learning, cognitive-Gestalt approaches, and more recent computer and mathematical models of problem solving. Recent empirical studies are categorized according to the type of behavior elicited by the task: overt or covert trial-and-error behavior. The review extends from January 1960 to June 1965.

Davis, G. A., Houtman, S. E., Warren, T. F., & Roweton, W. E. A program for training creative thinking: I. Preliminary field test. Technical Report No. 104. Out of print. 19 pp. November 1969. ED 036-019.

A three-part model conceptualizing the components of "creativity" as (1) appropriate creative attitudes, (2) various cognitive abilities, and (3) idea-generating techniques, suggests a structured approach for improving creative thinking.

Davis, G. A., Houtman, S. E., Warren, T. F., Roweton, W. E., Mari, S., & Belcher, T. L. program for training creative thinking: Inner city evaluation. Technical Report No. 224. 30 pp. April 1972. ED 070 809.

The effectiveness of a workbook for training creative thinking, Thinking Creatively: A Guide to Training Imagination, was evaluated with a sample of 198 inner-city students. The materials seek to teach attitudes which predispose an individual to behave more creatively and techniques for producing new combinations of ideas.

Despite the finding that both the training materials and the testing instruments were difficult for many of the Ss to read and thoroughly comprehend, most students and teachers felt that students had benefited from the creativity training experience. Two experimental classes showed modest gains in Torrance Test scores; Ss in all four experimental classes displayed more creative attitudes as indexed by a number of items in the 20-item attitude survey.

## TEACHING SEQUENCE

- What form of energy appeared during the experiment that caused the temperature to change?
- What was the source of the heat energy?
- Was the battery changed?

You might suggest to the class that the battery has lost something called "chemical energy" while it was producing heat energy.

- Can you now give a description of what happened when the blackened and unblackened bulbs were connected into electrical circuits?
- What form was the energy in before the start?
- What was this chemical energy converted to by the clear bulb?
- What was it converted to on the surface of the blackened bulb?

You might summarize the conversions with simple diagrams on the chalkboard such as:

## COMMENTARY

Heat energy.

The battery.

Yes. In fact, if left connected, breaks will eventually appear in the zinc and the chemicals will leak out. Also, the battery can be tested and shown to have lost some or all of its ability to light a flashlight bulb.

Chemical energy in the battery.

Radiant energy (plus some heat energy).

The first answer the children give may be "heat energy." But upon reflection, some children may realize that the inside of the bulb first made radiant energy (light), and that this was converted into heat energy when it struck and was trapped by the blackened surface of the bulb.

## TEACHING SEQUENCE

## COMMENTARY

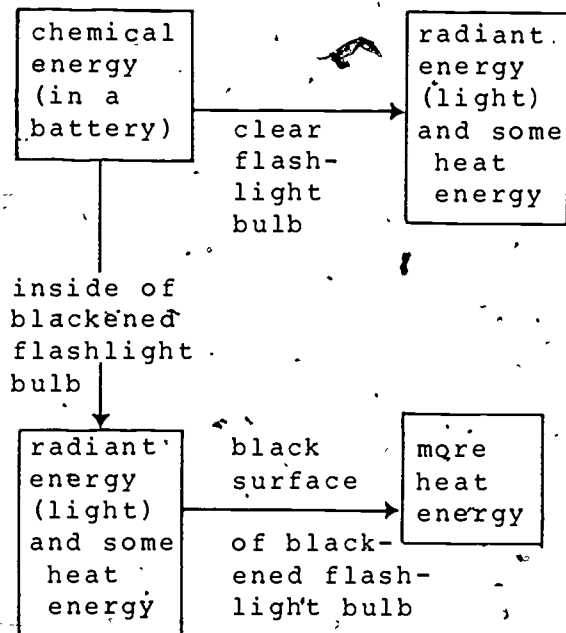

## EXTENDED EXPERIENCE:

Show the children the No. 6 dry cell and a piece of iron hair wire. Ask what they think might happen if you were to connect it between the two terminals on the top of the battery. After the children have discussed the possibilities, remove the two plastic caps from the terminals and wrap one end of the wire tightly around one of the terminals. Then pull the other end of the wire over against the other terminal. Soon the wire should begin to glow with red light. Do not keep the wire across the terminals for very long as this heavy load will quickly run down the battery. Do not touch the wire between the poles because it becomes very hot. Caution the children not to touch it either.

Dim the room light by lowering the shades, if possible, and turning out the room lights. Again, pull the wire against the battery terminals. The children should observe the glowing red wire. Help them to understand that light is coming from the hot wire.

Discuss the forms of energy that were involved: What kind of energy was involved when the wire became hot? (Heat energy). What was the source of the heat energy in the battery? (Chemical energy) Thus the sequence of transformations that take place is: chemical energy  $\rightarrow$  (electrical energy  $\rightarrow$ ) heat energy  $\rightarrow$  radiant energy. What is the final form of energy produced? (Radiant energy, or light, plus some heat).

Help the children to compare this activity with what they did earlier. There the conversion of radiant energy to heat was studied; here they have seen an example of the conversion of heat energy to radiant energy (light). They should be able to think of other examples, such as when a wire is heated in a candle flame.

### Activity 3 Chemical Energy (Food) to Heat Energy

In the previous two Activities, the children have observed that some heat energy is produced when energy is converted from one form to another. They detected this heat energy by measuring the increase in temperature with a thermometer following different energy transformations. In this Activity the children will investigate another kind of energy transformation, one that plays a very important role in living things. They will find that when seeds germinate and begin to grow (use chemical energy--food), a measurable amount of heat energy is produced. The children will find that when yeasts utilize apple juice, at least part of the chemical energy is also degraded to heat. The idea which is introduced here--that when energy is transformed, some heat energy is produced--is an important one in the degradation of energy conceptual scheme and the various experiences with it are preliminary to the types of interactions considered in Grade 6.

#### MATERIALS AND EQUIPMENT:

For each group of 4 or 5 children you will need:

- 2 thermos bottles, 1/2 pint size
- 2 thermometers, -20°C to 50°C

For the class you will need:

- 1 hot plate and pot with cover

clear plastic food wrap, 1 roll

seeds; black-eyed peas, peas, kidney beans, lima beans, corn or radish seeds or any other seeds which germinate fairly rapidly

paper towels

germination dishes, such as glass or plastic petri dishes

- 1 450x microscope (optional)

For each pair of children you will need:

- 2 polyfoam cups, 6-oz to 8-oz (180-240 ml)

- 2 thermometers,  $-20^{\circ}\text{C}$  to  $50^{\circ}\text{C}$
- 4 packages baker's yeast (1/4 ounce)
- 1 copy of Worksheet IV-1
- 2 stirring rods (popsicle sticks make good ones)
- 1 1-oz (approximately 30-ml) cup, waxed paper or plastic

#### PREPARATION FOR TEACHING:

A few days before you want to start this Activity, germinate seeds in germination dishes on moist paper towels. The children can help with this preparation, which is similar to what they will be doing in the next sequences (See Activity 4 of Minisequence V). Cover the trays loosely with plastic wrap. Each of the two thermos bottles will be half filled with seeds. Therefore germinate enough seeds (for each group) to about fill one thermos. Use large seeds such as kidney beans, black-eyed peas, peas, corn, lima beans, etc., all of which can be purchased in quantity at the supermarket. Radish seeds, although smaller, have the advantage of germinating in about 24 hours.

You might want to ask the children to bring in thermos bottles from home prior to beginning the Activity. Each group will need 2 bottles in the small, 1/2 pint size.

About 24 hours after the seeds have begun to germinate, divide the seeds into 2 groups, which may be designated as experimental and control. The control seeds will be killed before placing them in one of the two thermos bottles. Boil them in water for about five minutes and let them cool in the covered pot. The Activity should begin at this point.

#### ALLOCATION OF TIME:

Approximately 2 hours will be needed for this Activity, extended over a period of a week or so.

#### TEACHING SEQUENCE

1. Initiate a short discussion to review the idea that living things can grow, provided a food supply is available. If there is no food, there is no growth.

#### COMMENTARY

This idea was introduced in Grade 4 of COPES (Minisequence I) where mold was seen to grow on bread kept in a moist closed system.

## TEACHING SEQUENCE

- What happens when a living thing grows?

You may want to suggest that growth is a change, which is evidence of an interaction; therefore, one might expect that some conversion of energy would be involved.

- What do you think is the source of energy for living things?
- Do seeds require food energy for growth? Encourage what will probably be a lively discussion based upon the children's prior experiences and observations.
- What would you predict might happen to this food energy when it is transformed?

## COMMENTARY

Growth involves not only the obvious increase in size, which most children recognize readily, but also an increase in complexity. Those who do not recognize the latter can be asked, for instance, what happens when babies grow? Do they simply increase in size in becoming children?

Food is the source of energy for many living things.

There might be some confusion here. (Possible responses are: Yes, the seed gets its food from the storage leaves, the cotyledons. (Starch was detected in the storage leaves in a Grade 3 activity).. Yes, the seed gets its food from the soil. Yes, the seed gets its food (energy) from sunlight. No, seeds don't require a food source because they will germinate in plain water and in the dark.

The children hopefully will draw upon their past experiences with energy transformations. Heat energy is almost always produced when energy is converted from one form to another. If the children do not suggest that heat energy will be produced, you might ask them about the previous Activities in which heat energy was observed following different energy transformations. Take the time to introduce this



## TEACHING SEQUENCE

## COMMENTARY

Help the children to formulate the following hypothesis: If food energy is stored within the seed, then when the seed germinates and begins to grow and utilize the food energy, some heat energy should also be produced. We should be able to detect this heat energy.

In order to help the children design a system for detecting this type of energy conversion, raise the following questions:

- What will happen to the system if heat energy is produced?
- What will happen to the heat energy if it is produced?
- How can the loss of heat energy be minimized?

Next, show the children the seeds which have begun to germinate and explain that in order to show that the expected effect (the production of heat energy) would not be obtained by seeds which are unable to utilize the stored food, you have prepared a

idea with the children. It is an important understanding in the degradation of energy conceptual scheme.

There will be a rise in temperature. Therefore, thermometers will be needed to detect the heat energy.

It will be lost to the surroundings rather quickly.

Insulated containers could be used. Thermos bottles will be needed in this Activity because the germinating seeds produce a relatively small amount of heat energy over a long period of time. The rate of heat production must be greater than the rate of heat loss if a temperature rise is to be observed.

## TEACHING SEQUENCE

control group of boiled seeds which will be subjected to the same experimental conditions. They are to half fill each of two thermos bottles--one with the control seeds, and one with the experimental seeds.

At this point, the children should have two 1/2-pint thermos bottles, each of which is half full of seeds which have begun to germinate. One bottle (the control) contains dead seeds and the other living ones. They should crumple up some plastic wrap and place it in the neck of each thermos. Then place a thermometer into each thermos, sticking through the plastic wrap. Label the thermos bottles as to seed type, experimental or control, and data and time of placing the seeds inside.

Have the children record the temperature in each thermos about twice a day and record their data.

## COMMENTARY

The children can work in groups of 4 or 5 on this experiment, with some members of each team responsible for the experimental set-up and some for the control. The children should transfer the boiled seeds to the thermos as carefully as possible, trying to maintain aseptic conditions as much as possible. This is necessary since if too much mold gets into the thermos, the mold will grow and heat energy will be produced. If this happens, you will have to discuss this phenomenon with the children.

You might want to ask them to set up their own Worksheets similar to the following:

Time (Hours)	Temperature (°C)	
	Experimental	Control
Start		
5		
24		
29 etc.		

## TEACHING SEQUENCE

## COMMENTARY

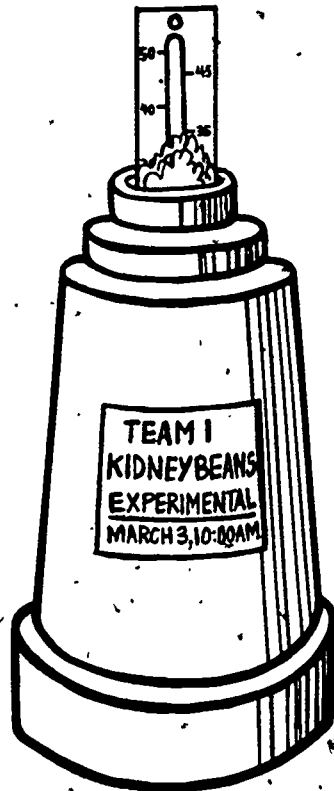

Once a large temperature increase has been measured, let the children examine the contents of the control and experimental thermos bottles.

The temperature of the experimental bottle will rise substantially in about 24 hours (to about 40°C) while there will be no significant increase in the temperature of the control bottle.

It is not necessary to keep the experiment running much more than 48 hours. Be sure that the temperature is not allowed to rise above the limit of the thermometer.

There will have been substantial growth in the experimental bottles and none in the

## TEACHING SEQUENCE

Conclude the activity with a brief discussion emphasizing the accumulated evidence to support the children's original hypothesis.

2. Suggest that it might be possible to detect an energy conversion in another living system. The children could see if heat is produced when yeasts utilize food energy.

## COMMENTARY

controls. Growth occurred, food (energy) must have been utilized and heat energy was produced. Where there was no growth, no heat energy was produced.

The children may also observe a change other than size in the seedlings as they begin to differentiate into the different plant parts studied by the children in Minisequence I. You may want to allow one group of the experimental seeds to continue to develop in order to emphasize the increase in organization that accompanies growth. The children could be encouraged to plant some of the seedlings.

Some children may not know that yeast is a living substance. It consists of many tiny plant cells which are so small that they cannot be separately identified with the 40x microscope the children have used during earlier sequences. Yeast cells do not contain chlorophyll and are incapable of producing their own food. One or two of the children might enjoy finding out something about yeast and reporting on it. If there is a high powered microscope available, such as a 450x, it would be well worth placing a drop of yeast culture on a slide during this activity so that the children can observe the yeast's uncellular character. A cover slip should be placed on the slide, as in other wet mounts.

## TEACHING SEQUENCE

- What is a good source of food for the yeasts?
- How can we show that apple juice, say, is a source of energy for yeast?
- How should the experiment be designed?

Tell the children that you have selected quantities of yeast, apple juice and water which the whole class will use. Ask one child in each team to collect the materials which you have assembled.

One child should place 1/2 oz

240

## COMMENTARY

If any of the children have found out something about yeasts, they will know that yeasts are particularly fond of sugar, such as that found in fruit juice.

Again, they need a control. If heat energy is produced by the yeasts and apple juice (which is largely water), we must show that it is not produced by yeasts and water alone.

Two systems (experimental and control) should be set up: The amount of water and apple juice should be the same in each cup. Similarly, the amount of yeasts should be the same.

This part of the Activity can readily be done in teams of 2, using polyfoam cups as the insulated containers. (Of course, the children can use the thermos bottles if they wish.)

The quantities of each material are very important to the success of this experiment. The amounts given here have been selected to give a maximum temperature rise of about 7 or 8°C. If too much apple juice is used, little or no temperature rise will be apparent because of the additional heat energy required to raise the temperature of the liquid; if too little apple juice is used, there will not be enough to wet all of the yeast cells. You may want to discuss these considerations with the class if they question the amounts used, but do this after the experiment.

253

TIME (MIN)	TEMPERATURE (°C)	OBSERVATIONS
0		
5		
10		
15		
20		
25		
30		

Total change in temperature: \_\_\_\_\_

## TEACHING SEQUENCE

(2 packages) of yeast in the bottom of each of 2 polyfoam cups. The other team member can pour 20 ml (about 2/3 ounce) of apple juice over the yeast in one cup and the same amount of water over the yeast in the second cup.

Ask the children to stir the contents of each cup vigorously for 20 or 30 seconds until the yeast and liquid form a thick syrup or paste. Each member of the team can stir one cup.

Distribute Worksheet IV-1. Have the children place a thermometer into each cup and observe for about 30 minutes. Once the thermometer is inserted, they should not disturb the systems any further. They can take turns observing and recording their observations.

Within about 30 minutes, the temperature of the mixture will have risen about  $8^{\circ}\text{C}$  in the cup containing apple juice, while no change in temperature will be apparent in the control cup. Give the children time to discuss their observations.

- Did an energy conversion take place?
- Is all of the energy in the apple juice transformed to heat energy?

Suggest that some of the energy may have been converted to additional growth or increased biological matter, as with the seeds. In this process, some

## COMMENTARY

The children can use the small 1-oz (30 ml) cups to measure the water and apple juice.

The children should use stirring rods or popsicle sticks for stirring rather than their COPES thermometers because the thermometers might break if used for mixing the thick syrup.

You may prefer to have them make their own Worksheets, as before.

The children may make additional observations. They may note that bubbles have started to form or that the mixture appears less thick. Encourage them to record all such observations on their Worksheet.

Yes--apparently food (chemical energy) was converted to heat energy.

The children have no way of knowing this.

Actually, the yeasts increase in number, although the children have no way of knowing this either. The degradation of energy is apparent from the

## TEACHING SEQUENCE

## COMMENTARY

of the energy is degraded to heat. change in temperature.

## EXTENDED EXPERIENCE:

If some children question that the yeasts are living things which utilized the sugar in the apple juice for food, but merely consider that they interact with apple juice and not with water, ask them how they stopped the growing process in the seeds. (They were heated in boiling water.) Were these "cooked" seeds able to utilize the food, grow, and produce heat energy? (The experimental evidence indicated that the control thermos showed no rise in temperature.) Then suggest that they repeat their experiment with the yeasts and apple juice, but this time, "cook" the yeasts first. This can be easily done by holding the sealed foil packages in boiling water for about five minutes. Then set up the experiment in an identical manner. Will heat energy be produced? Will the food energy of the sugar in the apple juice be used by the yeast? This additional experiment should help the children realize that the yeasts are like the seeds in that, if they are still alive, they can utilize a food source. In so doing, heat energy is the by-product.



## Activity 4 Kinetic Energy to Heat Energy

The concepts introduced in Minisequence II of Grade 5 are reviewed and extended in the present Activity. In the first Part the children sense the production of heat energy when a short piece of wire is flexed repeatedly; that is, heat energy resulting from a mechanical interaction. They then observe the disappearance of kinetic energy as heat energy is produced while pressing a thermometer against a spinning bicycle tire. The tire slows down as the thermometer registers an increase in temperature.

In Part B of this Activity, kinetic energy is converted to another type of energy, potential energy. When the conversion occurs, heat is again produced. That is, not all of the kinetic energy could be transformed to potential energy.

### MATERIALS AND EQUIPMENT:

- 30 pieces of bare copper wire, about #20, 4-in. (10-cm) (available at department stores as solid copper utility wire)
- 5 bicycles
- 10 thermometers,  $-20^{\circ}\text{C}$  to  $+50^{\circ}\text{C}$
- 2 wooden or plastic rulers per bicycle, 12 in. (30-mm) tape, transparent
- 5 or more roller skates
- 15 bricks
- 25 rubber bands, #18
- 5 spring scales, 500-g, e.g., Ohaus
- 10 metal lids, approximately 5-cm diameter

## PREPARATION FOR TEACHING:

Tape each thermometer to a ruler as shown in the sketch. The bulb side is outward and the tape covers the bulb. For added safety, tape the entire length of the glass stems with transparent cellophane tape.

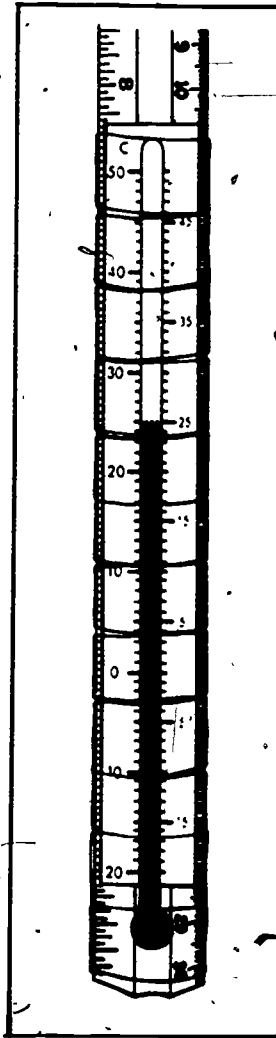

Next, loop two rubber bands together as shown in sketch A on page 246 to make a knot as shown in sketch B. Pull the knot very tight. Loop a third rubber band around one of the first two at a position close to the first knot, (not at the opposite end of the loop); and pull this second knot very tight as in sketch C. In the same way, loop a fourth rubber band to the third close to the second knot and pull this third knot very tight. Repeat the procedure with a fifth rubber band. This will give you a chain that looks like sketch D. Cut the three short segments marked X, which will leave a finished band as shown in sketch E.

Attach one end of the rubber-band chain to one end of one of the roller skates. You might use the same sort of looping technique you used to make the band; that is, put a loop through part of the skate frame, put the rest of the band through the loop and then pull it tight.



A



B

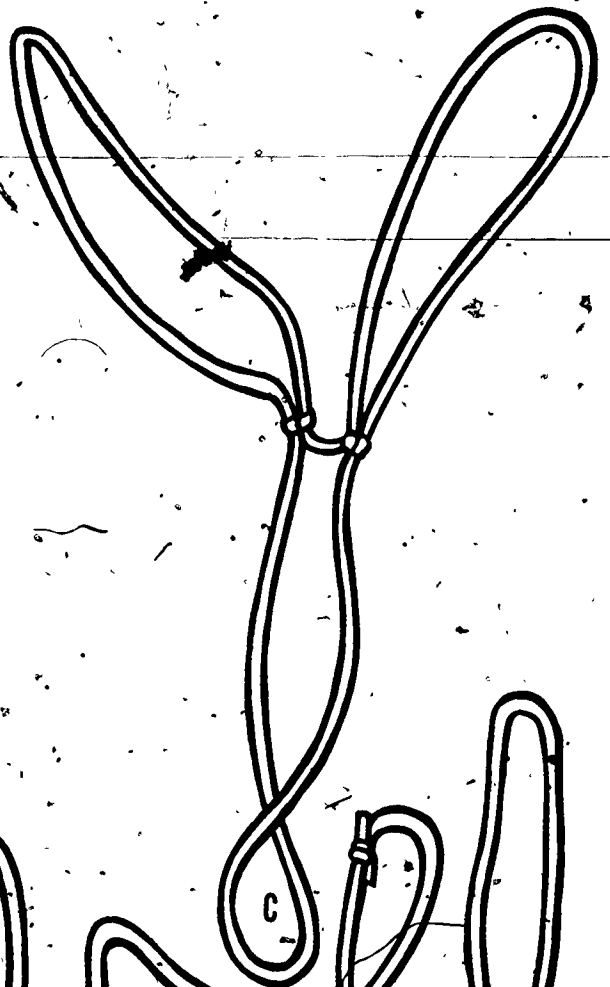

C

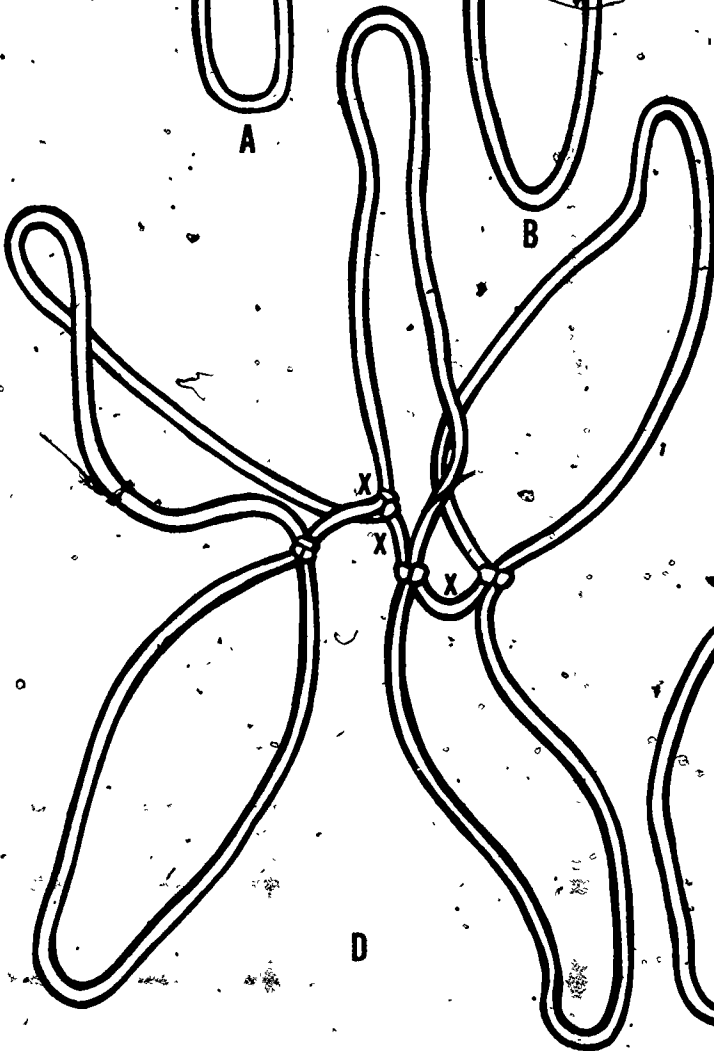

D

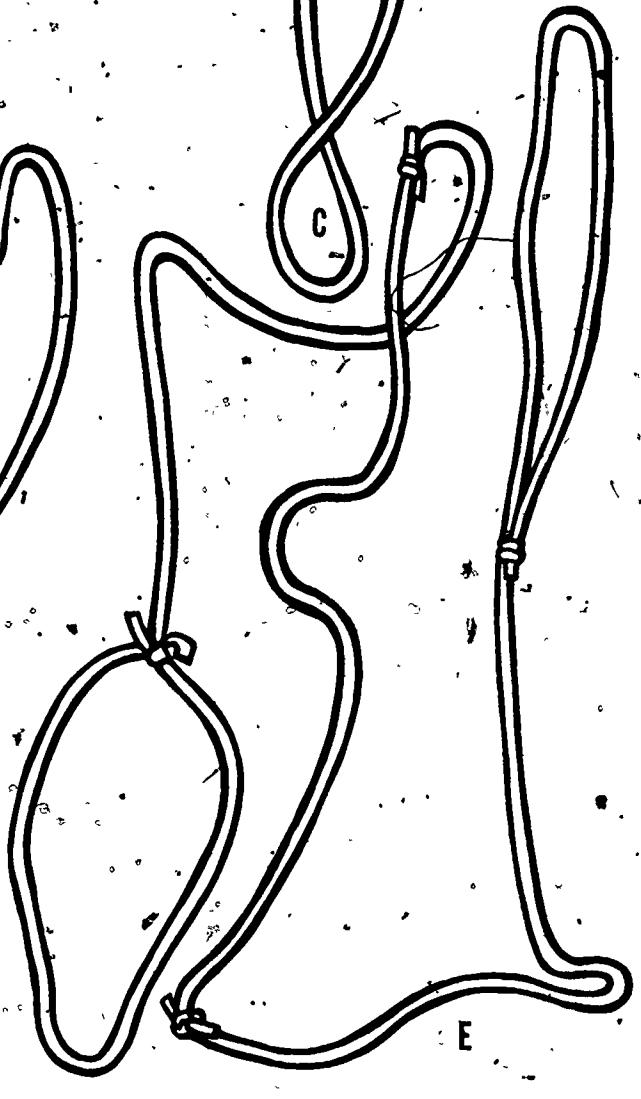

E

## ALLOCATION OF TIME:

The children will need about 1-1/2 hours for this Activity.

## TEACHING SEQUENCE

## PART A

1. Ask the children for examples of the conversion of different forms of energy into heat energy.

As the children give their answers, write them on the board in an arrangement something like that shown on the right.

Suggest that they try to produce heat in still another way. Give each child a piece of bare copper wire and ask that they work in pairs. Have one child in each pair hold the wire by the ends and rapidly

## COMMENTARY

The children should be able to suggest several of the following, or others that are similar:

## A. Conversion of Chemical Energy to Heat Energy.

a. A battery with a good conductor connected across it becomes warm.

b. A blackened bulb connected across a flashlight battery becomes warm as the battery's chemical energy is used up.

c. A candle produces heat energy as it burns.

d. Seeds and yeast cells use the chemical energy of food to produce some heat.

## B. Conversion of Radiant Energy to Heat Energy.

a. A black surface becomes warmer when it is in the sunlight.

b. A thermometer with a blackened bulb in a reflector shows a rise in temperature.

Keep this list on the board during the Activity as a useful summary.

## TEACHING SEQUENCE

bend and straighten the wire by moving his or her hands together and apart. After this has been done a few times, the other child in the pair should quickly touch the wire where it is bending. This can be repeated several times until the wire breaks. Then the two children in each pair can reverse roles and repeat the same process.

First ask what the children noticed. Then ask if any other kinds of energy were involved in bending the wire.

2. Bring the bicycle(s) into class--or bring the class out to the bicycles. Turn the bicycles upside down and assign one or two children to each to keep them from falling. Then have another child crank a pedal of the bicycle by hand to make the rear wheel spin fairly rapidly. He or she should then stop cranking and allow the wheel to coast. Have a third child read the temperature of one of the thermometers taped to a ruler and then hold the ruler so that the bulb presses against the side of the tire. When the tire stops, the

## COMMENTARY

The children could also quickly touch the wire to their lips, after bending it a few times, and feel the heat produced. (The lips are more sensitive to heat than the fingers.)

They will have observed that the wire became quite warm when it was bent back and forth. Hopefully, the children will recall their Activities in Grade 5, Minisequence II, and suggest that kinetic energy was involved since the wire was moving.

Return to the list on the chalkboard and add the following:

C. Conversion of Kinetic Energy to Heat Energy

a. Flexing a wire produces heat.

Be certain that the children keep a good grip on the rulers and do not put them where they

## TEACHING SEQUENCE

temperature of the thermometer should be read again.

## COMMENTARY

get tangled in the spokes.

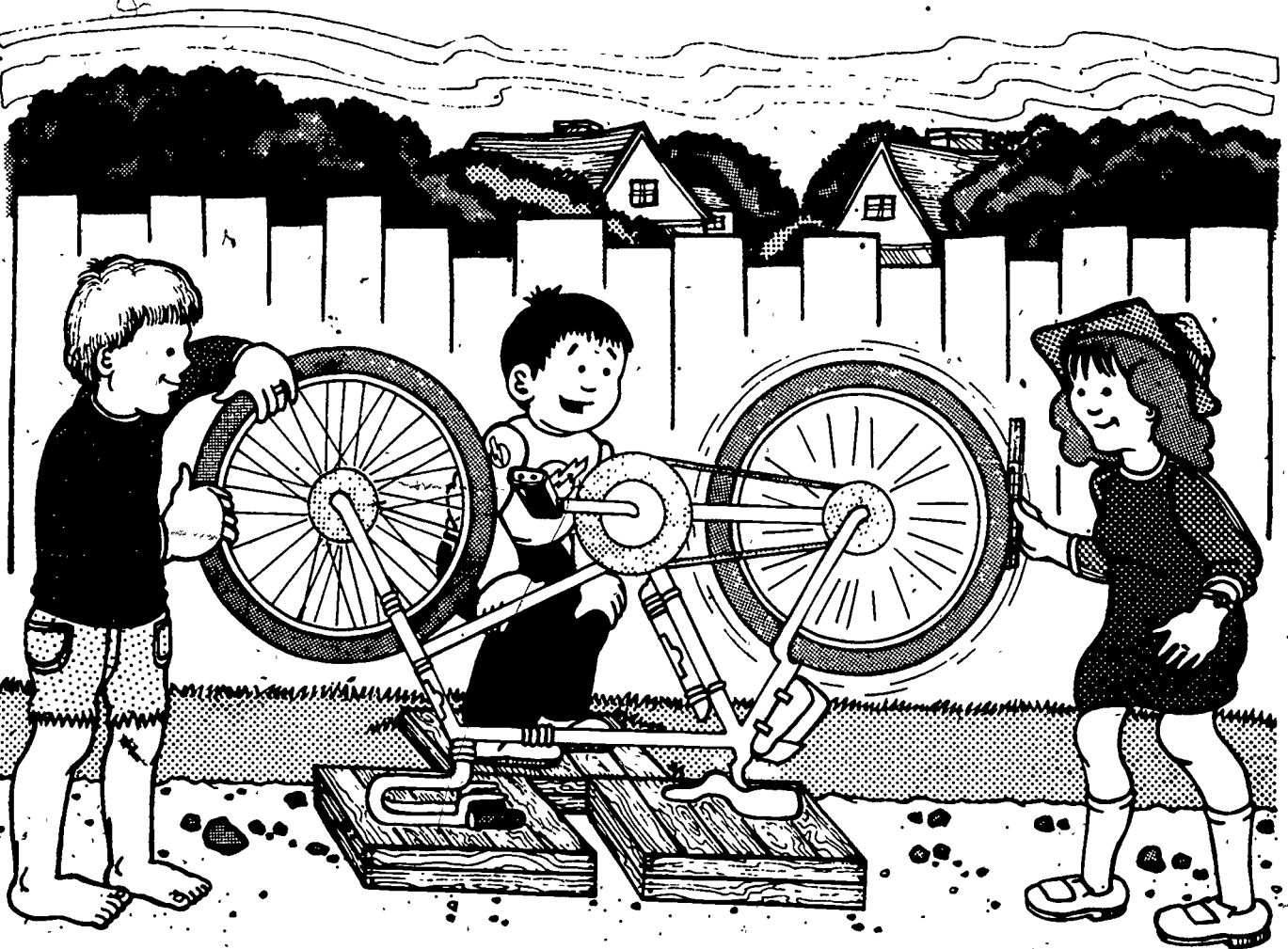

You may wish to let various children repeat the experiment, spinning the wheel at various speeds, pressing more or less hard with the thermometers, using two thermometers at once to stop the tire, or whatever else they wish to try out. Always be sure that the wheel is coasting when a thermometer is held against it.

The children should be aware of the need for using thermometers with similar starting temperatures for any comparisons they wish to make.

How long this part of the Activity continues will depend on you. The essential observation is that the thermometer bulb rubbing on the tire makes it stop more quickly than it otherwise would and that the tempera-

## TEACHING SEQUENCE

Discuss the results with the class. Then add another listing under the heading C. Conversion of Kinetic Energy to Heat Energy.

b. A turning bicycle wheel produces heat.

If any children tried using different initial speeds for the bicycle wheel, or if any tried using two thermometer bulbs to stop one wheel, let them discuss their results. This can help the children to realize that a turning wheel has a specific amount of kinetic energy which may be converted into a specific amount of heat energy.

- What made the bicycle wheel stop in this Activity?

Inform them that another word for this rubbing is "friction." This is the term that is used whenever surfaces rub together, converting kinetic energy into heat energy. Ask the children to give other examples of friction.

## COMMENTARY

ture shown by the thermometer goes up in the process. The children may also learn that a faster spinning wheel can produce a larger temperature rise, or that sharing the heat energy between two thermometers produces a smaller temperature rise in each.

It stopped because it rubbed against the thermometer bulb.

One possible example is the brakes that are used to stop a car or a bicycle. (The heat energy produced in the latter may be felt by touching the brake pads after braking down a long hill.) The children should be able to cite other examples from their work in Minisequence II.

## TEACHING SEQUENCE

- Would the turning bicycle wheel stop even if it weren't rubbing against a thermometer bulb?
- What happens to the kinetic energy in this case? Is it converted into some other kind of energy?

## PART B

1. Suggest that the children work in groups of 6 to experiment with the skate, bricks and rubber bands on their own.

Show the children a skate with three bricks on it. Set the skates at rest.

- Does the skate have kinetic energy? Why or why not?

You may want to ask for ways that the skate could be given kinetic energy (put into motion). Let the children demonstrate the ways that they mention.

## COMMENTARY

Yes. The children should know that a turning bicycle wheel will eventually coast to a stop.

The children should realize that there is still some friction in this case. Hopefully, some of them will suggest that heat energy is probably produced at the axle of the wheel but since it can spread out through the metal it is difficult to measure (the temperature doesn't go up much).

Another possibility is the friction due to the wheel "rubbing" against the air. In this case the heat energy would be spread out through the entire wheel. This friction is very small compared to that at the axle.

See the precursor to this Activity in the Grade 3 Teacher's Guide--Activity 2, Stretching Rubber Bands, in Minisequence II. The set-up is very similar.

No, it has no kinetic energy, because it is not moving.

For example, a child may push or pull the skate directly. Another child may pull on the rubber band which is attached to the skate. Yet another may suggest rolling a ball so that it



## TEACHING SEQUENCE

No matter what methods the children suggest, have them describe the form of energy that is converted into kinetic energy of the skate.

2. Attach the free end of the prepared string of rubber bands to something such as a table leg at one side of the room. Station one or two children nearby to catch the skate when necessary. Ask another child to pull the skate back several feet, stretching the rubber band to about twice its relaxed length. While he or she is still holding the skate, ask the children what will happen when it is released.

• Will the skate gain kinetic energy when it is released?

## COMMENTARY

collides with one end of the skate.

In most cases this will be the kinetic energy of their hands, or of objects that are moving.

If the children suggest letting the skate acquire energy by rolling down a ramp, as the marble did in Minisequence II, they should be able to see that, in this case, the source of the kinetic energy is the initial (gravitational) potential energy of the weighted skate.

Discuss what will happen before finally releasing the skate. This should help to focus the children's attention on the rubber band as the immediate source of energy which moves the skate.

At least the children will know that the skate should move toward the point where the rubber band is attached to the wall. They may explain this by saying that the rubber band will pull (exert a force) on the skate.

Yes. Since kinetic energy is associated with motion, the children should realize that the skate will gain kinetic energy.

## TEACHING SEQUENCE

Finally, ask the child holding the skate to release it while the children watch. After the skate has moved and been caught, have a child pull it back farther and hold it ready to be released again. Then discuss what was observed.

- If the rubber band is stretched farther than before, what difference should you observe?

Ask several children to try this experiment while the class watches. Repeat the experiment using different amounts of stretch.

- Why does the skate go faster in some cases?

Elicit from the children their earlier understanding that work units are equal to force units times distance units. Therefore, when both force and distance are increased, work must increase. This is how the skate gets more kinetic energy from a rubber band that is stretched farther.

- Does a stretched rubber band have some kind of energy that an unstretched rubber band does not?

When the children see that stretched rubber bands are a source of energy, you may tell them that the kind of energy

## COMMENTARY

The person who is to catch it should be in position and ready.

Be certain that the discussion includes the ideas that the rubber band did work on the skate by pulling it with a force through a distance, and that the skate acquired kinetic energy in the process.

They should expect that the skate will end up moving faster than before.

The rubber band pulls with more force (let the children feel the difference by holding onto the skate); and it pulls the skate through a greater distance, thus doing more work on it.

The children should realize that the stretched rubber band must have some kind of energy since it can do work to make kinetic energy. If not, ask them where a marble gets its kinetic energy from when it rolls down a ramp.

## TEACHING SEQUENCE

stored in stretched bands is called "elastic potential energy." The more a rubber band is stretched, the more work it can do, and therefore, the more elastic potential energy it has. With the children's help you might set up the following diagram:

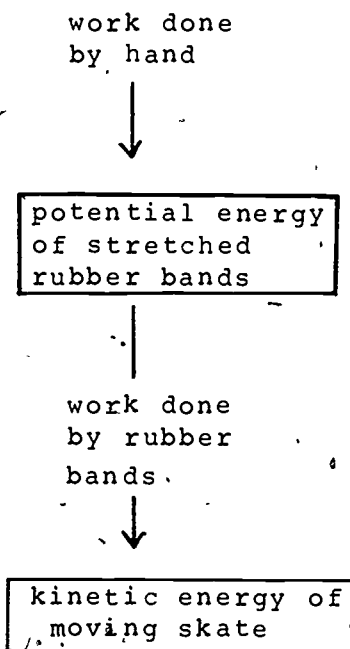

3. Next have a child hold the free end of the chain of rubber bands which is attached to the loaded roller skate. Have another child push the skate to start it rolling away from the first child while the class observes. Let the children discuss their observations. This may be repeated until the class agrees on its observations.

Ask the child who held the rubber band to report what he or she felt. Let others repeat the experiment and report what they feel. Then repeat

## COMMENTARY

The skate will move steadily until the rubber bands are extended. Then it will slow down, stop, reverse its direction and gain speed until the rubber bands are again relaxed.

The child should report feeling a force (pull) that began when the skate started to slow down and continued until it reached full speed on its return.

## TEACHING SEQUENCE

the experiment again using a spring scale attached to the free end of the rubber band. Have them observe on the scale that a force of a certain number of units is being applied. Ask what caused the force that was observed. If it is not clear that it was caused by the moving skate, repeat with the spring scale attached to a chair instead of being held.

Ask the children to describe any work that was done during the experiment. Remind them of the definition of work as a force exerted on an object times the distance through which it is exerted.

If the children see only the first push as an example of work, ask specifically if any work was done on the string of rubber bands. If necessary, duplicate the work done by the skate by having a child pull the rubber band out to an equivalent length with their hands.

- Was any more work done in the experiment?

Now ask the children to try pushing the skate across the floor when each of the front wheels is in an inverted metal jar lid. Then repeat without the lids. Discuss the differences that are observed. Have them use the spring balance to measure the force.

## COMMENTARY

This should help the children to see that it was the motion of the skate which caused the force observed in the rubber band.

Their first answer will probably be that the person who started the skate did work on it by pushing it through a distance.

They should then realize that the moving skate must have done work by exerting a force on the rubber bands through a distance.

Now the children should suggest that the rubber band pulling the skate back must have done work on it. If necessary, this can be duplicated by having a child pull the skate back as the rubber band did.

With its front wheels in lids the skate will be harder to push and will slow down much more quickly after it has been

## TEACHING SEQUENCE

needed to pull the skate across the floor in both cases.

Ask why the skate slows down so quickly when its wheels are in the lids. Have the children suggest how to represent what happened with a diagram like the one used before to show energies and work. For example.

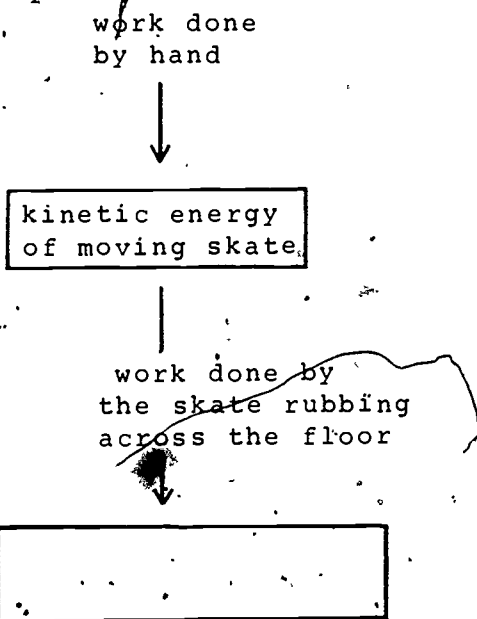

- Should some kind of energy go in the last box of the diagram?

## COMMENTARY

pushed.

The moving skate slows down sooner because of the greater force between it and the floor when its wheels are in the lids. The children should know from the first part of the Activity that this force is called "friction."

The suggested diagram might begin with a rectangle to show the initial kinetic energy of the skate. Then an arrow can be added to show that this came from work done by the hand that pushed the skate. Then another can be added to show that the kinetic energy was lost as the skate rubbed across the floor. You may suggest that the skate was doing work since it was pushing on the floor through a distance. The children should be able to see that this is similar to the previous section, where the skate did work against a rubber band as it slowed down.

Although no form of energy was visible, the children may suggest that some heat energy must have been produced by the rubbing. If not, remind them of what happened when a thermometer rubbed against a bicycle tire in the first part of the Activity. You may also ask them to try rubbing their hand across the top of their desk to feel the heat that is produced.

For some children it may prove more convincing to be able to measure the small temperature rise which is associated with the heat produced by friction. To do this, wrap a small piece

## TEACHING SEQUENCE

## COMMENTARY

of aluminum foil around the bulb of a thermometer. Tape the thermometer into one side of one of the metal lids so that the bulb is pressed against the metal of the lid near the point where the wheel of the skate will be. Place this lid under one of the wheels of the roller skate which is loaded with at least 2 bricks, and wait several minutes for the thermometer to reach floor temperature. Then the children can lift the skate, read the thermometer without touching the lid and replace the lid and skate. Next, they can try pulling the skate around the floor for a few minutes and observe the resulting temperature change. The temperature will be found to have increased by about one degree. This indicates that heat energy was produced. The temperature rise is small because much of the heat energy is left behind on the floor. If all the heat energy remained in the lid, the temperature rise would be much greater. If more weight is put on the skates by pushing down on it and if it is moved very rapidly, a temperature rise of about three degrees may be observed.

Conclude by returning to the list begun at the beginning of the Activity.

- What final item can be added to the list? Where should it go?

The final discussion should indicate that the children have

A third item can now be added under the heading, Conversion of Kinetic Energy to Heat Energy:

- c. A moving skate produces heat energy as a result of friction with the floor.

## TEACHING SEQUENCE

grasped two important concepts as a result of their work in this sequence:

1. Different forms of energy can be converted from one to another.
2. In all energy conversions in real life situations some heat energy is produced.

## COMMENTARY

# Minisequence IV Assessments

## Screening Assessments

The concepts being tested in this Minisequence are:

- a. Different forms of energy can be converted from one to another.
- b. In all energy conversions in real-life situations some heat energy is invariably produced.
- c. When light, a form of radiant energy, is absorbed by a surface some of it is converted into heat energy.
- d. The electrochemical energy of a battery can be converted to radiant and/or heat energy if it is made part of a completed electric circuit.
- e. As the chemical energy in food sources is converted to plant and animal growth, some heat energy is produced as a byproduct.

Distribute the assessment pages to the children. Have them write their names in the appropriate places. This assessment will take about 10 minutes for each of the 2 parts.

PART 1

Page A.

Ask the children to turn to page A.

I AM GOING TO ASK YOU SOME QUESTIONS. READ THE QUESTIONS SILENTLY AS I READ THEM ALOUD TO YOU. AFTER I HAVE READ THE QUESTIONS AND THE THREE CHOICES, DRAW A CIRCLE AROUND THE LETTER OF THE BEST CHOICE. (Allow 30 seconds for the children to respond to each item.)



1. IF YOU WANTED TO CONVERT POTENTIAL ENERGY INTO AS MUCH KINETIC ENERGY AS POSSIBLE, YOU WOULD:
  - A. TRY TO INCREASE THE AMOUNT OF HEAT ENERGY PRODUCED.
  - B. TRY TO DECREASE THE AMOUNT OF HEAT ENERGY PRODUCED.
  - C. NOT BE CONCERNED WITH HEAT ENERGY.
  
2. WHEN A BALL BOUNCES UP FROM THE GROUND, THE ELASTIC POTENTIAL ENERGY OF THE BALL IS CONVERTED INTO:
  - A. CHEMICAL ENERGY AND HEAT.
  - B. KINETIC ENERGY.
  - C. KINETIC ENERGY AND HEAT.
  
3. IF THERE WERE NO FRICTION, WE COULD CONVERT ONE FORM OF MECHANICAL ENERGY TO ANOTHER
  - A. WITHOUT ANY HEAT ENERGY BEING PRODUCED.
  - B. COMPLETELY, WITH ONLY A SMALL AMOUNT OF HEAT ENERGY PRODUCED.
  - C. MUCH MORE SMOOTHLY AND RAPIDLY.
  
4. DEAN HAS A BATTERY-OPERATED TOY CAR. WHEN HE RUNS IT, WHAT IS HAPPENING?
  - A. KINETIC ENERGY IS BEING TRANSFORMED TO ELECTRO-CHEMICAL ENERGY.
  - B. ELECTRO-CHEMICAL ENERGY IS BEING TRANSFORMED TO KINETIC ENERGY.
  - C. ELASTIC POTENTIAL ENERGY IS BEING TRANSFORMED INTO KINETIC ENERGY.

Page B

Have the children turn to page B.

5. DEAN REMOVES THE BATTERY FROM THE CAR AND PLACES THE CAR ON A PLATFORM AT THE TOP OF AN INCLINE, ALLOWING IT TO RUN DOWN. WHAT HAPPENS?

- 7
- A. ELECTRO-CHEMICAL POTENTIAL ENERGY IS CONVERTED TO KINETIC ENERGY.
  - B. KINETIC ENERGY IS CONVERTED TO GRAVITATIONAL POTENTIAL ENERGY.
  - C. GRAVITATIONAL POTENTIAL ENERGY IS CONVERTED TO KINETIC ENERGY.

6. WHILE THE CAR IS MOVING DOWN THE INCLINE WITHOUT THE BATTERIES, SOME HEAT IS PRODUCED. THE REASON THIS HAPPENS IS THAT:

- A. SOME KINETIC ENERGY IS CONVERTED TO HEAT ENERGY.
- B. SOME HEAT ENERGY IS ABSORBED AS POTENTIAL ENERGY.
- C. SOME POTENTIAL ENERGY IS CONVERTED DIRECTLY TO HEAT ENERGY.

7. WHEN WE EXERCISE, WE CONVERT

- A. CHEMICAL ENERGY TO KINETIC ENERGY.
- B. CHEMICAL ENERGY TO HEAT ENERGY.
- C. BOTH STATEMENTS A AND B ARE TRUE.

8. IN AREAS WHERE RAIN IS FREQUENT AND THE CLIMATE IS DAMP, MANY PEOPLE LEAVE A LIGHT BULB BURNING ALL THE TIME IN EACH CLOSET. THE MAIN PURPOSE OF THIS PRACTICE IS TO:

- A. CONVERT ELECTRICAL ENERGY TO HEAT ENERGY.
- B. MAKE IT EASIER TO FIND THINGS.
- C. CONVERT POTENTIAL ENERGY TO KINETIC ENERGY.

PART 2

Page C

NOW TURN TO PAGE C.

1. IN NORTHERN AREAS, WHEN THE SPRINGTIME SUN MELTS SNOW AND THE WATER EVENTUALLY TURNS TURBINES IN POWER PLANTS, THE CONVERSIONS OF ENERGY FROM ONE FORM TO ANOTHER ARE MANY. MATCH THE KIND OF CONVERSION TO THE EVENT BY WRITING THE NUMBER OF THE CONVERSION

IN THE SPACE PROVIDED.

CONVERSIONS OF ENERGY

1. RADIANT ENERGY TO HEAT ENERGY.
2. POTENTIAL ENERGY TO KINETIC ENERGY
3. KINETIC ENERGY TO ELECTRICAL ENERGY
4. POTENTIAL ENERGY TO HEAT ENERGY
5. HEAT ENERGY TO KINETIC ENERGY
6. ELECTRICAL ENERGY TO RADIANT ENERGY
7. RADIANT ENERGY TO CHEMICAL ENERGY

EVENTS

- A. SNOW MELTS AND COLLECTS INTO MOUNTAIN LAKES.
- B. TURBINES SPIN AND PRODUCE ELECTRICITY.
- C. WATER SPILLS FROM LAKES INTO BROOKS AND RIVERS.
- D. ELECTRIC POWER PROVIDES FREEWAY LIGHTING.
- E. PLANTS FLOURISH IN SPRING SUNLIGHT.

2. ON THE LEFT BELOW ARE DESCRIPTIONS OF SIX KINDS OF ENERGY CONVERSIONS. ON THE RIGHT ARE THE NAMES OF THESE CONVERSIONS. DRAW A LINE BETWEEN EACH DESCRIPTION AND EACH OF THE NAMES. THE FIRST DESCRIPTION IS ALREADY MARKED.

- |   |                                      |
|---|--------------------------------------|
| 1. A FLASHLIGHT SHINING ON A DARK WALL. | A. CHEMICAL ENERGY → RADIANT ENERGY  |
| 2. A CHILD RUBS HIS HANDS TOGETHER.     | B. POTENTIAL ENERGY → KINETIC ENERGY |
| 3. A BATTERY LIGHTS A BULB.             | C. RADIANT ENERGY → HEAT ENERGY      |
| 4. A STEAM ENGINE.                      | D. KINETIC ENERGY → HEAT ENERGY      |
| 5. DROPPING A ROCK.                     | E. HEAT ENERGY → KINETIC ENERGY      |

(Allow the children about 2-3 minutes to complete this question)

1. IF YOU WANTED TO CONVERT POTENTIAL ENERGY INTO AS MUCH KINETIC ENERGY AS POSSIBLE, YOU WOULD:
  - A. TRY TO INCREASE THE AMOUNT OF HEAT ENERGY PRODUCED.
  - B. TRY TO DECREASE THE AMOUNT OF HEAT ENERGY PRODUCED.
  - C. NOT BE CONCERNED WITH HEAT ENERGY.
  
2. WHEN A BALL BOUNCES UP FROM THE GROUND, THE ELASTIC POTENTIAL ENERGY OF THE BALL IS CONVERTED INTO:
  - A. CHEMICAL ENERGY AND HEAT.
  - B. KINETIC ENERGY.
  - C. KINETIC ENERGY AND HEAT.
  
3. IF THERE WERE NO FRICTION, WE COULD CONVERT ONE FORM OF MECHANICAL ENERGY TO ANOTHER.
  - A. WITHOUT ANY HEAT ENERGY BEING PRODUCED.
  - B. COMPLETELY, WITH ONLY A SMALL AMOUNT OF HEAT ENERGY PRODUCED.
  - C. MUCH MORE SMOOTHLY AND RAPIDLY.
  
4. DEAN HAS A BATTERY-OPERATED TOY CAR. WHEN HE RUNS IT, WHAT IS HAPPENING?
  - A. KINETIC ENERGY IS BEING TRANSFORMED TO ELECTRO-CHEMICAL ENERGY.
  - B. ELECTRO-CHEMICAL ENERGY IS BEING TRANSFORMED TO KINETIC ENERGY.
  - C. ELASTIC POTENTIAL ENERGY IS BEING TRANSFORMED INTO KINETIC ENERGY.

5. DEAN REMOVES THE BATTERY FROM THE CAR AND PLACES THE CAR ON A PLATFORM AT THE TOP OF AN INCLINE, ALLOWING IT TO RUN DOWN. WHAT HAPPENS?
- A. ELECTRO-CHEMICAL POTENTIAL ENERGY IS CONVERTED TO KINETIC ENERGY.
  - B. KINETIC ENERGY IS CONVERTED TO GRAVITATIONAL POTENTIAL ENERGY.
  - C. GRAVITATIONAL POTENTIAL ENERGY IS CONVERTED TO KINETIC ENERGY.
6. WHILE THE CAR IS MOVING DOWN THE INCLINE WITHOUT THE BATTERIES, SOME HEAT IS PRODUCED. THE REASON THIS HAPPENS IS THAT:
- A. SOME KINETIC ENERGY IS CONVERTED TO HEAT ENERGY.
  - B. SOME HEAT ENERGY IS ABSORBED AS POTENTIAL ENERGY.
  - C. SOME POTENTIAL ENERGY IS CONVERTED DIRECTLY TO HEAT ENERGY.
7. WHEN WE EXERCISE, WE CONVERT
- A. CHEMICAL ENERGY TO KINETIC ENERGY.
  - B. CHEMICAL ENERGY TO HEAT ENERGY.
  - C. BOTH STATEMENTS A AND B ARE TRUE.
8. IN AREAS WHERE RAIN IS FREQUENT AND THE CLIMATE IS DAMP, MANY PEOPLE LEAVE A LIGHT BULB BURNING ALL THE TIME IN EACH CLOSET. THE MAIN PURPOSE OF THIS PRACTICE IS TO:
- A. CONVERT ELECTRICAL ENERGY TO HEAT.
  - B. MAKE IT EASIER TO FIND THINGS.
  - C. CONVERT POTENTIAL ENERGY TO KINETIC ENERGY.

1. IN NORTHERN AREAS, WHEN THE SPRINGTIME SUN MELTS SNOW AND THE WATER EVENTUALLY TURNS TURBINES IN POWER PLANTS, THE CONVERSIONS OF ENERGY FROM ONE FORM TO ANOTHER ARE MANY. MATCH THE KIND OF CONVERSION TO THE EVENT BY WRITING THE NUMBER OF THE CONVERSION IN THE SPACE PROVIDED.

### CONVERSIONS OF ENERGY

1. RADIANT ENERGY TO HEAT ENERGY
2. POTENTIAL ENERGY TO KINETIC ENERGY
3. KINETIC ENERGY TO ELECTRICAL ENERGY
4. POTENTIAL ENERGY TO HEAT ENERGY
5. HEAT ENERGY TO KINETIC ENERGY
6. ELECTRICAL ENERGY TO RADIANT ENERGY
7. RADIANT ENERGY TO CHEMICAL ENERGY

### EVENTS

- A. SNOW MELTS AND COLLECTS INTO MOUNTAIN LAKES.
- B. TURBINES SPIN AND PRODUCE ELECTRICITY.
- C. WATER SPILLS FROM LAKES INTO BROOKS AND RIVERS.
- D. ELECTRIC POWER PROVIDES FREEWAY LIGHTING.
- E. PLANTS FLOURISH IN SPRING SUNLIGHT.

2. ON THE LEFT BELOW ARE DESCRIPTIONS OF SIX KINDS OF ENERGY CONVERSIONS. ON THE RIGHT ARE THE NAMES OF THESE CONVERSIONS. DRAW A LINE BETWEEN EACH DESCRIPTION AND EACH OF THE NAMES. THE FIRST DESCRIPTION IS ALREADY MARKED.

- |   |                                      |
|---|--------------------------------------|
| 1. A FLASHLIGHT SHINING ON A DARK WALL. | A. CHEMICAL ENERGY → RADIANT ENERGY  |
| 2. A CHILD RUBS HIS HANDS TOGETHER.     | B. POTENTIAL ENERGY → KINETIC ENERGY |
| 3. A BATTERY LIGHTS A BULB.             | C. RADIANT ENERGY → HEAT ENERGY      |
| 4. A STEAM ENGINE.                      | D. KINETIC ENERGY → HEAT ENERGY      |
| 5. DROPPING A ROCK.                     | E. HEAT ENERGY → KINETIC ENERGY      |

# Minisequence V

## Investigating Populations

In each Grade of the COPES program we have introduced the concept of variability in nature. In Grade 1 the children found that when measurements are made on a group (a population) of related objects (or events), some differences are always found. Such differences are to be expected since variability is a characteristic of any natural population. In Grade 3, Minisequence III, the concept of variability in nature was further developed in terms of sampling a population; i.e., inferring certain properties of an entire population from examination of a limited number of members of that population. The concepts of range and average, used to characterize a distribution of values, were also introduced. A new way of describing variability, by presenting data in the form of a histogram, was developed in Grade 4, Minisequence VI. This is a graphical (pictorial) presentation of data from which one can easily see the range (spread) of data as well as the most frequently occurring value. Also introduced in that Minisequence was the use of games of chance as analogies to the randomness one should expect to find in nature.

All of the above Activities were designed to help develop the overall conceptual scheme, The Statistical View of Nature. The present Minisequence continues to develop this major scheme, first by expanding upon the use of probability in games of chance, and then by applying statistical methods to an analysis of some properties of living things.

There is a fundamental difference between probability and statistics, the latter being used here in the sense of inferring the properties of a population by studying a sample of that population. Another sense in which the term is commonly used is in connection with the compilation of data, such as "birth statistics," "election statistics," "statistics of farm production," etc. for which complete populations are surveyed. This is not the sense here; rather, we are concerned with drawing inferences from limited data, i.e., by sampling populations. An example of the difference between probability and statistics may be helpful. Suppose you placed 5 red balls and 15 white balls into a container and then asked the probability of drawing a red ball on a single blind draw. Knowing the number of each color in the container, simple logic tells us that there are 5 chances in 20 of drawing a red ball, i.e., a probability of  $1/4$ . Or, the probability of throwing a head in a single toss of a coin is  $1/2$ ; the probability of getting a four in a single throw of a die is  $1/6$  (there being six sides to a cube), etc. In other

words, one can apply probability theory to situations where all the alternatives are known and one simply calculates before the fact (*a priori*) the chance that a given event will occur.

On the other hand, suppose you did not know the distribution of balls in the container and were required to determine it without actually counting all the balls. If you took a sample of, say, 5 balls and found 2 red and 3 white balls, you might infer that 40% of the balls in the container were red (and 60% white), whereas actually only 25% are red. Despite the incorrect result, this is the method of statistical sampling. Another sample of 5 balls might yield a different result, and another a still different result. Yet, if the sample size is properly chosen, or if enough samples are taken, statistical methods of analysis, which make use of the same type of reasoning used in probability theory, can lead one to correct inferences.

It should be evident that even though probability theory yields precise predictions in a mathematical sense, one cannot expect these predictions to be exactly verified experimentally, unless the number of events studied is so large as to result in certainty. For example, while the mathematical probability of throwing a head in a single toss of a coin is  $1/2$ , it does not mean that throwing a coin twice will necessarily result in one head and one tail, or that throwing it ten times must yield five heads and five tails. However, as the number of events increases, the actual outcome approaches closer and closer to the predicted outcome. Thus, the outcome of games of chance, for example, which motivated the initial development of probability theory, can be accurately predicted over the long term (large number of plays) but not for individual plays. And the same is true for any perfectly random process, which by definition is one in which the alternative possibilities can be determined beforehand. (Random events will be investigated in more detail in Grade 6 of COPEs.) For example, there is one chance in six of throwing a given number with a die. This is true only if the die is a perfect cube in every respect. If not, if it is unbalanced in any way, then clearly one cannot predict beforehand the outcome, even of a large number of throws. To make predictions in such a case one would have to apply statistical methods. That is, one could, after observing a number of throws (sampling) determine that the process were biased in some way, rather than being random, and then compute the probability of throwing a given number of subsequent throws.

The first Activity of the Minisequence deals with sampling. The children try to determine the distribution of colored marbles (only two colors) in a bag by drawing one marble at a time and constructing a simple frequency. In this case they can easily check their inferences by opening the bag and counting the marbles of each color. The concept of probability is introduced in the second Activity, where the children use a simple random process--tossing a cube (die)--to compare predicted outcome with the observed frequency distribution. A somewhat more complex



random process is also introduced, simultaneously throwing a pair of dice and predicting the probability of obtaining different sums of numbers. Here, as in Activity 1, the children find that their predictions are more nearly verified as the sample size increases.

Activity 3 is also concerned with probability and sampling, but this time in connection with a physical model that is more complex than a cube--namely, a thumbtack. If one drops a thumbtack, what is the probability that it will land point up? Obviously, this is not easily determined from its shape, as in the case of a cube, hence the children must determine it experimentally, i.e., by statistical sampling.

Application of statistical methods to living things is found in Activity 4, where the children study variability in the germination time of seeds. For a unique population, i.e., a population consisting of a single type of seed, one should expect to find a simple frequency distribution in a histogram showing the number of seeds that germinate in a given time. The distribution would show a single peak (mode) representing the most frequent germination time observed. If the population contained more than one type of seed--two, for example,--and their average germination times were sufficiently different, one should find two peaks in the histogram (a bimodal distribution). When one observes such distributions in nature, they often provide useful clues to the kind of populations or events being studied.

The final Activity has the children make use of their experience with statistical methods to study the effect of a chemical (copper sulfate) on the germination time of a single population of seeds. Such experiments, and their interpretation, are typical of what one does in scientific studies generally, particularly in the life sciences and social sciences where variability is so pronounced as to require the application of statistical techniques.

## Activity 1    Selecting Marbles

In this initial Activity "blind" or chance selections are made from a bag containing a collection of red and blue marbles. The bag of marbles is identified as a population whose make-up (hidden at that point) is being investigated by sampling. As the children continue to draw and return marbles to the bag, they build up data on the relative frequency with which each color appears and are thus able to infer what the ratio of colors might be in this collection. They find that the larger the sample, the more nearly "right" will be their inference about the marble population--a concept introduced in Grade 3 but considerably reinforced in these Grade 5 Activities.

The children can see how correct their inferences are because in this case the population of marbles can be checked by opening the bag. In subsequent Activities, entire populations cannot be inspected and the children will learn that information on their properties can only be inferred from sampling.

### MATERIALS AND EQUIPMENT:

For each team of two children you will need:

- 5 marbles of one color, e.g., red
- 5 marbles of another color, e.g., blue, of the same size
- 2 bags, opaque, e.g., brown paper/sandwich bags
- 2 Worksheets V-1
- additional marbles of a third color (optional)

In addition, you will need for the class:

- 3 red marbles
- 1 blue marble
- 1 opaque bag

### PREPARATION FOR TEACHING:

The marbles should all be the same size so that as the child

makes selections, the feel of the marbles will not influence his or her predictions. Chinese Checker marbles are ideal. Prepare a brown bag out of view of the children. Place in it 3 red marbles and 1 blue marble and then twist it shut. Do not display the entire collection of marbles until the children are ready to set up their own bag populations.

## ALLOCATION OF TIME:

The children will need about 1-1/2 hours to complete this Activity.

## TEACHING SEQUENCE

1. Show the class the bag you have prepared and tell them only that it contains four marbles, possibly or more than one color.

- If you selected a marble, without looking into the bag, could you say what color it might be before picking it out?
- Suppose one marble were picked out of the bag (without looking inside, of course). What could you then say?
- If this marble were then replaced, and another "blind" selection were made, would you know more about the color(s) of the four marbles in the bag?

Next, ask the children if 4 or 5 more draws were made--the marble being replaced after each draw--could they then say something about the color(s) of the marbles in the bag?

## COMMENTARY

No. There is no information on which to base a prediction.

One of the possible colors would then be known.

Only if, by chance, another color had been picked in the second draw.

More than likely--it is probable that after several draws some information about the color(s) would have been revealed since there are only four marbles in the bag.

## TEACHING SEQUENCE

Now suggest that the children try it. Have eight children come up and take turns in "blind" selecting a marble from the bag. Show the selection to the class and have another child record the draw on the chalkboard. Before the next child makes his selection, the marble must be returned, and between each selection you should tumble the marbles in the bag so that the replaced marble is not on top.

You might ask the children to predict the color of each draw ahead of time. After eight draws, the record made by the volunteer recorder might appear as in the chart below:

DRAW	RED	BLUE
1	1	
2	1	
3		1
4	1	
5	1	
6		1
7		1
8	1	
Totals	5	3

Once the data have been collected on the chart, prepare a tally of the selections below it.

## COMMENTARY

Since each draw is a chance selection, it cannot be predicted with certainty. The children are building up evidence, however, on the most likely ratio of colors in the bag. This selection is similar to any game of chance, as with the spinner in Activity 5, Minisequence VI of Grade 4. Whereas the individual spins could not be accurately predicted, the children built up evidence in 30 spins that enabled them to predict successfully the overall results. (If your children need more experience with such chance events, review the Grade 4 Activity with them.)

The tally will provide a visual picture of how often the different marbles turn up in the selection. Such tallies were introduced in earlier Grades and are commonly used in content areas other than the sciences, e.g., social studies.

## TEACHING SEQUENCE

After the children have seen the results of this first set of eight selections, tell them to call it "Sample 1." Then ask them whether one of the marbles in the bag might be green.

Ask them to predict the results of a second sample of eight selections:

- How many reds do you think will be drawn? How many blues?

Repeat the selection procedure to produce a new set of data. Again, each marble should be replaced after it is drawn, and the marbles should be mixed between selections. Call this "Sample 2."

Compare the data from the two samples. Then ask the children if they can now predict with certainty what colors the marbles are.

- Could you predict with more certainty if you combined the samples into a larger sample of 16 draws? Could you average the results of the two samples?

## COMMENTARY

Yes--one could be, but the chance is small that it would not have been chosen in the total of 8 draws made.

They may say that they cannot be sure, or they may predict that the second trial will be similar to the first. The latter is a better inference.

Select a new recorder, and eight different children from the class to make the chance draws for Sample 2.

They should realize that they still cannot be absolutely certain of their predictions.

The best prediction would be based on combining the two sets of data above. For example, if each sample gave 6 red out of 8 (12 out of 16 total), the best prediction would be that 3 out of the 4 marbles in the bag are red because 6 out of 8 (or 12 out of 16) is the same ratio as (reduces to) 3 out of 4. If the two samples gave different numbers of red, the best prediction would be based on the average of the two samples. For example, if the first sample gave 6 red and the second gave 5, the best

## TEACHING SEQUENCE

## COMMENTARY

- Which technique--comparing samples, or combining and averaging them--gives more information?

After the children have combined the samples, found the average, and made their predictions, open the bag to show the actual number of red and blue marbles.

2. Now have the children work in teams of two. Provide each team with two opaque bags and five of each of two different colored marbles.

Without letting his or her partner observe, one teammate

prediction would be based on the average which is 5.5. Since this is closer to 6 out of 8 (3 out of 4) than to any other possible combination of 4 marbles in two colors, the best prediction would again be 3 out of 4. Should it happen that the average is closer to some other possibility, discuss what might be found if another sample were taken. Although there is no guarantee that a third sample would "balance out," (the common belief that it would is a fallacy), the probability is very small that several consecutive samples would favor an inference other than the ratio of 3 reds to 1 blue.

Combining and averaging, because although comparing will yield information on variability among samples, averaging gives a better idea of the population value because of the larger sample (see Grade 3, Mini-sequence III).

If you are using red and blue marbles, each team should get 5 reds and 5 blues. Using 5 marbles at this stage will add to the interest by increasing the number of possible combinations of colors.

Any ratio of colors may be chosen, including 5 marbles of

Sampler's Name: \_\_\_\_\_

Recorder's Name: \_\_\_\_\_

Sampling Colored Marbles

DRAW	SAMPLE 1		SAMPLE 2		SAMPLE 3	
	RED	BLUE	RED	BLUE	RED	BLUE
1						
2						
3						
4						
5						
6						
7						
8						
9						
10						

TOTALS \_\_\_\_\_

Tally for Totals

MARBLE	DRAWS
RED	_____
BLUE	_____

Analysis of Data

- Variation in count of red marbles: The range found in the three samples was from \_\_\_\_\_ to \_\_\_\_\_ red marbles.
- Combination of the totals of three samples:

	RED	BLUE
SAMPLE 1	_____	_____
SAMPLE 2	_____	_____
SAMPLE 3	_____	_____
Combination	_____	_____
Average of the 3 (Combination/3)	_____	_____

- The best inference: The number of red marbles in the group of 5 in the bag is inferred to be \_\_\_\_\_.
- The actual number of red marbles in the bag is \_\_\_\_\_.

TEACHING SEQUENCE

should select five marbles from the total of ten and place them in the bag. It will be the task of the other teammate to make a reasonable inference about the number of marbles of each color in the bag after drawing, and replacing, three separate samples of 10 marbles each. The results of each draw should be entered on Worksheet V-1. A tally of the totals and an analysis of the data should also be made.

After the three samples are taken, the teammates should switch roles: the second child should make up a population of 5 marbles, selecting any ratio of colors. The first child should then take 3 samples and fill in the data on another copy of Worksheet V-1.

Discussion of their results should include the following:

- How close did your inferences come to the number of red marbles which made up each population?
- At which draw did you feel it was "safe" to make an inference about the composition of this "hidden" population?

COMMENTARY

one color and none of the other. The child who makes up the "population" may act as a recorder. Encourage the teammates to discuss the best inference about numbers of colors. Of course, one teammate knows the answer. However, he or she may be intrigued to see how close the sample data come to the actual ratio.

After each child has made an inference about the ratio of colors, the bag should be opened and the actual ratio checked.

In the discussion refer to the composition of each bag as a population of marbles. Help the children realize that the total population they are investigating is in the bag and that it is possible to check inferences about a population simply by opening the bag.

This will vary with the actual ratio made up by the teammate. But certainly the first draw would tell them less than later ones. After a number of selections--several 8 or 10-draw samples--were made, their averages could be used to provide a "safer" inference.



## EXTENDED EXPERIENCE:

Prepare a population of marbles containing a third color. For instance, place 3 green, 5 blue and 2 red marbles in a bag. The selector should be told that there are ten marbles in all. Again have the children draw, record and replace the marbles as before. Have them keep a record of a sample of ten selections. The results of one possible sample from the suggested ratio above are given below.

DRAW	BLUE	RED	GREEN
1	1		
2		1	
3	1		
4	1		
5		1	
6		1	
7			1
8			1
9		1	
10	1		
Totals	4	4	2

TALLY	
MARBLE	DRAWS
BLUE	1111
RED	1111
GREEN	11

How good would an inference be about the population based on this one sample? If several samples were taken and the results averaged, more confident inferences could be drawn. Therefore, after the first sample, have the children take two more samples of ten selections each. Does the average of these draws agree better with the population? Open up the bag and look!

## Activity 2 · Tossing Cubes

The primary objective of this Activity is to help children develop an idea of how frequently an action or event can occur merely by studying a physical model. By studying the physical characteristics of a cube, children develop an idea of what to expect about certain chance events, in this instance a throw of the cube. They predict that if the cube were thrown many times, any one face out of the six possible ones would appear as likely as any other. The children then construct an expected distribution of the frequency (in the form of a histogram) of the faces showing if they were to throw the cube a number of times. In addition, using the same kind of object--the cube, they predict how often the various sums of the numbers on the faces would show up if two cubes were thrown together. In this way, probability is introduced--as the expected number of times a particular sum of faces would appear out of all possible outcomes of throws of cube(s). In both cases, the expected or theoretical frequencies are then verified by the children actually performing the throws. As in the previous Activity, each individual throw is seen to be a chance event and not predictable. Only when the sample size becomes large does verification of their predictions emerge.

### MATERIALS AND EQUIPMENT:

For each child you will need:

- 1 small cube or die
- 1 cup, polyfoam or other opaque material
- 1 crayon
- 2 sheets of graph paper, 1 square per cm
- 1 Worksheet V-2

### PREPARATION FOR TEACHING:

Boxes of dice can be obtained in many hobby or game stores, or children can be asked to bring in dice from their games at home. If there are objections to the use of commercial dice, you can use white (unit) Cuisenaire rods suitably marked. Whatever

Cubes are used should be regular, so that each face is equally likely to turn up when the cube is thrown. For this reason it is inadvisable to substitute sugar cubes because the edges will wear and bias the children's data.

The graph paper usually called for is 2 squares per cm or 4 squares per in. These squares are unnecessarily small for the histograms. If you have no 1 sq/cm graph paper available (or no paper which has heavier markings at the cm lines), and do not want to duplicate your own, the children can use a pencil and ruler to mark off every other line on the 2 sq/cm paper and thus transform it to 1 sq/cm. Another substitute is to take regular lined pad paper and draw vertical lines for the intervals of the histogram. In Part A, there should be enough lines for 6 columns; in Part B, there should be enough for 11 columns (2 to 12 possibilities);

#### ALLOCATION OF TIME:

The children will need about 1-1/2 to 2 hours to complete this Activity.

#### PART A

##### TEACHING SEQUENCE

1. Give each child a cube, Ask them to count the number of its sides and then look at the size and shape of each side.

- What are the properties of this object?

##### COMMENTARY

This Activity is in two Parts. Part A is concerned with a single cube and the probabilities of each face showing up when thrown; Part B is concerned with the throws of combinations of two cubes. Although the cubes will not be thrown for a while, the children must have one in hand in order to think about the possible outcomes of a throw. The sides may also be referred to as the faces of the cube.

The cube has six faces, each of which is a square of the same size. In other words, each side of a cube is the same as every other side. They are indistinguishable unless they are marked in some way.

## TEACHING SEQUENCE

- If you tossed the cube, would there be any face that would turn up most of the time?

If regular dice are not being used, the children will have to decide how to tell one side (or face) from the others. At this point they could put numbers on the faces of the cubes.

- From the physical nature of this cube, what faces would you expect to turn up if you threw a large number of cubes, or if one cube were thrown many times?
- How could your prediction be pictured?

Draw a gridlike chart on the chalkboard and tell the children that you would like to represent the expected collection of data on this grid. Mark the base of the grid (the horizontal axis) so that each of six columns stands for one of the faces of the cube. Then the vertical axis, or height of each column, will represent the number of throws when that face turned up:

## COMMENTARY

Since each face is identical, there should be no one face most likely to turn up--1 would be as likely as 2 and so on.

They can write the numerals 1 through 6 on different faces of the cube. To make the cubes like dice, the opposite faces should add up to 7: 1 opposite 6, 2 opposite 5, and 3 opposite 4. Letters A through F would do as well as numbers for this Part. However, because of the later investigation involving the sums of the numbers on the faces, they should use numbers.

Since any one face is as likely as any other, the collection of faces would probably be evenly distributed, with just as many 1's as 2's, as 3's, etc, landing face up.

In the previous Activity the children kept a chart and a tally of the outcome of each selection. The same would be done for each imaginary throw of the cube (6 columns, 18 rows).

This will be in the form of a histogram, which was introduced in Minisequence VI of Grade 4. Before introducing the histogram, you may want the children to consider the simpler way of showing a frequency distribution that they used in Activity 1, especially if they have not had Grade 4 of COPES. If marks are entered for each time a given face is expected to show up, what would they expect the theoretical tally of, say, 18

## TEACHING SEQUENCE

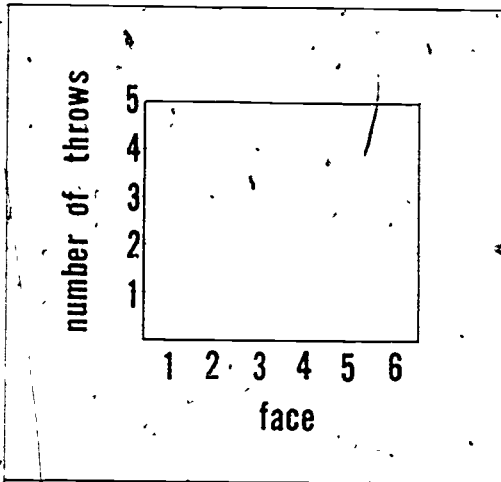

## COMMENTARY

throws to look like? (It would show the same number of tally marks--3--for each face--as shown below.)

FACE	NUMBER OF THROWS
1	111
2	111
3	111
4	111
5	111
6	111

In Grade 4, children were presented with a number of opportunities to construct histograms of data that they collected on measurements such as their ages in months, fingerlengths, etc. You may wish to review these Activities to establish the technique of constructing the histogram. Note that the base line is always divided into unit increments which increase regularly from left to right, and the column or bar above each position on the base represents how often that value turned up in the data.

- What might the histogram look like if, say, 18 cubes were thrown--or if one cube were thrown 18 times?

Help the children to realize that since any one face is as likely as any other, the heights of the columns in the histogram could be expected to turn out even. To emphasize this, shade in the

As the children discuss the possible throws, see if they realize that the chance of any one face turning up is one out of six--since there are six equally possible faces. Thus, in the theoretical illustration

## TEACHING SEQUENCE

columns on the grid on the chalkboard until they are all even. (If an overhead projector is available, this can be demonstrated on a transparency.)

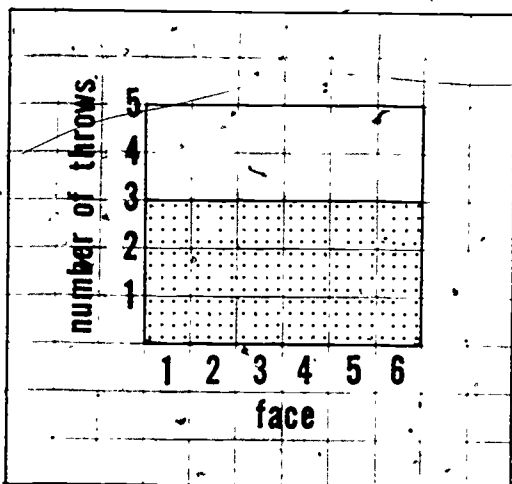

2. Now suggest that the children find out how well their actual data might approach this theoretical distribution. They should collect data on throws of their own cubes. Have them put the cube in the cup, shake it about a bit, and then invert it over the table. Have them repeat the procedure a few times.

• Does the same face turn up?

Give each child a copy of Worksheet V-2 and have the children toss the cube 18 times, recording each throw.

As they collect the data, ask if they can accurately predict an individual throw.

## COMMENTARY

of 18 throws, the face number 5 turns up 3 times. Three out of 18 throws is the same as 1 out of 6. If 600 throws were made, then any one face would theoretically turn up 100 times. This is similar to the findings and expectations, using the spinners in Grade 4.

No, generally they will find that the number on the face will vary. However, with only a few throws--that is, a small sample--it is possible that an individual child may get a particular face to repeat.

Some children may want to put a distinguishing mark on the Worksheet to indicate their prediction for a given throw.

Name: \_\_\_\_\_

THROW	FACE					
	1	2	3	4	5	6
1						
2						
3						
4						
5						
6						
7						
8						
9						
10						
11						
12						
13						
14						
15						
16						
17						
18						
TOTALS:						

Tally Record

FACE	THROWS	TOTALS
1		
2		
3		
4		
5		
6		

## TEACHING SEQUENCE

After the 18 throws are recorded, the children should add up the times that each face showed up and fill in the tally on the Worksheet. One sample of 18 throws of a cube resulted in the tally illustrated below:

FACES	THROWS	TOTALS
1	11	2
2	111	3
3	1111	4
4	111	3
5	11	2
6	1111	4

Now have each child take a piece of graph paper, set up the axes as you have illustrated on the board for the theoretical throws, and enter his or her data in the form of a histogram.

## COMMENTARY

and then see how well their prediction turns out. Since each throw is independent, the face turning up is a pure chance event. Just because a five, for instance, has not shown up for several throws, does not mean that a five is more likely on the next throw. There is still one chance out of six that a five will appear, no matter how many throws preceded it without turning up a five. It should be noted, however, that this is true only of a perfect cube. It is possible to bevel the corners and edges of dice so as to bias them in favor of a certain face or faces.

The Worksheet is specifically designed so that each throw is entered before the tally is made. In this way the children can readily see that there is no pattern to the sequence of faces turning up.

Note that the tally of throws is very similar to the one in Activity 1, except that here there are 6 categories to keep track of (the 6 faces) whereas in the first Activity there were only two (red and blue). The deviations from chance are well within those expected from small samples.



## TEACHING SEQUENCE

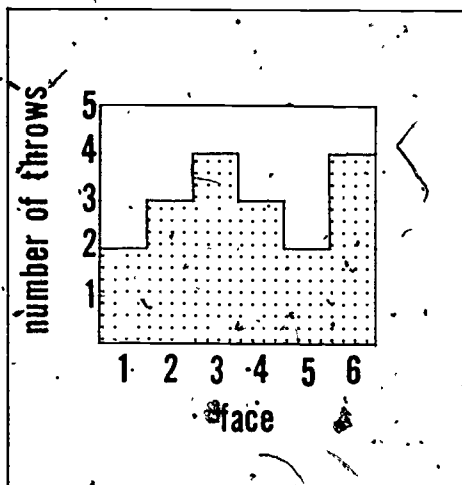

- How do your histograms compare with the theoretical one constructed on the chalkboard?
- Why do you think your histograms are unlike that you predicted?

Two children can combine their data to see what kind of histogram is obtained for, say, 36 throws. The class as a whole may want to combine all the data. Do not discourage them. See how well they approach the equal height columns of the theoretical histogram.

## PART B

1. Now hold up two cubes and refer to one as cube A and the other as cube B. Ask what sums of the numbers on the faces are

## COMMENTARY

Most of their histograms will show variation in the heights of the columns.

The children should suggest that the sample size is too small. If they combine their data, thus increasing the sample size, it should be expected that the resulting histogram would more closely approximate the theoretical.

If the heights of the six columns do not become even after collecting data for the entire class, the children should be encouraged to "figure out" why. There may have been variations in the surface on which the cubes landed, in the way they were thrown, or some children might have had biased cubes.

The possible sums are from 2 through 12; the lowest, 2, results from the combination of two 1's, while the highest, 12,

## TEACHING SEQUENCE

possible when both cubes are thrown at the same time.

- Are all of these sums equally likely?

To help them answer this question, ask the children, for instance, how many ways a sum of 2 may result.

- How many different combinations will yield a sum of 7?

- Since the sum of 7 can occur in more ways than a sum of 2, is it reasonable to expect that a 7 will be thrown more often than a 2?

Ask the children if they can devise a way to show all the possible sums when the two cubes are tossed at once and the numbers on the faces are added.

Construct a table on the chalkboard. Put the face numbers for Cube A along the top and for Cube B along the side, as shown in the illustration. With the class as helpers, fill in the values for each square, asking questions as you had before, e.g., what does the combination of a 1 and a 2 yield? 1 and a 3? 1 and a 4, etc.

## COMMENTARY

results from the combination of two 6's.

A sum of 2 can result only from a combination of two 1's. Hence there is only one way.

Cube A may show a 1 and cube B a 6, cube A may show 2 and cube B show 5; A may show 3 and B show 4. Also, the converses: A6 and B1, A5 and B2, A4 and B3.

In this physical model, with each face being equally likely, the answer is yes.

One way of ordering all possible sums is by means of a table containing squares in which each of the possible sums can be filled in:

		Cube A					
		1	2	3	4	5	6
Cube B	1						
	2						
	3						
	4						
	5						
	6						

You may find it desirable to prepare a blank grid on a worksheet and have the children fill in the squares on their

## TEACHING SEQUENCE

A completed table is shown below:

		Cube A					
		1	2	3	4	5	6
Cube B	1	2	3	4	5	6	7
	2	3	4	5	6	7	8
	3	4	5	6	7	8	9
	4	5	6	7	8	9	10
	5	6	7	8	9	10	11
	6	7	8	9	10	11	12

- How many possible combinations are there in all?
- Which sum will turn up most frequently?

Introduce the term probability at this point. The probability of obtaining the sum of seven upon throwing a pair of dice appears to be one out of six.

Now discuss the other possible sums.

- In how many ways can the sum 2 be made?
- Then what is the probability of throwing a 2?

## COMMENTARY

own grids as you develop the sums with them on the board.

As the table shows, there are 36 possible combinations yielding 11 different sums. And, as shown by the circled numerals there are six different ways of obtaining a sum of 7. In the class discussion, help the children to understand that a 7 will turn up more frequently than any other sum—6 times out of 36. Thus, theoretically, the probability of a 7 appearing is 1 out of 6 ( $6/36 = 1/6$ ).

Only one, a combination of 1 and 1.

Out of the 36 possibilities, the probability (chance) of throwing a 2 will be 1 out of 36.

## TEACHING SEQUENCE

- What is the probability of throwing a sum of 12?
- What is the probability of a 4 being thrown?

Ask the children to construct a histogram on graph paper showing the expected frequency for the various possible sums when two cubes are thrown together, as indicated on the table shown.

- How does this theoretical histogram compare with the one constructed for expected outcomes when a single cube was thrown?

## COMMENTARY

Again, there is only one combination which yields the sum of 12. Thus, its probability would also be 1 out of 36.

A 4 can be made by 3 different combinations: 3 and 1, 1 and 3, and 2 and 2. Thus the probability of obtaining a 4 will be 3 out of 36 (which reduces to 1 out of 12).

This would be a histogram of the theoretical expectancies for a trial of 36 throws. The completed theoretical histogram is illustrated below.

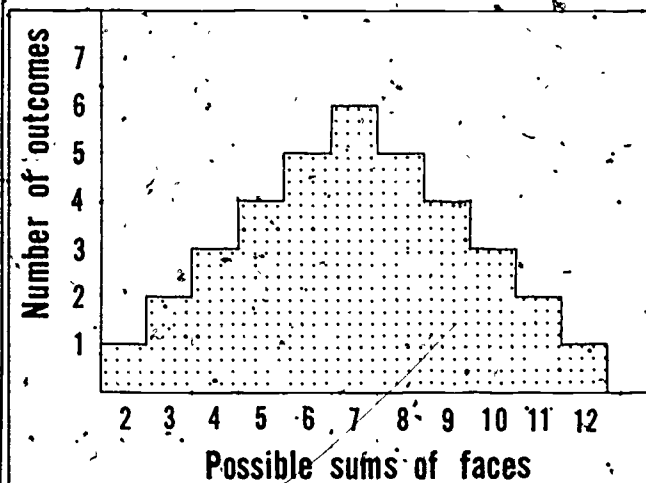

That one was flat, since any one face had the same expectancy as any other. Here the probability of throwing a sum of 2 is very different from the probability of a sum of 4, for instance. If you sense that they are having difficulty with this idea, ask them for the probabilities, in the case of the single cube, of throwing a 6, a 4, or a 5. In all instances, it is the same--one

## TEACHING SEQUENCE

As they discuss the frequency distribution of the expected outcomes, remind the children that it is an ideal histogram constructed from a consideration of possible outcomes rather than from the actual tossing of dice. Then ask them how closely they would expect a graph of the results of actual dice tossing to correspond to the graph of expected outcomes.

Now have the children work in teams of two to collect data on 36 throws of a pair of cubes. They can set up their own tally record similar to the one they used in Part A. But here they must provide space for 11 possible results (2 to 12), instead of 6.

The children should again use the cup to shake and throw, but this time using two cubes instead of one. Each team should throw the pair of dice 36 times, record the results, and construct a histogram showing the outcomes of their tosses.

## COMMENTARY

out of six. But not so for the combinations of two cubes.

Based on their previous experience in this and earlier Activities, they may expect that the larger the size of the sample, the more closely the histogram of actual outcomes of dice tossing will approximate the shape of the theoretical one.

You may also want them to record the outcome of each throw as in Part A. Then have them construct a chart similar to the one on Worksheet IV-2--but, again, provide for 11 possible results.

If they use a chart there should be 36 spaces for the entries (as there were 18 for the throws in Part A), since the teams will be throwing 36 times.

Since the theoretical histogram is on the board, the children can use it as a guide. The base line on the graph paper should be marked off from 2 to 12, running from left to right. Have them leave enough room above the histogram so they can combine their own data with

## TEACHING SEQUENCE

- What does your histogram of 36 actual throws look like? How does it compare in shape with the theoretical one?

Now ask them to increase the sample size by having two teams combine their data. Is a recognizable shape emerging?

Finally, pool all the data of the class in the form of a tally on the chalkboard. Give the children fresh graph paper. Have them mark off the axes as before, but the vertical one which records the number of times a number appears (that is, the frequency) should be marked off in five-unit intervals. This is the only way that the results of all 500 or so throws can be entered on 1 sq/cm graph paper.

When the class histogram is

## COMMENTARY

that from another team.

It probably will not compare very well. The sample of 36 is still too small. One such histogram is shown below:

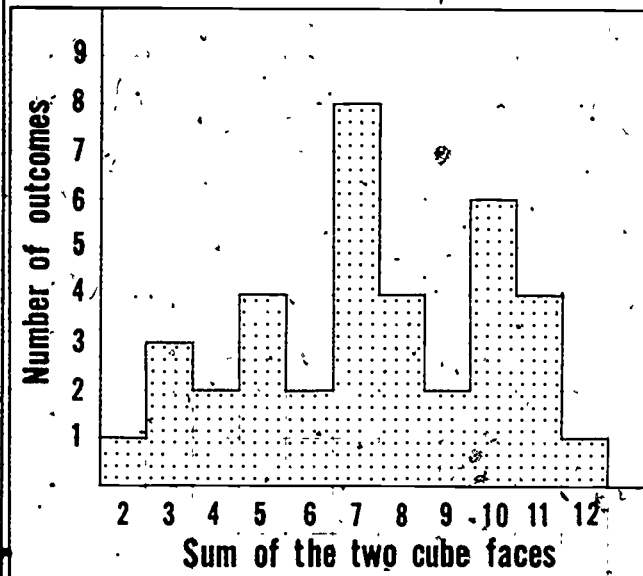

The peak at 7, which may or may not show up initially, should begin to emerge as the sample size increases. The low points of the histogram generally should fall at 2 and 12.

The combined histogram of all the results can also be done on the chalkboard.

Alternatively, you may want to use graph paper with smaller squares so that each event can still be represented by a single square.

## TEACHING SEQUENCE

completed, ask the children to compare its shape with that of the graph of expected results. Are the two graphs similar in shape?

- What could account for the differences?
- Would you expect the shapes to be still more alike if the graph of actual results were based on 1000 events instead of 500?

Thus, by analyzing a physical object which can be inspected and is not hidden from view (as the marbles were), we can come up with an expected histogram of frequency outcomes--and then come close to verifying them.

## COMMENTARY

They should be, although there are likely to be minor variations.

Differences are due, of course, to the property of variability or variation in any sampling operation.

By this time, most children will probably answer in the affirmative.

In the summary discussion be careful to differentiate between the theoretical outcomes possible and what was actually found when the cubes were thrown. In the former, the nice symmetrical curve with a maximum of 7 was obtained because a cube has six identical faces and the decision was made to add the face numbers when two cubes were thrown together. If we had decided to multiply or subtract the face numbers instead of adding them, the shape of the possible outcomes would be different. Similarly, the possible outcomes would be different if the model had been a shape other than a cube. Thus the form of the "model" dictates the shape of the expected outcome of frequencies. In our case, the model is that any one face has an equally likely chance to appear, and when two cubes are thrown we calculate the possible sums of all equally likely faces, end up with the table illustrated on page 286. In the following Activity, the model,

## TEACHING SEQUENCE

## COMMENTARY

will have to be inferred from the shape of a histogram of the measurements on a reasonably large sample because the model object--a tack--is not symmetrical and too difficult to analyze for expected outcomes.

As far as the actual throws are concerned, there is always variability due to sampling. Thus, each sample is an imperfect representation of the model's theoretical outcomes, but the larger the sample, the closer one comes to the model. If a large sample gives results that are noticeably inconsistent with what is expected from the model as defined, one may decide that the model is not a good explanation of the phenomenon being studied. If the results approach the theoretical histogram, as here, then we can say that the model in this case, a perfect cube, is probably correct.



### Activity 3 How Do Thumbtacks Land?

In this Activity the children again use sampling techniques to find out about the chances of certain events occurring for a particular population. The event of interest here is a thumbtack landing point up when dropped (a non-event is the tack landing in any other position). As in the preceding Activity the children will discover that there is a distribution in the number of such events for trials consisting of ten observations each. From this information predictions may be made about future trials (samples) taken from the population--in this case, thumbtacks in general. Unlike the first Activity, however, there is nothing that can be "opened up" for a physical check of the population. Nor can predictions easily be made based upon the physical structure of the tack, as in the case of the cube. Thus, information about the population can be gained only through the application of statistical sampling and averaging.

#### MATERIALS AND EQUIPMENT:

For each pair of children you will need:

- 10 thumbtacks, of the same kind
- 1 unit measure cup, 1 oz (30-ml)
- 2 copies of Worksheet V-3
- 2 sheets graph paper, 2 sq/cm or 4 sq/in.

#### PREPARATION FOR TEACHING:

Other than obtaining the necessary materials, no advance preparation is necessary.

#### ALLOCATION OF TIME:

About 1-1/2 hours should be sufficient time for the children to complete this Activity.

## TEACHING SEQUENCE

1. How do thumbtacks land when dropped? Show the class a thumbtack. Drop it a few times onto a hard surface such as a desk top so that the children can see that it sometimes lands point up and sometimes sideways.

- How does the dropping of the thumbtack compare with the throwing of the cube?

- What did you find is the probability of any one face on the cube showing up?

Ask the children what they think are the chances for the tack to land point up as compared with landing on its side. Is one way more probable than the other?

- How did you check your predictions in the case of the cubes?

- Applying the same approach, how could you find out how frequently a tack will land point up?

## COMMENTARY

Drop it from a height of about eight inches so that it doesn't bounce too far away.

This is analogous dropping a cube and sometimes seeing it land with one face up and sometimes another.

There are two different ways the tack can land--point up or on its side. In the case of the cube, it can land in any one of six ways.

Each face has a probability of showing up one time out of six.

In the case of the cube, they could make a prediction on the basis of the physical structure of the cube. In the case of the tack, it might be reasonable to guess that it will land point up more often than not because its head is the heavier end. But the tack is not as simple to analyze as was the cube. It lacks the simple, symmetry which made it easy to predict the expected outcomes for the cube.

In the case of the cubes, they checked their predictions by throwing a large number and then analyzing how frequently a particular face or sum of faces showed up, as demonstrated by constructing a frequency distribution graph--a histogram.

A more specific form of the question would be "if you threw 10 tacks, how many would land point up?" This form of question is analogous to asking, in

## TEACHING SEQUENCE

In order to find out, they could throw one tack a great many times, but that would take too long. Help them to see that, assuming that all the thumbtacks are near enough alike, they could collect data more quickly by throwing 10 tacks at once.

2. Divide the class into teams of two children. Each team should get 10 tacks in a 1-oz cup and a copy of Worksheet V-3. The children should find a place where they can spill the tacks onto a hard surface from a height of about 8 inches.

As the children make test spills of the 10 tacks, call each of the spills a "trial."

Each child in the team should now spill the 10 tacks five times and record the number which landed point up for each trial spill. (Each child can collect half the data needed for the team.)

- How could each team be sure of its accuracy in counting the points at each trial?

## COMMENTARY

the second Activity with a single die or cube, how many times in ten throws a specified face would turn up.

Even though a large sample will be needed to make a confident guess about the probability that any given tack will land point up, collecting such data is far less difficult than trying to make a projection on the basis of the physical properties of the tack.

A desk top is suitable, except that the tacks are likely to bounce onto the floor. If hard-surface floor space is not available, use larger cups, shake well, and spill from a lesser height onto a desk.

The definition of a sample here is important. When 10 tacks are dropped together, that is defined as one trial, with possible outcomes ranging from 0 through 10 points up. Each child's sample is then his or her set of 5 trials; each team's sample consists of 10 trials.

The team member who spills could count the points up while his or her teammate could count the number landing sideways. The count of points and sides for each trial must add up to 10, the total number of tacks

Team Member A \_\_\_\_\_

Team Member B \_\_\_\_\_

Data for Member A:

TRIAL NUMBER	NUMBER OF POINTS UP	NUMBER OF SIDES
1		
2		
3		
4		
5		

TOTAL:

Data for Member B:

TRIAL NUMBER	NUMBER OF POINTS UP	NUMBER OF SIDES
1		
2		
3		
4		
5		

TOTAL:

RANGE FOR A IS \_\_\_\_\_ TO \_\_\_\_\_

AVERAGE FOR A \_\_\_\_\_

RANGE FOR B IS \_\_\_\_\_ TO \_\_\_\_\_

AVERAGE FOR B \_\_\_\_\_

RANGE FOR TEAM IS \_\_\_\_\_ TO \_\_\_\_\_

AVERAGE FOR TEAM \_\_\_\_\_

TEACHING SEQUENCE

COMMENTARY

in the spill.

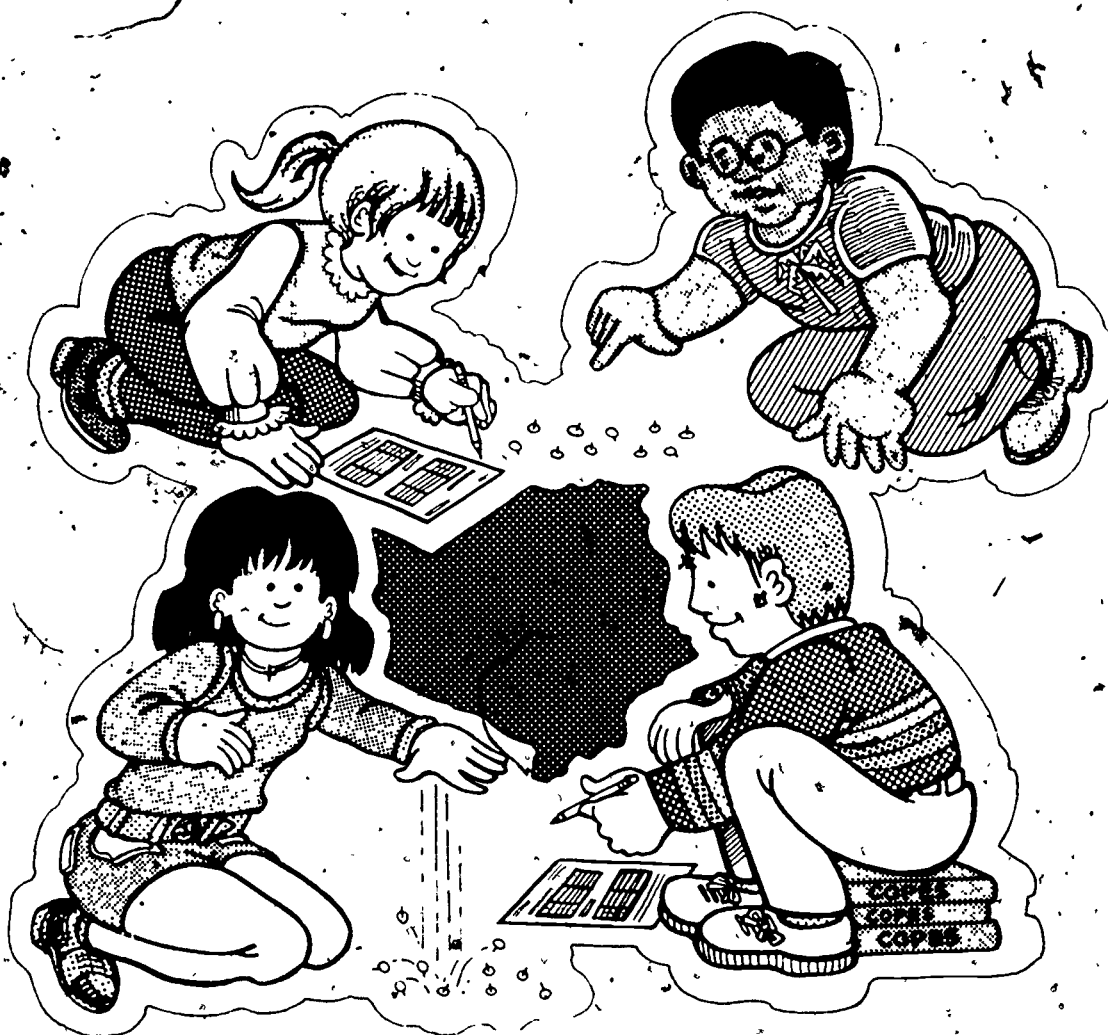

After each team member has collected a sample, the children can discuss their results.

Record the results on the chalkboard for use in the discussion and later. (Record only the points up obtained for each of the five trials.) Or each team can enter its results on the chalkboard as they obtain the data. The discussion can then follow.

- How can the data be organized so that we can answer the initial question as to

## TEACHING SEQUENCE

how thumbtacks behave when spilled?

For one thing, each child can determine the range in the number of points up obtained for his or her sample. Have them record this on the Worksheet. They can also compute the range for each team's sample. This range may be larger than either team member's since it includes both.

- How else can the data be organized?

Give each child a sheet of graph paper (2 sq/cm or 4 sq/in.) on which to enter the data. Have them set up appropriate axes as illustrated below.

If necessary, review with the

## COMMENTARY

Some typical results for one team are:

Team Member A

Trial Number	Number Of Points Up
1	5
2	2
3	4
4	6
5	5

Team Member B

Trial Number	Number Of Points Up
1	7
2	6
3	5
4	6
5	6

Range for A is 2 to 6

Range for B is 5 to 7

Range for the team is 2 to 7

By this time, the construction of the familiar histogram to portray the frequency distribution of "points up" should be readily suggested by the children.

The horizontal axis should be set up near the bottom of the paper so that more data can gradually be added.

## TEACHING SEQUENCE

children how to enter their data. Each column is identified on the base line (horizontal axis) with numbers 0 through 10. These stand for the number of points appearing up out of a spill of 10 tacks. The children should shade in a square above the appropriate column for each trial spill. The data given above would look as follows:

## COMMENTARY

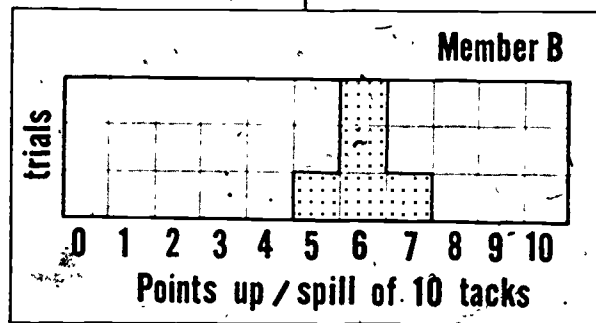
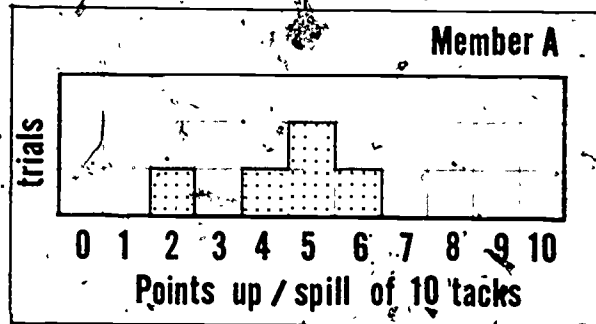

- What is the range you obtained in points up?
- Is there a most frequent value? Can you answer the question as to whether it is more likely for the tack to land on its side or with its point up?

They had already calculated it from the data, but on the histogram it would be the width.

It is unlikely that the children will be able to agree on a single most frequent value. The variation in their results is too great and the sample of five trials is really too small to give an overall answer.

## TEACHING SEQUENCE

- What technique could you use that would take into account the variability in your results?

Each child should now look at his or her data and calculate the average of the 5 trials. The average can be computed by adding the results and dividing by 5. They should enter their average on the Worksheet and mark its position on the histogram.

- How do the averages found by the team members compare?
- How could you determine the team average?

At this point, the children can add their teammate's data to their histograms. Each one will then have ten squares shaded in. They should record the team average and then place a mark on their combined histogram indicating its position.

- Are all the team averages the

## COMMENTARY

Averaging--this is another way to describe the data, along with the range and the frequency distribution.

For those children not adept at computing averages arithmetically, they can use the histogram they have just constructed and use the piling-in technique. As mentioned earlier, this technique was introduced in Minisequence VI of Grade 4 and referred to in Minisequence II. However, it would be preferable at this point to have the children consider how to find the average arithmetically because moving toward the center leads only to integers, and greater accuracy requires interpolation, an involved procedure.

The average will be in the midst of their marked squares.

Some may differ. In the example above, team member A had an average of 4.4; team member B had an average of 6.0.

An easy way to compute the team average is for the children to add up all 10 trials of the two members. The average would be this total divided by 10. Arithmetically, this division is done simply by placing a decimal point one unit in from the right. In the example above, the total sample for the team shows 52 points up; the team average is thus 5.2 points up per spill of 10 tacks. If this sort of computation fits in with your mathematics program, encourage the children to compute team averages this way.

Probably not. But the values



## TEACHING SEQUENCE

same?

- What is the range in these averages?

- Are you any closer to saying how a tack will probably land when spilled out of a cup?

3. A class histogram should be constructed now. This can be done on the chalkboard, or each child can add the additional data to the histogram containing the team's data.

- What is the most frequent value?

Ask the class to determine an overall class average.

- What is the relation of the sample averages of the overall average?

## COMMENTARY

will be closer together than the individual averages reported earlier.

In other words, the range will be much smaller. Since averaging is an evening technique, great differences in individual samples will disappear in averaging. This idea was presented and developed in Grade 3.

The children have already determined the average number of points up for a spill of 10 tacks. Note that each team's average, if divided by 10 again, (the number of tacks in each trial), represents the probability or expectancy that a single tack will land point up. In the example above, the probability would be 0.52. That is, we would expect points up about 52 times out of every 100 times a tack is dropped.

The class histogram will represent a sample consisting of 30 times 5 trials, assuming there are 30 children in the group. In such a case, there would be approximately 150 squares shaded in, as shown on page 301. Histograms for larger or smaller groups would vary accordingly.

The peak of the histogram. In the illustration it is at 6 points up per throw of 10 tacks.

Sample averages (for 5 trials) varied above and below the overall class average; however, their variability (range) was

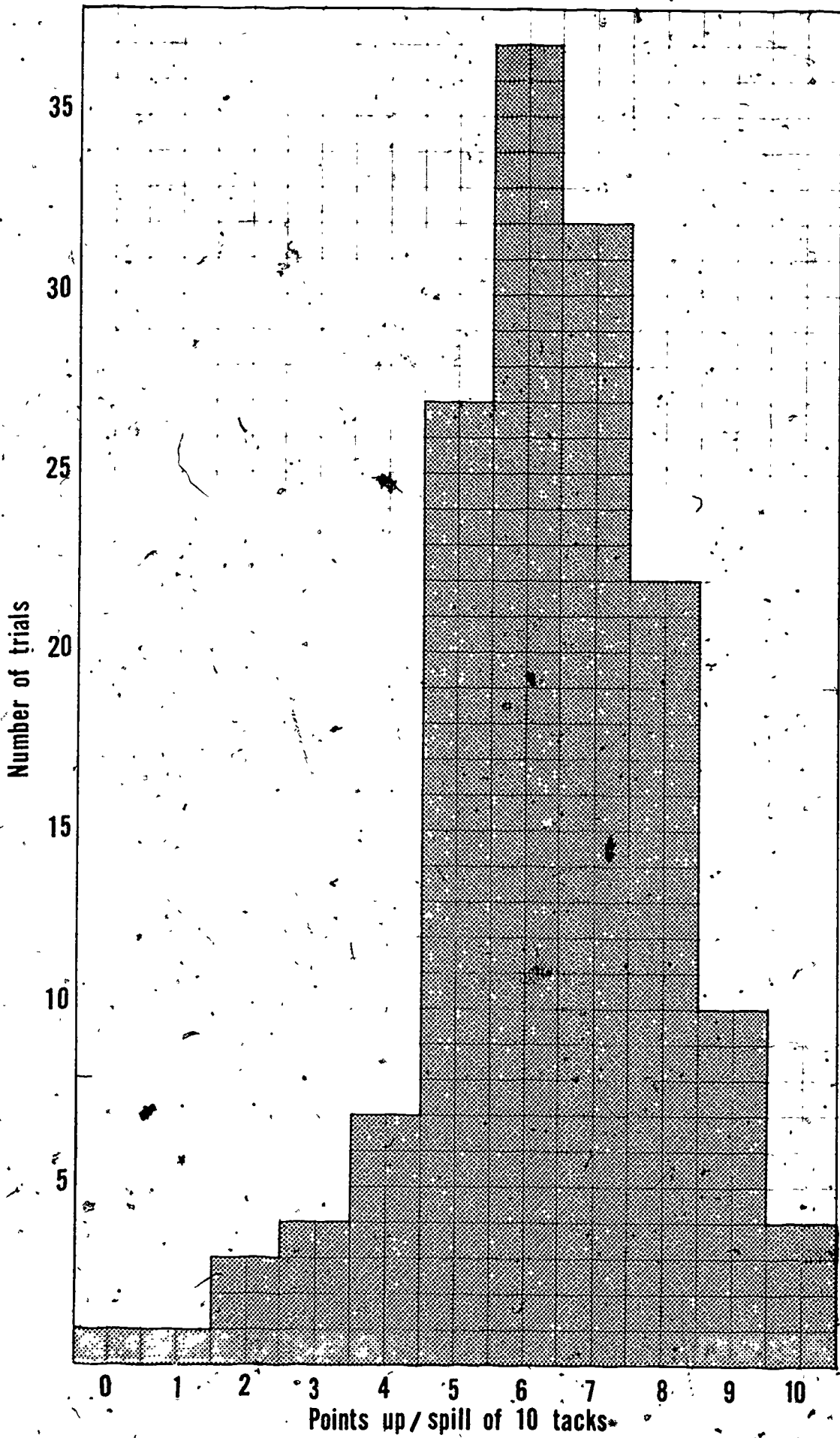

## TEACHING SEQUENCE

- How would you now answer the question as to how thumbtacks land?

- Is it now possible to tell for certain how a tack will land, on the average?

- Did any tacks land on their points? What is the probability of this occurring?

Finally, reintroduce the question as to the population about which they have been trying to get information. In the first Activity, the population was the bag of marbles. They sampled it and then could check the population by opening the bag. In the case of throwing cubes, the information they tried to get was about all cubes. There, because of the symmetrical physical structure, they could predict and then experimentally verify its behavior. In this Activity, the population is identified as all thumbtacks. From its physical structure it is too difficult to predict how it should behave. That is why a large

## COMMENTARY

less than that of the averages for a single trial.

It is now clear that a thumbtack is more likely to land with its point up than on its side. For the data shown on page 301, the average turns out to be 6.6 (a total of 982 points up ÷ 148 trials). This is a probability of 0.66.

No, even though a great quantity of data was collected, and the overall average is probably quite close to the true average for the tack "population", some variability still exists. The computed averages, however, will show less and less variability as the sample size becomes larger.

Obviously, the probability is practically zero. It is unlikely that any will be observed, but it is worthwhile discussing this question.

In some instances, a physical model can be constructed, but its complexity may be too great, thus making analysis difficult.

TEACHING SEQUENCE

sample of spills had to be analyzed for one to infer that it is more probable, but not certain, that a tack will land point up.

COMMENTARY

### Activity 4 When Do Seeds Germinate?

In this Activity the children are directed to the study of variable events in populations of living things. Earlier in the COPES curriculum children were introduced to the concept of expected variability in nature. In the present Activity this concept is reinforced; the children find variations in the time it takes a kind of seed of a specific population to germinate. The germination times are visually portrayed in the form of histograms whose characteristics are found to be similar for all samples from the same population of seeds. The range, the peak value, and the average time for germination are properties of the population. Thus, two kinds of seeds (different populations) with different peak germination times can be distinguished from one another by the shape of the histogram representing the frequency distribution of germination times. This is discovered when some children investigate an apparently homogeneous population of seeds and discover that the resulting histogram has two peak germination times. They then infer that their sample probably consists of a combination of two different kinds of seeds. Thus the shape of a histogram can provide clues as to whether a given sample is made up of cases from a single or from several populations.

#### MATERIALS AND EQUIPMENT:

You will need:

- 3 packets\* each of seeds such as radish or turnip and popcorn or dill, lettuce, etc.
- 2 packets\* of Forget-me-not seeds (*Myosotis*, not *Cynoglossum*)
- 1 packet\* of Celosia seeds
- 3 or 4 plastic spoons (1 for each bag of seeds)
- 3 or 4 plastic sandwich bags
- containers of water

In addition, for each pair of children, you will need:

- 2 plastic sandwich bags or plastic wrap
- 2 small dishes, 3-in. to 5-in. (7.6 to 12.5-cm) diameter and 1/4-in. to 1/2 in. (0.8 cm to 1.3-cm) deep

- 10 paper towels
- 1 medicine dropper
- 1 pair of tweezers (optional)
- 1 copy of Worksheet V-4
- 2 sheets of graph paper, 10 sq/in.

\*Note that seed packets contain widely different numbers of seeds. There should be enough so that each team of 2 children can take 100 seeds from one of the bags described under Preparation for Teaching.

#### PREPARATION FOR TEACHING:

Mix the packet of *Celosia* seeds with the two packets of Forget-me-not seeds. Put this mixture in a plastic bag and label it with a letter such as "C." There are two varieties of seeds commonly sold as Forget-me-not. You must obtain the one marked "*Myosotis*," not "*Cynoglossum*." The first is also known as scorpion grass, the latter as hound's tongue. It is *Myosotis* which will have enough of a difference in peak of germination times, compared with *Celosia*, so that a bimodal histogram will be obtained. The Forget-me-nots are only about 50% viable and therefore 2 packets of Forget-me-nots are needed to 1 packet of *Celosia* seeds.

Transfer the seeds from the other packets to separate plastic bags. Label these bags and the corresponding packets with other letters so that you can identify the seeds later. It would be best to include both a fast and a slow germinating seed. Radish and turnips are fast germinating; dill and popcorn are slower germinating seeds. If you are unsure of the germination time for the seeds you have, set up a sample of the seeds a week beforehand, just as the children will, and check the germination times yourself. Thus, what you should have when you have finished preparing the bags are:

1. A bag containing 3 packets of, say, radish seeds. This bag might be labeled "A."
2. A bag containing 3 packets of, say, popcorn seeds, labeled "B."
3. A bag containing 2 packets of Forget-me-nots and 1 packet of *Celosia*, labeled "C." Mix the seeds thoroughly. The mixture will appear homogeneous because these seeds are very similar in appearance.
4. A bag containing 3 packets of, say, lettuce seeds, labeled "D."

There should be about the same number of seeds in each bag. Place each bag of seeds in a different location to avoid getting them confused and provide spoons and small pieces of paper so that the teams can take their samples.

Put out the supplies of paper towels, dishes, and plastic bags where the teams of children can help themselves. Fill a few containers with water, from which the children can dampen the paper towels once they are placed in the dishes. Medicine droppers are convenient to use for this purpose.

#### ALLOCATION OF TIME:

About 2 hours, in all, will be needed over a period of a week to complete the Activity.

If the seeds are started Monday morning, peaks in germination will be observed from the first day after being set up (radish) to the fourth day (popcorn or dill) but the decrease on Saturday morning will not be observed. Therefore, the activity should be continued at home.

#### TEACHING SEQUENCE

1. Show the children the bags of seeds. Ask what they are and then what they do.

- Do you think they will grow into different plants?
- Will all the seeds sprout-- that is, germinate?
- Do you think there will be different germination times for the different seeds? For the seeds in the same group?

#### COMMENTARY

Many children will surely recognize that the small objects in the bags are seeds and are sure to suggest that they will grow into plants if they are placed in the ground.

Since the seeds are of different shapes, etc., it is more than likely that they will. (See Topic I, Activity 1, of Grade 2.)

Probably not--only the living seeds will sprout, as the children found in Grade 1 (Topic I, Activity 7).

Encourage discussion on this point by the children. In Grade 1, Topic IV, Activity 4, children investigated germination times and found some variability within one type of seed and a good deal among different kinds of seeds. Now they will

## TEACHING SEQUENCE

Refer to the groups of seeds as samples from populations of particular seeds and suggest that, using such samples, the children investigate the property of germination time for these populations.

- In setting up your experiments, would you want to observe the time it takes for one seed to germinate?--two seeds?

Larger numbers of seeds will be needed. The children can work in teams of two with each team taking a sample of 100 seeds from one of the larger samples of seed populations you have made available to them.

If necessary, remind the children that the seeds can be made to start growing if they are placed on top of moist paper towels. Show them how to do this: Fold a paper towel to fit the bottom of a dish. There should be about 15 to 20 layers. Moisten the towel, put some seeds on it, and place the dish in a plastic sandwich bag to keep the towel from drying out. There should be an air space between the seeds and the plastic.

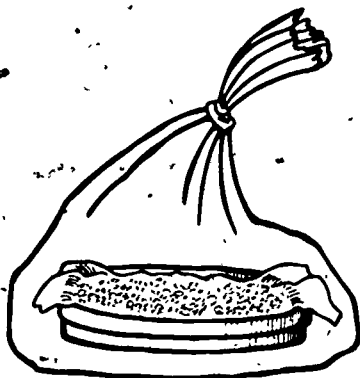

## COMMENTARY

pursue this in greater depth.

By this time, children should be reluctant to base inferences about a population on information derived from only a few members.

Plastic wrap may substitute for the plastic sandwich bags. The bags need not be completely closed.



## TEACHING SEQUENCE

Now point out to the children the supplies of paper towels, dishes, water, and plastic bags. Have each team select the particular seed it will investigate. After they prepare their dish and have the towel moistened with water, they should get a supply of 100 of the seeds.

Provide each team with a copy of Worksheet V-4 to be used to record the data. Each team should make a record of the bag from which they took their seeds and of the time (date and hour) when they set up their germinator. The children can also record the physical properties of the seeds they selected, such as comparative size, color, shape, etc. This can be noted on the Worksheet under "Comments." They should then set the germinating dishes aside in the classroom.

2. As soon as some seeds show signs of germination, discuss this with the children. As in Grade 1, a criterion for germination will have to be established. The seed will give evidence of starting to grow--

## COMMENTARY

If you wish, this part of the Activity can be conducted by small groups of children working on their own at various times. Be sure that at least a few teams select seeds from every bag so that there will be some data on each one.

They can use the spoons and small pieces of paper to bring the seeds over to a work area.

Since direct sunlight is not conducive to seed growth, the children should keep their dishes away from the windows. On the Worksheet, suggest that they include information as to where the germinator was kept. Subsequently, interested children may wish to pursue the effect of varying amounts of light (even darkness) and repeat the investigation under different conditions.

Some kinds of seeds, such as radish, should exhibit some germinations within one day.



## TEACHING SEQUENCE

that is, to germinate--when a bit of the root tip appears.

- Why have only some kinds of seeds germinated?

Starting with the first day that germination is observed, a better count of the number germinated on each successive day can be made if the children remove the germinated seed(s) from the dish as they are counted. These sprouted seeds should be placed on moistened towels in another dish where subsequent growth can be observed. Add the newly germinated seeds to this dish each day.

3. After the children have observed their seeds for several days and recorded the number of new germinations each day, have them report their results.

## COMMENTARY

Some seeds may interact with the water, swell, and the seed coat may crack, but it is only when the root tip appears that we can say the seed is starting to grow. The other observed changes may not be precursors to growth.

Encourage their discussion. They may say that different types of seeds take different times to germinate. There are differences in behavior among different populations of seeds. Another answer might be that seeds of the same kind show differences (variability) in their properties just as other living things do.

There may be interest in observing the type of plant produced from each group of seeds. Once the seeds have sprouted sufficiently in the second dish so that the children observe the type of structure emerging, they can plant the sprouts in cups containing a bit of soil.

The completed Worksheet on page 311 shows an example of data taken on radish seeds. For the seeds showing long germinating times, you may want to have the children take their germinators and their Worksheets home to continue taking data on the weekend.

Number of seeds 100 taken from bag lettered A

DAY	NUMBER OF NEW GERMINATIONS	COMMENTS
9/11 0	0	START
1	52	
2	38	
3	1	
4	1	
5	1	
6	STOP	7 DID NOT GERMINATE

## TEACHING SEQUENCE

Then, if the children have not already done so, suggest that they set up a histogram of the germination times for the samples of seeds they are investigating.

Give each child a sheet of graph paper.

Set up with the class the two axes on the graph. Be sure they see the similarity to the histograms they have been making. The base line now is marked off in increments of time (days) it took for germination to start. The vertical axis represents how many seeds showed signs of germination on that particular day. In the example illustrated on radish seeds, 52 seeds germinated the first day and 38 on the second. A histogram of the radish data is shown on page 313.

Discuss the different histograms that the children constructed from their data.

- On what day did most new germinations appear? What is the most frequent value?

## COMMENTARY

It may be wise to make a histogram on Friday of data then available. It can be updated and completed the following Monday.

Paper containing 10 squares per inch is suggested for this Activity because of the large number of seeds that must be represented on the vertical axis.

Their earlier histograms had axes marked off in numbers which could show up on the face(s) of a cube or in the number of points up (0 to 10) that occurred when a group of tacks was spilled.

The germination time of another seed--popcorn--is also illustrated, on page 314. For this seed, a different-shaped histogram is obtained.

Those teams having samples from different populations--for instance, radish and popcorn--will see a peak in germination on different days; those observing samples from the same group will probably see a peak on the same day--provided the surrounding conditions (light, moisture, etc.) were not too different during their observation periods. The most frequent value--the "peak" on the histogram--is called the mode.

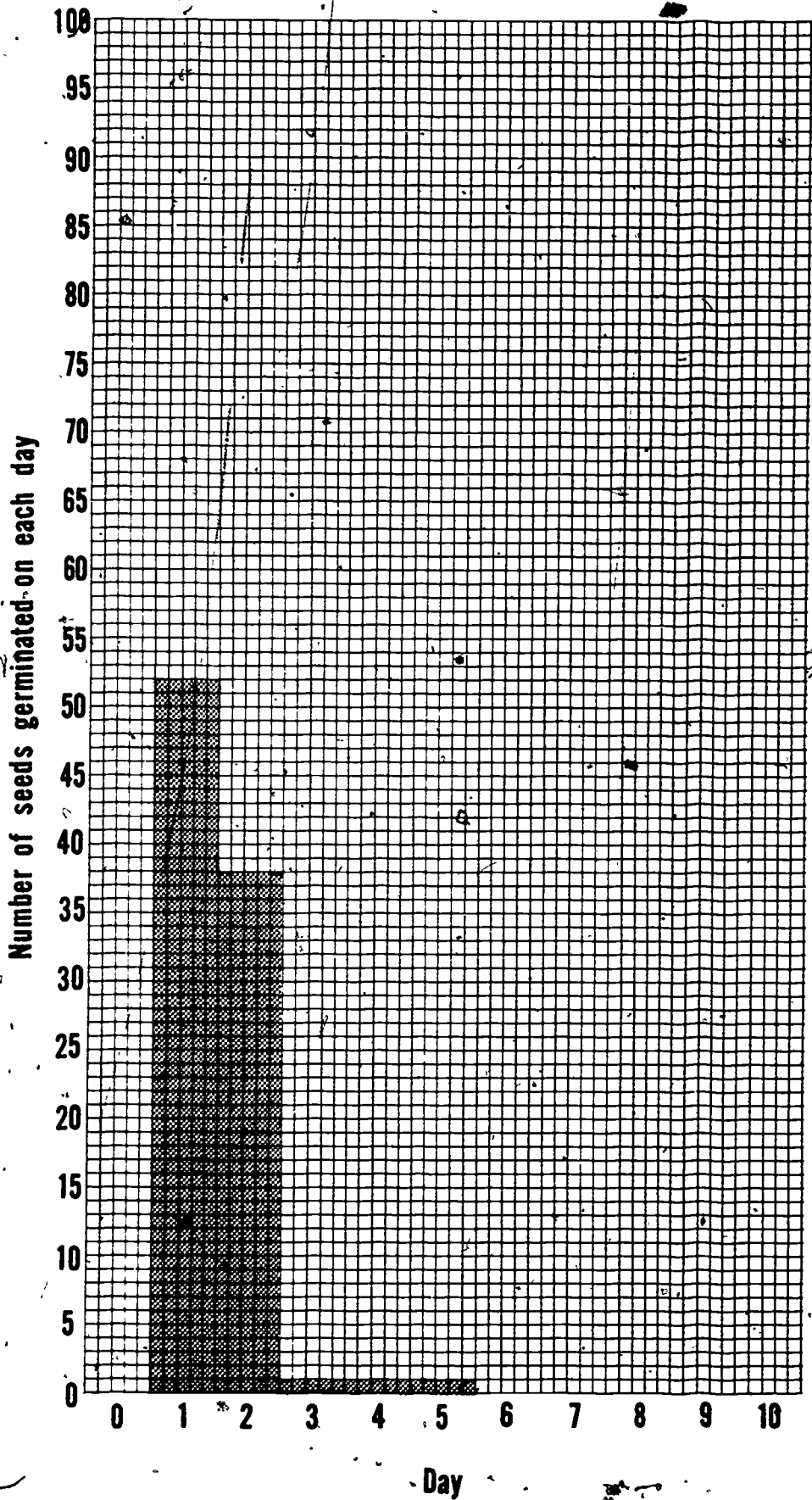

Day  
326

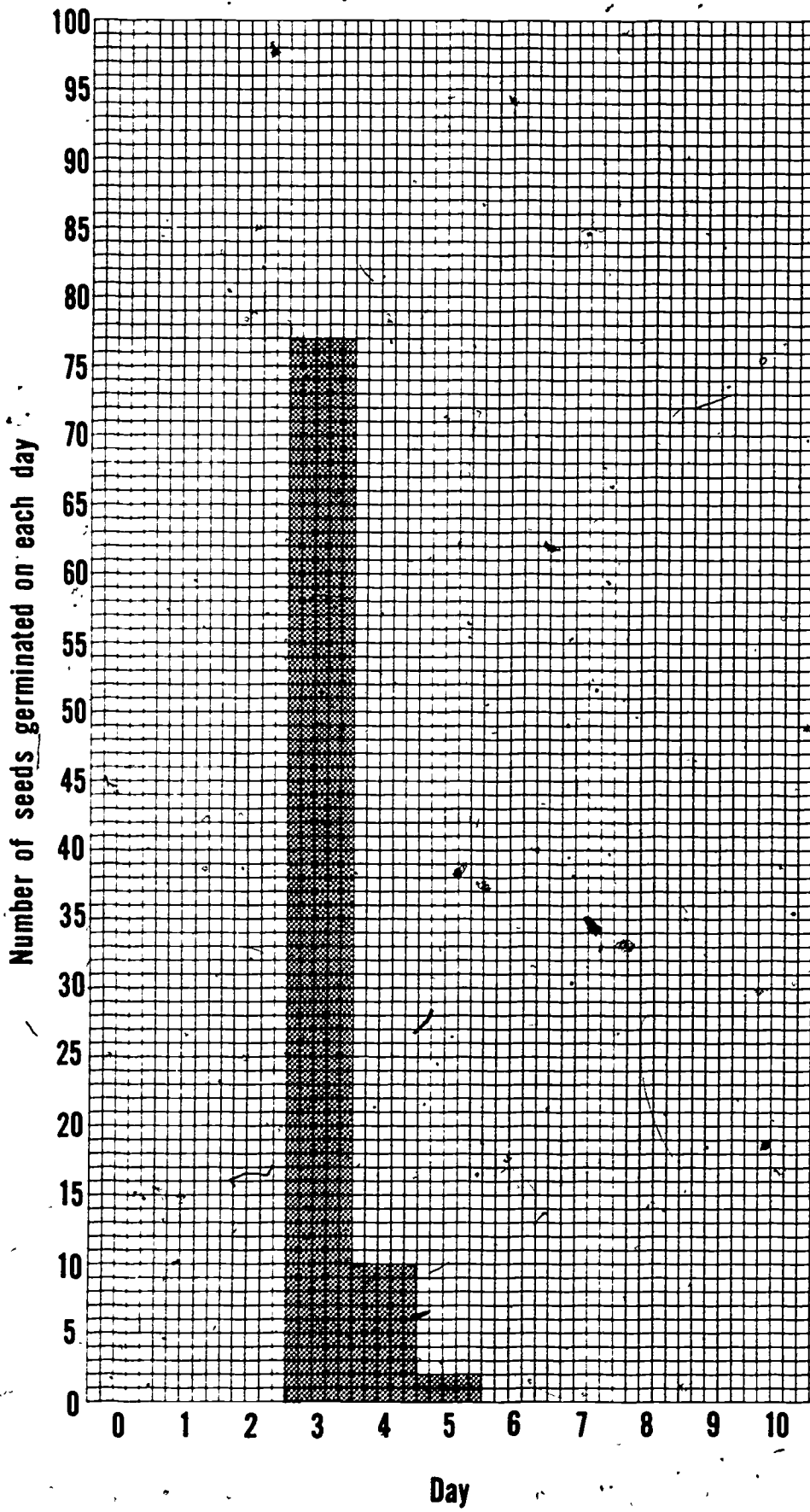

## TEACHING SEQUENCE

- If you took another sample from the same population, what would you predict for the peak germination time?

Choose some of the histograms from different teams to show to the class.

- How do the histograms for the same kind of seed compare generally?
- How do the histograms of different seeds compare?

Have the children report on the range in germination times they observed. Did seeds from the same population behave similarly?

- What is the average time of germination for each sample of seeds?
- Suppose you had taken only a few seeds, 5 for instance, would you have confidence

## COMMENTARY

The teams which investigated the apparently homogeneous "population" in Bag C may or may not raise questions, at this point, about the lack of a single peak on their graphs. If they do, accept their questions, admit that their observations are puzzling, but provide no explanation.

They should expect the peak to occur at the same number of days from the start--if all conditions are the same.

Do not pick the graphs from the teams that had the mixture of *Celosia* and *Forget-me-not* seeds, i.e., the graphs with two peaks.

They should be similar but generally not identical.

They may be very different, not only as to the day of peak germination, but also as to the value at the peak and to the range of days for germination. All these properties can be discussed in connection with the histograms prepared by the children.

Since the range in many instances is short, the average will probably be near the highest point on the frequency distribution portrayed in the histogram.

Some seeds did not germinate at all and some took longer times than others. The five selected



## TEACHING SEQUENCE

By now the children should see that in studying populations they must investigate as large a sample as is practicable, since they must expect some variations in results. Ask them if it would be acceptable to combine sets of data, as they have done in the previous Activities, to increase sample size. Perhaps they could then make even more confident predictions about germination time.

- But what about combining the data from different populations? Would useful information be obtained?

Exhibit two histograms of seeds with very different peak germination times, such as radish or turnip and dill or popcorn. Combine the data and make a histogram on the chalkboard or have the children combine them and plot the histogram on a fresh sheet of graph paper.

The children should see that such a combination gives a histogram with two peaks. An average germination time would mean little for such data since there would actually be two average germination times, one for each type of seed.

## COMMENTARY

might have included these seeds. Thus they might have concluded, erroneously, either that the seeds cannot germinate at all or that they take a very long time to germinate.

Discussion should bring out that it would be acceptable to combine sets of data from teams who used the same kind of seeds-- that is, seeds from the same bag.

Let the children discuss this problem. After they speculate about it, if a child has not already suggested it, combine some typical data.

A combined histogram for radish and popcorn seeds is shown on page 317.

Such a histogram is referred to as bimodal.

Similarly, the range of germination times for a mixture has little meaning because there are 2 different ranges, one for each population. Thus, when

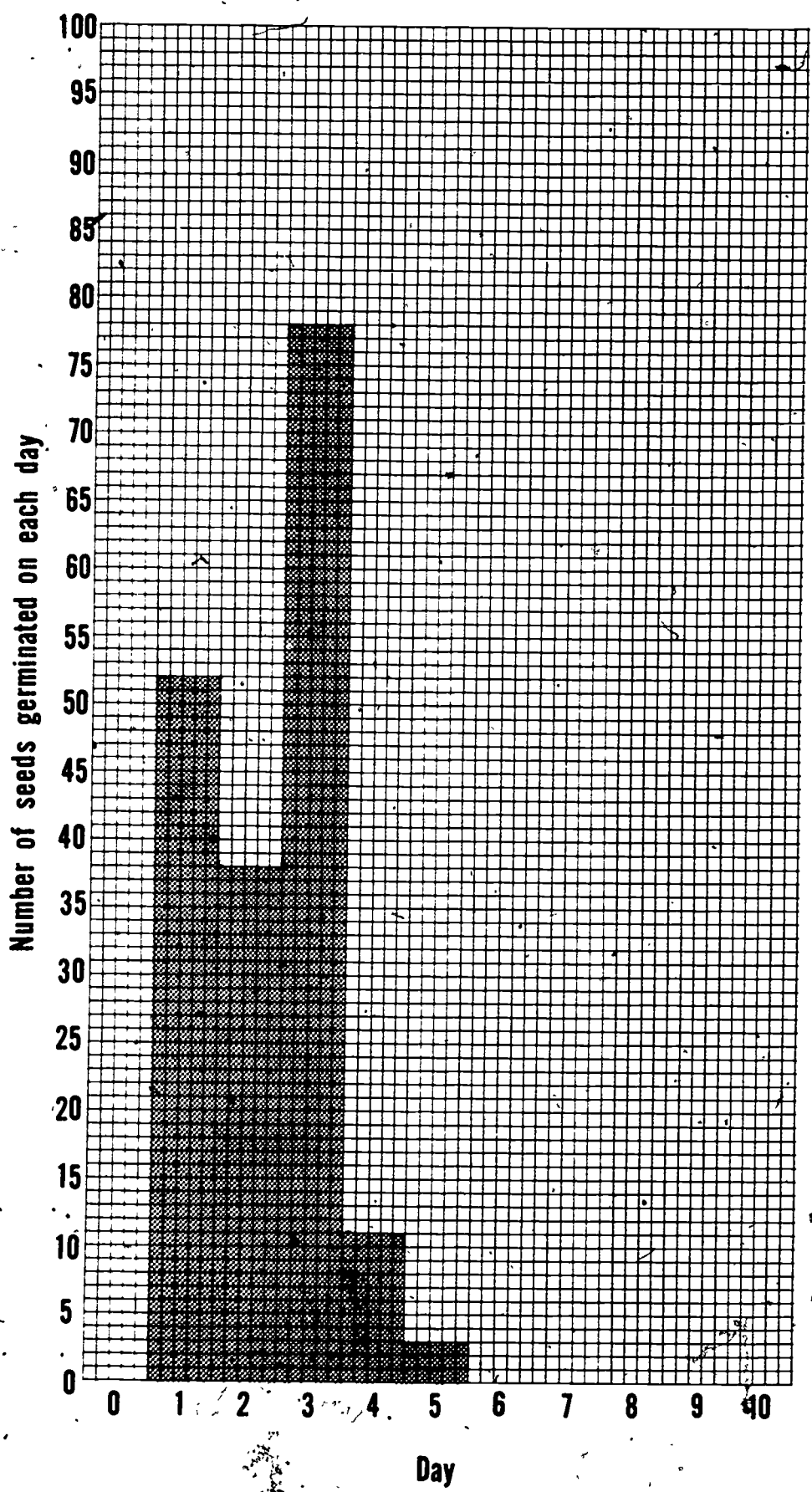

## TEACHING SEQUENCE

As the children discuss this histogram, ask how many populations are represented in it. Discussion should bring out the idea that the histograms with one peak represent data on single populations of seeds--radish seeds or dill seeds or turnip seeds, etc.--but the combined histogram exhibiting two peaks represents two populations of seeds, each with its own peak germination time.

4. At some point, those children who investigated the mixed *Celosia* and *Forget-me-not* seeds should begin to raise persistent questions about their own histograms. Ask them to share their results with the group.

## COMMENTARY

trying to get a better estimate of the average or range of a population, it is important to be certain you are dealing with a single population. Each population has its own average and range. This is really the meaning of the term "population" as used by scientists.

A histogram of the data collected on this mixture is illustrated below. Display such graphs for the entire group to observe.

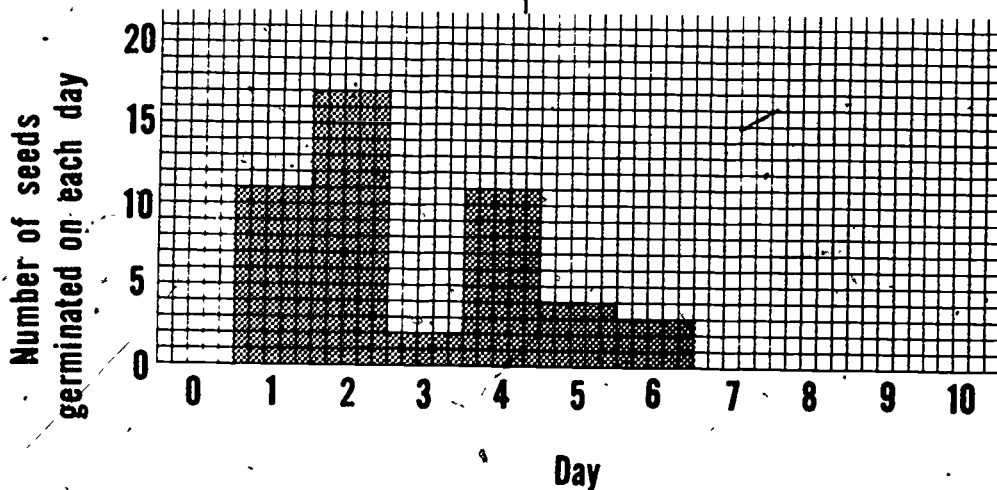

- What do you notice about the histograms of germination times for the seeds in Bag C?
- Why do you think these histograms have two peaks?

The histograms will be bimodal, just like those which they just constructed (although the two peaks will not occur on the same days or have the same values).

The children should come up with the idea that there were

## TEACHING SEQUENCE

- How could you verify the hypothesis that there are really two kinds of seeds in Bag C?

- Suppose you were investigating a group of objects that you suspected might really be two different populations. How would you go about finding out?

## COMMENTARY

two different kinds of seeds in Bag C, despite their similar appearance. Of course, there is some overlap on the histograms. Although the average time for the germination of population 1 is 2 days and the average time for the germination of population 2 is 4 days, a few seeds from population 2 must have germinated by the 2nd day and a few from population 1 must have germinated on the 4th day.

They could verify it by letting the tiny seedlings develop far enough to see the differences in the plants which form. Encourage the children to follow through with such a procedure. At that point, you might identify the seeds that were in the mixture. (See Extended Experiences for another verification procedure.)

Make a histogram of data on the group and see if it contained two peaks. This illustrates the use of a statistical procedure to find out something about a set of data. When a histogram for a certain measurement on a population shows two or more peaks, a factor can usually be found which accounts for the shape. Here the factor was that two different kinds of seeds were mixed. As another example, a histogram of the height of adult Americans would also show two peaks. The factor underlying this is the differences in height of men and women. Women, on the average, tend to be shorter than men.

The children may find that certain varieties of lettuce seeds show 2 peaks. Is this a

## TEACHING SEQUENCE

All these observations point up the use of statistical data in studying samples from apparently homogeneous populations. Although individual deviations occur (very short or long germinations), the peak or most probable time for germination can be confidently used for prediction with respect to the total population even when the total cannot be tested.

## EXTENDED EXPERIENCES:

1. Children can investigate the various factors which may affect the range and average time for germination of different seeds. They can set up samples from a packet of seeds under varying light conditions, (light versus dark); or the effects of different colors of light (using colored transparent plastic or cellophanes), the effect of watering, etc. This type of investigation is highly suitable to individual investigations, either at school or at home. In all instances, they should take their data on a large enough sample so as to make their results statistically sound.
2. Those children who had germinated the mixed populations of seeds may want to get the data on the individual populations and then combine the data on a histogram to see if it looks like the one they obtained of the mixture. If it does, this might also verify that it was a mixture.
3. Many commercial seeds are really mixtures, such as some grass seeds. Children might take germination-time data on samples to see if a histogram will confirm this. Sometimes, overlap of the bars obscures the separate peaks, however.

## COMMENTARY

characteristic of lettuce or does the package contain two varieties? Perhaps letting it grow to maturity will answer the question, but the shape of the histogram will raise the question.

Of course, apparent Homogeneity comes from observing that the seeds have the same size, shape, etc. That populations differ with respect to germination time is a reason that the latter is usually considered a more important property of the seeds than their outward appearance.

## Activity 5 How Do Chemicals Affect Germination?

What factors influence the germination of a seed? In the previous Activity the children found that they were able to grow most of the seeds under moist conditions; some may have investigated other variable factors, such as the presence or absence of light. They also observed variability in that seeds within a given population germinated at different times.

In Activity 5, the children investigate the influence of a chemical on the germination of one population of seeds. The children subject a small sample to specific, but different concentrations of copper sulfate solution and measure the number of germinations which occur at each concentration. Because of the variability of seeds, the results of any one team's experiment may not reveal the influence--the data will be too scattered. It is only when the sample is enlarged to include the data gathered by the entire class, and the average number of germinations is calculated for each concentration of chemical, that a meaningful relationship emerges. The averages, when plotted against concentration of copper sulfate on a coordinate graph, yield a trend-line or curve which shows that inhibition of germination increases with the concentration of chemical. The "scatter" or deviation of the data from the general trend is seen to result from the characteristic variability of the seeds and from expected experimental variations. This concept is applicable to any statistically variable measurement when investigating the effect of imposed factors on a property. Averages of several measurements provide more reliable results than the individual measurement and such averaged data will "fit" on a smooth trend-line or curve wherever individual values will not.

### MATERIALS AND EQUIPMENT:

For the class:

- 8 jars, 1-pint (500-ml), transparent, preferably identical supply of water
- 1 piece of white paper
- 1 stirrer, e.g., glass rod
- 1 marking crayon or felt-tipped pen

copper sulfate, blue hydrated crystals, about 45 g.

For each team of three or four children:

- 1 plastic ice cube tray, with separate molded compartments, or, molded plastic egg carton
- 90 seeds, to be selected from one of the populations studied in Activity 4
- scissors
- paper towels
- 9 cups, 1-oz (30-ml), waxed paper or plastic
- plastic wrap (enough to cover the tray)
- 3-4 pieces of paper, for carrying seeds
- magnifier (optional)
- 1 Worksheet V-5

For each child:

- 1 medicine dropper
- 1 piece of graph paper, 1 sq/in. (1 sq/cm)
- 1 colored crayon or pencil

#### PREPARATION FOR TEACHING:

The entire class should investigate the behavior of the same kind of seed but each team need not perform the experiment at the same time. Some may want to take the trays home to watch the developing seeds. Discussion on the accumulated data, however, should be done with the group as a whole.

Select a seed, such as radish, for which the children collected data in Activity 4. If you select a seed which takes a long time before its germination peaks, there is a possibility that mold will form, depending on the source of your seeds and the condition of the containers. In general, however, copper sulfate will inhibit mold formation as well as germination of the seeds.

Since it takes time, even with stirring, for the 45 g of copper sulfate to dissolve completely, you may want to initiate the Activity and prepare the solution in front of the children early in the day. The dilution series can then be done later in the day. In the interim they can be preparing the trays with the

paper toweling and counting out the seeds. If you would prefer not to wait so long, use hot water to make the solution.

Label each of the pint jars with a number, 1 through 8. You should have a mark on each jar that indicates where it is half-filled. If it is a straight-sided jar, measure the height with a ruler and put a crayon or felt-tipped-pen mark halfway up. Then, assuming all the jars are the same, put a similar line in the same position on the others. (You may substitute 8 jars of another capacity, if that is more convenient. If so, alter your requirements for copper sulfate accordingly.) You might want to enlist the help of children in pre-marking the jars.

Have the materials needed by each team available for the children to help themselves. Put the seeds out in a small jar, with a plastic spoon as a dispenser. Finally, prepare sufficient copies of Worksheet V-5.

#### ALLOCATION OF TIME:

The children will need about 1-1/2 to 2 hours, over a period of several days, to complete this Activity.

#### TEACHING SEQUENCE

1. Review with the class what they learned about germinating seeds in the previous Activity.

#### COMMENTARY

Encourage the children's responses. Be sure these include the observation that out of a sample of 100 seeds not all seeds germinated--that they could not predict which seed would germinate, and that, although more than one team may have investigated the same population of seeds, the exact number of seeds that germinated varied. Thus, they could conclude that there is variability in seeds. However, the shape of the histogram of germinating times was similar for seeds coming from the same population, but differed for different populations. (Of course a major idea was that a two-peaked histogram (bimodal) indicated that there might be two populations of seeds.)



## TEACHING SEQUENCE

- What factors are necessary for germination?
- Is water necessary for germination?
- How do you think germination of the seeds would be affected if a substance were dissolved in the water? Do you think the amount of the substance dissolved would make a difference?

Show the class the copper sulfate, identify it, and tell them that this is a chemical whose affect on germination they can investigate. But first they have to make up some solutions of the copper sulfate, each with a different amount of the substance in a unit of volume. Then, instead of keeping track of the number of seeds which germinate each day, they are going to count how many seeds can germinate on towels moistened with the different solutions. That is, they will try to find out if and how the concentration of the chemical affects germination.

## COMMENTARY

If any of the children studied the effect of different factors on the number of seeds which could germinate, have them report their results. Some may mention the presence or absence of light.

Evidently so, because when the seeds were dry, they didn't germinate.

The children may rightly surmise that the effect would be at least partly determined by the kind of substance it was. Some may think germination would be speeded up and others that it would be slowed down by difference amounts.

Copper sulfate will be used again, extensively, in Grade 6, where the children will try to find what structural units make it up. It is not referred to as copper sulfate there, but as blue vitriol. If the present group of children will be going on with Grade 6 of COPES, you may want to refer to the substance as blue vitriol here.

The variable investigated in Activity 4 was time for germination. Children observed that seeds germinated at different times--some on the first day, some on the second, etc. In the present Activity, the children measure the total number of seeds which germinate. However, they will put on each set of germinating seeds a solution of copper sulfate of different but known concentrations. Thus they will be trying to obtain information on how different concentrations of copper sulfate affect the germination of seeds.

## TEACHING SEQUENCE

Fill a small 1-oz cup with copper sulfate crystals. This will amount to about 45 g. (The exact amount is not important.) Then fill jar number 1 with water, add the copper sulfate, and stir until it is all dissolved.

2. Put the 7 other pint jars, in order, where all the children can easily see them. There should be a row of 8 jars with the filled jar (1) of copper sulfate solution at the beginning of the row.

Focus the children's attention on jar 2 and pose the following problem for them to consider:

- How can I make a solution in jar 2 that will be half as concentrated as that in jar 1?

After they have had a chance to discuss the question (some may want to fill jar 2 with water and add half of the 1-oz cup of copper sulfate to it), pour half of the solution in jar 1 into jar 2--that is, until the liquid comes up to the halfway mark. Show both solutions to the class, holding a piece of white paper behind the jars to improve visibility of the color of the solutions.

- How do the solutions compare in color?

## COMMENTARY

As mentioned in the Preparation for Teaching, it may take a while for all the crystals to dissolve. But the children should observe the initial solution being prepared. Then proceed with the dilution series and setting up of the germinating trays later in the same day.

In this Section of the Activity, a dilution series of copper sulfate solutions is made. Each of the 8 jars will contain  $1/2$  the concentration of copper sulfate in the preceding jar. If the children already have an understanding of such dilutions you can proceed with this rather rapidly. Otherwise, take each step slowly. It is important that the children realize that when an equal volume of water is added to one solution, the dissolved copper sulfate spreads throughout the total liquid and any sample from it would be half as concentrated as the solution was before water was added. Although they may not see the blue color of the copper sulfate in the final member(s) of the series, if they have poured in a portion of the preceding solution and diluted it, it can be inferred that the copper sulfate is still there and still at half the concentration. The gradation in blue color for the more concentrated solutions should be evidence for the children that the concentration is becoming less and less. Concentration is defined as the amount of material, here copper sulfate, in a unit volume of liquid.

If the jars are alike, the color of both solutions will appear the same. Of course, if one

## TEACHING SEQUENCE

- How much solution is in each jar?
- If all the liquid dried up, how much copper sulfate would there be in each jar?

Now add water to jar 2 until the jar is full.

- Is there any difference now in the amount of copper sulfate in each jar?

## COMMENTARY

jar is narrower, then the solution will appear lighter in color since the children will be observing through a thinner portion of solution.

(In earlier Grades, the children developed an understanding of conservation of volume by pouring liquids into different shaped vessels. As the same liquid was poured, it was understood that there was not change in the amount of liquid. Similarly, the children kept track of the amounts of liquid by measuring volumes. Here we are keeping track, not by adding volumes, but by halving them.)

Since the solution was divided in half, each jar contains the same amount--half of the original solution.

It is important that the children also understand that each jar contains the same amount of copper sulfate. On drying, each jar would be seen to have half of the original cup of copper sulfate in it.

The amount of copper sulfate is still the same. None was taken out. Of course, some children might respond that there is less because it has been diluted with water. That would be true if we compared equal-size samples removed from each jar: The sample from jar 2 would contain less copper sulfate per unit volume than the sample from jar 1--in fact, 1/2 as much. But the question here concerns the total amount of copper sulfate in each jar.

## TEACHING SEQUENCE

- How do the two solutions compare in color?

Help the children to realize that in jar 2 the copper sulfate has been spread out through liquid. It is a more dilute solution.

Now pour half the solution from jar 2 into jar 3. Again compare the color of the solution and the amount of copper sulfate in each jar.

Add water to jar 3 until it is full. How do the colors of the two solutions compare now?

- How does the concentration of copper sulfate in the solution in jar 3 compare with that in jar 2?

Continue this procedure and line of questioning until you have poured from jar 7 into jar 8. (In order to have all the jars only half full, you might pour out and discard half of the solution in jar 8.) Now you have 8 jars, each with a decreasing concentration of copper sulfate. As the jars are lined up, a gradation in

## COMMENTARY

This is an important idea and the children should not be rushed through it.

The children will observe that the liquid in jar 2 appears lighter in color. Since the dissolved material is blue, the color of the solution indicates not only the presence of the substance but differences in concentration as well.

If you have not already done so, you might introduce the term concentration here. Refer to the copper sulfate solution in jar 2 as having half the concentration of that in jar 1. Conversely, the concentration in jar 1 is twice that in jar 2.

The pre-marked, half-volume line should facilitate this operation. The solutions should be the same color and, again, there are equal amounts in both jars. The solution was merely divided in two equal parts.

The solution in jar 3 should now be lighter in color.

The solution in jar 3 is half the concentration of the one in jar 2.

By this time the color of the solution may be quite faint.

## TEACHING SEQUENCE

color of the solutions should be clearly noticeable.

Again, ask the children to compare the concentration of copper sulfate in the different jars.

3. The children are now ready to see how many seeds can germinate on towels moistened with the different copper sulfate solutions. For this part of the Activity, divide the class into ten teams. Have each team get its plastic ice cube tray and a supply of paper towels to make a seed germinator. They should place about 15 layers of paper towel in the bottom of each compartment. Then they should

328

## COMMENTARY

From the dilution operation, the children should conclude that the concentration in each succeeding jar is half the concentration of the one before it. A comparison of the concentrations in this series would be:

jar 1 original solution, call its concentration A.

jar 2  $1/2$  A

jar 3  $1/4$  A

jar 4  $1/8$  A

jar 5  $1/16$  A

jar 6  $1/32$  A

jar 7  $1/64$  A

jar 8  $1/128$  A

Note that since all dilutions were made from the original solution in jar 1, it doesn't matter how much copper sulfate is dissolved in it, only that each successive jar has  $1/2$  the concentration of the one before it.

Each team, as noted in the Materials and Equipment list, will work with one plastic ice cube tray. (A molded plastic egg box is an adequate substitute.) They will place 10 seeds in each compartment. It is recommended that the total for the class be 100 seeds per compartment. Therefore, the class should be divided into 10 working teams. If this is not possible, (if you cannot get 10 trays), then each team

341

## TEACHING SEQUENCE

get nine 1-oz cups, and mark 8 of them to correspond to each of the jars. The team members can share the responsibility of obtaining a sample of solution from each of the eight jars in the appropriately numbered cup and a sample of plain water in the ninth cup. If they pour about 1/2 a cupful into each one, that will be quite sufficient. Have them line up the cups in sequence.

## COMMENTARY

should investigate more seeds in each compartment so that the total for the class will still be 100. For instance, if five teams are formed, 20 seeds should be placed in each compartment.

They will be setting the tray up so that each compartment, which is physically separated from its neighbor, will be saturated with a different solution. The same number of seeds should be placed in each compartment.

The ninth cup can be marked with a "C" (for control) or "W" for water. The important idea behind the use of a control in such an investigation has been dealt with in several Activities of COPEs. If the children do not suggest the need for a control compartment of the tray--where the experimental conditions are identical except for the absence of the variable under investigation--take the time to develop the idea with leading questions, such as, how will you be able to tell that any observed effects on germination would not be obtained with water alone?

Caution the children that in working with copper sulfate, they must not let it come in contact with their skin. It can be handled very safely by using the droppers and keeping it in the cups. Caution them not to "poke" with their fingers at the towelings in the trays after it is saturated with the solutions. They can use a dropper or wood splint if they want to move the seeds about. Wipe up any spills with towelings.

## TEACHING SEQUENCE

- As you look down on the series of solutions, what do you observe?

Before they saturate each compartment with one of the solutions, be sure they put numbers on the tray to identify which compartment gets which solution, and which gets plain water.

Then each child should take a medicine dropper, and starting with the more dilute solution, saturate the corresponding compartment with it. Three or 4 droppersful of solution should be sufficient. Whatever is needed, the same amount of liquid should be placed in each compartment. Before the child takes the next more concentrated solution, be sure the dropper has expelled all the liquid possible. Then, instead of rinsing with water (which would dilute the solution), he or she should suck up some of the more concentrated solution and let it go back into the cup. In this way, the child is rinsing the

## COMMENTARY

and discard it.

A definite gradation in color--reflecting the difference in copper sulfate concentration from cup 1 to cup 8. (The solution in cup 8 may appear colorless since one is observing such a small amount of solution.) It might be desirable at this point to repeat the questioning about what the difference in concentration is between each of the samples to emphasize the point that each successive solution still has  $1/2$  the concentration of the one before it. Whether the solution is in a 16-oz jar or in a 1-oz cup, the concentration is the same.

Each child in the team can be responsible for a few of the compartments:

It is safer in this experiment, to "contaminate" the more concentrated solutions with the lesser ones, than the other way around.

In taking droppersful, use the technique described in Mini-sequence III to insure that the same amount is expelled each time. The exact amount needed in all will depend on the kind and amount of toweling used.

## TEACHING SEQUENCE

## COMMENTARY

walls of the dropper with the solution to be used. In the case of the plain water, rinse the dropper with water before taking the 3 droppersful.



Next, each team should get a supply of 100 seeds. (The combined class data should be for 100 seeds in each compartment, as noted earlier.) They can take the supply back to their work areas on small pieces of paper. Ten seeds should be put into each compartment, including the one with water.

Although they have gathered similar information on a sample of 100 seeds in the previous Activity, repeating it here serves two purposes. They will not only be observing the effect of added chemical under identical conditions, they will be able to confirm their predictions that the data they obtained in Activity 4 can be used to predict information about any other sample taken from the same population.

The trays should be covered



## TEACHING SEQUENCE

with plastic wrap (or put into a large plastic bag) to retard evaporation of the water. The children should then set the germinators aside, as they did in Activity 4.

4. After several days, have each team record the number of seeds which have germinated in each compartment. Some children may find it useful to use a magnifier in observing each seed to determine if it has germinated.

Give each team a copy of Worksheet V-5 in order to keep track of the count of germinations, or have them construct a similar one of their own. They should also describe the appearance of the sprouts in the different compartments. This information can be entered under "Comments" on the Worksheet.

Now have the children focus on the measurement of the number of germinations they counted. To the right is a set of typical data obtained by one team using radish seeds.

## COMMENTARY

Be sure that each team identifies its tray.

The time elapsed before they count should be long enough so that every seed which can germinate will have done so. They should use the criterion established in the previous Activity for germination. In other words, they should do the count after the maximum range in days they found for that particular seed has passed. In the case of radish, it might be 3 or 4 days; in the case of lettuce, 9 or 10. The exact time depends on light, moisture, temperature, etc.

They may observe that even though a seed will start to grow a root, some root tips appear black. They are affected by the copper sulfate-- although the root appeared, growth does not proceed. They may even pick up effects on the colors of leaves, if they form.

Compartment	Number of germinations
1	0
2	1
3	1
4	10
5	7
6	10
7	9
8	8
C	10

Team Members: \_\_\_\_\_  
 \_\_\_\_\_  
 \_\_\_\_\_

SEED IS: \_\_\_\_\_

COMPARTMENT	COPPER SULFATE CONCENTRATION	NUMBER OF GERMINATIONS	COMMENTS
1	HIGHEST		
2			
3			
4			
5			
6			
7			
8	LOWEST		
CONTROL (WATER)	NONE		

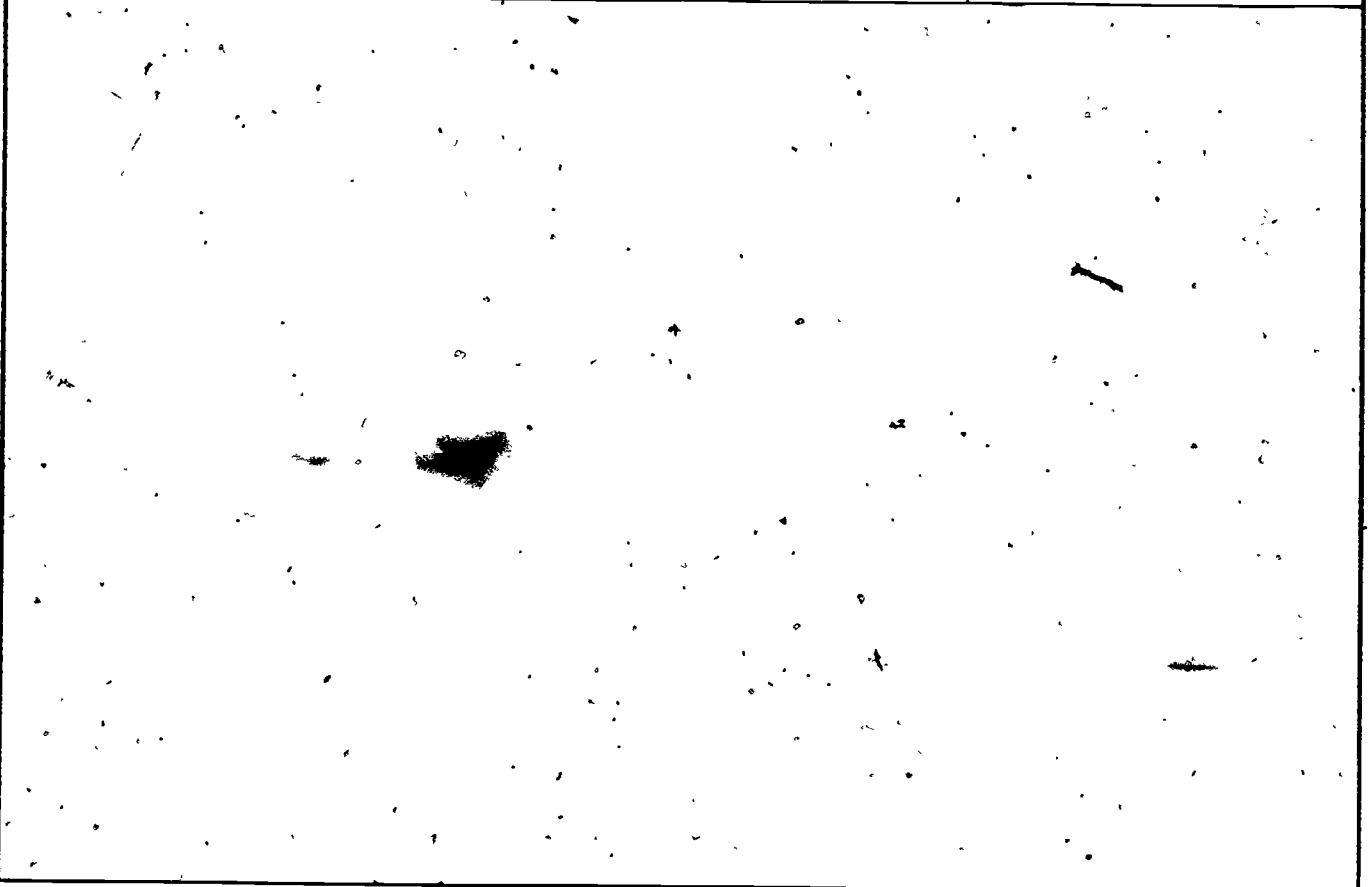

## TEACHING SEQUENCE

- Do the data tell you anything about how the seeds respond to copper sulfate?
- What generalizations can you make on the basis of your results?

At this point, the children should suggest that each team used too few seeds. Considering all the data for all the teams together may help them to resolve some of their disagreements over the interpretation of their results. Make a chart on the chalkboard and, as the teams report one by one, fill it in. The table that follows shows the data obtained by a class on radish seeds.

## COMMENTARY

In many instances, a comparison of the counts in each compartment will not show much of a trend. In fact, the data shown above jump all over. There will probably be general agreement that at the high concentrations of the chemical practically no germinations occurred. At the intermediate concentrations some teams may note that only a few seeds germinated out of the 10; others will observe many more than a few. In short, they will not be able to agree on inferences about the intermediate concentrations. At the lower concentrations some teams may report that a few of the 10 seeds may have been affected; the data of other teams may suggest that there is no difference in germinations between the lowest concentrations of copper sulfate and plain water (the control). The point is that consideration of the data, team by team, can lead to few definitive conclusions.

Leave enough space at the right so that the totals can be recorded, and averages calculated later.

## TEACHING SEQUENCE

## COMMENTARY

Teams

	A	B	C	D	E	F	G	H	I	J
1	0	0	0	1	0	1	0	0	0	0
2	2	1	3	0	0	0	6	1	1	0
3	1	1	7	3	3	5	5	1	3	3
4	2	3	8	7	5	5	6	10	7	7
5	5	5	7	7	10	8	6	7	8	10
6	8	10	10	9	9	9	9	10	8	10
7	10	10	10	10	9	10	10	9	10	10
8	10	8	10	10	10	10	9	8	10	10
C	10	10	10	10	9	10	10	10	10	10

Compartment

Now have the children make a coordinate graph of their collected data. Give each child a sheet of graph paper (1 sq. per cm). The axis along the base can be marked off in numbers from 1 to 8 and then by a letter C (for control) for the water. These marks correspond to the different compartments and represent decreasing copper sulfate concentrations. The vertical axis is marked off in units from 0 to 10, and corresponds to the count of germinated seeds. Both axes should be numbered on the lines. Columns will not be constructed--only intersects marked to correspond with the data.

Be sure the children realize that this is not a histogram. They will be graphing the variation of germinations with the concentration of copper sulfate. Coordinate graphing was introduced in Grade 4 of the COPES curriculum. (You may wish to review the introduction to this type of graphing in Activity 1 of Minisequence III in that grade.)

If your children have difficulty with this technique, work with them as they enter their initial data. For instance, if no seeds germinated in compartment 1, then a dot (or X) should be placed at the intersection of the line for 0 germinations with that for compartment 1. If a team counted 3 germinations in compartment 3, at that compartment line they should count up to the cross line representing a count of 3 germinations and place a mark at that inter-

## TEACHING SEQUENCE

The children should begin by entering the data for their own team. They can then go on to add the data for the other nine teams, one by one. In this way they can readily see the variability in their overall results.

- Do the collective data tell you anything more about how the seeds respond to copper sulfate?
- Could you draw a trend line through the data marks on your graph?

- What do you think accounts for the variations in the data?

Hopefully, the children will refer to their variable results as due not only to the variability of the seeds, but to the impossibility of repeating experiments exactly.

- How can this variability be taken into account, so that we can answer the question as to how the germination of seeds is affected by different concentrations of copper sulfate?

Once the idea of finding an average is introduced, refer back to the tabulation you have on the board. With the

## COMMENTARY

section (See illustration on page 339.)

This means that on each compartment line there will be ten marks. Some may be on top of one another, but most will be spread out a bit.

The children may be quite disappointed that the data, even for the entire class, seem to be quite scattered. A trend of the effect of copper sulfate on germination is not apparent except for zero or low germinations in compartments 1 and 2, and high germinations in compartments 8 and control. Therefore, it would be difficult to draw a trend line with any confidence.

They should be reminded of the variability they found in repeating measurements when they measured the distance a marble could roll in Minisequence II. They obtained different distances even though they tried to repeat the experiment in exactly the same way.

The children's previous experiences in this sequence have shown them that combining and then averaging will provide additional information about population samples. Averaging takes the variability among samples into account.

## TEACHING SEQUENCE

children's help add together all the values for each compartment. Enter these figures on the table in a column to the right.

- For each compartment, how many readings were made?

Help them calculate the average count of germinations for each compartment. For those adept at arithmetic computations, this can be done by adding all the counts for the compartment and then dividing by the number of compartments, which is ten. If your children are familiar with decimals, then dividing by ten should be relatively simple. (See Activity 3.) The averages below go with the data on radish seeds shown earlier.

	Sum	Average Germinations per 10 seeds
1	2	0.2
2	14	1.4
3	32	3.2
4	60	6.0
5	73	7.3
6	92	9.2
7	98	9.8
8	95	9.5
C	99	9.9

Compartment

- What is the probability that a single seed will germinate in, say, compartment 3?

## COMMENTARY

Ten--one for each team.

Some children may recognize that the ten observations entered for each compartment really constitute the data for a histogram. If they wish, they can use the class data to construct such a histogram for each compartment. Then they can perform a piling-in operation to find the average.

In addition to providing information on how these seeds are affected by the chemical as the

## TEACHING SEQUENCE

Compartment 7?

With a different colored pencil, or crayon, suggest the children enter the average values on their graphs.

• Can a trend be observed now?

Have them draw the best trend line. It need not include all the points, but in selecting where to draw the line, those points above the line should be approximately counterbalanced by those below it. An example of such a line through the average values appears in the graph on page 339.

## COMMENTARY

concentration changes, the average tells one the most probable number of seeds that will germinate under these conditions. In fact, since the average is based on an overall count of 100 seeds, it also represents the percentage of seeds germinated. For instance, if the average for one compartment was 3.2 germinations out of 10, it means that 32 out of 100 seeds, or 32%, would most probably germinate. If percent is being studied as part of your mathematics program, application to these calculations of averages would be most appropriate. The probability that a single seed out of the 100 will germinate at a given concentration can be found by dividing the team's average by 10 (the number of seeds) again. Thus, in the data shown, the probability that a single seed will germinate in compartment 3 would be 0.32; in compartment 7, it would be 0.98.

For each compartment, the average value will appear midway between the range of data entered for all ten teams.

In the graph illustrated, X's mark all the data except the averages, which are shown with dots.

TEACHING SEQUENCE

COMMENTARY

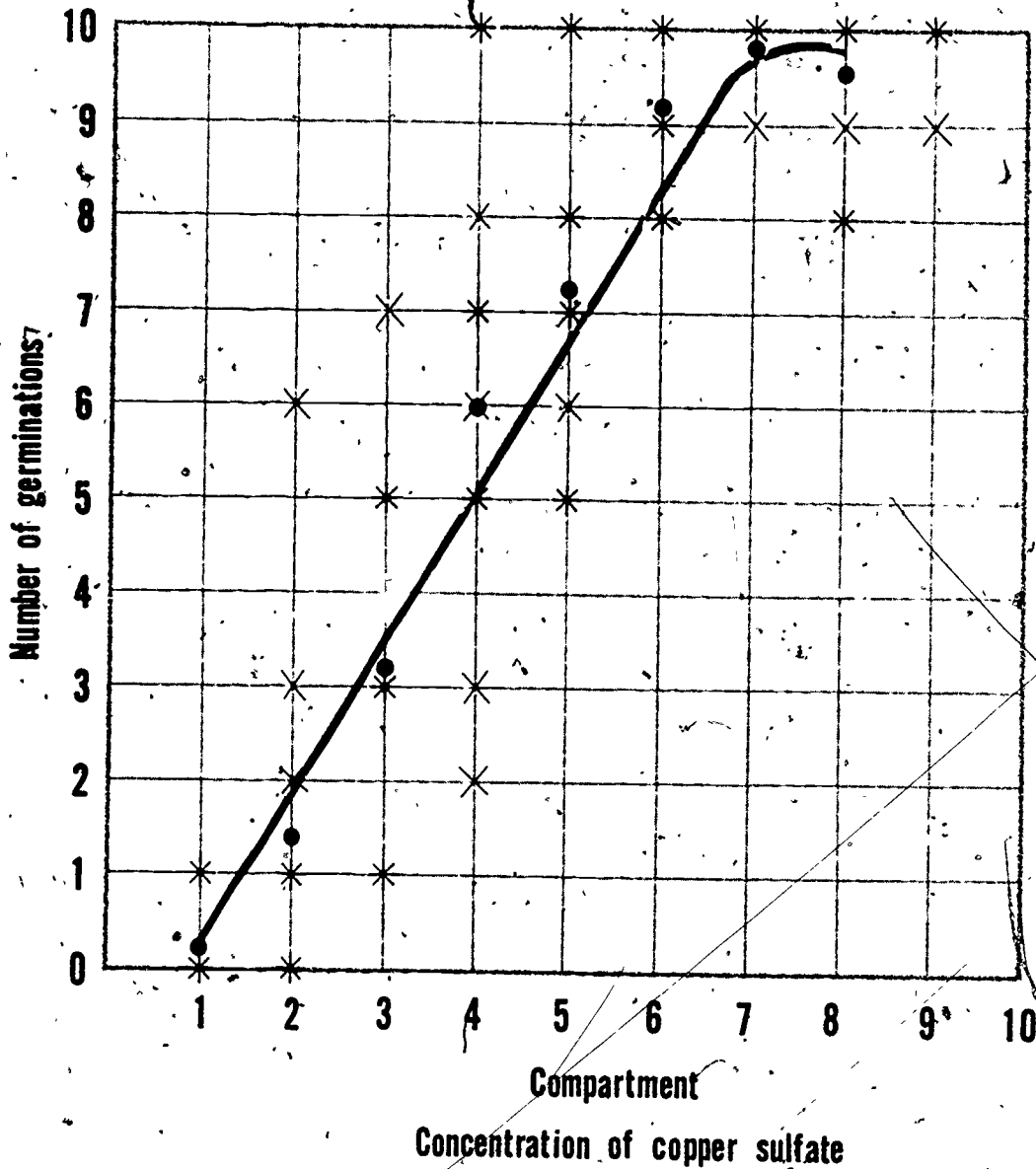

• What conclusions can you now draw?

Discussion should bring out that once they have combined data on many seeds and averaged them, the children could see a general trend of the response to different concentrations of copper sulfate: the greater the concentration of the chemical, the fewer the seeds that germinated. With the possible exception of the lowest concentrations, seed germination is not only inhibited by the pre-



## TEACHING SEQUENCE

## COMMENTARY

- Could you have come to this conclusion if you had put one seed in each compartment? Two? Ten?

sence of this contaminant, but is inhibited in direct proportion to the amount of copper sulfate present.

No--the tendency could not be detected even by examining 10 seeds at a time. An individual team's data did not always show this relationship. They had to examine a large number of germinations, average the results, and obtain a most probable value for each concentration. Similarly, in throwing dice or tacks, the individual throw could not be predicted in advance but the overall behavior of many throws exhibited a uniform pattern. It is important, in conclusion, that the children realize that such relationships are often hidden in an apparently erratic scatter of data.

## EXTENDED EXPERIENCES:

1. Children may be interested to see if other seeds respond in the same manner towards copper sulfate.
2. Is copper sulfate really present in the solution in jar 8? If the solution is colorless, this is a valid question, particularly if no difference in average germinations is found compared with the control. A sensitive test for the presence of dissolved copper sulfate can be demonstrated. (Because of the odor and sensitivity of some children to undiluted household ammonia, the demonstration should be done by you.) First, take a sample from one of the solutions which is distinctly blue and add some household ammonia solution. The mixture will turn deep blue (a precipitate may form first; if so, add more ammonia). This is characteristic of the interaction between ammonia and copper salt solutions. Then take a sample from jar 8--in a small sample, it will probably be colorless. Add ammonia to this. Formation of the characteristic deep blue color will be immediate. Will water do this?
3. This Activity can lead nicely into a discussion of the effects of water pollution on living things. Both quantitative observations on the decreased number of germinations and quantitative observations such as blackened root tips at the higher

concentrations of the copper sulfate and poor growth can lead children to a greater concern for the environment. It is not hard to imagine a child becoming interested in, say, doing a special project on the differing waste treatment facilities of chemical plants as a result of this investigation. The relationship of living things to their environment will be explored in the first Minisequence in Grade 6.

# Minisequence V Assessments

## Screening Assessments

The concepts to which this assessment is oriented are:

- a. A population of objects or groups of repeated events exhibits variability.
- b. If a physical model can be devised to represent a series of events, the variability in expected outcomes for these events generally can be predicted.
- c. The larger the sampling used in observing a property, the more confident is the prediction of the average and the frequency distribution of that property for the total population. Increase in confidence in the prediction can be obtained by increasing the size of the sample or combining a number of samples.
- d. The result of a single chance event is not useful in predicting the outcome of a large sample of these events.
- e. Where a simple physical model cannot be devised, inferences about an object or series of events can often be made by large-scale sampling.
- f. The shape of a frequency distribution bar graph (histogram) gives information about the population from which the sample was taken. This histogram exhibits a range and a single most frequent value (mode). A multi-modal histogram indicates that the sample consists of members of more than one population.
- g. In measuring the influence of an outside factor on members of a population, the effect on their properties can be observed only if a large sample of data is obtained and averages of the data are plotted against different values of the (imposed) factor.

The assessment is in two parts; if desired, Part 1 may be used after Activity 2. Part 1 deals with concepts a through d; Part 2 deals mainly with concepts e through g, with some brief incorporation of the earlier concepts. Part 1 consists of 6 questions.

and should require about 6 minutes for its administration. Part 2 consists of 11 questions, and requires about 10 minutes.

## PART 1

Pages A, B, and C

Distribute the assessment pages and direct the children as follows:

IN THIS ASSESSMENT, I SHALL READ ALOUD A DESCRIPTION OF A SITUATION SIMILAR TO THOSE WE HAVE BEEN WORKING ON. THEN I SHALL READ THREE QUESTIONS AND THREE POSSIBLE ANSWERS FOR EACH. I SHALL PAUSE BETWEEN QUESTIONS FOR YOU TO CIRCLE THE LETTER IN FRONT OF THE ANSWER YOU PREFER. THERE WILL BE TWO SITUATIONS IN THIS PART. HERE IS THE FIRST SITUATION. READ SILENTLY WHILE I READ ALOUD. (Allow about 1 minute per response to situations A and B. If you think it helpful to the children, repeat the question with its possible answers as they select their choices.)

Page A

**SITUATION A:** THE CUBE YOU WORKED WITH IN ACTIVITY 2 HAD SIX FACES. EACH ONE WAS A SQUARE. CONSIDER NOW ANOTHER SITUATION. LOIS HAD A DIFFERENTLY SHAPED SOLID--ONE WITH FOUR FACES. EACH FACE IS IN THE SHAPE OF A TRIANGLE. THE THREE SIDES OF THE TRIANGLE ARE ALL EQUAL. A PICTURE OF THE SOLID OBJECT IS SHOWN AT THE RIGHT. EACH FACE IS LABELLED WITH A LETTER: A AND B ARE ON THE FACES YOU CAN SEE. FACES C AND D ARE HIDDEN. THE ARROWS POINT TO THEM. HAVE YOU ANY QUESTIONS ABOUT THIS OBJECT? (If so, re-read the situation, but provide no further information.) HERE IS QUESTION 1.

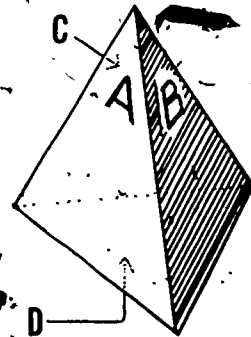

1. WHEN LOIS DROPS THIS OBJECT ON A TABLE, SHE CAN SEE THREE SIDES BUT NOT THE FOURTH ONE ON WHICH IT LANDS. ON WHICH FACE WOULD THE OBJECT BE EXPECTED TO LAND?

- A. FACE A IS MOST LIKELY.
- B. ANY FACE BUT D.
- C. ONE CAN'T PREDICT THE RESULT OF ONE DROP.

2. IF THIS OBJECT WERE DROPPED MANY TIMES, AND A RECORD KEPT OF THE FACES ON WHICH IT LANDED, WHICH OF THE FOLLOWING STATEMENTS WOULD BE MOST REASONABLE?

- A. THE FACES WOULD HAVE NEARLY EQUAL FREQUENCIES.
- B. THE RECORD WOULD BE CONSISTENT WITH THE PHYSICAL PROPERTIES OF THE OBJECT.
- C. BOTH STATEMENTS A AND B ARE TRUE.

3. SUPPOSE LOIS WERE TO DROP THIS OBJECT TWICE. OF THE RESULTS DESCRIBED BELOW FOR TWO DROPS, WHICH LANDINGS WOULD BE THE MOST LIKELY?

- A. FACE A ON THE FIRST DROP, FACE B ON THE SECOND.
- B. FACE B OR D ON THE FIRST DROP, FACE D OR B ON THE SECOND.
- C. IT WOULD LAND ON FACE C BOTH DROPS.

Page B

TURN TO PAGE B.

4. SUPPOSE INSTEAD OF LETTERS, LOIS NUMBERED THE SIDES: A=1; B=2; C=3; D=4. SHE THEN DROPPED THE OBJECT TWICE, AND ADDED UP THE NUMBERS OF THE FACES ON WHICH IT LANDED. WHICH SUM WOULD BE MOST LIKELY?

- A. THE SUM OF 2.
- B. THE SUM OF 8.
- C. THE SUM OF 5.

IN THE SPACES PROVIDED BELOW, WRITE THE VALUE OF THE MOST LIKELY SUM AND ITS PROBABILITY. USE THE TABLE TO HELP YOU DECIDE. MOST LIKELY SUM = \_\_\_\_ ITS PROBABILITY IS \_\_\_\_/16.

FACE	1	2	3	4
1		3		
2				
3				7
4				

Page c

Ask the children to turn to page C.

HERE IS *SITUATION B*: A BAG CONTAINS SOME MARBLES. SUPPOSE YOU MADE 14 DRAWS OF THE MARBLES OUT OF THE BAG, ONE MARBLE AT A TIME. YOU PUT EACH MARBLE BACK IN THE BAG BEFORE THE NEXT DRAW. THE NUMBER OF DRAWS FOR EACH TYPE OF MARBLE IS SHOWN BELOW.

<u>COLOR</u>	<u>FREQUENCY</u>
RED	2
BLUE	5
YELLOW	7

HERE ARE SOME QUESTIONS ABOUT THE BAG OF MARBLES.

- WHICH OF THE FOLLOWING STATEMENTS SEEMS MOST REASONABLE?
  - THE MARBLES IN THE BAG ARE EITHER RED, BLUE, OR YELLOW.
  - THE DRAWS WERE BIASED BECAUSE THE TALLIES SHOULD BE MORE NEARLY EQUAL.
  - THERE ARE EXACTLY THREE MARBLES IN THE BAG.
- IF YOU WERE TOLD THERE ARE ONLY SIX MARBLES IN THE BAG, HOW MANY WOULD YOU THINK ARE COLORED BLUE?
  - TWO MARBLES ARE BLUE.
  - FIVE MARBLES ARE BLUE.
  - NOT ENOUGH INFORMATION TO MAKE A GOOD GUESS.

PART 2

Pages D, E, and F

Distribute the assessment pages for Part 2 and direct the children as follows:

I SHALL NOW READ ALOUD A DESCRIPTION OF A SITUATION SOMEWHAT LIKE THOSE WE HAVE BEEN WORKING ON. THEN I SHALL READ THREE QUESTIONS AND THREE POSSIBLE ANSWERS FOR EACH. I SHALL PAUSE

BETWEEN QUESTIONS FOR YOU TO CIRCLE THE LETTER YOU PREFER. THERE ARE THREE SITUATIONS IN THIS PART. HERE IS THE FIRST SITUATION. READ SILENTLY WITH ME WHILE I READ ALOUD. (Part 2 should take about 10 minutes: Situations C and D about 40 to 45 seconds per response, Situation E 1 to 1-1/2 minutes per response.)

Page D

SITUATION C: YOU HAVE PROBABLY USED A SPINNER. HERE IS ONE WITH FOUR EQUAL SECTORS LABELLED A, B, C, D, AS SHOWN AT THE RIGHT. NANCY AND JOE MADE A TOTAL OF 60 SPINS. THE FREQUENCIES (OR NUMBER OF TIMES THE SPINNER STOPPED IN A PARTICULAR SECTOR) WERE A=5 TIMES, B=15 TIMES, C=30 TIMES, D=10 TIMES.

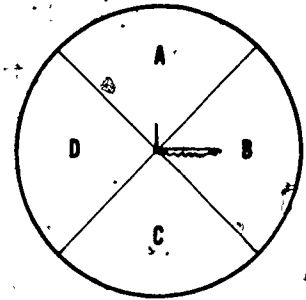

HERE ARE SOME QUESTIONS ABOUT THE SPINNER. CIRCLE THE LETTER OF THE ANSWER YOU PREFER.

1. WHICH OF THE FOLLOWING STATEMENTS IS MOST LIKELY CORRECT?

- A. THE DATA ARE WRONG, AS THIS RESULT IS IMPOSSIBLE.
- B. THE RESULTS ARE WITHIN EXPECTED VARIATION DUE TO CHANCE.
- C. THERE IS SOME INFLUENCE ON SECTOR C AT THE EXPENSE OF SECTOR A.

2. NANCY AND JOE KEPT TRACK OF EVERY TWO SPINS AS THEY COLLECTED THEIR DATA. WHICH OF THE FOLLOWING PAIRS OF SPINS WOULD BE MOST LIKELY?

- A. THE PAIR (A, C)
- B. THE PAIR (B, B)
- C. THE PAIR (B, C)

3. IF NANCY AND JOE MADE SURE THE SPINNER WERE PERFECTLY BALANCED (NOT INFLUENCED), AND THEN THEY SPUN IT, THEY WOULD FIND THAT:

- A. THE SPINNER WOULD ALWAYS STOP IN THE SAME SECTOR.
- B. THE SPINNER WOULD STOP AT EACH SECTOR THE SAME NUMBER OF TIMES (THE SAME FREQUENCY).
- C. NEITHER A NOR B IS TRUE.

Page E

NOW TURN TO PAGE E.

SITUATION D: THE HISTOGRAM AT THE RIGHT SHOWS THE FREQUENCY DISTRIBUTION OF HEIGHTS OF 100 CHILDREN. THE UNITS ON THE LINE ARE INCHES OF HEIGHT.

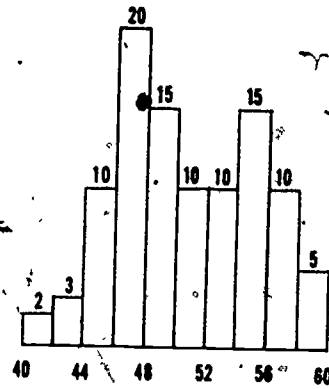

HERE ARE THE QUESTIONS. CIRCLE THE LETTER FOR THE ANSWER YOU PREFER.

- THE MOST FREQUENTLY OCCURRING HEIGHT IN THE TOTAL GROUP IS ABOUT:
  - 40-60 INCHES.
  - 47 INCHES.
  - 52 INCHES.
- WHICH OF THE FOLLOWING STATEMENTS IS MORE LIKELY CORRECT?
  - THERE ARE MANY ERRORS OF MEASUREMENT IN THESE DATA.
  - THE CHILDREN ARE APPARENTLY ALL FROM THE SAME POPULATION.
  - THE CHILDREN MAY COME FROM TWO DIFFERENT AGE GROUPS.
- IF THE CHILDREN ARE ALL FROM THE FIFTH GRADE IN A SCHOOL,
  - ABOUT 40 OF THEM ARE PROBABLY BOYS.
  - ALL THE DIFFERENCES ARE DUE TO VARIATIONS EXPECTED IN SAMPLING.
  - THE NUMBER OF CHILDREN AT EACH HEIGHT SHOULD BE THE SAME.
- IF THE DATA SHOWN REPRESENTED THE NUMBER OF GAMES WON BY CHILDREN IN A CHECKERS TOURNAMENT
  - ALL OF THE CHILDREN WOULD HAVE BEEN EQUALLY SUCCESSFUL.
  - ABOUT HALF OF THEM MAY HAVE HAD SPECIAL TRAINING.
  - NO INTERPRETATION OTHER THAN CHANCE SHOULD BE MADE.



Page F

Ask the children to turn to page F

*SITUATION E:* JOHN AND CAROL DECIDE TO MAKE THEIR OWN RUBBER BAND SCALE WHICH THEY CAN USE TO WEIGH OBJECTS. THEY HAVE AVAILABLE A STRONG RUBBER BAND, A CONTAINER, A SMALL UNIT MEASURE CUP, PLENTY OF STRING AND CARDBOARD, AND UNLIMITED AMOUNTS OF WATER. THEY DECIDE THEY NEED FIVE DIFFERENT POSITIONS ON THE SCALE TO CORRESPOND TO FIVE DIFFERENT UNITS OF WEIGHT. THE CONTAINER WILL HOLD 10 MEASURES OF WATER.

1. WHICH OF THE FOLLOWING PLANS WOULD BE MOST USEFUL TO THEM?
  - A. PUT A UNIT MEASURE OF WATER IN THE CUP AND SEE HOW MUCH IT STRETCHES THE RUBBER BAND.
  - B. PUT FIVE DIFFERENT NUMBERS OF MEASURES OF WATER IN THE CONTAINER AND MARK HOW FAR EACH STRETCHES THE RUBBER BAND.
  - C. MEASURE THE STRETCH FOR FIVE DIFFERENT NUMBER OF MEASURES OF WATER MANY TIMES EACH AND FIND THE AVERAGE POSITION FOR EACH MEASURED AMOUNT.
2. THE ANSWER YOU CHOSE ABOVE IS BEST BECAUSE:
  - A. IT ACCOUNTS FOR ALL THE STRETCH IN THE RUBBER BAND.
  - B. IT ALLOWS FOR ERROR IN REPEATING A MEASUREMENT.
  - C. IT IS THE EASIEST ONE TO DO.
3. IF JOHN AND CAROL HAD MADE REPEATED MEASUREMENTS, THEY WOULD HAVE THE MOST CONFIDENCE IN USING THE SCALE IF THE MARKS LOOKED LIKE:

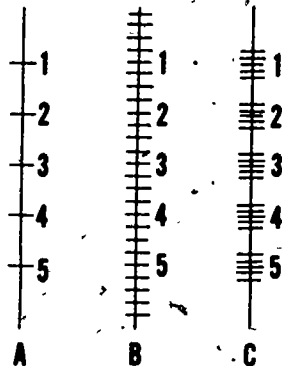

SITUATION A: THE CUBE YOU WORKED WITH IN ACTIVITY 2 HAD SIX FACES. EACH ONE WAS A SQUARE. CONSIDER NOW ANOTHER SITUATION. LOIS HAS A DIFFERENTLY SHAPED SOLID--ONE WITH FOUR FACES. EACH FACE IS IN THE SHAPE OF A TRIANGLE  $\triangle$ . THE THREE SIDES OF THE TRIANGLE ARE ALL EQUAL. A PICTURE OF THE SOLID OBJECT IS SHOWN AT THE RIGHT. EACH FACE IS LABELLED WITH A LETTER: A AND B ARE ON THE FACES YOU CAN SEE. FACES C AND D ARE HIDDEN. THE ARROWS POINT TO THEM. HAVE YOU ANY QUESTIONS ABOUT THIS OBJECT? HERE IS QUESTION 1.

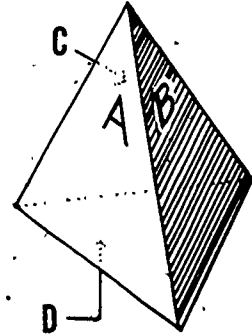

1. WHEN LOIS DROPS THIS OBJECT ON A TABLE, SHE CAN SEE THREE SIDES, BUT NOT THE FOURTH ONE ON WHICH IT LANDS. ON WHICH FACE WOULD THE OBJECT BE EXPECTED TO LAND?
  - A. FACE A IS MOST LIKELY.
  - B. ANY FACE BUT D.
  - C. ONE CAN'T PREDICT THE RESULT OF ONE DROP.
  
2. IF THIS OBJECT WERE DROPPED MANY TIMES, AND A RECORD KEPT OF THE FACES ON WHICH IT LANDED, WHICH OF THE FOLLOWING STATEMENTS WOULD BE MOST REASONABLE?
  - A. THE FACES HAVE NEARLY EQUAL FREQUENCIES.
  - B. THE RECORD WILL BE CONSISTENT WITH THE PHYSICAL PROPERTIES OF THE OBJECT.
  - C. BOTH STATEMENTS A AND B ARE TRUE.
  
3. SUPPOSE LOIS WERE TO DROP THIS OBJECT TWICE. OF THE RESULTS DESCRIBED BELOW FOR TWO DROPS, WHICH LANDINGS WOULD BE THE MOST LIKELY.
  - A. FACE A IN THE FIRST DROP, FACE B ON THE SECOND.
  - B. FACE B OR D ON THE FIRST DROP, FACE D OR B ON THE SECOND.
  - C. IT WOULD LAND ON FACE C BOTH DROPS.

4. SUPPOSE INSTEAD OF LETTERS, LOIS NUMBERED THE SIDES: A=1; B=2; C=3; D=4. SHE THEN DROPPED THE OBJECT TWICE, AND ADDED UP THE NUMBERS OF THE FACES ON WHICH IT LANDED. WHICH SUM WOULD BE MOST LIKELY?

- A. THE SUM OF 2.
- B. THE SUM OF 8.
- C. THE SUM OF 5.

IN THE SPACE PROVIDED BELOW, WRITE THE VALUE OF THE MOST LIKELY SUM AND ITS PROBABILITY. USE THE TABLE BELOW TO HELP YOU DECIDE.

MOST LIKELY SUM = \_\_\_\_\_ ITS PROBABILITY IS \_\_\_\_\_ /16.

FACE	1	2	3	4
1		3		
2				
3				7
4				

HERE IS *SITUATION B*: A BAG CONTAINS SOME MARBLES. SUPPOSE YOU MADE 14 DRAWS OF THE MARBLES OUT OF THE BAG, ONE MARBLE AT A TIME. YOU PUT EACH MARBLE BACK IN THE BAG BEFORE THE NEXT DRAW. THE NUMBER OF DRAWS FOR EACH TYPE OF MARBLE IS SHOWN BELOW.

<u>COLOR</u>	<u>FREQUENCY</u>
RED	2
BLUE	5
YELLOW	7

HERE ARE SOME QUESTIONS ABOUT THE BAG OF MARBLES.

- WHICH OF THE FOLLOWING STATEMENTS SEEMS MOST REASONABLE?
  - THE MARBLES IN THE BAG ARE EITHER RED, BLUE, OR YELLOW.
  - THE DRAWS WERE BIASED BECAUSE THE TALLIES SHOULD BE MORE NEARLY EQUAL.
  - THERE ARE EXACTLY THREE MARBLES IN THE BAG.
- IF YOU WERE TOLD THERE ARE ONLY SIX MARBLES IN THE BAG, HOW MANY WOULD YOU THINK ARE COLORED BLUE?
  - TWO MARBLES ARE BLUE.
  - FIVE MARBLES ARE BLUE.
  - NOT ENOUGH INFORMATION TO MAKE A GOOD GUESS.

**SITUATION C:** YOU HAVE PROBABLY USED A SPINNER. HERE IS ONE WITH FOUR EQUAL SECTORS LABELLED, A, B, C, D, AS SHOWN AT THE RIGHT. NANCY AND JOE MADE A TOTAL OF 60 SPINS. THE FREQUENCIES (OR NUMBER OF TIMES THE SPINNER STOPPED IN A PARTICULAR SECTOR) WERE A=5 TIMES, B=15 TIMES, C=30 TIMES, D=10 TIMES.

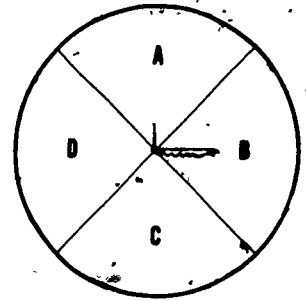

HERE ARE SOME QUESTIONS ABOUT THE SPINNER. CIRCLE THE LETTER OF THE ANSWER YOU PREFER.

- WHICH OF THE FOLLOWING STATEMENTS IS MOST LIKELY CORRECT?
  - THE DATA ARE WRONG, AS THIS RESULT IS IMPOSSIBLE.
  - THE RESULTS ARE WITHIN EXPECTED VARIATION DUE TO CHANCE.
  - THERE IS SOME INFLUENCE ON SECTOR C AT THE EXPENSE OF SECTOR A.
- NANCY AND JOE KEPT TRACK OF EVERY TWO SPINS AS THEY COLLECTED THEIR DATA. WHICH OF THE FOLLOWING PAIRS OF SPINS WOULD BE MOST LIKELY?
  - THE PAIR (A, C)
  - THE PAIR (B, B)
  - THE PAIR (B, C)
- IF NANCY AND JOE MADE SURE THE SPINNER WAS PERFECTLY BALANCED (NOT INFLUENCED) AND THEN THEY SPUN IT, THEY WOULD FIND THAT:
  - THE SPINNER WOULD ALWAYS STOP IN THE SAME SECTOR.
  - THE SPINNER WOULD STOP AT EACH SECTOR THE SAME NUMBER OF TIMES. (THE SAME FREQUENCY).
  - NEITHER A NOR B IS TRUE.

SITUATION D: THE HISTOGRAM AT THE RIGHT SHOWS THE FREQUENCY DISTRIBUTION OF HEIGHTS OF 100 CHILDREN. THE UNITS ON THE LINE ARE INCHES OF HEIGHT.

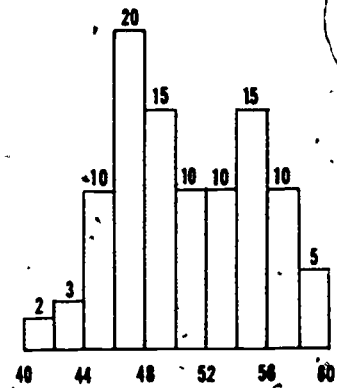

HERE ARE THE QUESTIONS. CIRCLE THE LETTER FOR THE ANSWER YOU PREFER.

1. THE MOST FREQUENTLY OCCURRING HEIGHT IN THE TOTAL GROUP IS ABOUT:
  - A. 40-60 INCHES.
  - B. 47 INCHES.
  - C. 52 INCHES.
  
2. WHICH OF THE FOLLOWING STATEMENTS IS MORE LIKELY CORRECT?
  - A. THERE ARE MANY ERRORS OF MEASUREMENT IN THESE DATA.
  - B. THE CHILDREN ARE APPARENTLY ALL FROM THE SAME POPULATION.
  - C. THE CHILDREN MAY COME FROM TWO DIFFERENT AGE GROUPS.
  
3. IF THE CHILDREN ARE ALL FROM THE FIFTH GRADE IN A SCHOOL,
  - A. ABOUT 40 OF THEM ARE PROBABLY BOYS.
  - B. ALL THE DIFFERENCES ARE DUE TO VARIATIONS EXPECTED IN SAMPLING.
  - C. THE NUMBER OF CHILDREN AT EACH HEIGHT SHOULD BE THE SAME.
  
4. IF THE DATA SHOWN REPRESENTED THE NUMBER OF GAMES WON BY CHILDREN IN A CHECKERS TOURNAMENT RATHER THAN HEIGHTS,
  - A. ALL OF THE CHILDREN WOULD HAVE BEEN EQUALLY SUCCESSFUL.
  - B. ABOUT HALF OF THEM MAY HAVE HAD SPECIAL TRAINING.
  - C. NO INTERPRETATION OTHER THAN CHANCE SHOULD BE MADE.

**SITUATION E:** JOHN AND CAROL DECIDE TO MAKE THEIR OWN RUBBER BAND SCALE WHICH THEY CAN USE TO WEIGH OBJECTS. THEY HAVE AVAILABLE A STRONG RUBBER BAND, A CONTAINER, A SMALL UNIT MEASURE CUP, PLENTY OF STRING, AND CARDBOARD, AND UNLIMITED AMOUNTS OF WATER. THEY DECIDE THEY NEED FIVE DIFFERENT POSITIONS ON THE SCALE TO CORRESPOND TO FIVE DIFFERENT UNITS OF WEIGHT. THE CONTAINER WILL HOLD 10 MEASURES OF WATER.

1. WHICH OF THE FOLLOWING PLANS WOULD BE MOST USEFUL TO THEM?
  - A. PUT A UNIT MEASURE OF WATER IN THE CUP AND SEE HOW MUCH IT STRETCHES THE RUBBER BAND.
  - B. PUT FIVE DIFFERENT NUMBERS OF MEASURES OF WATER IN THE CONTAINER AND MARK HOW FAR EACH STRETCHES THE RUBBER BAND.
  - C. MEASURE THE STRETCH FOR FIVE DIFFERENT NUMBERS OF MEASURES OF WATER MANY TIMES EACH AND FIND THE AVERAGE POSITION FOR EACH MEASURED AMOUNT.
  
2. THE ANSWER YOU CHOSE ABOVE IS BEST BECAUSE:
  - A. IT ACCOUNTS FOR ALL THE STRETCH IN THE RUBBER BAND.
  - B. IT ALLOWS FOR ERROR IN REPEATING A MEASUREMENT.
  - C. IT IS THE EASIEST ONE TO DO.
  
3. IF JOHN AND CAROL HAD MADE REPEATED MEASUREMENTS, THEY WOULD HAVE THE MOST CONFIDENCE IN USING THE SCALE IF THE MARKS LOOKED LIKE:

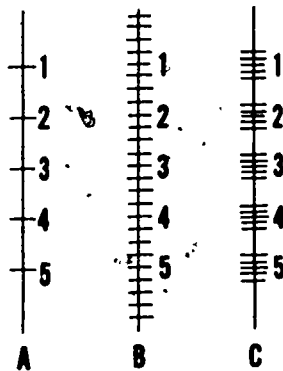

## Materials and Equipment

An alphabetical list of materials and equipment is included for your convenience in obtaining the materials necessary for teaching the Grade 5 sequence of COPES. The list includes the total amount of materials for the Grade 5 sequence. The children can often bring materials, such as marbles and empty baby food jars, from home. Some items--such as paper, pencils, and crayons--will be available in your school. Check also for equipment that may be available from a school science storeroom. Most of the remaining items can be purchased locally in grocery, stationery, drug, photography supply or hardware stores. A few items such as thermometers, spring scales, magnifiers, and some chemicals (see page 142), may have to be ordered from one of the scientific supply houses listed on the last page of this section. If you are ordering the  $-20^{\circ}\text{C}$  to  $+50^{\circ}\text{C}$  thermometers from Damon, Macalaster, or American Science and Engineering (A.S.&E.), be sure to specify the plastic backing. Some of their thermometers have metal backings which can not be used for the Activities in Minisequence III. The Macalaster thermometer (No. 2662) has a plastic backing:

Whether you are ordering from a supply house or purchasing items locally, keep in mind that, for convenience, the quantities are for a class of 30 children. If your class is larger or smaller you may want to vary the amount accordingly.

Often in COPES particular items of equipment or materials are used in more than one Activity, or Minisequence, or even grade level. Thus the nonconsumable items, and those consumables which are left over, should be stored for possible later use. To help you, the list contains a column indicating the Minisequence(s) and Activity (or Activities) where each item is used.

ITEMS	AMOUNT	MINISEQUENCE AND ACTIVITY
<u>Batteries and bulbs:</u>		
D batteries (Everready No. 925 or equivalent, not alkaline batteries)	32	IV, 2
Flashlight bulbs No. 14	15	IV, 2
Flashlights, any kind in good working order	15-30	IV, 1.



ITEMS	AMOUNT	MINISEQUENCE AND ACTIVITY
No. 6 "ignitor" cell (dry cell; this is the large (6 1/2 cm diameter by 16 cm) dry cell with two screw terminals on top)	1	IV, 2
Miniature sockets, screw base (A.S.&E. No. 006H002)	15	IV, 2
<u>Candles, Matches:</u>		
Candle 4 cm wide at base, 5 cm high	15-30	III, 4
Safety matches	32 books	III, 4
Paraffin shavings	1/4 cup	III, 1
Match boxes	90	II, 1; II, 2; II, 3; II, 4; II, 5
<u>Chemicals:</u>		
Ammonium alum	1 cup	III, 2
Ammonium chloride (sal ammoniac)	1 cup	III, 2
Copper sulfate (blue, hydrated crystals) (blue vitriol)	45 g	V, 5
Corn Starch (optional)	1 box (1 lb)	I, 3
Detergent, liquid	3 oz	I, 1; I, 2; I, 3
Epsom salts (hydrated magnesium sulfate)	1 cup	III, 2
Mineral oil	1 oz.	III, 1
Rubbing alcohol	17 oz.	III, 1
Salol (phenyl salicylate)	1/4 cup	III, 1
Sodium acetate (hydrated crystals, chemically pure)	1-2 cups	FII, 2; III, 4
Sodium chloride (table salt Kosher-style)	about 2-1/4 cups	III, 1; III, 2; III, 3
Sodium thiosulfate (variety sold in photo supply stores)	about 1 cup	III, 2; III, 3; III, 4
Sugar, granulated	1 oz	I, 1
Tincture of iodine	2 oz	I, 2; I, 3
Yeast, Baker's	60 1/4-dz packages	IV, 3
<u>Containers:</u>		
Cups		
plastic cup, 6-oz to 8-oz (180-ml to 250-ml)	30	I, 1; I, 2; I, 3; III, 2
plastic cup, or waxed paper,	151	I, 2; I, 3; II, 2;

ITEMS	AMOUNT	MINISEQUENCE AND ACTIVITY
1-oz (30-ml)		II, 3; II, 4; II, 5; III, 2; III, 3; IV, 3; V, 3; V, 5
polyfoam, (6-oz to 8-oz) (180-ml to 250-ml)	30-60	III, 1; III, 3; III, 4; IV, 3; V, 2
Bucket, 2-gal. (8 liter)	1	I, 2
Bottle with cork or cap, 1 pt (500-ml)	30	I, 2; I, 3
Wide-mouth container, glass, waxed paper, or plastic (e.g. short olive jars, cottage cheese containers, mugs, plastic bowls, etc.); 8 oz (250-ml)	6	III, 1; III, 2; III, 3; III, 4
Test tubes (100 mm x 25 mm)	30-60	III, 1; III, 3; III, 4
Jar (to hold test tubes)	15-30	III, 1; III, 3; III, 4
Jars, 1 pt (500-ml), trans- parent, preferably similar or identical	8	V-5
Insulated polyfoam containers, 3 qt (3 liter)	4	III, 2; III, 3; III, 4
Thermos, 1/2 pt.	15	IV, 3
<u>Dishes and trays:</u>		
Dishes, shallow to use as germination dishes		IV, 3
Plastic dishes	10	I, 1; I, 2; I, 3
Shallow saucer	1	I, 2
Serving trays	2	I, 3
Cookie sheet	1	III, 1
Dishes 4 in. diameter x 1/2 in. deep	30	V, 4
Plastic ice cube tray with separate molded compart- ments, or molded egg carton	8-10	V, 5
<u>Equipment:</u>		
Magnifying glass (A.S. & E. hand magnifiers, No. 2400 are recommended)	30-60	I, 1; III, 1; III, 3; V, 5
Hot plate	1	III, 1; IV, 3
Mirrors (5 cm x 7 cm or larger, e.g., purse mirrors)	15-30	IV, 1
Glass rod (to be used as a stirrer)	1	V-5

ITEMS	AMOUNT	MINISEQUENCE AND ACTIVITY
Pot, with cover	1	IV, 3
Microprojector (optional)	1	III, 3
*Microscope (40x), if available; otherwise, one for each group of two or three children	30	I, 1; I, 2; I, 3; III, 1; III, 3
Microscope, 450x (optional)	1	IV, 3
Plastic coverslip	30	I, 1; I, 2; I, 3
Medicine dropper	60	I, 1; I, 2; I, 3; III, 1; III, 3; III, 2; III, 3; III, 4; V, 4; V, 5
Wire stripper and cutter (optional)	1	IV-2
Thermometer (-20°C to +50°C)	30-60	III, 1; III, 4; IV, 2; IV, 3; IV, 4
<u>Measurement instruments:</u>		
Rulers, 12-in. (30-cm), wood or plastic	10	IV, 4
Rulers, 12-in. (30-cm), inflexible, mm markings, with groove	30	II, 1; II, 4; II, 3; II, 2
Meter stick or other long measuring device, with mm markings	15	II, 1
Spring scale, 0-500 g	15	II, 3; IV, 4
Platform balance, Ohaus, 1200 (optional)	1	II, 4
Clock with sweep second hand	1	IV, 2
<u>Miscellaneous:</u>		
Bricks	15	IV, 4
Metal lids, 5 cm diameter	10	IV, 4
Wastebasket	1	II, 3
Heavy books	several	II, 3; II, 4
Plastic spoons (standard 1/2 tsp. measuring spoon, or common available plastic spoons sold with ice cream or bought in packages)	supply	III, 2; III, 3; III, 4; V, 4
<u>Paper, Metal and Plastic products:</u>		
Paper towels	about 900	I, 1; I, 2; I, 3; III, 2; III, 3; III, 4; IV, 3; V, 4; V, 5

ITEMS	AMOUNT	MINISEQUENCE AND ACTIVITY
Facial tissues	2 boxes	I,1; I,2; I,3
Pictures from newspaper	30	I,1
Page of classified ads	1	I,1
Newspapers (for catching spills)	several, old	I,2; IV,1; IV,2
Waxed paper	2 rolls	I,2; I,3
Aluminum foil	supply	III,1; III,4; IV,1; IV,2
Paper, white	supply	III,2; III,3; IV,2; V,5
Paper (8-1/2 in. by 11 in.)	15 sheets	IV,1
Paper (2 in. by 2 in.) (optional)	60 pieces	III,4
Construction paper, (white) (15 cm sq)	30 pieces	IV,1
Construction paper (black) (15 cm sq)	30 pieces	IV,1
Gray paper (6 cm by 10 cm)	15 pieces	IV,1
Transparent plastic, about 15 cm square	15 pieces	IV,1
Cardboard (wider than a 1 oz cup, 1/2 as long)	16 pieces	II,2; II,3; II,4; II,5
Graph paper (1 sq/cm)	90 pieces	V,2; V,5
Graph paper (10 sq/in.)	30 pieces	V,4
Graph paper (2 sq/cm)	30 pieces	IV,2; V,3
Graph paper, any size	supply	II,3
Sand paper (optional)	1 piece	II,5
Corrugated cardboard (30 cm by 30 cm)	1 piece	IV,1
Cardboard boxes (uniform stackable), blocks, a book- case, steps, etc., to provide unit increments of weight	45-60	II,3
Brown paper bags	31	V,1
Plastic sandwich bags or plastic wrap	33-34	V,4
Plastic food wrap	1 roll, approx.	IV,3; V,5
Cloth: Towels, or strips of wool or felt cloth (if the floor is not carpeted)	30	II,1
Damp cloth	15-30	III,4
<u>Plants and seeds:</u>		
Elodea plants	3	I,1
Potted Begonia with flowers	1	I,2
Medium size onion bulb	1	I,2
Medium size ripe tomatoes	3	I,2

ITEMS	AMOUNT	MINISEQUENCE AND ACTIVITY
Germinated lettuce seeds Medium size carrots Unripe bananas Radish seeds	30 3 4 4 packs (at least 100 seeds per pack)	I, 2 I, 2 I, 3 V, 4; V, 5
Forget-Me-Nots ( <i>Myosotis</i> )	2 packs (100 seeds per pack)	V, 4
Celosia seeds	1 pack (100 seeds per pack)	V, 4
black-eyed peas, peas, kidney beans, lima beans, corn or radish seeds, or any other seeds which germinate fairly rapidly	supply	IV, 3
<u>Stationery supplies:</u>		
Modeling clay	1 lb. (450 g)	II, 2; II, 4; IV, 1
Black poster paint	2 jars	IV, 1; IV, 2
Staplers	1 or more	IV, 1
Glue	1 or more jars	IV, 1
Tape, transparent	supply	IV, 4
Rubber bands No. 18	25	IV, 4; II, 3
Masking tape	supply	II, 4; IV, 2
Crayons	31	V, 2; V, 5
Thumbtacks	150	V, 3
Camels hair paintbrush	5	I, 1
Smooth tape (e.g., Magic- mending)	supply	II, 2
<u>Tools:</u>		
Garden trowel	1	I, 2
Electric iron	1	IV, 1
Single edge razor blade	1	I, 2
Paring knives	5	I, 2; I, 3; III, 1
Scissors	5-15 pairs	V, 5
Tweezers (optional)	15 pairs	V, 4
<u>Toys:</u>		
Bicycles	5	IV, 4
Roller skates	5 or more	IV, 4

ITEMS	AMOUNT	MINISEQUENCE AND ACTIVITY
Marbles, 1 in.	15	II, 4; II, 5
Marbles 3/4" or 5/8"	30	II, 2; II, 2; II, 3; II, 4; II, 5
Red marbles	78	V, 1
Blue marbles	76	V, 1
Marbles (3rd color), optional Cube or die	30	V, 2
<u>Water:</u>		
Water	supply	III, 1 (hot); V, 4; V, 5
Chipped ice	supply	III, 1; III, 3
<u>Wire:</u>		
Iron hair wire (about 20 cm, No. 30C, available from Woolworth's and other department stores)	1 piece	IV, 2
Copper wire, bare, 10 cm about No. 20, (available at department stores as solid copper utility wire)	30 pieces	IV, 4
Copper or aluminum wire (with bared ends for con- necting leads in circuits, 12 in. (30 cm)	24 pieces	IV, 2
<u>Wood:</u>		
Toothpicks	90	I, 2; I, 3
Wooden splints (or popsicle sticks)	30	III, 1; III, 2; III, 3; III, 4; IV, 3
Block of wood (optional)	1 piece	II, 5
<u>Worksheets:</u>		
Worksheet II-1	30	II, 1; II, 2
Worksheet II-2	15	II, 5
Worksheet III-1	30	III, 2
Worksheet III-2	15	III, 3
Worksheet IV-1	15	IV, 3
Worksheet V-1	30	V, 1
Worksheet V-2	30	V, 2
Worksheet V-3	30	V, 3
Worksheet V-4	15	V, 4
Worksheet V-5	10	V, 5

## THE MICROSCOPE

In the COPES program magnifiers are introduced in Kindergarten and used subsequently whenever it is desirable for children to view enlarged images of the objects they are investigating. It is not until Grade 4 that it becomes necessary for children to use a microscope in order to examine the parts, or structural characteristics of objects when they are not visible with the unaided eye or with a magnifying glass.

There are several different microscopes that are suitable, however, the Bausch and Lomb Elementary School Microscopes have been found to be especially adaptable. Regardless of what kind of microscopes are available for your use, the following background material should be helpful in guiding children's experiences with them.

*What is a microscope?* Basically, a microscope is a device which has one or more lenses which will produce a magnified image of the object to be viewed. In addition, the microscope can be used to control light with which to view an object. As such, you can consider a microscope as two separate systems, a magnifier system and an illuminator system. Each system must be considered in making use of your microscope.

*What is the difference between a simple and a compound microscope?* Microscopes with a single lens are called simple microscopes. They are similar to ordinary magnifying glasses, although the curvature of the lens is greater allowing greater magnification than an ordinary magnifying glass. The image is not inverted in simple microscopes. Compound microscopes have two lenses giving a much greater range of magnification. The image is inverted in compound microscopes. Both simple and compound microscopes can be used effectively in the elementary school. The drawing on page 363 shows the parts of a compound microscope.

*What is the illuminator system?* As shown in the drawing, the light source or illumination system is found below the stage. It may consist of either a reflecting device (mirror) or a built-in light source. Each has its advantages and disadvantages. The simplest illuminator system consists of an adjustable mirror which can collect light from the classroom and reflect it through the specimen and the magnifying lenses (See the illustration on page 363. The mirror system will work well if your classroom is well lighted either by overhead lights or by natural light through large windows. If your room is not well lighted you may have to use flashlights or desk lamps as a source of light for your microscopes. Of course if your microscopes have built-in illuminators, you will not have to worry about other light sources.

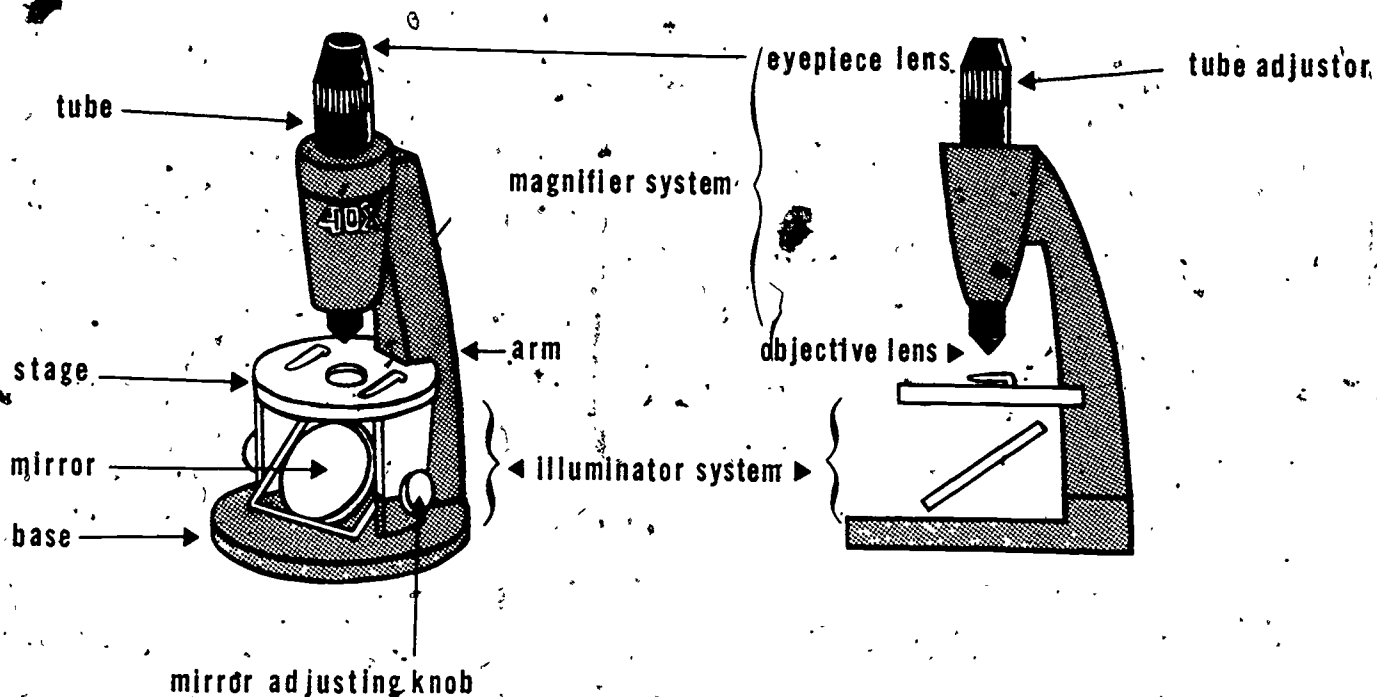

Adequate lighting is a prerequisite to good viewing with a microscope. If it cannot be provided in your room, you should not attempt to use the microscope.

What is the magnifier system? Magnification refers to the apparent size of the object when viewed through the microscope as compared with its actual size. For example if an object 0.1-mm in diameter appeared to be 1-mm in diameter when viewed with a microscope, the microscope would have a magnifying power of 10X (10 times 0.1). Magnification may vary from a few diameters, as in the simple microscopes, to 100 times as in the compound microscope, to many thousands of times in complex scientific instruments.

The magnifier system is located in a tube above the stage. In a compound microscope two lenses make up the magnifier system. One lens is located at the upper end of the tube in the eyepiece, and one is located in the lower end of the tube, in the objective.

What power of magnification is best? The higher the power of magnification, the greater must be the intensity of light in the illuminator system. Furthermore, high magnification requires more skill to focus upon objects and to view them satisfactorily.

Most of the COPEs Activities require no greater magnification than 40X. In a few instances 100X would be desirable. It is therefore recommended that some microscopes of each power



be made available.

*How should microscopes be maintained?* Most elementary school microscopes are relatively sturdy instruments. There is usually only one adjustor mechanism to be used in focusing. In the Bausch and Lomb microscope, it is located in the tube beneath the eyepiece and is operated by rotating. The exposed surface of lenses and the mirror should be clean before using the microscope. When dim or blurred images cannot be resolved by adjusting the light or focusing the microscope you can be sure that some of the optical surfaces are dirty. Dust can be removed by gently wiping with facial tissue. If liquid materials become encrusted upon the surface of the lens, soak the lens carefully with a wet tissue and then gently wipe it dry.

Microscopes should be lifted or carried only by the arm with one hand under the microscope to support the base. See the drawing to locate the arm of the microscope. Show the children how to handle the microscope to avoid accidents and damage to the instrument.

When not in use, microscopes should be stored in their cases or covered with plastic bags to prevent dust and lint from setting on them. Slides should be removed from the stages of all microscopes after they have been used. If the stage or other parts of the frame become soiled they should be wiped clean before the microscopes are stored.

SCIENTIFIC SUPPLY HOUSES

Allied Radio Shack  
100 N. Western Avenue  
Chicago, Illinois 60680  
(batteries, wires and flash-  
light bulbs)

American Science and Engineer-  
ing (A.S. and E.)  
20 Overland Street  
Boston, Massachusetts 02215  
(magnifying glasses and  
thermometers)

Central Scientific Co. (Ceneo)  
2600 South Kostner Avenue  
Chicago, Illinois 60613  
(school science supplies and  
Ohaus equipment)

Damon Educational Division  
80 Wilson Way  
Westwood, Massachusetts 02090  
(-20°C to +50°C thermometers)

Edmund Scientific Co.  
150 Edscorp Building  
Barrington, New Jersey 08007  
(school science supplies)

Fisher Scientific Co.  
52 Fadem Road  
Springfield, New Jersey 07081  
(chemicals, wire, and other  
laboratory supplies)

Learning Resource Center, Inc.  
10655 S.W. Greenburg Road  
Portland, Oregon 97223  
(heating stands and other school  
science equipment) (This company  
was formerly known as QMSI.)

Macalaster Scientific Corp.  
Division of Raytheon Educational  
Company  
Route 111 & Everett Turnpike  
Nashua, New Hampshire 03060  
(-20°C to +50°C thermometers)

Scientific Glass Apparatus Co.  
725 Broad Street  
Bloomfield, New Jersey 07003  
(funnels, filter paper and  
other laboratory supplies)

Science Kit, Inc.  
Tonawanda, New York 14150  
(school science supplies)

Selective Educational Equipment  
3 Bridge Street  
Newton, Massachusetts 92195  
(nichrome wire, medicine  
droppers, and magnifiers)

Sigma Scientific, Inc.  
P.O. Box 1302  
Gainesville, Florida 32601  
(school science supplies)

# Scoring Guide for the Assessments

This Scoring Guide is provided for easy reference in evaluating children's performances on the screening assessments. As noted elsewhere, these assessments are oriented to the mastery of concepts by each child, not to the possible objective of differentiating, or "grading", the children. Each teacher should decide on a quantity index for mastery, based on the time spent on the Activities; the items have been prepared so that 70% agreement with the Scoring Guide would be considered adequate for a mastery criterion. Should the children's overall performance fall below the criteria set by the teacher, the time spent on COPEs, the teacher's preparation, and the children's involvement in science, should be reviewed.

For each Minisequence, selected comments on the preferred and alternative responses are offered, as an aid to class discussion of the screening assessments as a feedback for learning, if desired. In addition, an example of a small-step dialogue is provided for one problem in each Minisequence, for use as an individual assessment-instruction for those children who do not show mastery on the screening assessments. The teacher may develop similar dialogues for other problems as needed.

## MINISEQUENCE I Screening Assessments

### PREFERRED RESPONSE

### COMMENTARY

#### PART 1 (only 1 part)

1. B

1. No comment necessary.

2. A

2. (C) They do have some similarity, such as a kind of wall around them and material inside.

3. (A) There are practically no duplicates in nature, ever, but (B) they are

PREFERRED RESPONSE

COMMENTARY

4. A

5. C

6. B

7. C

8. C

9. C

not usually greatly different, if from the same part.

4. No comment; see problem 6.

5. (A,B) Cells are found in all plants and animals.

6. (A) Molecules and atoms within all cells are smaller.

(C) See problems 3 and 4.

7. (A) No two cells are exactly the same.

(C) They are more "alike" than "different"; see 2. (C).

8. (A,B) Leaves and roots in their usual form are not found in all plants, but cells are.

9. No comment.

Individual Assessment.

An Example of a Small-Step Dialogue based on problem 7.

Key

T: Teacher statement or question.

C: Child's possible response

T: What would you expect to see if you looked at a potato cell?

C: Cell walls and possibly some material inside such as starch.

T: What would tell you there was starch present? (Child may need to be reminded of staining technique.)

C: The iodine stain test, which would color the starch particles in the cell.

T: What would the banana cells look like?

C: Walls and stuff. Starch.

T: How could you tell there were particles of starch in the banana?

C: It was stained; you could see them.

T: Do the starch granules look the same in both cells, except for color?

C: What's a granule?

T: A particle of the starch: they were darker.

C: No, the...granules...weren't the same.

T: Are the cells the same size and shape?

C: No, I guess that's because they're from different plants.

T: Right! Now, how are the cells from banana and potato alike? Remember what you've told me.

C: They both have walls and some material inside.

T: What can you say now about cells and plants?

C: Even different plants have cells, and the cells are alike because they have walls and material inside, but they can be different sizes and shapes and have different things in them.

T: Right you are. Very good.

Minisequence II Screening Assessments

PREFERRED RESPONSE

COMMENTARY

PART 1

1. B
2. C
3. B
4. B
5. C

1. More work is needed to bring Peggy to the top of the higher hill.
2. No motion, thus no kinetic energy.
3. Peggy had more potential energy to be converted.
4. More motion (speed) means more kinetic energy.  
  
(A) There is no increase in potential energy going down--only when a body is being lifted against the force of gravity.
5. Both girls are on the same level; thus both have had the same net work invested in them.

PART 2

1. C
2. B
3. C
4. A
5. A

1. Work = Force x Distance
2.  $500 = \frac{50}{10} \times 10$
3.  $100 \times 3 = 3 \times 100$
4. No distance was involved; thus no work was done by Arnold.
5. Kandy did not move anything through a distance; thus she did no work. (Actually, unless she sat perfectly

PREFERRED RESPONSE

PART 3

1. A

2. B

3. B

4. C

5. B

COMMENTARY

still for the whole time, she did some work, as hand, papers, etc., require small forces to move them.)

1. Bob worked to move himself up the stairs. The elevator did the work for Joe.
2. Potential energy is measured by the amount of work done no matter who or what did the work (required to bring the boy to the third floor. Thus force units are involved. More work is required to lift the heavier boy through the same distance and thus he would have more potential energy.
3. Joe's ball would possess kinetic energy because it would be moving, but Bob's would not be moving and thus would have no kinetic energy.
4. The two balls would be in the same position relative to the earth. Thus they would have equal potential energy.
5. Even though Joe would have been more tired from running, the work done is defined as force X distance, and time is not involved in this calculation.

## Individual Assessment

An Example of a Small-Step Dialogue based on Part 2, Problem 3.

T: What did Dean do?

C: Pushed a table.

T: How much force did it take?

C: It says 100 force units. What's a force unit?

T: It measures a push or pull. To lift an object, we have to pull against the force holding it down. This force is called its weight. We measure it in grams (or pound units). Force must be exerted to push an object. How far did Dean move it?

C: Three distance units--are those like feet?

T: Yes, like feet or meters or centimeters. How is a work unit measured?

C: In force units--100 of them?

T: Would you do more work if you moved a book from your desk to the next one, or carried it across the room?

C: Across the room. Oh, distance matters too!

T: Yes, indeed it does. Now, how much work did Dean do?

C: Force units and distance.... 100 units?.

T: Each force unit operates through each distance unit, so you have to multiply, not add. Dean had to push the table with the same force every foot of the way.

C: OK, 100 times 3 is 300 work units.

T: Good. Now, how about Joe?

C: Less work, only 3 force units.

T: Only 3 force units, but what about the distance? Same distance?

C: No, longer for Joe. Oh, I see. Joe did 3 and 100, that's 300 work units--the same, as Dean!

T: Right on.



MINISEQUENCE III Screening Assessments

PREFERRED RESPONSE

COMMENTARY

PART 1

1. B

1. The process of melting involves the breaking away of the molecules from the binding forces holding the solid in a set form.

(A) At the moment of "melting," solid and liquid are at the same temperature.

(C) There is no source of additional molecules (matter is conserved).

2. C

2. To "melt," the binding forces in the solid must be overcome; the addition of heat energy provides the energy for the molecules to break away.

3. G

3. (A) is the only case experienced by the children so far.

(B) is always the case-- otherwise the solid would not go into a liquid state.

4. A

4. A more rigorous explanation at a higher level could be given but the molecular or "parts" level will suffice for the present.

(B) This reaction is not true for NaCl as they observed.

(C) This description is not true; the molecules of

PREFERRED RESPONSE

COMMENTARY

parts of salt leave from the outside of the crystal--very rapidly. The interaction occurs from the time of contact of salt and water.

5. B

5. (A) the temperature drop will occur with salt at room temperature.
- (C) no apparent loss in water was observed. If some did, it would be too small to cause the observed temperature drop.

6. A

6. (A) Rain would dissolve the salts, leaving "clean" gashes and pits..
- (B) Salt in solid form will not evaporate readily, especially when only exposed to the sun.
- (C) Animals would seek rounded extrusions, in covered areas. Even if they used the outcrop as a salt lick, they would be unable to clean out great gashes and pits with tongue, hoof, and/or claw.

7. C

7. (A) Their experiences showed that only under certain conditions were solutions saturated. (excess solid, etc.)
- (B) No, it depends on the composition of the salt and the ratio of salt to water.
- (C) True for all solutions; the binding forces within the solid salt have

PREFERRED RESPONSE

8. B

9. C

PART 2

1. C

2. B

COMMENTARY

been broken and the molecules are free to move without the restrictions of the solid.

8. This is a saturated solution; since no more salt can be dissolved; no more heat energy is used, and thus no temperature change results.
9. Some of the water molecules at the surface go off into water vapor, at any temperature; this loss may create a supersaturated solution momentarily from which salt soon precipitates, reforming crystals.

1. This procedure is a common way to establish a supersaturated solution.
- (A) In a supersaturated solution, there is no solid precipitate.
- (B) The temperature is too high for ice.
- (C) No change in appearance from saturated to supersaturated solution. Both are all liquid.
2. (A, B) The heat energy lost during the cooling down in the refrigerator is being restored from an outside source and the system is thus restored to its original temperature.

PREFERRED RESPONSE

COMMENTARY

3. C

(C) There are no crystals to go into solution. See 1. (A) above.

3: Adding hypo. to a super-saturated solution of hypo would cause precipitation.

(A) This is incorrect, as there would be a change--precipitation occurs.

(B) This is incorrect as no heat energy is taken from the water; no dissolving is taking place. In fact, it is quite likely that the temperature would increase.

4. C

4. (A) This is an inconsistent explanation; adding heat energy weakens bonds.

(B) There is no mixing of X and Y to equalize the temperatures; given more information, it might be possible to compute the amount of salt to be added which would result in X and Y having equal temperatures, but that is beyond this activity.

(C) This explanation is consistent; precipitation releases heat energy, which would raise the temperature of the solution in Y.

5. A

5: This problem is best discussed in stages. First, after 4., which is the cooler system? It is X. What is the state of Y? It is saturated, as only the excess salt precipitated. Now, if the temperature of

PREFERRED RESPONSE

COMMENTARY

- 6. D
- 7. B
- 8. E
- 9. C

the cooler system, X, is brought to the temperature of Y, then X is definitely unsaturated, but Y is still saturated. Adding salt to X until it is saturated will safely decrease its temperature as more salt dissolves. Adding the same salt to Y will cause no change. It will simply add to the excess solid already in that system.

(A) True, see above discussion.

(B) No change; thus, the temperature of Y could not be the same as that of X, which decreased.

(C) contrary to (A), obviously wrong.

6, 7, 8, 9. These responses are consistent with the diagram used in the Activities. See that discussion for elaborations.

Individual Assessment

Two small-step dialogues are provided for this Minisequence. Dialogue A is intended for those children who have some difficulty with the fundamental ideas in Part 1, problems 1, 2, and 3; Dialogue B is based on Part 2, problem 5.

Dialogue A:

T: Can you tell me what three forms, or states, of matter we know about?

C: Yes.

T: What are they?

C: Solids, liquids, and gases.

T: Give me an example of the same thing in all three states.

C: Well, wood is solid; water is liquid; and air is a gas.

T: Those are good examples, but try to think of three states for the same substance. How about solid water?

C: Oh, I get it. You mean ice.

T: Yes, very good. Now how about water as a gas?

C: Steam? Clouds?

T: Pretty close. Steam and clouds are water droplets, not really gas. But when they disappear, or when it's very muggy after a rain....

C: Yeah, high humidity, like the guy says on the TV.

T: Right; water vapor is really tiny units of water suspended in the air; we can't see them, but we can tell they're there by measuring how much water will evaporate; if not much does, then we say the humidity is high; there's already almost as much water vapor as the air can hold for its temperature. We might say the air is saturated with water vapor. What would happen if you take heat energy away--if it gets cold?

C: Rain? So if you have water vapor, and you take heat energy away, you get liquid water?

T: That's it. And if you take heat energy away from liquid water?

C: You get ice!

T: What do you think now about different states of matter and heat energy?

C: They're really related. Does that go for metals, too?

T: Yes, the relation is the same. When a solid melts, or turns to liquid, then heat energy has been used to do it. Most metals melt at much higher temperatures than ice does, and they turn to vapor at much higher temperatures than water does.

C: What is melting,....really?

T: Now you're asking me to tell you about another idea--molecules.

C: OK, what's a molecule?

T: A molecule is the smallest amount of a specific material there can be, and still tell it from molecules of other materials. They are very very small, but each molecule of the same material is very much like every other molecule of that material.

C: Then how do we get big pieces of things?

T: Mostly molecules are moving when some molecules get close enough together, they seem to attract each other and binding forces hold them together. These binding forces cut down their ability to move about freely. When many molecules get together in a set pattern, we usually call that kind of object a solid. How strong the binding forces are in different materials depends mostly on the kind of molecule it is.

C: You said that solids had strong binding forces between the molecules. What does that have to do with melting?

T: Well, what do you think we have to do to get material from a solid state to a liquid state? Are there binding forces in liquids, too?

C: Yeah, I suppose there are, but they would have to be weaker than the forces in the solid.

T: Why is that?

C: Because the liquid runs around more. The molecules aren't so set in position, but it's still kind of together.

T: You're right. Binding forces in liquids are weaker than in solids of the same material. How could we make them less, or weaken those bonds? What happens to ice, or a candle?

C: You heat it--add heat energy--and solid goes to liquid, so heat energy must work against the binding forces.

T: Beautiful! Now let's look at those three problems you were working on. What do you think is the answer to number 1 now?

C: I think B, because if the binding forces are less in a liquid, the molecules should move more freely.

T: That's it. Molecules move more freely at higher temperatures.

C: Then why isn't A a good answer?

T: When a solid is changing its state, the mix of solid and liquid is all at the same temperature. When everything has changed to liquid, then applying more heat energy will get

you a higher temperature in the liquid. How about number 2?

C: Both A and B are right. You said heat energy lead to solids melting, and we talked about the binding forces getting weaker.

T: Great. Now how about number 3? It's a little different.

C: Salts are solid, right.

T: Yes.

C: So the solid is liquefying. Something is weakening its binding forces.

T: Right. And...?

C: Maybe it's getting heat energy from someplace. Can it get heat energy from water?

T: There's heat energy there. Yes, it can. Some parts of the salt can get heat energy from the water and some parts can link up with parts of the water more strongly than they did with the other parts of the salt.

C: Wild. Then there's less heat energy in the water?

T: Yes.

C: But the same amount of water?

T: Yes.

C: So that's why the temperature decreased when you put the salt on the water??!!

T: YES!

#### Dialogue B:

T: Let's go through number 5, in Part 2. First look at number 4.

C: OK.

T: The right answer for number 4 was alternative C. The liquid in which the temperature increased had been supersaturated, so when a little salt was added, a lot precipitated and that released the extra energy of the dissolved molecules as heat energy.



C: OK, I understand that part.

T: Now, Phil warmed up the cooler system. Which one was that?

C: System X would be cooler, as stated in question 4.

T: OK.. Now what about the saturation in these two systems? Is X saturated with the salt?

C: Probably. He put salt in X in question 4.

T: But, is X saturated with the salt? How can you tell whether a solution is saturated?

C: Whether there is a precipitate, or any solid left over.

T: Was there?

C: Didn't say.

T: Even if X were saturated, would it be after heating?

C: What does temperature have to do with it?

T: Remember when we talked about why the temperature decreased when salt was added?

C: Oh, yes. Something about heat energy being used to free the salt molecules from the binding forces in the solid.

T: Right. So if we add more heat energy?

C: There will be more heat energy available to free more molecules, so more salt will go into solution.

T: Very good. So is X saturated after it's heated?

C: No. Lots of room for more salt.

T: That's the idea. Now, what about System Y?

C: Well, it was saturated in the first place.

T: But didn't a lot of salt precipitate?

C: Yes, but not all of it.

T: Why not all of it?

C: It means that even though some salt precipitated out, what stayed in solution was enough to make it saturated.

T: Very good. So now X is unsaturated, and Y is saturated, and

both are at the same temperature. Now what happens?

C: Phil adds enough salt to saturate X.

T: How would he know when to stop?

C: The salt would begin to go to the bottom of the container without dissolving.

T: And what would happen to the temperature?

C: It would decrease because the heat energy was needed to free the salt he added so it would dissolve.

T: Meanwhile, what's happening with System Y?

C: Nothing

T: Nothing? But a lot more salt was added...?

C: OK. But the system was already saturated, so adding more salt would just mean it would fall to the bottom without dissolving and collect in the bottom with the rest.

T: So which alternative for problem 5 would you pick?

C: I'd pick A. The temperature decreased. But no temperature change happened in System Y, so the two temperatures couldn't be the same. They were before, but X decreased and Y didn't.

T: Right you are. Now we can go on.

MINISEQUENCE IV Screening Assessments

PREFERRED RESPONSE

COMMENTARY

PART 1

1. B

1. (A,B) If the conversion from potential energy to kinetic energy were perfect, no heat energy would be produced. The less the heat energy produced, the more complete is the conversion into kinetic energy.

2. C

2. (A) No chemical change occurs.

(B,C) As the ball is moving up, it possesses kinetic energy. Some of the elastic energy is converted to heat energy as the ball rebounds from the ground.

3. A

3. (A) Friction produces heat energy.

(B) We should be concerned with the amount of heat energy expected in a system from any source, as well as friction, e.g., crystallization in Minisequence III.

(C) These qualities are somewhat related to friction. For example, lubricants reduce the rubbing action of friction in the process of smoothing the energy conversion, but do not completely eliminate it. Hence choice (A) is best.

## PREFERRED RESPONSE

4. B

5. C

6. A

7. C

## COMMENTARY

4. The battery is an electrochemical source of energy, which, when connected to the car, results in moving the car. Thus, the car now possesses kinetic energy. (As the car moves on a surface, of course, some heat energy is also produced).

5. At the top of the incline, the stationary car possesses potential energy due to its position—called gravitational potential energy since it was lifted there against gravity. As the car runs down the incline, the potential energy it had acquired by Dean's doing the work to place it at the top is converted to the kinetic energy of the movement.

6. The rubbing action between the wheels and the surface on which the car is rolling (called friction) results in the production of heat energy. Thus, some of the kinetic energy is converted to heat energy. This heat energy has nothing to do with the position of the car, and thus is unrelated to its potential energy.

7. (A) Exercise means movement, thus kinetic energy is associated with it. The energy stored in food is chemical energy which is converted through the motion into kinetic energy.

(B) Vigorous exercise produces heat energy, as experience tells us.

PREFERRED RESPONSE

COMMENTARY

8. A

8. (A) The heat energy produced is useful in raising the temperature within the closet, thus reducing the humidity. This will reduce any tendency for mold to grow.

(B) If one simply wished to find things, he could turn on the light each time.

(C) No motion is involved, except perhaps a slight and inconsequential amount of air due to convection.

PART 2

1. Box A: 1

1. (A) The snow melts because radiant energy is absorbed by the snow and is converted into heat energy; as it runs off into lakes, the motion produces some kinetic energy, so Statement 5 is also possible. As the snow absorbs this added heat energy and melts, some may consider the increased energy of the liquid as chemical energy (choice 7). However, the ideas developed refer to the added energy of the liquid, thus Statement 1 is considered primary.

PREFERRED RESPONSE

Box B: 3

Box C: 2

Box D: 6

Box E: 7

2. Description 1: Conversion C

Des. 2: Conv. D

COMMENTARY

(B) The motion of the turbine - kinetic energy - ends up as electrical energy--as the statement says.

(C) While in the lake, water has potential energy due to the position of the lake with respect to the lower ground where the water spills; the moving water has kinetic energy. Thus, the conversion is from potential energy to kinetic energy.

(D) Electrical energy produces light, which is radiant energy; also, a substantial amount of heat energy is produced, as the experience of touching a light bulb will confirm; there is no statement dealing with the conversion of electrical to heat energy; thus (6) is the best choice.

(E) Through photosynthesis, plants use (convert) radiant energy to chemical sources of energy, as they grow and produce such things as carbohydrates.

There are no events for conversions 4 and 5.

2.1:C The radiant (light) energy is absorbed by the wall completely, thereby warming it.

2.D The motion of the hands is converted to heat as they are rubbed together.

PREFERRED RESPONSE

COMMENTARY

Description 3: Conversion A

3:A

The chemical energy of the battery is converted into light, or radiant energy of the glowing bulb. (Note that heat energy is also produced.)

Des. 4: Conv. E

4:E

Added heat energy increases the energy of molecules of water which boil and form steam. As the steam forms, the increase in pressure then moves the piston or turbine of the engine; the moving parts possess kinetic energy.

Des. 5: Conv. B

5:B

The rock has (gravitational) potential energy by virtue of its position. As it "drops," it comes closer to the ground so its potential energy is less; however, the dropping rock, in motion, has kinetic energy.

Individual Assessment

For these children who do not meet the teacher's standards of performance on the Screening Assessments, we suggest a review of the definitions of the different forms of energy, as presented in the Activities, and individual discussions of the Screening Assessment items, with some elaboration of the discussion given in the Scoring Guide for the preferred and alternative responses. No small-step dialogue example is offered for this Minisequence.

MINISEQUENCE V Screening Assessments

PREFERRED RESPONSE

COMMENTARY.

PART 1

SITUATION A:

1. C

1. (A) No reason for this inference.
- (B) An example of the "gambler's fallacy." Just because D is down in the drawing is no reason not to expect it on the next drop.
- (C) Any of the four faces is equally likely, hence one cannot predict.

2. C

2. (A) Strictly speaking, this alternative is true only if the tetrahedron is unbiased--that is, not influenced to land in a particular way. By analogy with the cube, this is a reasonable assumption.
- (B) This statement represents the theme of Activity 2.

3. B

3. (A) This outcome has a probability of  $(1/4) \times (1/4) = (1/16)$ , because a single face is specified on each drop, and the probability of getting a particular face on a single drop is  $1/4$ .
- (B) Each of the two outcomes, (B,D) and (D,B) has a probability of  $(1/16)$  but either is acceptable in the wording.



PREFERRED RESPONSE

4. C  
 Most likely sum = 5  
 Its probability =  $4/16$ .

SITUATION B:

1. A

COMMENTARY

of the alternative.  
 Thus the probability of  
 either (B,D) or (D,B)  
 is  $2(1/16) = (1/8)$

- (C). This outcome also has a  
 probability of  $(1/16)$ ,  
 for the same reason as  
 in (A).

4. See Filled-In Table below.

Face	1	2	3	4
1	2	3	4	5
2	3	4	5	6
3	4	5	6	7
4	5	6	7	8

There are four 5's in the table  
 of 16 sums above.

1. (A) This is the simplest  
 inference that one can  
 make and is probably  
 correct. It is possible  
 that there are marbles  
 of other colors still  
 in the bag undrawn after  
 14 draws, but it is not  
 very likely.

- (B) This response may dis-  
 tract those who believe  
 that the number of  
 categories (here three  
 different colors) always  
 determines how frequent-  
 ly it should appear in  
 a tally. Rather, it is  
 the percentage of each  
 color that determines  
 its frequency in any  
 given sampling.

PREFERRED RESPONSE

COMMENTARY

2. A

SITUATION C:

1. C

(C) There are at least 3 marbles since three colors appeared on the draws. However, there could easily be more than three and still give the same result on 14 draws.

2. (A) The frequency 5 for the blue marbles is approximately  $\frac{1}{3}$  of the total of 14 draws. It follows that  $\frac{1}{3}$  of the marbles should be blue, and  $\frac{1}{3}$  of 6 is 2.

(B) The children should see that drawing the same marble more than once is also a possibility; this alternative is consistent with the statement in 1 (B) above.

(C) From (A), there is enough information. In this type of experiment, one will never know for sure what the population consists of until one looks inside (if that is possible).

1. (A) The result is possible, as would be any result in which the four frequencies added up to 60; however, it is unlikely, if one assumes the spinner is unbiased.

(B) The results are statistically, as well as intuitively, more extreme than most would consider "chance."

PREFERRED RESPONSE

2. C

3. B

PART 2

SITUATION D:

1. B

COMMENTARY

(C) The spinner is clearly biased. It is not necessarily Nancy or Joe's doing, but may have been a fault in the manufacture.

2. (A) The probability of this outcome is the product of the separate probabilities:  $(5/60) \times (30/60) = (150/3600)$ .

(B) The probability here is  $(15/60) \times (15/60) = (225/3600)$

(C) The probability here is  $(450/3600)$  Since the total of 60 spins is the same for each probability calculation, some children may intuitively realize that the pair B, C is most likely because B and C both had the greatest frequencies.

3. (A) This outcome indicates as unbalanced spinner, such as was initially described in this situation.

(B) This outcome would be expected.

1. (A) This interval is the range, and is not precise enough.

(B) The most frequent height falls in the 46-48 interval, so "about 47" is

PREFERRED RESPONSE

COMMENTARY

2. C

the best choice.

(C) This height is near the average, but is not most frequent.

3. A

1. (A) There probably are some errors of measurement, as they are generally unavoidable. But many errors of measurement would be unlikely, and the result would not be bimodal.

(B) The fact that there are two peaks in the histogram discounts the possibility of the children being from the same population.

(C) If two populations are involved, see (B), then age is a reasonable explanation, as it is highly correlated with height in children.

3. (A) If age is known to be nearly the same, it cannot be used to explain the observed differences. (A) is a good possibility, however, because sex is also correlated with height in fifth-grade children. Checking the number of cases above the "saddle" in the higher height interval, the frequencies, from the right, add up as  $5+10+15+10$ , or about 40 in the "hump."

(B) Variation this marked is rarely due to sampling alone; there will be sampling errors in both girls and boys if they

PREFERRED RESPONSE

4. B

SITUATION E:

1. C

COMMENTARY

are considered representative of all fifth-grade children.

- (C) Uniform age does not necessarily imply an even distribution of height.
4. (A) As in problem 3, (C), one kind of homogeneity does not imply other kinds; from the data shown, there are clearly more children who won about 47 games than won, say, 52 games.
- (B) Training is a good explanation for different levels of performance. The right hand "hump" accounts for 40, more or less, which is about half of the total group of 100 children.
- (C) Obviously, success in playing checkers cannot be due to chance alone. Some skill must also be involved.
1. (A) This procedure will result in only one interval or mark on the scale. Even if 4 more equally spaced marks were made, it would be doubtful, because a rubber band does not stretch uniformly.
- (B) This procedure is more valid, but is not as useful as (C).
- (C) This procedure provides

PREFERRED RESPONSE

COMMENTARY

2. B

for both different marks  
for different weights  
and for averages at  
each position; averages  
are more useful as pre-  
dictors than single  
measurements.

1. (A) None of the methods  
necessarily stretch the  
band to its limit.

(B) As stated in (C) of pro-  
blem 1, this procedure  
allows for error of  
measurement and for de-  
creasing its effect by  
averaging the repeated  
measurements.

(C) The preferred response  
in problem 1 (C), is  
actually the hardest to  
do, but presumably the  
investment in time would  
be worth it.

3. C

3. (C) is preferred because the  
average positions are  
clearly separated, and  
the errors of measure-  
ment are relatively  
small.

Individual Assessment

No small-step dialogue example is offered for this Minisequence, because of the examples for previous Minisequence and the very detailed discussions in the commentary for the Screening Assessments above.

**Worksheet and Assessment Pages  
for  
Duplication**

1. RAMP POSITION	2. RELATIVE SPEED OF MARBLE	3. DISTANCE (mm)			4.	5.
		TRIAL 1	TRIAL 2	TRIAL 3		





SALT	TEMPERATURE OF THE SALT-WATER SYSTEM		CHANGE IN TEMPERATURE WITH TIME	OBSERVATIONS
	Start	Finish		
1				
2				✓
3				
4				

Before Heating

TEMP. \_\_\_\_\_ °C    TEMP. \_\_\_\_\_ °C

After Heating

TEMP. \_\_\_\_\_ °C    TEMP. \_\_\_\_\_ °C

Salt  
1

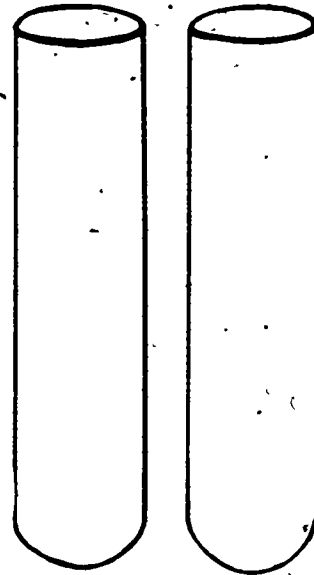
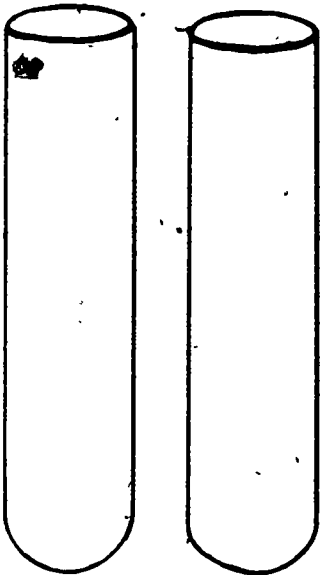

CONTROL

CONTROL

Before Heating

TEMP. \_\_\_\_\_ °C    TEMP. \_\_\_\_\_ °C

After Heating

TEMP. \_\_\_\_\_ °C    TEMP. \_\_\_\_\_ °C

Salt  
2

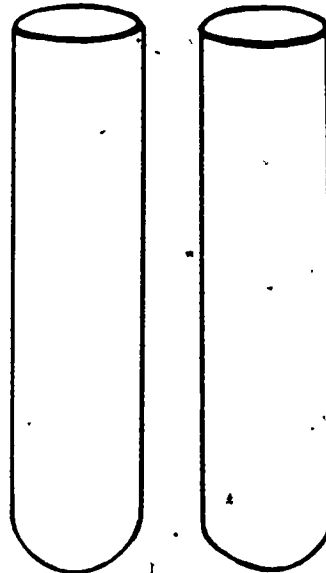
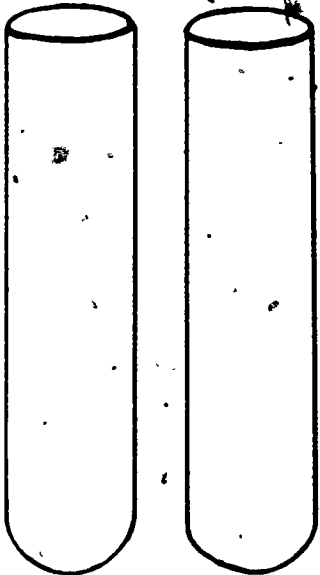

CONTROL

CONTROL

TIME (MIN)	TEMPERATURE (°C)	OBSERVATIONS
0		
5		
10		
15		
20		
25		
30		

Total change in temperature: \_\_\_\_\_

Sampling Colored Marbles.

DRAW	SAMPLE 1		SAMPLE 2		SAMPLE 3	
	RED	BLUE	RED	BLUE	RED	BLUE
1						
2						
3						
4						
5						
6						
7						
8						
9						
10						

TOTALS \_\_\_\_\_

Tally for Totals

MARBLE	DRAWS
RED	_____
BLUE	_____

Analysis of Data

- Variation in count of red marbles: The range found in the three samples was from \_\_\_\_\_ to \_\_\_\_\_ red marbles.
- Combination of the totals of three samples:

	RED	BLUE
SAMPLE 1	_____	_____
SAMPLE 2	_____	_____
SAMPLE 3	_____	_____
Combination	_____	_____
Average of the 3 (Combination/3)	_____	_____

- The best inference: The number of red marbles in the group of 5 in the bag is inferred to be \_\_\_\_\_.
- The actual number of red marbles in the bag is \_\_\_\_\_.

Name: \_\_\_\_\_

	FACE					
THROW	1	2	3	4	5	6
1						
2						
3						
4						
5						
6						
7						
8						
9						
10						
11						
12						
13						
14						
15						
16						
17						
18						
TOTALS:						

Tally Record

FACE	THROWS	TOTALS
1		
2		
3		
4		
5		
6		

Team Member A:

Team Member B:

Data for Member A:

TRIAL NUMBER	NUMBER OF POINTS UP	NUMBER OF SIDES
1		
2		
3		
4		
5		

TOTAL:

Data for Member B:

TRIAL NUMBER	NUMBER OF POINTS UP	NUMBER OF SIDES
1		
2		
3		
4		
5		

TOTAL:

RANGE FOR A IS \_\_\_\_\_ TO \_\_\_\_\_

AVERAGE FOR A \_\_\_\_\_

RANGE FOR B IS \_\_\_\_\_ TO \_\_\_\_\_

AVERAGE FOR B \_\_\_\_\_

RANGE FOR TEAM IS \_\_\_\_\_ TO \_\_\_\_\_

AVERAGE FOR TEAM \_\_\_\_\_







1. IF YOU EXAMINE A THIN SLICE OF AN APPLE AND THE LEAF OF AN APPLE TREE UNDER A MICROSCOPE, YOU WOULD FIND THAT THEY ARE BOTH MADE UP OF.
  - A. STARCH.
  - B. CELLS.
  - C. GREEN PARTICLES.
  
2. WHEN YOU STUDY THE CELLS FROM TWO DIFFERENT PARTS OF A PLANT, YOU WILL PROBABLY FIND THAT THE CELLS
  - A. DIFFER IN SIZE AND SHAPE.
  - B. HAVE THE SAME SIZE AND SHAPE.
  - C. ARE NOT AT ALL ALIKE.
  
3. CELLS WITHIN THE SAME PART OF A LEAF
  - A. ALWAYS LOOK EXACTLY THE SAME.
  - B. HAVE MANY DIFFERENT SIZES AND SHAPES.
  - C. USUALLY LOOK A LITTLE DIFFERENT FROM EACH OTHER.
  
4. CELLS ARE
  - A. LARGER THAN MOLECULES.
  - B. SMALLER THAN MOLECULES.
  - C. THE SAME SIZE AS MOLECULES.
  
5. CELLS CAN BE FOUND
  - A. ONLY AS PARTS OF PLANTS.
  - B. ONLY AS PARTS OF ANIMALS.
  - C. AS PARTS OF BOTH PLANTS AND ANIMALS.

6. THE CELLS IN A LEAF

- A. ARE THE SMALLEST PARTICLES IN THE PLANT.
- B. MAY HAVE SMALLER PARTICLES WITHIN THEM.
- C. HAVE THE SAME SIZE AND SHAPE.

7. IF YOU LOOKED AT POTATO AND BANANA CELLS UNDER A MICROSCOPE, YOU WOULD FIND THAT

- A. THEY ARE EXACTLY THE SAME BECAUSE BOTH CONTAIN STARCH.
- B. THEY LOOK VERY DIFFERENT BECAUSE THEY COME FROM QUITE DIFFERENT PLANTS.
- C. THEY ARE ALIKE IN HAVING WALLS SEPARATING THEM AND MATERIAL INSIDE THEM.

8. PHILIP FOUND A LONG, VERY THIN THREADLIKE PIECE OF GREEN MATERIAL IN A SAMPLE OF WATER HE HAD TAKEN FROM A POND. SINCE IT WAS GREEN HE THOUGHT THAT IT MIGHT BE SOME KIND OF A PLANT. HIS FRIENDS SUGGESTED THE FOLLOWING AS THINGS HE MIGHT DO TO FIND OUT FOR SURE. WHICH ONE DO YOU CONSIDER TO BE THE BEST SUGGESTION?

- A. USE A MICROSCOPE TO FIND OUT IF IT HAS LEAVES THAT CAN BE USED TO MANUFACTURE THE FOOD IT NEEDS.
- B. USE A MICROSCOPE TO FIND OUT IF IT HAS ROOTS THAT CAN BE USED TO TAKE IN THE WATER IT NEEDS.
- C. USE A MICROSCOPE TO FIND OUT IF IT IS MADE UP OF CELLS CLEARLY SEPARATED BY CELL WALLS.

9. IN AN ANIMAL, CELLS ARE

- A. MANY DIFFERENT SHAPES AND SIZES.
- B. ALIKE IN THAT THEY HAVE A WALL AND MATERIAL INSIDE.
- C. BOTH A AND B ARE TRUE.

THE PICTURE SHOWS TWO SKIERS AT THE BOTTOM OF TWO HILLS. BOTH SKIERS WEIGH THE SAME AMOUNT. BOTH HILLS HAVE THE SAME KIND OF SURFACE. BOTH SKIERS ARE EQUALLY GOOD.

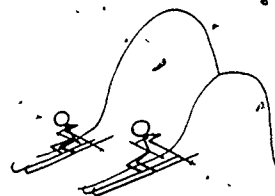

Peggy Jane

1. WHICH GIRL WILL HAVE MORE POTENTIAL ENERGY AT THE TOP OF HER HILL?
  - A. JANE.
  - B. PEGGY.
  - C. VERY CLOSE TO THE SAME.
  
2. WHO WILL HAVE MORE KINETIC ENERGY AS THEY PAUSE JUST BEFORE THEY START DOWN?
  - A. JANE.
  - B. PEGGY.
  - C. THE SAME.
  
3. AS EACH REACHES THE BOTTOM OF HER HILL, WHO WILL BE GOING FASTER?
  - A. JANE.
  - B. PEGGY.
  - C. VERY CLOSE TO THE SAME.
  
4. WHICH GIRL WAS GOING FASTER AT THE BOTTOM OF HER HILL?
  - A. THE ONE WHO INCREASED HER POTENTIAL ENERGY MORE GOING DOWN.
  - B. THE ONE WHO HAD THE MORE KINETIC ENERGY AT THE BOTTOM.
  - C. BOTH STATEMENTS A AND B ARE TRUE.
  
5. IN THE LOBBY OF THE SKI LODGE, WHO HAD THE MORE POTENTIAL ENERGY?
  - A. JANE.
  - B. PEGGY.
  - C. VERY CLOSE TO THE SAME.

1. MORRIS LIFTED A BOX WHICH WEIGHED 100 FORCE UNITS THROUGH A VERTICAL DISTANCE OF 5 UNITS. HOW MANY UNITS OF WORK DID HE DO?

- A. 5 UNITS.
- B. 100 UNITS.
- C. 500 UNITS.

2. DARRELL SAID HE DID AS MUCH WORK AS MORRIS BUT HE LIFTED HIS BOX 10 VERTICAL DISTANCE UNITS. HOW MUCH DID DARRELL'S BOX WEIGH?

- A. 5 FORCE UNITS.
- B. 50 FORCE UNITS.
- C. 100 FORCE UNITS.

3. DEAN USED 100 FORCE UNITS TO PUSH A TABLE OVER A DISTANCE OF 3 DISTANCE UNITS. JOE USED 3 FORCE UNITS TO PUSH A DIFFERENT TABLE ON THE SAME FLOOR 100 DISTANCE UNITS. WHO DID MORE WORK?

- A. DEAN.
- B. JOE.
- C. THEY DID THE SAME AMOUNT OF WORK.

4. PHIL USED 1 FORCE UNIT TO MOVE A PIECE OF PAPER 1 DISTANCE UNIT. ARNOLD EXERTED 500 FORCE UNITS ON THE WALL OF HIS HOUSE BUT IT DIDN'T MOVE. WHO DID MORE WORK?

- A. PHIL.
- B. ARNOLD.
- C. THEY DID THE SAME AMOUNT OF WORK.

5. KANDY SAID SHE WORKED VERY HARD ALL DAY. KANDY WEIGHS 25 FORCE UNITS AND SHE SAT IN A CHAIR FOR 3 HOURS. HOW MUCH WORK DID KANDY DO?

- A. NO WORK.
- B. 25 WORK UNITS.
- C. 75 WORK UNITS.

1. TWO BOYS LIVE IN AN APARTMENT BUILDING ON THE THIRD FLOOR. ONE AFTERNOON, BOB CLIMBED THE STAIRS AND JOE TOOK THE ELEVATOR. WHO DID MORE WORK?

- A. BOB.
- B. JOE.
- C. THEY DID THE SAME AMOUNT OF WORK.

2. IN QUESTION 1, WHICH BOY HAD MORE POTENTIAL ENERGY ON THE THIRD FLOOR?

- A. JOE.
- B. BOB.
- C. IT DEPENDS ON WHO IS HEAVIER.

3. BOB CARRIED HIS BALL DOWN STAIRS TO PLAY ON THE SIDEWALK. JOE DROPPED HIS BALL, WHICH WAS THE SAME KIND AS BOB'S, FROM THE THIRD FLOOR WINDOW TO WHERE BOB WAS STANDING. AT THE MOMENT BEFORE JOE'S BALL HIT THE SIDEWALK, WHOSE BALL HAD MORE KINETIC ENERGY?

- A. BOB'S.
- B. JOE'S.
- C. BOTH BALLS HAD THE SAME KINETIC ENERGY.

4. IN QUESTION 3, AT THE MOMENT WHEN BOB'S BALL WAS ON THE SIDEWALK AND JOE'S BALL HIT THE SIDEWALK, WHICH BALL HAD MORE POTENTIAL ENERGY?

- A. BOB'S.
- B. JOE'S.
- C. BOTH BALLS HAD THE SAME POTENTIAL ENERGY.

5. NEXT MORNING, JOE RAN UP THE STAIRS. IF HE HAD WALKED UP, HE WOULD HAVE DONE:

- A. MORE WORK.
- B. THE SAME AMOUNT OF WORK.
- C. LESS WORK.

1. WHEN A SOLID CHANGES TO A LIQUID,
  - A. THE TEMPERATURE OF THE SUBSTANCE ALWAYS INCREASES.
  - B. THE MOLECULES OF THE SUBSTANCE MOVE MORE FREELY.
  - C. THE NUMBER OF MOLECULES INCREASES.
  
2. MELTING ALWAYS INVOLVES:
  - A. THE ADDITION OF HEAT ENERGY TO THE SYSTEM.
  - B. THE OVERCOMING OF SOME BINDING FORCES IN THE SOLID.
  - C. BOTH STATEMENTS A AND B ARE TRUE.
  
3. MANY SALTS GOING INTO SOLUTION INVOLVE:
  - A. THE ABSORPTION OF HEAT ENERGY FROM THE WATER.
  - B. THE OVERCOMING OF SOME BINDING FORCES IN THE SOLID.
  - C. BOTH STATEMENTS A AND B ARE TRUE.
  
4. WHEN SODIUM CHLORIDE (TABLE SALT) GOES INTO SOLUTION,
  - A. THERE IS AN ATTRACTION BETWEEN THE SALT MOLECULES AND WATER MOLECULES.
  - ~~B. HEAT ENERGY IS GIVEN OFF.~~
  - C. HEAT ENERGY IN THE WATER MAKES THE SALT CRYSTAL SWELL AND BURST.
  
5. MORRIS ADDED A SALT TO WATER. THE TEMPERATURE OF THE LIQUID DECREASED. THE MOST LIKELY REASON FOR THIS OBSERVATION IS THAT:
  - A. THE SALT WAS VERY COLD AND COOLED THE WATER WHEN IT MELTED.
  - B. HEAT ENERGY WAS USED IN BREAKING APART THE MOLECULES OF SALT IN THE SOLID.
  - C. THE SALT CAUSED SOME WATER TO EVAPORATE, THUS COOLING THE SYSTEM.

6. SOMETIMES WE SEE ROCK OUTCROPPINGS WITH GREAT GASHES AND PITS IN THEM. IT IS MOST LIKELY THAT:

- A. LAYERS OF SOLUBLE SALTS WERE THERE WHEN THE ROCK WAS FIRST EXPOSED.
- B. EXPOSURE TO THE SUN EVAPORATED THE SALT.
- C. ANIMALS HAD USED UP ALL THE SALT AS A "SALT LICK".

7. WHEN DIFFERENT SALTS GO INTO SOLUTION IN WATER,

- A. ALL THE SOLUTIONS ARE SATURATED ONES.
- B. TEMPERATURE DECREASES ARE THE SAME FOR ALL SALTS.
- C. THE PARTICLES OF THE SALT MOVE MORE FREELY.

8. JANICE DISSOLVED SOME SALT IN WATER. THE TEMPERATURE DECREASES AS THE SALT GOES INTO SOLUTION, BUT SOME UNDISSOLVED SALT REMAINS IN THE CONTAINER. WHEN MORE OF THE SAME SALT IS ADDED, THE TEMPERATURE OF THE SYSTEM:

- A. CONTINUES TO DECREASE.
- B. STAYS THE SAME.
- C. INCREASES.

9. WHEN A SALT SOLUTION IS LEFT OPEN TO AIR,

- A. WATER MOLECULES TAKE UP HEAT ENERGY AND GO INTO A GAS.
- B. SALT MOLECULES RE-FORM INTO SOLID CRYSTALS AS THEY GIVE UP HEAT ENERGY.
- C. BOTH A AND B ARE TRUE.



QUESTIONS 1, 2, AND 3 HAVE TO DO WITH DARRELL'S EXPERIMENT. DARRELL COMPLETELY DISSOLVED A SAMPLE OF HYPO CRYSTALS IN WATER AT ROOM TEMPERATURE AND THEN STORED IT IN A REFRIGERATOR.

1. THE TEMPERATURE OF THE SOLUTION WHEN HE REMOVED IT WAS  $5^{\circ}\text{C}$ . WHICH OF THE FOLLOWING WOULD HE MOST LIKELY OBSERVE?

- A. A LOT OF HYPO CRYSTALS IN THE CONTAINER.
- B. ICE IN THE CONTAINER.
- C. NO CHANGE IN THE CONTENTS OF THE CONTAINER.

2. IF DARRELL WARMED THE SOLUTION UP TO ROOM TEMPERATURE AGAIN, THE FOLLOWING WOULD MOST LIKELY HAPPEN:

- A. THE HEAT ENERGY IN THE SYSTEM WOULD BECOME GREATER THAN BEFORE HE STORED IT IN THE REFRIGERATOR.
- B. THE HEAT ENERGY OF THE SYSTEM WOULD BECOME THE SAME AS BEFORE HE STORED IT IN THE REFRIGERATOR.
- C. MORE HYPO CRYSTALS WOULD GO INTO SOLUTION AS HE WARMED IT.

3. IF HE HAD ADDED A LITTLE MORE HYPO BEFORE HE WARMED THE ABOVE SOLUTION, THE MOST LIKELY RESULT WOULD HAVE BEEN:

- A. NO CHANGE IN THE SOLUTION.
- B. FURTHER DECREASE IN TEMPERATURE OF THE SOLUTION.
- C. HYPO PRECIPITATING FROM THE SOLUTION.

QUESTIONS 4 AND 5 HAVE TO DO WITH THIS SITUATION: PHIL HAS TWO CONTAINERS WITH THE SAME AMOUNT OF CLEAR LIQUID IN EACH. CONTAINER X HAS WATER IN IT, BUT HE DOES NOT KNOW WHAT IS IN CONTAINER Y:

4. HE DROPS THE SAME AMOUNT OF A SALT INTO EACH CONTAINER. THE TEMPERATURE IN CONTAINER X GOES DOWN. BUT THE TEMPERATURE IN CONTAINER Y GOES UP. WHICH OF THE FOLLOWING MOST LIKELY DESCRIBES WHAT HAPPENED?

- A. HEAT ENERGY WAS ABSORBED BY THE SALT GOING INTO SOLUTION IN CONTAINER X, THUS STRENGTHENING ITS MOLECULAR BONDS.
- B. THE TEMPERATURE IN X AND IN Y EQUALIZED SINCE THEY WERE DIFFERENT TO START WITH.
- C. THE LIQUID IN Y WAS SUPERSATURATED WITH THAT SALT AND IT PRECIPITATED.

5. AFTER OBSERVING THE ABOVE, PHIL MADE SURE THAT THE SOLUTIONS IN X AND Y WERE AT THE SAME TEMPERATURE BY WARMING UP THE COOLER SYSTEM. HE THEN ADDED MORE OF THE SAME SALT TO X UNTIL IT WAS SATURATED, AND ADDED THAT SAME AMOUNT OF THE SALT TO Y. WHICH OF THE FOLLOWING WOULD HE MOST LIKELY OBSERVE?

- A. THE TEMPERATURE OF THE SOLUTION IN X WOULD DECREASE.
- B. THE TEMPERATURES IN X AND Y WOULD REMAIN THE SAME.
- C. THE TEMPERATURE IN SOLUTION X WOULD INCREASE.

ALL SOLUTION (HIGH TEMPERATURE)

HEAT ENERGY GIVEN OFF

7.

SUPERSATURATED SOLUTION

8.

9.

EXCESS SALT + 6.

EXCESS SALT + SATURATED SOLUTION

HEAT ENERGY ABSORBED

SALT + WATER

- A. EXCESS SALT
- B. HEAT ENERGY ABSORBED
- C. HEAT ENERGY GIVEN OFF
- D. SATURATED SOLUTION
- E. SEED CRYSTAL ADDED
- F. SUPERSATURATED SOLUTION

1. IF YOU WANTED TO CONVERT POTENTIAL ENERGY INTO AS MUCH KINETIC ENERGY AS POSSIBLE, YOU WOULD:

- A. TRY TO INCREASE THE AMOUNT OF HEAT ENERGY PRODUCED.
- B. TRY TO DECREASE THE AMOUNT OF HEAT ENERGY PRODUCED.
- C. NOT BE CONCERNED WITH HEAT ENERGY.

2. WHEN A BALL BOUNCES UP FROM THE GROUND, THE ELASTIC POTENTIAL ENERGY OF THE BALL IS CONVERTED INTO:

- A. CHEMICAL ENERGY AND HEAT.
- B. KINETIC ENERGY.
- C. KINETIC ENERGY AND HEAT.

3. IF THERE WERE NO FRICTION, WE COULD CONVERT ONE FORM OF MECHANICAL ENERGY TO ANOTHER.

- A. WITHOUT ANY HEAT ENERGY BEING PRODUCED.
- B. COMPLETELY, WITH ONLY A SMALL AMOUNT OF HEAT ENERGY PRODUCED.
- C. MUCH MORE SMOOTHLY AND RAPIDLY.

4. DEAN HAS A BATTERY-OPERATED TOY CAR. WHEN HE RUNS IT, WHAT IS HAPPENING?

- A. KINETIC ENERGY IS BEING TRANSFORMED TO ELECTRO-CHEMICAL ENERGY.
- B. ELECTRO-CHEMICAL ENERGY IS BEING TRANSFORMED TO KINETIC ENERGY.
- C. ELASTIC POTENTIAL ENERGY IS BEING TRANSFORMED INTO KINETIC ENERGY.

5. DEAN REMOVES THE BATTERY FROM THE CAR AND PLACES THE CAR ON A PLATFORM AT THE TOP OF AN INCLINE, ALLOWING IT TO RUN DOWN. WHAT HAPPENS?

- A. ELECTRO-CHEMICAL POTENTIAL ENERGY IS CONVERTED TO KINETIC ENERGY.
- B. KINETIC ENERGY IS CONVERTED TO GRAVITATIONAL POTENTIAL ENERGY.
- C. GRAVITATIONAL POTENTIAL ENERGY IS CONVERTED TO KINETIC ENERGY.

6. WHILE THE CAR IS MOVING DOWN THE INCLINE WITHOUT THE BATTERIES, SOME HEAT IS PRODUCED. THE REASON THIS HAPPENS IS THAT:

- A. SOME KINETIC ENERGY IS CONVERTED TO HEAT ENERGY.
- B. SOME HEAT ENERGY IS ABSORBED AS POTENTIAL ENERGY.
- C. SOME POTENTIAL ENERGY IS CONVERTED DIRECTLY TO HEAT ENERGY.

7. WHEN WE EXERCISE, WE CONVERT

- A. CHEMICAL ENERGY TO KINETIC ENERGY.
- B. CHEMICAL ENERGY TO HEAT ENERGY.
- C. BOTH STATEMENTS A AND B ARE TRUE.

8. IN AREAS WHERE RAIN IS FREQUENT AND THE CLIMATE IS DAMP, MANY PEOPLE LEAVE A LIGHT BULB BURNING ALL THE TIME IN EACH CLOSET. THE MAIN PURPOSE OF THIS PRACTICE IS TO:

- A. CONVERT ELECTRICAL ENERGY TO HEAT.
- B. MAKE IT EASIER TO FIND THINGS.
- C. CONVERT POTENTIAL ENERGY TO KINETIC ENERGY.

1. IN NORTHERN AREAS, WHEN THE SPRINGTIME SUN MELTS SNOW AND THE WATER EVENTUALLY TURNS TURBINES IN POWER PLANTS, THE CONVERSIONS OF ENERGY FROM ONE FORM TO ANOTHER ARE MANY. MATCH THE KIND OF CONVERSION TO THE EVENT BY WRITING THE NUMBER OF THE CONVERSION IN THE SPACE PROVIDED.

#### CONVERSIONS OF ENERGY

1. RADIANT ENERGY TO HEAT ENERGY.
2. POTENTIAL ENERGY TO KINETIC ENERGY
3. KINETIC ENERGY TO ELECTRICAL ENERGY
4. POTENTIAL ENERGY TO HEAT ENERGY
5. HEAT ENERGY TO KINETIC ENERGY
6. ELECTRICAL ENERGY TO RADIANT ENERGY
7. RADIANT ENERGY TO CHEMICAL ENERGY

#### EVENTS

- A. SNOW MELTS AND COLLECTS INTO MOUNTAIN LAKES.
- B. TURBINES SPIN AND PRODUCE ELECTRICITY.
- C. WATER SPILLS FROM LAKES INTO BROOKS AND RIVERS.
- D. ELECTRIC POWER PROVIDES FREEWAY LIGHTING.
- E. PLANTS FLOURISH IN SPRING SUNLIGHT.

2. ON THE LEFT BELOW ARE DESCRIPTIONS OF SIX KINDS OF ENERGY CONVERSIONS. ON THE RIGHT ARE THE NAMES OF THESE CONVERSIONS. DRAW A LINE BETWEEN EACH DESCRIPTION AND EACH OF THE NAMES. THE FIRST DESCRIPTION IS ALREADY MARKED.

- |   |                                      |
|---|--------------------------------------|
| 1. A FLASHLIGHT SHINING ON A DARK WALL. | A. CHEMICAL ENERGY → RADIANT ENERGY  |
| 2. A CHILD RUBS HIS HANDS TOGETHER.     | B. POTENTIAL ENERGY → KINETIC ENERGY |
| 3. A BATTERY LIGHTS A BULB.             | C. RADIANT ENERGY → HEAT ENERGY      |
| 4. A STEAM ENGINE.                      | D. KINETIC ENERGY → HEAT ENERGY      |
| 5. DROPPING A ROCK.                     | E. HEAT ENERGY → KINETIC ENERGY      |

**SITUATION A:** THE CUBE YOU WORKED WITH IN ACTIVITY 2 HAD SIX FACES. EACH ONE WAS A SQUARE. CONSIDER NOW ANOTHER SITUATION. LOIS HAS A DIFFERENTLY SHAPED SOLID--ONE WITH FOUR FACES. EACH FACE IS IN THE SHAPE OF A TRIANGLE  $\triangle$ . THE THREE SIDES OF THE TRIANGLE ARE ALL EQUAL. A PICTURE OF THE SOLID OBJECT IS SHOWN AT THE RIGHT. EACH FACE IS LABELLED WITH A LETTER: A AND B ARE ON THE FACES YOU CAN SEE. FACES C AND D ARE HIDDEN. THE ARROWS POINT TO THEM. HAVE YOU ANY QUESTIONS ABOUT THIS OBJECT? HERE IS QUESTION 1.

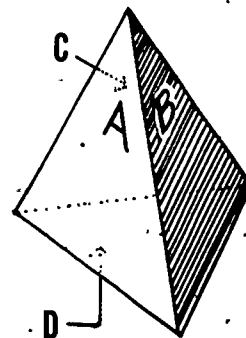

1. WHEN LOIS DROPS THIS OBJECT ON A TABLE, SHE CAN SEE THREE SIDES, BUT NOT THE FOURTH ONE ON WHICH IT LANDS. ON WHICH FACE WOULD THE OBJECT BE EXPECTED TO LAND?

- A. FACE A IS MOST LIKELY.
- B. ANY FACE BUT D.
- C. ONE CAN'T PREDICT THE RESULT OF ONE DROP.

2. IF THIS OBJECT WERE DROPPED MANY TIMES, AND A RECORD KEPT OF THE FACES ON WHICH IT LANDED, WHICH OF THE FOLLOWING STATEMENTS WOULD BE MOST REASONABLE?

- A. THE FACES HAVE NEARLY EQUAL FREQUENCIES.
- B. THE RECORD WILL BE CONSISTENT WITH THE PHYSICAL PROPERTIES OF THE OBJECT.
- C. BOTH STATEMENTS A AND B ARE TRUE.

3. SUPPOSE LOIS WERE TO DROP THIS OBJECT TWICE. OF THE RESULTS DESCRIBED BELOW FOR TWO DROPS, WHICH LANDINGS WOULD BE THE MOST LIKELY.

- A. FACE A IN THE FIRST DROP, FACE B ON THE SECOND.
- B. FACE B OR D ON THE FIRST DROP, FACE D OR B ON THE SECOND.
- C. IT WOULD LAND ON FACE C BOTH DROPS.

4. SUPPOSE INSTEAD OF LETTERS, LOIS NUMBERED THE SIDES: A=1; B=2; C=3; D=4. SHE THEN DROPPED THE OBJECT TWICE, AND ADDED UP THE NUMBERS OF THE FACES ON WHICH IT LANDED. WHICH SUM WOULD BE MOST LIKELY?

- A. THE SUM OF 2.
- B. THE SUM OF 8.
- C. THE SUM OF 5.

IN THE SPACE PROVIDED BELOW, WRITE THE VALUE OF THE MOST LIKELY SUM AND ITS PROBABILITY. USE THE TABLE BELOW TO HELP YOU DECIDE.

MOST LIKELY SUM = \_\_\_\_\_ ITS PROBABILITY IS \_\_\_\_\_ /16 .

FACE	1	2	3	4
1		3		
2				
3				7
4				



HERE IS *SITUATION B*: A BAG CONTAINS SOME MARBLES. SUPPOSE YOU MADE 14 DRAWS OF THE MARBLES OUT OF THE BAG, ONE MARBLE AT A TIME. YOU PUT EACH MARBLE BACK IN THE BAG BEFORE THE NEXT DRAW. THE NUMBER OF DRAWS FOR EACH TYPE OF MARBLE IS SHOWN BELOW.

<u>COLOR</u>	<u>FREQUENCY</u>
RED	2
BLUE	5
YELLOW	7

HERE ARE SOME QUESTIONS ABOUT THE BAG OF MARBLES.

1. WHICH OF THE FOLLOWING STATEMENTS SEEMS MOST REASONABLE?
  - A. THE MARBLES IN THE BAG ARE EITHER RED, BLUE, OR YELLOW.
  - B. THE DRAWS WERE BIASED BECAUSE THE TALLIES SHOULD BE MORE NEARLY EQUAL.
  - C. THERE ARE EXACTLY THREE MARBLES IN THE BAG.
  
2. IF YOU WERE TOLD THERE ARE ONLY SIX MARBLES IN THE BAG, HOW MANY WOULD YOU THINK ARE COLORED BLUE?
  - A. TWO MARBLES ARE BLUE.
  - B. FIVE MARBLES ARE BLUE.
  - C. NOT ENOUGH INFORMATION TO MAKE A GOOD GUESS.

SITUATION C: YOU HAVE PROBABLY USED A SPINNER. HERE IS ONE WITH FOUR EQUAL SECTORS LABELLED, A, B, C, D, AS SHOWN AT THE RIGHT. NANCY AND JOE MADE A TOTAL OF 60 SPINS. THE FREQUENCIES (OR NUMBER OF TIMES THE SPINNER STOPPED IN A PARTICULAR SECTOR) WERE A=5 TIMES, B=15 TIMES, C=30 TIMES, D=10 TIMES.

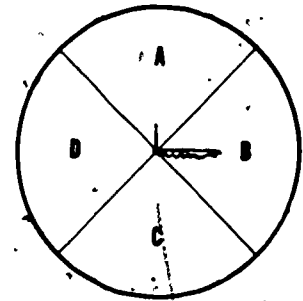

HERE ARE SOME QUESTIONS ABOUT THE SPINNER. CIRCLE THE LETTER OF THE ANSWER YOU PREFER.

1. WHICH OF THE FOLLOWING STATEMENTS IS MOST LIKELY CORRECT?
  - A. THE DATA ARE WRONG, AS THIS RESULT IS IMPOSSIBLE.
  - B. THE RESULTS ARE WITHIN EXPECTED VARIATION DUE TO CHANCE.
  - C. THERE IS SOME INFLUENCE ON SECTOR C AT THE EXPENSE OF SECTOR A.
  
2. NANCY AND JOE KEPT TRACK OF EVERY TWO SPINS AS THEY COLLECTED THEIR DATA. WHICH OF THE FOLLOWING PAIRS OF SPINS WOULD BE MOST LIKELY?
  - A. THE PAIR (A, C)
  - B. THE PAIR (B, B)
  - C. THE PAIR (B, C)
  
3. IF NANCY AND JOE MADE SURE THE SPINNER WAS PERFECTLY BALANCED (NOT INFLUENCED), AND THEN THEY SPUN IT, THEY WOULD FIND THAT:
  - A. THE SPINNER WOULD ALWAYS STOP IN THE SAME SECTOR.
  - B. THE SPINNER WOULD STOP AT EACH SECTOR THE SAME NUMBER OF TIMES (THE SAME FREQUENCY).
  - C. NEITHER A NOR B IS TRUE.

SITUATION D: THE HISTOGRAM AT THE RIGHT SHOWS THE FREQUENCY DISTRIBUTION OF HEIGHTS OF 100 CHILDREN. THE UNITS ON THE LINE ARE INCHES OF HEIGHT.

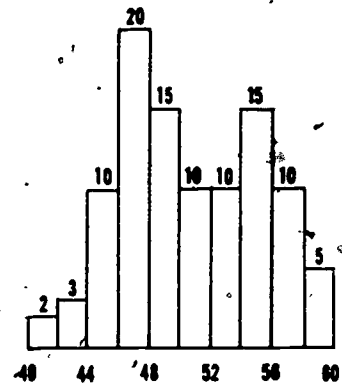

HERE ARE THE QUESTIONS. CIRCLE THE LETTER FOR THE ANSWER YOU PREFER.

- THE MOST FREQUENTLY OCCURRING HEIGHT IN THE TOTAL GROUP IS ABOUT:
  - 40-60 INCHES.
  - 47 INCHES.
  - 52 INCHES.
- WHICH OF THE FOLLOWING STATEMENTS IS MORE LIKELY CORRECT?
  - THERE ARE MANY ERRORS OF MEASUREMENT IN THESE DATA.
  - THE CHILDREN ARE APPARENTLY ALL FROM THE SAME POPULATION.
  - THE CHILDREN MAY COME FROM TWO DIFFERENT AGE GROUPS.
- IF THE CHILDREN ARE ALL FROM THE FIFTH GRADE IN A SCHOOL,
  - ABOUT 40 OF THEM ARE PROBABLY BOYS.
  - ALL THE DIFFERENCES ARE DUE TO VARIATIONS EXPECTED IN SAMPLING.
  - THE NUMBER OF CHILDREN AT EACH HEIGHT SHOULD BE THE SAME.
- IF THE DATA SHOWN REPRESENTED THE NUMBER OF GAMES WON BY CHILDREN IN A CHECKERS TOURNAMENT RATHER THAN HEIGHTS,
  - ALL OF THE CHILDREN WOULD HAVE BEEN EQUALLY SUCCESSFUL.
  - ABOUT HALF OF THEM MAY HAVE HAD SPECIAL TRAINING.
  - NO INTERPRETATION OTHER THAN CHANCE SHOULD BE MADE.

**SITUATION E:** JOHN AND CAROL DECIDE TO MAKE THEIR OWN RUBBER BAND SCALE WHICH THEY CAN USE TO WEIGH OBJECTS. THEY HAVE AVAILABLE A STRONG RUBBER BAND, A CONTAINER, A SMALL UNIT MEASURE CUP, PLENTY OF STRING AND CARDBOARD, AND UNLIMITED AMOUNTS OF WATER. THEY DECIDE THEY NEED FIVE DIFFERENT POSITIONS ON THE SCALE TO CORRESPOND TO FIVE DIFFERENT UNITS OF WEIGHT. THE CONTAINER WILL HOLD 10 MEASURES OF WATER.

1. WHICH OF THE FOLLOWING PLANS WOULD BE MOST USEFUL TO THEM?
  - A. PUT A UNIT MEASURE OF WATER IN THE CUP AND SEE HOW MUCH IT STRETCHES THE RUBBER BAND.
  - B. PUT FIVE DIFFERENT NUMBERS OF MEASURES OF WATER IN THE CONTAINER AND MARK HOW FAR EACH STRETCHES THE RUBBER BAND.
  - C. MEASURE THE STRETCH FOR FIVE DIFFERENT NUMBERS OF MEASURES OF WATER MANY TIMES EACH AND FIND THE AVERAGE POSITION FOR EACH MEASURED AMOUNT.
2. THE ANSWER YOU CHOSE ABOVE IS BEST BECAUSE:
  - A. IT ACCOUNTS FOR ALL THE STRETCH IN THE RUBBER BAND.
  - B. IT ALLOWS FOR ERROR IN REPEATING A MEASUREMENT.
  - C. IT IS THE EASIEST ONE TO DO.
3. IF JOHN AND CAROL HAD MADE REPEATED MEASUREMENTS, THEY WOULD HAVE THE MOST CONFIDENCE IN USING THE SCALE IF THE MARKS LOOKED LIKE:

