

DOCUMENT RESUME

ED 148 293

IR 004 298

AUTHOR Rosenthal, Robert
 TITLE Review of Network Access Techniques with a Case Study: The Network Access Machine.
 INSTITUTION National Bureau of Standards (DOC), Washington, D.C. Inst. for Computer Sciences and Technology.
 SPONS AGENCY National Science Foundation, Washington, D.C.
 REPORT NO NBS-TN-917
 PUB DATE Jul 76
 GRANT DCR 72-01206A06
 NOTE 35p.
 AVAILABLE FROM Superintendent of Documents, U.S. Government Printing Office, Washington, D.C. 20402 (C13.46:917, \$0.85)

EDRS PRICE MF-\$0.83 HC-\$2.06 Plus Postage.
 DESCRIPTORS Computers; Electronic Data Processing; Equipment; *Information Networks; *Input Output Devices; *Man Machine Systems; On Line Systems; Programing Languages; Telecommunication
 IDENTIFIERS Minicomputers; Network Access Procedures

ABSTRACT

With emphasis on currently operating and planned systems that assist users in accessing available network services, this report identifies the techniques used in network access devices. By examining these devices, the trend toward improving the interface between the user and the computer is brought more clearly into focus and up to date. One specific solution--A Network Access Machine (NAM)--is described in detail. It is a minicomputer system that acts as a network access point for a user at his terminal, and assists the user through the automatic execution of access procedures. It allows the user to specify (or to have specified) his own network command sequences for execution on a specified network and host. Computer responses are analyzed to assure agreement with those anticipated for specific commands. Conditional parameterized expansions allow the use of the same command on different host computers and different networks. (Author/DAG)

 * Documents acquired by ERIC include many informal unpublished *
 * materials not available from other sources. ERIC makes every effort *
 * to obtain the best copy available. Nevertheless, items of marginal *
 * reproducibility are often encountered and this affects the quality *
 * of the microfiche and hardcopy reproductions ERIC makes available *
 * via the ERIC Document Reproduction Service (EDRS). EDRS is not *
 * responsible for the quality of the original document. Reproductions *
 * supplied by EDRS are the best that can be made from the original. *

ED148293

A Review of Network Access Techniques with a Case Study: The Network Access Machine

Robert Rosenthal

Institute for Computer Sciences and Technology
National Bureau of Standards
Washington, D.C., 20234

Sponsored by the
National Science Foundation
1800 G Street, N W
Washington, D C 20550
Grant Number DCR 72-01206A06



U S DEPARTMENT OF HEALTH,
EDUCATION & WELFARE
NATIONAL INSTITUTE OF
EDUCATION

THIS DOCUMENT HAS BEEN REPRO-
DUCED EXACTLY AS RECEIVED FROM
THE PERSON OR ORGANIZATION ORIGIN-
ATING IT. POINTS OF VIEW OR OPINIONS
STATED DO NOT NECESSARILY REPRESENT OFFICIAL NATIONAL INSTITUTE OF
EDUCATION POSITION OR POLICY.

U.S. DEPARTMENT OF COMMERCE, Elliot L. Richardson, Secretary

Dr. Betsy Ancker-Johnson, Assistant Secretary for Science and Technology

NATIONAL BUREAU OF STANDARDS, Ernest Ambler, Acting Director

Issued July 1976

2

2

I R 0 0 4 2 9 8

National Bureau of Standards Technical Note 917

Nat. Bur. Stand. (U.S.), Tech. Note 917, 36 pages (July 1976)

CODEN: NBTNAE

U.S. GOVERNMENT PRINTING OFFICE
WASHINGTON: 1976

For sale by the Superintendent of Documents, U.S. Government Printing Office, Washington, D.C. 20402
Order by SD Catalog No. C13.46:917. Price 85 cents (Add 25 percent additional for other than U.S. mailing).

CONTENTS

ABSTRACT	1
Keywords	1
INTRODUCTION	2
ASSISTANCE	3
INTERFACES and PROTOCOLS	3
TECHNIQUES	4
Basic Communications Assistance	4
Resource Identification	5
Resource Connection	6
Resource Selection	7
Service Integration	8
Distributed Assistance	9
Minicomputer Hosts	10
Other Trends.	10
ARCHITECTURE	10
THE NAM	11
THE NAM FACILITY	14
Total Configuration	14
Communications Peripherals	15
Disk Peripherals	16
Other Peripherals	16
Software System	17
WORKING in the NAM ENVIRONMENT	17
APPLICATION of the NETWORK ACCESS MACHINE	22
SUMMARY	26
REFERENCES	27

Figures

<u>FIGURE</u>	<u>TITLE</u>	<u>PAGE</u>
1	Example Editor Call	12
2	The NAM Configuration	16
3	Modes of NAM Operation -- Normal and Procedure	18
4	Effects of Switching Modes	18
5	Example Editor Call Using NAM	19
6	A Programmed User	20
7	Macro Language Directives	20
8	An Example Macro	21
9	Example Use of .EXT Directive	22
10	Mediated NAM Access to Retrieval Systems	24

TABLE

<u>TABLE</u>	<u>TITLE</u>	<u>PAGE</u>
1	Selected Subset of Functions	25

A REVIEW OF NETWORK ACCESS TECHNIQUES
with a Case Study: The Network Access Machine

Robert Rosenthal
Institute for Computer Sciences and Technology
National Bureau of Standards
Washington, D. C., 20234

ABSTRACT

The computer industry's ability to serve a diverse and expanding user community is evidenced by the rapid growth of computer network services. Computer service providers design and market their own offerings as they deem best, given their own market and their own set of resources. This has led to a proliferation of similar resources requiring different user access procedures. With emphasis on currently operating and planned systems that assist users in accessing available network services, this report identifies the techniques used in network access devices. By examining these devices, the trend toward improving the interface between the user and the computer is brought more clearly into focus and up to date.

One specific solution -- A Network Access Machine (NAM) -- is described in detail. The NAM is a minicomputer system that acts as a network access point for a user at his terminal and assists the user through the automatic execution of access procedures. This minicomputer facility allows the user to specify (or to have specified) his own network command sequences for execution on a specified network and host connected to that network. Computer responses are analyzed to assure agreement with those anticipated for specific commands. Conditional parameterized expansions allow the use of the same commands on different host computers and different networks.

Key words: Access procedures; command language; computer networks; job control language; macros; minicomputers; protocols; teleprocessing.

INTRODUCTION

The computer industry's ability to serve a diverse and expanding user community is evidenced by the rapid growth of computer network services. Little over a decade ago, when people began to interact with computers in the routine performance of their jobs, few cared about the differences between similar service offerings -- all were eager to learn and experiment with that new technology.

Today, with the advent and growth of computer networks, that modest size group of scientists, engineers, and researchers has grown to include professionals in all sciences -- mathematical, physical, health, and social -- as well as students, stock brokers, and reservation clerks from many fields. Just as the number of users has grown, so has the number and diversity of computer services.

Computer service providers design and market their own offerings as they deem best, given their own market and their own set of resources. Trends in service growth, traceable through individual families of mainframes, operating systems, and service packages, lack direction and consistency from the user's point of view. The reasons for this fragmented growth might be justified considering constraints imposed by telecommunications facilities, peculiarities imposed by mainframes and their operating systems, and the personal preferences of system developers. Unfortunately, many of these services are characterized by different implementations of the logically similar steps that users must take in order to accomplish productive work.

Today we have a situation in which more and more users are consuming more and more services while the services themselves perpetuate differing user procedures for access to the same logical services. A reasonable question to ask is "what can be done to help the user?" Standardization of access procedures is a possible solution. However, a procedure for access that makes one service more attractive than another through enhanced features should not be compromised by a premature effort to standardize such procedures -- especially if the standard settles on "lowest common denominator" features. Encouraging competition among network service providers can be in the user's best interest if it leads to innovation in the amount and quality of service received and in the reduction of costs in providing the service. Rather than push for extensive user-oriented uniformity, it may be desirable to continue to permit and encourage such non-uniformity, but to compensate for it through network access assistance to the user.

ASSISTANCE

The concept of assisting users is not new to the computer industry. The notion of a compiler, for example resulted from this kind of motivation. Unfortunately, compilers were soon accompanied by complex operating system control languages. Once again, assistance techniques in the form of a control language macro capability or a catalogued procedure capability were employed to help the user. With these techniques the inexperienced user easily performed complicated job steps and the experienced user worried less about detail in setting up job steps.

This type of assistance, extended beyond a single computer system and placed in the interactive computer network environment, lessens the wearisome burden faced by users contending with separate and different services that accomplish logically similar tasks. In such an environment, the user should have resources readily available from different computers without regard for the specifics of how to obtain them; the user should be more concerned with what services are required.

Early attempts to provide computer network assistance are still in use today. One interesting technique makes use of function buttons that produce character sequences. These sequences represent the appropriate user protocols that identify terminals, users, and services, thus alleviating the need for the user to key in the required protocol. The familiar "who-are-you" drum is an example of this kind of technique. Other devices -- stunt boxes, automatic card dialers, and paper tape loops -- have been used successfully to assist users, but all of these devices are usually applicable only on dedicated connections to specific computer systems and services. In a modern computer network other more general techniques can be employed.

INTERFACES AND PROTOCOLS

Access assistance techniques in modern computer networks try to improve upon the interface that exists between a user at his terminal and a network based resource. For the terminal user of an interactive computer network the interface is two things. First, it is the physical equipment -- the teleprinter or CRT terminal and the communications equipment connecting it to the computer. Second, at a higher and more complex level, the interface is the protocol that a user must know to communicate with the network and its computers -- to express his needs or demands

on the computer and to understand the produced results or errors from the computer.

These user protocols, unlike the "well defined" link protocols of computer-to-computer communications (such as the ARPA Network IMP-IMP, HOST-IMP, or HOST-HOST protocols [POS 74]), manifest themselves in the interactive dialog between the user and the computer. And, these user-computer protocols are not "well defined." They are typically machine dependent and often installation dependent [NEU 73].

Interface and protocol standards groups are actively engaged in producing outputs directly related to the issue addressed here. At least one standards group in the Federal Government (FIPS Task Group 20) is studying low level user entry and exit protocols and procedures. The standards approach to access assistance represents a technique that is still in its infancy. With a three year projected completion date for the development and acceptance of the first entry and exit protocol standard for the Federal Government, the viability of this technique is yet to be realized. The beneficiaries of standards as an assistance technique will be the scientists, engineers, researchers, and those who work with them, who use, or have the potential for using, one or more computer services.

TECHNIQUES

These approaches to solving the problem of network access have been utilized by several groups in specific implementations of the access function. Pyke, in a recent paper [PYK 74], reviews these efforts with special emphasis on presently operating and planned access support configurations. Categorizing these examples and other related devices as reported in the open literature reveals the trend that is evident in network access techniques -- a trend toward improving the interface between the user and the computer through sophisticated assistance techniques and devices. By examining these devices -- their methodology, their purpose, and their scope -- this trend is brought more clearly into focus and up to date.

Basic Communications Assistance

Minicomputer based concentrators and packet or message switchers are well established solutions that provide the basic communications required of network users. Devices like the ARPA Network TIP [ORN 72] and the TYMNET Network

TYMSAT [TYM 71] satisfy these requirements through data rate identification, terminal compatibility transformations including carriage delay timing functions and character set transformations, and host computer selection specifications.

Over the last few years these devices have been modified to reflect the needs and demands of the user community. They utilize software packages that map character sets and provide carriage delays to accommodate different user terminals. These devices continue to evolve in an attempt to follow manufacturers' terminal innovations. In response to new terminal innovations, devices like the TIP and TYMSAT recognize the user's terminal speed; while default terminal characteristics for other parameters -- parity, full or half duplex, tab settings, etc. -- are assumed; provisions to specify different settings are available. Many computer service providers and mainframe manufacturers have followed this trend by providing communications support for a large variety of terminals and by utilizing front end computers with appropriate software packages.

Resource Identification

Access techniques only start with the basic communications assistance functions described above. Establishing connections to network host systems, logging into host systems, requesting resources, and initializing services or databases can be extremely complex and cumbersome. In one early ARPA Network attempt, a loose leaf notebook containing information on the resources available on the Network and the access methods to these resources has met with only very limited success. The Network Information Center's ARPANET Resource Notebook [ARP 73] existed in both an on-line and printed form and contained entries for all of the resources available at each serving host on the network. Unfortunately, no attempt was made to facilitate access to these resources other than listing individuals to contact. (A more recent edition of this notebook has been published in paperback form [ARP 75] and includes enough information for a user to access the desired resource.) Resource identification techniques of a more substantive nature developed.

The REX system, an ARPA Network based on-line user assistance facility, provides resource-specific information [BEN 74]. This system, designed with the eventual goal of automating access to various network resources, finds the location of a resource on the network, provides information

about the resource, and describes the method for acquiring it. REX provides a facility for dealing with a heterogeneous network as a coherent entity, regardless of the particular characteristics of the individual host.

A user language that provides commands to retrieve information about resources and to describe specific resources utilizes one of four keyword types -- a resource name, a resource attribute, a resource category, or a host name -- in conjunction with either a retrieval command -- FIND or DESCRIBE -- or the ACQUIRE command. An example is:

DESCRIBE FORTRAN AT MIT-MULTICS

The ACQUIRE command establishes a transparent connection to the resource without further action on the part of the user.

Resource Connection

Connections to resources that are available in computer networks require cooperation between the connection initiator -- the user or his surrogate -- and the resource that ultimately provides the service -- a coherent logical entity that exists in order to accomplish a specific task as viewed by the user. In a computer network environment it is not unusual for a multi-level hierarchy of access requests to occur to effect resource connection. Cooperation in traversing the network hierarchy may require several resource solicited identifications, passwords, and system or service names.

While the solicitation of user information occurs at the user level of interaction, many other protocols are used by the communications discipline employed. Usually these other disciplines are masked from the user and are transparent. In this way, a surrogate -- usually a process knowledgeable in the protocol or line discipline employed -- acts on behalf of a user to connect him to the requested service. For instance, users of the ARPA Network access resources with the cooperation of a TIP. It is feasible for the acquired resource to then request other resources on behalf of the user. In this example, the user level of interaction is the command language of the TIP; acting as a surrogate for the user, the TIP, knowledgeable in the IMP-IMP protocols, completes the resource connection for the user.

Hierarchical connections easily occur. In the ARPA Network, many host computer resources support a service known as FTP (File Transfer Protocol). This service establishes network connections to other resources on behalf of the user for the purpose of transferring files between host computers. Currently, the user need not identify himself to the TIP; however, a user account is required for the host system to execute the service FTP. For FTP to access the file system of the other resource, the user level protocols require the user identification and password for the other resource.

Resource Selection

Evidence in the published literature indicates that a trend in the use of intelligent terminals and their close cousins, "clustered" terminals, to assist users in the selection of resources is developing. A research program currently underway at the RAND Corporation aims to develop a prototype intelligent terminal system initially implemented on a minicomputer. The system, called the RAND Intelligent Terminal Agent (RITA), is based on sets of condition-action rules that encode complex sets of heuristics for handling interactions both with users and with external systems [AND 75].

RITA is capable of interacting with remote data systems, carrying out time-dependent tasks over extended periods of time in a semi-autonomous manner. The supposition that a rich set of heuristics for deciding communications levels of remote system interaction and for resource acquisition and graceful recovery from unexpected failure has in part motivated this effort [AND 76].

At the National Bureau of Standards a minicomputer-based device called a Network Access Machine (NAM) expands user-entered commands into command sequences executable on specific networks and host computers connected to that network [BLA 74]. The NAM analyzes system and network responses to assure agreement with those anticipated for specific commands. Conditional and parameterized expansions of user-entered commands are capabilities being added to the basic working NAM. This capability will allow the use of the same commands to permit access to resources on different host computers and different networks [ROS 75].

Other extensions to the NAM are currently being implemented. One function is to predict the expected response time of a particular computer for use in a specific

applications area such as compute-bound FORTRAN jobs, small BASIC jobs, interactive editing sessions, or some other category. Good indicators of computer response time can be calculated by the NAM in the following way. The NAM automatically connects to the particular computer in question in order to execute a predefined benchmark job representative of the applications area. By having the NAM automatically time the response for the job execution the NAM can present to the user the results of the calculations in the form of a prediction of expected response time. Several benchmarks have been successfully tried -- producing excellent predictions of expected response time.

One other intriguing function being added to the NAM to provide the user with network wide tutorial assistance. A profile, maintained for each NAM user, reflects the disposition of the user with respect to any particular computer that he might use. Data are maintained in the profile concerning recent use of specific computers, the use of internal indicators, and help assistance indicators. Using this data base, the NAM acts on behalf of the computer in assisting the user.

An example of somewhat specialized access support to a network user employing a microprocessor is the development of a "line processor" by the Stanford Research Institute [HAR 74]. This device interfaces a class of display terminals together with a pointing device called a "mouse" and a one-hand keyboard called a "key set" in such a way that the entire configuration can provide particularly effective access to a network-based interactive text manipulation system. The line processor has potential, however, for application beyond the initial intended use.

Service Integration

An important trend, motivated by the desire to interface one user to multiple resources, is evident in the work done in the information services community by Marcus at MIT. He has developed a system that involves the coupling of two bibliographic data retrieval systems in such a manner that the user perceives a single homogeneous system [MAR 75]. Specific applications support built within the MULTICS system at MIT includes a master index and thesaurus that stores the vocabulary of the separate data bases along with index term interrelationships. The user is also provided with a common bibliographic data structure in which the data elements for bibliographic information are organized and interrelated among different data bases. This approach has

been demonstrated experimentally using the ARPA Network for access to the National Library of Medicine Medline service and the MIT Intrex retrieval system.

Another Example is the Resource Sharing Executive (RSEXEC) for the ARPA Network [THO 73]. This executive system provides an environment for "inter-host" user-user interactions, for managing "multi-host" file directories, and for controlling multiple "jobs" on several hosts. In addition, the RSEXEC serves as a command language interpreter for the ARPA Network TIP users. Executing in any one of several available PDP-10 TENEX systems on the Network, RSEXEC can maintain communications through the Network with other TENEX systems. In this way the resources of all of the systems to which RSEXEC connects can be monitored and used. Facilities for monitoring status, logged in users, and load averages are available as well as the capability to build and create a composite file directory incorporating files from the various computers in the subnetwork. Provision is also available for initiating jobs at one or more cooperating sites at which valid accounts are maintained.

Distributed Assistance

Distributed assistance -- partially in host systems and partially in front end systems -- can provide better network response at less cost. The National Software Works (NSW) motivated by a desire to provide users with access to a number of general or specialized software applications packages, resides on a PDP-10, but will also be available on a minicomputer such as the PDP-11 [IRB 76]. NSW provides assistance in such a way so as to maintain a consistent user interface from package to package even across host systems. It is anticipated that heavily used common commands and grammars can be executed in the front end systems, thus increasing network response times and decreasing network communications costs.

Kimbleton and Schneider emphasize that the NSW is intended to be an environment for building software systems [KIM 75]. It is to include program preparation tools -- cross assemblers and compilers, editors, simulators and emulators, performance analyzers, program formatters, flowcharters, test-data generators, and other checking tools -- that build software systems. These systems will usually be removed and run in a different environment, since the NSW is not intended to support the recurring execution of end-user applications.

Minicomputer Hosts

A minicomputer installed as a network host computer can also perform substantial access functions for a community of users. The ELF system provides multiple, concurrent users with local computing and file capability including signal processing for speech applications as well as flexible access to ARPA Network resources [RET 75]. The ARPA Network Terminal System (ANTS) was a mini-host designed to facilitate use of the ARPA network by students at the University of Illinois. Use of this system promoted Remote Job Entry (RJE) use of the Burroughs 6700 at the University of San Diego as well as RJE use at the Campus Computing Network (CCN) at UCLA [BOU 73].

At the University of Chicago, Ashenurst has developed an interesting hierarchy of minicomputers and large scale computers to assist users in laboratories [ASH 74]. Minicomputers located in science laboratories throughout the campus are served by a larger minicomputer at a central site. Large compute-bound applications are served when the central minicomputer acquires resources on a large scale computer on behalf of the laboratory mini.

Other Trends

The work of Wyatt at Harvard, in planning for an access system to couple users to multiple serving systems and networks, includes a call for automatic transformation of job control statements to match those of remote systems and for facilities to support "transparent connection" of local terminal facilities to various communications networks [WYA 74]. Wyatt also proposes that the "translation/communication system" perform comprehensive accounting and billing for multiple user accounts.

ARCHITECTURE

The preceding examples suggest that alternative solutions exist and that the access assistance functions can reside in a process executing in a host system, in a dedicated minicomputer, or in a single user "intelligent" terminal or terminal "cluster".

When supported on a large host computer, the access assistance functions utilize the sophisticated and extensive subsystems that are available -- the file management systems, the language compilers, the utility processors and

on and on. But, this type of application can be accomplished with less sophisticated resources. For instance, the ARPA Network TIP, in part motivated by a desire to move the basic communications support and low level access functions out of the large host computers and into smaller, less expensive minicomputers, eliminates much of the overhead required to handle access functions in a larger host system. Minicomputers are often used extensively for store-and-forward functions and other applications such as remote concentrators and message switchers; it might make good economic sense to put the access function in a minicomputer also.

The minicomputer, placed in the communications link between the user terminal and the serving computer network, can allow multiple users to access different hosts on one network or even different networks. The minicomputer seems ideally suited for such an application especially when several users or user groups require a moderate file storage capability for small files and a minimum computational capability for communications processing, signal processing or other requirements.

Intelligent terminals can support access to multiple hosts on a single network or to multiple networks, but file storage and other terminal resources appear to be too expensive at this time to dedicate to a single user terminal. Also, intelligent terminals may require cooperation with larger host systems for initial program loads; such cooperation may not be available from candidate networks or host computers. At this time, the intelligent terminal does not have as great a potential as the "cluster" supported minicomputer to perform the required access functions. Based on predictions that within five to eight years inexpensive interactive terminals will be available with the power of today's minicomputers, the use of intelligent terminals to support the access function will be feasible.

THE NAM

The Network Access Machine, as pointed out earlier, is a programmed minicomputer supporting a "cluster" of user terminals. The NAM acts on behalf of a user at his terminal and automatically generates the necessary interaction or dialog that accomplishes the user's intended function. The function might be to connect the user's terminal to a specific computer on a network, to automatically identify the user to the computer (to log-in), or to select and initialize a subsystem on the computer -- a language processor such as FORTRAN or COBOL, or a data base for a

Bibliographic search.

These functions or access procedures, requested by users, are called macros. The NAM expands these macros to produce the correct machine dependent (specific computer) dialog. Complex access procedures, coded and stored on macro files, are given simple names by the user; macros are easily recalled by name and expanded.

At the time of the expansion, parameters can be passed to the macro. An example use for a parameter is to identify to the macro a particular computer, a particular user, and a particular subsystem. In this way, macros can be written like subroutines -- general in scope, but made specific by the parameters passed to them.

The use of simple names for complex access procedures and the ability to pass parameters to macros makes the NAM a flexible aid for any user of computers; especially when the user accesses a variety of different computers where the access protocols are typically machine dependent and often are installation dependent.

Consider a simple example. Figure 1 shows the user protocol required to access an editor on three different computers. While the dialog is similar in all three examples, differences in syntax, case, and editor name can lead to confusion.

<u>COMPUTER</u>	<u>PROTOCOL</u>
EDP-10 on ARPA Net	E @L 241 LOG RMR 115681 TECO
MULTICS on ARPA Net	E @L 44 enter Rosenthal CNet teco
General Electric Information Services	H abc12345, rosenthal TEDIT (X)

Figure 1 Example Editor Call

A reasonable question to ask is, what can be done to help the user?

A protocol that makes one network service appear to the user like any other is a general answer. However, as stated earlier, protocols that make one service more attractive than another through enhanced features should not be compromised by a premature effort to standardize such protocols. Encouraging competition among network service providers can be in the user's best interest if it leads to innovation in the amount and quality of service received and in the reduction of costs in providing the service. Rather than push for extensive user-oriented uniformity at the higher levels of user-network interaction, it may be desirable to continue to permit and encourage such non-uniformity, but to compensate for it through network access assistance to the user. By focusing on the low level user protocols like "log-in", "host selection", and "service selection", the user can become more concerned with the service he requires and less concerned with how to obtain it.

Several important user protocols can be improved upon. First, the initial user-computer connection procedure can be made more uniform. This starts with the physical connection of the user terminal to the computer network. Once the physical connection is made and the terminal's speed and identity have been established, the access procedures which follow are usually hierarchical, nested or even recursive. Usually one or more of the following procedures are performed by the user in the network environment:

- host computer selection
- host computer log-in
- host computer service selection
- service initialization
- service exit request
- host exit request
- network exit request

These are the specific user protocols that can be improved upon in current operational and experimental networks. The NAM facility, designed to assist users with these protocols, is briefly described.

THE NAM FACILITY

The NAM minicomputer facility gives the user the capability to automatically access the resources of a remote computer. This capability is made possible by the NAM's ability to act as a surrogate both in establishing the physical communications connection to the remote computer and in expanding macro procedures to produce the correct machine dependent interactive dialog for the remote computer.

This surrogate, acting on behalf of the user, functions as a "programmed user" -- a computer programmed to behave as a human user ... a programmed automaton. In establishing the physical communications connection, the programmed user utilizes an automatic calling unit for placing dial out calls; hard-wired connections are available for local computer connections. In accessing resources on remote computers, the programmed user sends requests; waits for replies; analyzes responses; and decides to either continue, or to seek user intervention.

While seemingly insignificant for a human to perform, these actions -- sending requests, waiting for replies, analyzing responses, and deciding what to do next -- represent non-trivial tasks for a computer to perform. How does the programmed user determine when the remote computer can accept the next request; how does it know when the remote computer has finished a reply; what is required to analyze a response so that the next request is logical and correct? Let us start answering these questions by stepping way back and first discussing the total picture -- the minicomputer configuration used to support the algorithms that execute to perform as a programmed user. Then, the programmed user itself can be discussed revealing its utility in the Network Access Machine.

Total Configuration

The word minicomputer is hard to "pin down" in a formal definition -- it has humorously been defined as any processor for which the manuals are free. For the purpose of this note, the definition of a minicomputer conjures up the idea of a relatively small inexpensive processor to which (often expensive) peripherals are attached. The processor itself is usually 12 to 18 bits wide and is usually supplied with up to 64k to 128k words of random access memory. A complement of standard peripherals includes disks -- floppy disks, fixed head disks, or disk

packs -- communications interface equipment, and other miscellaneous devices such as clocks, printers, and on and on. The term minicomputer applies to an integrated system consisting of this type of processor and these kinds of peripherals.)

The NBS NAM is implemented on a Digital Equipment Corporation PDP-11/45 minicomputer with 64k words of 16 bit core. Character asynchronous communications interfaces are used to interconnect user terminals to the NAM and the NAM to remote computers. A special peripheral called an automatic calling unit and line selector (ACU/LS) is used by the NAM to place dialed telephone calls to remote computers. A multi-programmed disk-based operating system supports the NAM and provides for individual user directories into which user macro files are catalogued and maintained. Other miscellaneous devices used by the NAM system include a line-frequency clock and a printer.

Communications Peripherals

The NAM, acting as a surrogate for the user, must interconnect the user's terminal to the remote computer. To do this, two character asynchronous interfaces are utilized -- one for the user terminal connection to the NAM, and one for the NAM connection to the remote computer.

The physical circuits for these connections are either dialed through the switched telephone network or directly connected by "twisted-pairs" -- wires that interconnect the equipment. As shown in figure 2, the NAM supports directly connected users and dial-up users. Connections to the remote computer are supported from the NAM to directly connected local facilities such as the NBS ARPA Network TIP, the NBS PDP-10 in the Experimental Computer Facility (ECF), and other minicomputers in the ECF, or to dialed out networks using the automatic calling unit.

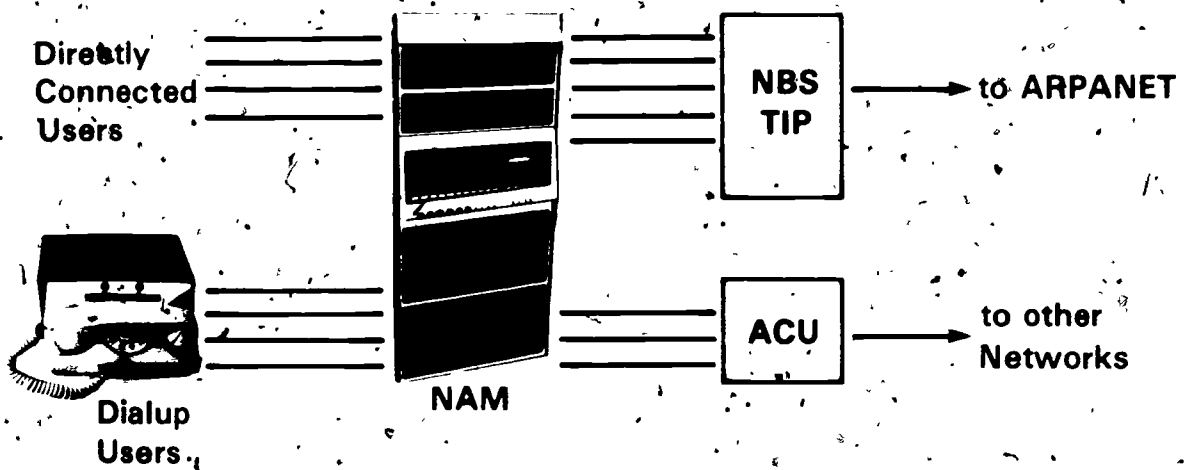

Figure 2 The NAM Configuration

Disk Peripherals

The disk, relatively large in storage capacity compared to the size of core, serves a dual purpose in the NAM. First, it supports the operating system under which the NAM runs. The operating system requires large amounts of storage for its state dependent information -- its tables, program modules and data -- and since all of this information will not fit into core at one time, it is maintained on the disk -- to be recalled when needed. Second, the disk provides users of the NAM with individual directories for cataloguing macro files. These directories are maintained by the user -- he creates new macros and he deletes obsolete ones.

Other Peripherals

Other miscellaneous peripherals are used in the NAM minicomputer configuration; most important is the line frequency clock. As a multi-user system in a multi-programmed environment, the NAM must allocate its processing power in time-slices -- the amount of processor time that a running program may utilize before another

program receives control. The clock controls the time slice allocations so that each user receives an equal share of the available processor time.

The line printer, another useful peripheral, can produce hard-copy transcripts of the interactive dialog. At the user's request, a disk file called the transcript file is produced as the NAM forwards characters to and from the terminal and remote computer. The user can request hard-copy of all or portions of the transcript file. When CRT display terminals are used, this printer -- a shared peripheral -- is often the only hard copy available.

Software System

When viewed as an extension to the hardware, the software system provides a foundation for building, developing, and supporting the applications programs that make up the NAM. The software system itself consists of two separable entities -- the operating system software and the applications software. The applications software utilizes the operating system software for input/output (I/O) requests, file management requests, and other requests including scheduling programs for execution, allocating core for programs, and arbitrating conflicts for peripheral requests.

The applications software is the set of programs that execute to provide the terminal user with a network access capability. These programs consist of the Macro File Expander, the remote computer dialog Response Analyzer and the terminal user Input Interpreter. These three applications programs make up the NAM environment.

WORKING IN THE NAM ENVIRONMENT

Characters sent to the NAM are normally stored and forwarded -- user characters are forwarded to the host system and the host system characters are forwarded to the user's terminal. Upon receipt of the special "^" character as the first character on a line from the user's input, the NAM enters "procedure" mode and leaves the normal store-and-forward mode of operation. In figure 3 these two modes of operation are illustrated.

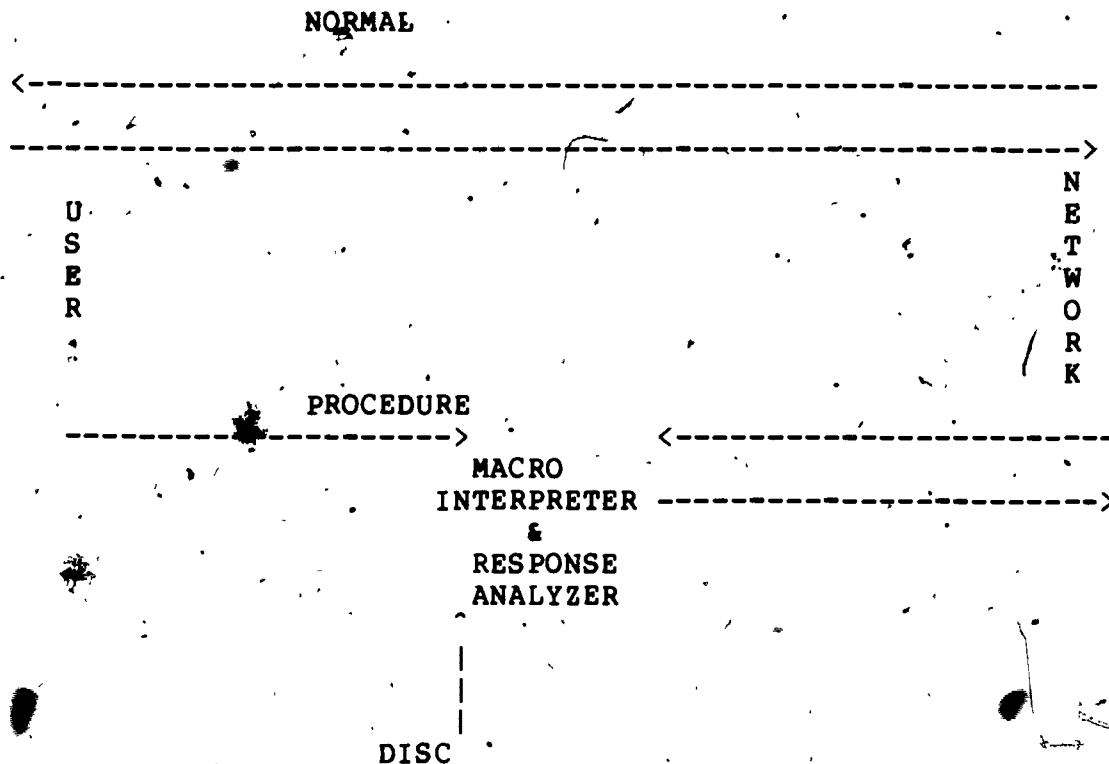

Figure 3 Modes of NAM Operation -- Normal and Procedure

The effect of switching modes is illustrated in figure 4 where a line of text preceded by the "~" produces a macro expansion as in the first and third lines. When the "~" is not used, characters are simply forwarded as in the second line of figure 4.

<u>User Types</u>	<u>NAM Outputs</u>
~LOGIN 241	E @1'241 LOG ROSENTHAL RMR 1
TECO	TECO
~LOGOFF	LOGOUT @c

Figure 4 Effects of Switching Modes

When the "^" character is used the rest of the text on the line containing the "^" character is treated as a NAM macro name complete with any user supplied parameters. In figure 5 the example editor call is again illustrated for three host computer systems, but this time the NAM assists the user by supplying the appropriate machine dependent dialog.

<u>SYSTEM or NETWORK</u>	<u>USER DIALOG</u>
BBN on ARPA Network	^EDIT BBN
MULTICS on ARPA Network	^EDIT MULTICS
GE INFORMATION SERVICES	^EDIT GE

Figure 5 Example Editor Call Using NAM

Access procedures can specify a complex series of interactions with the remote system. In this case -- the EDIT example -- each response to the NAM from the remote system is analyzed according to information supplied by the macro expansion. Simple Boolean combinations of character strings describe the anticipated host computer response. When the actual response meets this predefined criteria, the next line of the macro expansion is transmitted to the remote system. When the actual response fails to meet this predefined criteria, one of two procedures is followed. Most simply, the expansion is aborted and the offending response is displayed on the user's terminal. In addition, the response to the last line of the expansion is delivered to the user to indicate that he may proceed to enter more commands. However, the user has the option to explicitly define an abort procedure -- another macro to expand in the event of a response failure.

Thus, as previously asserted, the NAM's macro expander and response analyzer together form a "programmed user". The macro expander creates machine dependent commands to be sent to the computer network. NAM waits for the network to respond as would a human user. The response analyzer then decides if the network response is the anticipated response -- a human user would perform this same function. If the network response is found questionable, the decision to "try again", or "read the manual", or "quit" must be made. If the network response is acceptable (network response and

anticipated response agree) the macro expansion continues. Figure 6 illustrates this "programmed user" concept and equates the algorithm used by a human to accessing a network resource with the NAM.

NAM = Terminal + User

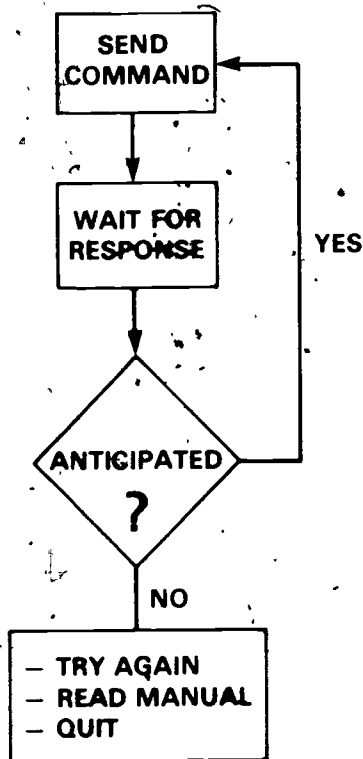

Figure 6 A PROGRAMMED USER.

Directives employed in the macro language allow the "programmed user" concept to be coded by real users and interpreted by the macro expander. The major directives in the language are shown in figure 7. Each directive in the language relates to a function normally performed by a human user.

<u>FUNCTION</u>	<u>DIRECTIVE</u>
Send Command	.SEND
Wait	.TERM
Compare (with actual response)	.MATCH
No Match	.ABORT

Figure 7 Macro Language Directives

These directives are illustrated in a sample dialog in figure 8. The macro in this example is used to log into a PDP-10 TENEX operating system at Bolt, Beranek and Newman (BBN) using the ARPA Network TIP.

MACRO DIRECTIVES

.MACRO LOGIN HOST
 .TERM 2 {CR LF}
 .MATCH HELLO
 .SEND E

.TERM [CR LF]@
 .MATCH OPEN
 .SEND @L HOST

.MATCH PREVIOUS
 .SEND LOG ROSENTHAL RMR 1[CR]

.ENDMACRO LOGIN

NAM SENDS/RECEIVES

E ↓
 HELLO 321 ↓

@1 241 ↓
 LOGGER
 OPEN
 BBN - TENEX ↓
 @

LOG ROSENTHAL RMR 1 ↓
 JOB 24 on TTY 16
 PREVIOUS LOGIN:
 25-FEB-76 ↓
 @

Figure 8 An Example Macro

The underlined strings in figure 8 indicate the characters sent to the remote network by the NAM. The "↓" character indicates that the carriage-return line-feed sequence was received or sent. Notice that these strings have a one-to-one correspondence to the arguments in the macro directives. In the first directive -- .MACRO -- the macro name -- LOGIN -- is specified and it has a formal parameter -- HOST. HOST appears again in the second .SEND directive. The NAM output for this second .SEND directive indicates that the ARPA host address 241 was actually sent. This macro LOGIN was invoked and expanded by the NAM when the user typed:

LOGIN 241 ↓

The .TERM and .MATCH directives used to specify the wait and compare states of the programmed user are specified before

the .SEND directive in the actual macro. While this is seemingly inconvenient, it is necessary since the Macro Expander facility in the NAM operates a line at a time and consequently the NAM must know the expected response before sending the expanded message to the remote system.

The NAM compares each character of the system response with the predefined characters in the .TERM directive. Once a string match occurs, the system response is considered complete and the NAM attempts to then match the complete response with the string in the .MATCH directive. The strings used in the .TERM and .MATCH directives remain in effect until they are changed or until an .ENDMACRO directive is encountered. Notice that prior to the last .SEND directive in figure 8, only a .MATCH directive is specified. The previous .TERM directive (.TERM [CR LF]) remains in effect.

APPLICATION OF THE NETWORK ACCESS MACHINE

Application of the NAM to a variety of useful access functions has led to the development of the .EXT directive. This directive enables the user to "penetrate" the network to various levels using the same macro names (command names) for different systems on the network. By appending an extension name to the access procedure file name, the NAM executes a macro specified for a particular host on the network. The example in figure 9 shows how the file extension is equated using formal macro parameters.

```
LOG BBN, ROSENTHAL, RMR, 1
```

```
.MACRO LOG HOST, USER, PASSWD, ACCT
.EXT = HOST
LOG USER, PASSWD, ACCT ///->
                                log.bbn rosenthal.rmr 1
.ENDMACRO
```

```
EDIT ///->
edit.bbn
```

Figure 9 Example Use of .EXT Directive

First, an access procedure called LOG is invoked. It has four parameters -- BBN, ROSENTHAL, RMR, and 1. In the text of the macro the extension is equated to the parameter HOST; in this invocation, to BBN. In the third line of the macro, the expander encounters a text line that is not a directive (not preceded by a "."); so, the expander assumes that this line is the name of another macro to be invoked. In this example, the text line after the .EXT directive is to be invoked much like a subroutine -- once completed, control returns to the following macro line. This subroutine call to macro LQG will actually be made to a macro called LOG.BBN as indicated by the expansion operator "///->" (this symbol is only used to illustrate that this particular expansion produces the indicated new macro name -- this symbol is not part of the macro text file). Finally, the last line in this example shows that once the extension has been set from within a macro call, it remains in effect for other macro invocations during the session. (Provision to reset the macro file extension is provided.) Using this capability, the user is able to create commands for accessing computer networks; these commands can be given the same name, thus providing for the user, a common network access language..

The NBS NAM, already proven as a useful tool in the NBS Experimental Computer Facility, is currently involved in an experiment designed to provide convenient access to resources likely to be found on heterogeneous computer networks. In this experiment, the NAM is used to provide "autonomous" access to any one of a selected set of interactive retrieval systems. Unlike the M.I.T. work [MAR 75] on the actual "coupling" of (two) interactive retrieval systems, the NAM has mediated but "autonomous" access to any one of a selected set of retrieval systems. The retrieval service selections are identified by the broad experimental framework depicted in figure 10.

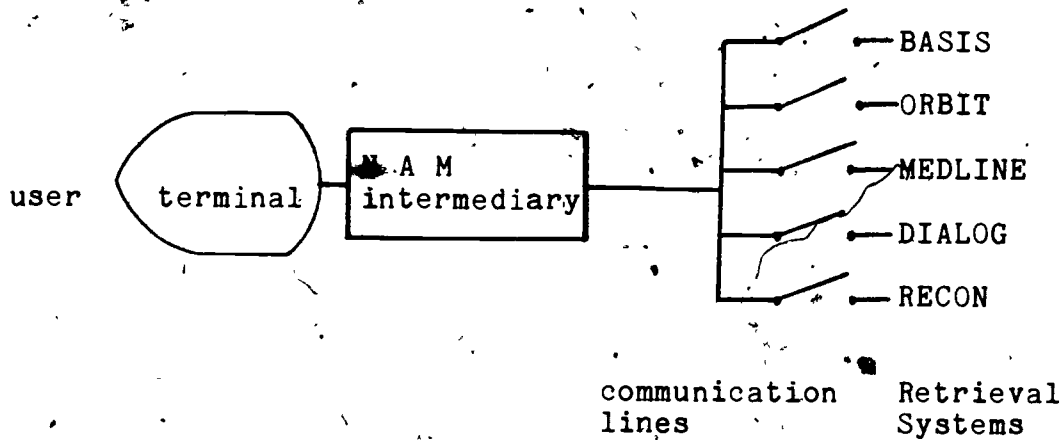

Figure 10 Mediated NAM Access to Retrieval Systems

The objective is to achieve a common command language for only a subset of the functions that must or can be performed in conjunction with on-line retrieval systems. The reason for this selectivity is based on the well established fact that some significant system differences can render corresponding user commands irreconcilable. Furthermore, the subset of functions to be addressed involving those listed in Table 1, should be realistic enough to make the experiment productive in a reasonably short period of time.

<u>TYPE</u>	<u>FUNCTION</u>
1. Administrative	a. Communication Linkup b. Login Procedure c. Logoff Procedure d. System Disconnection
2. Substantive	a. Files Identification b. File Selection c. Search Request (1) Term Entry (2) Logic Creation d. Search Result Output e. Search Term Display
3. Supportive	a. Command Explanation b. Procedural Help c. Output Interruption d. Input Editing (1) Single Character Erase (2) Line Erase

Table 1 Selected Subset of Functions

Although the experiment is purposely limited, several new features of the NAM are demonstrated. In addition to the "normal" or store-and-forward character-at-a-time transmission through the NAM a character string store-and-forward facility proves useful. This mode allows the NAM to selectively scan the user input data for possible retransmission in a suitable format for the particular host connection. This is particularly useful for correcting simple typographical errors or for user solicited "help" functions.

SUMMARY

Increased use of computer services by people in the routine performance of their jobs continues to grow steadily. To meet the demand, service providers design, implement, and market their services using the technologies and resources available to them. With the advent and growth of computer network technology it is not uncommon for people to use the resources of different computer systems. The non-uniformity in access to these resources and the services provided has led to the development of tools and techniques to assist the user.

Some of the tools and techniques that provide users with this access function have been described in this paper. By examining these devices -- their methodology, their purpose, and their scope -- and by discussing the current trends in network assistance architectures, a framework has been built for future discussions of this very important function that can be provided to computer network users.

Within this framework, one example device, the NBS Network Access Machine (NAM) is scrutinized to show its applicability in solving some of the problems currently frustrating users. The applicability of the NAM to provide a uniform network-wide command language has been explored. Access techniques are currently being employed to assist users in the data retrieval community. A proposed set of experiments that allow a user to perceive a common command language across a heterogeneous set of retrieval services found on different computer networks is currently in progress.

REFERENCES

[AND 75] Anderson, R. H., "Advanced Intelligent Terminals As A User's Network Interface," How to Make Computers Easier to Use (COMPCON '75 Digest of Papers, Sept 9-11, 1975) IEEE N.Y., 1975. pp-180-182. (IEEE Catalog No. 75ch0988-6c).

[AND 76] Anderson, R. H., and Gillogly, J. J., "The RAND Intelligent Terminal Agent (RITA) as a Network Access Aid," to be published in the Proc. NCC 1976.

[ARP 73] "ARPA NETWORK Network Resources Notebook," The Network Information Center NIC 6740, Augmentation Research Center, Stanford Research Institute, Menlo Park, California, 1973.

[ARP 75] ARPANET RESOURCE HANDBOOK (NIC 23200), Network Information Center, Stanford Research Institute, Menlo Park, California, 1975.

[ASH 74] Ashenurst, R. L., "Hierarchical Computing," in Greenberger, M., et. al., (eds.) Networks For Research and Education The MIT Press, Cambridge, Massachusetts, 1974., pp 74-88.

[BAL 73] Balzer, R. M., T. E. Cheatham, S. D. Crocker, and S. Warshall, National Software Works Design, USC/Information Sciences Institute, RR-73-16, November 1973.

[BEN 74] Benoit, J. W. and E. Graf-Webster, "Evolution of Network User Services--The Network Resource Manager," Computer Networks: Trends and Applications, IEEE Inc., New York, 1974, pp. 21-24. (Proceedings of the 1974 Symposium sponsored by the National Bureau of Standards, Gaithersburg, Maryland, and the IEEE Computer Society).

[BLA 74] Blanc, R. P., "Assisting Network Users with a Network Access Machine," Proc. ACM 1974, November 1974.

[BOU 73] Bouknight, W. J., G. R. Grossman and D. M. Grothe, "The ARPA Network Terminal System--A New Approach to Network Access," Proc. DATACOM 73, 1973 pp. 73-79.

[CAR 74] Carlson, W. E. and S. D. Crocker, "The Impact of Networks on the Software Marketplace," EASCON '74 Record, (IEEE Electronics and Aerospace Systems Convention) IEEE N.Y., October 1974, pp. 304-308.

[HAR 74] Hardy, M. E., Jr., "Microprocessor Technology to

"Extend the Utility of Computer Peripherals," Proc. COMPCON 74, February, 1974, pp. 299-302.

[IRB 76] Irby C. H., "The Control Meta Language System," to be published in Proc NCC, 1976.

[KIM 76] Kimbleton, S. R., and Schneider G. M., "Computer Communication Networks: Approaches, Objectives, and Performance Considerations," Computing Surveys, Vol. 7, No. 3, Sept. 1975, ACM.

[KWI 73] Kriloff, H. Z., "A High-level Language for use with Multicomputer Networks," Proc. NCC 1973, pp. 149-153.

[LUT 72] Luther, W., "Conceptual Bases of Cybernet," Computer Networks, ed. by Rustin and Randal, Prentice-Hall, Inc., New Jersey, 1972, pp. 111-146.

[MAR 75] Marcus, R. S., "Network Access for the Information Retrieval Application," Access to Computer Networks (Session 25, IEEE Intercon 75, IEEE Intercon Conference Record) IEEE N. Y., April 1975, pp. 25/4: 1-7.

[NEU 73] Neumann, A. J., "User Procedures Standardization for Network Access," NBS Technical Note 799, October 1973.

[ORN 72] Ornstein, S. M., F. Heart, et. al., "The Terminal IMP for the ARPA Computer Network," Proc. SJCC 1972, pp. 243-254.

[POS 74] Postel, J. B., et al., "ARPA Network Current Network Protocols," Network Information Center NIC 7104, Dec., 1974. (distributed by NTIS AD/A - 003 890).

[PYK 73] Pyke, T. N., Jr., "Some Technical Considerations for Improved Service to Computer Network Users," Proc. COMPCON 73, Feb. 1973, pp. 53-55.

[PYK 74] Pyke, T. N., Jr., "Network Access Techniques: Some Recent Developments," Proc. Third Annual Texas Conference, October 1974.

[RET 75] Retz, D. L., "ELF -- A System for Network Access," Access to Computer Networks (Session 25, IEEE Intercon 75, IEEE Intercon Conference Record) IEEE N. Y., April 1975, pp. 25/2: 1-5.

[ROB 70] Roberts, L. and B. Wessler, "Computer Network Development to Achieve Resource Sharing," Proc. SJCC 1970, pp. 543-549.

[REI 74] Reintjes, J. F. and R. S. Marcus, Research in the Coupling of Interactive Information Systems, Final Report No. ESL-FR-556, Electronic Systems Laboratory, Department of Electrical Engineering, MIT, June, 1974.

[ROS 74] Rosenthal, R. and S. Watkins, "Automated Access to Network Resources: A Network Access Machine," Computer Networks--Trends and Applications, NBS-ICST and IEEE Computer Society, May 1974.

[ROS 75] Rosenthal, R., "Accessing Online Network Resources with a Network Access Machine," Access to Computer Networks (Session 25, IEEE Intercon 75, IEEE Intercon Conference Record) IEEE N.Y., April 1975, pp. 25/3: 1-4.

[THO 73] Thomas, R. H., "A Resource Sharing Executive for the ARPANET," Proc. NCC 1973, June, 1973, pp. 155-163.

[TYM 71] Tymes, L. "TYMNET--A Terminal Oriented Communications Network," Prqc. SJCC 1971, pp. 211-216.

[WYA 75] Wyatt, J. B., "Management in Applications of Network Access," Access to Computer Networks (Session 25, IEEE Intercon 75, IEEE Intercon Conference Record) IEEE N.Y., April 1975, pp. 25/1: 1-6.

U. S. DEPT. OF COMM BIBLIOGRAPHIC DATA SHEET	1. PUBLICATION OR REPORT NO. NBS TN-917	2. Gov't Accession No.	3. Recipient's Accession No.
4. TITLE AND SUBTITLE A Review of Network Access Techniques with a Case Study: The Network Access Machine		5. Publication Date July 1976	6. Performing Organization Code
7. AUTHOR(S) Robert Rosenthal		8. Performing Organ. Report No.	
9. PERFORMING ORGANIZATION NAME AND ADDRESS NATIONAL BUREAU OF STANDARDS DEPARTMENT OF COMMERCE WASHINGTON, D.C. 20234		10. Project/Task/Work Unit No. 6502372	11. Contract/Grant No. DCR-72-01206
12. Sponsoring Organization Name and Complete Address (Street, City, State, ZIP) National Science Foundation 1800 G Street, N.W. Washington, D. C. 20550		13. Type of Report & Period Covered Interim	14. Sponsoring Agency Code
15. SUPPLEMENTARY NOTES			
<p>16. ABSTRACT (A 200-word or less factual summary of most significant information if document includes a significant bibliography or literature survey, mention it here.)</p> <p>The computer industry's ability to serve a diverse and expanding user community is evidenced by the rapid growth of computer network services. Computer service providers design and market their own offerings as they deem best, given their own market and their own set of resources. This has led to a proliferation of similar resources requiring different user access procedures. With emphasis on currently operating and planned systems that assist users in accessing available network services, this report identifies the techniques used in network access devices. By examining these devices, the trend toward improving the interface between the user and the computer is brought more clearly into focus and up to date.</p> <p>One specific solution--A Network Access Machine (NAM)--is described in detail. The NAM is a minicomputer system that acts as a network access point for a user at his terminal and assists the user through the automatic execution of access procedures. This minicomputer facility allows the user to specify (or to have specified) his own network command sequences for execution on a specified network and host connected to that network. Computer responses are analyzed to assure agreement with those anticipated for specific commands. Conditional parameterized expansions allow the use of the same commands on different host computer and different networks.</p>			
<p>17. KEY WORDS (max to twelve entries, alphabetical order, capitalize only the first letter of the first key word unless a proper name, separated by semicolons)</p> <p>Access procedures; command language; computer networks; job control language; macros; minicomputers; protocols; teleprocessing</p>			
<p>18. AVAILABILITY <input type="checkbox"/> Unlimited</p> <p><input type="checkbox"/> For Official Distribution. Do Not Release to NTIS</p> <p><input checked="" type="checkbox"/> Order From Sup. of Doc., U.S. Government Printing Office Washington, D.C. 20402, SD Cat. No. C13. 46:917</p> <p><input type="checkbox"/> Order From National Technical Information Service (NTIS) Springfield, Virginia 22151</p>		<p>19. SECURITY CLASS (THIS REPORT)</p> <p>UNCLASSIFIED</p>	<p>21. NO. OF PAGES</p> <p>36</p>
		<p>20. SECURITY CLASS (THIS PAGE)</p> <p>UNCLASSIFIED</p>	<p>22. Price</p> <p>\$0.85</p>