

DOCUMENT RESUME

ED 143 518

SE 022 996

AUTHOR Chinn, William G.; And Others  
 TITLE Developing Mathematics Readiness in Pre-School Programs.  
 INSTITUTION Stanford Univ., Calif. School Mathematics Study Group.  
 SPONS AGENCY National Science Foundation, Washington, D.C.  
 PUB DATE 67  
 NOTE 90p.; Not available in hard copy due to marginal legibility of original document

EDRS PRICE MF-\$0.83 Plus Postage. HC Not Available from EDRS.  
 DESCRIPTORS \*Arithmetic; \*Elementary School Mathematics; Geometry; \*Kindergarten; \*Number Concepts; Preschool Education; \*Teaching Guides  
 IDENTIFIERS \*School Mathematics Study Group

ABSTRACT

Represented are notes that have been compiled from meetings between teachers and members of the SMSG staff, discussing kinds of pre-school activities that might be appropriate for the development of various mathematical concepts. The sequence of concepts presented are, in the same order as they are developed in the SMSG kindergarten program. Some slight editorial modifications were made from the meeting notes. Each unit consists of a section on Background Notes, Readiness, Activities, and Vocabulary. Included are 15 units. These include the following: (1) Sets; (2) Equal Sets; (3) Subset; (4) A Set with One Member and the Empty Set; (5) One-to-One Correspondence; (6) More Than and Fewer Than; (7) Ordering of Sets; (8) Number Property of a Set; (9) Comparison of Numbers; (10) Operation with Sets; (11) Elements of Geometry; (12) Simple Closed Curves; (13) Figures in Three-Dimensions; (14) The Number Line; and (15) Arithmetic Operations. (Author/RH)

\*\*\*\*\*  
 \* Documents acquired by ERIC include many informal unpublished \*  
 \* materials not available from other sources. ERIC makes every effort \*  
 \* to obtain the best copy available. Nevertheless, items of marginal \*  
 \* reproducibility are often encountered and this affects the quality \*  
 \* of the microfiche and hardcopy reproductions ERIC makes available \*  
 \* via the ERIC Document Reproduction Service (EDRS). EDRS is not \*  
 \* responsible for the quality of the original document. Reproductions \*  
 \* supplied by EDRS are the best that can be made from the original. \*  
 \*\*\*\*\*

U.S. DEPARTMENT OF HEALTH,  
EDUCATION & WELFARE  
NATIONAL INSTITUTE OF  
EDUCATION

THIS DOCUMENT HAS BEEN REPRO-  
DUCED EXACTLY AS RECEIVED FROM  
THE PERSON OR ORGANIZATION ORIGIN-  
ATING IT. POINTS OF VIEW OR OPINIONS  
STATED DO NOT NECESSARILY REPRESENT  
OFFICIAL NATIONAL INSTITUTE OF  
EDUCATION POSITION OR POLICY.

PERMISSION TO REPRODUCE THIS  
MATERIAL HAS BEEN GRANTED BY

SMSC

TO THE EDUCATIONAL RESOURCES  
INFORMATION CENTER (ERIC) AND  
THE ERIC SYSTEM CONTRACTORS

## DEVELOPING MATHEMATICS READINESS IN PRE-SCHOOL PROGRAMS

The following is a list of all those who participated in the preparation  
of this volume:

William G. Chinn, San Francisco Unified School District, San Francisco  
Ruth K. Huston, San Ramon Elementary School, Mt. View, California  
Jeanne M. Lattleboy, San Ramon Elementary School, Mt. View, California  
Janet L. McClurg, San Ramon Elementary School, Mt. View, California  
Patrick A. O'Donnell, San Ramon Elementary School, Mt. View, California  
Jeanette O. Summerfield, San Francisco State College, San Francisco

© 1967 by The Board of Trustees of the Leland Stanford Junior University  
All rights reserved  
Printed in the United States of America

*Permission to make verbatim use of material in this book must be secured from the Director of SMSG. Such permission will be granted except in unusual circumstances. Publications incorporating SMSG materials must include both an acknowledgment of the SMSG copyright (Yale University or Stanford University, as the case may be) and a disclaimer of SMSG endorsement. Exclusive license will not be granted save in exceptional circumstances, and then, only by specific action of the Advisory Board of SMSG.*

*Financial support for the School Mathematics Study Group has been provided by the National Science Foundation.*

## Preface

In the summer of 1966, the principal of the San Ramon Elementary School in Mountain View, California, approached the Director of the School Mathematics Study Group for suggestions with regard to a pre-school program in mathematics for culturally disadvantaged children. As the School Mathematics Study Group had no previous experience with pre-schoolers, it could only offer to acquaint the San Ramon staff with the special kindergarten program that the SMSG had designed for a comparable population. Arrangements were then made to have the teachers meet regularly with members of the SMSG staff, discussing kinds of pre-school activities that might be appropriate for the development of various mathematical concepts.

The meetings were scheduled in two phases. The first phase consisted of a series of structured presentations in the fall of 1966. For these, Mrs. Jeanette Summerfield of the School Mathematics Study Group expanded on selected topics from the SMSG Studies in Mathematics, Volume 13, INSERVICE COURSE IN MATHEMATICS FOR PRIMARY SCHOOL TEACHERS, revised edition. The second phase took place in the spring of 1967. The initiative was then assigned the teachers of the pre-schoolers to propose various pre-school activities that might lend themselves to a program of readiness for mathematics.

Participating teachers from the San Ramon Pre-School for these meetings were: Miss Ruth K. Huston, Mrs. Jeanne M. Littleboy, Mrs. Janet L. McClurg, and Mr. Patrick A. O'Donnell, the principal of San Ramon Elementary School. Mrs. Jeanette O. Summerfield and Mr. William G. Chinn were the participants from the School Mathematics Study Group.

What follows on these pages represents notes that have been compiled from the meetings. Here, the sequence of relevant concepts presented are in the same order as they are developed in the SMSG kindergarten program. While the writers are not suggesting that there is only one suitable program in mathematics for pre-schoolers, they feel that these units offer a reasonable sequence. Some of the units, occurring later in the sequence, are occasionally predicated upon experiences and vocabulary developed in the earlier units. Some slight editorial modifications have been made from the notes of the meetings in order to gain uniformity and cohesiveness in format. Each unit consists of a section on Background Notes, Readiness, Activities, and Vocabulary. In each case, we tried to include some remarks that might clarify the particular concept that we have in mind. Thus, we felt free to discuss:

the topics more intensively than they are intended to be developed for the children at this level. This defining feature, we hope, would help to place the topics in proper perspective for an understanding of its role in elementary mathematics.

The writing group wishes to express its appreciation to the Director of the School Mathematics Study Group, Dr. E. G. Begle, for organizing these conferences and otherwise help in planning, guidance, and making the facilities of the SMSG headquarters available for the meetings.

## TABLE OF CONTENTS

Preface		1
Unit 1.	SETS . . . . .	1
Unit 2.	EQUAL SETS . . . . .	5
Unit 3.	SUBSET . . . . .	9
Unit 4.	A. SET WITH ONE MEMBER AND THE EMPTY SET . . . . .	13
Unit 5.	ONE-TO-ONE CORRESPONDENCE . . . . .	18
Unit 6.	MORE THAN AND FEWER THAN . . . . .	25
Unit 7.	ORDERING OF SETS . . . . .	29
Unit 8.	NUMBER PROPERTY OF A SET . . . . .	33
Unit 9.	COMPARISON OF NUMBERS . . . . .	40
Unit 10.	OPERATIONS WITH SETS . . . . .	44
Unit 11.	ELEMENTS OF GEOMETRY . . . . .	50
Unit 12.	SIMPLE CLOSED CURVES . . . . .	59
Unit 13.	FIGURES IN THREE-DIMENSIONS . . . . .	72
Unit 14.	THE NUMBER LINE . . . . .	75
Unit 15.	ARITHMETIC OPERATIONS . . . . .	77

## 1. SETS

### BACKGROUND NOTES

The concept of set is one that occurs over and over again in mathematics. This concept occurs, for example, in dealing with sets of points, sets of numbers, sets of objects, and so on. The most general of these are sets of objects, especially if we interpret "objects" in the broad sense as "entities". Not only are sets of objects the most general, but with judicious choice of objects, such sets can be also the most concrete in terms of visualization.

A set is a collection. Each object in a set is called a member or element of the set. For example, a collection of children in the classroom, or a collection of monkeys in the zoo, each constitutes a set of objects. Each child or each monkey is an element of the respective set.

It may be natural to think of a set as consisting of objects having some characteristic in common. In fact, it may appear that this is the only way sets could be formed. For instance, in the collection of children in the classroom, a common characteristic (common property) is that these objects or members are all children. However, having a common property is not a prerequisite to being members of a set. It is perfectly acceptable to think of a set consisting of these elements: Bobby Jones, paper clip, radio. That is to say, a set may consist of objects having no characteristic in common other than simply belonging to the same set.

Clearly, sets may have many members or few members. For a small number of members, we may even think of a set consisting of just one member. Even this may be regarded as a collection (such as: "a committee of one"). Furthermore, we may conceive of a set consisting of no member. This special set will be discussed later under "the empty set".

In examining a set, one of our questions may be: "Is there a characteristic shared by every member of the set?" As we have noted above, this question may or may not be answered in the affirmative. When we look at a variety of sets side-by-side, we may also want to pose the same question: "Is there a characteristic shared by every one of these sets?" Again, the answer may vary. However, there may be some common characteristic that may be inconspicuous at first blush. With this in mind, sets will be selected for study such as to bring out the property of having the same number of objects. Thus, sets help form a primitive basis for the number concept and serve as pre-number ideas.

## Describing Sets

There are various ways in which a set may be specified. If the set consists of the following members,

California, Oregon, and Washington,

then we may specify the set by listing all the members. A class roster is thus a means of specifying a particular set; a reading list is a means of specifying another set. In the later grades when special symbols are introduced, we can list the elements within braces { } to denote the set so specified. Thus, if the reading list consists of the book titles, The Story of Ping, A Day in Maine, and Make Way for Ducklings, we can enclose these titles within braces

{The Story of Ping, A Day in Maine, Make Way for Ducklings}

to denote "the set whose members are The Story of Ping, A Day in Maine, and Make Way for Ducklings." The braces are an abbreviation for the words "the set whose members are". Note that the items in the listings are separated by commas.

There are occasions when it is inconvenient or impractical to specify the set by listing all its members. For example, the set of all states of the United States requires a listing of 50 states; the set of all inhabitants in the United States may require a listing of more than 200 million names. If there is an explicit common property that may be used to characterize the members of the set, then such a description may be adequate. Thus,

{the states of the United States}

specifies the set being considered. For convenience, we may use a letter symbol to label a particular set, and once so identified, refer to this set by its label. Thus, if we agree to label the set of states of the United States by the letter A, then we can write

A = {the states of the United States}.

Thereafter, the set of states of the United States may be referred to simply as A. Conventionally, capital letters are used for this purpose.

We have mentioned that a class roster is a means of specifying a particular set. Note that a child's name is not listed more than once in specifying the set. Once he is listed, he is designated as a member of the set. By the same token, {d, e, r} is the set of all letters in the word "deer" as well as in the word "red" or in the word "erred",



## READINESS

At the pre-school level, the child's experiences with sets should be with concrete objects. Hence, the symbols "{" and "}" for denoting sets are not introduced. It is suggested that the teacher use the words "set" and "member" whenever possible. In pointing out sets of objects, be sure to include examples of a set whose members do not share a common property, such as the following

$$A = \{\text{marble, Susan, table}\}$$

as well as one whose members do share a common property, such as

$$B = \{\text{the musical instruments in the classroom}\}.$$

## ACTIVITIES

At this level, no formal learning procedure is advocated. Rather, attempt to create an atmosphere in which incidental learning can occur. A program for incidental learning, to be sure, is not merely a matter of allowing certain concepts to come into view; it is planned exposure to the concepts—more structured than accidental learning and less structured than formal learning. We list below some suggestions for the kinds of "planned exposure" that we have in mind relevant to the concept of a set.

- o In the classroom, attention can be called to sets of objects having similar members; for example, sets of blocks, sets of paint brushes, and so on.
- o Once the concept of sets begins to take shape and when danger of confusion is not likely, it is important to call attention to sets consisting also of dissimilar objects; for example, lunch table settings, first aid equipment, sandbox toys, etc.
- o Frequent conscious and intentional use of the vocabulary "set" should be a part of the program of planned exposure. This can seem strange at first, but becomes comfortable after some deliberate use.
- o Sets of objects located in various areas of the room can be described; for example, equipment found in the art area, doll area, block play area, etc.
- o A variety of sets may be constructed with children in the class as members; for example, as children work and play together, different groups may be identified as sets: "the set of boys at the slide", "the set of girls by the swing", and other such groupings.

- Specification of sets by category may be illustrated by such classifications or defining characteristics as: "table blocks", "floor blocks", "indoor clothes", "outdoor clothes", "boys' clothing", "girls' clothing", and the like.
- Lunch provides many opportunities for the discussion of sets; for example, with reference to silverware, napkins, plates, seating arrangements of the children.
- Family groups in stories may be identified as sets. Consider, for example, family groups mentioned in: Ping, Blueberries for Sal, The Three Bears, etc.
- Activities in sorting and classifying objects form important bases for sorting and classification of concepts for learning. Among the relevant properties of sets which might be discussed with children are the following:
  - size, color, shape, texture, straightness, curvedness, function, physical nature (solid, liquid, or gas), mass, weight, number of sides, length.
- Teachers can encourage readiness for this concept by alternately focusing on the child as an individual (member) and as part of a larger set (class). For example,
  - "Where is Michael? Michael is a member of our group."
  - "Is everyone in our group here?"

#### VOCABULARY

element of a set  
 member of a set  
 set.

BACKGROUND NOTES

In our discussion about sets, we have indicated that a set may be specified by various means such as by listing all the members or by description through some common properties. Each of these, we have noted, has its advantages and disadvantages.

The use of the first method depends heavily upon limitations of practicality: Does the length of the listing make it impractical to resort to this way of specifying the set? Or, are there inherent impossibilities for the listing? To illustrate the first point, "Can we indeed within reason list the names of 200,000,000 persons?" (No, if we consider taking on the task as individuals; possibly yes, if we consider the task as a national enterprise such as for census-taking.) To illustrate the second point, "Can we now list, for example, the names of all children born in California next year?"

On the other hand, we have also indicated that it is not always possible to specify a set by describing properties shared by all the members. In fact, sets may consist of elements with no other common property than that of belonging to the same set. Even if there were properties that the elements have in common, in using these to define the set, an obvious but necessary word of caution should be stated: as defining properties, not only should each member of the set possess all these properties; furthermore, no element possessing all these properties can fail to belong to the set in question.

For this level, the kinds of sets that we shall construct can usually be described by listing. For example, we may identify a set,  $A$ , as follows:

$$A = \{\text{Pat, Jean, Ruth}\}.$$

At this point, a word about the notation, " $A = \{\text{Pat, Jean, Ruth}\}$ " may be in order. When we use the symbol "=" in a sentence such as this, we shall mean that the two expressions are names for the same thing. In this case, " $A$ " and " $\{\text{Pat, Jean, Ruth}\}$ " are both different names for the same set. In the case

$$\{\text{Pat, Jean, Ruth}\} = \{\text{Pat, Jean, Ruth}\},$$

the expression at the left,  $\{\text{Pat, Jean, Ruth}\}$ , and the expression at the right,  $\{\text{Pat, Jean, Ruth}\}$ , are both names for the same set.

Now consider sets A and B, specified as follows:

$A = \{\text{Pat, Jean, Ruth}\}$

$B = \{\text{Jean, Ruth, Pat}\}$ .

We see that both of these sets consist of exactly the same members. Since a set is specified by its members, the elements belonging to A, namely

Pat, Jean, and Ruth,

equally well specify the set identified by the letter B. This fact may be described by saying that A and B are equal sets, and we write:  $A = B$ .

Examine the following specifications:

{the first five letters of the English alphabet};

{a, b, c, d, e}.

Since they contain exactly the same elements, we say that they are equal sets, and we may express this by stating

{the first five letters of the English alphabet} = {a, b, c, d, e}.

In general,

IF A IS A SET AND B IS A SET, THEN  $A = B$

IF BOTH SETS HAVE EXACTLY THE SAME MEMBERS.

Thus, since {Spain, France, England} has exactly the same members as {France, Spain, England}, we can write

{Spain, France, England} = {France, Spain, England}.

Note that the order in listing the elements of a set is immaterial in specifying the set. The same set may be specified by two different listings of the same members.

### READINESS

We want to communicate the concept that a set is defined by the members; it does not matter how widely spaced these members may be. For example,



is the same set of objects as

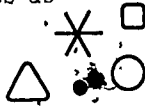

However, although we wish to emphasize that set membership is independent of spatial arrangement, we also recognize the intuitive aspects in visual perception. In a visual display, the spatial arrangement of a set of objects may suggest a natural grouping. Thus the arrangement

x x x x x      x x x x x      x x x x x  
x x x x x      x x x x x      x x x x x

might suggest 3 groups of ten objects.

Later on, when we examine the basis underlying our numeration system, we do capitalize on this tendency to group on the basis of spatial arrangement. For example, to arrive at a particular decimal numeral, a set of objects may be spatially grouped into sets of 10's and 1's, and so on.

#### ACTIVITIES

The fact that rearranging the members of a set does not change the set is not an easy concept to teach, and a variety of experiences may need to be provided leading to this notion. Some children are quite convinced that each time there is a new arrangement of the same members, a new set is formed. By way of illustrating that we still have the same set, a few examples are suggested below.

- o If Jimmy, Susie, Johnny, Bobby, and Louise sit at Table 1 for milk and crackers, it is the same set of children at the table even if Bobby and Louise were to exchange seats.
- o Johnny Jones' family consists of the same members even though Johnny Jones is in school, father is at work, and mother and Sissy are staying home.
- o Books may be arranged differently on a shelf. If there is no change in membership, then each arrangement gives us the same set of books.
- o As a certain set of children are gathered at the slide area, some may be going up the steps of the slide, some may be scooting down the slide, and others may be waiting in line to go up the steps. If none of these children leave this play area and no new members join in, then we have the same set of children at the slide area.

- o Questions such as "Where is Michael? Michael is a member of our group." and "Is everyone in our group here?" serve also to hint at the concept that a new arrangement of the same members does not change the constituency of a set. Michael still belongs to the group whether he happens to be off in the jungle gym or riding a tricycle.

The concept of equal sets is one that the students will be faced with again and again. To sharpen the notion, we may want to emphasize that if there is a change in membership, a different set is formed. For example:

- o In our illustration above of children at Table 1 for milk and crackers, if Jimmy, who was at Table 1, traded seats with Dotty, who was originally at Table 2, then the children in Table 1 after the exchange are no longer exactly the same ones as were there before.
- o Janet, Pat, and Jeanette are in the doll area; Barbara joins in with the group. Then the set

{Janet, Pat, Jeanette}

has been changed to a different set

{Janet, Pat, Jeanette, Barbara}

because of this change in membership.

#### VOCABULARY

equal sets

BACKGROUND NOTES

We can illustrate the concept of a set by constructing a variety of them. For example, a set of boys in the class might be

$$B = \{\text{Jim, Tom, Bob, Dave}\}.$$

Another set of boys in the class might be

$$S = \{\text{Jim, Bob, Dave}\}.$$

Notice that  $S$  can be formed by selecting members from  $B$ . It is true that we can always look for such special relationships between sets: in forming sets, the elements are usually drawn from another set serving as a source, so to speak.

Thus, when a set is formed consisting of children in the classroom, each of the members is drawn from the class; in building with blocks, each of the blocks going into a construction is drawn from a pool of blocks; a stack of books drawn from the bookshelf constitutes a set related to the set of books on the shelf in this special way. Likewise, given the set

$$A = \{a, b, c, d, e\},$$

another set,  $B$ , consisting of the elements  $a, c$ , and  $d$  from  $A$  may be formed:

$$B = \{a, c, d\}.$$

From the way that  $B$  is formed, we can see that each of its elements is an element of  $A$ . This last statement serves as the criterion by which the concept of a subset may be defined. We say that

IF  $A$  AND  $B$  ARE SETS, THEN  $B$  IS A SUBSET OF  $A$   
IF EACH ELEMENT OF  $B$  IS ALSO AN ELEMENT OF  $A$ .

Thus,  $\{\text{Jim, Bob, Dave}\}$  is a subset of  $\{\text{Jim, Tom, Bob, Dave}\}$ ; each member of

$$\{\text{Jim, Bob, Dave}\}$$

is a member of

$$\{\text{Jim, Tom, Bob, Dave}\}.$$

On the other hand,  $\{\text{Jim, Dave, Frank}\}$  is not a subset of  $\{\text{Jim, Tom, Bob, Dave}\}$  because Frank is not a member of  $\{\text{Jim, Tom, Bob, Dave}\}$ .

Consider now, sets A and B specified as follows:

$$A = \{a, b, c, d, e\} \text{ and } B = \{b, e, c, a, d\}.$$

We can verify that every element of B is an element of A (remember that the order of listing of the elements is immaterial); therefore, B is a subset of A. Observe now that both A and B consist of the same members; so  $A = B$ . This example illustrates that one of the subsets that can be formed from a given set may be simply the given set. This occurs, for example, when all the blocks in a container has been used in block-building. The set of blocks in the building is precisely the same set of blocks that was in the container.

The fact that one of the subsets that can be formed may be the given set may be so taken for granted that the need to make such a statement is not at all apparent. However, this fact will have some undertones for us, as for example, when we examine certain special cases for subtraction.

We have noted that if

$$A = \{a, b, c, d, e\} \text{ and } B = \{b, e, c, a, d\};$$

then B is a subset of A; it is equally true that A is a subset of B.

This leads to the following statement:

IF A IS A SUBSET OF B, AND IF B  
IS A SUBSET OF A, THEN  $A = B$ .

### READINESS

In introducing the word "subset", careful enunciation is needed as there may be confusion between the words "set" and "subset" because these terms may sound alike to the children.

Both the proper use of language and the deliberate stress on certain critical terms are particularly important in view of the listening habits of some children. Some may not be able to grasp all that is said. In addition to marked effort in the proper use of language, constant and natural use of new terms throughout the day as occasions arise has been found to be helpful. This is like working in "La plume de ma tante" at every opportunity one gets.

In order to make the idea of subset meaningful to the children, it may be necessary for a while to use the expression "set within a set". The set must be identified first in each instance before discussing subsets of that given set. In speaking of a subset, we must always have a reference set.



As we have pointed out, it is true that a set is a subset of itself. However, this notion is not simple and does not need to be given emphasis at this time. For this level, we can use examples, instead, in which the subset is a part of a larger set.

When the idea of subset is introduced, the children may tend to always select like objects as members of the subset. You will have to provide numerous opportunities for them to manipulate set materials and form various subsets so that they will understand that a subset may be any set within a given set. When identifying subsets of a set, make clear that since a subset is a set, a subset likewise may, but needs not, consist of like members.

In view of this, avoid having the children develop the misconception that a subset is a subset because the members belong together for reasons based on size, color, use, etc. You may find that it will be effective to do more "showing" than "telling".

It is true that each individual member of a set is a subset of that set. However, in the early activities with subsets, we suggest that you generally consider subsets that have at least two members. In this way, children are less likely to confuse the idea of "member of a set" with the idea of "subset of a set".

### ACTIVITIES

There may be many instances where examples of subsets can be pointed out. Appropriate vocabulary should be used where applicable. Activities can be planned so that there will be many incidental opportunities for discussion of this concept. Here are a few suggestions.

- o During play period, a subset of the class that is on team A might be identified.
- o A subset of the ducklings in the pond might be an appropriate subject for conversation during reading.
- o Members of the class who are playing specified instruments (e.g., drums, rhythm sticks, piano, etc.) is a subset of the class.
- o Pieces of a puzzle may be a subset of the puzzle.
- o A toy or group of toys might be a subset of a larger set of toys.
- o The rhythm records form a subset of the classroom set of records.

- o Various subsets may be identified in sets of parquetry blocks.
- o Members of the class at the painting area form a subset of the class.
- o The paint brushes are members of a subset of the painting equipment.

VOCABULARY

subset

BACKGROUND NOTES

When we say that a set is well-defined, we mean that it is clear what objects are to be members of the set and what objects are not to be members of the set. For example,

$$V = \{\text{the vowels in the English alphabet}\}$$

is well-defined. Given a letter of the English alphabet, we know whether it belongs to the set or not. Neglecting irregularities, the members of  $V$  are the letters: a, e, i, o, and u. Thus

$$\{a, e, i, o, u\}$$

describes or specifies the same set identified above by the letter  $V$ . With either description, the set is well-defined.

The description, "the set of all vowels in the word 'cat'", just as clearly specifies a set as the description, "the set of all vowels in the English alphabet". Using the criterion,  $V = \{a, e, i, o, u\}$ , we find that only one letter (namely the letter "a") of  $\{c, a, t\}$  fits the description,

$$\{\text{the vowels in the word "cat"}\} = \{a\}.$$

In other words,

$$\{\text{the vowels in the word "cat"}\} = \{a\}.$$

This is an example of a set with a single member.

It may conflict with our intuitive sense to think of a set with a single member since, in ordinary language, the word "set" connotes more than one object in the collection. Logically, however, unless the concept of a one-member set is considered appropriate, it would make no sense to come up with "a" as the set of all vowels in the word "cat"; for then, the letter "a" would not answer the question, "What is the set of all vowels in the word 'cat'?"

In thinking about a set with one member, there is a strong inclination to think of the set and the member that makes up this set as one and the same thing, and it is important to distinguish between the two. By this we mean, for example, that

the set whose only member is "a"

should not be confused with

the letter "a".

A case in point might be given, for example, in the cataloguing of books in the school library. Under the category of classics might be just the one book, Treasure Island. By itself, the book is not the same as the set of classics. If another book is added to the collection, the set of classics has changed; the book, Treasure Island, has not changed.

An even more bizarre set that we shall now describe is the set that has no members. Using the same criterion as above for the set of all vowels in the English alphabet, we may ask, "What is the set of all vowels in the word 'why'?" This set has no members! As another illustration, consider the set of all two-eyed Cyclops. This is also the set having no members: the empty set.

Both of the mathematical concepts--of a set with one member and of the set with no members--are convenient ones. Moreover, as in the case of a set with one member, the existence of the empty set is a vital question of logic. Neither the question, "What is the set of all vowels in the word 'cat'?" nor "What is the set of all vowels in the word 'why'?" can be answered unless the existence of a set with one member and the empty is admitted. A plea may be made that the questions themselves need to be reworded. Instead of asking, "What is the set of all vowels in the word 'cat'?", it may be more appropriate to ask, "What is the vowel in the word 'cat'?" Equally, instead of "What is the set of all vowels in the word 'why'?", it may be more appropriate to ask, "What, if any, is the vowel in the word 'why'?" This may sound sensible, but it does require a priori knowledge of the answer. Quite often, we do not know in advance, how many solutions we may have to a problem. With the understanding that there may be one, more than one, or no members in a set, there would be no need to rephrase the question each time a special situation is encountered. For example, the question, "What is the set of boys enrolled in this school?" might be equally applicable to the Yale, Columbia, or Vassar population--or to one in which just one boy happens to be enrolled.

The empty set is the set with no members. Thus, the set of all boys enrolled in Vassar is an example of the empty set. The set of all months having nine Sundays (Gregorian calendar) is another example of the empty set. A notation for the empty set is  $\{ \}$ . The empty space between the braces indicates that there are no members in the set.

Recall that B is said to be a subset of A if each member of B is also a member of A. Another way to say this is:

B IS A SUBSET OF A IF THERE IS NO MEMBER OF B WHICH IS NOT ALSO A MEMBER OF A.

Both statements say exactly the same thing. As a consequence of the second statement, the empty set is a subset of

$A = \{\text{Bob, Jim, Dave}\}.$

To see this, consider the two sets

$E = \{ \}$  and  $A = \{\text{Bob, Jim, Dave}\}.$

Can it be stated that there is no member of E that is not also a member of A? Since this is true, then it can be argued that the empty set is a subset of A. By the same token, we can say that

THE EMPTY SET IS A SUBSET OF EVERY SET.

### READINESS

As indicated above, the set with one member and the empty set may not seem to be easy concepts to present. Many teachers, however, report that children have been able to grasp these concepts quite easily. Since these sets will ultimately be associated with the number 1 and 0, they need to be included in our experiences with sets.

Familiar examples of one member sets may be

the set of clocks on the wall,  
the set of teachers in the class, or  
the set of American flags in the room.

As for sets with no members, reference may be made to such sets as

the set of live elephants seated at the teacher's desk.

Also, you may refer to such sets as

the set of crayons in a crayon container

when there are no crayons in the box.

The concept of the empty set being a subset of every set is a readiness task for the operation of subtraction. In doing the problem,  $2 - 0 = 2$ , the child imagines the operation as one of removing a subset with no members from a set with two members.

## ACTIVITIES

Children can be prepared for the concept of a set with a single member without being given a formal definition of the concept. In pre-kindergarten, this is surely the level for most of our activities in mathematics. Games can be devised along the lines of "I am thinking of ..." that would hint at specifying a set with one member by supplying enough clues. For example,

"I am thinking of a little girl in this classroom who has dark hair."  
(Silence?)

"This little girl has a bow in her hair." (More silence?)

"This little girl is wearing a red dress today." (Still more silence?)

"This little girl is sitting in the back row and is the tallest little girl in this class." (Ruthie!)

or,

"I am thinking of something that is in this room. It is made of cloth and is fastened to a stick. The cloth has a pattern on it of some red and white stripes, and of some white stars inside a blue patch..."

- o Readiness for the empty set may be provided first by the concept of empty. Children should have many concrete examples with the preconcept of emptiness. For example,

empty hands;

empty plate;

empty juice pitcher;

empty animal cage;

empty puzzle rack;

empty nail box...

- o For each empty container, we can discuss what could be there. For example,

animal cage: hamster, guinea pig, turtle, rabbit, etc.;

pitcher: milk, juice, Kool Aid, etc.;

puzzle rack: puzzles.

- o We can also discuss what was there:

pitcher: juice;

plate: meat, vegetables, etc.

We can remark, "Your plate is empty. You have eaten all of your meat, potatoes, and applesauce!"

- o In addition to planning experiences where the concept of empty can be isolated for the children, the teacher can make use of the many incidental opportunities in the daily program to point out empty sets. Use the vocabulary empty or empty set wherever possible. Do not use vocabulary where use would be artificial or forced. Thus, there will be fewer opportunities in the daily program to use the words, empty set, than to use the word, empty. Many concrete experiences with situations are more important at this level.

#### VOCABULARY

empty

empty set

## 5. ONE-TO-ONE CORRESPONDENCE

### BACKGROUND NOTES

One of the ways that we have used to specify a set is to describe it by the property or properties that the elements have in common. For example, the set

{vowels in the English alphabet}

is specified by the properties that every element of the set shares; namely, that of being an English letter and that of being a vowel. This commonness between elements within the set sorts out elements that belong to the set from elements that do not belong.

Oftentimes, common properties between different sets may be identified, and thus the method of classifying things can be extended to help distinguish one kind of set from another; that is, classification of things may be extended to classification of sets of things. For example, if

$A = \{\text{lion, tiger, leopard}\}$

and

$B = \{\text{elephant, deer, cow, horse}\},$

then it is not true that  $A = B$ . In fact, there is no element that the two sets have in common. However, one would agree that there is more in common between  $A$  and  $B$  than there is between either of these sets and

$C = \{\text{gold, wood, water, fire, earth}\}.$

The commonness that we recognize between  $A$  and  $B$  is that both of these are sets of animals; moreover, of land animals. While we may choose to distinguish  $A$  from  $B$  by the characteristics that  $A$  is a set of carnivorous animals and  $B$  is a set of herbivorous animals, the point is made here; that sets may nonetheless be compared with one another by various means.

One way of comparing two sets is by an element-by-element pairing.

Looking at the following sets,

$X = \{\text{bear, cat, cow, dog}\}$

and

$Y = \{\text{calf, cub, kitten, pup}\},$



we can note, as before, that  $X$  and  $Y$  have a common characteristic: both of these are sets of animals. More so,  $X$  and  $Y$  seem to be intimately related:  $X$  consists of certain animals, and  $Y$ , the young animal corresponding to each of those in  $X$

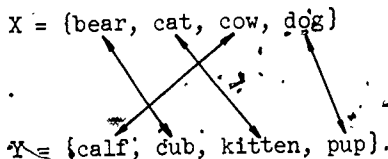

As illustrated in the above diagram, we can indicate a pairing by drawing a double-headed arrow between the corresponding members. Thus, the above shows that

bear is paired with cub;  
 cat is paired with kitten;  
 cow is paired with calf;  
 dog is paired with pup.

In this example, our pairing was motivated by an apparently natural tendency to pair certain elements belonging to the sets. As we shall see shortly, we may want to relax this constraint in looking for an element-by-element pairing. For example, we shall consider the following to be equally admissible as an element-by-element pairing between  $X$  and  $Y$ :

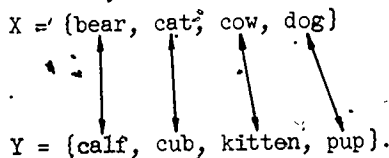

For our purpose, the concern will not be so much that "cat" is paired with "cub" nor that "cat" is paired with "kitten". Our main interest here is that exactly one member of  $X$  is paired with exactly one member of  $Y$ .

In the following example,

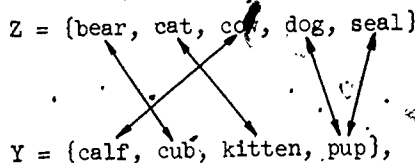

there is an element-by-element pairing, but it is not true that exactly one member of  $Z$  is paired with exactly one member of  $Y$  (both "dog" and "seal" are paired with "pup").

Another example of a comparison by pairing is the following:

A = {flower, truck, Mary}

B = {bat, bird, ball, block}.

Note that in this example, an element of B is left, and there is no element of A which is paired with it. Hence, we see that when we pair the elements of two given sets, it is possible to have every element in one set paired and to have elements left unpaired in the other set.

If there are no elements left unpaired, then we say that the two sets match. Another way of saying this is that we have a one-to-one correspondence between the elements of the two sets. It can be seen that whether we can get a one-to-one correspondence between the elements of two sets does not depend on which element of B is paired with which element of A.

Another way of saying that a set, A, matches a set, B, is to say that

A IS EQUIVALENT TO B.

There are three important properties of the equivalence relation. On the surface, the first two statements may seem rather trivial. However, they will have some repercussions later in dealing with numbers.

- (i) We can see that by our pairing process, it must be true in general, that

IF A IS EQUIVALENT TO B,

THEN B IS EQUIVALENT TO A.

- (ii) Recalling that by  $A \doteq B$ , we mean that both A and B represent the same thing (they are names for the same thing), it is clear that a set is equivalent to itself; that is,

A IS EQUIVALENT TO A.

- (iii) Finally, we can observe that

IF A IS EQUIVALENT TO B, AND IF B IS  
EQUIVALENT TO C, THEN A IS EQUIVALENT TO C.

This third property may be described by stating that the equivalence relation is transitive. To illustrate, we see that if

$A = \{\text{sun, moon, star}\},$   
 $B = \{\text{dam, block, rock}\},$   
 $C = \{\text{Jerry, Sue, Tony}\},$

and we have the following one-to-one correspondences:

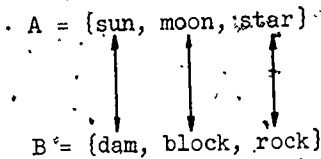

and

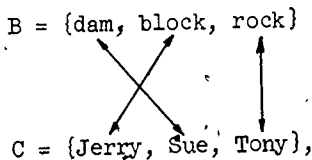

then, since

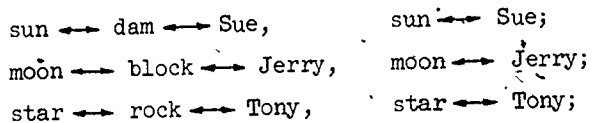

it is possible to get a one-to-one correspondence between A and C, thus:

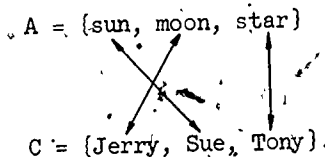

Therefore, we can conclude that A is equivalent to C from the fact that A matches B and B matches C.

### READINESS

Pairing two sets is an operation which leads to comparing two sets and, later, to comparing two numbers. It is also basic to the concept of counting.

Notice that pair is used as an active verb, and not as a noun as in the expression "a pair of shoes", etc. In fact; phrases like "a pair of mittens", or whatever, should be avoided when developing the idea of pairing members of sets. A more appropriate idea to use might be that of "partners", if this is a familiar one to children. This is suitable, however; only if partners are formed by associating a member of one set with a member of another set.

At the pre-school level, the teacher can pair sets concretely, such as pairing the set of boys with the set of girls. One can also place two sets on the flannel board and show the pairings with pieces of yarn. In any case, it is important to identify clearly the two sets which are to be paired.

We want to stress the fact that the order of pairing makes no difference. This fact is basic to the counting operation. In counting members of a set, it makes no difference in which order the members are counted--the end result is the same.

At first, it is easier for children to follow or perform the pairing operation if the members of the two sets being paired are in some way related. For instance, pair a set of aprons with a set of forks, or a set of boys with a set of ice-cream cones. However, eventually sets whose elements are not related should be introduced. For example, pair the set consisting of

a ball, an ice-cream cone, and a book  
to the set consisting of

a car, a doll, and a bird.

When two sets match, then express this fact by saying that one set has as many members as the other set.

In due course of time, you will find it convenient to bring into conversation several terms that apply when one set has as many members as another set: match, matching, equivalent. If one set has exactly as many members as another set, we may say that:

the two sets MATCH; or that

they are MATCHING sets; or that

the two sets are EQUIVALENT; or that

they are EQUIVALENT sets.

Your introduction and use of such terms should not be forced or hurried. Major concern is with the concept that is first expressed by the words as many members as. The vocabulary of match, matching, and equivalent should be used only to the extent that these words facilitate the development of that concept. It is important that children understand your use of the terms; but it is not particularly important or necessary that children use the terms readily in their own conversation although it has been reported that children can and do use these terms with understanding. It is sufficient if children understand a question such as, "Do the sets match?" or "Are the sets equivalent?" It is not essential that children themselves be able to say, for instance, "The set of books is equivalent to the set of dishes."

## ACTIVITIES

There are many opportunities for one-to-one correspondences in the pre-school program, and children should have such experiences in pairing. The pairing process should be consciously directed and deliberate. The use of the vocabulary should also be deliberate. Proceed with the activity slowly and quietly, and with sufficient delay so that attention is focused on the pairing process, being very careful to identify each set that is involved.

The identification of the two sets might first be accomplished by ringing each set with a piece of yarn (if the sets are on the flannel board or are objects on a table); by setting objects of one set on one table and the other on another table; or, in the case of children, with a piece of yarn on the floor, etc., or by wide separation between one set and the other. However, ringing by yarn, etc., can be overdone to the extent that children might not regard objects as belonging to a particular set because they "have no rings around them".

Below, are listed some sets in which an attempt at pairing might be considered to be "natural":

o Mealtime:

crackers to milk  
silver to dishes

o Clothing:

coats to children  
shoe to shoe in dress-up area

o Classroom activities:

paint brushes to paint containers  
scissors to children

o School-home activities:

children to notes to be sent home  
children to paintings to be sent home

The phrase "as many as" should be enunciated clearly and deliberately as some children may attend to only part of the phrases. For example, if a child were asked to construct a set with "as many members as" a given set, he may simply construct one with many members.

VOCABULARY

as many as

equivalent

match

matching

one-to-one correspondence

pairing

transitive property

## 6. MORE THAN AND FEWER THAN

### BACKGROUND NOTES

We have seen how sets may be compared using element-by-element pairing. When there is a one-to-one correspondence between all the elements of one set and the elements of another, we say that the sets are equivalent and that one set has as many members as the other. Often, we do not have equivalence between sets. For instance, in pairing the elements of A with those of B (shown below), there is a member of B which is not paired with any element of A. This will be so regardless of how the elements are paired. In this case, we say that B has more members than A.

$A = \{\text{cat, dog, mouse}\}$

$B = \{\text{Mary, John, Bill, Peggy}\}$

We can also say that A has fewer members than B. Thus we can compare sets according to three possible outcomes:

A matches B;

A has more members than B;

A has fewer members than B.

Furthermore, all this can be accomplished without counting. Suppose C is the set of all children in the school and S is the set of seats in the school auditorium. By pairing, we can determine without counting whether one set has more members than the other, one set has fewer members than the other, or the sets match.

Below, we consider three sets, A, B, C, where

$A = \{1, 2, 3, 4, 5\}$

$B = \{c, d, e, f\}$

and

$C = \{\text{oyster, walrus, carpenter}\}$ .

Note that A has more members than B and that B has more members than C. Moreover, it can be seen that A has more members than C. This illustrates an important property called the transitive property. Recall that we have observed such a property holding also with equivalence. In the statement

for the transitive property above, by replacing the phrase, "has more members than" each time it occurs with the phrase "is equivalent to", we have the statement for the transitive property for equivalence. This property is important because it provides us with some means of working with numbers later. The transitive property given above for "more than" may be stated in general terms as follows:

IF A HAS MORE MEMBERS THAN B,  
AND IF B HAS MORE MEMBERS THAN C,  
THEN A HAS MORE MEMBERS THAN C.

The transitive property is derived without recourse to counting. The conclusion sanctioned by this property gives us the comparison of A and C with a set, B, acting as intermediary. (In a sense, it tells us how A compares with C using B as a "yardstick".) Clearly, a transitive property is similarly applicable when A has fewer members than B, and B has fewer members than C. That is,

IF A HAS FEWER MEMBERS THAN B,  
AND IF B HAS FEWER MEMBERS THAN C,  
THEN A HAS FEWER MEMBERS THAN C.

Both of the relations, "more than" and "fewer than" are order relations. By means of either of these, we can order sets which have different numbers of members according to their "sizes". Thus if

A = {□, ○, △, ✱},

B = {C, I, M, V, W},

C = {cow, tree, blimp},

D = {walrus, carpenter, oyster, Alice, cabbage, king},

then, in order of increasing number of elements, the sets may be listed:

C, A, B, D.

In decreasing order, these sets are ordered, thus: D, B, A, C. Ultimately, through the order relation for sets, we derive order relations for numbers.

#### READINESS

For some children, the idea of "fewer members than" seems more difficult to grasp than the idea of "more members than". However, children's understanding of "more than" can be used to good advantage in developing an understanding of the related idea of "fewer than". Therefore, much time should be spent on the "more than" concept before introducing the idea of "fewer than".



Suppose, for instance, that in comparing the set of boys with the set of girls, we find that there are more members in the set of boys than in the set of girls. Simply mention that we may say this another way; namely, "the set of girls has fewer members than the set of boys".

It is important to stress the fact that the "more than" or "fewer than" relations depend upon the result of pairing. For instance, after pairing the two sets, say the following:

"The set of children has more members than the set of easels because there are children left who are not paired with an easel."

The concept of "more than" for sets is basic to the concept of "greater than" for numbers. Similarly, the "fewer than" relation for sets is associated with the "less than" relation for numbers.

### ACTIVITIES

Children should be given many opportunities for comparison, and such vocabulary should be used enough so that it becomes part of the speech pattern. For some children, there may be a prolonged delay before the concept of "fewer than" becomes understandable and meaningful. When it does, no one can be absolutely sure just what helped to put across the idea. The concept of "more than" is more easily taught and one can try to approach the "fewer than" concept by repeated contrast with "more than". This repeated contrast approach does not always appear to be successful, and many avenues need to be tried.

In activities introducing the "more than"-"fewer than" concepts, it is suggested that examples in which the comparison is by volume, weight, space (extent), size, and time be avoided. Try to limit examples to those having to do with quantity; that is, the "How many" type. Aside from greater difficulty in grasping volume, etc., volumetric, areal, and other kinds of sizes confuse the meaning of "Which set has more members?". Thus, while

"Tom has more milk in his glass than Pat."

is a meaningful statement, for the purpose of set comparison, it introduces confusion to the "more than" concept that we are trying to teach. Similarly, mashed potatoes, being measured by bulk rather than by discrete pieces, would not make a good example for this unit. Some suggestions that may be appropriate are listed on the following page.

- o Mealtime:  
compare number of cookies
- o Playtime:  
compare number of blocks
- o Classtime:  
compare chairs with children ("There are more chairs than children...")

VOCABULARY

fewer than  
greater than  
less than  
more than  
order  
transitive property

BACKGROUND NOTES

In Unit 5, we were concerned with one-to-one correspondences which led to the concept of equivalent sets. From the consideration of sets that are equivalent, it is natural to consider sets that are not equivalent. Hence, in Unit 6, the concepts of "more than" and "fewer than" were discussed. There, we mentioned that by the transitive property, we are able to order sets that do not match.

Conventionally, we think of increasing order as we proceed from left to right. This is merely a convenience in specifying a direction to agree with the usual custom in ordering numbers on the number line. Thus, if two sets do not match, the set with more members is located to the right of one with fewer members. We can also order vertically so that the set with more members is above the one with fewer members, and this would agree with a vertical number line arrangement such as exemplified by the thermometer, where numbers increase upwards.

Suppose we were to order the following three sets:

A = {cat, dog, bat}

B = {Mary}

C = {ball, cabbage}.

We start by comparing two sets at a time. Since A has more members than B, we place A to the right of B:

B, A.

Now we must determine where C is to go. There are three possible locations for C:



- (i) to the left of B, in which case the order is C, B, A;
- (ii) between B and A, in which case, the order is B, C, A;
- (iii) to the right of A, in which case, the order is B, A, C.

To determine which of these is the correct order, we compare C with B and A, two sets at a time. Comparing C with B, we see that C has more members than B, so C cannot go to the left of B:



Since the order is not as in (i), it must then be as in either (ii) or (iii). Now, comparing C with A, we see that A must be to the right of C since A has more members; in other words, C is to the left of A:

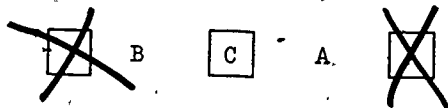

Thus, the order is: B, C, A.

For these same sets, the transitive property could have been used to order them. For instance,

- A has more members than C;
- C has more members than B; therefore
- A has more members than B;

hence the order is established as

B, C, A.

Equally well, the transitive property could have been used in conjunction with the "fewer than" relation to specify that:

- B is to the left of C;
- C is to the left of A; therefore,
- B is to the left of A;

and ultimately, arrive at the same order as before; namely, B, C, A. We shall see later, that ordering sets is the basis for ordering of numbers.

The fact that sets may be ordered according to how many members they have, leads to ordering of numbers, and in this connection, we have mentioned the number line. Numbers themselves, in turn are used to specify order when we think in terms of the ordinal numbers: first, second, third, and so on. In fact, we often use numbers in the ordinal sense without stating that this is so. For example, when we refer to page 57 of a particular book, we mean the fifty-seventh page of this book, and so we do intend 57 to be used in an ordinal sense. This certainly does not need to be mentioned at this level. However, the children still need the vocabulary: first, second, third, ....

#### READINESS

Ordering of sets is greatly facilitated if children are able to distinguish "right" from "left", and also "above" from "below". It is usually better to use the left to right order since it is a habit that we wish to develop for the children's later experiences in reading.

Since ordering sets requires children to arrange the sets in a row such as illustrated below,



any experiences that can be provided of this nature should be helpful.

### ACTIVITIES

Activities can be planned so that children have actual experience in comparing sets of objects. For example,

- o Have children seated in a semi-circular arrangement. Each of the children is given a set of objects. The children are paired off two-by-two, and then are encouraged to compare sets with their partners. One may have "more than" and the other "fewer than" his partner. Also, one may have "as many as" his partner.
- o Different children can be handed pre-counted sets of objects (toys, erasers, blocks, etc. in a container) consisting of different numbers of objects. Suppose Tom has 4 objects, Dick has 3, and Mary has 6. We can have Tom compare his set with Dick's by placing the sets side by side on the floor. After deciding that Tom should be located to the right of Dick, we next ask Mary to compare her set with Dick's and Tom's in turn. This kind of activity can be repeated with other sets and other children until each child has had some experience with set comparison. This type of activity should be very informal and should be relatively limited in duration.

There are many opportunities within the classroom for the serial arrangements of objects. At these times, the teacher can help the children observe and order the objects. Opportunities for exploration of this concept and for natural use of appropriate vocabulary should be very frequent throughout the program.

- o As snacks or meals are distributed, make reference to which child is served first, second, third, etc.
- o Discussions of the days of the week can involve ordinal number; for example, Sunday is the first day of the week.

- As children play with manipulative materials, the teacher can use this opportunity to point out and help children explore order. For example, order in stringing beads, and so on.
- There are many stories and songs which are based on the concept of ordinal number. These can profitably be included in the program. For example, Three Little Pigs (traditional) refers to the first pig, second pig, etc.

#### VOCABULARY

ordinal number

## 8. NUMBER PROPERTY OF A SET

### BACKGROUND NOTES

The concept of number is developed from the concept of sets. Recall that sets can be compared according to different criteria. A set of red balloons and a set of red blocks share the common characteristic of color. A set of blue blocks, a set of red blocks, and a set of green blocks are each composed of elements which are blocks.

If a one-to-one correspondence can be set up between the elements of two sets, they are said to be equivalent. For example, {Leon, Rosa, Eddy} is equivalent to {a, b, c} because their members can be paired, with none left over. It is certainly possible to name many other sets which are equivalent to these; indeed, we could never exhaust all the possibilities. It can be seen that

{animal, vegetable, mineral} is equivalent to {Leon, Rosa, Eddy},  
and by virtue of the fact that

{Leon, Rosa, Eddy} is equivalent to {a, b, c},

we have, by the transitive property of equality,

{animal, vegetable, mineral} is equivalent to {a, b, c}.

Clearly, by repeated use of this kind of reasoning, any set that is equivalent to any one of these sets is equivalent to each of them. Thus, the sets are all equivalent to each other. These sets share a common property: they have the same number of members.

Similarly, the sets

$A = \{a, b\}$

$B = \{ \text{cat}, \text{dog} \}$

$C = \{ \square, \bigcirc \}$

$D = \{ \text{Lenore}, \text{Kevin} \}$

are each equivalent to any other in this list. They share a common property of each having two elements.



WOOF!

Every set has this number property. We call this characteristic the number of the set.<sup>\*</sup> It is determined by the number of elements in the set. Sets which are equivalent have the same number. To simplify the terminology, we denote the number property of a set  $A$  as  $N(A)$ , thought of as "the number property of  $A$ ", or in short, " $N$  of  $A$ ". We can rephrase the statement that equivalent sets have the same number by saying:

IF THE SETS  $A$  AND  $B$  ARE  
EQUIVALENT, THEN  $N(A) = N(B)$ .

Note that this does not say  $A = B$ . The statement  $A = B$  is only true if  $A$  and  $B$  have the same members; it is not enough to have the same number of members to be equal sets.

### Ordered Sets

Frequently, the elements of a set present themselves in a natural order. For instance, most English-speaking people would list the members of the set of vowels as  $\{a, e, i, o, u\}$ . It is natural to list the elements in this order because this is the order in which they were learned. It is convenient because without undue checking one can be sure that he has not omitted any member. Similarly, it is natural to list the members of the set of letters of the alphabet as:

$\{a, b, c, d, e, f, g, h, i, j, k, l, m, n, o, p, q, r, s, t, u, v, w, x, y, z\}$ .

In ordinary writing, we write this set as

$\{a, b, c, \dots, z\}$ .

The three dots,  $\dots$ , mean "and so on in the same manner". They are used to indicate the omission of certain members.

Essentially, to "order" things is to list or arrange them in some particular fashion. One can then say of each element, which of the other elements it "precedes". We do this by comparing pairs of elements in the list and deciding which element precedes the other. The word "precedes" may be replaced by "above", "below", "shorter than", "greater than", and so on, depending on the elements to be ordered. For example, consider the set of names:

$\{\text{Snoopy, Charlie, Linus, Schroeder, Lucy}\}$ .

<sup>\*</sup>In the above example, the name of the number property is "two".



If we order these elements alphabetically, we have

{Charlie, Linus, Lucy, Schroeder, Snoopy}.

When an order is imposed on the elements of a set, such as we have in the second listing here, we call this set an ordered set.

### Standard Sets

Let us establish some ordered sets beginning with the set, {1}, and continuing in the following manner:

{1, 2},

{1, 2, 3},

{1, 2, 3, 4},

and so on.

From the way these sets have been constructed, we see that each of these sets is a subset of each of the following sets. Thus,

{1} is a subset of {1, 2},

{1, 2} is a subset of {1, 2, 3},

and so on.

These are called standard sets. By comparing these sets, we can determine which belongs before the others in ordering these sets. For example, we see immediately that {1, 2, 3} belongs before {1, 2, 3, 4, 5, 6} in ordering these standard sets. Thus we get a cataloguing of these sets in increasing order of the number of elements in each set. In the next section, we shall make use of this catalog of sets to arrive at the cardinality of a given set.

### Cardinality and Ordinality

Let us consider the sets

A = {Dorothy, Zaga}

B = {Lenore, Kevin}

C = {Ruth, Margaret}

D = {brick, house}.

Each of these sets is equivalent to any other in this list, since the elements of any two of the sets can be put into one-to-one correspondence. Let us consider all the sets that are equivalent to any one of these given sets. We have noted that the common property possessed by each of these sets is the number, two. Thus, we say the number property of the set A = {Dorothy, Zaga} is 2; or alternately,  $N(A) = 2$ . By the same token,

$$N(B) = 2, N(C) = 2, N(D) = 2.$$

This number property of a set is the cardinal number or cardinality of the set, and the number itself, a cardinal number.

Similarly, the number property of  $\{1\}$  is 1; of  $\{1, 2, 3\}$  is 3; of  $\{1, 2, 3, 4, 5, 6\}$  is 6; and so on. Notice that the number property of any standard set is the number named by the last element in the set. The words, "one", "eight", "ninety-nine", and so on, are names of cardinal numbers. This concept can be considered entirely separately from the phenomenon of order.

There is a cardinal number that is not named by the last element in any of the standard sets. This is the cardinal number for the empty set, the set consisting of no members, and therefore, a fortiori, no last member. The empty set is simply assigned the cardinal number zero; that is,  $N(\{\}) = 0$ .

Much has been said about the ordering of sets of elements within sets. In this reference, the words, first and last, have been used, and we recall that this kind of ordinal sense was mentioned in the previous unit: Ordering of Sets. In contrast with cardinality, the fact that we can talk about the third letter of the alphabet or the fiftieth State of the Union, depends upon the ordinality of numbers. The words first, second, thirty-eighth, and so on are names of ordinal numbers. These are independent of quantity and can only be considered relative to some frame of reference. That is, we cannot speak of the third quarter in a football game without implying that there were a first and a second quarter. However, the third quarter only refers to one of the implied three quarters.

Both aspects of number, its cardinality and its ordinality, are contained in the statement: Jimmy is the third of our seven children. Note that an ordinal number requires a set of at least the corresponding cardinal number of members. Jimmy is the third child requires at least a set of three. It makes no sense to say: Jimmy is the third of our two children. On the other hand, a cardinal number does not necessitate ordinality of its members. The number two is the cardinality of (chicken, egg); the question of the ordinality of the members of this set has occupied minds for years!

### READINESS

Before the children can determine the number property of a specific set, they have to know the names for the cardinal numbers. At this level, it seems wise to begin with sets having from one to five members. If the child knows the numbers from one to five, he essentially has the standard sets

$\{1\}$ ,  $\{1, 2\}$ ,  $\{1, 2, 3\}$ ,  $\{1, 2, 3, 4\}$ ,  $\{1, 2, 3, 4, 5\}$

in his repertoire. If the child is given the task of determining the cardinal number of a particular set, say the following,



he pairs the given set with one of the standard sets. However, he does not actually have to search through the five sets to find the correct one. Recall that each standard set is a subset of the next one in order, and furthermore, the last member of a standard set names the cardinal number of that set. Hence the child pairs each element of the given set with each element of an "open-ended" set of numbers,

$\{1, 2, 3, 4, 5, \dots\}$ .

When he runs out of elements in the given set, the last element he has paired from this open-ended "standard" set names the cardinal number of the given set. We call this process "counting" members of a given set.

Many occasions arise which call for counting members of a given set. We do not, at this time, wish to emphasize rote counting. The emphasis should be on comparison of sets, and the concepts of "as many as", "more than", and "fewer than". However, when "counting members of a given set" does come up, the set to be counted should be clearly defined and the children should be told that they are finding the number of the set. This avoids emphasis being placed on the last member counted. In other words, we associate the number "five" with the set of five members and not with the fifth member paired.

For instance,

"Here is a set of blocks. What is the number of this set of blocks?"

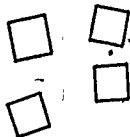

"Let us count the members."

"One, two, three, four."

"There are four blocks in the set."

We also wish to stress the fact that the order in which we count the elements does not change the number property of the set. Understanding this concept will be facilitated if the child has had many experiences in pairing sets, and if these experiences have shown that the order of pairing is immaterial. That is, if set A has more members than set B, then no matter what order is used for pairing, A will always have more members than B. Counting members of a set in different order may help to offset the emphasis that a particular member is always identified with a particular number.

Occasionally, a child may understand one-to-one correspondence and the process of counting but still may be unsuccessful because he cannot keep track of what he has counted and what he has not counted. For such a child, it may be necessary to actually suggest some systematic strategies in attacking the problem. For example, if the objects are in a horizontal row and he still skips around counting the objects in a random fashion, it might be suggested that he proceed from left to right as in reading.

In counting, it does not matter which element of a set is paired with a given element in the appropriate standard set. The same number property is obtained regardless of the pairings used. By contrast, in ordinal use of numbers, it is assumed that there is a pre-determined order in the given set as well as in the standard set. That is, the elements are ordered as associating with each element as the first, second, third element, and so on as the case may be. The ordinal numbers may not be in the vocabulary of some children. However, it has been observed that many children do know what these words mean. In such cases, apparently some incidental learning has occurred.

#### ACTIVITIES

The teacher should be aware of the many opportunities for making reference to quantity. Some of these activities, for example, may be used in the classroom to develop the idea of "How many?"

- o Count the number of children in the room.
- o Count the number of children present.
- o Count the number of children absent.
- o Sing counting songs with children.
- o Use counting records which encourage child participation and involvement.
- o Count toys such as balls, bean bags, etc.
- o Children should have many opportunities to compare sets which differ by one.

The concept that the last counting number is the cardinal number of the set may be taught using much repetition to reinforce verbal chains and staying with smaller quantities for counting at the start. The use of fingers for counting is quite satisfactory, and there is no reason to discourage such practice.

Whenever possible, rote counting should be developed only after children have had many opportunities to develop the meaning of numbers.

#### VOCABULARY

cardinal number

cardinality

number

number property

ordered set

ordinality

standard sets

BACKGROUND NOTES

The set of cardinal numbers, when arranged in order, is endless. Given any standard set, it is always possible to find another set with larger cardinality. We say that the set of cardinal numbers is infinite.

Any set  $A$  which is equivalent to a standard set is called a finite set. In other words, if  $A$  is a finite set, its elements can be counted unless the set has no members. Furthermore, the counting of the elements belonging to a finite set would come to an end. In the case of the empty set, there is no element to be counted, so the counting also comes to an end, and the empty set is also a finite set.

Examples of finite sets are:

$$P = \{a, b, c, \dots, x, y, z\},$$

$$Q = \{\text{children in this class}\},$$

$$R = \{\text{houses on Main Street}\}.$$

Examples of infinite sets are:

$$S = \{\text{cardinal numbers}\} = \{0, 1, 2, \dots\},$$

$$T = \{\text{even cardinal numbers}\} = \{0, 2, 4, 6, \dots\}.$$

Order of Numbers

The numbers named by the set of numerals

{zero, one, two, three, ...}

are called the whole numbers. As in the case of

{a, b, c, ..., x, y, z},

we have used the three dots to indicate the omission of certain elements.

The difference in the use of the three dots in

{zero, one, two, three, ...}

is that no end is indicated in the list of whole numbers. The set of whole numbers is an infinite set.

If zero is omitted from the set

{0, 1, 2, 3, ...},

we have the set of counting numbers or natural numbers. Thus, the set of counting numbers is

{1, 2, 3, ...}.

Counting numbers can be ordered by means of standard sets. Two sets such as

$$A = \{a, b, c, d, e\}$$

and

$$B = \{\Delta, \heartsuit, \square, \bar{x}, \otimes\}$$

are equivalent. Each of these sets is equivalent to the standard set,

$$\{1, 2, 3, 4, 5\}.$$

Hence, the cardinal number of these sets is 5.

If a standard-set  $S$  has fewer members than a standard set  $P$ , then the cardinal number of  $S$  is defined to be less than the cardinal number of  $P$ . For example,  $\{1, 2, 3\}$  has fewer members than  $\{1, 2, 3, 4, 5\}$ , and hence 3 is less than 5. We write this

$$3 < 5.$$

The symbol " $<$ " means "is less than". We see then, that the order relations, "more than" and "fewer than" pertaining to elements in sets impose the order relations, "is greater than" and "is less than" for the corresponding number properties.

When the elements of the set of whole numbers is written in order, 0, 1, 2, ..., each number is less than any number that succeeds it in the sequence. Thus

$$0 < 1 < 2 < 3 < 4 \dots$$

The statement,  $3 < 5$  may be written

$$5 > 3,$$

which is read, "5 is greater than 3". The symbols  $<$  and  $>$  mean "is less than" and "is greater than" respectively.

Note that the phrases "more than" and "fewer than" refer to sets, while "greater than" and "less than" refer to numbers.

If we choose any two whole numbers  $a$  and  $b$ , exactly one of the following statements is true:

$$a < b$$

$$a = b$$

$$a > b.$$

Thus, a given whole number separates all whole numbers into three classes:

- all whole numbers greater than the given number;
- all whole numbers equal to the given number;
- all whole numbers less than the given number.

This concept of separating numbers into three such classes will be extremely important in later mathematical studies. At this level, we make use of this idea in arranging numbers in order by comparison.

### READINESS

The concept of order for the cardinal number is dependent upon comparison of sets. Hence, the experiences a child has with comparison of sets by pairing will form a firm foundation for later experiences in comparing numbers. It is not necessary for the child to acquire the use of the terms "greater than" and "less than". It is, however, suggested that the teacher use these terms whenever possible, provided that he uses them correctly.

All comparisons should be performed with words and concrete objects. The symbols for numbers should not be specifically taught at this level. Nor do the labels, "counting numbers", "natural numbers", "whole numbers", need to be introduced at this time.

### ACTIVITIES

Activities involving the "more than" and "fewer than" concepts can be used to lead to the concepts of "greater than" and "less than". Certain stories can be used as a basis for ordering some of the characters by size or age. For example, the relative sizes of Papa Bear, Mamma Bear, and Baby Bear or the relative ages of Grandfather, Mother, and child may be used.

By correct usage, we can point to the notion that "more than" and "fewer than" refer to sets, while "greater than" and "less than" refer to numbers. For instance, suppose we are comparing the following two sets:

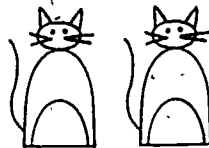



"We have a set of apples and a set of cats. How can we tell if these two sets match?" (By pairing.)

"Let us pair the two sets." (Do so.)

"Are there as many apples as there are cats?" (No.)

"Which set has more members?" (The set of apples.)

"How do we know that?" (Because there are some apples left unpaired.)

"How do we find the number of the set of apples?" (By counting.)

"How many members are in the set of apples?" (Four.)

"How many members are in the set of cats?" (Two.)

"The set of four apples has more members than the set of two cats; so we say that four is greater than two."

### VOCABULARY

counting numbers

finite

greater than

infinite

less than

natural numbers

whole numbers

BACKGROUND NOTESJoining Sets

Suppose we have the following sets:

$$A = \{\Delta, 0, \square\}$$

$$B = \{\circ, \boxtimes, \bar{x}, 0, \clubsuit\}$$

There is a natural way by which we can make up another set from these two. This is to construct a set, C, consisting of all the elements:

$$C = \{\Delta, 0, \square, \circ, \boxtimes, \bar{x}, 0, \clubsuit\}$$

The process (operation) by which we have evolved C from A and B is called joining. Since we join two sets at a time, joining is said to be a binary operation, and from the way this operation is defined, it is an operation on sets. That is, if A and B are two sets, it is possible to form a new set by joining A and B. This new set is called the union or join of A and B.

For our present purposes, we join two sets only if the two sets do not have any members in common. This is because we are thinking in terms of connecting this operation on sets with addition of numbers. Later, the union is given broader meaning for other purposes. We keep to the more simple process at this moment.

The union of A and B is written

$$A \cup B$$

and is read "A union B". If A and B are as above, then

$$A \cup B = \{\Delta, 0, \square, \circ, \boxtimes, \bar{x}, 0, \clubsuit\}$$

The elements  $\Delta, 0, \square$ , are members of A but not of B. It is equally true that none of the members of B is a member of A. If two sets do not have any members in common, as in this case, then we say that the sets are disjoint sets. In all of our examples for this level, when we join sets, we shall join those that have no members in common. For example, the set of boys in a classroom and the set of girls in the classroom are disjoint sets; the union of these two sets is the set of boys and girls in the classroom.

An important property of the joining operation is that the order of joining makes no difference. If

$$A = \{\text{Mary, Janice}\},$$

$$B = \{\text{Sue, Deborah, Myra}\},$$

then

$$A \cup B = \{\text{Mary, Janice, Sue, Deborah, Myra}\}$$

and

$$B \cup A = \{\text{Sue, Deborah, Myra, Mary, Janice}\}.$$

Since  $A \cup B$  has the same members as  $B \cup A$ , we write

$$A \cup B = B \cup A.$$

Another way of stating this fact is to say that

THE OPERATION OF UNION OF SETS IS COMMUTATIVE.

A second property that will be of interest to us is one illustrated by the example  $\{1, 2, 3\} \cup \{\}$ . As the union is composed of all the elements in each of the two sets, and since the empty set has no members, the union is precisely  $\{1, 2, 3\}$ . Therefore, we must have

$$\{1, 2, 3\} \cup \{\} = \{1, 2, 3\}.$$

In general, if  $A$  is a set, then it is true that

$$A \cup \{\} = A.$$

This is parallel to the situation in arithmetic when 0 is involved in addition, such as:  $3 + 0 = 3$ .

#### Remaining Set (Relative Complement)

In the previous section, we started with two sets and from them constructed a new set called their union. The construction of new sets from given sets is not a completely foreign notion to us. Recall that construction of new sets from a given set was done in obtaining subsets of a set. For example, from

$$A = \{1, 2, 3, 4, 5\},$$

we can form a subset of  $A$ , say,

$$B = \{1, 2\}.$$

With respect to  $A$  and  $B$ , another set may be readily associated. This is the set,  $C$ , consisting of the elements, 3, 4, and 5; namely, all the elements of  $A$ , that are not elements of  $B$ . The following display shows more clearly the interrelationships of  $A$ ,  $B$ , and  $C$ :

$$A = \{1, 2, 3, 4, 5\}$$

$$B = \{1, 2\}$$

$$C = \{3, 4, 5\}$$

In connection with  $A$ , and  $B$ ,  $C$  is called the remainder set, or the relative complement of  $B$  with respect to  $A$  (because  $C$  together with  $B$  completes the set,  $A$ ). Notice that to obtain a remainder set, we must first have a given set and a subset of the given set. We can think of the remainder set as obtained from the given set  $A$  by removing members of a subset from  $A$ .

If we consider the set of children in the class, the set of girls is a subset, and the set of boys is the remainder set (relative to the set of girls); or, if the set of boys is the subset being removed, then the set of girls is the remainder set.

From the description that " $C$  consists of all the elements of  $A$  that are not elements of  $B$ ", we see that  $C$ , as well as  $B$ , is a subset of  $A$ . What we mean is, if  $A$  is a given set, and  $B$  is a subset of  $A$ , then we immediately identify two subsets of  $A$  that go hand-in-hand:  $B$ , and the subset made up of members of  $A$  but not of  $B$ .

Notice that if we join the remainder set with the other subset, the union is the original given set. In the examples above,

$$B \cup C = \{1, 2, 3, 4, 5\} = A.$$

Also,

$$\{\text{boys}\} \cup \{\text{girls}\} = \{\text{boys and girls}\}.$$

A property which will have bearing on later work with numbers is the fact that if we remove the empty set from a given set, the remainder set is still the given set. We can perform this operation because, as stated in a previous section, the empty set is a subset of any given set. This concept is associated with the properties of the number zero. For instance, in problem such as  $3 - 0 = 3$ .

## READINESS

### Joining Sets

The joining process for sets is basic to the concept of addition of numbers. This means that if the child is to understand addition, he must have experience in joining sets.

At the pre-school level, the sets being joined will be concrete objects; therefore, they will most likely be disjoint. For instance, if we join the set of rhythm sticks with the set of tambourines, then we are joining two disjoint sets, because the sets have no common member.

An example of two concrete sets which are not disjoint is the following: the set of children with blue eyes and the set of children with blonde hair. These two sets are not disjoint because there may be a child who is a blue-eyed blonde. He would then be a member of both sets.

Before joining two sets, be sure to define each set clearly; then say,

"Now, let us form a new set by joining these two sets."

The concept of joining disjoint sets has been reported to be fairly easy for children to comprehend. Apparently, join is a word that is used occasionally in other situations. Sets of buttons, books, or other concrete objects may be joined with other sets of any concrete objects to communicate in a natural way the notion of a union.

The notion of a commutative operation can also be rendered in a concrete form such as books from the shelf joined with books on the desk and books on the desk joined with books on the shelf. In either case, the same set of books is in the union. The words "union" and "commutative" need not be introduced at this point.

Joining the empty set to a given set can be introduced as a game. For instance, one could join the set of children with the set of elephants in the class. It is then, not difficult for the children to agree that the only members of the new set are the children in the class.

#### Remainder Set

Just as the operation of joining sets is basic to addition, so is the concept of remainder sets fundamental to the operation of subtraction for numbers.

We wish to stress the given set and the subset being removed. In order to facilitate this process, the children should have had many opportunities to focus on subsets of a set; that is, seeing portions of sets as parts of a whole set.

The process of removing the empty set from a given set is a more sophisticated notion and should probably be avoided in pre-school.

## ACTIVITIES

### Joining Sets

The word "join" may be applied to a variety of activities having associated meanings, such as, "one group of children joining another" and the mathematical meaning indicated in these sections. All of these carry approximately the same idea, so this vocabulary may be used naturally. It is important to use the vocabulary "join" whenever possible. The concept may occur, for example, in these activities.

- o Have children collect sets in the room such as "all scissors" and "all paint brushes".
- o Help children to understand how two, three, or more classes "join" together on the playground.
- o Children can continue to add tools until they have a set of tools; for example, "a set of clay tools". The full set need not be defined ahead of time since the tools which they select to use will be their individual "set".

The commutative property may be illustrated by various unions;

- o In mixing paint, children can join different colors of paint in different orders without modifying the final results.
- o Children in Table 1 can be joined with those in Table 2, and vice versa.
- o Children can place water with salt or salt with water and end with the same salty solution. There is probably no need to carry the analogy beyond this point in the beginning.

### Remainder Set

The concept of remainder set or complement can be approached by making a game of "Who is left?" or "What is left?". If done judiciously, this can add to the play value of the experience. When mention is made of people who remain, point out that the remaining people form a group or set.

- o At the slide, "Who is left?" may refer to the children remaining at the top of the slide.
- o As children wash up for lunch, the teacher can point out who have finished washing and who are left to wash.

c. As the teacher distributes equipment, there are opportunities to illustrate and discuss "What are left?". For example,

rhythm instruments

wheel toys

snacks

notices to be taken home.

### VOCABULARY

binary operation

commutative property

complement, relative

disjoint

join

joining

remainder set

union

BACKGROUND NOTES

In the previous sections we have dealt with sets of objects and operations on these sets to form new sets. Now we are ready to consider sets of points and operations on these sets to generate various geometric figures. We shall begin our approach to geometry in a way that will be most helpful to teachers of small children. That is, we will consider concrete objects and abstract from them certain desired geometric information. We shall then shift to a more mathematically logical approach.

FIGURES IN THREE-DIMENSIONS

Observation of concrete objects such as those shown below will be helpful for an understanding of abstract representations of figures.

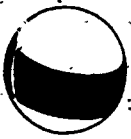

ball



ice cream cone

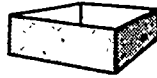

box



can

Discussion of the characteristics of these shapes facilitates familiarity with some of the vocabulary associated with them.

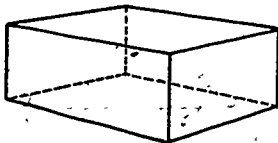
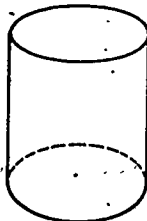
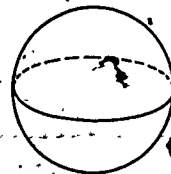
(a)  
rectangular prism(b)  
cylinder(c)  
sphere.

The above drawings are examples of typical representations of geometric figures in three-dimensions. There may be some difficulty in visualizing the 3-dimensional nature of the figures since the drawings are restricted to two dimensions. The dotted lines are included to aid perception. They represent parts of the figures which would not be visible from this vantage point.

In all these figures, the "inside" is not filled. The object identified by (a) looks like a block. It is not like a block in terms of being composed of matter such as wood. It is shaped like a block, but is hollow. Physical



objects which can be associated with the geometric figures illustrated in (a), (b), and (c) are a shoe box (including the lid), an empty oatmeal box with the lid on, and a balloon.

For our purposes in developing some basic concepts and vocabulary, we will concentrate only on Figure (a).

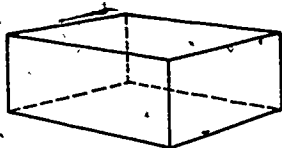

(a)

This "box" (more formally, a rectangular prism) is made of six flat surfaces which are called faces of the prism. The face of a 3-dimensional figure is a flat surface of the figure.

Where two faces meet is an edge. Each face of this figure has a boundary of four edges. The "skeleton" of the prism is made up of twelve edges.

One other characteristic which we wish to identify in the above figure is that it has "corners" where three edges come together. Each is a vertex (plural: vertices) of the prism. Note that any two of these three edges would meet in the same place and form the same geometric figure. Thus the two figures to the right below

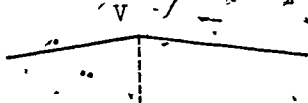
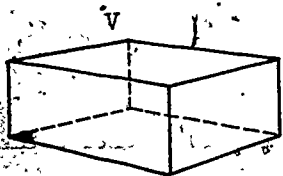

and

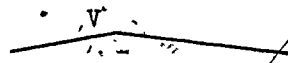

equally well locate the vertex of the prism identified by V. Thus, a vertex may be determined by the meeting of two edges of a face. A point of geometric figure may be designated a vertex, however, even though it is not the meeting of two edges of a face. This is the case, for example, with the vertex of a cone.

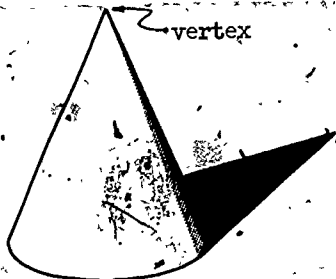

## Points and Paths

A point may be thought of as a precise location. Points are represented by dots on a paper or as the end of a sharply pointed pencil. All of these are visual aids to assist us in conceptualizing the nature of a point.

These representations are merely attempts to symbolize the idealized geometric entity called a point. The difficulty is that a point is an idea rather than a physical object. The point which we represent by a dot, no matter how small the dot, covers many locations.

When we arrive at the description of a point as an exact location, this is not a definition of a point in the formal sense. If we say a point is an exact location, "exact location" must be understood. The dictionary might define location as a "position in space". Position in space might refer us back to point. If none of these words were meaningful to us, the dictionary definitions would hardly clarify matters. However, the circularity in dictionary definitions is necessary, because there is only a finite number of words accessible in the dictionary. Eventually, some word in the chain of definitions must reappear. Implicit in this is that at least one word in the chain must be simply understood so that others may be defined in terms of it. "Point" is such a word in geometry. In a sense, it is the "first" word in the vocabulary of geometry, and we may say it is an undefined term.

Once the concept of point is understood, we will again rely on representing points by marks on paper to facilitate discussing them. They are commonly labeled by capital letters. The drawing represents point P, or simply P, by which a point is understood.

P

Every geometric figure is a set of points. A curve is a set of points followed in moving along a path from one point to another.



Thus the drawing above represents a path from point A to point B, or from point B to point A. It is evident that there are other curves from A to B; indeed there are infinitely many.

Inherent in the notion of path is the idea of continuity. There may not be gaps in a path. Neither of the drawings below is a path from C to D.

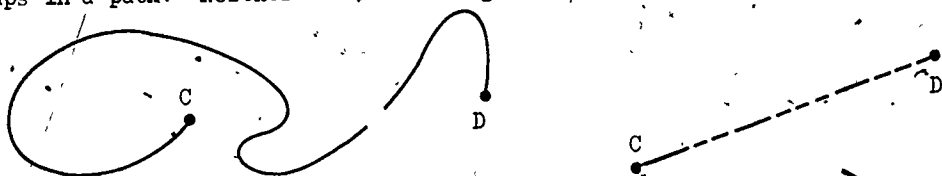

According to the strict mathematical definition, curves do not have to be continuous. We, however, will consider only those that are. Hereafter, by "curve" we shall mean a continuous curve.

Portions of the path or the entire path may be straight. As a path may be used to specify the set of points in a curve, any of the following figures represents a curve from P to Q.

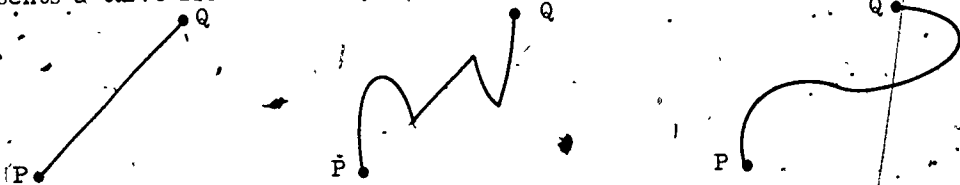

### Line Segments

Let us represent two points by the dots below labeled A and B. We now trace several paths from point A to point B as shown below. One of the paths

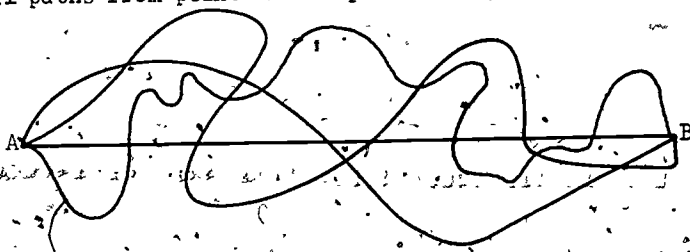

shown in the picture is of special importance. It is the most direct path from A to B. This path, represented below, is called a line segment.



The symbol for this line segment is  $\overline{AB}$  or  $\overline{BA}$  and the points A and B are called the endpoints of  $\overline{AB}$ . A line segment is named by its two endpoints. Since both  $\overline{AB}$  and  $\overline{BA}$  denote the same segment, the order in which the endpoints are named is irrelevant.

Any point of the line segment which is not an endpoint, is said to be between the two endpoints. Hence, to decide whether or not point  $C$  is between points  $A$  and  $B$ , we draw  $\overline{AB}$ , and if  $C$  lies on the line segment, we say that  $C$  is between  $A$  and  $B$ . When we say that a point is between two others, it will be our understanding that all three points are distinct points which lie on the same line segment.

### Line

Once a line segment is defined by the location of its two endpoints and all the points between them, it determines two directions. If we imagine extending a given segment indefinitely far in both of these directions, we conceive of a geometric line.

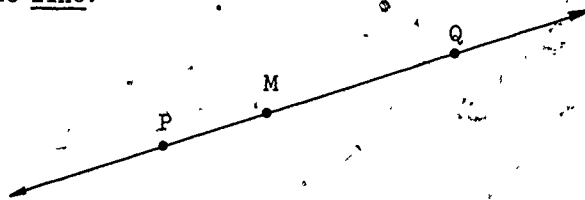

The drawing represents the line formed by extending  $\overline{PQ}$  in both of its determined directions. The arrowheads are used to indicate that the extension is infinite. We adopt the notation  $\overleftrightarrow{PQ}$  for the line containing the two points  $P$  and  $Q$  in order to distinguish it from line segment  $PQ$  written as  $\overline{PQ}$ . We can refer to the line in this drawing as  $\overleftrightarrow{PM}$ ,  $\overleftrightarrow{MQ}$ ,  $\overleftrightarrow{QM}$ , and so on, since each of these designates the same line. In general, any "two points in the set of points" in the line may be used to name it. Again, order does not matter.

It is important not to use this terminology loosely. A line has no endpoints, while a line segment must have two endpoints.

### Space

Now that we understand the geometric concept of a point, we may define geometric space or simply space as the set of all points.

The visual connotation of space is the set of all points in a three-dimensional extent. The notion of space in the more general sense, as simply, a set of all points, is extended to branches of mathematics other than geometry. (Thus, in probability, the set of all possible outcomes of a certain experiment is described as the sample space.) The meaning of space is generally determined by the context in which it is used. Unless otherwise indicated, space in this program will refer to infinite, three-dimensional space.

## Plane

Let us now consider a subset of the set of points of space called a plane. Again, we do not give a formal definition of the plane.

Any flat surface such as the floor, the top of the desk, or a piece of paper suggests the idea of a plane. Like the line, a plane is unlimited in extent. That is, any flat surface used to represent a plane only represents a portion of the plane. The notion of the infinite extent of the plane is approached by thinking in terms of an ever-increasing tabletop and so on.

## READINESS

Logically, as geometric figures are made up of points, one should begin the study of geometry with the concept of what constitutes a point. Lines, curves, planes, 3-dimensional figures, and spaces may be generated from a point.

Despite the logical basis, the sets of geometric objects that children have to manipulate are sets of three-dimensional objects. These are the concrete objects which provide children with experiences from which they can abstract the mathematical concepts. For this reason, we begin with models of figures in 3-dimensions. From the models, we identify faces, edges, and vertices. Once identified, we can use these primitive elements to construct other geometric figures. Children learn to recognize the shapes of objects about them. They become acquainted with these shapes by moving their fingers around the edges of such objects as a domino, a record, a can, and blocks. Through such activities, they begin to distinguish between surfaces which have a feeling of roundness and those which have corners; straight edges and round edges.

At this level, the vocabulary used should be as simple as possible without sacrificing correctness. Terms which can be used while handling simple 3-dimensional figures are box (rectangular prism), can (cylinder), and ball (sphere). The teacher can say, "This object is shaped like a can." The term "corner" may be used for "vertex". It would not be correct to say that a sphere is shaped like a circle, because "circle" refers to a shape in 2-dimensions.

The concept of a line segment may be extracted from a straight edge of a three-dimensional figure with the two corners of the edge being the endpoints. The concept of a line is more difficult, as the child has to imagine the line segment extending in both directions indefinitely. Straightness is a readiness task for the idea of a line.

The emphasis should be on recognition of simple basic shapes. This involves the use of some simple vocabulary and basic distinctions.

## ACTIVITIES

Many physical objects may be used as models to begin to orient thinking toward geometric concepts. The children can feel along edges of book shelves, for example, to determine straightness, and along the rims of oatmeal boxes or cans for rounded edges. (Incidentally, in the rim of the can, we see an instance of an edge that is not the boundary of two faces.) Note that we have used the word "corner" to introduce the notion of a vertex. A source of possible confusion lies in the use of the word "corner" in referring to various activity areas; for example, "the art corner", "the housekeeping corner", etc. For this reason, this kind of designation should be avoided. These locations should be referred to, instead, as "housekeeping area", and so on.

- o Industrial Arts activities provide many opportunities for the development of the concept of corners or vertices. As children engage in carpentry, the corners in their products can be pointed out and discussed.
- o The edge of a building can be used to illustrate the concept of corner. However, this will provide only an intermediate step toward the precise meaning or idea of vertex.
- o As a followup, draw a line around a corner of the building to help children see what it means to "turn the corner". Help them to distinguish between the corner they turn and the corner of the building.
- o / Songs such as "Three-Cornered Hat" provide further opportunity to apply and explore the concept.

In illustrating the concept of endpoints, the child may need help in distinguishing between the temporal and spatial meanings of "end" and in using each. Precise vocabulary should be used and specific references made to endpoints whenever possible. The activities listed below suggest possible references:

- o Children can be shown the endpoints of a climbing rope.
- o If children string the large wooden beads, the end beads can be used to demonstrate the endpoints. For the analogy to be reasonably close, the beads should be strung tightly together.
- o When children stand in a straight line, references to first and last child in line can be made. Whenever possible, refer to front and rear as ends of the line.
- o When the ruler is introduced to the child for experimentation, the teacher can talk about the straight lines which result and the endpoints of the line segments.

Below are listed suggested activities for the concept of between:

- o When children assemble in lines, point out a child or children who are between other children.
- o Use games where children put items between the palms of their hands. (Button, Button, Who Has ...)
- o For sandwiches, discuss the filling between the slices of bread.
- o Placement of characters in dramatic plays; for example, Tarzan is between the saber-toothed tiger and the Abominable Snowman.
- o Discuss arrangement of eating implements. The plate is between the spoon and the fork.
- o Art lessons involving lamination provide opportunities for exploration of the betweenness concept (pressing leaves and paper between waxed paper.)

At this level, restrict the use of "edge" to figures in three-dimensions. Try to provide children with many opportunities to use manipulative materials with clearly visible edges.

- o Point out edges in the environment:  
Table, chair, paper, plate, record, blocks.
- o Children can try to count the number of edges on various kinds of blocks.
- o In carpentry, we can refer to edges of the workbench, edges of pieces of wood, and talk about putting "two edges together".

From the concept of edges, we can lead to the concept of a line segment. Here are some examples of line segments:

- o As children use manipulative materials like Tinker Toys, point out likenesses between rods and line segments.
- o Use a ruler with pencil or crayon to connect two dots as a lead-up to dot pictures. Since children cannot read numerals at this level, use dot pictures utilizing colors to determine sequence of connections.
- o Let children plan and draw out line segments on the pavement for outdoor games.

Many materials in the room such as blocks, boxes, and pencil erasers present opportunities for illustrating the concept of a "face". The vocabulary "face" should be used whenever possible rather than the more general terms such as "side" and "end". That is, instead of speaking about the "side" or "end" of a box, the word "face" should be used.

VOCABULARY

ball

between

box

can

continuous

corner

curve

cylinder

edge

endpoint

face

line

line segment

plane

point

prism

rectangular prism

segment

space

sphere

three-dimensional figure

undefined term

vertex



BACKGROUND NOTES

In our discussions of segments, we considered paths between two points and observed that each of the paths describes a curve. A path thus specifies a set of points known as a curve from A to B. When A and B coincide, the curve is said to be closed. Thus, each of the diagrams illustrated represents a curve. The ones appearing on the second row are closed curves.

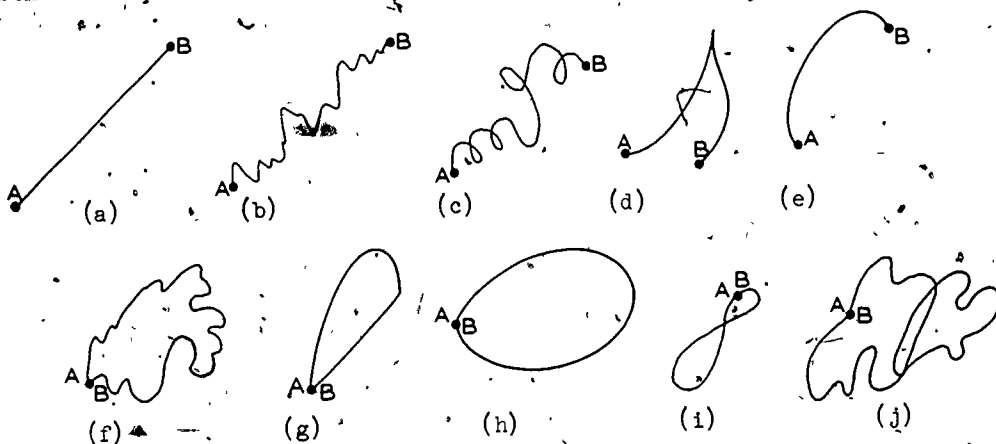

Of the closed curves that we have drawn, the first three are distinguished from the last two. None of the first three curves crosses itself. To describe the fact that the curve does not cross itself, we say it is simple. By simple closed curve, we shall mean a set of points in a plane, represented by a path that begins and ends at the same point and does not cross itself.

Simple closed curves have the important property of separating the rest of the plane into two disjoint subsets, the interior (the subset of the plane enclosed by the curve) and the exterior. Thus, with a simple closed curve, there is a natural partitioning of a plane into three disjoint subsets:

- (1) the set of points that are enclosed by the curve;
- (2) the set of points that are on the curve;
- (3) the set of points that are neither enclosed by the curve nor on the curve.

With the separation, any curve in the plane connecting a point of the interior with a point of the exterior necessarily intersects the simple closed curve. This is illustrated by the figure below, where C is the simple closed curve,

P is an interior point, Q is an exterior point, and A is a plane curve connecting P and Q.

exterior

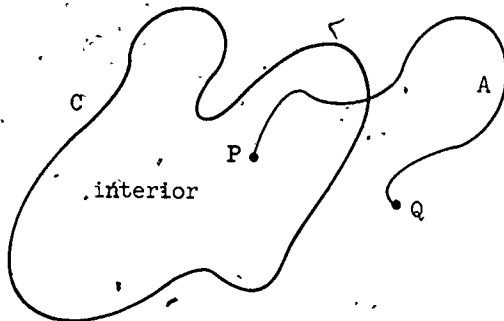

### Polygons

An important class of simple closed curves is the class of polygons. However, before we can give the definition of a polygon, we must extend our definition for union of two sets.

In our discussions of the union, the concept of this operation was made on the basis of two disjoint sets. The reason for this restriction is that eventually we intend to link this concept to the addition of whole numbers. Actually, the definition of union does not have this restriction.

THE UNION OF A AND B IS THE SET WHOSE ELEMENTS ARE MEMBERS OF A, OR MEMBERS OF B, OR OF BOTH A AND B.

That is to say, elements of  $A \cup B$  are members of at least one of the two sets, A, B. With this definition the concept of a union is broadened to encompass joining sets that have members in common as well as sets that are disjoint. For example, if

$$A = \{\star, \bigcirc, \triangle\} \text{ and } B = \{\star, \triangle, \square, \ominus, \smile\},$$

then

$$A \cup B = \{\star, \bigcirc, \triangle, \square, \ominus, \smile\}.$$

Note that the common members  $\star$  and  $\triangle$  are not listed more than once; this is in accord with our previous agreement on the specification of a set. The properties that we have noted before under the restricted operation still hold for the broader concept of union.

Since line segments are sets of points, we can take the union of two line segments to form a new set of points. For example, the union of two segments may again be a segment. In the picture below, the union of  $\overline{AB}$  and  $\overline{BD}$  is

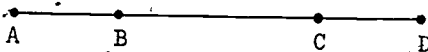

$\overline{AD}$ . In the picture below, the union of  $\overline{AB}$  and  $\overline{BC}$  is the curve.  $AC$ , which

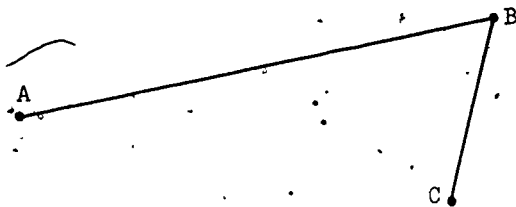

is not a line segment because it is not straight. In all of the above examples, the union is a simple curve, but not closed. Nor is any of the figures below a simple closed curve although each is a union of line segments. A polygon is a simple closed curve that is a union of line segments. Triangles,

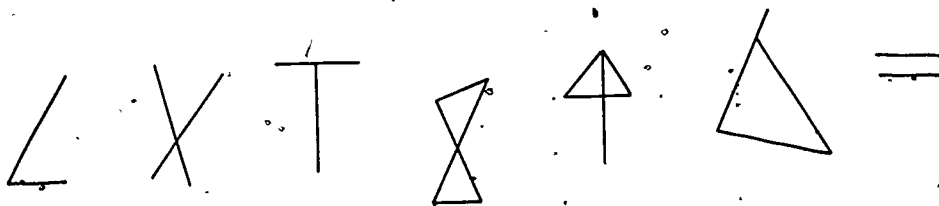

quadrilaterals, pentagons, and so on, are examples of polygons. Note that  $\overline{AD}$  above contains many other segments. For example,  $\overline{AB}$  is contained in  $\overline{AD}$ ,  $\overline{BC}$  is contained in  $\overline{AD}$ ,  $\overline{AD}$  is contained in itself, and so on. Likewise, with segments of a polygon, segments are contained in segments. If a segment of a polygon is contained in no segment other than itself, then this segment is called a side of the polygon. For example,  $\overline{PR}$  is a side of the triangle shown below.

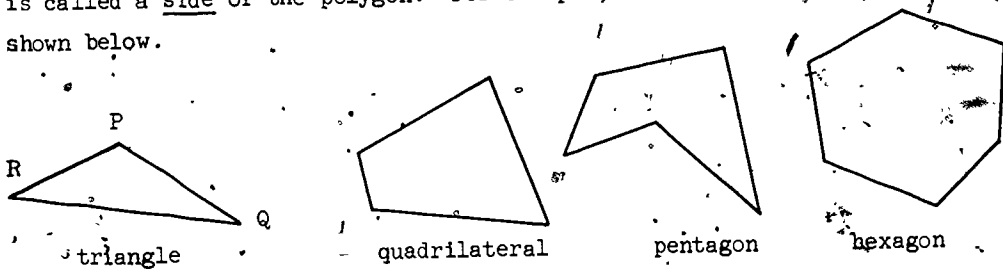

A polygon of three sides is a triangle; four sides, a quadrilateral; five sides, a pentagon; six sides, a hexagon; and so on. The endpoints of the sides are the vertices of the polygon. Observe that each vertex is a common endpoint of two sides. Note also that the number of sides is the same as the number of vertices.

### Rays

Another set of points which is important in geometry is a configuration which can be formed by extending a line segment in one direction only. This

figure is called a ray. A ray is indicated below.

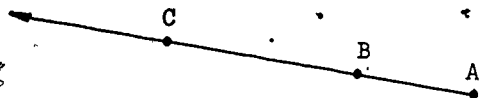

The ray shown above is formed by extending  $\overline{AB}$  through B or  $\overline{AC}$  through C. The notation for this ray is  $\overline{AB}$  or  $\overline{AC}$ . In contrast with the notation for segment and lines, in naming rays, the order of points is significant. A ray has one endpoint, and it is named first. The second letter can name any other point in the ray. As indicated below,  $\overline{MR}$  and  $\overline{NR}$  are not equal sets. There are common points in the two sets. However, point X is in  $\overline{NR}$  but is not a point in  $\overline{MR}$ .

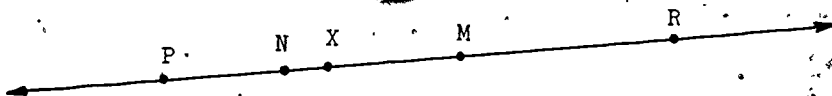

Note that the arrow in the nomenclature  $\overline{MP}$  designates which is the endpoint of the ray; it is not the intention to convey the orientation of the ray as it appears. In fact, it would be impossible to orient the arrows in conformity with all possible orientations of the ray.

### Angle

Another fundamental geometric figure recognized in many familiar shapes is an angle. The formal definition is: an angle is the union of two rays which have a common endpoint but which are not subsets of the same line.

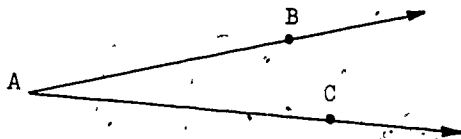

The example shown is the union of  $\overline{AB}$  and  $\overline{AC}$ . Their common endpoint is said to be the vertex of the angle. Recall that vertex also applies to 3-dimensional figures and their faces. In each case, it is the intersection of appropriate edges. Similarly, here, the vertex of an angle is the intersection of the two sets of points in the rays. The rays are called the sides of the angle.

Our angle is denoted by  $\angle BAC$  or  $\angle CAB$ , where the middle letter identifies the vertex. The other two letters name one point distinct from the vertex

on each of the two sides. Often, simply  $\angle A$  will be written instead of  $\angle BAC$ . This notation cannot be used if more than one angle is drawn at vertex  $A$ .

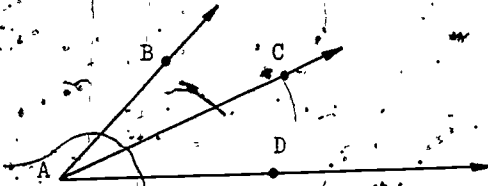

It would not be clear by  $\angle A$  which of  $\angle BAC$ ,  $\angle CAD$ , or  $\angle BAD$  were meant in the figure above.

### Regions

Since a polygon is a simple closed curve, it is the set of points on the curve. These points should be distinguished from the set of points enclosed by the curve which we call the interior; the two sets are disjoint. A circle is also a simple closed curve and it also has an interior.

The union of a simple closed curve and its interior is called a region. We refer to a triangular region, rectangular region, polygonal region, or circular region, etc., indicating that the simple closed curve is a triangle, rectangle, polygon, circle, etc.

To denote a plane region in a diagram, the interior of the simple closed curve is usually shaded. To denote the interior only, the interior is shaded, but the polygon is drawn in dashed outline as is shown in the figures below.



rectangle



rectangular region

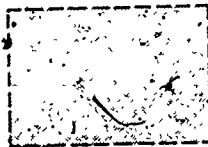

interior of rectangle



union of interior of rectangle and part of rectangle

### Congruent Figures

Congruence is a very important and complex idea with many consequences in geometry. We shall confine ourselves to an intuitive approach to the idea of congruence. That is, if one geometric configuration is an exact copy of another, we shall say that the two figures are congruent.

To decide whether two segments are congruent, we can make a tracing of one and see whether or not the tracing fits exactly on the other. If they fit exactly, the segments are said to be congruent. It is, in this sense, that markings on a ruler perform the function of the movable copies of segments.

Congruence may also apply to angles. Suppose we have two angles  $\angle ABC$  and  $\angle PQR$ , and we wish to find out if they are congruent. We make a tracing

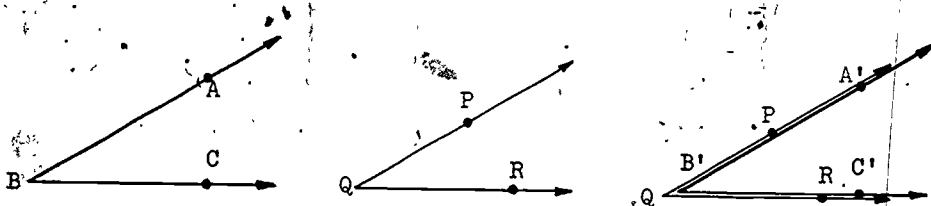

of  $\angle ABC$ , say  $\angle A'B'C'$ . We now place the tracing on  $\angle PQR$  such that ray  $\overrightarrow{B'C'}$  falls on  $\overrightarrow{QR}$  and  $B'$  falls on  $Q$ . (This is shown above at the right.) Now if  $\overrightarrow{B'A'}$  falls on  $\overrightarrow{QP}$ , we say that  $\angle ABC$  is congruent to  $\angle PQR$ .

A special angle that makes frequent appearances in mathematics is a right angle. No formal definition is given at this time. The drawing below represents two right angles,  $\angle YVX$  and  $\angle WVX$ . The angles are congruent, and the union of a side of one and a side of the other is a line.

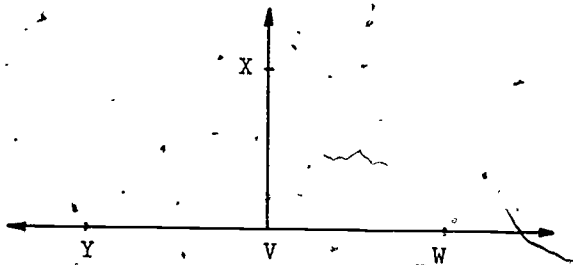

If a piece of paper were folded twice, as the drawing below indicates, and it were then unfolded, the creases suggest segments of two lines whose intersection is the point  $R$ . Thus,  $R$  is the vertex of four right angles whose sides are the extensions of appropriate pairs of creases.

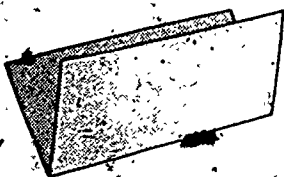

Fold 1

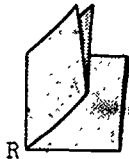

Fold 2

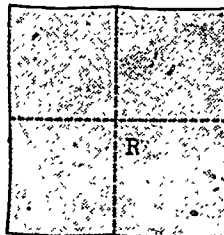

Unfolded with creases dotted

We have discussed congruent segments and congruent angles. In considering regions, we shall depend on the intuitive notion that two geometric regions are congruent if one is an exact copy of the other. Suppose we have the two triangles pictured below.

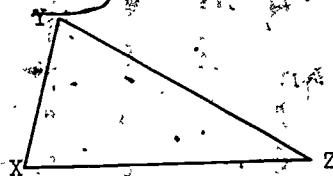
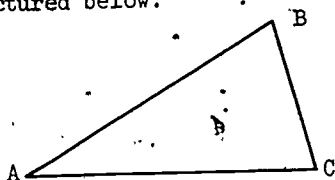

If we are to determine whether the triangular regions are congruent, first we make a tracing of one of the triangles, say  $\triangle ABC$ . Now we cut along the boundary, and place this tracing on  $\triangle XYZ$ , in any way that does not distort the region. If the tracing fits exactly the second region, we say that two regions are congruent and the boundaries are congruent.

To summarize, to decide whether or not two regions are congruent:

- (1) We make a tracing of the boundary of one region.
- (2) We try to match this tracing to the other region.
- (3) If the tracing matches the second region with no distortion to either, then the boundaries and the regions are congruent.

The movable copy is needed because the geometric figures to be compared are sets of points, and as such, have fixed locations. Clearly, we cannot continue this matching process too long. A copy of a spherical region may not be matched and fitted into another spherical region; many 3-dimensional figures cannot be tested for congruence by this means. A more refined concept of congruence is not attempted until the children study geometry from a more formal standpoint.

In the light of congruence, we may restate the requirements of special geometric figures. For example, any two edges of a cube are congruent segments, and any two faces of a cube are congruent regions. Similarly, we can note the congruent sides of a parallelogram and so on.

#### Classification of Quadrilaterals

A polygon is a simple closed curve that is a union of line segments. If it is a union of three line segments, it is a triangle; of four line segments, a quadrilateral; of five segments, a pentagon; of six segments, a hexagon,

and so on. Each of the figures below has four sides, so each is a quadrilateral.

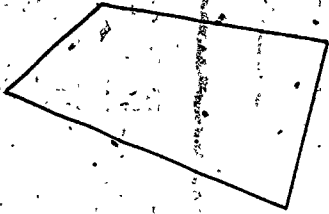

Within the category of quadrilaterals, there are special kinds that are of interest to us. For example, rectangles are special kinds of quadrilaterals that are of special interest. All the angles\* of a rectangle are congruent. Squares, in turn, are special kinds of rectangles. All the sides of a square are congruent. Thus, in the family of quadrilaterals,



square



rectangle

subfamilies are identified. The rectangles constitute a subfamily of the quadrilaterals, and the squares constitute a subfamily of the rectangles. Another subfamily of the quadrilaterals are the parallelograms. Their opposite sides are segments of lines which are on the same plane and which do not intersect. As rectangles also possess this characteristic, rectangles are a subfamily of parallelograms. Another subfamily of the parallelograms are the rhombi (singular: rhombus). Each side of a rhombus is congruent to each other side. So a square is both a special kind of a rectangle and a special kind of a rhombus.

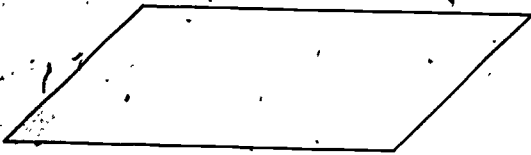

parallelogram

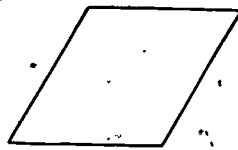

rhombus

By this kind of classification, we get a generic chain that may be depicted by the following diagram

\*The term "angle of a polygon" at a particular vertex is a language of convenience to mean the angle having that vertex and such that the particular sides of the polygon belong to the rays of the angle.



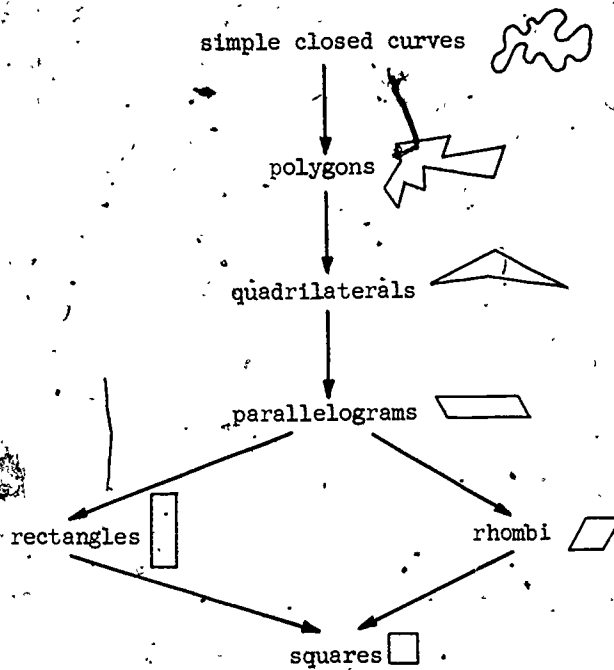

### Classification of Triangles

We have seen how quadrilaterals may be sorted into subfamilies according to their sides and angles. For example,

- a rhombus has each side congruent to any other side;
- a rectangle has each angle congruent to any other angle;
- a square has each side congruent to any other side and each angle congruent to any other angle;

and so on. There are other kinds of classifications of quadrilaterals such as whether the sides all bulge outward or whether some sides dent inward. However, in the elementary grades, classification by congruence of sides and angles is the main method of categorizing quadrilaterals.

Triangles too may be classified according to their sides and angles. There are three special kinds of triangles which shall be of special interest to us. They are the equilateral, the isosceles, and the right triangles.

An equilateral triangle is a triangle each of whose sides is congruent to any of the others. In other words, an equilateral triangle has three congruent sides.

An isosceles triangle is a triangle with at least two of its sides congruent. So, every equilateral triangle is also an isosceles triangle.

A right triangle is a triangle one of whose angles is a right angle.



right triangle



isosceles  
triangle

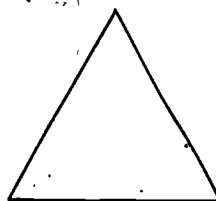

equilateral  
triangle

A right triangle may or may not be isosceles; but it cannot be equilateral.

As with quadrilaterals, there are other classifications for triangles. Later in the student's career, for example, he will be concerned with acute triangles, obtuse triangles, and scalene triangles, to mention a few.

### READINESS

Once children are able to identify faces, edges, and vertices (corners) of a three-dimensional object, these primitive elements can be used to construct other geometric figures. For children, the approach to closed figures is entirely intuitive. It is a good idea to display a set of wooden models of the basic shapes (rectangular prism, cylinder, and sphere) and encourage the children to examine and handle them for several days. Most pupils seem to be interested in finding objects at home which qualify as cylinders and rectangular boxes.

Have the children feel the surface of the ball with their hands and point out that it has a "rounded" surface. In contrast, have them feel a face of a block and point out that it is a "flat" surface. They can also trace the edges of a cylinder and feel the roundedness of the edge (it has no corners). By tracing the edges of one face of a rectangular block, they can feel the corners and the straight edges.

With these experiences, children can begin to distinguish the relationships among geometric curves, regions, and 3-dimensional figures. You can gradually introduce the idea that the terms circle, rectangle, and triangle refer to the edges of the 3-dimensional figures. When a child looks for one of the curves, say a rectangle, he is most likely to find examples such as the base of a block, a cupboard door, the top of the table, or a pane of glass in the window or door. Each shows not only a rectangle but also its interior. Again, with each region, emphasize that it is the edge that is a rectangle.

Once children have the idea of a closed curve such as a circle, the concept of inside (interior), outside (exterior), and on the curve can be introduced.

### ACTIVITIES

Children should have many opportunities to describe, explore, and manipulate various models of geometric shapes. Whenever possible, they should attempt to relate figures to subsequent drawings. Many of the Frostig Readiness materials for pre-school may be useful in providing relevant experience with closed curves.

- o For movement exploration, children can demonstrate closed curves by moving hands in a circular motion or by walking in circles.
- o Circles of children either in games or other activities provide opportunities to show that the circle begins at one child and returns to the same child. Show that the point of origin of the circle can shift from child to child.
- o Games and activities might be planned in which the child leaves the teacher, follows a prescribed path, and returns to the teacher. Try following the child's path on the floor with a flow pen or similar instrument.
- o Use paper and pencil exercises such as unfinished drawings to help children learn to connect line segments.
- o In Art projects children should have many opportunities to join two or more line segments.
- o Printmaking in Art provides additional opportunities for experience with shapes.

When involved in the study of polygons, frequent reference to the corners can be made. For example, children can walk along polygonal paths drawn on the pavement, taking special note of the corners as they come to them.

- o In Art, have children try to construct shapes with yarn or tape.
- o Use various kinds of form boards to allow children multi-sensory experiences with various polygons.
- o Make cardboard shapes to match standard unit blocks. Have children match cardboard shapes to blocks.

- o Nested cups in hexagonal forms will give children added experiences with forms.
- o Construct a grid with different shapes in each square. Allow child to move along a path following the shapes. (Colors may also be used as guides for determining paths.)

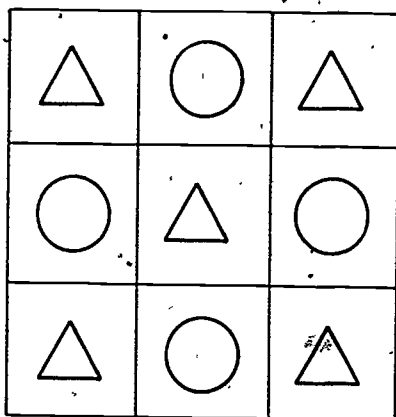

As a readiness for congruence, help children to identify sameness in any two classroom items such as unit blocks, same sizes of pre-cut paper, window panes, etc. Actual experience in congruence may be approached by activities similar to those that follow.

- o Use rhythm sticks to help children understand one-dimensional congruence.
- o Use games where children match blocks of a particular size and shape with cardboard shapes. A variation of this activity is to have tracings of faces of various 3-dimensional figures ready at the board. For example, a face of a cubical block, and end of a cylinder, etc. The children are to match the appropriate 3-dimensional figure with the different faces drawn.
- o Use mimeographed patterns together with sheets of construction paper cutouts in different shapes. The appropriate cutout is to be pasted onto the different outlines.

Since interior and exterior are usually taught in contrast, the activities for both are similar. At this level, limit the use of "interior" and "exterior" to two-dimensional space.

- o Some art projects can be used to help differentiate between interior and exterior. For example, color the interior of the circle blue.

- o Many games lend themselves to further differentiation between interior and exterior, such as Ring Around the Roses, All Circle Game, Go In and Out the Window, etc.
- o A closed curve may be formed with a piece of rope on the floor; children can toss bean bags inside, outside, on, the circle. (Few will be on the circle.)

### VOCABULARY

angle

congruent

equilateral

exterior

hexagon

interior

isosceles

parallelogram

pentagon

polygon

quadrilateral

ray

rectangle

region

rhombus

right angle

right triangle

side of an angle

side of a polygon

simple

simple closed curve

square

triangle

vertex of an angle

vertex of a polygon

### 13. FIGURES IN THREE-DIMENSIONS

#### BACKGROUND NOTES

Recall that a simple closed curve separates a plane into three subsets: the set of points which make up the interior of the curve, the set of points on the curve, and the set of points which make up the exterior of the curve.

Analogous to this separation property of a simple closed curve in the plane is the separation property of a simple closed surface in three-dimensional space (3-space). The boundary of a rectangular box (formed by the faces) is an example of a simple closed surface. The surface separates the rest of 3-space into two disjoint subsets, the interior and the exterior, so that any curve in space connecting a point of the interior with a point of the exterior necessarily intersects the simple closed surface. This is shown in the figure below.

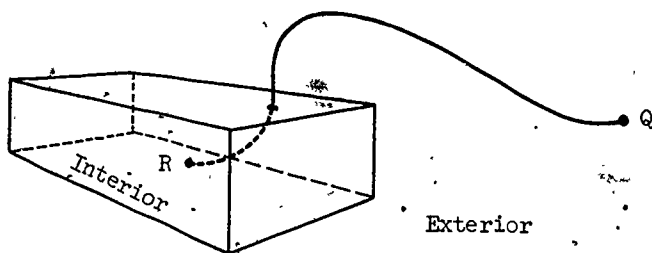

The classroom is another model of a simple closed surface; it separates space so that there is an interior and an exterior with reference to the room. A curve connecting an interior point to an exterior point must penetrate the wall.

Intuitively, we say that two 3-dimensional figures are congruent if they are of the same size and shape. In this example,

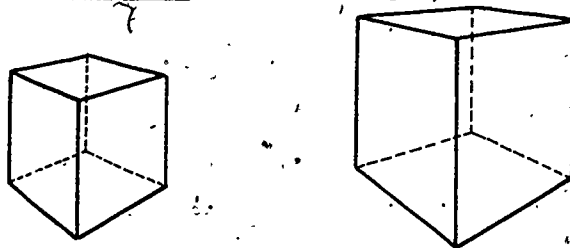

the two figures are of the same shape, but they are not the same size; so they are not congruent.

Suppose the capacity of each of these containers is one quart.

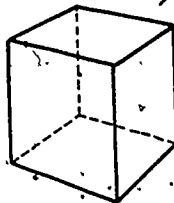
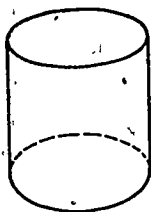

Then the figures they represent are of the same size (have equal volumes), but they are not the same shape; hence they are not congruent.

The following are of the same size and shape, and so are congruent.

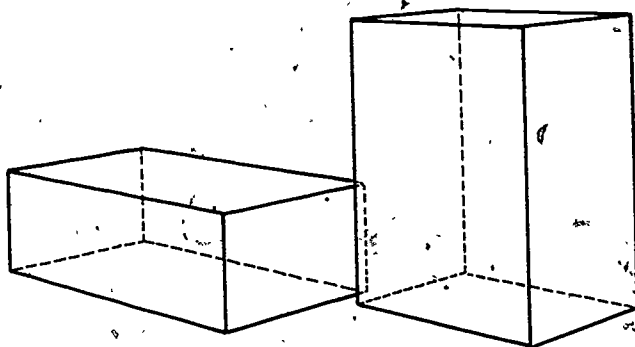

### READINESS

Readiness tasks for 3-dimensional figures are the same as some of those for other geometric concepts. In fact, manipulation with three-dimensional objects is itself a readiness for the more abstract ones involving one- or two-dimensional configurations. As mentioned in Unit 11, these are the concrete objects which provide children with experiences from which they can abstract the mathematical concepts.

### ACTIVITIES

The child should learn to focus on three dimensions simultaneously. Provide many informal experiences with three-dimensional objects. Block play with both wooden blocks and large wooden blocks provide opportunities for experimentation with three-dimensional space.

- o Children can gain experience with three-dimensional space by learning to return wooden blocks to proper cubical storage compartments.
- o Successful manipulation of "Nests of Blocks" requires that the child focus on three-dimensions simultaneously.
- o Water play materials should include containers where the child pours into containers with varying heights, widths, depths, while holding volume constant.

- o A cereal tray with varying containers should provide an experience similar to that obtainable through water play.
- o Shopping games can be played with the store displaying merchandise packaged in various sizes and shapes: cereal boxes, cans, etc. Different "items" are loaded into shopping bags. Later, children are asked to feel (without looking) into the shopping bag and guess what they touched. They provide reasons for their guesses: "It is large and flat; it has rounded edges; etc."

### VOCABULARY

simple closed surface



BACKGROUND NOTES

Congruent segments give us a way of relating numbers with points on a line. This is the case with the number line. Given any two points on a line, a segment is determined. We can continue to mark off points, one after another, so that each segment is congruent to the first.

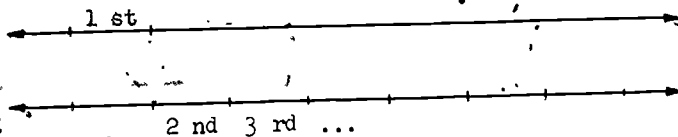

The points may be labelled 0, 1, 2, 3, 4, ..., in the order of the whole numbers. Although one can assign these labels from right to left, conventionally we proceed from left to right. When points are labelled thus, the numbers associated with the points are called the coordinates of the points, and the line together with its coordinates is called the number line.

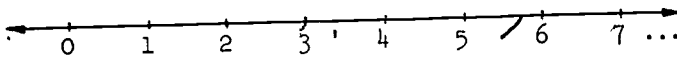

✓ The Number Line

The number line thus gives us a one-to-one correspondence between the set of endpoints of congruent segments and the set of whole numbers. That is, each endpoint is associated with one and only one whole number, and each whole number is associated with one and only one endpoint of the congruent segments on the line. This device is quite useful for us. It enables us to visualize the order of numbers by the position of corresponding points on the line. Operations in arithmetic can be connected with operations on the number line.

READINESS

Lining up unit blocks in rows may be used as a readiness task for the number line. Other readiness activities may include, for example, specifying a sequence of beads on stringing by color or shapes, where order is an underlying concept. Counting experiences are also very important in connection with this concept. Experiences with the number line in turn eventually lead to concepts of measurements.

## ACTIVITIES

Work with the number line at this level is mostly incidental. There are, however, a few activities that may be directly related to the number line; the following are some suggestions.

- o Give children practice in constructing equivalent line segments by using unit blocks.
- o Make a number line with the line segments being the length of Tinker Toy rods. Let children match Tinker Toy rods to units on the number line, and count the number of rods required to match up to designated units.
- o Paint a number line on the pavement in the yard with numerals 0 through 9, placing points at least a step apart. Count aloud as a child hops or walks the line. (This can be done casually, but routinely.)
- o Paste a number line on the table. The child pats a number an appropriate number of times as he comes to it.

## VOCABULARY

coordinates

number line

## 15. ARITHMETIC OPERATIONS

### BACKGROUND NOTES

#### Addition

The union of disjoint sets is the basis for the concept of adding whole numbers. If

$$A = \{a, b, c, d, e\}$$

and

$$B = \{x, y, z\},$$

then

$$A \cup B = \{a, b, c, d, e, x, y, z\}.$$

We know that  $N(A) = 5$ ,  $N(B) = 3$  and  $N(A \cup B) = 5 + 3$ , or 8.

The sum of the cardinal numbers of two disjoint sets is defined as the cardinal number of the union of the two sets.

We say

$$5 + 3 = 8.$$

Five and 3 are called addends; 8 is the sum.

When we start with two disjoint sets and form the union, we are operating on sets. When we start with two numbers and get a third, we are operating on numbers. Addition is a binary operation on the cardinal numbers associated with two disjoint sets.

We call addition a binary operation because we operate on just two numbers at a time. Union is an operation on sets. Addition is an operation on numbers. We join (form their union) sets and we add numbers.

#### Properties Under Addition

Since addition is associated with the union of sets, we can expect that properties under the union operation may have implications for the addition operation. We observe first, that the union of two sets is a set. This, of course, is from the definition of union. As a whole number may be assigned to any finite set, corresponding to the fact that

THE UNION OF TWO SETS IS A SET,

we have

THE SUM OF TWO WHOLE NUMBERS IS A WHOLE NUMBER.

Both of these are statements of closure properties. The first is the closure property of sets under union, and the second is the closure property of whole numbers under addition.

Another property of sets under union pertains to the order of operation. If  $A$  and  $B$  are sets, the result of joining  $A$  to  $B$  is the same as joining  $B$  to  $A$ . We summarize this by saying that the union is a commutative operation. For any sets  $A$  and  $B$

$$A \cup B = B \cup A.$$

Corresponding to this, we have the commutative property of whole numbers under addition. For any whole numbers  $a$  and  $b$ ,

$$a + b = b + a.$$

For instance, the sum of 3 and 4 (which may be written  $3 + 4$ ) and the sum of 4 and 3 (written  $4 + 3$ ) both are the same number, 7. For this reason, we can write..

$$3 + 4 = 4 + 3.$$

Both  $3 + 4$  and  $4 + 3$  name the same number.

Another property of sets under the union operation that is significant for the addition operation is one that is connected with the union of a set with the empty set. We have observed before that if  $A$  is a set, then  $A \cup \{ \} = A$ . Since the number property of the empty set is 0, if the number property of  $A$  is  $a$ , then the corresponding statement for the above observation is:

FOR ANY WHOLE NUMBER  $a$ ,

$$a + 0 = a.$$

Of course, because of the commutative property, we also have  $0 + a = a$ .

Since addition of 0 to any number produces that identical number, 0 is called the identity element with respect to addition. No other element plays this same role. The property referred to above is known as the property of zero under addition, or in short, the addition property of zero.

### Subtraction

Just as the union of two disjoint sets is the basis for addition, so is the removal of a subset a basis for subtraction. For example, if

$$A = \{ \circ, \triangle, \square, \star, \cup \}$$

and

$$B = \{ \circ, \square \};$$

then removing B from A forms a new set; namely,

$$\{ \triangle, \star, \smile \}.$$

We see that  $N(A) = 5$  and  $N(B) = 2$ , and  $N(\text{remainder set}) = 3$ .

The difference of the cardinal number of set A and the cardinal number of set B is the cardinal number of the remainder set. Hence,

$$N(A) - N(B) = N(\text{remainder set}).$$

The above definition depends upon the fact that B is a subset of A; therefore, B cannot have more elements than A. B can be the empty set or B can be identical to A. So if  $N(A) = a$  and  $N(B) = b$ , then  $b \geq 0$  and  $a \geq b$ ; that is, b has to be less than or equal to a. These limitations for subtraction are eventually relaxed when the set of numbers that we have to work with is extended to include more than just the whole numbers.

Recall that if the remainder set is joined to the subset which was removed, the set obtained is the original set. Thus, if

$$A = \{ a, b, c, d, e \}$$

and

$$B = \{ a, c \},$$

and if B is removed from A, we get the remainder set  $\{ b, d, e \}$ . Now if the remainder set,  $\{ b, d, e \}$ , is joined to B, we get the original set A:

$$\{ a, c \} \cup \{ b, d, e \} = \{ a, b, c, d, e \}.$$

In summary,

$$A \text{ removing } B = \{ b, d, e \}$$

and

$$B \text{ union } \{ b, d, e \} = A.$$

Hence we say that "union" and "removing a subset" are inverse operations. In effect, one operation "undoes" what is done by the other.

Corresponding to these properties under set operations, we have similar properties under addition and subtraction:

IF a AND b ARE WHOLE NUMBERS, AND IF  $b \leq a$ ,  
 THEN  $(a - b) + b = a$ ; AND, IF a AND b ARE  
 ANY WHOLE NUMBERS, THEN  $(a + b) - b = a$ .

Therefore, subtraction and addition are inverse operations whenever the two operations are possible or defined.

Note that there are different ways in which subtraction can be conceived, and the particular way conceived often depends on the kind of problem that is posed. One way is to think in terms of removing a given set from a starting set, arriving at the remainder set as explained above. This is the "take away" kind of procedure that might be characterized by such problems as the following.

"There were five birds in the tree; three of them flew away. How many are left?"

Another kind of problem requiring subtraction calls for comparison of numbers. This is the "how much more" kind of procedure that might be characterized by such problems as the following.

"Johnny has 3 marbles and David has 5. How many more marbles than Johnny does David have?"

Instead of starting with a set of 5 and removing a subset of 3, it is more natural in this problem to start with two disjoint sets: one consisting of 5 members, and one of 3 members. The question then turns to finding a third set, disjoint from the other two, and such that the union of this with the 3-member set would match the 5-member set:

five member set:  $A = \{ 1, 2, 3, 4, 5 \}$   
 three member set:  $B = \{ \star, \square, \triangle \}$   
 $C = \{ a, b \}$   
 $B \cup C = \{ \star, \square, \triangle, a, b \}$   
 $A = \{ 1, 2, 3, 4, 5 \}$

$\begin{array}{cccccc} & \uparrow & \uparrow & \uparrow & \uparrow & \uparrow \\ & \star & \square & \triangle & a & b \end{array}$

Then, the number property of  $C$  tells how many more 5 is than 3; that is,

$$5 - 3 = 2.$$

### Properties under Subtraction

We have noted the property of subtraction that points to its role as an inverse of addition. Two properties of the whole numbers under this operation that we want to highlight now involve the empty set. Recall that with the union, we have

$$A \cup \{ \} = A.$$

The corresponding statement for numbers is: for any whole number  $a$ ,

$$a + 0 = a.$$

By the above, we observe that

$$a + 0 = a \quad \text{and} \quad a = a - 0$$

say the same thing. Since  $a + 0 = 0 + a$ , we also have  $0 + a = a$ , which is the same as  $0 = a - a$ . Hence, in addition to the inverse properties,

$$\text{FOR ANY WHOLE NUMBERS } a \text{ AND } b, \text{ WITH } a \geq b, (a - b) + b = a,$$

$$\text{FOR ANY WHOLE NUMBERS } a \text{ AND } b, (a + b) - b = a,$$

we have the following two properties of zero under subtraction:

$$\text{FOR ANY WHOLE NUMBER } a, a - 0 = a;$$

$$\text{FOR ANY WHOLE NUMBER } a, a - a = 0.$$

### READINESS

At this level, aside from forming the union of sets, readiness experiences for addition consist essentially of counting activities. Joining a set of one to a given set will help put across the sequence from one number to the next higher number; repeated joinings will help with determining the results of various additions.

Comparison activities provide a readiness for subtraction. Formal work in addition and subtraction is not expected for this level.

### ACTIVITIES

Counting Activities may include counting two groups of children (or blocks, etc.) and then counting their union. Initially, one of the groups may be a set consisting of one element. This might be done, for example, along with the counting, "1, 2, 3, ..., plus one more makes \_\_\_\_\_."

- o Songs such as "Two Little Blackbirds", "Five Little Pumpkins", provide practice in counting.

Some of the comparison activities may occur in connection with distributing materials in the classroom along with verbalization of the subtraction process.

The following situations may be suggested.

- o "I started with three drums; I have given two away. How many are left?"
- o At juice time, subtraction experiences may be provided: "How many more children are there than glasses?"

As with addition, there are songs involving subtraction. For example,

- o "Six Little Ducks", "Ten in the Family", "Five Little Speckled Frogs", and "Five Little Chickadees".

VOCABULARY

addend

closure property

of sets under union

of whole numbers under addition

commutative property

of sets under union

of whole numbers under addition

difference

identity element

inverse operation

sum

zero

property of, under addition



INDEX

addend, 77  
 angle, 61  
 as many members as, 22

ball, 55  
 between, 54  
 binary operation, 44, 77  
 box, 55

can, 55  
 cardinal number, 35  
 cardinality, 35  
 closure property  
   of sets under union, 78  
   of whole numbers under addition, 78

commutative property  
   of sets under union, 45, 78  
   of whole numbers under addition, 78  
 complement, relative, 45

congruent, 63  
 continuous, 52  
 coordinate, 75  
 corner, 51  
 counting numbers, 41  
 curve, 52  
 cylinder, 50, 55

difference, 79  
 disjoint, 44

edge, 51  
 element, 1  
 empty, 16  
 empty set, 14  
 endpoint, 54  
 equal sets, 6  
 equilateral, 67  
 equivalent, 20  
 exterior, 59, 69

face, 51  
 fewer than, 25  
 finite, 40  
 greater than, 27

hexagon, 61  
 identity element, 78  
 infinite, 40  
 interior, 59, 69  
 inverse, 79  
 isosceles, 67

join, 44  
 joining, 44

less than, 27  
 line, 54  
 line segment, 53

match, 20  
 matching, 22  
 member, 1  
 more than, 25

number, 33  
 number line, 75  
 number property, 33; 34

one-to-one correspondence, 20  
 order, 26  
 ordered set, 34  
 ordinal number, 30, 36  
 ordinality, 36

pairing, 18  
 parallelogram, 66  
 pentagon, 61  
 plane, 55  
 point, 52  
 polygon, 61  
 prism, rectangular, 50, 55

quadrilateral, 61, 66

ray, 61  
 rectangle, 66  
 rectangular prism, 50, 55  
 region, 63  
 remainder set, 45  
 rhombus, 66  
 right angle, 64  
 right triangle, 67

segment, 53  
 set, 1  
 side  
   of angle, 62  
   of polygon, 61

simple, 59  
 simple closed curve, 59  
 simple closed surface, 72  
 space, 54  
 sphere, 50, 55  
 square, 66  
 standard sets, 35

subset, 9  
sum, 77

three-dimensions, figure in, 50  
transitive property, 20, 25  
triangle, 61

undefined term, 52  
union, 44, 60

vertex  
of angle, 62  
of polygon, 61  
of prism, 51

whole numbers, 40

zero, property of, under addition, 78