

DOCUMENT RESUME

ED 136 776

IR 004 563

AUTHOR Charconnet, Marie-George
 TITLE Development of Educational Methods and Techniques Adapted to the Specific Conditions of the Developing Countries. Peer Tutoring: Operational Description of Various Systems and Their Applications.
 INSTITUTION United Nations Educational, Scientific, and Cultural Organization, Paris (France). Div. of Methods, Materials, and Techniques.
 PUB DATE 75
 NOTE 72p.

EDRS PRICE MF-\$0.83 Plus Postage. HC Not Available from EDRS.
 DESCRIPTORS Cultural Factors; *Developing Nations; Educational Development; *Educational Methods; Educational Programs; Educational Technology; *International Studies; *peer Teaching; Teaching Techniques; *Tutorial Programs

ABSTRACT

This study describes various patterns of peer tutoring and is based on the use of cultural traditions and endogenous methods, on techniques and equipment acquired from other cultures, on problems presented by the adoption of educational technologies, and on methods needing little sophisticated equipment. A dozen peer tutoring systems are documented, primarily, the "Petites Ecoles" in France; the "Learning through Teaching," "Youth Teaching Youth," and "Keller Plan" in the United States; the "Madras System" in India; and the "Media-Activated Learning Groups" program in Denmark. It is concluded that peer tutoring is a flexible method, adaptable to different educational situations and to highly varied socio-cultural environments. It is equally adaptable to every educational level and is able to benefit from the most recent advancements in the field of media and from research findings in psychology and social psychology. It is thought to be a valid solution to certain problems in educational development in the countries of the Third World. (DAG)

 * Documents acquired by ERIC include many informal unpublished *
 * materials not available from other sources. ERIC makes every effort *
 * to obtain the best copy available. Nevertheless, items of marginal *
 * reproducibility are often encountered and this affects the quality *
 * of the microfiche and hardcopy reproductions ERIC makes available *
 * via the ERIC Document Reproduction Service (EDRS). EDRS is not *
 * responsible for the quality of the original document. Reproductions *
 * supplied by EDRS are the best that can be made from the original. *

ED 136776
ED 136776

UNITED NATIONS ORGANIZATION FOR EDUCATION
SCIENCE AND CULTURE

U.S. DEPARTMENT OF HEALTH,
EDUCATION & WELFARE
NATIONAL INSTITUTE OF
EDUCATION

THIS DOCUMENT HAS BEEN REPRODUCED EXACTLY AS RECEIVED FROM THE PERSON OR ORGANIZATION ORIGINATING IT. POINTS OF VIEW OR OPINIONS STATED DO NOT NECESSARILY REPRESENT OFFICIAL NATIONAL INSTITUTE OF EDUCATION POSITION OR POLICY

Division of Methods, Materials and Techniques

THE DEVELOPMENT OF EDUCATIONAL METHODS
AND TECHNIQUES ADAPTED TO THE SPECIFIC CONDITIONS
OF THE DEVELOPING COUNTRIES

PERMISSION TO REPRODUCE THIS
COPYRIGHTED MATERIAL BY MICRO-
FICHE ONLY HAS BEEN GRANTED BY

Edward Hegman

TO ERIC AND ORGANIZATIONS OPERATING UNDER AGREEMENTS WITH THE NATIONAL INSTITUTE OF EDUCATION. FURTHER REPRODUCTION OUTSIDE THE ERIC SYSTEM REQUIRES PERMISSION OF THE COPYRIGHT OWNER.

P E E R T U T O R I N G

Operational description of various systems
and their applications

- by Marie-George CHARCONNET

'DOCEMUR DOCENDO'

(We learn as we teach)

Comenius

(Great Didactic)

The views expressed by the author, the selection of facts presented and the opinions stated with regard to the facts are the responsibility of the author, and do not necessarily represent the views of Unesco.

I 2004563

PEER TUTORING

FOREWORD

Under the programme approved by the General Conference at its seventeenth session, the Secretariat is endeavouring to develop educational methods and techniques adapted to the pedagogical needs, the economic conditions, and the cultural characteristics of the developing countries.

This study on peer tutoring forms part of a series of works intended to inform Member States on such methods and, in particular, on:

Methods based on the use of cultural traditions and endogenous techniques;

Methods which call for techniques and equipment acquired from other cultures (cf. Education and Mass Media in Black Africa) Problems presented by the adaptation of educational technologies. Babacar Sine, September 1975 (in English, French and Spanish).⁽¹⁾;

Methods which may be divested of unduly cumbersome and expensive equipment. (cf. i) Simple duplicating processes. John Hilmer, December 1974;

(ii) Radiovision using non-projected visuals. A.W. Bartram, March 1975;

(iii) Recent approaches on micro-teaching and allied techniques which can be implemented easily in developing countries. Arye Perlberg, July 1975.

It seemed to us that peer tutoring, which is one of the oldest educational approaches, might be an interesting field to explore more systematically with a view to discovering fresh uses for it and ways of integrating it into educational systems in order to make them more effective and better designed to meet development needs. Peer tutoring procedures require relatively simple and inexpensive methods — using untapped educational resources — which are easily adapted to different cultural and pedagogical situations, but which are little known or analysed.

It was therefore considered necessary to carry out a documentary study in order to describe a dozen peer tutoring systems which have been used effectively from the nineteenth century to the present day in States as different from one another as Canada, Colombia, Denmark, Ethiopia, France, India, Switzerland and the United States of America, and which have been applied in both primary and higher education, and in respect of pre-school-age children and adults alike.

(1) The studies are available from the ED/MMT Division of the Secretariat of Unesco.

This initial study may pave the way for pilot experiments which will help, in particular, to develop peer tutoring procedures that are adapted to the urgent tasks of development, especially through their combination with other techniques of organization or communication, such as programmed instruction and radio instruction. (1)

(1) See in this connection:

- (i) Enseignement programme et radio. Jerry Pocztar and Genevieve Jacquinet, May 1973, Unesco ED/MMT
- (ii) The use of peer tutoring and programmed radio instruction. Viable alternatives in education. Wallace H. Hannum and Robert M. Morgan, 1975, Unesco ED/MMT.

CONTENTS

Pages

I	INTRODUCTION	1
II	BRIEF NOTE ON ANTECEDENTS.	1 - 5
III	SOME SYSTEMS OF PEER TUTORING	5 - 32
III.1	The "Petites ecoles" in France and Switzerland in 1820	5 - 6
1.1	Purposes.	6 - 7
1.2	Subjects taught	7 - 8
1.3	Accommodation and equipment	9 - 11
1.4	Operation of the system	12 - 16
III.2	Peer tutoring in the U. S. : 3 experiments with children and adolescents	16 - 32 16
2.1	Background	16 - 17
2.2	'Learning through teaching'	17 - 18
2.3	The fundamentals of L. T. T.	19 - 22
2.4	Operation of the system	23--26
III.3	An experiment in teaching spelling	26 - 32
IV	PEER TUTORING AND PROGRAMMED LEARNING	32 - 41
IV.1	The "Keller Plan"	32 - 38
1.1	Basic principles.	33 - 34
1.2	The way the system works.	34 - 38
IV.2	The "Madras System"	39 - 41
V	PEER TUTORING AND AUDIO-VISUAL MEDIA	42 - 47
V.1	Epidiascope and audio-cassettes	42 - 43
V.2	Television	43

CONTENTS - 2 bis

	<u>Pages</u>
V.3 Radio43 - 44
3.1 Radio forums44
3.2 Educational broadcasting44 - 47
VI. A PIONEERING VENTURE: THE ASERE HAWARIAT SCHOOL, ADDIS ABABA48 - 52
VII. THE BASIC SECONDARY SCHOOL IN CUBA52
VIII. SOME PROBLEMS OF PEER TUTORING CONSIDERED.52 - 58
VIII.1 The need for communication52 - 54
VIII.2 A more active role for the pupil54 - 55
VIII.3 Two possible objections to the method55
VIII.4 A word about teachers, tutors and tutees55 - 58
IX. CONCLUSION58 - 59
X. BIBLIOGRAPHY.60 - 61
XI. AFTERWORD62 - 63

I. INTRODUCTION

All educators are more or less aware that, at the beginning of the industrial revolution, generations of children in western Europe learnt to read and write through mutual instruction.

Moreover, chroniclers and travellers have reported very early practices - for instance, in India, Ethiopia, and the countries of Moslem tradition - whereby children, adolescents and adults engaged in mutual instruction. We are therefore justified in thinking that this educational technique was, in one form or another, a feature of the traditions of those countries.

In the Third World today, the number of children and adults needing education is, as we know, enormous. The material and human resources available for this purpose are far from sufficient; the present educational systems are totally inadequate; deriving as they do from foreign models, they help to create a rootless elite. In addition, they are often extremely costly.

It is necessary to devise new educational systems adapted to the cultural, social and economic conditions obtaining in the developing countries.

Could mutual instruction form a part of these new systems?

Is it adapted, or could it be adapted to the conditions obtaining in the Third World? If so, how?

We have attempted to provide at least a partial answer to these questions, which are deserving of a more exhaustive study.

II. BRIEF NOTE ON ANTECEDENTS

On his way through India in 1623, the Italian traveller Pietro della Valle came upon four children sitting by the roadside and teaching each other arithmetic. They used their fingers to write sums in the sand. Sometimes they recited things together or asked each other questions in turns, then resumed their figurework and discussed it with eagerness. Each one went over his sums alone with the others looking on, so that, as Pietro della Valle relates, 'error on the same point was ruled out' - a debatable opinion.

Those children were following a custom immemorial in India, and a similar scene was witnessed by Dr. Bell, principal of a college in Madras, a hundred and seventy-four years later, during a country walk. The Malabar children he encountered belonged to a school in which each class was split up into

groups. Each such group was in the charge of a pupil, and the children often worked among themselves without any help from the teacher. They did so with a thorough concentration and industry which deeply impressed Dr. Bell.

A systematic study of the traditional teaching methods obtaining in different parts of the world probably would reveal that mutual instruction has long been among them and has been practised in a variety of ways. As we have already seen, it was customary in India. The same applies to the countries of Moslem tradition, where it is habitually used in the Koranic schools. This is clearly apparent from a study of the Koranic schools in Mauretania now being carried out by M. Andre Lecourtois. In the mahadra, (a Koranic school which includes adults), directed by Ahmed Bezaid Ould Hayani at Akjoujt, a hundred pupils of various ages are learning the Koran:

"The more advanced pupils help the backward ones. It is interesting to note this characteristic feature of Koranic instruction, as compared with the supreme egoism of everyone for himself that prevails in the official schools. In the mahadra it is taken for granted that the stronger pupils help the weaker - a practice that simplifies the teacher's task in this individualized instruction, and gives a high place to the pupil-monitor principle; it is a real school for the training of leaders who are familiar with the local environment."

(A. Lecourtois: Etude experimentale sur les écoles coraniques. IBRD IDA Scheme - Credit 459.MAU)

Going further back in time, we find that, according to Plutarch, mutual instruction or peer tutoring was practised in Sparta, but for warlike ends. The Spartan children were divided into groups, each group being placed in charge of 'the bravest and most skilful'.

Quintilian's 'Institutio Oratoria' contains the following sentence, which was often quoted and commented on by the advocates of peer tutoring in the nineteenth century:

"Incipientibus condiscipulorum quam praeceptoris jucundior, hoc ipso quod facilius, imitatio est.",

that is to say:

"For those who are beginning to learn, it is easier and pleasanter to emulate their fellow pupils than to follow a teacher."

And Comenius puts the essence of peer tutoring into these two words, likewise often quoted:

"Docemur decendo."

('We learn as we teach'.).

Dictionaries of education inform us that, in the 17th century, Madame de Maintenon at St. Cyr, and Jacqueline Pascal at Port-Royal, were firm believers in the merits of this method. In 1747, at the Hospice de la Pitié in Paris, M. Herbault set up seven classes for poor children, with pupils of the top class teaching those of the six lower classes.

Strongly encouraged by Louis XVI, the chevalier Pawlett established in 1774 schools for 200 soldiers' sons. He put into practice there a system under which each pupil could take a turn at teaching "in the prescribed forms of military discipline".

However, it is to Dr. Andrew Bell (1753-1832), a Scotsman and an Anglican, that we owe the revival of peer tutoring. His meeting with those Malabar children on the road to Madras was for him a kind of revelation. Dr. Bell was employed by the East India Company and was in charge of the education of some 200 boys - children of European soldiers. On his return to the college which he directed, he tried to persuade his colleagues of the value of what he had discovered. At first, this was labour lost. He then hit upon the idea of entrusting to an eight-year-old boy, John Frisken, the task of teaching the A B C's to his fellow pupils. As often happens, this putting of trust in a child proved right; for John Frisken quickly achieved excellent results. Dr. Bell's colleagues were won over, and other classes were similarly organized with other children in charge. The 'monitorial system' was born. In 1797, Bell published a book explaining his educational method.

At about this time there lived in Southwark (London) a Quaker, Joseph Lancaster. He was very young - not yet 20. He was a deeply religious man with a great love for the people, and he believed that he had received from God the mission of improving the lot of the masses by means of education. He opened a school for poor children and undertook to teach them reading, writing and arithmetic. Too poor to buy books, Lancaster used boards on to which he fixed sheets of paper. Paper, pens and ink being beyond his means, he got the children to write with chalk on slates. Unable to pay teachers, he had the idea of using the senior and the most diligent pupils in their stead.

Lancaster had not read Bell's book, but had heard of it. Four years after its publication, in 1801, he in turn published a book setting forth his method. This work, entitled: "Improvements in education, as it respects the industrious classes of the community", was a great success, selling six editions in four years.

Lancaster's school was attended by a thousand boys, and he was the sole teacher. His two sisters shared between them the instruction of 200 girls. In 1805 the King saw Lancaster and helped him. This enabled him to set up a teacher training school, in which his methods were taught. The 'Lancaster schools' took in children irrespective of religious denomination, but Lancaster, being a Quaker, was often in conflict with the Anglicans.

His ideas spread to France, Switzerland, even to Senegal and Sierra Leone. In France, the method made its appearance in 1815 under the patronage of the Société pour l'instruction élémentaire, the oldest undenominational association for primary

education, established by decree on the eve of the battle of Waterloo. The primary aim of this association was to spread peer tutoring in schools known as the 'nouvelles écoles pour les pauvres'.

In an article entitled "Une offensive des libéraux éclairés au début du 19^{me} siècle: l'introduction de l'enseignement mutuel" ("An offensive launched by the enlightened liberals at the beginning of the 19th century: the introduction of peer tutoring") which appeared in the 'Nouvelles pages d'histoire vaudoise' (Lausanne, 1967), Georges Panchaud tells us that a great deal was said about these English methods at the Congress of Vienna. It should be noted that, both in Switzerland and in France, it was the liberals, imbued with their civic responsibilities towards their fellow citizens, who quickly emerged as enthusiastic adepts in the new method. The notion of peer tutoring always had a revolutionary tinge which caused many people to hold it in suspicion.

How, then, are we to explain the rise of peer tutoring from 1815 onwards?

In the first place, the ideas produced by the French Revolution were alive, and among these, in particular, the need to provide elementary instruction for the people. Apart from purely humanitarian considerations, there were two sound practical reasons for this: the fitting of workers for the accomplishment of tasks which the development of technology was making more complex, and the training of citizens for the exercise of new political responsibilities. How, then, was education designed for a minority to be turned into a school for all? This question and the answers to it are of fundamental importance, in our time, too, when the same problem arises, in other forms, in respect of the countries of the Third World.

The liberal minds of 1815 were fired by the idea of peer tutoring because they saw in it the solution to this problem.

From the outset, however, there was no lack of violent and even injurious criticism. Was not this method calculated to produce a turbulent mass in the place of quiet and orderly people? What would be the reaction of these thousands of poor children who were being accustomed, by turns, to covet or to despise the monitor's baton? Then, did not the old system produce excellent results? Would it not be wiser to go slowly and carefully, rather than rushing into experiments involving thousands of children? And, lastly, these ideas came from abroad; they might be all right in England; but surely not in France? in Switzerland? — sheer madness, this anglomania ...

Then, again, the idea of getting children to teach other children at an age when the mind is irresponsible and fanciful!

The teachers felt themselves assailed in their cherished prestige and in their professional routine. What would happen to their livelihood if they were replaced by children?

Yet other arguments were advanced: the method was reproached with having been sponsored by Carnot during the Hundred Days. Carnot's followers were suspected of wanting to secularize

education. Similar arguments were put forward in Switzerland, where the method was represented as "an offensive launched by the liberals.

Despite this opposition, the schools where peer tutoring was practised increased in numbers. In France, for instance, while 165,000 children had been attending the petites écoles in 1816, the figure rose to 1,123,000 by the end of 1820.

To assist their development, funds were paid out of the Privy Purse - the grumbling of the diehards notwithstanding. A teachers' training course in peer tutoring was launched in Paris, and 18 model schools were set up. This admirable innovation was celebrated in verse; it was even chosen as a competition subject for the Academie Française poetry prize in 1818.

The diehards continued their grumbling. As Cornet d'Incourt put it: "Give me the name of a single enemy of religion who is not a fanatical upholder of peer tutoring and I will cease asking for its abolition". As early as 1822, Royer-Collard had to fight hard for the cause of peer tutoring, inveighing against those "otherwise worthy persons who see ignorance as right and proper, since it keeps the lower orders in their place and makes them easier to govern: in a word, since it conduces to order".

In an article in the Nouveau dictionnaire de pédagogie, edited by F. Boisson, O. Gréard tells us that the opponents of peer tutoring held that it was a method "likely to undermine the bases of the social order by handing over to children a power which should appertain to grown men alone".

And so, from 1821 onwards, the "petites écoles" began to disappear in France, and along with them the teachers who had been trained in the methods of peer tutoring.

By 1830 in France, and by 1834 in Switzerland, there were virtually no schools of this type remaining. It another hundred and thirty years before the idea was revived.

* * *

III. SOME SYSTEMS OF PEER TUTORING

1

The "petites écoles" in France in 1820

The system of teaching described below obtained in France in 1820. It was directly inspired by Bell and Lancaster. I shall also have occasion to refer incidentally to the Lancaster schools in Switzerland.

III.1.1 Purposes:

The chief purpose of the petites écoles was to provide for all an elementary instruction in reading, writing, arithmetic. To these basic techniques were added religious and ethical education, and the elements of drawing. The pupils were also taught to sing.

The founders of the petites écoles thought that if reasonable subsidies were granted by the State for several years, "a whole generation of the French poor could be educated within 12 years, and there would nowhere be any individual inferior to another as far as those essential elements of instruction were concerned".

The decision to place responsibility in the hands of children was a remarkable and very new departure. Some attributed it to Christian inspiration, which is what Lancaster had felt so strongly. Using children as auxiliaries in the endeavour to educate other children appeared as an almost evangelist undertaking.

Moreover, once the child had been brought to master a subject well enough to pass it on, and had been trained to direct his co-pupils, it was certain that he would by the same process have learned to obey, giving his willing and intelligent cooperation. This, then, was the right answer to those who maintained that the practice of peer tutoring would undermine discipline and bring about chaos.

A further aim was to inculcate in the children a sense of equity, by accustoming them to conduct trials among themselves. In these classes, juries of children were occasionally set up, to settle disputes arising between pupils, to discuss misdemeanours or incidents of a more or less serious nature. The spirit of earnestness, fairness and restraint with which the children took these responsibilities was a source of amazement to adults. This constituted an ethical and civic training of great value, as the supporters of peer tutoring have always been well aware, in both France and Switzerland. They saw their schools as training grounds for the great republican virtues of liberty, equality, fraternity. May we quote from the 'Encyclopédie générale de l'éducation française' :

"A school which practises peer tutoring is like a tiny republic; the presence of a regent could not turn it back into a monarchy, for he is no more than the chief magistrate whose task it is to see that the laws are observed. Each monitor, armed with board and baton, directs and teaches his little party; his orders are rarely questioned, and a boy no more than four feet high may inspire respect in one a head taller."

Observers were impressed by the atmosphere of earnestness and industry - one might almost say of fervour - which prevailed in the Lancaster schools. In 1818 Joseph Hamel, who wrote for H.M. the Emperor of Russia a book entitled "L'enseignement mutuel, ou histoire de l'introduction et de la propagation de cette méthode par les soins du Docteur Bell, de J. Lancaster et d'autres", (Peer tutoring: an account of the introduction

and propagation of this method by Dr. Bell, J. Lancaster and others.), relates that he was astonished beyond words on seeing for the first time in England a Lancaster school where 600 children were working together under the direction of one other child.

He compares this new method with those used in industry, again in England:

"This method owes its excellence to the distribution of tasks, a principle which in England has already produced marvellous effects in all branches of industry. After it had been tried out with signal success in connection with mechanical work, the idea occurred of applying it to the cultivation of the mind — with equally gratifying results."

Here we have another aspect of the question: a sort of anticipation of the Taylor system applied in the field of education. While necessary, it also represented a potential danger for peer tutoring, from which it was not to escape altogether.

In this system, the functions of each member of the association are known and all the rules of conduct are determined in advance. Both teacher and pupils know what they have to do, and are constantly occupied.

A teaching method of this kind of course called for precise objectives and content, firm and clearly defined theoretical bases, as well as a clear and subtle analysis of the functions within the system. It also required accommodation and equipment very different from those which had been used for earlier schools.

We have already seen what were the purposes of the petites écoles. Now let us consider the content of the education which they provided.

III.1.2 Subjects taught

We already know what was the ideal "profile" of school leavers from the petites écoles: They should be able to read and write, have some knowledge of arithmetic, of ethical and religious principles, and of the elements of drawing. They had also done a great deal of singing, at all times of the day. This probably gave them a certain pleasure — a factor not to be overlooked. Bell reckoned that 18 to 24 months were needed to achieve these results. Experience showed, however, that much more time was required.

Reading was traditionally taught by progression from alphabet to syllables, thence to words and sentences, with the aid of big boards hung on the walls. Ethical and religious instruction were "integrated" in this process, as can be seen from the "spelling boards" used in the canton of Fribourg. Religious, ethical and educational preoccupations, and sometimes an ingenuous lyricism, revealed themselves with a candour which may prompt a smile. The following are some of the short

sentences set before pupils in the 42nd spelling lesson:

God sees you and is with you everywhere.

A son insulted his mother — how dreadful!

I am in school and I like it.

Did you see the lovely rainbow?

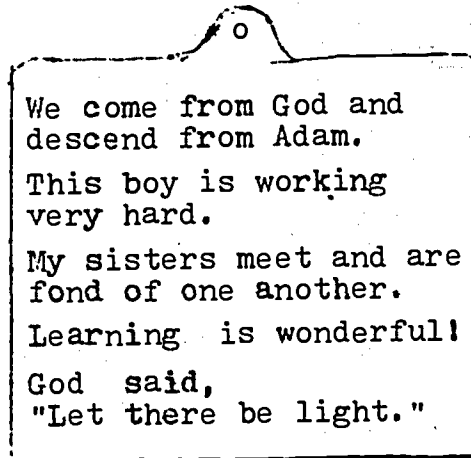
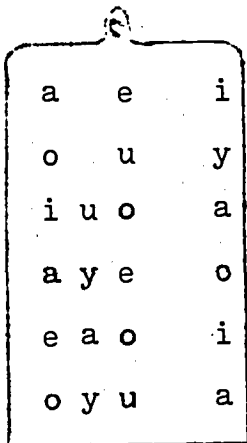

The "spelling boards" were hung up on the classroom walls and used for exercises in which 10 pupils at a time took part.

Writing was taught by a similar process:

First, strokes; then whole letters; then syllables, followed by words and sentences — first on a slate, then on paper with pencil or pen.

Children have also been seen writing with their fingers in fine sand or ground eggshell, spread over a tray painted black with parallel lines to help the keeping of proper proportions in the letters, especially in those which project beyond the lines. These trays were known as 'grammographic tables'. As early as 1528, according to Erasmus, children learnt to write with an awl on trays covered with fine dust.

As will be seen, the novelty does not reside in the teaching methods used but in the way of applying traditional methods. Both in reading and in writing the syllabic method readily lends itself to a stage-by-stage process of learning. 'Every lesson' says Bell, 'is first split up into small parts'. Each part is then completely assimilated, all the pupils being individually assessed at all times. Any lesson which has not been fully understood is repeated from the beginning. This procedure recalls the principles of micro-teaching: No new exercise is begun till the previous one has been grasped by all. Any pupil who cannot keep up is demoted to a lower grade.

III.1.3 Accommodation and equipment

For this type of instruction, special premises and equipment were required. In the first place, it necessitated halls large enough to accommodate hundreds of pupils. Buisson's Dictionnaire Pédagogique gives the following dimensions:

20 m x 10 m
ceiling 5 - 6 m high

These halls contained rows of tables seating 10, 15 or 20 each. At the end of each table was the monitor's desk and the 'model letter board'. A French lithograph dated 1825 shows all the pupils sitting at their desks and facing the teacher's chair. But the 'school furniture' drawn in 1823 by David Nicole for Swiss schools (Nouveau guide de l'enseignement mutuel, Lausanne, 1823) shows double desks to seat two pupils face to face. At the end of every row of desks there is a seat for the monitor, with a drawer for his materials.

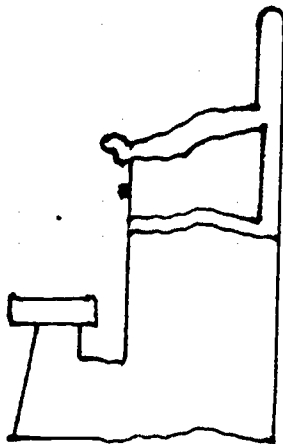

Profile of a desk facing the teacher

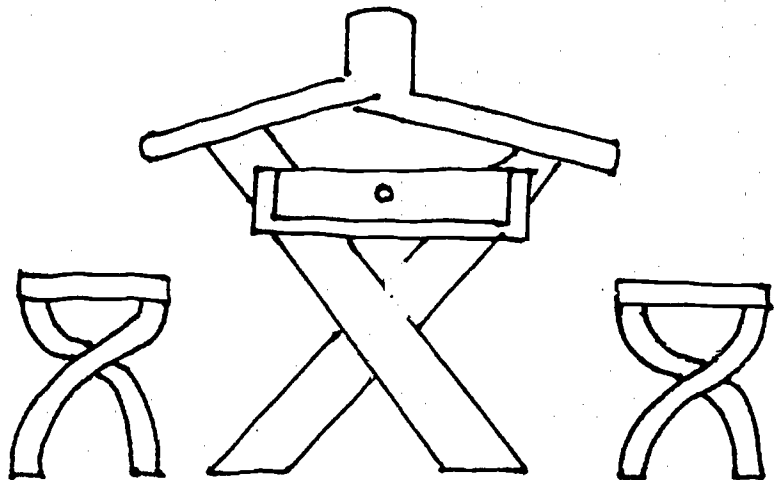

Profile of a double desk

Semi-circular wooden alcoves were built along the walls for group work; these could seat 10 pupils with a monitor. On the walls were blackboards at eye level, for exercises in arithmetic; they were fitted with devices for hanging up reading tables.

At the very end of the hall stood the teacher's chair, approached by steps and surrounded by a railing. From that vantage point he conducted, like a ship's captain on his bridge, the whole manoeuvre of the teaching process. A few steps lower, at the feet of the teacher, was the desk of the leading monitor, who acted as the captain's lieutenant.

The teacher is seated at his desk, on a platform. He has a whistle and a rod.

The leading monitor has a desk a little below that of the teacher and in front of it.

The teacher's chair is surrounded by a railing. At the end of each of the long tables is a monitor with a rod. There is also a monitor in charge of each group of 10 pupils working in the semi-circular wooden alcoves, in front of the blackboard or the movable boards for reading or arithmetic. There are thus 24 monitors to 224 pupils.

Including the monitors, there are 248 pupils here, but there could be as many as a thousand. A large school of this type once functioned at the Halle aux Draps in Paris.

Movements within these vast halls took place at a word of command, to a rhythm and often accompanied by singing. They were carefully regulated so as to avoid any scramble.

The exercises followed one another in an order strictly determined in advance. There were three places for school work:

- (i) at the desks
- (ii) in the semi-circular alcoves
- (iii) at the long tables arranged round the teacher's chair, for writing, arithmetic or drawing.

Contemporary observers, and pupils' families, were amazed at these vast long halls which accommodated an entire school. They were fascinated by the movements executed with such exactness and in such perfect order.

PLAN OF A SCHOOL FOR 248 PUPILS

LAUSANNE, 1823

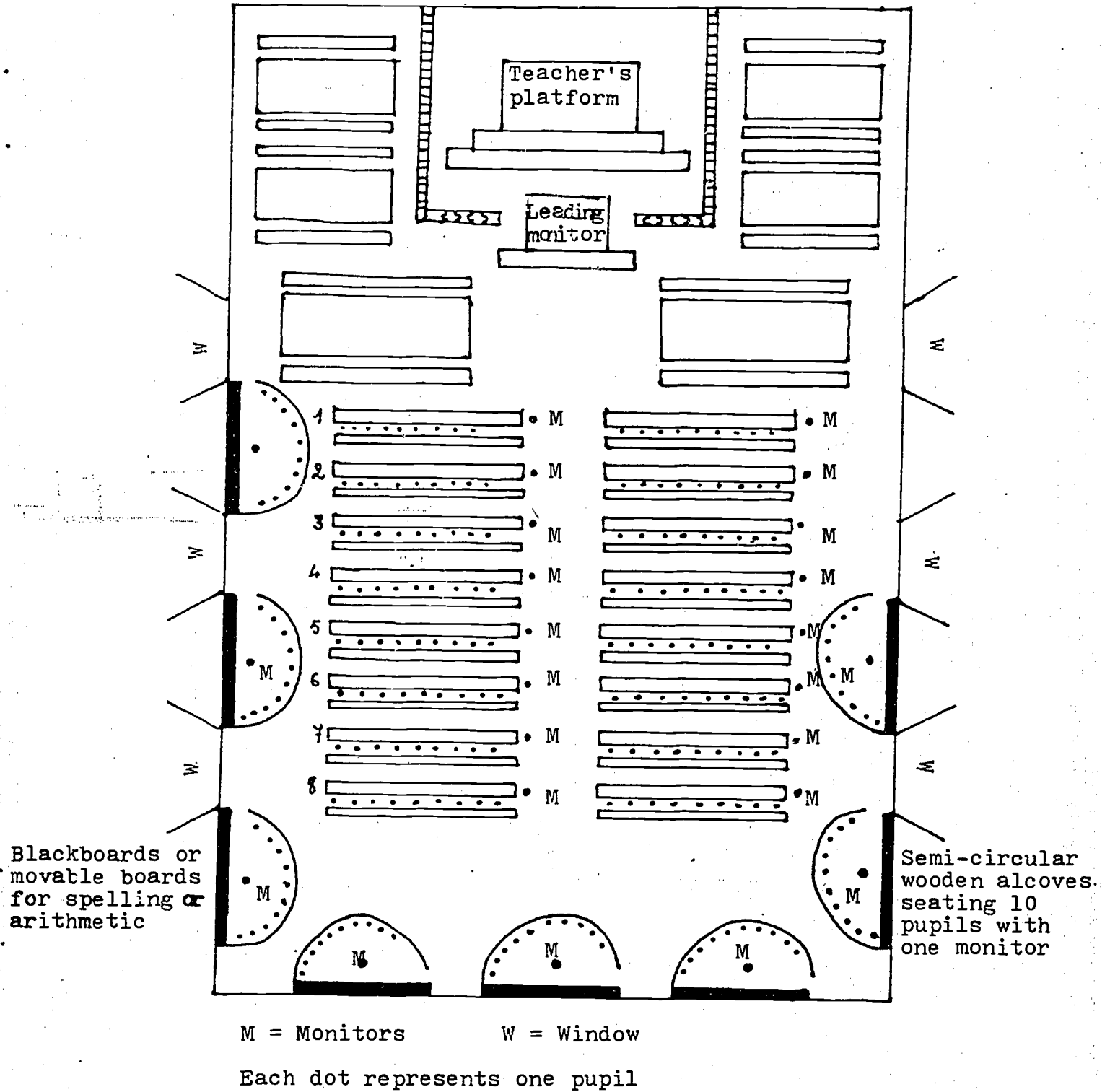

III. 1.4 Operation of the system

Let us now take a closer look at the way in which the system worked. Its underlying principle, formulated by Bell, was as follows:

"The basic principle of this method consists in reciprocal instruction, the pupils teaching one another and the more able among them acting as teachers for those who are less able."

To this, Bell adds a further key concept:

"The pupils who are acting as teachers instruct themselves as they teach."

(This recalls Comenius' dictum: 'Docemur docendo')

But what about the monitor? How will he be chosen?

Bell tells us that the monitor can, of course, be chosen by the teacher; but he is convinced that 'children are sound judges of each other's ability' and that, consequently, the monitor can be chosen by his fellow pupils.

The pupils were divided into grades according to the level they had achieved, and "constant competition" attended the assignment of places at the long tables, since these were allotted according to merit. Zeal was maintained by the continual fostering of emulation.

Bell advocated the keeping of monitors in the same place for as long as possible, so that they might get to know their pupils well. This view is open to question if we admit from the outset that the best way of learning is to teach.

Each monitor had an assistant to help him or to replace him when he was absent.

The teacher also had an assistant: the leading monitor.

In a very large school there might be two or three assistant leading monitors.

Responsibility for the maintenance of order and discipline was also in the hands of the children. Besides the monitors, there were 'inspectors', i.e., supervisors. Their business was to ensure that any case of negligence or inattention was immediately brought to light and corrected without any intervention on the part of the teacher. The teacher, as Bell says, had only to act as chief inspector, and for that reason he was able to handle a very large number of children - where the premises allowed, even as many as a thousand - without this causing any difficulty in regard to supervision or instruction. And never was there room for despotism or bad temper on the teacher's part.

The system was thus extremely graded, and every pupil was all the time superintended. It made no difference that his superintendents were his fellow pupils: it would have been well-

nigh impossible for students to do anything which interfered with the rigorous order of the exercises. Their freedom was therefore very restricted. There was no corporal punishment, but there were sanctions of a different kind, which could be endlessly varied. This offers food for thought. In Bell's schools, all omissions, faults, or infractions were recorded in a 'black book'. Progress was regularly noted in registers.

It may be wondered, in these circumstances, to what extent the "pupils' juries" were able to exercise free and independent judgment - although they had seemed at first and in their essence to represent so daring and valid an innovation.

It may also be feared that the constant supervision of pupils by other pupils, when it is not limited to pure techniques of learning - and in that they necessarily conceal a content of ideas and sentiments, the techniques of learning to read and write can never be "pure", may result in a strengthening of the prevailing errors and prejudices of the environment. Because of his insufficient training, the monitor is hardly able to have a broad enough mastery of the subject matter which he is called upon to transmit; he is therefore liable to distort it, unless he is himself constantly supervised. The teachers in the peer tutoring system were partially aware of this risk. They therefore took great care over the training of monitors. Every morning, for two hours, these were taken in hand by the teacher. But the task was hard and complicated. The teacher could do little more than instruct them in the 'manoeuvres' of which they would have to take charge during the day. He handed them a series of set questions with the right answers to them. But the monitors were seldom capable of varying the explanations, of coping with an unexpected situation, of passing lightly over a matter or of stressing it according as the case might demand. It was soon found necessary to set up schools for monitors and to raise the level of their knowledge.

The monitors spent two hours at the beginning of the morning, with the teacher, who gave them instructions for the day and made sure that these had been understood. After that, the monitors had about four hours' teaching to do and, when pupils had gone, they had to make a report to the teacher on the day's work.

We may imagine the teacher in his chair, with his rod and whistle. The rod is not an instrument of punishment; it serves as an extension of his arm, for pointing to a pupil or calling attention to some detail on the boards. The leading monitor is at his desk just below the teacher, ready to pass on the latter's orders. The date is 1820. The teacher is wearing a top hat, which he keeps on in school. Round the stiff white collar reaching half way up his ears is wrapped a huge cravat. He is dressed in a frock-coat. The pupils are wearing caps. One of them seems even to have a top hat, though his feet are in clogs.

The pupils come into class. Each file is guided by a "leader" who knows which way to go to seat the members of his group. The movement of the files has to be strictly regulated to enable some hundreds of children to find their places quickly, calmly and without confusion. The whole manoeuvre takes place in an atmosphere of earnestness, orderliness and restraint.

"The slightest preliminaries involved a whole series of attitudes subject to the rules of a sort of tactic."

There was a code, in which use was made of gesture, mimicry, speech, bell and whistle.

For example, "for turning the pupils towards the side to which they are to march," the monitor calls "Attention" and shows the direction with a movement of his hand. At the word, "Attention!" all the pupils have to look at the monitor; at the movement of his hand they make a quarter turn in the direction indicated.

For stopping the march: a blast of the whistle.

For making the pupils turn towards the teacher's platform: a ring of the bell.

For preparing to take place at the benches: the arms extended horizontally, right arm forward, left arm back. At the command "To writing class!" the pupils step forward, behind their 'leader'. They file into the benches from the end opposite the 'writing model board' known as 'the telegraph'.

At the command "Monitors!" these take down the roll-call lists, with pencil attached, that are hanging on the wall opposite each row of desks. They note who is present, without uttering a word. When this is done they turn towards the teacher's platform. Meanwhile, the assistant monitors are distributing copy-books, models, pencils, pens, chinks. At the signal (a ring of the bell), the monitors report the roll call to the teacher.

Contemporary observers much admired this silent animation and the "magical effect" of the slightest ring of the bell. While the movements were taking place, nothing was heard but the muffled sound of children's feet moving in step.

Once the pupils are seated at their desks and the roll-call is taken, the teacher sends out the order appropriate to the next activity: "Writing monitors!" At a bell signal, the writing monitors and their assistants immediately step up on the little platforms reserved for them at the end of the rows of desks, and near the "telegraphs". They call "Attention", and all heads turn their way.

The monitors then mimic the motions for 'preparing and cleaning slates', i.e., right hand to mouth and left to belt level. The pupils respond at once: right hand to mouth, left hand on slate. When they see their monitor moving his hand round horizontally, they apply their hands to the slates to clean them. The day's writing exercise then takes place under the monitors' direction, with the aid of the "telegraph" on which the models are beautifully written.

Work continues till every pupil has carried out the exercise to perfection. The monitor never hits, never threatens, but notes every incident for his report to the teacher. Each pupil's efforts are supervised. When all have put down their chinks, pencils or pens, a bell is rung and the monitors march back to their places, in perfect line, after which they sit down.

This "mise-en-scène" was a source of satisfaction to the children's families:

"Of all the causes which have contributed to the popularization of peer tutoring, probably none has appealed as strongly to the imagination as this organization based on the word of command."

Yet it is this quasi-military form of organization which is most distasteful to us today. It might have happened to amuse the children, because they like playing at soldiers - more so, in 1820 than in 1975 - but it may be wondered whether these 4 hours a day of restraint and coercion, the habit of immediate and passive obedience to orders, did not have a disastrous effect on the development of their personalities.

Children, no less than adults, have a strong tendency to imitate their fellows, to follow their example. This concept of imitation, at one time somewhat overlooked, was brought back into the limelight by psychologists and sociologists in the sixties. It is undoubtedly important, and it is a major component in the moulding of the individual by the society to which he belongs. But there is a very evident danger in proposing no more than a narrow and servile imitation of ready-made models.

It must also soon have become apparent that, for the task of education, more was required than the setting up of machinery. From 1833 onwards, in Switzerland as well as in France, it came to be realized that peer tutoring could not solve all the problems of mass education.

"The system of peer tutoring was attacked in the name of education itself, once primary education began to be looked upon as more than a means for the mechanical teaching of reading, writing, arithmetic, and the elements of singing and drawing."

In a report dated 1834, entitled De l'instruction publique dans le Canton de Vaud (Public Education in the Canton of Vaud), a Swiss professor named André Gindroz makes several interesting observations. He remarks that, "although peer tutoring might be an effective instrument for the rapid spread of education in countries where the majority of the population can neither read nor write," it is less appropriate in countries like Switzerland "where people have got beyond the A B C stage". This opinion offers food for thought. In a country where there are many illiterates and people with a low level of education, much can be achieved by asking anyone and everyone who possesses some knowledge to pass it on to those who have none. Even then, it would be necessary to create the structures (social, economic, etc.) that would enable this transmission of knowledge to take place.

It was with some regret that our Swiss professor in 1834 gave up the principle of peer tutoring because, as he says, this method "has the advantage of keeping the young pupils constantly occupied in an active, interesting way. In a school of the older type you will find them as a rule inactive, squatting or lying on their benches, worn out with boredom, with the fatigue of idleness, which is the worst form of fatigue. But if you go

into a peer tutoring school, you will be surprised to see children of 5 or 6 busy, active and happy." Consequently, Professor Gindroz ends by advising us to retain what is of value in the method, combining it with the simultaneous and individual methods. It would thus seem that there is room for research at the present time in this direction.

I would add that in genuine peer tutoring, the relationship between 'tutor' and 'tutee' should be really and fully two-way, with each one receiving (being taught) and giving (teaching) in turn, thus meeting a basic need for communication. The personality develops in this relationship, and if the need for communication is not satisfied, it develops badly. This dual movement of giving and receiving was not properly achieved in the system applied in the petites écoles of 1820, where the teacher sat enthroned above his pupils and where implicit obedience was the rule.

Peer tutoring no longer amounts to much if it ceases to serve for human and social training, if it does not develop the paying of attention to others, respect for their freedom of opinion and expression - even in the case of children 6 years old - if it leaves no scope for initiative, imagination, freedom.

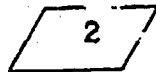

Peer tutoring in the U.S.:

Three experiments with children and adolescents

III. 2.1 Background

In 1818 Joseph Lancaster emigrated to the United States. There he propagated his ideas, which took on and remained in vogue for about three decades before they fell out of favour. More than a century had to pass by before Americans concerned with education again gave their minds to the idea of peer tutoring.

It is now Europe's turn to rediscover it:

" It is a piquant experience to see coming from the United States, in up-to-date, pragmatic, descriptive form, ideas and experimental approaches which were familiar many years ago in Europe."

Louis Legrand

(A preface to translation of Gartner, Conway, Kohler, and Riessman, Children Teach Children, 1971)

Interest in peer tutoring in the United States was first stimulated by the urgent problem of providing elementary education

for a large number of children - negro and Porto Rican - without the necessary number of qualified teachers.

A National Commission on Resources for Youth was set up to combat juvenile poverty, delinquency, and unemployment. This Commission drew up a number of programmes for education. One of the most important of these schemes, worked out by Mary Conway Kohler, is known by the initials Y.T.Y. (Youth Teaching Youth). Other educational programmes intended for youth made their appearance at the same time, the first such programme being the work of Peggy and Ronald Lippitt, who, in 1960, were more or less pioneers for a rebirth of peer tutoring. The programmes of the Lippitts and Mary Conway Kohler are in fact based on the principle of 'Learning through Teaching' (L.T.T.). This is the method I shall now describe.

III. 2.2 'Learning through Teaching' (L.T.T.)

2.2.1 The monitor system

1960: Without stepping outside the framework of the American school system, Peggy and Ronald Lippitt hit upon the idea of using pupils from the top grades of primary school and the bottom grades of junior high school - i.e., 11-to-13-year-olds - as monitors for those still in kindergarten. Their chief objectives were:

- (i) to give the older children a sense of group integration
- (ii) to help the younger children.

The monitors (aged 11 to 13) assisted the teacher three times weekly for about 45 minutes. This was but a modest beginning: only two monitors at a time were introduced into a class. These helped the children with their exercises in reading, writing, spelling and physical training. A general monitors' meeting was held once weekly, which gave them an opportunity to compare notes and try to improve on their work.

This very successful experiment was continued.

2.2.2 Camps

The Lippitts then arranged for children between the ages of 4 and 12 to live together in camps. Here again the aim was to promote group integration.

Before the children of different age groups actually began living together, the Lippitts had devised activities designed to bring them into relationship with each other, such as communal meals, joint swimming sessions or handicrafts sessions where they could join in making toys, everyday objects, etc. The adults also gave the older children some training in how to understand younger children and establish a rapport with them.

The adult personnel supervising the camps were given a week's training before the children arrived.

This experiment also proved a success and was repeated.

2.2.3 The Y.T.Y. programme (Youth teaching Youth)

This is a night school programme functioning in cooperation with the N.Y.C. (Neighbourhood Youth Corps), which groups together a variety of neighbourhood committees set up by young volunteers. The N.Y.C. cooperates with the Ministry of Labour in the campaign against unemployment among the young, particularly by giving them jobs as monitors in educational programmes.

In this case, the aim was to teach backward schoolchildren from the negro and Porto Rican quarters to read.

The programme was worked out in 1967 and a start was made just before the riots of July 1967.

This endeavour was based on the neighbourhood and the monitors themselves came from the poorer sections of the population. They worked for 22 hours a week; 6 hours' training and 16 hours' monitor duty. In addition to this, they could follow personal enrichment courses for 6 hours a week. Each monitoring session lasted 2 hours.

At Newark (New York), an attempt was made to secure genuine community participation, viz. that of the local population. Committees were set up composed of parents and others from outside the teaching profession, special stress being laid on the participation of mothers. Members of these committees were given training in group dynamics and in ways of teaching children to read, and very soon proved capable of contributing, in most cases enthusiastically, to the solution of specific educational problems..... Through their discussions, they made a major contribution in particular to devising suitable teaching materials for the Y.T.Y. classes.

As far as the monitors were concerned, they themselves showed rapid improvement in their reading standard:

"Although the monitors in Newark were genuinely retarded in respect of educational achievement, they made significant progress in a variety of reading exercises, their reading age increasing by as much as 3, 7 years."

(NCRY Report, 1968)

The zeal displayed by the monitors was remarkable.

Finally, these children and adolescents who had scarcely ever owned a book grew used to publications disappearing from the shelves and circulating among members of the groups no less than their written work: Reading and writing had in fact become part of their lives."

III. 2.3 The fundamentals of L.T.T.

(Learning through teaching)

- 1./ The method rests above all on the finding that a child learns more, and more quickly, when he is teaching other children.

It follows from this that the same child will be tutee (pupil) and tutor (monitor) successively. It will be noted that competition is absent from such a system:

"The acquisition of knowledge and skills comes about not by any competitive striving for marks, but as an essential process of interaction with others."

(Herbert A. Thelen:
'The human person defined',
November 1967)

When a child is acting as tutor, he must acquire new knowledge or consolidate the knowledge he already has, in order to transmit it. He is obliged to grasp a problem thoroughly before he tries to explain it to his fellow-pupils; what he knows must be well ordered in his mind so that he may give it lucid form, at the same time observing his pupil so as to ~~discover~~ the best way of entering into contact with him, and so as to find the right "tone" making for free and easy communication. He must constantly adjust his approach to the other's receptivity. In this manner he acquires and assimilates teaching skills which may prove useful to him in many other fields of knowledge and action.

Moreover, application of the "helper therapy principle" has revealed that the helper is the one to gain most from the relationship. It will occasion little surprise to find the tutor making quicker progress than the tutee; it would therefore be a mistake to keep monitors in their roles for too long, as was done in the petites écoles of 1820. Tutor and tutee should change round often.

As a rule, the tutor enjoys his task. The trust placed in him enhances his sense of being and worth. The situation in which he is placed causes him to adopt a new, more positive, more dynamic attitude towards learning. No longer is he the mere passive receptacle for words dispensed by a teacher, who is the sole custodian of all knowledge.

While engaged in preparing to instruct their classmates, many monitors come to discover in their own fund of knowledge fundamental gaps which go right back to kindergarten age or to the beginnings of primary education. Indeed, these blanks in our mental equipment can be carried right through the school career into adult life, because some inhibition or fear of ridicule stopped us asking the necessary question at the right moment.

The tutor, then, has perforce to take the situation in hand, becoming his own teacher. He finds means of filling the gap and derives great satisfaction from doing so. In this way he

rapidly acquires new knowledge and his progress can be measured by tests. What is less easy to assess is the development of his analytical powers and his powers of synthesis, discernible not merely in his school work, but in every kind of situation. An attempt is being made by American psychologists to work out a scale of valuation which would enable us to measure the progress achieved by monitors in regard to creativity, learning techniques, the widening of interest and the main mental faculties.

2./ In any peer tutoring system, several hypothetical types of grouping are possible, bringing together:

- (i) individuals of the same age
- (ii) individuals of slightly differing ages
- (iii) individuals of widely differing ages.

In the experiment carried out by Peggy and Ronald Lippitt at a school run on traditional lines, seniors of 11 to 13 years of age were put together with juniors of 4 to 6. The senior's standing in the eyes of the junior, and the tenderly protective feelings the former may experience for the latter, are factors working in favour of the rapport. The Lippitts attach much value to giving the seniors a chance to play a constructive, positive role in fostering group integration among the juniors, and their whole system is really based on this relationship between older and younger children.

However, other grouping patterns are conceivable, such as bringing together:

- (iv) individuals of different communities, say, black and white, believers and unbelievers. Thelen suggests that this might prove an effective way of combating social and racial prejudice.
- (v) individuals from varying cultural backgrounds and social milieux (students and workers, intellectuals and farmers).

3./ The peer tutoring system allows for a certain amount of individualization in the teaching process. By judicious organization of the teams, and recourse to programmed instruction and other forms of educational technology, for example, every pupil can be taught at his own pace and can have access at all times to a tutor of whom he can ask the questions he is unable to answer for himself, or which do not appear explicitly in the programme. The possibility of resort to a monitor who is always available brings a factor of human warmth, openness and emotional security into the situation.

4./ The system, then, affords an immediate feedback which is personal and intimate. The monitor can adjust to his pupil and may even do so spontaneously; he can explain things to him in a language he understands, making due allowance for his individual characteristics. Thus, for example, one child may need to be shown concrete examples while another may

be helped by drawing comparisons. The tone struck or style of approach will vary from listener to listener; some will call for good humour, smiles and gentleness, while others respond to a firm, straightforward approach. There are children who take offence at jokes or puns - which others find entertaining.

5./ When put into practice, this system brings about significant changes in children's relationships with each other and with adults. The child or adolescent who has been given responsibility, and has thereby felt confirmed in his worth, will as a matter of course be led to give thought to problems of order, authority and organization. He will no longer put up with the more humiliating and stupidly restrictive features of the conventional school system: excessively tight supervision, punishments, prohibitions of all kinds. He may even go so far as to question the curricula set for him and make alternative suggestions.

6./ The monitors are, of course, given some preparation for their task. As we have seen, this was the case in the camps organized by the Lippitts. Their concept was genuine cooperation between adults and children, with no trace of condescension. Children and adolescents are completely trusted to carry out important tasks. The confidence placed in them serves to confirm their sense of personal worth. This relationship with adults also enables them to resolve, in a more or less conscious way, the problems they had with their parents. Similarly, their new relationship with younger children can help them resolve their personal conflicts with brothers and sisters, playmates, etc. (Lippitt & Lohmann: Cross-age relationship).

7./ In the Y.T.Y. experiment, the idea was to get the community (in this case a New York neighbourhood) to assume responsibility for its own problems. And it did so with remarkable earnestness and zeal. The monitors' interest and involvement were unflagging: after the five days of rioting in 1967, occurring at the end of the second week of the programme, all monitors returned to their posts. The participation of 'non-teachers', i.e., ordinary people drawn from the community, was also a success.

8./ The monitor system can take various forms:

(a) Binary:

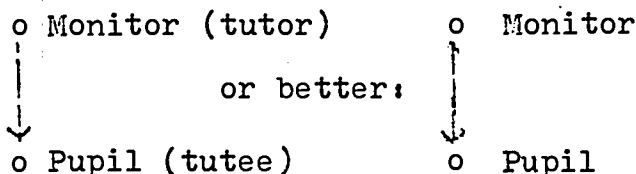

The 'tutor' may act in various ways: by his mere presence and mute goodwill; by attentive listening; by giving advice or guidance; or by offering stimulus. The bond between tutor and tutee may be a one-way or two-way relationship, but a two-way relationship must be achieved quickly in any worthwhile system of peer tutoring; a proportion of the information and discoveries must come from the 'tutee';

(b) multiple (one monitor, several pupils)

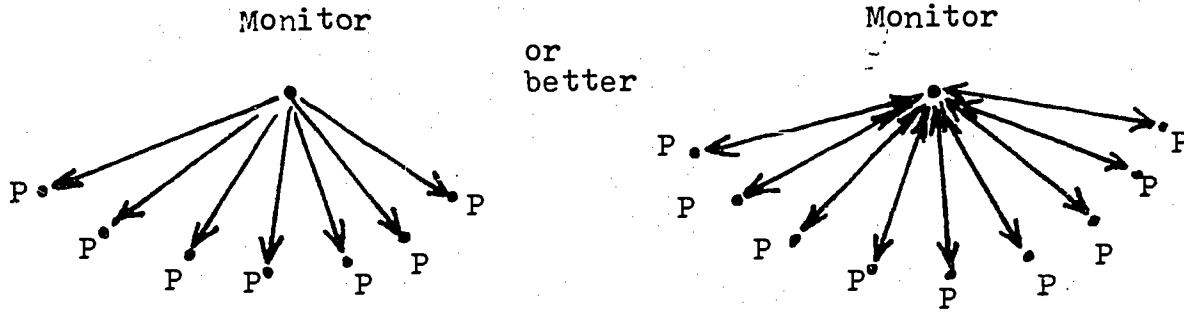

The monitor may be chosen from within the class or appointed from outside;

(c) children of different ages grouped together (or adolescents, or adults, or persons of any age) working at one task, the more advanced ones assisting the others and everyone joining in discovering something and communicating what he has learnt.

Task = T

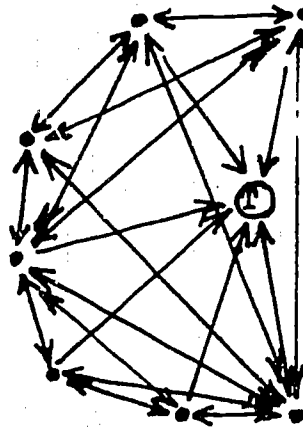

III. 2.4 Operation of the system

What did the 'Youth-teaching Youth' programme, devised by A. Gartner, Mary Conway Kohler and F. Riessman, look like in operation?

This programme hinges on training and promoting the development of monitors. As has been mentioned, those chosen monitors were educationally backward teenagers whose handicaps arose chiefly out of their social origins (negroes and Porto Ricans), and youngsters who had been mediocre school performers — even problem children:

"The first selection of monitors included maladjusted children who had been regarded as problem pupils in their own classes."

Newark and Melaragno
(Annual report 1968-69)

Of course, monitor recruitment could be done on very different bases from these.

It was thought that by conferring responsibility on these adolescents, by giving them the role of helpers vis-à-vis younger children from the same environment, opportunities were being created for the display and development of their innate talents. After a time their self-image changed, they acquired self-respect and proper pride. And the attitude of others towards them changed too.

1./ Training the monitors: the recruits receive very little in the way of preparation for their new function: a few days are devoted to the task of boosting their self-confidence. This programme begins with some games of 'self-discovery': the prospective monitor is invited to make up an effigy of himself by sticking things together, or he may be asked to write a paragraph about himself or to act a role. The accent is not on the production of specialists in methods of teaching how to read. At the start of the venture an attempt was made to provide the monitors with teaching advisers of a kind, 'experts' in the art of teaching people to read, but these 'counsellors' were decisively rejected by the monitors, because all the negative emotions they had felt towards their teachers during their failed studies reappeared with these advisers.

So it is no good trying to impose knowledge from outside. The right way is to get the monitors to 'learn how to learn'. The traditional image of 'school and 'schoolmasters' must be discarded. This is easier said than done, for this image is anchored in our minds from childhood up. This traditional image was retained in its entirety in the 'petites écoles' of 1820: of school as a place where fun is barred, where the master sits on high, disposing, organizing and controlling a place remote from the ordinary concerns of life. From all this, the Y.T.Y. programme represents a radical departure. Monitors are invited to pay heed to their surroundings, and everything that goes on there, to open their minds to people's real problems, habits, and aspirations, and to

observe men as they go about their daily business. It is by drinking in this living environment in all its rich variety that they will find the right words to describe it and to get their young tutees to express themselves. Thus the environment will itself provide the essential content of the educational programme.

2./ A creative role for the monitor:

The monitor can then be left considerable latitude for working out, largely by his own efforts, a teaching method to suit himself. His creative imagination will be gradually aroused, suggesting new ways of enlisting his pupils' interest and stimulating their efforts. He may be asked to invent games, new materials or teaching procedures:

"Monitors have been found to do better with their own materials than with the standard equipment, which should be used only for back-up purposes."

The following examples, given by Gartner, Conway Kohler & Riessman, may serve to illustrate the kind of things that can be done in this respect:

- a) A cardboard tree with branches for hanging up word cards; the words on the cards denote things seen while out on a walk

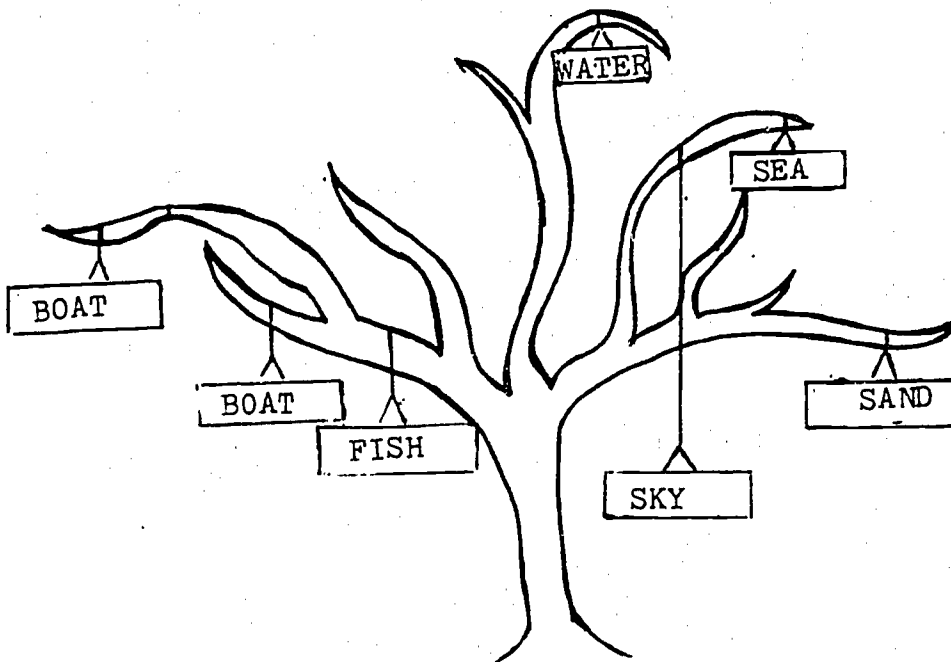

Making the cardboard tree itself is a joint effort, all contributing something to it. There is great scope for imagination in devising simple equipment of this type. The pupils themselves may come up with ideas, e.g., the use of colours to distinguish nouns from adjectives, etc.;

- b) A picture book for glueing in photographs or illustrations cut out of magazines — useful for language exercises;
- c) A sentence-building set: the words are written on little cards and arranged in boxes by grammatical category. The children use them to make up sentences, which can be as funny or deliberately nonsensical as they choose.

The monitors have limitless scope for their imagination. If they wish, they can have recourse to audio-visual equipment: some monitors have prepared tape-recorded interviews with the help of their tutees. First of all, the questions are formulated; then they are put to passers-by in the street. The completed interview serves as raw material for language and reading lessons.

Other monitors keep a diary and make daily entries in it with their tutees.

Still others go out taking snapshots with a Polaroid camera, the resulting photos serving as a source of inspiration for language lessons.

Working together at the production of teaching materials, etc., does much more to weld the group together than an ordinary class or conversational exercise to a set pattern.

3./ Choice of premises: a report that appeared in 1969 advises against the use of classrooms which by their layout and atmosphere are calculated to re-~~re~~voke the old attitudes towards school. The ideal setting for the purpose would be something rather more like a workshop.

In the Y.T.Y. system the monitor has to do with one or two pupils only, for one-and-a-half to two hours at a time, and it is of course conceivable to have systems where the composition of the team is subject to frequent changes.

In some cases, but not in others, it is desirable to have a mixed boy-girl team. Character and disposition must be taken into account. 'A big boy who is slow mixes badly with a small one who is bright.' (Lippitt and Eiseman: Cross-age helping program, 1969).

It is a good idea to provide suitable spaces where tutor and tutee can work undisturbed: cubicles, improvisation of screens, etc. As essential materials, a few fountain-pens, paper, pencils, old magazines, scissors, etc., will do. To this equipment will be added the articles produced by the room, and storage spaces will also be necessary. Once the children have learned to read they will need a supply of books and manuals to exercise their skill, so bookshelves will be necessary.

We enter the work area and wonder whether there is a teacher at all: he has no 'throne', no dais, no special desk — merely a space, somewhere, for his materials. As likely as not his presence will be hidden by a crowd of sprawling children, at a table or on the floor. They work in groups, independently, move about freely, after materials or books, ask each other questions,

go and see what the others are up to. All monitors and pupils alike, are on familiar, first-name terms, and a group may go out with their monitor for a walk.

The monitor has prepared his programme for the day and keeps a diary. It may happen that the programme is modified, because what matters most at any moment is the pupil's state of receptivity. Quite often the tutor-tutee relationship continues after hours: the group eats together or goes off to see a film or go for a swim.

An important feature of the system is the monitors' meeting, at which experiences are discussed and methods swapped. Weekly sessions lasting several hours are devoted to this purpose in the Y.T.Y. programme.

3

An experiment in teaching spelling

In the experiments described above, seniors invariably played the part of 'tutor' to juniors. In the experiment we shall now consider (defined by Peter S. Rosenbaum as 'Peer-mediated instruction') the same child takes turns at being tutor and tutee—a principle of which I entirely approve.

The experiment in question was conducted in 1970-71 at Stony Brook (New York) by a University of New York team investigating peer tutoring. The project was concerned with teaching young children to spell.

As a rule, spelling lessons involve written dictations for correction by a teacher, a method which rarely arouses much enthusiasm in class. The method has a further unquestionable drawback: there is too long a time-lag between a mistake and its correction. With the Stony Brook method, however, tutees have the chance to see their mistakes at once even where the tutor is not sure of the correct spelling himself.

Tutor and tutee are seated face to face,

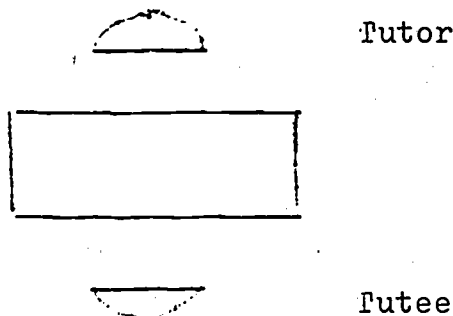

changing roles in turn. Corrections are frequent, which leads to a lively dialogue.

In this system, then, the teaching process is individualized. The amount of time spent correcting mistakes will vary with the child's aptitude and starting equipment: all progress at their own pace.

The system is very simple, easy to learn and easy to practice. Nobody gets bored and there are no failures. The following equipment is needed:

- (i) A cardboard box labelled 'spelling', containing
- (ii) Two work-books, one for the tutor and one for the tutee, eight pages each. Every page in the tutor's work-book contains a spelling lesson, with fourteen words to be learned.

The following is a facsimile of a page in the tutor's work-book:

<input type="checkbox"/>	<u>green</u>	Mrs. Turtle wore a <u>green</u> shell	<u>green</u>
<input type="checkbox"/>	<u>weed</u>	Robert wants to let the <u>weed</u> grow	<u>weed</u>
<input type="checkbox"/>	<u>teeth</u>	Without <u>teeth</u> , you wouldn't have fun eating	<u>teeth</u>
<input type="checkbox"/>	<u>meat</u>	I dreamed I ate candy and <u>meat</u> for lunch	<u>meat</u>
<input type="checkbox"/>	<u>lean</u>	If you <u>lean</u> the other way, you'll fall	<u>lean</u>
<input type="checkbox"/>	<u>mean</u>	I look <u>mean</u> in my Halloween mask	<u>mean</u>
<input type="checkbox"/>	<u>she</u>	<u>She</u> sneezed a mighty sneeze	<u>she</u>
<input type="checkbox"/>	<u>room</u>	Let us find the <u>room</u> with all the toys	<u>room</u>
<input type="checkbox"/>	<u>spoon</u>	Use your <u>spoon</u> to stir the soda	<u>spoon</u>
<input type="checkbox"/>	<u>toot</u>	<u>Toot</u> is the only word the train can say	<u>toot</u>
<input type="checkbox"/>	<u>food</u>	I ate all the <u>food</u> on my plate	<u>food</u>
<input type="checkbox"/>	<u>true</u>	It's not <u>true</u> . I am a cowboy	<u>true</u>
<input type="checkbox"/>	<u>blue</u>	<u>Blue</u> rhymes with true	<u>blue</u>
<input type="checkbox"/>	<u>glue</u>	My <u>glue</u> bottle stuck to my desk	<u>glue</u>

The composition of each page is as follows:

14 lines of text; each line containing one of the words to be assimilated during the lesson — in this case, English words with vowels or diphthongs (e, ee, ea, eo, ue) pronounced in a more or less identical manner. Each line begins with a blank diamond to be used as indicated below.

The tutee's work-book is an exercise book in which the tutee writes down the words to be learned. Each page is printed as follows:

1	6	11
2	7	12
3	8	13
4	9	14
5	10	15

Every child is issued with a box containing both work-books: the one acting as tutor works with the books belonging to the child who is acting as tutee. Before the lesson starts, it is decided who is to be tutor; the tutee keeps for himself the tutee's work-book from his own box, and gives his tutor's work-book to the tutor. Work can then begin.

How the system functions: The tutor reads out the first line on the page to be studied:

"green Mrs. Furtle wore a green shell green"

The tutee attempts to write down the word in question on the top line in the first square of his page. He then passes his book to the tutor for approval or correction.

The tutor does this and returns the book to the tutee. The process of correction can be represented as follows:

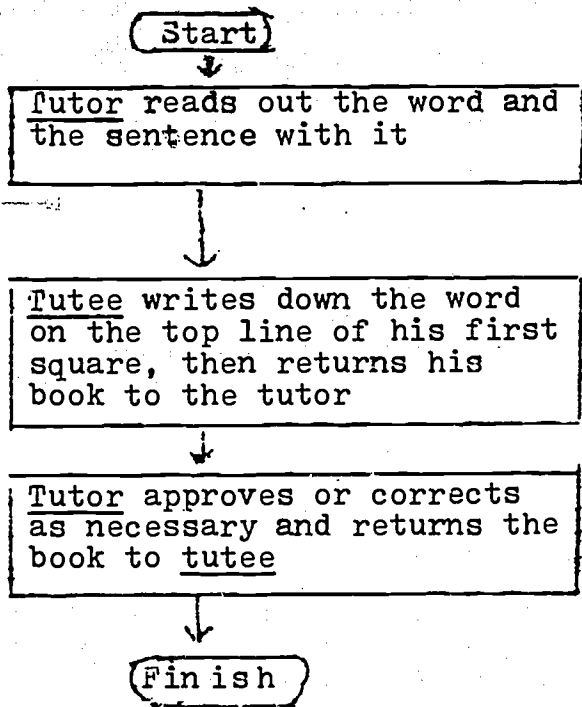

(i) Tutee has the benefit of immediate and individual correction

(ii) as well as personal exchange with tutor

(iii) Tutee's attention is kept constantly on the alert.

The stimulus is here the spoken word.

The response involves the ordering of several elements: letters making up a word

It would not be enough to correct the pupil by simply telling him he has spelt the word well or badly. This would impart no information to him and he would have no idea how to go about improving his results, nor would he realize in what way his effort falls short of what he should have done. A more positive process of correction is needed, namely, one which takes account of the three possible types of error and their combinations:

- (i) omission of letters;
- (ii) substitution of incorrect for correct letters;
- (iii) insertion of unnecessary letters.

Over-sophisticated methods of correction are no good; time is lost and the pupil loses interest. Errors are corrected in the following manner:

The tutor examines the word written by the tutee letter by letter:

```

    faulty answer . . . . . g r e a n
                               ↓ ↓ ↓ ↓ ↓
    correction. . . . . g r e e n
  
```

When he reaches the mistake he draws a vertical line through the word:

```

    g r e | a n
  
```

crossing out the remainder; after this partial correction he returns the book to the tutee. (The process is analogous to what a teaching machine might do.) The message is therefore quite clear: everything left of the vertical line is right, but somewhere further on there is a mistake.

The tutee tries again. If his answer is still wrong, the tutor will correct it in the same manner, but in addition he will



enter the right answer on the third line of the square, thus:

Tutee g r e ~~a~~n

Tutee ~~g~~ r e ~~n~~e

Tutor g r e e n

If the tutee succeeds first try, a mark is entered in the blank diamond which begins every line of the lesson. Words which have failed to earn this mark are included in a further exercise, till all have been learned properly. This system of peer tutoring in spelling is represented by the following diagram:

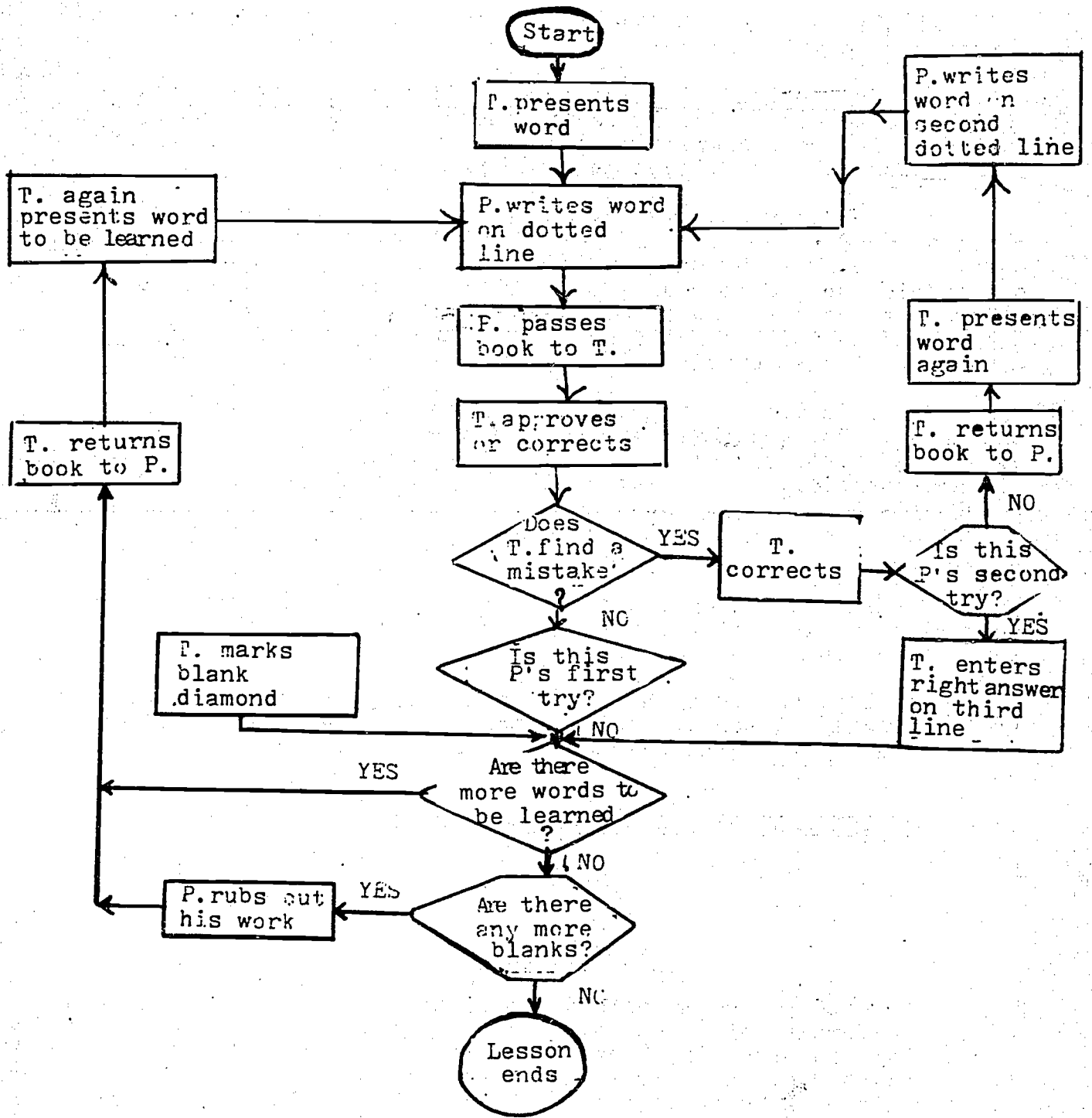

T = Tutor
P = Pupil (Tutee)

Another advantage of this method is that it is very easy to take in for the teacher who will act as 'instructor' to the children. As he uses it, he will build up a new system of communication within the class.

As the teacher watches his pupils at work, he will be struck by two main points:

1) The aptitude for acquiring skills varies from pupil to pupil. There are the dullards and there are the bright ones. The dullards give poor answers to tests and work slowly; the bright ones answer well and also make rapid progress.

In the Stony Brook experiment, the running-in phase showed what happened when one paired very bright pupils with very dull ones. There is a threshold which must not be crossed — on pain of matching up people who will never be able to understand each other. As Rosenbaum puts it, it is as if they spoke different languages; he thinks such a situation leads inevitably to a breakdown of the 'dyadic relationship';

2) This method of instruction involves an inter-personal encounter. The encounter has to be acted out according to rules, but these rules are not of a kind the youthful actor is capable of comprehending. The relationship between tutor and tutee may be unsatisfactory. Rosenbaum's answer is to recommend a frequent switching of partners, allowing chance to play its part as far as possible.

Yet another advantage of this method is that it quickly does away with problems of discipline, and more particularly those which arise out of boredom.

Finally, although the question has not yet been gone into systematically, Rosenbaum appears to be convinced that with this method the tutor learns every bit as much as the tutee.

IV - BEER TUTORING AND PROGRAMMED LEARNING

1

The "Keller Plan"

The Fred S. Keller method was first put to the test in 1963 at the University of Columbia. Shortly afterwards, the system was applied in Brasilia, where a Department of Psychology was to be established at the University. These tests won the enthusiasm of students and the University authorities alike. Unfortunately, disturbances within the University, involving the resignation or dismissal of 200 lecturers, put an abrupt end to the experiment.

In 1965, Keller and Professor J. G. Sherman, working on the same pattern, organized the teaching of psychology at the University of Arizona. In 1969, the Keller Plan was used for physics teaching at the Massachusetts Institute of Technology.

Since then, this system has met with resounding success. Keller set out the principles of his method in an article entitled "Goodbye, teacher" (Journal of Applied Behaviour Analysis, 1968).

IV - 1.1 Basic principles

It should be understood at the outset that, for Keller, the essential role of the teacher is not to disseminate information, but to perfect and apply a "system".

In this system, the pupil is not a passive receptacle. He must participate. He is an active ingredient in the teaching process.

"obviously, one cannot teach a pupil to play the violin simply by conveying information to him about the right way to set about playing the violin".

The subject for study must first be divided into one-week "units of instruction. Keller thinks that small 'units' assimilable in two or three days, provide the strongest motivation. When the skills or aptitudes to be acquired by the students have been clearly and distinctly defined, graded exercises must be devised to enable the students to acquire these skills.

The teacher compiles a study book, which should be short (2-10 pages). It indicates the objectives to be reached in the course of the week, set out in as operational a manner as possible. It also contains a list of specific questions to which the answers must be learnt. It lists reading assignments, and, where applicable, laboratory work.

The units follow one another in a fixed order.

In the Keller system, there are 30 such units to one semester. One must master the content of one work unit thoroughly before being allowed to pass on to the next.

Keller believes that students' participation should be increased, particularly by using students as tutors.

The tutors will thus be at the disposal of the students. The work will be carried out in a large classroom. Each tutor will be responsible for 10 students, or at most, 12. The best arrangement consists of three two-hour sessions per week.

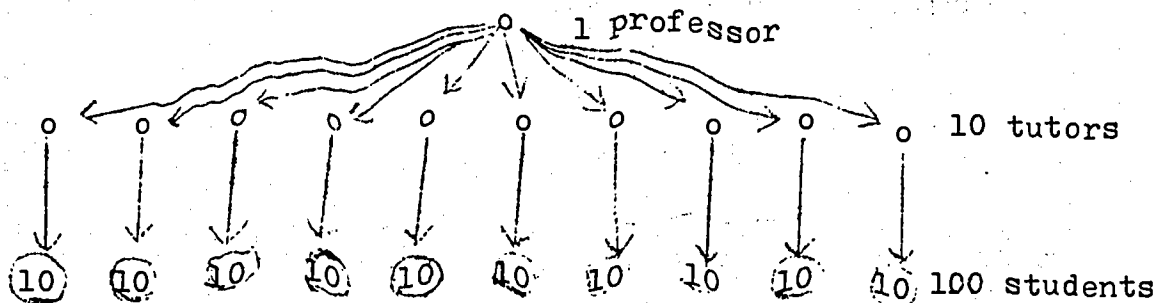

The tutors form the nucleus of the system. Keller thinks that it is preferable to select them from among students who have recently taken the same course; they will thus be better able to understand the difficulties of their tutees. The responsibilities placed upon them must be very clearly defined and must not exceed their capabilities. They work according to a precise plan and on topics with which they are perfectly familiar.

The tutor is a volunteer. Sometimes he is paid, but more often not.

The teacher in charge of the programme also compiles tests corresponding to each unit of instruction. When the student considers that he has gained sufficient mastery of his unit, he applies to take the corresponding test.

Each student works at his own speed, and rapidity is never taken to be a yardstick of value. Even if a student fails a test repeatedly, his failures are not held against him.

The student is given the test by the tutor assigned to him. Lessons, in the strict sense of the term, are given only to the pupil who has proved, by passing his tests, that he is ready for them. Lessons, lectures and demonstrations are intended to motivate the student, rather than to provide him with information. Moreover, they are optional, and no examination will be based on them.

A student may be tested 40 or 50 times by his tutor in the course of a term. He is continually given individual attention, and all errors are corrected immediately. The "socio-personal" relationship, which is a very important part of the educational process, is thereby strengthened. An "incorrect" answer may be defended by the tutee; if his defense is cogently argued, it may modify the tutor's evaluation of him. All social, economic, cultural and ethnic differences are entirely subordinated to a friendly, intellectual relationship between two young people, which lasts for at least 15 weeks.

IV - 1.2 The way the system works

In "Goodbye, teacher", Keller describes a week in the life of John Pilgrim, an imaginary first-year student in an American university. He is doing a course in psychology.

He will thus be one of a group of 100 students of both sexes who are also beginning their course. He learns that he must be present on Tuesdays and Thursdays from 9:15 to 10:30 a.m. There will also be laboratory work, for which the time-table is still to be set.

On the first day, the lecturer gives out printed information concerning the method to be followed. He says a few words to the students; among other reassuring things, he tells them that they will be able to work at their own speed, that the tutors will be constantly at their disposal, and that there will be no plain ex cathedra lectures. To be sure of obtaining the diploma at the end of the year, one must pass 2 units per week. If John Pilgrim does not take at least one test in the first fortnight of the semester, he must withdraw from the course. He is informed that the tests are taken on Wednesday and Saturday afternoons.

He is then given a study-book in which the objectives of the first unit of instruction are clearly set out and which contains a list of programmed questions, texts to be read and, where applicable, laboratory experiments to be carried out. Students may have access to the laboratory at any time; one need only ask the assistant in charge. 40

John Pilgrim is free to study whenever he likes, but he is strongly encouraged to make use of the large study-hall provided for that purpose, since he will find the best working conditions there, i. e., other pupils who are engaged in the same activities, a tutor (or proctor) who can help him to clarify a passage which he finds obscure, or to understand a difficult concept, dictionaries and reference books. A mere glance at the study-hall reveals that everyone there is hard at work.

The foregoing events occurred on Tuesday. On Thursday, John Pilgrim returns. He wishes to continue studying in the study-hall, where approximately half the students are assembled, but he finds it difficult to concentrate. He therefore decides to go and work at home. The tutor pays no attention to his departure. On the following Tuesday John Pilgrim returns, ready to take his first test. The tests are held on Wednesdays and Saturdays, so he puts his name down for Wednesday. He arrives, with neither books nor notes, in the testing-room. The tutor gives him his test and an exercise book with his name on it. He sits down among 20 or so other students and sets to work.

The test consists of ten questions to be answered. Next he must write a short essay in reply to another question. This does not seem particularly difficult. John takes 10 minutes to answer the questions.

The tutors are waiting for the students. Each tutor is sitting at a table, in a small cubicle. John Pilgrim's personal tutor is called Anne Merit. She took the same course as John last year, and has obtained her first diploma. She does 4 hours of tutoring per week; in addition, she attends a general conference of tutors which lasts for 2 hours. She has 10 students under her personal care. When the tests are taken, she cannot allot more than 5 to 10 minutes to each student.

John Pilgrim takes his completed test to Anne Merit. She rapidly scans the answers. She marks 2 as incorrect and puts a question mark against the short final essay. Then she asks John why he answered these 3 questions in the way he did. John's replies show that he had misunderstood the first 2 questions of the test; he had understood the last question satisfactorily, but had expressed himself clumsily in his answer.

Anne goes through the 2 questions with John. She makes certain that, this time, he has understood them properly. Another discussion on the little essay and Anne writes "O.K." for the test as a whole. She congratulates John and warns him that the next test will be a little more difficult than this one. She notes John's success on a chart hanging on the wall in the tutors' room and gives him the next study-book. She keeps the exercise book in which John has been working and makes out a file card in his name.

On leaving the testing-room, John notes that a 20-minute lecture will be given by the lecturer on the following Thursday for all students who have taken unit 3, and he decides that he will be there.

TESTING ROOM

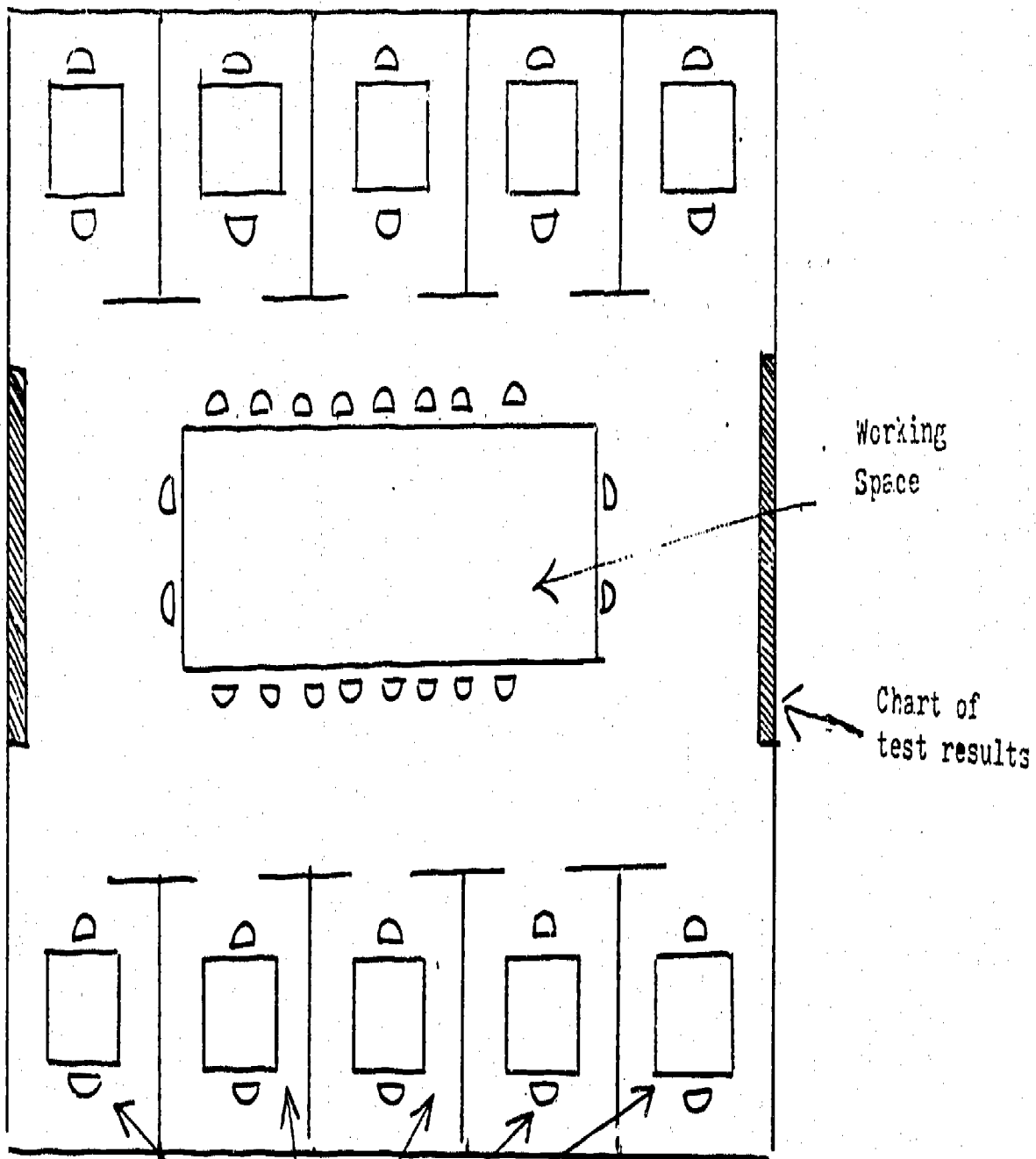

Cubicles for the tutor and his student

42

43

- 36 -

If John had made more errors, he would have been sent away to study for at least half an hour, and urged to pay closer attention. And if he had made more than four errors, the tutor would not have bothered to consider his other answers one by one; she would simply have told him that he was not yet ready to take the test. If he had made no mistakes at all, he would probably have been asked to explain one or two of his answers, in order to make sure that he had really done the work himself. Subsequently, John failed his first test on unit 2 and his first two tests on unit 4 (which prove a stumbling-block for nearly everyone). He missed the first lecture by the lecturer but was able to attend the second. There were seven lectures during the semester, attended by approximately half the students who were entitled to do so. Having taken his first 5 units, John failed a revision test which was a stepping-stone to the sixth unit. On average, for the rest of the course, he had to take the tests twice in order to obtain one unit. Failing a test is never purely negative, since it leads to discussion with the tutor and sometimes helps to clarify ideas.

Despite a week's absence, John Pilgrim, thanks to being able to take tests on Wednesdays and Saturdays, so was able to acquire all his units approximately a week before the final examination.

Having "swotted" other subjects during this last week, he did not do enough revision on his psychology course, and obtained only a B in the examination, though this did not affect the A that he obtained for the course as a whole. Before the end of the semester, he had been asked to comment on certain aspects of the teaching which he had received. Anonymity ensured that his opinions were objective. His reply, together with others, gives an overall idea of what the students thought.

The students take the view:

- that this form of work requires a fuller grasp of the subjects to be learned;
- that it calls for better memorization of details;
- that it is conducive to deeper understanding of fundamental concepts;
- that regular work habits are formed;
- that one very quickly loses one's fear of examinations;
- that it is a form of work which encourages freedom; one works when one likes (within reason, naturally) and at one's own speed. The method is not competitive. One is neither held back by those who are slower than oneself; nor pushed recklessly ahead by those who are quicker.

Some students felt, however, that the need to follow a strict, predetermined order in the acquisition of units was restrictive. To mitigate this disadvantage, Keller has designed study-books which may be thought of as "catalogues" or, better still, as "menus". This is what Keller calls the "Chinese restaurant method". The tutor chooses from the menu those objectives which he considers important for his pupil.

Alternatively, here is the so-called "add the eggs" method: the study-book is left elaborately incomplete, so that the tutor is free to take initiatives. Clearly, this method cannot always be recommended: everything depends on the quality of tutors available.

The students consider that this method sets up an important and extremely beneficial "non-academic" relationship with the tutor. Discussion with him is really helpful.

Many feel that it would be desirable for tutors to air their views, both on the content of the programmes and on the way the tests are compiled.

The tutors, who were also questioned, summed up their views as follows:

- they find that their own knowledge is strengthened by the practice of tutoring;
- that it gives them pleasure to see their tutees working well. The image which they form of themselves and their capabilities is heightened by the experience; they appreciate the kind of respect shown them by their juniors.
- however, some tutors feel that their freedom is very limited. They are not able to introduce anything original into the course. In extreme cases, it is even possible for them to perform their duties without feeling really involved.

A final advantage of the method is that it requires little equipment, and certainly no specialized equipment. As described, it has been able to function without subsidies. It calls for no teaching machines, audio-visual aids or computers. Obviously, it would be conceivable to introduce such equipment into a system of this kind, but Keller is not eager to do so. Individualization of education brought about by the introduction of "automation" is a solution which he considers very unsatisfactory.

The fundamental criticism to be made of the method concerns the extreme fragmentation and parcelling out of the subject to be taught. There is a serious risk, namely, that only the most gifted pupils will succeed in piecing together the knowledge which they acquire.

Keller's reply is that, in any case, the pupil can learn only one thing at a time. When the teacher thinks that the time has come to do revision, he creates a unit for that purpose.

He also replies that there are various ways of dividing the subject to be taught and asking questions. All the teacher's pedagogical talent will be brought into play in the way in which he breaks down the content of the course and picks up the right questions, i.e., those which will tax the student's intelligence and his faculties of analysis and synthesis; this is the specific task of the teacher. Once the experiment is under way, he will be able to make use of his observations and of analysis of the tests taken by the pupils in order to improve his method. He will judge how quickly the students are able to work; he will establish optimum periodicity for revision; he will be able to graduate the difficulties more effectively.

He will then launch another programme, advise and encourage the tutors, hold discussions with the students and be prepared to listen humbly to the criticisms of all.

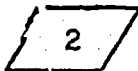

The "Madras system"

An Indian educationist, Sivasailam Thiagarajan, echoes Keller's ideas, but proposes a new structure for tutor-tutee relationships. (Educational Technology, December 1973).

He begins by recalling all the benefits which children or adolescents stand to gain from peer tutoring.

Benefits for the tutee: he receives undivided, individualized attention from his tutor, who speaks the same language as himself, and comes up with examples and explanations which are within his grasp; he feels that he is understood by somebody who has recently had the same problems as himself and has surmounted the same difficulties; he is not on the defensive, since he does not have to confront adult authority; finally, he feels free to ask any questions he likes, fearlessly, and above all without fear of ridicule.

Benefits for the tutor: these are even greater. He gains from repetition, revision and reformulation; he learns to appreciate his tutee's answers with greater subtlety, to exclude the "near miss" and demand the absolutely accurate answer; his attitude towards his teacher or professor changes, since he realizes that the latter is not an adversary; he even becomes his collaborator. It is a game in which all three players (the teacher, the tutor and the tutee) are winners. Such games are rare indeed.

Unfortunately, says Thiagarajan, in the Keller system, tutoring takes place only at the time of testing.

With the aim of rectifying this shortcoming, he proposes a system in which every pupil must do the following:

- 1) learn the content of the unit of instruction;
- 2) teach the content of the unit of instruction;
- 3) take the test corresponding to the unit of instruction;
- 4) test another learner on the same unit.

Only then will he be able to move on to study of the next unit.

How the system works

Our Indian pupil is called Raja.

1./ Raja is, initially, a tutee. With a tutor, he learns the content of a unit of instruction. Then, with another pupil who acts as the tester, he takes the test which corresponds to that unit of instruction.

2./ Raja becomes a tutor in order to teach the same unit of instruction. He thus teaches another pupil what he has just learnt. When this has been done, another pupil (the tester) gives Raja's tutee the test corresponding to the unit of instruction studied.

3./ Raja finally becomes a tester: he gives a pupil who has been the tutee of another tutor the test which corresponds to the first unit of instruction.

This process is repeated for each unit of instruction, and, when the programme has been exhausted, the pupil is declared successful and is awarded a diploma. Needless to say, the tests may be taken as many times as is necessary to attain complete success.

The change of role is excellent for two main reasons: it is conducive to richer and more subtle inter-personal relationships, and it promotes consolidation of knowledge.

Obviously, the first pupil wishing to study the unit of instruction will not find a tutor: the lecturer or class-teacher will therefore start the ball rolling by taking first the role of tutor, then the role of first tester. From this point on, the system is self-sustaining.

In homage to his home-town as well as in memory of the work of Dr. Bell, Thiagarajan christened his method the "Madras system".

Then, as a felicitous and seemingly providential coincidence, he noticed that from the letters forming the name of this town he could make a very fine acrostic:

Mutual

Achievement through

Didactic

Role

Alternation

Strategy

HOW THE "MADRAS SYSTEM" WORKS

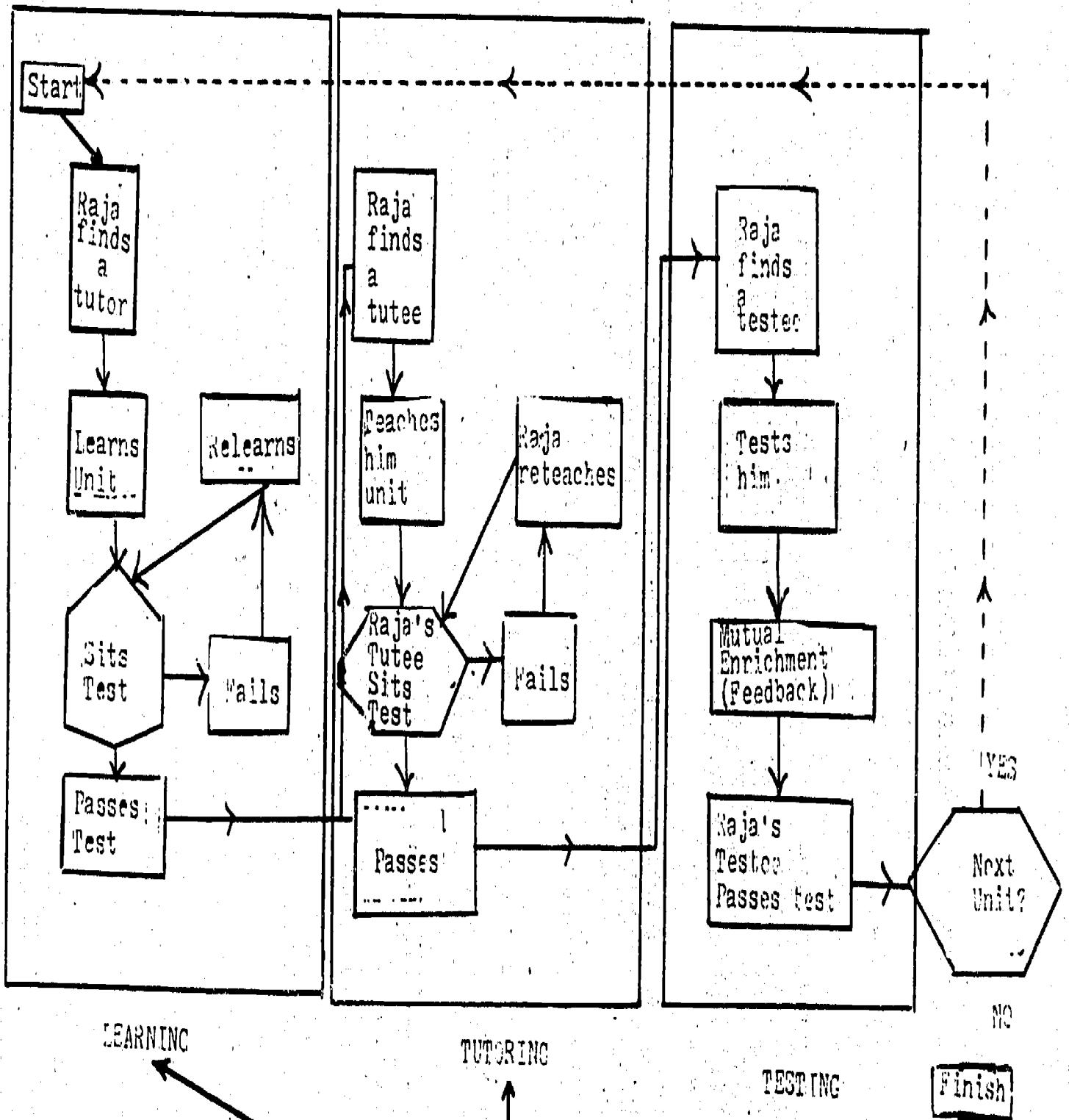

47

V. PEER TUTORING AND AUDIO-VISUAL MEDIA

1

Epidiascope and Audio-cassettes

The MALG programme

(Media— Activated Learning Groups)

Technical University of Denmark, 1974-75 (A. I. Berman)

This programme is one of those which are based on the training of independent learning groups, in which the students are personally responsible for what they have to learn. It is a fairly strictly controlled programme, which offers the advantage of introducing relatively simple audio-visual equipment (in this case, slides and audio-cassettes). The system works in the following way:

1./ The students form their learning groups: five to six individuals per group. Together they hold discussions, without any interference from the teacher, on the content of the course to be taken: What objectives are to be attained? What reading must be done? How should the subject-matter of the course be organized and subdivided? Berman calls this the orientation phase.

2./ Next comes what is called a stimulation phase: the students listen to a lecture recorded on an audio-cassette. The lecture, which is very short, is followed by the presentation of a problem which can be solved by group-work alone.

3./ The response to stimulus: this consists in the solutions proposed by the students. They may, at times, work alone, or else combine their efforts when they feel the need to do so. They then pool the results of their research and compare the means whereby they have arrived at those results.

4./ The teacher's solution has been recorded on a cassette. This is accompanied by all the diagrams, tables and calculations which may be studied and commented upon at leisure with the help of an epidiascope. The students may listen to the tape several times and look repeatedly at the slides. This is the consolidation phase.

5./ The teacher may then step forward, give explanations and justify the way in which he has solved the problem posed. If the students consider that the programme has faults, they are quite free to mention them to the teacher, so that he may put them right: this is the validation phase.

6./ Lastly, the students and teacher together carry out a kind of revision of the work accomplished. The teacher ensures that each student has fully understood and accurately interpreted everything he has studied.

The new University of Roskilde in Denmark has designed its curricula entirely on the basis of such learning groups, in which the teacher acts as an adviser rather than a dispenser of knowledge.

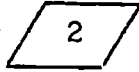

Television

In 1967, the University of Michigan used a system somewhat similar to that of Berman. The aim was to teach the art of public speaking to a large number of students.

First, they all watched a number of televised lessons on the principles of public speaking. They then split up into learning groups (six to eight students per group) and each in turn spoke in front of his fellow students. The teacher was sometimes present during these oratorical exercises. Each was invited to express his views on the performance of the others. Nobody was reluctant to take the floor, and all the students thoroughly enjoyed themselves. The teacher's presence was not indispensable, and, when he came to hear the students, his opinion of the value of their work did not, as a rule, differ from the general view.

The system would have been still more effective if the students had had access to portable video-tape recorders, which would have enabled them to see and hear themselves, as one sees and hears another person - a powerful means of personal assessment and self-correction.



Radio

Radio, especially since the invention of the transistor, has become a favorite medium. It is not in the least surprising that it should have been taken up by the developing countries, being as it were an extension of oral cultures. In isolated villages, people gather spontaneously to listen to it. It can be taken into the fields or into the shop; the weaver places it beside his loom; the tailor sets it next to his sewing-machine. All the investigations carried out by educationists point to its very high educational effectiveness.

Wallace H. Hannum and Robert H. Morgan, in a paper on "The use of peer tutoring and radio instruction" (1974), go so far as to affirm that:

"instructional radio, supplemented with appropriate printed material, can be used to teach most subjects as effectively as a live classroom instructor or instructional television".

However, radio has one major disadvantage; it delivers a one-way monologue. "Inter-personal means of communication" must therefore be found to remedy this defect.

The two most interesting means of communication are:

- radio forums;
- educational broadcasting.

V.- 3.1 Radio Forums

The first radio forums were held in Canada, approximately 30 years ago, on the following pattern:

- Listeners come together for collective listening. The listeners are selected according to the content of the broadcasts — e.g., as farmers, mothers, adolescents, etc.

- Tutors will also listen to the broadcast. These tutors may be residents in the village or may have been detailed by a government department. Their role is to stimulate discussion, to explain the content of the broadcasts clearly and to help the listeners present to compare notes.

The radio broadcast comprises the following elements:

. information on a specific topic: how to plant a tree, for example; how to dig an irrigation channel; how to prepare a baby's feeding-bottle;

. a series of answers to listeners' questions, since, in such a system, it is absolutely indispensable that there should be contact between those who plan the broadcasts and those who listen to them;

. presentation of subjects for discussion, as a sort of stimulus to the discussion which will follow the broadcast.

The Canadian model was adopted in 145 villages in India in 1956 (Poona project). It appears from the surveys carried on that the people learnt a great deal: from the content of the broadcast, certainly, but quite as much from exchanges among themselves. Awareness developed of many family, social, religious and political problems. The discussions were very animated: the experience was one of free, informal peer tutoring. Similar experiments were carried out in Togo (1964), Dahomey (1972), Ghana (1965) and Senegal; they are extremely worthwhile and can be highly effective if, at the same time, structures are set up to provide backing for the initiatives taken by the villagers (McAnany, Radio's role in development, 1973).

V. - 3.2 Educational broadcasting

I shall refer at this point to an old and well-known experiment: the Acción Cultural Popular (ACPO) experiment in Colombia. It started in 1947 (Mgr. Salcedo, in Sutatenza), but in 1975 its guiding principle and its approach are still the same. It began with a few hundred listeners, whose numbers have now swollen to hundreds of thousands, and it is a striking example of the efficiency of a system in which large numbers of tutors are employed.

The teaching system is based on listening to the radio. All the listeners are adults. The tutors are volunteers from the same villages as those whom they are to teach.

The broadcasts are produced by teams with their headquarters in Bogotá. The local stations are free to produce broadcasts of local interest.

There are three main courses:

1) The "basic course", designed to teach reading and writing (half an hour a day for 6 months). The pupils come to listen to it, together with a tutor, in a small "radio school". As a rule, the tutor has learnt to read and write by the same method. The pupils have a textbook, specially printed for them.

2) The "progressive course" (6 one-hour lessons a week). This is the principal ACPO course. There are 5 basic subjects, for each of which there is a textbook:

- Health
- The Spanish language
- Economics and work
- Arithmetic
- Religion

The pupils listen to the broadcasts in small groups, under the guidance of a tutor. The members of the group help one another and ask one another questions, and they organize group work. Most pupils stop after two years of study.

3) The "complementary course" brings the pupils up to primary school-leaving standard. This course lasts 3 years. A small library is placed at the pupils' disposal.

ACPO also broadcasts other programmes:

- plays
- round-table discussions
- letters from listeners
- interviews
- special programmes
- entertainment programmes.

Above all, ACPO publishes a weekly newspaper: "El Campesino" (The Country-Dweller), containing articles which tie up closely with the broadcasts. This newspaper gives regional, national and inter-national information and serves as a platform from which farmers may express their views. In 1974 it had a circulation of 70,000, but its success is still growing. One may take it that each copy is read by ten or more people, so that the number of readers may be estimated at approximately 700,000. A rural worker who has recently become literate may often be seen reading "El Campesino" aloud to a group of illiterates: thus peer tutoring continues.

This programme has roused the rural population to enthusiasm. They take an active part in it, and are helping to set up new "radio schools" in the villages. There is no shortage of tutors, whose training has become increasingly highly organized, thanks to the establishment of a specialized institute and a system of scholarships.

It should be mentioned that, in the ACPO programme, teaching methods remain traditional. Radio gives powerful assistance to the tutors, but it does not alter the powers of teaching — at least, not radically.

Hannum and Morgan, (who have described the Colombian experiment, along with several others), strongly recommend a system which would combine programmed instruction, radio broadcasts and peer tutoring. They believe that the cost of such a system would not be beyond the financial means of most developing countries.

They propose an organizational chart which gives some idea of the working of the system and the various needs for staff and equipment. The diagram shown on the next page is based on this chart.

The study by Jerry Pocztar and G. Jacquinet, compiled for Unesco following a mission to Guinea, ("Enseignement programme et radio", Unesco, Division of Methods, Materials and Techniques, 1973—-French only) points in much the same direction; it does not give special prominence to peer tutoring, but it does provide very specific models and guidelines which are highly relevant to the developing countries.

ADVISORY COUNCIL + GOVERNING BOARD

PROJECT DIRECTOR AND HIS ASSISTANTS

1

TECHNICAL SUPPORT

- Technical facilities (external and radio)
- Vehicles
- Premises for listening and work
- Production of printed matter (accompanying documents, books, drawings and diagrams, photographs, etc.)
- Distribution of transistor radios
- Staff: sound engineers, producers, sound effects experts, etc.

2

INSTRUCTIONAL DEVELOPMENT

- Overall design and gradation of the instruction model
- Design of programmes and accompanying documents
- Preparation of these programmes with the technicians
- Time-tables
- Training of tutors, training courses, re-training
- Work in village to adapt message to listeners
- Feedback

3

LOCAL ORGANIZATION

- Equip premises for listening and work
- Coach tutors
- Direct day-to-day questions
- Receive, classify and distribute documents

4

PLANNING AND EVALUATION

- Analysis of the model
- Evaluation
- Research: imaginative

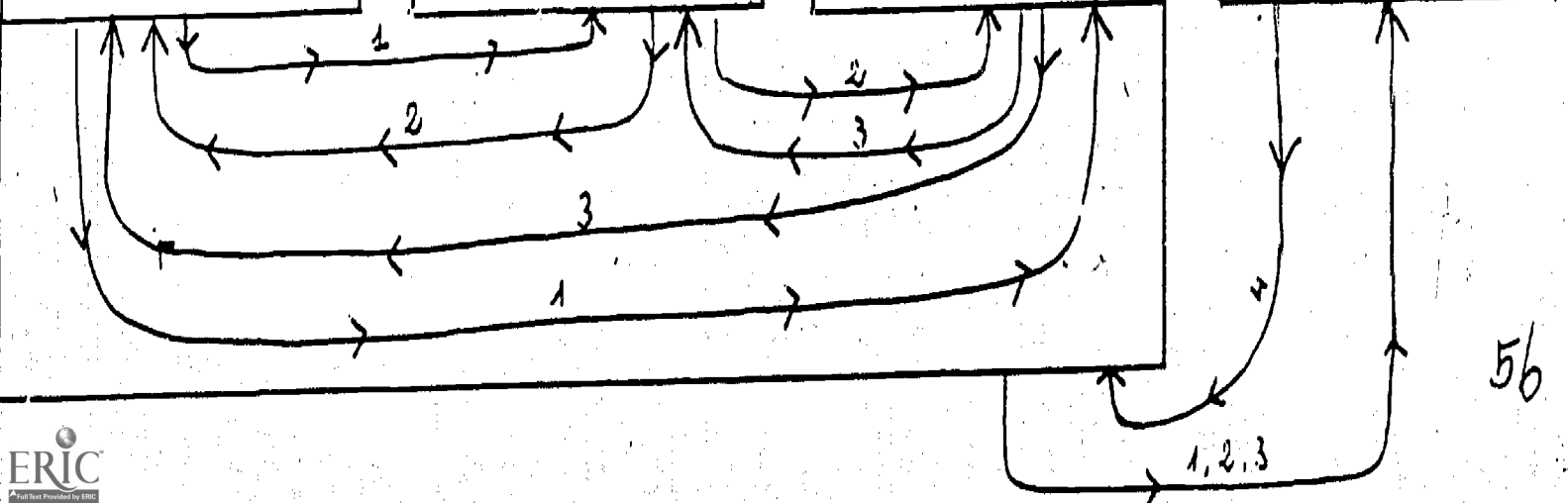

VI. A PIONEERING VENTURE: THE ASERE HAWARIAT SCHOOL
ADDIS ABABA

The model I shall now describe is very different from those described previously; it combines a great variety of teaching methods, and makes full use of the active collaboration of the pupils and the local population.

The Asere Hawariat School, Addis Ababa, is a school founded by Mr. Asfaw Yemirru, for the benefit of poor children. This was no outside venture, but a local initiative, making do initially with the very scanty resources available.

Having got together a number of children and adolescents, Yemirru set about building a school for them with their help, using indigenous materials. Land was purchased on credit, the many eucalyptus trees which grew on it serving as raw material for the timber work. A traditional technique of semi-timbering was used, the spaces between the framework being made up as mud walls, with a mixture of clay and chopped straw.

It is not hard to visualize the educational value which this undertaking in itself represented. Involving as it did the pupils, the teacher, the village craftsmen whose advice was needed, the parents who had to be consulted or informed, the local authorities to be reckoned with, a very dense network of inter-personal communications was brought into being. A joint undertaking, especially one with a socially useful purpose of acknowledged importance, is a powerful stimulus to the establishment of a peer tutoring system. Those involved had to put their heads together, deliberate, seek answers to a variety of questions: What sort of soil do we have? Where should we put the buildings? How do we go about cutting down these trees? What tools are we going to need? To find all the right answers, free-and-easy contacts had to be established with a large number of people.

It was essential to be on good terms with the local population, particularly people who had knowledge of building techniques. Teams then had to be formed and taught to work together. At that stage, the teacher alone could read, and with his help it was possible to consult books. With him, for the first time, it was possible to give thought to the problem of how to draw up a plan.

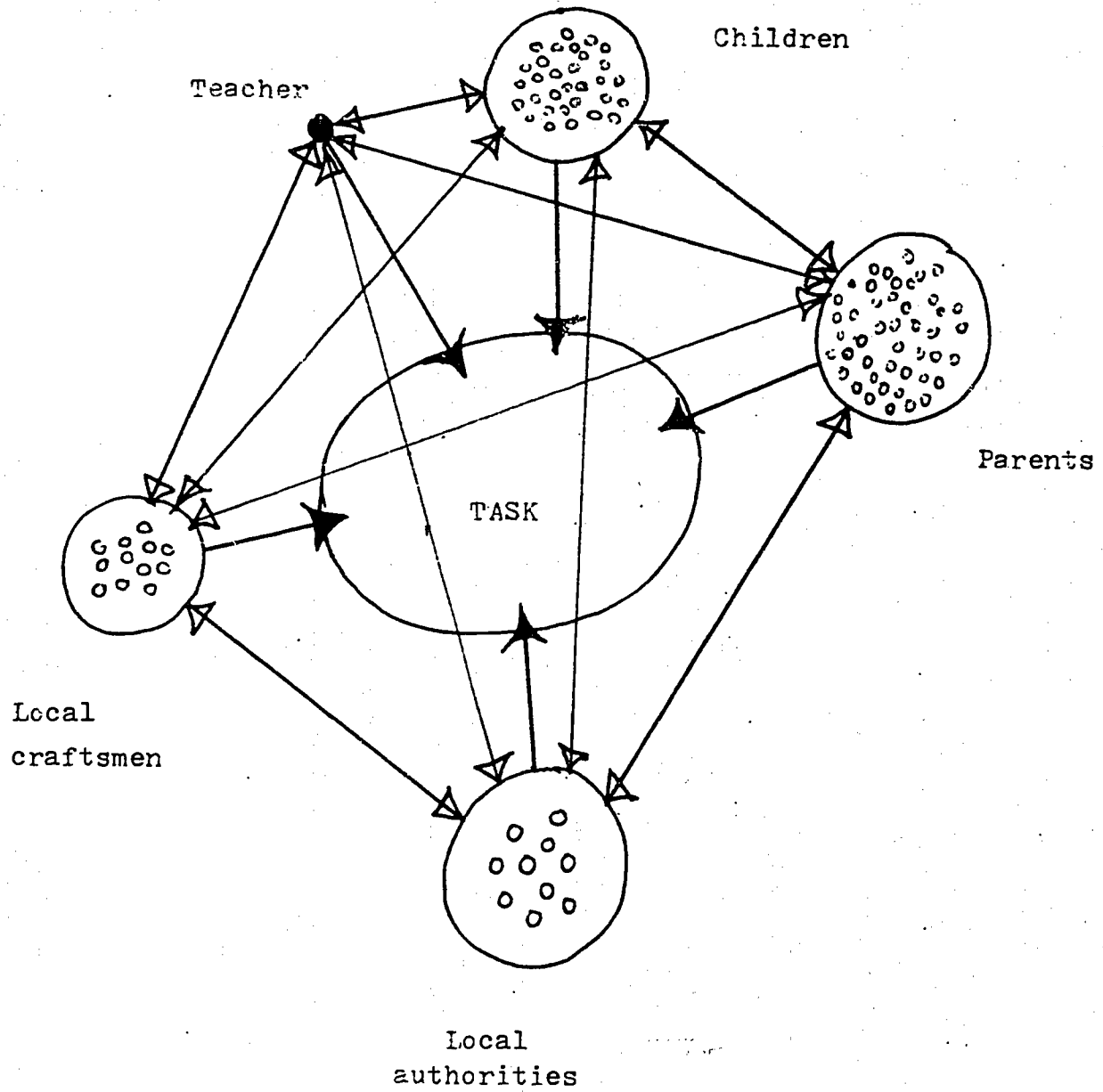

Yemirru called his school "Moya" - traditional Amharic name for a meeting place where people come to exchange experiences and work together.

"Our Moya" he says, "is a new type of school suited to Ethiopia's present needs."

Plunged into the situation described above, the children and adolescents quickly woke up to the need for instruction, and Yemirru worked out an extremely interesting curriculum for them, designed to preserve this spirit of common effort and mutual aid.

The 'Moya' programme begins with 4 years' elementary instruction in the following subjects:

- i) Amharic
- ii) English
- iii) Science
- iv) Mathematics
- v) History and geography, particularly of Ethiopia
- vi) Health and hygiene

There is an emphasis on self-training, and for this reason special attention is paid from the outset to the following skills:

- learning how to formulate questions,
get the most out of one's reading,
make use of libraries,
consult experts,

After this elementary stage, 90% of the pupils do 2 or 3 years' work in the practical sections, while the remainder continue their studies. For this 10%, a secondary school has been organized. Its main purpose is to train teachers for the elementary stage. The secondary students are required to devote a year to tutoring the elementary-stage pupils and people from neighbouring communities, before getting down to preparing for their school-learning examinations.

Ethiopia being a primarily agricultural country, the 'Moya' educational experiment is chiefly concerned with farming. Plots are allotted to groups of students, who cultivate them under guidance and instruction, using simple tools which they can either make themselves - the school has a smithy - or purchase locally. The subjects taught include the use of farm animals for traction, and principles of farm management.

Together the students have built an earth dam and reservoir for drinking water. They have also built 29 classrooms and 2 main halls measuring 600 square meters. One of these is fitted out as a weaving mill with 20 looms; the other serves as an information centre. In addition, residents have fitted out a carpenter's shop, and a pottery with kiln. The products of these various workshops, (weaving, pottery, smithy, carpentry) are sold and go towards the school's running costs.

The information centre is a feature of special interest. It is a community facility for use by:

- i) first- and second-stage pupils, who can use the hall for common pursuits, meetings and free discussions;

ii) illiterate people from the area, who come here in order to learn to read, under the guidance of second-stage pupils using the centre's stock of audio-visual equipment;

iii) those who, having recently learned to read, also make use of this equipment and find in the centre documents written in an appropriately simple language;

iv) the entire local population, who use the centre for gatherings or discussions.

Gratifying results have already been achieved by the use of second-stage pupils as tutors for those at the elementary stage, illiterates, those recently taught to read, and other people from the district. Second-stage pupils are encouraged to come up with new ideas in teaching; they have not lacked for inspiration and try out their new methods with diligence and enthusiasm. Yemirru hopes that this first 'Moya' will set an example and that similar centres will be set up throughout the country; also, that the new teaching methods developed by the pupils themselves will catch on.

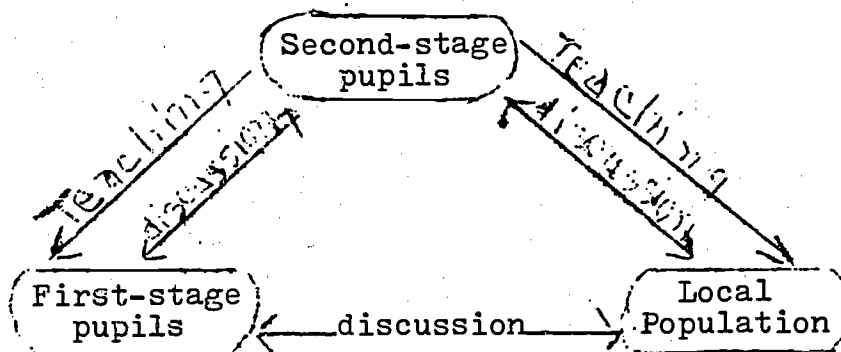

The second-stage pupils have a key role in the system:

- i) they act as tutors to the first-stage pupils;
- ii) they act as tutors to the population at large.

The three groups are interlinked by communication lines and can meet freely for discussion, practical work, slide lectures, listening in to broadcasts, etc.

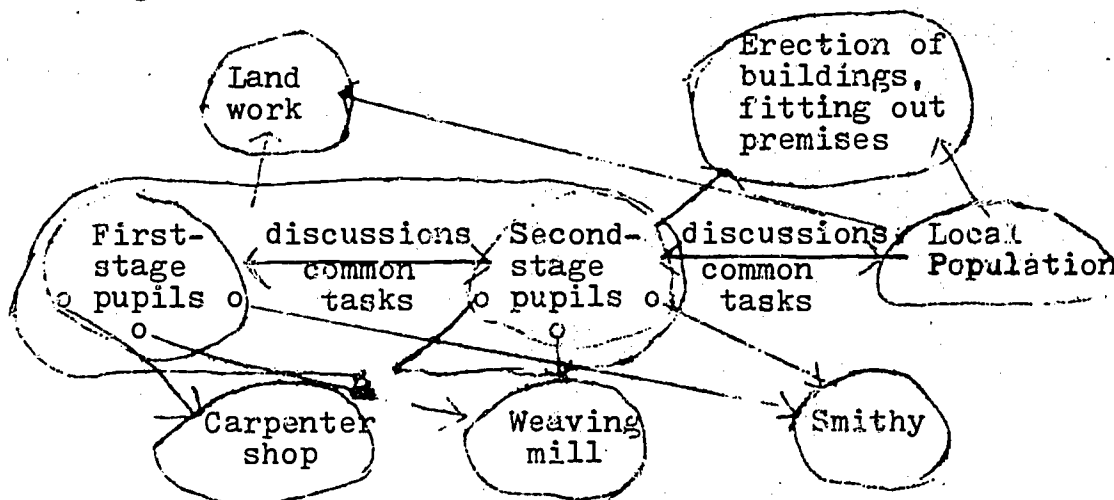

Pupils of both first- and second stages may be found in the various workshops, doing metalwork, carpentry, weaving, etc. They can freely discuss their experiences together, organize joint reading sections, film and slide shows, etc.

All these pursuits may be followed in the information centre, which comprises the library and stock of audio-visual equipment.

Both first- and second-stage pupils are required to work on the farm and help with building as well as with the fitting out and maintenance of the premises. The population also takes part in these operations, and the relationships which result are a source of enrichment to all.

VII. THE BASIC SECONDARY SCHOOL IN CUBA

The Cuban "basic secondary school in the country districts", an experiment which rests on the principle of linking study and employment, bears a certain resemblance to the Asere Hawariat school, although it is run in a much more methodical way.

This type of school has adopted a tutoring system under which the more advanced pupils help those who are behind to get over their difficulties (I.B.E., "The basic secondary school in the country: an educational innovation in Cuba").

Admittedly, the role of peer tutoring in this experiment is still too limited. Even so, it opens up a worthwhile avenue of research: how is the peer tutoring method to be utilized in a system of education which tries to combine academic and everyday work and, by integrating studies with life, lay the foundations of a new ethic and a new type of man?

It seems to me that the kind of relationship which develops between teacher and pupils, as well as between one pupil and another, render peer tutoring a very good instrument for the achievement of such aims.

VIII. SOME PROBLEMS OF PEER TUTORING CONSIDERED

VIII. 1. The need for communication

The system of education most commonly practised in our societies, whereby a teacher gives instruction to a group of children or adolescents, can leave the pupil feeling very much alone. The teacher conducts a monologue with his pupils listening, or pretending to. There is no genuine communication, each remaining shut in his own ivory tower.

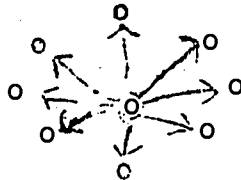

A teacher with some awareness of the problem will try to build a bridge to his pupils, but his attempts at reaching out towards them often get no further than a pseudo-dialogue. The pupils just try to supply the answers that are wanted, as in a

puzzle. The result, at its best, may be represented by the following diagram:

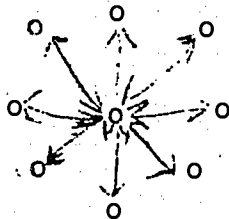

In this case there is a certain measure of communication between teacher and pupils, sometimes good, sometimes less so.

After more than 45 years' research, Theodore Newcomb, a university professor in the United States, in 1974 reported it is his finding that teachers have little influence over their pupils; and that those who think otherwise are victims of the current self-deception which is particularly prevalent in the teaching world.

The thing that really matters is what goes on between the pupils, even when there seems to be little or no communication between them.

Newcomb also tells us that the avowed aims of educators and the curriculum they have drawn up are quite remote from the true interests of the pupils. To discover what these are, one has to ask them — really ask them, not merely make a show of doing so.

For the pupils, peer tutoring may represent:

- i) opening a door to communication
- ii) a chance to speak up
- iii) a new part to play.

Role-playing games are recommended for the would-be tutor; he learns to be the one who puts the questions and the one who helps to find the answers instead of being a passive consumer of pre-digested information. With communication now travelling backwards and forwards in all directions, the diagram will look like this:

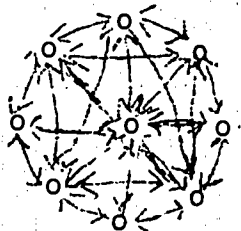

Any system of peer tutoring should as far as possible meet the need for untrammelled communication, invite self-expression, let all views be heard and bring down all ivory towers, the teacher's included.

It is possible to conceive of systems based on peer tutoring in which the exchange of knowledge takes place between persons differing widely in age, background, culture, race, and, of course,

sex. This is recommended by A. Gartner, Mary Conway Kohler and F. Riessman, who feel that teaching relationships of this kind might well prove to be an effective means of bringing down the barriers raised by culture, background, race and sex.

VIII. 2. A more active role for the pupil

It is essential that the one who learns should play an active part in the process of his own education. In any system based on peer tutoring there can be no room for spoonfeeding information from pulpits of omniscience to rows of gaping listeners with notebooks at the ready. The 'authority' — be he teacher, professor or expert — may ask for the pupils' attention, to make some point clear (even this being a two-way process) or to convey facts and/or explanations not otherwise available to them.

Tutor and tutee — in the most interesting systems the roles are interchangeable — both learn something from their pedagogical relationship, even where the tutor is teaching well below the level he himself has reached.

In this form of intercourse, the tutor obviously has a particularly active part to play. He is led to take a fresh look at what he knows and re-state it in a way the tutee can take in. This intellectual process of reformulating one's thoughts is of the first importance. The pupil in the tutor's role has to organize his facts and ideas in such a way as to render them clearly intelligible to the tutee. He must learn to explain the same idea in various ways, to convey the message with better examples and more effective illustrations. The effort this requires serves to exercise the intelligence; it is the need to reformulate their knowledge that explains the startling progress made by tutors during the peer tutoring process.

It will be apparent from the above how important it is to devise educational systems in which the same pupil can take turns at being tutor and tutee. As Gartner, Conway Kohler and Riessman put it in "Children teach children",

"If it be true that one learns while teaching, it follows that a school which really fulfils its educational function is one which allows every pupil to teach."

The appraisals we have so far made show that the method owes much of its efficiency to the fact that it obliges those acting as tutors to fill the gaps in the knowledge they have already acquired. A tutor may suddenly realize that he has learned very badly, and in a new flash of understanding everything fits clearly and coherently into place; he gains all the benefits of a refresher course, but one in which he is both the teacher and the taught, and at the same time acquires improved working habits. So we see what an important part self-instruction is bound to play in the tutor's training.

Finally, the tutor-tutee relationship cultivates a cooperative disposition not marred by the competitive spirit which is such an unpleasant and destructive factor in classrooms. In my

view, the ideal system of peer tutoring would be one in which tutor and tutee had the task of discovering a truth together, rather than exchanging one already formulated. From this standpoint the 'closed' nature of programmed instruction can be seen to be very frustrating.

VIII. 3. Two possible objections to the method

1) Peer tutoring systems are often represented as inexpensive, making it possible to replace teachers or professors by pupils. This line is calculated to arouse the opposition of teachers and their organizations, as well as that of parents, older pupils or students.

It is also asserted that this type of instruction can make do with simpler and cheaper teaching equipment and materials.

In my opinion the business of inventing, trying out and putting into practice new systems of education based on the peer tutoring principle calls for a liberal supply of educators with a sound training in psychology and sociology. And I know that the practice of peer tutoring, and the self-instruction which that method involves necessitate libraries, and audio-visual documentation centres to supply the tutors with the information they need. Finally, there must be workshops for individual study and suitable facilities for undisturbed group work.

2) Peer tutoring has also come in for some criticisms from the political angle. Let us consider, for example, what happens in an American university where second-year students are used to initiate freshmen into the methods of instruction practised at the university. Essentially, the process consists in involving the freshman as quickly and as effectively as possible in the existing procedures. It should therefore occasion no surprise if those who challenge the existing system strongly oppose these methods.

In Germany, tutoring is regarded as a means of exerting more efficient control and closer surveillance of university education, and thus of increasing the established order's hold over the minds of the young. (L. Huber: 'Ziele und Aufgaben von Tutoren. Hochschuldidaktische Stichworte' (The aims and tasks of the tutor. Essentials of University education), 1972).

Without question, we should see to it that peer tutoring remains an 'open system' - one which leaves plenty of scope for the pupils' imagination, freedom and initiative. A setup which encouraged pupils or students to take an active part in their own education would quickly fit them also to participate in the transformation, development and management of their school or university.

VIII. 4. A word about teachers, tutors and tutees

The effort to get a peer tutoring system under way is likely to raise a number of problems. Before taking the plunge,

the team will be well advised to give thorough consideration to the new relationship which is to be established between the teacher or professor and the pupils who are for the first time to exercise an 'educating function.

In the first place, by whom and on what basis are the pupils who will act as tutors to be chosen? Quite clearly, the answers to both questions will depend on the model of peer tutoring adopted and will have far-reaching effects on the results.

In some systems, it is the teacher who selects the tutor. He may have various reasons for singling out a particular pupil, e.g.:

- i) a high level of general knowledge;
- ii) special skills or ability;
- iii) a gift for good communication;
- iv) enthusiasm and the qualities of a 'good mixer': a capacity for sympathy and goodwill and natural ability to achieve rapport may prove a more essential ingredient in the recipe for success in 'tutoring' than sheer intellectual brilliance.

Just as conceivably, a tutor may be elected by his fellow-pupils. Is he to be chosen within the same age-group, or not?

The tutorial system commonly employed in English-language countries, which has long been a traditional feature of British universities, involves the use of someone who has taken his degree to help an undergraduate with his studies. By bringing people of very different ages together in one group and thus demonstrating that the "generation gap" can be bridged, one would be helping to counteract this very prevalent form of segregation which ends in driving a wedge between one age-group and another.

From my experience, I believe an eleven-year-old can be quite usefully consulted concerning the instruction he is receiving. I am even convinced that one can reasonably seek the opinions of much younger children.

In many systems, however, it will be advisable for the tutoring to be between people of the same age. The ideal postulated by D. G. Born (Instructor manual for development of a personalized instruction course, 1971) is no doubt a good model to be followed. According to him the tutor should:

- i) be perfectly familiar with the content of the course;
- ii) approach his task in a conscientious, dependable manner;
- iii) be polite;
- iv) take a lively interest in his tutees;
- v) be a good listener.

Obviously, all these qualities add up to rather a tall order. On the negative side, the tutor/tutee relationship is vulnerable to a number of disturbing factors:

- i) it may well prove difficult, if not impossible, to get a highly introverted pupil to work with a very extraverted one, or a bright one with a dullard;

- ii) in certain situations and social backgrounds it is not feasible to put a boy and a girl together;
- iii) a child or adolescent may be prey to an anxiety which blocks the relationship;
- iv) an urge to dominate may spoil the relationship.

Group dynamics may contribute much to the study of these problems and some of the difficulties may be cleared up by this means. The group context may also serve to throw light on reactions to:

- i) Approval: what approach is required to avoid any undermining of the child's sense of worth?
- ii) Criticism: how are evaluations to be conveyed so that they are not seen as frustrations or punishments?

As a rule it may be said of peer tutoring that the smallest groupings (fewer than 6 pupils together) are the most effective. The minimum unit (the pair) is of particular interest because the roles can be reversed at frequent intervals, thus checking the trend towards passivity in one or the other partner. A serious problem which may rear its head in larger groupings is the emergence of a leader-personality who dominates the others.

When peer tutoring is introduced, the teacher has to prepare himself for an entirely new role. The first thing he needs to realize is that there is no question of his 'abdicating'. Initially, he may offer some resistance. Even in 1815, schoolmasters felt their position and prestige threatened. These are reactions we may encounter again. The teacher is no longer to be the sole dispenser of knowledge - the one who knows and speaks while his pupils know nothing and remain silent. Nor will he any longer be the sole source of authority in his class. Time-honoured routines will now have to be dropped; it is almost as if the teacher has to learn a new trade.

Soon, however, compensatory satisfactions will appear in the form of rapid transformations in his pupils. For them, of course, the whole teaching process will be denuded of its mystery, and the teacher may well come in for some rough treatment. But there is another side to the coin: these newly emboldened pupils will be better able to understand the teacher's point of view, having had to face situations with which he is familiar. Conversely, the teacher, seeing how the pupils interpret his role, will see himself, as it were, through their eyes. This can be a highly enlightening experience and, however testing a matter it may be, this profound change in a traditional relationship may well prove extremely fruitful.

The success of peer tutoring depends in large measure on the structural forms in which it is clothed. The organization of peer tutoring creates a new situation in which vigilant attention must at all times be given to:

- i) a clear definition of the aims to be pursued;
- ii) a clear definition of roles;
- iii) matching up the partners and giving them suitable places to work in (which may raise practical problems), with a carefully planned timetable and sequence;

- iv) spelling out the tasks;
- v) maintaining the structures decided on while not precluding fresh ideas.

Failure to give peer tutoring the organization and structure it requires may result in total failure or, at best, diminished benefits. These hazards must be brought home to the pupils themselves. Open discussions should be held at very frequent intervals between teachers, tutors and tutees. Pupils' ideas on the nature of teaching and learning need to be constantly re-examined and put to the test. The competitive approach must be abandoned completely and replaced by a principle of active cooperation with all members of the team.

Since in most cases the pupils will have been taught a passive role, they will not find it easy, in the early stages, to exercise initiative and adopt the active, creative attitudes needed in order to find where to seek reliable information, knowing how to formulate questions, get on the right terms with their tutee, and form a friendly, fruitful relationship with him.

Few will succeed at the first try, but good preparation will pave the way. This should include:

- i) the study of successful precedents in peer tutoring;
- ii) film or video-tape shows illustrating the practice of peer tutoring;
- iii) classes in group dynamics and role-playing games;
- iv) bringing in psychologists and sociologists for team work on communication problems;
- v) frequent discussion between all parties concerned.

Once the system has been got under way, the pupils take to it. They quickly wake up to the fact that they can now be themselves and that they are capable of assuming a major responsibility for their own education. As for the teacher, he will as a rule come to terms with his new role as partner in a common venture.

No peer tutoring programme can hope to succeed or to hold its own without the full backing of the entire teaching staff of the establishment where it has been introduced. Continuous evaluation will be necessary - by means to be devised for that purpose.

IX. CONCLUSION

It is hoped that the examples given in this survey will show that peer tutoring is a pedagogical practice whose scope of application is very wide and varied. Not enough use has been made of it so far. It would indeed appear that the teaching profession is still shy of placing the necessary trust in children, adolescents and non-teachers generally.

However, in view of the results achieved with some of the experiments described above, particularly the 'Youth teaching Youth' programme and the 'Madras system', we are able to give affirmative answers to the questions posed in the Introduction and say that peer tutoring could be a key component in any new systems of education devised to suit the economic, social and cultural conditions which obtain in the developing countries. It is open to each country

concerned to devise its own form of peer tutoring, which may well be rooted in still extant cultural traditions while in its turn serving to revive these by enriching them with the contributions of present-day pedagogical thought.

It will be the task of research workers and educators to work out systems of peer tutoring suited to the needs of their public and to try them out in a scientific way. It is our fervent wish that this survey may encourage them in that work. Any readers with criticisms or suggestions to make, or who have knowledge of instructive experiences in this field, are invited to get in touch with UNESCO, Division of Materials, Methods and Techniques, 7, Place de Fontenoy, 75700 Paris.

BIBLIOGRAPHY

While the list is obviously not exhaustive, the books and articles mentioned below afford a fairly clear and comprehensive picture of the various systems of peer tutoring which have been practised from 1820 up to our day.

AUDEMARS D., BOREL M. and JACOT J. - Le petit guide du parrain. Chaire de pédagogie et didactique, Ecole polytechnique fédérale, Lausanne 1974.

BELL (Andrew) - Bell's Mutual Tuition and Moral Discipline. London, G. and F. Livingston, 1832.

BLOOM, (B.S.) - Learning for Mastery. UCLA. CSEIP, Evaluation Comment, 1968.

BRUNER (Jerome S.) - The Process of Education, N.Y. 1963.

BUISSON - Les écoles d'enseignement mutuel en France (Dictionnaire de pédagogie).

COUTURE, Claude-Paul - Deux applications de l'enseignement mutuel en Seine-Maritime (Annales du Centre Régional de documentation pédagogique, Rouen, 1970).

FLEMING (J. Carl) - "Pupil tutors and tutees learn together". Today's Education, October 1969.

GARTNER (A.), CONWAY KOHLER (M.) & RIESSMAN (F.) - Children Teach Children. New York, Harper and Row, 1971. Extensive bibliography.

GLASSER (W.) - Schools Without Failure. New York, Harper and Row, 1969.

GOLDSCHMID (Barbara and Marcel) - Peer teaching in Higher Education: a Review. Faculty of Pedagogy and Didactics, Ecole polytechnique fédérale, Lausanne, June 1975. Extensive bibliography.

GREEN (Ben A.) - "Physics teaching by the Keller Plan at the Massachusetts Institute of Technology". American Journal of Physics, July 1971.

GREEN (Ben A.) - "Is the Keller Plan catching on too fast?" Journal of College Science Teaching, October 1971.

HAMMEL (Joseph) - L'enseignement mutuel ou histoire de l'introduction et de la propagation de cette méthode par les soins du Docteur Bell, de J. Lancaster et d'autres, 1818.

KELLER (Fred S.) - "Goodbye, teacher!". Journal of Applied Behaviour Analysis, Spring 1968.

KELLER (Fred S.) - Ten Years of Personalized Instruction. Teaching of psychology, 1974.

KIDDER (Mary Jane) - Students as Resources, Retrospective Search.

LANCASTER (Joseph) - Improvements in Education, London, Collins and Perkins, 1806.

LIPPIET (Peggy) - "Children can teach other children". The Instructor, No. 9, May 1969.

MOHAN (M.) - "Peer tutoring as a technique for teaching the unmotivated". Child Study Journal, 1971.

PANCHAUD (Georges) - Une offensive des libéraux 'éclairés' au début du XIXe siècle: l'introduction de l'enseignement mutuel. Nouvelles pages d'histoire vaudoise, Lausanne, 1967.

RIESSMAN (F.) - "The 'helper therapy' principle". Social Work, April 1965, No. 2.

ROSENBAUM (P.S.) - Peer-Mediated Instruction. New York, Teachers College Press, 1973.

THELEN (H.A.) - "Learning by Teaching. Stone Brandel Center, University of Chicago, 1968.

THELEN (H.A.) - "Tutoring by students: what makes it so exciting?" The School Review, 77, No. 3. September 1969.

THIAGARAJAN (S.) - "Madras system revisited: a new structure for peer tutoring". Educational Technology 1973.

AFTERWORD

This document describes various patterns of peer tutoring, which may be divided into three groups:

empirical forms;
systematic methods;
conjunctural systems.

1) Empirical forms of peer tutoring have been a virtually natural development in traditional educational systems, in India, in Ancient Greece and in the Muslim countries.

In such types of teaching one finds the cooperation between children of different age-groups and adults which is customary in the productive work of the community. Adaptation to the local culture has been achieved spontaneously, and this system confines itself to handing on the values and the knowledge of the social group in which it has developed.

2) Systematic methods of peer tutoring were perfected by British educators, who observed methods of traditional peer tutoring and adapted them to the needs created by the first industrial revolution in Western Europe. There was an urgent need to train a plentiful labour force which would be docile, literate and quickly broken in to the discipline of the factory floor and to fragmented tasks.

This system, which was adopted in France, was heavily influenced by the cultural conditions prevailing at the time: this was the era of the birth of the Napoleonic legend, and the military models were extremely restrictive. Adaptation to this cultural model was all the easier in that the military discipline of the French petites écoles was a preparation for the discipline of the new factories. Moreover, this type of peer tutoring was a response to the slenderness of resources in teachers and funds available to the new educational establishments.

When needs, cultural conditions and resources changed, this system of peer tutoring which had been elaborated in Great Britain, France and Switzerland was abandoned.

3) Very varied systems of peer tutoring have been developed in the United States of America, Denmark, India, Ethiopia and Cuba. to deal with special problems: The education of children from black and Porto Rican ghettos or the development of higher education in the United States; the improvement of the educational system in India; the development of community-based education in Ethiopia; and the reform of the educational system and the education-employment link-up in Cuba.

In every case, the method has been adapted to the particular needs of the sector under consideration and to the socio-cultural conditions of the environment concerned. On occasion, especially in the United States, in Denmark and in Ethiopia, a complex "system" has been built up by integrating various media into peer tutoring: slides for projectors and audio-cassettes, radio broadcasts, closed circuit television and printed documents,

programmed or otherwise.

Peer tutoring emerges as a flexible method which may be adapted to different educational situations and to highly varied socio-cultural environments: it may be used at every educational level (from pre-school to higher education), and is able to benefit from the most recent achievements in the field of the media and from research findings in psychology and socio-psychology.

Peer tutoring might constitute a valid alternative solution to certain problems entailed by the development of education in the countries of the Third World.

The Secretariat earnestly hopes that this study may give practical encouragement to those in charge of education at the various levels in their search for new solutions which are both methodologically satisfactory and adapted to the needs, resources and socio-cultural conditions of their countries.

It is planned that the Organization's programme of participation in the activities of Member States will provide support in this field, especially in the form of studies and advisory services.