

DOCUMENT RESUME

ED 136 065

08

CE 010 388

TITLE Lincoln Career Education Project. Final Report. Book 2. Elementary Learning Centers.

INSTITUTION Lincoln Public Schools, Nebr.

SPONS AGENCY Office of Education (DHEW), Washington, D.C.

BUREAU NO F7136VW

PUB DATE Aug 76

GRANT OEG-9-73-5290

NOTE 579p.; Six pages have been removed because of copyright. For related documents see CE 010 145 and CE 010 390-391

EDRS PRICE MF-\$1.16 HC-\$31.47 Plus Postage.

DESCRIPTORS *Career Awareness; Career Education; Curriculum Guides; Elementary Education; *Fused Curriculum; Instructional Materials; *Learning Activities; Skill Development; Student Development; *Units of Study; Values

IDENTIFIERS Nebraska; Nebraska (Lincoln)

ABSTRACT

Curriculum materials from the Lincoln Career Education Project, Nebraska, are presented for career education learning activities at the elementary level. The guide contains complete materials for 12 learning center units infusing career education as well as personal/social growth and cultural awareness in some. Units are organized under the following topics: Subject area and career education themes, teacher and student objectives, pre-assessment, student activities, teacher preparations, recordkeeping, and evaluation. Worksheets and drawings for duplication are included. For kindergarten the unit is "Feet and Shoes: Measuring," relating to math and language, career and economic awareness, and self-awareness. Metric measures are used. For grade 1 "Looking in a Looking Glass" is the unit, relating to health career information. For grade 2 the units are "Feelings: Mine and Others" and "Tools." These units relate to language, career awareness, values clarification, and creativity. Units for grade 3 are "Keep Your Bones Busy," relating to science, language, career awareness and self-awareness, and "Playmaking," which relates to language arts and creative drama. Units for grade 4 are "Which Worker's Wastebasket?" which relates to career awareness and decisionmaking, "Posy Power: Thinking About Values," relating to language and art and values clarification. For grade 5, units are "Dream On! Your Career Is Sooner Than You Think" and "Alternative Careers." These relate to language, reading, social studies, and career and lifestyle awareness. Units for grade 6 are "Death: Feelings and Careers," relating to language and art and career awareness with special emphasis on careers related to death, and "Environmental Careers," which relates to language arts, mathematics, and environmental problems (values). (TA)

Documents acquired by ERIC include many informal unpublished materials not available from other sources. ERIC makes every effort to obtain the best copy available. Nevertheless, items of marginal reproducibility are often encountered and this affects the quality of the microfiche and hardcopy reproductions ERIC makes available via the ERIC Document Reproduction Service (EDRS). EDRS is not responsible for the quality of the original document. Reproductions supplied by EDRS are the best that can be made from the original.

ED136065-

FINAL REPORT

LINCOLN CAREER EDUCATION PROJECT

BOOK 2

ELEMENTARY LEARNING CENTERS

U.S. DEPARTMENT OF HEALTH,
EDUCATION & WELFARE
NATIONAL INSTITUTE OF
EDUCATION

THIS DOCUMENT HAS BEEN REPRO-
DUCED EXACTLY AS RECEIVED FROM
THE PERSON OR ORGANIZATION ORIGIN-
ATING IT. POINTS OF VIEW OR OPINIONS
STATED DO NOT NECESSARILY REPRESENT
OFFICIAL NATIONAL INSTITUTE OF
EDUCATION POSITION OR POLICY

Exemplary Project in Vocational Education
Conducted under
Part B of Public Law 90-576

School District 2, City of Lincoln
P.O. Box 82889, Lincoln, Nebraska 68501

John Frasch, Superintendent

August 1976

CE 010 388

FINAL REPORT

1976

LINCOLN CAREER EDUCATION PROJECT

Project No. F71 86W
Grant No. CE3-9-73-5290

Exemplary Project in Vocational Education
Conducted under
Part D of Public Law 90-576

The project reported herein was performed pursuant to a grant from the Office of Education, U.S. Department of Health, Education, and Welfare. Contractors undertaking such projects under Government sponsorship are encouraged to express freely their professional judgment in the conduct of the project. Points of view or opinions stated do not, therefore, necessarily represent official office of Education position or policy.

Submitted by
Lincoln Public Schools
John Frasch, Superintendent
Carl Spencer, Project Director

August, 1976

The first step in the process of identifying and defining the problem is to determine the nature and scope of the problem. This involves a thorough review of the available information and a clear statement of the problem in terms of its objectives and constraints.

The second step is to identify the key stakeholders and their interests. This involves a thorough review of the available information and a clear statement of the problem in terms of its objectives and constraints.

The third step is to identify the key stakeholders and their interests. This involves a thorough review of the available information and a clear statement of the problem in terms of its objectives and constraints.

The fourth step is to identify the key stakeholders and their interests. This involves a thorough review of the available information and a clear statement of the problem in terms of its objectives and constraints.

The fifth step is to identify the key stakeholders and their interests. This involves a thorough review of the available information and a clear statement of the problem in terms of its objectives and constraints.

The sixth step is to identify the key stakeholders and their interests. This involves a thorough review of the available information and a clear statement of the problem in terms of its objectives and constraints.

The first part of the document discusses the importance of maintaining accurate records of all transactions. It emphasizes that proper record-keeping is essential for the integrity of the financial system and for the ability to detect and prevent fraud. The text also mentions the need for regular audits and the role of independent auditors in ensuring the accuracy of financial statements.

The second part of the document focuses on the role of the accounting profession. It highlights the need for accountants to adhere to high standards of ethical conduct and to maintain their professional competence through continuous education. The text also discusses the importance of transparency and accountability in the accounting process and the role of professional associations in promoting these values.

The third part of the document addresses the challenges facing the accounting industry. It identifies several key areas of concern, including the increasing complexity of financial transactions, the rapid pace of technological change, and the growing demand for more sophisticated financial reporting. The text also discusses the need for regulatory reform and the role of government in ensuring the integrity of the financial system.

The fourth part of the document provides a summary of the key findings and recommendations. It emphasizes the need for a comprehensive approach to financial reporting reform, one that addresses the underlying causes of the problems identified in the previous sections. The text also discusses the importance of stakeholder engagement and the role of the accounting profession in promoting transparency and accountability.

The final part of the document provides a conclusion and a call to action. It emphasizes the need for all stakeholders to work together to address the challenges facing the accounting industry and to ensure the integrity of the financial system. The text also discusses the importance of ongoing monitoring and evaluation of the reform process and the need for continued collaboration between all parties involved.

---Old Learning Centers

5. **APPROACHING THE FUTURE: Social Studies; career and life-time awareness, decision making.** Students progress from examining unique careers in far-off San Francisco to unusual careers elsewhere, turning a unique hobby or interest into a career as practiced by four men in Lincoln, Nebraska. Finally, students set goals for themselves and establish procedures to practice and perfect a skill they demonstrate for others. Individual and paired work; sharing both as designed and uncreated.
6. **DEATH: FRIELINKS AND CAREERS.** Language and art; career awareness with special emphasis on careers related to death, personal/social development. A unique center for understanding teachers--the teacher plan contains a rationale relating the necessity of establishing a more positive attitude toward death and people who work in death related careers; an appreciation for life as a natural outgrowth of this study of death; about death. Students use media and make feelings if they desire; creative art activities such as illustrating stories, collage of death related. Writing: comic epitaphs from in our nation--write one; write your own obituary; compare students to look at themselves and look into the future setting goals and hopes.
7. **ENVIRONMENTAL CAREERS.** Language Arts, Mathematics; career awareness, personal-social skills, environmental problems (values). The students achieve the objective set through six activities of games, puzzles, research from a comic book (provided), math, science, reading involved. Objectives: students will--gain knowledge of the need for careers in ecology, a variety of environmental careers, use research and study skills, improve listening skills, language arts skills, personal skills.

May Loren
Clinton

Fran Reicher
Elliott

Anne Reicher
Perkins



Career Information Learning Center

FEET AND SHOES

Measuring

K

by Elizabeth Cronin Miller, Student

Book #375 Lincoln, Nebraska

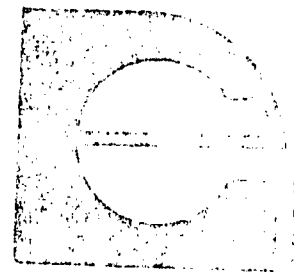

LINCOLN
CAREER
EDUCATION
PROJECT

The materials presented in this document were developed under a grant from the Office of Education, U.S. Department of Health, Education, and Welfare. Contractors undertaking such projects under Government sponsorship are encouraged to express freely their professional judgement in the conduct of the project. Points of view or opinions stated do not, therefore, necessarily represent official Office of Education position or policy.

Submitted by
+ Lincoln Public Schools
John Prasch, Superintendent
Carl Spencer, Project Director

1976

8

Learning Center
Career Education
Feet and Shoes: Measuring

K

By: [unclear]
[unclear]
[unclear]

Teacher's Plan

1. Subject Area: Math and Language Development

Career Education Themes:

Career and Economic Awareness
Self Awareness

Teacher's Objectives:

Students will be able to:

2. Develop a concept of linear measurement and explain the terms of height, length and width.

Recognize the difference between a centimeter and a meter.

Identify and use comparative terms such as: tall, taller, tallest
Short, shorter, shortest

Describe their own physical characteristics such as height, length (when lying down) of their own bodies. Length and width of hand and foot.

Observe the making, fitting, selling and repair of shoes.

Become aware of the many careers related to shoes - such as repair; manufacturing and selling of laces, polish, shoe shining, etc.

Student Objectives:

I will be able to measure and record length or height of a person.

I will be able to tell how tall or long I am.

I will be able to measure and record the length and width of both my hand and my foot.

I will be able to match the labels of:

tall - taller - tallest

short - shorter - shortest

wide - wider - widest

length

height

centimeter

meter

Pre-Assessment :

3.

Students can match the labels:

tall
short
length - (long)
height - (tall)
centimeter
meter

with actual objects on a table; or teachers could cut figures from a catalog - mount them on oaktag and have them available both for pre-assessment and the final evaluation. - asking children to use the terms above in talking about the pictures.

If a teacher feels that the child has a thorough knowledge and mastery of linear measurement, he need not work through the unit. However, the extensions such as a field trip to a shoe store, walking trip, to shoe repair, etc. would certainly enhance a child's horizons and be a launching pad for individualized activities more sophisticated than presented here. Since several of the experiences have a social aspect incorporated and are group oriented I would recommend that more detailed kinds of measuring and recording be provided for very advanced children.

Since this center is planned as an adult-directed activity, levels of ability will be met in the way the student performs the task at the center. For example in the first activity, a child in the preoperational stage may only match the labels (or he might only be ready to label and identify body parts) whereas a child working more toward the symbolic stage might be able to record the measurement and a gifted child in the concrete operational stage may be able to measure other objects in the room and make further predictions and comparisons.

Teacher Preparation for Each Activity:

The sequence should be followed as numbered activity 1-8 and finally pages E for evaluation, because the activities build from the introduction of linear measurement and comparisons of larger figures (Mr. Giraffe and Mr. Alligator and their own bodies) to finer measurements (-hand -foot)

I. Materials:

Large figure of Mr. Alligator
Large figure of Mr. Giraffe
Graph paper
Meter sticks
Other materials for measuring such as ribbons of different lengths - belts, plastic sticks (AAAS has a number of various lengths)

II. Tasks:

Duplicate worksheets on newsprint
Duplicate notebook cover "My Measurement Book" on colored paper, oaktag, or construction paper folded in half to form a folder.

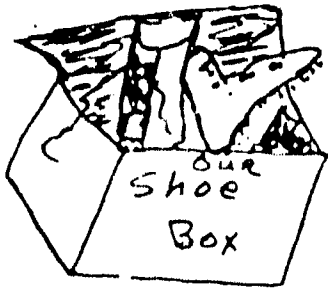

Order films
Collect a variety of shoes representing various occupations and interests in life. (children have to help with this)

Optional Arrange for a field trip or walking trip to a shoe store and to a shoe repair or if possible make arrangements to borrow a shoe measuring device.

Teacher resource materials which will be helpful in developing a background for teachers as well as expanding the activities with many more ideas and opportunities.

Nuffield Mathematics Project - by John Wiley and Sons, Inc. New York
Beginnings - Book I pages 69-80
Computation and Structure - Book II pages 7-23

These reference books are available in all Follow Through schools.

Today's Education (IRA Journal) Sept. - Oct. 1975
"Puppet, The Six Year Old and Modern Math" by Ethel O'Hara pages 33-36

Films - available from PSAB

- Clap #1929-04
- Fantasy of Feet #1948-04
- Magic Hands #1928-04
- Magic Sneakers #1923-04
- Toes Tell #1949-04
- Worse Shoes #1928-04

ACTIVITIES:

Activity One:

4.

In the mode of Follow Through one could have either a door chart or an invitation (or both) introducing the activity and inviting the children to participate:

"Good Morning! Please come in and meet our new friend, Mr. Giraffe."

or

"I wonder where you will fit when you stand next to Mr. Giraffe?"

step 1.

Depending on your classroom situation this activity could be handled either in small group or in a large group. Begin by discussing how tall our new friend is and speaking in comparative terms have students predict whether they are as tall or taller than Mr. Giraffe. Include the heights of teacher and other adults in the discussions introducing tall, taller, tallest short, shorter, shortest.

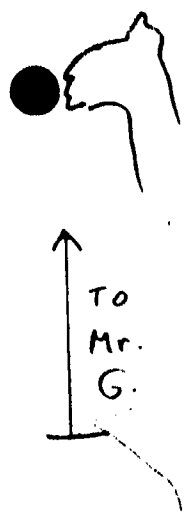

2. With masking tape, mark where each child's height is on the chart (just a small piece of masking tape with their name or initials is sufficient for marking and can easily be removed for use by another class later on).
3. Follow this general introduction by explaining the measurement book - all worksheets can be kept in this book which acts as a folder until the unit is completed and then fastened together to conference and later to take home.
4. Children do worksheet #1. The child may choose a friend to measure and record name and height on the bottom section.
5. Other experiences with measuring and comparing can be provided at this time - using ribbon, sticks, etc. objects can be measured and recorded according to the students ability and the amount of time the teacher has available.

Activity Two:

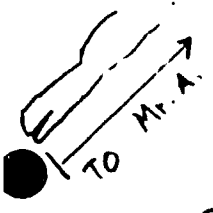

Following the same format as in Activity I - introduce Mr. Alligator measuring students and adults as they lay down beside the alligator or lay on it and mark where each child fits - placing the child's head in front of Mr. Alligator's head and marking the length. It is best if adults are measured also because it gives more basis for comparisons. Use worksheet #2, measuring a friend after self as before. Children should compare their height and length noting that they measure the same whether standing or lying down.

Activity Three:

Extending body measurements into finer dimensions, have children trace their hand on centimeter graphic paper (worksheet #3). Be sure they place their hand on or near the numbered centimeter so they can count the number of centimeters long and wide - if they place it in the middle of the page the numbers will not be helpful in counting the centimeters for length and width. Record on worksheet #4.

Activity Four:

Using the centimeter graph paper (worksheet #5) have the children trace their feet with their shoes on. (They usually need help doing this - sometimes one child can help another).

Record the measurements on worksheet #6.
Pages #7 and #8 are extended measuring activities for gifted students.

Activity Five:

Take either a field trip in a bus or a walking trip to a shoe store. If this is not possible try to borrow a shoe measuring tool so children can see the relationship of measuring feet to the problems of the economic world as manufacturers and salespeople must provide for all sizes, both lengths and widths.

A large wooden foot (or shoe) measuring device can be purchased from:

S.E.E. Inc.
Three Bridge Street
Newton, MA 02195

and some schools already have them.

The foot measures both the length and width of a person's foot in inches and computes U.S. shoe sizes. Cost \$6.70 (We have one at Elliott which measures both in metric system and in inches).

ART options →

Options at this time might be to do finger painting - hand painting (adult directed) and also painting with feet. This is even more fun when done to music. You will need:

4 or 5 oblong cake pans. Mix 4 or 5 different colors of tempera with water and add some powdered soap obtained from the custodian. This helps in easy removal both from feet and clothing!

1 large pail with warm water and soap

Several newspapers

Large white sheets of paper for each child.

Old towels or rags.

This type of activity works best in a secluded area of the classroom, coat room, hall or even another room if one is available. Adult directed.

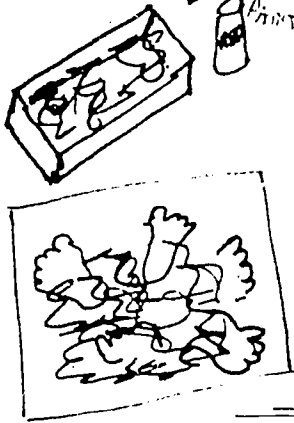

Use of films from L.P.S. Library is most appropriate at this time:

Toes Tell } ← Painting with feet!
Fantasy of Feet

Activity Six: All kinds of shoes

Graphing experience as well as observation lesson. See pages labeled Δ as examples of how to make the large chart.

Cut shoes from a catalog or newspaper that might represent the different kinds of shoes worn by your students. Paste them on a chart. Heading on chart: "What Kind of shoes are you wearing?" Cut squares and place each child's name on a square of paper. Have the child place his name by the kind of shoe he is wearing today. When all have pasted on their squares it is then important to interpret the data - example $\frac{8}{3}$ children are wearing tennis shoes buckle shoes Etc.

This activity can also be extended into colors -

6 children have on white shoes
3 children have on red shoes
8 children have on brown shoes
 etc.



Use the song "Old Woman in the Shoe" (included in this kit). The ancient rhyme is printed below for teacher reference. Discuss variety of styles and uses for shoes as a lead-in to Activity #7.

There was a little old woman,
 and she liv'd in a shoe,
 She had so many children
 She didn't know what to do.
 She crumm'd 'em some porridge
 Without any bread;
 And she borrow'd a beetle (a mallet)
 And she knocked 'em all o' the head.
 Then out went th' old woman
 To bespeak 'em a coffin,
 And when she came back,
 She found 'em all a-loffeing.

Activity Seven:

This activity is excellent for language development and might be extended over a longer period. Collect several kinds of shoes representing different occupations, life styles, or interests.

Example:

football - baseball shoes
 cowboy boots
 dancing shoes (children love gold and silver)
 engineer boots
 ballet slippers
 tennis shoes
 men's dress shoes
 ladies' dress shoes
 snow boots
 bedroom slippers
 beach shoes
 baby shoes

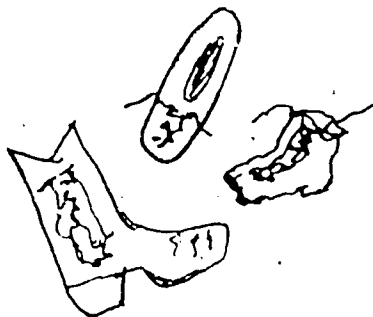

Pictures of these various shoes cut out and mounted on oaktag will also work. Children will usually want to try on the shoes and just talk about them for the first session.

The film "Magic Sneakers" is a great launching pad for working with the various occupations etc. Ask questions such as prepared in the guide for Magic Sneakers. Follow this with:

- Who might wear this kind of shoe?

5. Record Keeping:

Teachers can check the measurements book, i.e. the folder where each child is placing his completed worksheets. When all centers are completed, the pages should be fastened in with brass fasteners or laced together as a shoe for taking the book home.

Students names on graph squares and on the masking tape for the giraffe and alligator measuring show which children took part in these activities.

6. Evaluation:

Pages labeled E can be used to evaluate student understandings. Teachers record for students who cannot write. Talking over pages in the measurement book with students is another way to evaluate.

Teacher conferencing is one of the most effective ways to evaluate understandings and abilities about measurement, language growth in using comparative terms and the economic concepts gained through the community visits. The chilos' attitude toward the center activities should be assessed to help the teacher change the center to better meet their needs, build on activities that were not successful, and plan extended activities.

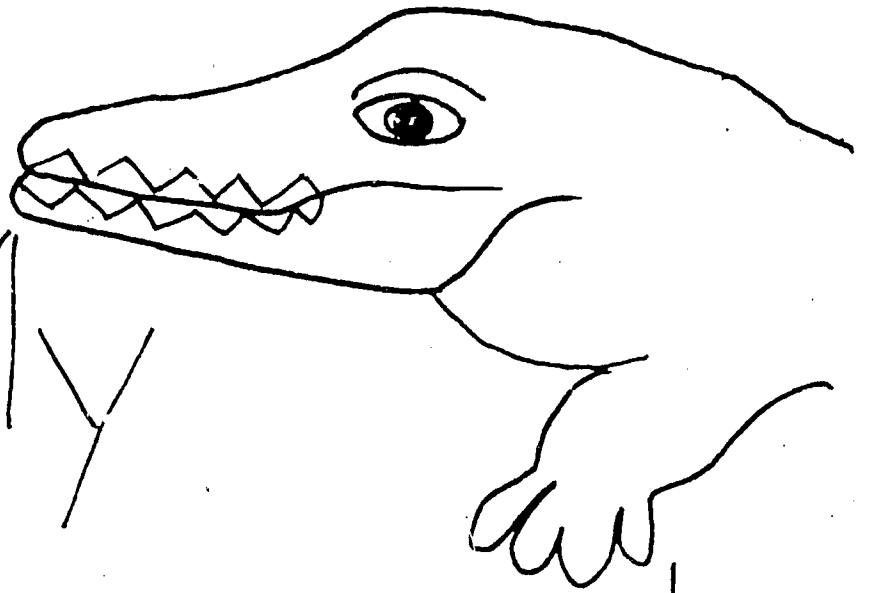

My
Measurement

Book

by

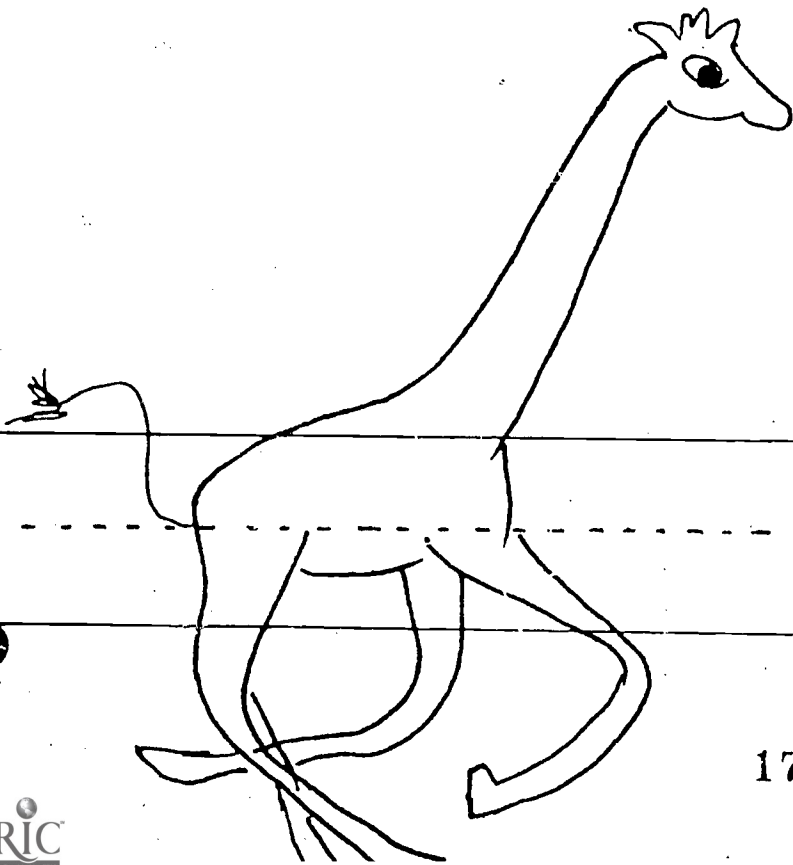

Mr. Giraffe is

— cm tall.

I am — cm

tall.

is — cm tall.

2.

Mr. Alligator

is _____ cm long.

I am _____ cm

long.

is _____ cm long.

My hand

3.

20																			
19																			
18																			
17																			
16																			
15																			
14																			
13																			
12																			
11																			
10																			
9																			
8																			
7																			
6																			
5																			
4																			
3																			
2																			
1	2	3	4	5	6	7	8	9	10	11	12	13	14	15	16	17	18	19	20

4.

My hand is

— cm long.

My hand is

— cm wide.

My foot

5

20																			
19																			
18																			
17																			
16																			
15																			
14																			
13																			
12																			
11																			
10																			
9																			
8																			
7																			
6																			
5																			
4																			
3																			
2																			
1	2	3	4	5	6	7	8	9	10	11	12	13	14	15	16	17	18	19	20

6

My foot is
_____ cm long.

My foot is
_____ cm wide.

7.

Our rug is

— cm. long

— cm. wide

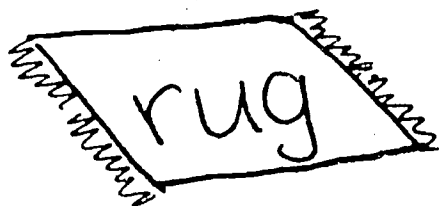

The teacher's

desk is

8.

— cm. long.

— cm. wide



Our blackboard

is — cm. long.

— cm. wide.

What kind
of shoes
are you
wearing?

Sample Charts (A) for teacher follow:

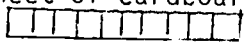
These charts would be larger or printed on a large sheet of cardboard - possibly 24 x 36 with several spaces behind each shoe  The squares of paper with children's names on can be attached with masking tape so that the chart could be used over again. These are some suggested styles - you might need to include more styles depending on the season and the kind of shoes your children wear.

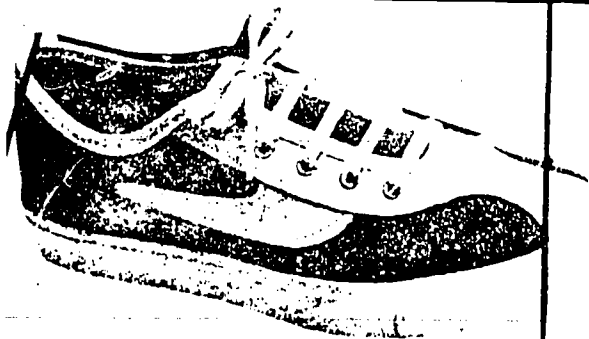
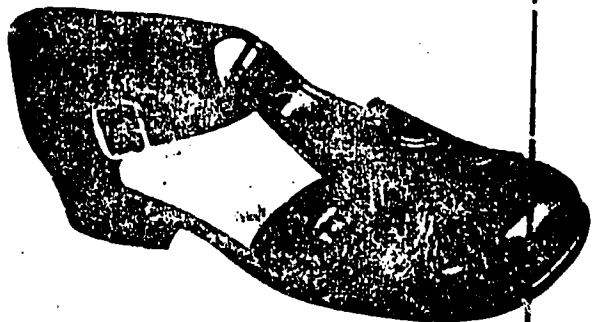
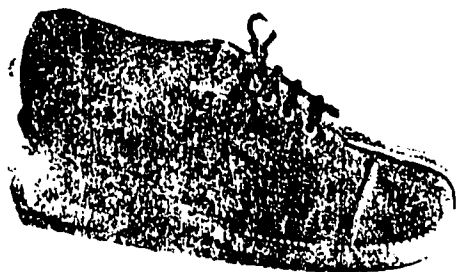
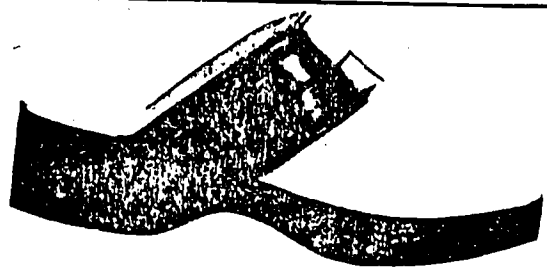

• Our Shoes

— children have
on clogs.

— children have
on laced shoes.

— children have

shoes with buckles.

— children have
on tennis shoes.

— children have
on boots.

Old Woman in the Shoe

There was an old wo - man who lived in a shoe. She

The first system of musical notation consists of a treble and bass staff. The treble staff contains the melody, starting with a treble clef and a 6/8 time signature. The bass staff provides a simple harmonic accompaniment with a bass clef. The lyrics are written below the treble staff.

had so man - y chil - dren, she did - n't know what to do; She

The second system of musical notation continues the melody and accompaniment. The treble staff shows the vocal line with lyrics, and the bass staff shows the piano accompaniment.

fed them on broth with - out an - y bread, And

The third system of musical notation continues the melody and accompaniment. The treble staff shows the vocal line with lyrics, and the bass staff shows the piano accompaniment.

spanked them all sound - ly and sent them to bed.

The fourth system of musical notation concludes the piece. The treble staff shows the vocal line with lyrics, and the bass staff shows the piano accompaniment. The piece ends with a double bar line.

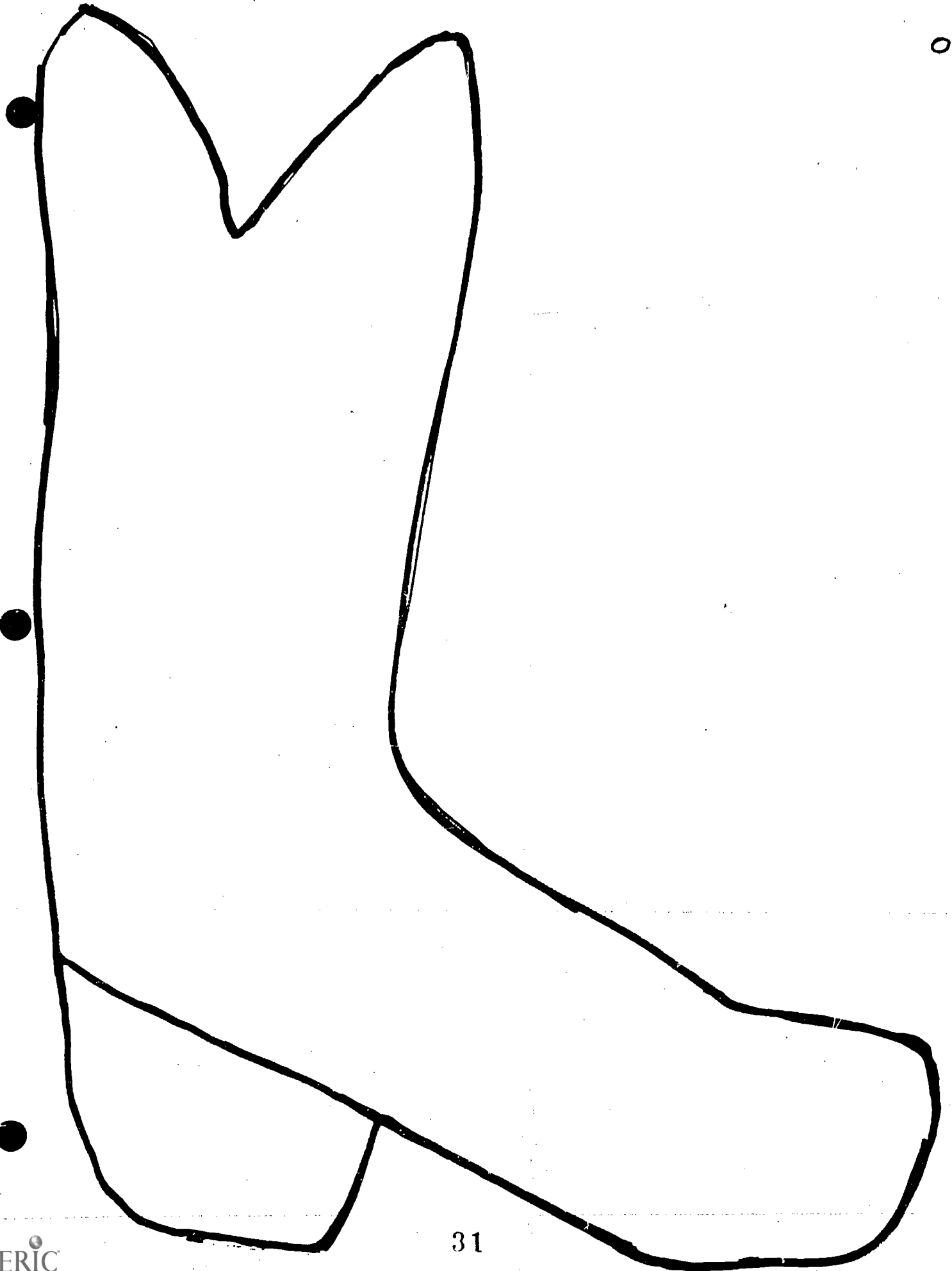

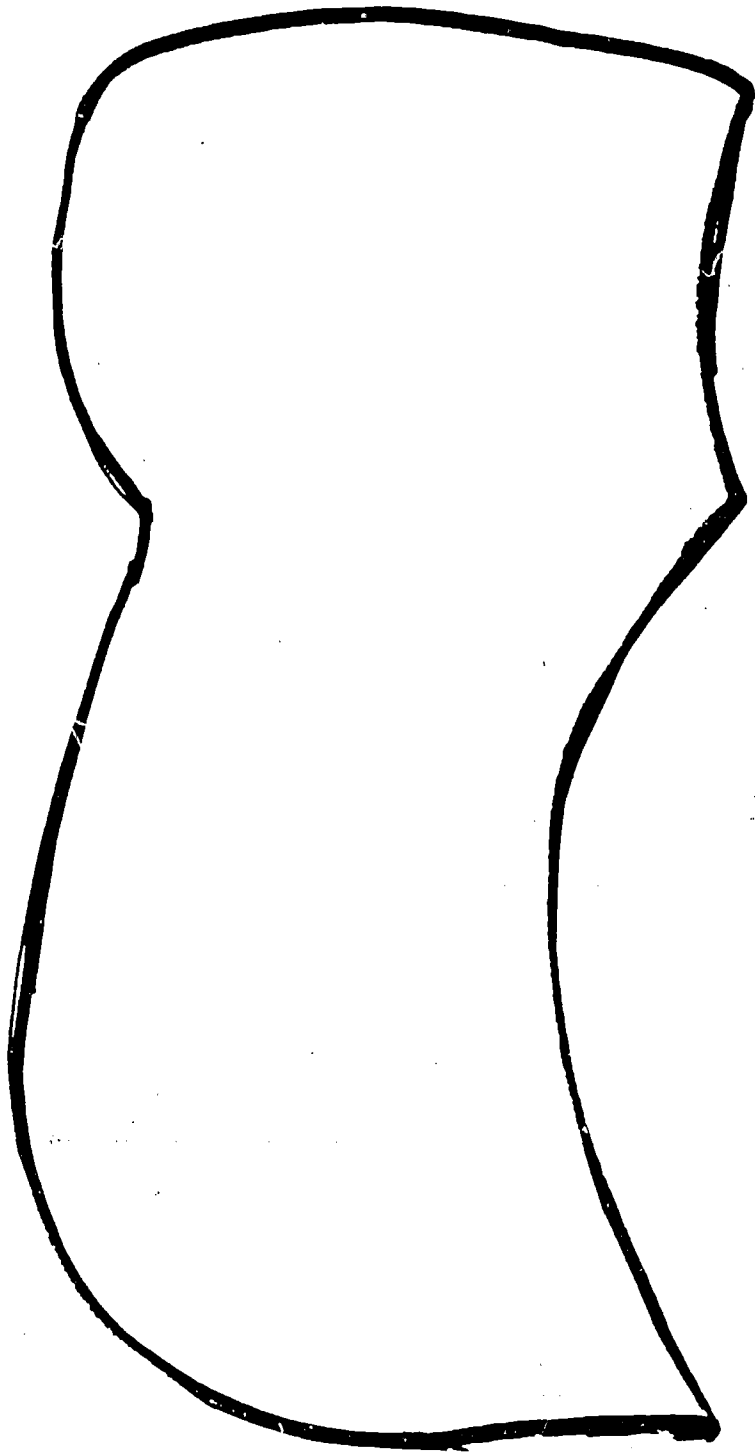

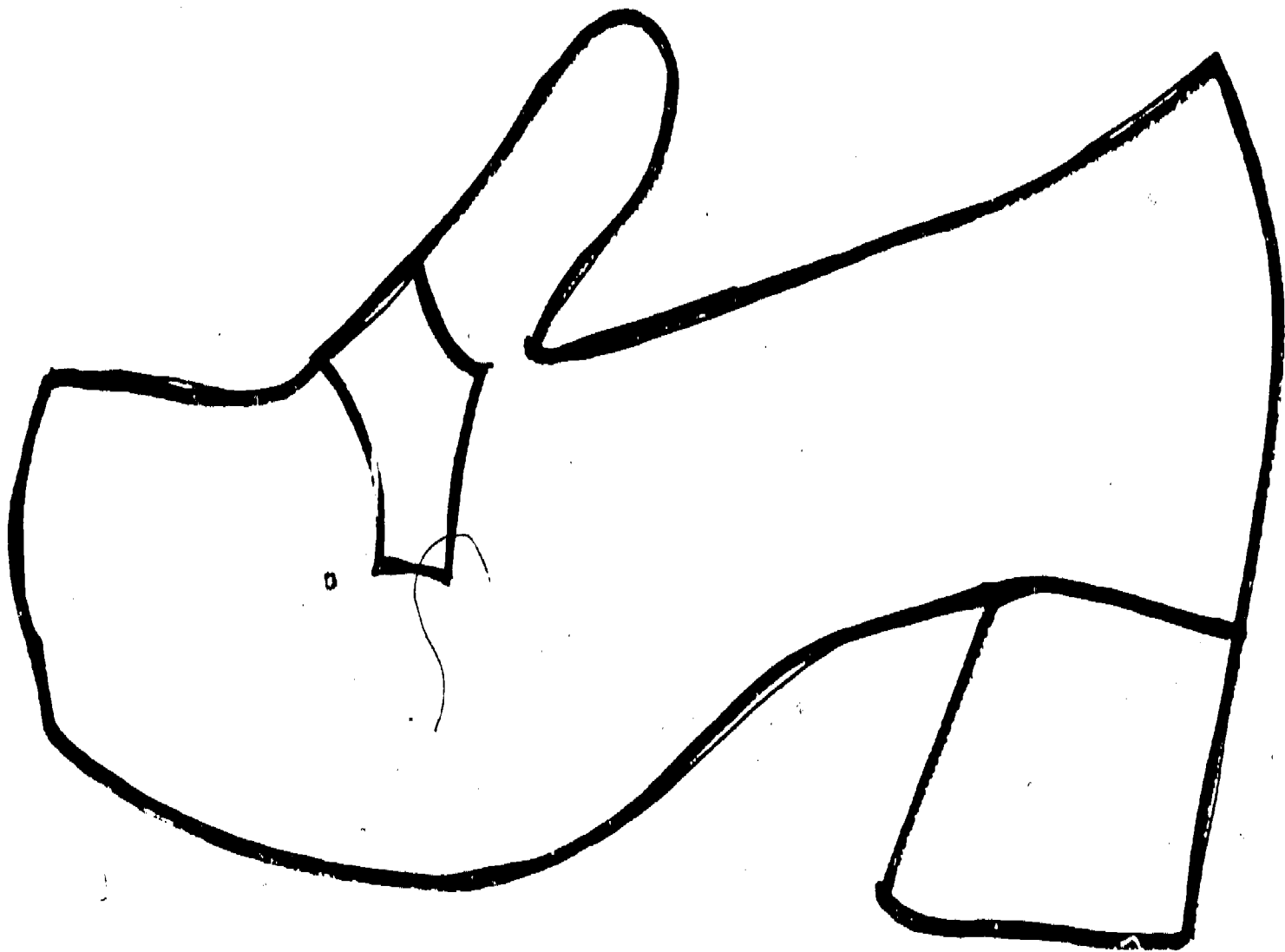

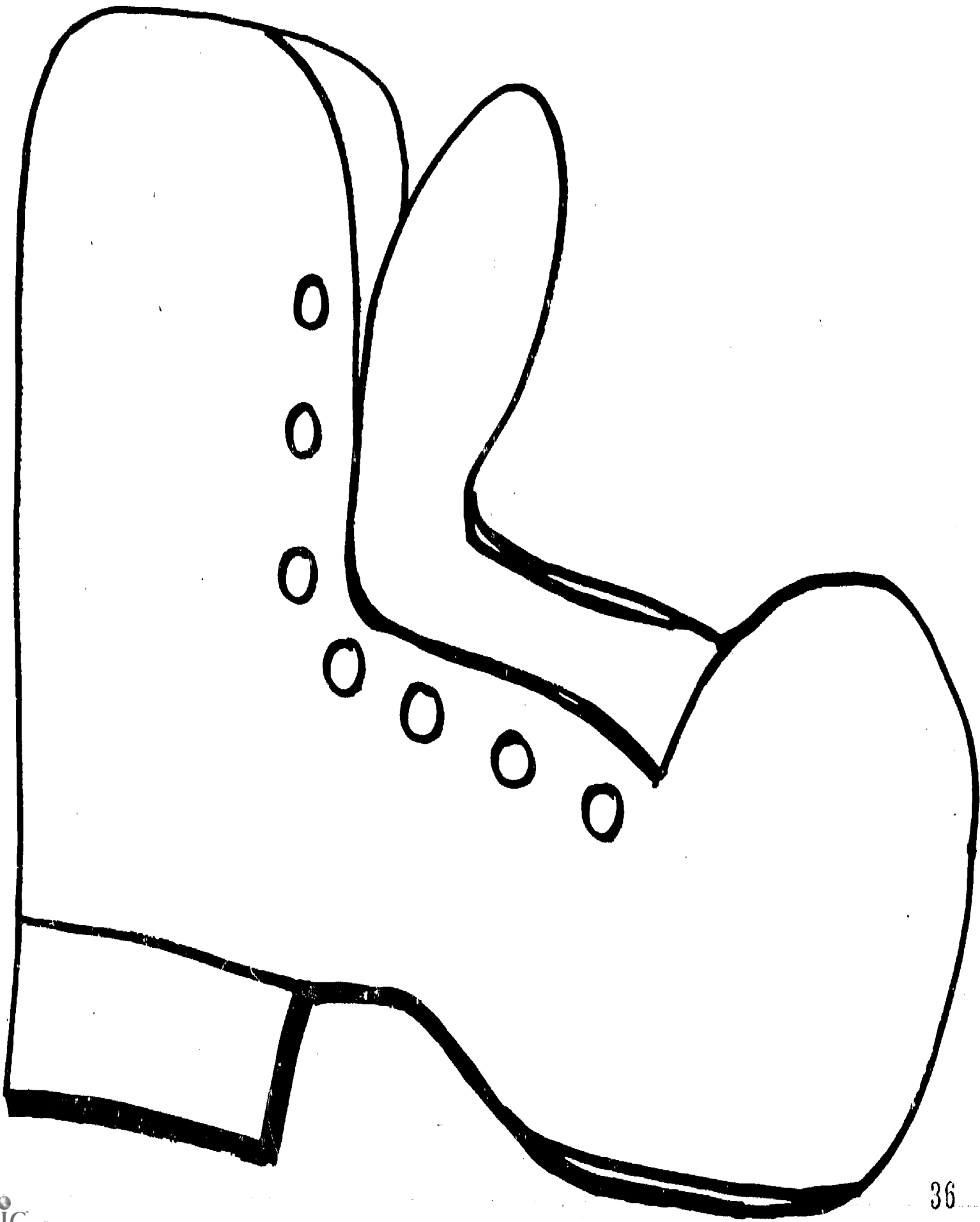

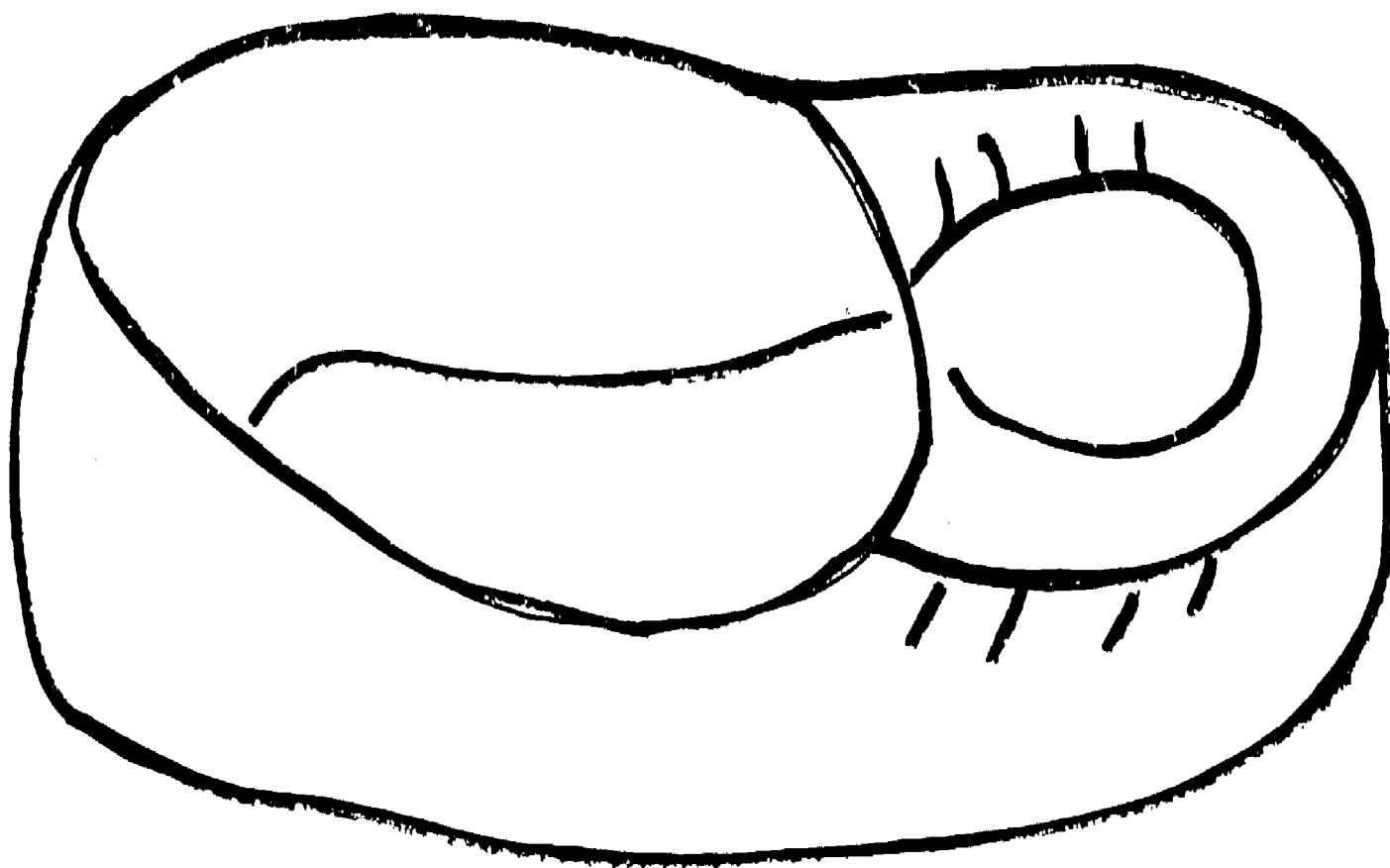



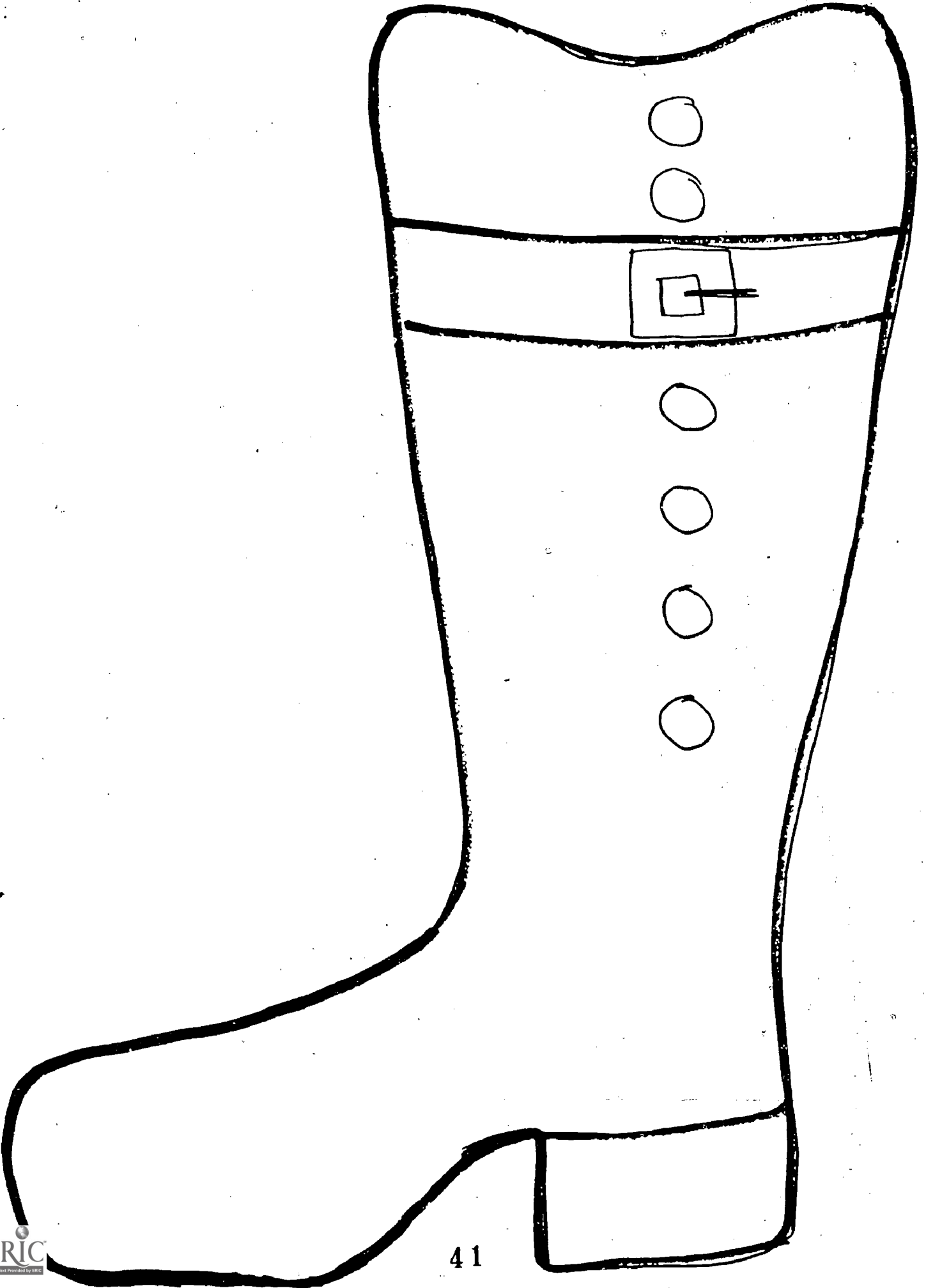

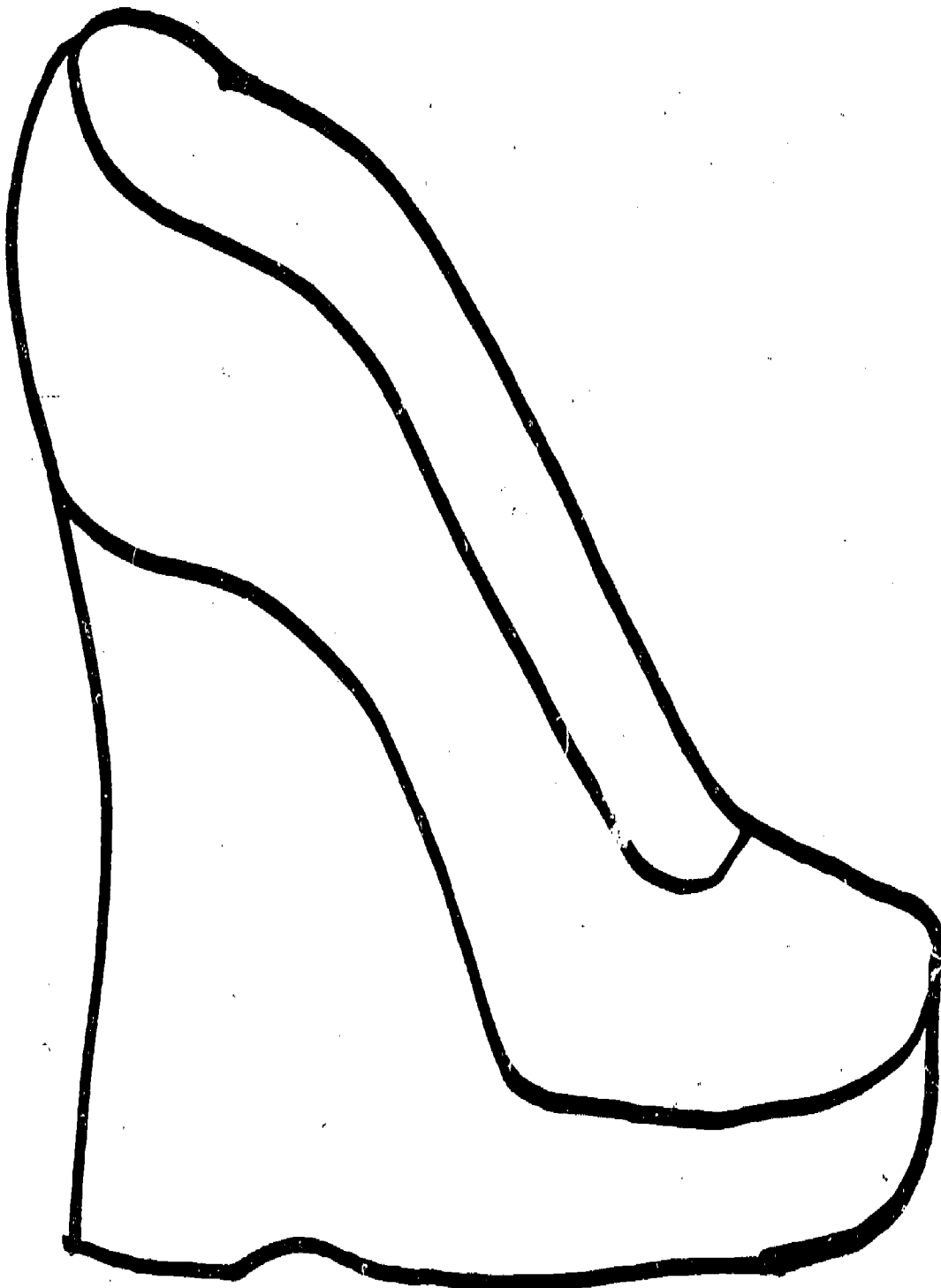

Oaktag - Use strings that are provided for stringing beads. This pattern works well

because it can be used over the child's shoe.

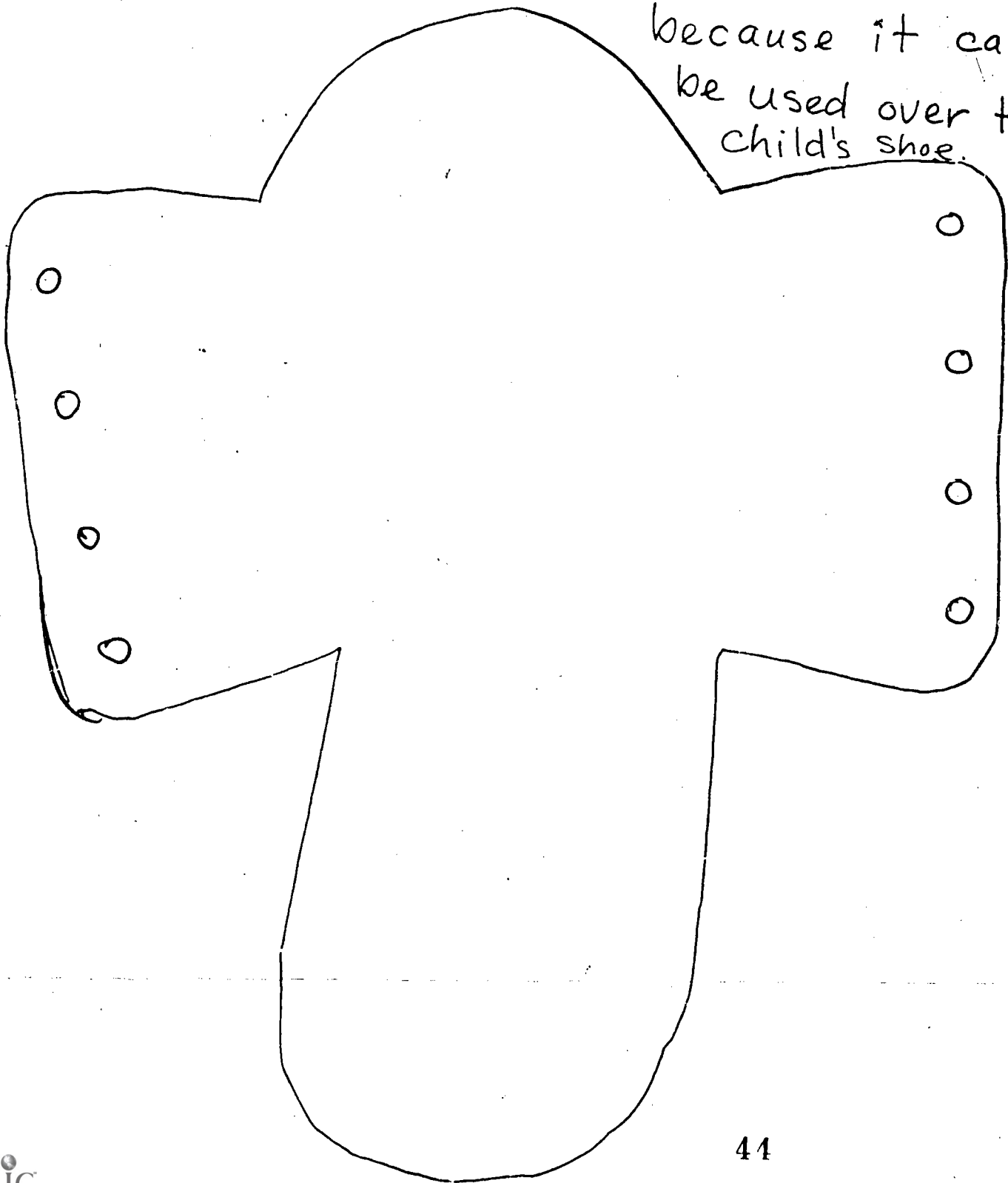

E

The tallest

boy

The tallest

girl

The shortest

boy

E.

The shortest

girl

I am _____ cm.

tall. I am

_____ cm long.

For Feet and Shoes: Measuring
CE Learning Center

Enlarge Mr. Alligator to about 8 meters long.

Mark centimeters along bottom of paper.

Color green, with tempera.

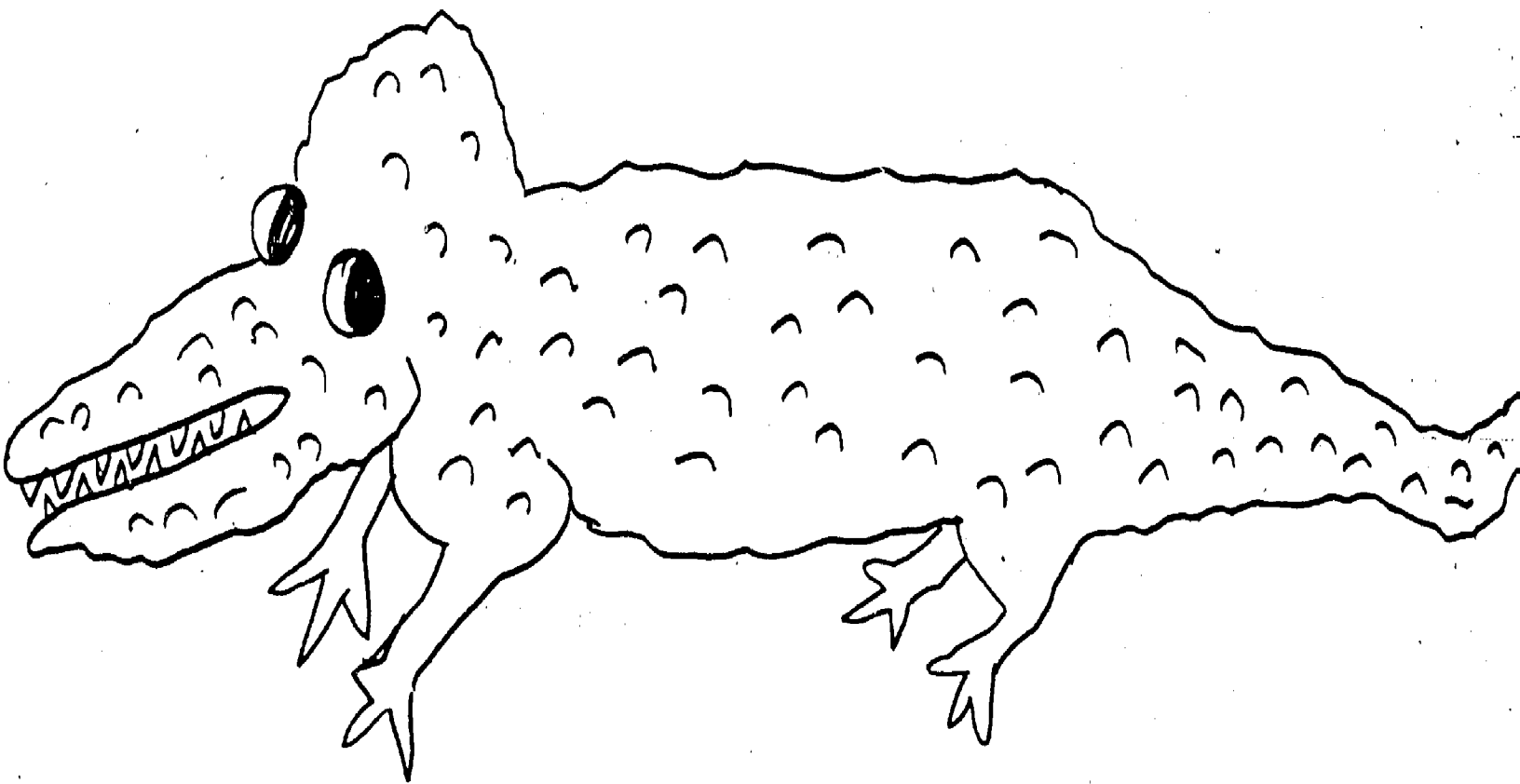

For Feet and Shoes:
Measuring
CE Learning Center

Enlarge Mr. Giraffe
to about 8 meters
in height. Mark
centimeters along
side. Color in with
tempera paint—yellow
+ brown.

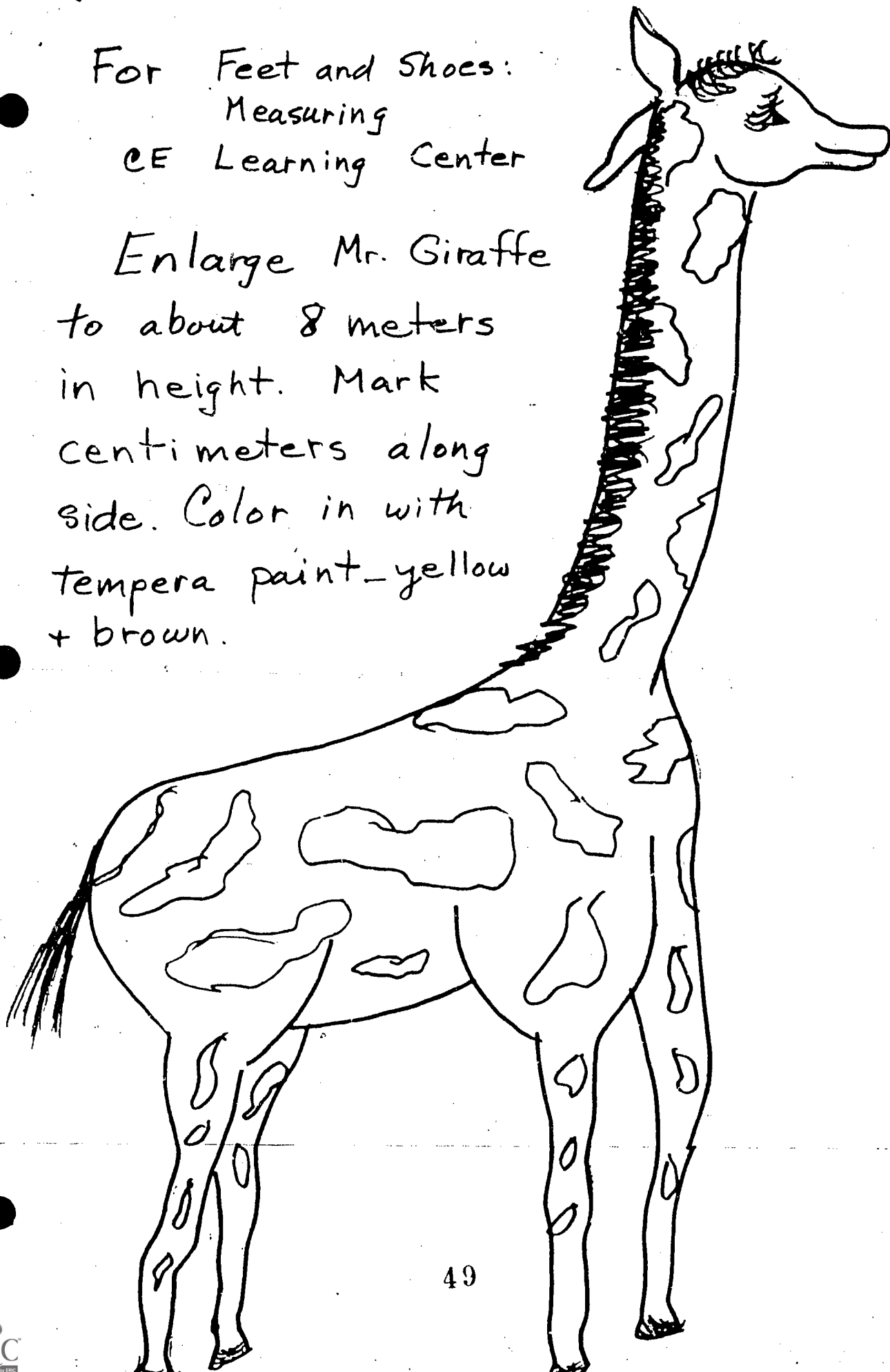

Career Education Learning Center

LOOKING IN A LOOKING GLASS

**by Carol Schmidt Brownell School
Fall 1975 Lincoln, Nebraska**

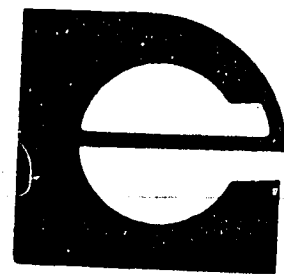

**LINCOLN
CAREER
EDUCATION
PROJECT**

The materials presented in this document were developed under a grant from the Office of Education, U.S. Department of Health, Education, and Welfare. Contractors undertaking such projects under Government sponsorship are encouraged to express freely their professional judgement in the conduct of the project. Points of view or opinions stated do not, therefore, necessarily represent official Office of Education position or policy.

Submitted by
Lincoln Public Schools
John Prash, Superintendent
Carl Spencer, Project Director

1976

TEACHER'S PLAN

SUBJECT AREA: Health

1. Involving Career Education themes:
Career Information and Awareness
Personal and Social Development

Correlated areas involved are:
Social Studies
Language Arts
Reading
Economics
Science

TEACHER'S OBJECTIVES:

- 2.
1. Students will be able to identify and classify an occupation through materials used by the worker.
 2. Students will be able to apply social skills through peer teaching.
 3. Students will be able to know themselves and their role to the community.
 4. Students will be able to achieve habits of cleanliness, orderliness and attractiveness.
 5. Students will be able to identify occupational stereotypes.



STUDENT'S OBJECTIVES:

1. I will identify and classify an occupation through materials used by a worker.
2. I will use social skills by working with my classmates.
3. I will learn about my role to the community.
4. I will learn to keep myself and things around me, clean and neat so others are glad to know me.
5. I will learn about the work of community health workers especially the physician, dentist, nurse, sanitation worker, pharmacist, hair stylist.

PRE-ASSESSMENT:

Pages are marked "A".

3.

Students play CAREER MATCH game as a pre-assessment. The game boards of workers' tools (A) are used for each of the three levels-- gifted , average , readiness  and therefore three copies of each game board and each worker match set (A-1) are included in this kit. The method of recording answers varies by level and is explained below.







Plastic shopping bags are provided for storage of the Career Match Game materials and for ease in use as children carry the bags to the place where they play the game.





Page XX provides labels so that the shopping bags can be identified. Teachers should cut the sections apart, punch a hole in an upper corner, fasten the label with yarn through the hole and tie to the handle of the shopping bag. The second set of labels are to be pasted on folders which hold the Post Tests for each level.



SUMMARY: Each shopping bag should be labeled with a shape which designates the level. Inside each bag is a game board (A), the six pictures of workers cut apart (A-1), the answer sheet for that level. Teachers make a master ditto of pages A-2 and A-3 for students to record answers on. Place A-2 ditto copies in the  bag and A-3 in the  bag. No recording is done at the readiness level. It helps to organize these paper materials if they are placed in a folder made of construction paper with pocket stapled on the folder to hold the answer key. Place a box of crayons in  level bag and a pencil in  level bag.

*Playing
the
CAREER
MATCH
GAME*

Gifted level--Students match the picture of the worker with the equipment used by that worker. They write the name of the worker on the recording sheet (A-2) as directed on the top. They check answers with the answer sheet A-2  which includes the name of the tool as vocabulary building for gifted students.

Average level--Students play the game the same as above but record answers by drawing pictures on sheet A-3 as directed. They check answers (A-3 ).

Readiness level--Game played as above but are not required to record their answers. Students can check their own using key A-4  or perhaps a gifted student can help them check.

4.

ACTIVITIES: Same level designations used

 =gifted

 =average

 =readiness

Suggested teacher-directed activity: Gifted children draw around other students as they lay full length on brown paper on the floor. Teacher or aide may help draw these body shapes.

Each child paints clothes on his drawing in the "uniform of one of the six community workers used in this unit--(opera paint is best to use. These figures can be placed on each child's chair for open house. (This is number 10 on the "Pick a Number" record-keeping sheet)

 Activity 1:

Set up the mirror provided in the kit at the center. Use the sheet labeled 000 (on pink tag) at the center to direct children to draw themselves. Place drawing paper and crayons on the table.

Gifted students help others read directions. They may draw the student they are working with as well as themselves and then talk in their pairs about what they saw in the mirror. Compare pictures they drew of the same person. (Number 9 - Pick a Number)

Gifted and average can work with readiness students in pairs. They use a tape measure to measure and chart the height of readiness & other students. Keep this chart and compare at the end of the year to see how much they grew. (Number 8 - Pick a Number)

 Activity 2:

Place the following materials at the center: scissors, paste, old magazines, construction paper and brass fasteners.

ONE: Children are directed to make a scrapbook of construction paper put together with brass fasteners. They cut pictures out of magazines that show the six community workers of this unit...their equipment or tools...things in the community they influence (such as cleaning up solid wastes and helping in tornados, etc.)

TWO: At this same center, make collages. Children use large sheets of paper and several youngsters work together pasting pictures of community workers, their tools, etc. These make good classroom decorations.

 Activity 3:

Puppet making: Materials--Paper sacks (lunch size), dittoed copies of the puppet patterns (PP) provided in this kit (use patterns if desired or urge children to design their own). Colored scrap paper, crayons, yarn, buttons, bits of cloth, paste and scissors. Paper and pencils for riddles.

Children are directed to make a puppet representing our community workers, and then write a riddle to go with the puppet. Other children guess who their worker is.

Discuss use of women and all races in professions as well as "traditionally accepted" work roles. In order to avoid stereotyping workers by sex or race, cut the puppet patterns apart before putting them out for children's use. They should choose any head part (to paste on the bottom of the sack) and choose a pattern body or design the body with colors, clothes, paint, etc. to fit this worker. The body goes below the fold and puppet works with hand inside. If they are able to make their own without patterns out of bits of cloth, paint and yarn, encourage this creativity. They may make a male nurse puppet, a black woman doctor puppet, a woman sanitation worker, etc.

Activity 4: Teacher-directed, class activity...optional but rewarding!

Set up a beauty and barber shop. Include a table for the receptionist's desk; place proper equipment on this desk such as telephone, cash register, play money, an appointment book made from 12 x 18 construction paper folded in half with paper stapled inside--two columns only: Name and appointment date and time.

Use page **□□□** in this kit to ditto off appointment cards to be given to customers. Chairs and magazines make a real waiting room.

Send a note home to parents to inform them, to ask their permission and their help. The sample page **□□** may be used. This letter should help obtain equipment and materials for the shop: old hair dryers, wigs, wash basin, empty hair spray cans, rollers, curlers, etc.

Each child must have his own comb for health reasons. Teachers should label the combs with the children's names and use this activity to teach cleanliness, good grooming, understanding of hygiene rules.

When the shop is ready and the workers chosen, youngsters come in for appointments. (Number 7 - Pick a Number)

Activity 5:

ME, THE TOOTH: Place the sheet marked MM at the center as an invitation to the activity.

Make a ditto master from sheet MMS and place ditto copies, pencils and the mirror at the center. Children follow directions on the sheet at the center. They place their completed sheet in a folder. (Number 6 - Pick a Number)

Activity 6: Suggested for Gifted and Average

Crossword puzzles about the doctor and dentist.

Prepare the center with two folders for each puzzle--total of four folders. One folder labeled "Doctor Puzzles" in which ditto copies of page DD are placed along with the answer key DDK in the pocket of the folder. The second folder of this set is for children's completed papers after they have checked their answers. Do the same with the dentist crosswords. (TT) and answer key (TTK). (Numbers 4 and 5 - Pick a Number sheet).

*** Stereotyping Discussion - Teacher Directed**

It would be fun and inviting to blow up (on the overhead projector) the six worker pictures in the kit (pages marked BB). Or - these pictures could be cut apart and children arrange them on a bulletin board. Discussion of workers placed in roles by race and sex should result from displaying these pictures. Teachers should be prepared to lead a discussion about stereotyping workers. Sample questions: Can women be doctors and dentists? Why or why not? Do you know a women doctor? Tell us about her. Etc. for Blacks, Chicanos, Native Americans.

Resources:

MEDIA MATERIALS (available from PSAB Media Career Education Center)

Drug Store Workers--filmstrip and tape

Careers in Dental Laboratory Technology, Nat'l Association of Certified Dental Laboratories, Inc.--slides

Books:

Come Work With Us In the Hospital, Sextant Series. By Jean and Ned Wilkinson

I Want to Be Series (Children's Press)

- Dentist
- Doctor
- Nurse
- Beauty operator

A Worthwhile Purchase:

Nellie The Nurse, Multimedia Package by Encyclopaedia Britannica; this makes a complete center in itself. Includes: nurse's hat to wear, book of information, ditto masters for work pages, film-strip and tape.

RECORD KEEPING :

5. 1 PICK A NUMBER sheet (marked #) in this kit may be used. Each center is designated by a triangle shape on the sheet. The activities are not numbered in the order given here which indicates that these are not sequential - can be done in mixed order. The student X's off the center after he has completed it. Each child has his own sheet. Can be filed in an upright position in a box for easy access.
- 2 The finished activity could also be your record.
3. Teacher can keep a chart for her own records by posting the following chart.

Activities We Finished										
Name	1	2	3	4	5	6	7	8	9	10
Bobby J.			✓		✓				✓	
Sheryl	✓							✓		✓
Elizabeth	✓		✓		✓	✓				
John										
Dick	✓		✓			✓		✓		
Mark	✓			✓						
Sue	✓			✓				✓		
Mary		✓		✓	✓					
Bill	✓									

STUDENT EVALUATION:

6.

Teachers may evaluate student growth and the effect of the center upon the students by using the post tests provided. Students may evaluate their progress by taking the post test and check their own answers with the key. A pupil-teacher conference may follow.

Teacher Preparation of Post Tests:

Prepare 3 folders, paste a label on outside of each (from page XX) to designate the test level found within that folder. Children should test from the same shape label as they used for the pre-assessment. Presumably teachers designated which shape (i.e. level) each child should follow.

Make ditto masters and student copies of the page marked B-1, B-2 which is the recording sheet for gifted and average.

Each folder should have - page B, the game board, answer key for that level - \circ + Δ folders also have dittoed recording sheets. \square folder has game board, 18 squares of tools to match and answer key.

POST Tests

\circ Δ Gifted and Average use page B on pink tag and the student recording sheet marked B-1, B-2 (made into dittoed copies for students). After they have drawn their answers, they return to the folder for the answer key (B-1 \circ , B-2 Δ) which has a variety of tools. If they have other tools drawn, they can justify their choices to the teacher in conference.

\square Readiness use page B on pink tag as the game board. Teachers cut apart the 18 pictures of workers' tools on the 3 pages marked B-3; these pictures are used by readiness students to match with the worker who uses this tool. The answer key shows the correct matching. (B-3 \square).

Note \rightarrow *

Children may need to discuss the breaking of worker stereotypes shown in the Post Test pictures. A short session using the game board as an example may be necessary before they take the post test especially if they did not mix sex roles in their puppet making, or discuss the pictures (BB) mentioned as discussion starters.

LOCATION OF CENTER:

7.

This center would work great in a room set aside as a Learning Center. This would almost be enough to take care of all centers in the room for three weeks. The room could be monitored by a teacher aide, student teacher or parent. Also, the unit could be placed on a cart and moved from classroom to classroom.

This unit may be put on a desk, counter, table, or on the floor in a corner of a classroom. If possible, a bulletin board for the background is great.

A carpet or rug on the floor makes a good place to play the games.

To close off the corner from the rest of the room--make chains from different colors of yarn and pieces of Pringle cans covered with colored wallpaper. Open up paper clips to use for hangers to extend them down from the ceiling.

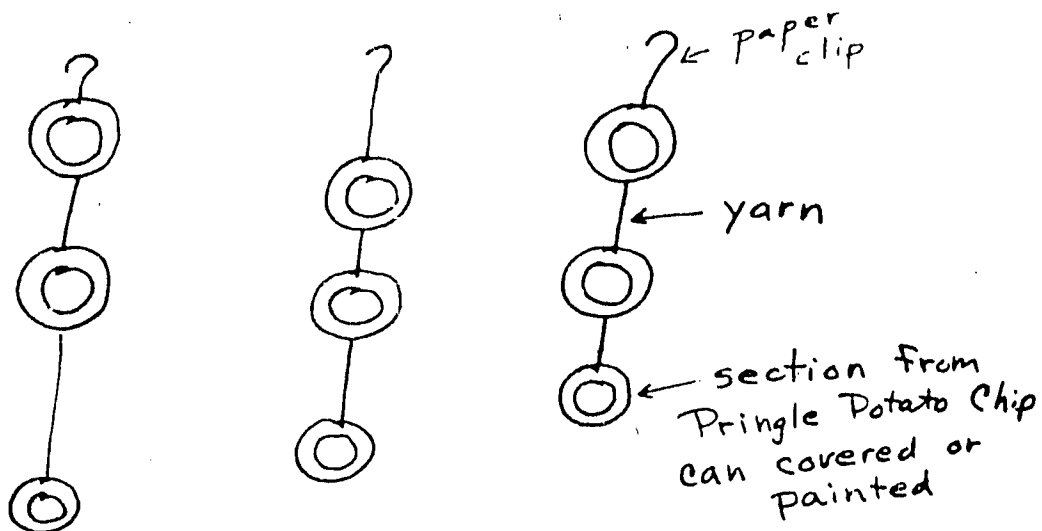

One of the pages marked BB is a suggestion for making a class poster about getting enough sleep. This could be up in the room for a greater share of the year. It works great to go back and read it together once in awhile. Best to be made on 24 x 36 oaktag.

SCHEDULING:

8.

The teacher can decide who is to use the center for the day. She may assign a specific activity or the student may get to choose. The PICK A NUMBER sheet (page #) will show which center is not completed.

If the kit is used in another room outside of the regular classroom, passes are used. Maybe the child earns the pass by doing special work or maybe the teacher just assigns it. If an aide, parent or student teacher is in charge, different colors of passes may be the clue as to the level of the activity the child is able to handle. Using sheet ⑦, make a ditto master and run it on pink, yellow and blue paper. Figure out a code for monitor to use. Example: Pink--gifted youngsters, yellow--average, blue--readiness. This pass is needed to get to the Learning Center room. It can be used also in a classroom, if the teacher finds the need, by handing them out at the beginning of the day, children can use them when they have free time or time designated as learning center time.

9.

TEACHER-STUDENT EVALUATION OF CENTER:

1. Student-teacher conferences are very helpful. Students may come up with suggestions for improving the center.
2. First graders like suggestion boxes. Readiness students might drop a paper in the box with a smiling or sad face on it according to their feelings about the activities. Average and gifted youngsters could write a sentence or two.

3. On the PICK A NUMBER sheet (page #) the child could draw a happy or sad face on the activity listed, according to their feelings about that activity. This is an indicator of the most popular activities and which activities need to be revised.

Record-Keeping Evaluation:

A chart could also be made where each child checks himself on the grooming habits listed in the poem. This chart could be kept individually during the duration of this unit of study.

HABIT	DAYS						
	M	T	W	TH	F	S	S
Hair combed	X	X					
Shoes shined	X	X					
Teeth brushed	X	X					
Fingernails cleaned		X					
clean clothes	X	X					
Use hanky	X						
NAME	Sandra						

use
1/2 inch
graph
paper

This poem is on the orange tag for an invitation to the center.

MY GROOMING QUOTE

How do I look to everyone?
I'll check the things that I have done.

My hair I combed,
My shoes I shined,
On all of me
No dirt you'll find.

I cover every
rough and sneeze
With handkerchief.
"Excuse me, please."

I brushed my teeth
To keep them bright,
My fingernails
I'll not bite.

"I'll try to pass this daily test
So I may always look my best."

The clothes I wear
Are not my best,
But they are clean
And I'm well behaved.

MY GROOMING GUIDE

How do I look to everyone?
I'll check the things that I have done.

My hair I combed,
My shoes I shined,
On all of me
No dirt you'll find.

I brushed my teeth
To keep them bright,
My fingernails
I did not bite.

The clothes I wear
Are not my best,
But they are clean
So I'm well dressed.

I cover every
cough and sneeze
With handkerchief,
"Excuse me, please."

I'll try to pass this daily test
So I may always look my best.



LOOKING
in a
Looking Glass

A

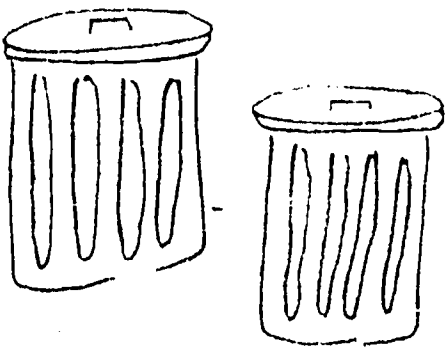
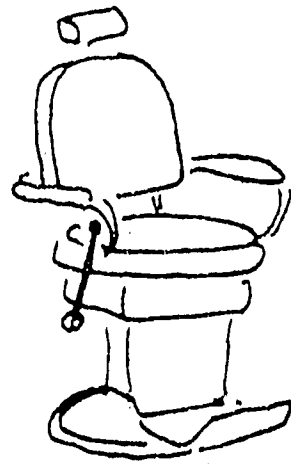
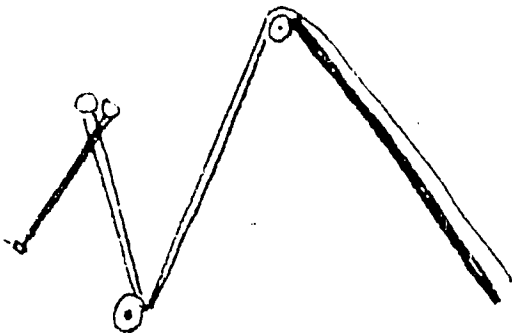
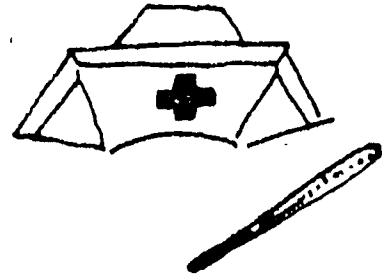
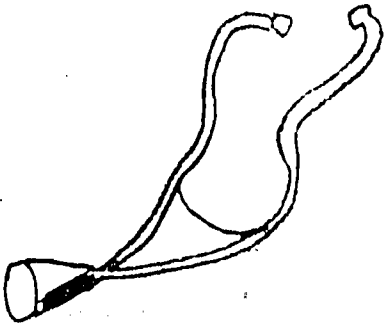

A

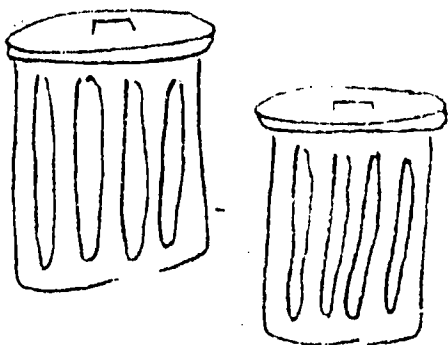
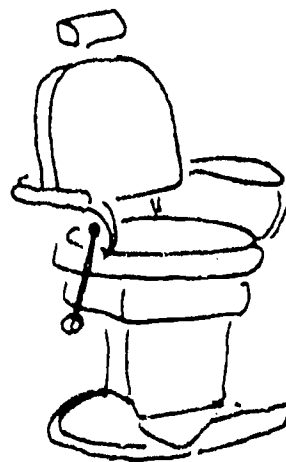
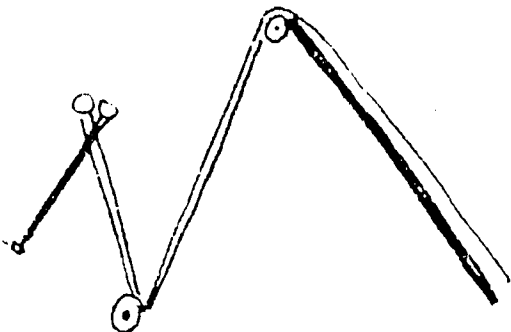
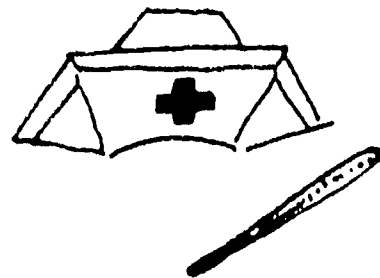
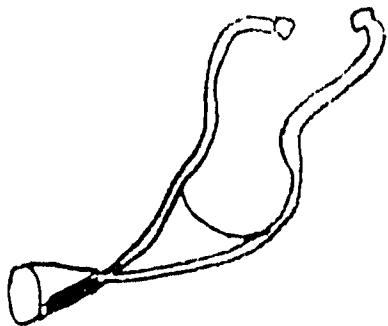

A

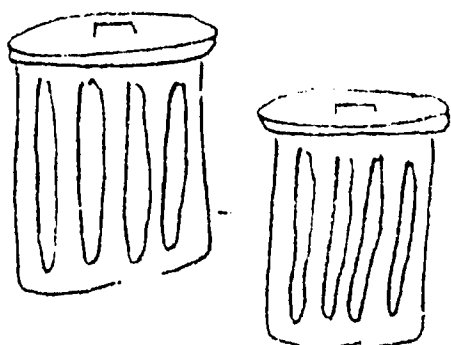
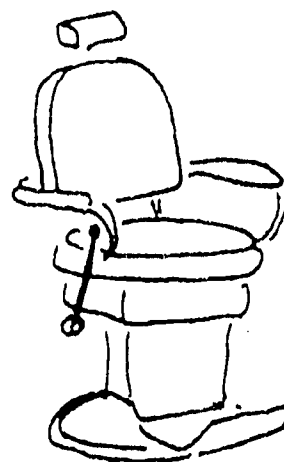
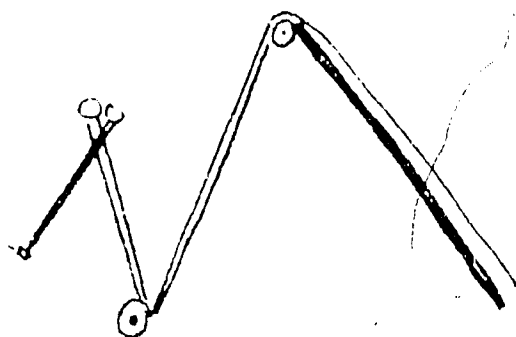
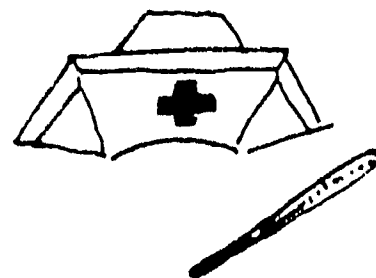
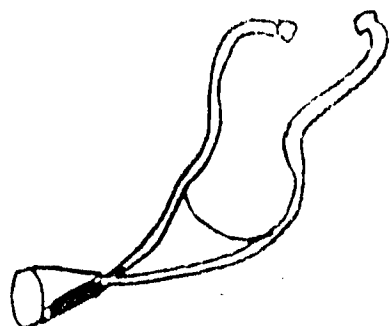

Cut apart for Career Match Game A-1

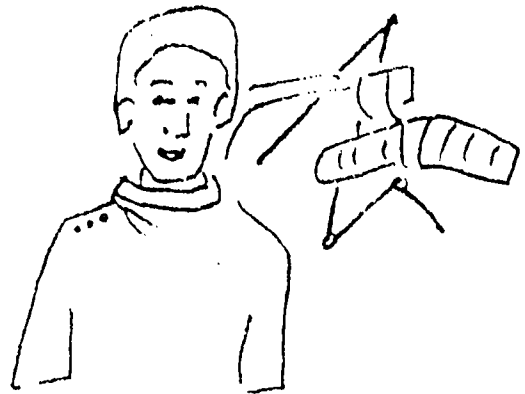
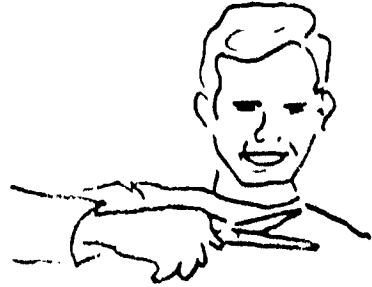
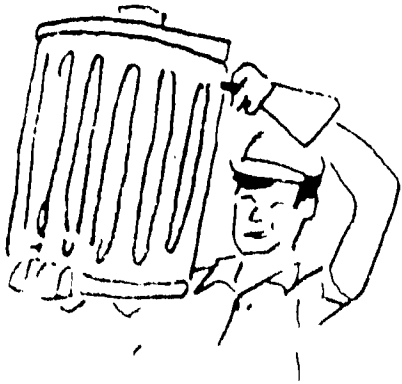

Cut apart for Career Match Game A-1

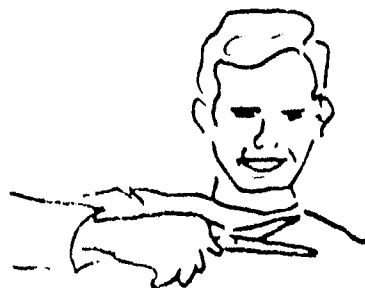
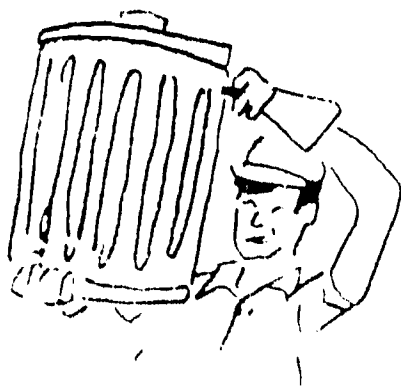

Cut apart for Career Match Game A-1

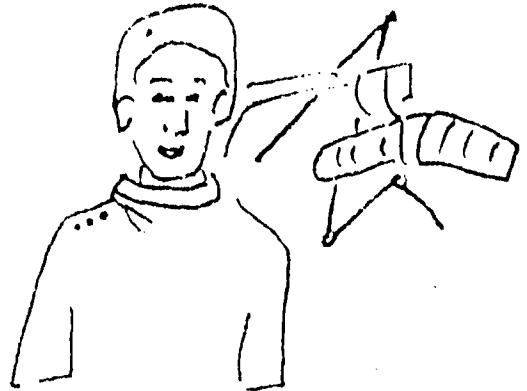
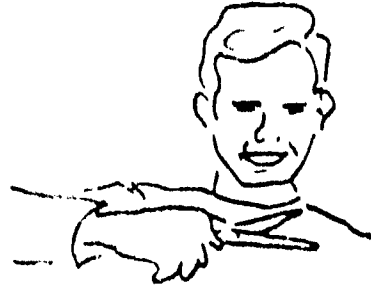
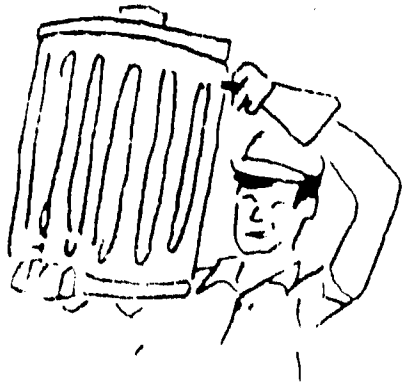

Write the name of the worker who uses this tool.

Draw a picture of the worker who uses this tool.

Key

Did you get the right answers? A-20

Doctor



stethoscope

Nurse

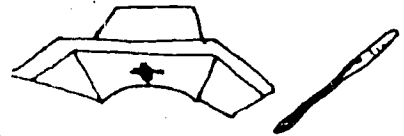

cap thermometer

Dentist

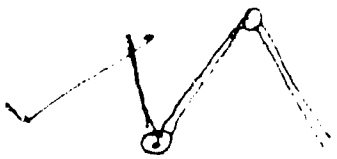

drill

Barber



chair

Sanitation
Worker



garbage
cans

Pharmacist



crucible
for
medicine

Key

A-3 Δ

Did you get the right answers?

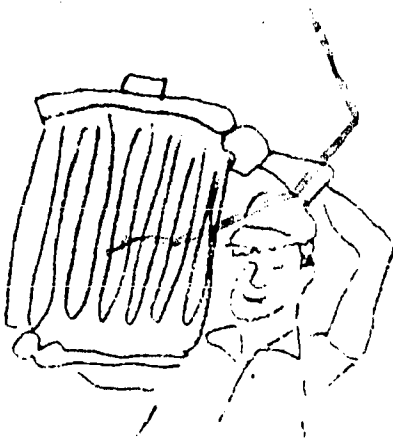
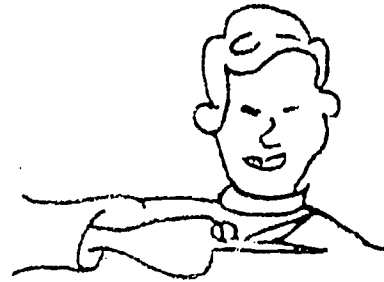

Key

A-3 Δ

Did you get the right answers?

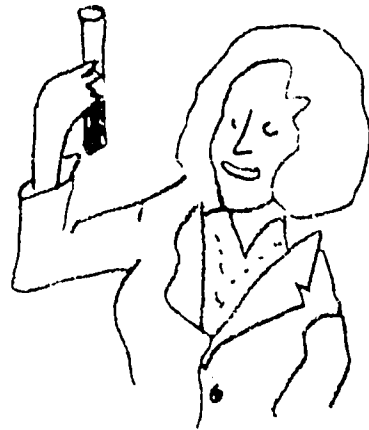
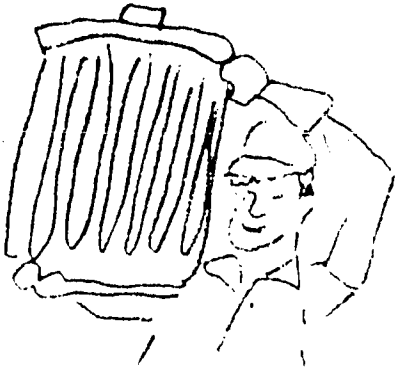
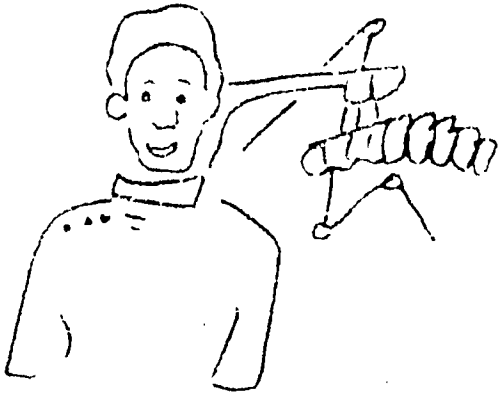

Cut on lines. Punch hole in corner. Hang on handle of plastic bag.

XX

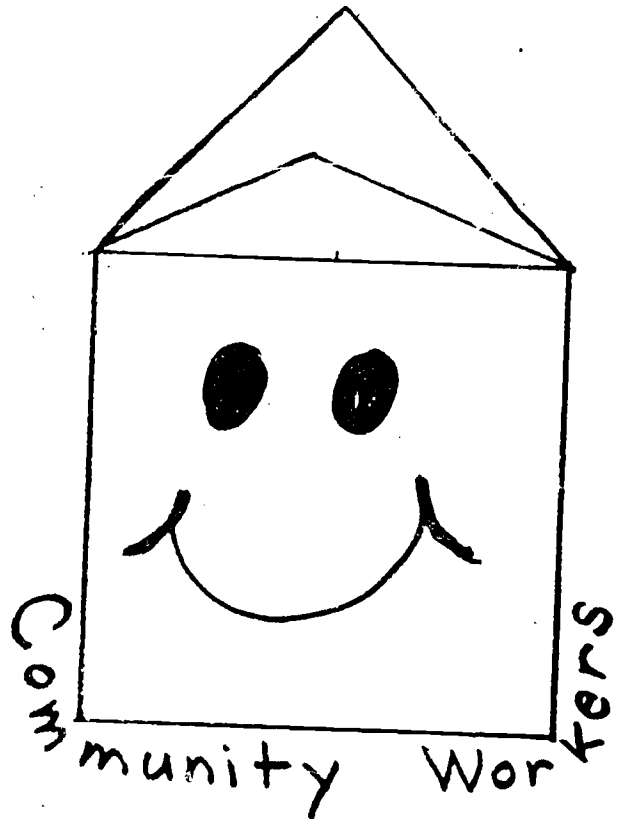
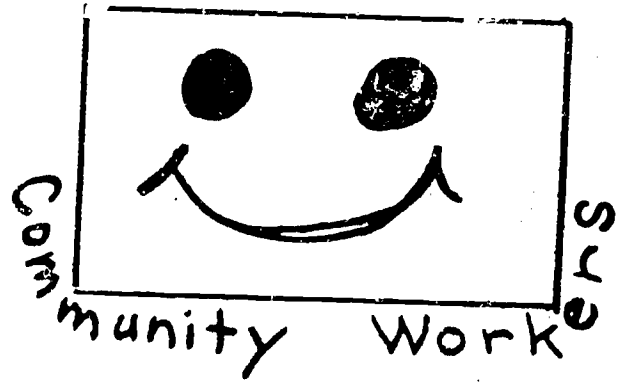

Cut on lines. Punch hole in corner. Hang on handle of plastic bag.

XX

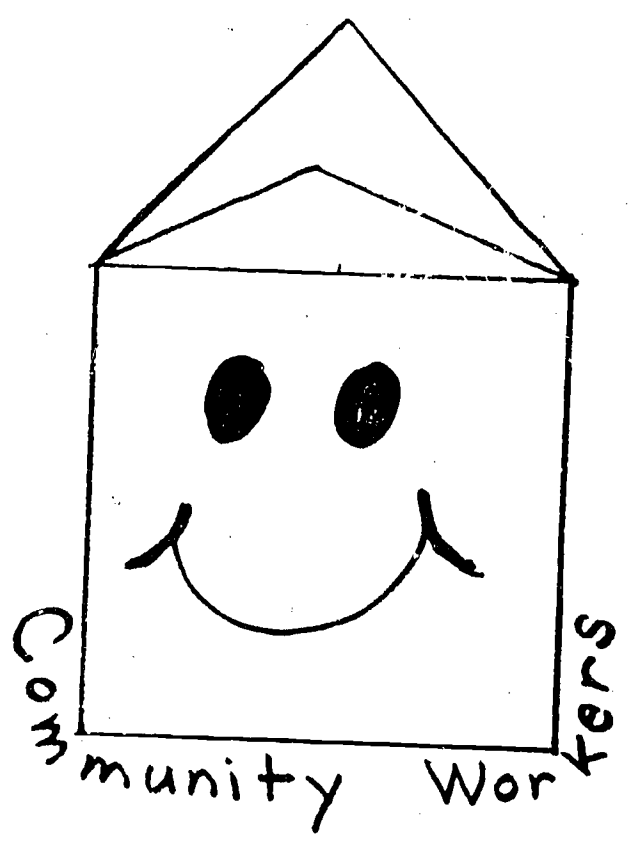
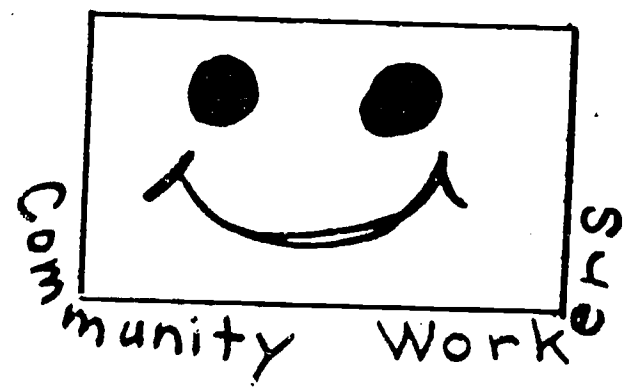

1. Look at yourself.
2. What color is your hair?
3. How do your eyes, nose, mouth, ears, chin and cheeks look?
4. Draw a picture of yourself.

- 1. Color
- 2. Cut out

3. Paste top half here



Bottom half here

- 4. Decorate rest of bag to make a Sanitation Worker

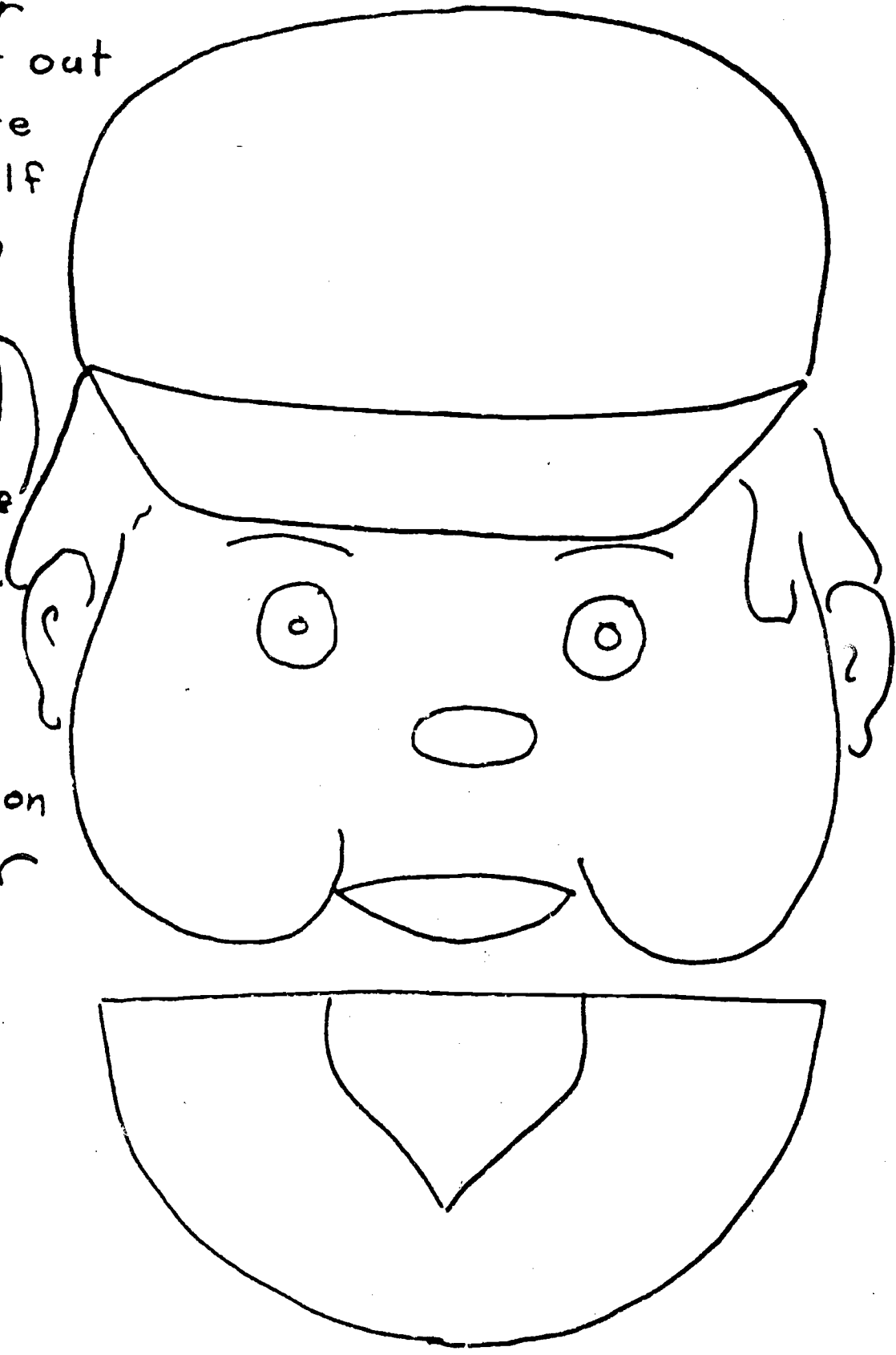

- 1. Color
- 2. Cut out
- 3. Paste top half here



Bottom half here

- 4. Decorate rest of bag to make a dentist



1. Color

2. Cut out

3. Paste top half here



Bottom half here

4. Decorate

to make a pharmacist.



- 1. Color
- 2. Cut out
- 3. Paste top half here



Bottom half here

4. Decorate rest of bag to make beauty operator



Beautician

- 1. Color
- 2. Cut out
- 3. Paste top half here

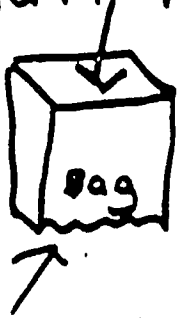

Bottom half here

4. Decorate rest of bag to make a doctor

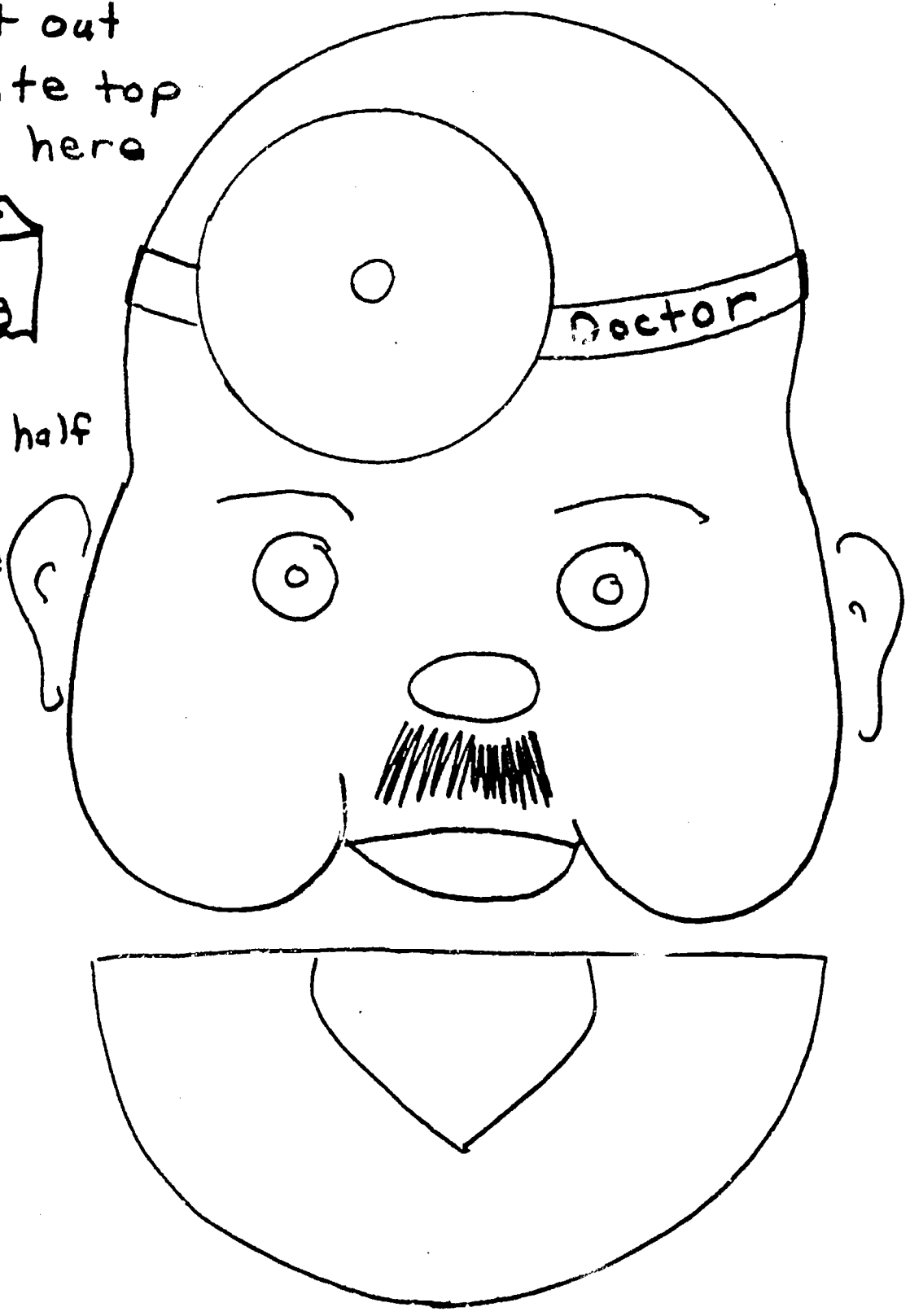

- 1. Color
- 2. Cutout
- 3. Paste top half here



Bottom half here

- 4. Decorate rest of bag to make a doctor.

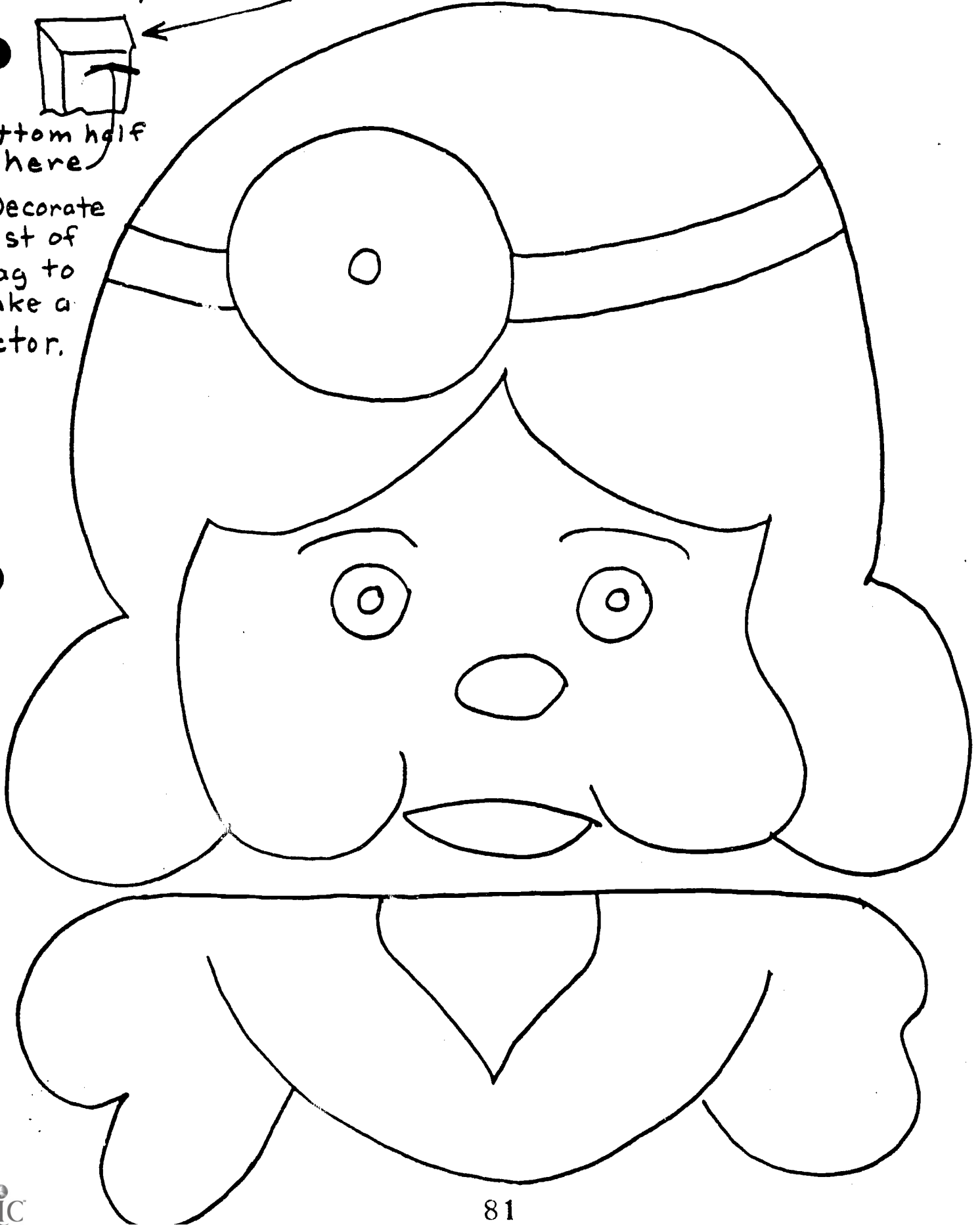

Look your best

Appointment date :

Time :

Look your best
School Beauty Shop

Look your best

Appointment date :

Time :

Look your best
School Barber Shop

Dear Parents:

We are doing a unit on community workers. One of the occupations we will focus on is cosmetology and the tonsorial arts (beauticians and barbers).

A "hands-on-experience" will be role-playing as beauticians and/or barbers. The children will each be given a comb with their name on it. They will work on each other's hair. They will also be given the opportunity to style, set, and cut wigs.

If, as a parent, you feel it in any way distasteful for students to "work on" each other's hair, please call me. Provisions will be made for your child to have other experiences during this time.

If you have any wigs, wigheads, or other related materials which you would like to donate, please send them to school.

Sincerely,

ME, THE TOOTH

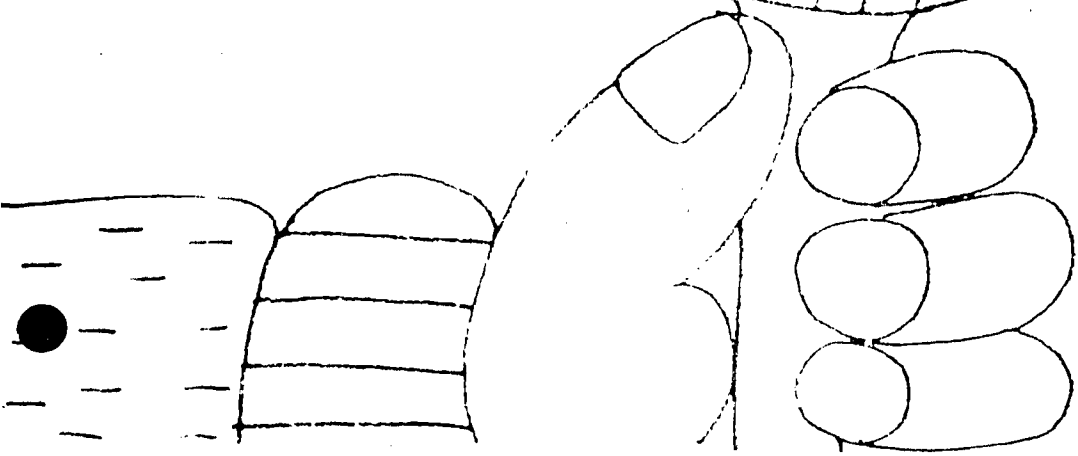
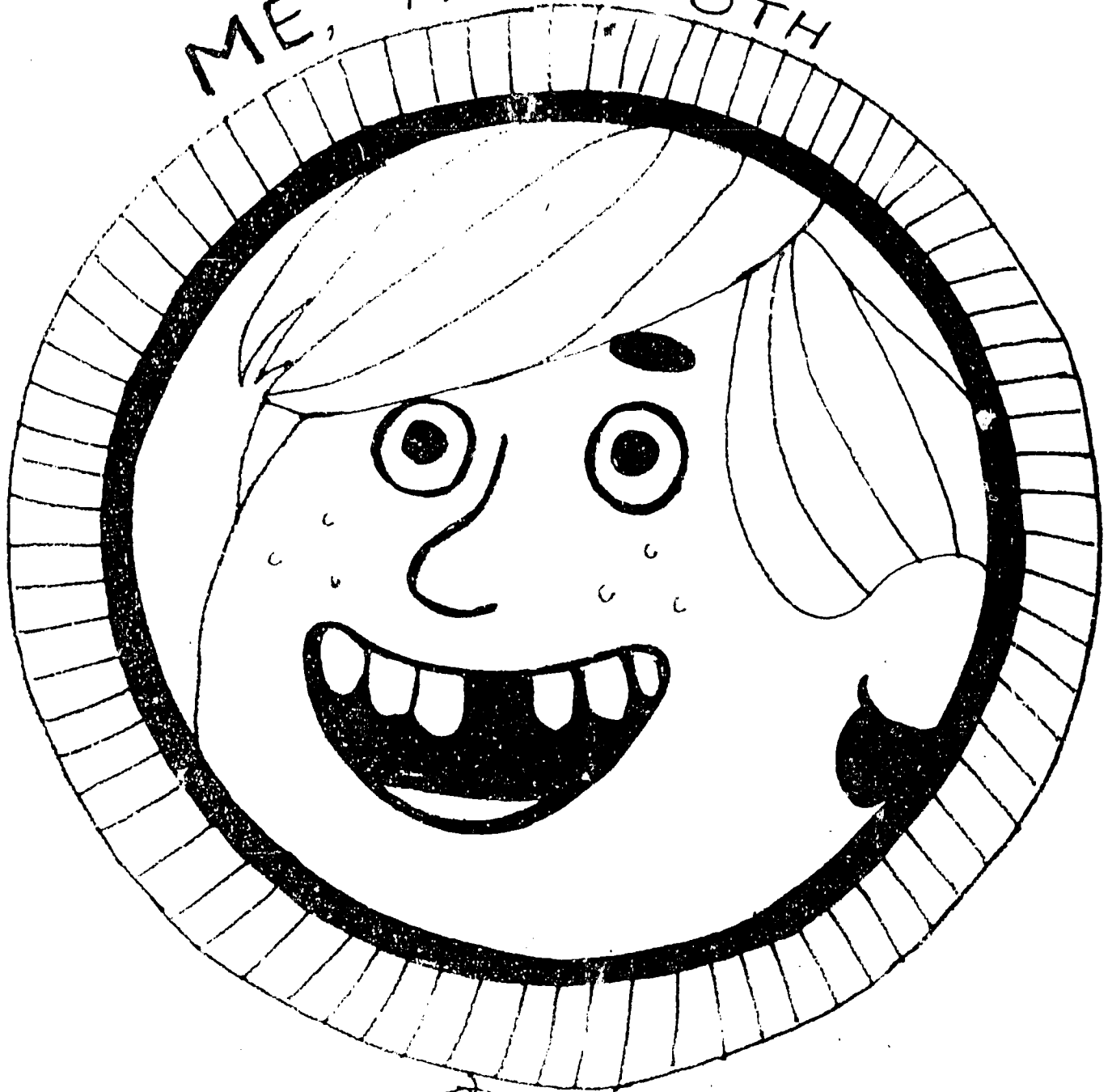

Look in the mirror and examine your teeth.

Name _____

MMS

1. Look in the mirror
2. Describe a day in the life of a tooth in your mouth.
3. Use your imagination,
4. Be sure to give your tooth a name!

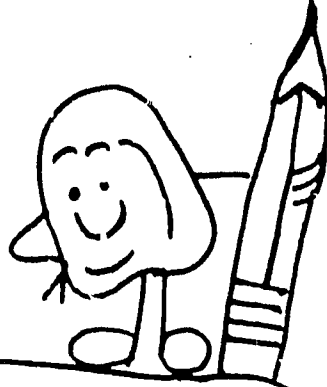

Me, the tooth

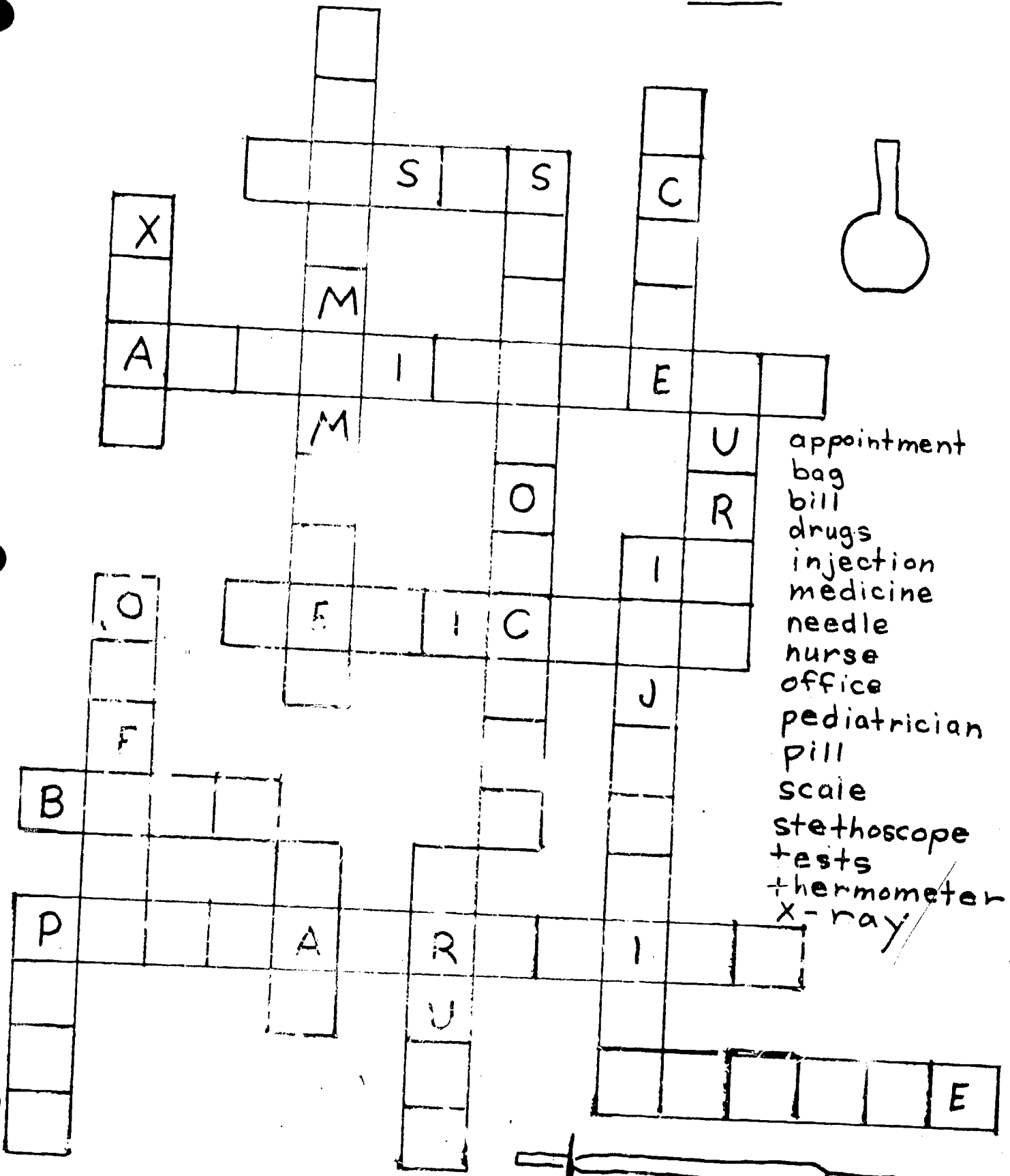

- appointment
- bag
- bill
- drugs
- injection
- medicine
- needle
- nurse
- office
- pediatrician
- pill
- scale
- stethoscope
- tests
- thermometer
- X-ray

Doctor

Answer Key

A crossword puzzle grid with the following words filled in:

- Vertical words:**
 - THURSDAY
 - OFFICE
 - BILL
 - PEDIATRICIAN
 - ILL
 - SCALE
 - NEEDLE
- Horizontal words:**
 - TEST
 - APPOINTMENT
 - MEDICINE
 - BILL
 - PEDIATRICIAN
 - NEEDLE

The grid is partially filled with letters, and some cells are empty. The words listed on the right are: appointment, bag, bill, drugs, injection, medicine, needle, nurse, office, pediatrician, pill, scale, stethoscope, tests, thermometer, X-ray.

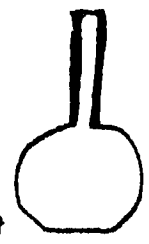

- appointment
- bag
- bill
- drugs
- injection
- medicine
- needle
- nurse
- office
- pediatrician
- pill
- scale
- stethoscope
- tests
- thermometer
- X-ray

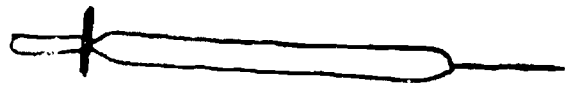

Dentist

TT

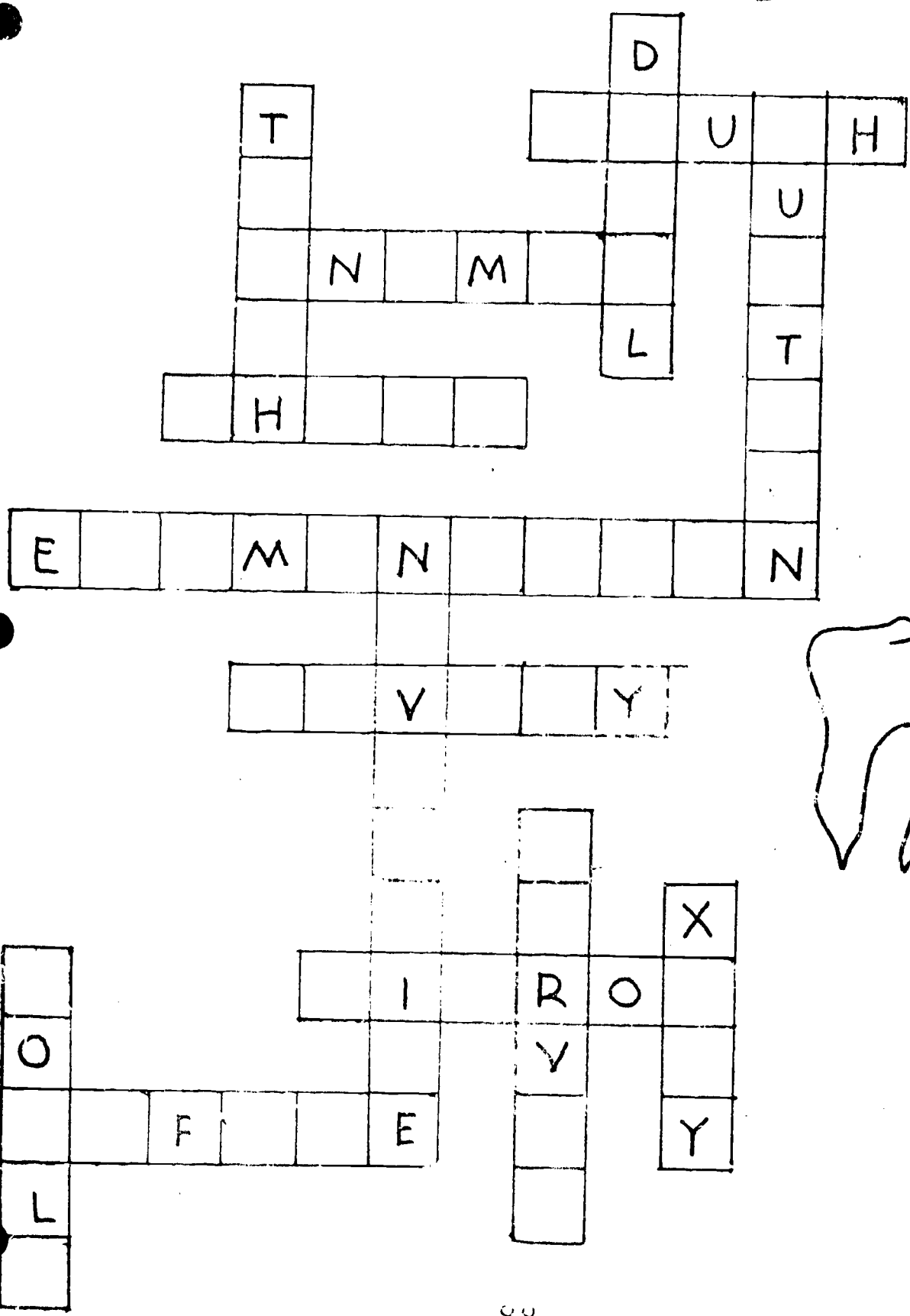

- brush
- cavity
- chair
- drill
- enamel
- examination
- mirror
- nerves
- novocaine
- office
- suction
- teeth
- tools
- x-ray

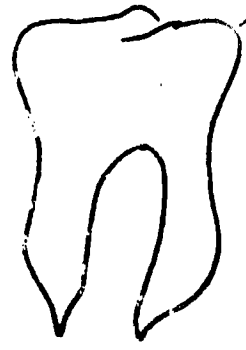

Answer key

Dentist

TTK

D
 T B R U S H
 E I U
 E N A M E L C
 T L T
 C H A I R I
 O
 E X A M I N A T I O N

- brush
- cavity
- chair
- drill
- enamel
- examination
- mirror
- nerves
- novocaine
- office
- suction
- teeth
- tools
- x-ray

C A V I T Y

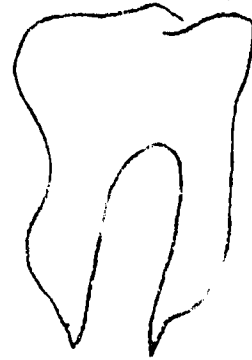

T N
 O E X
 O F F I C E
 L S
 M I R R O R
 N V
 E Y
 S

Adapted from the LPS Primary One Health Guidelines







BB

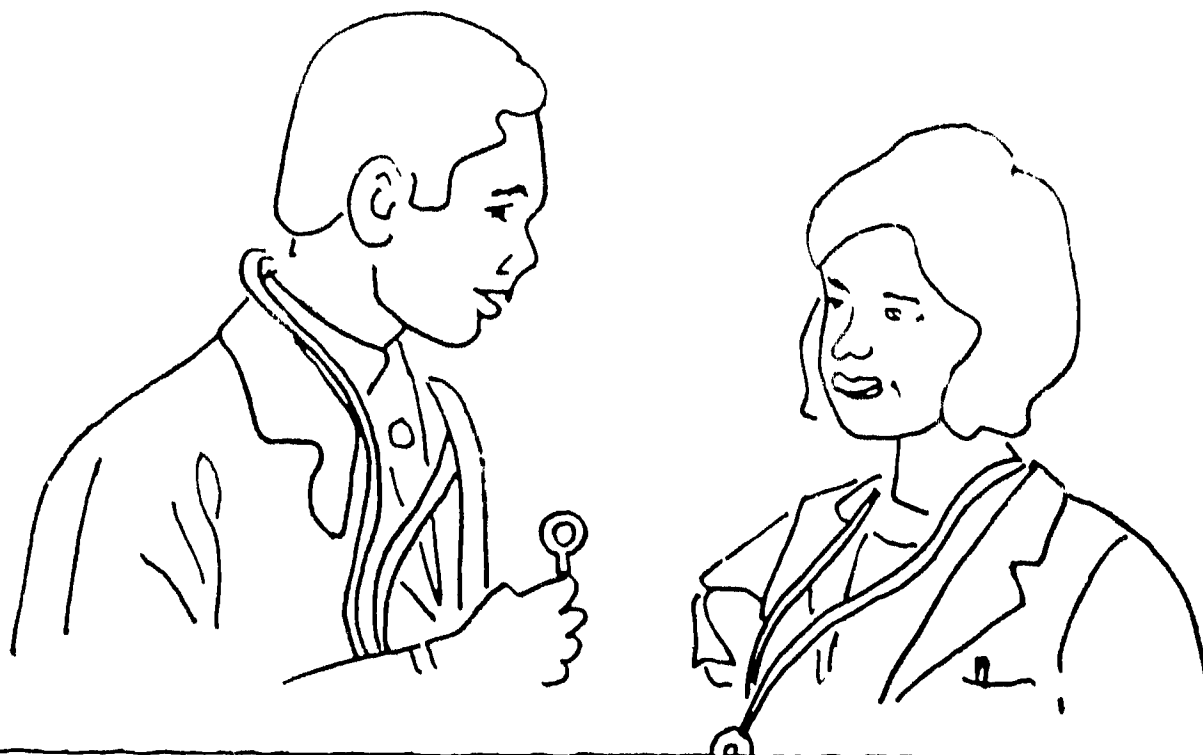

LL

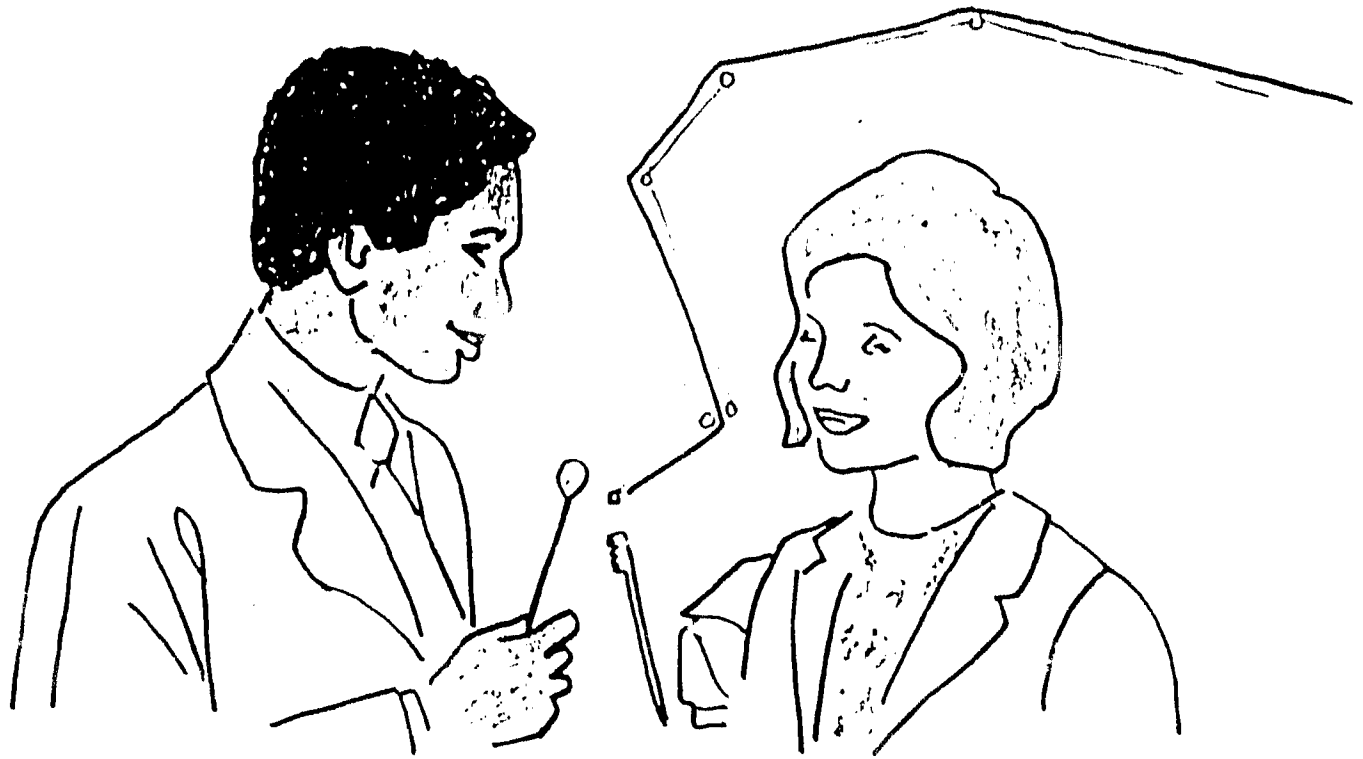

#

Pick a Number

1
Scrapbook

2
Collage

3
Puzzles

4
Dentist
Puzzle

5
Doctor
Puzzle

6
Me,
The Tooth

7
Beauty-
Barber
Shop

8
Measuring
each other

9
Looking
in Mirror

10
Draw
around
a Friend

Name _____

Draw 3 things each worker uses in his daily work

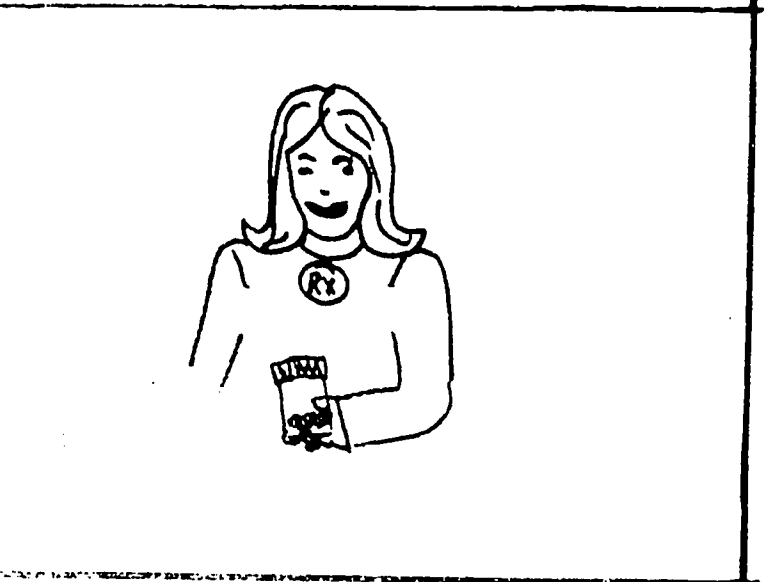
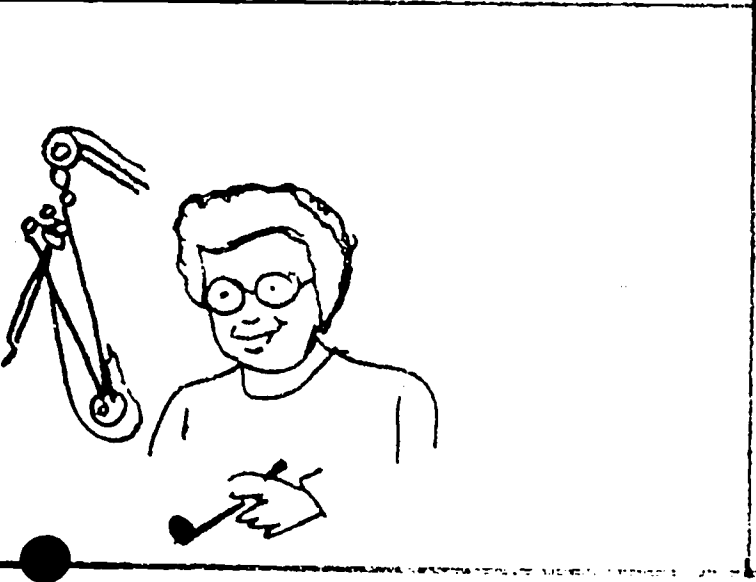
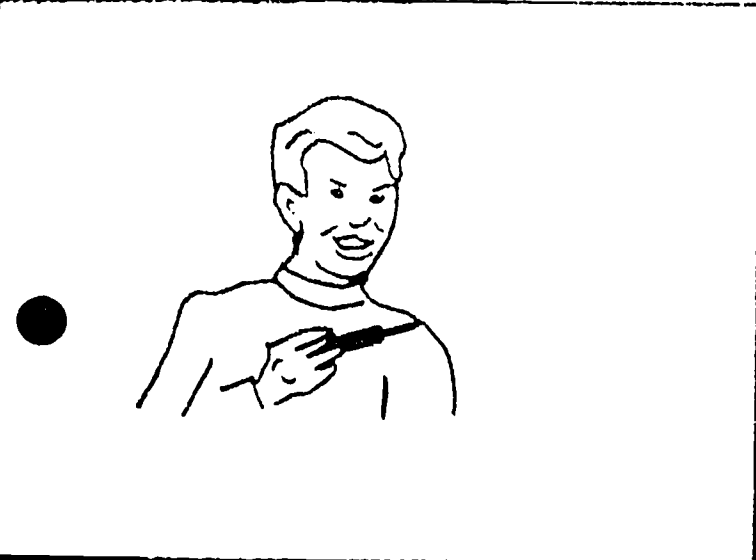

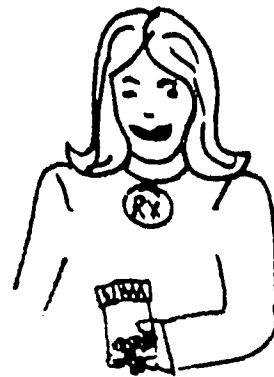
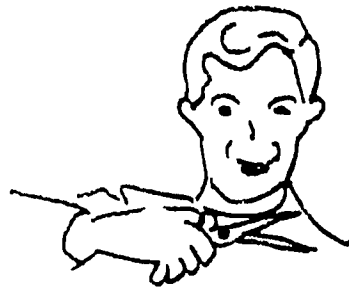
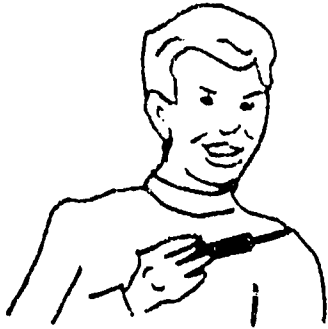

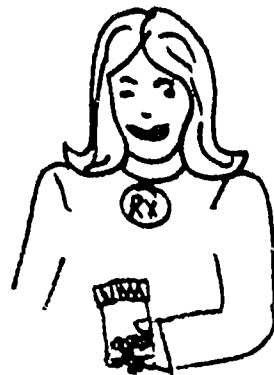
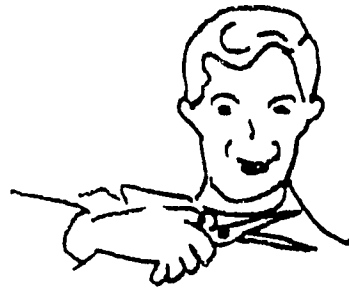
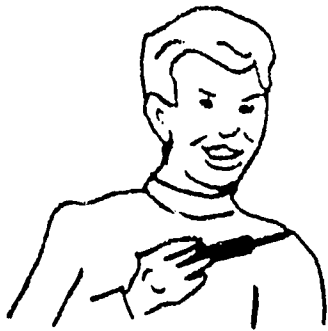

Cut apart - Match to pictures on card B

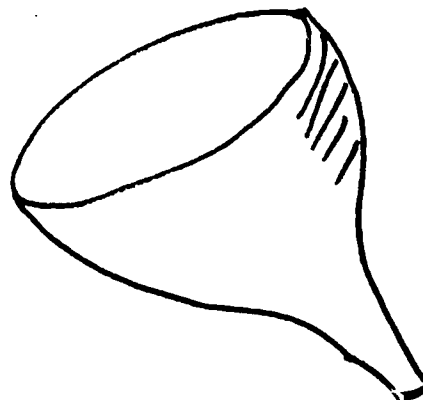
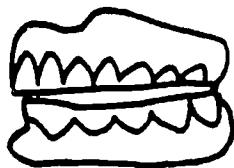
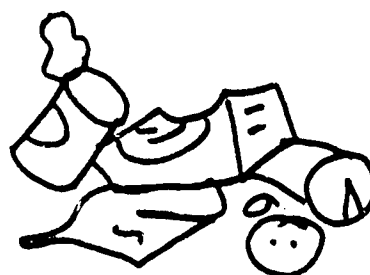
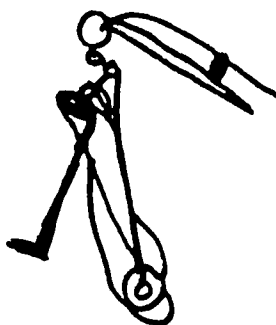
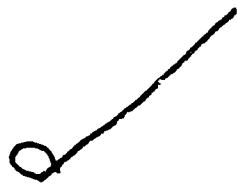

Cut apart - Match to pictures on card B B-3

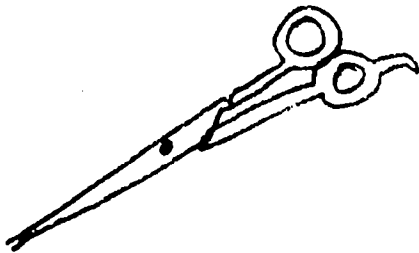
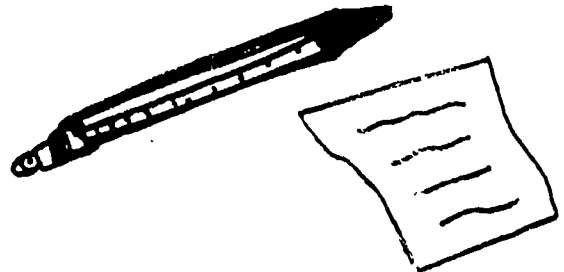
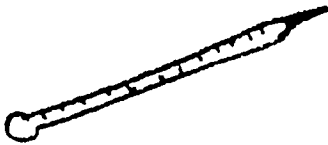

Cut apart - Match to pictures on card B B-3

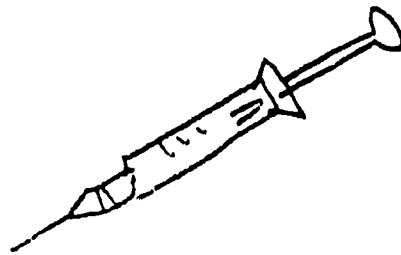
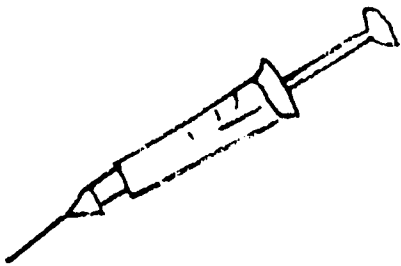
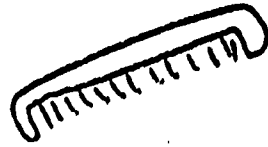

KEY

Did you have at least 3 of each?

B-1 O
B-2 A

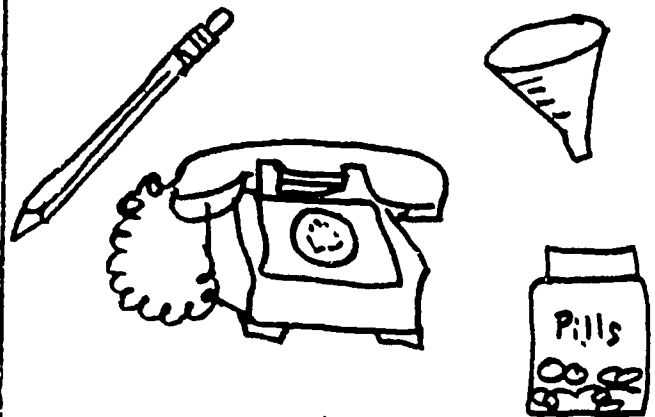
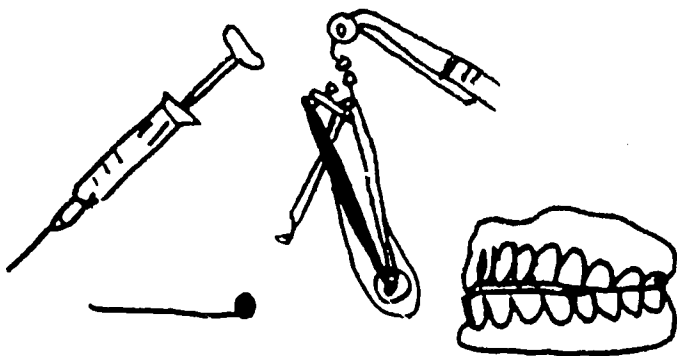
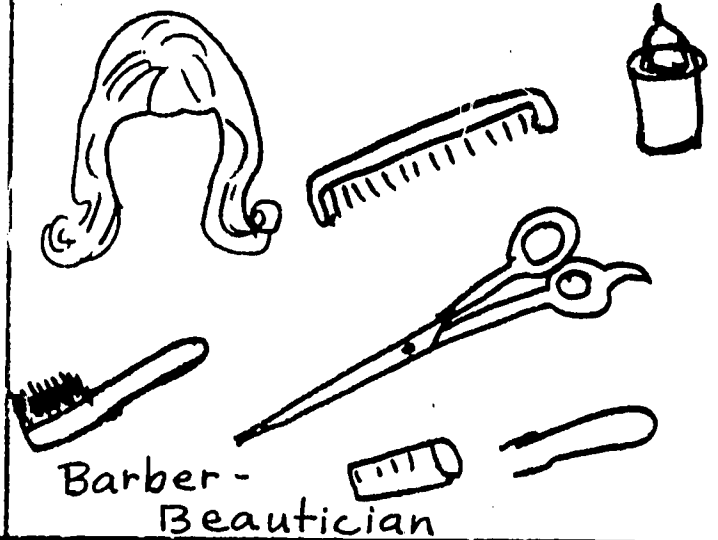
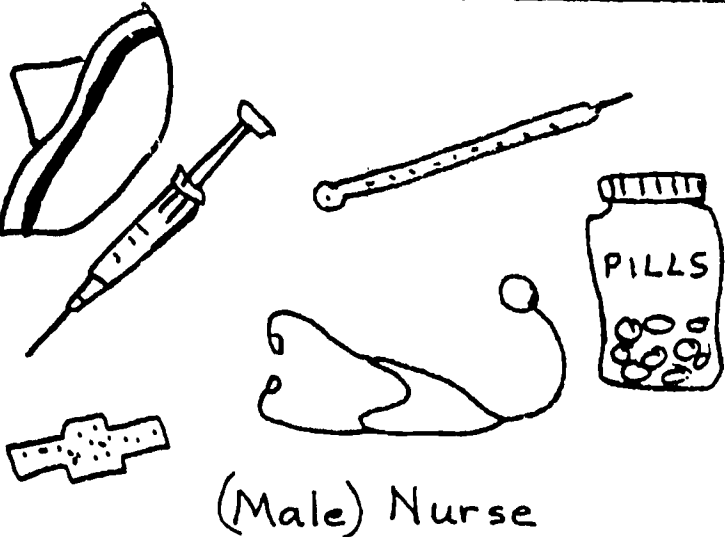
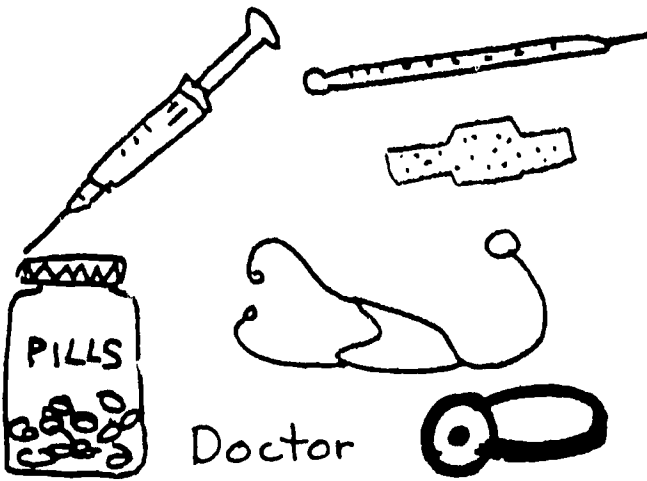

KEY

B-1 0
B-2 Δ

Did you have at least 3 of each?

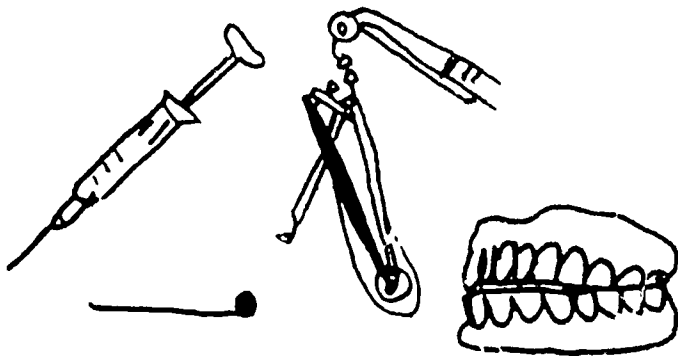
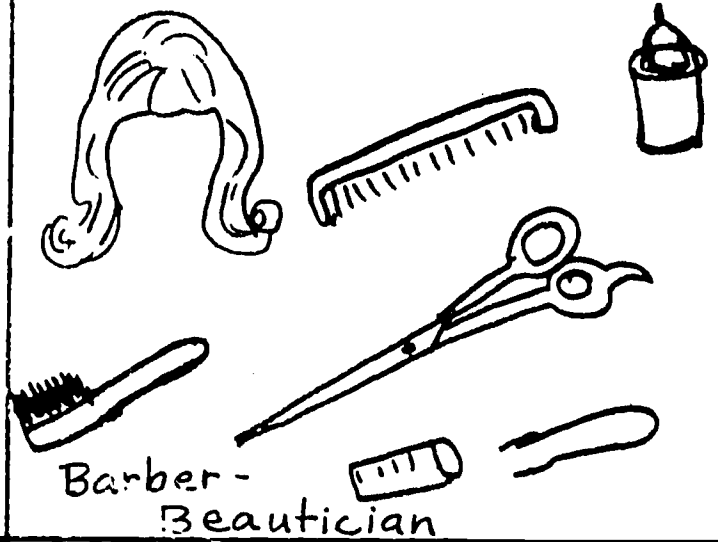
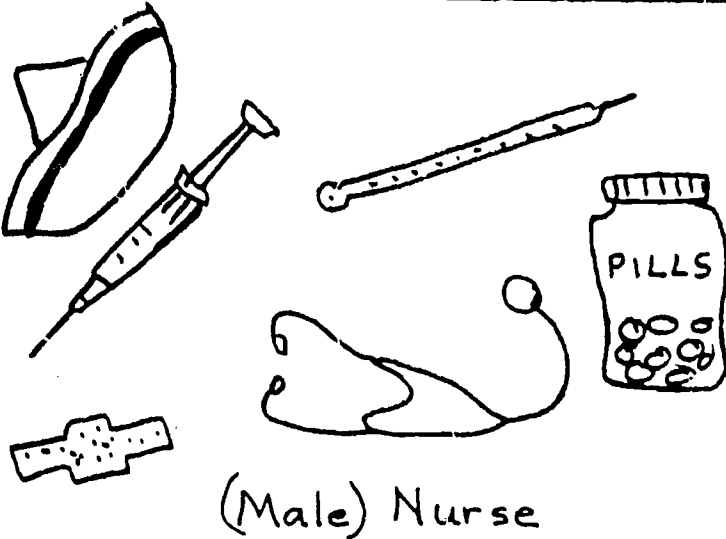
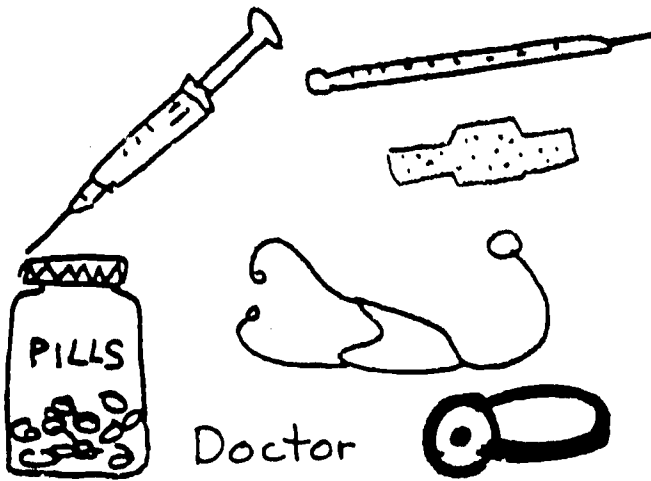

KEY

B-3 □

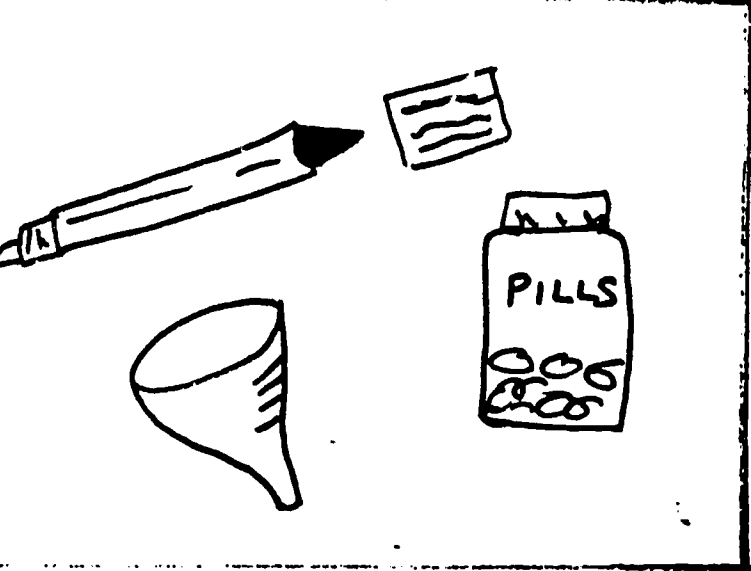
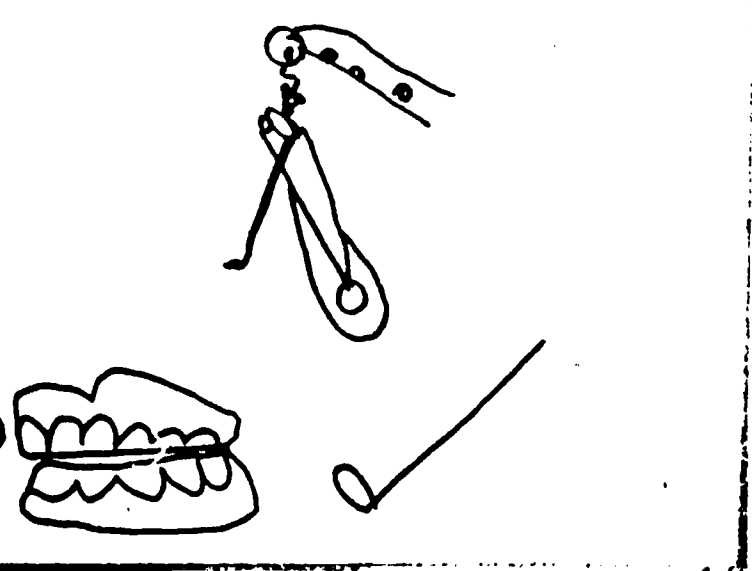
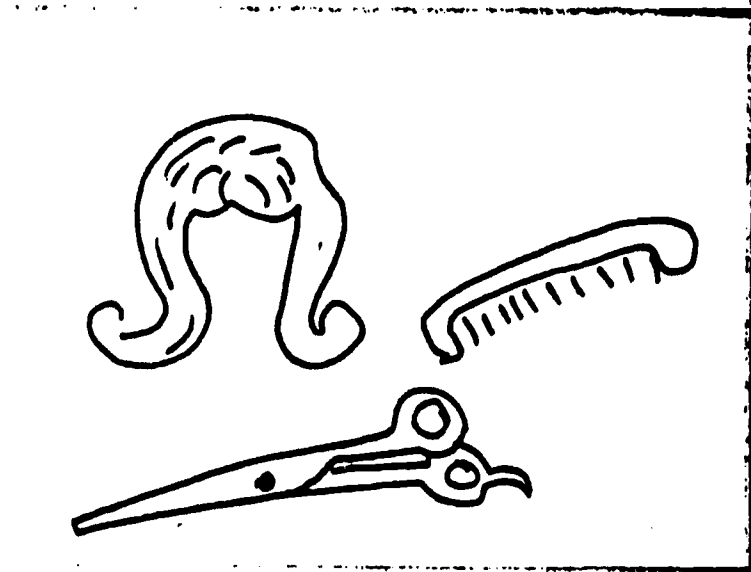
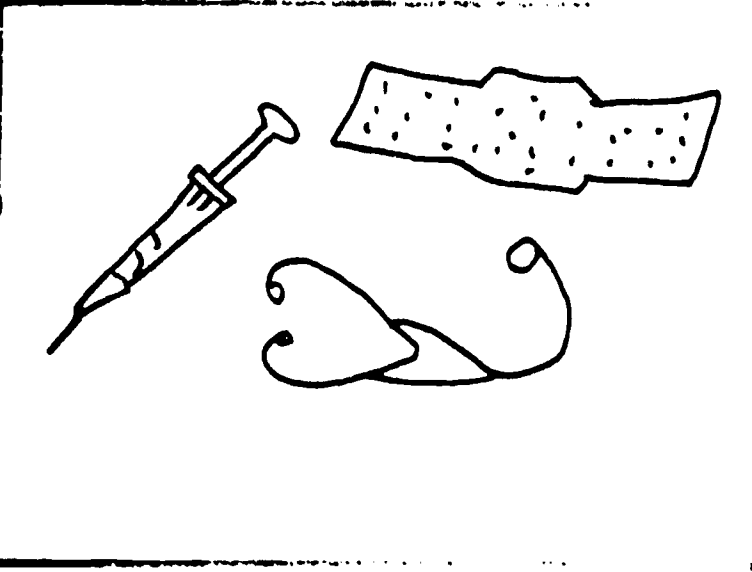
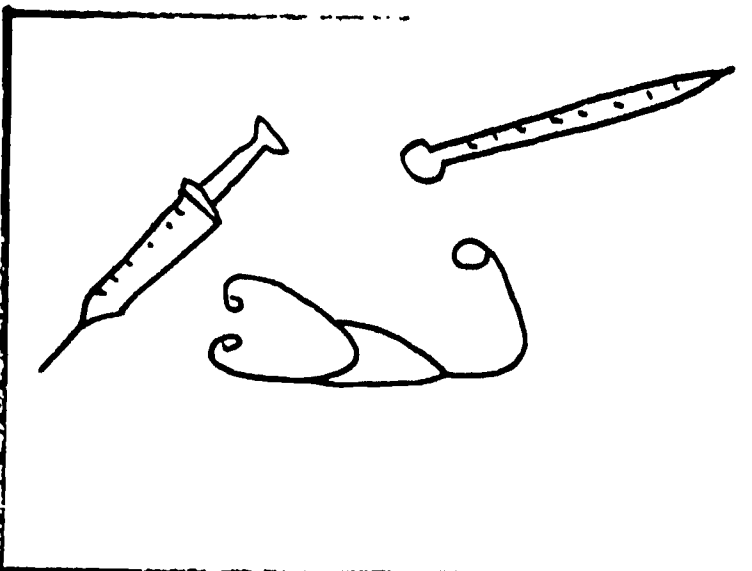

How do you look when you come to school—

HAPPY or SAD?

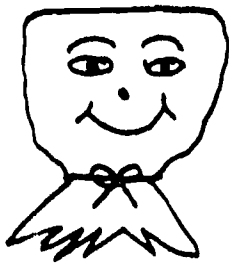

← sacks
stuffed with
newspaper →

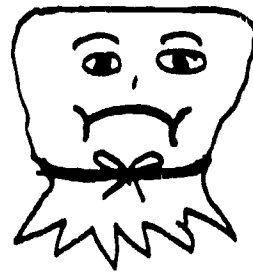

To have a Happy Face, you must get enough sleep.

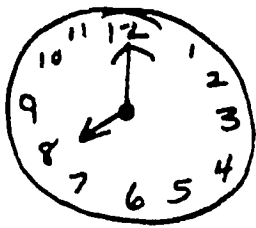

← Paper
plates →

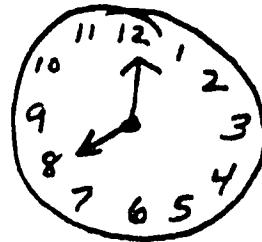

If you get up at this time in the morning.

Go to bed at this time at night.

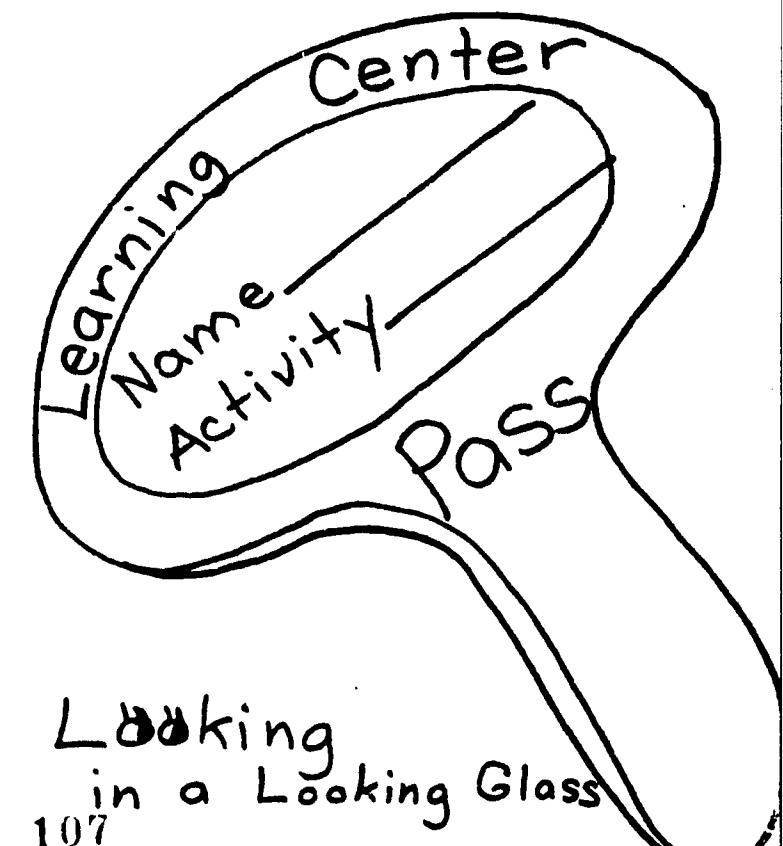
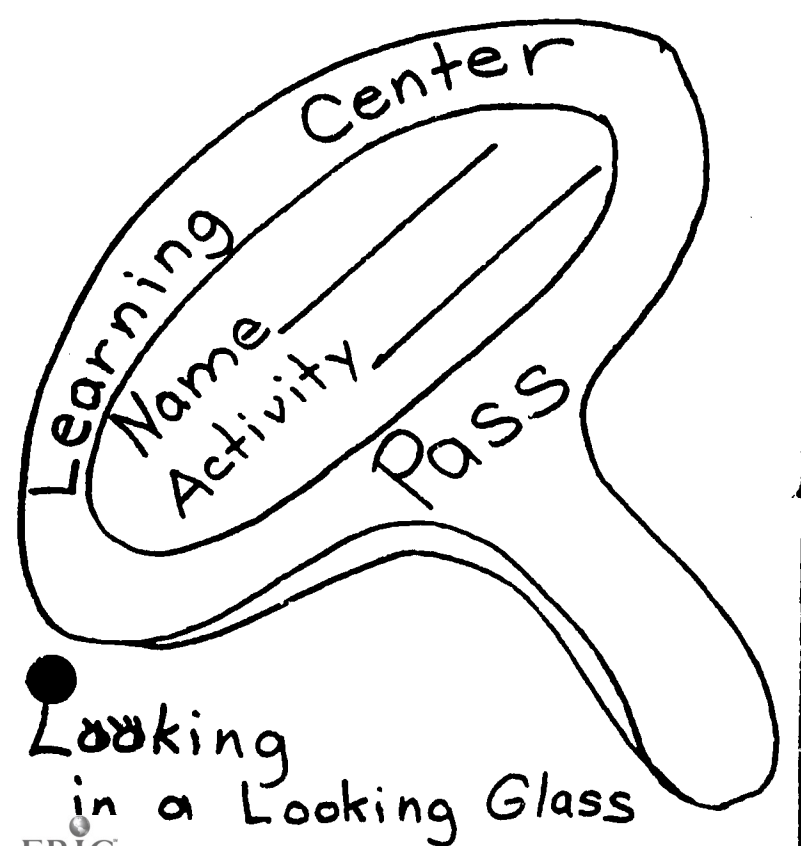
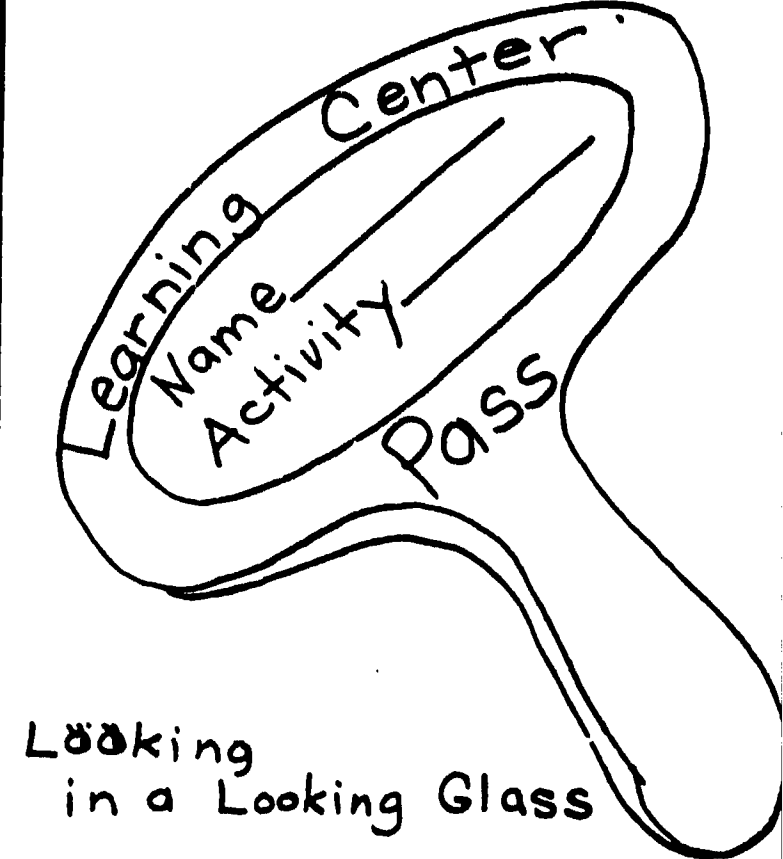
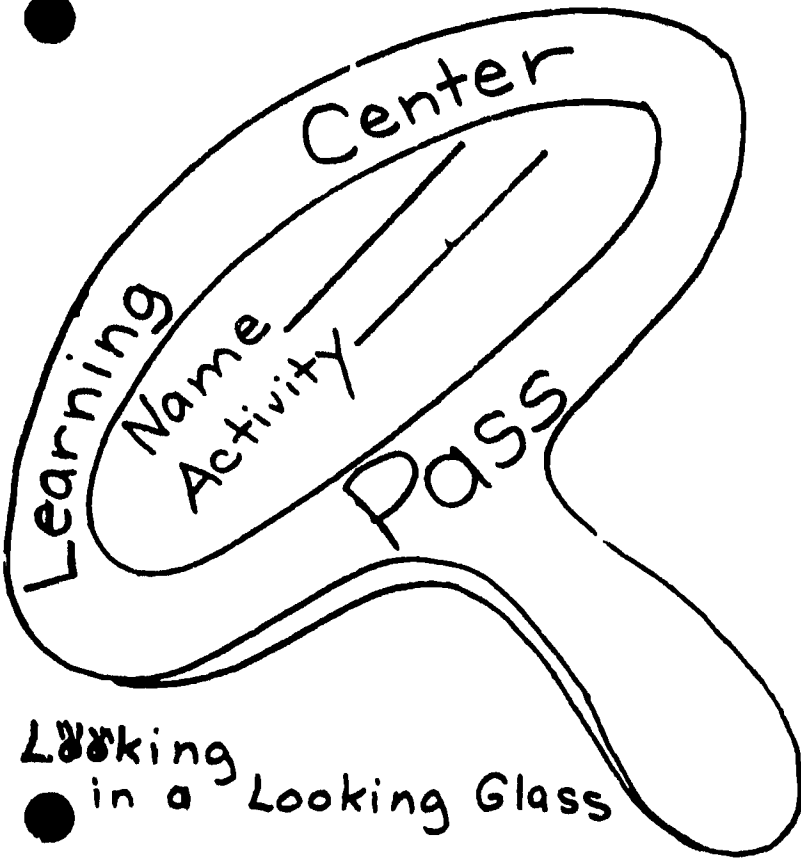

Career Education Learning Center

.TOOLS

2

by LaRae Onstad Elliott
Fall 1975 Lincoln, Nebraska

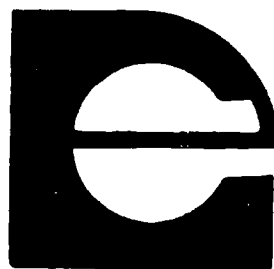

**LINCOLN
CAREER
EDUCATION
PROJECT**



The materials presented in this document were developed under a grant from the Office of Education, U.S. Department of Health, Education, and Welfare. Contractors undertaking such projects under Government sponsorship are encouraged to express freely their professional judgement in the conduct of the project. Points of view or opinions stated do not, therefore, necessarily represent official Office of Education position or policy.

Submitted by
Lincoln Public Schools
John Prasch, Superintendent
Carl Spencer, Project Director

1976

109

Teacher's Plan

SUBJECT AREA: Language Arts

1. CAREER EDUCATION THEMES: Career Awareness
Problem Solving

TEACHER'S OBJECTIVES:

- 2.
1. Expand the concept of tools to include any implement a worker uses to do his job.
 2. Expand the concept that many workers use the same tools.
 3. Students will develop creativity by exercises to substitute the use of one tool for another.

STUDENT OBJECTIVES

(these can be discussed or charted)

1. I will complete one activity from each tool-shaped task card.
2. I will find out about things workers use to do their jobs.
3. I will invent some new tools

PRE-ASSESSMENT

3. Readiness Level -- Students use game card and tools on strings (as described below) to: match the worker to the tool he would most likely use and check it with an answer sheet.

Average Level -- Duplicate sheet labeled Φ . Students draw or write the name of two tools the worker might use. Students need to talk to teachers to justify their answers. For example: An artist might use the saw to make an easel or as a paperweight for his paintings. The clothes pin can be used by a businessman to hold papers together. Any answer the child can explain should be accepted. Creativity and ingenuity are to be encouraged.

Gifted Level -- Duplicate the sheet labeled Φ . Students draw or write the name of two workers who might use the tools.

Note: Students need to talk to teacher to justify their answers.

Teacher Preparation of Pre-Assessment Activities -- Cut out the 10 cards with tools pictured (labeled $\circ\circ$). Punch holes along the side where the holes are marked on the worker card (\circ) and the ten cards with tools on them ($\circ\circ$). Tie strings in the holes of the card and then to the ten cards with tools, leave strings long enough to match across the board. Students match the worker with the tool they would most likely use.

Duplicate sheets Φ and Φ for use by students.

ACTIVITIES

4.

The tasks are on colored tag and each task is on a tool-shaped card. The tool-shaped cards should be cut out and displayed so the students can read them. The tasks are based on different levels of ability. The students are free to choose the activity they are interested in and feel they are capable of doing. The students should complete one activity from each tool-shaped task card --eg, there are four trowel shaped task cards, but the students just choose one.

Preparation:

1. It would be helpful to have parents visit the classroom and bring some of the tools of their trade. One purpose of the center is to expand the concept of tool. A comb is a tool if their mother is a beautician. Try to get away from the concept that tools are only objects found in a carpenter's tool chest.
2. Brainstorm the week before setting up the center. Teacher and students can collect an assortment of tools and put them in a box. A Student selects a tool and brainstorms with the class: "How workers might use this." Accept any answer the student can explain. Example: spoon/stir food; dig hole to plant; to prop open a window; to mix paint; to pry lid off a can; as a paperweight; push tacks into soft wood; to help get shoes on; and so on. Paperclip/to hold papers; to hang papers; to hang lightweight clothes; to make jewelry to make ornaments; to punch holes in soil of small planter; to open letters; and so on.

*Creativity:
Brain
STRETCHERS*

3. Put up two large sheets of newsprint, and let the children work on them by themselves. Discuss the papers later. 3

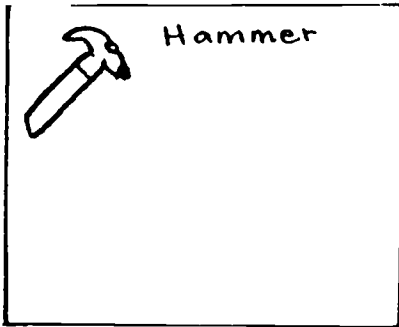

Label / What Workers Might Use The Hammer?

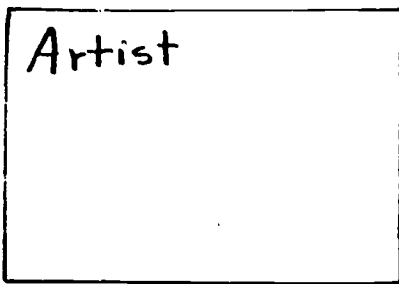



Label / What Tool Might the Artist Use?

4. It might be difficult to find vocabulary words for tools in their dictionaries; therefore, you might send two sheets of paper home and ask the students to trace around two tools their parents use. Cut the tool shapes out. Label the shape with the tool name and what worker uses it. Make a bulletin board of these tool shapes. For vocabulary building and for aid in spelling activities.
5. The teacher needs to collect an assortment of actual tools and/or catalogs such as: Wards, Penny's, Ardans, or magazines such as: Farmers' Almanac, Popular Science, Popular Mechanics, Better Homes and Gardens, Newspapers for tools pictured in ads.

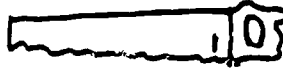

Procedure:

1. Best working conditions are for a maximum of six students to be in the center at one time.
2. Display all cards at one time on a portable chart or a bulletin board.
3. Students freely choose a task card; this free choice avoids labeling tasks as slow, average or gifted. Students will usually choose one they are able to do. Teaming gifted students with those having trouble will help the center un smoothly.



4. Saw Cards have art activities

Task	SAW CARD	MATERIALS
collage	 ALL LEVELS	magazines, background paper
mobile	 ALL LEVELS	wire, branch, paper for form, string, magazines, drawing paper
invent a new tool	 ALL LEVELS	boxes, cans, paper cups, odds-and-ends paper, writing paper, tape recorder

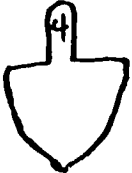

5. Trowel cards require booklet or chart.
Prepare broom handle and cup hooks as described below.

TASK	TROWEL CARD	MATERIALS
Chart of a tool and different workers who might use it.	 ALL LEVELS	Chart paper, drawing paper, magazines
ABC tool booklet	 ALL LEVELS	paper for booklets; (kids like to make their own shape booklet) might make dictionaries
Tool Riddle Book	 AVERAGE GIFTED	paper for booklets; (let the kids decide where to put the answers -- Might want to make a shape booklet
Problem solving	 AVERAGE GIFTED	Prepare the broom by screwing the cup hooks in the broom handle. Cut out dustpan shape cards (%); punch holes to hang dust pans from cup hooks; place prepared broom in center. Pro- vide paper for booklet.

6. Ax Cards - More detailed research

TASK	AX CARDS	MATERIALS
Label tool parts	 READINESS	Chart paper, magazines drawing paper
Facts about a tool	 AVERAGE GIFTED	Chart paper or writing paper, magazines, drawing paper
Research facts about a tool	 GIFTED	Chart paper or writing paper, magazines

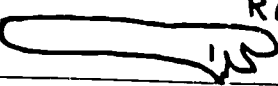
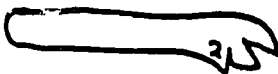
7. Wrench Cards - worksheets and game

TASK	WRENCH CARDS	MATERIALS
Tool and use	 READINESS	Duplicate worksheet 1 (labeled •)
Compare tools to simple machines	 AVERAGE GIFTED	Duplicate worksheet 2 (labeled •)
Answer questions based on teacher objectives	 AVERAGE GIFTED	40 question cards cut apart on sheets labeled •



Wrench Card #3. Tool Card Game.

Play with two or more players. Place 40 question cards like a deck of cards face down on the table. First player draws a card. Player answers the question and explains his answer. Since most questions have many possibilities for answers, they need to be justified. If players can't answer, they put card on bottom of deck and they wait until next turn to draw again. If they answer satisfactorily, they keep the card. Object is to have the most cards at game's end.

5.

RECORD KEEPING

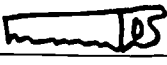
The finished activity is the record form*. Students sign their names in "students" column. When they finish a task they mark the number of the task card under the tool shape on the evaluation form. They could indicate their feelings about the task with a word or drawing.

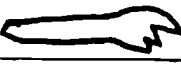
Name				
Ken	3	4 ☉	2	3

The sheets marked † can be used as patterns to make ABC Tool booklet and the riddle booklet in shape of a tool. Make booklets with construction paper covers and lined or plain paper inside.

6.

EVALUATION

Student Evaluation

1. Conference with the teacher
2. Draw happy or sad faces and drop into a center evaluation box
3. Use the record keeping form and respond with a word or picture as they check completion.

TEACHER EVALUATION

1. Did the students at least start an activity?
2. Do they need more time?
3. Did it hold their interest?
4. Did they stay at the center?
5. Should I extend the activity?

ADDITIONAL ACTIVITIES

1. Choose 8 - 10 tool words and count the syllables.
2. Choose 8 - 10 tool words and alphabetize them.
3. Write creative stories about a worker and his tools.

4. Write a play about a worker and his tools.
5. Many basic lessons can be written on tools.
6. Challenge them to learn to spell the names of 15 tools
7. This center can lead into a science center on simple machines and tools.

MATERIALS IN THIS PACKET

1. 13 tool shaped task cards * to be cut out
2. Saw and wrench patterns † for riddle or alphabet books
3. 2 worksheets to be duplicated for wrench task cards 1 and 2
4. 40 question cards to be cut apart for wrench task card 3.
5. 14 dustpan shape cards% to be cut out for trowel task card 4
6. Pre-assessment c, cc, φ, Φ
7. Check sheet for pre-assessment c is ⊙
8. Record keeping *



cook

barber

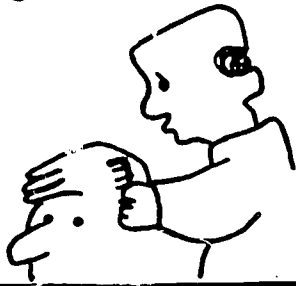

nurse

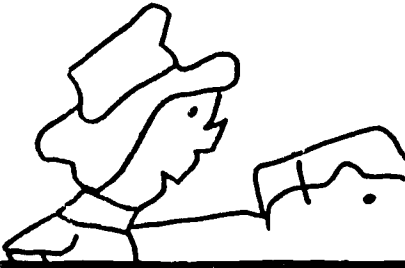

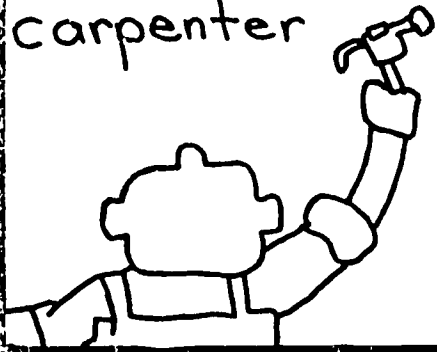

carpenter



seamstress

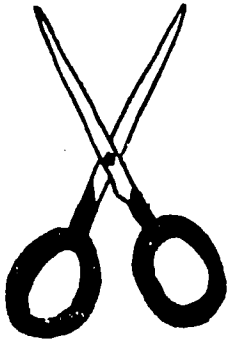

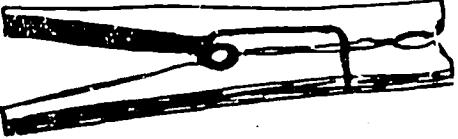
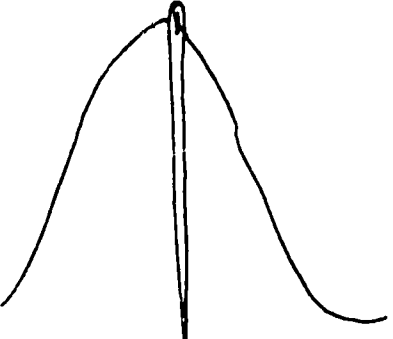

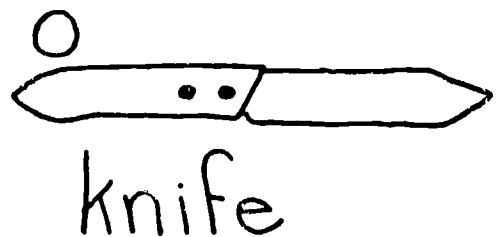
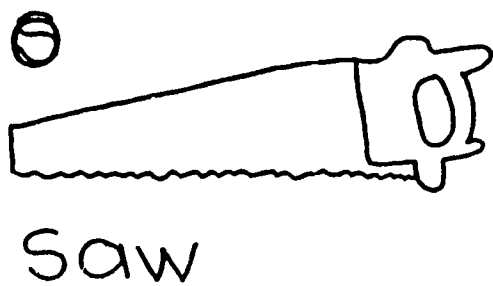
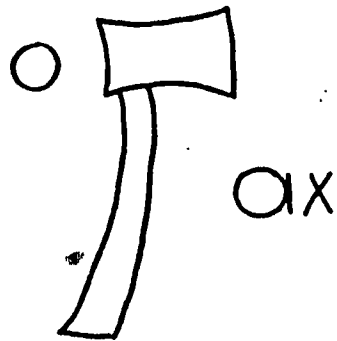
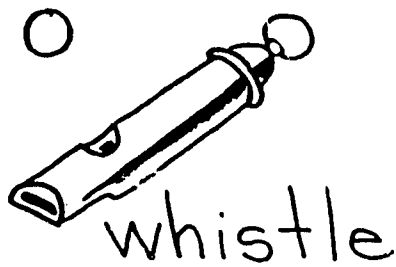
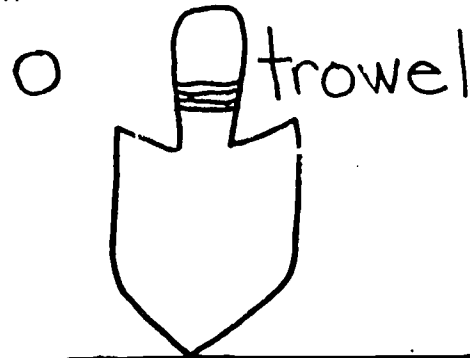
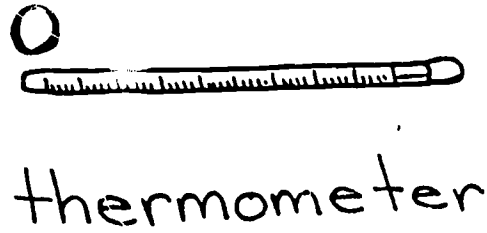
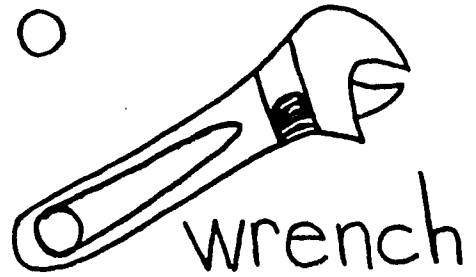
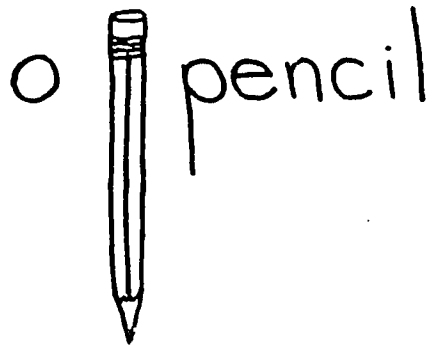

secretary

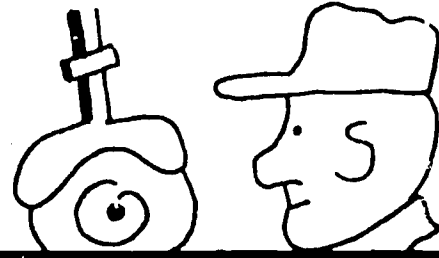

doctor



farmer



gardner

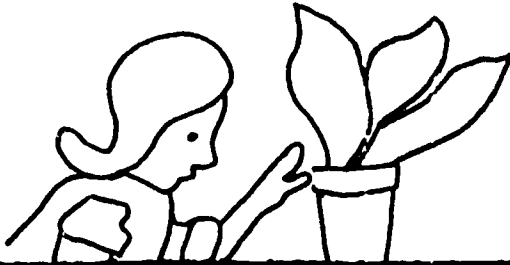

seamstress



policeman



fireman



carpenter

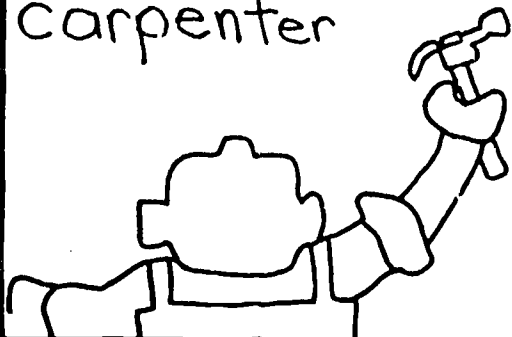

cook



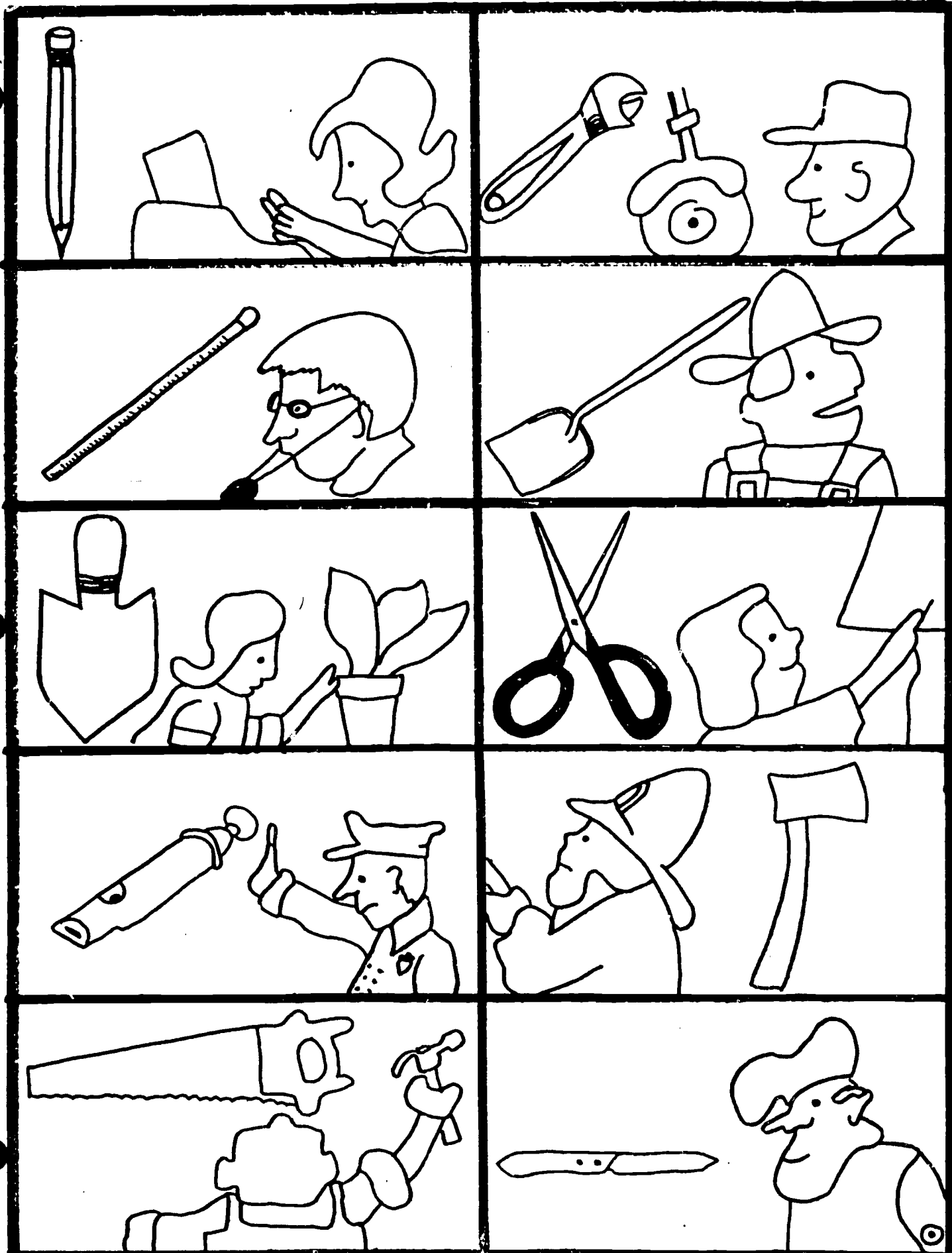

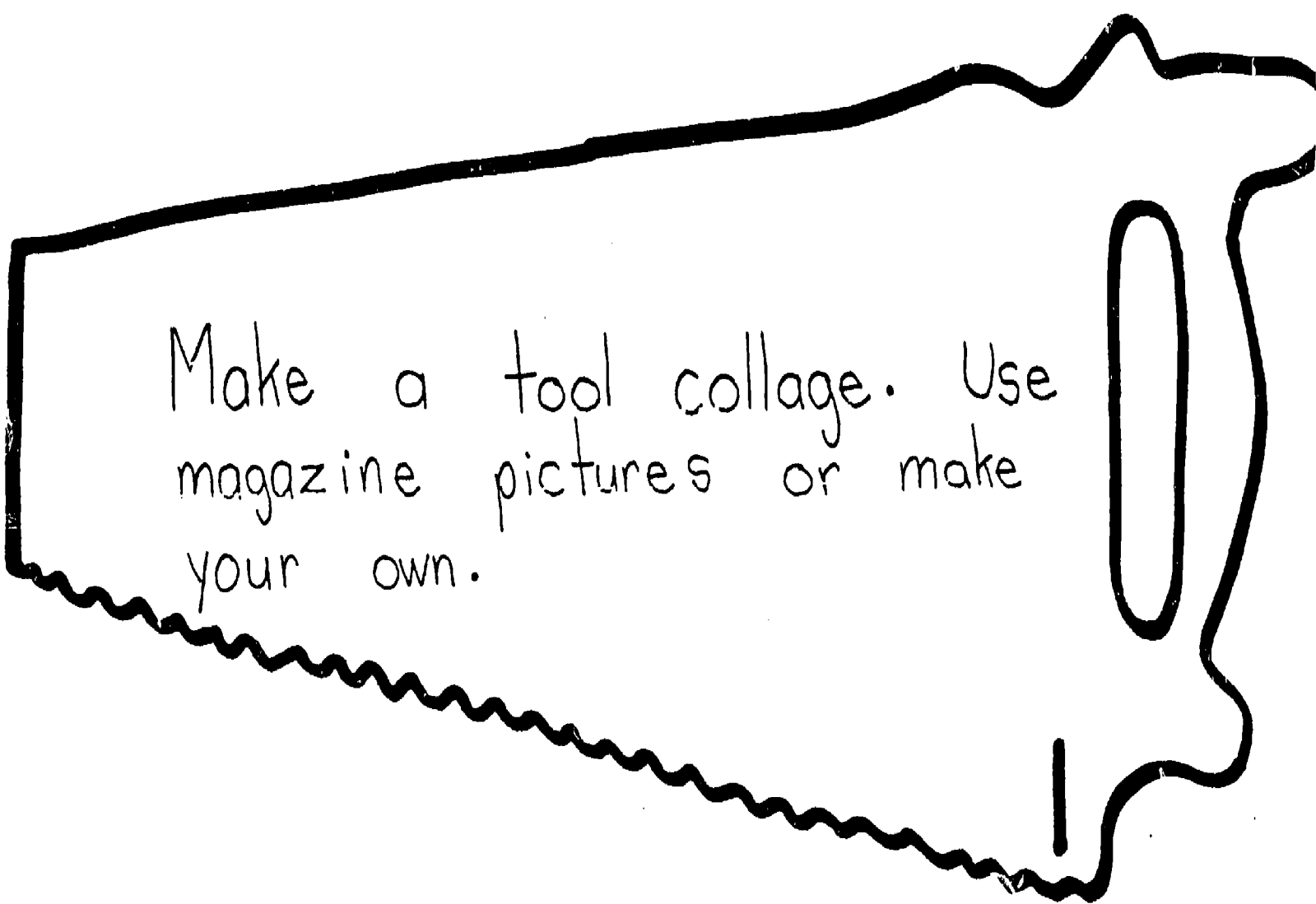

Make a tool collage. Use magazine pictures or make your own.

#

Pick a worker. Make a mobile of the worker and his tools.

2

#

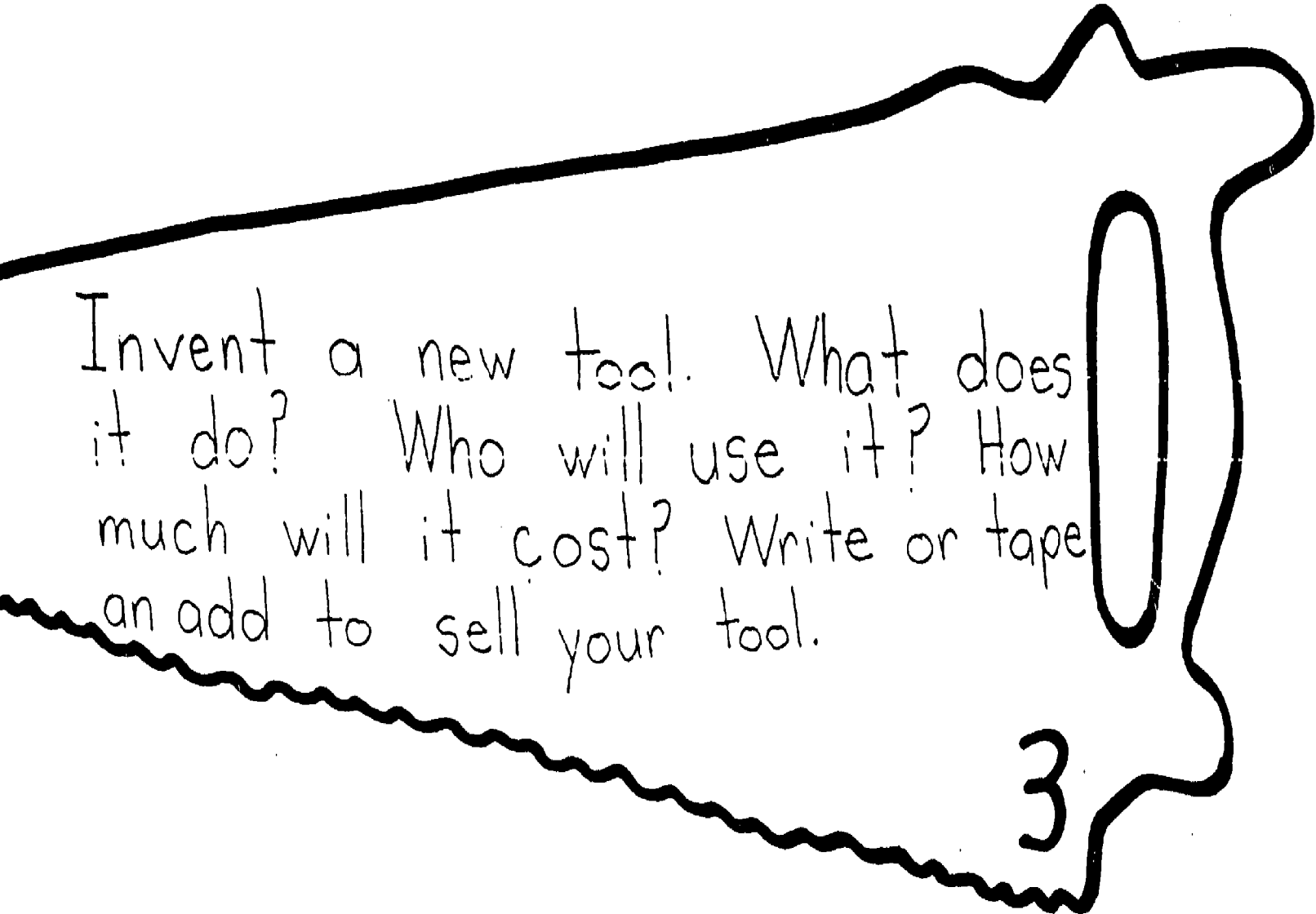

Invent a new tool. What does it do? Who will use it? How much will it cost? Write or tape an add to sell your tool.

3

#

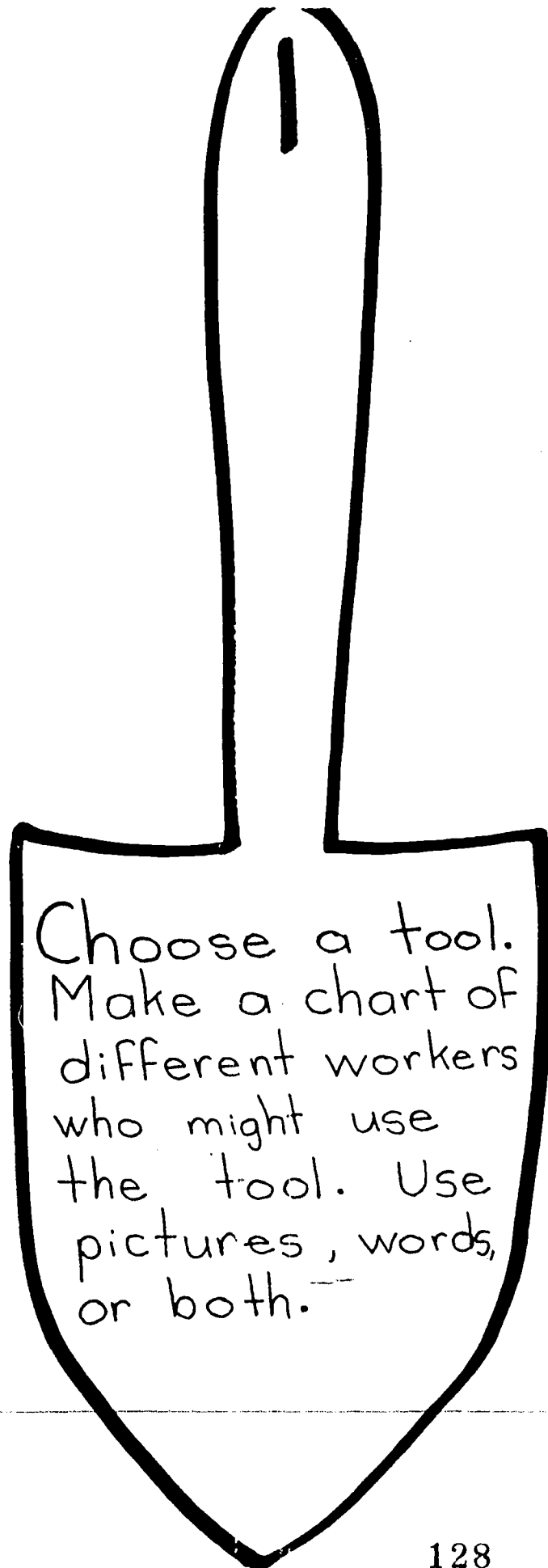

Choose a tool.
Make a chart of
different workers
who might use
the tool. Use
pictures, words,
or both.

#

2

Make an
ABC tool
booklet.

#

3

Make a tool
riddle booklet.

#

4

Select four
problems from
the hooks.
Make a
problem solving
booklet.



90

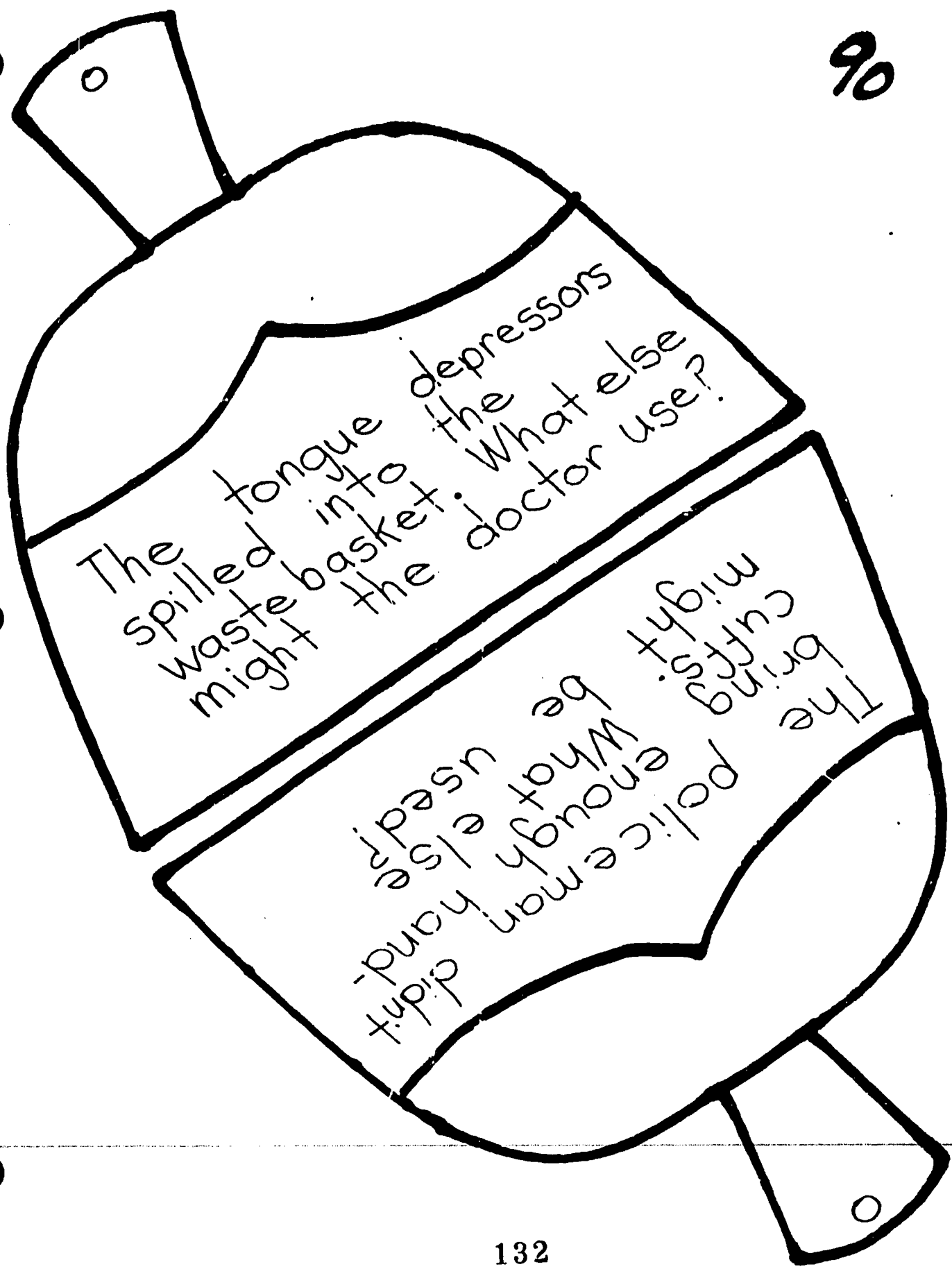

90



The farmer's spade
is broken. What
else can be used?

The artist forgot
at the home. What
brushes might be used?

90

The secretary can't
find a paperclip.
What else can be used?

The construction
worker lost the
hammer. What
can be used?

90

All the spoons
are dirty. What
else can the
cook use?

The
flyswatter
has a hole in
it. What else
might a librarian
use?

90

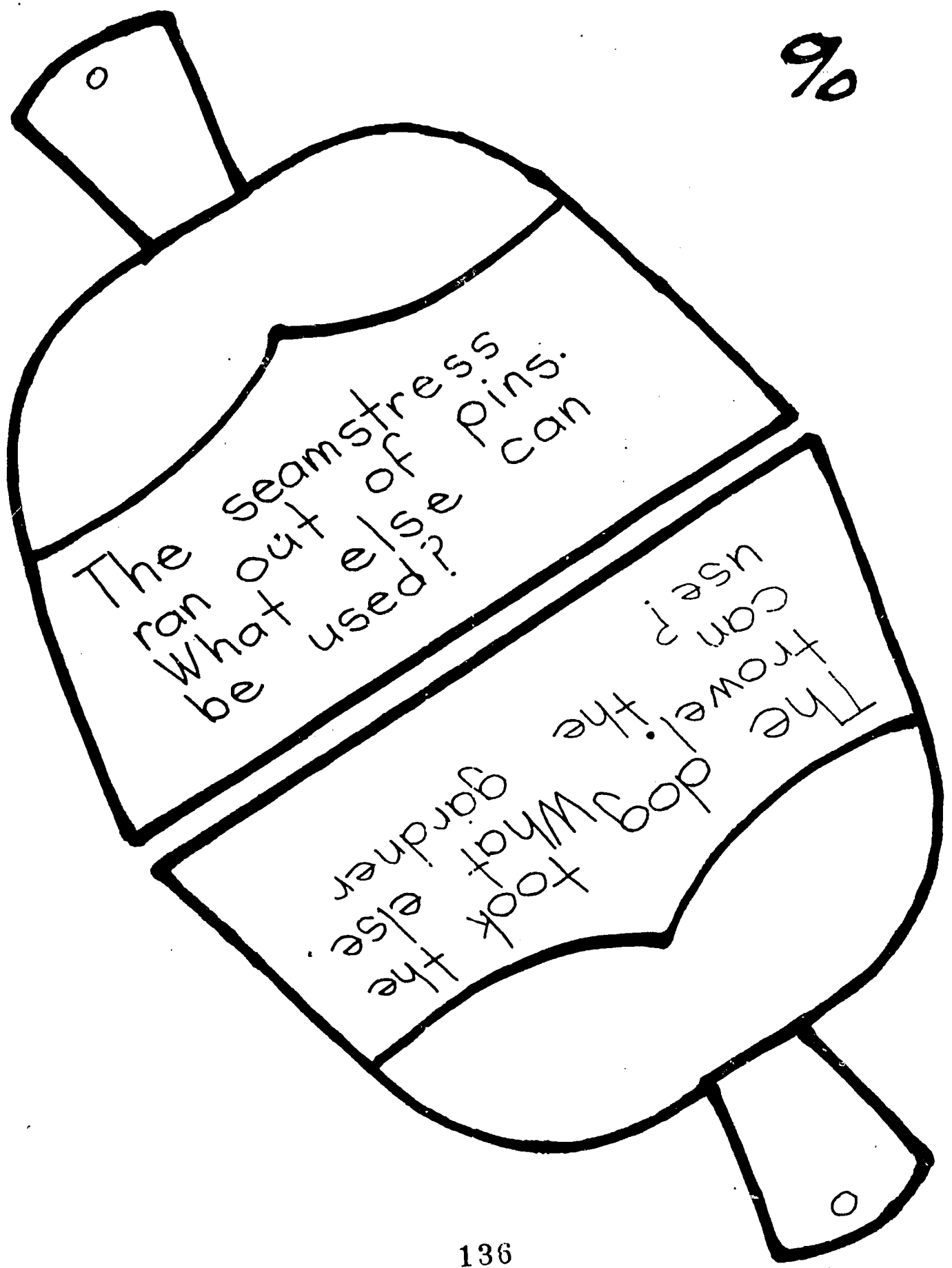

The seamstress
ran out of pins.
What else can
be used?

The dog took
the trowel. the
gardener. the
can use?

90



%



The teacher can't
find a pencil. What
else can be used?

The dentist!
What else can they
use?

The scissors are
missing. What are
they used for?

%



The teacher can't
find a pencil. What
else can be used?

The scissors are
missing. What
else can the
dentist use?

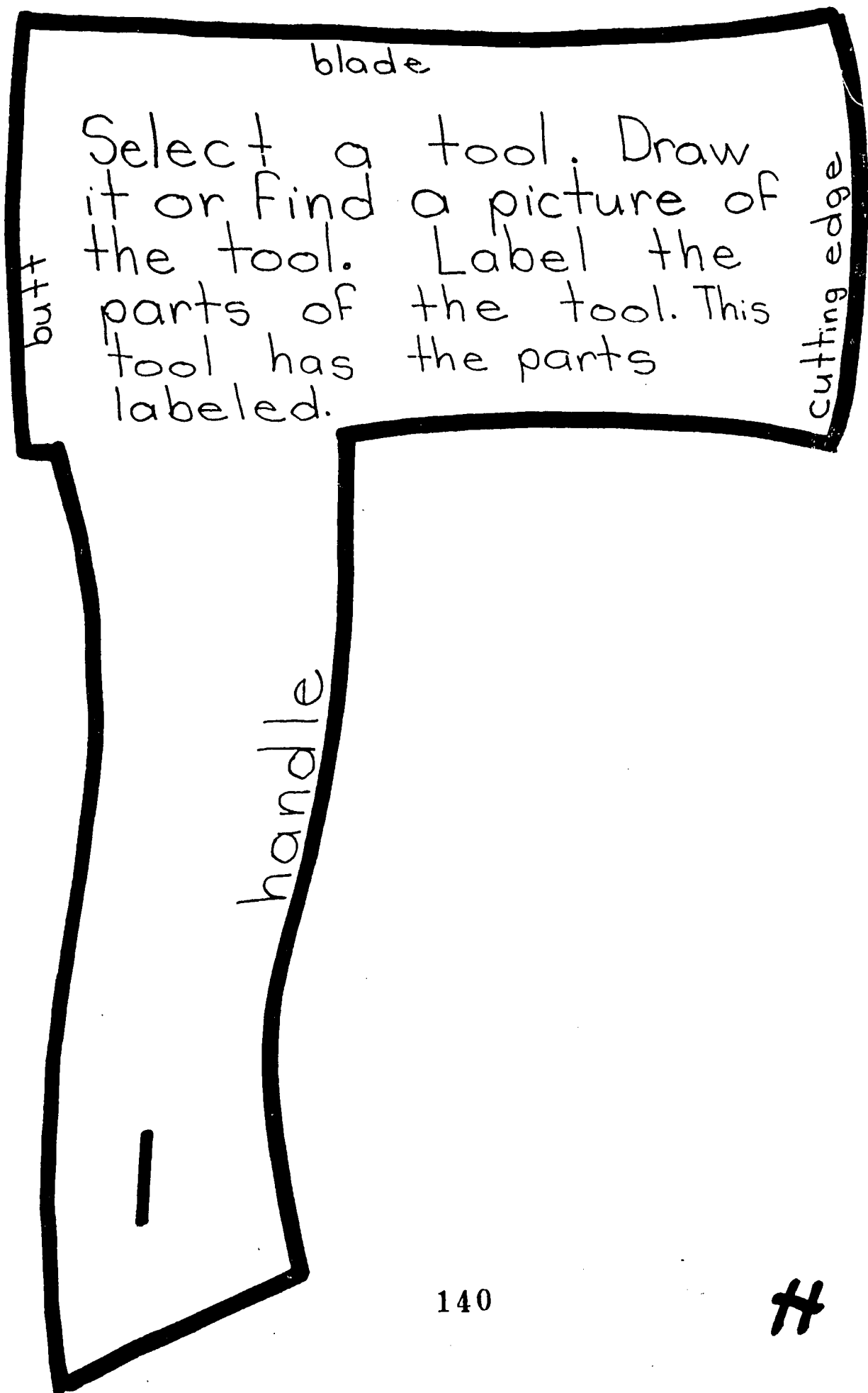

Select a tool. Draw it or find a picture of the tool. Label the parts of the tool. This tool has the parts labeled.



Choose a tool.

Write seven facts
about it.

2

#

Select a tool and do some research.

- Where can you buy it?
- What does it do?
- How much does it cost?
- Does it come in different styles, colors or models?
- Does it have a guarantee?

3

Complete worksheet number 1

#

Do worksheet number 2

2

#

#

Play the tool card game

3

#

TOOLS

Tool Name

Picture

Use

Tool Name	Picture	Use

Tools and Machines

2

A hammer pounds. What machines pound?
Use pictures, words or both.

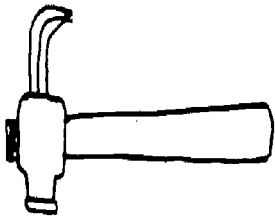

hammer = pounds



screwdriver = turns



knife = cuts or slices

What is sawdust?

What could you use in place of a spade?

What is a guarantee?

What could you use in place of a screwdriver?

What is a handle?

What could you use in place of a clothespin?

Why is a toolbox handy?

What could you use in place of a paint brush?

What is a tool?

What could you use in place of a rolling pin?

Name three tools
a forest ranger
might use.

Tell two facts
about a knife.

Name two tools
a doctor might
use.

Tell two facts
about a comb.

Name two tools
a mechanic
might use.

Tell two facts
about a ruler.

Name three tools
a teacher might
use.

Tell two facts
about a pencil.

Name three tools
a librarian
might use.

Tell two facts
about a nail
file.

Name three tools
a cook might
use.

Tell two facts
about scissors.

Name two tools
an artist might
use.

Tell two facts
about a paint-
brush.

Name two tools
a secretary
might use.

Tell two facts
about a needle.

Name three tools
a carpenter might
use.

Tell two facts
about a screw-
driver.

Name two tools
a gardner might
use.

Tell two facts
about a hammer.

Name three tools
a cook might
use.

Tell two facts
about scissors.

Name two tools
an artist might
use.

Tell two facts
about a paint-
brush.

Name two tools
a secretary
might use.

Tell two facts
about a needle.

Name three tools
a carpenter might
use.

Tell two facts
about a screw-
driver.

Name two tools
a gardner might
use.

Tell two facts
about a hammer.

What could you use in place of a hammer?

One use of a drill is —

What could you use in place of scissors?

State one way scissors and saws are alike.

What could you use in place of a rake?

State one way a hammer and a spade are alike.

What could you use in place of a spatula?

State one way a wrench and a screwdriver are alike.

What could you use in place of a shoe horn?

State one way a knife and a spoon are alike.

Name





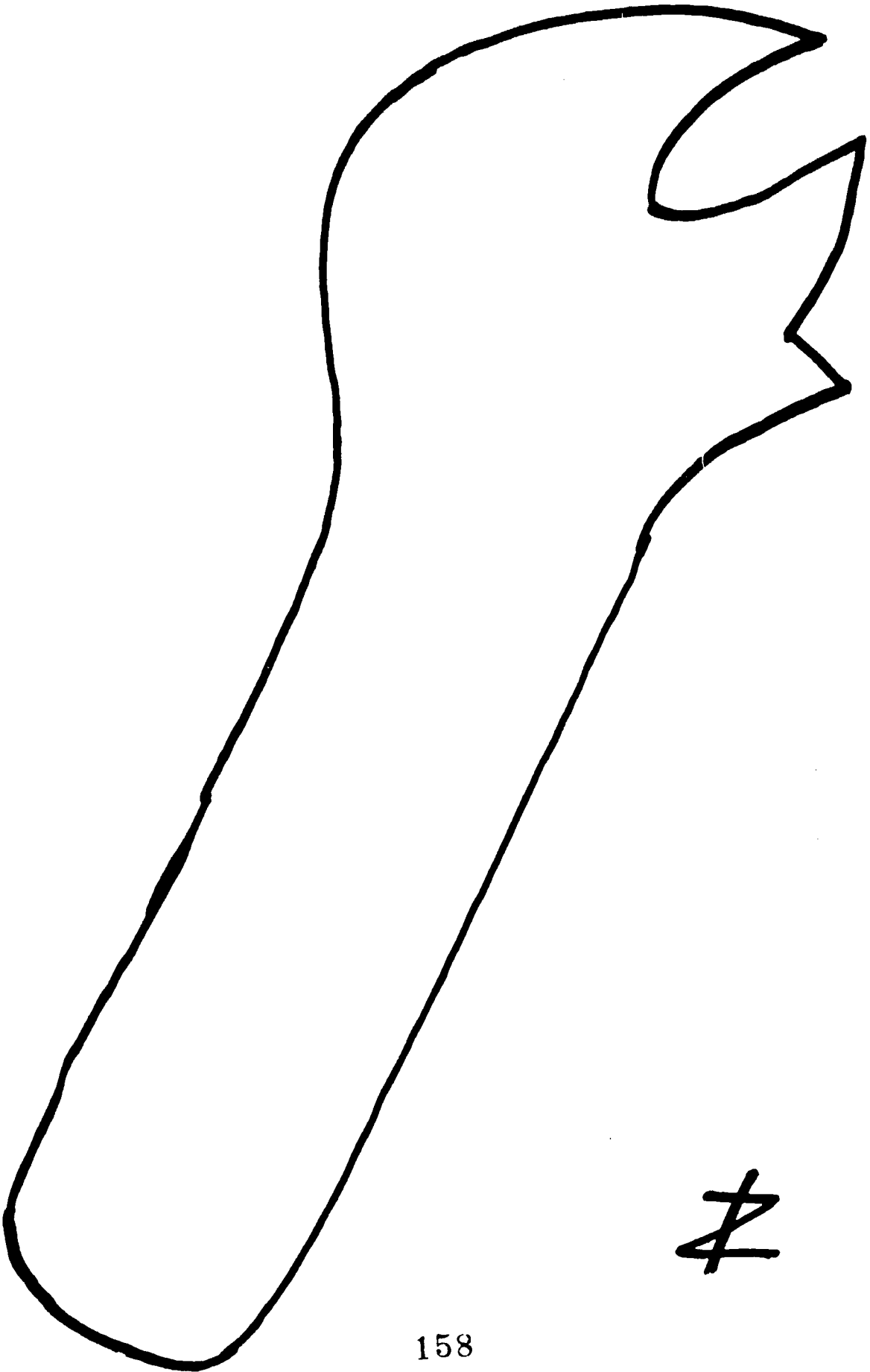

✱

#

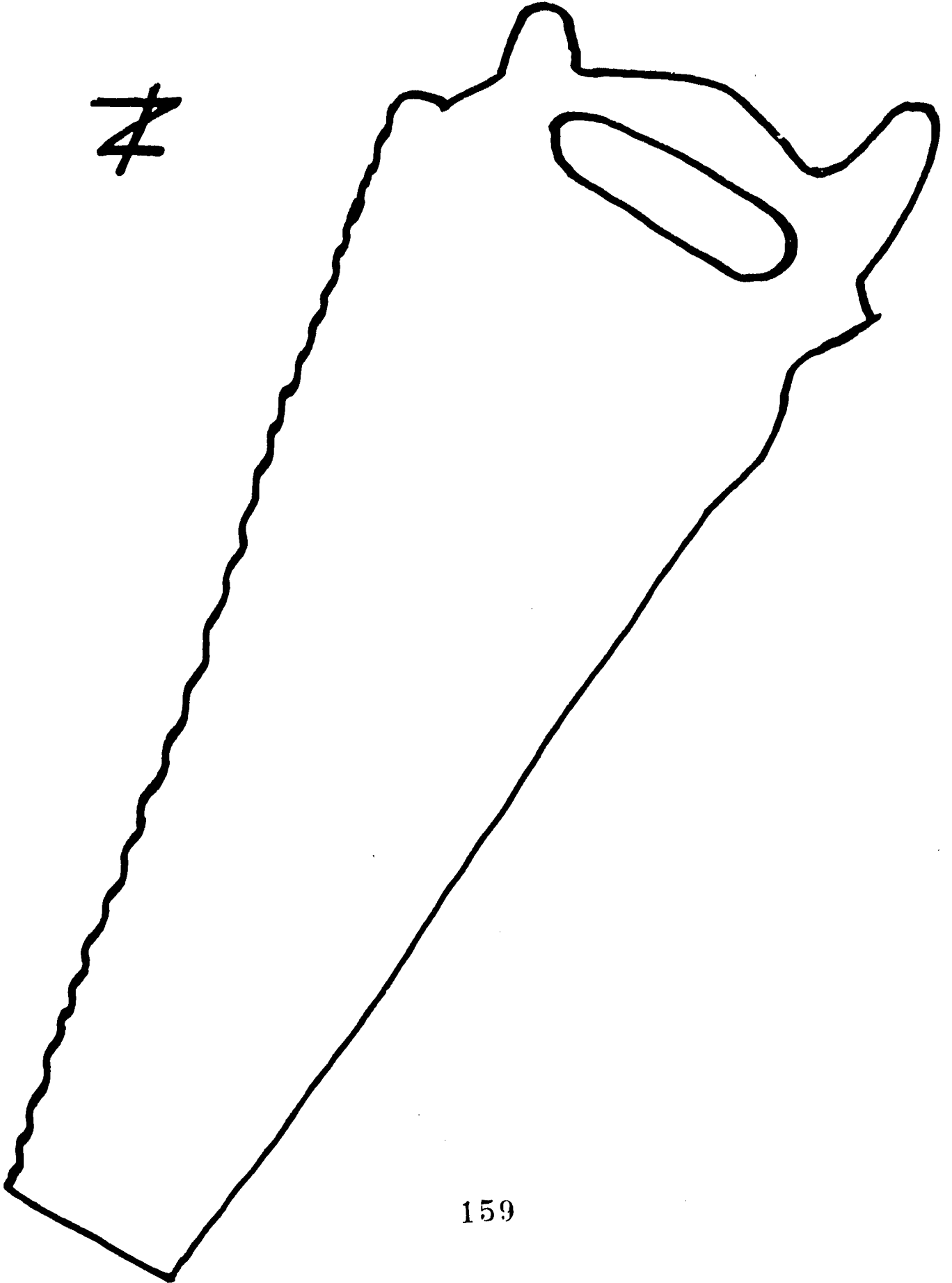

Career Education Learning Center

FEELINGS:

Mine and Others

2

by LaBee Onstad Hilliard School

Fall 1975 Lincoln, Nebraska

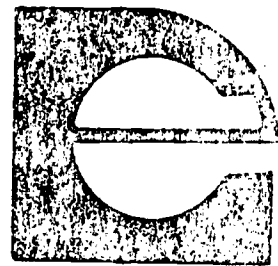

LINCOLN
CAREER
EDUCATION
PROJECT

The materials presented in this document were developed under a grant from the Office of Education, U.S. Department of Health, Education, and Welfare. Contractors undertaking such projects under Government sponsorship are encouraged to express freely their professional judgement in the conduct of the project. Points of view or opinions stated do not, therefore, necessarily represent official Office of Education position or policy.

Submitted by
Lincoln Public Schools
John Prasch, Superintendent
Carl Spencer, Project Director

1976

Date

To

From

Subject FERRINGS: Mine and Others Career Ed. Learning Center

Media needed: 6 colorful plastic helmets (i.e. hard hats) available at Treasure City. Remove labels at front and use magic marker to make faces of the three emotions shown in packet of materials--2 helmets with happy, 2 sad, 2 angry.

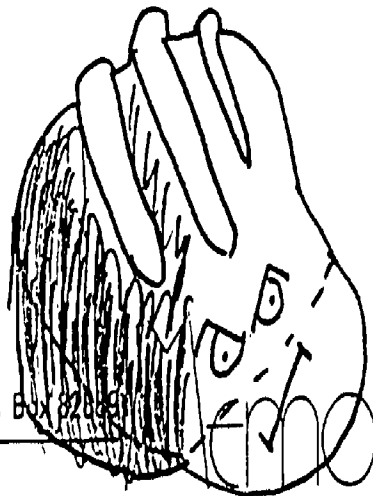

Lincoln Public Schools Box 820431

Lincoln, Nebraska 68501

Learning Center
Career Education **2**
FEELINGS--MINE AND OTHERS

TEACHER'S PLAN

1. **SUBJECT AREA:** Language Arts

CAREER EDUCATION THEMES: Career Awareness
Personal and Social Development
Values Clarification

TEACHER'S OBJECTIVES:

2.

Students will be able to relate reasons for their feelings toward a selected career.

Students will understand own feelings and why they feel certain emotions.

Students will understand that others have feelings too; they will feel empathy for workers and their feelings.

STUDENT'S OBJECTIVES

(These can be displayed at the center on a chart, etc.)

I WILL UNDERSTAND MY FEELINGS AND WHAT MAKES ME HAPPY, SAD, ANGRY.

I WILL UNDERSTAND MY FEELINGS TOWARD WORKERS.

I WILL UNDERSTAND HOW WORKERS MAY FEEL.

3. **PRE-ASSESSMENT**

Using copies of page 3 marked **+** students respond with why they might feel the emotion pictured when they come in contact with the worker named and pictured.

Reading level--students may respond orally.

Average level--students respond with a written statement or a picture.

Gifted level--using copies of page 3 marked **o** students respond with a written statement or a picture explaining two different feelings about one occupation.

ACTIVITIES:

4.

The activity instructions to students are on colored tag and each activity is printed inside the shape of a worker's hat. These hats should be cut out and displayed so that students may read, decide which one(s) they are capable of doing and then choose one to do. This free choice provides for the levels of ability without marking the cards or telling children to do a certain one. Children will choose one they are able to do.

Set One activities are marked \neq and Set Two are marked ϕ

Teachers should follow this One -- Two sequence in order to build from own feelings to feelings of others.

IT IS IMPORTANT TO REMEMBER THAT THE TWO SETS OF ACTIVITY CARDS ARE NOT USED ON THE SAME DAY. Most teachers will want to have Set One cards out for several days before exchanging them for Set Two.

PREPARING THE CLASS: It is often helpful to discuss the activities before the students go to the center. A quick brainstorming session will save explanation time later on. Instructions for brainstorming before each set are detailed below. Teaming more capable students with those having trouble will help the center run more smoothly and aid children in gaining independence. Introduction page \neq is displayed in center to help direct students.

PROCEDURE: (For both sets of activities)

*See Introduction Page marked \neq



1. The center will accommodate six students at a time.
2. Each child chooses a hat to wear while doing the activities; he/she uses the emotion shown by the face on the hat *for all the activities done while wearing that hat.
3. The career cards* (on pink tag with name and a picture of an occupation) should be cut apart. These are spread out face up allowing students to choose one with which they are familiar. A blind choice might result in frustration if they could not relate to the occupation drawn.
4. Students freely choose a hat-shaped activity card--freely chosen so it is something they can do. Options on the task cards allow for levels of ability; example: "tape or write..."
5. Students write and draw responses in prepared booklet (directions follow) or in another manner described in directions.
6. Before leaving the center, each student records which activity he/she completed using the record form #5, marked to match Set One \neq or Set Two ϕ and explained below.

SET ONE ✖ :

Prepare booklet for  task card:



1. Cut out the six faces printed on white tag, use a razor blade to cut out features and hair line.
2. Fold colored construction paper in half for a booklet cover.
3. With magic marker, trace through the stencils making several copies of all three emotions and of both boys and girls faces.
4. Place the face drawing so there is room to print the following above or below it:

I feel (angry, happy, sad) when
I see a _____.





The child is to fill in the blank with the name of the worker he draws from the career cards. The emotion the teacher prints will match the face shown on the booklet.

5. Inside the cover, place some unlined paper for picture drawing. The booklet may be stapled, tied or use brass fasteners. (Optional: lined paper can be included for stories, poems or plays)

Brainstorming with the class for readiness:





Hold up a prepared booklet; read from the cover: Example: I feel (happy) when I see a (truck driver). Encourage the children to respond why this might be. A few suggestions from the teacher may be needed to start, such as: ...He drives a big truck ...he travels a lot ...he gets to be outside.

Set One activities:

OBJECTIVE	TASK CARDS	MATERIALS NEEDED
for students to express feelings about specific occupations	Work hat (readiness)  maid hat (all levels)  fireman helmet (all levels)  football helmet (gifted) 	Prepared booklets Writing paper Tape recorder Art materials for puppets and flannel boards 20 career cards (*) 4 hat-shaped task cards ✖ 6 hats with emotion faces Record sheet ✖

SET TWO ϕ :

Brainstorming with the class for readiness: Hold up the picture of the teacher or the plumber (●). Example: Why might the plumber feel mad? ...he got seven bills in the mail ...his clothes are wet ...he has a headache ...he didn't get any breakfast ...his pants are too tight.

OBJECTIVE	TASK CARDS	MATERIALS NEEDED
for each student to build empathy for workers and their feelings	<p>hard hat (all levels) </p> <p>nurse hat (all levels) </p> <p>uniformed worker's hat (i.e., police, custodian, mail carrier...) (all levels) </p> <p>artist hat (gifted) </p>	<p>Construction paper</p> <p>Paper for murals</p> <p>Writing paper</p> <p>Tape recorder</p> <p>20 Career cards (*)</p> <p>4 hat-shaped task cards ϕ</p> <p>6 hats with emotion faces</p> <p>Record sheet ϕ</p>

RECORD KEEPING:

5. The finished activity is one record.

Copy the record forms (#5, #4, ϕ), have student sign their names in "students" column. When they complete a task card, they are instructed to mark under the hat-shape matching the task they chose. Markings may be a simple \checkmark or \times or perhaps they could express how they felt about doing the activity by a facial expression.....



EVALUATION:

6. Self Check: This center is based on personal experiences and feelings. Therefore there are no wrong or right answers to be checked.

Student evaluation:

1. conference with teacher
2. draw happy or sad faces dropped into a center evaluation box
3. use the record keeping form (#5) and respond with happy or sad face as they check completion.

Teacher evaluation:

1. Did the students at least start an activity?
2. Do they need more time?
3. Did it hold their interest?
4. Did they stay at the center?
5. Should I extend the activity?
6. What changes could I make?

ADDITIONAL ACTIVITIES:

1. Students choose a career card and write about or illustrate how they would feel before seeing the worker and after seeing the worker.
2. Students select a hat to wear and a career card. Then they put themselves in the place of the worker's hat or shoes and write about why the hat or shoes feels the emotion represented on their hat. Example: "I am a pair of rancher's boots. I'm mad because I'm all muddy."
3. Students draw from three containers. One container has careers, one has emotions, and one word cards of odds and ends items. Examples of odds and ends items: key, flat tire, ice cube, ant, rubber band, jack, sack, and so on. This time there are not choices of careers or emotions. After drawing from each container, the student will write a story using the information drawn. If the student draws nurse, happy, and tack; he will write a story about a tack and why the nurse is happy.
4. The teacher or a student is a reporter. A set number of students act out different careers and emotions as the others watch. The reporter interviews the workers to determine their careers and the reasons for their feelings.

MATERIALS INCLUDED IN THIS PACKET

1. Introduction + to be placed at the center
2. 4 Set One Task Cards H to be cut out
3. 4 Set Two Task Cards O to be cut out
4. 5 sheets of Career Cards X to be cut apart
5. Two brainstorming pictures ● use is optional
6. Pre-assessment † and %
7. Record Keeping X and O
8. 6 Tagboard faces to be used as stencils
9. 6 plastic hats with emotion faces.
10. Complete teacher directions (5 pages)

banker



librarian

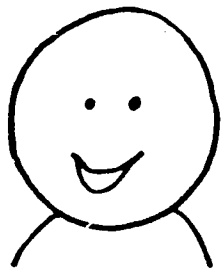

carpenter

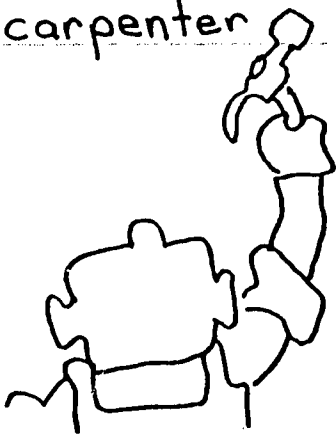

Waitress



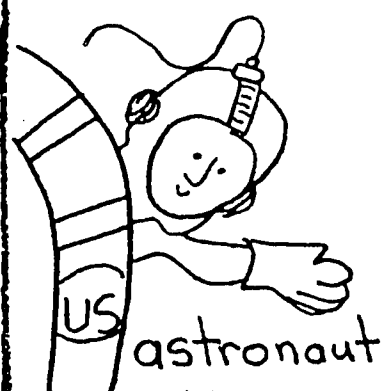

astronaut

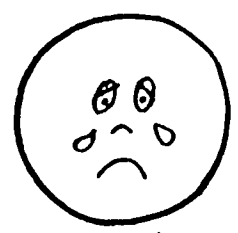
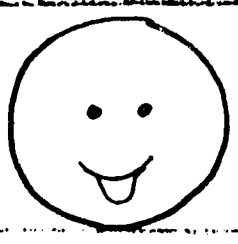

baker

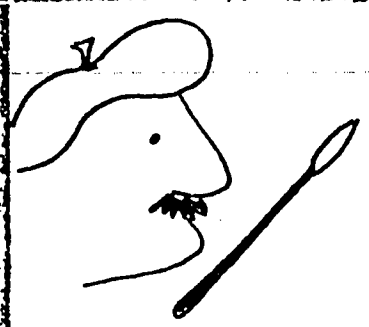
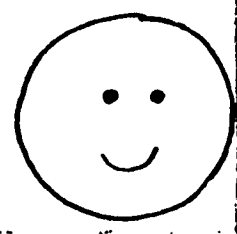

artist

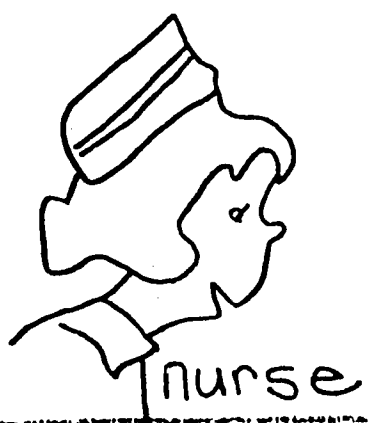
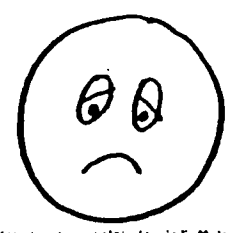

nurse

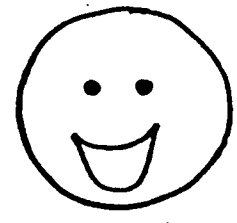

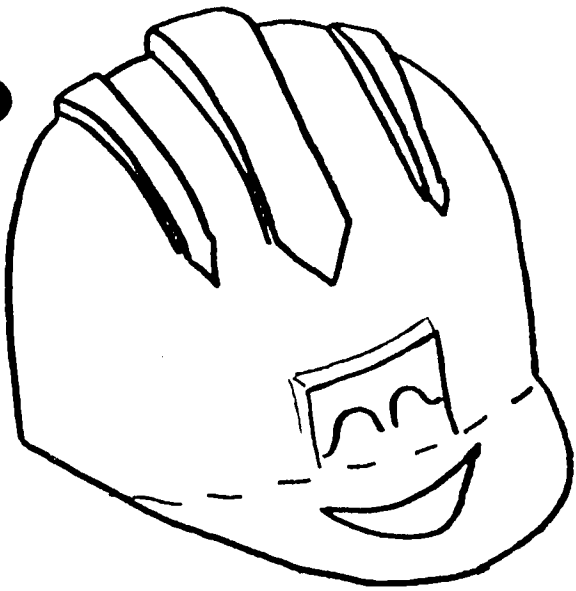

Select a hat.
Identify the emotion on it.
Complete one or more of the
activities.

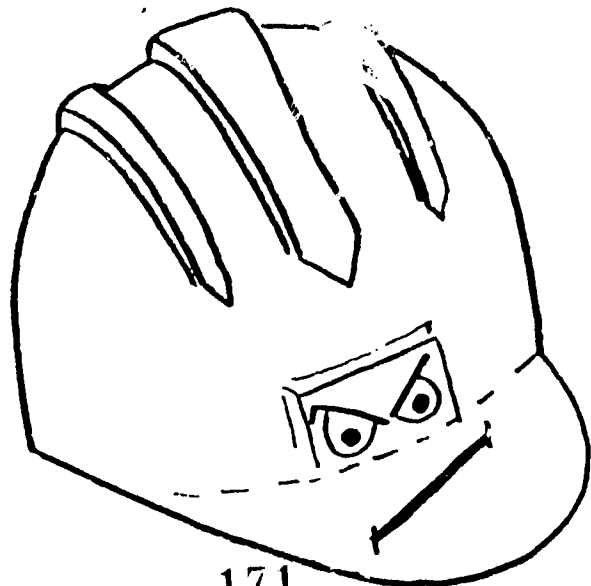

truck driver



mailman



librarian

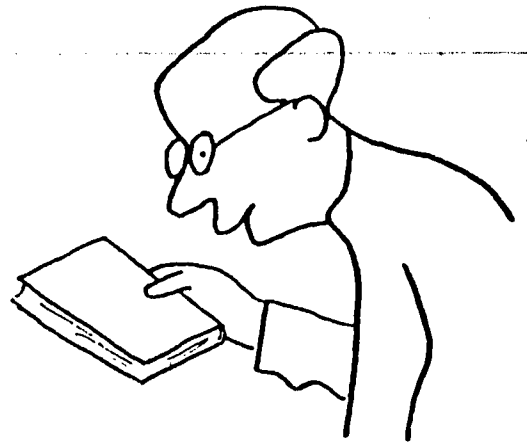

garbage
collector

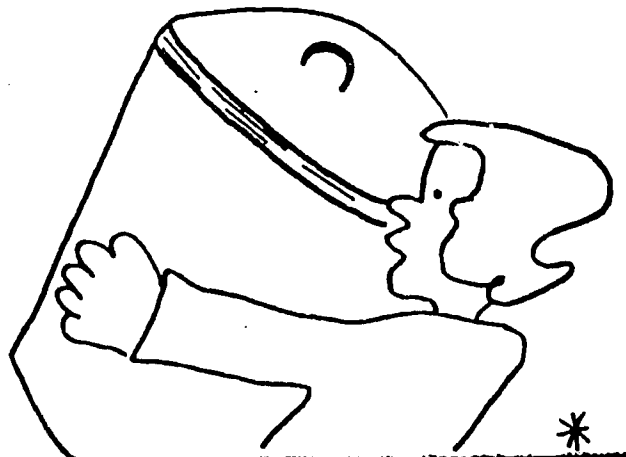

Carpenter



Seamstress

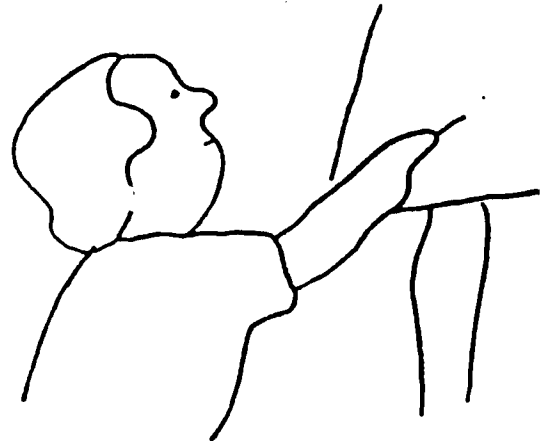

mechanic

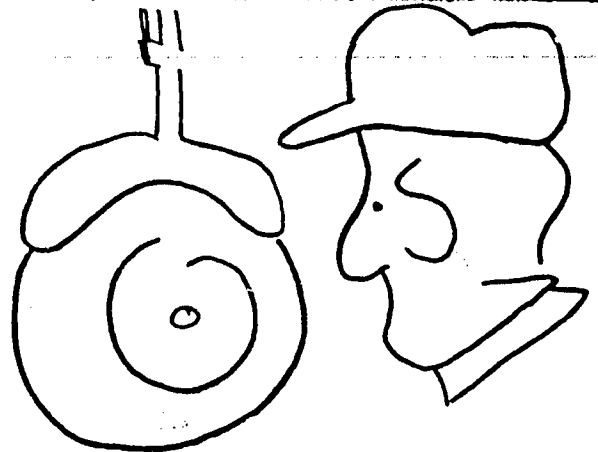

nurse

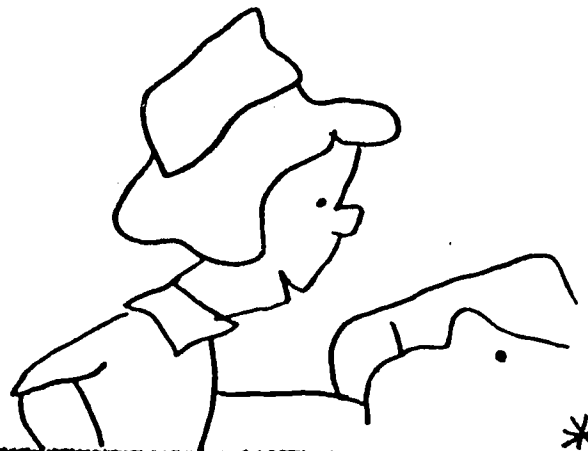

gas station attendant

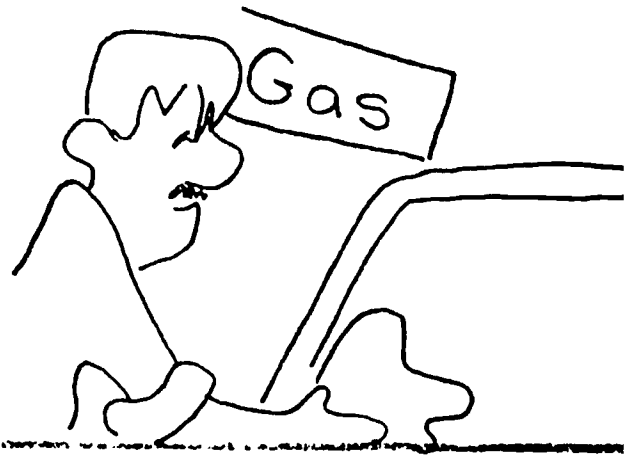

fireman

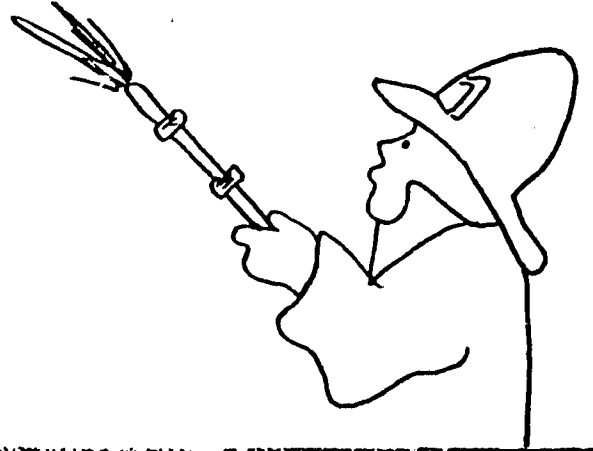

cook



dentist



doctor



forest
ranger

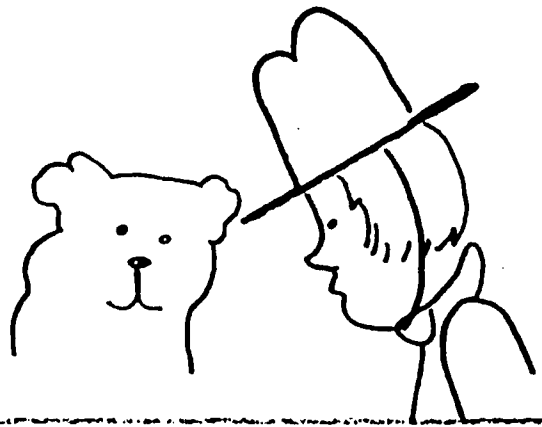

secretary

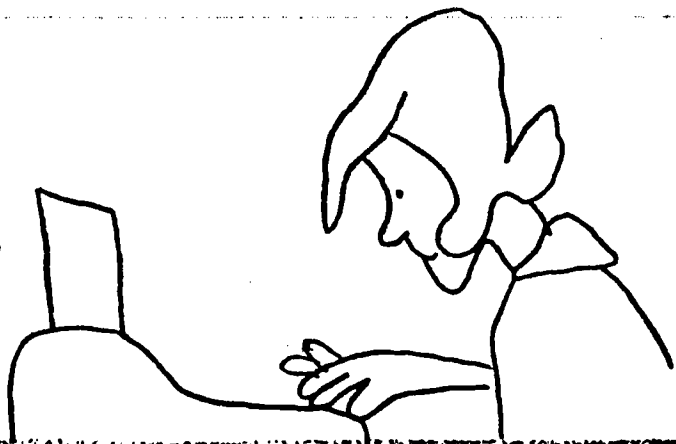

gardner



plumber

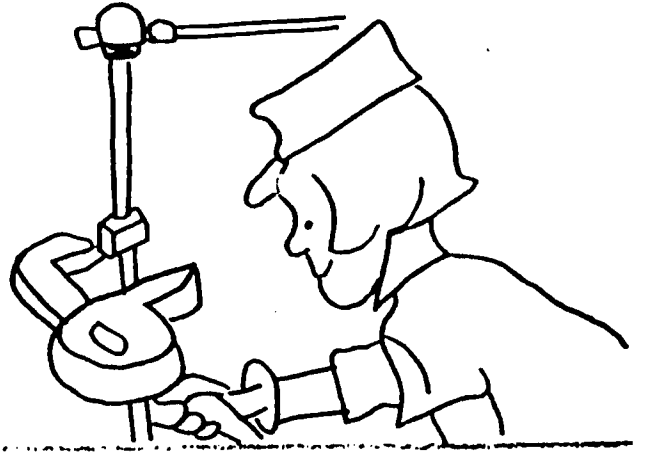

barber

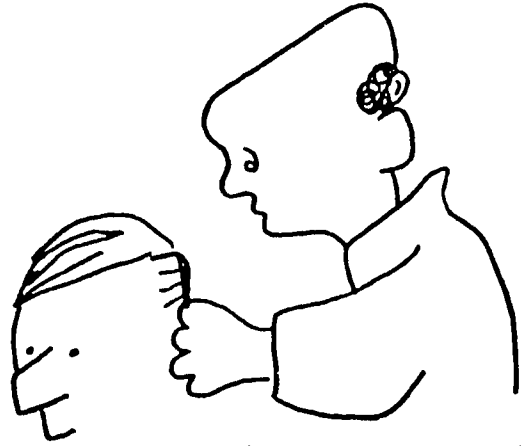

farmer



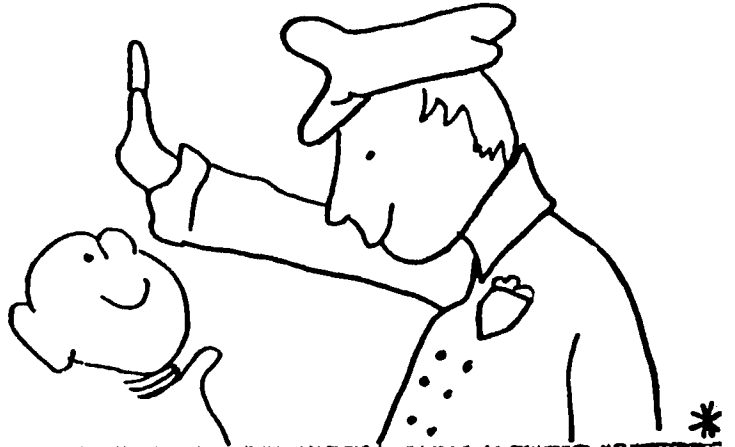

policeman

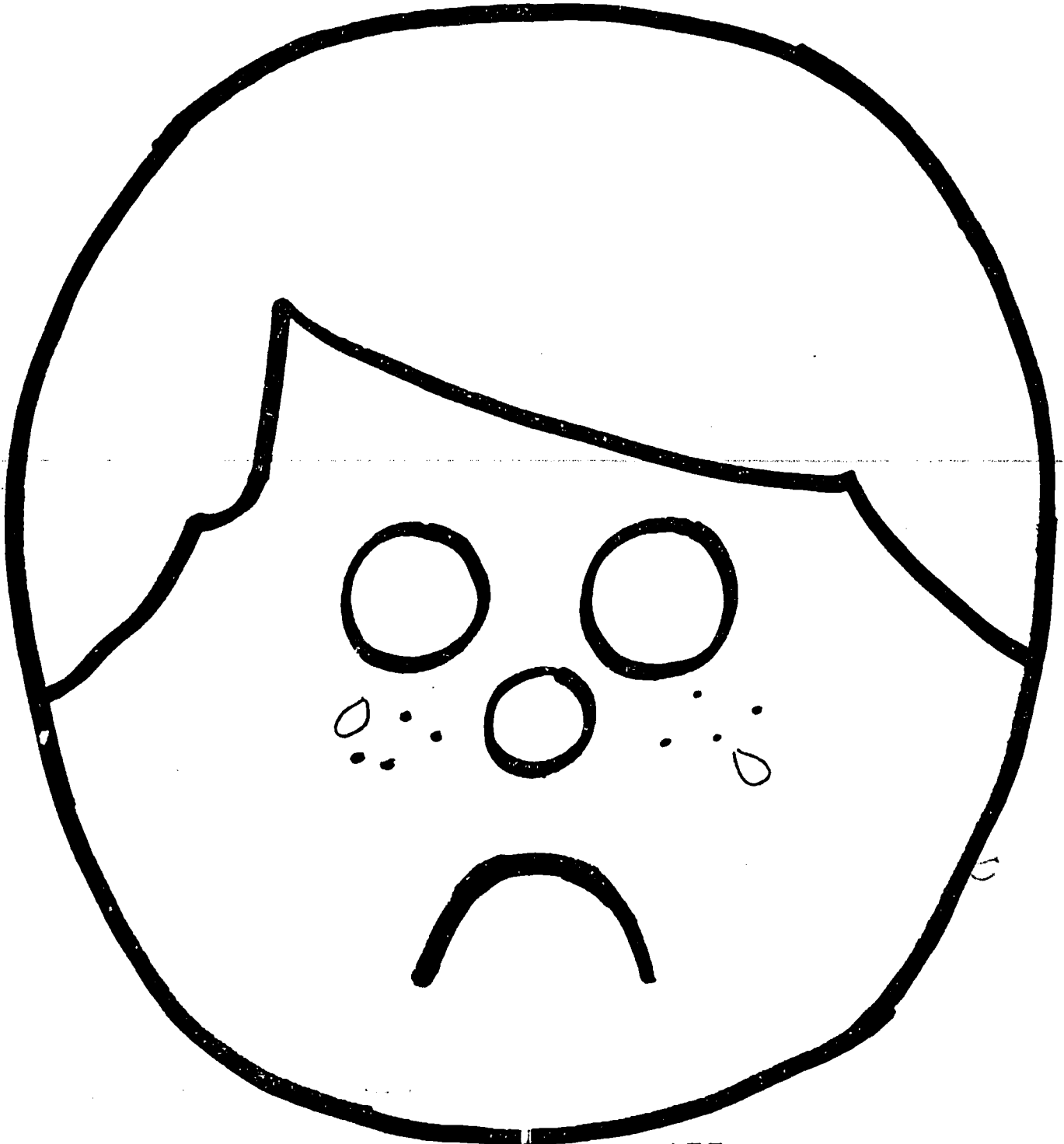

1. cut out and use as a stencil to make prepared booklets for the  shaped task card

2: eyes  



1. cut out and use as a stencil to make prepared booklets for the  shaped task card

2. eyes  

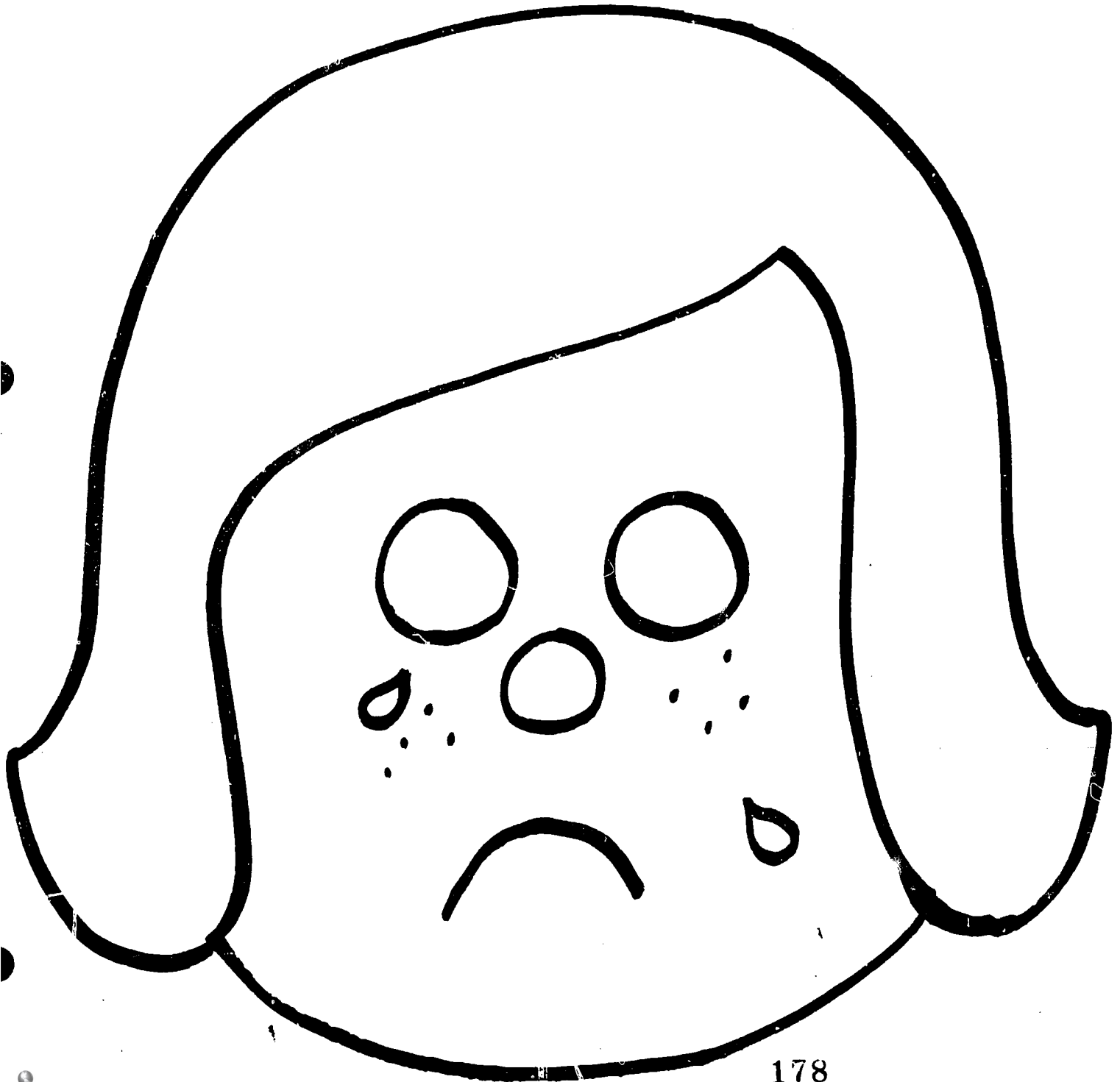

1. to be cut out and used as a stencil
to make prepared booklets for
shaped task card

2. eyes 

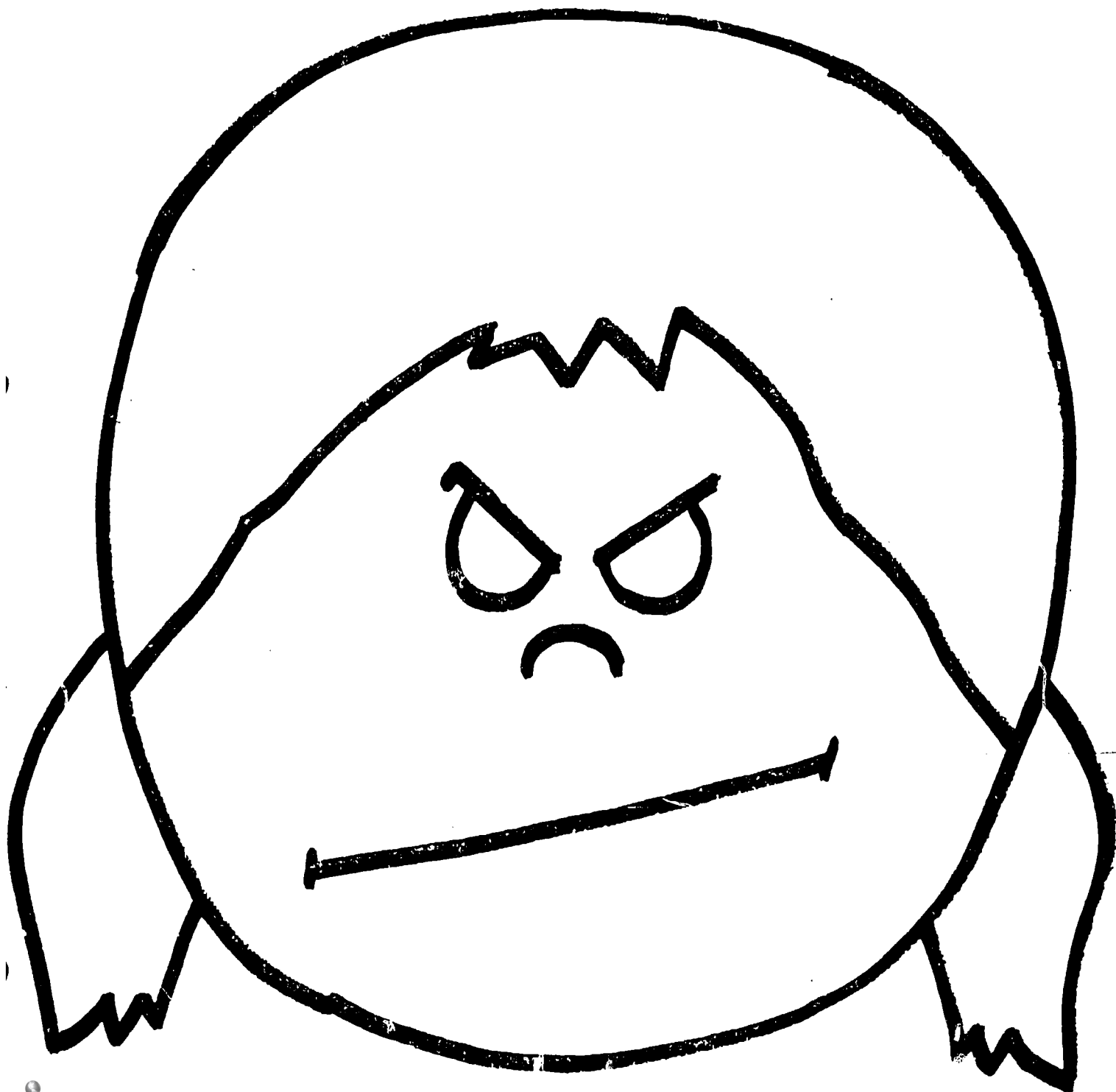

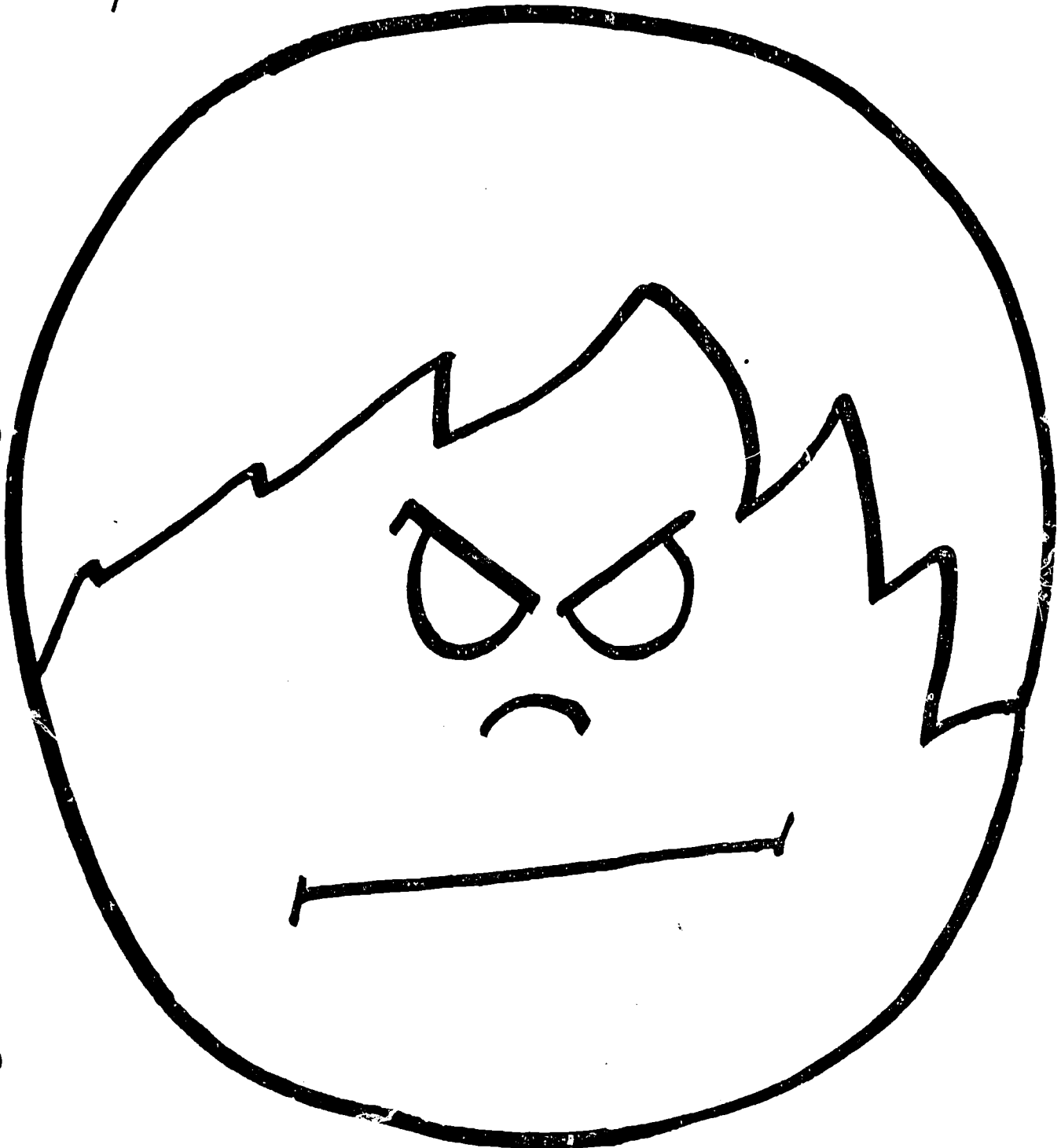

1. to be cut out and used as a stencil
to make prepared booklets for 
shaped task card

2 eyes 

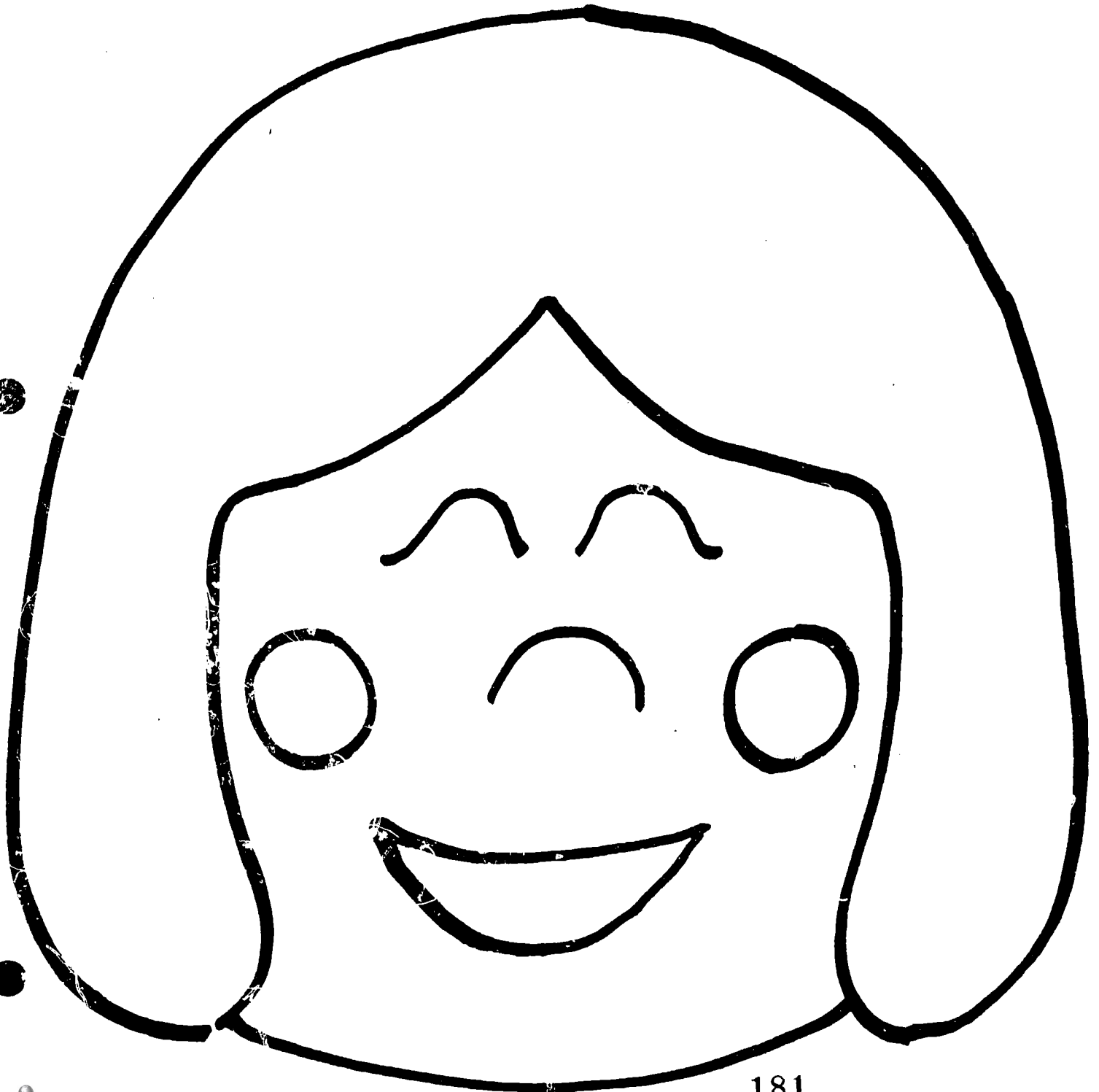

to be cut out and used as a stencil to make prepared booklets for the  shaped task card



to be cut out and used as a
stencil to make prepared booklets
for the  shaped task card

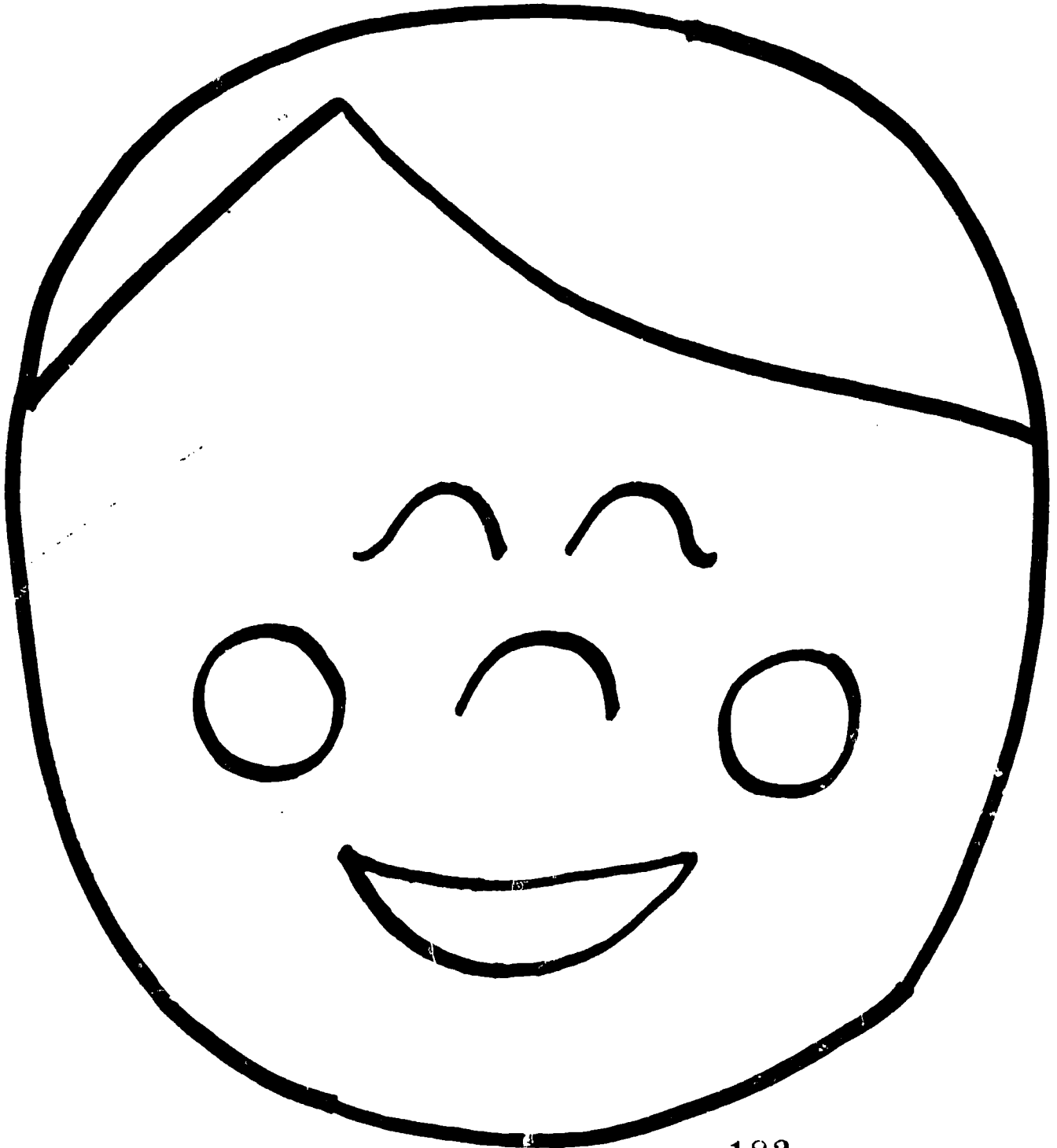

Find the booklet that matches the emotion on your hat. Fill in the space on the front of your booklet with the career you select.

On each page draw a picture showing reasons a person might feel _____ seeing a _____

Prepare a
Flannel board
story about why
a person might feel
seeing a
You may:

1. tell your story as you
present it

2. tape your
story first

Write a play about feeling
and seeing a
You may:

1. work alone or in a group

2. use your hats as
characters

3. make puppets to
help tell the story

4. make props

5. give the play
to the class

body
seeing a

Write or tape
or poem about a story, song,
might feel why some-

What are some of the reasons a teacher might feel happy?



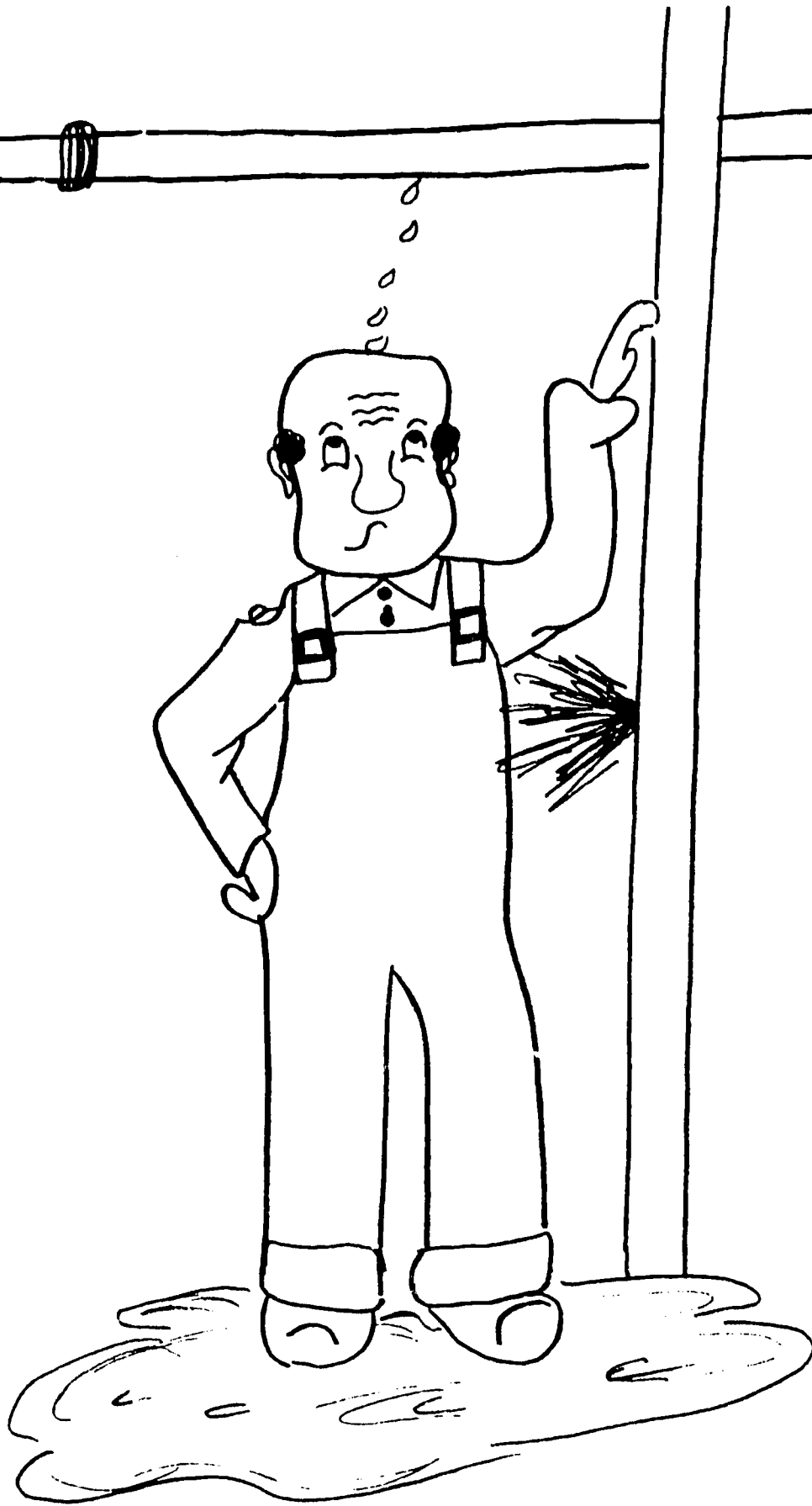

Why might the plumber feel mad?

Write or tape a story, song,
or poem about a worker, song,
the emotion on you nat. and g.

Ø

Select a career card. On a large piece of paper print the career and the emotion on your hat.

Construct a chart showing why the worker might feel _____. Use words, pictures, or both.

Choose a career card. Write a skit about
the emotion on your hat and the worker
on the card you chose.

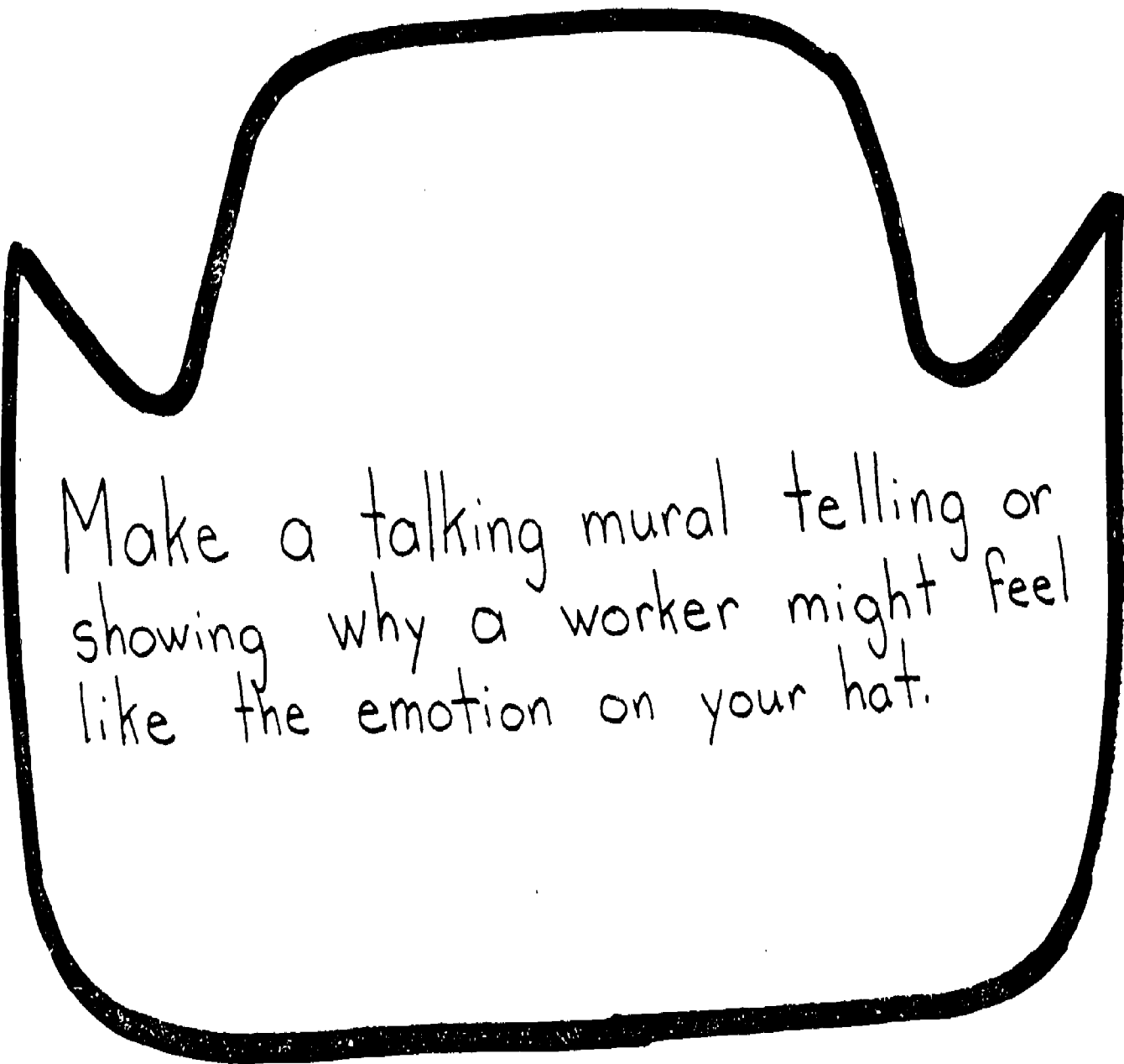

Make a talking mural telling or showing why a worker might feel like the emotion on your hat.

Q

Students

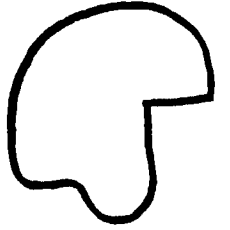
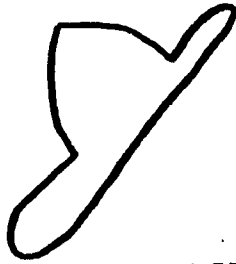

Students



Career Education Learning Center

PLAYMAKING

3

**by Faye Boe Belmont School
Fall 1975 Lincoln, Nebraska**

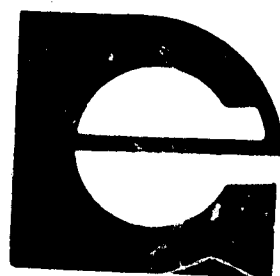

**LINCOLN
CAREER
EDUCATION
PROJECT**

The materials presented in this document were developed under a grant from the Office of Education, U.S. Department of Health, Education, and Welfare. Contractors undertaking such projects under Government sponsorship are encouraged to express freely their professional judgement in the conduct of the project. Points of view or opinions stated do not, therefore, necessarily represent official Office of Education position or policy.

Submitted by
Lincoln Public Schools
John Prasch, Superintendent
Carl Spencer, Project Director

1976

199

Date

To

From

Subject

PLAYMAKING Career Ed. Learning Center

Media needed: roulette game from dime store (Treasure City) for 75¢ or teacher make a large spinner with red and black sections numbered as described in activity Pantomime. 12 oval mirrors (small--size of emotion faces on printed material yellow sheet)--paste faces on mirrors. Styrofoam balls for puppet heads; 1" wide rubber bands for large puppets. Set of 6 hats with emotion faces "How Do You Feel" are optional and would need to be teacher made since they are no longer sold.

Lincoln Public Schools Box 82889

Memo

Lincoln, Nebraska 68501

512143

Learning Center
Career Education
Playmaking

3

By Lynn Kay
Belmont School
Lincoln, NE

1.

SUBJECT AREA:

Language arts
Creative Drama

CAREER EDUCATION THEMES:

Personal - Social Development
Values clarification



2

TEACHER'S OBJECTIVES:

1. The student will explore his imagination, concerns, and feelings.
2. The student will express experiences and ideas through actions or words.
3. The student will analyze expressions and movements seen in the world.
4. The student will solve given value roles through dramatization.



STUDENT'S OBJECTIVES:

Post the objectives for students as well as poster "How to meet them and "Words to Know" (3 pages labeled Δ) at the center or enlarge to a chart and place near or above the center.



PRE-ASSESSMENT:

3.

Teacher takes class to the playground to observe behaviors as others play. Then return to classroom and write what they saw happening and how the people felt (actions and feelings). Encourage use of words other than "happy" and "sad". The growth of vocabulary concerning feelings is another objective of this center.

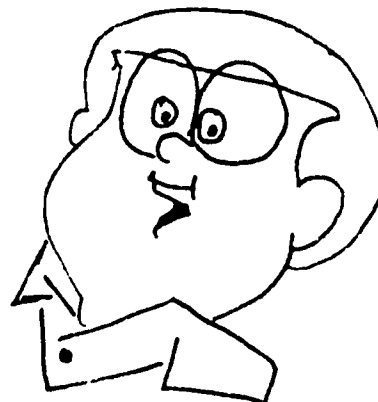



In this unit "playmaking" is composed of pantomime, poems and choral reading, puppetry, story dramatization, and role playing.

Before setting up the "playmaking" center do the following activities with your group.

1. Discuss the "Words to Know" chart or card (Δ) Read over the definitions.
2. Discuss the "student objectives" and "how" charts (Δ) Tell the children that these types of playmaking will help them express their feelings and experiences in words and in ways other than with words.
3. Decide on a place to set up your playmaking center.
4. Have the children choose a name for the center and make a sign.

A teacher using this unit may wish to concentrate on one of the areas with the whole group or gradually put all the color coded task cards in the center. The suggested order to introduce each new unit is numbered below (1 and 2 are reversible) as the skills build to more complex and difficult performance. The color coding on the task cards is:

1. Pantomime - yellow
2. Poetry - orange and blue
3. Puppetry - green
4. Story dramatization - white
5. Role playing - pink

The children may need guidance in the beginning of this unit on what to do; but should not be told how to do movements and expressions.

Teachers will notice task cards are not numbered indicating there is no sequence to when the cards are done within the unit. If teachers are looking over answers as an evaluative measure, they may prefer to number the cards and ask children to put the card number on their reaction papers. There is no checking as these are opinions and feelings not right or wrong.

ACTIVITY ONE: Pantomime (on yellow tag and paper)

Teacher preparation:

For Roulette:

1. Read directions for students on page "Pantomime Roulette"; this explains how the file box works.
2. Cut out file label and 2 dividers on page labeled ; color divider labels black and red as indicated by printed words; glue label on outside of file box.
3. Cut out the pages of yellow tag which are divided into 8 cards per page. These are the actions and feelings to be pantomimed as the roulette gives number and color.
4. File the cards (#3 above) behind (or in front) of the proper color divider in the file box.
5. Put out task cards and roulette game in this kit at center.

For Mirror activities:

1. Cut out faces on the "Select a face" page (as directed) and glue one face to each of the small oval mirrors provided (glue on front or back of mirror as desired).
2. Children use the "Match the mirror to a feeling" page to place the mirror and attached face over the word which describes the feeling (vocabulary building as well as preparation for pantomime).
3. Make a ditto master of yellow paper page "What are your feelings?"; duplicate copies for students to write on as directed in task card "Dictionary of Feelings" (more vocabulary building etc.)
4. Place the four yellow task cards, match the mirror to a feeling card and prepared mirrors at center. Along with dittoes of worksheet "What are your feelings?"
5. Plan for collecting and/or sharing written reactions from some tasks - folder at the center, pin them to bulletin board for display.

Here is a complete list for the "Dictionary of Feelings" worksheet as an aid for teachers.

DICTIONARY OF FEELINGS

A - angry
 B - bad, bedraggled, bitter
 C - conceited
 D - disagreeable, dangerous
 E - eager
 F - frightened, friendly, funny
 G - great surprise
 H - hate, hostile, happy
 I - innocent
 J - jealous
 K - kidding, kooky
 L - love
 M - mean, misery, merry, mischievous
 N - nasty, natty
 O - oddly, ornery
 P - pleasant, peppy
 Q - quiet
 R - reckless, rotten, red-eyed, robust, refreshed
 S - silly, secure, sick, sleepy, sad, surprise
 T - tough guy
 U - unfriendly, unsure
 V - vain, valiant, vicious
 W - wise, "wise guy", weak, weary
 X - X-ray, look into yourself - How do you feel?
 Y - yielding, young, yukky
 Z - zealous, zingy, zippy

Readiness for pantomime:

The teacher might wish to introduce each activity in this section to the entire group first; then place them in the playmaking center for children to work on independently.

ACTIVITY TWO: Poetry - orange and blue tag

Before presenting these poems to the class, the teacher might wish to read them during group time and then place copies of them in the "playmaking" center. Your class might wish to start collecting poems to act out. These should be added to the center.

All the task cards for children are self-explanatory. The task cards may be laminated for longer wear. At center: Put out task cards, writing and drawing paper, pencils and crayons, provide a place to share answers such as pinning pictures to a bulletin board, place in a folder to be made into a book (cover picture chosen by students) or meet in pairs or three-somes to share ideas.

ACTIVITY THREE: Puppets - green tag

Procedure for teachers;

1. Begin with a simple styrofoam ball for puppet head and hand for puppet's body. (see diagram)



hole for finger

2. Explore with the children body movement and gestures through the following suggested questions:
 - a. How does a person express his feelings?
Possible answers:
face
talk
quiet
head movement
walk
words
 - b. Show me how a person walks when he's happy? sad? angry?
 - c. What do you see or notice about the head? The hands and head together?
 - d. How is a happy person different from a surprised one?
Show me the head and hand movements
3. Observe various people walking. Discuss the movement and the feeling walking can portray. Try to imitate feelings through movement of a puppet.
4. Pass out styrofoam balls and ask the children to show how a person moves when he feels: happy, angry, silly, sad, frightened, sleepy, in love, peppy, amused.
5. After exploring this as a group, put out the styrofoam balls and task cards in the center.
6. Introduce other puppet forms after giving children enough time to explore with styrofoam ball.
The teacher, with the help of a small group of children might wish to construct a simple puppet stage like the one next page (p. 6).

Puppet Stage:

Need 2 large cardboard cartons:

6

1. Turn one carton so that the bottom is facing up and cut according to illustration.
2. Cut one least side off of second carton.
3. Place cartons together as in illustration.
4. Secure in place with butcher tape.
5. Decorate.

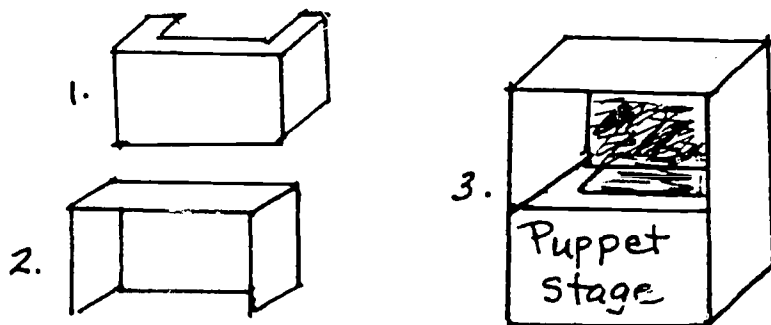

7. Use the pattern (pages *) and trace the puppet bodies onto the felt. We won't call them boys and girls, but one has a dress for the hand and one has pants on so a slit in back is necessary for the hand; the front is like the back with no slit. Lace up the sides with yarn and decorate (hair, etc.)
8. For task card "Be a Star" assemble as follows:
 - a. on page cut out rectangle which fits the stage, glue or staple the bottom and sides of this piece to the task card stage as indicated. This makes a pocket on the stage.
 - b. Cut out little cards on page and place these small task cards in the pocket on the stage.
 - c. Set up the task card on a stand at center or fasten it to the wall or bulletin board.
9. Assemble the following materials and place in the center.

Styrofoam balls
paper plates - 2 for each student
stapler
11 x 14 eased paper
colored construction paper
one inch rubber bands
brass (metal) fasteners
tempera paint
tongue depressors -- one for each puppet
felt
yarn
needles to lace up puppets made of felt.

ACTIVITY FOUR: Story Dramatization - white tag

Readiness: Ideas for teachers

The children will probably need an adult guide to help develop story dramatization. The adult should guide, but not dictate the story planning. Planning includes:

1. selecting a story to dramatize
2. determining the characters
3. story sequence
4. simple props that will be needed.

With encouragement children can decide which story to dramatize and make up their own dialogue. Familiar stories are usually the best.

Story ideas might include:

The Three Billy Goats Gruff
Caps for Sale
The Three Bears
Hansel and Gretel
Rumpelstiltskin
William's Doll

Children might also wish to change familiar stories: Cinderella to Cinderfella and the Beautiful Step brothers, Sleeping Beauty to Awake Ugly. Story plot should also be opposite of the original. Before placing the following scripts in the "playmaking" center, read and act out the story during group time. "Hah Hah" is fun to do as choral reading - all chant their part on cue.

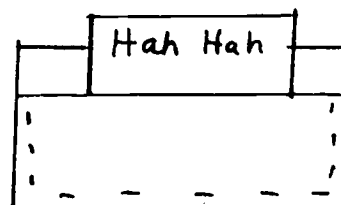
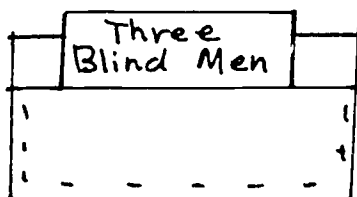

Teacher prepares pockets as pictured above; keep script copies in pockets (as shown). Attach envelopes to wall or bulletin board at center.

Spin a Story Game (pages labeled #)

Before placing Spin a Story in the playmaking center, the teacher should introduce the game to the whole group. To assemble the game, cut out the circles and mount on cardboard. To make the spinner, place a metal fastener through the base of a safety pin and attach to the middle of each circle.

Game I (2 to 4 players)

Use the animal or people character circle and the description circle.

Player one spins both spinners and then acts out the character. For example an angry king. Other players, all at once, act out of the same character.

Player one claps his hands and the acting stops. The next player takes his turn until everyone has spun a character.

Note * → May need teacher direction to start; rules for noise level permitted may need to be established.

Game II

Play the same as game I except, after everyone has had one turn, the group selects one or more of the characters that have been dramatized and make up a short story.

Act out the story or draw pictures of the characters.

Game III

Each child in the group spins an animal or people character and a description. One player spins a setting. Players may write a story using all the characters in the selected setting or each player may write his own story for that setting.

ACTIVITY FIVE: Role Playing - Pink paper

Assemble "How do you Feel" hats at center, put out task cards.

* Guiding remarks for teachers:

In role playing, a situation involving two or more persons is given but not resolved. It is a problem solving devise and the children are asked to act out the story ending. The role players, with reinforcement from peers, make value choices.

The teacher should make no negative comments on the child's decision, even if the value statement is anti-social. The teacher's role is to lead a follow-up discussion.

If the role players become silly or uncertain, stop them and ask them to think how the character would act

Once the situation has been enacted with the group and a discussion has followed; the story cards may be placed in the playmaking center. Children may wish to write their own situation to act out as problems arise in school.

RECORD KEEPING:

5. Make dittoed copies of the tic tac toe sheet (marked 00). Explain its use to children according to your requirement as the classroom teacher, example:

1. Color in each square with the color of that unit (pink for role playing), Yellow for pantomime, etc.)
2. You should have --- (a full card, a diagonal, a straight row) when our playmaking center is finished.

3. Store your tic tac toe sheet by --- (placing it in your folder or brown envelope in the center --- pinning it to the bulletin board --- etc.)

EVALUATION:

6. Use same playground activity suggested for pre-assessment. Look for use of enlarged vocabulary in discussing feelings; assess increased understanding of our feelings and actions as well as those of others.

Some units have written answers useful in evaluating growth of understanding and vocabulary. Attitudes can be assessed by checking to see who did the activities (tic tac toe charts).



Record
Keeping

Color in the tic tac toe squares with the color of the task cards after you do an activity.

story dramatization	role playing	pantomime
puppetry	poetry	story dramatization
role playing	pantomime	puppetry

Name _____

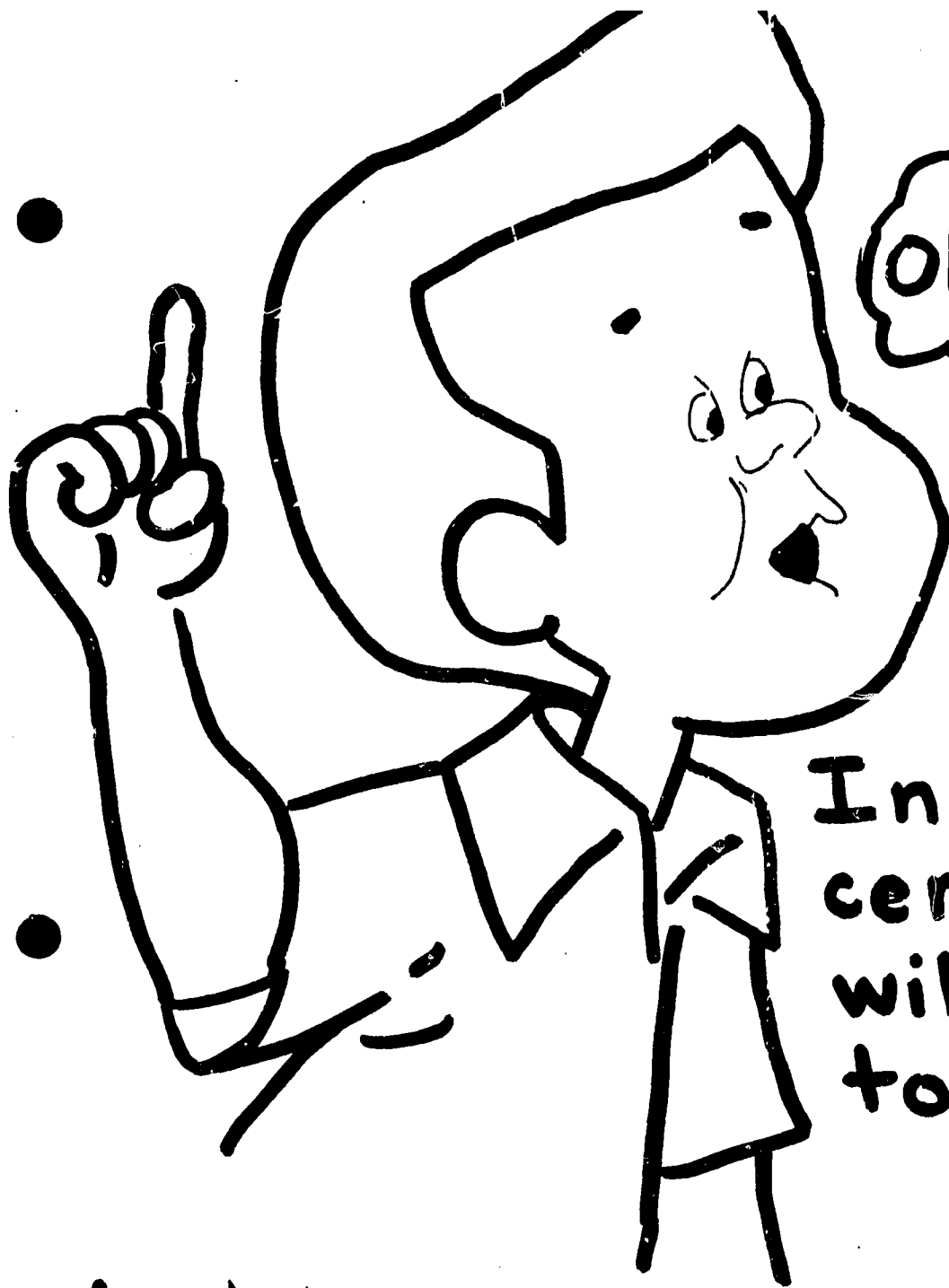

Objectives:

In this center you will be able to :

1. Act out or tell about your feelings, experiences, and ideas.
2. Think about and imitate the movements and expressions you have seen.
3. Role play given situations.

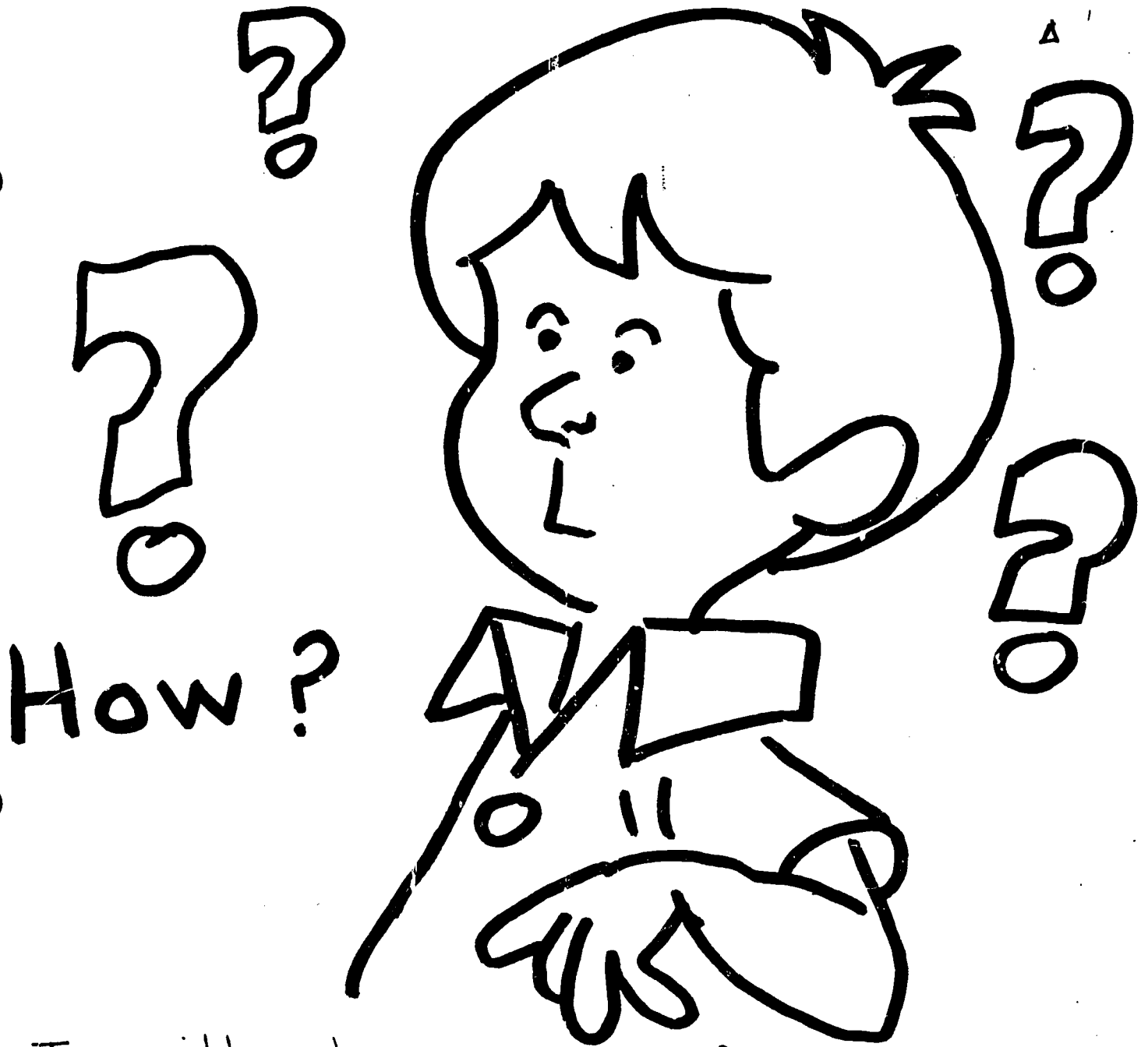

I will choose one of these methods to meet these objectives:

1. Pantomime
2. Poetry
3. Puppets
4. Story Dramatization
5. Role playing

• Words to know:



- Pantomime — acting without using words

Story Dramatization — acting out a story

Role Playing — a story is given to players to act out an appropriate ending

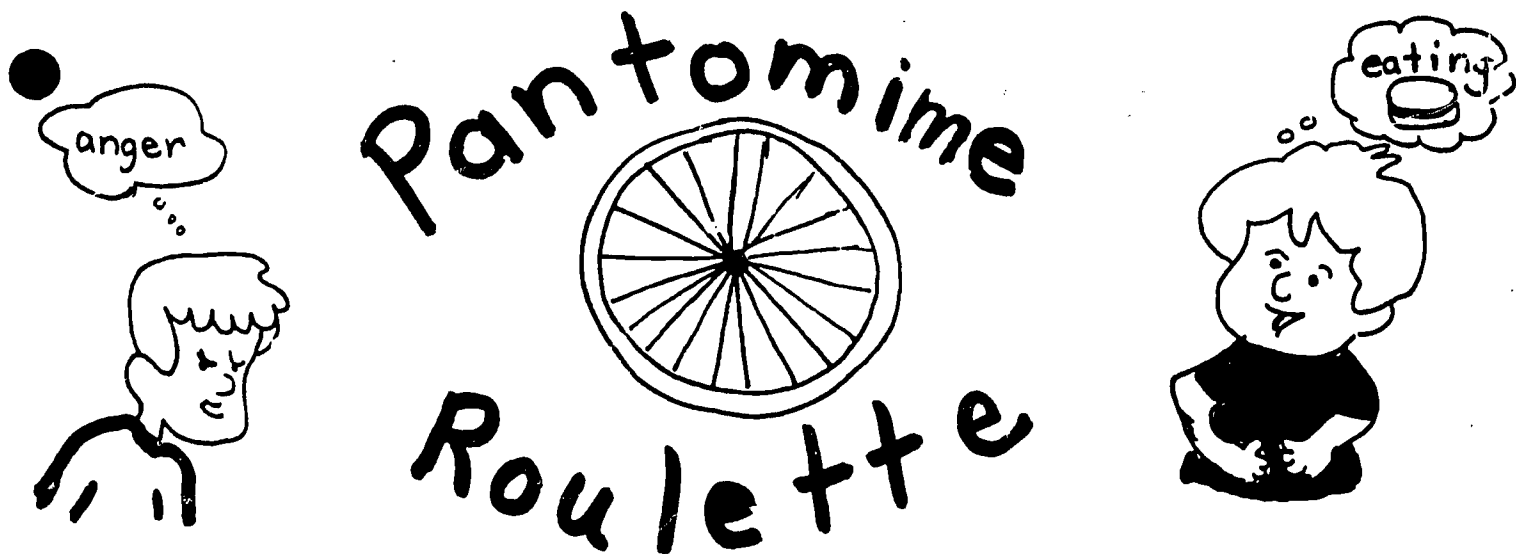

Pantomime or a feeling
an action.

SPIN THE ROULETTE WHEEL. WHEN THE WHEEL STOPS SPINNING, LOOK AT THE COLOR AND NUMBER ABOVE THE SPOT WHERE THE BALL LANDED. FIND THIS COLOR DIVIDER AND THEN THE NUMBER IN THE PANTOMIME BOX. READ THE CARD.

PANTOMIME THE ACTION OR FEELING A PERSON MIGHT FEEL IN THAT SITUATION.

Cut out
and glue
sign to
file box.

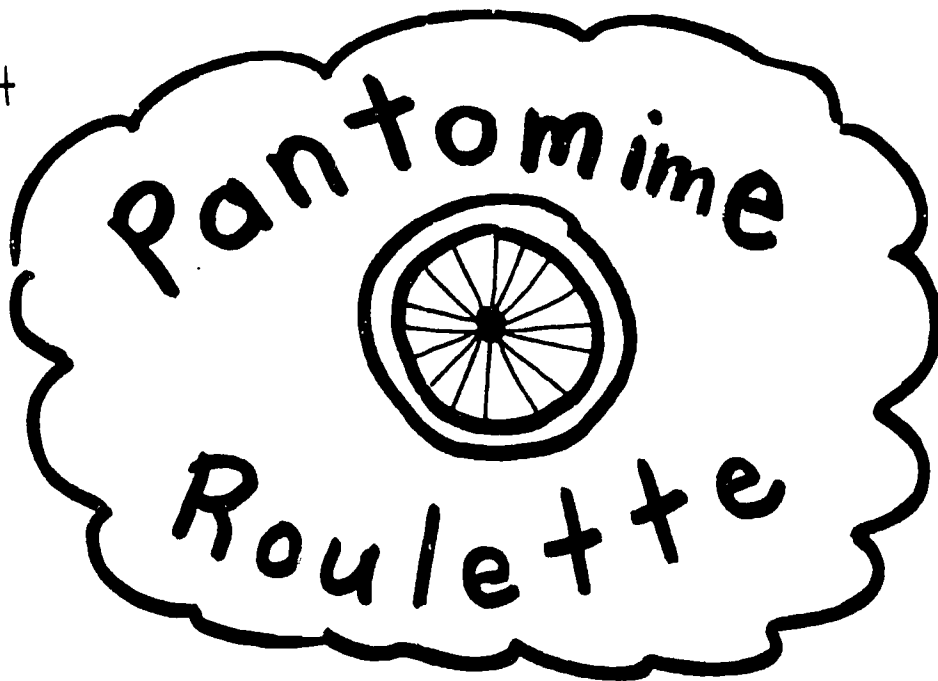

Black

eating

Black
Action
Pantomimes

Dividers
for
file box.

Red

anger

Red
Feeling
Pantomimes

7 BLACK

RIDING A BICYCLE

8 RED

FEEL TIRED AFTER RAKING THE
YARD

9 BLACK

ROLLER SKATING

10 RED

YOU ARE THIRSTY AFTER RUN-
NING HOME FROM SCHOOL.

12 BLACK

PLAYING FOOTBALL

11 RED

YOU JUST LOST THE BALL GAME.

14 BLACK

BAKING COOKIES

13 RED

YOUR BEST FRIEND MOVES AWAY

31 RED

YOU ARE ASKED TO JOIN THE CIRCUS

32 BLACK

PICKING FLOWERS

33 RED

YOU DO NOT KNOW THE ANSWER TO A
MATH PROBLEM

34 BLACK

JUMPING ROPE

35 RED

GET EXCITED AS A BEE COMES CLOSER AND
CLOSER TO YOU

36 BLACK

EATING A CHICKEN LEG

15 RED

WALK TO SCHOOL ON VERY, VERY COLD DAY

16 BLACK

WATCHING TELEVISION

17 RED

YOU ARE ALONE AND HEAR STRANGE NOISES
OUTSIDE

18 BLACK

READING A BOOK

19 BLACK

GETTING OUT OF BED

20 RED

YOU DISLIKE A PRESENT YOU
RECEIVED FROM A FRIEND

21 BLACK

FISHING

22 RED

YOU TASTE SOMETHING STRANGE
ON YOUR SANDWICH

218

0 BLACK

00 RED

PETTING A DOG

OPENING A BIRTHDAY PRESENT

1 BLACK

2 RED

EATING AN ICE CREAM CONE

STRIKING OUT IN A BALL GAME

3 BLACK

4 RED

BRUSHING YOUR TEETH

FEEL PAIN WHEN YOU FALL FROM
THE JUNGLE GYM

5 BLACK

6 RED

PUSHING A GROCERY CART

YOU FIND \$10 ON THE PLAY-
GROUND

23 BLACK

WORKING AT SCHOOL

24 RED

THE DOOR IS LOCKED AND
NO ONE IS HOME

25 BLACK

MAKING A SNOWBALL

26 RED

YOUR MOTHER VISITS SCHOOL

27 BLACK

TRICK OR TREATING

28 RED

YOU FIND A BUG IN YOUR FAVORITE
CAKE

29 RED

ACT DISAPPOINTED BECAUSE YOUR MOTHER
WOULD NOT LET YOU PLAY AT A FRIENDS
HOUSE

30 BLACK

WALKING IN THE RAIN

220

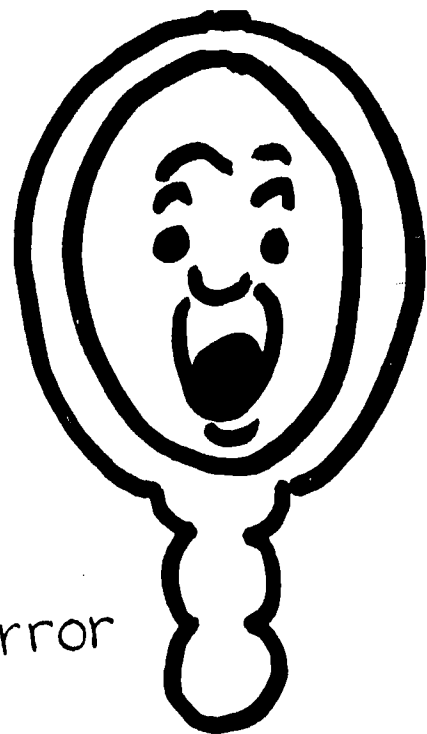
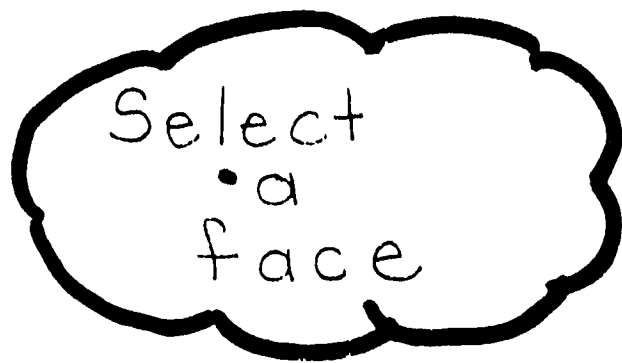
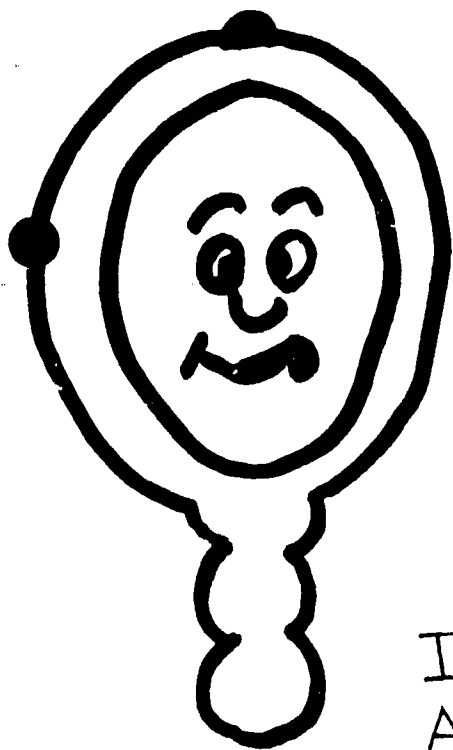

The Mirror
I looked in the mirror
And saw a face
I'd know real well
In any place.

Somedays, though,
I look and see
A person who
Amazes me.

Do you look different every day?
Tell me, what does the mirror say

1. Select a face. Imitate the face you have selected. Match the face to a feeling.

2. Work with a friend. Each of you select a face and design a situation which would cause that feeling. Pantomime it. 221

Match the mirror to a feeling...

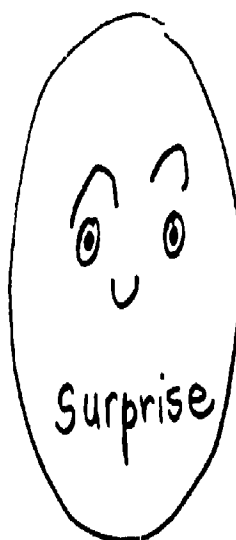
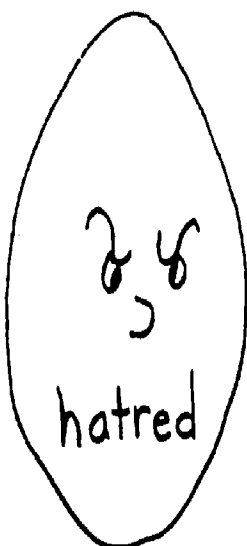
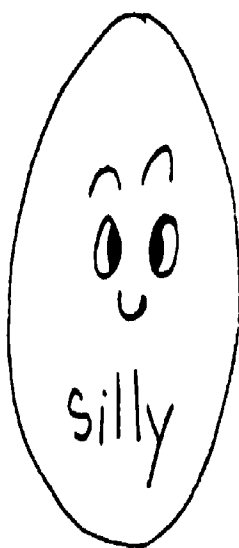
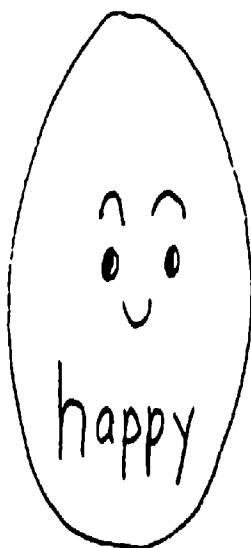

Select-a-face

Cut out faces and glue them onto the mirrors.

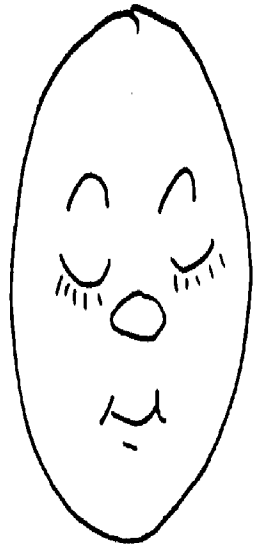
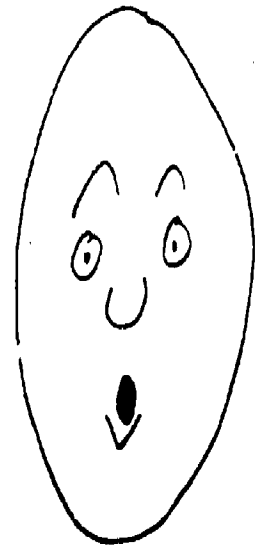
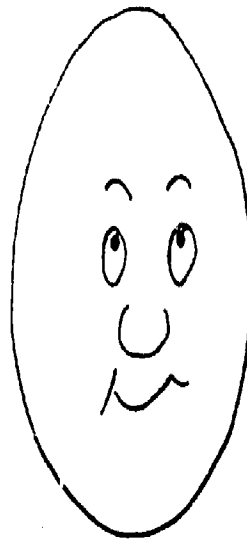
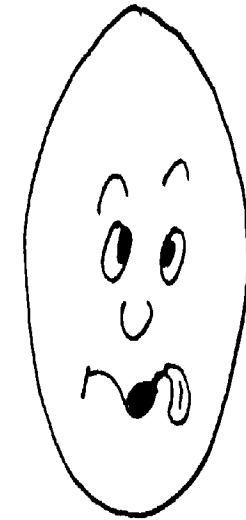
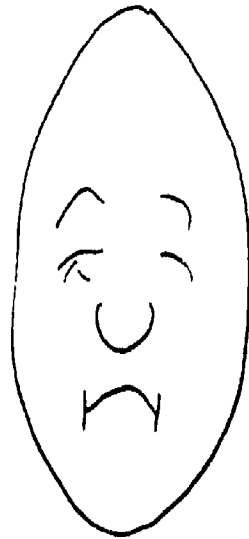
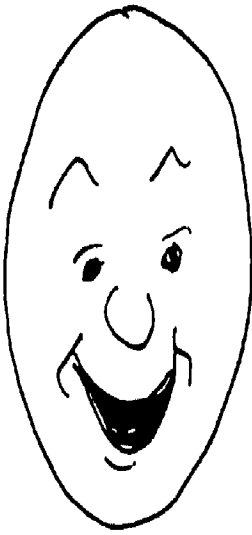
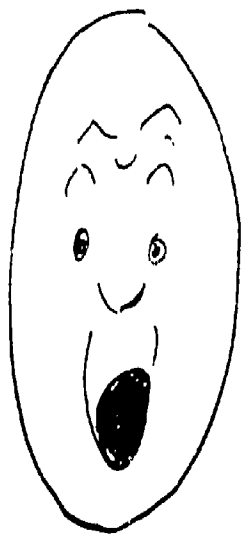

Mirror ... Mirror ...



Mirror, mirror on the wall,
I am growing very tall.
I can _____

1. Make a list of the things which you can do now that you could not do when you were smaller. Pantomime the items on your list, and see if a friend can guess them.

2. Make a list of things which you will be able to do when you are an adult. Pantomime the items for a friend. Is this list longer than the list in activity one? Why?

3. Imagine that you grew and grew and grew. You have become a giant. Show how you walk as a careful giant, a clumsy giant. Draw or write about the things that you see or do.



WORK IN PAIRS FACING EACH OTHER. ONE OF THE PARTNERS MAKES SLOW MOVEMENTS. THE PERSON FACING HIM BECOMES THE "MIRROR" AND , AT THE SAME TIME, IMITATES THE EXACT MOVEMENTS.

TO CHANGE ROLES ONE OF THE PARTNERS CLICKS HIS FINGERS.

REMEMBER:

DURING THE PANTOMIME NO TALKING IS ALLOWED BETWEEN PARTNERS.

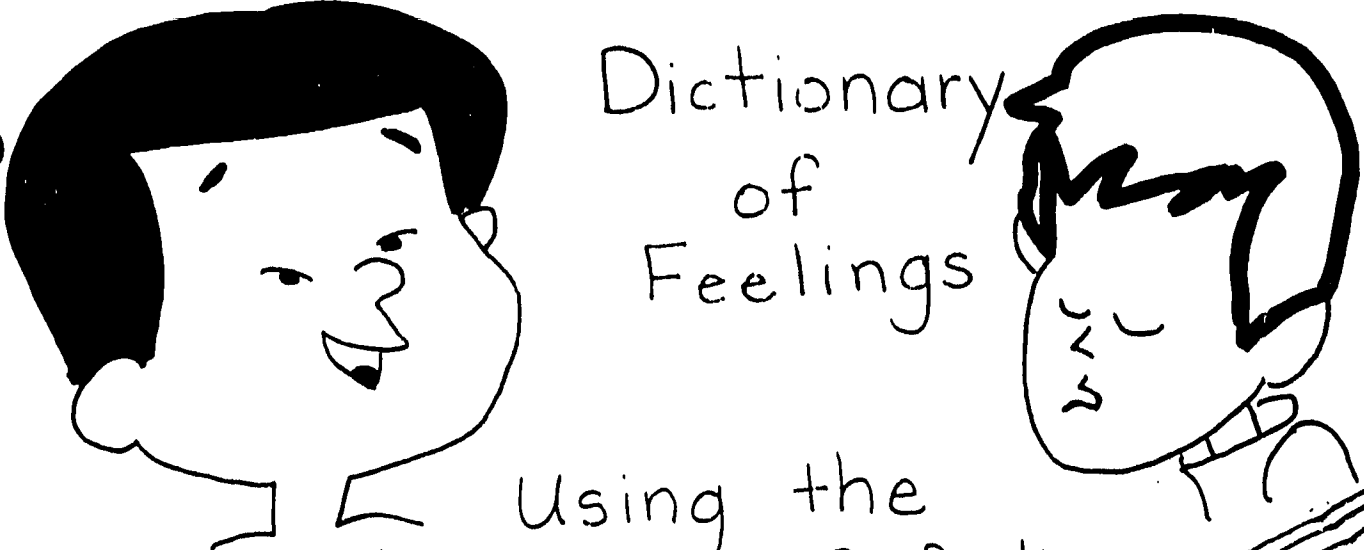

Dictionary of Feelings

Using the
dictionary of feeling -
Select a feeling -

1. Pantomime it for a friend.
2. Predict what might have caused this feeling.
Pantomime the situation.
3. Make your own dictionary of feelings. What feelings can you add?

What are your feelings?



Add to the list:

Dictionary of Feelings

A = angry,

B = bad, bedraggled, bitter

C = conceited,

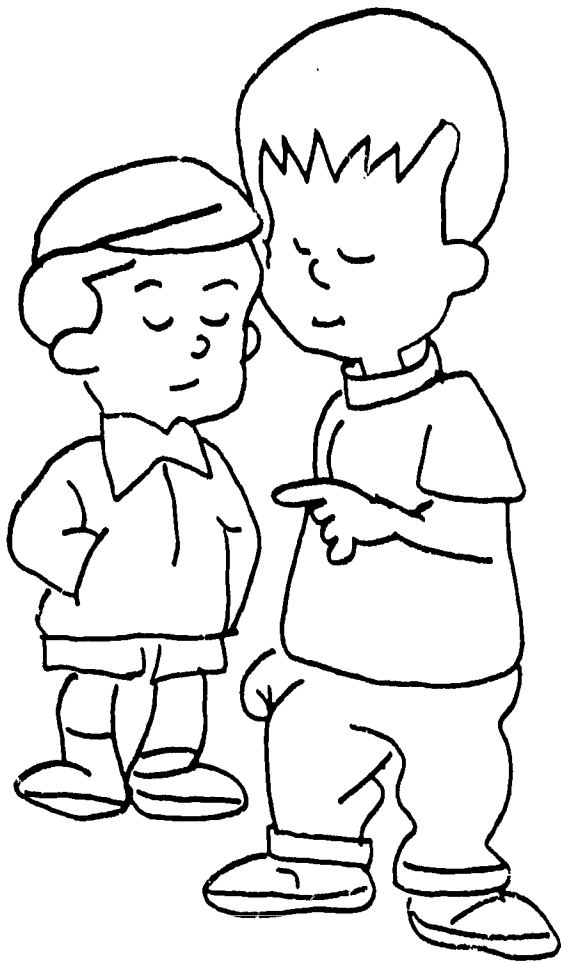

Choosing Teams

I wait in line
For them to say,
"We'll pick you first,
You've got to play!"

"We need you badly
On our side,
Without you there
They'll skin our hide."

But all the kids
In school know
In baseball games
I'm very slow.

I want to play,
But don't run fast.
That's the reason
I'm picked last.

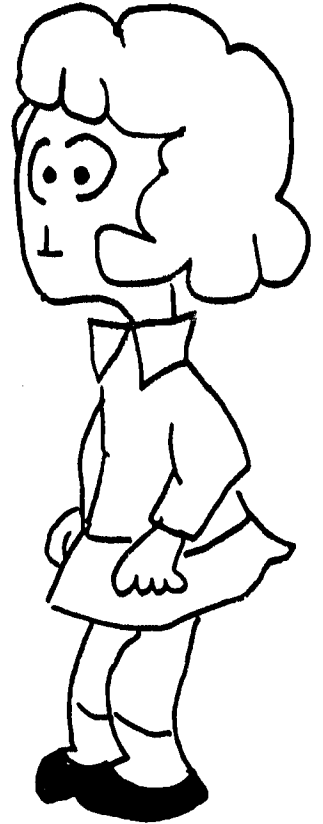

1. Make a list of things you do well. Make a list of things you do not do as well.

<i>Things I do well</i>	<i>Things I do not well</i>
_____	_____
_____	_____
_____	_____

2. Have you ever been chosen last? How did you feel? Write about it or act it out.

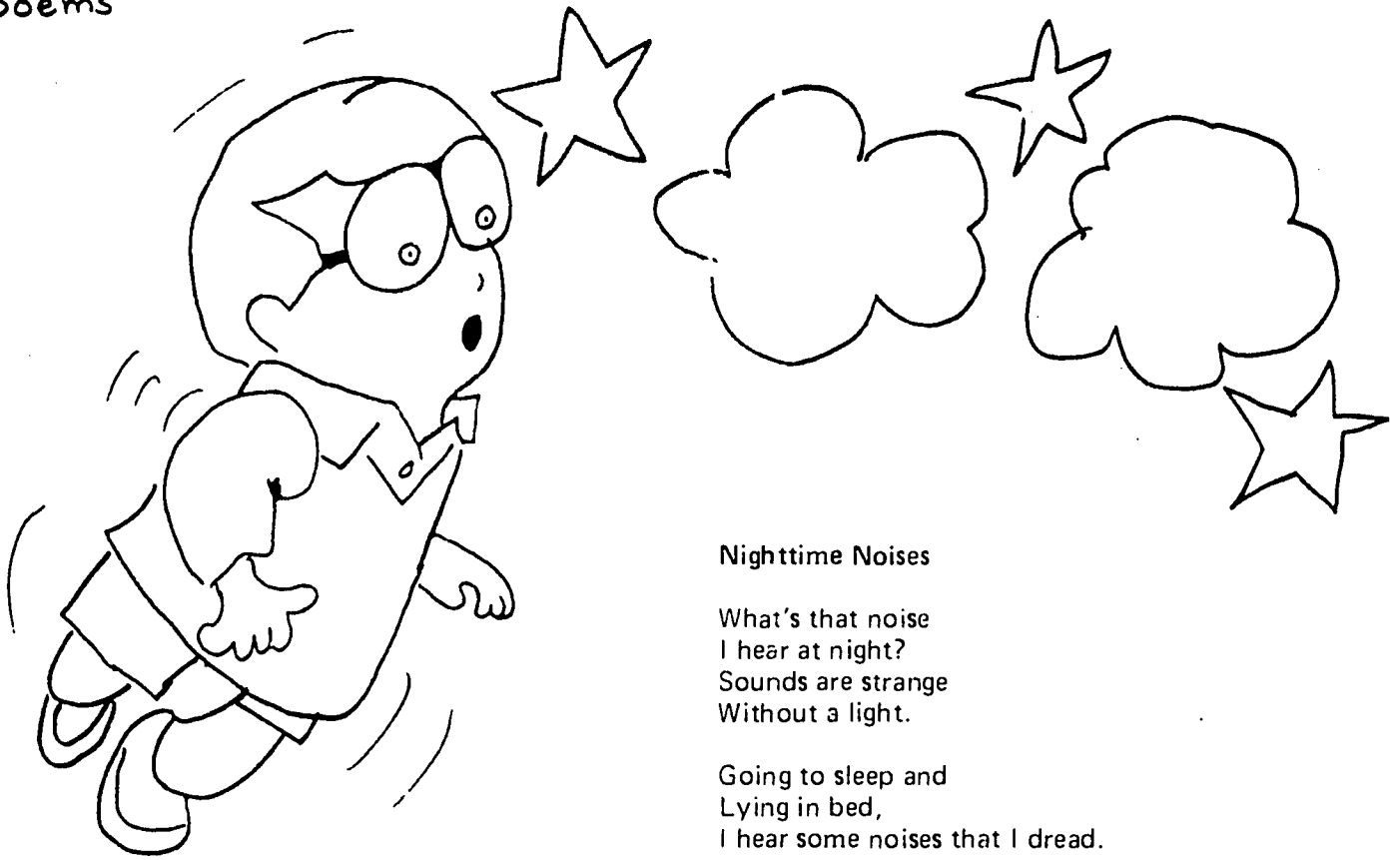

Nighttime Noises

What's that noise
I hear at night?
Sounds are strange
Without a light.

Going to sleep and
Lying in bed,
I hear some noises that I dread.

What could they be.
The people next door?
The neighbors upstairs
Pacing the floor?

Whatever they are
I worry and wonder.
Oh, no, that noise...
I hope it's just thunder.

1. Read the poem and then pantomime it.
2. Compare the night noises of the city to those of the country. Which are the most frightening? Why?
3. Draw a picture of something that you have imagined at night. A robber? A monster?

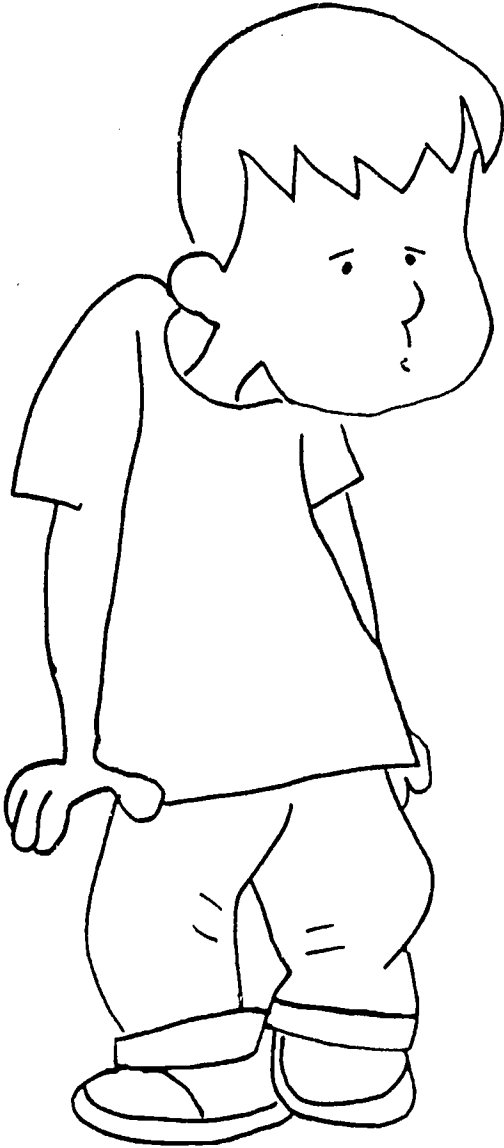

Tired Tim

Walter de la Mare

Poor tired Tim! It's sad for him,
He lags the long bright morning through,
Ever so tired of nothing to do;
He moons and mopes the livelong day,
Nothing to think about, nothing to say;
Up to bed with his candle to creep,
Too tired to yawn, too tired to sleep:
Poor tired Tim! It's sad for him.

1. Read this poem while a friend acts it out. Change roles. Think: How does a tired person move? hold his head? walk? facial expression?
2. Make a list of things which make you tired. Compare this list with a friend's. Discuss the things which are alike and different.
3. What do you think of "poor tired Tim"? Draw a picture of how you think he looks or write a description of him.

poems

Hop Up
and
Jump Up

All: Hop up and jump up and whirl around, whirl around.

High Voices: Gather love, here it is, all around, all around.

All: Hop up and jump up and whirl around, whirl around.

Low Voices: Gather love, here it is, all around, all around.

All: Here is love flowing 'round, catch it as you whirl around.

Medium Voices: Reach up and reach down, here it is all around.

All: Here is love flowing 'round, catch it as you whirl around.
Reach up and reach down, here it is all around.

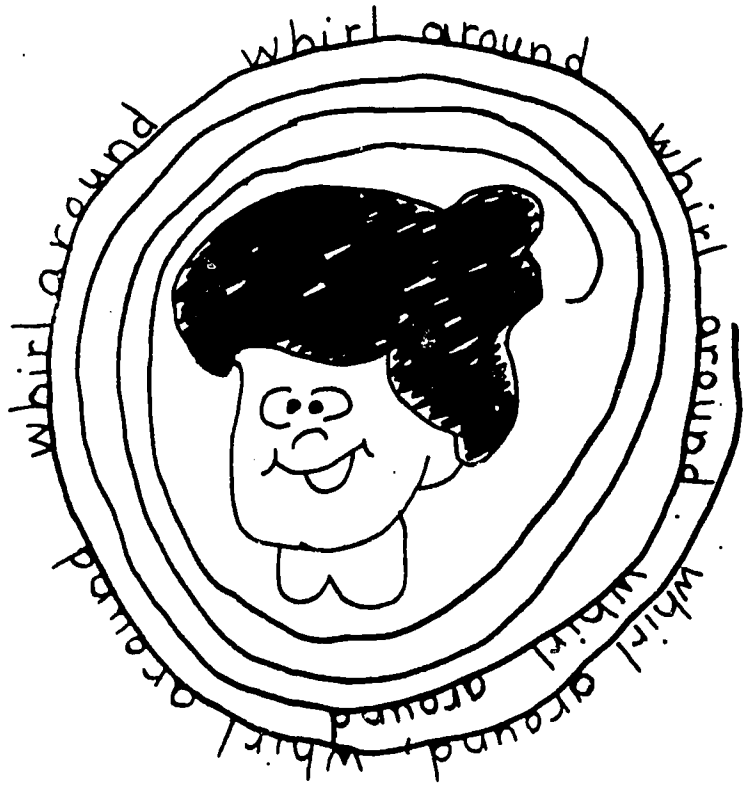

1. Read this poem changing your voice from high to low to medium.
2. Ask two friends to read this poem with you.
3. Ask four friends to work with you. As three of you are reading the poem, have one person clap to its rhythm and another act out the poem. Change parts.

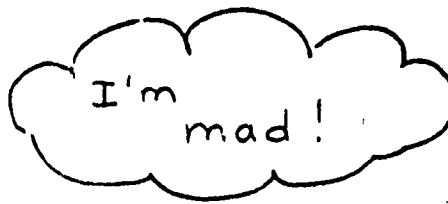
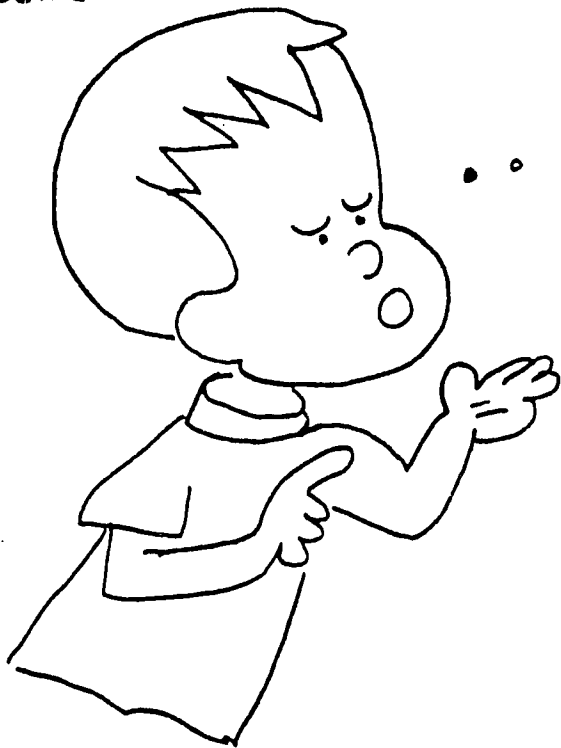

Upset

What do you do
When you get upset?
Scream and yell,
Or don't you tell?

Are you quiet
When you're mad
Or will you talk
About trouble you've had?

I get so mean
When I'm upset,
You'd wish
We'd never met.

1. Draw a picture of yourself when you are upset.
2. How do you show anger at home? At school? Is there a difference? Why?
3. Does it help make you feel better to yell when you're upset? Why?
4. Pantomime ways to show that you are upset.

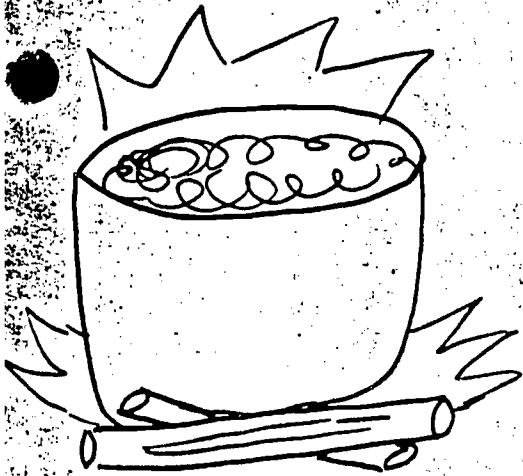

Read the folktale, "The Conjure Wives," using a scratchy, wicked voice for the "conjure wives" and a deep, harsh sound for the "voice."

1. A "conjure" according to the dictionary is one who brings a spirit or the devil by a magic call. What things have been "conjured up" in our world? Make a list of them.
2. Tell a ghost story which once frightened you.
3. Write your own ghost story to read to the class.



THE CONJURE WIVES

a folktale for reading aloud

Once on a time,
when a Halloween night came
on the dark o' the moon,
a lot o' old conjure wives
was a-sittin' by the fire
an' a-cookin' a big supper
for theirselves.
The wind was a-howlin' 'round
like it does on Halloween nights,
an' the old conjure wives
they hitched theirselves
up to the fire
an' talked about the spells
they was a-goin' to weave
long come midnight.
By an' by
there come a-knockin' at the door.
"Who's there?"
called an old conjure wife.

*"Who-o? Who-o?
One who is hungry
and cold,"*
said a voice.

Then the old conjure wives
they all burst out laughin'
an' they called out:
*"We's a-cookin' for ourselves.
Who'll cook for you?
Who? Who?"*

The voice didn't say nothin',
but the knockin' just kept on.

"Who's that a-knockin'?"
called out another conjure wife.
"Who? Who?"

Then there come a whistlin',
wailin' sound:
*"Let me in, do-o-o-o!
I'se cold thro-o-o-o
an' thro-o-o-o,
an' I'se hungry too-o-o!"*

Then the old conjure wives
they all burst out laughin',
an' they commenced
to sing out:
*"Git along, do!
We's a-cookin' for ourselves.
Who'll cook for you?
Who? Who?"*

An' the voice didn't say nothin',
but the knockin' just kept on.

Then the old conjure wives
began to get scared-like,
an' one of 'em says,
*"Let's give it somethin'
an' get it away
before it spoils our spells."*

An' the voice didn't say nothin',
but the knockin' just kept on.
Then the conjure wives
they took the littiest piece of dough,
as big as a pea,
an' they put it in the fry pan.
An' the voice didn't say nothin',
but the knockin' just kept on.
An' when they put the dough
in the fry pan,
it begun to swell an' swell,
an' it swelled over the fry pan
an' it swelled over the top
o' the stove
an' it swelled out on the floor.
An' the voice didn't say nothin',
but the knockin' just kept on.
Then the old conjure wives
got scared
an' they ran for the door,
an' the door was *shut tight*.
An' the voice didn't say nothin',
but the knockin' just kept on.
An' then the dough
it swelled an' it swelled
all over the floor
an' it swelled up into the chairs.

An' the old conjure wives
they climbed up
on the backs of the chairs
an' they were scarer
and scarer.
An' they called out,
*"Who's that a-knockin'
at the door? Who? Who?"*

An' the voice didn't say nothin',
but the knockin' just kept on.
An' the dough kept a-swellin'
an' a-swellin',
an' the old conjure wives
began to scrooge up
smaller an' smaller,

an' their eyes
got bigger an' bigger
with scaredness,
an' they kept a-callin',
"Who's that a-knockin'?"
Who? Who?"

An' then the knockin' stopped,
and the voice called out,
"Fly out the window, do!
There's no more house for you!"

An' the old conjure wives
they spread their wings
an' they flew out the windows
an' off into the woods,
all a-callin',

"Who'll cook for you?
Who? Who?"

An' now if you go into the woods
in the dark o' the moon,
you'll see
the old conjure wife owls
an' hear 'em callin',
"Who'll cook for you?
Who-o! Who-o!"

Only on a Halloween night
you don't want to go
'round the old owls,
because *then*
they turns to old conjure wives
a-weavin' their spells.

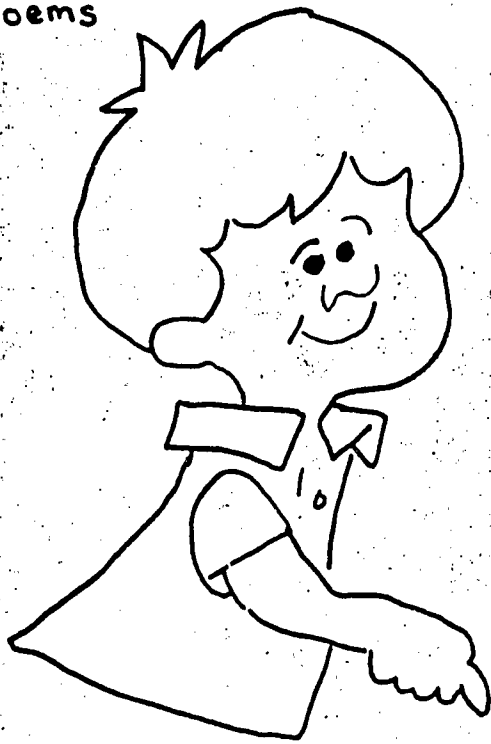

Hinges

I'm all made of hinges,
'Cause everything bends,
From the top of my neck
Way down to the end.
I'm hinges in the front,
I'm hinges in the back,
But I have to be hinges
Or else I will crack.

1. Read the poem. Have a friend pantomime the actions.
2. Suppose your body did not have "hinges." Show how you would move.
3. Compare how you move with "hinges" to without "hinges."



Raggedy Ann



Raggedy Ann is my best friend.
She is so relaxed; just see her bend,
First at the waist, and then at the knee.
Her arms are swinging, oh, so free!
Her head rolls around like a rubber ball.
She hasn't any bones at all.
Raggedy Ann is stuffed with rags.
That's why her body wags and wags.

1. Read the poem while a friend acts it out.
2. Change Raggedy Ann to Raggedy Andy. Does this change the actions to the poem? If so, how?
3. Compare Raggedy Ann to Barbie. How are they alike? Different? Write a poem for Barbie. What actions could go with the poem?



Sing a Song

of Feeling --

Whistle a Happy Tune

Oscar Hammerstein

Whenever I feel afraid,
I hold my head erect
And whistle a happy tune,
So no one will suspect
I'm afraid.

1. Songs tell a story just like books do. Write the story that this song tells.
2. What makes you frightened? Act out the situation.
3. This song is about feeling afraid. Write a song to describe another feeling.

puppetry

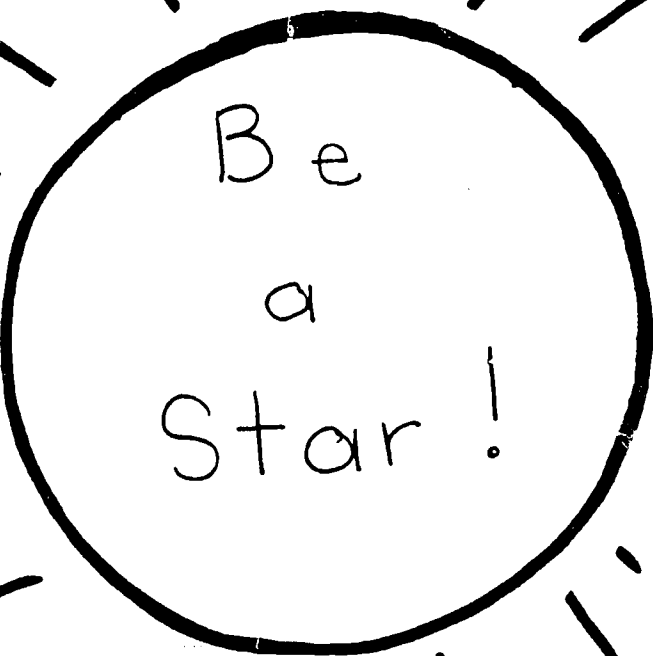

Choose one of the puppet show themes in the stage pocket.

Select a puppet and act out the theme.

You may add words and actions to the theme.

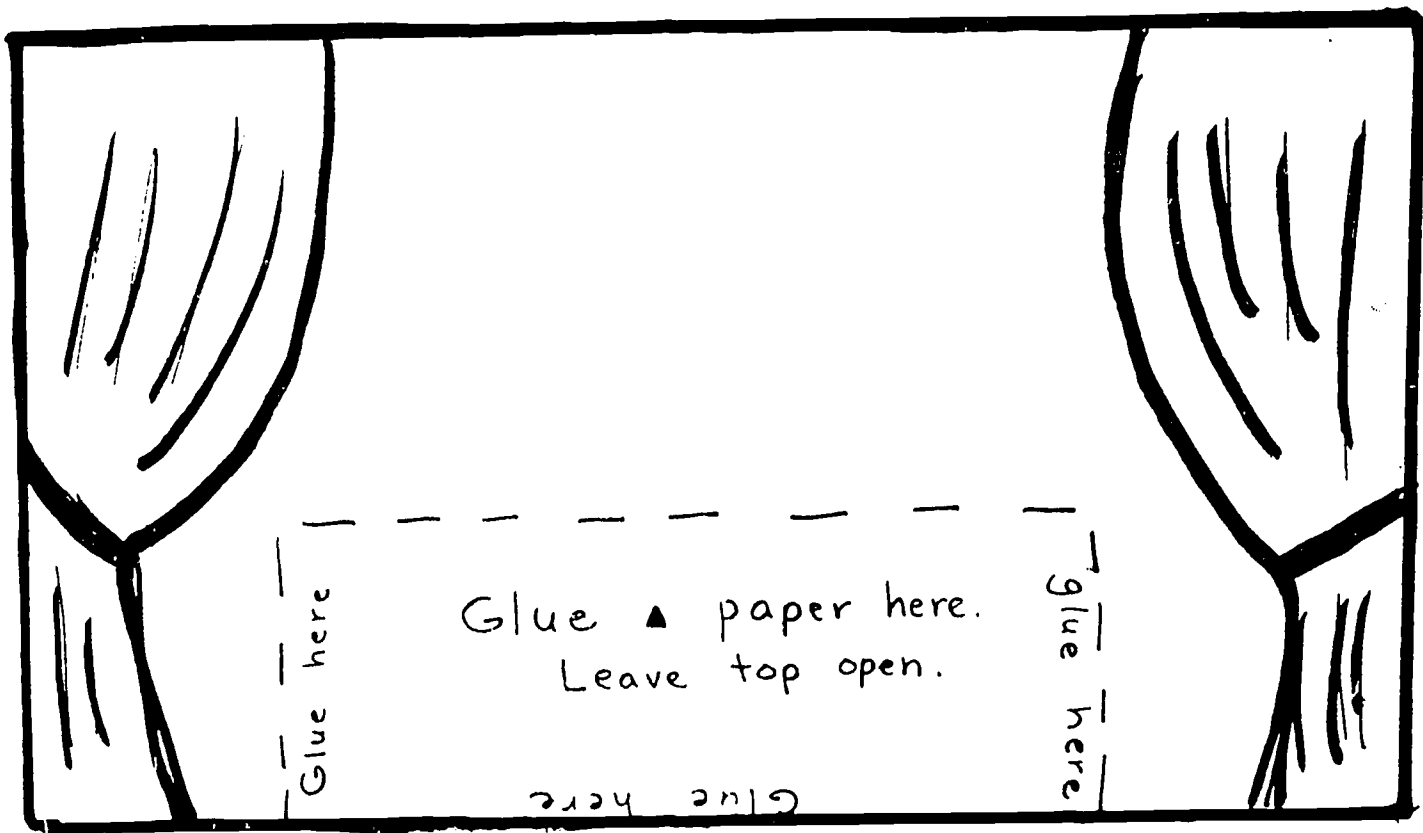

The song "Walking Happy" has been removed
because of copyright.

Puppetry

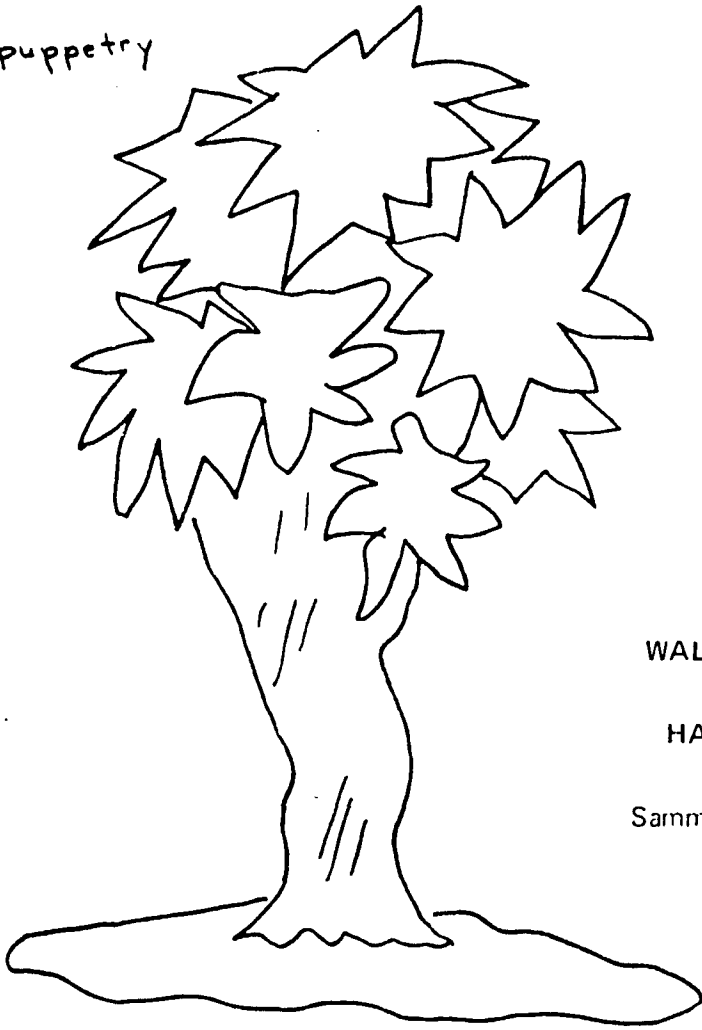

WALKING

HAPPY

Sammy Cahn



Work in pairs.
One person read the poem "Walking Happy" while another acts out the walk using a felt puppet.
Change roles.

puppetry



PUPPET

MOVEMENT

Using the styro ball and your hand as a puppet, list the movements and the feeling it might show.

Describe the movement of the head.

Describe the movements of the head and hands together.

<u>movement</u>	<u>feeling</u>
the head bent down	tired

1. Jump out of bed because this is the morning you go on a camping trip with your friends. You discover that you have the measles and can not go on the trip.

5. You are playing baseball. Once you strike out and once you hit a home run.

2. You are going grocery shopping for your mother. When you arrive at the store, you discover the grocery list is missing. Feeling very sad, start home, find the list, go back for the groceries.

6. You are Betsy Ross finishing the sewing on the flag. There's a knock at the door.

3. You are Cinderella feeling very sad as you do the housework. Your stepsisters have all gone to the ball. Your fairy god mother appears and grants your wish.

7. You are a circus performer

4. You have gone on a fishing trip with your dad. You have caught your first fish and begin to reel it in.

8. You are a ballet dancer.

*Teacher:
Cut out the rectangles on this page. Glue the blank one to the stage (▲) of the sheet entitled "Be a Star." Place the others in this stage pocket as task cards for children to draw out and perform the action with puppets.*

Puppet Pattern
1.

Cut 2 (front
and back).

Sew together
along edges.

Puppet Pattern

Cut out along
dotted lines for
back only

Cut out Puppet
Pattern. Trace

2 on felt.
Cut out for
hand in
back only.

Lace or sew
together on
edges.

insert hand
in back

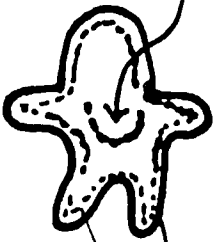

sew or
lace front
and back
together.

Puppet pattern 2.

Trace on felt.
Cut out two.
Sew together.

Puppet Pattern

Cut 2. Sew together
along edges - leave
bottom of dress open
for hand.

Decorate with
eyes, mouth, hair; etc.



insert
hand at
bottom
of dress.

⚡ Do Not Sew at Bottom ⚡

puppetry



How do you
feel?

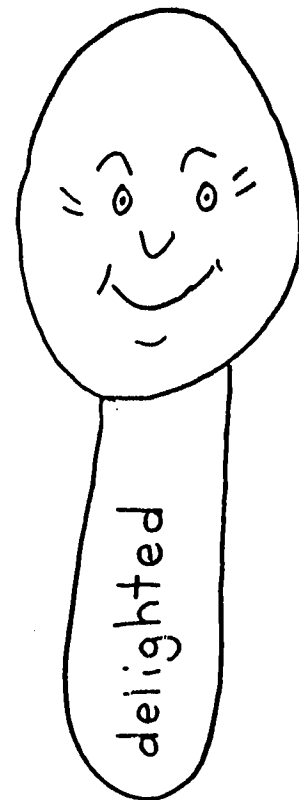

Draw and cut out a paper face which shows a feeling.

Paste the face onto a tongue depressor.

Write the feeling on the stick.

Write a puppet show which tells why a person might feel that way.

Think up a way to change that feeling.

puppetry

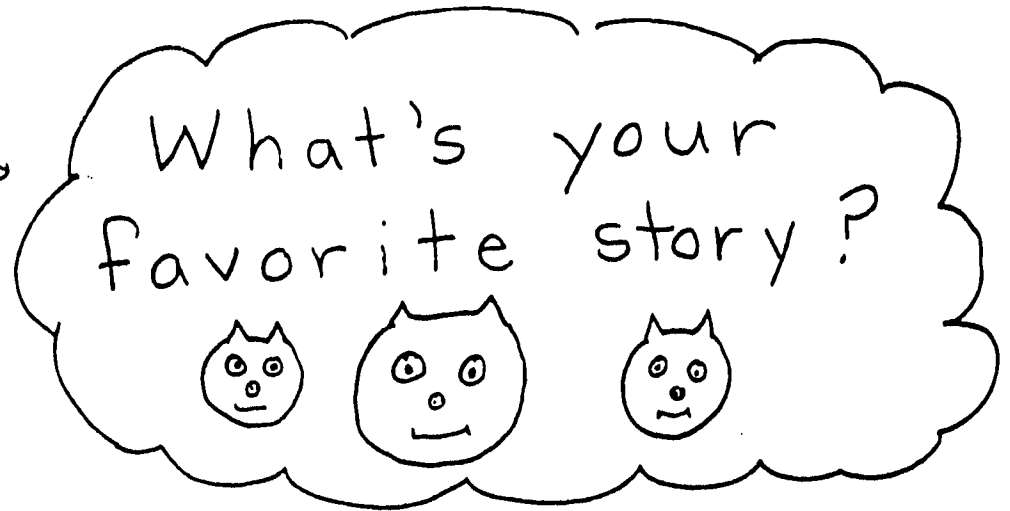
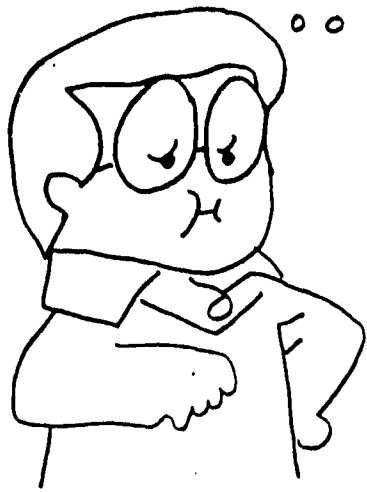

You will need:

- A group of friends to act out your story.
- large paper (11 x 14)
- one inch rubber bands
- metal fasteners
- paint

Directions:

1. Decide on a story to act out, for example, "The Three Pigs."
2. Draw the characters needed for the puppet show. Remember to make them BIG!
3. Paint the characters.
4. Cut them out.
5. Put 2 one-inch rubber bands on the back with metal fasteners, leaving room for your hand.
6. Act out your story.

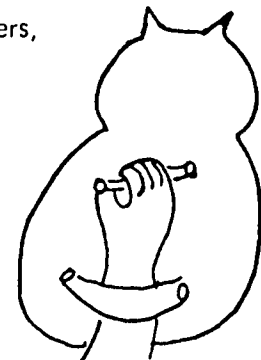

puppetry

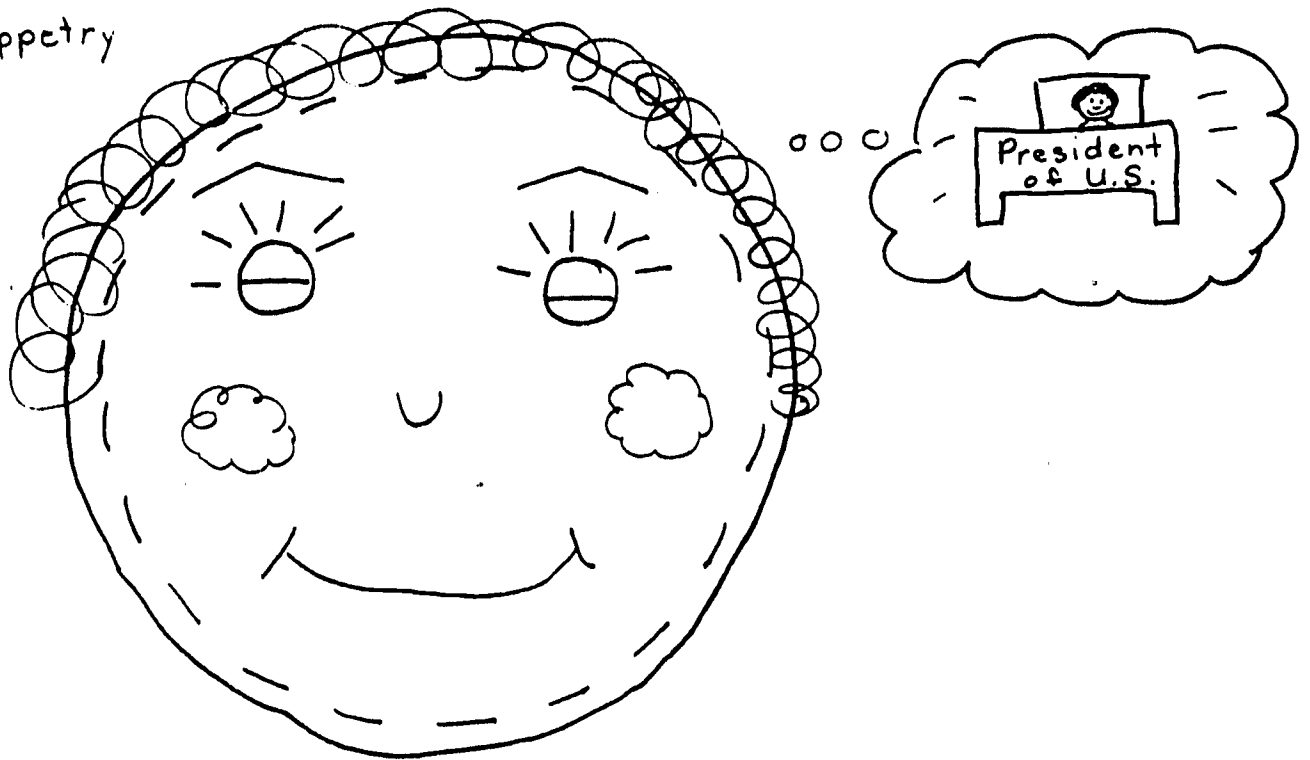

WHAT WOULD YOU LIKE TO BE?

WHY?

- Think of what you would like to do for a day.
- Draw or paint your face on a paper plate. Draw the back of your head on another plate.
- Staple the two plates together leaving enough space for your hand.
- Do you need special clothes for your job? Cut out clothes from construction paper and paste to the front of the plate.
- Act out your job for the day. What do you do first at work? second? next? What's the last thing you do?

#

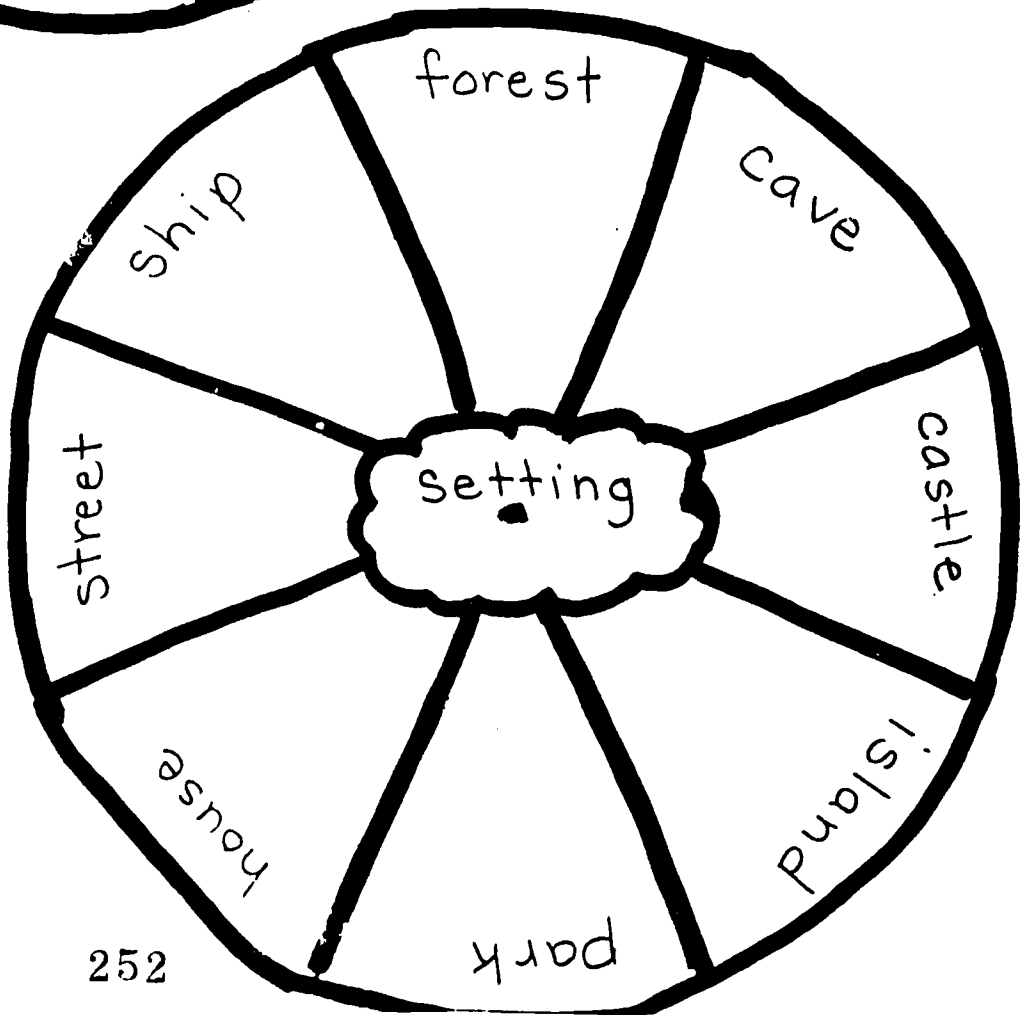
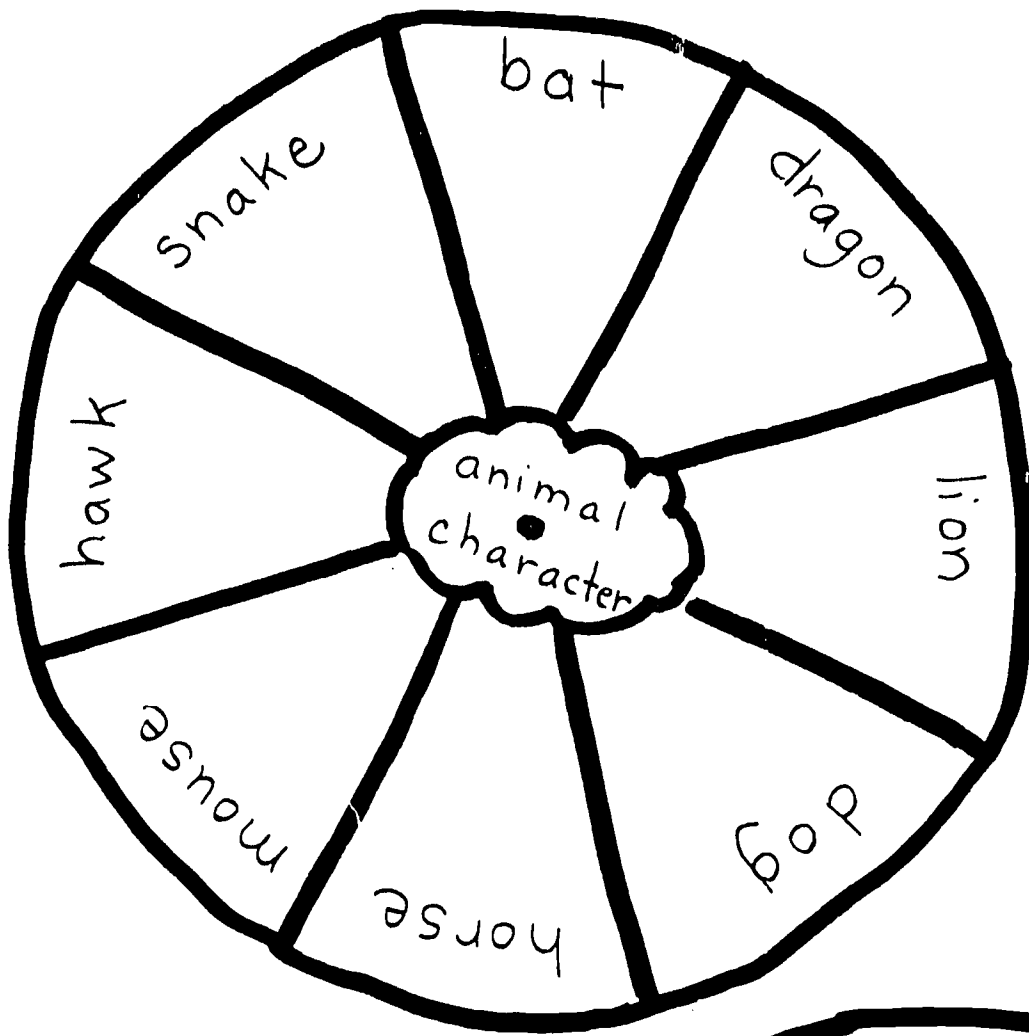

#

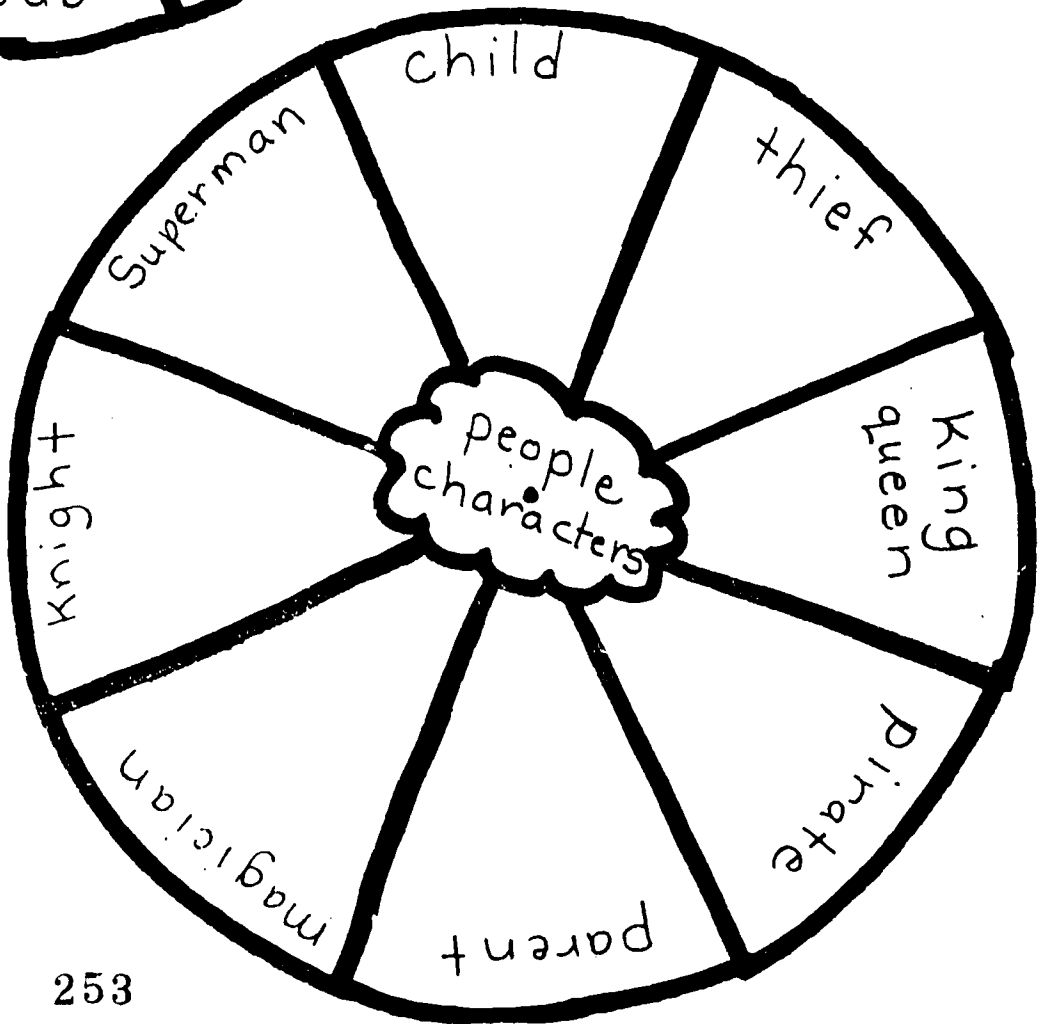
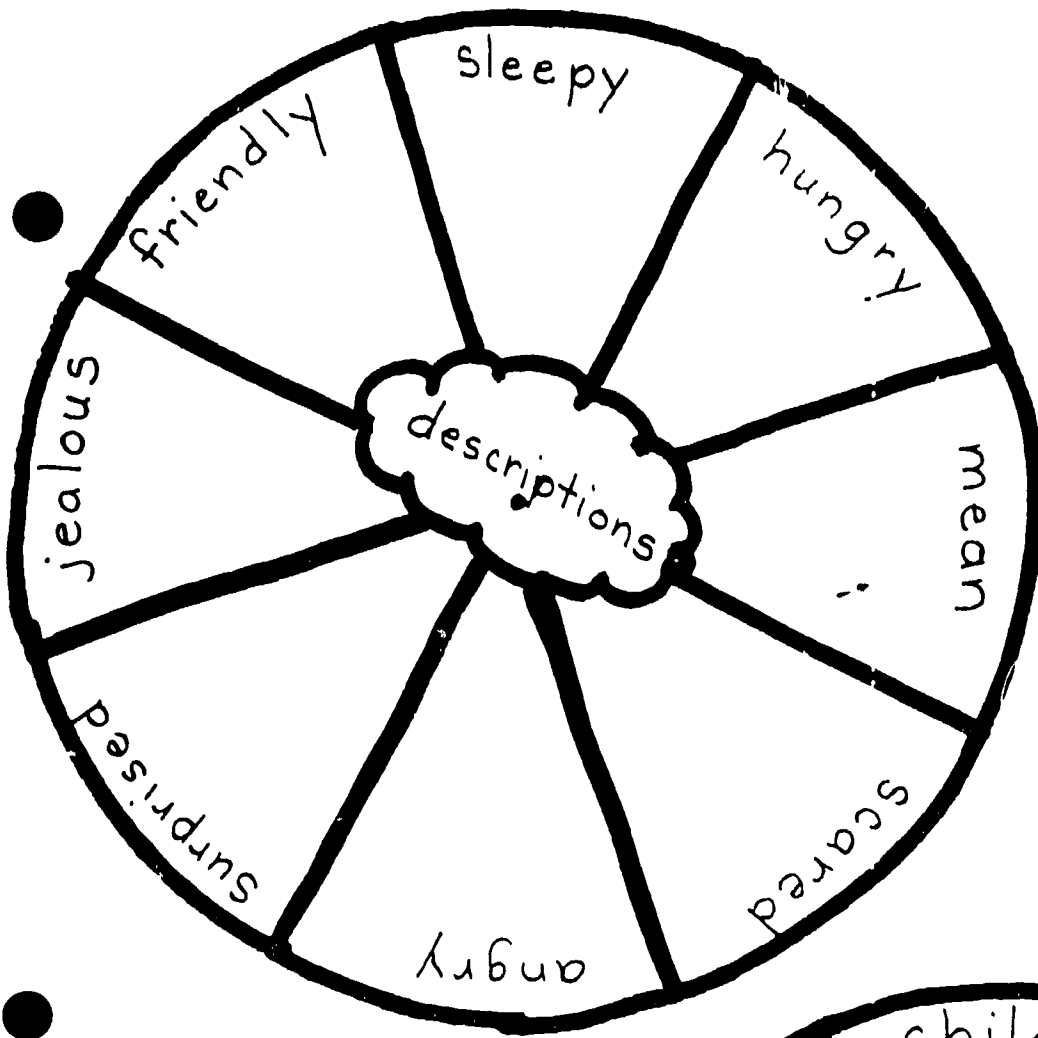

HAH HAH, HAH HAH HAH

Ma is on stage by herself. Ma: "*Boo Hoo, Boo Hoo Hoo!*"

Pa comes on stage. Pa: "What's the matter, Ma?"

Ma answers Pa. Ma: "We ain't got the money for the mortgage on the cow!"

Pa questions Ma. Pa: "We ain't got the money for the mortgage on the cow???"

Ma answers Pa. Ma: "No, we ain't got the money for the mortgage on the cow."

Ma and Pa together. Ma and Pa: "*Boo Hoo, Boo Hoo Hoo!*"

Cow gets into act. Cow: "*Moo Moo, Moo Moo Moo!*"

Milkman speaks. Milkman: "*Swish, Swish, Swish Swish Swish!*"

Sis comes on stage. Sis: "What's the matter, Ma? What's the matter, Pa?"

Ma and Pa together. Ma and Pa: "We ain't got the money for the mortgage on the cow!"

Sis questions Ma and Pa. Sis: "We ain't got the money for the mortgage on the cow?"

Ma and Pa together. Ma and Pa: "No, we ain't got the money for the mortgage on the cow."

Ma, Pa, and Sis together. Ma, Pa, and Sis: "*Boo Hoo, Boo Hoo Hoo!*"

Cow speaks. Cow: "*Moo Moo, Moo Moo Moo!*"

Milkman speaks. Milkman: "*Swish, Swish, Swish Swish Swish!*"

Brother comes on stage. Brother: "What's the matter, Ma? What's the matter, Pa? What's the matter, Sis?"

Ma, Pa, and Sis together. Ma, Pa, and Sis: "We ain't got the money for the mortgage on the cow!"

Brother questions. Brother: "We ain't got the money for the mortgage on the cow?"

Ma, Pa, and Sis together. Ma, Pa, and Sis: "No, we ain't got the money for the mortgage on the cow."

Ma, Pa, Sis, and Brother together: "*Boo Hoo, Boo Hoo Hoo!*"

Cow speaks: "*Moo, Moo, Moo Moo Moo!*"

Milkman speaks: "*Swish, Swish, Swish Swish Swish!*"

Villain comes on stage. Villain: "I'll take the money for the mortgage on the cow!"

Ma, Pa, Sis, and Brother: "You'll take the money for the mortgage on the cow???"

Villain: "Yes, I'll take the money for the mortgage on the cow!!"

Ma, Pa, Sis, and Brother: "*Boo Hoo, Boo Hoo Hoo!*"

Cow speaks: *"Moo Moo, Moo Moo Moo!"*

Milkman speaks: *"Swish, Swish, Swish Swish Swish."*

Hero comes on stage. Hero: *"I'll pay the money for the mortgage on the cow!"*

Ma, Pa, Sis, and Brother question: *"You'll pay the money for the mortgage on the cow?"*

Sis exclaims. *"My Hero."*

Villain slinks off stage hissing. *"Ss Ss Ss Ss Ss."*

Cow speaks. *"Moo, Moo, Moo Moo Moo!"*

Milkman speaks. *"Swish, Swish, Swish Swish Swish!"*

Ma, Pa, Sis, Brother, Hero, Cow and Milkman in unison:
Hah, Hah, Hah Hah Hah!

The poem, "The Blind Men and the Elephant" by John G. Saxe has been removed because of copyright.

role playing

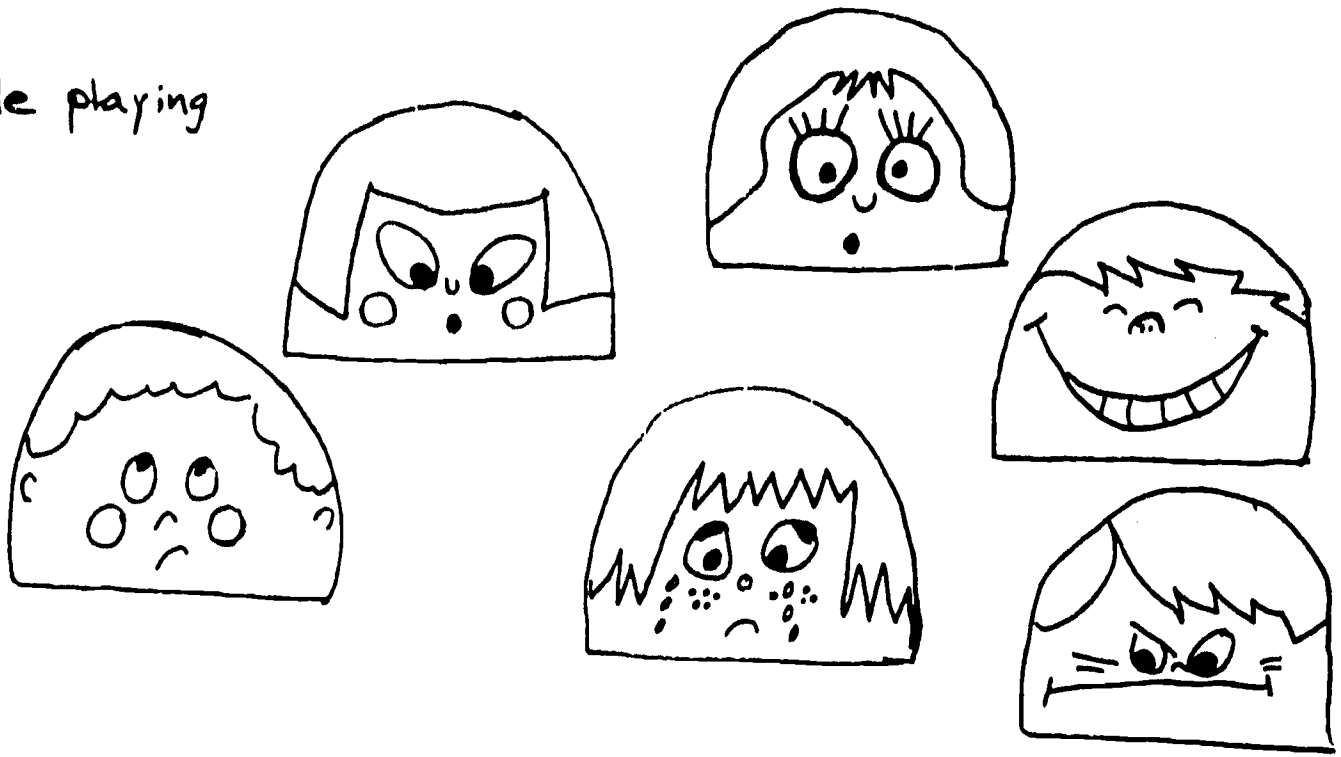

Use the "How Do You Feel?" Hats

These story cards stop, but they are not finished. Act out the way you think they should end.

role playing



The Pet

I was walking home from school and saw a hurt dog. He was limping so I picked him up. He liked me and started wagging his tail.

I took him home and nursed him back to health. My mother said that she would put an ad in the paper and that if no one claimed the dog, I could keep him.

The first night that the ad was in the paper, no one came.

The second night a man and small boy came. When the small boy saw the dog, he called "Benji" and ran to him.

My heart fell.

What should I do?

role playing

Teasing!
What should I do?



Cindy wore her new clothes to school. She went into her classroom expecting the children to say how pretty she looked today. Instead they began to tease her.

"Hey, look at Cindy. She's all dressed up."

"Where do you think you're going today?"

"Who do you think you are? A queen?"

Although she smiled, the teasing hurt her feelings.

What hat shows her feelings?

What should she do?

role playing

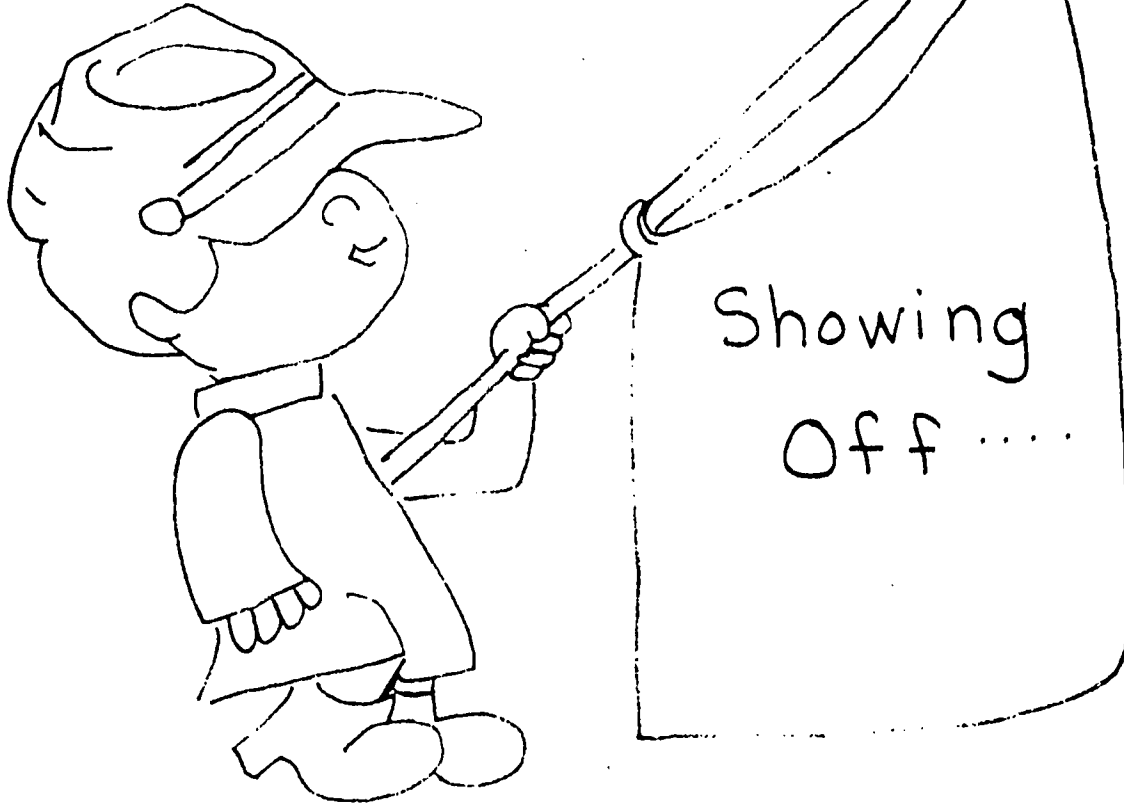

My sisters are always "showing off," especially when I have my friends over.
Last night my friends and I were playing in my room and my sisters began to show-off.
They would open the door and yell or come in and dance around.
I was very embarrassed.

What should you do?

● role playing



The Quarrel

Put on a "feeling" hat and describe your feeling during —

A Quarrel

One day, two boys came toward each other in opposite directions. One of the boys turned to yell at a friend. The second boy was reading a book while walking. POW! The boys ran right into each other.

They began to quarrel.

What happens next?

Act out the ending.

role
playing

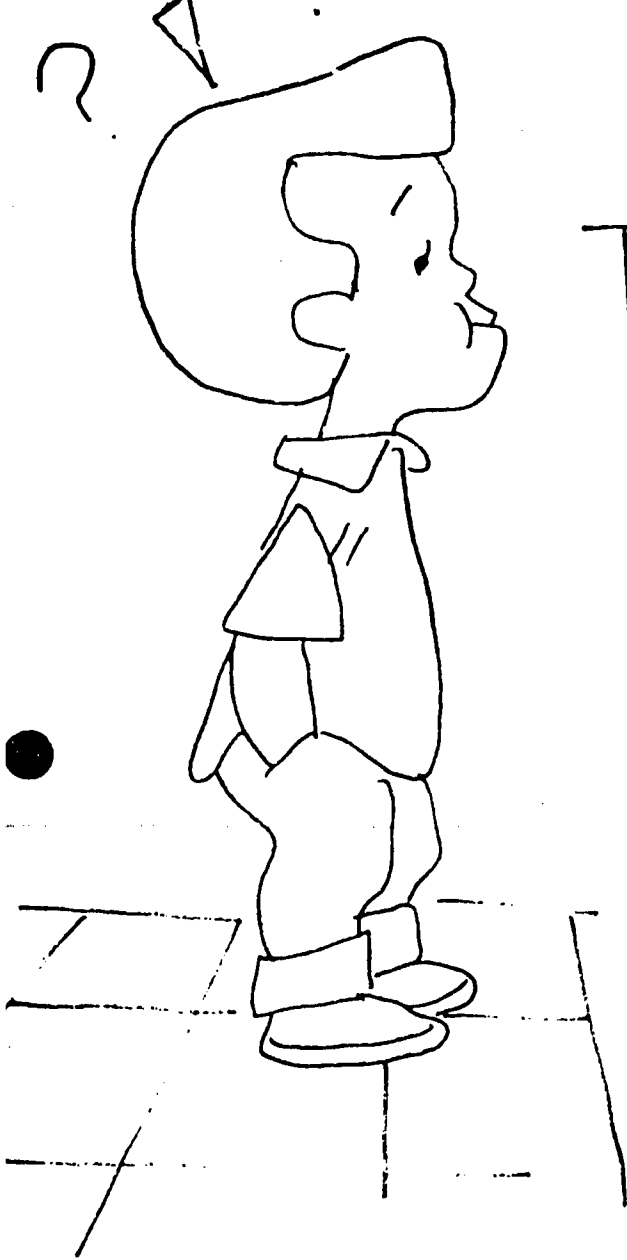

What will Tommy do?

Friends had asked Tommy to go roller skating. Tommy's mother did not have any money for Tommy to go. He felt disappointed.

Tommy's mother asked him to go to the store for bread. On the way home Tom noticed that the grocery had given him too much change. It would be just enough to go roller skating.

Put on a "feeling" hat that describes Tommy's feelings.

What will Tommy do?

Act out the ending.

Career Education Learning Center

• **KEEP YOUR
BONES BUSY**

3

**by Lynn McCown Belmont School
Fall 1975 Lincoln, Nebraska**

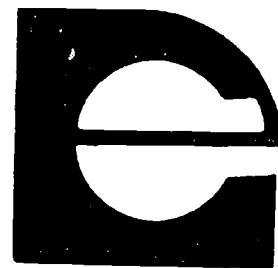

**LINCOLN
CAREER
EDUCATION
PROJECT**

The materials presented in this document were developed under a grant from the Office of Education, U.S. Department of Health, Education, and Welfare. Contractors undertaking such projects under Government sponsorship are encouraged to express freely their professional judgement in the conduct of the project. Points of view or opinions stated do not, therefore, necessarily represent official Office of Education position or policy.

Submitted by
Lincoln Public Schools
John Prasch, Superintendent
Carl Spencer, Project Director

1976

264

Learning Center
Career Education

3

"Keep Your Bones Busy"

By Lynn McGown
Belmont School
Lincoln, NE

1. Subject Area: Science, Language Arts

Career Education Themes: Career Awareness
Self-awareness

2. Teacher's Objectives:

1. The child will be able to understand the importance of the skeletal system.
2. The child will learn about various careers associated with the skeletal system.
These careers might include:
Orthopedic Doctor
Physician
School Nurse
X-Ray Technician
Dentist
Veterinarian
Museum Curator
Ambulance Technician
Teacher

Student's Objectives:

Printed on page labeled ○ for display in the center.

3. Pre - Assessment:

To find out what children know about the skeletal system give them the pre - test labeled #. It is best to check this orally (in groups, pairs, etc) so children can justify their answers. Especially the careers with bones. No key is needed as all the answers are YES for 1-6.

4. Record Keeping:

Have booklets made for each child by folding 12 x 18 construction paper. Staple or glue a paper pocket on one side of booklet for them to keep their notes, research, etc. Staple in some pages for the children to record from Bone Task Cards.
Title Booklet - "Keep Your Bones Busy"

Pre - Activities: Readiness

- Suggested readiness activity for the class; teacher - directed (or able students may read it for themselves). Teacher reads "The Shiny Bone" in Bill Martin Series Sounds of Mystery. Some of your children may enjoy this story so much that they may want to present it as a puppet show. • Teacher and students must assemble the "Human skeleton kit" by Renwal (included in center packet) before the center can be opened with Activity 1. A,B,C,D below are suggested ways to form teacher-led groups of students. Teachers work with Team A one day, continue with Team B and then C (etc.) until skeleton is completed.

The questions below can be used to form the groups or teams. The answers to these questions could be graphed with teacher help because children will need to know how to graph the number of broken bones (question A) for Task Card 5. Keep the tabulations as children sign up on question sheets to refer to during this unit.

- A.) How many children have had broken bones?
- B.) How many of you have ever gone for a ride in an ambulance?
- C.) How many of you have ever visited a doctor's office?
- D.) How many of you have ever visited a museum? or seen a fossil?

These questions can be placed on separate sheets of paper as shown below.

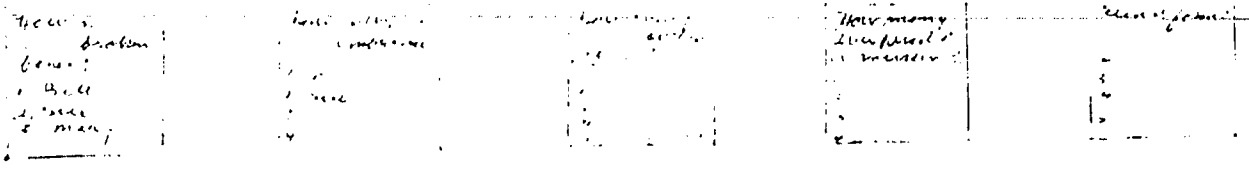

Use teams to assemble the kit. If teams are very uneven, choose teams by having each child draw a bone from a hat with number 1,2,3, or 4 take turns working with the teams.

5.

ACTIVITIES:

Activity 1:



Once the kit is assembled start the activities using the bone activity Task Cards. These cards are not sequential; they are numbered for ease in recording answers.



The task cards should be cut out and placed at the center, along with this equipment.

1. Measuring tape (metric or inch)
2. Graph paper
3. Crayons or marking pens
4. Rulers

Teacher may control the number of tasks cards students do or give extra credit for all etc. Gifted and interested students add other tasks to do or teachers may make extra bone task cards using page 6 - activity 1 sheet.

Readiness for Activity 2

When children have gained some knowledge of our skeletal system, begin introducing the careers that are involved.

Class or group discussion using questions such as the following:

- a. What kinds of things do you see when you go to a museum?
- b. What are fossils?
- c. How do the people that work in the museum know how old these fossils or bones are? Introduce the name Museum Curator.
- d. What importance do these bones and fossils have for the Museum Curator?

Take the group to Morrill Hall or invite the Curator to the Classroom to display some bones or fossils and explain the importance of his job. Call Dr. Allen Griesemer, Curator and Director of Educational Services (472-2637) to arrange for a speaker. Children could bring in bones for display table. They should label the bones, such as:

- Chicken Bones - wing - thigh and leg
- Fish bones

Activity 2:

Use the X-Ray that is included with this kit or obtain an X-ray from a doctor's office. Children work with a partner to answer questions on the page labeled □ (activity 2); it can be dittoed. Extended questions for gifted could be added such as:

- Can you tell what bone is shown in the X-ray?
- Research about X-ray cameras and X-ray photos.
- Find out about some careers that deal with bones such as (Doctor, Nurse, Ambulance Technician, X-ray Technician) by interviewing a worker or reading about the career.

Activity 3:

Readiness may be necessary; class discussion about health-related careers (that deal with bones).

The sheet labeled □ □ for activity 3 should be dittoed and placed in the center or display the directions on a chart. Put out magazines to cut up, scissors, paste.

Readiness for Activity 4:

Class activities:

Invite your school nurse to the classroom to discuss "How to Build up Strong Bones." She would be an ideal resource person. Her discussion could include

- a. diet
- b. care
- c. our body frame work
- d. posture

Invite a doctor or teacher from Physiology Department to come and talk to class about the importance of our skeletal system. What happens to broken bones - how they mend. The kind of training they must have to do their jobs.

If possible, have a small group (3-5) take a trip to a doctor's office (preferably Orthopedic Physician) and report to the class.

Activity 4:

Use the Unscramble Career sheet at this center (4-A) and answer sheet 4-A with a challenge activity (4-B) on the bottom half. Ditto copies for students.

Readiness for Activity 5:

Invite a Veterinarian to your class. He or she might be able to bring some skeletons of different animals. Conduct a discussion about how some animals have bones, some don't.

Activity 5:

Ditto copies for students. Put out drawing and writing paper, crayons, pencils. Put out The Skeleton Book - by Livaridars and Dunne, published by Scholastic Book Services. Put animal-creature drawings made on a bulletin board entitled "Featured Skeleton Creatures"

Art Activites 6:

Children may choose to do one, two or all of these activities.

Teacher prepares by cutting out the bone task cards to display at the center--or make dittoed copies for students if preferred.

Put out the following art supplies:

Black construction paper
 White crayons and/or chalk
 Scissors
 Glue
 Paper straws
 Marking pens
 Large white butcher paper length of child
 Cardboard tubes
 Empty spools
 Styrofoam balls for head
 Wire or string

*and ** activities are challenge ones and perhaps should be teacher-directed. The ** activity could be used as Post Test.

Optional Culminating Activity: Teacher directed for interested students.

Get a whole chicken; cook chicken, then scrape meat from bones and try to rearrange the chicken's skeleton back together again.

You might check with the University and see if any Physiology student might be interested in helping.

Resources and Bibliography: Teachers gather for student use:

The Skeleton Book: An Inside Look at Animals. Livaudais and Dunne;
 Scholastic Book Services
Built To Survive by Anne Terry White, Gerald S. Leitz M.D.
The Human Skeleton Benjamin N. Schuman M.D.
Bone for Bone Margaret Cosgrove
Me and My Bones Roy A. Gallant
Sounds of Mystery Bill Martin Series; Holt, Rinehart, Winston
 Filmstrip - Eye Gatehouse Inc.
 "Your Body and How to Take Care of It".
 "Your Bones and Muscles"

Audio-visual: #2010-94 Human Body Kit - K-6

Films: #2037-94 Human Bones 4-6
 #1997-04 Our Wonderful Body How It Moves K-3
 #1976-04 Our Wonderful Body How It Grows K-3

6. Location of Center:

See page labeled Δ for ideas of location and arrangement.

7. Evaluation:

Use the ** Art Activity 6 for a Post Test or re-test with the initial pre-test labeled #.

Childrens Objectives:

- 1.) I will be able to explain the importance of bones.
- 2.) I will learn about special careers that deal with bones.

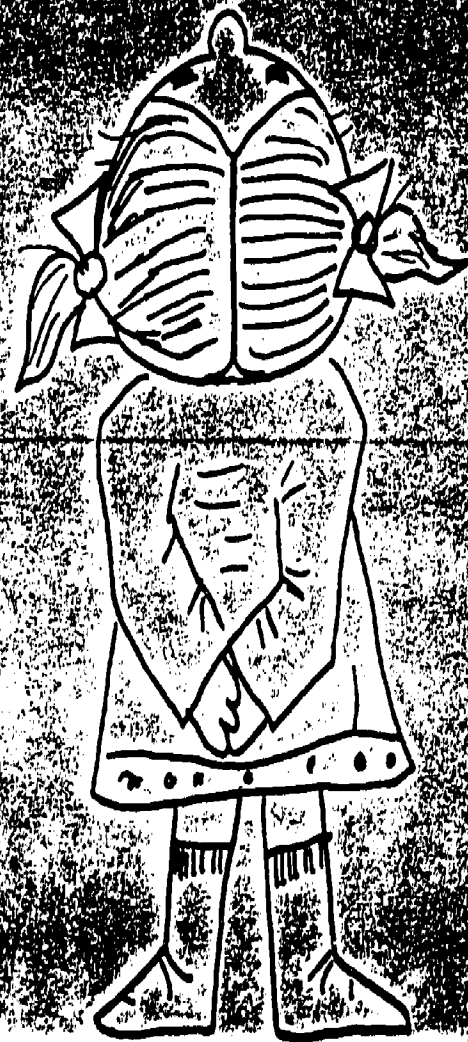

Name _____

#

{ Read the questions.
Circle either yes or no

- 1.) Do all animals have bones? yes no
- 2.) Do we have over 100 bones
in our body? yes no
- 3.) Do broken bones mend? yes no
- 4.) Can we take pictures of bones? yes no
- 5.) Is your ear lobe a bone? yes no
- 6.) Did man ever use bones for tools? yes no

Underline the people who you think work and study bones :

Museum Curator
Student
Ambulance technician
Doctor
Plumber

Teacher
X-Ray Technician
Banker
Principal
Nurse

Score: _____

Directions :

Take one of these bone task cards.
Read the directions carefully.

What can you learn from this skeleton?

Record your findings in your "Keep Your Bones Busy Book"

Task
Card # 1

How many ribs do we have in our skeletal system?

▲ Count the number of ribs on our skeleton. Record in your booklet.

#1

Task
Card #2

How many bones do we have in our spinal column?

▲ Count the number of bones in our spinal column. Record your findings in your booklet.

Task
Card #3

Which bone looks the longest?

▲ Measure find which bone in the skeleton is the longest. Record your findings.

#1

Task Card #4

How many bones are there in the entire skeleton?

▲ Try to count how many bones are in the entire skeleton. (Be careful of feet and hand bones.) Record your findings

Task Card #5

How many children have had a broken bone?

▲ Make a bar or picture graph to show how many children have had broken bones. Keep in your Booklet.

Task
Card # 6

How long are some of your bones?

▲ Measure with a friend's help. Measure the distance between the elbow and wrist. Do yours and your friend's. What is the difference? Record your findings.

Task
Card # 7

How long are some of your bones?

▲ Measure with a friend's help. Measure the distance between the knee and the ankle. Do yours and your friend's. What is the difference? Record your findings.

#1

5

Task
Card # 8

What do our hand bones look like?

▲ Trace your hand in the booklet. Try to draw in the bones that are in your hand.

Task
Card # 9

How tall is your skeleton?

▲ Measure the length of your skeletal frame. Use a friend to help. Record your findings.

* Make up some task cards on your own.
Kids could help you.

#1

6

Task
Card #10

Task
Card #11

Activity 2



Meet with a partner. Read these questions and answer them in your Bone Booklet.

- 1. Who might have taken these pictures?
- 2. Where could they have been taken?
- 3. If you were badly hurt how would you get to the Hospital? (Write or Draw what this is.)
- 4. Make a list of people who work in jobs where they need to know about bones.

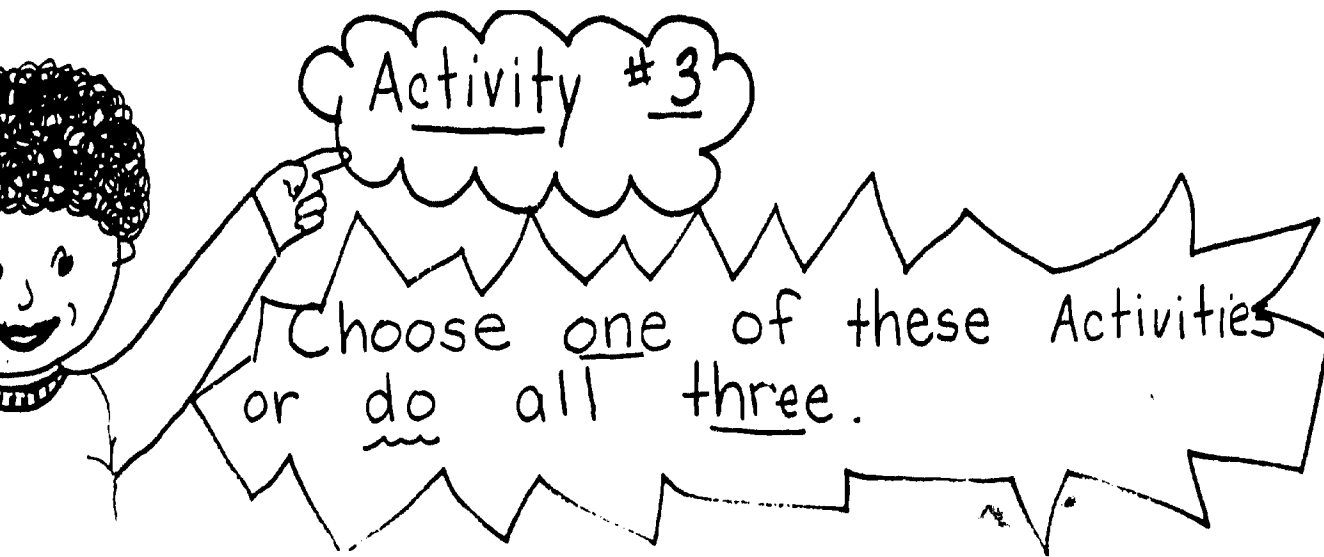

Make a list of good safety rules.
Choose one or more to illustrate.

I think it would be fun to be a
Doctor or Nurse) because

Look through magazines. Cut out or draw
pictures of health related careers.

NAME _____

Activity #4.A

Unscramble these Careers!



1.) cDtroo _____

2.) esNru _____

3.) +Ve _____

4.) rXya nThceanici

5.) mlbAucnae rDvine _____

6.) ctaehre _____

7.) meMsuui +Cauroor _____

✓ Check your work using the answer sheet. Then try Activity #4.B for fun!

How I did.

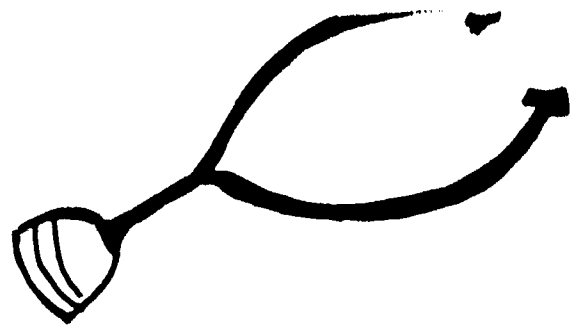

Activity # 4-A

Answer Sheet

✓ Check your own paper. Put your score in the Bone on the bottom of the paper.

- | | |
|---------------------|---------------------|
| 1. Doctor | 5. Ambulance Driver |
| 2. Nurse | 6. teacher |
| 3. Vet | 7. Museum Curator |
| 4. X-Ray Technician | |

*** Try this!

Activity # 4-B

*** Make up a word scramble on your own. Use health related careers. Put them on the Bulletin Board for other children to do.

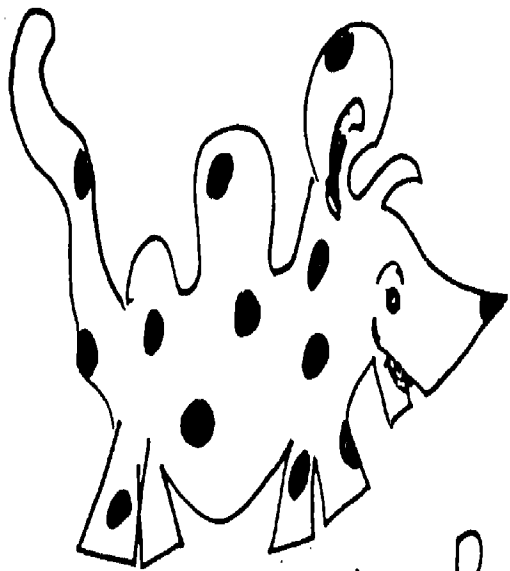

Activity #5



▲ Read all about bones of Animals in The Animal Bone book.

▲ Then choose a partner. One will draw a skeleton of an imaginary animal. The other will draw a picture of what they think the animal looks like.

▲ Together you will write a description of how your animal looks. You might want to give your creature a name.

▲ Put on Bulletin Board for others to see!

Art
Activity
#6

Straw Skeleton

- ▲ Material: Scissors, paper straws, black construction paper, glue.
- ▲ Directions: Assemble your skeleton by cutting the straws into different lengths and paste them on the black paper to look like a skeleton.

Art
Activity
#6

** Your Skeleton

▲ Material: Marking Pens, Large white butcher paper the length of you.

Choose a partner

▲ Directions: Lie down on top of the white paper. Have your partner trace your body. Help your partner do his. Then working alone or with your partner fill in your skeletal parts.

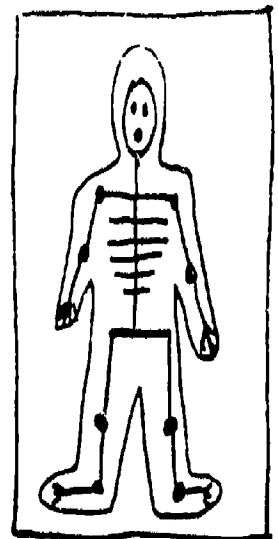

Art
Activity
#6

* Mobile Skeleton

▲ Material: Cardboard tubes, spools (empty) Styrofoam ball for head, wire to connect tubes.

▲ Directions: Try to build a 3-D Mobile Skeleton. Use styrofoam ball for head. Connect wires to cardboard tubes, use empty spools for arm and knee joints. Try to make your skeleton tall. (You might want a group of children to help.)

Art
Activity
#6

Action Skeleton

▲ Material: Black Construction paper, White crayons, or chalk.

▲ Directions:

Make a skeleton by drawing it on the black construction paper. The skeleton must be doing an action. (For example: running, walking, hopping, jumping, skipping, sitting etc.) Or you think of a good action that your skeleton could be doing.

- List the action words in your bone booklet.

▲ Location of Center

24.
1/20/...

This may be located on table or counter. Preferably where there is a wall or partition behind it to place title of Center, terms of Vocabulary, etc.

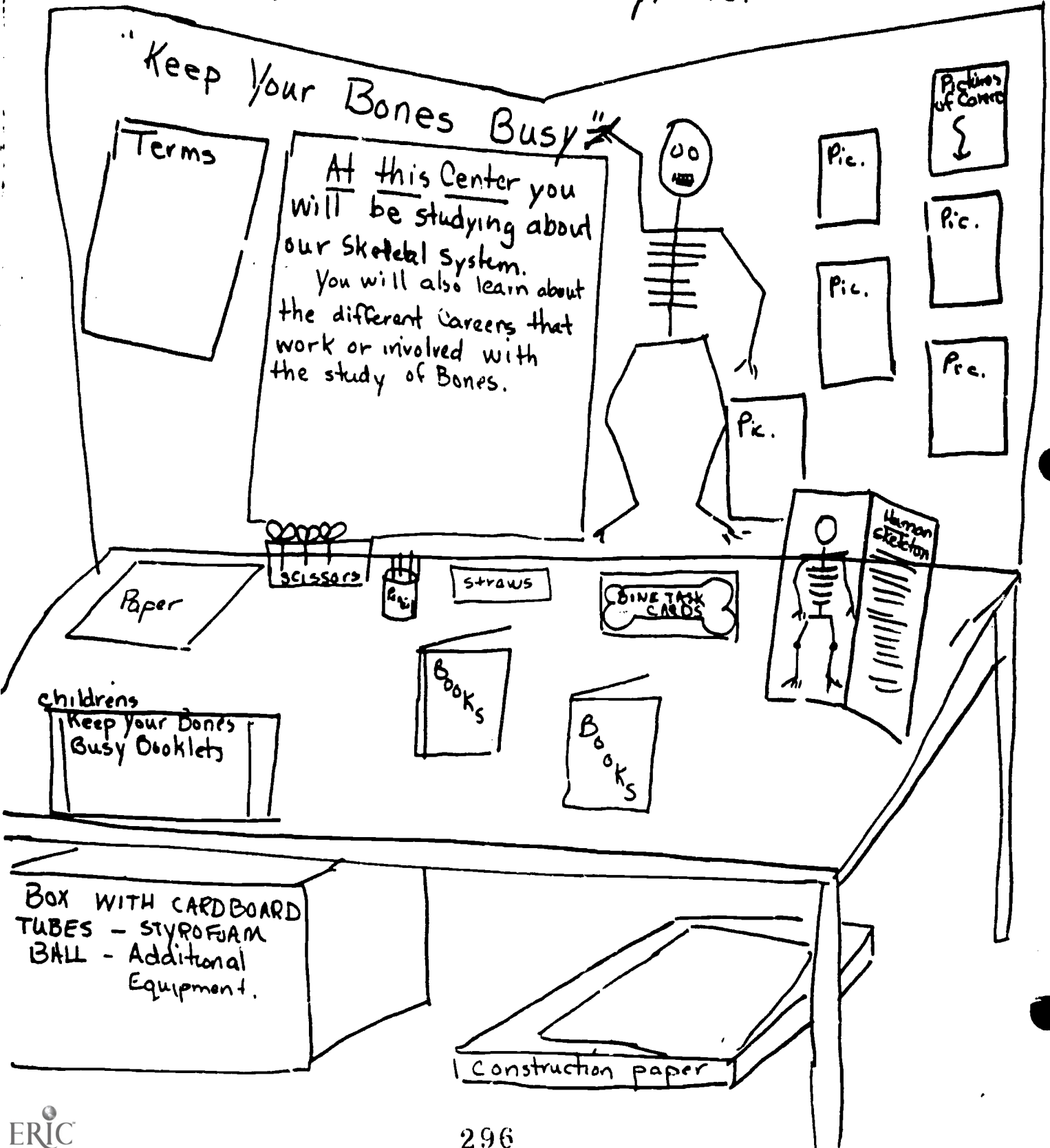

Career Education Learning Center

POSY POWER: Thinking About Values

4

**by Wilma Boles Brownell School
Fall 1975 Lincoln, Nebraska**

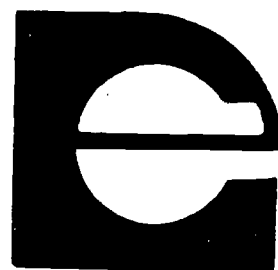

**LINCOLN
CAREER
EDUCATION
PROJECT**

The materials presented in this document were developed under a grant from the Office of Education, U.S. Department of Health, Education, and Welfare. Contractors undertaking such projects under Government sponsorship are encouraged to express freely their professional judgement in the conduct of the project. Points of view or opinions stated do not, therefore, necessarily represent official Office of Education position or policy.

Submitted by
Lincoln Public Schools
John Prash, Superintendent
Carl Spencer, Project Director

1976

298

Learning Center
 Career Education
 POSY POWER-Thinking About Values

4

by Hilma Boles
 Brownell School
 Lincoln, Nebraska

TEACHER'S PLAN

1.

SUBJECT AREA: Language Arts, Creative Art

CAREER EDUCATION THEMES: Career Awareness - Life Styles
 Personal/Social Development
 Decision-Making Skills
 Special Emphasis in Values clarification and Thinking skills

TEACHER'S OBJECTIVES:

Students will be able to-

2.

- Describe their physical characteristics
- Gain pride in their individual qualities
- Evaluate their own abilities, hobbies, and interests through decision making.
- Appreciate the likenesses and differences of themselves and others and appreciate how people change
- Utilize verbal skills by expressing feelings about themselves and others
- Determine qualities that make a good friend
- Speculate about their occupation and life style in terms of their own interests and abilities
- Discuss the concept of pride in achievement in a job well done
- Practice language arts skills
- Utilize their artistic and creative ideas.

STUDENT'S OBJECTIVES:

See student objectives sheet in the kit.
 This sheet may be duplicated for each student using the center.
 This sheet may be posted in the center.
 This sheet may be enlarged into chart form, or bulletin board.

PRE-ASSESSMENT:

3. Students should show the ability to express their personal feelings, interests, and values through written or oral exercises. If teachers feel the child has a healthy attitude toward himself, he need not work through the unit.

Provided in the unit is the worksheet entitled WHO ARE YOU? for a student's written summary. A student may also talk into a tape recorder revealing facts about himself. The teacher may also wish to interview a child about certain areas she feels he needs to work on in the unit. An appropriate film or filmstrip may spark enthusiastic discussion with the whole class before beginning the unit activities.

MULTI LEVEL ACTIVITIES:

4. After the student assessment, the teacher may decide that a student need not use the unit or the student may skip to the post test activities, or the student will work through the complete unit on his own level of ability. In this unit * is used to designate the multi level activities.

- * indicates work on Level 1 - EASIER
- ** indicates work on Level 2 - AVERAGE
- *** indicates work on Level 3 - MORE DIFFICULT

Look for these * notations on each activity listed in this unit. The teacher or the student may choose the activities to complete. * Level 1 students may work with a friend or teacher aide who can help explain vocabulary, write down answers, or answers may be given into a tape.



Teacher preparations for each activity follow. The sequence should be followed as numbered (1 to 7) as the activities build from awareness of self to how others see me; appreciation for diversities; relationship of hobbies, interests and understanding of self to work and play and friendship. The center may have only one activity set up at a time and the next added to or replacing it as children complete the sequence.

To prepare the kit for use:

1. Materials - 5 flower pots
1 mirror on a stand.
other materials listed under each activity.
2. Make ditto masters and copies (on colored ditto or construction paper if desired) of the 2 ticket book pages marked Δ. Cut out the tickets and staple together in order by numbers in lower left corner of each ticket. Make ditto copies of pre-assessment "Who Are You?"
3. Cut out the label on white page • for "Posy Power completed Tickets", glue it to construction paper for stiffening, fasten this on a dowel or popsickle stick and anchor it in the flower pot where students are to place their completed tickets as directed in "Record Keeping" section.

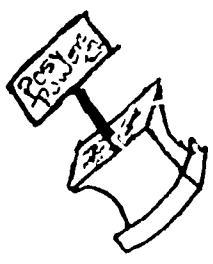

- If manilla envelopes are to be used as record keeping, to conference with teacher, gather enough envelopes for each child to have one.
- Suggestion - Laminate white tag sheets for display in center: "It's All Up To You" "Student Objectives" "Posy Power"; also, this could be run off for students as a cover on notebooks made of the unit; or use as a title sign over the center.



ACTIVITY 1: Yellow pages, labeled "Posy Power"

Teacher Preparations:



1. Cut out Posy Power flower pattern, trace on to bright colored construction paper and cut out 24 flowers of various colors.

2. Cut out yellow tag flower centers with activities printed on them; glue centers on flowers made above.

3. Flowers may be laminated if desired.

4. Pin these flowers on a bulletin board or place in a stack at the center for children to sort through, choosing which ones they want to answer first.

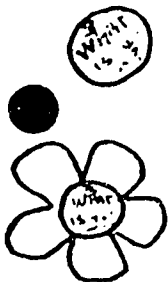

5. Make ditto master and then student copies of answer sheet entitled "Posy Power" (yellow paper). Students are directed on the sheet to write answers to flower-center questions on this sheet following the number which matches the number on the flower center.

ACTIVITY 2: Yellow pages, labeled "feelings".

Teacher Preparations:

1. The picture of four children displaying four different emotions and labeled "feelings" may be used in various ways: a) display at center, b) post on a bulletin board, c) make a master ditto to use this picture as a cover for a student booklet made from activity sheets from activity 2 or as a section divider if a notebook is made of the entire unit; see section #9 for discussion of evaluation by teacher and student.

2. Set up the mirror on its stand at the center.

3. There are six pages of activities (2a through 2f) plus a page of vocabulary words for feelings*. Make master dittoes and copies of these pages to place at the center. Gather six empty ditto boxes from office supply to keep pages organized at center.



* The vocabulary words "Feelings" may be posted on a bulletin board rather than having separate copies for each child.

ACTIVITY 3: Green pages, labeled "How Do Others See Me?"

Teachers Preparations:

1. The directions for students (marked 3a, "How do others see me?") and the list of words "PERSONALITY: qualities & traits" (both on green tag) may be posted or displayed in the center or used to make master dittoes and copies for students to use.
2. Make master dittoes and copies for students of answer sheet 3a and 3b. Page 3a has three sections which the student will cut apart taking each part to the person who is to complete it. The completed sections should all be placed in the record keeping folder for sharing or conferencing later.



ACTIVITY 4: Mixed colors and white pages, labeled "Just a Matter of Choice"

Teacher Preparations:

1. Find white sheet headed "Teachers: "Just a Matter of Choice", follow directions about gluing the 3 labels to 3 flower pots. The labels may be colored before gluing if desired. Materials needed are listed.
2. Place a foam ball in each flower pot in order to hold the flowers, leaves and designs with pipe cleaner stems made by students as directed in the activities.
3. The directions are on white tag, marked Activity 4, Just a Matter of Choice. These may be displayed in the center or cut apart and directions for "A" placed by flower pot "A" etc.
4. As a language arts activity, children are building vocabulary; spelling is also reinforced. Favorite Flavors (Activity 4a on yellow tag) Favorite Colors (Activity 4b on pink tag) and Leisure time activities (Activity 4c on green tag) can be laminated before displaying on a bulletin board or on a stand in the center.
5. Children may need a short brainstorming session about vocabulary in general and specifically the meaning of "Leisure time" before starting in the center.
6. The flower pots call for flowers and leaves but if students prefer making an "outer-space flower" designed to resemble their favorite... (flavor) they may be encouraged to depart from nature in their flower-pot additions! Activity C calls for some creative, artistic ideas if carried out as directed--brainstorming before using the center or placing a teacher-designed sample in the flower pot may help them get started.
7. Materials: pipe cleaners, construction paper, glue, stapler, scissors, yarn and other materials for flowers designed in 4c.

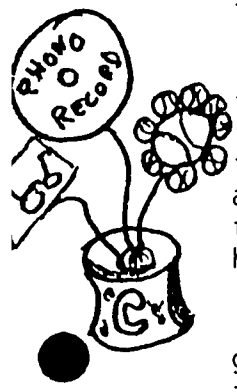

8. It is important that children take time to read what others put in the flower pots--noting differences and similarities compared to their own choices.

9. Optional- Activities 4d (white paper) can be used to make a master ditto and copies for students; or cut apart each suggested activity on the sheet and let students draw out one. Plan some way for sharing when they complete these activities.

ACTIVITY 5: Green pages, labeled WORK AND PLAY
Teacher Preparations:

1. Make Master dittoes and student copies of the four activities 5a, b, c, and d. The answers for 5b may be run off if desired or put on a card at the center. Planning ahead for activity 7, the teacher may decide to run this answer ditto on yellow paper so the happy notes look happier.

2. Students may need to brainstorm about changing interests--past and present--to prepare for 5c and 5d.

3. The students are to write their interests on the buds (earliest stage--past) and how their interests have changed on the flowers (present interests). There should be some way to share these pages--post on a bulletin board, etc.



ACTIVITY 6: Pink pages, labeled "Friendship"
Teacher Preparations:

1. Prepare the flower pot used for this activity by gluing on the label "Best Friend Posy Power Pot" (●)

2. On pink tag sheet marked "teacher sheet, Act. 6", cut out the flower for a pattern to trace and cut a colorful paper flower. Cut out the pink center "Qualities wanted in a best friend" and glue it on to the flower. Fasten flower to a dowel stick and place in the prepared flower pot (#1 above). This is the receptacle for children to share their ideal qualities.

3. Make a ditto using the tickets "My best friend has this quality _____" (●) as a pattern. Run off copies to cut apart and place at the center for activity 4b which is to be filled in after completing 4c. Children should be encouraged to share these ideas of friendship, qualities of personality, etc.

4. Make master dittoes and student copies of 5 pages-- 6a,b,c, two pages of d. Pages a,b, and c are continuous so should be placed at the center at one time; 5d has two pages--the activity choices and the poem.

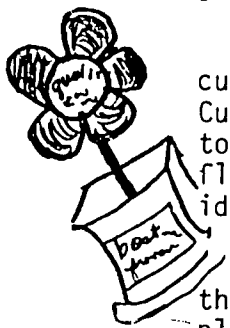

5. Use the list "PERSONALITY: qualities & traits" from activity 3 (on green tag) to display in the center as an aid for vocabulary building. The poem "Friends" (on pink tag) may be laminated if desired before displaying in the center.

ACTIVITY 7: Buff pages, labeled TA--Warm fuzzy or Cold prickly

Teacher Preparations:

1. Teacher and students unfamiliar with "TA for Tots" may want to use that kit book, filmstrip, etc. as preparation before doing this center.
2. Make master dittoes and student copies of four pages 7a, b, d --c is optional as teacher may prefer that students design their own card.
3. To share 7b, students may cut sheet in half and display their answers (with or without names) on bulletin boards entitled Warm Fuzzies--Cold Pricklies. It is important for some kind of sharing by those willing to share; it would be helpful in improving social skills.
4. The happy notes (run off on a previous ditto) from activity 5 are optional if children wish to write a happy thought, feeling, observation to someone and deliver it.

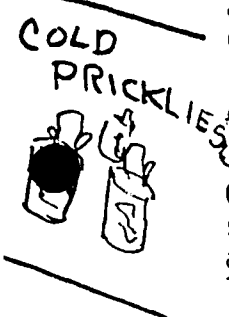

ENRICHMENT ACTIVITIES: Color coded on buff tag

Optional use: these may be cut apart, laminated and placed in a box for students to draw out for extended activities. Or the sheets could be dittoed and each child keeps one in his/her manilla envelope to do when desired. There is a ticket in the ticket book to mark these off when completed.

Post Tests- a,b,c- pink pages
See section #9--Student-Teacher Evaluation

Post test a - student directions are on pink tag; may be laminated and displayed or ditto copies made. Make ditto copies of Post test b and c. To share their discoveries about themselves, students may fasten completed "bodies" (with or without names) on a clothes line or bulletin board.

Resource Materials Available:

Located at: PSAB Media--Career Ed. Section
Elementary Schools Media Centers

BOOKS:

- CAREERS FOR ALL, ALIKE AND DIFFERENT, Benific Press
- " PLANS AND THE FUTURE, "
- " INTERESTS AND CHOICES, "
- " TEACHER'S GUIDE "

THIS I CAN BE, Text and T. Ed. Benetic Press
 CAREER DEVELOPMENT ACTIVITIES, (Section 3, Understanding Yourself)
 OCCUPATIONAL PROFILES, Chronicle Guidance
 WHATCHA GONNA DO? Encyclopaedia Brit.
 MY CAREER WORKBOOK, CFI
 CAREERS, Exploration and Decision, Prentice Hall
 THE MIND IS A FUNNY THING, E.S. Denison Co.

LPS CURRICULUM GUIDE, Grade 4, Mental Health, Mood Modifiers
 TV GUIDE. KALEIDOSCOPIK KAPERS
 Valuing Approach to Career Education Kit
 THE LITTLE FOX IN THE MIDDLE, Collier Books
 WHAT MAKES ME FEEL THIS WAY? Growing Up With Human Emotions, Collier
 WHO AM I?, Grove Press

Non-print Media

FREE TO BE ME, record and book
 ME, filmstrips, EBC
 CAREERS KIT (hobby game) Scholastic
 WHAT DO I LOOK LIKE, Myself and Me (5 sound filmstrips), EBEC
 MOST IMPORTANT PERSON KIT, Feelings, Identity, Getting Along with Others, Attitudes, Creative Expression.
 GETTING TO KNOW ME, QED Productions, (2fs/1 Cassette)
 Adventures of the Lollipop Dragon (6 fs/3 cassettes)
 Plus- Teacher Selected Materials from Building Media

RECORD KEEPING:

5.

Example: Teacher may use a grade book or chart and record the progress of each student.

Example: The student keeps track of his own progress by using the POSY POWER TICKET BOOK. The two sheets of twelve ticket pages in the kit should be cut apart and stapled together in proper sequence by the teacher (see numbers in lower left corner of each ticket.) The child works on an activity exercise, puts an X on the ticket and completes all the exercises in that one activity. The student then tears out the ticket and places it in the pot marked "Posy Power Completed Tickets". There is a minimum of checking answers in this unit.

6.

STUDENT EVALUATION:

There is a minimum of checking for "correct" answers in this unit. Students are encouraged to think carefully about themselves so the teacher should check periodically to make sure the student is taking the activity exercises seriously. Any silly answers should be erased and thought about again. Some children find questions about themselves difficult to answer and feel it is "bragging" to say nice things about themselves. If a student would rather not answer a question or exercise he should not be forced to do so, however, this may be revealing deep feelings the child has about himself and should not be overlooked by the teacher.

7. LOCATION OF CENTER:

This center may be placed in a corner, counter, desk, table or floor. The brightly colored flowers made by the teacher (patterns in Kit) may be used to decorate the center. The flower pots in the kit also add to the attractiveness of the center. The FOSY POWER sheet may be used as a bulletin board idea, duplicated for an invitation to each child to work in the center, may be duplicated as a cover for a student's brown activity envelope. Something bright and catchy must appeal to the child's curiosity of the center activities.

8. HOW AND WHEN THE CENTER IS TO BE USED: (SCHEDULING)

Organization of the center is of utmost importance. The student may choose the center, the teacher may assign a specific center activity or the student may use the activities as extra credit activities.

The success or failure of a center depends on whether the student understands exactly what he is to accomplish, how much time he is allowed and his expected behavior. He must understand before he enters the center that if these expectations are not met, he will not be able to return to the center and stick to it! (There are always exceptions, however, as a tape breaking, recorder malfunction etc.) No exceptions for poor behavior!

See the PASS in the kit. Four flower passes are on one sheet and must be cut apart before giving one to the students. A pass can become a magic tool for responsibility when the above items are included and checked by the teacher or aide. The teacher or child fills out the top half of the pass. The student shows it to the aide, etc. when entering and leaving the center. The aide checks the expectation and behavior and initials the pass. The pass is immediately returned to the teacher for instant teacher-student praise, encouragement, evaluation, etc. The pass could be duplicated on colored paper for easier identification.

9. STUDENT-TEACHER EVALUATION:

Each student keeps his worksheets either in a brown envelope or in a booklet form. This provides excellent teacher-student conference material. Students may be apprehensive about sharing some of their personal answers with the teacher and should not be forced to do so. This sharing time is the best time to really get to know your students. Listen to suggestions about improving the center. Post test activities are provided and should be used in the conference. The student should share his answers if he wishes. These could be put on the bulletin board, a clothes line, etc.

Who are you?

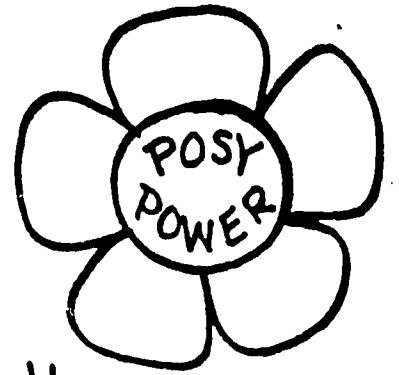

Think about yourself as honestly as you can.

Write a paragraph about yourself.
(you may also use the back of this paper)



Name _____

VE

This is your ticket book,
tear out each completed
activity ticket and put
it in the finished work
Posy Pot. X off activities
completed on each ticket.



Activity 1

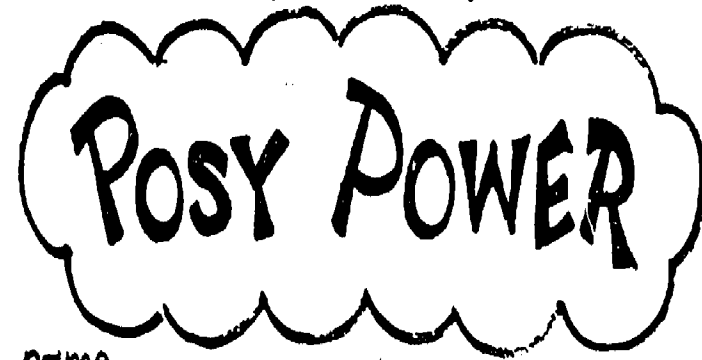

name _____
4 answer all posy power question:

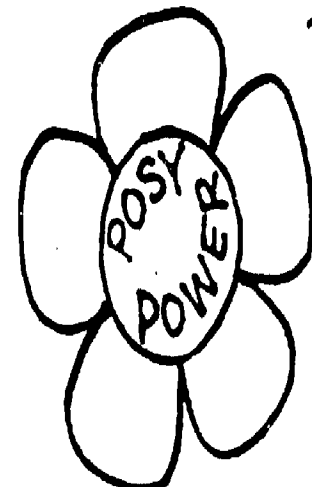

Pre-assessment

Who are you?

read objectives

3 name _____

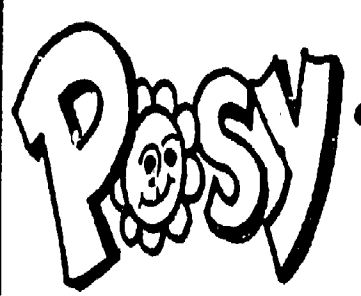

ticket

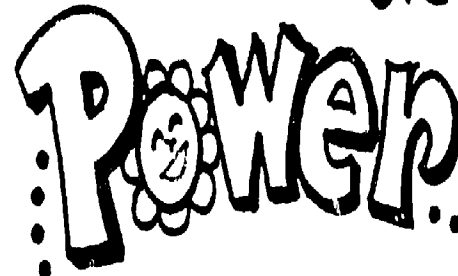

book

name _____



Feelings

Activity 2

2a 2b 2c 2d 2e 2f

name _____

Activity 3

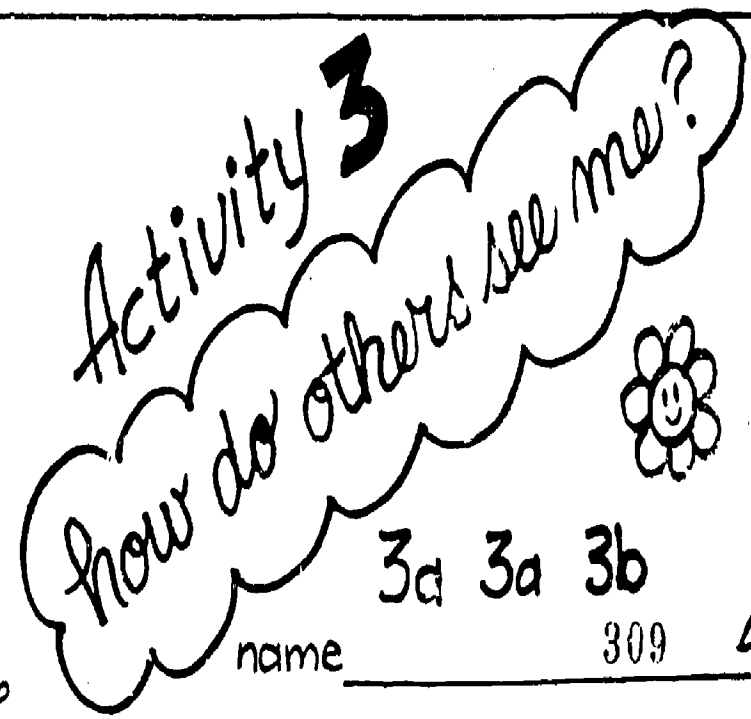

3a 3a 3b

6 name _____ 309 4

Just A Matter Of Choice!

Activity 4

4A 4B 4C 4D 

7 name _____

WORK and PLAY

Activity 5

5a 5b 5c 5d

8 name _____

Activity 6

friendship

6a 6b 6c 6d 

9 name _____

Activity 7

WARM FUZZY

or

COLD PRICKLY

7a 7b 7c 7d 

10 name _____

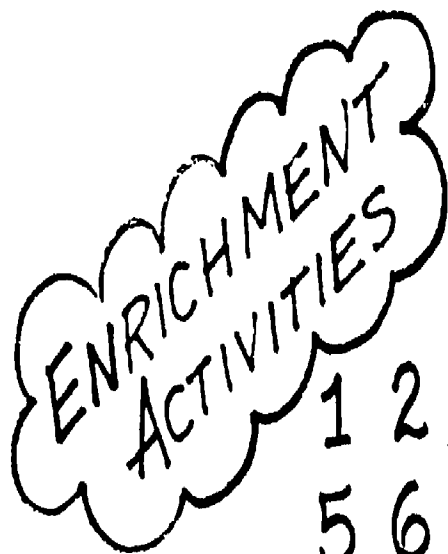
 ENRICHMENT
ACTIVITIES

1 2 3 4
5 6 7 8 

name _____

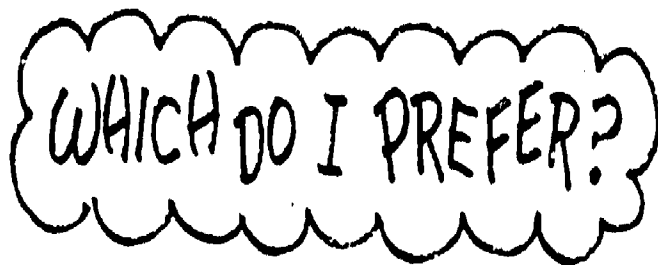
 WHICH DO I PREFER?

post test a
post test b
post test c 

12 name _____

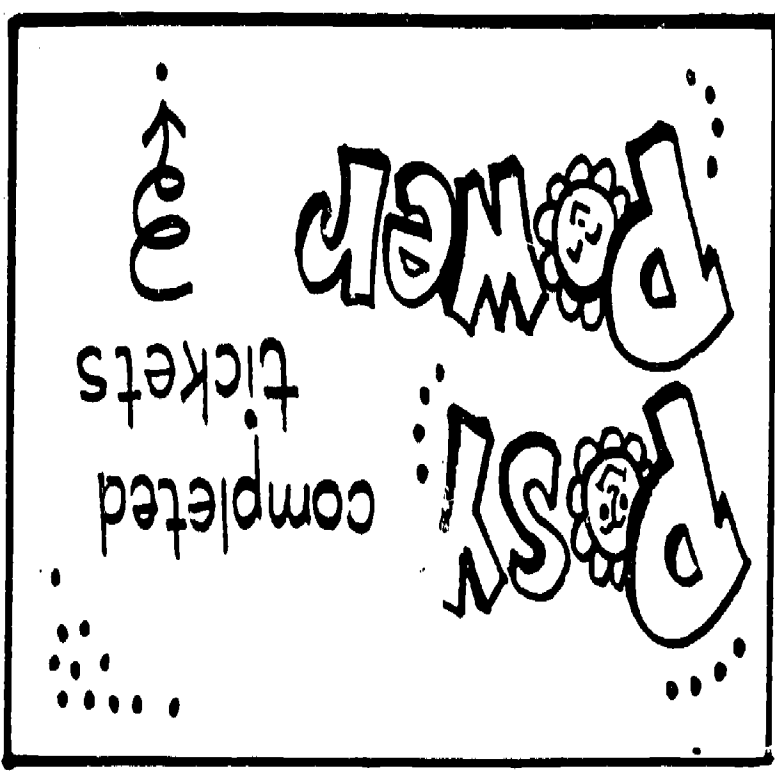

MY BEST FRIEND HAS
THIS QUALITY: _____

MY BEST FRIEND HAS
THIS QUALITY: _____

MY BEST FRIEND HAS
THIS QUALITY: _____

MY BEST FRIEND HAS
THIS QUALITY: _____

↳ Cut out, color, stick in flower pot

→ best friend activity notes
to be placed in flower pot
by students in Act. 6

↳ label for flower Pot Act. 6



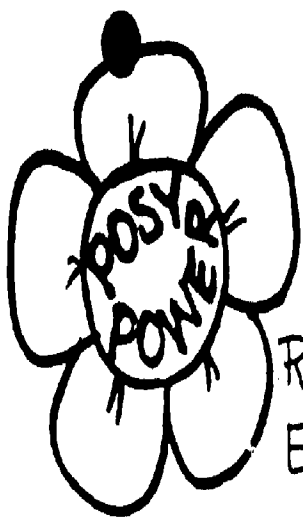

PASS

Name _____

Activity _____

Return time _____

Expectation _____

Expectation met? yes no

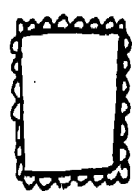
Behavior: Acceptable
Unacceptable 



PASS

Name _____

Activity _____

Return time _____

Expectation _____

Expectation met? yes no

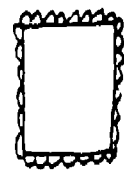
Behavior: Acceptable
Unacceptable 

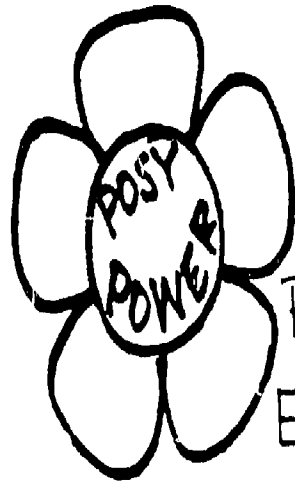

PASS

Name _____

Activity _____

Return time _____

Expectation _____

Expectation met? yes no

Behavior: Acceptable
 Unacceptable 

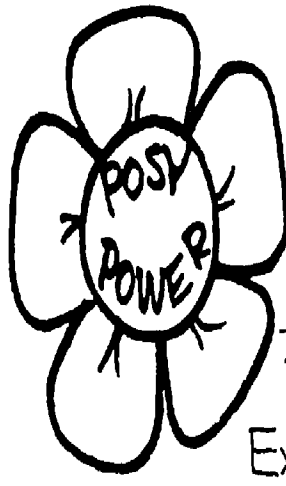

PASS

Name _____

Activity _____

Return time _____

Expectation _____

Expectation met? yes no

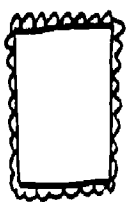
Behavior: Acceptable
 Unacceptable 

student objectives

By Using This Center I Will:

-Describe how I look.

-Recognize how people change and appreciate the likenesses and differences of myself and others.

-Clarify my attitudes, feelings, values and be proud that I am special.

-Explore my feelings and feelings of others by talking about them.

-Discover which qualities I like in a friend.

-Identify and evaluate my abilities, interests, and hobbies by making choices.

-Learn to be proud of a job well done.

-Think about my future occupation and lifestyle by knowing my likes and dislikes.

-Practice my language arts skills.

-Use my artistic and creative ideas.

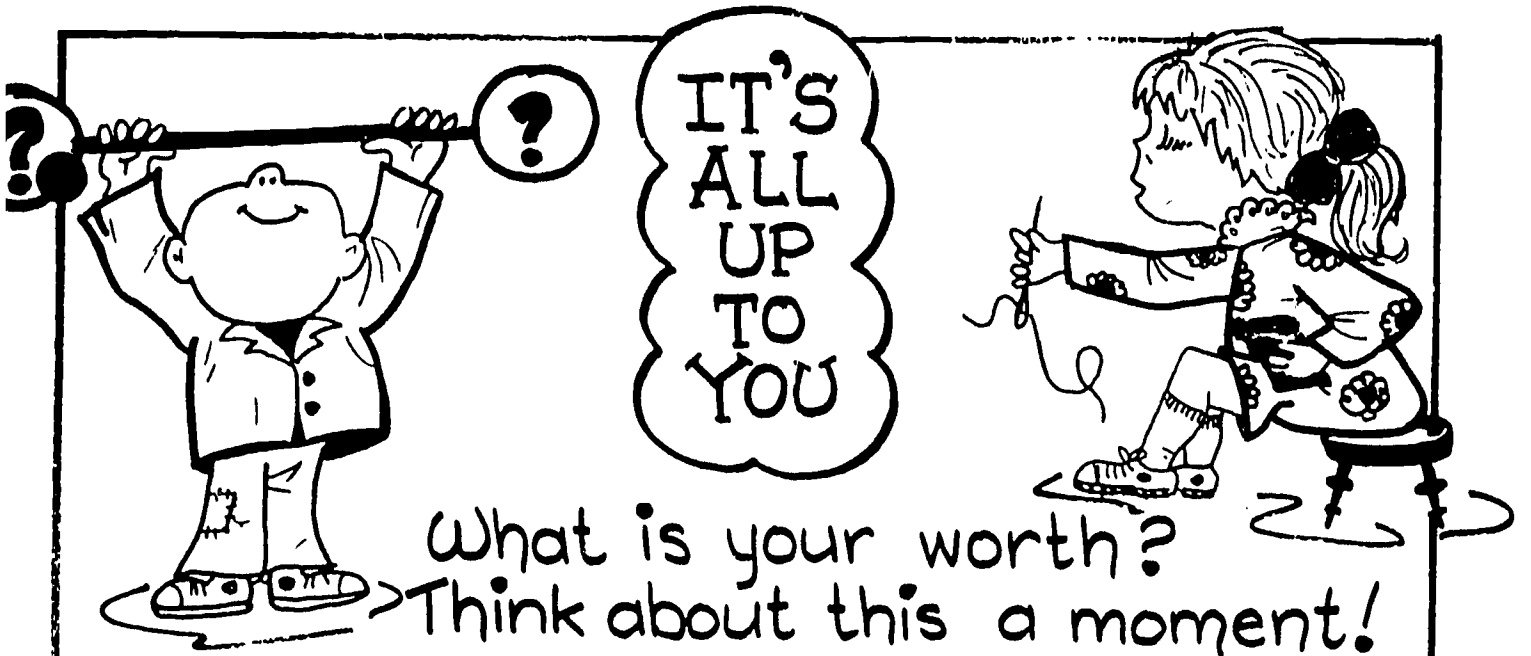

What is your worth?

Think about this a moment!

A plain bar of iron is worth about \$5.00
Made into horseshoes, it is worth \$10.50
Made into screwdrivers or kitchen
● cutlery it may be worth \$250.00
Made into needles, it is worth \$3,250.00
Made into balance springs for
watches, it's worth \$250,000.00



The same is true of
another kind of material
---- YOU!!

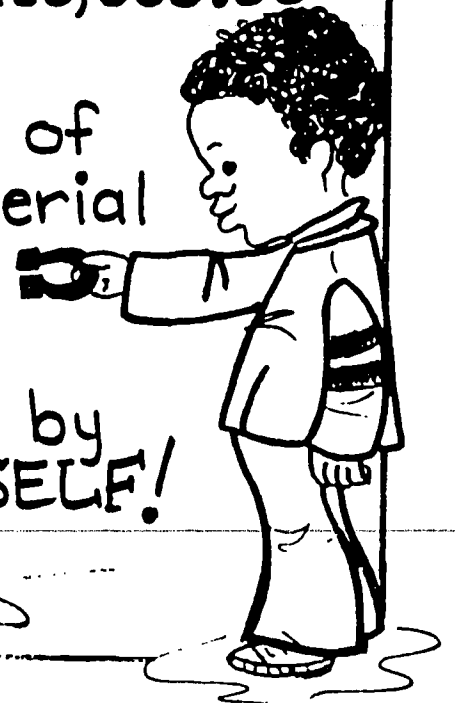

The value is determined by
what YOU make of YOURSELF!

Daisy

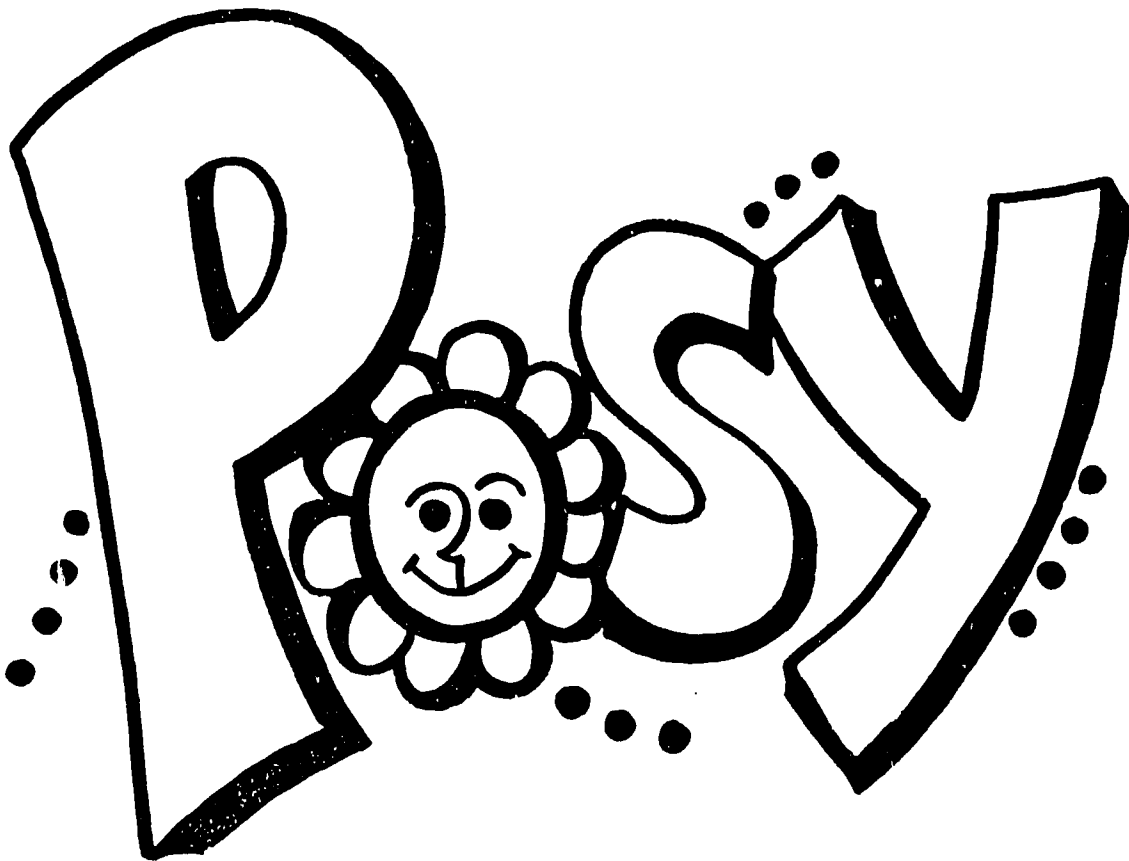
The word "Daisy" is written in a large, bubbly, outlined font. A smiling sunflower character with a face and a stem is integrated into the letter 'A'. The sunflower has a round face with two eyes and a smiling mouth, and several petals around it. Small black dots are scattered around the word.

Pinner

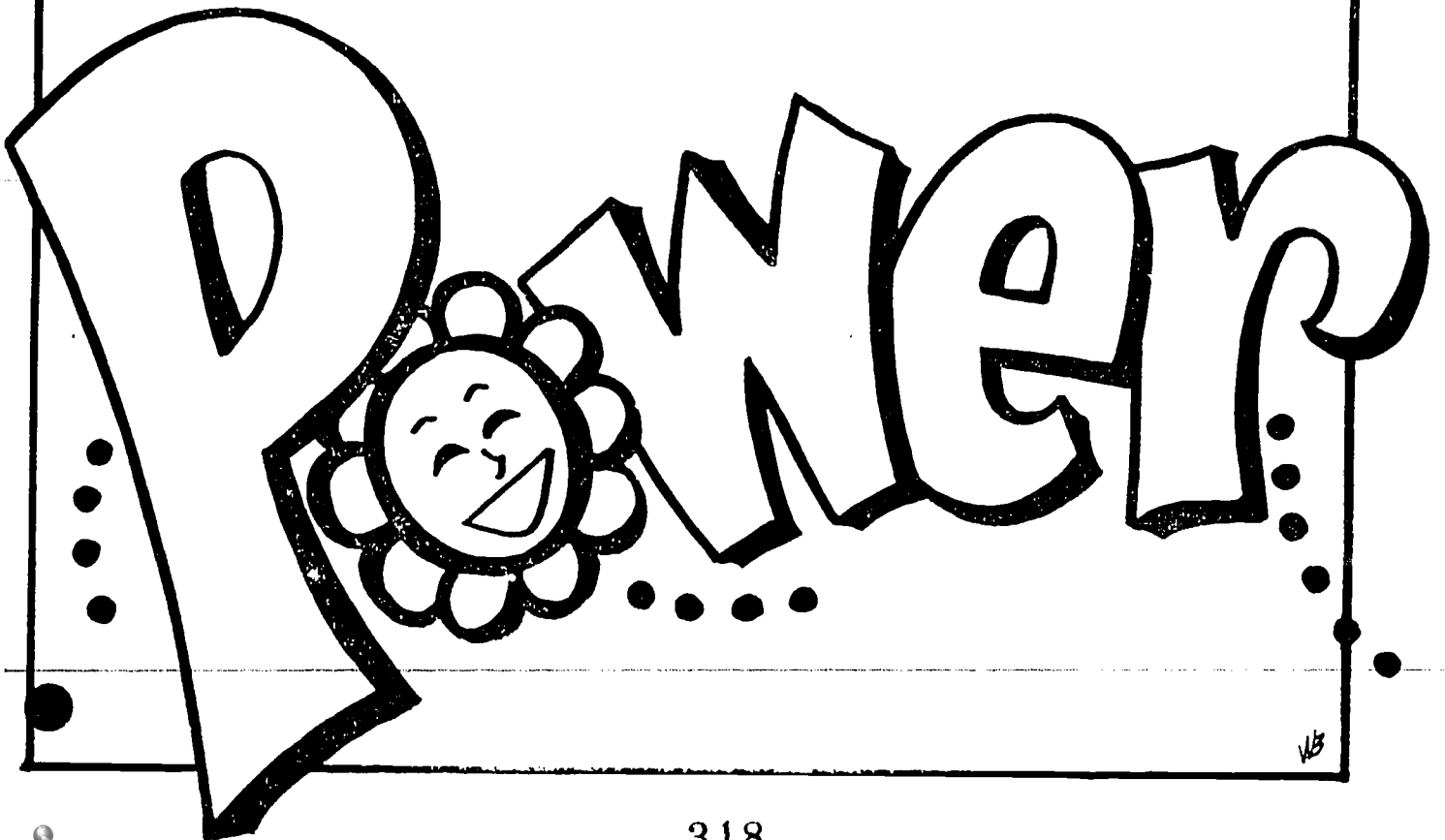
The word "Pinner" is written in a large, bubbly, outlined font. A smiling sunflower character with a face and a stem is integrated into the letter 'A'. The sunflower has a round face with two eyes and a smiling mouth, and several petals around it. Small black dots are scattered around the word.

45

ACTIVITY 1

POSY POWER

NAME _____
DATE _____

directions →

1. _____
2. _____
3. _____
4. _____
5. _____
6. _____
7. _____
8. _____
9. _____
10. _____
11. _____
12. _____
13. _____
14. _____
15. _____
16. _____
17. _____
18. _____
19. _____
20. _____
21. _____
22. _____
23. _____
24. _____

Answer the Posy Power questions today and then answer again in one month. Compare your answers. How much did your answers change? Keep your answers private or you may share your answers with a friend.*** ** *

↑ DIRECTIONS ↑
ACTIVITY 1 ↑

teachers → * ** *** Activity 1

Cut out flowers from brightly colored construction paper.

Cut out the round questions on the following pages for the center of each flower. See example.

flowers may also be used with Posy Power Game

flowers may be laminated for longer use in kit

Posy power pattern
paste round question centers here

24 yellow centers with questions - glued in the middle of each flower.

cut 24 flowers in various colors

teachers:

Activity 1

- Cut out these round questions to use as centers for the flowers made from the pattern on the previous page. See example in kit.

1
WHAT IS
YOUR
FAVORITE
SONG?

2
IF YOU
COULD CHANGE
SOMETHING IN THE
WORLD, WHAT
WOULD YOU
CHANGE?

3
HOW
WOULD
YOU SPEND
\$5.00?

4
WHICH
TELEVISION
PROGRAM DO
YOU ENJOY THE
MOST?

cut
out

teachers!

Activity 1

5

WHAT IS
YOUR
FAVORITE
SPORT?

6

WHAT IS
THE MOST
BEAUTIFUL THING
YOU HAVE
EVER SEEN?

↑
cut
← out →
↓

8

WHEN DO
YOU
FEEL
GRUMPY?

7

WHAT KIND
OF WORK
DO YOU LIKE
TO DO?

● teachers:

- Activity 1

9

WHAT IS THE HARDEST THING FOR YOU TO DO?

10
WHEN DO YOU FEEL PROUD?

↑ cut →
← out ↓

11
WHAT IS THE BEST MOVIE THAT YOU HAVE EVER SEEN?

12
WHEN DO YOU FEEL THE VERY BEST?

feelings

** ***
USE WITH ACTIVITY 2e-2b

fear disappointed angry	jealous kind amused	trusting safe sorry
surprised unhappy delighted	confused sad curious	generous miserable scared
shame lonely alarm	fright peaceful excited	depressed grumpy hurt
terror happy courage	cheerful stupid concerned	crabby frantic friendly
joyful envious puzzled	ugly anxious love	lost gloomy apologetic
nervous relief satisfied	bored ashamed proud	frustrated hurried mad

feelings

ACTIVITY 2a

*** **

"Mirror, mirror on the wall,
Who is the fairest of them
all?" asked the wicked queen
in Snow White.

"You are." answered the mirror.
The queen asked the mirror
this question because she
needed to feel good about
herself.



Do you like yourself?
You will need to think
seriously about yourself.
(no one else can do
this for you) #

Does it
make any difference
to you what others
in the class think
of you? #
Why? _____

Does school have
any part in how
you feel about
yourself? #
Why? _____

Does your family
and home affect how
you feel about yourself?
Why? _____

A page with cartoon illustration has been removed because of copyright.

Feelings

Activity 2c

* ** ***

Look in the mirror. Write 5 things you see.

1. _____
2. _____
3. _____
4. _____
5. _____

Now write the way you feel.

Make faces in a mirror. Pretend you are:

- angry
- happy
- sad
- hurt
- worried
- bashful
- frightened
- bored

Make your faces for a friend. Can he guess your feelings.

Watch people's faces today. Which feelings do you see on their faces while reading at recess, in math, at lunch, singing, etc. Watch your family's faces at home, too.

name _____

Collect magazine pictures of faces showing different feelings. Glue them on paper or pin them on a bulletin board in your classroom.

ACTIVITY 2d

* * * * *

Feelings

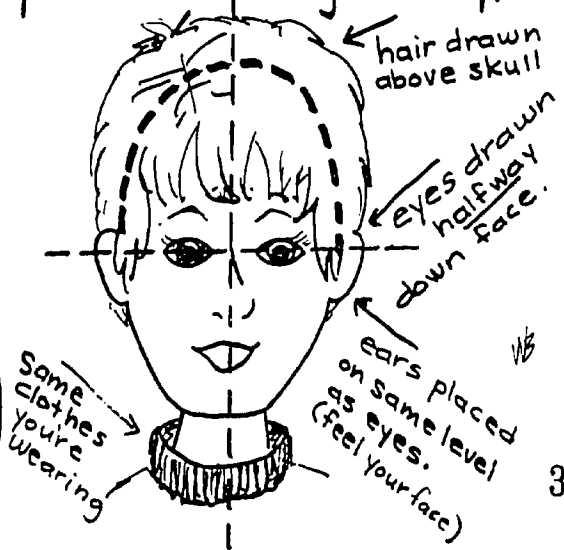
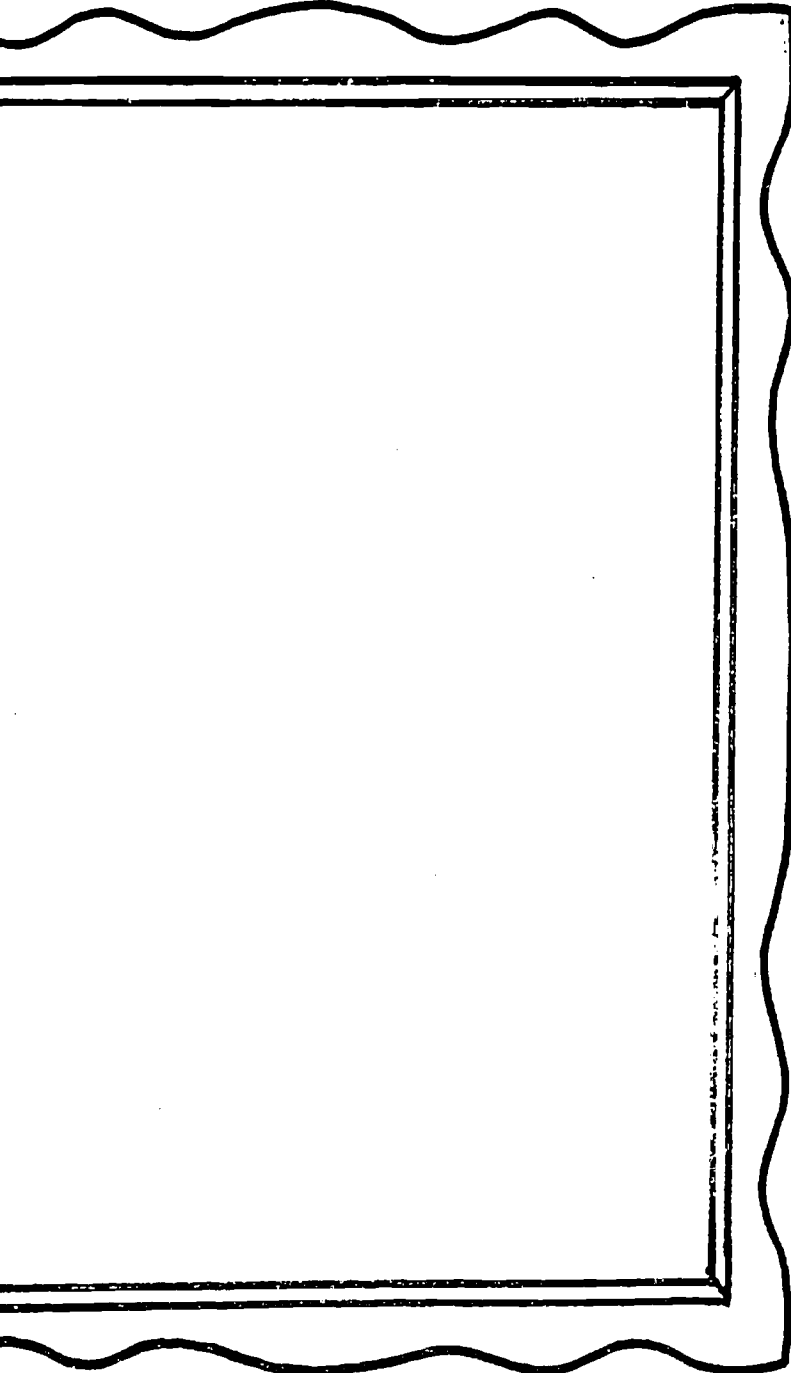

Look in the mirror. Draw a picture of yourself. Draw exactly what you see: shape of face, eyes, eye brows, eyelashes, hair style, freckles, dimples, scars, nose shape, lips, ears (if they show) clothes you're wearing today, etc.



Artist's name _____

words alive!

Think of other "feeling" words. Draw cartoons using that word and showing that feeling. Use the "feelings list" for ideas.

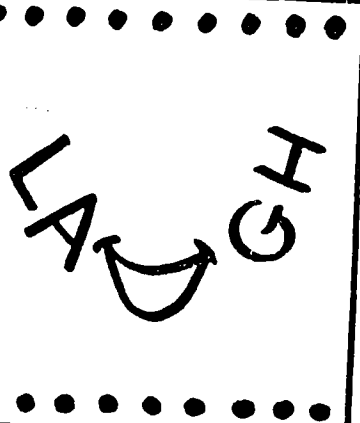
name _____

VB

Lemons and Apples

One day I might feel mean
And squinched up inside
Like a mouth sucking
On a lemon.

The next day I could feel
Whole and happy
And right
Like an unbitten apple.

Mary Neville

Now add your own feelings

Name _____



Personality: qualities & traits

admired
afraid
alert
aloof
ambitious
angry
artistic
athletic
awkward
babyish
boastful
careful
careless
cheerful
clever
clownish
concerned
confident
confused
cool
courageous
courageous
crazy
creative
cruel
daring
decent
dependable
depressed
discourteous
dishonest
disorganized
dull
easy-going
efficient
embarrassed
friendly
funny
fussy

gentle
gloomy
happy
happy-go-lucky
hard-working
helpful
honest
imaginative
impatient
intelligent
jumpy
kind
lazy
likable
lonely
loud
loving
loyal
mean
moody
narrow-minded
neat
nervous
optimistic
orderly
organized
outgoing
patient
pleasant
polite
popular
practical
pushy
quick
quiet
reckless
relaxed
reliable
religious

resourceful
sarcastic
scared
selfish
sensitive
short-tempered
show-offish
shy
skillful
sloppy
slow
smooth
sneaky
stable
strong
stubborn
stuck-up
stuffy
surprising
suspicious
tense
thoughtful
thoughtless
thrifty
timid
tough
tricky
trusting
trustworthy
uncertain
undependable
understanding
unhappy
unpredictable
unstable
warm
weak
withdrawn
worried

How do others see me?

* ** ***

How you feel is very important to you. It makes a difference in the way you act.

Think of the seven dwarfs.

Each of them had a special way he seemed to people around him. In the story the name of the dwarf told you what he was like. GRUMPY was crabby or bad-tempered, while HAPPY was joyful. Suppose you were always tired like SLEEPY. Your friends would expect you to be sleepy because you acted that way most of the time.

Do you think you feel the same most of the time? What different kinds of feelings do you have? How do others see you?

Do an experiment to find out how your feelings about yourself compare with how others feel about you and your actions.

Cut apart the three sections on your paper and then follow the directions. Compare all the answers and learn more about yourself. Do you need to change your feelings?



how do others see me?

* ** ***

Write down 5 words that describe you. (adjectives) You may use the word list.



- 1. _____
- 2. _____
- 3. _____
- 4. _____
- 5. _____

NAME

cut

Ask a friend to write down 5 words that describe (adjectives) you. (may use list)

- 1. _____
- 2. _____
- 3. _____
- 4. _____
- 5. _____

NAME

cut

Your Choice: Now ask a parent, teacher, an adult friend or principal to write 5 adj. about you.

- 1. _____
- 2. _____
- 3. _____
- 4. _____
- 5. _____

NAME



** ***

Activity 3b

In days of old, a sad, gloomy King would send for his court jester to cheer him up. When the King felt better, he would happily continue his royal duties.

It is important for us to discover what we can do to cheer ourselves up when we feel blue.

To cheer myself up, I can 

Things other people do are 

Name

Date

Teachers: * ** ***

Just a Matter of Choice

Activity 4

cut out

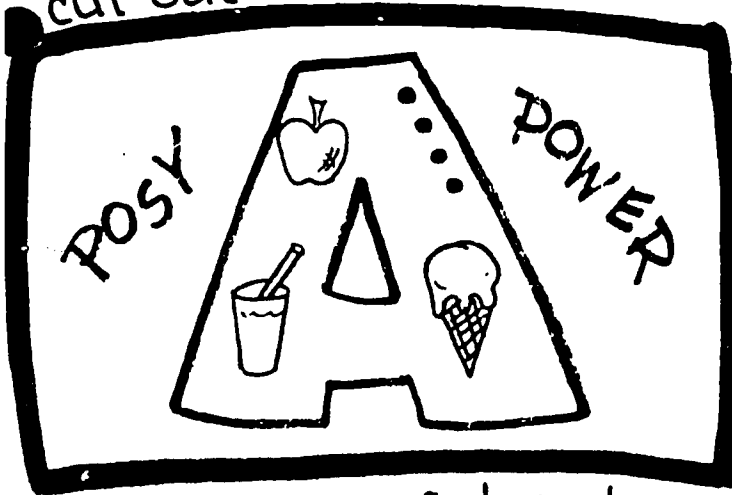

cut out

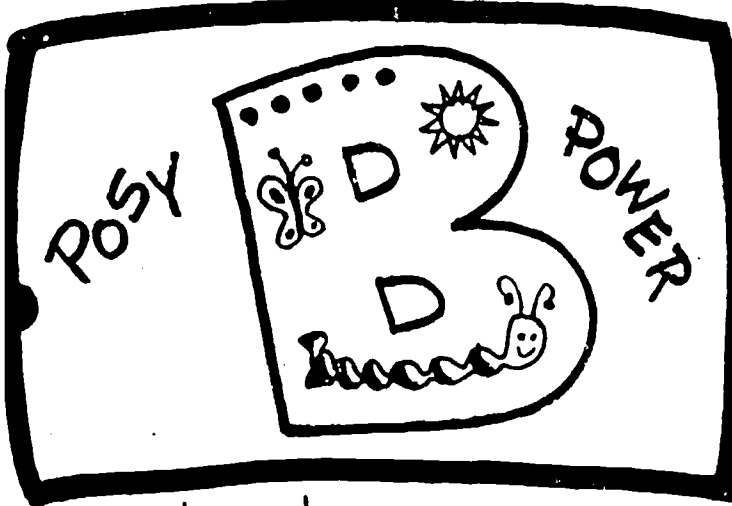

cut out

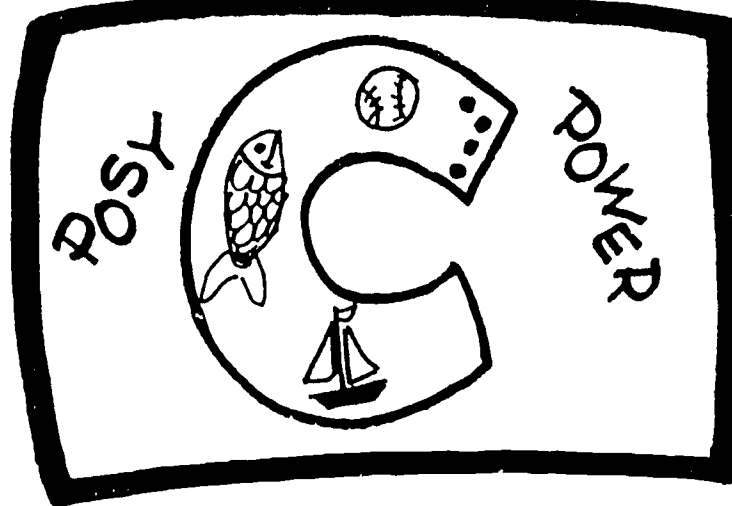

For teachers:

← cut out the A, B, C labels and tape or glue them on the 3 flower pots

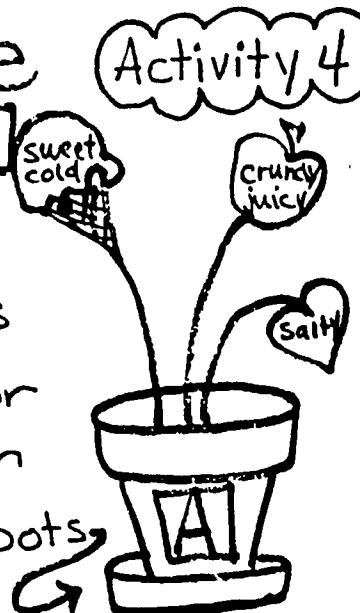

A - students make a leaf (or shape) and write down adjectives (may use list) describing favorite tastes and puts it in the pot.

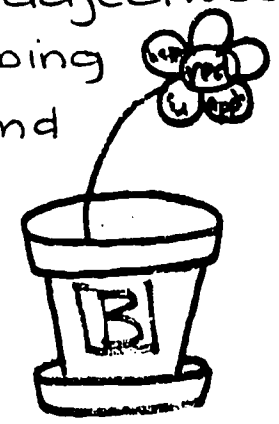

B - child makes a flower (may use pattern) write down adjectives describing favorite color and why and sticks it in the pot.

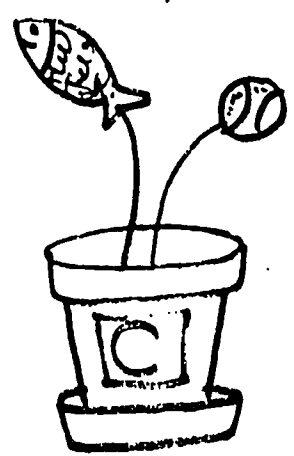

C - leisure time adj. are written on own design "flower" and stuck in pot.

MATERIALS NEEDED: 1 direction sheet, 3 adj. lists, 3 flower pots with labels (above) 3 foam balls, pen, pipe cleaners, construction paper, glue, stapler, scissors

Just A Matter Of Choice!



* ** *** Activity 4

Spinach! Ugh! Ice Cream! Wow! Have you ever thought about how your likes and dislikes tell a lot about you?

In this activity you will be thinking a lot about yourself and what you like best.

A. Read the FAVORITE FLAVORS and tastes list. Choose the words that describe what you like to eat best. Make a leaf ^(or shape) telling which words you chose and why. Glue your leaf ^(or shape) to a pipe cleaner and stick it in POSY POWER POT A to share with others.

B. Read the FAVORITE COLORS list. Choose the words that describe the color you like best. Make a flower in your favorite color and write on it why you like that color best. Staple or glue your flower on a pipe cleaner and stick in POSY POWER POT B to share with others.

C. Read the LEISURE TIME ACTIVITIES list. Use your own ideas or choose ideas from the list that best describe what you like to do in your free time. Make a flower in a design that tells about what you like to do best. (example: a record of  your favorite song.) Staple or glue your "made-up" flower on a stem and put in POSY POT C. 

Favorite Flavors

A.

Strawberry

tastes

crispy
buttered
fluffy
soggy
thick
thin

sliced
icy
sharp
mild
canned
whole

upside down
flaked
barbecued
unbaked
fondued
carmelized

sour
spicy
salty
bitter
sweet
tangy

tart
hot
cold
soft
hard
doughy
creamy

boiled
broiled
unsweetened
semi-sweet
moist
liquid
crushed
grated
chilled

raw
cooked
fresh
dried
toasted
candied
pickled
fudgy

rich
mild
nutty
sliced
shredded
powdered
grilled
chopped
glazed
creamed
mashed
whipped
swirled
frozen

And add your own ideas, too!

VB

favorite colors

orange
sky blue
turquoise
green
yellow-green

peach
goldenrod
gray
tan
crimson

scarlet
tangerine
silver
blue-violet
bronze

pink
purple
salmon
maroon
periwinkle

red
yellow-orange
blue
orchid
olive green

yellow
brown
black
green
copper

burnt orange
forest green
lavender
violet
brown

aqua
maize
gold
lemon
umber

melon
magenta
flesh
white
bittersweet

apricot
beige
cream
plum
pine

red-violet
blue green
red orange
blue gray
baby blue,

mulberry
hot pink
lime
chartreuse
wine

And add your own ideas, too!

16

C. leisure time activities

golf
tennis
sew
cook
ski
travel
fish

eating
gardening
swim
run
talking
write
study

teach
shop
act
repair
clean up
paint
softball

football
woodworking
ride bikes
hike
camp
play piano
ride horses

know lawn
paper route
mini-biking
minature golf
picnic
build models
collections

earn money
color
babysit
photography
bubble bath
scouts
track
animal care

volleyball
soccer
play records
read
sing
jump rope
boardgames

crafts
draw
sleep
toy time
baseball
television
radio

design
skate
movie
day dream
your ideas

VB

Without using any words, act out these feelings for people. See if they can guess which feeling you show.

MAD
HAPPY
BORED
SURPRISED
BASHFUL
SCARED

use the back of this sheet!

SAD
STUBBORN
HURT

Activity 4D

List three things you like very much. Then list three things you dislike very much. Give reasons why.

Take a survey of a class of people and dislikes. Compare their answers to see which things show up most often.

Many of us have bad habits we would like to break. Think of a habit that you have, that you would like to change.

Make a plan that could help you break your bad habit and try it for 2 weeks. Then write a paragraph telling whether or not you were successful. Give reasons why.

WORK and PLAY

Talk to a worker, this might be a neighbor, friend, parent, or teacher.

Ask this worker about hobbies, and leisure time (play) activities.

Are the workers' leisure time activities tied to their work?

_____ Or is the worker's job completely different? _____

Are their play activities used as recreation only? _____

do people change?

Talk with an adult or a student 3 years older than you. Ask about their favorite tastes, colors, and play activities. Have these interests changed from what they were a few years ago? _____

How? _____

Name _____

VB

WORK and PLAY ACTIVITY 5

Give three examples of your likes and dislikes that have changed from a few years ago.

Write your past interests on the flower buds

Write your interests now on the blooming flowers

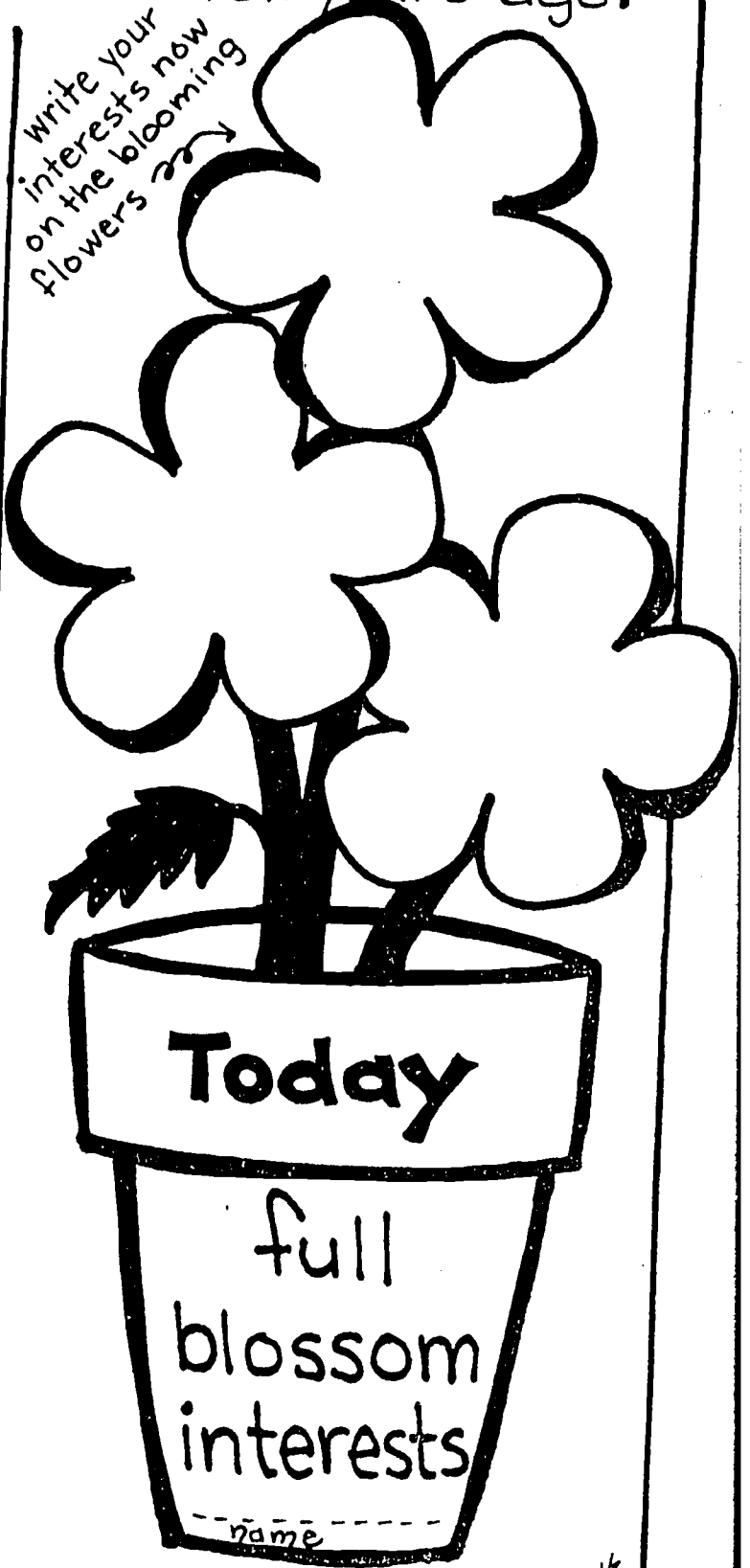

WS

WORK and PLAY

answers (Act. 5b)

1. Which activities are work or play?
These circled answers will be your own opinion, won't they?

2. WORKERS (any good answers are o.k.)

- a. professional baseball player
- b. commercial fisherman
- c. astronomer
- d. gardener
- e. veterinarian
- f. carpenter

cut here

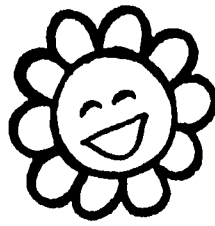

happy
note

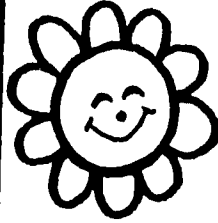

happy
note

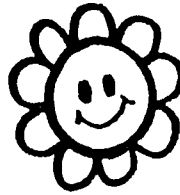

happy
note

optional:

← teachers
Happy notes may be cut out and used with Act. 7. Students write a "warm fuzzy" note to anyone they wish. Or all students may write a note to a selected person each week. (30 "warm fuzzy" notes given to one kid - WOW!)

WORK and PLAY

Many people combine their likes and dislikes in their work, for example, a carpenter may work very hard but may enjoy building his things very much.

1. Which of the following activities are work and which are play for you?

name

circle?
WP
WP
WP
WP
WP
WP

a. playing baseball

b. fishing

c. watching stars through a telescope

d. planting a flower garden

e. taking care of a sick dog

f. building a birdhouse

2. Now go back and write some workers (jobs) who might do these things as a part of their jobs. Ask for an answer sheet to check your own paper.

WB

WORK and PLAY

What are some things that you do at school that you would call work? _____

What are some things you do at school that you might call play? _____

Which of these things do you like enough to do ALL DAY? _____

Which of these things is your favorite, even though you might not want to do it all day? _____

How would you spend your day if you never had to go to school? _____

name _____

VB

friendship

Most of us have several friends. Think about the different friends that you have. Are your friends very much alike or are they different?

There is some-
thing about each
of your friends that
you like. It is a
quality or trait that
this person your friend and
makes you like this person.
discuss with
someone

continued
on next
sheet →

Think a bit!
What are qualities or
traits most
important to you in
a friend?
How does a friend
show he is a friend?
Are the qualities you
like in your friends the same
as your good qualities?

What do you have
to do to keep friends?
How do you want a
friend to treat you?

friendship

continued

ACTIVITY 6b

How will you decide who your best friend is?

Does everyone need friends?
** ***

Would you like to have yourself for a friend?

Why do friends stop being friends?

Have you ever thought about your friends' good points?

GO ON TO THE NEXT WORKSHEET

Pretend you could can, bottle or package the qualities you want in a friend. On your worksheet fill in the labels on the products with qualities or traits that you would like in your friend. Choose the quality you think is the most important,

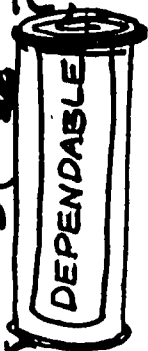

write it down on a note and put it in the BEST FRIEND POST POWER POT for sharing. (Use the personality traits list for help.)

friendship **ACTIVITY 6C** ** **

FILL IN THE LABELS WITH "FRIENDSHIP QUALITIES" THAT YOU WANT IN A BEST FRIEND!

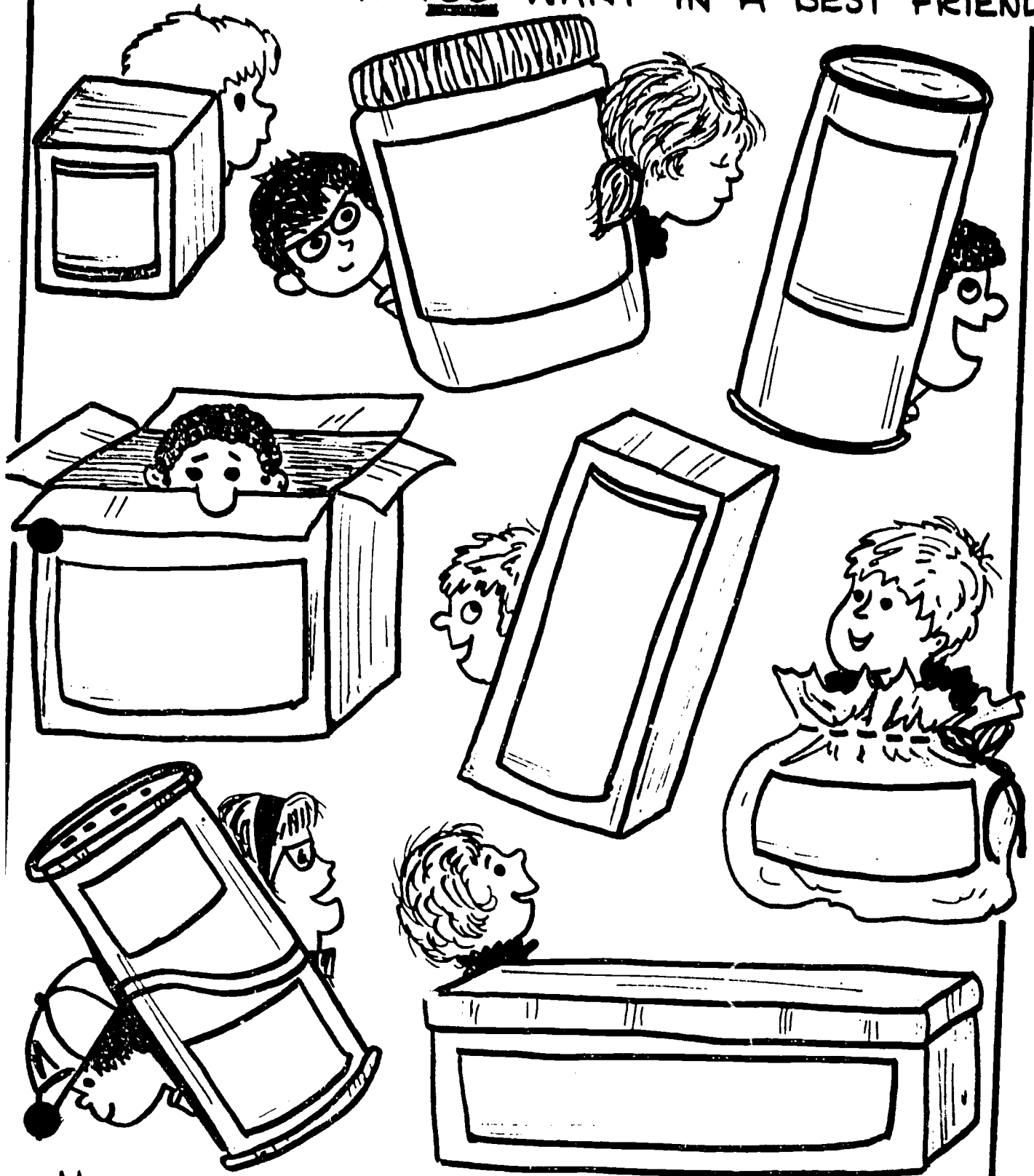

Name _____

VB

ACTIVITY 6d

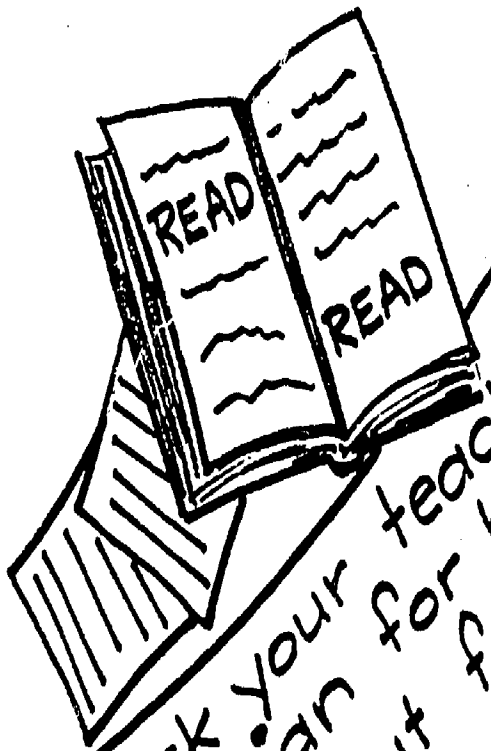

Find a place where
you can visit with a
friend about what a
good friend makes

Ask your teacher
or librarian for books,
values, or friendship.

Ask your teacher or
librarian for filmstrips,
tapes or records,
values or friends

Write a poem
about your feelings
or a paragraph
about what you
are really like.

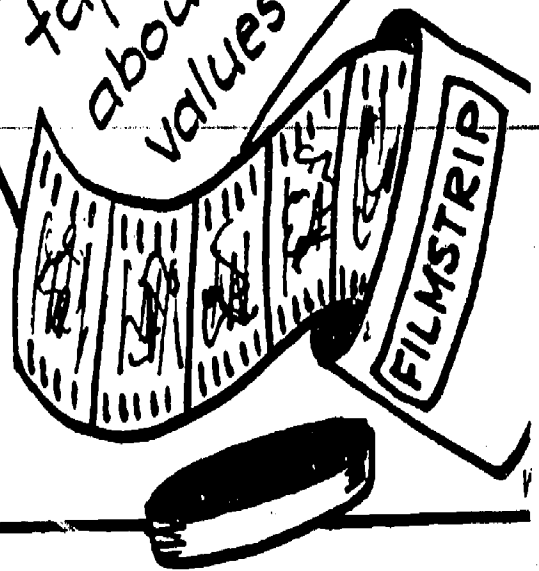

Some People

Isn't it strange how some people
Make you feel so tired inside,
Your thoughts begin to shrivel up
Like leaves all brown and dried.

But when you're with some other
Friends, it's stranger still to find
Your thoughts as thick as fireflies
All shiny in your mind!

Rachael Field

Now you write about friends

Name _____

Friends

Once in a while
you find someone
who's a friend
right from the start.

You can tell by a smile
or a word or a touch.
It's a feeling you have
in your heart.

It's a wonderfully
comfortable feeling...
like you've known them
for many a year.

You can tell by the way
they will brighten
even the gloomiest day.

And how they stand by you
and help you... and cheer you
After others have gone
their own way.

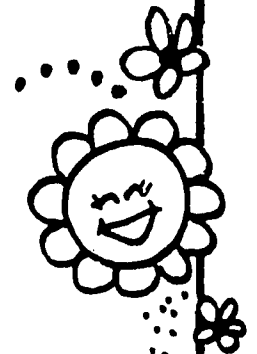
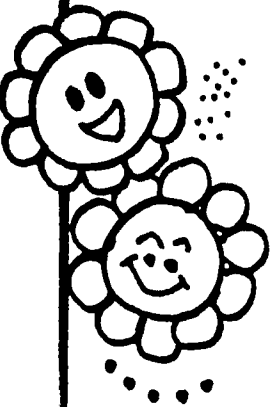
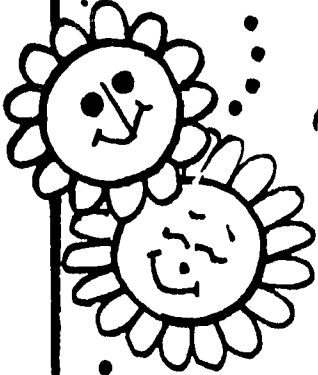
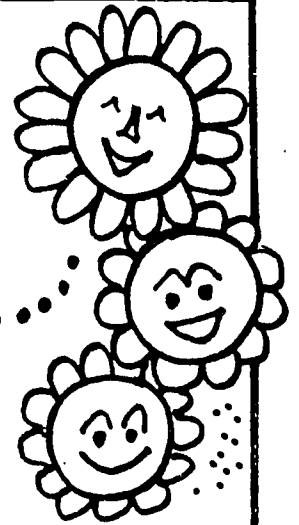

You can tell by the way
they will listen
to your troubles
the big... and the small...

And then say that they
understand you
so you don't feel so bad
after all.

Yes once in a while
a friendship is made
that will last
a whole life through.

It really does happen
just once in a while...
It happened to me...
and you!

adapted
Carl Joeller

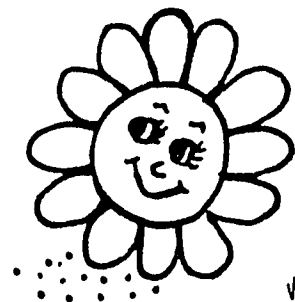
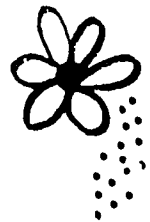
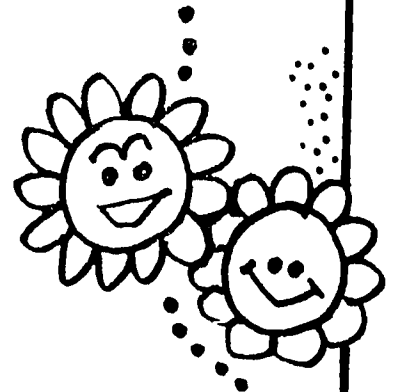
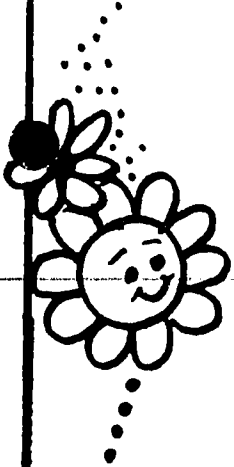
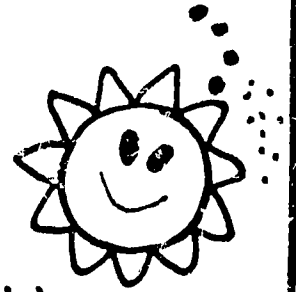
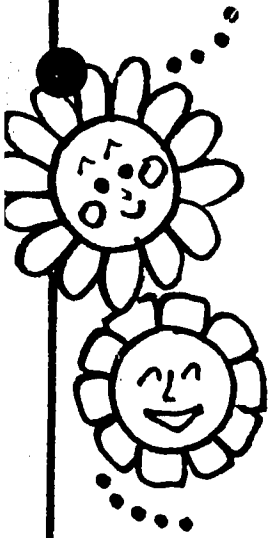

teacher
sheet

Act. 6

may also
be pinned
on a
bulletin
board

invite the
children to
read
others
ideas.

flower
pattern
bright
color

cut out
center

flower should be
put on a dowel stick
and stuck inside the
flower pot. Children
write down best friend
qualities on notes and
place them in the pot.



● WARM FUZZY or COLD PRICKLY

Have you ever read about the warm fuzzy or cold prickly things people say or do to each other every day?

a **warm fuzzy** is a compliment that someone gives you. It makes you feel all warm and good inside.

a **cold prickly** "stings" when someone says something that hurts your feelings. It makes you feel all cold and prickly inside.

7b
On your worksheet, write down on the warm fuzzy flower pot some things that people say to you that make you feel all good inside.

Now write on the cold prickly flower pot some things that people say to you or about you that hurt your feelings.

7c
Design a warm fuzzy card or use the one already made. Write a warm fuzzy message to your best friend, parent, teacher. Mention the things that you especially like about that person.

* ** ***

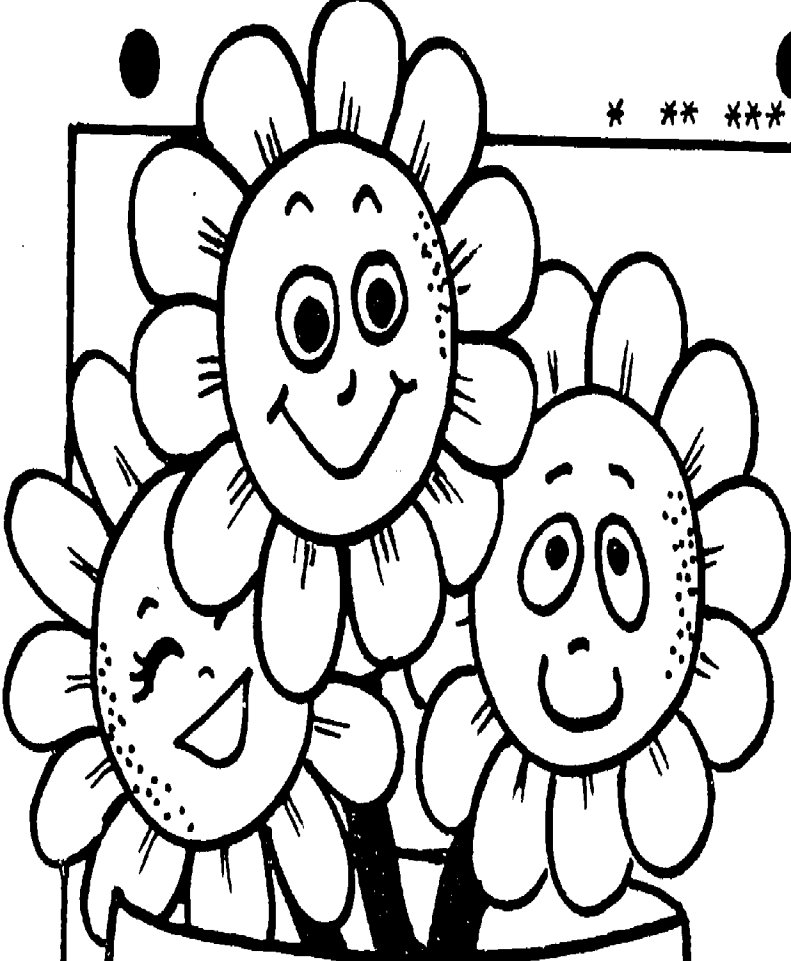

WARM FUZZY

name
THINGS THAT MAKE
ME FEEL GOOD!



COLD PRICKLY

name
THINGS THAT
HURT ME!

VB

VB

FOLD HERE



1/8
• a warm fuzzy.
card

name _____

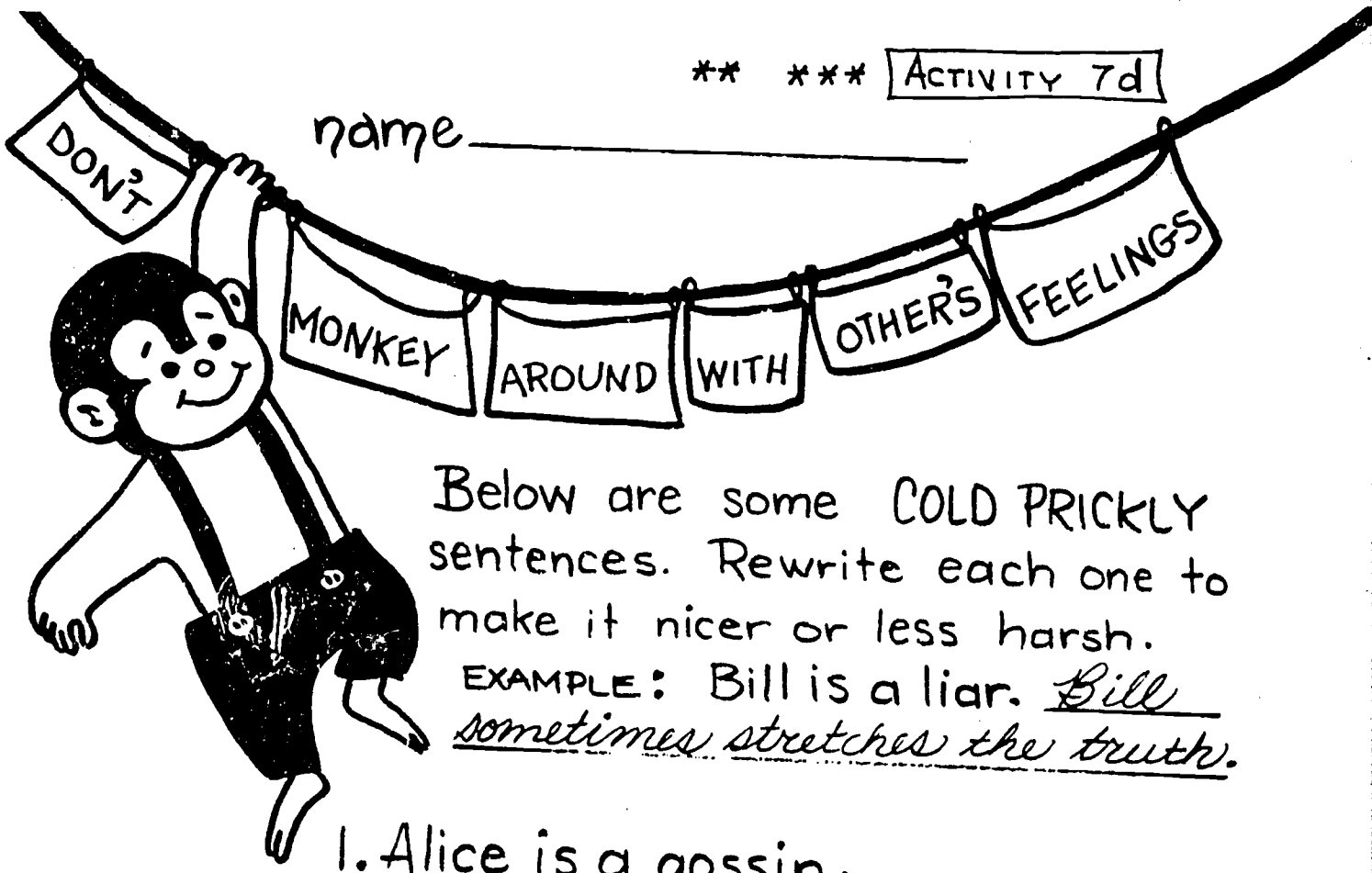

Below are some COLD PRICKLY sentences. Rewrite each one to make it nicer or less harsh.

EXAMPLE: Bill is a liar. Bill sometimes stretches the truth.

1. Alice is a gossip. _____

2. Fred is fat. _____

3. Tom is a penny pincher. _____

4. Kevin is a bully. _____

5. He is a coward. _____

6. She is so skinny. _____

7. That lady is ugly. _____

8. Sally is rude. _____



WHICH DO I PREFER?

Now that you have completed these activities you have thought more about yourself and perhaps have learned more about what you like and what you don't like.

The job you choose will depend on your likes and dislikes. Think carefully about the list on your worksheet. Circle the things that are the most important to you. Make a paper body and write in it, the things from the list that appeal to you most. Which things would you enjoy best?

name _____

WHICH DO I PREFER?

circle one in each pair!

- 1. working alone or with people ?
- 2. near or on dry land or in water ?
- 3. dangerous job with high pay or safe job with lower pay ?
- 4. noisy work or quiet work ?
- 5. regular hours or irregular hours ?
- 6. challenge or easy ?
- 7. same work each day or different work each day ?
- 8. indoors or outdoors ?
- 9. dirty job or clean job ?
- 10. a travel job or same place ?
- 11. work with people or work with tools, machines, lumber ?
- 12. work at night or daytime ?
- 13. sit quietly at desk or stand for long periods ?
- 14. work with numbers or work with hands ?
- 15. dislike job but high pay or be happy and get low pay ?
- 16. hot dry place or cold place ?
- 17. quiet - little talking or use voice as in selling ?

continued on next page

Post test c

Cut out the paper body or make your own.

Write in your body, the things you circled on your work sheet. (post test b)

WHICH DO I PREFER?

IN MY WORK I WOULD PREFER

In which kinds of jobs would you be happy?

Five horizontal lines for writing job preferences.

Pin your body on a bulletin board or hang on a class clothesline to share with others. You do not have to write your name on it unless you wish.

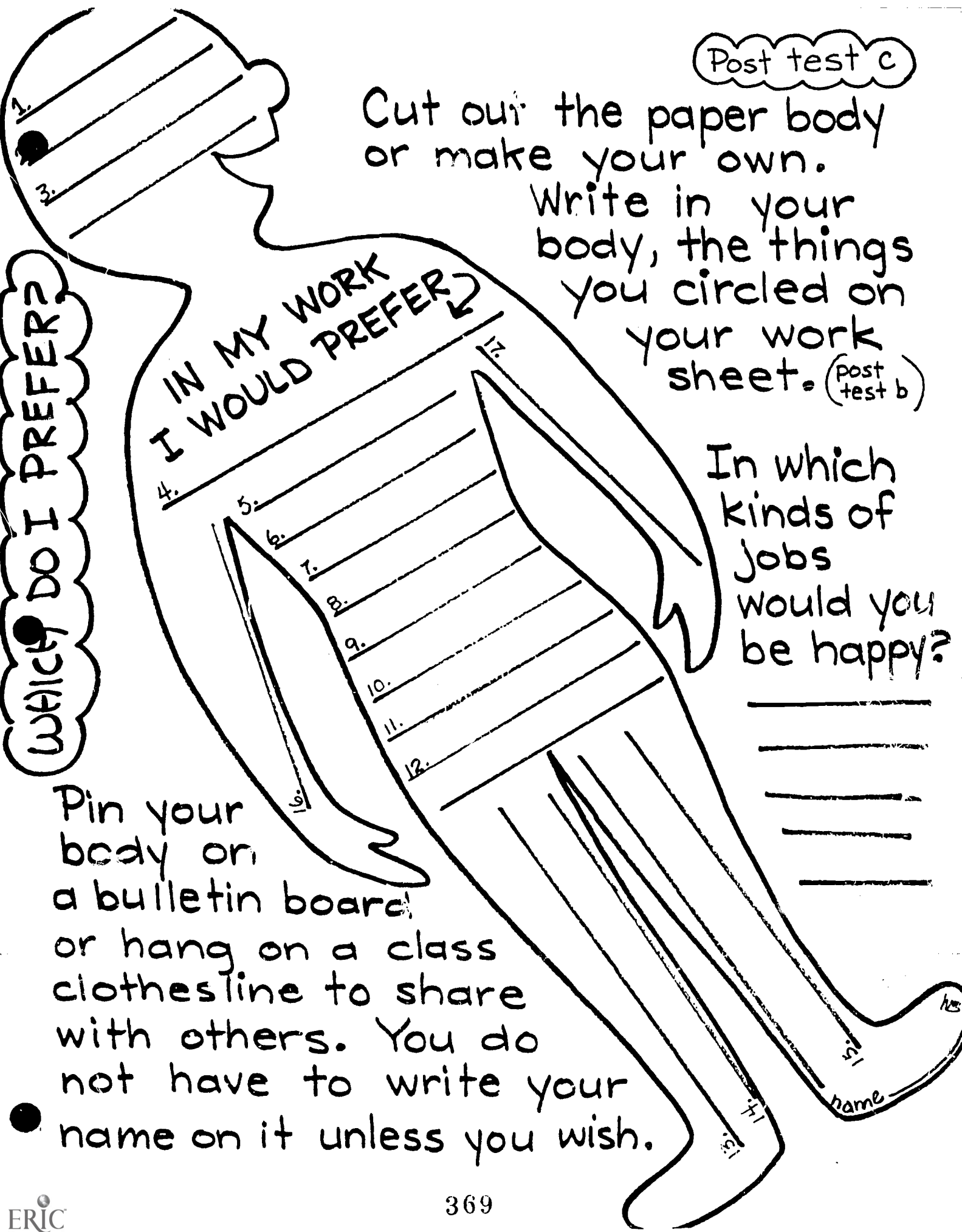

(ENRICHMENT ACTIVITIES)

MAY BE CUT APART

BABY BAFFLE

1. Ask mother if you can bring a baby picture of yourself to school. Secretly pin it on a bulletin board. Ask the teacher to ask the class to guess who the baby is. What is alike or different about your baby picture and how you look now?

Arts

2. Draw a picture of yourself showing a feeling. Cut the picture into about 10 puzzle pieces. Exchange puzzles



with a friend and try to put the puzzle back together. Guess the feelings shown.

PANTOMINE

3. Act out some things that you like to do in your spare time. Classmates should see how many activities they can guess on the first try.



Music

4. Many songwriters write songs about feelings. Listen to a radio and count the number of songs you hear in one hour that tell about feelings. Write down the feelings in the songs.



MAY BE CUT APART

5. Everyone has something they can do well. Choose something you like to do and entertain the class or a small group. You might want to sing a song, play the piano, dance, read a poem, tell a story, do a magic trick, give puppet show, etc.

6. **DRAMATICS** Use puppets or act out these situations:

1. Make a new student feel welcome.
2. An argument over the phone.
3. Helping someone with a hard task.
4. Little brother broke your glasses.
5. You just lost a race to a friend.
6. Mother says "NO" to a new bike.

Which job?

7. Think about which occupations you would be interested in when you grow up. Act out by yourself or by using others, what you would do in this job. See if classmates can guess which job you chose.

8. **ART**

Why do some colors seem happy or sad, loud or soft, friendly or unfriendly? Color or paint a picture using certain colors to show special feelings. Ask a friend to guess the emotions shown.

Career Education Learning Center

• **WHICH WORKERS' WASTEBASKET?**

4

**by Wilma Boles Brownell School
Fall 1975 Lincoln, Nebraska**

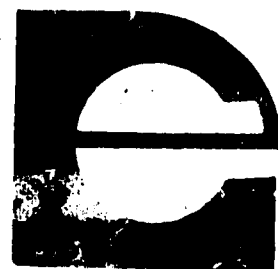

**LINCOLN
CAREER
EDUCATION
PROJECT**

The materials presented in this document were developed under a grant from the Office of Education, U.S. Department of Health, Education, and Welfare. Contractors undertaking such projects under Government sponsorship are encouraged to express freely their professional judgement in the conduct of the project. Points of view or opinions stated do not, therefore, necessarily represent official Office of Education position or policy.

Submitted by
Lincoln Public Schools
John Prasch, Superintendent
Carl Spencer, Project Director

1976

374

Learning Center
Career Education
WHICH WORKER'S WASTEBASKET?

TEACHER'S PLAN (page 1 in START booklet)

1.

SUBJECT AREA:

- Career awareness
- Decision-making skills
- Personal/Social growth
- Values Clarification
- Thinking Skills
- Identifying and Classifying
- Research Skills

2.

TEACHER'S OBJECTIVES:

- Students will be able to practice steps of decision-making based on career awareness.
- Students will be able to practice research skills.
- Students will be able to identify and classify an occupation through materials used by the worker.
- Students will be able to utilize thinking skills.
- Students will be able to apply social skills through peer teaching.
- Students will be able to observe and compare values of workers through interviewing.

STUDENT'S OBJECTIVES:

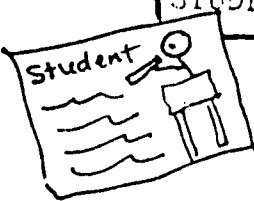

- See student objectives sheet in kit. (boy with telescope)
- This sheet may be duplicated for each student using the center.
- This sheet may be posted in the center.
- This sheet may be enlarged into chart form.

3.

PRE-ASSESSMENT:

LEVEL 1 * ** ###
 LEVEL 2
 LEVEL 3

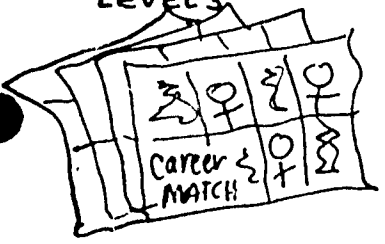

Students play CAREER MATCH game. Pupils match the worker with the things in the worker's wastebasket. The matched letters and numbers are written on the provide answer sheet and given to the teacher, The teacher may then check the answers or give the child an answer sheet (in kit) to self check. The game is on four sheets in the kit and must be cut apart before the children use it.

PRE-ASSESSMENT: (continued)

2

LEVEL 2
LEVEL 3

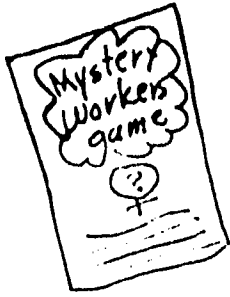

Students play MYSTERY WORKERS GAME. This game is found on twelve sheets in your kit. The names of various workers are found on five sheets which must be cut apart before the students can play the game. The directions are provided in the kit. Students may do all the workers or choose only those he knows for sure. The ANSWERS sheet may be cut apart and only one answer box given out at a time for self checking or may be teacher checked. Students are encouraged to give their own ideas for their decisions. Results of these tests will determine which activities the teacher will assign to the students.

4. MULTI LEVEL ACTIVITIES:

Stars are used to indicate to the teacher the difficulty of the tests and activities and games.

Look →

- * Indicates Level 1 - EASIER
 - ** Indicates Level 2 - AVERAGE
 - *** Indicates Level 3 - MORE DIFFICULT
- ENRICHMENT activities are keyed to levels with * ** ***



← Levels 2 and 3 only



← level 1 only

MULTI MEDIA ACTIVITIES:

- Tapes
- Drawings
- Filmstrips
- Tapes
- Pencil/pen
- Books

MATERIALS NEEDED:

- duplicate worksheets
 - duplicate answer sheets
 - duplicate paper
 - paper/pencil
 - large brown envelope (for pupil work)
 - duplicate student passes
 - red pencils for student self check
 - discard materials from workers
 - wastebaskets (numbers taped on)
 - box or wastebasket with room number
 - for student's work envelopes
 - empty little center boxes (office clerk)
 - encyclopedias
 - career / occupation books
- suggestions;
- Occupational Dictionary for Children
 - Ind. Trade Books (Sextant System)
 - My Career Workbook 1 (Career Futures)
 - Occupational Profiles (Chronicle Pub.) (may borrow from Jr. High)
 - Yellow Pages Learning Resources (Geo)
 - City Telephone Book Yellow Pages
 - Selected Library Books



The Which Worker pages are the main activities of the center. They are used with the filled wastebaskets.

MATERIALS NEEDED:

- (continued)
- Library Careers Study Prints
- Community Workers Posters (Milton-Brad.)
- Filmstrip Viewer
- Tape Recorder
- Microphone for recorder
- ear phones
- Selected filmstrips and tapes
- suggestions:
- What Does Your Dad Do? (Scott Ed.)
- 6 filmstrips and 6 tapes

5. RECORD KEEPING:

Example: Teacher uses a grade book or chart and records the progress of each student.

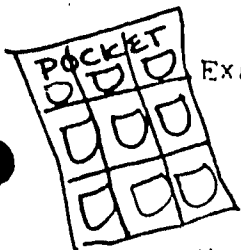

Example: A TIC TAC TOE sheet such a PICK A POCKET (in kit) may be used. Each center is designated by a pocket. The student X off the center when all activities are completed. Centers may be assigned by the teacher or be student's own choice to make a TIC TAC TOE pattern.

Example: The student keeps track of his own progress. SEE MY PROGRESS RECORD sheet in the kit. Each boxed area shows an activity to be completed in the Career Education center only. The student completes an activity, checks own work, makes corrections, X out the activity box, evaluates feelings by circling a face, shows his work to the teacher (she may initial the box) and places the finished (or unfinished) work in the MY PROGRESS RECORD sheet in his brown envelope. These student envelopes are kept in a box in the center and are subject to the teacher's reference at any time.

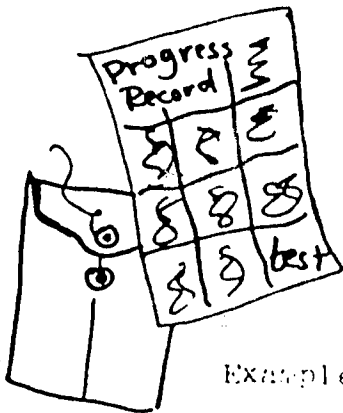

Example: A wall pocket chart may be utilized where students slip their name card into the completed center pocket.

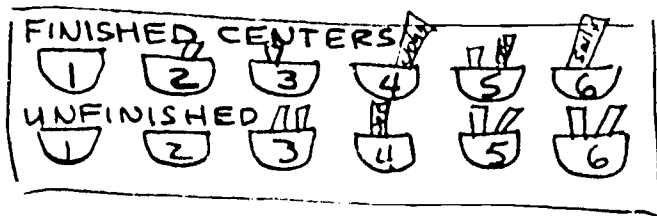

6. STUDENT EVALUATION:

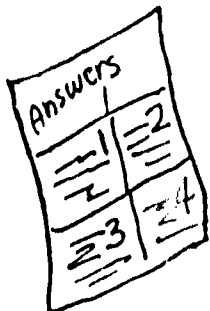

Students may evaluate their own progress by using the answer sheets provided in the kit. The answer sheets are kept by the teacher and are given to the student when he shows her his completed paper. The teacher may scan the paper to see if directions have been followed, etc. (The answer sheets are designed so they may be cut apart allowing for different ability levels.) The student then marks an X on the activity box completed on the MY PROGRESS RECORD sheet.

Students become aware of their emotions when they are asked to circle the feelings faced of each activity on the MY PROGRESS RECORD sheet. This reveals to the teacher if the child is feeling success or failure, which activities are most popular, and which activities need revision.

The MY PROGRESS RECORD is shared with the teacher after each X is made. The teacher may initial the box if necessary. MY PROGRESS RECORD and all work finished or unfinished is always kept in the student's brown envelope, which should minimize lost papers. Students should be made aware that his work envelope is always available for teacher evaluation. Class envelopes are stored in a box or "wastebasket" near the center.

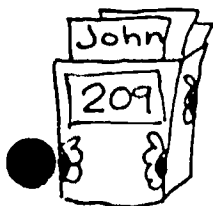

Success of the child's accomplishments will be indicated on the post-test provided in the kit.

7. LOCATION OF CENTER:

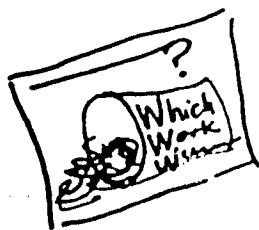

This center may be put in a corner, counter, desk, table, or floor of the homeroom. It may be set up in another room designated as the Learning Center. This room is monitored by a teacher aide, teacher, student teacher, parent aide, or older student. The unit may also be placed on a cart and moved easily from room to room. SEE "WHICH WORKER'S WASTEBASKET" in the kit. This may be indicated as a personal invitation to a child to work in the center or may be enlarged to a bulletin board area. Something bright and catchy must appeal to the child's curiosity of the center activities!

SEE drawing of POSSIBLE PHYSICAL SETTING in the kit.



8. HOW AND WHEN THE CENTER IS TO BE USED: (SCHEDULING)

Organization and scheduling is of utmost importance. The child may choose to do the center, the teacher may assign a specific center activity or the student may use the activities as extra credit activities.

The success or failure of a center depends on whether the student understands exactly what he is to accomplish, how much time he is allowed and his expected behavior. He must understand before he enters the center that if these expectations are not met, he will not be able to return to the center and stick to it! (There are always exceptions, however, as a tape breaking, recorder malfunction etc.) No exceptions for poor behavior!

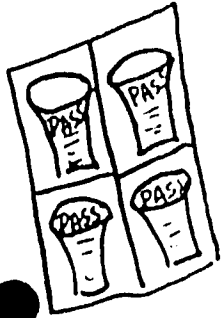

SEE THE PASS in the kit. The basketball shaped passes are on one sheet and must be cut apart before giving one to students. A pass can become a valuable tool for responsibility when the above items are filled out and checked by the teacher. The teacher (or child) fills out the top half of the pass. The student shows it to the aide, etc. when entering and leaving the center. The aide checks the expectation and behavior and initials the pass. The pass is immediately returned to the teacher for instant teacher-student praise, accuracy of self evaluation. The pass could be duplicated on colored paper for easier identification.

9. STUDENT - TEACHER EVALUATION OF CENTER:

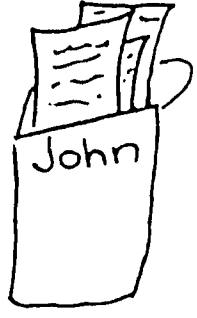

The student's brown envelope contains all the work he has completed in the center. This provides excellent student-teacher conference material. The smiling or frowning faces indicated by the child may be discussed...how much help the student needed or if most was done independently.... and please do listen to the student for suggestions on improving the center. They do come up with great ideas that an adult could never think of. If you feel the child would offer ideas or criticism better by using a suggestion box, make one for the center.

Post tests are keyed to levels of ability (* ** ***). No tests are included with answer sheets for student self check and conferencing with teacher.

Student Objectives

IN THIS CENTER

- I will learn about careers, through decision-making.
- I will practice research skills.
- I will identify and classify an occupation through materials used by a worker.
- I will use social skills by working with others.
- I will use thinking skills.
- I will observe and compare values of workers through interviewing.

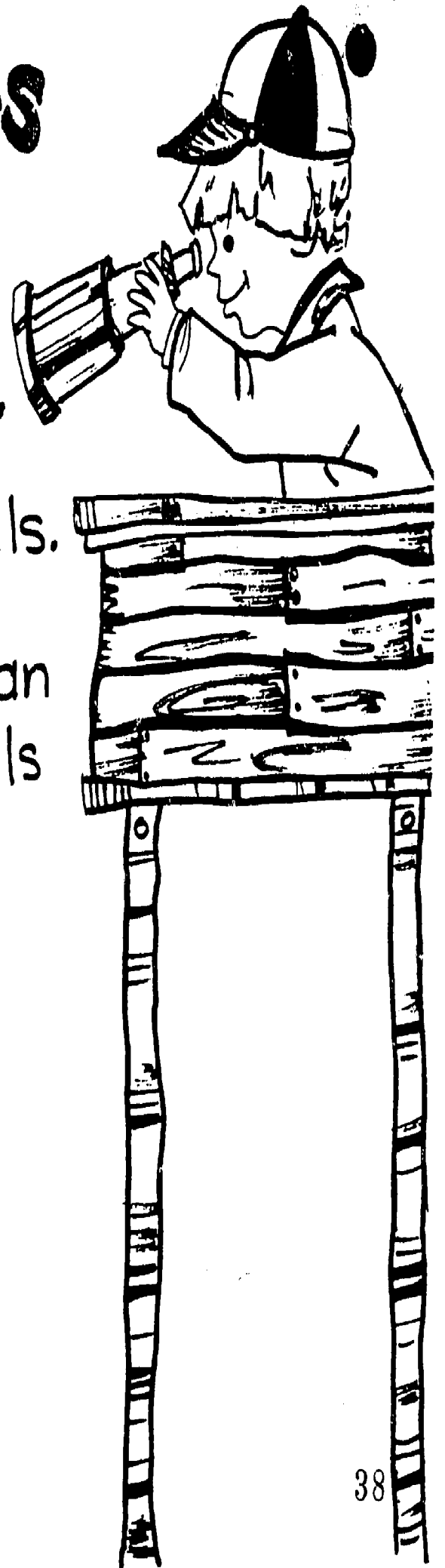

WASTE BASKET

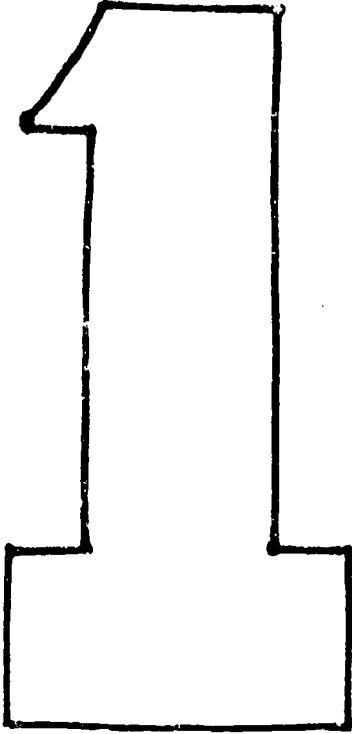

WASTE BASKET



WASTE BASKET

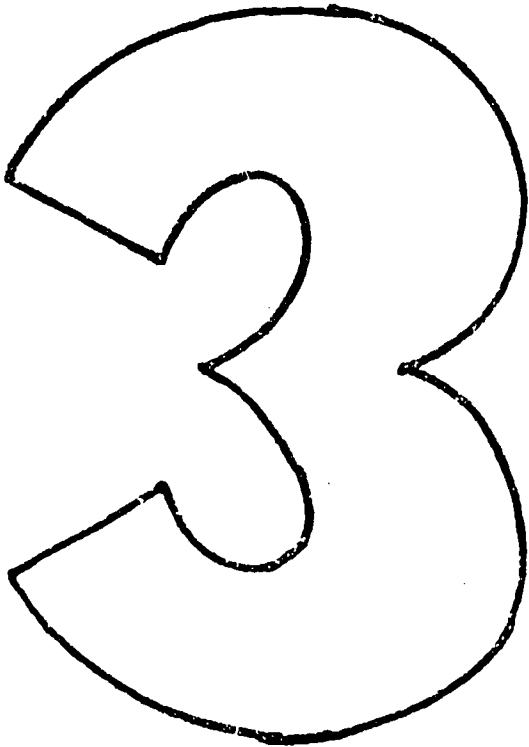

WASTE BASKET

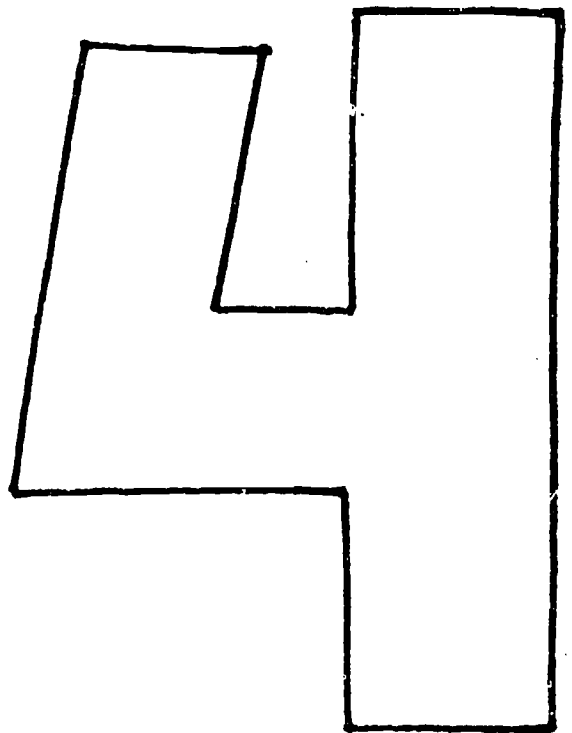

WASTE BASKET



WASTE BASKET

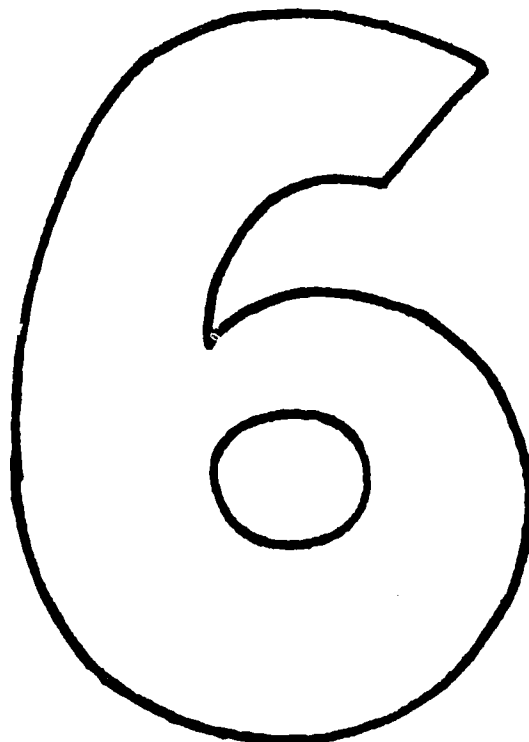

WASTE BASKET

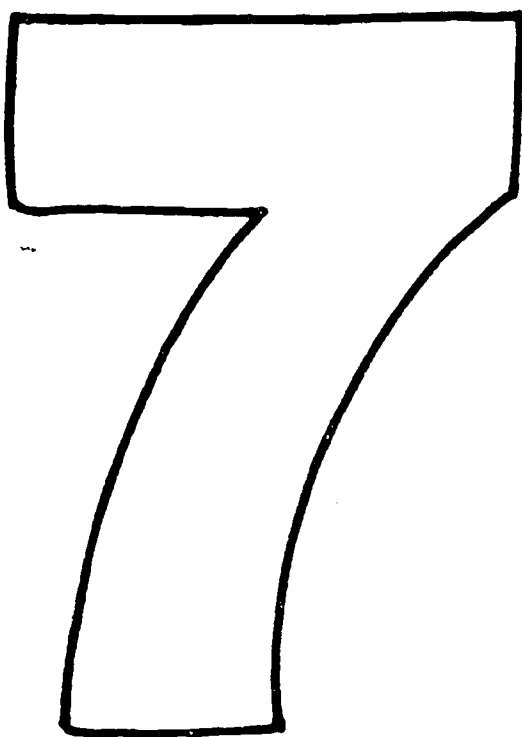

WASTE BASKET

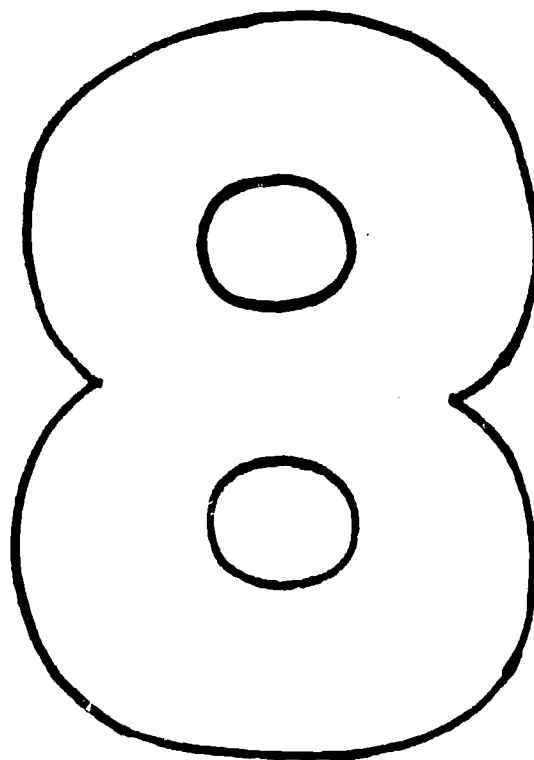

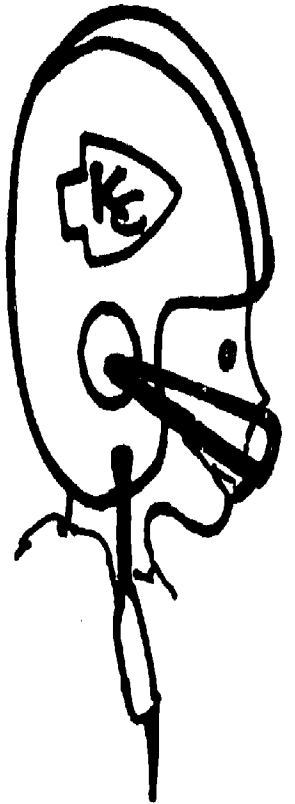

?

Can you match

Directions

Match each worker with the things that might be found in his or her wastebasket.

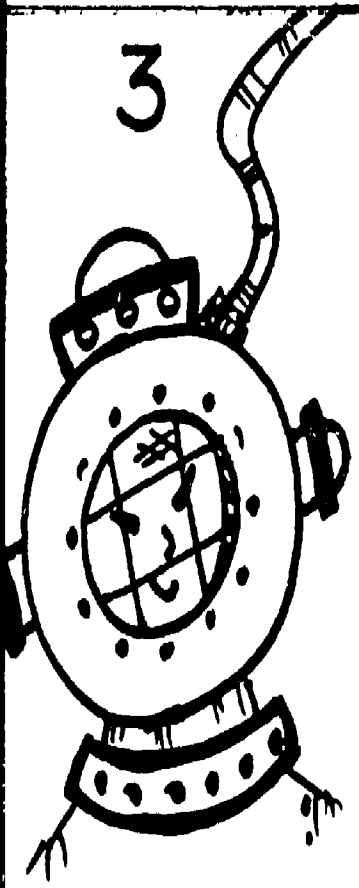

* ** ***

• ? Career Match

Match each picture of a worker with the things that might be found in that worker's wastebasket.

Write the correct letter beside each number ↑

My answers

- 1
- 2
- 3
- 4
- 5
- 6
- 7
- 8
- 9
- 10
- 11
- 12
- 13
- 14
- 15

Ask the teacher for an answer sheet.

cut apart

Career Match Answers

- 1-N
- 2-M
- 3-O
- 4-K
- 5-L
- 6-J
- 7-I
- 8-A
- 9-B
- 10-C
- 11-D
- 12-E
- 13-F
- 14-G
- 15-H

A

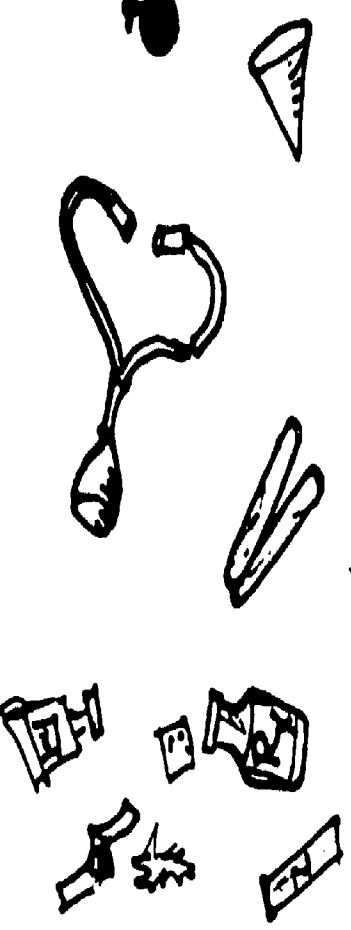

8



B

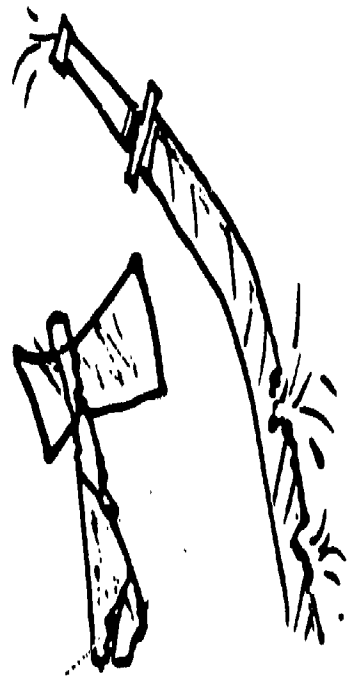

9



C

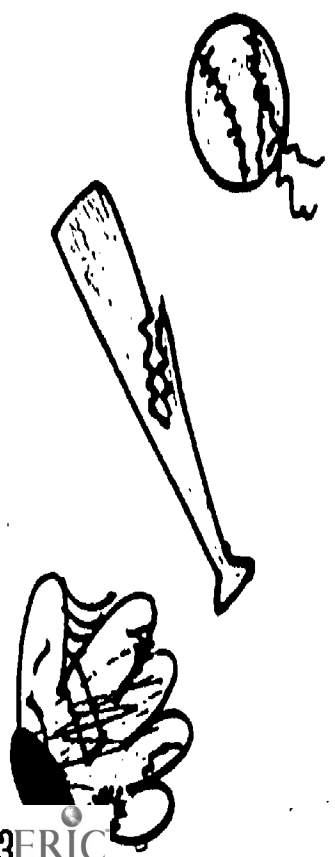

10



D

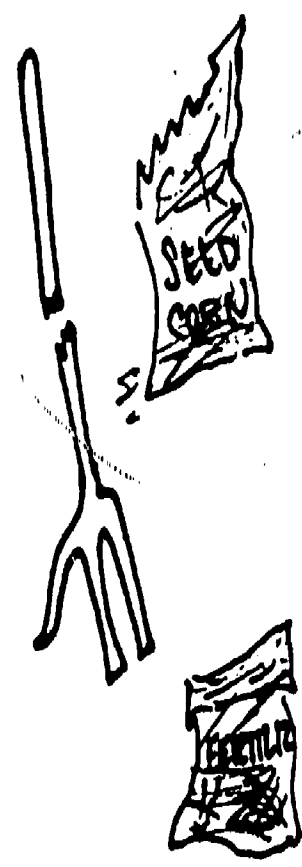

11



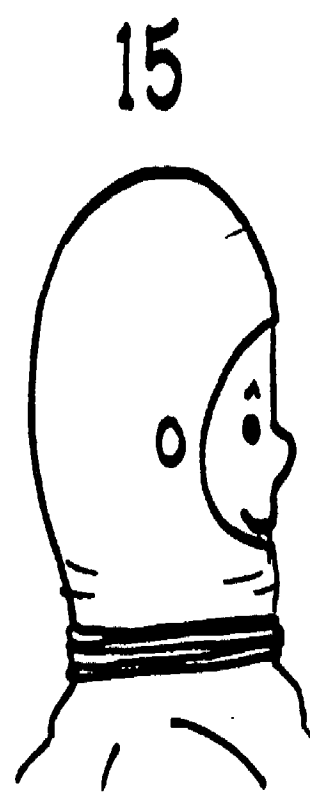
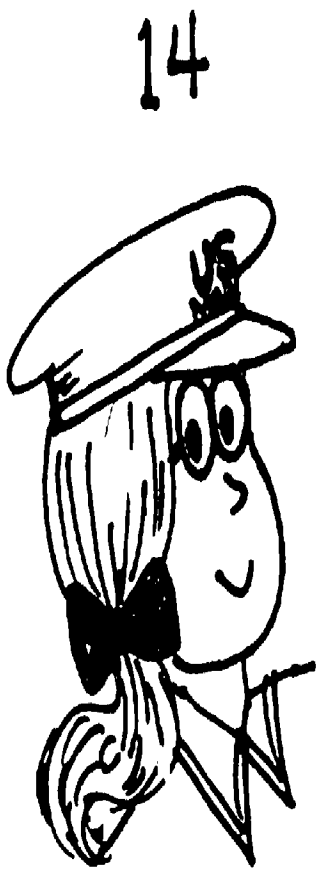
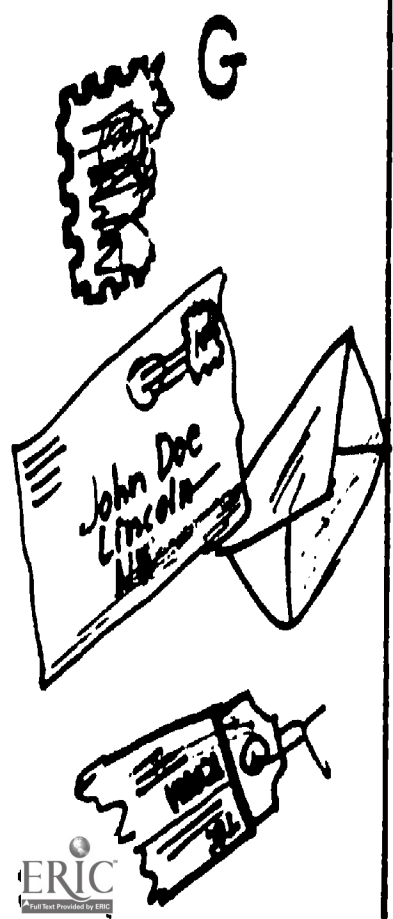
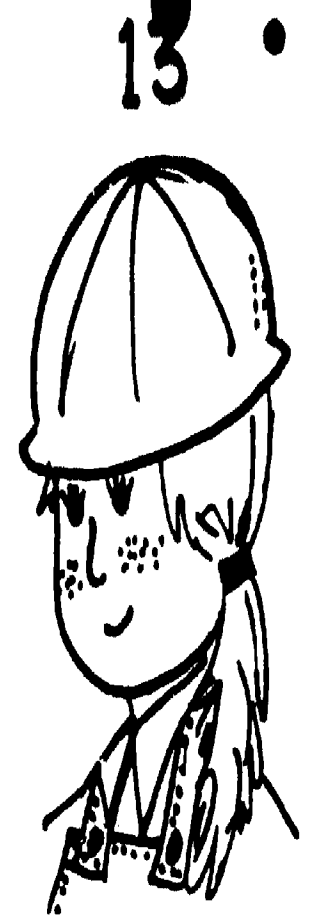
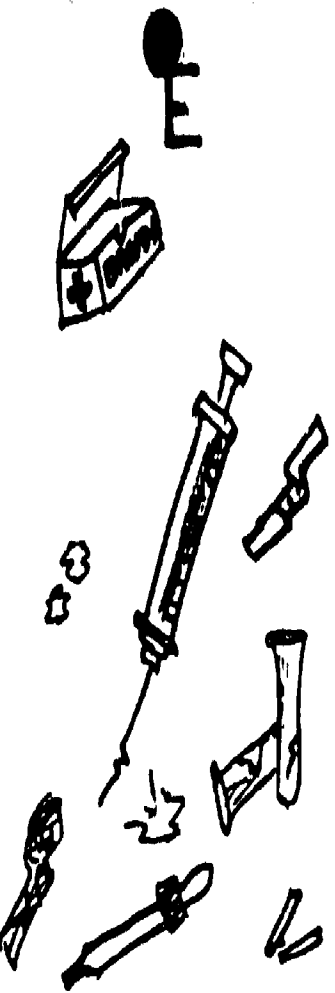

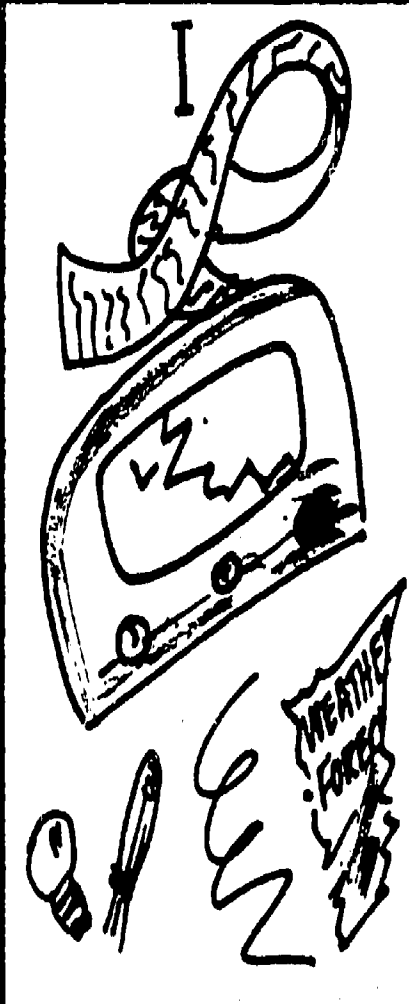
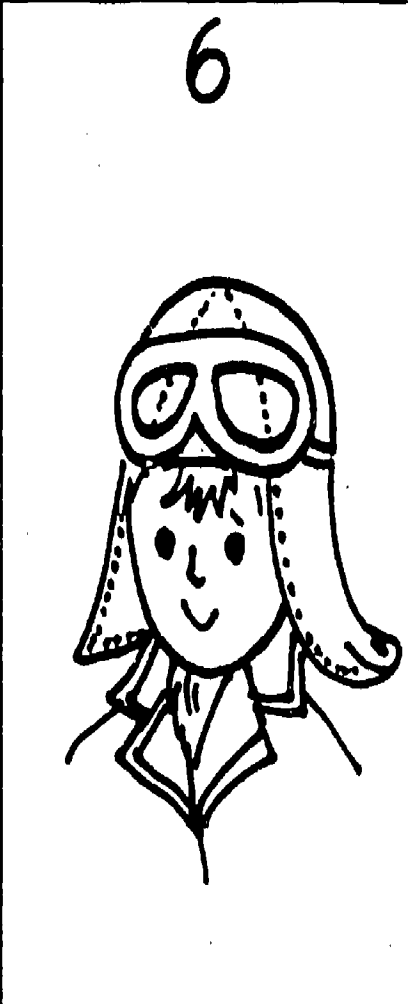
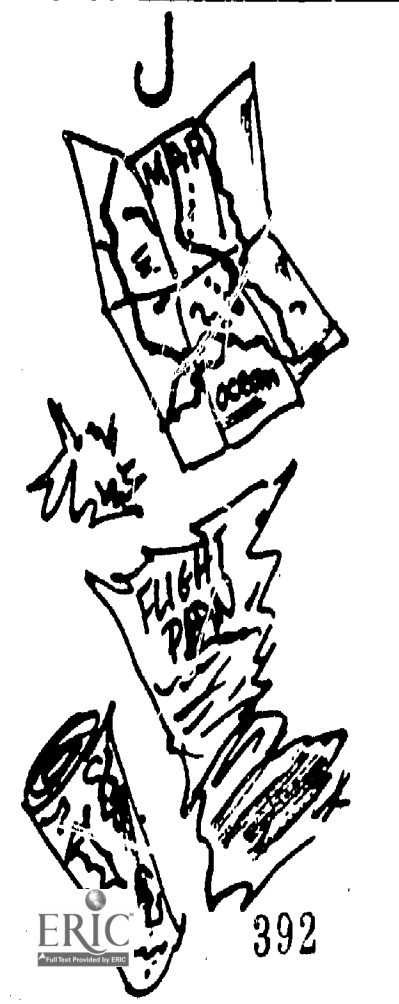
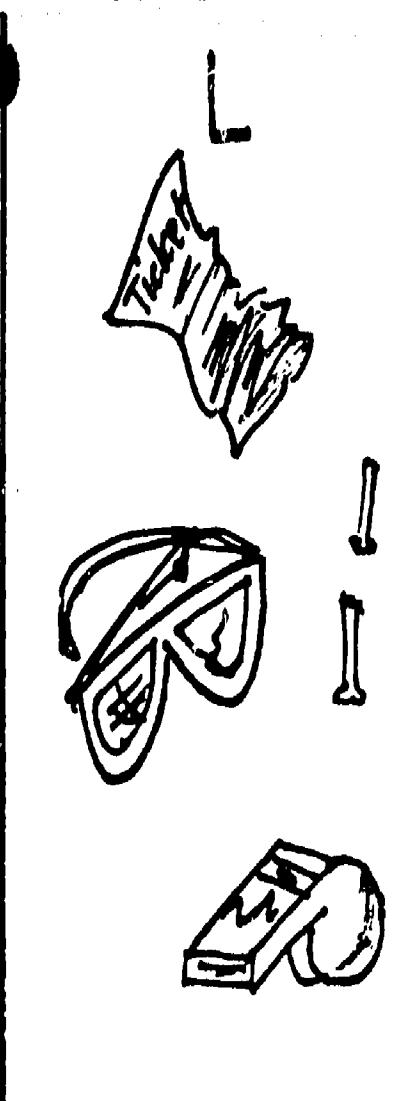

- teachers:
- duplicate the 5 "clues playboards" on oaktag.
 - duplicate workers on oaktag (5 sheets)
 - cut apart to make a skill deck
 - use with "mystery workers game"
-

Forester

Florist

Landscaper

Seed Grower

Nurseryman

* Skill deck *

• Artist

Letterer

Sign Maker

• Photographer

Cartoonist

Fashion Designer

• Illustrator

Pediatrician

Dentist

Doctor

Pharmacist

Nurse

Orthodontist

Veterinarian

• Detective

Guard

Policeman

• Jailer

Patrolman

Armored Car Guard

• duplicate the 5 "clue playboards" on oaktag
- duplicate workers on oaktag. (5 sheets)
- cut apart to make a skill deck. 397
use with "mystery workers game." ▲

• Actor / Actress

Disk Jockey

TV Newsman

• Sports Announcer

Entertainer

Ventriloquist

• Comedian

* mystery workers game *



Many workers have related occupations. They have similar qualifications and tools of the trade.

DIRECTIONS:

- * Place the 5 playboards on the floor or table in front of you.
- * Read the list of clues on each playboard.
- * Then read the names of the workers in the skill deck.
- * Decide which worker best matches the clues listed on the playboard.
- * Place the worker card on the correct "Answers" space.

When you are finished, ask the teacher for a checking sheet. If you disagree with answer sheet, please tell whv.

PLAYBOARD

A

● These workers should have:

- honesty
- alertness to problems
- calmness under stress
- good relations with people
- good physical condition
- dependability
- courage

**
**
**

These workers might use:

- weapons
- uniforms
- radio equipment
- keys
- flashlight

1

mystery workers game

place
Answers
here



400

PLAYBOARD

● These workers should have:

artistic talent
observing eyes
creativity
neatness
patience
imagination
a steady hand
good color perception

2

**
**

These workers might use:

pencils
paper
easel
paint
paintbrushes
ink
pen
felt tip pens
eraser
ruler
colors
camera

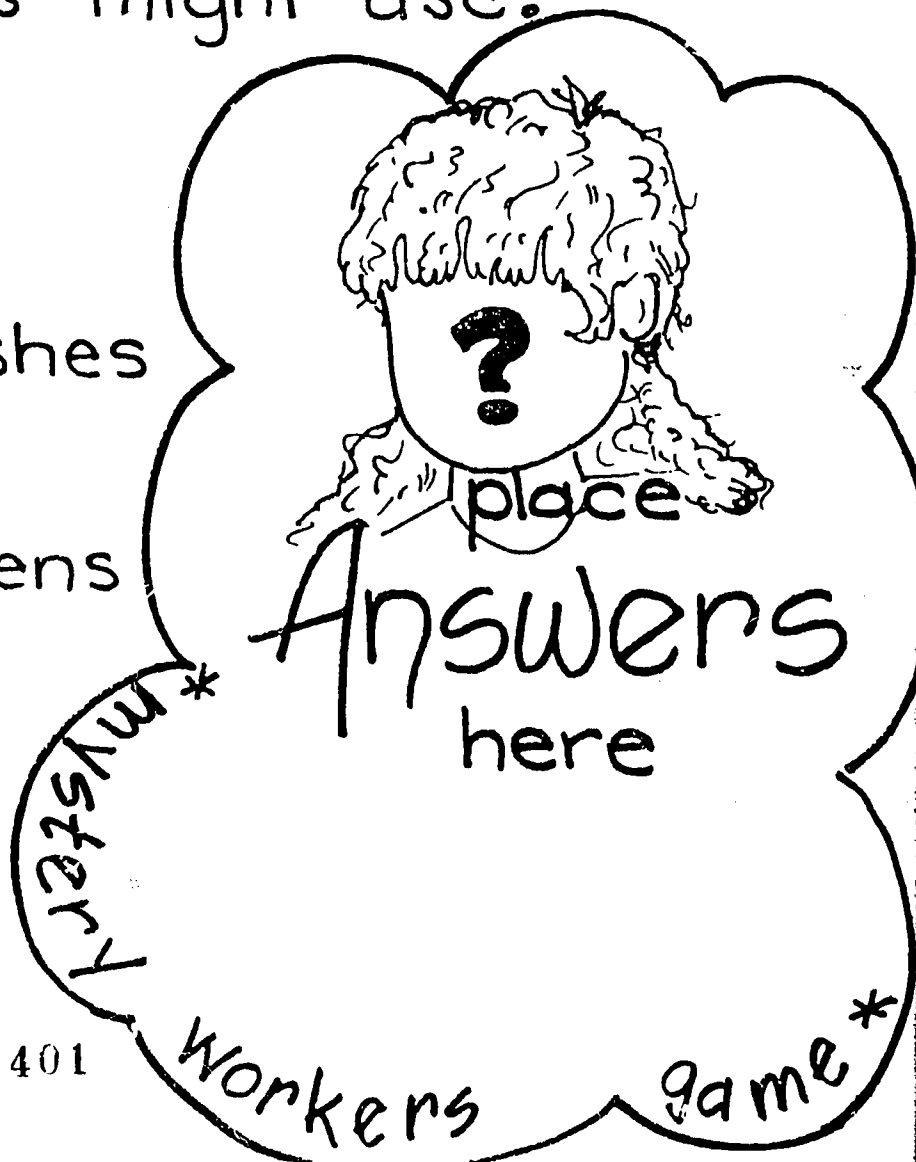

PLAYBOARD

● These workers should have:

Showmanship
well controlled voice
excellent enunciation
good sense of timing
confidence
talent for acting
determination
ability to read well or memorize

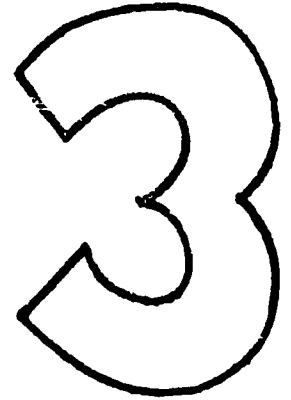

*
*
*
*
*

These workers might use:

a spotlight
records or film
sound equipment
costumes
script
microphone



PLAYBOARD

These workers should have:

a delicate touch
scientific skill
liking for people
high morals
visual memory
dependability
patience
intelligence
careful work habits
calmness under stress
accuracy

4

*
*
*
*
*

These workers might use:

drugs
cotton
rubbing alcohol
patient's records
precision instruments
hypodermic needle
powders

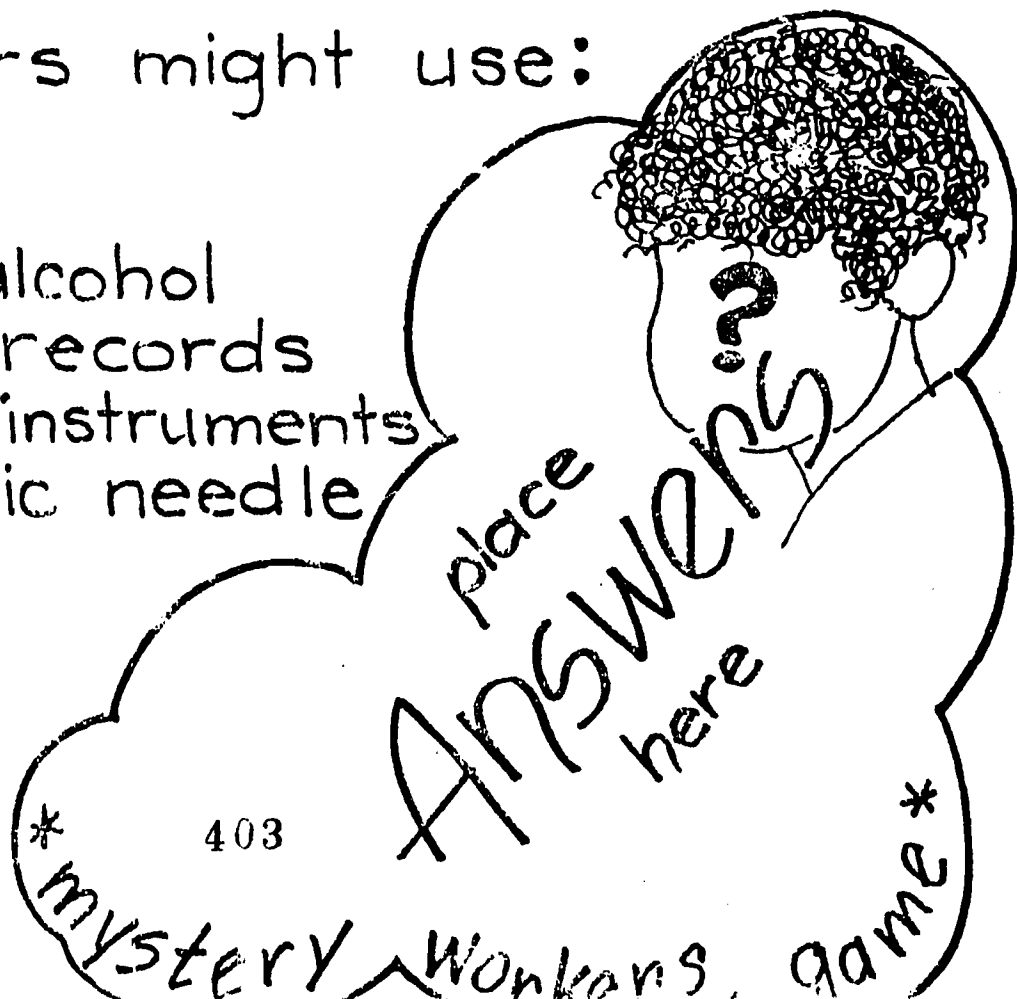

PLAYBOARD

These workers should have:

- a love for growing things
- imagination
- feeling of arrangement
- enjoyment of working with hands
- good color perception
- knowledge of weather

These workers might use:

- shovel
- water
- shrubs
- flowers
- trees
- fertilizer
- soil
- flower pots
- clippers

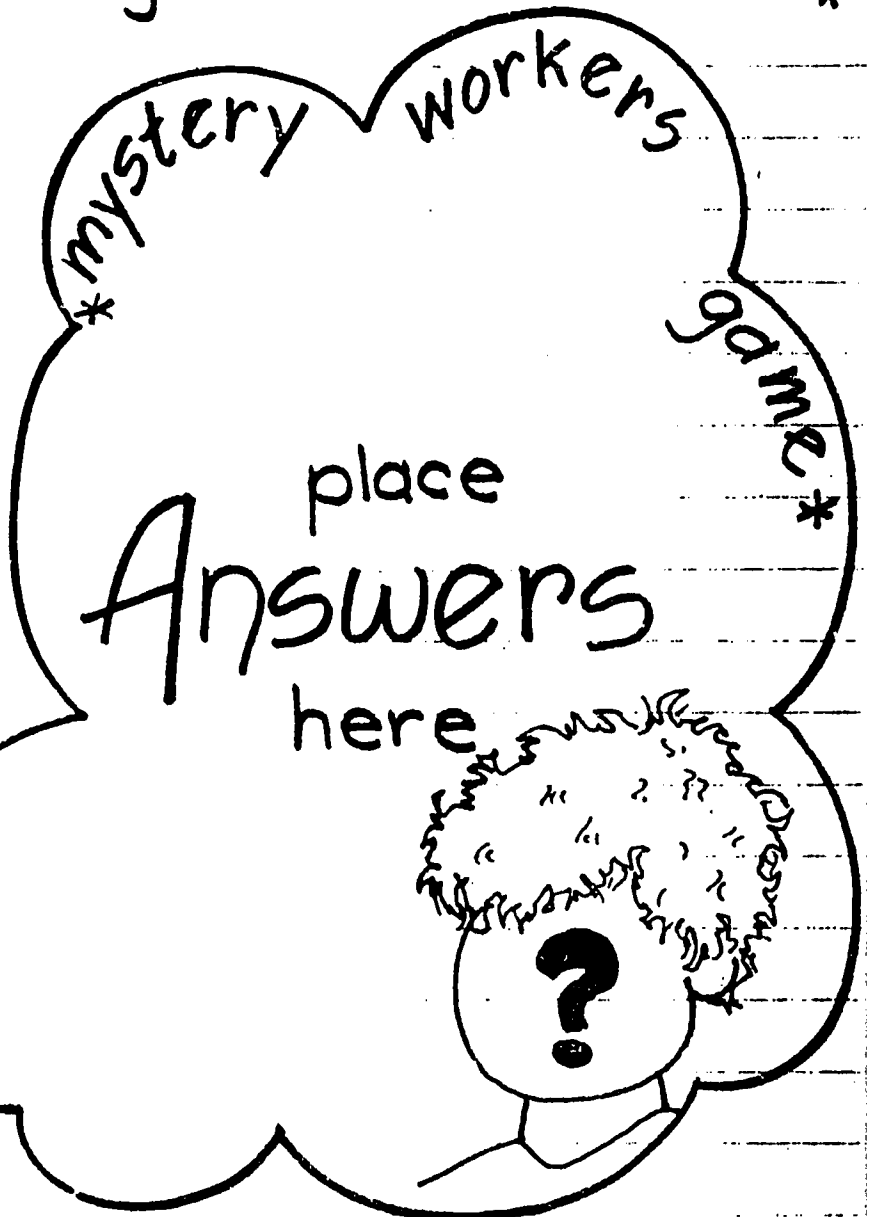

5

Answers

*mystery
workers
game*

may be cut apart

self check

mystery workers game 1

Guard
Policeman
Jailer
Patrolman
Armored Car Guard
Detective

mystery workers game 2

Artist
Letterer
Sign Maker
Photographer
Cartoonist
Fashion Designer
Illustrator

mystery workers game 3

Disk Jockey
Actor/Actress
TV Newsman
Sports Announcer
Entertainer
Ventriloquist
Comedian

mystery workers game 4

Veterinarian
Pediatrician
Dentist
Doctor
Pharmacist
Nurse
Orthodontist

mystery workers game 5

Forester
Florist
Landscape
Seed Grower
Nurseryman

Which Worker - Answers

self check

4

may be torn apart

medicine boxes
 prescription bottles
 part of store sack
 film box
 cotton
 candy wrapper
 lids
 eye dropper
 tissues
 other

wastebasket **1**

Best Choice
 Pharmacist

tiny polishing brush
 jewel box
 chain parts
 tiny round sand-paper
 file
 jewelry parts
 dirty polishing cloth
 ring box
 other

wastebasket **2**

Best Choice
 Jeweler

scotch tape carton
 notes
 letter to be typed
 supply order
 student census file
 calendar number
 folder
 carbons
 other

wastebasket **3**

Best Choice
 Secretary

syringe
 tongue depressor
 appointment card
 paper cups
 band-aid
 cotton balls
 tape ring
 cotton swabs
 tissues
 other

wastebasket **4**

Best Choice
 Nurse/Doctor

fabric bolt
 pattern envelope
 empty spools
 pins
 needle - dull
 thread
 rick rack package
 button
 snaps
 other

wastebasket **5**

Best Choice
 Seamstress

permanent papers
 hair rinse box
 bottles
 cotton
 pink tape
 hair
 broken clip
 bobby pins
 perm. wave tube
 tissues

wastebasket **6**

Best Choice
 Beautician



Which Worker?



directions

*
*
*
*
*

1. These wastebaskets were used by workers in their jobs.
2. Look carefully in each wastebasket.
3. Choose a wastebasket and empty the worker's throw-aways on the floor.
4. Examine the contents carefully.
5. Write down on your worksheet, all the things you find in the wastebasket. These are clues to help you identify the worker!
6. Put all the throw-aways back.
7. Now read through all your clues.
8. List the workers you think might have used these throw-aways.
9. Find the worker you feel is your best choice and copy it by the star.
10. Do at least four wastebaskets or try them all!
11. Put your finished work in your envelope.



Which Worker?



number

5. Clues (things in wastebasket)

8. Workers that might use these things

★ 9. My best choice is _____
 because _____

Name _____

My Progress Record

Cut completed Activities

Career match game

mystery workers game

MY FEELINGS: 😊 ☹️

MY FEELINGS: 😊 ☹️

Which Worker?

1 2 3
4 5 6

number of baskets completed

ACTIVITY 1

View Filmstrips

number of filmstrips viewed.



RESEARCH

ACTIVITY 2

number of books I read.

MY FEELINGS: 😊 ☹️

MY FEELINGS: 😊 ☹️

MY FEELINGS: 😊 ☹️

ACTIVITY 3

Interview a worker who?

** *** ACTIVITY 4

Visit a worker on the job.

* * * * * ACTIVITY 5

Fill a wastebasket with CLUES

number of baskets I did.

MY FEELINGS: 😊 ☹️

MY FEELINGS: 😊 ☹️

MY FEELINGS: 😊 ☹️

extra credit

my choice:

ACTIVITIES WERE

MY FAVORITE

I NEEDED HELP ON 409

test

MY SCORE

😊 ☹️

Pick A Pocket

Draw an X through each center you complete

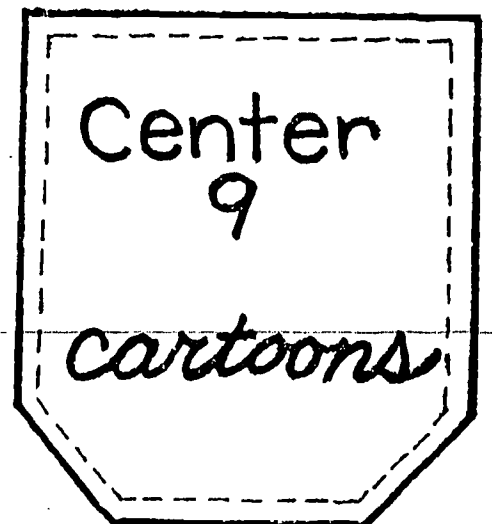
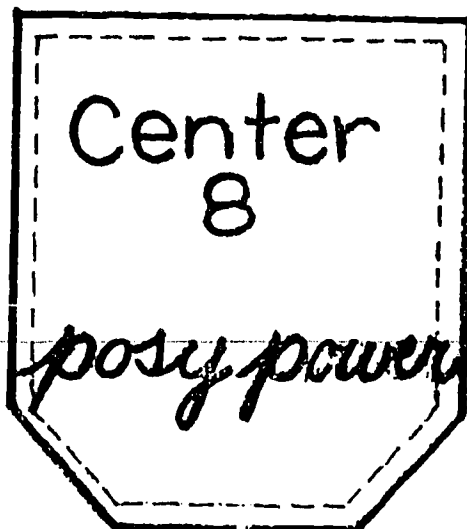
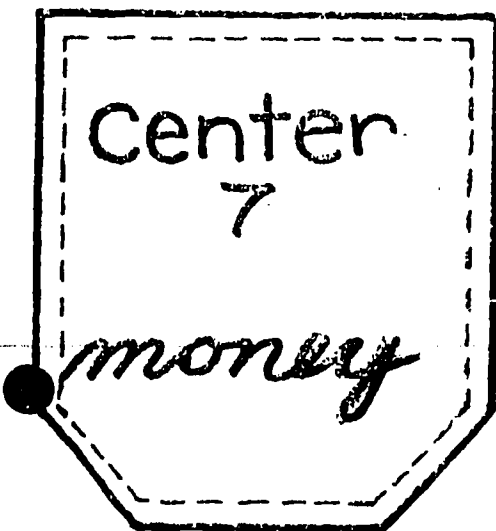
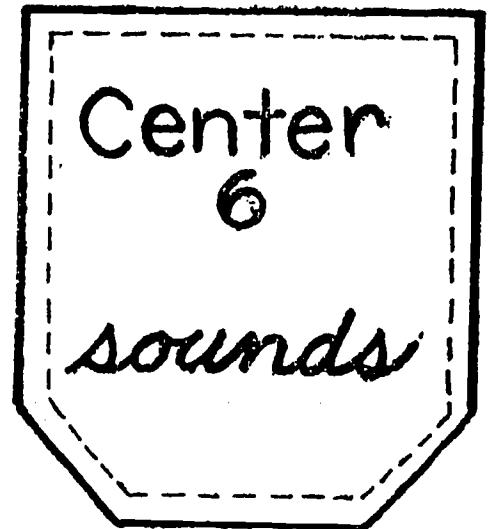
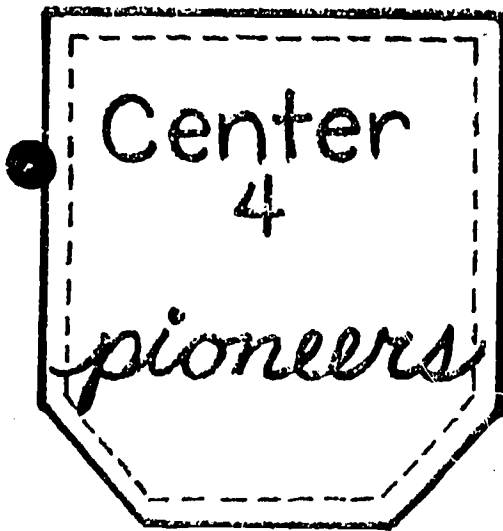
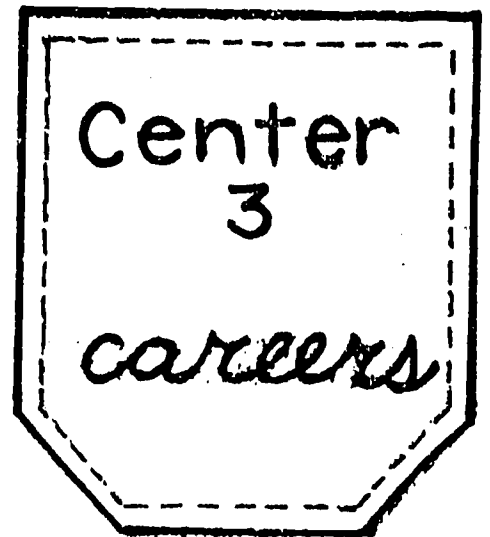
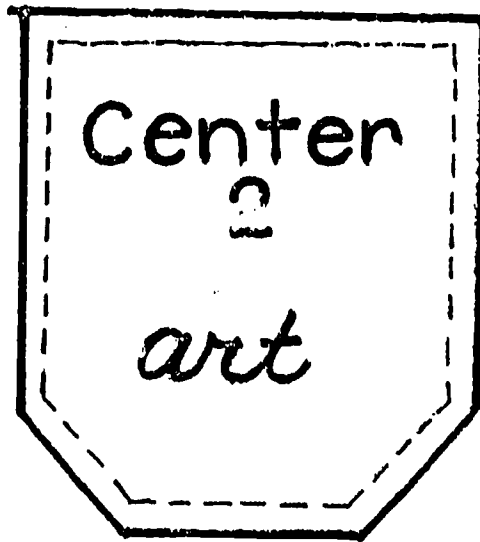
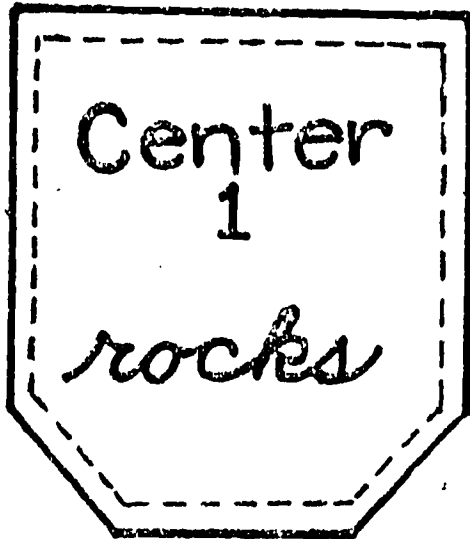

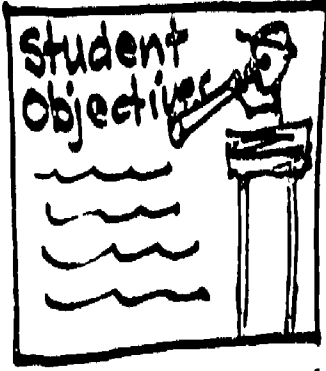

posted student objectives

bright eye-catching letters and border

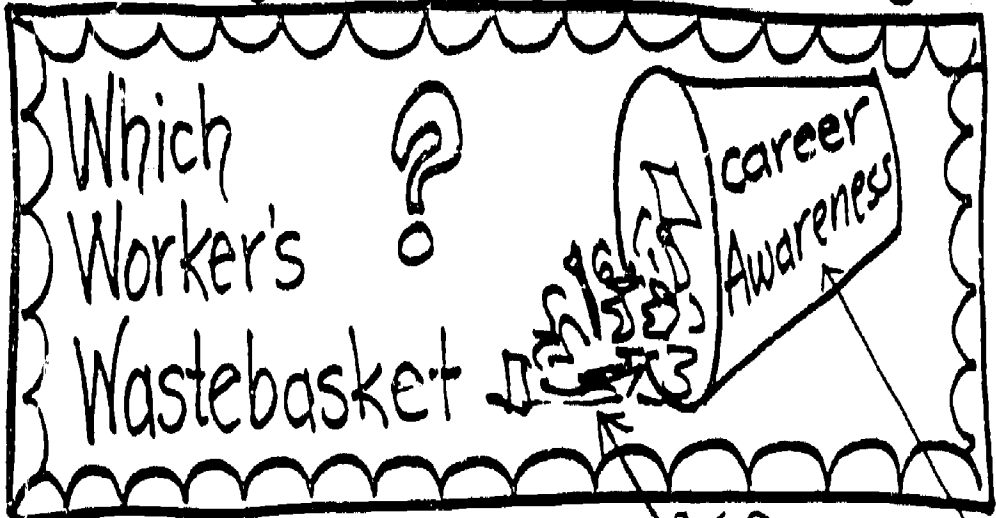

BULLETIN BOARD IDEA ↑

actual waste materials of a teacher are pinned up.

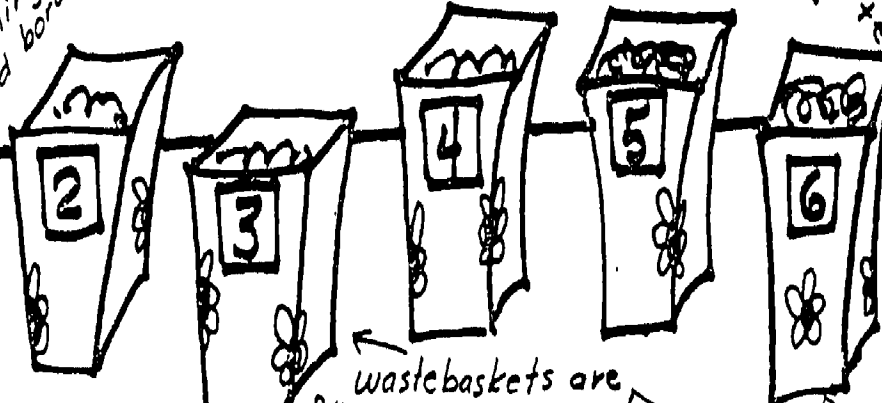

wastebaskets are filled with throw-away clues of a worker

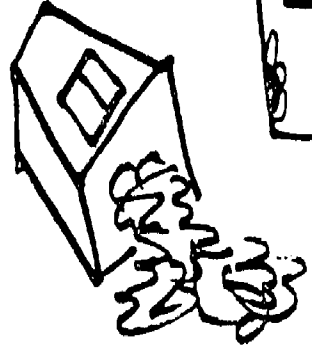

Wastebasket 1 contents are spilled out to identify worksheets for student written on answers for research

empty ditto master boxes from office clerk make handy containers for worksheets



pencils

BOX WITH ROOM NO. CONTAINS STUDENT'S BROWN WORK ENVELOPES

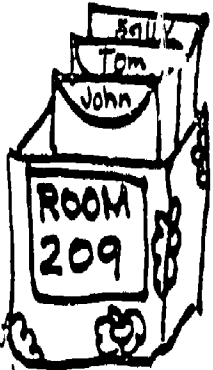

Books available for research Also use LIBRARY 2

SIZE OF AREA WILL DETERMINE NUMBER OF STUDENTS ALLOWED TO WORK IN CENTER. POST A SIGN → 6 workers only

MEDIA EQUIPMENT IS SET UP IN CENTER

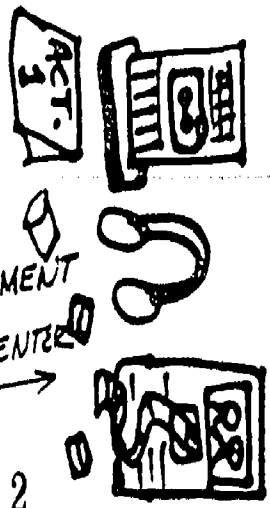

1. Look at the picture below

What does this worker do?

2. Name some things this worker would use to do his job.

3. Write down some names for this worker's job.

Circle your best choice.

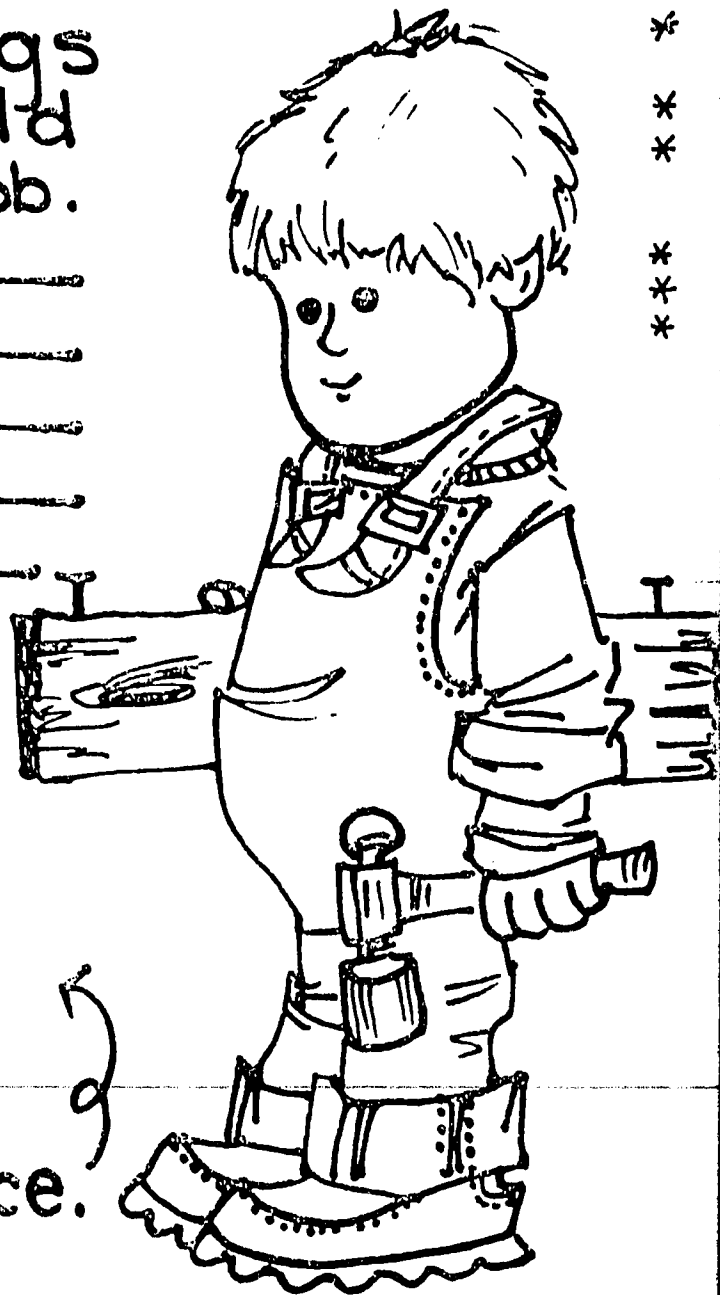

*
*
*
*
*
*

ANSWER SHEET

* ** *** 9

TEST 1

1. builds houses, apartments, buildings
makes cupboards
makes window frames
makes doors
builds stairways
lays floors
makes furniture
builds bridges
- (others possible)

2. hammer wrench
saw pliers
screwdrivers measurers
nails nuts and bolts
screws tool box
drill (others possible)
plane
pulley

3. carpenter brick layer
construction worker steel worker
engineer tile setter
farmer bridge builder
cabinet maker (others possible)
wood boat building

TEST 2

Name _____

1. Look at the picture below
What does this worker do?

2 Name some things
this worker would
use to do his work.

3. Give names
for this
worker's job.

Circle your
best answer
in number 3.

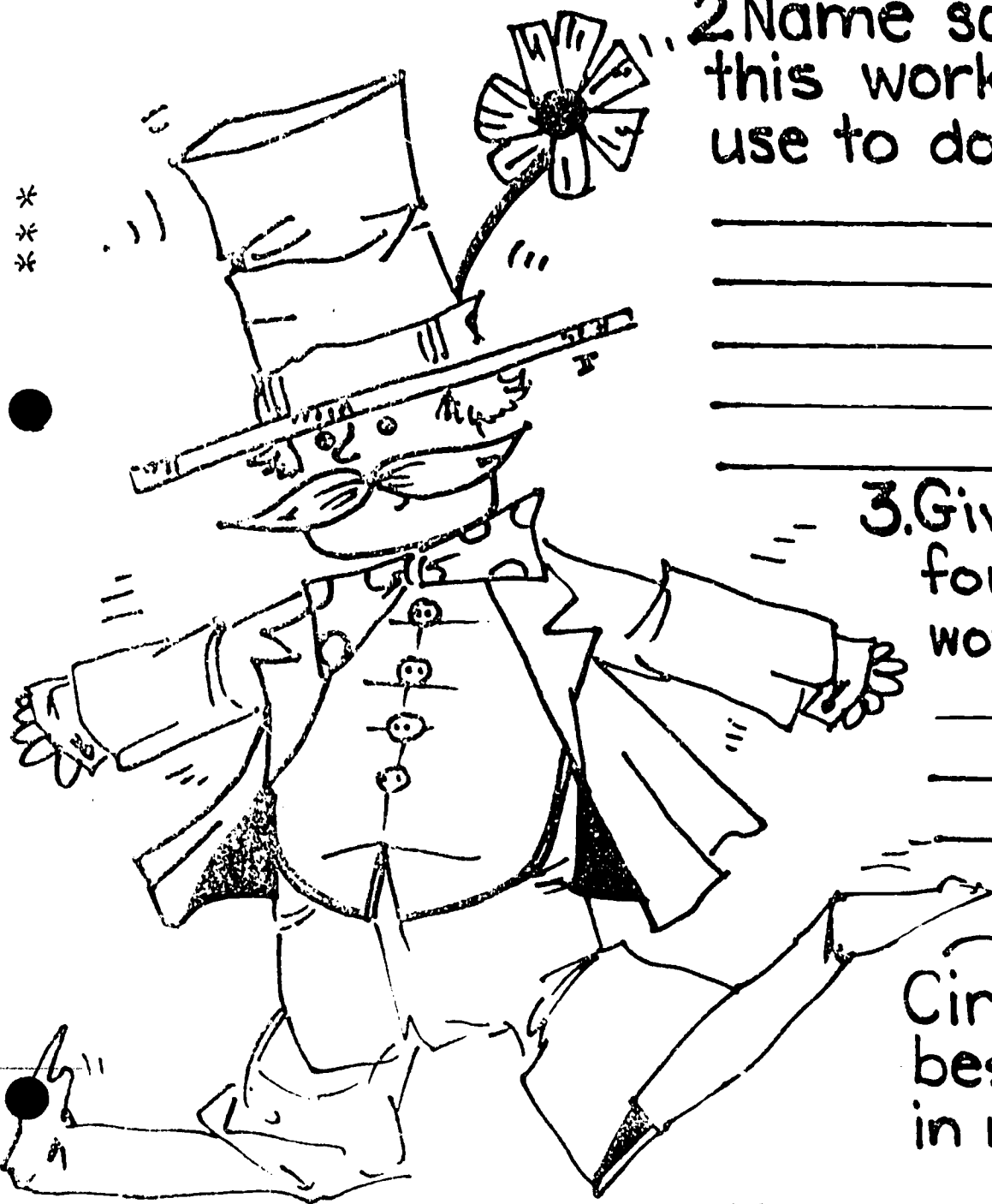

ANSWER SHEET

TEST 2

1. makes people laugh
acts
keeps audience in suspense
entertains
talks
sings
dances
tells jokes

(others possible)

2. make-up
spotlight
costumes
partner
script
microphone
props - cane, umbrella etc.
music

audience
stage
(others possible)

3. clown
actor or actress

(others possible)

entertainer

- comedian
ventriloquist
performer



LEARNING CENTER
* PASS *

Which Worker's Wastebasket

Name _____

Center Activity _____

Return Time _____

Expectation _____

Expectation met?
YES NO

Behavior:
 Acceptable
 Unacceptable

LEARNING CENTER
* PASS *

Which Worker's Wastebasket

Name _____

Activity _____

Return Time _____

Expectation _____

Expectation met?
YES NO

Behavior:
 Acceptable
 Unacceptable

Learning Center
* PASS *

Which Worker's Wastebasket

Name _____

Activity _____

Return Time _____

Expectation _____

Expectation met?
YES NO

Behavior:
 Acceptable
 Unacceptable

LEARNING CENTER
* PASS *

Which Worker's Wastebasket

Name _____

Activity _____

Return Time _____

Expectation _____

Expectation met?
YES NO

Behavior:
 Acceptable
 Unacceptable

* ENRICHMENT ACTIVITIES

4

1. View filmstrips

- choose occupations filmstrips
- write down things this worker would use in his job.

2. Research occupations

- read about a worker.
- use the encyclopedia or ask your teacher or librarian for help in finding books.

3. Interview a worker

- see the "Hints on Interviewing" sheet.
- share what you've learned with a friend, parent or teacher.

4. Visit a worker on the job

- ask him or her to help you gather throw away clues for a new basket which you may add to our center.
- be sure your clues clearly point to the worker you choose.
- check your throwaway clues for safety and show them to your teacher.

Name _____

See as many filmstrips as you wish.

Write down things this worker would use in his job.

worker _____

worker _____

worker _____

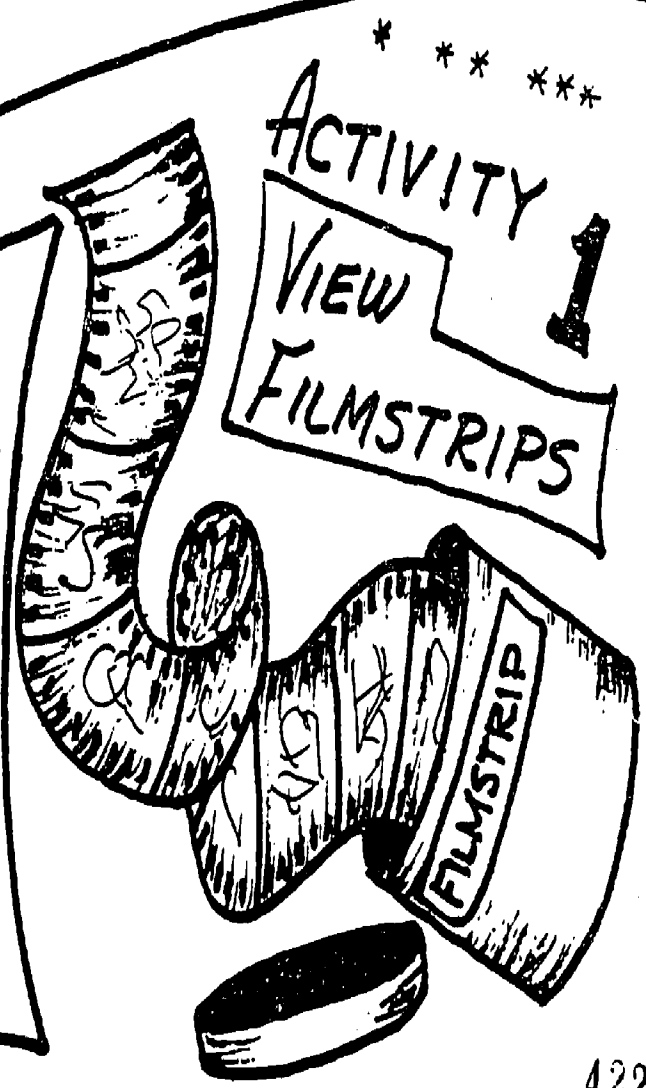

** ***

ENRICHMENT ACTIVITY 3

the Interview

1
read the
Interview
Hints sheet

2
read the
INTERVIEW
TECHNIQUES
SHEET

3
Think of a worker
you would like
to interview

4
write down
some questions
you will ask
in the interview

Worker- _____

1. _____
2. _____
3. _____
4. _____
5. _____
6. _____
7. _____
8. _____
9. _____
10. _____
11. _____
12. _____
13. _____
14. _____

An interview may be made in person or over the telephone. 423

Hints on Interviewing!

enrichment activity 3

- Decide which worker to interview.
- Make an appointment with the worker
- Introduce yourself.
- Be courteous.
- Speak clearly and to the point.
- Take complete notes (or use tape recorder)
- Thank the worker for giving the interview.

Possible Questions TO Ask In An Interview:

- What is your occupation?
- What made you choose your job?
- When you were my age, what did you want to be?
- What preparation did you need to do?
- What's the most important thing you do?
- Could both men and women do your job?
- What do you like about your job?
- What do you dislike about your work?
- Are you satisfied with the money you earn?
- Did you have another job before this one?
- Do you think you will remain in this job until you retire?

Name _____

* enrichment activity

**

- Now it's your turn to fill a wastebasket with clues.
- Think of a different worker.
- Write or draw things that the worker might throw away.
- Write the name of the worker's job upside down below the wastebasket.
- Get extra credit for each additional basket completed!

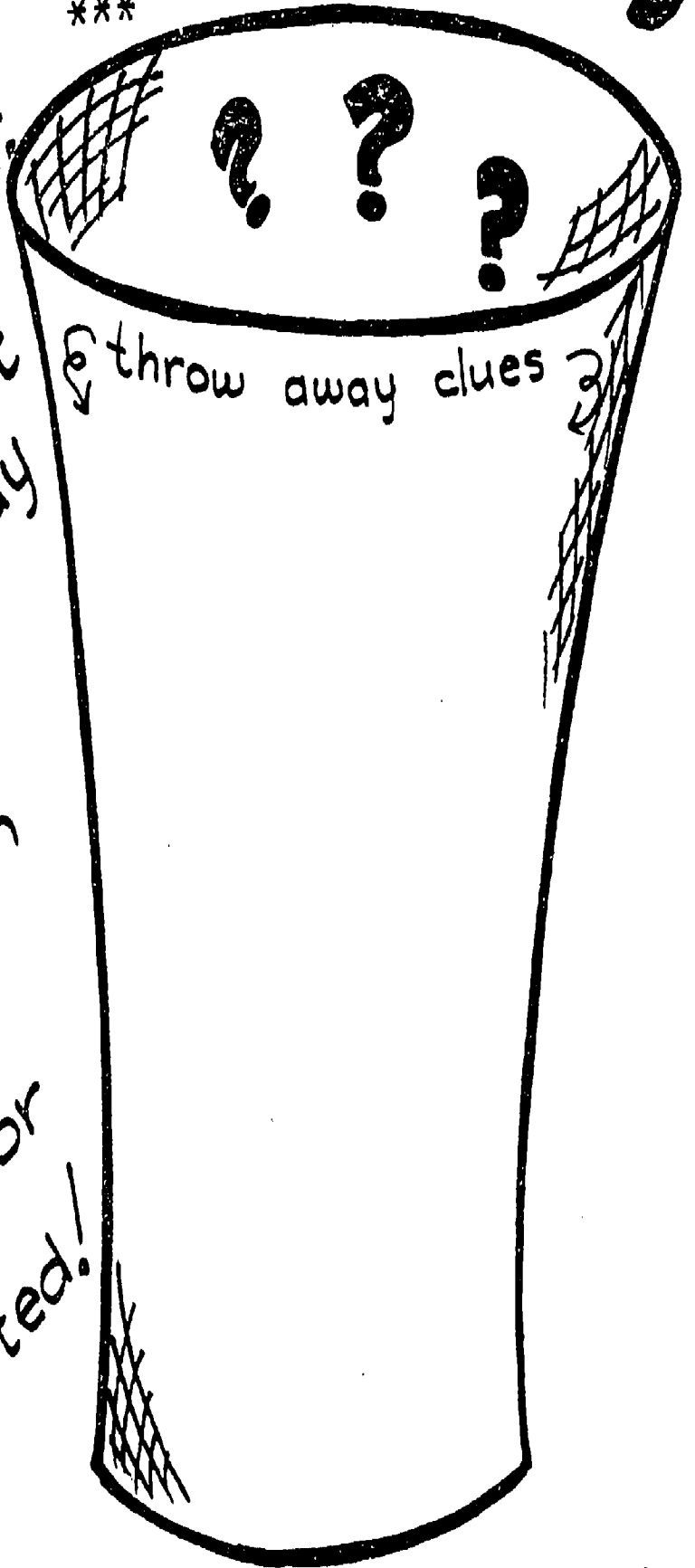

Answer

ENRICHMENT ACTIVITY 3

INTERVIEWING TECHNIQUES

This tool is designed to aid teachers to adequately prepare pupils for obtaining desired information at the resource site, for interviewing resource people in the classroom, and for interviewing by telephone.

General questions for resource site

1. The number of different jobs in existence at the resource site.
2. The number of people employed in each job.
3. Nature of the work done.
4. Whether a particular job is expanding or declining.
5. Educational and training requirements.
6. The route to getting a particular job.
7. Age requirements to work in different areas.
8. Physical requirements.
9. Hours per week workers are required to work.
10. Opportunities for advancement.
11. Whether union or other membership is required.
12. Vacation time allotted.
13. Whether or not there are health insurance and retirement or pension plans.

Specific interviews for individual resource people

1. What do you do on the job?
 - a. What time did you go to work this morning?
 - b. What was the first thing you did?
 - c. How long did that take (cover the entire day)?
 - d. Did you do anything yesterday that was different from today?
2. Why did you take this job?
3. Was this your first job choice?
4. How many times did you change your mind about what you wanted to be before you went to work?

5. What part of job do you like best? Is there a part of your job you do not like? Are there any hazards?
6. Who depends upon your work?
7. What experiences and training on this job might prepare you for some other kind of job should you ever want to change?
8. Do you work nights or days?
9. Are you tired when you get home? On your job do you have to be nice to even people who are crabby and ill-mannered?
10. What inventions could put you out of work?
11. Are people with your kind of skills usually needed even when business may be bad? Is your work at all seasonal? Is this type of work limited to geographical areas?
12. What type of education is necessary for this work?
13. What classes did you have in the sixth grade that help you now in your work?
14. Is there any personal quality required for this job?
15. Give us a general idea about the starting salaries in this type of work?
16. When does your boss compliment you or when do you compliment your employees?
17. When are people fired?
18. What school did you attend?
19. What changes have taken place recently?
20. Do you expect any changes in the near future?
21. What qualifications do you need to get your job such as
 - a. Age
 - b. Height
 - c. Weight
 - d. Sex
 - e. Marital status
 - f. Veterans

- g. Union
 - h. License
22. Is it permissible to get another employee to cover your job if you want time off?
 23. Did any of your leisure activities increase your ability to obtain this job or help you to perform better on this job?
 24. Did you have to make a decision between two or more jobs?
 25. Is there anything we need to know about the job that has not been asked?

Interviews by telephone

1. What are the different types of workers found in this plant?
2. What type of work do the majority of employees do?
3. Is the work outdoors or indoors?
4. What are the job duties?
5. What are the educational and experience requirements for these jobs?
6. What are the physical requirements?
7. What are possible weekly or monthly earnings?
8. What are the future opportunities?
9. Approximately how many workers are in the plant?
10. What are some of their specific job titles?

Elementary pupils can be prepared for formal interviews through 1) Role playing, 2) Informal taped interviews with peers 3) Informal interviews with adults (teachers, parents, and community people).

Prior to a mock interview, it will be necessary for pupils to gather facts about the job to be discussed. The student who acts as an interrogator must know what questions to ask. The person playing the role of the worker must know enough about the occupation to reply.

The following is a list of helpful hints for teachers and pupils when preparing for interviews:

1. Teachers should be aware and make students aware that misinformation may result from an interview. The worker may misunderstand the questions, or he may not have the detailed information that the student is seeking.
2. It may be helpful to send the talent a list of questions the class is considering.

3. Familiarize pupils with questions and have them mark the questions they would like to ask.
4. Inform pupils before an interview that the resource person does not have to answer a question if he does not want to.
5. Teachers should be alert to step in and help facilitate communication if either the student or resource is not understanding what the other has said.
6. The teacher should feel free to clarify questions and answers whenever it is desirable to do so.
7. Pupils should be given the opportunity to discuss the reason why a worker may oversell or undersell his field, such as a need to impress his listeners, a lack of information due to limited experiences in the field, or a need to rationalize his own success or failure on the job.

(NOTE: These interviewing techniques may be deleted from or added to in any way to meet the needs of a given group of pupils.)

References:

Nelson, Richard C. *Guidance and Counseling in the Elementary School*. New York: Holt, Rinehart, and Winston Inc., 1972.

Norris, Willa A. *Occupational Information in the Elementary School*. Chicago, Illinois: S.R.A.

Wernick, Walter. *Able Model Program*. Dekalb, Illinois, 1972.

Career Education Learning Center

DREAM ON!

**Your Career is Sooner
than You Think**

5

**by Mabel Stansbury Pershing School
Fall 1975 Lincoln, Nebraska**

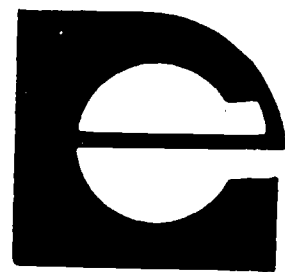

**LINCOLN
CAREER
EDUCATION
PROJECT**

The materials presented in this document were developed under a grant from the Office of Education, U.S. Department of Health, Education, and Welfare. Contractors undertaking such projects under Government sponsorship are encouraged to express freely their professional judgement in the conduct of the project. Points of view or opinions stated do not, therefore, necessarily represent official Office of Education position or policy.

Submitted by
Lincoln Public Schools
John Prasch, Superintendent
Carl Spencer, Project Director

1976

432

This is the script for Activity 1 directions. Our tape is done with echo effect and a background of futuristic (electronic) music.

As you look into the crystal ball imagine yourself in 20 years. How old will you be? Around 30? That will be near your parents' ages won't it?

Your parents have responsibilities as you very possibly will have too. Do you see in the crystal ball -- yourself with a family, a home, an automobile or perhaps a helicopter? And of course to be able to have all of these things you'll have to have a job. A good job that pays you wages enough. You'd also like to have a job you enjoy doing and that you are well prepared to do, wouldn't you?

Look in the crystal ball again; what do you see for yourself?

Think of today in your life and 20 years from now. Dream a little and start thinking -- your career is sooner than you think.

* * * * *

MATERIAL NEEDED TO MAKE THIS "DREAM ON" CENTER OPERABLE:

- ✓ Audio tape for activity 1--script given above.
- ✓ Crystal ball--teachers can purchase a glass ball with a mirror in the base at Treasure City; fill the glass ball with angel hair to make it look like a crystal ball.
- ✓ Popeye Career Awareness Library (career comic books, career game and posters) Available at Stephenson Supply for about \$8.00

Learning Center
Career Education

5

DREAM ON, YOUR CAREER IS SOONER THAN YOU THINK

By Mabel Stansbury
Pershing School
Lincoln, NE

1. CAREER EDUCATION THEMES:

Career Awareness, Self-awareness

SUBJECT AREAS:

Language Arts, Reading, Social Studies

2. TEACHER'S OBJECTIVES:

Students will be able:

1. To become aware of many careers within the basic occupational fields, and to project himself into a situation.
2. To realize that individuals have assets and limitations as they relate to job requirements.
3. To know that an occupation can influence the life style of an individual and that a preferred life style influences the occupational choice.
4. To help the child know himself better in terms of aptitude and interests in the world of work.

3. STUDENT OBJECTIVES:

Post sheet with student objectives at center.

RECORD KEEPING
EVALUATION

Scrapbooks.

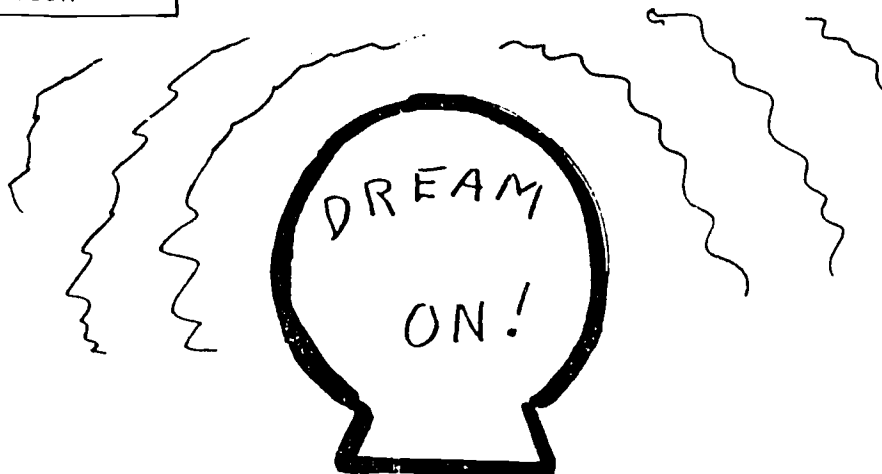

Resources that could be used to enrich this center.

1. Film loop - "Dream On, Your Career Is Sooner Than You Think" a film written and produced by Pershing School pupils in spring of 1975. This film loop would be excellent motivational material for students as they use this learning center. This can be checked out from PSAB Media; ask for the title above by Mabel Stansbury and students.
2. Sound - film strips series. Produced by Denoyer Geppert
 - Wonderful World of Work
 - K-3 - Utility Workers
 - Home Service Workers
 - Retail Store Workers
 - 4-6 - The Utility Occupations
 - Distributive Occupations
 - Natural Resources
 - Personal Services
 - Technical and Industrial
 - Home Economics
 - Health Services
3. Picture Story Study Prints - Produced by SVE
 - Dairy Helpers
 - Hospital Helpers
 - Supermarket Helpers
 - Postal Helpers
4. Come Work With Us book series - published by Childrens Press
 - Wilkinson, Jean and Ned - Come Work With Us in a Bank
 - Forward by Sam Levenson " Hospital
 - " Toy Factory
 - " Newspaper
 - " Aerospace
 - " Dept. Store
5. "Futuristic" electronic and wireless music such as the "Machine Music" by Hiller used as background for the cassette tape in this center. Order from PSAB Media Center:
 - #789.98 Ussachevsky, Vladimir - "Wireless Fantasy" record and filmstrip of images to match the music.
 - #400024-R Hiller - Electronic music from University of Illinois

Media Centers have many career related books that could be used for further enrichment on any research, for Activity #2 especially.

TEACHER DIRECTIONS

This learning center is designed to motivate a child through looking into a crystal ball, imagining possibilities for his future. The activities completed are to be mounted on scrapbooks pages and put together to be kept for examination 20 years hence, if desired.

Materials to place in this center:

1. Crystal ball - located where children can use it for Activity #1 and Activity #3.
2. Popeye Career Awareness Library.
 - a. The large career poster cards may be used to add interest to the center in any way you choose.
 - b. The comic books should be in a box with Activity #2.
 - c. Yellow job description cards should be placed in a box with Activity #3.
3. Ten or twelve sheets of colored construction paper punched at the left side for scrap book pages to be put together at the end of the activities.
4. Old magazines and newspapers to cut up for art activities #1.
5. Pipe cleaner (12 inch colored) to fasten the book together.
6. Lined writing paper for Activity #4 (for writing letter).
7. Envelopes for letter.
8. Large brown envelope for storing scrapbook pages as they accumulate and before they are fastened together.
9. Each activity will need a box for dittoed work pages. A large Popeye pattern is included for use on the box if desired for Activities #2 and #3. A large crystal ball pattern is included to be used with Activities #1 and #4. Also, use the Crystal ball on the cover page of the notebook if desired.

* Note to Teachers:

The notebook should definitely be personal - and private to the child. An agreement should be made with the child before he or she makes the notebook whether or not you, the teacher, will be reading the material in it and your intentions in evaluating his work. Each teacher will decide their involvement and inform the student. The notebook will be the record keeping activity for the center.

of.

ACTIVITIES:

Activity 1:

Teacher Preparation: cut out 3 crystal ball task cards on sheet one. Place these at the center with the following materials:

- cassette tape from this kit
- tape player
- old magazines to cut up
- scissors
- paste
- brown envelopes prepared with hole punched
- colored paper
- a pipe cleaner

Also put out any resource materials available such as films, loops, books, etc.



Optional center activity could be set up based on electronic music and abstract art. See teacher resource list for music.

Activity 2

Make ditto master and copies for students of the worksheet. Put out dittoed worksheets and "Popeye Career Awareness" library of comic books.

Provide materials for options such as dioramas and instructions about where to go and who to talk to for arranging to bring a speaker, take a trip, etc.

Activity 3

Make ditto copies for students of this worksheet. Put out crystal ball with mirror in base, yellow job description cards from "Popeye Career Awareness" library.

Activity 4

Ditto worksheet; put out in center with recent newspapers to cut up, and envelopes for letter.



Activity 5

Ditto worksheet. Use this as a post test and conference sheet with student.

5.

EVALUATION:

Activity 5 used for conferencing with student plus looking through the students Dream On! book if he wishes to share it.

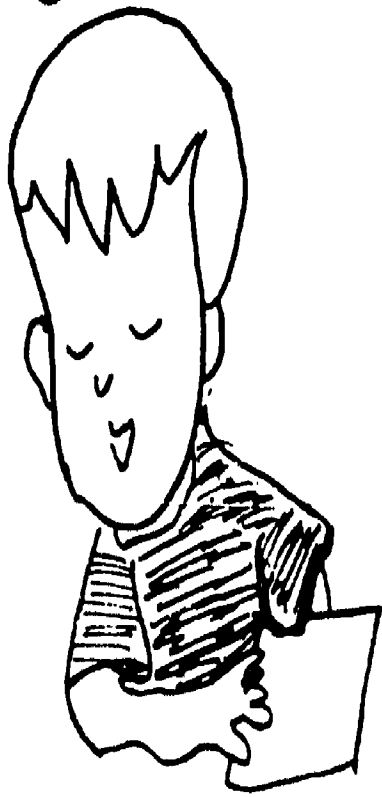

STUDENT OBJECTIVES

1. I will be able to study the occupational fields and pick out jobs that interest me.
2. I will look at my own aptitudes and interests.
3. I will study the descriptions of the duties of several occupations.
4. I will match my aptitudes and interests with some jobs that correspond.

DREAM
ON!

Your Career Is Sooner
Than You Think

Name _____ 441

C'mon Kids!
Dream a little dream –
Shiver My Timbers
Your Career is Sooner than You Think!



C'mon Kids!
Dream a little dream –
Shiver My Timbers
Your Career is Sooner than You Think!



Activity 2

Investigate

Look through the "Popeye Career Awareness" library. From the fifteen job areas presented choose *three* that you are most interested in. Read through each comic chosen. Complete this work page answering the questions with information you learned from reading the comic books. Do one page for each comic read. Put the completed pages in your scrapbook.



1. Identify the job area:

2. List 3 jobs in this area that interest you. Tell the kind of training you would need for a specific job.

Job	Training
1. _____	_____
2. _____	_____
3. _____	_____

(Check one)

3. These jobs require people who like to:

Example: Work indoors _____ or outdoors _____

1. _____
2. _____
3. _____

4. Do these jobs provide

Goods for people to consume _____ or Services for people _____

5. In these jobs do you work mostly with other people _____

or with things _____ or with facts (data) _____

6. Do these jobs need mostly physical skills _____ or mental skills _____

Did you become aware of any jobs you hadn't known about before that interest you?

Name them: _____

If you find a career you'd like to find out more about, check out a book from the library related to the job area.

You might want to follow this activity by sharing with your classmates:

1. A brief book review
2. A diorama about the book
3. Arranging for a resource person to speak to your class about the job you've studied.
4. Arranging for a field trip to show the class the job you have investigated.

Activity 3

A LOOK AT ME

Turn the crystal ball over and look at yourself in the mirror very carefully.

Think about things you especially like to do or do not like to do.

(Check your preferences:)

	Yes	No
Do you like to read and study	_____	_____
Do you like working with your hands	_____	_____
Do you enjoy working with people	_____	_____
Do you like working indoors	_____	_____
Do you like working outdoors	_____	_____
Are you strong physically	_____	_____
Do you like to do things for people	_____	_____
Do you like to do research about things	_____	_____
Are you interested in science	_____	_____
Would you like working at night	_____	_____
Do you like to be told what to do	_____	_____
Do you like to tell other people what to do	_____	_____

List anything you especially like to do.

List anything you especially do not like to do.

Look at the yellow job description cards in the "POPEYE Career Awareness" library that you think interest you the most. Choose a yellow card and compare the job qualifications listed on it, with the preferences you

you listed about yourself. Do they match? Choose the job you think fits you the best.

CAREER THAT BEST FITS ME: _____

List 5 reasons why you chose this job.

1. _____
2. _____
3. _____
4. _____
5. _____

Activity 4

TODAY IN MY LIFE....

1. Prepare pages for your scrapbook with the title: TODAY IN MY LIFE using the newspapers of a given date and cut out
 1. headlines and special news items about today.
 2. styles of today from ads.
 3. grocery ads for today.
 4. entertainment today.

Add any other pages you'd like to keep in your book.

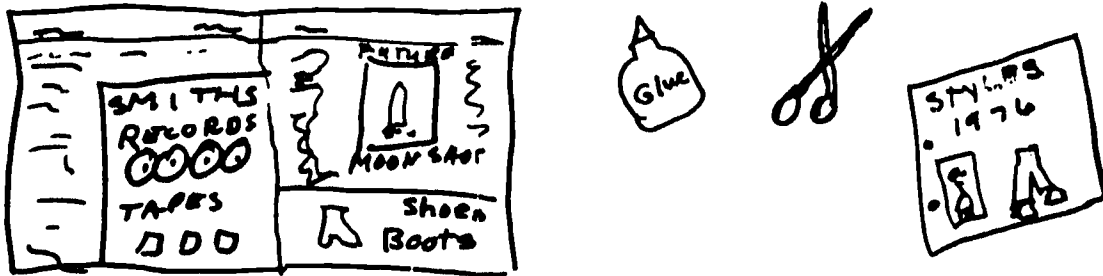

2. Write yourself a letter to be opened and read in 20 years. Here are some suggestions of ideas you might want to include in your letter:

Paragraph 1 –

I think the career field that suits me best is _____
What would I have to do to have that job?
What about me makes me think this job would be right for me?
What are some special advantages of this job for me?

Paragraph 2 –

What my life is like today! Do I like going to school?
Do any special problems bother me?
Do any special things make me happy?

Paragraph 3 –

What do I think my life in the future will be like?
Do I predict any really big changes in the way I live?

After your letter is written, put it in an envelope with your name on it--to be opened 20 years from today. Glue it to the last page of your "Dream On" book. Before sealing the envelope flap, you may share your letter with the teacher, your friends or your parents *if* you wish.

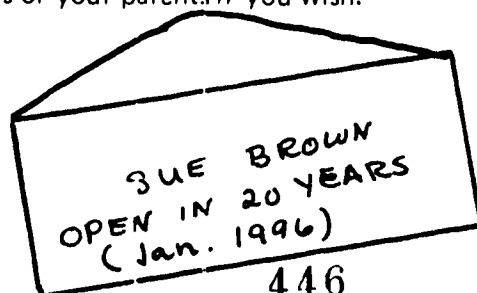

Activity 5

Put all the pages of your scrapbook together; fasten them with the pipe cleaner through the holes.

Look through your book then answer these questions on this work page.

Share this worksheet with your teacher before you paste it into your "Dream On!" book.

1. Did I learn about some jobs I didn't know about before? _____

List some: _____

2. Did I think about jobs I might like more than others? _____

What are some examples? _____

3. Did I learn anything about myself? _____

What things especially? _____

4. Did I realize that certain jobs have special qualifications? _____

Examples: _____

5. Did I learn some special qualifications I have? _____

What are a few? _____

6. As I think about myself 20 years from now, I wonder if the job I chose will provide the life style I'm dreaming of.

What life style do I dream of? _____



DREAM ON
447

Career Education Learning Center

ALTERNATIVE

CAREERS

5

**by Mary Zeman Clinton School
Fall 1975 Lincoln, Nebraska**

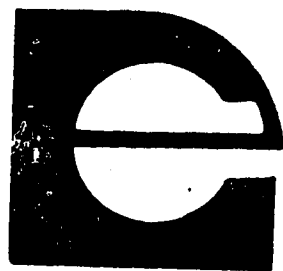

**LINCOLN
CAREER
EDUCATION
PROJECT**

The materials presented in this document were developed under a grant from the Office of Education, U.S. Department of Health, Education, and Welfare. Contractors undertaking such projects under Government sponsorship are encouraged to express freely their professional judgement in the conduct of the project. Points of view or opinions stated do not, therefore, necessarily represent official Office of Education position or policy.

Submitted by
Lincoln Public Schools
John Prasch, Superintendent
Carl Spencer, Project Director

1976

Teacher's Plan

1. SUBJECT AREA: Social Studies

CAREER EDUCATION THEMES: Career and Life-style awareness
Decision making

2. TEACHER OBJECTIVES:

The teacher will provide students the opportunity to discover that there are careers they have never considered, and that many careers may be "tailor-made" for a person.

STUDENT OBJECTIVES:

Students will become aware of careers they may have never considered.

Students will select and learn a skill that could become a career, or could enrich them as a hobby or recreation.

3. PRE-ASSESSMENT:

Use sheet A as a pre-assessment activity. The student will demonstrate his or her level of awareness of careers. This pre-assessment also serves as readiness for the first activity in which the student views people in alternative careers.

4. ACTIVITIES:

ACTIVITY 1: Looking at Unique Careers

The first general activity will help to develop awareness and appreciation for people working in unusual careers. The following activities should be used in sequence as numbered.

Teacher Preparation: Filmstrip projector
Filmstrip - Unique People in Unique Jobs (in this packet)
Activity 1 worksheet to be duplicated for each student
Cassette recorder and blank tapes
Task card of directions for students - Activity 1
Paper for letter writing and envelopes

Answer sheet for jobs shown on filmstrip; put it in the center or have children ask teacher or aide for answers when ready.

ACTIVITY 2: People from our town follow their interests.

Put out card (Δ) which describes unique hobbies and careers based on a real interest, and the Task Card for Activity 2.

Gather books, newspaper, filmstrips, magazines which tell of unusual careers or hobbies.

Supplies needed to write, or tape or draw for reports. Provide a place (bulletin board, etc.) to display reports and/or to share information with friends (meet in groups).

ACTIVITY 3: Why Not You?

Put task card in center and materials to write, tape or draw. Books telling of hobbies may be helpful for reference.

ACTIVITY 4: A Plan of Action

Duplicate worksheets for students. Provide paper to make covers for log books.

Help students choose a skill or knowledge reasonable for them. Encourage pairs for practice. Provide sharing times and adequate time to show and/or tell when they are prepared to do so.

RECORD KEEPING

The students will have:

1. The pre-assessment as entering awareness level
2. Their letter or "conversation" suggesting another career to someone
3. Their written or oral responses to the filmstrip on the worksheet for activity 1.
4. Their reports of unusual careers.
5. Their creation of a job for themselves.
6. A log of their progress - - - in distinct parts:
 1. How and why I chose to learn this skill
 2. Where I looked and what I found out about how to learn this skill
 3. How and when I practiced this skill

STUDENT EVALUATION:

6. The record-keeping "tools" will provide good evaluation for student performance on these activities. Students may want to evaluate themselves as a fourth part of their log by reporting emotions they felt during the successful and frustrating periods of learning their skill.

LOCATION OF CENTER:

7. This center can be anywhere there is enough space for the student to view the filmstrip and do the activities. The students will need to have voluntary use of the media center and perhaps some area where they can practice their skill without being a great distraction to others.

HOW AND WHEN THE CENTER IS TO BE USED - SCHEDULING

8. The students will most likely select themselves for this activity by finishing other activities early, or by showing that they have a potential to do these skills. They should be allowed to work independently by contracting with the teacher to do the activities.

STUDENT TEACHER EVALUATION

- 9.
- a. Pre-assesment (A) may be repeated as a post-test type of experience - the teacher should note whether the student broadens his responses to the kinds of work.
 - b. The student could demonstrate his or her developed skill to a group of people in class (or to another class) if he/she feels ready - as suggested in Activity 4. This could be left optional as not all children will attain levels where they wish to display their talents (i.e. skills, knowledge).

Date
To
From
Subject

ALTERNATIVE CAREERS Career Ed. Learning Center

Media needed: Filmstrip produced by LPS and available through
media services (423-0282) entitled "Unique People in Unique Jobs"

Lincoln Public Schools Box 82889

Memo

Lincoln, Nebraska 68501

512143

A.

WHAT DO YOU KNOW OF CAREERS?

MAKE A LIST OF ALL THE JOBS YOU CAN WHERE THE WORKER:

- A. DRIVES SOMETHING
- B. WEARS A HAT
- C. USES AN ELECTRIC MACHINE
- D. WEARS A UNIFORM
- E. IS THEIR OWN BOSS
- F. PLAYS AN INSTRUMENT
- G. USES THEIR HANDS
- H. WORKS OUTSIDE
- I. TALKS WITH PEOPLE

Activity 1.
UNIQUE PEOPLE
IN
UNIQUE JOBS



1. OBSERVE THE FILMSTRIP AT THIS CENTER "UNIQUE PEOPLE IN UNIQUE JOBS" WHICH SHOWS PEOPLE IN UNUSUAL OCCUPATIONS (TAKEN IN SAN FRANCISCO, CA).
2. DECIDE HOW EACH PERSON MAKES A LIVING.
3. EVERY JOB HAS 3 ELEMENTS:
 - A. SKILL AND KNOWLEDGE
 - B. PAYMENT
 - C. PLEASURE AND SELF-SATISFACTION

FOR EACH OF THE JOBS SHOWN, CHART THESE THREE ELEMENTS; ANSWER THE QUESTIONS..."WHAT IS ..." ETC. ON WORKSHEET FOR ACTIVITY 1.

4. ON THE FILMSTRIP THERE ARE 13 JOBS SHOWN PLUS 3 CHALLENGE ONES. SOME JOBS HAVE SEVERAL PICTURES IN A SERIES AND THE WORKSHEET IS NUMBERED TO SHOW THIS. THE LAST 3 PICTURES (NUMBERS 18, 19, and 20) ARE CHALLENGE ONES; SEE IF YOU CAN THINK OF A JOB THESE PEOPLE MIGHT BE DOING. CHECK YOUR OWN ANSWERS AFTER IDENTIFYING THE JOBS. TALK TO THE TEACHER OR A FRIEND TO EXPLAIN YOUR ANSWERS.
5. IMAGINE OTHER WAYS EACH OF THESE PEOPLE COULD USE THEIR TALENT IN OTHER JOBS. SELECT A DIFFERENT JOB FOR EACH ONE. SUGGEST THE NEW JOB TO ONE OF THESE PERSONS IN WRITING BY COMPOSING A LETTER TO HIM OR HER; OR YOU COULD RECORD YOUR SUGGESTIONS ON TAPE - PRETEND YOU ARE ACTUALLY HAVING A CONVERSATION WITH HIM OR HER. EXPLAIN AND DEVELOP YOUR REASONS WHY THIS NEW JOB WOULD SUIT THIS PERSON.

Activity 1.

ANSWER KEY:

"UNIQUE PEOPLE IN UNIQUE JOBS" FILMSTRIP

YOU MAY HAVE A DIFFERENT ANSWER AND STILL BE RIGHT IF YOU CAN EXPLAIN WHY YOU THINK IT IS A DIFFERENT JOB THAN LISTED BELOW.

THE LAST 3 ARE UP TO YOU. THERE IS NO "RIGHT" ANSWER. EXPLAIN YOUR ANSWERS IF YOU TRIED THESE CHALLENGE ONES.

ANSWERS TO WORKSHEET: "UNIQUE PEOPLE IN UNIQUE JOBS" FILMSTRIP

1. FLAGMAN TO STOP TRAFFIC; OR WORKER REPAIRING STREETS; OR TELEPHONE WORKER RUNNING MACHINE THAT HOLDS CABLE.
- 2,3. SHOE SHINE BOY AND GIRL
- 4,5,6. CLOWN
- 6,7. BALLOON SELLER (AND NEWSPAPER SELLER)
- 7,8. NEWSPAPER SELLER
9. SELLER OF CLAMS, LOBSTERS, AND OTHER FISH IN A FISH SHOP: OR RETAIL CLERK
10. PALM READER OR FORTUNE TELLER
11. DRUMMER OR MUSICIAN
12. ARTIST (PENCIL DRAWINGS); CARTOONIST OR ARTIST WHO DRAWS PORTRAITS
13. ARTIST OR ENGRAVER OF SOUVENIR PENNIES.
14. SALESPERSON OF WOODEN ANIMALS; OR CRAFTSWOMAN WHO MAKES TOYS.
- 15,16. BAG PIPER (SCOTTISH INSTRUMENT); or BANDSMAN.
17. TROLLEY CAR OR CABLE CAR CONDUCTOR

CHALLENGE ONES:

- 18.
19. ANY REASONABLE ANSWER ACCEPTED.
- 20.

ACTIVITY 1:

STUDENT WORKSHEET

NAME _____

WHAT IS THE
WORKER DOING?

SKILL AND KNOWLEDGE
NEEDED.

DO YOU THINK THE PAY-
MENT RECEIVED IS GREAT?
SMALL?

DOES IT LOOK LIKE
THEY FEEL PLEASURE
AND SELF-SATISFACTION
FROM THIS JOB?

NEW JOB (ALTERNATIVE
CAREERS) SUGGESTED FOR
THIS PERSON.

1

2&3

4,5&6

6&7

7&8

9

10

11

12

13

14

15&16

17

Challenge!

18

19

20

Activity 2.

PEOPLE FROM OUR TOWN FOLLOW THEIR INTERESTS.



TASK CARD FOR ACTIVITY 2

1. READ ABOUT THE FOUR PEOPLE FROM LINCOLN, WHO FOLLOWED UNUSUAL HOBBIES TO UNIQUE CAREERS, ON THE CARD AT THE CENTER.
2. FIND INFORMATION FROM MAGAZINES, BOOKS, NEWSPAPERS, FILMS, ETC. ABOUT UNIQUE CAREERS.
3. PREPARE A REPORT ABOUT A UNIQUE CAREER THAT INTERESTS YOU. YOU MAY WRITE THE REPORT, TAPE IT, DRAW PICTURES TO SHOW IT.
4. PLAN A WAY TO SHARE AND THEN SHARE YOUR INFORMATION WITH FRIENDS: TELL THEM, LET THEM READ IT, PUT ON BULLETIN BOARD, ETC.



MANY PEOPLE FROM OUR TOWN FOLLOW THEIR INTERESTS AND HOBBIES TO CAREERS.

JEK KELLY DID. DOUG BOILSEN DID. MICH ZEMAN DID. AND THAT'S HOW TV'S JOHNNY CARSON GOT HIS START -- ALL RIGHT HERE IN LINCOLN, NEBRASKA, AND ALL FOLLOWING AN INTEREST, LEARNING HOW AND THEN DOING SOMETHING MOST PEOPLE DON'T BOTHER TO LEARN HOW TO DO.

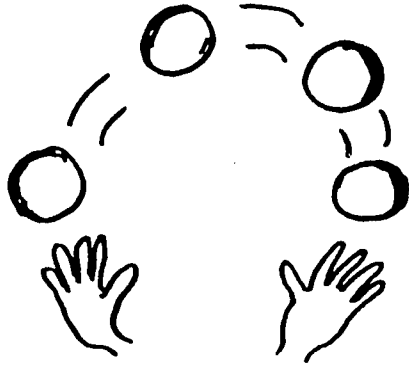

1. JEK KELLY WANTED TO JUGGLE. SO ONE DAY HE PICKED UP SOME TENNIS BALLS AND STARTED TOSSING THEM IN THE AIR. AFTER PLAYING AWHILE HE DECIDED HE COULD GET SOME HELPFUL INFORMATION IN A LIBRARY AND FOUND A BOOK ABOUT JUGGLING. WITHIN A SHORT TIME HE TAUGHT HIMSELF TO JUGGLE AND NOW IS EARNING MONEY AND HAVING FUN JUGGLING.

TRY IT!

2. DOUG BOILSEN BEGAN COLLECTING OLD (ANTIQUE) RECORDS AND RECORD PLAYERS WITH HIS PAPER ROUTE MONEY. HE NOW IS AN ANTIQUE DEALER AND HOPES TO OPEN A MUSEUM SOON.

YOU TOO COULD TURN SOMETHING YOU LIKE INTO A CAREER. IT'S INTERESTING.

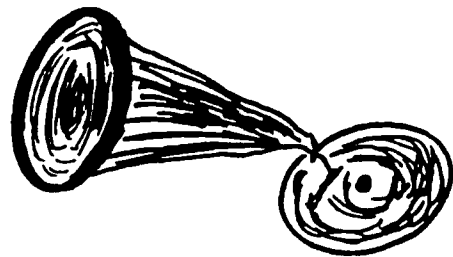

3. MICH ZEMAN HAD SOME FRIENDS WHO PLAYED GUITARS AND BANJOS AND HE WANTED TO MAKE MUSIC WITH THEM. HE TAUGHT HIMSELF HOW TO PLAY THE JUG! THEN, HE PLAYED THE JUG WITH THE BAND FOR SEVERAL YEARS EARNING MONEY, BUT ALSO RECEIVING A LOT MORE IN PLEASURE AND SELF-SATISFACTION.



ANY OLD JUG THAT'S CLEAN CAN BE TURNED INTO A GREAT INSTRUMENT. DO A LITTLE LISTENING AND A LOT OF PRACTICE. YOU CAN DO IT. THERE MIGHT NOT BE A GREAT DEMAND FOR JUG PLAYERS TODAY, BUT WHO KNOWS! THERE MAY BE SOMETIME AND IF YOU LIKE IT... WHO CARES?

4. JOHNNY CARSON STARTED DOING MAGIC TRICKS THAT HE LEARNED FROM A BOOK IN ELEMENTARY SCHOOL. HE KEPT DOING MAGIC TRICKS EARNING HIS WAY THROUGH COLLEGE AND INTO SHOW BUSINESS. HE IS NOW ONE OF THE MOST FAMOUS (AND WEALTHIEST) TELEVISION PERSONALITIES.

YOU CAN DO IT! BE A MAGICIAN. ALL YOU NEED (ALONG WITH SOME EFFORT AND CONCENTRATION) IS A BOOK! YOU CAN FIND ONE IN THE LIBRARY -- SO, GET YOURSELF STARTED.

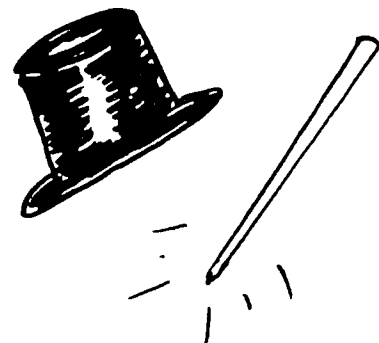



Activity 3
WHY
NOT
YOU?

TASK CARD FOR ACTIVITY 3: Why Not You?

1. Think of some skill you have - or would like to develop. Decide if you could use that skill - or knowledge in a job. What is the job?
2. Create a job (preferably a job that no one has ever done) that needs that skill. Write a convincing description, or tape a convincing argument explaining your job and telling why you should be paid to "do that job."
3. You may draw pictures of duties required in the job you created. You may want to design the uniform or costume - the clothing you would wear in this work.
4. Display your pictures and written job description on the bulletin board. Play your tape explaining your job for the teacher and your friends.



LOG BOOK FOR _____

My Skill/Knowledge to Develop is _____

How and Why I Chose This Skill _____

(Where), What, or Who I Found to Teach This Skill to ME. _____

The Date I Plan to Be Good Enough to Show (or tell) Others. _____

How and When I Practice _____

DATE:

PROGRESS REPORT:

DATE:

PROGRESS REPORT:

DATE:

PROGRESS REPORT:

Activity 4.

A PLAN OF ACTION



TASK CARD FOR ACTIVITY 4: A Plan of Action

Many unusual skills are self-taught rather than learned in school.

1. Plan how to develop the skill you designed a job for in Activity 3.
2. Use the worksheets for Activity 4 and make a cover for them fastening the pages into a "Log Book of My Job Skill and Practice"; in the program report make notes of how to improve; what is good and should be repeated, etc.
3. Try to work with a friend to check each other's progress and perhaps to help each other practice (even if you chose different skills, it helps to have someone else who is interested and helping you.)
4. If your skill or knowledge is something you can show to the class, plan with the teacher for a date when you will be good enough to demonstrate or exhibit your knowledge to the class. Work to be ready on that date.

Career Education Learning Center

DEATH:

Feelings and Careers

6

by Fran Reinehr Elliott School

Fall 1975 Lincoln, Nebraska

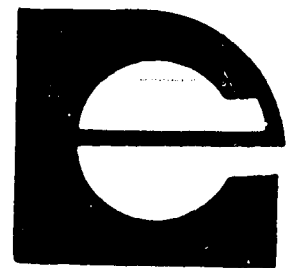

**LINCOLN
CAREER
EDUCATION
PROJECT**

The materials presented in this document were developed under a grant from the Office of Education, U.S. Department of Health, Education, and Welfare. Contractors undertaking such projects under Government sponsorship are encouraged to express freely their professional judgement in the conduct of the project. Points of view or opinions stated do not, therefore, necessarily represent official Office of Education position or policy.

Submitted by
Lincoln Public Schools
John Prash, Superintendent
Carl Spencer, Project Director

1976

465

Date
To
From
Subject

MEMO: Feelings and Careers Career Ed. Learning Center
is needed: Filmstrip with cassette produced by LPS and
available through media services (473-0282) entitled "What Can You
Learn at a Cemetery?"; book "Comic Epitaphs" published by Peter Pauper
Press and available in stationery stores; 3 sympathy cards of various
design; package of 3/4" lettering stencil; sand paper (rough); reprint
of Reader's Digest article "How to Prepare Your Own Funeral" (Oct. 1975)
or similar article; book "A Taste of Blackberries" by Doris Buchanan
Smith, Scholastic Book Services.

Lincoln Public Schools Box 82889

Memo

Lincoln, Nebraska 68501

512143

Date May, 1966
To Teacher using the center: Death: Feelings and Careers
From Mike Holmes, Career Education Coordinator
Subject

It is suggested that the activities involved with careers in this learning center be used with all classes but the activities which deal with feelings about death be used only after a careful examination by the teacher-- choosing and planning for these sections as the needs and background of the students dictate.

Lincoln Public Schools B x 82889

Memo

Lincoln, Nebraska 68501

512143

Lincoln Public Schools

Administrative Offices Located 720 South 22 Street
Mail: Box 82889, Lincoln, Nebraska 68501 / 402-475-1081

Dear Parents,

Careers relating to death (such as morticians, embalmers, grave diggers, coroners) have often been viewed with fear and/or revulsion. Because the persons who work in these areas are as important to the community as persons in other fields of endeavor, it is useful for students to gain knowledge and understanding about them.

The children in your child's class will soon be working in a learning center which deals with careers related to death. The activities in the center will be done individually or in pairs; examples are as follows:

- "What can you learn at a cemetery?" View a filmstrip made in Lincoln (Wyuka Cemetery) and play a game to match careers with descriptions for mortician, embalmer, florist, doctor, newspaper writer, etc.
- Art and newspaper reading activity: Make a collage from news items about death; then list careers involved in each case.
- Research a career related to death: Speaker from the community to come in or individual students do research.
- Last Will and Testament: Students learn about wills and then will their possessions to friends and relatives... "Remember to will your smile!"
- Vocabulary and Sayings: Word study, vocabulary building.
- Art-life appreciation: Make a poster about your favorite things in life.
- The Great Cycle of Life: Show the cycle of life in nature with a drawing of grass, flowers, birds and a tree which draws life from the sun, rain, soil. Read *A Taste of Blackberries*, a book by Doris Buchanan Smith.
- Evaluation: Write what you learned about death and people who help when death happens.

If you would prefer that your child not take part in any or all of these activities, please notify me in writing and other projects will be substituted for him or her.

You are invited to visit school while this center is in use. We welcome visitors at any time.

Sincerely,

Teacher

TEACHER'S PLAN

Subject Areas: Language Arts
Creative Arts

1. Career Education Themes: Career Awareness with Special emphasis on careers related to death
Personal Social Development

Teacher Objectives: Students will be able to:

1. Identify careers related to death.
2. Appreciate the likenesses and differences of themselves and others and appreciate how people come to choose certain careers.
3. Utilize skills by expressing feelings about death and relating to at least one person whose career is related to helping people who have experienced death.
4. Practice Language Arts skills.
5. Utilize artistic and creative ideas.

Student Objectives:

1. Student will confront feelings about death and deal with these feelings.
2. Student will read about death, and talk with persons whose jobs relate to death.

Background for teachers: Careers relating to death, i.e., morticians, undertakers, grave diggers, coroners, have often been viewed with fear and/or repulsion. Because the persons who work in these areas are so important to the community in persons in other fields of endeavor, it is useful for students to gain knowledge and understanding about them.

Death will be a natural event for every living thing to deal often thought about with fear or repulsion. It is useful for students to deal with these attitudes i.e.; learning to openly express their own emotions and to help establish a more positive attitude toward death and related careers. These activities will help students consider their feelings about death; it will also allow them opportunities to gain knowledge about persons who help when a

death occurs in a family.

With all of the release by our society today and children's exposure to this death and grief on TV, news wires, etc. It is important that children are given opportunities to express feelings, fears and emotions about death. It is especially important that they are motivated to appreciate the life—for themselves and for others. Response: Death diminishes me...

Pre-Assessment - Readiness:

3.

There are films and film strips available which will be good to use to begin this unit. For those teachers who wish to begin with some subject other than human beings, I suggest the film available thru PSAB, "My Turtle Died Today", #1716-04. This film deals with the death of a pet which is often the first encounter with death a child experiences. After viewing this film the teacher should begin a discussion with the students about death. Sample questions follow:

1. What did you find out in the film?
2. Have any of you ever had this experience?
3. What were your feelings?
4. What made you feel the way you did?
5. Have you ever wondered about the death of any person you know?
6. What are some of the questions that you have?

Multi-Level Activities

4. After assessing the students readiness for this subject, the teacher will allow the students to work in the center. Since this is an unusual subject, all of the activities can be pursued by the students if they choose but those marked with ** indicate a more difficult level for students with real interest in the subject and may require adult assistance. The activities are not sequential, but it would be good to begin with activity one. There should not be more than three activities out in the center at any one time to prevent overwhelming the students.

Activity One:

Filmstrip in this packet, "What Can You Learn at a Cemetery?" Career Game (2 sheets labeled □)

Teacher Preparation:

1. Make ditto copies of 2 game sheets □ for each student; provide folders to keep sheets when completed.
2. Put out Task Card in center displayed any way you wish.
3. Set out filmstrip projector, tape recorder, filmstrip and scissors.

death occurs in a family.

With all of the violence, terrorism, drug, and child abuse that we see on the news, etc., it is important that children are given opportunities to express feelings, fears and emotions about death. It is especially important that they are motivated to appreciate life—for themselves and for others. *Memories to Death* diminishes me...

Pre-Assessment - Readiness:

3.

There are films and film strips available which will be good to use to begin this unit. For those teachers who wish to begin with some subject other than human beings, I suggest the film available thru PSAB, "My Turtle Died Today", #1716-04. This film deals with the death of a pet which is often the first encounter with death a child experiences. After viewing this film the teacher should begin a discussion with the students about death. Sample questions follow:

1. What did you find out in the film?
2. Have any of you ever had this experience?
3. What were your feelings?
4. What made you feel the way you did?
5. Have you ever wondered about the death of any person you know?
6. What are some of the questions that you have?

Multi-Level Activities

4. After assessing the students readiness for this subject, the teacher will allow the students to work in the center. Since this is an unusual subject, all of the activities can be pursued by the students if they choose but those marked with ** indicate a more difficult level for students with real interest in the subject and may require adult assistance. The activities are not sequential, but it would be good to begin with activity one. There should not be more than three activities out in the center at any one time to prevent overwhelming the students.

Activity One:

Filmstrip in this packet, "What Can You Learn at a Cemetery?" Career Game (2 sheets labeled)

Teacher Preparation:

1. Make ditto copies of 2 game sheets for each student; provide folders to keep sheets when completed.
2. Put out Task Card 1 in center displayed any way you wish.
3. Set out filmstrip projector, tape recorder, filmstrip and scissors.

Procedure:

After viewing the filmstrip and hearing ^{the} tape, the student will cut apart career cards and play the game matching the career cards to the job description on "People Who Help" worksheet. They are to write answers on this worksheet when they finish the game. To share and/or evaluate, post the work sheet on bulletin board or keep in a folder; the career titles learned now will be used in a later activity.

Activity Two: Newspaper Collage

Teacher Preparation: Gather newspapers, construction paper, scissors, glue and paper for recording. Display Task Card 2. Students will find as many instances of death as they can in one daily newspaper. After locating these, they will make a collage of the selected items. The students number the articles as they paste them onto the paper. They choose at least two, listing which careers would be involved in each case. Resources: Career Cards.

Activity Three: Comic Epitaph

Teacher Preparation: Put out Task Card 3. White ditto paper, sandpaper, black crayon, lettering stencils, and the book, Comic Epitaphs, published by Peter Pauper Press, included in this packet. Students read the book and then design their own epitaphs. They rub black crayon over a sheet of paper placed on top of a sheet of sandpaper - this creates a rough effect. Then they print or trace stencil letters to print their own original epitaph. Place in folder after displaying on bulletin board for sharing.

Activity Four: Stories

Materials: Two stories, reprinted for student use. Teacher Preparation: Put out Task Card 4; make a booklet of the story From Mother With Love printed on tag; make ditto copies of Grandmother so each child has a copy to illustrate. From Mother With Love is a more difficult story in terms of reading level and emotional impact than the Grandmother. Students choose the story they wish to read and do the activity for that story. Teacher should use discretion in assigning From Mother With Love (could be read aloud to class and discussed in a group). The Grandmother story is American Negro in origin.

Activity Five: Obituaries

Put out Task Card 5. Make ditto copies of worksheet "My Obituary". Teacher Preparation: Make a collage of obituaries from the newspaper or use the sample in this packet labeled #).

Students will observe what is included in an obituary and write one of their own on the worksheet, "My Obituary". Extension activity: "For those students who want a challenge; have them write their obituary if they died today and then project their lives 30 years from now and write one for that projected life also.

Activity Six: Find Out About Specific Careers

Teacher Preparation: Put out Task Card 6. Call a mortuary or other career listed on job cards to make sure that at least one member of the staff could come to talk with the students. Students read "How to Prepare Your Own Funeral" reprint from Readers Digest, Oct. 1975. They may want to see the sound filmstrips in this packet again. Have children look through the career cards (from activity 1) to think of which career they especially want to find out about. Students then make up a list of questions they would want to ask some person whose career relates to death. Samples: What do you do at your job? How did you choose this work, etc. They can work in groups to write their questions. A resource person should be invited to the classroom so that students can interview using their questions. The teacher should hold a group discussion after the interview. Sample questions for group discussion: What did you learn from _____ visit? What did you find out that surprised you? What about _____ work still makes you wonder? How will you find more information?

Activity Seven: Last Will and Testament

Teacher Preparation: Put out Task Card 7.
Materials: Pencils and ditto copies of worksheet entitled "The Last Will and Testament". Preparation for doing the center activity: Teacher talks with students about possessions and the practice of willing what you own to those who live after you. Children think about possessions and make up a Last Will sheet using a dittoed worksheet. Don't forget to will your smile! Display wills to share; keep in folders later.

Activity Eight: Sympathy Cards

Teacher Preparation: Put out Task Card 8. Make up a display of sympathy cards using the ones in this packet plus any others as desired.
Materials: Paper, glue, scissors, crayons, markers.
Design sympathy card for people you know who might need it. They may give the card to this person. Students discuss questions 3 and 4 with teacher and others.

**
Activity Nine: Vocabulary and Sayings

Teacher Preparation: Put out Task Card 9. Dittoed copies of worksheet "Vocabulary and Sayings"; dictionaries and encyclopedias. Children will write answers on the worksheet. For gifted and interested students.

For
to do
ALL
LIFE
Activity Ten: Affirm Life

Teacher Preparation: Put out Task Card 10.

Materials: poster paper, markers, crayons, lettering stencils, other supplies as needed.

Encourage children to think about life: What they like about living... their favorite things to do. Make poster.

**
Activity Eleven: Extended individual activity for students who show an intense interest in the center.

Teacher Preparation: Set out Task Card 11 and the following: The book A Taste of Blackberries by Iris Buchanan Smith, Scholastic Book Service.

Materials: Brown wrapping paper, construction paper, tissue paper, glue, scissors, pencils.

5. Location of the Center

The center may be placed on a table, in a corner, or counter. A bulletin board near would be nice for the children to share their finished work, or display by fastening activities on clothes line with clothespins.

The center should be done in bright colors and a poster could set it off. The poster might use this saying by Epicurus Diogenes Laertius,

"To wish for nothing more, since what we have, is all that we need and what is left has no more value."

This would be thought-provoking and make children think about the subject. A mobile made with the career cards on bright colored paper hanging over the center would add interest.

6. Record Keeping:

A chart in the center with the activities numbered across top and each child's name down the side would provide the opportunity for the children

to keep track of what they have done in the center as well as a check for the teacher to see which activities are being pursued. Some task cards key the students to check off their names when work is completed. The children's work should be displayed as sharing these feelings are important if they agree to this. It may be kept private if the student desires. At the end of all activities the folders could be made into books by fastening the pages.

Student Evaluation:

1. There is a minimum of checking for correct answers in this center. Students are encouraged to think carefully about their feelings concerning death and life and about the careers of persons who help when a death has occurred. The teacher will have to check the center often so students are neither overwhelmed by the activities or unduly silly. If a student chooses not to do one or all of the activities he should be allowed due to the nature of the subject. However, a teacher should be aware of these students and try to find out the reasons for these feelings and help when possible. There is a student evaluation sheet (labeled Δ) included for teacher's use if desired. Conferences based on the folder of completed work are especially valuable as evaluations after a unit such as this.

Resources for the Teacher and Students:

1. Wadlow's Mortuary: Mr. Wadlow has four excellent slide/tape presentations to view. He is also an excellent resource person. He has said that he would come to the classroom to show these slide/tapes and hold discussions. He will not check out the audio visual's but will bring them to show one or two presentations. Presentations available at Wadlow's are as follow:

- * Life/Death -- Designed to help encourage a healthy attitude toward death as a normal part of the total life cycle, this sound filmstrip explores a variety of topics and concepts in a manner appropriate for the middle school child. Photographs and original art are combined in an honest and sensitive discussion of the normalcy of death for all living things... what happens when something dies... our feelings of grief and sadness in the face of death ... modern and historical attitudes toward death major causes of death ... and other related topics.

Exploring the Cemetery -- A young boy enters a cemetery to prove to a friend that he isn't afraid. Once inside, he meets the cemetery manager, who takes him through the cemetery. As knowledge replaces misunderstanding the boy begins to lose his needless fears and misconceptions. This filmstrip describes the cemetery as an historical resource, as well as describing the function of the cemetery and the responsibilities of the people who work there. Burial, memorials, cremation, symbols and cemetery regulations are among the topics covered.

Facts About Funerals -- The funeral is often the first occasion where children must confront their feelings about death. Unfortunately they are usually not prepared for this significant event. Stressing the inquiry approach to learning, this filmstrip tells of a boy who visits a funeral home. He then reports to his class on what he has found out about funerals and the work of the funeral director. The various steps in the funeral process and the reason for them are discussed.

A Taste of Blackberries -- When a young boy's best friend dies suddenly, he must find the courage to face his loss and the enormity of his grief. With insight, directness and understanding, this filmstrip tells how the boy moves from denial, anger and guilt to an acceptance of his friend's death and the realization that life must go on even in the face of tragedy and sorrow. Adapted from the book by Doris Buchanan Smith.

Children and Death -- How do you tell a child about death? Why is it important to help children build an understanding of death? What should you say and not say? Should children be allowed to go the funeral? How do you handle the situation when a pet dies? These and other questions of concern to parents and teachers are answered in this filmstrip. A valuable resource for in-service groups, PTA sessions and for use with community groups.

* Life/Death is the best one to fit into this unit. Each presentation takes about 10 minutes. It would be too much to try to have Mr. Wadlow show all of them during one visit because they take too long.

2. Other local mortuaries. Did you know there is a woman mortician?
Betty Umberger - Sheaff
3. L.P.S. Films
 - a. My Turtle Died Today #1716-04 Available at PSAB.
 - b. At Your Age #1142-04
 - c. No Man Is An Island #2119-04

Cut apart the career cards and place on the matching description on the sheet "People Who Help". Then write the career title on the line.

Career Cards	clergy man	Tombstone Engraver
Funeral Director	Embalmer	Grave Digger
Florist	Casket Maker	Coroner
Doctor	Newspaper Writers	Printers
Department of Vital Statistics	Under taker	Mortician

From the career cards, choose the one you think best fits each job description. Print the name of the career on the line.

People Who Help →

Issues certificate of death:

Determines cause of death not due to natural causes:

Designs sympathy cards, prayer cards and thank you cards:

Writes information on marker:



Prepares the earth for a burial:

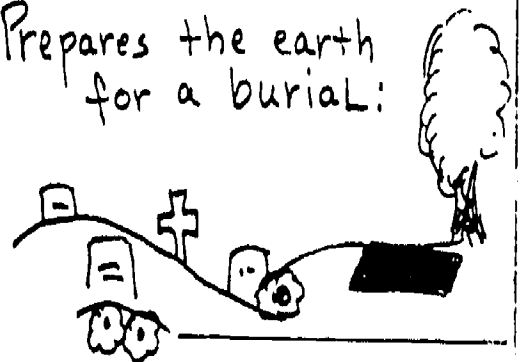

Prepares the body of the dead person for burial:

Coordinates all the funeral activity:

Prepares flower arrangements:

Conducts the burial service and consoles the people who are sad:

Pronounces the moment of death:

Use a dictionary or encyclopedia if you need it.



(Several career cards can fit in one box.)

Match the Careers to Job Description

1. Look at the film-strip. Listen to the questions
2. Match the person to the job description
3. Mark the chart when you finish

Extra: READ ALL ABOUT IT!

1. Find as many articles that report death in one daily newspaper as you can
2. Cut them out. Paste them on a large sheet of paper
3. Choose 2 articles. Make a list of all the career persons who help in each example.

check your name when you finish

Example:

Write YOUR OWN
epitaph

1. Read Comic Epitaphs
2. Write the most unusual one you can dream up.
3. Rub a piece of paper with a crayon. Put sand paper beneath it to give it a rough look.
4. Print your saying on your rubbing.
5. Cut out in shape you choose

check your name
when you finish

Two Stories

The Grand. Mother

Mom: Mother
still Love

Choose one
or
Both

Story 1

Story 2

1. Read the story
2. Write about the feelings you had when you read it.
3. Write a new ending

1. Read the story
2. DRAW pictures to go with the story. Space is provided for you.

check your name when you finish

FROM MOTHER , WITH LOVE

It began like any other Saturday, with Minta lying in bed an extra hour. Breakfast was always lazy and unhurried on Saturday mornings. The three of them in the breakfast room -- Minta's father engrossed in his paper, her mother flying around in a gayly colored housecoat, mixing waffles and frying bacon, Minta setting the table.

They talked, the casual happy talk of people who love each other and don't have to make conversation. About neighborhood doings . . . about items in the paper . . . about the clothes Minta would need when she went to school in a couple of weeks.

It was after the dishes were finished that Minta's father asked her if she would like to go down to the beach for a little while. They started walking up the beach slowly, not toward the group of people digging clams, but in the other direction, toward the jagged pile of rocks that jutted out into the bay.

She heard a strange voice, her own voice.

"I thought . . . I thought you wanted to talk to me about school, but it isn't that, is it, Father?"

His fingers tightened around hers. "In a way it is . . . about school."

And then, before the feeling of relief could erase the fear, he went on. "I went to see Dr. Morton last week, Minta. I've been seeing him pretty regularly these last few months."

She flashed a quick frightened look up at him. "You aren't ill?"

"No." He sighed and it was a heartbreaking sound.

"No. It isn't me. It's your mother."

She broke off and stopped walking and her hand was steady on his arm. "Tell me," she said quietly.

The look was back in his eyes again but this time Minta scarcely noticed it. She was aware only of his words, the dreadful echoing finality of his words.

Her mother was going to die.

Her mother.

To die, the doctor said. Three months, perhaps less . . .

Her mother who was gay and scatterbrained and more fun than anyone else in the world. Her mother who could be counted on to announce in the spring, that she was going to do her Christmas shopping early this year, and then would leave everything until the week before Christmas.

She wasn't ever sick -- except for the headaches and the operation last year which she had laughingly dismissed as a rest cure.

"I shouldn't have told you." Her father was speaking in a voice that Minta had never heard from him before.

"Of course you had to tell me," she said steadily. "Of course I had to know." And then -- "Three months, but Dad, that's Christmas."

He took her hand and tucked it under his arm and they started walking again.

Just before they reached home he reached over and took her hand in a tight hurting grip.

"We can't tell her, Minta. The doctor left it up to me and I said not to tell her. We have to let her have this last time . . . this last little time . . . without that hanging over her. We have to go on as if everything were exactly the same."

It seemed impossible that life could go on exactly as before but Minta and her father knew that they must try.

The small private world peopled by the three of them was kept as snug and warm and happy as though no shadow had touched them.

They watched television and argued good-naturedly about the programs. Minta's friends came and went and there was the usual round of parties and dances and games. Her father continued to bowl two evenings a week and her mother became involved in various pre-holiday pursuits.

"I really must get at my Christmas shopping," she mentioned the day she was wrapping trick-or-treat candy for Halloween.

Minta shook her head and sighed gustily.

Her mother started this "I-must-get-at-my-Christmas-shopping" routine every spring and followed it up until after Thanksgiving but she never actually got around to it until two or three days before Christmas.

It was amazing that Minta could laugh and say, "Oh, you . . ." the way she did year after year.

That night she wakened in the chilly darkness of her room and began to cry softly, her head buried in the curve of her arm. At first it helped, loosening the tight bands about her heart, washing away the fear and the loneliness, but when she tried to stop she found that she couldn't. Great wracking sobs shook her until she could no longer smother them against her pillow. And then the light was on and her mother was there bending over her, her face concerned, her voice soothing.

"Darling, what is it? Wake up, baby, you're having a bad dream."

"No . . . no, it isn't a dream," Minta choked. "It's true . . . it's true."

The thin hand kept smoothing back her tumbled hair and her mother went on talking in the tone she had always used to comfort a much smaller Minta.

She was aware that her father had come to the doorway. He said nothing, just stood there watching them while Minta's sobs diminished into hiccupy sighs.

Her mother pulled the blanket up over Minta's shoulder and gave her a little spank. "The idea! Gremlins, at your age," she said reprovingly. "Want me to leave the light on in case your spook comes back?"

Minta shook her head, blinking against the tears that crowded against her eyelids, even managing a smile.

She never cried again.

Not even when the ambulance came a week later to take her mother to the hospital. Not even when she was standing beside her mother's high white hospital bed, holding her hand tightly, forcing herself to chatter of inconsequential things.

"Be sure that your father takes his vitamin pills, won't you Minta? He's so careless unless I'm there to keep an eye on him."

"I'll watch him like a beagle," Minta promised lightly. "Now you behave yourself and get out of here in a hurry, you hear?"

Not even at the funeral . . .

The friends and relatives came and went and it was as if she stood on the sidelines watching the Minta who talked with them and answered their questions. As if her heart were encased in a shell that kept it from breaking.

She went to school and came home afterwards to the empty house. She tried to do the things her mother had done but even with the help of well-meaning friends and neighbors it was hard. She tried not to hate the people who urged her to cry.

"You'll feel better, dear," her Aunt Grace had insisted and then had lifted her handkerchief to her eyes and walked away when Minta had only stared at her with chilling indifference.

She overheard people talking about her mother.

"She never knew, did she?" they asked.

And always Minta's father answered, "No, she never knew. Even at the very last, when she looked around the bedroom and said, "I must get these curtains done up before Christmas."

One night Minta's father came to the door of her room where she was studying.

"I wonder if you'd like to go through those clothes before your Aunt Grace takes them to the church bazaar," he began haltingly. And then when she looked up at him, not understanding, he went on gently, "Your mother's clothes. We thought someone might as well get some good out of them."

She stood up and closed the book and went past him without another word, but she closed the door behind her when she went into her mother's room.

At the very back of the closet were the two pieces of matched luggage that had been her mother's last birthday gift from her father. They were heavy when she tried to move them -- too heavy.

She brought them out into the room and put them side by side on her mother's bed. Her breath caught in her throat when she opened them.

Dozens and dozens of boxes, all tied with bright red ribbon, the gift tags written out in her mother's careful script. Gayly colored Christmas stickers, sprigs of holly.

To Minta from Mother and Dad . . . to Grace from Mary . . . to John from Mary . . . to the Kelly Gremlins from Aunt Mary . . . to Uncle Art from the Hawley Family . . .

"So you knew," Minta whispered the words. "You knew all the time."

She looked down in surprise as a hot tear dropped on her hand and she dashed it away almost impatiently.

She picked up another package and read the tag. To Minta from Mother . . . with love.

She put all the other packages back in the suitcases and carried the cases back into the closet.

Poor Dad, she thought.

"She never knew," she could hear him saying. "Not even at the last."

Minta opened the box beside the bed and took out a sweater and pale green slip.

She brushed the tears away and went down the stairs and out into the cheerless living room.

"I'd like to keep these things, Dad," she said in her most matter-of-fact voice, and she shoved him the sweater and slip. "The slip is a little big but I'll grow into it. It . . . it looks like her, I think."

She went around the room, snapping on the lamps, turning on the television that had been silent for so long. She was aware that his eyes followed her, that he could hardly avoid noticing the tear stains on her cheeks.

"I think I'll have an apple," she said. "Want one?"

He nodded. "Sure. Bring me one as long as you're making the trip."

It was natural. It was almost like old times, except that the blue chair by the fireplace was vacant.

She went out into the kitchen hurriedly.

"I'll tell him that I pestered mother to do her shopping early this year," she told herself as she got the apples from the refrigerator. "I'll tell him that it was my idea about the packages. She wanted him to believe that she didn't know."

The vitamin pills were pushed back on a shelf. She took them out of the refrigerator and put them on the window sill where she would be sure to see them in the morning.

When she came back into the living room she noticed that a light in a Christmas wreath was winking on and off in the Kelly's window across the street.

"I guess we should start thinking about Christmas, Dad." She tossed him an apple as she spoke and he caught it deftly.

She hesitated for just a moment and then walked over and sat down in the blue chair by the fire, as if she belonged there, and looked across at her father, and smiled.

The Grandmother

by Jan Simpson

The Grandmother was old and ready
to die. Death said, I am here.

And the Grandmother answered,
Yes, I see you Death.

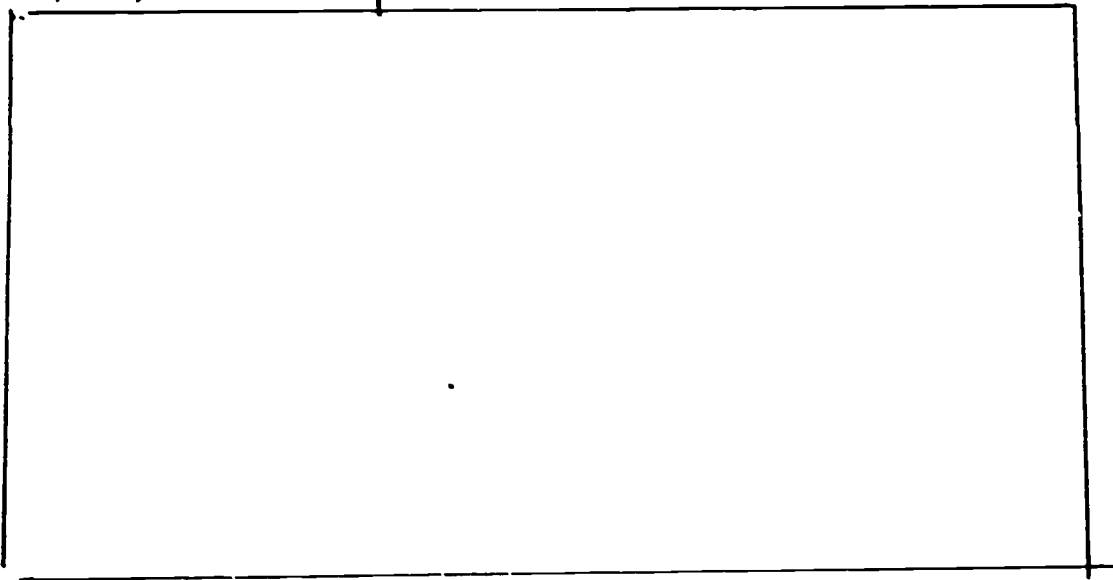

So the Grandmother called all her
children together saying,

My life has been long

My sorrows few

My joys many

But now I am weary and ready
to die.

But the oldest daughter of the
Grandmother began pulling her hair
out crying,

Ayee, Mother, do not leave us
for we have formed a chain and you are
the clasp that binds us. 1.

But the second daughter of the Grandmother
began beating her breast, crying,
Aye, Mother do not leave us,
for we have formed a bridge
and you are the strength that binds us.
And the Grandmother who greatly loved
her children

told Death

once more to wait a little while.

The Grandmother lived on and on. Then a
third time Death came and said, I Am here.
and the Grandmother answered, Yes I
see you Death. So the Grandmother
called all of her children together saying

My life has been long

My sorrows few

My joys many

But now I am weary and ready to die.

But the youngest Daughter of the Grandmother
began hitting her head on the ground, crying

And the Grandmother, who greatly loved her children told death to wait a little while.

The Grandmother lived on and on. Then Death said, I am here, and the Grandmother answered, Yes I see you, Death. So the Grandmother called all her children together, saying,

My life has been long

My sorrows few

My joys Many

But now I am weary and ready to die.

Ayee, Mother do not leave us,
for we have formed a circle
and you are the life that binds us.
And the Grandmother, who greatly loved her
children even again told Death to wait.

The Grandmother lived on and on.

Then one night as always the oldest
daughter brought a bowl of cooked cereal
and the second daughter
brought a taste of honey
and the youngest daughter
brought a cupful of cool
milk. The Grandmother
ate, and when she
finished, she called
her daughters to her
and kissed them on the
lips and closed her
eyes to press the
images of them in
her mind.

Ah, she thought, it is
done. My children are
good and strong. My grandchildren
are strong and healthy. I have bid
them all farewell. I have pressed
their images in my mind forever.
And I leave behind my love to
light the way. I Am ready.

And Death came and took her to rest
in the Kingdom that is his.

5.

What would they say about you?

1. Read some of the obituaries on the card.
2. Notice that the name of the person always appears. What else is included?
3. Write your own obituary on the sheet
check your name when you finish

And Funerals White Cloud Deaths

Funerals

Anderson
Bernier
Croy

Taught public relations at School of Commerce for one year. Tour guide at Nebraska State Capitol for about seven years. Member of Lincoln Clarion Orchestra in Lincoln for about 20 years. Played violin, trumpet and sax. Member of First Christian Church, former member of Grand Island YMCA and Elks Club. Kluge and Fork and Elks Club in Lincoln. National State and Local Teachers Assn. and Retired Teachers of America. Survivors: wife, Hazel L. Lincoln; daughter, Mrs. Bee Drury, Los Angeles; nieces, Mrs. Los Angeles; Mrs. Umberger, Washburn; Mrs. Umberger, Washburn.

Salem Lutheran Church, St. Edward. Grace Lutheran Church, Splain. 1040 A. 7926 C

Anderson Bernier Croy
Doran
Fisher
Gardner
Hess
Kramer
Lester
Mason
Meyer
Nelson
Parker
Rosenberg
Sullivan
Tamm
Thompson
Wagner
Wright
Zander

Funeral home services
DORAN - William, 79, 150, Pawnee died Tuesday. Born in Pigeon, Lincoln resident 40 years. Painter for Cushman Motors. Member South United Methodist Church. Survivors: wife, Mrs. Lester Lincoln; four great-grandchildren. Service: Roper & Sons Chapel, 6037 1/2 N. 16th St., Lincoln, 10:30 a.m. Tuesday, 12:25 p.m. 920 N. 16th St. Monday, 10:30 a.m. Born in Nance County, 96. Fullerton and North Platte resident. National Guard drummer boy prior to attending Nebraska Wesleyan University. Former trumpeter at St. Paul's Methodist Church. Had two meetings in Grand Island. Former trumpeter with Buffalo Bill's Path Hornet Troupe for 35 years. Toured colleges and high schools throughout the United States. Superintendent of schools at Nebraska State Penitentiary for five years.

Accident Victim Dies At Age

Dr. White Cloud Smith, a colorful figure in Nebraska folklore, died Monday after an accident at his home. He was 96. According to police reports, Smith was injured when he was struck by his wife who was backing the car out of the driveway. The police did not know when the accident itself was the cause of Smith's death. Smith was many things - a teacher, a poet, an actor, a philosopher - but his first love was music. He was born in a covered wagon in November 1879 between McCook and North Platte. His mother, who was part Pawnee Indian, named Smith after the first thing she noticed from the covered wagon.

White Cloud

White Cloud Smith
After studying drama with Alice Howell, a university professor for whom Howell Theater is named, he traveled with the first chautauquas in the state. Later, he launched a 35-year career, presenting one-man shows throughout the country. Smith was best-known for his play about the life of Davy Crockett. He wrote the play after meeting the only book available on Crockett at that time - a book which was not allowed out of the Alamo. When he was forced to cancel his bookings at the beginning of World War II because of the shortage, he became superintendent of schools at the Nebraska State Penitentiary. He retired from that position five years later. In 1949, he stepped out of retirement and became a tour guide at the Nebraska State Capitol. The folksy bits of philosophy which were part of his presentations earned him the title "poet laureate of the State Capitol." During the 1930's, the University of Tennessee awarded Smith an honorary doctors degree to recognize his contribution in making Davy Crockett a national hero. He is survived by his wife, Hazel, and a daughter, Mrs. Bee Drury of Los Angeles.

Deaths

CROW - Charlotte Webster, 63, Denver, Colo., died Monday. Born in Lincoln. Worked at Federal Center in Denver. Havelock High School graduate, attended University of Nebraska. Member Havelock Methodist Church. Survivors: son, D. Bradley, San Diego, Calif.; daughter, Colette Cort, Glenview, Ill.; stepmother, Mrs. Anise (Mrs. L. A. Webster), Lincoln; sisters, Marie Blackman, California; Helen Christie, Massachusetts; Audrey Roper & Son, Lincoln, 11 a.m. Tuesday. The Rev. Roper & Sons Chapel, 6037 1/2 N. 16th St., Lincoln.

Dead

White Cloud Smith
White Cloud Smith
White Cloud Smith

Fatal

beautiful cemetery

Crash Claims One

Murder

Services Held For G
Angels Man
OME

Deaths



I WONDER What He Does ON His Job?

6.

1. Read the article, "How to prepare Your OWN Funeral"

2. Go back to the job cards.
Select one job. Make
up a list of questions
You'd ask the person:

Sample: What do you do at your job?
How did you choose that kind
of work?

3. Arrange to have the
person who has that
job to come talk to
the class. (Several can
work together) Check your
name when you
finish.



1. Take a Last Will & Testament sheet

2. Make a list of your things

3. Next to each thing write the name of the person or pet you will it to.

Check your name when you finish

(don't forget your smile)

Sympathy Cards

1. Look at the Samples

2. Design a sympathy card

3. When do you send sympathy cards?

4. Could a sympathy card ever be funny?
When?

check your name by box when you finish

Find Out:

Use dictionaries and encyclopedias to help you find out more about the words and sayings on worksheet.

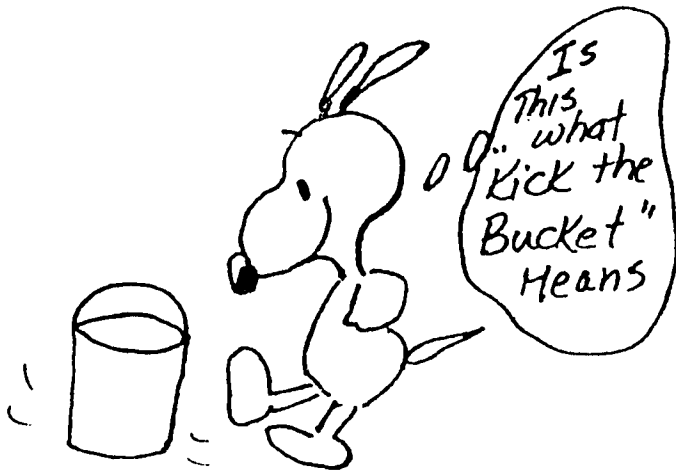

Check your name when you finish -

FIND OUT ABOUT WORDS AND SAYINGS: (the dictionary and encyclopedia are good places to look.)

1. MORTICIAN MORTUARY MORTAL WOUND MORTALITY RATE

Look at these words. What do they all have in common? Go to a dictionary or encyclopedia to find the meaning for MORT-. Explain how each of the words gets its meaning from its beginning syllable, MORT.

2. Deceased, terminated, died, croaked: How many words that mean a person has died can you think of? Write them here: _____, _____, _____, _____.

What does your family say when they speak of someone who has died? _____.

3. Undertaker: Where does this word come from? What are some other words for a person who has this job? What are some of the most recent names for a person who has this job?

4. Embalming: What does this word mean? What did it mean 300 years ago? Who in the community held this job 4 and 5 hundred years ago? (World Book: Mortician).

5. What is the difference between a coffin and a casket?

6. What does the saying "turn over in his grave" mean?

7. What is a wake? What does it have to do with a person who has died?

8. Who is the "death angel?"

9. Draw the most used symbol of death.

Life is Great!

10



M-M I
can smell
the food
from
here!

Make a Snoopy poster (or design your own) about your favorite things in life.

The Great Cycle of Life:

1. Cut out a tree from brown wrapping paper. Make leaves, grass, flowers and birds out of colored paper. Glue on and around tree.
2. Show dead leaves and earth around tree.
3. Tell the life cycle of a tree and how it draws life from sun, rain, and the dead plants and animals in the soil.

Read
A Taste of
Blackberries

Career Education Learning Center

ENVIRONMENTAL CAREERS

6

by Ann Reisher Pershing School
Fall 1975 Lincoln, Nebraska

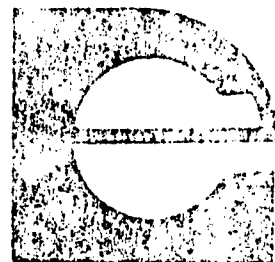

LINCOLN
CAREER
EDUCATION
PROJECT

The materials presented in this document were developed under a grant from the Office of Education, U.S. Department of Health, Education, and Welfare. Contractors undertaking such projects under Government sponsorship are encouraged to express freely their professional judgement in the conduct of the project. Points of view or opinions stated do not, therefore, necessarily represent official Office of Education position or policy.

Submitted by
Lincoln Public Schools
John Prasch, Superintendent
Carl Spencer, Project Director

1976

511

The materials presented in this document were developed under a grant from the Office of Education, U.S. Department of Health, Education, and Welfare. Contractors undertaking such projects under Government sponsorship are encouraged to express freely their professional judgement in the conduct of the project. Points of view or opinions stated do not, therefore, necessarily represent official Office of Education position or policy.

Submitted by
Lincoln Public Schools
John Prasch, Superintendent
Carl Spencer, Project Director

1976

512

Date

To

From

Subject

ENVIRONMENTAL CAREERS Career Ed./Learning Centers

Media needed: 7 audio tapes/^{which} read all print material to students--available through media services (473-0262) entitled Environmental Careers set (7 tapes). 5 (or more) Popeye Environmental Careers Comics, published by King Publisher; 5 reprints from Ranger Rick Magazine (as many as needed for class size)--as follows:

Ranger Rick Magazines: Water - What Would We Do Without It?, Air Pollution, Pesticides, Recycling, The Best Present et Al - Published by National Wildlife Federation

Lincoln Public Schools Box 82889

Memo

Lincoln, Nebraska 68501

512143

A page with cartoon illustration has been removed because of
copyright.



MULTI-LEVEL ACTIVITIES:

Activities are starred by difficulty. * indicates easier work
 ** indicates average difficulty
 *** indicates more difficult work

Children should not be locked into a particular track. Each should be encouraged to work on activities commensurate with his or her ability, but any student should be permitted to try any activity which is interesting or challenging to him. Following the pre-assessment activity the student and the teacher together may decide generally which track he or she will follow.

Teacher preparation:

- Well in advance of the unit the teacher should ask her students to bring one pound coffee cans from home to be covered with the tulip-patterned paper to represent the Lincoln Park Department's "Pitch-In" trash containers. Each child should have a container of his own. (These will hold the small ecology flags to be made by each student as he or she finishes each activity.) A pattern for the tulip cover is included in the student packet.
- Masters and straws for the ecology flags are included.
- A master for the cover of the scrapbook (to be made on oaktag) is included. Students should complete the covers to suit their own tastes. The back cover should be of oaktag as well. Use two or three brads per scrapbook so the students can add all puzzles and other written materials from each of the six activities. (The scrapbook will later be used in evaluation.)
- The letters forming the words "Environmental Careers" are included to be placed (if desired) over the counter or table holding the tulip trash cans.
- Masters to be used for puzzles and other written activities are included in the student packet.
- Order the filmstrip and record set, "Ecology and You," to be used as an optional activity at the end of each activity. (Available from PSAB Media Center, "574.5'E")
- Collect six ditto box lids or bottoms for the duplicated materials for each of the six activities.
- Duplicate each of the six student activity pages to be used for self-direction.
- A Popeye bulletin board or poster design is included.
- A puzzle answer key is included in the student packet.

ACTIVITY 1 White pages labeled "Introduction to Environmental Careers"

Teacher preparations:

1. Laminate the green oaktag sheets of the game "Environmentalist."
(Two sets each of rules, game boards, and alphabet cards)
2. Provide materials for students to make ecology flags for each completed activity. (Students cut out and color flags, write activity number on the back, and label with a smile, straight face, or a frown for evaluation. Then they glue flags to straws and put them in their tulip trash cans.)
3. Provide a tape recorder (cassette), filmstrip machine, and record player for this activity. (Most of the activities will require this equipment.)
4. Make ditto copies from the masters labeled 1-B, 1-C, 1-D, 1-E, 1-F, 1-G, and 1-H (in student packet)
5. Help students get started on these first activities. Some puzzles will be unfamiliar to them.
6. Remind students to put all puzzles and written materials in their scrapbooks.

ACTIVITY 2 Light green sheets labeled "Water"

Teacher preparations:

1. Make ditto copies from the master labeled 2-C
2. Provide equipment listed in Activity 1.
3. Students put all written materials in scrapbook.

ACTIVITY 3 Light yellow sheets labeled "Air Pollution"

Teacher preparations:

1. Make ditto copies from the masters labeled 3-C, 3-E, 3-F, 3-G, 3-H, and 3-I.
2. Provide equipment listed in Activity 1.
3. Students put all written materials in scrapbook.
4. Provide unlined paper for diagram activity 3-D.

ACTIVITY 4 Light pink sheets labeled "Pesticides"

Teacher preparations:

1. Make ditto copies from the masters labeled 4-C, 4-D, 4-E, 4-F, and 4-G.
2. Provide lined paper for Activity 4-B.
3. Provide equipment listed in Activity 1.
4. Students put all written work in their scrapbooks.

ACTIVITY 5 Light orange sheets labeled "Recycling"

Teacher preparations:

1. Make ditto copies from the masters labeled "Recycling A," "Pollution B," and "Pollution C."
2. Provide equipment listed in Activity 1.
3. Provide lined paper for Activity 5-B
4. Students put all written work in their scrapbooks.

ACTIVITY 6 White sheets labeled "Energy"

Teacher preparations:

1. Provide unlined paper for steam or solar energy diagrams.
2. Students will need permission to use the media center for research on solar energy (Activity 6-C).
3. Provide a cassette tape recorder. (Activity 6-A)

5.

RECORD KEEPING: The student adds to his scrapbook as he or she selects appropriate activities. The teacher, as she finds time, periodically goes through the scrapbook with the student to review his accomplishments. She may keep a check list of the completed activities for each child.

The student places his ecology flags in his tulip trash can as he finishes each activity.

6.

STUDENT EVALUATION: There is little need for formal checking in this unit. Some puzzles indicate the answers are provided on another sheet. (The teacher will decide where to keep the answer sheets for students' use.)



LOCATION OF CENTER: It is suggested that, if possible, the center be arranged on a counter with a wall behind it for the title display. The students' tulip trash cans will add a bright note lined up or grouped on the counter. If this arrangement is not feasible place the cans on a grouping of three or four desks, two tables, or even on the floor in a corner with the title behind them. Set the six boxes beside the grouping of cans.



HOW AND WHEN THE CENTER IS TO BE USED (SCHEDULING): Much of the information in this unit complements the Game and Parks Environmental Education science curriculum materials. This learning center would work as a natural adjunct for extra credit activities with these materials.

The teacher and student may also develop a contract to decide how many activities should be completed.

Students may work in the center during study time as they finish other assignments, or the teacher may decide to set aside time for the whole class to work since there are ample materials. Small groups could also work effectively within the framework of the center.



STUDENT-TEACHER EVALUATION: It is suggested that the teacher use the pre-assessment as a post-test if she feels a formal written test is most reliable in determining a student's achievements.

Students could use a class meeting to discuss good and bad points of the unit and to make suggestions for additions or deletions.

Students should put a smile, a straight face, or a frown on the back of each of their ecology flags for further evaluation. Student and teacher should review these evaluations together if time permits.

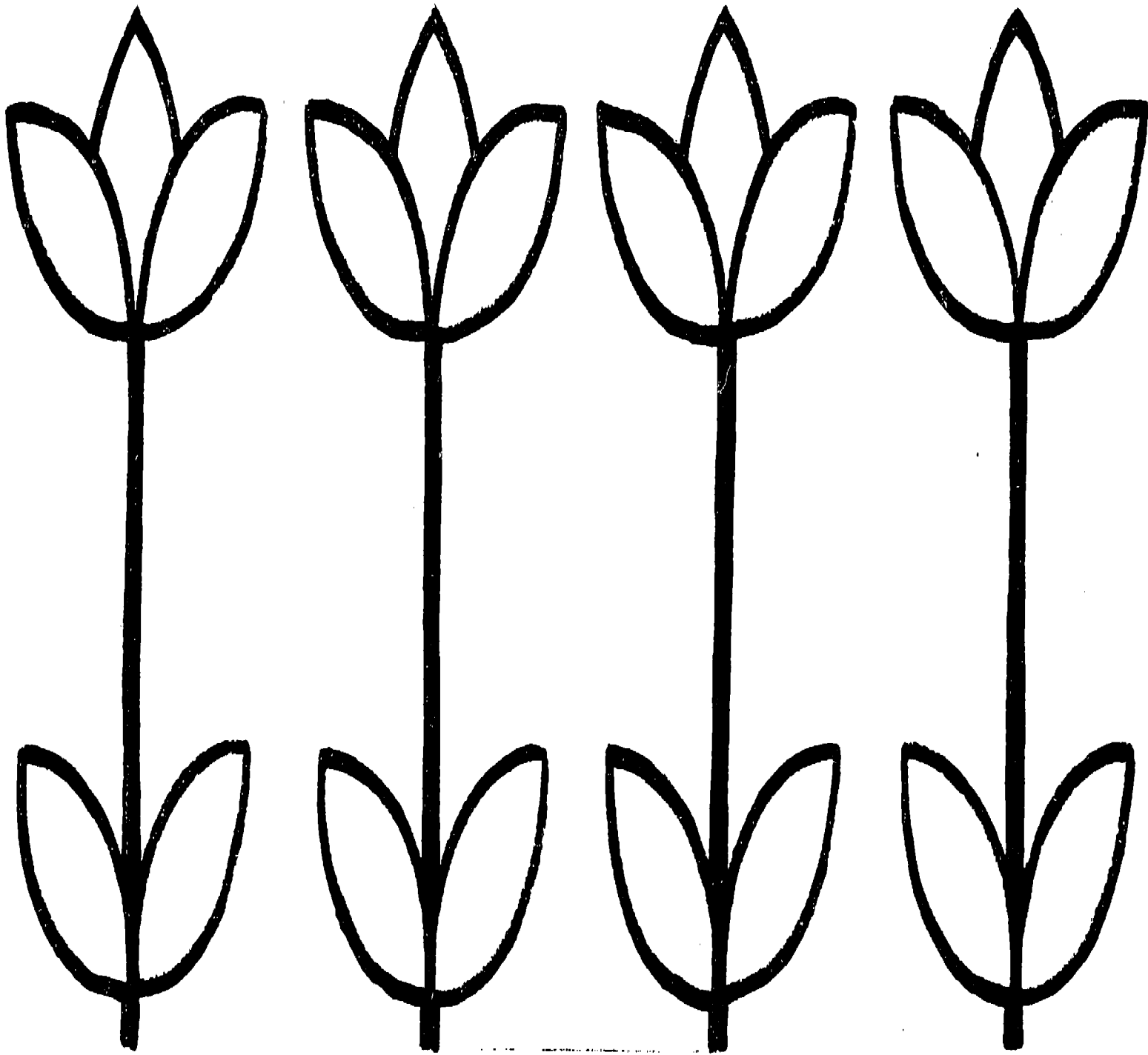

As yellow leaves fall, you can try to make petals in any color you wish. The petals of a tulip are, of course, yellow. The stem and leaves are green. You may also make other flowers. Try to make a tulip with a long stem (bottom

Wrap this tab around straw.

Green

Cut

Green

Green

Cut
Wrap this tab around straw

Green

Green

Wrap this tab around straw

- ← Green
- ← white
- ← Green
- ← white
- ← Green
- ← white
- ← Green
- ← white
- ← Green
- ← white
- ← Green

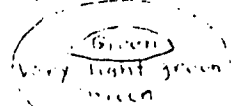

The Ecology Flag: Greek letter, Theta, warning of death, symbolizes the threat to earth and its atmosphere. Green stripes are for unspoiled land; and white for pure air.

1) Pre-Assessment

Name _____

1. Without using a dictionary, define the word ecology.

2. Without using a dictionary, define the word environment.

3. What is meant by an environmental career?

4. ^{A.} List five environmental careers, and ^{B.} tell the work done in each.

1. _____

2. _____

3. _____

4. _____

5. _____

Environmental Careers

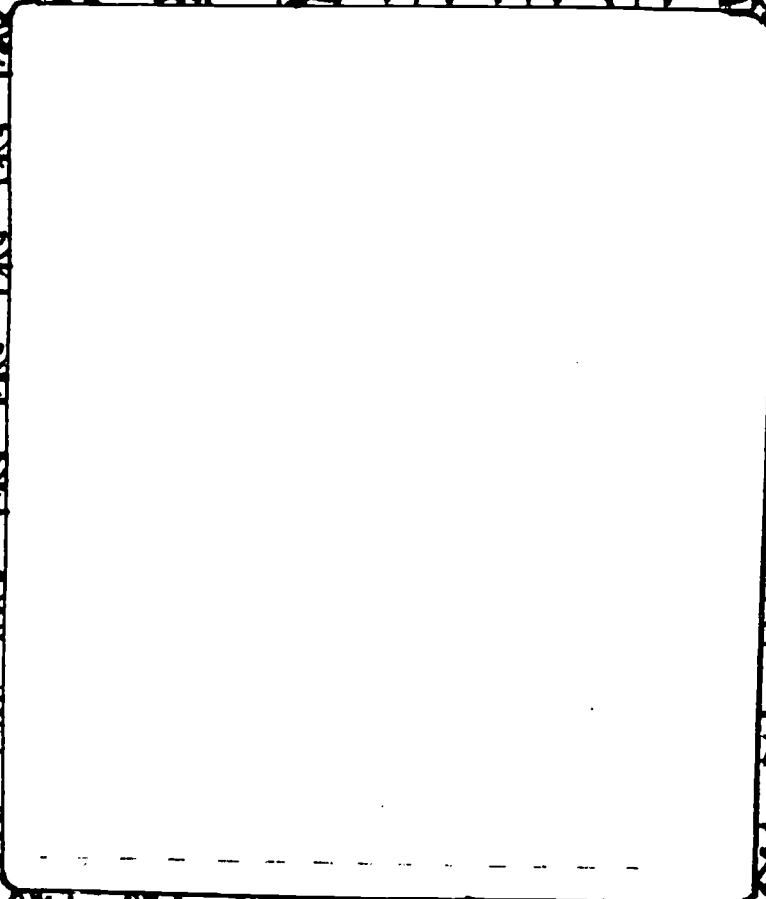

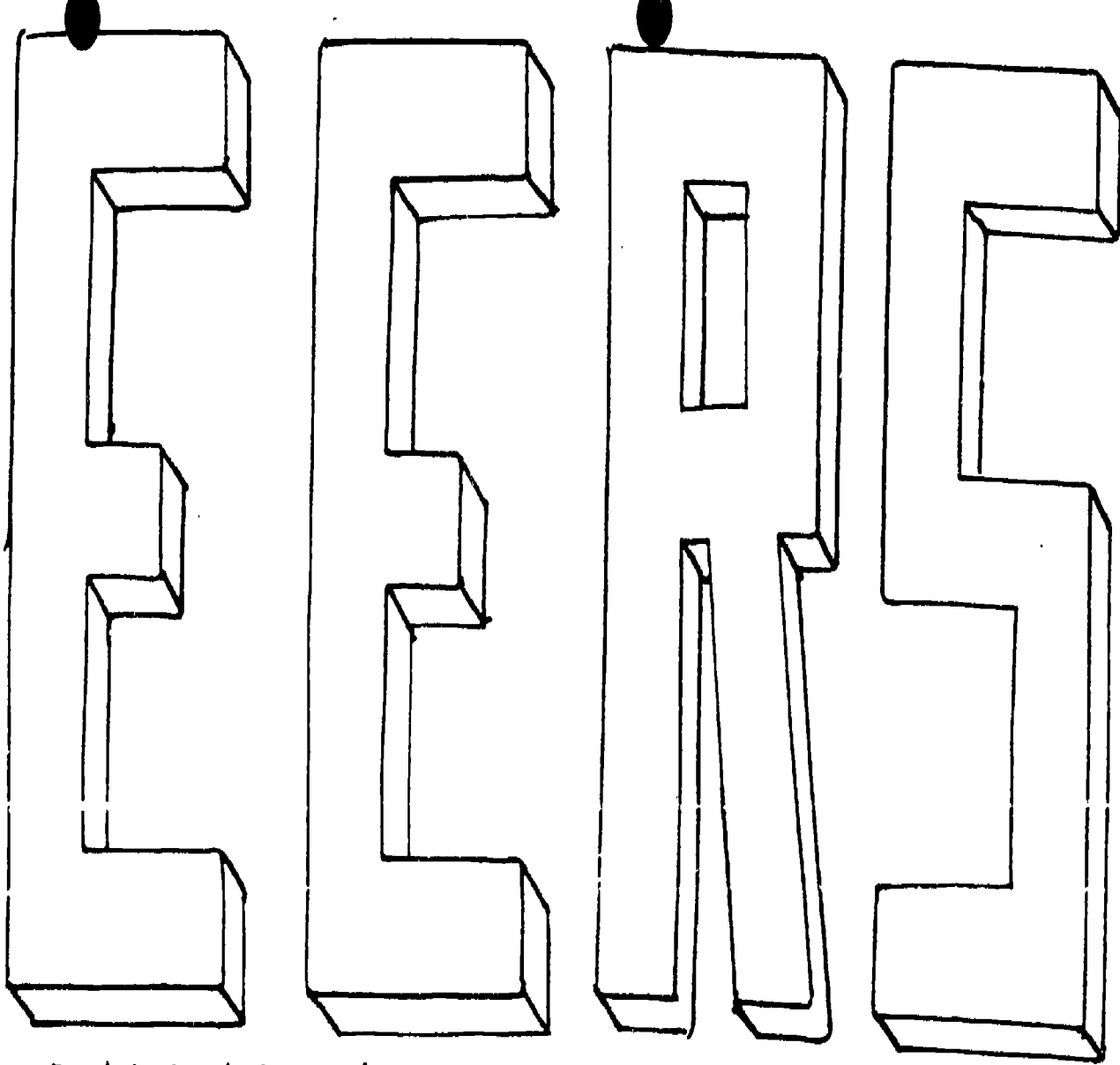

ENVIRONMENTAL CAREERS

(You may wish to shade in the third dimension.)

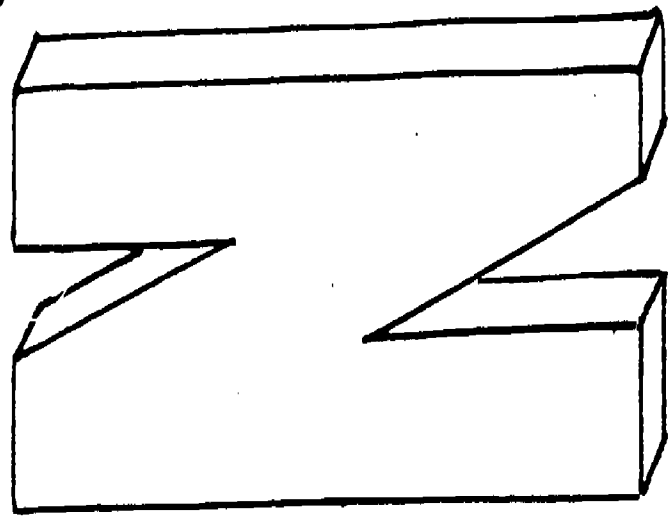
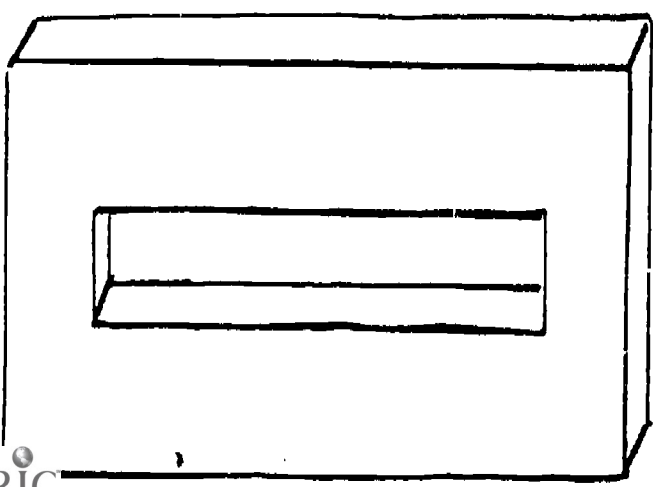
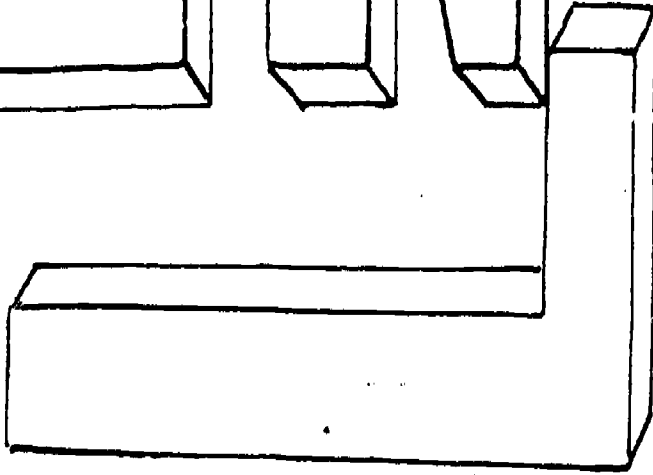
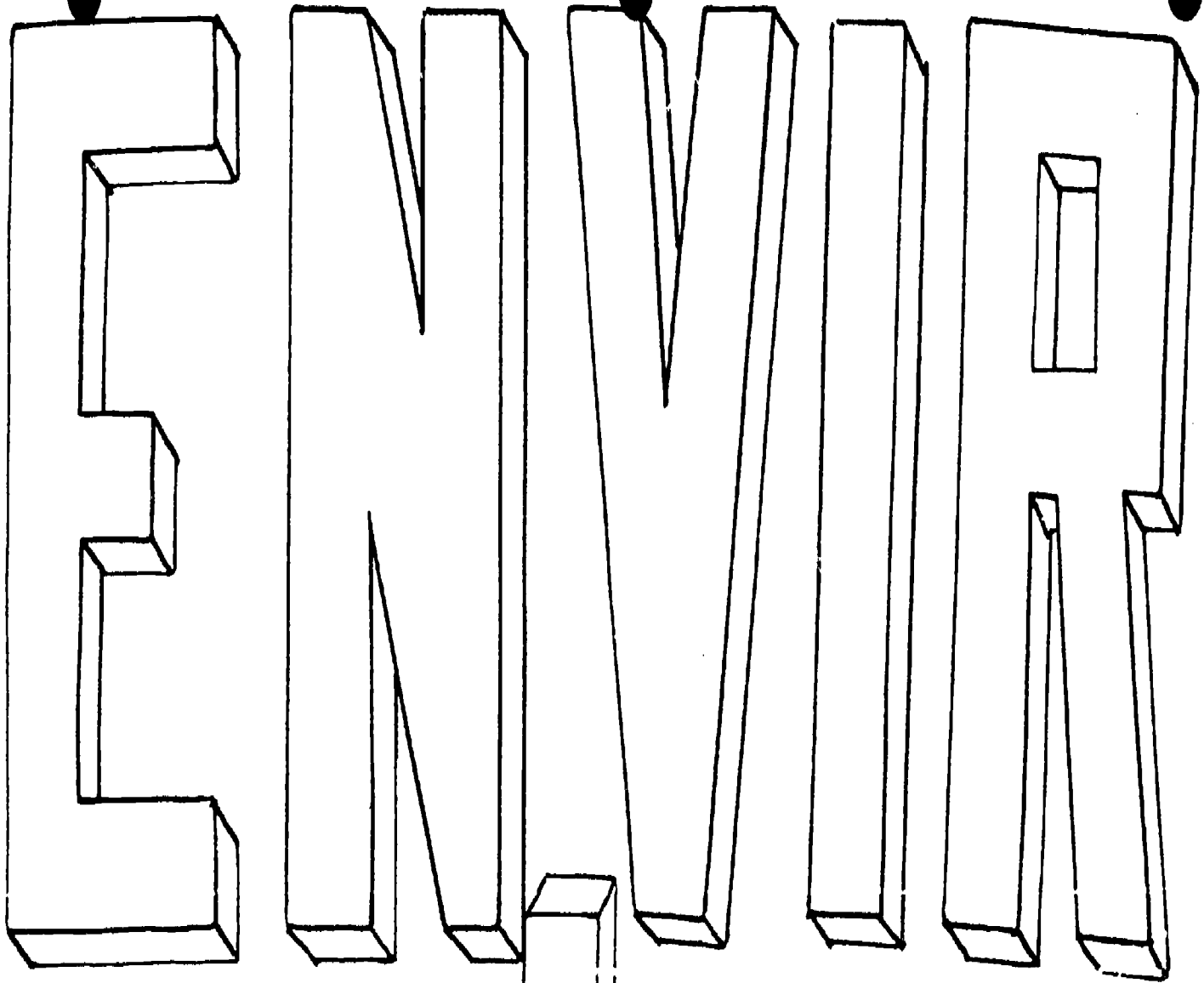

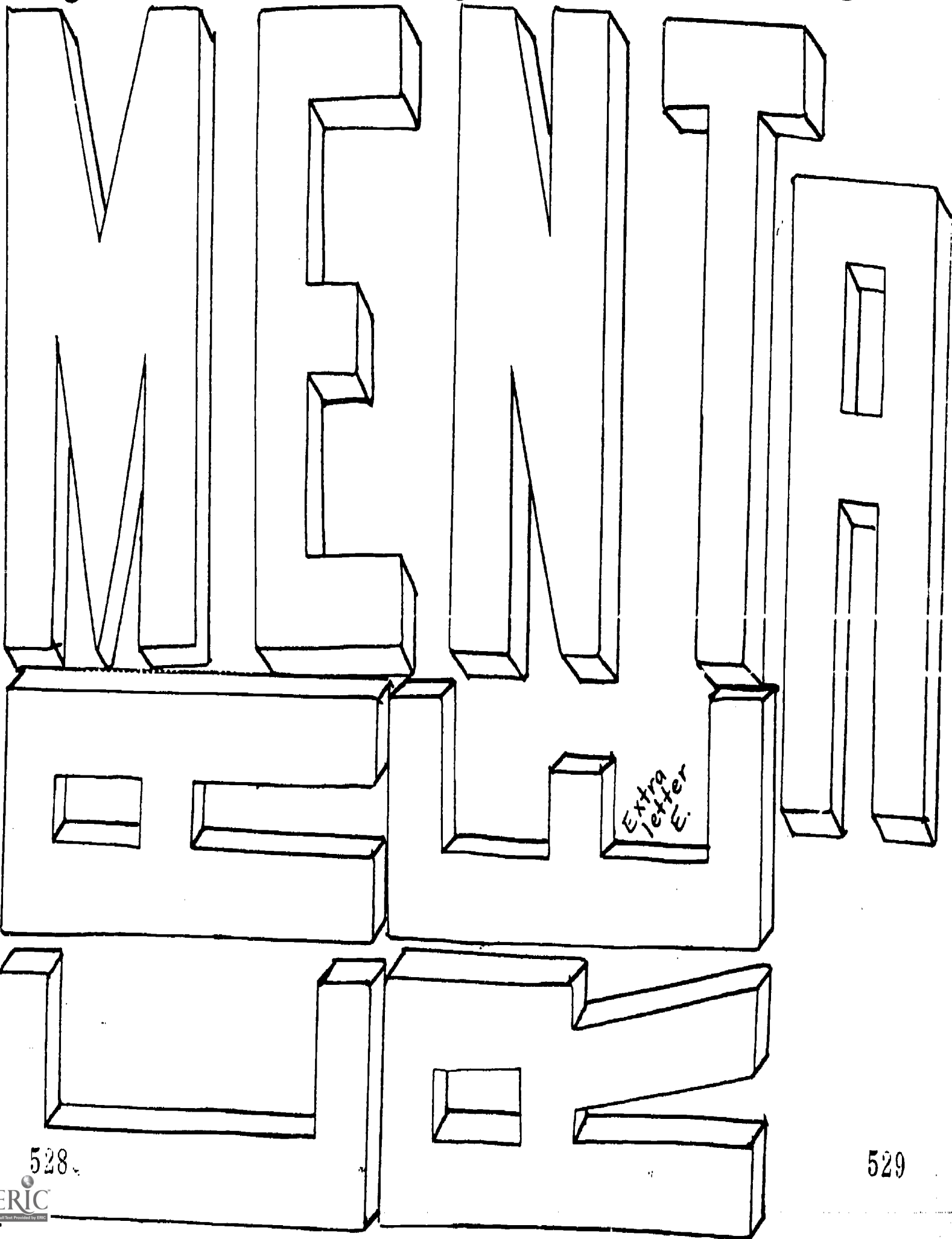

Extra
letter
E.

A Cartoon (for use as bulletin board or poster) has been removed because of copyright.

STUDENT ACTIVITY 1

Introduction to Environmental Careers

- * ** *** 1-A Read the comic book, "Popeye and Environmental Careers." may listen to the accompanying tape if you wish.
- ** *** 1-B Answer the questions on the ditto copy of the last page of the comic. Share your answers with several students in a small group to see if your responses are correct. Include this sheet in your scrapbook.
- * ** *** 1-C Do the strip puzzle labeled 1-C. First read the directions at the bottom of the page. Then look at the example showing how the puzzle is done. Ask your teacher for help if you are not sure how to do the puzzle.
- * ** *** 1-D Listen to the tape of an interview with Mr. Dean Sandahl of the Nebraska Game and Parks Department. See how many answers to the interview questions you can record on the ditto included. (It is labeled 1-D.)
You may wish to listen to the tape twice to verify or add to your information.
- * ** *** 1-E Do the Seek and Find puzzle labeled 1-E. (Environmental Careers--You should look in a dictionary for any career names you do not recognize.)
- * ** *** 1-F From the twenty four conservationists and three conservationist organizations, choose one or more subjects for research. Record your information on the second page. (Both are labeled 1-F.)
- * ** *** 1-G Do the strip puzzle labeled 1-G.
- ** *** 1-H Do the strip puzzle labeled 1-H.
- * ** *** 1-I Read the rules to the game "Environmentalist." Ask some other students to play the game with you. (They should have finished most of the activities on this page.) Use a paper punch to make dot-markers of different colors to indicate your position on the game board.

REMEMBER TO INCLUDE ALL PUZZLES AND OTHER WRITTEN WORK IN YOUR SCRAPBOOK!

CAN YOU ANSWER THESE?

1. LIST FIVE JOBS IN ENVIRONMENTAL CAREERS YOU MIGHT LIKE. NEXT TO EACH JOB LIST THE TRAINING YOU WOULD NEED. THE ANSWERS ARE IN THIS BOOK.

JOBS	TRAINING
_____	_____
_____	_____
_____	_____
_____	_____
_____	_____

2. DID YOU FIND ANY JOBS YOU DID NOT KNOW ABOUT?
- | | | |
|--|-------|-------|
| | YES | NO |
| | _____ | _____ |

3. LIST SIX ENVIRONMENTAL JOBS YOU DID NOT KNOW ABOUT.
- _____
- _____

4. ENVIRONMENTAL JOBS ARE POSSIBLE WITH TRAINING THAT INCLUDES:
- | CHECK ONE | YES | NO | YES | NO |
|------------------------|-------|-------|-------------------------|-------|
| HIGH SCHOOL DIPLOMA | _____ | _____ | COLLEGE DEGREE | _____ |
| JUNIOR COLLEGE DEGREE | _____ | _____ | GRADUATE DEGREE | _____ |
| ON THE JOB TRAINING | _____ | _____ | APPRENTICESHIP TRAINING | _____ |
| NO HIGH SCHOOL DIPLOMA | _____ | _____ | VOCATIONAL SCHOOL | _____ |

5. ENVIRONMENTAL JOBS MAY BE FOUND IN:
- | CHECK ONE | YES | NO | YES | NO |
|--------------------------|-------|-------|--------------------|-------|
| BUSINESS AND INDUSTRY | _____ | _____ | AGRICULTURE | _____ |
| MANY CITY AGENCIES | _____ | _____ | THE SEA | _____ |
| FORESTS | _____ | _____ | WEATHER STATIONS | _____ |
| NATIONAL AND STATE PARKS | _____ | _____ | WORKING IN BIOLOGY | _____ |

6. ENVIRONMENTAL CAREER WORKERS ARE TRYING TO SOLVE PROBLEMS IN:
- | YES | NO | YES | NO |
|-----------------|-------|--------------------------|-------|
| AIR POLLUTION | _____ | NOISE POLLUTION | _____ |
| WATER POLLUTION | _____ | BALANCE NEEDED FOR SOUND | _____ |
| | | ECOLOGY | _____ |

7. HAS THE THOUGHTLESSNESS OF MAN CAUSED SOME OF OUR ANIMALS AND BIRDS TO BECOME NEARLY EXTINCT?
- | | | |
|--|-------|-------|
| | YES | NO |
| | _____ | _____ |

8. NAME ONE BIRD AND ONE ANIMAL THIS COUNTRY HAS NEARLY LOST.
- BIRD _____ ANIMAL _____

9. THERE ARE MANY ENVIRONMENTAL JOBS FOR:
- | | | | | | |
|-------------|-------|-------|-------|-------|-------|
| TECHNICIANS | YES | NO | AIDES | YES | NO |
| | _____ | _____ | | _____ | _____ |

10. EACH ONE OF US MUST HELP PRESERVE OUR ENVIRONMENT
- | | | |
|--|-------|-------|
| | YES | NO |
| | _____ | _____ |

11. ARE ENVIRONMENTAL CAREERS LIMITED TO PEOPLE WITH COLLEGE DEGREES?
- | | | |
|--|-------|-------|
| | _____ | _____ |
|--|-------|-------|

12. DOES POPEYE THINK IT IS IMPORTANT TO STUDY AND FINISH SCHOOL IF YOU WANT AN ENVIRONMENTAL CAREER?

1-C

THESE ECOLOGISTS ARE EXPERTS ON:

Example: TREE

LUMBER AND PAPER PRODUCER

STATELY



Cut off here.

MATERIALS ARTS AND TREES

TREES

INTERNATIONAL

AND OTHER PLANTS

FOREST SOILS

PLANTING AND HARVESTING

AND WOODS

EXPERTS ON

Directions:

Arrange the strips to finish the sentence at the top of the page. Boxed letters will form a word (See example). Then glue the strips down.

Puzzle Answers

1-C FORESTERS

Environmental Careers 1-E

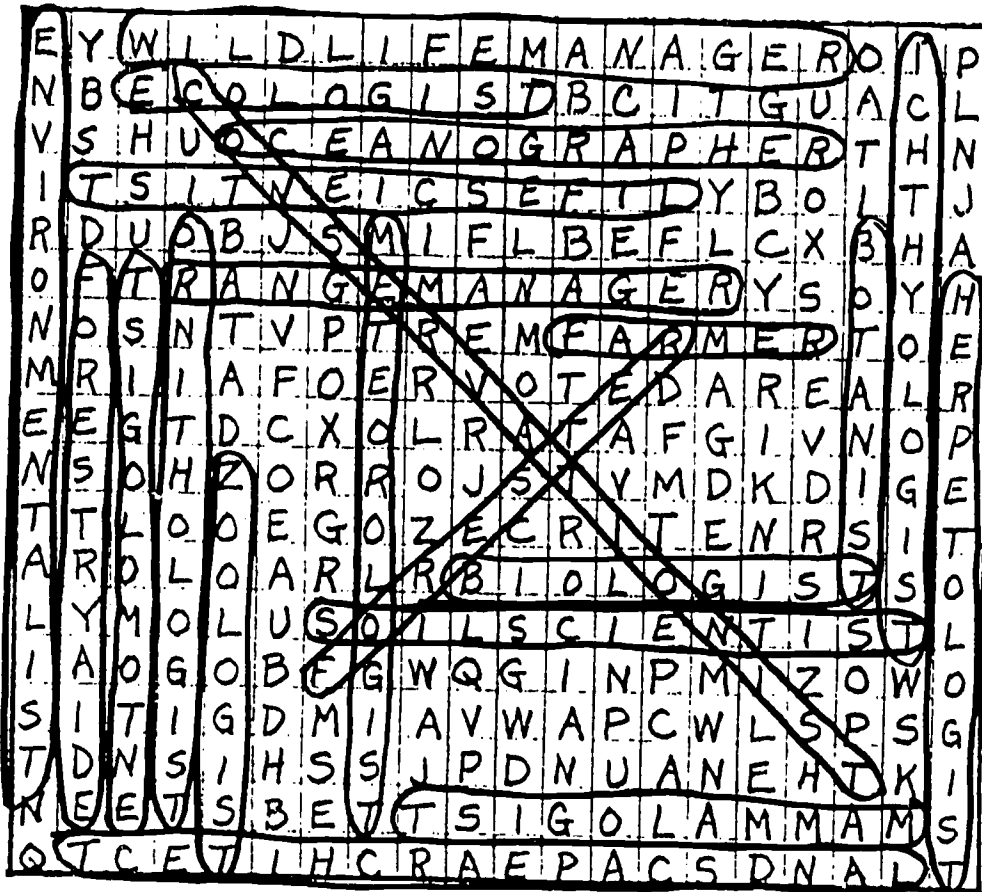

1-G ECOLOGISTS

1-H METEOROLOGISTS

Puzzle Answers

2-C ENVIRONMENTAL ENGINEERS

Use the career clues
from the list below.

1-H

M. □ T □ O □ O □ O □ I □ T □

Cut out and rearrange the
following clues to identify
a career in ecology.
Glue the strips in their
proper location.

STUDY CLOUD PATTERNS

TRACE STORM CONDITIONS

PREDICT WEATHER

WEATHER SATELLITES

TRACK HURRICANES

USE LONG RANGE RADAR

USE WEATHER BALLOONS

□ c □ L □ □ □ S □ S are

P
I
C
T
U
R
E

P
I
E
C
E
S
O
F
O
U
R

O
F
T
H
E
W
O
R
L
D

S
C
I
E
N
T
I
S
T
S

J
I
G
S
A
W
P
U
Z
Z
L
E

W
H
O
P
U
T
T
O
G
E
T
H
E
R

Unscramble these six words and phrases to finish the definition of this career. Then glue the strips in their proper locations.

Use the forms below for recording the information about your subject(s). Use back of the form if you need more space. You may also wish to illustrate your subject.

1-F
(cont.)

54

Name of Researcher _____ Date _____

Name of Conservationist _____

Major Contributions to Conservation _____

Other Important Achievements (if any) _____

Sources of Information _____

t

Name of Researcher _____ Date _____

Name of Conservationist _____

Major Contributions to Conservation _____

Other Important Achievements (if any) _____

Sources of Information _____

Famous Conservationists

1-F

From the list below select several conservationists. In your media center or library find their major contributions to conserving the natural resources and/or environment of the United States.

- | | |
|-------------------------------|------------------------------|
| 1. Audubon, John James | 13 Pinchot, Gifford |
| 2 Carson, Rachel | 14 Powell, John W. |
| 3 Clements, Frederick (Neb.) | 15 Rockefeller, John D., Jr. |
| 4 Condra, George (Neb.) | 16 Rockefeller, Lawrence |
| 5 Darling, Jay ("Ding") | 17 Roosevelt, Franklin D. |
| 6 Douglas, William O. | 18 Roosevelt, Theodore |
| 7 Gabrielson, Ira N. | 19 Seton, Ernest Thompson |
| 8 Grinnell, George B. | 20 Smokey the Bear |
| 9 Hutchinson, D.E. (Neb.) | 21 Stuart, Robert |
| 10 Leopold, Aldo | 22 Udall, Stewart L. |
| 11 Morton, J. Sterling (Neb.) | 23 Van Hise, Charles |
| 12 Muir, John | 24 Wilson, Alexander |

You may also pick from these organizations:

- | | |
|-------------------------|------------------------------|
| 25. Izaak Walton League | 27. National Audubon Society |
| 26. Sierra Club | 539 |

Environmental Careers

1-E

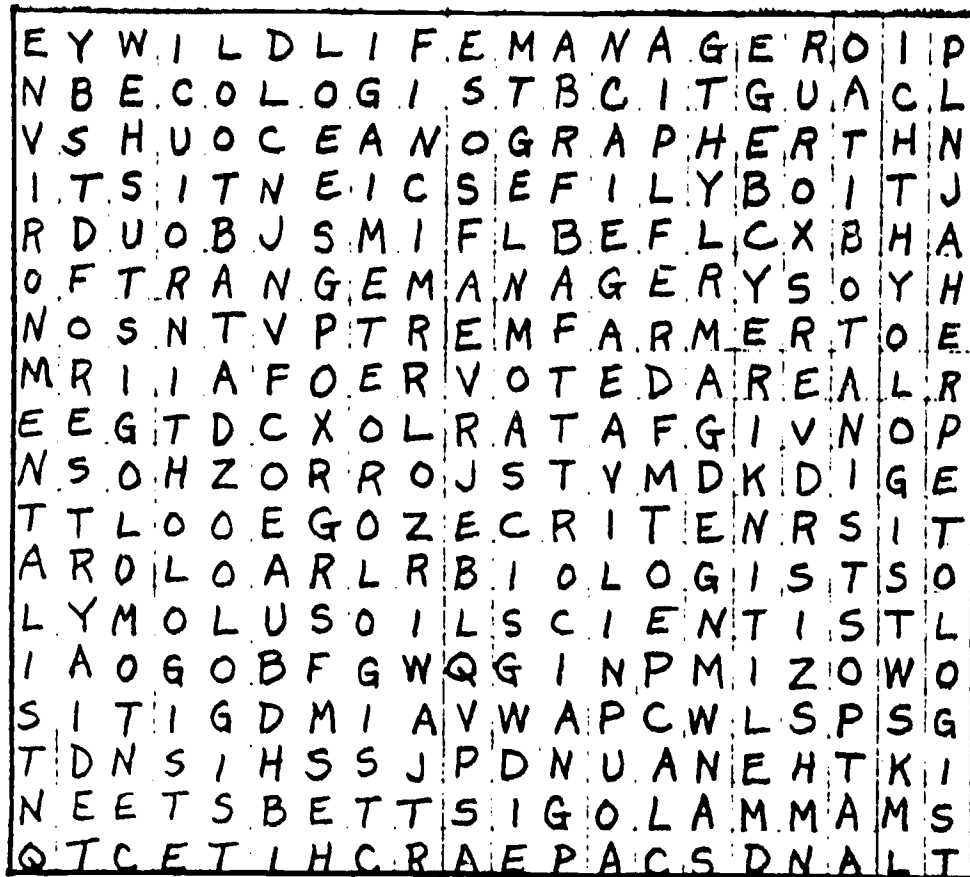

environmentalist

landscape architect

forestry aide

mammalogist

entomologist

soil scientist

conservationist

wildlife manager

forester

ornithologist

ecologist

farmer

botanist

oceanographer

ichthyologist

life scientist

herpetologist

range manager

meteorologist

zoologist

biologist

* Look up any words you don't know.

5. Why did you decide on an environmental career?

As a boy born and raised on the family farm in Northeast Nebraska during the depression and the drought of the 1930's, I gained a keen sense of the importance conservation has in the lives of each of us. Seeing grass-hoppers eating wood fence posts and top soil without any grass cover being eroded or blown away by wind during terrible dust storms into drifts like winter snow-dust blizzards; these scenes are still very vivid in my mind and I'm certainly glad they are past history. We should try to keep in mind to improve our environment in every way possible.

6. Why are environmental careers necessary?

Environmental careers are needed to further develop and encourage research in this field to gain additional knowledge. With analysis of these results, the public needs to be alerted to the problems and possible solutions through education and the media. The role of the scientist, particularly that of the biologist in the wildlife field, is very important in order to maintain a satisfactory "balance of nature" in our ever-changing environment.

7. What do you consider to be the most critical environmental problem today?

The most critical environmental problem today is the unwise and careless use of our natural resources. All too often plans, standards, and controls established to curb pollution are not implemented for one reason or another. Quite often they are impossible to meet. Stream pollution is an ever-increasing problem due to domestic and industrial wastes and urban and agricultural runoff. The increased use of agricultural chemicals and commercial fertilizers is also contaminating ground water as well as stream flow. Uncontrolled urbanization of prime agricultural land is an ever-increasing problem.

Questions and responses to interview

THIS IS MR. DEAN SANDAHL OF THE NEBRASKA GAME AND PARKS COMMISSION WHO WILL TALK TO YOU ABOUT ENVIRONMENTAL CAREERS.

1. How would you define the career of environmentalist?

The environmentalist studies all factors involving our surroundings or our being surrounded. He is ever striving to improve all the conditions, circumstances, and influences that affect each of us daily. He makes us aware of how dependent we are upon our natural resources.

2. What is the title of your present environmental career?

Chief of the Engineering Division of the Nebraska Game and Parks Commission.

3. What does your job involve?

My position involves the administration of the Engineering Division which is a service unit offering engineering services to our agency consisting of detailed planning, design, drawings, charts and graphs, specifications, cost estimates, and supervising construction of capital improvements. We do land surveys, coordinate construction work, review consultant contracts and their services, review plans for facilities for improvements in towns and cities, such as swimming pools, tennis courts, golf courses, etc. Our division also provides information and technical assistance to the other divisions of this agency and also assist with problem situations in existing facilities.

4. Have you been employed in other environmental related careers?

Yes, for over 20 years with the Nebraska Department of Roads in supervision of maintenance, construction, and design work. The most recent was as Hydraulics Engineer concerned with streams and waterways crossed by state highways. This included design; building; and seeding of wide, flat bottoms, roadside ditches, and grassed waterways to prevent erosion by having adequate vegetation to cover the soil and prevent erosion, both by water and wind. Another concern was with design of structures such as roadway culverts, i.e., pipes or concrete box culverts carrying water under the road; erosion control structures to hold back water from rainfall runoff or to allow water to drop to a lower level without erosion. These drop structures allow the energy in the falling water to be dissipated and used up harmlessly by being scattered out over a larger area in an effort to eliminate erosion.

While working on routine maintenance of the Interstate highways, it became apparent that we would be unable to mow all of the roadside as was customary. The decision to not mow the native grasses except that adjacent to the roadway has resulted in considerable savings as well as a pleasing view to the traveler and wonderful habitat for wildlife. This is complimented by the voluntary "Acres for Wildlife" program. With farming interests, I can especially appreciate this conservation.

STUDENT ACTIVITY 2

Water

- * ** *** 2-A Read the Ranger Rick reprint of "Water--What Would We Do Without It?"
(You may listen to the accompanying tape, if you wish.)
- ** *** 2-B Choose one of the three categories at the end of the reprint,
Water Department, Sewage Treatment Plant, or the Mayor, and write for
the answers to the questions listed.
- * ** *** 2-C Do the strip puzzle labeled 2-C to find this ecological career.
- * ** *** 2-D Optional: With a small group watch the filmstrip and listen to the
record of "Ecology and You--Water."

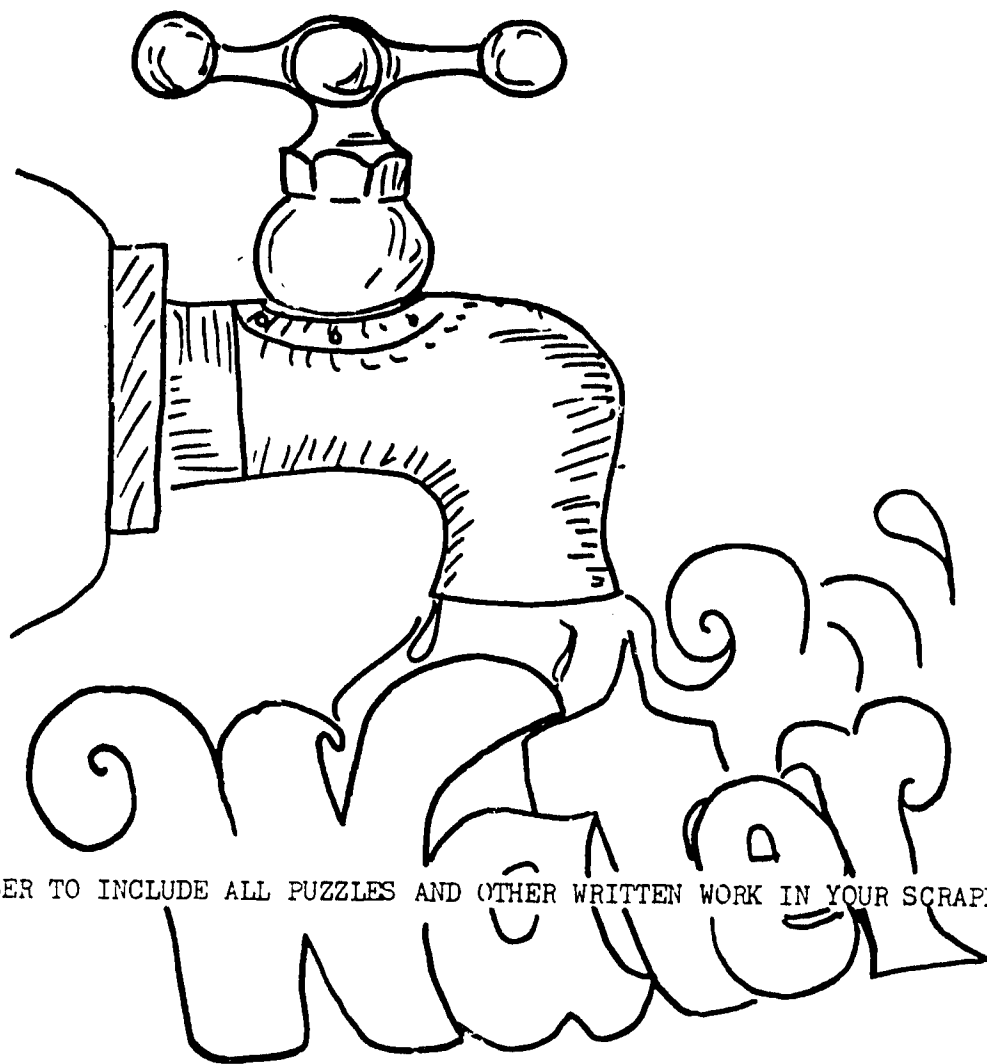

REMEMBER TO INCLUDE ALL PUZZLES AND OTHER WRITTEN WORK IN YOUR SCRAPBOOK.

Rules for the game of-

ENVIRONMENTALIST

1. Alphabet cards are shuffled before play begins and stacked face down.
(There are 56 cards including two complete alphabets and four free cards.
Two to six players may participate in a game.)
2. Each player in turn draws a card.
3. If the player can name an environmental career beginning with the letter he has drawn, he may advance his marker to the next space.
4. Players drawing the free cards may name any environmental career and advance one space.
5. If the player can correctly name more than one environmental career beginning with that letter, he may advance one space for each correct response.
6. Another player may call, "Environmental challenge!" to any response he thinks is not an environmental career or is incorrectly pronounced.
"Environmental challenge!" may also be called by another player with a demand for a correct definition of that career. (Prove with a dictionary.)
7. If the player can respond correctly to the challenge he may move ahead one extra space, and the challenger must move back one space.
8. If the player cannot respond correctly to the challenge he moves back one space, and the challenger moves ahead one extra space.
9. The player may by-pass the loops of the **E** if he can name at least two environmental careers beginning with the letter he has drawn or any two if he has drawn a free card. (In other words he may move from #2 to 8 and/or # 17 to 25.)
10. The winner is the first player to reach #38, the truck of the tree.

Rules for the game of-

*E*NVIRONMENTALIST

1. Alphabet cards are shuffled before play begins and stacked face down.
(There are 56 cards including two complete alphabets and four free cards.
Two to six players may participate in a game.)
2. Each player in turn draws a card.
3. If the player can name an environmental career beginning with the letter he has drawn, he may advance his marker to the next space.
4. Players drawing the free cards may name any environmental career and advance one space.
5. If the player can correctly name more than one environmental career beginning with that letter, he may advance one space for each correct response.
6. Another player may call, "Environmental challenge!" to any response he thinks is not an environmental career or is incorrectly pronounced.
"Environmental challenge!" may also be called by another player with a demand for a correct definition of that career. (Prove with a dictionary.)
7. If the player can respond correctly to the challenge he may move ahead one extra space, and the challenger must move back one space.
8. If the player cannot respond correctly to the challenge he moves back one space, and the challenger moves ahead one extra space.
9. The player may by-pass the loops of the *E* if he can name at least two environmental careers beginning with the letter he has drawn or any two if he has drawn a free card. (In other words he may move from #2 to 8 and/or # 17 to 25.)
10. The winner is the first player to reach #38, the truck of the tree.

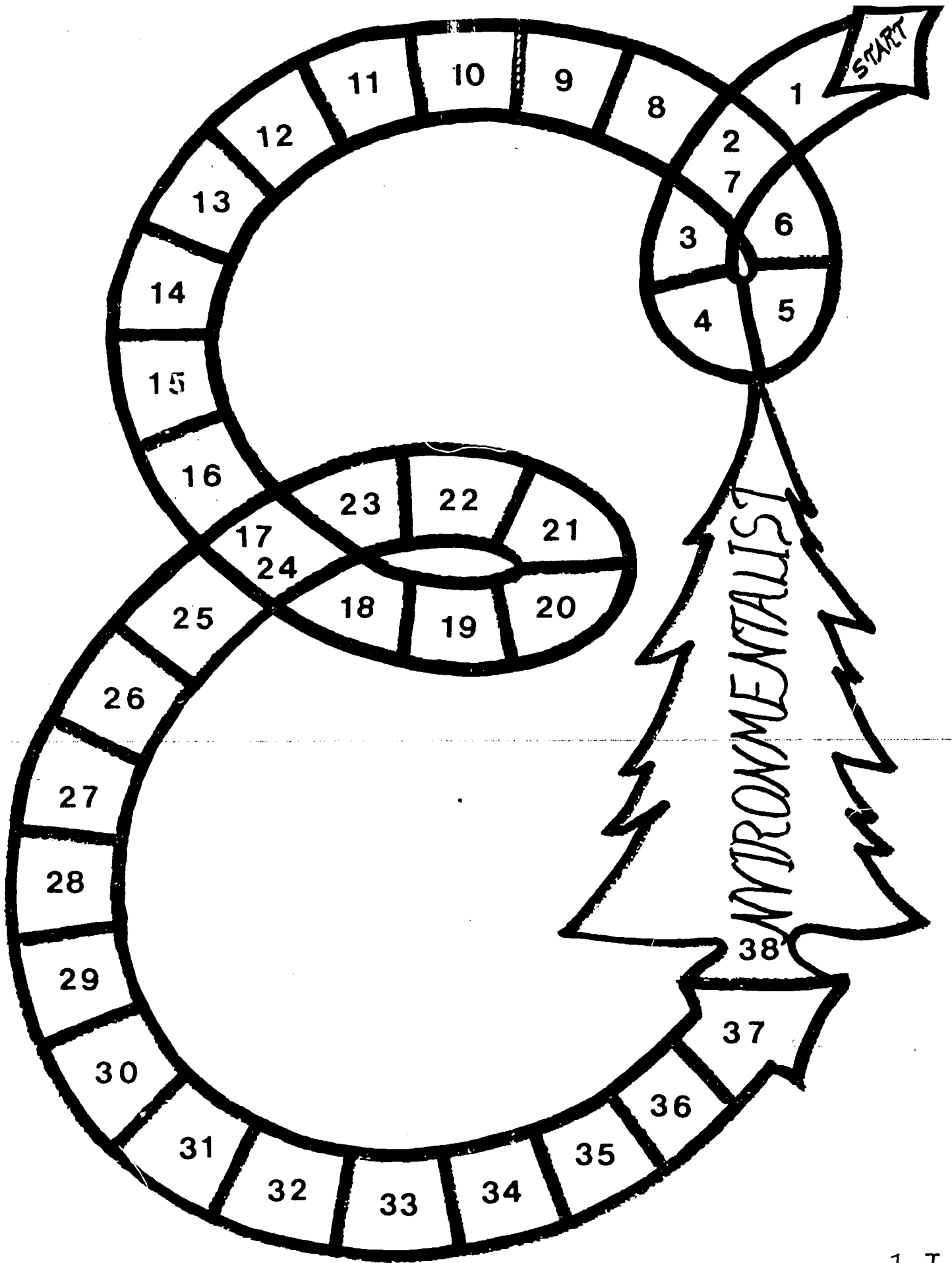

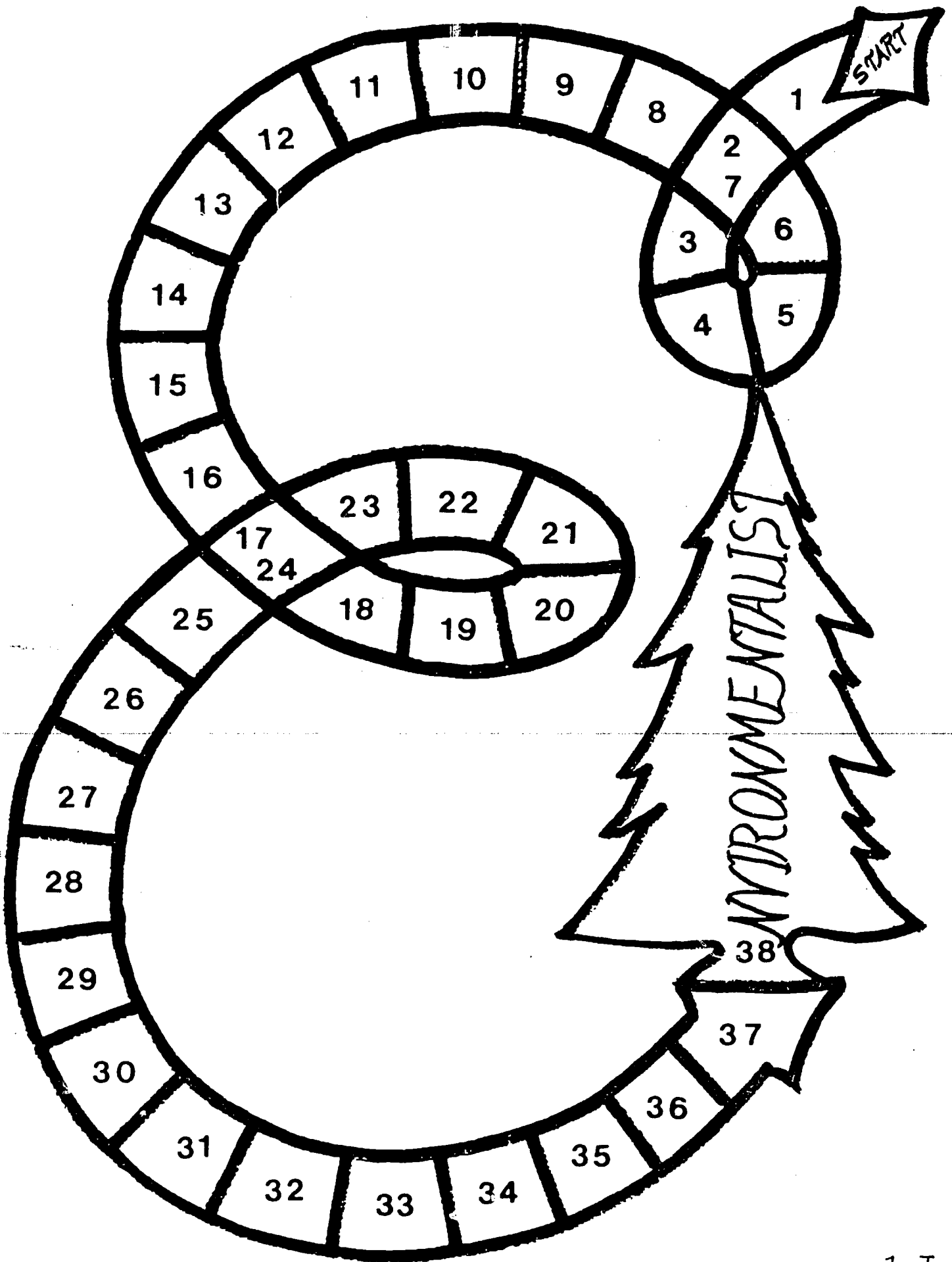

Laminate and cut out two sets for each game.

A

B

C

D

E

F

G

H

I

J

K

L

M

N

O

P

Q

R

S

T

U

V

W

X

Y

Z

FREE

FREE

CARD

CARD

549

Laminate and cut out two sets for each game.

A

B

C

D

E

F

G

H

I

J

K

L

M

N

O

P

Q

R

S

T

U

V

W

X

Y

Z

FREE

FREE

CARD

CARD

550

ERIC
Full Text Provided by ERIC

551

Laminate and cut out two sets for each game.

A

B

C

D

E

F

G

H

I

J

K

L

M

N

O

P

Q

R

S

T

U

V

W

X

Y

Z

FREE

FREE

CARD

CARD

553

Laminate and cut out two sets for each game.

A

B

C

D

E

F

G

H

I

J

K

L

M

N

O

P

Q

R

S

T

U

V

W

X

Y

Z

FREE

FREE

CARD

CARD

555

2-C

CLEAN UP OUR ENVIRONMENT

DEVELOPED DEGRADABLE PACKAGING

RESEARCH NEW POWER SOURCES

REDUCED EXHAUST POLLUTION

N I R O N M E N A N I N E R

PLAN FOR A CLEARER FUTURE

C	R	D	C	S	D	S
O	E	O	O	E	E	T
M	V	M	M	K	V	U
P	E	P	P	A	E	D
A	C	A	A	N	L	S
C	T	C	C	S	O	O
T	E	L	L	W	L	L
E	D	O	O	E	C	I
S	A	P	S	R	O	P
O	N	E	O	S	L	R
L	D	D	S	T	O	O
I	S	S	W	I	A	L
D	R	W	A	E	G	A
W	E	S	S	E	E	S
A	W	T	W	C	N	P
S	W	R	A	S	P	P
T	A	E	T	O	A	R
E	R	T	F	G	C	O
F	T	F	O	I	A	B
O	R	R	R	C	L	L
R	O	A	A	P	R	L
O	A	D	T	R	O	L
B	B	B	M	E	B	L
U	I	I	P	L	L	E
I	L	L	L	L	L	M
D	D	L	L	L	L	M
I	I	L	L	L	L	M
N	N	L	L	L	L	M
G	G	L	L	L	L	M

Finish this puzzle for an ecology career.

Cut out these strips and glue them in the correct spot.



STUDENT ACTIVITY 3

Air Pollution



- * ** *** 3-A Read the Ranger Rick reprint, "Air Pollution." You may wish to listen to the accompanying tape.
- * ** *** 3-B Interview one of your parents and one other adult about local sources of air pollution. Write their responses on lined paper and include them in your scrapbook.
- ** *** 3-C Count the number of occupants per car that pass your house in a thirty minute period from 4:45 to 5:15 PM. Then at school make a bar graph of this information on the ditto labeled 3-C. (On the home phase of this project you may need help keeping track of the cars and occupants since this is a busy time of day.) File the graph in your scrapbook.
- * ** *** 3-D In a media center resource or in a science book find the animal-carbon dioxide-plant-oxygen cycle and make a diagram showing the process.
Use unlined paper for your diagram. File it in your scrapbook.
- * ** *** 3-E Do the Seek and Find puzzle on pollution. It is labeled 3-E.
(See how many of the thirty-three words you can find.)
- *** 3-F Do the crossword puzzle entitled "Nature's Wonderlands--Our National Parks." (Labeled 3-F)
- *** 3-G Do the crossword puzzle entitled "Plant a Tree!" (Labeled 3-G)
- * ** *** 3-H Do the Seek and Find puzzle entitled "National Parks." (Labeled 3-H)
- *** 3-I Do the puzzle-pair entitled "Up a Tree." (Labeled 3-I)
- * ** *** 3-J Optional: With a small group, watch the filmstrip and listen to the record of "Ecology and You--Air."

REMEMBER TO INCLUDE ALL PUZZLES AND OTHER WRITTEN WORK IN YOUR SCRAPBOOK!

Number of Cars
and Passengers Per Car
- Passing My Home
from 4:45-5:15 P.M. on _____
(date)

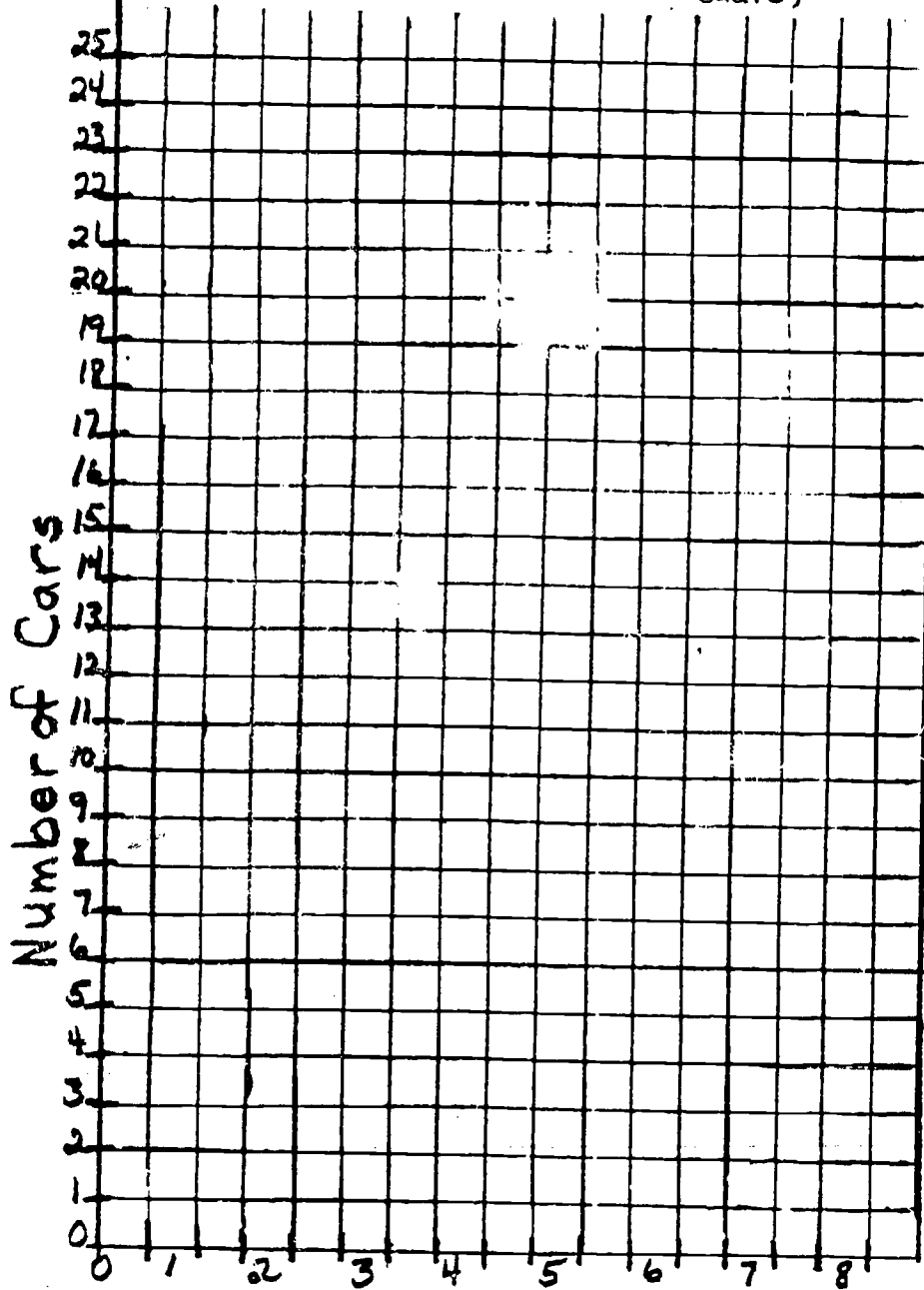

Number of Occupants
Per Car (Bar Graph)

558

Name _____

Pollution Solution

Circle all the words below that relate to pollution and ecology. (Horizontal, vertical, diagonal or reversed) See how many of the thirty-three words you can find!

B	D	E	C	A	Y	O	R	G	A	N	I	C	A
L	X	R	Q	T	O	F	A	L	L	O	U	T	R
C	E	O	D	L	I	T	T	E	R	S	U	D	S
P	E	S	T	I	C	I	D	E	S	T	W	L	R
O	F	I	H	S	E	W	A	G	E	O	A	I	R
L	R	O	T	M	G	I	N	O	I	S	E	H	S
L	P	N	A	O	E	S	O	O	T	L	T	S	I
U	B	H	C	G	R	E	C	Y	C	L	E	T	N
T	C	E	O	D	G	F	I	S	H	G	S	N	V
I	Y	H	M	S	Y	J	K	R	A	H	F	A	E
O	G	T	P	O	P	L	O	P	I	M	O	T	R
N	O	R	O	I	M	H	J	U	N	K	R	U	S
S	L	A	S	L	N	W	A	T	E	R	E	L	I
M	O	E	T	B	A	D	D	T	C	S	S	L	O
O	C	G	A	R	B	A	G	E	E	S	T	O	N
K	E	N	V	I	R	O	N	M	E	N	T	P	R
E	P	R	E	M	E	R	C	U	R	Y	S	T	U

559

(File in your scrapbook)

NATURE'S WONDERLANDS—OUR NATIONAL PARKS

Our National Parks, maintained by the Department of the Interior, are our country's invitation to us to enjoy nature at first hand. There are ten parks in this puzzle.

ACROSS

- 1. Glacier National Park is located in the _____ eastern part of this state (abbr.).
- 5. Make orderly.
- 9. Biblical garden.
- 10. Republic of Ireland.
- 11. Wind Cave National Park is in southwestern _____ (abbr.).
- 12. Levy placed upon goods sold.
- 14. Old Testament (abbr.).
- 15. Remnant of a fire.
- 17. Acadia National Park is in _____.
- 19. Either.
- 21. Street (abbr.).
- 22. Grand _____ National Park in Wyoming features spectacular mountains.
- 25. Runner used to glide on snow.
- 28. Boat for burden.
- 29. Sequoia, Lassen Volcanic, and Yosemite are National

l Parks in this state (abbr.).

- 31. Noun: pronoun.
- 32. Delicate fiber produced by special worms.
- 34. The largest island in Lake Superior, _____ Royal National Park, is located in Michigan.
- 36. Remain.
- 37. Tropical tree.

DOWN

- 1. Prehistoric cave dwellings may be seen in _____ Verde National Park, Colorado.
- 2. Straps are called _____ and ends.
- 3. Northeast (abbr.).
- 4. Short for dynamite.
- 5. Big Bend National Park is on the Rio Grande in _____.
- 6. Blade Island (abbr.).
- 7. Important metal.
- 8. Portion cut.

1	2	3	4	5	6	9	8
9				10			
11		12	13		14		
15		16	17		18		
22	23			24	25	26	27
28		29		30	31		
32		33		34	35		
36				37			

- 13. Morning (abbr.).
- 16. _____ Springs National Park is in Alaska.
- 18. Belonging to it.
- 20. Altitudes over 14,000 feet are reached in _____ Mountain National Park, Colorado.
- 22. Throw with a flip of the hand.
- 23. A way out.
- 24. North America (abbr.).
- 26. Slay.
- 27. Bit of news or information.
- 30. Part of the mouth.
- 33. Sixth note of the musical scale.
- 35. South America (abbr.).

Plant a Tree

By planting the tree described in each starred definition, you'll soon have most of this puzzle filled in.

1	2	3	4	5	6	7	8
9				10			
11		12	13		14		
15		16	17		18		
19	20			21			
22	23			24	25	26	27
28		29		30	31		
32		33		34	35		
36				37			

ACROSS

- 1. Tree that grows in hot climates.
- 5. Tree that bears smooth-skinned purple fruit.
- 9. Long-legged bird of Egypt.
- 10. River in northeastern Spain.
- 11. Abbreviation for *north-east*.
- 12. Twitching of the muscles.
- 14. Preposition showing *where*.
- 15. Shade tree.
- 17. Tree that yields sap containing sugar.
- 19. Abbreviation for *apostle*.
- 21. Thirteenth letter of Greek alphabet.
- 22. Tree that bears green and red fruit.
- 25. Small evergreen tree with many leaves.
- 28. To exist.
- 29. Trouble or fuss.
- 31. Myself.
- 32. Get money in return for work.
- 34. To declare openly.
- 36. Large leafy plant.
- 37. Gesture of affection.

DOWN 3-G

- 1. Evergreen tree.
- 2. Victim of first murderer.
- 3. Chemical abbreviation for *lithium*.
- 4. Abbreviation for *Mountain Standard Time*.
- 5. Nut-bearing tree.
- 6. Abbreviation for *pound*.
- 7. Mountain range in the U.S.S.R.
- 8. Speck of dust.
- 13. Contraction for *I am*.
- 16. Chart of earth's surface.
- 18. Abbreviation for *publisher*.
- 20. Another name for the sycamore tree.
- 22. To encourage or help.
- 23. Tree that bears yellow fruit.
- 24. Abbreviation for *editor*.
- 26. A book of the Old Testament.
- 27. Evergreen trees with fine-grained wood.
- 30. Tree with hard wood and acorns.
- 33. Second tone of musical scale.
- 35. Abbreviation for *Virgin Islands*.

Puzzle: Answers

3-E Pollution Solution

B	D	E	C	A	Y	O	R	G	A	N	I	C	A
L	X	R	2	T	O	F	A	L	L	O	U	T	R
C	E	D	D	L	I	T	T	E	R	S	U	B	S
P	E	S	T	I	C	I	D	E	S	J	W	L	R
O	F	H	S	E	W	A	G	E	O	A	I	R	
L	R	C	T	M	G	I	N	O	I	S	D	H	S
L	P	N	A	O	E	S	O	O	T	L	T	S	I
U	B	H	C	G	R	E	C	Y	C	I	E	T	N
T	C	E	O	D	G	F	I	S	H	G	S	N	V
I	Y	H	M	S	Y	J	K	R	A	H	F	A	E
O	G	T	P	O	P	L	O	P	I	M	O	T	R
N	O	R	O	I	M	H	J	U	N	B	R	U	S
S	L	A	S	L	N	W	A	T	E	R	E	L	I
M	O	E	T	B	A	D	D	T	C	S	S	L	O
O	C	G	A	R	B	A	G	E	E	S	T	O	N
K	E	N	V	I	R	O	N	M	E	N	T	P	R
E	P	R	E	M	E	R	C	U	R	Y	S	T	U

3-F

NATURE'S WONDERLANDS—OUR NATIONAL PARKS

M	O	N	T	T	R	I	M
E	D	E	N	E	I	R	E
S	D	T	A	X	O	T	
A	S	H	M	A	I	N	E
O	R	S	T				
T	E	T	O	N	S	K	I
O	X	C	A	L	I	T	
S	I	L	K	I	S	L	E
S	T	A	Y	P	A	L	M

Plant a Tree 3-G

P	A	L	M	P	L	U	M
I	B	I	S	E	B	R	O
N	E	T	I	C	A	T	
E	L	M	M	A	P	L	E
A	P	N	U				
A	P	P	L	E	B	A	Y
B	E	A	D	O	M	E	
E	A	R	N	A	V	O	W
T	R	E	E	K	I	S	S

UP A TREE

Don't let this puzzle put you up a tree. Begin by unscrambling the three or four tree names in each scramble. Use every letter in each scramble. The capitals are the beginning letters of the trees named. When you have finished the unscrambling, locate the tree names in the puzzle.

aacHikllnooPprrtuWy
acdeeiLLnnooqSstuu
acceillmoprSSuuWw
aaaCCCeehlpprssstttuy
aaaBCdeghilMnoorxy
aBceeeehllMoppTu
aaBcCdehhioorrW
AAAdeeeellpprs
aaceehilmnPP
aaceehilmnPPuw
aBREFhilmrsy

H C R I B
S E Q U O I A
S U C E D A R
M L E R M U N E P S A
L Y A A R I A A R H B P A O T
O R G P P F S E C P A L L U
C R N L Y H N A T B S U D E N
U E C A C I E W U E S M E P L
S H L T P P D I N E W W R U A
T C I A T I N L T C O A E T W
A C A R I L S H O H S
K P L O E O D
O T W H N
P R A C A
L W Y E C
A Y A B E
R M L A P
E L P A M

SEEK & FIND—NATIONAL PARKS

B E C I N A C L O V N E S S A L E B N H C
 R E I N I A R T M H M O N T P R E R O A E
 F S S E N S E D A L G R E V E A N Y Y O V
 M E S A V E R D E E L O P E S C E C N D T
 E N T M Y K C O R N I R T D A A T E A N W
 S O E R E I C A L G O S N R T D I C C A N
 M D I V I K N E T Y B T L U N I M A D N S
 T E N N A F I B N W A S S E Y A E N N E B
 M L U A E C I N P O B T R W R F S Y A H S
 C E I N L G H E G A T A S T O O O O R S G
 K V M A B S A T D S E E H L V L Y N G T N
 I A T E I H I C O F C E T A W S L A O N I
 N C N A T O A N I M O A A D W I N F L O R
 L D N L V U S I P M R N T N A A R Y E P
 E N S T E H E Q A G E A E Y T A I B M O S
 Y I D R Z I O N E N R O M S O A R I P R T
 E W N K E R E R U S D I C A T N L G I O O
 O S E K A L R E T A R C V S E V E P C L H

Acadia—Maine
 Big Bend—Texas
 Bryce Canyon—Utah
 Carlsbad Caverns—New Mexico
 Crater Lake—Oregon
 Everglades—Florida
 Glacier—Montana
 Grand Canyon—Arizona
 Grand Teton—Wyoming
 Hawaii—Island of Hawaii
 Hot Springs—Arkansas

Isle Royale—Michigan
 Kings Canyon—California
 Lassen Volcanic—California
 Mammoth Cave—Kentucky
 Mesa Verde—Colorado
 Mt. McKinley—Alaska
 Olympic—Washington
 Petrified Forest—Arizona,
 Idaho, Montana, Wyoming
 Platt—Oklahoma
 Mt. Rainier—Washington

Rocky Mt.—Colorado
 Sequoia—California
 Shenandoah—Virginia
 Virgin Islands—St. John Island
 Windcave—South Dakota
 Yellowstone—Arizona,
 Idaho, Montana, Wyoming
 Yosemite—California
 Zion—Utah

STUDENT ACTIVITY 4

Pesticides

- * ** *** 4-A Read the reprint entitled "Pesticides." You may listen to the accompanying tape also, if you wish.
- ** *** 4-B Choose #1 or #2 from the back of this reprint and write your survey responses on lined paper to include in your scrapbook. Don't forget to label your paper "Pesticides."
- * ** *** 4-C Do the Seek and Find puzzle entitled "Endangered Species." It is labeled 4-C.
- ** *** 4-D Interview about ten adults (teachers would be fine) to learn how many use pesticides. Record their answers on the enclosed bar graph labeled 4-D. On the same sheet list their reasons for using (or not using) pesticides.
- * ** *** 4-E Find the missing letters in the strip puzzle labeled 4-E for another environmental career.
- ** *** 4-F Do the "Hidden Wildlife" puzzle. It is labeled 4-F. Directions are on the page.
- ** *** 4-G Do the crossword puzzle, "The Animal Kingdom." It is labeled 4-G.
- * ** *** 4-H Optional: With others in a small group view and hear the filmstrip and record, "Ecology and You--Animals."

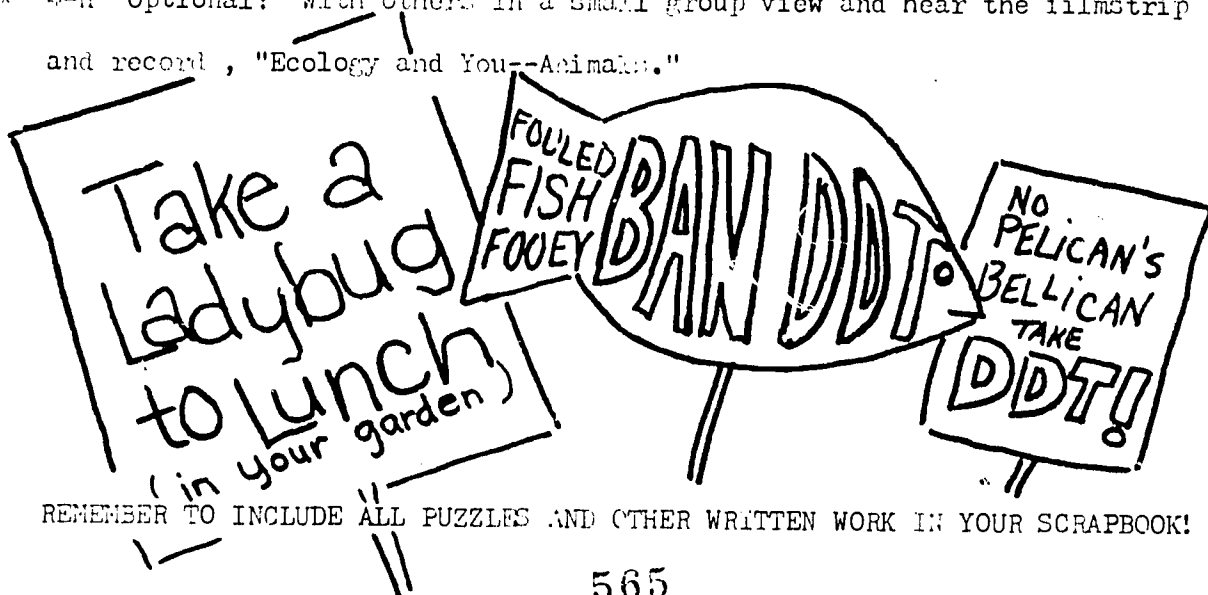

REMEMBER TO INCLUDE ALL PUZZLES AND OTHER WRITTEN WORK IN YOUR SCRAPBOOK!

ENDANGERED SPECIES

4-C

C	S	D	S	R	I	G	H	T	W	H	A	L	E	H	E	W	Z	
A	O	A	M	E	R	I	C	A	N	A	L	L	I	G	A	T	O	R
L	N	L	N	S	P	E	R	M	W	H	A	L	E	I	L	I	O	A
I	O	L	U	O	J	P	F	R	L	H	Q	B	S	F	E	H	D	E
F	R	D	I	M	C	M	A	I	W	P	F	M	E	G	L	W	P	B
O	A	A	K	W	B	G	E	K	N	B	O	L	D	R	A	B	E	R
R	N	G	P	H	U	I	C	J	H	B	A	V	C	T	H	O	C	A
N	P	C	L	O	V	A	A	S	I	H	A	O	A	G	W	B	K	L
I	R	S	C	O	B	Q	U	N	W	G	W	C	Y	U	D	D	E	O
A	O	A	E	P	H	B	R	Y	W	S	S	R	K	M	A	E	R	P
C	N	G	M	I	R	M	A	X	I	H	E	F	O	W	E	K	L	E
O	G	U	K	N	J	R	F	N	L	E	I	Z	U	J	H	S	P	L
N	H	G	X	G	Z	E	M	D	T	W	T	F	R	W	A	W	G	
D	O	A	H	C	I	A	B	Y	H	W	H	O	E	L	O	M	L	A
O	R	L	E	R	T	D	E	A	O	A	A	I	P	T	B	C	Y	E
R	N	R	Q	A	I	K	M	O	R	L	L	U	N	E	A	S	H	D
D	P	B	U	N	N	T	E	P	S	T	E	C	H	G	U	I	X	L
K	B	L	U	E	W	H	A	L	E	N	I	V	A	B	K	V	L	A
A	I	T	E	R	R	E	F	D	E	T	O	O	F	K	C	A	L	B

whooping crane

black-footed ferret

cougar

woodpecker

wild horse

masked bobwhite

Sonoran pronghorn

Key deer

Columbian whitetail

right whale

polar bear

bald eagle

American alligator

California condor

blue whale

sperm whale

bowhead whale

humpback whale

sei whale

finback whale

gray whale

Pesticide Questionnaire

4-D

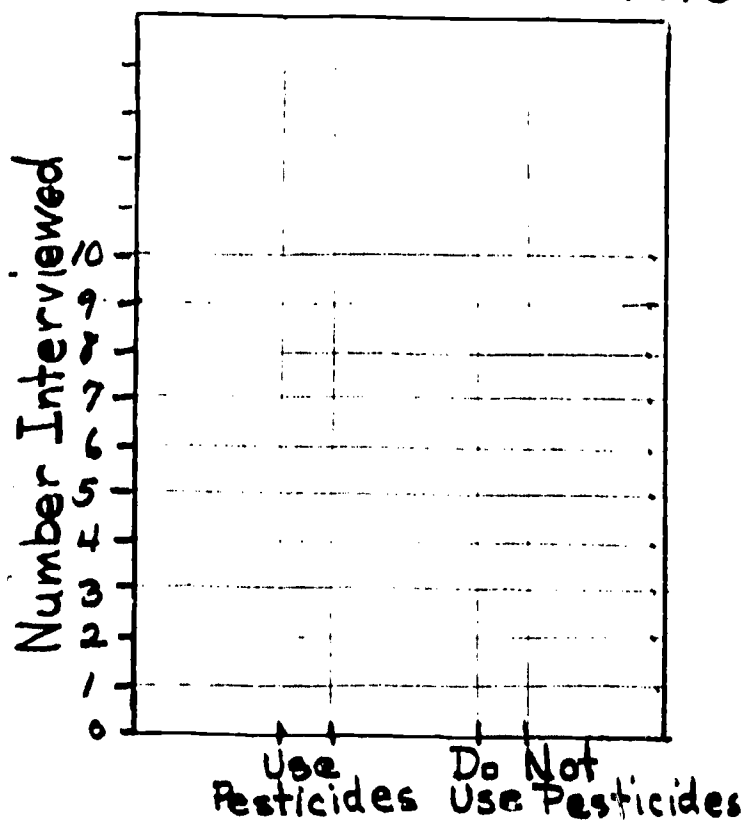

Reasons given for using pesticides:

Reasons given for not using pesticides.

□ o □ s □ y □ t □ n □ t □

cut off here.

PLUS WATER, SOIL

CROPS

AND PEOPLE

SUCH AS

TREES, GRASS AND WILDLIFE

COAL OR OIL

AND SUNSHINE

RENEWABLE RESOURCES SUCH AS

RESOURCES

AND NONRENEWABLE

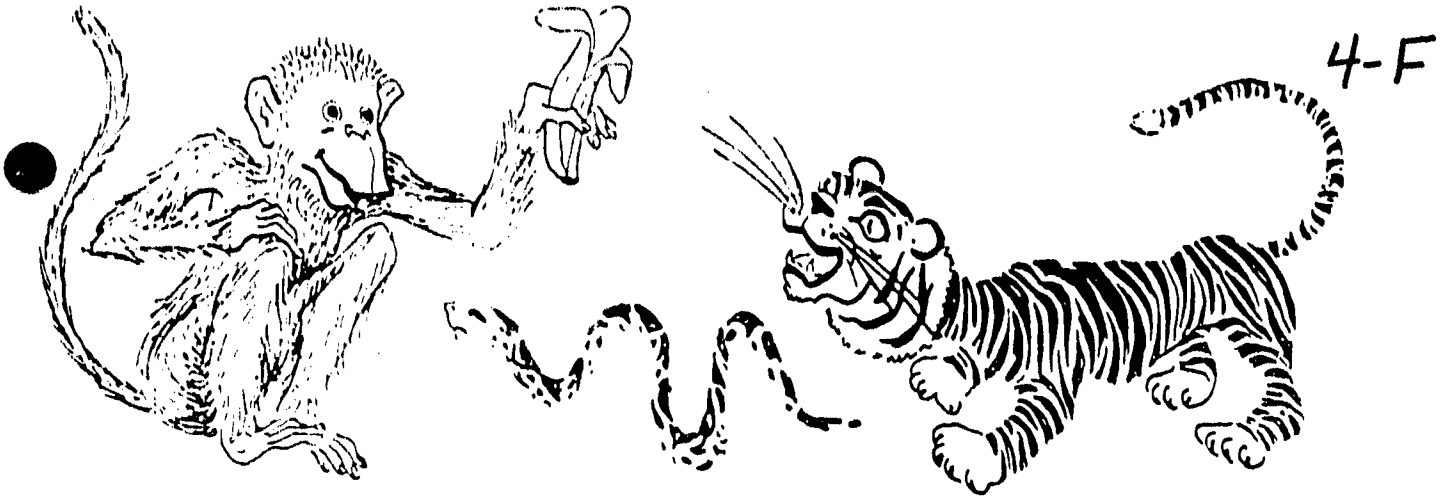

HIDDEN WILD LIFE

Various beasts, birds and reptiles in many distant lands may be found amid the sentences that follow. A hidden name appears with all its letters in their proper order. There are 22 in all, so see how many you can find!

We were counting numbers and marking them up when the king came late and I showed him palaces where I took a picture of the most richly furnished rooms. He was in a daze, but not camera shy, enabling me to meet the gaze Llewellyn gave me and to gaze bravely back until I only could say a king is just a person, after all. So I think I will tell a man to give them oars for their boats so they can go away happy tho not a vestige remains, as among our clientele phantoms are included. Don't worry if the baby is crying or ill, as he fits his crib exactly.

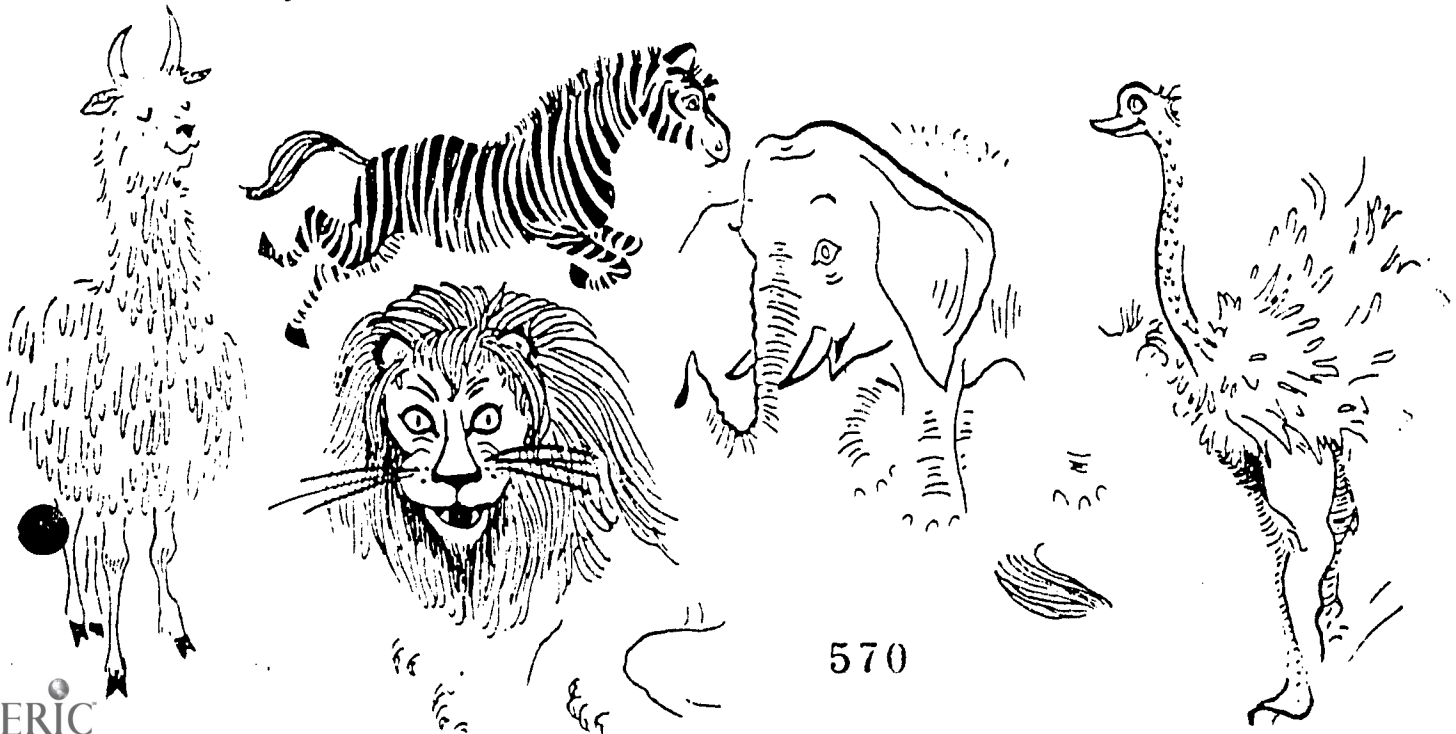

Cryptic Crosswords

Each of the following crossword puzzles is built around a familiar subject or theme. Words which refer to the subject or theme are starred (*).

The Animal Kingdom

Starred words refer to animals.

ACROSS

- *1. The young of 5 across.
- *5. They can be ridden or raced.
- 7. Lone Star state (*abbr.*)
- *8. Said to be best friend of 10 across.
- *10 *Homo sapiens*.
- 11. Fruit-filled pastry.
- 13. Apostle (*abbr.*)
- 14. Before noon (*abbr.*)
- *15. Don't ever buy one of these in a poke.
- *17. Large antelope.
- *18. First cousin to a mouse.
- *20. Flying mammal.
- *21. Burrowing rodent.
- *24. Hunters of large wild animals are after big _____

DOWN

- *1. The folklore character of Reynard is a _____
- *2. Conjunction meaning *either*.
- 3. Adverb meaning *equally*.
- 4. Took the lead.
- *5. Female of fowl.
- 6. To soak in liquid.
- *7. Large piglike animal of South or Central America.
- 9. Very large being.
- 10. Chart.
- *12. Large nonflying bird.
- 16. Choke.
- *17. Long fish.
- 19. Dress (*colloq.*)
- *20. Busy insect.
- 22. Short for *father*.
- 23. Abbreviation for *Her Majesty*.

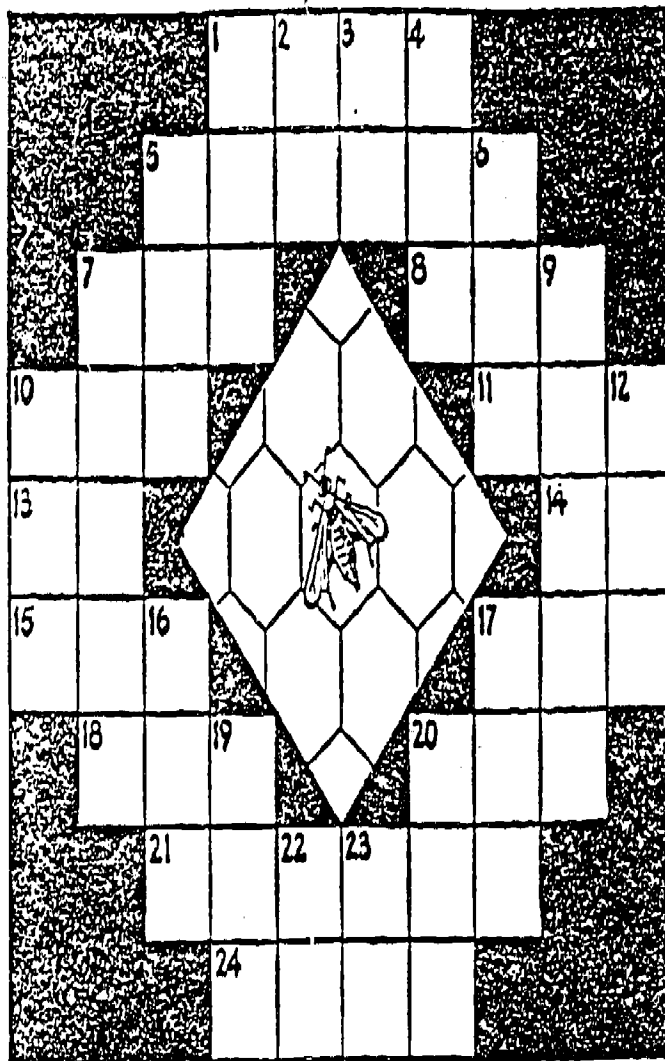

Puzzle Answers

4-C

ENDANGERED SPECIES

4-E

CONSERVATIONISTS

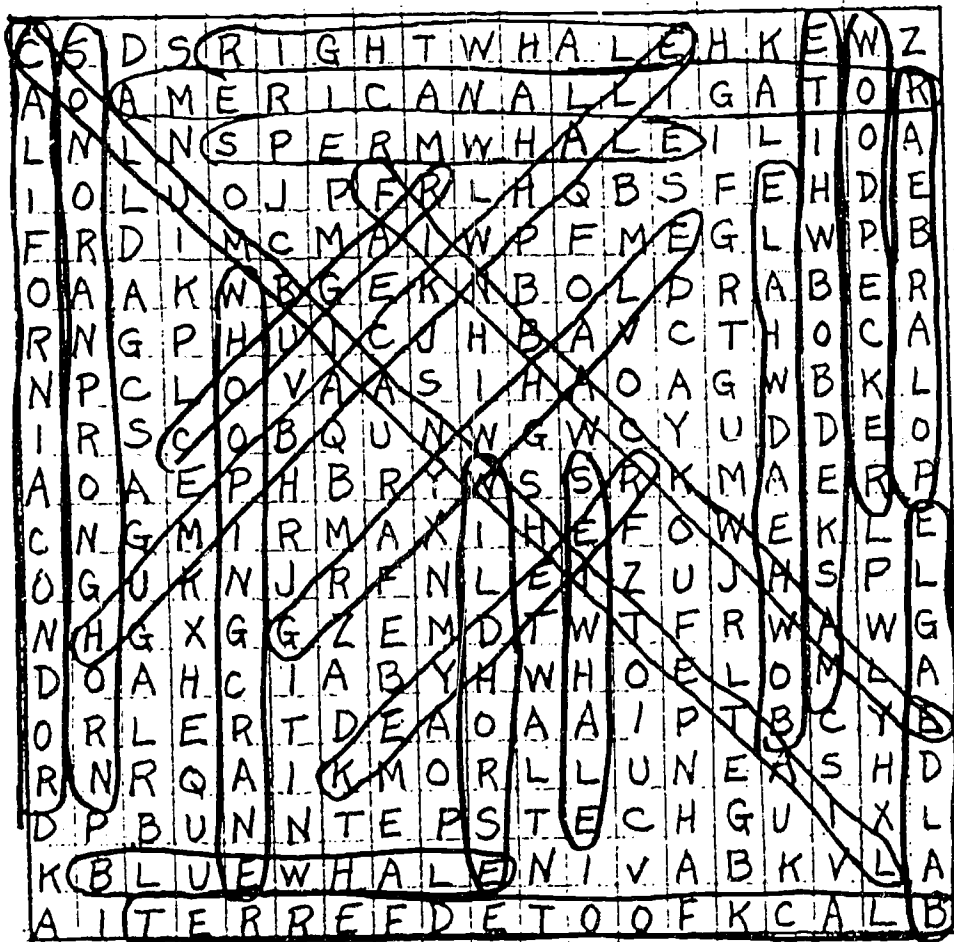

4-G The Animal Kingdom

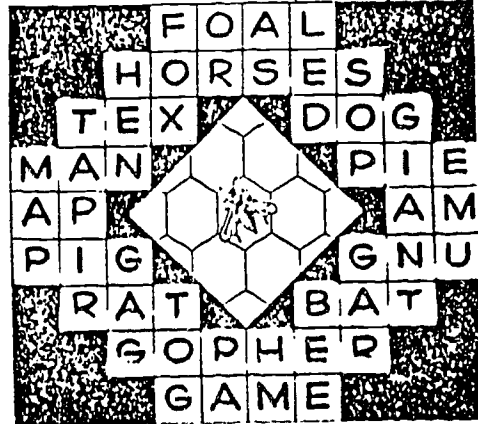

4-F HIDDEN WILD LIFE

Various beasts, birds and reptiles from many distant lands may be found amid the sentences that follow. Each hidden name appears with all its letters in their proper order. There are 22 in all, so see how many you can find!

We were counting numbers and marking them up when the king came late and I showed him palaces where I took a picture of the most richly furnished rooms. He was in a daze, but not camera shy, enabling me to meet the gaze Llewellyn gave me and to gaze bravely back until I only could say a king is just a person, after all. So I think I will tell a man to give them oars for their boats so they can go away happy tho not a vestige remains, as among our clientele phantoms are included. Don't worry if the baby is crying or ill, as he fits his crib exactly.

STUDENT ACTIVITY 5

Recycling

* ** *** 5-A Read the Ranger Rick reprint, "Recycling." You may listen to the accompanying tape if you wish as you read the article.

** *** 5-B On the back cover of this reprint there is a newspaper recycling survey. Lincoln recyclers do not presently pay for old papers, so we will set a reasonable figure of $40¢$ per 100 lb. for item # 2. This will permit you to complete the survey. Itemize each of the six survey statements with the correct mathematical calculation on lined paper and include your statistics in your scrapbook. Label the paper

Newspaper Recycling Survey

* ** *** 5-C Complete recycling ditto A.

*** 5-D Complete pollution ditto B.

** *** 5-E Complete pollution ditto C.

* ** *** 5-F Optional: With a small group view and hear the filmstrip and record of "Ecology and You--Earth."

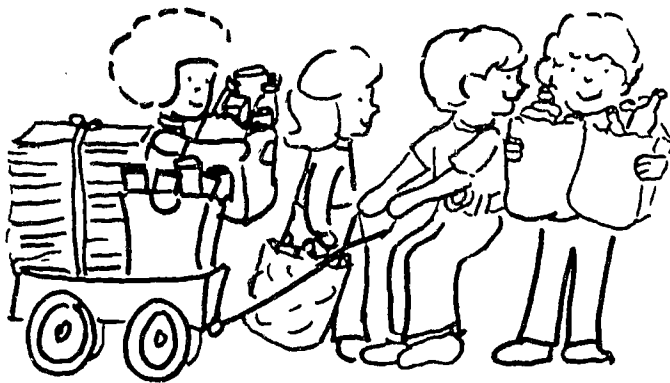

REMEMBER TO INCLUDE ALL WRITTEN WORK IN YOUR SCRAPBOOK!

Recycling

1. Recycling is _____

2. Three kinds of wastes that can be recycled are

and _____

3. Choose one kind of waste that can be recycled, and describe the process. You may use a resource book for reference.

4. Tell how the material can be used after the recycling process.

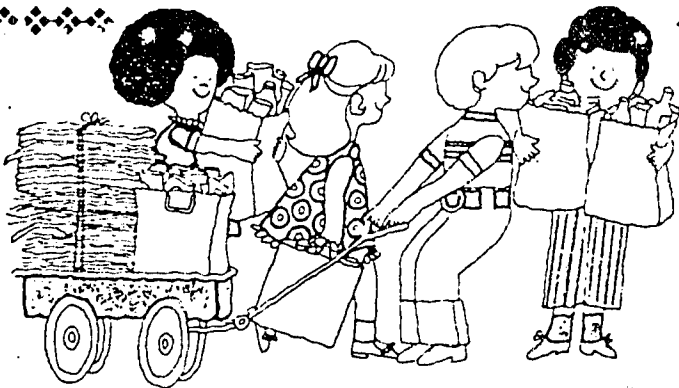

Take a Newspaper Recycling Survey

5-B

It might be interesting to see how much newsprint your family uses. Here's one way to find out: Collect the newspapers your family received in the last 7 days. Weigh them. Divide the weight by seven to get average weight of an issue. If you can't find all seven days, you might call the newspaper office and ask the approximate weight of an average week's newspapers.

About how much would one year's papers delivered to your house weigh?

Call the local used newspaper dealer and find out how much he is paying for old papers. ...\$ 40 per
100 lb.

If your family sold all its newspapers for a year, how much recycled return would you receive?\$

If all the students in your class received the same newspaper and saved them for a year, how much recycled return would you get? ..\$

If everyone in your school got the same paper — they probably don't — how much return could you get in a year?\$

Call up the newspaper and ask how many copies of the paper are printed in one year. (If you called them about average weight, you can ask this question at the same time.)
If all of these used papers were resold, how much recycled return would there be?\$

If your school saved newspapers for one year and sold them for recycling, what could you use the money for? A tree for the front of the school?

Keep in mind that not all the money you would get back from old newspapers would be profit. You would have to deduct travel expenses in collecting the papers and cost of getting them to the dealer.

Pollution

Pollution affects all of us, and unfortunately we do some polluting ourselves. Take a look at these facts and do some figuring for yourself.

1. Wisconsin banned DDT in 1970. It continues to circulate for fifteen years though. What year will Wisconsin be completely free of DDT? _____
2. Man dumps three hundred million gallons of waste into the Hudson River every day. How much is dumped in a week?
_____ In a month? _____
3. In our country we use forty-eight billion cans a year. Aluminum cans are worth one-half cent on the scrap market. If all these cans were aluminum, how much would they be worth?

4. Since we use forty-eight billion cans and there are two hundred seven million people - how many cans does each person use yearly? _____
5. In a lifetime you will pollute three million gallons of water. Your family will pollute _____ gallons of water.
6. During your lifetime you will eat ten thousand pounds of meat. Your family will eat _____ pounds of meat.
7. You will contribute nine thousand bottles to waste during your life. Your family will add _____ bottles.
8. You will use twenty-one thousand gallons of gas in a lifetime. Your family will use _____ gallons.
If there are ten thousand people in your town, how much gas will they use in a lifetime? _____

Pollution

Use an encyclopedia or one of the resource books in your center to help you complete the following sentences.

1. Environmental pollution is _____

2. Four kinds of pollution are _____,
_____, _____,
and _____.
3. Air pollution can cause _____.
4. Water pollution can cause _____.
5. The development of technology has caused pollution by

6. Our economy has caused pollution by _____

7. Convenience or social pollution is caused by _____

8. Four ways man is trying to control pollution are
_____, _____,
_____, and _____.

STUDENT ACTIVITY 6

Energy

* ** *** 6-A Read the Ranger Rick reprint, "The Best Present of All." You may listen to the accompanying tape if you wish.

* ** *** 6-B On unlined paper make a simple copy of the steam energy diagram on pages 6 and 7 of the reprint, or copy the solar heat model shown on page 22. Label either diagram correctly. Include it in your scrapbook.

*** 6-C In your media center find some information on solar heating, and write a short report on the subject. Include your report in your scrapbook.

* ** *** 6-D Optional: View and listen to the filmstrip and record, "Ecology and You--Our World Today."

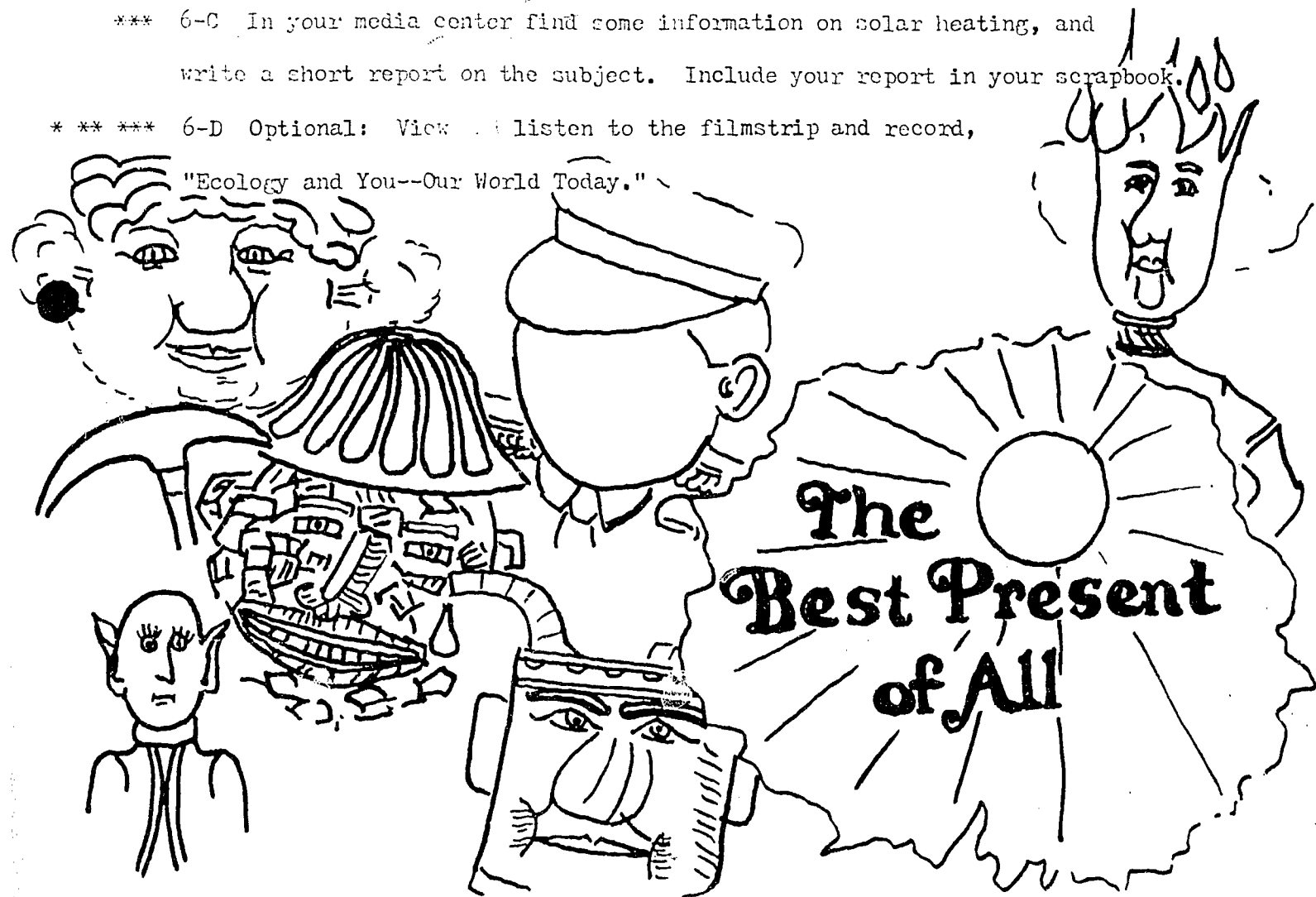

REMEMBER TO INCLUDE ALL WRITTEN MATERIALS IN YOUR SCRAPBOOK!

22001033

