

## DOCUMENT RESUME

ED 133 978

EC 092 988

AUTHOR Schiefelbusch, Richard L.; Lent, James R.  
 TITLE Programmatic Research to Design and Develop Improved Instructional Technology for Handicapped Children. Final Report.  
 INSTITUTION Kansas Univ., Lawrence. Bureau of Child Research.; Parsons State Hospital and Training Center, Kans.  
 SPONS AGENCY Bureau of Education for the Handicapped (DHEW/OE), Washington, D.C.  
 REPORT NO 26-2364  
 PUB DATE May 75  
 GRANT OEG-0-71-0449(607)  
 NOTE 247p.; Project MORE (Mediated Operational Research for Education); For related information, see ED 131 609-611; Charts in appendices may be marginally legible due to small size of type

EDRS PRICE MF-\$0.83 HC-\$12.71 Plus Postage.  
 DESCRIPTORS \*Daily Living Skills; Demonstration Projects; Exceptional Child Research; Females; \*Material Development; Mentally Handicapped; Normalization (Handicapped); \*Program Descriptions; \*Program Development; \*Self Care Skills; \*Trainable Mentally Handicapped

## ABSTRACT

Presented is the final report for Project MORE (Mediated Operational Research for Education), a program to create a full-scale operational system for developing product prototypes (methods and materials packages) for teaching personal appearance and hygiene skills to the trainable mentally retarded child. Reviewed in part I is the history of the Mimosa project, a demonstration program for intensive training of institutionalized mentally retarded girls (6-21 years old), which served as an underlying basis for Project MORE. The project's objectives are discussed in part II in terms of four interrelated functions: design of educational materials, development of programs to design and test materials, mediation through continuous professional service to research personnel, and dissemination of the products produced through research. Outlined in part III are the procedures used which led to the validation of 17 programs and five Project More products. Discussed individually in a final section are program results which include development of daily living skill programs which are available to the public; workshops designed to teach trainers how to use specific Project MORE materials and to acquaint them with behavior modification; and publication of articles, books, and book chapters on various subjects. Also provided are appendixes with a narrative description of the implementation lattice, field test data, and vita of persons mentioned. Figures appear throughout the document and include a teaching strategy diagram, daily cost accounting form, and a table on the percentage of research staff time spent on activities. (SBH)

Documents acquired by ERIC include many informal unpublished materials not available from other sources. ERIC makes every effort to obtain the best copy available. Nevertheless, items of marginal reproducibility are often encountered and this affects the quality of the microfiche and hardcopy reproductions ERIC makes available via the ERIC Document Reproduction Service (EDRS). ERIC is not responsible for the quality of the original document. Reproductions supplied by EDRS are the best that can be made from

ED133978

U.S. DEPARTMENT OF HEALTH,  
EDUCATION & WELFARE  
NATIONAL INSTITUTE OF  
EDUCATION

Final Report

Project No. 26-2364

Grant No. OEG-0-71-0449 (607)

Programmatic Research to Design and Develop Improved Instructional Technology  
for Handicapped Children

PROJECT MORE  
(Mediated Operational Research for Education)

Principal Investigators:

James R. Lent  
Richard L. Schiefelbusch

University of Kansas  
Bureau of Child Research  
Project MORE

Parsons State Hospital & Training Center  
Parsons, Kansas 67357

May 9, 1975

The research reported herein was performed pursuant to a grant with the Office of Education, U.S. Department of Health, Education, and Welfare. Contractors undertaking such projects under Government sponsorship are encouraged to express freely their professional judgment in the conduct of the project. Points of view or opinions stated do not, therefore, necessarily represent official Office of Education position or policy.

US DEPARTMENT OF  
HEALTH, EDUCATION, AND WELFARE

Bureau of Education for the Handicapped

2

i

EC092988

## TABLE OF CONTENTS

SECTION I.	HISTORY	1
SECTION II.	OBJECTIVES	10
	Design	12
	Development	13
	Mediation	17
	Dissemination	30
SECTION III.	PROCEDURES	41
	Design	41
	Development	49
	Systems	50
	Evaluation	59
	Mediation	63
	Dissemination	73
SECTION IV.	RESULTS	79
	Programs	80
	Workshops	88
	Publications	91
	MORE News	96
	Supplementary Materials	97
	Accountability Data	98
	Field Test Data	120
SECTION V.	CONCLUSION	121
LIST OF APPENDIXES		
Appendix A	Narrative Description of Implementation Lattice	125
Appendix B	Field test data on Project MORE programs in print as of January 31, 1975	139
Appendix C	Field test data on Project MORE programs in production by Edmark Associates as of January 31, 1975	150
Appendix D	Field test data on Project MORE programs on which data analysis is complete, but which had not been sent to Edmark Associates as of January 31, 1975	166
Appendix E	Vita of persons mentioned in the conclusion of this report	191

## LIST OF FIGURES

Figure A	Teaching Strategy Diagram	21
Figure B	Daily-Living Skills Lattice	23
Figure C	Personal Appearance Lattice	24
Figure D	Personal Hygiene Lattice	25
Figure E	Original Implementation Lattice	42
Figure F	Implementation Lattice	43
Figure G	Implementation Modules: Criteria for Completion	44
Figure H	Long Range Implementation Schedule, Care of Simple Injuries Program	51
Figure J	Implementation Schedule (Monthly)	52
Figure K	Daily Cost Accounting Form	54
Figure L	Pert Chart - Implementation Lattice for Program Development	55
Figure M	Trainer Reactor Scale	61
Figure N	Students' Attitudes: Evaluation Questionnaire	62
Figure O	Program Design and Development	81
Figure P	Number of Modules Completed per Month	99
Figure Q	Cumulative Number of Modules Completed per Month	101
Figure R	Amount of Money Spent on Program Development - Research - Direct Costs Only	102
Figure S	Cumulative Amount of Money Spent on Program Development - Research - Direct Costs Only	103
Figure T	Amount of Money Spent on Program Development - Media - Direct Costs Only	104
Figure U	Cumulative Amount of Money Spent on Program Development - Media - Direct Costs Only	105
Figure V	Amount of Money Spent on Program Development - Entire Project - Direct and Indirect Costs	106
Figure W	Cumulative Amount of Money Spent on Program Development - Entire Project - Direct and Indirect Costs	107
Figure X	Percentage of Research Staff Time Spent on Activities	108

Figure Y	Percentage of Media Staff Time Spent on Activities	109
Figure Z	Pert Chart - Length of Time in Months for Each Activity in Program Development	118
Figure AA	Pert Chart - Cumulative Amount of Time in Months Needed to Complete Each Module Shown on Program Development Implementation Lattice	119

LIST OF TABLES

Table 1	Chart of Project MORE Production	27
Table 2	List of Products	28
Table 3	Bibliographic Listing of Publications by Project MORE Staff Members	36
Table 4	Programs/Products Scheduled for Transmission to Publisher by 9-1-74	111
Table 5	Programs/Products Scheduled for Transmission to Publisher by 1-31-75	112
Table 6	Programs/Products Scheduled for Transmission to Publisher by 9-30-75	113
Table 7	Other Products Developed - to 9-30-75	115

## ABSTRACT

The Bureau of Education for the Handicapped allocated funds in 1971 for a three-year grant titled Programmatic Research to Develop and Disseminate Improved Instructional Technology for Handicapped Children. At Parsons State Hospital and Training Center, the project is part of The University of Kansas Bureau of Child Research. Principal Investigators are Dr. James R. Lent and Dr. Richard L. Schiefelbusch. Project MORE designs, validates, and replicates programs for trainable mentally retarded persons to teach personal appearance and hygiene skills, and has developed a program in stimulus shift articulation for speech handicapped children. Since programs are of maximum effectiveness only if they are readily understandable and available, products are developed, mediated and disseminated. Through systems techniques, the Project monitors its operation through a technology which implements objectives. After four years of funding (January 1975), 17 programs had been validated, and five products were available to the public. The Project received a funding extension to September 30, 1975, to complete mediation and dissemination of 42 major products which had been researched and developed during original funding.

FINAL REPORT FOR PROJECT MORE



## I. HISTORY

Underlying Project MORE (Mediated Operational Research for Education) was an earlier project called A Demonstration Program for Intensive Training of Institutionalized Mentally Retarded Girls. Also conducted at Parsons State Hospital and Training Center under the aegis of the Department of Health, Education, and Welfare, Program Director James R. Lent and Assistant Program Director Dorothy Childress implemented and demonstrated psychological procedures, using behavioral techniques, for training mentally retarded girls from six to 21 years of age in certain skills.

Because the cottage the girls lived in was called Mimosa, the project popularly became known as the "Mimosa project." On the basis of an earlier pilot study of positive reinforcement techniques, conducted by Dr. Frederick Girardeau and Dr. Joseph Spradlin, which showed that such reinforcement was effective in changing behavior patterns in residents on one floor of Mimosa cottage, Dr. Lent and Dr. Judith LeBlanc, who helped organize and implement the project's activities during its early days, espoused their concepts of behavior changing and proposed federal financial support for the program at Mimosa, which subsequently was funded and in existence from 1965 to 1970.

The necessary first steps were:

- 1) to decide what responses were required of the girls for their adjustment to the community, and
- 2) to decide upon methods of motivating them to acquire new skills.

Specific objectives for the program included training the girls in personal skills (cleanliness, grooming), in social skills (speech, interpersonal relations), in occupational skills, and in educational skills (word recognition, writing, time-telling). Additionally, outreach efforts

were to include training personnel at the institution to apply the techniques demonstrated in the program in their own training programs, and demonstrating and encouraging other institutional personnel to use the techniques.

The girls in the program had I.Q.'s of approximately 25 to 55 which, while still in the "moderate" level of retardation, was lower than the intelligence level of persons for whom most extant materials and techniques had been proven successful.

The primary objective of the Mimosa program was to train the girls for life outside of an institution. Considering that the cost at that time to the State of Kansas to institutionalize one person for a lifetime was conservatively in excess of \$100,000, the funding of the program provided excellent cost benefit. That is, as a result of the Mimosa project more than half the girls who participated in the training left the institution, thereby lowering the cost to maintain the institution in terms of cash outlay. Further, since the techniques used were thought to be exportable, they could be used by other institutions in some cases. Moreover, the project upgraded the quality of patient or resident care and provided those who were trained with a measure of independence and self-pride.

The training setting, the cottage, was first evaluated. Certain physical modifications were made to engender a more home-like atmosphere and allow for training. Next a list of behaviors deemed critical to community acceptance was compiled. Baseline data were collected and analyzed. The basic reinforcement system and its contingencies were instituted. Seven categories of personal and social skills were developed from the list of crucial needs for community acceptance. The categories of the checklist served as a rough guide for developing training projects.

When target behaviors had been selected, it became relatively easy to determine what training programs were needed. The following programs were developed for use with the Mimosa children:

Hair care: The aim of this program was to teach girls to set and style their own hair and to maintain it at all times in an acceptable manner. A local beautician instructed the girls in these skills.

Complexion care: Teenage complexion problems were managed in a once-a-week program. Proper diet, hygiene, and cosmetic care relieved some girls of acne. Some girls had to be made aware that a bad complexion can be a social handicap. As with many of the programs, liberal use of mirrors and Polaroid photography proved very beneficial.

Fingernail care: This area of personal appearance is frequently ignored in institutions. Initially, all girls had dirty, poorly cut, and/or bitten nails. Polaroid pictures of weekly progress aided in developing and maintaining this skill.

Walking: One of the earliest discoveries was that many institutionalized children can be identified as retarded by the way they walk. Analysis of the girls' walking behavior and subsequent programming to correct the behavior resulted in the staff being able to modify the behavior during training sessions. Generalization to other stimulus conditions, however, proved only moderately successful.

Sewing: Detailed instructions for teaching hand and machine sewing were written, as well as criteria for judging responses in all areas. Pretest performance was established for each child, the training program was implemented, and then the checklist administered again as a posttest to assess progress. Several girls made such clothing items as skirts, blouses, and dresses, while others only mastered mending and stitching.

Ironing: As with all training programs for this group, the relatively casual techniques used to instruct the normal and even educable level retarded were not adequate. It was necessary to break the task into very small components, arrange them sequentially for teaching, and make provisions for data gathering.

Clothing selection: A color movie of models wearing outfits of various combinations was shown as a pretest. The girls were asked questions about the appropriateness of the models' dress to provide pretest data. They were then systematically taught, in a manner similar to programmed instruction, to select clothes that match in color, style, and pattern, and which were appropriate to the season and the occasion.

Dancing: Dancing and related social skills were taught to the girls and to boys from other cottages who were invited for the training sessions. The dance program was found to be somewhat lacking, in that the actions of "normal" teenage people were not properly modeled. It did provide, however, some social interaction between the girls of Mimosa and the boys.

Sex education: Frank explanations were given concerning basic sex-hygiene facts. Equally frank discussions of the implications of promiscuity were held in small groups for all girls.

Leisure time activities: Games and activities were made available to the girls at the demonstration cottage and they were instructed in their use. Initially, points were given for merely participating. Later, the reinforcement value of playing the games and the subsequent interaction with peers and adults was sufficient to maintain their participation. Games were chosen which had absolute carry-over value to the community. After

introduction of games, the girls watched television only occasionally, instead of continuously as they had done previously.

Social behavior: Cooperation and politeness were typically taught in the context of evening games and activities. Preliminary observations indicated that this approach was not totally adequate.

Town orientation: Going from place to place in the community in a purposeful manner is a critical skill. Children must be able to select the appropriate type of store for a given purchase, find the store, negotiate the purchase, and return to the cottage. Tight control typified the initial instruction, and gradually children were trained to go about the community independently.

Cooking: Classes were held for four girls each at breakfast and supper times. The children learned to plan menus, shop for food, and prepare meals, skills which should be occupationally useful, as well as socially critical. The meals were prepared in the model living area of the cottage. They ate the meals in the model dining room next to the kitchen.

Housecleaning: The ability to clean a house thoroughly and independently was regarded as a most valuable skill for these girls. A written program had to be developed, however, before success was achieved. The first training sessions were held in the model living area at the cottage. Succeeding sessions were held in a variety of local homes to insure generalization of the cleaning skills from one environment to another.

In relation to personal appearance, many of the bizarre and noticeable deviations among residents were seen to be related to life in the institution itself and were, therefore, correctable. Hospital staff consciousness had to be raised to understand and discriminate the different personal appearance demands of different social settings before the girls them-

selves could be trained. A checklist of good grooming was developed. First the staff checked the girls; then the girls checked themselves. Although this was somewhat useful, even better results were obtained when a systematic grooming program was introduced in the cottage. Along with systematic training in grooming, reinforcement procedures were maintained, and data collection begun. The final goal of the personal grooming program was to develop self-initiated and self-maintained skills.

In the area of social skills, particularly those of communication, another tenet of what is now basic project philosophy jelled. This was that institutional personnel tend to set their expectations far too low for all retarded children and, in the case of lower-level retarded persons, there seemed to be almost no expectation of speech and language production. An articulation program, undertaken jointly by the speech and hearing department of the hospital and the Mimosa project staff, sought to: 1) provide a speech therapist in the living environment of the girls, 2) develop a program using words and phrases actually used by the children, and 3) design follow-up materials for use by research assistants. Data from the program indicated a general trend toward greater improvement of nonverbal communication than verbal communication. The program was revised to use nonverbal techniques to teach item recognition and some parts of speech.

In the area of educational skills, programs took two general directions, one for older girls who were good prospects for work placement in the community, and the other for those of intermediate age (10-15 years).

The first program was designed to provide skills needed to function adequately in the community at some foreseeable date in the future. The skills included reading (directions, menus, food labels, etc.), time-telling, and change making. For the girls of intermediate age, a readiness program was designed to provide concepts, experiences, and preacademic skills necessary for better academic achievement. Satisfactory results were obtained in all these programs.

In addition to the programs discussed earlier herein, the project conducted intensive inservice training with cottage aides, research assistants, and aides, produced a film on behavior modification, published two articles, and conducted site visits for those interested in the happenings at Mimosa.

At the end of the fifth year of funding, these were the results: a total of 40 girls from the original group of 71 had been returned to the community in a sheltered community adjustment which gave them some supervision and care during nonworking hours. Several girls returned to their natural homes, and others began to live in hotels or halfway houses for the retarded.

While this record is commendable, and the results encouraged future work in this field by Dr. Lent, the record could have been perhaps even better if there had been at that time the current emphasis on deinstitutionalization and return to the community, with complementary supportive auxiliary services.

## DRAWBACKS TO MIMOSA'S SUCCESS

Beginning in the first year of operation, Mimosa Cottage had become a model for others to emulate. Visitors came from all over the United States and several foreign countries to observe and learn. The staff was continually consulting and lecturing. By the third year, enough places had attempted to establish similar projects that the "ripple effect" of Mimosa could be evaluated. In one major way, however, the project had not succeeded--others could not easily and effectively emulate, with their own subject populations in their own settings, the successes of Mimosa.

There were two main reasons for the lack of replicability:

- 1) many procedures were not documented, and
- 2) prototypical programs were in such a rough form that they could only be used by personnel trained by the project.

It became obvious that in order to have a viable outreach program which explicated the tools of applied behavior analysis the project had successfully developed, an additional element was necessary. By adding a media support component to the systems already developed, professionally replicable instructional programs could be mediated, tested, and finally disseminated to others. The project would no longer be solely reliant upon demonstration-type efforts, which, though worthwhile, have limited effectiveness.



ORIGINAL PROPOSAL FOR PROJECT MORE

On January 1, 1971, a five year proposal to conduct extensive work in four areas was submitted to the Bureau of Education for the Handicapped. Dr. Lent and Richard L. Schiefelbusch, Director of the Bureau of Child Research at the University of Kansas, were to be principal investigators. Working in four operational areas, Project MORE proposed to correct:

- a) deficits in specific social behaviors,
- b) deficits in specific academic areas,
- c) deficits in prearithmetical quantitative skills, and
- d) deficits in the phonological system.

BEH granted funds over a three-year period to carry out work in social and academic behaviors, in speech articulation, and in mediation and dissemination of the ensuing instructional products.

## II. OBJECTIVES

As stated in the original proposal, the overall objective of the Project was implicit in its name: Programmatic Research to Develop and Disseminate Improved Instructional Technology for Handicapped Children.

### BACKGROUND

". . . instructional technology is more than a sum of its parts. It is a systematic way of designing, carrying out, and evaluating the total process of learning and teaching in terms of specific objectives, based on research in human learning and communication, and employing a combination of human and nonhuman resources to bring about more effective instruction. The widespread acceptance of this broad definition belongs to the future. Though only a limited number of institutions have attempted to design instruction using such a systematic, comprehensive approach, there is reason to believe that this approach holds the key to the contribution technology can make to the advancement of education. It became clear, in fact, as we pursued our study, that a major obstacle to instructional technology's fulfillment has been its application by bits and pieces." (From A Report to the President and the Congress of the United States by the Commission on Instructional Technology. Committee on Education and Labor, House of Representatives, Washington, 1970, pp. 19-20.)

The major objective of the Project was described as development and dissemination of improved educational technology for handicapped children.

The major objective would be achieved through the following subobjectives:

1. The development and empirical validation of specific, behavioral instructional objectives,
2. The development of systems-directed procedures,
3. The development and dissemination of instructional packages and related techniques of service delivery.

The research program would be combined with a media support system designed to develop the materials to a point of demonstration and dissemination.

The intent would be to create a full-scale operational system for developing

product prototypes (methods and materials packages) for use by those who teach the trainable child.

The Project would come to refer to its various interrelated functions as Design, Development, Mediation, and Dissemination.

Through the use of systems techniques, these four forces would be combined into a technology for research and program development.

## DESIGN

The Project would establish a model program to design, test, and produce educational materials for mentally retarded children. Some of the training program packages involving recognition and discrimination would be designed for direct presentation to the subject population. On the other hand, most of the programs would take the form of materials to be presented to adults who would, in turn, teach the children. The materials would be appropriate for use not only by teachers but also by psychiatric aides, teacher aides, nurses, and parents.

Described in the proposal were several types of programs, among them those teaching personal skills, such as grooming and dressing; social skills, such as nonverbal communication skills; and vocational skills, such as sewing, ironing, cooking, and housekeeping. In addition, the Project proposed to produce a speech articulation package, and stimulus shift supplementary materials.

It was noted in the application for funding that many of the training programs described had proved to be successful with trainable-level retarded girls who were residents at Mimosa Cottage. "However," the application said, "as yet we have no evidence that they would be as useful when applied to a different subject population or when they are administered by adults who are not trained by Mimosa Cottage staff. In order to make the programs generally useful, extensive testing and revising would be necessary."

The proposal reiterated the need for the Project to focus on the form of presentation as well as the content of the program materials, and stated that Media staff members would participate in the design and testing of materials at each step of program development.

## DEVELOPMENT

The proposed method to approach development of these programs was to pinpoint specific problems and reduce them to small components that could be further analyzed. The components would be analyzed in terms of the subject population characteristics and then arranged in a logical sequence. Thus, complexity would be reduced by identifying component parts of a problem and analyzing and arranging these parts in sequence.

The systems approach was applicable for identifying and representing the needed educational techniques to solve the problems of the handicapped. It was developed to deal with behavioral problems rather than those of a mechanical nature. Basically it is a management technique that helps to 1) pinpoint a problem, 2) design a solution for the problem, 3) develop software and hardware needed to solve the problem, 4) implement the software and hardware, and 5) continuously evaluate and modify the software and hardware so that it does indeed solve the original problem. This systems approach differs in one respect from other systems approaches in that it uses a behavioral graphic, or lattice, to illustrate components and relationships of components within problems or solutions. Stated another way, the lattice can be conceived as a model, to be used in the same manner as an engineer uses a blueprint.

The lattice system, as well as other forms of systems technology, would be used by researchers to design, develop, implement, and operate the various research projects. The particular systems approach to be used would depend upon the unique needs of the individual research project.

In the individual research project proposals, both program and implementation lattices would be used. The program lattice is viewed as a blueprint to illustrate a program; the implementation lattice is a blueprint to illustrate a system for developing and implementing the program.

#### Rationale for Systems Technology

Systems technology would be used to help organize research projects. Specific problems of the handicapped would be identified and the ambiguity of the major problem areas further reduced through identification of increasingly finite behaviors. The simpler alternative behaviors would be determined through both conceptual and task analysis; and the final target behaviors would be selected on the basis of cost benefits, the evaluation process, and research variables. The behaviors, and relationships of the behaviors, would be illustrated on the program lattice as research models.

After a program model was designed, an implementation system would be developed. Specific tasks, in the form of staff behaviors, or activities, needed to initiate the research project and take it through to its completion, would be identified. These behaviors would then be set in sequence and illustrated on the Implementation Lattice. At this point time and costs could be estimated and responsibility assigned. Software or hardware components would be developed, integrated, tested, modified, and disseminated. The process would be controlled so that all activities begin or are completed on specific dates. Should discrepancies occur, the principal investigator and staff members can make decisions in order to bring the activities back on schedule. Thus, the major objective of completing the research project could be reached efficiently and effectively.

Identified as the basic steps in the complete cycle of the Project were the following items related to design and development of instructional programs:

- hiring staff and delineating job descriptions,
- establishing a data collection system, including isolating critical developmental behavior,
- developing training procedures, including remediation, phase-back, and teacher training,
- evaluating the reliability of the procedures and of complete programs or packages and issuance of a program prototype,
- establishing a field test population and feedback and evaluation of prototypical programs in terms of relevant data,
- establishing network dissemination of finalized products,
- demonstrating Project techniques to groups and individuals,
- disseminating programs, packages, and ultimately, the technology of program development itself, and
- possibly modifying programs or packages according to feedback, and recycling and retesting.

#### Relation of Mediation, Dissemination, and Evaluation of Instructional Materials

Evaluation of packages is essentially evaluation of the training that occurs as a result of exposure to and interaction with the content of each Project MORE package. The attainment of specific skills or behaviors would be monitored and measured by the use of pre- and posttests, for both intermediate and terminal-level skills. Self-evaluation by the target populations would be accomplished by programming appropriate feedback systematically throughout the course of the package. The basic measure of the *effectiveness* of a package lies in its ability to guide the learning behaviors from a state of little or no skill to a state of learned and

demonstrated skill within a specific area designated by the objectives of the package.

The *efficiency* of the training potential of a package may be determined by comparing it with other methods of training. The variables which could be compared would include the levels of skill learning accomplished by each method and the amount of time involved.



## MEDIATION

The Media system's role in Project MORE was to provide continuous professional service to research efforts by assuming a major role in the preparation of instructional packages. Media staff were to advise and support research personnel, design alternative approaches to packaging, and interact with research personnel at every stage of prototype and final product production.

"Research findings must be brought to the schools under conditions and in forms that make them useful. There is no point in disseminating ideas which are not packaged for practical use." So said the Commission on Instructional Technology in its report (p. 36) in March of 1971 to the House Committee on Education and Labor.

The primary function of the mediation component of the programmatic project was to transmit such research findings to consumers in the educational arena in just such useful packages. The media team would provide the technology so that research in human learning and instructional methodology would actually be enabled in terms of its effectiveness and efficiency in educational settings. The original research would be empirically validated and instructional-program replicability thus insured.

The basic goal of Project MORE's mediation efforts has always been to produce a useable product, one which enables anyone, regardless of training or artfulness, to produce the desired results in the persons being taught a skill.

The Media system was to have two components: print and audiovisual. The print media component would carry the heaviest concentration of work

on programs per se, with the audiovisual component providing back-up support and production of workshop materials and certain supplementary materials.

Print media would be equipped with basic duplicating and finishing equipment, enabling low-cost in-house production of *prototypical* materials needed for testing. A graphics staff would provide expertise in layout and design, which would enhance the form and content of programs. An MT/ST would be installed to store a variety of typed copy.

The editorial staff would be professionally equipped to edit programs, reports, working papers, assist in production of supplementary materials, and, importantly, work cooperatively with research personnel on a continuing basis. Media's obligation to research was to assist research in forming solid prototypes, making revisions as indicated by testing, but *not* to change substantially the work tested and validated by research persons.

Selection of print media as the most viable form to use was based on several factors: the ability to produce, and control, in-house production, rather than be dependent upon "outside" facilities; the lower-cost factor of printing, as opposed to films, slides, etc; the ultimate usability of the product by the consumer, and the ultimately more reasonable cost to potential consumers of printed material.

During its first six months, Media was to work on programs in personal appearance (Hair Rolling and Ironing), personal hygiene (Showering), and on the Stimulus Shift Articulation package. The remainder of the first year was to be used to work on a Hair Rolling program for blacks, two Shaving programs, and a Direction-Following program. Audiovisual personnel were to produce materials for workshop presentations.

The second year's proposed Media activities included work on the following programs: Oral Hygiene (now Toothbrushing), Change Making, Complexion Care, Appropriate Dress, Eating Etiquette, Use of Telephone, Feminine Shaving, Face Shaving, Ironing, and Showering. A filmstrip on the articulation therapy program was planned by audiovisual staff, as well as still photos for various programs.

An article was planned for submission to a professional journal on the theoretical overview of the Stimulus Shift and Response Development programs. Further work was planned on a 16 mm color film presenting the basic components of articulation therapy, as well as two films to describe the basic training steps of the procedures. The films were to be videotaped, subjected to field test evaluation, and then reshot on 16 mm film.

Projections were made for Media for the third grant year to continue development on the following programs:

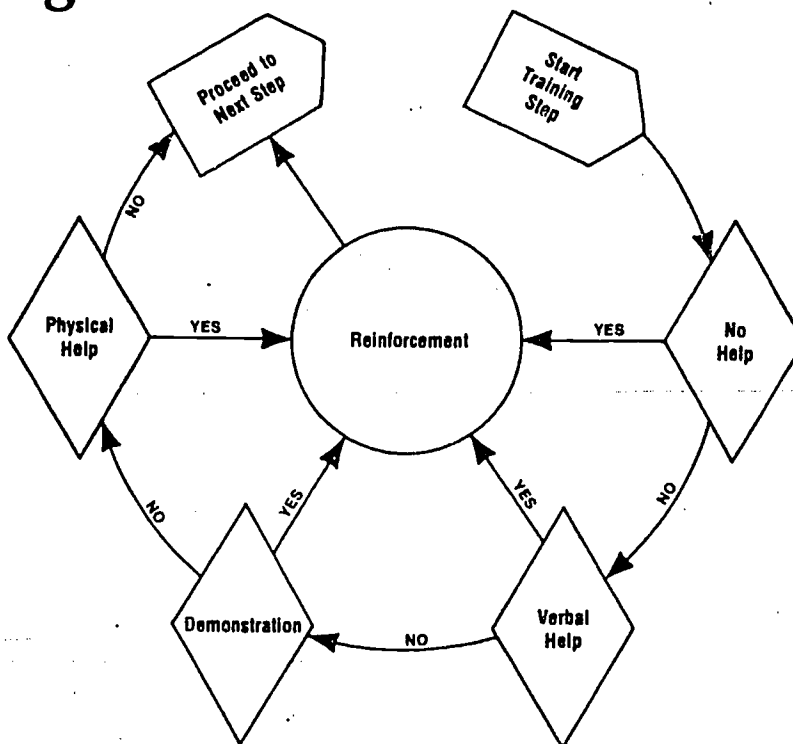
- Showering
- Ironing
- Face Shaving
- Appropriate Mode of Clothing
- Use of Telephone
- Complexion Care
- Eating Skills for Daily Living
- Toothbrushing
- Leg and Underarm Shaving
- Hair Rolling

In addition, new work was to begin on the Use of Deodorant, Use of Sanitary Napkins, Care of Fingernails, Hand Washing, Nose Wiping, and Hair Washing programs.

Development of a text, designed as a prepackage to accompany all Project MORE programs requiring the four-level teaching strategy (see Figure A), was another goal set during the third year. The text would be readable, interesting, and informative and would detail teaching strategies. Such a text would also enable production of less-bulky programs, in that lengthy explanation of those procedures in each individual program would be eliminated. Having such a book would, however, necessitate changes in programs as they were written.

Toward the end of the third year grant, Media was to begin work on the Care of Eyeglasses program, six units of the Care of Simple Injuries program, the Use of Public Restrooms program, and the Direction-Following program. (For details of program and product production, see the Results section of this report.)

# Teaching Strategy Diagram



◇ KEY

Can the student perform the training step correctly at the cue level specified in the diamond? If yes — follow the arrow to "Reinforcement" and "Next Step." If no — follow the arrow to the next cue level.

### Proposal Submitted to Continue Project Activities

On November 15, 1973, a comprehensive proposal was submitted to BEH to request continued funding for the Project after the initial three-year proposal had terminated. The proposal outlined activities planned from February 1, 1974, to January 31, 1975.

### Mediation Activities

A lattice for proposed program development (see Figure B) indicated subject matter of past, then present, and future programs. The Project proposed to complete products in the areas of personal appearance and personal hygiene (see Figures C and D).

Proposed for completion during this fourth grant period were texts for the following:

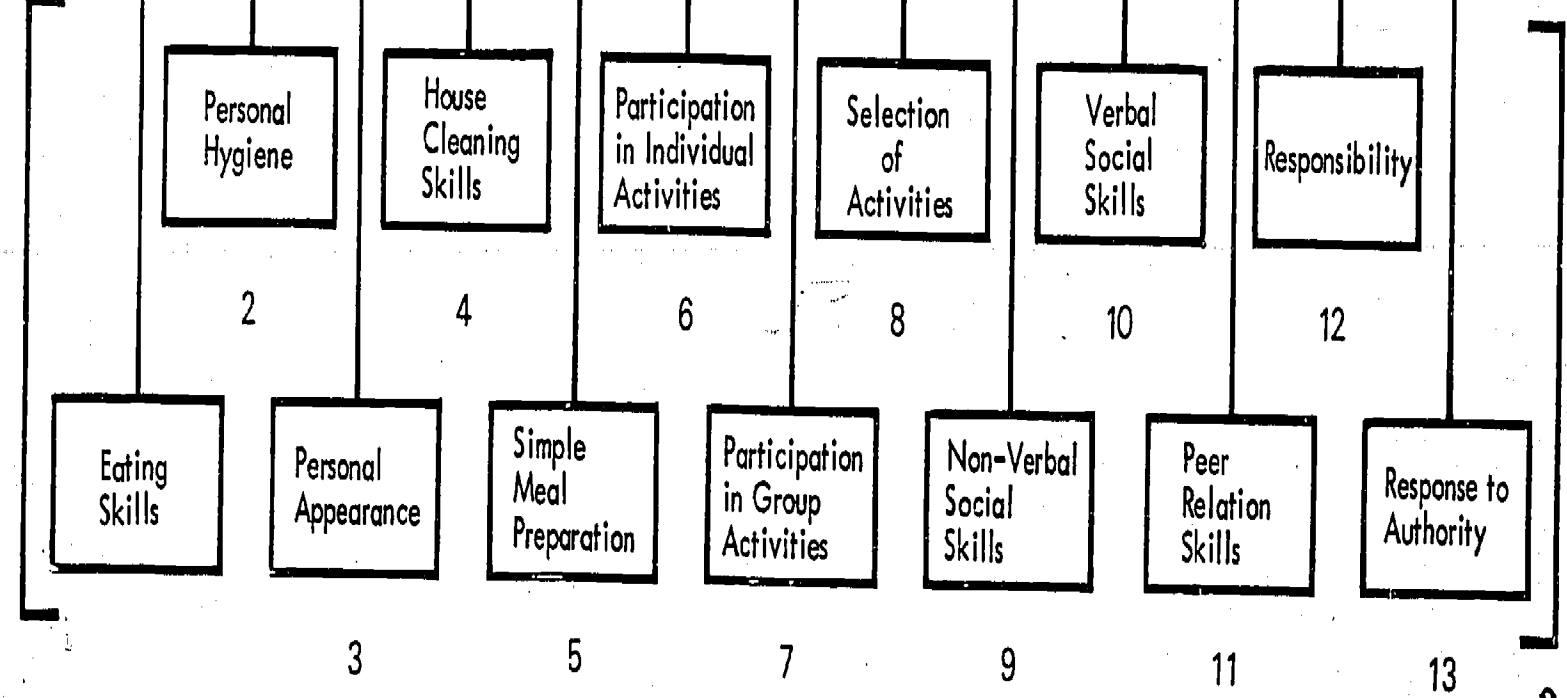
Hand Washing	Hair Washing
Nose Blowing	Ironing
Complexion Care	Showering
Face Shaving	Leg and Underarm Shaving
Eating Skills	Toothbrushing
Hair Rolling	Feminine Hygiene
Deoderant	Nail Care
Use of Restrooms	Care of Burns
Use of Telephone	Care of Cuts
Care of Eyeglasses	Speech (8)
Eye Contact	Animal/Insect Bites
Simple Directions	Direction: Alternates
Prepackage (to accompany programs)	Prepackage (to accompany speech manual)

Project MORE

DAILY-LIVING SKILLS LATTICE

October 1973

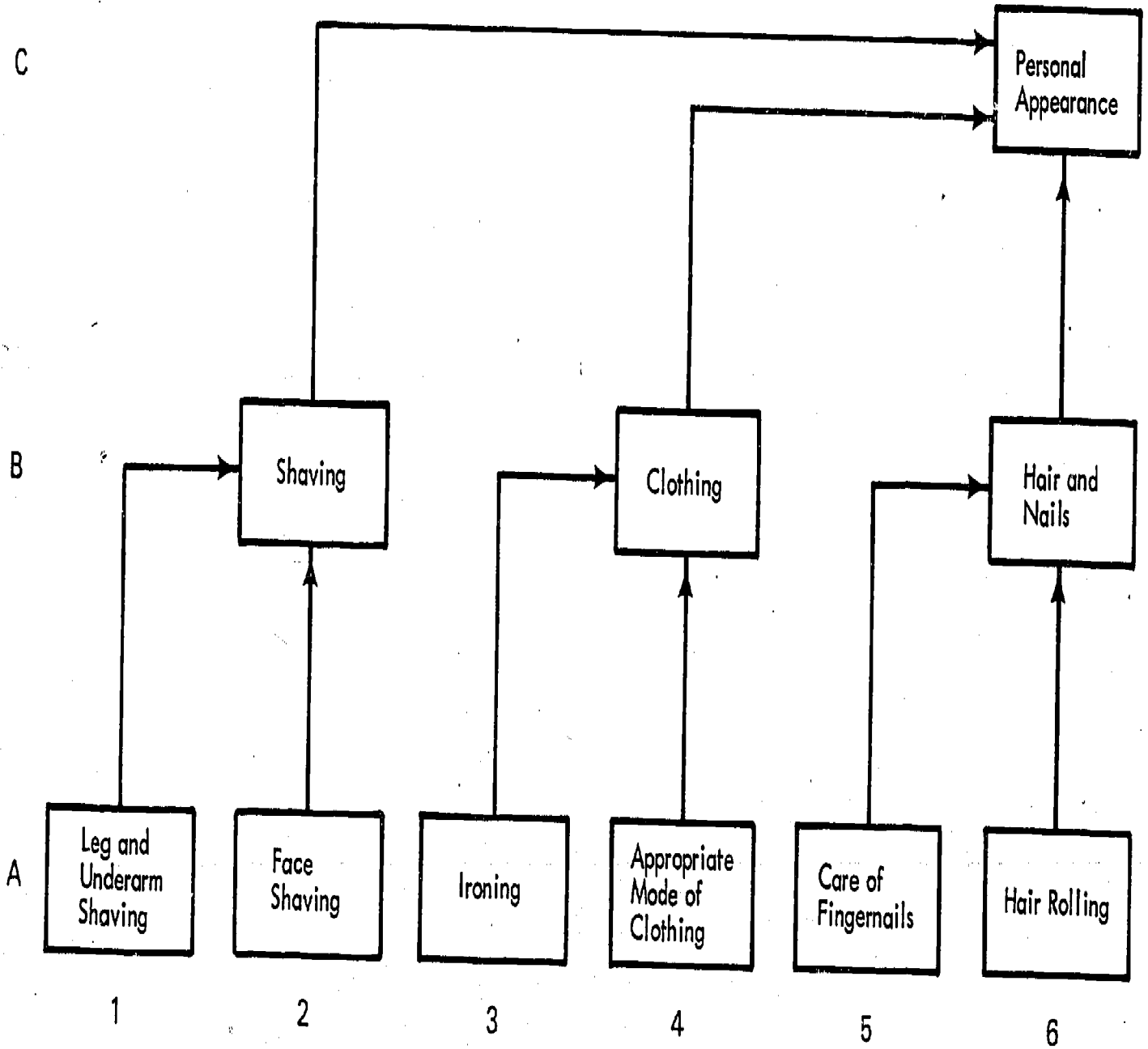
23



21

32

Project MORE  
PERSONAL APPEARANCE  
October 1973



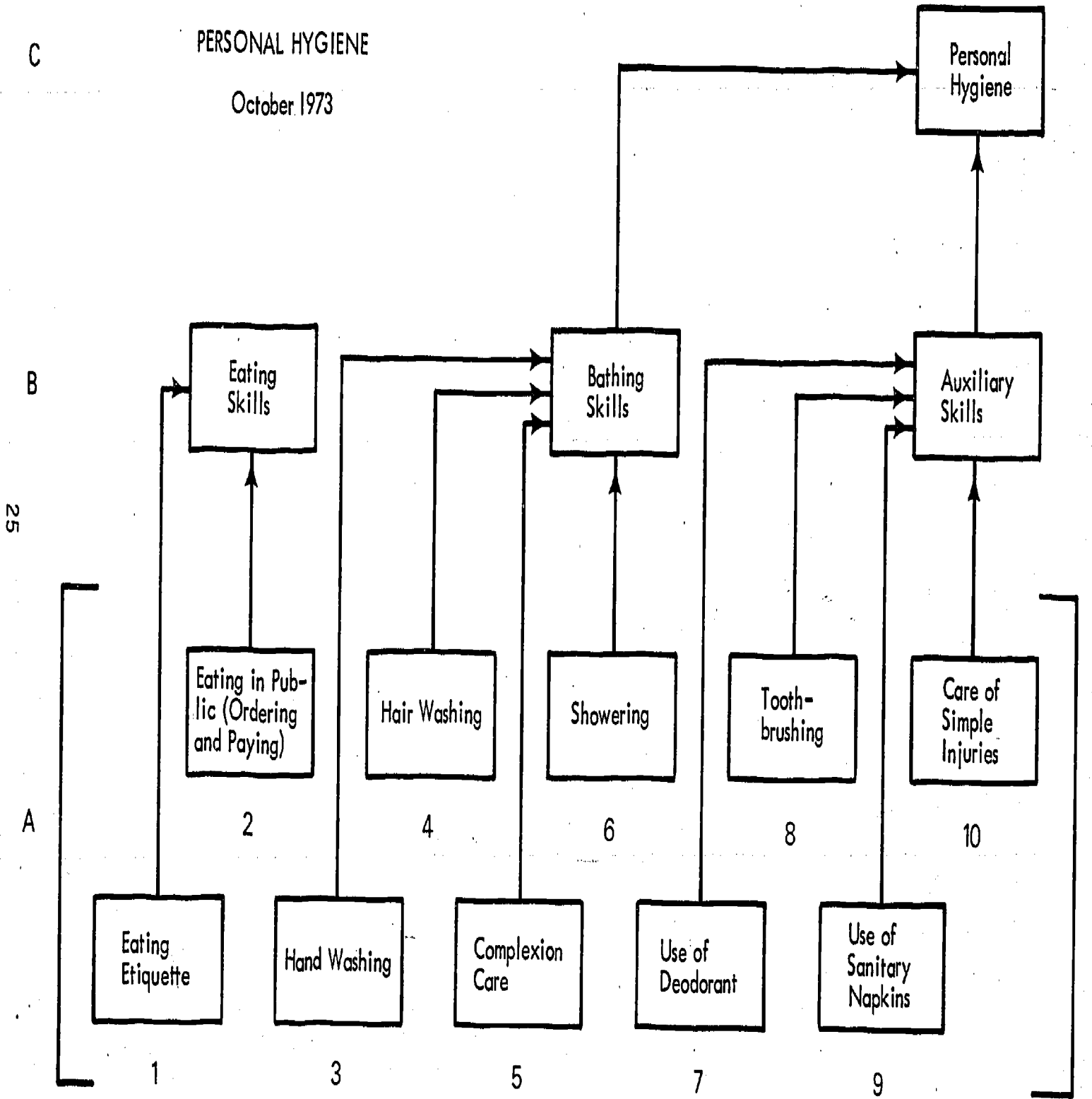
24



Project MORE

PERSONAL HYGIENE

October 1973



Additionally, Media was to continue work in various program-related areas: working papers, supplementary materials, filmstrips, and posters.

Continued Funding Requested to Complete Mediation of Products

In September of 1974, BEH was approached by the Project to request additional funding to complete work begun during 1973. While a significant number of programs (17) had been validated, these programs had not reached final mediation. A production schedule was developed which detailed products promised for submission to the publisher, Edmark Associates, and which included a total of 95 finished products by September 30, 1975.

(See Tables I and II.)

TABLE 1

## PROJECT MORE PRODUCTION

Project MORE production to date, to the end of the current funding period, and through the proposed 8-month funding period (February-September, 1975) is illustrated in Tables 1 and 2.

	A To Publisher by 9/1/74	B To Publisher by 1/31/75	C Completed Through Validation by 1/31/75	D To Publisher by 9/30/75	E Total Products to Publisher by 9/30/75
Program Manuals	8	15	17	17	40
Film Strips	3	0	1	1	4
16 mm Movies	0	1	0	0	1
Kinescopes	0	3	0	0	3
Workshop Packages	0	2	0	0	2
Posters	1	0	20	20	21
Still Photo Packages	0	1	1	1	2
Audiotapes	3	1	1	1	5
Slide Shows	0	1	0	0	1
Working Papers	2	0	7	7	9
Games and Puzzles	0	0	7	7	7
Total in Each Period	17	24	54	54	95

TABLE 2

A. To Publisher by 9/1/74

Toothbrushing (Revision)  
Eating Skills  
Complexion Care  
Nose Blowing  
Face Shaving  
Leg and Underarm Shaving  
Care of Simple Injuries  
    Unit One - Applying Cream Antiseptic  
How to Do MORE  
Filmstrips (3) - Care of Simple Injuries  
Reinforcement Poster  
Working Papers (2)  
Audiotapes (3) - Care of Simple Injuries

B. To Publisher by 1/31/75 (End of Period Covered in Final Report)

Care of Simple Injuries  
    Unit Two - Applying Adhesive Bandages (on the body)  
    Unit Three - Applying Adhesive Bandages (on arms or hands)  
    Unit Four - Using Gauze and Tape  
Hand Washing  
Hair Rolling (Revision)  
Showering  
Stimulus Shift Articulation Program (9)  
Kinescope - Workshop  
Kinescope - Speech and Sound Discrimination  
Workshop Packages (2)  
Slide Show - Workshop  
Showering Kinescope  
Showering Audiotape  
Showering Movie  
Still Photo Package - Use of Telephone

C. Completed Through Validation by 1/31/75 (End of Period Covered in Final Report)

Care of Simple Injuries  
    Unit Five - Telephoning for Help  
    Unit Six - Minor burns  
    Unit Seven - Serious Burns  
    Unit Eight - Bruises and Swellings  
    Unit Nine - Nosebleeds  
    Unit 10 - Animal Bites  
    Unit 11 - Insect Bites  
    Unit 12 - Setting up a Medicine Chest

Use of Telephone  
Unit One - Answering the Telephone  
Unit Two - Dialing a Seven-Digit Number  
Unit Three - Reporting an Emergency  
Care of Eyeglasses  
Hair Washing  
Using Deodorant  
Feminine Hygiene  
Nail Care  
Unit One - Care of Fingernails  
Unit Two - Care of Toenails  
Filmstrip - Care of Burns  
Audiotape - Care of Burns  
Still Photo Package (1) - Care of Burns

D. To Publisher by 9/30/75 (End of Funding Period February-September, 1975)

Care of Simple Injuries  
Unit Five - Telephoning for Help  
Unit Six - Minor Burns  
Unit Seven - Serious Burns  
Unit Eight - Bruises and Swellings  
Unit Nine - Nosebleeds  
Unit 10 - Animal Bites  
Unit 11 - Insect Bites  
Unit 12 - Setting up a Medicine Chest  
Use of Telephone  
Unit One - Answering the Telephone  
Unit Two - Dialing a Seven-Digit Number  
Unit Three - Reporting an Emergency  
Care of Eyeglasses  
Hair Washing  
Using Deodorant  
Feminine Hygiene  
Nail Care  
Unit One - Care of Fingernails  
Unit Two - Care of Toenails  
Filmstrip - Care of Burns  
Audiotape - Care of Burns  
Still Photo Package (1) - Care of Burns  
Working Papers (7)  
Games and Puzzles (7)  
Posters (approx. 20)

## DISSEMINATION

As implied in the name of the grant Project MORE's basic intent has always been to "disseminate" the products produced through research. Dissemination activities, however, did not actively begin until the second grant year (1972).

During April of that year the Project contacted John Dostal, a consultant in the marketing of educational materials. Dostal visited the site and recommended that the Project should begin activities to enhance the consumer market for its products.

As a first priority, Dostal recommended selecting an appropriate label for the Project, one which could be used universally to identify all of the products developed. The acronym Project MORE, standing for Mediated Operational Research for Education, was thus formulated as the Project identifier. This acronym has been registered as a service mark with the U.S. Patent Office.

Several other steps were taken during 1972 to assure that Project MORE products would reach the intended consumer. A distribution/dissemination plan was devised to allow Project MORE personnel to continue to control the quality and validity of programs and, at the same time, to provide an avenue for these products to reach the consumer for whom they were designed and produced.

In May an exhibit displaying selected Project products was shown at the National AAMD Convention in Minneapolis. As an outgrowth of this exhibit and other presentations by Project staff members, a distribution agreement was negotiated between the University of Kansas, as grantee, and Psychologists and Educators, Inc., of Jacksonville, Illinois, a commercial distributing company. This agreement was approved by USOE, and a two-year experimental copyright was negotiated.

The agreement authorized the Extramural Independent Study Center of the University of Kansas to act as agent for the grantee, and experimental versions of the Hair Rolling program were placed on the market. Five Project MORE programs were then listed as available for consumers in the 1973 Education-Psychology Catalog of Psychologists and Educators, Inc. The agreement between the grantee and the distributing company provided that the company would sell the programs on consignment. Market data would be retrieved.

In addition, professional book exhibitors were contacted during 1972 and arrangements were made to have Project MORE products exhibited at conferences that Project staff members would be unable to attend. The Combined Book Exhibit of Briarcliff Manor, New York, and Academia Book Exhibits of Fairfax, Virginia, agreed to add Project MORE to their list of exhibitors. These two book exhibit firms displayed Project MORE products at conventions in Pittsburgh, Baltimore, Oklahoma City, and Frankfurt, Germany, during August and October of 1972.

These efforts to provide public exposure of Project MORE programs resulted in the creation of demands for Project programs, enhancing their marketability. This exposure included a Project brochure and a display exhibited at several conferences, including the National AAMD Convention and the 5th International Congress on Mental Retardation in Montreal.

To aid the marketing of its products, Project MORE compiled mailing lists for the University of Kansas Extramural Independent Study Center and Psychologists and Educators, Inc. The lists included the addresses of those interested in Project MORE products. The names and addresses

were gathered from three major sources:

- 1) from replies to a brochure about Project MORE,
- 2) from letters of inquiry to the Project, and
- 3) from a list compiled at the 1972 National AAMD Convention.

Early in the 1973 grant year, Dostal and Tom Chastain, then a consultant to the IMC network, visited the site and conferred with Project personnel regarding marketing procedures. The major topics discussed during that visit include:

- 1) Image building--The Project needs to work toward:
  - a) more visual and graphic representation in reports and publicity;
  - b) taking a stance which is more "authoritative" and less "apologetic/democratic" in its presentations and releases;
  - c) establishing an advisory group of distinguished, prestigious persons in industry, related fields, and services;
  - d) making even more definite the imprimatur or identifying qualities of programs, reports, and releases, and
  - e) disseminating a newsletter to various mailing lists with emphasis on programs released, new programs in development, and data.
- 2) Expanding and stabilizing the Project--The Project should:
  - a) investigate other sources of (additional) funding;
  - b) offer its services and competencies to other projects through such groups as the National Media Center and BEH;
  - c) arrange site visits for influential persons;
  - d) emphasize the curricular aspects of the product line of programs in production and programs in planning--identifying them as already recommended curricular needs for the trainable;
  - e) trade on the fact that public schools are mandated to educate all of the handicapped--including the trainable retarded--and that 22 states already faced litigation regarding this mandate, and
  - f) in regard to the above two points, reassess the audience for the Project and, in particular, the market for products in order to more clearly define that audience and market.
- 3) Field testing--In setting up procedures for field testing and other forms of evaluation, the Project should consider:
  - a) using a broad base for market retrieval data;
  - b) selecting specific influential clinics, schools, and institutions, including those recommended as sites by persons in BEH and other key agencies or institutions;
  - c) inaugurating training in "sparse" areas such as Nevada and Colorado;
  - d) using many visuals of actual training experiences in all reports and releases, with captions identifying all cooperating persons and programs, and
  - e) requesting or contracting for additional funds to train personnel on site, deliver consultant and service input to other agencies and programs, validate programs in such a manner as to assure replicability, and to negotiate directly with other BEH-funded groups.



All of these suggestions were considered in detail and many of them, including the newsletter, were implemented quickly. Others, such as establishment of the advisory group, took months of planning before implementation.

In the meantime an additional daily-living skill program, Toothbrushing, was placed on the market. Project MORE's plan of using both a noncommercial disseminator--the Extramural Independent Study Center--and a commercial disseminator--Psychologists and Educators, Inc.--enabled the Project to compare the two methods of dissemination to determine which would reach the greatest number of consumers working with the handicapped.

By May 1973, however, the commercial disseminator had received only seven inquiries and had sold only one program, while the noncommercial disseminator had received 39 inquiries and had sold 72 programs. Although supplied with a mailing list, the commercial disseminator had taken no noteworthy follow-up action and, in consequence, the University of Kansas, as grantee, terminated the agreement with Psychologists and Educators, Inc.

At the same time the University began negotiating with Edmark Associates of Bellevue, Washington, in an effort to reach a new and more comprehensive commercial dissemination agreement. Edmark had first expressed interest in the Project MORE programs following the 1972 AAMD National Convention.

After nearly two years of effort, the University and Edmark agreed on the various legal issues involved in a contract for publication of Project MORE materials. The final contract with Edmark was signed in the spring of 1974 (see Procedures section). With the advent of this agreement, Edmark took over all publishing and dissemination duties for Project MORE programs and products, and the agreement with the Extramural Independent Study Center was terminated.

## Copyright

Project MORE began copyrighting its materials through two-year development copyright authorization agreement with the USOE. The grantee (through Project MORE) was thus able to market experimental versions of its products until September 15, 1974. Prior to that date, however, the grantee had the option, if it reached a satisfactory agreement with a publisher, to submit to the USOE Copyright Administrator a copy of that agreement for approval. If such approval was granted, the grantee would then receive an authorization to market products commercially as final materials.

Under this developmental copyright authorization agreement, the Project used its two-year marketing period as a means to improve its products further. To accomplish this, Project MORE included in each copy of the disseminated programs a postage-paid form to be completed by the teacher of the program. The form contained information that would be vital in determining the effectiveness of the program when used in a variety of settings and environments.

## Workshops

Since January 1973 workshops have been an integral part of the Project MORE dissemination effort. (See Procedures and Results sections for more information on workshops).

## Publications

The Project MORE newsletter, MORE News, has also proved to be a valuable dissemination tool. The first newsletter was issued in October 1973 and five subsequent issues have been released on a quarterly basis.

The newsletter features articles on new programs, Project personalities, research activities, supplementary activities, new books published by Project

personnel, and other items which might prove of interest to prospective consumers and to workers in the field of mental retardation. Newsletter distribution has increased almost 800 percent since the initial issue, with mailing lists compiled both by Project MORE and by Edmark Associates.

In addition to the newsletter, published working papers, technical reports, and chapters in textbooks have played an important role in the dissemination effort. Table 3 lists publications by Project MORE staff members. All working papers and technical reports written by Project staff members which concern Project-related activities are on file with Edmark Associates and are being distributed through them.

In recent months, too, three working papers, a technical report, and three progress reports have been submitted to the ERIC Clearinghouse on Information Resources. The reports are listed in ERIC's February 1975 issue of Research in Education and may be purchased from ERIC in either microfiche or Xerox hardcopy form.

### Presentations

Since the Project's early days, staff members have considered presentations at conventions and meetings another important dissemination route. Beginning with the 1972 AAMD National Convention and the 5th International Congress on Mental Retardation, the Project has made an effort to have representatives at every major conference held on the subject of mentally handicapped persons. These have included not only AAMD conferences, but also those sponsored by the Council for Exceptional Children, the American Psychological Association, and the recent 5th International Symposium on Behavior Modification in Caracas, Venezuela, to which the Project Director was invited as one of 14 presenters.

TABLE 3  
BIBLIOGRAPHIC LISTING OF PUBLICATIONS  
BY PROJECT MORE STAFF MEMBERS

- Bieberly, C. J., Lent, J. R., & Keilitz, I. *How to do MORE*. Bellevue, WA: Edmark Associates, 1974.
- Ferneti, C. L., Lent, J. R., & Stevens, C. J. *Eating*. Bellevue, WA: Edmark Associates, 1974.
- Ferneti, C. L., Lent, J. R., & Miller, C. W. *Face shaving*. Bellevue, WA: Edmark Associates, in press.
- Horner, R. D., Billinois, C. S., & Lent, J. R. *Toothbrushing*. (Rev. ed.) Bellevue, WA: Edmark Associates, 1975.
- Horner, R. D., & Lent, J. R. *Leg and underarm shaving*. Bellevue, WA: Edmark Associates, in press.
- Ingenthron, D., Ferneti, C. L., & Keilitz, I. *Nose blowing*. Bellevue, WA: Edmark Associates, 1975.
- Keilitz, I. Attention: General or selective. *Perpetual and Motor Skills*. 1973, 136, 130.
- Keilitz, I., Tucker, D. J., & Horner, R. D. Increasing mentally retarded adolescents' verbalizations about current events. *Journal of Applied Behavior Analysis*, 1973, 6, 621-630.
- Keilitz, I., Horner, R. D., & Brown, K. H. *The complexion care program*. Bellevue, WA: Edmark Associates, in press.
- Lent, J. R. Mimosa cottage: Experiment in hope. *Psychology Today*, 1968, 2, 51-58.
- Lent, J. R. Principles of behavior modification and habilitation of deaf/blind children. *Proceedings of Workshop in Behavior Modification Programs for Deaf-Blind Children*. Alexandria-Pineville, LA: Pinecrest State School, 1970, 1-20.
- Lent, J. R., LeBlanc, J., & Spradlin, J. E. Designing a rehabilitative culture for moderately retarded adolescent girls. In R. Ulrich, T. Stachnik, & J. Mabry (Eds.), *Control of human behavior*, Vol. II. Glenview, IL: Scott, Foresman, 1970, 121-135.
- Lent, J. R., Schiefelbusch, R. L., McLean, B. M., & Dixon, M. H. The Hansons. In B. B. Hauch & M. F. Freehill (Eds.), *The mentally retarded: Case studies*. Dubuque, IA: William C. Brown Co., 1972.
- Lent, J. R., Holvoet, J. F., Ferneti, C. L., Keilitz, I., & Tucker, D. J. Direction-following of retarded and non retarded adolescents. *American Journal of Mental Deficiency*, 1973, 78, 316-322.

- Lent, J. R., & McLean, B. M. The trainable retarded: The technology of teaching. In N. G. Haring & R. L. Schiefelbusch (Eds.), *Teaching special children*. New York: McGraw-Hill, in press.
- Lent, J. R., & Williams, J. *Hair rolling*. (Rev. ed.) Bellevue, WA: Edmark Associates, in press.
- Lewis, P. J., Ferneti, C. L., & Keilitz, I. *Hair washing*. Bellevue, WA: Edmark Associates, in press.
- Long, L. D., Raymore, S. L., McLean, J. E., & Brown, K. H. *More about it book: A guide to the stimulus shift articulation program*. Bellevue, WA: Edmark Associates, in press.
- Mayer, W. V. (Ed.) *Planning curriculum development: With examples from projects for the mentally retarded*. I. Keilitz, J. R. Lent, & B. M. McLean, contributing authors. Boulder, CO: Biological Sciences Curriculum Study, 1975.
- McLean, J. E., Yoder, D. E., & Schiefelbusch, R. L. (Eds.) *Language intervention with the retarded: Developing strategies*. (B. M. McLean, technical editor) Baltimore: University Park Press, 1972.
- McLean, J. E. Language development and communication disorders. In N. G. Haring (Ed.), *Behavior of exceptional children: An introduction to special education*. Columbus, OH: Charles E. Merrill, 1974.
- McLean, J. E., Long, L. D., & Raymore, S. L. *Stimulus shift articulation program: L*. Bellevue, WA: Edmark Associates, in press.
- McLean, J. E., Long, L. D., & Raymore, S. L. *Stimulus shift articulation program: R*. Bellevue, WA: Edmark Associates, in press.
- McLean, J. E., & Raymore, S. L. *Stimulus shift articulation program: CH*. Bellevue, WA: Edmark Associates, in press.
- McLean, J. E., & Raymore, S. L. *Stimulus shift articulation program: F*. Bellevue, WA: Edmark Associates, in press.
- McLean, J. E., & Raymore, S. L. *Stimulus shift articulation program: K*. Bellevue, WA: Edmark Associates, in press.
- McLean, J. E., & Raymore, S. L. *Stimulus shift articulation program: S*. Bellevue, WA: Edmark Associates, in press.
- McLean, J. E., & Raymore, S. L. *Stimulus shift articulation program: SH*. Bellevue, WA: Edmark Associates, in press.
- McLean, J. E., & Raymore, S. L. *Stimulus shift articulation program: TH*. Bellevue, WA: Edmark Associates, in press.
- Lent, J. R. Developing daily-living skills for the mentally retarded. In J. M. Kaufmann & J. S. Payne (Eds.), *Mental retardation: Introduction and personal perspectives*. Columbus, OH: Charles E. Merrill, in press.

McLean, L. P., & McLean, J. E. A language training program for nonverbal autistic children. *Journal of Speech and Hearing Disorders*, 1974, 39.

Raymore, S. L., & McLean, J. E. A clinical program for carry-over of articulation therapy with retarded children. In J. E. McLean, D. E. Yoder, & R. L. Schiefelbusch (Eds.), *Language intervention with the retarded: Developing strategies*. Baltimore: University Park Press, 1972.

Stevens, C. J., Ferneti, C. L., & Lent, J. R. *Hand washing*. Bellevue, WA: Edmark Associates, 1975.

Stevens, C. J., Keilitz, I., & Lent, J. R. *Care of simple injuries: Unit I*. Bellevue, WA: Edmark Associates, in press.

Stevens, C. J., Keilitz, I., & Lent, J. R. *Care of simple injuries: Units 2, 3, & 4*. Bellevue, WA: Edmark Associates, in press.

Project staff members concerned with mediation of products have also made an effort to participate in the conventions of the Association on Educational Communications and Technology (of which the Association for Special Education Technology is a subgroup) and Women in Communications, Inc. These conventions have given Media staff members an opportunity to assimilate new methods of production and to establish working relationships with other professionals in the field of mediation and communication.

### Advisory Board

Consultants Dostal and Chastain, in their 1973 report, had stressed the importance of establishing an advisory group of distinguished, prestigious persons in industry, related fields, and services. This idea came to fruition in May 1974, when the first Project MORE advisory board meeting was held.

Formation of the advisory board was preceded by months of planning and correspondence. Invitations to serve on the board were accepted by nine educators, business persons, and specialists. Many of the new board members were well versed in the problems surrounding the training of mentally retarded persons, but others encompassed areas not in the direct realm of those educational problems, including industry personnel who could give business advice, and media experts who could offer suggestions for marketing and promotion. The goal of garnering a well-rounded group of experts was achieved.

To date, two full advisory board meetings have been held and suggestions on implementation of production and dissemination goals are being acted upon. Interaction with the advisory board gives the Project staff an excellent opportunity to "pick the brains" of knowledgeable persons who care about effective services in mental retardation. In addition, one meeting has been held with

the executive committee of the board. Serving on that committee are: Richard B. Cray, John J. Dostal, Alex A. Lazzarino, William V. Mayer, Margot Sherman, and Helen Sims.



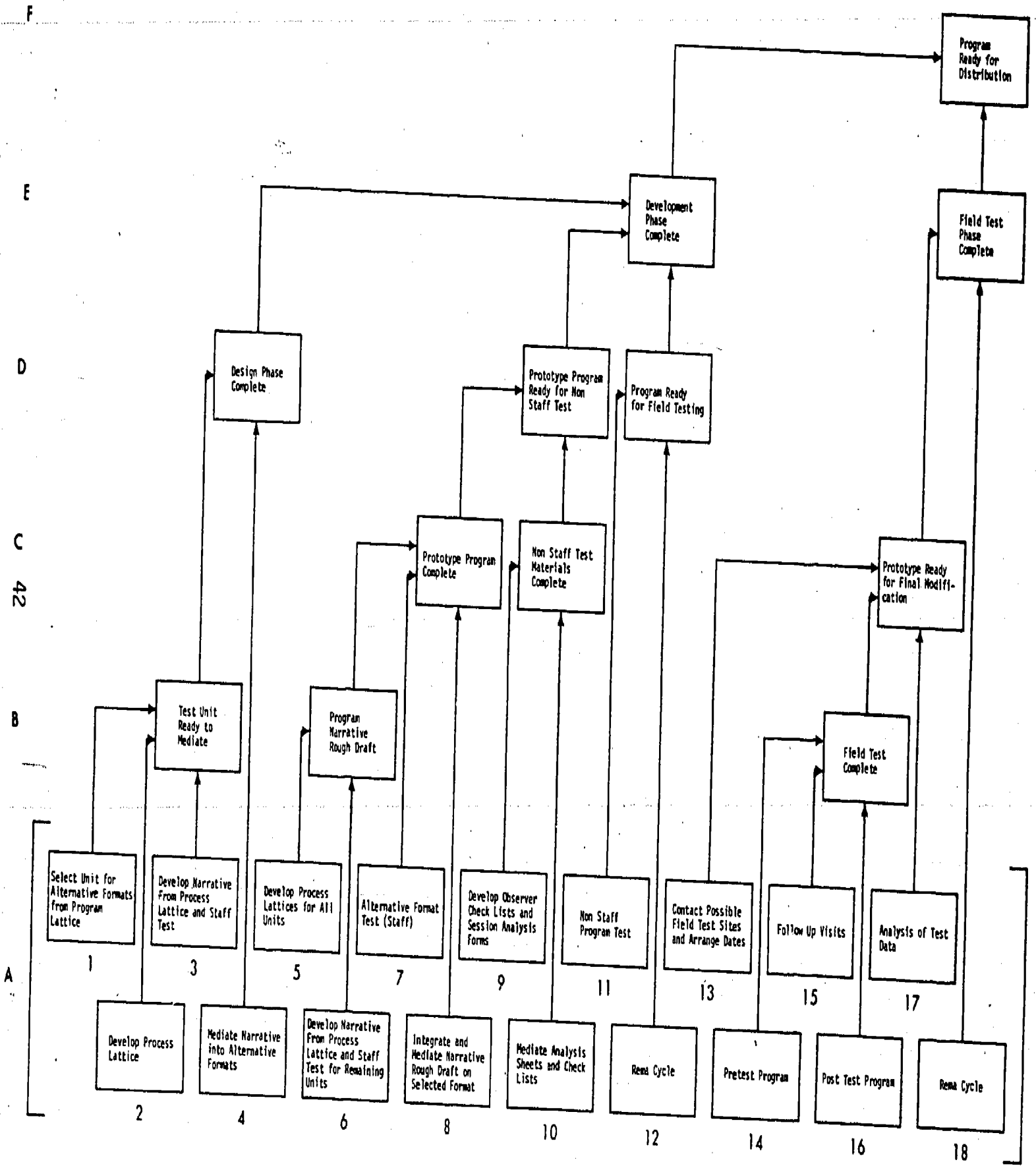
### III. PROCEDURES

#### DESIGN

During the four years of the grant, the technology (see original Implementation Lattice, Figure E) required for systematic design, development, and validation of programmed materials for the severely handicapped has been implemented, revised, and refined. It resulted in the Implementation Lattice (see Figure F) which has been used during the last year of the grant. This lattice has been used as the basis for planning all program design and development activities for this past year, and has also served as the basis for the accountability system (see Results). The revisions made in the Implementation Lattice over the first three years of the grant have resulted in a lattice that provided a solid basis for this past year's activities and will continue, without further revision, to serve as the basis for further program planning.

To understand the detailed activities associated with the lattice, see the chart showing Criteria for Completion for each module (Figure G) and the Narrative Description of the Implementation Lattice (Appendix A).

The design phases of the technology include the need and feasibility assessment of a given area, a literature search, observation of both normal and retarded individuals performing the task, a task analysis, pilot testing by the individuals who wrote the program, another feasibility assessment, and consultation with Media staff regarding development of a rough draft, then a prototypical program, and final copy for the publisher.



PROJECT MORE  
 IMPLEMENTATION LATTICE  
 February 1974

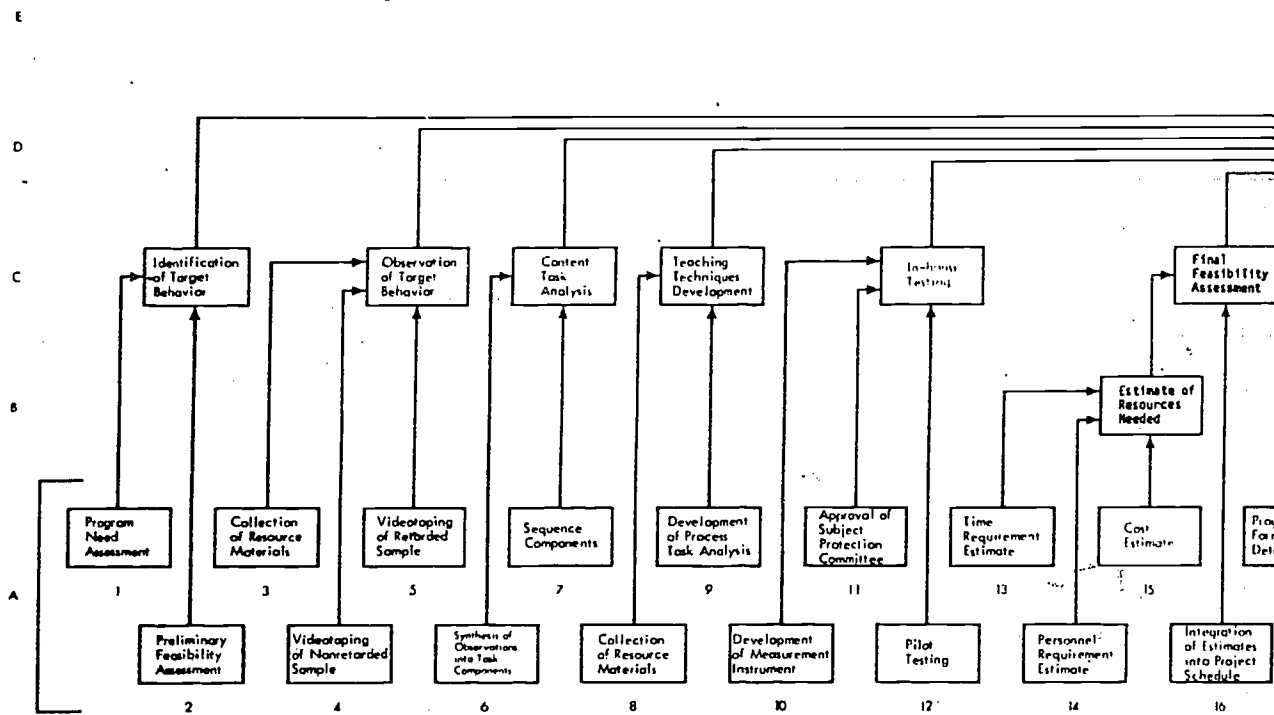
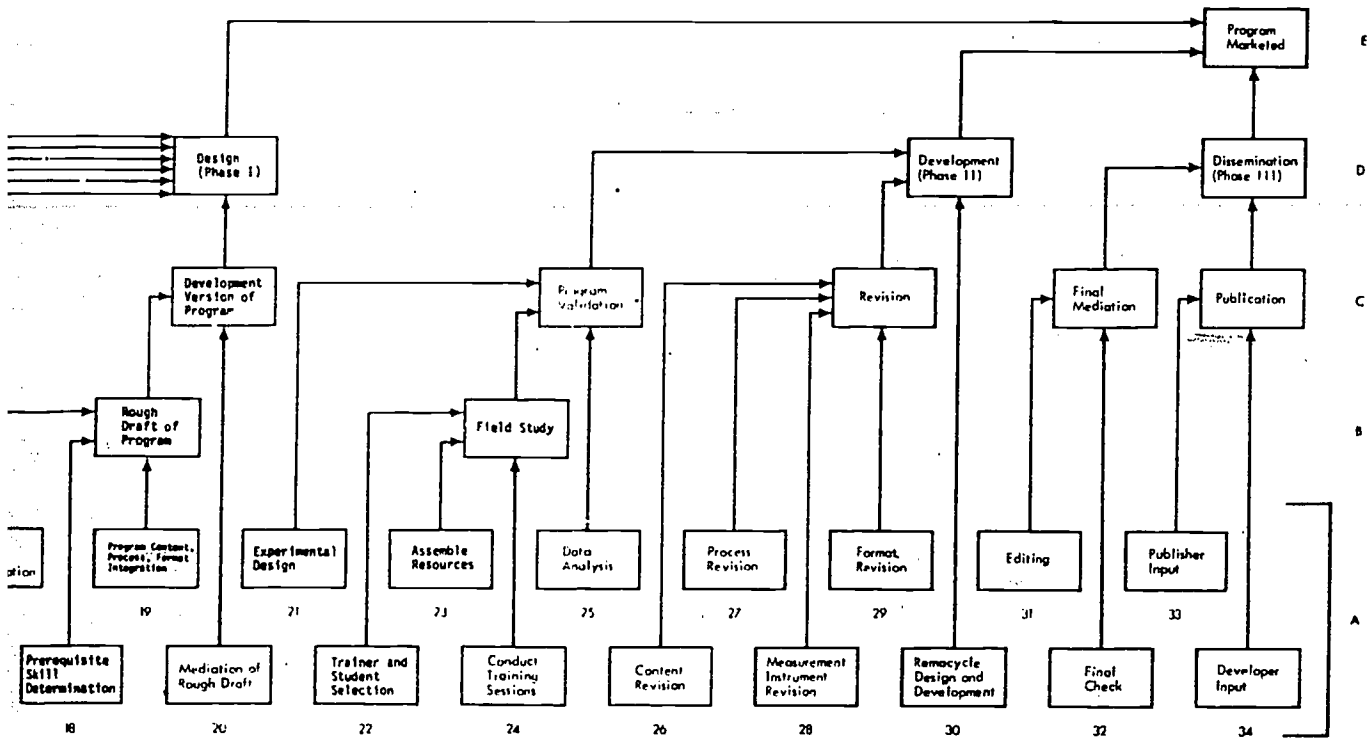


Figure F



©1974 by The University of Kansas (Project MORE)

MODULE	PERSONNEL	CRITERIA FOR COMPLETION
A-1 Program Need Assessment	Project Director Program Managers Media Services Director	Specific program need is identified, described, and communicated to Research Assistant and Program Manager for program development.
A-2 Preliminary Feasibility Assessment	Project Director Program Managers Research Assistant Media Services Director Writer/Editor	A tentative target behavior(s) is selected and the decision is reached to either proceed with the program or to terminate it and recycle to A-1.
A-3 Collection of Resource Materials	Program Manager Research Assistant	Program Manager decides that the search is completed.
A-4 Videotaping of Nonretarded Sample	Research Assistant	A videotape or written description of steps included in the performance of the tentative target behavior for at least two non-retarded individuals is on file.
A-5 Videotaping of Retarded Sample	Research Assistant	A videotape or written description of steps included in the performance of the tentative target behavior for at least three retarded individuals is on file. (Audio recording may also be included.)
A-6 Synthesis of Observations into Task Components	Research Assistant Program Manager	A task analysis of the tentative target behavior is completed.

©1974 by The University of Kansas (Project MORE)

## MODULE

## PERSONNEL

## CRITERIA FOR COMPLETION

A-7 Sequence Components	Research Assistant Program Manager	A decision is made on the order in which the steps listed in the task analysis are to be taught.
A-8 Collection of Resource Materials (for the Teaching Strategy)	Research Assistant Program Manager	Program Manager decides that the search is completed.
A-9 Development of Process Task Analysis	Research Assistant Program Manager	A decision is made on the teaching procedures or strategy to be used in this program.
A-10 Development of Measurement Instrument	Research Assistant Program Manager	A measurement instrument (typically a data sheet) is prepared for in-house testing.
A-11 Approval of Subject Protection Committee	Research Assistant Program Manager (Committee Members)	The committee approves the program for testing with students. (If they disapprove, remacycle above or discontinue program.) Disapproval leads to remacycle A-3 through A-10, as necessary, or discontinuation of program.
A-12 Pilot Testing	Research Assistant Program Manager	At least two students reach criteria of over 90 percent for three successive days. (If this doesn't occur on first test, remacycle A-3 through A-11, as necessary, or discontinue program.)

45

60

61

## MODULE

## PERSONNEL

## CRITERIA FOR COMPLETION

A-13 Time Estimate Requirement	Research Assistant Program Manager Writer/Editor	Estimate of the length of time required to complete Design, Development, and Dissemination of the program through A-34. (Assume two field tests.)
A-14 Personnel Requirement Estimate	Research Assistant Program Manager	Estimate of the number of people (staff, trainers, students, etc.) required to complete the program through A-34. (Assume two field tests.)
A-15 Cost Estimate	Program Manager Research Assistant Writer/Editor	Estimate of the Project cost for all materials, personnel, and equipment needed to complete the program through A-34.
A-16 Integration of Estimates into Project's Schedule	Program Manager Writer/Editor Research Assistant	On the basis of information collected in A-13, A-14, and A-15, program time-line is re-estimated through A-34 including necessary adjustment for other Project responsibilities. Criterion for completion may be program discontinuation.
A-17 Program Format Determination	Program Manager Writer/Editor Research Assistant	Format of the program for the rough draft is decided.
A-18 Prerequisite Skill Determination	Research Assistant Program Manager	Prerequisite skills assumed by program are determined.
A-19 Program Content, Process, Format Integration	Writer/Editor Program Manager Research Assistant	All of the information that is to be included in the mediated rough draft is written and compiled.

## MODULE

## PERSONNEL

## CRITERIA FOR COMPLETION

A-20 Mediation of Rough Draft	Writer/Editor Graphics Artist Program Manager Research Assistant	A mediated rough draft is ready for field study.
A-21 Experimental Design	Program Manager Research Assistant	Experimental Design of the field study is determined (variables to be included and how their effect will be measured).
A-22 Trainer and Student Selection	Research Assistant Program Manager	On the basis of A-21 students and their trainers are selected and scheduled for first field study.
A-23 Assemble Resources	Research Assistant	All training materials are obtained, the training site is secured, and the program is ready for validation.
A-24 Conduct Training Sessions	Research Assistant	At least 75 percent of the students reach the criterion of 90 percent correct for three successive sessions. <u>Or</u> the decision is made by the Research Assistant and the Program Manager to stop testing and proceed to A-25 for remecycle decisions.
A-25 Data Analysis	Research Assistant Program Manager	Program Manager decides that data analyses is completed. Decisions for revision are completed.
A-26 Content Revision	Research Assistant Program Manager Writer/Editor	On basis of A-25, necessary revisions are completed.



## MODULE

## PERSONNEL

## CRITERIA FOR COMPLETION

A-27 Process Revision	Research Assistant Program Manager	On the basis of A-25, necessary revisions of teaching procedures or strategy are completed.
A-28 Measurement Instrument Revision	Research Assistant	On the basis of A-25 and A-27, necessary revisions of the measurement instrument(s) are completed.
A-29 Format Revision	Program Manager Writer/Editor Research Assistant	On the basis of A-25, A-26, A-27, and A-28, necessary revisions of the format are completed.
A-30 Remacyle Design and Development	Staff	Final remacyle through Design and Development, as necessary.
A-31 Editing	Managing Writer/Editor Editor/Writer Program Manager Artist	Typed manuscript is completed, final artwork for steps prepared, a dummy layout of artwork for introductory pages readied, and the managing writer/editor has decided the program is complete
A-32 Final Check	Project Director Media Services Director	Print-ready copy, final art, and proposed artwork are submitted to the publisher.
A-33 Publisher Input	Publisher	Publisher makes suggestions for final dissemination of program to Media Services Director.
A-34 Developer Input	Media Services Director Publisher Staff	Program goes to press.

## DEVELOPMENT

---

Upon completion of the design phase, a program moves into development where it is tested by individuals who are hired to field test the programs. Upon completion of field testing, the data is analyzed, necessary revisions are made on the basis of the data, and the program is discussed with Media and prepared for final mediation and transmission to the publisher or, depending on the revisions, the program is taken back through the appropriate steps in the implementation procedure.

The use of nonstaff trainers and the use of observers who maintain high reliability assures replicability of the final program by the consumer. For evaluation purposes, data is collected on student performance, teacher performance, student affect, and teacher affect.

## SYSTEMS

The Implementation Lattice (see Figure F) has provided the basis for our systems approach to program development. Each of the programs is timed at the beginning of the grant year to indicate approximately how long development is expected to take. This is the "loosest" estimate that is made. Figure H gives an example of the longterm timeline made in 1973 for all of the units in the Care of Simple Injuries program.

On a monthly basis, then, each research assistant makes projections of which modules of the Implementation Lattice she/he expects to complete within that month on each of the programs for which she/he is responsible. The editor associated with that program assists in these monthly projections. This monthly projection takes into account what modules had been completed ahead of or behind schedule, as well as the long-term commitments made originally. An example of the monthly loading charts for one unit of the Care of Simple Injuries program is shown in Figure J. These monthly projections are given to the Program Manager for that program, and weekly meetings are held to ensure that progress is being made as expected and to clear up any problems that may arise. At the end of each month, the monthly projection sheet is again given to the Program Manager with an indication of which modules have been completed. The Criteria for Completion Chart (see Figure G) provides an objective criterion for the completion of each of the modules in the Implementation Lattice.

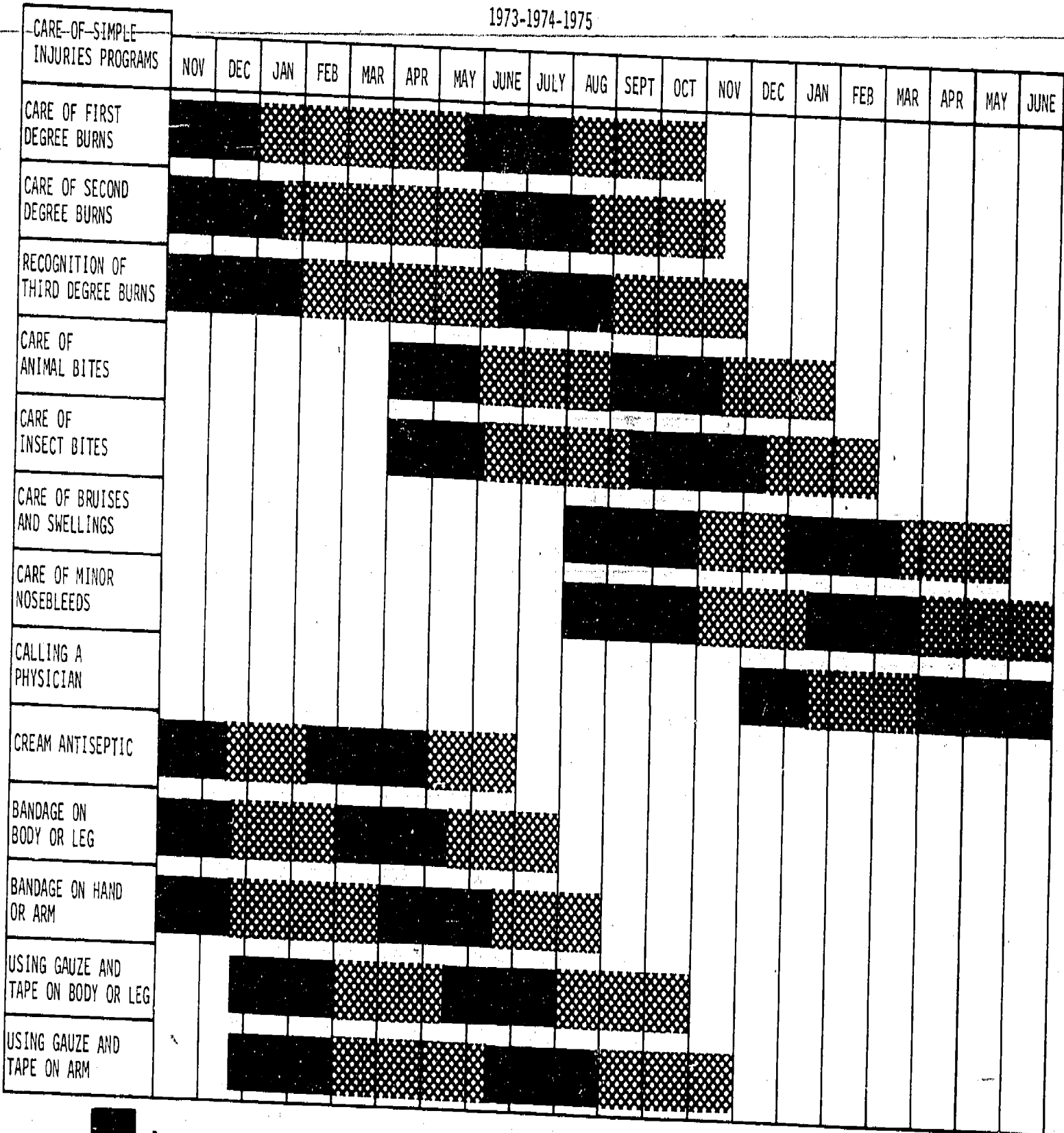
The Implementation Lattice also provides the basis for a cost accountability system which is used to give accurate statements of the direct and indirect costs for every product developed. All editors, research assistants, and other personnel involved in the development of programs keep a daily tally of the amount of time that they spend on all activities

LONG RANGE IMPLEMENTATION SCHEDULE

CARE OF SIMPLE INJURIES PROGRAM

FIGURE H

1973-1974-1975



51

■ Programs in Research  
 ■ Programs in Mediation

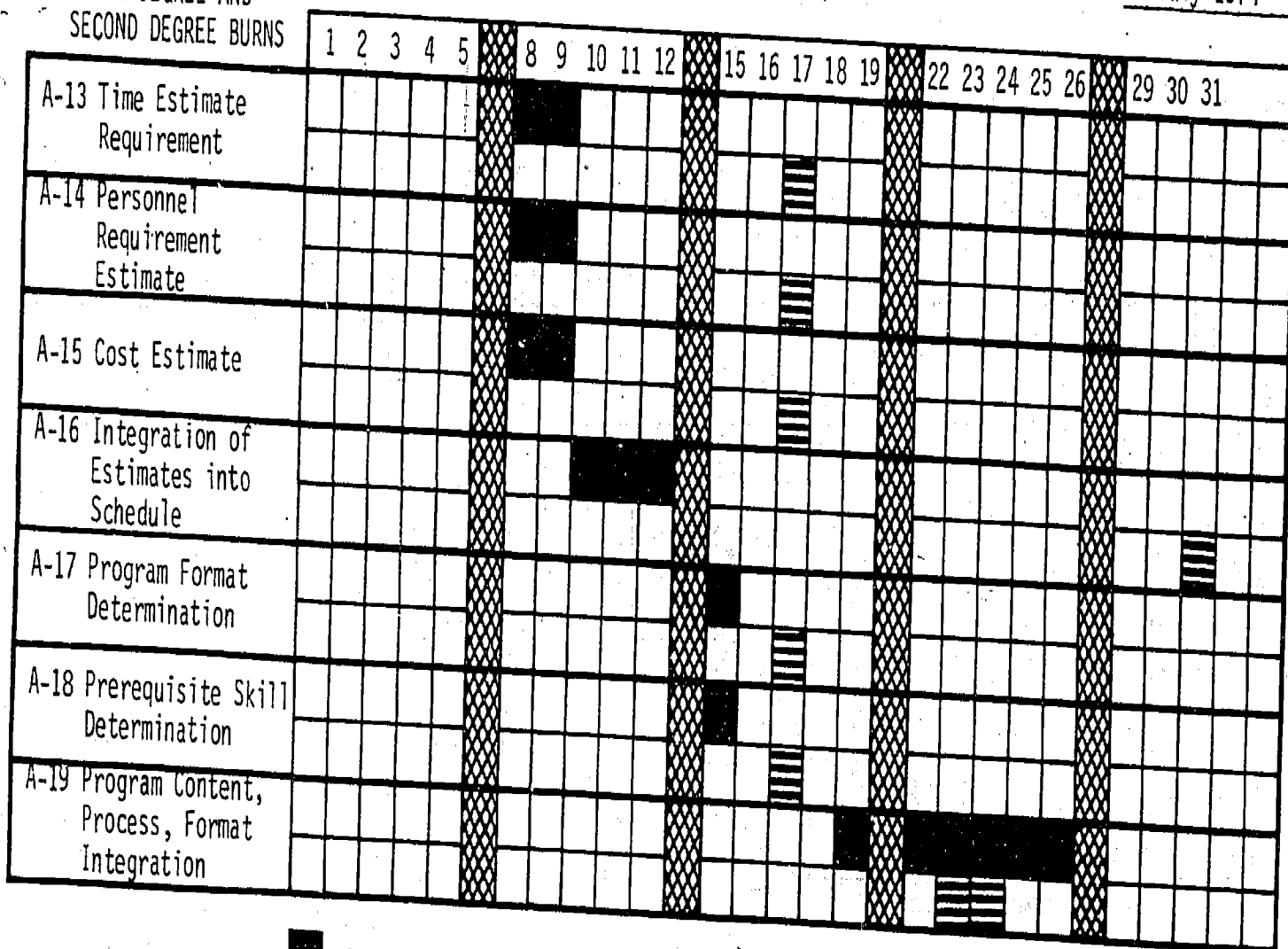
© 1975 The University of Kansas (Project MORE)

IMPLEMENTATION SCHEDULE (Monthly)

CARE OF SIMPLE INJURIES

MONTH July 1974

FIRST DEGREE AND SECOND DEGREE BURNS



■ Days projected to be spent on task

▨ Actual days spent to complete task

© 1975 The University of Kansas (Project MORE)

(see Figure K for an example). Time spent on programs is listed by the program and the module worked on. (Other categories are also kept. For a complete listing of the categories and the results of this system, see the Results Section, Accountability Records.) The time spent on each program module can be translated into dollar cost by multiplying the hours spent by the hourly wage for each position. Totals of both hours and direct dollar costs are kept on each program. An additional benefit of this system is that it provides an empirical method for determining expected time values for a PERT chart for the 34 modules in the implementation system (see Figure L).

# DAILY COST ACCOUNTING FORM

Name JENNIFER

X \$ for Program Managers  
for 1/2 hour = \$4.05

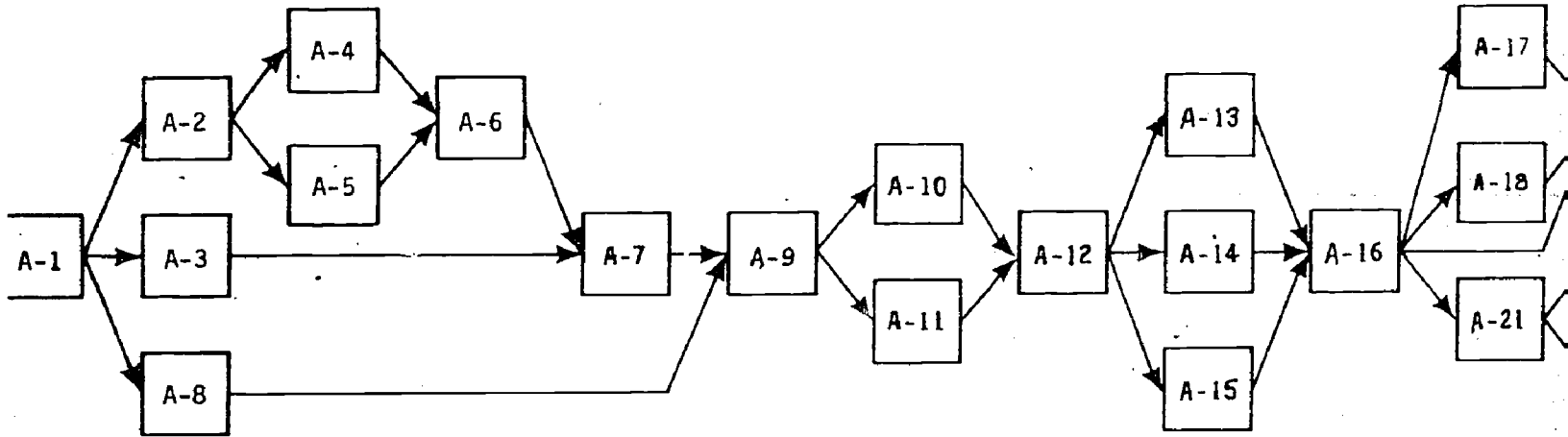
Date 6/18/74

X \$ for Research Assistants  
for 1/2 hour = \$1.90

MODULE	TIME	8:00				9:00				10:00				11:00				1:00				2:00				3:00				4:00				TOTAL
		1	2	3	4	1	2	3	4	1	2	3	4	1	2	3	4	1	2	3	4	1	2	3	4	1	2	3	4					
STAFF DEV. (FILM)	S																											3.80						
	Hr	✓	✓	✓	✓																									1.00				
CSI V A-25	S																											2.85						
	Hr					✓	✓	✓	✓																					.75				
EYE CONTACT A-6	S																											9.50						
	Hr									✓	✓	✓	✓	✓	✓	✓	✓					✓								2.50				
CSI F.S. II	S																											4.75						
	Hr													✓								✓	✓	✓	✓					1.25				
ACCOUNTABILITY	S																											1.90						
	Hr																	✓								✓				.50				
CSI VIII A-17	S																											6.65						
	Hr					✓	✓	✓	✓																	✓	✓			1.75				
NW	S																											.95						
	Hr																									✓				.25				
TOTAL	Hr																																	

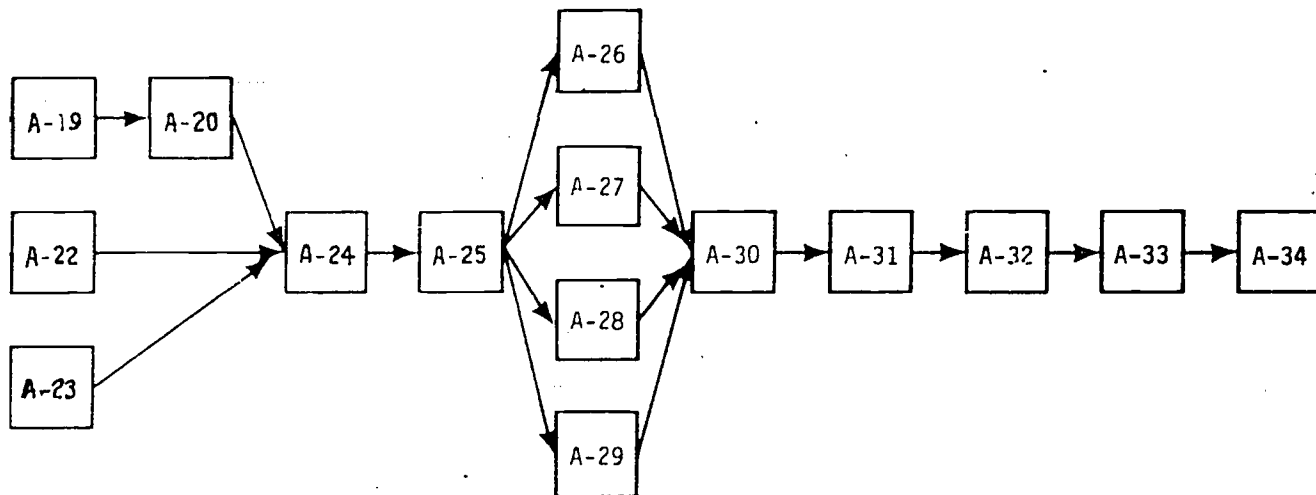


Figure L - PERT CHART  
IMPLEMENTATION LATTICE





FOR PROGRAM DEVELOPMENT



©1974 by The University of Kansas (Project MORE)

## FIELD TESTING

---

After each program has successfully undergone pilot testing and has been mediated in a rough draft form, it is scheduled for pilot testing. In order to obtain reliable data on all aspects of the program, Project MORE has devised a field testing procedure which can be conducted in-house, but which obtains wide generalization through the use of nonstaff trainers.

By hiring community people to conduct the training programs, the Project is able to get field test results which reflect how well students perform in the programs when they are trained by individuals who are not involved in the program writing, and who are given only the information available in the prototypical program and in How To Do MORE, the book which details Project techniques. While the nonstaff trainers use the programs, Project MORE staff takes data on student skill acquisition and teacher performance. Since students are scheduled for training by Project MORE, data on student and teacher characteristics can be obtained easily.

After field testing, the nonstaff trainers complete forms asking for their overall impression of the program and whether they felt that the students enjoyed participating in the training program. In this way general affective information is obtained as well as session-by-session performance data on both trainers and students. Results of the data indicate whether or not trainers follow the program as written, how well the students perform under those circumstances, and how well both the trainer and the student appear to like the program.

Reliability measures are taken throughout training on student and trainer performance data. Assessment of the validity of this student and trainer performance data is based on the fact that the data collected is positively related to the final performance of the student. Indications of the validity and reliability of the affective measures are still being evaluated.

Most of the field test data is collected by using a multiple baseline design across students. Several days of baseline or pretest information is collected on students within each field test. When their data achieves a stable level (almost always within two to six days), the training procedures are instituted. In this way the Project demonstrates that simple exposure to the training materials is not sufficient to produce adequate student gains in the target behavior.

Training continues with all students in the field test until a student has achieved 90 percent or better on both total behaviors and critical behaviors in the program. Students achieve points according to what level of the teaching strategy they require in order to do each step in the program correctly (see How To Do MORE). If the student performs the step without assistance, she/he receives three points; if the student requires verbal help, she/he receives two points; if the student requires a demonstration, she/he receives one point; if the student requires physical assistance or cannot perform the behavior, she/he receives no points. The total points for the session are added up and graphed daily in order to get points on total behaviors.

Critical behaviors are isolated within each program to ensure that the student is also learning the most essential skills, as well as the ones of lesser importance. For instance, in the Hand Washing program, in addition to scrubbing the palms, backs, and between the fingers on the hands, the program specifies that students roll up their sleeves, remove any jewelry on the hands, and wipe up the water around the sink when they have finished washing their hands. These behaviors are not considered critical to hand washing, but are included in the task analysis. In order to avoid giving these behaviors undue weighting in the data, they are eliminated from the critical behaviors and graphed separately. Achievement of the 90 percent criterion on both total and critical behaviors is required before students are considered to have learned the program.

When all students have reached the 90 percent criteria, the field tests are terminated. If not all of the students achieve the criteria after 20 days of training, the data are evaluated to see if the students are still progressing, or if their data have stabilized below the 90 percent level. Field testing continues if their data still reflect an upward trend. On programs where the students do not progress, field testing is terminated, and the data are analyzed for content revision purposes. Data analysis is conducted for all field test data to ensure that every single step is being learned by students in the test. If that were not the case, the step would be revised.

## EVALUATION

---

When a field test for a program has been completed, the data collected on the program undergo analysis in order to make decisions on content revisions for the program. The following data are tabulated for each step within the program:

- 1) The mean number of points that each student earned on all of the training days,
- 2) The mean number of points that each student earned on that student's last six days of training,
- 3) The number of students who required no help for three days of training, and
- 4) The number of teacher errors for each student.

In addition, items that the nonstaff trainer indicates are ambiguous or misleading are checked. Steps are then revised if any of the following situations are found:

- 1) If 50 percent or more of the students have less than 1.5 as the mean number of points for that step for all training days or for the last six days of training,
- 2) If 50 percent or more of the students failed to attain three consecutive days of no help on a step, or
- 3) If the item had over 10 percent teacher errors per step.

If observers had difficulty maintaining high reliability during training (below 85 percent), then steps which had high disagreement are also revised.

Steps are revised in several ways. In some cases the step is divided into two or more additional steps. In other cases another program is made into prerequisite for the one being tested. For instance, hand washing is one of the steps in the Feminine Hygiene program in which 50 percent or fewer of the students obtained three consecutive days of no help. Instead of revising the step within this program, it was recommended that students be taken through the Hand Washing program (which had already been validated) before entering the Feminine Hygiene program. Another type of revision is to reword the behavioral definition of a step. This is usually indicated on steps with either a high number of teacher errors or on steps that observers have difficulty in obtaining reliable agreement.

Work is currently being done to make the decisions for revision more systematic. Successive field testing of the revised programs provides a statement on the validity of the current procedures. The student and trainer affective data obtained on the Trainer Reactor Scale (Figure M) and on the Student Reactor Scale (Figure N) have been reviewed for data analysis but, as yet, their impact on systematic program revision has not been defined. A technical report is currently being prepared to present the details on content revision.

Trainer Reaction Scale

Trainer's Name \_\_\_\_\_ Settings) \_\_\_\_\_  
 Position \_\_\_\_\_ Program \_\_\_\_\_  
 Date \_\_\_\_\_

Purpose: To assess trainer's attitudes, perceptions, and reactions to instructional programs.

Instructions to the trainer: Use one TRAINER REACTION SCALE for each program rated. (1) Rate instructional program on each of the items listed below by circling the appropriate number on the five-point scale. The higher the number circled, the greater agreement is indicated with the description on the right side of the scale. (2) Make suggestions for improvements. Your ratings and suggested improvements will be read, analyzed, and used for program revisions.

PROGRAM STEPS

1. Too few steps	1 2 3 4 5	Appropriate number of steps
2. Too many steps	1 2 3 4 5	Appropriate number of steps
3. Ambiguous, confusing	1 2 3 4 5	Clear and specific
4. Poorly ordered	1 2 3 4 5	Well ordered
5. Unrealistic to the training of the mentally retarded	1 2 3 4 5	Realistic to the training of the mentally retarded

Suggested Improvements for Program Steps:

TEACHING STRATEGY

6. Described poorly	1 2 3 4 5	Clearly described
7. Unrealistic to the training of the mentally retarded	1 2 3 4 5	Realistic to the training of the mentally retarded
8. Difficult to follow	1 2 3 4 5	Easy to follow and remember
9. Not enough detail	1 2 3 4 5	Described in detail
10. Too rigid for use	1 2 3 4 5	Easily used in training
11. Unusable without major major modifications	1 2 3 4 5	No modification necessary

Suggested Improvements for Program Steps:

DATA COLLECTION

12. Insufficient detail provided	1 2 3 4 5	Good detail provided
13. Interfered with training	1 2 3 4 5	Did not interfere with training

Project MORE Mediated Operational Research for Education

DATA COLLECTION (continued from page 1)

- |  |           |                                    |
|--|-----------|------------------------------------|
| 14. Data obtained unnecessary and not useful | 1 2 3 4 5 | Data obtained necessary and useful |
| 15. Too rigid and complex                    | 1 2 3 4 5 | Simple and straightforward         |

Suggested Improvements for Data Collection:

PROGRAM LANGUAGE AND FORMAT

- |  |           |                                     |
|--|-----------|-------------------------------------|
| 16. Poorly organized                         | 1 2 3 4 5 | Well organized                      |
| 17. Too long or too short for topic          | 1 2 3 4 5 | Optimal length for topic            |
| 18. Wordy, rambling                          | 1 2 3 4 5 | Brief, concise                      |
| 19. Too formal or too informal               | 1 2 3 4 5 | Suitable style                      |
| 20. Too many or too few illustrations        | 1 2 3 4 5 | Appropriate number of illustrations |
| 21. Illustrations distracting and misleading | 1 2 3 4 5 | Helpful illustrations               |

Suggested Improvements of Program Language and Format:

OVERALL PROGRAM

- |  |           |   |
|--|-----------|---|
| 22. Ineffective  | 1 2 3 4 5 | Highly effective                                      |
| 23. Useless for my purposes  | 1 2 3 4 5 | Very useful for my purposes                           |
| 24. Compares unfavorably with other programs dealing with the same skill | 1 2 3 4 5 | Better than other programs directed at the same skill |
| 25. Would not recommend program to others                                | 1 2 3 4 5 | Would highly recommend program to others              |

Suggested Improvements and Other General Comments:

GENERAL INFORMATION

26. How many students have you trained using this program? \_\_\_\_\_
27. Classify these students (check where appropriate)
- Moderately retarded \_\_\_\_\_
- Severely retarded \_\_\_\_\_
- Other (specify) \_\_\_\_\_
28. How many years of experience do you have in teaching mentally retarded persons? \_\_\_\_\_
29. Indicate years of formal education (circle the appropriate number).
- |                   |           |
|-------------------|-----------|
| High School       | 1 2 3 4 5 |
| College           | 1 2 3 4 5 |
| Graduate training | 1 2 3 4 5 |



## STUDENTS' ATTITUDES: EVALUATION QUESTIONNAIRE

Instructions: It is important to evaluate students' reactions and attitudes toward program training apart from their progress in mastering the skills involved. Complete this questionnaire and answer the questions based on your personal contact and observation of students participating in program training. Write on the back of this sheet if more space is needed.

Name: \_\_\_\_\_

Role: \_\_\_\_\_ Trainer/Teacher, \_\_\_\_\_ Observer, \_\_\_\_\_ Other \_\_\_\_\_

Program: \_\_\_\_\_

Number of students: \_\_\_\_\_

1. Do students have a positive reaction or attitude toward program training?

2. How did you decide that these reactions and attitudes existed? (How could you tell?)

3. Did all the students have this attitude? If not, explain.

## MEDIATION

### February 1971 to January 1972 Grant Year

Media Support Services began its work in February 1971. From the beginning the Media staff was efficient in producing prototypical instructional materials for research staff. This system relieved the research of the technical demands of physical production of these materials.

Most of the problems associated with task analyzing, writing, testing, and revising programs centered around matters of format, or how to present the materials, rather than how to write a program. Basically, the content of a given program needed to be presented in such a way that the consumer is attracted, even compelled, to attend to the materials and to use them in their intended manner.

The severely retarded need considerably more breakdown or finer fragmentation of their curriculum. The program content must be highly explicit and carefully followed by the teacher. This was the Media staff's most consistent finding in the search for successful teaching methods, although writing a systematic and highly explicit program initially created, as well as solved, problems. The programs first produced by the Project were very lengthy and, to the teacher's eye, more redundant and less interesting. This appeared to be true of the Hair Rolling and Ironing programs during the Project's first grant year.

In addition to the issues of content and format, there was another issue for Media staff: the method of presentation, or how the teacher conveys the information to the learner. Explicit and systematic programming could take care of many, but not all, of these problems. In order to provide

additional assistance in this regard to untrained teachers the Project decided to use certain forms of audiovisual products to supplement certain printed materials. It was at this time a decision was made to make a film related to the Showering program.

Specific program activities during the first year included:

- 1) Format input, artwork, layout, editing, and printing of the Ironing program;
- 2) Artwork, graphics, printing of several units of the Ironing program;
- 3) Format input, editing, artwork, graphics, and printing of a prototype for the Showering program, as well as script work for the Showering film;
- 4) Printing, design, and production of materials for use with the Change-Making and Direction-Following programs, and
- 5) Format input for the Shaving program.

Additionally, workshop materials, training materials, and reports were produced.

#### February 1972 to January 1973 Grant Year

During the first part of the second grant year, the Media component adapted several trial formats for the Toothbrushing and Eating Etiquette programs, and worked with research personnel on rough drafts for the Appropriate Dress and Use of Telephone programs.

Prototypes for seven phoneme training manuals were written for the Speech Articulation program, as well as a draft for the training of

paraprofessionals in speech therapy. Manuals related to response development were also produced.

The Media system also undertook a complete study of itself. Individuals wrote job descriptions and, with the help of systems analyst James F. Budde, set up procedures for production of work.

During this same period, the Audiovisual component moved into the University Affiliated Facility, which allowed for necessary expansion of print media into its existing facility.

By January 31, 1973, Media had accomplished the following:

- 1) Dissemination of the Hair Rolling program (see Dissemination, Objectives);
- 2) Mediation of rough drafts for the Feminine Shaving (now Leg and Underarm Shaving), Face Shaving, Complexion Care, and Hand Washing programs;
- 3) Revisions of major portions of the Eating Etiquette (now Eating) program;
- 4) Rewriting of an introduction to the Use of Telephone program, and
- 5) Mediation of parts of the Appropriate Mode of Clothing program.

Problems facing Media staff included difficulties with the Ironing program (over 500 behaviors were to be taught), and with Showering (cues in the "Showering Song" needed to be more specific).

Since Media has always existed to support research activities, revisions in programs, changes due to the results of data collection, and even research and media personnel changes have affected Media's work. During the first two years of Project MORE, these were especially dominant factors, resulting in various delays and revisions of programs. Hair

Rolling, Showering, Ironing and Feminine Shaving are particular examples of programs which have undergone extensive reworking by Media as a result of these various factors.

Nevertheless, in addition to the work cited earlier during this period, the Media staff also produced a slide presentation and a portable display of Project MORE products to demonstrate educational technology procedures at conventions and workshops.

#### February 1973 to January 1974 Grant Year

During the early part of the third grant year, the following were significant activities of the Media staff:

- 1) The "Shower Song" was completely revised to add more detail to the washing part and to add a drying sequence, and the song was recorded on cassette tape;
- 2) The visual format of the Face Shaving program was redesigned to enhance the appearance of the program;
- 3) The Leg and Underarm Shaving (formerly Feminine Shaving) program was also mediated in final form in the same format as the Face Shaving program;
- 4) The Toothbrushing program was completed, printed, and entered its first dissemination;
- 5) The Eating Skills for Daily Living program underwent extensive re-editing;
- 6) The Complexion Care program underwent complete revision to make its use more practical and applicable to training mentally retarded students; revisions by Media staff included adding sections to train a student how to use a cleansing lotion and how to take care of blemished skin;

- 7) The Hair Washing program was printed in prototypical form for testing, and was returned to Media for final mediation;
- 8) The Nose Blowing (formerly Nose Wiping) program was also printed in prototypical form for testing, and was subsequently returned to Media for final mediation;
- 9) The Hand Washing program was returned to Media for final mediation;
- 10) A rough draft of the Nail Care program was prepared for testing purposes, and
- 11) The format was revised for all units of the Stimulus Shift Articulation program, extensive editing and artwork was completed for those manuals, as well as artwork for flash cards which accompany the program.

During this period work also began on the procedures manual which accompanies the Stimulus Shift Articulation program, several brochures were produced, and a style book was produced detailing literary style to be used on Project MORE programs and products.

Multimedia workshop packages were produced and included notebooks, simulation materials, brochures, kinescopes, and films.

The Media component also produced the Systematic Planning with Evaluation Criteria (SPEC) manual, which was instigated by systems analyst James F. Budde and was sponsored by the University of Kansas University Affiliated Facility. Also, at the suggestion of the National Association for Retarded Citizens, a second edition of the Mental Retardation Films catalog was undertaken.

As the grant year progressed it became evident that consolidating certain portions of the programs into a separate text would facilitate program development. This text, designed to accompany all Project MORE programs requiring the four-levels-of-assistance teaching strategy, is called How To Do MORE. Besides being a highly readable text, this consolidation made it possible to eliminate duplication of the same material at length in each program.

This consolidation did, however, make it necessary to revise the introductory pages in programs formerly considered "print ready." Those introductory pages were changed to include the following information: supplies required, entry behaviors, samples of completed data sheets and graphs, and information on how to conduct training sessions. The introductory pages also contain a brief synopsis of the teaching strategy, reinforcement techniques, and data collection procedures.

Along with development of How To Do MORE, the following activities were completed by Media during the last half of the third grant year:

- 1) The Toothbrushing program was revised in anticipation of its second printing;
- 2) The introductory pages and data collection system of the Eating (formerly Eating Skills for Daily Living) program were revised;
- 3) The introductory pages of the Complexion Care, Face Shaving, and Leg and Underarm Shaving programs were revised;
- 4) A prototype for the Feminine Hygiene program was mediated;
- 5) Prototypical programs for testing were prepared for five units of the Care of Simple Injuries program, the Nail Care program, and two units of the Telephone program;

- 6) Initial drawings for sound-loaded pictures were completed for five Stimulus Shift Articulation program manuals, and
- 7) Revisions of both the first and second generation workshops was accomplished.

February 1974 to January 1975 Grant Year

Project MORE's Media staff produced more program prototypes during the period of February to June 1974 than ever before. Nine prototypical printed programs were completed, and testing was begun on these programs. The prototypes mediated during the first half of the year were:

- 1) Care of Simple Injuries, Unit One  
(Cream Antiseptic)
- 2) Care of Simple Injuries, Unit Two  
(Adhesive Bandages on the Body or a Leg),
- 3) Care of Simple Injuries, Unit Three  
(Gauze and Tape on the Body or a Leg),
- 4) Care of Simple Injuries program, Unit Four  
(Gauze and Tape on the Body or a Leg),
- 5) Care of Simple Injuries, Unit Five  
(Gauze and Tape on an Arm or Hand),
- 6) Use of Telephone program, Unit One  
(Answering)
- 7) Feminine Hygiene program (revised prototype),
- 8) Care of Eyeglasses program, and
- 9) Nail Care program.

How To Do MORE was completed and published by Edmark Associates. In comic book format, it quickly proved to be popular, as well as useful.

In addition, signing of the contract with Edmark Associates enabled



Media staff to render earlier prototypes in final form for submission to the publisher for printing. Four programs (Eating, Face Shaving, Leg and Underarm Shaving, and Complexion Care) were sent to Edmark. Revisions of the Toothbrushing program, the first printing of which was already in dissemination by Edmark, were sent to Edmark for the programs second edition. The Nose Blowing program and the first unit of the Care of Simple Injuries program were being prepared for transmission to Edmark at the end of June.

Other program-related work was begun. Artwork and scriptwork got underway for two filmstrips to accompany certain units of the Care of Simple Injuries program, as well as flash cards depicting burns. A poster giving a number of examples of verbal reinforcement was completed and sent to Edmark. The poster is to accompany all programs. A rendition of a certificate, to be awarded to a student after completing training in a particular program, was designed and sent to Edmark.

Media also produced over 200 workshop manuals for first and second generation workshop participants, as well as workshop handouts, information releases, brochures, address cards, and complete Project MORE information packages, which were mailed to persons who had attended the Project's presentation at the Council for Exceptional Children conference in New York City.

Work also began on a book to discuss strategies for developing instructional packages for mentally retarded persons (see the Dissemination Results section of this report).

As noted earlier, four programs had been transmitted to Edmark Associates prior to June. During July Edmark Editor John Garre visited Project MORE and conferred with both research and Media personnel. In relation to both prototypical programs, and to those which had been sent in final form to Edmark, Garre provided input as to suggested changes and improvements in the Project's programs. He recommended strongly that the format and design for programs should be standardized as much as possible, and that artwork be as realistic as possible.

In accord with the contract with Edmark, these changes were discussed and it was agreed to resubmit several programs to the publisher after making the changes mutually agreed upon during Garre's visit.

Subsequently, the remainder of the summer was spent in making the copy and art changes. Revised final versions of Nose Blowing; Care of Simple Injuries, Unit One; Leg and Underarm Shaving; Face Shaving; Eating; Complexion Care and Toothbrushing were then retransmitted to Edmark in August. The integrity of the timelines formerly established was still maintained during this period.

From August 1974 to January 31, 1975, the following prototypes were completed by Media:

- 1) Telephoning, Unit Two  
(Seven-Digit Numbers)
- 2) Telephoning, Unit Three  
(Emergencies)
- 3) Care of Simple Injuries, Unit Five  
(Medical Help)
- 4) Care of Simple Injuries, Unit Six  
(Minor Burns)
- 5) Care of Simple Injuries, Unit Seven  
(Serious Burns and Burn Discrimination)

- 6) Care of Simple Injuries, Unit Eight  
(Bruises and Swellings)
- 7) Care of Simple Injuries, Unit Nine  
(Nosebleeds)
- 8) Care of Simple Injuries, Unit Ten  
(Animal Bites)
- 9) Care of Simple Injuries, Unit Eleven  
(Insect Bites)
- 10) Showering (revised prototype)
- 11) Fingernail Care (revised prototype)

Twenty prototypes had been produced during the 12-month period.

Transmitted in final form to the publisher were Units Two, Three and Four of the Care of Simple Injuries program (Applying Bandages), revisions of the Hand Polling program (second edition), the Hand Washing program, and eight phoneme manuals and the accompanying procedural text (MORE About It Book) for the Stimulus Shift Articulation program.

Twenty-two texts had been finalized and submitted to Edmark for publication in the 12-month period.

Three newsletters were also printed during the year, as well as workshop materials, brochures describing Project MORE, supplementary materials, books, book chapters, and speeches (see Dissemination Results section of this report), a pocket-sized book on residents' rights and responsibilities in Kansas institutions for the mentally retarded, and a revision of a catalog of films available on mental retardation, which is distributed by the National Association for Retarded Citizens.

## DISSEMINATION

### Edmark Contract

A publishing agreement was reached in February 1974 between the University of Kansas, Project MORE, and Edmark Associates, forming a limited partnership under the laws of the State of Washington.

The following provisions were included in the contract:

- 1) Edmark was granted the full, sole, exclusive license to print, publish, distribute, market, and otherwise disseminate Project MORE daily-living skill programs and supplements for the full term of any copyright authorized by USOE;
- 2) Edmark agreed to publish at its expense each daily-living skill program submitted by Project MORE within 12 months from the date of receipt, unless that program was unacceptable;
- 3) Edmark agreed to keep the published programs "in print";
- 4) Edmark agreed to provide Project MORE with sufficient market data to enable the Project to continue research and development, and
- 5) Edmark agreed to pay royalties to Project MORE (see the following section of this proposal).

Other sections of the contract detail procedures for the transmission of products to the publisher, procedures to be followed in making changes in final copy, and Project MORE's and Edmark's obligations and rights in marketing the materials.

### Royalties

Royalties for the sale of Project MORE products and programs were set contractually at four percent of the net sales price. Half of this amount is paid to Project MORE and half to the government.

An additional six percent of the net sales price for the first 5,000 copies sold and eight and a half percent of sales in excess of 5,000 copies reverts to an endowment fund set up by the University of Kansas. These funds enable Project MORE to actively engage in educational research in order to produce marketable daily-living skill programs.

Quarterly reports of the sales of materials by Edmark are sent to Project MORE within 60 days of the close of each calendar quarter.

### Copyright

The signing of the contract with the Edmark Associates mandated that the developmental copyright authorization be changed. In the spring of 1974, therefore, a Copyright Authorization Agreement was signed by government officials, the University of Kansas, Project MORE officials, and Edmark Associates. The agreement provided for a 10-year copyright on Project MORE materials.

## Workshops

The first workshops were originally written for presentation at conventions, seminars, and professional meetings. The workshops' basic goal was to tell participants about Project MORE and show the audience how to write their own programs by using Project techniques.

In the second year the workshop format was changed to include the use of a Project MORE program. Plans for workshop activities became more systematic and consistent. And, in August of 1973, Project MORE and the University of Kansas Special Education Instructional Materials Center (SEIMC) staff members finalized arrangements for a specific procedure for workshop presentations in the SEIMC region during the nine month period which followed. The workshop format used for presentations during the first six months of Workshop Director Sandra Grafton's employment served as a basis for the format used in these SEIMC presentations. These workshops served several purposes for the Project:

- 1) retrieval of feedback information on consumer use of the Project's programs;
- 2) retrieval of market data on Project MORE programs;
- 3) familiarization of TMR trainers in the field with Project MORE programs;
- 4) teaching trainers using the programs the basic techniques used by the Project, and
- 5) training people outside the Project to be workshop leaders for training second-generation workshop participants.

In the cooperative effort on workshop presentations, the SEIMC made initial contact with state departments of education in each of the states in its region. All states in the region expressed interest in the presentations. The state departments then selected dates and a site for the sessions and submitted names of key persons in the state to attend. SEIMC sent applications to these suggested people and selected the participants from these applications.

Participants were selected in teacher-administrator teams. This model was selected because implementation of a program is more likely to occur if the administrators are aware of and support the teachers' efforts. Approximately nine teams were selected for each session. Each participant selected signed a precommitment form. This commitment was to insure the objectives of the workshop and create participants' interest in the programs. With this precommitment the teachers agreed to:

- 1) select one Project MORE program for use in a TMR classroom;
- 2) train one, two, or three classroom students in this program;
- 3) attend two workshop sessions led by the Project MORE workshop director;
- 4) conduct a second generation workshop for other people working with TMR students, and
- 5) file report forms on results on the use of the program and use of the workshop with the Project MORE workshop director.

The presentations given in each state consisted of two one-day sessions. The first session was a training presentation of the basic techniques used in the Project MORE programs: teaching strategy,

reinforcement techniques, and the measurement system. These were explained and demonstrated by the workshop director and each participant practiced them through simulation exercises. Actual practice with the Project MORE program that the teachers selected to use in the classroom was also a major part of this session.

The second one-day session was given six weeks later to the same group. This session was a follow-up on the programs after four weeks of classroom use. The teacher-administrator teams helped other teams solve problems encountered and discussed the successes that they achieved in using the programs. This session also included instruction for each team on conducting the second-generation workshop.

A new prototype workshop package was developed to meet the needs of the workshop aims and field tested at Lakemary Center in Paola, Kansas, and in the Lawrence public school district in Lawrence, Kansas. Revisions from these field tests were made before workshops were presented in Nebraska, Iowa, Kansas, Missouri, North Dakota, and South Dakota.

To help the second-generation workshop leaders, a kinescope explaining and demonstrating the techniques of the Project MORE programs was produced. Duplicates of this kinescope were made available for teachers to use in the second generation workshops. A slide show with synchronized tape narration was also made to explain the philosophy of the Project, give background information about it, and explain the processes used in developing programs. This too was duplicated and made available for the second generation. A workshop leader's manual was added to the workshop package, as well as new transparencies.



Second-generation workshop participants consisted of TMR teachers, paraprofessionals, and parents in the geographical areas of the workshop leaders (the teacher-administrator teams). These participants signed precommitment forms in which they agreed to:

- 1) select one Project MORE program for training;
- 2) buy the Project MORE program selected for use;
- 3) train one, two, or three students in the program;
- 4) attend the workshop session, and
- 5) file a report form on the use of the program with the Project MORE workshop director.

New information retrieved by the Project from these sessions included a Use of the Workshop evaluation form returned by the second-generation workshop leaders (see Results sections for more information on workshops).

#### IV. RESULTS

With development and dissemination of improved educational technology for handicapped children as a major objective of Project MORE, the results of the Project efforts have taken many different forms. The most obvious products are the daily-living skill programs which are available to the public through Edmark Associates.

These programs are aimed at helping the professional or para-professional trainer use a proven simple teaching strategy to teach a retarded person a necessary skill.

Other Project MORE efforts have resulted in workshops designed to teach trainers how to use specific Project MORE materials and to acquaint them with behavior modification in general.

Project members have also transmitted much of their findings in educational research methods to their colleagues through the publication of articles, books, and book chapters on various subjects.

The Project MORE newsletter has kept individuals who have expressed interest in Project MORE materials informed of up-to-date developments.

A number of supplementary materials have been designed to assist both trainers and students who use the programs.

Other results include an accountability system which is used to plan the Project's daily operations, and field test data generated through work with PSHTC residents.

Each of these results is discussed individually at length in this section.

## PROGRAMS

During the early years of the Project, products available on the market represented only the "tip of the iceberg" when compared to the massive effort placed on evaluation and research for development. This situation gradually began to change when the Project signed a contract with a commercial publisher in the spring of 1974.

The Program Design and Development Chart (Figure 0) reflects the various stages of production of all programs as of February 1, 1975.

### How To Do MORE

A manual detailing basic teaching strategies, procedures, and theories necessary for successful use of all Project MORE programs was the first work to be published. Titled How To Do MORE, the book was made available to the public in April 1974.

How To Do MORE was produced in a cartoon format and was designed to be the front runner for the Project's daily-living skills programs. For this reason, the price of the manual was kept as low as possible (\$2) to encourage potential consumers to become acquainted with Project MORE materials. Contents of How To Do MORE include reinforcement techniques, a four level of assistance teaching strategy to insure that the student reaches self-sufficiency, and data keeping procedures.

### Eating

Project MORE's second program on the market after publication by Edmark Associates was the Eating program. Before this program was produced a good deal of consultation was required with the publisher in order to maintain continuity between products. It was decided that all Project MORE programs should have basically the same art, format, and

# Program Design and Development

PROGRESS ON 40 PROGRAM UNITS AS OF FEBRUARY 1, 1975

	Definition of Target Behavior	Task Analysis	Design of Teaching Techniques	Development of Loading Chart	Pilot Testing	Rough Draft of Program	Mediation of Program Prototype	Program Testing	Data Analysis	Program Revisions	Final Testing	Final Mediation	Transmission to Publisher	Final Production by Publisher	Dissemination	Program Revisions	Dissemination of Revised Programs
Hair Rolling																	
Toothbrushing																	
How To Do MORE																	
Eating																	
Complexion Care																	
Face Shaving																	
Legs and Underarm Shaving																	
Nose Blowing																	
Hand Washing																	
Stimulus Shift (8 manuals)																	
MORE About It																	
Hair Washing																	
Use of Deodorant																	
Care of Eyeglasses																	
Feminine Hygiene																	
Nail Care																	
1. Fingernails																	
2. Toenails																	
Showering																	
Care of Simple Injuries																	
1. Cream Antiseptic																	
2. Adhesive Bandages on the Body or Legs																	
3. Adhesive Bandages on the Arms or Hands																	
4. Gauze and Tape																	
5. Medical Help																	
6. Minor Burns																	
7. Serious Burns																	
8. Bruises, Swellings, and Black Eyes																	
9. Nosebleeds																	
10. Animal Bites																	
11. Insect Bites																	
12. Setting up a Medicine Chest																	
Using a Telephone																	
1. Answering																	
2. Seven-Digit Numbers																	
3. Emergencies																	

■ Completed Activities as of February 1, 1975

▨ Activities in Progress

© 1975 The University of Kansas (Project MORE)

typographical style. This decision necessitated several changes in earlier work. Once these changes were made, work again began to flow smoothly and the Eating program became available for purchase in December, 1974.

All Project MORE programs were divided into three groups and plans were made to market these groups together as color-coded "families." Eating was considered part of the Social Skills family, which are designated by a blue cover. Other groupings are Personal Appearance (green) and Personal Hygiene (orange).

#### Nose Blowing

The next program to become available from Edmark was the Nose Blowing program. This program is part of the Personal Hygiene group and was often used as a sample program for simulation in Project MORE workshops. The program is a prime example of the four-level teaching strategy in action. It consists of 13 steps, and like all other Project MORE programs, it is marketed with a packet of data sheets and graph sheets. These data-keeping materials can be duplicated by the trainer if the need arises.

Training is usually done on a one-to-one basis and requires only a box of tissues and an ordinary wastebasket for instructional purposes. The program also includes a review of the teaching strategies and procedures explained in the How To Do MORE manual. The practice of reviewing these subjects is found in all programs.

#### Toothbrushing

The revised edition of the Toothbrushing program went on the market

in January, 1975. The program outlines a simple teaching strategy for training students in the proper way to brush their teeth. The program is part of the Personal Hygiene group.

#### Hand Washing

The Hand Washing program teaches the fundamental hygiene skill of washing one's hands unsupervised, a prerequisite of several Project MORE programs. It is recommended that the program also be taught in conjunction with the Eating program.

The Hand Washing program went on the market in January, 1975.

#### Stimulus Shift Articulation

A speech articulation program with eight manuals for sounds to be trained and a procedures manual for the trainers is among the later works developed by Project MORE. The program has been submitted to the publisher for final publication.

The Stimulus Shift Articulation program is designed to be used not only by speech clinicians, but also by speech therapy aides and student clinicians.

In addition to the nine manuals, supplementary materials have been prepared for the program. These include data and record sheets, flash cards, and a series of picture booklets to be used for evaluating and teaching generalization capabilities.

#### Hair Washing

Project MORE's Hair Washing program teaches a commonly-accepted method of washing hair using two shampoo-rinse cycles. The student adjusts the water for correct temperature, washes and then dries the hair with a towel. The program is classified as a Personal Hygiene skill,

but it is also an important part of personal appearance. Hair Washing is in final mediation.

#### Use of Deodorant

The Use of Deodorant program teaches the student how to remove the cap from a can of spray deodorant, shake the can, and spray under each arm. Spray deodorant was chosen for this program because a single can may be used by more than one person without causing a health hazard. For those who prefer not to use spray cans there is an optional section which teaches the use of roll-on deodorant. This program is in final mediation.

#### Showering

Project MORE's Showering program teaches the single most important element of personal hygiene, washing the body. The student learns this important skill with the help of a specially written song which aids the student in remembering the order in which to wash body parts. Supplementary showering materials include a recording of the "Shower Song." Three students may be taught the program at a time. The Showering program is in final testing.

#### Feminine Hygiene

Designed for female students from prepubescence to menopause, the Feminine Hygiene program teaches how to put on a sanitary belt and napkin, how to take off the belt and napkin, and how to dispose of the napkin properly. The program is in final mediation.

#### Nail Care

Project MORE's Nail Care program teaches a student how to clean,

file, and clip fingernails and toenails. The skill is important for both health and appearance reasons. It is part of the hygiene group and is currently being field tested.

#### Complexion Care

Students are taught to clean their faces by using two different methods--with soap and water, and with a skin cleanser--in Project MORE's Complexion Care program. Additional steps are included to teach applying blemish corrective cream or moisturizer. The program can be used with male as well as female students. It has been sent to Edmark Associates in completed form and is awaiting publication by that organization.

#### Face Shaving

Students learn to shave themselves using a safety razor and shaving cream in the 21 step Face Shaving program. Special provisions are made in the program for teaching those steps which may be dangerous or particularly difficult for a student. This program has been sent to Edmark and is awaiting final publication.

#### Leg and Underarm Shaving

Leg and Underarm Shaving is a Personal Appearance program designed for adolescents and older women. Students learn to shave their underarms and legs using a safety razor and soap. This program has been sent to Edmark and is awaiting publication.

#### Care of Eyeglasses

Project MORE's Care of Eyeglasses program teaches students how to clean their eyeglasses by using hot water and lint-free tissue. The



program may also be helpful for those who do not wear prescription glasses, but who do wear sunglasses. This program is in final mediation.

### Hair Rolling

Hundreds of Hair Rolling programs have been sold in an original edition. This program was recently re-edited, updated, and submitted to Edmark for publication of the revised edition. Hair Rolling is designed to teach mentally retarded girls to roll their own hair. The program teaches combing and parting hair, applying setting gel, putting rollers in the hair, and removing rollers. A section is also included in the manual to teach black girls to roll their hair.

### Care of Simple Injuries

The Care of Simple Injuries is a series of 12 units designed to teach the student how to care for minor injuries and thereby lessen his dependence on others in the community. The first four units have been sent to the publisher and are in final production. These units are 1) Cream Antiseptic, 2) Adhesive Bandages on the Body or Legs, 3) Adhesive Bandages on the Arms or Hands, and 4) Gauze and Tape.

Five units of the program are in final mediation. These include 5) Medical Help, 6) Minor Burns, 8) Bruises, Swellings and Black Eyes, 9) Nosebleeds, and 10) Animal Bites. Three units of the Care of Simple Injuries have not reached final mediation: these are 7) Serious Burns, 11) Insect Bites, and 12) Setting up a Medicine Chest.

### Using a Telephone

Another program which consists of multiple units is the Using a Telephone program. In the first unit the student learns to answer the telephone in a socially acceptable manner and deal with the caller. This

might include explaining that the party requested is not home, getting the party requested, or conversing with the caller.

The second unit teaches the student how to dial a seven-digit number, how to respond when the phone is answered, or is busy, or is unanswered after ten rings. The third unit teaches correct procedures for reporting emergencies over the telephone. The programs are in final mediation.

This program requires the use of a telephone simulator and a group of flashcards which have already been developed by Project MORE.

## Workshops

In addition to SEIMC workshops discussed in the Procedures section of this report, workshops were also presented at several national conventions during this period. These included presentations in 1974 in March at the Association for Educational Communications and Technology, Inc., convention in San Francisco; in April at the national Council for Exceptional Children convention in New York; and in June at the American Association for Mental Deficiency convention in Toronto.

### Project MORE - KU/SEIMC Presentations Schedule - 1973-74

<u>DATE</u>	<u>PLACE</u>	<u>TYPE OF PRESENTATION</u>
October 17	Topeka, KNI	Presentation to the Governor's Conference on Mental Retardation
October 19	Paola, Kansas	#2 IMC Workshop Field Test
October 23-25	Wichita, Kansas	AAMD Region V Conference: Symposium
October 29	Arlington, Texas	Veda Knox School: Workshop Follow-up
October 30	Lawrence, Kansas	#2 IMC Workshop Field Test
December 1	Kearney, Nebraska	#1 IMC Workshop - State of Nebraska
December 8	Lincoln, Nebraska	#1 IMC Workshop - State of Nebraska
January 7	Lincoln, Nebraska	#2 IMC Workshop - State of Nebraska
January 15 & 16	Lake of Ozarks Tan-Tar-A	#1 IMC Workshop - State of Missouri
January 24	Wichita, Kansas	#1 IMC Workshop - State of Kansas
January 30 & 31	Grafton, North Dakota	#1 IMC Workshop - State of North Dakota
February 4	Aberdeen, South Dakota	#1 IMC Workshop - State of South Dakota
February 13	Glenwood, Iowa	#1 IMC Workshop - State of Iowa
February 14	Woodward, Iowa	#1 IMC Workshop - State of Iowa
February 25	St. Louis, Missouri	#2 IMC Workshop - State of Missouri
March 1	Kansas City, Missouri	#2 IMC Workshop - State of Missouri

March 12-15	San Francisco	Educational Technology National Convention: Workshop Demonstration
March 17-22	Atlantic City	AECT National Convention Workshop Demonstration
April 10	Glenwood, Iowa	#2 IMC Workshop - State of Iowa
April 11	Woodward, Iowa	#2 IMC Workshop - State of Iowa
April 14-19	New York City	CEC National Convention: Workshop Demonstration
May 23-24	Alton, Illinois	Workshop for Alton State Hospital Staff
June 1-4	Toronto	AAMD National Convention Symposia

When scheduling these workshops, 25 participants were considered to be the ideal number. In many cases, however, it was necessary to include more than 25 in a single workshop. Final count of the total number of participants in all KU/SEIMC workshops came to 300.

Adding to this figure were the number of people who participated in workshops presented at conventions and professional meetings throughout the United States and Canada. The Project MORE workshops were well accepted at these functions and often were not able to accommodate the number of people desiring to participate.

Due to the high number of participants at the Council for Exceptional Children convention presentation in April 1974, most of the people attending did not receive Project materials at the workshop session. A package of materials, including an information sheet about the Project, an outline of the session, excerpts from the workshop manual, a brochure, and the latest newsletter, was sent to each of those attending the CEC/convention session. Project MORE media produced and mailed 500 of these packages.

Materials for all workshops were produced by the Project MORE media department. These materials included workshop manuals, workshop handouts, information releases, ordering information for Project materials, brochures, address cards, and prototype programs (for workshop use only) for the workshop package.

## Publications

Project staff have also spent time writing articles and other materials for publication. These materials were directed to individuals interested in special education. Many of these are aimed at helping others share the system for developing programs now in use by Project MORE.

## Design and Development Book

During 1974 Project MORE accelerated development of a manuscript to make teaching, program planning, and program development for the handicapped a simpler and more effective task.

Funded by the Bureau of Education for the Handicapped through the National Center on Educational Media and Materials for the Handicapped, Project MORE staged two conferences with recognized authorities in the instructional materials production field. The dialogue between these individuals and key Project MORE staff members forms the basis for The Design and Development of Instructional Products for the Handicapped: An Emerging Technology.

The work explains how to develop and disseminate instructional materials for use in educating handicapped persons, while comparing and contrasting Project MORE with other projects' technologies for instructional product development.

Aimed at both laymen and professionals, the text provides a full range of material on instructional technology, including specific examples of design, development, mediation, and dissemination. It is the only existing work to provide details pertinent to the interaction among the various components of an instructional technology.

The Design and Development of Instructional Products for the Handicapped: An Emerging Technology is designed for use by special education school system curriculum developers who determine what a large number of teachers will teach. At present these individuals have no consultive compendium for curriculum planning. The book is also useful as a text for students who plan to become special education teachers or administrators.

Public school teachers and parents of handicapped persons who want to train their students on an individual basis will find the text contains information on individual program planning material. Federal granting agencies and foundations and organizations with grants programs make up a fourth potential audience. Through the text these groups can acquire a knowledge of what to look for when preparing to fund an instructional product development group.

Format plays a special part in the book. The text features wide margins which contain cross references, references, and illustrations. This design provides easy access to reference material, highlights important comments, and makes the page more inviting visually.

An introduction by Dr. R. L. Schiefelbusch, director of the University of Kansas Bureau of Child Research, describes the rationale for the book. The preface identifies the contributors and outlines the book's organizational plan. An index which categorizes the various major topics discussed in the text has been compiled.

To date, The Design and Development of Instructional Products for the Handicapped: An Emerging Technology has been publicized only through MORE News, Project MORE's quarterly newsletter. As a result of three

articles carried in the newsletter, the Project has received a number of requests for the text. Although these requests represent only a sample response to the book, they are indicative of the number of inquiries a full advertising campaign would garner.

The manuscript is currently being made camera-ready and will be published by Edmark Associates.

#### Focus Article

Project Director James R. Lent completed an article scheduled for inclusion in the March 1975 issue of Focus on Exceptional Children.

The article, titled "The Severely Retarded: Are We Really Programming for Their Future?," discusses the effects of daily decisions on the course of society's future in terms of quality of life for all, with emphasis on the needs of the retarded population. The role of technology in education of the future, as well as the need for new and more effective methods of teacher training are also considered at length.

Focus on Exceptional Children is published quarterly by Love Publishing, Denver, Colorado.

#### Teaching Special Children Chapter

"The Trainable Retarded: The Technology of Teaching," a chapter by Dr. Lent and Barbara M. McLean, will appear as a chapter in Teaching Special Children being published by McGraw-Hill.

The Lent-McLean chapter concerns the technology of teaching as applied to trainable-level retarded children, including discussions of task analysis and methods of practical and effective environmental management for such children. The study guide for the entire textbook was written by Barbara McLean and Sandra Grafton of the Project staff.



Teaching Special Children, which is edited by N. G. Haring and R. L. Schiefelbusch, is designed for use as an undergraduate textbook for special education students and is scheduled for release in mid-1975.

#### Mental Retardation Chapter

Dr. Lent has completed a chapter scheduled for inclusion in a new book published in 1975 by the Charles E. Merrill Company.

Dr. Lent's chapter, "Developing Daily-Living Skills for the Mentally Retarded," will appear in Mental Retardation: Introduction and Personal Perspectives. The text, edited by J. M. Kauffman and J. S. Payne, relates personal experiences and observations by a number of authorities in the area of mental retardation. The book is scheduled for release in March.

#### NARC Film Catalog

The Project recently reprinted the second edition of "Mental Retardation Films," a catalog of 16mm films on subjects concerning mental retardation.

For the second printing, the catalog was expanded with the addition of a 16 page section listing 56 additional films. Seven new suppliers were added and supplier addresses were updated.

Like earlier catalogs, the new one tells how to order the films, as well as providing information about each film. Most listings feature a short synopsis of the film, provide rental and purchase information, and include the film length. Some listings give date and producer, and tell whether the film is black and white or color.

### Venezuela Presentation

Dr. Lent was one of 14 guest speakers at the International Symposium on Behavior Modification in Caracas, Venezuela, in December 1974. Dr. Lent's presentation, "Forward to a Technology of Behavior Change for the Mentally Retarded," emphasized the need for the evolution of an educational technology if disadvantaged peoples are to be given the advantages of everyday life in their particular societies. More than 1,000 symposium participants heard his remarks.

The symposium was aimed at impelling in Latin America a movement which would bring about a series of applications of the principles and theories derived from experimental work in psychology, particularly in the area of learning.

The speaker's presentations, including Dr. Lent's paper, will be published in both Spanish (Editorial Trillas) and in English (Academic Press) and should be available in mid-1975.

## MORE NEWS

The Project MORE newsletter, MORE News, is now in its second year of production. Its circulation has grown from 1,000 to over 8,000.

Circulation increase has been at a steady rate, resulting from referral by other newsletter recipients and requests at workshops, conventions, and similar professional meetings.

MORE News has been published six times and serves to keep its readership up to date on research developments and availability of Project MORE programs and materials. It has also announced the completion and availability of a revised National Association for Retarded Citizens Film Catalog, dates and locations for Project MORE workshops, and information concerning publications by Project staff. In this sense the newsletter has served to take the place of separate letters to each individual regarding updates on their original requests for information. On occasion, copies of the newsletter are also used in lieu of a letter when the Project receives a new inquiry.

The newsletter has proven to be the simplest and most economical way of keeping interested persons and potential consumers informed about Project developments.

An effort is now being made to expand the newsletter's scope. Future issues will include information beyond the immediate activities of Project MORE. Project staff plan to include information passed on from other educational research organizations, media centers, and similar professional publications. In this way there will be a cross-over of readership and an expanded knowledge of available sources of educational materials.

### Supplementary Materials

Project staff have developed ideas for posters to accompany Project MORE programs. Each program will have at least one poster intended to remind the student of when or why to perform a skill. This aspect of the Project's supplementary materials effort is awaiting confirmation by the publisher as to design before artwork is finalized.

Another poster designed for use by teachers has been sent to Edmark along with the drafts for posters for students. This poster is designed as a progress chart which may be used for several students in a class. It lists a number of skills and includes space where the student may receive a star or mark if the skill is performed correctly.

A poster giving a number of examples of suggested verbal reinforcement has been completed. The poster was sent to the publisher and will eventually accompany all printed programs.

Slides and audio tapes were completed for use with the Care of Simple Injuries program. These materials have been sent to the publisher for conversion into filmstrips. Flash cards depicting burns are another supplementary material for the Simple Injuries program.

A rendition of achievement certificates for each program has also been submitted to the publisher. The basic certificate design will name the skill learned by the student and the program used, and will include a picture of the skill on the certificate. A basic design will be used for all certificates with these items adapted for each program as it comes on the market.

## ACCOUNTABILITY DATA

The accountability data collected during the last year has resulted in 1) a systematic planning procedure for all staff persons; 2) a continual monitoring device for assessing current progress in relation to overall goals; 3) a statement of total cost per program or product, based on actual staff time; and 4) a more refined process for planning future activities.

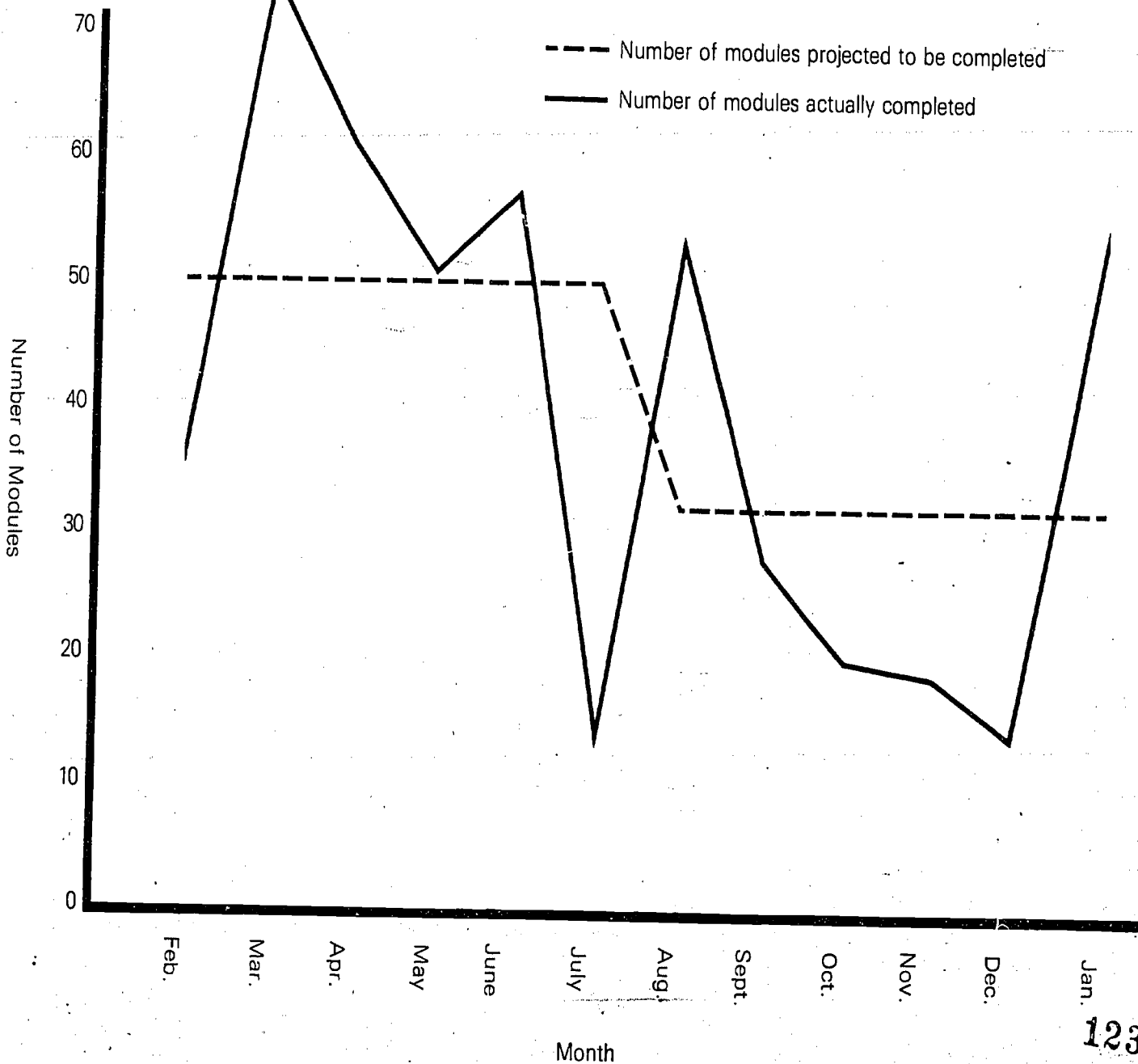
### Systematic Planning for Current Year

Figures P-Y give examples of the use of the accountability system for planning. Because each program moved systematically through all 34 steps in the implementation procedure, communication between media and research staff was facilitated. Monthly projections were made which took into account all personnel activities which were needed. For instance, in order to plan for a month's activities, decisions could be made in advance on graphics time anticipated to complete a job, use of presses, scheduling of students and nonstaff trainers, and the purchase of supplies.

### Monitoring Device for Current Activities

Various charts were kept on a monthly basis in order to reflect the current overall progress of the grant. One of the main indexes used was the number of modules completed each month. At the beginning of the year projections were made about the number of modules which needed to be completed each month in order to fulfill the grant's obligations. Figure P presents this data in graphic form, using a dotted line. The solid line reflects the number of modules actually completed each month. Although there was a great deal of month-to-month variation

**Figure P: Number of Modules Completed per Month**



(probably because the modules differ greatly in the amount of time each takes), the Project generally stayed on target. This can be seen better in Figure Q, which is the same information presented in cumulative graph form.

A second monitoring index was the amount of dollars spent directly on product development. The goal here was estimated at 35 percent of staff time to be spent monthly directly on products. (Other categories were vacation, administration, etc.) Figure R represents the goal (dotted line), and the actual amount of money spent (solid line), directly on products by only the research staff. Figure S represents the same information for media staff alone. It appears from both graphs that the entire combined staff spends more than 35 percent of their time directly on products. Figures T and U present the same information in cumulative graphs.

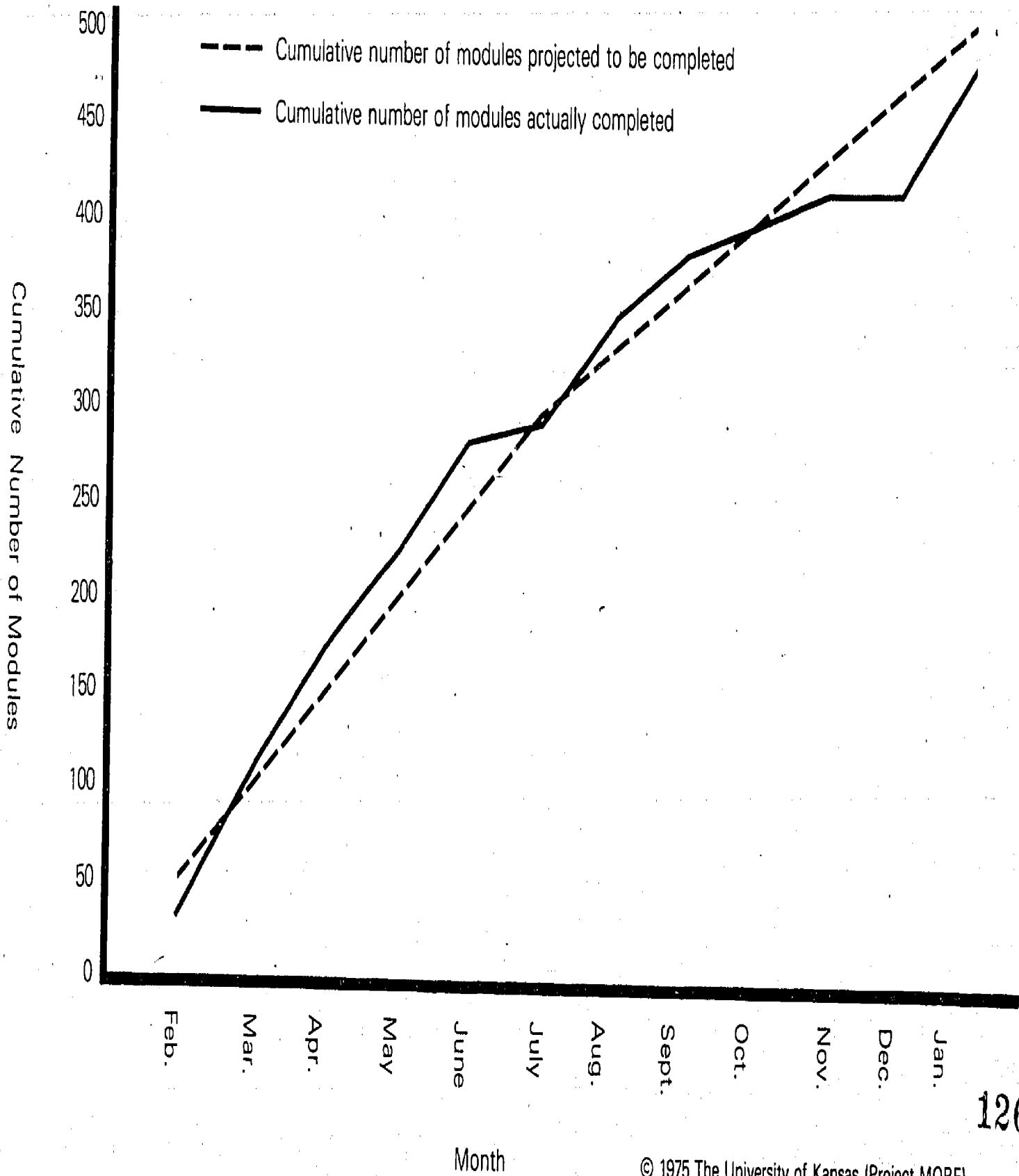
In order to obtain information on total money spent, all indirect ~~costs were prorated over all products.~~ The indirect costs included not only those indirect costs paid to the University on personnel salaries, but also internal costs such as administration, vacation time, supplies, travel, etc., which couldn't be attributed to a product. Figures V and W represent the total costs spent each month. The goal line represents one-twelfth of the yearly budget.

Two final charts are presented in Figures X and Y. They give the percent of time that research and media staff spent on all activities.

By referring to the charts, one can see how the accountability system monitors program costs and progress.

Figure Q:

### Cumulative Number of Modules Completed per Month

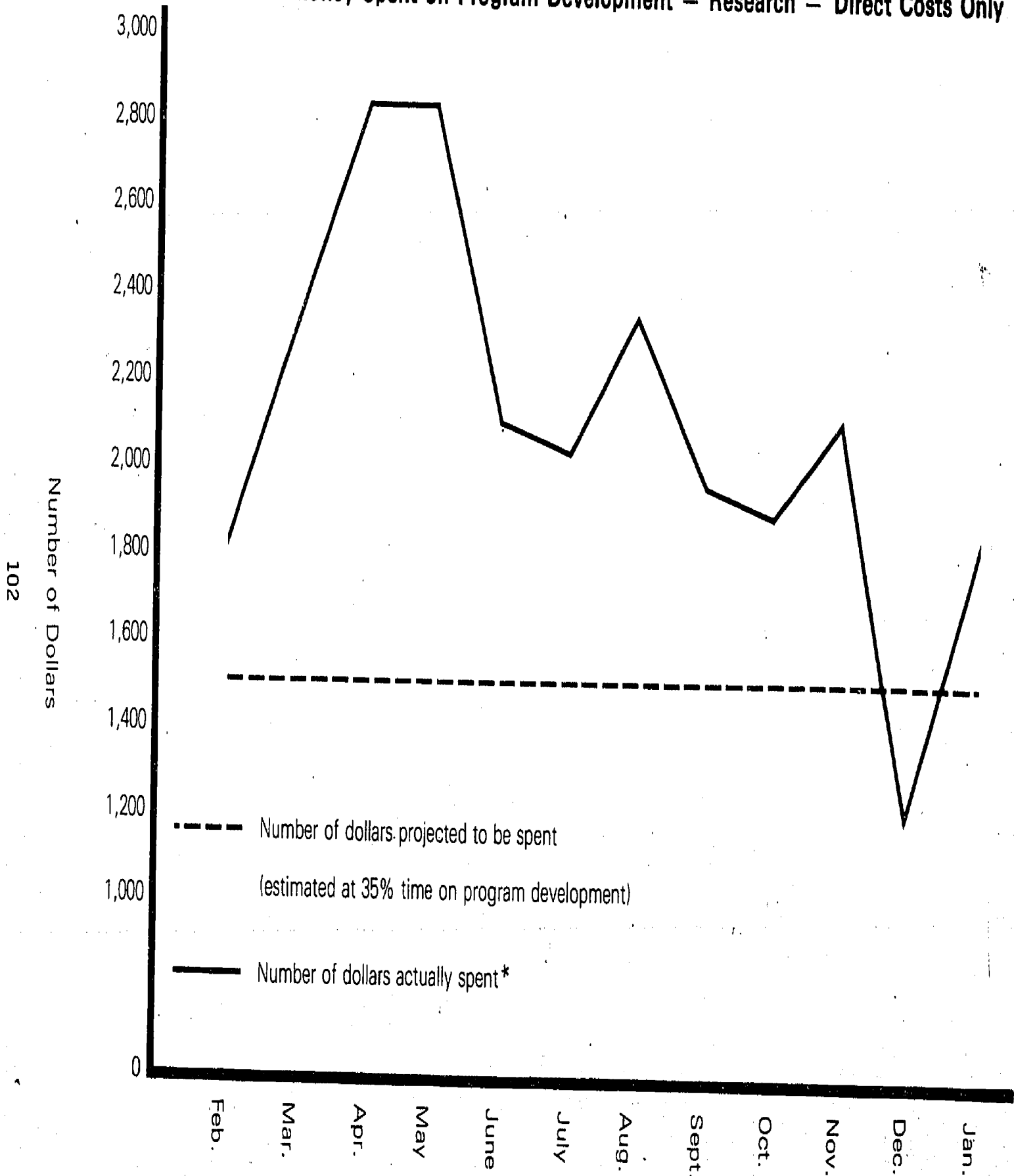


101



Figure R:

Amount of Money Spent on Program Development – Research – Direct Costs Only



102

\*More than 35% of Research personnel time was spent on program development.

Month



Figure S:

### Cumulative Amount of Money Spent on Program Development – Research – Direct Costs Only

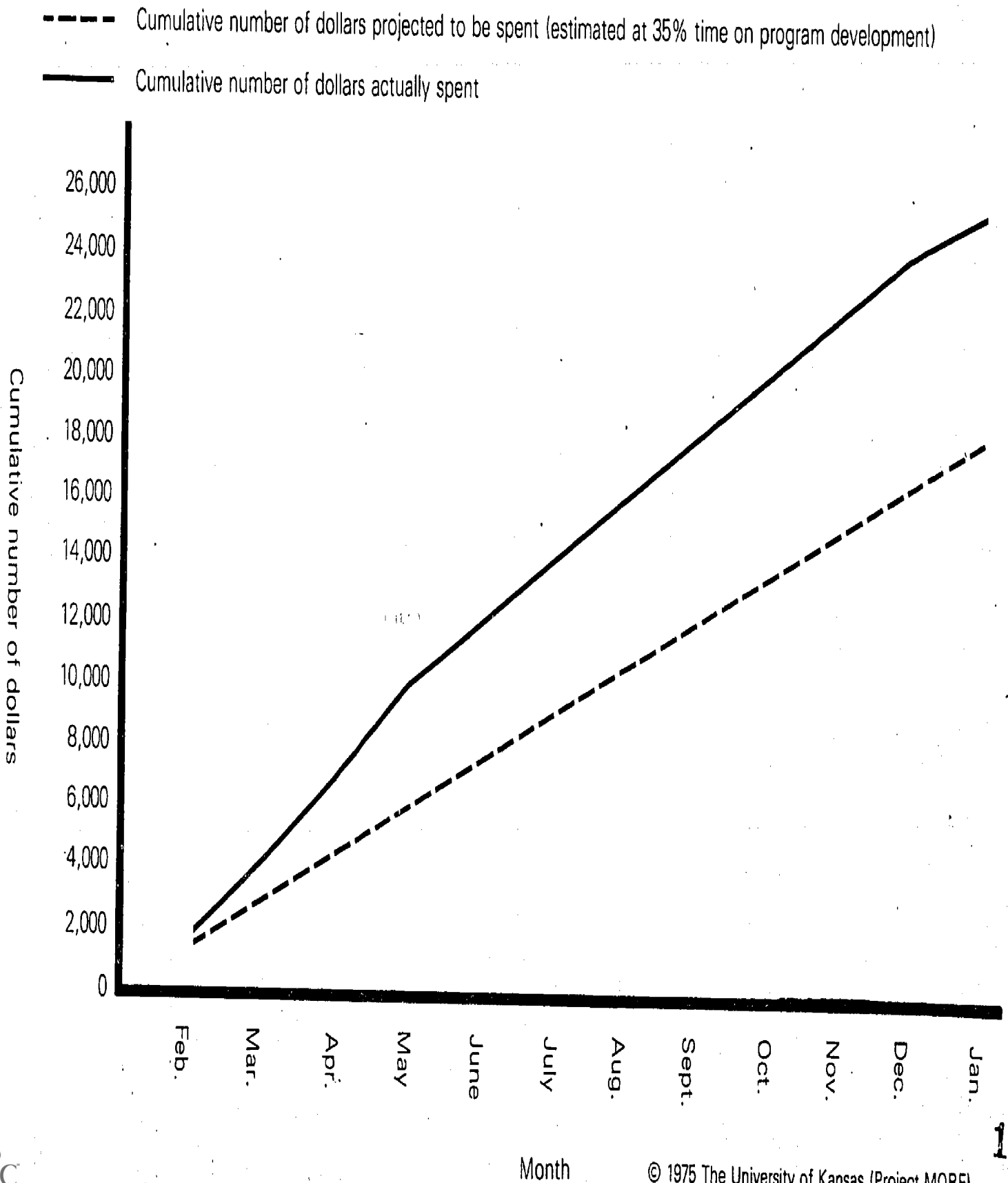


Figure T:

Amount of Money Spent on Program Development – Media – Direct Costs Only

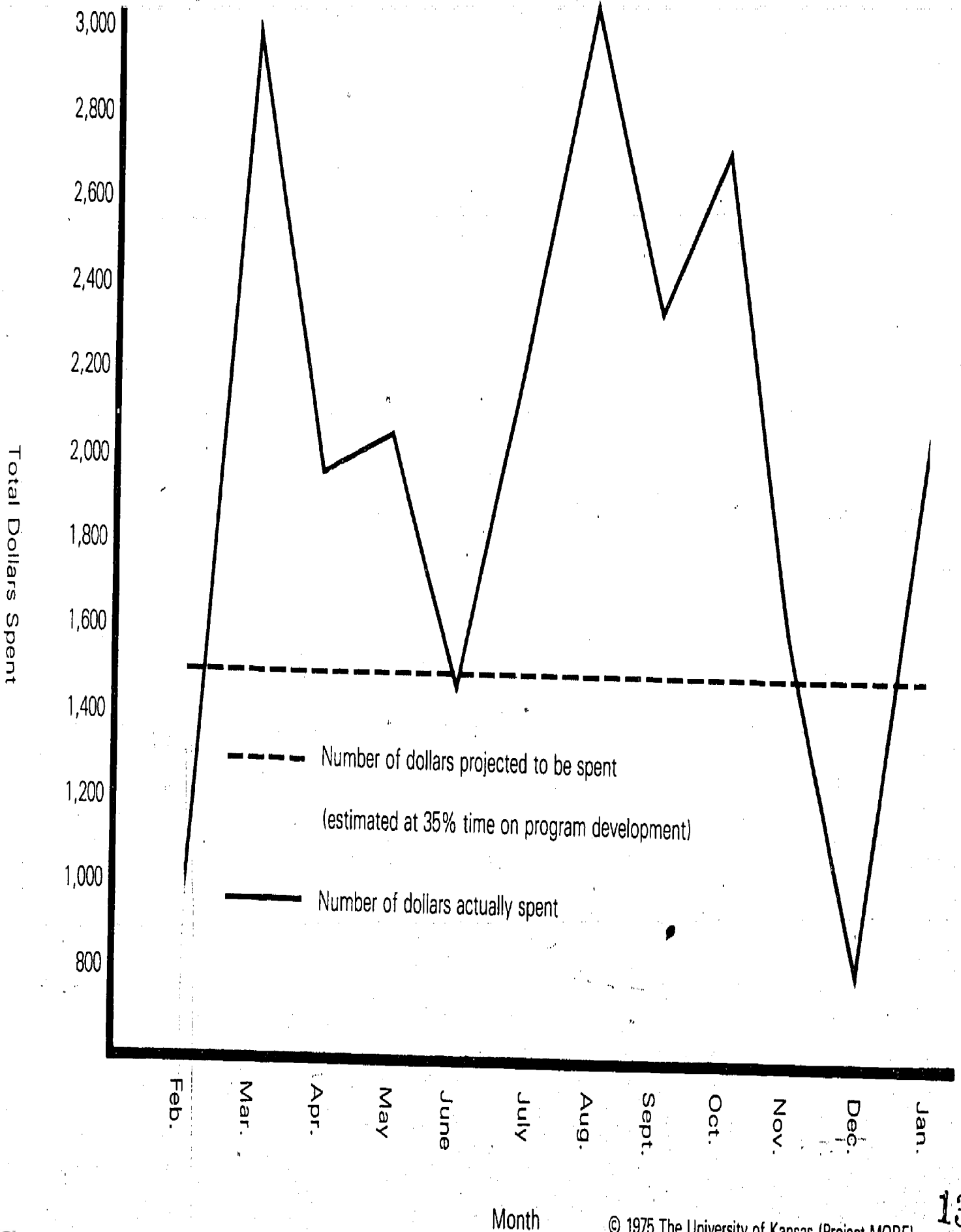
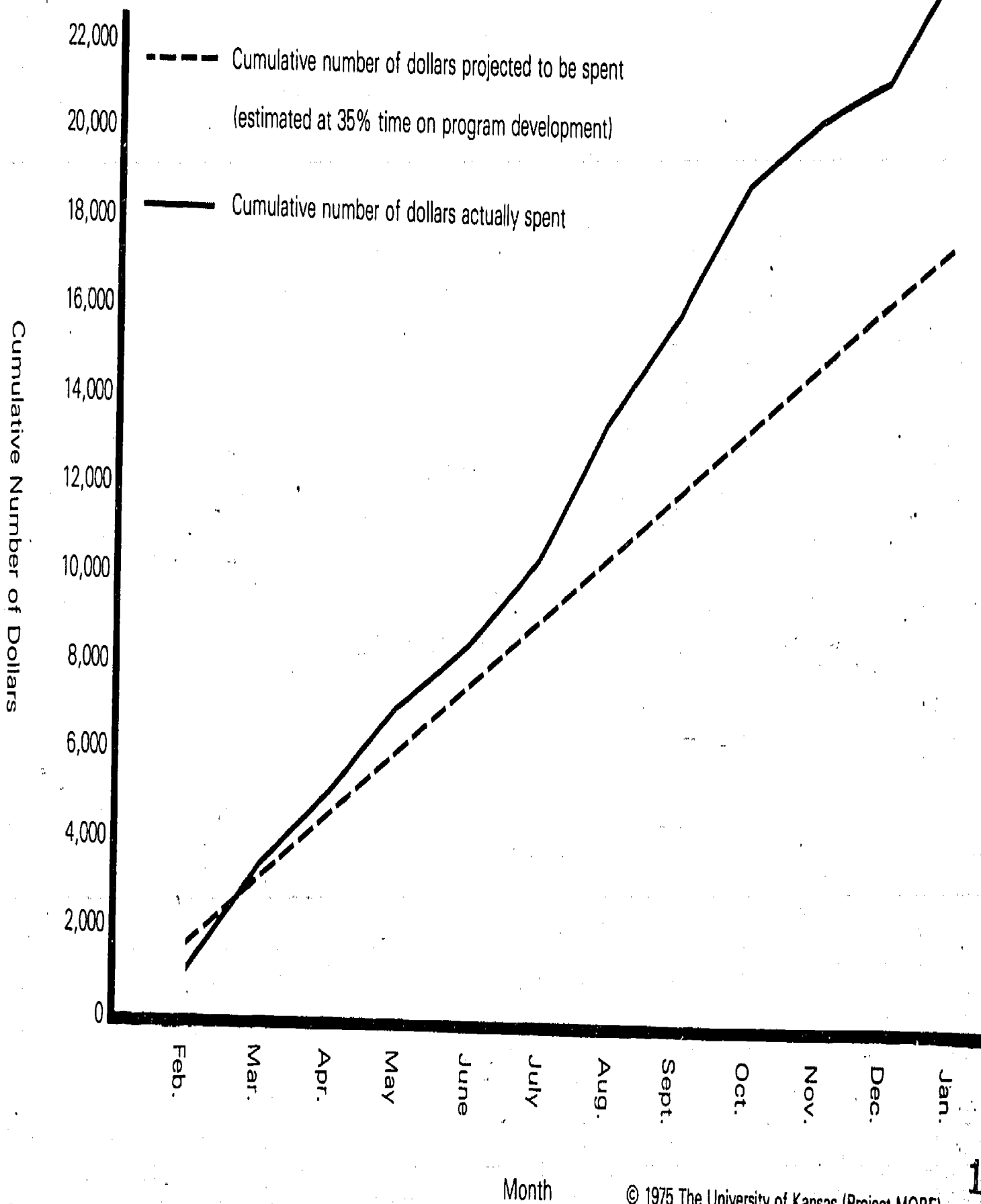


Figure U: •

### Cumulative Amount of Money Spent on Program Development – Media – Direct Costs Only



105

Figure V:  
Amount of Money Spent on Program Development – Entire Project – Direct and Indirect Costs

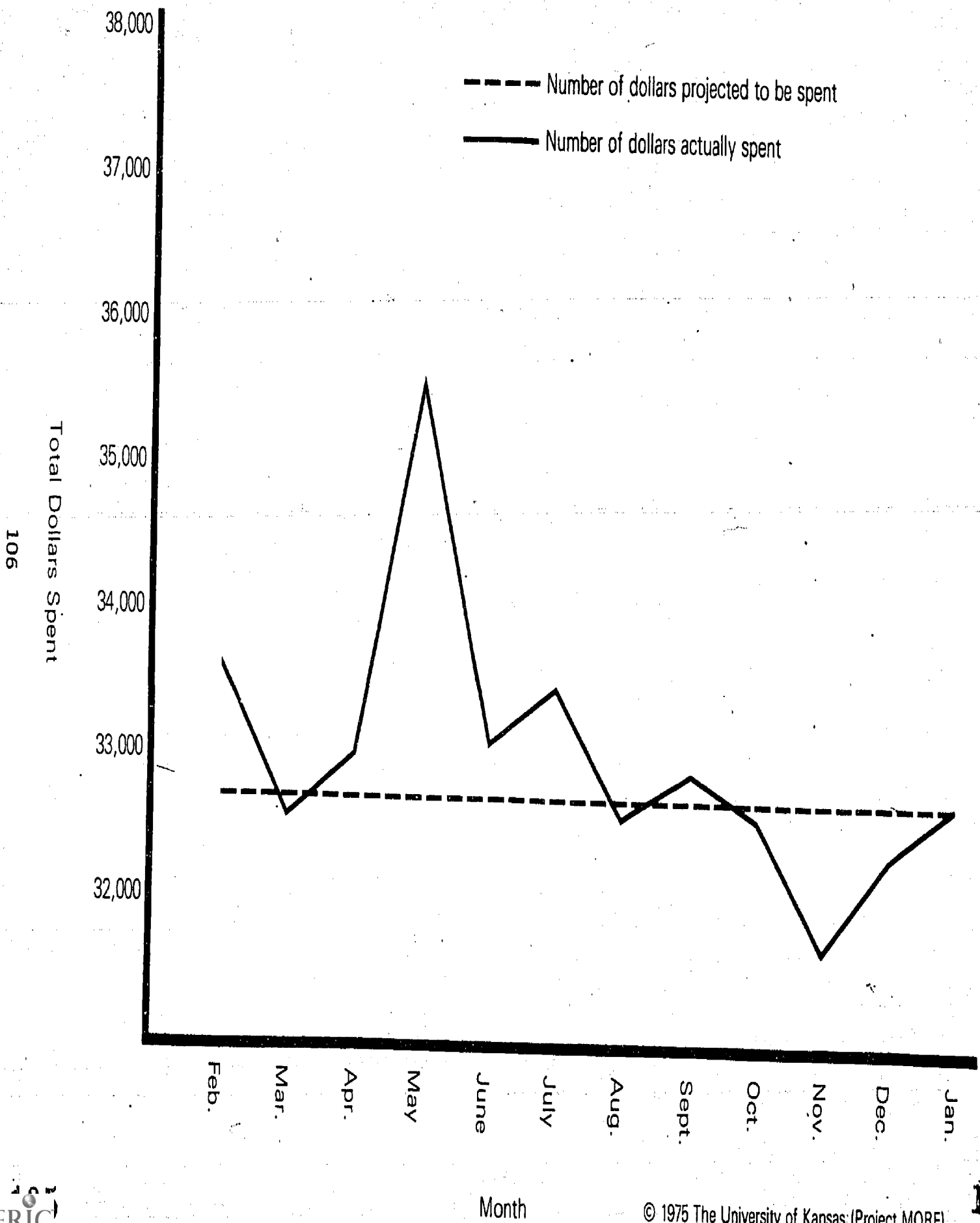
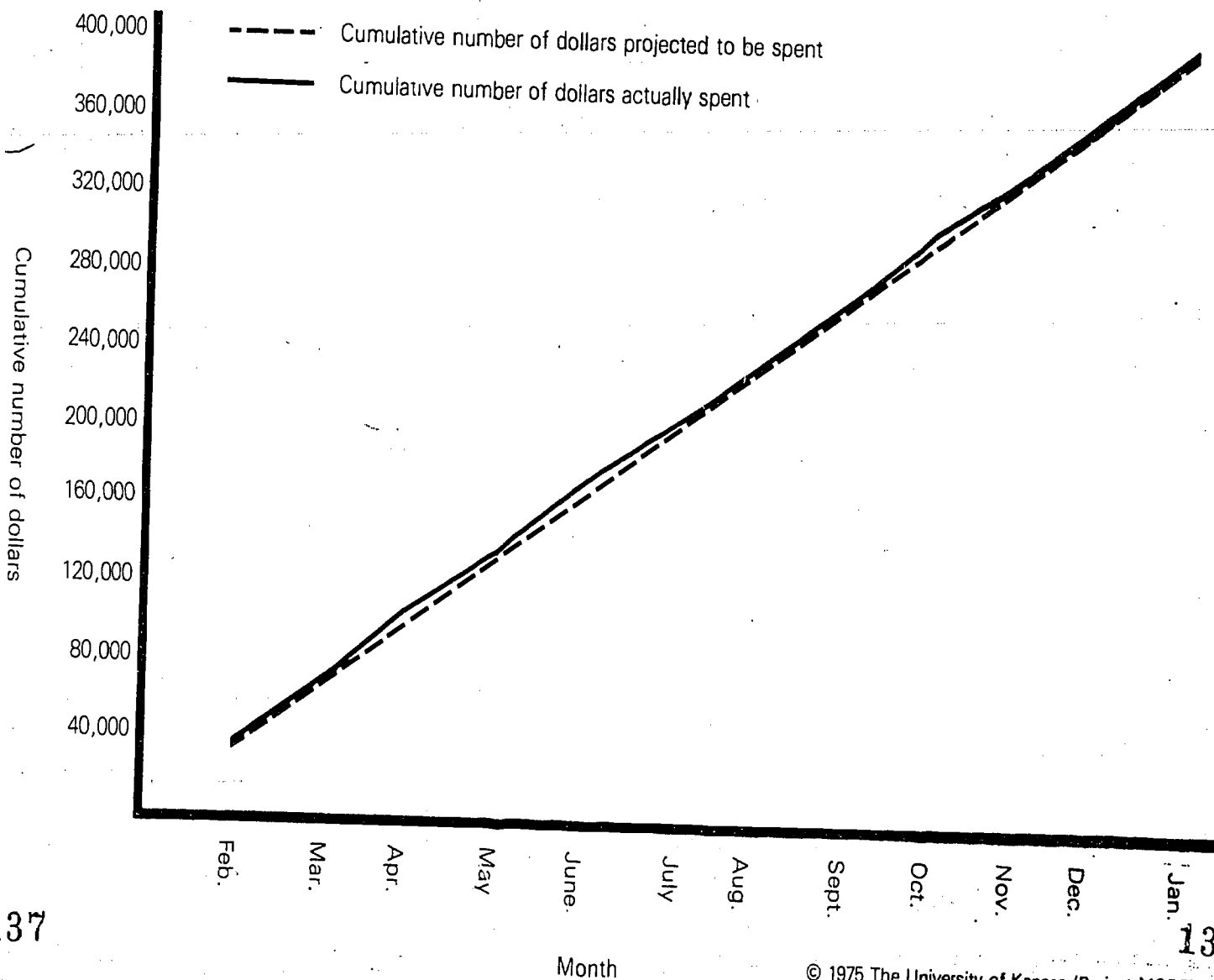


Figure W:

Cumulative Amount of Money Spent on Program Development — Entire Project — Direct and Indirect Costs



**Figure X:**

**Percentage of Research Staff Time Spent on Activities**

	Feb.	Mar.	Apr.	May	June	July	Aug.	Sept.	Oct.	Nov.	Dec.	Jan.
Program Development	30	37	43	41	35	32	38	33	33	36	20	29
Accountability	7	4	7	4	3	4	3	4	3	4	3	5
Vacation, sick, off	17	12	15	18	20	21	19	27	16	24	38	19
Not Working (N/W)	13	9	9	8	8	8	8	9	8	6	7	8
Staff Development	3	4	4	5	8	3	4	4	3	2	1	4
Administration	13	8	5	4	4	7	6	5	3	2	2	9
Miscellaneous	15	10	8	6	5	13	7	9	8	7	6	10
Government Reports	1	0	0	1	1	2	0	1	0	0	0	1
Professional Activities	0	14	8	9	13	8	12	5	9	1	1	3
Project Development	0	0	0	0	0	1	3	3	11	11	14	2
Secretarial (general)*	0	0	0	0	0	0	0	0	5	6	8	10

108

\*Secretarial help began keeping data in October.

© 1975 The University of Kansas (Project MORE)

**Figure Y:**

Percentage of Media Staff Time Spent on Activities

	April	May	June	July	Aug	Sept	Oct	Nov	Dec	Jan
Program Development	49	34	25	37	54	40	43	27	14	33
Accountability	2	2	1	1		1	0	0	0	1
Vacation, sick, off	7	16	11	19	7	24	13	20	24	19
Not working (N/W)		7	8	7	8	5	3	3	4	2
Meetings	4	2	1	4	1	1	1	1	1	2
Staff Development		2	2	0	0	0	1	0	1	1
Other Activities		2	1	1	1	0	1	1	0	0
Miscellaneous	16	21	26	26	26	25	27	36	24	38
Government Reports		1	20	1	1	1	0	0	0	2
Non-Project Work	18	6	4	3	1	2	6	12	7	2
Advisory Board		2				0	0	0	0	0
Workshops	1	1						0	0	0
Mailing List	3	4	1	1	1	1	0	0	0	0
Project Development							2	0	25	0
Professional Activities							3	0	0	0

© 1975 The University of Kansas (Project MORE)



### Cost Per Program

In order to obtain estimates of the cost of each program or product developed, direct costs were obtained as described earlier, and indirect costs were prorated over all products. In addition to the products described in the continuation application for completion by February 1, 1975, and other products scheduled for completion by October 1, 1975, other products were also worked on. Total costs to date are given in Tables 4, 5, 6, and 7. Also indicated in these tables are the number of modules still to be completed for each program and the current status of other programs.

### Process for Planning Future Activities

Projections for future projects will be based on the data compiled during the past year from the current project. A PERT chart reflecting the process by which modules are completed is given in Figure L, page 55. Modules that can be done simultaneously are above one another. Arrows indicate that the module(s) on the left is(are) prerequisite for the module(s) on the right of the arrow. The data accumulated during the last year enables the Project to make empirical estimates of the length of time (in months) required for completion of all activities described in the Implementation Lattice. These times are shown in Figure Z.

From these figures the critical path through the network was calculated. Cumulative time required for completion of a program through any stage in the Implementation Lattice is shown in Figure AA. These figures are based on the mean length of time in months actually required for all programs developed during the current grant year.

TABLE 4

## SCHEDULED FOR TRANSMISSION TO PUBLISHER BY 9/1/74

<u>Cost</u>	<u>Program/Product</u>	<u>Modules Completed</u>	<u>Status</u>
\$ 486	Toothbrushing (Revision)	33-34	To publisher-in print
\$ 6,537	Eating	33-34	To publisher-in print
\$ 367*	Complexion Care	32	To publisher-in press
\$11,461	Nose Blowing	27-34	To publisher-in print
\$ 4,719	Face Shaving	31-32	To publisher-in press
\$ 5,176	Leg and Underarm Shaving	31-32	To publisher-in press
\$22,328	Care of Simple Injuries #1- Cream Antiseptic	19-32	To publisher-in press
\$ 7,652	How To Do MORE	NA	To publisher-in print
\$ 5,209	Field Study #1 (Care of Simple Injuries slides and audiotape)	NA	
\$ 3,674	Field Study #2 (Care of Simple Injuries slides and audiotape)	NA	
\$ 3,623	Field Study #3 (Care of Simple Injuries slides and audiotape)	NA	
\$ 2,522	Reinforcement Poster	NA	To publisher-in press
\$ 570	Technical Report #1 - Instructional Program Evaluation: Goodness of Fit Between Questions and Instruments	NA	To publisher-in print
\$ 2,805	Toothbrushing Working Paper	NA	To publisher-in print

Note: In press means the program or product is in the process of being prepared for publication; in print means the program or product has been released by the publisher and is available to the public.

\*The cost figure for this program is comparatively low because much of the program was completed prior to initiation of the cost accountability system.

TABLE 5

SCHEDULED FOR TRANSMISSION TO PUBLISHER BY 1/31/75

<u>Cost</u>	<u>Program/Product</u>	<u>Modules Completed</u>	<u>Status</u>
\$11,783	Care of Simple Injuries #2- Adhesive Bandages (on the body)	19-32	To publisher-in press
\$ 7,234	Care of Simple Injuries #3- Adhesive Bandages (on hands or arms)	19-32	To publisher-in press
\$11,531	Care of Simple Injuries #4- Gauze and Tape	19-32	To publisher-in press
\$ 2,976	Hand Washing	30-32	To publisher-in print
\$11,143	Hair Rolling (Revision)	33-34	To publisher-in press
\$20,455*	Showering	0	In testing
\$28,929	Stimulus Shift Articulation (9 manuals)	NA	To publisher
\$17,534**	Kinescope-Workshop	NA	To publisher
**	Workshop Packages (2)	NA	To publisher
**	Slide Show (Workshop)	NA	To publisher
***	Showering Kinescope	NA	In testing
***	Showering Audiotape	NA	In testing
--	Showering Movie	NA	Not begun
\$ 226	Still Photo Package Telephone #3 (Drawings)	NA	In final mediation
\$17,035	Newsletters (4)	NA	In print

\*This program has been remacycled

\*\*Workshop products not costed-out separately

\*\*\*Showering audiovisual products not costed-out separately

TABLE 6

SCHEDULED FOR TRANSMISSION TO PUBLISHER BY 9/30/75

<u>Cost</u>	<u>Program/Product</u>	<u>Modules Completed</u>	<u>Status</u>
\$ 5,535	Care of Simple Injuries #5 Medical Help	3-30	In final mediation
\$ 8,963	Care of Simple Injuries #6 Minor Burns	3,8,9,13-30	In final mediation
\$ 2,442	Care of Simple Injuries #7 Serious Burns	3,9,10,12-23	In testing
\$ 6,397	Care of Simple Injuries #8 Bruises and Swellings	6-30	In final mediation
\$ 5,580	Care of Simple Injuries #9 Nosebleeds	6-30	In final mediation
\$ 7,690	Care of Simple Injuries #10 Animal Bites	3-30	In final mediation
\$ 7,015	Care of Simple Injuries #11 Insect Bites	1-23	In testing
\$ 1,905	Care of Simple Injuries #12 Medicine Chest	2-11	In pilot testing
\$12,425	Telephone #1 - Answering	9,13-30	In final mediation
\$13,351	Telephone #2 - Dialing	8,12-30	In final mediation
\$ 9,807	Telephone #3 - Emergencies	3,6,8,9,10,12-30	In final mediation
\$10,148	Care of Eyeglasses	16,19-30	In final mediation
\$ 691	Hair Washing	29-30	In final mediation
\$ 140	Use of Deodorant	29-30	In final mediation
\$10,003	Feminine Hygiene	24-30	In final mediation
\$26,951	Nail Care #1 - Fingernails	12-29	In testing
\$ 1,238	Nail Care #2 - Toenails	12-29	In testing

<u>Cost</u>	<u>Program/Product</u>	<u>Modules Completed</u>	<u>Status</u>
\$ 2,748	Field Study - Burns (Slides and Audio)	NA	Under preparation
\$ 1,302	Still Photo Package Care of Simple Injuries - Burns	NA	Under preparation
\$ 3,049	Working Paper #310 - Data Collection by the teacher: Interference or Stimulus Control?	NA	In final mediation
\$ 1,061	Monitoring Trainer Effectiveness Using Videotape Model Sequences	NA	In final mediation
\$ 1,164	Technical Report #2 - A Hypo- thetical Application of A Needs Analysis Methodology for Specific Educational Materials: A Scenario	NA	To publisher-in print
\$ 962	Technical Report #4 - An Imple- mentation Model for A Supple- mentary Filmstrip	NA	To publisher-in print
\$ 2,217	Working Paper #318 - Social Interactions of Mentally Retarded Persons: A Compara- tive Study of Mouth Control	NA	To publisher
\$ 0	Working Paper #301 - Bridging the Research Consumer Gap: Systematic Procedures to Obtain Commercial Dissemination of Educational Materials	NA	To publisher
\$ 1,969	Games and Puzzles (7)	NA	To publisher
\$ 2,578	Posters (Design)	NA	To publisher
	Technical Report #4 - An Implementation Model for a Supplementary Filmstrip	NA	In final mediation
	Developing Daily Living Skills - For the Mentally Retarded	NA	Paper presented at AAMD, 1974
	The Severely Retarded: Are We Really Programming for Their Future	NA	In print
	Analysis and Change of Critical Nonverbal Social Behaviors in Mentally Retarded Individuals: Why Do They Look Retarded?	NA	Paper presented at AAMD, 1975
	"Taking the Shopping Out of Workshopping"	NA	Presentation to Association for Educational Communi- cations and Technology, April, 1975.

TABLE 7

## OTHER PRODUCTS DEVELOPED - TO 9/30/75

<u>Cost</u>	<u>Product</u>	<u>Modules Completed</u>	<u>Status</u>
\$7,857	Body Language	1,3,4,5	To research
\$3,274	Eye Contact	2,3,4,5,8,11	Cancelled/no need
\$1,302	Following Directions - #1	0	To pilot testing
\$2,165	Following Directions - #2	1-11	To pilot testing
\$ 338	Telephone - #4	3,4,5,8	To pilot testing
\$ 595	Telephone - #5	3-19	To prototype
\$ 641	Telephone #6	2-5, 8-11	To pilot testing
\$ 168	Telephone - #7	1-11	To pilot testing
\$ 83	Telephone - #8	0	To task analysis
\$ 921	Response to Criticism	2	To task analysis
\$ 713	Finding Public Restrooms - #3	1-5	To task analysis
\$3,065	Use of Public Restrooms - #4	3, 6-19	To prototype
\$ 147	Use of Television	0	To feasibility assessment
\$1,243	Use of Bathroom	1-19	To prototype
\$ 118	Field Study - Restrooms (Slides and Tape)	NA	Preliminary planning
\$ 64	Working Paper #299- Mand Interaction in Retarded and Non-retarded Adolescents: An Observational Study in Vocational Settings	NA	In press
\$ 16	Training Proficiency: How Good is Good?	NA	Paper presented at AAMD, 1974
\$1,695	Working Paper #283 - The Direction Following Behavior of Mentally Retarded Adolescents as a Function of Verbal Rehearsal	NA	Paper presented at AAMD, 1974

147

<u>Cost</u>	<u>Product</u>	<u>Modules Completed</u>	<u>Status</u>
\$1,536	Annotated Bibliography #1 - Daily Living Skills Program	NA	Preliminary draft
--	Working Paper #281 - A Selected Bibliography for Research in EEG-Alpha Rhythm Feedback in the Mentally Retarded and Emotionally Disturbed	NA	Preliminary draft
\$ 124	Cream Antiseptic Working Paper (Care of Simple Injuries)	NA	Preliminary planning
\$ 391	Working Paper #300 - The Effects of Pictorial Stimuli on Direc- tion Following of Mentally Retarded Adolescents	NA	To publisher
\$ 493	Technical Report #3 - Empirical Bases for Program Revision	NA	Preliminary draft
\$ 49	Systems Working Paper	NA	Presented at a convention
\$2,247	How To Do MORE With Less	NA	To publisher
\$ 454	Research Implementation Lattice	NA	Completed
\$ 833	Direction Following/Question Asking (Research)	NA	Preliminary draft
\$ 249	Follow-up Study (Maintenance)	NA	Student writing into thesis
\$ 59	Accountability Working Paper	NA	Preliminary draft
\$ 803	Working Paper #311 - Social Interaction of Mentally Retarded Persons: A Comparative Study of Eye Contact	NA	To mediation
\$ 949	Research on Prerequisite Behaviors (Matrix)	NA	In analysis
\$1,109	Telephone - #2 (Research)	NA	In process
\$2,089	Body Language - #2 (Research on hands on face)	NA	In preparation
\$ 481	Body Language - #3 (Research on facial expression)	NA	In analysis

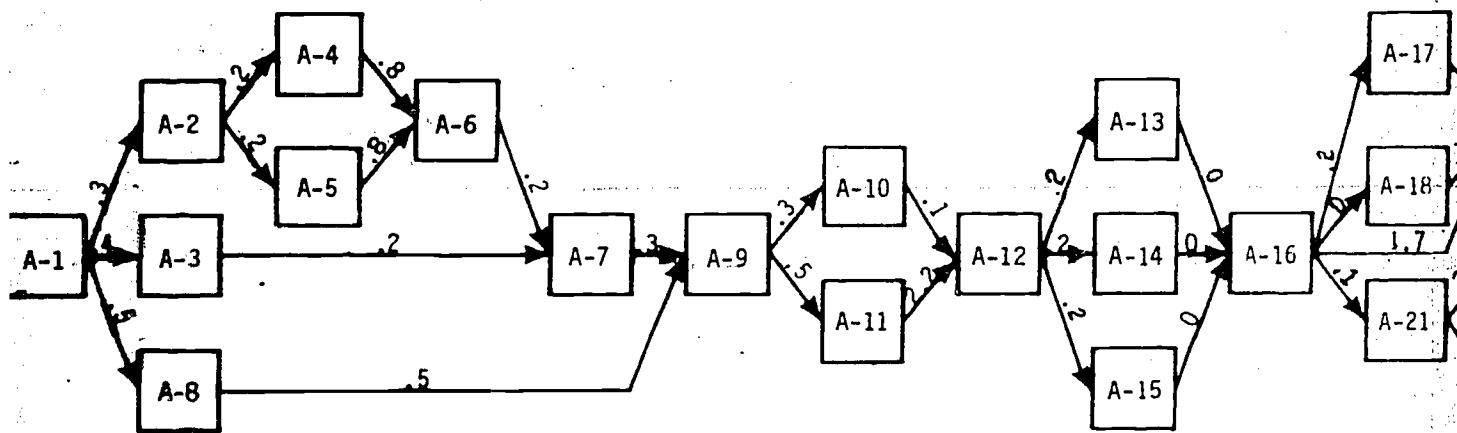
148

116

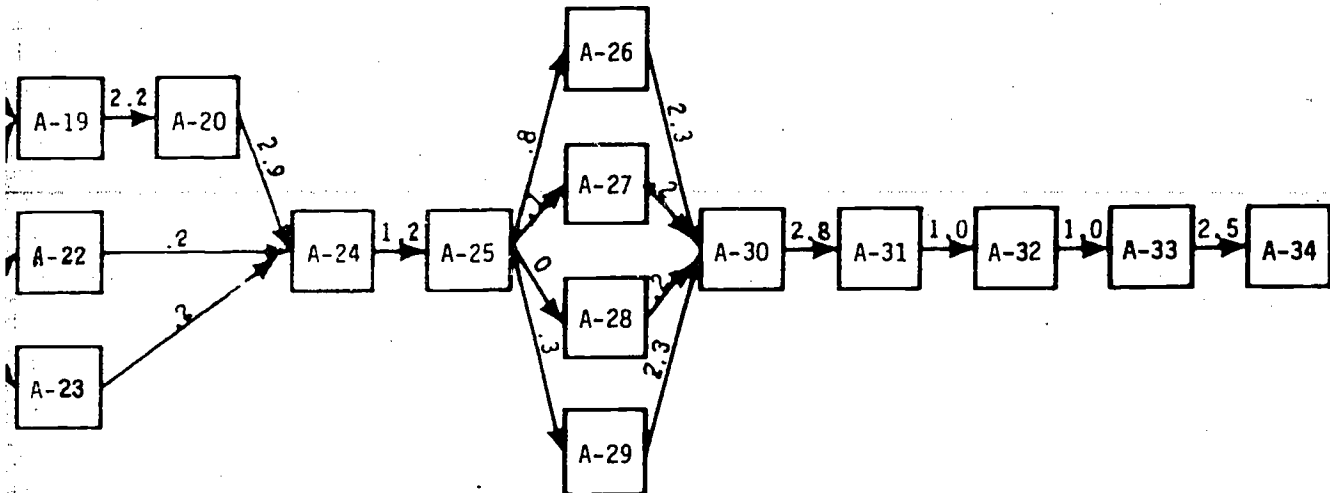
<u>Cost</u>	<u>Product</u>	<u>Modules Completed</u>	<u>Status</u>
\$ 567	Body Language - #4 (Research on interviews)	NA	In draft stage
\$ 125	Body Language - #5 (Research on orientation)	NA	In analysis
\$ 84	Body Language - #6 (Research on mouth open)	NA	In analysis
\$ 194	Hair Washing Working Paper	NA	In rough draft
\$ 207	Deodorant Working Paper	NA	In rough draft
\$1,348	Project MORE Brochure	NA	Completed



Figure Z - PERT CHART  
(LENGTH OF TIME IN MONTHS FC)

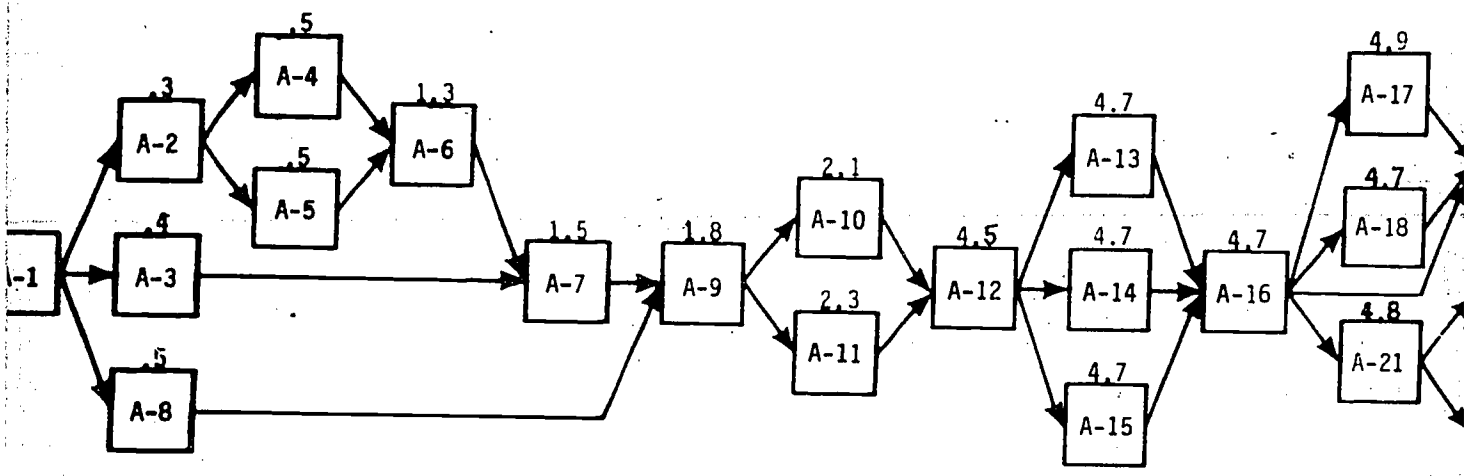


EACH ACTIVITY IN PROGRAM DEVELOPMENT)

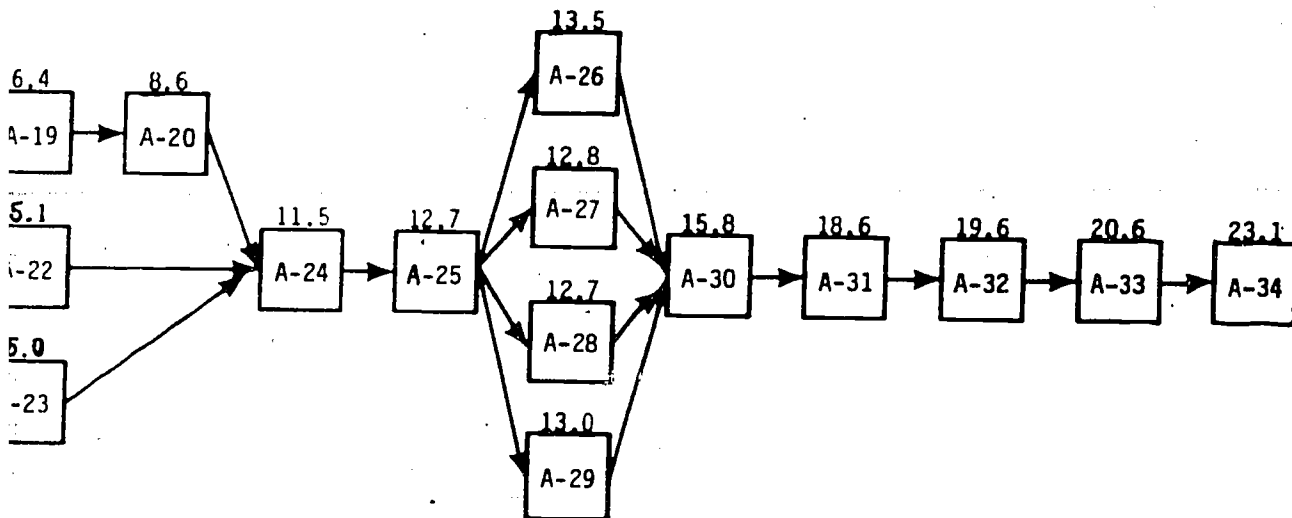


©1974 by The University of Kansas (Project MORE)

Figure AA - PERT CHART  
 (CUMULATIVE AMOUNT OF TIME  
 MODULE SHOWN ON PROGRAM DE



MONTHS NEEDED TO COMPLETE EACH  
 OPMENT IMPLEMENTATION LATTICE)



©1974 by The University of Kansas (Project MORE)

## FIELD TEST DATA

Field test data are included in Appendixes B, C, and D.

Appendix B includes data on programs in print as of January 31, 1975.

Appendix C includes data on programs in production by Edmark Associates as of January 31, 1975.

Appendix D includes data on programs completed but not sent to Edmark Associates as of January 31, 1975.

The cover sheet for each appendix lists the programs for which data are included.

## V. CONCLUSION

The early efforts of Dr. Lent, working with Dr. Joseph Spradlin and Dr. Judith LeBlanc at Mimosa Cottage at Parsons State Hospital and Training Center, were both encouraging and enlightening.

Trainable mentally retarded persons could be taught; their behavior could be changed in positive ways with humane methods; their progress and setbacks could be monitored and analyzed. When necessary, changes in ways of teaching could be made and subsequently judged in an objective way. It was also learned that it was always difficult to ascertain which skills would be most useful to mentally retarded persons and which skills could then be developed within the budget and time limitations of the Project, and which skills would lend enhancement and independence to a retarded person and make him or her more comfortable and more acceptable in either an institutional or community environment. In addition, it also became obvious that the way to teach a skill had to be tried and tested and then defined in a manner in which a non-skilled person, a nonexceptional teacher, could understand, use, and produce valid results. It became obvious that, once the basic and essential elements of what and how to teach were clearly defined, there would be a need to make this information available beyond the immediate environs in which that information had been developed. It was time for the emergence of Project MORE.

The thrust of program development was to be toward skills which could be used daily: practical, essential skills such as toothbrushing, hand and hair washing, and nose blowing. Acquisition of these skills,

the research staff maintained, would lessen the obvious differences in appearance and behavior of mentally retarded people.

With these insights, Dr. Lent built a four-phase technology of design, development, mediation, and dissemination. He brought in creative specialists to lend judgment and guidance to meeting those goals established as the Project's reason for being.

Richard L. Schiefelbusch, director of the University of Kansas Bureau of Child Research, would become co-investigator for the Project. Besides Dr. Schiefelbusch's obvious expertise in the area of working with retarded people, he provided a necessary and valuable liaison with the University of Kansas, under which the Project functioned administratively.

James F. Budde, of the University of Kansas, was to develop sophisticated, yet workable, systems management techniques through which the Project could set goals and evaluate progress in meeting its goals, and account internally and externally for the time and money invested in it by the federal government for the three-year period.

Barbara M. McLean, English instructor and writer with a varied and extensive background in instructional media, was to instigate a system to "mediate packages"--mediation being the selection of an appropriate design and format to enhance presentation of an idea, and packages being well-rounded and varied products which have coherence and meaning to the audience. McLean's expertise was to be expanded as the Project made its products available to the general public by utilizing a commercial publisher, with the capability of handling production and sales of Project materials. McLean was also to be responsible for piloting work in the area of copy-righting of materials produced under a federal grant, and for efforts to continue Project development through continuation of funding.

First Ingo Keilitz, then Carol Foster, were responsible for program design and development. Foster designed programs, administered a staff of curriculum developers, engineered and evaluated pragmatic yet reliable evaluation instruments, and worked closely with the systems designer to chart the Project's own accountability system.

Since the funding of the Project provided for production of programs for the speech handicapped, James E. McLean, an experienced speech clinician and instructor, joined the Project to oversee development of a Stimulus Shift Articulation program. Dr. McLean was also Director of the Speech and Hearing Department of Parsons State Hospital and Training Center.

The Project entered its first year knowing that it must face all the problems inherent in starting up a pioneer operation. Staff were hired, training of staff conducted, assessment of program needs undertaken, preliminary programs written and tested, and arrangements for handling fiscal and administrative matters were undertaken with the University of Kansas and with Parsons State Hospital and Training Center.

By the start of the second year, the climate was calmer and efforts could be focused upon refining program development methods and mediation techniques. The second year was strongest in the design and development phases of the technology and results were such as to forecast even more success.

During the third year, the various gears had begun to mesh. Design of programs, testing of programs, and mediation of programs flowed more quickly and with less faltering at any one phase. Research personnel could more effectively judge the success of programs, Media personnel could edit and produce prototypes on time for use in field testing and



could work cooperatively with the staff of the Project's commercial publisher. The publisher, working in concert with McLean, could manage production of programs in an attractive and cost-efficient way, handle sales and distribution of programs and supplementary materials, and work with Project personnel in informing the public of the purpose, type, and availability of materials coming from Project MORE.

Without pretending to state that the Project has solved all the problems it was initially faced with, it is fair to say it has met its objectives: programs for the mentally retarded are designed, tested, validated, replicated, and made available to the consumer. As the public uses the products, they can be improved. As the Project expands into areas beyond those of daily-living skills, more intricate skills and behaviors may be researched and eventually taught to the retarded. As mentally retarded people themselves learn and use the skills, their lives will be better, richer, fuller, more satisfying, and more dignified.

APPENDIX A  
NARRATIVE DESCRIPTION OF  
IMPLEMENTATION LATTICE

## NARRATIVE DESCRIPTION OF IMPLEMENTATION LATTICE

### (A-1)

#### PROGRAM NEED ASSESSMENT

Definition: To determine the types of daily-living skills needed by severely-moderately retarded individuals.

Implementation Activity: Review of pertinent literature by personnel. Such literature might include that produced by the National Association of Retarded Children, information from the Instructional Materials Center, and the Adaptive Behavior Scale. Relevant information would be assessed in the context of Project MORE training objectives.

Personnel Involved: The director of Project MORE, one program director, one research assistant, and the media person who handles dissemination of Project MORE materials.

### (A-2)

#### PRELIMINARY FEASIBILITY ASSESSMENT

Definition: To determine the feasibility of the proposed program.

Implementation Activity: Assess the time necessary for the development of the new program, including time for training and for production of written and visual materials, taking into account the current and projected work load of the staff, and the demands for such a program. Decide if the new program appears to be feasible at this time.

Personnel Involved: The director of Project MORE, one program director, one writer/editor, one research assistant, and the media person who handles dissemination of Project MORE materials.

(A-3)

COLLECTION OF RESOURCE MATERIALS

Definition: To conduct extensive research of materials already published on the subject of the proposed new program and to determine if the quantity and/or quality of such materials pre-empts or substantiates the need for development of a program by the Project MORE staff.

Implementation Activity: Find all possible materials related to the proposed program in journals, textbooks, commercial publications, and popular literature.

Personnel Involved: One writer/editor and one research assistant to locate and evaluate materials, with a written evaluation and summary to be presented to the director of Project MORE and to one program director. If it is decided the program may be undertaken, verification will be given by written notice to the instructional media analyst and to the research assistants.

(A-4)

VIDEOTAPING OF NONRETARDED SAMPLE

Definition: To record for analysis the manner in which nonretarded individuals performed the given task.

Implementation Activity: Enlist from three to six persons to serve as subjects; schedule the tapings with audiovisual personnel and do the taping.

Personnel Involved: Besides the subjects, three research assistants and one audiovisual technician.

(A-5)

VIDEOTAPING OF RETARDED SAMPLE

Definition: To record for analysis the manner in which moderately retarded (Level III) individuals perform the given task.

Implementation Activity: Select individuals with varying capabilities to perform the task. Some of the sample will already be capable of performing the skill adequately, some will be unable to do so, and some will have the potential to perform the task. Schedule the tapings with audiovisual personnel and other personnel. Tape the individual performing the task.

Personnel Involved: Selection of subjects will be done by a research assistant and scheduling of the taping by a secretary. Involved in the taping will be three research assistants and one audiovisual technician. The workshop coordinator will attend as an observer, as segments of the tapes might be utilized later for workshops.

(A-6)

SYNTHESIS OF OBSERVATIONS INTO TASK COMPONENTS

Definition: Analyzing the steps which are necessary to perform the given task.

Implementation Activity: View all videotapes, noting the similarities and differences in the way the task is performed. Define the steps necessary to most adequately do the task and write the behavioral definitions. Edit the task analysis and the behavioral definitions.

Personnel Involved: Two program directors and two research assistants to view and analyze the tapes, determine the task analysis, and write the behavioral definitions. One writer/editor is needed to edit the copy.

(A-7)

SEQUENCE COMPONENTS

Definition: To order in consecutive steps the components which make up the correct execution of the task.

Implementation Activity: Review the task analysis and order the steps in logical sequence.

Personnel Involved: One research assistant who will give this sequencing to a program director for input and approval.

(A-8)

COLLECTION OF RESOURCE MATERIALS

Definition: To gather for evaluation a number of teaching strategies which might be applicable to the training program.

Implementation Activity: Review teaching strategies on programs similar to the one being undertaken by Project MORE and to review other possible teaching strategies.

Personnel Involved: Two research assistants and two program directors.

(A-9)

DEVELOPMENT OF PROCESS TASK ANALYSIS

Definition: To decide on the most effective order in which to teach the steps involved in the correct implementation of the task.

Implementation Activity: Design and develop the teaching strategy.

Personnel Involved: A research assistant, two program directors, and one writer/editor.

(A-10)

DEVELOPMENT OF MEASUREMENT INSTRUMENT

Definition: To decide what types of data or tests are necessary to determine the progress of individual students.

Implementation Activity: To review possible measurement instruments and discuss their respective value and usefulness. To decide on the instruments to be used and on their possible inclusion in the written program.

Personnel Involved: One program director, one research assistant, and one writer/editor.

(A-11)

APPROVAL OF SUBJECT PROTECTION COMMITTEE

Definition: To obtain approval of the content of a program and the teaching strategy to be used prior to conducting training; to ascertain that students' rights will not be violated by either the program or in the procedures used to teach it.

Implementation Activity: A copy of the steps to be taught and the teaching procedures is transmitted to the seven-member committee which reviews proposed research activities. The committee either approves or disapproves the research. If approval is given, the committee signs the proposal and routes it back to the Project.

Personnel Involved: One research assistant, and, on occasion, the director of Project MORE.

(A-12)

PILOT TESTING

Definition: To make an initial investigation of program effectiveness.

Implementation Activity: Teach the skill to a small group (one, two, or three) of retarded students using the tentative teaching strategy and task analysis.

Personnel Involved: Two research assistants and three students.

(A-13)

TIME REQUIREMENT ESTIMATE

Definition: To estimate the time it will take to validate the program.

Implementation Activity: Compute the time it will take to validate the program.

Personnel Involved: One program director and one research assistant.

(A-14)

PERSONNEL REQUIREMENT ESTIMATE

Definition: To estimate the total number of Project staff needed to validate the program.

Implementation Activity: Estimate the number of staff members needed for testing and training the program.

Personnel Involved: One program director and one research assistant.



(A-15)

COST ESTIMATE

Definition: To compute the total financial cost of developing the program, validating it, and producing it for consumer use.

Implementation Activity: Consider the types and amounts of supplies needed, any auxiliary equipment needed, and any other known cost for production.

Personnel Involved: One program director, one research assistant, the program disseminator, and one writer/editor.

(A-16)

INTEGRATION OF ESTIMATES INTO PROJECT SCHEDULE

Definition: Integrate the estimates for time, personnel, and cost with the current Project schedule. Determine how the new program can be included.

Implementation Activity: Assess the required time, personnel, and cost estimates in consideration of the current Project MORE schedule.

Personnel Involved: The director of Project MORE, both program directors, the program disseminator, one writer/editor, one research assistant, and one audiovisual representative.

(A-17)

PROGRAM FORMAT DETERMINATION

Definition: To decide what general format the particular program will follow.

Implementation Activity: Familiarize staff with the skill to be depicted in the program, the consumer level, and the teaching strategy. Formats for the program can then be discussed and one format selected.

Personnel Involved: The program directors and one research assistant to clarify the aim of the program, one writer/editor, one graphics person, and the Project MORE program disseminator.

(A-18)

PREREQUISITE SKILL DETERMINATION

Definition: To determine if there are any motor skills or other prerequisite behaviors which a student must have before entering a particular training program, and what these skills are.

Implementation Activity: Review the steps of a program and decide what abilities a student must have prior to entering training.

Personnel Involved: One research assistant and one program manager.

(A-19)

PROGRAM CONTENT, PROCESS, AND FORMAT INTEGRATION

Definition: To translate the task analysis and teaching strategy into readily understandable form.

Implementation Activity: To review the task analysis and teaching strategy and determine an accurate and clear way of depicting both.

Personnel Involved: One program director, one research assistant, one writer/editor, and one graphics person.

(A-20)

MEDIATION OF ROUGH DRAFT

Definition: To prepare a working draft of the program for initiation of field study.

Implementation Activity: To pull together the various components of the program (task analysis, behavioral objectives, teaching strategy, tests and data sheets) into usable written form.

Personnel Involved: The program directors, one research assistant, one writer/editor, one graphics person, and the disseminator of Project MORE programs.

(A-21)

EXPERIMENTAL DESIGN

Definition: To determine the design of the evaluation activity (activities).

Implementation Activity: To adopt or modify an existing design, or devise a new evaluation methodology.

Personnel Involved: The director of Project MORE and two program directors.

(A-22)

TRAINER AND STUDENT SELECTION

Definition: To decide which students and trainers will be used in evaluation.

Implementation Activity: Same as above.

Personnel Involved: A program director, research assistant, and a secretary.

(A-23)

ASSEMBLE RESOURCES

Definition: To gather the materials necessary for training prior to the beginning of the program.

Implementation Activity: To review the rough draft of the program and note the materials necessary; to gather those materials.

Personnel Involved: A research assistant and secretary.

(A-24)

CONDUCT TRAINING SESSIONS

Definition: To conduct field tests using a prototypical program and non-staff trainers in order to validate the program.

Implementation Activity: Teach the program to selected students, using nonstaff persons as trainers and staff trainers as their supervisors. Collect data on reliability and student performance. Training sessions continue until the students reach criterion or for 20 days.

Personnel Involved: A program manager, two nonstaff trainers, and one research assistant.

(A-25)

DATA ANALYSIS

Definition: To review the data obtained during the training.

Implementation Activity: To compile the data, analyze it, and write a study of the findings, to decide if revisions are either necessary or would be helpful in the program content or process.

Personnel Involved: Two program directors, the Project director, and a research assistant.

(A-26)

CONTENT REVISION

Definition: If warranted by the data analysis, make revisions in the content of the program.

Implementation Activity: Revise the content.

Personnel Involved: One program director, one research assistant, and a writer/editor.

(A-27)

PROCESS REVISION

Definition: To revise the process if it is necessary. The "process" refers to the series of instructional units through which the program proceeds.

Implementation Activity: To determine any weaknesses in the process and nature of any weaknesses and to correct them by a change in procedure.

Personnel Involved: One program director, one research assistant, and a writer/editor.

(A-28)

MEASUREMENT INSTRUMENT REVISION

Definition: To improve the instruments used to measure the students' progress, if necessary.

Implementation Activity: Assess whether the instruments used in the training were adequate; if they were not, to revise them.

Personnel Involved: One program director and one research assistant.

(A-29)

FORMAT REVISION

Definition: To change the format of any part of the developmental program, if necessary.

Implementation Activity: To decide if the format is adequate for the program as originally designed, or to make changes in the format consistent with changes in the revision of the content, process, or instruments.

Personnel Involved: The director of Project MORE, one program director, one research assistant, a writer/editor, and the disseminator of Project MORE materials.

170

(A-30)

REMACYCLE DESIGN AND DEVELOPMENT

Definition: To take the program back through any or all phases of its development.

Implementation Activity: To scrutinize the revised program and route back to research or media persons for necessary or desired changes.

Personnel Involved: Depending on the areas remacycled, this could range from one person to everyone previously involved.

(A-31)

EDITING

Definition: To edit the developmental program to make the program appropriate for typesetting.

Implementation Activity: To review the typewritten copy carefully, to make changes in word usage and in format, where necessary, and to ensure clarity of instructions.

Personnel Involved: One writer/editor.

(A-32)

FINAL CHECK

Definition: Prepare the program manual for submission to the publisher.

Implementation Activity: Prepare copy as it is to be printed, with accompanying instructions for headlines, special effects, pagination, etc. Prepare camera-ready art and instructions on placement of art.

Personnel Involved: A writer/editor, one or more graphics persons, one or more secretaries, the director of the Project, one program director, one research assistant, and the program disseminator.

171

(A-33)

PUBLISHER INPUT

Definition: The reactions of the publisher to the program manual will be directed back to the Project staff.

Implementation Activity: The comments, criticisms, and suggestions from the publisher will be received and discussed by Project staff.

Personnel Involved: The director of the Project and the disseminator of program materials.

(A-34)

DEVELOPER INPUT

Definition: To receive the input from the publisher and respond to it.

Implementation Activity: Besides receiving and responding to what the publisher has to say about the program, this step might involve revisions of the program to comply with the publisher's wishes. It is possible also that the publisher's response might be to accept the program as designed and developed, but to make suggestions pertinent to development of future programs.

Personnel Involved: The program disseminator, two program directors, and the director of the Project.

APPENDIX B

Field test data on Project MORE programs in print as of January 31, 1975.

Toothbrushing

Hand Washing

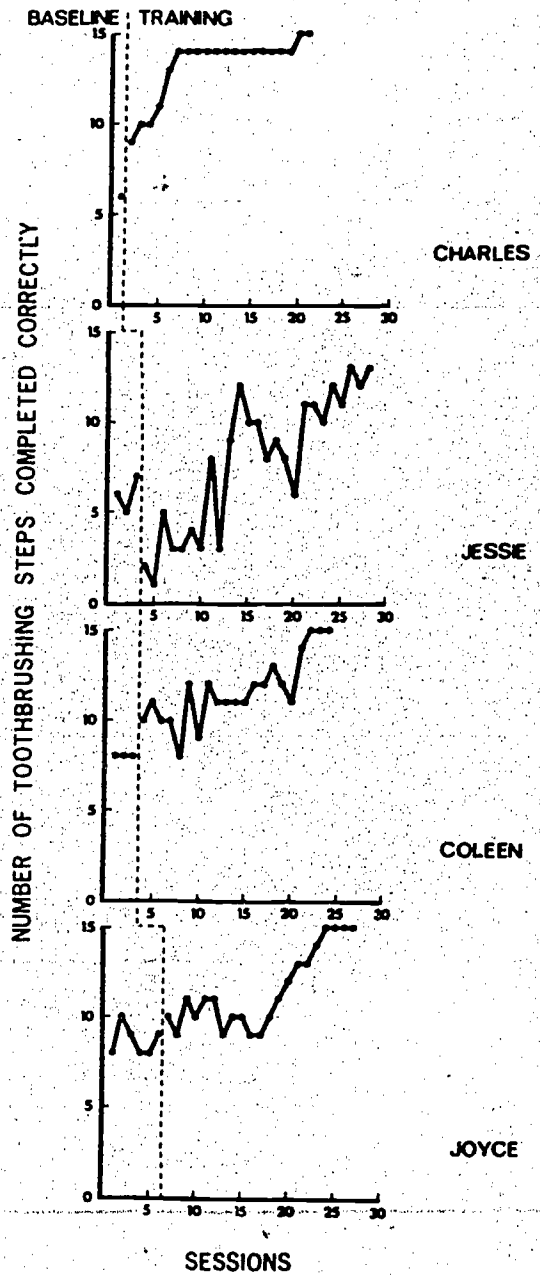
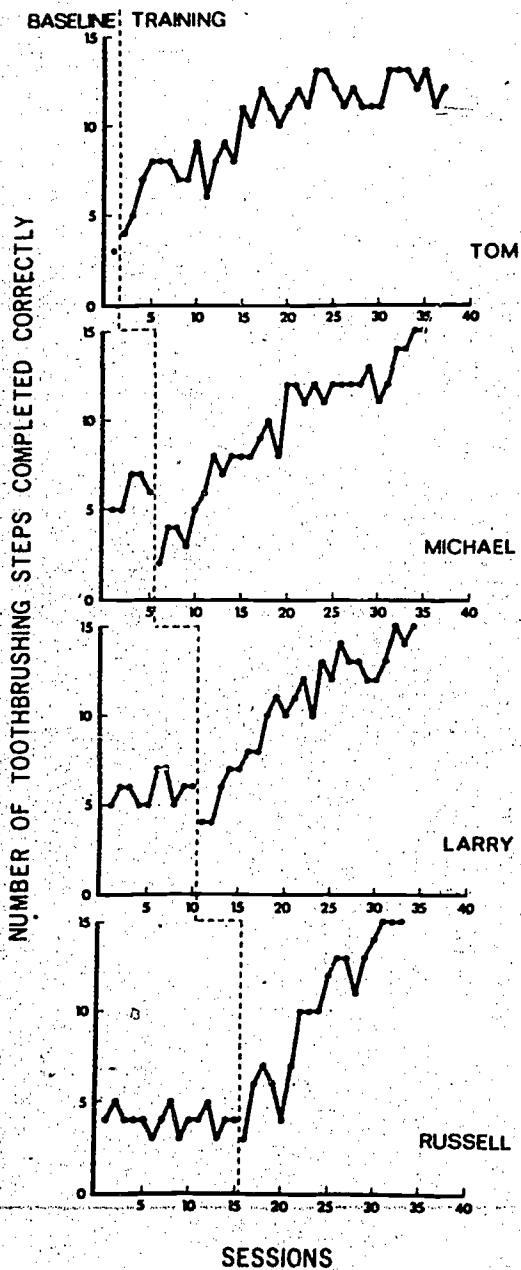
Nose Blowing

Eating



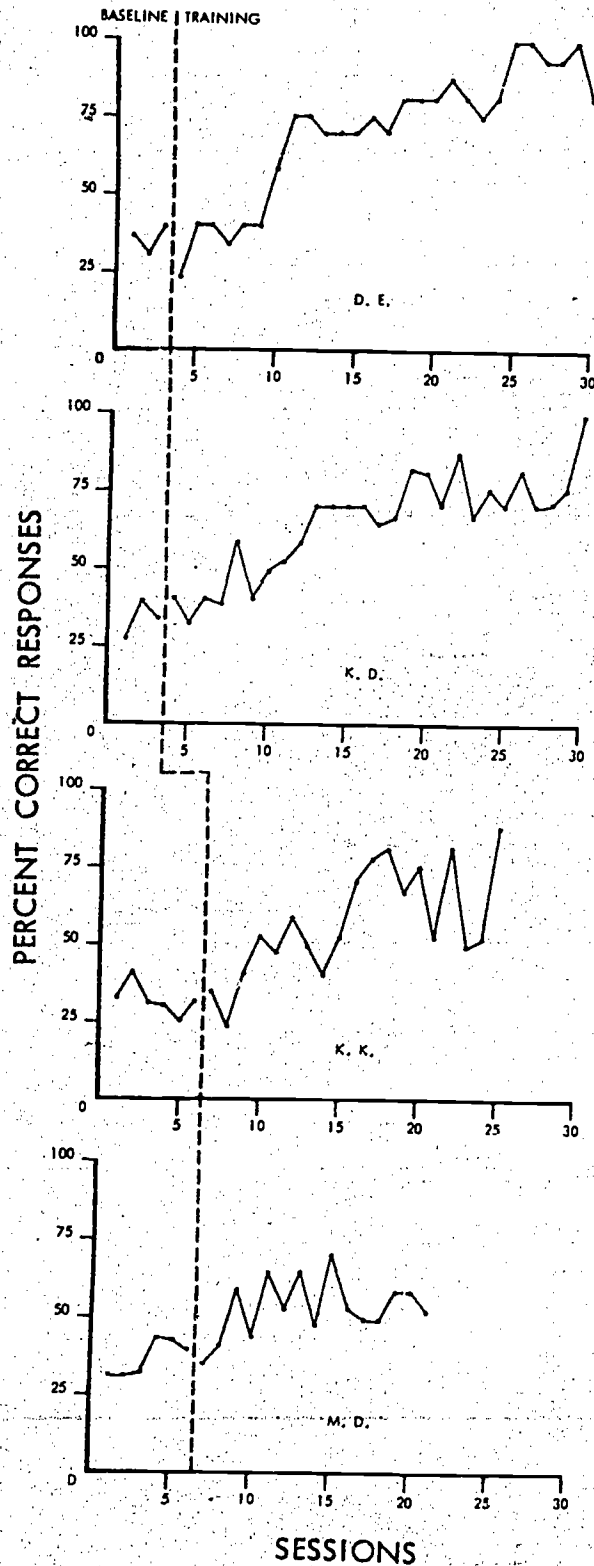
## Toothbrushing Program

The results of the testing of the Toothbrushing program on two groups of four students are each presented in the data. The baselines on the first group of four fluctuated around five of 15 toothbrushing behaviors. This went to a final performance of 14 to 15 behaviors for three of the four and 11 to 13 for the fourth student. The baselines on the second group of four fluctuated around seven to eight of the 15 toothbrushing behaviors. This went to a final performance of 14 to 15 behaviors for three of the four and 12 to 13 for the fourth student.



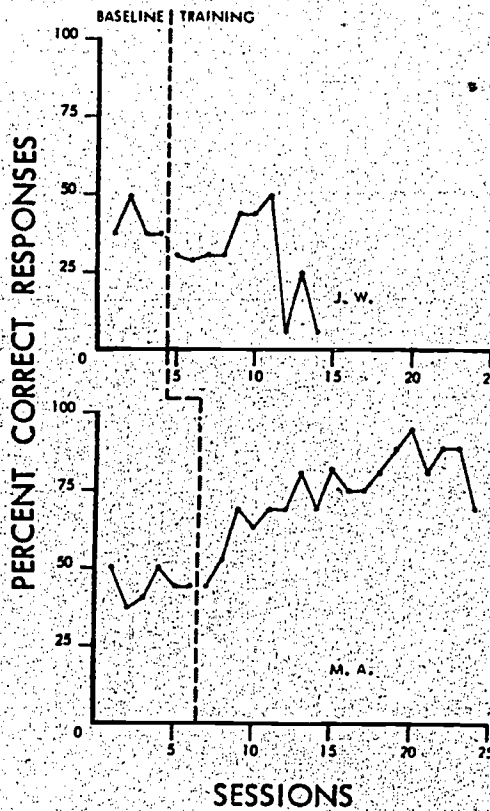
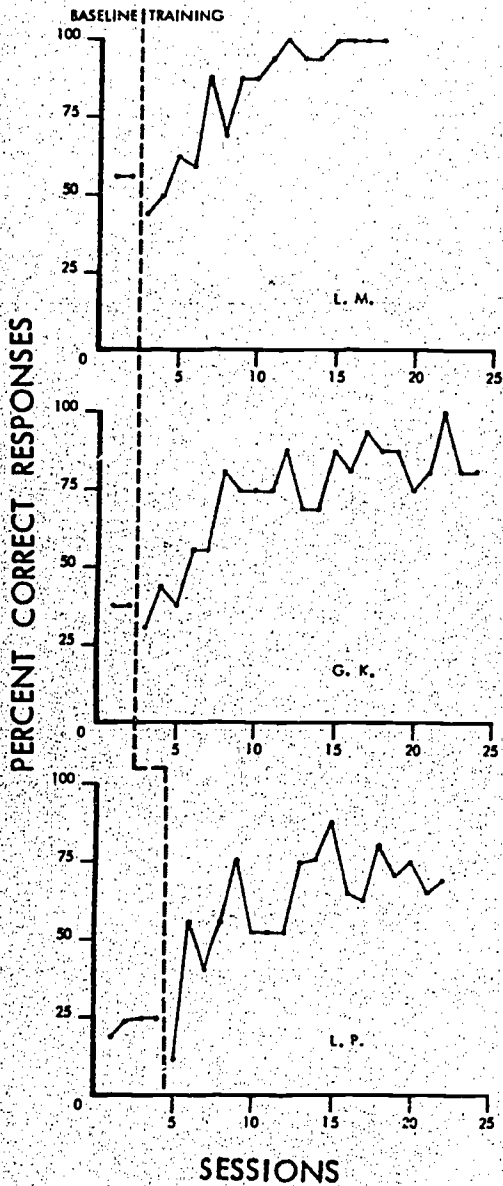
## Hand Washing - Field Study I

Field Study I tested a developmental version of this program with four subjects. The results of this study are shown below.

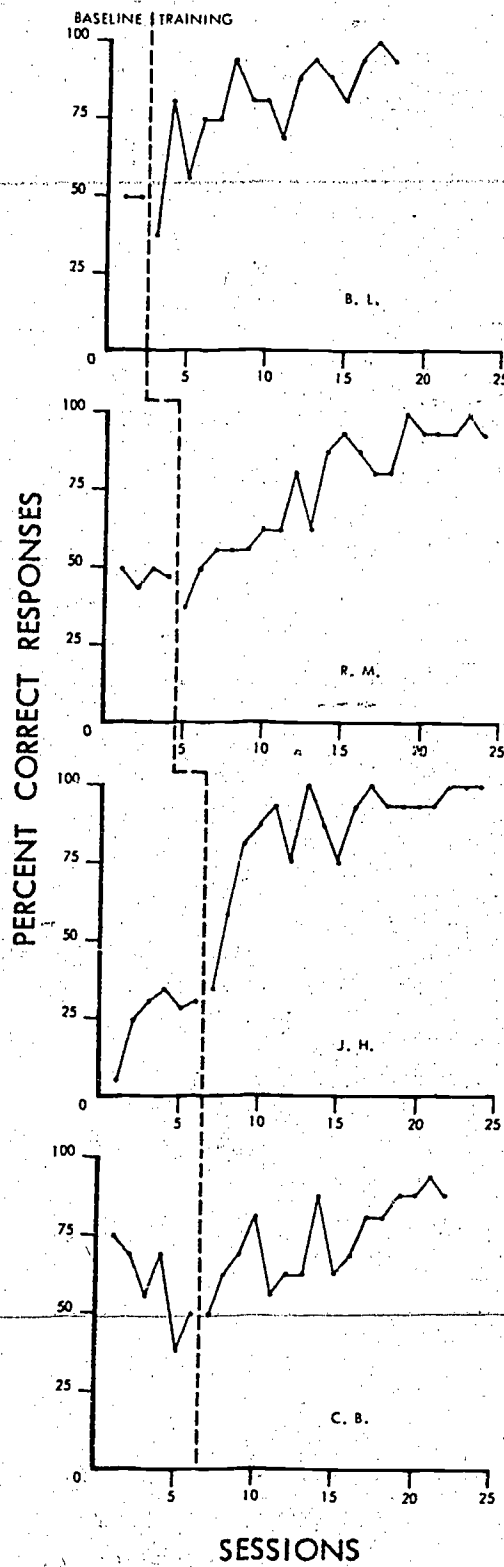


## Hand Washing - Field Study II

Field Studies II and III tested a revised version of this program. Nine subjects were trained in Field Study II, seven responding at the 90 percent level or better on at least one day of training.

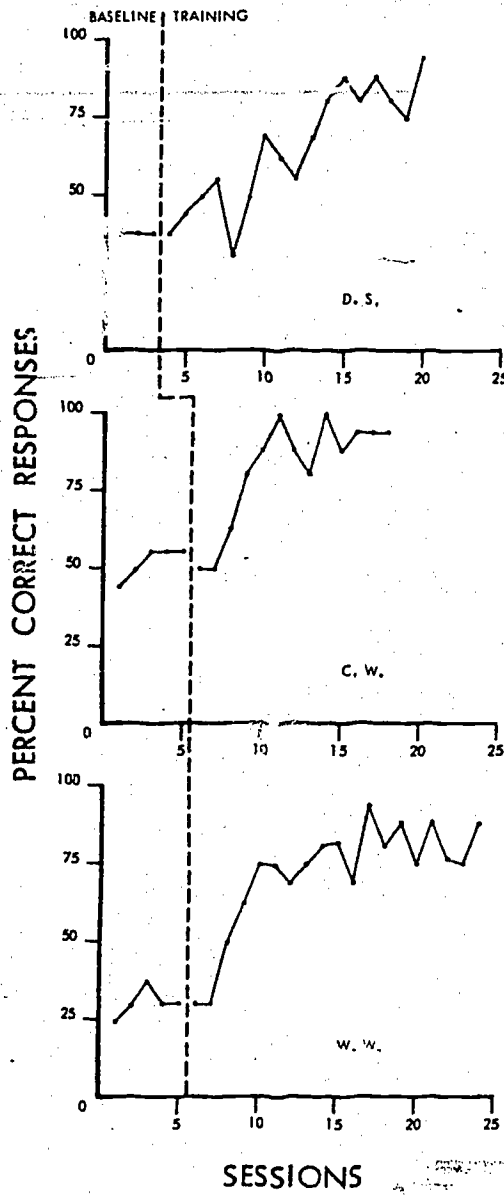


# Hand Washing - Field Study II (Continued)



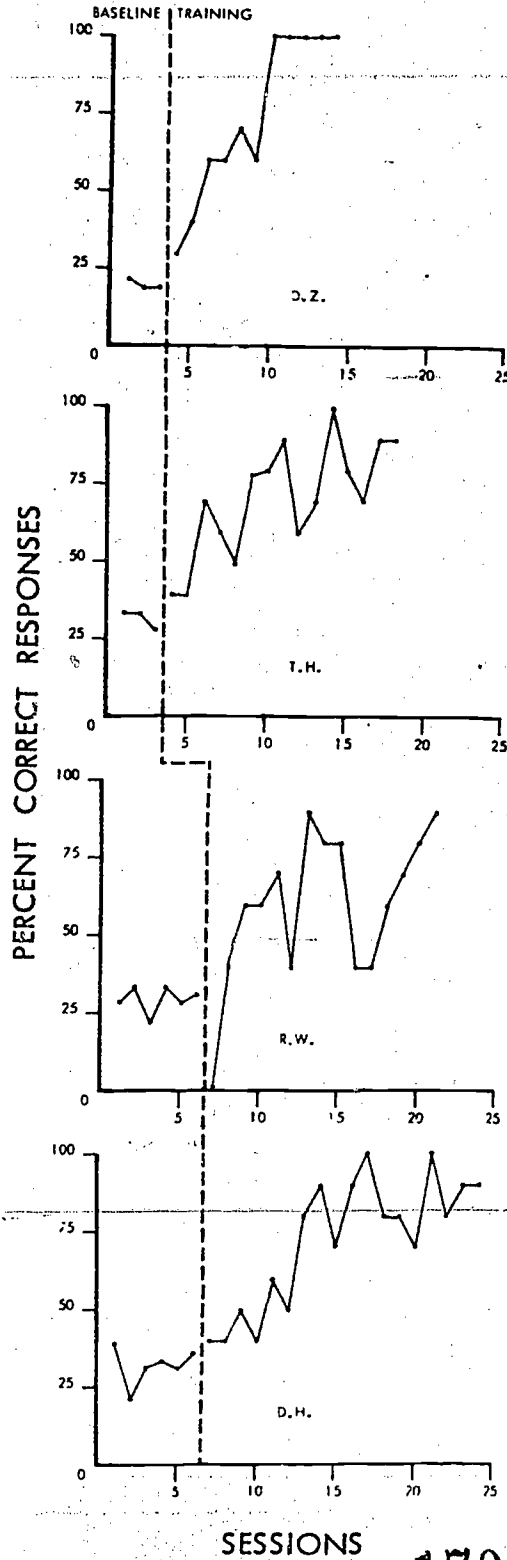
### Hand Washing - Field Study III

Three subjects were trained in this field study. All students met a 90 percent level or better.



## Nose Blowing - Field Study I

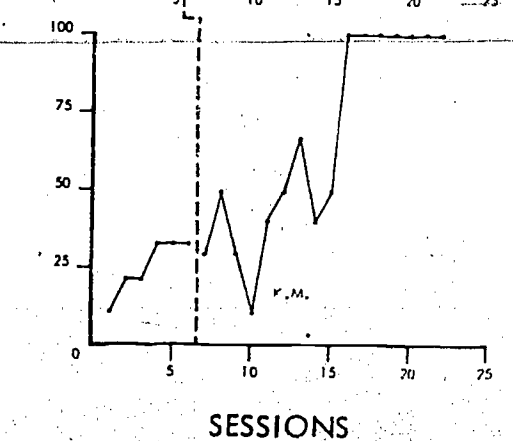
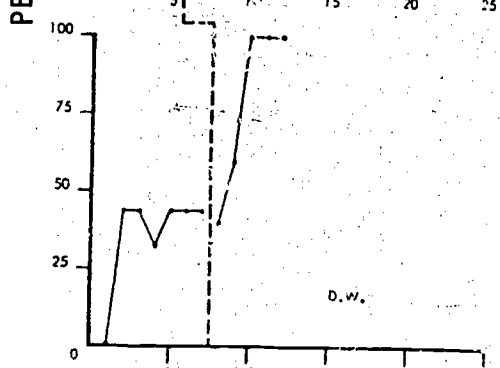
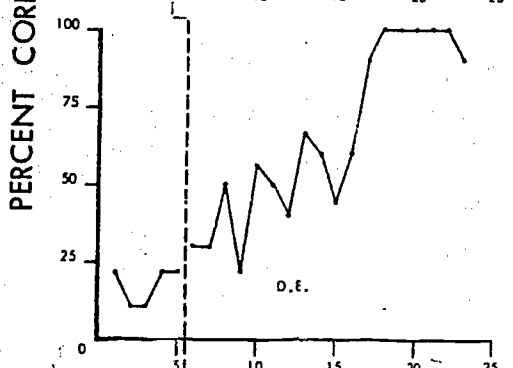
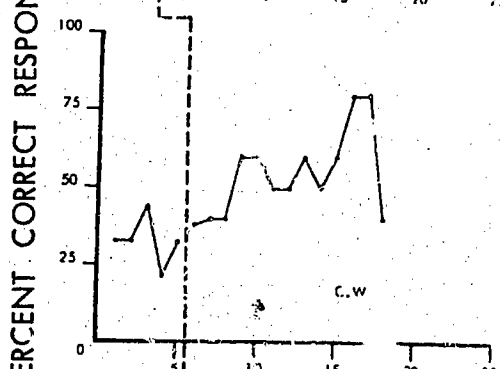
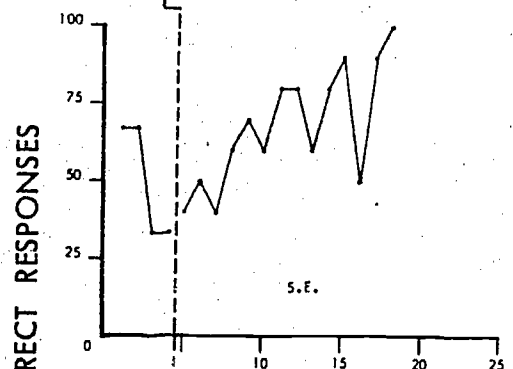
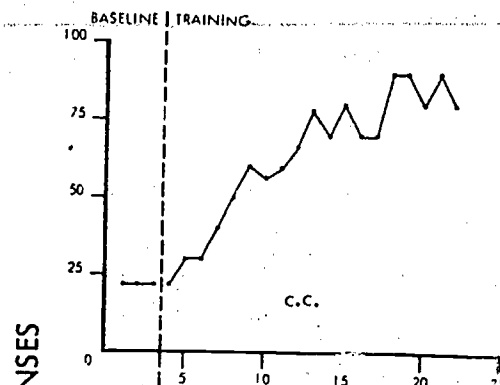
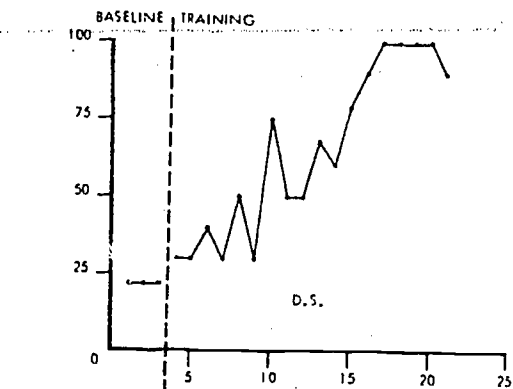
Field Study I was conducted with four subjects. All subjects met a 90 percent level or better in under 25 days of training.



SESSIONS

## Nose Blowing - Field Study II

Field Study II involved seven subjects. Only one failed to achieve a criterion of 90 percent. After Field Studies I and II, the "repeat step" was expanded to include all five subskills involving positioning, blowing, pinching, wiping, and folding.

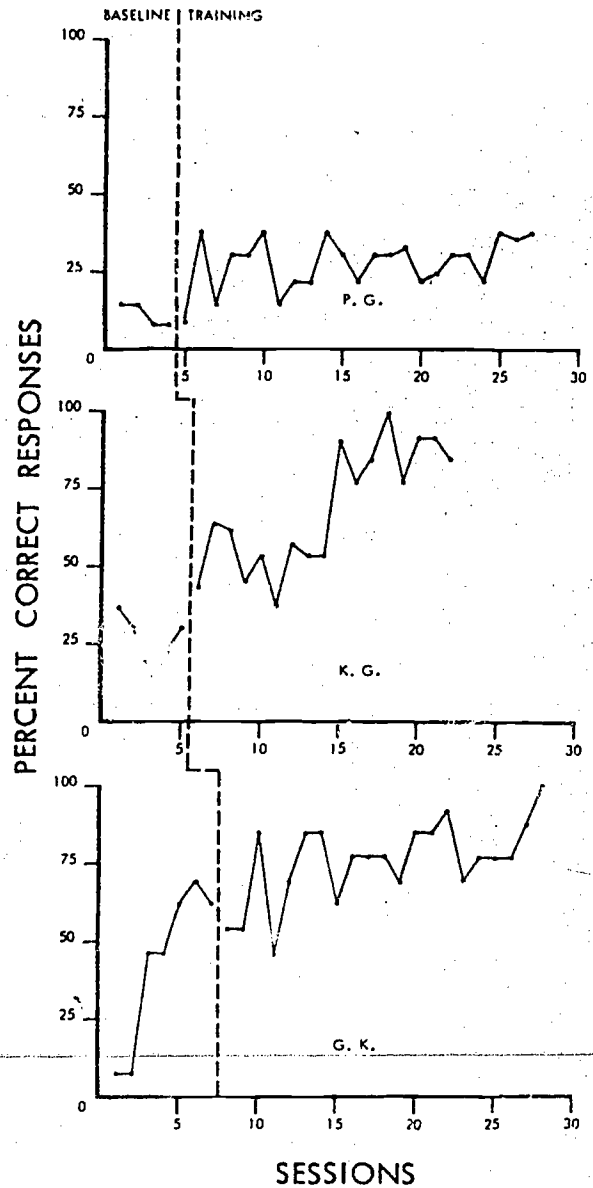
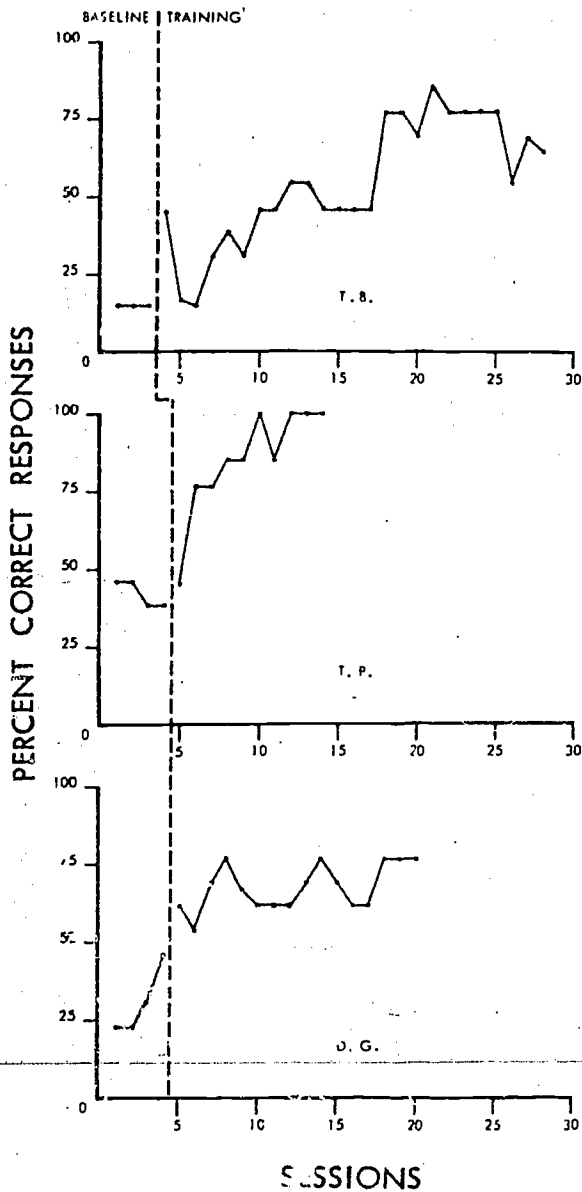


180

146

### Nose Blowing - Field Study III

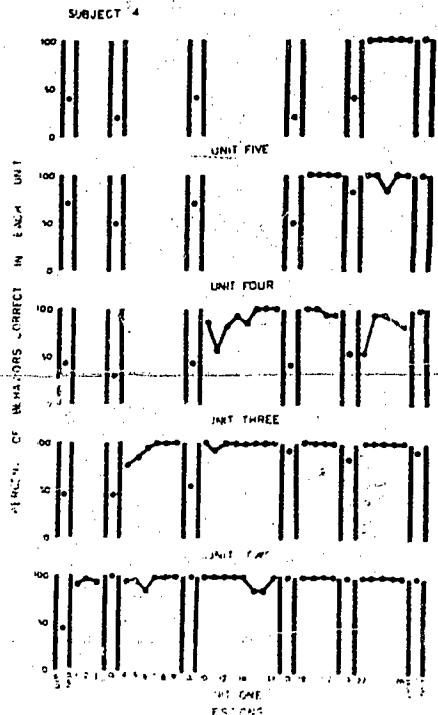
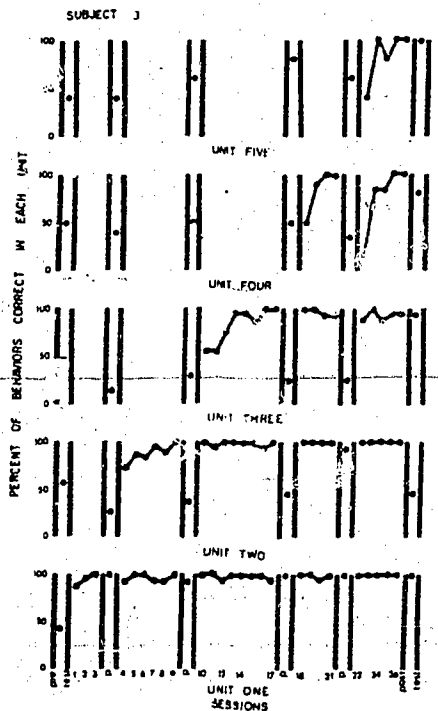
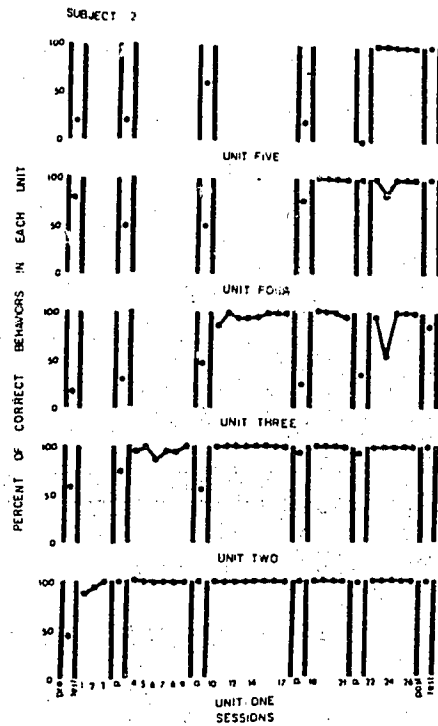
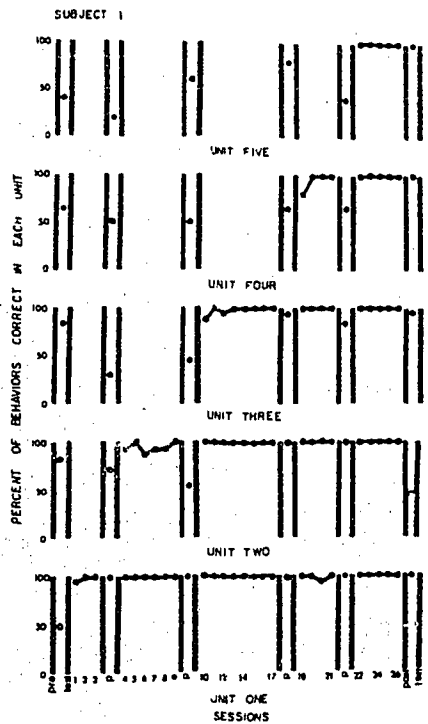
Six very low level trainable subjects were tested in the expanded version of this program in Field Study III. Two failed to make significant gains above baseline after initial progress in the first three training sessions. One subject was heavily medicated during training sessions to control seizures.



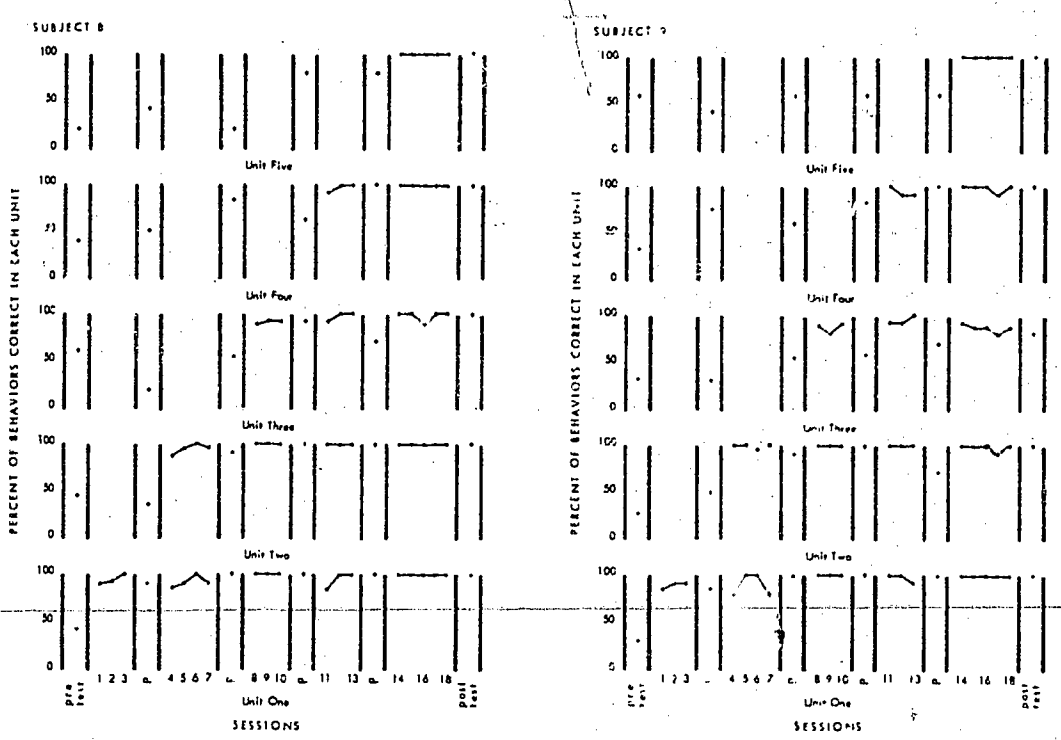
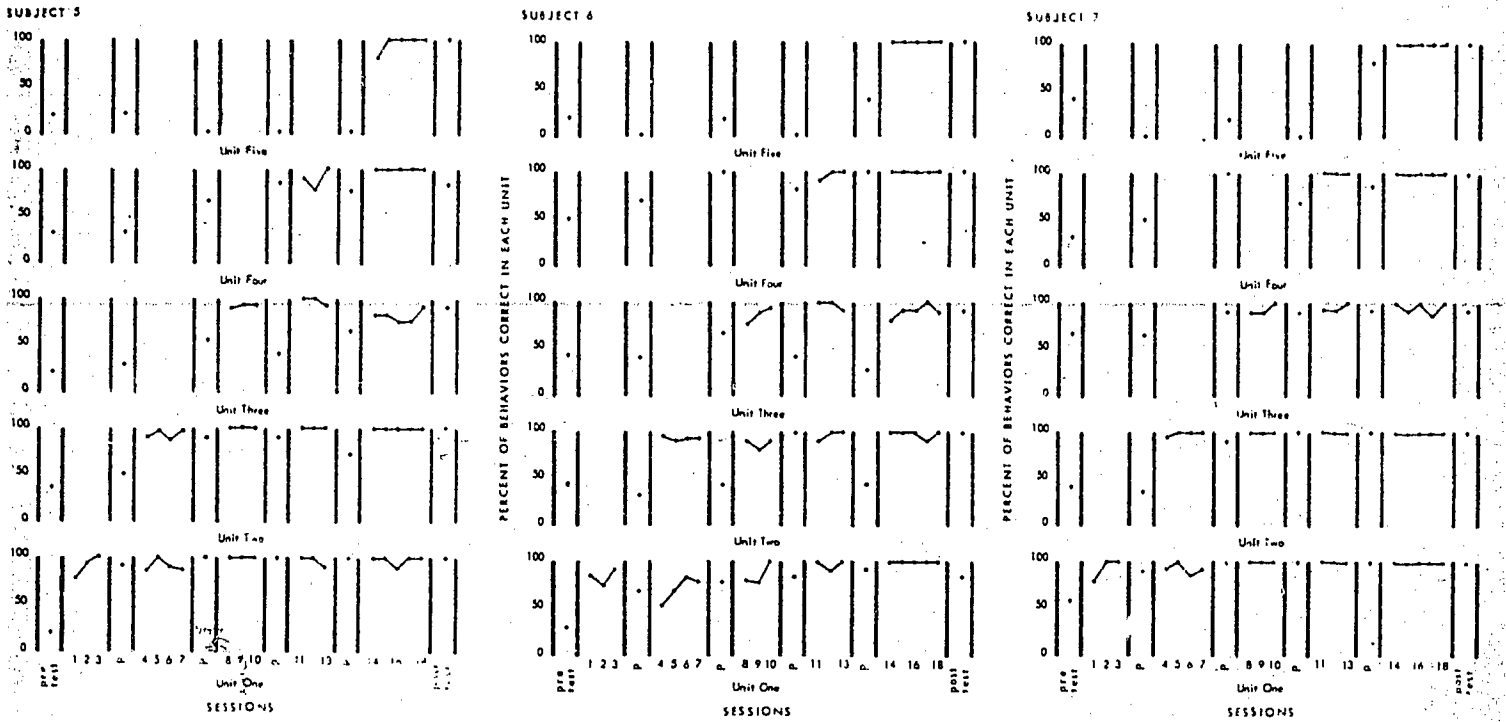


## Eating Program - Field Study I

The data on the nine students show that eight of the nine students increased their performance after training. The percent of increase averaged 50 percent and ranged from 19 percent to 67 percent. This increase produced final performance averaging 94 percent and ranging from 83 percent to 100 percent. One student did not do as well as the other eight. This student has a 30 percent increase over the pretest, producing a final performance of 77 percent of the total eating skills behaviors. This student tended to be disruptive during mealtime and a recommended procedure for dealing with disruptive mealtime behavior has been added to the program.



# Eating Program - Field Study I (Continued)



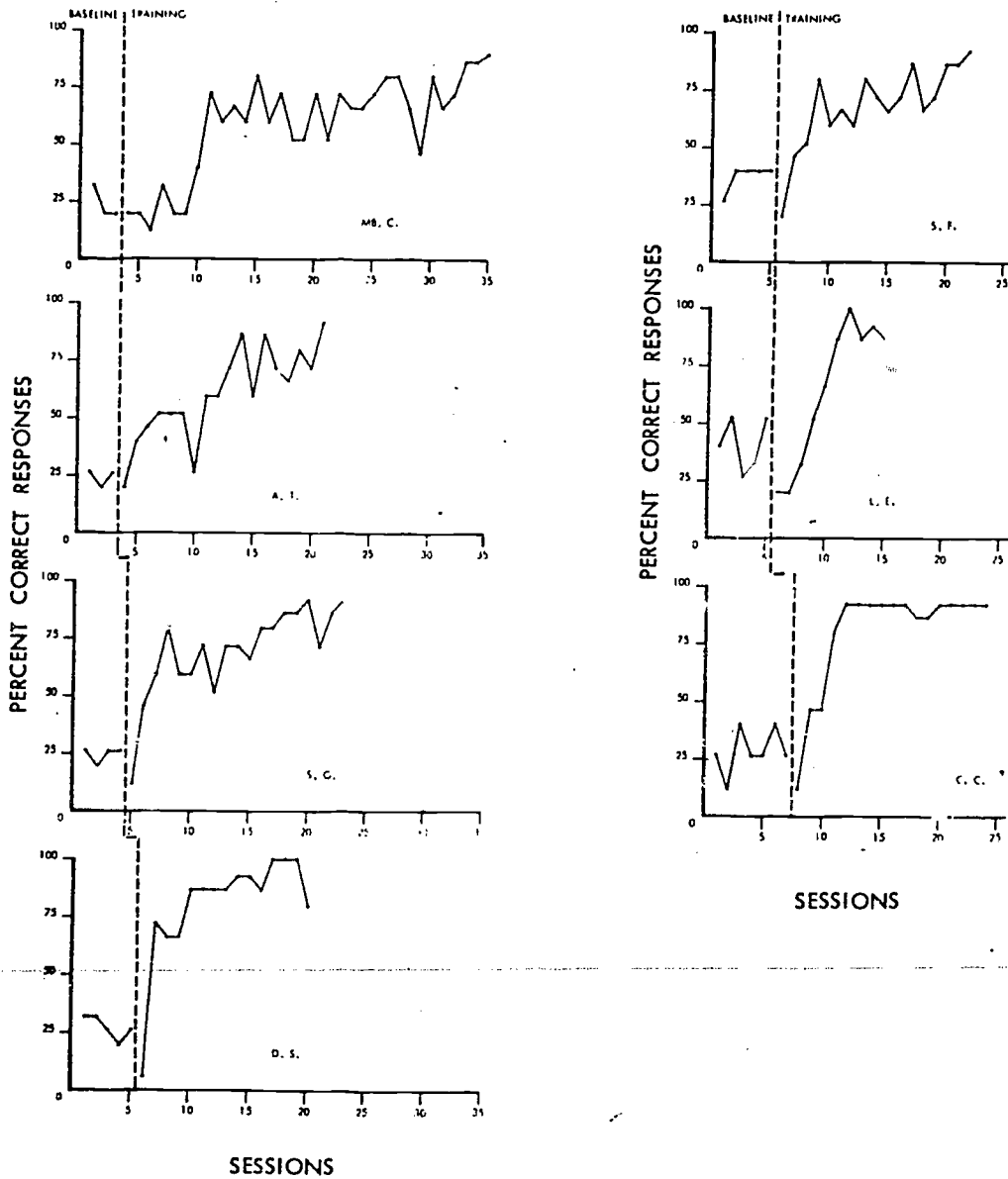
APPENDIX C

Field test data on Project MORE programs in production by Edmark Associates as of January 31, 1975.

Complexion Care  
Face Shaving  
Leg and Underarm Shaving  
Care of Simple Injuries (Unit One)  
Care of Simple Injuries (Unit Two)  
Care of Simple Injuries (Unit Three)  
Care of Simple Injuries (Unit Four)  
Stimulus Shift Articulation

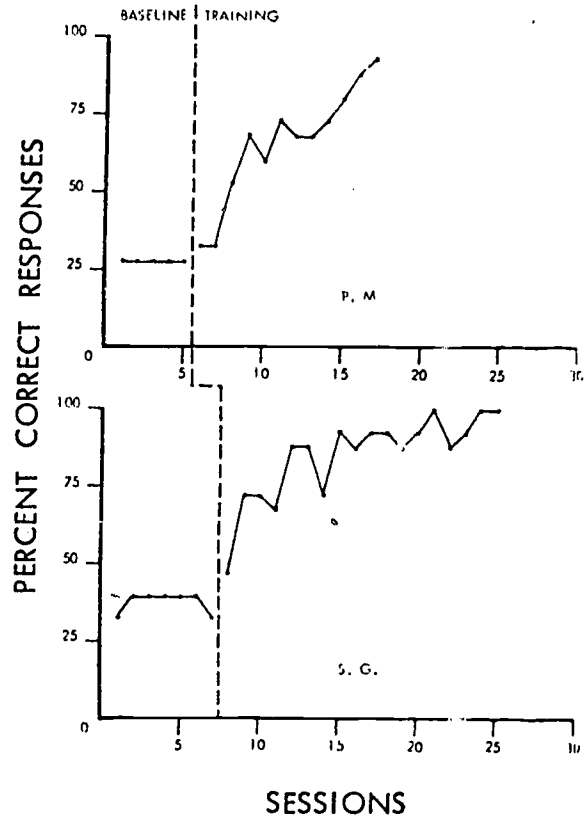
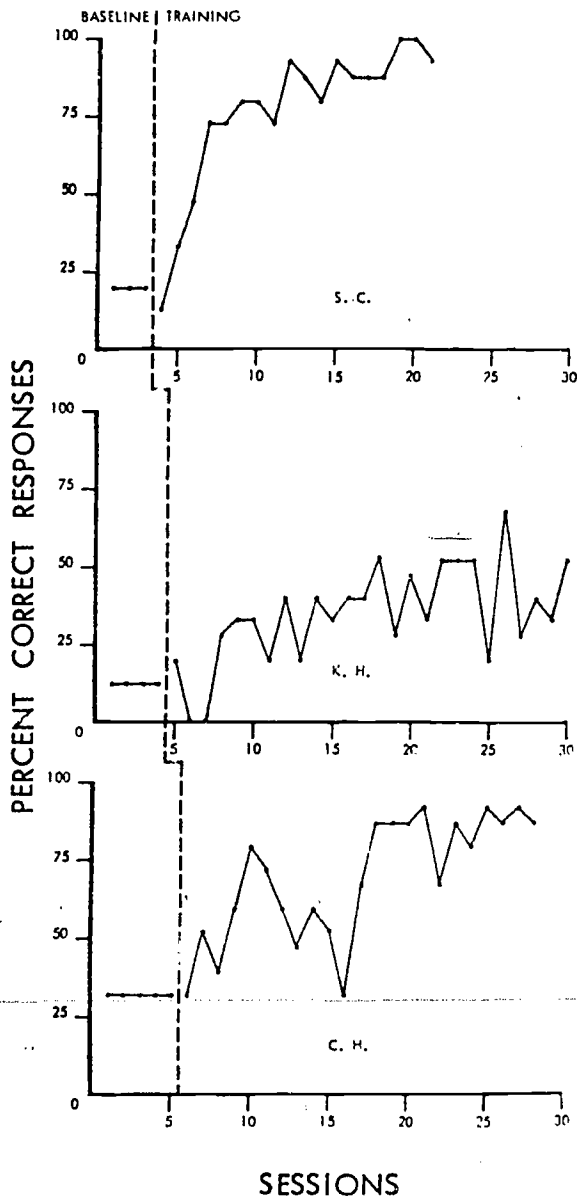
## Complexion Care - Field Study I

Seven students participated in Field Study I. All seven subjects achieved significant gains over baseline. Although there was variability in the number of required training sessions, all seven subjects achieved levels of performance of 90 percent.



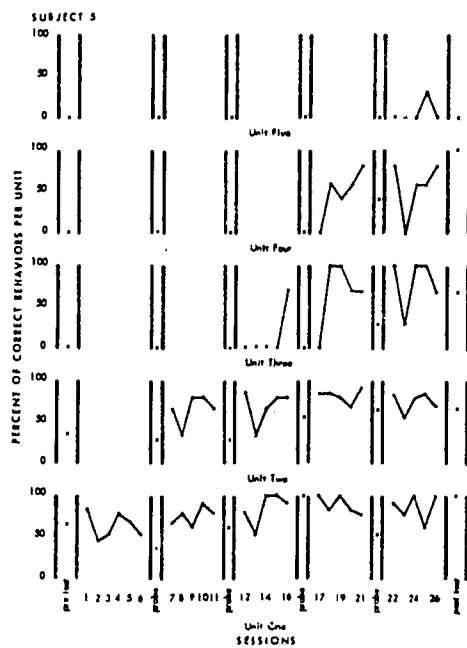
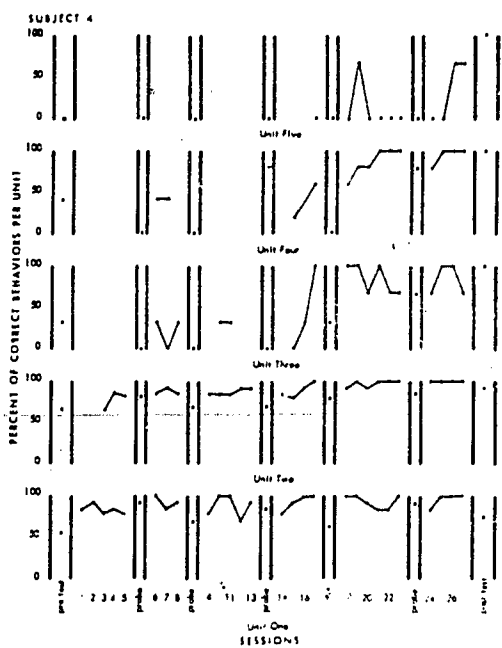
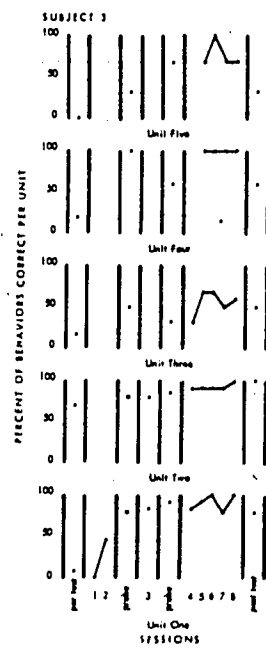
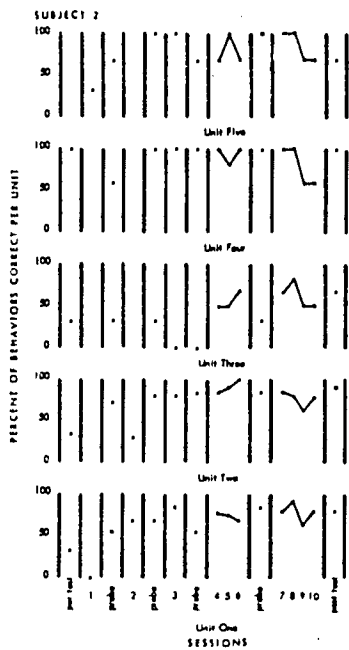
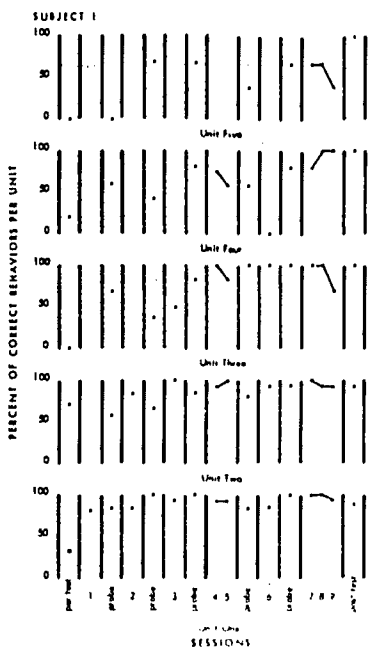
## Complexion Care - Field Study II

Field Study II yielded results comparable to those of Field Study I. One subject (K.H.) achieved performance levels which did not consistently exceed 50 percent. While this level is substantially superior to the baseline level, the effectiveness of the program with this subject without supplemental training was questionable.



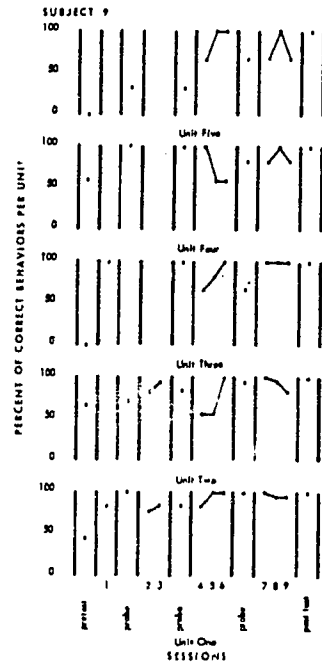
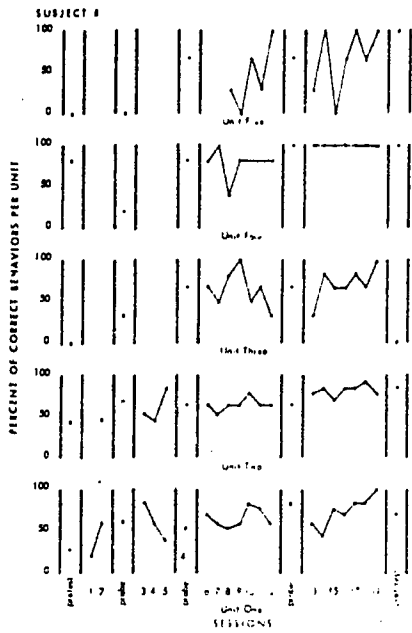
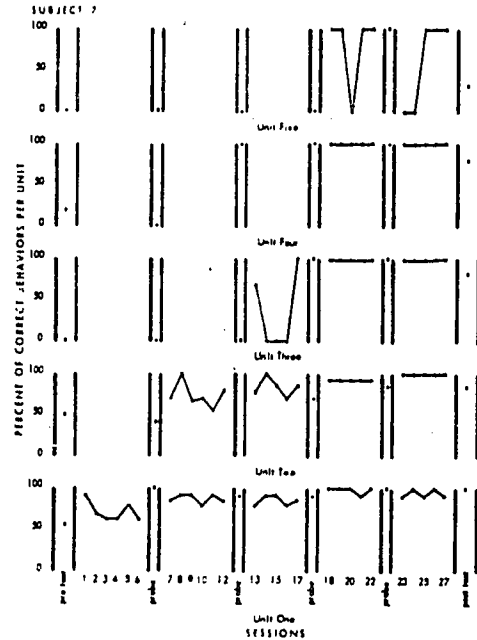
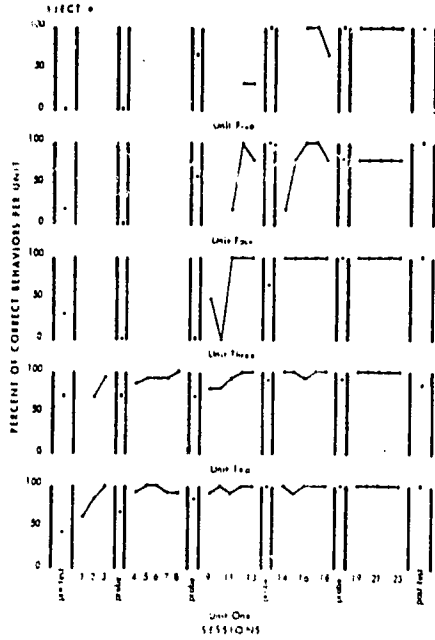
## Face Shaving Program

Session-by-session data is presented on 13 of the 19 students tested in this program.



187

## Face Shaving Program (Continued)

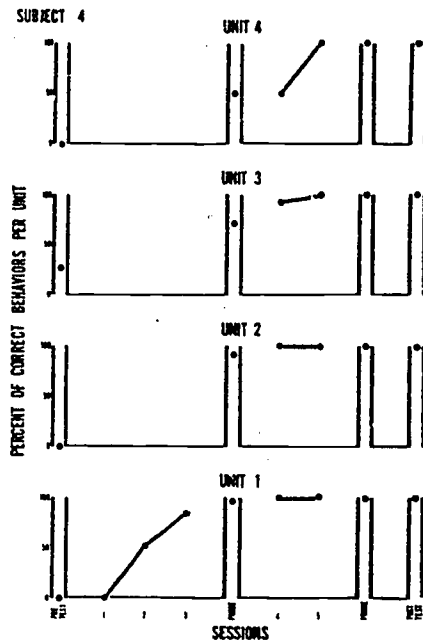
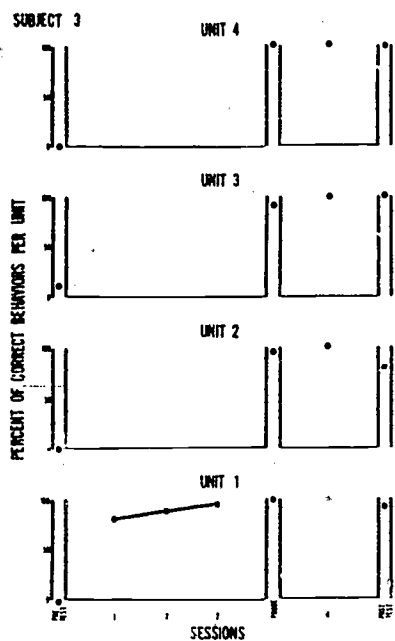
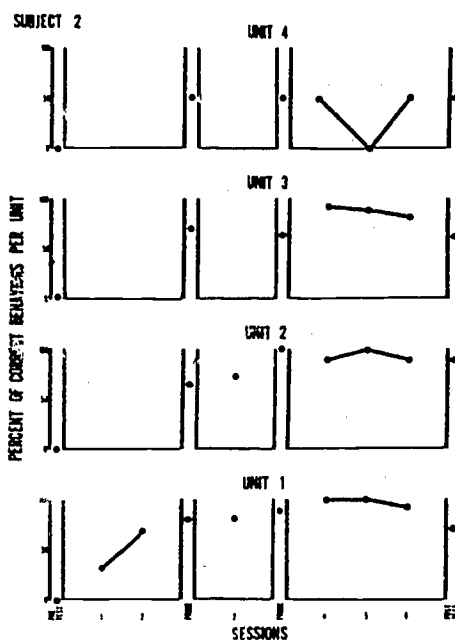
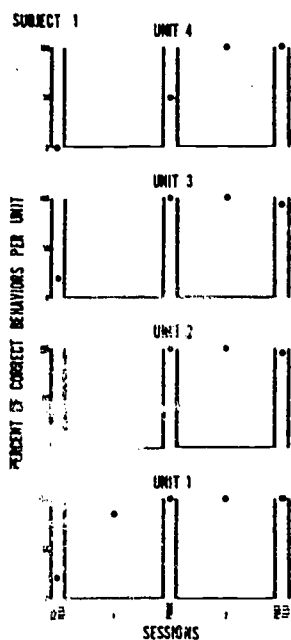




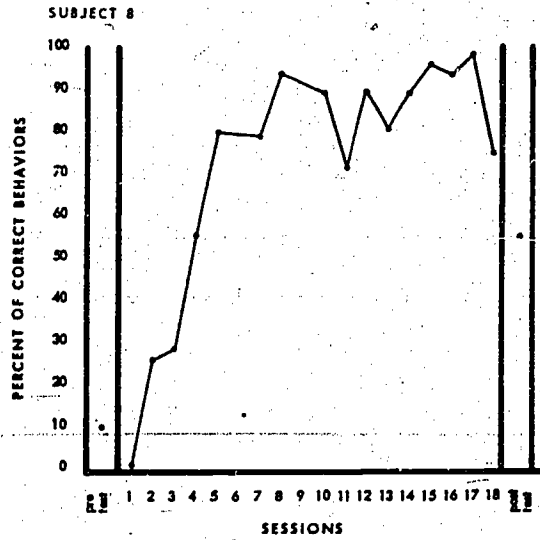
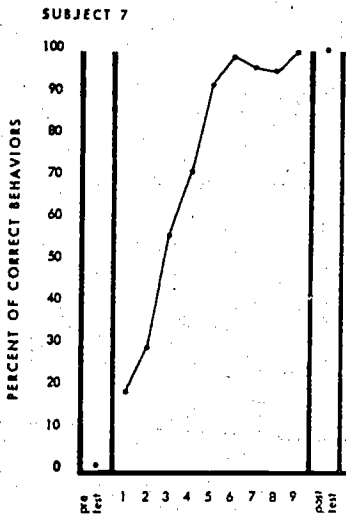
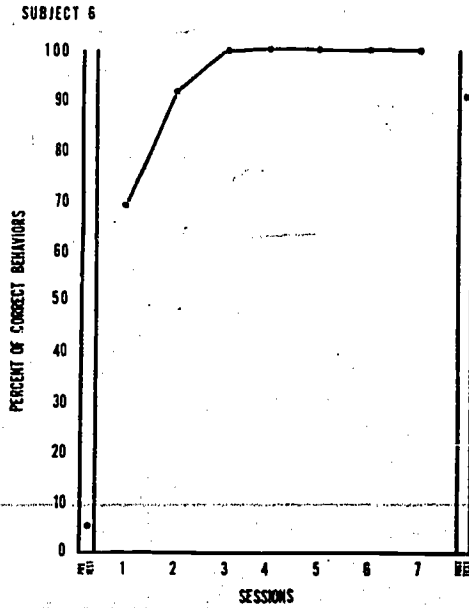
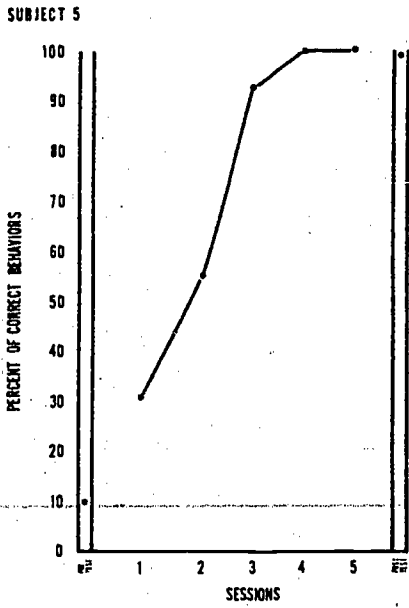


## Leg and Underarm Shaving

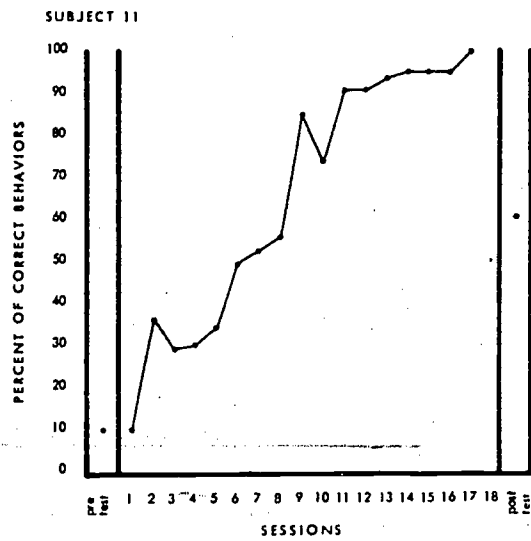
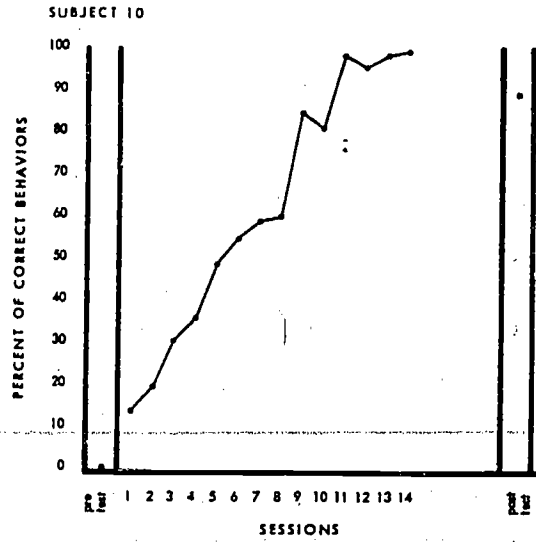
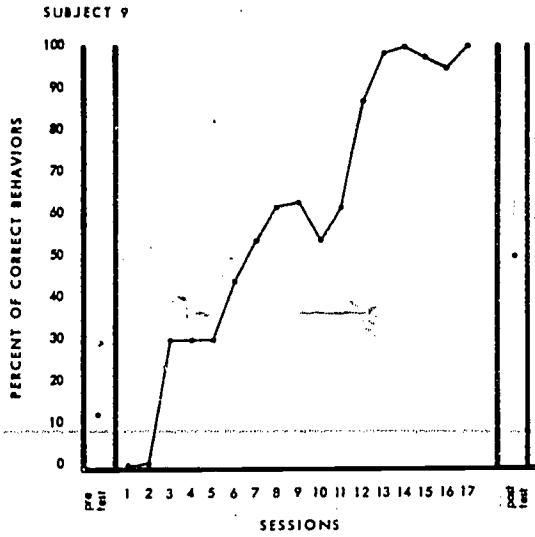
Session-by-session data are presented on 11 of the 15 students tested on this program



Leg and Underarm Shaving Program (Continued)

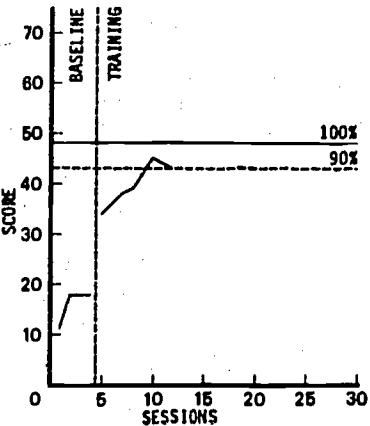
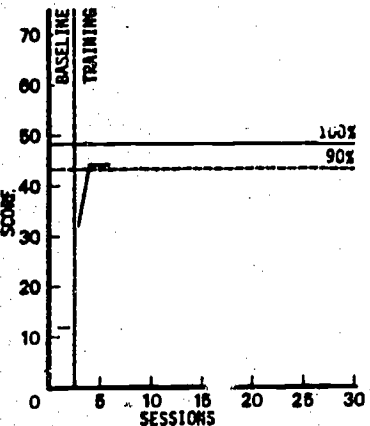
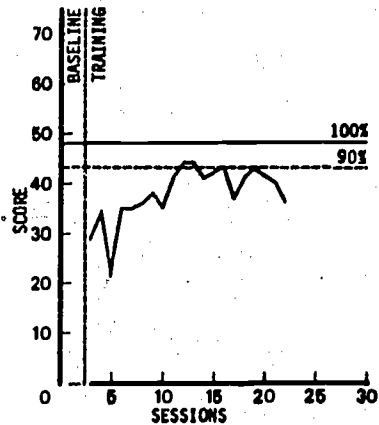
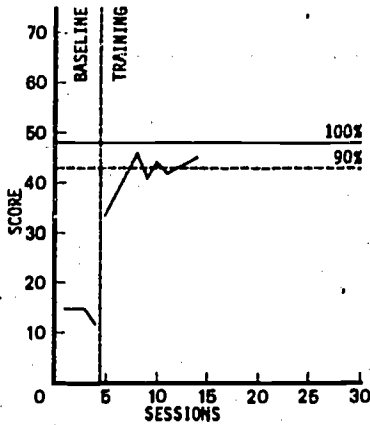
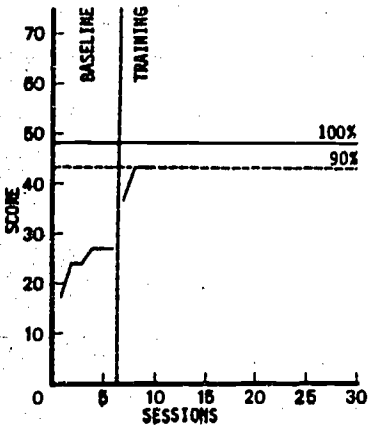
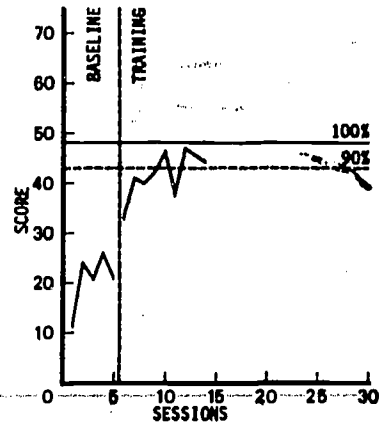
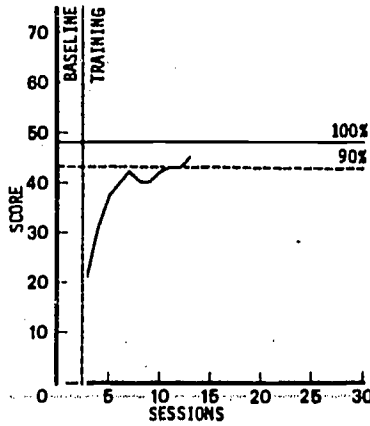
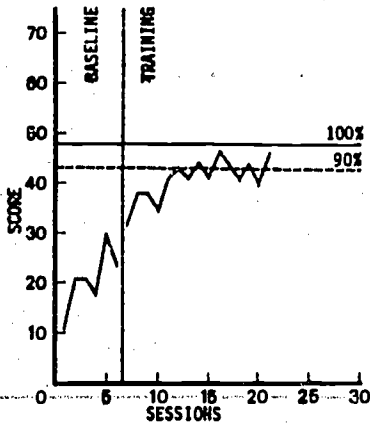


Leg and Underarm Shaving Program (Continued)



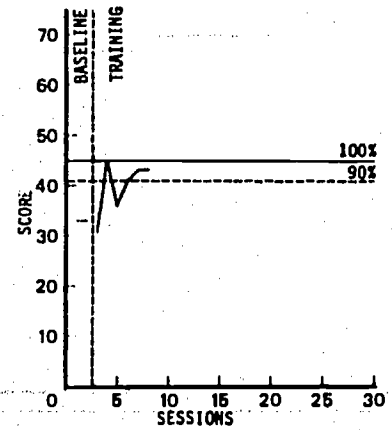
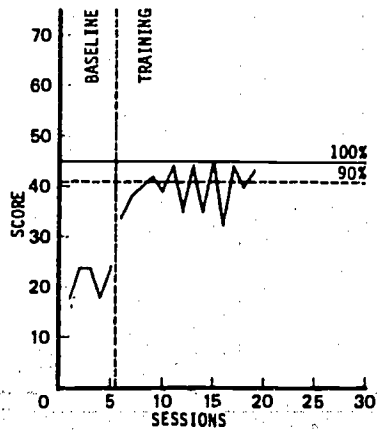
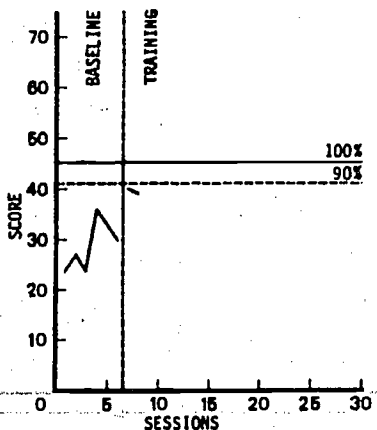
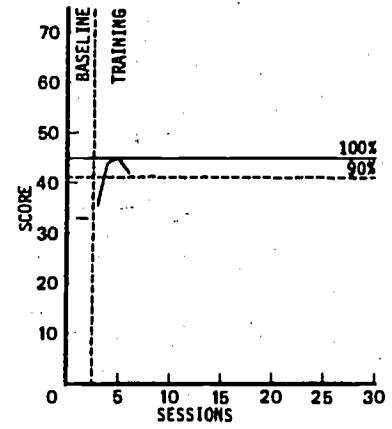
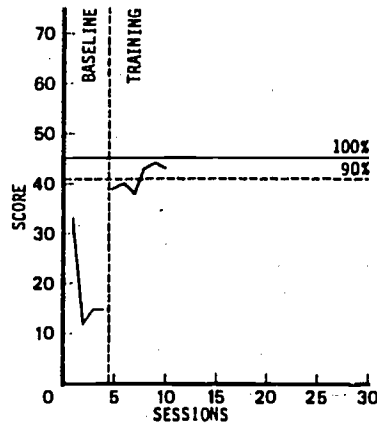
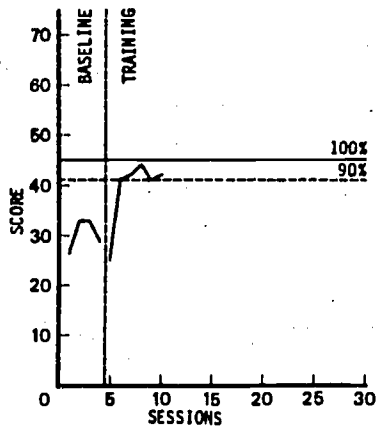
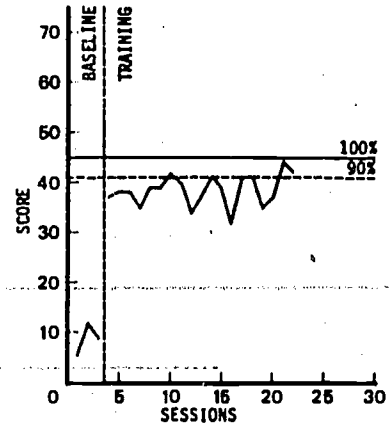
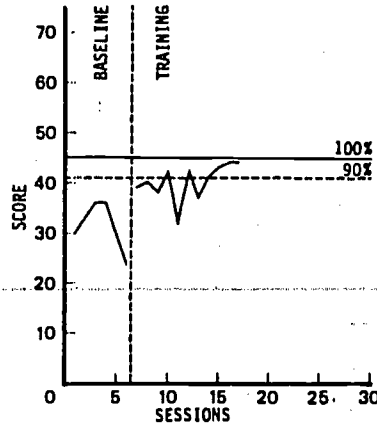
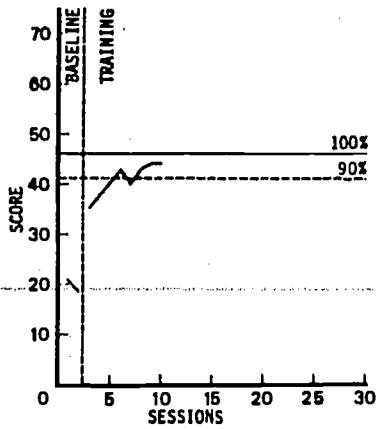
Care of Simple Injuries - Unit One - Cream Antiseptic

Seven out of eight students met criterion within 20 days. Item analyses of program content demonstrated that item revision was unnecessary.



Care of Simple Injuries - Unit Two - Applying an Adhesive Bandage on the Body or a Leg

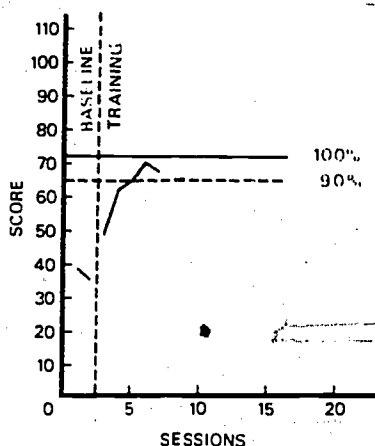
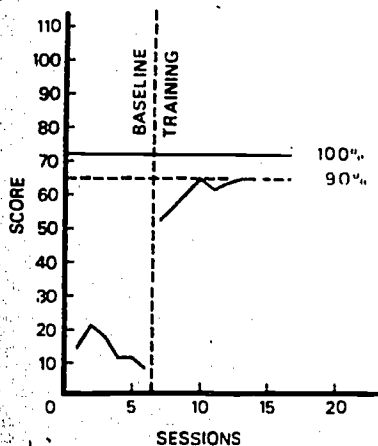
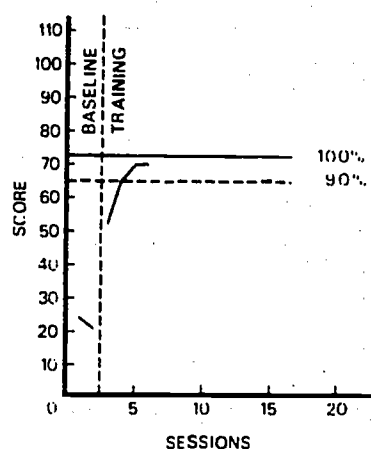
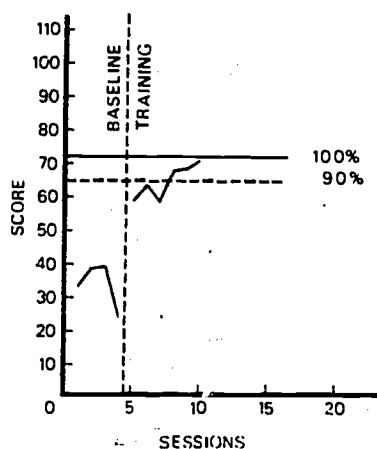
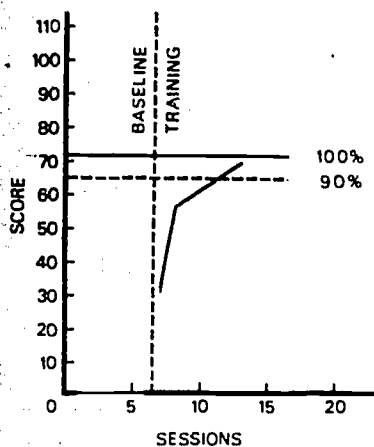
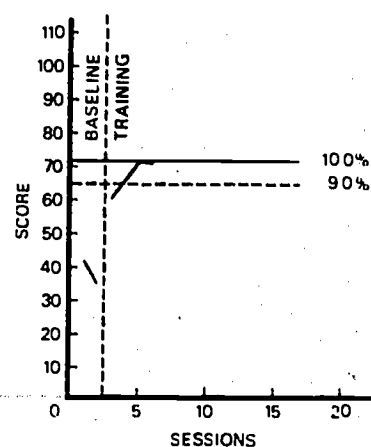
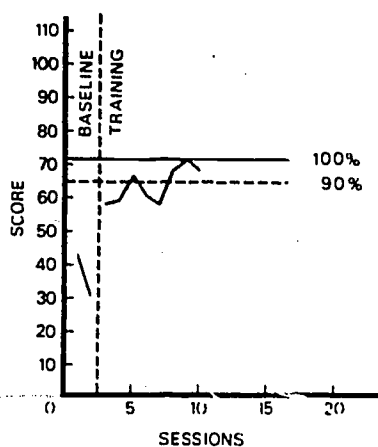
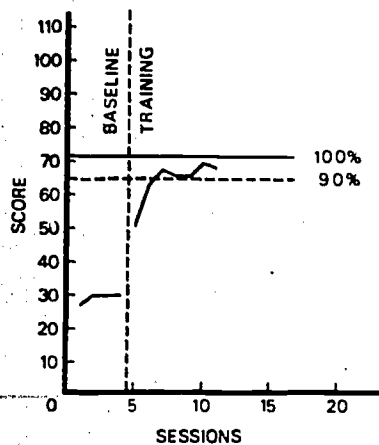
Nine students were involved in this field study. Eight met criterion in less than 20 days, and the ninth student left the facility for an extended home visit after two days of training. Data analysis revealed one step of the program required revision.





Care of Simple Injuries - Unit Four - Using Gauze and Tape on the Body or Legs

Eight students were involved in Field Study I. All eight students met criterion in fifteen or fewer days. Data analysis showed that only minor revisions are necessary for this program.



### Stimulus Shift Articulation

This Field Study was conducted in a public elementary school with 16 students. All were screened and selected for participation by a speech clinician. Eleven students completed the training program by demonstrating phoneme generalization to conversation at the 85 percent or better level. One student was terminated with 84.3 percent phoneme generalization. Four students did not complete the program. The table below shows the percentage of correct phonemic responses in conversation before and after training on this program.

NAME	PHONEME & GRADE		PRETEST (CONV) %				POSTTEST (CONV) %			
			I	M	F	AVG	I	M	F	AVG
*RS	l	K	50	25	-	42	95	100	-	96
SW	th	1	0	33	20	14	100	100	100	100
LS	th	1	0	0	0	0	100	100	100	100
BW	th	1	50	0	0	20	93	100	100	97
CS	l	1	0	0	-	0	100	100	-	100
KM	th	1	100	0	0	23	100	100	100	100
CF	s	2	40	0	25	29	96	100	87	98
HF (D)	th	2	20	0	0	7	100	75	78	89
JT	r	2	11	58	22	33	75	100	100	91
CR	sh	2	27	17	25	23	100	100	100	100
KK	th	2	86	25	40	56	100	100	100	100
GG (D)	th	3	0	0	0	0	100	100	83	95
AVERAGE % SCORE			32	13	12	21	97	98	95	97

(D): Dialect spoken in home environment

\* : Previous Response Development training on designated phoneme



### Stimulus Shift Articulation

Target phonemes for this Field Study included the /th/, /l/, /s/, /r/, and /sh/ phonemes. All students demonstrated significant gains in terms of generalized phonemic responses. The table below shows that the average percent of improvement was 77 percent with a range of improvement from 44 to 100 percent. The figures were computed by subtracting the posttest scores from the pretest scores to obtain the number of percentage points difference.

Subject	% Improvement	Subject	% Improvement
SW	86	HF	82
LS	100	JT	57
BW	77	CR	77
CS	100	*RS	54
KM	77	KK	44
CF	69	GG	95
AVERAGE % IMPROVEMENT			77

\*Previous Response Development Training

### Stimulus Shift Articulation

Previous studies indicated that the mean length of therapy was nine hours and ten minutes. In this Field Study, for the revised program, the mean length of therapy time for all subjects on all phoneme programs was eight hours and 33 minutes. The average number of therapy sessions, including conversation sessions, was 22, with the average number of training blocks to criterion being 155. The average number of conversation training sessions needed to meet the 96 percent correct termination criterion was 4.7 sessions. The table below shows the duration of therapy needed to reach termination criterion on the program in this 1972-73 study.

SUBJECT	PHONEME	GRADE	TRAINING BLOCKS <sup>1</sup>	NUMBER OF SESSIONS	THERAPY TIME <sup>2</sup>	CONV <sup>3</sup>	CONV TIME <sup>4</sup>	TOTAL TIME <sup>5</sup>
RS <sup>6</sup>	l	K	147	20	8'20"	3	45"	9'05"
SW	th	1	183	21	8'45"	4	60"	9'45"
LS	th	1	183	18	7'30"	6	90"	9' 0"
BW	th	1	143	17	7'05"	4	60"	8'05"
CS	l	1	155	17	7'05"	2	30"	7'35"
KM	th	1	96	13	5'25"	5	75"	6'40"
CF	s	2	230	23	9'35"	8	120"	10'35"
HF (D)	th	2	117	16	6'40"	6	90"	8'10"
JT	r	2	164	20	8'20"	5	75"	9'35"
CR	sh	2	153	17	7'05"	4	60"	8'05"
KK	th	2	129	15	6'15"	4	60"	7'15"
GG (D)	th	3	155	18	7'30"	5	75"	8'45"

1 Training Blocks: For most programs, 10 training items in each training block

2 Therapy Time: Approximately 25" per session

3 Conversation: Number of sessions needed to reach termination criterion (96%) correct in conversation

4 Conversation Time: Approximately 15" per session/conversation

5 Total Time: Sum of Therapy and Conversation Times

6 Previous Response Development Training 165

#### APPENDIX D

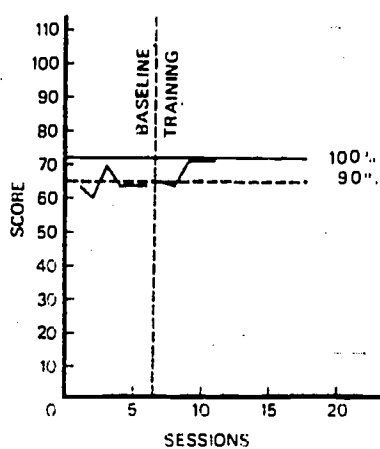
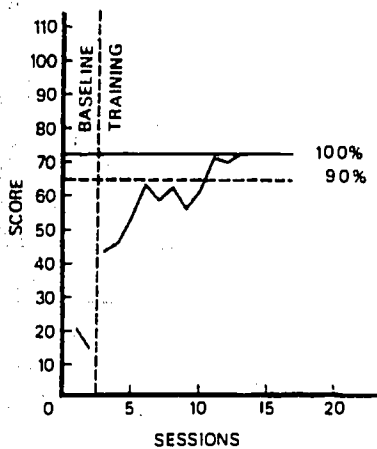
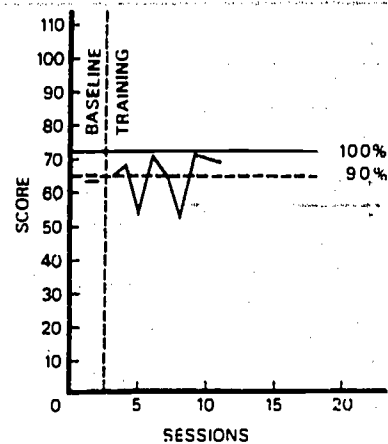
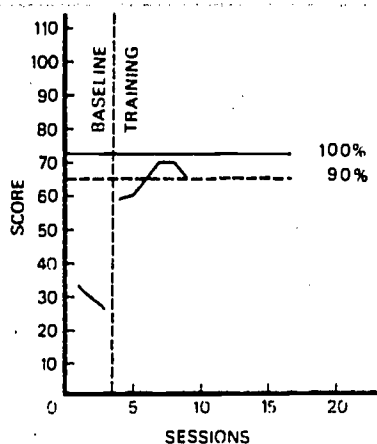
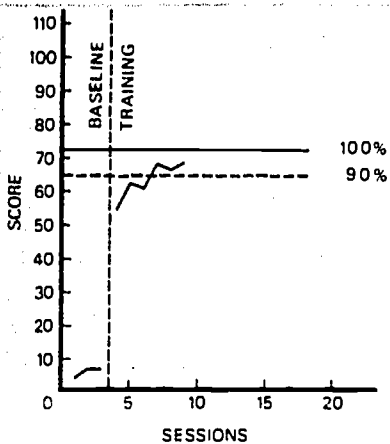
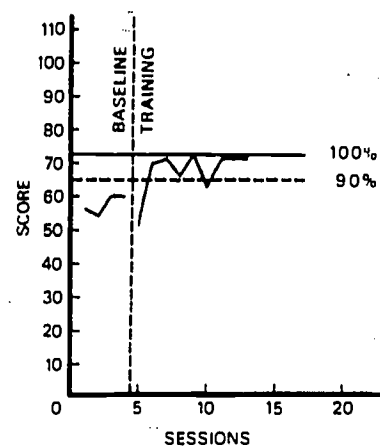
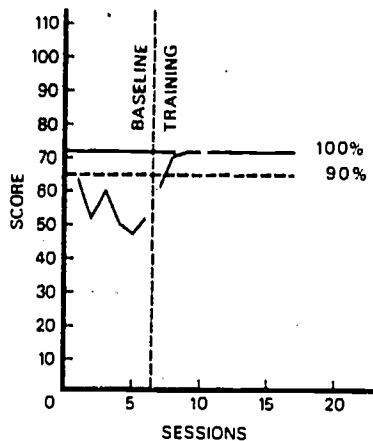
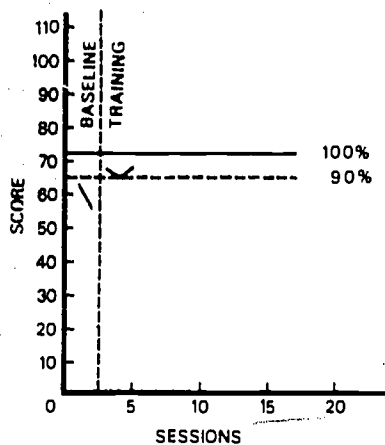
Field test data on Project MORE programs on which data analysis is complete, but which had not been sent to Edmark Associates as of January 31, 1975.

Care of Simple Injuries (Unit Five)  
Care of Simple Injuries (Unit Six)  
Care of Simple Injuries (Unit Eight)  
Care of Simple Injuries (Unit Nine)  
Care of Simple Injuries (Unit Ten)  
Care of Eyeglasses  
Feminine Hygiene  
Use of Deodorant  
Hair Washing  
Use of Telephone (Unit One)  
Use of Telephone (Unit Two)  
Use of Telephone (Unit Three)  
Hair Rolling (Second Edition)

# Care of Simple Injuries - Unit Five - Using

## Gauze and Tape on Hand and Arm

Eight students were involved in this field study. All eight students met criterion in 12 or fewer days. After completion of this field study, Units Four and Five of the Care of Simple Injuries Program were combined into one unit - Using Gauze and Tape. These two units were combined because the majority of the steps in both units are identical.



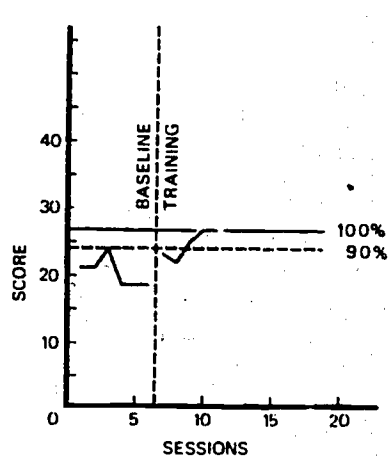
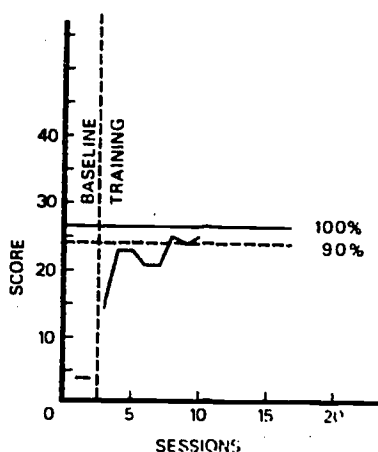
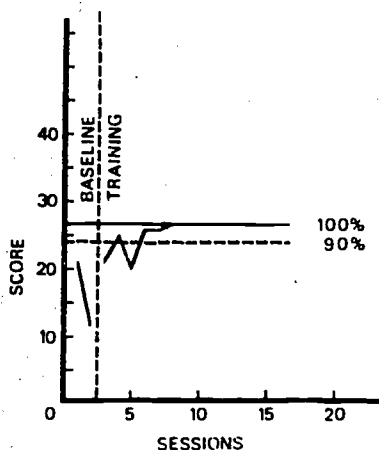
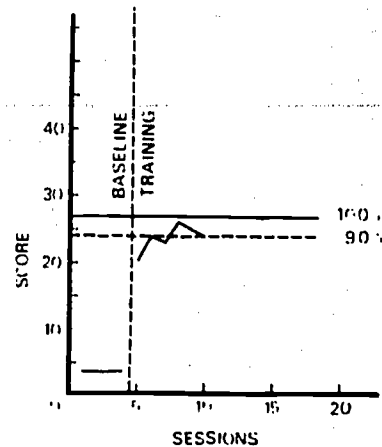
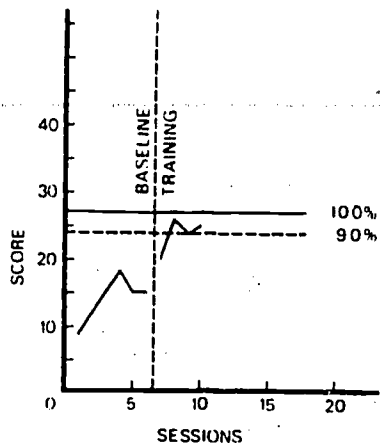
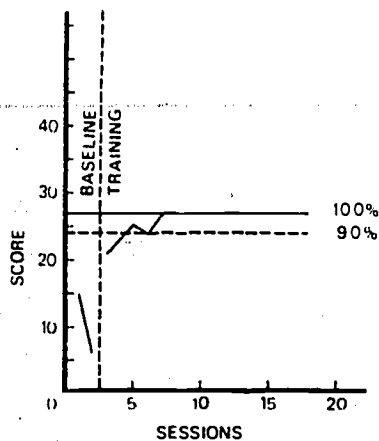
## Care of Simple Injuries - Unit Six - Part One,

### Minor Burns (First Degree)

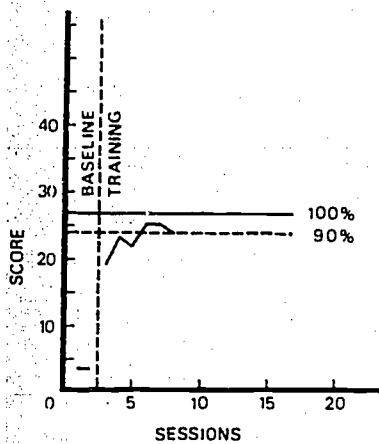
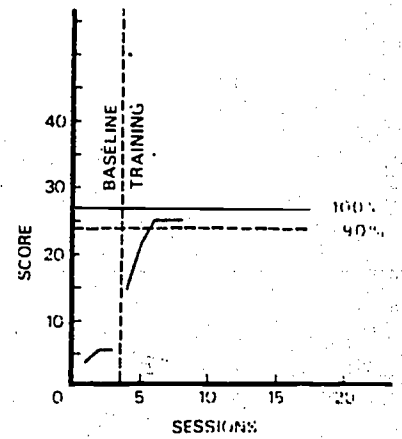
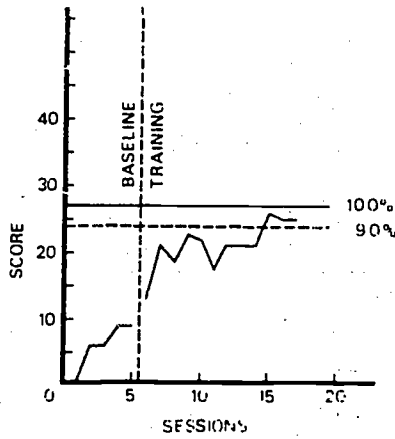
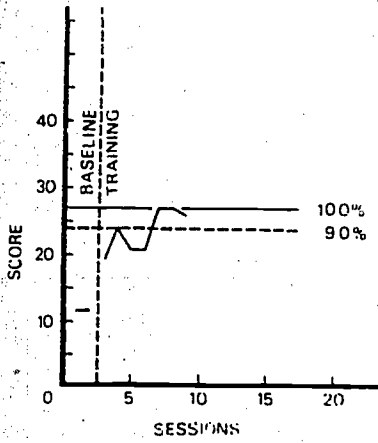
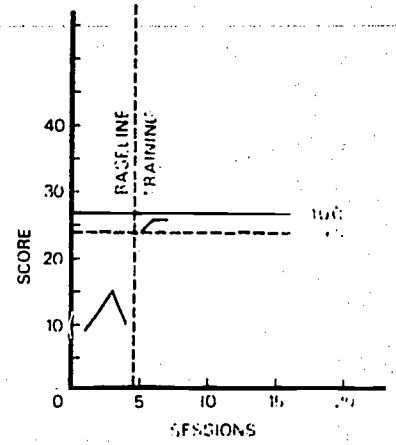
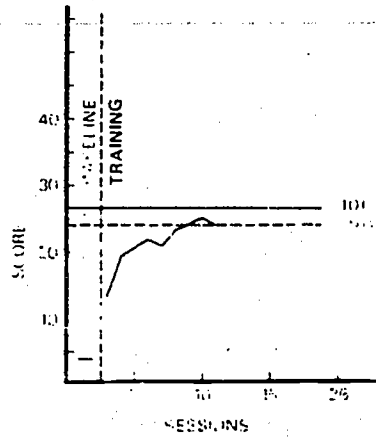
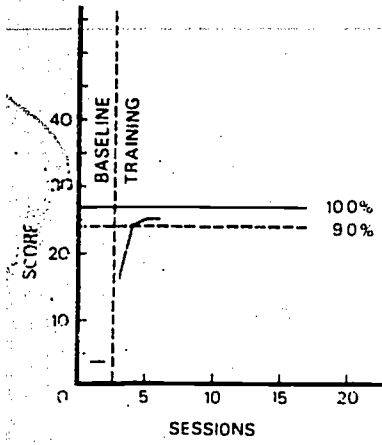
This program was taught on alternate days from the Second Degree Burns (Unit Six - Part Two). Fourteen students participated in the field testing. Three of these students had participated in the prerequisite units (Applying Cream Antiseptic and Using Gauze and Tape) prior to testing this unit. One student did not complete the program due to a lengthy home visit taken after five days of training. His data is not included in data analysis. All other students met the performance criterion of 90% correct for three consecutive days.

Step by step analysis of the data showed only one step, Putting on Cream Antiseptic, on which less than half of the students met the performance criterion. Criterion was to perform the step correctly three consecutive days with No Help. Further analysis of this step showed that three students were able to do the step with No Help, nine needed Verbal Help, and one needed a Demonstration.

It was decided not to revise the step, since the error rate appeared to be due to students not having the prerequisite skills.



Care of Simple Injuries - Unit Six - Minor Burns - First Degree



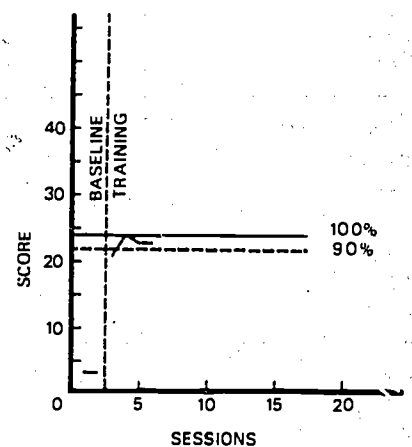
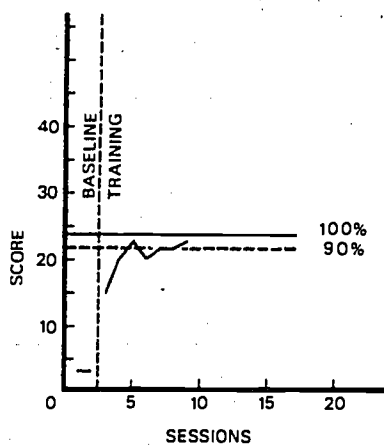
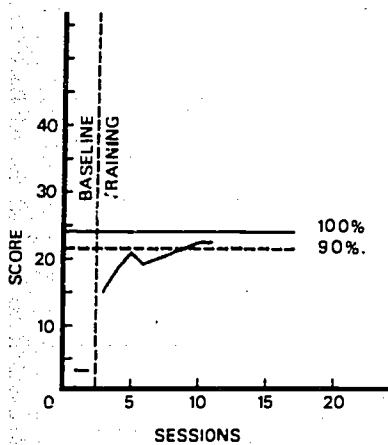
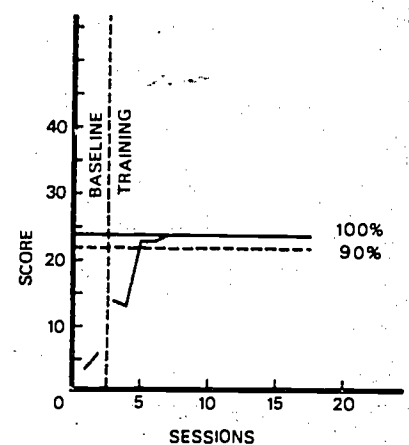
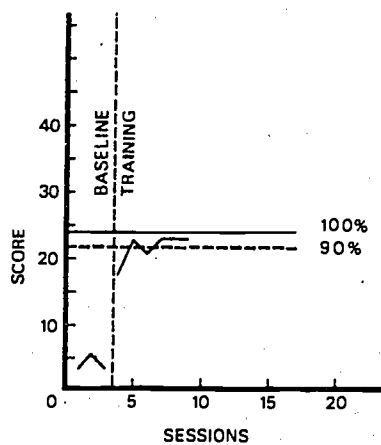
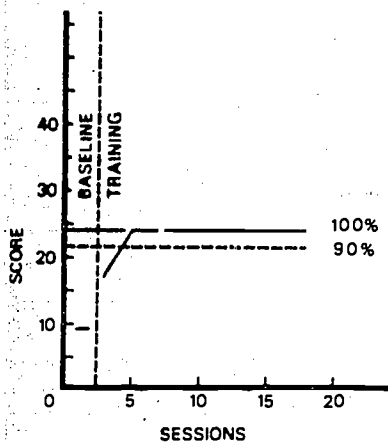
## Care of Simple Injuries - Unit Six - Part Two,

### Minor Burns (Second Degree)

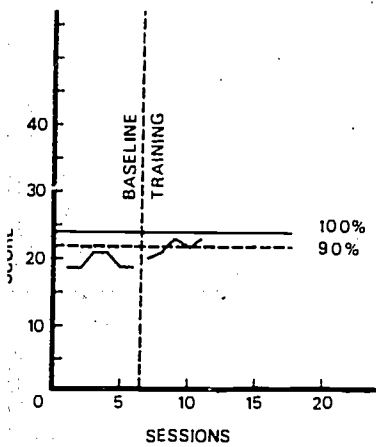
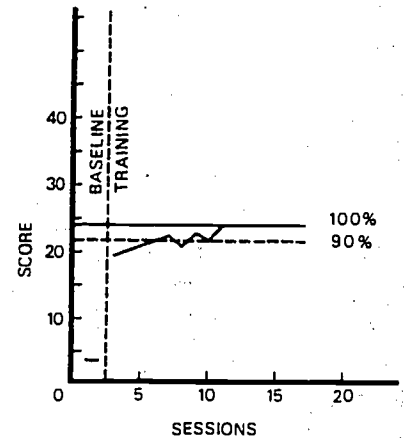
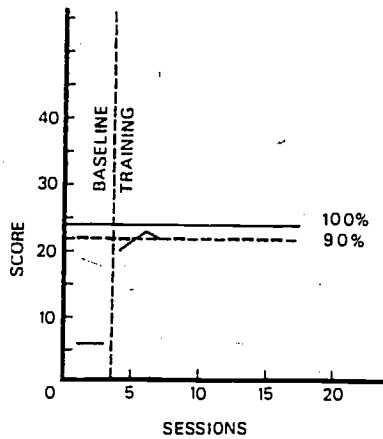
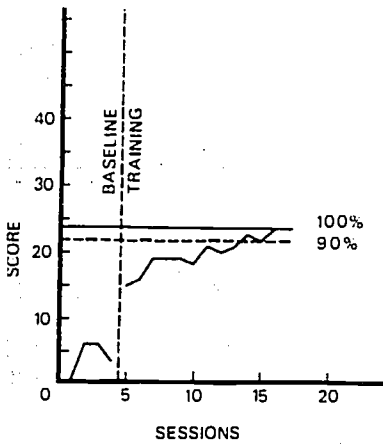
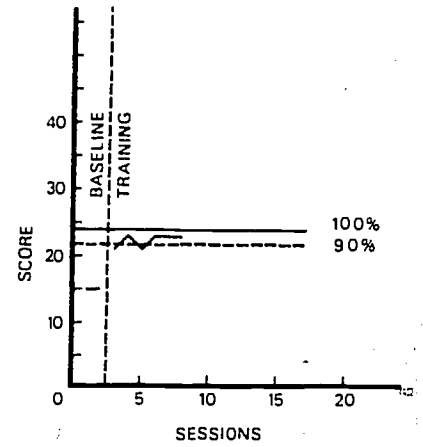
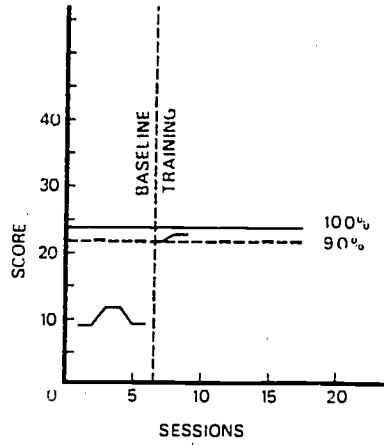
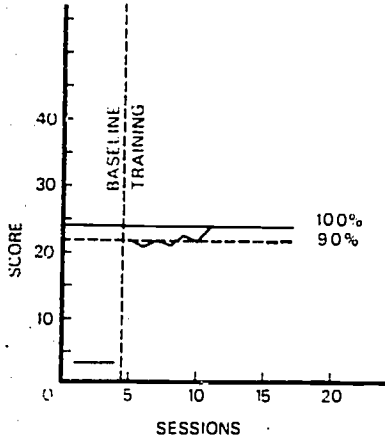
This program was taught on alternate days from the First Degree Burns (Unit Six - Part One). Fourteen students participated in the testing. Three of these students had participated in the prerequisite units (Applying Cream Antiseptic and Using Gauze and Tape) prior to this testing. One student did not complete the program due to a lengthy home visit after six days of training. His data is not included in data analysis.

Step by step analysis of the data showed only one step, Putting on a Bandage, on which less than half of the students met criterion. Criterion was to perform the step correctly three consecutive days, with No Help. Further analysis of this step showed that only four students performed the step with No Help, eight students needed Verbal Help, and one student needed a Demonstration. Further, there was a high percentage of teacher error on this step.

It was decided that the step would not be revised, since the error rate appeared to be due to students not having the prerequisite skills and because teachers were unfamiliar with the previous units.



Care of Simple Injuries - Unit Six - Minor Burns - Second Degree



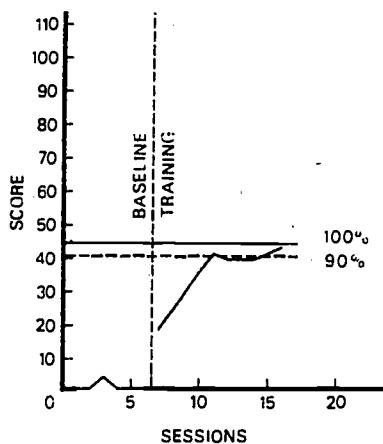
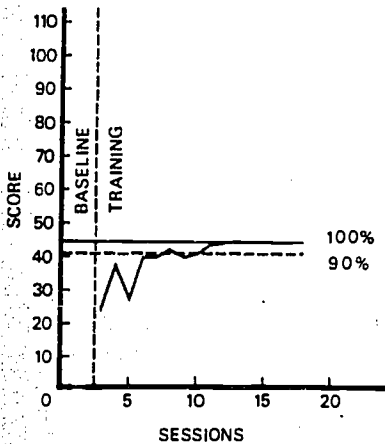
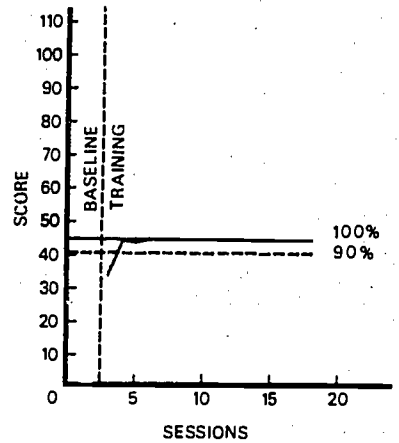
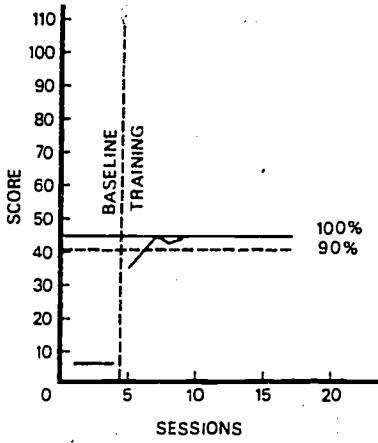
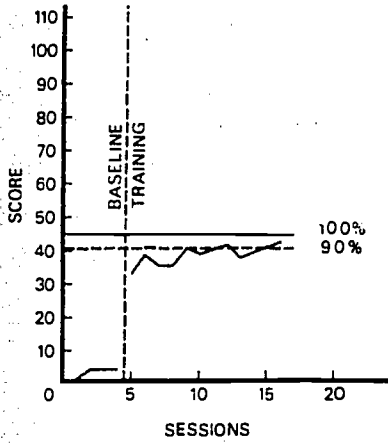
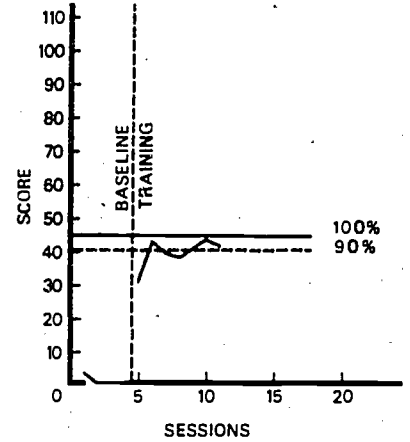
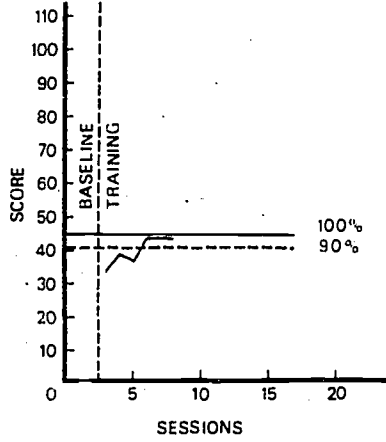
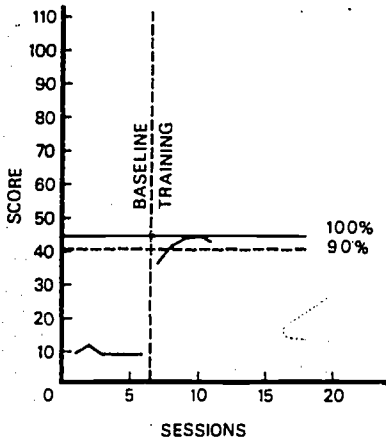
205

171



# Care of Simple Injuries - Unit Eight - Bruises and Swellings (Part One)

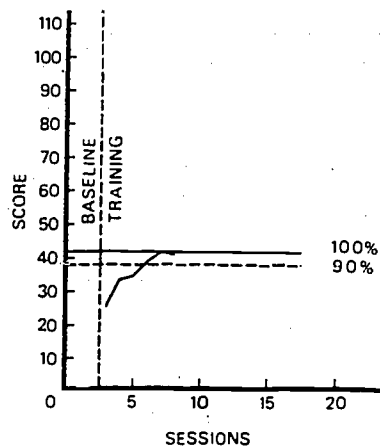
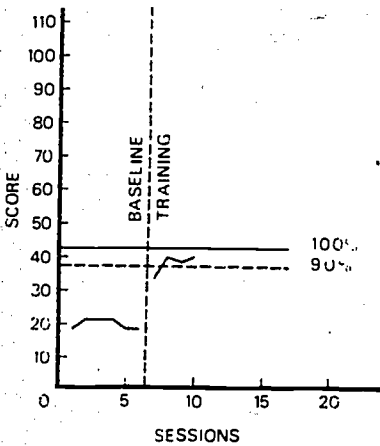
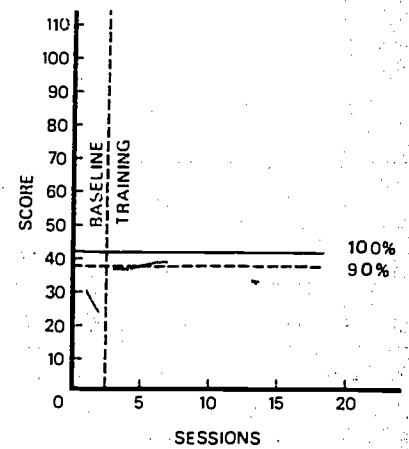
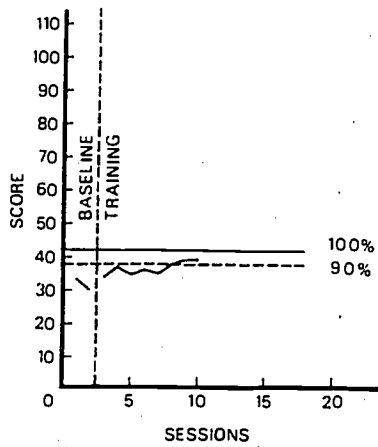
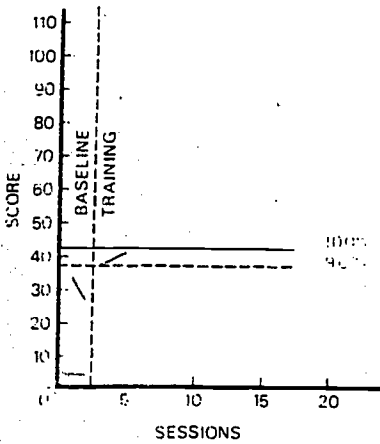
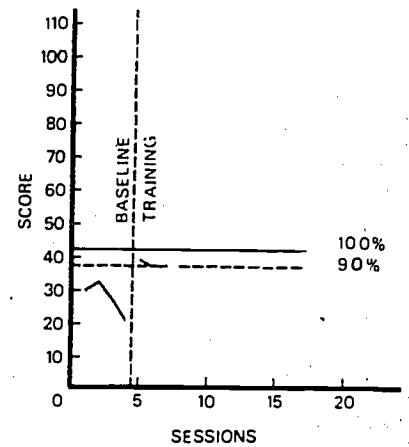
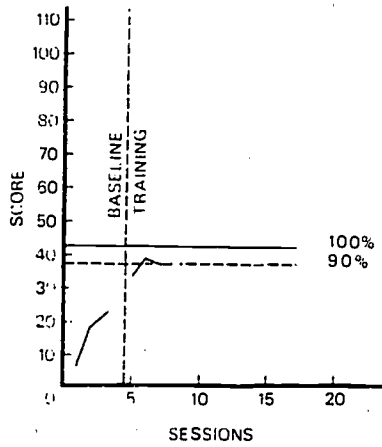
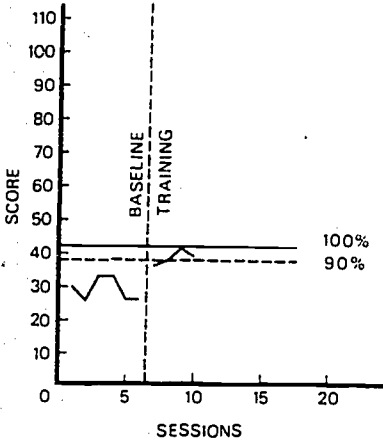
Eight students were involved in this field study. All met criterion in fewer than 20 days. Data analysis revealed one step of the program requires revision.



Care of Simple Injuries - Unit Eight - Black Eyes (Part Two), Field Study I

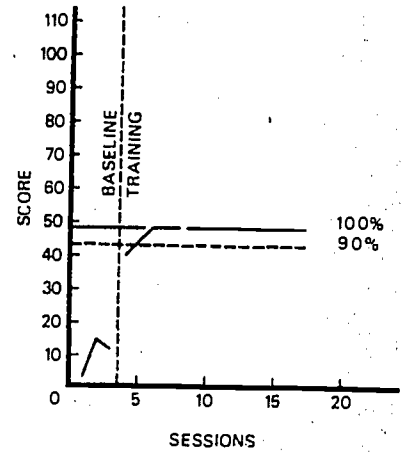
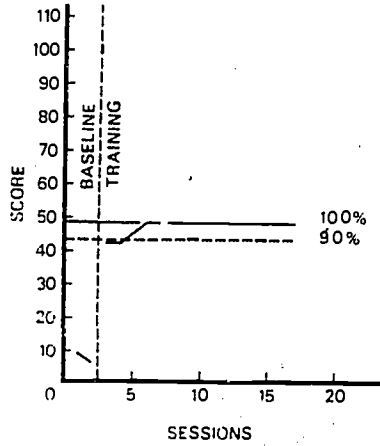
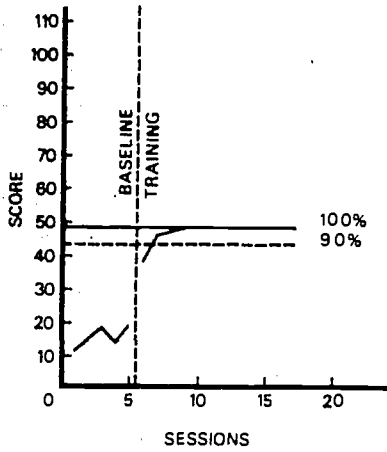
In this study, all eight students met criterion within 10 days.

Item analysis revealed one step of the program was too comprehensive and needed revision.



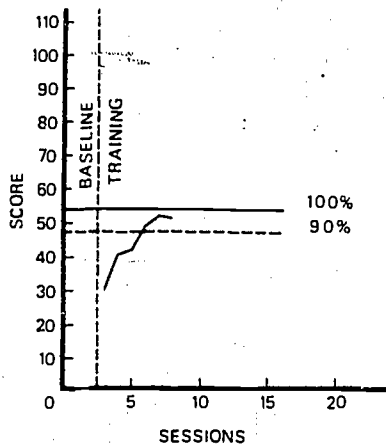
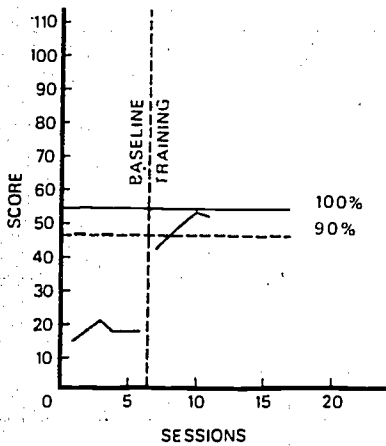
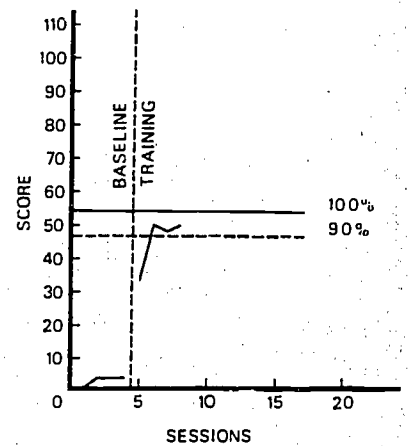
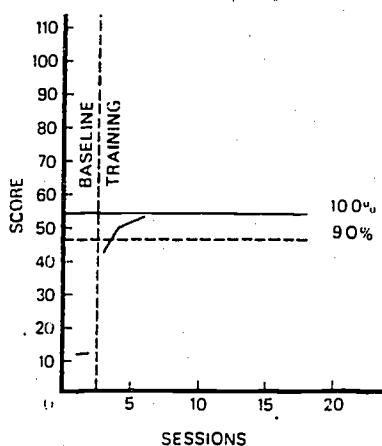
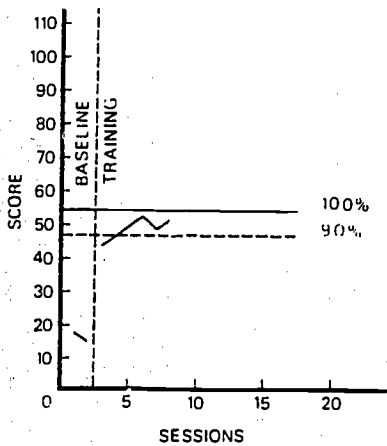
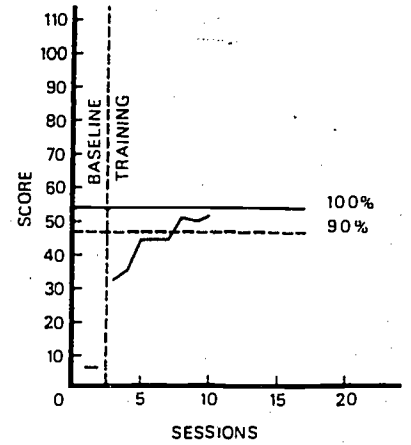
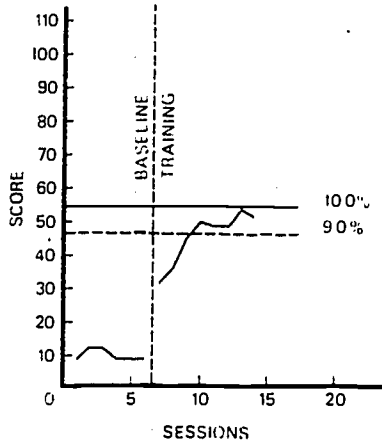
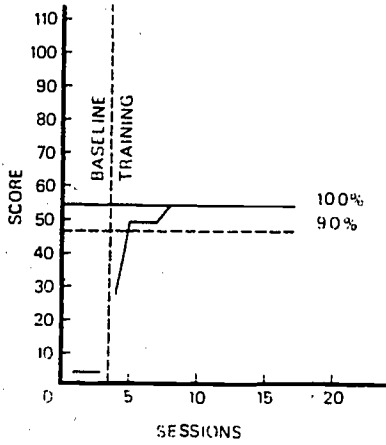
Care of Simple Injuries - Unit Eight - Black Eyes (Part Two), Field Study II

Three students were involved in this field study. All met criterion in fewer than 10 days. Data analysis revealed that no further item revision is necessary.



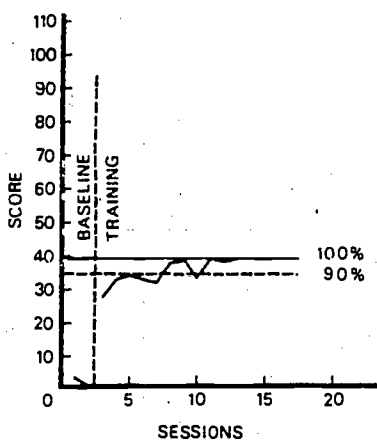
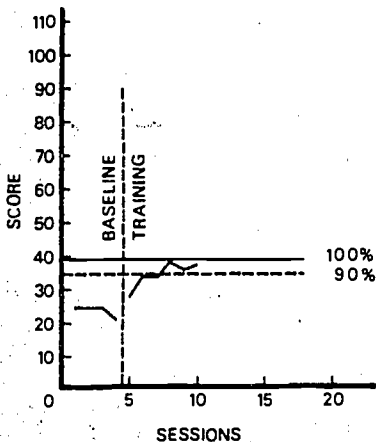
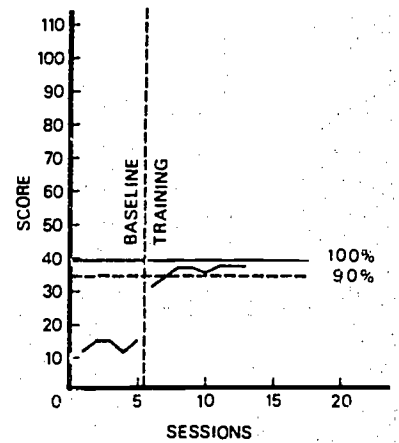
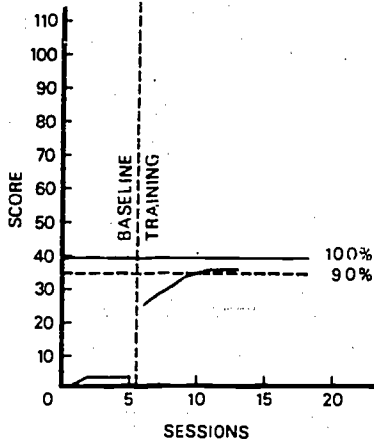
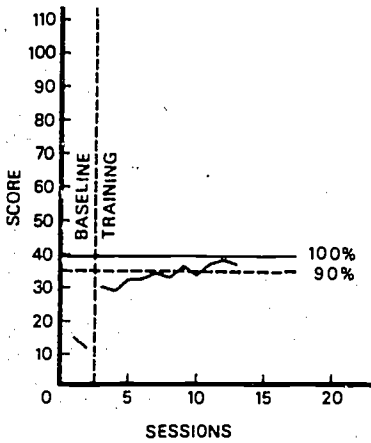
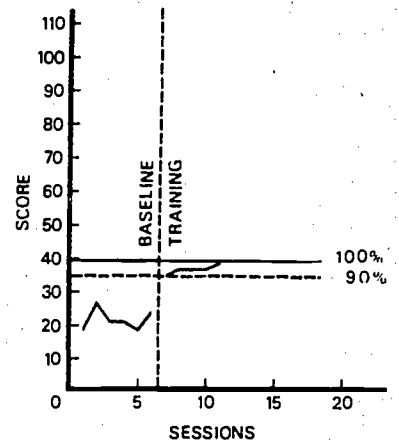
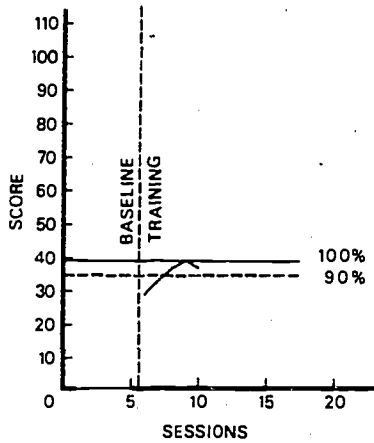
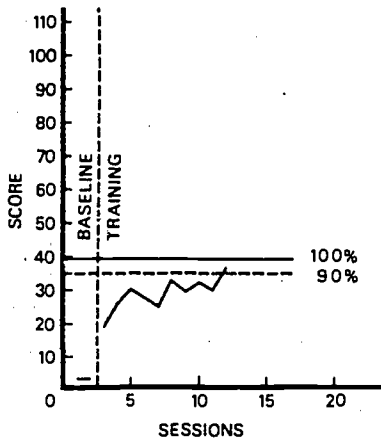
## Care of Simple Injuries - Unit Nine - Nosebleeds

Eight students participated in the field testing for this program, with all students meeting criterion in fewer than 10 days of training. Item analysis of program content demonstrated that a second method of telling time was needed, so use of a kitchen timer was added. The step teaching calling the doctor will also be revised in accordance with the revisions made in the Black Eyes Unit. The program is now ready for final mediation.



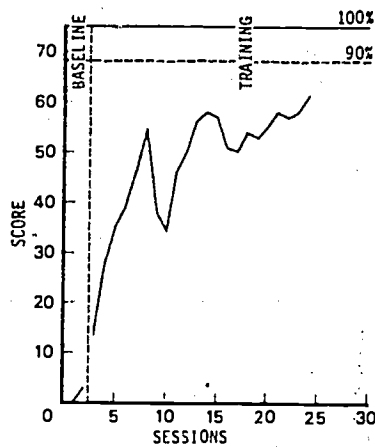
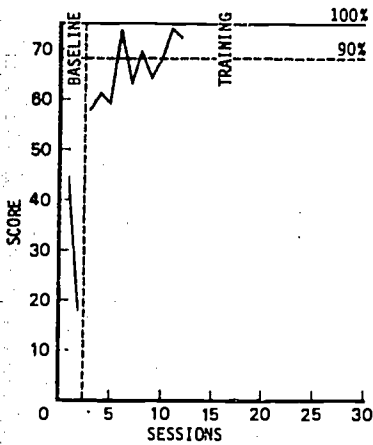
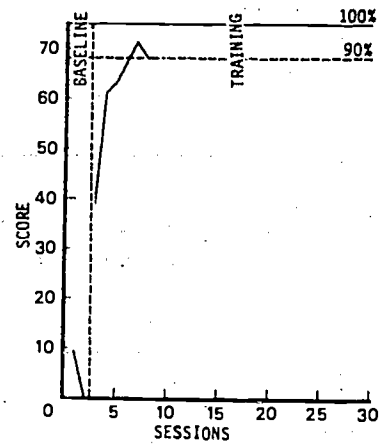
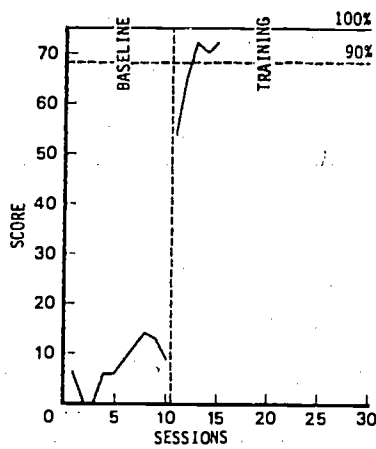
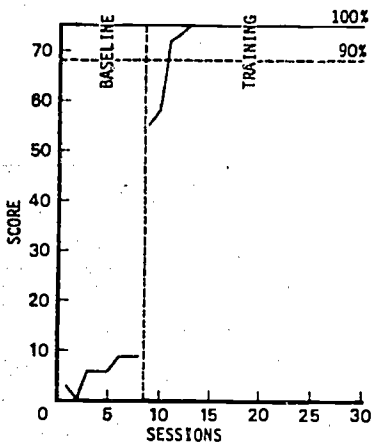
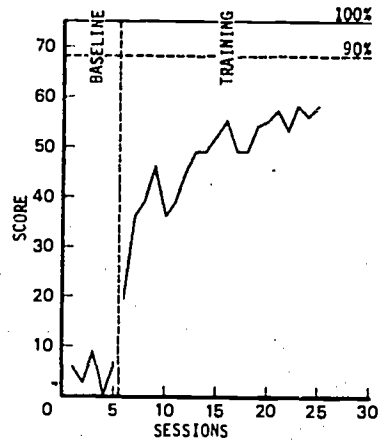
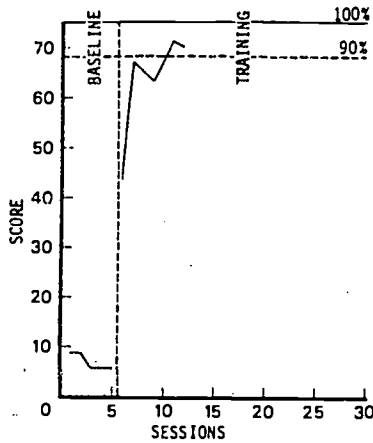
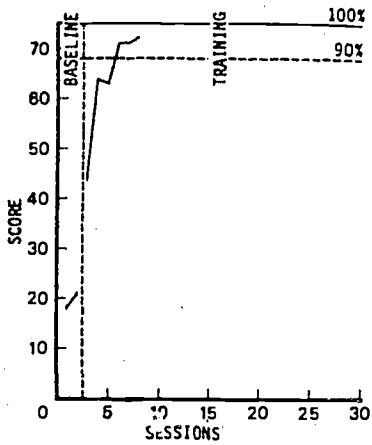
## Care of Simple Injuries - Unit 10 - Animal Bites

To date, seven of the eight students have met criterion in this field study and one student remains in training. The seven students who have completed the program, finished in 12 days or fewer. At this time it appears that only minor revisions will be necessary for this program.



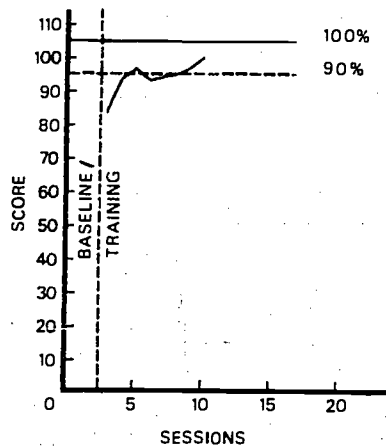
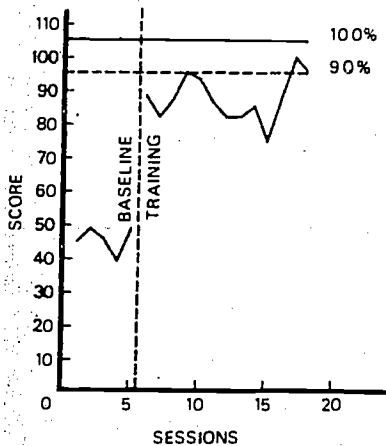
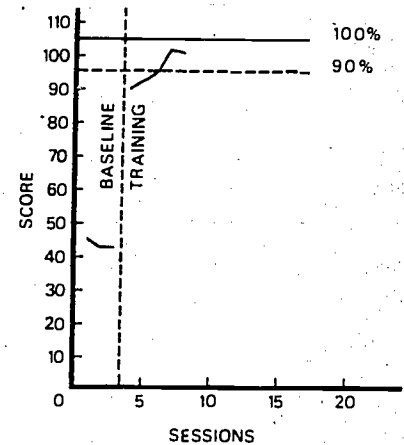
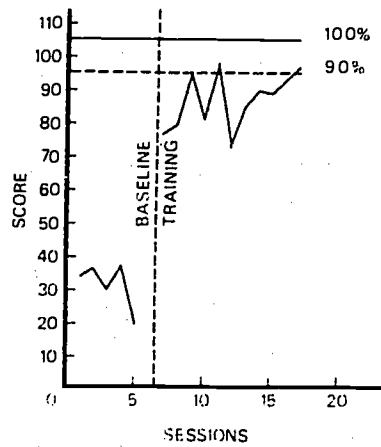
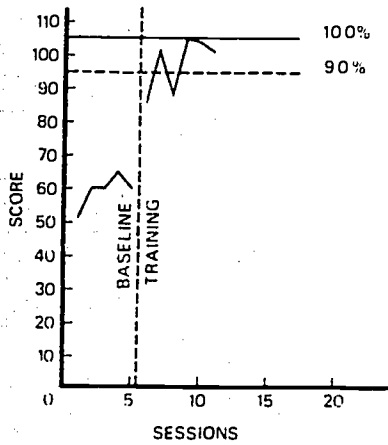
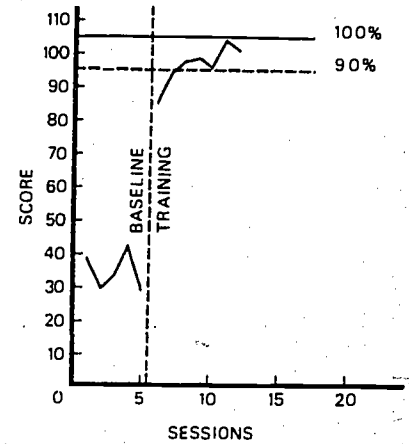
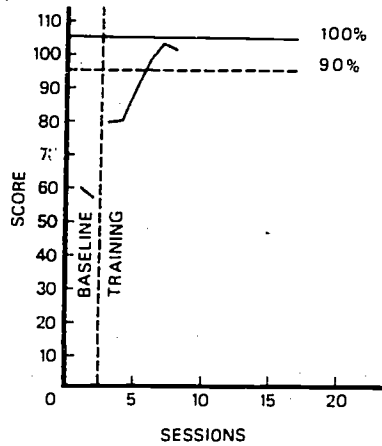
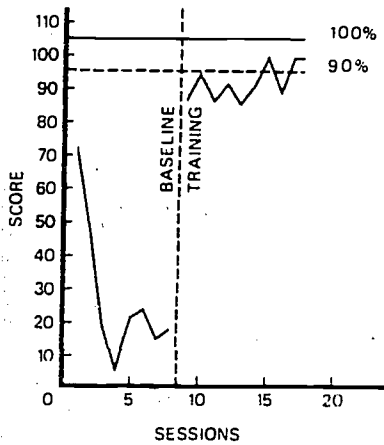
## Care of Eyeglasses

Eight students were involved in this field study. Six of the eight reached criterion, one was discharged, and one failed to meet criteria. Minor revisions were made on the basis of data analysis.



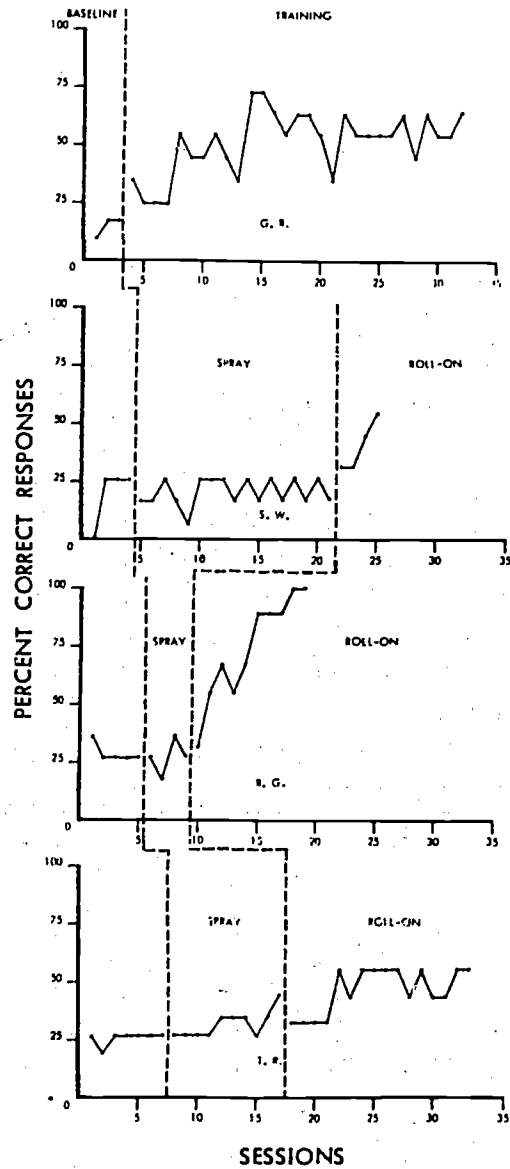
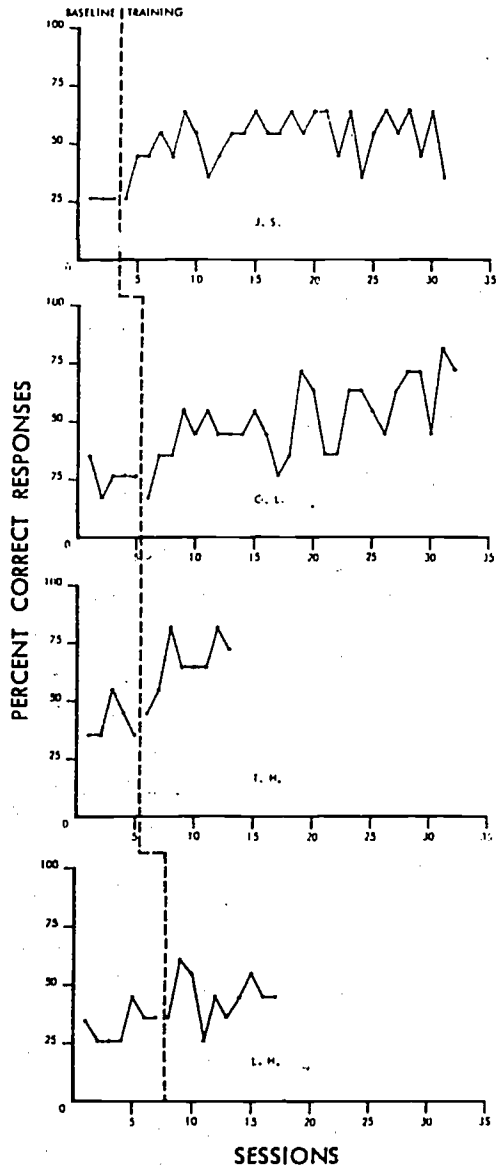
## Feminine Hygiene Program - Field Test I

Eight students participated in the second and final field study of this program. The mean number of training days was 10, with the least number of training days being five and the most number of training days being 18. No further revisions were required on this program and it is now in final mediation.



## Use of Deodorant - Field Studies I, II, and III

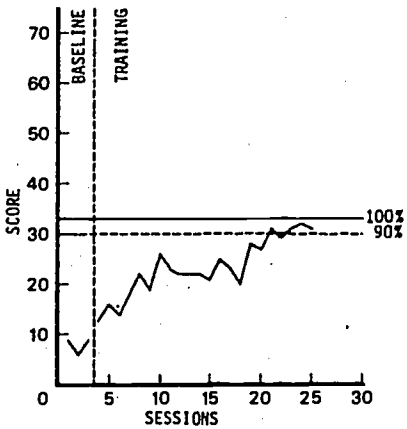
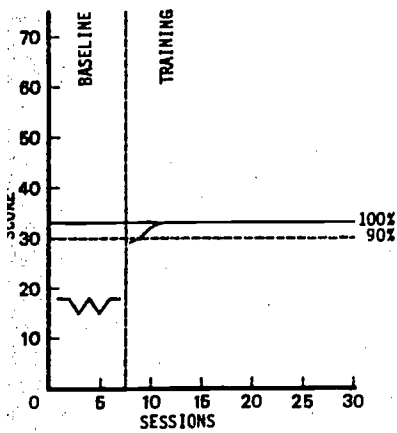
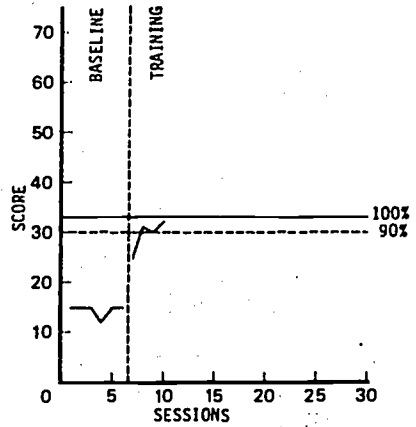
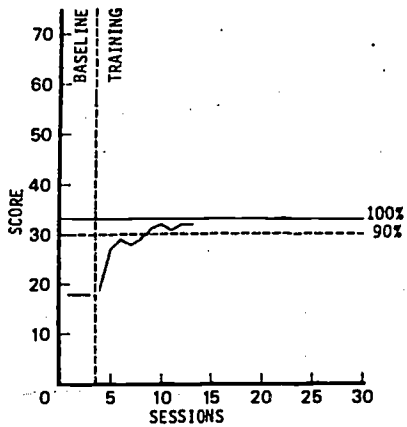
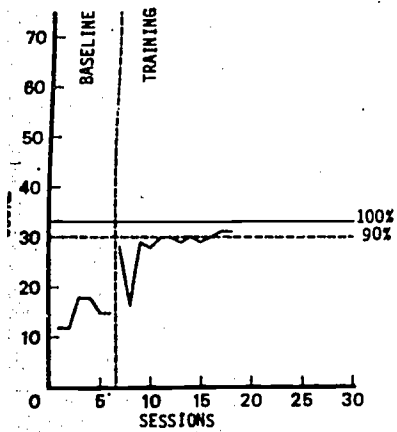
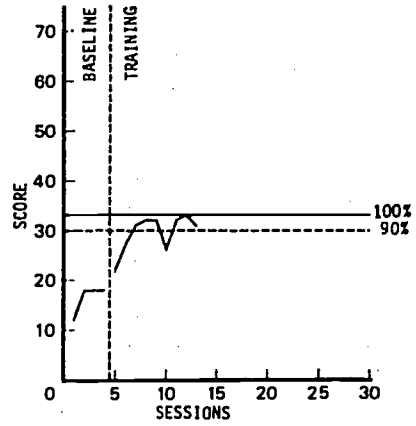
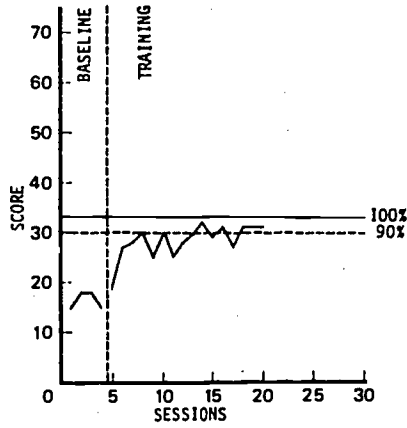
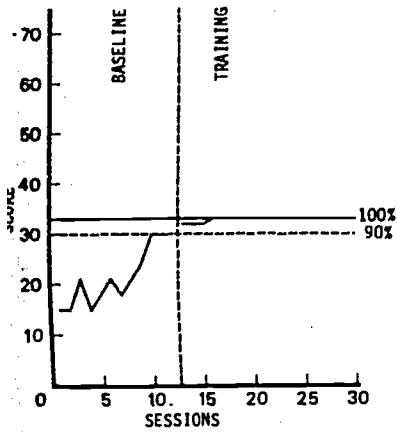
Three field studies involving 19 subjects were conducted. The data collected in Field Study III is presented here. The first two field studies had dictated major revisions of the program and subsequent additional evaluation and validation. Inspection of the performance data of the eight subjects in Field Study III clearly demonstrated the overall ineffectiveness of this developmental version of the program. Only one subject (R.G.) met a 90 percent criterion, and this was only after the trainer used the roll-on option. Program revisions were undertaken.





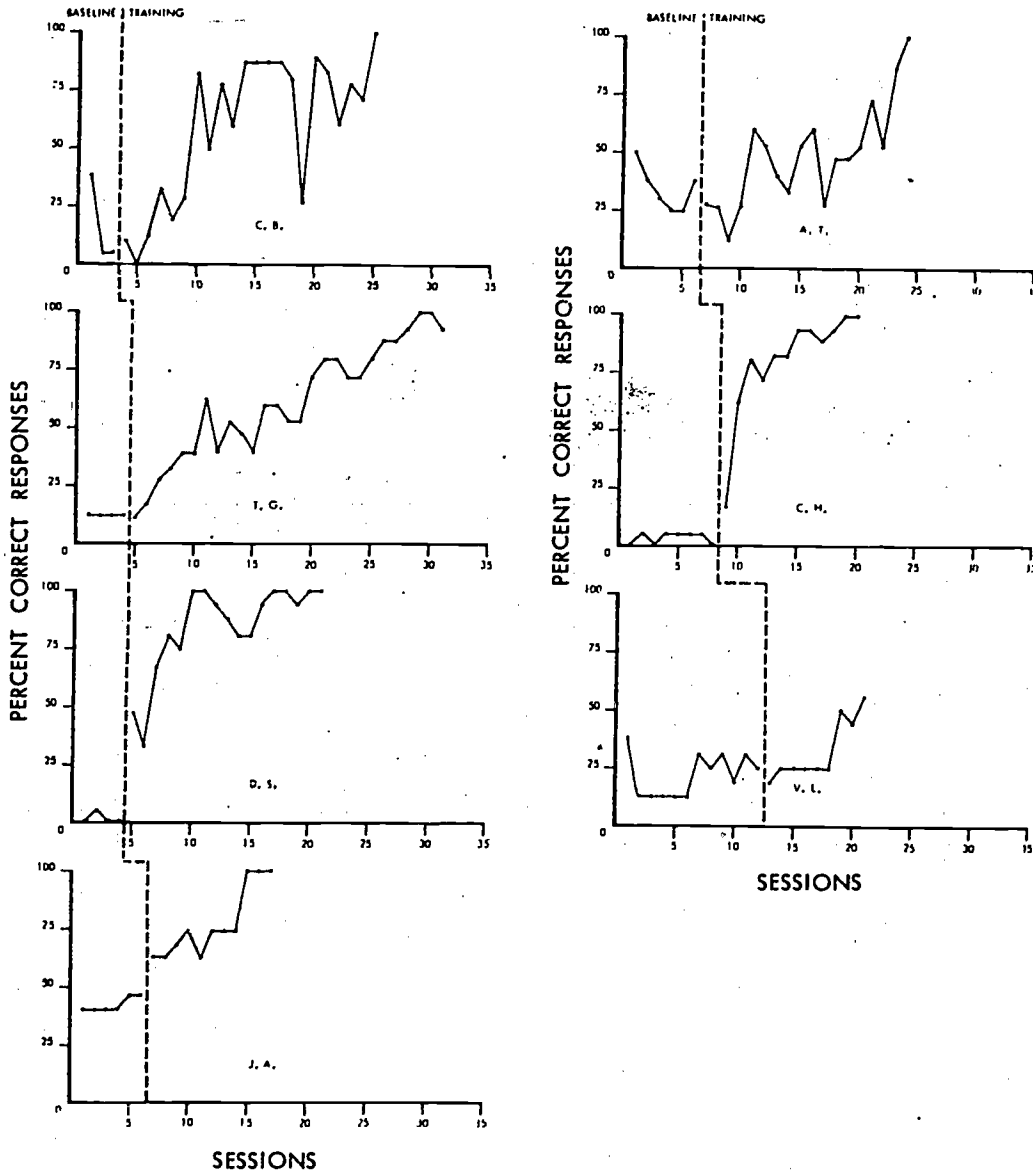
## Use of Deodorant - Field Study IV

All eight students in this field study met criterion within 20 training sessions.



## Hair Washing - Field Study I

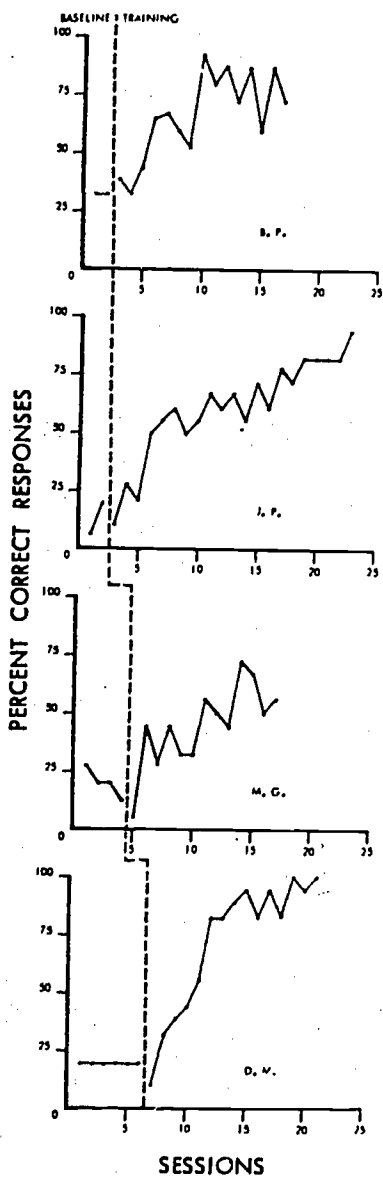
Field Study I of this program was conducted with seven subjects using a developmental version of the program containing 18 behavioral subskills. Multiple baseline data for those seven subjects are shown below. All but one subject (V.L.) made significant gains over baseline.



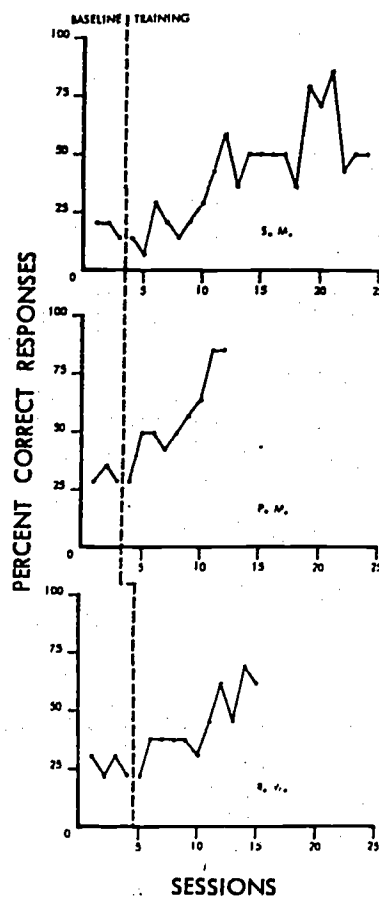
## Hair Washing - Field Studies II and III

A revised version of the program was tested in Field Studies II and III. There were four subjects in Field Study II. All but one made substantial gain over baseline. Field Study III was undertaken to determine whether problems encountered in testing the program were due to the trainer. This third group was tested with another trainer using the revised program. Comparable results were obtained.

### Field Study II



### Field Study III



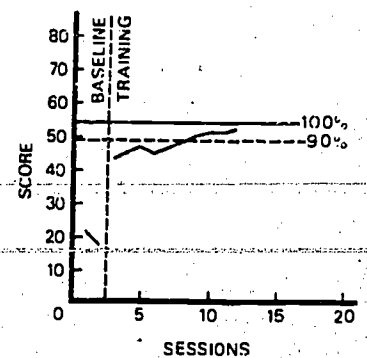
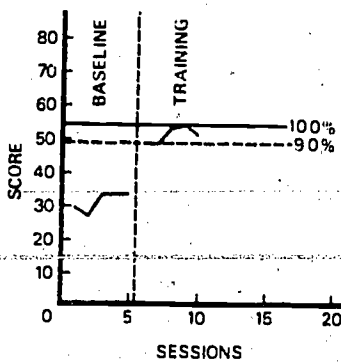
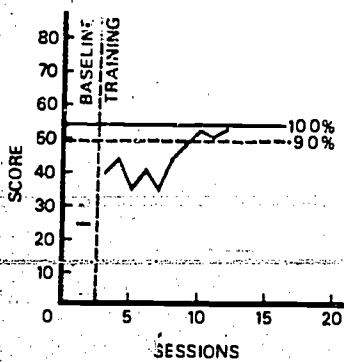
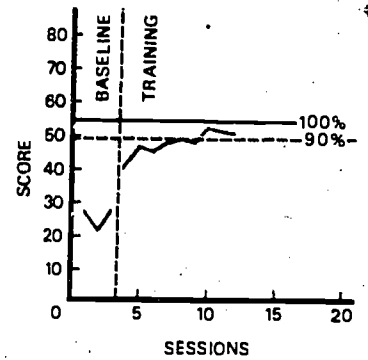
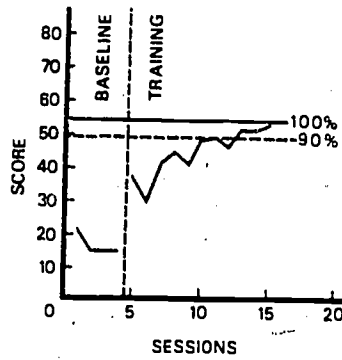
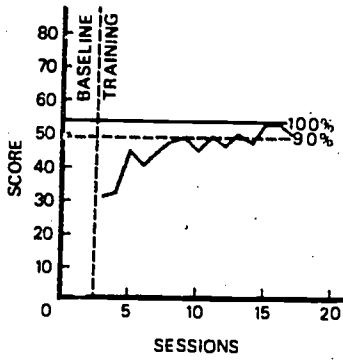
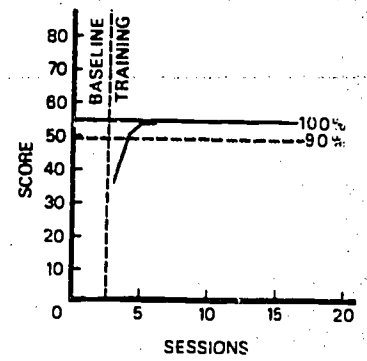
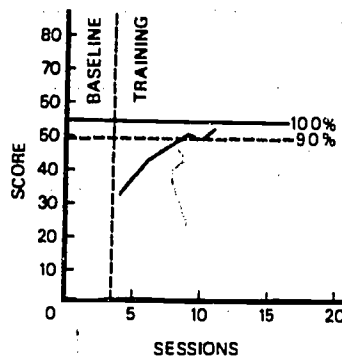
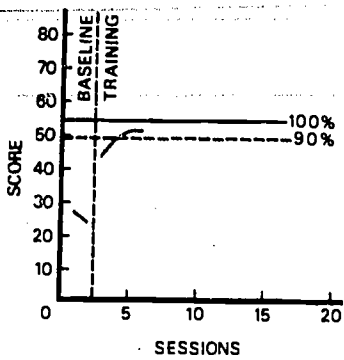
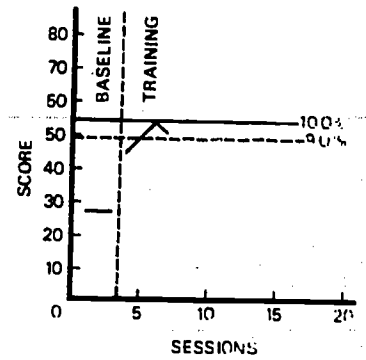
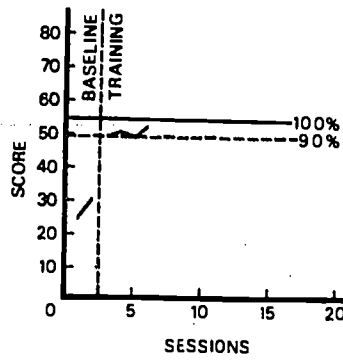
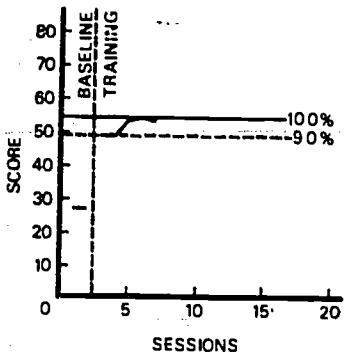
### Use of Telephone Program - Answering (Unit One)

Twelve students were run in Field Study I of Unit I, Answering. The mean number of training days was 6.75, with the least number of training days being four and the most number of training days being 15. Data analysis revealed that half of the students did not meet criteria on Steps 3, 4, 6, and 15. New definitions for these steps were written to allow a wider range of acceptable performance. The criteria for completion of the unit was extended from three days of 90% or better correct performance to five days of 90% or better.

Eleven different students were run in Field Study II, 10 of which completed the unit. A calculation error was made on the eleventh student's data and she was dismissed from training with only four consecutive days of criteria performances. The mean number of training days was 8.72, with the least number of training days being five and the most number of training days being 13. Data is on the following pages.

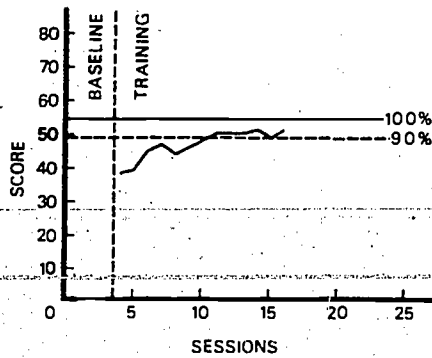
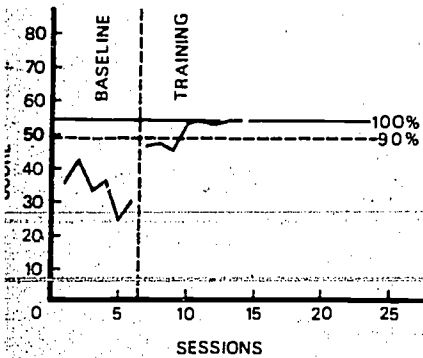
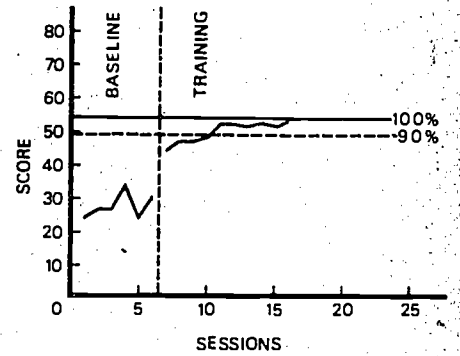
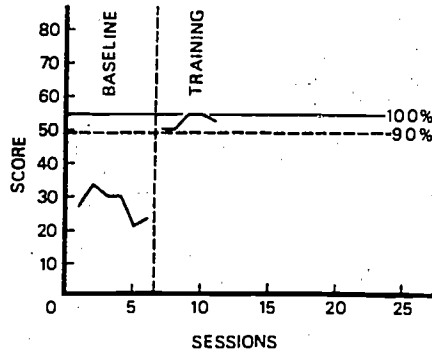
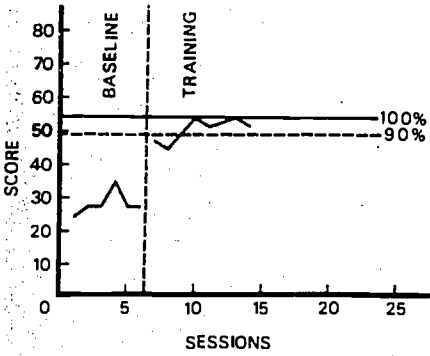
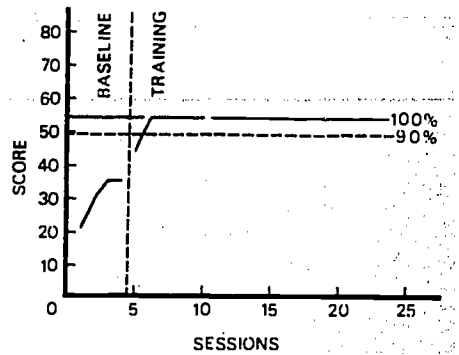
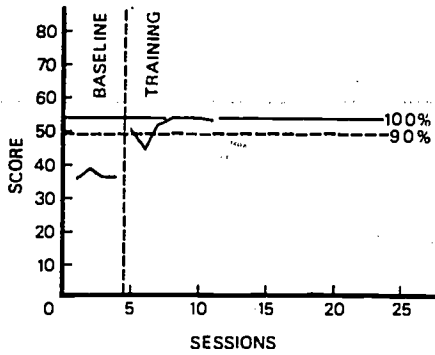
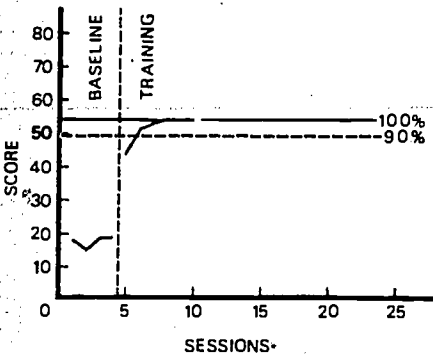
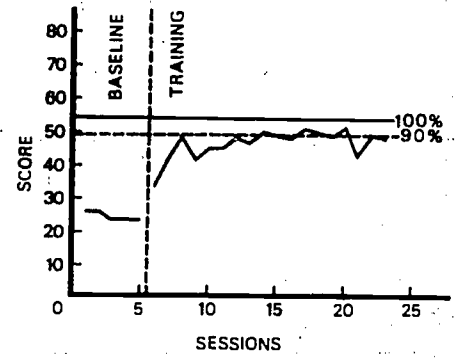
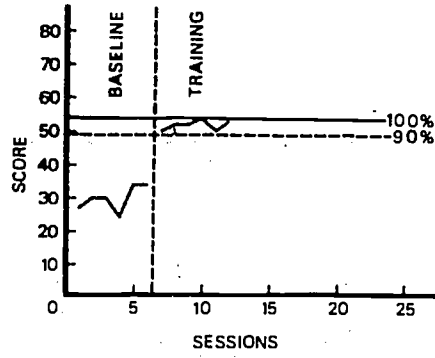
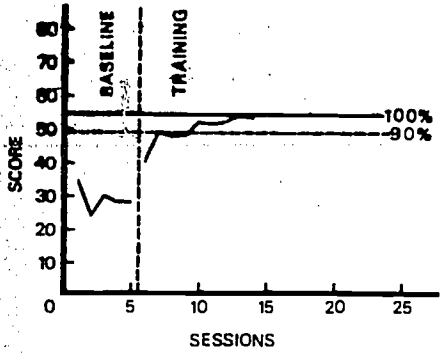
# USE OF TELEPHONE PROGRAM - ANSWERING (Unit One)

## Field Study I



USE OF TELEPHONE PROGRAM - ANSWERING (Unit One)

Field Study II



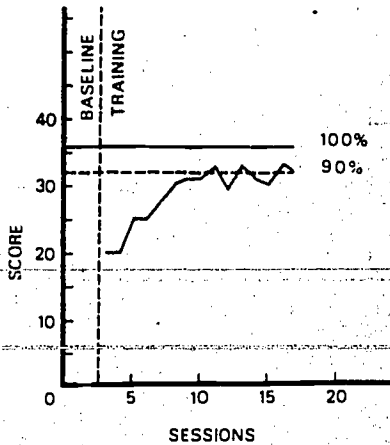
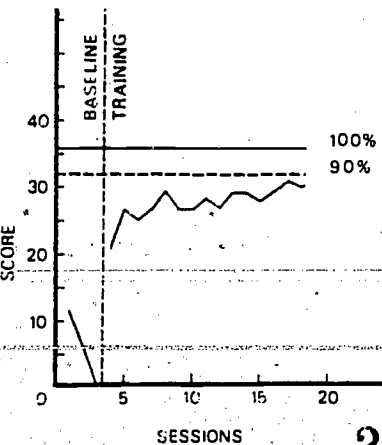
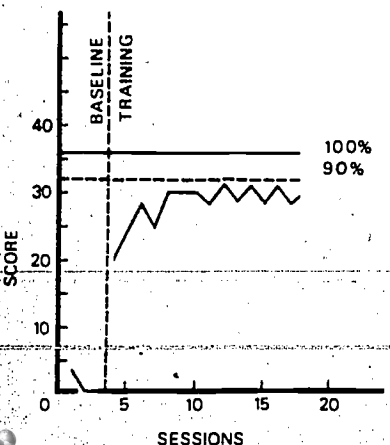
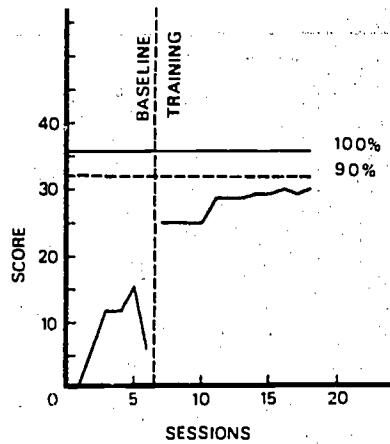
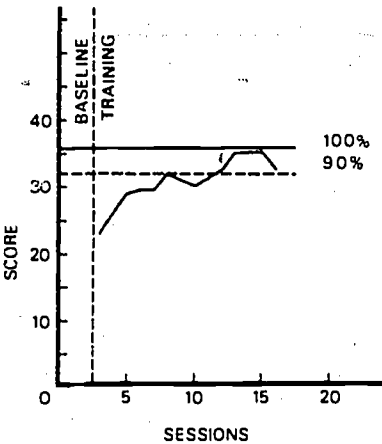
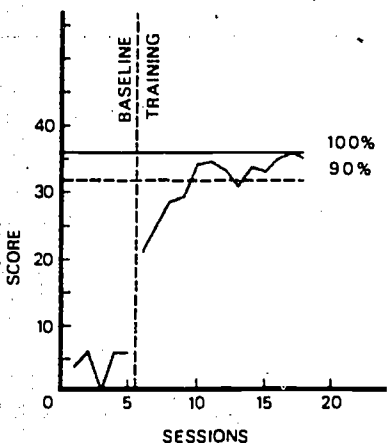
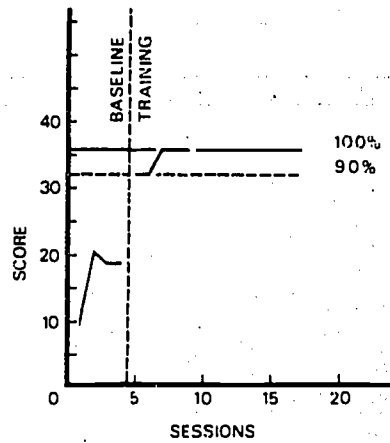
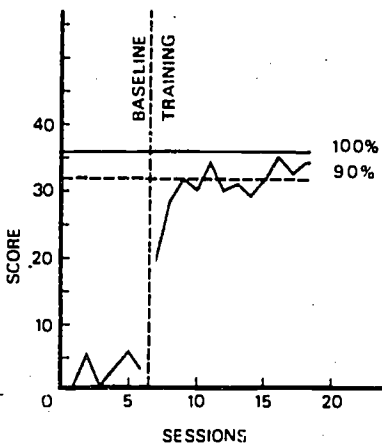
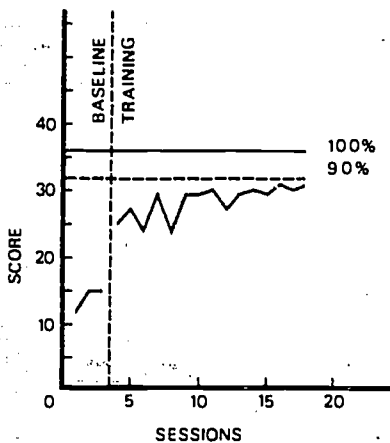
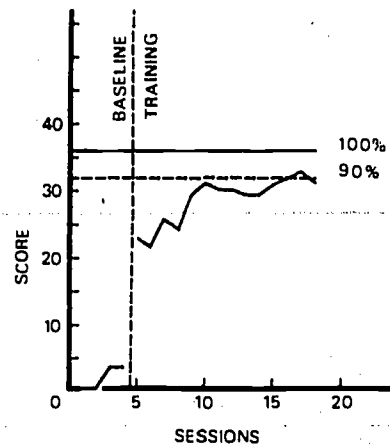
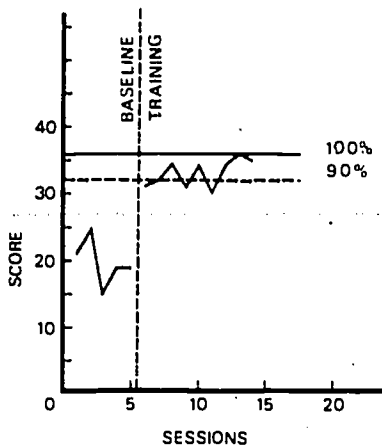
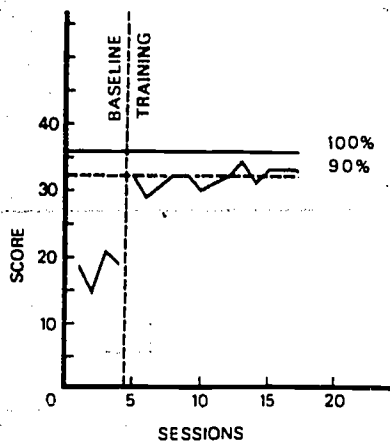
### Use of Telephone Program - Dialing (Unit Two)

Twelve students were run in Unit II, Dialing. The mean number of training days was 19.5, with the least number of training days being five and the most number of training days being 36. The verbal cues for steps A-3, B-3, and C-3 were rephrased and the definitions changed to include a verbal identification by the student of the two signals heard on the receiver. Students were taught both dialing and push button methods. Data for both push button and standard dialing are on the following pages.



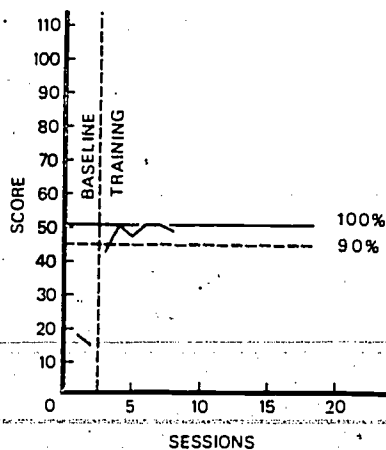
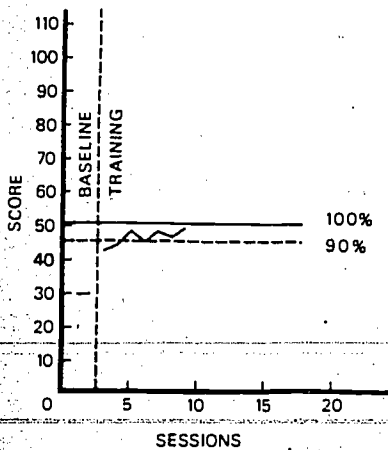
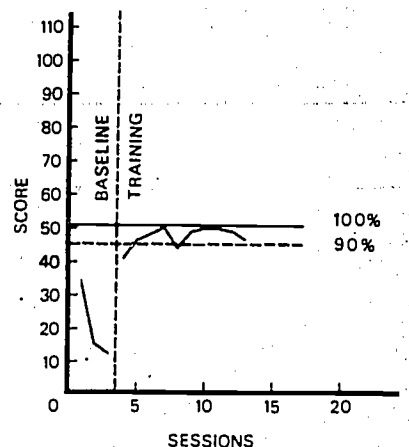
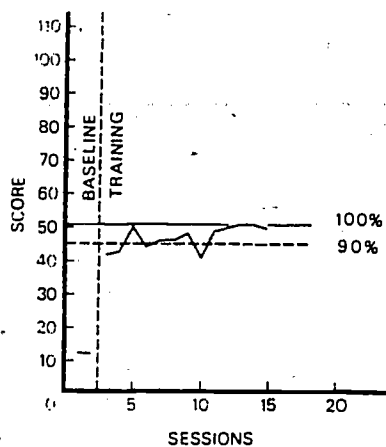
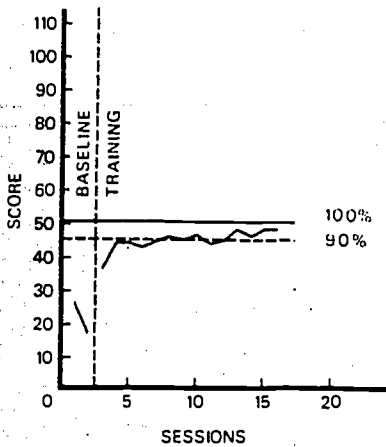
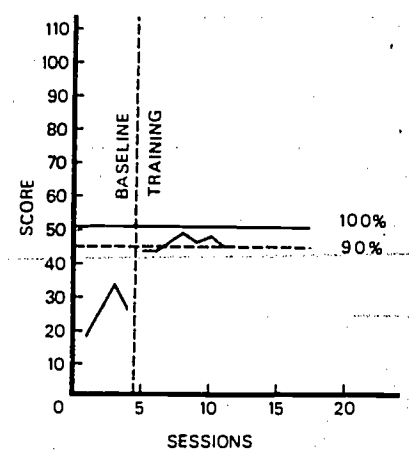
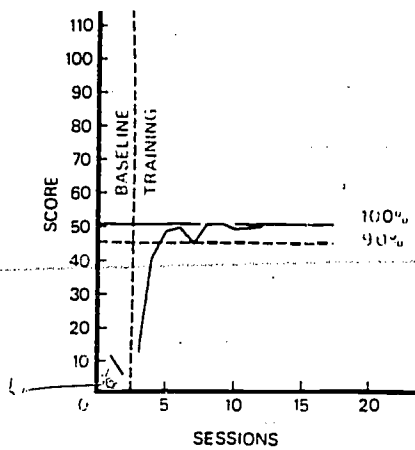
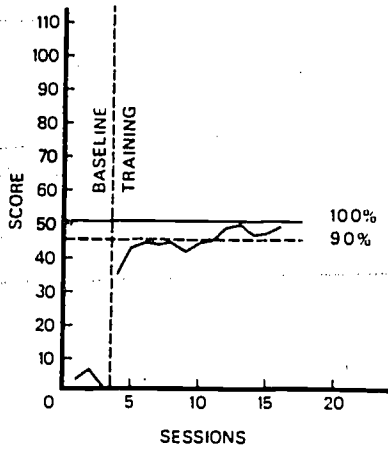


# PUSH BUTTON



### Use of Telephone Program - Emergencies (Unit Three)

Eight students were run on Unit III, Emergencies. The mean number of training days was 9.87, with the least number of training days being six and the most number of training days was 14. No revisions were required on Unit III.



### Hair Rolling Program

The data from field-testing the Hair Rolling Program indicated several minor revisions were needed in teachers' instructions in order to more effectively communicate what the teacher is to do. Unit Five (teaching insertion of picks into rollers) was found to be an easier task than anticipated and was deleted as a unit and incorporated as two additional steps in Unit Four of the program. Pre- to posttest change is reflected in the data.

### HAIR ROLLING PROGRAM

#### Pre to Post Test Change

N= 20

CATEGORIES <sup>1</sup>	IMPROVED	WORSE	NO CHANGE	CHI SQUARE <sup>2</sup>	SIGNIFICANCE LEVEL
COMBING OUT TANGLES	12	4	4	3.06	< .10
APPLYING SETTING GEL	17	1	2	12.5	< .001
RECOMBING	15	0	5	13.06	< .001
PARTING	13	0	7	11.08	< .001
SECTIONING	18	2	0	11.25	< .001
ROLLING	17	3	0	8.45	< .01
INSERTING PICKS	18	2	0	11.25	< .001
REMOVING PICKS	17	2	1	10.32	< .01
REMOVING ROLLERS	17	1	2	12.5	< .001
BRUSHING HAIR	12	3	5	3.37	< .10
OVERALL SCORE	19	1	0	14.45	< .001

<sup>1</sup> Optional unit teaching use of bobby pins was not used for any of the twenty subjects. The optional unit for taping was used for two subjects and both would be tabulated under "improved."

<sup>2</sup> Using McNemar's test for the significance of change. Siegel, S. Nonparametric Statistics, New York: McGraw-Hill, 1956, pp. 63-67.

---

APPENDIX E  
VITA OF PERSONS MENTIONED  
IN CONCLUSION

---

225

191

JAMES F. BUDDÉ

TITLE: Assistant Director  
Bureau of Child Research - L

Date of birth: January 26, 1937  
Place of birth: Wisner, Nebraska

Sex: Male  
Present Nationality: American

Educational Experience:

Bachelor of Fine Arts in Education, Wayne State College, Wayne, Nebraska,  
Business, 1962  
Master of Science, University of Nebraska, Omaha, Nebraska, Education, Guidance,  
and Counseling, 1968  
Doctoral work in Administration and Special Education, University of Kansas

Professional History:

Instructor and Coach, Technical High School, Omaha Board of Education, Omaha,  
Nebraska, 1962-1965  
Counselor, Technical High School, Omaha Board of Education, Omaha, Nebraska,  
1965-1967  
Project Director, Department of Labor Research Project (TIDE), Nebraska State  
Employment Services, Summer, 1965-1967  
Systems Specialist, Northern Systems Company, Omaha, Nebraska, 1967-1968  
Project Director, Glenwood State Hospital School, State of Iowa, 1968-1970  
Area Administrator, HIP Grant, Glenwood State Hospital School, State of  
Iowa, 1969-1970  
Chairman, Superintendents Committee on Planning and Development, Glenwood  
State Hospital School, 1969-1970  
Assistant Director, Bureau of Child Research, University of Kansas, 1970-  
present  
Associate Director, Kansas Center for Mental Retardation and Human Development,  
University of Kansas, 1971-present

Memberships in Professional Organizations:

American Association on Mental Deficiency  
National Society for Autistic Children  
Council for Exceptional Children

Publications:

Budde, J. F., & Menolascino, F. J. Utilization of systems technology for the  
vocational habilitation of the severely and moderately retarded. *Mental  
Retardation*, 1971, 2(1), 11-16.  
Budde, J. F. The lattice systems approach: A developmental tool for behavioral  
research and program models. *Educational Technology*, 1972, 12(2), 75-79.  
Budde, J. F. Will institutionalization survive: A systems view of redeveloping  
program models for the retarded. *Mental Retardation*, 1972, 12, 24-28.  
Budde, J. F. Systems models solutions for complex educational problems,  
in press.  
Budde, J. F., Hanna, J. P., & Eklund, E. M. Formative management: A means of  
molding and shaping winning programs, in press.

JAMES F. BUDDE (Con't.)

Other Publications:

Tool station training, an instructor's manual. Northern Systems Co., 1968.  
PEP social and emotional training guides, module I, II, III, and IV. Glenwood State Hospital School.  
PEP progressive choice training curriculum, module I, II, III, and IV. Glenwood State Hospital School, 1969.  
PEP instructor's manual. Glenwood State Hospital School, 1969.  
Ward control and management system. Glenwood State Hospital School, 1970.  
Systematic planning with evaluation criteria (manual). Rehabilitation Service Administration and Developmental Disability Publication, 1972.

Credits:

Budde, James F. The utilization of a systems approach for a prevocational experience program for low-moderate and severely retarded. Paper presented at the 93rd Annual Convention of the American Association on Mental Deficiency, San Francisco, 1969.  
Lent, J. R., Keilitz, I., McLean, B. M., & Budde, J. The educational researchers design and develop systematic training programs. Presentation in Systematic training: A solution to institutional crises, American Association on Mental Deficiency Annual Meeting, Atlanta, May 1973.

Supplemental Information:

Director, Feedback Assessment and Continuous Tracking System (FACTS) Technical Assistance for Planning and Evaluation (Iowa, Kansas, Missouri, Nebraska)  
Chairman, Evaluation and Information Systems Committee, Kansas University Affiliated Facility, Research Center  
National Board of Director, Judevine Center for Autistic Children, St. Louis  
Consultant, Training Education and Research Corporation, Montgomery, Alabama  
Consultant, Behavior Modification Technology, Columbus, Ohio  
Consultant, Columbus State Institute, Columbus, Ohio  
Consultant, Glenwood State Hospital, Glenwood, Iowa  
Consultant, Educational Technology, New York  
Consultant, United Cerebral Palsy of Kansas, Wichita  
Consultant, Center for Developmental and Learning Disorders, University of Alabama, Birmingham  
Member, National AUAF Evaluation Committee  
Member, Kansas Easter Seals Committee

CAROL D. "Sunny" FOSTER

TITLE: Research Assistant  
Bureau of Child Research - P

Date of birth: April 10, 1942

Sex: Female

Place of birth: New Brighton, Pennsylvania Present Nationality: American

Educational Experience:

Bachelor of Arts, Southern Methodist University, Psychology and Mathematics,  
1964

Graduate work in the Department of Mathematical and Experimental Statistics,  
Southern Methodist University, and the Department of Behavioral Disabilities,  
University of Wisconsin

Professional History:

Research Assistant, Psychology Department, Southern Methodist University,  
1961-1964

Research Director, University College, Southern Methodist University, 1964-1965

Child Welfare Aide, Department of Welfare, Jasper County, Missouri, 1965-1966

Research Assistant, Assistant Program Supervisor, Mimosa Project, University  
of Kansas Bureau of Child Research, Parsons State Hospital and Training  
Center, Parsons, Kansas, 1966-1969

Cottage Director, Training Coordinator, Dixon State School, Dixon, Illinois,  
1969-1970

HIST Grant Instructor, Director, State Home and Training School, Pueblo,  
Colorado, 1970-1972

Teacher, North Aurora Center, North Aurora, Illinois, 1972

Director of Training, North Aurora Center, North Aurora, Illinois, 1972-1973

Research Assistant, University of Kansas Bureau of Child Research, Parsons  
State Hospital and Training Center, Parsons, Kansas, 1973-present

Supervisor of Program Development, Project MORE, Bureau of Child Research,  
University of Kansas, Parsons State Hospital and Training Center, Parsons,  
Kansas, 1973-present

Publications:

Foster, R., & Foster, C. D. MRC program #1: Compliance training. *Mental Retardation Center Behavior Modification Newsletter*, March 1971, 2(1), 2-3.

Foster, C. D., & Foster, R. Program for cyclic instruction. *Mental Retardation Center Behavior Modification Newsletter*, March 1971, 2(1), 10-11.

Foster, C. D., & Foster, R. MRC program #3: Toilet-training. *Mental Retardation Center Behavior Modification Newsletter*, April 1971, 2(2), 1-3.

Foster, C. D. *Development of self-control*. Kalamazoo, Mich.: Behaviordelia, in press.

Credits:

Foster, R., & Foster, C. D. The measurement of change in adaptive behavior. Paper presented to the South Central Region of the American Association on Mental Deficiency, 1967.

CAROL D. "Sunny" FOSTER (Con't.)

Foster, C. D. Control of maladaptive behaviors in a sheltered workshop setting. Paper presented at the Community Workshop Series at Singer Zone Center, Rockford, Ill., January 1973.

Foster, C. D. Programming techniques: An individualized approach to inservice education. Paper presented at Behavior Modification Symposium, Lincoln State School, Lincoln, Ill., May 1973.

Keilitz, I., & Foster, C. D. The first important step: Instructional programs for daily living skills. Symposium presented at the American Association on Mental Deficiency Region V Annual Meeting, Wichita, October 1973.

Foster, C. D. Diagnostic evaluation and decision making: How do you know what to program. Paper presented at Services for the Severely Handicapped, Indianapolis, March 1974.

Foster, C. D. Systematic delivery of programs: Accountability and goal attainment. Paper presented at Services for the Severely Handicapped, Indianapolis, March 1974.

Foster, C. D. The role of in-service training in staff management, Symposium in Behavioral Programming, Lincoln State School, Lincoln, Ill., May 1974.

Supplemental Information:

Consultant, Sacred Heart Home, Pueblo, Colorado, 1971-1972  
Guest Reviewer, *Journal of Applied Behavior Analysis*

Fields of Major Scientific Interest:

Programming techniques in mental retardation



INGO KEILITZ

TITLE: Director of Research  
St. Louis County (Missouri)  
Special School District

Date of birth: February 25, 1946  
Place of birth: Hamburg-Altona, Germany

Sex: Male  
Present Nationality: American

Educational Experience:

Bachelor of Arts, Drew University, Psychology and Philosophy, 1968  
Master of Science, Kansas State University, Experimental Psychology, 1970  
Doctor of Philosophy, Kansas State University, Experimental Psychology, 1971

Professional History:

Teaching Assistant, Department of Psychology, Kansas State University,  
Manhattan, 1968-1970  
Research Assistant, Department of Psychology, Kansas State University,  
Manhattan, 1969  
Research Assistant, Department of Speech Pathology, Kansas State University,  
Manhattan, 1970  
Predoctoral Research Trainee (National Institute of Mental Health), Department  
of Psychology, Kansas State University, Manhattan, 1968-1971  
Postdoctoral Research Trainee (National Institute of Child Health and Human  
Development), Bureau of Child Research, University of Kansas, Parsons  
State Hospital and Training Center, Parsons, Kansas, 1971-1972  
Behavior Modification Specialist, Four County Mental Health Center,  
Independence, Kansas, 1972-1973  
Research Associate, Bureau of Child Research, University of Kansas, 1973-  
present  
Associate Director, Project MORE, Bureau of Child Research, University of  
Kansas, Parsons State Hospital and Training Center, Parsons, Kansas, 1973-  
present

Memberships in Professional Organizations:

American Psychological Association (pending)  
Midwestern Psychological Association  
Southwestern Psychological Association  
American Association on Mental Deficiency  
Council for Exceptional Children

Publications:

Keilitz, I., & Frieman, J. Transfer of training following errorless discrimi-  
nation learning. *Journal of Experimental Psychology*, 1970, 85, 293-299.  
Keilitz, I. Attention: General or selective. *Perceptual and Motor Skills*,  
1973, 36, 130.  
Keilitz, I., Tucker, D. J., & Horner, R. D. Increasing mentally retarded  
adolescents' verbalizations about current events. *Journal of Applied  
Behavior Analysis*, 1973, 6, 621-630.  
Lent, J. R., Holvoet, J. F., Ferneti, C. L., Keilitz, I., & Tucker, D. J.  
Direction following of retarded and nonretarded adolescents. *American  
Journal of Mental Deficiency*, 1973, 78, 316-322.  
Bieberly, C. J., Lent, J. R., & Keilitz, I. *How to do More*. Seattle: Edmark  
Associates, 1974.

230

196

6-74

INGO KEILITZ (Cont'd.)

- Keilitz, I., Horner, R. D., & Brown, K. H. *The complexion care program*. Seattle: Edmark Associates, in press.
- Behavioral Sciences Curriculum Study. *MR Curriculum Developer's Handbook* (BEH Monograph). D. E. Meyer, project editor, J. R. Lent, B. M. McLean, & I. Keilitz, contributing editors. Boulder, Colo.: BSCS, in press.

Credits:

- Keilitz, I. Transfer of training following discrimination learning without errors. Paper presented at the Midwestern Psychological Association Annual Meeting, Cincinnati, May 1970.
- Keilitz, I., & Frieman, J. General vs. selective attention: A procedural consideration. Paper presented at the Midwestern Psychological Association Annual Meeting, Detroit, May 1971.
- Keilitz, I. Effects of inhibitory training on transfer. Paper presented at the Southwestern Psychological Association Annual Meeting, Oklahoma City, April 1972.
- Keilitz, I. Nonverbal responses to language: The role of modeling, imagery, and imitation. Paper presented at the Gatlinburg Conference on Research and Theory in Mental Retardation, Gatlinburg, Tennessee, 1973.
- Keilitz, I. Effective use of television as an instructional medium. Paper presented at the Atlanta Behavior Modification Workshop, Atlanta, March 1973.
- Lent, J. R., Keilitz, I., McLean, B. M., & Budde, J. The educational researchers design and develop systematic training programs. Presentation in Systematic training: A solution to institutional crises, American Association on Mental Deficiency Annual Meeting, Atlanta, May 1973.
- Keilitz, I. An overview of an instructional technology. Paper presented at the American Association on Mental Deficiency Region V Annual Meeting, Wichita, October 1973.
- Keilitz, I., & Foster, C. D. The first important step: Instructional programs for daily living skills. Symposium presented at the American Association on Mental Deficiency Region V Annual Meeting, Wichita, October 1973.
- Keilitz, I. Factors influencing the performance of multiple directions. Paper presented at the American Association on Mental Deficiency Annual Meeting, Toronto, June 1974.
- Keilitz, I. Training proficiency: How good is good enough? Paper presented at the American Association on Mental Deficiency Annual Meeting, Toronto, June 1974.
- Ferneti, C. L., Lent, J. R., & Stevens, C. J. *The eating skills for daily living program*. (R. D. Horner, I. Keilitz, & C. J. Stevens, research assistants) Seattle: Edmark Associates, in press.
- Horner, R. D., Billionis, C. S., & Lent, J. R. *The toothbrushing program*. (C. S. Billionis, J. F. Holvoet, I. Keilitz, P. J. Lewis, research assistants) Seattle: Edmark Associates, in press.
- Horner, R. D., & Lent, J. R. *The leg and underarm shaving program*. (C. Allen, M. Bland, I. Keilitz, & K. E. Moore, research assistants) Seattle: Edmark Associates, in press.

Supplemental Information:

Adjunct Faculty, Labette Community Junior College, Parsons, Kansas  
Consultant, Unified School Districts, Southeast Kansas

INGO KEILITZ (Cont'd.)

Consultant, Elgin State Hospital, Elgin, Illinois

Consultant, Department of Special Education, Abilene School District,  
Abilene, Texas

Co-Investigator, Communications Research with Retarded Children, National  
Institute of Child Health and Human Development, Grant HD 00870-08,  
Parsons Research Center, Parsons State Hospital and Training Center, 1972-  
1973.

Guest Reviewer, *Journal of Applied Behavior Analysis*

Fields of Major Scientific Interest:

Applied behavior analysis; educational technology; program evaluation;  
mental retardation

JAMES R. LENT

TITLE: Research Associate  
Bureau of Child Research - P

Date of birth: July 1, 1929  
Place of birth: Denver, Colorado

Sex: Male  
Present Nationality: American

Educational Experience:

Bachelor of Arts, University of Denver, 1952  
Master of Arts, Syracuse University, 1955  
Doctor of Education, Syracuse University, 1959

Professional History:

Clinician, Children's Speech and Hearing Center, University of Denver, 1951-1952  
Psychometrist and Research Assistant, Syracuse University, 1954-1955  
Assistant to Dean of Summer Sessions, Syracuse University, 1955-1956  
Teacher, Special Class for Mentally Handicapped Children, Liverpool, New York, 1956-1958  
Research Assistant, U.S. Office of Education, Contract M-2514, 1958-1959  
Director of Special Education, University of Houston, 1959-1961  
Director of Programs in Mental Retardation, University of Oregon, 1961-1964  
Postdoctoral Research Fellow, NINDB, Grant 2 TI NB 5362-02A1, Bureau of Child Research, University of Kansas, 1964-1965  
Research Associate, Bureau of Child Research, University of Kansas, 1965-present  
Director, A Demonstration Program for Intensive Training of Institutionalized Mentally Retarded Girls (Mimosa Cottage), Parsons State Hospital and Training Center, Parsons, Kansas, 1965-1969  
Director, Project MORE, Bureau of Child Research, University of Kansas, Parsons State Hospital and Training Center, Parsons, Kansas, 1971-present

Memberships in Professional Organizations:

Council for Exceptional Children  
American Association on Mental Deficiency  
National Association for Retarded Children  
Association for Special Education Technology

Publications

- Lent, J. R. Mimosa cottage: Experiment in hope. *Psychology Today*, 1968, 2, 51-58.
- Lent, J. R. Principles of behavior modification and habilitation of deaf/blind children. *Proceedings of Workshop in Behavior Modification Programs for Deaf-Blind Children*. Alexandria-Pineville, La.: Pinecrest State School, 1970, 1-20.
- Lent, J. R., LeBlanc, J., & Spradlin, J. E. Designing a rehabilitative culture for moderately retarded adolescent girls. In R. Ulrich, T. Stachnik, & J. Mabry (Eds.), *Control of human behavior*, Vol. II. Glenview, Ill.: Scott, Foresman, 1970, 121-135.

JAMES R. LENT (Cont'd.)

- Lent, J. R., et al. The Hansons. In B. B. Hauch & M. F. Freehill (Eds.), *The mentally retarded: Case studies*. Dubuque, IA: William C. Brown Co., 1972.
- Lent, J. R., et al. Direction-following of retarded and nonretarded adolescents. *American Journal of Mental Deficiency*, 1973, 78, 316-322.
- Bieberly, C. J., Lent, J. R., & Keilitz, I. *How to do More*. Bellevue, WA: Edmark Associates, 1974.
- Ferneti, C. L., Lent, J. R., & Stevens, C. J. *Eating*. Bellevue, WA: Edmark Associates, 1974.
- Behavioral Sciences Curriculum Study. *MR Curriculum Developer's Handbook* (BEH Monograph). D. E. Meyer, project editor, J. R. Lent, B. M. McLean, & I. Keilitz, contributing editors. Boulder, CO: BSCS, in press.
- Ferneti, C. L., Lent, J. R., & Miller, C. W. *Face Shaving*. Bellevue, WA: Edmark Associates, in press.
- Horner, R. D., Billionis, C. S., & Lent, J. R. *Toothbrushing*. (Rev. ed.) Bellevue, WA: Edmark Associates, in press.
- Horner, R. D., & Lent, J. R. *Leg and underarm shaving*. Bellevue, WA: Edmark Associates, in press.
- Lent, J. R. Developing daily-living skills for the mentally retarded. In J. M. Kauffman & J. S. Payne (Eds.), *Mental retardation: Introduction and personal perspectives*. Columbus, OH: Charles E. Merrill, in press.
- Lent, J. R., & McLean, B. M. The trainable retarded: The technology of teaching. In N. G. Haring & R. L. Schiefelbusch (Eds.), *Teaching special children*. New York: McGraw-Hill, in press.
- Lent, J. R., & Williams, J. *Hair rolling*. (Rev. ed.) Bellevue, WA: Edmark Associates, in press.
- Stevens, C. J., Ferneti, C. L., & Lent, J. R. *Hand Washing*. Bellevue, WA: Edmark Associates, in press.
- Stevens, C. J., Keilitz, I., & Lent, J. R. *Care of simple injuries: Unit I*. Bellevue, WA: Edmark Associates, in press.

Other Publications:

- Lent, J. R. *Showering program*. (A 16mm film, teacher's manual, and disc recording). Parsons, Ks.: Project MORE, Media Support Services of University of Kansas Bureau of Child Research, 1971.
- Lent, J. R. *Operation behavior modification*. R. K. Hoyt (screen writer). Parsons, Ks.: University of Kansas Bureau of Child Research & Parsons State Hospital and Training Center, 1967.

Credits:

- Lent, J. R. Reduction of negative social behaviors in a workshop setting. Paper presented at American Association on Mental Deficiency Convention, Miami, June 1965.

JAMES R. LENT (Cont'd.)

- Lent, J. R. The application of operant procedures in the modification of behaviors of retarded children in a free social situation. Paper presented at American Association for the Advancement of Science Convention, Berkeley, December 1965.
- Lent, J. R. (Faculty member) Behavior modification seminar. University of Alabama in Birmingham Mental Retardation Staff Development Program, Birmingham, March 1967.
- Lent, J. R. Overview of film *A cottage demonstration project*. Paper presented at American Psychological Association Convention, Washington, D.C., September 1967.
- Lent, J. R. (Faculty member) The Parsons project: Teaching the profoundly and severely retarded. An evaluation symposium of Pinecrest's Behavior Shaping Program, Pinecrest State School, Alexandria-Pineville, La., January 1968.
- Lent, J. R. Who does that new little girl over there belong to? Paper presented to Richard P. Toister, Mailman Center for Child Development, University of Miami, Miami, April 1971.
- Lent, J. R. (Faculty member) Atlanta behavior modification technology workshop, Atlanta, 1972.
- Lent, J. R. (Faculty member) The Leiden behavior modification technology workshop, University of Leiden, Holland, 1972.
- Lent, J. R., McLean, B. M., & Grafton, S. S. How to do More with less. Workshop at the Minnesota State Convention, Council for Exceptional Children, Duluth, March 1973.
- Lent, J. R., & McLean, B. M. Project MORE. Presentation in The adult retarded: Extending services, President's Commission on Mental Retardation, Santa Barbara, Calif., March 1973.
- Lent, J. R., Keilitz, I., McLean, B. M., & Budde, J. The educational researchers design and develop systematic training programs. Presentation in Systematic training: A solution to institutional crises, American Association on Mental Deficiency Annual Meeting, Atlanta, May 1973.
- Lent, J. R., McLean, B. M., & Grafton, S. S. How to do More with less: Teaching daily living skills with systematic instructional packages. Workshop presented at the Fourth Annual National Educational Technology Conference, Western Conference, San Francisco, March 1974.
- Lent, J. R., Grafton, S. S., & McLean, B. M. How to do More with less: Project More daily-living skills programs for the trainable mentally retarded. Workshop presented at the national meeting of the Council for Exceptional Children, New York, April 1974.
- Lent, J. R. Chairman, Integrating training needs and training programs into an entire system of habilitation. American Association on Mental Deficiency Convention, Toronto, June 1974.
- Lent, J. R., McLean, B. M., Semmel, D., Dostal, J. J., Becker, J. W., & Bleil, G. B. Issues in the dissemination of training materials produced through federal grants or contracts. Paper presented to American Association on Mental Deficiency Convention, Toronto, June 1974.
- Lent, J. R. Paper presented to Executive Training Seminar in Mental Retardation, University of Wisconsin, June 1974.
- Lent, J. R., McLean, B. M., & Bocher, D. A. Issues in the mediation and dissemination of training materials produced through federal grants or contracts. Paper presented to Early Childhood Education Program Directors (BEH), Washington, D.C., October 1974.

JAMES R. LENT (Cont'd.)

Lent, J. R. Forward to a technology of behavior change for the mentally retarded. Paper presented to 5th International Symposium on Behavior Modification, Clinical Application of Behavior Modification, Caracas, Venezuela, December 1974.

Supplemental Information:

Co-principal Investigator, Project MORE, OEG-0-71-0449(607), 1971-present  
Director, "A Demonstration Program for Intensive Training of Institutionalized Mentally Retarded Girls" (Mimosa Cottage), (MR 1801) Public Health Service, Department of Health, Education, and Welfare, July 1965 to June 1969

Fields of Major Scientific Interest:

Application of behavior modification techniques; operant conditioning psychology; programmed learning



BARBARA MALAN McLEAN

TITLE: Director of Media Services  
Bureau of Child Research - P

Date of birth: February 6, 1929

Sex: Female

Place of birth: Pinckneyville, Illinois

Present Nationality: American

Educational Experience:

Park College, Parkville, Missouri, 1947-1949

A.B., Indiana University, Bloomington, English and Journalism, 1951

Teaching credentials, Washburn University, Topeka, Kansas, 1959

M.A., University of Kansas, Lawrence, English, 1965

Work toward Ph.D. in English-Education, University of Kansas, Lawrence

Professional History:

Archives, President's Office, University of Indiana, Bloomington, 1950-1951  
Editor, Law Copy Department, Bobbs-Merrill Publishing Company, Indianapolis, 1951

Editor/Business Manager, The Hoosier Banker, Indiana Bankers Association, Indianapolis, 1952-1953

English Teacher, LaHarpe Public Schools, LaHarpe, Kansas, 1954

Program Director, Y.W.C.A. of Kansas City, Missouri, 1953-1954

Health Education Instructor, Topeka Y.W.C.A., Topeka, Kansas, 1957-1958

English Teacher, Topeka Public Schools, Topeka, Kansas, 1958-1960

English Assistant Instructor, University of Kansas, 1961-1962

English and Journalism Teacher, Perry Public Schools, Perry, Kansas, 1962-1963

English Teacher, Lawrence Public Schools, Lawrence, Kansas, 1963-1965

Consultant, Bell Educational Enterprises, Washington, D.C., 1965

Editor, Extramural Independent Study Center, University of Kansas, 1966-1968

Instructor in Expository Writing, English Department, University of Kansas, 1966-1971

Director of Instruction, Extramural Independent Study Center, University of Kansas Extension Division, 1968-1970

Instructor, Directed Readings, Extramural Independent Study Center, University of Kansas, 1968-present

Director of Media Services, Media Support Services, Project MORE, Bureau of Child Research, University of Kansas, Parsons State Hospital and Training Center, Parsons, Kansas, 1970-present

Memberships in Professional Organizations:

National Council of Teachers of English

Kansas Association of Teachers of English

College English Association

Women in Communications, Inc.

American Association of Junior Colleges: Curriculum Consultant

American Association on Mental Deficiency

Association for Special Education Technology: Secretary-Treasurer, 1973-1974

American Association of University Professors

Publications:

McLean, B. M. Three untitled poems. *Carruth Poetry Collection*. Lawrence, Ks.: University of Kansas, 1962.



BARBARA MALAN McLEAN (Con't.)

- McLean, B. M. Untitled poem. *American Haiku*, 1965, 1(1).
- McLean, B. M. *The risk takers: A good gamble for the schools*. The University of Kansas Bulletin of Education, 1966, 21(1). Reprinted in: The Education Digest, 1967, 32.
- McLean, B. M., & Willingham, J. R. *Willa Cather: A study syllabus*. Lawrence, Ks.: Extramural Independent Study Center, University of Kansas, 1968.
- McLean, B. M., & Morgan, P. *A new independent study curriculum in English*. University of Kansas Bulletin of Education, 1968, 23(2).
- McLean, B. M. Chokecherry monstrosity (five poems). *Cottonwood review series*. Lawrence, Ks.: University Extension, University of Kansas, 1968, 23(3).
- Burton, R. A., Spear, R. L., & Wallacker, B. E. *Eastern civilizations readings: 1) China; 2) India-Japan; 3) The family*. A. A. Lazzarino, B. M. McLean, & L. McCleary (Eds.) Dubuque, Ia.: William C. Brown Co., 1969.
- McLean, B. M. *A primer for term paper writers*. (Rev. ed.) R. Carlson (Ed.) Lawrence, Ks.: Extramural Independent Study Center, University of Kansas, 1969.
- McLean, B. M. Acculturation & Ashes have (classically) created groundbirds (two poems). *Kansas English, The Bulletin of the Kansas Association of Teachers of English*. Manhattan, Ks.: Kansas State University, December 1969.
- McLean, B. M., Nelick, F., & Bruce, S. J. *The name and nature of poetry* (A study syllabus and videotaped series). Lawrence, Ks.: Extramural Independent Study Center, University of Kansas, 1971.
- McLean, B. M. Appendix X (a poem). *The beam*. Kansas City: Alexander Electronics, Inc., July 1971.
- McLean, B. M. *Advanced composition: A study syllabus* (English 50). Lawrence, Ks.: Extramural Independent Study Center, University of Kansas, 1971.
- McLean, B. M. Muchachomundo & To one who loved like Dylan but would not (two poems). *Kansas English, The Bulletin of the Kansas Association of Teachers of English*. Manhattan, Ks.: Kansas State University, February 1972.
- McLean, J. E., Yoder, D. E., & Schiefelbusch, R. L. (Eds.) *Language intervention with the retarded: Developing strategies*. (B. M. McLean, project editor) Baltimore: University Park Press, 1972.
- Lent, J. R., Schiefelbusch, R. L., McLean, B. M., & Dixon, M. H. The Hansons. In B. B. Hauch & M. F. Freehill (Eds.), *The mentally retarded: Case studies*. Dubuque, Ia.: William C. Brown Co., 1972.
- Lent, J. R., & McLean, B. M. The trainable retarded: The technology of teaching. In N. G. Haring & R. L. Schiefelbusch (Eds.), *Teaching special children*. New York: McGraw-Hill, in press.
- Behavioral Sciences Curriculum Study. *MR Curriculum Developer's Handbook* (BEH Monograph). D. E. Meyer, project editor, J. R. Lent, B. M. McLean, & I. Keilitz, contributing editors. Boulder, Colo.: BSCS, in press.

Credits:

- Lent, J. R., McLean, B. M., & Grafton, S. S. How to do More with less. Workshop at the Minnesota State Convention, Council for Exceptional Children, Duluth, March 1973.
- Lent, J. R., & McLean, B. M. Project More. Presentation in The adult retarded; Extending services, President's Commission on Mental Retardation, Santa Barbara, Calif., March 1973.

BARBARA MALAN McLEAN (Con't.)

- Lent, J. R., Keilitz, I., McLean, B. M., & Budde, J. The educational researchers design and develop systematic training programs. Presentation in Systematic training: A solution to institutional crises, American Association on Mental Deficiency Annual Meeting, Atlanta, May 1973.
- Grafton, S. S., & McLean, B. M. How to do MORE with less. Workshop at the Staff Development Conference, Province of Ontario, Toronto, June 1973.
- Lent, J. R., McLean, B. M., & Grafton, S. S. How to do More with less: Teaching daily living skills with systematic instructional packages. Workshop presented at the Fourth Annual National Educational Technology Conference, Western Conference, San Francisco, March 1974.
- Lent, J. R., Grafton, S. S., & McLean, B. M. How to do MORE with less: Project MORE daily-living skills program for the trainable mentally retarded. Workshop presented at the national meeting of the Council for Exceptional Children, New York, April 1974.
- Lent, J. R., McLean, B. M., Semmel, D., Dostal, J. J., Becker, J. W., & Bleil, G. B. Issues in the dissemination of training materials produced through federal grants or contracts. Paper presented to American Association on Mental Deficiency Convention, Toronto, June 1974.
- Lent, J. R., McLean, B. M., & Bocher, D. A. Issues in the mediation and dissemination of training materials produced through federal grants or contracts. Paper presented to Early Childhood Education Program Directors (BEH), Washington, D. C., October 1974.

Supplemental Information

Consultant for Community College Teaching, Extramural Independent Study Center,  
Division of Continuing Education, University of Kansas  
Consultant, Yes I Can Project, Michigan State University  
Editorial Consultant, Menninger Foundation, Topeka, Kansas

JAMES E. McLEAN

TITLE: Associate Professor  
Department of Special Education  
George Peabody College for Teachers

Date of birth: March 19, 1926  
Place of birth: South Bend, Indiana

Sex: Male  
Present Nationality: American

Educational Experience:

Bachelor of Science, Indiana University, Speech Pathology, 1951  
Master of Arts, University of Kansas, Speech Pathology, 1958  
Doctor of Philosophy, University of Kansas, Speech Pathology and Audiology, 1965

Professional History:

Speech Clinician, Public Schools, 1951-1957  
Director, Speech and Hearing Programs, Kansas State Division of Special Education, 1957-1961  
Instructor, Speech Pathology, University of Kansas, 1961-1963  
NINDB Research Fellow, Bureau of Child Research, University of Kansas, 1963-1965  
Specialist, Unit on Speech and Hearing Programs, Division of Educational Personnel Training, U.S. Office of Education, 1965-1966  
Research Coordinator, Handicapped Children and Youth Branch, Bureau of Research, U.S. Office of Education, 1966  
Research Associate, Bureau of Child Research, University of Kansas, and Director, Speech and Hearing Department, Parsons State Hospital and Training Center, 1966-1972  
Field Director, Demonstration Grant: Communication Therapy for Retardates, NIMH 14977, 1966-1970  
Director, Speech and Hearing Department, Parsons State Hospital and Training Center, 1967-1972  
Associate Professor, Department of Special Education, George Peabody College for Teachers, 1972-present  
Chairman, Department of Special Education, George Peabody College for Teachers, 1973-present

Memberships in Professional Organizations:

Fellow, American Speech and Hearing Association  
Kansas Speech and Hearing Association (President, 1957; Executive Vice-president, 1960-1962)  
Phi Delta Kappa

Publications:

McLean, J. E. Extending stimulus control of phoneme articulation by operant techniques. In F. L. Girardeau & J. E. Spradlin (Eds.), *A functional analysis approach to speech and language behavior*, ASHA Monograph 14, American Speech and Hearing Association, Washington, D.C., January 1970.  
Raymore, Sandra, & McLean, J. E. A clinical program for carry-over of articulation therapy with retarded children. In J. E. McLean, D. E. Yoder, & R. L. Schiefelbusch (Eds.), *Language intervention with the retarded: Developing strategies*. Baltimore: University Park Press, 1972.  
McLean, J. E., Yoder, D. E., & Schiefelbusch, R. L. (Eds.). *Language intervention with the retarded: Developing strategies*. Baltimore: University Park Press, 1972.

JAMES McLEAN (Cont'd.)

- McLean, J. E. Language development and communication disorders. In N. G. Haring (Ed.), *Behavior of exceptional children: An introduction to special education*. Columbus, Ohio: Charles E. Merrill, 1974.
- McLean, L. P., & McLean, J. E. A language training program for nonverbal autistic children. *Journal of Speech and Hearing Disorders*, 1974, 39.

Other Publications:

- McLean, J. E. Shifting stimulus control: A clinical procedure for articulation therapy. Produced by Bureau of Child Research, University of Kansas, 1970.

Credits (since 1968):

- Application of behavior modification techniques in speech correction and language training. Short course presented at the American Speech and Hearing Association Annual Meeting, Denver, Colorado, November 1968.
- Programming speech and language for retarded children. Paper presented to the Postgraduate Medical Education Symposium on the Handicapped Child, Great Bend Kansas, January 1969.
- Applying programmed instruction techniques in speech therapy. Paper presented to the Postgraduate Medical Education Symposium on Speech and Hearing, Kansas University Medical Center, Kansas City, Kansas, February 1969.
- Behavior modification approach to articulation therapy. Special Study Institute, Iowa City, Iowa, March 1969.
- Strategies and tactics for treating speech and language problems among mentally retarded children. Paper presented to the Tennessee Speech and Hearing Association, Nashville, March 1969.
- Developing a strategy for communication therapy with mentally retarded children. Seminar on the principles of behavior modification presented at Woodbridge State School, April 1969.
- Programming stimulus discrimination with mentally retarded children. Paper presented to the Council for Exceptional Children, Denver, Colorado, April 1969.
- A systems approach to clinical speech programs for mentally retarded children. Paper presented to the American Association on Mental Deficiency, San Francisco, California, May 1969.
- Behavior modification approaches in speech pathology. Paper presented at Central Missouri State College, Warrensburg, Missouri, June 1969.
- Learning theory applications in speech pathology. Workshop presented at Emerson College, Boston, Massachusetts, July 1969.
- Implications of operant procedures in articulation therapy. Paper presented at the New Mexico State University Symposium, September 1969.
- Learning theory applications in articulation therapy. Paper presented at the University of New Mexico Symposium, September 1969.
- Functional analysis of the speech therapy process. Paper presented at the University of Alabama, Tuscaloosa, March 1970.
- A strategy for developing appropriate language programs. Paper presented to the California Speech and Hearing Association, Fresno, April 1970.
- Applying operant learning principles in articulation therapy. Seminar presented to the California Speech and Hearing Association, Fresno, April 1970.
- Functional analysis of articulation therapy. Workshop presented at Eastern Oregon College, Camp Meadowood Springs, August 1970.

JAMES McLEAN (Cont'd.)

- Development of new phoneme responses. Paper presented to the Northern Iowa University Speech and Hearing Conference, Cedar Falls, October 1970.
- Carry-over of newly learned phoneme responses. Paper presented to the Northern Iowa University Speech and Hearing Conference, Cedar Falls, October 1970.
- Programming for response development and carry-over of new phoneme learning. Workshop presented to the Minnesota Division of Special Education, Cool Ridge, April 1971.
- A behavioral model for language learning. Mailman Center for Developmental Disabilities, University of Miami, Florida, April 1971.
- Intervention programs for language skills of retarded children. Conference at John Hopkins, Baltimore, Maryland, March 1971.
- Systematic intervention in phonology and syntax of retarded children. Workshop presented to the Institute for the Study of Mental Retardation and Related Disabilities, University of Michigan, Ann Arbor, March 1971.
- Programmed articulation therapy for public schools. Workshop presented at the Annual State Council for Exceptional Children Meeting, Topeka, Kansas, February 1971.
- Programming for articulation disorders. Seminar presented at Bloomsburg State College, Bloomsburg, Pennsylvania, July 1971.
- Functional analysis of behavior in clinical speech therapy. Paper presented to the American Speech and Hearing Association Meeting, Chicago, Illinois, November 1971.
- Operant conditioning principles in speech therapy. Seminar presented at Texas Women's University, Denton, Texas, February 1972.
- Functional analysis approach to articulation modification. Seminar presented at the University of the Pacific, Stockton, California, July 1972.
- Programmed learning approach to articulation therapy. Workshop presented for DeKalb County Public Schools, Atlanta, Georgia, December 1972.
- Language intervention: Clinical strategies. Workshop presented for Montgomery County Public Schools, Lansdale, Pennsylvania, March 1973.
- Language intervention for mentally retarded children. Paper presented to the North Carolina Speech and Hearing Association, Boone, North Carolina, April 1973.
- Functional analysis of articulation therapy. Paper presented to the Pennsylvania Speech and Hearing Association, Harrisburg, Pennsylvania, April 1973.

Supplemental Information:

- Principal Investigator, OEG 0-9-262019-2325(032) for production of Demonstration Film, 1969-1970
- Co-principal Investigator, NICHD Grant Systematic Procedures in Speech Pathology and Audiology, 1971-1972
- Co-principal Investigator, OEG 0-71-0449(607), Improving Technology on Articulation Therapy, 1971-present
- Certificate of Clinical Competence in Speech Pathology, American Speech and Hearing Association

Fields of Major Scientific Interest:

Speech pathology; mental retardation; learning theory

RICHARD L. SCHIEFELBUSCH

TITLE: Director  
Bureau of Child Research - L

Date of birth: July 23, 1918  
Place of birth: Osawatomie, Kansas

Sex: Male  
Present Nationality: American

Educational Experience:

Bachelor of Science, Kansas State Teachers College, Social Studies, 1940  
Master of Arts, University of Kansas, Speech Pathology and Psychology, 1947  
Ph.D., Northwestern University, Speech Pathology, 1951

Professional History:

Assistant Instructor, Speech Pathology and Audiology, University of Kansas,  
1946-1947  
Instructor, Speech Pathology and Audiology, University of Kansas, 1947-1948  
Assistant Professor, Speech Pathology and Audiology, University of Kansas,  
1949-1953  
Director, Speech and Hearing Clinic, University of Kansas, 1949-1956  
Member of clinical and research teams, University of Kansas Medical Center,  
1951-1957  
Associate Professor, Speech Pathology and Audiology, University of Kansas,  
1953-1959  
Director, Bureau of Child Research, University of Kansas, 1955-present  
Professor, University of Kansas and University of Kansas Medical Center,  
1959-1969  
Professor of the University, 1969-present  
Coordinator, Kansas Center for Research in Mental Retardation, 1966-1969  
Coordinator, Kansas University Affiliated Facility, 1967-1969  
Director, Kansas Center for Mental Retardation and Human Development,  
1969-present

Memberships in Professional Organizations:

Fellow, American Speech and Hearing Association  
Fellow, Society for Research in Child Development, Inc.  
Fellow, American Association on Mental Deficiency  
Council for Exceptional Children  
Clinical Certification, American Speech and Hearing Association

Publications:

Schiefelbusch, R. L., & Bair, H. V. Language and communication--outline of  
program for research and training of mentally retarded children. *Journal  
of the Kansas Medical Society*, 1958, 59, 137-140  
Schiefelbusch, R. L., & Lindsey, M. J. A new test of sound discrimination.  
*Journal of Speech and Hearing Disorders*, 1958, 23, 153-159.  
Schiefelbusch, R. L. Speech and hearing as it relates to special education.  
*Educational Administration and Supervision*, January 1959, 45.  
Schiefelbusch, R. L. Hearing conversation: An outline of the plan for school  
children in Kansas. *Journal of the Kansas Medical Society*, February 1959, LX.  
Schiefelbusch, R. L., & Bair, H. V. Joint setting for research: Training  
school and university. *APA Mental Hospital*, 1960, 11, 34-36.



RICHARD L. SCHIEFELBUSCH (Con't.)

- Schiefelbusch, R. L., & Bair, H. V. Language behavior of mentally retarded children. *Medical Times*, 1960, 88, 989-993.
- Schiefelbusch, R. L., & Spradlin, J. E. Language and communication: A progress report on the Parsons Research Project. *Journal of the Kansas Medical Society*, 1960, 61, 321-326.
- Schiefelbusch, R. L. Language and communication abilities of children who are mentally retarded. *International Education Reporter*, December 1960, 1.
- Schiefelbusch, R. L. The Kriegies speak. *Today's Speech*, 1962, 10, 4-6.
- Schiefelbusch, R. L. Establishing an interdisciplinary research team in a training school. *American Journal of Mental Deficiency*, 1962, 66, 634-640.
- Schiefelbusch, R. L. Children with speech and language impairments. S. Kirk & B. Weiner (Eds.), *Behavioral research on exceptional children*, Council for Exceptional Children, 1963.
- Schiefelbusch, R. L. (Ed.) Language studies of mentally retarded children. *Journal of Speech and Hearing Disorders*, Monograph Supplement No. 10, January 1963.
- Schiefelbusch, R. L., & Dodd, J. Our underachieving children. *Public Information Series No. 4*, Bureau of Child Research, University of Kansas, June 1963.
- Schiefelbusch, R. L. A discussion of language treatment methods of mentally retarded children. *Mental Retardation*, 1965, 3, 4-7.
- Schiefelbusch, R. L., Copeland, R. H., & Smith, J. O. (Eds.) *Language and mental retardation: Empirical and conceptual considerations*. New York: Holt, Rinehart, & Winston, 1967.
- Haring, N. G., & Schiefelbusch, R. L. (Eds.) *Methods in special education*. McGraw-Hill, 1967.
- Schiefelbusch, R. L. Methods of studying language of retarded children. In E. F. Waldon (Ed.), *Differential diagnosis of speech and hearing problems of mental retardates*. The Catholic University of America Press, 1968.
- Schiefelbusch, R. L. Language functions of retarded children. *Folia Phoniatica*, 1969, 21, 129-144.
- Schiefelbusch, R. L. Language disorders of cognitively involved children. In M. Marge and J. Irwin (Eds.), *Language disabilities in children*. New York: Appleton-Century-Crofts, 1972.
- Schiefelbusch, R. L. (Ed.) *The language of the mentally retarded*. Baltimore: University Park Press, 1972.
- Lent, J. R., et al. (R. L. Schiefelbusch). The Hansons. In *Case studies in mental retardation*. Dubuque, Iowa: William C. Brown Co., 1972.
- McLean, J. E., Yoder, D. E., & Schiefelbusch, R. L. *Language intervention with the retarded: Developing strategies*. Baltimore: University Park Press, 1972.
- Schiefelbusch, R. L. Language perspective: Acquisition, retardation, and intervention. In *Mental Retardation: An Annual Review Vol. 5*. New York: Grune and Stratton, in press.
- Haring, N. G., & Schiefelbusch, R. L. (Eds.) *Teaching special children*. New York; McGraw-Hill, in press.
- Schiefelbusch, R. L., & Lloyd, L. L. (Eds.) *Language perspectives: Acquisition, retardation and intervention*. Baltimore: University Park Press, in press.

Supplemental Information:

Consultant, State Department of Education, 1952-1954  
Director, Parsons Project in Language and Communication of Mentally Retarded Children (OM-111), 1958-1964

RICHARD L. SCHIEFELBUSCH (Con't.)

- Special Consultant, U.S. Office of Education, 1964-present  
Special Consultant, National Institutes of Mental Health, 1963-1965  
Special Consultant, National Institute of Child Health and Human Development, 1964-1965  
Special Consultant, National Institute of Neurological Diseases and Stroke, 1965-present  
Director of Grant, Program of Research in Communication Disorders of Mentally Retarded Children (HD-00870), Public Health Service, Department of Health, Education, and Welfare, October 1, 1963, to September 30, 1970  
Director of Grant, Demonstration of Therapy for Retardates with Communication Disorders (MH-01127), National Institutes of Mental Health, September 1, 1963, to August 31, 1966  
Director of Grant, Research Training Program in Mental Retardation (MH-8262), National Institutes of Mental Health, July 1, 1963, to June 30, 1966  
Director of Grant, Communicative Disorders Training Grant (NB-5362), National Institute of Neurological Diseases and Stroke (NINDS), July 1, 1962, to June 30, 1969  
Director of Grant, A Program of Research on the Development of Culturally Deprived Children (HD-03144), 1967-1971  
Director of Grant, Studies in Perception of Speech Events (NS-10468), 1972-1975  
Associate Editor, ASHA, A Journal of the American Speech and Hearing Association, 1962-1964  
Associate Editor, International Review of Research in Mental Retardation, 1965-1966  
Member, Committee on Examination, Speech Pathology: American Speech and Hearing Association, 1964-1965  
Member, Joint Committee on Audiology and Education of the Deaf, ASHA, 1963-1967  
Chairman, American Speech and Hearing Association Committee on Mental Retardation, 1966-1967  
Member, Education Review Committee, Accreditation Council for Facilities for the Mentally Retarded

Fields of Major Scientific Interest:

Communication behavior; learning process; language development; mental retardation



JOSEPH E. SPRADLIN

TITLE: Research Associate  
Bureau of Child Research - L

Date of birth: July 12, 1929  
Place of birth: Bloom, Kansas

Sex: Male  
Present Nationality: American

Educational Experience:

Bachelor of Arts, University of Kansas, Philosophy, 1951  
Master of Science, Fort Hays, Kansas State College, Psychology, 1954  
Ph.D., George Peabody College, Psychology, 1959

Professional History:

Psychometrician, Fort Hays, Kansas State College, Psychological Clinic, 1953-1954  
Clinical Psychologist, Winfield (Kansas) State Hospital, 1954-1956  
Research Associate, Bureau of Child Research, University of Kansas, 1958-1959  
Field Director, Parsons (Kansas) Project, Bureau of Child Research, 1959-1963  
Coordinator of Research, Bureau of Child Research and Parsons State Hospital, 1963-1969  
Associate Director, Bureau of Child Research, University of Kansas, 1966-1969  
Research Associate, Bureau of Child Research, University of Kansas, 1969-present  
Professor, Department of Human Development and Family Life, University of Kansas, 1969-present

Memberships in Professional Organizations:

American Psychological Association

Publications (Selected):

- Spradlin, J.E., B.J. Locke, and R.T. Fulton. Conditioning and audiologic assessment. In R.T. Fulton and L.L. Lloyd (Eds.), Audiometry for the retarded with implications for the difficult-to-test. Baltimore: Williams and Wilkins, 1969.
- Spradlin, J.E. Environmental factors and the language development of retarded children. In S. Rosenberg and J.H. Koplin (Eds.), Institute in applied psycholinguistics papers. New Jersey: MacMillan, 1968, 261-290.
- Spradlin, J.E. Procedures for evaluating processes associated with receptive and expressive language. In R.L. Schiefelbusch, R.H. Copeland, and J.O. Smith (Eds.), Language and mental retardation. New York: Holt, Rinehart, and Winston, 1967, 118-136.
- Spradlin, J.E., F.L. Girardeau, and G.L. Hom. Stimulus properties of reinforcement during extinction of a free operant response. Journal of Experimental Child Psychology, 1966, 4, 369-380.
- Spradlin, J.E., and F.L. Girardeau. The behavior of moderately and severely retarded persons. In N. Ellis (Ed.), The international review of research in mental retardation. New York: Academic Press, 1966, 257-298.

Supplemental Information:

Consultant, U.S. Department of Health, Education, and Welfare, NINDB Division, Paranatal Research Branch  
Consultant, U.S. Department of Health, Education, and Welfare, U.S. Office of Education, Children and Youth Branch, Elementary and Secondary Research

JOSEPH E. SPRADLIN (Con't.)

Fields of Major Scientific Interest:

Psychology; analysis of complex human behavior

247

213