

DOCUMENT RESUME

ED 132 709

EA 009 000

AUTHOR Morrow, G. W.; Johnson, N. B.  
TITLE Development of a School Bus Fuel System Integrity Compliance Procedure. Final Report.  
INSTITUTION Ultrasytems, Inc., Phoenix, Ariz. Dynamic Science Div.  
SPONS AGENCY National Highway Traffic Safety Administration (DOT), Washington, D. C.  
REPORT NO R-DOT-HS-801-529  
PUB DATE Apr 75  
CONTRACT DOT-HS-4-00872  
NOTE 66p.; Photos and graphs may reproduce poorly  
AVAILABLE FROM National Technical Information Service, Springfield, Virginia 22161 (Order No. PB-241 639/4GA, Photocopy \$4.50, Microfiche \$3.00)

EDRS PRICE MF-\$0.83 HC-\$3.50 Plus Postage.  
DESCRIPTORS Accident Prevention; Fire Protection; \*Fuels; Measurement Instruments; \*Performance Criteria; Performance Specifications; Safety; \*School Buses; \*Simulation; \*Systems Analysis; \*Traffic Accidents

ABSTRACT

This report presents a program that derived a compliance test procedure for school buses with a gross vehicle weight of 10,000 pounds or greater. The objective of this program was to evaluate Fuel System Integrity (FMVSS 301) in relation to school buses, conduct a limited state-of-the-art survey and run full-scale dynamic tests to produce an effective procedure that will improve the crashworthiness of school bus fuel systems. (NTIS)

\*\*\*\*\*  
\* Documents acquired by ERIC include many informal unpublished \*  
\* materials not available from other sources. ERIC makes every effort \*  
\* to obtain the best copy available. Nevertheless, items of marginal \*  
\* reproducibility are often encountered and this affects the quality \*  
\* of the microfiche and hardcopy reproductions ERIC makes available \*  
\* via the ERIC Document Reproduction Service (EDRS). EDRS is not \*  
\* responsible for the quality of the original document. Reproductions \*  
\* supplied by EDRS are the best that can be made from the original. \*  
\*\*\*\*\*

U S DEPARTMENT OF HEALTH,  
EDUCATION & WELFARE  
NATIONAL INSTITUTE OF  
EDUCATION

THIS DOCUMENT HAS BEEN REPRO-  
DUCED EXACTLY AS RECEIVED FROM  
THE PERSON OR ORGANIZATION ORIGIN-  
ATING IT. POINTS OF VIEW OR OPINIONS  
STATED DO NOT NECESSARILY REPRESENT OFFICIAL NATIONAL INSTITUTE OF  
EDUCATION POSITION OR POLICY.

DOT HS-801 529

# **DEVELOPMENT OF A SCHOOL BUS FUEL SYSTEM INTEGRITY COMPLIANCE PROCEDURE**

**Contract No. DOT-HS-4-00872**

**April 1975**

**Final Report**

**PREPARED FOR:**

**U.S. DEPARTMENT OF TRANSPORTATION**

**NATIONAL HIGHWAY TRAFFIC SAFETY ADMINISTRATION**

**WASHINGTON, D.C. 20590**

Document is available to the public through  
the National Technical Information Service,  
Springfield, Virginia 22161

"Prepared for the Department of Transportation, National Highway Traffic Safety Administration, under Contract No. DOT-HS-4-00872. The opinions, findings, and conclusions expressed in this publication are those of the authors and not necessarily those of the National Highway Traffic Safety Administration."

This document is disseminated under the sponsorship of the Department of Transportation in the interest of information exchange. The United States Government assumes no liability for its contents or use thereof.

TECHNICAL REPORT STANDARD TITLE PAGE

|  |  |   |   |  |           |
|--|--|---|---|--|-----------|
| 1. Report No.<br>DOT HS-801 529  |  | 2. Government Accession No.                             |   | 3. Recipient's Catalog No.   |           |
| 4. Title and Subtitle<br>DEVELOPMENT OF A SCHOOL<br>BUS FUEL SYSTEM INTEGRITY COMPLIANCE<br>PROCEDURE  |  |   |   | 5. Report Date<br>APRIL 1975   |           |
|  |  |   |   | 6. Performing Orgn Code  |           |
| 7. Author(s) G.W. Morrow, N.B. Johnson   |  |   |   | 8. Performing Orgn Rpt No.<br>2310-75-90                               |           |
| 9. Performing Organization Name and Address<br>Ultrasystems, Inc.<br>The Dynamic Science Division<br>1850 West Pinnacle Peak Road<br>Phoenix, Arizona 85027  |  |   |   | 10. Work Unit No.  |           |
|  |  |   |   | 11. Contract or Grant No.<br>DOT-HS-4-00872 Mod. 5                     |           |
| 12. Sponsoring Agency Name and Address<br>U.S. Department of Transportation<br>National Highway Traffic Safety Admin.<br>Washington, D. C. 20590   |  |   |   | 13. Type of Report and<br>Period Covered<br>Final Report<br>March 1975 |           |
|  |  |   |   | 14. Sponsoring Agency Code   |           |
| 15. Supplementary Notes  |  |   |   |  |           |
| 16. Abstract<br><br>This report presents a program that derived a compliance test procedure for school buses with a gross vehicle weight of 10,000 pounds or greater.<br><br>The objective of this program was to evaluate FMVSS 301 in relation to school buses, conduct a limited state-of-the-art survey and run full-scale dynamic tests to produce an effective procedure that will improve the crashworthiness of school bus fuel systems. |  |   |   |  |           |
| 17. Key Words School Bus, Fuel System Integrity, Crashworthiness, Compliance Procedure   |  |   | 18. Distribution Statement<br>DOCUMENT IS Available through the National Technical Information Service, Springfield, Virginia 22161 |  |           |
| 19. Security Classif.<br>(of this report)<br>Unclassified  |  | 20. Security Classif.<br>(of this page)<br>Unclassified |   | 21. No. Pages<br>59  | 22. Price |

Form DOT F 1700.7 (8-69)

## CONTENTS

|   | <u>Page</u> |
|---|-------------|
| 1.0 INTRODUCTION . . . . .                            | 1           |
| 2.0 EXAMINATION OF PERFORMANCE REQUIREMENTS . . . . . | 2           |
| 2.1 EXISTING SCHOOL BUS FUEL SYSTEMS . . . . .        | 2           |
| 2.2 CURRENT PERFORMANCE REQUIREMENTS . . . . .        | 5           |
| 2.3 RECOMMENDED PERFORMANCE REQUIREMENTS . . . . .    | 7           |
| 3.0 SCHOOL BUS TESTING . . . . .                      | 9           |
| 3.1 FMVSS 301 MOVING BARRIER TEST . . . . .           | 9           |
| 3.2 TEST PROCEDURE MODIFICATION . . . . .             | 22          |
| 3.3 MODIFIED MOVING BARRIER TEST . . . . .            | 29          |
| 4.0 DEVELOPMENT OF COMPLIANCE PROCEDURE . . . . .     | 42          |
| 4.1 TEST DATA REVIEW . . . . .                        | 42          |
| 4.2 PROCEDURE DEVELOPMENT . . . . .                   | 42          |
| 4.3 DRAFT OF FUEL SYSTEM INTEGRITY STANDARD . . . . . | 44          |
| 4.4 DRAFT OF COMPLIANCE TEST PROCEDURE . . . . .      | 46          |
| 5.0 SUMMARY . . . . .                                 | 53          |

## ILLUSTRATIONS

| <u>Figure</u> |   | <u>Page</u> |
|---------------|---|-------------|
| 1             | Typical Fuel Tank Installation . . . . .                            | 4           |
| 2             | Dynamic Science Crash Facility Layout. . . . .                      | 10          |
| 3             | Tests 1 and 2, Instrumentation Locations<br>in School Bus. . . . .  | 11          |
| 4             | Test 1, Camera Layout. . . . .                                      | 13          |
| 5             | Test 1, Pre- and Post-test Positions of<br>School Bus . . . . .     | 14          |
| 6             | Test 1, Filler Spout Failure, Close-up<br>View . . . . .            | 15          |
| 7             | Test 1, Filler Spout Failure, Overall View . . . . .                | 15          |
| 8             | Test 1, Position 1 Acceleration Data . . . . .                      | 16          |
| 9             | Test 1, Position 2 Acceleration Data . . . . .                      | 17          |
| 10            | Test 1, Position 3 Acceleration Data . . . . .                      | 18          |
| 11            | Test 1, Position 4 Acceleration Data . . . . .                      | 19          |
| 12            | Test 1, Position 5 Acceleration Data . . . . .                      | 20          |
| 13            | Test 1, Position 1 Displacement Data . . . . .                      | 21          |
| 14            | Test 1, Position 2 Displacement Data . . . . .                      | 21          |
| 15            | Test 1, School Bus and Barrier Interface,<br>Close-up View. . . . . | 23          |
| 16            | Test 1, School Bus and Barrier Alignment . . . . .                  | 23          |
| 17            | Test 1, School Bus and Barrier Interface,<br>Overall View . . . . . | 24          |
| 18            | Test 1, Lateral Shift of Floor Structure . . . . .                  | 24          |
| 19            | Test 1, Exterior Impact Damage . . . . .                            | 25          |
| 20            | Test 1, Barrier Penetration of Fuel Tank<br>Area . . . . .          | 25          |
| 21            | Car/School Bus Interface . . . . .                                  | 27          |

ILLUSTRATIONS (CONTD)

| <u>Figure</u> |  | <u>Page</u> |
|---------------|--|-------------|
| 22            | Car/School Bus Interface. . . . .  | 27          |
| 23            | Car/School Bus Interface. . . . .  | 28          |
| 24            | Car/School Bus Interface. . . . .  | 28          |
| 25            | School Bus/Barrier Interface. . . . .                                    | 30          |
| 26            | School Bus and Barrier Alignment. . . . .                                | 30          |
| 27            | Test 2, Camera Layout . . . . .  | 32          |
| 28            | Barrier Penetration of Fuel Tank Area . . . . .                          | 33          |
| 29            | Test 2, Pre- and Post-Test Positions<br>of School Bus . . . . .          | 34          |
| 30            | Test 2, Fuel Tank Damage, Close-up View . . . . .                        | 35          |
| 31            | Test 2, Fuel Tank Damage, Overall View. . . . .                          | 35          |
| 32            | Test 2, Fuel Tank Damage Made by Internal<br>Structure of Tank . . . . . | 36          |
| 33            | Test 2, Position 1 Acceleration Data. . . . .                            | 37          |
| 34            | Test 2, Position 2 Acceleration Data. . . . .                            | 38          |
| 35            | Test 2, Position 3 Acceleration Data. . . . .                            | 39          |
| 36            | Test 2, Position 4 Acceleration Data. . . . .                            | 40          |
| 37            | Test 2, Position 5 Acceleration Data. . . . .                            | 41          |

TABLES

| <u>Table</u> |  | <u>Page</u> |
|--------------|--|-------------|
| I            | Fuel Tank Locations. . . . .                     | 2           |
| II           | Fuel Spillage From School Bus Test No. 1 . . . . | 22          |



## 1.0 INTRODUCTION

This report documents a program conducted for the National Highway Traffic Safety Administration under Contract DOT-HS-4-00872 to develop compliance test procedures for school bus fuel system integrity.

FMVSS 301, Fuel System Integrity, now excludes motor vehicles in excess of 10,000 pounds and, therefore, excludes most school buses. However, the National Transportation Safety Board has reported one instance where the fuel tank of a school bus was dislodged and ruptured during a crash. Considering the location of the school bus fuel tank, being near the service door, a potential fire hazard exists that could trap children on board the bus. Therefore, the objective of this program was to investigate and recommend compliance procedures that would extend the FMVSS 301 requirements to include school buses in excess of 10,000 pounds.

The overall program was accomplished in the following manner:

- A limited state-of-the-art survey was conducted to evaluate existing school bus fuel systems and the recommended performance requirements.
- A 30 mile-per-hour contoured moving barrier impact test was conducted on a school bus using the FMVSS 301 procedures.
- The test procedures were modified, based on the results of the first test, to better evaluate the integrity of school bus fuel systems.
- A second compliance test was performed on a school bus using the modified procedures.
- A final recommended compliance test procedure was formulated for evaluating the integrity of school bus fuel systems.

The draft of a compliance test procedure included in this report is based on modified procedures of FMVSS 301. The modifications are a direct result of the knowledge and experience gained from the two tests that were performed during the program. Adoption of these test procedures would greatly increase the integrity of the fuel system of all school buses.

## 2.0 EXAMINATION OF PERFORMANCE REQUIREMENTS

### 2.1 EXISTING SCHOOL BUS FUEL SYSTEMS

The location of fuel tanks in school buses is not specified in any FMVSS, and the "safest" or "best" location for such tanks has not been established by any Federal Agency. National Education Association (NEA) Standard specifications suggest that the best position is on the right side, directly behind the service door. The Vehicle Equipment Safety Commission Regulation VESC-6 states that school bus fuel tanks shall have a minimum capacity of 30 gallons, shall be mounted directly on the right side of the chassis frame, and shall be filled and vented entirely from outside the body. Truck manufacturers of school bus chassis units (because of the NEA Specifications) generally install the tanks on the right side, directly behind the service door. Fuel tank locations are tabulated in Table I.

| Chassis Model     | Tank Location      |
|-------------------|--------------------|
| <u>Ford</u>       |                    |
| B500, B600        | Right Side - Front |
| B600 through B750 | Right Side - Front |
| B-7000            | Right Side - Front |
| <u>Dodge</u>      |                    |
| S600              | Right Side - Front |
| <u>GMC</u>        |                    |
| SS/SE60           | Right Side - Front |
| SM/GG60           | Right Side - Front |
| <u>Chevrolet</u>  |                    |
| SE-53102          | Right Side - Front |

During a trip to a school bus service facility at a local high school, it was noted that the gas tanks on two of the school buses were located in the right rear. The mechanic states that their school buses were mostly large 99-passenger units powered by diesel engines. Tanks for most of these buses were located at the right rear or right center.

Engine location largely determines gas tank location. Buses with engines in the rear generally have tanks near the rear, and buses with engines in the front have tanks on the right front side. The mechanic pointed out that it is desirable to locate the tank near the engine for the most efficient fuel pump operation.

School bus fuel tanks in all side locations are mounted between the body skirt and the longitudinal frame member, as shown in Figure 1. The tank is secured in place by straps that fasten to the frame. Although the tank mounting is fairly secure, the tank has little protection from an impact in this area.

Two contracts which have been awarded to improve school bus crashworthiness were reviewed to determine if improvements in the fuel system were being considered. Contract DOT-HS-046-3-394, "School Bus Improvement Project" with Dynamic Science, did not include improvements to the fuel system nor tests of the fuel system. Contract DOT-HS-4-00969, "Development of a Unitized School Bus" with AMF, Goleta, California, requires that "the fuel tank, filler tube and gas lines will be located in a manner which provides maximum impact and fire protection".

Highway Accident Report NTSB-HAR-72-2 provides a well documented account of a side impact accident to a school bus by a full-size sedan impacting in the fuel tank service door area. This case was an intersection accident in which the driver of the sedan failed to yield at a stop sign and impacted the side of the school bus at approximately 25 miles per hour. The sedan struck the service door area, rotated into the fuel tank area, and dislodged the fuel tank from the school bus. The school bus came to

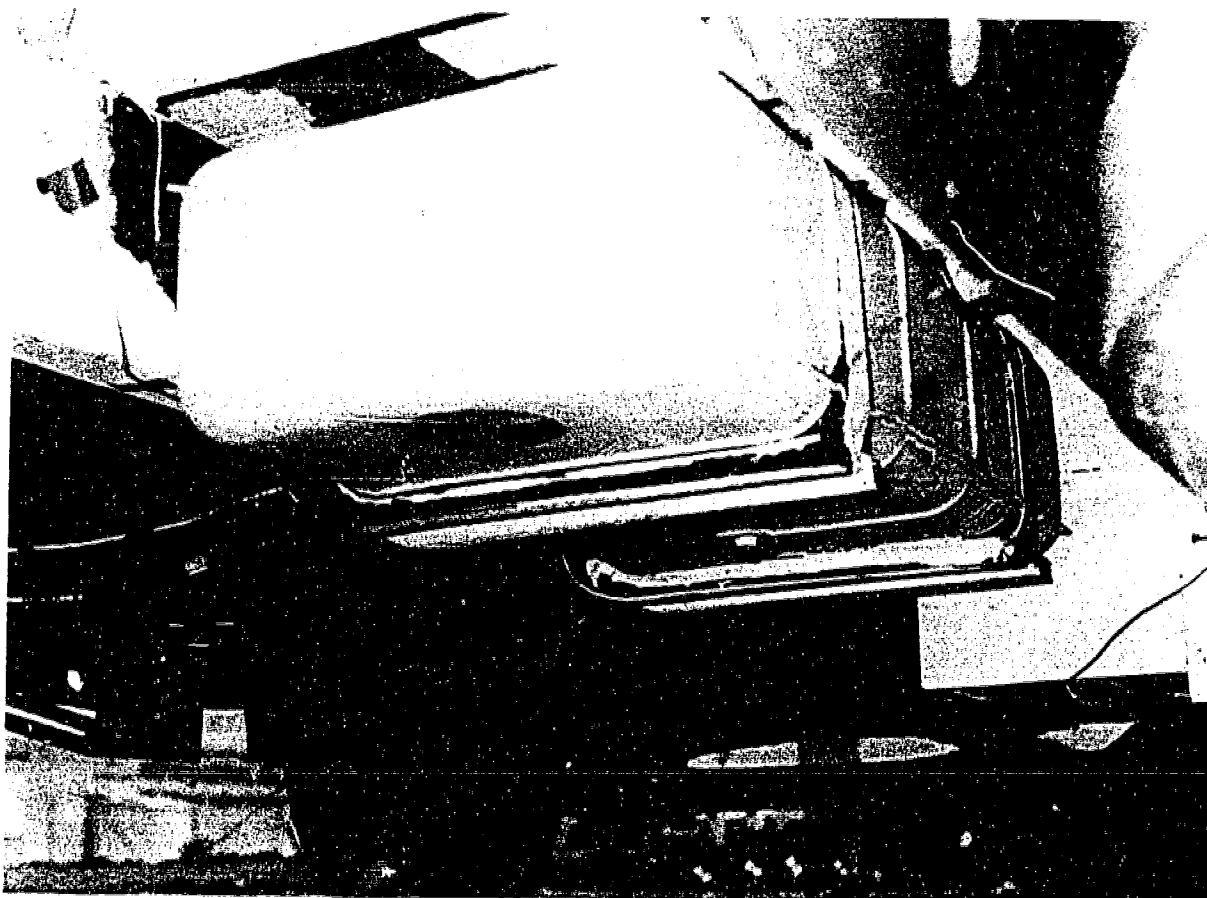

Figure 1. Typical Fuel Tank Installation.

rest in a culvert to the left side of the road. The sedan came to rest off the right side of the same road after rotating approximately 120 degrees. The fuel tank of the school bus came to rest in front of the sedan. A fire resulted from the impact, burning spilled fuel from the point of impact to the final stopping point of the tank. The fuel tank damage was a result of the vehicle passing under the floor structure and penetrating the fuel tank area.

The School Bus Manufacturer's Institute has compiled data on bus accidents during the years 1969, 1970, and 1971. In the year 1969, 204 of the 1410 accidents surveyed, or 14.5 percent, were side impact collisions. In the year 1970, 15.8 percent of the

accidents were side collisions, and during the year 1971, 15.5 percent were side impacts. In each year the front end type collision was considered most likely to occur, and the side collision was considered to be the next most likely to occur. Side collisions assume an important role in their relationship to school bus safety.

## 2.2 CURRENT PERFORMANCE REQUIREMENTS

FMVSS No. 301 presently applies to passenger cars and multipurpose passenger vehicles, trucks and buses having a GVWR of 10,000 pounds or less, and using fuel with a boiling point above 32°F. The standard specifies three types of impact tests be conducted to assess fuel system integrity.

The frontal barrier crash is conducted at 30 miles per hour with the vehicle impacting a fixed collision barrier that is perpendicular to the line of travel of the vehicle, or at any angle up to 30 degrees in either direction from the line of travel. Fuel spillage shall not exceed 1 ounce by weight from impact until motion of the vehicle has ceased, and shall not exceed a total of 5 ounces by weight in the 5-minute period following cessation of motion. For the subsequent 10-minute period, fuel spillage during any 1-minute interval shall not exceed 1 ounce by weight.

The lateral moving barrier crash is conducted at 20 miles per hour with the vehicle impacted laterally on either side by a SAE standard barrier. Fuel spillage requirements are the same as the frontal barrier crash requirements.

The rear moving barrier test is conducted at 30 miles per hour with the vehicle being impacted longitudinally in the rear by a SAE standard barrier. Fuel spillage requirements are the same as the other two tests.

To evaluate the performance requirements recommended in FMVSS 301, which is designed to minimize the possibility of crash induced fuel spillage and/or fire, a review was conducted of two

previous NHTSA research contract final reports in the fuel system area.

Activities conducted under Contract DOT-FH-11-7347, "Prevention of Electrical Systems Ignition of Automotive Crash Fire", consisted of surveying approximately 200 passenger vehicles of 1,000 to 6,000 pounds curb weight on dealer lots and in wrecking yards to assess the probability of damage to electrical systems. Based on the results of this survey, it was concluded that automobile fires do occur because of crash-damage to electrical systems when fuel is spilled. Electrical system damage can be reduced by a combination of the following: (1) relocating components and wiring away from vulnerable areas; (2) shielding of components and wiring against impact damage; and (3) incorporation of an impact-sensitive device to inert the electrical system.

Results from Contract DOT-FH-11-7579, "An Assessment of Automotive Fuel System Fire Hazards", were also considered. This program concluded that, although fire occurs in only about 0.5 percent of all injury-producing automobile accidents, injuries and fatalities are disproportionately higher in fire accidents. The two most probable ignition sources for spilled fuel are sparks from damaged electrical systems and friction sparks generated by the impact.

Fuel spillage and fires were considerably higher in rear end collisions than for all other impacts. The velocity of the striking vehicle determined the amount of tank damage. Serious fuel spillage is caused by: (1) fuel tank rupture and (2) the tank filler neck being pulled from the fuel tank during impact, although the tank itself is not badly damaged.

There are two inescapable conclusions. One is that, even though the rate of fire accidents is very low, the number of fire accidents is large enough to present a significant hazard because of the large total number of accidents which do occur. Secondly, data clearly indicates that fuel system leakage and fire accidents can and do occur in all types of accident situations.



Current results from an ongoing contract, DOT-HS-4-00872, "Spilled Fuel Ignition Sources and Countermeasures", being conducted by Dynamic Science, indicates that it is desirable to relocate passenger car fuel tanks to provide better crashworthiness, or to improve the tank's crashworthiness by redesign. Inerting of the vehicles' electrical systems during impact will significantly reduce the number of crash fires, but, will not eliminate all of them. The only means to completely eliminate such fires is to control fuel spillage.

### 2.3 RECOMMENDED PERFORMANCE REQUIREMENTS

It must be concluded that, in its present location and without additional crash protection, the school bus fuel tank presents a real and unnecessary hazard. For example, a moderate side impact and underride by a passenger car can simultaneously render the service door inoperative and rupture the fuel tank. Thus the performance requirements for school bus fuel system integrity must be, at least, as stringent as those required for smaller passenger vehicles.

The FMVSS 301 requirements form a strong foundation on which to base school bus fuel system requirements. The rear moving barrier test for passenger vehicles in FMVSS 301 offers a realistic test of fuel system integrity, in that the impact is centered in the fuel tank area of most vehicles. This is quite important because of the high incidence of fuel spillage and crash fires resulting from this type of impact. The rear end test is also representative of typical real-world accidents which must be the case in any usable compliance test requirement.

The general recommended performance requirements for school bus fuel system integrity can thus be summarized as follows:

1. The compliance test impact should be centered in the bus fuel tank area.
2. The test conditions must be representative of real-world accidents.
3. Allowable fuel spillage should not exceed current FMVSS 301 requirements.



### 3.0 SCHOOL BUS TESTING

Two school bus tests were conducted during this program. The first test served as a baseline test to evaluate the FMVSS 301 standard, as applied to school buses. The test chosen for an evaluation of the fuel system integrity was the side impact by a SAE J972A moving barrier. The contoured, rather than the flat moving barrier was selected since it was felt to be more representative of the actual front-end structure of an automobile. This test was performed as discussed in Section 3.1. The results of the first test indicated several test conditions required modifications to produce more realistic results that would closely parallel accidents that occur in a real environment. The second test was performed utilizing the revisions indicated from Test 1. The combined results from both tests were then used as the basis for the recommended compliance test procedure.

#### 3.1 FMVSS 301 MOVING BARRIER TEST

The first test was performed using FMVSS 301 and Notice 2 of the revision to FMVSS 301 as a guideline. A 1970 Thomas school bus body mounted on a Chevrolet chassis served as the test vehicle.

The school bus was aligned on the Dynamic Science Crash Facility (see Figure 2), so that its longitudinal axis was normal to the longitudinal centerline of the impacting contoured moving barrier. The fuel tank centerline was aligned to the centerline of the monorail guide track. The SAE J972A moving contoured barrier was then towed into the school bus at an impact velocity of  $29.4 \pm 0.5$  miles per hour. The barrier was released from the tow system just prior to impact, but was guided by the monorail throughout the test, as required by FMVSS 208.

The school bus fuel tank area was prepared for the test by first cleaning and then painting the area. The background area was painted white and the supporting structure was painted light blue. The fuel tank itself was painted light yellow.

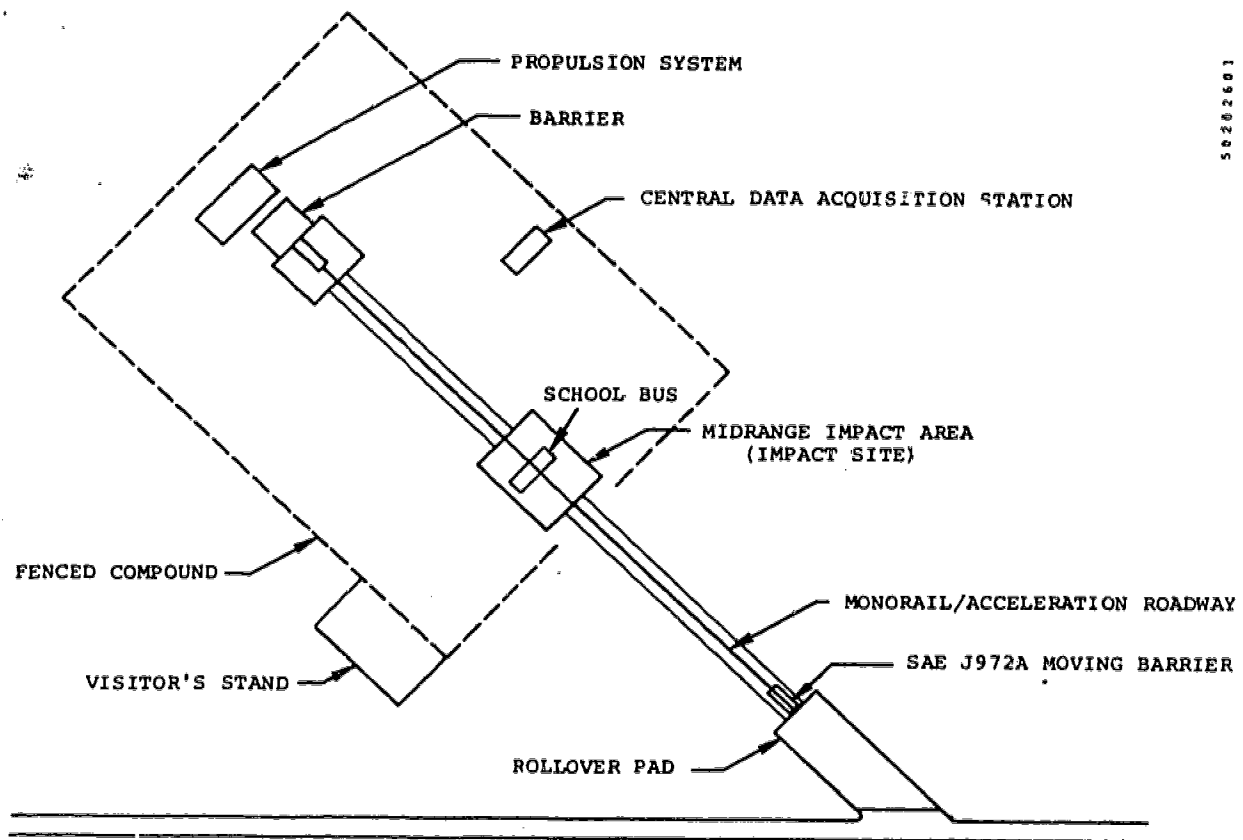
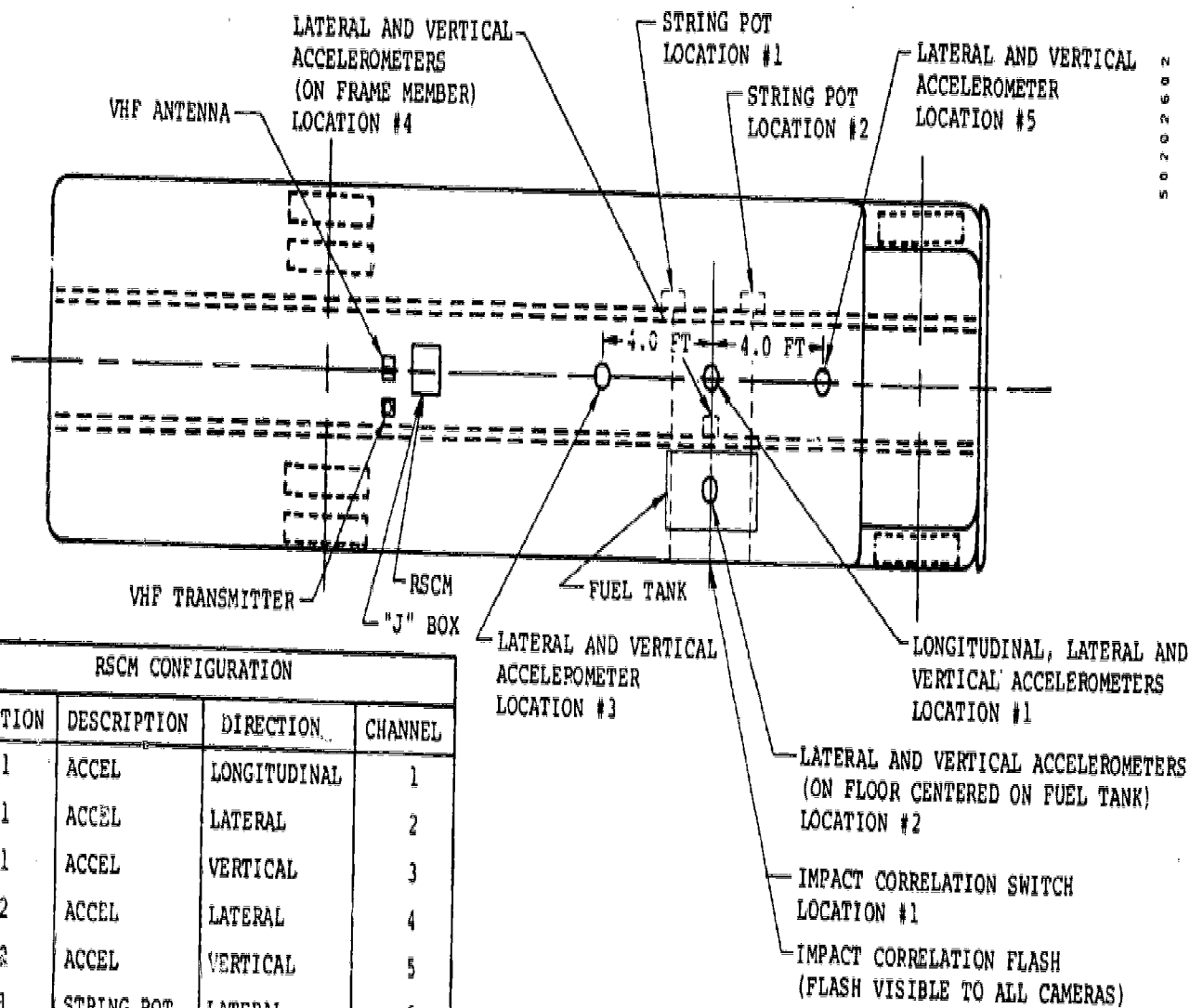

Figure 2. Dynamic Science Crash Facility Layout.

The school bus exterior was marked with a level line with targets on one-foot centers. The top of the bus was also targeted down the centerline for the overhead camera. The fuel tank was marked with three targets on one-foot centers. Placards were placed in the view of all cameras so that the test could be identified.

The instrumentation consisted of eleven accelerometers, two displacement string pots, and one impact indicator. Transducer outputs were passed through a remote signal conditioning module (RSCM) and then transmitted to a magnetic tape recorder by means of telemetry and through an umbilical cable. The instrumentation locations are shown in Figure 3.

S 0 2 0 2 6 0 2



| RSCM CONFIGURATION |             |              |         |
|--------------------|-------------|--------------|---------|
| LOCATION           | DESCRIPTION | DIRECTION    | CHANNEL |
| 1                  | ACCEL       | LONGITUDINAL | 1       |
| 1                  | ACCEL       | LATERAL      | 2       |
| 1                  | ACCEL       | VERTICAL     | 3       |
| 2                  | ACCEL       | LATERAL      | 4       |
| 2                  | ACCEL       | VERTICAL     | 5       |
| 1                  | STRING POT  | LATERAL      | 6       |
| 1                  | IMPACT      | -            | 7       |
| 3                  | ACCEL       | LATERAL      | 8       |
| 3                  | ACCEL       | VERTICAL     | 9       |
| 4                  | ACCEL       | LATERAL      | 10      |
| 4                  | ACCEL       | VERTICAL     | 11      |
| 2                  | STRING POT  | LATERAL      | 12      |
| 5                  | ACCEL       | LATERAL      | 13      |
| 5                  | ACCEL       | VERTICAL     | 14      |

Figure 3. Tests 1 and 2, Instrumentation Locations in School Bus.

The fuel tank was filled to 95 percent of its capacity with Stoddard solvent. The engine was operated until the solvent completely filled the fuel system.

After all preparation had been completed, the school bus was weighed. The total weight for the school bus, as tested, was 13,490 pounds with 8,355 pounds on the rear wheels and 5,135 pounds on the front wheels.

When the school bus was ready for test, it was positioned over the midrange photo pit of the crash facility. Seven high-speed cameras and two hand-held real-time cameras were positioned as illustrated in Figure 4.

When all of the instrumentation and photographic equipment was ready, the moving barrier was accelerated to a speed of  $29.4 \pm 0.5$  miles per hour. The barrier was released just prior to impact, and impact velocity was 29.38 miles per hour. The barrier impacted the bus and then rebounded straight backward because of the barrier guide shoes. The school bus rotated 20.7 degrees during impact and was pushed sideward several feet as shown in Figure 5. The maximum roll that occurred during the event was 9 degrees. Fuel leakage was immediate, the first timed sample being started as soon as test personnel could get to the leakage. The fuel spillage was measured in four two-minute samples, as listed in Table II. The fuel leakage occurred from an area on the filler spout that was partially separated from the fuel tank. The failure was in the union of the angle fitting of the filler spout to the main tank, as shown in Figures 6 and 7.

The accelerometer data are presented in Figures 8, 9, 10, 11, and 12. Data from the two displacement string pots are shown in Figures 13 and 14.

The impact of the moving barrier was primarily resolved by the floor support structure as shown by the high acceleration levels on the floor and the lateral shift of the floor structure inside the bus. The alignment of the moving barrier to the

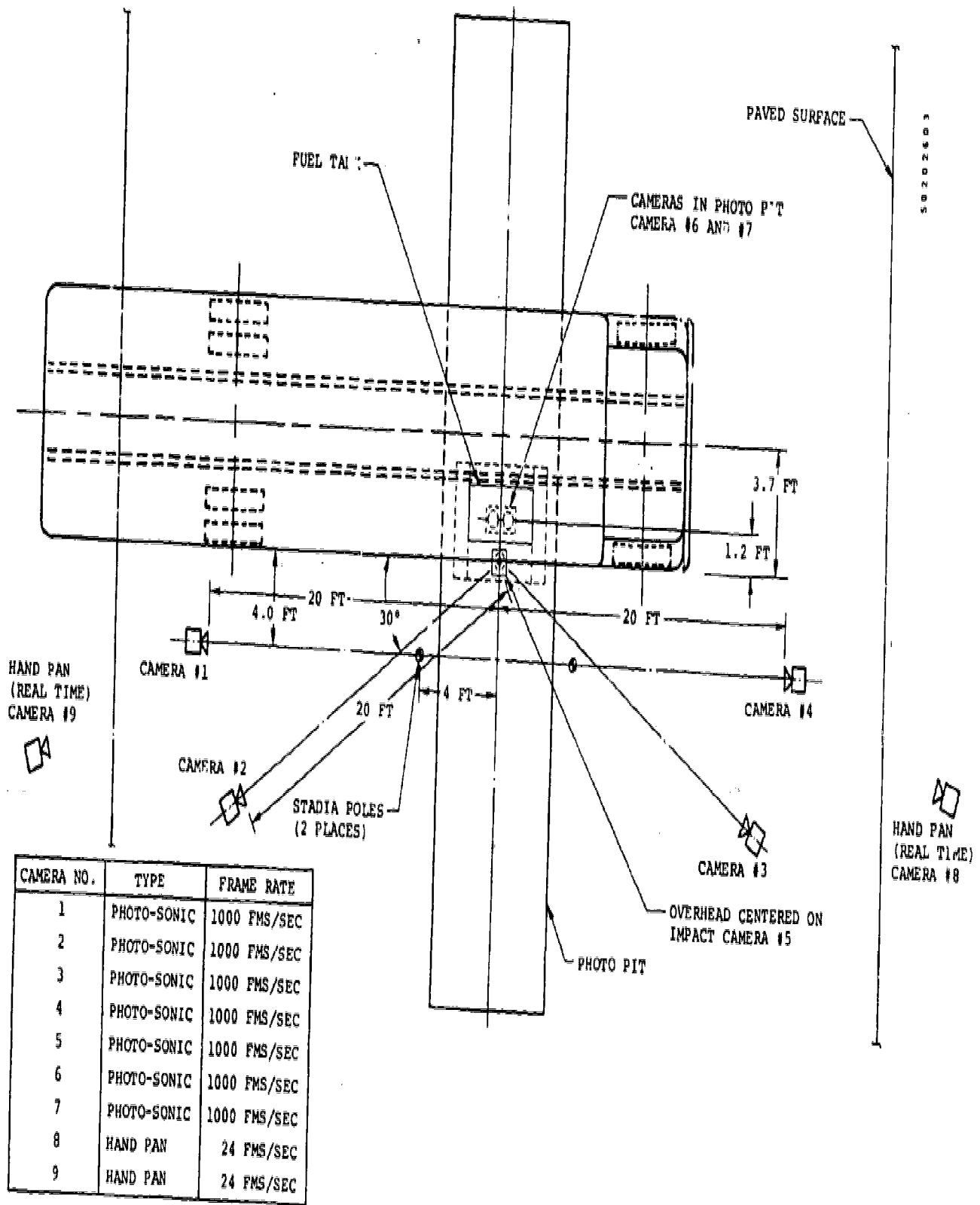

Figure 4. Test 1, Camera Layout.

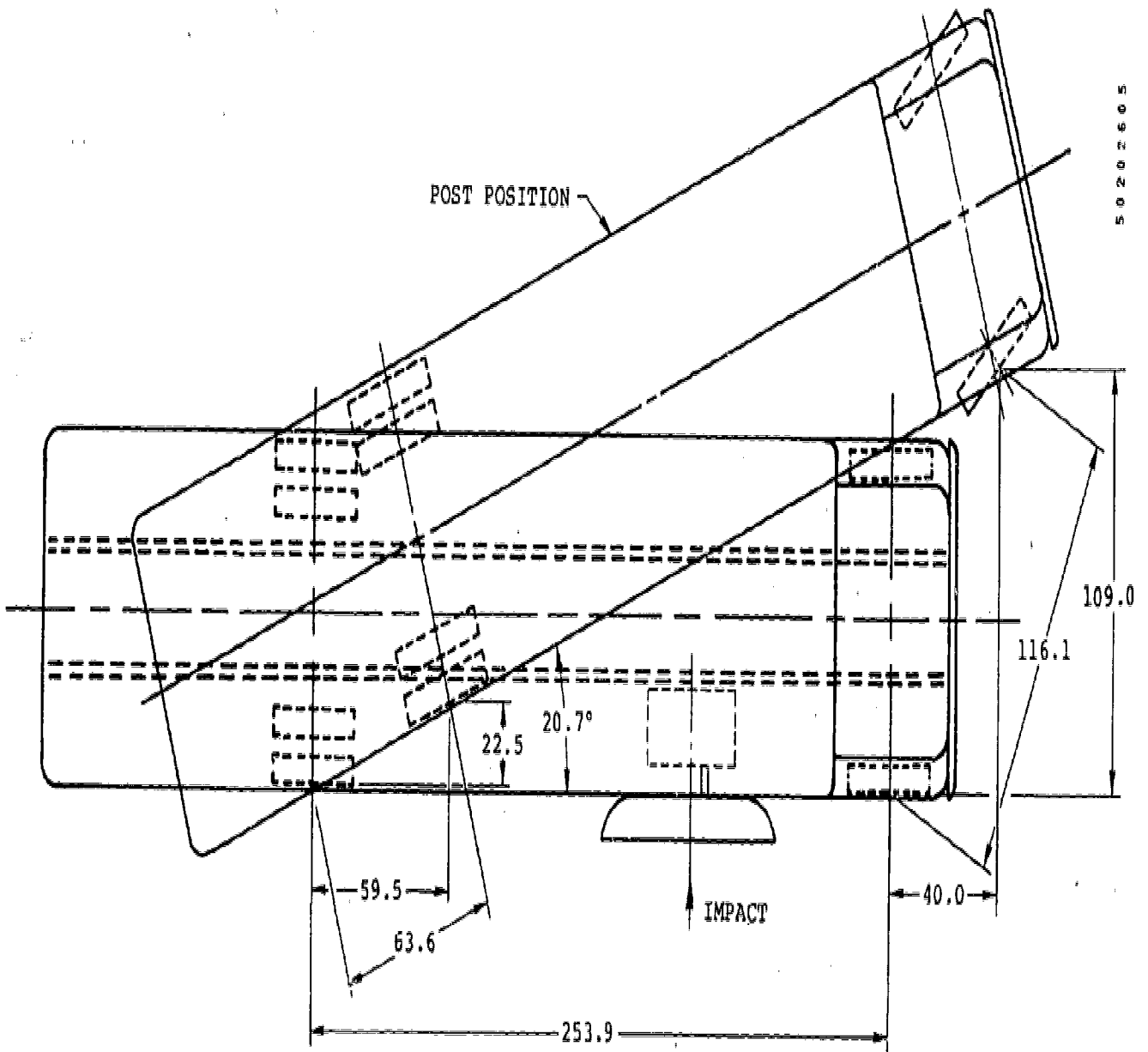

Figure 5. Test 1, Pre- and Post-Test Positions of School Bus.



Figure 6. Test 1, Filler Spout Failure, Close-up View

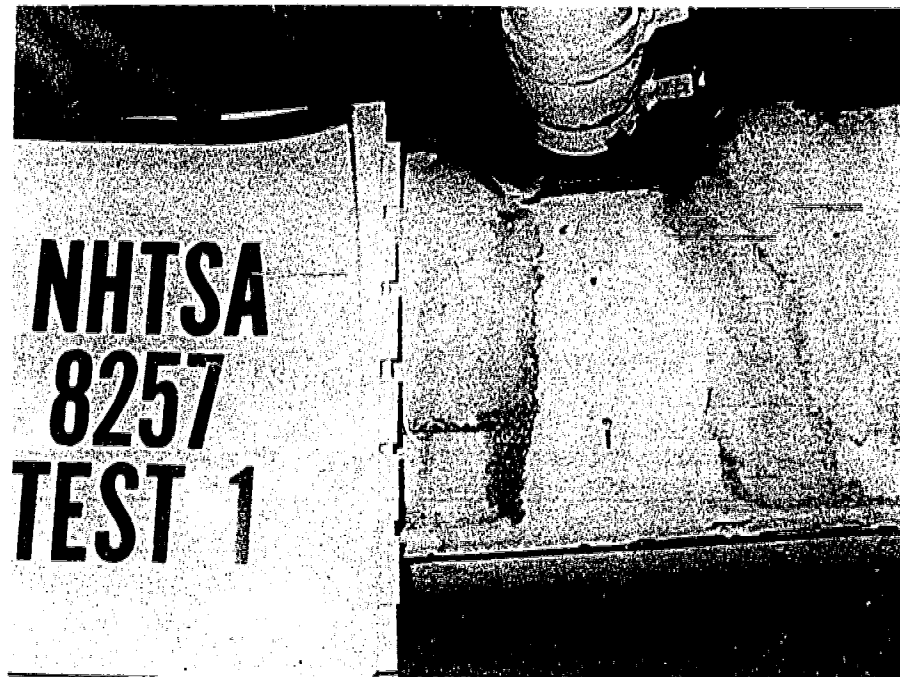

Figure 7. Test 1, Filler Spout Failure, Overall View.



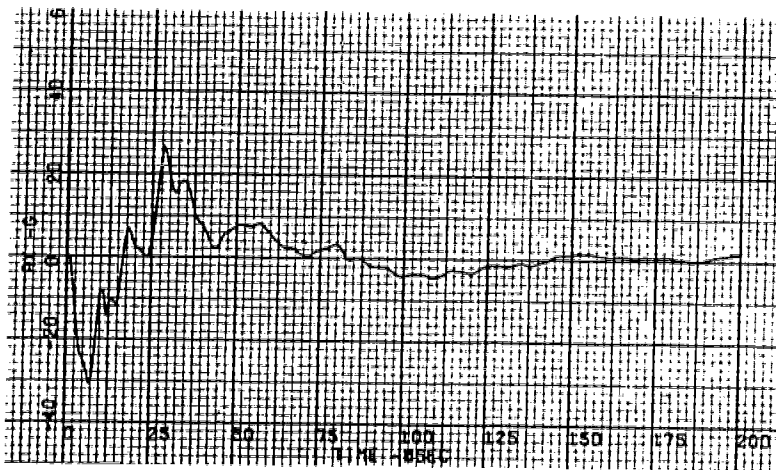
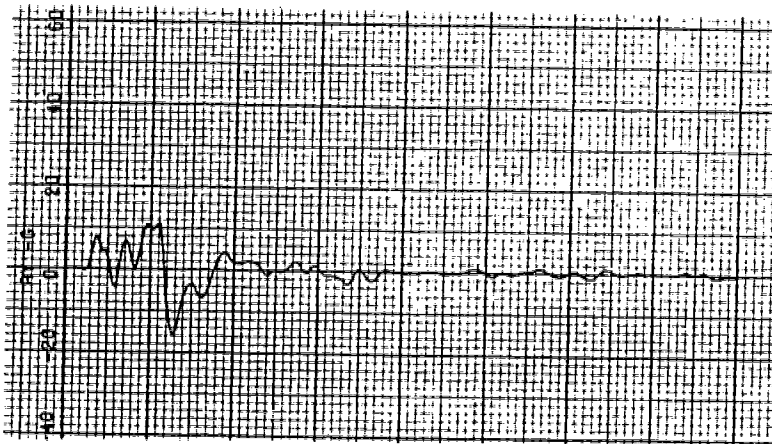
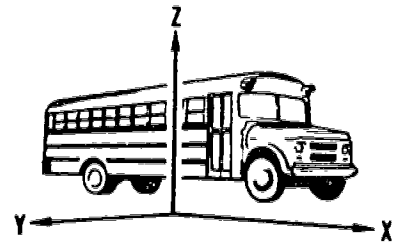
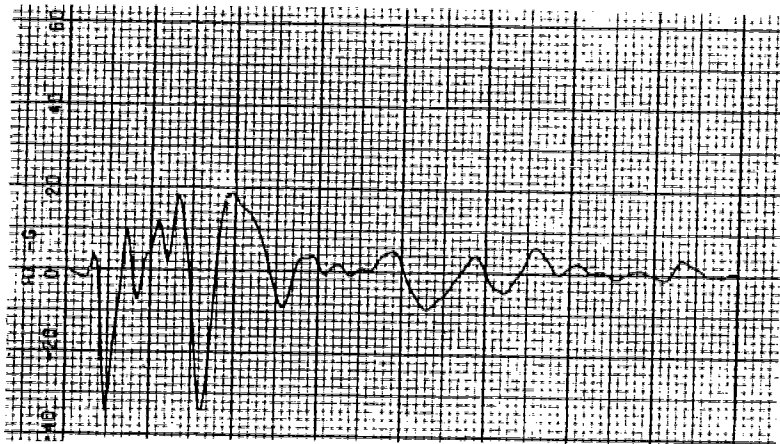

Figure 8. Test 1, Position 1 Acceleration Data.



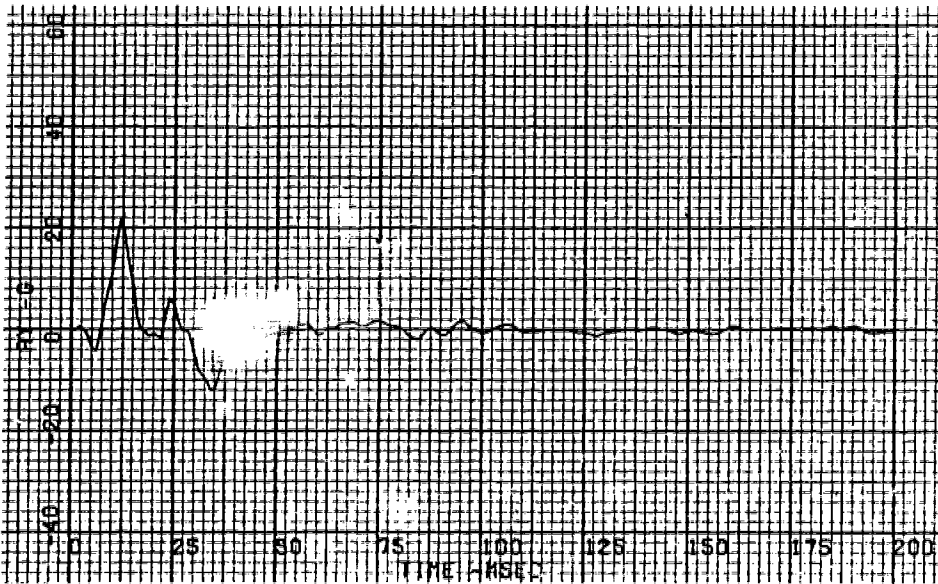
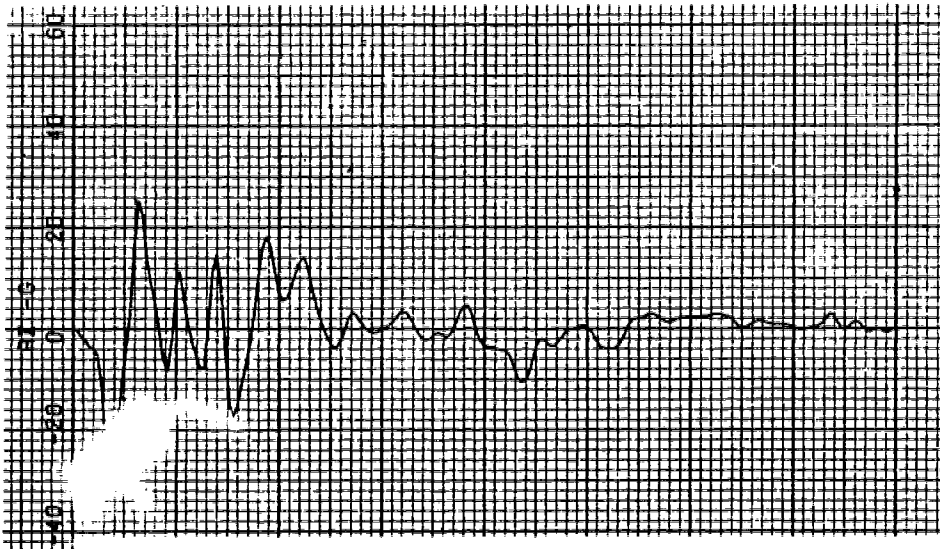
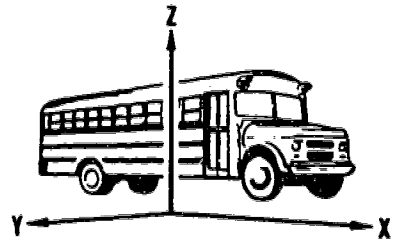

Figure 9. Test 1, Position 2 Acceleration Data.

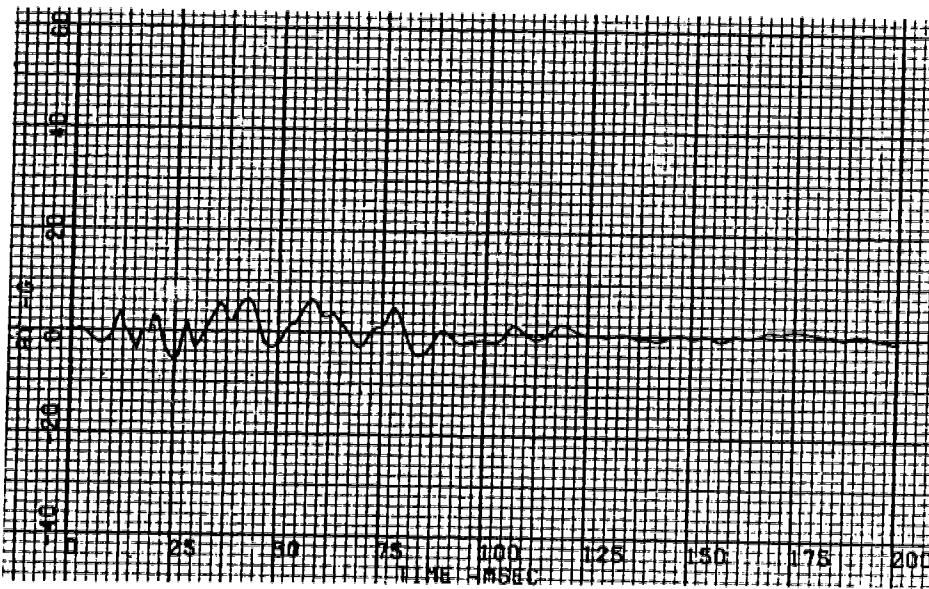
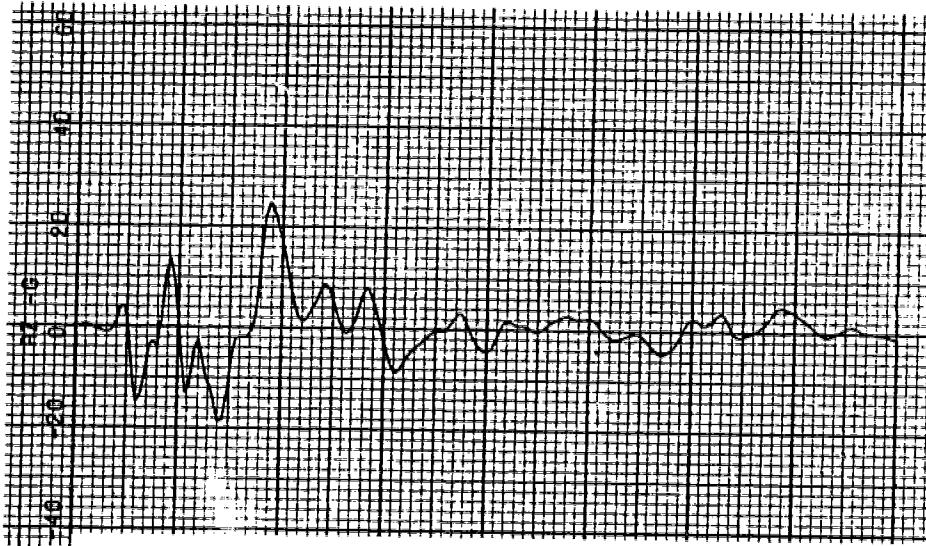
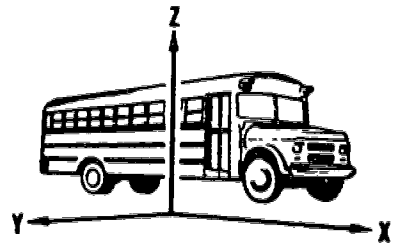

Figure 10. Test 1, Position 3 Acceleration Data.

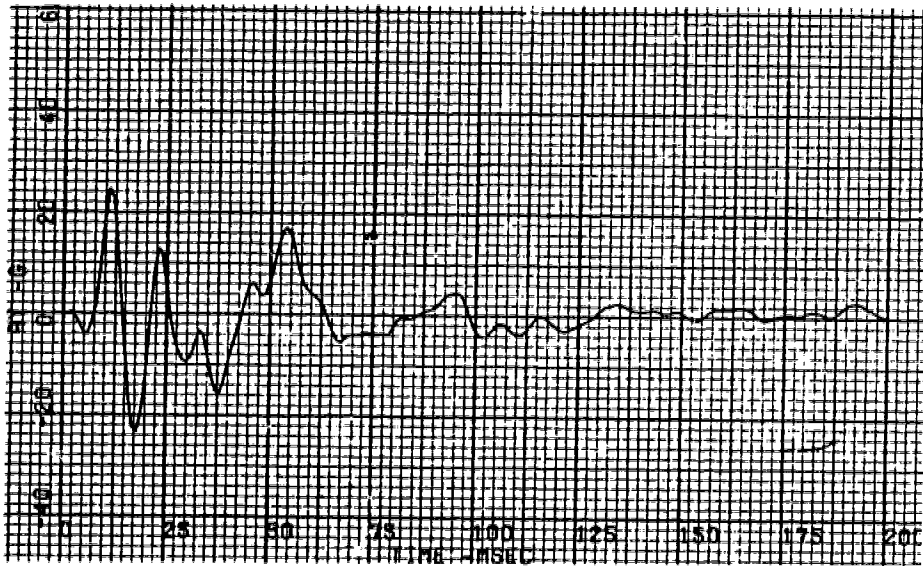
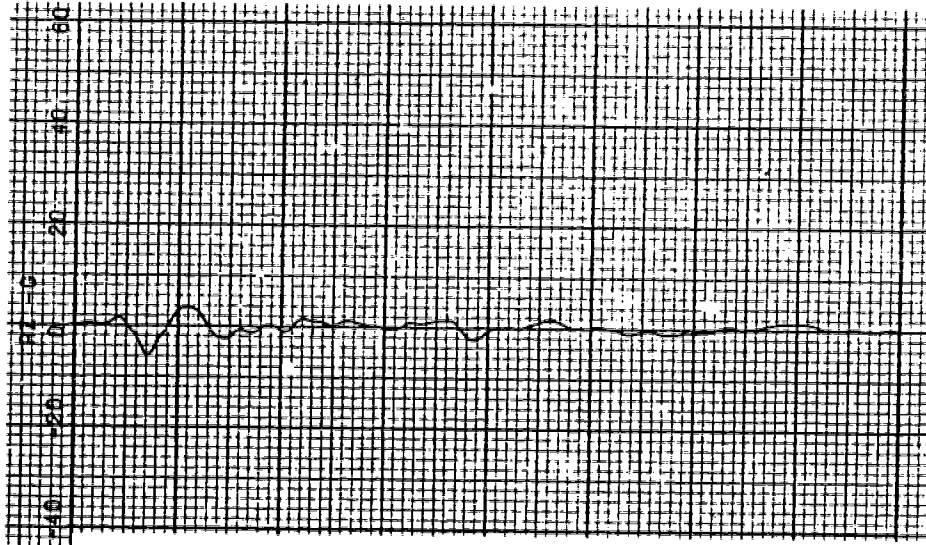
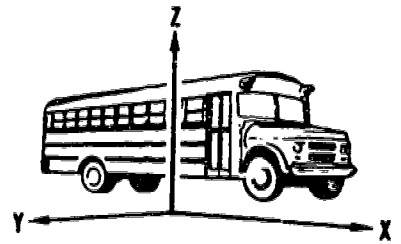
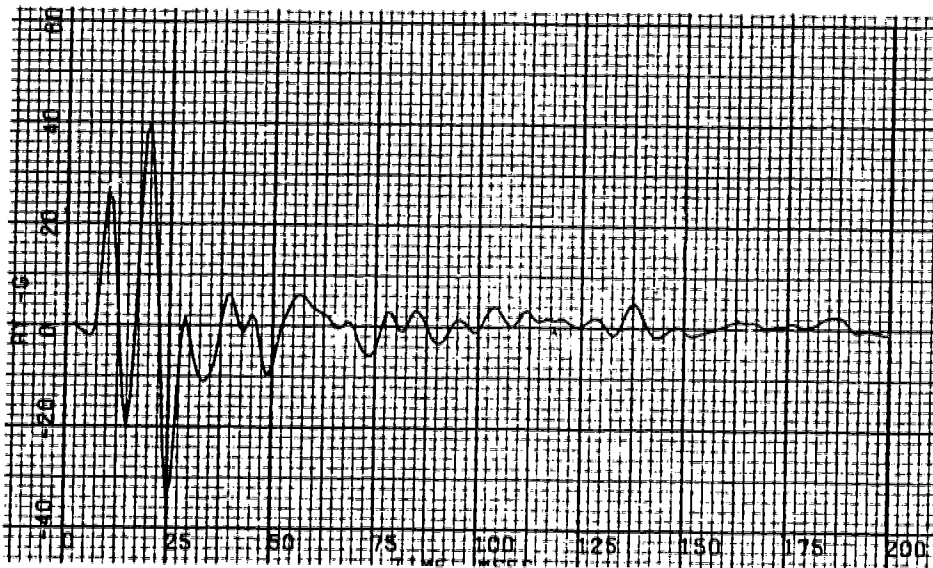
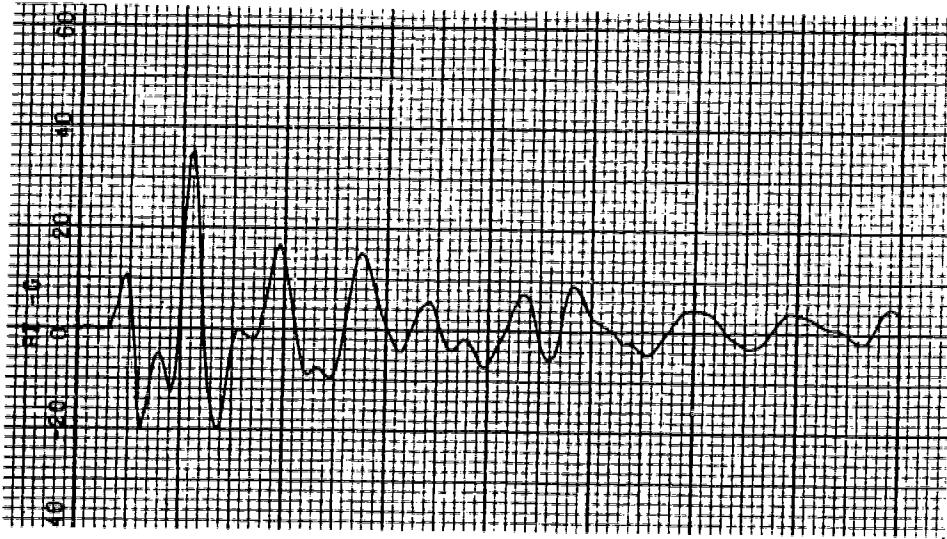
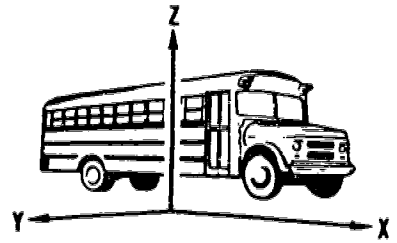

Figure 11. Test 1, Position 4 Acceleration Data.



31

Figure 12. Test 1, Position 5 Acceleration Data.



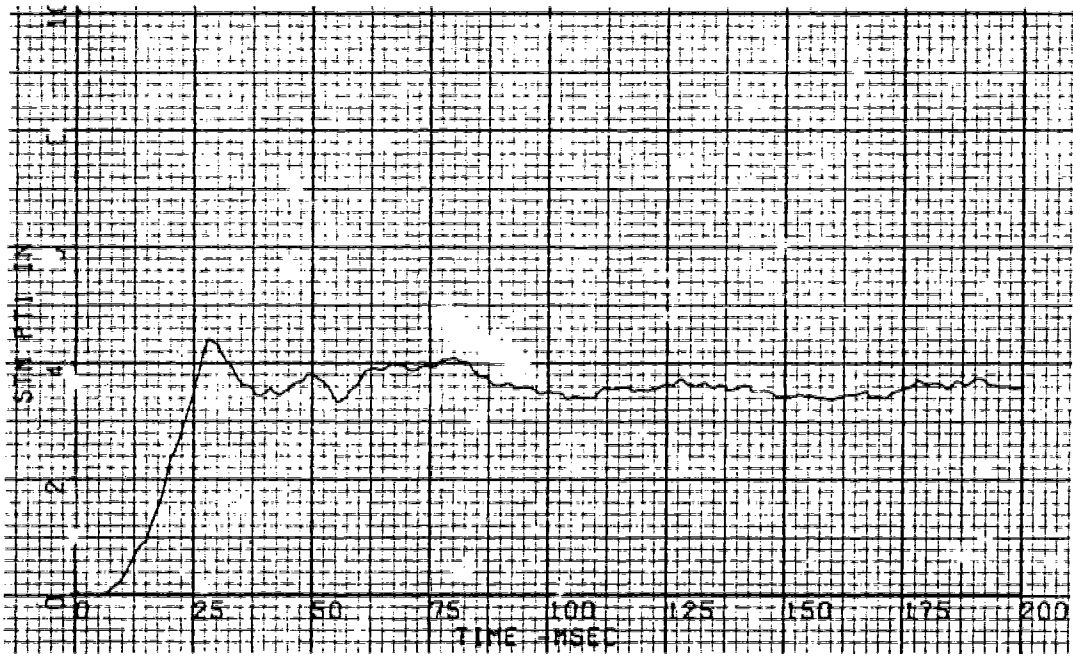

Figure 13. Test 1, Position 1 Displacement Data.

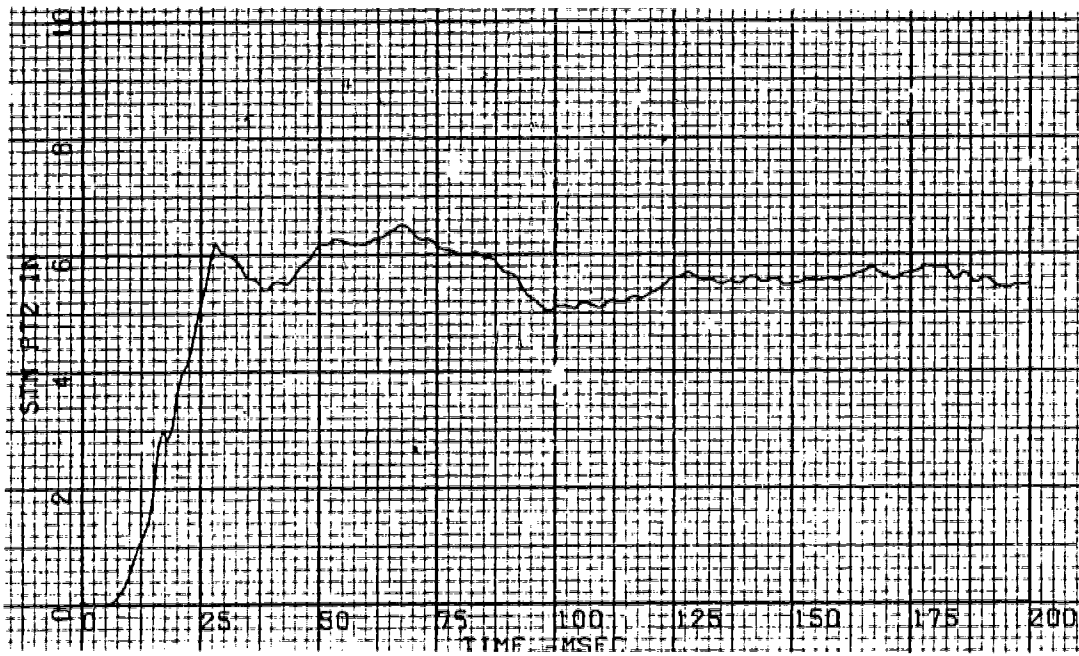

Figure 14. Test 1, Position 2 Displacement Data.

| 2 MINUTE SAMPLES | OUNCES WT | FT <sup>3</sup> | IN <sup>3</sup> | OUNCES VOLUME | QUARTS VOLUME |
|------------------|-----------|-----------------|-----------------|---------------|---------------|
| SAMPLE NO. 1     | 234       | 0.335           | 578.88          | 320.69        | 10.03         |
| SAMPLE NO. 2     | 44        | 0.063           | 108.86          | 60.31         | 1.89          |
| SAMPLE NO. 3     | 9         | 0.0128          | 21.11           | 11.69         | 0.37          |
| SAMPLE NO. 4     | 5.9       | 0.0084          | 14.51           | 8.04          | 0.25          |

school bus is shown in Figures 15, 16, and 17. The lateral shift of the floor structure is shown in Figure 18 and the exterior impact is shown in Figure 19. Penetration of the moving barrier in relation to the fuel tank is shown in Figure 20.

### 3.2 TEST PROCEDURE MODIFICATION

The purpose of the test procedure is to evaluate the integrity of the school bus fuel system, by establishing the minimum criteria for an acceptable system. Test criteria would be a pass or fail situation. The test should be representative of a situation that could readily occur in a real environment.

Evaluation of the impact results indicated that the test conditions of the first test were not as representative of a real accident as desirable. Four modifications were considered in order to make the test more representative of a school bus that is involved in a side impact by an automobile. These modifications were:

1. Ballast the school bus so that the mass and energy relationships of the test vehicles are similar to a school bus containing passengers, where the hazard potential is of even greater concern. The amount of ballast to be considered could achieve either the worst case, or an average case. This alternative

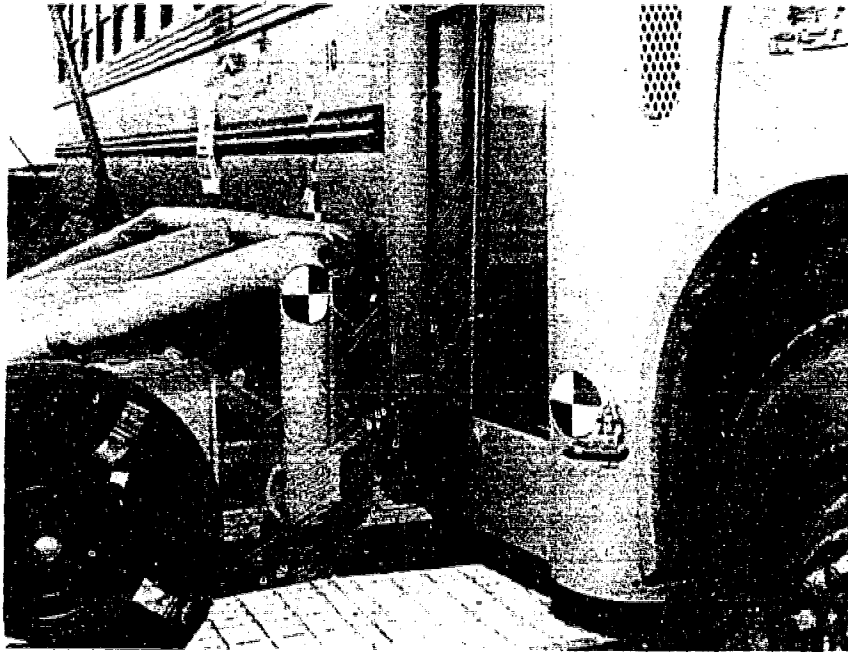

Figure 15. Test 1, School Bus and Barrier Interface, Close-up View.

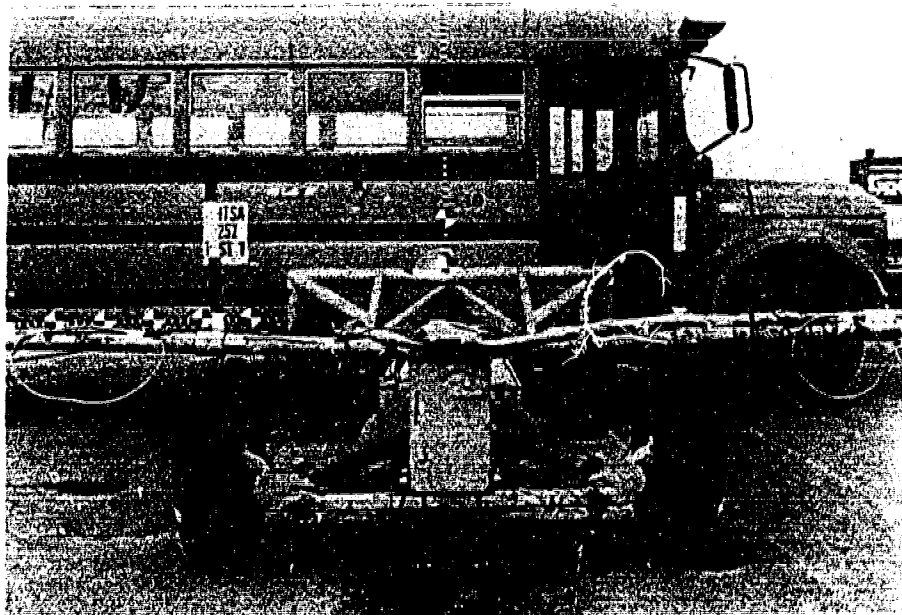

Figure 16. Test 1, School Bus and Barrier Alignment.

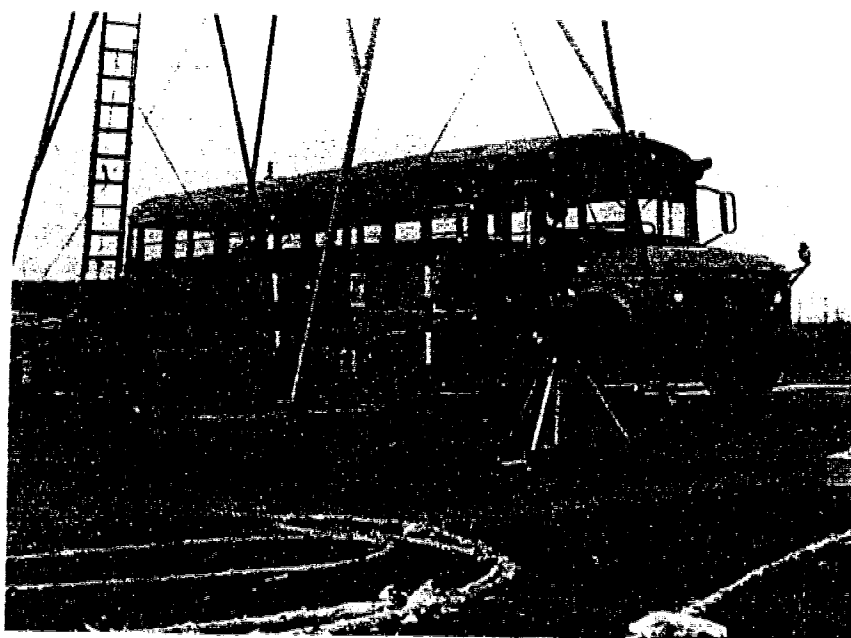

Figure 17. Test 1, School Bus and Barrier Interface, Overall View.

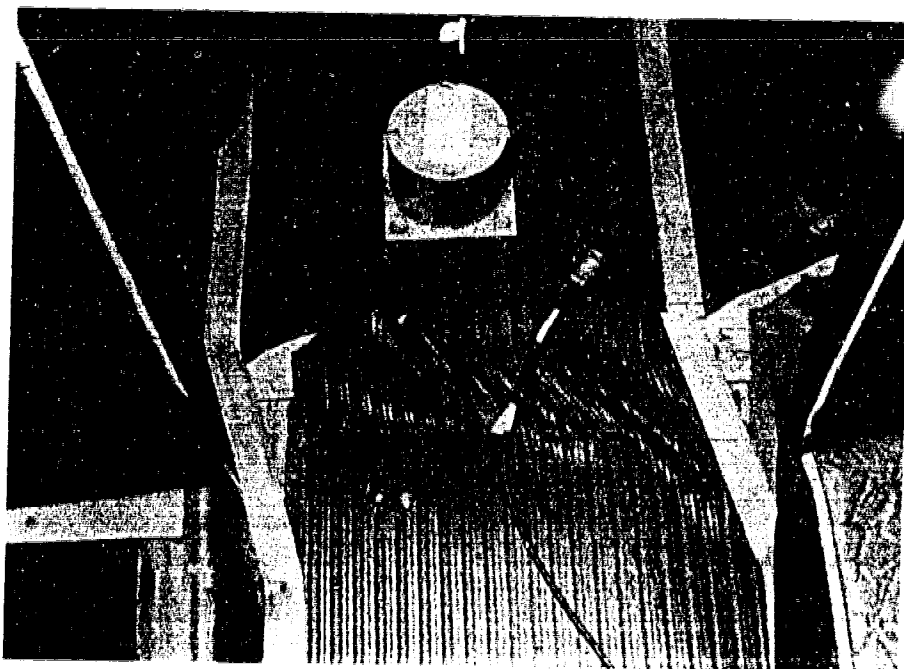

Figure 18. Test 1, Lateral Shift of Floor Structure.



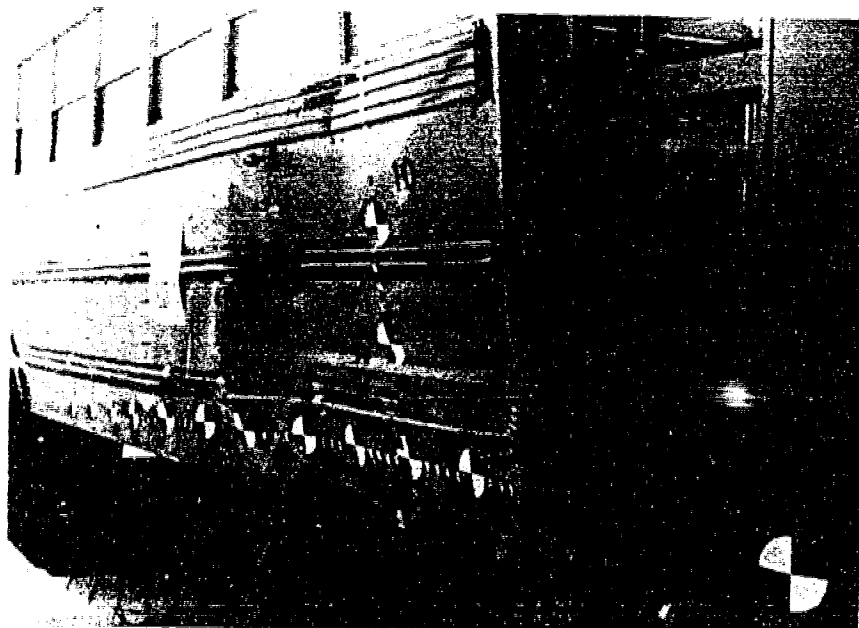

Figure 19. Test 1, Exterior Impact Damage.

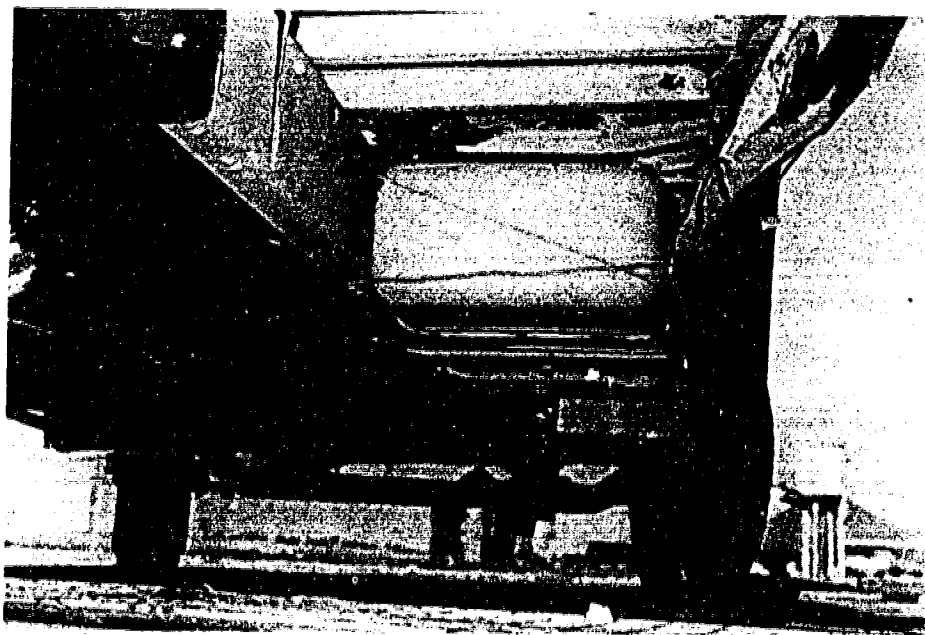

Figure 20. Test 1, Barrier Penetration of Fuel Tank Area.

would dictate whether the school bus would be loaded to its gross vehicle weight, or to possibly two-thirds of its gross vehicle weight.

2. An evaluation of Test 1 indicates that the majority of the impact energy from the moving barrier was resolved through the floor of the school bus. A brief survey of 1975 automobiles indicated that the hood would probably pass under the floor and the floor structure during an accident. Figures 21, 22, 23, and 24 show the relationship of the school bus floor and floor structure to the various automobiles. This relationship is also indicated in Accident Report NTSB-HAR-72-2 where a 1961 Chevrolet Impala sedan impacted the side of the school bus and passed under the floor, rupturing and dislodging the fuel tank from the school bus with a resulting fire. The barrier impact for the second test could be made more representative of the vehicle interface by using a lower contoured moving barrier that would represent the height of the substantial structure of an automobile's front end.
3. Consideration was given to the attachment of the moving barrier to the guide rails as required by FMVSS 208. On the first test the barrier did not follow through the impact, but rather rebounded straight backward and stopped. The barrier could be released at impact and react as a free vehicle.
4. The angle of impact and point of impact was another area for discussion. An oblique angle could be used to represent the rotation that occurs during the impact. Consideration could also be given to a case where the vehicle strikes the school bus, normal to its longitudinal axis, in the fuel tank area just missing the service door structure. These changes would result in a test that would represent the worst possible conditions.

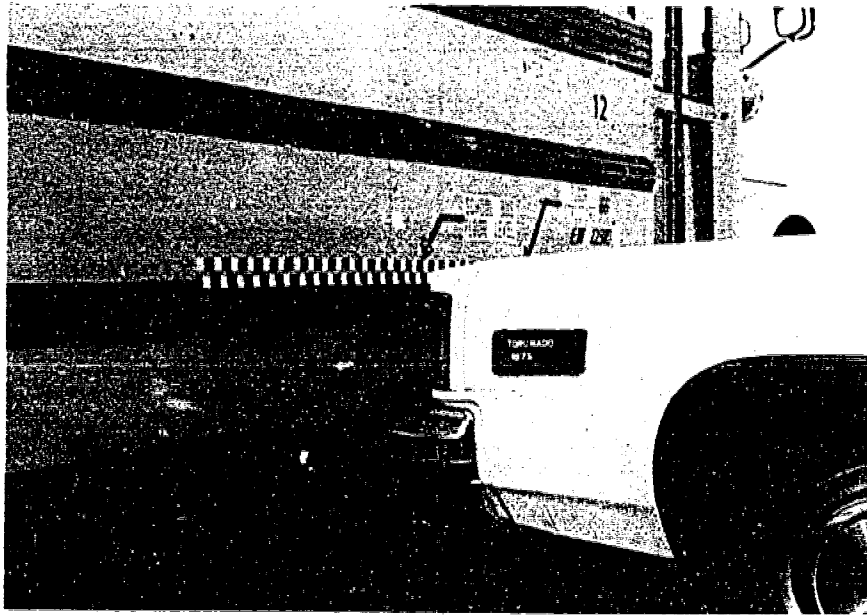

Figure 21. Car/School Bus Interface.



Figure 22. Car/School Bus Interface.

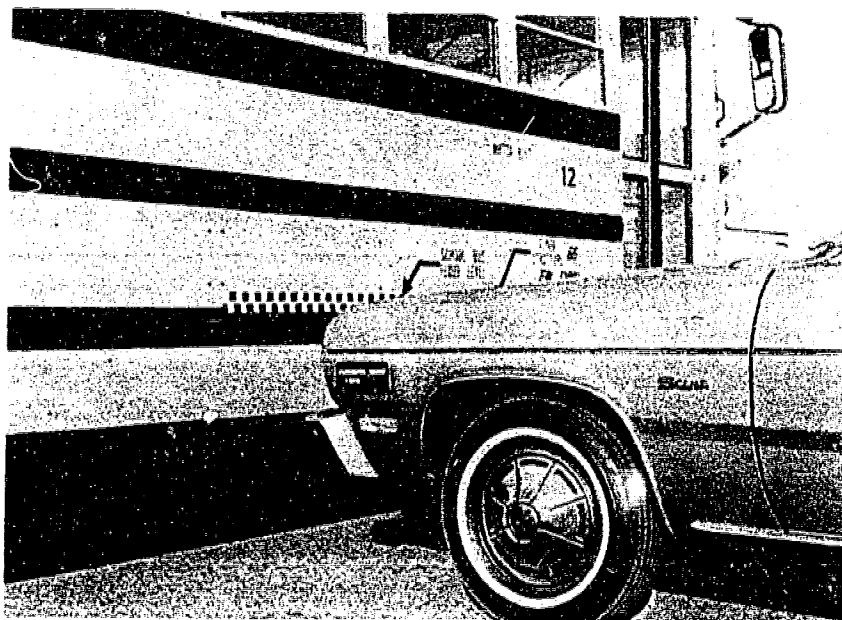

Figure 23. Car/School Bus Interface.

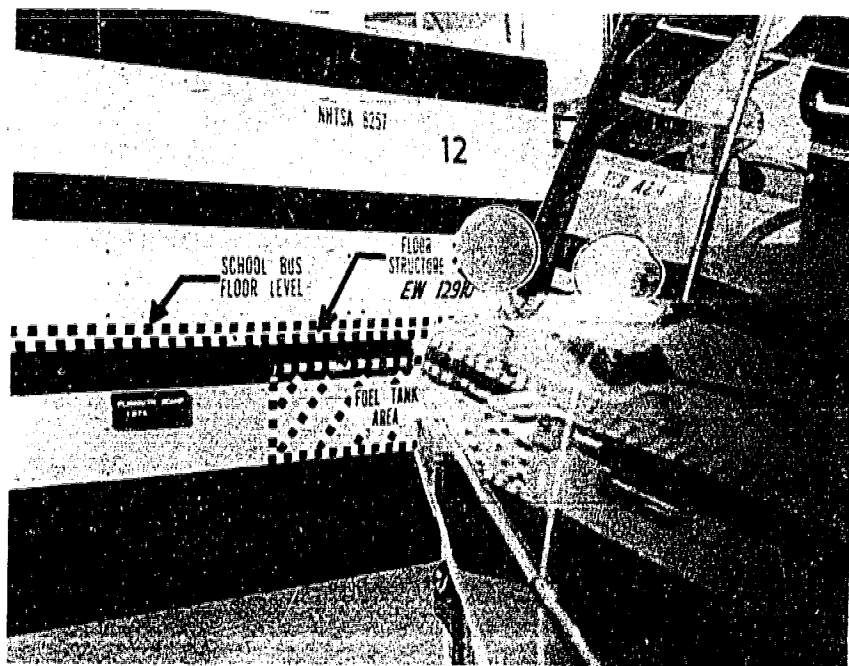

Figure 24. Car/School Bus Interface.

Further analysis indicated that the first three modifications would probably be sufficient to duplicate real-world accidents. The fourth proposed modification was not deemed necessary, nor applicable, provided the first three were adopted. Thus the first three modifications were incorporated into the test procedure for the second school bus test.

### 3.3 MODIFIED MOVING BARRIER TEST

The second test of this program utilized the results of the first test, employing FMVSS 301 as a guide. Three basic changes were incorporated for the second test as follows:

1. Ballast was added to the school bus to weight the vehicle to two-thirds of its gross vehicle weight by placing 240 pounds in each passenger seat and 150 pounds in the driver's seat.
2. The SAE J972A barrier face was lowered so that the top surface was 30 inches from the ground, representing the rigid portion of an automobile front end.
3. The barrier guidance system was released just prior to impact so that the barrier would react as a free vehicle during the entire crash sequence.

The test conditions for the second test then consisted of the following:

1. 29.4  $\pm$ 0.5 mile-per-hour impact speed.
2. School bus ballasted to two-thirds of its gross vehicle weight. The school bus was an identical model to that used in the first test.
3. Side impact on bus by modified SAE J972A barrier.
4. Impact centered on the centerline of the fuel tank.
5. Impact normal to the longitudinal axis of the school bus. Alignment of the vehicles is shown in Figures 25 and 26.



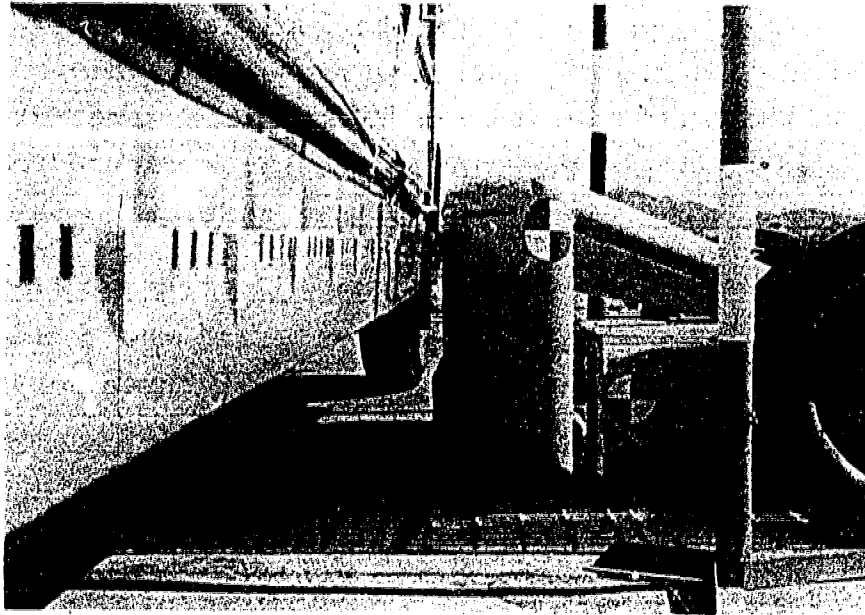

Figure 25. School Bus/Barrier Interface.



Figure 26. School Bus and Barrier Alignment.

The school bus fuel tank area was prepared for the test by first cleaning and then painting the area. The background area was painted white and the supporting structure painted light blue. The fuel tank itself was painted light yellow.

The school bus exterior was marked with a level line with targets on one-foot centers. The fuel tank was marked with three targets on one-foot centers. Placards identifying the test were placed in the view of all cameras.

The instrumentation consisted of eleven accelerometers, two displacement string pots, and one impact indicator. The transducer outputs were conditioned by a remote signal conditioning module (RSCM). Data was received at the tape recorder by means of telemetry and through an umbilical cable. The instrumentation locations are identical to Test 1, as shown in Figure 3.

The fuel tank was filled to 95 percent of its capacity with Stoddard solvent. The engine was operated until the solvent completely filled the fuel system.

The school bus was weighed when all of the test preparations were completed. The total test weight for the school bus was 18,760 pounds, with 12,890 pounds on the rear wheels and 5,870 pounds on the front wheels.

The school bus was then moved to midrange of the crash facility and positioned over the camera pit. Seven high-speed cameras and two real-time cameras were used as shown in Figure 27.

When all instrumentation and photographic equipment were ready and the detailed checklist had been completed, the barrier was accelerated to  $29.4 \pm 0.5$  miles per hour. The barrier was released just prior to impact at a velocity of 29.06 miles per hour. The barrier impacted the bus and penetrated the fuel tank area as shown in Figure 28. Fuel spillage was immediate and copious (approximately 2 gallons per minute). The school bus rotated 22.8 degrees during impact and the front end was pushed sideways as shown in Figure 29. The maximum roll during the impact was 8 degrees.

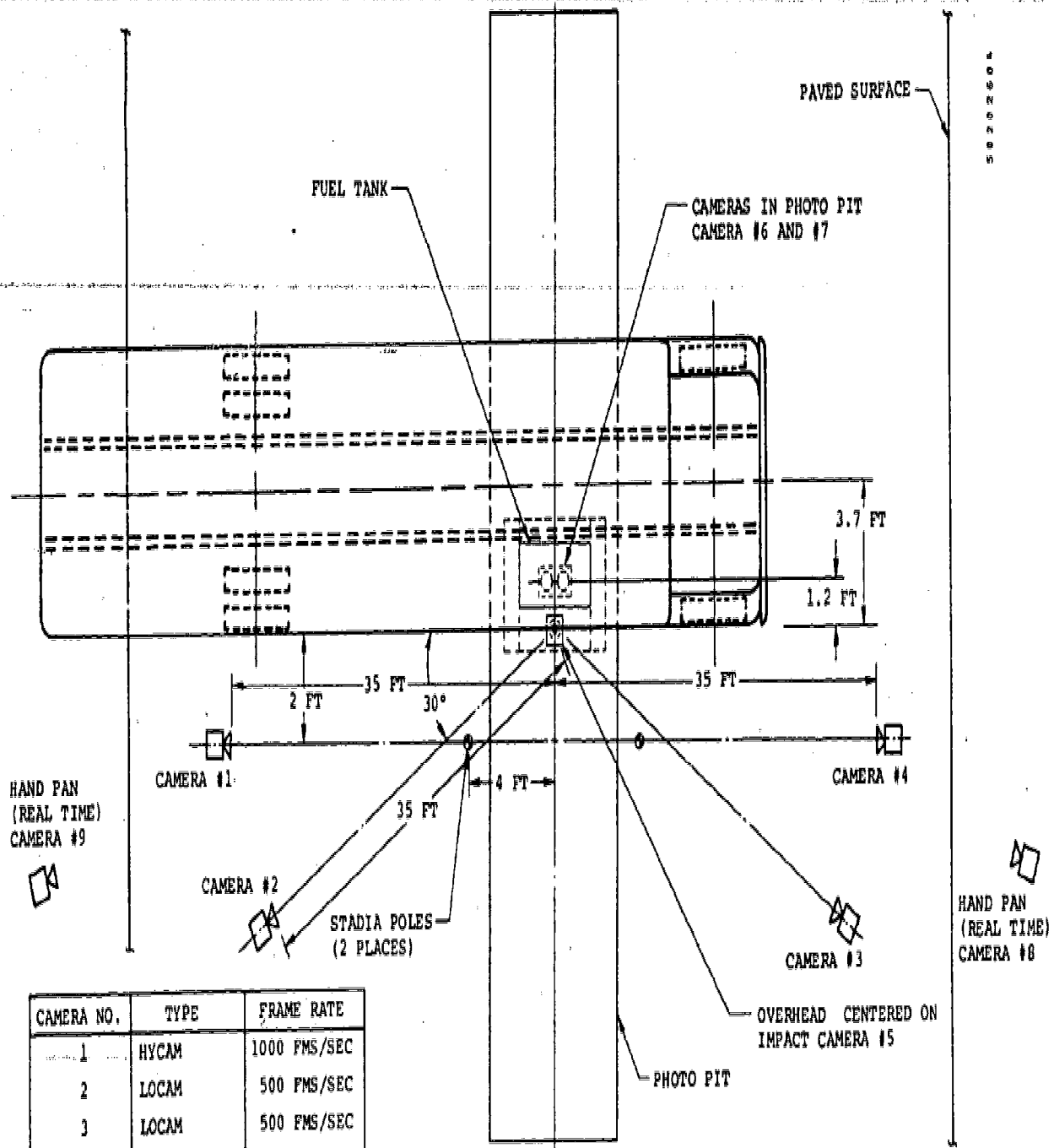

| CAMERA NO. | TYPE        | FRAME RATE   |
|------------|-------------|--------------|
| 1          | Hycam       | 1000 FMS/SEC |
| 2          | Locam       | 500 FMS/SEC  |
| 3          | Locam       | 500 FMS/SEC  |
| 4          | Hycam       | 1000 FMS/SEC |
| 5          | PHOTO-SONIC | 1000 FMS/SEC |
| 6          | PHOTO-SONIC | 1000 FMS/SEC |
| 7          | PHOTO-SONIC | 1000 FMS/SEC |
| 8          | HAND PAN    | 24 FMS/SEC   |
| 9          | HAND PAN    | 24 FMS/SEC   |

Figure 27. Test 2, Camera Layout.



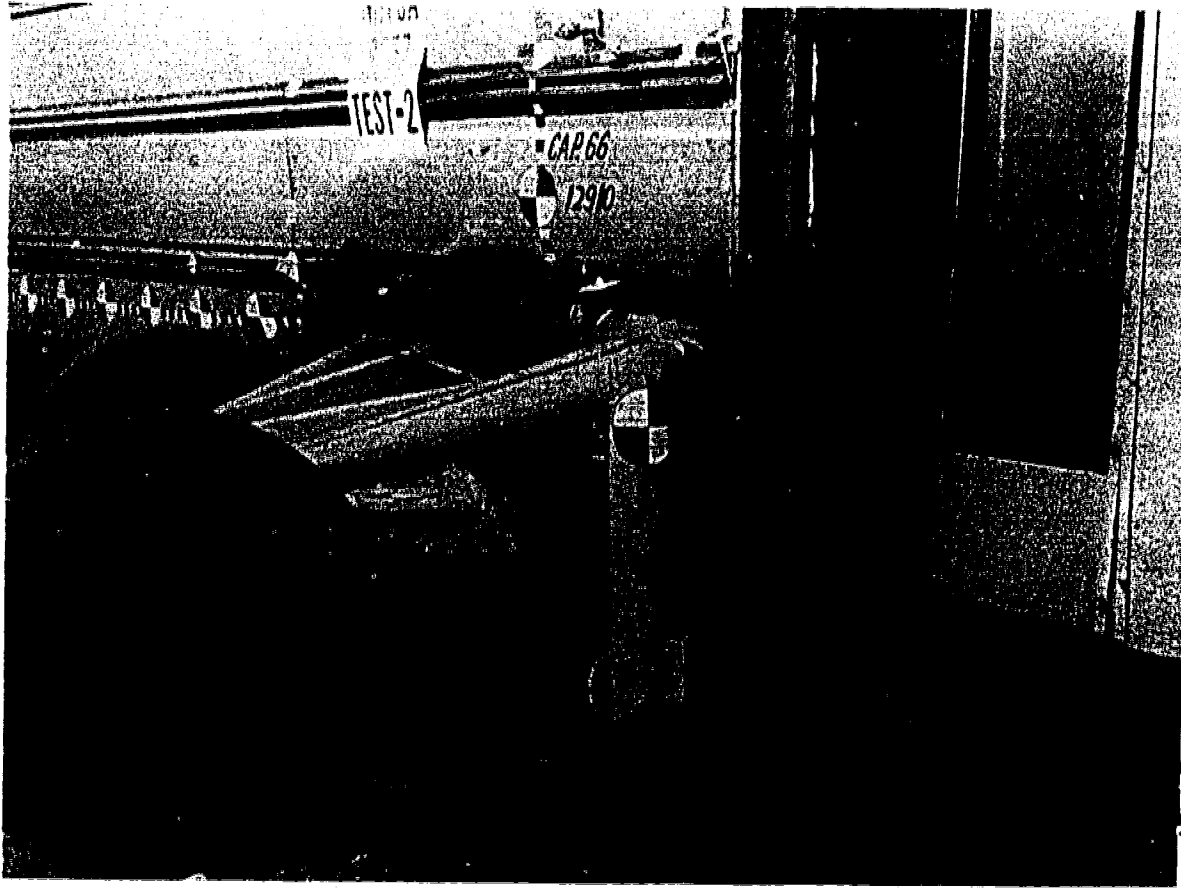

Figure 28. Barrier Penetration of Fuel Tank Area.

Post-test examination indicated that the tank filler spout had been torn back on the tank and both ends of the tank were split open. The tank had a hole near the bottom in the side facing the barrier intrusion, apparently caused by part of the internal structure of the tank. This hole permitted the tank to completely drain. The fuel tank damage is shown in Figures 30, 31, and 32.

The post-test static crush measured 15 inches at the rear post of the service door and 20 inches at the aft end of the fuel tank. The skirt of the school bus was folded up just below the bus floor level (32.5 inches from the ground). The dynamic crush that occurred during the impact measured 17.9 inches at the rear

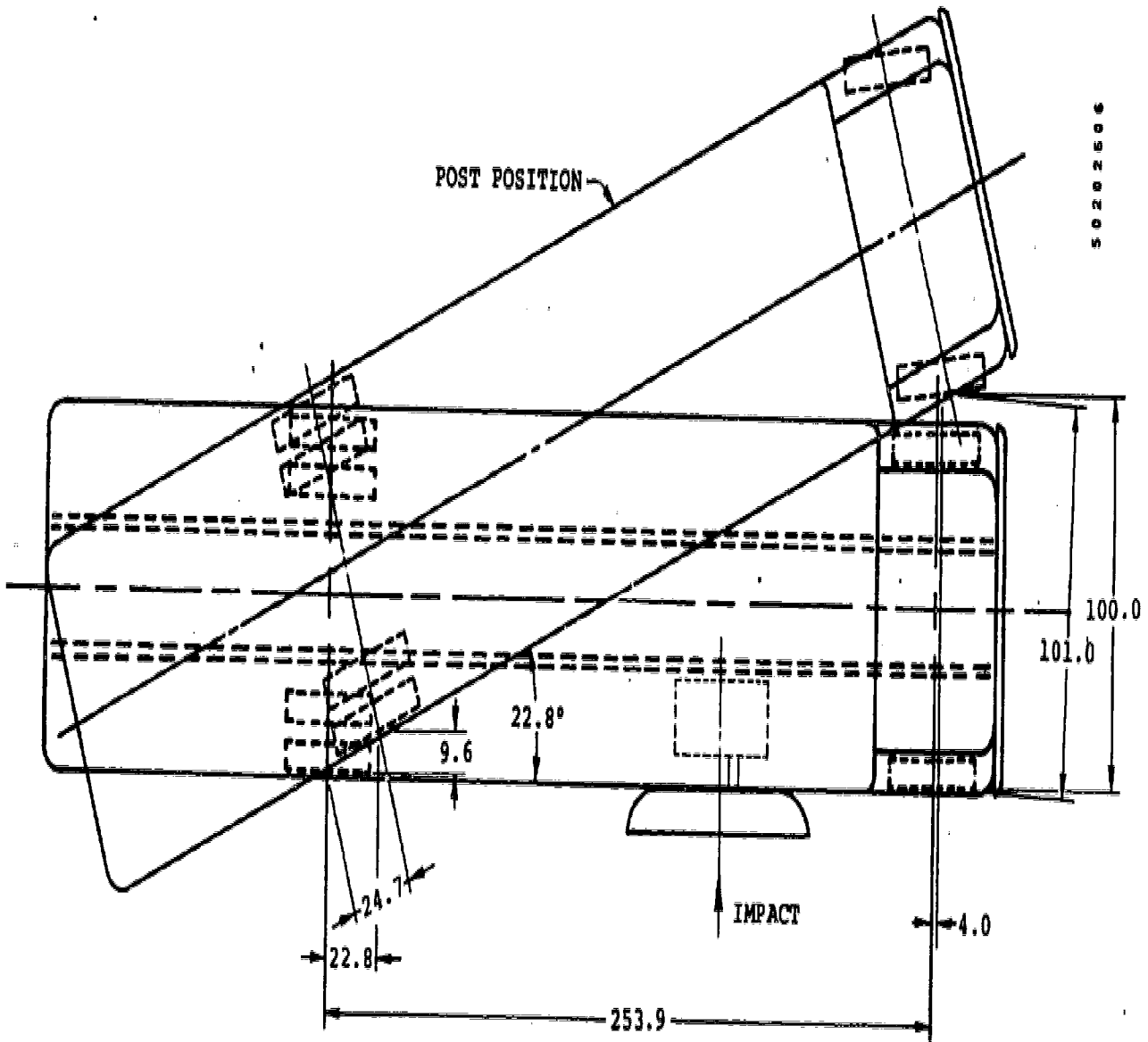

Figure 29. Test 2, Pre- and Post-Test Positions of School Bus.

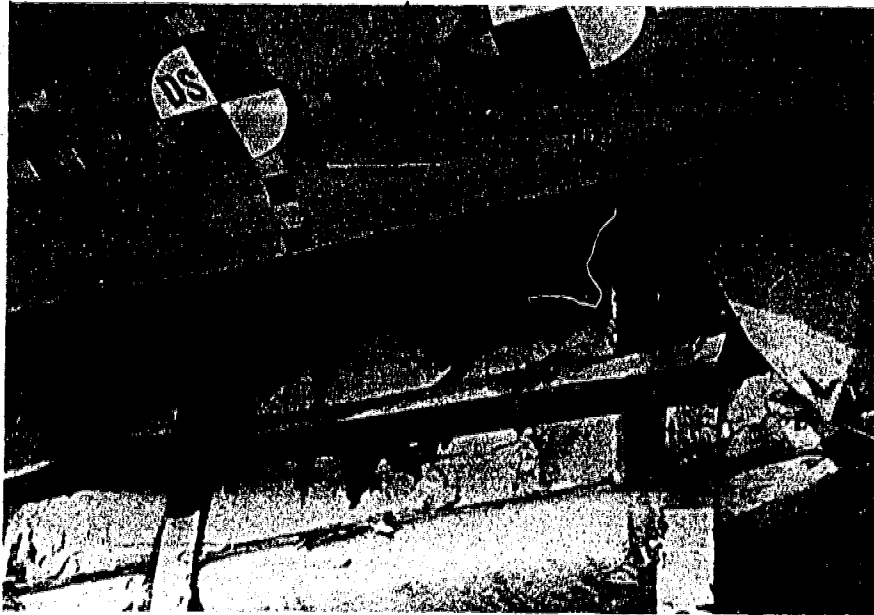

Figure 30. Test 2, Fuel Tank Damage, Close-up View.

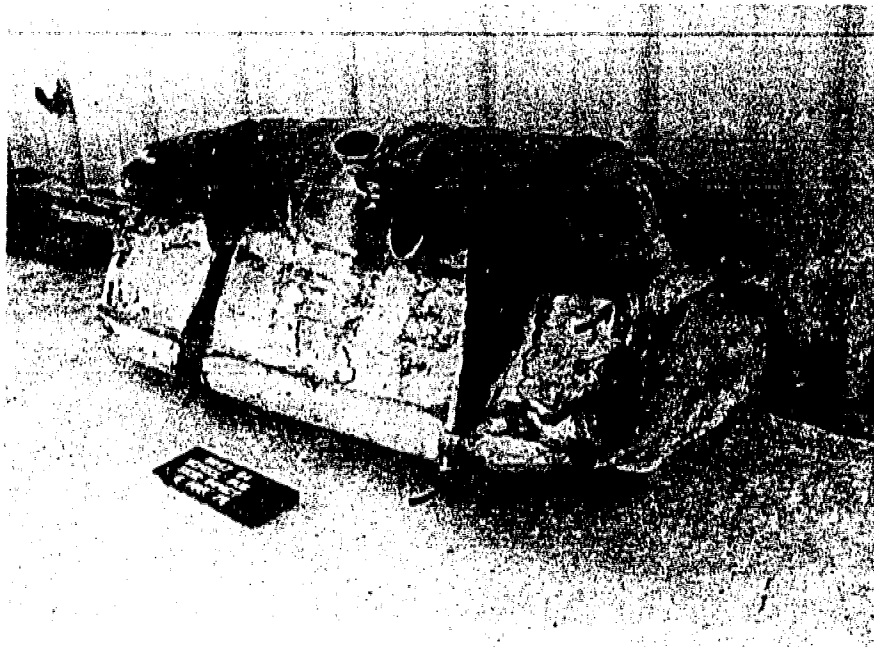

Figure 31. Test 2, Fuel Tank Damage, Overall View.

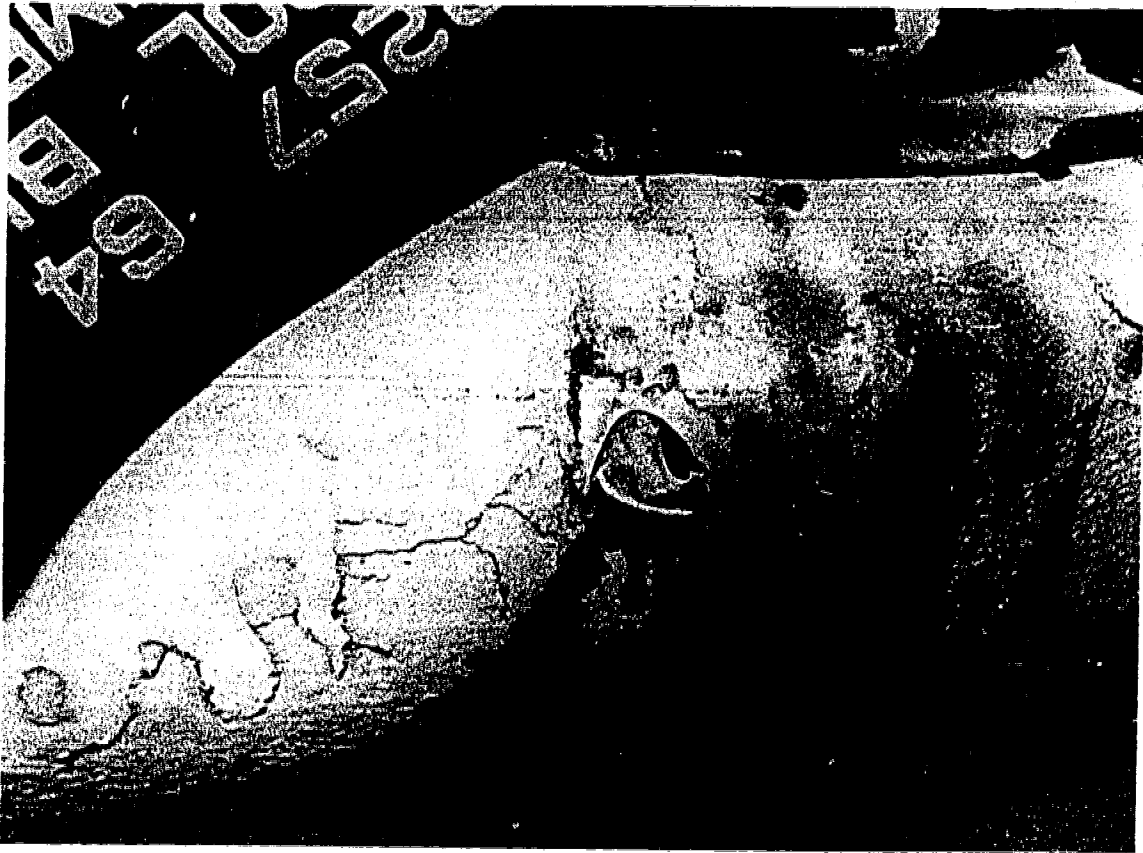

Figure 32. Test 2, Fuel Tank Damage Made by Internal Structure of Tank.

post of the service door and 24.6 inches at the aft end of the fuel tank.

The accelerometer data are presented in Figures 33, 34, 35, 36, and 37. Data from the two displacement string pots could not be interpreted because their attachments to the side skirt were destroyed during the impact.

The greater damage that occurred during the second test was primarily a result of the modified moving barrier passing under the floor structure as an automobile would, thus inflicting greater local damage to the fuel tank area.

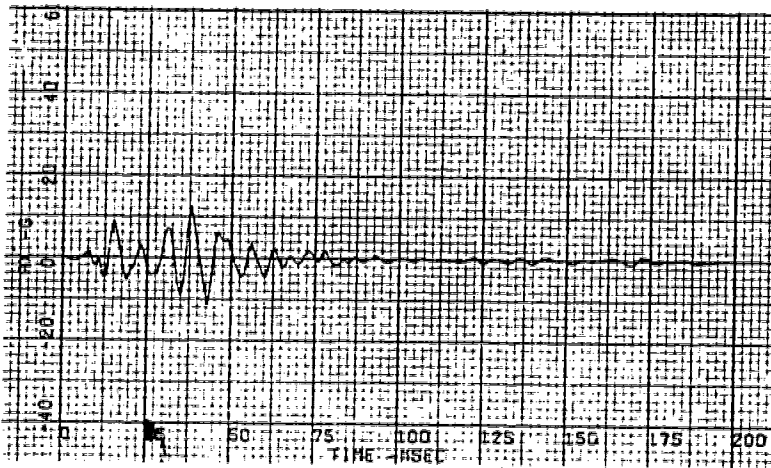
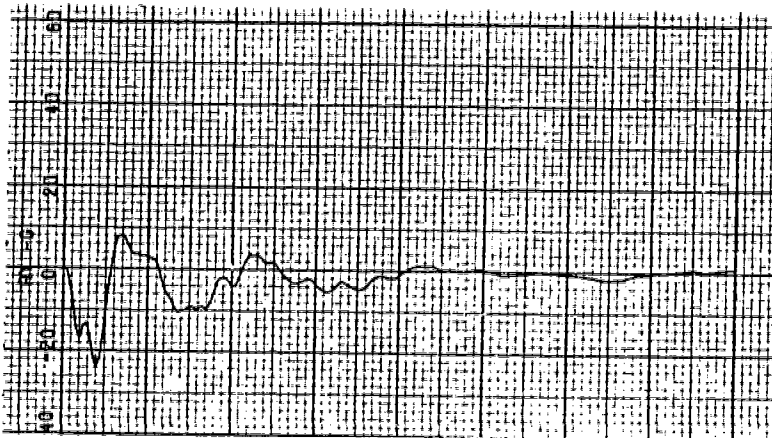
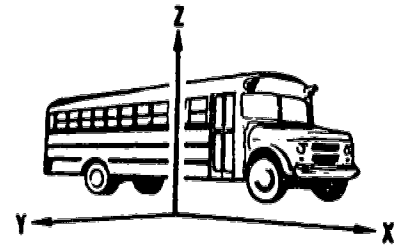
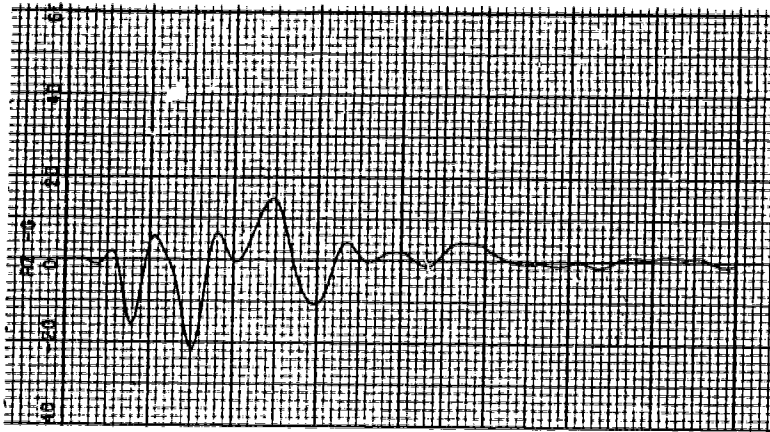

Figure 33. Test 2, Position 1 Acceleration Data.



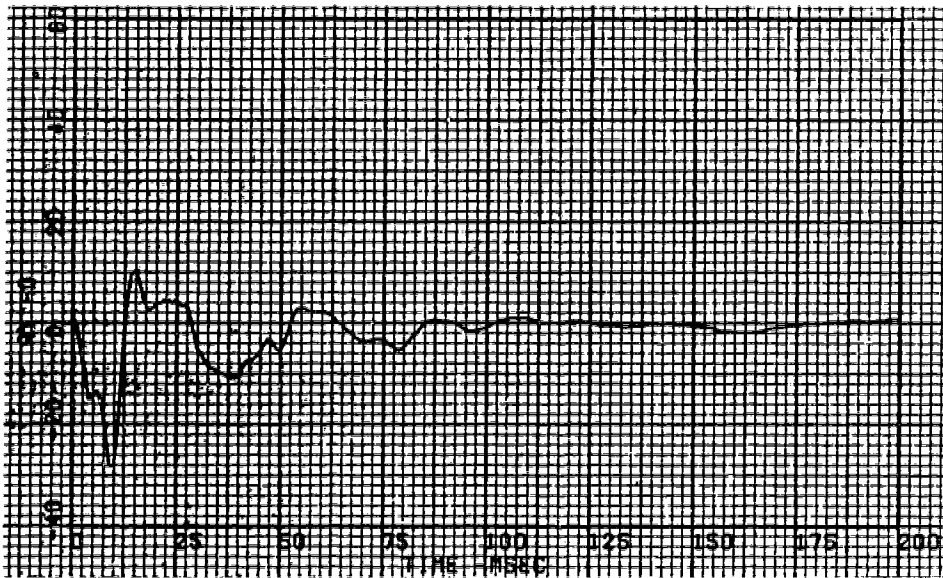
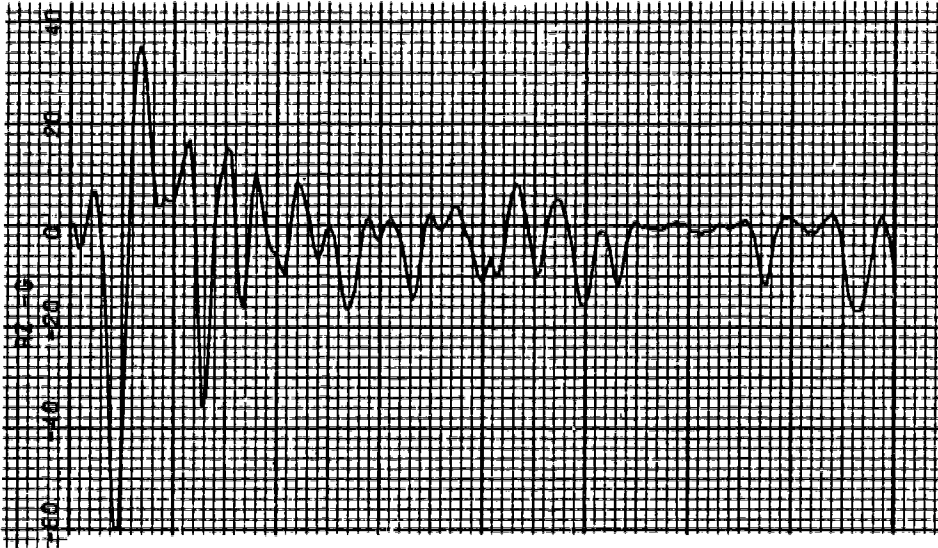
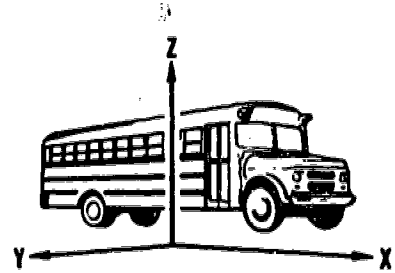

Figure 34. Test 2, Position 2 Acceleration Data.



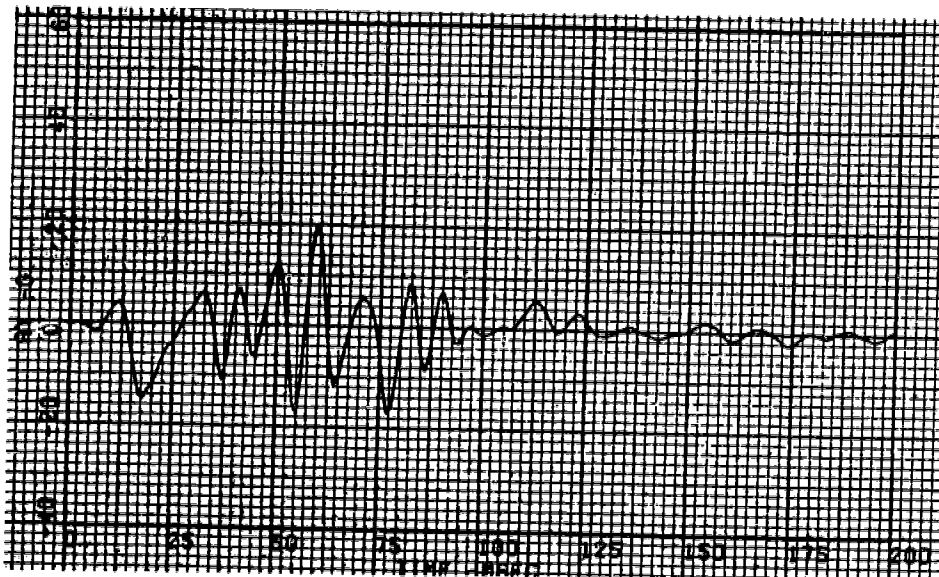
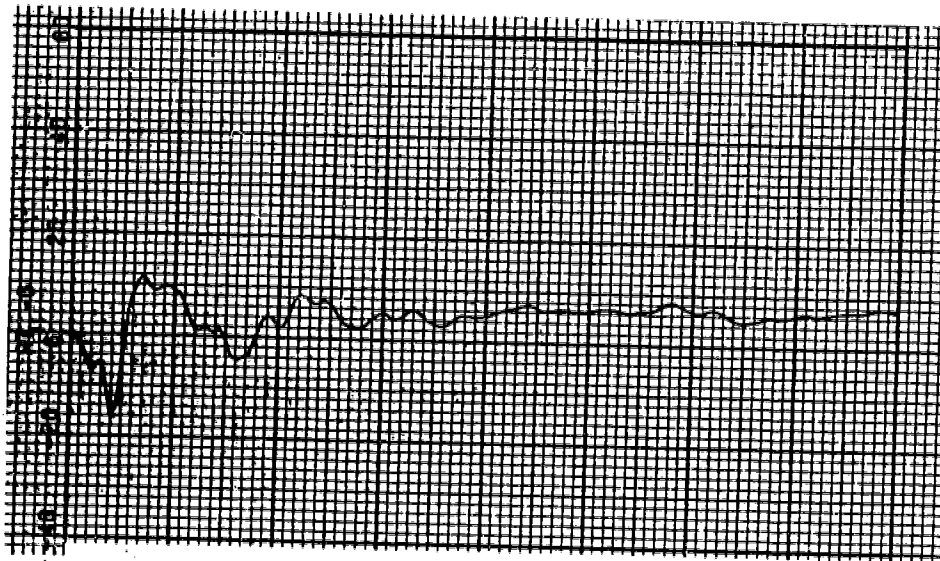
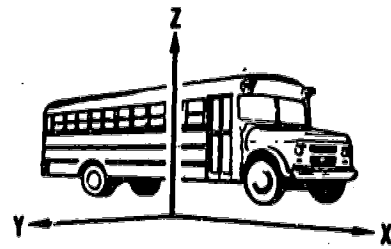

Figure 35. Test 2, Position 3 Acceleration Data.

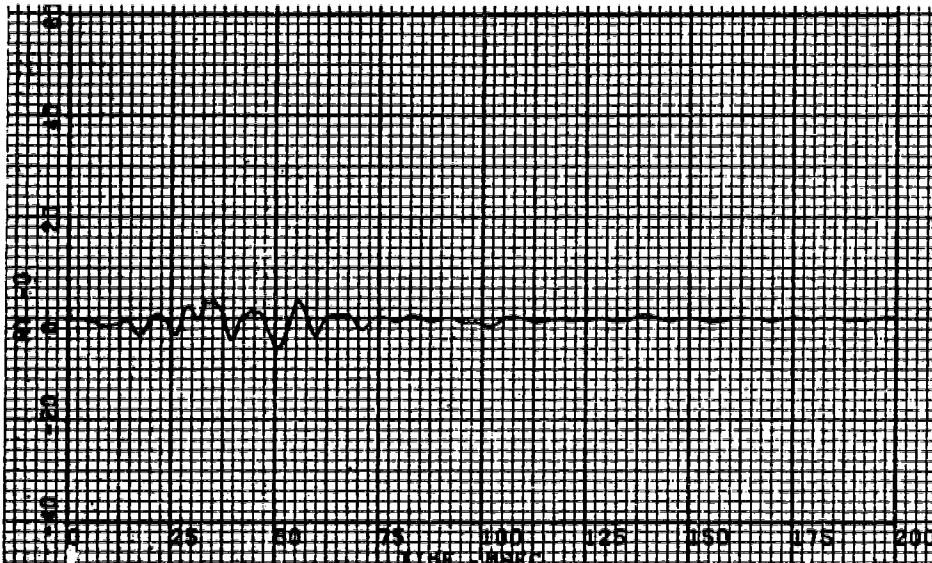
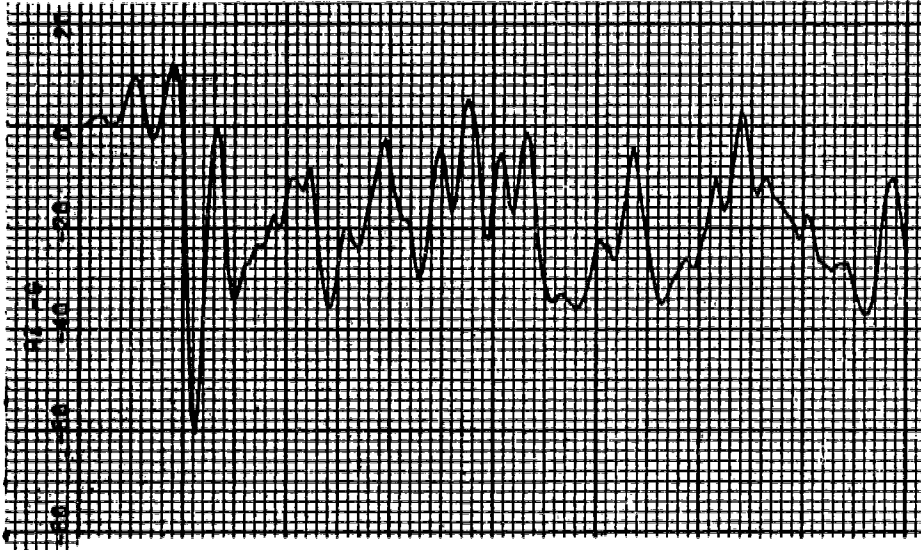
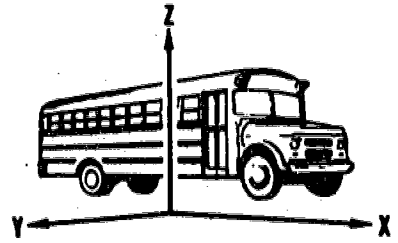

Figure 36. Test 2, Position 4 Acceleration Data.

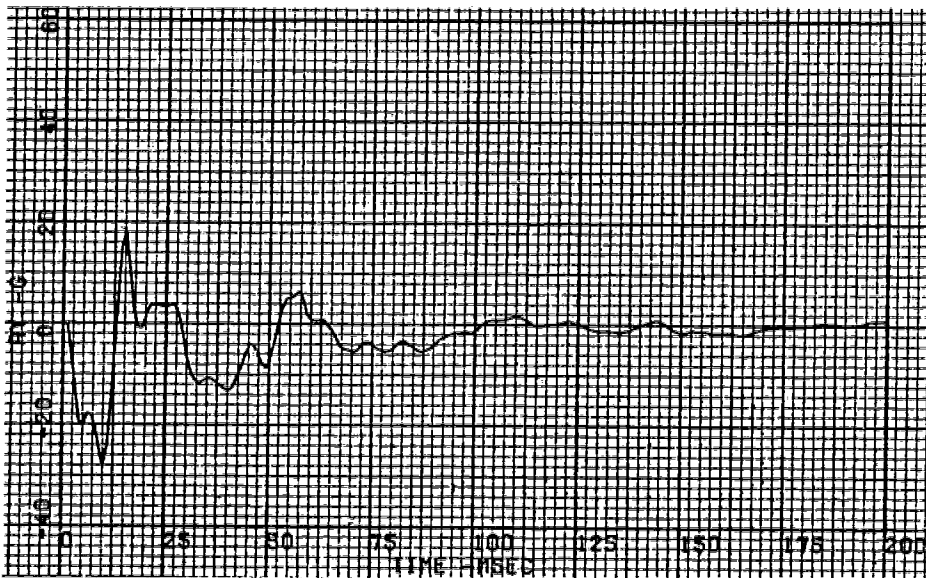
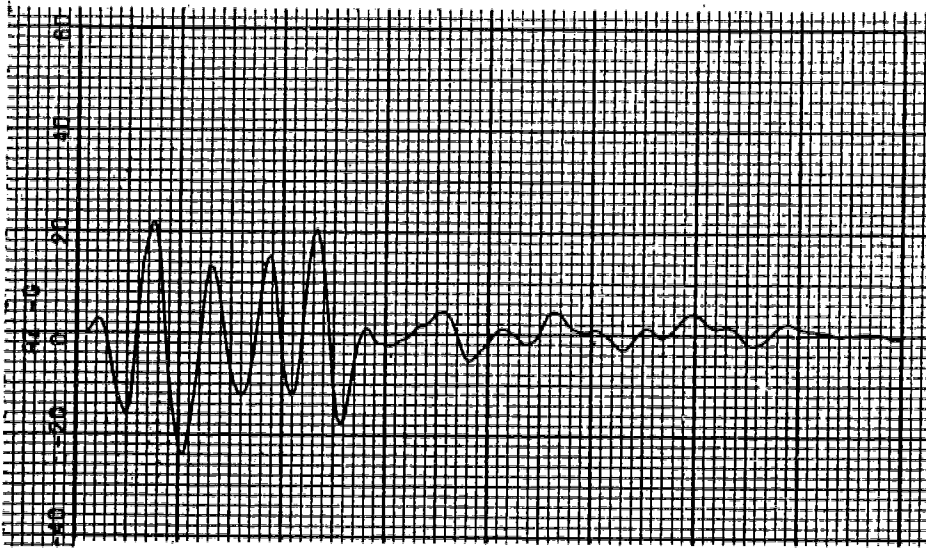
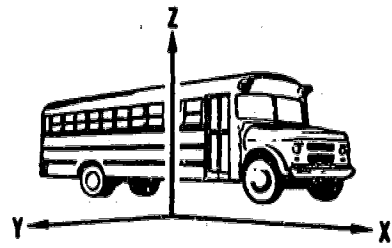

Figure 37. Test 2, Position 5 Acceleration Data.

## 4.0 DEVELOPMENT OF COMPLIANCE PROCEDURE

### 4.1 TEST DATA REVIEW

Resulting data from Test Numbers 1 and 2 provided a base from which to derive an effective procedure. The standard SAE J972A moving contoured barrier used in the first test did not produce test results representative of the interface between the school bus and an automobile. The second test using the lowered contoured barrier did produce results that were similar to the documented accident presented in Section 2.0 in this report.

The school bus had greater resistance to the impact of the contoured moving barrier when in the ballasted condition and the resulting crush damage provided a more realistic environment. In the second test the barrier rotated slightly because of the school bus movement and greater resistance of the service door structure. This rotation caused the left edge of the barrier to turn into the fuel tank area. In a real-life situation, with both vehicles moving, this rotation would be greater. This fact is also indicated in the accident report referenced in Section 2.0.

### 4.2 PROCEDURE DEVELOPMENT

The results of these development tests indicate sound criteria upon which to base a realistic procedure for evaluating the integrity of the fuel system of a school bus with a gross vehicle weight of 10,000 pounds or greater.

Six primary areas were evaluated in deriving this procedure. The areas that were considered were impact velocity, impact location, moving barrier configuration, ballast condition, leakage rate, and fuel level.

An impact velocity of  $29.4 \pm 0.5$  miles per hour was selected to be consistent with the criteria previously established in FMVSS 301 for the evaluation of the rear mounted fuel tanks in automobiles.

The impact location is a function of the tank location. Since the fuel tank is the principal source of spilled fuel, the recommended procedure was designed to be flexible in the evaluation of the fuel tank regardless of location. The contoured moving barrier will impact normal to the exterior surface closest to the fuel tank such that the centerline of the fuel tank's projected area on the outside of the bus is aligned with the longitudinal axis of the moving barrier.

The moving barrier used in the tests will consist of SAE J972A contoured moving barrier, but with the barrier face lowered so that the top edge is 30 inches above the ground. This barrier modification will enable it to act in the same manner as an automobile.

The school bus will be ballasted to two-thirds of its passenger load to simulate an in-service school bus.

The leakage rate from FMVSS 301 was adopted on the basis that it has been an accepted rate that will permit the achievement of a safe crash environment.

The fuel level, 90 to 95 percent of its capacity, was adopted from FMVSS 301.

A combination of all of the above considerations was used to generate the draft compliance standard and test procedure presented in the following sections.



### 4.3 DRAFT OF FUEL SYSTEM INTEGRITY STANDARD

#### STANDARD NO. XXX; FUEL SYSTEM INTEGRITY

##### 1.0 SCOPE

This standard specifies requirements for the integrity of school bus fuel systems for school buses with a gross vehicle weight of 10,000 pounds or greater.

##### 2.0 PURPOSE

The purpose of this standard is to reduce deaths and injuries occurring from fires that result from fuel spillage during and after school bus crashes.

##### 3.0 APPLICATION

This standard applies to school buses with a gross vehicle weight that is 10,000 pounds or greater.

##### 4.0 DEFINITION

"Fuel Spillage" means the fall, flow, or run of fuel from the vehicle but does not include wetness resulting from capillary action.

##### 5.0 GENERAL REQUIREMENTS

###### 5.1 COMPLIANCE DATE REQUIREMENTS (DATES FOR EFFECTIVITY OF STANDARD)

###### 5.2 FUEL SPILLAGE: MOVING BARRIER CRASH

The fuel spillage in the barrier crash shall not exceed 1 ounce by weight from impact until motion of the vehicle has ceased and shall not exceed a total of 5 ounces by weight in the 5-minute period following the cessation of motion. For the subsequent 10-minute period, fuel spillage during any 1-minute interval shall not exceed 1 ounce by weight.



## 6.0 TEST REQUIREMENTS

### 6.1 MOVING BARRIER CRASH

When the school bus is impacted at 30 mph by the contoured moving barrier normal to the exterior surface closest to the fuel tank such that the centerline of the fuel tank's projected area on the outside of the bus is aligned with the longitudinal axis of the moving barrier, under the conditions of Part 7.0, fuel spillage shall not exceed the limits of 5.2.

## 7.0 TEST CONDITIONS

The requirements of 5.0 and 6.0 shall be met under the following conditions.

### 7.1 GENERAL TEST CONDITIONS

The following conditions apply to all tests.

7.1.1 The fuel tank is filled to any level from 90 to 95 percent of the capacity with Stoddard Solvent, having the physical and chemical properties of Type 1 Solvent, Table I, ASTM Standard D 484-71, "Standard Specifications for Hydrocarbon Dry Cleaning Solvents".

7.1.2 The fuel system other than the fuel tank is filled with Stoddard Solvent to its normal operating level.

7.1.3 If the vehicle has an electrically-driven fuel pump that functions when the vehicle's electrical system is activated, it shall be operating at the time of the barrier crash.

7.1.4 The parking brake is disengaged and the transmission is in neutral.

7.1.5 The vehicle including test devices and instrumentation is loaded as follows:

The school bus shall be loaded to two-thirds of its gross vehicle weight by evenly distributing ballast throughout the vehicle, simulating a student passenger weight of 120 pounds and a driver weight of 150 pounds.

7.1.6 Tires are inflated to manufacturer's specifications.

#### 4.4 DRAFT OF COMPLIANCE TEST PROCEDURE

This document provides a list of the required equipment and the procedures that are necessary to conduct the fuel system integrity compliance test for school buses with a gross vehicle weight of 10,000 pounds or greater.

##### 4.4.1 Test Equipment Requirements

1. A modified moving contoured barrier as defined in the Society of Automotive Engineers Handbook (SAE J972A). The modification consists of lowering the barrier face from 37.0 inches to 30.0 inches above the ground.
2. A straight and level tow and guidance system for accelerating and guiding the moving barrier.
3. A camera pit under the impact area to permit photography of the fuel tank motion throughout impact.
4. Two timing traps to measure the velocity of the moving barrier, located within five feet of impact, with a 1.5 percent accuracy. The impact from one of the speed traps to be permanently recorded. The velocity measuring equipment to be traceable to the National Bureau of Standards.
5. The necessary photography equipment to provide 16mm, 1000 frames/second color coverage with cameras positioned as follows:
  - a. Two broadside cameras positioned normal to and on each side of the direction of travel of the moving barrier with a field of view that is wide enough to photograph the entire event.
  - b. A pit camera to record the fuel tank motion and initial fuel spillage located to compensate for the movement of the school bus during impact.
  - c. A hand-held camera to photograph the measuring of the spilled fuel.

6. The camera locations to be documented prior to the test for future reference.
7. Camera timing to be provided on the 1000 frame/second cameras with a minimum frequency of 100 CPS and marking the edge of the film for event timing and correlation.
8. An impact switch that will initiate a visual indication of the instant of impact in view of the cameras for film correlation.
9. A moving barrier velocity indicator, calibrated for a test velocity of 29.4 miles per hour to monitor the barrier velocity prior to impact.
10. An abort system to be installed that is operable from the towing station and one other location. Any external abort system attached to the moving barrier shall not exert any loads on the barrier, either before or during impact.
11. A means of removing the tested vehicle from the test site without inflicting additional damage.
12. Test fluid having the physical and chemical properties of Type 1 solvent ASTM Standard D484-71 "Standard Specification for Hydrocarbon Dry Cleaning Solvents" (STODDARD SOLVENT).
13. Calibrated measuring equipment for filling the fuel tank with test fluid to the prescribed capacity.
14. Containers for the collection of the post-impact spilled fuel.
15. A calibrated stop watch for timing the fluid collection intervals.
16. Calibrated equipment for weighing the fluid spillage samples.

#### 4.4.2 Pre-impact Procedures

1. Inspect test vehicle upon delivery, recording any damage that could affect the results of the test. Wash and clean vehicle, as necessary.
2. Complete vehicle and general data portions of Office of Standards Enforcement Test Summary and Data Sheets.
3. Obtain and record actual weight of vehicle with maximum capacity of fuel, oil, and coolant ( $\pm 20$  pounds per axle).
4. Check and record vehicle attitude.
5. Obtain pre-test photographs of fuel tank, tank mountings, fuel filler pipes, vent lines, and fuel tubes to tank connections.
6. Drain all fuel from the tank and operate the engine until system is depleted of fuel.  
  
Place the one-foot photographic reference points on the side of the test vehicles in the field of view of the cameras.
8. Paint fuel tank and supporting members with distinctly different colors for photographic analysis of fuel system component movement during impact.
9. Attach placards to the vehicle so they will be in view of each camera and the vehicle's name and NHTSA number.
10. With the vehicle on a level surface, fill the tank with the test fluid to the "spill point", accurately measuring the volume or weight required to fill to capacity. Siphon off 5.0 percent of the "spill point" volume. Record both "spill point" and test volumes.
11. Add ballast in the seats to two-thirds of the passenger weight and secure the ballast to withstand the test impact. Ballast shall be evenly distributed throughout the vehicle.

12. Obtain and record vehicle test weight.
13. Adjust and record the tire pressures to the manufacturer's recommended cold inflation pressure.
14. Place one-foot photographic reference points on each side of the moving barrier.
15. Install and check operation of moving barrier abort system.

#### 4.4.3 Execution Procedures

1. Calibrate tow system and impact speed indicating instrument immediately prior to the test.
2. Position trap timers and electronic readout equipment. Check out operation of all timing trap equipment.
3. With the modified contoured barrier attached to the guide shoe and rail, position it to the impact location on the school bus and conduct the following operation while in contact with the barrier:
  - a. Place a stadia pole beside the contoured barrier directly in line with one of the barrier's photographic reference points, as viewed through the cameras that are parallel to the school bus and normal to the contoured barrier direction of travel. This will provide an additional means of determining the instant of impact.
  - b. Aim, load, focus, and check operation of all cameras. (Note and record each camera's position.)
4. Place fuel collection equipment in the school bus vicinity. (Stop watch, funnel, drip pan, fuel collection bottles, and related equipment.)
5. Place the contoured barrier at its starting position and perform the following checks and operations:
  - a. Attach tow cable to the SAE J972A modified contoured moving barrier.
  - b. Arm timing traps, cameras, and brake abort systems.

- c. Alert all concerned personnel.
- d. Upon signal of engineer in charge, tow contoured barrier into the school bus and record impact speed of moving barrier.

NOTE: Office of Standards Enforcement Procedure requires an impact velocity of 29.4  $\pm$ 0.5 miles per hour.

#### 4.4.4 Post-impact Procedures

1. Inspect fuel system for damage and evidence of fuel leakage. If leakage occurs, collect initial five-minute timed samples and 10 subsequent one-minute timed samples, encase each sample and obtain weight immediately using a balance scale calibrated to an accuracy of  $\pm$ 0.05 ounce.
2. Using a hand-held motion picture camera, photograph fuel leakage. Take still photographs of fuel tank fittings, filler pipes, and tank connectors.
3. Transfer vehicle to security storage area.



SUMMARY OF RESULTS - FMVSS NO. \_\_\_\_\_

FINAL REPORT NO. \_\_\_\_\_

VEHICLE DATA:

Chassis Manufacturer \_\_\_\_\_ Model \_\_\_\_\_ Model Year \_\_\_\_\_  
 Body Manufacturer's \_\_\_\_\_ Model \_\_\_\_\_  
 Body Style \_\_\_\_\_ Build Date \_\_\_\_\_  
 VIN \_\_\_\_\_ NHTSA No. \_\_\_\_\_  
 Delv Wt \_\_\_\_\_ lb Test Wt \_\_\_\_\_ lb GVWR \_\_\_\_\_ lb  
 Engine: No. of Cylinders \_\_\_\_\_ and Displacement \_\_\_\_\_ cu.in.

REMARKS: \_\_\_\_\_  
\_\_\_\_\_

GENERAL TEST CONDITIONS:

Contoured Barrier Impact Speed: Trap #1 \_\_\_\_\_ Trap #2 \_\_\_\_\_ mph Avg \_\_\_\_\_ mph  
 Speed Range \_\_\_\_\_ to \_\_\_\_\_ mph  
 Ambient Temperature at time of test \_\_\_\_\_ °F  
 Date of Test \_\_\_\_\_ Time \_\_\_\_\_

SUMMARY FOR FMVSS NO. \_\_\_\_\_

|  | ACTUAL<br>DATA | STD.<br>REQ.                | PASS | FAIL |
|--|----------------|-----------------------------|------|------|
| 1. Transimpact Fluid Loss (oz)                   |                | 1 oz<br>max.                |      |      |
| 2. Post-impact Fluid Loss (oz) - First 5 minutes |                | 5 oz<br>max.                |      |      |
| 3. Post-impact Fluid Loss (oz) - Next 10 minutes |                | 1 oz<br>max.<br>per<br>min. |      |      |
| 4. Details of Leakage _____<br>_____<br>_____    |                |                             |      |      |

LABORATORY INFORMATION: Project Engineer \_\_\_\_\_ Date \_\_\_\_\_  
 Project Manager \_\_\_\_\_ Date \_\_\_\_\_



TEST DATA SHEET FOR FMVSS NO. \_\_\_\_\_

FINAL REPORT NO. \_\_\_\_\_

VEHICLE DATA: Tire Size and Type \_\_\_\_\_

Cold Tire Inflation Pressure: RF \_\_\_\_\_, LF \_\_\_\_\_, RR \_\_\_\_\_, LR \_\_\_\_\_, SP \_\_\_\_\_

Delivered Vehicle Weight: Front Axle \_\_\_\_\_ Rear Axle \_\_\_\_\_

Static Crush: \_\_\_\_\_ in. (Right Side) and \_\_\_\_\_ in. (Left Side)

Rebound Distance: Right \_\_\_\_\_ in. Left \_\_\_\_\_ in.

SPECIFIC TEST DATA FOR FMVSS \_\_\_\_\_ :

Test Fluid \_\_\_\_\_ Specific Gravity \_\_\_\_\_

Kinematic Viscosity \_\_\_\_\_ Saybolt Seconds

Spill Point Volume \_\_\_\_\_ gal/lb Liquid Temp. \_\_\_\_\_ °F

Test Volume \_\_\_\_\_ gal/lb Liquid Temp. \_\_\_\_\_ °F

Details of Fuel Tank, Filler Pipes, and Connections:

## 5.0 SUMMARY

This program produced a procedure for evaluating the integrity of fuel systems of school buses that have a gross vehicle weight of 10,000 pounds or greater. This procedure was derived from the existing FMVSS 301 Test Procedure, a limited state-of-the-art survey and full-scale dynamic tests that provided the required data to substantiate unknown areas. All of these data were then reduced to a logical effective procedure that could be adopted for fuel system integrity compliance tests.