

DOCUMENT RESUME

ED 131 218

CE 008 178

AUTHOR Bennett, Gordon D.
 TITLE Techniques of Water-Resources Investigations of the United States Geological Survey. Book 3, Applications of Hydraulics. Chapter B2, Introduction to Ground-Water Hydraulics: Programed Text for Self-Instruction.
 INSTITUTION Geological Survey (Dept. of Interior), Reston, Va.
 PUB DATE 76
 NOTE 183p.
 AVAILABLE FROM Superintendent of Documents, U.S. Government Printing Office, Washington, D.C. 20402

EDRS PRICE MF-\$0.83 HC-\$10.03 Plus Postage.
 DESCRIPTORS Autoinstructional Aids; Geology; *Hydraulics; *Mathematical Concepts; Programed Instruction; Programed Texts; Science Instruction; Specialization; Technical Education; *Water Resources

ABSTRACT

This programmed text of self-instruction is one of a series of manuals on techniques describing procedures for planning and executing specialized work in water-resources investigations. It has been prepared on the assumption that the reader has completed standard courses in calculus and college physics and is presented in eight parts. Part I introduces some fundamental hydrologic concepts and definitions. Part II discusses Darcy's law for unidirectional flow. Part III considers the application of Darcy's law to some simple field problems. The concept of ground-water storage is introduced in Part IV. A text-formal discussion at the beginning of Part V deals with partial derivatives and their use in groundwater equations; the basic partial differential equation for unidirectional nonequilibrium flow is developed in the programmed material of Part V. In Part VI, the partial differential equation for radial confined flow is derived and the "slug-test" solution, describing the effects of an instantaneous injection of fluid into a well, is presented and verified. Part VII introduces the general concepts of finite-difference analysis. Part VIII is concerned with electric-analog techniques. (HD)

 * Documents acquired by ERIC include many informal unpublished *
 * materials not available from other sources. ERIC makes every effort *
 * to obtain the best copy available. Nevertheless, items of marginal *
 * reproducibility are often encountered and this affects the quality *
 * of the microfiche and hardcopy reproductions ERIC makes available *
 * via the ERIC Document Reproduction Service (EDRS). EDRS is not *
 * responsible for the quality of the original document. Reproductions *
 * supplied by EDRS are the best that can be made from the original. *

ED131218-



Techniques of Water-Resources Investigations of the United States Geological Survey

Chapter B2

INTRODUCTION TO GROUND-WATER HYDRAULICS

A Programed Text for Self-Instruction

By Gordon D. Bennett

U.S. DEPARTMENT OF HEALTH,
EDUCATION & WELFARE
NATIONAL INSTITUTE OF
EDUCATION

THIS DOCUMENT HAS BEEN REPRO-
DUCED EXACTLY AS RECEIVED FROM
THE PERSON OR ORGANIZATION ORIGIN-
ATING IT. POINTS OF VIEW OR OPINIONS
STATED DO NOT NECESSARILY REPRESENT
OFFICIAL NATIONAL INSTITUTE OF
EDUCATION POSITION OR POLICY.

Book 3

APPLICATIONS OF HYDRAULICS

821 800 178
EE 008

UNITED STATES DEPARTMENT OF THE INTERIOR

THOMAS S. KLEPPE, Secretary

GEOLOGICAL SURVEY

V. E. McKelvey, Director

UNITED STATES GOVERNMENT PRINTING OFFICE, WASHINGTON : 1976

**For sale by the Superintendent of Documents, U.S. Government Printing Office
Washington, D.C. 20402**

PREFACE

The series of manuals on techniques describes procedures for planning and executing specialized work in water-resources investigations. The material is grouped under major subject headings called books and further subdivided into sections and chapters; Section B of Book 3 is on ground-water techniques.

This chapter is an introduction to the hydraulics of ground-water flow. With the exception of a few discussions in standard text format, the material is presented in programmed form. In this form, a short section involving one or two concepts is followed by a question dealing with these concepts. If the correct answer to this question is chosen, the reader is directed to a new section, in which the theory is further developed or extended. If a wrong answer is chosen, the reader is directed to a section in which the earlier material is reviewed, and the reasons why the answer is wrong are discussed; the reader is then redirected to the earlier section, to choose another answer to the question. This approach allows students who are either partially familiar with the subject, or well prepared for its study, to proceed rapidly through the material, while those who require more explanation are provided it within the sections that deal with erroneous answers.

In the preparation of any text, difficult choices arise as to the material to be included. Because this text is an introduction to the subject, the discussion has been restricted, for the most part, to the flow of homogeneous fluid through an isotropic and homogeneous porous medium—that is, through a medium whose properties do not change from place to place or with direction. Emphasis has been placed upon theory rather than application. Basic principles of ground-water hydraulics are outlined, their uses in developing equa-

tions of flow are demonstrated, representative formal solutions are considered, and methods of approximate solution are described. At some points, rigorous mathematical derivation is employed; elsewhere, the development relies upon physical reasoning and plausibility argument.

The text has been prepared on the assumption that the reader has completed standard courses in calculus and college physics. Readers familiar with differential equations will find the material easier to follow than will readers who lack this advantage; and readers familiar with vector theory will notice that the material could have been presented with greater economy using vector notation.

The material is presented in eight parts. Part I introduces some fundamental hydrologic concepts and definitions, such as porosity, specific discharge, head, and pressure. Part II discusses Darcy's law for unidirectional flow; a text-format discussion at the end of Part II deals with some generalizations of Darcy's law. Part III considers the application of Darcy's law to some simple field problems. The concept of ground-water storage is introduced in Part IV. A text-format discussion at the beginning of Part V deals with partial derivatives and their use in ground-water equations; the basic partial differential equation for unidirectional nonequilibrium flow is developed in the programmed material of Part V. In Part VI, the partial differential equation for radial confined flow is derived and the "slug-test" solution, describing the effects of an instantaneous injection of fluid into a well, is presented and verified. A text-format discussion at the end of Part VI outlines the synthesis of additional solutions, including the Theis equation, from the "slug-test" solution. Part VII introduces the gen-

eral concepts of finite-difference analysis, and a text format discussion at the end of Part VII outlines some widely used finite-difference techniques. Part VIII is concerned with electric-analog techniques. The material in Part VI is not prerequisite to that in Parts VII and VIII; readers who prefer may proceed directly from Part V to Part VII.

A program outline is presented in the table of contents of this report. This outline indicates the correct-answer sequence through each of the eight parts and describes briefly the material presented in each correct-answer section. Readers may find the outline useful in review or in locating discussions of particular topics, or may wish to consult it for an overview of the order of presentation.

It is impossible, in this or any other form of instruction, to cover every facet of each development, or to anticipate every difficulty which a reader may experience, particularly in a field such as ground water, where readers may vary widely in experience and mathematical background. An additional difficulty inherent in the programmed text approach is that some continuity may be lost in the process of dividing the material into sections. For all these reasons, it is suggested that the programmed instruction presented here be used in conjunction with one or more of the standard references on ground-water hydraulics.

This text is based on a set of notes used by the author in presenting the subject of ground-water hydraulics to engineers and university students in Lahore, West Pakistan, while on assignment with the U.S. Agency for International Development. The

material has been drawn from a number of sources. The chapter by Ferris (1959) in the text by Wisler and Brater and that by Jacob (1950) in "Engineering Hydraulics" were both used extensively. Water-Supply Paper 1536-E (1962) by Ferris, Knowles, Brown, and Stallman was an important source, as was the paper by Hubbert (1940), "The Theory of Ground Water Motion." The text "The Flow of Homogeneous Fluids through Porous Media" by Muskat (1937) and the paper "Theoretical Investigation of the Motion of Ground Waters" by Slichter (1899) were both used as basic references. The development of the Theis equation from the "slug-test" solution follows the derivation given in the original reference by Theis (1935). The material on analog models is drawn largely from the book, "Analog Simulation," by Karplus (1958). In preparing the material on numerical methods, use was made of the book, "Finite-Difference Equations and Simulations," by Hildebrand (1968), and the paper "Selected Digital Computer Techniques for Groundwater Resource Evaluation," by Prickett and Lonquist (1971). A number of additional references are mentioned in the text.

The author is indebted to Messrs. David W. Greenman and Maurice J. Mundorff, both formerly Project Advisors, U.S. Geological Survey-U.S.A.I.D., Lahore, for their support and encouragement during preparation of the original notes from which this text was developed. The author is grateful to Patricia Bennett for her careful reading and typing of the manuscript.

CONTENTS

	Page
Preface	III
Program outline	VI
Instructions to the reader	1
Part	
I. Definitions and general concepts	3
II. Darcy's law	14
Beginning of programed instruction	14
Text-format discussion: Generalizations of Darcy's law	31
III. Application of Darcy's law to field problems	34
IV. Ground-water storage	53
V. Unidirectional nonequilibrium flow	69
Text-format discussion: Partial derivatives in ground-water-flow analysis	69
Beginning of programed instruction	72
VI. Nonequilibrium flow to a well	88
Beginning of programed instruction	88
Text-format discussion: Development of additional solutions by superposition	112
VII. Finite-difference methods	119
Beginning of programed instruction	119
Text-format discussion: Techniques of finite-difference solution of the ground-water-flow equation	136
VIII. Analog techniques	153
References	171

SYMBOLS

Symbol	Dimensions (M, mass; L, distance; T, time)	Explanation	Symbol	Dimensions (M, mass; L, distance; T, time)	Explanation
A	L^2	face area of aquifer, gross cross-sectional area of flow	e		base of natural logarithms
a	L	node spacing in finite-difference grid	F_r	MLT^{-3}	gravitational force
b	L	aquifer thickness	f_t	MLT^{-2}	component of gravitational force parallel to conduit
C	farad (coulombs/volt)	electrical capacitance	f_n	MLT^{-2}	component of gravitational force normal to conduit
			g	LT^{-2}	gravitational acceleration
			h	L	head; static head
			h_p	L	pressure head

Symbol	Dimensions	Explanation	Symbol	Dimensions	Explanation
I	amperes (coulombs/ second)	electrical current	u		$r^2S/4Tt$ —argument of the well function ₁
K	LT^{-1}	hydraulic conductivity	V	L^3	fluid volume
k	L^2	intrinsic permeability	v	LT^{-1}	velocity
l	L	length	$W(u)$		well function
n		porosity	w	L	width
p	$ML^{-1}T^{-2}$	pressure	z	L	elevation above datum
Q	L^3T^{-1}	volumetric fluid discharge	β		fraction of the total water in storage that can be drained by gravity
q	LT^{-1}	specific discharge—discharge per unit face area of aquifer, Q/A	$\Delta_x h$	L^1	finite-difference approxima- tion to $\partial^2 h/\partial x^2$
R	ohms (volts/ ampere)	electrical resistance	$\Delta_y h$	L^1	finite-difference approxima- tion to $\partial^2 h/\partial y^2$
S		storage coefficient	ϵ	coulomb	electrical charge
S_s	L^{-1}	specific storage	μ	$ML^{-1}T^{-1}$	dynamic viscosity
S_y		specific yield	ρ	ML^{-3}	fluid density
T	L^2T^{-1}	transmissivity (transmissi- bility)	ρ_e	ohm-metres	electrical resistivity
			σ	mhos/metre	electrical conductivity
			ϕ	volts	voltage or electrical potential

UNIT CONVERSION

English	Factor for converting English units to international system of units	Metric SI
ft (foot)	3.048×10^{-1}	m (mètre)
gal (gallon)	3.785	l (litre)
ft ³ /s (cubic foot per second)	2.832×10^{-2}	m ³ /s (cubic metre per second)

PROGRAM OUTLINE

This program outline is provided to assist the reader in review, and to facilitate the location of particular topics or discussions in the text. Hopefully, it may also provide some feeling for the organization of the material and the order of presentation, both of which tend to be obscured by the programed format.

The section numbers in the left margin correspond to correct answers in the programed instruction; they give the sequence of sections which will be followed if no errors are made in answering the questions. An outline of the content of each of the correct-answer sections is given to the right of the section number. Two numbers are listed beneath each of these section outlines. These numbers identify the wrong-answer sections for the question presented in the outlined correct-answer section. The correct answer to this question is indicated by the next entry in the left margin.

The discussions written in standard text format are also outlined. For these discussions, page numbers corresponding to the listed material are given in parentheses in the left margin.

Part I. Definitions and general concepts:

Section:

- 1 porosity
13; 18
- 9 effective porosity; saturation
12; 29
- 6 porosity, saturation (review); point velocity variations; tortuous path effects
4; 21
- 3 tortuous flow path effects (review); problems in determining actual cross-sectional flow area; relation of discharge per unit face area to flow velocity
28; 10
- 14 relation of discharge per unit face area to flow velocity (review); definition of specific discharge or specific flux; definition of head
11; 17
- 24 omission of velocity head in ground water; relation between pressure and height of fluid column (Pascal's law)
25; 19
- 16 Pascal's law (review); head as potential energy per unit weight; elevation head as potential per unit weight due to elevation; dimensions of pressure
7; 15
- 26 pressure as a component of potential energy per unit volume; pressure head as a component of potential energy per unit weight; total potential energy per unit weight (question)
20; 23
- 22 head as potential energy per unit weight (review); total potential energy per unit volume
5; 27
- 8 total potential energy per unit volume (review)

Part II. Darcy's law:

Section:

- 1 outline of approach—method of balancing forces; friction force proportional to velocity; pressure force on face of a fluid element in a sand-packed pipe (question)
25; 16
- 8 relation between pressure and force; net pressure force on a fluid element (question)
23; 12
- 31 net pressure force on a fluid element (review); pressure gradient; net pressure force in terms of pressure gradient (question)
5; 14
- 26 net pressure force in terms of pressure gradient; gravitational force; mass of fluid element in terms of density, porosity, and dimensions (question)
3; 17
- 15 gravitational force in terms of density, porosity, and dimensions; component of gravitational force contributing to the flow (question)
22; 18
- 33 resolution of gravitational force into components parallel and normal to the conduit; expression for magnitude of component parallel to the conduit (question)
6; 37
- 35 expression for component of gravitational force parallel to conduit (review); substitution of $\Delta z/\Delta l$ for cosine in this expression (question)
32; 4
- 11 substitution of $\Delta z/\Delta l$ for cosine in expression for gravity component along conduit (review); expression for total driving force on fluid element attributable to pressure and gravity (question)
24; 10
- 19 assumptions regarding frictional retarding force; expression for frictional retarding force consistent with assumptions (question)
2; 34
- 20 balancing of driving forces and frictional force to obtain preliminary form of Darcy's law
36; 27
- 28 Darcy's law in terms of hydraulic conductivity; replacement of
$$\frac{1}{\rho g} \frac{dp}{dl} + \frac{dz}{dl}$$
by dh/dl (question)
9; 30
- 7 discussion of hydraulic conductivity and intrinsic permeability; flow of ground water in relation to differences in elevation, pressure, and head (question)
29; 13
- 21 Darcy's law as a differential equation; analogies with other physical systems; ground-water velocity potential

Text-format discussion—Generalizations of Darcy's law:

- (p. 31) specific discharge vector in three dimensions; definition of components of specific-discharge vector
- (p. 31) Darcy's law for components of the specific-discharge vector; Darcy's law using the resultant specific-discharge vector
- (p. 31) velocity potential; flownet analysis; Darcy's law for components of the specific-discharge vector in anisotropic media
- (p. 32) flowlines and surfaces of equal head in the anisotropic case; solution by transformation of coordinates
- (p. 32) anisotropy of stratified sedimentary material

- (p. 33) use of components of pressure gradient and components of gravitational force in each of the three major permeability directions; hydraulic conductivity tensor
- (p. 33) aquifer heterogeneity
- (p. 33) fluid heterogeneity; Darcy's law for a heterogeneous fluid in an anisotropic aquifer, using intrinsic permeability

Part III. Application of Darcy's law to field problems:

Section:

- 1 differential equations and solutions
15; 23
- 7 infinite number of solutions to a differential equation
29; 14
- 8 slope-intercept concept applied to solutions of differential equations
5; 20
- 10 application of Darcy's law to one-dimensional equilibrium stream seepage problem; selection of particular solution to satisfy the differential equation and to yield correct head at the stream (question)
22; 36
- 24 boundary conditions in differential equations; interpretation of head data observed in a field situation (question)
42; 21
- 25 application of Darcy's law to a problem of one-dimensional steady-state unconfined flow, using Dupuit assumptions
26; 43
- 9 substitution of $\frac{1}{2} \frac{d(h^2)}{dx}$
for $h \frac{dh}{dx}$
in the unconfined flow problem; testing for solution by differentiation and substitution of boundary conditions (question)
16; 4
- 41 parabolic steepening of head plot in the Dupuit solution; problem of radial flow to a well; cross-sectional area of flow at a distance r from the well (question)
12; 6
- 27 decrease in area along path of radial flow; relation between decreasing area and hydraulic gradient (question)
11; 32
- 40 signs in radial flow problem; application of Darcy's law to the flow problem (question)
33; 17

- 35 expression of radial flow differential equation in terms of

$$\frac{dh}{d(\ln r)}$$

39; 13

- 2 interpretation of radial flow differential equation expressed in terms of

$$\frac{dh}{d(\ln r)}$$

18; 31

- 38 interpretation of radial flow differential equation (review); solution equation as taken from a plot of h versus $\ln r$; conversion to common logs; characteristics of the semilog plot
34; 37
- 19 logarithmic cone of depression; equation for drawdown at the well (question)
28; 30
- 3 applications of the drawdown equation; general characteristics of well-flow problems

Part IV. Ground-water storage:

Section:

- 1 relation between volume of water stored in a tank and water level in the tank
10; 9
- 11 relation between volume of water stored in a sand-packed tank and water level in the tank
31; 12
- 14 slope of V versus h graph for sand-packed tank
17; 22
- 26 capillary effects; assumption that a constant amount of water is permanently retained; relation between volume of water in recoverable storage and water level, under these conditions (question)
18; 2
- 16 slope of V versus h graph for sand-packed tank with permanent capillary retention
4; 29
- 33 slope of V versus h graph for prism of unconfined aquifer
28; 19
- 32 dependence of V, h relationship on surface area, A ; definition of specific yield (question)
7; 27
- 6 confined or compressive storage; V, h relationship for a prism in a confined aquifer
23; 30
- 21 dependence of V, h plot for a prism of confined aquifer on base area
3; 34
- 20 definition of confined or compressive storage coefficient; specific storage
5; 15

- 25 storage equation—relation between time rate of change of volume of water in storage and time rate of change of head
8; 24

- 13 relation between time rate of change of volume in storage and time rate of change of head (review)

Part V:

Text-format discussion—Partial Derivatives in Ground-Water-Flow Analysis:

- (p. 69) Partial derivatives; topographic map example
(p. 70) Calculation of partial (space) derivatives
(p. 70) Partial derivative with respect to time
(p. 70) Space derivatives as components of slope of the potentiometric surface; dependence on position and time; time derivative as slope of hydrograph; dependence on position and time
(p. 72) Vector formulation of the specific discharge; Darcy's law for components of the specific discharge vector

Unidirectional nonequilibrium flow:

Section:

- 1 relation between inflow and outflow for a tank
29; 17
- 21 equation of continuity; relation of $\partial h/\partial t$ for a prism of aquifer to difference between inflow and outflow (question)
6; 5
- 30 combination of continuity and storage equation to obtain relation between $\partial h/\partial t$ and inflow minus outflow (review); expression for inflow through one face of a prism of aquifer (question)
8; 3
- 22 implications of difference between inflow and outflow in a prism of aquifer (question)
14; 26
- 33 expression for inflow minus outflow, for one dimensional flow, in terms of difference in head gradients (question)
18; 15
- 9 change in a dependent variable expressed as a product of derivative and change in independent variable (question)
25; 20
- 15 change in a dependent variable as product of derivative and change in independent variable (review); change in derivative as product of second derivative and change in independent variable (question)
31; 13
- 7 second derivatives and second partial derivatives; expression for change in $\partial h/\partial x$ in terms of second derivative (question)
4; 23

- 32 expression for change in $\partial h/\partial x$ in terms of second derivative (review); expression for inflow minus outflow using second derivative (question)
27; 2

- 34 definition of transmissivity; expression for inflow minus outflow for one dimensional flow through a prism of aquifer, in terms of T and $\partial^2 h/\partial x^2$; equating of this inflow minus outflow to rate of accumulation; expression for rate of accumulation in terms of storage coefficient (question)
28; 12

- 10 equating of rate of accumulation, expressed in terms of storage coefficient, to the expression for inflow minus outflow, to obtain the partial differential equation for one-dimensional nonequilibrium flow (question)
11; 24

- 19 partial differential equation for two-dimensional nonequilibrium flow; partial differential equations and their solutions; review of method of deriving partial differential equations of ground water flow

Part VI. Nonequilibrium flow to a well:

Section:

- 1 expression for flow through inner face of cylindrical element (question)
34; 36
- 15 combination of r and $\partial h/\partial r$ into a single variable; expression for inflow minus outflow for cylindrical element
30; 25
- 7 use of

$$\frac{\partial \left(r \frac{\partial h}{\partial r} \right)}{\partial r} \Delta r$$

in place of

$$\left(r \frac{\partial h}{\partial r} \right)_2 - \left(r \frac{\partial h}{\partial r} \right)_1$$

expression for

$$\frac{\partial \left(r \frac{\partial h}{\partial r} \right)}{\partial r}$$

26; 8

- 28 final expression for inflow minus outflow for cylindrical element; expression for rate of accumulation in storage in the element (question)
12; 16
- 37 combination of inflow minus outflow term with rate of accumulation term to obtain partial differential equation
22; 32
- 27 procedure of testing a function to determine whether it is a solution to the partial differential equation; calculation of first radial derivative of test function
4; 2

5 calculation of second radial derivation of test function
23; 9

35 calculation of time derivation of test function
3; 31

20 expressions for

$$\frac{S}{T} \frac{\partial h}{\partial t}$$

and

$$\frac{\partial^2 h}{\partial r^2} + \frac{1}{r} \frac{\partial h}{\partial r}$$

for test function

17; 24

21 verification that test function is a solution; instantaneous injection (slug test) problem; development of boundary conditions required at $t = 0$

10; 19

18 verification that test function satisfies the boundary conditions for $t = 0$; graphical demonstration of its behaviour as $t \rightarrow 0$; development of boundary condition for $r \rightarrow \infty$

29; 6

33 relation between condition that $(\partial h / \partial r) \rightarrow 0$ as $r \rightarrow \infty$ and condition that $h \rightarrow 0$ as $r \rightarrow \infty$; demonstration that test function also satisfies $h \rightarrow 0$ as $t \rightarrow \infty$; development of condition

$$V = \int_{r=0}^{\infty} S \cdot h_{r,t} \cdot 2\pi r dr$$

11; 14

13 demonstration that the test function satisfies

$$V = \int_{r=0}^{\infty} S \cdot h_{r,t} \cdot 2\pi r dr;$$

discussion of significance of slug test solution

Text-format discussion—Development of additional solutions by superposition:

(p. 112) Linearity of radial equation; superposition; equation for head at t due to injection at $t' = 0$

(p. 112) superposition to obtain effect of two injections

(p. 112) expression for head change due to instantaneous withdrawal; superposition to obtain effect of repeated bailing

(p. 113) variable rate of continuous pumping as a sequence of infinitesimal withdrawals; effect of withdrawal during an infinitesimal time dt' ; use of superposition to obtain head change due to pumping during a finite time interval

(p. 114) implementation of superposition by integration of the expression for head change due to instantaneous withdrawal, for case of variable pumping rate

(p. 115) transformation of integral into exponential integral, for case of constant pumping rate

(p. 116) definition of u ; evaluation of the exponential integral by means of series

(p. 116) definition of well function; equation for case where $h \neq 0$ prior to pumping; equation in terms of drawdown; Theis equation

(p. 117) development of the modified nonequilibrium (semilog approximation) formula

(p. 117) review of assumptions involved in derivation of the partial differential equation for radial flow

(p. 117) review of assumption involved in the instantaneous injection solution and in the continuous pumpage (constant rate) solution

(p. 118) review of assumptions involved in the semilog approximation; citations of literature on extensions of well-flow theory for more complex systems

Part VII Finite-difference methods:

Section:

1 finite-difference expression for first space derivative (question)
7; 26

12 finite-difference expression for second space derivative (question)
27; 22

15 finite-difference expression for

$$\frac{\partial^2 h}{\partial x^2} + \frac{\partial^2 h}{\partial y^2}$$

(question)
28; 24

3 finite-difference expression for

$$\frac{\partial^2 h}{\partial x^2} + \frac{\partial^2 h}{\partial y^2}$$

(review);
notation convention for head at a node
14; 5

2 expression for

$$\frac{\partial^2 h}{\partial x^2} + \frac{\partial^2 h}{\partial y^2}$$

PROGRAM OUTLINE

XI

- using subscript notation convention
20; 18
- 4 third subscript convention for time axis
9; 23
- 10 expression for

$$\frac{\partial^2 h}{\partial x^2} + \frac{\partial^2 h}{\partial y^2}$$

- at a particular point and time using the subscript notation; approximations to $\partial h/\partial t$; finite forward-difference approximation to the ground water flow equation, using the subscript notation (question)
8; 19
- 16 application of forward-difference equation in predicting head values; iterative (relaxation) techniques (definition); finite-difference equation for steady-state two-dimensional flow (question)
11; 13
- 25 solution of the steady-state equation by iteration
21; 6
- 17 general discussion of numerical methods

Text-format discussion—Finite difference methods:

- (p. 136) Forward-difference and backward difference approximations to time derivative
- (p. 137) Forward-difference simulation of the ground-water flow equation; explicit method of solution
- (p. 137) Errors; stable and unstable techniques
- (p. 138) Backward-difference simulation of the ground-water flow equation; simultaneous equation sets
- (p. 139) Solution by iteration or relaxation techniques
- (p. 139) Solution of the steady-state equation by iteration
- (p. 139) Solution of the nonequilibrium equation, backward-difference simulation, by iteration
- (p. 140) Iteration levels; superscript notation; iteration parameter
- (p. 140) Successive overrelaxation; alternating direction techniques
- (p. 141) Forward-difference and backward-difference simulations of the ground-water flow equation using Δ notation
- (p. 141) Alternating direction implicit procedure
- (p. 144) Thomas algorithm for solution of equation sets along rows or columns

- (p. 147) Iteration of the steady-state equation using alternating direction method of calculation
- (p. 149) Iterative solution using the backward-difference simulation and the alternating direction technique of computation

Part VIII. Analog techniques:

Section:

- 1 Ohm's law; definitions of current and resistance
19; 8
- 6 definitions of resistivity and conductivity; Ohm's law in terms of resistivity
24; 3
- 28 Ohm's law in terms of conductivity; analogy between Ohm's law and Darcy's law for one-dimensional flow
12; 7
- 26 analogy between Darcy's law and Ohm's law for one-dimensional flow; extension to three dimensions; current density; flow of charge in a conducting sheet
25; 23
- 11 analogy between flow of charge in a conducting sheet and flow of water through a horizontal aquifer; method of setting up a steady-state analog; parallel between line of constant voltage and line of constant head (question)
16; 17
- 21 nonequilibrium modeling; storage of charge in a capacitor, and analogy to storage of ground water; capacitor equations
13; 16
- 9 relation between time rate of change of voltage and time rate of accumulation of charge for a capacitor; relation between current toward a capacitor plate and time rate of change of voltage
20; 18
- 4 relation between time rate of change of voltage and time rate of accumulation of charge for a capacitor (review); electrical continuity relation; relation between currents and time rate of change of capacitor voltage, for a system of four resistors connected to a capacitor; transformation of this relation to an equation in terms of voltages and $d\phi/dt$ (question)
15; 27
- 22 analogy between equation for capacitor—four resistor system with finite-difference form of two-dimensional ground-water flow equation; method of nonequilibrium modeling
2; 14
- 5 general discussion of the analog technique; heterogeneity; cross-sectional analogs; radial flow analogs

INTRODUCTION TO GROUND-WATER HYDRAULICS—A PROGRAMMED TEXT FOR SELF-INSTRUCTION

By Gordon

Instructions to the Reader

This programed text is designed to help you learn the theory of ground-water hydraulics through self-study. Programed instruction is an approach to a subject, a method of learning; it does not eliminate mental effort from the learning process. Some sections of this program need only be read; others must be worked through with pencil and paper. Some of the questions can be answered directly; others require some form of calculation. You may have frequent occasion, as you work through the text, to consult standard texts or references in mathematics, fluid mechanics, and hydrology.

In each of the eight parts of the text, begin the programed instruction by reading Section 1. Choose an answer to the question at the end of the section, and turn to the new sec-

tion indicated beside the answer you have chosen. If your answer was correct, you will turn to a section containing new material and another question, and you may proceed again as in Section 1. If your answer was not correct, you will turn to a section which contains some further explanation of the earlier material, and which directs you to go back for another try at the question. Usually, in this event, it will be worthwhile to reread the material of the earlier section. Continue in this way through the program until you reach a section indicating the end of the part. Note that although the sections are arranged in numerical order within each of the eight parts, you would not normally proceed in numerical sequence (Section 1 to Section 2 and so on) through the instruction.

Part I. Definitions and General Concepts

Introduction

In Part I, certain concepts which are frequently used in ground-water hydraulics are introduced. Among these are porosity, specific discharge, hydraulic head, and fluid pressure. Rigorous development of theorems

relating to these terms is not attempted. The material is intended only to introduce and define the terms to provide an indication of their physical significance.

The porosity of a specimen of porous material is defined as the ratio of the volume of open pore space in the specimen to the bulk volume of the specimen.

0.5 cubic feet
0.2 cubic feet
0.8 cubic feet

Turn to Section:
13
18
9

QUESTION

What volume of solid material is present in 1 cubic foot of sandstone, if the porosity of the sandstone is 0.20?

1.

Nowhere in Part I is there an instruction to turn to Section 2. Perhaps you have just read Section 1 and have turned to Section 2 without considering the question in Section 1. If so, return to Section 1, choose an answer

to the question, and turn to the section indicated opposite the answer you select.

2.

Your answer in Section 6 is correct. Any flow path between A and B will be longer than the linear distance AB ; it is generally impossible to know the actual distance that a particle of fluid travels in moving through a section of porous material.

a problem may arise if we attempt to define average fluid velocity as a ratio of discharge to cross-sectional area, as is customarily done in open-flow hydraulics.

In the same way, it is difficult to know the actual cross-sectional area of the flow, when dealing with flow in a porous medium. Any cross-sectional area selected will be occupied partly by grains of solid material and partly by pores containing the fluid. For this reason,

Con.— 3.

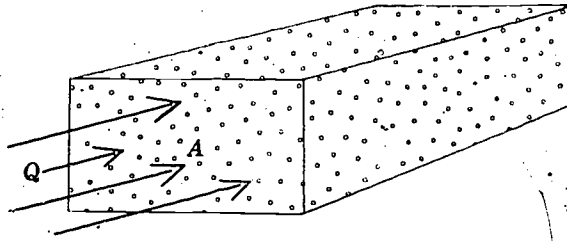

3. —Con.

QUESTION

In the block of saturated porous material in the figure, a fluid discharge, Q , is crossing the area, A , at right angles. A represents the gross area of the block face, including both solid particles and fluid-filled pore space. The quotient Q/A would be:

less than	14
equal to	28
greater than	10

Turn to Section:

the average velocity of the fluid particles

Your answer in Section 6 is not correct. The particle would move a distance equal to the linear interval AB if the two points were

connected by a straight capillary tube, but the probability of such a connection is essentially zero in a normal porous medium. In general, the possible paths of flow between any two points will be tortuous in character.

Return to Section 6 and select another answer.

4.

Your answer in Section 22 is not correct. Pressure does represent potential energy per unit volume due to the forces transmitted

through the surrounding fluid, but z represents potential energy per unit *weight* due to elevation. The question asked for total potential energy per unit volume.

Return to Section 22 and select another answer.

5.

Your answer in Section 9 is correct. Thirty percent of the interconnected pore space in a porous medium whose effective porosity is 0.20 is 6 percent of the bulk volume, or 0.06 cubic feet. In the remainder of this program, fully saturated conditions will be assumed unless unsaturated flow is specifically mentioned.

Variation in the flow velocity of an individual fluid particle is inherent in the nature of flow through porous media. Within an individual pore, boundary resistance causes the velocity to decrease from a maximum along

the centerline to essentially zero at the pore wall. Another form of velocity variation is imposed by the tortuous character of the flow—that is, the repeated branching and reconnecting of flow paths, as the particles of fluid make their way around the individual grains of solid. This anastomizing or braided pattern causes the velocity of a fluid particle to vary from point to point in both magnitude and direction, even if its motion occurs along the centerline of the pore space. However, if we view a small segment of the medium but one which is still large enough to contain a great number of pores, we find that the microscopic components of motion cancel in all except one resultant direction of flow.

6. —Con.

QUESTION

In the porous block in the figure, a particle of fluid moving from point A to point B would travel a distance:

	Turn to Section:
greater than the linear distance AB	3
equal to the linear distance AB	4
less than the linear distance AB	21

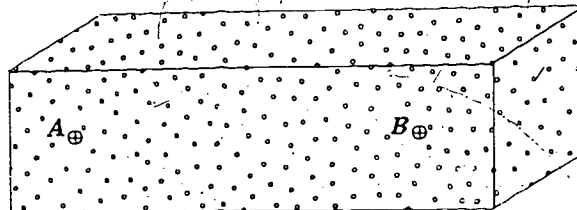

Con.—6.

Your answer in Section 16 is not correct. If we were considering the height of a static column of water above a point, which as we have seen is given by $p/\rho g$, we would be dealing with dimensions of potential energy per unit volume. The question in Section 16, however, asks for the units of pressure alone. These units are force per unit area—for example, pounds of force per square foot of area, which can be written

in the form pounds/ft². Now we may “multiply” these units by the term ft/ft to obtain an equivalent set of units applicable to pressure.

Return to Section 16 and choose another answer.

7.

Your answer, $p + \rho g z$, in Section 22 is correct. We have seen that pressure is equivalent to potential energy per unit volume attributable to forces transmitted through the surrounding fluid. Potential energy per unit volume due to elevation is obtained by multiplying the potential energy per unit weight due to elevation—that is, z —by the weight per unit volume, ρg . The total potential energy per unit volume is then the sum of these two terms, that is, $p + \rho g z$.

No discussion of flow energy would be complete without mention of kinetic energy. In the mechanics of solid particles, the kinetic energy, KE, of a mass, m , moving with a velocity v , is given by

$$KE = mv^2/2.$$

Now suppose we are dealing with a fluid of mass density ρ . We wish to know the kinetic energy of a volume V of this fluid which is moving at a velocity v . The mass of the volume is ρV , and the kinetic energy is thus

$$KE = \rho V v^2 / 2.$$

If we divide by the volume, V , we obtain

as the kinetic energy per unit volume of fluid; and dividing this in turn by the weight per unit volume, ρg , gives $v^2/2g$ as the kinetic energy per unit weight of fluid. Each of these kinetic energy expressions is proportional to the square of the velocity. The velocities of flow in ground-water movement are almost always extremely low and therefore the kinetic energy terms are extremely small compared to the potential energy terms. Consequently, in dealing with ground-water problems we can generally neglect the kinetic energy altogether and take into account only the potential energy of the system and the losses in potential energy due to friction. This is an important respect in which ground-water hydraulics differs from the hydraulics of open flow.

This discussion concludes Part I. In Part II we will consider Darcy's law, which relates the specific discharge, q , to the gradient of hydraulic head, in flow through porous media.

8.

Your answer in Section 1 is correct; if 0.20 of the cube is occupied by pore space, 0.80 of its volume must be solid matter. In ground-water studies we are normally interested in the interconnected, or effective, porosity, which is the ratio of the volume of interconnected pore space—excluding completely isolated pores—to the bulk volume. As used in this text the term “porosity” will always refer to the interconnected or effective porosity. Ground water is said to occur under saturated conditions when all interconnected pore space is completely filled with water,

and it occurs under unsaturated conditions when part of the pores contain water and part contain air. In problems of unsaturated flow, the degree of saturation is often expressed as a percentage of the interconnected pore space.

QUESTION

What volume of water is contained in 1 cubic foot of porous material, if the effective porosity is 0.20 and saturation expressed as a percentage of the interconnected pore space is 30 percent?

Turn to Section:

0.30 cubic feet	12
0.06 cubic feet	6
0.20 cubic feet	29

9.

Your answer in Section 3 is not correct. The area A represents the gross cross-sectional area of the porous block, normal to the direction of flow. A part of this area is occupied by grains of solid, and a part by open pore space. Let us say that 20 percent of the area A represents pore space; the actual

cross-sectional area available for the flow is thus $0.2 A$. If we were willing to take the ratio of discharge to flow area as equal to the average velocity, without considering any other factor, we would have to use the ratio $Q/0.2A$. The actual average particle velocity would presumably exceed even this figure, because of the excess distance traveled in tortuous flow.

Return to Section 3 and choose another answer.

10.

Your answer in Section 14 is not correct. The column of water in the piezometer is static, but h_p is the elevation of the top of this column above the point of measurement,

h_p (is sometimes referred to as the pressure head at point 0). We have defined head as the elevation above datum of the top of a static column of water that can be supported at the point.

Return to Section 14 and choose another answer.

11.

Your answer in Section 9 is not correct. Saturation is expressed here as a percentage of the interconnected pore space, not as a percentage of the sample volume; that is,

30 percent of the interconnected pore space is occupied by water. Since the effective porosity was given as 0.20, and the sample volume as 1 cubic foot, the volume of interconnected pore space is 0.20 cubic feet.

Return to Section 9 and choose another answer.

12.

Your answer in Section 1 is not correct. Porosity is defined by the equation

$$n = \frac{V_p}{V_s + V_p} = \frac{V_p}{V_g}$$

where V_p is the volume of pore space in the specimen, V_g is the gross volume of the specimen, and V_s is the volume of solid material in the specimen (note that $V_g = V_s + V_p$). The

question in Section 1 asked for the volume of solid material, V_s , in a specimen for which the gross volume, V_g , is 1 cubic foot and the porosity, n , is 0.20.

Return to Section 1 and choose another answer.

13.

Your answer in Section 3 is correct. Q/A will be less than the average velocity of fluid motion since the gross cross-sectional area, A , will be greater than the actual cross-sectional area of flow. In many porous media, the ratio of actual area of flow to gross cross-sectional area can be taken as equal to the interconnected porosity of the material.

We have seen that it is generally difficult or impossible to know or measure the actual velocity of fluid motion or the actual cross-sectional area of flow in a porous medium. For this reason, we usually work in terms of discharge and gross cross-sectional area. That is, we use the quantity Q/A , where Q is the discharge through a segment of porous material, and A is the gross cross-sectional area of the segment. This quantity is referred to as the specific discharge, or specific flux, and is designated by the symbol q .

Another quantity we will use frequently is the static head, or simply the head. In ground-water problems, the head at a point is taken as the elevation, above an arbitrary datum, of the top of a static column of water that can be supported above the point. In using this definition, we assume that the density of the water in the measuring column is equal to that of the ground water, and that the density of the ground water is uniform.

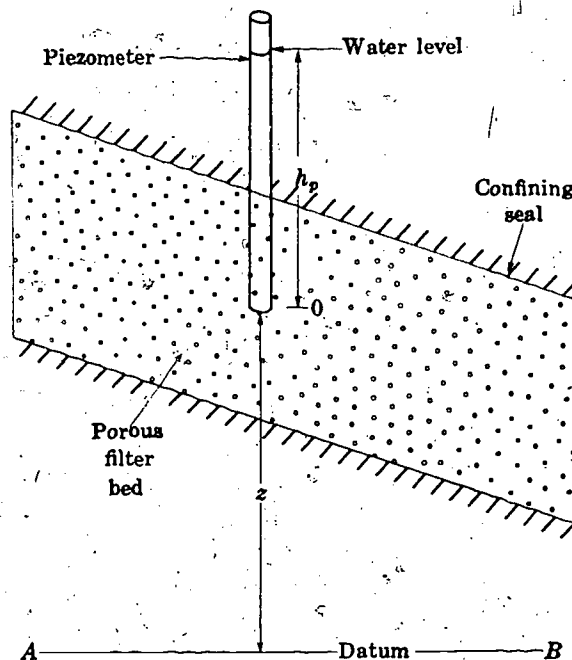

QUESTION

The diagram represents an enclosed porous filter bed; the plane AB is taken as the datum and a piezometer is inserted to the point O . What is the head at point O ?

Turn to Section:

The distance h_p	11
The distance z	17
The distance $h_p + z$	24

14.

Your answer in Section 16 is not correct. Pressure is usually expressed as force per unit area—for example, as pounds per square foot, which may be written pounds/ft². A term having units of work or energy per unit area, such as ft-pounds/ft², would represent

15.

Your answer, $p/\rho g$, in Section 24 is correct. The column of water inside the pipe is static and must obey the laws of hydrostatics. Thus the pressure at the bottom of the pipe is related to the height of the column of water in the pipe by Pascal's law, which here takes the form

$$p = \rho g h_p$$

or

$$h_p = p/\rho g$$

h_p thus actually serves as a measure of the pressure at the point occupied by the end of the pipe and, for this reason, is termed the pressure head at that point. It is added to the elevation of the point to yield the head at the point.

Head in ground water is actually a measure of the potential energy per unit weight of water. This is an important concept.

The elevation term, z , in the diagram represents the potential energy of a unit weight of water at point 0 that accrues from the position of the point above the datum. For example, if z is 10 feet, 10 pounds of water in the vicinity of point 0 could accomplish 100 foot-pounds of work in falling to the datum; the potential energy per unit weight of water at point 0 due to the elevation of the point alone would thus be 10 feet. Similarly, the pressure term, h_p , represents the potential energy of a unit weight of water at point 0 originating from the forces exerted on the point through the surrounding fluid. This concept is considered farther in the following sections.

the product of pressure and a term having units of distance, feet. We are interested here in an equivalent set of units for pressure alone. Now note that if a pressure term were multiplied by a dimensionless factor having "units" of ft/ft, we would obtain a result still having the units of pressure.

Return to Section 16 and select another answer.

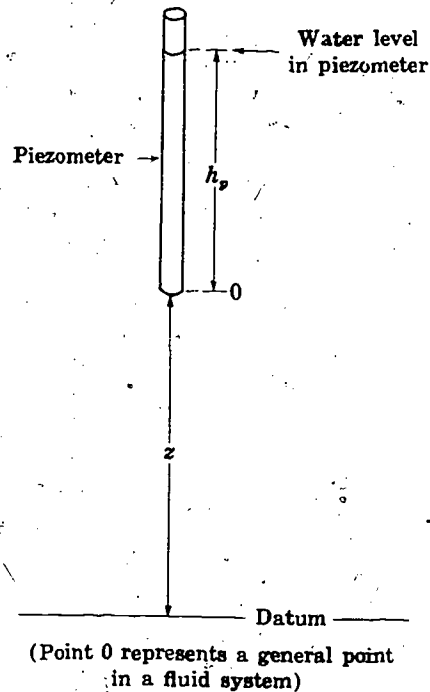

QUESTION

Pressure is normally thought of as force per unit area. Dimensionally this is equivalent to:

energy per unit weight	7
energy per unit volume	26
work per unit area	15

16.

Your answer in Section 14 is not correct. z is the elevation of the point above the datum; we defined head as the elevation, above datum, of the top of a static column of water that can be supported at the point. The column of water in the piezometer is static

when conditions in the porous medium are at equilibrium.

Return to section 14 and choose another answer.

17.

Your answer in Section 1 is not correct. If the porosity is 0.20, there will be 0.20 cubic foot of pore space in a specimen of 1-cubic-foot volume. The question asked for the volume of solid material in the specimen.

Return to Section 1 and choose another answer.

18.

Your answer in Section 24 is not correct. The column of water inside the pipe is static and must obey the laws of hydrostatics. The pressure at a depth d beneath the water surface, in a body of static water, is given by Pascal's law as

$$p = \rho g d$$

where again ρ is the mass density of the water, g is the acceleration due to gravity, and the pressure at the water surface is taken as zero. This relation may be applied

to the water inside the pipe in the question of Section 24. If you are not familiar with Pascal's law it would be useful to read through a discussion of hydrostatics, as given in any standard physics text, before proceeding further in the program.

Return to Section 24 and choose another answer.

19.

Your answer in Section 26 is not correct. Potential energy is a scalar term; when it consists of contributions from different sources, these are simply added to obtain the total potential energy. The potential energy of the unit weight of water due to its eleva-

tion is z , while that due to the forces exerted on it through the surrounding water is h_p .

Return to Section 26 and choose another answer.

20.

Your answer in Section 6 is not correct. The line AB is, of course, the shortest distance between the two points, and no flow path could be any shorter than this.

Return to Section 6 and select another answer.

21.

Your answer in Section 26 is correct. The unit weight of water has hydraulic potential energy due to its elevation and due to the forces exerted on it by the surrounding fluid. The potential energy due to its elevation is z , and the potential energy due to the forces exerted on it through the surrounding fluid is $p/\rho g$ or h_p . The sum of z and h_p is of course the head, h , (as used in ground-water hydraulics) at the point in question. The two terms making up the head at a point—the elevation of the point itself above datum and the elevation of the top of a static column of water that can be supported above the point—measure respectively the two forms of hydraulic potential energy per unit weight. Their sum indicates the total hydraulic potential energy per unit weight of fluid at the point.

QUESTION

Which of the following expressions would indicate total hydraulic potential energy of a unit volume of fluid in the vicinity of point A in the diagram?

22.

Your answer in Section 26 is not correct. z represents the potential energy of a unit weight of water in the vicinity of point O, due to its elevation above the datum. A unit

23.

Your answer in Section 14 is correct. Head consists of two terms in ground-water systems: the elevation of the point itself above datum, and, the height of a static column of

24. —Con.

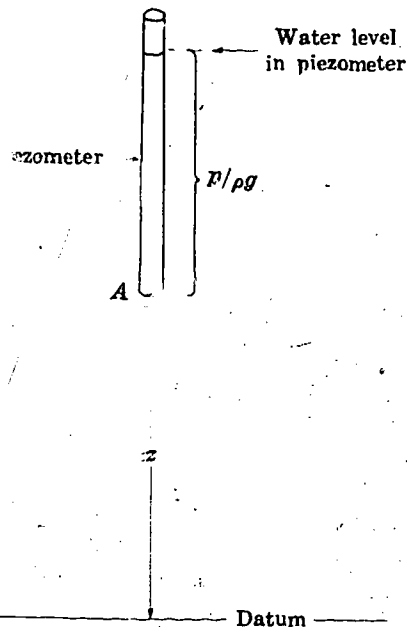

$$p + \rho g z$$

$$p + z$$

$$p/\rho g + z$$

Turn to Section:

8
5
27

weight of water in this vicinity will also possess potential energy because of the forces exerted upon it through the surrounding water. The question asked for total hydraulic potential energy.

Return to Section 26 and select another answer.

water that can be supported above the point. In this case, the column of water in the piezometer is the static column above the point.

The height of the column of water above the point is a measure of the pressure at the point and is sometimes termed the pressure

head. Readers familiar with open flow hydraulics may recognize that the head we have defined here differs from the total head used in open flow hydraulics in that the term, $v^2/2g$, is missing. Velocities are usually small in ground-water systems, and the term $v^2/2g$ is almost always negligible in comparison to the elevation and pressure terms.

QUESTION

Suppose a pipe, open only at the top and bottom, is driven into the ground. The bottom of the pipe comes to rest at a point below the water table where the pressure is p . Water rises inside the pipe to a height h_p above the

lower end of the pipe. The pressure on the water surface within the pipe (which is actually the atmospheric pressure) is here taken as zero. The height of the column of water inside the pipe above the bottom of the pipe, will be given by:

$$h_p = p / \rho g$$

$$h_p = g / \rho p$$

$$h_p = p \rho g$$

Turn to Section:

16

25

19

where ρ is the water density, or mass per unit volume, and g is the gravitational constant.

Con.— 24.

Your answer in Section 24 is not correct. Pressure within a body of static water varies in accordance with Pascal's law, which may be stated

$$p = \rho g d$$

where ρ is the mass density of water, g is the acceleration due to gravity, and d is the depth below the surface at which the pressure is measured. The pressure on the upper surface of the water (sometimes denoted p_0 in textbooks of hydraulics) is here considered to be zero. If you are not familiar with this relation, it would be a good idea to read through

a discussion of hydrostatics, as presented in any standard physics text, before proceeding further with the program.

In the problem of Section 24, the column of water in the pipe is static, and Pascal's law may be used to give the pressure at any point within this column—even at its base, where it joins the ground-water system.

Return to Section 24 and choose another answer.

25.

Your answer in Section 16 is correct. Pressure may in fact be thought of as potential energy per unit volume of liquid. Physically, this concept is perhaps most easily appreciated using the example of a simple hydraulic cylinder, or hydraulic press, shown schematically in the diagram. Liquid under a pressure p is fed in through the port at 0. As the liquid enters, the piston is displaced to the right. Pressure is a measure of force per unit area, and it follows that the total force on the piston is given by the product of the pressure, p , and the face area of the

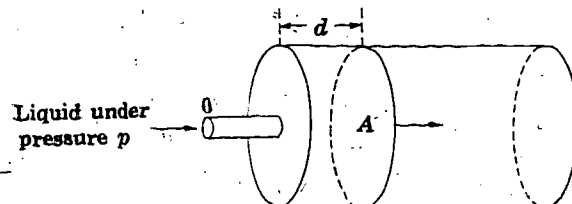

Con.— 26.

piston, which we designate A . Thus, $F = p \times A$, where F is the force on the piston.

The work accomplished in moving the piston is given as the product of the force and the distance through which it acts. If the piston moves a distance d , the work done is given by

$$W = F \times d = p \times A \times d$$

where W is the work accomplished in moving the piston. The product $A \times d$ is the volume of fluid in the cylinder at the completion of the work; and we could say that this volume of liquid is capable of doing the work W , provided the liquid is at the pressure p .

Potential energy is often termed the ability to do work. That is, if a system is capable of doing 10 foot-pounds of work, we say that it possesses a potential energy of 10 foot-pounds. In the case of our cylinder, the potential energy we assign depends upon how far we are willing to let the piston travel. If the piston is allowed to travel a distance $d=5$, the work that can be done is $p \times 5A$; if the piston is allowed to travel a distance $d=10$, the work that can be done is $p \times 10A$. Thus the assignment of a potential energy in this case is not altogether straightforward, since the distance which the piston will travel—or, equivalently, the volume of fluid which will be admitted to the cylinder under the pressure p —must be specified before the potential energy can be assigned. In this case, therefore, it is more convenient to talk about a potential energy per unit volume of liquid. For example, if we are told that the potential energy is 10 foot-pounds per cubic foot of water in the cylinder, we can calculate the particular potential energy associated with the admission of any specified volume of fluid to the cylinder. The work which can be done if a volume $A \times d$ of liquid is admitted is $p \times A \times d$; dividing this by the volume $A \times d$ gives the work which can be done per unit volume of liquid—that is, the potential energy per unit volume of liquid. This potential energy per unit volume turns out to be

the pressure, p , under which the fluid is admitted to the cylinder.

This concept of pressure as potential energy per unit volume can be extended to general systems of flow, provided that we understand this potential energy to be only that due to forces exerted on a fluid element by the surrounding fluid. To obtain total potential energy, we would have to add the potential energy due to the force of gravity acting directly on the fluid element.

If pressure, representing potential energy per unit volume, is in turn divided by ρg , weight per unit volume, we obtain $p/\rho g$ —or simply h_p , the height of a static column of water above the point—as the potential energy per unit weight that is due to the forces transmitted through the surrounding fluid.

QUESTION

Referring to the diagram, which of the following expressions will give the total hydraulic potential energy of a unit weight of water located in the vicinity of point 0?

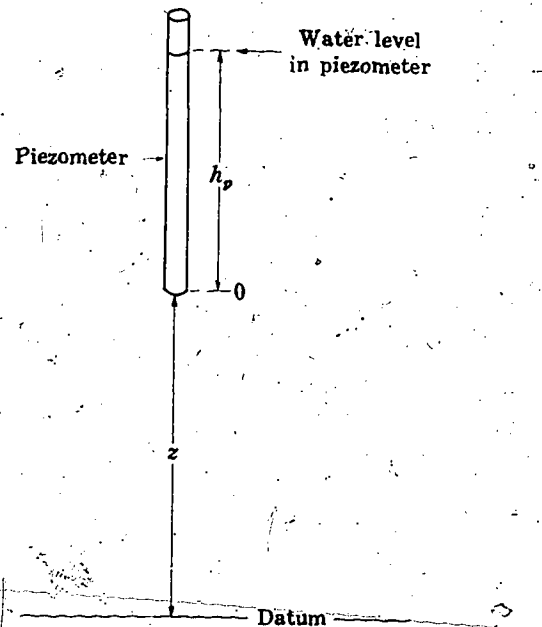

drainage potential energy of a unit weight of water located in the vicinity of point 0?

Turn to Section:

23

22

20

26.—Con.

z

$h_p + z$

$h_p - z$

Your answer in Section 22 is not correct. We have already seen that $p/\rho g + z$ was equal to the total potential energy per unit weight of water. To obtain potential energy per unit volume, we must multiply by weight per unit volume.

Return to Section 22 and choose another answer.

27.

Your answer in Section 3 is not correct. The quotient, Q/A , would yield an average velocity if we were dealing with an open flow. Here, however, A is not the cross-sectional area of flow; it is, rather, the cross-sectional area of the porous block normal to the flow. Only that fraction of this area which consists of open pore space can be considered the cross-sectional area of flow. Suppose, for

example, that this pore area represents 20 percent of the total face area, A . The flow area would then be $0.2 A$.

Return to Section 3 and choose another answer.

28.

Your answer in Section 9 is not correct. The volume of interconnected pore space is 0.20 cubic feet, but since saturation is less than 100 percent, the volume of water in the specimen cannot equal the volume of interconnected pore space. Keep in mind that we are expressing saturation as a percentage of the interconnected pore space.

Return to Section 9 and choose another answer.

29.

Part II. Darcy's Law

Introduction

Part II gives a development of Darcy's law. This law relates specific discharge, or discharge per unit area, to the gradient of hydraulic head. It is the fundamental relation governing steady-state flow in porous media. The development given here should not be taken as a rigorous derivation; it is no more

than a plausibility argument, and is presented in order to give the reader some appreciation for the physical significance of the relation.

Following the program section of Part II a short discussion on generalization of Darcy's law is given in text format.

(1)

In mechanics, when considering the steady motion of a particle, it is customary to equate the forces producing the motion to the frictional forces opposing it. The same approach may be followed in considering the steady movement of fluid through a porous medium. In studying the motion of a solid particle through a fluid, we find that the force of friction opposing the motion is proportional to the velocity of the particle. Similarly, in flow through a porous medium, we will assume that the frictional forces opposing the flow are proportional to the fluid velocity. Our approach, then, will be to obtain expressions for the forces driving a flow and to equate these to the frictional force opposing the flow, which will be assumed proportional to the velocity. More exactly, we will take the vector sum of the forces driving and opposing the flow and set this equal to zero. What we are saying is that because the fluid motion is steady—that is, because no acceleration is observed—the forces on the fluid must be in balance, and therefore that their vector sum is zero, at all points. The equation that we obtain from this process of balancing forces

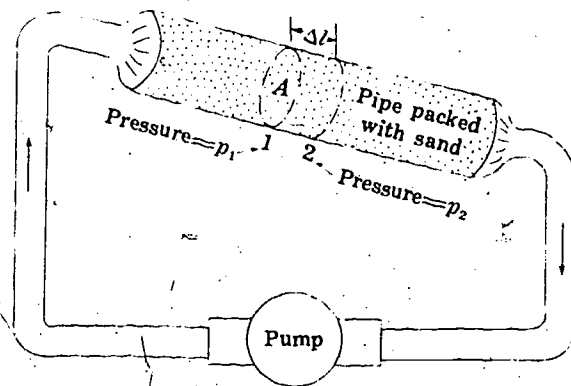

will be a form of Darcy's law. We begin by considering the forces which drive the flow.

QUESTION

Suppose we have a pipe packed with sand, as in the diagram. The porosity of the sand is n . Liquid of density ρ is circulated through the pipe by means of a pump. The dotted lines mark out a small cylindrical segment in the pipe, of length Δl , and of cross-sectional area A , equal to that of the pipe. A

(1)—Con.—

small volume, or element, of the moving fluid occupies this segment. The fluid pressure at point 1, at the upstream side of the segment, is p_1 .

Which of the following expressions would best represent the force exerted on the up-

stream face of the fluid element by the adjacent fluid element?

$p_1 A$

$p_1 n A$

$p_1 \rho g$

Turn to Section:

25

8

16

(2)

Your answer in Section 19,

$$-\frac{1}{k} \mu Q (\Delta l \cdot n \cdot A),$$

is not correct. Our assumptions were that the frictional retarding force would be proportional in some way to the dynamic viscosity (μ), to the volume of fluid in the element ($\Delta l \cdot n \cdot A$), and to the specific discharge, or flow per unit area (Q/A). While the answer

which you have chosen is not incompatible with these assumptions, it does not fit them as well as one of the other answers. Your answer assumes the retarding force to be proportional more particularly to the full discharge, Q , than to the specific discharge, Q/A .

Return to Section 19 and choose another answer.

(3)

Your answer in Section 26 is not correct. The term $\Delta l \cdot n \cdot A$ gives the volume of fluid in the element; the question asked for the mass of fluid in the element. Keep in mind that ρ ,

the density of the fluid, represents its mass per unit volume.

Return to Section 26 and choose another answer.

(4)

Your answer in Section 35 is not correct. The term $\sqrt{(\Delta z)^2 + (\Delta x)^2}$ is obviously equal to Δl , so that the answer you selected is equivalent to the term $\rho \cdot n \cdot A \cdot g \cdot \Delta l$. But as we saw in Section 15, this term gives the magnitude of the *total* gravitational force on our fluid element; what we want here is an ex-

pression for the *component* of this total force in the direction of flow. We have seen that this component is given by the expression $\rho \cdot n \cdot A \cdot g \cdot \Delta l \cdot \cos \gamma$; the idea of the question is to find a term equivalent to $\cos \gamma$ and to substitute it into the above expression.

Return to Section 35 and choose another answer.

(5)

Your answer in Section 31,

$$\frac{dp}{dl} nA,$$

is not correct. The expression obtained previously for the net force was $(p_1 - p_2)nA$, or $-\Delta p nA$. You have substituted the pressure gradient, or rate of pressure change per foot, for the small pressure change, $-\Delta p$. To obtain a net change, or increment, from a gradient, or rate of change per unit distance, we must multiply the rate per unit distance by the distance over which this change takes place. For example, dp/dl in the figure represents the slope of a graph of pressure, p , versus distance, l . To obtain the pressure change, $p_2 - p_1$, we must multiply this slope by the length of the interval, Δl ; and since we actually require the quantity $p_1 - p_2$, we must insert a negative sign. (In the situation shown at left, p_1 is greater than p_2 —that is, pressure is decreasing in the direction of flow, l . The derivative dp/dl is therefore an

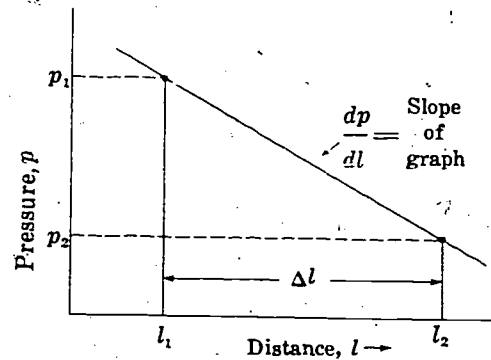

$$p_2 - p_1 = \text{Pressure change, } \Delta p = \frac{dp}{dl} \times \Delta l$$

intrinsically negative quantity itself—the graph has a negative slope. By inserting another negative sign, we will obtain a positive result for the term $p_1 - p_2$.)

Return to Section 31 and choose another answer.

(6)

Your answer in Section 33 is not correct. The term $\rho \cdot n \cdot \Delta l \cdot A \cdot g$ gives the magnitude of the total gravitational force vector, F_g . However, we require the component of this force vector in the direction l since only this component is effective in producing flow along the pipe. In the vector diagram, the length of the arrow representing the gravitational force, F_g , is proportional to the magnitude of that force, and the length of the arrows representing the two components, f_l and f_n , are proportional to the magnitudes of those components. Using a diagram to show the resolution of a vector into its components makes it easy to visualize the following general rule: the magnitude of the component of a vector in a given direction is obtained by multiplying the magnitude of the vector by the cosine of the angle between the direction of the vector and the direction in which the component is taken.

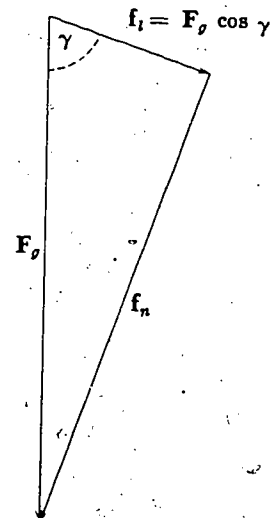

Return to Section 33 and choose another answer.

(7)

Your answer in Section 28,

$$\frac{Q}{A} = -K \frac{dh}{dl},$$

is correct. This relation between specific discharge and head gradient, or hydraulic gradient, dh/dl , was obtained experimentally by Henri Darcy (1856) and is known as Darcy's law for flow through porous media. The constant K , in the current usage of the U.S. Geological Survey, is termed the hydraulic conductivity and has the dimensions of a velocity. The constant k , again in the current usage of the Geological Survey, is termed the intrinsic permeability; its dimensions are (length)², and its units depend upon the units of density and viscosity employed. In the current usage of the Geological Survey, where ρ is measured in kg/m³, g in m/s², and μ in kg/(m s), k would have the units of m².

As noted in Section 28, hydraulic conductivity, K , is related to intrinsic permeability, k , by the equation

$$K = k \frac{\rho g}{\mu}$$

where ρ is the fluid density, μ the dynamic viscosity of the fluid, and g the gravitational constant. Hydraulic conductivity thus incorporates two properties of the fluid and cannot be considered a property of the porous medium alone. Intrinsic permeability, on the other hand, is normally considered to be only a property of the porous medium. In groundwater systems, variations in density are normally associated with variations in dis-

solved-mineral content of the water, while variations in viscosity are usually due to temperature changes. Thus in problems involving significant variations in mineral content or in water temperature, it is preferable to utilize intrinsic permeability.

The entire theory of steady-state flow through porous media depends upon Darcy's law. There are certain more general forms in which it may be expressed to deal with three-dimensional motion; some of these are considered in the text-format discussion at the end of this chapter. The development presented in this chapter involves numerous arbitrary assumptions, and thus should not be considered a theoretical derivation of Darcy's law. It has been presented here to illustrate, in a general way, the physical significance of the terms appearing in the law.

QUESTION

Consider the following statements:

- ground water flows from higher elevations to lower elevations.
- ground water flows in the direction of decreasing pressure.
- ground water moves in the direction of decreasing head.

Based on Darcy's law as given in this chapter, which of these statements should always be considered true?

Turn to Section:

all three	29
(b) and (c) but not (a)	13
only (c)	21

(8)

Your answer, $p_1 nA$, in Section 1 is correct. The overall cross-sectional area of the upstream face of the segment is A . The area of fluid in the upstream face is nA , if we assume the ratio between fluid area and overall area to be equal to the porosity. The pressure, or force per unit area, multiplied

by the fluid area then gives the total force on the fluid element through the upstream face. Similarly, if p_2 is the fluid pressure at the downstream face, $p_2 nA$, gives the magnitude of the force exerted on the downstream face of the fluid element by the adjacent downstream element.

(8)—Con.

QUESTION

Let us assume that the pressure p_1 is greater than the pressure p_2 . Which of the following expressions would best represent the *net* pressure-force on the element in the direction of flow?

$$\begin{array}{l} p_1 nA + p_2 nA \\ \frac{p_1 nA + p_2 nA}{2} \\ p_1 nA - p_2 nA \end{array}$$

Turn to Section:

28

12

31

(9)

Your answer in Section 28 is not correct. We saw in Part I that head, h , was given by

$$h = \frac{p}{\rho g} + z.$$

It follows that

$$\frac{dh}{dl} = \frac{d(p/\rho g)}{dl} + \frac{dz}{dl}$$

Use this result in selecting a new answer to the question of Section 28.

(10)

Your answer in Section 11 is not correct. We have obtained expressions for two forces acting in the direction of flow—the net pressure force, which was calculated as the difference between forces exerted on the upstream and downstream faces of the element by adjacent elements of fluid (see Section 26); and the component of the gravitational force in the direction of flow (see Section 11). The question asks for the combined net force due to both pressure and gravity.

Forces are combined by means of vector addition. In this case, however, the net pressure force and the component of gravity we are considering are oriented in the same direction—in the direction of flow. Vector addition in this instance therefore becomes a simple addition of the magnitudes of the two terms.

Return to Section 11 and choose another answer.

(11)

Your answer,

$$\rho \cdot n \cdot \Delta l \cdot A \cdot g \frac{\Delta z}{\Delta l},$$

in Section 35, is correct. $\Delta z/\Delta l$ is the equivalent of $\cos \gamma$; it simply gives the change in elevation per unit distance *along the path of flow*. (It thus differs from *slope* which by definition is the change in elevation per unit horizontal distance.) In the notation of calculus, $\Delta z/\Delta l$ would be represented by the derivative, dz/dl , implying the limiting value

of the ratio $\Delta z/\Delta l$ as smaller and smaller values of Δl are taken. The force component along the pipe must be positive, or oriented in the direction of flow, if z decreases in the direction of flow—that is, if dz/dl is negative. It must be negative, or oriented against the flow, if z increases in the direction of flow—that is if dz/dl is positive. We therefore introduce a negative sign, so that we have finally

$$f_i = -\rho \cdot n \cdot A \cdot \Delta l \cdot g \cdot dz/dl$$

where f_i is the component of the gravitational

(11) — Con. —

force parallel to the pipe, as in Section 33. The total force driving the flow is the sum of this gravity component and the pressure force.

QUESTION

Which of the following expressions give the net force on the fluid in the direction of flow, due to pressure and gravity together?

$$\left(-\frac{dp}{dl} - \rho g \frac{dz}{dl} \right) \Delta l \cdot n \cdot A$$

Turn to Section:

19

$$-\cos \gamma + n \cdot \Delta l \cdot A \cdot \frac{dz}{dl}$$

24

$$n \cdot \Delta l \cdot A \cdot g \cdot \frac{dz}{dl} - \frac{dp}{dl}$$

10

(12)

Your answer in Section 8 is not correct. The expression $(p_1 n A - p_2 n A)/2$ would be approximately equal to the force in the direction of flow against a cross-sectional area taken at the midpoint of our fluid element; it does not give the net force on the element itself in the direction of flow.

The fluid element extends along the pipe a short distance. Over this distance, pressure decreases from p_1 at the upstream face to p_2 at the downstream face. The force on the element at the upstream face is the force acting in the direction of flow; the force on

the element at the downstream face is a force acting against the direction of flow. That is, it is a "back pull" from the adjacent fluid element, against the element we are considering. Its magnitude is again given as a product of pressure, porosity, and face area, $p_2 n A$, but we now insert a negative sign to describe the fact that it acts in opposition to the force previously considered. The net force in the direction of flow is obtained by algebraic addition of the two force terms.

Return to Section 8 and choose another answer.

(13)

Your answer in Section 7 is not correct. Ground water frequently percolates downward from the water table; the pressure is greater at depth than at the water table, so in these cases water is moving in the direction of increasing pressure. Keep in mind

that Darcy's law relates flow per unit area to the gradient of head, not to the gradient of pressure.

Return to section 7 and choose another answer.

(14)

Your answer in Section 31 is not correct. We have seen that the net pressure force was equal to $-\Delta p n A$. It cannot be equal to this and to $\Delta p (dp/dl) n A$ (unless dp/dl happens to equal -1 , in a particular case).

We wish to substitute an expression involving the derivative, dp/dl , in place of the

pressure change term, $-\Delta p$. To obtain an expression for a change, or an increment, from a derivative, it is necessary to multiply the derivative—that is, the rate of change per unit distance—by the distance over which the increment or change occurs. For example, the diagram shows a graph of pres-

(14) — Con.

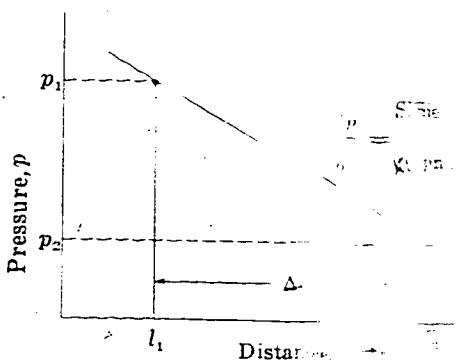

$p_2 - p_1 =$ Pressure change

pressure versus distance. The slope of this graph is the derivative, dp/dl . If we wish to obtain the change in pressure, $p_2 - p_1$, occurring over the interval Δl , we must multiply the rate of change per unit distance, dp/dl , by the distance Δl . Since we actually require the negative of this quantity, $p_1 - p_2$, we must insert a negative sign. (As shown on the graph, p_1 exceeds p_2 —pressure is decreasing in the direction of flow, l . The derivative of pressure with respect to distance, dp/dl , is therefore a negative quantity itself—that is, the graph has a negative slope. By inserting another negative sign we will obtain a positive result for the term $p_1 - p_2$.)

Return to Section 31 and choose another answer.

(15)

Your answer, $m = \rho \cdot \Delta l \cdot n \cdot A$ in Section 26 is correct; mass density, ρ , times volume of fluid, $n \cdot \Delta l \cdot A$, where n is porosity, gives the mass of fluid. The magnitude of the total force of gravity on our fluid element will, therefore, be $\rho \cdot \Delta l \cdot n \cdot A \cdot g$. This gravitational force acts vertically downward. As a force, however, it is a vector quantity; and like any other vector quantity it can be resolved into components acting in other directions.

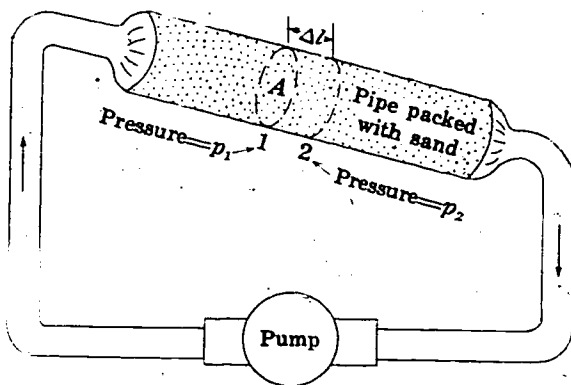

QUESTION

The diagram again shows the flow system we have postulated. Which of the following statements is correct?

Turn to Section:

- The entire gravitational force is effective in causing flow along the pipe. 22
- Only the component of the gravitational force parallel to the axis of the pipe contributes to flow along the pipe. 33
- Only the horizontal component of the gravitational force contributes to flow along the pipe. 18

(16)

Your answer in Section 1 is not correct. The force on the element will be given by the pressure, or force per unit area, multi-

plied by the area of fluid against which the pressure acts.

Return to Section 1 and choose another answer.

(17)

Your answer in Section 26 is not correct. The term $\rho \Delta l \cdot A$ would give the mass of a fluid element having a volume $\Delta l \cdot A$. In our problem, however, only a part of the volume

$\Delta l \cdot A$ is occupied by fluid; the balance is occupied by solid sand grains, so that the actual volume of fluid is less than $\Delta l \cdot A$.

Return to Section 26 and choose another answer.

(18)

Your answer in Section 15 is not correct. Gravity, as we are considering it, has no horizontal component. No vector can have a component perpendicular to its own direction. For our purposes we consider the gravitational force vector, F_g , to be always directed vertically downward; there can be no horizontal component of this force.

The diagram shows the gravitational force vector resolved into two components—one parallel to the direction of flow, f_t , and one perpendicular to the direction of flow, f_n . Fluid velocity itself may be considered a vector, in the direction L . As such, it has no component in the direction of f_n , normal to the pipe—and a force component normal to the

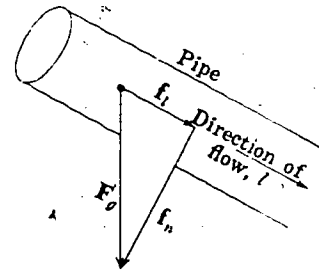

pipe could not contribute in any way to the fluid velocity.

Return to Section 15 and choose another answer.

(19)

Your answer in Section 11,

$$\left(-\frac{dp}{dl} - \rho g \frac{dz}{dl} \right) \Delta l \cdot n \cdot A$$

is correct. The net force per unit volume of fluid due to pressure and gravity would thus be

$$-\left(\frac{dp}{dl} + \rho g \frac{dz}{dl} \right),$$

since $\Delta l \cdot n \cdot A$ gives the volume of the fluid element.

Our approach in this development is to equate the net force driving the flow to the frictional force opposing it; more exactly, we will obtain the vector sum of these opposing forces and set the result equal to zero. The resulting equation will be a statement of Darcy's law. We have obtained an expression for the net force driving the flow. We now consider the force opposing the motion. This force is due primarily to friction between the moving fluid and the porous medium. In some

(19) — Con.

other systems of mechanics—for example in the case of a particle moving through a viscous fluid at moderate speed—the frictional retarding force is observed to be proportional to the velocity of movement. By analogy we assume a similar relation to hold for our element of fluid. However, as indicated in Part I, the actual pore velocity varies from point to point and is difficult or impossible to determine. For practical purposes therefore, we consider the frictional force on our fluid element to be proportional to the specific discharge; or flow per unit cross-sectional area, through the porous material. (See Section 14, Part I.) The specific discharge, which has the dimensions of a velocity (and is in fact a sort of apparent velocity), is determined by the statistical distribution of pore velocities within the fluid element; and we are, in effect, assuming that the total frictional retarding force on the element is likewise determined by this statistical distribution of pore velocities. In addition, we assume the total frictional retarding force on the fluid element to be proportional to the volume of fluid in the element, on the theory that the total area of fluid-solid contact within the element, and therefore the total frictional drag on the element, increases in proportion to the volume of the element. Finally, we assume that the retarding force is proportional to the dynamic viscosity of the fluid, since we would expect a fluid of low viscosity to move through a porous medium more readily than a highly viscous liquid.

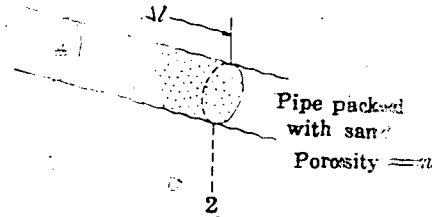

QUESTION

Following the various assumptions outlined above, which of the following expressions would you choose as best representing the frictional retarding force on the fluid element of Section 1. (Shown again in the diagram.)

Turn to Section:

$$-\frac{1}{k} \mu Q (\Delta l \cdot n \cdot A) \quad 2$$

$$\frac{1}{k} \frac{Q^2 \mu}{\Delta l \cdot n \cdot A} \quad 34$$

$$-\frac{1}{k} \mu (\Delta l \cdot n \cdot A) \frac{Q}{A} \quad 20$$

where $1/k$ indicates a constant of proportionality, μ is the dynamic viscosity of the fluid, and Q is the fluid discharge through the pipe.

(20)

Your answer in Section 19,

$$-\frac{1}{k} \mu (\Delta l \cdot n \cdot A) \frac{Q}{A}$$

is correct. The negative sign is employed to indicate that the frictional retarding force will be opposite in direction to the fluid movement. We assume that our fluid motion is steady—that is, that the fluid velocity is not

changing with time, or in other words, that there is no fluid acceleration. In this condition, the forces producing the motion must be in balance with the frictional retarding force. The vector sum of these forces must therefore be zero; and because the force components contributing to the motion are all directed along the pipe, this vector sum is simply an algebraic sum.

(20)—Con.

QUESTION

We have seen that the net driving force on the fluid element—that is, the net force in the direction of flow due to pressure and gravity—taken together—is given by

$$\left(\frac{dp}{dl} + \rho g \frac{dz}{dl} \right) \Delta l \cdot n \cdot A.$$

Suppose we take the algebraic sum of this force and our retardation force, and set the result equal to zero. Which the following

equations may then be derived from the result?

Turn to Section:

$$\frac{dp}{dl} + \rho g \frac{dz}{dl} + \frac{\mu}{k} \frac{Q}{A} = \Delta l \cdot n \cdot A \quad 36$$

$$k \left(\frac{dp}{dl} + \rho g \frac{dz}{dl} \right) = \frac{Q}{A} \quad 28$$

$$\left(\frac{dp}{dl} + \rho g \frac{dz}{dl} \right) \Delta l \cdot n \cdot A = \frac{\mu}{k} \frac{Q}{A} \quad 27$$

(21)

Your answer in Section 7 is correct. Darcy's law, as an equation containing a derivative, is actually a differential equation. It relates flow per unit area, or flux, to the energy consumed per unit distance by friction. Analogies can readily be recognized between Darcy's law and the differential equations governing the steady flow of heat or electricity. The hydraulic conductivity, K , is analogous to thermal or electrical conductivity; while hydraulic head, h , is a po-

tential analogous to temperature or voltage. (To be more correct, the term Kh constitutes a ground-water velocity potential—that is, a function whose derivative yields the flow velocity—provided both the fluid and the porous medium are homogeneous and the medium is isotropic.)

This concludes the programmed instruction of Part II. A discussion in text format dealing with generalizations of Darcy's law begins on the page following Section 37.

(22)

Your answer in Section 15 is not correct. The diagram shows the gravitational force vector, F_g , resolved into two components, one parallel to the direction of flow, f_t , and one perpendicular to it, f_n . If the flow were vertically downward—that is, collinear with F_g —the entire gravitational force would be effective in producing flow. In the situation shown, however, one component of the gravitational force— f_t , or that perpendicular to the flow—is balanced by static forces exerted by the walls of the pipe. To view this in another way, we may note that the fluid velocity itself is a vector, in the direction \vec{L} . No vector can have a component perpendicular to its own direction; so the velocity vector

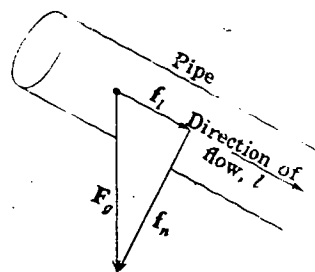

has no component in the direction of f_n . The force component f_n can therefore contribute nothing to the fluid velocity.

Return to Section 15 and choose another answer.

(23)

Your answer in Section 8 is not correct. The pressure at a point in a fluid is a scalar quantity; it is not directional in character, and we say that it "acts in all directions." However, if we choose any small cross-sectional area within the fluid, we can measure a force against this area attributable to the pressure, regardless of the orientation of the area. This force is a vector, or directed quantity; it acts in a direction normal to the small area and has a magnitude equal to the product of the pressure and the area. In the example of Sections 1 and 8, we consider the pressure at two points, the upstream and downstream faces of our fluid element. At the upstream face we write an expression

$p_1 A$ for the magnitude of the force in the direction of the flow. At the downstream face we are interested in a force opposing the flow—that is, acting in a direction opposite to the flow. The magnitude of this force is again given as a product of pressure, porosity, and face area, $p_2 n A$; but because we are interested in the force acting *against* the flow or in a direction opposite to that originally taken, we now introduce a negative sign. The net force on the fluid element along the axis of the pipe can now be obtained by algebraic addition of the two force expressions.

Return to Section 8 and choose another answer.

(24)

Your answer in Section 11 is not correct. The idea here is simply to combine the expressions obtained for the net pressure force (see Section 26) and for the component of the gravitational force parallel to the pipe (see Section 11). Forces are always combined by means of vector addition. In this case, however, the two vectors we are considering are oriented in the same direction. That is,

both the net pressure force and our component of the gravitational force are oriented in the direction of the flow. In this case, therefore, vector addition amounts to no more than the simple scalar addition of the magnitudes of the two components.

Return to Section 11 and choose another answer.

(25)

Your answer in Section 1 is not correct. If we were dealing with open flow in the pipe, the force on the fluid element would indeed be given by the term $p_1 A$. Here, however, a part of the area A is occupied by solid sand grains and the remainder by the upstream

face of the fluid element. For our purposes here, we may assume that the ratio of fluid area to total area is equal to the porosity, n .

Return to Section 1 and choose another answer.

(26)

Your answer in Section 31,

$$-\frac{dp}{dl} \Delta l n A,$$

is correct. The gradient or derivative of pressure, dp/dl , multiplied by the length interval, Δl , gives the change in pressure, $p_2 - p_1$, occurring in that interval. Since we require the term $p_1 - p_2$, we use a negative sign. Multiplication by the fluid area, nA , then gives the net pressure force on the element.

Our purpose in this chapter is to develop Darcy's law by equating the forces driving a flow to the frictional force retarding it. We have considered the pressure force, which is one of the forces driving the flow. In addition to this pressure force, the element of fluid is acted upon directly by the force of gravity. The total gravitational force on the element is given by the acceleration due to gravity, g , multiplied by the mass, m , of fluid in the element.

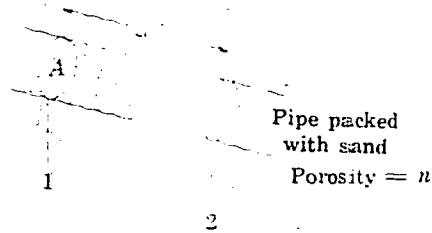

QUESTION

Which of the following equations for the mass of fluid in our element, which is shown again in the diagram, is correct?

- $m = \Delta l \cdot n \cdot A$
- $m = \rho \cdot \Delta l \cdot A$
- $m = \rho \cdot \Delta l \cdot n \cdot A$

Turn to Section:

- 3
- 17
- 15

(27)

Your answer,

$$\left(\frac{dp}{dl} + \rho g \frac{dz}{dl} \right) \Delta l \cdot n \cdot A = \frac{\mu}{k} \frac{Q}{A}$$

in Section 20 is not correct. Each of the force terms—the net driving force and the retarding force—contains the expression $\Delta l \cdot n \cdot A$

representing the volume of fluid in the element. When these force terms are added and their sum set equal to zero, the term $\Delta l \cdot n \cdot A$ may be divided out of the equation.

Return to Section 20 and choose another answer.

(28)

Your answer in Section 20,

$$-\frac{k}{\mu} \left(\frac{dp}{dl} + \rho g \frac{dz}{dl} \right) = \frac{Q}{A}$$

is correct. For the case of a fluid of uniform density and viscosity, the terms μ and ρ are constants and may be combined with the other constants in the problem to form a new constant, K , defined as

$$K = \frac{k \rho g}{\mu}$$

Using this new constant we may rewrite our equation in the form

$$-K \left(\frac{dp}{dl} + \frac{dz}{dl} \right) = \frac{Q}{A}$$

(continued on next page)

(28)—Con.

QUESTION

Keeping in mind that the term $1/\rho g$ is a constant, so that

$$\frac{1}{\rho g} \frac{dp}{dl} = \frac{d\left(\frac{p}{\rho g}\right)}{dl}$$

which of the equations given below constitutes a valid expression of the equation we have just obtained?

Turn to Section:

$$\frac{Q}{A} = -K \frac{dh}{dl} \quad 7$$

$$\frac{Q}{A} = -K \left(\frac{dp}{dl} + \frac{dz}{dl} \right) \quad 9$$

$$\frac{Q}{A} = -K \left(\frac{1}{\rho g} \frac{dp}{dl} + \frac{dh}{dl} \right) \quad 30$$

h represents the head as defined in Part I—that is,

$$h = \frac{p}{\rho g} + z.$$

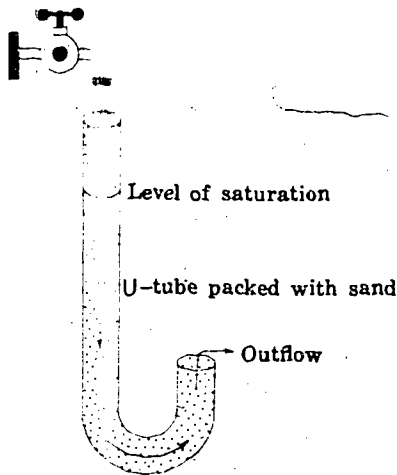
(29)

Your answer in Section 7 is not correct. Ground water frequently discharges upward into stream valleys; and in the figure, upward flow occurs in the shorter arm of the U-tube. Thus statement (a) of Section 7 cannot always be true.

Return to Section 7 and choose another answer.

(30)

Your answer in Section 28 is not correct. We saw in Part I that hydraulic head, h , was given by

$$h = \frac{p}{\rho g} + z.$$

The derivative of h with respect to distance, l , is therefore given by

$$\frac{dh}{dl} = \frac{d\left(\frac{p}{\rho g} + z\right)}{dl}$$

Using this relation, return to Section 28 and choose another answer.

(31)

Your answer in Section 8 is correct. The net force in the direction of flow is given by the difference between the two opposing forces exerted upon the opposite faces of the element by the adjacent elements of fluid. We may now factor out the common term nA and obtain as our expression for net pressure force $(p_1 - p_2)nA$, or $-\Delta p nA$, where Δp indicates the small pressure difference, $p_2 - p_1$, between the downstream face of the fluid element and the upstream face.

Since pressure is varying from point to point within our system, we may speak of a pressure gradient; that is, a rate of change of pressure with distance, l , along the flow path. This gradient might be expressed, for example, in pounds per square inch (of pressure) per foot (of distance); it is represented by the symbol dp/dl , and is referred to as the derivative of pressure with respect to distance in the direction l . If we were to plot a graph of pressure versus distance, dp/dl would represent the slope of the graph.

QUESTION

Which of the following expressions is approximately equivalent to the net pressure

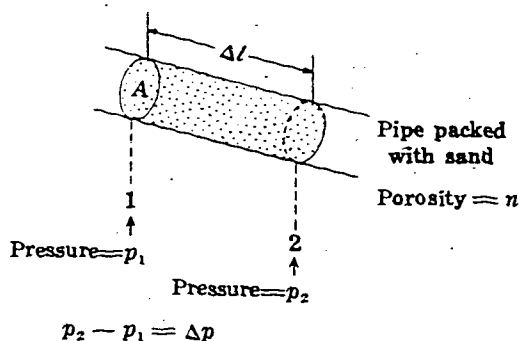

force, $-\Delta p nA$, on our element of fluid (shown again in the diagram)?

Turn to Section:

$\frac{dp}{dl} \Delta l nA$	26
$\frac{dp}{dl} nA$	5
$\Delta p \frac{dp}{dl} nA$	14

(32)

Your answer, $\rho \cdot n \cdot \Delta l \cdot A \cdot g \cdot \sin \gamma$, in Section 35 is not correct. We have already seen that the magnitude of our force component is given by $\rho \cdot n \cdot \Delta l \cdot A \cdot g \cdot \cos \gamma$. In the answer you have chosen, $\sin \gamma$ has been substituted for $\cos \gamma$ in our original expression—and this can be true only for a particular value of the

angle γ . It is true, however, that the idea of this question is to find an equivalent term for $\cos \gamma$ and substitute it in our previous expression for the force component.

Return to Section 35 and choose another answer.

(33)

Your answer in Section 15 is correct; we may resolve the gravitational force, F_g , into two orthogonal components, f_t and f_n , parallel to and perpendicular to the axis of the pipe as shown in the figure. There is no movement perpendicular to the pipe; the component of the gravitational force in this direction is

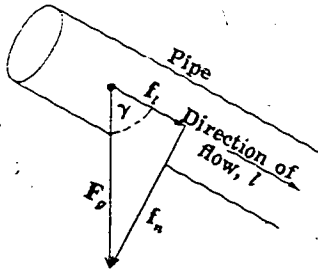

balanced by static forces exerted against the fluid element by the wall of the pipe. The component parallel to the pipe does contribute to the motion and must be taken into account in equations describing the flow.

QUESTION

The magnitude of the total gravitational force upon the element is given by the mass of the element multiplied by the acceleration due to gravity; that is, $F_g = mg$, where m is the mass of the fluid element. Referring to the diagram shown, which of the following expressions gives the magnitude of the component of the gravitational force parallel to the axis of the pipe?

Turn to Section:

$f_t = \rho \cdot n \cdot \Delta l \cdot A \cdot g$	6
$f_t = \rho \cdot n \cdot \Delta l \cdot A \cdot g \cdot \cos \gamma$	35
$f_t = n \cdot \Delta l \cdot A \cdot g \cdot \tan \gamma$	37

(34)

Your answer in Section 19,

$$\frac{1}{k} \frac{Q^2 \mu}{\Delta l \cdot n \cdot A}$$

is not correct. Our assumptions were that the retarding force would be proportional in some way to the dynamic viscosity (μ), to the volume of fluid in the element ($\Delta l \cdot n \cdot A$), and to the specific discharge, or flow per unit area (Q/A). Your answer represents the retard-

ing force as proportional to the square of fluid discharge, which might be compatible with the assumptions, but as inversely proportional to the volume of fluid in the element, which is not compatible with the assumptions.

Return to Section 19 and choose another answer.

(35)

Your answer, $\rho \cdot n \cdot \Delta l \cdot A \cdot g \cdot \cos \gamma$, in Section 33 is correct. The mass of the fluid element, as we have seen is $\rho \cdot n \cdot \Delta l \cdot A$; multiplication by the acceleration, g , gives the total gravitational force on the element. The component of this force parallel to the pipe, as indicated by the vector diagram, will be found by multiplying the total force by the cosine of γ .

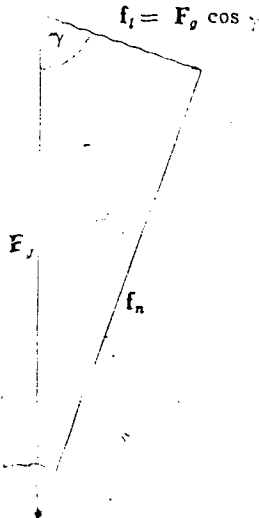
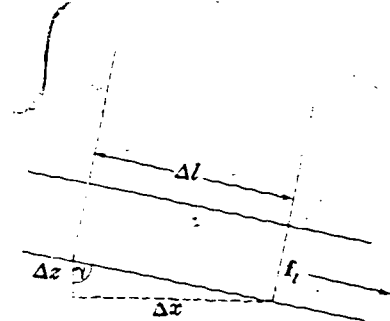

QUESTION

Suppose we now draw a small right triangle, taking the hypotenuse as Δl , the length of our fluid element, and constructing the two sides Δz and Δx as in the diagram. Which of the following expressions may then be used for the magnitude (without regard to sign) of the component of gravitational force parallel to the flow?

- Turn to Section:
- $\rho \cdot n \cdot \Delta l \cdot A \cdot g \cdot \sin \gamma$ 32
 - $\rho \cdot n \cdot A \cdot g \cdot \sqrt{(\Delta x)^2 + (\Delta z)^2}$ 4
 - $\rho \cdot n \cdot \Delta l \cdot A \cdot g \cdot \frac{\Delta z}{\Delta l}$ 11

(36)

Your answer in Section 20 is not correct. If the sum of the two force expressions is set equal to zero, we have

$$-\left(\frac{dp}{dl} + \rho g \frac{dz}{dl}\right)(\Delta l \cdot n \cdot A) - \frac{1}{k} \mu (\Delta l \cdot n \cdot A) \frac{Q}{A} = 0.$$

We may divide through by the term $\Delta l \cdot n \cdot A$, representing the volume of fluid in the element, and rearrange the resulting equation to obtain the required result.

Return to Section 20 and choose another answer.

(37)

Your answer in Section 33 is not correct. The total gravitational force on the element is given by mg , where m is the mass of fluid in the element and g is the acceleration due to gravity. The mass of fluid in the element is in turn given by the volume of fluid in the

element multiplied by the mass per unit volume, or mass density, of the fluid, which we have designated ρ . The volume of fluid in the element, as we have seen is $n \cdot \Delta l \cdot A$, where n is the porosity. The mass is therefore $\rho \cdot n \cdot \Delta l \cdot A$; and the total force of gravity on the fluid element is given by

$$F_g = \rho \cdot n \cdot \Delta l \cdot A \cdot g.$$

We require the component of this gravitational force parallel to the axis of the pipe. The sketch shows a vector diagram in which the length of each arrow is proportional to the force or component it represents. The gravitational force is represented by the arrow F_g and the components are represented by the arrows f_t and f_n . The rule for the resolution of a vector into components can be visualized from geometric considerations. The magnitude of the component of a vector in a given direction is the product of the magnitude of the vector and the cosine of the angle between the direction of the vector and the given direction.

Return to Section 33 and choose another answer.

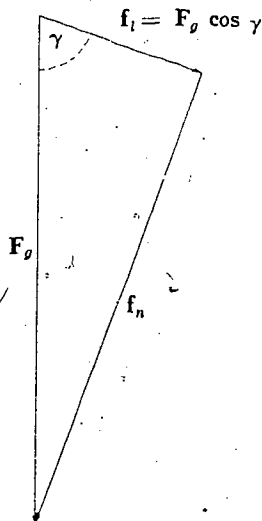

Generalizations of Darcy's Law

The form of Darcy's law considered in the preceding program is useful only for one-dimensional flow. The discussion in this section indicates, in general outline, the manner in which Darcy's law is extended to cover more complex situations. Vector notation is used for economy of presentation, and this discussion is intended primarily for readers familiar with this notation. Those concepts which are essential to material covered later in the program are treated again as they are required in the development—without the use of vector notation. The material presented here is not difficult, and readers not familiar with vector notation may find it possible to follow the mathematics by reference to a standard text on vector analysis. However, those who prefer may simply read through this section for familiarity with qualitative aspects of the material and may then proceed directly to Part III.

For three-dimensional flow, we may consider the specific discharge, q or Q/A , to be a vector quantity, with components iq_x , jq_y , and kq_z in the three coordinate directions. i , j , and k represent the standard unit vectors of the Cartesian system. We consider a small area, A_x , oriented at right angles to the x axis at a point 0, and observe the fluid discharge through this area to be Q_x ; the limiting value of the ratio Q_x/A_x , as A_x is made to shrink toward the point 0, gives the value of q_x applicable at point 0. q_y and q_z are similarly defined for the y and z directions. The specific discharge at point 0 is given by the vector sum

$$q = \frac{Q}{A} = iq_x + jq_y + kq_z.$$

q is thus a vector point function; its magni-

tude and direction may vary with location in steady flow and with location and time in unsteady flow.

If the porous medium is homogeneous and isotropic and if the fluid is of uniform density and viscosity, the components of the specific-discharge vector are each given by a form of Darcy's law, utilizing the partial derivative of head with respect to distance in the direction in question. That is, the components are given by

$$q_x = -K \frac{\partial h}{\partial x}$$

$$q_y = -K \frac{\partial h}{\partial y}$$

$$q_z = -K \frac{\partial h}{\partial z}$$

where K is the hydraulic conductivity.

It follows that the specific-discharge vector in this case will be given by

$$q = -K \left\{ i \frac{\partial h}{\partial x} + j \frac{\partial h}{\partial y} + k \frac{\partial h}{\partial z} \right\}$$

or

$$q = -K \nabla h$$

where ∇h denotes the head-gradient vector.

Thus, if the medium is isotropic and homogeneous, $-Kh$ constitutes a velocity potential; and the various methods of potential theory, as applied in studying heat flow and electricity, may be utilized in studying the ground-water motion. Since the specific-discharge vector is colinear with ∇h , it will be oriented at right angles to the surfaces of equal head, and flownet analysis immediately suggests itself as a useful method of solving field problems.

In practice, one does not usually find homogeneous and isotropic aquifers with which to work; frequently, however, simply for lack of more detailed data, aquifers are assumed to be homogeneous and isotropic in obtaining initial or approximate solutions to ground-water problems.

The situation in many aquifers can be represented more successfully by a slightly more general form of Darcy's law, in which a different hydraulic conductivity is assigned to each of the coordinate directions. Darcy's law then takes the form

$$q_x = -K_x \frac{\partial h}{\partial x}$$

$$q_y = -K_y \frac{\partial h}{\partial y}$$

$$q_z = -K_z \frac{\partial h}{\partial z}$$

where K_x , K_y , and K_z represent the hydraulic conductivities in the x , y , and z directions, respectively, and again

$$q = iq_x + jq_y + kq_z.$$

This form of Darcy's law can be applied only to those anisotropic aquifers which are characterized by three principal axes of hydraulic conductivity (or permeability) which are mutually orthogonal, so that the direction of maximum hydraulic conductivity is at right angles to the direction of minimum hydraulic conductivity. These axes must correspond with the x , y , and z axes used in the analysis. The implication is that one of the principal axes of conductivity must be vertical; for unless the z axis is taken in the vertical direction, the term $\partial h / \partial z$ cannot be used to represent the sum of the vertical pressure gradient and the gravitational force term.

It is easily demonstrated that the specific-discharge vector and the lines of flow are no longer orthogonal to the surfaces of equal head in this anisotropic case, and that the conditions for the existence of a velocity potential are no longer satisfied. Formal mathematical solutions to field problems are essentially as easy to obtain as in the isotropic case, however, since a relatively simple

transformation of scales can be introduced which converts the anisotropic system to an equivalent isotropic system (Muskat, 1937). The problem may then be solved in the equivalent isotropic system, and the solution retransformed to the original anisotropic system.

Probably the most common form of anisotropy encountered in the field is that exhibited by stratified sedimentary material, in which the permeability or hydraulic conductivity normal to the bedding is less than that parallel to the bedding. If the bedding is horizontal, the form of Darcy's law given above may be applied, using $K_x = K_y$. The anisotropy in this case is two-dimensional, with the axis of minimum permeability normal to the bedding, and the axis of maximum permeability parallel to it. In many cases, aquifers are assumed to exhibit simple two-dimensional anisotropy of this sort when in fact they are characterized by heterogeneous stratification and discrete alternations of permeability. This type of simplifying assumption frequently enables one to obtain an approximate solution, where otherwise no solution at all would be possible.

For many problems, however, this generalized form of Darcy's law is itself inadequate. As an example, one may consider a stratified aquifer, exhibiting simple two-dimensional anisotropy, which is not horizontal, but rather is dipping at an appreciable angle. The direction of minimum permeability, normal to the bedding, does not in this case coincide with the vertical. One may choose new coordinate axes to conform to the new principal directions of conductivity. If this is done, the component of the specific discharge in each of these new coordinate directions must be expressed in terms of the pressure gradient in the direction concerned, and the component of the gravitational force in that direction. Reduction of the equations to the simple form already given, using the principal directional derivatives of h , is not possible. Alternatively, one may retain the horizontal-vertical coordinate system, in which case the principal axes of conductivity do not coincide with the coordinate axes. In this case, hydraulic conductivity must be ex-

pressed as a tensor; the component of the specific discharge in one coordinate direction will not depend solely on the head gradient in that direction, but upon the head gradients in the other coordinate directions as well.

In addition to these considerations regarding aquifer anisotropy, practical problems require that attention be paid to heterogeneity, both of the aquifer and of the fluid. If the aquifer is heterogeneous, hydraulic conductivity must be treated as a function of the space coordinates; in this case, hydraulic conductivity (or in some cases intrinsic permeability) is usually defined as a tensor which varies with position in the aquifer.

If the fluid is heterogeneous, its viscosity and density cannot be treated as constants, as was done in the program section of Part II. Equations cannot be reduced to terms of the hydraulic conductivity and head gradients, but must rather be retained in terms of specific permeability, viscosity, pressure gradients, and components of the gravitational force (which depend upon fluid density, and will vary with position, and possibly with time, as fluid density varies). A special case of some importance is that in which the aquifer is horizontal, with principal axes of permeability in the x , y , and z directions, but

the fluid varies in both density and viscosity. Darcy's law for this case may be written

$$q_x = -\frac{k_x}{\mu_{x,y,z}} \frac{\partial p}{\partial x}$$

$$q_y = -\frac{k_y}{\mu_{x,y,z}} \frac{\partial p}{\partial y}$$

$$q_z = -\frac{k_z}{\mu_{x,y,z}} \left(\frac{\partial p}{\partial z} + \rho_{x,y,z} g \right)$$

and again

$$q = i q_x + j q_y + k q_z.$$

In these equations, k_x , k_y , and k_z are the intrinsic permeabilities in the x , y , and z directions; $\mu_{x,y,z}$ is the dynamic viscosity function; $\rho_{x,y,z}$ is the density function; and the other terms are as previously defined. Since gravity is assumed to have no components in the horizontal plane, density does not enter into the expressions for q_x and q_y . In natural aquifers, variations in density are related primarily to variations in dissolved-solid content of the water, while variations in viscosity are related primarily to variations of ground-water temperature. The equations given above thus have utility in situations where water quality and water temperature are known to vary in an aquifer.

Part III. Application of Darcy's Law to Field Problems

Darcy's law, as mentioned in the discussion at the close of Part II, may be generalized to deal with three-dimensional flows; and it may be combined with other laws or concepts to develop equations for relatively complex problems of ground-water hydraulics. Even in the simple form developed in the program

of Part II, however, Darcy's law has direct application to many field problems. In Part III we shall consider a few examples of such direct application. Later, in Part V and VI, we will consider the combination of Darcy's law with other concepts to yield equations for more complex problems.

I □

In Part II we pointed out that Darcy's law is a differential equation—that is, an equation containing a derivative. It gives us some information about the rate at which head changes with distance, under given conditions of flow. In general, in dealing with ground-water problems, we will require expressions that relate *values* of head, rather than the rate of change of head, to flow conditions. To proceed from a differential equation, describing the rate of change of head, to an algebraic equation giving values of head, is to obtain a solution to the differential equation. There are various techniques for doing this. We need not go into these techniques of solution here. For our purposes, it will be sufficient if we can recognize a solution when we are given one—that is, if we can test an algebraic equation to determine whether it is a solution to a given differential equation. This is just a matter of differentiation. When we wish to know whether an algebraic equation is a solution to a differ-

ential equation, we may simply differentiate the algebraic equation. If we obtain a result which is equivalent to the given differential equation, then the algebraic equation is a solution to the differential equation. Should we fail to obtain an equivalent result, the algebraic equation is not a solution. Thus, for our present purposes at least, we may consider a solution to a differential equation to be an algebraic equation which, when differentiated, will yield the given differential equation.

QUESTION

Which of the following algebraic equations is a solution to the differential equation

$$\frac{dy}{dx} = K ?$$

$$y = Kx^2$$
$$x = 2y + K$$
$$y = Kx + 5$$

Turn to Section:

15

23

7

□ 2

Your answer in Section 35,

$$\frac{dh}{d(\ln r)} = \frac{Q}{2\pi K b}$$

is correct. This equation is equivalent to the original differential equation for the problem and states that the rate of change of hydraulic head, with respect to change in the natural logarithm of radial distance, is constant and equal to

$$\frac{Q}{2\pi K b}$$

QUESTION

Suppose we were to plot a graph of hydraulic head versus the natural log of radial distance from the well, in our discharging well problem. Which of the following statements would apply to this graph?

Turn to Section:

- (a) The plot would become progressively steeper with decreasing values of $\ln r$ —that is, as the well is approached. 18
- (b) Equal changes in head would be observed over intervals representing equal changes in r . 31
- (c) The plot would be a straight line. 38

□ 3

Your answer in Section 19 is correct. If the head in the well (and throughout the aquifer) prior to pumping is equal to h_e , the term $h_e - h_w$ is actually the drawdown in the pumping well (assuming that there are no additional losses in head associated with flow through the well screen, or within the well itself). Thus the equation in your answer allows us to predict the drawdown associated with any discharge, Q . Alternatively, the equation can be viewed as a method of calculating the hydraulic conductivity, K , of the aquifer on the basis of field measurements of Q and $h_e - h_w$, or on the basis of head measurements at any arbitrary radii, r_1 and r_2 , using observation wells. The theory of steady-state flow to a well as developed here is often referred to as the Thiem theory, after G. Thiem, who contributed to its development (Thiem, 1906).

While it would not be common, in practice, to find a well conveniently located at the center of a circular island, the example is a very useful one. The hydraulic operation of any well is similar, in many important respects, to that of the well on the island. In

particular, the decrease in cross-sectional area of flow as the well is approached, leading to the logarithmic "cone of depression" in the potentiometric surface, is a feature of every discharging well problem. It is in fact the dominant feature of such problems, since the head losses close to the well, within this "cone of depression" are normally the largest head losses associated with the operation of a well. The radial symmetry assumed in the Thiem analysis usually prevails, at least in the area close to the well, in most discharging well problems.

Readers familiar with differential equations will note that the equations of radial flow developed here can be obtained more directly by separating variables in the differential equation

$$\frac{Q}{2\pi b r} = K \frac{dh}{dr}$$

and integrating between the limits r_1 and r_2 , or r_w and r_e . That is, these radial-flow equations, which state that head will vary with the logarithm of radial distance, are actually solutions to this differential equation

3 □ —Con.

tion; if they are differentiated with respect to r , the differential equation is obtained. Again readers familiar with the general concepts of potential theory will recognize the pattern of head loss around the well as an example of the "logarithmic potential" asso-

ciated with potential-flow problems involving cylindrical symmetry in other branches of physics.

You have completed Part III. You may go on to Part IV.

4 □

Your answer in Section 9,

$$h = h_0 - \frac{2Q}{Kw}x$$

is not correct. If we differentiate this equation, treating h_0 as a constant, we obtain the result

$$\frac{dh}{dx} = -\frac{2Q}{Kw}$$

which is not the differential equation de-

veloped for the problem. Keep in mind that in order to find a solution to the differential equation

$$\frac{d(h^2)}{dx} = -\frac{2Q}{Kw}$$

we must find an expression which will yield this equation upon differentiation.

Return to Section 9 and choose another answer.

5 □

Your answer in Section 8 is not correct. The differential equation tells us that any solution we obtain, giving h as a function of x , must be such that the derivative of h with respect to x , dh/dx is a constant, $-(Q/KA)$. Thus we know that (1) since the derivative is a constant (does not involve x), the plot of h versus x for any solution must have a constant slope—that is, the plot must be a straight line; and (2) since the constant has

the same value for any solution, the graphs of different or distinct solutions must all have the same slope—that is, these plots must be parallel straight lines. A family of curves all intersecting the x axis at a common point, as in the answer which you chose, could not have these characteristics.

Return to Section 8 and choose another answer.

6 □

Your answer in Section 41 is not correct. The direction of flow in this problem is radial, toward the well as an axis. The cross-sectional area of flow must be taken at right angles to this radial flow direction; that is, it must be a cylindrical surface within the aquifer having the centerline of the well as its

axis. At a radial distance r from the well, the cross-sectional area of flow will be the area of a cylindrical surface of radius r and of height equal to the thickness of the aquifer.

Return to Section 41 and select another answer.

□ 7

Your answer, $y = Kx + 5$, in Section 1 is correct; of the three expressions given, it is the only one which yields $dy/dx = K$ upon differentiation. However, $y = Kx + 5$ is obviously not the only equation which will give this result upon differentiation. For example, differentiation of the equations $y = Kx + 7$, $y = Kx - 3$, or $y = Kx$ will also yield $dy/dx = K$. The constant term which is added or subtracted on the right does not affect the differentiation regardless of the value of the constant, the derivative of y with respect to x always turns out to be K . Since we have an infinite choice of constants to add or subtract, there are an infinite number of algebraic equations which qualify as solutions to our differential equation. This is a general characteristic of differential equations—the solutions to a differential equation are always infinite in number.

- (a) $h = -\frac{Q}{KA}x$
- (b) $h = h_0 - \frac{Q}{KA}x$
- (c) $h = h_0 - \frac{Q}{KA}x^2 + 7$

where h_0 , Q , K , and A are constants; which of the equations are solutions to the differential equation

$$\frac{Q}{A} = -K \frac{dh}{dx} ?$$

QUESTION

Given the following three algebraic equations relating head, h , to distance, x .

- all three
- only (a)
- (a) and (b) but not (c)

Turn to Section:

29
14
8

□ 8

Your answer in Section 7 is correct. Either (a) or (b), when differentiated and rearranged, will yield the equation

$$\frac{Q}{A} = -K \frac{dh}{dx}$$

Differentiation of (c) leads to an entirely different equation.

In the preceding example, the algebraic equations deal with values of hydraulic head, h , at various distances from some reference point; while the differential equation deals with the rate of change of head with distance. The differential equation is, of course, Darcy's law and states that if head is plotted versus distance, the slope of the plot will be constant—that is, the graph will be a straight

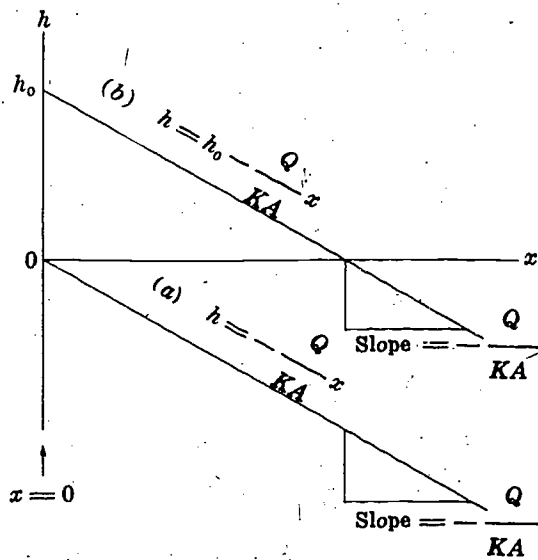

8 □ —Con.

line. The graphs of equations (a) and (b) of Section 7 are shown in the diagram. Each is a straight line having a slope equal to

$$-\frac{Q}{KA};$$

the intercept of equation (a) on the h axis is $h=0$, while the intercept of equation (b) on the h axis is $h=h_0$. These intercepts give the values of h at $x=0$; they provide the reference points from which changes in h are measured.

QUESTION

If we were to graph all possible solutions to the differential equation

$$\frac{dh}{dx} = -\frac{Q}{KA},$$

the result would be:

Turn to Section:

A family of curves, infinite in number, each intersecting the x axis at

$$x = -\frac{Q}{KA}$$

5

An infinite number of parallel straight lines, all having a slope

$$-\frac{Q}{KA},$$

and distinguished by different intercepts on the $x=0$ axis.

10

A finite number of parallel straight lines, all having a slope

$$-\frac{Q}{KA},$$

which intersect the $x=0$ axis at various positive values of h .

20

9 □

Your answer in Section 25,

$$Q = -Kwh \frac{dh}{dx},$$

is correct. From the rules of differentiation, the derivative of h^2 with respect to x is given by

$$\frac{d(h^2)}{dx} = 2h \frac{dh}{dx}.$$

Therefore, substituting

$$\frac{1}{2} \frac{d(h^2)}{dx}$$

for $h(dh/dx)$ in the equation

$$Q = -Kwh \frac{dh}{dx}$$

and rearranging, we have

$$\frac{d(h^2)}{dx} = \frac{-2Q}{Kw}.$$

In this rearranged form, the differential equation states that the derivative of h^2 with respect to x must equal the constant term

$$\frac{-2Q}{Kw}.$$

QUESTION

Which of the following expressions, when differentiated, yields the above form of the differential equation—that is, which of the following expressions constitutes a solution to the differential equation? (h_0 is a constant, representing the value of h at $x=0$.)

Turn to Section:

$$h^2 = h_0^2 - \frac{2Q}{Kw} x^2 \quad 16$$

$$h^2 = h_0^2 - \frac{2Q}{Kw} x \quad 41$$

$$h = h_0 - \frac{2Q}{Kw} x \quad 4$$

Your answer in Section 8 is correct. Any straight line having the slope

$$\frac{Q}{KA}$$

will be the graph of a solution to the differential equation

$$\frac{dh}{dx} = \frac{Q}{KA}$$

There are an infinite number of lines which may have this slope, corresponding to the infinite number of solutions to the differential equation.

The figure shows a confined aquifer of thickness b . The aquifer is completely cut by a stream, and seepage occurs from the stream into the aquifer. The stream level stands at an elevation h_0 above the head datum, which is an arbitrarily chosen level surface. The direction at right angles to the stream is denoted the x direction, and we take x as 0 at the edge of the stream. We assume that the system is in steady state, so that no changes occur with time. Along a reach of the stream having length w , the total rate of seepage loss from the stream (in, say, cubic feet per second) is denoted $2Q$. We assume that half of this seepage occurs through the right bank of the stream, and thus enters the part of the aquifer shown in our sketch. This seepage then moves away from the stream in a steady flow along the x direction. The resulting distribution of hydraulic head within the aquifer is indicated by the dashed line marked "potentiometric surface" in the sketch. This surface, sometimes referred to as the "piezometric surface," actually traces the static water levels in wells or pipes tapping the aquifer at various points. The differential equation applicable to this problem is obtained by applying Darcy's law to the

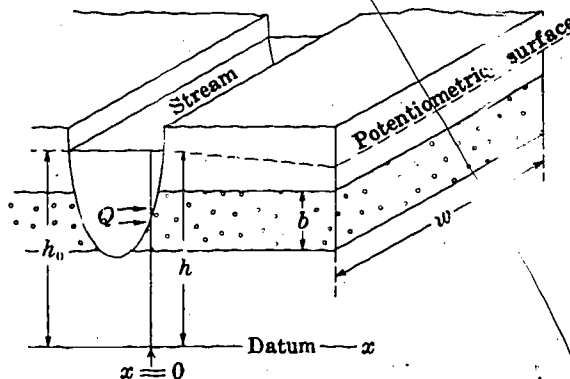

flow, Q , across the cross-sectional area, bw , and may be written

$$\frac{dh}{dx} = -\frac{Q}{Kbw}$$

where K is the hydraulic conductivity of the aquifer. The head distribution—that is, the potentiometric surface—is described by one of the solutions to this differential equation. In addition to satisfying the differential equation, the required solution must yield the correct value of h at the edge of the stream—that is, at $x=0$.

QUESTION

Which of the following expressions gives the particular solution (to the above differential equation) which applies to the problem described in this section?

Turn to Section:

$$h = -\frac{Q}{Kbw}x \quad 22$$

$$h = 2Q - \frac{Q}{Kbw}x \quad 36$$

$$h = h_0 - \frac{Q}{Kwb}x \quad 24$$

11 □

Your answer in Section 27 is not correct. The decrease in radius does not compensate for the decrease in cross-sectional area; it is, rather, the cause of this decrease in cross-sectional area. The decreasing cross-sectional area, along the path of flow, is a fundamental

characteristic of the problem we are considering. It has a major—in fact, dominant—effect upon the solution to the problem.

Return to Section 27 and choose another answer.

12 □

Your answer in Section 41 is not correct. The flow of water is directed radially inward toward the well. Any cross-sectional area of flow, taken normal to this radial direction of movement, would be a cylindrical surface in the aquifer, having the centerline of the well

as its axis. The area of flow at a radial distance r from the well would thus be the area of a cylindrical surface of radius r , having a height equal to the thickness of the aquifer.

Return to Section 41 and choose another answer.

13 □

Your answer in Section 35,

$$(\ln r) \frac{dh}{dr} = \frac{Q}{2\pi Kb}$$

is not correct. The differential equation as given in Section 35 was

$$r \frac{dh}{dr} = \frac{Q}{2\pi Kb}$$

In your answer, $\ln r$ has simply been sub-

stituted for r . This is obviously not what we want; $\ln r$ is not equal to r . The relations given in Section 35 can be used to obtain an expression which is equivalent to dh/dr . This expression can then be substituted for dh/dr in the above differential equation to obtain the required result.

Return to Section 35 and choose another answer.

14 □

Your answer in Section 7 is not correct. It is true that expression (a),

$$h = -\frac{Q}{KA}x,$$

yields the result

$$\frac{dh}{dx} = -\frac{Q}{KA}$$

upon differentiation and is thus a solution to the given equation. However, it is not the only one of the given expressions which yields the required result upon differentiation.

Return to Section 7 and test the remaining expressions, by differentiation, in order to find the correct answer.

□ 15

Your answer, $y = Kx^2$, in Section 1 is not correct. If we differentiate the equation $y = Kx^2$, we obtain

$$\frac{dy}{dx} = 2Kx,$$

which is not the differential equation with which we started. Our differential equation was

$$\frac{dy}{dx} = K,$$

and we are looking for a solution to this differential equation—that is, we are looking for an algebraic expression which, when differentiated, will produce the differential equation $(dy/dx) = K$.

Return to Section 1 and test the remaining choices, by differentiating them, to see which will yield the given differential equation.

□ 16

Your answer in Section 9,

$$h^2 = h_0^2 - \frac{2Q}{Kw} x^2,$$

is not correct. If we differentiate this answer, treating h_0^2 as a constant, we obtain

$$\frac{d(h^2)}{dx} = -\frac{2Q}{Kw} \cdot 2x,$$

since the derivative of x^2 with respect to x

is $2x$. This result is not the differential equation with which we started, so the equation of your answer is not the solution we require.

Return to Section 9 and choose another answer. Keep in mind that the equation you select must yield the result

$$\frac{d(h^2)}{dx} = -\frac{2Q}{Kw}$$

when it is differentiated.

□ 17

Your answer in Section 40,

$$\frac{Q}{2\pi r b} = K \frac{d(h^2)}{dr},$$

is not correct. Darcy's law states that flow, divided by cross-sectional area, must be proportional to the head gradient. Your answer

states that flow, divided by cross-sectional area, is proportional to the gradient of the square of head. Thus it cannot be a valid application of Darcy's law to the problem.

Return to Section 40 and choose another answer.

□ 18

Your answer in Section 2 is not correct. The equation in Section 2 states that the derivative of head with respect to $\ln r$ is a constant. This derivative is simply the slope of a plot of h versus $\ln r$. If such a plot changes

slope, as in the answer you chose, the derivative cannot be constant.

Return to Section 2 and choose another answer.

19 □

Your answer in Section 38 is correct; inasmuch as $\log r$ changes by the same amount between 10 and 1 as it does between 1,000 and 100, the head changes by the same amount in these two intervals. If we were to replot head directly versus radius, r , rather than versus $\log r$, we would no longer have a straight line, but rather a "logarithmic" curve, as shown in the sketch. The gradient becomes progressively steeper as we approach the well, to compensate for the decreasing cross-sectional area of flow. This logarithmic pattern of head decline is sometimes referred to as the "cone of depression" in the potentiometric surface around the well.

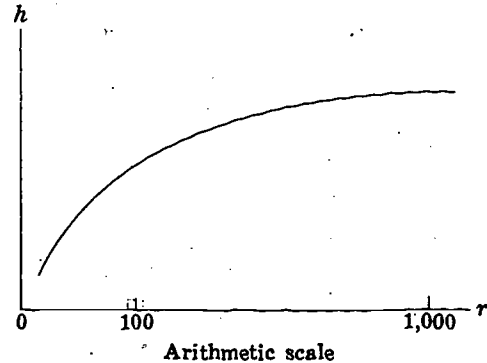

well which of the following expressions would result from this procedure?

QUESTION

The equation obtained in Section 38 can be applied between the radius of the island, r_e , and the radius of the well, r_w , to obtain an expression for the head difference between the well and edge of the island. If h_e represents the head at the edge of the island (that is, the level of the open water surrounding the island) and h_w represents the head in the

Turn to Section:

$$h_e - h_w = \frac{2.3Q}{2\pi Kb} \log \frac{r_w}{r_e} \quad 28$$

$$h_e - h_w = \frac{2.3Q}{2\pi Kb} \log \frac{r_e}{r_w} \quad 3$$

$$h_e - h_w = \frac{2.3Q}{2\pi Kb} (\log r_w - \log r_e) \quad 30$$

20 □

Your answer in Section 8 is not correct. If we were to write the solution to the equation

$$\frac{Q}{A} = -K \frac{dh}{dx}$$

in the most general form, we would write

$$h = -\frac{Q}{KA}x + c$$

where c could represent any constant term we wish. No matter what value we assign c , so long as it is constant (not dependent on x) its derivative with respect to x will be zero. Thus regardless of the value of c , differentiation will yield the result

$$\frac{dh}{dx} = -\frac{Q}{KA}$$

which is equivalent to our given differential equation. Clearly we can assign an infinite number of values to the term c , and obtain an infinite number of distinct equations (solutions) which we can differentiate to obtain our differential equation. Each of these solutions is the equation of a straight line; that is, each has a slope, dh/dx , equal to $-(Q/KA)$, and each has a distinct intercept on the h axis, where $x=0$. This intercept is simply the value of the constant c , since if we set $x=0$ in the solution we obtain $h=c$.

Return to Section 8 and choose another answer.

□ 21

Your answer in Section 24 is not correct. According to Darcy's law, the specific discharge, Q/A , is given by

$$\frac{Q}{A} = -K \frac{dh}{dx}$$

If the specific discharge increases as the stream is approached, the head gradient dh/dx must also increase—that is, become

steeper—as the stream is approached. A plot of h versus distance would thus be some sort of curve. In the statement of the problem in Section 24, however, head was described as increasing *linearly* with distance away from the stream. Since head increases in a linear fashion, dh/dx is constant.

Return to Section 24 and choose another answer.

□ 22

Your answer in Section 10,

$$h = -\frac{Q}{Kbw}x,$$

is not correct. It is true that differentiation of this equation yields the result

$$\frac{dh}{dx} = -\frac{Q}{Kbw}$$

which is our given differential equation; but this in itself is not enough to make it the answer to our problem. If we set x equal to zero in the expression

$$h = -\frac{Q}{Kwb}x,$$

we obtain the result $h=0$. That is, this equation says that where x is zero, at the edge of the stream, hydraulic head is also zero. Ac-

cording to the statement of our problem, however, head is equal to h_0 , the elevation of the stream surface above datum, at $x=0$. The solution which we require must not only have the property of yielding the given differential equation

$$\frac{dh}{dx} = -\frac{Q}{Kbw}$$

when it is differentiated; it must also have the property that when x is set equal to zero in the solution, hydraulic head will be h_0 . This is an example of what is meant by a *boundary condition*; the solution must satisfy a certain condition ($h=h_0$) along a certain boundary ($x=0$) of the problem.

Return to Section 10 and choose another answer.

□ 23

Your answer, $x=2y+K$, in Section 1 is not correct. We can rearrange the equation you selected as follows

$$y = \frac{1}{2}x - \frac{K}{2}$$

Now if we differentiate this equation, we obtain

$$\frac{dy}{dx} = \frac{1}{2},$$

which is not the differential equation with

which we started. We were asked to find a solution to the differential equation

$$\frac{dy}{dx} = K;$$

that is, we were asked to find an algebraic equation which, when differentiated, would yield the result $dy/dx=K$.

Return to Section 1 and test the remaining answers by differentiation, to see which one satisfies this condition.

24 □

Your answer in Section 10,

$$h = h_0 - \frac{Q}{Kbw}x$$

is correct. The differential equation tells us that a plot of h versus x will be a straight line with slope

$$-\frac{Q}{Kbw};$$

While from the other information given, we know that at $x=0$, h is equal to h_0 . Thus, to describe h as a function of x we require the equation of a straight line, with h_0 as the intercept and $-(Q/Kbw)$ as the slope. We can make two tests to verify that we have obtained the correct solution; first, we may differentiate the solution with respect to x , to see whether we obtain the differential equation; second, we may let x equal 0 in the solution to see whether the condition that h is h_0 at $x=0$ is satisfied. Only if our equation meets both of these tests is it the solution we require. The condition that h must be h_0 at $x=0$ is an example of what is commonly termed a *boundary condition*; it is a condition which states that h must have a certain value along one or another of the boundaries of our problem. The differential equation,

$$\frac{dh}{dx} = -\frac{Q}{Kbw},$$

is in itself insufficient to define head as a function of x . It establishes that the graph of h versus x will be a straight line with slope

$$-\frac{Q}{Kbw}$$

25 □

Your answer in Section 24 is correct. This serves to illustrate the dual utility of flow equations in ground-water hydraulics—they enable us to predict the head distributions associated with various conditions of flow and they enable us to draw conclusions regarding ground-water flow on the basis of head distributions observed in the field.

but there are an infinite number of such straight lines which we might draw. The additional information given by the boundary condition—that h must be h_0 at $x=0$ —permits us to pick out the particular straight line we require, by giving us its intercept. A boundary condition is thus a bit of information on the value of head at a known point; it provides a reference from which the changes in head indicated by a differential equation may be measured. The processes of (1) differentiation to establish that a given equation is a solution to a differential equation and (2) application of boundary conditions to establish that it is the particular solution that we require may be applied to problems much more complex than the one we have considered here.

QUESTION

Suppose that, in measuring observation wells tapping a confined aquifer, we observe a linear increase in head with distance away from a stream or channel which cuts completely through the aquifer; and suppose this pattern remains unchanged through a considerable period of time. Which of the following conclusions could we logically draw on the basis of this evidence?

Turn to Section:

- | | |
|--|----|
| There is no flow within the aquifer. | 42 |
| There is a steady flow through the aquifer into the stream. | 25 |
| A flow which increases in specific discharge as one approaches the stream occurs in the aquifer. | 21 |

Con.— □ 25

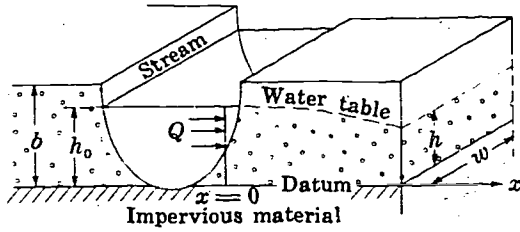

Along a reach of the stream having a length w , seepage into the aquifer occurs at a rate $2Q$; and we assume that half of this seepage moves to the right, into the part of the aquifer shown in the sketch.

QUESTION

According to the assumptions outlined above, which of the following relations is obtained by applying Darcy's law to this problem?

Turn to Section:

- $Q = -Kxw \frac{dh}{dx}$ 26
- $\frac{Q}{bw} = -K \frac{dh}{dx}$ 43
- $Q = -Kwh \frac{dh}{dx}$ 9

assume that vertical components of flow are negligible. This assumption is never wholly satisfied, as movement cannot be entirely lateral in and near the free surface, owing to the slope of the surface itself. Frequently, however, the vertical velocity component is slight compared to the lateral and therefore can be neglected, as we are doing here. An important difference between this problem and the confined-flow problem is that here the cross-sectional area of flow diminishes along the path of flow, as h decreases, whereas in the confined problem it remains constant.

□ 26

Your answer in Section 25,

$$Q = -Kxw \frac{dh}{dx}$$

is not correct. Darcy's law states that the flow is the product of the hydraulic conductivity, the cross-sectional area of flow, and the (negative) head gradient. Referring to

the diagram of Section 25, the cross-sectional area of the flow—that is, the cross-sectional area taken at right angles to the direction of movement—can be seen to be equal to wh . In the answer which you chose, the term xw appears as the area of flow.

Return to Section 25 and choose another answer.

□ 27

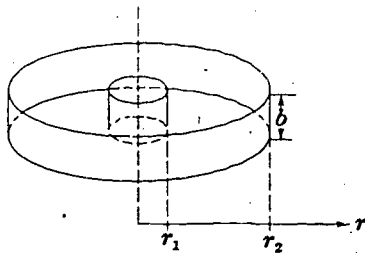

Your answer, $2\pi r b$, in Section 41 is correct. The flow is radially inward in the (negative) r direction—that is, parallel to the r axis of

polar coordinates. The cross-sectional area of flow is a surface which is everywhere normal to this direction of flow; hence it is a cylindrical surface, and its area is given by the expression for the area of a cylinder.

As we proceed inward along the path of flow in this problem, the cylindrical area of flow becomes smaller and smaller, as illustrated in the sketch. This is also evident from our expression for the cross-sectional area, which tells us that as r decreases, the area must decrease.

27 --Con.

QUESTION

Which of the following statements is correct?

(a) Although cross-sectional area is decreasing, radius is also decreasing. These factors combine in such a way that the hydraulic gradient remains constant.

11

(b) Cross-sectional area decreases along the path of flow, while discharge remains constant; therefore, the hydraulic gradient must increase along the path of flow.

40

(c) Cross-sectional area of flow decreases along the path of flow, but this is offset by convergence of the flowlines toward the well, and no increase in the hydraulic gradient occurs.

32

Turn to Section:

28

Your answer in Section 19,

$$h_c - h_w = \frac{2.3Q}{2\pi Kb} \log \frac{r_w}{r_c},$$

is not correct. If we let h_c and r_c be represented by h_2 and r_2 , and if we let h_w and r_w be represented by h_1 and r_1 , your answer can be restated in the form

$$h_2 - h_1 = \frac{2.3Q}{2\pi Kb} \log \frac{r_1}{r_2}.$$

Comparison with the equations in Section 38 will show that this is not the form which we require.

Return to Section 19 and choose another answer.

29

Your answer in Section 7 is not correct. The given differential equation

$$\frac{Q}{A} = -K \frac{dh}{dx}$$

can be rearranged to

$$\frac{dh}{dx} = -\frac{Q}{KA}$$

In order for all three of the given expressions to be solutions to this equation, all three would have to yield $-(Q/KA)$ as the derivative of h with respect to x . But if we differentiate expression (c), for example, which was

$$h = h_0 - \frac{Q}{KA} x^2 + 7,$$

we obtain

$$\frac{dh}{dx} = -\frac{2Q}{KA} x,$$

which is not the given differential equation. Thus we can see that at least expression (c) does not satisfy the given equation.

Return to Section 7 and test the remaining expressions, by differentiation, in order to find the correct answer.

□ 30

Your answer in Section 19,

$$h_c - h_w = \frac{2.3Q}{2\pi K b} (\log r_w - \log r_c),$$

is not correct. The term $\log r_c$ will obviously be greater than $\log r_w$, since r_c is much greater than r_w . Thus the expression on the

right in your answer will be negative, implying that h_w is greater than h_c . This does not make sense; the head in a discharging well cannot be greater than the head at the radius of influence of the well.

Return to Section 19 and choose another answer.

□ 31

Your answer in Section 2 is not correct. If equal changes in head were observed over intervals representing equal changes in r , we could write

$$\frac{\Delta h}{\Delta r} = \text{constant}$$

where Δh is the change in head which is always observed over any interval of radial width Δr . In derivative form this would be

$$\frac{dh}{dr} = \text{constant},$$

and this is not the condition which has been shown to apply to this problem. The condition our plot must satisfy, rather, is

$$\frac{dh}{d(\ln r)} = \text{constant}.$$

Return to Section 2 and choose another answer.

□ 32

Your answer in Section 27 is not correct. The convergence of flowlines toward the well does not compensate for the decrease in flow area; it is, rather, caused by this decrease in flow area. The decrease in flow area as the well is approached is a fundamental charac-

teristic of the discharging well problem; in effect the decreasing flow area has a dominant influence on the form of the head distribution around the well.

Return to Section 27 and select another answer.

□ 33

Your answer in Section 40,

$$\frac{Q}{A} = K \frac{dh}{dx},$$

is not correct. The x coordinate was not used in our analysis of this problem; we did not

set up an x axis along which head could vary. The answer which you selected involves a derivative of head with respect to x and thus cannot apply to our problem.

Return to Section 40 and choose another answer.

34 □

Your answer in Section 38 is not correct. The equation

$$h_2 - h_1 = \frac{2.3Q}{2\pi Kb} \cdot \log \frac{r_2}{r_1}$$

indicates that if the ratio r_2/r_1 —that is, the ratio of the outer radius to the inner radius—

is the same for two different intervals, then the head drops across those intervals must be equal. For the two intervals mentioned in the answer which you chose, these ratios are 10/1 and 1000/100.

Return to Section 38 and choose another answer.

35 □

Your answer in Section 40 is correct. The hydraulic gradient here is dh/dr , since flow is in the r direction. We assume radial symmetry around the well, so that the angular polar coordinate, θ , need not appear at all. We now rewrite the equation which you selected in the form:

$$r \frac{dh}{dr} = \frac{Q}{2\pi Kb}$$

and we focus our attention for a moment on the left-hand member. According to the rules of differentiation we may write:

$$\frac{dh}{dr} = \frac{dh}{d(\ln r)} \cdot \frac{d(\ln r)}{dr}$$

where $\ln r$ denotes the natural logarithm of r ; and we may recall from introductory calculus that the derivative of $\ln r$ with respect to r is given by

$$\frac{d(\ln r)}{dr} = \frac{1}{r}$$

QUESTION

Using these expressions, which of the following may be obtained as a correct restatement of the differential equation for the problem?

Turn to Section:

$$\frac{dh}{dr} = \frac{Q(\ln r)}{2\pi Kb} \quad 39$$

$$\frac{dh}{d(\ln r)} = \frac{Q}{2\pi Kb} \quad 2$$

$$(\ln r) \frac{dh}{dr} = \frac{Q}{2\pi Kb} \quad 13$$

36 □

Your answer in Section 10,

$$h = 2Q - \frac{Q}{Kwb}x,$$

is not correct. This answer is indeed a solution to our differential equation, for when we differentiate it we obtain the differential equation

$$\frac{dh}{dx} = -\frac{Q}{Kbw}$$

However, if we set x equal to zero in the answer which you chose, we find that hydraulic head, h , is equal to $2Q$ at the point where x is zero—that is, at the edge of the

stream. In the discussion of Section 10, however, it was stated that hydraulic head was equal to h_0 at the edge of the stream— h_0 being the elevation of the stream surface above datum. This problem illustrates what is meant by the term *boundary condition*; the solution must satisfy a condition along one boundary ($h = h_0$ at $x = 0$) in addition to satisfying the given differential equation. There are an infinite number of possible solutions to the above differential equation, but only one which satisfies this required boundary condition.

Return to Section 10 and choose another answer.

□ 37

Your answer in Section 38 is not correct. If the equation

$$h_2 - h_1 = \frac{2.3Q}{2\pi Kb} \log \left(\frac{r_2}{r_1} \right)$$

is applied to the two intervals in question, we have

$$h_{100} - h_1 = \frac{2.3Q}{2\pi Kb} \log \left(\frac{100}{1} \right) = \frac{2.3Q}{2\pi Kb} \cdot 1$$

and

$$h_{100} - h_{10} = \frac{2.3Q}{2\pi Kb} \log \left(\frac{100}{10} \right) = \frac{2.3Q}{2\pi Kb} \cdot 1.$$

Return to Section 38 and choose another answer.

□ 38

Your answer in Section 2 is correct. The equation states that the derivative of h with respect to $\ln r$ is a constant. Thus a graph of h versus $\ln r$ will be a straight line, which will have a slope equal to

$$\frac{Q}{2\pi Kb}$$

The sketch shows such a graph. As $\ln r$ changes from $\ln r_2$ to $\ln r_1$, head decreases from h_2 to h_1 ; and as with any straight line function, the change in head can be obtained by multiplying the change in the independent variable by the slope of the line; that is,

$$h_2 - h_1 = \frac{Q}{2\pi Kb} (\ln r_2 - \ln r_1).$$

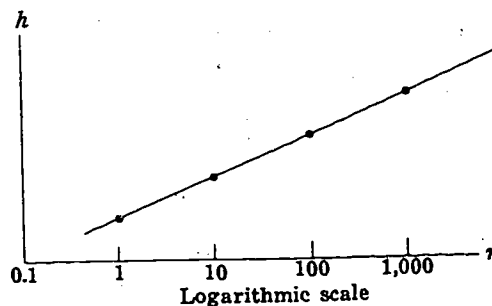
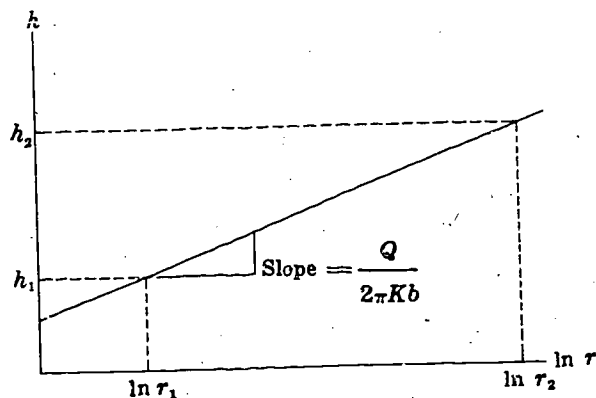

This can be written in the equivalent form

$$h_2 - h_1 = \frac{Q}{2\pi Kb} \log \frac{r_2}{r_1}$$

inasmuch as the difference between $\ln r_2$ and $\ln r_1$ is simply the log of the quotient $\ln (r_2/r_1)$. At this point it is convenient to change from natural logs to common logs. This involves only multiplication by a constant—that is $\ln r = 2.3 \log r$, where $\log r$ denotes the common logarithm, or log to the base 10. Making this change, our equation takes the form

$$h_2 - h_1 = \frac{2.3Q}{2\pi Kb} \log \left(\frac{r_2}{r_1} \right)$$

or

$$h_2 - h_1 = \frac{2.3Q}{2\pi Kb} (\log r_2 - \log r_1).$$

Again a graph can be plotted of h versus $\log r$ —or, to do the same thing more con-

38 □ —Con.

veniently, a graph can be plotted of h versus r on semilog paper, as shown in the sketch. Since we have only multiplied by a constant, the graph remains a straight line.

QUESTION

On the basis of the graph shown in the figure and the equations given above, which of the following statements is correct?

- Turn to Section:
- (a) The head drop between $r=10$ and $r=1$ is equal to that between $r=1,000$ and $r=100$. 19
- (b) The head drop between $r=10$ and $r=1$ is less than that between $r=1,000$ and $r=100$. 34
- (c) The head drop between $r=10$ and $r=1$ is much greater than that between $r=100$ and $r=10$. 37

39 □

Your answer in Section 35,

$$\frac{dh}{dr} = \frac{Q(\ln r)}{2\pi Kb}$$

is not correct. The following relations were given in Section 35:

$$\frac{dh}{dr} = \frac{dh}{d(\ln r)} \cdot \frac{d(\ln r)}{dr}$$

and

$$\frac{d(\ln r)}{dr} = \frac{1}{r}$$

Combining these,

$$\frac{dh}{dr} = \frac{1}{r} \cdot \frac{dh}{d(\ln r)}$$

In the question of Section 35, the idea is to substitute the term

$$\frac{1}{r} \cdot \frac{dh}{d(\ln r)}$$

for the term

$$\frac{dh}{dr}$$

in the differential equation for our problem.

Return to Section 35 and choose another answer.

40 □

Your answer in Section 27 is correct. The decrease in cross-sectional area must, according to Darcy's law, be accompanied by a steepening of the hydraulic gradient. When we apply Darcy's law to this problem, we will omit the customary negative sign. This is done because Q , the well discharge, must itself carry a negative sign in this problem, since it is oriented toward the well, in the direction of decreasing values of r . The negative sign on Q combines with the negative sign used by convention in Darcy's law to yield an equation in positive terms.

QUESTION

Which of the following expressions is a valid application of Darcy's law to this problem, and hence a valid differential equation for the problem?

$$\frac{Q}{A} = K \frac{dh}{dx}$$

33

$$\frac{Q}{2\pi rb} = K \frac{dh}{dr}$$

35

$$\frac{Q}{2\pi rb} = K \frac{d(h^2)}{dr}$$

17

□ 41

Your answer in Section 9,

$$h^2 = h_0^2 - \frac{2Q}{Kw}x,$$

is correct. The solution indicates that h will have the form of a parabola when plotted versus x in this case. The parabolic steepening of the hydraulic gradient compensates for the progressive decrease in flow area, in such a way that Darcy's law is always satisfied. This approximate theory of unconfined flow was introduced by Dupuit (1863) and the assumptions involved in it are frequently referred to as the Dupuit assumptions. If the method is used in cases where these assumptions do not apply, serious errors can be introduced.

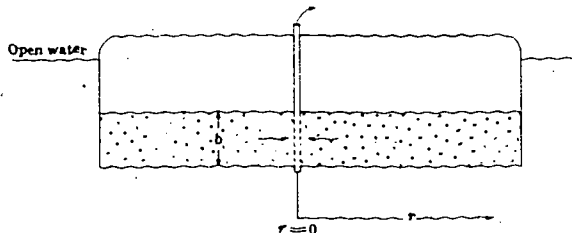

We next consider another problem in which the cross-sectional area of flow diminishes along the path of flow, leading to a progressive steepening of the hydraulic gradient. In this case, however, the decrease in area is generated by cylindrical geometry rather than by the slope of a free surface.

The figure shows a well located at the center of a circular island. The well taps a confined aquifer which is recharged by the open water around the perimeter of the island. During pumping, water flows radially inward toward the well. We assume that the open water around the island maintains the head at a constant level along the periphery of the aquifer and that the recharge along this periphery equals the well discharge. Since the well is at the center of the island and the island is circular, we can assume that cylindrical symmetry will prevail; we can therefore introduce polar coordinates to simplify the problem.

QUESTION

If b represents the thickness of the aquifer, which of the following expressions represents the cross-sectional area of flow at a radial distance r from the axis of the well?

$2\pi rb$	27
$\pi r^2 b$	12
$2\pi r^2$	6

Turn to Section:

□ 42

Your answer in Section 24 is not correct. The statement that there is a linear increase in head with distance away from the stream implies that there is a *non-zero* slope, dh/dx , in the potentiometric surface, and this in turn implies that flow exists in the aquifer. Darcy's law states that

$$Q = -KA \frac{dh}{dx}$$

Hydraulic conductivity, K , may be very low,

but cannot be considered equal to zero as long as we are dealing with an aquifer in the normal sense of the word. Thus in order for Q to be zero, through a given area A , the head gradient dh/dx normal to A must be zero. In this case we have observed a head gradient which is not zero in the aquifer, so we know that flow of some magnitude must exist in the aquifer.

Return to Section 24 and choose another answer.

43

Your answer in Section 25,

$$\frac{Q}{bw} = -K \frac{dh}{dx},$$

is not correct. You have taken the cross-sectional area of flow to be bw —that is, the product of aquifer thickness and width of section. An examination of the figure in Sec-

tion 25 will show that this does not represent the actual area of flow. The aquifer is not saturated through its full thickness, but rather to a distance h above the base of the aquifer. Thus, the cross-sectional area of flow is wh , rather than bw .

Return to Section 25 and choose another answer.

Part IV. Ground-Water Storage

Introduction

In Parts II and III we dealt with aquifers and porous media only as conduits—that is, we discussed only their properties relating to the transmission of water in steady flow. Aquifers have another very important hydraulic property—that of water storage. In Part IV we will examine this property of ground-water storage and develop an equation to describe it. In Part V we will develop

the differential equations for a simple case of nonequilibrium flow by combining the storage equation with Darcy's law, by means of the equation of continuity, which is simply a statement of the principle of conservation of mass. In Part VI, we will repeat this process for the case of nonequilibrium radial flow to a well and will obtain an important solution to the resulting differential equation.

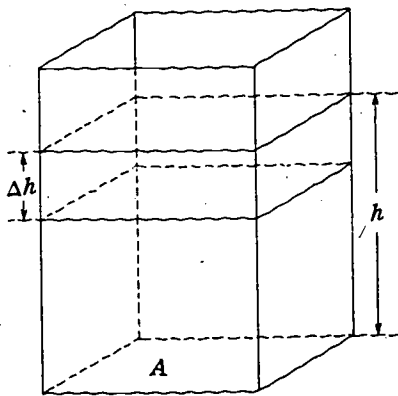

The picture shows an open tank, having a square base of area A . If a volume of water, ΔV , is poured into this tank, the water level will rise by an increment, Δh , such that

$\Delta V = A \cdot \Delta h$. The total volume, V , of water in storage in the tank at any time can be determined by measuring the depth, h , of water in the tank and multiplying this depth by A .

QUESTION

Suppose the total volume of water in storage is plotted as a function of the level of water in the tank, so that the volume associated with any water level can be read directly from the plot. The graph will be:

Turn to Section:

- | | |
|--|----|
| (a) a parabola with slope $\frac{\Delta V}{\Delta h}$ | 10 |
| (b) a straight line with slope $\frac{\Delta V}{\Delta h} = A$ | 11 |
| (c) a logarithmic curve | 9 |

2

Your answer in Section 26 is not correct. The volume of water present in the sand initially was hAn . A certain fraction, β , of this fluid volume was drained off by gravity, leaving the fraction $1-\beta$ still occupied by fluid. β thus represents the fraction of the total pore space, below the level h , which does not already contain water, and which

must be refilled in order to resaturate the sand to the level h . That is, in order to resaturate the sand to the level h , a volume of water equal to this unoccupied pore volume must be pumped into the tank.

Return to Section 26 and choose another answer.

3

Your answer in Section 21 is not correct. In the imaginary experiment described in Section 21, it was stated that doubling the base area of the prism had the effect of doubling the slope of the V, h plot—that is, of doubling the term dV/dh . Thus, dV/dh

depends upon the size of the prism considered, as well as upon the type of aquifer material; it cannot be considered a constant representative of the aquifer material.

Return to Section 21 and choose another answer.

4

Your answer in Section 16,

$$\frac{\Delta V}{\Delta h} = \frac{dV}{dh} = n\beta,$$

is not correct. It neglects the effect of the base area, A , of the tank.

We have seen that when the tank is drained by gravity and then resaturated to the level h , the relation between V and h is

$$V = hAn\beta$$

where n is the porosity of the sand and β the fraction of the water in the sand that can be drained out by gravity. Now if, instead of

draining the sand to the bottom of the tank, we simply remove a small volume of water, ΔV , so that the water level in the tank falls by a small amount Δh , we should expect ΔV and Δh to be related in the same way as V and h in our previous experiment. If we are resaturating the sand by increments, when it has previously been saturated and then drained by gravity, the same relation should hold.

Return to Section 16 and choose another answer.

5

Your answer in Section 20 is not correct. If each well penetrated both aquifers, there would be no reason for the responses of the two wells to differ. The form of the response might be difficult to predict, but at least it should be roughly the same for each well.

Keep in mind that the storage coefficient of the artesian zone will probably be smaller than the specific yield of the water-table aquifer by at least two orders of magnitude.

Return to Section 20 and choose another answer.

6

Your answer in Section 32 is correct. Specific yield figures for normal aquifer materials may range from 0.01 to 0.35. It is common to speak of the specific yield of an unconfined aquifer as a whole; but it should be noted that the process of release from unconfined storage really occurs at the water table. If the water table falls or rises within an aquifer, into layers or strata having different hydraulic properties, specific yield must change. In addition, of course, specific yield can vary with map location, in response to local geologic conditions.

Unconfined storage is probably the most important mechanism of ground-water storage from an economic point of view, but it is not the only such mechanism. Storage effects have also been observed in confined or artesian aquifers. The mechanism of confined storage depends, at least in part, upon compression and expansion of the water itself and of the porous framework of the aquifer; for this reason confined storage is sometimes referred to as compressive storage. In this outline we will not attempt an analysis of the mechanism of confined storage, but will concentrate instead on developing a mathematical description of its effects, suitable for hydrologic calculations. A discussion of the mechanism of confined storage is given by Jacob (1950, p. 328-334), and by Cooper (1966).

The diagram shows a vertical prism extending through a uniform confined aquifer. The base area of the prism is A . Although the prism remains structurally a part of the confined aquifer, we suppose it to be isolated hydraulically from the rest of the aquifer by imaginary hydraulic barriers, so that water added to the prism remains within it. We further imagine that we have some method of pumping water into the prism in measured increments, and that we have a piezometer, as shown in the diagram, through which we can measure the head within the prism.

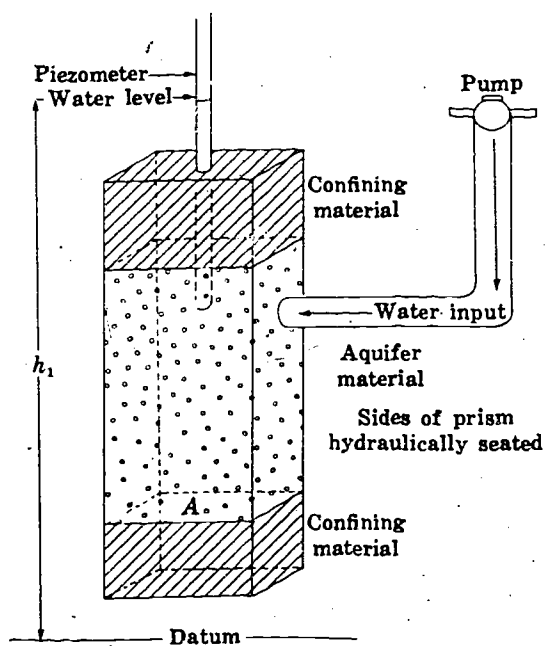

(continued on next page)

6—Con.

QUESTION

Suppose that head is initially at the level h_1 , which is above the top of the aquifer, indicating that the prism is not only saturated, but under confined hydrostatic pressure. We

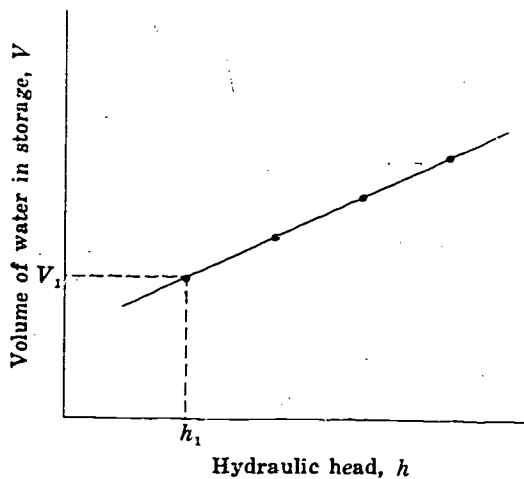

designate the volume of water in storage in this initial condition as V_1 . Now suppose more water is pumped into the prism by increments; and that the head is measured after each addition, and a graph of the volume of water in storage versus the hydraulic head in the prism is plotted. If the resulting plot had the form shown in the figure, which of the following statements would you accept as valid?

Turn to Section:

- (a) The rate of change of volume of water in confined storage, with respect to hydraulic head, h , is constant; that is $\frac{dV}{dh} = \text{constant}$ 21
- (b) The rate of change of hydraulic head with respect to volume in storage depends upon the volume in storage. 23
- (c) The rate of change of volume in storage, with respect to the base area of the prism, is equal to Δh . 30

7

Your answer in Section 32 is not correct. One important concept which is missing from the definition you selected is that specific yield refers to a unit base area of the aquifer. The definition you selected talks about the volume of water which can be drained from the aquifer—this would vary with extent of the aquifer and would normally be a

very large quantity. As we wish specific yield to represent a property of the aquifer material, we define it in terms of the volume that can be drained per unit map area of aquifer.

Return to Section 32 and choose another answer.

8

Your answer in Section 25 is not correct. The relation given in Section 25 for the rate of release of water from storage was

$$\frac{dV}{dt} = SA \frac{dh}{dt}$$

where S is the storage coefficient, A the area of aquifer under study, and dh/dt the rate

of change of head with time within that area of aquifer. In the question of Section 25, the specific yield of the water-table aquifer was given as 0.20, and the rate of decline of water level in the shallow well was given as 0.5 foot per day. The surface area of a section of the aquifer within a 10 foot radius of the well would be $\pi \times 10^2$, or 314 square feet. The

8—Con.

rate of release from storage in this section would therefore be

$$\frac{dV}{dt} = SA \frac{dh}{dt} = 0.2 \times 314 \times 0.5$$

$$= 31.4 \text{ cubic feet per day.}$$

Return to Section 25 and choose another answer.

9

Your answer in Section 1 is not correct. Whenever we add a fixed volume of water—say 10 cubic feet—to the tank, the water level must rise by a corresponding fixed amount. If the base area of the tank is 5 square feet, the addition of 10 cubic feet of water must always produce an increase of 2 feet in h ; the addition of 15 cubic feet of water must produce an increase of 3 feet in h ; and so on. The ratio $\Delta V/\Delta h$ in this case must always

be 5. In other words, the ratio $\Delta V/\Delta h$ is constant and is equal to the base area, A , of the tank.

Now if we plot V versus h , the slope of this plot will be $\Delta V/\Delta h$, by definition. This slope, as we have seen above, must be a constant. A logarithmic curve does not exhibit a constant slope.

Return to Section 1 and choose another answer.

10

Your answer in Section 1 is not correct. The increment in the volume of water within the tank, resulting from an increase in water level of Δh , is given by $\Delta V = A\Delta h$. Thus,

$$\frac{\Delta V}{\Delta h} = A$$

where A , the base area of the tank, is a constant. If we construct a plot of V , the vol-

ume of water in the tank, versus h , the level in the tank, the slope of the plot will by definition be $\Delta V/\Delta h$; but since $\Delta V/\Delta h$ is a constant, the plot cannot be a parabola. The slope of a parabola changes continuously along the graph.

Return to Section 1 and choose another answer.

11

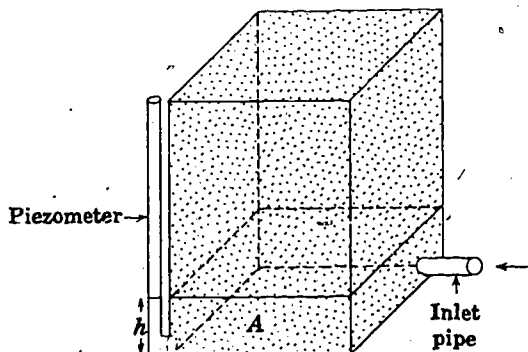

Your answer in Section 1 is correct. The slope of the graph, $\Delta V/\Delta h$ or dV/dh , is constant and equal to A . Thus the volume of water in storage per foot of head (water level) in the tank is A .

Now consider the tank shown in the sketch. It is similar to the one we just dealt with, except that it is packed with dry sand having an interconnected (effective) porosity denoted by n . The tank is open at the top and has a base of area A . Water can be

11—Con.

pumped into the tank through a pipe connected at its base, and the water level within the tank—that is, the level of saturation in the sand—can be measured by means of a piezometer, also connected at the base of the tank.

QUESTION

Suppose we pump a small volume of water, V , into the tank and observe the level, h , to

which water rises in the piezometer. Neglecting all capillary effects, which of the following expressions would constitute a valid relation between the volume of water pumped into the tank and the rise in water level above the base of the tank?

	Turn to Section:
$V = Ah$	31
$h = VAn$	12
$V = hAn$	14

12

Your answer in Section 11 is not correct. If the water rises to a level h above the base of the tank, the bulk volume of saturated sand (neglecting capillary effects) will be hA . This bulk volume must be multiplied by the porosity to obtain the total volume of sat-

urated pore space. A review of the definition of porosity as given in Part I may help to clarify this.

Return to Section 11 and choose another answer.

13

Your answer in Section 25 is correct. The release from storage in a given area in the water-table aquifer is given by

$$\frac{dV}{dt} = S_p A \frac{dh}{dt} = 0.2 \times A \times 0.5 = 0.1A.$$

The release from storage in an equal area in the artesian aquifer would be

$$\frac{dV}{dt} = SA \frac{dh}{dt} = 2 \times 10^{-4} \times A \times 5 = 0.001A.$$

Thus the water-table contribution exceeds the artesian release by a factor of 100.

This completes our introductory discussion of aquifer storage. You may go on to Part V, in which we will combine the concept of aquifer storage with Darcy's law, using the equation of continuity, to develop the differential equation for a simple problem in non-equilibrium ground-water flow.

14

Your answer, $V = hAn$, in Section 11 is correct. Now suppose water is added to the tank in increments, and h is measured after the addition of each increment; and suppose a graph of V versus h is plotted, where V is the total or cumulative volume which has been added, and h is the water level in the tank.

QUESTION

Again neglecting all capillary effects, the resulting graph would be:

- | | Turn to Section: |
|---|------------------|
| (a) a straight line with slope $\frac{\Delta V}{\Delta h} = \frac{1}{An}$ | 17 |
| (b) a straight line with slope $\frac{\Delta V}{\Delta h} = An$ | 26 |
| (c) a logarithmic curve with slope depending on h | 22 |

15

Your answer in Section 20 is not correct. The specific yield of the water-table aquifer would normally be greater than the storage coefficient of the artesian zone by at least two orders of magnitude. A seasonal fluctuation in pumpage would usually involve a brief withdrawal from storage, or a brief period of accumulation in storage. The two aquifers are pumped at about the same rate, so presumably seasonal adjustments in the pumpage will be of the same order of magnitude

for each. However, the response of the two aquifers to withdrawal (or accumulation) of a similar volume of water would be completely different, and would be governed by their storage coefficients. The aquifer with the higher storage coefficient could sustain the withdrawal with less drawdown of water level than could the aquifer with the lower storage coefficient.

Return to Section 20 and choose another answer.

16

Your answer, $V = hAn\beta$, in Section 26 is correct. This expression gives the volume of water withdrawn in draining the tank by gravity, and the volume which must be added to resaturate the sand to the original level, under our assumption that the fraction held by capillary forces is constant.

QUESTION

Suppose, subject to the same assumption, that the tank is drained by removing increments of water (or resaturated by adding increments of water) and a graph of the volume of water in storage, V , versus the level

of saturation, h , is plotted from the results of the experiment. Which of the following expressions would describe the slope of the resulting graph?

$$\frac{\Delta V}{\Delta h} = \frac{dV}{dh} = n\beta$$

$$\frac{\Delta V}{\Delta h} = \frac{dV}{dh} = An\beta$$

$$\frac{\Delta V}{\Delta h} = \frac{dV}{dh} = hAn\beta$$

Turn to Section:

4

33

29

17

Your answer in Section 14 is not correct. We have seen that if a volume of water, V , is pumped into the tank when it is initially dry, the equation

$$V = h \cdot A \cdot n$$

describes the relation between V and h , the level of water in the sand. If the sand is

already saturated to some level, and an additional volume of water, ΔV , is pumped in, the water level will rise by an increment Δh , such that

$$\Delta V = \Delta h \cdot A \cdot n.$$

Return to Section 14 and use this relation in choosing another answer.

18

Your answer in Section 26 is not correct. $h \cdot A \cdot n$ would represent the volume of water required to raise the water level to a distance h above the base of the tank, if the sand were initially dry. In this case, however, the sand is not initially dry. Some of the pore space is already occupied by water at the beginning of the experiment, since after drainage by gravity, capillary effects cause some water to be held in permanent retention. The volume of water which must be added to resaturate the sand to the level h is equal to the volume of pore space below the level h which

does not already contain water. The total volume of pore space below the level h is $h \cdot A \cdot n$; when the sand was initially saturated, this entire volume contained water. When the sand was drained, a certain fraction of this water, which we designate β , was removed. The remaining fraction, $1 - \beta$, was held by capillary retention in the sand. Thus β represents the fraction of the pore space which is empty when we begin to refill the tank.

Return to Section 26 and choose another answer.

19

Your answer in Section 33 is not correct. Because the aquifer material is identical to the sand of our tank experiments and because the base area of our prism of aquifer is equal to the base area of our tank, we should expect the relation between volume released from storage and decline in water level within the prism to be identical to that obtained for the tank. In the answer which you selected, how-

ever, there is no description of the effect of capillary retention. Remember that the factor β , which was used in the tank experiment to describe the fraction of the water which could be drained by gravity, as opposed to that held in capillary retention, must appear in your answer.

Return to Section 33 and choose another answer.

20

Your answer in Section 21 is correct. The results of the imaginary experiment suggest that the term

$$\frac{1}{A} \frac{dV}{dh}$$

is a constant for the aquifer material.

In practice, in dealing with the confined or compressive storage of an aquifer, it is usually assumed that the quantity $(1/A) (dV/dh)$ is a constant for the aquifer, or is at least a constant for any given location in the aquifer. This quantity, $(1/A) (dV/dh)$, is denoted S and is called the confined or compressive storage coefficient, or simply the storage coefficient, of the aquifer.

It would of course be difficult or impossible to perform the experiment described in Section 6. However, if storage coefficient is defined by the equation

$$S = \frac{1}{A} \frac{dV}{dh}$$

a nonequilibrium theory can be developed from this definition which explains many of the observed phenomena of confined flow.

The following points should be noted regarding confined storage coefficient:

- (1) The storage coefficient is the volume of water released from storage in a prism of unit area, extending through the full thickness of the aquifer, in

 20—Con.

response to a unit decline in head. This statement can be appreciated by a review of the hypothetical experiment described earlier, or by letting $A=1$ in the finite-difference form of the definition, $S = (1/A) (\Delta V/\Delta h)$.

- (2) The definition of storage coefficient is similar to that of specific yield, in the sense that each is defined as the term $(1/A) (dV/dh)$, for a prism extending through an aquifer. Thus in many applications, the two terms occupy the same position in the theory. In the case of an unconfined aquifer the specific yield is often referred to as the storage coefficient.
- (3) It should be noted, however, that the processes involved in the two types of storage are completely different. Withdrawal from or addition to unconfined storage takes place at the water table; it is spoken of as occurring in a prism of aquifer because it is usually the only significant form of storage within such a prism in most water-table situations. Confined storage effects, on the other hand, are distributed throughout the vertical thickness of an aquifer.
- (4) Confined storage coefficient values are generally several orders of magnitude less than specific yield values. Specific yields range typically from 0.01 to 0.35, whereas confined storage values usually range from 10^{-5} to 10^{-3} .

The definition of confined storage in terms of a prism extending through the aquifer is adequate where the flow is entirely horizontal—that is, where no differences in head or in lithology occur along a vertical within the

aquifer. Where vertical differences do occur, one must allow for the possibility of different patterns of storage release at different points along the vertical, and a storage definition based on a prism is no longer adequate. Use is therefore made of the *specific storage*, S_s , which is defined as the volume of water released from confined storage in a unit volume of aquifer, per unit decline in head. In a homogeneous aquifer, S_s would be equal to S divided by the thickness of the aquifer.

QUESTION

Consider a small ground-water basin that has both an artesian aquifer and a water-table aquifer. Regional withdrawal from the artesian aquifer is about equal to that from the water-table aquifer, and seasonal fluctuations in pumpage are similar. Records are kept on two observation wells, neither of which is in the immediate vicinity of a discharging well. One well shows very little fluctuation in water level in response to seasonal variations in pumpage, while the other shows great fluctuation. Which of the following statements would more probably be true?

Turn to Section:

- (a) The well showing little fluctuation taps the water-table aquifer, while that showing great fluctuation taps the artesian zone. 25
- (b) Each well penetrates both aquifers. 5
- (c) The well showing great fluctuation taps the water-table aquifer, while that showing little fluctuation taps the artesian zone. 15

21

Your answer in Section 6 is correct. The plot is a straight line, so the slope, dV/dh , is a constant. Now suppose the prism is expanded to twice its original base area, and our imaginary experiment is repeated; and suppose we observe that, as a result of the increase in base area, the slope of our V, h plot is twice its original value.

QUESTION

Let A now represent the base area of any general (vertical) prism through the aquifer; or in general, let A represent the surface area of the section of the aquifer we are isolating for discussion. On the basis of the evidence described, which of the following statements would you be inclined to accept?

(a)

$$\frac{dV}{dh}$$

is a constant for the aquifer material

3

(b) The term

$$\frac{1}{A} \frac{dV}{dh}$$

is a constant for the aquifer material

20

(c) The term

$$A \frac{dV}{dh}$$

is a constant for the aquifer material

34

Turn to Section:

22

Your answer in Section 14 is not correct. We have seen that, neglecting capillary effects, there is a linear relationship between the volume of water, V , pumped into the tank when it is initially dry, and the level of water, h , above the base of the tank. That is, a constant coefficient, An , relates these two quantities: $V = h \cdot A \cdot n$. This linearity holds

as well if the water is added to the tank in increments. Each incremental volume of water, ΔV , pumped into the tank produces an increment in head, Δh , such that

$$\Delta V = \Delta h \cdot A \cdot n.$$

Return to Section 14 and choose another answer.

23

Your answer in Section 6 is not correct. The ratio of the change of volume of water in storage, to the change in hydraulic head is by definition the slope, $\Delta V/\Delta h$ or dV/dh , of a plot of V versus h . If this rate of change of V with h were to depend upon V , the plot of V versus h would show a different slope

at different values of V . The plot, in other words, would be some sort of curve. The plot shown in Section 6, however, is a straight line—it has a constant slope, the same for any value of V .

Return to Section 6 and choose another answer.

24

Your answer in Section 25 is not correct. The relation given in Section 25 for the rate of release of water from storage was

$$\frac{dV}{dt} = SA \frac{dh}{dt}$$

where S is the storage coefficient, A the area of aquifer under study, and dh/dt the rate of change of head with time within that area of aquifer. In the question of Section 25, S was given as 2×10^{-4} for the artesian aquifer, and dh/dt , as measured in the deep well,

was 5 feet per day. A section of the aquifer within a 10 foot radius of the observation well would have a surface area of $\pi \times 10^2$, or 314 square feet. The rate of release of water from storage in this section would therefore be

$$\frac{dV}{dt} = SA \frac{dh}{dt} = 2 \times 10^{-4} \times 314 \times 5 = 0.314 \text{ cubic feet per day.}$$

Return to Section 25 and choose another answer.

25

Your answer in Section 20 is correct. Because of the higher storage coefficient of the water-table aquifer, release or accumulation of a comparable volume of water will cause a much smaller fluctuation of water level in the water-table aquifer than in the artesian aquifer. In effect, we have introduced time variation into the problem here, since we are discussing changes in head with time. To bring time into the equations, we may proceed as follows.

Let S represent either specific yield or storage coefficient. Then according to our definitions we may write, using the finite-difference form,

$$S = \frac{1}{A} \frac{\Delta V}{\Delta h}$$

The relation between the volume of water taken into or released from aquifer storage in a prism of base area A and the accompanying change in head, is therefore:

$$\Delta V = SA \Delta h.$$

Now let us divide both sides of this equation by Δt , the time interval over which the decline in head was observed. We then have:

$$\frac{\Delta V}{\Delta t} = SA \frac{\Delta h}{\Delta t}$$

or, if we are talking about a vanishingly small time interval,

$$\frac{dV}{dt} = SA \frac{dh}{dt}$$

Here dV/dt is the time rate of accumulation of water in storage, expressed, for example, in cubic feet per day; and dh/dt is the rate of increase in head, expressed, for example, in feet per day. If we are dealing with release from storage, head will decline, and both dV/dt and dh/dt will be negative. The partial derivative notation, $\partial h/\partial t$, is usually used instead of dh/dt , because head may vary with distance in the aquifer as well as with time. This equation is frequently referred to as the storage equation.

The equation can also be obtained using the rules of differentiation. For the case we are considering we have

$$\frac{dV}{dt} = \frac{dV}{dh} \cdot \frac{dh}{dt},$$

but from the definition of storage coefficient, $dV/dh = SA$, so that by substitution

$$\frac{dV}{dt} = SA \frac{dh}{dt}$$

(continued on next page)

25—Con.

QUESTION

Suppose we record the water levels in a deep observation well, penetrating a confined aquifer which has a storage coefficient of 2×10^{-4} , and a shallow observation well, tapping a water-table aquifer which has a specific yield of 0.20. The water level in the deep well falls at a rate of 5 feet per day, while that in the shallow well falls at a rate of 0.5 foot per day. Considering the release of water from storage in each aquifer within a radius of 10 feet of the observation well, which of the following statements would be most accurate?

- Turn to Section:
- (a) within a radius of 10 feet of the shallow well, water is being released from storage in the water-table aquifer at a rate of 5 cubic feet per day. 8
- (b) the rate of release of water from storage in the water-table aquifer, within 10 feet of the shallow well, is 100 times as great as that in the artesian aquifer, within 10 feet of the deep well. 13
- (c) within a radius of 10 feet of the deep well, water is being released from storage in the artesian aquifer at a rate of 1 cubic foot per day. 24

26

Your answer in Section 14 is correct. If there were no capillary effects, the result of filling the tank with sand would simply be to take up some of the volume available for storage of water. Thus the slope of the plot of V versus h for the sand-filled tank would differ from that for the open tank (Section 1) only by the factor n , which is the ratio of the storage volume available in the sand-filled tank to that available in the open tank.

In practice, of course, capillary effects cannot be neglected. In this development we will take a simplified view of these effects, as a detailed examination of capillary phenomena is beyond the scope of our discussion. Let us assume that due to capillary forces, a certain constant fraction of the water in the sand is permanently retained. That is, we assume that following the initial saturation of the sand, we can never drain off by gravity the full volume of water which was added during the initial saturation. A part of this initially added water remains permanently held in the pore spaces by capillary attrac-

tion; thus the amount of water which can be alternately stored and recovered is reduced.

QUESTION

Suppose the tank is initially saturated to a level h and is then drained by gravity. Suppose further that the ratio of the volume of water drained to that initially added is observed to be β ; that is, the fraction of the added water which can be drained is β , while the fraction retained in the sand by capillary forces is $(1-\beta)$. Subject to our assumption that the fraction retained is a constant, which of the following expressions gives the volume of water which would have to be restored to the tank, after draining, in order to resaturate the sand to the same level, h , as before?

- Turn to Section:
- $V = hAn$ 18
- $V = hA \frac{n}{\beta}$ 2
- $V = hAn\beta$ 16

27

Your answer in Section 32 is not correct. Your answer defines specific yield as the quantity (presumably the total quantity) of water which can be drained by gravity from a unit area of the aquifer. In the preceding analysis, we developed the concept of specific yield in terms of the quantity of water which can be drained *per unit decline in water level*.

A verbal definition of specific yield must therefore include this latter concept in some manner—that is, it must indicate that we are referring to the quantity released from storage per unit decline in head.

Return to Section 32 and choose another answer.

28

Your answer in Section 33 is not correct. The aquifer material was given as identical to the sand of the tank experiments described previously, and the base area of the prism was taken as equal to the base area of the tank. We are considering only storage within the prism itself, in relation to water level in the prism, and are not concerned with what goes on in the aquifer beyond the boundaries

of the prism. At this rate, we should expect the relation between the volume of water drained from storage and the accompanying decline in water level to be the same for our prism of aquifer as for the tank of the earlier experiments.

Return to Section 33 and choose another answer.

29

Your answer in Section 16,

$$\frac{\Delta V}{\Delta h} = \frac{dV}{dh} = hAn\beta$$

is not correct. This answer would indicate that the relation between V and h —that is, the slope of a plot of V versus h —is a function of h . However, we have already seen that if we refill the tank after it has been drained by gravity, we will find V and h to be related by a constant $An\beta$. That is, we

will find that $V = hAn\beta$ or that the ratio of V to h is the constant $An\beta$. If the tank is drained by increments, or refilled by increments after draining, we would expect the same relationship to hold between the increments of fluid volume, ΔV , and the increments of head, Δh , as was observed between V and h in the initial problem. That is, we would expect to find that $\Delta V = \Delta h \cdot An\beta$.

Return to Section 16 and choose another answer.

30

Your answer in Section 6 is not correct. Δh represents a simple change in the hydraulic head, h . It does not represent any form of rate of change; when we describe a rate of change, we always require two variables, since we always consider the ratio of change of one variable to that of another. At this point of our discussion, moreover,

we are considering the relation between the volume of water in storage and the hydraulic head. We have not yet taken into consideration the effect of varying the base area of our prism of aquifer.

Return to Section 6 and choose another answer.

 31

Your answer in Section 11 is not correct. The sand-filled tank of Section 11 differs from the open tank of Section 1, in that any quantity of water pumped into the sand-filled tank can utilize only the interconnected pore volume as its storage space; in the open tank of Section 1 the full capacity of the tank was available. If the sand-filled tank is initially empty and a volume of water, V , is pumped in, this water will occupy the total volume of interconnected space between the base of the tank and the height to which the sand is saturated (neglecting capillary

effects). If the water level in the sand is a distance h above the base of the tank, the bulk volume of the saturated part of the sand will be $h \cdot A$, where A is the base area of the tank. However, the volume of injected water will not equal this bulk saturated volume, but rather the interconnected pore volume within the saturated region. A review of the definition of porosity as given in Part I may help to clarify this.

Return to Section 11 and choose another answer.

 32

Your answer in Section 33,

$$\frac{dV}{dh} = An\beta,$$

is correct. The aquifer material is assumed to be identical to the sand in the tank experiments; if the area of the prism is equal to that of the tank, the two plots of storage versus water level should be identical. Note, however, that area is a factor in the expression for dv/dh ; if we were to choose a prismatic section of larger area, it would provide more storage, per foot of head change, than one of smaller area, just as a tank of larger base area would provide more storage, per foot of water-level change, than a tank of smaller area. If the base of our prism of aquifer were unity, the expression for dV/dh would be simply $n\beta$; and in general, an expression could be written for the change in storage volume per unit head change, per unit area of aquifer, as

$$\frac{1}{A} \cdot \frac{dV}{dh} = n\beta.$$

The term $n\beta$ is referred to as the specific yield of an aquifer, and is usually designated S_y . Because we have assumed $(1-\beta)$, the fraction of water retained by capillary forces, to be constant, we obtain the result that S_y is a constant; and for many engineering applications, this is a satisfactory approximation. It should be noted, however, that it is only an approximation; the fraction of water held in capillary retention may change with time, for various reasons, leading to apparent variations in S_y with time.

Specific yield describes the properties of an aquifer to store and release water (through unconfined storage) just as permeability describes its properties of transmitting water. Mathematically, specific yield is equivalent to the term $(1/A)(dV/dh)$ for an unconfined aquifer.

(continued on next page)

32—Con.

QUESTION

On the basis of the above discussion, which of the following statements would you select as the best verbal definition of specific yield?

- (a) The specific yield of an unconfined aquifer is the volume of water which can be drained by gravity from the aquifer in response to a unit decline in head.

Turn to Section:

7

- (b) The specific yield of a horizontal unconfined aquifer is the volume of water which is drained by gravity from a vertical prism of unit base area extending through the aquifer, in response to a unit lowering of the saturated level.

6

- (c) The specific yield of an unconfined aquifer is the quantity of water which can be drained from a unit area of the aquifer.

27

33

Your answer in Section 16,

$$\frac{\Delta V}{\Delta h} = \frac{dV}{dh} = An\beta,$$

is correct. The slope of the graph of volume of water in storage versus water level—or in other words, the derivative of V with respect to h —would be constant and equal to $An\beta$.

Now suppose that we are dealing with a prismatic section taken vertically through a

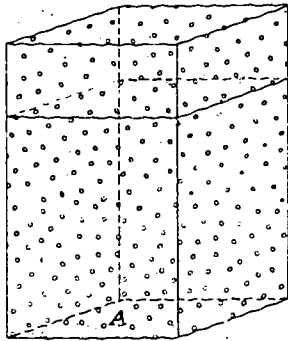

uniform unconfined aquifer as shown in the figure. The base area of the prism is again denoted A . Suppose the aquifer material is identical in its hydraulic properties to the sand of our tank experiments. We wish to construct a graph of the water in recoverable storage within the prism versus the level of saturation, or water-table level, in the aquifer in the vicinity of the prism. We are interested only in water which can be drained by gravity; water in permanent capillary retention will not be considered part of the storage.

QUESTION

Which of the following expressions would describe the slope of this graph?

Turn to Section:

$$\frac{dV}{dh} = Ahn\beta \quad 28$$

$$\frac{dV}{dh} = An \quad 19$$

$$\frac{dV}{dh} = An\beta \quad 32$$

34

Your answer in Section 21 is not correct. In the imaginary experiment described in Section 21, it was stated that doubling the base area, A , of the prism had the effect of doubling the slope, dV/dh , of the V, h plot. Thus the term $A(dV/dh)$ would be four times as great for the prism of doubled area, as for the original prism. That is, the term

$A(dV/dh)$ would depend upon the size of the prism considered, as well as upon the type of aquifer material, and could not be considered a constant representative of the aquifer material.

Return to Section 21 and choose another answer.

Part V. Unidirectional Nonequilibrium Flow

Introduction

In Part V, our purpose is to develop the differential equation for a problem of non-equilibrium flow. To do this, we utilize the storage equation,

$$\frac{dV}{dt} = SA \frac{dh}{dt},$$

developed in Part IV, and we utilize Darcy's law. These two relations are linked by means of a relation called the equation of continuity, which is a statement of the principle of conservation of mass.

In Part VI we will develop the same type of equation in polar coordinates and will discuss a solution to this equation for a particular flow problem. In the course of working through Parts V and VI, the reader may realize that the relations describing the storage and transmission of ground water can be combined to develop the differential equa-

tions for many other types of flow; and that solutions to these equations can be developed for a variety of field problems.

Before the start of the program of Part V, there is a brief discussion, in text form, of the significance of partial derivatives, their use in ground-water equations, and in particular their use in a more general form of Darcy's law. This form of Darcy's law was introduced in the text-format discussion at the end of Part II. The discussion here is intended primarily for readers who may not be accustomed to using partial derivatives and vector notation. It may be omitted by readers conversant with these topics. This discussion is not intended as a rigorous treatment of partial differentiation. Readers who are not familiar with the subject may wish to review such a treatment in any standard text of calculus.

Partial derivatives in ground-water flow analysis

When a dependent variable varies with more than one independent variable, the partial derivative notation is used. A topographic map, for example, may be considered a representation of a dependent variable (elevation) which is a function of two independent variables—the two map directions, which we will call x and y , as shown in figure *i*. If elevation is denoted E , each contour on the map represents a curve in the x - y plane along which E has some constant value. In general, if we move in the x direction, we will cross elevation contours—that is, E will change. Let us say that if we move a distance Δx parallel to the x axis, E is observed to change by an amount ΔE_x . We may

form a ratio, $\Delta E_x / \Delta x$, of this change in elevation to the length of the x interval in which it occurs. If the interval Δx becomes vanishingly small, this ratio is designated $\partial E / \partial x$ and is termed the partial derivative of E with respect to x . $\partial E / \partial x$ is actually the slope of a plot of E versus x , at the point under consideration, or the slope of a tangent to this plot, as shown in figure *i*. Note that in obtaining $\partial E / \partial x$ we move parallel to the x axis—that is, we hold y constant, considering only the variation in E due to the change in x .

Similarly, if we move a small distance, Δy , parallel to the y axis, E will again change by some small amount, ΔE_y . We again form a ratio, $\Delta E_y / \Delta y$; if the distance taken along

the y axis is vanishingly small, this ratio is designated $\partial E/\partial y$ and is termed the partial derivative of E with respect to y . Note that this time we have moved parallel to the y axis; in effect we have held x constant and isolated the variation in E due to the change in y alone.

If it happened that land surface varied so regularly over the map area that we could actually write a mathematical expression giving elevation, E , as a function of x and y , then we could compute $\partial E/\partial x$ simply by differentiating this expression with respect to x , treating y as a constant. Similarly, we could compute $\partial E/\partial y$ by differentiating the expression with respect to y , treating x as a constant. For example, suppose that after studying the contour map, we decide that elevation can be expressed approximately as a function of x and y by the equation

$$E = 5x^2 + 10y + 20.$$

Differentiating this equation with respect to x , treating y as a constant, gives

$$\frac{\partial E}{\partial x} = 10x.$$

We could, therefore, compute $\partial E/\partial x$ at any point by substituting the x -coordinate of that point into the above equation. Differentiating the equation with respect to y , treating x as a constant, gives

$$\frac{\partial E}{\partial y} = 10,$$

indicating that $\partial E/\partial y$ has the same value, 10, at all points of the map. In this example, $\partial E/\partial x$ turned out to be independent of y and $\partial E/\partial y$ turned out to be independent of both x and y . In general, however, $\partial E/\partial x$ may depend on both x and y , and $\partial E/\partial y$ may also depend on both x and y . For example, if E were described by the equation

$$E = 5x^2 + 5y^2 + 8xy + 20,$$

differentiation with respect to x would give

$$\frac{\partial E}{\partial x} = 10x + 8y$$

while differentiation with respect to y would give

$$\frac{\partial E}{\partial y} = 10y + 8x.$$

In the topographic-map example, $\partial E/\partial x$ and $\partial E/\partial y$ are space derivatives—that is, each describes the variation of E in a particular direction in space. In the discussion given in this chapter we will use the space derivative of head, $\partial h/\partial x$, giving the change in hydraulic head with respect to distance in the x direction. In addition, however, we will use the time derivative of head, $\partial h/\partial t$, giving the change in head with respect to time, if position is held fixed. $\partial h/\partial t$ is a partial derivative, just as is $\partial h/\partial x$, and it is computed according to the same rules, by considering all independent variables except t to be constant. We could in fact make a “map” of the variation of head with respect to distance and time by laying out coordinate axes marked x and t , and drawing contours of equal h in this x, t plane. The discussion given for directional derivatives in the topographic-map example could then be applied to $\partial h/\partial t$ in this example.

The partial derivative of head with respect to distance, $\partial h/\partial x$, gives the slope of the potentiometric surface in the x direction at a given point, x , and time, t . This is illustrated in figure *ii*. If x or t are varied, then in general $\partial h/\partial x$ will vary, since the slope of the potentiometric surface changes, in general, both with position and with time.

The partial derivative of head with respect to time, $\partial h/\partial t$, gives the time rate at which water level is rising or falling—that is, the slope of a hydrograph—at a given point, x , and time, t . This is shown in figure *iii*. Again, if x or t are varied, then in general $\partial h/\partial t$ will vary. In other words, $\partial h/\partial x$ is a function of both x and t , and $\partial h/\partial t$ is also a function of both x and t , in the general case.

Physically, $\partial h/\partial x$ may be thought of as the slope of the potentiometric surface which

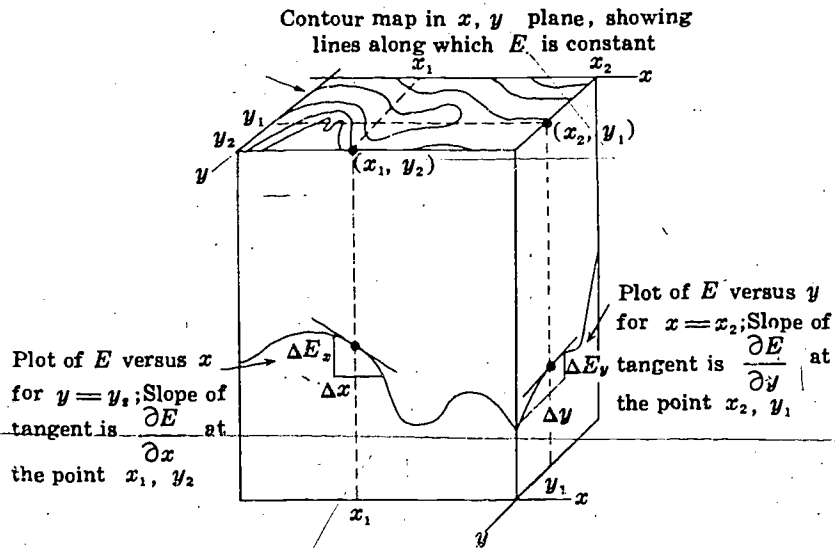

fig. i

will be observed if time is suddenly frozen at some value. If an expression is given for h , as a function of x and t , $\partial h / \partial x$ can be calculated by differentiating this expression with respect to x , treating t as a constant. In the same way, $\partial h / \partial t$ may be visualized as the slope of a hydrograph recorded at a particu-

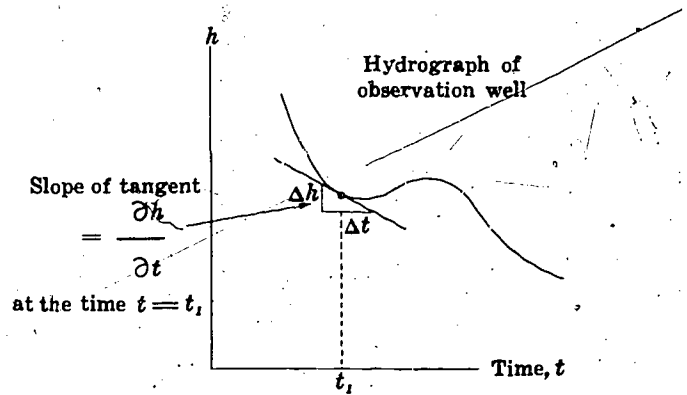

fig. iii

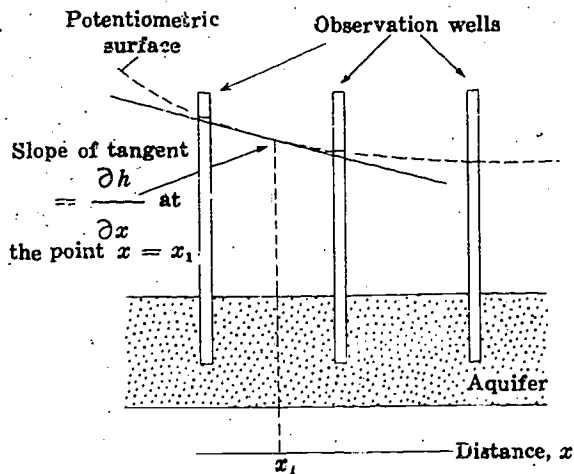

fig. ii

lar location (x value). If h is given as a function of x and t , an expression for $\partial h / \partial t$ may be obtained by differentiating with respect to t , treating x as if it were a constant.

In the discussion in Part V the problem is restricted to only one space derivative, $\partial h / \partial x$, and the time derivative. In the general case, we would have to consider all three space derivatives— $\partial h / \partial x$, $\partial h / \partial y$, and

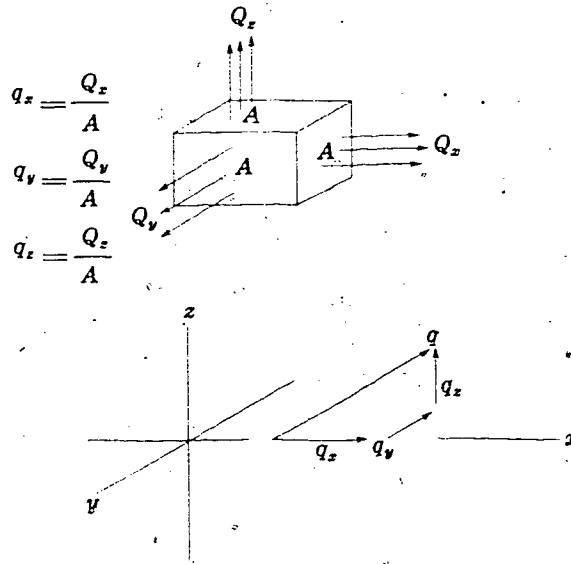

fig. iv

$\partial h / \partial z$ —in addition to the time derivative. In such a case, as noted in the discussion at the close of Part II, we would utilize Darcy's law in a somewhat more general form. When flow may occur in more than one direction, we consider the specific discharge, $q = Q/A$ to be a vector, having the three components q_x , q_y , and q_z . If the medium is isotropic, each of these components is given by a form of

Darcy's law, in which the partial derivative of head in the direction concerned is employed. The expressions for the apparent velocity components are

$$q_x = -K \frac{\partial h}{\partial x}$$

$$q_y = -K \frac{\partial h}{\partial y}$$

$$q_z = -K \frac{\partial h}{\partial z}$$

where K is the hydraulic conductivity.

q_x actually represents the fluid discharge per unit area in the x direction—that is, the discharge crossing a unit area oriented at right angles to the x axis. Similarly, q_y and q_z represent the discharges crossing unit areas normal to the y and z axes, respectively. The three components are calculated individually and added vectorially to obtain the resultant apparent velocity of the flow. (See figure iv.)

We now proceed to the programmed material of Part V.

I

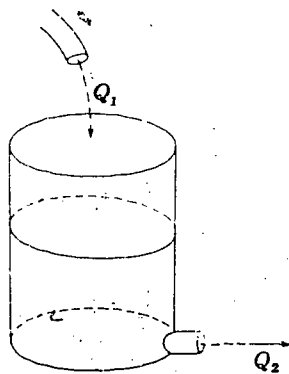

The picture shows an open tank with an inflow at the top and an outlet pipe at the base. Water is flowing in at the top at a rate Q_1 and is flowing out at the base at a rate Q_2 .

QUESTION

Suppose we observe that the volume of water in the tank is increasing at a rate of 5 cubic feet per minute. Which of the following equations could we consider correct?

- | | |
|---|------------------|
| | Turn to Section: |
| $Q_1 = 5$ cubic feet per minute | 29 |
| $\frac{Q_1 + Q_2}{2} = 2.5$ cubic feet per minute | 17 |
| $Q_1 - Q_2 = 5$ cubic feet per minute | 21 |

Your answer in Section 32,

$$Q_1 - Q_2 = K \frac{\partial h}{\partial x},$$

is not correct. The inflow through face 1 of the prism is given, according to Darcy's law, as a product of the hydraulic conductivity, the head gradient at face 1, and the cross-sectional area, $b\Delta y$, of face 1; that is,

$$Q_1 = -K \left(\frac{\partial h}{\partial x} \right)_1 b\Delta y.$$

Similarly, the outflow through face 2 is given as a product of hydraulic conductivity, head gradient at face 2, and the cross-sectional area of face 2, which is again $b\Delta y$; that is

$$Q_2 = -K \left(\frac{\partial h}{\partial x} \right)_2 b\Delta y.$$

Inflow minus outflow is thus given by

$$Q_1 - Q_2 = Kb\Delta y \left\{ \left(\frac{\partial h}{\partial x} \right)_2 - \left(\frac{\partial h}{\partial x} \right)_1 \right\}.$$

In the preceding sections, we have seen that the term

$$\left\{ \left(\frac{\partial h}{\partial x} \right)_2 - \left(\frac{\partial h}{\partial x} \right)_1 \right\}$$

can be written in an equivalent form using the second derivative.

Return to Section 32 and use this second derivative form in the above equation to obtain the correct answer.

" 2

Your answer in Section 30,

$$Q_1 = \frac{-K}{b\Delta y} \left(\frac{\partial h}{\partial x} \right)_1,$$

is not correct. Darcy's law states that the flow through a given plane—in this case, face 1 of the prism—is given as the product of hydraulic conductivity, area, and head gradi-

ent. Your answer gives the flow as the product of hydraulic conductivity and head gradient, divided by area.

Return to Section 30 and choose another answer.

" 3

Your answer in Section 7,

$$\frac{\partial^2 h}{\partial x^2} \frac{\partial h}{\partial x},$$

is not correct. We wish to find the change in the quantity $\partial h/\partial x$ over a small interval, Δx , of the x -axis. We have seen in the preceding sections of Part V that the change in a variable over such an interval is given by the derivative of the variable times the length

of the interval. Here, the variable is $\partial h/\partial x$ and the interval is Δx ; thus we require the derivative of $\partial h/\partial x$ with respect to x and must multiply this by the interval Δx .

Return to Section 7 and choose another answer.

" 4

5 "

Your answer in Section 21 is not correct. A falling water level in the piezometer would indicate that water was being released from storage in the prism of aquifer. The slope of a plot of piezometer level versus time would in this case be negative; that is, $\partial h/\partial t$ would be negative, since h would decrease as t increased. According to the storage equation,

$$\frac{dV}{dt} = SA \frac{\partial h}{\partial t}$$

and therefore the rate of accumulation in storage, dV/dt , would also have to be negative. That is, we would have depletion from storage, rather than accumulation in storage. The question in Section 22, however, states that inflow to the prism exceeds outflow; thus, according to the equation of continuity, accumulation in storage should be occurring.

Return to Section 21 and choose another answer.

6 "

Your answer in Section 21 is not correct. If the water level in the piezometer were constant with time, a plot of the piezometer readings versus time would simply be a horizontal line. The slope of such a plot, $\partial h/\partial t$, would be zero. From the storage equation, then, the rate of accumulation of water in storage in the prism would have to be zero, for we would have

$$\frac{dV}{dt} = SA \frac{\partial h}{\partial t} = SA \cdot 0 = 0.$$

The question states, however, that inflow to the prism exceeds outflow; according to the equation of continuity, then, the rate of accumulation of water in storage cannot be zero. Rather, it must equal the difference between inflow and outflow.

Return to Section 21 and choose another answer.

7 "

Your answer in Section 16,

$$\left(\frac{dy}{dx}\right)_2 - \left(\frac{dy}{dx}\right)_1 = \left(\frac{d\left(\frac{dy}{dx}\right)}{dx}\right)_{1-2} (x_2 - x_1),$$

is correct. In this case, the derivative itself is the variable whose change is required, and for this we must use the derivative of the derivative,

$$\frac{d\left(\frac{dy}{dx}\right)}{dx}$$

evaluated at an appropriate point within the interval. This term is called the second derivative of y with respect to x , and the notation d^2y/dx^2 is used for it. That is,

$$\frac{d^2y}{dx^2} = \frac{d\left(\frac{dy}{dx}\right)}{dx}$$

= slope of a plot of $\frac{dy}{dx}$ versus x .

The terms and notations used in the case of partial derivatives are entirely parallel. The notation $\partial^2 h/\partial x^2$ is used to represent the second *partial* derivative of h with respect to x , which in turn is simply the partial derivative of $\partial h/\partial x$ with respect to x . That is,

Con.— " 7

$$\frac{\partial^2 h}{\partial x^2} = \frac{\partial \left(\frac{\partial h}{\partial x} \right)}{\partial x}$$

= slope of a plot of $\frac{\partial h}{\partial x}$ versus x .

Again, the partial derivative notation indicates that we can expect $\partial h/\partial x$ to vary with t (or some other variable) as well as with x ; $\partial^2 h/\partial x^2$ measures only its change due to a change in x , all other independent variables being held constant.

QUESTION

In Section 9, we saw that inflow minus outflow for our prism of aquifer could be expressed in the form

$$Q_1 - Q_2 = Kb\Delta y \left\{ \left(\frac{\partial h}{\partial x} \right)_2 - \left(\frac{\partial h}{\partial x} \right)_1 \right\}$$

and that the term

$$\left\{ \left(\frac{\partial h}{\partial x} \right)_2 - \left(\frac{\partial h}{\partial x} \right)_1 \right\}$$

represented the change in the hydraulic gradient occurring across the prism. If the width of the prism in the x direction (that is, parallel to the x -axis) is Δx , which of the following expressions could most reasonably be substituted for

$$\left\{ \left(\frac{\partial h}{\partial x} \right)_2 - \left(\frac{\partial h}{\partial x} \right)_1 \right\}?$$

Turn to Section:

$$\frac{\partial^2 h}{\partial x^2} \cdot \frac{\partial h}{\partial x} \quad 4$$

$$\frac{\partial \left(\frac{\partial h}{\partial x} \right)}{\partial x} \quad 23$$

$$\frac{\partial^2 h}{\partial x^2} \cdot \Delta x \quad 32$$

Your answer in Section 30,

$$Q_1 = -Kb\Delta x\Delta y \left(\frac{\partial h}{\partial x} \right)_1,$$

is not correct. According to Darcy's law, the flow through face 1 should equal the product of the hydraulic conductivity, the cross-sectional area of the face, and the head gradi-

ent at face 1. The cross-sectional area of face 1 is simply $b\Delta y$.

Return to Section 30 and choose another answer.

Your answer in Section 33,

$$Q_1 - Q_2 = -Kb\Delta y \left\{ \left(\frac{\partial h}{\partial x} \right)_1 - \left(\frac{\partial h}{\partial x} \right)_2 \right\},$$

is correct. We may change the term in braces to $(\partial h/\partial x)_2 - (\partial h/\partial x)_1$ and drop the negative sign to obtain the form

$$Q_1 - Q_2 = Kb\Delta y \left\{ \left(\frac{\partial h}{\partial x} \right)_2 - \left(\frac{\partial h}{\partial x} \right)_1 \right\}.$$

The term $(\partial h/\partial x)_2 - (\partial h/\partial x)_1$ represents the change in hydraulic gradient from one side of the prism of aquifer to the other. We wish now to express this change in hydraulic gradient in a slightly different form.

(continued on next page)

9" —Con.

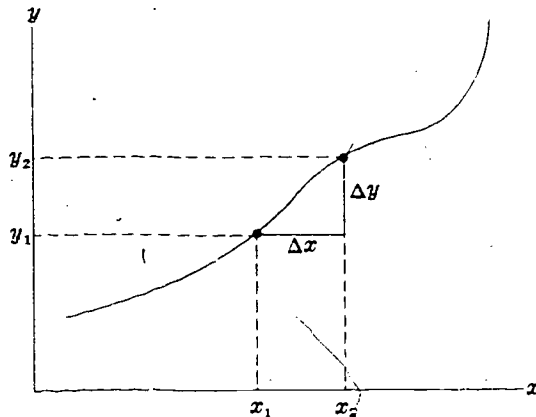

QUESTION

In the figure, a variable y is plotted as a function of an independent variable, x . As x changes from x_1 to x_2 , y changes from y_1 to y_2 ; $(dy/dx)_{1-2}$ represents the slope of the plot at a point between x_1 and x_2 . If the change in x is small, which of the following expressions would you use to obtain an approximate value for the change in y ?

Turn to Section:

$$y_2 - y_1 = \left(\frac{dy}{dx} \right)_{1-2} (x_2 - x_1) \quad 16$$

$$= \left(\frac{dy}{dx} \right)_{1-2} + (x_2 - x_1) \quad 25$$

$$y_2 - y_1 = m(x_2 - x_1) + \frac{\Delta y}{\Delta x} \quad 20$$

10"

Your answer in Section 34,

$$\frac{dV}{dt} = S \Delta x \Delta y \frac{\partial h}{\partial t}$$

is correct. (We should note that for a finite prism, $\partial h / \partial t$ may vary from point to point between the two faces; and we require an average value, which will yield the correct value of dV/dt for the prism. In fact there is always at least one point within the prism at which the value of $\partial h / \partial t$ is such an average, and we assume that we can measure and use $\partial h / \partial t$ at such a point. If we allow the prism to become infinitesimal in size, only one value of $\partial h / \partial t$ can be specified within it, and this

value will yield an exact result for dV/dt .)

Using the equation of continuity we may now set this expression which we have obtained for rate of accumulation equal to our expression for inflow minus outflow.

QUESTION

Which of the following equations is obtained by equating the above expression for dV/dt to that obtained in Section 34 for $Q_1 - Q_2$?

Turn to Section:

$$\frac{\partial^2 h}{\partial x^2} = \frac{S}{T} \frac{\partial h}{\partial t} \quad 19$$

$$T \frac{\partial^2 h}{\partial x^2} \Delta x \Delta y = S \frac{\partial h}{\partial t} \quad 11$$

$$T \Delta y \Delta x \frac{\partial h}{\partial x} = S \Delta x \Delta y \frac{\partial h}{\partial t} \quad 24$$

Your answer in Section 10 is not correct. We used Darcy's law to obtain expressions for inflow and outflow from the prism of aquifer, and we used the second derivative notation to express the difference between inflow and outflow. This led, in Section 34, to the equation

$$Q_1 - Q_2 = T \Delta x \Delta y \frac{\partial^2 h}{\partial x^2}$$

for inflow minus outflow. According to the equation of continuity, inflow minus outflow must equal rate of accumulation in storage; that is

$$Q_1 - Q_2 = \frac{dV}{dt}$$

Your answer in Section 34,

$$\frac{dV}{dt} = \frac{S}{K} \frac{\partial h}{\partial t}$$

is not correct. The storage equation tells us that the rate of accumulation of water in storage within the prism of aquifer must equal the product of storage coefficient, rate of change of head with time, and base area of the prism. Hydraulic conductivity, K , is

" 11

We obtained an expression for dV/dt through the storage equation, which states that rate of accumulation in storage must equal the product of storage coefficient, surface (or base) area, and time rate of change of head; that is

$$\frac{dV}{dt} = S \Delta x \Delta y \frac{\partial h}{\partial t}$$

Substitution of the first and third equations into the second will yield the correct result.

Return to Section 10 and choose another answer.

" 12

not involved in the storage equation. In the answer which you selected, there is no term describing the base area of the prism, and hydraulic conductivity appears on the right side of the equation.

Return to Section 34 and choose another answer.

Your answer in Section 16,

$$\left(\frac{dy}{dx}\right)_2 - \left(\frac{dy}{dx}\right)_1 = \left(\frac{dy}{dx}\right)_1^2 (x_2 - x_1),$$

is not correct. In this case, the dependent variable, plotted on the vertical axis, is dy/dx . As we have seen in preceding sections, the change in the dependent variable is given by the slope of the graph, or derivative of the dependent variable with respect to x ,

" 13

multiplied by the change in x . Thus we require the derivative of dy/dx with respect to x in our answer. In the answer shown above, however, we have only the square of the derivative of y with respect to x .

Return to Section 16 and choose another answer.

14 "

Your answer in Section 22 is not correct. It is true that if inflow differs from outflow

the water level in the prism of aquifer must change with time. However, it need not rise; if inflow is less than outflow, it will fall.

Return to Section 22 and choose another answer.

15 "

Your answer in Section 33,

$$Q_1 - Q_2 = \frac{S}{K} \left(\frac{\partial h}{\partial x} \right)_2$$

is not correct. This answer associates storage coefficient, S , with a space derivative of head, $(\partial h / \partial x)_2$; this in itself should be sufficient

to indicate that it is incorrect. In the storage equation, S is associated with the time derivative of head, $\partial h / \partial t$. Again, the answer chosen involves only the head gradient at the outflow face. Since we are seeking an expression for inflow *minus* outflow, we would expect head gradients at both faces to be involved in the answer.

Return to Section 33 and choose another answer.

16 "

Your answer in Section 9,

$$y_2 - y_1 = \left(\frac{dy}{dx} \right)_{1-2} (x_2 - x_1),$$

is correct. The change in the dependent variable, y , is found by multiplying the change in the independent variable, x , by the slope of the plot, dy/dx . Note that dy/dx must be the slope in the vicinity of the interval x_1 to x_2 ;

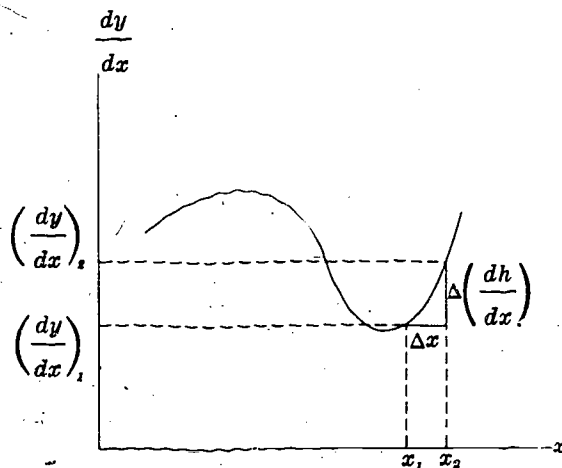

frequently, it is considered to be the slope at the midpoint of this interval. The approximation becomes more and more accurate as the size of the interval, $x_2 - x_1$, decreases. The above equation is often written in the form

$$\Delta y = \frac{dy}{dx} \cdot \Delta x.$$

(In a more formal sense, it can be demonstrated that if y is a continuous function of x and if dy/dx exists throughout the interval from x_1 to x_2 , then there is at least one point somewhere in this interval at which the derivative, dy/dx , has a value such that

$$\frac{dy}{dx} = \frac{y_2 - y_1}{x_2 - x_1}$$

or

$$y_2 - y_1 = \frac{dy}{dx} (x_2 - x_1).$$

This is known as the law of the mean of differential calculus. It guarantees that the approximation can always be used, provided we are careful about the point within the interval at which we take dy/dx . Further, since this law must hold no matter how small

(continued on next page)

the interval $(x_2 - x_1)$ is taken, the approximation must become exact as the interval is allowed to become infinitesimal.)

QUESTION

Now suppose we measure the slope of our curve, dy/dx , at various points, and construct a plot of dy/dx versus x , as shown in the figure. Again, suppose we wish to know the change in dy/dx which occurs as x changes from x_1 to x_2 . The subscript 1-2 is again used to denote evaluation at a point between x_1 and x_2 . Which of the following expressions would give an approximate value for this change?

$$\left(\frac{dy}{dx}\right)_2 - \left(\frac{dy}{dx}\right)_1 = (x_2 - x_1) \left(\frac{dy}{dx}\right)_{1-2} \quad 31$$

$$\left(\frac{dy}{dx}\right)_2 - \left(\frac{dy}{dx}\right)_1 = \left(\frac{dy}{dx}\right)_{1-2}^2 (x_2 - x_1) \quad 13$$

$$\left(\frac{dy}{dx}\right)_2 - \left(\frac{dy}{dx}\right)_1 = \left(\frac{d\left(\frac{dy}{dx}\right)}{dx}\right)_{1-2} (x_2 - x_1) \quad 7$$

Turn to Section:

Con.— " 16

" 17

Your answer in Section 1 is not correct. The rate of accumulation in the tank does depend upon both Q_1 and Q_2 , but not in the way that your answer implies. The inflow to the tank must be balanced by outflow, by ac-

cumulation of water in the tank, or by a combination of these factors.

Return to Section 1 and choose another answer.

Your answer in Section 33,

$$Q_1 - Q_2 = K \left(\frac{\partial h}{\partial x}\right)_1 - K \left(\frac{\partial h}{\partial x}\right)_2$$

is not correct. The answer treats both inflow and outflow as products of hydraulic conductivity and head gradient; but we have seen, in our application of Darcy's law to the

problem, that each should be a product of hydraulic conductivity, head gradient, and flow area.

Return to Section 33 and choose another answer.

" 18

Your answer in Section 10,

$$\frac{\partial^2 h}{\partial x^2} = \frac{S}{T} \frac{\partial h}{\partial t}$$

is correct. This equation describes groundwater movement under the simple conditions which we have assumed—that is, where the aquifer is confined, horizontal, homogeneous, and isotropic, and the movement is in one direction (taken here as the x direction).¹ If horizontal components of motion normal to

" 19

the x -axis were present, we would have to consider inflow and outflow through the other two faces of the prism; that is, the two faces normal to the y -axis. We would find this inflow minus outflow to be

$$Q_{y1} - Q_{y2} = Kb \Delta x \Delta y \frac{\partial^2 h}{\partial y^2}$$

The total inflow minus outflow for the prism would then be $(Q_{x1} - Q_{x2}) + (Q_{y1} - Q_{y2})$,

¹A rigorous and more general development of the ground water equation is given by Cooper (1966).

19 " —Con.

where $Q_{x_1} - Q_{x_2}$ represents the term we obtained previously, $Kb\Delta x\Delta y(\partial^2 h/\partial x^2)$. Finally, equating this total inflow minus outflow to the rate of accumulation, we would have

$$Kb\Delta x\Delta y \frac{\partial^2 h}{\partial x^2} + Kb\Delta x\Delta y \frac{\partial^2 h}{\partial y^2} = S\Delta x\Delta y \frac{\partial h}{\partial t}$$

or, using the notation $T = Kb$, and dividing through by $T\Delta x\Delta y$,

$$\frac{\partial^2 h}{\partial x^2} + \frac{\partial^2 h}{\partial y^2} = \frac{S}{T} \frac{\partial h}{\partial t}$$

These equations are *partial differential equations*; that is, they are equations containing partial derivatives. The relation given above for two-dimensional flow is a partial differential equation in three independent variables x , y , and t . For simplicity, we continue the discussion in terms of the equation for unidirectional flow,

$$\frac{\partial^2 h}{\partial x^2} = \frac{S}{T} \frac{\partial h}{\partial t}$$

This is a partial differential equation in two independent variables, x and t . It relates the rate of change of head with time, to the rate at which the slope of the potentiometric surface, $\partial h/\partial x$, changes with distance. When we say that we require a *solution* to this partial differential equation, we mean that we are looking for an expression giving head,

h , as a function of position, x , and time, t , such that when this expression is differentiated twice with respect to x (to obtain $\partial^2 h/\partial x^2$) and once with respect to t (to obtain $\partial h/\partial t$), the results will satisfy the condition

$$\frac{\partial^2 h}{\partial x^2} = \frac{S}{T} \frac{\partial h}{\partial t}$$

As with ordinary differential equations, there will always be an infinite number of expressions which will satisfy a partial differential equation; the particular solution required for a given problem must satisfy, in addition, certain conditions peculiar to that problem. As in ordinary differential equations, these additional conditions, termed boundary conditions, establish the starting points from which the changes in h described by the differential equation are measured.

This concludes Part V. In Part VI, we will make a development similar to the one made in Part V, but using polar coordinates, and dealing with the problem of non-equilibrium flow to a well. Our approach will be the same: we will express inflow and outflow in terms of Darcy's law and rate of accumulation in terms of the storage equation; we will then relate these flow and storage terms through the equation of continuity. We will go on to discuss a particular solution of the resulting partial differential equation and will show how this solution can be used to build up other solutions, including the well-known Theis equation.

20 "

Your answer in Section 9,

$$y_2 - y_1 = m(x_2 - x_1) + \frac{\Delta y}{\Delta x}$$

is not correct. If y is plotted as a function of

x , the change in y corresponding to a small change in x is given by the relation
Change in $y =$ (Slope of curve)

\cdot (Change in x),

where the slope of the curve is measured in the vicinity in which the change is sought. This follows directly from the definition of the slope of the curve.

Return to Section 9 and choose another answer.

Your answer in Section 1 is correct. If water is accumulating in the tank at a rate of 5 cubic feet per minute, inflow must exceed outflow by this amount. This is essentially a statement of the principle of conservation of mass. Since matter cannot be destroyed (except by conversion into energy, which we need not consider here), the difference between the rate at which mass enters the tank and that at which it leaves the tank must equal the rate at which it accumulates in the tank. Further, because compression of the water is not significant here, we may use volume in place of mass. In general terms, the relation with which we are dealing may be stated as:

$$\text{Inflow} - \text{Outflow} = \text{Rate of accumulation.}$$

This relation is often termed the equation of continuity.

Note that if outflow exceeds inflow, the

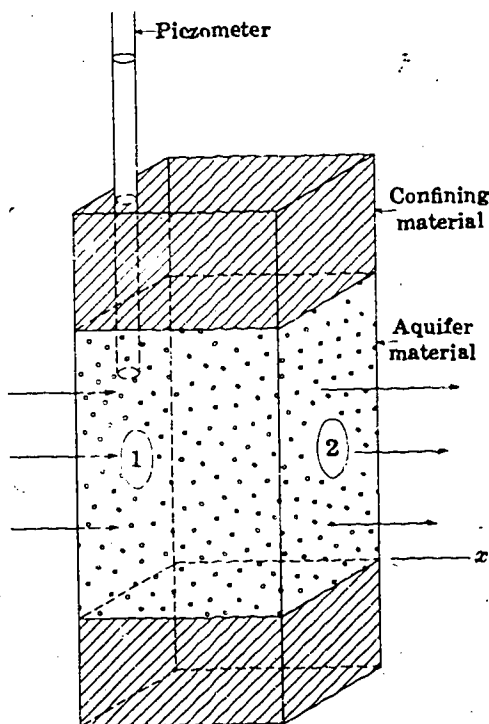

rate of accumulation will be negative—that is, we will have depletion rather than accumulation. An important special case of this equation is that in which inflow and outflow are in balance, so that the rate of accumulation is zero. As an example, consider a tank in which the inflow is just equal to the outflow. Rate of accumulation in the tank is zero, and the water level does not change with time. The flow is said to be in equilibrium, or in the steady state. The problems which we considered in Part III were of this sort; no changes of head with time were postulated, so the assumption that inflow and outflow were in balance was implicit. The flow pattern could be expected to remain the same from one moment to the next.

Forms of the equation of continuity occur in all branches of physics. In electricity, for example, if the flow of charge toward a capacitor exceeds that away from it, charge must accumulate on the capacitor plate, and voltage must increase. In heat conduction, if the flow of heat into a region exceeds that leaving it, heat must accumulate within the region, and the temperature within the region must rise.

QUESTION

The sketch shows a prismatic section through a confined aquifer. Water is flowing in the x direction, that is, into the prism through face 1 and out of the prism through face 2. A piezometer or observation well measures the hydraulic head within the prism. Let us suppose that the volumetric rate at which water is entering through face 1 exceeds that at which it is leaving through face 2. The water level in the piezometer will then:

remain constant with time
fall steadily
rise

Turn to Section:

6

5

30

22 "

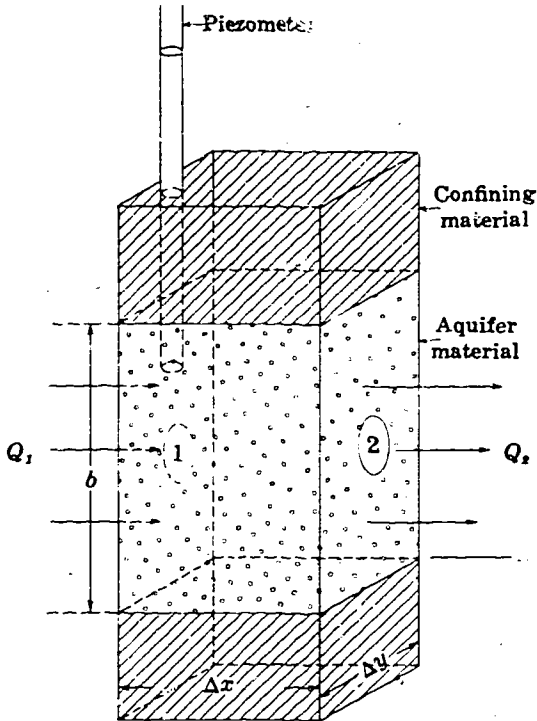

Your answer in Section 30,

$$Q_1 = -Kb\Delta y \left(\frac{\partial h}{\partial x} \right)_1,$$

is correct. $(\partial h/\partial x)_1$ is the hydraulic gradient at the particular point and time in which we are interested. We simply insert it in Darcy's law to obtain the required flow rate.

We are dealing with nonequilibrium flow here; that is, in general, inflow and outflow will not be equal. Flow occurs only in the x direction; thus the outflow from our prism of aquifer must take place entirely through face 2, as shown in the sketch.

QUESTION

Assuming that outflow differs from inflow and that the hydraulic conductivity and thickness of the aquifer are constant, which of the following statements is correct?

Turn to Section:

- | | |
|--|----|
| The water level in the prism must rise | 14 |
| The hydraulic gradient at face 2 of the prism must differ from that at face 1 of the prism | 33 |
| The rate of withdrawal from storage must be given by Darcy's law. | 26 |

23 "

Your answer in Section 7,

$$\frac{\partial \left(\frac{\partial h}{\partial x} \right)}{\partial x},$$

is not correct. As we have seen in earlier sections of this chapter, the change in a

dependent variable, over a small interval of the x -axis, Δx , is given by the derivative of the variable times the length of the interval. Here, the variable is $\partial h/\partial x$ and the term $\partial(\partial h/\partial x)/\partial x$ of your answer is certainly its derivative. However, this derivative is not multiplied by the interval along the x -axis; thus the answer gives only the *rate* of change of $\partial h/\partial x$ with distance—not its actual change across the interval Δx .

Return to Section 7 and choose another answer.

24 "

Your answer in Section 10 is not correct. The rate of accumulation in storage is given by

$$S\Delta x\Delta y \frac{\partial h}{\partial t},$$

as in the answer which you chose. However, the expression for inflow minus outflow requires a second derivative, as it deals with

the difference between two flow terms, each of which incorporates a first derivative. In the answer which you chose, inflow minus outflow is expressed in terms of a first derivative.

Con.—" 24

Review Sections 9, 32, and 34 and then return to Section 10 and choose another answer.

Your answer in Section 9,

$$y_2 - y_1 = \left(\frac{dy}{dx} \right)_{1-2} + (x_2 - x_1),$$

is not correct. From the definition of slope, the change in y can be found by multiplying the change in x by the slope of the curve, measured in the interval x_1 to x_2 . In the an-

swer which you chose, the slope of the curve is added to the change in x .

Return to Section 9 and choose another answer.

Your answer in Section 22 is not correct. Darcy's law describes the transmission of ground water, not its withdrawal from storage. The storage equation, developed in Part IV, deals with changes in the quantity of water in storage.

" 26

Return to Section 22 and choose another answer.

Your answer in Section 32,

$$Q_1 - Q_2 = K \frac{\partial^2 h}{\partial x^2} \Delta x,$$

is not correct. Your answer includes the hydraulic conductivity, K , and the term

$$\frac{\partial^2 h}{\partial x^2} \Delta x,$$

which, as we have seen, is equal to

$$\left\{ \left(\frac{\partial h}{\partial x} \right)_2 - \left(\frac{\partial h}{\partial x} \right)_1 \right\}.$$

Thus if we were to expand your answer, expressing it in the original head gradient terms, we would have

$$Q_1 - Q_2 = K \left\{ \left(\frac{\partial h}{\partial x} \right)_2 - \left(\frac{\partial h}{\partial x} \right)_1 \right\} = K \left(\frac{\partial h}{\partial x} \right)_2 - K \left(\frac{\partial h}{\partial x} \right)_1.$$

This states that inflow is a product of hydraulic conductivity and head gradient, and that outflow is similarly a product of hydraulic conductivity and head gradient. We know from Darcy's law, however, that both inflow and outflow must be given as products of hydraulic conductivity, head gradient, and flow area. Your answer thus fails to incorporate flow area into the expression for inflow minus outflow.

Return to Section 32 and choose another answer.

28 "

Your answer in Section 34,

$$\frac{dV}{dt} = Sb\Delta x \frac{\partial h}{\partial t},$$

is not correct. The storage equation states that the rate of accumulation of water in

storage in the prism of aquifer is equal to the product of storage coefficient, rate of change of head with time, and base area of the prism. In your answer the rate of accumulation is equated to the product of the storage coefficient, the rate of change of head with time, and the area, $b\Delta x$, of one of the vertical faces of the prism.

Return to Section 34 and choose another answer.

29 "

Your answer in Section 1 is not correct. Some of the inflow to the tank is balanced by outflow at the base. In order for your an-

swer to be correct, the outflow, Q_2 , would have to be zero. Only in that case would the rate of accumulation in the tank equal the inflow.

Return to Section 1 and choose another answer.

30 "

Your answer in Section 21 is correct. According to the equation of continuity, if inflow to the prism of aquifer exceeds outflow, water must be accumulating in storage within the prism. According to the storage equation, if water is accumulating in storage within the prism, hydraulic head in the prism must be increasing with time. Specifically, we have

$$\text{Inflow} - \text{Outflow} = \text{Rate of accumulation,} \\ \frac{dV}{dt}$$

and

$$\frac{dV}{dt} = SA \frac{\partial h}{\partial t}$$

where A is the base area of the prism. Therefore,

¹ Here again we use volume in place of mass in the equation of continuity, even though slight compression and expansion of the water can be a factor contributing to confined storage. The changes in fluid density from point to point in a normal groundwater situation are sufficiently small to permit this approximation. In fact, if this were not the case, it would not be possible to use the simple formulation of storage coefficient, defined in terms of fluid volume, which we have adopted.

$$\text{Inflow} - \text{Outflow} = SA \frac{\partial h}{\partial t}$$

If the term (Inflow-Outflow) is positive—that is, if inflow exceeds outflow—then $\partial h/\partial t$ must be positive, and water levels must be increasing with time. In the above equations, we have used the partial derivative of head with respect to time, $\partial h/\partial t$; and in the equations that follow, we will use the partial derivative of head with respect to distance, $\partial h/\partial x$. These notations are used because, in this problem, head will vary both with time and with distance.

QUESTION

The sketch again shows the prism of Section 21. We assume this prism to be taken in a homogeneous and isotropic aquifer which is horizontal and of uniform thickness. Suppose we let $(\partial h/\partial x)$, represent the hydraulic gradient (in the x direction, which is the direction of the flow) at face 1 of the prism. We wish to write an expression for the inflow through face 1 of the prism. Let

Con. — " 30

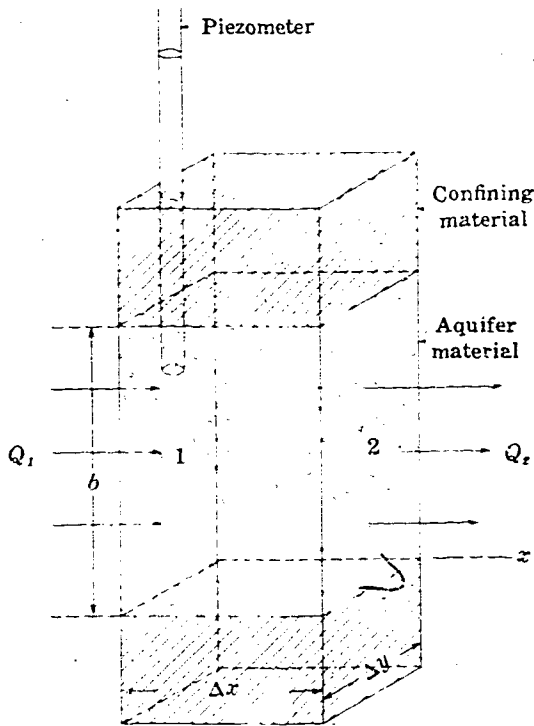

us denote this inflow Q_1 , and let us further denote the height of the prism (thickness of the aquifer) by b . The width of the prism normal to the x axis is denoted Δy , the length of the prism along the x axis is denoted Δx , and the hydraulic conductivity of the aquifer is denoted K . Which of the following equations gives the required expression for the inflow at face 1?

Turn to Section:

$Q_1 = -Kb\Delta y \left(\frac{\partial h}{\partial x} \right)_1$ 22

$Q_1 = -Kb\Delta x\Delta y \left(\frac{\partial h}{\partial x} \right)_1$ 8

$Q_1 = \frac{-K}{\Delta y} \left(\frac{\partial h}{\partial x} \right)_1$ 3

Your answer in Section 16,

$$\left(\frac{dy}{dx} \right)_2 - \left(\frac{dy}{dx} \right)_1 = (x_2 - x_1) \left(\frac{dy}{dx} \right)_{1-2}$$

is not correct. In the preceding sections we saw that the change in the dependent variable is given by the change, $x_2 - x_1$, in the independent variable, times the derivative of the dependent variable with respect to x . Here the dependent variable is dy/dx ; but

in your answer, we do not have the derivative of this dependent variable with respect to x — we have, rather, only the derivative of y with respect to x .

Return to Section 16 and choose another answer.

" 31

Your answer in Section 7,

$$\frac{\partial^2 h}{\partial x^2} \Delta x$$

is correct. This term is equivalent to the term

$$\left\{ \left(\frac{\partial h}{\partial x} \right)_2 - \left(\frac{\partial h}{\partial x} \right)_1 \right\}$$

provided that we choose a suitable point within the interval $x_2 - x_1$ at which to evalu-

ate $\partial^2 h / \partial x^2$. The product $(\partial^2 h / \partial x^2) \Delta x$ represents the slope of a plot of $\partial h / \partial x$ versus x , multiplied by the interval along the x axis, Δx , and thus gives the change in $\partial h / \partial x$ over this interval.

(continued on next page)

" 32

32" —Con.

QUESTION

Using this expression for

$$\left\{ \left(\frac{\partial h}{\partial x} \right)_2 - \left(\frac{\partial h}{\partial x} \right)_1 \right\},$$

which of the following forms is the correct expression for inflow minus outflow, $Q_1 - Q_2$, for our prism of aquifer, which is shown again in the diagram?

Turn to Section:

$$Q_1 - Q_2 = K \frac{\partial^2 h}{\partial x^2} \Delta x \quad 27$$

$$Q_1 - Q_2 = Kb \Delta y \Delta x \frac{\partial^2 h}{\partial x^2} \quad 34$$

$$Q_1 - Q_2 = K \frac{\partial h}{\partial x} \quad 2$$

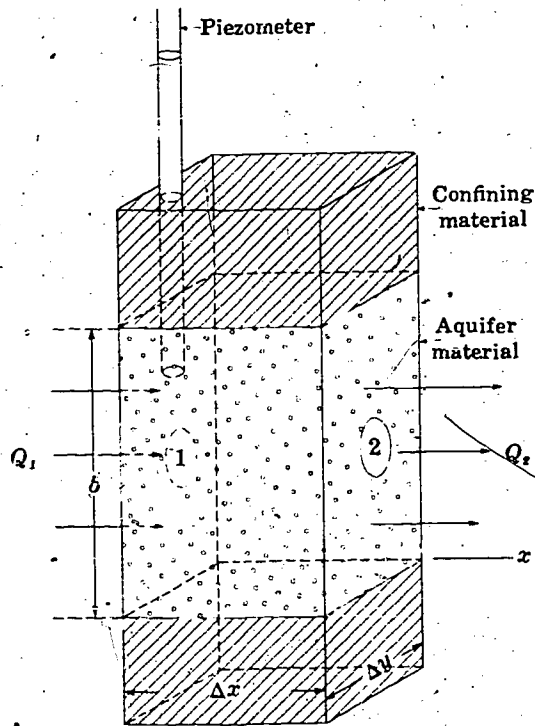

33"

Your answer in Section 22 is correct. If we apply Darcy's law at face 2, we have

$$Q_2 = -Kb \Delta y \left(\frac{\partial h}{\partial x} \right)_2$$

where at face 1 we had

$$Q_1 = -Kb \Delta y \left(\frac{\partial h}{\partial x} \right)_1$$

K , b , and Δy do not change. Thus if the outflow, Q_2 , is to differ from the inflow, Q_1 , the hydraulic gradients at the inflow and outflow

faces must differ—that is, $(\partial h / \partial x)_2$ must differ from $(\partial h / \partial x)_1$.

QUESTION

Using the expressions we have developed for inflow and outflow, which of the following terms would describe inflow *minus* outflow for the prism?

Turn to Section:

$$Q_1 - Q_2 = K \left(\frac{\partial h}{\partial x} \right)_1 - K \left(\frac{\partial h}{\partial x} \right)_2 \quad 18$$

$$Q_1 - Q_2 = \frac{S}{K} \left(\frac{\partial h}{\partial x} \right)_2 \quad 15$$

$$Q_1 - Q_2 = -Kb \Delta y \left\{ \left(\frac{\partial h}{\partial x} \right)_1 - \left(\frac{\partial h}{\partial x} \right)_2 \right\} \quad 9$$

Your answer in Section 32,

$$Q_1 - Q_2 = Kb\Delta y\Delta x \frac{\partial^2 h}{\partial x^2},$$

is correct. The term Kb , representing the hydraulic conductivity of the aquifer times its thickness, is called the transmissivity or transmissibility of the aquifer, and is designated by the letter T . Using this notation, the expression for inflow minus outflow becomes

$$Q_1 - Q_2 = T\Delta y\Delta x \frac{\partial^2 h}{\partial x^2}.$$

Now according to the equation of continuity, this inflow minus outflow must equal the rate of accumulation of water in storage within the prism of aquifer, which is shown in the figure.

QUESTION

We represent the average time rate of change of head in the prism of aquifer by $\partial h/\partial t$ and note that the base area of the prism is $A = \Delta x\Delta y$. Using the storage equation, which of the following expressions gives the rate of accumulation in storage within the prism?

$$\frac{dV}{dt} = Sb\Delta x \frac{\partial h}{\partial t} \quad 28$$

$$\frac{dV}{dt} = \frac{S}{K} \frac{\partial h}{\partial t} \quad 12$$

$$\frac{dV}{dt} = S\Delta x\Delta y \frac{\partial h}{\partial t} \quad 10$$

Turn to Section:

" 34

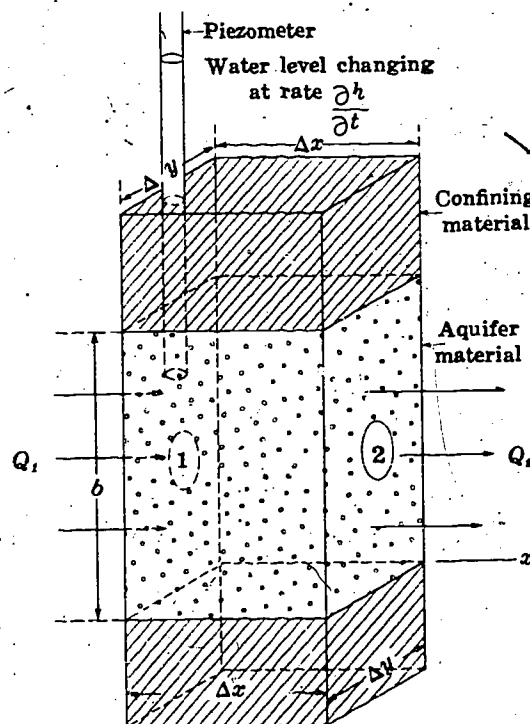

Part VI. Nonequilibrium Flow to a Well

Introduction

In Part V we developed the equation

$$\frac{\partial^2 h}{\partial x^2} = \frac{S}{T} \frac{\partial h}{\partial t}$$

for one-dimensional nonequilibrium flow in a homogeneous and isotropic confined aquifer. We indicated, in addition, that extension to two-dimensional flow would yield the equation

$$\frac{\partial^2 h}{\partial x^2} + \frac{\partial^2 h}{\partial y^2} = \frac{S}{T} \frac{\partial h}{\partial t}$$

In Part VI we consider a problem involving flow away from (or toward) a well in such an aquifer. As in the steady-state problem of flow to a well, which we considered in Part III, we will find it convenient here to use polar coordinates. The two-dimensional differential equation

$$\frac{\partial^2 h}{\partial x^2} + \frac{\partial^2 h}{\partial y^2} = \frac{S}{T} \frac{\partial h}{\partial t}$$

can be transformed readily into polar coordinates by using standard methods. However, it is both easy and instructive to derive the

equation again from hydraulic principles in the form in which we are going to use it. After we have developed the differential equation in this way, we will consider one of its solutions, corresponding to an instantaneous disturbance to the aquifer. In the terminology of systems analysis, this solution will give the "impulse response" of the well-aquifer system. In considering this solution, we will first show by differentiation that it satisfies the given differential equation; we will then develop the boundary conditions applicable to the problem and show that the solution satisfies these conditions. Following the programed section of Part VI, a discussion in text format has been added showing how the "impulse response" solution may be used to synthesize solutions corresponding to more complex disturbances to the aquifer. In particular, solutions are synthesized for the case of repeated withdrawal, or bailing, of a well and for the case of continuous pumping of a well. The latter solution, for the particular case in which the pumping rate is constant, is the Theis equation, which is commonly used in aquifer test analysis.

I +

The figure shows a well penetrating a confined aquifer. A cylindrical shell or prism, coaxial with the well and extending through the full thickness, b , of the aquifer has been outlined in the diagram. The radial width of this cylindrical element is designated Δr ;

the inner surface of the element is at a radius r_1 from the axis of the well, which is taken as the origin of the polar coordinate system; and the outer surface of the element is at a radius r_2 from this axis. We assume all flow to be in the radial direction, so that

1 + —Con.—

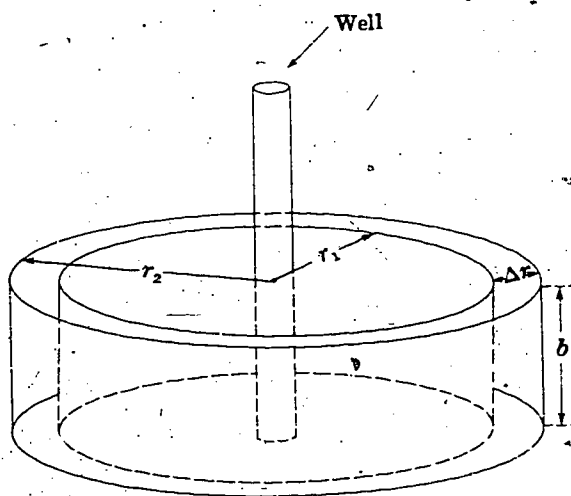

we need not consider variation in the vertical or angular directions. We further assume that we are dealing with injection of water into the aquifer through the well, so that flow is outward, away from the well, in the positive r direction. The hydraulic conductivity of the aquifer is denoted K , the transmissivity T , and the storage coefficient S .

QUESTION

If $(\partial h/\partial r)_1$ represents the hydraulic gradient at the inner face of the cylindrical element, which of the following expressions will be obtained for the flow through this face, by an application of Darcy's law?

Turn to Section:

$$Q_1 = -K\pi r_1^2 \left(\frac{\partial h}{\partial r} \right)_1 \quad 34$$

$$Q_1 = -K2\pi r_1 b \left(\frac{\partial h}{\partial r} \right)_1 \quad 15$$

$$Q_1 = \frac{-Kb \left(\frac{\partial h}{\partial r} \right)_1}{2\pi r_1} \quad 36$$

2 +

Your answer in Section 27,

$$\frac{\partial h}{\partial r} = \frac{V}{4\pi T t} e^{-(Sr^2/4Tt)},$$

is not correct.

You are correct in your intention to multiply the derivative of $e^{-(Sr^2/4Tt)}$ by the "constant" coefficient $V/(4\pi T t)$ to obtain the derivative of the product

$$\frac{V}{4\pi T t} e^{-(Sr^2/4Tt)},$$

with respect to r . However, your differentiation of $e^{-(Sr^2/4Tt)}$ is not correct. The deriva-

tive of e raised to some power is not simply e raised to the same power, as you have written, but the product of e raised to that power times the derivative of the exponent. That is,

$$\frac{de^u}{dr} = e^u \frac{du}{dr}$$

Thus, in this case, we must obtain the derivative of the exponent, $-(Sr^2/4Tt)$, and multiply $e^{-(Sr^2/4Tt)}$ by this derivative to obtain the derivative of $e^{-(Sr^2/4Tt)}$ with respect to r .

Return to Section 27 and choose another answer.

3 +

Your answer in Section 35,

$$\frac{\partial h}{\partial t} = \frac{V}{4\pi Tt} \cdot e^{-(Sr^2/4Tt)} \left(\frac{Sr^2}{4Tt^2} \right),$$

is not correct. In your answer, the term $e^{-(Sr^2/4Tt)}$ is differentiated correctly with respect to time. However, your answer gives only the derivative of this factor times the first factor itself, $V/(4\pi Tt)$. According to the rule for differentiation of a product, we must add to this the second factor, $e^{-(Sr^2/4Tt)}$,

times the derivative of the first factor. The first factor, $V/(4\pi Tt)$ was treated as a constant coefficient when we were differentiating with respect to r , since it does not contain r . It does, however, contain t and cannot be treated as a constant when we are differentiating with respect to t . Its derivative with respect to t is given in the discussion of Section 35.

Return to Section 35 and choose another answer.

4 +

Your answer in Section 27,

$$\frac{\partial h}{\partial r} = e^{-(Sr^2/4Tt)} \cdot \left(\frac{-2Sr}{4Tt} \right),$$

is not correct.

When an expression is multiplied by a constant coefficient, the derivative of the product is simply the constant coefficient times the derivative of the expression. For example, the derivative of the expression x^2 , with respect to x , is $2x$; but if x^2 is multiplied by the constant coefficient c , the derivative of the product, cx^2 , is $c \cdot 2x$.

In the question of Section 27, the term $e^{-(Sr^2/4Tt)}$ is actually the expression in which

we must differentiate with respect to r . The term $V/(4\pi Tt)$, represents a constant coefficient—constant with respect to this differentiation, because it does not contain r . Thus whatever we obtain as the derivative of $e^{-(Sr^2/4Tt)}$ must be multiplied by this coefficient, $V/(4\pi Tt)$, to obtain the derivative of the product

$$\frac{V}{4\pi Tt} e^{-(Sr^2/4Tt)}$$

Your differentiation of $e^{-(Sr^2/4Tt)}$ is correct, but your answer does not contain the factor $V/(4\pi Tt)$ and thus cannot be correct.

Return to Section 27 and choose another answer.

5 +

Your answer in Section 27,

$$\frac{\partial h}{\partial r} = \frac{V}{4\pi Tt} e^{-(Sr^2/4Tt)} \cdot \left(\frac{-2Sr}{4Tt} \right),$$

is correct.

We now wish to differentiate this expression for $\partial h/\partial r$, in order to obtain $\partial^2 h/\partial r^2$. To do this, we treat the expression as the product of two factors. The first is the function we just differentiated,

$$\frac{V}{4\pi Tt} e^{-(Sr^2/4Tt)};$$

the second is

$$\left(\frac{-2Sr}{4Tt} \right).$$

Once again we are differentiating with respect to r , so that t is treated as a constant.

5 + —Con.—

QUESTION

If we follow the rule for differentiation of a product (first factor times derivative of second, plus second factor times derivative of first), which of the following results do we obtain for $\partial^2 h / \partial r^2$?

$\frac{\partial^2 h}{\partial r^2} = \frac{V}{4\pi Tt} \left\{ e^{-(Sr^2/4Tt)} \cdot \left(\frac{-2S}{4Tt} \right) + \left(\frac{-2Sr}{4Tt} \right) \cdot e^{-(Sr^2/4Tt)} \cdot \left(\frac{-2Sr}{4Tt} \right) \right\}$	Turn to Section: 35
$\frac{\partial^2 h}{\partial r^2} = \frac{V}{4\pi Tt} \cdot e^{-(Sr^2/4Tt)} \cdot \left(\frac{-2S}{4Tt} \right) + \left(\frac{-2Sr}{4Tt} \right) \cdot e^{-(Sr^2/4Tt)} \cdot \left(\frac{-2Sr}{4Tt} \right)$	23
$\frac{\partial^2 h}{\partial r^2} = \frac{V}{4\pi Tt} \left\{ e^{-(Sr^2/4Tt)} \cdot \left(\frac{-2S}{4Tt} \right) + \left(\frac{-2Sr}{4Tt} \right) \cdot e^{-(Sr^2/4Tt)} \right\}$	9

6 + —

Your answer in Section 18 is not correct. The answer which you chose states that head becomes infinite as radial distance becomes small. The behavior which we are trying to describe is that in which head dies

out, or approaches zero, as radial distance becomes very large.

Return to Section 18 and choose another answer.

7 + —

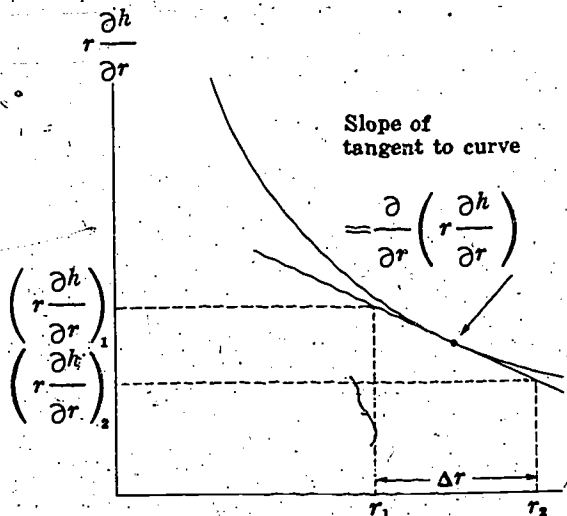

Your answer in Section 15,

$$Q_1 - Q_2 = 2\pi T \left\{ \left(r \frac{\partial h}{\partial r} \right)_2 - \left(r \frac{\partial h}{\partial r} \right)_1 \right\},$$

is correct. The term

$$\left\{ \left(r \frac{\partial h}{\partial r} \right)_2 - \left(r \frac{\partial h}{\partial r} \right)_1 \right\}$$

actually represents the change in the variable $r(\partial h/\partial r)$ between the radial limits, r_1 and r_2 , of our element. If we imagine a plot of $r(\partial h/\partial r)$ versus r , as in the figure, we can readily see that this change will be given approximately by the slope of the plot times

(continued on next page)

7 + **Con.**

the radial increment, Δr . That is, approximately

$$\left(\frac{\partial h}{\partial r}\right)_2 - \left(\frac{\partial h}{\partial r}\right)_1 = \frac{\partial\left(r\frac{\partial h}{\partial r}\right)}{\partial r} \Delta r$$

where the derivative

$$\frac{\partial\left(r\frac{\partial h}{\partial r}\right)}{\partial r}$$

represents the slope of our plot, at an appropriate point within the element. This slope, or derivative, is negative in our illustration, so that

$$\left(\frac{\partial h}{\partial r}\right)_1 > \left(\frac{\partial h}{\partial r}\right)_2$$

The approximation inherent in the above equation becomes progressively more accurate as Δr decreases in size.

QUESTION

Recalling that the rule for differentiation of a product is "first factor times derivative of second plus second factor times derivative of first," which of the following equations gives the derivative of $r(\partial h/\partial r)$ with respect to r ?

Turn to Section:

$$\frac{\partial\left(r\frac{\partial h}{\partial r}\right)}{\partial r} = r\frac{\partial\left(\frac{\partial h}{\partial r}\right)}{\partial r} + \frac{\partial h}{\partial r} \quad 26$$

$$\frac{\partial\left(r\frac{\partial h}{\partial r}\right)}{\partial r} = r\frac{\partial^2 h}{\partial r^2} + \frac{\partial h}{\partial r} \quad 28$$

$$\frac{\partial\left(r\frac{\partial h}{\partial r}\right)}{\partial r} = 2r\frac{\partial^2 h}{\partial r^2} \quad 8$$

8 +

Your answer in Section 7,

$$\frac{\partial\left(r\frac{\partial h}{\partial r}\right)}{\partial r} = 2r\frac{\partial^2 h}{\partial r^2}$$

is not correct. We are required to take the derivative of the product $r(\partial h/\partial r)$. The rule for differentiation of a product is easy to remember: first factor times derivative of second, plus second factor times derivative of first; that is

$$\frac{d(uv)}{dx} = u\frac{dv}{dx} + v\frac{du}{dx}$$

A derivation of this formula can be found in any standard text of calculus. Our first factor is r , and our second factor is $\partial h/\partial r$. Thus we must form the expression: r times the derivative of $\partial h/\partial r$ with respect to r , plus $\partial h/\partial r$ times the derivative of r with respect to r .

Return to Section 7 and choose another answer.

9 +

Your answer in Section 5,

$$\frac{\partial^2 h}{\partial r^2} = \frac{V}{4\pi Tt} \left\{ e^{-(Sr^2/4Tt)} \cdot \left(\frac{-2S}{4Tt} \right) + \left(\frac{-2Sr}{4Tt} \right) \cdot e^{-(Sr^2/4Tt)} \right\},$$

is not correct. If we remove the braces and separate your answer into two terms, we have

$$\frac{\partial^2 h}{\partial r^2} = \frac{V}{4\pi Tt} \cdot e^{-(Sr^2/4Tt)} \cdot \left(\frac{-2S}{4Tt} \right) + \left(\frac{-2Sr}{4Tt} \right) \cdot \frac{V}{4\pi Tt} \cdot e^{-(Sr^2/4Tt)}.$$

The first term, according to the rule for differentiation of a product, is correct, since it represents the first factor,

$$\frac{V}{4\pi Tt} \cdot e^{-(Sr^2/4Tt)}$$

multiplied by the derivative of the second (with respect to r), which is simply

$$\frac{-2S}{4Tt}$$

The second term of your answer, however, is not correct:

$$\frac{-2Sr}{4Tt}$$

is the second factor of the product we wish to differentiate but

$$\frac{V}{4\pi Tt} \cdot e^{-(Sr^2/4Tt)}$$

does not represent the derivative of the first factor. This first factor is itself

$$\frac{V}{4\pi Tt} \cdot e^{-(Sr^2/4Tt)}$$

and its derivative with respect to r was obtained in answer to the question of Section 27.

Return to Section 5 and choose another answer.

10 +

Your answer in Section 21 is not correct. We established in the discussion of Section 21 that the rise in head within the well at $t=0$, due to injection of the volume V , would be given by V/A_w , where A_w is the cross-sectional area of the well bore. If the well radius approaches zero, A_w must approach zero. The smaller A_w becomes, the larger the quotient V/A_w must become; for example, $1/0.001$ is

certainly much greater than $1/1$. Your answer, that the head change is zero, could only be true if the area of the well were immeasurably large, so that the addition of a finite volume of water would produce no measurable effect.

Return to Section 21 and choose another answer.

11 +

Your answer in Section 33 is not correct. The integration in the equation

$$V = \int_{r=0}^{r=\infty} S \cdot h_{r,t} \cdot 2\pi r dr$$

cannot be carried out until we substitute some clearly defined function of r for the term $h_{r,t}$. Until this is done, we do not even know what function we are trying to integrate. But even if the integration could be carried out and the result were found to be

$$\frac{V}{4\pi T t} e^{-(r^2 S/4Tt)}$$

then we would be left with the result

$$V = \frac{V}{4\pi T t} e^{-(r^2 S/4Tt)}$$

which clearly can never be satisfied except perhaps at isolated values of r and t .

Return to Section 33 and choose another answer.

12 +

Your answer in Section 28,

$$\frac{dV}{dt} = S\pi r^2 \frac{\partial h}{\partial t}$$

is not correct. The storage equation states that the rate of accumulation in storage is equal to the product of storage coefficient, rate of change of head with time, and base area of the element (prism) of aquifer under consideration. Your answer contains the storage coefficient, S , and the time rate of change, $\partial h/\partial t$. However, the base area of the prism which we are considering is not given by πr^2 .

This term gives the area of a circle extending from the origin to the radius r ; our prism is actually a cylindrical shell, extending from

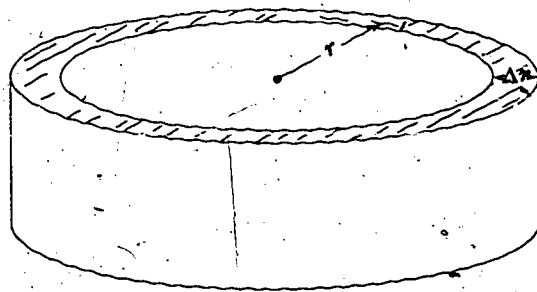

the radius r_1 to the radius r_2 . Its base area is the area of the shaded region in the figure. This region has a radial width of Δr and a mean perimeter of $2\pi r$.

Return to Section 28 and choose another answer.

13

Your answer in Section 33 is correct. Our proposed solution, giving h as a function of r and t is

$$h_{r,t} = \frac{V}{4\pi Tt} e^{-(r^2S/4Tt)}$$

To test this solution for conformity with the required condition we substitute

$$\frac{V}{4\pi Tt} e^{-(r^2S/4Tt)}$$

for $h_{r,t}$ in the equation

$$V = \int_{r=0}^{r=\infty} S \cdot h_{r,t} \cdot 2\pi r dr$$

and evaluate the integral to see whether the equation is satisfied. The substitution gives

$$V = \int_{r=0}^{r=\infty} S \cdot \frac{V}{4\pi Tt} e^{-(r^2S/4Tt)} \cdot 2\pi r dr.$$

Constant terms may be taken outside the integral; in this case, we are integrating with respect to r , so t may be treated as a constant and taken outside the integral as well. We leave the factor 2 under the integral for the moment and take the remaining constants outside to give

$$V = \frac{SV}{4Tt} \int_{r=0}^{r=\infty} e^{-(r^2S/4Tt)} \cdot 2r dr.$$

To evaluate the integral in this form, we make use of a simple algebraic substitution. Let

$$z = r^2;$$

then

$$dz = 2r dr;$$

and let

$$a = \frac{S}{4Tt}$$

Substituting these terms in the above equation, we obtain:

$$V = aV \int_{z=0}^{z=\infty} e^{-az} dz.$$

The indefinite integral of e^{-az} is simply

$$-\frac{1}{a} e^{-az};$$

that is,

$$\int e^{-az} dz = -\frac{1}{a} e^{-az} + c$$

where c is a constant of integration. The infinite upper limit in our problem is handled by the standard method; the steps are as follows:

$$\begin{aligned} \int_{z=0}^{z=\infty} e^{-az} dz &= \lim_{b \rightarrow \infty} \int_0^b e^{-az} dz \\ &= \lim_{b \rightarrow \infty} \left(-\frac{1}{a} e^{-az} \Big|_{z=0}^{z=b} \right) = \lim_{b \rightarrow \infty} \left(-\frac{1}{a} \cdot \frac{1}{e^{ab}} - \left(-\frac{1}{a} \cdot \frac{1}{e^0} \right) \right) \\ &= -\frac{1}{a} \left(\lim_{b \rightarrow \infty} \left(\frac{1}{e^{ab}} \right) \right) + \frac{1}{a} \end{aligned}$$

but

$$\lim_{b \rightarrow \infty} \left(\frac{1}{e^{ab}} \right) = 0,$$

so that

$$\int_{z=0}^{z=\infty} e^{-az} dz = \frac{1}{a}.$$

Therefore

$$aV \int_{z=0}^{z=\infty} e^{-az} dz = aV \cdot \frac{1}{a} = V.$$

This verifies that our function

$$\frac{V}{4\pi Tt} e^{-(r^2S/4Tt)}$$

(continued on next page)

13 + —Con.

actually satisfies the required condition—that is, that when we substitute this term for $h_{r,t}$ in the expression

$$\int_{r=0}^{r=\infty} S \cdot h_{r,t} \cdot 2\pi r dr$$

and perform the integration, the result is actually equal to V , the volume of injected water, as required by the condition.

We have shown, then, that the expression

$$h = \frac{V}{4\pi T t} e^{-(r^2 S / 4T t)}$$

satisfies the differential equation for radial flow in an aquifer and satisfies as well the boundary conditions associated with the instantaneous injection of a volume of water through a well at the origin, at $t=0$. It is, therefore, the particular solution required for this problem. It is an important solution for two reasons. First, it describes approximately what happens when a charge of water is suddenly added to a well in the

standard "slug test" (Ferris and Knowles, 1963) and provides a means of estimating transmissivity through such a test.¹ Second, and more importantly, it gives the "impulse response" of the well-aquifer system—the solution corresponding to an instantaneous disturbance. Solutions for more complicated forms of disturbance, such as repeated injections or withdrawals, or continuous withdrawal, can be synthesized from this elementary solution. Following Section 37, a discussion is given in text format outlining the manner in which solutions corresponding to repeated bailing and continuous pumping of a well may be built up from the impulse response solution.

This concludes the programed instruction of Part VI. You may proceed to the text-format discussion following Section 37. Readers who prefer may proceed to Part VII.

¹ A subsequent publication (Cooper, Bredehoeft, and Papadopoulos, 1967) has provided a more accurate description of the actual effect of adding a charge of water to a well, by considering the inertia of the column of water in the well. This factor was neglected in the original analysis.

14 +

Your answer in Section 33 is not correct. The condition to be satisfied was

$$V = \int_{r=0}^{r=\infty} S \cdot h_{r,t} \cdot 2\pi r dr.$$

A solution to our differential equation is by definition an expression giving the head, h , at any radius, r , and time, t , in a form that satisfies the differential equation. Here, the idea is to test such a solution to see if it also satisfies the condition phrased in the above

equation. The solution actually represents the head, $h_{r,t}$; if we substitute it for the quantity $2\pi r$, as your answer suggests, there will be two terms, $h_{r,t}$ and our solution, both representing head in the resulting equation. Moreover if the result of the integration were $2\pi S$ we would be left with the result $V = 2\pi S$, which does not satisfy the required condition.

Return to Section 33 and choose another answer.

15 +

Your answer in Section 1,

$$Q_i = -K 2\pi r_i b \left(\frac{\partial h}{\partial r} \right)_i$$

is correct. The terms 2π , K , and b are all constants; we will denote the product Kb by

T , as before. The variable terms, r and $\partial h / \partial r$, may be combined and treated as a single variable, $r(\partial h / \partial r)$. The value of this variable at the inner face of the cylindrical element will be designated $(r \partial h / \partial r)_i$. Using these notations, our expression for inflow

15 + — Con. —

through the inner face of the cylindrical element is now

$$Q_1 = -2\pi T \left(r \frac{\partial h}{\partial r} \right)_1$$

QUESTION

Suppose we continue to treat the product $r(\partial h/\partial r)$ as a single variable, and let $(r\partial h/\partial r)_2$ denote the value of this variable at the outer face of the cylindrical element. The expression for the outflow, Q_2 , through the outer cylindrical surface can then be written in terms of $(r\partial h/\partial r)_2$, in a form similar to

that for the inflow. Which of the following equations would we then obtain for the inflow minus outflow, $Q_1 - Q_2$, for our cylindrical element?

Turn to Section:

$$Q_1 - Q_2 = 2\pi T \left\{ \left(r \frac{\partial h}{\partial r} \right)_2 - \left(r \frac{\partial h}{\partial r} \right)_1 \right\} \quad 7$$

$$Q_1 - Q_2 = 2\pi T \left(r \frac{\partial h}{\partial r} \right)_1 - \left(r \frac{\partial h}{\partial r} \right)_2 \quad 30$$

$$Q_1 - Q_2 = 2\pi T \left\{ \left(\frac{\partial h}{\partial r} \right)_2 - \left(\frac{\partial h}{\partial r} \right)_1 \right\} \quad 25$$

16 + —

Your answer in Section 28,

$$\frac{dV}{dt} = \frac{S}{2\pi r \Delta r} \frac{\partial h}{\partial t}$$

is not correct. The storage equation tells us that rate of accumulation in storage should equal the product of storage coefficient, rate of change of head with time, and base area

of the element (prism) of aquifer with which we are dealing. Our element, or prism, of aquifer is a cylindrical shell extending from the radius r_1 to the radius r_2 . Its base area is given by the term $2\pi r \Delta r$. However, in your answer this area term is divided into the term $S(\partial h/\partial t)$.

Return to Section 28 and choose another answer.

17 + —

Your answer in Section 20,

$$\frac{\partial^2 h}{\partial r^2} + \frac{1}{r} \frac{\partial h}{\partial r} = \frac{V}{4\pi T t} e^{-(S^2/4Tt)} \left\{ \frac{-2S}{4Tt} + \frac{2S^2 r^2}{16T^2 t^2} \right\}$$

is not correct. The mistake in this answer results from an algebraic error in simplifying the second term of the expression for $\partial^2 h/\partial r^2$. The product

$$\left(\frac{-2Sr}{4Tt} \right) \left(\frac{-2Sr}{4Tt} \right)$$

is not equal to

$$\frac{2S^2 r^2}{16T^2 t^2}$$

Return to Section 20 and choose another answer.

18 +

Your answer in Section 21 is correct; head is immeasurably great, or infinite, at the well at $t=0$. Taking this result together with our requirement that head must be zero elsewhere in the aquifer at $t=0$, we may phrase the boundary condition for $t=0$ as follows

$$h \rightarrow \infty, \text{ for } r=0 \text{ and } t=0$$

$$h=0, \text{ for } r>0 \text{ and } t=0.$$

We now test our solution to see if it satisfies this requirement. Probably the easiest way to do this is to expand the term $e^{-(r^2S/4Tt)}$ in a Maclaurin series. The theory of this type of series expansion is treated in standard texts of calculus; the result, as applied to our exponential function, has the form

$$e^x = 1 + x + \frac{x^2}{2!} + \frac{x^3}{3!} + \dots$$

or for a negative exponent,

$$e^{-x} = \frac{1}{1 + x + \frac{x^2}{2!} + \frac{x^3}{3!} + \dots}$$

In our case, x is the term $r^2S/4Tt$, and

$$e^{-(r^2S/4Tt)} = \frac{1}{1 + \left(\frac{r^2S}{4Tt}\right) + \frac{\left(\frac{r^2S}{4Tt}\right)^2}{2!} + \frac{\left(\frac{r^2S}{4Tt}\right)^3}{3!} + \dots}$$

so that

$$\frac{V}{4\pi Tt} e^{-(r^2S/4Tt)} =$$

$$\frac{V}{4\pi Tt + r^2S + \frac{r^4S^2\pi}{4Tt \cdot 2!} + \frac{r^6S^3\pi}{16T^2t^2 \cdot 3!} + \dots}$$

Now as t approaches zero, the first term in the denominator approaches zero; the second remains constant, and the third and all higher terms become infinite, provided r does not also approach zero. If any term in the

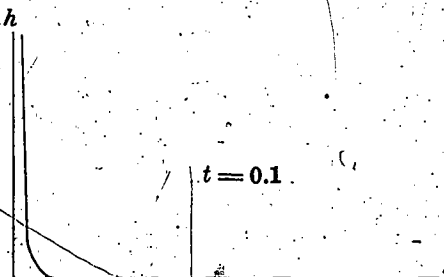
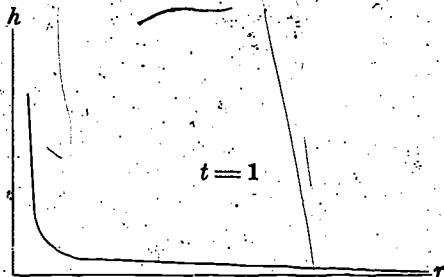
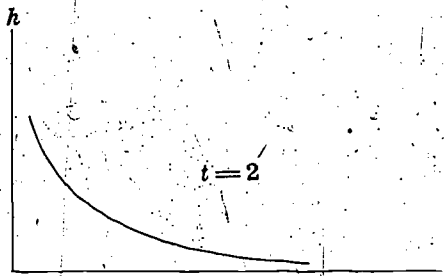
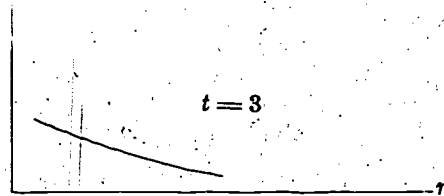

18 + —Con.—

denominator is infinite, the fraction as a whole becomes zero. Thus the expression

$$\frac{V}{4\pi Tt} e^{-(r^2S/4Tt)}$$

is zero for $t=0$ and $r \neq 0$, and satisfies the first part of our condition.

If r and t are both allowed to approach zero, the first two terms in the denominator of our fraction will be zero. The third will behave in the same manner as the fraction cx^4/kx behaves as x approaches zero, since r and t are both approaching zero in the same way. The limit of cx^4/kx as x approaches zero is 0, since

$$\frac{cx^4}{kx} = \frac{c}{k} x^3.$$

Therefore the third term in the denominator must also approach the limit zero as r and t approach zero. By a similar analysis it can be shown that the limit of every succeeding term in the denominator is zero as r and t approach zero. Thus the entire denominator is zero, and the fraction as a whole is infinite, so that the term

$$\frac{V}{4\pi Tt} e^{-(r^2S/4Tt)}$$

is infinite when r and t are both zero, satisfy the second part of our condition.

Another and very instructive way to in-

vestigate the behavior of the function

$$\frac{V}{4\pi Tt} e^{-(r^2S/4Tt)}$$

is to construct plots of this function versus r , for decreasing values of time. The figures show the form that such a series of plots will take. It may be noted that as time approaches zero the function approaches the shape of a sharp "spike," or impulse, at $r=0$. The shape of these curves suggests a head distribution which we might sketch intuitively, if we were asked to describe the response of an aquifer to the injection of a small volume of water. It is suggested that the reader construct a few of these plots, in order to acquire a feeling for the behavior of the function.

QUESTION

The aquifer is assumed to be infinite in extent, and the volume of water injected is assumed to be small. We would therefore expect the effects of the injection to die out at great radial distances from the well. Which of the following expressions is a mathematical formulation of this behavior and could be used as a boundary condition for our problem?

$h \rightarrow 0$ as $r \rightarrow \infty$	33
$h \rightarrow \infty$ as $t \rightarrow \infty$	29
$h \rightarrow \infty$ as $r \rightarrow 0$	6

Turn to Section:

19 +

Your answer in Section 21 is not correct. We established in the discussion of Section 21 that the rise in water level in the well at $t=0$ should be given by the expression $h = V/A_w$, where A_w is the cross-sectional area of the well bore and V is the volume of water injected. In order for h to have the instantaneous value of 1 foot, V , in cubic feet, would have to be numerically equal to A_w , in square feet. However, we are assuming

the well to have an infinitesimally small radius, so that A_w , its cross-sectional area, approaches zero. If smaller and smaller values are assigned to the denominator, A_w , while the numerator, V , is held constant, the fraction V/A_w must take on larger and larger values.

Return to Section 21 and choose another answer.

20

Your answer in Section 35,

$$\frac{\partial h}{\partial t} = \frac{V}{4\pi Tt} e^{-(Sr^2/4Tt)} \left(\frac{Sr^2}{4Tt^2} \right) + e^{-(Sr^2/4Tt)} \left(\frac{-V}{4\pi Tt^2} \right),$$

is correct. If the term

$$\frac{V}{4\pi Tt} e^{-(Sr^2/4Tt)}$$

is factored from this expression we have

$$\frac{\partial h}{\partial t} = \frac{V}{4\pi Tt} e^{-(Sr^2/4Tt)} \left\{ \frac{Sr^2}{4Tt^2} - \frac{1}{t} \right\}$$

and if we multiply this equation by S/T , we obtain

$$\frac{S}{T} \frac{\partial h}{\partial t} = \frac{V}{4\pi Tt} e^{-(Sr^2/4Tt)} \left\{ \frac{S^2 r^2}{4T^2 t^2} - \frac{S}{Tt} \right\}$$

Our expression for $\partial h / \partial r$, obtained in answer to the question of Section 27 was

$$\frac{\partial h}{\partial r} = \frac{V}{4\pi Tt} e^{-(Sr^2/4Tt)} \left(\frac{-2Sr}{4Tt} \right)$$

The term $(1/r) (\partial h / \partial r)$ is therefore given by

$$\frac{1}{r} \frac{\partial h}{\partial r} = \frac{V}{4\pi Tt} e^{-(Sr^2/4Tt)} \left(\frac{-2S}{4Tt} \right)$$

In answering the question of Section 5, we saw that the expression for $\partial^2 h / \partial r^2$ was

$$\frac{\partial^2 h}{\partial r^2} = \frac{V}{4\pi Tt} \left\{ e^{-(Sr^2/4Tt)} \left(\frac{-2S}{4Tt} \right) + \left(\frac{-2Sr}{4Tt} \right) e^{-(Sr^2/4Tt)} \left(\frac{-2Sr}{4Tt} \right) \right\}$$

20 + —Con.—

QUESTION

Which of the following expressions is obtained for

$$\frac{\partial^2 h}{\partial r^2} + \frac{1}{r} \frac{\partial h}{\partial r}$$

by combining the two expressions given above and factoring out the term

$$\frac{V}{4\pi T t}$$

Turn to Section:

$$\frac{\partial^2 h}{\partial r^2} + \frac{1}{r} \frac{\partial h}{\partial r} = \frac{V}{4\pi T t} e^{-(S r^2 / 4 T t)} \left\{ \frac{-S}{T t} + \frac{S^2 r^2}{4 T^2 t^2} \right\} \quad 21$$

$$\frac{\partial^2 h}{\partial r^2} + \frac{1}{r} \frac{\partial h}{\partial r} = \frac{V}{4\pi T t} e^{-(S r^2 / 4 T t)} \left\{ \frac{-2S}{4 T t} + \frac{2 S^2 r^2}{16 T^2 t^2} \right\} \quad 17$$

$$\frac{\partial^2 h}{\partial r^2} + \frac{1}{r} \frac{\partial h}{\partial r} = \frac{V}{4\pi T t} e^{-(S r^2 / 4 T t)} \left\{ \frac{-4S}{T t} + \frac{S^2 r^2}{8 T t} \right\} \quad 24$$

21

Your answer in Section 20,

$$\frac{\partial^2 h}{\partial r^2} + \frac{1}{r} \frac{\partial h}{\partial r} = \frac{V}{4\pi T t} e^{-(S r^2 / 4 T t)} \left\{ \frac{-S}{T t} + \frac{S^2 r^2}{4 T^2 t^2} \right\}$$

is correct. Now note that this expression is identical to that given for $(S/T) (\partial h / \partial t)$ in Section 20. Thus we have shown that if head is given by

$$h = \frac{V}{4\pi T t} e^{-(S r^2 / 4 T t)}$$

then it is true that

$$\frac{\partial^2 h}{\partial r^2} + \frac{1}{r} \frac{\partial h}{\partial r} = \frac{S}{T} \frac{\partial h}{\partial t}$$

21 + —Con.

In other words, the expression

$$h = \frac{V}{4\pi T t} e^{-(Sr^2/4Tt)}$$

satisfies the partial differential equation, and constitutes one particular solution to it. In fact, this expression is the solution which describes the hydraulic head in an infinite, horizontal, homogeneous, and isotropic artesian aquifer, after a finite volume of water, V , is injected suddenly at $t=0$ into a fully penetrating well of infinitesimal radius located at $r=0$, assuming that head was everywhere at the datum prior to the injection—that is, assuming h was everywhere zero prior to $t=0$.

Proof that our function is the solution corresponding to this problem requires, in addition to the demonstration that it satisfies the differential equation, proof that it satisfies the various boundary conditions peculiar to the problem. We now wish to formulate these conditions.

The charge of fluid is added to the well at the instant $t=0$. At this instant, there has been no time available for fluid to move away from the well, into the aquifer. Therefore, at all points in the aquifer except at the well (that is, except at $r=0$), the head at $t=0$ must still be zero. In the well, on the other hand, the addition of the volume of

water produces an instantaneous rise in head. For a well of measurable radius, this instantaneous head buildup, Δh , would be given by

$$\Delta h = \frac{V}{A_w} = \frac{V}{\pi r_w^2},$$

where A_w is the cross-sectional area of the well bore, and r_w is the well radius. For example, if A_w is 1 square foot and we inject 1 cubic foot of water, we should observe an instantaneous rise in head of 1 foot in the well; and because head was originally at 0 (datum level), we can say that the head in the well at $t=0$ should be 1 foot. If A were 0.5 square foot, the head in the well at $t=0$ should be 2 feet; and so on.

QUESTION

For purposes of developing the boundary conditions, we have assumed the radius of our well to be infinitesimally small—that is, to approach zero. Which of the following statements describes the behavior of head at the well at $t=0$, subject to this assumption?

Turn to Section:

- | | |
|--|----|
| head at the well will be 0 feet at $t=0$ | 10 |
| head at the well will be 1 foot at $t=0$ | 19 |
| head at the well will be immeasurably large—that is, infinite—at $t=0$ | 18 |

22 +

Your answer in Section 37 is not correct. The expression obtained in Section 28 for inflow minus outflow was

$$Q_1 - Q_2 = 2\pi T \left\{ r \frac{\partial^2 h}{\partial r^2} + \frac{\partial h}{\partial r} \right\}$$

Our expression for dV/dt was

$$\frac{dV}{dt} = 2\pi r \Delta r \frac{\partial h}{\partial t}$$

The expression for inflow minus outflow may be equated to that for dV/dt , and the result simplified to yield the correct answer.

Return to Section 37 and choose another answer.

Your answer in Section 5,

$$\frac{\partial^2 h}{\partial r^2} = \frac{V}{4\pi Tt} \cdot e^{-(Sr^2/4Tt)} \left(\frac{-2S}{4Tt} \right) + \left(\frac{-2Sr}{4Tt} \right) \cdot e^{-(Sr^2/4Tt)} \cdot \left(\frac{-2Sr}{4Tt} \right),$$

is not correct. The rule for differentiation of a product is: first factor times derivative of second plus second factor times derivative of first. The two factors, in this case, are

$$\frac{V}{4\pi Tt} e^{-(Sr^2/4Tt)}$$

(which we have already differentiated in the question of Section 27) and

$$\frac{-2Sr}{4Tt}$$

The first term of your answer is correct; the first factor,

$$\frac{V}{4\pi Tt} e^{-(Sr^2/4Tt)}$$

is multiplied by the derivative of the second, which is

$$\frac{-2S}{4Tt}$$

(t is simply treated as part of the constant coefficient of r , since we are differentiating with respect to r). The second term of your answer, however, is not correct; you have written the derivative of the first factor as

$$e^{-(Sr^2/4Tt)} \cdot \left(\frac{-2Sr}{4Tt} \right).$$

Compare this with the correct answer to the question of Section 27 and you will see that it does not represent the derivative of

$$\frac{V}{4\pi Tt} e^{-(Sr^2/4Tt)}.$$

Return to Section 5 and choose another answer.

24 +

Your answer in Section 20,

$$\frac{\partial^2 h}{\partial r^2} + \frac{1}{r} \frac{\partial h}{\partial r} = \frac{V}{4\pi T t} e^{-(Sr^2/4Tt)} \left\{ \frac{-4S}{Tt} + \frac{S \cdot r^2}{8Tt} \right\},$$

is not correct. This answer contains algebraic errors, both in the addition of the two terms

$$\left(\frac{-2S}{4Tt} \right)$$

and in the multiplication of the two terms

$$\left(\frac{-2Sr}{4Tt} \right)$$

Return to Section 20 and choose another answer.

25 +

Your answer in Section 15,

$$Q_1 - Q_2 = 2\pi T \left\{ \left(\frac{\partial h}{\partial r} \right)_2 - \left(\frac{\partial h}{\partial r} \right)_1 \right\},$$

is not correct. The expression for inflow through the inner cylindrical face was shown to be

$$Q_1 = -2\pi T \left(r \frac{\partial h}{\partial r} \right)_1$$

Applying Darcy's law in a similar fashion to the outer cylindrical face, at radius r_2 , the

expression for outflow through this face is found to be

$$Q_2 = -2\pi T \left(r \frac{\partial h}{\partial r} \right)_2$$

These two equations may be subtracted to obtain an expression for inflow minus outflow. The radius, r , does not disappear in this subtraction. Your answer, which does not include radius, must therefore be wrong.

Return to Section 15 and choose another answer.

26 +

Your answer in Section 7,

$$\frac{\partial \left(r \frac{\partial h}{\partial r} \right)}{\partial r} = r \frac{\partial \left(\frac{\partial h}{\partial r} \right)}{\partial r} + \frac{\partial h}{\partial r} \cdot r,$$

is not correct. The derivative of a product is given by the first factor multiplied by the derivative of the second, plus the second factor multiplied by the derivative of the first. Your first term, above is correct; the first factor, r , is multiplied by the derivative of $\partial h/\partial r$, although it would be more conventional to use the second derivative notation,

rather than

$$\frac{\partial^2 h}{\partial r^2}$$

$$\frac{\partial \left(\frac{\partial h}{\partial r} \right)}{\partial r}$$

Your second term, however, is not correct. The derivative of r with respect to r is not equal to r .

Return to Section 7 and choose another answer.

27 +

Your answer in Section 37 is correct. The basic differential equation for the problem is

$$\frac{\partial^2 h}{\partial r^2} + \frac{1}{r} \frac{\partial h}{\partial r} = \frac{S}{T} \frac{\partial h}{\partial t}$$

In seeking a solution to this equation, we are seeking an expression giving h as a function of r and t , such that when $\partial h/\partial r$, $\partial^2 h/\partial r^2$, and $\partial h/\partial t$ are obtained by differentiation and substituted into this equation, the equation is found to be satisfied. For example, consider the function

$$h = \frac{V}{4\pi T t} \cdot e^{-(Sr^2/4Tt)}$$

in which V (as well as S and T) is constant and e is the base of natural logarithms. This happens to be an important function in the theory of well hydraulics, as we shall see; and we wish now to test it, to see whether it satisfies the above differential equation. To do this we must differentiate the expression once with respect to t and twice with respect to r ; these operations are not difficult if the rules of differentiation are applied carefully. First we will differentiate with respect to

r ; in doing so, we treat t as a constant, so that the factor $V/(4\pi T t)$ becomes simply a constant coefficient. In the exponent, as well, the term $-(S/4Tt)$ may be considered a constant coefficient of r^2 ; and the problem is essentially one of finding the derivative of $e^{-(S/4Tt)r^2}$ and multiplying this by the constant factor $V/(4\pi T t)$. The derivative of a function e^u with respect to a variable r is given simply by $e^u \cdot (du/dr)$. Here, u is the term $-(S/4Tt)r^2$.

QUESTION

Following the procedure outlined above, which of the following expressions is found for $\partial h/\partial r$?

$$\frac{\partial h}{\partial r} = e^{-(Sr^2/4Tt)} \cdot \left(\frac{-2Sr}{4Tt} \right) \quad \text{Turn to Section: } 4$$

$$\frac{\partial h}{\partial r} = \frac{V}{4\pi T t} e^{-(Sr^2/4Tt)} \cdot \left(\frac{-2Sr}{4Tt} \right) \quad 5$$

$$\frac{\partial h}{\partial r} = \frac{V}{4\pi T t} e^{-(Sr^2/4Tt)} \quad 2$$

28 +

Your answer in Section 7,

$$\frac{\partial \left(r \frac{\partial h}{\partial r} \right)}{\partial r} = r \frac{\partial^2 h}{\partial r^2} + \frac{\partial h}{\partial r}$$

is correct. Our expression for

$$\left(r \frac{\partial h}{\partial r} \right)_2 - \left(r \frac{\partial h}{\partial r} \right)_1$$

may therefore be written

$$\left(r \frac{\partial h}{\partial r} \right)_2 - \left(r \frac{\partial h}{\partial r} \right)_1$$

$$= \frac{\partial \left(r \frac{\partial h}{\partial r} \right)}{\partial r} \Delta r = \left\{ r \frac{\partial^2 h}{\partial r^2} + \frac{\partial h}{\partial r} \right\} \Delta r$$

Our expression for inflow minus outflow therefore becomes

(continued on next page)

28 + —Con.—

$$Q_1 - Q_2 = 2\pi T \left\{ \left(r \frac{\partial h}{\partial r} \right)_2 - \left(r \frac{\partial h}{\partial r} \right)_1 \right\}$$

$$= 2\pi T \left\{ r \frac{\partial^2 h}{\partial r^2} + \frac{\partial h}{\partial r} \right\} \Delta r.$$

As before, we wish to equate this expression for inflow minus outflow to the rate of accumulation of water in storage in our element. The surface area of the cylindrical element is given approximately by

$$A = 2\pi r \Delta r.$$

The term $2\pi r$ is the perimeter of a circle taken along the midradius of the element; multiplication by the radial width, Δr gives the surface area, or base area, of the cylindrical shell.

QUESTION

Using this expression for the surface area of the cylindrical element, and letting $\frac{\partial h}{\partial t}$ denote the time rate of head buildup in the element, which of the following expressions is obtained for the rate of accumulation of water in storage in the element?

Turn to Section:

$$\frac{dV}{dt} = 2\pi r \Delta r \frac{\partial h}{\partial t} \quad 37$$

$$\frac{dV}{dt} = S\pi r^2 \frac{\partial h}{\partial t} \quad 12$$

$$\frac{dV}{dt} = \frac{S}{2\pi r \Delta r} \frac{\partial h}{\partial t} \quad 16$$

29 +

Your answer in Section 18 is not correct. The behavior we are trying to describe is the disappearance of the effect of injection, at great radial distances from the well. The answer which you chose describes head, h ,

as going to infinity, rather than disappearing; and it describes a restriction on h with time, rather than with distance.

Return to Section 18 and choose another answer.

30 +

Your answer in Section 15,

$$Q_1 - Q_2 = 2\pi T \left(r \frac{\partial h}{\partial r} \right)_1 - \left(r \frac{\partial h}{\partial r} \right)_2,$$

is not correct. We established in Sections 1 and 15 that inflow through the inner cylindrical face of the element is given by Darcy's laws as

$$Q_1 = -2\pi T \left(r \frac{\partial h}{\partial r} \right)_1.$$

Using a similar approach, we can show that outflow through the outer cylindrical face is given by

$$Q_2 = 2\pi T \left(r \frac{\partial h}{\partial r} \right)_2.$$

These two equations can be subtracted to obtain an expression for inflow minus outflow for the cylindrical element.

Return to Section 15 and choose another answer.

31 +

Your answer in Section 35,

$$\frac{\partial h}{\partial t} = \frac{V}{4\pi T t} \frac{Sr^2}{4Tt^2} + e^{-(Sr^2/4Tt)} \left(\frac{-V}{4\pi T t^2} \right),$$

is not correct. Application of the product rule—first factor times derivative of second plus second factor times derivative of first—is correct; but your expression for the time derivative of $e^{-(Sr^2/4Tt)}$ is not correct.

Recall that the derivative of an exponential, e^u , with respect to t is given by $e^u du/dt$. Letting u represent $-(Sr^2/4Tt)$, your answer gives only $\partial u/\partial t$ in the place where it should give

$$e^u \frac{\partial u}{\partial t}.$$

Return to Section 35 and choose another answer.

32 +

Your answer in Section 37 is not correct. In Section 28, we saw that the expression for inflow minus outflow could be written

$$Q_1 - Q_2 = 2\pi T \left\{ r \frac{\partial^2 h}{\partial r^2} + \frac{\partial h}{\partial r} \right\} \Delta r$$

while the expression we obtained for dV/dt was

$$\frac{dV}{dt} = S 2\pi r \Delta r \frac{\partial h}{\partial t}.$$

If we equate the terms

$$2\pi T \left\{ r \frac{\partial^2 h}{\partial r^2} + \frac{\partial h}{\partial r} \right\} \Delta r$$

and

$$S 2\pi r \Delta r \frac{\partial h}{\partial t}$$

and then divide through the resulting equation by

$$2\pi T r \Delta r,$$

we obtain the correct answer to the question of Section 37.

Return to Section 37 and choose another answer.

33 +

Your answer in Section 18, $h \rightarrow 0$ as $r \rightarrow \infty$ is correct. From a mathematical point of view, we should perhaps have used, instead, the condition that $(\partial h/\partial r) \rightarrow 0$ as $r \rightarrow \infty$. This condition is required as r increases toward infinity, because the cross sectional area of flow within the aquifer—a cylindrical area coaxial with the well—expands toward infinity. Thus if we were to apply Darcy's law to determine the flow of the injected water away from the well, we would obtain the result that this flow increases toward an infinite value with increasing distance from the well, unless we postulated that the head

gradient, $\partial h/\partial r$, decreased toward zero with increasing r . However, the condition that h approaches a constant, 0, as $r \rightarrow \infty$ implies that $\partial h/\partial r$ must also approach zero as r increases; and it is a somewhat easier condition to establish.

Our task, then, is to show that the function

$$\frac{V}{4\pi T t} e^{-(r^2 S/4Tt)}$$

satisfies this condition—that is, we must test

33 + —Con.

this function to see whether its value approaches zero as r approaches infinity. It is easy to show that for any finite value of time the condition is satisfied. However, we are also interested in what happens as t approaches infinity along with r —that is, we would like our condition to be satisfied for all times, even those immeasurably large. For this reason, it is convenient to use the series expansion form given in Section 18; that is we use

$$\frac{V}{4\pi Tt} e^{-(r^2S/4Tt)}$$

$$\frac{V}{4\pi Tt + r^2 S \pi + \frac{r^4 S^2 \pi}{4Tt \cdot 2!} + \frac{r^6 S^3 \pi}{16T^2 t^2 \cdot 3!}}$$

In order that the fraction on the right approach zero, it is sufficient that any one of the individual terms in the denominator becomes infinite. If r and t both approach infinity, the first two terms clearly become infinite; in fact, the remaining terms become infinite as well, although we need not show this. If one term is infinite, the entire denominator is infinite, and the fraction is zero. For a finite value of t , all terms except the first clearly become infinite as $r \rightarrow \infty$, and again the expression as a whole tends to zero. Thus the expression

$$\frac{V}{4\pi Tt} e^{-(r^2S/4Tt)}$$

satisfies the condition of tending to zero as $r \rightarrow \infty$, for any value of time. Again, this can be demonstrated by extending the plots described in Section 18 to large values of r .

We could also add the condition that h must approach zero as time becomes infinite, everywhere in the aquifer—that is, that the effect of the injection must eventually die out with time everywhere throughout the aquifer, since we are injecting a finite vol-

ume of water into an aquifer which is assumed to be infinite in extent. We have just shown that h approaches zero at infinite time, as r also becomes infinite; we need only show that this behavior holds when r is finite. We will show this through direct use of the function, although it is also evident using the series expansion form. As t becomes infinitely large the factor

$$\frac{V}{4\pi Tt}$$

must approach zero; the factor

$$e^{-(r^2S/4Tt)}$$

which is equivalent to

$$\frac{1}{e^{(r^2S/4Tt)}}$$

must approach the value

$$\frac{1}{e^{r^2S/4t}}$$

or

$$\frac{1}{e^0}$$

if r is finite. But e^0 is simply 1, so that the product

$$\frac{V}{4\pi Tt} e^{-(r^2S/4Tt)}$$

must approach zero as t becomes infinitely large, at any finite value of r .

We now consider the last condition which our function should satisfy. In the sketch, the aquifer has been divided into cylindrical elements of radial width Δr , coaxial with the well. At any given time t after injection, the injected volume of fluid, V , is distributed in some way among these cylindrical elements.

33 + —Con.—

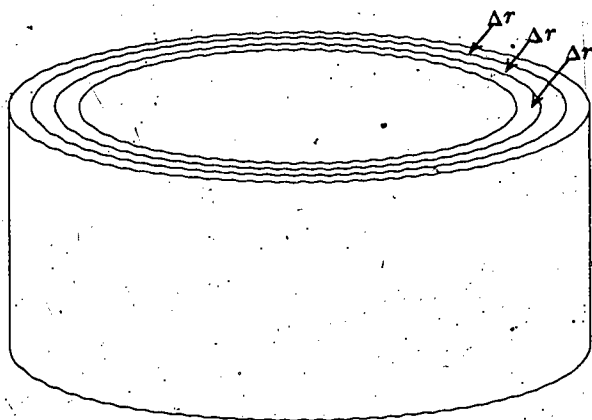

We assumed head to be at the datum, or zero, prior to injection, so that h actually represents only the head increase due to the injection. From the definition of storage coefficient, the quantity of the injected fluid contained within a given cylindrical element will be given by

$$\Delta V = S \cdot h_{r,t} \cdot 2\pi r \Delta r$$

where r is the median radius of the element, so that $2\pi r \Delta r$ is the base area of the element; $h_{r,t}$ gives the average head in the element (that is, at the radius r) at the time in question; and S is the storage coefficient. (Recall the definition of storage coefficient—the volume in storage is the product of storage coefficient, head, and base area.) Now if we sum the volumes in storage in every cylindrical element in the aquifer, the total must equal the injected volume, V , at any time after injection. That is,

$$V = \sum \Delta V = \sum S \cdot h_{r,t} \cdot 2\pi r \Delta r$$

where the summation is carried out over all of the cylindrical elements in the aquifer. Again, it should be kept in mind that $h_{r,t}$ represents only the head increase associated with the injection, so that its use in the storage equation leads only to the volume of water injected, not to the total volume in storage. Now since we are dealing with a continuous system, we replace the summation in the above equation by an integration.

That is, we let the width of each element become infinitesimally small, denoting it dr , so that the number of elements becomes infinitely great; and we rewrite our equation as

$$V = \int_{r=0}^{r=\infty} S \cdot h_{r,t} \cdot 2\pi r dr.$$

The limits of integration extend from $r=0$ to $r=\infty$, indicating that the cylindrical elements extend over the entire aquifer. This equation then is the final condition which our function should satisfy if it is in fact the solution we are seeking.

QUESTION

How do you think our proposed solution should be tested to see if it satisfies this boundary condition?

Turn to Section:

The integration indicated in the equation should be carried out. The result should equal

$$\frac{V}{4\pi T t} e^{-(r^2 S / 4T t)} \quad 11$$

The expression

$$\frac{V}{4\pi T t} e^{-(r^2 S / 4T t)}$$

should be substituted for

$$2\pi r$$

in the equation, and the integration should be carried out; the result should be

$$2\pi S. \quad 14$$

The expression

$$\frac{V}{4\pi T t} e^{-(r^2 S / 4T t)}$$

should be substituted for

$$h_{r,t}$$

in the equation, and the integration should be carried out; the result should equal

$$V. \quad 13$$

34 +

Your answer in Section 1,

$$Q_1 = -K\pi r_1^2 \left(\frac{\partial h}{\partial r} \right)_1$$

is not correct. Darcy's law states that flow is given by the product of hydraulic conductivity, head gradient in the direction of flow, and cross-sectional area normal to the direction of flow. In this problem as in the steady flow to a well treated in Part III, the

direction of flow is the radial, or r , direction. An area which is everywhere normal to the radial coordinate would be a cylindrical area, coaxial with the well. That is, the flow area that we require here is a cylindrical area—in particular, the inner face of the cylindrical prism shown in Section 1. The area of a cylinder is given by the product of its height and its perimeter.

Return to Section 1 and choose another answer.

35 +

Your answer in Section 5,

$$\frac{\partial^2 h}{\partial r^2} = \frac{V}{4\pi T t} \left\{ e^{-(Sr^2/4Tt)} \cdot \left(\frac{-2S}{4Tt} \right) + \left(\frac{-2Sr}{4Tt} \right) \cdot e^{-(Sr^2/4Tt)} \cdot \left(\frac{-2Sr}{4Tt} \right) \right\}$$

is correct. We now wish to differentiate the equation

$$h = \frac{V}{4\pi T t} \cdot e^{-(Sr^2/4Tt)}$$

with respect to time, to obtain an expression for $\partial h / \partial t$. In doing this, we consider r to be a constant, and treat our expression as the product of the two functions of t ,

$$\frac{V}{4\pi T t}$$

and

$$e^{-(Sr^2/4Tt)}$$

The derivative of

$$\frac{V}{4\pi T t}, \text{ or } \frac{V}{4\pi T} \cdot t^{-1}$$

with respect to t is

$$-\frac{V}{4\pi T} \cdot t^{-2}, \text{ or } \frac{-V}{4\pi T t^2}$$

To differentiate

$$e^{-(Sr^2/4Tt)}$$

we again apply the rule

$$\frac{de^u}{dt} = e^u \frac{du}{dt}$$

where u is

$$-\frac{Sr^2}{4Tt}, \text{ or } -\frac{Sr^2}{4T} \cdot t^{-1},$$

and its derivative with respect to t is

$$\frac{Sr^2}{4T} \cdot t^{-2}, \text{ or } \frac{Sr^2}{4T t^2}$$

QUESTION

Applying the rule for differentiation of a product, together with the above results, which of the following expressions, is obtained for $\partial h / \partial t$?

35 + —Con.—

Turn to Section:

$$\frac{\partial h}{\partial t} = \frac{V}{4\pi T t} \cdot e^{-(Sr^2/4Tt)} \cdot \left(\frac{Sr^2}{4Tt^2} \right)$$

3

$$\frac{\partial h}{\partial t} = \frac{V}{4\pi T t} \cdot e^{-(Sr^2/4Tt)} \left(\frac{Sr^2}{4Tt^2} \right) + e^{-(Sr^2/4Tt)} \cdot \left(\frac{-V}{4\pi T t^2} \right)$$

20

$$\frac{\partial h}{\partial t} = \frac{V}{4\pi T t} \cdot \frac{Sr^2}{4Tt^2} + e^{-(Sr^2/4Tt)} \left(\frac{-V}{4\pi T t^2} \right)$$

31

36 + —

Your answer in Section 1,

$$Q_i = \frac{-Kb \left(\frac{\partial h}{\partial r} \right)_1}{2\pi r_1}$$

is not correct. Darcy's law tells us that flow is given by the product of hydraulic conductivity, head gradient in the direction of flow, and cross-sectional area normal to the direction of flow. In this case, as in the steady state flow to a well in Part III, the direction

of flow is the radial direction and the cross-sectional area normal to the flow is a cylindrical surface—the inner surface of the cylindrical shell shown in Section 1. In your answer, however, there is no factor representing the area of this surface. The height of the cylinder, which is b , appears in the numerator of your answer; its perimeter, which is $2\pi r_1$, appears in the denominator of the answer which you chose.

Return to Section 1 and choose another answer.

37 + —

Your answer in Section 28,

$$\frac{dV}{dt} = S 2\pi r \frac{\partial h}{\partial t}$$

is correct. As before, we will next use the equation of continuity to link the storage and flow equations.

QUESTION

If the expression obtained for inflow minus outflow is equated to that given above

for rate of accumulation in storage, which of the following equations may be obtained?

Turn to Section:

$$r \frac{\partial^2 h}{\partial r^2} + \frac{1}{2\pi r} \frac{\partial h}{\partial r} = S \frac{\partial h}{\partial t}$$

22

$$2\pi T \Delta r \left(\frac{\partial^2 h}{\partial r^2} + \frac{\partial h}{\partial r} \right) = S \frac{\partial h}{\partial t}$$

32

$$\frac{\partial^2 h}{\partial r^2} + \frac{1}{r} \frac{\partial h}{\partial r} = \frac{S}{T} \frac{\partial h}{\partial t}$$

27

Development of Additional Solutions by Superposition

The differential equation

$$\frac{\partial^2 h}{\partial r^2} + \frac{1}{r} \frac{\partial h}{\partial r} = \frac{S}{T} \frac{\partial h}{\partial t}$$

is linear in h ; that is, h and the various derivatives of h occur only in the first power—they are not squared, cubed, or raised to any power except 1, in any term of the equation. Equations of this type have the property that solutions corresponding to two individual disturbances may be added to obtain a new solution describing the effect of the two disturbances in combination. This is termed superposition of solutions; it is a technique which is often used intuitively by hydrologists—for example when calculating the drawdown produced by several wells, by adding drawdowns calculated for individual operation.

The solution obtained in the preceding

programed instruction was developed for an injection of fluid at $t=0$. If the injection does not occur at $t=0$, the term t in the solution is simply replaced by Δt , the time interval between the injection and the instant of head measurement. For example, if the injection occurs at time t' , and the head change due to this injection is measured at some later time t , the interval $t-t'$ is used in the solution in place of t , giving

$$h_{r,t} = \frac{V}{4\pi T(t-t')} \cdot e^{-\left(\frac{r^2 S}{4T(t-t')}\right)}$$

Now suppose two injections occur, one at t_1' and one at t_2' , and the head is measured at some time t following both injections. Using superposition, the head change due to the combined disturbances is

$$h_{r,t} = \frac{V_1}{4\pi T(t-t_1')} \cdot e^{-\left(\frac{r^2 S}{4T(t-t_1')}\right)} + \frac{V_2}{4\pi T(t-t_2')} \cdot e^{-\left(\frac{r^2 S}{4T(t-t_2')}\right)}$$

where V_1 is the volume injected at t_1' and V_2 is the volume injected at t_2' .

If we consider removal of a volume of water from the well, rather than injection, we need only introduce a change of sign, taking V as negative. For example, if a bailerfull of water is removed at $t=t_1'$, the head change at time t , due to this removal is

$$h_{r,t} = \frac{-V_1}{4\pi T(t-t_1')} \cdot e^{-\left(\frac{r^2 S}{4T(t-t_1')}\right)}$$

where V_1 is the volume removed by the bailer. If the well is bailed repeatedly, as may happen during completion, the head change due to bailing is obtained by super-

posing the disturbances due to each individual withdrawal:

$$h_{r,t} = \frac{V_1}{4\pi T(t-t_1')} e^{-\left(\frac{r^2 S}{4T(t-t_1')}\right)} - \frac{V_2}{4\pi T(t-t_2')} e^{-\left(\frac{r^2 S}{4T(t-t_2')}\right)} - \frac{V_3}{4\pi T(t-t_3')} e^{-\left(\frac{r^2 S}{4T(t-t_3')}\right)} - \dots - \frac{V_n}{4\pi T(t-t_n')} e^{-\left(\frac{r^2 S}{4T(t-t_n')}\right)}$$

where t is the time at which h is measured; $t_1', t_2', t_3', \dots, t_n'$ are the times at which the individual withdrawals are made; and $V_1, V_2, V_3, \dots, V_n$ are the volumes removed by the bailer in the successive withdrawals. The "bailer method" of determining transmissivity from the residual drawdown of a well that has been bailed was developed from this equation (Skibitzke, 1963).

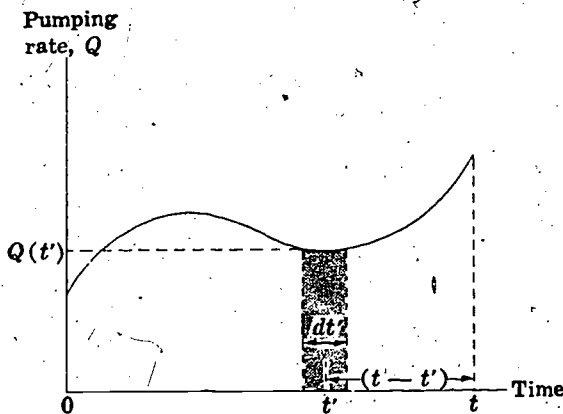

Now suppose a well is pumped continuously during the time interval from zero to t , and we wish to know the head change at

time t due to this continuous withdrawal. The rate of pumping, in volume of water per unit time, may vary from one instant to the next. The figure shows a plot of pumping rate versus time for a hypothetical case. Pumping starts at time = 0 and extends to time = t , the instant at which we wish to know the head change. We consider first the head change at t due to the action of the pump at one particular instant, t' , during the course of pumping. We consider an infinitesimal time interval, dt' , extending to either side of the instant t' ; the average rate of pumping during this interval is denoted $Q(t')$. The volume of water withdrawn from the well during the interval is the product of the pumping rate, $Q(t')$, and the time interval, dt' ; that is,

$$-V = -Q(t') dt'.$$

Again negative signs are used to indicate withdrawal as opposed to injection. The product $Q(t') dt'$ is equal to the area of the shaded element in the graph shown in the preceding figure; the height of this element is $Q(t')$, and its width is dt' . The time interval between the instant of withdrawal and the instant of head measurement is $t-t'$. Using the solution obtained in the programmed instruction for the head change due to instantaneous withdrawal of a volume of water, the head change at time t due to the withdrawal at t' is given by

$$\frac{-V}{4\pi T(t-t')} \cdot e^{-\left(\frac{r^2 S}{4T(t-t')}\right)} = \frac{-Q(t') dt'}{4\pi T(t-t')} \cdot e^{-\left(\frac{r^2 S}{4T(t-t')}\right)}$$

The total head change at t , due to the continuous withdrawal from zero to t , is obtained through superposition, by adding the head changes due to the instantaneous withdrawals throughout the interval from zero to t .

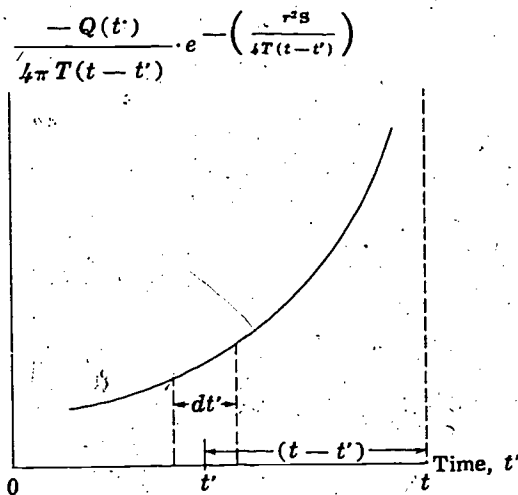

The figure shows a graph in which, instead of plotting only discharge versus time, we plot the entire function

$$\frac{-Q(t')}{4\pi T(t-t')} \cdot e^{-\left(\frac{r^2 S}{4T(t-t')}\right)}$$

versus time. The area of the element at t' is now

$$\frac{-Q(t')}{4\pi T(t-t')} \cdot e^{-\left(\frac{r^2 S}{4T(t-t')}\right)} \cdot dt'$$

—thus it is just equal in magnitude to the head change at t , caused by the withdrawal at t' . If elements of the type shown in the figure are constructed all along the time axis, from zero to t , the area of each element will give the head change at t due to operation of the pump during the time interval represented by the element; the total head change at t due to all of the instantaneous withdrawals throughout the interval from zero to t will therefore be equal to the sum of these areas, or the total area under the curve from zero to t . This total area is the integral of the function

$$\frac{-Q(t')}{4\pi T(t-t')} \cdot e^{-\left(\frac{r^2 S}{4T(t-t')}\right)}$$

over the interval from zero to t , that is, the total head change is given by

$$h = \int_{t'=0}^{t'=t} \frac{-Q(t')}{4\pi T(t-t')} \cdot e^{-\left(\frac{r^2 S}{4T(t-t')}\right)} dt'$$

It should be noted that we are now using t' to denote the time *variable* or variable of integration, rather than to specify one particular instant. The function being integrated involves the difference, $t-t'$, between the upper limit of integration and the variable of integration. Evaluation of the integral will yield a function of the upper limit, t , and of r ; that is, the head change due to the pumping will be specified as a function of r and of t (the time of head measurement.)

For the particular case when the rate of discharge is a constant, Q , the integral equation can be transformed directly into a form suitable for computation. We have

$$h = \int_{t'=0}^{t'=t} \frac{-Q}{4\pi T(t-t')} - \left(\frac{r^2 S}{4T(t-t')} \right) dt'$$

The term $-Q/4\pi T$ is a constant and may be taken outside the integral, giving

$$h = \frac{-Q}{4\pi T} \int_{t'=0}^{t'=t} \frac{1}{t-t'} - \left(\frac{r^2 S}{4T(t-t')} \right) dt'$$

We introduce the algebraic change of variable,

$$\psi = \frac{r^2}{4T(t-t')}$$

We differentiate this expression with respect to t' , treating t , at this stage, as a constant; this gives

$$\frac{d\psi}{dt'} = \frac{r^2 S \cdot 4T}{(4T(t-t'))^2} = \frac{r^2 S}{4T(t-t')} \cdot \frac{1}{t-t'}$$

$$= \frac{r^2 S}{4T(t-t')} \left(\frac{\frac{r^2 S}{4T(t-t')}}{\frac{r^2 S}{4T}} \right) = \frac{\psi^2}{4T}$$

Therefore

$$d\psi = \frac{\psi^2}{r^2 S} \cdot dt'$$

and

$$dt' = \frac{r^2 S}{4T} \frac{d\psi}{\psi^2}$$

The value of ψ corresponding to the upper limit of integration; $t'=t$, is

$$\psi = \frac{r^2}{4T(t-t)}$$

While the value of ψ corresponding to the lower limit of integration; $t'=0$, is

$$\psi_0 = \frac{r^2 S}{4T(t-0)} = \frac{r^2 S}{4Tt}$$

We now return to our integral equation and substitute ψ for

$$\frac{r^2 S}{4T(t-t')} ;$$

$$\frac{r^2 S}{4T} \frac{d\psi}{\psi^2}$$

for

$$dt';$$

and the values obtained above for the limits of integration. This gives

$$h = \frac{-Q}{4\pi T} \int_{\frac{r^2 S}{4Tt}}^{\infty} \frac{1}{t-t'} e^{-\psi} \cdot \frac{r^2 S}{4T} \frac{d\psi}{\psi^2}$$

But since

$$\frac{1}{t-t'} \left(\frac{r^2 S}{4T} \right) = \psi,$$

the above integral becomes

$$h = \frac{-Q}{4\pi T} \int_{\frac{r^2 S}{4Tt}}^{\infty} \frac{e^{-\psi}}{\psi} d\psi.$$

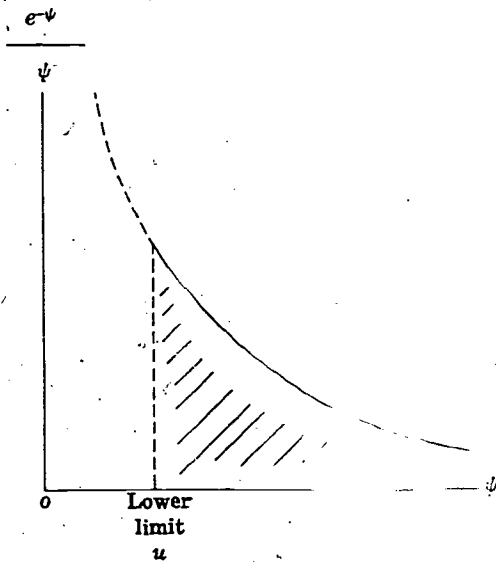

This integral is called the exponential integral. It is a function of its lower limit, as suggested by the figure, which shows a graph of the function $e^{-\psi}/\psi$ versus ψ . The area under this graph is equal to the value of the integral. The upper limit is infinite, and the function $e^{-\psi}/\psi$ approaches zero as ψ becomes infinite; the area under the curve, or the value of the integral, depends only upon the point where the lower limit is taken—that is, upon the value of $r^2S/4Tt$. This term is often denoted u in the literature, so that the equation for head change is often written

$$h = \frac{-Q}{4\pi T} \int_u^\infty \frac{e^{-\psi}}{\psi} d\psi$$

where

$$u = \frac{r^2S}{4Tt}$$

It can be shown that the above integral is equal to an infinite series involving the lower limit. Specifically,

$$\int_u^\infty \frac{e^{-\psi}}{\psi} d\psi = -0.5772 - \ln(u) + u - \frac{u^2}{2 \cdot 2!} + \frac{u^3}{3 \cdot 3!} - \frac{u^4}{4 \cdot 4!} + \dots$$

Values of the integral for various values of the lower limit have been computed, using this series, and tabulated. In the hydrologic literature, the value of the integral is commonly referred to as $W(u)$ or “well function of u .” Tables of $W(u)$ versus u are available in the reference by Ferris, Knowles, Brown, and Stallman (1962) and in numerous other references. In the forms presented above, the equations yield the head change, or simply the head, assuming h was zero prior to pumping. If head was at some other constant level, h_0 , prior to pumping, the expressions are still valid for head change, $h - h_0$. That is, we have

$$h - h_0 = \frac{-Q}{4\pi T} \int_u^\infty \frac{e^{-\psi}}{\psi} d\psi = \frac{-Q}{4\pi T} \cdot W(u)$$

where

$$u = \frac{r^2S}{4Tt}$$

or in terms of drawdown, $h_0 - h$, we have

$$s = h_0 - h = \frac{Q}{4\pi T} \int_u^\infty \frac{e^{-\psi}}{\psi} d\psi = \frac{Q}{4\pi T} \cdot W(u)$$

The result we have obtained here is known as the Theis equation, after C. V. Theis who first applied it in hydrology (Theis, 1935). An excellent discussion of the significance of this equation in hydrology is given in another paper by Theis (1938).

It was recognized by Cooper and Jacob (1946) that at small values of u , (that is, at large values of t), the terms following $\ln(u)$ in the series expansion for

$$\int_u^{\infty} \frac{e^{-\psi}}{\psi} d\psi$$

become negligibly small. In this condition the value of the integral is given simply by

$$-0.5772 - \ln(u),$$

or

$$-0.5772 - \ln\left(\frac{r^2 S}{4Tt}\right).$$

The sign of the logarithmic term may be changed by inverting the expression in brackets,

$$-\ln\left(\frac{r^2 S}{4Tt}\right) = \ln\left(\frac{4Tt}{r^2 S}\right)$$

and the constant, 0.5772, may be expressed as the natural logarithm of another constant,

$$0.5772 = \ln\left(\frac{4}{2.25}\right)$$

so that

$$\begin{aligned} -0.5772 - \ln\left(\frac{r^2 S}{4Tt}\right) &= \ln\left(\frac{4Tt}{r^2 S}\right) - \ln\left(\frac{4}{2.25}\right) \\ &= \ln\left(\frac{2.25Tt}{r^2 S}\right) = 2.3 \log_{10}\left(\frac{2.25Tt}{r^2 S}\right). \end{aligned}$$

Thus when pumping has continued for a sufficient length of time so that u , or $r^2 S/4Tt$, is small we may write

$$s = \frac{Q}{4\pi T} \int_u^{\infty} \frac{e^{-\psi}}{\psi} d\psi \approx \frac{2.3Q}{4\pi T} \log_{10}\left(\frac{2.25 \cdot Tt}{r^2 S}\right).$$

This is the modified nonequilibrium formula, which forms the basis of the "semilog plot" techniques often used by hydrologists in the analysis of pumping test data. These techniques are generally applied for values of u less than 0.01.

The Theis equation and the modified nonequilibrium formula are extremely useful hydrologic tools, provided they are used within the limits of application established by the assumptions made in their derivation. Before leaving this subject, we will briefly review the assumptions that have been accumulated during the course of the derivation. We first developed the equation

$$\frac{\partial^2 h}{\partial r^2} + \frac{1}{r} \frac{\partial h}{\partial r} = \frac{S}{T} \frac{\partial h}{\partial t}$$

by assuming that:

1. The aquifer was confined;
2. There was no vertical flow;
3. All flow was directed radially toward (or away from) the origin;
4. S and T were constant—that is, the aquifer was homogeneous and isotropic;
5. There was no areal recharge applied to the aquifer

In writing the solution corresponding to instantaneous discharge or input of a volume of water, V , we added the assumptions that:

6. The aquifer was infinite in extent;
7. There was no lateral discharge or recharge except at the well
8. The head was uniform and unchanging throughout the aquifer prior to $t=0$.
9. All of the injected water was taken into storage (or conversely, all discharged water was derived from storage).
10. The well was of infinitesimal radius.

Finally, when we integrated the above solution to obtain the continuous discharge solution

$$s = h_0 - h = \frac{Q}{4\pi T} \int \frac{e^{-\psi}}{\psi} d\psi$$

we added the condition that

11. The discharge, Q , was constant throughout the duration of pumping.

These assumptions should be kept in mind whenever the Theis equation is applied. The assumption that all flow is lateral implies that the well must fully penetrate the aquifer and that the aquifer is horizontal.

If the semi-log approximation is used, we add the assumption that the time is great enough and radius small enough that the term $r^2S/4Tt$ is less than 0.01, and the later terms in the series expression for the integral can therefore be neglected.

The Theis equation was the first equation to describe flow of water to a well under nonequilibrium conditions. In subsequent work, Papadopoulos and Cooper (1967) have accounted for the effects of a finite well radius; Jacob (1963) and several other writ-

ers have examined the problem of discharge from partially penetrating wells. Stallman (1963a), Lang (1963), and numerous other investigators have utilized image theory to account for lateral aquifer boundaries; Jacob and Lohman (1952) have analyzed discharge at constant drawdown, rather than at constant rate; numerous writers, including in particular Jacob (1946), Hantush (1952, 1960, 1967a, 1967b) and Hantush and Jacob (1955) have treated the problem of discharge from an aquifer replenished by vertical recharge through overlying and underlying strata; and several writers, including Boulton (1954), have attacked the general problem of three-dimensional flow to a well. Weeks (1969) has applied various aspects of the theory of flow toward wells to the problem of determining vertical permeability from pumping test analysis.

Part VII. Finite-Difference Methods

Introduction

In preceding chapters we have considered formal mathematical solutions to the differential equations of ground-water flow. In practice, however, we find that such formal solutions are available only for a small minority of field problems, representing relatively simple boundary conditions. In most

cases, we are forced to seek approximate solutions, using methods other than direct formal solution. In Part VII, we consider one such method—the simulation of the differential equations by finite difference equations, which in turn can be solved algebraically or numerically.

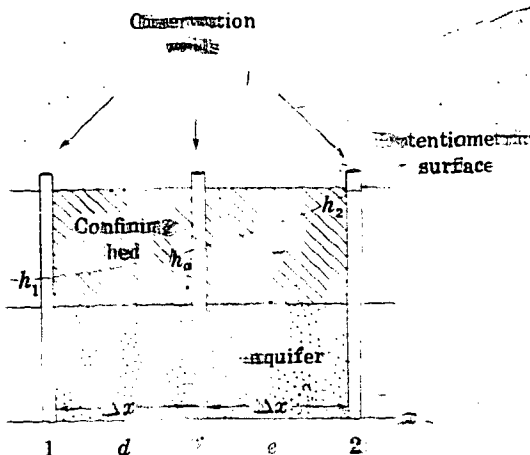

Three observation wells tap a confined aquifer. The wells are arranged in a straight line in the x direction at a uniform spacing, Δx . The water levels in the three wells are designated h_1 , h_0 , and h_2 as indicated in the figure.

QUESTION

Which of the following equations gives a reasonable approximation for the derivative, $\partial h / \partial x$, at point d , midway between well 1 and well 0?

Turn to Section:

- | | |
|--|----|
| $\left(\frac{\partial h}{\partial x}\right)_d \approx \frac{h_1 - h_2}{\Delta x}$ | 7 |
| $\left(\frac{\partial h}{\partial x}\right)_d \approx \frac{h_2 - h_1}{2\Delta x}$ | 26 |
| $\left(\frac{\partial h}{\partial x}\right)_d \approx \frac{h_0 - h_1}{\Delta x}$ | 12 |

2 □ □

Your answer, $h_{i,j}$, in Section 3 is correct.

QUESTION

Following the same conventions, which of the following expressions would serve as a finite-difference approximation to the term

$$\frac{\partial^2 h}{\partial x^2} + \frac{\partial^2 h}{\partial y^2}$$

at the point $h_{i,j}$:

- Turn to Section:
- $\frac{\partial^2 h}{\partial x^2} \approx \frac{h_{i-2,j} + h_{i-1,j} + h_{i+1,j} + h_{i+2,j} - 4h_{i,j}}{a^2}$ 20
 - $\frac{\partial^2 h}{\partial y^2} \approx \frac{h_{i,j+1} + h_{i,j} + h_{i,j-1} - h_{i-2,j} - 4h_{i,j}}{a^2}$ 18
 - $\frac{\partial^2 h}{\partial x^2} \approx \frac{h_{i-1,j} - h_{i-1,j} + h_{i,j-1} + h_{i,j+1} - 4h_{i,j}}{a^2}$ 4

3 □ □

Your answer in Section 15,

$$\frac{\partial^2 h}{\partial x^2} + \frac{\partial^2 h}{\partial y^2} \approx \frac{h_1 + h_2 + h_3 + h_4 - 4h_0}{a^2}$$

is correct. These approximations to $\partial^2 h / \partial x^2$ and $\partial^2 h / \partial y^2$ can be obtained more formally through the use of Taylor series expansions. A certain error is involved in approximating the derivatives by finite differences, and we can see intuitively that this error will generally decrease as a is given smaller and smaller values.

Now let us place a rectangular grid of intersecting lines, as shown in the diagram

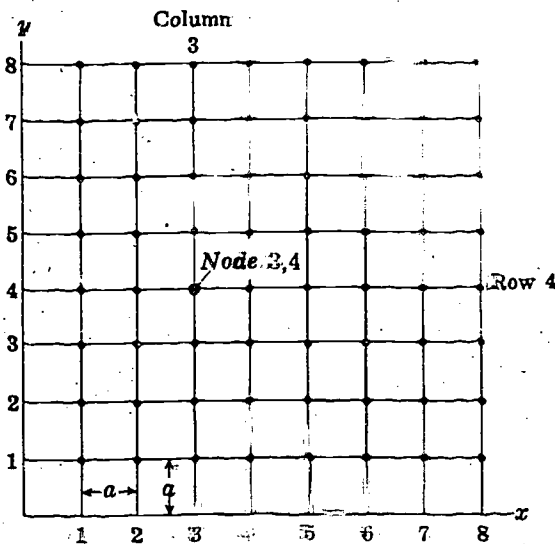

over the x, y plane. The lines are drawn at a uniform spacing, a , and are numbered successively from the origin. Lines parallel to the x -axis are termed rows, while lines parallel to the y -axis are termed columns. The intersections of the grid lines are termed nodes and are identified by the numbers associated with the intersecting lines. For example, the node 3, 4 is that formed by the intersection of the third column to the right of the y -axis with the fourth row above the x -axis. The spacing, a , may be thought of as a unit of measurement; the node numbers then give the number of units of distance of a given node from the x and y axes. The head at a given node is indicated by using the node numbers for a subscript notation; for example, the head at node 3, 4 would be indicated by $h_{3,4}$.

QUESTION

Following this convention, now would we indicate the head at a node located i units to the right of the y axis and j units above the x axis (that is, at the point $x = i \cdot a, y = j \cdot a$, in the conventional Cartesian notation)?

- $h_{j,i}$
- $h_{i,j}$
- $h_{ia,ja}$

- Turn to Section:
- 14
 - 2
 - 5

4 □ □

Your answer in Section 2 is correct. We next consider the time axis and divide it as shown in the sketch into segments of length Δt , again numbering the division marks successively from $t=0$. We also introduce a third subscript, indicating the time at which a given head value is observed; for example,

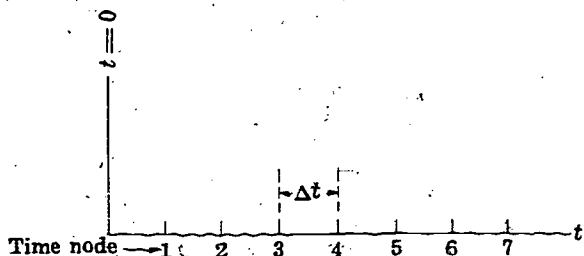

$h_{i,j,n}$ refers to the head at the node i, j of the x, y plane at the time indicated by the n th division mark on the time axis.

QUESTION

Again assuming $\Delta x = \Delta y = a$, which of the following would give the actual coordinate distances and time of measurement associated with the term $h_{i,j,n}$?

Turn to Section:

- $h_{i,j,n}$ = head at $x = i \cdot a, y = j \cdot a, \text{ time} = n \cdot \Delta t$ 9
- $h_{i,j,n}$ = head at $x = i \cdot \Delta x, y = j \cdot \Delta y, \text{ time} = n \cdot \Delta t$ 23
- $h_{i,j,n}$ = head at $x = i \cdot a, y = j \cdot a, \text{ time} = n \cdot \Delta t$ 10

5 □ □

Your answer, $h_{ia,ja}$, in Section 3 is not correct. You have used the distances from the two coordinate axes as subscripts. That is,

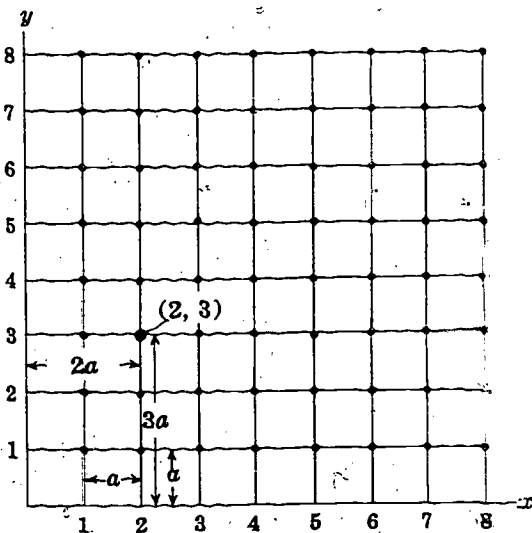

you have used ia , which is actually the x coordinate of the node, or its distance from the y axis, as the first subscript, and you have used ja , which is actually the y coordinate of the node, or its distance from the x axis, as the second subscript. The convention introduced in Section 2, however, does not have this form. If the finite-difference grid is superimposed on the x, y plane, as in the sketch, then the subscript associated with the point $x = 2a, y = 3a$ is simply 2, 3; the head at this point is designated $h_{2,3}$. If we number the lines of the grid in succession along each axis, starting with the axis as 0, we can obtain the subscript of a given node, or grid intersection, by looking at the numbers assigned to the two grid lines which intersect there; point 2, 3 is at the intersection of vertical line number 2 and horizontal line number 3.

Return to Section 3 and choose another answer.

6

Your answer in Section 25 is not correct. Your formulation for the calculation of the new value of $h_{i,j}$ in the first step is incorrect. The finite-difference equation which we developed stated that the value of $h_{i,j}$ should be the average of the values of h at the four surrounding nodes, that is

$$h_{i,j} = \frac{1}{4}(h_{i-1,j} + h_{i+1,j} + h_{i,j-1} + h_{i,j+1}).$$

The idea in the relaxation process is to compute a new value of $h_{i,j}$ as the average of the previous values of h at the four surrounding nodes. That is

$$\begin{aligned} h_{i,j}(\text{New Value}) = & \frac{1}{4}(h_{i-1,j} + h_{i+1,j} \\ & + h_{i,j-1} + h_{i,j+1}) \text{ (Previous Values)}. \end{aligned}$$

When this calculation has been made, the idea is to compare the new value of $h_{i,j}$ with the previous value of $h_{i,j}$. If these two are very close, everywhere in the grid, there is no point in continuing the process further, since additional iterations will produce little additional change. The solution, in other words, has converged to values of h which satisfy the difference equation. In the second step, therefore, rather than setting $R_{i,j}$ equal to the average of the new and previous values of $h_{i,j}$ as in the answer you selected, $R_{i,j}$ should be set equal to the difference between $h_{i,j}$ (New Value) and $h_{i,j}$ (Previous Value). This difference may then be tested throughout the grid, and if it is sufficiently small at all points, the iteration process can be terminated.

Return to Section 25 and choose another answer.

7

Your answer in Section 1,

$$\frac{h_1 - h_2}{\Delta x}$$

is not correct. In introducing the notion of a derivative, it is customary to begin with the finite-difference form—that is, to consider the finite change in h , Δh , occurring over a finite interval, Δx , along the x axis. The derivative notation, dh/dx , is then introduced to represent the value of the ratio $\Delta h/\Delta x$, as Δx becomes infinitesimal in size. Here, the idea is to move in the opposite direction. We started with the derivative, $\partial h/\partial x$, and we wish to approximate it by a ratio of finite differences. Moreover, we want an expression which applies at point d , midway between well 0 and well 1. The finite change in h occurring between these two wells is $h_0 - h_1$. The finite distance separating them is Δx .

Return to Section 1 and choose another answer.

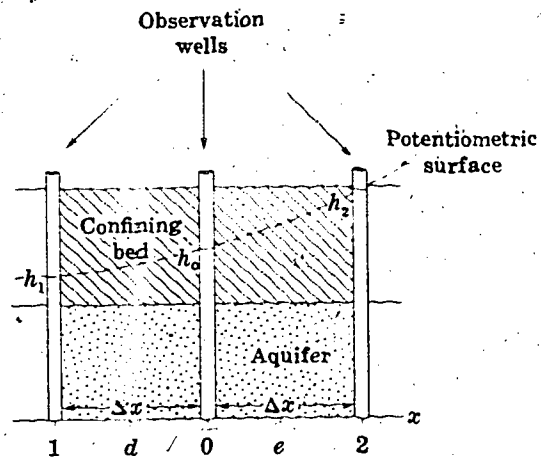

8 □ □

Your answer in Section 10 is not correct. You have used the correct formulation for the forward-difference approximation to $\partial h / \partial t$ —that is,

$$\frac{\partial h}{\partial t} \approx \frac{h_{i,j,n+1} - h_{i,j,n}}{\Delta t}$$

—but your approximation for $(\partial^2 h / \partial x^2) + (\partial^2 h / \partial y^2)$ is not correct. To obtain an approximation for $\partial^2 h / \partial x^2$, we move along the x axis, holding y constant. In this process i , the subscript denoting node position on the x axis will change, whereas j , the subscript denoting node position in the y direction, will remain unchanged. Our result will be

$$\frac{\partial^2 h}{\partial x^2} \approx \frac{\frac{h_{i+1,j,n} - h_{i,j,n}}{a} - \frac{h_{i,j,n} - h_{i-1,j,n}}{a}}{a} = \frac{h_{i+1,j,n} + h_{i-1,j,n} - 2h_{i,j,n}}{a^2}$$

Similarly, in obtaining an approximation for $\partial^2 h / \partial y^2$, we move along the y axis, so that i remains fixed, while the y -subscript, j , varies. The result is

$$\frac{\partial^2 h}{\partial y^2} \approx \frac{\frac{h_{i,j+1,n} - h_{i,j,n}}{a} - \frac{h_{i,j,n} - h_{i,j-1,n}}{a}}{a} = \frac{h_{i,j+1,n} + h_{i,j-1,n} - 2h_{i,j,n}}{a^2}$$

Addition of these two expressions will give the correct approximation for $(\partial^2 h / \partial x^2) + (\partial^2 h / \partial y^2)$.

Return to Section 10 and choose another answer.

9 □ □

Your answer in Section 4 is not correct. The subscripts i, j, n tell us that head $h_{i,j,n}$ occurs at a certain node, i, j of the finite-difference grid on the x, y plane and at a certain point, n , of the finite-difference scale along the time axis. The coordinate values are found by multiplying the number of nodes along a given axis by the node spacing. Along the x axis the node i, j lies a distance $i \cdot a$ from the origin (i nodes, each with

spacing a). Along the time axis, the point n occurs at a time $n \cdot \Delta t$ (n time marks, each at a spacing Δt). The same procedure should be applied in determining the y coordinate, keeping in mind that there are j nodes along the y axis between the origin and point i, j , and that these nodes fall at a spacing a .

Return to Section 4 and choose another answer.

10 □ □

Your answer in Section 4 is correct. On each axis, x , y , and t , the value of the independent variable is found by multiplying the subscript, or node number, by the node spacing along the axis. Using the conventions we have adopted, therefore, the approximation

to

$$\frac{\partial^2 h}{\partial x^2} + \frac{\partial^2 h}{\partial y^2}$$

at the time $t = n\Delta t$, and at the point $x = i \cdot a$, $y = j \cdot a$ would be given by

$$\left(\frac{\partial^2 h}{\partial x^2} + \frac{\partial^2 h}{\partial y^2}\right)_{n\Delta t} \approx \frac{h_{i-1,j,n} + h_{i+1,j,n} + h_{i,j-1,n} + h_{i,j+1,n} - 4h_{i,j,n}}{a^2}$$

Now in order to simulate the differential equation

$$\frac{\partial^2 h}{\partial x^2} + \frac{\partial^2 h}{\partial y^2} = \frac{S}{T} \frac{\partial h}{\partial t}$$

at the instant $t = n\Delta t$ we require in addition an approximation to $\partial h / \partial t$ at this instant.

In practical methods of computation, however, the approximations

$$\left(\frac{\partial h}{\partial t}\right)_{n\Delta t} \approx \frac{h_{n+1} - h_n}{\Delta t}$$

or

$$\left(\frac{\partial h}{\partial t}\right)_{n\Delta t} \approx \frac{h_n - h_{n-1}}{\Delta t}$$

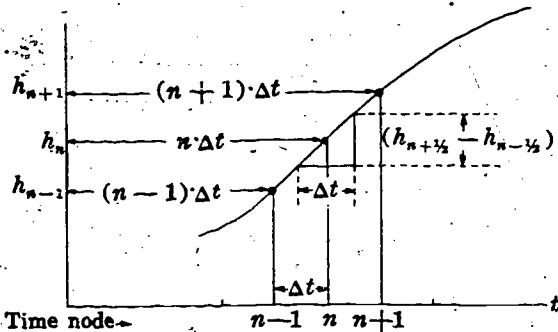

are often found preferable. Here, we are simulating the derivative at $t = n\Delta t$ by, respectively, a "forward difference" taken between the times $n \cdot \Delta t$ and $(n+1) \cdot \Delta t$, and a "backward difference," taken between $(n-1) \cdot \Delta t$ and $n \cdot \Delta t$. The error involved will depend largely upon our choice of Δt , and can be reduced to tolerable limits by choosing Δt sufficiently small.

The sketch shows a graph of h versus t in the vicinity of this time. A reasonable approximation to $\partial h / \partial t$ in the vicinity of the n th time mark would obviously be

$$\frac{\partial h}{\partial t} = \frac{h_{(n+1/2)} - h_{(n-1/2)}}{\Delta t}$$

QUESTION

Using the forward-difference approximation to $\partial h / \partial t$ given above, which of the following results is obtained as a finite-difference simulation of the equation

$$\frac{\partial^2 h}{\partial x^2} + \frac{\partial^2 h}{\partial y^2} = \frac{S}{T} \frac{\partial h}{\partial t}$$

at the point $x = ia$, $y = ja$, and at the time $t = n\Delta t$?

10 □ □ —Con.

Turn to Section:

$$\frac{h_{i-1,j,n} + h_{i+1,j,n} + \bar{h}_{i,j-1,n} + \bar{h}_{i,j+1,n} - 4h_{i,j,n}}{a^2} = \frac{S}{T} \frac{h_{i,j,n+1} - h_{i,j,n}}{\Delta t} \quad 16$$

$$\frac{h_{i-1,j-1,n} + h_{i+1,j+1,n} + \bar{h}_{i+1,j-1,n} + \bar{h}_{i-1,j+1,n} - 4h_{i,j,n}}{a^2} = \frac{S}{T} \frac{h_{i,j,n+1} - h_{i,j,n}}{\Delta t} \quad 8$$

$$\frac{h_{i-1,j,n} + h_{i+1,j,n} + \bar{h}_{i,j-1,n} + \bar{h}_{i,j+1,n} - 4h_{i,j,n}}{a^2} = \frac{S}{T} \frac{h_{i,j,n+\frac{1}{2}} - h_{i,j,n-\frac{1}{2}}}{\Delta t} \quad 19$$

11 □ □

Your answer in Section 16 is not correct. For the steady-state condition, $\partial h / \partial t = 0$; so, our equation,

$$\frac{\partial^2 h}{\partial x^2} + \frac{\partial^2 h}{\partial y^2} = \frac{S}{T} \frac{\partial h}{\partial t}$$

becomes simply

$$\frac{\partial^2 h}{\partial x^2} + \frac{\partial^2 h}{\partial y^2} = 0.$$

To obtain a finite-difference approximation to this equation, we need only take our finite-difference approximation to $(\partial^2 h / \partial x^2)$

and set it equal to zero. Our approximation to this sum, using the subscript notation associated with the finite-difference grid, was

$$\frac{h_{i-1,j} + h_{i+1,j} + h_{i,j-1} + h_{i,j+1} - 4h_{i,j}}{a^2}$$

This expression can be set equal to zero, and the resulting equation multiplied through by the constant a^2 to obtain the finite-difference equation which we require.

Return to Section 16 and choose another answer.

12 □ □

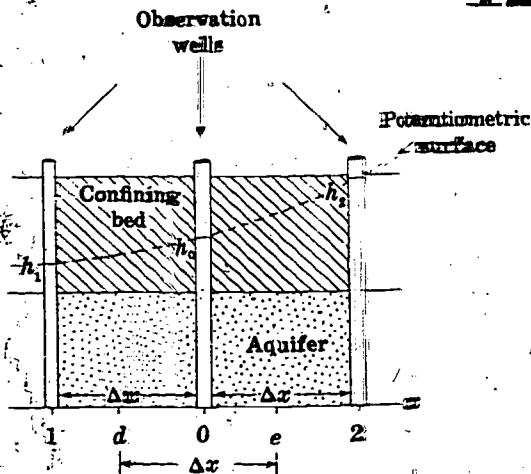

Your answer in Section 1,

$$\left(\frac{\partial h}{\partial x} \right)_e \approx \frac{h_0 - h_1}{\Delta x}$$

is correct. Similarly the derivative at point e, midway between well 0 and well 2 is approximated by

(continued on next page)

12 □ □ —Con.

$$\left(\frac{\partial h}{\partial x}\right)_c \approx \frac{h_2 - h_0}{\Delta x}$$

QUESTION

Which of the following expressions gives a reasonable approximation for the second derivative, $\partial^2 h / \partial x^2$, at point 0—that is, at the location of the center well?

Turn to Section:

$$\frac{\partial^2 h}{\partial x^2} \approx \frac{h_2 - h_1}{2\Delta x} \quad 27$$

$$\frac{\partial^2 h}{\partial x^2} \approx \frac{h_1 + h_2 - 2h_0}{(\Delta x)^2} \quad 15$$

$$\frac{\partial^2 h}{\partial x^2} \approx \frac{\frac{h_2 - h_0}{\Delta x} - \frac{h_0 - h_1}{\Delta x}}{2\Delta x} \quad 22$$

13 □ □

Your answer in Section 16 is not correct. The finite-difference expression approximating

$$\frac{\partial^2 h}{\partial x^2} + \frac{\partial^2 h}{\partial y^2}$$

was

$$\frac{h_{i-1,j} + h_{i+1,j} + h_{i,j-1} + h_{i,j+1} - 4h_{i,j}}{a^2}$$

To approximate the equation

$$\frac{\partial^2 h}{\partial x^2} + \frac{\partial^2 h}{\partial y^2} = 0$$

this finite-difference expression need only be equated to zero. The resulting equation can be multiplied through by the constant a^2 .

Return to Section 16 and choose another answer.

14 □ □

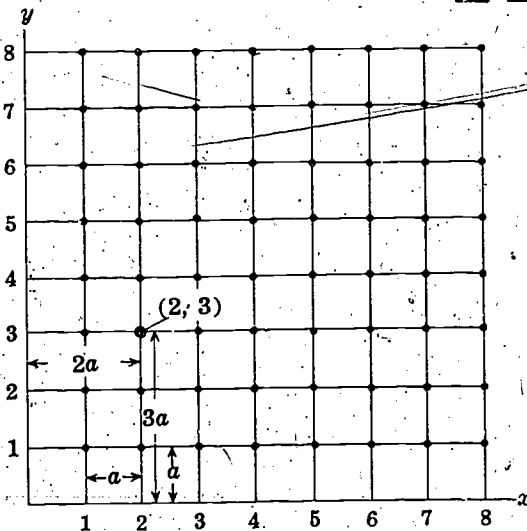

Your answer, $h_{j,i}$, in Section 3 is not correct. The sketch shows a diagram of the x, y plane, with the finite-difference grid superimposed upon it. Node 2, 3 is at a distance $2a$ from the y axis ($x=2a$) and a distance $3a$ from the x axis ($y=3a$). That is, the node having the coordinates $x=2a, y=3a$ is the node 2, 3; and the head at this node is designated $h_{2,3}$. The same rules apply for the node in the question of Section 3 which was at a distance $i \cdot a$ from the y axis and a distance $j \cdot a$ from the x axis. The coordinates of this node are $x=i \cdot a, y=j \cdot a$.

Return to Section 3 and choose another answer.

15

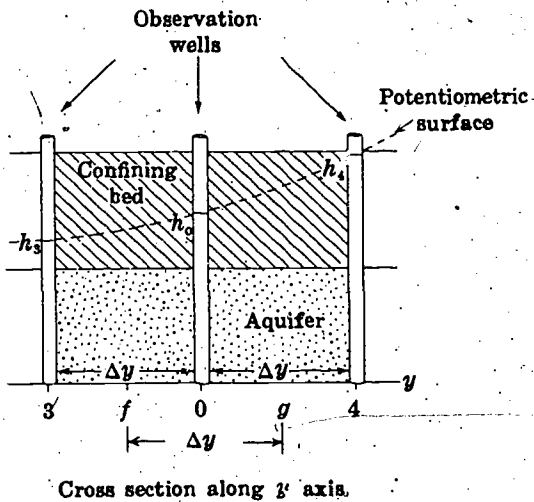
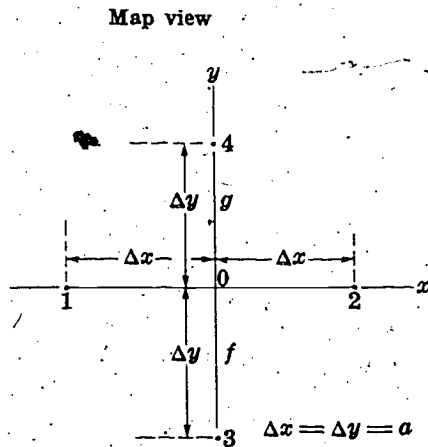

Your answer in Section 12,

$$\frac{\partial^2 h}{\partial x^2} \approx \frac{h_1 + h_2 - 2h_0}{(\Delta x)^2}$$

is correct. If we were to consider, in addition, the wells 3 and 4 along a line parallel to the y axis (see figure), we would similarly have as an approximation for $\partial^2 h / \partial y^2$ at point 0,

$$\frac{\partial^2 h}{\partial y^2} \approx \frac{h_3 + h_4 - 2h_0}{(\Delta y)^2}$$

QUESTION

If the spacing of the wells in the diagram is uniform—that is, if $\Delta x = \Delta y = a$ —which of the following expressions may be obtained for

$$\frac{\partial^2 h}{\partial x^2} + \frac{\partial^2 h}{\partial y^2} ?$$

Turn to Section:

- $\frac{\partial^2 h}{\partial x^2} + \frac{\partial^2 h}{\partial y^2} \approx \frac{h_1 + h_2 + h_3 + h_4 - 4h_0}{a^2}$ 3
- $\frac{\partial^2 h}{\partial x^2} + \frac{\partial^2 h}{\partial y^2} \approx \frac{h_1 + h_2 + h_3 + h_4}{a^2}$ 28
- $\frac{\partial^2 h}{\partial x^2} + \frac{\partial^2 h}{\partial y^2} \approx \frac{(h_1 + h_2 - h_3 + h_4)}{a^2}$ 24

16

Your answer in Section 10 is correct. Note that the equation which we have obtained is actually an algebraic equation, involving the terms $h_{i-1,j,n}$, $h_{i+1,j,n}$, $h_{i,j-1,n}$, $h_{i,j+1,n}$, $h_{i,j,n}$, and $h_{i,j,n+1}$; that is, we have simulated a differential equation by an algebraic equation. If the values of head are known at all nodes

of the x, y plane for some initial time, $t=0$, then the head value at each internal node for the succeeding time, $t=1 \cdot \Delta t$, can be obtained by applying the equation we have just obtained at the two times 0 and $1 \cdot \Delta t$ ($n=0$ and $n=1$). This would give

$$\frac{h_{i-1,j,0} + h_{i+1,j,0} + h_{i,j-1,0} + h_{i,j+1,0} - 4h_{i,j,0}}{a^2} = \frac{S}{T} \frac{h_{i,j,1} - h_{i,j,0}}{\Delta t}$$

16 □ □ —Con.

This equation is applied in turn at each internal node of the plane and solved for $h_{i,j,n}$ at each point, using the appropriate values of h from the $t=0$ distribution. Additional conditions must be given from which head values at nodes along the boundaries of the x, y plane at the new time can be determined. When the head values are determined throughout the plane for the new time ($n=1$), the procedure may be repeated to determine head values at the next point on the time axis ($n=2$); and so on.

This is termed the explicit procedure of solution. It suffers from the shortcoming that if Δt is chosen too large, errors may be introduced which grow in size as the stepwise calculation proceeds, so that for large values of time the solution bears no relation to reality, even as an approximation. To circumvent this difficulty, other schemes of computation are often used, some involving the backward-difference approximation to $\partial h/\partial t$, and others involving entirely different simulations of the differential equation.

Many of these schemes of solution involve iterative techniques, in which the differences between members of an equation are successively reduced by numerical adjustment. These techniques are sometimes termed re-

laxation methods; they are of sufficient importance that it will be worthwhile to see how they operate, through a simple example.

Suppose we are dealing with a problem of two-dimensional steady-state ground-water flow. For a steady state situation, the term $\partial h/\partial t$ of our differential equation, and therefore the term

$$\frac{h_{i,j,n+1} - h_{i,j,n}}{\Delta t}$$

of our finite-difference equation, is zero. The differential equation is simply

$$\frac{\partial^2 h}{\partial x^2} + \frac{\partial^2 h}{\partial y^2} = 0.$$

QUESTION

Using the notation developed above, but dropping the third subscript since time is not involved, which of the following would represent a valid finite-difference approximation to this steady-state equation?

<small>Turn to Section:</small>	
$h_{i-1,j} + h_{i+1,j} + h_{i,j-1} + h_{i,j+1} - 4h_{i,j} = 0$	25
$h_{i-1,j} + h_{i+1,j} + h_{i,j-1} + h_{i,j+1} + 4h_{i,j} = a^2$	11
$h_{i-1,j} + h_{i+1,j} + h_{i,j-1} + h_{i,j+1} = \frac{4h_{i,j}}{a^2}$	18

17 □ □

Your answer in Section 25 is correct. If we were to "flow chart" the relaxation procedure for solution on a digital computer, we would have to incorporate these steps in some way:

Numerous other techniques exist for the numerical solution of the differential equations of flow. The efficiency of various methods, in terms of computational labor or machine time, varies widely depending upon the problem under study. Care must be exercised in selecting a method that is well suited to the problem, or unreasonable investments of time and effort may be required to obtain a solution.

In this discussion we have given only a brief indication of the way in which numerical methods may be applied in ground-water hydrology. Numerical analysis is a broad and complex field in itself. Interested readers will find an extensive literature dealing both with theory and with a wide range of applications. Examples of the use of numerical techniques in ground water may be found in the work of Prickett and Lonquist (1971), Stallman (1956), Remson, Appel, and Webster (1965), Pinder and Bredehoeft (1968), Rubin (1968), Bredehoeft and Pinder (1970), Freeze (1971), Prickett and Lonquist (1973), Trescott, Pinder, and

17 — Con. —

Jones (1970), Trescott, (1973), and many others. An excellent summary of numerical methods as applied in ground-water hydrology is given by Remson, Hornberger, and Molz (1970).

You have completed the programed instruction of Part VII. A discussion giving further details of some of the standard finite-difference techniques is presented in standard text format following Section 28.

18

Your answer in Section 2 is not correct. The sketch shows the five-well array which we used earlier to develop an approximation for $(\partial^2 h / \partial x^2) + (\partial^2 h / \partial y^2)$, but with the wells now redesignated according to the scheme of subscripts associated with our

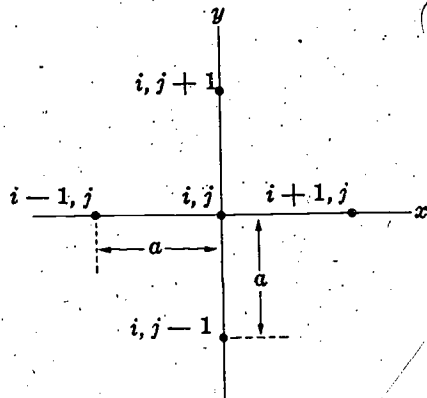

finite-difference grid. The head at the central well is designated $h_{i,j}$ rather than h_0 ; the heads at the two wells along the x axis are $h_{i-1,j}$ and $h_{i+1,j}$, rather than h_1 and h_2 and the heads at the two wells along the y axis are designated $h_{i,j-1}$ and $h_{i,j+1}$, rather than h_3 and h_4 . Our previous expression for

$$\frac{\partial^2 h}{\partial x^2} + \frac{\partial^2 h}{\partial y^2}$$

was

$$\frac{h_1 + h_2 + h_3 + h_4 - 4h_0}{a^2}$$

The question only requires that this be translated into the notation associated with the finite-difference grid.

Return to Section 2 and choose another answer.

19

Your answer in Section 10 is not correct. Your approximation for $(\partial^2 h / \partial x^2) + (\partial^2 h / \partial y^2)$ is correct, but you have not used the forward-difference formulation to approximate $\partial h / \partial t$, as required by the question. The approximation which you have used,

$$\frac{\partial h}{\partial t} = \frac{h_{i,j,n+\frac{1}{2}} - h_{i,j,n-\frac{1}{2}}}{\Delta t}$$

is normally a more accurate approximation to $\partial h / \partial t$ at i, j, n , than is the forward-difference formulation, since the difference is

taken symmetrically about the point at which $\partial h / \partial t$ is to be approximated. Unfortunately, however, it is not always as useful in the calculation of actual numerical solutions as is the forward-difference or backward-difference formulation. These formulations are unsymmetrical in the sense the difference is measured entirely to one side or the other of the time $t = n\Delta t$, which is the instant at which $\partial h / \partial t$ is to be approximated; but they are better suited to many techniques for computing solutions.

Return to Section 10 and choose another answer.

20

FIGURE A

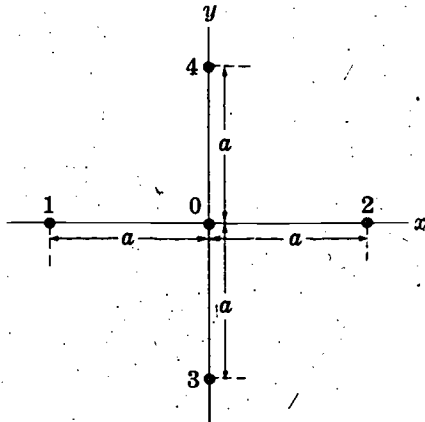

Your answer in Section 2 is not correct. The upper part of the figure shows the array which we used in developing our finite-difference approximation for $(\partial^2 h / \partial x^2) + (\partial^2 h / \partial y^2)$. The well at the center of the array was labeled 0; the surrounding wells were labeled as indicated. The expression we obtained for

$$\frac{\partial^2 h}{\partial x^2} + \frac{\partial^2 h}{\partial y^2}$$

was

$$\frac{h_1 + h_2 + h_3 + h_4 - 4h_0}{a^2}$$

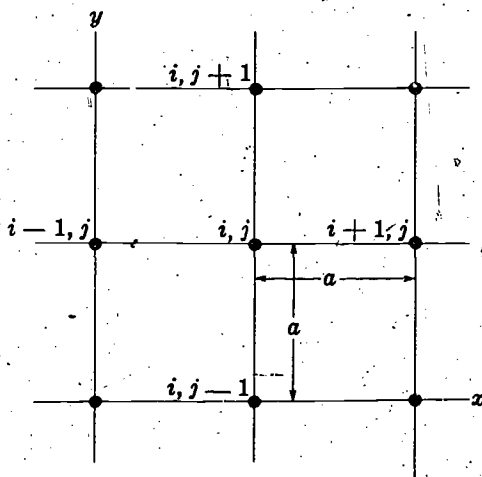

Using the notation introduced for our finite-difference grid, shown in the lower part of the figure, the well at the center of the array would be denoted i, j ; the remaining wells would be designated: $i-1, j$; $i+1, j$; $i, j-1$; and $i, j+1$, as shown. It is simply a matter of substituting these designations for the designations, 0, 1, 2, 3, and 4 used in our earlier development.

Return to Section 2 and choose another answer.

21

Your answer in Section 25 is not correct. Your initial step, giving the formulation for computing the new value of $h_{i,j}$ using the previous values of $h_{i-1,j}$, $h_{i+1,j}$, $h_{i,j-1}$, and $h_{i,j+1}$, is correct. However, your second step is not correct. The idea is to continue the process until the difference between the previous value of $h_{i,j}$ and the new value of $h_{i,j}$

becomes very small everywhere in the grid. Thus $R_{i,j}$ should represent the difference between $h_{i,j}$ (New Value) and $h_{i,j}$ (Previous Value); and the process should be continued until $|R_{i,j}|$ is negligible throughout the grid.

Return to Section 25 and choose another answer.

22

Your answer in Section 12,

$$\frac{\partial^2 h}{\partial x^2} \approx \frac{\frac{h_2 - h_0}{\Delta x} - \frac{h_0 - h_1}{\Delta x}}{2\Delta x},$$

is not correct. The numerator in your answer gives the difference between two terms: $(h_2 - h_0)/\Delta x$, which approximates $\partial h/\partial x$ at point e ; and $(h_0 - h_1)/\Delta x$, which approximates $\partial h/\partial x$ at point d .

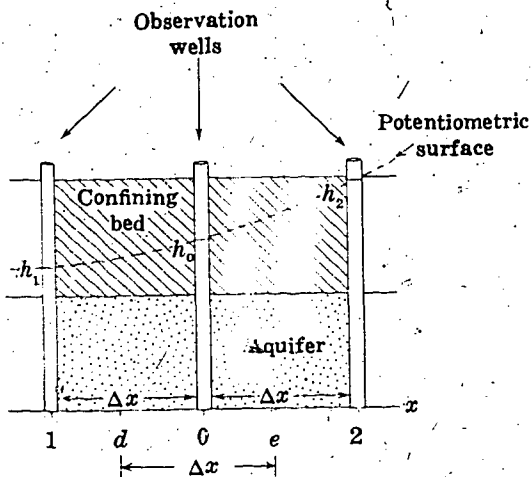

The numerator thus represents the difference

$$\left(\frac{\partial h}{\partial x}\right)_e - \left(\frac{\partial h}{\partial x}\right)_d,$$

that is, it approximates the change in $\partial h/\partial x$ between point d and e . Thus if it were divided by Δx , the interval between points d and e , we would have an approximation to

$$\frac{\partial\left(\frac{\partial h}{\partial x}\right)}{\partial x},$$

that is, to $\partial^2 h/\partial x^2$ at the midpoint, 0, of the interval between d and e . In the answer which you selected, however, the quantity

$$\frac{h_2 - h_0}{\Delta x} - \frac{h_0 - h_1}{\Delta x}$$

is divided by $2\Delta x$, rather than by Δx .

Return to Section 12 and choose another answer.

23

Your answer in Section 4 is not correct. The coordinate of a point, in space or time, is found by multiplying the number of nodes between the origin and the point in question, along the appropriate axis, by the node spacing along that axis. Thus the x coordinate of a node i, j, n , is $x = i \cdot a$, since there are i nodes along the x axis from the origin

to i, j , and the node spacing is a . The same procedure may be applied along the y and t axes, keeping in mind that the node spacing along the y axis is a , while that along the time axis is Δt .

Return to Section 4 and choose another answer.

24 □ □

Your answer in Section 15,

$$\frac{\partial^2 h}{\partial x^2} + \frac{\partial^2 h}{\partial y^2} = \frac{(h_1 + h_2) - (h_3 + h_4)}{a^2}$$

is not correct. The approximate expression which we obtained for $\partial^2 h / \partial x^2$ was

$$\frac{h_1 + h_2 - 2h_0}{(\Delta x)^2}$$

or, since we have taken $\Delta x = a$,

$$\frac{h_1 + h_2 - 2h_0}{a^2}$$

The expression given in Section 15 for $\partial^2 h / \partial y^2$ was

$$\frac{h_3 + h_4 - 2h_0}{(\Delta y)^2}$$

or again, since we have taken $\Delta y = a$,

$$\frac{h_3 + h_4 - 2h_0}{a^2}$$

These two expressions need only be added algebraically to obtain an approximation for

$$\frac{\partial^2 h}{\partial x^2} + \frac{\partial^2 h}{\partial y^2}$$

Return to Section 15 and choose another answer.

25 □ □

Your answer in Section 16

$$h_{i-1,j} + h_{i+1,j} + h_{i,j-1} + h_{i,j+1} - 4h_{i,j} = 0$$

is correct. To solve this by an iteration technique we rewrite the equation in the form

$$h_{i,j} = \frac{1}{4} (h_{j-1,i} + h_{i+1,j} + h_{i,j-1} + h_{i,j+1}),$$

and we divide the x, y plane into a grid as shown in the sketch, with the grid intersections forming the nodes at which we will compute values of h . In the form in which

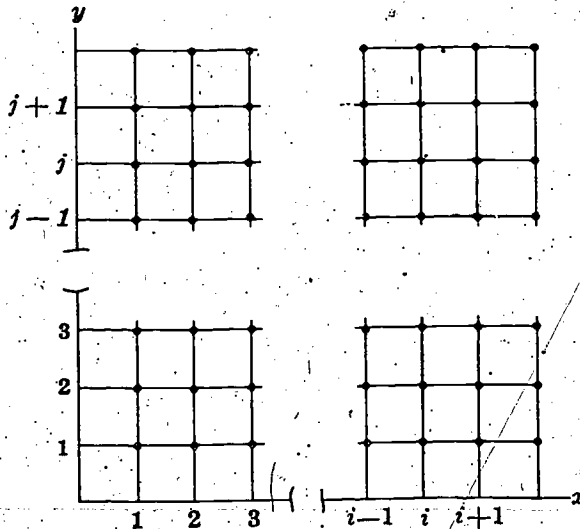

we have written it, it is easy to see that what our equation actually says is that the head at each node must be the average of the heads at the four adjacent nodes. We begin by entering known values of head along the boundaries of the grid—that is, by applying the boundary conditions. We then insert assumed values of h at each interior grid point. These initial values of h may be anything we wish, although a great deal of work can be saved if we can choose them in a way that roughly approximates the final head distribution. We then move through the grid, in any order or direction, and at each interior node cross out the value of head, writing in its place the average of the head values at the four adjacent nodes. At each node we note not only the new value of h , but the change in h , from the initial value, resulting from the calculation. When we have completely traversed the grid, we start again, and proceed through the grid in the same way, replacing each h value by the average of the heads at the four adjacent nodes, and noting the change in h that this causes. After a number of repetitions we will find that the change in h caused by each new calculation becomes very small—in other words, that the value of head at each point is already essentially equal to the aver-

25 □ □ — **Con.** —

age of those at the four neighboring points, so that inserting this average in place of h produces little or no additional change. At this point our head distribution represents an approximate solution to our difference equation and thus to the differential equation which the difference equation simulates.

The process just described, as noted earlier, is an example of a relaxation technique.

In general, since the head at each node is used in calculating the head at each of the four surrounding nodes, several complete traverses of the grid may be required before the changes in head are everywhere sufficiently small. This method can readily be used in hand calculation; it is also well adapted to solution by digital computer.

QUESTION

Which of the following would you choose as a "shorthand" description of the method of calculation described above?

Turn to Section:

$$h_{i,j}(\text{New Value}) = \frac{1}{4}(h_{i-1,j} + h_{i+1,j} + h_{i,j-1} + h_{i,j+1}) \quad (\text{Previous Values})$$

$$R_{i,j} = h_{i,j}(\text{New Value}) - h_{i,j}(\text{Previous Value})$$

Continue calculation until $|R_{i,j}| \approx 0$ for all points in grid.

17

$$h_{i,j}(\text{New Value}) = \frac{1}{4}(h_{i-1,j} + h_{i+1,j} + h_{i,j-1} + h_{i,j+1}) \quad (\text{Previous Values})$$

$$R_{i,j} = h_{i,j}(\text{New Value})$$

Continue calculation until $|R_{i,j}| \approx 0$ for all points in grid.

21

$$h_{i,j}(\text{New Value}) = \frac{1}{4}(h_{i+1,j} - h_{i-1,j} + h_{i,j+1} - h_{i,j-1}) \quad (\text{Previous Values})$$

$$R_{i,j} = \frac{h_{i,j}(\text{New Value} + h_{i,j})(\text{Previous Value})}{2}$$

Continue calculation until $|R_{i,j}| \approx 0$ for all points in grid.

6

26 □ □ —

Your answer in Section 1,

$$\left(\frac{\partial h}{\partial x}\right)_0 \approx \frac{h_2 - h_1}{2\Delta x}$$

is not correct. This answer would be a reasonable approximation for the derivative at point 0, in the center of the array, because it gives the ratio of a change in h , $h_2 - h_1$, to the corresponding change in distance, $2\Delta x$,

26 □ □ —Con.

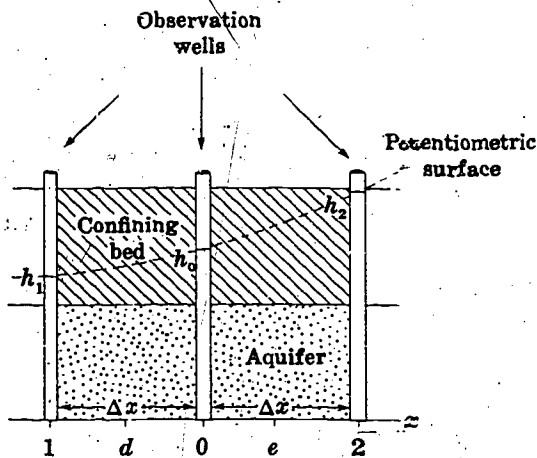

over an interval which is centered at 0. For the derivative at point d , however, midway between well 1 and well 0, we can do a little better. The change in h over an interval centered at d is simply $h_0 - h_1$, and the corresponding interval of distance is simply Δx .

Return to Section 1 and choose another answer.

27 □ □

Your answer in Section 12,

$$\frac{\partial^2 h}{\partial x^2} \approx \frac{h_2 - h_1}{2\Delta x}$$

is not correct. $h_2 - h_1$ gives the change in h between points 1 and 2, and $2\Delta x$ gives the distance between these points. Thus the term $(h_2 - h_1)/2\Delta x$ is an approximation to the first derivative, $\partial h/\partial x$, at the midpoint of the distance interval—that is, at point 0. The question however, asked for a term approximating the second derivative, $\partial^2 h/\partial x^2$, at this point. The second derivative is actually the derivative of the first derivative; that is

$$\frac{\partial^2 h}{\partial x^2} = \frac{\partial}{\partial x} \left(\frac{\partial h}{\partial x} \right)$$

To obtain a finite-difference expression for this term, we must consider the change in the first derivative, $\partial h/\partial x$, between two points, and must divide this change in $\partial h/\partial x$ by the distance separating these two points. We have seen that $\partial h/\partial x$ at point d , midway between wells 1 and 0, can be approximated by the expression $(h_0 - h_1)/\Delta x$; and that $\partial h/\partial x$ at point e , midway between

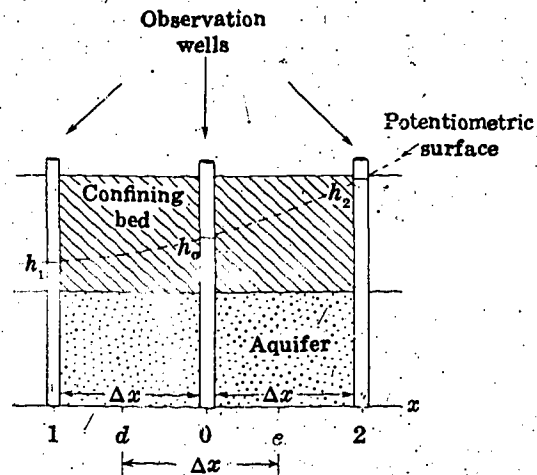

wells 0 and 2 can be approximated by the term $(h_2 - h_0)/\Delta x$. Points d and e are themselves separated by a distance Δx , and point 0 is at the midpoint of this interval. Thus if we subtract our approximate expression for $\partial h/\partial x$ at d , from that for $\partial h/\partial x$ at e , and divide the result by the interval between d and e , Δx , we should obtain an expression for $\partial^2 h/\partial x^2$ at point 0.

Return to Section 12 and choose another answer.

28

Your answer in Section 15,

$$\frac{\partial^2 h}{\partial x^2} + \frac{\partial^2 h}{\partial y^2} \approx \frac{h_1 + h_2 + h_3 + h_4}{a^2}$$

is not correct. The term $-2h_0$ appeared in the numerator of both of our approximate

expressions — that for $\partial^2 h / \partial x^2$ and that for $\partial^2 h / \partial y^2$. When we add these two expressions to obtain an approximation for $(\partial^2 h / \partial x^2) + (\partial^2 h / \partial y^2)$, these terms in h_0 do not drop out.

Return to Section 15 and choose another answer.

Techniques of Finite-Difference Solution of the Ground-Water-Flow Equation

Certain techniques of numerical solution which are commonly used in ground-water modeling are described in the following discussion. No attempt has been made to discuss such topics as stability or rate of convergence in theoretical terms; the reader is referred to the paper by Peaceman and Rachford (1955) for discussion of these subjects. Similarly, no attempt has been made to give the details of the programming procedure. The paper by Prickett and Lonquist (1971) analyzes some typical programs and in addition provides an excellent summary of the hydrologic and mathematical foundations of digital modeling; the paper by Trescott (1973) describes a versatile program for areal aquifer simulation. The discussion presented here is limited to a description of some of the common techniques of approximation and calculation.

In Section 10 of Part VII we introduced two methods of approximating the time derivative in finite-difference simulations of the ground-water equation. One of these was termed the forward-difference approximation, and the other the backward-difference approximation. Figure A shows a plot of head versus time which we may use to review these approximations. The time axis is divided into intervals of length Δt . The head at the end of the n th interval is termed h_n ; that at the end of the preceding interval is termed h_{n-1} ; and that at the end of the subsequent interval is termed h_{n+1} . We wish to approximate $\partial h/\partial t$ at the end of the n th interval, that is, at the time $n\Delta t$. If we utilize the head difference over the subsequent time interval, we employ the forward-difference approximation to the time derivative; if we utilize the head difference over the preced-

ing interval, we employ the backward-difference approximation. The forward-difference approximation is given by

$$\left(\frac{\partial h}{\partial t}\right)_{n\Delta t} \approx \frac{h_{n+1} - h_n}{\Delta t} \quad (1)$$

Where $(\partial h/\partial t)_{n\Delta t}$ represents the derivative at time $n\Delta t$. The backward-difference approximation is given by

$$\left(\frac{\partial h}{\partial t}\right)_{n\Delta t} \approx \frac{h_n - h_{n-1}}{\Delta t} \quad (2)$$

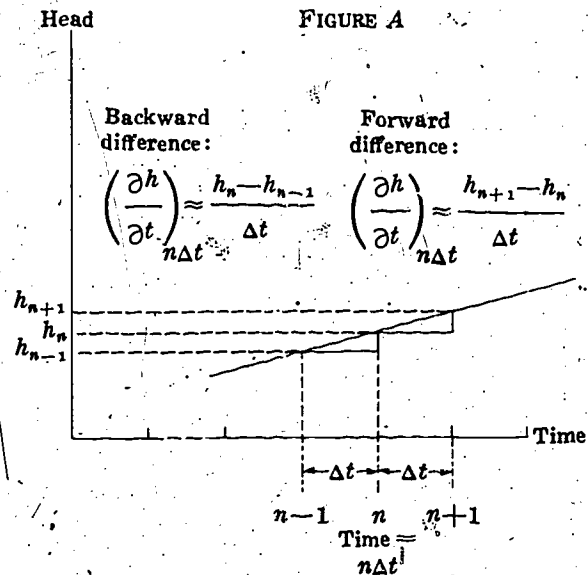

Forward-difference simulation: Explicit solution

The ground-water-flow equation, as it was given in Part V for two-dimensional flow, is

$$\frac{\partial^2 h}{\partial x^2} + \frac{\partial^2 h}{\partial y^2} = \frac{S}{T} \frac{\partial h}{\partial t} \quad (3)$$

where S represents storage coefficient and T transmissivity. In order to simulate this equation using either the forward-difference or backward-difference formulation, we would first write an approximate expression for the term

$$\frac{\partial^2 h}{\partial x^2} + \frac{\partial^2 h}{\partial y^2}$$

at the time $n\Delta t$ —that is, at point n on the time axis of figure A. Thus the forward-difference simulation is characterized by the fact that we approximate $\partial h/\partial t$ over a time interval which follows the time at which we approximate $(\partial^2 h/\partial x^2) + (\partial^2 h/\partial y^2)$, whereas the backward-difference simulation is characterized by the fact that we approximate $\partial h/\partial t$ over the time interval which precedes the time at which we approximate $(\partial^2 h/\partial x^2) + (\partial^2 h/\partial y^2)$. In the question of Section 10, Part VII, we obtained the following forward-difference simulation to equation 3:

$$\frac{h_{i-1,j,n} + h_{i+1,j,n} + h_{i,j-1,n} + h_{i,j+1,n} - 4h_{i,j,n}}{a^2} = \frac{S}{T} \frac{h_{i,j,n+1} - h_{i,j,n}}{\Delta t} \quad (4)$$

where a is the node spacing, S is the storage coefficient, and T is the transmissivity. We wish to know the new value of head at the time $(n+1)\Delta t$ for the point i, j . Figure B shows the computation stencil for this simulation; the head at node i, j at the time $(n+1)\Delta t$ depends on the head in a five-node array at the preceding time, $n\Delta t$. The five values of h at the time $n\Delta t$ are all known. We need only to rearrange the equation, solving for $h_{i,j,n+1}$, and to insert the known

values of $h_{i-1,j,n}$, $h_{i+1,j,n}$, $h_{i,j-1,n}$, $h_{i,j+1,n}$, and $h_{i,j,n}$. There is no need to use simultaneous equations; the head at each node is computed explicitly, using the head at that node and the four neighboring nodes from the preceding time. The sequence in which we move through the x, y plane, calculating new values of head, is immaterial. The solution at one point does not require information on the surrounding points for the same time—only for the preceding time. For all these reasons, the forward-difference technique is computationally simpler than the backward-difference technique.

However, as we noted earlier, the forward-difference method does suffer from a serious drawback. Unless the ratio $\Delta t/a^2$ is kept sufficiently small, errors which grow in magnitude with each step of the calculation may appear in the result. More exactly, let us suppose that an error of some sort does arise, for whatever reason, at a certain node at a particular time step. Unless the ratio $\Delta t/a^2$ is sufficiently small, this error will increase in magnitude at each succeeding time

FIGURE B

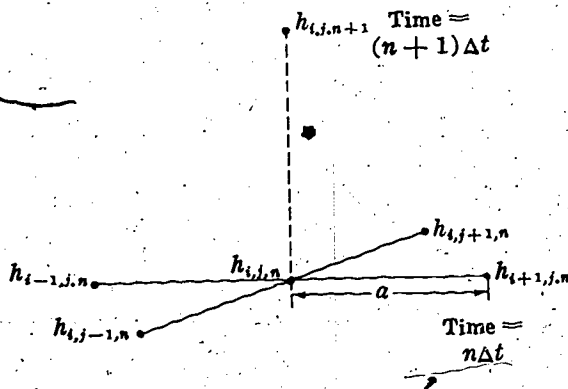

step in the calculation until eventually the error completely dominates the solution. The term "error," as used here, refers to any difference between the computed head at a node i, j and time $n\Delta t$, and the actual value of head—that is, the value which would be given by the exact solution to the differential equation at that point and time. Such errors are inevitable in the normal application of finite-difference methods; they generally ap-

pear throughout the mesh in the first steps of the calculation. If the restriction on $\Delta t/a^2$ is satisfied, these errors will tend to die out as the computation sequence continues; the solution is then said to be stable. If the restriction is not satisfied, the errors will grow with each succeeding time step and will eventually destroy any significance which the solution might have; in this case, the solution is said to be unstable.

Backward-difference simulation: Solution by iteration

Because of this limitation in the forward-difference approach, attention has been given to a variety of alternative methods. One of these is simulation of the differential

equation 3 through use of the backward-difference approximation to the time derivative as given in equation 2. The resulting finite-difference equation is

$$\frac{h_{i-1,j,n} + h_{i+1,j,n} + h_{i,j-1,n} + h_{i,j+1,n} - 4h_{i,j,n}}{a^2} = \frac{S}{T} \frac{h_{i,j,n} - h_{i,j,n-1}}{\Delta t} \quad (5)$$

Figure C shows a diagram of the computation stencil for equation 5. The time derivative is simulated over an interval which precedes the time at which $(\partial^2 h / \partial x^2) + (\partial^2 h / \partial y^2)$ is simulated; the equation incorporates five unknown values of head, corresponding to the time $n\Delta t$, and only one known value of head, corresponding to the time $(n-1)\Delta t$. Clearly we cannot obtain an

explicit solution to a single equation of the form of equation 5, the way we could to a single equation of the form of equation 4. We can, however, write an equation of the form of equation 5 for each node in the x, y plane; then since there is one unknown value of head (for time $t = n\Delta t$) at each node in the plane, we will have a system in which the total number of equations is equal to the total number of unknowns. We should therefore be able to solve the entire set as a system of simultaneous equations, obtaining the new value of $h_{i,j,n}$ at each node. The only drawback to this approach is that a great deal of work may be involved in solving the set of simultaneous equations; offsetting this drawback is the advantage that the technique is stable regardless of the size of the time step—that is, that errors tend to diminish rather than to increase as the computation proceeds, regardless of the size of Δt relative to a^2 .

The work required in utilizing the back-

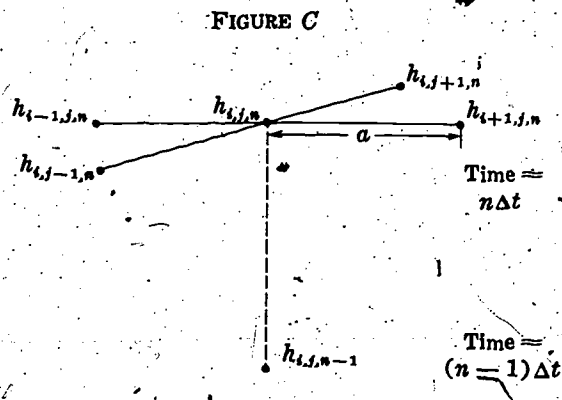

ward-difference technique depends upon the size of the problem—that is, upon the number of equations in the simultaneous set. If this number becomes large, as it does in most ground-water problems, the work entailed becomes very great, particularly when the standard direct methods of solving simultaneous equations are used. For this reason it is worthwhile to look for efficient methods of solving these sets of equations; and it turns out that iteration or relaxation—the process described in Section 25 of Part VII, in connection with solution of the steady-state equation—provides us with a reasonably efficient approach.

The equation that we were trying to solve by iteration in Section 25 of Part VII rewritten here using the i, j subscript notation, is

$$\frac{1}{4}(h_{i-1,j} + h_{i+1,j} + h_{i,j-1} + h_{i,j+1}) = h_{i,j} \quad (6)$$

This equation states that the head at the node i, j should be the average of the heads at the four surrounding nodes. No time subscripts are involved, since we are dealing with a steady-state situation. Our method is simply to move through the x, y plane, replacing the head at each node by the average of the heads at the four surrounding nodes. This process is continued until the head changes become negligible—that is, until the head at each node remains essentially unchanged after each traverse through the plane, indicating that equation 6 is satisfied throughout the plane.

In applying iteration to our nonequilibrium problem, the idea is to carry out a similar series of traverses of the x, y plane at every time step, using equation 5 rather than equation 6 as the basis of the calculation at each node. Thus to compute heads for the time $n\Delta t$ we would rearrange equation 5 as follows

$$h_{i,j,n} = \left(\frac{1}{\frac{4}{a^2} + \frac{S}{T\Delta t}} \right) \left\{ \frac{h_{i-1,j,n} + h_{i+1,j,n} + h_{i,j-1,n} + h_{i,j+1,n}}{a^2} + \frac{S}{T\Delta t} h_{i,j,n-1} \right\} \quad (7)$$

We can envision an x, y plane for the time $n\Delta t$, initially containing specified values of $h_{i,j,n}$ at a few nodes, corresponding to the boundary conditions, and trial values of $h_{i,j,n}$ at the remaining nodes. We write an equation of the form of equation 7 for every node not controlled by a boundary condition; and we write equations expressing the boundary conditions for the nodes at which these conditions apply. In equation 7, the value of $h_{i,j,n}$ is expressed in terms of the head at the four surrounding nodes for the same time, and the head at the same node for the preceding time. In solving the set of equations for values of $h_{i,j,n}$ the values of $h_{i,j,n-1}$ actually constitute known or constant

terms, determined in the preceding step of the operation. Thus equation 7 relates the head at each node to the head at the four surrounding nodes, in terms of a set of constants or known quantities. The equation is a little more cumbersome than equation 6 in that instead of multiplying the sum of the heads at the surrounding nodes by $1/4$, we must now multiply by the term

$$\frac{1}{\left(\frac{4}{a^2} + \frac{S}{T\Delta t} \right) a^2}$$

and we must add the known term

$$\frac{\frac{S}{T\Delta t}}{\frac{4}{a^2} + \frac{S}{T\Delta t}} \cdot h_{i,j,n-1}$$

on the right side. These changes, however, do not make the equation appreciably more difficult to solve. We can still use the process of iteration; that is, we can move through the x, y plane, replacing each original trial value of $h_{i,j,n}$ by a new value, calculated from the four surrounding values by equation 7. At each node we note the difference between the new value of $h_{i,j,n}$ which we have calculated, and the trial value with which we started. If this difference turns out to be negligible at every node, we may conclude that our starting values already satisfied equation 7 and that further computation of new values is pointless. More commonly, however, we will note a measurable change in the value of h at each node, indicating that the initial values did not satisfy equation 7, and that the iteration procedure is producing an adjustment toward new values which will satisfy the equation. In this case we traverse the x, y plane again, repeating the procedure; each value of $h_{i,j,n}$ which we calculated in the first step (or iteration) is replaced by a new value calculated from the heads at the four surrounding nodes by equation 7. Again the difference between the new value and the preceding value at each node is recorded; and a test is made to see whether this difference is small enough to indicate that the new array of head values approximately satisfies equation 7. The process is continued until the difference between newly computed and preceding values is negligible throughout the array, indicating that equation 7 is essentially satisfied at all points.

The technique described above is often referred to as the Gauss-Seidel method; it is basically the same procedure that was applied in Section 25 of Part VII to the steady-state problem. It is an example of a relaxation technique—a method of computation in which the differences between the two sides

of an equation are successively reduced by numerical adjustment, until eventually the equation is satisfied. There are a number of varieties of relaxation techniques in use, differing from one another in the order or sequence in which the x, y plane is traversed in the calculation and in certain other respects.

It has been found that the number of calculations required to solve the set of finite-difference equations can frequently be reduced by the inclusion of certain "artificial" terms in these equations. These terms normally take the form

$$\lambda (h_{i,j,n}^{m+1} - h_{i,j,n}^m)$$

The superscripts m and $m+1$ indicate levels of iteration; that is, $h_{i,j,n}^m$ represents the value of $h_{i,j,n}$ after m traverses of the x, y plane in the iteration process, and $h_{i,j,n}^{m+1}$ represents the value of $h_{i,j,n}$ obtained in the next following calculation, after $m+1$ traverses. λ is termed an "iteration parameter"; it is a coefficient which, either on the basis of practical experience or theoretical analysis, has been shown to produce faster rates of solution. As the iteration process approaches its goal at each time step, the difference between the value of $h_{i,j,n}$ obtained in one iteration and that obtained in the next iteration becomes negligible—that is, the term $(h_{i,j,n}^{m+1} - h_{i,j,n}^m)$ approaches zero, so that the difference equation appears essentially in its original form, without the iteration parameter term; and the solution which is obtained thus applies to the original equation. In some cases, λ is given a sequence of different values in successive iterations, rather than a single constant value. Again, the particular sequence of values is chosen, either through theoretical analysis or through practical experience, in such a way as to produce the most rapid solution. When an iteration parameter or sequence of iteration parameters is utilized, the relaxation process is termed "successive overrelaxation" and is frequently designated by the initials *SOR*. Discussions of this technique are given by Forsythe and Wasow (1960) and many others.

Alternating-direction implicit procedure

The work required to obtain a solution by relaxation techniques is frequently tedious, particularly for a problem of large dimensions. For this reason, a great deal of effort has gone into the development of alternative approaches. Peaceman and Rachford (1955) proposed a technique of computation which has received wide use in a variety of forms. The name "alternating direction" has been applied to the general procedures of calculation which they proposed.

To simplify our discussion of their techniques we will introduce some new notation. We saw in Sections 12 and 15 of Part VII that an approximation to $\partial^2 h / \partial x^2$ is given by the term

$$\frac{h_1 + h_2 - 2h_0}{(\Delta x)^2};$$

or, in terms of our subscript notation,

$$\frac{h_{i-1,j} + h_{i+1,j} - 2h_{i,j}}{(\Delta x)^2}$$

In the discussion which follows, we will let the symbol $\Delta_{xx}h$ represent this approximation to $\partial^2 h / \partial x^2$. That is, we say

$$\frac{\partial^2 h}{\partial x^2} \approx \Delta_{xx}h = \frac{h_{i-1,j} + h_{i+1,j} - 2h_{i,j}}{(\Delta x)^2} \quad (8)$$

In addition, we will use a subscript to indicate the time at which the approximation is taken. For example, $(\Delta_{xx}h)_n$ will indicate an approximation to the second derivative at the time $n\Delta t$, or specifically

$$(\Delta_{xx}h)_n = \frac{h_{i-1,j,n} + h_{i+1,j,n} - 2h_{i,j,n}}{(\Delta x)^2} \quad (9)$$

$(\Delta_{xx}h)_{n-1}$ will represent an approximation to the second derivative at time $(n-1)\Delta t$, and so on. Similarly, we will use the notation $\Delta_{yy}h$ to represent our approximation to $\partial^2 h / \partial y^2$, that is,

$$\frac{\partial^2 h}{\partial y^2} \approx \Delta_{yy}h = \frac{h_{i,j-1} + h_{i,j+1} - 2h_{i,j}}{(\Delta y)^2} \quad (10)$$

and again $(\Delta_{yy}h)_n$ will represent our approximation to $\partial^2 h / \partial y^2$ at the time $n\Delta t$, that is

$$(\Delta_{yy}h)_n = \frac{h_{i,j-1,n} + h_{i,j+1,n} - 2h_{i,j,n}}{(\Delta y)^2} \quad (11)$$

and so on.

Using this notation, our forward-difference approximation to the equation

$$\frac{\partial^2 h}{\partial x^2} + \frac{\partial^2 h}{\partial y^2} = \frac{S}{T} \frac{\partial h}{\partial t} \quad (3)$$

as given in equation 4, would be rewritten

$$(\Delta_{xx}h)_n + (\Delta_{yy}h)_n = \frac{S}{T} \frac{h_{i,j,n+1} - h_{i,j,n}}{\Delta t} \quad (12)$$

In this formulation, $\partial^2 h / \partial x^2$ and $\partial^2 h / \partial y^2$ are simulated at the beginning of the time interval over which $\partial h / \partial t$ is simulated.

Again using the notation introduced above, our backward-difference approximation to equation 3, as given in equation 5, would be rewritten

$$(\Delta_{xx}h)_n + (\Delta_{yy}h)_n = \frac{S}{T} \frac{h_{i,j,n} - h_{i,j,n-1}}{\Delta t} \quad (13)$$

In this formulation, $\partial^2 h / \partial x^2$ and $\partial^2 h / \partial y^2$ are simulated at the time $n\Delta t$, while $\partial h / \partial t$ is simulated over the time interval between $(n-1)\Delta t$ and $n\Delta t$; thus both $\partial^2 h / \partial x^2$ and $\partial^2 h / \partial y^2$ are approximated at the end of the time interval over which $\partial h / \partial t$ is approximated.

In the form in which it was originally proposed, Peaceman and Rachford's technique is usually termed the alternating-direction implicit procedure. In this form, the

simulation utilizes two equations, applicable over two successive time intervals. In the first equation, $\partial^2 h / \partial x^2$ is simulated at the beginning of a time interval, and $\partial^2 h / \partial y^2$ at the end of that interval; $\partial h / \partial t$ is simulated using the change in head occurring over the interval. The second equation applies over the immediately following time interval; here the order is reversed— $\partial^2 h / \partial y^2$ is simulated at the beginning of the time interval, $\partial^2 h / \partial x^2$ is simulated at the end, and again $\partial h / \partial t$ is simulated using the head difference occurring over the interval.

Using the notation introduced above, this simulation may be represented by the following equation pair

$$(\Delta_{xx}h)_{n-1} + (\Delta_{yy}h)_n = \frac{S}{T} \frac{h_{i,j,n} - h_{i,j,n-1}}{\Delta t} \quad (14)$$

$$(\Delta_{yy}h)_n + (\Delta_{xx}h)_{n+1} = \frac{S}{T} \frac{h_{i,j,n+1} - h_{i,j,n}}{\Delta t} \quad (15)$$

For the first time interval, $\partial^2 h / \partial x^2$ is simulated at $(n-1)\Delta t$; $\partial^2 h / \partial y^2$ is simulated at $n\Delta t$; and $\partial h / \partial t$ is simulated by the change in $h_{i,j}$ between $(n-1)\Delta t$ and $n\Delta t$. For the second time interval $\partial^2 h / \partial y^2$ is simulated at $n\Delta t$; $\partial^2 h / \partial x^2$ is simulated at $(n+1)\Delta t$; and $\partial h / \partial t$ is simulated by the change in $h_{i,j}$ between $n\Delta t$ and $(n+1)\Delta t$.

Figure D illustrates the form of this simulation. It may be recalled from Section 3 that lines parallel to the x -axis in the finite-difference grid are termed rows and that lines parallel to the y -axis are termed columns. As shown in figure D, then, three values of h are taken along row j at time $(n-1)\Delta t$ to simulate $\partial^2 h / \partial x^2$, while at the time $n\Delta t$ three values of h are taken along column i to simulate $\partial^2 h / \partial y^2$. The time derivative is simulated using the difference between the central h values at these two times. For the succeeding time interval, the three values of h along column i are taken first to simulate $\partial^2 h / \partial y^2$ at time $n\Delta t$; while at the time $(n+1)\Delta t$, three values of h are taken along row j to simulate $\partial^2 h / \partial x^2$. Again the time derivative is simulated using the

difference between the central h values.

The forward-difference and backward-difference techniques are characterized by symmetry in their simulation of the expression $(\partial^2 h / \partial x^2) + (\partial^2 h / \partial y^2)$. Both terms of this expression are simulated at the same time, using a five-node array centered about a single value of head, $h_{i,j,n}$. However, the

FIGURE D

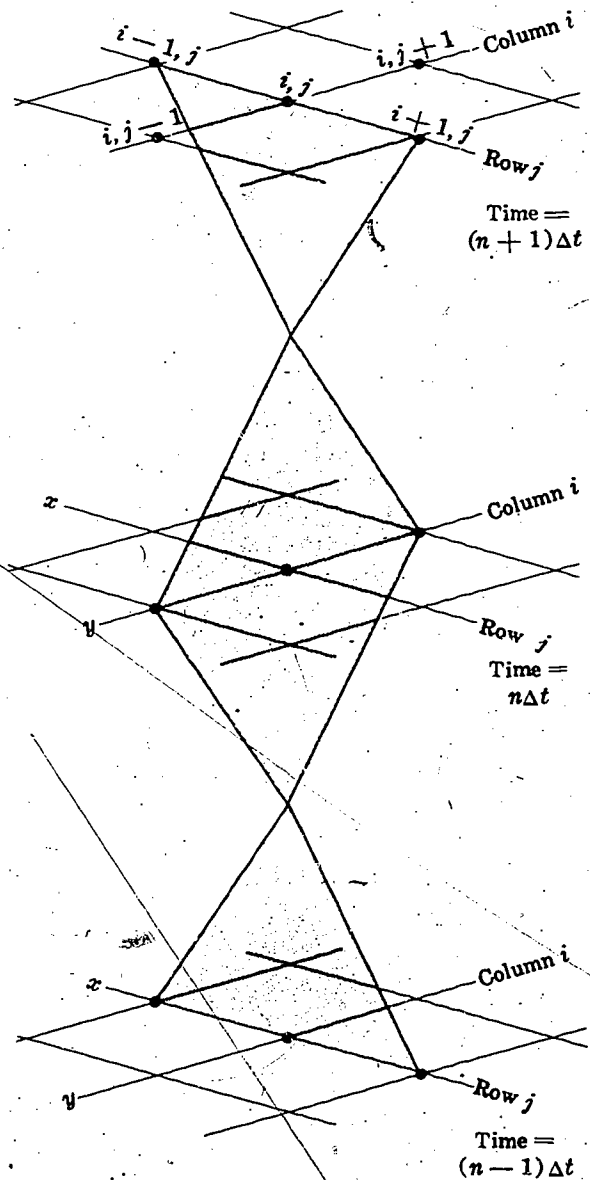

simulation of $\partial h/\partial t$ in these formulations is asymmetrical, in the sense that it is not centered in time about $h_{i,j,n}$ but extends forward or backward from the time $n\Delta t$. In either case, however, if we allow Δt to become very small, the effects of this asymmetry die out; the approximation then approaches more and more closely the value of $\partial h/\partial t$ at the time $n\Delta t$. In the alternating-direction implicit procedure, by contrast, $\partial^2 h/\partial x^2$ and $\partial^2 h/\partial y^2$ are not simulated at the same time, and in this sense the simulation of $(\partial^2 h/\partial x^2) + (\partial^2 h/\partial y^2)$ cannot be termed symmetrical. It is again helpful, however, to visualize what will happen if Δt is allowed to become very small, so that the times $(n-1)\Delta t$ and $n\Delta t$ at which the individual simulations occur, fall more and more closely together. In this case, $(\Delta_{xx}h)_{n-1}$ should begin to approximate the value of $\partial^2 h/\partial x^2$ at $(n-1/2)\Delta t$, while $(\Delta_{yy}h)_n$ should begin to approximate the value of $\partial^2 h/\partial y^2$ at $(n-1/2)\Delta t$. In this sense, then, the expression

$$(\Delta_{xx}h)_{n-1} + (\Delta_{yy}h)_n$$

can be considered an approximation to

$$\frac{\partial^2 h}{\partial x^2} + \frac{\partial^2 h}{\partial y^2}$$

at the time $(n-1/2)\Delta t$. The simulation of $\partial h/\partial t$ is symmetrical with respect to this time, since it utilizes the head difference $h_n - h_{n-1}$. Thus even though a certain asymmetry exists in the expression by which $(\partial^2 h/\partial x^2) + (\partial^2 h/\partial y^2)$ is approximated in the alternating-direction technique, it can be argued that there is symmetry with respect to time in the simulation of $\partial h/\partial t$. Moreover, we may expect intuitively that if an error is generated by the fact that we simulate $\partial^2 h/\partial x^2$ prior to $\partial^2 h/\partial y^2$ during one time interval, some sort of compensating error should be generated during the following time interval, when we simulate $\partial^2 h/\partial y^2$ prior to $\partial^2 h/\partial x^2$; and in fact it turns out that this alternation in the order of simulation is essential to the stability of the method. If the order of simulation is reversed in

this way, then regardless of the size of the time step, the calculation will not be affected by errors which grow at each step of the calculation. A further condition for stability is that the time intervals represented in the two steps of the simulation (equations 14 and 15) must be equal. The length of the time interval may differ from one pair of time steps to the next, but within a given pair, as used in equations 14 and 15, the two values of Δt must be kept the same. Finally, there must be an even number of total time steps; $\partial^2 h/\partial y^2$ must be simulated prior to $\partial^2 h/\partial x^2$ as often as $\partial^2 h/\partial x^2$ is simulated prior to $\partial^2 h/\partial y^2$.

If equations 14 and 15 are written out using the earlier notation we have

$$\frac{h_{i-1,j,n-1} + h_{i+1,j,n-1} - 2h_{i,j,n-1}}{(\Delta x)^2} + \frac{h_{i,j,n-1} + h_{i,j,n+1} - 2h_{i,j,n}}{(\Delta y)^2} = \frac{S}{T} \frac{h_{i,j,n} - h_{i,j,n-1}}{\Delta t} \quad (16)$$

and

$$\frac{h_{i-1,j,n+1} + h_{i+1,j,n+1} - 2h_{i,j,n+1}}{(\Delta x)^2} + \frac{h_{i,j,n+1} + h_{i,j,n-1} - 2h_{i,j,n}}{(\Delta y)^2} = \frac{S}{T} \frac{h_{i,j,n+1} - h_{i,j,n}}{\Delta t} \quad (17)$$

Equation 16 involves three values of head along row j at time $(n-1)\Delta t$ and three values of head along column i at time $n\Delta t$. Let us assume that the head values for the earlier time, $(n-1)\Delta t$, have been calculated throughout the x, y plane and that we are concerned with calculation of head values for the time $n\Delta t$. Equation 16 then contains three known values of head, for the time $(n-1)\Delta t$ and three unknown, for the time $n\Delta t$. Since we have three unknowns in one equation, we will again need to use simultaneous equations. In this case the three unknowns occur along a single column; and by considering other equations which apply along this column we can develop a convenient method of solution.

Let us suppose that there are m nodes along column i and that the head is specified at the two end nodes by boundary conditions, but must be determined for all of the interior nodes. The first node is identified by the subscript $j=1$ (we assume that the x -axis, where $j=0$, lies outside the problem area); the final node is identified by the subscript $j=m$. Thus $h_{i,1,n}$ and $h_{i,m,n}$ are specified by boundary conditions, while $h_{i,2,n}$ through $h_{i,m-1,n}$ must be determined.

We can write an equation of the form of equation 16 for each interior node along column i . As we set up the equation at each node, we pick up three known values of head from the $(n-1)\Delta t$ "time plane"; these known values fall along a three-column band, as shown in figure E. Each equation also incorporates three values of head for the new time, $n\Delta t$, all lying along column i ; and when we have set up an equation of the form of equation 16 for each interior node along the column, we have a system of $m-2$ equations in $m-2$ unknowns, which can be solved simultaneously. The solution of this set of equations is undertaken independently from the solutions for adjacent columns in the mesh; thus, instead of dealing with a set of, say, 2,500 simultaneous equations in a 50 by 50 array, we deal in turn with separate sets of only 50 equations. Each of these sets corresponds to a column within the mesh; and

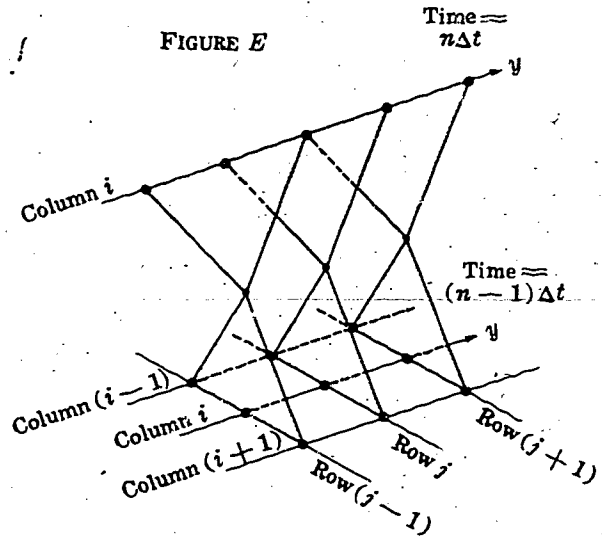

each is much easier to solve than the 2,500 equation set, not only because of the smaller number of equations, but also because a convenient order of computation is possible. We are able to utilize this order of computation through a technique developed by H. L. Thomas (1949) that is known as the Thomas algorithm.

To illustrate this method, we rearrange equation 16, putting the unknown values of head, corresponding to time $n\Delta t$, on one side, as follows:

$$\frac{h_{i,j-1,n}}{(\Delta y)^2} - \left(\frac{S}{T\Delta t} + \frac{2}{(\Delta y)^2} \right) h_{i,j,n} + \frac{h_{i,j+1,n}}{(\Delta y)^2} = - \frac{h_{i-1,j,n-1}}{(\Delta x)^2} - \left(\frac{S}{T\Delta t} - \frac{2}{(\Delta x)^2} \right) h_{i,j,n-1} - \frac{h_{i+1,j,n-1}}{(\Delta x)^2} \quad (18)$$

The right-hand side consists entirely of known terms, and it is convenient to replace this side of the equation by a single symbol, D_j , that is

$$D_j = - \frac{h_{i-1,j,n-1}}{(\Delta x)^2} - \left(\frac{S}{T\Delta t} - \frac{2}{(\Delta x)^2} \right) h_{i,j,n-1} - \frac{h_{i+1,j,n-1}}{(\Delta x)^2}, \quad (19)$$

The single subscript, j , is sufficient to designate D for our purposes. As suggested in figure E, the sequence of calculation is along the column i . At each node—that is, for each value of j —there is only one value of D , taken from the three-column band in the preceding time plane. We are limiting consideration here to one set of equations, corresponding to one column, and aimed at calculating the heads for one value of time; the subscripts designating the column and

time are therefore not required. Thus we can omit the subscripts i and n from the values of h on the left side of the equation. With these changes, equation 18 takes the form

$$A_j h_{j-1} + B_j h_j + C_j h_{j+1} = D_j \quad (20)$$

where, in the problem which we have set up

$$A_j = \frac{1}{(\Delta y)^2},$$

$$B_j = -\left(\frac{S}{T \Delta t} + \frac{2}{(\Delta y)^2} \right),$$

and

$$C_j = \frac{1}{(\Delta y)^2}.$$

The coefficients A , B , and C are constant for the problem which we have postulated. In some problems, however, where variation in T , S , or the node spacing is involved, they may vary from one node to another. To keep the discussion sufficiently general to cover such cases, the coefficients have been designated with the subscript j .

If we solve equation 20 for h_j , the central value of the three-node set represented in the equation, we obtain

$$h_j = \frac{D_j - A_j h_{j-1} - C_j h_{j+1}}{B_j} \quad (21)$$

h_1 , the head at the initial node of the column, is specified by the boundary condition. We apply equation 21 to find an expression for h_2 ; this gives

$$h_2 = \frac{D_2 - A_2 h_1 - C_2 h_3}{B_2} \quad (22)$$

We rewrite this equation in the form

$$h_2 = g_2 - b_2 h_3 \quad (23)$$

where

$$g_2 = \frac{D_2 - A_2 h_1}{B_2} \quad (24)$$

and

$$b_2 = \frac{C_2}{B_2} \quad (25)$$

b_2 consists of known terms, and since h_1 is known, g_2 can be calculated; equation 23 thus gives us an equation for h_2 in terms of the next succeeding value of head, h_3 . If we can continue along the column, forming equations which give the head at each node in terms of that at the succeeding node—that is, which give h_j in terms of h_{j+1} —we will eventually reach the next to last node in the column, where we will have an equation for h_{m-1} in terms of h_m , the head at the last node. Then since h_m is known, from the boundary condition, we will be able to calculate h_{m-1} ; using this value of h_{m-1} we can calculate h_{m-2} , and so on back down the column, until finally we can calculate h_2 in terms of h_3 using equation 23. This is the basic idea of the Thomas algorithm. We now have to see whether we can in fact obtain expressions for each head, h_j , in terms of the succeeding head, h_{j+1} , along the column.

We first apply equation 21 to find an expression for h_3 obtaining

$$h_3 = \frac{D_3 - A_3 h_2 - C_3 h_4}{B_3} \quad (26)$$

To eliminate h_2 from this equation, we substitute from equation 23, obtaining

$$h_3 = \frac{D_3 - A_3 (g_2 - b_2 h_3) - C_3 h_4}{B_3} \quad (27)$$

Equation 27 is now solved for h_3 as follows

$$\tilde{h}_3 - \frac{A_3 b_2}{B_3} h_3 = \frac{D_3 - A_3 g_2 - C_3 h_4}{B_3}$$

$$h_3 = \frac{D_3 - A_3 g_2 - C_3 h_4}{B_3 \left(\frac{B_3 - A_3 b_2}{B_3} \right)}$$

or

$$h_3 = \frac{D_3 - A_3 g_2}{B_3 - A_3 b_2} - \frac{C_3}{B_3 - A_3 b_2} h_4 \quad (28)$$

Now again we have an equation of the form

$$h_3 = g_3 - b_3 h_4 \quad (29)$$

where here

$$g_3 = \frac{D_3 - A_3 g_2}{B_3 - A_3 b_2} \quad (30)$$

and

$$b_3 = \frac{C_3}{B_3 - A_3 b_2} \quad (31)$$

Since g_2 and b_2 are known from the preceding step of the calculation (equation 24 and 25), g_3 and b_3 can be calculated, and equation 29 then gives us an expression for h_3 in terms of h_4 . In effect, we have eliminated h_2 from equation 26, so that h_3 is expressed in terms of the succeeding value of head alone.

If we continue this process, we find that at each step we can obtain an equation of the form

$$h_j = g_j - b_j h_{j+1} \quad (32)$$

relating the head at each node to that at the succeeding node; and we find that g_j and b_j can always be determined from the preceding values of g and b by equations of the form of equations 30 and 31. That is, we find that

$$g_j = \frac{D_j - A_j g_{j-1}}{B_j - A_j b_{j-1}} \quad (33)$$

and

$$b_j = \frac{C_j}{B_j - A_j b_{j-1}} \quad (34)$$

These general formulas apply even to the calculation of g_2 and b_2 if we specify the starting conditions $g_1 = h_1$ and $b_1 = 0$.

In summary, then, we may start at node 1 and move up the column calculating values of g_j and b_j . At each node, these values are calculated by equations 33 and 34, using the preceding values, g_{j-1} and b_{j-1} , and using the coefficients A_j , B_j , and C_j and the term D_j .

Ultimately, at the next to last node of the column, g_{m-1} and b_{m-1} are calculated; then since h_m is known from the boundary condition, h_{m-1} can be calculated from equation 32. We then proceed back down the column, calculating the value of h_j at each node from

the value of h_{j+1} using equation 32, until finally a value for h_2 has been calculated and heads have been determined throughout the column.

The whole process is actually one of Gaussian elimination, taking advantage of a convenient order of calculation. The solution of the difference equation 16 is obtained directly for points along the column through this process; we are not dealing with an iterative technique which solves the set of algebraic equations by successive approximation. When the head has been calculated at all nodes along column i , the process is repeated for column $i+1$, and so on until the entire plane has been traversed.

In a sense, this process of calculation stands somewhere between the forward-difference technique and the backward-difference technique. In the forward-difference technique the head at every node, for a given time level, is computed independently from the heads at the four adjacent nodes for that time level; the technique of computation is said to be explicit. In the backward-difference technique, the calculation of the head at each node incorporates the heads at the four adjacent nodes for the same time level; the method of calculation is termed implicit. In the alternating-direction technique the calculation of the head at a given node, as we move along a column, incorporates the heads for that time level at the two adjacent nodes along the column, but not at the two adjacent nodes in the adjoining columns. The method of calculation, for this step, is said to be implicit along the columns, but explicit in the transverse direction, along the rows.

When the heads have been calculated everywhere throughout the plane by the process of traversing the columns, calculations for the following time, $(n+1)\Delta t$ are initiated using equation 17. The procedure followed is the same as that described above, except that the calculation now moves along rows, rather than along columns. This alternation of direction again, is necessary in order to insure the stability of the method of calculation.

Solution of the steady-state equation by iteration using the alternating-direction method of calculation

In their initial paper proposing the alternating-direction implicit procedure, Peaceman and Rachford point out that the technique of solving alternately along rows and columns can be used effectively to iterate the steady-state equation. That is, suppose we must deal with the problem considered in Section 16 and 25 of Part VII, and reviewed earlier in the present discussion, in which the steady-state equation

$$\frac{\partial^2 h}{\partial x^2} + \frac{\partial^2 h}{\partial y^2} = 0 \quad (35)$$

is to be solved. In Section 25, we considered a technique of iteration, or relaxation, to solve this equation. In this technique we wrote the finite-difference approximation given in equation 6 as a simulation of equation 35; this gave

$$h_{i,j} = \frac{1}{4} (h_{i-1,j} + h_{i+1,j} + h_{i,j-1} + h_{i,j+1}). \quad (6)$$

To apply equation 6, we would move through the x, y plane replacing values of $h_{i,j}$ at each interior node by the average of the heads at the four surrounding nodes. At the end of one complete traverse of the plane we would have a set of values of $h_{i,j}$ which would be somewhat closer to satisfying equation 6 than were the values with which we started; and after several traverses, we would have a set of head values which would essentially satisfy equation 36 throughout the plane. This would be indicated by the fact that the values of $h_{i,j}$ obtained in each step would differ very little from those obtained in the preceding step.

Our objective here is to outline a more efficient technique of carrying out this itera-

tion process, based upon Peaceman and Rachford's method and the Thomas algorithm. We begin by introducing some nomenclature and notation. In our discussion of nonequilibrium problems, we spoke of "time planes"—that is, representations of the x, y plane in which the heads calculated for a given time were displayed. In discussing the solution of steady-state problems by iteration we can similarly speak of "iteration planes"—that is, representations of the x, y plane in which the values of head obtained after a certain number of iterations are displayed. Again, in our discussion of nonequilibrium problems we used the subscript n to designate the time level of a given head value— $h_{i,j,n}$ referred to a head value at the time $n\Delta t$. In a similar way, we will use a superscript m to denote the iteration level in the steady-state problem. $h_{i,j}^0$ will be used to designate the starting values of head, prior to any iterations; $h_{i,j}^1$ will indicate head values after one iteration—that is, the head values in the first iteration plane; and in general, $h_{i,j}^m$ will indicate head values after m iterations, or in the m th iteration plane.

Next we rewrite our approximation to equation 35 in a slightly different form. We rearrange equation 6 to give

$$h_{i-1,j} + h_{i+1,j} - 2h_{i,j} = -h_{i,j-1} - h_{i,j+1} + 2h_{i,j} \quad (36)$$

This can be obtained also by rewriting equation 35 in the form

$$\frac{\partial^2 h}{\partial x^2} = -\frac{\partial^2 h}{\partial y^2}$$

and then using the approximations given in equation 8 and 10 for $\partial^2 h / \partial x^2$ and $\partial^2 h / \partial y^2$.

We are interested in applying equation 36 to calculate head values for a new iteration level, using head values from the preceding

iteration level. In the procedure which we will employ it is necessary to consider two successive iteration steps. Using the superscript notation described above, and using $\Delta_{xx}h$ and $\Delta_{yy}h$ to represent our approximations to $\partial^2h/\partial x^2$ and $\partial^2h/\partial y^2$ as in equations 8 and 10, the method of calculation may be summarized as follows

$$-\Delta_{yy}h^m = \Delta_{xx}h^{m-1} \quad (37)$$

and

$$\Delta_{xx}h^{m+1} = -\Delta_{yy}h^m \quad (38)$$

or, in the notation of equation 36,

$$\begin{aligned} -h_{i,j-1}^m - h_{i,j+1}^m + 2h_{i,j}^m \\ = h_{i-1,j}^{m-1} + h_{i+1,j}^{m-1} - 2h_{i,j}^{m-1} \end{aligned} \quad (39)$$

and

$$\begin{aligned} h_{i-1,j}^{m+1} + h_{i+1,j}^{m+1} - 2h_{i,j}^{m+1} \\ = -h_{i,j-1}^m - h_{i,j+1}^m + 2h_{i,j}^m \end{aligned} \quad (40)$$

As these equations indicate, the idea here is first to simulate $\partial^2h/\partial x^2$ at one iteration level and $\partial^2h/\partial y^2$ at the next; in the succeeding iteration, the order is reversed; $\partial^2h/\partial y^2$ is simulated at the earlier iteration level, and $\partial^2h/\partial x^2$ at the next. Figure D, which illustrated the simulation technique for the nonequilibrium problem, is reproduced as figure F, but with the time planes now relabeled as iteration planes. Equation 39 relates three values of head at iteration level m to three values at iteration level $m-1$; and, following the technique described above for the nonequilibrium case, we may move along column i in iteration plane m , at each node picking up three known values of h^{m-1} from a three column band in the preceding iteration plane, and thus generating a set of equations in which the unknowns are all values of h^m along column i .

As in the nonequilibrium case, the set of equations along a given column is solved directly by the Thomas algorithm—that is, by

FIGURE F

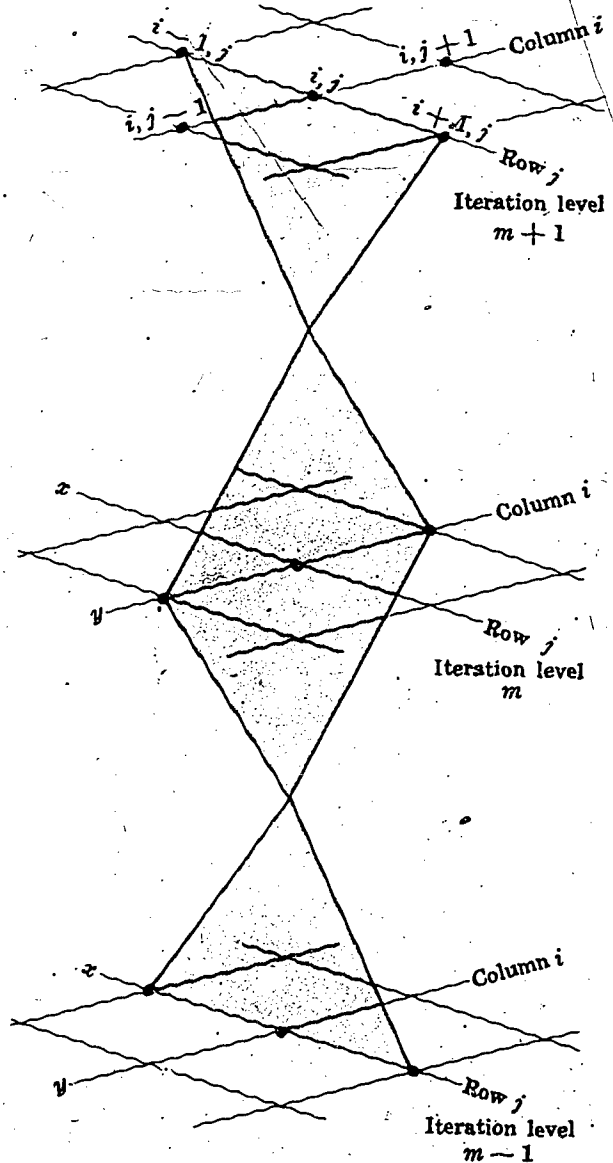

the process of Gaussian elimination outlined in equation 20 through 34. When this has been done for every column in the x, y plane, we have a new set of head values throughout the plane. These values, however do not necessarily constitute a solution to equation 35. The process we have described, of replacing the earlier head values with new values calculated through equation 39, accomplishes the same thing as the relaxation process of Section 25—it produces a new set of values which is closer to satisfying equation 35 than was the earlier set. This does not guarantee that the new set will constitute an acceptable solution. The test as to whether or not a solution has been found is carried out as in the relaxation technique of Section 25—

the values of head in iteration plane m are compared to those in iteration plane $m-1$. If the difference is everywhere negligible, equation 35 must be satisfied throughout the x, y plane; otherwise a new iteration must be initiated. In this new iteration we would utilize equation 40, moving along a row of the model to set up a system of equations for the head values along that row. As in the nonequilibrium problem this alteration of direction is necessary for stability. In summary then, we are utilizing an indirect iterative procedure of solution; but we use a direct method, Gaussian elimination, along each individual column or row, to move from one set of approximate head values to the next during the iterative process.

Backward-difference simulation: Solution by iteration using the alternating-direction method of calculation (iterative alternating-direction implicit procedure)

Peaceman and Rachford found that iteration of the steady-state equation by the alternating-direction procedure was considerably more efficient than the most rapid relaxation techniques that had been used prior to the time of their work. The use of the alternating-direction technique in this sense, as a method of iteration, has accordingly gained great popularity in recent years. As a method of solving the nonequilibrium equation 3, however, the alternating-direction implicit procedure, as embodied in equations 14 and 15 or 16 and 17, has not always proved advantageous. Although stability is assured, that is the calculation will not be affected by errors which necessarily increase in magnitude at each step, there is still a possibility for large error at any one time step and at any given node; and in many problems these errors have proved uncontrollable and unacceptable. This undesirable feature has inevitably led to renewed interest in the backward-difference formulation of equations 5 and 13. As we have noted,

solution by this method must generally be accomplished through iteration, for example using equation 7; the systems of simultaneous equations involved are usually too large to admit of an easy solution by direct methods. We have seen that the alternating-direction procedure of Peaceman and Rachford provides an effective method of iterating the steady-state equation; this suggests that the same technique may be used to iterate the backward-difference equation, 5 or 13. Equation 13, which utilized the abbreviated notation, is reproduced below

$$(\Delta_{xx}h)_n + (\Delta_{yy}h)_n = \frac{S}{T} \frac{h_{i,j,n} - h_{i,j,n-1}}{\Delta t} \quad (13)$$

$(\Delta_{xx}h)_n$ is an approximation to $\partial^2 h / \partial x^2$ at the time $n\Delta t$, while $(\Delta_{yy}h)_n$ is an approximation $\partial^2 h / \partial y^2$ at the time $n\Delta t$. We again introduce the superscript m to indicate the level of iteration; using this notation we rewrite equation 13 as it will be used in two

successive steps of the iteration process under consideration,

$$(\Delta_{xx}h)_{n^{m-1}} + (\Delta_{yy}h)_{n^m} = \frac{S}{T} \frac{h_{i,j,n^m} - h_{i,j,n-1}}{\Delta t} \quad (41)$$

$$(\Delta_{xx}h)_{n^{m+1}} + (\Delta_{yy}h)_{n^m} = \frac{S}{T} \frac{h_{i,j,n^{m+1}} - h_{i,j,n-1}}{\Delta t} \quad (42)$$

Several points about equations 41 and 42 should be noted carefully. The simulations of both $\partial^2 h / \partial x^2$ and $\partial^2 h / \partial y^2$, in both equations, are made at time $n\Delta t$; and again, in both equations, $\partial h / \partial t$ is simulated by the change in head at node i, j from time $(n-1)\Delta t$ to time $n\Delta t$. In equation 41, $(\partial^2 h / \partial x^2)_{n\Delta t}$ is simulated at the $(m-1)$ th iteration level, whereas $(\partial^2 h / \partial y^2)_{n\Delta t}$ is simulated at the m th iteration level; $h_{i,j,n}$, in the simulation of the time derivative, is represented at the m th iteration level. In equation 42, $(\partial^2 h / \partial y^2)_{n\Delta t}$ is simulated at the m th iteration level, while $(\partial^2 h / \partial x^2)_{n\Delta t}$ is simulated at the $(m+1)$ th iteration level; $h_{i,j,n}$, in the simulation of the time derivative, is again represented at the higher iteration level,

which is here $m+1$. No iteration superscript is attached to $h_{i,j,n-1}$ the head at the preceding time level, in either equation. The iteration process is designed to compute heads for the new time level, $n\Delta t$, and in this process the head at the preceding time level is simply a constant; it retains the same value throughout the series of iterations.

Rewriting equation 41 using the expanded notation for $\Delta_{xx}h$ and $\Delta_{yy}h$ (as given in equations 8 and 10), we have

$$\frac{h_{i-1,j,n^{m-1}} + h_{i+1,j,n^{m-1}} - 2h_{i,j,n^{m-1}}}{(\Delta x)^2} + \frac{h_{i,j-1,n^m} + h_{i,j+1,n^m} - 2h_{i,j,n^m}}{(\Delta y)^2} = \frac{S}{T} \frac{(h_{i,j,n^m} - h_{i,j,n-1})}{\Delta t} \quad (43)$$

We wish to calculate head values at the new iteration level, m , on the basis of values which we already have for the preceding iteration level, $m-1$. We therefore rearrange equation 43, placing unknown terms on the left and known terms on the right. This gives

$$\frac{h_{i,j-1,n^m}}{(\Delta y)^2} + \frac{h_{i,j+1,n^m}}{(\Delta y)^2} - \left(\frac{S}{T\Delta t} + \frac{2}{(\Delta y)^2} \right) h_{i,j,n^m} = \frac{h_{i-1,j,n^{m-1}}}{(\Delta x)^2} - \frac{h_{i+1,j,n^{m-1}}}{(\Delta x)^2} + \frac{2}{(\Delta x)^2} h_{i,j,n^{m-1}} - \frac{S}{T\Delta t} h_{i,j,n-1} \quad (44)$$

The unknown terms are the head values for iteration level m ; the known terms are the head values for the preceding iteration level, $m-1$, and one head value from the preceding time level, $n-1$. We may therefore proceed as in equation 19, replacing the entire right side by a single symbol, D_j , representing the known terms of the equation. We will then have an equation of the form of equation 20,

$$A_j h_{i,j-1,n^m} + B_j h_{i,j,n^m} + C_j h_{i,j+1,n^m} = D_j \quad (45)$$

which can be solved by the Thomas algorithm, as outlined in equations 21-34. In the next step we utilize equation 42; here the unknown terms consist of three values of h for time $n\Delta t$ and iteration level $m+1$, while the known terms consist of three values of h for time $n\Delta t$ and iteration level m , and again one value of h for the time level $(n-1)\Delta t$. After this step, the heads which we obtain

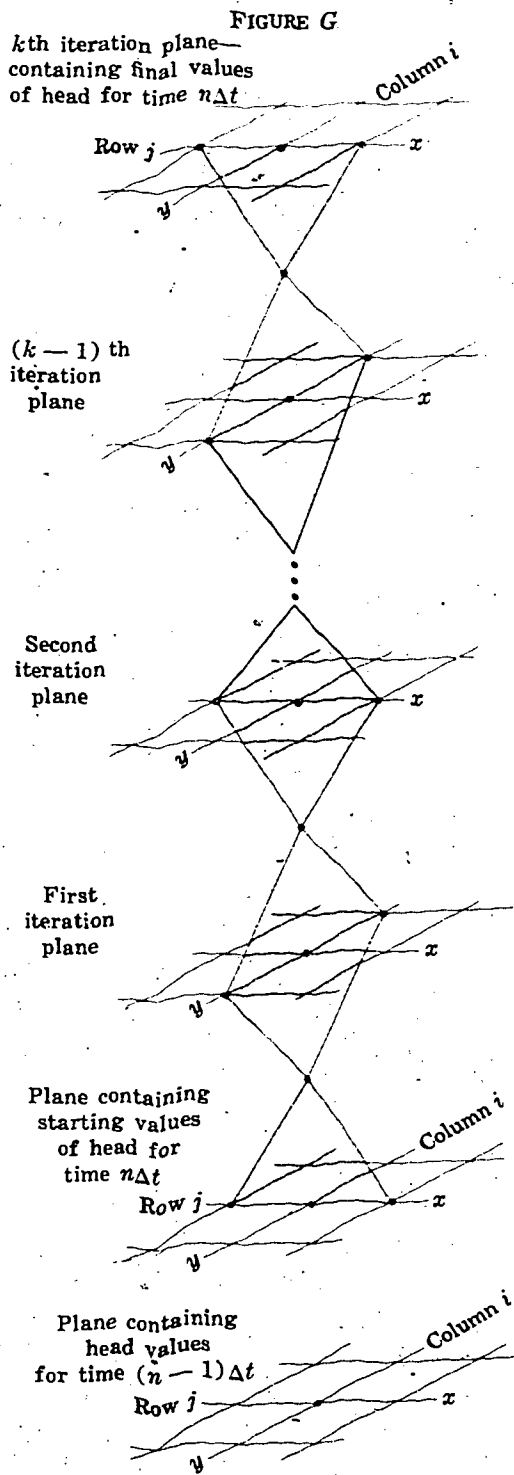

are compared with those obtained in the preceding step. If the difference is everywhere negligible, the values of h^{m+1} are taken as a sufficiently close approximation to the heads for time $n\Delta t$.

It's important to note that while at each step we solve directly, (by Gaussian elimination, along columns or rows) to obtain a new set of head values, these new values do not generally constitute a solution to our differential equation. Rather, they form a new approximation to a solution, in a series of iterations which will ultimately produce an approximation close enough for our purposes. We may review the sequence of computation by referring to figure G, which illustrates the process of calculation schematically. The lowermost plane in the figure is a time plane, containing the final values of head for the preceding time level, $(n-1)\Delta t$. The plane immediately above this contains the initial assumed values of head for the new time, $n\Delta t$; we use three values of head, h_{i-1,j,n^0} , h_{i,j,n^0} , and h_{i+1,j,n^0} from this plane, together with one value of head $h_{i,j,n-1}$ from the $n-1$ time plane, on the right side of equation 44. On the left side of equation 44 we have three unknown values of head in the first iteration plane, $h_{i,j-1,n^1}$, h_{i,j,n^1} , and $h_{i,j+1,n^1}$. We set up equations of the form of equation 44 along the entire column i and solve by the Thomas algorithm (equations 21-34). We then repeat the procedure along all other columns, thus determining head values throughout the first iteration plane; these new head values constitute a somewhat closer approximation to the heads at time $n\Delta t$ than did the initial values. Next we set up a system of equations of the form of equation 42, arranged so that in each equation three head values from the first iteration plane and one from the $n-1$ time plane form the known terms, while three head values from the second iteration plane from the unknown terms. If we rewrite equation 42 in the expanded notation and rearrange it so that the unknown terms appear on the left and the known terms on the right we have

$$\frac{h_{i-1,j,n}^{m+1}}{(\Delta x)^2} + \frac{h_{i+1,j,n}^{m+1}}{(\Delta x)^2} - \left(\frac{S}{T\Delta t} + \frac{2}{(\Delta x)^2} \right) h_{i,j,n}^{m+1} = \frac{h_{i,j-1,n}^m}{(\Delta y)^2} - \frac{h_{i,j+1,n}^m}{(\Delta y)^2} + \frac{2}{(\Delta y)^2} h_{i,j,n}^m - \frac{S}{T\Delta t} h_{i,j,n-1} \quad (46)$$

Applying equation 46 between the first and second iteration planes, m would be taken as 1 and $(m+1)$ as 2. The four known terms on the right side of the equation would consist of three head values from the first iteration plane $h_{i,j-1,n}$, $h_{i,j,n}$, and $h_{i,j+1,n}$, and again one head value from the $n-1$ time plane, $h_{i,j,n-1}$. It is important to note that we return to the $n-1$ time plane—the lowermost plane in figure G—at each iteration level in the series, to pick up the constant values of $h_{i,j,n-1}$ that are used in simulating the time derivative. On the left side of equation 46 we would have the three unknown values of head corresponding to the new iteration level—that is, the second iteration plane). Again we would use the Thomas algorithm (equations 21-34) to solve for these new values of head throughout the plane. At the end of this solution procedure the head values in the second iteration plane are compared with those in the first iteration plane. If the difference is sufficiently small at all points, there is nothing to be gained by continuing to adjust the head values through further calculation—equation 3 is already approximately satisfied throughout the plane. If significant differences are noted, the procedure is continued until the differences between the head values obtained in successive iteration levels becomes negligible. At this point the heads for time $n\Delta t$ have been determined, and work is started on the next time step, computing heads for the time $(n+1)\Delta t$. Thus while direct solution and an alternating-direction feature both play a part in this procedure of calculation, the technique is basically one of iteration, in which, using the backward-difference formulation of equations 5 or 13, we progressively adjust head values for each time level until we arrive at a set of values which satisfies the equation. The method combines the advantages of the backward-

difference technique with the ease of computation of the alternating-direction procedure; it is the basis of many of the digital models presently used by the U.S. Geol. Survey. It is sometimes referred to as the iterative alternating-direction implicit procedure.

Prickett and Lonquist (1971) further modify this method of calculation by representing the central head value, $h_{i,j}$ only at the advanced iteration level; and by representing the head in the adjacent, previously processed column also at the advanced iteration level. That is, they do not simulate $\partial^2 h / \partial x^2$ and $\partial^2 h / \partial y^2$ in two distinct iteration planes, but rather set up the calculation as a relaxation technique, so that the new value of head at a given node is calculated on the basis of the most recently computed values of head in the surrounding nodes. They do, however, perform the calculations alternately along rows and columns using the Thomas algorithm.

In the discussions presented here we have treated transmissivity, storage coefficient, and the node spacings Δx and Δy , as constant terms in the x, y plane. In fact these terms can be varied through the mesh to account for heterogeneity or anisotropy in the aquifer or to provide a node spacing which is everywhere suited to the needs of the problem. Additional terms can be inserted into the equations to account for such things as pumpage from wells at specified nodes, retrieval of evapotranspiration loss, seepage into streams, and so on. Some programs have been developed which simulate three-dimensional flow (Freeze, 1971; Bredehoeft and Pinder, 1970; Prickett and Lonquist, 1971, p. 46); however, the operational problems encountered in three-dimensional digital modeling are sometimes troublesome.

The reader may now proceed to the programmed instruction of Part VIII.

Part VIII. Analog Techniques

Introduction

In Part VIII we consider another technique of obtaining solutions to the differential equation of ground-water flow. This is the method of the electric analog. It is a powerful technique which has been widely used. The technique depends upon the mathematical similarity between Darcy's law, describing flow in a porous medium, and Ohm's law, describing flow of charge in a conductor. In

the case of nonequilibrium modeling, it depends also upon the similarity between the ground-water storage-head relation and the equation describing storage of charge in a capacitor; and upon the similarity between the electrical continuity principle, involving the conservation of electric charge, and the equation of continuity describing the conservation of matter.

Ohm's law states that the electrical current through a conducting element is directly proportional to the voltage difference, or potential difference across its terminals. The sketch represents a conducting element, or resistor, across which the voltage difference is $\phi_1 - \phi_2$. That is, the voltage at one terminal of the resistor is ϕ_1 , while that at the other end is ϕ_2 . The current through the resistor is defined as the net rate of movement of positive charge across a cross-sectional plane within the resistor, taken normal to the direction of charge flow. The standard unit of charge is the coulomb, and current is normally measured as the number of coulombs per second crossing the plane under consideration. A charge flow of 1 coulomb per second is designated 1 ampere. The symbol I is frequently used to represent current.

Symbol representing a conducting element, or resistor

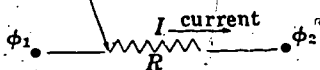

R represents value of resistance (ohms)

For the resistor shown in the diagram, Ohm's law may be stated as follows

$$I = \frac{1}{R}(\phi_1 - \phi_2)$$

where I is the current through the resistor, and $\phi_1 - \phi_2$, as noted above, is the voltage difference across its terminals. The term $1/R$ is the constant of proportionality relating current to voltage; R is termed the resistance of the element. It depends both upon the dimensions of the element and the electrical properties of the conductive material used. The unit of resistance is the ohm. A resistance of 1 ohm will carry 1 ampere of current under a potential difference of 1 volt.

QUESTION

Suppose the voltage at one terminal of a 500-ohm resistor is 17 volts, and the voltage at the other terminal is 12 volts. What would the current through the resistor be?

Turn to Section:

- | | |
|----------------------------------|----|
| 10 amperes | 19 |
| 0.10 ampere, or 100 milliamperes | 8 |
| 0.01 ampere, or 10 milliamperes | 6 |

2.

Your answer in Section 22 is not correct. The finite-difference form of the equation for two-dimensional nonequilibrium groundwater flow is

$$h_1 + h_2 + h_3 + h_4 - 4h_0 = \frac{Sa^2 \Delta h_0}{T \Delta t},$$

while the equation for our resistance-capacitance network is

$$\phi_1 + \phi_2 + \phi_3 + \phi_4 - 4\phi_0 = RC \frac{d\phi_0}{dt}.$$

Comparison of these equations illustrates that resistance, R , may be considered to be analogous to the term $1/T$; voltage, ϕ , is analogous to head, h ; and capacitance, C , may be considered analogous to the term Sa^2 .

In the answer which you selected, voltage is treated as analogous to transmissivity, in that the procedure calls for increasing voltage in areas of high transmissivity.

Return to Section 22 and choose another answer.

3.

Your answer in Section 6,

$$I = \frac{A}{RL} (\phi_1 - \phi_2),$$

is not correct. The idea here is to obtain an expression for the current which involves the resistivity, ρ_c , of the material composing the resistance. Your answer involves the resistance, R , rather than the resistivity. It is

not a valid statement of Ohm's law in any case, for Ohm's law in terms of resistance was given in Section 1 as

$$I = \frac{1}{R} (\phi_1 - \phi_2).$$

Return to Section 6 and choose another answer.

4.

Your answer in Section 9,

$$\frac{1}{R} (\phi_1 - \phi_c) = C \frac{d\phi_c}{dt},$$

is correct. The quantity C , as we have seen, is actually the derivative $d\epsilon/d\phi_c$; thus $C(d\phi_c/dt)$ is equivalent to $(d\epsilon/d\phi_c) \cdot (d\phi_c/dt)$, or simply $d\epsilon/dt$.

Without referring to it explicitly, we made use in Section 9 of an electrical equivalent to the hydraulic equation of continuity. In an electric circuit, charge is conserved in the same way that fluid mass is conserved in a hydraulic system. Kirchoff's current law, which is familiar to students of elementary physics, is a statement of this principle. In the circuit of Section 9, we required that the rate of accumulation of charge in the capacitor

be equal to the time rate at which charge was transported to the capacitor plate through the resistor—that is, to the current through the resistor. In the circuit

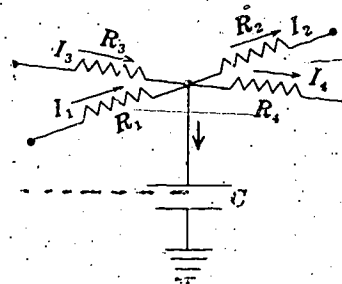

shown in the figure, in which four resistors are connected to a single capacitor, the net

Con.—4•

inflow minus outflow of charge, through all four resistors, must equal the rate of accumulation of charge on the capacitor. Let I_1 and I_3 represent currents toward the capacitor, through resistors R_1 and R_3 ; and let I_2 and I_4 represent currents away from the capacitor, through resistors R_2 and R_4 . Then the time rate of inflow of charge, toward the capacitor, will be $I_1 + I_3$; the rate of outflow charge, away from the capacitor, will be $I_2 + I_4$. The net inflow minus outflow of charge will be $I_1 - I_2 + I_3 - I_4$; and this must equal the rate of accumulation of charge on the capacitor. That is, we must have

$$I_1 - I_2 + I_3 - I_4 = \frac{d\epsilon}{dt}$$

QUESTION

The diagram again shows the circuit described above, but we now assume that the

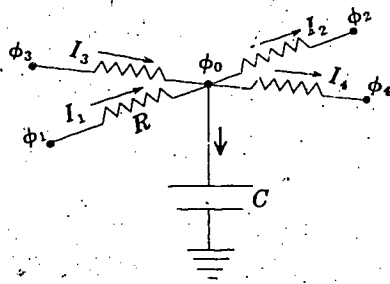

four resistances are equal—that is, we assume

$$R_1 = R_2 = R_3 = R_4 = R.$$

Let ϕ_0 represent the voltage on the capacitor plate—this is essentially equal to the voltage at the junction point of the four resistors (the resistance of the wire connecting the capacitor to the resistor junction point is assumed negligible). The voltages at the extremities of the four resistors are designated ϕ_1 , ϕ_2 , ϕ_3 , and ϕ_4 , as shown in the diagram. If Ohm's law is applied to obtain an expression for the current through each resistor and the capacitor equation is applied to obtain an expression for the rate of accumulation of charge on the capacitor, which of the following equations will be obtained from our circuit equation

$$I_1 - I_2 + I_3 - I_4 = \frac{d\epsilon}{dt} ?$$

Turn to Section:

$$\frac{\phi_1 - \phi_2 + \phi_3 - \phi_4}{R} = C \frac{d\phi_0}{dt} \quad 15$$

$$\frac{1}{C} (\phi_1 - \phi_2 + \phi_3 - \phi_4 + \phi_0) = R \frac{d\phi_0}{dt} \quad 27$$

$$\phi_1 + \phi_2 + \phi_3 + \phi_4 - 4\phi_0 = RC \frac{d\phi_0}{dt} \quad 22$$

5•

Your answer in Section 22 is correct. This is of course one indication of the power of the analog method, in that problems involving heterogeneous aquifers are handled as easily as those involving a uniform aquifer. Complex boundary conditions can also be accommodated, and three-dimensional problems may be approached by constructing networks of several layers. The method is applicable to water-table aquifers as well as to confined aquifers, provided dewatering

is small in relation to total saturated thickness. Some successful simulation has been done even for cases in which this condition is not satisfied, using special electrical components which vary in resistance as voltage changes.

Steady-state problems are sometimes handled by network models constructed solely of resistors—that is, not involving capacitors—rather than by analogs constructed of a continuous conductive mate-

5 • —Con.

rial. Such steady-state networks are particularly useful when heterogeneity is involved.

In some cases, the symmetry of a ground-water system may be such that a two-dimensional analog in a vertical plane—that is, representing a vertical cross section through an aquifer, or series of aquifers—may be more useful than a two-dimensional analog representing a map view. In this type of model, anisotropy is frequently a factor; that is, permeability in the vertical direction is frequently much smaller than that in the lateral direction. This is easily accommodated in a network by using higher resistances in the vertical direction; or, equivalently, by using a uniform resistance value but distorting the scales of the model, so that this resistance value is used to simulate different distances and cross-sectional areas of flow in the two directions.

An important special type of network analog is that used to simulate conditions in a vertical plane around a single discharging well. The cylindrical symmetry of the discharging well problem is in effect built into the network; the resistances and scales of

the model are chosen in such a way as to simulate the increasing cross-sectional areas of flow, both vertically and radially, which occur in the aquifer with increasing radial distance from the well.

This concludes our discussion of the electric-analog approach. We have given here only a brief outline of some of the more important principles that are involved. The technique is capable of providing insight into the operation of highly complex ground-water systems. Further discussion of the principles of simulation may be found in the text by Karplus (1958). The book "Concepts and Models in Ground-Water Hydrology" by Domenico (1972) contains a discussion of the application of analog techniques to ground water, as does the text "Ground-Water Resource Evaluation" by Walton (1970). Additional discussions may be found in papers by Skibitzke (1960), Brown (1962), Stallman (1963b), Patten (1965), Bedinger, Reed, and Swafford (1970), and many others.

This concludes the studies presented in this text.

6 •

Your answer in Section 1 is correct.

The resistance of an electrical element is given by the formula

$$R = \rho_e \frac{L}{A}$$

where L is the length of the element in the direction of the current, A is its cross-sectional area normal to that direction, and ρ_e is the electrical *resistivity* of the material of which the resistor is composed. The inverse of the resistivity is termed the *conductivity* of the material; it is often designated σ ; that is, $\sigma = 1/\rho_e$. Resistivity and conductivity are

normally taken as constants characteristic of a particular material; however, these properties vary with temperature, and the linear relationships usually break down at extremes of voltage. Moreover, a small change in the composition of some materials can produce a large change in electrical properties. Resistivity is commonly expressed in units of ohm-metre²/metre, or ohm-metres. With this unit of resistivity, the formula,

$$R = \rho_e \frac{L}{A}$$

Con.-6

will yield resistance in ohms if length is expressed in metres and area in square metres.

QUESTION

The sketch shows a resistor of cross-sectional area A and length L , composed of a

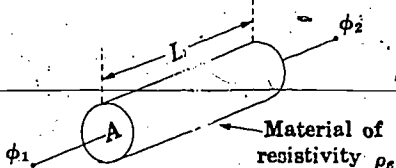

material of resistivity ρ_c . The potential difference across the resistor is $\phi_1 - \phi_2$. Which of the following expressions is a valid expression of Ohm's law, giving the current through the resistor?

Turn to Section:

$I = \frac{A}{\rho_c L} (\phi_1 - \phi_2)$ 28

$I = \frac{\rho_c A}{L} (\phi_1 - \phi_2)$ 24

$I = \frac{A}{RL} (\phi_1 - \phi_2)$ 3

7

Your answer in Section 28,

$$Q = \frac{K}{A_p} \frac{L_p}{h_1 - h_2}$$

is not correct. Darcy's law states that flow is directly proportional to cross-sectional area and to the (negative) gradient of head. In

the answer which you chose, flow is given as inversely proportional to cross-sectional area, and proportional to the term $L_p/h_1 - h_2$, which is actually the inverse of the negative head gradient.

Return to Section 28 and choose another answer.

8

Your answer in Section 1 is not correct. Ohm's law was given as

$$I = \frac{1}{R} (\phi_1 - \phi_2),$$

and the discussion pointed out that a resistance of 1 ohm would carry a current of 1 ampere under a potential difference of 1 volt. Thus when the voltage difference is ex-

pressed in volts and the resistance ohms, the quotient

$$\frac{\phi_1 - \phi_2}{R}$$

will give the correct current in amperes.

Return to Section 1 and choose another answer.

9.

Your answer in Section 21 is correct.

If we monitor the voltage on a capacitor plate in a given circuit and observe that it is changing with time, we know from the relations given in Section 21 that charge is accumulating on the capacitor plate with time. An expression for the rate at which charge is accumulating can be obtained by dividing the capacitor equation by a time increment, Δt . This gives

$$\frac{\Delta \epsilon}{\Delta t} = C \frac{\Delta \phi}{\Delta t}$$

or, in terms of derivatives,

$$\frac{d\epsilon}{dt} = C \frac{d\phi}{dt}$$

The figure shows a hydraulic system and an analogous electrical system. The rate of

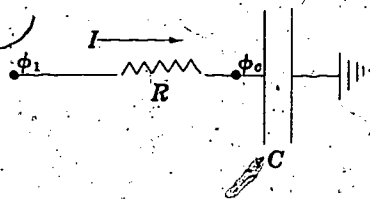
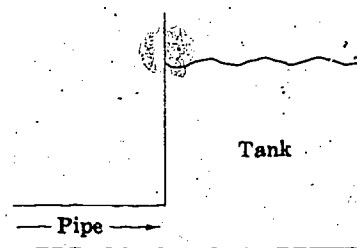

accumulation of fluid in the tank is equal to the rate of flow of water through the pipe supplying it. Similarly, the rate of accumulation of charge on the capacitor plate is equal to the rate of flow of charge through the resistor connected to the plate. This rate of flow of charge is by definition the current through the resistor. (Recall that the units of current are charge/time—for example, coulombs/second.) We thus have

$$I = \frac{d\epsilon}{dt}$$

where I is the current through the resistor, and $d\epsilon/dt$ is the rate at which charge accumulates on the capacitor.

QUESTION

Suppose the voltage at the left terminal of the resistor is ϕ_1 , while the voltage at the right terminal, which is essentially the voltage on the capacitor plate, is ϕ_c . If we use Ohm's law to obtain an expression for I , in terms of the voltages, and the capacitor equation to obtain an expression for $d\epsilon/dt$, which of the following relations will we obtain. (R denotes the resistance of the resistor, and C the capacitance of the capacitor.)

Turn to Section:

$$\frac{1}{R}(\phi_1 - \phi_c) = C \frac{d\phi_c}{dt} \quad 4$$

$$R(\phi_c - \phi_1) = C \frac{d\phi_c}{dt} \quad 20$$

$$RC(\phi_c - \phi_1) = \frac{d\phi_c}{dt} \quad 18$$

10

Your answer in Section 21 is not correct. The equation which we developed for the capacitor was

$$C = \frac{\Delta \epsilon}{\Delta \phi}$$

where C was the capacitance, $\Delta \epsilon$ the quantity of charge placed in storage in the capacitor, and $\Delta \phi$ the increase in the voltage difference across the capacitor plates, observed as the charge $\Delta \epsilon$ is accumulated. For the prism of aquifer used in developing the ground-water equations in Part V, we had

$$\Delta V = SA \Delta h$$

where ΔV was the volume of water taken into storage in the prism, Δh the increase in head associated with this accumulation in storage, S the storage coefficient, and A the base area of the prism. This equation can be rewritten

$$SA = \frac{\Delta V}{\Delta h}$$

to facilitate comparison with the capacitor equation.

Return to Section 21 and choose another answer.

11

Your answer in Section 26 is correct. Note that this equation,

$$\frac{I}{w \cdot b} = -\sigma \frac{\partial \phi}{\partial x}$$

is analogous to the equation we would write for the component of specific discharge in the x direction, through a section of aquifer of width w and thickness b ; that is,

$$\frac{Q}{w \cdot b} = -K \frac{\partial h}{\partial x}$$

In practice, steady-state electric-analog work may be carried out by constructing a scale model of an aquifer from a conductive material and applying electrical boundary conditions similar to the hydraulic boundary conditions prevailing in the ground-water system. The voltage is controlled at certain points or along certain boundaries of the model, in proportion to known values of head at corresponding points in the aquifer; and

current may be introduced or withdrawn in proportion to known values of inflow and outflow for the aquifer. When the boundary conditions are applied in this manner, voltages at various points of the model are proportional to heads at corresponding points in the aquifer, and the current density vector in various sections of the model is proportional to the specific-discharge vector in the corresponding sections of the aquifer.

QUESTION

Suppose an analog experiment of this type is set up, and the experimenter traces a line in the model along which voltage has some constant value. To which of the following hydrologic features would this line correspond?

Turn to Section:

- | | |
|----------------------------|----|
| a flowline | 16 |
| a line of constant head | 21 |
| a line of uniform recharge | 17 |

12 •

Your answer in Section 28,

$$Q = -K \frac{\partial^2 h}{\partial x^2} A_p,$$

is not correct. Darcy's law states that flow is equal to the product of hydraulic conductivity, cross-sectional area, and (negative) head gradient. The gradient of head is

by definition a first derivative—the derivative of head with respect to distance. The answer which you chose involves a second derivative. The correct answer must either include a first derivative, or an expression equivalent to or approximating a first derivative.

Return to Section 28 and choose another answer.

13 •

Your answer in Section 21 is not correct. We have seen in dealing with the analogy between steady-state electrical flow and steady-state ground-water flow that voltage is analogous to hydraulic head, whereas current, or rate of flow of charge, is analogous to the volumetric rate of flow of fluid. In the analogy between the capacitor equation and the storage-head relation, voltage must still be analogous to head, or capacitors

could not be used to represent storage in a model incorporating the flow analogy between Darcy's law and Ohm's law. Similarly, charge must represent fluid volume, so that rate of flow of charge (current) can represent volumetric fluid discharge. Otherwise the storage-capacitance analogy would be incompatible with the flow analogy.

Return to Section 21 and choose another answer.

14 •

Your answer in Section 22 is not correct. Increasing both R and C , as suggested in the answer which you chose, has the effect of increasing the factor RC in the equation

$$\phi_1 + \phi_2 + \phi_3 + \phi_4 - 4\phi_0 = RC \frac{d\phi_0}{dt}$$

On the other hand, an increase in T in the aquifer causes the factor Sa^2/T to decrease, in the equation

$$h_1 + h_2 + h_3 + h_4 - 4h_0 = \frac{Sa^2}{T} \frac{\Delta h}{\Delta t}$$

Thus the proposed technique fails to simulate the hydrologic system.

Notice that head and voltage are analogous and that increases in T can be simulated by decreases in R .

Return to Section 22 and choose another answer.

15.

Your answer in Section 4 is not correct. The rate of accumulation of charge on the capacitor plate must equal the net rate at which charge is being transported to the capacitor through the four resistors. To set up the problem, we assume that the current is toward the capacitor in resistors 1 and 3, and away from the capacitor in resistors 2 and 4 in the diagram. The current toward the capacitor in resistor 1 is given by Ohm's law as

$$I_1 = \frac{1}{R}(\phi_1 - \phi_0),$$

while that in resistor 3 is given by

$$I_3 = \frac{1}{R}(\phi_3 - \phi_0).$$

The current away from the capacitor in resistor 2 is given by

$$I_2 = \frac{1}{R}(\phi_0 - \phi_2),$$

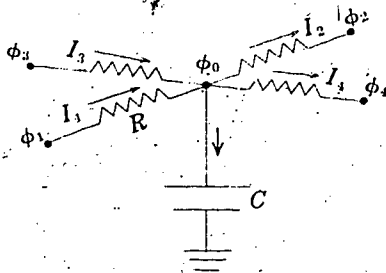

while that in resistor 4 is given by

$$I_4 = \frac{1}{R}(\phi_0 - \phi_4).$$

If it turns out that any of these currents are not actually in the direction initially assumed, the current value as computed above will be negative; thus the use of these expressions remains algebraically correct whether or not the assumptions regarding current direction are correct.

The net rate of transport of charge toward the capacitor will be the sum of the inflow currents minus the sum of the outflow currents, or

$$I_1 + I_3 - I_2 - I_4.$$

This term must equal the rate of accumulation of charge on the capacitor plate, $d\epsilon/dt$,

$$\frac{d\epsilon}{dt} = C \frac{d\phi_0}{dt}.$$

That is we must have

$$I_1 + I_3 - I_2 - I_4 = C \frac{d\phi_0}{dt}.$$

The correct answer to the question of Section 4 can be obtained by substituting our expressions for I_1 , I_2 , I_3 , and I_4 into this equation and rearranging the result.

Return to Section 4 and choose another answer.

16.

Your answer in Section 11 is not correct. In steady-state two-dimensional flows, one can specify a function which is constant along a flowline. However, this function—which is termed a stream function—is not analogous to voltage (potential) in electrical theory; thus a flowline, or line along which stream function is constant, cannot correspond to an equipotential, or line along

which voltage is constant. In developing the analogy between flow of electricity and flow of fluid through a porous medium, we stressed that voltage is analogous to head; current is analogous to fluid discharge; and electrical conductivity is analogous to hydraulic conductivity.

Return to Section 11 and choose another answer.

17

Your answer in Section 11 is not correct. The forms of Darcy's law and Ohm's law which we have used for comparison are repeated below:

Darcy's law:

$$\frac{Q}{w \cdot b} = -K \frac{\partial h}{\partial x}$$

where Q is the volumetric fluid discharge through a cross-sectional area of width w and thickness b , taken at right angles to the x direction; K is the hydraulic conductivity; and $\partial h / \partial x$ is the derivative of head in the x direction.

Ohm's law:

$$\frac{I}{w \cdot b} = -\sigma \frac{\partial \phi}{\partial x}$$

where I is the current through a cross-sectional area of width w and thickness b , taken at right angles to the x direction; σ is the electrical conductivity; and $\partial \phi / \partial x$ is the derivative of voltage, or potential, in the x direction.

A comparison of these equations shows that voltage, or potential, ϕ , occupies a position in electrical theory exactly parallel to head, h , in the theory of ground-water flow. Current, I , is analogous to discharge, Q ; while σ , the electrical conductivity, is analogous to the hydraulic conductivity, K . These parallels should be kept in mind in answering the question of Section 11.

Return to Section 11 and choose another answer.

18

Your answer in Section 9 is not correct. The question concerns a capacitor which is connected to a resistor. The idea is to equate the rate of accumulation of charge on the capacitor plate to the rate at which charge is carried to the capacitor through the resistor—that is, to the current through the resistor. The rate at which charge accumulates on the capacitor plate is given by the capacitor equation as

$$\frac{d\epsilon}{dt} = C \frac{d\phi_c}{dt}$$

The current through the resistor, or rate at which charge flows through the resistor, is given by Ohm's law as

$$I = \frac{1}{R} (\phi_1 - \phi_c)$$

Return to Section 9 and choose another answer.

19

Your answer in Section 1 is not correct. Ohm's law was given in the form

$$I = \frac{1}{R} (\phi_1 - \phi_2)$$

If R is in ohms and the difference $\phi_1 - \phi_2$ is

in volts, current, I will be in amperes. In the example given, $\phi_1 - \phi_2$ was 5 volts and R was 500 ohms. Substitute these values in the equation to obtain the amount of current through the resistor.

Return to Section 1 and choose another answer.

20.

Your answer, in Section 9,

$$R(\phi_c - \phi_1) = C \frac{d\phi_c}{dt},$$

is not correct. The rate of accumulation of charge on the capacitor, $d\epsilon/dt$, is equal to $C(d\phi_c/dt)$, and this part of your answer is correct. However, the idea is to equate this rate of accumulation of charge on the capacitor to the rate of transport of the charge

toward the capacitor, through the resistor—that is, to the current through the resistor. This current is to be expressed in terms of resistance and voltage, using Ohm's law; and this has not been done correctly in the answer which you chose. Ohm's law states that the current through a resistance is equal to the voltage drop across the resistance divided by the value of the resistance in ohms.

Return to Section 9 and choose another answer.

21.

Your answer in Section 11 is correct. The line of constant voltage, or equipotential line, is analogous to the line of constant head in ground-water hydraulics.

The analogy between Darcy's law and Ohm's law forms the basis of steady-state electric-analog modeling. In recent years, the modeling of nonequilibrium flow has become increasingly important; and just as Darcy's law alone is inadequate to describe nonequilibrium ground-water flow, its analogy with Ohm's law is in itself an inadequate basis for nonequilibrium modeling. The theory of nonequilibrium flow is based upon a combination of Darcy's law with the storage equation, through the equation of continuity. To extend analog modeling to nonequilibrium flow, we require electrical equations analogous to the storage and continuity equations.

The analog of ground-water storage is provided by an electrical element known as a capacitor. The capacitor is essentially a storage tank for electric charge; in circuit diagrams it is denoted by the symbol shown in figure A. As the symbol itself suggests, capacitors can be constructed by inserting two parallel plates of conductive material into a circuit, as shown in figure B. When the switch is closed, positive charge flows from the battery to the upper plate and ac-

cumulates on the plate in a manner analogous to the accumulation of water in a tank. At the same time, positive charge is drawn from the lower plate, leaving it with a net negative charge. Figure C shows a hydraulic circuit analogous to this simple capacitor circuit; when the valve is opened, the pump delivers water to the left-hand tank, draining the right-hand tank. If the right-hand tank is connected in turn to an effectively limitless water supply, as shown in figure D, both the volume of water and the water level in the right-hand tank will remain essentially constant, while water will still accumulate in the left-hand tank as the pump operates. The analogous electrical arrangement is shown in figure E; here the additional symbol shown adjacent to the lower plate indicates that this plate has been grounded—that is, connected to a large mass of metal buried in the earth, which in effect constitutes a limitless reserve of charge. In this situation, the quantity of charge on the lower plate remains essentially constant, as does the voltage on this plate, but the battery still causes positive charge to accumulate on the upper plate. The voltage on the lower plate is analogous to the water level in the right-hand tank, which is held constant by connection to the unlimited water supply.

21 • —Con.

FIGURE A

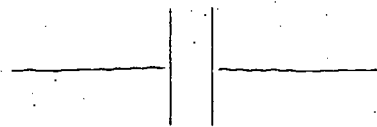

FIGURE B

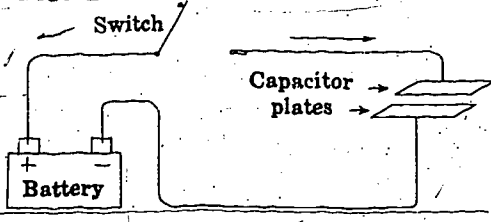

FIGURE C

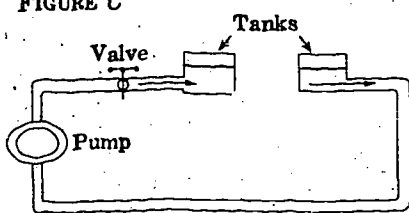

FIGURE D

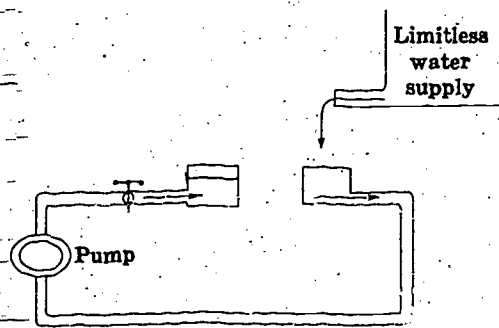
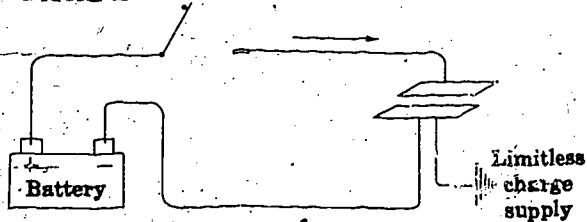

FIGURE E



In a circuit such as that shown in figure E, it is customary to designate the constant voltage of the ground plate as zero. This is done arbitrarily—it is equivalent for example, to setting head equal to zero at the constant water level of the right-hand tank of figure D. With the voltage of the grounded plate taken as zero, the voltage difference between the plates becomes simply the voltage, ϕ , measured on the upper plate. In the circuit of figure E, this voltage is equal to the voltage produced by the battery.

Now suppose an experiment is run in which the battery in the circuit of figure E is replaced in turn by batteries of successively higher voltage. At each step the charge on the positive plate is measured in some way, after the circuit has reached equilibrium. The results will show that as the applied voltage is increased, the charge which accumulates on the positive plate increases in direct proportion. If a graph is constructed from the experimental results in which the charge, ϵ , which has accumulated on the positive plate is plotted versus the voltage in each step, the result will be a straight line, as shown in the figure. The slope of this line, $\Delta\epsilon/\Delta\phi$, is termed the capacitance of the capacitor, and is designated C ; that is,

$$C = \frac{\Delta\epsilon}{\Delta\phi}, \quad C = \frac{d\epsilon}{d\phi}$$

or simply

$$C = \frac{\epsilon}{\phi}$$

Capacitance is measured in farads; or more commonly in microfarads; a farad is equal to 1 coulomb per volt.

These equations serve to define the operation of a capacitor and provide the analog we require for the equation of ground-water storage. It will be recalled that the relation between volume in storage and head can be written

$$\Delta V = S \cdot A \cdot \Delta h$$

Con.—21•

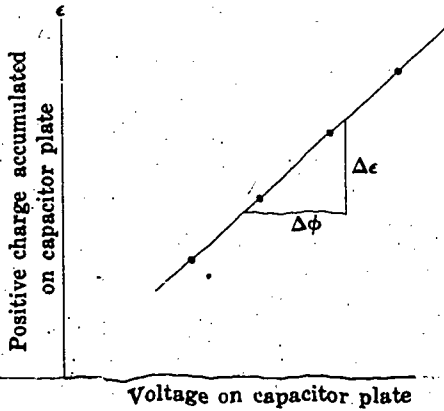

QUESTION

Which of the following statements correctly describes the analogy between the capacitor equation and the ground-water-storage—head relation?

Turn to Section:

Charge is analogous to head, voltage is analogous to volume of water, and capacitance, C , is analogous to the factor SA . 13

Charge is analogous to volume of water, voltage is analogous to head, and capacitance, C , is analogous to the factor SA . 9

Charge is analogous to volume of water, voltage is analogous to head, and capacitance, C , is analogous to the factor

$$\frac{1}{SA} \quad 10$$

where ΔV is the volume of water taken into or released from storage in a prism of aquifer of base area A , as the head changes by an amount Δh .

22•

Your answer in Section 4,

$$\phi_1 + \phi_2 + \phi_3 + \phi_4 - 4\phi_0 = RC \frac{d\phi_0}{dt}$$

is correct. In Part VII, we obtained a finite-difference approximation to the differential equation for two-dimensional non-steady-state ground-water flow,

$$\frac{\partial^2 h}{\partial x^2} + \frac{\partial^2 h}{\partial y^2} = \frac{S}{T} \frac{\partial h}{\partial t}$$

This approximation can be written

$$\frac{h_1 + h_2 + h_3 + h_4 - 4h_0}{a^2} = \frac{S}{T} \frac{\Delta h_0}{\Delta t}$$

or

$$h_1 + h_2 + h_3 + h_4 - 4h_0 = \frac{Sa^2}{T} \frac{\Delta h_0}{\Delta t}$$

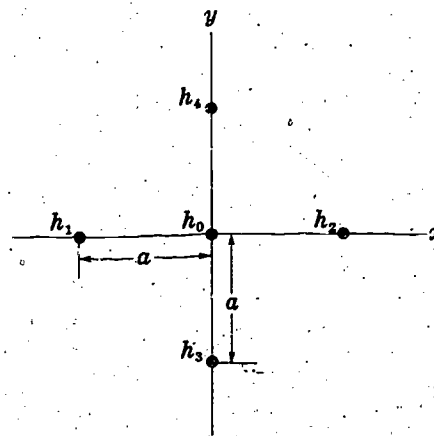

22 • — Con.

where $h_0, h_1, h_2, h_3,$ and h , represent the head values at the nodes of an array such as that shown in the sketch; a is the node spacing; S is storage coefficient; T is transmissivity; and $\Delta h_0/\Delta t$ represents the rate of change of head at the central node. The circuit equation which we have just obtained is directly analogous to this finite-difference form of the ground-water equation, except for the use of the time derivative notation $d\phi_0/dt$ as opposed to the finite-difference form, $\Delta h_0/\Delta t$. In other words, the circuit element composed of the four resistors and the capacitor behaves in approximately the same way as the prism of confined aquifer which was postulated in developing the ground-water equations. It follows that a network composed of circuit elements of this type, such as that shown in the figure, should behave

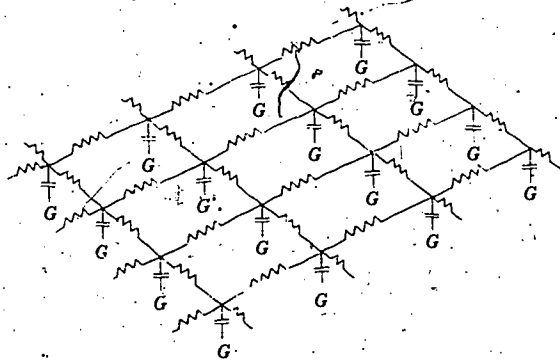

G indicates grounded terminal

in the same way as a two-dimensional confined aquifer of similar geometry. The non-equilibrium behavior of such an aquifer may be studied by constructing a model of the aquifer, consisting of a network of this type; electrical boundary conditions similar to the observed hydraulic boundary conditions are imposed on the model, and voltage is monitored at various points in the network as a function of time. The voltage readings constitute, in effect, a finite-difference solution to the differential equation describing head

in the aquifer. The time scale of model experiments is of course much different from that of the hydrologic regime. A common practice is to use a very short time scale, in which milliseconds of model time may represent months in the hydrologic system. When time scales in this range are employed, the electrical excitations, or boundary conditions, are applied repeatedly at a given frequency, and the response of the system is monitored using oscilloscopes. The sweep frequency of each recording oscilloscope is synchronized with the frequency of repetition of the boundary-condition inputs, so that the oscilloscope trace represents a curve of voltage, or head, versus time, at the network point to which the instrument is connected.

QUESTION

Suppose we wish to model an aquifer in which transmissivity varies from one area to another, while storage coefficient remains essentially constant throughout the aquifer. Which of the following procedures would you consider an acceptable method of simulating this condition in a resistance-capacitance network analog?

Turn to Section:

Construct a network using uniform values of resistance and capacitance, but apply proportionally higher voltages in areas having a high transmissivity. 2

Construct a network in which resistance and capacitance are both increased in proportion to local increases in transmissivity. 14

Construct a network in which resistance is varied inversely with the transmissivity to be simulated, while capacitance is maintained at a uniform value throughout the network. 5

23.

Your answer in Section 26,

$$\frac{I}{w \cdot l} = -\sigma \frac{\partial \phi}{\partial z},$$

is not correct. The answer which you chose actually expresses the component of current density in the z direction. $w \cdot l$ is an area taken normal to the z direction. If I represents the current through this area, $I/w \cdot l$ will give the component of current density in the z direction; and this should equal $-\sigma$

times the directional derivative of voltage in the z direction, $\partial \phi / \partial z$. However, the question asked for the current density component in the x direction; and in fact, the problem stated that the current flow was two dimensional confined to the x, y plane. This implies that the current component in the vertical direction is zero, and thus that $\partial \phi / \partial z$ is zero as well.

Return to Section 26 and choose another answer.

24.

Your answer in Section 6 is not correct. Ohm's law was given in Section 1 as

$$I = \frac{1}{R} (\phi_1 - \phi_2)$$

where $\phi_1 - \phi_2$ is the voltage difference across a resistance, R , and I is the current through the resistance. In Section 6 the expression

$$R = \rho_e \frac{L}{A}$$

was given for the resistance, where ρ_e is the electrical resistivity of the material of which the resistance is composed; L is the length of the resistance, and A is its cross-sectional area. This expression for resistance should be substituted into the form of Ohm's law given above to obtain the correct answer.

Return to Section 6 and choose another answer.

25.

Your answer in Section 26;

$$\frac{I}{w \cdot l} = -\sigma \frac{\partial \phi}{\partial y},$$

is not correct. The component of current density in a given direction is defined as the charge crossing a unit area taken normal to that direction, in a unit time. Here we are concerned with the current density component in the x direction; we must accordingly use an area at right angles to the x direc-

tion. In your answer, the area is $w \cdot l$, which is normal to the z direction. Again, the component of current density in a given direction is proportional to the directional derivative of voltage in that direction. Since we are dealing with the component of current density in the x direction, we require the derivative of voltage in the x direction. The answer which you chose, however, uses the derivative of voltage with respect to y .

Return to Section 26 and choose another answer.

26

Your answer in Section 28 is correct. The term,

$$\frac{h_1 - h_2}{L_p}$$

is equivalent to the negative of the head gradient, $-\partial h/\partial x$, so that this formulation of Darcy's law is equivalent to those we have studied previously. Now let us compare this form of Darcy's law with Ohm's law.

Our expression for Darcy's law was

$$Q = K \frac{h_1 - h_2}{L_p} A_p$$

Our expression for Ohm's law in terms of electrical conductivity was

$$I = \sigma \frac{\phi_1 - \phi_2}{L} A$$

In terms of electrical resistivity, we obtained

$$I = \frac{1}{\rho} \frac{\phi_1 - \phi_2}{L} A$$

In these forms, the analogous quantities are easily identified. Voltage takes the place of head, current takes the place of fluid discharge and as noted in the preceding section σ , or $1/\rho$, takes the place of hydraulic conductivity. We note further that since current is defined as the rate of movement of electric charge across a given plane, while fluid discharge is the rate of transport of fluid volume across a given plane, electric charge may be considered analogous to fluid volume.

In Part II, we noted that Darcy's law could be written in slightly more general form as

$$q_x = \frac{Q_x}{A} = -K \frac{\partial h}{\partial x}$$

$$q_y = \frac{Q_y}{A} = -K \frac{\partial h}{\partial y}$$

and

$$q_z = \frac{Q_z}{A} = -K \frac{\partial h}{\partial z}$$

where q_x is the component of the specific-discharge vector in the x direction, or the discharge through a unit area at right angles to the x axis; q_y is the component of the specific-discharge vector in the y direction, and q_z is the component in the z direction. The three components are added vectorially to obtain the resultant specific discharge. $\partial h/\partial x$, $\partial h/\partial y$, and $\partial h/\partial z$ are the directional derivatives of head in the x , y , and z directions; and K is the hydraulic conductivity, which is here assumed to be the same in any direction. We may similarly write a more general form of Ohm's law, replacing the term $\phi_1 - \phi_2/L$ by derivatives of voltage with respect to distance, and considering components of the current density, or current per unit cross-sectional area, in the three space directions. This gives

$$\left(\frac{I}{A}\right)_x = -\frac{\sigma}{\rho} \frac{\partial \phi}{\partial x} = -\frac{1}{\rho} \frac{\partial \phi}{\partial x}$$

$$\left(\frac{I}{A}\right)_y = -\frac{\sigma}{\rho} \frac{\partial \phi}{\partial y} = -\frac{1}{\rho} \frac{\partial \phi}{\partial y}$$

$$\left(\frac{I}{A}\right)_z = -\frac{\sigma}{\rho} \frac{\partial \phi}{\partial z} = -\frac{1}{\rho} \frac{\partial \phi}{\partial z}$$

Here $(I/A)_x$ is the current through a unit area oriented at right angles to the x axis, $(I/A)_y$ is current through a unit area perpendicular to the y axis, and $(I/A)_z$ is the current through a unit area perpendicular to the z axis. These terms form the components of the current density vector. $\partial \phi/\partial x$, $\partial \phi/\partial y$, and $\partial \phi/\partial z$ are the voltage gradients, in units of volts/distance, in the three directions. These three expressions simply represent a generalization to three dimensions of the equation given in Section 1 as Ohm's law.

Con.—26.

QUESTION

The picture shows a rectangle in a conductive sheet, in which there is a two-dimensional flow of electricity. The flow is in the plane of the sheet, that is, the x, y plane; the thickness of the sheet is b , and the dimensions of the rectangle are l and w . Which of the following expressions gives the magnitude of the component of current density in the x direction?

Turn to Section:

$$\frac{I}{w \cdot b} = -\sigma \frac{\partial \phi}{\partial x} \quad 11$$

$$\frac{I}{w \cdot l} = -\sigma \frac{\partial \phi}{\partial y} \quad 25$$

$$\frac{I}{w \cdot l} = -\sigma \frac{\partial \phi}{\partial z} \quad 23$$

(I represents the current through the area utilized in the equation, $w \cdot b$ or $w \cdot l$.)

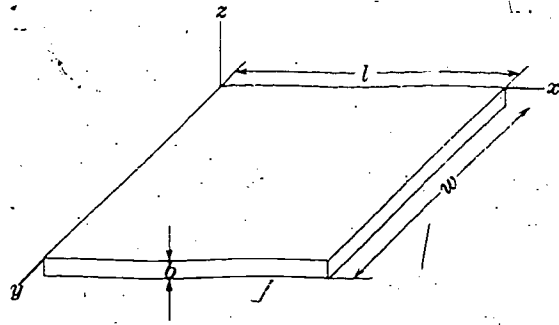

27.

Your answer in Section 4 is not correct. The essential idea here is that the rate of accumulation of charge on the capacitor must equal the net inflow minus outflow of charge through the four resistors. The inflow of charge through resistor 1 is the current through that resistor, and is given by Ohm's law as

$$I_1 = \frac{1}{R} (\phi_1 - \phi_0).$$

The outflow through resistor 2 is similarly given by

$$I_2 = \frac{1}{R} (\phi_3 - \phi_2).$$

The inflow through resistor 3 is

$$I_3 = \frac{1}{R} (\phi_3 - \phi_0),$$

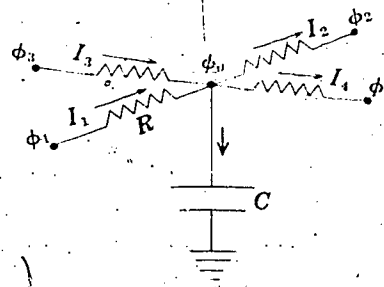

27 • —Con.

while the outflow through resistor 4 is

$$I_4 = \frac{1}{R}(\phi_0 - \phi_2).$$

The net inflow minus outflow of charge to the capacitor is

$$I_1 + I_3 - I_2 - I_4,$$

and this must equal the rate of accumulation of charge on the capacitor, $d\epsilon/dt$, that is

$$I_1 + I_3 - I_2 - I_4 = \frac{d\epsilon}{dt}.$$

According to the capacitor equation, $d\epsilon/dt$ is given by

$$\frac{d\epsilon}{dt} = C \frac{d\phi_0}{dt}.$$

The answer to the question of Section 4 can be obtained by substituting the appropriate expressions for I_1 , I_2 , I_3 , I_4 and $d\epsilon/dt$ into the relation

$$I_1 + I_3 - I_2 - I_4 = \frac{d\epsilon}{dt},$$

and rearranging the result.

Return to Section 4 and choose another answer.

28 •

Your answer in Section 6 is correct.

Electrical conductivity, or 1/resistivity, is the electrical equivalent of hydraulic conductivity. In terms of electrical conductivity, Ohm's law for the problem of Section 6 becomes

$$I = \frac{\sigma A}{L}(\phi_1 - \phi_2)$$

where σ is electrical conductivity.

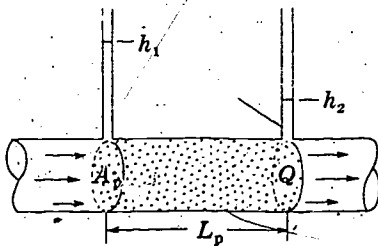

The analogy between Darcy's law and Ohm's law is easily visualized if we consider the flow of water through a sand-filled pipe, of length L_p and cross-sectional area A_p , as shown in the diagram. The head at the inflow end of the pipe is h_1 , while that at the outflow end is h_2 . The hydraulic conductivity of the sand is K .

QUESTION

Which of the following expressions is obtained by applying Darcy's law to this flow? (Q represents the discharge through the pipe.)

Turn to Section:

$$Q = -K \frac{\partial^2 h}{\partial x^2} A_p \quad 12$$

$$Q = K \frac{h_1 - h_2}{L_p} A_p \quad 26$$

$$Q = \frac{K}{A_p} \frac{L_p}{h_1 - h_2} \quad 7$$

References

- Bedinger, M. S., Reed, J. E., Wells, C. J., and Swafford, B. F., 1970, Methods and applications of electrical simulation in ground-water studies in the lower Arkansas and Verdigris River valleys, Arkansas and Oklahoma: U.S. Geol. Survey Water-Supply Paper 1971, 71 p.
- Boulton, N. S., 1954, The drawdown of the water table under nonsteady conditions near a pumped well in an unconfined formation: Proc. Civil Engineers (British), p. 564-579.
- Bredehoeft, J. D., and Pinder, G. F., 1970, Digital analysis of areal flow in multi-aquifer ground water systems: A quasi three-dimensional model: Water Resources Research, v. 6, no. 3, p. 883-888.
- Brown, R. H., 1962, Progress in ground water studies with the electric analog model: Am. Waterworks Assoc. Jour., v. 54, no. 8, p. 943.
- Cooper, H. H., 1966, The equation of ground water flow in fixed and deforming coordinates: Jour. Geophys. Research, v. 71, no. 20, p. 4785-4790.
- Cooper, H. H., Bredehoeft, J. D., and Papadopoulos, S. S., 1967, Response of a finite diameter well to an instantaneous charge of water: Water Resources Research, v. 3, no. 1.
- Cooper, H. H., and Jacob, C. E., 1946, A generalized graphical method of evaluating formation constants and summarizing well-field history: Am. Geophys. Union Trans., v. 27, no. 4, Aug. 1946, p. 526-534.
- Darcy, Henri, 1856, Les fontaines publiques de la ville de Dijon (The water supply of Dijon): Paris, Victor Dalmont, 647 p.
- Domenico, P. A., 1972, Concepts and models in ground water hydrology: New York, McGraw-Hill Book Co., 405 p.
- Dupuit, Jules, 1863, Etudes théoriques et pratiques sur le mouvement des eaux courantes (Theoretical and practical studies on the movement of running water): Paris, Carillon-Goery et V. Dalmont, 275 p.
- Ferris, J. G., 1959, Ground water, Chapter 6 in Wisler, C. O., and Brater, E. F., Hydrology (2d edition): New York, John Wiley and Sons.
- Ferris, J. G., and Knowles, D. B., 1963, The slug-injection test for estimating the transmissibility of an aquifer in Methods of determining permeability, transmissibility, and drawdown: U.S. Geol. Survey Water-Supply Paper 1536-I, 299 p.
- Ferris, J. G., Knowles, D. B., Brown, R. H., and Stallman, R. W., 1962, Theory of aquifer tests: U.S. Geol. Survey Water-Supply Paper 1536-E, 174 p.
- Forsythe, G. E., and Wasow, W. R., 1960, Finite difference methods for partial differential equations: New York, John Wiley and Sons.
- Freeze, R. A., 1971, Three-dimensional, transient, saturated-unsaturated flow in a ground water basin: Water Resources Research, v. 7, no. 2, p. 347-366.
- Hantush, M. S., 1959, Nonsteady flow to flowing wells in leaky aquifers: Jour. Geophys. Research, v. 64, no. 8, p. 1043.
- 1960, Modification of the theory of leaky aquifers: Jour. Geophys. Research, v. 65, no. 11, p. 3713-3725.
- 1967a, Flow of ground water in relatively thick leaky aquifers: Water Resources Research, v. 3, no. 2, p. 583.
- 1967b, Flow to wells in aquifers separated by a semipervious layer: Jour. Geophys. Research, v. 72, no. 6, p. 1709.
- Hantush, M. S., and Jacob, C. E., 1955, Nonsteady radial flow in an infinite leaky aquifer: Am. Geophys. Union Trans., v. 36, no. 1, p. 95.
- Hildebrand, F. B., 1968, Finite-difference equations and simulations: Englewood Cliffs, N.J., Prentice-Hall Inc., 338 p.
- Hubbert, A. K., 1940, The theory of ground-water motion: Jour. Geology, v. 48, no. 8, pt. 1, p. 935-944.
- Jacob, C. E., 1946, Radial flow in a leaky artesian aquifer: Am. Geophys. Union Trans., v. 27, no. 2, p. 198.
- 1950, Flow of ground water, Chapter 5 in Rouse, Hunter, Engineering Hydraulics: New York, John Wiley and Sons, 1039 p.
- 1963, Correction of drawdown caused by a pumped well tapping less than the full thickness of an aquifer in Methods of determining permeability, transmissibility, and drawdown: U.S. Geol. Survey Water-Supply Paper 1536-I, p. 272-282.
- Jacob, C. E., and Lohman, S. W., 1952, Nonsteady flow to a well of constant drawdown in an extensive aquifer: Am. Geophys. Union Trans., v. 33, no. 4, p. 559-569.
- Karplus, W. J., 1958, Analog simulation: New York, McGraw-Hill Book Co., 434 p.
- Lang, S. M., 1963, Drawdown patterns in aquifers having a straight line boundary in Shortcuts and special problems in aquifer tests: U.S. Geol. Survey Water-Supply Paper 1545-C.
- Muskat, M., 1937, The flow of homogeneous fluids through porous media: Ann Arbor, Mich., J. W. Edwards, Inc. [repr. 1946].

- Papadopoulos, S. S., and Cooper, H. H., 1967, Drawdown in a well of large diameter: *Water Resources Research*, v. 3, no. 1.
- Patten, E. P., 1965, Design, construction and use of electric analog models, in Wood, L. A., and Gabrysch, R. K., *Analog model study of ground water in the Houston District, Texas*: Texas Water Comm. Bull. 6568.
- Peaceman, D. W., and Rachford, H. H., 1955, The numerical solution of parabolic and elliptic differential equations: *Jour. Soc. Indust. Appl. Math.*, v. 3, no. 1, March, 1955.
- Pinder, G. F., and Bredehoeft, J. D., 1968, Applications of digital computer for aquifer evaluation: *Water Resources Research*, v. 4, no. 5, p. 1069-1093.
- Prickett, T. A., and Lonquist, G. C., 1971, Selected digital computer techniques for groundwater resource evaluation: *Illinois State Water Survey Bull.* 55, 62 p.
- 1973, Aquifer simulation model for use on disk supported small computer systems: *Illinois State Water Survey Circ.* 114, 21 p.
- Remson, Irwin, Appel, C. A., and Webster, R. A., 1965, Ground water models solved by digital computer: *Jour. Hydr. Div., Am. Soc. Civil Engineers*, v. 91, no. HY3, p. 133-147.
- Remson, Irwin, Hornberger, G. M., and Molz, F. J., 1971, *Numerical methods in ground water hydrology*: New York, Wiley Interscience Division, John Wiley and Sons, 389 p.
- Rubin, Jacob, 1968, Theoretical analysis of two-dimensional transient flow of water in unsaturated and partly unsaturated soils: *Soil Sci. Soc. America Proc.*, v. 32, no. 5, p. 607-615.
- Skibitzke, H. E., 1960, Electronic computers as an aid to the analysis of hydrologic problems: *Internat. Assoc. Scientific Hydrol. Pub.* 52, Comm. Subterranean waters, Gentbrugge, Belgium, p. 347.
- 1963, Determination of the coefficient of transmissibility from measurements of residual drawdown in a bailed well in *Methods of determining permeability, transmissibility, and drawdown*: U.S. Geol. Survey Water-Supply Paper 1536-I, p. 293.
- Slichter, C. S., 1899, Theoretical investigation of the motion of ground waters: U.S. Geol. Survey, 19th Ann. Rept., pt. 2, p. 295.
- Stallman, R. W., 1956, Numerical analysis of regional water levels to define aquifer hydrology: *Am. Geophys. Union Trans.*, v. 37, no. 4, p. 451-460.
- 1963a, Type curves for the solution of single boundary problems in Shortcuts and special problems in aquifer tests: U.S. Geol. Survey Water-Supply Paper 1545-C, p. 45-47.
- 1963b, Electric analog of three dimensional flow to wells and its application to unconfined flow: U.S. Geol. Survey Water-Supply Paper 1545-C, p. 38 p.
- Theis, C. V., 1935, The relation between the lowering of the piezometric surface and the rate and duration of discharge of a well using ground water storage: *Am. Geophys. Union Trans.*, pt. 2, Aug. 1935, p. 519-524.
- 1938, The significance and nature of the cone of depression in ground water bodies: *Econ. Geology*, v. 33, no. 8, p. 889-902.
- Thiem, Gunther, 1906, *Hydrologische methoden (Hydrologic methods)*: Leipzig, J. M. Gebhardt, 56 p.
- Thomas, L. H., 1949, Elliptic problems in linear differential equations over a network: Watson Scientific Computing Laboratory, Columbia Univ., N.Y.
- Truscott, P. C., 1973, Iterative digital model for aquifer evaluation: U.S. Geol. Survey open-file rept., June 1973, 63 p.
- Truscott, P. C., Pinder, G. F., and Jones, J. F., 1970, Digital model of alluvial aquifer: *Jour. Hydr. Div., Proc. Am. Soc. Civil Engineers*, HY 96, p. 1115-1128.
- Walton, W. C., 1970, *Ground water resource evaluation*: New York, McGraw-Hill Book Co., 264 p.
- Weeks, E. P., 1969, Determining the ratio of horizontal to vertical permeability by aquifer-test analysis: *Water Resources Research*, v. 5, no. 1, p. 196-214.