

DOCUMENT RESUME

ED 130 038

CE 008 231

AUTHOR Isaacson, Annette  
 TITLE You've Got It, Danny! Language Development in Graphic Arts.  
 INSTITUTION Rutgers, The State Univ., New Brunswick, N.J. Curriculum Lab.  
 SPONS AGENCY New Jersey State Dept. of Education, Trenton. Div. of Vocational Education.  
 PUB DATE Jun 76  
 NOTE 102p.; Page 59, containing two illustrations of bus schedules, will not reproduce well due to small, faint type  
 AVAILABLE FROM New Jersey Vocational-Technical Curriculum Laboratory, Bldg. 4103, Kilmer Campus, Rutgers University, New Brunswick, N. J. (\$2.50 plus postage)  
 EDRS PRICE MF-\$0.83 HC-\$6.01 Plus Postage.  
 DESCRIPTORS Elementary Education; \*Graphic Arts; Intermediate Grades; Job Application; \*Language Development; \*Learning Activities; Printing; \*Skill Development; Teaching Guides; Vocabulary Development

ABSTRACT

This language development activity book is for students who are being trained in one or more skills in the graphic arts industry. It can be used either as an introductory experience for beginning students or as a review for advanced students. Terms of the trade and related business vocabulary are introduced and reinforced through a 9-chapter story, seven sequential lessons on offset lithography procedures, a variety of language development exercises, and a glossary of over 140 graphic arts and business terms. It is suggested that the lessons pertaining to vocational skills be given in conjunction with the student's shop experience. A separate answer key section is provided. (SH)

\*\*\*\*\*  
 \* Documents acquired by ERIC include many informal unpublished \*  
 \* materials not available from other sources. ERIC makes every effort \*  
 \* to obtain the best copy available. Nevertheless, items of marginal \*  
 \* reproducibility are often encountered and this affects the quality \*  
 \* of the microfiche and hardcopy reproductions ERIC makes available \*  
 \* via the ERIC Document Reproduction Service (EDRS). EDRS is not \*  
 \* responsible for the quality of the original document. Reproductions \*  
 \* supplied by EDRS are the best that can be made from the original. \*  
 \*\*\*\*\*

ED130038

State of New Jersey  
Department of Education  
Division of Vocational Education

**YOU'VE GOT IT, DANNY!**

**LANGUAGE DEVELOPMENT IN GRAPHIC ARTS**

Prepared by:  
Annette Isaacson, Instructor

Neal B. Perkins, Superintendent  
Bergen County Vocational Schools  
Paramus, New Jersey

Vocational-Technical  
Curriculum Laboratory  
Rutgers - The State University  
Building 4103 - Kilmer Campus  
New Brunswick, New Jersey

June 1976

CF 008 231

**NEW JERSEY DEPARTMENT OF EDUCATION**

**FRED G. BURKE, COMMISSIONER**

**RALPH H. LATAILLE, DEPUTY COMMISSIONER**

**DIVISION OF VOCATIONAL EDUCATION**

**WILLIAM WENZEL, ASSISTANT COMMISSIONER (Acting)**

**JOHN E. RADVANY, DEPUTY ASSISTANT COMMISSIONER**

**HAROLD R. SELTZER, DEPUTY ASSISTANT COMMISSIONER (Acting)**

**BENJAMIN SHAPIRO, DIRECTOR, VOCATIONAL-CURRICULUM LABORATORY**

**CURRICULUM LABORATORY**

**RUTGERS – THE STATE UNIVERSITY**

**BUILDING 4103 – KILMER CAMPUS**

**NEW BRUNSWICK, NEW JERSEY**

## ACKNOWLEDGEMENTS

Paul Lehman Jr.  
Highway Printing Company  
Paramus, New Jersey

## INTRODUCTION

This language development activity book is for students who are being trained in one or more skills in the graphic arts industry. It can be used either as an introductory experience for beginning students or as a review for advanced students.

Terms of the trade and related business vocabulary are introduced and reinforced through a nine-chapter story, seven sequential lessons on offset lithography procedures, a variety of language development exercises, and a glossary of over 140 graphic arts and business terms.

Ideally, the lessons pertaining to vocational skills should be given in conjunction with the student's shop experience. For example, the lesson on platemaking could be given when the student is being taught this skill in his shop class.

## TABLE OF CONTENTS

	Page
Chapter 1.	
"Rise and Shine" (Expressions) . . . . .	1
Chapter 2.	
"Good Luck, Danny" (Using the Yellow Pages) . . . . .	6
Chapter 3.	
Danny Meets the Boss (Job Applications) . . . . .	11
Chapter 4.	
Danny is Hired (Work Schedule, Paste-Up, Cold Type) . . . . .	19
Chapter 5.	
An Embarrassing Moment (Paste-Up Practice, Photographing Copy). 31	
Chapter 6.	
A Quick Tour (Floor Plan, Business Cards, . . . . .	42
Developing the Negative)	
Chapter 7.	
"How Do I Get There?" (Bus Schedule, Stripping and Opaquing) . . 54	
Chapter 8.	
Some Good Advice (Burning a Plate, Developing a Plate) . . . . .	62
Chapter 9.	
Danny Meets the Crew (Printing from a Plate, . . . . .	71
Measurement for Printers )	
Glossary . . . . .	81

## Chapter 1

### "RISE AND SHINE"

- (1) The house was very quiet. Everyone was sleeping. Outside, the sky began to brighten. As the sunlight shone through the window, Danny Greene opened his eyes. He was awake before the alarm clock buzzed.
- (2) Danny usually **depended** upon the alarm clock to wake him. But today was different. The job **interview** was on his mind. The interview was at 10 o'clock that morning. He was excited and feeling a little **up-tight**.
- (3) Danny was hoping to get into a **work-study program** at school. The interview was **arranged** by Mr. Labrese. He is the **Cooperative Industrial Education Coordinator** at Beacon County **Vocational School**. A short title for Mr. Labrese is C. I. E. Coordinator.
- (4) This was Danny's second interview. He didn't get the first job. Danny knew he wasn't careful about his **appearance**. He thought that was the reason he didn't get the job. He wasn't taking any chances at this interview. He wanted to work for the Hi-Way Printing Company.
- (5) This time he was **prepared**. His shoes were polished. His shirt and pants were cleaned and pressed. He showered and shaved before the family was awake. Getting up early gave him extra time to get ready. When Danny finished dressing, he heard his mother call to the family, "Rise and shine, you sleepyheads. It's 7:15 and time to get up."

Note: The paragraphs in each chapter are numbered in parentheses. Some of the exercises contain these **paragraph numbers**. These numbers are given to help you find the answers to the questions. A paragraph number looks like this: (1).

#### MATCH THE WORD WITH THEIR MEANINGS

Directions: Choose the correct word for each meaning. Write the word in the blank next to its meaning. The paragraph number is the key to the answer. The first one has been done for you.

1. Trusted, relied upon (2)                     depended                      
                    arranged                      interview                      depended
2. A place for learning printing or other trades. (3)                       
                    appearance                      vocational school                      prepared
3. Ready (5)                       
                    prepared                      industrial                      arranged
4. To meet and talk with an employer (2)                       
                    coordinator                      interview                      program
5. The look of a person or thing (4)                       
                    work-study                      up-tight                      appearance
6. Feeling tense, nervous (2)                       
                    depended                      vocational                      up-tight
7. Planned, put into proper order (3)                       
                    arranged                      cooperative                      interview
8. A plan for bringing together learning at school and on-the-job training. (3)  
                      
                    education                      coordinator                      work-study program

#### FIND THE MEANING IN THE GLOSSARY

Directions: Use the **glossary** at the back of this book to find the meanings of the words below. Write the meanings in the spaces next to the words.

1. cooperative
2. industrial
3. education



4. coordinator \_\_\_\_\_
5. Cooperative Industrial Education Coordinator \_\_\_\_\_

**WORD ENDINGS**

Directions: There is another ending for each word below. Find the words in the story. Write them in the blanks. The paragraph number will help you find the words. The first one has been done for you.

- |                                 |                       |
|---------------------------------|-----------------------|
| 1. appear (4) <u>appearance</u> | 4. prepare (5) _____  |
| 2. vocation (3) _____           | 5. industry (3) _____ |
| 3. educate (3) _____            | 6. depend (2) _____   |

**SPLITTING WORDS**

Directions: Divide the words into syllables. Use the **dictionary** for this activity.

Example: family fam-i-ly

- |                     |                       |
|---------------------|-----------------------|
| 1. prepare _____    | 7. nervous _____      |
| 2. depend _____     | 8. program _____      |
| 3. interview _____  | 9. coordinator _____  |
| 4. vocational _____ | 10. education _____   |
| 5. arrange _____    | 11. industrial _____  |
| 6. appearance _____ | 12. cooperative _____ |

Arrange the words above in **ALPHABETICAL ORDER**.  
Write them in the blanks below.

- |          |           |
|----------|-----------|
| 1. _____ | 7. _____  |
| 2. _____ | 8. _____  |
| 3. _____ | 9. _____  |
| 4. _____ | 10. _____ |
| 5. _____ | 11. _____ |
| 6. _____ | 12. _____ |

## FIND THE MISSING WORDS

Directions: Refer to the story to find the missing words. Write the words in the blanks.  
The **paragraph number is the key** to the answer.

1. Danny will have an \_\_\_\_\_ (2) at 10 o'clock.
2. Danny feels \_\_\_\_\_ (2) about the interview.
3. Danny hoped to get into a \_\_\_\_\_ (3).
4. A short title for Mr. Labrese is \_\_\_\_\_ (3).
5. Danny was careful about his \_\_\_\_\_ (4).
6. Danny \_\_\_\_\_ (2) upon the alarm clock to wake him.
7. Danny is a student at the \_\_\_\_\_ (3).
8. Danny wants to work for the \_\_\_\_\_ (4).

## EXPRESSIONS

When people speak, they often use expressions. Expressions have a special meaning. They help tell how a person feels about someone or something.

Here are two expressions from Chapter 1:

- a. up-tight
- b. rise and shine

What do you think these expressions mean? Write about it in the spaces below.  
Your teacher may want to discuss the meanings with the class.

a. \_\_\_\_\_  
\_\_\_\_\_

b. \_\_\_\_\_  
\_\_\_\_\_

Watch for other expressions in future chapters. Think about the meanings. In Chapter 2, you will see the expression "striking out." You will get the clue to the meaning from the other words in the sentence.

If you can think of an expression, write it in the space below.

---

---

---



## Chapter 2

### "GOOD LUCK, DANNY!"

- (1) Danny's sister Karrie pulled the covers over her head. Mrs. Greene shook her. "C'mon lazy daisy! Get out of bed, or you'll have a two-mile hike to Glenwood High." Danny's twin brothers, Tony and Tom, heard their mother. They jumped out of bed, and raced for the bathroom.
- (2) The mornings were always a mad rush. Mrs. Greene helped get the twins off to school. Then she went to her job. She was a sewing **machine operator**.
- (3) "Is that all you're eating for breakfast, Danny?" asked Mrs. Greene. "I'm not very hungry today, Mom. I guess I'm a little worried about striking out again in an interview."  
"You look great today, Danny! This should help you feel more **confident**."
- (4) Danny looked through the window. He could see Mrs. Frisby driving the school bus along Pine Street. "Here comes the bus! I have to leave now. 'Bye Mom. 'Bye kids." The twins followed Danny to the door. He looked down at his little brothers and said, "See you later, squirts."
- (5) On the way out he heard his family call, "Good luck, Danny! Hope you get the job!"

### MATCH THE WORDS WITH THEIR MEANINGS

Directions: The words in the list match the meanings below. Write the correct words in the blanks beside their meanings.

#### New Words

machine operator (2)

confident (3)

#### Review Words

depended

appearance

arranged

1. \_\_\_\_\_ — a skilled worker who runs a machine.
2. \_\_\_\_\_ — trusted, relied upon.
3. \_\_\_\_\_ — planned, to put in proper order.
4. \_\_\_\_\_ — to be sure of oneself, feel good about yourself.
5. \_\_\_\_\_ — the look of a person or thing.

## FIND IT IN THE GLOSSARY

Directions: There are words in the glossary which rhyme with each of the words below. Read the meaning of each word. Write the word in the blank. The first letter is your clue.

- |                              |                             |
|------------------------------|-----------------------------|
| 1. fellows <u> b </u> _____  | 5. grow up <u> b </u> _____ |
| 2. mountain <u> f </u> _____ | 6. basking <u> m </u> _____ |
| 3. mixer <u> f </u> _____    | 7. sat <u> f </u> _____     |
| 4. plug <u> s </u> _____     | 8. mica <u> p </u> _____    |

## SPLIT THE WORDS INTO SYLLABLES

Use the **dictionary** for this activity.

- |                                  |                  |
|----------------------------------|------------------|
| 1. hungry <u> hun-gry </u> _____ | 5. brother _____ |
| 2. operator _____                | 6. Danny _____   |
| 3. confident _____               | 7. machine _____ |
| 4. striking _____                | 8. worried _____ |

Arrange the above words in **ALPHABETICAL ORDER**.

Write the words in the blanks below.

- |          |          |
|----------|----------|
| 1. _____ | 5. _____ |
| 2. _____ | 6. _____ |
| 3. _____ | 7. _____ |
| 4. _____ | 8. _____ |

## KNOWING THE FACTS

Directions: Answer **Yes** or **No** after each sentence.

1. Danny has twin brothers. \_\_\_\_\_
2. Mrs. Greene works as a bus driver. \_\_\_\_\_
3. Tony and Tom are older than Danny. \_\_\_\_\_

4. Danny was very confident. \_\_\_\_\_
5. Danny wasn't hungry. \_\_\_\_\_
6. Mrs. Frisby is a sewing machine operator. \_\_\_\_\_
7. The Greene family lives two miles from Glenwood High School. \_\_\_\_\_
8. Karrie raced for the bathroom. \_\_\_\_\_
9. Danny lives on Walnut Street. \_\_\_\_\_
10. The family wished Danny good luck. \_\_\_\_\_

### SPELLING STAIRWAYS

Directions: Spell out the words in the squares. Choose from the words below. The first one has been done for you. Circle the words that do not fit in the squares.

W	O	R	R	Y				
R					N			
M						E		
P							D	
C								T

S				Y				
D					D			
C						S		
O							R	
V								S

PREPARED  
INTERVIEW  
CONFIDENT  
REASON

WORRY  
VOCATIONAL  
MACHINE

CHANCES  
STUDY  
VOCATIONS  
APPEARANCE

DEPEND  
OPERATOR  
EDUCATION

### ABBREVIATIONS

Words are often printed in the shortened form. A **word made shorter** is an **abbreviation**.

Below are some abbreviations of **titles** and **places**.

#### TITLES

Mr. for Mister  
Mrs. for Mistress  
Dr. for Doctor  
Lt. for Lieutenant  
St. for Saint

#### PLACES

N. J. for New Jersey  
U.S. for United States  
St. for Street  
Rd. for Road  
Rte. for Route

The above abbreviations begin with a capital letter. Do you know why?

Directions: Fill each blank with the abbreviated form of the word.

1. \_\_\_\_\_ Wellman opened an office on Bleeker \_\_\_\_\_  
Doctor Street
2. Danny lives in Glenwood, \_\_\_\_\_  
New Jersey
3. \_\_\_\_\_ Marks Place is a small street in the city of \_\_\_\_\_  
Saint New York
4. The bus made many stops on \_\_\_\_\_ 17.  
Route
5. The Ridge \_\_\_\_\_ bus stop is near the Hi-Way Printing \_\_\_\_\_  
Road Company
6. He is a \_\_\_\_\_ Army officer. He is \_\_\_\_\_ James Gray.  
United States Lieutenant

### USING THE YELLOW PAGES

Suppose you are looking for a job.

You want to work in a printing company.

You would like to find a job in your community.

You need the **names, addresses, and phone numbers** of printers.

You plan to write or phone for a job application.

You can find the information in the Yellow Pages.

Look in the Yellow Pages under **PRINTERS** and **LITHOGRAPHERS**.

Find 4 printing companies.

Write the information in the spaces below.

Sample: Hi-Way Printing Company  
122 Route 17  
Paramus, New Jersey  
262 - 7001



1. \_\_\_\_\_  
\_\_\_\_\_  
\_\_\_\_\_

2. \_\_\_\_\_  
\_\_\_\_\_  
\_\_\_\_\_

3. \_\_\_\_\_  
\_\_\_\_\_  
\_\_\_\_\_

4. \_\_\_\_\_  
\_\_\_\_\_  
\_\_\_\_\_





## DANNY MEETS THE BOSS

- (1) Mr. Labrese drove Danny to the front **entrance** of the Hi-Way Printing Company. He entered the building. He was in the front office. He **introduced** himself to the **receptionist**.
- (2) Mr. Golden shook Danny's hand. Danny gripped his hand **firmly**. They went into Mr. Golden's office and sat down. Though this was Danny's second interview, he still felt **nervous**. He hoped Mr. Golden would **hire** him.
- (3) Mr. Golden looked over Danny's job **application**. Danny remembered how carefully he had prepared it. He printed all the **information** neatly. Mr. Labrese helped him prepare the application.
- (4) "I can see this will be your first job with a printing company," said Mr. Golden. You are being **trained** in a good vocational school. How serious are you about getting some on-the-job training?"  
"I really would like a chance to work here," answered Danny.
- (5) Mr. Golden asked Danny some questions. They talked about the **graphic arts** shop at school. Then he said, "We have our own way of training people. I'll explain it to you."

### MATCH THE WORDS WITH THEIR MEANINGS

Directions: Choose the correct word for each meaning. Write the word in the blank next to its meaning. The paragraph number is the key to the answer. Some of the words are also in the glossary.

1. Educated, especially in a vocation (4) \_\_\_\_\_  

receptionist	information	trained
--------------	-------------	---------
2. A door, a place to enter (1) \_\_\_\_\_  

hire	entrance	introduce
------	----------	-----------
3. Hold tightly (2) \_\_\_\_\_  

entrance	receptionist	firmly
----------	--------------	--------

4. Arts such as drawing, printing, lithography, etc. (5) \_\_\_\_\_

information                      graphic arts                      trained

5. A person who greets visitors and answers telephone calls (1) \_\_\_\_\_

job application                      introduce                      receptionist

6. A printed form to fill out with facts about the person seeking a job (3) \_\_\_\_\_

job application                      hire                      entrance

7. To employ, to pay a person for his work (2) \_\_\_\_\_

hire                      information                      firmly

8. To present someone; example: "Mary, I would like you to meet John." (1)

\_\_\_\_\_

introduce                      trained                      application

9. Facts (3) \_\_\_\_\_

job application                      receptionist                      information

WORD ENDINGS

Look at these words.      hope      hoping      take      taking

What happens to the letter 'e' when you add 'ing' to hope and take?

Directions: Give different endings to each word in the list. The first one has been done for you.

	END WITH 'ing'	END WITH 'd' or 'ed'
train	training _____	trained _____
arrange	_____	_____
hire	_____	_____
explain	_____	_____
prepare	_____	_____
interview	_____	_____
depend	_____	_____

## SPLITTING WORDS

Directions: Divide the words into syllables. Use the **dictionary** for this activity.

- |                       |                      |
|-----------------------|----------------------|
| 1. office _____       | 7. information _____ |
| 2. introduce _____    | 8. graphic _____     |
| 3. receptionist _____ | 9. training _____    |
| 4. gripped _____      | 10. nervous _____    |
| 5. firmly _____       | 11. entrance _____   |
| 6. application _____  | 12. company _____    |

Arrange the words above in **ALPHABETICAL ORDER**

Write the words in the blanks below

- |          |           |
|----------|-----------|
| 1. _____ | 7. _____  |
| 2. _____ | 8. _____  |
| 3. _____ | 9. _____  |
| 4. _____ | 10. _____ |
| 5. _____ | 11. _____ |
| 6. _____ | 12. _____ |

**REVIEW WORDS** – Write a sentence for each of these words:

depended

prepared

program

- |          |
|----------|
| 1. _____ |
| 2. _____ |
| 3. _____ |

## CHOOSE ONE

Directions: Put a circle around the letter for each correct answer.

1. This was Danny's (4)
  - a. first interview.
  - b. third interview.
  - c. second interview.

2. Danny introduced himself to (1)
  - a. Mr. Labrese
  - b. the receptionist.
  - c. the photographer.
  
3. Danny's school shop is (5)
  - a. Graphic Arts.
  - b. Office Occupations.
  - c. Landscaping.
  
4. Mr. Golden looked over Danny's (3)
  - a. head.
  - b. tool box.
  - c. job application.
  
5. Mr. Labrese helped Danny prepare his (3)
  - a. breakfast.
  - b. application.
  - c. homework.

Below is the application blank Danny filled out.

If you were applying for a job, how would you fill out the job application on the next page?

### APPLICATION BLANK FOR EMPLOYMENT

DATE March 5, 1976

NAME (please print) Greene Daniel Robert  
Last First Middle

ADDRESS 763 Pine Street  
No. Street

CITY Glenwood STATE New Jersey ZIP CODE 07439 TELEPHONE NO. 417-6023

SEX:  Male  Female AGE 17 BIRTH DATE October 10 19 59

HEIGHT 5 ft. 10 in. WEIGHT 149 lbs. MARRIED? no NUMBER OF CHILDREN none

SOCIAL SECURITY NO. 154 - 0 - 8064

FATHER LIVING? no AGE — OCCUPATION —

MOTHER LIVING? yes AGE 42 OCCUPATION sewing machine operator

#### EDUCATIONAL HISTORY

	Name of school	Years attended		Last grade completed
		from	to	
Elementary School	<u>Glenwood Public</u>	<u>9/62</u>	<u>6/71</u>	<u>grade 8</u>
Junior High School	<u>—</u>	<u>—</u>	<u>—</u>	<u>—</u>
High or Vocational School	<u>—</u>	<u>9/71</u>	<u>still attending</u>	<u>—</u>

#### WORK EXPERIENCE

Name and Address of Employer	Kind of work	Dates	Reason for leaving

#### PERSONAL REFERENCES

Name	Address	Occupation
<u>Mr. Thomas Crane</u>	<u>62 Oak St., Glenwood, N.J.</u>	<u>salesman</u>
<u>Mrs. Sally Slater</u>	<u>742 Pine St., Glenwood, N.J.</u>	<u>housewife</u>

Daniel R. Greene  
Signature of Applicant

**AN APPLICATION BLANK FOR YOU TO FILL OUT**

APPLICATION BLANK FOR EMPLOYMENT				
				DATE _____
NAME (please print) _____				
Last		First		Middle
ADDRESS _____				
No.		Street		
CITY _____	STATE _____	ZIP CODE _____	TELEPHONE NO. _____	
SEX: <input type="checkbox"/> MALE	<input type="checkbox"/> FEMALE	AGE _____	BIRTH DATE _____	19
HEIGHT _____ Ft.	_____ in.	WEIGHT _____ lbs.	MARRIED? _____	NUMBER OF CHILDREN _____
SOCIAL SECURITY NO. _____				
FATHER LIVING? _____		AGE _____	OCCUPATION _____	
MOTHER LIVING? _____		AGE _____	OCCUPATION _____	
EDUCATIONAL HISTORY				
	Name of school	Years attended from	to	Last grade completed
Elementary School				
Junior High School				
High or Vocational School				
WORK EXPERIENCE				
Name and Address of Employer	Kind of work	Dates	Reason for leaving	
PERSONAL REFERENCES				
Name	Address	Occupation		
				Signature of Applicant _____

It is good practice to fill out different application forms.  
 Try filling out the form below.

### EMPLOYMENT APPLICATION

Name in Full \_\_\_\_\_ Phone \_\_\_\_\_

Address \_\_\_\_\_  
 (If R.F.D. or P.O. Box, Give Street or Road Name)

Social Security # \_\_\_\_\_ Number of Dependents \_\_\_\_\_  
 (Include self)

Married  Single  Date of Birth: Month \_\_\_\_\_ Day \_\_\_\_\_ Year \_\_\_\_\_

Birth Place \_\_\_\_\_ Citizen  Naturalized  When Naturalized \_\_\_\_\_

In Case of Accident - Notify Name \_\_\_\_\_ Date Entered U.S. \_\_\_\_\_

Address \_\_\_\_\_

EDUCATION	
Elementary _____	Yrs.
High School _____	Yrs.
College _____	Yrs.
Correspondence _____	<input type="checkbox"/>
Eve. or Bus. School _____	<input type="checkbox"/>
Other _____	

Height \_\_\_\_\_ Feet \_\_\_\_\_ Inches

Weight \_\_\_\_\_ Lbs.

Color of Hair \_\_\_\_\_ Color of Eyes \_\_\_\_\_

Physical Handicap \_\_\_\_\_

Glasses - Yes  No

Relatives Working Here?

Give Names \_\_\_\_\_

PREVIOUS EMPLOYERS			
1.	Position	From - To	Wages
2.			
3.			
4.			

(The Above Must Cover a Period of 5 Years or More)  
 (Also Service Record, if any.)

References: \_\_\_\_\_ Address \_\_\_\_\_  
 \_\_\_\_\_ Address \_\_\_\_\_  
 \_\_\_\_\_ Address \_\_\_\_\_

Interviewed By: \_\_\_\_\_ Signature of Applicant \_\_\_\_\_

## WORD FIND REVIEW

**Directions:** There are 21 words listed below. Find them in the puzzle. Draw a line around each word.

**FOR EXTRA CREDIT:** Look for other words in the puzzle. Draw a line around them. Add them to the list. Then arrange all the words in **alphabetical order**. Use the space below.

```

R D C O P Y M A R G O R P F A R
R E V O C A T I O N A L H N B E
E P C C O N F I D E N T O W S L
L A P E M P L O Y E E I T U I Y
I R A A P P L I C A T I O N N A
E T P X A T R A P A A V G R F P
D M P Q N F I R M E R Q R I O I
U E E S Y V D O M E F P A D R N
C N A B A R R A N G E D P E M T
A T R O F F I C E I Z L H P A R
T R A I N I N G W A S P I E T O
E U N I M A C H I N E T C N I D
Z W C I N T E R V I E W H D O U
P R E P A R E D W O R K E R N C
S T U D Y I N D U S T R I A L E
E N T R A N C E O P E R A T O R
    
```

INFORMATION  
RECEPTIONIST  
APPLICATION  
TRAINING  
NERVOUS  
PHOTOGRAPH  
APPEARANCE

PROGRAM  
VOCATIONAL  
INTERVIEW  
DEPEND  
INDUSTRIAL  
ENTRANCE  
GRAPHIC

INTRODUCE  
OFFICE  
EMPLOYEE  
MACHINE  
OPERATOR  
CONFIDENT  
DEPARTMENT



## Chapter 4

### DANNY IS HIRED

- (1) "We have a job open in our **offset printing department**. You have learned quite a lot about offset printing. You will be given a chance to try each step in the **process**. For example, you will begin with **paste-up** work. This is step one. Step two is **photographing the copy**. There are seven steps in all. After the steps have been completed, we will decide where you should be **placed**."
- (2) "We have just placed a young lady. Her name is Jodi. She tried each step. Now she has a steady job doing paste-ups. By the way, Jodi got her training in a vocational school. It has a graphic arts program much like the one in the Beacon County Vocational School."
- (3) Mr. Golden looked at a chart on the wall. The words **EMPLOYEES WORK SCHEDULE** were printed across the top. "We can fit you in two days a week. How about Tuesdays and Thursdays? Would 8:30 a.m. to 4:30 p.m. be all right?"  
"Sure," replied Danny. "Does that mean I have the job?"  
Mr. Golden smiled and said, "You've got it, Danny."

#### MATCH THE WORDS WITH THEIR MEANINGS

Directions: There are three words to choose for each meaning. Choose the **correct word**. Write it in the space next to the meaning. The first one has been done for you. Refer to the **glossary** if you are not sure of the meaning.

1. A special or separate place (1) department  
process                      placed                      department
2. Employed, given a job (1) \_\_\_\_\_  
schedule                      copy                      placed
3. Camera-ready copy. Paste the copy to the artboard (1) \_\_\_\_\_  
paste-up                      department                      schedule

4. A timetable, a list of details (3) \_\_\_\_\_  
 schedule employees paste-up
5. A special way of doing something (1) \_\_\_\_\_  
 placed process department
6. A kind of printing based on the fact that water and oil do not mix (1) \_\_\_\_\_  
 copy photographing offset
7. People who work for pay (3) \_\_\_\_\_  
 employees schedules processes
8. The lettering and pictures used in the paste-up (1) \_\_\_\_\_  
 offset copy process
9. Taking pictures with a camera (1) \_\_\_\_\_  
 photographing printing paste-up

.....

**CLASSIFY THE WORDS**

Directions: Write the words in the list under the correct headings.

mother	teacher	occupation	education
classroom	hire	C.I.E. Coordinator	living room
interview	employee	machine operator	family

**HOME**

**SCHOOL**

**INDUSTRY**

_____	_____	_____
_____	_____	_____
_____	_____	_____
_____	_____	_____

**TABLE OF CONTENTS**

Directions: Find the Table of Contents in this book. Use it to answer the questions.

1. The Glossary begins on page \_\_\_\_\_

2. What is the title of Chapter 7? \_\_\_\_\_
3. What is listed first in the Table of Contents? \_\_\_\_\_

**SPLITTING WORDS**

Directions: Divide the words into syllables. Use the **dictionary** for this activity.

- |                     |                     |
|---------------------|---------------------|
| 1. offset _____     | 6. placed _____     |
| 2. printing _____   | 7. photograph _____ |
| 3. department _____ | 8. employee _____   |
| 4. process _____    | 9. schedule _____   |
| 5. copy _____       | 10. program _____   |

Arrange the words above in **ALPHABETICAL ORDER**  
Write the words in the spaces below

- |          |           |
|----------|-----------|
| 1. _____ | 6. _____  |
| 2. _____ | 7. _____  |
| 3. _____ | 8. _____  |
| 4. _____ | 9. _____  |
| 5. _____ | 10. _____ |

**FIND IT IN THE GLOSSARY**

Directions: Find the words **offset lithography** in the glossary. Read the meaning of the words. Then write a sentence, using the words **offset lithography** on the lines below.

---



---

**KNOWING THE FACTS**

Directions: Write **Yes** or **No** after each sentence.

1. A paste-up can be done on a piece of art board. \_\_\_\_\_
2. Offset lithography is a printing process based on the fact that water and grease do not mix. \_\_\_\_\_
3. The paste-up is the last step in the offset lithography printing process. \_\_\_\_\_
4. A process is a special place. \_\_\_\_\_
5. A schedule can show the working hours of employees. \_\_\_\_\_
6. Jodi has a steady job as a paste-up artist. \_\_\_\_\_

**HOW MANY WORDS IN A WORD?**

Directions: Using as many or as few of the letters in the word "LITHOGRAPHY," how many words can you make? You may not use any letter more often than it appears in the word. Write the words in the blanks below.

_____	_____	_____
_____	_____	_____
_____	_____	_____
_____	_____	_____
_____	_____	_____

## UNDERSTANDING A SCHEDULE

Directions: Refer to the schedule and the story to answer the questions below.  
What do the **arrows** mean? How are **days off** shown?

EMPLOYEES' WORK SCHEDULE – Offset Department							
NAME	MON.	TUES.	WED.	THURS.	FRI.	SAT.	Total Hours
Bill	8:30 a.m. to 4:30 p.m.	→					35
Sue	8:30 a.m. to 4:30 p.m.	→					35
Jodi	8:30 a.m. to 4:30 p.m.	8:30 a.m. to 4:30 p.m.	Day Off	Day Off	8:30 a.m. to 4:30 p.m.		21
Tim	8:30 a.m. to 4:30 p.m.	→					35
Joe	Day Off	8:30 a.m. to 4:30 p.m.	→			9:00 a.m. to 12:00 p.m.	31
Sal	8:30 a.m. to 4:30 p.m.	→					35

Note: The regular workday is 7 hours plus 1 hour for lunch, Monday through Friday. Do not include lunch when you total the working hours. Saturday is not a regular workday.

- Write Danny's name under Sal in the schedule.
- Write Danny's working hours in the correct spaces in the schedule. Write in his **days off** and **total hours**. (3)
- What are Bill's hours on Tuesday? \_\_\_\_\_
- On which day does Joe work three hours? \_\_\_\_\_
- Jodi and Danny work the same day one day a week. Name the day. \_\_\_\_\_

6. How many employees are there in the offset department? \_\_\_\_\_
7. How many hours does Tim work in one week? \_\_\_\_\_
8. Joe's day off is \_\_\_\_\_

**MORE ABBREVIATIONS**

Directions: Write the abbreviations for the days of the week and the months of the year.

- |                    |                   |
|--------------------|-------------------|
| 1. Monday _____    | 4. Thursday _____ |
| 2. Tuesday _____   | 5. Friday _____   |
| 3. Wednesday _____ | 6. Saturday _____ |
|                    | 7. Sunday _____   |

- .....
- |                   |                    |
|-------------------|--------------------|
| 1. January _____  | 5. August _____    |
| 2. February _____ | 6. September _____ |
| 3. March _____    | 7. October _____   |
| 4. April _____    | 8. November _____  |
|                   | 9. December _____  |

Three months of the year are not listed. Do you know why?

.....

**Other Important Abbreviations**

**Co.** for Company (Hi-Way Printing Co.)  
**no.** for number  
**p.** for page  
**pp.** for pages  
**mi.** for mile

**m.p.h.** for miles per hour  
**a.m.** for morning  
**p.m.** for afternoon  
**vol.** for volume

## THE SEVEN STEPS IN OFFSET LITHOGRAPHY

There are seven basic **procedures** or steps in offset printing. In this book, you will be introduced to this method of printing. Each step is given in lesson form. If you already know the procedures, these lessons will be a good review. The seven steps are:

- I. Paste-up
- II. Photographing the Copy
- III. Developing the Negative
- IV. Stripping and Opaquing
- V. Burning a Plate
- VI. Developing a Plate
- VII. Printing from a Plate

## STEP I - PASTE-UP

Paste-up is the first step in the offset lithography process.

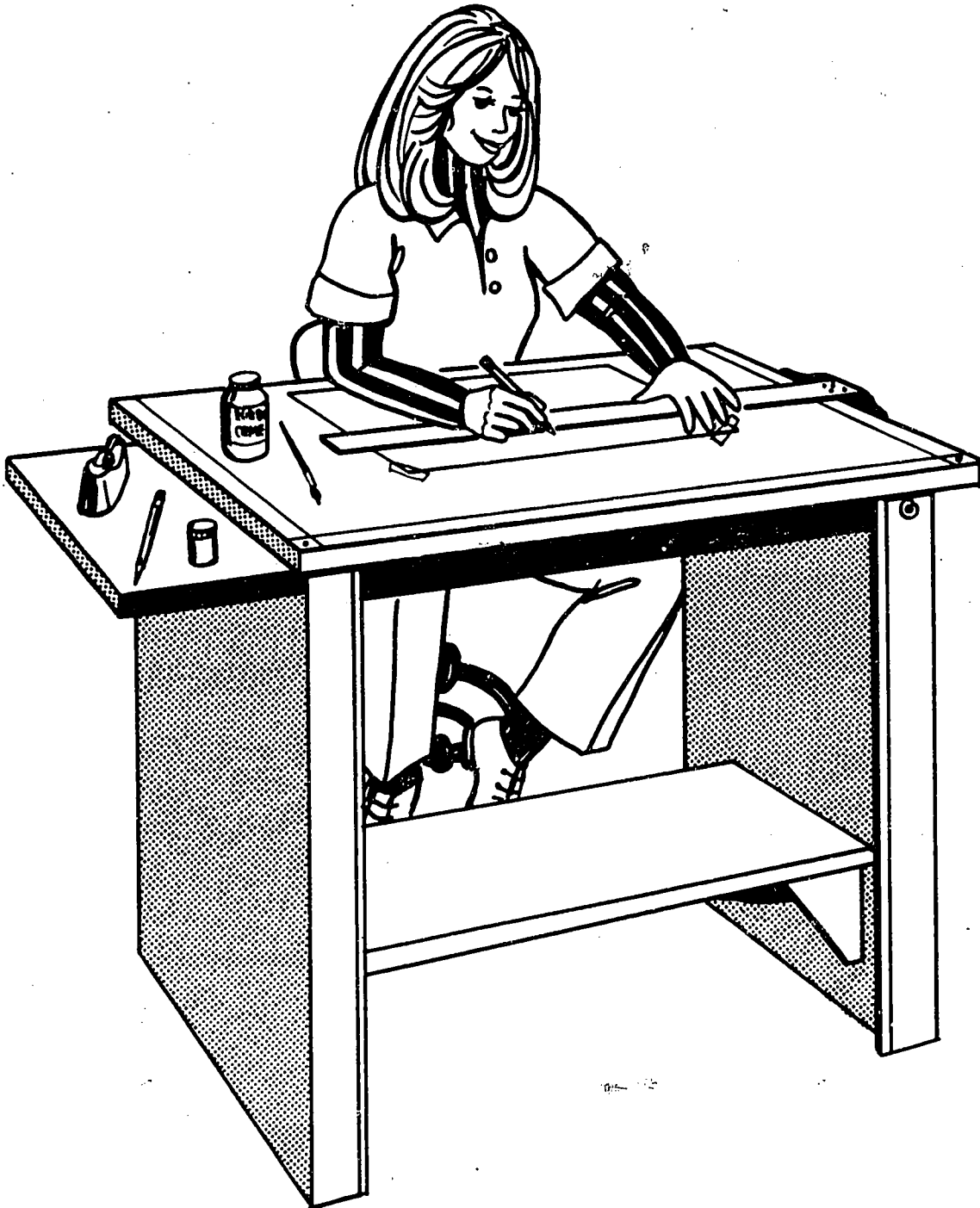

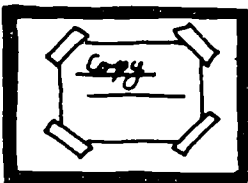
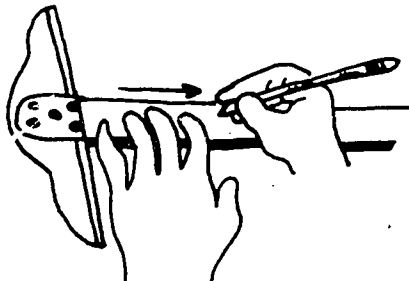
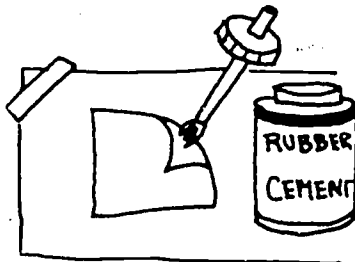

**PASTE-UP – STEP 1**  
in the  
**OFFSET LITHOGRAPHY PROCESS**

What You Need	How You Use It
<p>1. Light Table or Drawing Board</p> 	<ul style="list-style-type: none"> <li>• This is the table on which you do your work.</li> </ul>
 <p>2. Art Board also called Bristol Board or Illustration Board</p>	<ul style="list-style-type: none"> <li>• Tape the corners of the art board to the table.</li> </ul>
<p>3. T Square Triangle Pencil</p> 	<ul style="list-style-type: none"> <li>• Use the T Square and triangle to lay out evenly spaced straight lines of copy.</li> <li>• Draw the guidelines with a pencil.</li> </ul>
 <p>4. Rubber Cement</p>	<ul style="list-style-type: none"> <li>• Paste the copy to the art board with rubber cement.</li> </ul>
<p>5. Proofreader</p>	<ul style="list-style-type: none"> <li>• Spelling and punctuation errors are found and corrected by the proofreader.</li> </ul>

Directions: Refer to page on Paste-up for answers to these questions.

1. What is needed for step 1 in the paste-up? \_\_\_\_\_
2. What is used to help keep the lines of copy straight? \_\_\_\_\_
3. What is taped to the light table? \_\_\_\_\_
4. What is used to paste the copy to the art board? \_\_\_\_\_
5. Why is proofreading important? \_\_\_\_\_

#### OTHER MATERIALS USED FOR PASTE-UP

What You Need	How You Use It
opaque paint, white and black, paint brush	Paint over unwanted spots etc.
Varietyper stock lettering – transfer type	Lay out the lettering. See next page on COLD TYPE.
French curves	For drawing curved lines.
gum or kneaded eraser	To erase pencil marks.
single-edge razor blade, exacto knife, stylus	For cutting and separating lettering from the backing.

#### SAFETY TIPS

**The Light Table** – The top is made of glass. Treat it with care, or it can break and cause serious injury.

**Razor Blade, Exacto Knife** – When not in use, be sure to store them. When cutting against a curved or a straight edge, keep your fingers away from the edge.

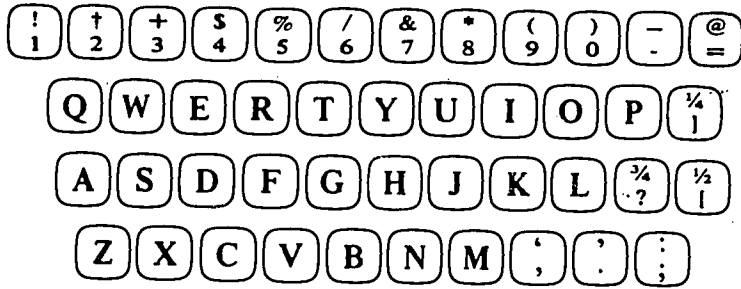

A Composing Machine Keyboard

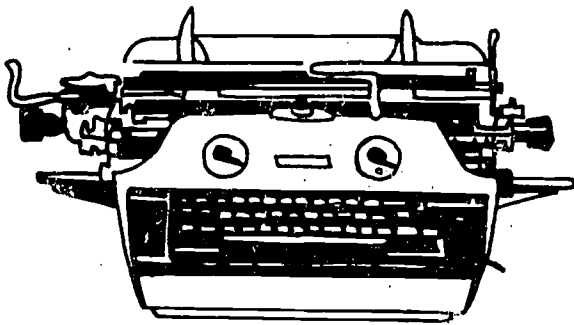

A VariType Composing Machine

- 10 pt. Gothic Bold Condensed (FL970-10B)  
**ABCDEFGHIJKLMN OPQRSTUVWXYZ & AB**  
**abcdefghijklmnopqrstuvwxy abcdefghijklm**
- 10 pt. Bodoni Book (600-10B)  
**ABCDEFGHIJKLMN OPQRSTUVWXYZ & AB**  
**abcdefghijklmnopqrstuvwxy abcdefghijklm**
- 10 pt. Bodoni Bold (780-10B)  
**ABCDEFGHIJKLMN OPQRSTUVWXYZ & AB**  
**abcdefghijklmnopqrstuvwxy abcdefghijklm**
- 10 pt. Bookman (630-10B)  
**ABCDEFGHIJKLMN OPQRSTUVWXYZ & AE**  
**abcdefghijklmnopqrstuvwxy abcdefghijklm**
- 10 pt. Cartoon Type (940-10A)  
**ABCDEFGHIJKLMN OPQRSTUVWXYZ**  
**ABCDEFGHIJKLMN OPQRSTUVWXYZ ABCDEFGI**

Examples of VariType  
 Hundreds of changeable type are available.

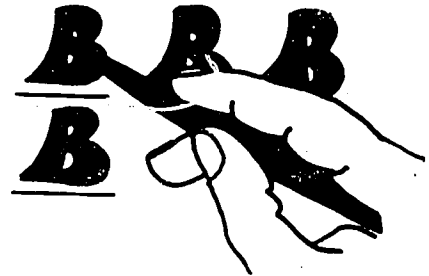

1. Place the letter  
 Then rub it on.

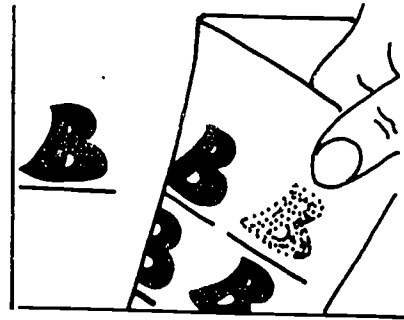

2. Pull away the  
 transfer sheet.

Stick-on Stock Type



1. Cut out and lift up  
 the letters with a  
 stylus.

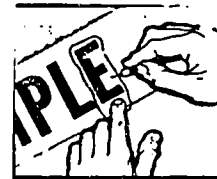

2. Place and press down  
 the letters on the art  
 board.

## PASTE-UP MATERIALS QUIZ

1. Find the meaning of the words **cold type** in the glossary. Write the meaning in the blank space. \_\_\_\_\_  
\_\_\_\_\_
2. A VariTyper machine looks somewhat like a typewriter you might see in a business office. Answer yes or no. \_\_\_\_\_
3. For what kind of lettering would you use a razor blade or an Exacto knife? \_\_\_\_\_
4. What is used to paint over unwanted spots on the layout or pasteup? \_\_\_\_\_
5. French curves are used for \_\_\_\_\_
6. The VariTyper can produce hundreds of styles of type. Answer yes or no. \_\_\_\_\_
7. How is transfer type used?  
\_\_\_\_\_  
\_\_\_\_\_  
\_\_\_\_\_  
\_\_\_\_\_



## AN EMBARRASSING MOMENT

- (1) When the interview ended, Danny was very excited. He stood up too quickly. Then, he **accidentally** backed into a chair. The chair fell. Danny reached to grab it. But he lost his balance. The chair went down, and Danny went with it.
- (2) Danny was **embarrassed**. He picked himself up. He picked up the chair. He wanted to **apologize** to Mr. Golden. But before he could speak, Mr. Golden said, "I can see you're okay, Danny. You got back on your feet fast. You must be excited about the job. That's good. I once bumped into a wall after a job interview. I was excited too."
- (3) "Please stay ten more minutes, Danny. I want you to see the rest of the building. Here is a **diagram** of the building. You can follow it while you are being shown around." Mr. Golden looked at the clock. "I have an **appointment** with a paper **salesman**. Please excuse me. I'll ask Marty to show you the building."
- (4) Mr. Golden pushed one of the buttons on the phone. He lifted the receiver and dialed 24. The phone rang in the **letterpress** department. "Could you come to my office, Marty? I would like you to meet Danny Greene, a new employee."

### MATCH THE WORDS WITH THEIR MEANINGS

Directions: The words in the list match the meanings below. Write the correct words in the blanks beside the meanings. Refer to the glossary if you are not sure of the meaning.

accidentally (1)

embarrassed (2)

apologize (2)

diagram (3)

appointment (3)

salesman (3)

letterpress (4)

1. \_\_\_\_\_ (2) to feel silly, ashamed, or self-conscious.
2. \_\_\_\_\_ (2) to show you are sorry, excuse oneself.
3. \_\_\_\_\_ (4) printing from a plate with a raised (relief) surface.

4. \_\_\_\_\_ (1) happening in an unexpected way.
5. \_\_\_\_\_ (3) a man whose work is selling.
6. \_\_\_\_\_ (3) setting a date to meet someone.
7. \_\_\_\_\_ (3) a drawing of a floor plan for a building.  
Also, a map or chart.

### REVIEW WORDS

Directions: Write in a word you can use in place of the word next to each blank. Use the row of words below.

confident                      depended                      employees                      appearance

- Danny \_\_\_\_\_ (*relied*) on the radio for weather reports.
- The \_\_\_\_\_ (*workers*) had one hour for lunch.
- Danny will feel more \_\_\_\_\_ (*self assured*) when he has gotten some experience.
- Mr. Golden liked Danny's \_\_\_\_\_ (*looks*).

### SPLITTING WORDS

Directions: Divide the words into syllables. Use the **dictionary** for this activity.

- |                 |                  |                |       |
|-----------------|------------------|----------------|-------|
| 1. accidentally | ac—ci—den—tal—ly | 6. letterpress | _____ |
| 2. embarrassed  | _____            | 7. salesman    | _____ |
| 3. apologize    | _____            | 8. receiver    | _____ |
| 4. diagram      | _____            | 9. excuse      | _____ |
| 5. appointment  | _____            | 10. building   | _____ |

Arrange the above words in ALPHABETICAL ORDER

Write the words in the spaces below.

- |          |           |
|----------|-----------|
| 1. _____ | 6. _____  |
| 2. _____ | 7. _____  |
| 3. _____ | 8. _____  |
| 4. _____ | 9. _____  |
| 5. _____ | 10. _____ |

**ONE OUT OF TWO**

Directions: There are two words under each blank. Choose one to complete each sentence.

- Danny was given a \_\_\_\_\_ of the building.  
                                    diagram    interview
- Marty was in the \_\_\_\_\_ department.  
                                    snack        letterpress
- Danny was \_\_\_\_\_ after his accident.  
                                    confident    embarrassed
- Danny wanted to \_\_\_\_\_ to Mr. Golden.  
                                    apologize    complain
- The interview was \_\_\_\_\_  
                                    diagram        arranged

**ABBREVIATIONS** – How much do you remember?

Directions: Write the abbreviation for each of the words listed.

- |                  |                          |
|------------------|--------------------------|
| 1. October _____ | 7. page _____            |
| 2. Street _____  | 8. morning _____         |
| 3. pound _____   | 9. New Jersey _____      |
| 4. gallon _____  | 10. miles per hour _____ |
| 5. Mister _____  | 11. Thursday _____       |
| 6. Company _____ | 12. number _____         |

Do you know why Street and Company begin with a capital letter?

## SPELLING STAIRWAYS

Directions: Spell out the words in the squares. They fit across only. Choose from the words below. Circle the words that do not fit in the squares.

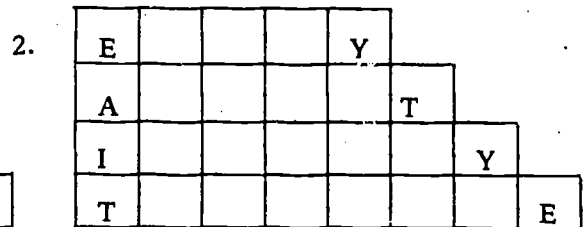
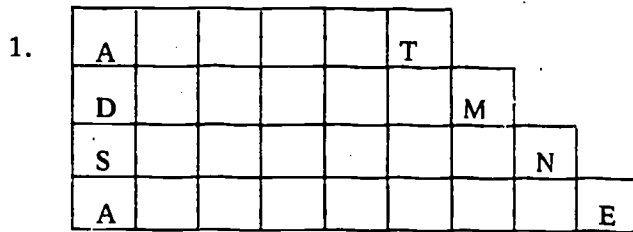

1. apologize  
salesman  
vocation

- diagram  
copy  
August

2. timetable  
review  
appoint

- relied  
employ  
industry

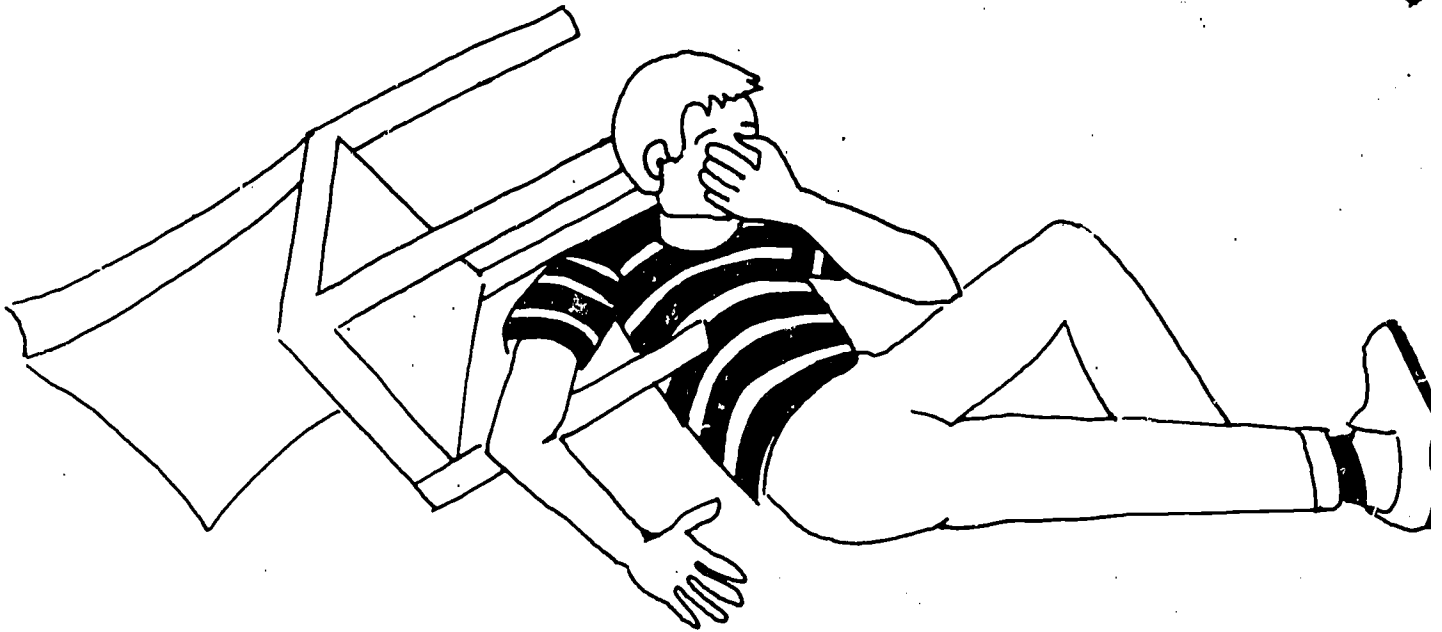



## THE HORIZONTAL COPY CAMERA

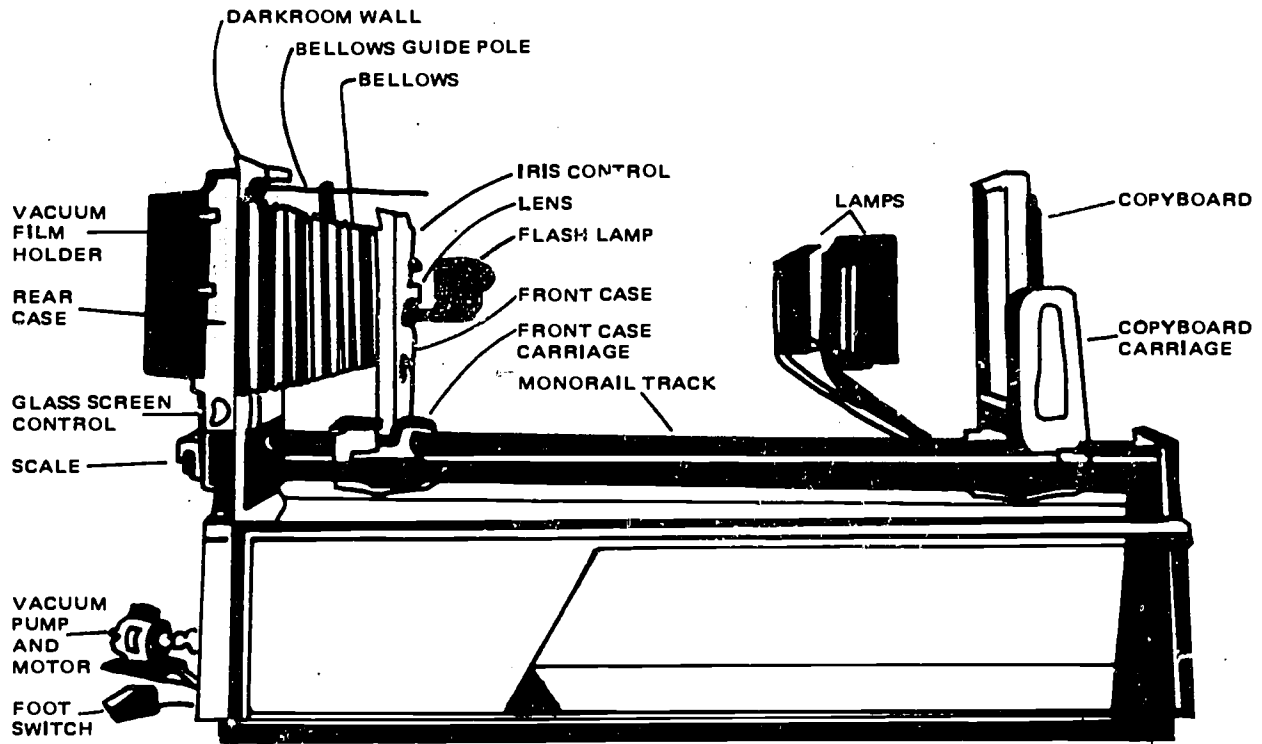

**DARKROOM END**  
(back end)

**COPY END**  
(front end)

The main parts of a copy camera are:

- |            |                            |                   |
|------------|----------------------------|-------------------|
|            | Front End                  |                   |
| 1. lens    | 2. copyboard               | 3. lights (lamps) |
|            | Back End                   |                   |
| 1. bellows | 2. camera back (rear case) |                   |

### NAME THE PARTS

A. There are six parts labeled for the section of the camera which is located in the darkroom. List the parts in the blanks below.



1. \_\_\_\_\_
2. \_\_\_\_\_
3. \_\_\_\_\_

4. \_\_\_\_\_
5. \_\_\_\_\_
6. \_\_\_\_\_

**B. Name four parts of the camera located outside the darkroom.**

\_\_\_\_\_

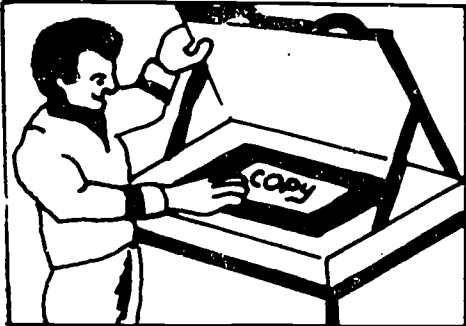
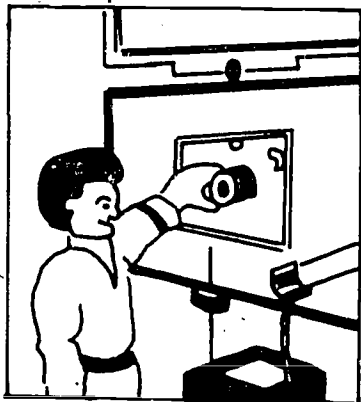
**PHOTOGRAPHING THE COPY – STEP 2**  
in the  
**OFFSET LITHOGRAPHY PROCESS**

What You Need	How You Use It
<p>1. You need a <b>copy camera</b>.</p>	<p>Prepare the camera to <b>shoot a negative</b> of the copy.</p>
 <p>2. Copyboard at the copy end of the camera. (front end)</p>	<p>Place the <b>paste-up</b> on the <b>copyboard</b> of the camera. Put the glass cover over the paste-up. Be sure the glass is very clean.</p> <p>The words <b>copy</b>, <b>paste-up</b>, and <b>layout</b> are often used in place of each other.</p>
 <p>3. Aperture and lens at the copy end of the camera. (front end)</p>	<p>a. Set the <b>aperture</b> (lens opening) and <b>lens</b> according to the directions for the film.</p> <p>b. Use <b>lens cleaning tissue</b> to clean the lens.</p>
 <p>4. Film for darkroom end of the camera. (back end)</p>	<p>a. Load the camera with the film.</p> <p>b. Handle the film under <b>safelights</b>.</p> <p>c. Wear dry rubber gloves to prevent scratching the negatives.</p> <p>d. Place the exposed film in a <b>light-tight</b> box until ready to develop.</p>

Directions: Refer to the page on Photographing the Copy to answer the questions below.

1. What kind of camera is used to take a picture of the copy? \_\_\_\_\_  
\_\_\_\_\_
2. Is it correct to use the word **copy** in place of the words **paste-up**? Get your clue from Part 2, How You Use It, for the answer. Write yes or no in this space. \_\_\_\_\_
3. What is used to clean the lens? \_\_\_\_\_
4. If a spot of dirt is not removed from the glass that covers the copy, will it show on the negative? Answer yes or no. \_\_\_\_\_
5. Which end of the camera is in the darkroom? \_\_\_\_\_
6. What kind of lights are used in a darkroom? \_\_\_\_\_
7. To prevent scratching the negatives, wear \_\_\_\_\_
8. What is put into a light-tight box? \_\_\_\_\_

#### GO TO THE GLOSSARY

Directions: Use the Glossary at the back of the book to find the meaning for each word. Write the meaning in the space next to the word.

1. aperture \_\_\_\_\_
2. safelight \_\_\_\_\_
3. copyboard \_\_\_\_\_
4. lens \_\_\_\_\_

## PASTE-UP PRACTICE

Directions: Cut out the pictures and the lines of type on this page. Arrange them on the blank page. Then paste-up the layout.

## EXTRA CREDIT ACTIVITY

Cut pictures and words out of magazines. Use them to do a layout and paste-up.

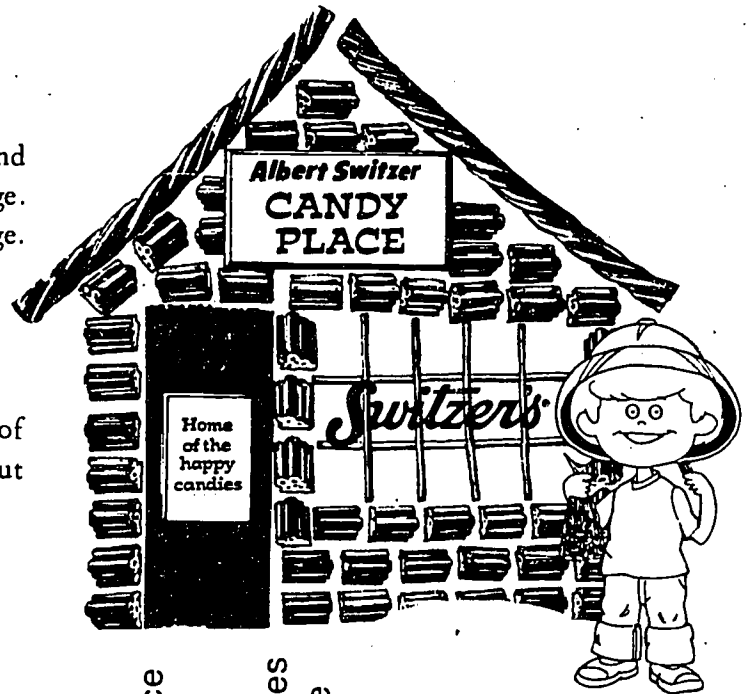

**Albert Switzer**  
Boy Candy Lover



Switzer's—the name that means Cherry Red, Licorice Black and Groovy Grape Candies. In a variety of shapes kids enjoy. Favorites of all ages because they're good.



# Switzer's®

## SIZES • FLAVORS • SHAPES

## From Bars to Superbags

Switzer Candy Co., Div. of Beatrice Foods Co.  
621 N. First St., St. Louis, MO 63102



## MAKE A PUZZLE

Directions: Make a word find puzzle. You may use your own words. You can also use the words from the list below. Make copies of your puzzle for the class.

copy  
grip  
study  
firm  
total

company  
clock  
offset  
order  
table

review  
hire  
work  
excuse  
hour

job  
placed  
press  
salesman  
train

## A QUICK TOUR

- (1) "Hello, Danny. I'm Marty Golden. Glad to have you with us." Danny thought Marty must be Mr. Golden's son. He was right. Marty is a printer's **apprentice**. He hopes to become a **master printer** like his father.
- (2) "This will have to be a quick **tour** I hope you won't mind," apologized Marty. "We've got a letterpress job to finish. Two thousand **business cards** have to be printed and packed by 1:30 p.m. The **order** is for a big **account**. We try to please all **customers**. Our small accounts are just as important as the big ones. Let's get on with the tour. Have you got the diagram?"
- (3) Danny was prepared. The diagram was unfolded and ready for use. Marty showed Danny how to understand it. When they stopped in a department, Marty would point to it on the **diagram**. He explained why the machinery, paper, and other equipment were set in certain parts of the building. It was planned to help **production** run smoothly.
- (4) The tour took 10 minutes. Marty walked Danny to the employees' **exit**. He showed him where to find his **time card**. It would be placed in the rack next to the **time clock**. Marty wished Danny good luck. Danny thanked him. "I'm **punching in** at 8:30 a.m. on Tuesday," said Danny. "See you then."
- (5) When Danny left the building, he was excited and happy. He also felt a little afraid. He saw Mr. Labrese waiting to drive him back to school. "Congratulations Danny," said Mr. Labrese. The grin on your face tells me you got the job. Your shop teacher, Mr. Russo, will want to hear the good news."
- (6) On the way home from school, Danny talked about the job. He and his friend Bert always sat together on the bus. He told Bert it was going to be great. He would have extra money. He could begin saving for a car. He might treat a date to a movie. Maybe he could help his mother pay the bills. It was not easy for her to make ends meet since his father died. Then he thought about Jodi. Without saying a word to Bert, he wondered, "What will Jodi be like?"

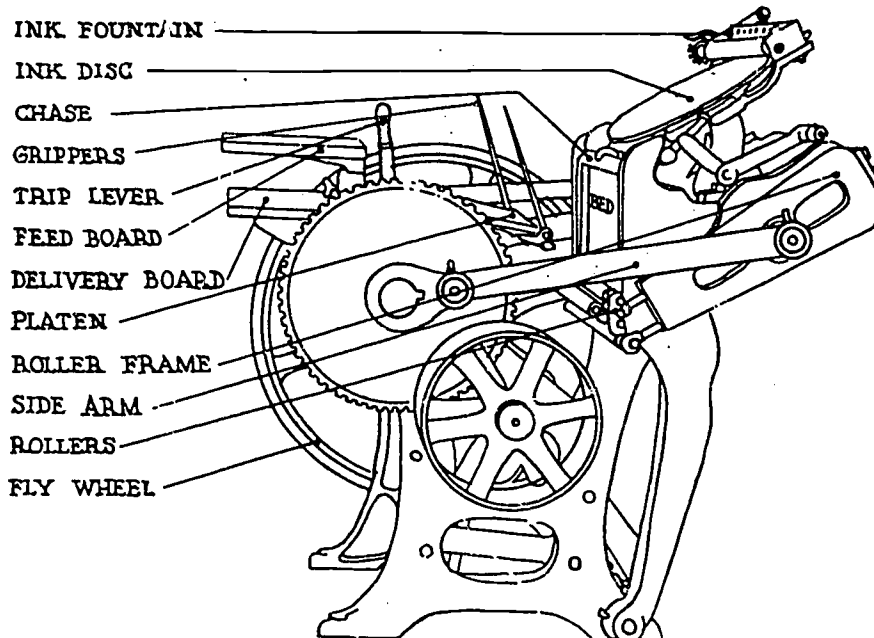

### PLATEN PRESS

Danny saw a large platen press like this one. Business cards were being printed with this press. Danny had used a small press of this type at school. He also printed business cards. The platen press is a **letterpress**. Do you know how letterpress differs from **offset lithography**?

### MATCH THE WORDS WITH THEIR MEANING

Directions: There are three words to choose from for each meaning. Choose the correct word. Write it in the space next to the meaning. The first one has been done for you.

1. An account, a buyer (2) customer

master printer      production      customer

2. An expert printer, a skilled printer in business for himself (1) \_\_\_\_\_

account      master printer      apprentice



3. A clock, which when punched, will show the number of hours a person has worked (4) \_\_\_\_\_

time clock

business card

tour

4. A small card (usually 3" x 1½") on which is printed the name, address, phone number and salesman's name for a business (2)

apprentice

business card

time card

5. A person learning a trade from skilled workers by practical experience (1) \_\_\_\_\_

customer

account

apprentice

6. To punch a time clock (4) \_\_\_\_\_

punching in

tour

order

7. A walk around, a short trip (2) \_\_\_\_\_

tour

production

exit

8. Making something, producing, manufacturing (3) \_\_\_\_\_

punching in

production

customer

9. A card for showing the number of hours a person works (4) \_\_\_\_\_

order

apprentice

time card

10. A customer (2) \_\_\_\_\_

account

printer

exit

11. The way out; leaving a building or a room (4) \_\_\_\_\_

punching in

exit

tour

12. A paper or form which shows what a customer wants to buy (2) \_\_\_\_\_

order

apprentice

time card

## WORD REVIEW

Directions: Choose from the words below to complete the sentences.

diagram

salesman

letterpress

appointment

1. Mr. Labrese arranged an \_\_\_\_\_ for an interview.
2. It would be easy to find the rooms if he followed a \_\_\_\_\_
3. The business cards were printed on the \_\_\_\_\_
4. The \_\_\_\_\_ left his business card with Mr. Golden.

## SPLITTING WORDS

Directions: Divide the words into syllables. Use the **dictionary** for this activity.

- |                     |                     |
|---------------------|---------------------|
| 1. apprentice _____ | 6. customer _____   |
| 2. master _____     | 7. production _____ |
| 3. business _____   | 8. punching _____   |
| 4. order _____      | 9. understand _____ |
| 5. account _____    | 10. machinery _____ |

Arrange the above words in **ALPHABETICAL ORDER**

Write the words in the spaces below.

- |          |           |
|----------|-----------|
| 1. _____ | 6. _____  |
| 2. _____ | 7. _____  |
| 3. _____ | 8. _____  |
| 4. _____ | 9. _____  |
| 5. _____ | 10. _____ |

## PHRASES

Directions: Draw a line under the phrases from Chapter 6.

1. two thousand business cards
2. a cable car ride in Kalamazoo
3. punching in at 8:30
4. joking with Mr. Del Monte
5. a master printer
6. try to please all customers

## FIND THE MISSING WORDS

Directions: Find the missing words in the story. Fill in the blanks. The paragraph number is the key to the answer.

1. Two thousand \_\_\_\_\_ (2) had to be printed.
2. Marty hoped to become a \_\_\_\_\_ (1) like his father.
3. The different departments were set in the building to help \_\_\_\_\_ (3) run smoothly.
4. Marty is learning the printing business. He is a printer's \_\_\_\_\_ (1).
5. Hi-Way Printing tries to please all \_\_\_\_\_ (2).
6. Danny said he would be \_\_\_\_\_ (4) at 8:30 on Tuesday.
7. The \_\_\_\_\_ (3) for business cards was for a big \_\_\_\_\_ (3).
8. Marty walked Danny to the employees \_\_\_\_\_ (4).
9. Danny will find his \_\_\_\_\_ (4) in the rack next to the \_\_\_\_\_ (4).
10. Marty said the \_\_\_\_\_ (2) would have to be quick.

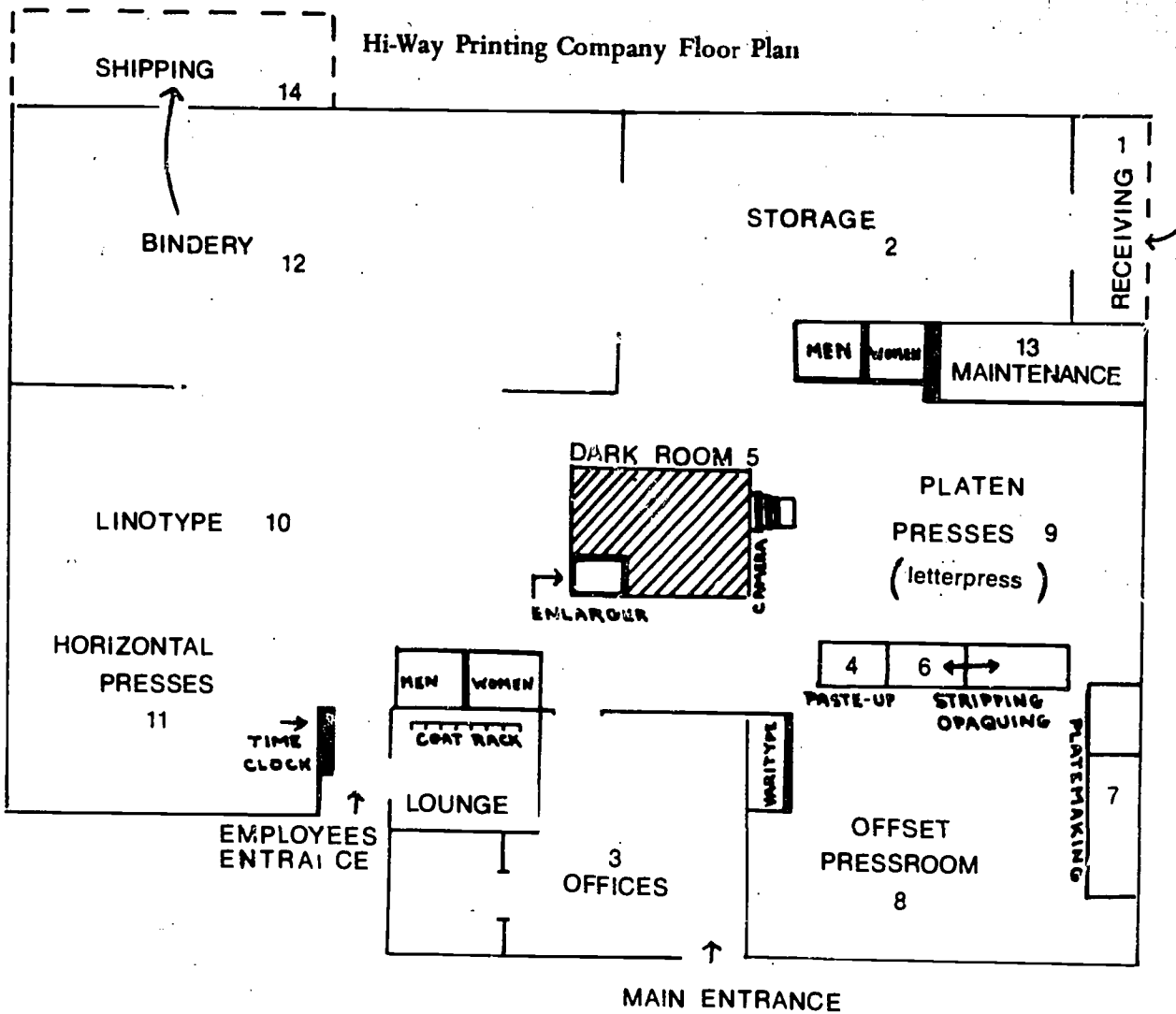

Listed below are some of the equipment and supplies Danny saw in the different departments.

**STORAGE**

paper  
ink  
camera film  
rubber cement  
chemicals for developing  
and printing

**DARKROOM**

copy camera (rear)  
enlarger  
developing tank

**OFFSET PRESSROOM**

ATF Chief  
Multilith press  
AB Dick duplicator  
platemaker  
light table  
goldenrod paper  
red tape  
metal ruler

**LINOTYPE**

Linecasting  
machines (hot type)

**BINDERY**

paper cutters  
foot stapler  
folder  
hole puncher  
stitcher  
adhesive  
cord  
padding rack

**HORIZONTAL PRESSES**

Miehle No. 29 press  
Kelly cylinder press

See Glossary for word definitions.

## UNDERSTANDING A DIAGRAM

Directions: Refer to the Hi-Way Printing Company floor plan to answer the questions.

1. Which department is Number 1 on the diagram? \_\_\_\_\_
2. The main entrance opens into the \_\_\_\_\_
3. Name two machines Danny saw in the bindery department. \_\_\_\_\_  
\_\_\_\_\_
4. Shipping is located near what department? \_\_\_\_\_
5. Which entrance is near the time clock? \_\_\_\_\_
6. Name the three presses listed under Offset Pressroom. \_\_\_\_\_  
\_\_\_\_\_
7. What kind of press is near the linecasting machine? \_\_\_\_\_
8. What kind of paper is listed under Offset Pressroom? \_\_\_\_\_
9. What is shown as Number 6 on the diagram? \_\_\_\_\_
10. What is shown in the darkroom? See the diagram and the list to answer this question.  
Name two things. \_\_\_\_\_
11. What kind of press is under Platen Presses? \_\_\_\_\_
12. What is listed under Storage? \_\_\_\_\_  
\_\_\_\_\_

## THE BUSINESS CARD

The order blank below was filled out before the business cards could be printed for the Dykes Lumber Company. How many cards were ordered? \_\_\_\_\_ How much was the customer charged? \_\_\_\_\_ What color ink was used? \_\_\_\_\_ What weight was the paper? \_\_\_\_\_

Hi-Way Printing Company 122 Route 17 Parma, New Jersey 262-7001			
Order No. 6170	Date 3/15	Due Date	3/29
NAME <i>Dykes Lumber Company</i>			
ADDRESS <i>1901 Park Avenue</i>			
CITY <i>Weehawken</i>	STATE <i>New Jersey</i>	PHONE	<i>867-0391</i>
PRINTING	<input type="checkbox"/> 1,000	<input checked="" type="checkbox"/> 2,000	<input type="checkbox"/> 5,000 <input type="checkbox"/> 10,000    Cards
COLOR OF INK	<i>Black</i>		
PAPER WEIGHT	<i>Medium</i>	PAPER COLOR	<i>White</i>
TYPE STYLE <i>M34</i>			
TOTAL PRICE			<i>\$22.50</i>

<b>DYKES LUMBER COMPANY, INC.</b> 1901 PARK AVENUE WEEHAWKEN, N.J. 07087	
EDWIN L. FARRELL Sales Representative	Telephone (212) 929-3580 (201) 867-0391

## FILLING OUT AN ORDER BLANK

**Directions** Refer to the picture of the business card below to help you complete the Job Ticket.

Use the following information for completing the form.

1. Number of cards ordered: 5,000 at \$10.00 per 1,000; total price \$50.
2. Paper weight: medium.
3. Type Style: M36.
4. Paper color: cream.
5. Color of ink: dark brown

### JOB TICKET

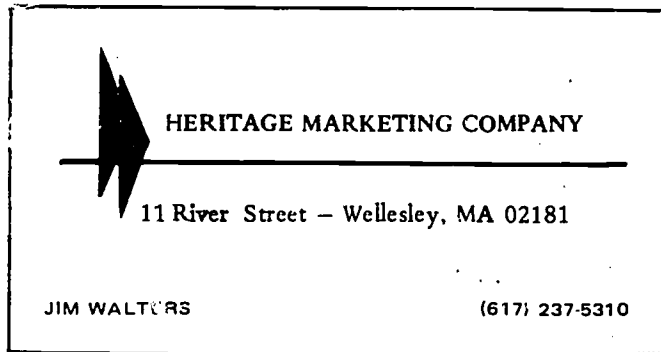

Order No. 6270	Date	Due Date
NAME		
ADDRESS		
CITY	STATE	PHONE
PRINTING	<input type="checkbox"/> 1,000 <input type="checkbox"/> 2,000	<input type="checkbox"/> 5,000 <input type="checkbox"/> 10,000    Cards
Color of ink		
Paper weight		Paper color
Type Style		
Total Price		



# DEVELOPING THE NEGATIVE – STEP 3

in the

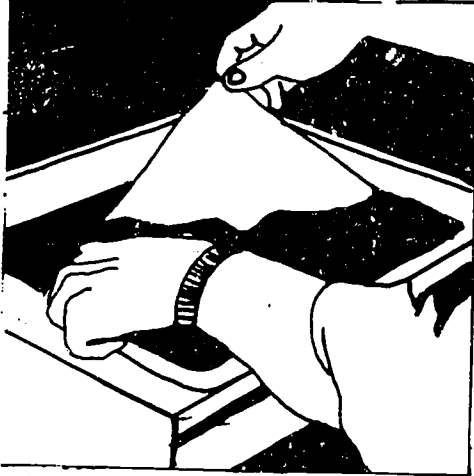
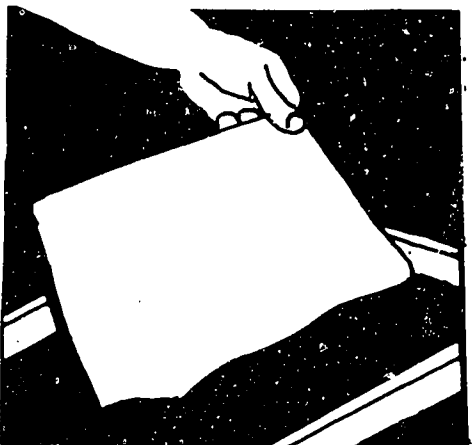
## OFFSET LITHOGRAPHY PROCESS

What You Need	How You Use It
 <p>1. One tray larger than the negative, developer, thermometer, clock and a darkroom.</p>	<p>a. Pour the developer into the tray. b. Dip the negative into the developer. c. Keep the negative in the developer for 3 minutes at 68 degrees. d. Remove negative and allow to drip until almost dry.</p> <p>This process is done in a <b>darkroom</b>.</p>
 <p>2. Fixer and another tray.</p>	<p><b>SAFETY TIP</b> – Do not mix chemicals in a darkroom unless there is an exhaust fan in operation. Do not inhale the fumes.</p> <p>a. Pour the fixer into the tray. b. Dip the negative into the fixer. c. Leave it in the fixer for 5 minutes.</p> <p>This process is also done in the <b>darkroom</b>.</p>
 <p>3. A sink and running water. A sponge.</p>	<p><i>A darkroom is not needed for this step.</i></p> <p>a. Thoroughly rinse the negative in running water for 5 to 10 minutes. b. Sponge the negative. Hang it to dry.</p>

**SAFETY TIP** – Wear rubber gloves to protect skin from chemicals.



## Developing the Negative

1. What materials are needed for Step 1? \_\_\_\_\_  
\_\_\_\_\_
2. Is Step 1 done in lots of light? \_\_\_\_\_
3. How large is the tray that holds the negative? \_\_\_\_\_
4. What is the recommended temperature for the developer? \_\_\_\_\_
5. In what kind of room is the fixing process done? \_\_\_\_\_
6. How many minutes must a negative remain in the fixer? \_\_\_\_\_
7. How many minutes are given to rinsing the negative? \_\_\_\_\_
8. What materials are needed for Step 2? \_\_\_\_\_  
\_\_\_\_\_
9. What is done with the negative after it is rinsed? \_\_\_\_\_  
\_\_\_\_\_
10. Which step need not be done in a darkroom? \_\_\_\_\_  
\_\_\_\_\_

## WORD FIND REVIEW

Directions: There are 21 words listed below. Find them in the puzzle. Draw a line around each word.

**FOR EXTRA CREDIT:** Look for other words in the puzzle. Draw a line around them. Add them to the list. Then arrange all the words in **alphabetical order**. Use the space below.

E	Z	N	G	F	R	O	A	B	D	F	A	Q	P	A
S	M	B	F	R	E	M	O	T	S	U	C	U	R	P
A	A	B	N	P	O	Y	Q	O	E	V	C	I	O	P
T	Z	E	A	L	A	R	M	U	N	I	O	C	D	O
U	E	S	T	R	X	A	Y	R	D	E	U	K	U	I
L	E	T	T	E	R	P	R	E	S	S	N	S	C	N
A	L	T	H	G	O	A	R	T	V	A	T	A	T	T
C	O	N	A	T	B	U	S	I	N	E	S	S	I	M
C	T	I	I	M	P	R	E	S	S	I	O	N	O	E
I	D	R	S	A	L	E	S	M	E	N	A	R	N	N
D	M	P	L	A	C	E	D	V	W	D	D	R	A	T
E	A	P	O	L	O	G	I	Z	E	E	S	T	A	Y
N	S	P	U	N	C	H	Q	P	R	O	G	R	A	M
T	T	C	L	O	C	K	A	P	P	L	I	E	D	E
Q	E	X	A	P	P	R	E	N	T	I	C	E	O	N
V	R	P	L	A	T	E	M	A	K	E	R	N	A	P

EMBARRASSED  
DEPART  
BUSINESS  
LETTERPRESS  
IMPRESSION  
CLOCK  
PLATEMAKER

PRODUCTION  
APOLOGIZE  
APPRENTICE  
MASTER  
APPLIED  
APPOINTMENT  
DIAGRAM

ORDER  
ACCOUNT  
CUSTOMER  
SALESMEN  
PLACED  
TOUR  
PUNCH

## "HOW DO I GET THERE?"

- (1) "Now that I have a job, how do I get there?" asked Danny. "Remember, we talked about it before you **applied**," answered Mrs. Greene. "You don't own a car yet. This is one reason you applied at Hi-Way Printing. You can use **public transportation** to get there."  
"That's right, now I remember, I can take a bus."
- (2) "I stopped at the Safe-Line **Bus Terminal** today," said Mrs. Greene. "I asked for a **bus schedule**. Let's have a look at it."
- (3) Danny looked at the schedule. He saw the tiny print. The words were crowded. There were many rows of numbers. "I'll never figure this out," complained Danny.  
"It isn't easy a. first," said Mrs. Greene. "Let's find when the bus **departs** and **arrives**. Draw a line under the **information**. The line makes the **timetable** easier to read. Keep the schedule with you. Your wallet is a good place to hold it."

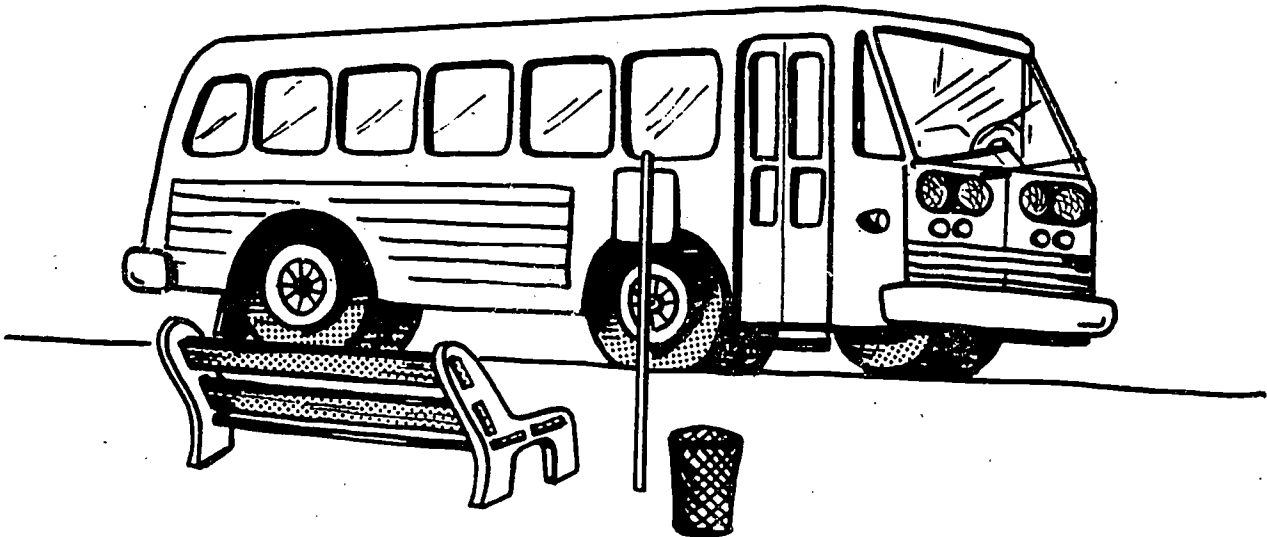

- (4) Mrs. Greene helped Danny understand the timetable. The Number 10 bus looked best. It departs at 7:55 a.m. at the corner of Main Street and Pine Street. The bus arrives at Ridge Road at 8:15 a.m. Danny would have to walk one block to Hi-Way Printing. He could easily be at work by 8:30 a.m.
- (5) Danny folded the bus schedule and put it in his wallet. "I'll take a walk to the bus stop now, Mom. I want to know how many minutes the walk will take."
- (6) Danny walked three blocks to Main Street. It took seven minutes. He saw the sign that said BUS STOP. There was a bench on the sidewalk. In front of the bench, the curb was painted yellow. A bus pulled over to the yellow curb. **Passengers** got on and off the bus. Danny thought, "In a few days, I'll be a passenger too."

### MATCH THE WORDS WITH THEIR MEANINGS

Directions: The words in the list match the meanings below. Write the correct words in the blanks beside the meanings.

applied (1)	departs (3)
public transportation (1)	arrives (3)
bus terminal (2)	timetable (3)
bus schedule (2)	passengers (6)

- |          |  |
|----------|--|
| 1. _____ | (3) leaves, goes away, opposite of arrives.  |
| 2. _____ | (3) a schedule of trains or buses etc., showing the time of arrival and departure. |
| 3. _____ | (3) to come to a place, to get there; opposite of departs.                         |
| 4. _____ | (6) travelers in a bus, train, boat, etc.  |
| 5. _____ | (1) to make application for a job.   |
| 6. _____ | (2) a bus timetable.   |
| 7. _____ | (1) travel for the people. A way to travel that is not private.                    |
| 8. _____ | (2) a bus station; either end of a bus line.                                       |

## WORD REVIEW

Directions: Write a sentence for each of the words below.

1. tour

2. order

3. customer

1. \_\_\_\_\_
2. \_\_\_\_\_
3. \_\_\_\_\_

## SPLITTING WORDS

Directions: Divide the words into syllables. Use the **dictionary** for this activity.

- |                   |          |              |       |
|-------------------|----------|--------------|-------|
| 1. applied        | ap-plied | 6. arrive    | _____ |
| 2. public         | _____    | 7. timetable | _____ |
| 3. transportation | _____    | 8. passenger | _____ |
| 4. terminal       | _____    | 9. Danny     | _____ |
| 5. depart         | _____    | 10. wallet   | _____ |

Arrange the above words in **ALPHABETICAL ORDER**

Write the words in the spaces below.

- |          |           |
|----------|-----------|
| 1. _____ | 6. _____  |
| 2. _____ | 7. _____  |
| 3. _____ | 8. _____  |
| 4. _____ | 9. _____  |
| 5. _____ | 10. _____ |

## MORE THAN ONE

Write the plural for each word. Use the correct word ending. For words ending in y, remember to change the y to i and add es. Add s or es to the other words.

Examples: city – cities; state – states

employee \_\_\_\_\_

office \_\_\_\_\_

press \_\_\_\_\_

process \_\_\_\_\_

company \_\_\_\_\_

production \_\_\_\_\_

duplicator \_\_\_\_\_

copy \_\_\_\_\_

### KNOWING THE FACTS

Directions: Write Yes or No after each sentence.

1. Danny can use public transportation to get to work. \_\_\_\_\_
2. Danny walked 33 blocks to the bus stop. \_\_\_\_\_
3. A bus schedule and a bus timetable are the same. \_\_\_\_\_
4. The bus arrives at Ridge Road at 8:14 a.m. \_\_\_\_\_
5. Danny folded the bus schedule and put it in his bonnet. \_\_\_\_\_
6. A bus pulled over to the yellow curb. \_\_\_\_\_
7. A timetable tells you when buses depart and arrive. \_\_\_\_\_
8. A person who travels on a bus is called a passenger. \_\_\_\_\_
9. Traveling by bus is private transportation. \_\_\_\_\_
10. Danny applied for a job at Hi-Way Printing because he could use public transportation to get to work. \_\_\_\_\_

### OUT-OF-SIGHT LETTERS

Hidden in these lines are 20 letters. Find them and list them in the numbered blanks.

- |          |           |           |           |
|----------|-----------|-----------|-----------|
| 1. _____ | 6. _____  | 11. _____ | 16. _____ |
| 2. _____ | 7. _____  | 12. _____ | 17. _____ |
| 3. _____ | 8. _____  | 13. _____ | 18. _____ |
| 4. _____ | 9. _____  | 14. _____ | 19. _____ |
| 5. _____ | 10. _____ | 15. _____ | 20. _____ |

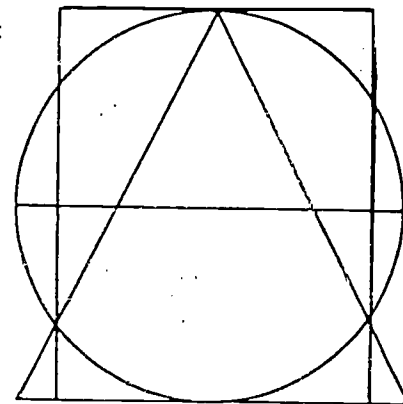

## BUS SCHEDULE

Directions: Refer to the timetable to answer the questions below.

SAFE LINE		RUMSEY – PARMA Timetable			
Bus Numbers	4	6	18	10	22
	A. M. Daily	A. M. Daily	A. M. Sun. Hol.	A. M. Daily	A. M. Daily
Rumsey	6:49	7:19	7:45	7:49	8:19
Glenwood	6:55	7:25		7:55	8:25
Allenville	7:01	7:31	Express ↓	8:01	8:31
Walden	7:06	7:36		8:06	8:36
Hokus	7:11	7:41		8:11	8:41
Ridge Rd. Parma	7:15	7:45		8:15	8:45
Parma Terminal Rte. 17	7:19	7:49	8:15	8:19	8:49

Hol. – Holiday

1. What time does the Number 10 bus stop in Rumsey? \_\_\_\_\_
2. What is the next stop after Rumsey on the Number 10 bus? \_\_\_\_\_
3. The express bus is Number \_\_\_\_\_? On what days does it run? \_\_\_\_\_
4. If Danny took the Number 22 bus to work, what time would he get to Ridge Road?  
\_\_\_\_\_ Would he get to work on time? \_\_\_\_\_
5. What time does the Number 6 bus arrive at the Parma Terminal? \_\_\_\_\_
6. The Number 4 bus arrives in Waldon at \_\_\_\_\_ A.M.

See if you can understand these schedules. Which buses go from Mahwah to Paramus?  
Which buses go from Paramus to Ramsey?

**OAKLAND—FRANKLIN LAKES—WYCKOFF—NEW YORK  
MAHWAH—FARDALE—RAMSEY—NEW YORK Via North Central Avenue**  
Daily except Saturdays, Sundays and Holidays

**TABLE NO. 10**  
6:30-9:00

	526 AM	500 AM	350 AM	502 AM	352 AM	504 AM	506 AM	508 AM	354 AM	510 AM	356 AM	528 AM
Mahwah, W. Arden St. & Island Rd., N.J.			6:30		6:30				6:30			6:30
Ramsey, W. Main St. & N. Cent. Ave., N.J.			6:31		6:31				6:31			6:31
Fardale, Forest Road, Mahwah, N.J.			6:31		6:31				6:31			6:31
Mahwah Jct., Routes 7 & 202, N.J.			6:31		6:31				6:31			6:31
Deerhaven, Route 202, Mahwah, N.J.			6:31		6:31				6:31			6:31
Munichia Blvd. & Seneca Ave., Oak., N.J.			6:31		6:31				6:31			6:31
Haworth Blvd. & 174th Ave., Oak., N.J.			6:31		6:31				6:31			6:31
Stony Ave. & Rte. 202, Oakland, N.J.			6:31		6:31				6:31			6:31
Lk. Shore Dr. & Powder Mill Rd., Oak., N.J.			6:31		6:31				6:31			6:31
<b>OAKLAND, R.R. Sta., Rte. 202, N.J.</b>			6:31		6:31				6:31			6:31
Colonial Rd. & Rte. 202, Fr. Lakes, N.J.			6:31		6:31				6:31			6:31
Franklin Lakes, Franklin Ave., N.J.			6:31		6:31				6:31			6:31
Wyckoff, Franklin & Wyckoff Ave., N.J.			6:43		6:43				6:43			6:43
Wyckoff, Russell & Wyckoff Ave., N.J.			6:43		6:43				6:43			6:43
Wyckoff, Grandview & Wyckoff Ave., N.J.			6:43		6:43				6:43			6:43
Wyckoff, Grandview Ave. & Route 202, N.J.			6:43		6:43				6:43			6:43
Wyckoff, Franklin & Gordon Ave., N.J.			6:43		6:43				6:43			6:43
<b>WALDWICK, Crescent Ave., N.J.</b>			6:45		6:45				6:45			6:45
Waldwick, Fk'n Tpk. & Wyckoff Ave., N.J.			6:45		6:45				6:45			6:45
Hobokus, Franklin Tpk., N.J.			6:45		6:45				6:45			6:45
Holmgrove Ave., Route 17, N.J.			6:45		6:45				6:45			6:45
<b>PARAMUS, Route 17, N.J.</b>			6:45		6:45				6:45			6:45
<b>PORT AUTHORITY BUS TERMINAL</b> 83rd St. & 9th Ave., N.Y.C.	6:45	6:45	6:45	6:45	6:45	6:45	6:45	6:45	6:45	6:45	6:45	6:45

**NEW YORK—WYCKOFF—FRANKLIN LAKES—OAKLAND  
NEW YORK—RAMSEY—FARDALE—MAHWAH Via North Central Avenue**  
Daily except Saturdays, Sundays and Holidays

**TABLE NO. 4**  
6:30-7:30

	625 PM	527 PM	501 PM	351 PM	503 PM	505 PM	507 PM	353 PM	509 PM	355 PM	511 PM	529 PM
<b>PORT AUTHORITY BUS TERMINAL</b> 83rd St. & 9th Ave., N.Y.C.	6:45	6:45	6:00	6:10	6:15	6:25	6:30	6:30	6:48	6:50	6:10	6:15
<b>PARAMUS, Route 17, N.J.</b>	6:10	6:00		6:35				6:55		6:15		6:40
Holmgrove Ave., Route 17, N.J.	6:15	6:05		6:40				6:00		6:20		6:45
Hobokus, Franklin Tpk., N.J.	6:22	6:12		6:50				6:10		6:30		6:52
Waldwick, Fk'n Tpk. & Wyckoff Ave., N.J.	6:25	6:15		6:55				6:15		6:35		6:55
<b>WALDWICK, Crescent Ave., N.J.</b>	6:31	6:21		6:00				6:20		6:40		6:01
Wyckoff, Franklin & Gordon Ave., N.J.	6:35	6:25		6:05				6:25		6:45		6:06
Wyckoff, Grandview Ave. & Route 202, N.J.		6:45	6:45	6:00	6:00			6:30	6:30	6:45		
Wyckoff, Grandview & Wyckoff Ave., N.J.		6:46	6:46	6:01	6:01			6:31	6:31	6:46		
Wyckoff, Russell & Wyckoff Ave., N.J.		6:46	6:46	6:01	6:01			6:31	6:31	6:46		
Wyckoff, Franklin & Wyckoff Ave., N.J.	6:40	6:30	6:55	6:05	6:05			6:27	6:27	6:47		6:08
Franklin Lakes, Franklin Ave., N.J.	6:40	6:30	6:55	6:05	6:05			6:27	6:27	6:47		6:11
Allen Ave. & Franklin Ave., Oakland, N.J.	6:43	6:32	6:57	6:12	6:12			6:27	6:27	6:47		6:13
Shelley St. & Route 202, Oakland, N.J.	6:45	6:34	6:59	6:13	6:13			6:27	6:27	6:47		6:15
<b>OAKLAND, R.R. Sta., Route 202, N.J.</b>	6:45	6:38	6:03	6:13	6:13			6:27	6:27	6:47		6:15
Powder Mill & Lake Shore Dr., Oak., N.J.	6:45	6:40	6:05	6:13	6:13			6:27	6:27	6:47		6:19
Stony Ave. & Route 202, Oakland, N.J.	6:45	6:43	6:08	6:13	6:13			6:27	6:27	6:47		6:21
Deerhaven, Route 202, Mahwah, N.J.	6:45	6:51	6:16	6:13	6:13			6:27	6:27	6:47		6:24
Mahwah Jct., Routes 7 & 202, N.J.	6:45	6:51	6:16	6:13	6:13			6:27	6:27	6:47		6:26
Fardale, Forest Road, Mahwah, N.J.	6:45	6:55	6:20	6:14	6:14			6:27	6:27	6:47		6:30
Ramsey, W. Main St. & N. Cent. Ave., N.J.				6:20	6:20			6:27	6:27	6:47		6:35
Mahwah, W. Arden St. & Island Rd., N.J.				6:25	6:25			6:27	6:27	6:47		6:35
<b>PORT AUTHORITY BUS TERMINAL</b> 83rd St. & 9th Ave., N.Y.C.	6:45	6:45	6:45	6:45	6:45	6:45	6:45	6:45	6:45	6:45	6:45	6:45



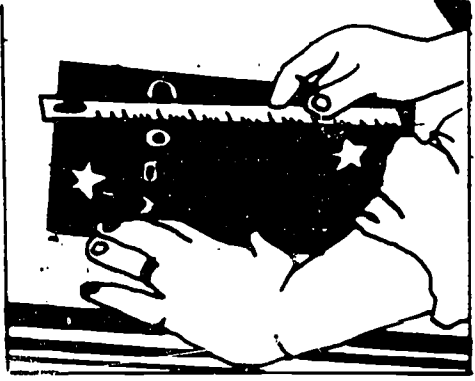
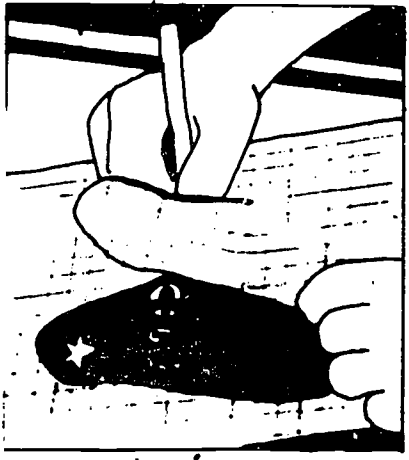
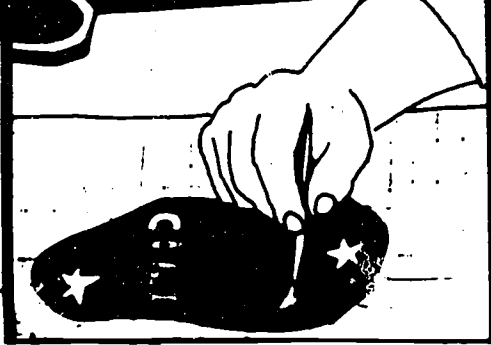

**STRIPPING AND OPAQUING – STEP 4**  
in the  
**OFFSET LITHOGRAPHY PROCESS**

What You Need	How You Use It
 <p>1. Light table, goldenrod paper, negative, T-square, tape.</p>	<p>a. Place goldenrod paper on the light table. Square the paper with the straight edges. Tape the goldenrod to the table.</p> <p>b. With the emulsion (dull) side up, place the negative on the goldenrod. Use a T-square for correct positioning.</p> <p>c. Tape the negative to the goldenrod.</p> <p style="text-align: center;"><b>You now have a flat.</b></p>
 <p>2. A flat, Exacto knife or a single edge razor blade.</p>	<p>a. Turn the flat over. Carefully cut away the goldenrod paper allowing the negative to show. Only the area to be printed should show.</p> <p>b. Take care not to cut through the negative.</p> <p style="text-align: center;"><b>You now have a stripped flat.</b></p> <p><b>SAFETY TIP</b> – When cutting, keep fingers away from the blade.</p>
 <p>3. Opaque paint, a small pointed paint brush.</p>	<p>To opaque the negative</p> <p>a. Use opaque paint and a brush to paint out scratches and unwanted areas on the negative.</p> <p>b. It is now ready for the “burning-in” step.</p>

## STRIPPING AND OPAQUING

1. What materials are needed for Step 1? \_\_\_\_\_
2. Which side of the negative is facing up when attached to the goldenrod paper? (1b.)  
\_\_\_\_\_
3. What is used to cut the goldenrod paper? \_\_\_\_\_
4. Does a flat hold a negative in the proper position for making a plate? \_\_\_\_\_
5. An Exacto knife or razor blade should cut through the negative. Answer yes or no.  
\_\_\_\_\_
6. What kind of paint is used to fill up little holes or scratches in a negative? \_\_\_\_\_
7. The flat gets burned into the (3b.) \_\_\_\_\_
8. Check the position of the negative with a (1b.) \_\_\_\_\_
9. When cutting, keep fingers away from the (2) \_\_\_\_\_

## Chapter 8

### SOME GOOD ADVICE

- (1) The bell rang at 8:30 a.m. The school doors opened, and Danny entered the building with a crowd of students. Mr. Del Monte, the principal, saw Danny. He greeted him with a big smile and said, "Congratulations Danny! I heard you got the job." Mr. Del Monte gave Danny a friendly handshake.
- (2) When the homeroom period ended, Danny went to his shop class. He went straight to his teacher. "Mr. Russo, I've got a problem," said Danny. "I begin my new job on Tuesday. Mr. Golden is starting me on paste-ups. I want to make a good **impression**. But pasting up copy has never been my 'thing.' What am I going to do?"
- (3) "I wouldn't worry," said Mr. Russo. You may not be great with paste-ups. But you have a good idea of what it's all about. I know Mr. Golden. I know how he **breaks in** beginners. You are in a work-study **program**. You aren't expected to be a master yet. You have two school days before Tuesday. You can use them to review what you have learned. You'll feel more confident if you review."
- (4) "I'm going to goof, I know. I wish Mr. Golden would start me on **platemaking**. Platemaking is my thing," said Danny. "I'll tell him on Tuesday, right after I punch in."
- (5) "You'll have to understand this," said Mr. Russo. "When you are employed, you are not the boss. The boss runs his business in his own way. He wants to start you on paste-ups, so that's what you'll do. Okay? We know you're a good platemaker. Mr. Golden will find out. But he'll find out in his own way."
- (6) Danny knew he could trust Mr. Russo. He never pulled any punches. You didn't have to guess what he was trying to tell you. At first, Danny thought Mr. Russo was hard on his students. When he got to know him, Danny liked and **respected** him.
- (7) "I understand what you are saying," said Danny. "I might not have given a good impression of myself. Thanks for the good **advice**, Mr. Russo."  
"Anytime, Danny. Here is a paste-up job for you. It's for our yearbook. You can start reviewing now."

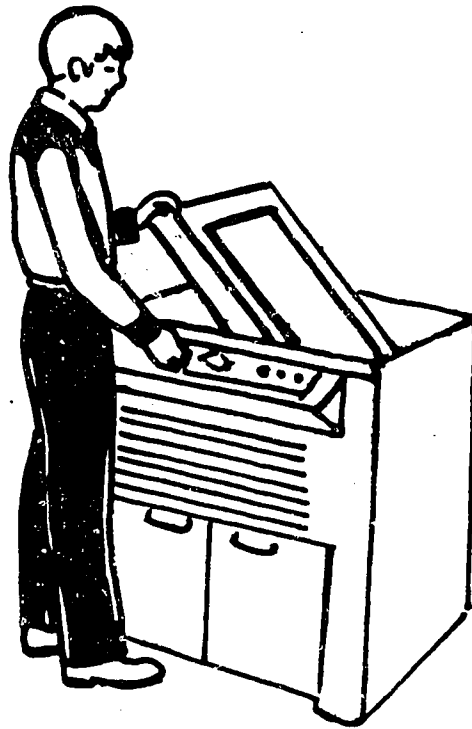

Flip Top Platemaker

**MATCH THE WORDS WITH THEIR MEANINGS**

Directions: The words in the list match the meanings below. Write the correct words in the blanks next to the meanings.

impression (1)  
program (2)

platemaking (3)  
break in (2)

respected (6)  
advice (7)

1. \_\_\_\_\_

(2) to train someone for work.

2. \_\_\_\_\_

(1) 1. What others think of you. 2. a printed copy. (see glossary)

3. \_\_\_\_\_

(6) Looked up to, or honored.

4. \_\_\_\_\_

(3) in offset printing, making a zinc or aluminum lithographic printing plate by a process called burning.

5. \_\_\_\_\_

(7) an opinion about what should be done.

6. \_\_\_\_\_

(2) a plan of what is to be done.

## WORD REVIEW

Synonyms are words having nearly the same meaning.

**Directions:** Complete each sentence. Fill in each blank with a word you can use **in place** of the underlined word. Choose from the words below. One word does not belong.

timetable          terminal          departs          passengers          advice

1. The bus \_\_\_\_\_ (leaves) at 7:20 a.m.
2. Danny looked at \_\_\_\_\_ (schedule) to find out when the bus would depart.
3. Danny will join the other \_\_\_\_\_ (travelers) on the bus.
4. Mrs. Greene got the timetable at the bus \_\_\_\_\_ (station).

## SPLITTING WORDS

**Directions:** Divide the words into syllables. Use the **dictionary** for this activity.

- |                      |                   |
|----------------------|-------------------|
| 1. impression _____  | 6. Marty _____    |
| 2. program _____     | 7. review _____   |
| 3. platemaking _____ | 8. students _____ |
| 4. respected _____   | 9. yearbook _____ |
| 5. advice _____      | 10. teacher _____ |

Arrange the above words in **ALPHABETICAL ORDER**

Write the words in the spaces below.

- |          |           |
|----------|-----------|
| 1. _____ | 6. _____  |
| 2. _____ | 7. _____  |
| 3. _____ | 8. _____  |
| 4. _____ | 9. _____  |
| 5. _____ | 10. _____ |

## OPPOSITES

An **antonym** is a word that means the opposite of another word.

**Directions:** Look at the words in the numbered list. Write in the **opposite** for each word.  
Choose from this group of words.

arrive          public          loose          confident          depart          hire

- |                |                    |
|----------------|--------------------|
| 1. firm _____  | 4. private _____   |
| 2. leave _____ | 5. unsure _____    |
| 3. fire _____  | 6. get there _____ |

**BURNING A PLATE – STEP 5**  
in the  
**OFFSET LITHOGRAPHY PROCESS**

An offset plate has an **emulsion** on it. The emulsion is sensitive to light. When a special kind of light passes through the negative on the flat, the emulsion hardens. A picture of what is to be printed is now on the plate. When the plate is developed, the emulsion, which has not been exposed to the light, is sponged off.

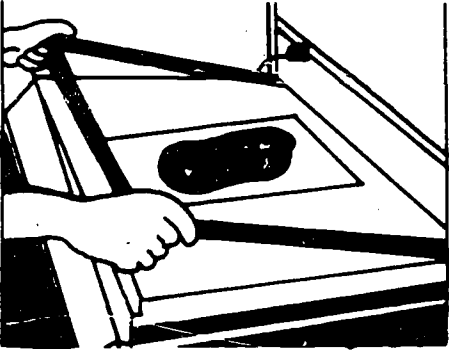
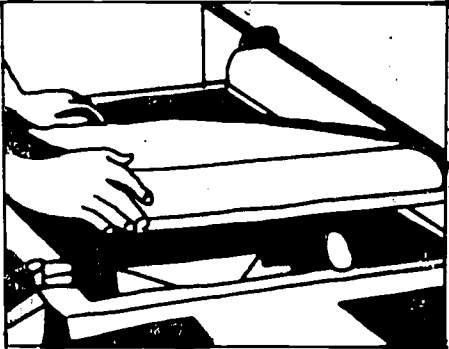
What You Need	How You Use It
<p>1. A Plate Maker and a Photosensitive Plate usually made of aluminum.</p>	<p>a. Place the flat on the sensitized plate with emulsion side up.</p> <p>b. The flat must cover the entire plate.</p>
 <p>2. A Vacuum Frame</p>	<p>a. Place the flat and plate on the vacuum frame.</p> <p>b. Close the glass over the frame.</p> <p>c. Be sure the flat is in perfect position.</p> <p>d. Set the vacuum pressure at 25 to 30 pounds.</p>
 <p>3. Carbon Arc Light or a No. 1 Photoflood Lamp. This will depend on the type of plate maker being used.</p>	<p>a. Turn on the light. Expose the plate to the light.</p> <p>b. With No. 1 photoflood, expose for 8 minutes.</p> <p>c. With carbon arc, expose for 2 minutes.</p> <p><b>WARNING:</b> Do not look at the carbon arc light when it is burning. It will damage your eyes.</p>

## BURNING A PLATE



Some types of offset plates are **presensitized**. This means that the emulsion has been applied by the plate manufacturer. Plates made of aluminum are widely used. Plates are also made of plastic, paper, zinc, steel, and a mixture of metals.

Answer the following questions:

1. What kind of machine is used to burn a plate? \_\_\_\_\_
2. What is the flat placed on? (1a.) \_\_\_\_\_
3. Is the emulsion side up?(1a.) \_\_\_\_\_
4. What are sensitized plates often made of? (1) \_\_\_\_\_
5. The flat and plate are placed on the (2a.) \_\_\_\_\_
6. What closes over the frame? \_\_\_\_\_
7. How many pounds of pressure are needed to hold the plate in position? (2d.) \_\_\_\_\_
8. Name two kinds of lights used for burning a plate. (3) \_\_\_\_\_
9. How many minutes should the negative be exposed when using a No. 1 photoflood light? \_\_\_\_\_
10. How many minutes should the negative be exposed when using a carbon arc light? \_\_\_\_\_ Should you look at the light? \_\_\_\_\_

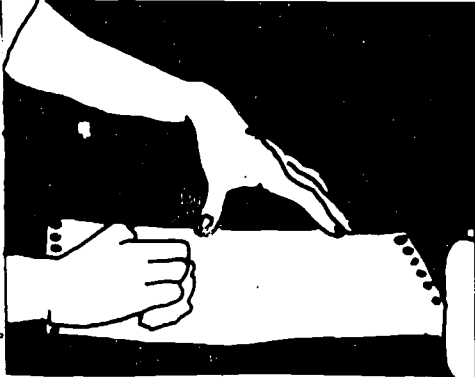

**DEVELOPING A PLATE – STEP 6**  
in the  
**OFFSET LITHOGRAPHY PROCESS**

What You Need	How You Use It
 <p>1. Gum Arabic Solution, Sponge</p>	<p>a. Place plate on a clean dry surface.</p> <p>b. Pour a small amount of gum arabic on the plate.</p> <p>c. Spread the solution over the entire plate with a sponge.</p> <p>d. Remove excess gum. Leave a thin coat on the plate.</p>
 <p>2. Developer and another Sponge, Gum Arabic Solution:</p>	<p>Before the gum dries:</p> <p>a. Pour about a teaspoon of the developer on the plate.</p> <p>b. Use a clean sponge to rub the developer into the plate. Do so in a circular motion.</p> <p>c. Rub until a clear image (picture) appears. Add a little gum if the developer begins to dry.</p>
 <p>3. Water and a Soft Clean Cloth, Gum Arabic Solution, Sink</p>	<p><b>SAFETY TIP</b> – If skin is sensitive, wear rubber gloves. Label all containers holding chemicals.</p> <p>a. Wash the plate with luke warm water.</p> <p>b. Sponge off excess water.</p> <p>c. Apply gum again.</p> <p>d. Polish it dry with a clean soft cloth.</p> <p>For small plates less than 14" X 20" it is not necessary to wash the plate before applying the gum.</p>

## DEVELOPING A PLATE

Answer the following questions:

1. Should a large amount of gum arabic be poured on the plate? (1b.) \_\_\_\_\_
2. What is used to spread the gum arabic solution evenly over the plate? (1c.) \_\_\_\_\_
3. A thick coat of gum arabic must remain on the plate. Answer yes or no. (1d.) \_\_\_\_\_
4. Use a circular motion to rub the developer into the plate. Answer yes or no. (2b.) \_\_\_\_\_
5. What is added if the developer begins to dry before you have finished using it? (2c.) \_\_\_\_\_
6. About how much developer is needed? (2a.) \_\_\_\_\_
7. What is used to wash the plate? (3) \_\_\_\_\_
8. What is used to make the image appear (2) \_\_\_\_\_
9. Is a sponge used to polish the plate until it is dry? \_\_\_\_\_
10. In this process we begin and end using the same liquid. What is the name of it? \_\_\_\_\_

**MATCH THE EXPRESSIONS**

**Directions:** Fill in the number of the picture that matches the **expression**.

"I'm worried about striking out in an interview." \_\_\_\_\_

"See you later, squirts." \_\_\_\_\_

He never pulls any punches. \_\_\_\_\_

It wasn't easy to make ends meet. \_\_\_\_\_

1.

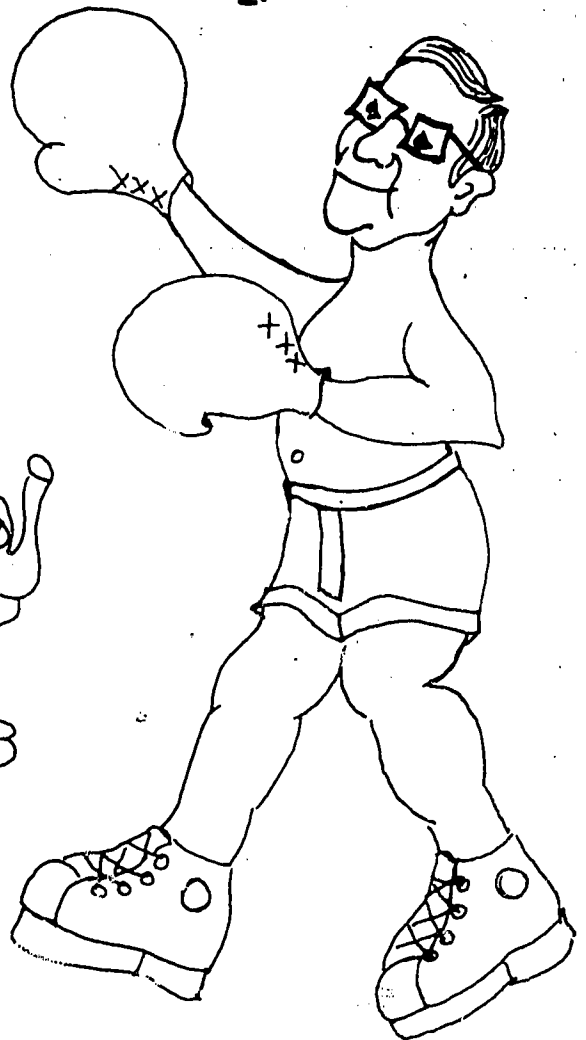

2.

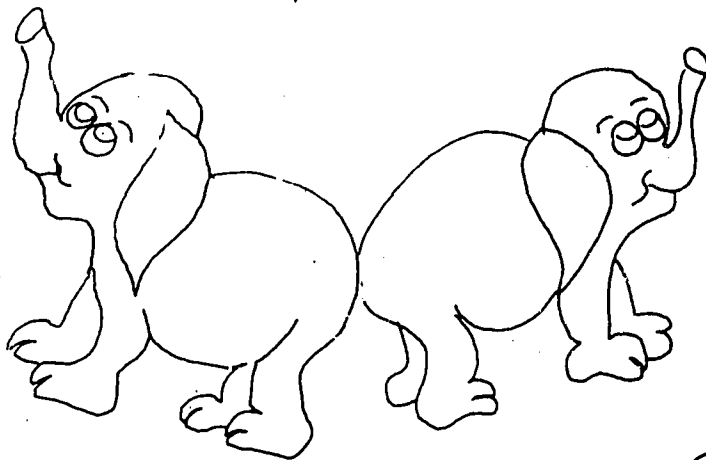

3.

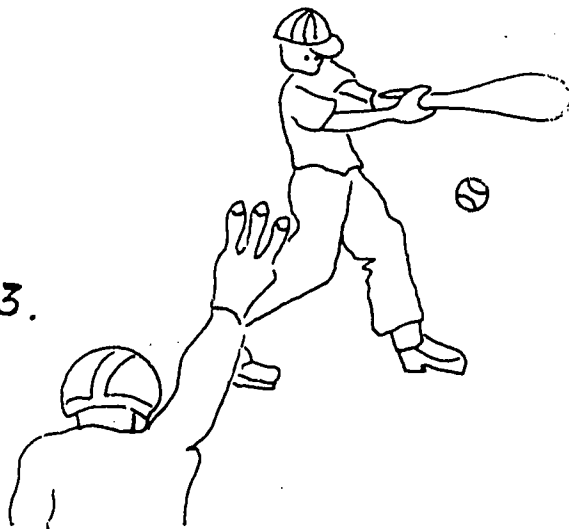

4.

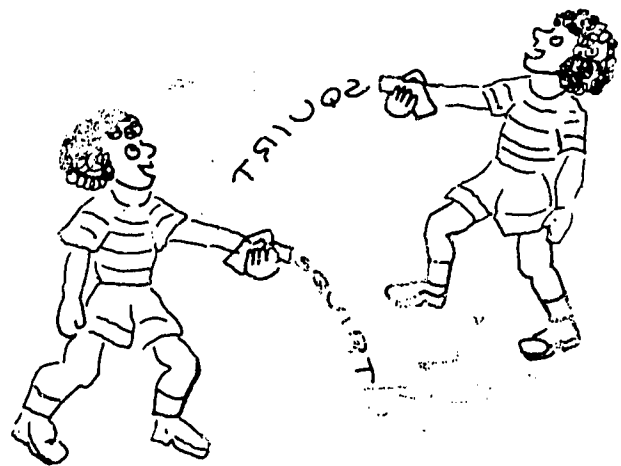

## DANNY MEETS THE CREW

- (1) "So far, so good," thought Danny. He had gotten to work on time. He found his time card, and he punched in. Then he went to the offset lithography department.
- (2) Danny looked around. Everyone was busy. The presses began to roll. Danny liked the familiar sound. He also knew the sound of the **VariTyper**. He heard sound coming from other rooms. He could hear the **folding machine** and the **foot stapler**. Someone had begun **operating** the **hole puncher**. These machines are in the **bindery room**. Danny thought, "The printing business is exciting."
- (3) Danny wanted to be busy too. He was getting a little nervous. When would he get started? Then he noticed a pretty girl with long dark hair. She walked up to him and said, "Good morning! You must be Danny. I'm Jodi. Mr. Golden told me to expect you. I guess you know you're doing paste-ups today. We'll be working together. We've got a busy day ahead. But we can take time out to meet the **crew**."
- (4) Danny was introduced to **Bill**, the **cameraman**. Sue was seated at the **light table**. Her job is **stripping** and **opaquing** the **negatives**. Tim was the man Danny was eager to meet. He is the **platemaker**. He met **Joe** and **Sal**. They do the **presswork**.
- (5) Danny knew he learned a lot at school. He wanted to get started. He also knew he was still having problems with paste-ups. Then he thought, "I may have problems, but this should be an interesting day. Jodi is even prettier than I imagined."

### MATCH THE WORDS WITH THEIR MEANINGS

Directions: There are three words to choose from for each meaning. Choose the **correct word**. Write it in the space next to the meaning. You can refer to the **glossary** for this activity.

1. A photographer (4) \_\_\_\_\_  
negatives                      operating                      cameraman
2. A composing machine for setting cold type in many typefaces. (2) \_\_\_\_\_  
foot stapler                      VariTyper                      presswork

3. Laying out the negatives on goldenrod paper according to the way it is to be printed.  
(4) \_\_\_\_\_  
light table    cameraman    stripping
4. A machine on a stand which staples when pressing a foot pedal. (2) \_\_\_\_\_  
foot stapler    folding machine    VariTyper
5. A group of people working together. (3) \_\_\_\_\_  
crew    opaquiring    operating
6. Painting out unwanted spots on a negative. (4) \_\_\_\_\_  
presswork    opaquiring    stripping
7. A machine for folding paper. (2) \_\_\_\_\_  
light table    foot stapler    folding machine
8. Light and dark reversed on film. (4) \_\_\_\_\_  
negative    presswork    crew
9. A layout table with a glass top under which a light is placed. (4) \_\_\_\_\_  
operating    light table    cameraman
10. A place where printed material is put together with adhesive, staples, thread, etc. (2)  
\_\_\_\_\_  
bindery room    opaquiring    VariTyper
11. Work produced on a printing press. (4) \_\_\_\_\_  
stripping    presswork    negative
12. Running a machine. (2) \_\_\_\_\_  
operating    crew    stripping

## SPELLING STAIRWAYS

Directions: Spell out the words in the squares. Choose from the words below. Two of the words under each puzzle will not fit.

l				t			
c					a		
s						r	
o							g

t				e			
o					e		
o						e	
s							r

1. arrive      light      opaquing  
stapler      camera      negative

2. crew      stripper      operate  
table      presswork      opaque

## SPLITTING WORDS

Directions: Divide the words into syllables. Use the **dictionary** for this activity.

1. VariTyper \_\_\_\_\_

7. table \_\_\_\_\_

2. folding \_\_\_\_\_

8. stripping \_\_\_\_\_

3. stapler \_\_\_\_\_

9. opaquing \_\_\_\_\_

4. bindery \_\_\_\_\_

10. negative \_\_\_\_\_

5. operating \_\_\_\_\_

11. presswork \_\_\_\_\_

6. cameraman \_\_\_\_\_

12. interesting \_\_\_\_\_

Arrange the above words in **ALPHABETICAL ORDER**

Write in the spaces below.

1. \_\_\_\_\_

7. \_\_\_\_\_

2. \_\_\_\_\_

8. \_\_\_\_\_

3. \_\_\_\_\_

9. \_\_\_\_\_

4. \_\_\_\_\_

10. \_\_\_\_\_

5. \_\_\_\_\_

11. \_\_\_\_\_

6. \_\_\_\_\_

12. \_\_\_\_\_

## FIND IT IN THE GLOSSARY

Look up the words **hole puncher** in the glossary. Write the meaning in the space below.

\_\_\_\_\_

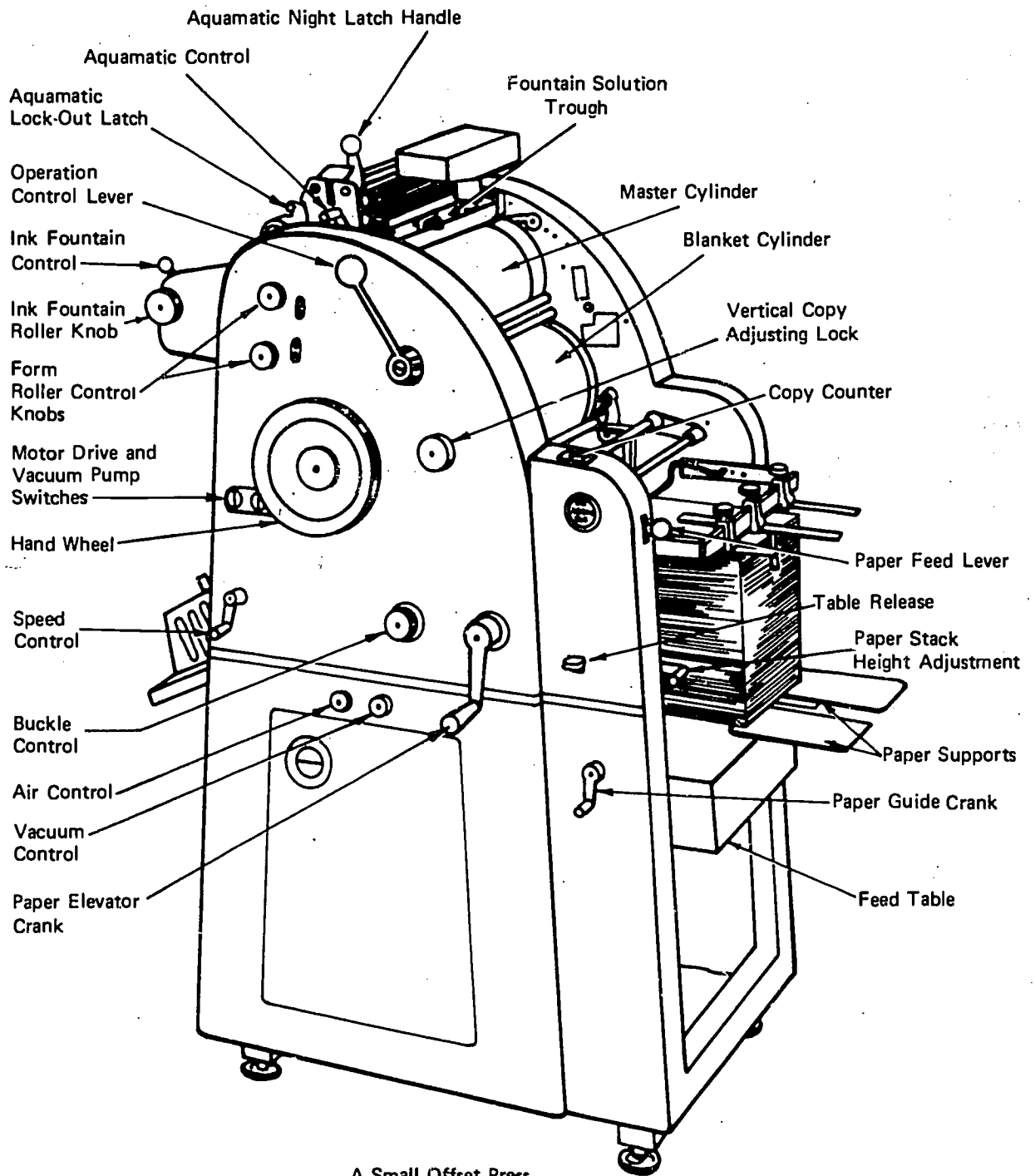

A Small Offset Press

Directions: Label the Parts.

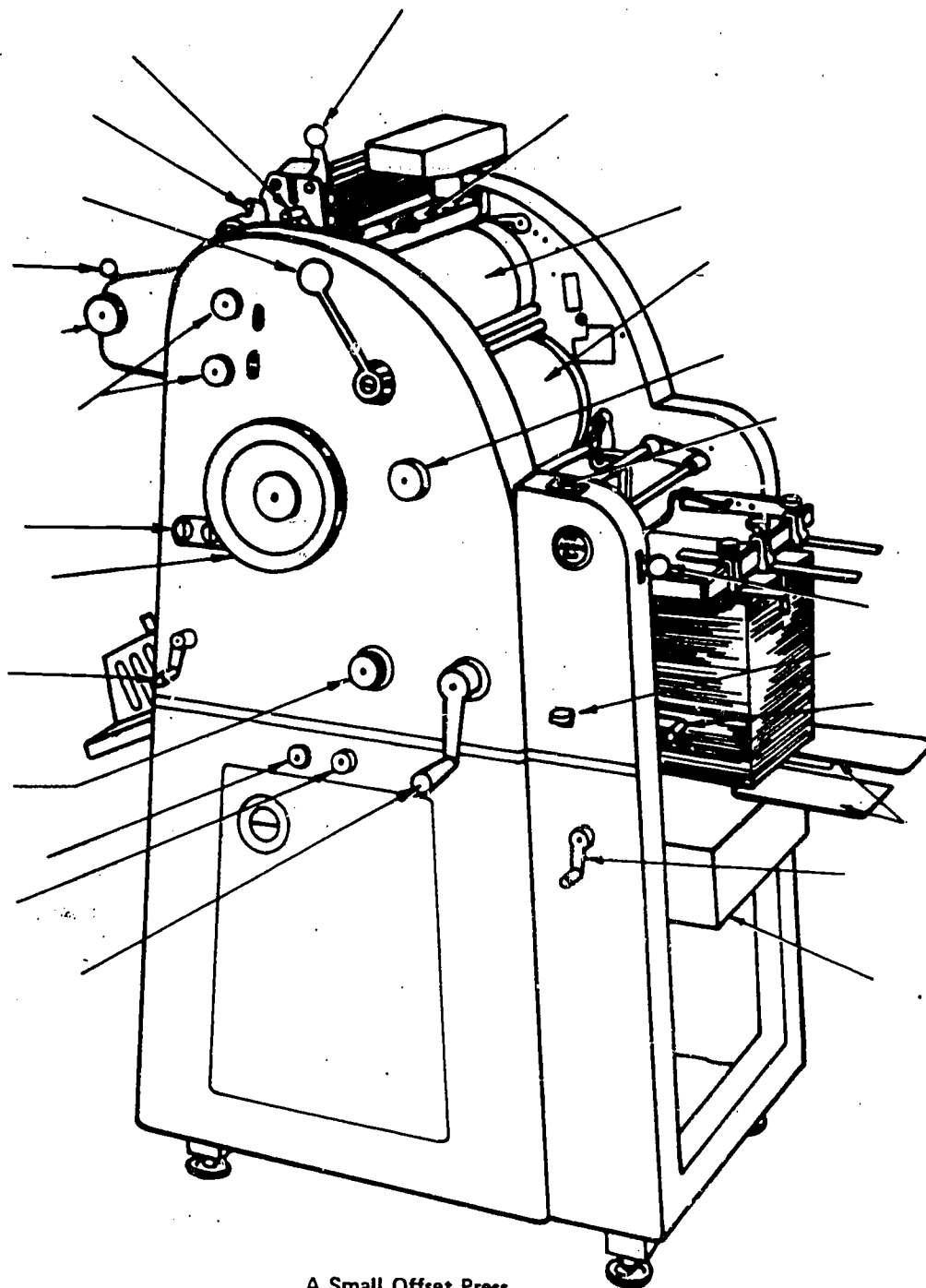

A Small Offset Press



**PRINTING FROM A PLATE – STEP 7**  
in the  
**OFFSET LITHOGRAPHY PROCESS**

The offset lithography process is based on the principle that **water and grease do not mix**. Before a plate is used for printing, it is made wet and then it is inked. The ink sticks only to the parts of the plate with the burned in picture. An offset press has two fountains, one for inking the plate and one for the water solution.

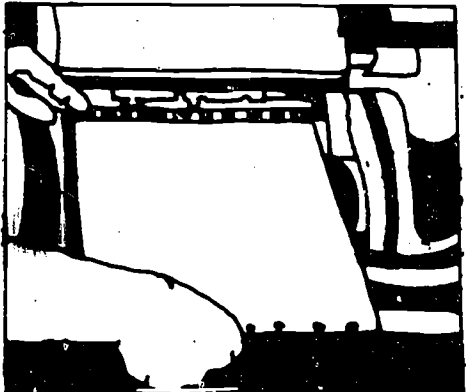
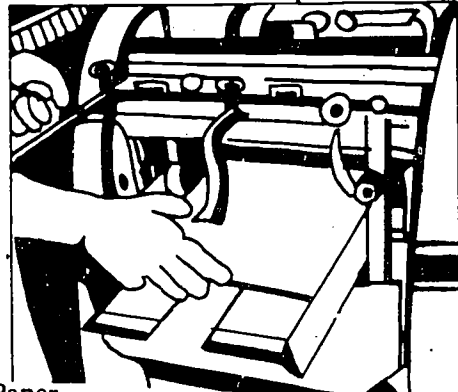
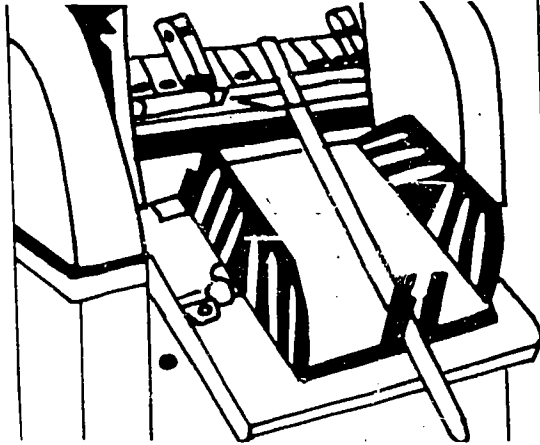
What You Need	How You Use It
 <p>1. An Offset Press, the Plate, Fountain Solution, Ink</p>	<ul style="list-style-type: none"> <li>a. Wet the plate with primary solution.</li> <li>b. Place the plate on the plate cylinder of the press.</li> <li>c. Mix the fountain solution. Pour it in the fountain.</li> <li>d. Run the press until the dampening rollers are wet.</li> <li>e. Pour the ink in the ink fountain.</li> <li>f. Ink flow is regulated with the ink adjusting screws.</li> </ul>
 <p>2. Paper</p>	<p><b>SAFETY TIP</b> Keep fingers away from moving rollers.</p> <ul style="list-style-type: none"> <li>a. Set the feeder for the size of paper (stock).</li> <li>b. Test by running some blank sheets through the machine.</li> <li>c. Start the press. Turn on the fountain solution and ink rollers. Set the impression lever.</li> </ul>
 <p>3. Gum Arabic, Cleaning Solution, Sponge</p>	<p><b>SAFETY TIP</b> Never clean a press in motion without supervision.</p> <ul style="list-style-type: none"> <li>a. Check for quality of printing.</li> <li>b. Keep the proper balance of ink and water.</li> <li>c. If too light, use less water. If too dark, use less ink.</li> <li>d. Complete the run. Carefully remove the freshly printed stock.</li> <li>e. Remove the plate. Coat it with light gum arabic solution.</li> <li>f. Wash the cylinders and rollers. Empty and wash the fountains.</li> </ul>

## PRINTING FROM A PLATE

Directions: Draw a line under the correct answer for each question:

1. The offset lithography process is based on the principle that
  - a. water and grease will mix.
  - b. ink and water will mix.
  - c. water and grease do not mix.
2. An offset press has two fountains,
  - a. one for cleaning the plate, the other is for the solution.
  - b. one is for inking the plate, the other is for the solution.
  - c. one for wetting the paper, one for inking the feeder.
3. The ink flow is regulated with the
  - a. plate cleaning fluid.
  - b. ink adjusting screws.
  - c. dampening rollers.
4. The ink is poured into the
  - a. well.
  - b. primary solution
  - c. ink fountain.
5. Another word for paper is
  - a. stock.
  - b. fountain.
  - c. press.
6. Set the feeder for the
  - a. size of the cylinder.
  - b. size of the paper.
  - c. for the birds.
7. Keep the proper balance of
  - a. gum arabic and cleaning solution.
  - b. ink and gum arabic.
  - c. ink and water.

8. The sponge is used to clean the
  - a. cylinders and rollers.
  - b. the stock.
  - c. the ink.
  
9. If the print is too light, use
  - a. more water.
  - b. less water.
  - c. less ink.
  
10. If the print is too dark, use
  - a. less ink.
  - b. more ink.
  - c. less water.

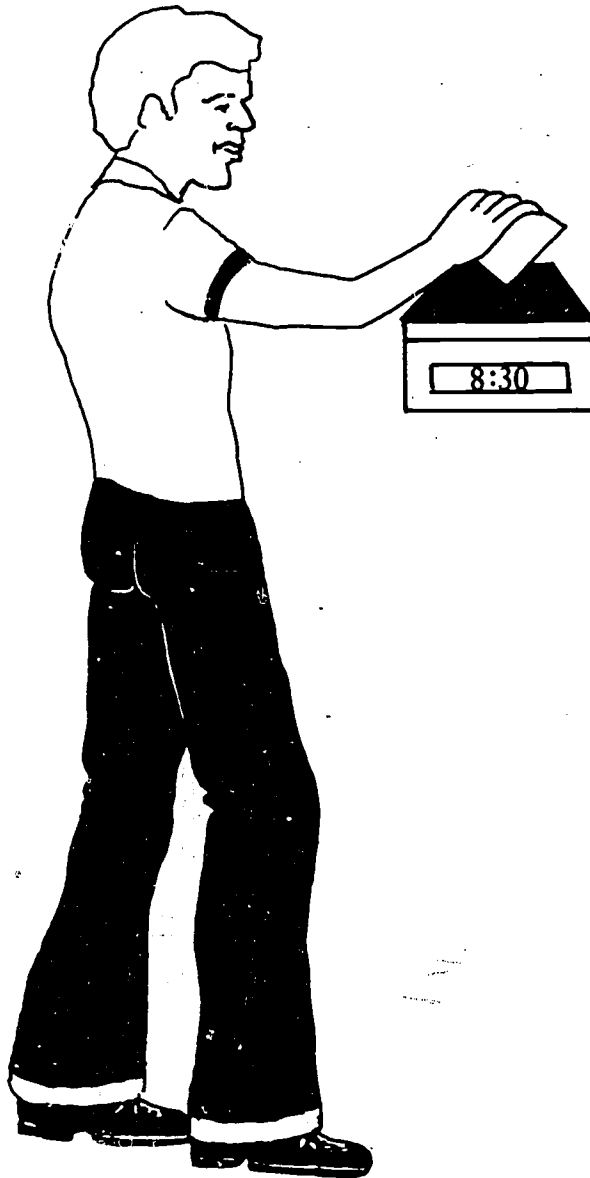
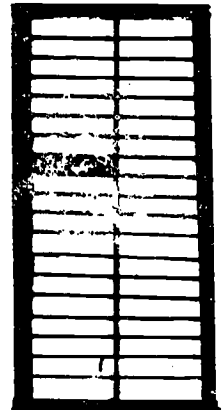
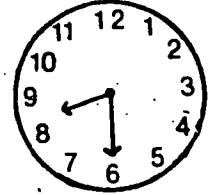

# MEASUREMENT FOR PRINTERS

## The Pica Ruler

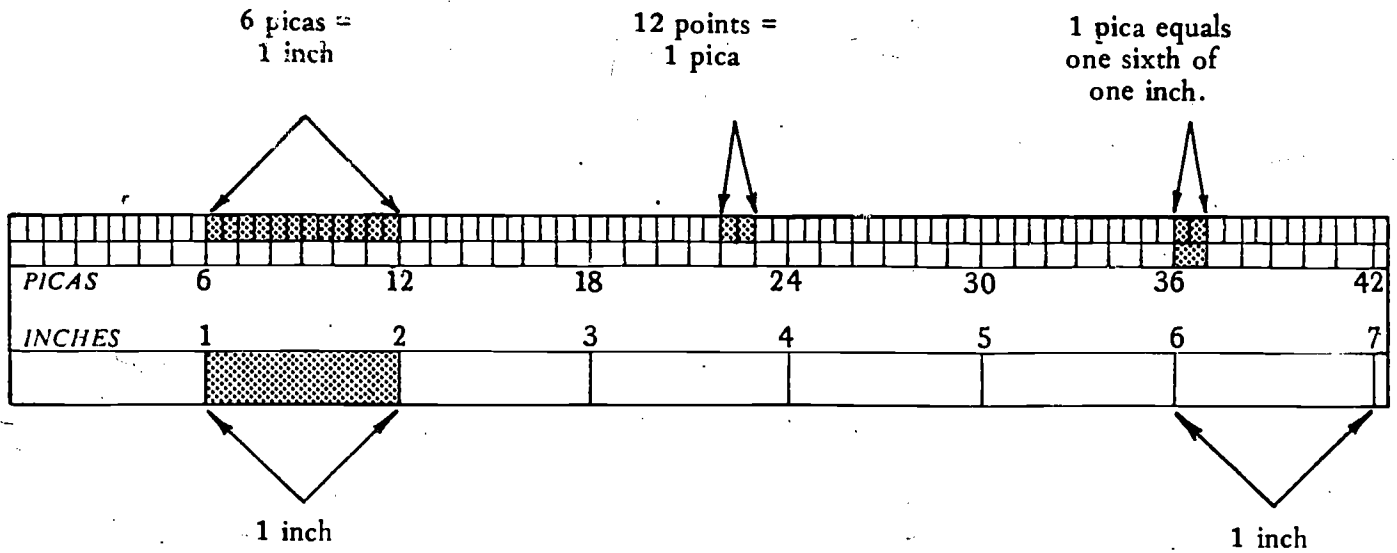

Directions: Use the scale above to answer the questions below.

- How many picas are in 1 inch? \_\_\_\_\_ How many picas in two inches? \_\_\_\_\_  
How many picas in 7 inches? \_\_\_\_\_
- How many points are in 1 pica? \_\_\_\_\_
- If you had to set a line of type 3 inches wide, how many picas would that be equal to?  
\_\_\_\_\_
- How many inches are on this ruler? \_\_\_\_\_ How many picas are on this ruler?  
\_\_\_\_\_
- How many picas to  $\frac{1}{2}$  inch? \_\_\_\_\_
- If you had to set a line of type 12 picas wide, how many inches would that equal?  
\_\_\_\_\_
- 2 picas equal \_\_\_\_\_ points.

## WORD FIND REVIEW

**Directions:** There are 21 words listed below. Find them in the puzzle. Draw a line around each word.

**FOR EXTRA CREDIT:** Look for other words in the puzzle. Draw a line around them. Add them to the list. Then arrange all the words in **alphabetical order**. Use the space below.

```

T S C H E D U L E G D Z B E E
E P A S S E N G E R E B U S T
R I P P A S T E U P P A R T R
M A K E U P R O G R A M N A A
I H I R E I B N X A R T U R N
N O P A Q U I N G S T O R E S
A V I D S P N X R E V I E W P
L A Z V P E D R A R R I V E O
A R W I T N E A S T A P L E R
F I R C E P R E S S W O R K T
T T I E I E Y E A R B O O K A
S Y T I M P R E S S I O N Q T
O P E A W T I M E T A B L E I
V E C L I T H O G R A P H Y O
C R E W T S C H E D U L E E N
    
```

OPAQUING	PRESSWORK	IMPRESSION
STRIPPING	VARITYPER	TIMETABLE
BINDERY	STAPLER	SCHEDULE
CAMERA	ARRIVE	CREW
NEGATIVE	DEPART	YEARBOOK
PASTE-UP	ADVICE	PASSENGER
LITHOGRAPHY	REVIEW	TRANSPORTATION

## GLOSSARY OF PRINTING AND BUSINESS TERMS

- account (ak kount) – a customer, a record of what is bought by a customer.
- adhesive (ad HE siv) – a sticky substance, a type of glue.
- aperture (AP er chur) – the lens opening through which light enters the camera.
- applicant (AP li kant) – one who applies for something such as a job.
- appointment (ap POINT ment) – setting a date to meet someone.
- apprentice (ap PREN tiss) – a person learning a trade, one who may work without pay while learning a trade.
- art board (ART BORD) – illustration board, paper board on which the paste-up is done.
- Art Type (ART TIPE) – a trade name for acetate lettering or shading, a form of cold type.
- ATF Chief (A-T-F CHEEF) – trade name for an offset press distributed by American Type Founders.
- bed (BED) – the flat part of a letterpress on which the type form rests.
- bellows (BELL ohz) – a flexible enclosure which is light tight. It connects the lensboard and the camera back.
- bindery (BINE der ee) – a place where books and pamphlets are put together.
- blanket (BLANG ket) – fabric backed rubber sheet which is wrapped around the impression cylinder on the offset press.
- blow up (BLOH UP) – to enlarge a photograph.
- bristol board (BRISS tull BORD) – a lightweight cardboard used for illustrations and layouts.
- brochure (bro SHURE) – a pamphlet or booklet.
- burning a plate (BURN ing a PLAYT) – to print (expose) a photolithographic plate under bright light in a vacuum frame (platemaker).
- business card (BIZ niss KARD) – a small card, (usually 3" x 1½" ) on which is printed the name, address, phone number and salesman's name for a business.
- bus schedule (BUSS SKED jool) – a timetable showing when busses arrive and depart.

carbon arc light (KAR bun ARK LITE) – a lamp containing carbon rods that produce arced light in the platemaker.

cold type (KOLD TIPE) – setting type by using a composing machine such as a VariTyper, or with the use of Art Type, transfer type or any method other than the hot type method.

company (KUM puh nee) – a place of business.

composing machine (kum POHZ ing Muh SHEEN) – a machine for setting type; e.g., VariTyper.

cooperative (koh OP er uh tiv) – willing to work together with others.

Cooperative Industrial Education Coordinator –The person who is in charge of the work-study program in a school (see work-study program).

coordinator (koh OR di nay ter) – in a school, one who brings together different departments so they may work well together.

copy (KOP ee) – the lettering and pictures used in the paste-up and made ready for photographing, e.g., camera ready copy.

copy board (KOP ee bord) – the part of the copy camera on which the copy is placed for photographing.

copy camera (KOP ee KAM ruh) – also called process camera; a large camera used for offset photography, one end of which is in a darkroom, in horizontal type.

crew (KROO) – a group of people working together.

customer (KUS tuh mer) – an account or buyer.

dampening roller (DAM pen ing ROH ler) – the roller that puts the wetting solution on the printing plate on an offset lithographic press.

darkroom (DARK room) – a room for developing photographs. It must be light tight. Only a safelight may be used for light.

department (dee PART ment) – a special or separate place; e.g., bindery department.

developer (dee VEL up per) – a solution containing chemicals for developing photographs.

developing a plate (dee VEL up ping uh PLAYT) – rubbing developer onto a plate which has a burned in image so that the image will appear.

**diagram** (DIE uh gram) – a plan or drawing showing what a thing is. A floor plan of a building, etc.

**drawing board** (DRAW ing BORD) – a board which may be adjusted to different positions for making illustrations or layouts.

**education** (edj uh KAY shun) – schooling, knowledge gained through training.

**employee** (em PLOY ee) – a person who works for pay.

**employees entrance** – a special doorway through which the workers enter the building in which they work.

**employment** (em PLOY ment) – work

**emulsion** (ee MULL shun) – a liquid containing light sensitive salts used for coating photographic plates.

**enlarger** (en LAHR jer) – a projection printer, a camera which projects the negative onto a sheet of photographic paper so that the print can be made larger. It is a camera in reverse.

**Exacto knife** (egg ZAK toh nife) – a tool for cutting adhesive type and border designs in the preparation of copy, like a razor blade with a handle.

**exit** (EGG zit) – a way out, a way out of a building.

**feeder platform** (FEED er PLAT form) – board on which the paper is piled and fed into the press.

**fixer** (FIX er) – commonly called hypo, a solution which stops the action of the developer in photography.

**flat** (FLAT) – in offset lithography, negatives which have been placed and stripped and made ready for platemaking.

**floor plan** (FLOR PLAN) – a diagram showing the layout of a building or printing plant, shows location of rooms or departments.

**folder** (FOLD er) – a machine for folding paper in a print shop or bindery.

**foot stapler** (FOOT STAY pler) – a power stapler on a stand operated with a foot pedal.

**fountain** (FOUN tin) – containers on an offset press for holding ink or a water solution.

**fountain solution** (FOUN tin suh LOO shun) – called the “water,” the chemical solution for the offset press.

**French curves** (FRENCH KERVZ) – plastic curved shaped forms for drawing curved lines.



- goldenrod paper (GOHL den rod PAY per) – graph ruled yellow paper of which a flat is made, supports and masks the negatives.
- graphic arts (GRAF fik arts) – arts, such as drawing, printing, lithography, etc.
- guidelines (GIDE lines) – in layout or copy preparation, the ruled lines made with a T-square or ruler to keep the lines of copy straight.
- gum arabic solution (gum AR uh bik suh LOO shun) – used to preserve offset lithographic plates.
- hire (HIRE) – to employ, to pay a person for his work.
- hole puncher (HOLE PUNCH er) – a machine for drilling holes in paper.
- horizontal press (hor i ZON tull PRESS) – an elongated press, such as the Miehle 29.
- hot type (HOT TIPE) – type made by slug casting machines such as Linotype or Intertype. Type cast in metal.
- illustration board (ill uh STRAY shun BORD) – lightweight cardboard for drawings or layouts.
- image (IM ij) – the part of the plate which prints or receives the ink.
- impression cylinder (im PRESH un SILL in der) – the cylinder that carries the paper at the time it is being printed.
- industry (IN dus tree) – a branch of business or trade; the printing industry.
- information (in fer MAY shun) – facts, knowledge.
- ink fountain (INK FOUN tin) – a container on an offset press which feeds the ink to the printing rollers.
- interview (IN ter vyou) – a meeting of (usually) two people to discuss something, a job interview.
- introduce (in truh DOOSS) – to present someone, e.g., “Dan, I would like you to meet Jodi.”
- job application (JOB ap luh KAY shun) – a printed form to be filled out with facts about the person seeking a job.
- job ticket (JOB TIK et) – a paper with instructions for the workers.

**kneaded eraser** (NEED ed ee RACE er) – a self cleaning eraser that can be shaped, it's like a thick dough.

**lamp** (LAMP) a light or light bulb.

**layout** (LAY out) – a drawing showing size, position, color and instructions for printing of the lettering and pictures.

**lens** (LENZ) – as in a camera, a piece of optical glass for focusing the amount of light to enter when making a picture.

**letterpress** (LET ter PRESS) – printing from a raised surface.

**light table** (LITE TAY bl) – a table with a glass top under which a light is placed, used for opaquing and art work.

**light-tight** (LITE TITE) – without light, where light cannot enter. Light sensitive photographic paper is stored in a light-tight box.

**linecasting** (LINE kass ting) – machines that cast slugs of type in which all the letters are made in one piece for each line.

**Linotype** (LINE uh tipe) – a linecasting machine. Like the Intertype machine. Linotype and Intertype are trade names.

**machine operator** (muh SHEEN OP er ray ter) – one who runs a machine.

**make ready** (MAKE red dee) – getting the press ready for proper printing.

**masking** (MASS king) – protecting or blocking out parts of the negative or copy. Masking tape, red tape and goldenrod paper are used for masking.

**master printer** (MASS ter PRIN ter) – an expert printer, a skilled printer in business for himself.

**mechanical** (mi KAN i kul) – completed copy for photographing, a paste-up.

**Miehle** (MEEL) – trade name for several types of letterpress machines. Others are Heidelberg, Miller, Kelly, etc.

**Multilith** (MULL ti lith) – trade name for a small offset press.

**negative** (NEG uh tiv) – a photographic image in which the lights and shadows are reversed on a film. The negative image on a photographic plate. Prints are made from both.

occupation (ok you PAY shun) – a trade or employment. His occupation is platemaking.

offset lithography (OFF set li THOG ruh fee) – a printing process based on the principle that water and grease do not mix. An impression is made from a freshly printed sheet onto another sheet.

order or order blank (OR der blangk) – a paper or form which shows what a customer wants to buy. He wrote an order for 100 cards. Also called a job ticket.

opaquing (oh PAY king) – use of opaque paint to paint over spots on a negative where light is not supposed to come through.

opaque paint (Oh PAYK PAYNT) – a thick water base paint through which no light passes.

padding rack (PAD ding RAK) – a rack for holding a stack of paper to which adhesive is applied. The stack is then split into pads of paper. The rack keeps the paper from shifting.

paper cutter (PAY per KUT ter) – a machine for cutting paper. It may operate by hand or electricity, depending upon the type of machine used.

passenger (PASS in jer) – a traveler on a train, bus, ship, plane, etc.

paste-up (PAYST up) – copy pasted to the art board and made ready for the camera.

personal references (PURR suh null REFF uh renss) on a job application blank, the section asking for a list of friends or relatives who may be called upon to comment on your character.

photoflood lamp (FOH toh fludd LAMP) – a light used for burning a plate in a platemaker.

photographer (foh TOG ruh fer) – one who makes pictures with a camera.

photosensitive plate (foh toh SEN si tiv PLAYT) – in offset lithography, the thin sheet of aluminum or other material which has been coated with chemicals that are sensitive to light.

pica (PIE kuh) – the standard unit of measurement for printing. 12 points equal one pica, 6 picas equal one inch.

placed (PLAYSS) – employed, given a job.

platemaker (PLAYT MAY ker) – one skillful in the processes of burning and developing a lithographic plate. A machine that prints a picture from a negative onto a printing plate.

platen press (PLAY ten PRESS) – a letterpress which makes a print from a flat surface containing raised letters.

point (POINT) – a unit of measurement in printing. 12 points equal 1 pica or one sixth of one inch.

presensitized plate (pree SEN si tized PLAYT) – a lithographic plate which is manufactured with a photosensitive coating.

procedure (Proh SEED jer) – a way or method of doing something.

proofread (PROOF reed) – to read and mark errors to be corrected.

receptionist (ree SEP shun ist) – a person who greets visitors and answers telephone calls in a place of business.

reduce (ree DOOSS) – to make smaller as in photography, to make a picture smaller than the original.

relief printing (ree LEEF PRINT ing) – printing from a raised surface, such as letterpress.

roller (ROH ler) – the inking and dampening rollers on a printing press.

rubber cement (RUB ber si MENT) – rubber dissolved in benzol, used for paste-up work.

run (RUN) – the number of copies to be printed in a particular job.

safelight (SAYF lite) – a colored light used in a darkroom.

salesman (SAYLZ man) – a person whose work is selling.

schedule (SKED jool) – a timetable, a list of details.

sensitizing (SEN si tiz ing) – coating any material with an emulsion which is sensitive to light (photosensitive). Coat a plate with bichromated albumen solution.

sheet fed press (SHEET FED PRESS) – a press fed with individual sheets of paper, such as the ATF Chief or Multilith.

shelf life (SHELF LIFE) – the length of time sensitized material can be kept without spoiling.

shoot a negative (SHOOT A NEG uh .iv) – take a picture with a camera.

slug (SLUGG) – a piece of lead over 6 points thick. A linecast made on a linecasting machine.

solution (suh LOO shun) – a mixture of liquids and solids.

stick-on type (STIK-on TIPE) – stock or manufactured type with a sticky backing, used for setting type in a layout.

stock (STOK) – paper.

stock type (STOK TIPE) – cold type which is manufactured on sheets of acetate to be transferred onto layout or mechanical. Press-type, Art Type and Instatype are examples.

stripping (STRIP ping) – arranging negatives on goldenrod paper, making flats.

stripping table (STRIP ping TAY bl) – a light table. (see light table).

stylus (STY luss) – a writing tool with a metal point which is useful for lifting up letters of stick-on type.

time card (TIME KARD) – a card punched in a time clock showing the number of hours a person has worked.

time clock (TIME KLOK) – a clock with a device for punching the time onto a card.

tour (TOOR) – a short walk around. He was given a guided tour of the building.

trained (TRAYND) – educated in a trade.

transfer type (TRANSS fer TIPE) – stock type which is rubbed onto another surface.

T-square (T-skwair) – a T shaped ruler used for drawing parallel lines; in layout design it is used to keep the lines of type straight.

VariTyper (VAR i tip er) – a composing machine which has a keyboard similar to a typewriter. A large variety of type can be produced by changing the type faces.

vocational school (voh KAY shun ul SKOOL) – a place for learning a trade, such as printing, typing, sewing, etc.

web press (WEB PRESS) – a large rotary press that prints from a continuous roll of paper.

work schedule (WERK SKED jool) – a chart showing employees' working hours.

work-study program (WERK STUD ee PROH gram) – a plan for bringing together learning at school and on-the job training.

STATE OF NEW JERSEY  
DEPARTMENT OF EDUCATION  
DIVISION OF VOCATIONAL EDUCATION

ANSWER KEY FOR  
YOU'VE GOT IT, DANNY!  
LANGUAGE DEVELOPMENT IN GRAPHIC ARTS

ANNETTE ISAACSON, INSTRUCTOR  
BERGEN COUNTY VOCATIONAL SCHOOL  
PARAMUS, NEW JERSEY

EN-384A

## CHAPTER 1

### Match the Words

1. depended
2. vocational school
3. prepared
4. interview
5. appearance
6. up-tight
7. arranged
8. work-study program

### Word Endings

1. appearance
2. vocational
3. education
4. prepared
5. industrial
6. depended

### Splitting Words

1. pre-pare
2. de-pend
3. in-ter-view
4. vo-ca-tion-al
5. ar-range
6. ap-pear-ance
7. ner-vous
8. pro-gram
9. co-or-din-a-tor
10. ed-u-ca-tion
11. in-dus-tri-al
12. co-op-er-a-tive

### Alphabetical Order

1. appearance
2. arrange
3. cooperative
4. coordinator
5. depend
6. education
7. industrial
8. interview
9. nervous
10. prepare
11. program
12. vocational

### Find The Missing Word

1. interview
2. up-tight
3. work-study program
4. C.I.E. Coordinator
5. appearance
6. depended
7. Beacon County  
Vocational School
8. Hi-Way Printing  
Company

### Expressions

Any reasonable answer  
\*\*\*\*\*

## CHAPTER 2

### Match the Words

1. machine operator
2. depended
3. arranged
4. confident
5. appearance

### Find It In the Glossary

1. bellows
2. fountain
3. fixer
4. slug
5. blow-up
6. masking
7. flat
8. pica

### Split the Words

1. hun-gry
2. op-er-a-tor
3. con-fi-dent
4. strik-ing
5. broth-er
6. Dan-ny
7. ma-chine
8. wor-ried

### Alphabetical Order

1. brother
2. confident
3. Danny
4. hungry
5. machine
6. operator
7. striking
8. worried

### Knowing the Facts

- |        |         |
|--------|---------|
| 1. yes | 6. no   |
| 2. no  | 7. yes  |
| 3. no  | 8. no   |
| 4. no  | 9. no   |
| 5. yes | 10. yes |

### Spelling Stair

worry  
reason  
machine  
prepared  
confident  
sorry  
depend  
chances  
operator  
vocations

### Abbreviations

1. Dr., St.
  2. NJ
  3. St., NY
  4. Rte.
  5. Rd., Co.
  6. U.S., Lt.
- \*\*\*\*\*

## CHAPTER 3

### Match the Words

1. trained
2. entrance
3. firmly
4. graphic arts
5. receptionist

CHAPTER 3 cont.

Match the Words

- 6. job application
- 7. hire
- 8. introduce
- 9. information

Word Endings

- arranging, arranged
- hiring, hired
- explaining, explained
- preparing, prepared
- interviewing, interviewed
- depending, depended

Splitting Words

- 1. Of-fice
- 2. in-tro-duce
- 3. re-cep-tion-ist
- 4. gripped
- 5. firm-ly
- 6. ap-pli-ca-tion
- 7. in-for-ma-tion
- 8. graph-ic
- 9. train-ing
- 10. ner-vous
- 11. en-trance
- 12. com-pa-ny

Alphabetical Order

- 1. application
- 2. company
- 3. entrance
- 4. firmly
- 5. graphic
- 6. gripped
- 7. information
- 8. introduce
- 9. nervous
- 10. office
- 11. receptionist
- 12. training

Choose One

- 1. c, 2. b, 3. a,
- 4. c, 5. b.
- \*\*\*\*\*

CHAPTER 4

Match the Words

- 1. department
- 2. placed
- 3. paste-up
- 4. schedule
- 5. process
- 6. offset printing
- 7. employees
- 8. copy
- 9. photographing

Classify

- HOME, mother, living room, family
- SCHOOL, classroom, teacher, CIE Coord. education
- INDUSTRY, interview, hire, employee, occupation, machine operator

Splitting Words

- 1. off-set
- 2. print-ing
- 3. de-part-ment
- 4. pro-cess
- 5. cop-y
- 6. placed
- 7. pho-to-graph
- 8. em-ploy-ee
- 9. sched-ule
- 10. pro-gram

Alphabetical Order

- 1. copy
- 2. department
- 3. employee
- 4. offset
- 5. photograph

CHAPTER 4 cont.

- 6. placed
- 7. printing
- 8. program
- 9. process
- 10. schedule

Knowing Facts

- 1. yes      4. no
- 2. yes      5. yes
- 3. no

Abbreviations

- 1. Mon.      4. Thurs.
- 2. Tues.     5. Fri.
- 3. Wed.     6. Sat.
- 7. Sun.

- 1. Jan.      6. Sept.
- 2. Feb.      7. Oct.
- 3. Mar.      8. Nov.
- 4. Apr.      9. Dec.
- 5. Aug.

Understand a Sched.

- 2. Tues., Thurs. 8:30 to 4:30
- 3. 8:30 to 4:30
- 4. Sat.
- 5. Tues.
- 6. 6 + Danny
- 7. 35
- 8. Mon.

Paste-up

- 1. light table or drawing board
- 2. T square
- 3. The art board
- 4. rubber cement
- 5. find errors



CHAPTER 4 cont.

Materials Quiz

1. see glossary
2. yes
3. stick-on
4. opaque paint
5. drawing curved lines
6. yes
7. rubbed on

CHAPTER 5

Match the Words

1. embarrassed
2. apologize
3. letterpress
4. accidentally
5. salesman
6. appointment
7. diagram

Review

1. depended
2. employees
3. confident
4. appearance

Splitting Words

2. em-bar-rassed
3. a-pol-o-gize
4. di a-gram
5. ap-point-ment
6. let-ter-press
- 7 sales-man
8. re-ceiv-er
9. ex-cuse
10. build-ing

Alphabetical Order

1. accidentally
2. apologize
3. appointment
4. building
5. diagram
6. embarrassed
7. excuse

CHAPTER 5 cont.

8. letterpress
9. receiver
10. salesman

One Out Of Two

1. diagram
2. letterpress
3. embarrassed
4. apologize
5. arranged

Abbreviations

- |         |            |
|---------|------------|
| 1. Oct. | 7. p.      |
| 2. St.  | 8. a.m.    |
| 3. lb.  | 9. N.J.    |
| 4. gal. | 10. MPH    |
| 5. Mr.  | 11. Thurs. |
| 6. Co.  | 12. no.    |

Spelling Stairs

1. August  
diagram  
salesman  
apologize
2. employ  
appoint  
industry  
timetable

Photographing Copy

1. copy camera
2. yes
3. lens cleaning tissue
4. yes
5. back end
6. safelights
7. rubber gloves
8. exposed film

Glossary

Refer to glossary

CHAPTER 6

Match the Words

1. customer
2. master printer
3. time clock
4. business card
5. apprentice
6. punching in
7. tour
8. production
9. time card
10. account
11. exit
12. order

Word Review

1. appointment
2. diagram
3. letterpress
4. salesman

Splitting Words

1. ap -pren-tice
2. mas-ter
3. busi-ness
4. or-der
5. ac-count
6. cus-to-mer
7. pro-duc-tion
8. punch-ing
9. un-der-stand
10. ma-chin-ery

Alphabetical

- account  
apprentice  
business  
customer  
machinery  
master  
order  
production  
punching  
understand

### Phrases

1, 3, 5, 6

### Find Missing Word

1. business cards
2. master printer
3. production
4. apprentice
5. customers
6. punching in
7. order, account
8. exit
9. time card, time clock
10. tour

### Understand a Diag.

1. receiving
2. offices
3. paper cutter, foot stapler, folder, etc.
4. bindery
5. employees
6. ATF Chief, Multilith, offset dup.
7. horizontal
8. goldenrod
9. stripping, opaquing
10. enlarger, tank, copy camera
11. letterpress
12. paper, ink, film, etc.

### Business Card

2,000, \$22.50  
black, medium

### Develop the Neg.

1. tray, developer thermometer, clock darkroom.

### CHAPTER 6 cont.

2. no
3. larger than the negative
4. 68 degrees
5. darkroom
6. 5 minutes
7. 5 to 10 minutes
8. fixer, tray
9. sponge it, hang to dry
10. Step 3

### CHAPTER 7

#### Match the Words

1. departs
2. timetable
3. arrives
4. passenger
5. applied
6. bus schedule
7. public transportation
8. bus terminal

#### Splitting Words

2. pub-lic
3. trans-por-ta-tion
4. ter-min-al
5. de-part
6. ar-rive
7. time-ta-ble
8. pas-sen-ger
9. Dan-ny
10. wal-let

#### Alphabetical

1. applied
2. arrived
3. Danny
4. depart
5. passenger
6. public
7. terminal
8. timetable
9. transportation
10. wallet

### More Than One

employees, presses, companies, duplicators, offices, processes, productions, copies

### Knowing the Facts

- |        |         |
|--------|---------|
| 1. yes | 6. yes  |
| 2. no  | 7. yes  |
| 3. yes | 8. yes  |
| 4. no  | 9. no   |
| 5. no  | 10. yes |

### Out of Sight Letters

A, C, D, E, F, G, H, I, J, K, L, M, O, P, Q, R, T, U, V, Z.

### Bus Schedule

1. 7:49
2. Glenwood
3. 18, Sun., Hol.
4. 8:45, no
5. 7:49
6. 7:06

### Quiz, Stripping, Opaq.

1. light table, goldenrod paper, negative tape, T-square
2. dull side
3. exacto knife, razor blade
4. yes
5. no
6. opaque paint
7. plate
8. T-square
9. blade

### CHAPTER 8

#### Match the Words

1. break in
2. impression
3. respected
4. platemaking
5. advice
6. program

### Word Review—Synonyms

1. departs
2. timetable
3. passengers
4. terminal

### Splitting Words

1. im-pres-sion
2. pro-gram
3. plate-mak-ing
4. re-spect-ed
5. ad-vice
6. Mar-ty
7. re-view
8. stu-dent
9. year-book
10. teach-er

### Alphabetical

advice, impression  
Marty, platemaking,  
program, respected,  
review, student,  
teacher, yearbook

### Opposites

1. loose
2. arrive
3. hire
4. public
5. confident
6. depart

### Burning a Plate

1. platemaker
2. sensitized plate
3. Yes
4. aluminum
5. vacuum frame
6. the glass
7. 25-30
8. photoflood, carbon arc
9. 8 min.
10. 2 min., No.

### Developing a Plate

1. No.
2. a sponge
3. No.
4. Yes
5. a little gum
6. a teaspoon
7. lukewarm water
8. developer and a sponge
9. No. 10. gum arabic

### Match the Expression

3, 4, 1, 2.

### CHAPTER 9

#### Match the Word

1. cameraman
2. VariTyper
3. stripping
4. foot stapler
5. crew
6. opaquing
7. folding machine
8. negative
9. light table
10. bindery room
11. presswork
12. operating

#### Spelling Stairways

light, camera, stapler  
opaquing.  
table, opaque, operate,  
stripper.

#### Splitting Words

1. Vari-Typ-er
2. fold-ing
3. stap-ler
4. bind-er-y
5. op-er-at-ing
6. cam-er-a-man
7. ta-ble
8. strip-ping

### CHAPTER 9 cont.

9. o-paqu-ing
10. neg-a-tive
11. press-work
12. in-ter-est-ing

### Alphabetical

bindery, cameraman  
folding, interesting  
negative, opaquing  
operating, presswork  
stapler, stripping  
table, VariTyper

### Print from a Plate

1. c, 2. b, 3. b,
4. c, 5. a, 6. b,
7. c, 8. a, 9. b,
10. a

### Measurement for Printers

1. 6 picas, 12 picas,  
42 picas
2. 12 points
3. 18 picas
4. 7 inches, 42 picas
5. 3 picas
6. 2 inches
7. 24 points

Word Find Review

R D C O P Y M A R G O R P F A R  
 R E V O C A T I O N A L H N B E  
 E P C C O N F I D E N T O W S L  
 L A P E M P L O Y E E I T U I Y  
 I R A A P P L I C A T I O N N A  
 E T P X A T R A P A A V G R F P  
 D M P Q N F I R M E R Q R I O I  
 U E E S Y V D O M E F P A D R N  
 C N A B A R R A N G E D P E M T  
 A T R O F F I C E I Z L H P A R  
 T R A I N I N G W A S P I E T O  
 E U N I M A C H I N E T C N I D  
 Z W C I N T E R V I E W H D O U  
 P R E P A R E D W O R K E R N C  
 S T U D Y I N D U S T R I A L E  
 E N T R A N C E O P E R A T O R

INFORMATION  
 RECEPTIONIST  
 APPLICATION  
 TRAINING  
 NERVOUS  
 PHOTOGRAPH  
 APPEARANCE

PROGRAM  
 VOCATIONAL  
 INTERVIEW  
 DEPEND  
 INDUSTRIAL  
 ENTRANCE  
 GRAPHIC

INTRODUCE  
 OFFICE  
 EMPLOYEE  
 MACHINE  
 OPERATOR  
 CONFIDENT  
 DEPARTMENT

CHAPTER 6.

Word Find Review

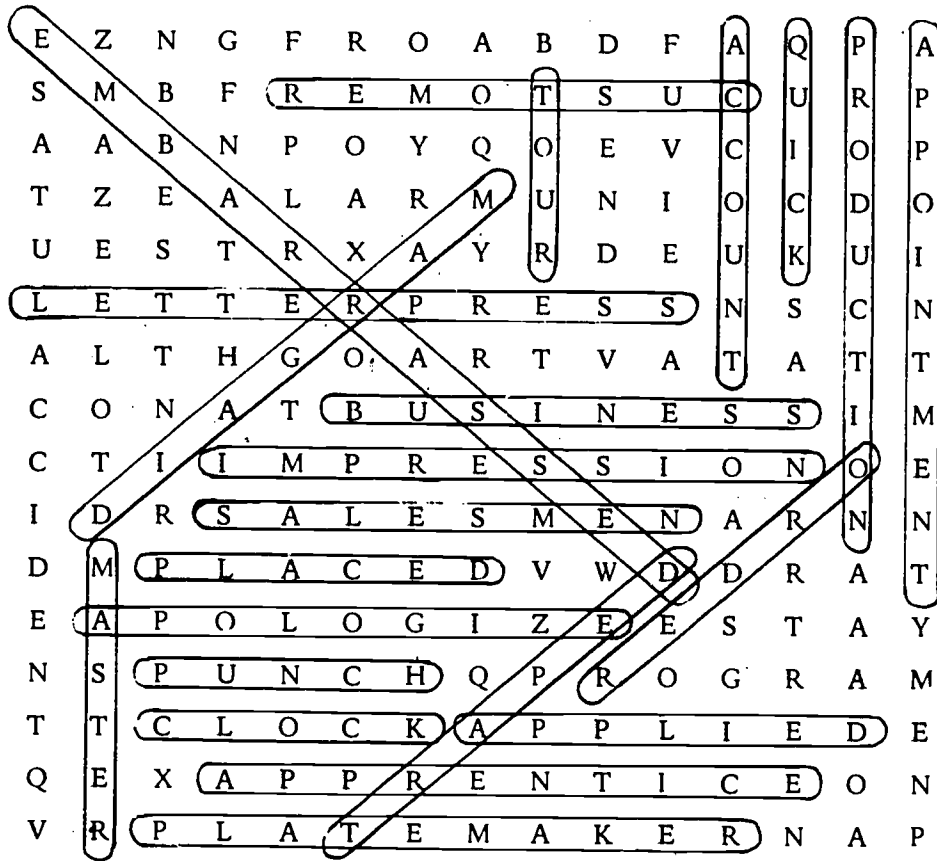

EMBARRASSED  
 DEPART  
 BUSINESS  
 LETTERPRESS  
 IMPRESSION  
 CLOCK  
 PLATEMAKER

PRODUCTION  
 APOLOGIZE  
 APPRENTICE  
 MASTER  
 APPLIED  
 APPOINTMENT  
 DIAGRAM

ORDER  
 ACCOUNT  
 CUSTOMER  
 SALESMEN  
 PLACED  
 TOUR  
 PUNCH

CHAPTER 9.

Word Find Review

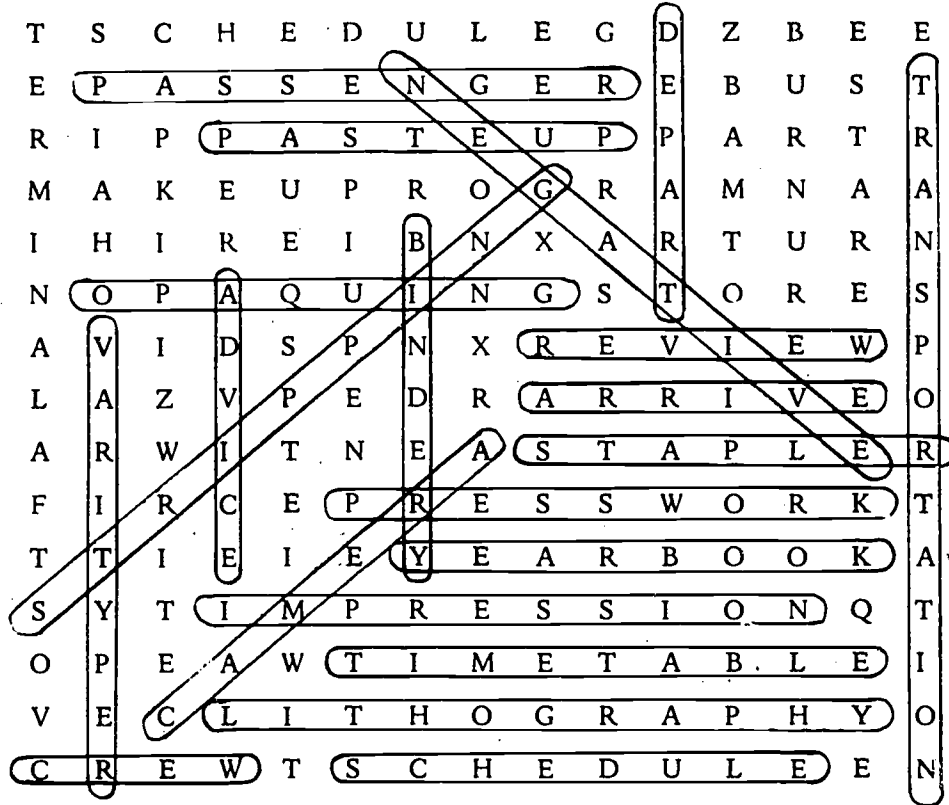

OPAQUING

PRESSWORK

IMPRESSION

STRIPPING

VARITYPER

TIMETABLE

BINDERY

STAPLER

SCHEDULE

CAMERA

ARRIVE

CREW

NEGATIVE

DEPART

YEARBOOK

PASTE-UP

ADVICE

PASSENGER

LITHOGRAPHY

REVIEW

TRANSPORTATION