

DOCUMENT RESUME

ED 129 587

SE 021 179

AUTHOR Petrie, Edwin T.
TITLE Air Age Education. Aviation Career Awareness Program.
INSTITUTION Cessna Aircraft Co., Wichita, Kans.
PUB DATE Nov 75
NOTE 83p.; Kit to make model airplane and several small instruction pamphlets are not included
AVAILABLE FROM Cessna Aircraft Company, Air Age Education Department, P.O. Box 1521, Wichita, Kansas 67201 (\$4.95)

EDRS PRICE MF-\$0.83 HC-\$4.67 Plus Postage.
DESCRIPTORS *Aerospace Education; Aviation Technology; Career Education; Careers; Elementary Education; *Elementary School Science; *Instructional Materials; Science Education; *Teaching Guides

ABSTRACT

Described is a program designed to help introduce the broad scope of occupational careers available with general aviation. The program is designed to aid the teacher in presenting the basic principles of flight, essential facts about general aviation as well as its occupational opportunities. It replaces previous elementary student materials, and integrates career awareness lesson plans and activities with the most popular items incorporated in the previous kits. The program offers a series of booklets, cloud charts, an airplane model with movable control surfaces, a flight chart and a road map. Each of the units in this book begins with objectives related to learning basic principles of aviation and objectives designed to provide awareness of careers appropriate to each unit. The objectives are linked to teaching strategies and resource materials. (Author/EB)

* Documents acquired by ERIC include many informal unpublished *
* materials not available from other sources. ERIC makes every effort *
* to obtain the best copy available. Nevertheless, items of marginal *
* reproducibility are often encountered and this affects the quality *
* of the microfiche and hardcopy reproductions ERIC makes available *
* via the ERIC Document Reproduction Service (EDRS). EDRS is not *
* responsible for the quality of the original document. Reproductions *
* supplied by EDRS are the best that can be made from the original. *

AIR AGE EDUCATION

AVIATION CAREER AWARENESS

PROGRAM

A GROUP OF UNITS FOR ELEMENTARY SCHOOLS
TO PROVIDE AN AWARENESS OF GENERAL AVIATION
AND THE CAREERS IT OFFERS

by

Edwin T. Petrie

The Ohio State University

Cessna 

Air Age Education Department
Cessna Aircraft Company
Wichita, Kansas 67201



033681172

1111111111

TABLE OF CONTENTS

	To the Teacher	iii
UNIT I:	Airplanes are Manufactured in Different Sizes and Shapes	1
UNIT II:	How Airplanes Fly: Instruments and Controls . . .	8
UNIT III:	How Airplanes Fly: Forces, Motions and Attitudes	17
UNIT IV:	Flight Planning and Navigation from Place to Place	27
UNIT V:	Weather and Aviation	35
UNIT VI:	The Airport and Your Community	45
UNIT VII:	The History and Growth of General Aviation	48
	An Elementary Aviation Glossary	50
	Answers	54

ACKNOWLEDGMENTS

I wish to acknowledge and thank Phil Woodruff and Dave Pishko of Cessna for initiative, assistance, guidance and counsel through the preparation of this program. Special thanks also to Amy Kiggins, who provided the illustrations, and Faye Malone who typed the manuscript through two drafts and the final product. And deep appreciation to Judy who persevered through many late nights of "building paper airplanes".

Edwin T. Petrie

November 1975
Columbus, Ohio

TO THE TEACHER

Each of the units in this book begins with objectives to enable your students to learn the basic principles of flight and of general aviation. The units also contain objectives designed to provide the student with an awareness of the careers that are appropriate to each unit. The objectives are accompanied by teaching strategies and resources that may be used. The strategies include hints on coordination of this material with your regular subject matter.

In many cases, the suggested resources are included right along with the unit. These sheets are designed for two different uses: first, you may use them with electro-sensitive acetate in an electrographic copier to make overhead transparencies; and secondly, you may use them with electro-sensitive ditto masters in the same machine to make enough copies so that each student may have one for a work sheet to keep. (The 3M Thermofax or the A. B. Dick 204 Master Maker are two of many such copiers. Your school should have one.)

Attempts have been made to provide activities appropriate to all ability levels in the elementary grades. Some of them may be either too elementary or too advanced for your students. Here is your chance to use a bit of creativity in adapting them to your students.

In compiling this guide, attempts have been made to anticipate the needs and problems in implementing an innovative program of this kind. Should these attempts have fallen short, fortunately there is one factor in the classroom that can usually succeed in the most difficult of conditions. That factor is you, the teacher, a guide and helper who is actually there with the students. In implementing this program you will share aviation and career awareness with your students. Ultimately, their success will be your success. Good Luck!

UNIT I: AIRPLANES ARE MANUFACTURED IN DIFFERENT SIZES AND SHAPES

UNIT GOAL: To Introduce The Student To The General Aviation Airplane; Its Size, Its Shape, How It Is Manufactured, And By Whom.

OBJECTIVE	STRATEGY	RESOURCES	SOURCE
<p>1. The student will be able to identify several different general aviation airplanes in terms of size.</p> <p>a) How many engines do they have? b) How many people can ride in them? c) How fast do they fly? d) How high do they fly?</p>	<p>This identification can best be done with pictures.</p> <p>a) Cut from aviation magazines, labeled and made into individual student collages or as a class on the bulletin board (art, spelling). b) Use the pictures in this kit for the bulletin board with large labels. c) Write for free catalogues or pictures from airplane manufacturers. (English) Not too many and remember to write thank you letters. d) Use models or toys on loan from students, their parents or relatives. Be sure to write thank you letters. (English) e) Have students cut out various geometrical shapes from colored paper and arrange them into interesting airplane shapes. They could paste their best one onto a plain sheet of paper for display. (math and art)</p>	<p>Aviation magazines of general interest. Save what is left of them for use in later units.</p> <p>Airplane coloring books (make sure that airplanes are real rather than "stylized").</p> <p>Airplane Sales Catalogues. Airplane Publicity Pictures.</p> <p>Geometrical shapes pattern sheet.</p> <p><i>Scale Models, Teaching Ideas for Aviation Education, Vol. II, p. 1.</i></p>	<p>By subscription or at a newsstand. Newsstand at the nearest large airport is excellent. Interested parents. Other aviation interested teachers.</p> <p>Newsstand, drug store, super market - again, the airport is a good bet. Interested parents.</p> <p>Local fixed base operators (look in the yellow pages under Airplane Dealers). Write directly to airplane manufacturers (see Directory).</p> <p>Included with this Unit.</p> <p>Cessna Aircraft Co.</p>
<p>2. The student will be able to identify several different general aviation airplanes in terms of shape and markings.</p> <p>a) What is the fuselage shape? b) How are the wings placed? c) How are the engine(s) placed? How many? Where? d) Do they have distinctive paint and markings? e) Are the registration numbers different? Why?</p>			



OBJECTIVE	STRATEGY	RESOURCES	SOURCE
<p>3. The student will gain knowledge of the airplane manufacturing process and become aware of the various careers involved in the process.</p> <ul style="list-style-type: none"> a) Production Planning - Budget, time & efficiency, plant layout, materials. b) Design and Layout - Engineers, designers, draftsmen. c) Cut-out and Basic Manufacture - Sheet metal, cut-out, stamping, machining. d) Assembly - Assemblers, basic, finish. e) Paint and Finish - Painters, finishers, polishers, upholsterers. 	<p>Have the whole class participate in forming a "company" and using the manufacturing process as outlined at the left. Make the situation as realistic as possible. The process may be as simple or as complex as you like, based upon your class size, grade level, etc. Jobs should be assigned based upon student awareness, interest, ability, etc. Accounting, budget, personnel and sales departments may be added on the same basis. Students should plan their own operation sheets.</p> <p>The product to be manufactured is an airplane based upon the plastic model supplied with this kit. Planning should be done using this as an available "prototype". Enough airplanes should be manufactured so that each student will have one for use in future units.</p> <p>In the studying process, the student should experiment with the simple task repeated many times, as opposed to the more modern multiple task assembly to minimize boredom, etc.</p>	<p>Plastic airplane model "prototype" for planning.</p> <p>Airplane pattern and instruction sheet.</p> <p><i>Job Operation Sheet</i></p> <p><i>Form An Airplane Manufacturing Company, Teaching Ideas for Aviation Education, Vol. II, p. 7.</i></p> <p>Industrial Engineer or production planner to assist in planning the manufacturing process, "plant" layout, etc.</p> <p>A worker in the manufacturing process.</p>	<p>Furnished with this kit.</p> <p>Included with this Unit.</p> <p>Included with this Unit.</p> <p>Cessna Aircraft Co.</p> <p>Any local manufacturer or assembly plant. Possibly a parent could help.</p> <p>Any local manufacturing or assembly plant. Possibly a parent could help.</p>



OBJECTIVE	STRATEGY	RESOURCES	SOURCE
	<p>Students should be allowed to "custom order" their "paint" job in a color of their own choice (another planning problem?). They should also choose (and apply?) their own registration number. There are three options: (1) N followed by 5 digits, (2) N followed by 4 digits followed by 1 letter, (3) N followed by 3 digits followed by 2 letters. Remember, no letter I's or O's (might be confused with one or zero). The pattern airplane belongs to a couple named Judy and Pete whose wedding anniversary is July 30th.</p>		

GEOMETRICAL SHAPES

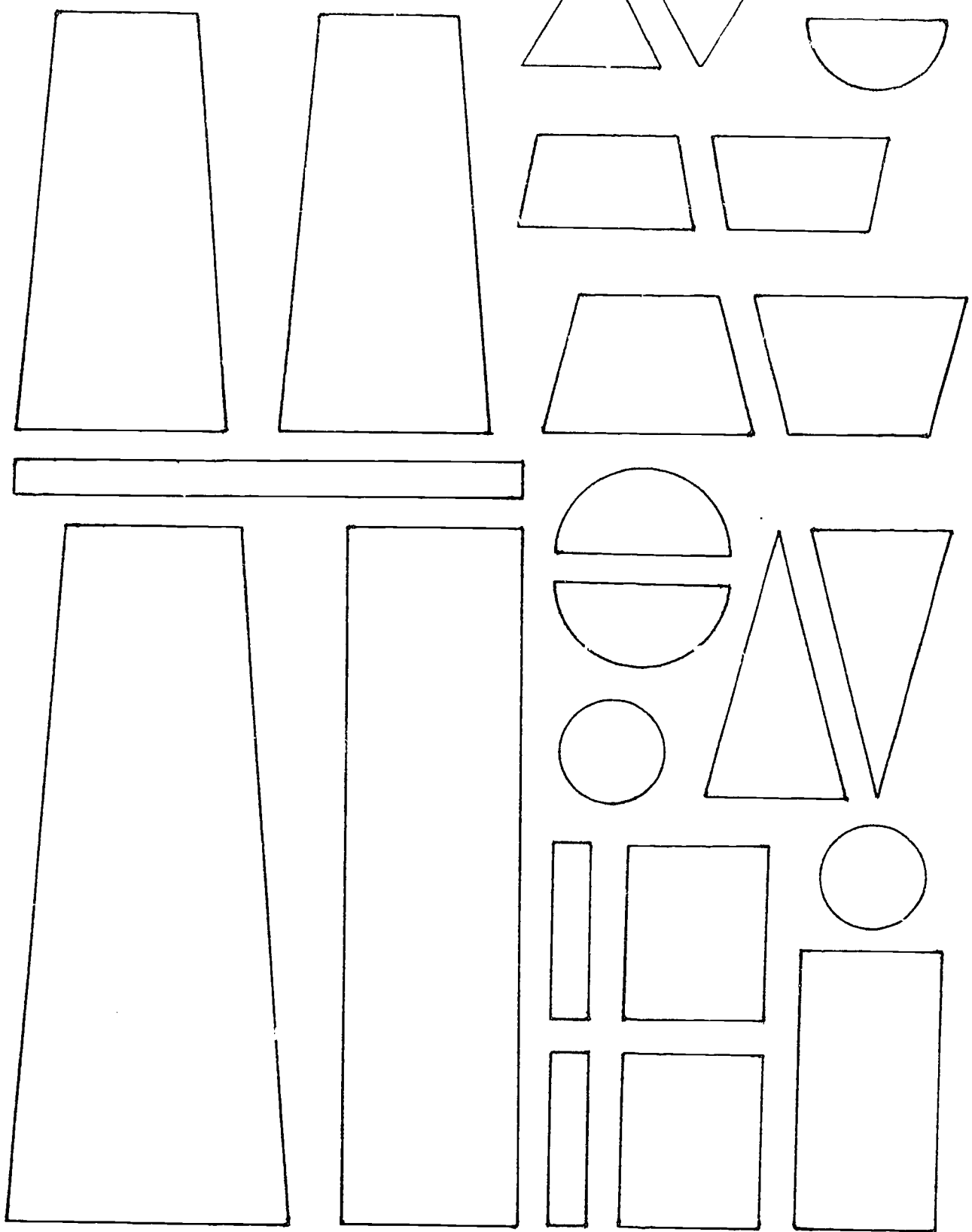

AIRPLANE MANUFACTURING INSTRUCTIONS

Materials: Scissors Cardboard Tablet Backs
 White Glue Paints (or Crayons)
 Magic Tape Carbon Paper

1. Production planners should plan the manufacture of the airplanes using these instructions as a guide. Each student should have a job and detail the operations of that job on the Job Operation Sheet on the following page.
2. Pattern makers, using carbon paper, should transfer the pattern from page 6 onto cardboard or good, rigid tagboard and cut it out for use as templates. The templates should be labeled with the part names from the pattern. Templates could be cut out of thin plastic for better durability.
3. Layout people should use the templates to lay out the parts on tablet backs. Can you get better usage by laying out one whole airplane on one sheet? or by laying out all wings on one, all tail assemblies on one, etc.?
4. Sheet metal workers should cut out the parts with scissors and bend the wing struts at the fold line.
5. Painters and finishers should paint the parts using the Cessna design shown or students' individual designs. All painting could be done now using standard colors or students could "order" their color. An alternative method would be to allow students to paint their own after complete assembly.
6. Primary assemblers should assemble parts into major units: (1) Ailerons and flaps to wing; (2) Rudder to fuselage; (3) Elevator to horizontal stabilizer; and (4) The three parts of the stand. Assemblies 1, 2 and 3 should be done with Magic Tape, allowing a clearance equal to the thickness of the cardboard, so that they are moveable. Don't use regular transparent tape as it will crack and split. Magic Tape is plastic and pliable and will last much longer.
7. Final assemblers should assemble the major units into the finished airplane. The wing should be bent slightly and slipped into the notch on top of the fuselage. The tail assembly should be slid into the slot on the fuselage. Wing struts should be glued to both the wing and fuselage with white glue.

Help the students plan how much shared assembly line work or how much individual work will be done. Budget time, materials and costs. You may decide to combine some of the job categories, such as paint layout and painting. You may decide to combine or spread out responsibilities, as one person assembling the wing or four people with each adding one part. Throughout the manufacturing process, students may hold one job throughout or sample several. You should stress the awareness of how individual jobs combine to make the whole job, how to work together, etc.

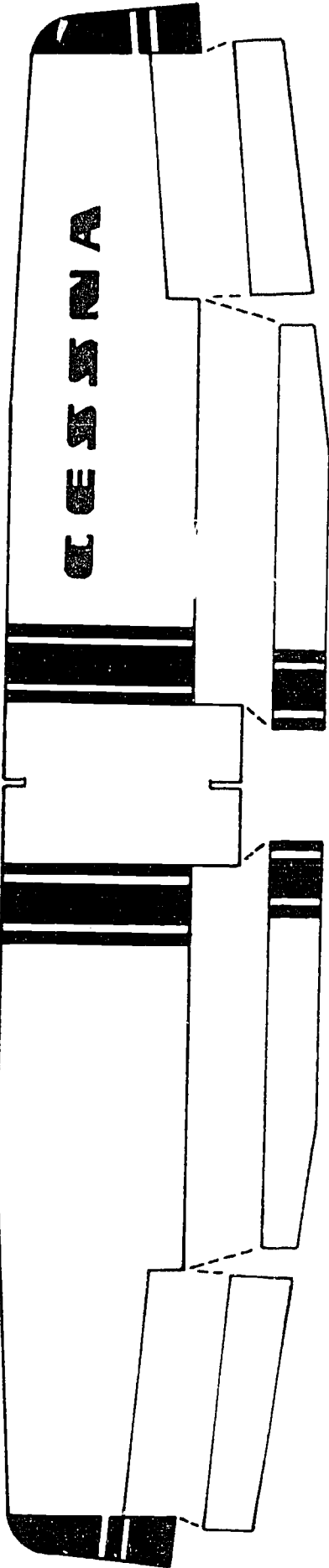

Wing Assembly



Horizontal Tail Assembly

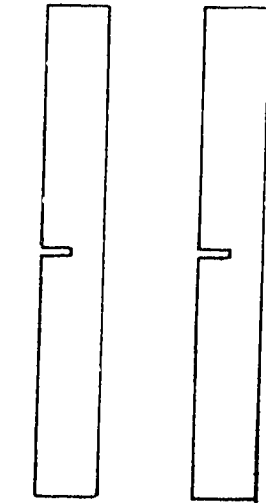

MODEL
AIRPLANE
PATTERNS



Stand Assembly



Wing Struts



Fuselage Assembly

JOB OPERATION SHEET

Name _____

Job Title _____

1. In the left-hand column list the tasks required in the performance of your job.
2. In the second column list how often each task is performed using words like often, seldom, occasionally, regularly, etc.
3. In the third column indicate how important each task is using words like some, great, very great, etc.
4. In the last column indicate how difficult each task is using words like easy, fairly easy, moderate, difficult, very difficult.

Task	Performance	Importance	Difficulty

UNIT II: HOW AIRPLANES FLY: INSTRUMENTS AND CONTROLS

UNIT GOAL: To Introduce The Student To The Control Surfaces of The Airplane, The Controls That Operate Them And The Instruments That Record What Is Happening.

OBJECTIVE	STRATEGY	RESOURCES	SOURCE
<p>1. The student will be able to identify the major parts of an airplane.</p> <ul style="list-style-type: none"> a) Fuselage b) Wings c) Engine(s) d) Tail Assembly e) Landing gear 	<p>Use the <i>Main Parts of an Airplane</i> sheet following to make an overhead transparency and a ditto master and distribute copies to the students. Have them discuss these parts of the airplane, have them point out the various parts on the models built in Unit I, and then fill in the blanks.</p>	<p>The <i>Main Parts of an Airplane</i> Sheet. Plastic Airplane Model Individual Airplane Models</p>	<p>Included with this Unit. Furnished with this kit. Manufactured in Unit I by your students.</p>
<p>2. The student will be able to identify the major controls of an airplane and correlate them with the control surfaces which they operate.</p> <ul style="list-style-type: none"> a) Wheel (stick) with the ailerons and the elevator b) Rudder pedals with the rudder c) Flap Control with the flaps d) Trim Control with the trim tab e) Throttle with engine speed 	<p>Use the <i>Instrument Panel</i> sheet following to make an overhead transparency and a ditto master and distribute copies to the students. Have them discuss the major controls and the control surface which each operates. Make sure that they can point out the control on the <i>Instrument Panel</i> sheet and the surface which it operates on their model airplane. Have them fill in the blanks that name the controls.</p>	<p>The <i>Instrument Panel</i> Sheet. Plastic Airplane Model Individual Airplane Models <i>Panel Mock-Up, Teaching Ideas for Aviation</i> Vol. I, p. 2. Instrument Panel Photographs & Posters</p>	<p>Included with this Unit. Furnished with this kit. Manufactured in Unit I by your students. Cessna Aircraft Co. Included with this kit.</p>

OBJECTIVE	STRATEGY	RESOURCES	SOURCE
<p>3. The student will be able to identify the basic instruments and how they respond to control changes.</p> <ul style="list-style-type: none"> a) Compass b) Turn & Bank Indicator c) Altimeter d) Tachometer e) Airspeed indicator f) Clock <p>General Items for use with all three of the above objectives.</p>	<p>Using the <i>Instrument Panel Sheet</i> transparency and dittos from objective 2 above, have the students point out and discuss the basic instruments on the panel. Make sure that they can point out the instrument and correlate it with the control and control surface that causes the instrument to react. Have them fill in the blanks that name the instruments and the switches. Have students now complete, from memory, the exercise indicated on the <i>Basic Instruments Sheet</i>.</p> <p>Make, with the help of your students, a cardboard box simulator. Let each student have a turn operating the controls and "flying" the simulator.</p> <p>On an airport visit, inspect an airplane to see the controls and instruments. Ask a pilot to show the children how the controls move the control surfaces. If possible allow them to sit in the pilot seat and operate them.</p>	<p>See Objective 2 above. <i>Basic Instruments Sheet</i> Demonstration size, working models of all flight instruments.</p> <p>Cardboard Box Flight Simulator</p>	<p>See Objective 2 above. Included with this Unit. Aeroproducts Research, Inc or other commercial supplier (see Directory). Instructions for making Simulator included with this unit.</p>

OBJECTIVE	STRATEGY	RESOURCES	SOURCE
<p>4. The student will understand the occupations of people who are involved in the manufacture, maintenance and repair of the airplanes power, frame, controls and instruments.</p> <p>a) Airframe and Powerplant mechanic b) Instrument Mechanic c) Radio Repairman</p>	<p>Use the <i>I Investigate an Occupation</i> sheet and the <i>Job Operation Sheet</i> from Unit I to make ditto masters and distribute copies to the students. Have them use the resources listed, and others, to investigate these occupations and fill in the sheets.</p> <p>Have resource people in to talk to the class about their occupations. Have the students prepare, in advance, questions to ask them during a question and answer period.</p>	<p><i>I Investigate an Occupation</i> sheet. <i>Job Operation Sheet</i>. <u>Occupational Outlook Handbook</u> <u>Dictionary of Occupational Titles</u> Occupational Briefs</p> <p>A person in any one or more of these occupations.</p>	<p>Included with this Unit. Included with Unit I in this kit. Your school or local library or the U. S. Department of Labor (see Directory). Your school or local library or the U. S. Department of Labor (see Directory). Several publishers have these, SRA is the most notable (see Directory). Local fixed base operators (look in the yellow pages under Airplane Repairs). Check with interested parents, friends, relatives, etc.</p>

The Main Parts of an Airplane

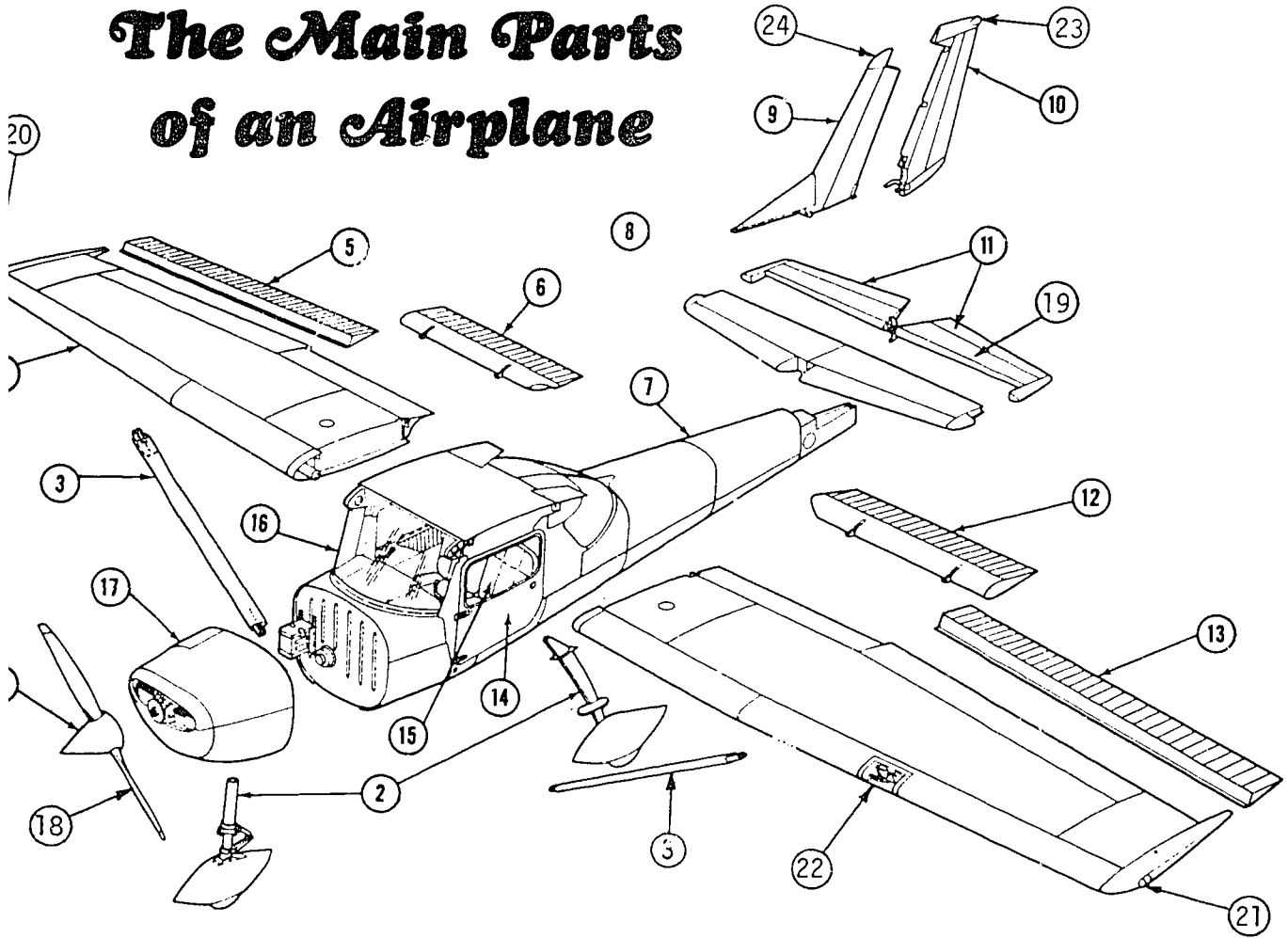

- | | |
|-----------|-----------|
| 1. _____ | 13. _____ |
| 2. _____ | 14. _____ |
| 3. _____ | 15. _____ |
| 4. _____ | 16. _____ |
| 5. _____ | 17. _____ |
| 6. _____ | 18. _____ |
| 7. _____ | 19. _____ |
| 8. _____ | 20. _____ |
| 9. _____ | 21. _____ |
| 10. _____ | 22. _____ |
| 11. _____ | 23. _____ |
| 12. _____ | 24. _____ |

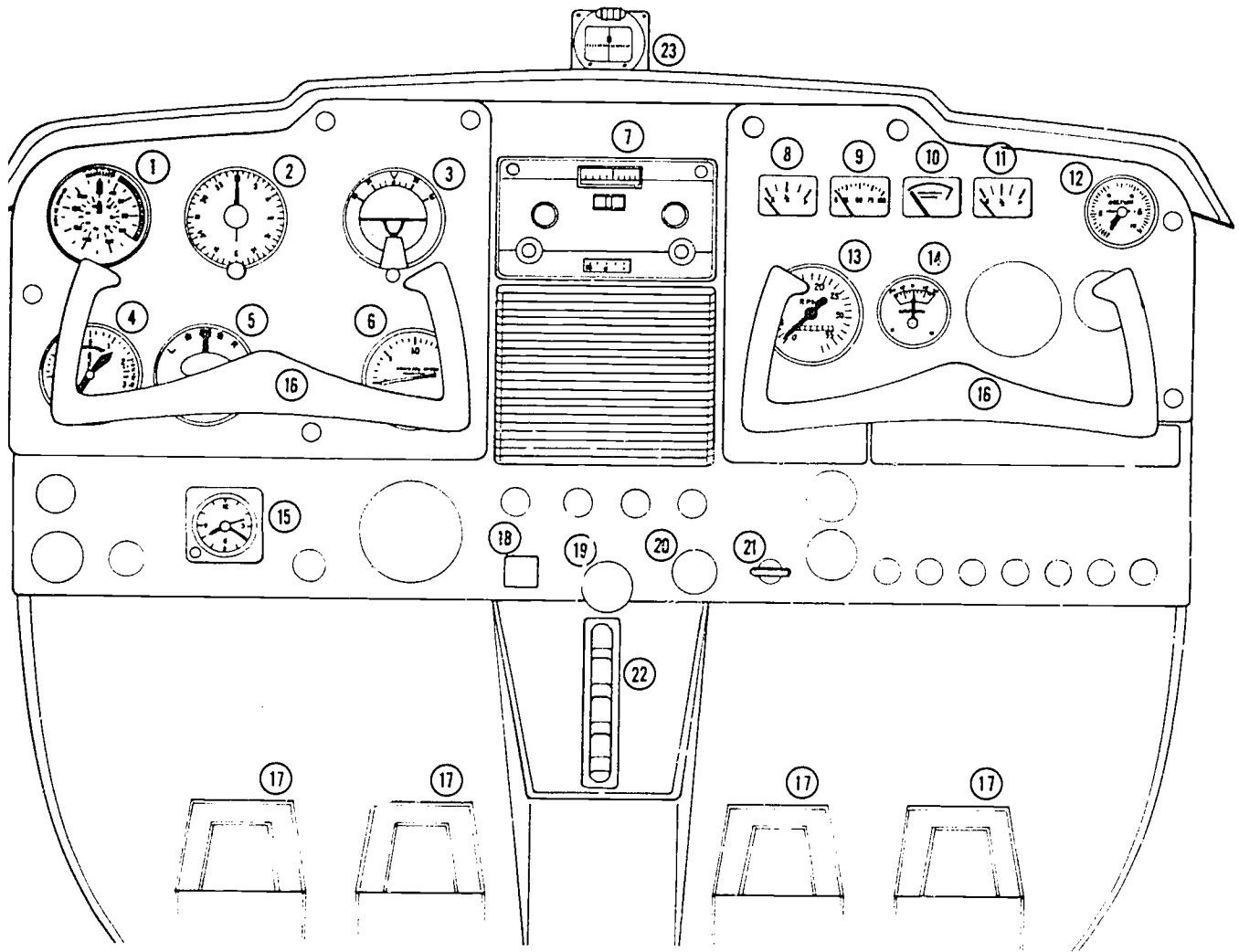

Instrument Panel

- | | |
|----------|----------|
| 1. | 13. |
| 2. | 14. |
| 3. | 15. |
| 4. | 16. |
| 5. | 17. |
| 6. | 18. |
| 7. | 19. |
| 8. | 20. |
| 9. | 21. |
| 10. | 22. |
| 11. | 23. |
| 12. | |

YAW AXIS

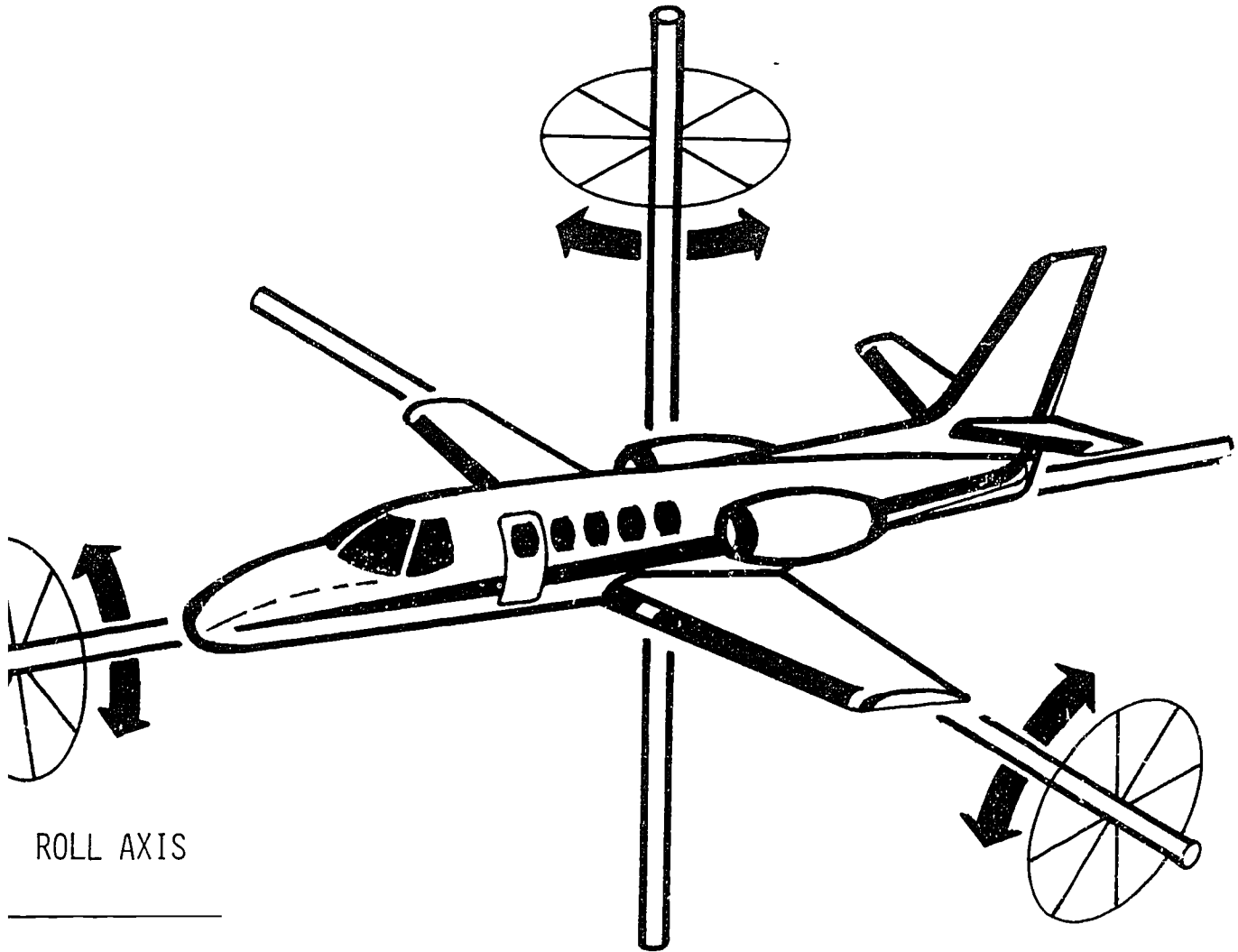

ROLL AXIS

PITCH AXIS

THE MOTIONS OF FLIGHT

CARDBOARD BOX FLIGHT SIMULATOR

INSTRUCTIONS

1. Get a corrugated carton from a console model TV set. Ask a local TV dealer; they are usually glad to get rid of them.

2. Paste the instrument panel photograph from this kit to the front for small children. For larger ones you will need to use a full-size photograph. They are available from many sources. One is the United Aviation Group, P. O. Box 1136, Santa Monica, CA 90406.

They have a good selection and charge \$3.95 for one and \$2.95 each for two or more.

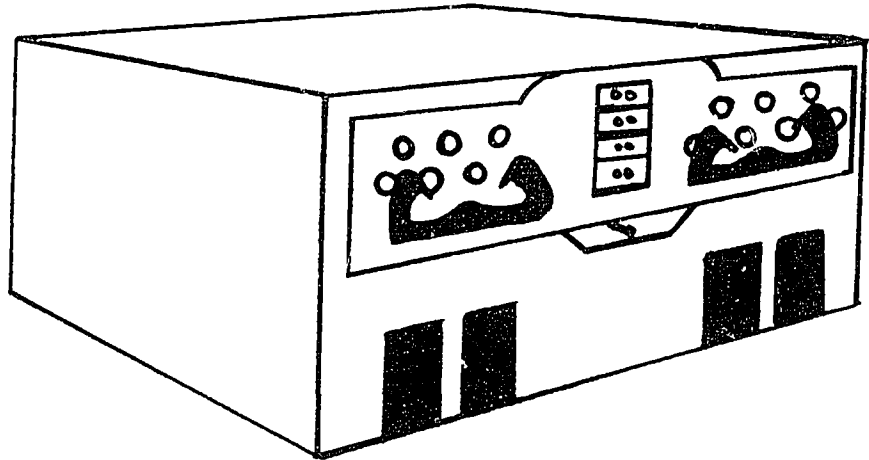

3. Trace the control wheel on the photograph, transfer it to heavy corrugated cardboard and cut it out. Two thicknesses glued together and wrapped with tape make it sturdy and durable. (Make two.) Nail each wheel to a piece of broomstick or dowel that will stick out of the box about a foot in both the front and the back. Install it in the right place as shown in the sketch below.

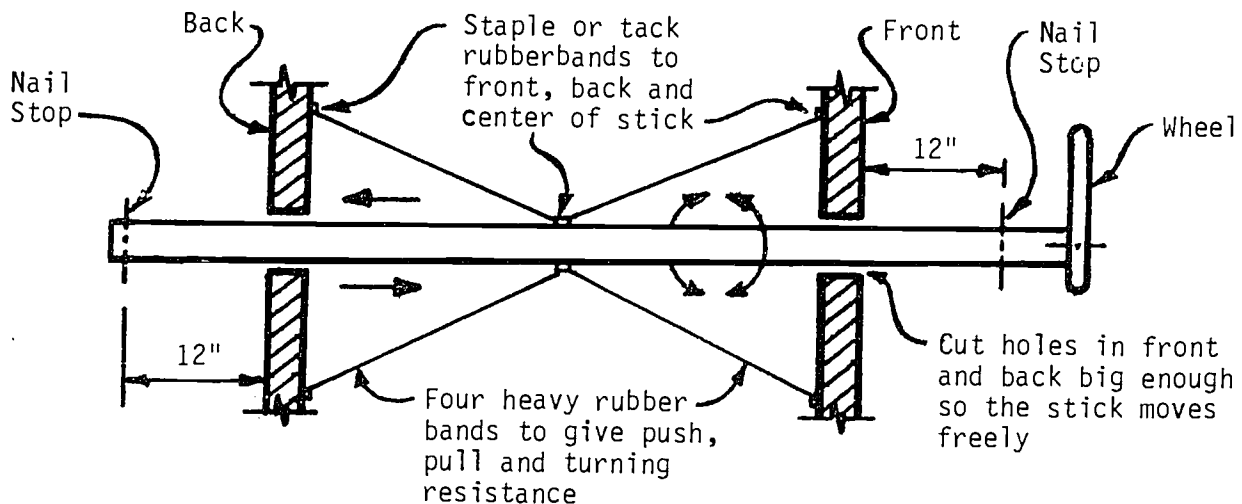

CONTROL WHEEL INSTALLATION

4. Make a throttle by attaching an old TV or radio knob to a piece of dowel about 10" long and install it as shown at the right. Glue several pieces of corrugated to the inside of the box as shown for strength and sliding resistance. Be sure to cut the holes in these pieces before you glue them on.

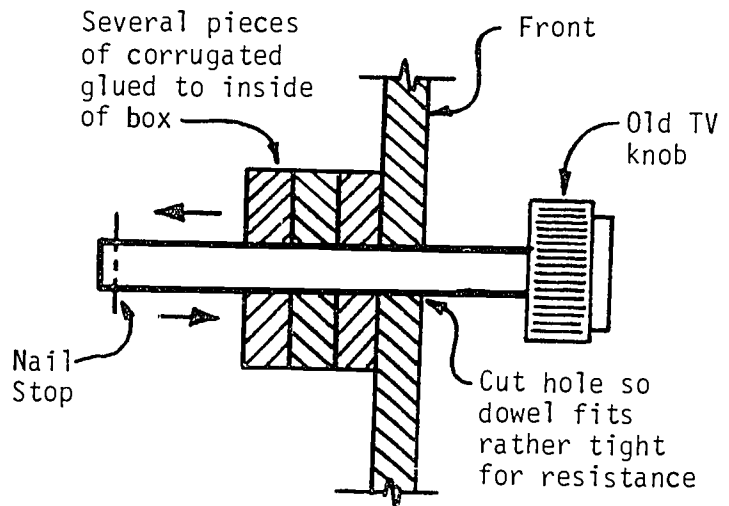

THROTTLE INSTALLATION

5. For rudder pedals, cut out two pairs of 3-sided flaps in the right place as shown at the left. Attach 2 rubber bands to each pedal for resistance and return. Be sure to make them large enough so that everyone's feet will fit. You might also tape the edges of both the pedal and the cutout for better durability.

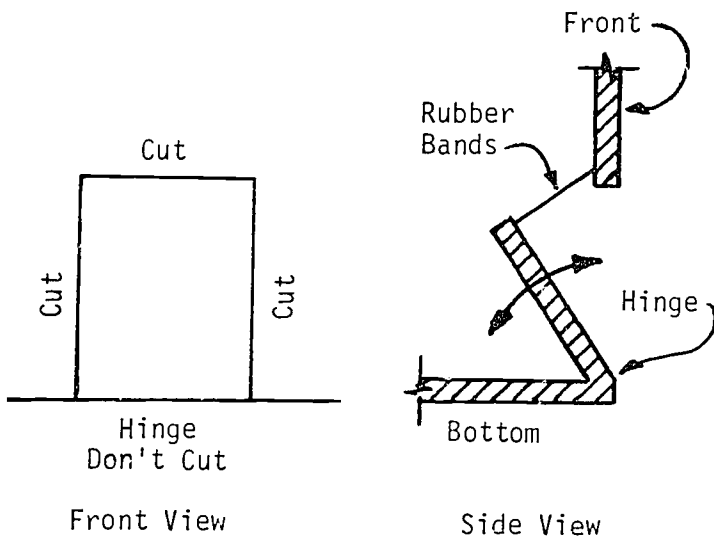

RUDDER PEDAL INSTALLATION

6. You now have a workable flight simulator. Everything you do from this point on will make it just that much more realistic. Using the panel photograph for size and patterns you might cut needles for the instruments from white plastic lids. Just put a pin thru them and the cardboard box and set them at different places for different problems. You can surely find some old cabinet or radio knobs, switches, etc. Just punch a hole in the box and screw them on from the inside. Be sure to leave them just loose enough to turn with a little friction.

7. Pull up two classroom chairs, seat a pilot and co-pilot and you're off into the wild blue yonder.

I INVESTIGATE AN OCCUPATION

1. Name of the occupation _____
2. Job Title _____
3. Exactly what does the worker do? _____

4. What tools or equipment are used? _____

5. How much education do you need for this job? High School? _____
Technical School? _____ College? _____ Special School? _____
Other? _____ What other? _____
6. What other special qualifications are needed? Physical, Mental, etc. _____

7. Working conditions and hours? _____
8. Geographic location? _____
9. Opportunities for advancement? _____
10. What interests of yours would this job satisfy? _____

11. What abilities do you have that are related to this job? _____

12. Will this job require more or less workers in the future? Why? _____

13. List some related jobs that you might consider as alternatives. Why? _____

UNIT III: HOW AIRPLANES FLY: FORCES, MOTIONS AND ATTITUDES

UNIT GOAL: To Introduce The Student To The Motions, Forces And Attitudes Of Flight And The Surfaces That Control Them.

OBJECTIVE	STRATEGY	RESOURCES	SOURCE
<p>1. The student will understand the four forces of flight, what produces these forces, how the major controls affect them and what instruments are affected by changes in these forces.</p> <ul style="list-style-type: none"> a) Lift (Wing) b) Thrust (Engine and Propeller) c) Drag (Aerodynamic Shape) d) Gravity (The Earth) 	<p>Use the <i>Forces of Flight, How Thrust Produces Lift, and The Effect of Flaps</i> sheets following to make overhead transparencies and ditto masters and distribute copies to the students. Discuss these forces and what produces them. Point out what controls affect them and what instruments are affected by changes in them. Have the students fill in the blanks on their sheets. (science)</p>	<p><i>Forces of Flight, How Thrust Produces Lift, and The Effect of Flaps</i> Sheets. <i>Wind Tunnel, Teaching Ideas for Aviation, Vol. II, p. 1.</i> <i>Simple Lift Demonstrations, Teaching Ideas for Aviation, Vol. II, p. 2.</i></p>	<p>Included with this Unit. Cessna Aircraft Co. Cessna Aircraft Co.</p>
<p>2. The student will understand the three basic motions of flight, how the major controls affect them and what instruments are affected by changes in these motions.</p> <ul style="list-style-type: none"> a) Roll (Longitudinal) b) Pitch (Lateral) c) Yaw (Vertical) 	<p>Use the <i>Motions of Flight, Effect of the Ailerons, Effect of the Elevator and Effect of the Rudder</i> sheets following to make overhead transparencies and ditto masters and distribute copies to the students. Discuss these motions and the controls and instruments involved with the students. Have them fill in the blanks. (science)</p>	<p><i>Motions of Flight, Effect of the Ailerons, Effect of the Elevator and Effect of the Rudder</i> sheets. <i>Visual Stall Demonstration, Teaching Ideas for Aviation, Vol. II, p. 10.</i></p>	<p>Included with this Unit. Cessna Aircraft Co.</p>



OBJECTIVE	STRATEGY	RESOURCES	SOURCE
<p>3. The student will understand the four basic attitudes of flight, how the major controls are used to execute or maintain them and what instruments reflect this.</p> <p>a) Climb b) Straight and Level c) Turn d) Glide</p>	<p>Use the <i>Paper Airplane Model</i> sheet to make a ditto master and distribute copies to the students. Have them cut out, fold, tape and clip the model according to the instructions and build the plane. Have them use the rudders, ailerons and elevators to demonstrate the different motions of flight. Have them experiment with different positions of the control surfaces to produce different motions. (science)</p> <p>Have the students go back to the aviation magazines you used in Unit 1 and cut out pictures of airplanes in the various attitudes of flight. Have them label them and put them in their notebooks.</p> <p>Have the students draw pictures of airplanes in the various attitudes of flight. (art)</p> <p>Have the students use the paper airplane models from objective 2 above to demonstrate the various attitudes of flight. Again, adjustment of the control surfaces should produce all of the basic attitudes and maneuvers and some pretty weird ones as well.</p>	<p><i>Paper Airplane Model</i> sheet for making ditto master.</p> <p>Model Aircraft Laboratory. GA-20-71.</p> <p>How to Make and Fly Paper Airplanes</p> <p>Aviation magazines of general interest. Save what is left of them for use in later units.</p> <p>Art supplies.</p> <p>See paper airplane resources in Objective 2 above.</p>	<p>Included with this Unit.</p> <p>FAA (see Directory).</p> <p>Scholastic Book Services (see Directory).</p> <p>By subscription or at a newsstand. Newsstand at the nearest large airport is excellent. Interested parents. Other aviation interested teachers.</p> <p>Should be on hand in your classroom.</p> <p>See Objective 2 above.</p>

OBJECTIVE	STRATEGY	RESOURCES	SOURCE
<p>4. The student will understand the pilot occupation as it applies to both the pilot who flies as a basic occupation and the pilot who flies to help in his or her basic occupation.</p>	<p>Use the <i>I Investigate an Occupation</i> sheet from Unit II and the <i>Job Operation Sheet</i> from Unit I to make ditto masters and distribute copies to the students. Have them use the various resources listed to investigate the pilot's occupation. Have them also look at other occupations which don't require one to be a pilot but where it would be a big help if one were.</p> <p>Have resource people in to talk about their occupations to the class. You might have them prepare questions to ask based upon the sheets to be filled out.</p>	<p><i>Job Operation Sheet</i> from Unit I and <i>I Investigate an Occupation</i> sheet from Unit II.</p> <p><u>Occupational Outlook Handbook</u></p> <p><u>Dictionary of Occupational Titles</u></p> <p>Occupational Briefs</p> <p>A pilot who flies to make his living.</p> <p>A pilot who is in another occupation but uses his flying to help him in his job.</p>	<p>Included with Unit I and Unit II in this kit.</p> <p>Your school or local library or the U. S. Department of Labor. (see Directory)</p> <p>Your school or local library or the U. S. Department of Labor. (see Directory)</p> <p>Several publishers have these, SRA is the most notable. (see Directory)</p> <p>Local fixed base operators (look in the yellow pages under Airplane Charters) Check with interested parents or relatives.</p> <p>Check with interested parents, relatives and friends. Check with local business concerns.</p>

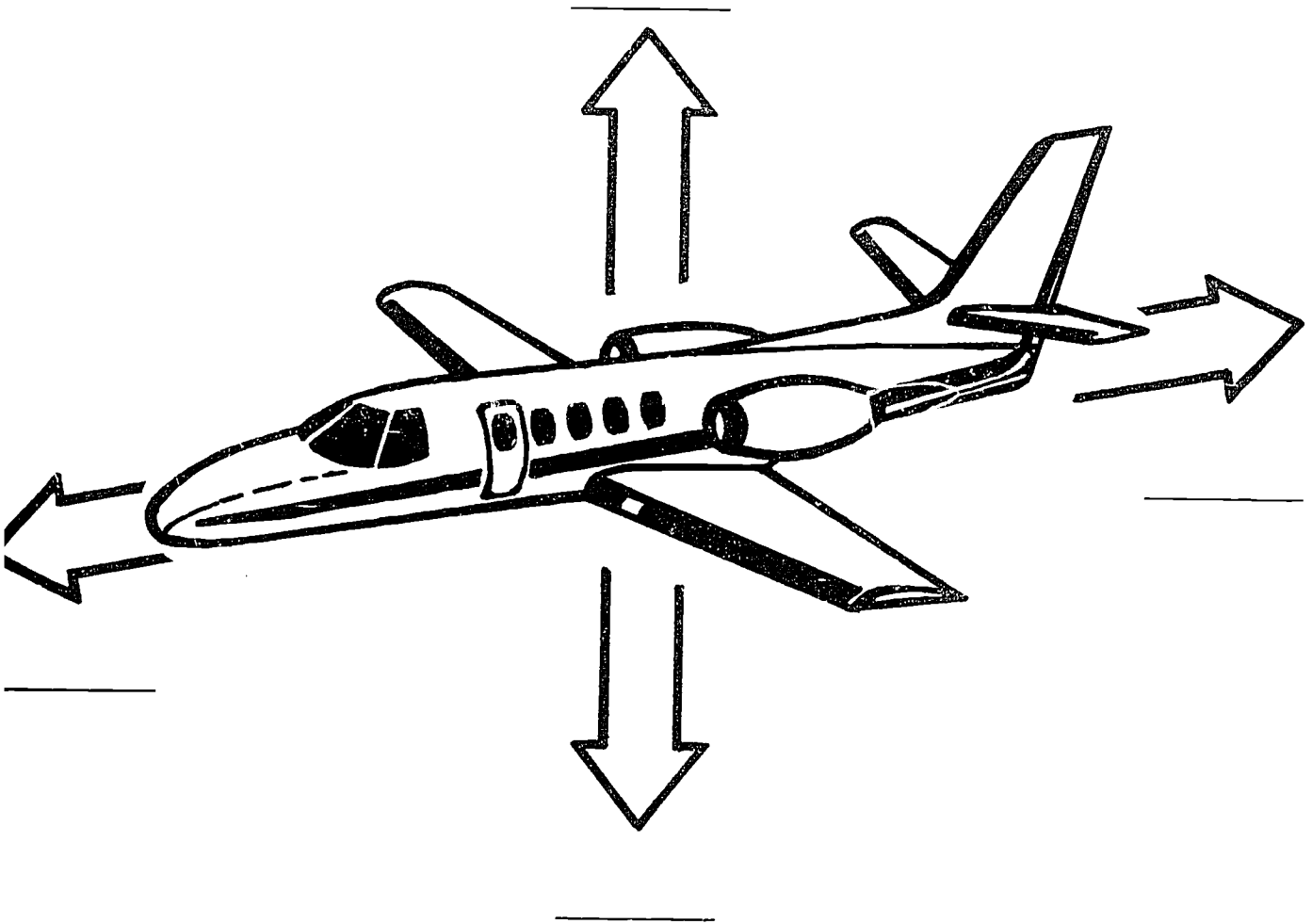

THE FORCES OF FLIGHT

24

20

HOW THRUST PRODUCES LIFT

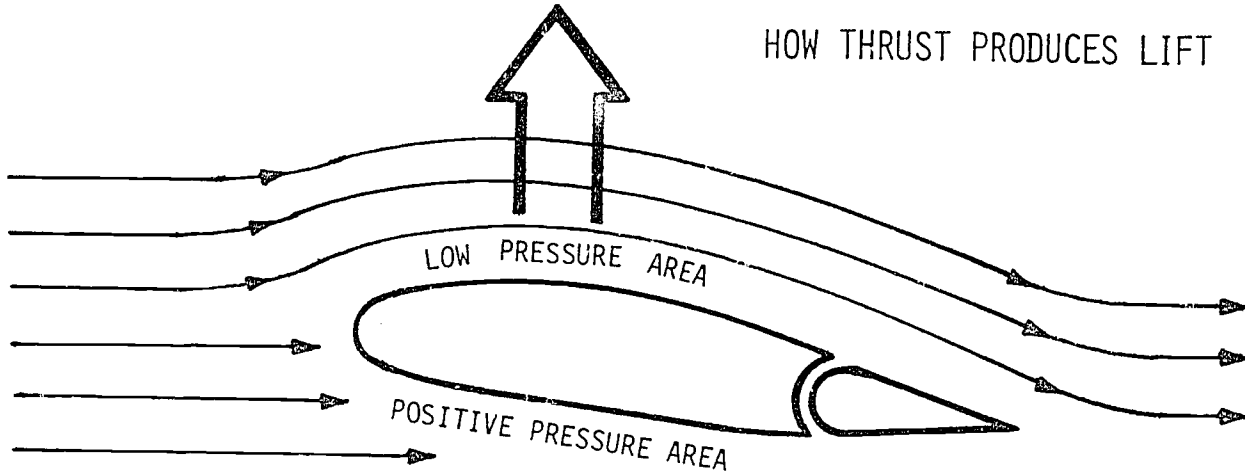

THE _____ IN PRESSURE BETWEEN THE _____ WING SURFACE AND THE _____ WING SURFACE PRODUCES _____

THE EFFECT OF FLAPS

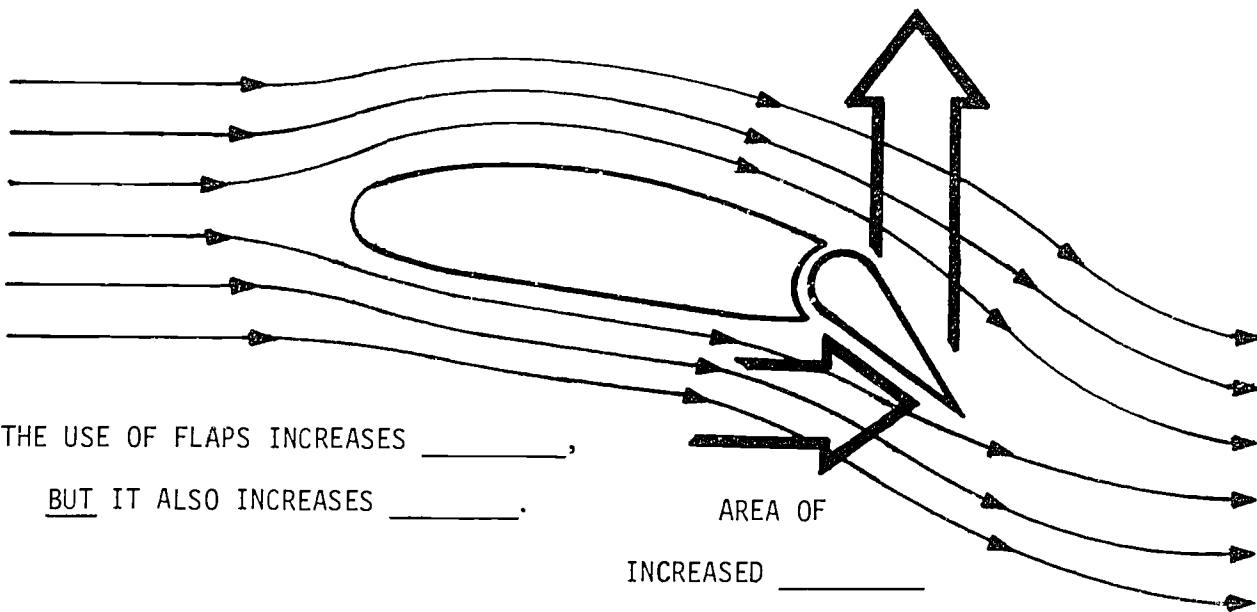

THE USE OF FLAPS INCREASES _____, BUT IT ALSO INCREASES _____.

YAW AXIS

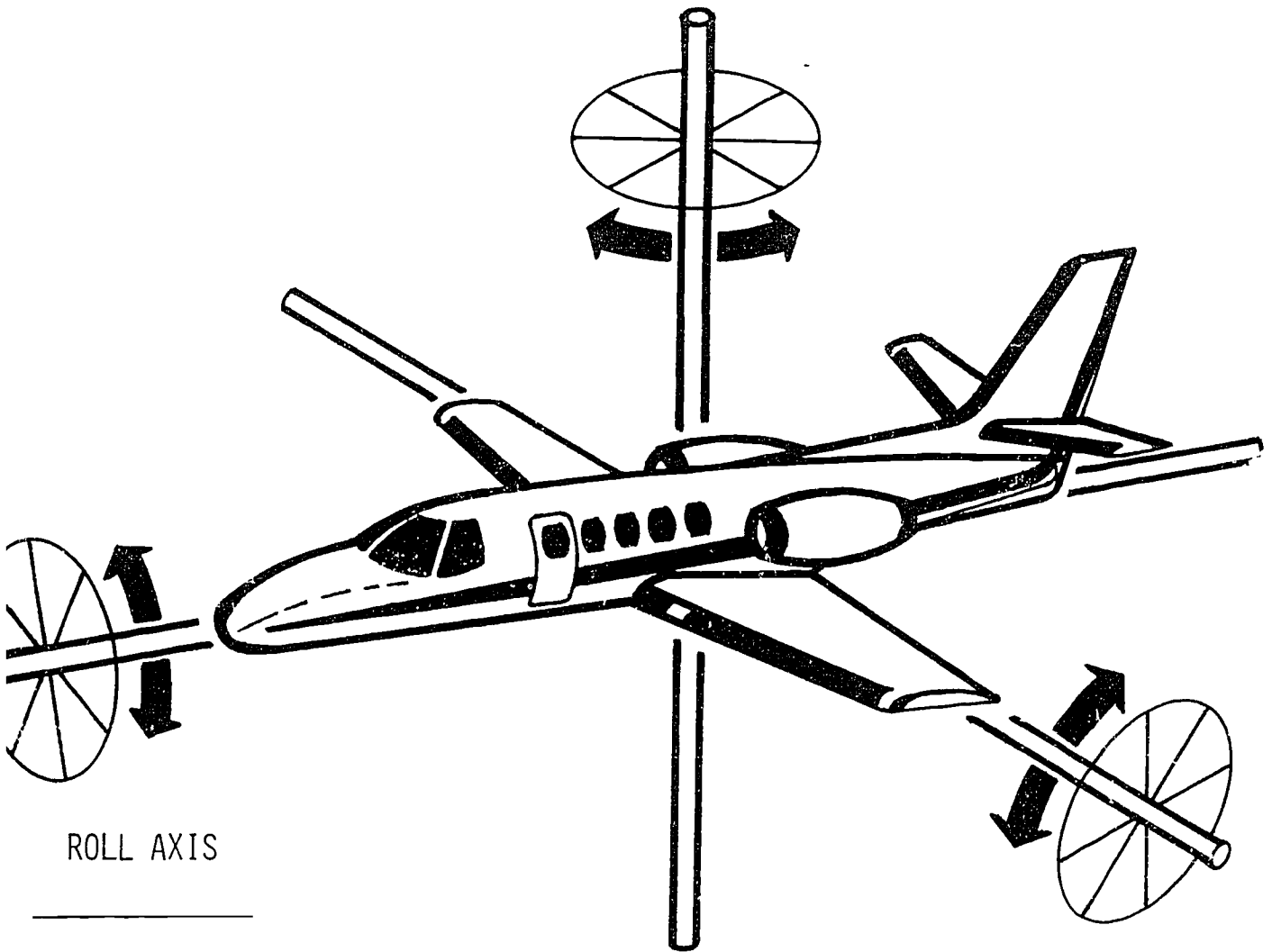

ROLL AXIS

PITCH AXIS

THE MOTIONS OF FLIGHT

26

EFFECT OF THE AILERONS

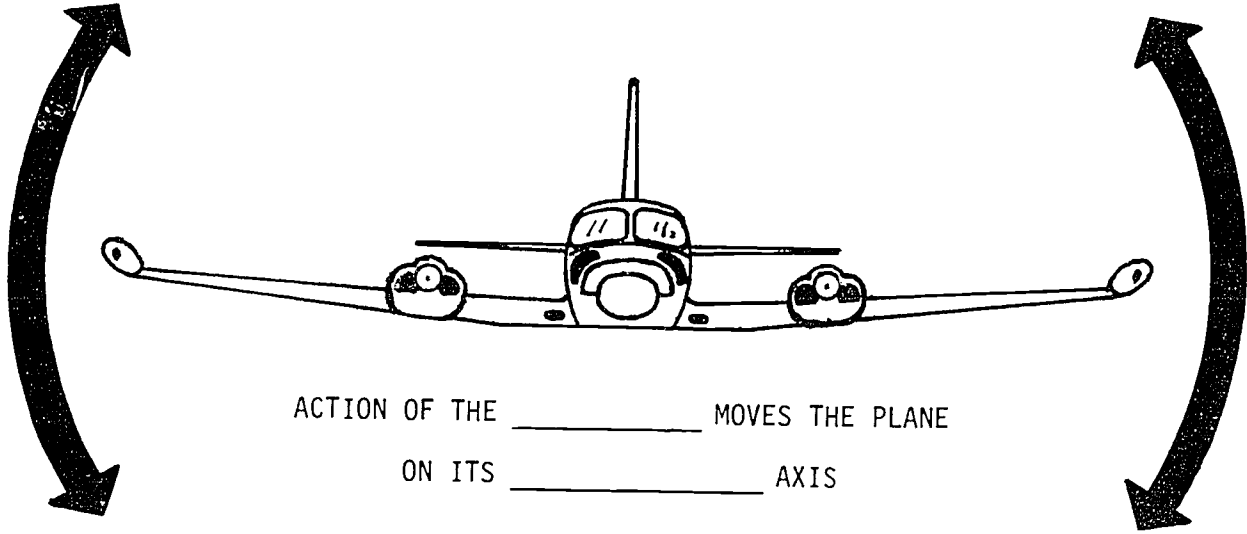

ACTION OF THE _____ MOVES THE PLANE
ON ITS _____ AXIS



NORMAL LIFT

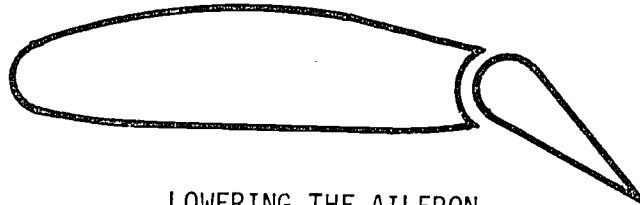

LOWERING THE AILERON

_____ LIFT AND _____ THE WING

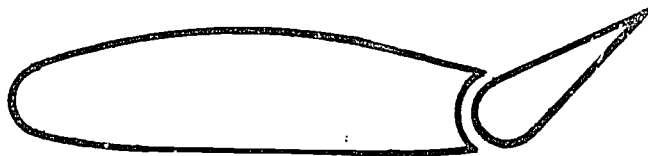

RAISING THE AILERON

_____ LIFT AND _____ THE WING

EFFECT OF THE ELEVATOR

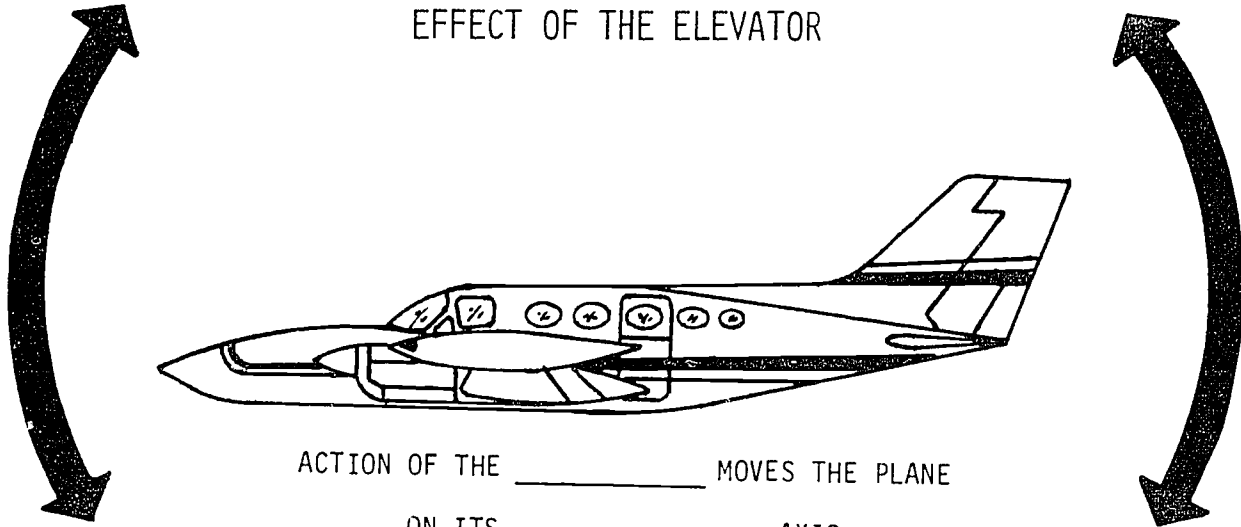

ACTION OF THE _____ MOVES THE PLANE
ON ITS _____ AXIS



RAISING THE ELEVATOR

FORCES THE TAIL _____ AND THE NOSE _____



NORMAL LIFT

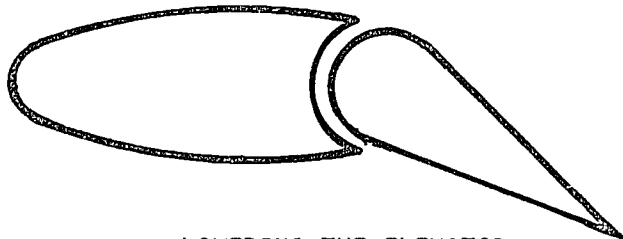

LOWERING THE ELEVATOR

FORCES THE TAIL _____ AND THE NOSE _____

EFFECT OF THE RUDDER

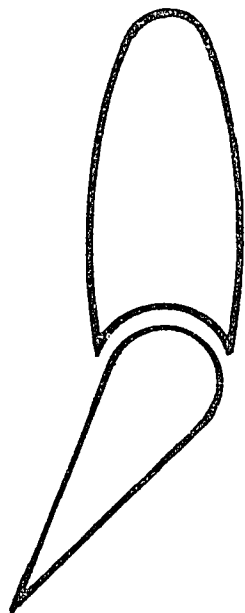
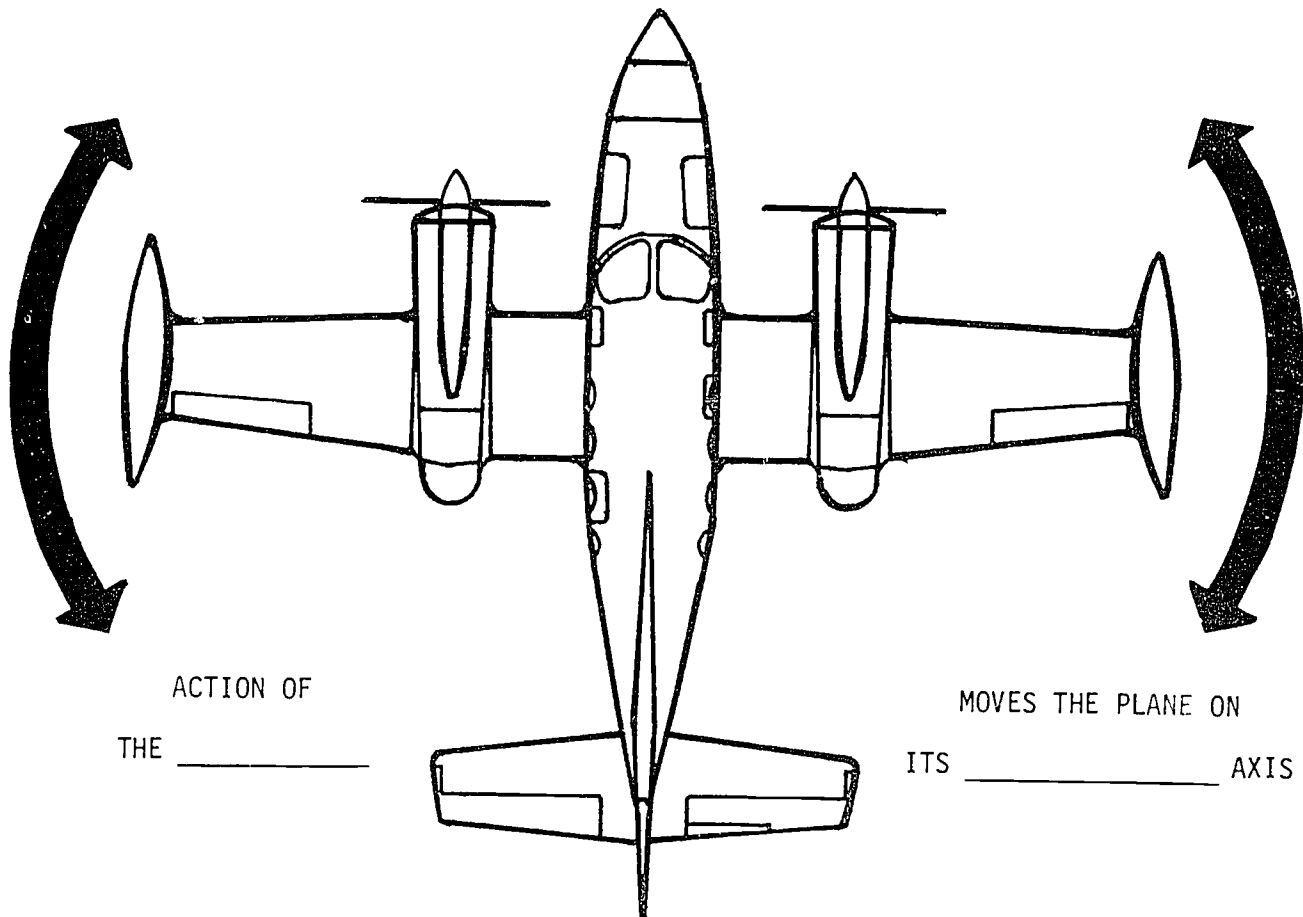

MOVING THE RUDDER TO THE _____
FORCES THE TAIL TO THE _____

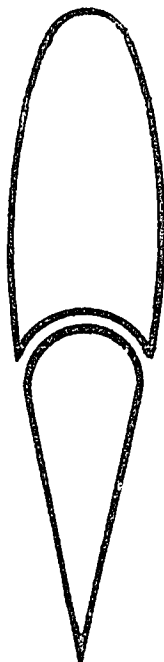

NEUTRAL

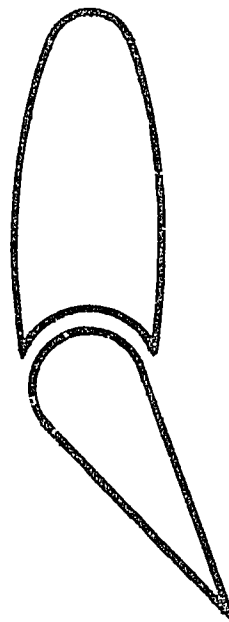

MOVING THE RUDDER TO THE _____
FORCES THE TAIL TO THE _____

PAPER AIRPLANE MODEL

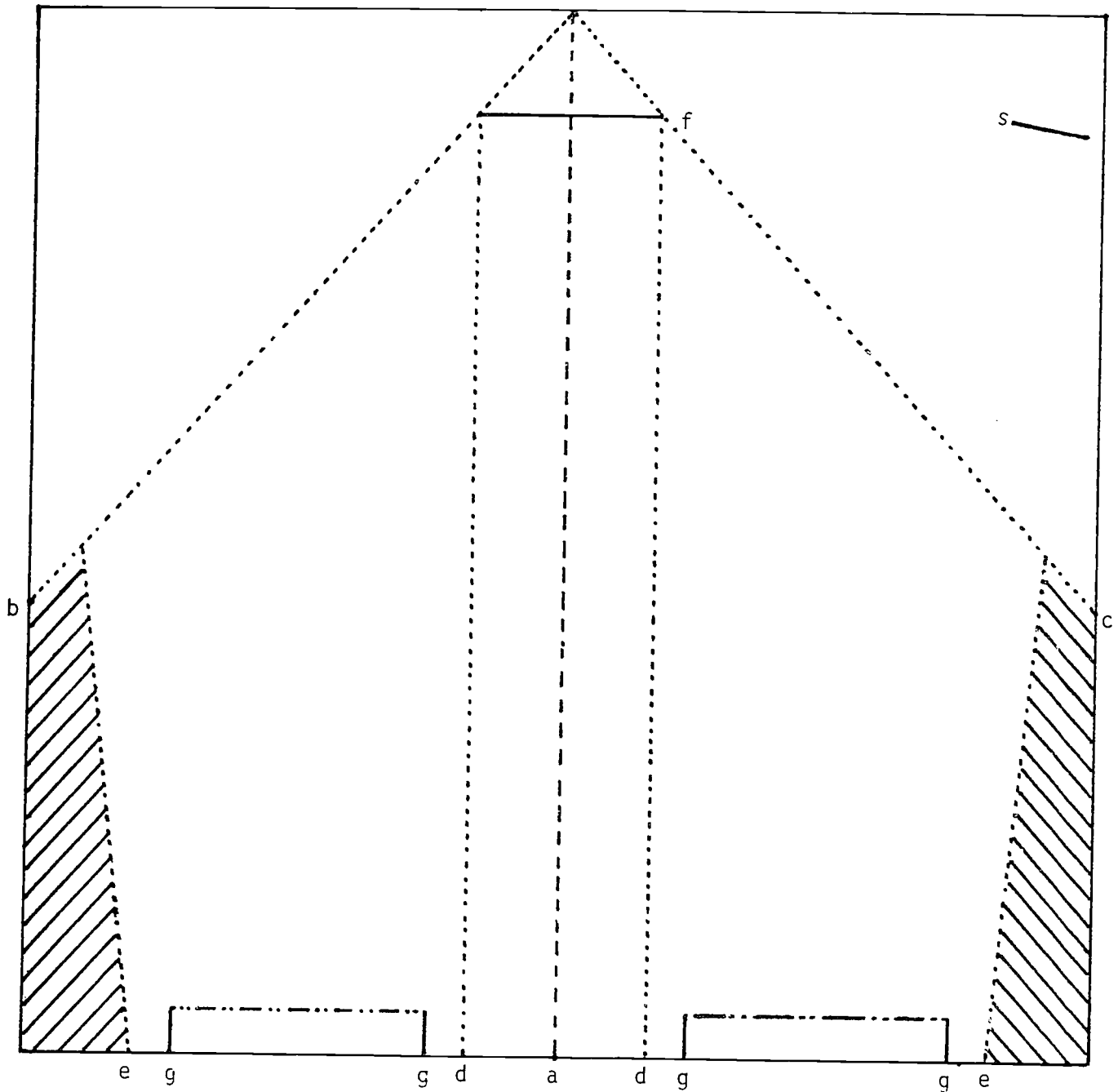

1. Cut out and fold up on line a.
2. Unfold a and fold down lines b then c.
3. Fold a up again and staple at s.
4. Fold down lines d and e.
5. Cut off nose at line f and decorate with paints or crayons.
6. Put a paper clip on the nose and launch for flight.
7. Cut at lines g and fold elevators up or down or both to execute different maneuvers. Use them as ailerons also.

UNIT IV: FLIGHT PLANNING AND NAVIGATION FROM PLACE TO PLACE

UNIT GOAL: To Introduce The Student To The Basic Techniques of Navigation And The Planning Of Airplane Flight.

OBJECTIVE	STRATEGY	RESOURCES	SOURCE
<p>1. The student will understand the basic information and tools a pilot needs to navigate and plan a flight.</p> <p>a) Maps and charts b) Computer and Plotter c) Compass and Clock d) Speed and Distance e) Wind Speed and Direction f) Flight Plan Forms</p>	<p>Begin by familiarizing the students with directions and compass use by playing the compass rose game. (Geography)</p> <p>Have the students study maps and charts for airway navigation. Point out the compass roses on the chart and compare with the game. Also compare air navigation charts with road maps of the same area. Demonstrate the use of the navigation plotter. (Geography)</p>	<p><i>Compass Rose Game</i></p> <p>Air Chart-Road Map comparison poster</p> <p>Sectional and World Air Charts (SAC) and (WAC)</p> <p>Road Maps</p> <p><i>Integrated Learning: Transparency, Teaching Ideas for Aviation Education, Vol. I, P. 4.</i></p> <p><i>Visual Aid for Map Work, Teaching Ideas for Aviation Education Vol. II, p. 5.</i></p>	<p>Included with this Unit.</p> <p>Furnished with this kit.</p> <p>Local Cessna Dealer or Flying Service. Obsolete charts are free.</p> <p>Local Filling Station.</p> <p>Cessna Aircraft Co.</p> <p>Cessna Aircraft Co.</p>

OBJECTIVE	STRATEGY	RESOURCES	SOURCE
	<p>Make a ditto master of the simple computer and distribute a copy to each student. Have them cut-out and assemble the computer. Mathematics lessons could be built around the simple equation $d=rt$ where distance (d) equals speed (r) multiplied by time (t). Have them use the computer to find any one of the variables when the other two are known. Wind problems are simple addition and subtraction to find net speed when the wind is in the direction you're going or opposite to it.</p> <p>Have your students use all of the above to plan a cross country flight. If the FAA Flight Plan form is too complicated, devise a simpler one of your own.</p>	<p><i>Navigation Computer/Plotter sheet.</i></p> <p>Speed Information Time Information</p> <p>Distance Information</p> <p>Wind Speed and Direction</p> <p>FAA Flight Plan Forms</p> <p><i>Flight Plans at Corsicana, Teaching Ideas for Aviation Education, Vol. III, p. 5.</i></p>	<p>Included with this Unit.</p> <p>Aircraft specification sheets included with this kit.</p> <p>Sectional Air Charts.</p> <p>Current local weather reports and forecasts.</p> <p>Local Flying Service.</p> <p>Cessna Aircraft Co.</p>

OBJECTIVE	STRATEGY	RESOURCES	SOURCE
<p>2. The student will understand the various uses for the communication aspect of the radio, to whom and why the pilot talks.</p> <ul style="list-style-type: none"> a) <i>Control Tower</i> for take-off and landing instructions. b) <i>Ground Control</i> for movement instructions on the ground. c) <i>Flight Service Stations</i> for reporting position and getting current enroute weather and traffic info. d) <i>Other Airplanes</i> for general information and assistance. 	<p>It is best to begin by letting the students listen to actual aircraft radio communications using recordings or a radio that will tune to aircraft frequencies.</p> <p>Have the students practice and learn the phonetic alphabet, aircraft call signs, special words and phrases and other radio communication procedures. The suggested resource has all of this, including a workbook for the student. (language arts, English)</p> <p>Use the <i>Milk Carton Radio</i> sheet to make a ditto master and distribute a copy to each student. Have each construct a radio using the cut-outs and instructions. They can then practice radio communication. If your school has a language laboratory you might use that. (language arts, English)</p>	<p>Aircraft radio tuned to local airport, Flight Service Station or Air Traffic Control Center.</p> <p>Recorded Radio Communications</p> <p><u>Teaching Guide for an Aerospace Communication Laboratory.</u> GA-20-18-8R</p> <p><i>Milk Carton Radio</i> sheet.</p> <p>Language Lab</p> <p><i>Radio Communications, Teaching Ideas for Aviation Education, Vol. I, p. 1.</i></p>	<p>Any radio store or an interested parent or friend may let you borrow one.</p> <p>Several Aviation Education Aids Suppliers (see Directory)</p> <p>FAA (see Directory).</p> <p>Included with this Unit.</p> <p>Your school.</p> <p>Cessna Aircraft Co.</p>

OBJECTIVE	STRATEGY	RESOURCES	SOURCE
<p>3. The student will understand the various uses of the navigation aspect of the radio and other electronic devices and instruments used to aid the pilot in flight.</p> <ul style="list-style-type: none"> a) Omni range stations (VOR) b) Automatic Direction Finders (ADF) c) Air Traffic Control Centers (ATCC) d) Distance Measuring Equipment (DME) e) Instrument Landing Systems (ILS) 	<p>This familiarization can best be done by a professional on a trip to the airport. Have him or her explain these various instruments and their uses and show the children in a real airplane. For classroom explanations you might use demonstration models. This objective may be too advanced for younger children.</p>	<p>Commercial/Instrument rated pilot Demonstration Models An Airport Trip, GA-300-94</p>	<p>Local Cessna Dealer or Flying Service. Several Aviation Education Aids Suppliers (see Directory). FAA (see Directory)</p>

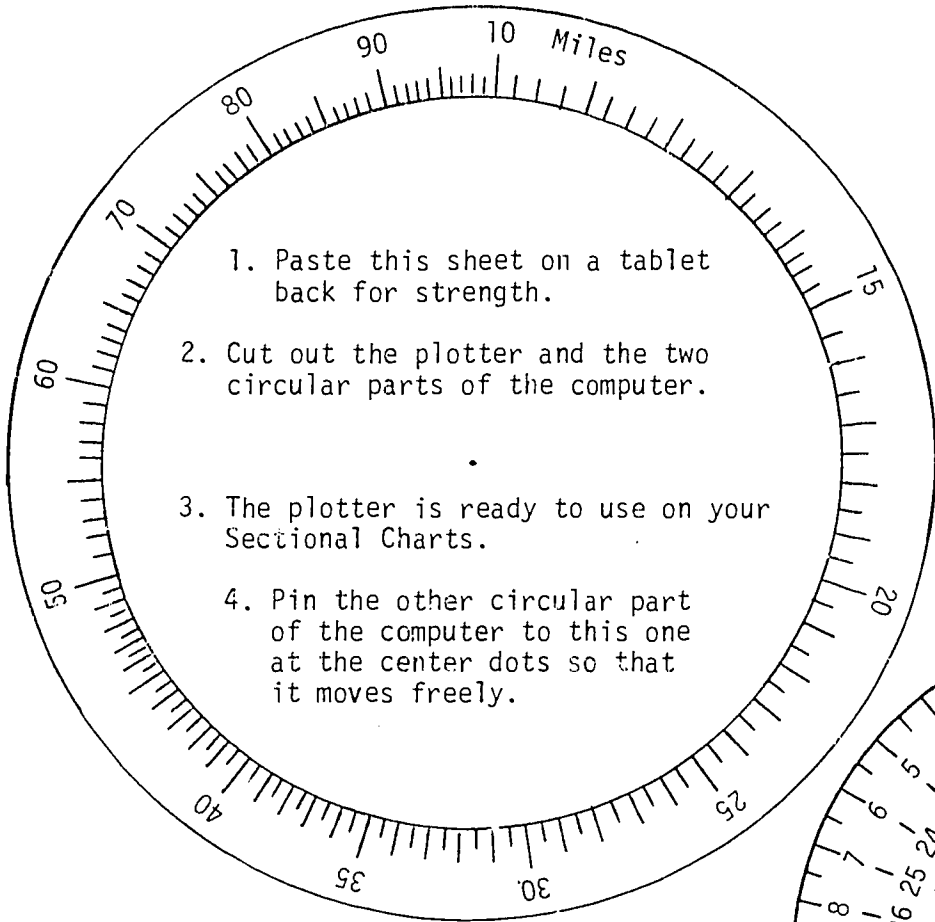

NAVIGATION COMPUTER AND PLOTTER

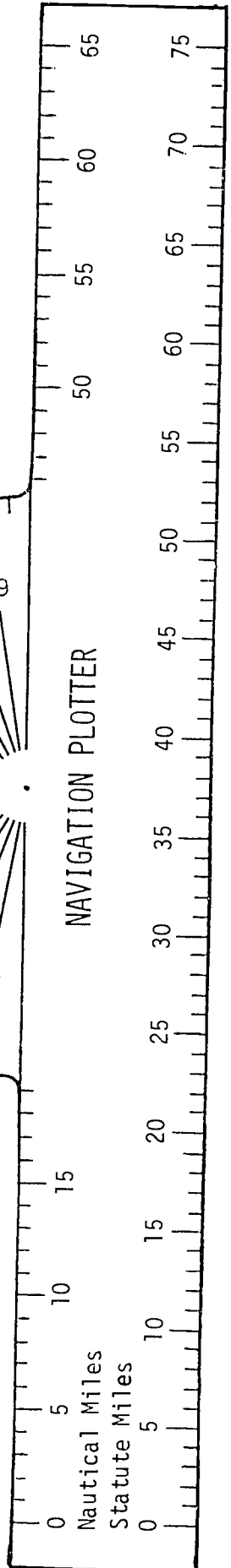
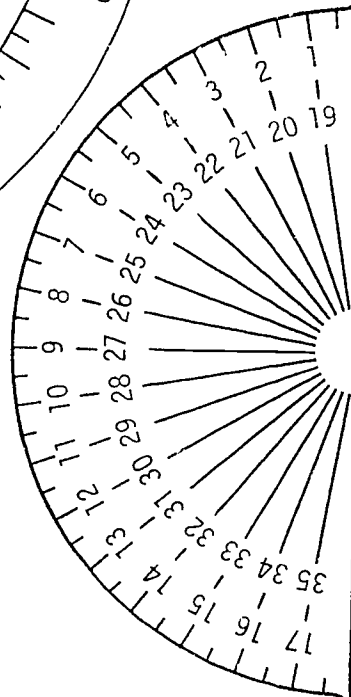
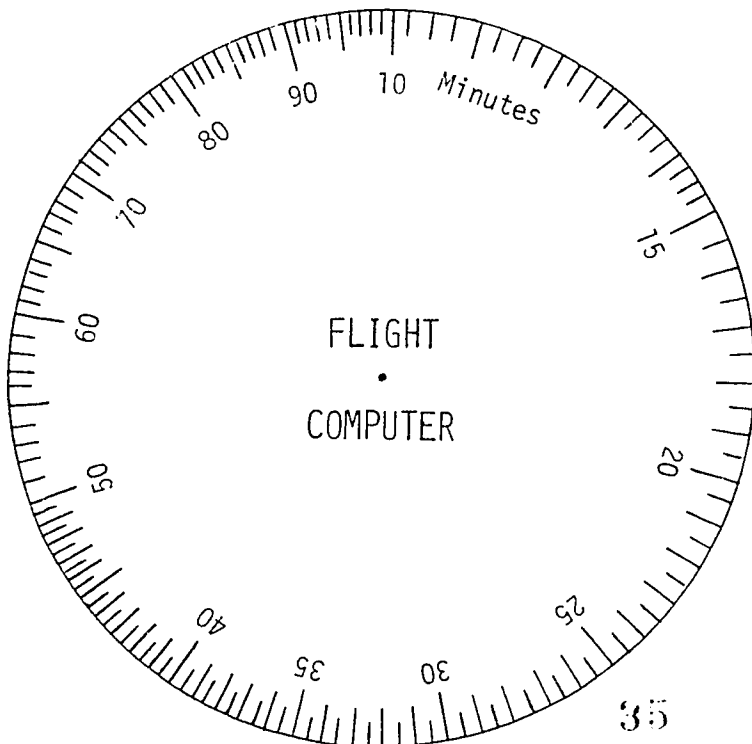

MILK CARTON RADIO

1. Take an empty half-gallon milk carton, flatten out the pointed end, tape it shut and paint it black. You may want to put a brick or something to weight it down first.
2. Cut out the radio face on this sheet and glue or paste it to one side of the carton.

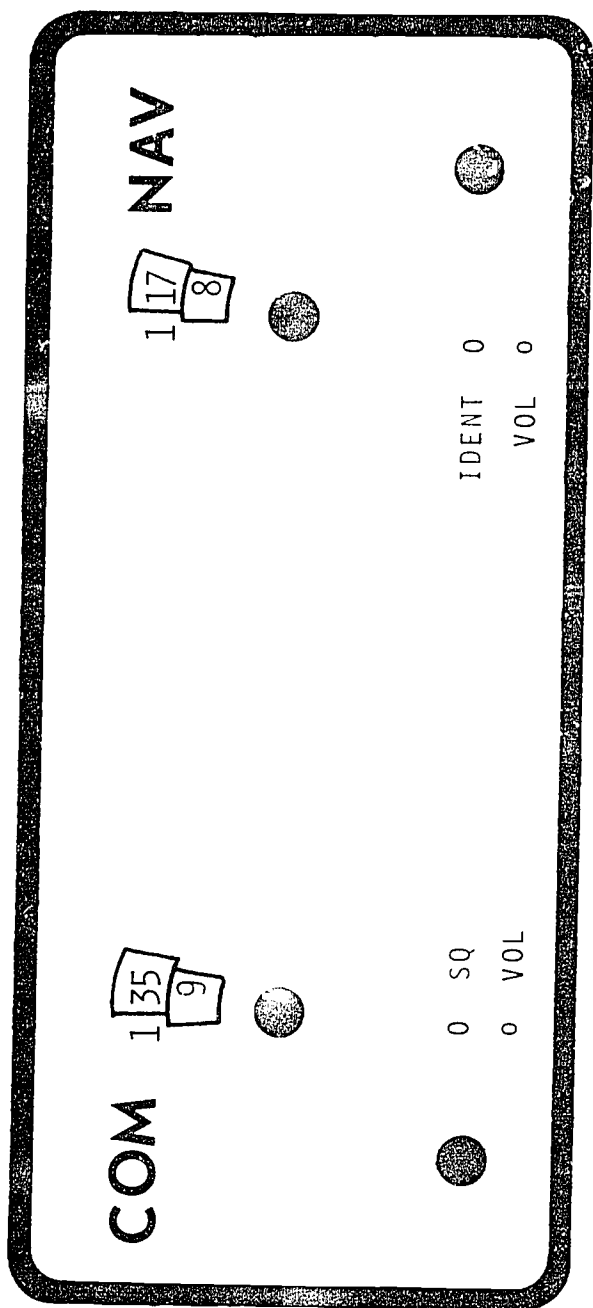

3. Glue on four old radio knobs over the four black circles on the radio face. You may want to screw them on so that they will turn.
4. Take an old jewelry box such as men's cuff links or tie bars come in, tape or glue it shut and paint it black. Decorate it so that it looks like the microphone shown below.
5. Attach the microphone to the radio with an appropriate length of cord. An old coiled telephone cord is the most realistic.
6. You are now ready to use this simulated radio in your work with airplane communication and navigation.

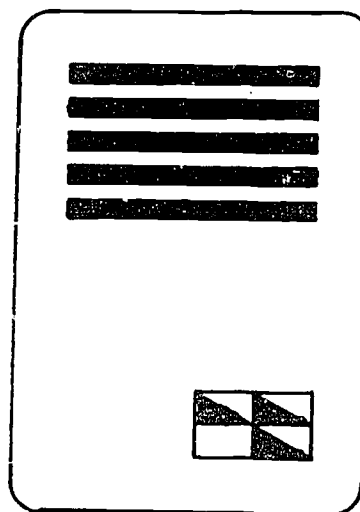

UNIT V: WEATHER AND AVIATION

UNIT GOAL: To Introduce The Student To The Various Aspects Of Basic Weather Observation, Forecasting And Reporting And The Jobs Of The People Who Do This.











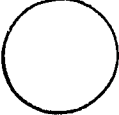

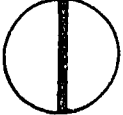

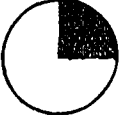

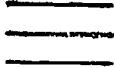

OBJECTIVE	STRATEGY	RESOURCES	SOURCE
<p>1. The student will understand the basic kinds of weather information that a pilot needs to know.</p> <ul style="list-style-type: none"> a) Nature of the Atmosphere (Temperature, Pressure) b) Wind (Direction, Velocity, Circulation, Turbulence, Ground, Aloft) c) Moisture (Humidity, Temperature, Dew Point) d) Condensation (Dew, Frost, Ice, Rain, Snow, Fog, Clouds, Cloud types, Ceiling, Visibility) e) Air Masses and Fronts (Warm Fronts, Cold Fronts, Occluded Fronts, Warm and Cold Air Masses) 	<p>Your students can learn about these different kinds of weather by teacher demonstrations or performing simple experiments. These might be running into the wind, making pin-wheels, flying kites, boiling water and watching steam form, watching water drops form on a cold glass of water in a warm room, blowing up balloons and weighing them to show that air has weight or squeezing it to demonstrate air pressure. (Science)</p>	<p>Your Science textbook is an excellent source.</p> <p><i>Chapters 4-11, Pilot's Handbook of Aeronautical Knowledge, AC 61-23A</i></p> <p>An Introduction to Aerospace Education, pp. 54-5, 65-7, 125-7.</p>	<p>Your own school.</p> <p>Superintendent of Documents U. S. Government Printing Office, \$4.00.</p> <p>New Horizon Publishers (see Directory)</p>

OBJECTIVE	STRATEGY	RESOURCES	SOURCE
<p>2. The student will be able to read weather maps and reports to gain information about the basic weather picture.</p> <ul style="list-style-type: none"> a) Weather Maps (General and Aviation) b) Weather Symbols c) Teletype Sequences 	<p>Have your students clip weather reports and weather maps from the local newspaper for study. Have them keep them over a period of time to interpret patterns, etc. On a trip to the airport, pick up teletype weather reports that are no longer current. Use these and non-current weather maps you can also pick up. Have a person at the airport save some of these for you. Have the students study the weather symbols that are used. They could also listen to weather reports on the radio. (Science)</p>	<p><i>Weather Symbol and Front Sheets.</i></p> <p><i>Chapter 11, Pilot's Handbook of Aeronautical Knowledge, AC 61-23A.</i></p> <p>Weather Radio</p>	<p>Included with this Unit.</p> <p>Superintendent of Documents, U. S. Government Printing Office, \$4.00.</p> <p>Nearby radio store.</p>
<p>3. The student will become familiar with the occupations of people who observe, forecast and report the weather.</p>	<p>Students might be able to take a trip to a nearby weather station and discuss occupations and operations with the workers there. An alternative would be to invite a worker to address the class, or even a radio or television weather man. Students should use the <i>Investigate an Occupation</i> and <i>Job Operation</i> sheets from previous units to study these jobs. (English)</p>	<p>U. S. Weather Service</p> <p><i>I Investigate an Occupation Form.</i></p> <p><i>Job Operation Sheet</i></p>	<p>Nearby large airport.</p> <p>Included with Unit II in this kit.</p> <p>Included with Unit I in this kit.</p>

OBJECTIVE	STRATEGY	RESOURCES	SOURCE
<p>4. The student will become familiar with the basic instruments used in recording and forecasting the weather.</p> <ul style="list-style-type: none"> a) Thermometer b) Barometer c) Aneometer d) Rain Gauge 	<p>Students can construct simple weather recording and forecasting instruments using easy to obtain materials. Have them set up a school weather station and report and forecast weather for the entire school. They can make maps and reports for reproduction and distribution to other classes. As an alternative, if someone has more sophisticated instruments you might borrow them. Students should use their job observation data from above to choose jobs in the school weather station. (Science, art)</p>	<p><i>School Operated Weather Center, Teaching Ideas for Aviation Education, Vol. II, p. 7-8.</i></p>	<p>Cessna Aircraft Co.</p>

SKY COVER

OBSTRUCTIONS & PRECIPITATION

	CODE 0 NO CLOUDS CLEAR		HAZE
	CODE 1 1/10 OR LESS SCATTERED		SMOKE
	CODE 2 2/10 OR 3/10 SCATTERED		DUSTSTORM OR SANDSTORM
	CODE 3 4/10 SCATTERED		FOG
	CODE 4 5/10 SCATTERED		DRIZZLE
	CODE 5 6/10 BROKEN		RAIN
	CODE 6 7/10 OR 8/10 BROKEN		SNOW
	CODE 7 9/10 BROKEN		SHOWERS
	CODE 8 COMPLETELY COVERED OVERCAST		HAIL
	CODE 9 SKY OBSCURED DUST, HAZE, SMOKE		THUNDERSTORM

WEATHER MAP SYMBOLS

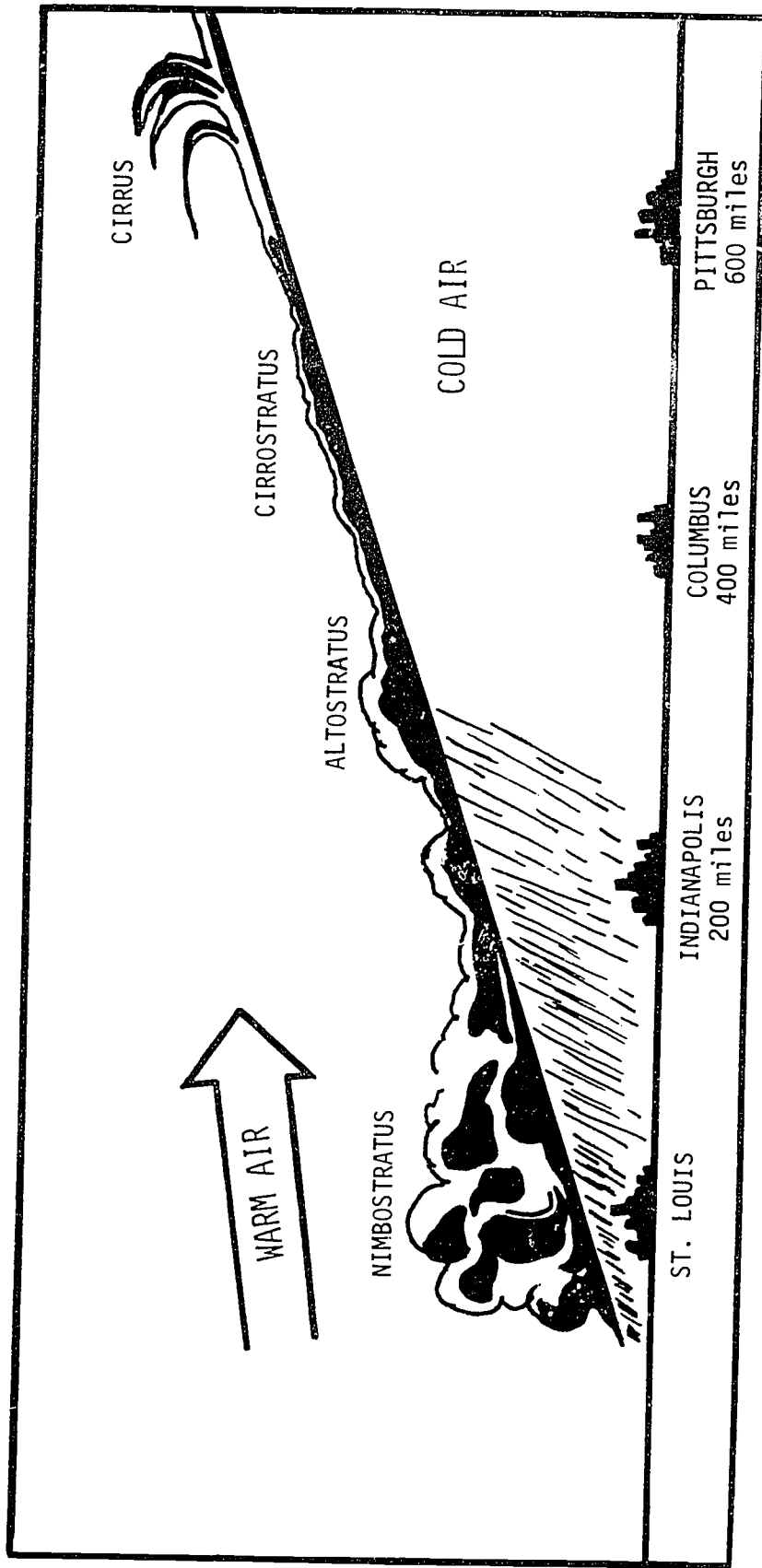

A WARM FRONT

Compare the cross-sectional picture above with the teletype reports from the four cities shown at the right.

STL M10⊕1R-- 020/65/65 ↗ 18/960
 IND M4⊕50⊕3R 068/59/59 ↑ ↘ 12/973
 CMH E60⊕6H 125/56/50 ↘ 18/990
 PIT 150-⊕ 166/53/34 ↘ 12/002

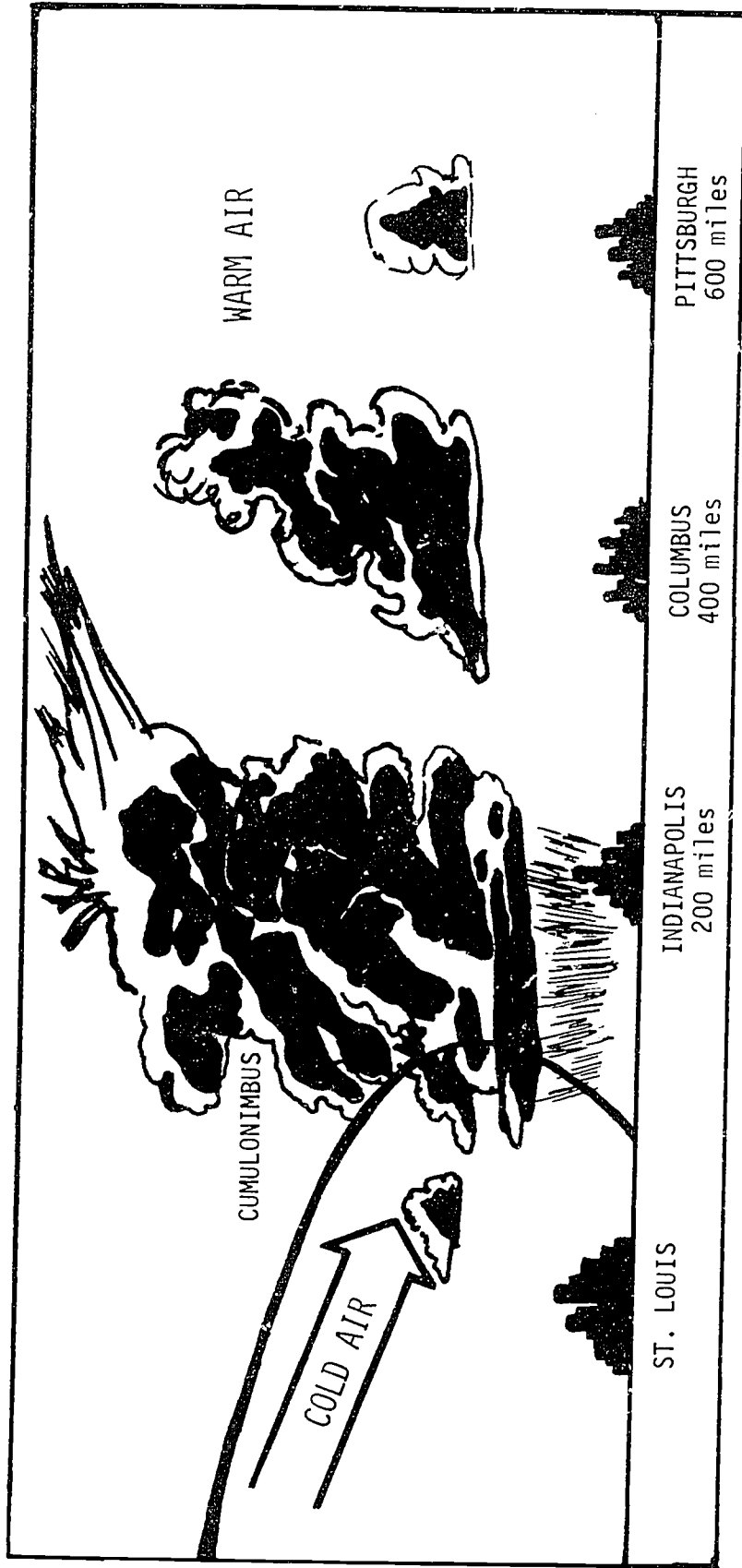

A COLD FRONT

Compare the cross-sectional picture above with the teletype reports from the four cities shown at the right.

- STL E50⊕120⊕8RW- 088/46/33→\18/979
- IND 20⊕E100⊕7 071/74/71↑↗24/974
- CMH 15⊕100⊕EH 102/77/73↑↗12/983
- PIT 15⊕M20⊕3K 122/75/70↑↗12/989

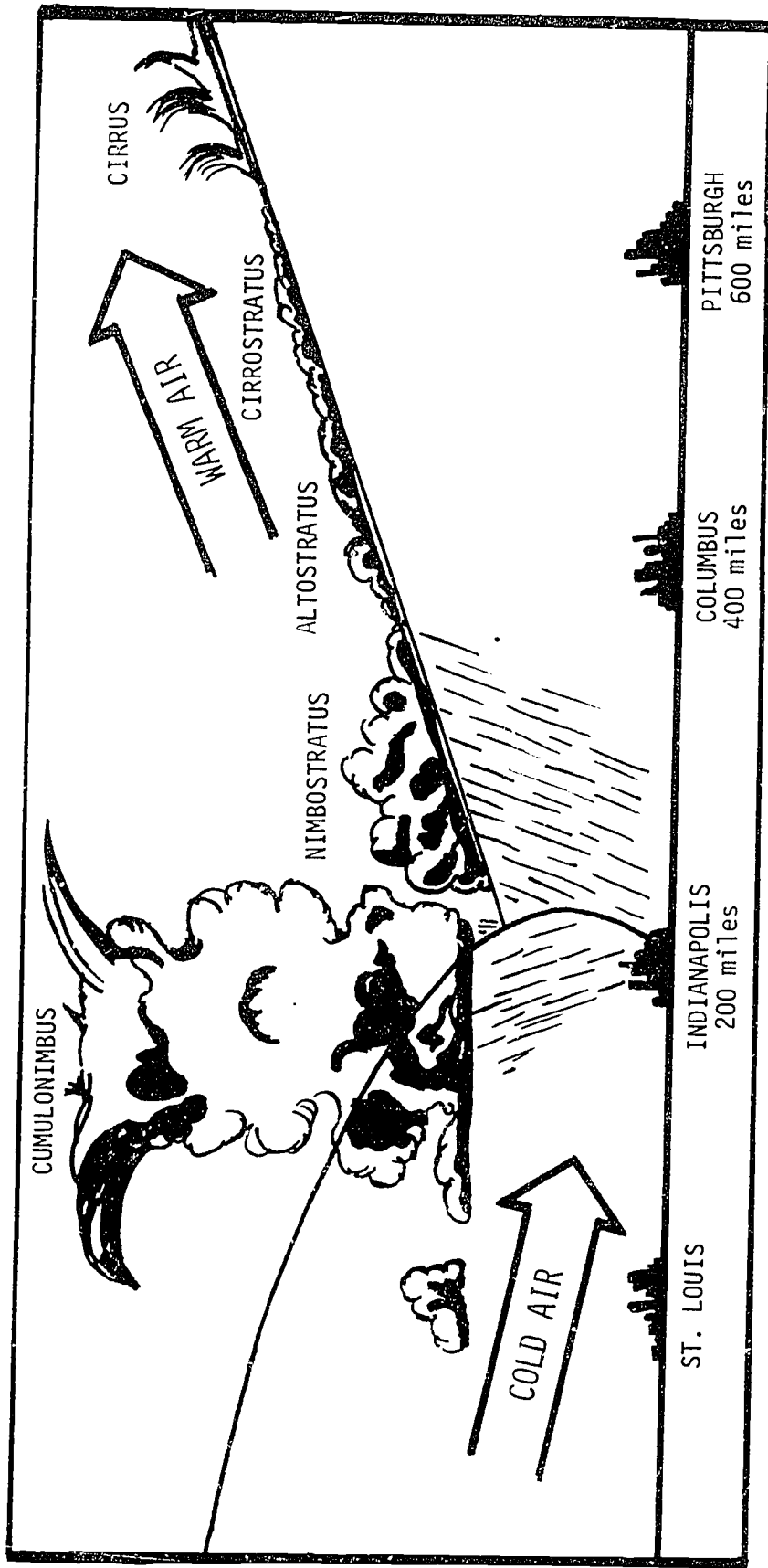

STL 3508 078/42/26 → 23+40/976
 IND E501/2TA-RW 058/66/62 28+45/570
 CMH B8002R-F 142/52/51 ↑ 17/995
 PIT E13007 200/47/40 12/012

AN OCCLUDED FRONT

Compare the cross-sectional picture above with the teletype reports from the four cities shown at the right.



INTERPRETATION OF WEATHER REPORTS SENT BY TELETYPE

DCA 212100Z 15 ① E30 ⊕ 11/2VTRW --BD 152/68/60→↘ 18 + 30 ↑ 1548E/996/DRK NW VSBY 1V2

SYMBOL	ITEM	INTERPRETATION	TRANSLATION
DCA 212100Z	Station identification. Date and Greenwich time	<p style="text-align: center;">GROUP I. --DCA 212100Z</p> <p>Indicated by call letters. Call letters and all abbreviations are available at weather offices.</p> <p>The first two digits indicate the day of the month; the next four digits give the time (on the 24-hour clock) in Greenwich time. To convert to local time <i>subtract</i> 5 hours for eastern standard time, 6 hours for central, 7 hours for mountain, and 8 hours for Pacific. Regular sequences are sent each hour on the hour. When crucial changes occur between reporting times, a special report may be sent. In this case the date-time data will follow the station identification symbol, and the letter "S", followed by a numeral, will be added.</p>	<p>Washington, D.C.</p> <p>21st day of the month, 4:00 p.m., eastern standard time.</p>



SYMBOL	ITEM	INTERPRETATION	TRANSLATION
15⊙	Sky cover	<p>GROUP II.—15⊙E30⊕11/2VTRW—BD</p> <p>Figures represent hundreds of feet (15 = 1,500 feet). Symbol indicates amount of cover: ○ = clear; ⊙ = scattered; ⊕ = broken; ⊕ = overcast The letter "X" will be used instead of these symbols whenever fog, dust, smoke, or precipitation obscure the sky. If clouds are at varying levels, two or more sets of figures and symbols are entered in ascending order of height.</p>	Scattered clouds at 1,500 feet.
E30⊕	Ceiling	<p>The ceiling figure will always be preceded by one of the following letters: E = estimated; M = measured; W = indefinite; B = balloon; P = precipitation; A = reported by aircraft. If the ceiling is below 3,000 feet and is variable, the ceiling symbol will be followed by the letter "V", and in the remarks the range of height will be indicated.</p>	Ceiling estimated 3,000 feet.
11/2V	Visibility	<p>Figures represent miles and fractions of miles. Followed by "V" if less than 3 miles and variable. If the visibility is 6 miles or less, the reason is always given under "Precipitation" or "Obstruction."</p>	Visibility 1½ miles, variable.
TRW—	Precipitation, thunderstorm, or tornado.	<p>R = Rain; L = drizzle; E = sleet; A = hail; S = Snow; W = showers; T = Thunderstorm; Z = freezing. Sometimes followed by + meaning heavy, or by — meaning light. Item omitted if there is no precipitation. Tornado is spelled out.</p>	Thunderstorm; light rain shower.
BD	Obstructions to vision.	<p>F = Fog; H = Haze; D = Dust; N = smoke (sometimes the above letters are preceded by G = ground; I = ice; B = blowing).</p>	Blowing dust.

SYMBOL	ITEM	INTERPRETATION	TRANSLATION
152/ 68/ 60 → ↘ 18 — 30 ↑ 1548E/	Pressure Temperature Dew point Wind	<p>GROUP III. — 152/68/60 → ↘ 18 — 30 ↑ 1548E/996/DRK NW VSBY 1V2</p> <p>Most of the items in this group are separated by diagonal lines (/). Stated in millibars using same system as on the weather map (omitting initial "g" or "10").</p> <p>In degrees Fahrenheit In degrees Fahrenheit</p> <p>Wind direction is shown by arrows, either singly or in combination: ↓ = North; ↘ = North-northeast; ← ↘ = East-northeast; ← = East, etc. Wind speed is indicated by figures indicating knots. (C for calm.) If followed by = gusts; figures following the indicate intensity of the gust peaks. If a wind shift has occurred at the station, it is indicated by an additional arrow, followed by figures showing time of shift.</p>	<p>Pressure 1015.2 millibars. Temperature 68° F. Dew point 60° F.</p> <p>Wind west-northwest, 18 knots; gusts to 30 knots; wind shift from south at 3:48 p.m., eastern time.</p>
996/ DRK NW VSBY 1V2	Altimeter setting. Remarks	<p>Barometric pressure in inches for the setting of altimeters on aircraft. Given in three figures with the initial 2 or 3 omitted. A number beginning with 5 or higher presupposes an initial 2; a number beginning with 4 or lower presupposes an initial 3. (993 = 29.93; 002 = 30.02, etc.)</p> <p>Any additional remarks are given in teletype symbols and in abbreviations of English words. Any items which are normally sent, but for some reason are missing from the transmission, are represented by the letter "M".</p>	<p>Altimeter setting at 29.96 inches.</p> <p>Dark overcast to the northwest. Visibility variable 1 to 2 miles.</p>

UNIT VI: THE AIRPORT AND YOUR COMMUNITY

UNIT GOAL: To Introduce The Student To The Airport, Its Importance In Serving The Needs Of The Community And The People Who Work At The Airport.

OBJECTIVE	STRATEGY	RESOURCES	SOURCE
<p>1. The student will understand the basic considerations of need and use that go into a decision to establish an airport in a community.</p> <p>a) Business Travel b) Pleasure Travel c) Goods and Services</p>	<p>Begin to accomplish this objective by discussing with the students all of these basic planning considerations. Have them list questions that arise for which they do not have the answers. Then invite a member of the local airport commission to discuss the matter with the class. You might also have the airport manager as well, to gain insight into another side of the question. You are more fortunate if there is a small airport as well as one that serves commercial airlines. Use the two for comparison purposes.</p>	<p>Airport Commission Member Airport Manager <i>Airport Design</i>, Teaching Ideas for <u>Aviation Education</u>, Vol. II, p. 9. <u>Aircraft and the Environment</u>, GA-300-104</p>	<p>Local Government. Local Airport. FAA (see Directory)</p>
<p>2. The student will understand the considerations that go into the decision to locate the airport in a particular place.</p> <p>a) Land Availability b) Runway Direction and Wind</p>	<p>Have the students use the information gained in the performance of the above objective to begin to plan for the location of a new airport for the community. Use the same resource people as for the above objective. Write letters to various people asking how they</p>	<p>Same as Objective 1 <i>Airport Models</i>, Teaching Ideas for <u>Aviation Education</u>, Vol. I, p. 2.</p>	<p>Same as Objective 1 Cessna Aircraft Co.</p>

OBJECTIVE	STRATEGY	RESOURCES	SOURCE
<p>c) Accessibility to the Location d) Congestion and Noise e) Availability of Support Services f) Commercial Airlines</p>	<p>use these considerations in locating airports. Have the students form an airline company that will be involved with the location of the airport. (English)</p>	<p><i>Form an Airline Company Teaching Ideas for Aviation Education, Vol. II, p. 7.</i></p>	<p>Cessna Aircraft Co.</p>
<p>3. The student will be familiar with the various facilities at an airport.</p> <p>a) Runways and Taxiways b) Ramps and Terminals c) Buildings and Hangars d) Fuel Storage Areas e) Communication and Navigation Facilities - Unicom f) Fixed Base Operators g) Flight Service Station - FAA</p>	<p>Take the students on a trip to the local airport. Again, use both a large one and a small one if they are available. Have the students prepare by considering the list of facilities in the objective and prepare a list of things that they will want to observe. Upon their return you can have them participate in a class project to construct an airport model. This can best be done with the whole class working on one model on a 4' by 8' sheet of plywood. (Art, Industrial Arts)</p>	<p>Commercial Airlines and Airports, GA-300-III. Same as Objective 2 An Airport Trip, GA-300-94.</p>	<p>FAA (See Directory) Same as Objective 2 FAA (see Directory)</p>

OBJECTIVE	STRATEGY	RESOURCES	SOURCE
<p>4. The student will become familiar with the many career opportunities available at the airport.</p> <ul style="list-style-type: none"> a) Line Service People b) Maintenance and Repair - both Airplanes and Buildings and Grounds c) Flying Jobs - Pilots, Charter, Instructor d) Air Traffic Controller, Tower Controller 	<p>On their trip to the airport, have the students observe and ask questions of various people who work there. They can prepare for this by studying the jobs listed beforehand to prepare questions to ask to get the information they need. (English)</p>	<p><i>Job Operation Sheet</i></p> <p><i>I Investigate an Occupation</i> sheet.</p> <p><u>Occupational Outlook Handbook</u></p> <p><u>Dictionary of Occupational Titles</u></p> <p><u>Air Traffic Control Simulation, Teaching Ideas for Aviation Education, Vol. I, p. 2</u></p>	<p>Included with Unit I this kit.</p> <p>Included with Unit II this kit.</p> <p>Your school or local 1 or the U. S. Department Labor.</p> <p>Your school or local 1 or the U. S. Department Labor.</p> <p>Cessna Aircraft Co.</p>

UNIT VII: THE HISTORY AND GROWTH OF GENERAL AVIATION

UNIT GOAL:

To Introduce The Student Early Attempts Of Man To Fly,
The Recent History And Spectacular Growth Of General
Aviation And The Important Part It Plays In Transportation
In America And The World.

OBJECTIVE	STRATEGY	RESOURCES	SOURCE
<p>1. The student will become familiar with man's early attempts to fly from myths and legends to the first flight of the Wright Brothers.</p>	<p>Have the students read myths and legends showing man's desire to fly, particularly those stories of Daedalus and Icarus, Mercury, Pegasus, etc. Have them also look at later designs such as those of Leonardo De Vinci and Sir George Cayley. Have them look into lighter than air craft (balloons and dirigibles) as well as heavier than air craft. Have the children draw or paint pictures of early airplanes and balloons. (Science, art)</p>	<p>Books on legend and mythology such as Bullfinch Clyde Cessna's Silver Wings <u>Commemoration of Wright Brothers' Flight, GA-20-52</u> <u>How We Made the First Flight, GA-20-62</u> <i>The General Aviation Story</i>, Film and Brochure General Resource Books and Encyclopedias</p>	<p>Your school or local library. Included with this kit. FAA (see Directory) FAA (see Directory) General Aviation Manufacturers Association (GAMA) (see Directory) Your school or local library.</p>
<p>2. The student will become familiar with the recent history and spectacular growth of general aviation.</p>	<p>Have the children observe the GAMA film on the story of general aviation. Have them work together on a chart of the time line sort tracing the history and growth of general aviation. Have them include commercial and military aviation milestones as they relate to the growth of general aviation. (Social Studies)</p>	<p><i>The General Aviation Story</i>, Film and Brochure General Resource Books and Encyclopedias</p>	<p>General Aviation Manufacturers Association (GAMA) (see Directory) Your school or local library.</p>

OBJECTIVE	STRATEGY	RESOURCES	SOURCE
<p>3. The student will become familiar with the transportation system of our country and the world and understand the part that general aviation plays.</p>	<p>A skit or original play could be planned and produced with children taking parts of such people as Wilbur and Orville Wright, Amelia Earhart, Charles Lindbergh, Eddie Rickenbacker, Jacqueline Cochrane, etc. Use original costumes and quotations telling why they flew. (English, Art)</p> <p>Have the children study transportation in conjunction with social studies. Bring in general aviation at its proper time and have them study it in relation to the overall transportation picture in the world and in our country in particular.</p>	<p>General Resource Books and Encyclopedia of the proper level.</p> <p>Films and Filmstrips</p> <p>Transportation, <u>Managing Man on the Move</u>, Paul M. Danforth, Doubleday Science Series</p>	<p>Your school or local library.</p> <p>Your local school source or see Directory.</p> <p>Doubleday & Company, Inc. (see Directory)</p>

ANSWERS

Page 11

1. Spinner
2. Landing Gear
3. Wing Strut
4. Wing
5. Right Wing Aileron
6. Right Wing Flap
7. Fuselage
8. Horizontal Stabilizer
9. Fin and Dorsal
10. Rudder
11. Trim Tabs
12. Left Wing Flap
13. Left Wing Aileron
14. Door
15. Seat
16. Windshield
17. Engine Cowling
18. Propeller
19. Elevator
20. Right Navigation Light (Red)
21. Left Navigation Light (Green)
22. Landing and Taxi Lights
23. Rear Position Light (White)
24. Rotating Beacon (Red)

Page 12

1. Airspeed Indicator
2. Heading Indicator
3. Attitude Indicator
4. Altimeter
5. Turn-and-Slip Indicator
6. Vertical Velocity Indicator
7. VHF Navigation-Communication Radio
8. Fuel Gauge (Left Tank)
9. Oil Pressure Gauge
10. Oil Temperature Gauge
11. Fuel Gauge (Right Tank)
12. Suction Indicator
13. Tachometer
14. Battery-Generator Indicator
15. Clock
16. Control Wheel
17. Rudder Pedals
18. Carburetor Heat Control
19. Throttle Control
20. Fuel-Air Mixture Control
21. Wing Flaps Control
22. Elevator Trim Tab Control
23. Magnetic Compass

Page 20

LIFT
THRUST DRAG
GRAVITY

Page 22

VERTICAL
LONGITUDINAL
LATERAL

Page 21

DIFFERENCE, UPPER
LOWER, LIFT

LIFT
LIFT
DRAG
DRAG

Page 23

AILERONS
LONGITUDINAL
INCREASES, RAISES
DECREASES, LOWERS

Page 24

ELEVATOR
LATERAL
DOWN, RAISES
UP, DROPS

Page 25

RUDDER, VERTICAL
LEFT RIGHT
RIGHT LEFT

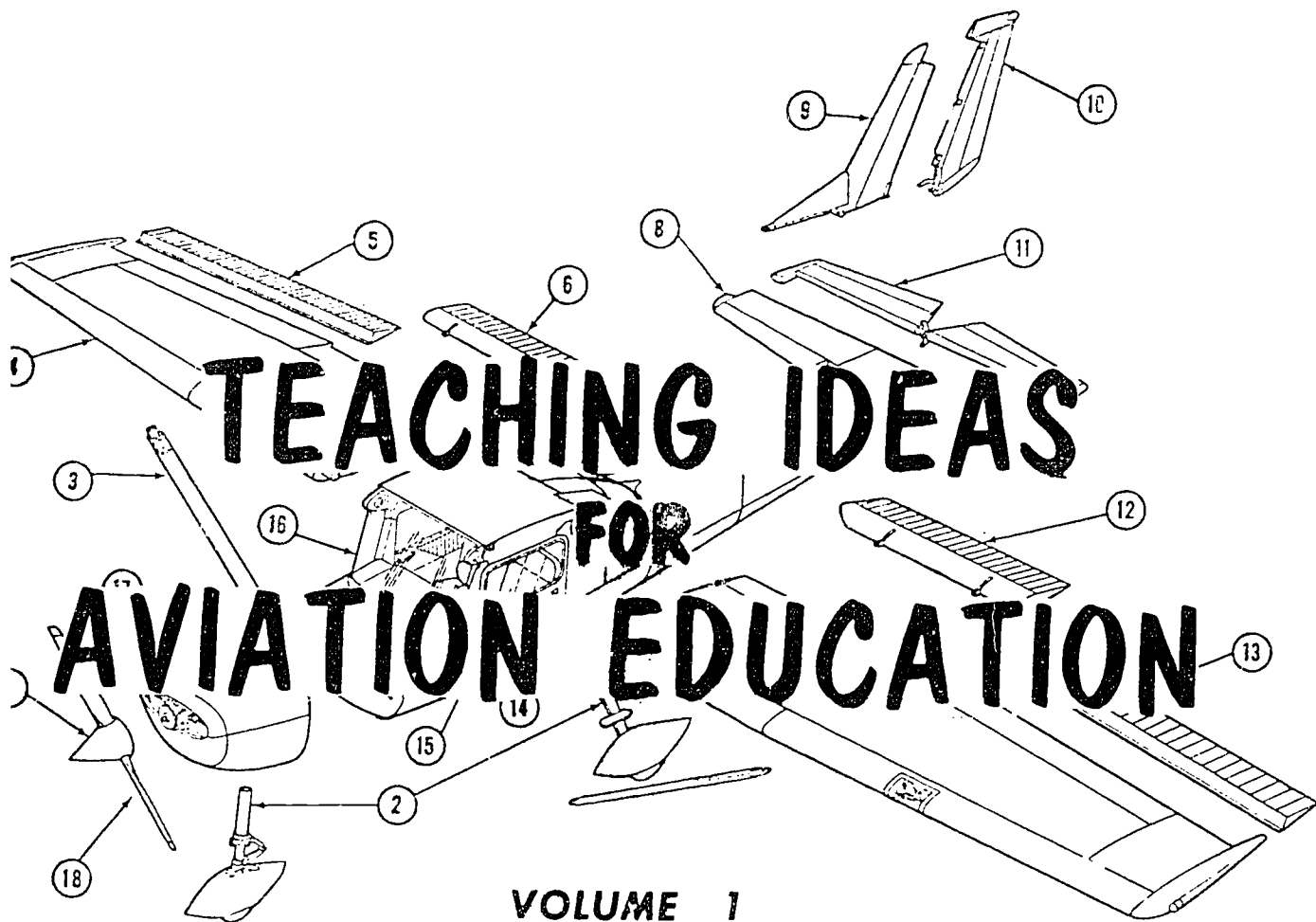

from the
third annual high school teachers seminar
August 4-8, 1969

Air Age Education Division

CESSNA AIRCRAFT COMPANY



P R E F A C E

The following selected excerpts from the first three volumes of Teaching Ideas For Aviation Education have been compiled to assist you in enhancing aviation units in your classrooms. We hope you find these suggestions and experiences motivating and enlightening, whether for enrichment of an existing program or for getting a new one "off the ground". The ideas included in these volumes represent the efforts and ingenuity of teachers throughout the country.

The Air Age Education Department would like to continue furnishing you with more Teaching Ideas. To do this we would like to have communication from you regarding teaching strategies, curriculum ideas and motivational uses of aviation that prove successful in your classroom. When enough responses are received, we will publish another Teaching Ideas. Thank you for your enthusiasm and interest in purchasing our Elementary Kit. Please forward your suggestions to:

Teaching Ideas
Air Age Education Dept.
Cessna Aircraft Co.
P.O. Box 1521
Wichita, Kansas 67201

DEAD RECKONING PROBLEM SOLVED USING DATA PROCESSING COMPUTER

BY

Mr. Wayne Fox, North High School, 2960 North Speer Blvd., Denver, Colorado 80211

This is an excellent method to use in tying in with another school department. The computer teacher is often on the lookout for practical applications of his machine, and using the computer to solve a cross-country navigation problem is an interesting and helpful one.

Fortran computer language was used in an IBM 360, Model 40, and this was the procedure:

1. Determine the number of legs (J), wind direction (W), wind velocity (VI), and airspeed (AI).
2. Determine the true course and distance (C and D) for each leg.
3. Add this data to the program and feed to the computer.
4. From the computer, you will receive wind correction angles, true heading, ground speed, estimated time enroute for each leg, and total ETE.

RADIO COMMUNICATIONS

BY

Mr. James Logan, Vernon High School, Vernon, Texas 76384

Equipment needed for this exercise is a foreign language laboratory with individual student headsets and microphones and a filmstrip of radio communication illustrating communications normally conducted on a cross-country flight.

The students plan ahead of time the cross-country trip. The teacher directs the planning to coincide with communications called for in the filmstrip.

After radio phraseology is studied and practiced (using the same filmstrip and record combination), the students each put on a headset and communicate with ground control, tower, FSS, and so on, played by the teacher at the console. As each filmstrip frame is flashed on the screen, each student makes the appropriate call and is answered by the teacher.

ADVANTAGES OF THIS SYSTEM INCLUDE:

- *Lack of embarrassment in front of class.
- *Familiarity with microphone.
- *Teacher's selection of individuals for extra help.
- *Teacher's communication with entire class or individuals.
- *Tie-in to navigation, flight planning.

RADIO COMMUNICATIONS: PANEL MOCK-UP: AIRPORT MODELS

BY

Mr. David Whypp, Lawrence High School, Trenton, New Jersey 08601

1. To overcome the difficulty experienced by students in understanding tower/airplane transmissions, a tape was borrowed from a local FAA tower and, after some tape speed and dead time difficulties, transcribed to 1/4" tape. Scripts were made and students could follow the conversations in class while they listened. The tapes were kept in the library for individual study, also.
2. Students were unfamiliar with instruments and panel layout. After studying pictures and actual panels, students designed and constructed 6" diameter replicas out of plastic lids, cardboard, brads, or whatever their own imaginations produced. These were backed with sandpaper and displayed on a dark flannel board. Questions about arrangement arose, and new layouts were tried. Many seemed more practical and logical than those in real airplanes.
3. Scale models on 3'x3' panels were student-constructed to illustrate and clarify the following:
 - a. Airport layout-runways, taxiways, accesses, buildings.
 - b. Tower control zone.
 - c. Airport environs-checkpoints for reporting, prominent features, distances. Necessitated extensive research by students.
 - d. Traffic patterns, using coat hangar wire on an airport model. Numbers placed on wire to indicate first tower call, power reduction, altitude requirement, carburetor heat, etc.
 - e. Airways, VOR's, topography (small scale).

Numbers 2 and 3 make good open house, PTA, civic club, etc. displays.

AIR TRAFFIC CONTROL SIMULATION

BY

Mr. Terry Schubert, Midpark High School, Middleburg Heights, Ohio 44130

Sparked by a locally congested airport problem, this concept of control was conceived. First, the airport and environs were simulated on the gym floor. Airport diagram came from approach plates, student photo and airport map. Facilities on the airport were gleaned from AIM and a visit. Control zone, reporting points, and radio facilities were gotten from a local chart (or sectional). Buildings were cardboard boxes. Checkpoints were photographed from the air, blown up by the photo department to 24" square, and placed to scale on the floor.

ATIS, FSS, tower, were tuned in on a radio to be as realistic as possible. All research and work was done by students, including modifying battery-driven cars with aircraft features and rheostats to provide realism in appearance, type, and speed control. Students decided the type of airplane they wanted to be. Owner's manuals and research provided performance facts.

A question arose: Do we need control? With 2 or 3 planes, no. As students directed cars with sticks around the floor, no problems were encountered. But as traffic increased, weather worsened, and wind changed (student acted as Mother Nature to change conditions), need for control was admitted. Teacher acted as controller using walkie-talkies, and even with added runways and students snatched from study hall to fly as strangers in the pattern, order remained. Students worked all positions to gain an insight into responsibilities and problems.

This activity, plus films, speakers, and a field trip to a real tower, heightened appreciation for safety and discipline in flying. Geography, careers, plus student involvement in doing the research and preparation added to the success of the activity.

AIRCRAFT CONSTRUCTION PROJECT

BY

Mr. Don Roberts, Noblesville High School, Noblesville, Indiana, 46060

As a project for an advanced class, Aviation II, it was decided to build a Mead Primary Glider. Since the Industrial Arts Department had no budget for this, the following was "procured":

1. Scrap wood from an overhead garage door company.
2. Main wing spars from football bleacher seats. (Aircraft named "X-16 Flying Grandstand").
3. Elmer's glue by the gallon.
4. Wing silk from Army surplus.
5. Dope donated by Lake Central Airlines.

Total cost for finished product - \$40.00. Time to build - 8 months.

The glider was flown from a towline several times before a news reporter stalled it. Rebuilt, it was sold to a Franklin, Wisconsin museum for \$150.00. Student pride, community interest, and press coverage, added to practical skills learned by builders, made for a successful project. A magazine story brought 26 inquiries from other schools.

New project is a powered homebuilt. The school district plans a new building and equipment for the department. A well-publicized project SELLS YOUR PROGRAM.

Students bought surplus flight suits for 25 cents. Extra silk made scarves. Graduates of the course got special certificates. Complete construction process was photographed regularly.

An idea was born, the horns were tooted, and results achieved.

INTEGRATED LEARNING; TRANSPARENCY

BY

Mr. Frank Ely, Montrose High School, Montrose, Pennsylvania, 18801

Flying is not done in units or sections. It is an integrated activity calling for piloting, navigating, communicating, monitoring, etc, all at the same time. So it should be with aviation education. Computer, performance, FAR's, weather, are all part of navigation and should be integrated and studied as such.

An overlay transparency illustrates this. Starting with a basic cross-section of topography (Southern California with coastal range, valley, and Sierras, plus lowest and highest elevation), four other transparencies are taped on, one to each side, and overlaid in sequence to illustrate the following:

1. 1200 ft. AGL outline for VFR weather minimums (title is placed to add another sentence to first transparency).
2. 3000 ft. AGL outline for hemispherical rule for VFR cruising altitudes
3. 10,000 ft. MSL line for VFR weather minimums
4. 14,500 ft. MSL line for continental control area.

Five (original and 4 overlays) different altitude regulations are presented visually with one basic transparency.

This overlay idea can be adapted to building traffic pattern legs, instrument parts or groupings, engine functions, pre-flight inspections, or any other multi-step or multi-phase procedure. Attaching the overlays to each side of the original eliminates a bulky edge.

BARBER CHAIR VERTIGO DEMONSTRATION; SKIT

BY

Mr. Jerry Clark, Kennedy High School, Bloomington, Minnesota, 55420

A barber chair was acquired from the basement of a remodeled barber shop - at no cost. During physiology study, students were belted in, told to close eyes and bend over. A fast spin followed by a fast stop, then head up and eyes open, caused the room to go right over (Coriolis effect). Another experiment was a slow spin with students eyes closed and thumb movements to indicate left, right, or no turning. Gradual changes cause inner ear follicles to give incorrect information, demonstrating need for dependence on instruments. Same student holds a bicycle wheel gyro in his hands, closes eyes, and can immediately detect changes.

A corny but entertaining skit for elementary schoolers or a high school assembly can be good publicity. A cross-country flight by Captain Cool (helmet, goggles, scarf, etc.) illustrates just what takes place. Airplane is cardboard suspended from a stage batten or worn like a sandwich board. Captain Cool preflights (Kicked tire falls off), calls weather (weatherman holds balloon and is hauled aloft by cable from backstage), calls tower (student on ladder), flies XC, (student with cardboard cloud on a stick walks by, another squirts with "rain" gun) gets into IFR weather and consults instruments (Masonite panel with head-size cutouts-student faces shout things at him, such as "Your left wing is low," "2000 feet!" or "You're turning left.")

Goofs are accepted as part of the skit. Can be narrated by student or teacher. Props can be as elaborate as desired. Based on factual procedures, but disguised in slapstick, this is a learning experience plus entertainment.

SHORT APPROACHES

Invite an administrator to sit in on your ground school portion. One teacher had the janitor and the principal attending - the principal now has his student license.

Get your photo department to take close-ups of instruments. Blow them up for study prints or display.

Invite your school photographer to go on an orientation flight to get an aerial shot of the school. Good publicity!

Contact your state Redistribution and Salvage Center for surplus goods. A complete panel mock-up was built for \$12.00.

Get parents involved - keep them informed. Invite them to visit your class or fly with the students. One effort resulted in the parent purchase of an airplane and assistance in flight orientation.

Rent a weather teletype machine - \$75 per month. Contact ESSA office in Maryland for permission forms; superintendent signs and returns contract. Permission slip shown to telephone company. One circuit plus relays brings in hourly sequences from the entire U.S.

ATC simulation can be done on a transparency with students moving airplanes like on a radar scope. Class can view on projection. Transparency has squares like graph paper and planes move ahead a square or two (depending on type) every 10 seconds, rung or clicked by a timekeeper. Normal, short, straight in or out patterns, ground control, holding, emergency, plus other situations can be developed without using floorspace.

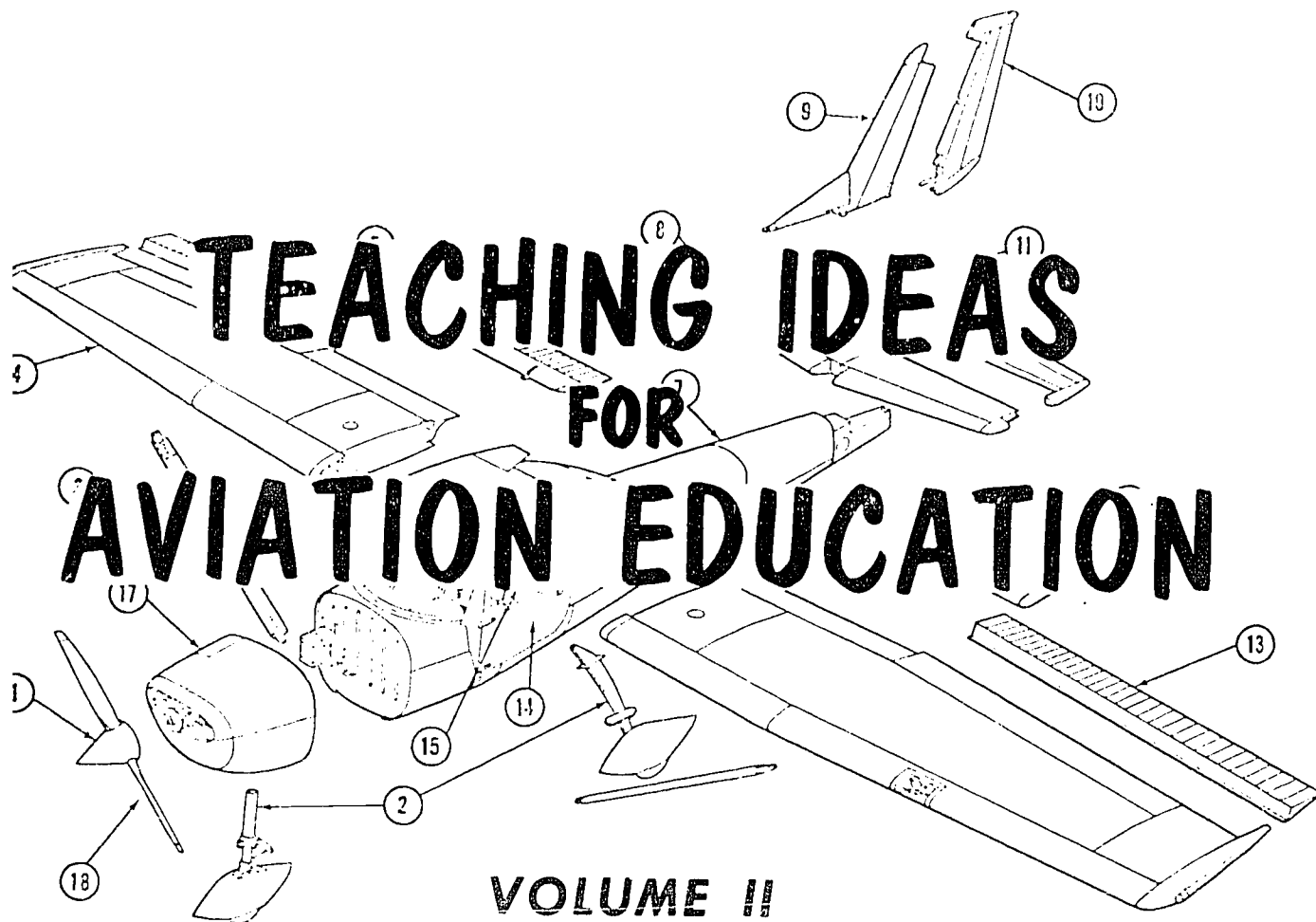

from the
fourth annual high school teachers seminar
national aerospace education congress
high school aviation teachers of america

Air Age Education Division

CESSNA AIRCRAFT COMPANY



WICHITA, KANSAS

The Aviation Club of Jardine Junior High School was organized in September, 1970 under the direction of Thomas L. Spriggs, a seventh and ninth grade science teacher at Jardine.

It came about simply because Spriggs recognized the pressing need to give positive guidance to the young ideas and interests which would otherwise be wasted. His answer to the problem was the special interest club and, as a pilot himself, an aviation club was the logical answer.

Posters were made and displayed in the school asking students who were interested to get in touch with Spriggs to talk about forming an aviation club. The result was 35 interested ninth-grade students.

As an extra-curricular activity, the club has given students a chance to explore the whole field of aviation, covering such areas as pre-flight procedures, aviation weather, job opportunities and the vocational training available in Wichita.

The club was immediately fortunate in the amount of aid and support given by both people and organizations in the area. For example, a 65 h.p. Continental engine was given the club by one supporter while another one not only provided aircraft instruments but also had the technical information the club needed on aircraft engines.

Cessna was able to provide resource information and written material dealing with aviation education as well as arranging a guided tour of the Cessna facilities.

Admitting that aviation-minded people are certainly in the majority in the Wichita community, the support and gifts which made the club a success have been outstanding. However, with the interest and enthusiasm generated everywhere by general aviation, the same sort of support should be available almost anywhere.

An idea of the range of interest demonstrated by the club can best be given by some of its past activities. The FAA Film Library in Oklahoma City has provided films such as "Aviation Workshop", "How Airplanes Fly", and "Aeronautical Oddities". Guest speakers have included a flight instructor, the director of the local weather bureau, a representative from a local high school which offers aviation classes and several speakers on the vocational aspects of aviation.

Particularly meaningful has been the trip to the Wichita Municipal Airport including, as it did, visits to the control tower, radar room, Weather Bureau and Flight Service Station.

The highlight for everyone, of course, comes at the end of the year when each member is given the opportunity to take a light-plane ride as an introduction to the new medium he's been studying.

The Aviation Club at Jardine has been an unqualified success, doing much to mold and hold youthful interest and, above all, it has again helped to prove that "We're never too young". The most important fact though is that this success story could be duplicated almost anywhere--few communities lack the technology and interest to support such a club. The only key to success is the interest and energy of the concerned adults--it has to equal that of the youngsters if they're to become better citizens.

VERTIGO DEMONSTRATION

(Note: Volume I of TEACHING IDEAS FOR AVIATION EDUCATION included a brief item by Jerry Clark of Kennedy High School, Bloomington, Minnesota, on the use of a barber chair to demonstrate vertigo. The following is a more complete description on the experiment, its results and its meaning.)

Air safety is the universal concern of both pilots and passengers. However, while commercial and military pilots receive constant training to make their flying safer and more reliable, the average private pilot doesn't have that opportunity. Particularly, he may be completely unfamiliar with normal physiological limitations which, under certain circumstances, can seriously hamper his judgement.

An example of such a normal, physiological limitation is the one responsible for vertigo or spatial disorientation. All too few pilots have experienced this phenomenon and few know how to guard against it.

To overcome some of this lack of experience, aviation education students at Kennedy High School are given an opportunity, in a laboratory situation, to become fully aware of the danger of always trusting his earth-oriented senses when he's flying.

First, of course, it is necessary to understand the physiological mechanisms involved. Several films, available from the U.S. Air Force, will show the student that the three semi-circular canals in the inner ear are the cause of most of the trouble. While they are a major source of reference data for the brain, they still are secondary--the eyes are still the primary source of data as long as some sort of horizon can be seen.

But, when the horizon disappears or gets fuzzy, the brain looks to the semi-circular canals for data. Each of the three fluid-filled canals is oriented in one of the three axes of space.

The canal senses motion in a very simple manner. To demonstrate, take a glass of water and rotate it in your hands. While the glass obviously turns, the water in it seems to stand still. The fluid in the semi-circular canal acts the same as the water in the glass. When the body and the canal move, the fluid tends to stand still. Sensors in the canal detect this difference in movement between the canal and the fluid and send a message to the brain saying "tip" or

or "turn", depending on the axis involved.

But, like a good many other systems, this one, too, isn't completely fool-proof. For example, if the movement or rotation continues for more than a few seconds, the fluid in the canal starts to move with the canal just as the water in the glass would eventually start turning with the glass if you rotate it long enough. When that happens, the sensors in the canal detect no difference in movement and the brain gets the message "no movement". If the horizon isn't visible, the brain accepts that message, even though the body is actually moving or turning. This is a graveyard spiral if the body is strapped in an airplane and will not or cannot use other orientation signals such as the instruments.

Slow or slight movements of the canal are not detected by the sensors because the fluid moves right with the canals. Try rotating the glass very slowly and watch the water move with it. This shows graphically that a body strapped in an airplane could easily go into a gradual turn but feel that it was straight and level if no other input information is used.

The three canals operate in three axes but are all connected at a common base. So, if the body moves in two axes simultaneously, causing movement of the fluid in two of the canals at the same time, enough pressure is generated at this base to move the fluid in the third canal. This time the brain gets the signal that there's movement in the third axis when actually there isn't any. Again, with no other inputs, the body would believe it was tipping or turning in a false direction. This is called the Coriolis Phenomenon or true vertigo.

Fortunately, it is quite easy to demonstrate the phenomenon of dis-orientation. It can be done by closing the eyes while flying an airplane, but it is a lot safer and cheaper to do it as a classroom or laboratory demonstration.

All that's needed is an old barber chair. It may take some searching, but they do exist and, when found, are usually quite inexpensive. The barber chair is ideal for this demonstration because it floats on a cushion of oil and small movements cannot be easily detected. If no barber chair is available for purchase or donation, the demonstration can always be conducted after hours in a barber shop. It makes a fun evening out for the class or flying club.

INSENSITIVITY DEMONSTRATION

The student sits straight up in the chair and keeps his eyes closed for the entire demonstration. Spin the chair at the rate of one or two revolutions to start with. After about a minute of such rotation let the chair coast to a stop. The student then indicates the direction in which he thinks he is spinning by pointing with his thumb. If he thinks he's standing still, the signal is thumbs up. As the chair slows down, the student usually feels he has stopped long before the chair has actually come to rest. In this case, the fluid in the semi-circular canals is rotating at the same speed as the canal.

HOW THE GYRO HELPS

To show the greater sensitivity of a mechanical gyro compared to that of the semi-circular canals, the student sits in the chair with eyes closed and the chair is turned very slowly. If, in the meantime, the instructor talks about another part of the demonstration or distracts the student in some other way, it is possible for him to be turned through 180 degrees in a minute or less without his being aware of the rotation. Then, to show the sensitivity of a gyro, a weighted bicycle wheel with an extended axle can be used. The student holds the bicycle wheel by the axle and it is then spun rapidly. Now a very slight rotation of the chair will make the wheel or "gyro" tip and it is almost impossible to rotate the chair more than a few degrees without the student detecting it. This helps to demonstrate the more reliable sensitivity of aircraft instruments using gyros.

"I'D RATHER BE FLYING"

To focus attention on aerospace education activities, Mrs. Elaine Chappel of Atoka High School, Atoka, Okla., came up with a grand idea for a float to be used in any appropriate parade.

The picture tells most of the story except for the simplicity of construction. The propeller and tail section are made from styrofoam but the wing section, which rests over the top of the car, should be made from quarter-inch plywood. According to Mrs. Chappel, a first attempt, using styrofoam for the wing resulted in an apt demonstration of "lift" resulting in fracture of the styrofoam wing.

As a part of the project, a school-wide competition was held to select an "Aviation Sweetheart" or "Miss Aviation" to ride on the car during the parade. The class president is the "pilot" with one of the other officers as "co-pilot".

FLIGHT PLANS AT CORSICANA

Jim Stephenson, of Corsicana, Texas, has a unique two-pronged effort underway. As a result of unique Texas legislation, the local high school qualifies as a Certified Ground School. Classes, therefore, end with the student's passage of the FAA written examination.

At the same time, Stephenson, a certified flight instructor as well as a pharmacist, has organized a flying club on an extracurricular basis. Club activities are aimed at private licenses for all members and, as a result, 15 of the present 24 members are so licensed.

An important aspect of the club's flight program is the use of flight plan forms. In cross country flights, for example, three students and an instructor fly a three-leg course, with a different student flying each of the legs. Since none of the students know in advance which of the three legs he will fly, each of them must show a flight plan for the complete trip.

In addition to the full-sized flight plan forms, students are also provided with a booklet of pocket-sized forms duplicating the standard FAA form.

Since flight planning constitutes such an important aspect of the "plan ahead" criterion, such flight plan forms could easily be used for classroom exercise as well as for actual flights. For that reason, we present them here in the event anyone would like to use them. The pocket version is shown while the front and back of the standard form are shown on the next two pages.

FEDERAL AVIATION AGENCY FLIGHT PLAN				Form Approved. Budget Bureau No. 04-R072.3			
		1. TYPE OF FLIGHT PLAN		2. AIRCRAFT IDENTIFICATION			
		TYPE		TYPE			
		IFR		OVFR			
3. AIRCRAFT TYPE/SPECIAL EQUIPMENT		4. TRUE AIRSPEED		5. POINT OF DEPARTURE		7. INITIAL CRUISING ALTITUDE	
		EMOIS		PROPOSED (Z)		ACTUAL (Z)	
8. ROUTE OF FLIGHT							
9. DESTINATION (Name of airport and city)				10. REMARKS			
11. ESTIMATED TIME EN ROUTE		12. FUEL ON BOARD		13. ALTERNATE AIRPORT(S)		14. PILOT'S NAME	
HOURS MINUTES		HOURS MINUTES					
15. PILOT'S ADDRESS AND TELEPHONE NO. OR A RECAPT HOME BASE				16. NO. OF PERSONS ABOARD		17. COLOR OF AIRCRAFT	
						18. FLIGHT WATCH STATIONS	
CLOSE FLIGHT PLAN UPON ARRIVAL				19. SPECIAL EQUIPMENT (Use 1-9) A - Dual & VFR Code Instruments 1 - A/C Code Instruments B - Dual & 400 Code Instruments 2 - VFR Code Instruments C - Dual 3 - 400 Code Instruments 3 - VFR Code Instruments D - Dual 4 - 400 Code Instruments 4 - VFR Code Instruments			

Discover Flying		Reported	Forecast	Winds Aloft	Icing and Freezing Level	Turbulence and Cloud Tops	NOTAMS
Departure							
En Route							
Destination							
Alternate							

FAA FLIGHT PLAN						
1. Type	2. Aircraft	3. Aircraft Type	4. Time	5. Departure Point	6. Departure Time	7. Cruising Altitude
VFR		Special Equipment	Actual	Actual	Proposed (Z)	Actual (Z)
IFR						
OVFR						
10. Flight En Route (If Required)						
11. En Route, Altitude, Frequency, and Weight Restrictions (If Available)						
12. Fuel (Gallons)						
13. Remarks						
14. Remarks						
15. Remarks						
16. Remarks						
17. Remarks						
18. Remarks						
19. Remarks						
20. Remarks						
21. Remarks						
22. Remarks						
23. Remarks						
24. Remarks						
25. Remarks						
26. Remarks						
27. Remarks						
28. Remarks						
29. Remarks						
30. Remarks						
31. Remarks						
32. Remarks						
33. Remarks						
34. Remarks						
35. Remarks						
36. Remarks						
37. Remarks						
38. Remarks						
39. Remarks						
40. Remarks						
41. Remarks						
42. Remarks						
43. Remarks						
44. Remarks						
45. Remarks						
46. Remarks						
47. Remarks						
48. Remarks						
49. Remarks						
50. Remarks						
51. Remarks						
52. Remarks						
53. Remarks						
54. Remarks						
55. Remarks						
56. Remarks						
57. Remarks						
58. Remarks						
59. Remarks						
60. Remarks						
61. Remarks						
62. Remarks						
63. Remarks						
64. Remarks						
65. Remarks						
66. Remarks						
67. Remarks						
68. Remarks						
69. Remarks						
70. Remarks						
71. Remarks						
72. Remarks						
73. Remarks						
74. Remarks						
75. Remarks						
76. Remarks						
77. Remarks						
78. Remarks						
79. Remarks						
80. Remarks						
81. Remarks						
82. Remarks						
83. Remarks						
84. Remarks						
85. Remarks						
86. Remarks						
87. Remarks						
88. Remarks						
89. Remarks						
90. Remarks						
91. Remarks						
92. Remarks						
93. Remarks						
94. Remarks						
95. Remarks						
96. Remarks						
97. Remarks						
98. Remarks						
99. Remarks						
100. Remarks						

WEATHER SYSTEMS	

NOTES	
CLOSE FLIGHT PLAN WITH _____ FSS	
1. Remarks	
2. Remarks	
3. Remarks	
4. Remarks	
5. Remarks	
6. Remarks	
7. Remarks	
8. Remarks	
9. Remarks	
10. Remarks	
11. Remarks	
12. Remarks	
13. Remarks	
14. Remarks	
15. Remarks	
16. Remarks	
17. Remarks	
18. Remarks	
19. Remarks	
20. Remarks	
21. Remarks	
22. Remarks	
23. Remarks	
24. Remarks	
25. Remarks	
26. Remarks	
27. Remarks	
28. Remarks	
29. Remarks	
30. Remarks	
31. Remarks	
32. Remarks	
33. Remarks	
34. Remarks	
35. Remarks	
36. Remarks	
37. Remarks	
38. Remarks	
39. Remarks	
40. Remarks	
41. Remarks	
42. Remarks	
43. Remarks	
44. Remarks	
45. Remarks	
46. Remarks	
47. Remarks	
48. Remarks	
49. Remarks	
50. Remarks	
51. Remarks	
52. Remarks	
53. Remarks	
54. Remarks	
55. Remarks	
56. Remarks	
57. Remarks	
58. Remarks	
59. Remarks	
60. Remarks	
61. Remarks	
62. Remarks	
63. Remarks	
64. Remarks	
65. Remarks	
66. Remarks	
67. Remarks	
68. Remarks	
69. Remarks	
70. Remarks	
71. Remarks	
72. Remarks	
73. Remarks	
74. Remarks	
75. Remarks	
76. Remarks	
77. Remarks	
78. Remarks	
79. Remarks	
80. Remarks	
81. Remarks	
82. Remarks	
83. Remarks	
84. Remarks	
85. Remarks	
86. Remarks	
87. Remarks	
88. Remarks	
89. Remarks	
90. Remarks	
91. Remarks	
92. Remarks	
93. Remarks	
94. Remarks	
95. Remarks	
96. Remarks	
97. Remarks	
98. Remarks	
99. Remarks	
100. Remarks	

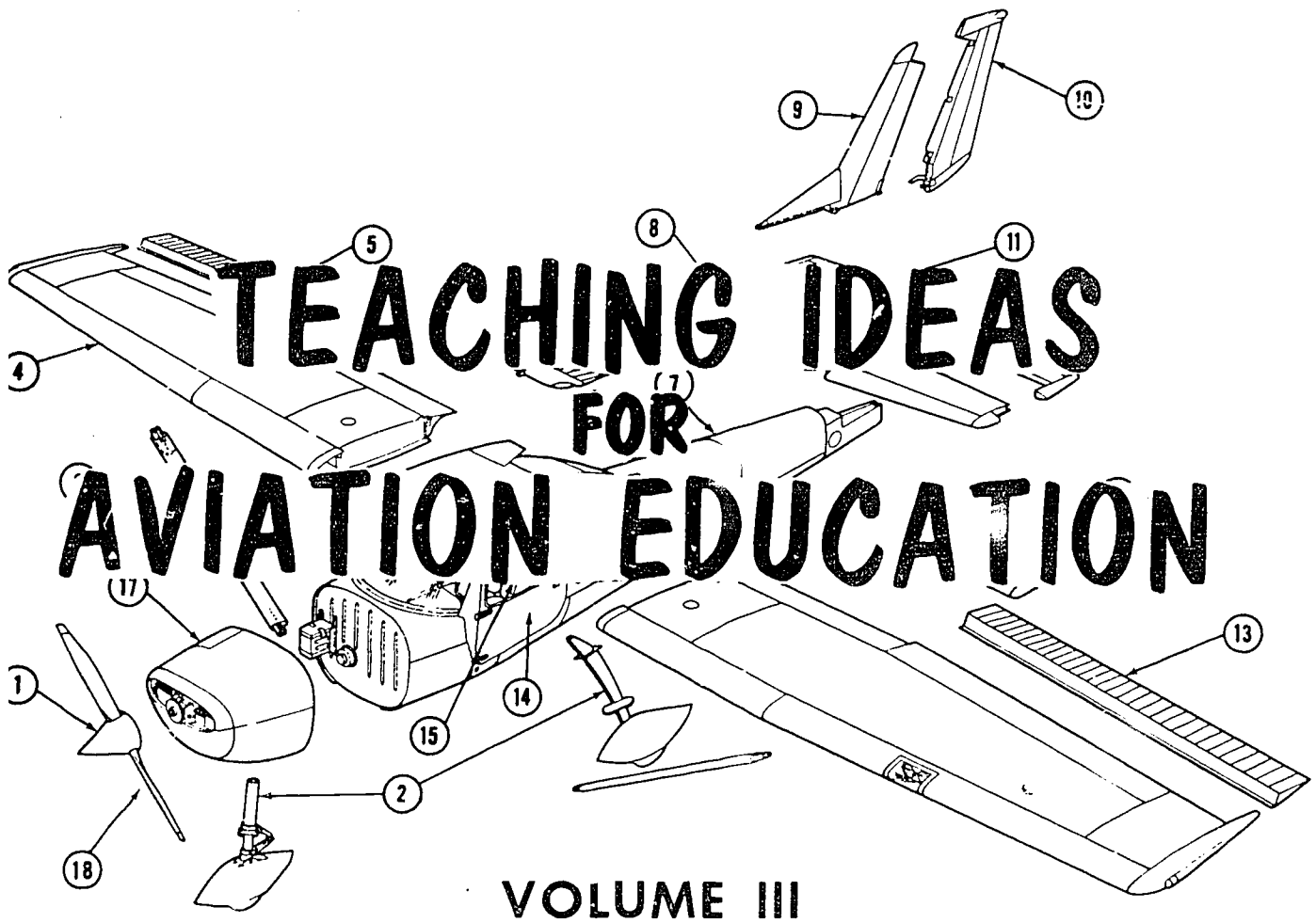

A special compilation of projects developed by active classroom aviation teachers.

Cessna 

AIR AGE EDUCATION



SCALE MODELS

BY

Lavon O. Bohling, Geneva Public High School, Geneva, Nebraska, 68361

Building model airplanes can be an important part of the aviation class. My students use class time and do more than just assemble the kit.

Students choose their own airplanes. They research on their own the history of the aircraft, including particular squadron markings, performance, theater of action, etc., in the case of military models. Those with similar scales (1/72" is most common) are displayed together to show relative sizes.

Rocket and space vehicles in model form may be built. "Airfix," an English model manufacturer, has some excellent models, including a 747 with BOAC markings, a 24" wingspan, for about six dollars.

WIND TUNNEL

BY

Omar W. Fricke, Meridian High School, Meridian, Idaho, 83642

Students built a wind tunnel, using the basic plan from Estes model rocket manufacturer. Cost was low.

Then they built and inserted various shapes with threads attached to show airflow. A cube produced poor airflow and twisted threads. A sphere did the same, although not quite as extreme. A teardrop shape caused airflow to be smooth with threads straight.

Then various shapes of airfoils were used, and various angles of attack. Student-built, threads were attached to the tips and showed definite vortices. Stalls and burbling were produced, and a spoiler on one half of an airfoil illustrated the definite loss of airflow.

A follow-up project required each student to build a flying apparatus (any material, any shape) that would fly for 13 seconds. Knowing the theory of lift produced many and varied shapes, but few unsuccessful flights.

SIMPLE LIFT DEMONSTRATION

BY

Roy L. Hall, Battle Creek Central High School, Battle Creek, Michigan, 49014

"I hear and I forget; I see and I remember; I do and I understand."

Students can do this with you. Stick a piece of paper in a closed hardback book so that most of it is exposed (enough so that the paper flops over). Blow across the curved flat surface of the paper. Bernoulli's theory is illustrated as the paper seems to rise up into the flow of air.

Or, hold two pieces of paper together and blow between them. They don't separate; instead, they almost cling together in the reduced pressure area.

Again, draw or outline in tape on the floor a large airfoil cross-section. Exaggerate the curve of the upper wing. Have two students walk the outline from the leading edge, one the bottom and one the top. The student on top has to walk faster to arrive at the trailing edge at the same time.

AIRFLOW SMOKE DEMONSTRATION

BY

William K. Law, Richland Center High School, Richland Center, Wisconsin, 53581

A wind tunnel or other moving air apparatus, a model airplane with a curved wing, and titanium tetrachloride are needed for this experiment. An adequate room ventilation system is also desirable.

Coat the leading edge with the chemical and turn on the air. Smoke is produced and airflow is visible. Angle of attack can be changed to show burbling. Vortices show plainly. Movies can be taken to use more economically later.

These top students also devised a visual aid for showing aircraft in real settings. A rear screen projector showed mountains, VOR, and other scenes. A model airplane was supported on a clear glass shaft in front of the rear projection to illustrate various problems and solutions. Pictures were taken of the situation, or sequence of situations, to show a completed navigation, pattern, or procedure area. The model airplane can also be attached to a flat pane of glass and lighted to eliminate any glare.

VISUAL STALL DEMONSTRATION

BY

Donald G. Williams, Northeast High School, St. Petersburg, Florida, 33703

After students persisted in describing an aircraft stall as an engine failure (as in a stalled car engine), a simple experiment done by the teacher and then the students cleared up the problem.

A simple balsa glider was used. Through a movable wing or a movable nose weight, various balance points were achieved. When the students compared gliding flight to nose-up flight with a resultant stall, and caused each themselves, they could better understand and remember lack of thrust, loss of speed, loss of lift, and stalls. When the glider occasionally fell off on one wing, this prompted other discussion of stability and spins.

Any kind of visual aid, no matter how crude or simple, will drive home a principle much more effectively than none at all.

THESE TEACHING IDEAS CAME FROM THE FOLLOWING HIGH SCHOOL AVIATION EDUCATORS ATTENDING THE "IDEAS" SESSION AT THE NATIONAL AEROSPACE EDUCATION CONGRESS IN SEATTLE, WASHINGTON, ON MARCH 19-21, 1970.

Robert H. Bentley, Fairport New York
John W. Bingham, Washington, D.C.
Alyce L. Blackhall, Wichita, Kansas
Robert C. Bowman, Willcox, Arizona
Ed Bradshaw, Snohomish, Washington
Gail L. Brees, Redmond, Washington
Edward A. Cushman, Indianapolis, Indiana
Roy Hall, Battle Creek, Michigan
Bernell Loveridge, Salt Lake City, Utah
Daniel McElroy, Seattle, Washington
Robert F. O'Neil, Washington, D.C.
Dick Pedee, Eugene, Oregon
Fay Roe, Maxwell AFB, Alabama
Nina Rookaird, Pinole, California
Evelyn Sedivy, Lincoln, Nebraska
David L. Smith, Portland, Oregon
David Story, North Bay, Ontario, Canada
Albert Udd, Redmond, Washington
Willard E. Wilvert, Santa Barbara, California

Call on FAA personnel to come in during any classroom study of traffic control. They have been instructed to take part in educational projects.

There is an FAA booklet that has many simple and instructive demonstrations for the aviation teacher. Its title is "Demonstration Aids for Aviation Education." Originally prepared by the Civil Air Patrol, it can now be ordered from the FAA, Office of General Aviation Affairs Aviation Education (GA-20), the Department of Transportation, Washington D.C., 20590.

On another subject, contact the Experimental Aircraft Association or a member nearby for cooperation in building an airplane. EAA members have agreed to provide assistance to local school aircraft construction projects.

Build a half-scale model of an old airplane, using the home economics class for the fabric work.

Here's a career-day idea. Place the students with working people in aviation for a half-day of on-the-job experience. Top it off with a banquet that evening for a full day of airplane and job talk.

The FAA control tower in San Diego took one student per week from an aviation class as an observer. A report was made to the class upon completion of each student's time in the cab.

Call your airport, airline, etc., offices and ask about a cooperative training project--formal or informal. Students can learn more easily by doing. Check with the state and federal agencies for child labor law requirements regarding liability.

Make a large mobile of model airplanes constructed by students. This will be a weight and balance problem in itself. Hang it in an airflow (near a door, window, or air inlet) so that it will move.

Many airlines sell an inflatable plastic 747 out of their seat-back catalog. This is good as an attention-getter.

A flying classroom is employed to teach geography. Students study their own area in the classroom and then report to the airport in groups of six for a small plane flight to actually view that particular area. This is a good project for intense study of a local area.

CAUTION on the following demonstrations: Fire burns things, and hair spray vapors are heavy and can cause breathing difficulty if inhaled in any quantity. Good judgment and common sense must be used.

A Jetex engine (refillable with power pellets) mounted on a Thermic 20 balsa wood glider (approximately 59¢ at a hobby shop) can produce 30 to 90 minutes of flight and 600-700 feet of altitude.

The Sig-cub rubber band model with a 24" wing span can also be converted to Jetex power. The Jetex is from England, costs about \$1.50, and extra fuel pellets cost about a dollar.

Put a wooden block on a roller skate and attach a Jetex on the top. The orifice in the engine can be changed and mass ejection controlled. The thrust can be measured by mass and distance. A large orifice gives greater thrust but for a much shorter period of time. Six tests are possible in a half hour. Good physics applications.

Another simple thrust experiment. Wrap foil around a match head. When the other end of the match is lighted, the stick will burn into the foil and the match head will ignite. This causes a brief but impressive burst of power out of the hole where the stick was.

Again, every commercial hair spray has varnish in it as a vehicle. Hold a candle under the hair spray nozzle, point it up, push the button, and the spray will ignite, sounding like a rocket blast, and producing a colorful flame, depending on the brand of spray. This illustrates the simple rocket theory--the need for something to burn, an orifice to expel it through, and a flame. This can be turned on and off as with a staged rocket burn.

Also, put a blowtorch on the roller skate on a flat surface, and when the torch is lighted, thrust is produced and the skate will roll.

VISUAL AID FOR MAP WORK

BY

McFarland, Burges High School, 7800 Edgemere Boulevard, El Paso, Texas, 79925

DEVICE:

Color slides of sectional aeronautical chart, projected to demonstrate landmarks, symbols, scales, airway markings, course plotting, wind triangle problems, headings, and time-distance problems, and dead reckoning and radio navigation.

EQUIPMENT:

1. Color slides (or overhead transparencies) of sectional chart and smaller included area.
2. Plastic-covered $\frac{1}{2}$ inch plywood board painted dull white, 3' x 5' for projection screen. Mark in light pencil two marks along the bottom of the board, 14 $\frac{7}{16}$ " apart (representing 100 N.M. at twice the scale of the sectional chart.)
3. Demonstration map plotter twice the size of the standard plotter.
4. Erasable or dissolving marking pencil or pen.
5. Slide or overhead projector.
6. VOR - OMNI - ADF demonstrator.
7. Sectional charts, plotters, pencils (for students).

PROCEDURE:

1. Project the full sectional chart (with problem areas outlined) for orientation, identification of landmarks, scales, airway markings, marginal notations, etc.
2. Project a problem area (smaller included area). Adjust the projector distance so that 200 N.M. on the slide corresponds to the two miles on the projection board; now the projected area is exactly twice the size of the student's charts. The demonstration plotter will measure true mileage.
3. The teacher demonstrates course marking, distance marking, etc., with the demonstration equipment. Students follow through at their tables. (An assistant instructor is helpful to assist students.)

Although a 35 mm camera may be used for the slides, a reflex-type produces sharper images. Use of this device is limited only by the number of problem areas photographed, and the teacher's imagination.

PICTORIAL HISTORY OF A CROSS-COUNTRY FLIGHT

BY

Morris Hackworth, Churubusco High School, Churubusco, Indiana, 46723

This project is useful for encouraging prospective members of the aviation class as well as showing officials of other schools and parents just what occurs on the cross-country flight.

A prime requisite for this is having a good slide camera (I used a 35mm) and a competent photographer. Some students do very well.

Pictures are taken to show a chronological evolution of the flight. Students arriving at the airport, pre-flighting the aircraft, taking off, aerial shots along the course (and air-to-air shots if it can be arranged), approaching the airports, landing, and then the return approach and landing at the home airport, are all included. Some would need to be taken by a person other than the students involved, or course.

When the slides are returned from the developer, the students arrange them in logical sequence and write their own narration. When it is ready to be taped, appropriate instrumental music is chosen as background.

The students get very excited about this project, and the key word is INVOLVEMENT.

FORM AN AIRPLANE MANUFACTURING COMPANY

Make it as realistic as possible. The entire class can get involved in one company, and then you can divide them into three groups and let each individual group design and sell a product to a buyer, (airline, military).

Start by forming divisions (perhaps patterned after a nearby company you can call upon for advise). Design, manufacturing, sales, budget, and so on, all need to be considered. What you plan to build and who the market will be, are important primary considerations.

After the company is formed and the details have been decided upon, split the group into three equal companies. Give specifications for a particular airplane you want built, such as a short range airliner, a turbine-powered light aircraft, or maybe a jumbo jet or STOL airplane. Let each of the three companies work on a design, budget, and production schedule and submit bids to a non-partisan panel. The panel can be made up of school people or of local airport and airline officials. The winning company can be treated by the other two to cokes or some other trivial but meaningful reward.

This can also be applied to forming an airline company, perhaps in your own community, and deciding desirable routes, aircraft needed to accomplish the flights, schedules, passengers needed to break even, employee needs, and other economical and geographical considerations. This is a real education in the social studies implications of aviation. It is also a wonderful excuse to invite guest speakers from the real environment.

SCHOOL-OPERATED WEATHER CENTER

BY

Harold Lee, Fort Morgan High School, Fort Morgan, Colorado, 80701

Since many of the basic considerations involved in aviation and space activities are understanding the weather, the Fort Morgan High School Aerospace Club has developed a school-operated weather center.

The success of the weather analysis is the consistent recording of data by many observers. This is accomplished by a schedule that excuses students from other classes for a time long enough to make necessary observations at given times of day. By altering report times, no student is over-burdened or taken from any one class too often.

Weather systems are followed across Wyoming, into Colorado, then on to Kansas or Nebraska. Three basic techniques are used: U.S. Government weather maps by subscription from Washington, local newspaper weather maps and weather radio receivers in the school.

Data collected is recorded on a simple left-to-right chart, with each new reading recorded below the previous one. Headings on the chart read: Time, Wind (dir. & vel.), Barometer (current reading, fall, steady, rise, slow, fast), Precipitation (rain, snow, total), Cloud type, Temperature, Relative humidity, Dew point, Forecast, and Name of recorder. This chart shows broad tendencies: exact readings are transferred to master wall map.

Students constructed barometers from peanut butter jars, rubber sheet and a balsa wood pointer. Calibration of the scale was done by comparison with a mercury barometer and a sensitive altimeter using the known elevation and reading the correct pressure.

Wet and dry bulb thermometers were mounted in a box with a circulating heater fan to determine relative and absolute humidity and dew point.

Wind direction is determined from an eight-segment electrical contact system on the roof and a light system in the building. Wind speed comes from a homemade anemometer made from aluminum funnels mounted on bearings attached to a small generator sending current to a milliammeter in the building. Calibration was done at the local airport on several days.

This detailed recording schedule, plus the actual construction and knowledge of the instruments, certainly makes the students aware of the weather and its importance to flying.

THE HIGH SCHOOL LIBRARY AS A MOTIVATIONAL TOOL

BY

Phil Hirschy, Seneca Valley Senior High School, R.D. 1, Harmony, Pennsylvania

The school library can be a great help in advertising your aviation course to the student body. There are a great many excellent aviation books the librarian can order to enhance the aviation resource center as well as the library stock. Aviation fiction, aviation history, biographies of famous fliers, and technical aviation works are all good. There is an excellent aerospace encyclopedia set out now, entitled ABOVE AND BEYOND that provides excellent research information.

Besides displaying these books on special shelves or in the library showcase, aircraft pictures from manufacturers and airlines make excellent display materials. Also, your librarian should have an "Aviation Career Opportunities" file that can be featured at an appropriate time, perhaps near career day. If your city or state has a special aviation week or celebration, another special display can be arranged.

The library can become a big booster of your aviation program in stimulating interest and in motivating students to investigate your aviation class as a possible course selection.

AIRPORT DESIGN

What would be a good location for an airport in your community?

What kind of airport should it be?

What will be the aviation needs of your community ten years from now?

These questions and others related make a good class project involving much more than just a study of ground school subjects. Local research often brings up more questions than it answers. Students will surely become more aware of their environment if they have to find out what it really is.

A good way to start is to have some aerial views of the area to look at. These can be taken by you or obtained from your city planning department. City maps or just regular road maps are also good. Previous growth patterns and current trends are all brought into play as the students figure out just where an airport would fit best now and in the future.

Noise pollution comes up in the study of traffic patterns. Ground transportation becomes important as the airport gets farther away from the city it serves. The amount of land needed and the extent of airport services have to be taken into consideration when deciding upon whether or not jumbo jets will ever land there.

Carried to its extreme, models can be constructed from styrofoam or other lightweight material and shown to city officials. Or, backing up a step, city and aviation officials can be brought in as advisors from the beginning.

Large community or small, this can be a challenging problem and an exciting experience in learning for both the student and the teacher (not to mention the non-aviation public that hears about it).

SHORT APPROACHES

With the assistance of a student, film completely the flight of a Cessna 150. Include detailed interior and exterior shots, instruments in action, control movements, take-offs, approaches, landings, etc. Can be narrated in person or on tape. Careful editing can improve logical sequence of events or teaching aims.

Take the students outside. From a common starting point, let each student walk a pre-determined compass heading using a hand-held compass. Place small rewards (candy, gum) at the property destinations. Familiarizes students with relative compass degree headings.

Check with your state pilot's association, aviation newsletter staff, and aeronautics department to see if they can use your journalistic-minded aviation student for some writing assignments. This could lead to excellent writing experience, if not flights to aviation events or flight time. It might also focus attention on your class and aviation education in general.

Conduct a debate in your aviation class. Topic: "Resolved: The high wing light airplane is superior to the low wing light aircraft." Vice-versa if you're a low-wing fan or take your flights in one. Call on the forensics teacher for assistance.

If you have a large blank wall in your classroom, cover it with a full set of World Aeronautical Charts (WAC) of the country, or with several sectionals of your area. It will promote interest as well as be instructional in providing geographical perspective. Overlays on large plastic sheets of flight paths, directions, weather fronts, etc. Also use bright color yarns to show same.

Take aerial color slides of your city, town, farmland, conservation project, etc. for a social study of land use, growth patterns, parking, farming methods, recreational areas, and other environmental subjects. Many students will never have seen their surroundings from this angle. Even a large city can be photographed in a well planned one hour flight.

Call in a former aviation student who has gotten his private or higher type of pilot's license to show that it can be done. A recounting of the experiences of a peer often has a greater impact than if it is done by an adult. One former student volunteered to return, after some arm-twisting by the teacher, and his half hour turned into an entire class period that would have gone on even longer if it hadn't been for the class change.

One student, whose parents have two-way radios in their vehicles, brought his base radio from home and contacted one of their mobile units during class to demonstrate radio communications.

A SUGGESTED TEACHING STRATEGY

Basic to understanding maps and their application to finding one's way on the earth's surface is a thorough knowledge of the compass. From the ancient mariners to today's private pilots, the compass utilizing the magnetic north pole has been the primary instrument of navigation.

This "game" or activity is designed to help the children gain a basic understanding of cardinal directions in terms of the compass, and to refine that knowledge into understandings of the circle, angles, the great circle routes, and skills in identifying compass directions.

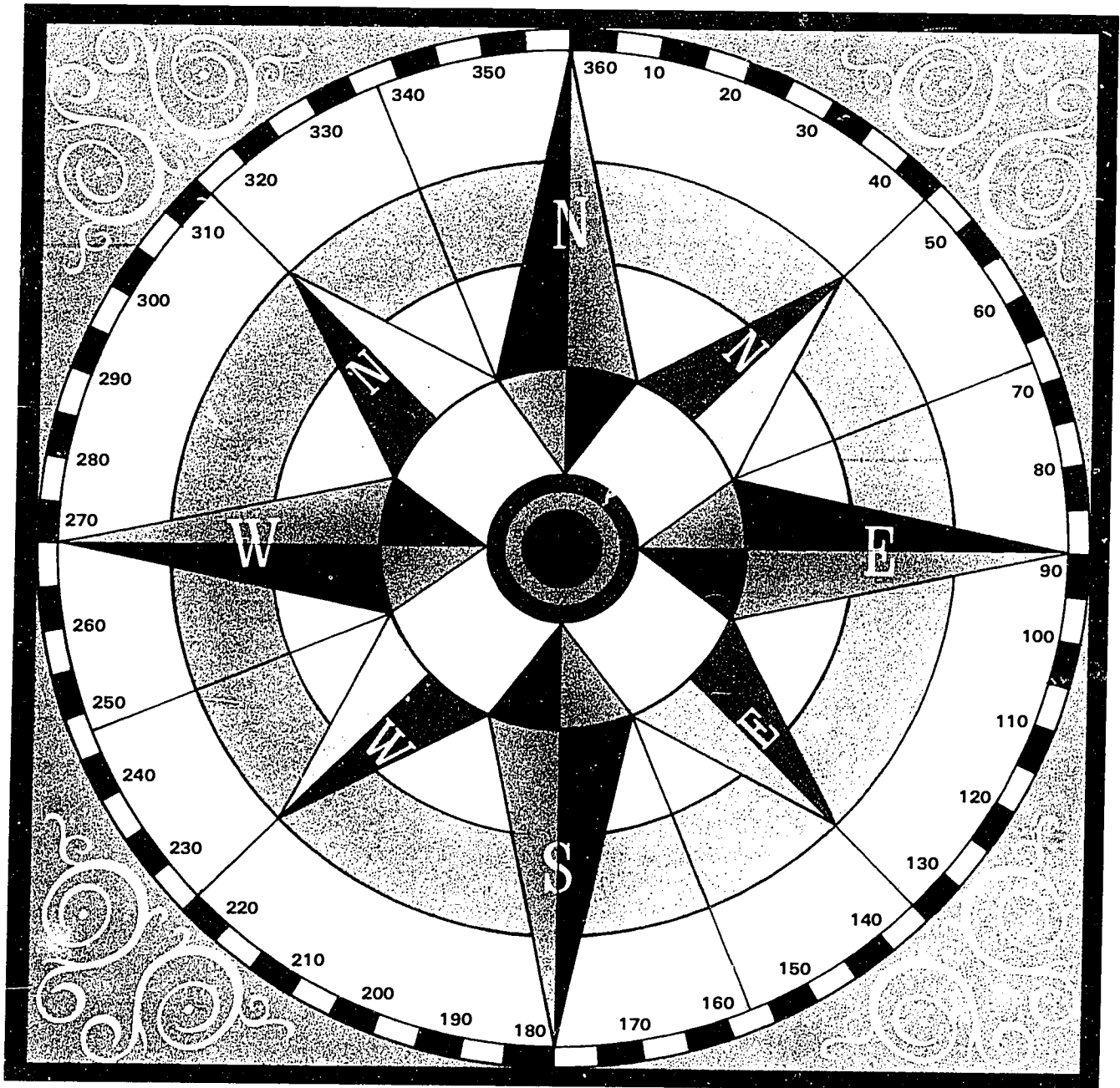

The Compass Rose

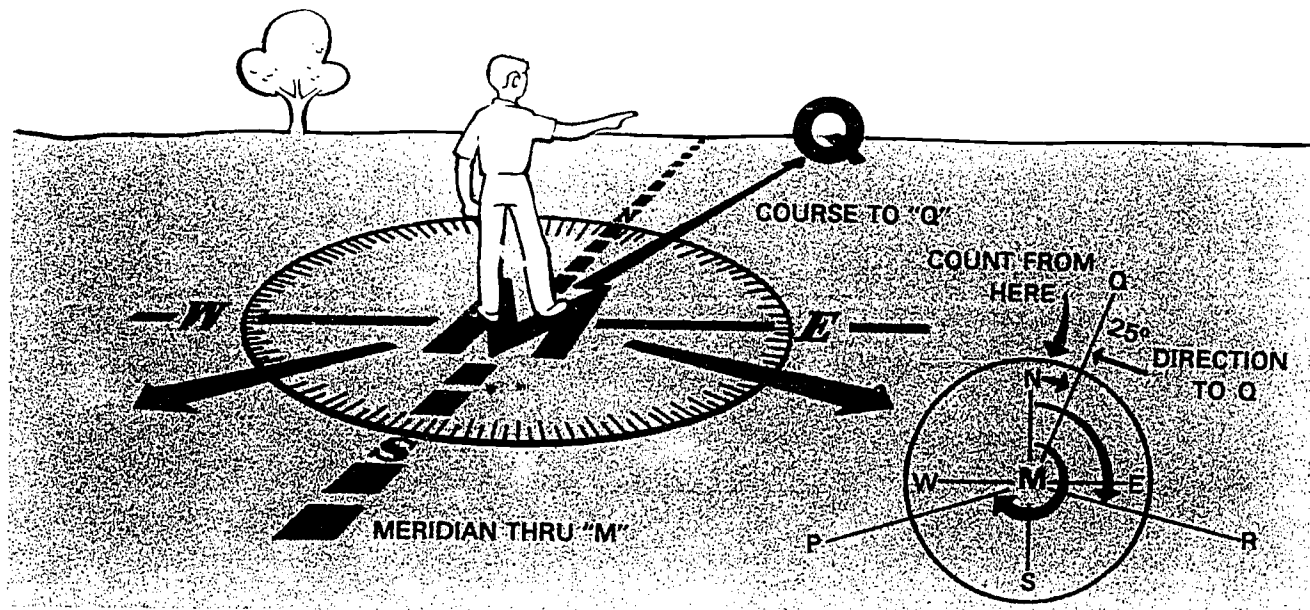

The direction from any given point on the earth's surface to any given point on the earth's surface is always measured as a certain number of degrees from north. One nautical mile is equal to one minute of arc at the equator and on all the lines of longitude. Sixty minutes of arc is equal to one degree.

The Game

Draw a large compass rose on a large piece of butcher paper, or draw with chalk directly on the floor. Have north, or 360°, correspond to actual north. Mark the center of the compass rose where a child will stand.

Divide the class into teams, and let each member of each team take turns standing in the compass rose. Members of the other team can call out compass headings from 001° (one degree) to 360° to the child standing in the center of the compass rose, who turns and faces the direction called for. He must turn to his **right** to be correct, since degrees are counted from north to east to south to west to north.

Variations on this activity can be made to be appropriate to several ability levels. For example, some children can face a given direction and be directed to turn **right** or **left** a given number of degrees. If he is facing 035° and is directed to turn left 020°, he will turn left and be facing 015° when he stops. Or he can face 280° and be directed to make a 180° right turn. When he stops he will be facing 100°.

NOTE: In writing compass headings in numbers, one always writes three digits. If the compass heading is from one to nine, it is written 001°, 002°, 003°, etc. For headings over one hundred, no zero is placed before the number, as 180°, 283°, etc.

Orally, these directions, as they may be given to a pilot by a traffic controller or on the radio, would be read "zero-zero-three degrees," or "zero-one-five degree", or "two-seven-zero degrees". Have the children use this terminology in performing the activity.

An Elementary Aviation Glossary

101 WORDS AND DEFINITIONS

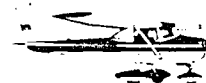

- AEROOYNAMICS**—Study of the forces of air acting on objects in motion relative to air
- AILERON**—Control surfaces hinged at the back of the wings which by deflecting up or down helps to bank the airplane
- AIR**—A mixture of gases making up the atmosphere which surrounds the earth
- AIRFOIL**—A streamlined surface designed in such a way that air flowing around it produces useful motion
- AIRPLANE**—A mechanically-driven, fixed-wing, heavier-than-air craft
- AIRPORT**—A tract of land or water for the landing and takeoff of aircraft. Facilities for shelter, supply, and repair are usually found there
- AIRSPEED**—Speed of the aircraft relative to the air through which it is moving
- AIRWAY**—An air route marked by aids to air navigation such as beacons, radio ranges and direction-finding equipment, and along which airports are located
- ALTIMETER**—An instrument for measuring in feet the height of the airplane above sea level
- ALTITUDE**—The vertical distance from a given level (sea level) to an aircraft in flight
- AMPHIBIAN PLANE**—An airplane that can land on both land and water
- ANEMOMETER**—Instrument to measure speed of wind
- ASCEND**—Climb
- ATMOSPHERE**—Blanket of air surrounding the earth
- ATTITUDE**—Position of the airplane relative to the horizon, i.e., a climbing attitude, straight-and-level attitude, etc.
- AVIATION**—A term applied to all phases of the manufacture and operation of aircraft
- BANK**—A flight maneuver in which one wing points toward the ground and the other to the sky
- BAROMETER**—An instrument to measure pressure of the atmosphere
- BEACON**—A light or other signal indicating direction
- CEILING**—Height above ground of cloud bases
- CHART**—An aeronautical map showing information of use to the pilot in going from one place to another
- CIRRUS**—Type of high thin cloud
- COCKPIT**—The portion of the inside of the airplane occupied by the person(s) operating the airplane, and containing the instruments and controls
- COMPASS**—An instrument indicating direction
- CONTACT**—Switching on the ignition of an aircraft engine or turning the propeller by hand. "Contact" is a word of warning that someone is about to turn on the ignition
- CONTROL TOWER**—A glassed-in observation tower on the airport from which control tower operators observe and direct airport air and ground traffic
- COURSE**—The direction over the earth's surface that an airplane is intended to travel
- CROSSWIND**—Wind blowing from the side, not coinciding with the path of flight
- CUMULUS**—Type of cloud formed in puffs or dome-shaped
- CURRENT**—Stream of air, also, up-to-date
- ENGINE**—Landing made without the engine operating
- DEGREE**—1/360 of a circle, or 1/90 of a right angle
- DIVE**—A steep angle of descent
- DRIFT**—Deviation from a course caused by crosswind currents of air
- ELEVATION**—The height above sea level of a given land prominence, such as airports, mountains, etc.
- ELEVATORS**—Control surfaces hinged to the horizontal stabilizer which controls the pitch of the airplane, or the position of the nose of the airplane relative to the horizon
- ENGINE**—The part of the airplane which provides power, or propulsion, to pull the airplane through the air
- FIN**—A vertical attachment to the tail of an aircraft which provides directional stability. Same as vertical stabilizer
- FLAPS**—Hinged or pivoted airfoils forming part of the trailing edge of the wing and used to increase lift at reduced airspeeds
- FLIGHT PLAN**—A formal written plan of flight showing route, time enroute, points of departure and destination, and other pertinent information
- FORCE**—A push or pull exerted on an object
- FREIGHT**—Cargo
- FRONT (weather)**—Boundary of two overlapping air masses. When cold air is advancing on warm air, it is said to be a cold front; warm air advancing on cooler air is a warm front.
- FUSELAGE**—The streamlined body of an airplane to which are fastened the wings and tail
- GEAR**—The understructure of an airplane which supports the airplane on land or water—wheels, skis, pontoons. Retractable gear folds up into the airplane in flight. Gear that does not retract is called "fixed"
- GLIDE**—A motion of the airplane where the airplane descends at an angle to the earth's surface
- GLIDER**—A fixed wing, heavier-than-air craft having no engine

GRAVITY—Force toward the center of the earth.

HAIL—Lumps or balls of ice falling to the earth out of thunderstorms

HANGAR—Building on the airport in which airplanes are stored or sheltered.

HAZARD—Obstructions or objects or threats to the safety of the passenger and aircraft.

HIGH PRESSURE AREA—Mass of air characterized by high barometric pressure.

HORIZONTAL—Parallel to the horizon.

HUMIDITY—Amount of invisible moisture in a given mass of air.

INSTRUMENTS—Dials or gauges by which information about the flight, airplane, or engine is relayed to the pilot. When the pilot flies the airplane solely by reference to the gauges, he is said to be flying "on instruments".

KNOT—A measure of speed, one knot being one nautical mile per hour

LAND—The act of making the airplane descend, lose flying speed, and make contact with the ground or water, thus ending the flight

LANDING PATTERN—A set rectangular path around the airport which airplanes follow to land

LIFT—An upward force caused by the rush of air over the wings, supporting the airplane in flight

LOW PRESSURE AREA—Mass of air having low atmospheric pressure.

METEOROLOGY—The scientific study of the atmosphere.

MOISTURE—Water in some form in the atmosphere

MONOPLANE—An airplane having one set of wings

MULTI-ENGINE—Having more than one engine.

PARACHUTE—A fabric device attached to objects or persons to reduce the speed of descent

PEDALS—Foot controls in the cockpit by which the pilot controls the action of the rudder

PILOT—Person who controls the airplane

PRECIPITATION—Any falling visible moisture: rain, snow, sleet, hail.

PRESSURE—Force in terms of force per unit area.

PROPELLER—An airfoil which the engine turns to provide the thrust, pulling the airplane through the air

RADAR—Beamed radio waves for detecting and locating objects. The objects are "seen" on the radar screen, or scope

RAMP—Area outside of airport buildings where airplanes are parked to be serviced or to pick up and discharge passengers and cargo.

RUDDER—Control surface hinged to the back of the vertical fin.

RUNWAY—A surface or area on the airport designated for airplanes to take-off and land.

SEAT BELT—Belts attached to the seat which fasten around the pilot and passengers to hold them firmly in their seats in bouncy air and during take-offs and landings.

SEAPLANE—An airplane that operates from water.

SLIPSTREAM—Current of air driven back by the propeller.

STABILIZER—Horizontal surface which stabilizes the airplane around its lateral axis.

STALL—The reduction of speed to the point where the wing stops producing lift.

STATIONARY—Something that does not move is said to be stationary. A front along which one air mass does not replace another.

STRATUS—Layered clouds

STREAMLINE—An object shaped to make air flow smoothly around it.

TACHOMETER—Instrument which measures the speed at which the engine crankshaft is turning, hence the propeller speed in r.p.m.'s (rounds per minute).

TAIL—The part of the airplane to which the rudder and elevators are attached. The tail has vertical and horizontal stabilizers to keep the airplane from turning about its lateral axis.

TAKE-OFF—The part of the flight during which the airplane gains flying speed and becomes airborne.

TERMINAL—Building on the airport where people board planes, buy tickets, and have their luggage handled. Flight services are frequently located at the air terminal.

THRUST—Forward force.

TRANSMITTER—Microphone, or part of the radio that sends the message.

TRICYCLE LANDING GEAR—Airplane's landing wheels: two under the wings and one under the nose.

TURBULENCE—Irregular motion of air, uneven currents of air.

TURN—Maneuver which the airplane makes in changing its direction of flight.

UPDRAFT—Vertical current of air.

VELOCITY—Speed.

VERTICAL—Ninety degrees from the horizon

VISIBILITY—Distance toward the horizon that objects can be seen and recognized. Smoke, haze, fog, and precipitation can hinder visibility.

VORTEX—A circular, whirling movement of air forming a space in the center toward which anything caught in the vortex tends to move.

WEATHER—Condition of the atmosphere at a given time with respect to air motion, moisture, temperature, and air pressure.

WIND—Air in motion, important to aviation because it influences flight to a certain degree.

WIND SOCK—A cone-shaped, open-ended cylinder of cloth to catch the wind and show its direction

WINGS—Part of the airplane shaped like an airfoil and designed in such a way to provide lift when air flows over them.

ZOOM—The climb for a short time at an angle greater than the normal climbing angle, the airplane being carried upward at the expense of airspeed.