

DOCUMENT RESUME

ED 129 585

SE 021 157

TITLE Introduction to Sonar, Naval Education and Training Command. Revised Edition.

INSTITUTION Naval Education and Training Command, Pensacola, Fla.

REPORT NO NAVEDTRA-10130-C

PUB DATE 76

NOTE 223p.; Photographs and shaded figures may not reproduce well

AVAILABLE FROM Superintendent of Documents, U.S. Government Printing Office, Washington, D.C. 20402 (Stock Number 0502-LP-050-6510; No price quoted)

EDRS PRICE MF-\$0.83 HC-\$12.71 Plus Postage.

DESCRIPTORS Acoustics; *Inservice Education; *Instructional Materials; *Marine Technicians; Military Personnel; Military Training; *Physics; Science Education; *Technical Education; Textbooks

IDENTIFIERS *Navy; *Sonar

ABSTRACT

This Rate Training Manual (FTM) and Nonresident Career Course form a self-study package for those U.S. Navy personnel who are seeking advancement in the Sonar Technician Rating. Among the requirements of the rating are the abilities to obtain and interpret underwater data, operate and maintain upkeep of sonar equipment, and interpret target and oceanographic data. Designed for individual study and not formal classroom instruction, this book provides subject matter that relates directly to the occupational qualifications of the Sonar Technician Rating. Included in the book are chapters on the physics of sound, the bathythermograph, principles of sonar, basic fire control, test equipment and methods, and security. (Author/MH)

 * Documents acquired by ERIC include many informal unpublished *
 * materials not available from other sources. ERIC makes every effort *
 * to obtain the best copy available. Nevertheless, items of marginal *
 * reproducibility are often encountered and this affects the quality *
 * of the microfiche and hardcopy reproductions ERIC makes available *
 * via the ERIC Document Reproduction Service (EDRS). EDRS is not *
 * responsible for the quality of the original document. Reproductions *
 * supplied by EDRS are the best that can be made from the original. *

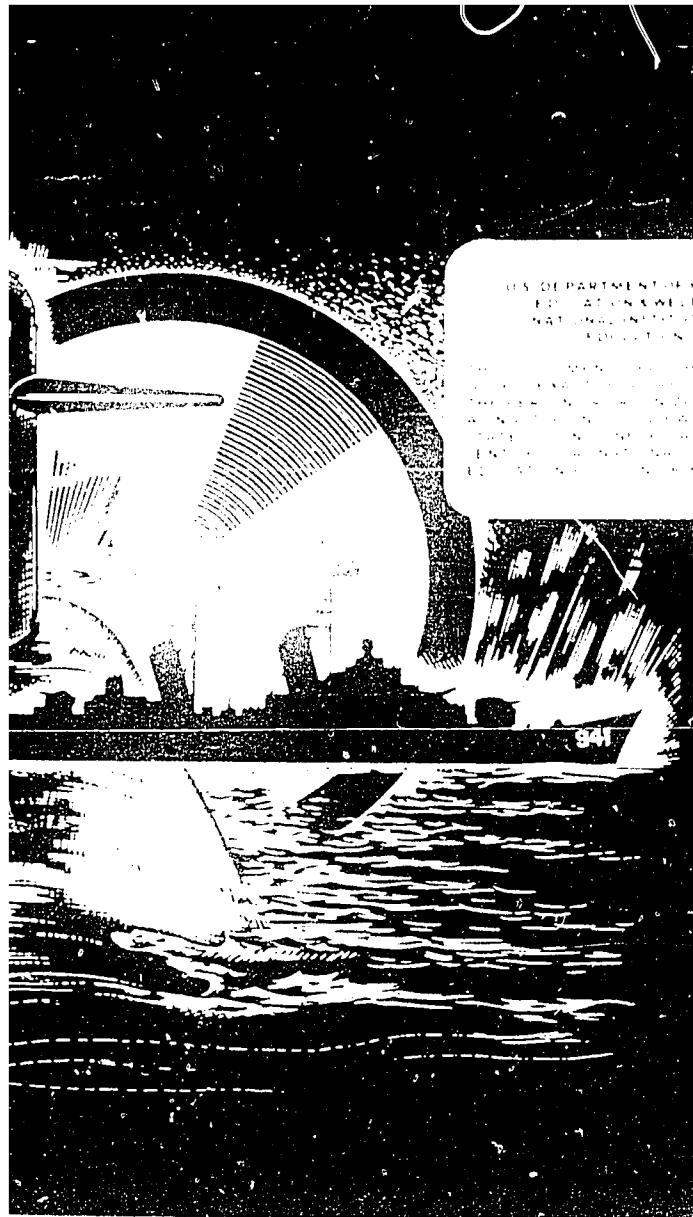

U.S. DEPARTMENT OF
EDUCATION
NATIONAL INSTITUTE OF
EDUCATION

INTRODUCTION TO SONAR

NAVY AND TRAINING COMMAND

TRAINING MANUAL

RESIDENT CAREER COURSE

VEDTRA 10130-C

PREFACE

This Rate Training Manual and Nonresident Career Course (RTM/NRCC) form a self-study package for those personnel who are seeking advancement in the Sonar Technician Rating. This package will enable these personnel to help themselves fulfill the requirements of the rating. Among these requirements are the abilities to obtain and interpret underwater data for operational use; operate and maintain upkeep of sonar equipment; perform as a member of an antisubmarine (A/S) attack team; interpret target and oceanographic data; perform intermediate maintenance on sonar and allied equipment; and to work with records and reports associated with sonar operations.

Designed for individual study and not formal classroom instruction, the RTM provides subject matter that relates directly to the occupational qualifications of the Sonar Technician Rating.

The NRCC provides the usual way of satisfying the requirements for completing the RTM. The set of assignments in the NRCC includes learning objectives and supporting items designed to lead students through the RTM.

This training manual and nonresident career course was prepared by the Naval Education and Training Program Development Center, Pensacola, Florida, for the Chief of Naval Education and Training. Technical assistance was provided by Fleet Antisubmarine Warfare Training Center Pacific, San Diego, California; Naval Submarine School, Groton, Connecticut; Naval Underwater Sound Lab, New London, Connecticut; and Naval Intelligence Support Center, Washington, D.C.

Revised 1976

Stock Ordering No.
0502-LP-050-6510

Published by
NAVAL EDUCATION AND TRAINING SUPPORT COMMAND

UNITED STATES
GOVERNMENT PRINTING OFFICE
WASHINGTON, D.C.: 1976

i

3

THE UNITED STATES NAVY

GUARDIAN OF OUR COUNTRY

The United States Navy is responsible for maintaining control of the sea and is a ready force on watch at home and overseas, capable of strong action to preserve the peace or of instant offensive action to win in war.

It is upon the maintenance of this control that our country's glorious future depends; the United States Navy exists to make it so.

WE SERVE WITH HONOR

Tradition, valor, and victory are the Navy's heritage from the past. To these may be added dedication, discipline, and vigilance as the watchwords of the present and the future.

At home or on distant stations we serve with pride, confident in the respect of our country, our shipmates, and our families.

Our responsibilities sober us; our adversities strengthen us.

Service to God and Country is our special privilege. We serve with honor.

THE FUTURE OF THE NAVY

The Navy will always employ new weapons, new techniques, and greater power to protect and defend the United States on the sea, under the sea, and in the air.

Now and in the future, control of the sea gives the United States her greatest advantage for the maintenance of peace and for victory in war.

Mobility, surprise, dispersal, and offensive power are the keynotes of the new Navy. The roots of the Navy lie in a strong belief in the future, in continued dedication to our tasks, and in reflection on our heritage from the past.

Never have our opportunities and our responsibilities been greater.

CONTENTS

CHAPTER	Page
1. The Sonar Technician	1
2. History and Development of ASW	15
3. Physics of Sound	35
4. Bathythermograph	58
5. Bearings and Motion	71
6. Principles of Sonar	85
7. Basic Fire Control	109
8. Communications	127
9. Test Equipment; Test Methods; Maintenance	141
10. Security	162
APPENDIX	
I. Glossary	173
INDEX	178
Occupational Standards	185
Nonresident Career Course Follows Occupational Standards	

CHAPTER 1

THE SONAR TECHNICIAN

A substantial force of conventional and nuclear-powered submarines, many of them capable of launching nuclear missiles, represents a potential threat to our country's security and a continuing challenge to our Navy's antisubmarine forces.

To meet this challenge, U.S. Navy ships and submarines continually conduct exercises in antisubmarine warfare (ASW) operations, revising tactics and evaluating new methods and equipment used for detecting and destroying enemy underwater craft. Destroyers, frigates, and cruisers are our main antisubmarine (A/S) surface vessels. They provide protection against submarines for major surface ships by forming a sonar screen around the ship. Upon detection of a submarine trying to penetrate the screen, the A/S vessel initiates an attack, and the main body turns away from the contact area. Our own submarines—particularly nuclear-powered types with their generally superior detection equipment—play an equally important role in ASW. They are capable of selecting the depth that provides the best underwater detection conditions. Additionally, they have the endurance to conduct surveillance operations over wide ocean areas.

The Sonar Technician—whether on a submarine or a surface ship—is an indispensable contributor to our nation's defense. The primary task of all sonar personnel is to provide underwater data for operational use.

In relation to that task, several responsibilities are applicable to all branches of the rating. All Sonar Technicians must be able to operate the sonar equipment installed on their particular ships. This responsibility includes manipulation and interpretation of data derived from sonar equipment, fire control equipment

(as applicable), and associated gear. They must also be able to perform both operational and preventive maintenance on the equipment they operate. This training manual is designed to help you meet the professional qualifications for advancement to Third Class Sonar Technician. The most sensible approach to your studies is to first understand the general makeup of the text. This book is a self-study manual written to help you become a Sonar Technician with the least possible outside assistance. To aid you in this respect, chapters with related subject matter are grouped together to make studying easier.

Even though there always is the temptation to skip the front matter of a book and get on with studying the text, this practice is a costly shortcut and should be avoided. If you skimmed through the front matter of this training manual to get on to chapter 1, go back, now read that material.

The table of contents gives you an overall picture of the subject matter covered in this manual. By using it, you can locate a general subject, such as underwater sound equipment for submarine detection and navigation. The preface tells you the purpose of the manual, who wrote it, and who provided technical assistance.

While you are studying this manual, you will find the index at the back of the book a time-saving reference. By checking the index, you can locate specific data about a particular sonar set or piece of sonar equipment. It is actually an alphabetical list of the important points or keywords in this book, along with the page(s) where each subject is discussed.

Each chapter has been prepared to satisfy the latest change in the *Manual of Navy Enlisted Manpower and Personnel Classifications and*

INTRODUCTION TO SONAR

Occupational Standards, NAVPERS 18068-D, and covers only the occupational (professional) qualifications, not the military requirements.

The remainder of this chapter gives information calculated to help you in working for advancement. It is highly recommended that you study this chapter carefully before you begin intensive study of the remainder of the manual.

ENLISTED RATING STRUCTURE

Within the enlisted rating structure, two types of ratings—general and service—are of concern to you. These ratings are applicable to both the Regular Navy and Naval Reserve.

GENERAL RATINGS identify broad occupational fields of related duties and functions. Some general ratings include service ratings; others do not.

SERVICE RATINGS identify subdivisions or specialities within a general rating. Although service ratings can exist at any petty officer level, they are most common at the PO3 and PO2 levels. As of 1 March 1975, the ST rating was split into service ratings up through E-8.

SONAR TECHNICIAN RATING

Navy ratings are divided into 12 groups, with the ratings in each group being occupationally related. Sonar Technician is a general rating in group 1, called the deck group. Following is an outline of the tasks applicable to the divisions of the Sonar Technician rating at the second and third class levels.

Surface Sonar Technician (STG)

The Surface Sonar Technician operates installed sonar equipment. He must be able to manipulate, control, evaluate, and interpret data derived from surface passive and active sonar equipment, oceanographic equipment, associated surface auxiliary sonar equipment, and surface fire control equipment. He also must be able to perform organizational and intermediate maintenance on surface sonar and allied equipments. As STG 3 or 2, your billets in

most cases will be limited to the sonar gang of an operating surface ASW ship such as a destroyer.

Submarine Sonar Technician (STS)

The Submarine Sonar Technician operates installed sonar equipment. He must be able to manipulate, control, evaluate, and interpret data derived from submarine passive and active sonar equipment, oceanographic equipment, and associated submarine auxiliary sonar equipment. He also must be able to perform organizational and intermediate maintenance on submarine sonar and allied equipments. As STS 3 or 2, your billets in most cases will be limited to the sonar gang of an operating submarine.

REWARDS AND RESPONSIBILITIES OF ADVANCEMENT

Advancement brings both increased responsibilities and increased rewards. You should start looking ahead and considering the responsibilities and rewards right now while you are preparing for advancement.

By now, you should be aware of many of the advantages of advancement: higher pay, greater prestige, more interesting and challenging work, and the satisfaction of getting ahead in your chosen career. You will also discover that one of the most enduring rewards of advancement is the personal satisfaction you find in developing your skills and increasing your knowledge.

The Navy also benefits by your advancement since highly trained personnel are essential to the functioning of the Navy. Each advancement increases your value to the Navy in two ways. First, you become more valuable as a technical specialist in your own rating. Second, you become more valuable as a man who can supervise, lead, and train others and thus make far-reaching and long-lasting contributions to the Navy.

LEADERSHIP RESPONSIBILITIES

The extent of your contribution to the Navy depends, in large measure, upon your willingness

and ability to accept increasing responsibilities as you advance. When you assume your PO duties, you must accept a certain amount of responsibility for military matters as well as for occupational requirements of the ST rating.

Military Leadership

Your military leadership responsibilities are about the same as those of petty officers in other ratings since every petty officer is a military person before becoming a technical specialist. Your responsibilities will extend both upward and downward. Senior petty officers and junior enlisted personnel alike will expect you to translate general orders into detailed, practical, on-the-job language that can be understood and executed by even relatively inexperienced personnel. In dealing with your juniors, it is up to you to see that they perform their work properly. At the same time, you must be able to explain to your leading PO any important needs or problems of these men.

Although some broad aspects of military leadership are included in this text, the training manual is not designed to give you extensive information on military requirements for advancement to petty officer third or second. Material covering these requirements is found in *Military Requirements for PO 3 & 2*, NAVEDTRA 10056 (current edition), and should be studied carefully.

Technical Leadership

Your responsibilities for technical leadership are special to your rating and are directly related to the nature of your work. The dual role of operating and maintaining the ship's sonar systems is a job of vital importance. It requires an exceptional kind of leadership ability that can be developed only by personnel who have a high degree of technical competence and a deep sense of personal responsibility. Even if you are fortunate enough to be serving with highly skilled and well-trained sonar personnel, you will find that training is still necessary. In this respect, you will be expected to assist in the training of lower rated men for advancement. Also, if some of the skilled men are transferred,

inexperienced or poorly trained men may be assigned to replace them. In such a circumstance, your skill and experience must be used to help bring these men up to the standard of those they replaced.

KEEPING UP WITH NEW DEVELOPMENTS

You are responsible for keeping up with new developments within the Navy. Practically everything in the Navy is subject to change--policies, procedures, equipment, publications, systems, and so on. As third class and even more as second class, you must make every effort to keep yourself informed of all changes and new developments that might affect your rating or your work.

Some changes will be called directly to your attention, but you must look for others. Try to develop a special kind of alertness for new information. Above all, keep an open mind on the subject of new sonars and associated equipment. Openmindedness is especially important in the Sonar Technician rating because the Navy, in an effort to keep up with modern advances in submarine development, is experimenting constantly with new detection, fire control, and weapons systems.

WORKING WITH OTHERS

As you advance to third class and then to second class, you will be taking a greater part in planning for the training of ASW personnel on your ship. At times, this training will affect a large number of personnel not in your division or even your department. It becomes increasingly important, therefore, to understand the duties and responsibilities of personnel in other ratings. The more you know about related ratings, the more complete and comprehensive will be your training plans--especially those that require an interdivisional effort to achieve their goals.

Communicating Effectively

As your responsibilities for planning with others increase, so also must your ability to communicate clearly and effectively. The basic

requirement for effective communication is a knowledge of your own language. Use appropriate language in speaking and in writing. Remember that the basic purpose of all communication is understanding. To lead, supervise, and train other men, you must be able to speak and write in such a way that they can understand exactly what you mean.

A second requirement for effective communication in the Navy is a sound knowledge of the "Navy way" of saying things. Some Navy terms have been standardized for the purpose of ensuring efficient communication. When a situation calls for standard Navy terminology, use it.

Still another requirement for effective communication is precision in the use of technical terms. A command of the technical language of the Sonar Technician rating will enable you to receive and convey information accurately and to exchange ideas with others. Proper use of technical terms is particularly important when you are dealing with lower rated men—carelessly used technical terms will confuse an inexperienced man. A person who does not understand the precise meaning of terms used in connection with the work of his own rating is handicapped when he tries to read official publications related to his work. He is also at a disadvantage when he takes the written examinations for advancement.

Increasing Retention

Have you ever wondered why we have to go into a port and starboard sonar watch, during operating periods, or why our sea duty tours are so long? Let's face facts: Naval operations are not going to change very much in the near future. In fact, due to budget cuts, we will probably be doing the same job with fewer men. Therefore, retention of the lower rated Sonar Technician has become a critical factor and we must direct our attention toward this very real problem.

The Navy recognizes the problem and has instituted many new "People Programs" designed to humanize the Navy effort, highlighting the individual within the group.

These programs are designed to increase morale on a large scale with increased retention as the logical by-product.

The Navy has taken great strides in improving its living standards. The food is better and even the pay has become reasonable. These factors fulfill a man's basic survival and security needs, but we must use other motivating factors also to promote retention. By learning to recognize positive motivation factors and to use them correctly, we will obtain better job performance and our subordinates will realize more satisfaction from their jobs. We are all capable of performing if motivated properly.

No one has all of the answers to effective management. However, the highest degree of effectiveness is realized when leadership techniques are based upon the following list of assumptions:

1. People are not by nature lazy, indifferent, uncooperative, or uncreative. Work is as natural as play or rest.
2. Tight controls and threats of punishment are not the only means of getting men to work. Men will exercise self-direction and self-control toward objectives to which they are committed.
3. Every man must have a meaningful job. Without meaningful work he is bored and useless.
4. Man is a growing, learning animal who craves recognition.
5. Most men learn to accept and to seek responsibility.
6. The average man's intellectual potentials are only partially utilized. Most are capable of a high degree of imagination, ingenuity, and creativity.
7. Man by his nature is gregarious. One of his basic urges is his desire to be an integral part of some group. He must feel that he is an important, contributing member of the group.

Do we, as leaders, really consider the needs and desires of our subordinates? Most of us have preconceived ideas of what a person's needs are. We try to compare a subordinate's reactions to various management techniques, and to what we think our own reactions would be under similar circumstances. Thus, we set up a model subordinate, usually based upon ourselves, and

decide to manage according to our model's desires, treating everyone the same. But this is entirely the wrong approach since no two individuals are alike. We each react differently to different situations. Therefore, a good leader must know and understand his men and be flexible enough to adjust his management techniques according to each individual. Flexibility is a key to successful leadership.

Job assignments should be planned to challenge the ability of each individual. When a man masters one task, make his next one just a little more difficult, keeping in mind that, for motivating purposes, succeeding is better than success. For example, turn-counting is a great challenge to a new ST striker; but, once he becomes proficient, his job must be changed. If not, he will become bored and his efficiency will drop. If it's not possible to change his job right away, then encourage competition among the watchstanders. Use any challenge you can think of to keep him interested, and his high performance should continue until his job can be changed.

Each subordinate must be assigned responsibility no matter how large or small the responsibility. We could make many changes in this area. For example, in most compartments, a card is posted on the bulkhead designating the man responsible for that compartment. Normally, the designated man is a senior petty officer. Let's change that. Assign the responsibility for the appearance of the compartment to the compartment cleaner himself. When he realizes that he, and not his senior petty officer, will have to answer for the compartment if it is not ship-shape, he will take more interest and will do a better job. He will also work harder for another reason: he knows that when he does a good job, he will receive the "well done" himself.

Many of the factors used to motivate an individual can also be used to motivate a group. Certainly, a good attack team must function as a group. Some sonar controls are manned by groups and others are manned by "bunches of individuals." To be effective, all of the efforts of your team must be group efforts for the accomplishment of group goals. Competition

within the group should be encouraged. An operator takes great pride in the fact that he was the first to detect a distant target. Likewise, competition with other groups can be stimulating. "Our sonar gang can figure the solution to any maneuvering board problem quicker than any Quartermaster in the ship!"

Whenever possible, group decisions should be encouraged. For example, during a pre-exercise briefing, why not ask the group for opinions? "How do you think we should handle this part of the exercise, Jones?" Listen to your men and respect their opinions. They may come up with a good idea that you hadn't thought of. Every man will naturally work harder toward an objective if he takes part in making the decision because he now has a personal interest in the task.

These are some of the ideas that can be employed to improve individual and group performance. Certainly, there are many others. The important thing is that we, as leaders, must consider morale and retention, which go hand-in-hand, two of our most important responsibilities. We should occasionally examine our leadership techniques and keep an open mind for new and useful methods. The new Navy management trend is toward a softer approach, recognizing individual needs. However, the strong, stern approach is still available for use when necessary. The next few years are going to be very challenging to all of us in the naval service. Challenge is our lifeblood, the driving force that keeps us going. Admiral Halsey once said—"There are no great men. Great men are just normal men who are forced to meet the greatest challenge."

STUDYING FOR THE TEST

The Sonar Technician, like his contemporaries in other ratings, normally has access to every publication used as reference material for the questions contained on his advancement-in-rating examination.

Trying to read and study every manual or publication on sonar is a waste of time and effort. We each have a saturation point which most certainly would be exceeded if we tried to

INTRODUCTION TO SONAR

study everything. However, a pamphlet is produced which indicates exactly which reference material is used in writing the exam. This pamphlet, *Bibliography for Advancement Study*, NAVEDTRA 10052 (current edition), is available at your Information and Education Office.

The *Bibliography* is an important reference when preparing for advancement. It is based on the *Manual of Navy Enlisted Manpower and Personnel Classifications and Occupational Standards*, NAVPERS 18068 (current edition), and lists the training manuals and other publications prescribed for use by all personnel concerned with advancement-in-rate training and with advancement examination writing. Thus, the *Bibliography* provides a working list of material for enlisted personnel to study in preparation for advancement examinations, and it's the same list used by the item writers at the Naval Education and Training Program Development Center.

The first few pages of the pamphlet show the military requirements references which apply to all ratings. This part of the *Bibliography* is of special importance at the E4/E5 levels because separate examinations on military subjects are given locally at those rate levels. The remainder of the booklet contains reference listings by ratings, using the five-column format shown in figure 1-1.

Column (1) Ratings. The names and abbreviations of both service and general ratings are contained. All of the references for Sonar Technician are grouped together on one list covering one or more pages.

Column (2) Publication Titles. Titles and applicable parts of Rate Training Manuals and other publications are shown in this column. Notice that, when only certain parts of a book apply as references for a particular rate, just those parts (paragraphs or chapters) are listed. (See fig. 1-1.)

Column (3) Text Identification Numbers. This column identifies the references more specifically. The publication and

NAVPERS/NAVEDTRA numbers listed are the most recent editions and may contain a letter, such as NAVPERS 10144-A edition.

Column (4) Nonresident Career Course Identification Numbers. NAVPERS/NAVEDTRA number(s) of the courses covering subject matter of any prescribed text(s) described in columns 2 and 3 are listed. In a few cases, completion of the course is mandatory.

Column (5) Applicable Rate Levels. Except for training manuals that are mandatory, the lowest rate level for which a publication is applicable is listed in this column. If a publication is mandatory, then all of the rate levels for which it is mandatory are shown. Note that, as pointed out in the *Manual of Navy Enlisted Manpower and Personnel Classifications and Occupational Standards*, NAVPERS 18068, all higher pay grades may be held responsible for the material contained in publications listed for lower rates in their paths of advancement. Asterisks which appear throughout the listings indicate the Rate Training Manuals or Nonresident Career Courses whose mandatory completion is specified by the *Advancement Manual*.

The rate training manuals are based on the professional and military quals from the *Manual of Navy Enlisted Manpower and Personnel Classifications and Occupational Standards*. With a few exceptions, sufficient information is presented in these manuals to cover every qual. Obviously a qual like "encode and decode tactical signals" cannot be realistically covered. Nor can a Secret qual be covered in a Confidential or unclassified manual. For these types of quals you have to go to other publications for the information. The *Bibliography* tells you where to look.

This rate training manual plus either the STC or STS manual and *Military Requirements for PO 3 & 2* cover the majority of E4 and E5 ST quals. *Bibliography* (NAVEDTRA 10052, current edition) references cover those quals that cannot be adequately covered by these two manuals.

Chapter 1 THE SONAR TECHNICIAN

Ratings (1)	Publications Titles (2)	Text Identification Number (3)	Course Identification Number (4)	Applicable Rate Levels (5)
GROUP 1. DEPT-Continued				
SONAR TECHNICIAN SUBMARINE (SSNA) (Continued)	Department of the Navy Information Security Program Regulation (Ch 1, Sec 2-5; Ch 5, Sec 1-2; Ch 6; Ch 7, Sec 1, Para 7-100, 7-101, 7-102, and 7-103, and Sec 2, Para 7-204 thru 7-208, 7-210 thru 7-212; Sec 3; Ch 8; Ch 9; Ch 11, Sec 2, Para 11-204, and Sec 3, Para 11-300, 11-301, and 11-303 thru 11-310) (Ch 2, Sec 3, Para 2-300 thru 2-304, and 2-309) (Ch 10)	OPNAVINST 5510.11		E-4 E-5 E-6 E-7
	Basic Electronics, Vol 1 (Ch 3, 5-7, 13-15, 17, 21; App VI)	NAVPERS 10087-C	10445-B	E-4
	Tools and Their Uses (Ch 1, 2)	NAVPERS 10085-B	91228-2A	E-4
	Transistorized and Printed Circuits, Servicing Techniques	NAVTPA 38001		E-4
	Allied Antisubmarine Warfare Manual USN Addendum (Ch A2, A4, A16; App AA, AC)	ATP-28		E-4
	Allied Antisubmarine Warfare Manual (Ch 1-4, 6, 9, 10, 12)	ATP-28		E-4
	Handbook of Test Methods and Practices (Sec 3-13)	NAVSHIPS 0967-000-0130 (Rev/1970)		E-5
	Digital Computer Basics	NAVEDTRA 10088-A	10441-A	E-5

Figure 1-1.—Bibliography format.

71.132

INTRODUCTION TO SONAR

NAVEDTRA PUBLICATIONS

Some of the NAVEDTRA publications that you will need to study or refer to as you prepare for advancement have been discussed earlier in this chapter. Some additional publications that you will find useful are listed here.

Tools and Their Uses, NAVEDTRA 10085
(current edition)

Basic Electricity, NAVEDTRA 10086
(current edition)

Basic Electronics, Vols. 1 and 2,
NAVEDTRA 10087 (current edition)

*Servicing Techniques for Transistorized and
Printed Circuits*, NAVEDTRA 38001
(current edition)

NAVSEA (FORMERLY NAVSHIPS) PUBLICATIONS

Several publications issued by the Naval Sea Systems Command will be of interest to you. Although you do not need to know everything that is given in the publications mentioned here, you should have a general idea of where to find information in NAVSEA publications.

NAVSEA Technical Manual

The *Naval Ships Technical Manual* (now *NAVSEA Technical Manual*), NAVSHIPS 0901-000-0000, is the basic doctrine publication of former Naval Ship Systems Command. The manual is kept up to date by means of quarterly changes. All copies of the manual should have all changes made in them as soon as possible after the changes are received.

Naval Sea Systems Command Journal (formerly, Technical News)

The *NSSC Journal*, a monthly technical publication, contains current unclassified information on all aspects of shipboard problems. The magazine is particularly useful because it presents information that supplements and clarifies articles in the *NAVSEA Technical*

Manual and because it contains data on new equipment, policies, and procedures.

MANUFACTURER'S TECHNICAL MANUAL

When new sonar equipment is purchased by the Navy, the company manufacturing that equipment is normally tasked with providing a manufacturer's technical manual (instruction book). These instruction books are then assigned NAVSEA numbers by the Navy. For example: Sonar communication set AN/BQC-1B, 1C was approved by the Navy in September 1964. The DYN-A-EMPIRE, INC. submitted a manufacturer's technical manual and it was assigned the NAVSHIPS number 95728. A large change was made to the manual in March 1968, and the manual was reassigned NAVSHIPS number 0967-932-2011. These manuals provide all of the technical information for a given piece of sonar equipment and are indispensable to the Sonar Technician maintaining that equipment.

EIBs AND EIMBs

The *Electronics Information Bulletin* (EIB) is a biweekly authoritative publication containing advance information on field changes, installation techniques, maintenance notes, beneficial suggestions, and technical manual distribution. Articles of lasting interest are later transcribed into the *Electronics Installation and Maintenance Book* (EIMB), except for field changes and corrections to publications, which subsequently are reproduced and stocked at NPFC, Philadelphia. These two publications are essential because of the advance information and the reference information available to the sonar maintenance technician.

PUBLICATIONS PROMULGATED BY CNO

The following publications series are sponsored by CNO.

COMTAC Series

The term COMTAC is a label assigned to that group of nonregistered communication and

tactical publications which CNO has designated to be part of every command's allowance of required publications. The following publications are included in the COMTAC series.

- Naval Warfare Publications (NWP)
- Naval Warfare Information Publications (NWIPs)
- Fleet Exercise Publications (FXPs)
- Allied Tactical Publications (ATPs)
- Allied Exercise Publications (AXPs)
- USN Addenda to Allied Publications
- Miscellaneous Allied Publications

Registered Publications Series

A few of the publications sponsored by CNO are distributed through the Registered Publications System (RPS). These publications must be accounted for, safeguarded, extracted, and destroyed in accordance with applicable instructions and directives published by RPS, supplemented where necessary by individual letters of promulgation. Tactical publications in the RPS are as follows:

- ATP-6 Allied Doctrine of Mine Countermeasures
- ATP-24 Tactical Instructions for Conduct of Mine Countermeasures
- AMP-5 Mine Identification and Disposal Manual
- AXP-5 NATO Experimental Tactics and Amplifying Tactical Instructions

PUBLICATIONS PROMULGATED BY COMNAVCOMM

The following publications are within the cognizance of Commander Naval Communications (COMNAVCOMM):

- Allied Communications Publications (ACPs)
- U.S. Naval Communications Instructions (DNCs)
- Joint Publications (JANAPs)

U.S. NAVY TACTICAL DOCTRINE PUBLICATIONS

The titles of all publications and the descriptive paragraphs appearing here and under subsequent headings in this section are unclassified. The classification of each publication is indicated at the end of the descriptive paragraph. Those publications marked with an asterisk are of particular interest to the STS.

NWP 0 TACTICAL DOCTRINE PUBLICATIONS GUIDE includes the periodic review program and procedures, publication procurement, a general summary of each publication, and guidance for the operation of a COMTAC publication library. (Unclassified)

NWP 1-4 EXPERIMENTAL TACTICS contains experimental tactics and procedures and assigns their evaluation. If accepted by fleet evaluation, the material is transferred to the appropriate publication in the NWP series. (Confidential)

NWIP 11-20 MISSIONS AND CHARACTERISTICS OF U.S. NAVY SHIPS AND AIRCRAFT contains information on U.S. Navy and Coast Guard ships and aircraft, and illustrations of representative types. It includes the missions, characteristics, armament, and endurance of the various ship classes, and performance data of aircraft currently in service. (Confidential)

NWP 16 BASIC OPERATIONAL COMMUNICATIONS DOCTRINE establishes the basic doctrine, policies, and principles governing operational communications. (Confidential)

*USN ADDENDUM TO ATP 28 (REPLACES NWP 24 SERIES) presents the basic concepts and principles of ASW operations and amplifies the ASW chapters in ATP 1, Vol. I. (Confidential)

*NWP 33 ELECTRONIC WARFARE provides doctrine and procedures for electronic warfare and includes information on electronic

INTRODUCTION TO SONAR

countermeasures, counter-countermeasures, and acoustic warfare. It also provides information on types of electronic equipment and guidance for employment of electronic warfare in naval operations. (Secret)

NWP 37 NATIONAL SEARCH AND RESCUE MANUAL is a joint publication coordinated by the U.S. Coast Guard. It provides the various military forces and civilian agencies with a standard procedure for search and rescue. (Joint service publication) (Sponsor: Coast Guard) (Unclassified)

USN ADDENDUM TO NWP 37, SUBMARINE DISASTER SEARCH AND RESCUE OPERATIONS, outlines procedures particularly applicable to the search phase of peacetime submarine disaster search and rescue operations. (Unclassified)

*FXP 1 SUBMARINE AND ANTISUBMARINE EXERCISES establishes tactics and procedures for conducting submarine exercises with criteria for evaluating results. (Confidential)

FXP 3 SHIP EXERCISES provides exercises for all types of surface ships and guidance to exercise observers in evaluating the exercises. (Confidential)

J.S. COMMUNICATIONS PUBLICATION

JANAP 119 JOINT VOICE CALL SIGN BOOK contains the voice call signs of all U.S. activities. (Confidential)

NATO/ALLIED TACTICAL DOCTRINE PUBLICATIONS

ATP 1 (VOL. I) ALLIED MARITIME TACTICAL PROCEDURES contains basic maneuvering instructions, tactics, and doctrine for all Allied navies. (Custodian: United States) (Confidential)

ATP 1 (VOL. II) ALLIED NAVAL SIGNAL BOOK contains standard maneuvering,

operating, and the more common administrative signals. (Custodian: United States) (Confidential)

USN ADDENDUM TO ATP 1 (VOL. II), U.S. NAVAL SIGNAL BOOK, provides additional basic material, supplementing and/or modifying ATP 1, Vol. II, for intraservice use by the U.S. Navy when operating separately from the other Allied navies. (Confidential)

ATP 3 ANTISUBMARINE EVASIVE STEERING covers evasive steering by formations, convoys, and ships to avoid attack by submarines. It is intended for use by Allied navies. (Custodian: United States) (Confidential)

SUPPLEMENT TO ATP 3, ZIGZAG PLANS 10, 14, 15, and 17. (Confidential)

ATP 10 SEARCH AND RESCUE contains doctrine concerning search and rescue and is the Allied version of NWP 37. An appendix contains Annex 12 to the Convention of International Civil Aviation and presents international standards and recommended practices for search and rescue. (Custodian: United Kingdom) (Confidential)

*AXP 1 ALLIED SUBMARINE AND ANTISUBMARINE EXERCISE MANUAL establishes tactics and procedures for evaluating the exercises. (Custodian: Canada) (Confidential)

AXP 2 ALLIED TACTICAL EXERCISE MANUAL contains standard seamanship, gunnery, torpedo, and miscellaneous exercises for use by Allied navies in training their forces for participation in Allied Operations. (Custodian: United States) (Confidential)

ALLIED COMMUNICATION PUBLICATIONS

ACP 125 COMMUNICATIONS INSTRUCTION RADIOTELEPHONE PROCEDURE prescribes the basic radiotelephone procedure that shall be used for radiotelephone communications. (Custodian: United States) (Unclassified)

ACP 165 OPERATIONAL BREVITY contains code words or phrases that are used for standardization and abbreviation. The code words are designed for speed and conciseness of transmission. (Custodian: United States) (Confidential)

THE ADVANCEMENT EXAMINATION

All of the ST advancement examinations are written by an item writer at the Naval Education and Training Program Development Center, Ellyson, Pensacola, Florida. The item writer is responsible for constructing the 150-question ST examinations. The writer has a bank of many items that have been used on previous examinations, and he will use many of the items from his bank when he constructs an examination. He will also write new items.

The examination questions are grouped by subject matter into categories, or sections. There may be from 5 to 12 sections on a particular test. Each item is carefully checked and rechecked to make sure it is a valid item.

Unfortunately, there is an unavoidable delay built into the examination system since the *Bibliography* is printed and distributed about one year in advance. For example, the *Bibliography* for the 1974 exams was printed in the spring of 1973. As soon as the *Bibliography* is made available to him, the item writer at NETPDC begins writing the ST exams for the following year. During this period of time, many changes may be made to the reference publications listed in the *Bibliography*. These changes may invalidate some of the exam questions.

However, this will not affect your examination grade. On the day that you take the advancement exam, the item writer at NETPDC also takes that same test. For your benefit, he thoroughly checks every item on the examination to make sure none are outdated. Any outdated questions that he finds will not be considered when the test is graded. This has the same affect as counting all four answers correct because any answer you pick for an outdated question is correct. Thus, you do not have to worry about test items that contain superseded information.

Two important restrictions are placed upon the item writer: First, his examination must cover all of the quals, as indicated by the *Manual of Navy Enlisted Manpower and Personnel Classifications and Occupational Standards*, NAVPERS 18068 (current edition), for the particular rate. Second, his references are restricted to those listed in the *Bibliography for Advancement Study*, NAVEDTRA 10052 (current edition), or the secondary references contained in the references in the *Bibliography*. Let's say for example, that somewhere in the *STS 3 & 2 Rate Training Manual*, which is listed in the *Bibliography*, a reference is made to a publication which is not listed in the *Bibliography*; then that publication is also fair game for test question material.

Many of us are led to believe that we must at least pass each section of the test. Not so. No numerical grade is even assigned to each section. For profile sheet purposes, a letter is assigned to each section to point out weak areas. This enables you to better prepare for the next exam. Of course, if you miss most of the questions in one section of the exam, it may pull your overall grade down below the passing score; but it is your overall grade that determines whether you pass or fail, not your performance on each individual section of the test. Thus, your test grade is determined by the total number of questions that you answer correctly and your relative standing among your peers—nothing else.

HOW TO QUALIFY FOR ADVANCEMENT

What must you do to qualify for advancement? The requirements may change from time to time, but usually you must satisfy the following:

1. Have a certain amount of time in your present grade.
2. Complete the required military and rating manuals.
3. Demonstrate your ability to perform all the PRACTICAL requirements for advancement by completing the Record of Practical Factors, NAVEDTRA 1414/1.

INTRODUCTION TO SONAR

REQUIREMENTS *	E1 to E2	E2 to E3	# E3 to E4	#E4 to E5	E5 to E6	† E6 to E7	† E7 to E8	† E8 to E9
SERVICE	4 mos. service- or completion of Recruit Training.	8 mos. as E-2.	6 mos. as E-3. 2 years time in service.	12 mos. as E-4. 3 years time in service.	24 mos. as E-5. 6 years time in service.	36 mos as E-6. 9 years time in service.	36 mos. as E-7. 8 of 12 years time in service must be enlisted.	36 mos. as E-8. 10 of 15 years time in service must be enlisted.
SCHOOL	Recruit Training. (C.O. may advance up to 10% of graduating class.)		Class A for PR3, DT3, PT3, AME 3, HM 3, PN 3, FTB 3, MT 3,			Navy School for AGC, MUC, MNC.††		
PRACTICAL FACTORS	Locally prepared check-offs.	Record of Practical Factors, NavEdTra 1414/1, must be completed for E-3 and all PO advancements.						
PERFORMANCE TEST			Specified ratings must complete applicable performance tests before taking examinations.					
ENLISTED PERFORMANCE EVALUATION	As used by CO when approving advancement.		Counts toward performance factor credit in advancement multiple.					
EXAMINATIONS **	Locally prepared tests.	See below.	Navy-wide examinations required for all PO advancements.			Navy-wide selection board.		
RATE TRAINING MANUAL (INCLUDING MILITARY REQUIREMENTS)		Required for E-3 and all PO advancements unless waived because of school completion, but need not be repeated if identical course has already been completed. See NavEdTra 10052 (current edition).					Nonresident career courses and recommended reading. See NavEdTra 10052 (current edition).	
AUTHORIZATION	Commanding Officer		NAVEDTRA PRODEV CEN					

* All advancements require commanding officer's recommendation.
 † 3 years obligated service required for E-7, E-8, and E-9.
 # Military leadership exam required for E-4 and E-5.
 ** For E-2 to E-3, NAVEDTRA PRODEV CEN exams or locally prepared tests may be used.
 †† Waived for qualified EOD personnel.

Figure 1-2.—Active duty advancement requirements.

Chapter 1—THE SONAR TECHNICIAN

REQUIREMENTS *	E1 to E2	E2 to E3	E3 to E4	E4 to E5	E5 to E6	E6 to E7	E8	E9
TOTAL TIME IN GRADE	4 mos.	8 mos.	6 mos.	12 mos.	24 mos.	36 mos. with total 8 yrs service	36 mos. with total 11 yrs service	24 mos. with total 13 yrs service
TOTAL TRAINING DUTY IN GRADE †	14 days	14 days	14 days	14 days	28 days	42 days	42 days	28 days
PERFORMANCE TESTS			Specified ratings must complete applicable performance tests before taking examination.					
DRILL PARTICIPATION	Satisfactory participation as a member of a drill unit in accordance with BUPERSINST 5400.42 series.							
PRACTICAL FACTORS (INCLUDING MILITARY REQUIREMENTS)	Record of Practical Factors, NavEdTra 1414/1, must be completed for all advancements.							
RATE TRAINING MANUAL (INCLUDING MILITARY REQUIREMENTS)	Completion of applicable course or courses must be entered in service record.							
EXAMINATION	Standard Exam		Standard Exam required for all PO advancements. Also pass Military Leadership Exam for E-4 and E-5.				Standard Exam. Selection Board.	
AUTHORIZATION	Commanding Officer		NAVEDTRA PRODEV CEN					

* Recommendation by commanding officer required for all advancements.

† Active duty periods may be substituted for training duty.

Figure 1-3.—Inactive duty advancement requirements.

INTRODUCTION TO SONAR

4. Be recommended by your commanding officer after the petty officers and officers supervising your work have indicated that they consider you capable of performing the duties of the next higher rate.

5. Demonstrate your KNOWLEDGE by passing written examinations on the occupational and military qualification standards for advancement.

Some of these general requirements may be modified in certain ways. Figure 1-2 gives a more detailed view of the requirements for advancement of active duty personnel; figure 1-3 gives this information for inactive duty personnel. Remember that the qualifications for advancement can change. Check with your division officer or training officer to be sure that you know the most recent qualifications.

Advancement is not automatic. Even though you have met all the requirements, including passing the written examinations, you may not be able to "step on the crow" or "add a stripe." The number of men in each rate and rating is controlled on a Navywide basis. Therefore, the number of men who may be advanced is limited by the number of vacancies that exist. When the number of men passing the examination exceeds the number of vacancies, another system must be used to determine which men may be advanced and which may not. The system used is the "final multiple" and is a combination of three types of advancement systems.

Merit rating system
Personnel testing system
Longevity, or seniority, system

The Navy's system provides credit for performance, knowledge, and seniority; and, while it cannot guarantee that any one person will be advanced, it does guarantee that all men within a particular rating will have equal advancement opportunity.

A change in promotion policy, starting with the August 1974 examinations, changed the passed-but-not-advanced (PNA) factor to the high quality bonus point (HQP) factor. Under this policy, a man that passed the examination, but was not advanced, can gain points toward promotion in his next attempt. Up to three multiple points can be gained in a single promotion period. The points can then be accumulated over six promotion periods up to a maximum of 15. The addition of the HQP factor, with its 15-point maximum, raises the number of points possible on an examination multiple from 185 to 200. This gives the examinee added incentive to keep trying for promotion in spite of repeated failure to gain a stripe because of quota limitations.

All of the above information (except the examination score and the HQP factor) is submitted with your examination answer sheet. After grading, the examination scores for those passing and the HQP points are added to the other factors to arrive at the final multiple. A precedence list which is based on final multiples, is then prepared for each pay grade within each rating. Advancement authorizations are then issued, beginning at the top of the list, for the number of men needed to fill the existing vacancies.

METRIC SYSTEM

The Metric System Single-Subject Training Manual and its associated OCC-ECC form a self-study package (NAVEDTRA 475-01-00-75) to train Navy personnel in conversion from the U. S. Customary System to the International System. Order the SSTM by stock number 0507-LP-475-0000 from NPFC, Philadelphia, and the OCC-ECC by NAVEDTRA 475-01-00-75 from the NAVEDTRAPRODEVEN, Ellyson, Pensacola, Florida.

CHAPTER 2

HISTORY AND DEVELOPMENT OF ASW

During World War II, submarines sent millions of tons of shipping to the bottom. Early in the war, England's lifelines were nearly strangled by German submarines. American submarines played a large role in the defeat of Japan by sinking nearly all her merchant marine. Obviously, the submarine is a potent weapon, requiring equally effective countermeasures. The United States and Great Britain were successful in developing equipment, weapons, and tactics that enabled the destruction of the German submarine force. Japan, however, never was able to develop an effective defense against our submarines.

Since World War II the submerged endurance of the submarine has become sufficient to cause difficulty in locating it. The problem increases as the submarine goes constantly faster, deeper, and stays down longer. To cope with the modern submarine, we now have better detection devices, more modern weapons, and newer ships; but the battle for supremacy is a never-ending one.

THE SUBMARINE

All Sonar Technicians are concerned with the hunt for and destruction of enemy submarines. It is especially important, therefore, that you know the capabilities of enemy submarines, and know them well. Innumerable questions will come to you over a period of time or after a course of events in antisubmarine warfare (ASW) operations: How fast can a submarine dive or turn? How does the submarine use depth? What is the submarine's top speed when submerged? Because this text is unclassified, many of the answers are of a

general nature. In your studies, though, you will learn many details about submarine characteristics and tactics. Such knowledge makes it easier for you to detect submarines and hold contact after detection. Most of this text concerns our own submarines, but foreign navies usually have submarines of comparable ability.

HISTORY AND DEVELOPMENT

The first successful submarine was built in 1620 by Cornelius Van Drebel, a Dutch physician. During repeated trials in the Thames River, he maneuvered his craft successfully at depths of 12 to 15 feet beneath the surface.

Various other European designers of that time constructed submersible craft also, but they failed to arouse the interest of any navy in an age when the potentialities of submarine warfare were inconceivable.

Most of the early craft were wooden frames, covered with greased leather or similar material, and propelled by oars. Different methods of submerging were thought of and some were even tried. One inventor's design consisted of a number of goatskin bags built into the hull, each connected to an aperture in the bottom. He planned to submerge the craft by filling the skins with water and to surface it by forcing the water out of the skins with a "twisting rod." Although his vessel was never built, it seems that this design was the first approach to the modern ballast tank. Another inventor actually submerged his craft by reducing its volume as a result of contracting the sides through the use of hand vises.

Ideas were plentiful. Some of them were fanciful and grotesque, but some contained elements capable of practical application. Lack

INTRODUCTION TO SONAR

of full understanding of the physical and mechanical principles involved, coupled with the almost universal conviction that underwater navigation was impossible and of no practical value, kept postponing the attempt to utilize a submarine in naval warfare during the early period.

A submarine was first used as an offensive weapon during the American Revolutionary War. The *TURTLE*, a one-man submersible designed by an American inventor named David Bushnell and hand operated by a screw propeller, attempted to sink a British man-o-war in New York Harbor. The plan was to attach a charge of gunpowder to the ship's bottom with screws and to explode it with a time fuze. After repeated failures to force the screws through the copper sheathing of the hull of *HMS EAGLE*, the submarine gave up and withdrew, exploding its powder a short distance from the *EAGLE*. Although the attack was unsuccessful, it caused the British to move their blockading ships from the harbor to the outer bay.

On 17 February 1864, a Confederate craft, a hand-propelled submersible, carrying a crew of eight men, sank a Federal corvette that was

blockading Charleston Harbor. The hit was accomplished by a torpedo suspended ahead of the Confederate *HUNLEY* as she rammed the Union frigate *HOUSATONIC*, and is the first recorded instance of a submarine sinking a warship.

The submarine first became a major component in naval warfare during World War I, when Germany demonstrated its full potentialities. Wholesale sinking of Allied shipping by the German U-boats almost swung the war in favor of the Central Powers. Then, as now, the submarine's greatest advantage was that it could operate beneath the ocean surface where detection was difficult. Sinking a submarine was comparatively easy, once it was found; but finding it before it could attack was another matter.

During the closing months of World War I, the Allied Submarine Devices Investigation Committee was formed to obtain from science and technology more effective underwater detection equipment. The committee developed a reasonably accurate device for locating a submerged submarine. This device was a trainable hydrophone, which was attached to

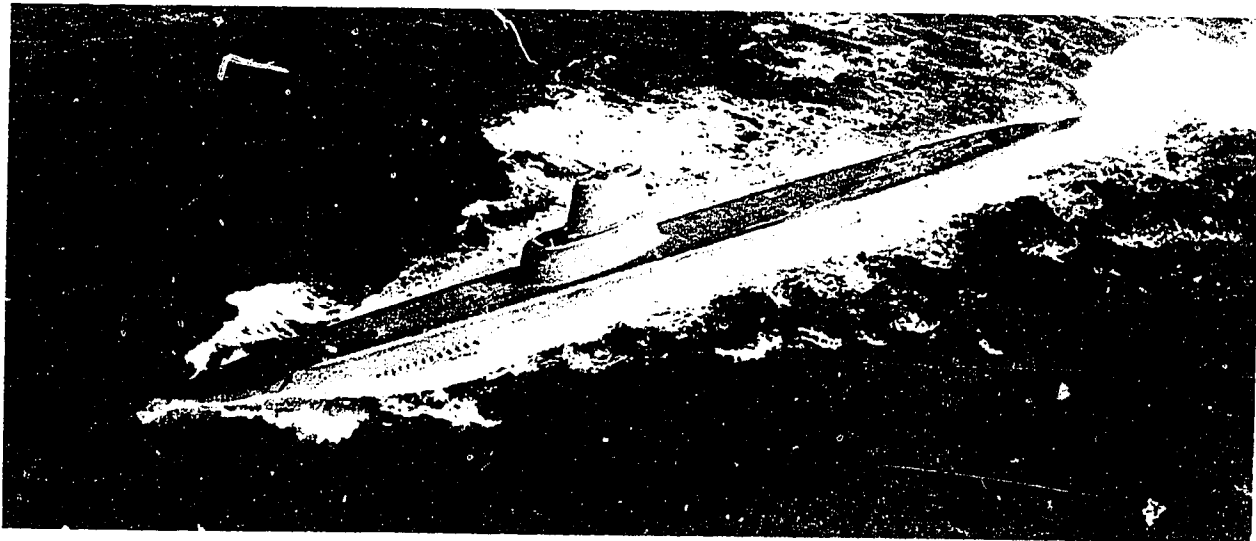

21

Figure 2-1.—Guppy submarine.

71.1-346

the bottom of the ASW ship and used to detect screw noises and other sounds that came from a submarine. Although the committee disbanded after World War I, the British made improvements on the locating device, during the interval between then and World War II, and named it ASDIC after the committee.

American scientists further improved on the device, calling it sonar, a name derived from the underlined initials of the words sound navigation and ranging.

At the end of World War II, the United States improved the snorkel (a device for bringing air to the crew and engines when operating submerged on diesels) and developed the Guppy (short for greater underwater propulsion power), a conversion of the fleet-type submarine of World War II fame. A Guppy submarine is shown in figure 2-1. The superstructure was changed by reducing the surface area, streamlining every protruding object, and enclosing the periscope shears in a streamlined metal fairing. Performance increased greatly with improved electronic equipment, additional battery capacity, and the addition of the snorkel.

The world's pioneer nuclear-powered submarine is the *USS NAUTILUS* (SSN 571). (See fig. 2-2.) The *NAUTILUS*, commissioned in September 1954, is 320 feet in length, with a standard surface displacement (SSD) of 3180 tons, and is designed for traveling faster under the water than on the surface.

One of our fastest submarines is the *USS SKIPJACK* (SSN 585), figure 2-3, whose hull is a radical departure from the conventional idea of submarine hulls. Her diving planes are on the sail, resulting in increased maneuverability.

An intensive building program for nuclear submarines has been in effect for several years, and many new ships have joined the fleet. The *USS GEORGE WASHINGTON* (SSBN 598) was the first submarine designed to launch, while submerged, the POLARIS missile.

GENERAL DESCRIPTION

A submarine ranges in length from about 50 feet to more than 400 feet. Diving is accomplished by controlled flooding of ballast

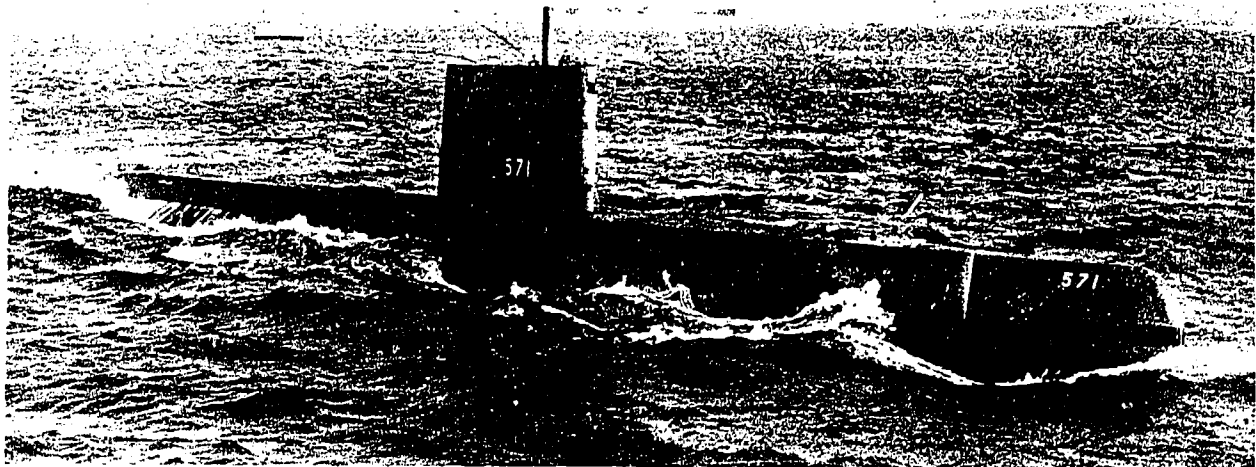

22

Figure 2-2.—USS NAUTILUS (SSN 571).

71.1-571

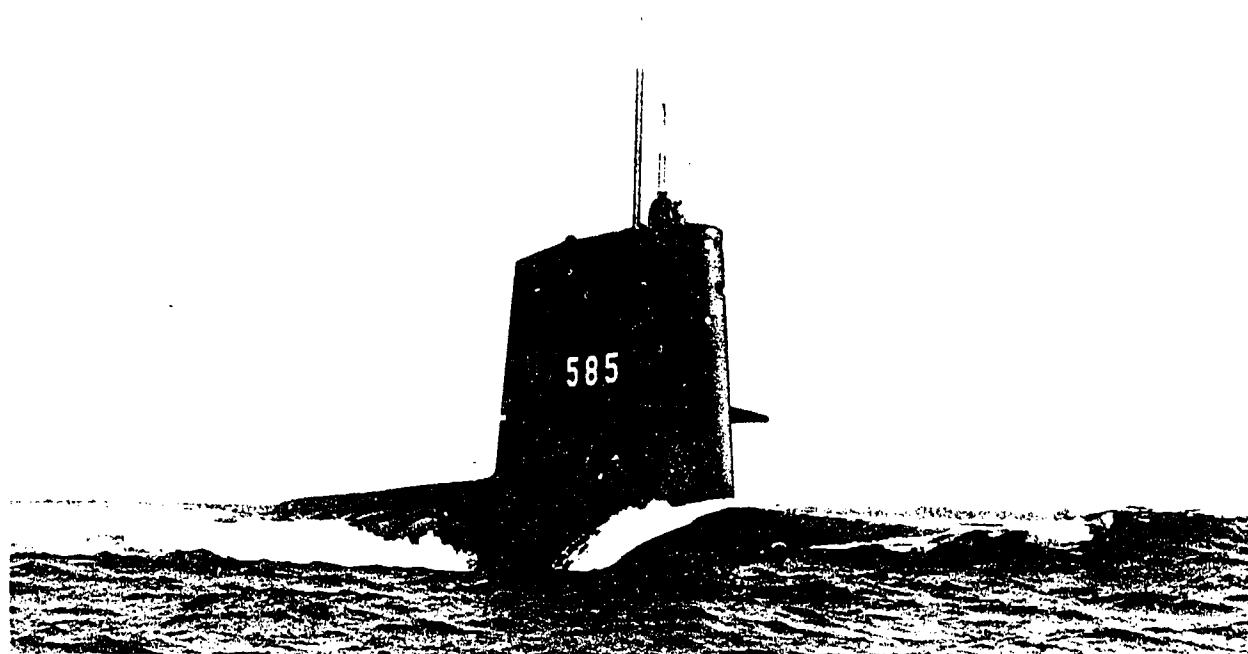

Figure 2-3.—USS SKIPJACK (SSN 585).

71.1-585

tanks. To surface the submarine, compressed air expels the water from the tanks.

Probably the smallest submarines in the world belong to the ex-German SEAHOUND class (now in Russian possession). They are 49 feet long and displace only 15 tons. Somewhat heavier, but still in the midget submarine class, are the U.S. Navy's X-1 and the British SHRIMP class. The X-1 is less than 50 feet long and displaces 25 tons. Boats of the SHRIMP class are slightly longer and displace 30 to 35 tons.

At the other extreme are the bulk of the U.S. Navy's submarines, including the latest nuclear-powered submarines. Some of these ships are over 400 feet long and displace more than 7000 tons (SSD). Others, designed for speed and maneuverability, are not quite as long and displace less tonnage.

Some submarines can cruise in excess of 20 knots submerged. A type of diesel submarine used by the Germans in World War II, which is a part of the Russian fleet, can dive at a rate of

1-1/2 feet per second and can turn 90° in a little over 1 minute, using full rudder and 5 knots of speed.

Propulsion

Diesel electric submarines use diesel engines for propulsion, when surfaced, and batteries when submerged. Nuclear-powered submarines get their propulsion from atomic reactors.

NUCLEAR SUBMARINES.—Atomic power has brought close to reality the dream of having a true submarine; that is, one of unlimited submerged endurance and range. The *NAUTILUS* refueled for the first time over 1 year after she commenced operating. The *TRITON* circumnavigated the world completely submerged. The *NAUTILUS* and *SKATE* pioneered exploration of the north polar seas beneath the icecap, all made possible only by nuclear energy. The human factor and the quantity of supplies that can be carried are the

main limitations to the endurance of modern submarines.

FLEET BALLISTIC MISSILE SUBMARINES (SSBN)

The basic purpose for the creation of a weapons system such as the FBM (fig. 2-4) is to act as a nuclear deterrent to a general war. The FBM is perhaps the most sophisticated and costly weapons system in existence and is capable of wreaking havoc on a potential enemy.

These ships are capable of high speeds, great depths, and prolonged submergence. As formidable as these ships appear to be, effective countermeasures have been developed which make the FBM vulnerable to detection and destruction. For an FBM to remain a deterrent, it must cloak itself in nearly absolute silence. It must patrol a given area without being detected and must maintain the capability of detecting enemy ships over great distances.

ATTACK SUBMARINES (SSN)

The FBM is primarily designed as a threat to a nation's land areas. On the other hand, consider the dangers which the modern attack submarines (SSN), figure 2-5, pose on a nation's surface fleet. History has amply demonstrated the strategic importance of the attack submarine. The combination of new hull design and nuclear power have made the SSN greatly superior to its predecessor. This superiority is so great that most nations have been forced to develop newer and more effective ASW programs to maintain the balance of power. Moreover, the primary mission of the attack submarine is ASW.

SUBMARINE ARMAMENT

Armament of a submarine depends on its design and mission. USN attack submarines

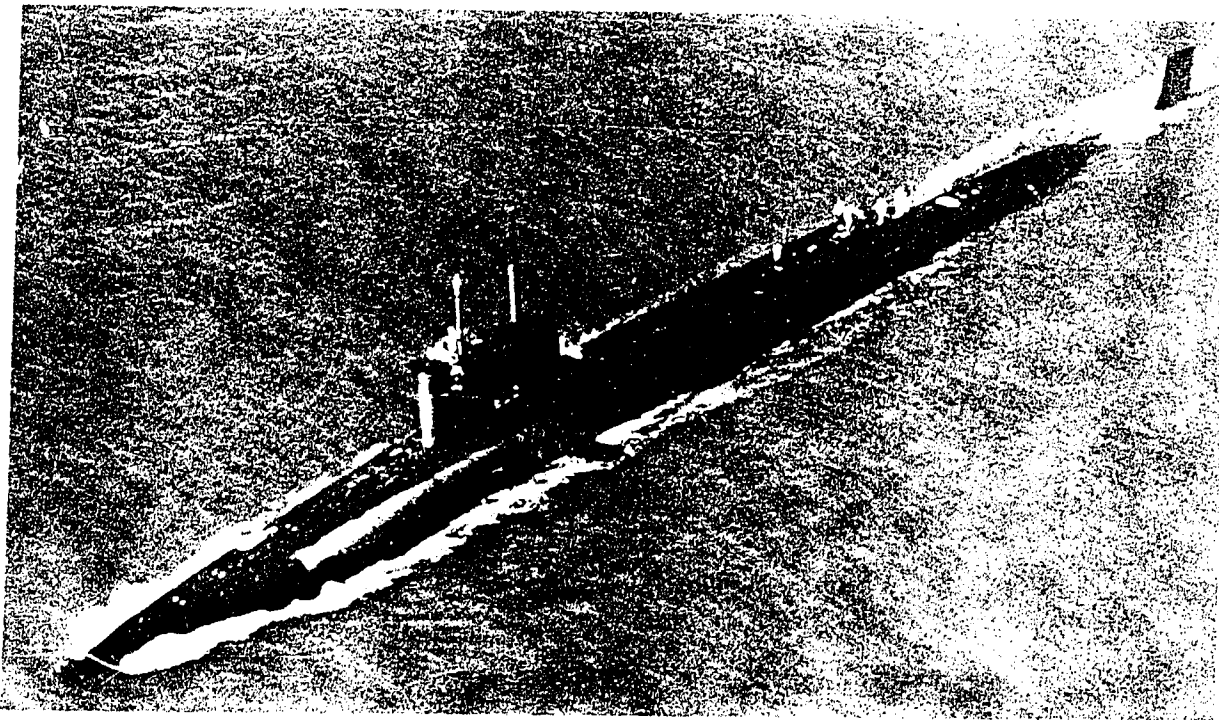

Figure 2-4.—Ballistic missile submarine (SSBN).

71.1-629

INTRODUCTION TO SONAR

normally carry only torpedoes and SUBROC, but they may be employed as minelayers. Fleet ballistic missile submarines, depending on type, carry 16 POLARIS or 16 POSEIDON missiles, in addition to torpedoes. In the case of the new and larger TRIDENT submarines, the missile complement is 24 TRIDENT missiles. FBMs are also equipped with torpedo tubes for self-defense.

TORPEDOES

The torpedo is a self-propelled underwater weapon having either a high-explosive or a nuclear warhead. Conventional warheads are

loaded with up to 1000 pounds of HBX explosive.

Underwater explosion of the torpedo warhead increases its destructive effect. When a projectile explodes, a part of its force is absorbed by the surrounding air. Upon explosion of the torpedo warhead, the water transfers almost the full force of the explosion to the hull of the target ship.

Guppy submarines (now in possession of foreign allies) are fitted with 10 tubes, 6 in the bow and 4 in the stern. Spare torpedoes are carried in ready racks near the tubes. On war patrol, a submarine of this type usually puts to sea with a load of 28 torpedoes aboard.

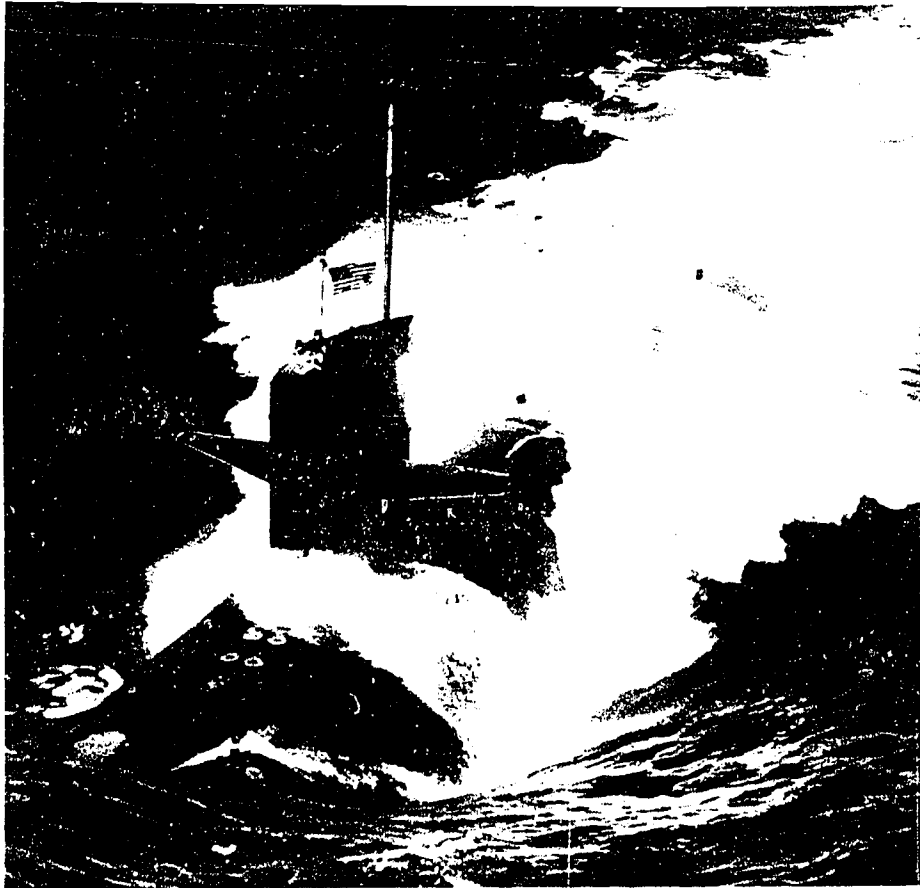

Figure 2-5.—Attack submarine (SSN).

71.128

Torpedoes are propelled by gas turbines or electric motors. Turbine types have maximum speeds of 30 to 45 knots, with an effective range of as much as 7-1/2 miles. Electric torpedoes usually have less speed and range than turbine types; but, from the submariner's point of view, they have the advantage of leaving no visible wake.

Torpedoes are of the straight-running, acoustic-homing, or wire-guided types. The straight-running torpedo has automatic control devices that hold it on a preset course at a preset depth, whereas the acoustic-homing type can steer itself toward its target. It may be either active or passive. The active acoustic torpedo sends out pulses of sound and homes on the echoes that return from the target. Passive types home on the noises emanated by the target. The wire-guided type of torpedo is directed to the target by signals sent through the wire from the launching submarine.

Mk 37 Torpedo

The Mk 37 torpedo is an electrically controlled and propelled two-speed torpedo with an active-passive acoustic homing system. This torpedo, launched from submarines is effective against either surface or submarine targets. Some mods are wire-guided, making them invulnerable to several enemy countermeasures.

Mk 48 Torpedo

The Mk 48 torpedo is a high-speed, deep-running, long-range, submarine-launched weapon used against submarines and surface ships. Both acoustic and nonacoustic operating modes are available. Acoustic modes are active, passive, or combination. The torpedo may be operated in the acoustic mode when used against surface or submerged targets. Nonacoustic operation may be used against surface targets only.

Command guidance (wire link) may be used for both acoustic and nonacoustic shots. This allows the launch vessel's on-board computer to update torpedo guidance and control logic with

the latest tactical information, thereby providing the weapon with maximum adaptability. The torpedo guidance and control circuitry receive initial run plan instructions (preset) from the fire control system. And, after each launch, fire control may update initial instructions by command guidance.

MINES

Navy mines are thin-cased underwater weapons with a heavy load of high explosives. They may be laid by both aircraft and surface craft, but submarines are employed for minelaying when secrecy is required or when the area to be mined is beyond the range of aircraft. Mines may be of the bottom or moored type. Bottom mines rest on the ocean floor and are highly effective in shallow water. Moored mines are positively buoyant. A cable, attached to an anchor on the sea bottom, holds the mine at a predetermined depth beneath the surface. Mines may be actuated by contact with a vessel, by a vessel's magnetic field, by noise, or by pressure differences created when a vessel passes over the mine. Acoustic-, pressure-, and magnetic-influenced mines may be set to permit the passage of several ships, then explode under the next one to pass over.

FLEET BALLISTIC MISSILE SYSTEM

The fleet ballistic missile is a two-stage underwater-to-surface inertially-guided ballistic missile. It has undergone several evolutionary stages since 1960. The first unit, the POLARIS A-1, has a range of 1200 nautical miles. The A-2 model, first test-fired in 1961, reached a target at 1500 NM. Next came the A-3 (2500 NM), first successfully fired by the *USS ANDREW JACKSON* (SSBN 619) in 1963. Currently the POSEIDON (C-3) is being used in the FBM fleet in addition to the POLARIS A-3. The next generation is the TRIDENT missile of which 24 are carried on board the new TRIDENT class submarine.

The first version is planned to have a range of 4000 NM. With such a range, the launching submarine could hide in any ocean and send a missile to any major city in the world.

INTRODUCTION TO SONAR

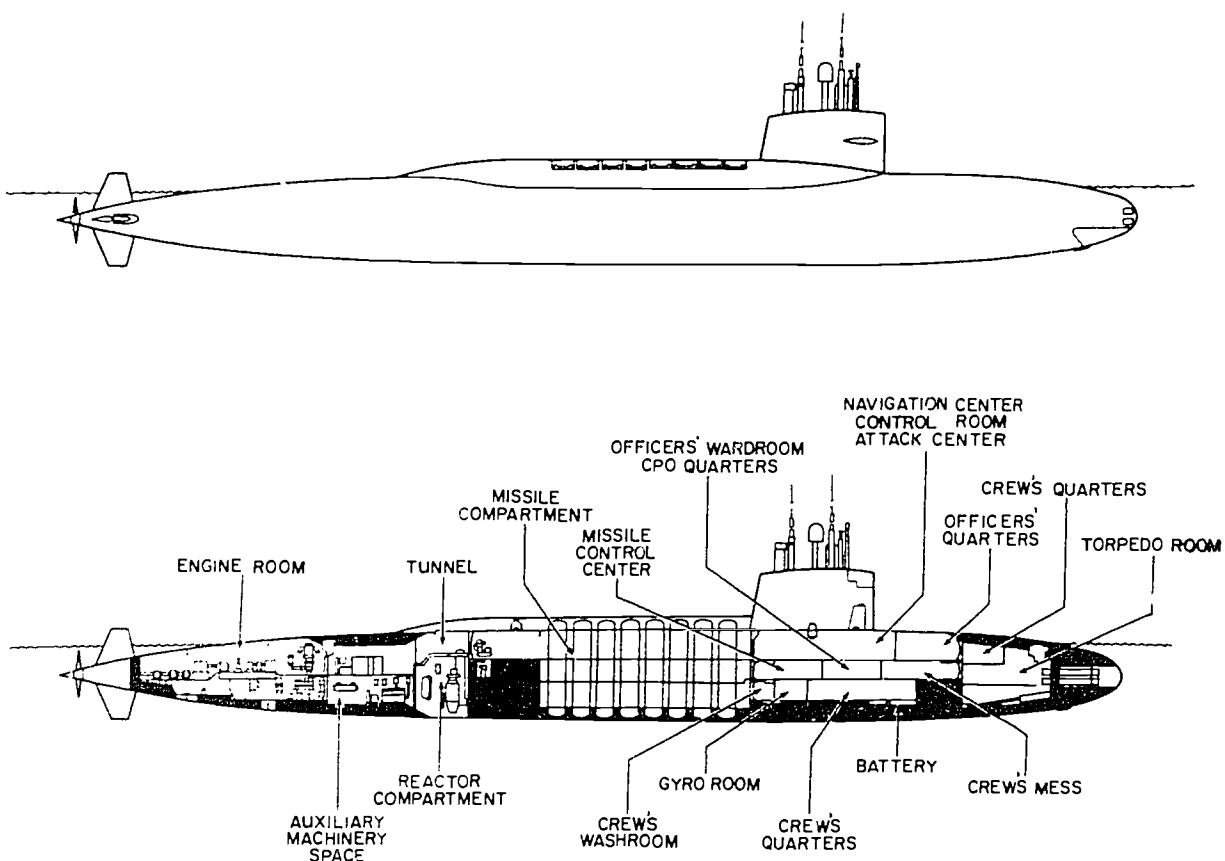

71.1

Figure 2-6.—SSBN class submarine; interior arrangement.

The FBM (fig. 2-6) is designed to be launched from a submarine cruising (or stationary) below the ocean's surface. The two powerful solid-propellant rocket motors are capable of lifting the warhead high above the range of any known antimissile missile, at a speed exceeding ten times that of sound, and of placing it into a free fall trajectory which will carry it to its target with deadly accuracy. Each warhead of the POLARIS or POSEIDON is a compact and powerful nuclear device. The explosive power in one shipload of sixteen missiles exceeds the total amount of explosive power expended by all of the participating countries in World War II, INCLUDING the two atomic bombs dropped on Japan.

After launch, ignition of the first stage rocket takes place shortly after the missile breaks the surface of the sea (fig. 2-7). This is the beginning of powered flight and the inertial guidance portion of the trajectory. The first stage propels the missile far into the atmosphere. The first stage then separates and the second stage rocket motor continues to propel the missile to a point above the earth's atmosphere. When the missile has reached the proper velocity and point on the trajectory, the reentry body separates and the warhead follows a ballistic trajectory to the target. MIRV warheads can be separately targeted. The time of reentry body separation determines the range which the missile warhead will span. The range can be

varied in this way from about 575 to about 2500 nautical miles.

Since there are no external control surfaces on POLARIS or POSEIDON, changes in the trajectory are accomplished by deflecting the jet stream from its motors. A pre-computed ideal trajectory is preset into the missile. The preset information takes into account the movements of the target, of the launching point, and of the missile with respect to inertial space during the time of flight. The warhead release velocity which the missile must attain along its trajectory on the basis of a fixed time-of-flight is also preset. The launching submarine accurately determines its launching position by use of an inertial navigation system, and the position of the target on the earth surface is a known factor. While in the power stage of flight, the missile continuously measures its linear accelerations on the basis of its inertial system and alters its trajectory to offset the outside forces causing unwanted accelerations. When the missile is on a proper trajectory and a correct velocity has been attained, the warheads are released and proceed toward the target with no further correction possible.

Each warhead dives on its target at a steep angle and at several times the speed of sound. The materials for the outer surface of the warhead have been specially developed to resist the high temperatures generated by friction with the atmosphere at reentry speeds, and suitable insulation is provided between the outer skin and the internal components to prevent damage to the warhead.

The SSBN provides a mobile launching platform which is extremely difficult to detect. It can remain submerged for very long periods of time and cruise to almost any position within the oceans of the world. By use of its inertial navigation system, it can provide the precise fire control data required to place each warhead on target.

SUBROC MISSILE SYSTEM

SUBROC is an underwater-to-air-to-underwater missile designed to destroy enemy submarines at long range. The missile consists essentially of a nuclear depth bomb and a rocket motor joined together. The launching submarine carries the equipment for detecting and tracking the enemy submarine, the fire control

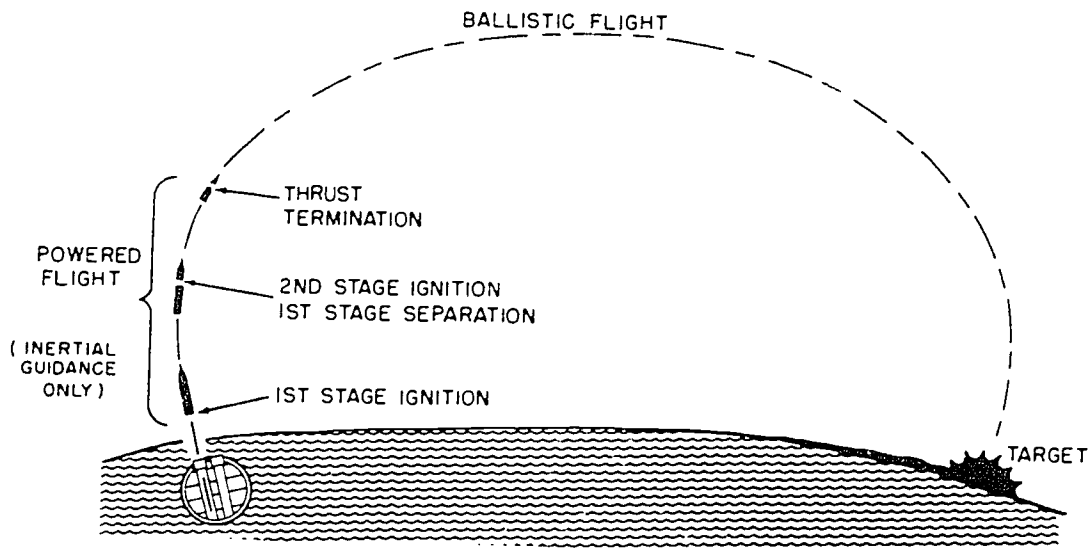

Figure 2-7.--POLARIS trajectory (not to scale).

33.269

INTRODUCTION TO SONAR

equipment for computing the target information and providing the necessary pre-launch missile information, and the equipment for launching the missile. The missile is designed to be launched (fig. 2-8) from a standard submarine torpedo tube, using conventional ejection methods. Upon being launched, the rocket motor is ignited at a safe distance from the firing ship. The missile's flight through the air is controlled by an inertial guidance system which functions in accordance with the fire control information set-in prior to launch. In addition to providing the propulsive force for the missile, the rocket motor furnishes power for controlling the thrust vectoring mechanism, during the boost phase, and the thrust reversal necessary to accomplish rocket motor separation. At the proper point in its trajectory, the rocket motor separates and the missile continues in a free-fall flight. At the time of separation, the control of

the missile is switched from the thrust vectoring mechanism to aerofins. During the ballistic portion of the flight, the aerofins control the missile in roll and azimuth. Pitch guidance is initiated at or near the zenith of the trajectory to direct the missile to the desired point of impact on the water surface. Guidance is terminated at a predetermined height above the water, and the last portion of its above-water trajectory is free fall. At water impact, a timer mechanism starts and causes the warhead to detonate at the proper time.

More detailed information on SUBROC, POSEIDON, and POLARIS can be found in the appropriate classified publications.

ANTISUBMARINE UNITS

The appearance of new equipment and weapons and the modification of their older

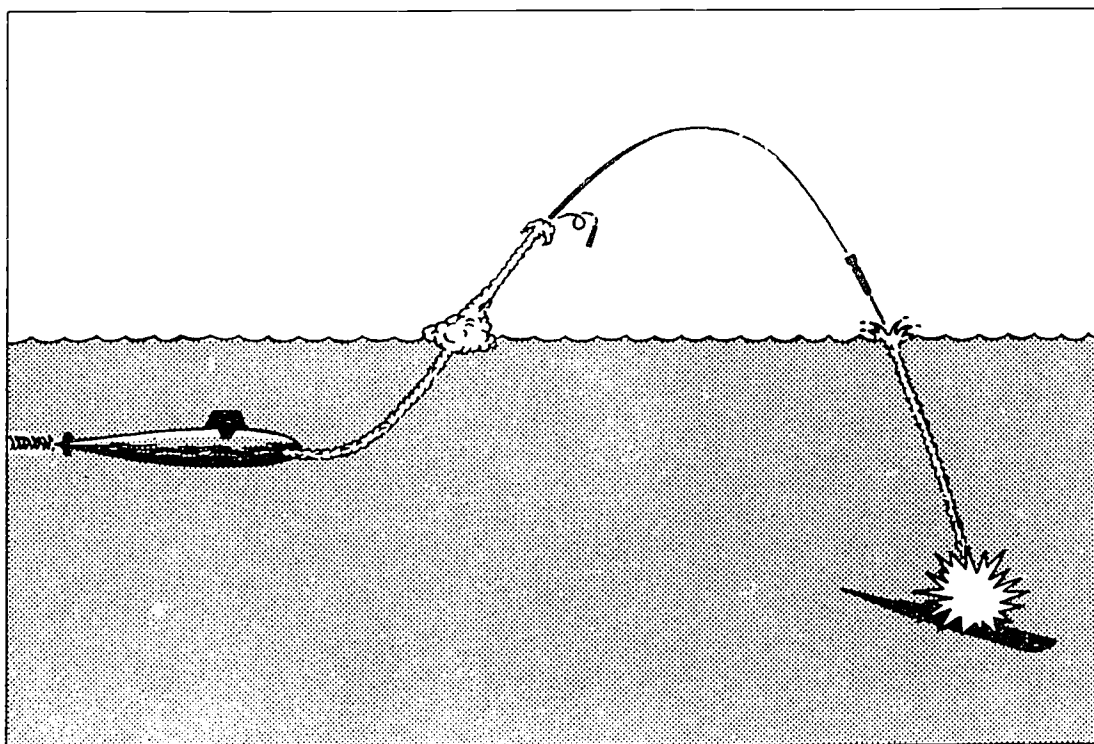

29

Figure 2-8.—Artist's view of the trajectory of SUBROC.

42.227

counterparts have resulted in the demand for more modern versions of ASW units. These may be brand new units or highly modified ships or submarines of our ASW forces. Some examples of ASW units follow.

AIRCRAFT CARRIER (CV)

One of the missions of the (CV) is to support and operate aircraft for antisubmarine warfare operations in addition to its normal mission as an actual carrier.

DESTROYER (DD)

All destroyer-type ships are named for deceased members of the Navy, Marine Corps, and Coast Guard, and Secretaries of the Navy. Destroyers (fig. 2-9) are multipurpose ships useful in almost any kind of naval operation. They are fast ships with a variety of armament but little or no armor. For protection, they depend on their speed and mobility.

The principal function of destroyers is to operate offensively and defensively against submarines and surface ships, and to defend against air attack. They also provide gunfire support for amphibious assaults and perform patrol, search, and rescue missions.

Armament consists of 5-inch and 3-inch guns, and a variety of antisubmarine weapons, such as torpedoes and ASROC (antisubmarine rocket).

Displacement varies from about 3000 tons to over 7000 tons. The newest type of destroyer in the fleet (fig. 2-10), the DD 963 (Spruance) class, has a displacement of approximately 7800 tons, a length of 560 feet, and a beam of over 50 feet. Armament consists of two 5-inch/54-caliber guns, ASROC, torpedoes, surface-to-surface missiles, and two ASW helicopters. This destroyer is driven by an all-gas turbine propulsion system and two controllable pitch propellers.

GUIDED-MISSILE DESTROYER (DDG)

The DDGs of the Charles F. Adams class have a displacement of about 4500 tons. Their armament consists of two 5-inch/54-caliber single-gun mounts (one fore and one aft) and a twin TARTAR missile launcher aft (some have a single launcher aft). All have an ASROC launcher amidships (fig. 2-11). Several of the postwar FORREST SHERMAN class (fig. 2-12) have been converted to DDGs by replacing the number 2 gun mount with a TARTAR missile launcher.

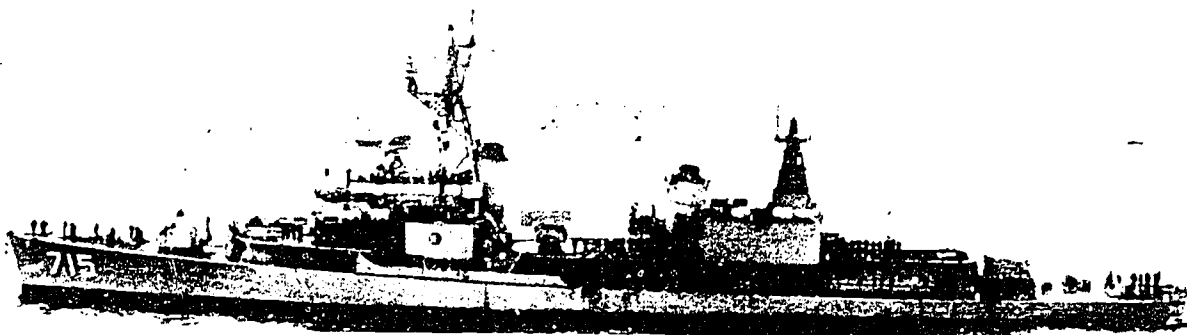
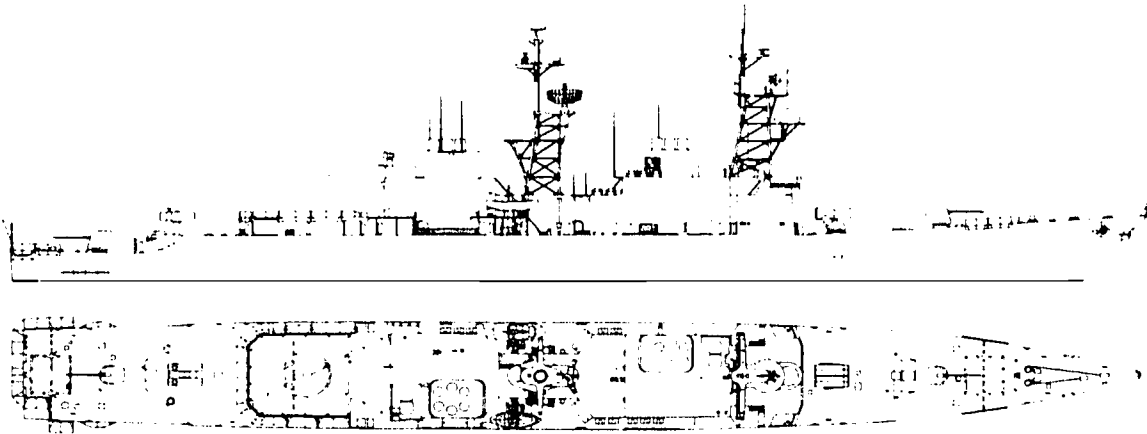

Figure 2-9.—USS WILLIAM M. WOOD (DD 715).



71.130

Figure 2-10.—DD 963 (SPRUANCE) class.

FRIGATE (FF)

Frigates (fig. 2-13) resemble destroyers in appearance; but they are slower, having only a single propeller, and carry less armament. The mission of FFs is to screen support forces and convoys and to operate offensively against submarines. They also may be used for shore bombardment. Frigates, formerly destroyer escorts, have grown in size from about 1500

tons in World War II to over 4000 tons in the KNOX (FF 1052) class. Their armament varies from class to class; that of the KNOX consists of a single 5-inch/54-caliber gun, ASROC, LAMPS, and antisubmarine torpedoes.

GUIDED-MISSILE FRIGATE (FFG)

Guided-missile frigates are basically the same as frigates with the addition of single TARTAR missile launcher. (See fig. 2-14.)

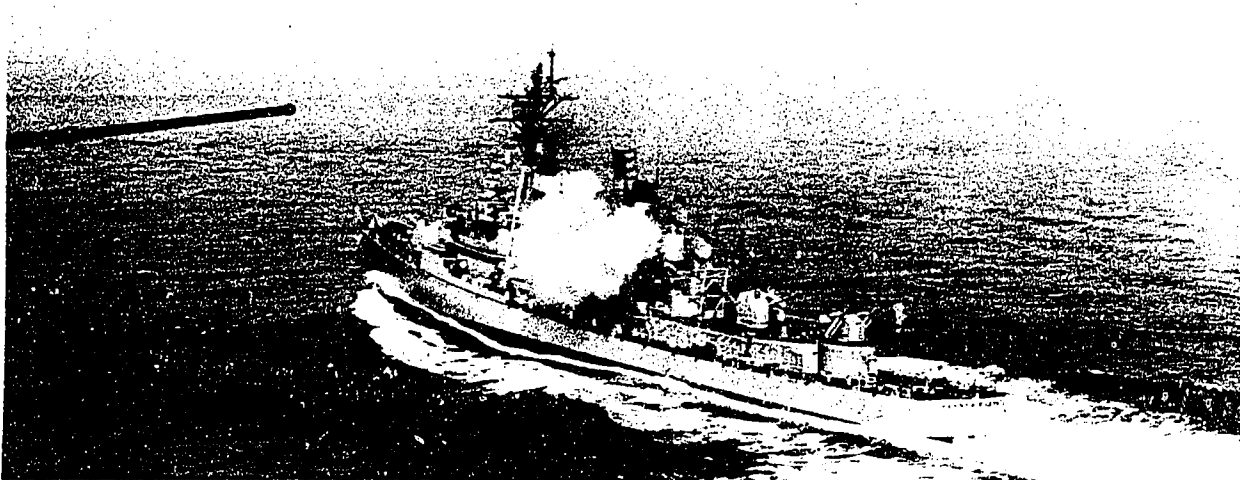

33.272

Figure 2-11.—ASROC launch from USS HENRY B. WILSON (DDG 7).

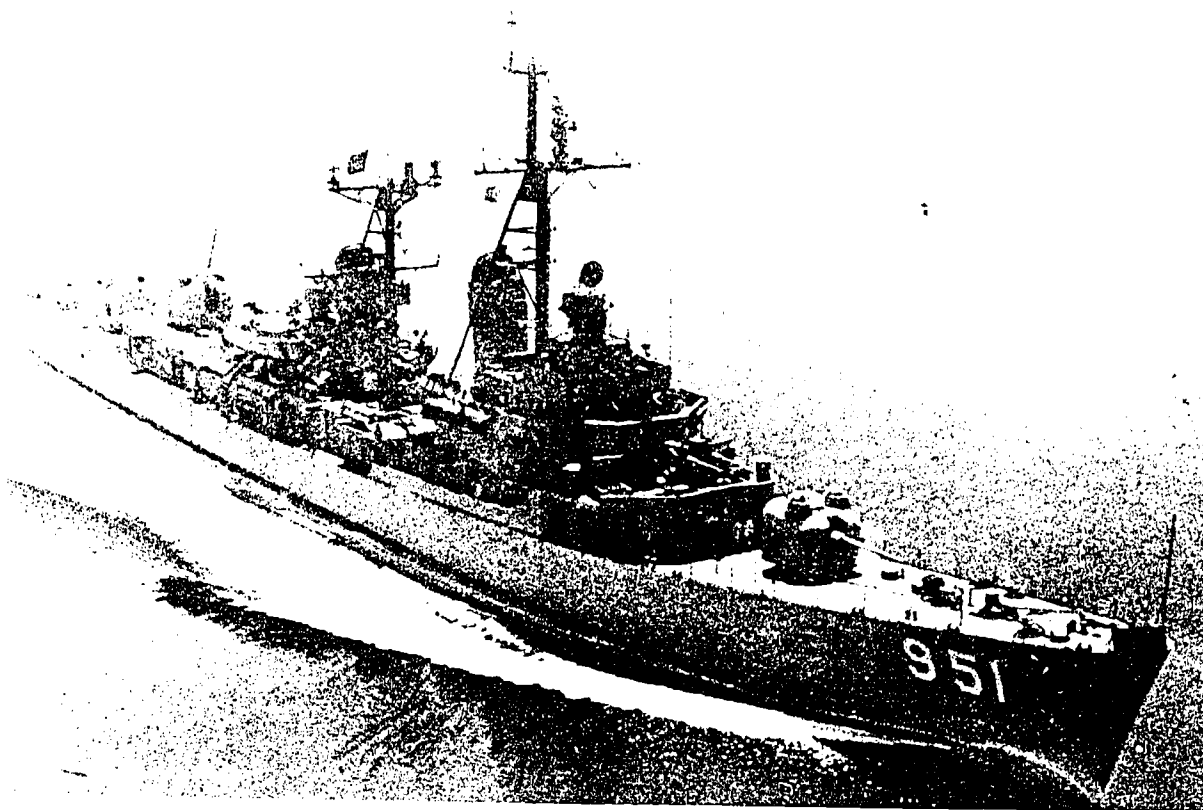

Figure 2-12.—FORREST SHERMAN class destroyer (DD).

3.76

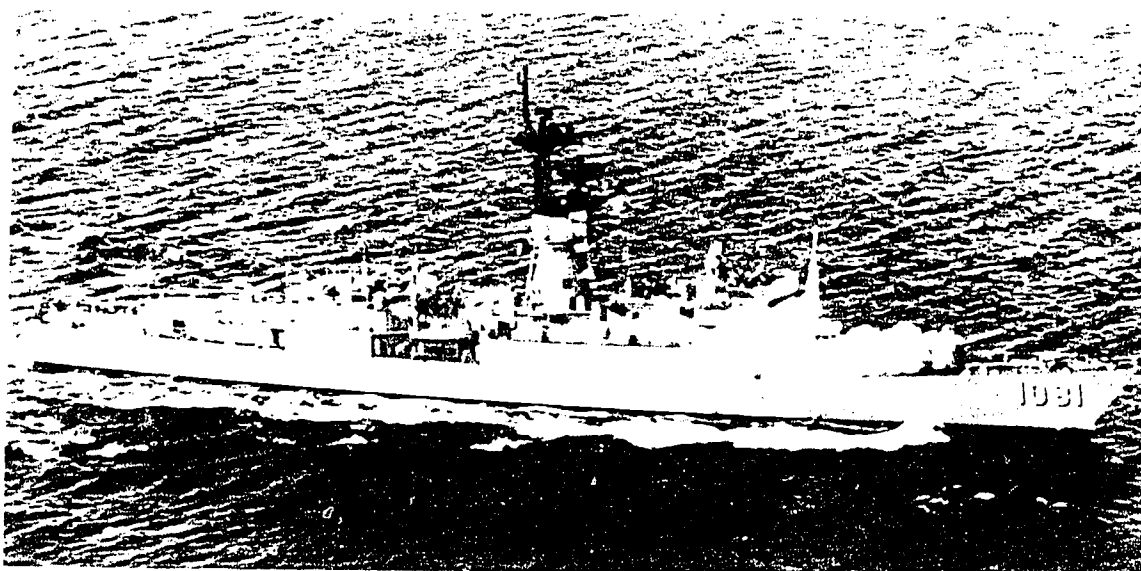

Figure 2-13.—USS ALYWIN (FF 1081) firing ASROC.

134.87-1081

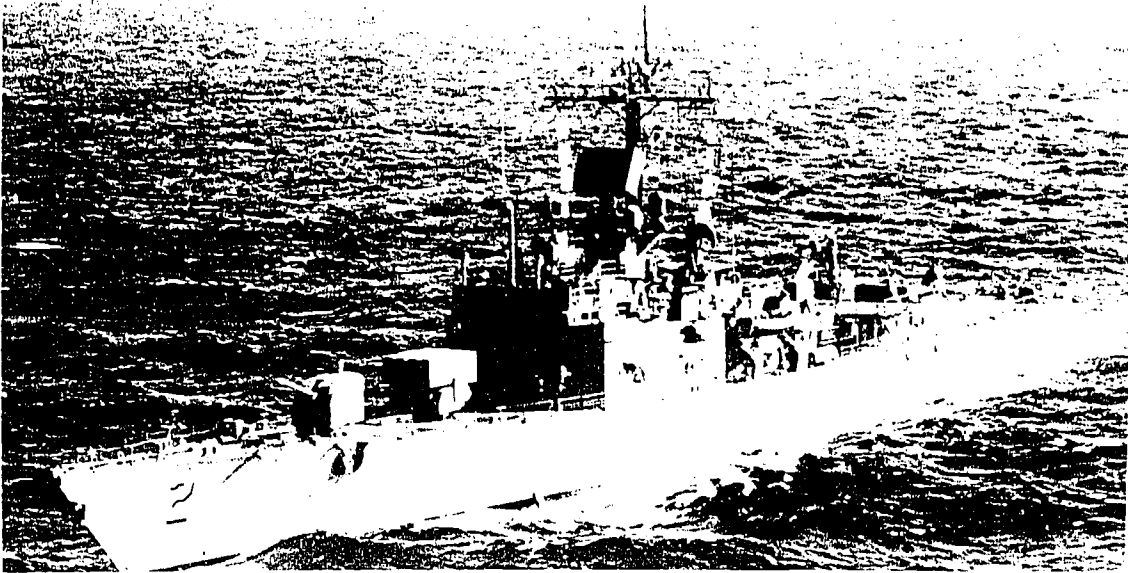

Figure 2-14.—USS RAMSEY FFG-2 (BROOKE class).

71.131

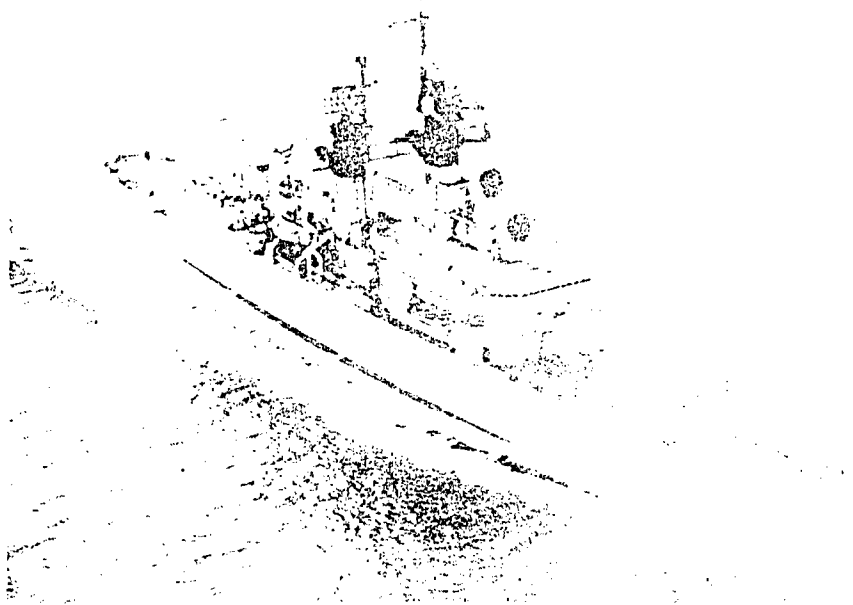

Figure 2-15A.—USS GRIDLEY (CG 21).

134.84

**GUIDED-MISSILE
CRUISER (CG) (CGN)**

Guided-missile cruisers are of several classes, differing from each other mainly in type and placement of their armament, although some are smaller than others. The *USS BELKNAP* (CG 26), for instance, displaces 6700 tons. She has a twin launcher forward that can fire both TERRIER missiles and ASROC, a single 5-inch/54-caliber gun aft, and two 3-inch guns amidships. The *USS LEAHY* (CG 16) displaces 5600 tons, has a twin TERRIER launcher fore and aft, four 3-inch guns, and an ASROC launcher amidships. The nuclear-powered *USS BAINBRIDGE* (CGN 25) is about 1000 tons heavier than the *BELKNAP*, with essentially the same armament. A guided-missile cruiser is shown in figure 2-15A. Figure 2-15B shows the

newer nuclear-powered guided-missile cruiser, *USS SOUTH CAROLINA* (CGN 37). She has an overall length of 596 feet, a beam of 61 feet, and a speed in excess of 30 knots. She is equipped with the most advanced sonar and antisubmarine weapons.

ANTISUBMARINE ARMAMENT

One factor is responsible for effective countermeasures against submarines: that is, the sound the submarine itself generates. As ASW programs have been developed, a vast array of acoustic weapons have been produced. These weapons operate by using sound detecting methods and feature active sonar, passive sonar and a combination of both. Such countermeasures, of course, become less

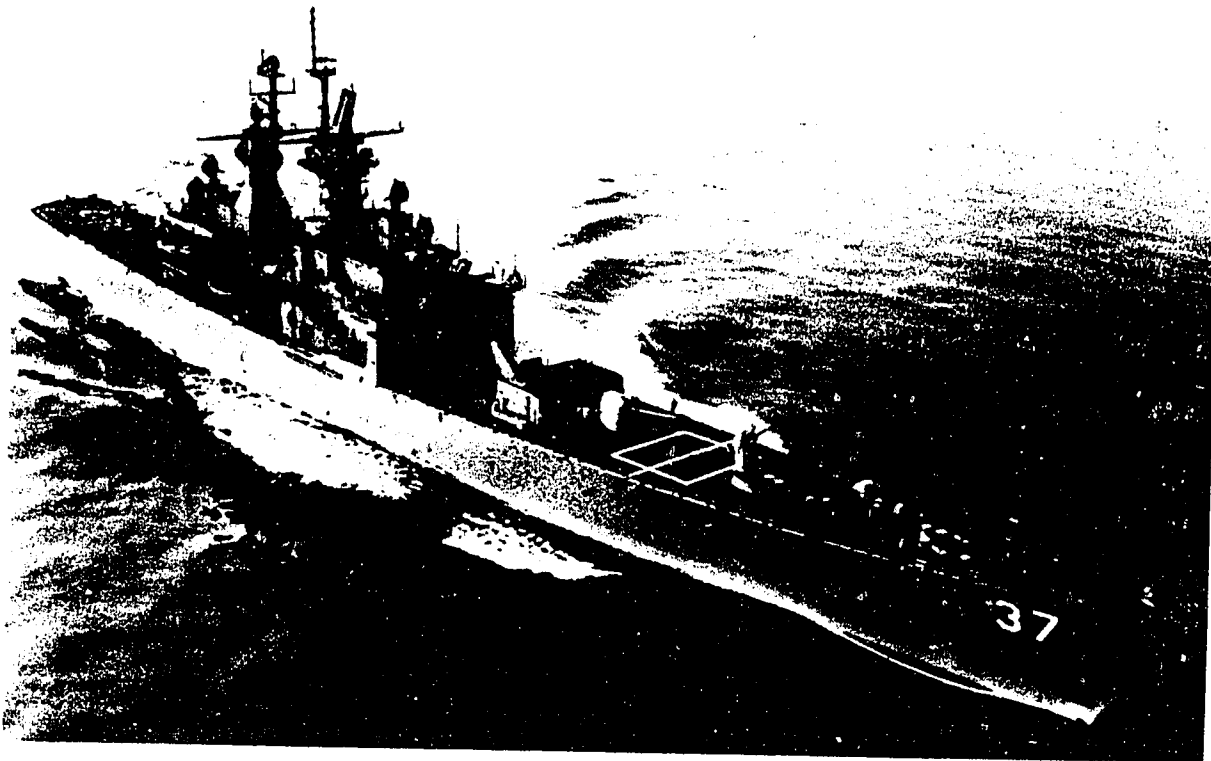

Figure 2-15B.—Underway view of *USS SOUTH CAROLINA* (GN 37).

71.132

INTRODUCTION TO SONAR

effective as submarines are designed to generate less noise.

ASROC

The ASROC, whose launcher is shown in figure 2-16, is a subsonic, shipboard-launched, solid-fuel, rocket-propelled antisubmarine

ballistic projectile. The missile has two configurations—one with a depth charge and one with a torpedo.

The goal achieved by ASROC is the destruction of submarines at long ranges. This objective is achieved by delivery of a torpedo or nuclear depth charge through the air to a point in the water from which it can either attack under the most favorable circumstances or have the submarine within its lethal radius (fig. 2-17). The payload is a part of an unguided missile which is propelled by a rocket motor and stabilized by an airframe throughout its powered flight. Separation timers jettison the airframe and motor after a preset time. From separation to water entry, different methods of stabilization are employed, depending on the payload. The depth charge descent is stabilized by a fin network during the entire drop. The torpedo also has such a network; but it employs, in addition, parachute stabilization. Besides stabilizing the torpedo descent, the parachute also decelerates it to a safe water entry velocity to avoid damaging the highly sensitive electronic components.

Before the missile is launched, the submarine is located by sonar; and the range, bearing, and other pertinent data are transmitted to the fire control system. The fire control system automatically computes the anticipated target position, sets the rocket motor thrust cutoff velocity and the time to airframe separation into an ignition and separation assembly, located within the airframe, on the desired water entry point. In this way, the missile can be fired at will by simply closing the firing circuit.

TORPEDOES

There are four principal ways to launch a torpedo: by letting it swim out of the tube, by firing it from a tube, by dropping it from a rack, or by propelling it part of the way to its target as a rocket payload.

Aircraft drop torpedoes from launching racks. Usually, an aircraft carries two torpedoes; a helicopter can carry one or two torpedoes for ASW work.

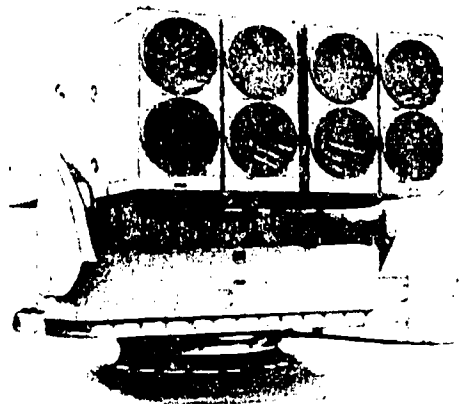

LEFT REAR

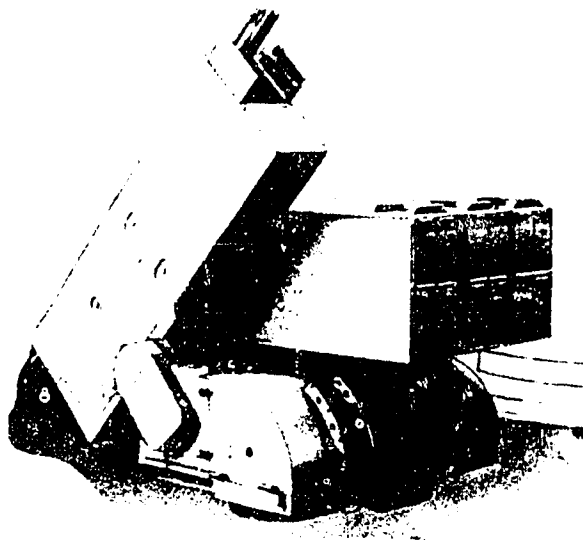

RIGHT FRONT

Figure 2-16.—ASROC launcher.

15.106

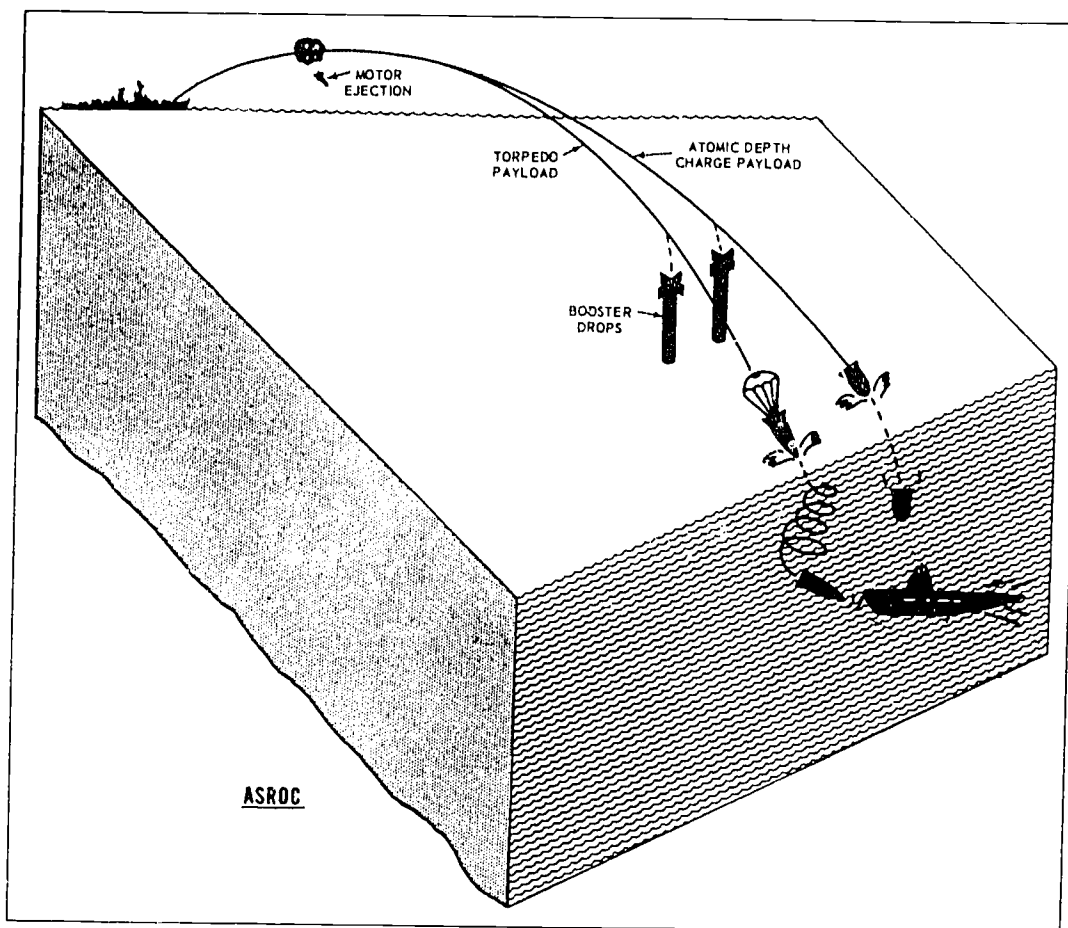

Figure 2-17.—ASROC.

15.114

The Navy's older destroyers, as well as FRAM destroyers, DDGs, and CGs, carry torpedoes in the 3-barrel Mk 32 launcher (fig. 2-18).

Twin mounts can fire from either side. They can be trained through a wide arc so that torpedoes may be fired through a wide range of bearings. Compressed air expels the torpedoes from the tube with enough force to clear the ship.

Mk 44 Torpedo

The Mk 44 torpedo (being phased out) is an electrically controlled and electrically propelled antisubmarine weapon with an active acoustic

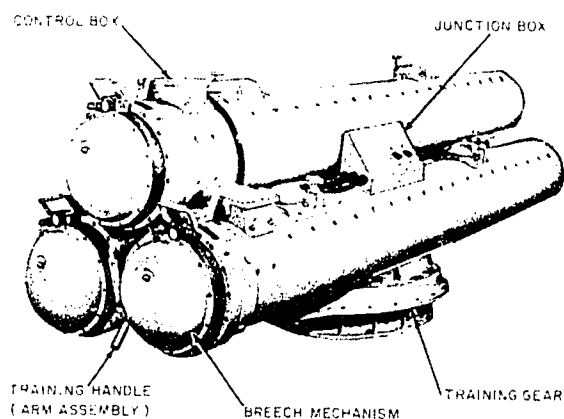

Figure 2-18.—Mk 32 torpedo tube.

3.129



Figure 2-19.—P-3 ORION, land-based long-range patrol craft.

134.95

homing system. The torpedo can be launched from surface ships or aircraft and is one of the torpedo payloads for ASROC.

The torpedo is designed to attack submerged submarines traveling at moderate speeds. After enabling, the torpedo searches for a target by active acoustic means while maneuvering in a depth varying helical path. Echoes from the target cause the torpedo to steer toward the target until contact is made. If the torpedo loses the target, it searches for a short time in the general direction in which it is traveling and, if unsuccessful in relocating the target, resumes a helical search.

The acoustic homing system of the torpedo also has a passive feature that allows the torpedo to respond to an acoustic noise source whose frequency level is within the sensitivity range of the receiver. During the torpedo's normal search pattern, passive homing on a target noise source aids in target acquisition, increasing the attack capabilities of the weapon.

Mk 46 Torpedo

The Mk 46 torpedo is the successor to the Mk 44. The principal difference between the two is the improved propulsive power of the Mk

46, which gives it greater speed, range, and depth capabilities.

AIRCRAFT

The use of aircraft in conjunction with ships and submarines adds greater capability and versatility to ASW. Areas of surveillance can be enlarged; ranges can be extended for detection and attack; and diversified weapons can be used. Two types of aircraft are used in ASW: the helicopter for close ranges and the fixed-wing aircraft for long ranges. The helicopter uses a dipping sonar; that is, one that may be lowered from the aircraft for searching and retracted for flight. Both helicopters and fixed-wing aircraft use magnetic anomaly detection (MAD) equipment whereby they detect the submarine by variations in the Earth's magnetic lines of force.

Aircraft also use other devices for detecting the presence of submarines. One of these devices is the sonobuoy, which is dropped into the water by the aircraft and then monitored by radio. Sonobuoys are described in chapter 6.

The aircraft also can be used as a tactical vehicle to launch a weapon at the submarine.

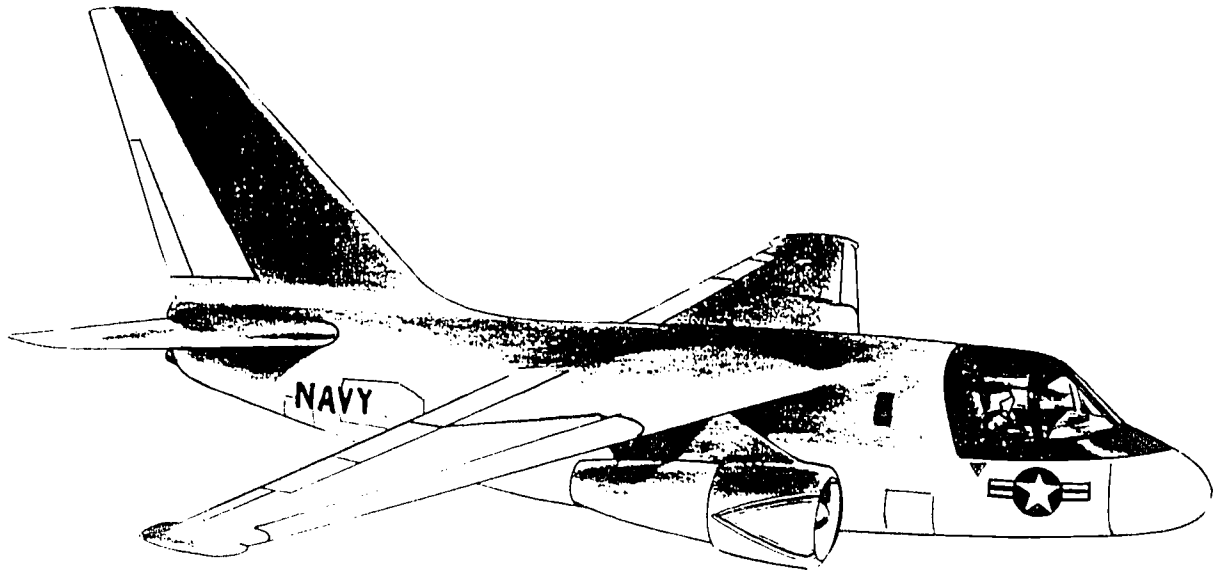

Figure 2-20.—S-3A VIKING A/S search and attack aircraft.

71.133



Figure 2-21.—LAMPS helicopter (SH-2F).

71.134

Among the weapons that can be launched from an aircraft are the homing torpedo and the nuclear depth charge.

PATROL PLANE

Patrol planes are land-based, long-range, multi-engine aircraft used for detecting, tracking, and attacking enemy shipping and submarines.

The P-3 ORION (fig. 2-19) is the Navy's principal patrol plane. To carry out its primary mission of locating and attacking submarines, it has a variety of sensors, including radar, sonobuoys, magnetic anomaly detector (MAD), and electromagnetic intercept (ESM) equipment. ORION's armament includes torpedoes, rockets, depth bombs, air-to-surface missiles, and conventional bombs. It also can be used for aerial mining.

ANTISUBMARINE AIRCRAFT

Shipboard aircraft used for antisubmarine (ASW) missions are the S-3A VIKING

fixed-wing aircraft and the SH-2F SEASPRITE, the Light Airborne Multi-Purpose System (LAMPS) helicopter. Both are integral parts of ASW search-attack units.

The S-3A VIKING (fig. 2-20) is a carrier-based jet-powered A/S search and attack aircraft. Detection equipment includes radar, ESM receivers, sonobuoys, and MAD gear. Ordnance equipment includes torpedoes, rockets, and depth bombs.

The SH-2F (LAMPS) (fig. 2-21) helicopters are found aboard a variety of ASW ships. They provide the ship with an extended antiship missile defense and ASW system. Detection equipment includes active and passive sonobuoys, magnetic anomaly gear, and radar. Secondary functions include all-weather search and rescue, plane guard duties, gunfire observation, personnel transfer, and vertical replenishment. Weapons include torpedoes and depth bombs.

CHAPTER 3

PHYSICS OF SOUND

Sonar is an electronic device that uses sound energy to locate submerged objects such as submarines. Sonar equipment may be either active or passive. Active sonar transmits sound energy into the water and depends on the returning echoes bouncing off the target to provide bearing and range information. Passive sonar uses sounds originated by the target (such as screw cavitation, machinery noises, etc.) to determine bearing information. This chapter deals with sound and its behavior in seawater.

Sound travels in the form of waves which may be classified as transverse or longitudinal. A transverse wave is one in which the particles of the medium through which the wave is passing move at right angles vertically to the wave's direction. In a longitudinal wave, the particles move back and forth along the wave's direction of travel, resulting in compression and rarefaction of the wave.

An example of a transverse wave is a water wave. Throw a stone into a pool. A series of circular waves travels away from the disturbance. In figure 3-1, such waves are

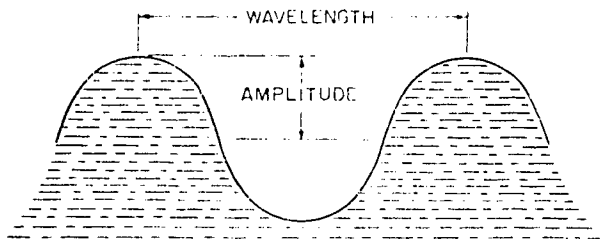

71.19

Figure 3-1.—Elements of a wave.

diagramed as though seen in cross section. Observe that the waves are a succession of crests and troughs. The wavelength (1 cycle) is the distance from the crest of one wave to the crest of the next wave. The amplitude of a transverse wave is half the distance, measured vertically from crest to trough, and serves to indicate the intensity of the wave motion.

Sound waves vary in length according to their frequency. A sound having a long wavelength is heard at a low pitch; one with a short wavelength is heard at a high pitch. A complete wavelength is called a cycle, and the number of cycles per second is the sound's frequency.

Frequencies are now measured in the Hertz system, 1 hertz (Hz) being equal to 1 cycle per second. Frequencies of 1000 cps or more are measured in kilohertz (kHz). Normally, sounds below 20 Hz or above 15 kHz are beyond the human hearing range. Between these two frequencies is the average human audible range. In short, sound is the physical cause of your sensation of hearing; anything that you hear is a sound.

REQUIREMENTS FOR SOUND

Before sound can be produced, three basic elements must be present. These elements are a source of sound, a medium to transmit the sound, and a detector to hear it. In the absence of any one element, there can be no sound.

You may recall the experiment in which a bell was placed inside a jar containing a vacuum. You could see the bell striking, but you could hear nothing because there was no medium to transmit sound from the bell to you. What about

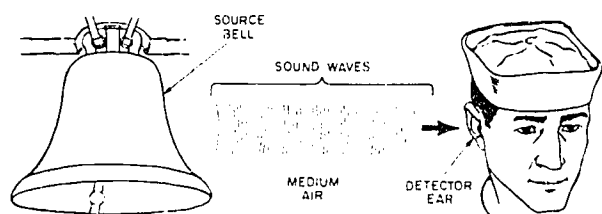

71.18

Figure 3-2.—The three elements of sound.

the third element, the detector? You may see a source (such as an explosion) apparently producing a sound, and you know the medium (air) is present, but you are too far away to hear the noise. So far as you are concerned, there was no detector and, therefore, no sound. For purposes of this text, we must assume that sound can exist only when an auditory vibration is caused by a source, is transmitted through a medium, and is heard by a detector. Figure 3-2 illustrates this assumption. The bell vibrates on being struck, thus acting as a sound source. The vibrating bell moves the particles of air—the medium—in contact with it. And the sound waves travel to the ear, which acts as the detector.

Source

Any object that moves rapidly to and fro, or vibrates, and thus disturbs the medium around it may become a sound source. Bells, radio loudspeaker diaphragms, and stringed instruments are familiar sound sources.

Medium

Sound waves are passed along by the material through which they travel. The density of the medium determines the ease, distance, and speed of sound transmission. The greater the density, the greater the speed of sound. The speed of sound through water is about four times that through air and through steel it is about 15 times greater than through air.

Detector

The detector acts as the receiver of the sound wave. Because it doesn't surround the source of the sound wave, the detector absorbs only part of the wave's energy and requires an amplifier to boost the signal's energy to permit reception of weak signals.

THE EAR AS A SOUND DETECTOR.—The limits of human hearing are determined by two interacting physical variables, frequency and intensity, and several other conditions that are dependent on the individual variables (including age, state of health, attention, and prior exposure). The limits of hearing, however, are normally between 20 Hz and 20 kHz for young, healthy persons, provided the upper and lower frequencies are sufficiently intense. For healthy, middle-aged persons, however, the upper limit may lie between 12 and 16 kHz, the low-frequency threshold remaining about 20 Hz. For purposes of this text, sounds capable of being heard are called sonics. Sounds below 20 Hz are called subsonics, and those above 15 kHz are known as ultrasonics or supersonics. The term "ultrasonic" merely refers to acoustic phenomena above the level of human hearing. A 15-kHz vibration might be "ultrasonic" for the average 60-year-old person.

Early active sonar equipments transmitted ultrasonic sounds through the water. Along with other sounds, they received echoes of these ultrasonic sounds and converted them into audible ones. Modern active sonars transmit sounds within the audible range. Because these transmissions are very high tones, however, the equipment converts them into lower ones better suited for listening.

The human ear is a good sound detector. It can detect a wide range of frequencies but does not respond equally well to all of them. Figure 3-3 illustrates the variation in the amount of power that is barely audible to the average ear at different frequencies. It is evident from this chart that the ear is most sensitive to frequencies in the range from about 1000 Hz to 2000 Hz. The average person finds an 800-Hz note a rather pleasant one to listen to for long periods of time. In underwater echo ranging equipment,

41

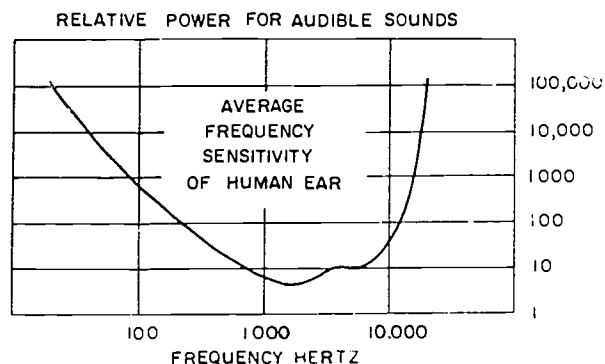

71.46

Figure 3-3.—Frequency sensitivity of the human ear.

the echo frequency commonly is converted to an 800-Hz note.

Never turn up the volume on sonar equipment so that echo sounds are louder than necessary. One reason is that the ear is not a sensitive detector of relative changes in sound intensity. An increase or decrease of about one-fourth of the total power must take place before the ear notices any difference.

An intensely loud sound slightly paralyzes the ear, reducing its ability to hear low-intensity sounds that follow immediately. This effect is similar to one you probably have experienced with light. If you look into a very strong light, your eyes are blinded momentarily.

The ear is a sensitive detector of change in pitch. An average person can tell when sounds differ a few hertz in pitch, even though they cannot detect the change in intensity. This faculty is known as pitch discrimination. It is a great help in selecting from a background of reverberations a submarine echo of slightly different pitch, that is, one with doppler.

Here's a summary of your ear's characteristics:

1. Your ear does not readily detect small relative changes in sound intensity. It is not sensitive to high and low audible frequencies.
2. Your ear is sensitive to the 800-Hz note for which sonar equipment is designed. Your ear

temporarily is paralyzed by very loud signals so that you may not hear the weaker signals that follow.

3. Your ear has the property of pitch discrimination. This characteristic will aid you in selecting an echo from the background of noise and reverberation.

Heavy gunfire may cause permanent deafness or other injury to your ears. Use ear protectors or cotton when near gunfire, and take every possible precaution to protect your hearing. As a Sonar Technician, you are essential to the successful mission of your ship. Your ability to operate the sonar depends on the effectiveness of your hearing.

SOUND WAVES

Sound waves are longitudinal or compression waves, set up by some vibrating object such as a sonar transducer. In its forward movement, the vibrating transducer pushes the water particles lying against it, producing an area of high pressure, or compression.

On the backward movement of the transducer, the water particles return to the area from which they were displaced during compression and travel beyond, producing an area of low pressure, or a rarefaction. The compression moves outward by pushing the water particles immediately in front of the compressed particles. The rarefaction follows the compression, transferring the pull produced by the backward movement to the particles immediately ahead. The next forward movement of the transducer produces another compression and so on. In figure 3-4 the compressions are represented by dark rings. As the sound waves spread out, their energy simultaneously spreads through an increasingly large area. Thus the wave energy becomes weaker as distance increases.

Another way of representing the actions of a sound wave is illustrated in figure 3-5. Compressions are shown as hills above the reference line, and rarefactions as valleys below it. The wavelength is the distance from one point on a wave to the next point of similar

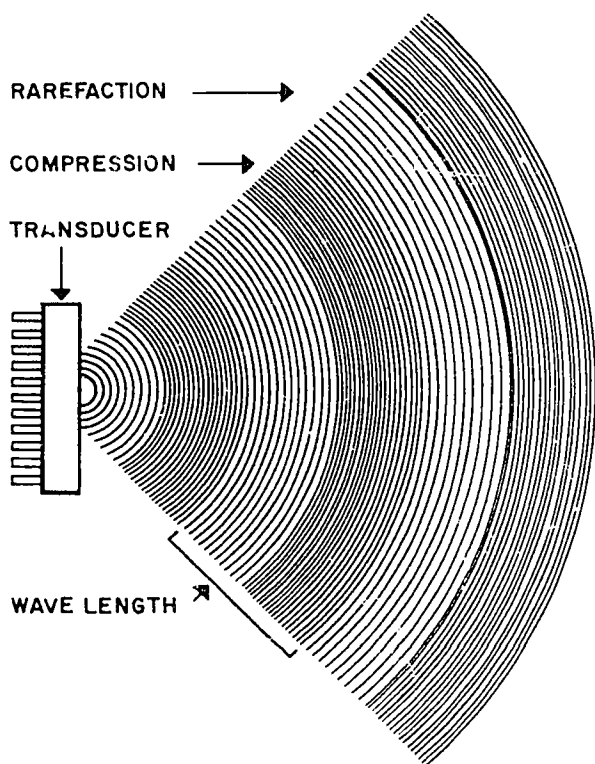

4.221

Figure 3-4.—Longitudinal waves.

compression. The change occurring in compression and rarefaction in the space of 1 wavelength is called a cycle.

Frequency

The frequency of a sound wave is the number of vibrations per second produced by the sound source. A sonar transducer, for example, may transmit on a frequency of 5 kHz, or 5000 vibrations per second. Motion is imparted to the sound wave by the back-and-forth movement of the particles of the medium, in effect passing the wave along, although the particles themselves have very little actual movement. The wave, however, may travel great distances at a high rate of speed.

Density

Perhaps you've heard people speak of a heavy fog as being "thick as pea soup." This murky condition would be a dense fog caused by the atmosphere being filled with small particles of water called vapor condensation. A fog-filled atmosphere is heavier (because of the weight of the water particles in it) than a clear atmosphere. The measure for this "thickness" of a substance is called density, and is defined as "weight per unit volume." In the study of general physics, density of any substance is a comparison of its weight to the weight of an equal volume of pure water. Because of the salt content (salinity) of seawater, it has a density greater than that of freshwater.

Density is also an indication of the sound transmission characteristics of a substance, or medium. When a sound wave passes through a medium, it is transmitted from particle to particle. If the particles are loosely packed (as they are in freshwater as compared with seawater), they have a greater distance to move to transmit the sound energy. During the movement, time is consumed, and the overall result is a slower speed of sound in a less dense medium.

Density and elasticity are the basic factors that determine sound velocity. The formula for determining velocity is:

$$C = \sqrt{\frac{E}{P}}$$

where C equals velocity, E equals the medium's elasticity, and p equals the medium's density. Variations in the basic velocity of sound in the sea are caused by changes in water temperature, pressure, and density, as will be seen in the section on sound propagation. In freshwater of 65° F, sound velocity is approximately 4790 feet per second (fps). In seawater, velocity depends on pressure and temperature in addition to salinity. For all practical purposes, you can assume that sound travels at a speed of 4800 fps in seawater of 39° F.

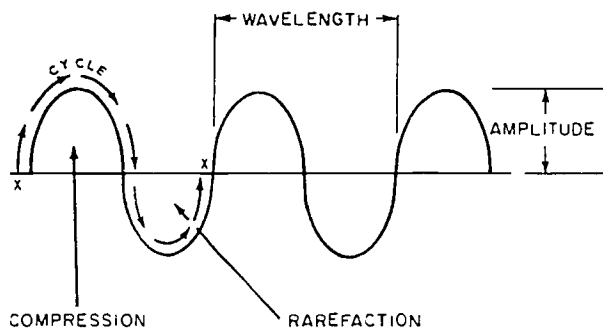

Figure 3-5.—The sound wave. 71.21

Wavelength

If a sonar transducer vibrates at the rate of 25,000 vibrations per second and if the temperature is 39°F, the first wave will be 4800 feet away at the end of the first second. Between the transducer and the front of this wave there will be 25,000 compressions. Thus, the wavelength (that is, the distance between points of similar compression) must be $4800 \div 25,000$, or 0.192 foot, because there are 25,000 compressions extending through a distance of 4800 feet. The wavelength always can be found if the frequency and the velocity are known. Formula:

$$\text{Wavelength} = \frac{\text{Velocity.}}{\text{Frequency}}$$

Suppose the wavelength is 0.4 foot and the frequency is 12 kHz. What is the velocity?

$$0.4 = \frac{\text{Velocity.}}{12,000}$$

Expressed another way, velocity = $0.4 \times 12,000 = 4800$ fps. If the wavelength and velocity are known, the frequency can be found in a similar manner.

$$0.4 = \frac{4800.}{\text{Frequency}}$$

Or, frequency = $4800 \div 0.4 = 12$ kHz.

CHARACTERISTICS OF SOUND

Sound has three basic characteristics: pitch, intensity, and quality. Together they make up

the tone of a sound. With the proper combination of characteristics, the tone is pleasant. With the wrong combination, the sound quality degenerates into noise.

Pitch

An object that vibrates many times per second produces a sound with a high pitch, as in the instance of a whistle. The slower vibrations of the heavier wires within a piano cause a low-pitched sound. Thus, the frequency of vibration determines pitch. When the frequency is low, sound waves are long; when it is high, the waves are short.

Intensity

Intensity and loudness often are mistakenly interpreted as having the same meaning. Although they are related, they are not the same. Intensity is a measure of a sound's energy. Loudness is the effect of intensity on an individual in the same manner that pitch is the effect of frequency. Increasing the intensity causes an increase in loudness but not in a direct proportion. To double the loudness of a sound requires about a tenfold increase in the sound's intensity.

Quality

The quality of a sound depends on the complexity of its sound waves. Most sounds consist of a fundamental frequency (called the first harmonic) plus several other frequencies that are exact multiples of the fundamental. The fundamental is the lowest frequency component of the sound wave. By combining different fundamentals in suitable proportions, a tone can be built up to a desired quality. Musical tones are produced by regular vibrations of the source; when the source vibrates irregularly, the sound is called noise. By sounding together the proper organ pipes, the tone of any vowel sound can be imitated. On the other hand, drawing a fingernail across a blackboard only creates a noise.

INTRODUCTION TO SONAR

MEASUREMENT OF SOUND

Throughout your Navy career as a Sonar Technician, you will be using decibels as an indicator of equipment performance. Power output and reception sensitivity of a sonar equipment are measured in decibels, which are used to express large power ratios.

In the decibel system, the reference level is zero decibel (0-db), which is the threshold of hearing. The pressure level, or signal strength, of underwater sounds is compared to the 0-db level and is given either a positive or a negative value. Sonar receivers are capable of detecting sounds having a signal strength below the 0-db level. In such instances, the signal is given a minus db value.

The reason for using the decibel system when expressing signal strength may be seen in table 3-1. It is much easier to say that a source level has increased 50 db, for example, than it is to say the power output has increased 100,000 times. The amount of power increase or decrease from a reference level is the determining factor—not the reference level itself. Whether power output is increased from 1 watt to 100

watts, or from 1000 watts to 100,000 watts, it still is a 20-db increase.

Examine table 3-1 again, and take particular note of the power ratios for source levels of 3 db and 6 db (also 7 and 10 db). It can be seen that to increase a sonar's source level by 3 db, it is necessary to double the output power. As a typical example, if the sonar source level drops from 140 db to 137 db, the sonar has lost half its power. Any 3-db loss, no matter what the source level, means loss of half the former power.

Now let's see what is required to increase a sonar's range. To double the range of a sonar requires a source level increase of approximately 27 db. This power increase is equivalent to about 500 times, which obviously is impractical. By another method, such as increasing receiver sensitivity, the range can be increased fairly easily, although it may not be doubled.

So far we have discussed the decibel mainly in relation to power output, but the decibel also is used to determine receiver sensitivity. Receiver sensitivity is measured in minus numbers, which represent the number of decibels below a reference level that signal can be detected by the receiver. The larger the negative number, the better the sensitivity. Although the range would not be doubled, it is more practical, for instance, to increase a receiver's sensitivity from 112 db to 115 db than it is to double the output power of the sonar transmitter. Also, it is not always necessary to increase the sensitivity of the receiver itself. An effective increase of several decibels may be achieved if local noise levels can be reduced in such sources as machinery, flow noise, crew noise, etc.

Table 3-1.—Decibel Power Ratio Equivalents

Source Level (db)	Power Ratio
1	= 1.3
3	= 2.0
5	= 3.2
6	= 4.0
7	= 5.0
10	= 10
20	= 100
30	= 1000
40	= 10,000
50	= 100,000
60	= 1,000,000 = 10^6
70	= 10,000,000 = 10^7
100	= 10^{10}
110	= 10^{11}
140	= 10^{14}

NOISE

The most complex sound wave is one in which the sound consists of numerous frequencies across a wide band. Such a form of sound is called noise because it has no tonal quality. The source of several types of noises may be identified easily, however, because of the standard sound patterns of the noises. Ship noise, for instance, consists of many different

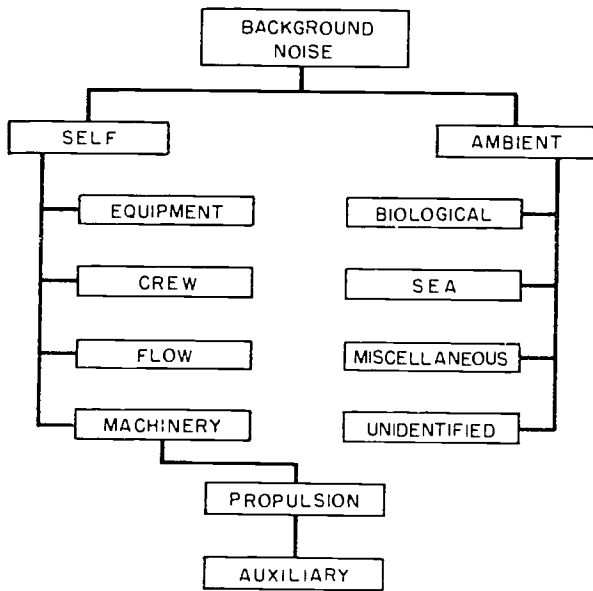

Figure 3-6.—Noise sources.

71.116

sounds mixed together. You may be unable to distinguish a particular sound but, on the whole, you can recognize the sound source as a ship. Some noise sources are shown in figure 3-6. The sources of many noises detected by sonar have not yet been identified. Explanations of some kinds of noises that have an adverse effect on a sonar operator follow.

AMBIENT NOISE

Ambient noise is background noise in the sea that is due to natural causes. Different phenomena contribute to the ambient background noise. Many of the sources are known and their effects are predictable, but many are still unknown. From this unwanted background noise, the sonar operator must be able to separate weak or intermittent target noises. In general, the average operator requires a target signal strength of 4 db above background noise.

THERMAL NOISE.—The absolute minimum noise in the ocean is called thermal noise. As the

name implies, it is a function of temperature. This noise is created by the motion of the molecules of the liquid itself and is difficult to measure.

SURFACE AGITATION.—For a sizable region above the residual minimum noise, the ambient noise levels appear to be related to the surface agitation. Usually, agitation of the surface of the sea is measured as sea state. Surface windspeed, however, ordinarily is a more reliable measure of expected ambient noise than sea state. As the wind rises, the surface becomes more and more agitated, causing the ambient noise level to rise. Normally noise levels in this region are associated with what is called sea noise to distinguish them from other noises which really are not caused by the sea itself. A heavy rain, for instance, will add greatly to the ambient noise.

Flow Noise

As an object moves through water, there is a relative flow between the object and the medium. This flow is easiest to understand by assuming that the object is stationary and that the water is moving past the object. If the object is reasonably streamlined, its surface is smooth, and if it is moving very slowly, a flow pattern known as laminar flow is set up. Such a pattern is shown in view A in figure 3-7, where the lines

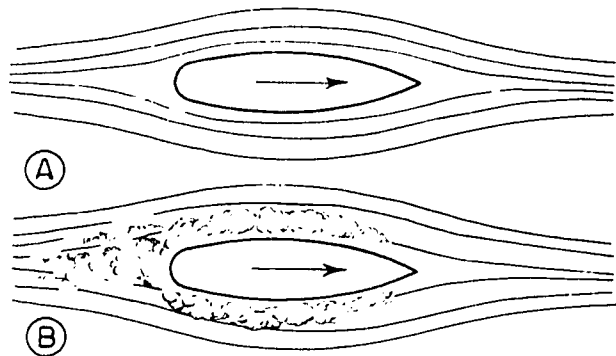

Figure 3-7.—Patterns of flow noise: A—laminar flow; B—turbulent flow.

71.22

represent the paths followed by the water as it flows around the object. If the flow is laminar, all lines are smooth. Although laminar flow produces little, if any, noise, it occurs only at very low speeds—perhaps less than 1 or 2 knots.

If the speed of the water is increased, whorls and eddies begin to appear in the flow pattern, as seen in part B in figure 3-7, and the phenomenon is called turbulent flow. Within these eddies occur points where the pressure is widely different from the static pressure in the medium. Thus we have, in effect, a noise field. If a hydrophone is placed in such a region, violent fluctuations of pressure will occur on its face, and flow noise will be observed in the system.

As pressures fluctuate violently at any one point within the eddy, they also fluctuate violently from point to point inside the eddy. Moreover, at any given instant, the average pressure of the eddy as a whole differs but slightly from the static pressure. Thus, very little noise is radiated outside the area of turbulence. Hence, although a ship-mounted hydrophone may be in an intense flow noise field, another hydrophone at some distance from the ship may be unable to detect the noise at all. Flow noise, then, is almost exclusively a self-noise problem.

Actually, not much information is known about flow noise, but general statements may be made about its effect on a shipborne hydrophone: (1) It is a function of speed with a sharp threshold. At very low speeds there is no observable flow noise. A slight increase in speed changes the flow pattern from laminar to turbulent, and strong flow noise is observed immediately. Further increases in speed step up the intensity of the noise. (2) It is essentially a low-frequency noise. (3) It has very high levels within the area of turbulence but low levels in the radiated field. In general, the noise field is strongest at the surface of the moving body, decreasing rapidly as you move away from the surface.

As the speed of the ship or object is increased still further, the local pressure drops low enough at some points to allow the formation of gas bubbles. This decrease in pressure represents the onset of cavitation. The noise associated with this phenomenon differs from flow noise.

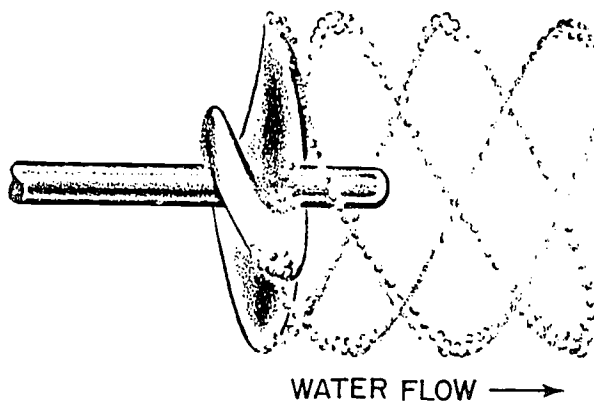

71.23
Figure 3-8.—Blade tip cavitation.

Cavitation

Cavitation is produced whenever a solid object moves through the water at a speed great enough to create air bubbles. After a short life, most of the bubbles collapse. The sudden collapse of the bubbles causes the acoustic signal known as cavitation noise. Each bubble, as it collapses, produces a sharp noise signal.

Because the onset of cavitation is related to the speed of the object, it is logical that cavitation first appears at the tips of the propeller blades, inasmuch as the speed of the blade tips is considerably greater than the speed of the propeller hub. This phenomenon known as blade tip cavitation is illustrated in figure 3-8.

As the propeller speed increases, a greater portion of the propeller's surface is moving fast enough to cause cavitation, and the cavitating area begins to move down the trailing edge of the blade. As the speed increases further, the entire back face of the blade commences cavitating, producing what is known as sheet cavitation. This form of cavitation is shown in figure 3-9. Cavitation noise is referred to as hydrophone effects. The amplitude and frequency of cavitation noise are affected considerably by changing speeds. Cavitation noise versus speed at a constant depth is diagramed in figure 3-10. The curves shown are idealized; they do not represent any particular

submarine. Note the great difference in noise level caused by the addition of only 20 turns, from 90 rpm to 110 rpm. At 90 rpm there is no cavitation; the noise level is due to flow noise and background noise. At 110 rpm cavitation has started, and the noise level has gone up many decibels, with a peak amplitude at about 400 Hz. As speed is increased further, the amplitude peak tends to move toward the lower frequencies. The amplitude increases at a lesser rate, but covers a broader frequency band. The curves are also characteristic of a submarine on the surface and of surface warships although the amplitude levels may be different.

Cavitation noise versus depth at a constant speed (170 rpm) is shown in figure 3-11. The upper curve is the same as the upper curve in figure 3-10. As the submarine goes deeper, the cavitation noise decreases and moves to the higher frequency end of the spectrum in much the same manner as though speed had been decreased. This decrease in noise is caused by the increased pressure with depth, which tends to compress cavitation noise. The curves are not exactly the same as those shown in figure 3-10, but the similarity is readily apparent.

Machinery Noises

Machinery noise is produced aboard ship by the main propulsion machinery and by any or all of a large number of auxiliary machines that may or may not be connected with the main propulsion system. Machinery noise usually is produced by rotating or reciprocating machines. Most noise of this type is generated by dynamic imbalance of the rotating portion of the machinery that causes a vibration within the machine. Such a vibration may then be transmitted through the machine mounts to the hull from where it is radiated into the water as acoustic energy.

Shipboard Noise

In addition to the machinery discussed so far, there are many other shipboard noise sources over which you probably will not have any control. Some of the noise sources are fire and flushing pumps, air compressors, refrigeration

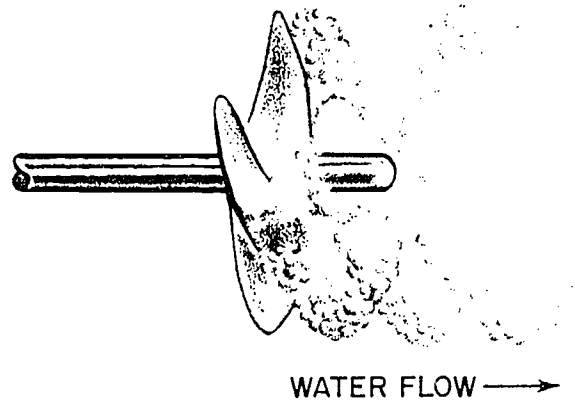

35.50

Figure 3-9.—Sheet cavitation.

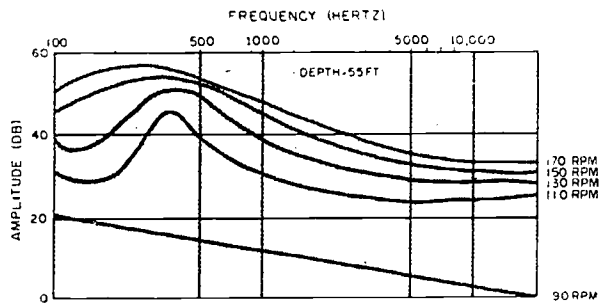

71.24

Figure 3-10.—Speed effect on cavitation noise.

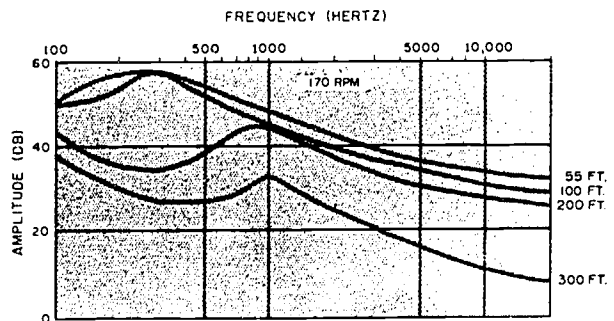

35.51

48 Figure 3-11.—Depth effect on cavitation noise.

INTRODUCTION TO SONAR

machinery, air conditioning systems, diesel generators, gasoline pumps, blower motors, and portable power tools. Any (or all) of the aforementioned equipment may be operating at any one time, adding greatly to the noise radiated by the ship and therefore entering the sonar receiver. If the combination of these noises becomes too great for effective sonar search, ask your watch supervisor to request the OOD to secure all nonessential equipment. Another noise source is circuit noise, generated within the sonar equipment itself. This noise may be in the form of a 60-hertz hum, staticlike noises from electric cables due to improper cable shielding, or leakage currents from other sources entering the receiver stages. Unlike ambient noise, however, this type of generated noise may be controlled.

Marine Life

A sonar operator may hear many strange sounds during his time on watch. He may have to listen to (and try to identify) the source of whistles, shrieks, buzzes, pings, knocks, cracklings, and other strange noises not ordinarily associated with the sea. Most of these noises probably come from different species of fish, but only a few have been identified positively. Following are descriptions of a few marine life noises.

Porpoises give out a whistling sound and sometimes a sound like a chuckle. These mammals are found in all ocean areas of the world. (Submarine hydroplanes and rudders sometimes also give off a whistling sound.)

Snapping shrimp are common around the world between latitudes 45°N and 45°S, usually in waters less than 30 fathoms deep. As you approach a bed of snapping shrimp, you hear a buzzing sound. As you go closer, the sound resembles fat sizzling on a fire, then becomes similar to that given off by burning brush.

Whales, which are found in all oceans, give off a variety of sounds, including knocks, groans, pings, and one resembling a swinging rusty gate. The knocking sound of the sperm whale resembles the noise of hammering. Sperm whales and other large species seldom are heard in waters shallower than 100 fathoms. Blackfish,

which are similar to whales, emit a whistling sound like a porpoise but clearer in tone.

The preceding examples of marine life noises are just a few that you will encounter. Do not let the strange sounds mislead or distract you. A valid target may be just beyond the whale you are listening to. Available tapes and films describe many biologic noises. All Sonar Technicians should review these tapes and films periodically to maintain proficiency in their recognition of sounds.

Torpedo Noise

Torpedo noise is distinct from all others. When a torpedo is fired from a submarine, the first indication might be the sound of escaping air, quickly followed by a propellerlike noise. The rhythm is too rapid for the beats to be counted (as you can count those of a ship's propeller), and it increases swiftly in intensity as it approaches, resembling the whine of a jet engine, but not as high pitched.

UNDERWATER SOUND PULSE

Now that you know something of the theory of sound, you are ready to take a closer look at what happens to an underwater sound pulse.

To gain the full benefit of echo ranging sonar equipment, you must be able to transmit an underwater sound pulse and recognize the returning echo from a target. Detection of the echo depends on its quality and relative strength, compared with the strength and character of other sounds that tend to mask it.

Sonar Technicians must know (1) what can weaken sound as it travels through water, (2) what conditions in the sea determine the path and speed of sound, and (3) what objects affect the strength and character of the echo.

TRANSMISSION LOSSES

As a sound pulse travels outward from its source, it becomes weaker and weaker. Much of its energy is lost because of sea conditions and distance. Three factors directly related to sound transmission losses are divergence, absorption, and scattering. The latter two are referred to as

attenuation loss and are dependent on transmission frequency. Divergence loss is independent of frequency.

Divergence

When a sound wave is projected from a point source, it assumes a spherical shape, spreading equally in all directions. This spreading is called divergence; and the further the wave travels, the more energy it loses. The energy lost by a sound wave due to spherical divergence is inversely proportional to the square of the distance from its source, or 6 db each time it doubles.

In shallow water areas, the surface and bottom are boundaries that limit the vertical divergence of the sound wave. Consequently, the expanding wavefront is cylindrical, rather than spherical, in shape. Cylindrical spreading loss is only half that of a sphere, or 3 db each time the distance is doubled. Spreading loss at close range is very high, but beyond about 2000 yards the loss becomes less significant.

Absorption

In the topic on sound waves, you learned how a sound pulse moves through water. The repeated compressions and rarefactions of the sound wave causes the water molecules to move back and forth, thus passing the sound wave along. An old saying goes: "You can't get something for nothing." In our illustrative case, energy is lost (in the form of heat) by the sound pulse in its efforts to compress the water. Energy lost to the medium in this manner is called absorption loss.

Scattering

Besides losses caused by divergence and absorption, a sound wave loses energy due to the composition of the medium through which it passes. Composition of the sea naturally varies from place to place and from time to time. In general, however, seawater contains large amounts of minute particles of foreign matter and many kinds of marine life of all shapes and sizes. Each time the sound wave meets one of these particles, a small amount of the sound is

reflected away from its direction of movement and is lost. The reflection losses to the water are known as scattering losses. Some of the scattered energy is reflected back to the sonar receiver and is then called volume reverberation (discussed later in this section).

REFLECTIONS

When a sound wave strikes the boundary between two mediums of different densities, the wave will be reflected, just as light is reflected by a mirror. Some of the energy will be lost, but most of it will be reflected at an angle equal to the angle of incidence. The angle of incidence is the angle, with respect to the perpendicular, at which the wave strikes the boundary. According to the physics law of regular reflection (reflection from a smooth surface), the angle of reflection equals the angle of incidence.

Reflection takes place whenever the sound hits the boundary between sea and air (sea surface) and between sea and bottom, and when it hits a solid object, such as a submarine. The amount of energy reflected depends on the object's density, size, shape, and aspect. More energy is reflected by a submarine broadside to the sound beam than by one that is bow on.

Surface Effect

Because the density of water is several hundred times that of air, practically all of a sound wave is reflected downward when it strikes the surface boundary. This effect is true only when the surface is quite smooth, however. When the surface is rough, scattering takes place.

Bottom Effect

The bottom of the sea reflects sound waves, too. In deep water, this aspect need not be considered; but, in waters of less than 100 fathoms, the sound may be unwantedly reflected from the bottom. Other considerations being equal, transmission loss is least over soft mud. Over rough and rocky bottoms, the sound is scattered, resulting in strong bottom reverberations.

INTRODUCTION TO SONAR

REVERBERATIONS

You probably are acquainted with the effect in an empty room where your voice seems to echo all around you as you talk. After you stop talking, the sound continues to bounce around the room from wall to wall until it finally is absorbed by the walls and the air. The sound level in the room while you are talking is higher than normal because of the reverberation effects. The same effects can also be observed in the ocean. Reverberation in the ocean usually is divided into three categories. They are reverberations from the mass of water, from the surface, and from the bottom.

The following discussion on reverberations may seem like a repetition of the topic on reflections, but the two phenomena are not the same. Although reverberations are reflections, all reflections do not become reverberations. All the processes contributing to reverberation are random in nature, with the result that reverberation amplitudes vary over wide limits. Moreover, reverberation level is proportional to source level and to pulse length. Another point to remember is that, when you are in company with another ship, you may hear reverberation effects from her sonar in addition to your own.

Volume Reverberation

Reverberation from the mass of water is called volume reverberation, which was mentioned in the discussion on scattering. Suppose a short pulse of sound is sent out from a stationary underwater source, which is immediately replaced by a listening hydrophone. As the pulse of sound travels through the water, it encounters various particles that reflect and scatter the sound. Because almost all of these particles are much smaller than a wavelength of the sound, they do not reflect the sound as a flat mirror reflects light. Instead, they absorb energy from the sound wave and reradiate this energy in all directions. Some reradiated energy from each particle returns to the hydrophone at the source location and is heard as a gradually fading tone at the same frequency as the source.

Surface Reverberation

Some of the sound energy from the source strikes the surface, the point of impingement

moving farther and farther from the source as the sound travels. If the surface were perfectly flat, this sound energy would be reflected as though from a mirror, and would bounce away from the source in accordance with the laws of reflection. But the surface is not perfectly smooth, and each wavelet tends to reflect the sound in all directions. Some reflected sound returns to the hydrophone, adding to the reverberation.

Bottom Reverberation

In general, reverberation effects from both the mass of water and the surface are small compared to bottom reverberation. The bottom is usually much rougher than the surface. Thus, more of the sound is reflected in other directions than those expected of a reflecting mirror. If the water is fairly deep, no bottom reverberation occurs for quite some time after the pulse, because the sound must be given time to reach the bottom and be reflected. Normally, a sharp rise eventually occurs in the reverberation level after the source is cut off.

REFRACTION

If there were no temperature differences in the sea, a sound wave would travel approximately in a straight line because the speed of sound would be roughly the same at all depths. As indicated in figure 3-12, the sound would spread and become weakened by attenuation at a relatively constant rate.

Unfortunately, however, the speed of sound is not the same at all depths. The velocity of sound in seawater increases from 4700 feet per second to 5300 feet per second as the temperature increases from 30° to 85° F. As will be seen later in the chapter, salinity and pressure also affect sound speed, but their effects usually are small in relation to the large effects commonly produced by temperature changes. Because of the varying temperature differences in the sea, the sound does not travel in a straight line. Instead, it follows curved paths, resulting in bending, splitting, and distortion of the sound beam.

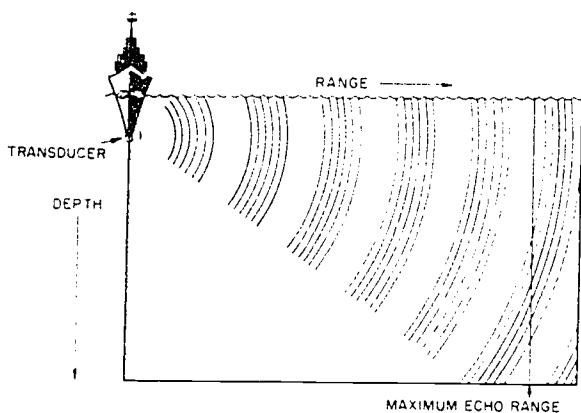

71.26

Figure 3-12.— Sound travel in water of constant temperature.

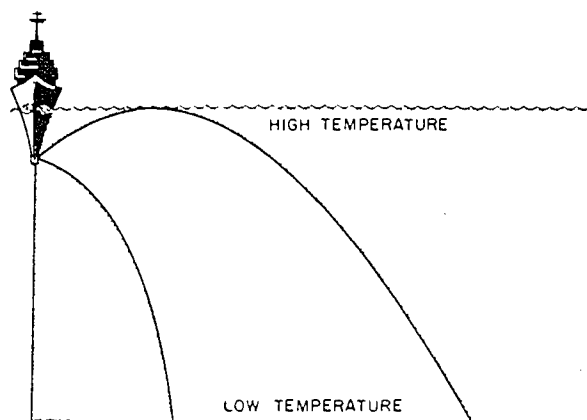

71.27

Figure 3-13.—A refracted sound beam.

When a beam of sound passes from one medium in which its speed is high (such as warm water) into one in which its speed is low (such as cool water), the beam is refracted (bent). A sound beam bends away from levels of high temperatures and high sound velocity, and bends toward levels of low temperature and low sound velocity. Figure 3-13 illustrates the refraction of a sound beam. As a result of refraction, the range at which a submarine can be detected by sound may be reduced to less than 1000 yards. This range may change sharply with changing submarine depth.

QUENCHING

In strong winds and heavy seas, the roll and pitch of the echo ranging ship make it difficult to keep the sound directed on the target. Additionally, the turbulence produces air bubbles in the water, weakening the sound waves. Occasionally this envelope of air bubbles blankets the sound emitted by the transducer. Sonar operators can tell, by a dull thudding sound, when the sound beam is being sent out into air. This action is known as quenching.

PROPAGATION OF SOUND IN THE SEA

We have discussed the various basic phenomena that cause power loss in transmitting

sound: divergence, attenuation (absorption, and scattering), reflections, reverberations, refraction, and quenching. Now, we must consider the structure of the sea as an acoustic medium and learn the effects of this structure on the transmission of sound.

STRUCTURAL CONDITIONS

The speed of sound wave travel through the water is controlled by three conditions of the sea: (1) temperature, which takes the form of slopes and gradients; (2) pressure, caused by increased depth; and (3) salinity, or the salt content of the water.

Temperature

With presently operational sonars, temperature is by far the most important of the factors affecting the speed of sound in water. Depending on the temperature, the speed of sound increases with increasing temperature at the rate of 4 to 8 feet per second per degree of change. Inasmuch as the temperature of the sea varies from freezing in the polar seas to more than 85°F in the tropics, and may decrease by more than 30°F from the surface to depth of 450 feet, it is clear that temperature has a great effect on the speed of sound. Remember: The speed of sound increases when the temperature of water increases.

INTRODUCTION TO SONAR

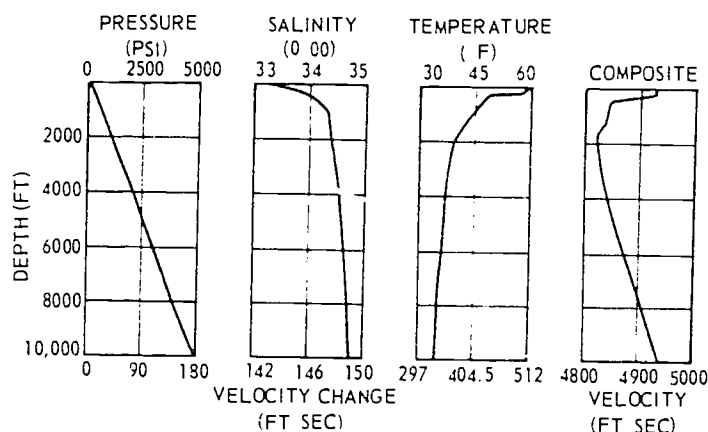

Figure 3-14.—Normal curves for pressure, salinity, and temperature.

35.5

Pressure

Sound travels faster in water under pressure. Pressure increases as depth increases, so the deeper a sound wave travels, the faster it travels. Pressure effect on transmitted sound, although rather small in comparison to temperature effects, cannot be neglected. The speed of sound increases about 2 feet per second each 100 feet of depth.

Salinity

Seawater has a high mineral content. Salt content is spoken of as the salinity of the water. The weight of the higher density seawater is about 64 pounds per cubic foot; that of freshwater is about 62.4 pounds per cubic foot. This variation is the result of the salt content in the seawater.

The overall effect of increasing the salinity of water is to increase the speed of the sound, which means that, when sound passes through water that varies in salinity, it travels faster in the saltier water. In the open ocean, the values of salinity normally lie between 30 and 35 parts per thousand. In the region of rivers and other freshwater sources, the salinity values may fall to levels approaching zero. The speed of sound increases about 4 feet per second for each part per thousand increase in salinity. Salinity has a lesser effect on the speed of sound than does temperature, but its effect is greater than that of pressure.

Composite

Figure 3-14 shows reasonably normal curves for temperature, salinity, and pressure as a function of depth in the Pacific Ocean and also the resulting velocity structure. It should be noted that the salinity variation plays a minor part in the form of the depth velocity curve. This effect is almost entirely evident in the first 500 feet below the surface. The temperature curve also shows wide variations in the top 500 feet. From 2000 feet, downward, the temperature is nearly uniform as the water approaches the maximum density point at about 40°F. The pressure effect is represented by a straight line as the velocity increases linearly with depth.

On the composite curve, it easily can be seen that the velocity in the top 2000 feet is a somewhat skewed replica of the temperature curve. Below 2000 feet it follows closely the straight line gradient of the pressure curve.

Depth/Temperature Effect

Except at the mouths of great rivers, where salinity may be a determinant, the path followed by sound is governed by the water temperature and the pressure effect of depth.

The pressure effect is always present and always acts in the same manner, tending to bend the sound upward. Figure 3 15 illustrates the situation when the temperature does not change

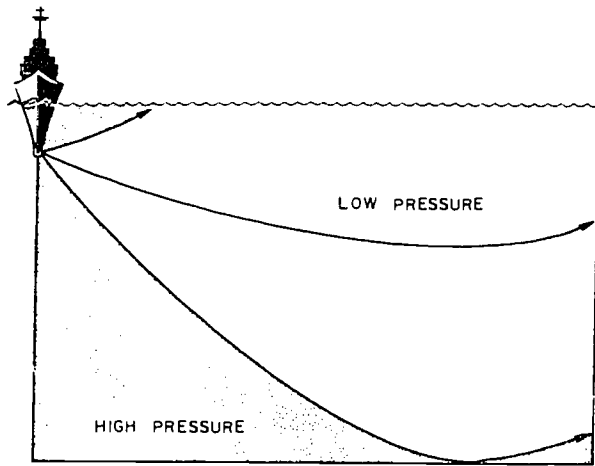

71.29
Figure 3-15.—Pressure tends to bend the sound beam upward.

with depth. Even though the temperature does not change, the speed of sound increases with depth, due entirely to the effect of pressure, and the sound bends upward.

Figure 3-16 shows what happens when temperature increases steadily with depth. When the surface of the sea is cooler than layers

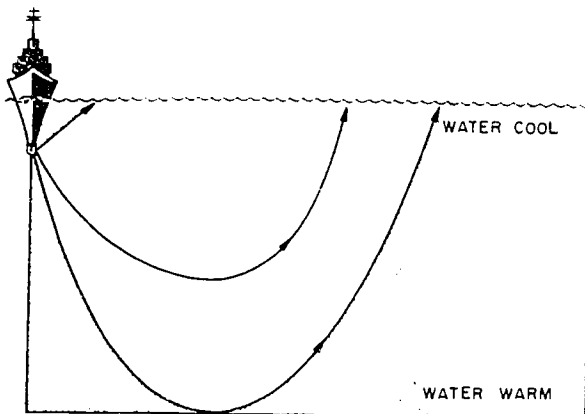

71.30
Figure 3-16.—Positive thermal gradient tends to bend the sound wave upward.

beneath it, the water has a positive thermal gradient. Although this condition is unusual, it does happen and causes the sound to be refracted sharply upward. In certain areas of the Red Sea, between Africa and Arabia, temperatures of well over 100°F have been recorded in depths exceeding 1 mile. Moreover, the salinity of the water in those areas approaches 30%, compared to between 3% and 4% in most ocean areas.

When the sea grows cooler as the depth increases, the water is said to have a negative thermal gradient. Here the effect of temperature greatly outweighs the effect of depth, and the sound is refracted downward. This common condition is illustrated in figure 3-17.

If the temperature is the same throughout the water, the temperature gradient is isothermal (uniform temperature). In figure 3-18 the upper layer of water is isothermal: beneath this layer the temperature decreases with depth. This temperature change causes the transmitted sound to split and bend upward in the isothermal layer and downward below it.

Don't forget: When no temperature difference exists, the sound beam bends upward. When the temperature changes with depth, the sound beam bends away from the warmer water.

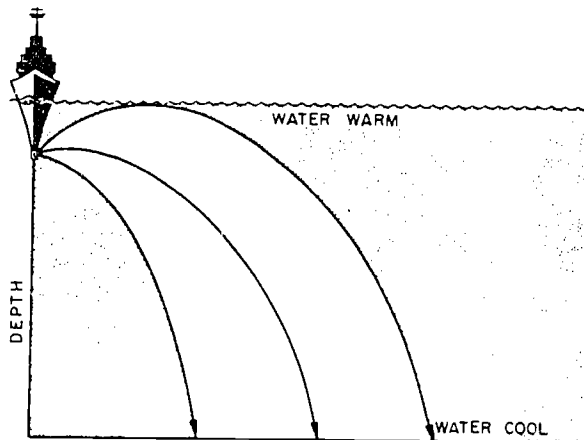

71.31
Figure 3-17.—Negative thermal gradient tends to bend sound downward.

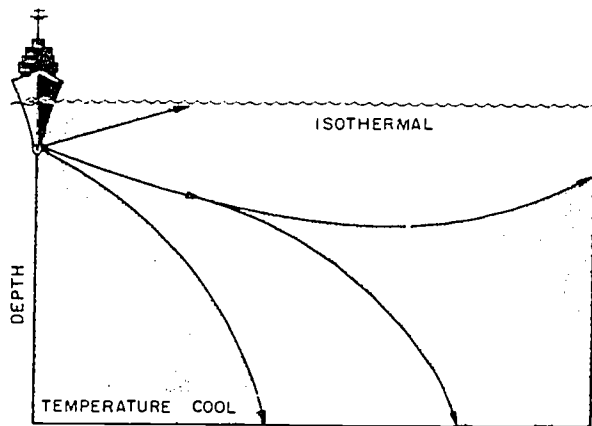

71.32

Figure 3-18.—Sound wave splits when temperature is uniform at surface and cool at bottom.

Under ordinary conditions the sea has a temperature structure similar to that in figure 3-19. This temperature structure consists of three parts: A surface layer of varying thickness, with uniform temperature (isothermal) or a relatively slight temperature gradient; the thermocline, a region of relatively rapid decrease in temperature; and the rest of the ocean, with slowly decreasing temperature down to the bottom. If this structure changes, the path of a beam of sound through the water also changes.

LAYER DEPTH.—Layer depth is the depth from the surface to the top of a sharp negative gradient. Under positive gradient conditions, the layer depth is at the depth of maximum temperature. Above layer depth, the temperature may be uniform. If it is not uniform, a positive or weak negative gradient may be present.

LAYER EFFECT.—Layer effect is the partial protection from echo ranging and listening detection a submarine gains when it submerges below layer depth. Sometimes a submarine, diving through a sharp thermocline while taking evasive action, loses the screw noises of the enemy ASW ship. Although usually the pinging can still be heard, it is as a low

intensity signal. On the ASW ship, ranges on submarines are reduced greatly when the submarine dives below a sharp thermocline. Often, the echoes received are weak and mushy.

SHALLOW WATER EFFECT.—Echo ranging is difficult in shallow water because the sound is reflected from the bottom. When the ship is in shallow water and the ocean floor is smooth, the sound bends down from the surface to the bottom then back up to the surface, and again down to the bottom. When the transmitted sound acts in this manner, there are spaces empty of sonar coverage into which a submarine can pass and be undetected. In figure 3-20 you will notice how a sonar contact on a submarine can be lost when the submarine enters the shaded area.

The shaded spaces in figure 3-20 are called shadow zones. Contact is regained when the submarine enters the wave path again. As shown in the illustration, contact is made at long range (point A), is lost (point B), and is regained at short range (point C). Note however that, without the reflection, the maximum range would have been the short range at which the contact was regained (point C).

The reason for the loss of contact at short range is shown at point D where the submarine

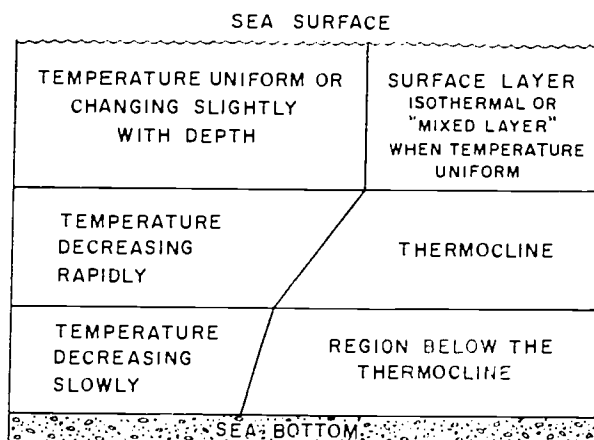

71.33

Figure 3-19.—Typical layers of the sea.

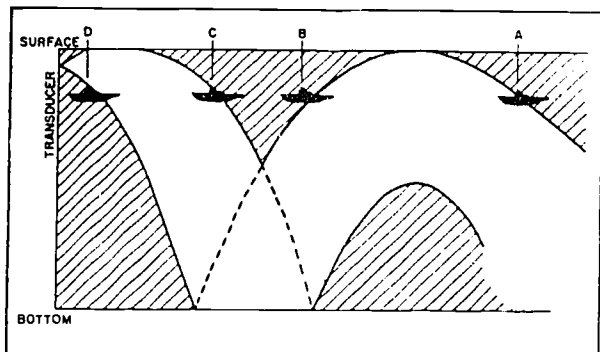

71.28

Figure 3-20.—Shallow water effect on transmitted sound.

passes beneath the sound. The distance at which contact is lost at short range depends on the depth of the submarine. Here is a rule of thumb for estimating a submarine's depth:

The range in yards at loss of contact is roughly equal to the depth of the submarine in feet. A contact lost at 300 yards would thus be presumed to be about 300 feet deep.

Once the behavior of sound in seawater is known, it is possible to predict sound conditions in the sea. From the temperature gradient of the water, an experienced person can judge the maximum range to expect. A new Sonar Technician is not expected to know how to predict sound conditions, but he should understand why results are poor one day and good another day. He should know what is meant by shadow zones, and the reasons why sound does not travel in a straight line. He also should be able to distinguish between poor equipment adjustment and poor sound conditions.

Following are some general conditions for hearing echoes.

1. Usually poor near coasts (50 miles) as compared to sea conditions farther out.

Conditions for hearing are particularly poor at the mouths of rivers.

2. Better in winter than in summer.

3. Better at night than in the middle of the day, especially in spring and summer.

4. Better in morning than in the afternoon, in spring and summer, but little change if whitecaps are present. In many localities, however, conditions are better in the afternoon than in the morning because of the effect of prevailing winds that freshen in the afternoon.

DEEP WATER SOUND PROPAGATION

From the preceding discussions, it can be concluded that the behavior of the sound wave is influenced considerably by the structure of the sea. Most of our discussion so far has pointed out the adverse effects on a sound beam in comparatively shallow water—say 100 fathoms or less. Now, let's examine some of the phenomena that take place in very deep water.

Direct Path

Theoretically, if the sound waves were not affected by velocity gradients, all the sound waves would be straight lines and would travel in a direct path at whatever angle they left the source. In actual practice, however, the sound beam follows a path, or paths, as determined by the sea condition at the time.

Sound Channel

Figure 3-21 illustrates a combination of two gradients of equal slope, one negative and one

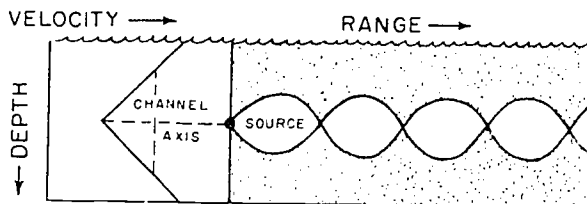

71.34

Figure 3-21.—Strong negative and strong positive gradients forming a sound channel.

positive. Their junction is a point of minimum velocity. If a sound source transmits at this depth of minimum velocity, all of the sound beams that start in an upward direction will be bent back down, and those that start downward will be bent back up. When such a condition occurs, we have a sound channel. The depth of minimum velocity is the axis of the channel. In this symmetrical situation, a beam that starts out downward will rise as high above the channel axis as it went below it, and then will be bent downward again. Sound will remain in the channel, as far as the channel exists, and will suffer very little loss as it progresses through the channel.

Although sound channels are a rarity in shallow water (under 100 fathoms), they are always present in the deep water areas of the world. The depth of the axis of the channel is about 350 fathoms in the central Pacific and somewhat over 500 fathoms in the Atlantic. In the polar regions, where the surface water is materially colder, the axis of the channel lies nearer the surface.

Convergence Zone

Another effect that is closely related to the deep sound channel is the convergence zone effect. The convergence zone effect, now applied to long-range active sonar, has long been used by submarine sonar operators. If the sound source is placed near the surface instead of near the axis of the sound channel, the path followed by the sound beam looks somewhat like that in figure 3-22.

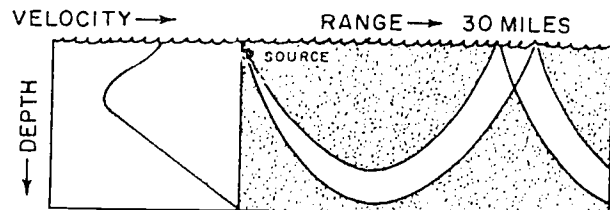

Figure 3-22.—Convergence zone.

51.8

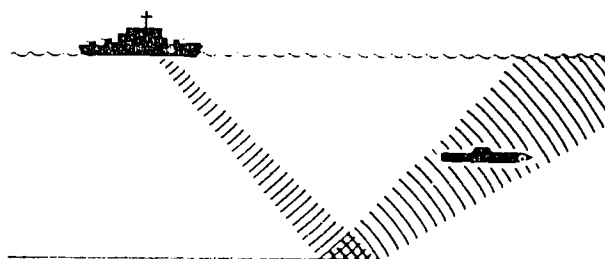

Figure 3-23.—Bottom bounce effect.

51.7

Sound energy from a shallow source travels downward in deep water. At a depth of several thousand feet, the signal is refracted, due to pressure, and returns to the surface at a range of about 30 miles. The surface zone is from 3 to 5 miles wide.

The sound that reaches the surface in the first convergence zone is reflected or refracted at the surface and goes through the same pattern again. It produces a zone approximately 6 miles wide at 60 miles, and another 9 miles wide at about 90 miles. Experienced Sonar Technicians are familiar with this convergence zone effect. Often they have picked up strong noise signals from targets that appear suddenly, show up strongly for a few minutes, and then disappear.

A surface or near-surface contact detected in the first convergence zone will have about the same signal strength as a target detected at 3 miles when no zone is present. Minimum depth required along the path of the sound beam is about 1000 fathoms. The usual requirement is 2000 fathoms for conducting convergence zone searches. The minimum depth required is related to the surface velocity of the sound and increases as the velocity increases.

Bottom Bounce

For long-range search in water depths over 1000 fathoms, newer sonar equipment may operate in a bottom bounce mode. The transducer is tilted downward at an angle so that the sound beam strikes the bottom and is reflected back to the surface, as shown in figure 3-23.

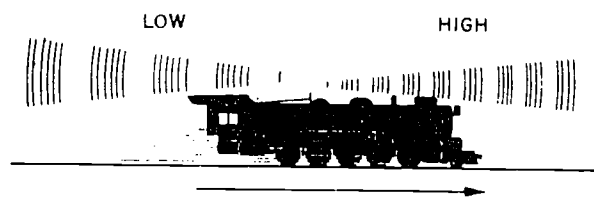

71.37

Figure 3-24.—Doppler effect.

Because of the depression angle (15° to 45°), the sound beam is affected less by velocity changes than are sound pulses transmitted in the normal mode. At great depths (2500 fathoms and greater) however, the sound beam usually will be refracted before reaching the bottom, thus producing a convergence zone effect.

DOPPLER EFFECT

You probably are familiar with the changing pitch of a train whistle as the train passes near you at high speed. As the train approaches, the whistle has a high frequency. As the train goes by, the frequency drops abruptly and becomes a long, drawn-out sound. The apparent change in frequency of a signal resulting from relative motion between the source and the receiver is known as doppler effect. Figure 3-24 illustrates doppler effect.

Each sound wave produced by the whistle is given an extra "push" by the motion of the train. As the train comes toward you, the resultant effect is an increase in pitch, caused by compression of the waves. As the train moves away from you, the sound waves are spread farther apart, resulting in lower pitch.

Although a stationary receiver was used for illustrative purposes, the same effects can be observed if the receiver is moving toward a stationary source.

Because doppler effect varies inversely with the velocity of sound, the effect is much less marked in the sea than it is in the air. Doppler can, however, be noted by the Sonar Technician if he listens carefully.

DOPPLER AND REVERBERATIONS

Earlier in this chapter you learned that, as a sound pulse moves through the water, it loses some of its energy to the water particles. The particles reradiate the energy in all directions. Part of the reradiated sound is returned to the sonar receiver, and the effect known as reverberation is heard. The water particles become sound sources and, as your ship moves through the water, doppler effect is noticed. The following example should help clarify doppler effect for you.

Your ship is underway at a speed of 15 knots; sound velocity is 4800 feet per second; sound frequency is 14 kHz. The sonar is keyed, and 1 second later it is keyed again. During the 1-second interval, the first pulse travels 4800 feet. When the second pulse is transmitted, it is only 4775 feet from the first one because the ship has traveled 25 feet. Using the formulas given in connection with wavelength, you can easily determine that the apparent frequency of the reverberations from ahead of you is approximately 14.1 kHz, whereas those from behind your ship have a frequency of about 13.9 kHz. Reverberations from the beam will have the same frequency as the transmitted pulse because the ship is neither going toward the particles nor away from them. The doppler effect of reverberations is illustrated in figure 3-25. To determine echo doppler, the Sonar Technician compares the tone of a target echo to the tone of the reverberations.

No Doppler

Consider the echo from a submarine that is neither going away from nor toward the sound beam. It either is stopped or is crossing the sound beam at a right angle. If the submarine is in either of these situations, it reflects the same sound as the particles in the water, and its echo has exactly the same pitch as the reverberations, which means the submarine echo has no doppler. Therefore, whenever the pitch of the submarine echo is the same as the pitch of the reverberations, you know that the submarine is stopped or that you are echoing off its beam.

INTRODUCTION TO SONAR

and you would report "No doppler." Figure 3-26 illustrates a "No doppler" situation.

Doppler Up

Suppose the submarine is coming toward the echo ranging ship. In this situation, it is as though the submarine were a train approaching a car at a crossing. The sound transmission reflected from the approaching submarine is heard at a higher pitch than the reverberations. When the echo from the oncoming submarine is higher than the reverberations, report "Doppler up." When making this report, you are telling the conning officer that the submarine is heading toward your ship and making way through the water. This form of doppler is illustrated in figure 3-27. Notice in the illustration that the echo frequency of the submarine on the ship's starboard quarter is the same as the ship's sonar frequency, yet it has up doppler. Remember, doppler is determined by comparing the tone of the target echo and the tone of the reverberations.

Doppler Down

Just as the tone of a train's whistle decreases in pitch as the train moves away from you, so does the doppler of a submarine moving away from your ship. No matter where the submarine is located in relation to your ship, if he is heading away from you, the tone of his returning echo will be lower in pitch than the tone of the reverberations. Figure 3-28 illustrates two situations when you would report "Doppler down" to the conning officer.

DOPPLER REPORTS

To summarize what you have just learned about doppler: Doppler is the difference in pitch between the reverberations and the echo. When the echo is higher than the reverberations, you will sing out "Doppler up." If it's the same as the reverberations, report "No doppler." If the echo is lower than the reverberations, say "Doppler down."

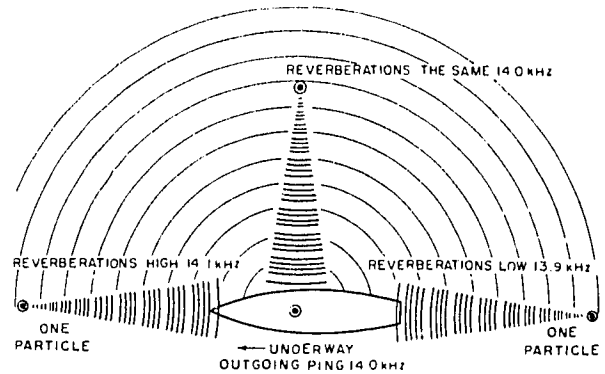

71.39

Figure 3-25.—Illustration of doppler.

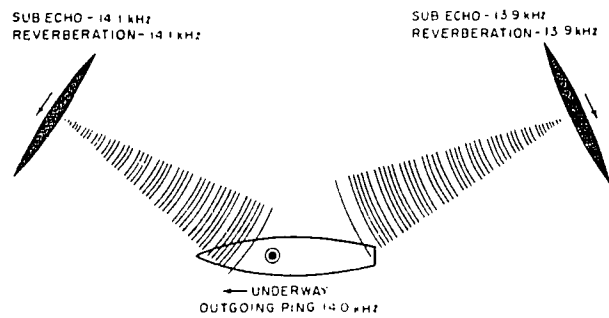

71.40

Figure 3-26.—No doppler.

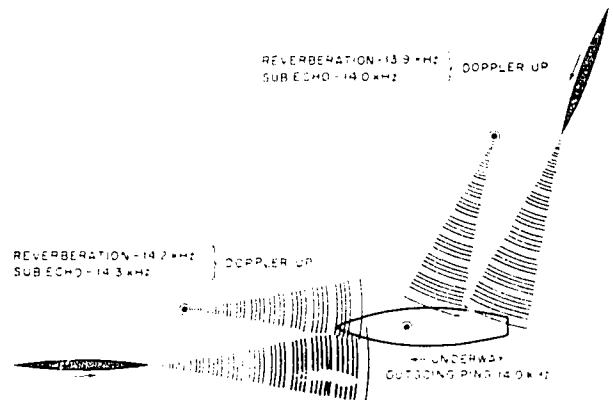

71.41

Figure 3-27.—Doppler up.

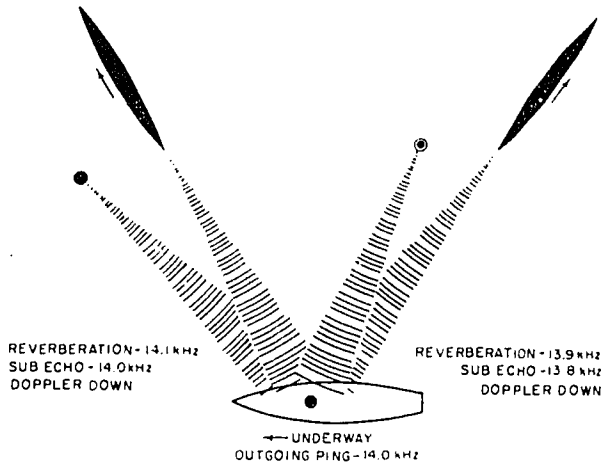

71.42
Figure 3-28.—Doppler down.

When you become a really skilled operator, you will be able to give the degree of doppler, that is, how high or low it is. For instance, a submarine coming directly toward your ship at 6 knots returns a higher echo than a submarine

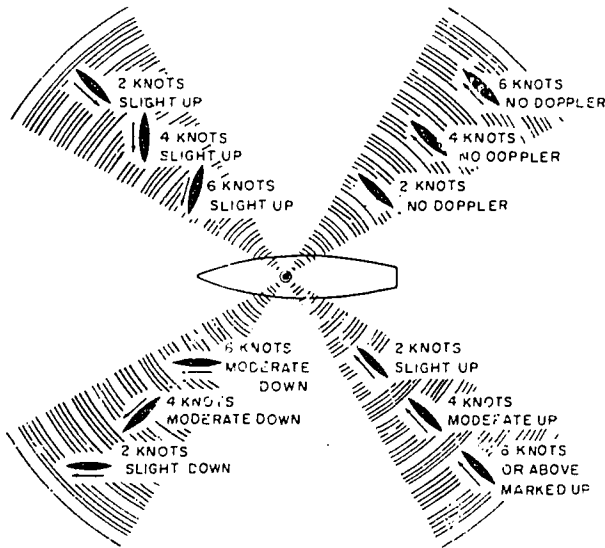

71.43
Figure 3-29.—Doppler conditions.

coming directly toward the ship at 2 knots. Also, a submarine coming directly toward the ship at 6 knots returns a higher echo than a 6-knot submarine that is heading only slightly toward the ship.

The importance of prompt and accurate reports cannot be overemphasized. Two details count: How much speed the submarine is making, plus how much it is heading toward or away from the ship. The combination of these two considerations is spoken of as the component of the submarine's speed toward or away from the ship. If the submarine's speed component is more than 6 knots, report "Doppler marked, up (or down)." When it is 3 to 6 knots, inclusive, report "Doppler moderate, up (or down)." If less than 3 knots, then call it "Doppler slight, up (or down)." (See figure 3-29.)

You now realize how important it is to give an accurate report of doppler to the conning officer. It tells whether the submarine is coming toward or going away from your ship, and gives the component of the submarine's motion. Remember that any contact that does have doppler must be moving in the water; if it is not a surface ship, chances are that it is a submarine or a large fish. Figure 3-30 gives an idea of the value of doppler.

INTERPRETING ECHOES

Sonar Technicians learn to recognize one echo from another by listening to recordings of reverberations and echoes and by practicing with the sonar aboard ship. The following remarks may be helpful; however, they cannot substitute for actual practice.

DOPPLER/NO DOPPLER

As we said previously, an echo with doppler is probably a submarine or a large fish or mammal. A whale, for instance, may have echo characteristics closely resembling those of a submarine. A strong current or tide will cause an echo to have a doppler effect, but such an occurrence is unusual.

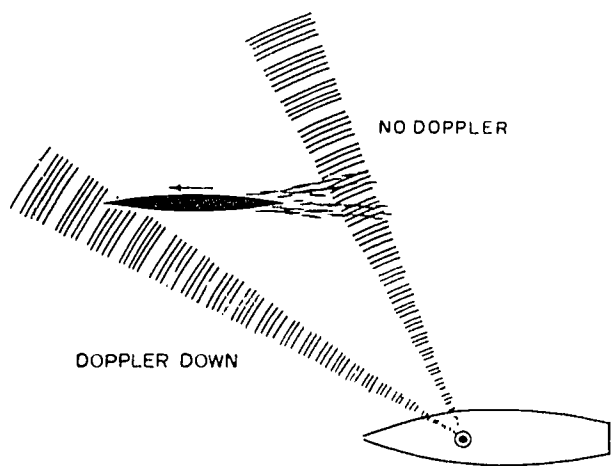

71.44

Figure 3-30.—Value of doppler.

If an echo has no doppler, it may be from a submarine's beam or wake, from a stopped submarine, or other large, solid surface. Such large reflecting surfaces produce sharp, clear echoes; the larger the area of the target, the greater the strength of the echo. A weak, mushy echo, without doppler, is heard from such objects as riptides, kelp beds, schools of small fish, and wakes that are breaking up. The numerous small reflections combine in random fashion to form an irregular echo wave.

ECHO STRENGTH

The strength of the echo depends on the power of the incoming wave. This power depends on the sound output of the transducer; the size, position, and movement of the target; and the conditions of sound transmission in the sea.

Often, you will receive the worst type of echoes from the stern of a submarine. The target area is small and is broken into multiple surfaces by the screws, the wake, and such, so that there is a combination of reduced power and interference. Don't dismiss weak, poor-sounding echoes as nonsubmarine. Experienced sonar operators will tell you that, although an echo

from dead astern of the target is hardest for an operator to identify, it can be done with a little perseverance.

ECHOES FROM FALSE TARGETS

Echoes may be heard not only from whales but from large fish, such as blackfish. Schools of herring or other small fish sometimes are large enough to reflect a strong echo.

If the water is shallow and the bottom is hard, rocky, or covered with coral heads, sound waves are reflected strongly. Often these reflections return as loud and clear as echoes from a target, but they have no doppler. Also, in shallow water as along the Continental Shelf on the eastern coast of the United States, hulls of long-sunken ships may return a very convincing echo. Because Nazi U-boats were so effective in this area during World War II the shelf is littered with dead ships capable of hoaxing the

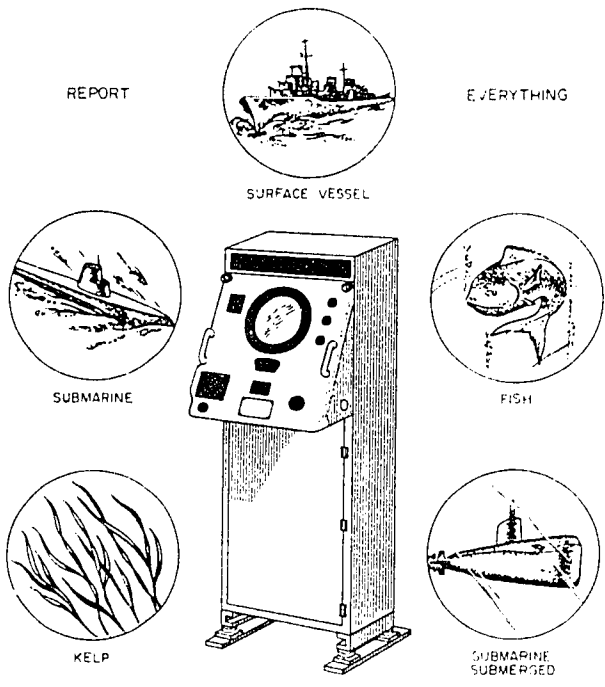

71.45

Figure 3-31.—Report everything you hear.

unsuspecting sonar operator into believing his contact is actually a submarine.

REPORT EVERYTHING YOU HEAR

One of the Sonar Technician's most important tasks is to distinguish the target echoes from other noises that tend to mask them. Sonar operators hear many kinds of echoes. Rocks, shoals, buoys, mines, surface craft, whales, schools of fish, wakes of surface craft and submarines, as well as the submarines themselves, can reflect sound.

Report every sound you hear, regardless of whether you can identify the echo. Figure 3-31 illustrates a few of the many objects that may return an echo or emit a sound. Do not delay making your report while you try to determine what you have detected. By the time you decide it's a submarine, it may be too late. Don't be afraid to make a report that may turn out to be nonsubmarine. The safety of your ship and the lives of your shipmates are worth more than the time spent or the ordnance expended on a false contact.

CHAPTER 4

BATHYTHERMOGRAPH

The travel of sound waves in the sea was discussed in the preceding chapter. The factors that affect sound travel in water, also mentioned earlier, are pressure, salinity, and temperature. Sonar Technicians must have a thorough knowledge of these factors to interpret correctly the information displayed by sonar equipment.

Increases in pressure speed up the velocity of sound, making the speed of sound higher at extreme depths. An increase in salinity also increases the velocity of sound. The effects of pressure and salinity are not nearly as great, however, as the effects of temperature changes--particularly abrupt changes.

Information about the ocean temperature at a given time can be used to predict what will happen to transmitted sound as it travels through the water. Because thermal conditions of the sea are of the utmost importance to Sonar Technicians, a device, the bathythermograph (BT), is available for measuring water temperature at various depths. From such measurements, we can arrive at fairly accurate conclusions regarding the maximum range at which a submarine may be detected, as well as the most favorable depth for the submarine to avoid detection. These two fundamentals are important considerations in antisubmarine warfare. They influence the types of screens used and aid in determining the spacing of ships in the screen.

Much of the data used in conjunction with BT information for determining sonar detection ranges cannot be included in this text because of the classified nature of the subject matter. Sonar

range prediction methods are presented in other publications, such as *Sonar Technician G 3 & 2*, NAVEDTRA 10131 and *Sonar Technician S 3 & 2*, NAVEDTRA 10132.

EFFECTS OF TEMPERATURE

The speed of sound through water increases at the rate of between 4 and 8 feet per second for each 1°F rise in temperature. This 4- to 8-fps change depends on the temperature range of the water. At water temperatures in the 30° range, for instance, a 1° rise increases the rate of travel differently than does a 1° rise in the 70° range.

Ships and submarines of the U.S. Navy operate in all sea temperatures--from near freezing in the polar regions to the upper 80s in the tropics. To provide accurate range data, sonar equipment must be adjusted to the changes in sound velocity.

Under some conditions, a pulse transmitted by sonar equipment may travel easily through water that varies greatly in temperature. Under different conditions, the pulse transmitted may be unable to penetrate a 5° temperature change layer at all because it is reflected and scattered instead.

TEMPERATURE LAYERS

A pulse of acoustical power may provide sonar reception out to several thousand yards of range. The same pulse, if transmitted into a layer of water (such as a sound channel that tends to keep the pulse confined within it), may be able to provide sonar data on contacts many miles distant.

Sound has a natural tendency to seek paths toward the cooler layers of the sea. Because the temperature of the sea normally decreases with depth, the path of a transmitted pulse of sound is usually in a downward direction.

If a cross section or a profile of the sea's temperatures were taken, a normal condition might show a layer of water of uniform temperature (less than $1/2^\circ$ temperature change) from the surface to varying depths. This condition is called isothermal. Next, there would be a region of water in which the temperature decreased rapidly with depth. Such an area is known as a thermocline. Finally, for the remainder of the measured depth, the temperature would decrease only slightly with depth.

Thermoclines

The thermocline can play havoc with a pulse of acoustical energy. As the transmitted sound pulse reaches the thermocline, one of two effects is apparent.

First, the thermocline can prevent passage of the pulse, reflecting it back to the surface. Targets beneath the thermocline may be undetected. This possibility is one of the reasons submarine commanding officers seek the cover of such thermoclines, hoping to evade detection by surface ships or aircraft.

Second, the thermocline can allow passage of the sound pulse but alter its direction considerably in so doing. This effect is called refraction. If a sound pulse enters a thermocline at, for instance, a 30° angle from the sea's surface, it is possible for the angle to be altered to 70° or more while traveling through the thermocline, and change again as it emerges. The result of this refraction can be a distorted path of sound travel that affects the accuracy of target presentation at the sonar console.

SUBMARINE BATHY THERMOGRAPH SYSTEMS

More information is required from a submarine BT than from its surface ship

counterpart. Because salinity, temperature, and pressure affect the ability of a submarine to maintain desired operating depth, knowledge of these conditions and their effect on buoyancy is necessary so that the diving officer can maintain trim of the submarine.

The AN/BQH-1A and the SSXBT (submarine expendable bathythermograph) provide the necessary data.

DEPTH-SOUND SPEED MEASURING SET AN/BQH-1A

The AN/BQH-1A is a completely transistorized device used to provide accurate information concerning sound ranging conditions in the surrounding water and buoyancy during diving operations.

The equipment is capable of measuring sound velocity in seawater over a range of 4600 to 5100 fps. Accurate depth measurement is provided by a depth element and its associated circuitry. Velocity of sound and depth of the sensing element which measures this velocity are displayed on a two-channel (pen and drum) servomechanism recorder (fig. 4-1).

Maintaining the trim of a moving submarine is aided greatly by indicating on the recorder chart a series of isoballast lines. These lines are precalculated for various classes of submarines. Charts must be selected with isoballast lines printed for that particular class of submarine. In indicating a trace that crosses the isoballast lines, action of the pen and drum gives the amount of water to pump or flood to maintain the submarine's trim.

Buoyancy changes, indicated by crossings of isoballast lines, may be related to submarine depth and also to velocity of sound in water. Both submarine buoyancy (upon which trim depends) and velocity of sound in water are definite functions of salinity, temperature, and pressure. Inasmuch as a moving submarine encounters changing conditions of salinity, temperature, and pressure, the AN/BQH-1A recording equipment must measure these changes in terms of absolute values of velocity of sound in water. Sensitivity of the velocity-measuring portion of this equipment is

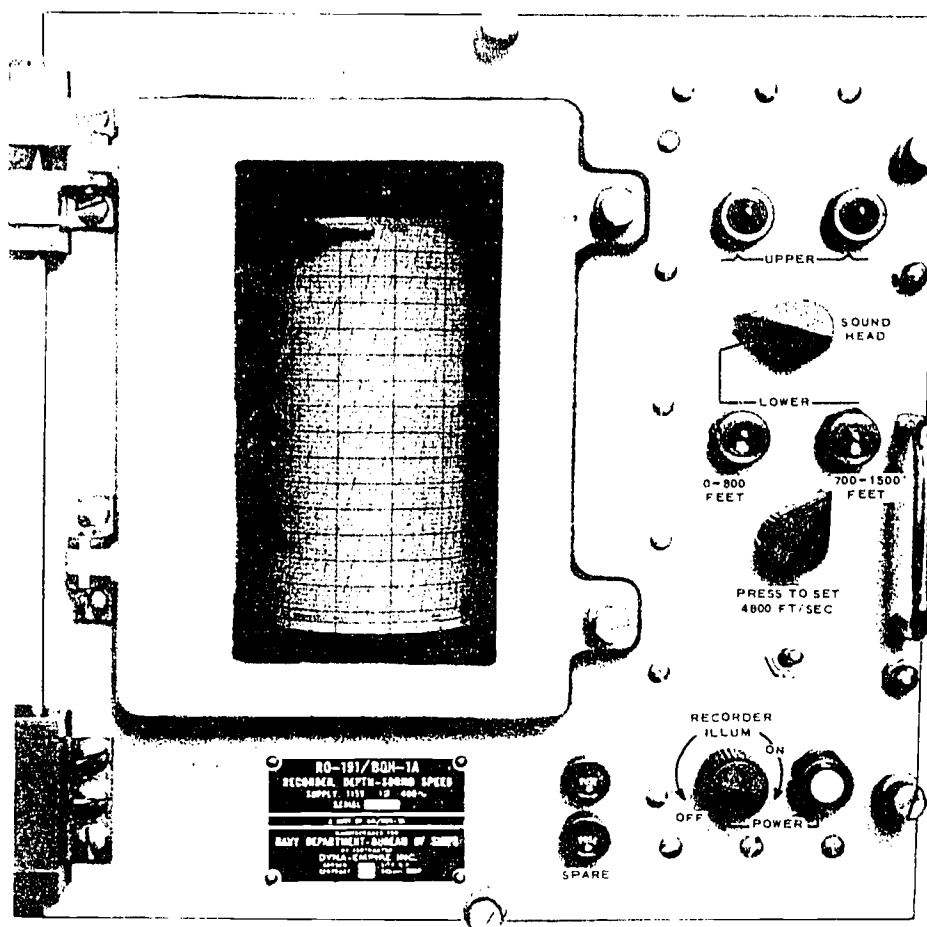

Figure 4-1.—Depth-sound speed measuring set AN/BQH-1A.

35.156

sufficient to indicate changes in sound velocity of 1 fps when passing through a thermal gradient. Equipment pressure circuits are capable of indicating changes in depth of approximately 1 foot. This measurement represents the minimum readable definition of the recorder chart's pressure portion.

Isoballast curves are calculated in such a way that individual curves pass through all points where a loss in buoyancy with depth exactly equals any gain in buoyancy resulting from a decrease in water temperature or increase of salinity.

65

Functional Operation

To measure sound velocity and to ascertain velocity gradients in the surrounding water, two transducer assemblies (sound heads) are provided with each depth-sound speed measuring equipment. One assembly is mounted on the upper (or sail) portion of a ship. The other device is mounted at the keel.

To obtain accurate information concerning changing gradients and subsequent effects on buoyancy during diving operations, it is advisable to use the lower sound head while diving, and the upper sound head while

ascending. By following this pattern, radiated heat from the skin of the ship will wash away from the sound head. Radiated heat, consequently, will not interfere with measurements of gradients and indications of corresponding buoyancy changes.

Sound velocity in water is measured in the following manner: The AN/BQH-1A transmits into the water a pulse of acoustic energy. This pulse travels from a transmitting transducer through the water and is received by a second receiving transducer. The time required for a pulse to travel from transmitter to receiver is measured by means of electronic timing circuits. Thus, a direct measurement of sound velocity is made. This method of direct measurement eliminates the need for correlating various factors of the ocean: salt content, density, and temperature, plus pressure corresponding to depth at which velocity is measured.

Description of Controls

Operating controls of the AN/BQH-1A depth-sound speed measuring set are described for the recorder and repeater. (Refer to fig. 4-1.)

RECORDER.--Following are the major operating control switches on the recorder.

1. Power on/off recorder illumination control: This control applies 400-hertz primary power to the recorder. It varies the brightness of the internal chart illumination.

2. Sound head select: A two-position switch that permits an operator to select either the upper or lower sound head for displaying sound velocity on the recorder drum.

3. Depth scale select: A two-position switch that permits an operator to select either of two overlapping depth scales. One depth scale is 0 to 800 feet; the other, 700 to 1500 feet.

4. Press-to-set 4800 fps: A spring-loaded switch, that, when depressed, applies a calibrating signal internally generated in the particular sound head in use. The switch acts as a system check of performance and accuracy of sound velocity indication. It also assists in proper positioning of new recorder charts.

REPEATER.--The repeater unit is identical to the recorder unit, but the repeater has no operational controls. The only control on the repeater is the power on/off illumination switch. The repeater cannot be operated unless the recorder is also operating.

Operating Procedures

Because the AN/BQH-1A and its associated sound heads and depth circuitry are completely transistorized, no warmup time is required for proper operation. Following is the normal operating procedure recommended for the set.

1. After lighting off the equipment and selecting the desired sound head, the recorder illumination control is adjusted to provide sufficient light to clearly view the chart. (NOTE: When surfaced, the upper sound head is not immersed. Care must be taken to avoid energizing this head until the submarine completely submerges.)

2. The depth scale select switch is set to the desired depth setting (0-800 feet or 700-1500 feet). The equipment is now ready for normal operation.

3. The press-to-set 4800 fps switch is depressed and held until the velocity indicating drum reaches a steady position. Indicated velocity position should be 4800 fps. (NOTE: For each sound head the absolute value of the 4800-foot calibrate velocity varies slightly. Test data sheets supplied for the sound head in use should be consulted for exact calibrated readings.)

4. In the preceding step, when the drum steadies, the press-to-set switch is released. The drum should rotate and indicate the sound velocity in the water at the sound head in use.

5. When both sound heads are immersed, the sound head select switch may be rotated to select first one, then the other, sound head. Each time the select switch is changed, the drum should rotate to a position that shows the velocity of sound at the sound head selected. When shifting from one head to the other, the recorder also indicates the difference in depth between the two sound heads.

6. The press-to-set 4800 fps switch is depressed. When the drum rotates to a velocity

INTRODUCTION TO SONAR

reading of 4800 fps, the switch is released. The drum then will rotate and begin to give a continuous record of velocity and depth for the sound head in use.

Checks and Adjustments

Minimum front panel controls and adjusting knobs are contained on the AN/BQH-1A. Periodically, the operator should depress the press-to-set switch and verify that the initial calibration accuracy of the equipment is maintained throughout an operating period.

Emergency Use

Because the velocity display and depth display on the AN/BQH-1A are independent of each other, the recorder is capable of emergency operation on either independent channel. If failure of the depth circuitry occurs, an operator may continue to supply useful velocity information by manually positioning the depth pen to a readable portion of the chart. In the event of failure in the sound heads or drum circuitry, depth information may still be supplied independently.

SUBMARINE EXPENDABLE BATHYTHERMOGRAPH (SSXBT)

The SSXBT automatically obtains and records ocean temperature data without the necessity of changing the submarine's depth. The SSXBT is launched from the left signal ejector of a submarine and provides a complete temperature profile from the surface of the ocean down to 2500 feet. All of this is accomplished in less than four minutes.

The submarine bathythermograph consists of a ballistically-shaped BT probe contained in a float assembly. The float assembly also contains a lifting body. When the assembly is launched from the signal ejector, the lifting body separates from the float assembly and is attached to the submarine by an insulated steel cable and a signal cable. The lifting body floats in suspension behind the submarine and pays out a fine two-conductor cable as required. The float assembly rises to the surface dereeling the same fine cable as required by the ascent rate.

When the float assembly reaches the surface, atmospheric pressure actuates a pressure release mechanism and the probe is released for its trip to the bottom, trailing the fine wire behind it. The wire relays back to the submarine the temperature information until the probe reaches the bottom or 2500 feet. At this time, the entire unit is detached from the ship and sinks to the bottom.

SURFACE SHIP EXPENDABLE BATHYTHERMOGRAPH SYSTEM

The surface ship expendable bathythermograph system (fig. 4-2) has a sensor probe, a canister, a launch mechanism, and a temperature-depth recorder. The expendable portion of the system, consisting of the canister and the probe, is seen in figure 4-3 and figure 4-4. The probe weighs about 1 pound and

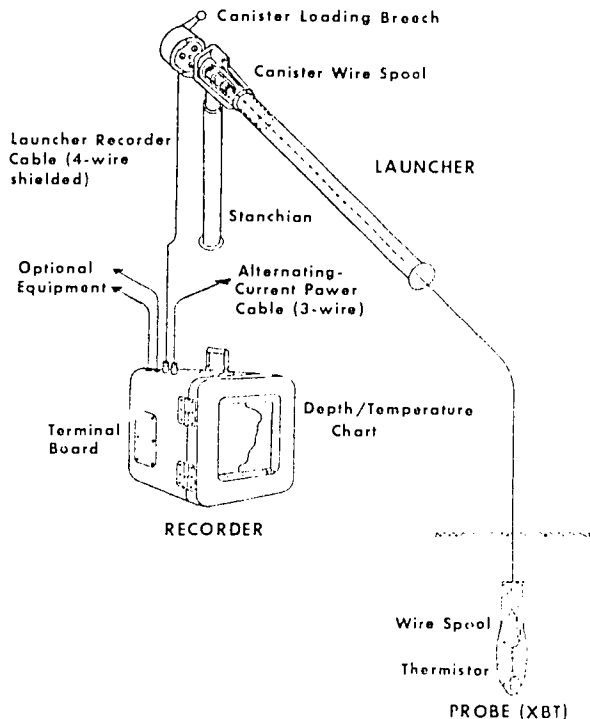

71.126

Figure 4-2.—Expendable BT system.

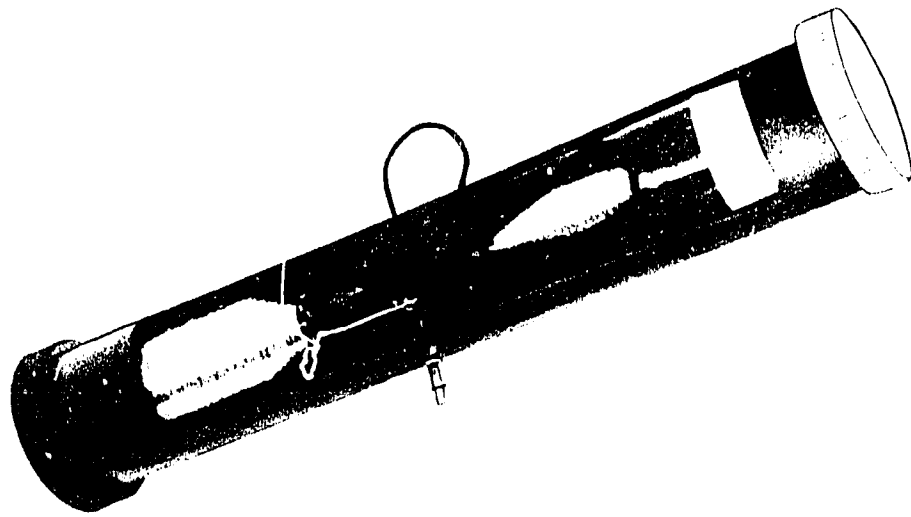

Figure 4-3.—Expendable BT probe in its cannister.

71.118

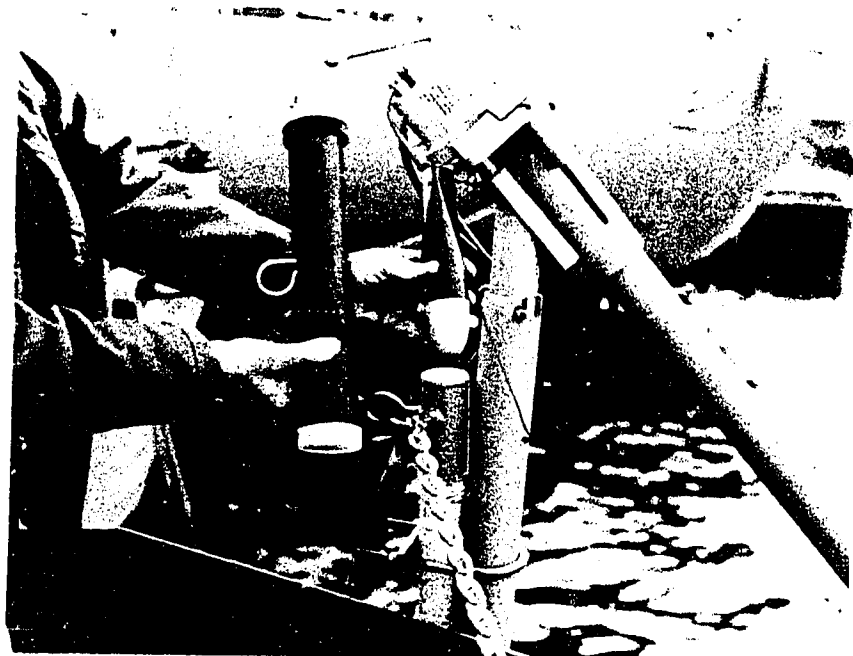

Figure 4-4.—Expendable components and launcher.

71.127

INTRODUCTION TO SONAR

is spin stabilized. It contains a thermistor, which senses temperature changes, and a reel of special wire. The cannister also contains a reel of wire, and holds the probe. The launcher is essentially a tube for holding the cannister. It can be installed to provide through-the-hull launching of the probe, eliminating the necessity for sonar personnel to be on deck in rough weather. The recorder (fig. 4-5) plots a track on a strip chart of temperature versus depth in real time. The strip chart is synchronized to the probe's rate of descent.

OPERATION

When you place the cannister in the launch tube, a watertight electrical connection is formed between the probe and the recorder, causing the recorder to run for 2 seconds. This action sets the automatic starting circuits, which are activated when the probe hits the water. The probe is held in position by a pin protruding from the launcher. Pulling the pin permits the probe to fall free of the cannister, into the

water. (The cannister remains in the launcher.) As the probe starts its free fall, the wire commences unreeling from the probe and from the cannister. This double unreeling action allows the probe to sink straight down and permits the ship to proceed unhindered.

When the probe strikes the water, an electrode triggers the recorder. The thermistor transmits temperature changes to the recorder where they are plotted on the strip chart by a stylus. At a depth of 1500 feet, the probe's wire is exhausted and the recorder stops. A complete readout is obtained in 90 seconds from time of launch. Temperature range of the probe is 28°F to 96°F, with an accuracy of 0.4°F. Depth accuracy is 2 percent or 15 feet, whichever is greater.

Figure 4-6 shows a representative temperature-depth profile. Only 6 inches of chart paper are needed for each 1500-foot drop.

READING XBT RECORDER TRACES

The XBT, as already pointed out, provides a continuous visual record of the temperatures from the surface of the sea to a depth of either 1500 feet, 2500 feet, or a point at which the wire breaks. The temperatures of various ocean depths recorded on the chart are represented as a graph of temperature against depth.

From the temperature curve, one can discover the sound pattern of the sea at the time of the bathythermograph observation. It is from the sound pattern that an estimate of maximum sonar range can be made.

The variation of temperature with depth can be quite complicated. Many different conditions may be represented by the different types of traces.

It is convenient to consider the water as layers. In each layer the temperature can change from top to bottom. Create a mental picture of the location of these layers from the appearance of the chart. Visualize, too, how the

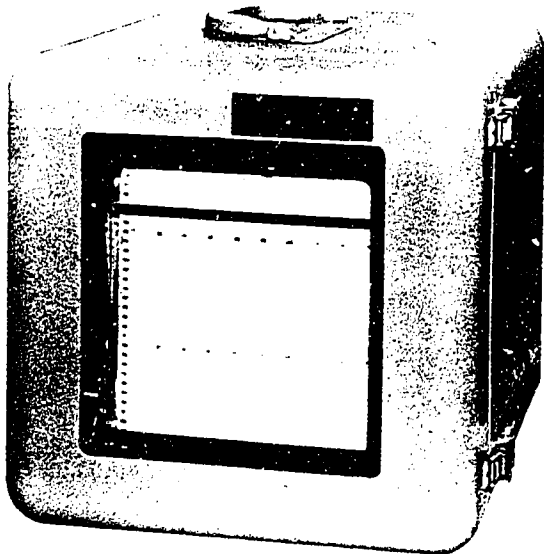

Figure 4-5.—BT recorder.

71.119

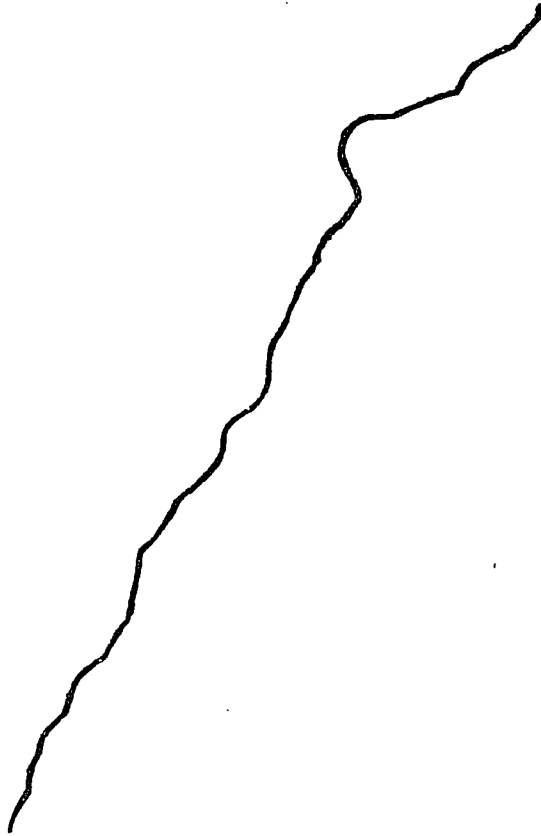

Figure 4-6.—Recorder chart.

71.120

temperature is changing. Study the following examples until each kind of layer can be identified easily.

NEGATIVE GRADIENT

A negative gradient condition exists when the temperature of the water decreases with depth. An XBT, lowered through a negative gradient, produces a graph with the trace sloping to the left as depth increases. Figure 4-7 represents a trace showing a negative gradient. This illustration depicts a particularly sharp gradient, which is quite common. Negative

gradients spell trouble for sonar operators because they result in short sonar ranges.

POSITIVE GRADIENT

Sometimes, layers are found in which the temperature increases with depth. The trace slopes to the right. Although usually observed in coastal waters, this condition may be found anywhere. In figure 4-8 a positive gradient is shown to exist down to a certain depth, beyond which a negative gradient is formed. Depending on the depth of the start (top) of the negative gradient, such a trace can also mean trouble for

INTRODUCTION TO SONAR

the Sonar Technician. As a result of this condition, the shipboard sonar operator observes unusually long ranges to targets near the surface. Little of the pulse's power penetrates the negative gradient, however. The reason is that the higher temperatures in the lower part of the positive gradient bend the pulse back up toward the surface of the sea from which it is reflected downward again, and so on, forming a surface channel.

Any energy of the pulse that does pass through the negative gradient is reduced greatly, and the sound beam is bent sharply downward. Submarines operating 50 feet or more beneath

the top of the negative gradient are difficult targets to detect. The shipboard Sonar Technician may get extremely long ranges on a submerged target near the surface (such as the underwater section of the hull of another screening ship), but he may be unable to detect a submarine just a few thousand yards away. Should the submarine enter the positive gradient, however, it probably would be detected.

ISOTHERMAL LAYER

An isothermal layer of water is one of uniform or nearly uniform temperature

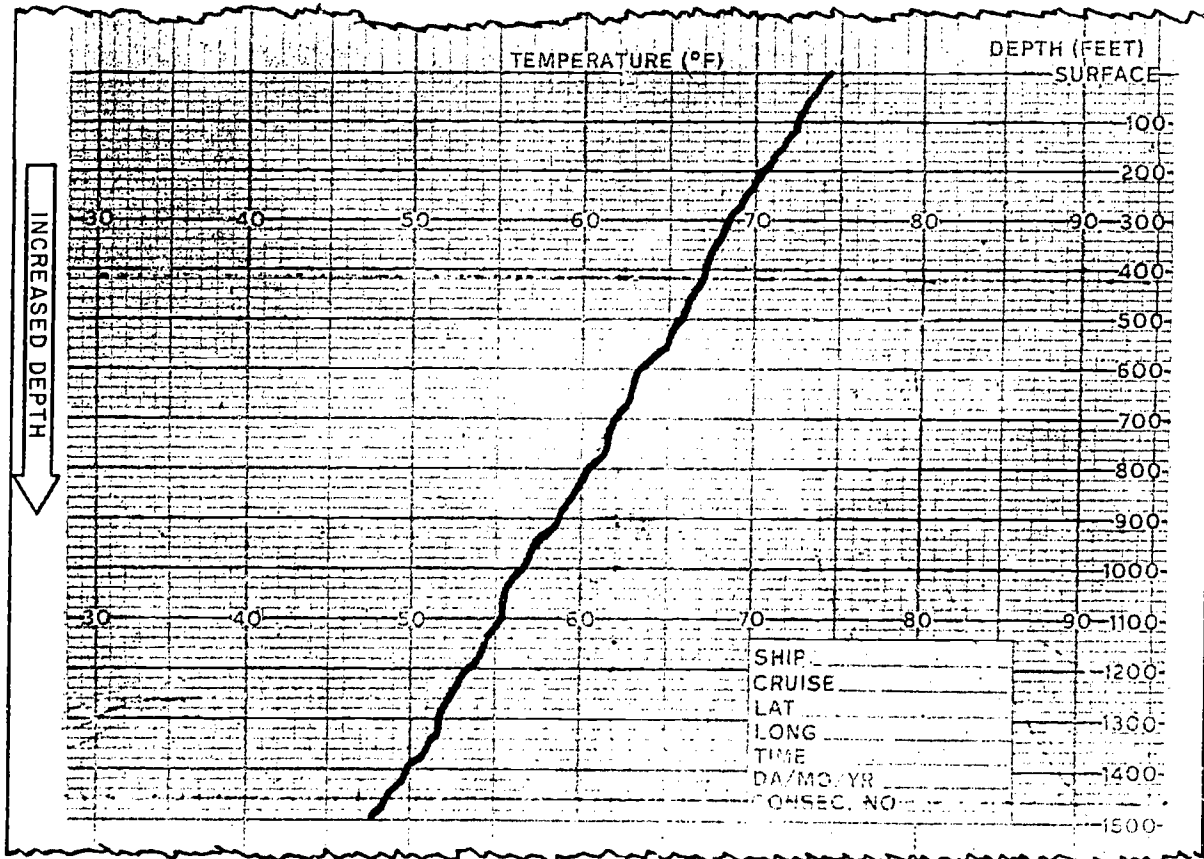

Figure 4-7.—Negative gradient.

throughout. This condition is not confined necessarily near the surface of the sea, but often is found between layers or gradients of markedly different temperatures. An isothermal condition can be caused by waters of two different temperatures mixing. In this respect, it sometimes is referred to as a mixed layer. Isothermal layers are of importance in predicting the path the sound pulse will follow. For this reason Sonar Technicians must be able to read accurately the top and bottom depths of such a layer. You are shown an isothermal condition in figure 4-9. Now look at figure 4-10 to see how isothermal layers sometimes are located in a

temperature profile of the sea. Notice that every time a straight, vertical BT trace is recorded, the layer of water between its limits is known to be isothermal.

DAILY HEATING

Daily heating of the surface water layer has a marked effect on sonar ranges. It produces a condition ASW men call afternoon effect.

When the surface is heated by the summer sun, and the winds are not strong enough to keep the surface water well mixed, the water

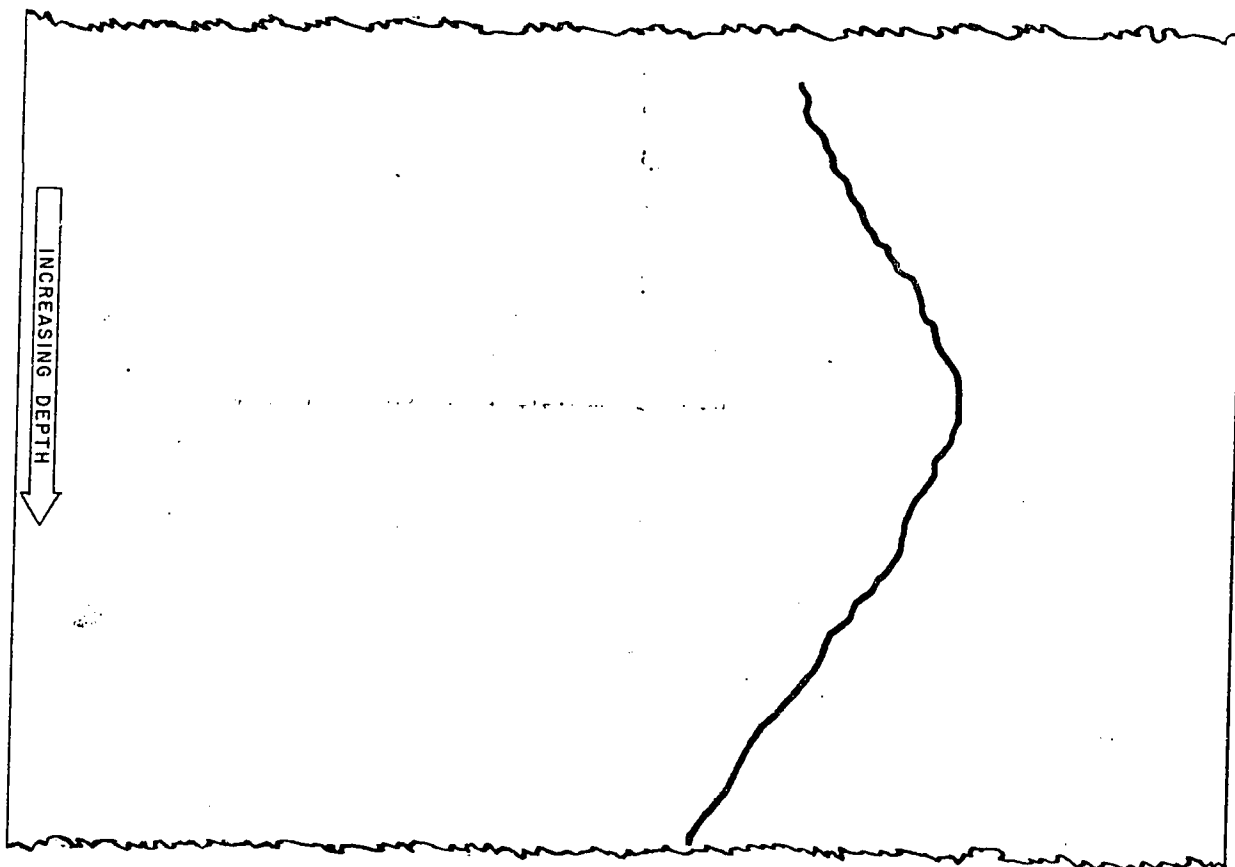

72

Figure 4-8.—Positive gradient.

71.129

INTRODUCTION TO SONAR

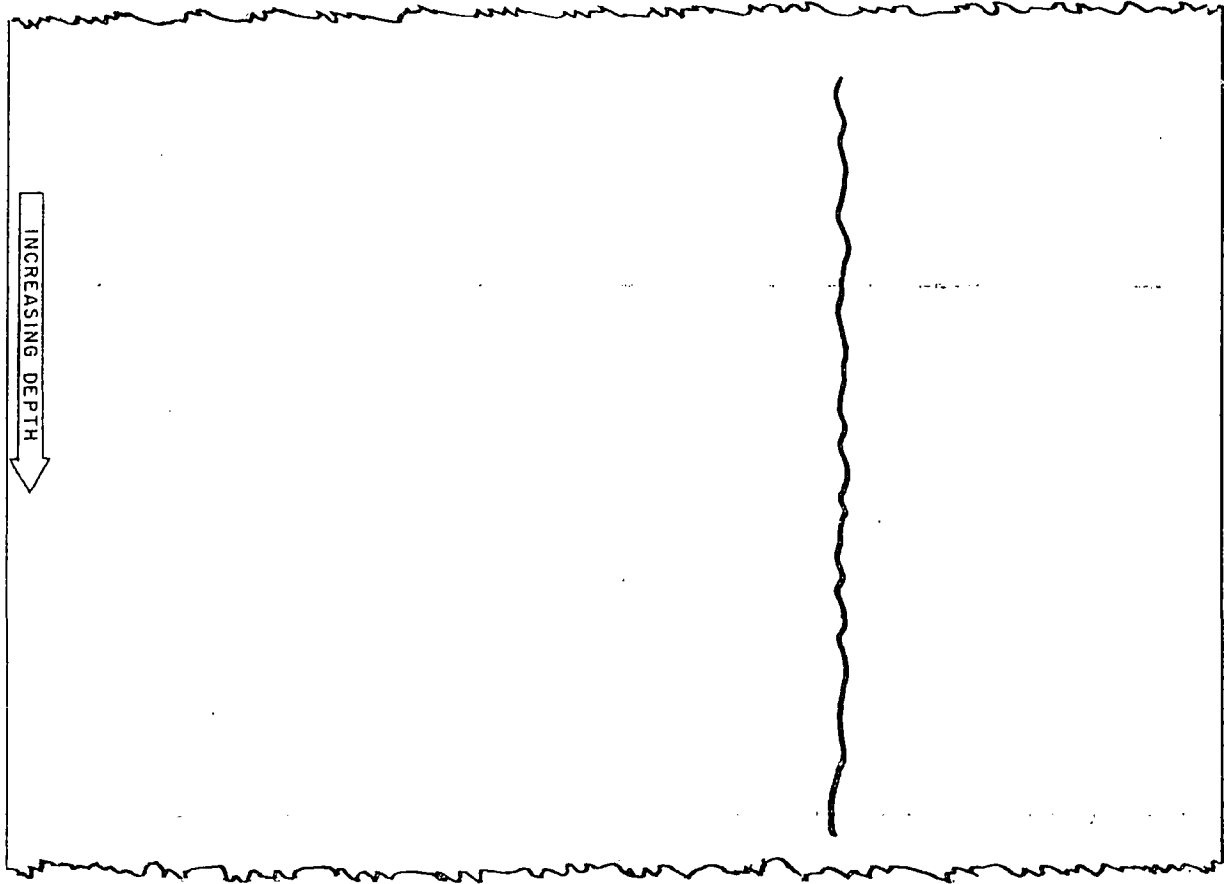

71.130

Figure 4-9.—Isothermal layer.

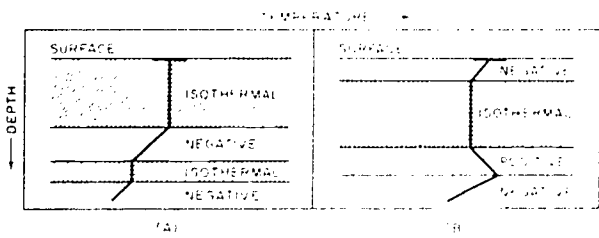

71.89

Figure 4-10.—Temperature profiles.

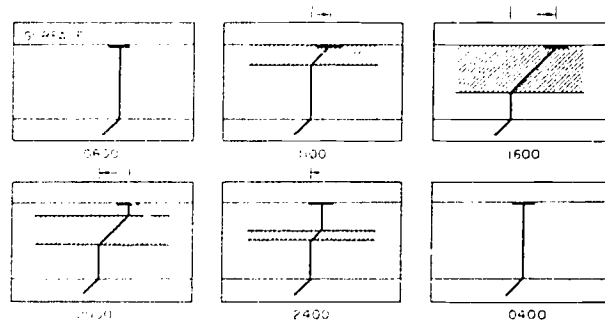

71.90

Figure 4-11.—Effect of daily heating.

Chapter 4—BATHYTHERMOGRAPH

71.92

OCEANAV 3167(16-72)
NOAA Form 77 - 22 (11-72)

BATHYTHERMOGRAPH LOG

Prepared by the OCEANOGRAPHER OF THE NAVY
and the NATIONAL OCEANIC AND ATMOSPHERIC ADMINISTRATION
in accordance with specifications established by the
INTERGOVERNMENTAL OCEANOGRAPHIC COMMISSION (IOC)
and WORLD METEOROLOGICAL ORGANIZATION (WMO)

FOR NAVY AIRCRAFT USE
5C UNAPPROVED
SP. NO. 4162848

SHIP TYPE	HULL NUMBER	YR.	MON.
B	A	1	Z
SODN TYPE	SODN NUMBER	YR.	MON.
B	A	1	Z

TIME GMT	HOUR	MIN	SEC
0	8	8	8
DATE	MONTH	DAY	YEAR
0	8	8	8

SHIP NAME	DESIGNATOR
COUNTRY	INSTITUTION
PROJECT	INSTRUMENT
OBSERVATION NUMBER	STATION NUMBER

SODN TYPE	SODN NUMBER
B	A
YR.	MON.
1	Z

II. OPTIONAL ENVIRONMENTAL INFORMATION											
DEPTH	WIND	SEA LEVEL	AIR TEMP.	AIR TEMP.	DRY BULB	WET BULB	WIND	SEA TEMP.	WAVE	SWELL	SOLAR
1	0	0	0	0	0	0	0	0	0	0	0

III. RADIO MESSAGE INFORMATION											
MESSAGE PREFIX	TIME GMT	DATE	MONTH	DAY	YEAR	DEPTH	TEMP.	DEPTH	TEMP.	DEPTH	TEMP.
J J X X	0	0	8	8	8	0	0	0	0	0	0

I. REFERENCE INFORMATION											
STATION NUMBER	OBSERVATION NUMBER	INSTRUMENT	DEPTH	TEMP.	DEPTH	TEMP.	DEPTH	TEMP.	DEPTH	TEMP.	DEPTH
0	0	0	0	0	0	0	0	0	0	0	0

I. REFERENCE INFORMATION											
STATION NUMBER	OBSERVATION NUMBER	INSTRUMENT	DEPTH	TEMP.	DEPTH	TEMP.	DEPTH	TEMP.	DEPTH	TEMP.	DEPTH
0	0	0	0	0	0	0	0	0	0	0	0

I. REFERENCE INFORMATION											
STATION NUMBER	OBSERVATION NUMBER	INSTRUMENT	DEPTH	TEMP.	DEPTH	TEMP.	DEPTH	TEMP.	DEPTH	TEMP.	DEPTH
0	0	0	0	0	0	0	0	0	0	0	0

I. REFERENCE INFORMATION											
STATION NUMBER	OBSERVATION NUMBER	INSTRUMENT	DEPTH	TEMP.	DEPTH	TEMP.	DEPTH	TEMP.	DEPTH	TEMP.	DEPTH
0	0	0	0	0	0	0	0	0	0	0	0

Figure 4-12.—BT log sheet.



INTRODUCTION TO SONAR

close to the surface may be several degrees warmer than the water 20 to 30 feet down. This effect is maximum in the late afternoon, and usually disappears at night as the surface cools off and water continues to mix. Figure 4-11 is a simplified illustration showing how traces may indicate daily heating or cooling near the surface.

An isothermal layer is seen at 0600 (local time) on a calm, clear day. From 0600 to 1600 the surface is shown gaining heat from the sun faster than it can dissipate the heat back into the atmosphere. The surface temperature increases, and a negative gradient layer, represented by the crossed lines, is established. This layer deepens as the heat penetrates, and diffuses downward by conduction during the time the surface is gaining heat.

After 1600 the surface cools off by evaporation faster than it receives heat from the declining sun. The cooler and denser surface water mixes and may destroy the negative gradient layer. Sufficient cooling may occur during the night to reestablish a single isothermal layer, as shown at 0400.

XBT TRACE MARKING

The graph of each XBT drop must be annotated to have any meaning. The readings obtained from a drop are not used only on your ship; the information is also used to make up range prediction vehicles such as SHARPS Ship/Helicopter Acoustic Range Prediction System). If the time, date, location, etc., were not known, the information would be useless for most drop purposes.

How to Mark the XBT Recorder Chart

The marking of the XBT recorder chart has been standardized, and the proper method is explained below.

Enter on the face of each XBT recorder chart the information listed below in the same sequence. If the format for this information is not preprinted on the XBT recorder chart, write in.

Record N or S and E or W after latitude and longitude, respectively. Record time and date according to GMT. DO NOT OBSCURE THE TEMPERATURE TRACE.

Ship
Cruise
Latitude
Longitude
Time (GMT)
Da/Mo/Yr
Observation #
Bottom Depth*

*optional entry.

BATHYTHERMOGRAPH LOGS

The BT Log, OCEANAV 3167/1(6-72), figure 4-12, is designed to meet two basic needs: (1) provide a message format for radio transmission of synoptic BT data for oceanographic forecasting, and (2) provide the National Oceanographic Data Center (NODC) with information required for BT analog and digital processing. This radio message format supersedes all other formats previously used for shipboard or aircraft BT message reporting.

The instructions provided with the log sheet describe (1) how and where to mail log sheets and recorder charts; (2) how to obtain additional log sheets; (3) how to address radio messages; (4) how to mark the XBT recorder chart after the observation is taken; (5) the procedures for filling in the "REFERENCE INFORMATION," "OPTIONAL ENVIRONMENTAL INFORMATION," and "RADIO MESSAGE INFORMATION" portions of the log sheet; (6) the required interpretation of the temperature-depth trace, and (7) special instructions for Navy use.

These instructions also serve to amplify the following directives, the latest editions of which are applicable and should be rigidly followed:

1. OCEANAVINST 3160.9
2. COMSCINST P3121.3
3. COMSCINST P3120.2
4. COMDT USCG INST 3161.1
- 75 5. NAVWEASERVCOMINST 3140.1.

CHAPTER 5

BEARINGS AND MOTION

In studying bearings and motion, you must remember that they are of two types. The two types of bearings are true bearing, which uses true north as a reference, and relative bearing, which uses ship's head as a reference. True motion is the movement of an object across the Earth. Relative motion is the movement of one object in relation to another object.

This chapter discusses both types of bearings and both types of motion. It shows how they are applied in determining the location and movement of an underwater target, such as a submarine.

With modern sonar, it is possible to locate and track a submarine with dependable accuracy. To make full use of precision equipment, it is necessary to evaluate bearings and motion correctly and thus avoid setting erroneous values into the equipment computers.

REQUIREMENTS FOR LOCATING SUBMARINES

Many landmarks and familiar objects on land can be utilized for establishing a position and determining the location of a particular point. In civilian life we were accustomed to such descriptive terms as "The third house on the right," or "Just a mile down the highway at the big signboard." At sea, though, we must adjust ourselves to doing without the convenience of familiar objects and use other means at our disposal for locating a target. Targets visible on the surface or in the air can be pointed out, but an unseen underwater object must be located in a manner that is both clear and accurate. This method of location is accomplished by using sonar to determine the object's direction and

distance from the sound transmitting ship. In chapter 3 you read about the numerous variables affecting the travel of sound beam in water. These variables greatly affect the precision with which the exact location of an underwater target can be determined. With present-day equipment we are able to compensate for many of the variables and obtain exact positioning information. Electromechanical computers are utilized in solving many of the problems of target bearing and motion. It must be borne in mind, however, that direction and distance must be obtained first, then reported by the operator before the computer can be set up to produce a correct solution. Thus, the ability to determine and report the correct bearing and range as speedily as possible is of the utmost importance to the entire attack problem.

SONAR INFORMATION

Sonar provides the two items of information—direction and distance—from which we derive all subsequent data. Direction and distance are referred to as bearing and range. Correct interpretation and transmittal of bearing and range information are deciding factors in successfully conducting any attack.

Bearing

The direction of the echo from the sound transmission source is called the bearing. Bearing is measured clockwise in degrees of azimuth in three figures from 000° through 360°. Azimuth is defined as a horizontal arc of measurement of the horizon in degrees. One quarter of a circle is 90° and a full circle is 360°.

INTRODUCTION TO SONAR

Until a few years ago, an allowance of $2\text{-}1/2^\circ$ for error in bearing was considered within limits of tolerance in antisubmarine attacks. Today, this standard of tolerance has been reduced to approximately 1° . A bearing error of $2\text{-}1/2^\circ$ at 100 yards amounts to a position error of 4.36 yards; at 2000 yards this error is 87.2 yards. With a bearing error of 1° , we are off target only 1.75 yards at 100 yards, and 35 yards off at 2000 yards. As you can see, modern equipment has provided greater bearing accuracy. No doubt future sonars will give even better accuracy, but remember that the finest equipment will always need a competent operator.

Range

The distance from the sound source to the target is called range. In sonar, range always is expressed in yards. With modern sonar equipment, range detection varies from less than 100 yards to thousands of yards. Ranges can be measured to an accuracy of 1% of the range scale in use. To achieve this accuracy, you must have up-to-date knowledge of water conditions and be able to make adjustments to the equipment to compensate for variations in the velocity of sound.

Range is reported in thousands and hundreds of yards. Some sample ranges and the manner in which they are reported are listed here for your information.

- 3000—"Range three thousand, closing."
- 2500—"Range two five hundred."
- 1750—"Range one seven five zero."
- 1100—"Range one one hundred."
- 1000—"Range one thousand."
- 800—"Range eight hundred."
- 600—"Range six six zero."
- 500—"Range one five zero."
- 400—"Range four hundred, opening."

It should be noted that the word "yards" is never included in a report because ranges always are given in yards.

One range report by itself is insufficient to conduct an attack although such information as whether the range is opening, closing, or

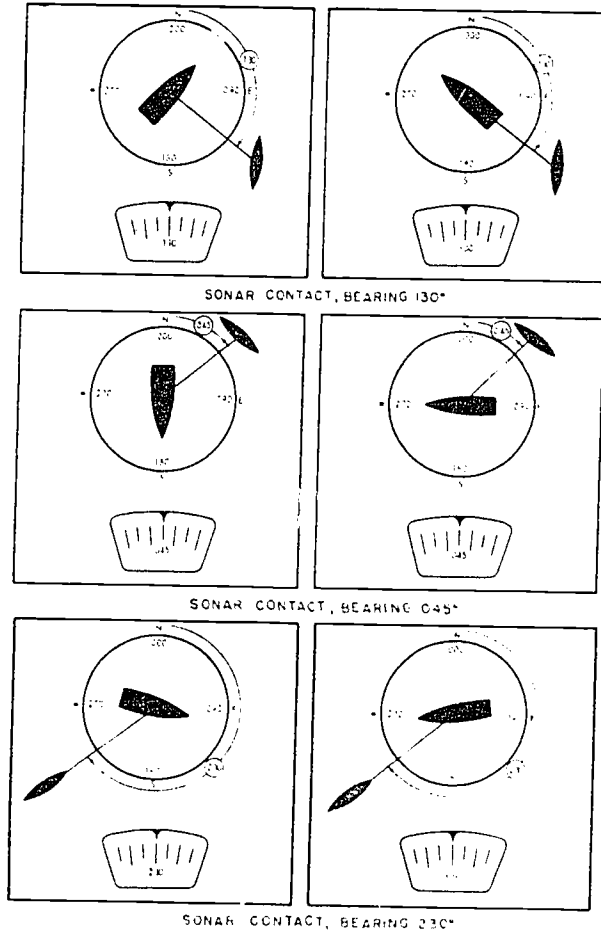

71.3

Figure 5-1.—True bearings are independent of ship's head.

constant is of vital significance. A succession of both bearing and range reports is required to determine target and location and motion.

BEARINGS

In establishing a bearing, we invariably must have a reference point to ensure that the direction is always the same. True bearing is referenced to true north regardless of the direction or motion of the ship. Relative bearing is always referenced to the ship's bow. In all

instances, bearings are reported in degrees and are read clockwise.

Sonar bearings are reported in three figures, and you say "zero" instead of "oh." A sonar contact due east of your ship is reported as "Sonar contact, bearing zero niner zero." If the contact were due west, it would be reported as "Sonar contact, bearing two seven zero."

Notice in the foregoing examples that the word "true" is not used. Unless stated otherwise, always assume that bearings are reported as true bearings. If a gyro failure occurs, relative bearings must be used, and the sonar operator will add the word "relative" to his bearing report. If he wishes, the operator can avoid saying "relative" after each report by stating "All bearings will be relative until further notice."

TRUE BEARINGS

To illustrate that true bearings are independent of the ship's heading, figure 5-1 shows three different bearings. The ship and the

contact have been drawn in to show that, although the ship has a different course, the true bearing of the contact remains the same. In the illustration, compare the examples on the left with the examples on the right.

All shipboard and submarine sonar sets utilize a gyrocompass input to provide true target bearing by reading the sonar bearing marker against the dial. Figure 5-2 shows this dial as it is in a standard shipboard sonar set. The section enclosed within the dotted lines is the area visible to the sonar operator through the glass window. The marker at the top, which can be seen through the transparent bearing dial, indicates the bearing to which the operator has trained the cursor on the scope. Because the cursor normally is positioned in the middle of the target presentation, the dial marker indicates the center bearing of the contact.

RELATIVE BEARINGS

True bearings are the ones of principal concern to Sonar Technicians because standard

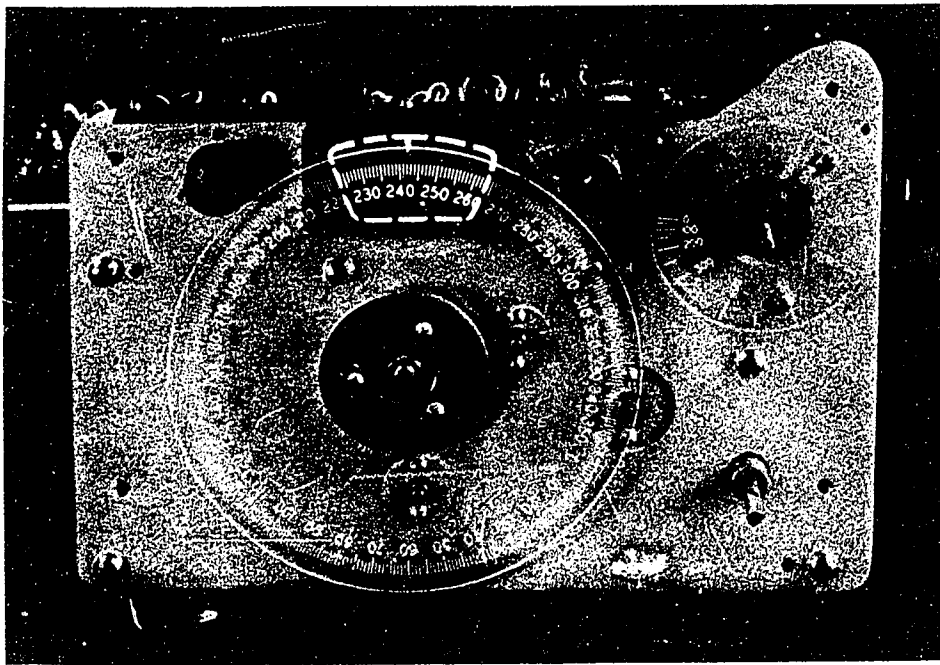

Figure 5-2.—Bearing dial assembly.

45.29A

INTRODUCTION TO SONAR

operating procedures are based on true bearings. You need to understand relative bearings, however, inasmuch as casualties to the gyrocompass necessitate shifting to relative bearing procedures.

Relative bearings are read in degrees clockwise from the ship's bow, which is always 000° . If a contact is broad on your ship's port quarter, the relative bearing is 225° . If a contact is on your starboard beam, the relative bearing is 090° . Figure 5-3 diagrams these two examples, illustrating how relative bearings are determined.

When the ship changes course, the relative bearing of a target changes. In figure 5-4 the ship changes course 60° to the right. This course change causes the relative bearing of the target to change from 090° relative to 030° relative.

Relative bearings can be read on the sonar console from the same dial that gives true bearings, although not at the same time. If a complete gyro failure should occur, this dial automatically indicates relative bearing. Occasionally, the gyro may act erratically for a few moments, causing the picture on the scope to jump, making it difficult for the operator to track the target. To obtain a presentation with

more stability, the operator can control the equipment so that a relative picture is presented on the scope, the dial indicating relative bearing.

Figure 5-5 typifies a bearing indicator from which true and relative bearings may be read simultaneously. This type of indicator, used in earlier sonars, is a good example for showing the comparison of true and relative bearings.

The outer dial, which is fixed, indicates relative bearing. The inner dial is free to rotate. When connected electrically to the ship's master gyrocompass, it acts as a gyro repeater and shows ship's course and true bearing. The diamond-shaped pointer between the two dials indicates the direction in which the sound receiver is trained. Both relative bearing and true bearing are read by observing the position of the pointer.

True course is read on the inner dial opposite 000° relative on the outer dial. As shown in figure 5-5, ship's course is 045° , and a contact broad on the starboard bow (045° R) has a true bearing of 090° .

STERN LINE INDICATOR

With modern scanning sonars the sonar operator has an ideal picture of antisubmarine

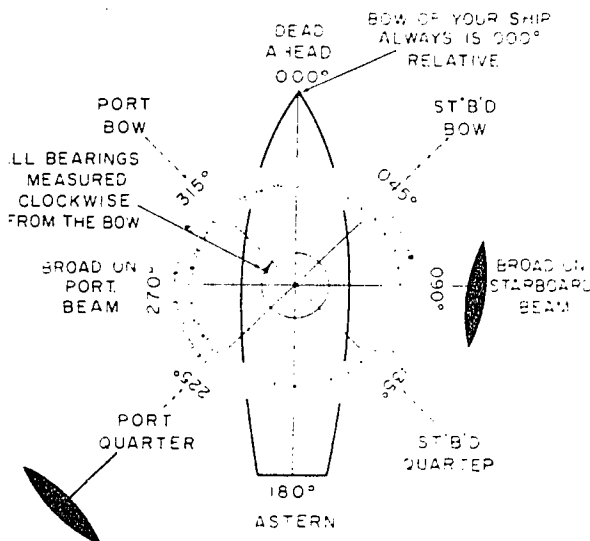

Figure 5-3.—Relative bearings.

45.29B

79

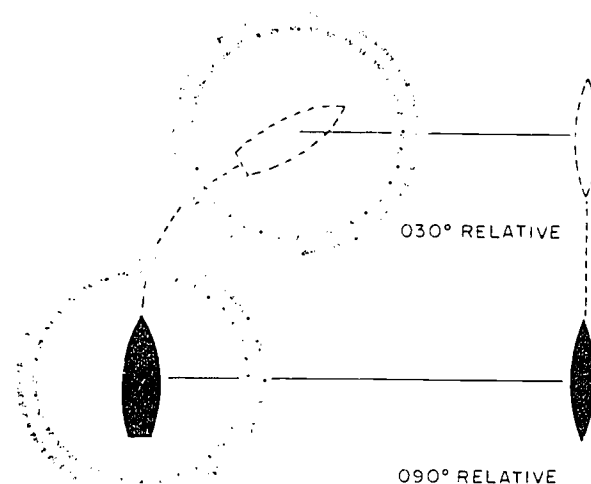
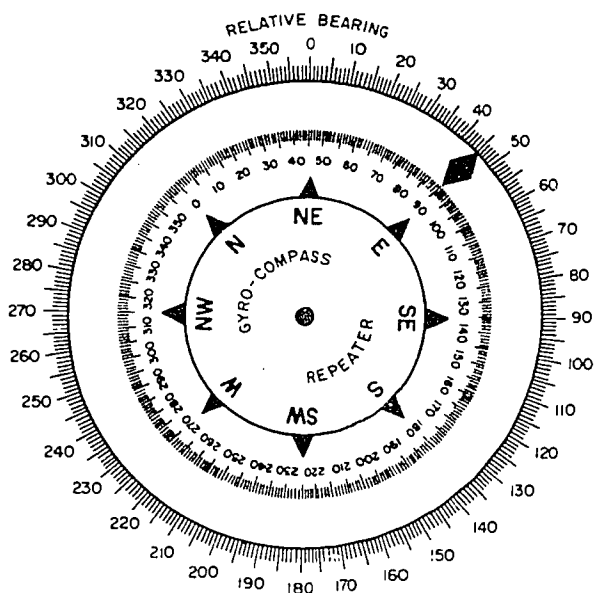

Figure 5-4.—Relative bearing change.

45.29C



45.29K

Figure 5-5.—Bearing and course indicator.

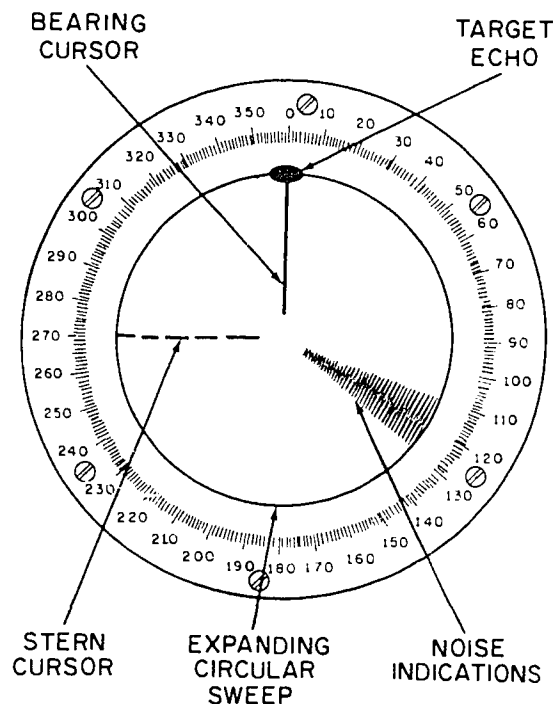

45.29J

Figure 5-6.—Stern line indicator.

action. He not only receives the audio response but is aided by a video presentation 360° in azimuth. The presentation is a true picture of the area surrounding the ship, and (with exceptions noted later in the text) it does not change with alterations in ship's course.

Although the video presentation is independent of ship's heading, the Sonar Technician needs to be constantly aware of the ship's course for purposes of conducting search arcs, performing control manipulations, and reporting sonar information. Ship's course information is provided in the form of a stern line on the face of the scope. The stern line, illustrated in figure 5-6, is presented as an illuminated broken line, which, as its name implies, indicates the direction of the ship's stern. If this line indicated the bow of the ship, it would be much easier to interpret ship's course. Because most sonar information comes from forward, however, the addition of the stern line indicator in that direction would tend to clutter the scope unnecessarily.

Normally, with the ship's gyro operating, own ship's movement does not appreciably alter

the presentation on the scope. Only the stern line indicator shows when the ship is turning or if a course change has occurred. When turning right, the stern line moves clockwise; when turning left, it moves counterclockwise. Movement of the stern line alerts the operator to course changes so that he then can be prepared to make adjustments to keep the bearing cursor on target.

When looking at the scope it is best to picture the ship as in the center of a small segment of the ocean, with the ocean always oriented to true north at the top of the scope. The ship turns in the center, and its direction is shown by the stern line to indicate the reciprocal of the true course.

GYRO FAILURE

When the gyro is operating, the top of the scope is north (000°T). When the gyro is

INTRODUCTION TO SONAR

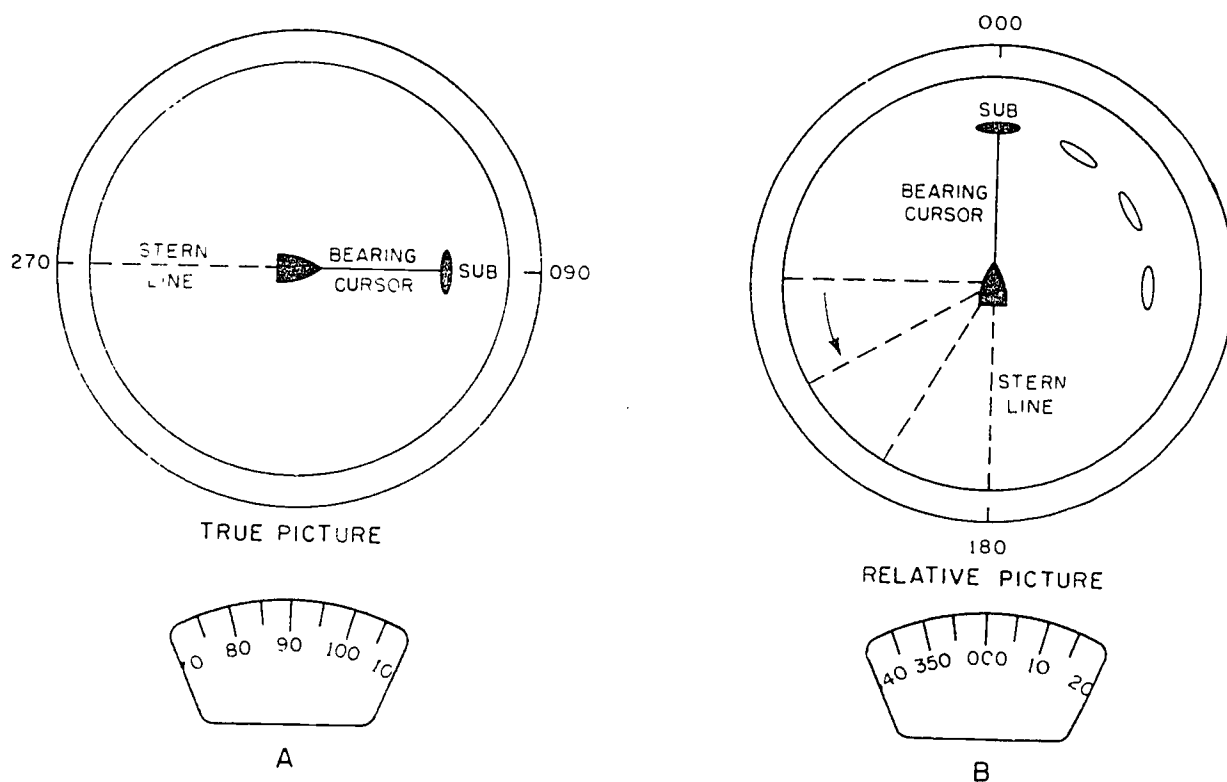

Figure 5-7.—Effect of gyro failure.

71.4

inoperative, the top of the scope is 000° relative (ship's head).

The first indication of a gyro casualty is the erratic movement of the stern line or the illumination of the red GYRO OFF light on the sonar console. Any failure of gyro input to the sonar causes the stern line to swing to 180° relative, where it remains as long as the gyro inputs are cut off. If the ship is headed for a target when the gyro fails, the target echo moves to 000° relative. Thus, the ship may be heading for a target bearing 090° true, but the target echo is presented at the top of the scope.

The effect of gyro failure is illustrated in figure 5-7. Part A shows the scope with normal gyro input. The submarine is located to the right of center. The stern line is at 270° and indicates that the ship is on course 090° true and headed for the contact.

With a gyro casualty, the stern line will swing 90° counterclockwise. The entire video presentation will change a like amount in the same direction as shown in part B of the illustration. To remain on target, the bearing cursor must also be trained 90° counterclockwise. The dials below the scopes in the illustration indicate the direction in which the bearing cursor is trained to maintain contact.

CONVERTING TRUE AND RELATIVE BEARING

Even though you lose gyro input to the sonar, you can easily determine the true bearing of the target if you know your ship's course and the relative bearing of the target. If the relative bearing is 029° and the ship's course is 027° true, as in figure 5-8, you can see that true bearing of the target is 056°. The true bearing is

Chapter 5—BEARINGS AND MOTION

obtained by adding the ship's course and the target's relative bearing. Thus, by the formula we have:

$$027^{\circ}T + 029^{\circ}R = 056^{\circ}T$$

Now examine figure 5-9. The ship is on a course of 180° true, and the target is at 251° relative. Again, it is easy to determine true target bearing by applying the formula as before:

$$180^{\circ}T + 251^{\circ}R = 431^{\circ}T$$

This time the bearing is greater than 360° . When the answer exceeds, 360° , you must subtract this figure to obtain the correct answer. Thus:

$$180^{\circ}T + 251^{\circ}R = 431^{\circ}T - 360^{\circ}T = 071^{\circ}T$$

Rules for Conversion

Certain rules are established for converting true and relative bearings. After each rule is stated, the mathematical formula representing

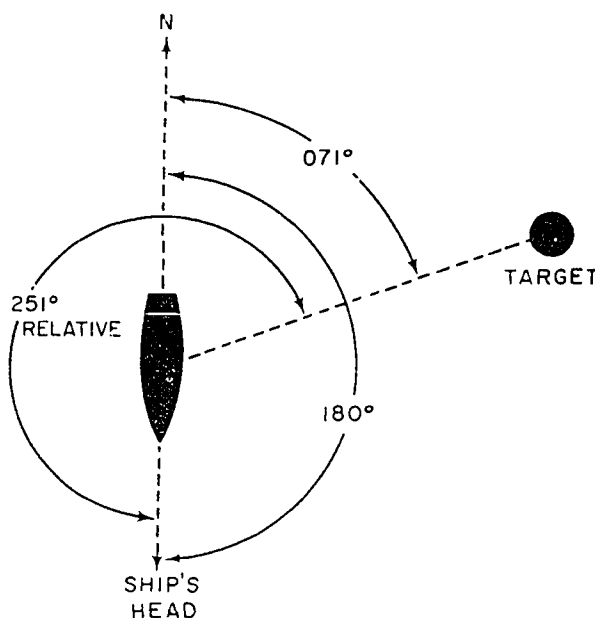

45.29G.2

Figure 5-9.—Target at 071° true.

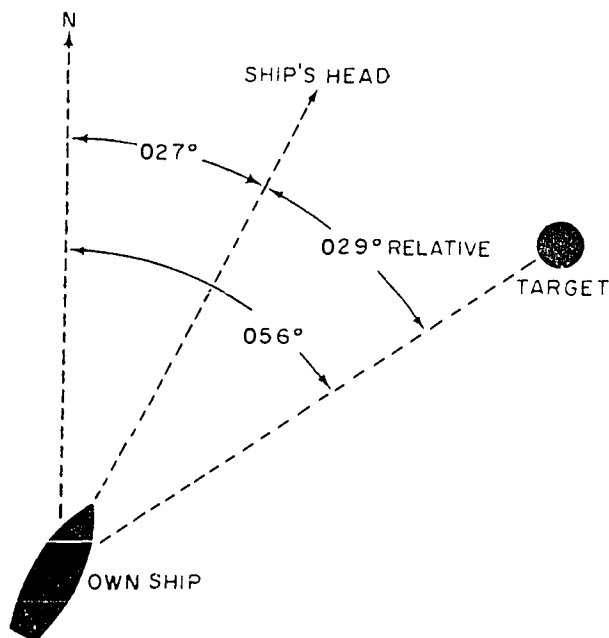

45.29F.2

Figure 5-8.—Target at 056° true.

the rule is given. The formulas are expressed in fire control symbols. By means of these symbols, we avoid detailed explanations of the values or measurements. Following are the fire control symbols used in these formulas.

- By—True target bearing
- B—Relative target bearing
- Co—Own ship's course

True target bearing equals relative target bearing plus own ship's course. In formula, this rule is expressed thus:

$$By = B + Co$$

If the true bearing, as computed, is greater than 360° , that value must be subtracted from the total. Our rule now is: True target bearing equals relative target bearing plus own ship's course minus 360° .

$$By = B + Co - 360^{\circ}$$

If you know your course and the true target bearing, the formula may be worked in reverse

INTRODUCTION TO SONAR

to obtain the relative target bearing. Relative target bearing equals true target bearing minus own ship's course.

$$B = B_t - C_o$$

If the true bearing is less than the ship's course, 360° must be added to the true bearing before subtracting ship's course. Relative target bearing equals true target bearing plus 360° minus own ship's course.

$$B = B_t + 360^\circ - C_o$$

If the true target bearing is 045° true and ship's course is 270° true, for example, we find the target's relative bearing thus:

$$045^\circ T + 360^\circ = 405^\circ - 270^\circ = 135^\circ R$$

MOTION

As mentioned at the beginning of this chapter, the two types of motion are true and relative. The Sonar Technician must have a thorough understanding of both types of motion to interpret target movement correctly and to give assistance in making an attack.

TRUE MOTION

True motion is the movement of an object across the Earth, using true (geographic) north as the reference point.

RELATIVE MOTION

Relative motion is the apparent movement of an object in relation to another object. Do not confuse the concept of relative motion with relative bearing. Relative motion is measured as apparent movement with respect to own ship.

You may have been unaware at the time, but on many occasions you have witnessed the solution of relative movement problems. When a baseball player races to catch a high fly ball or when a football quarterback throws downfield to a receiver, the players are estimating relative

movement. As an example, assume your ship is on a course of 000° at a speed of 20 knots. You are overtaking and will pass close aboard a ship that is also on course 000° but whose speed is only 10 knots. As you close the ship, the bearings to him draw aft. Eventually you pass him and he falls further and further behind. His relative movement from you is approximately 180° , but his true movement is 000° .

Following are three rules pertaining to relative motion that you must remember when making an attack on a submarine. Figure 5-10 illustrates these relative motion situations.

1. If range is closing and the bearings are drawing toward the bow, your ship will pass astern of the submarine.
2. If range is closing and the bearing remains steady, the ship will pass directly over the submarine. (If the submarine were on the surface, a collision would result.)
3. If range is closing and the bearings are drawing aft, the ship will pass ahead of the submarine.

ADVANCE AND TRANSFER

When a ship changes course to head for a new bearing, she does not move as a car does on land. Water is a fluid substance, and it does not allow the ship the advantage of good traction. As rudder is applied to a ship, a short period ensues before the rudder takes hold in the water. During the turn, the stern of the ship actually slides through the water. As it slides, the ship tends to advance in the same direction of her original course. The distance the ship moves in the original direction until she is on the new course is called advance. The amount of advance depends on ship's speed, amount of turn, and amount of rudder angle applied.

During the change in course, the ship also moves at right angles to the original course. The distance the ship moves at right angles to the original course during the turn is called transfer. The amount of transfer, as with advance, depends on the amount of turn, ship's speed, and amount of rudder angle.

Advance and transfer vary with each type of ship and even with ships of the same type. Each ship, therefore, makes her own advance and

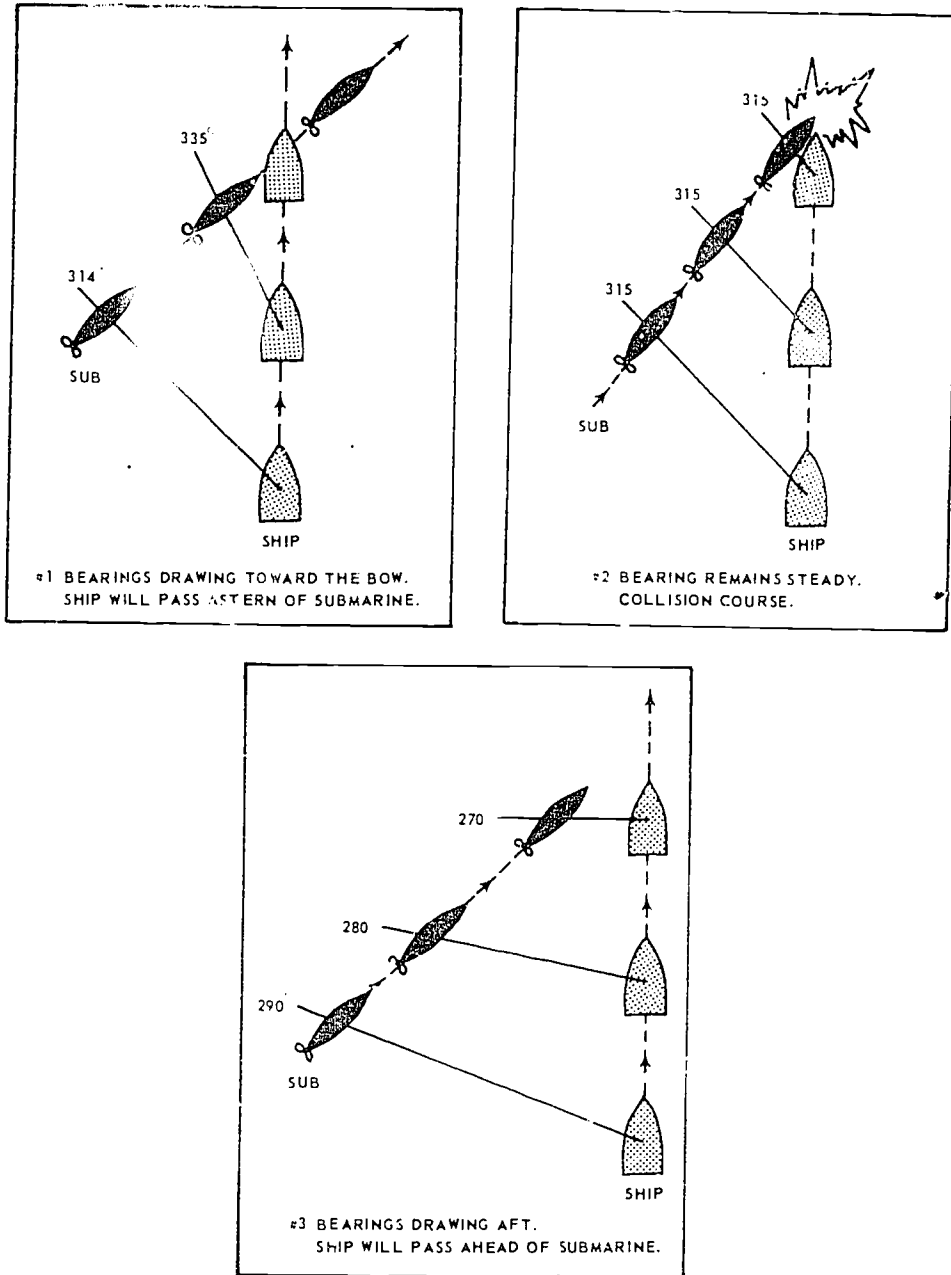
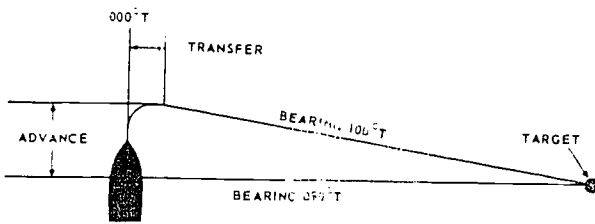

Figure 5-10.—Relative motion situations.

71.5

INTRODUCTION TO SONAR



71.6
Figure 5-11.—Effect of advance and transfer on bearing.

transfer tables for various rudder angles and at different speeds.

As you can imagine, advance and transfer will affect target bearings during a turn. All possible situations cannot be explained here because there are almost unlimited combinations of target and attacker relative movements. If the target is on your port beam, for example, and has the same course and speed you have, when you turn left to head for him, his bearing will change to the right. Figure 5-11 illustrates the effect of advance and transfer on bearing when the target is stationary or nearly so.

BEARING DRIFT

When the sonar operator detects an underwater target, he reports the bearing and range. The conning officer then turns the ship to head for the reported target. As the ship turns, the bearing cursor is trained back and forth across the target to check for bearing width, and the target is classified. The operator then places the cursor in the center of the target pip. The cursor shows direction of sound reception. Its length indicates range when the cursor line is adjusted to touch the target echo. With the ship headed for the target on a steady course and at a constant speed, with the cursor bisecting the echo, any change in target bearing results from target movement. If the target moves to the right, the operator must train his cursor to the right to remain on target, reporting "Bearing drift right." If the target moves to the left, he trains his cursor to the left, to remain on target, and reports "Bearing drift left."

In an attempt to evade the attacking ship, the submarine will maneuver. The attacking ship, in turn, changes course as necessary to reach optimum weapon firing position while maintaining sonar contact. Regardless of the number of course changes of the ship or maneuvers by the submarine, the job of the operator is to keep the cursor on the target. Correct bearings, ranges, audio response, and other target data can be obtained only when the cursor is kept positioned properly on the target echo.

DOPPLER AND TARGET ASPECT

When contact is made on an underwater object, these questions require answers: (1) What is it? (2) Is it moving? (3) In which direction is it moving?

Classification steps, when executed properly, give the answer to the first question. Doppler helps to answer all questions. Doppler, an acoustic phenomenon was explained fully in chapter 3. Remember that doppler up means the target is headed toward you; doppler down means the target is headed away from you; and no doppler means the target is either broadside to you and neither coming toward you nor headed away, or it is stationary. Assume that you have contact with a submarine. It has doppler, so it must be moving but in which direction? By this time the ship has turned to head for the target, enabling you to arrive at the answer to the third question. If doppler is up, the target is moving toward the ship. If doppler is down, the target is moving away from the ship.

The operator's job is to determine the direction of target movement and report it. If the submarine is headed directly at the ship, the target aspect will be direct bow and doppler will be up. If you are headed at the target and the target has bearing drift to the right with no doppler, the target aspect is starboard beam. Figure 5-12 shows the five basic target aspects and their associated doppler. The degree of doppler is dependent on target speed. For example: Doppler of a direct bow target with a high closing speed would be reported as "marked up."

Chapter 5--BEARINGS AND MOTION

Target aspect is best described as the relative position of the submarine with respect to the sound beam. Perhaps the easiest way of deciding which aspect the submarine is presenting is to visualize it in the center of four quadrants and, by the process of elimination, solve for the proper quadrant. This procedure gives a rough aspect, and doppler and bearing drift will further define the exact aspect. Look at figure 5-13 to see how this solution is accomplished. Assume that your ship is headed for the target and that initially you have a steady bearing with high up doppler, which indicates that the ship and the submarine are headed directly for each other. Next, you detect a bearing drift to the right, with slight up doppler. Quadrants A and B are eliminated because a target in either quadrant would have down doppler. A target in quadrant C will have up doppler, but the bearing drift will be to the left. Therefore, you would report "Starboard bow aspect."

As the ship attacks, she makes minor course and speed changes, but these changes have little

or no effect on target aspect of doppler. If the ship circles the submarine, however, or if the submarine makes a change in course, target aspect will change. A change in doppler is the first indication that the submarine is changing course, and this change must be reported immediately. As soon as the new aspect can be determined, it also must be reported. During an antisubmarine attack (or series of attacks), aspect changes often. The sonar operator's job is to detect, evaluate, and report each change as it occurs.

COMPUTING TARGET ANGLE

Target angle, which is a relative bearing, gives more precise information on the course of a ship or submarine than does target aspect, but target angle is more difficult to obtain than is target aspect. In considering a destroyer making an attack on a submarine target angle is the relative bearing of the destroyer from the submarine.





SUBMARINE										
ASPECT	DIRECT BOW		STBD BOW PORT BOW		STBD BEAM ----- PORT BEAM		PORT QTR STBD QTR		DIRECT STERN	
BEARING DRIFT	NONE		RIGHT LEFT		RIGHT ----- LEFT		LEFT RIGHT		NONE	
DOPPLER	UP		MODERATE UP		NO		MODERATE DOWN		DOWN	

Figure 5-12.—Target aspect.

71.7

INTRODUCTION TO SONAR

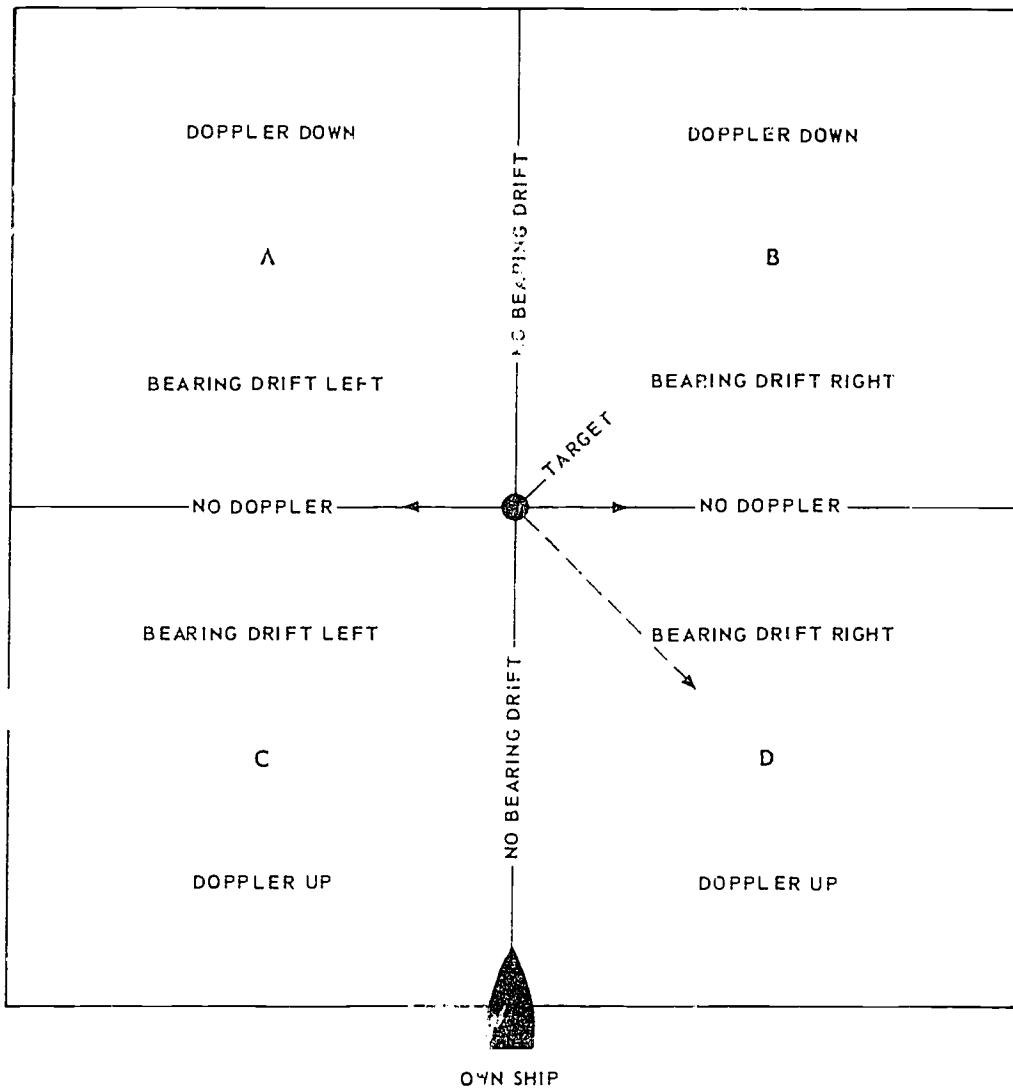

Figure 5-13.—Solving target aspect.

71.8

Imagine that you are on board a submarine looking at an approaching destroyer. The relative bearing of the destroyer is 090° , which indicates it is approaching on the submarine's starboard beam. As viewed from the destroyer, the submarine's target angle is 090° because target angle is the relative bearing of the ship from the target, measured in the horizontal plane from the bow of the target clockwise from

000° to 360° . Like target aspect, target angle depends on the ship's heading. When the submarine changes course, target angle changes accordingly.

Figure 5-14 illustrates several target angles. Also shown are angles on the bow (discussed later) and related doppler. Notice that no matter which direction the ship is heading, the course of the submarine governs target angle.

Chapter 5--BEARINGS AND MOTION

You may be curious as to why target aspect is so important when target angle provides more accurate information. Aspect is given as a general indication and can be reported after only four or five transmissions, based on doppler and the first indication of bearing drift. Target angle, on the other hand, is derived from more precise data. It is necessary to know the submarine's course, which can be determined only by tracking the submarine for several minutes. In many attacks, it is difficult to report an accurate target angle because of radical maneuvers by the submarine or because of insufficient time to determine target angle. In such instances, target aspect information necessarily must suffice for the conning officer to estimate the target angle and adjust own ship's course accordingly.

In antisubmarine warfare, there is little time between detection and attack. Target aspect

thus affords a means of reporting reliable information quickly.

Aboard a submarine, target angle is derived by a method known as angle on the bow (Ab). Whereas the ship uses 360° for computing target angle, the submarine uses only 180°, specifying port or starboard side. To illustrate, a destroyer has a submarine bearing 070° relative. Aboard the submarine, the target angle would be reported as "Angle on the bow, starboard 70." A relative bearing of 345° from ship to target is reported on the submarine as "Angle on the bow, port 15." Figure 5-14 illustrates some angles on the bow.

Target angle is not all guesswork. It can be computed accurately by using this formula: target angle equals true bearing plus 180° minus target course. Expressed in fire control symbols, the formula reads: $Bts = By + 180^\circ - Ct$ where:

- Bts = target angle
- By = true bearing
- Ct = target course.

Assume that you are on a ship and tracking a submarine bearing 270°, course 135°. Find the target angle by applying the preceding formula. Thus:

$$\begin{aligned} Bts &= 270^\circ + 180^\circ - 135^\circ \\ Bts &= 450^\circ - 135^\circ \\ Bts &= 315^\circ \end{aligned}$$

An example of computing this target angle is seen in figure 5-15. In effect, the +180° in the formula allows the viewer to change places so that he may see his own relative bearing from the target. Compare the relative bearing of the destroyer from the submarine with the angle computed for target angle.

If the product of $By + 180^\circ$ is less than target course, 360° must be added to the equation before subtracting target course. Example: A target is on course 270°, bearing 010°.

$$\begin{aligned} Bts &= 010^\circ + 180^\circ \\ Bts &= 190^\circ + 360^\circ \\ Bts &= 550^\circ - 270^\circ \\ Bts &= 280 \end{aligned}$$

Angle on the bow (Ab) may be computed in the same manner as target angle, with one

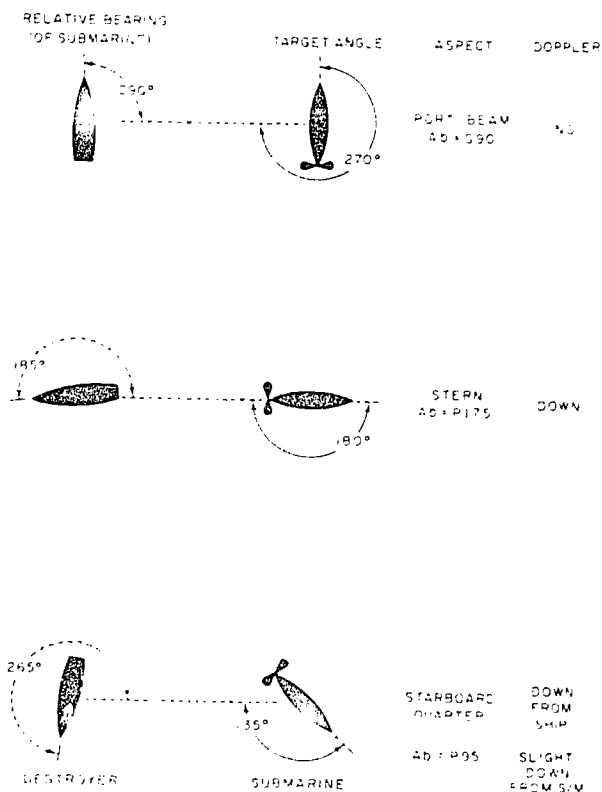
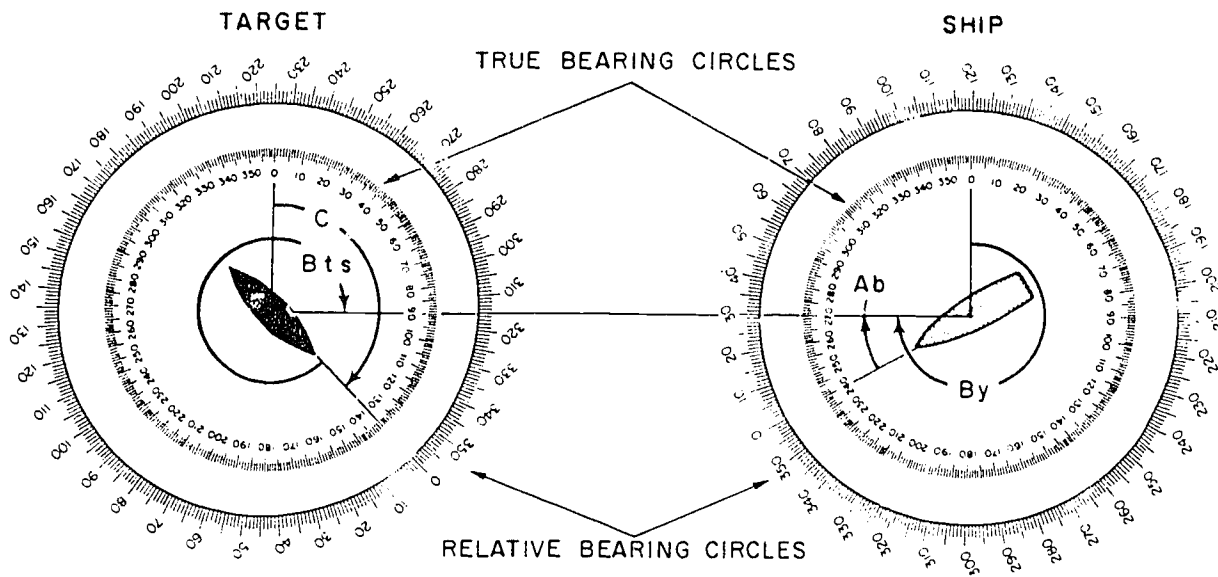

Figure 5-14.—Target angle.

71.9

INTRODUCTION TO SONAR



45.29H

Figure 5-15.—Computing target angle.

exception. Because the answer is in degrees of relative bearing, it must be converted to degrees port or starboard. Referring again to figure 5-15, you see that the destroyer bears 090° true and is on course 240° .

$$\begin{aligned} Ab &= 090^{\circ} + 180^{\circ} = 240^{\circ} \\ Ab &= 270^{\circ} - 240^{\circ} \\ Ab &= 030^{\circ} \text{ or starboard } 30 \end{aligned}$$

If the answer is greater than 180° , subtract the answer from 360° to obtain angle on the bow to port.

Target course can be determined by the formula $Ct = By \pm (180 - Ab)$. If Ab is to port, the resultant of the figures in parentheses is subtracted from By . Conversely, if Ab is to starboard, the solution within parentheses is added to true bearing.

CHAPTER 6

PRINCIPLES OF SONAR

The earliest sonar equipment was a passive device, a simple hydrophone lowered into the water and used to listen for noise created by a submarine. The only indication of a target was an audio tone. Bearing accuracy was doubtful, and ranges were strictly guesswork.

Today's sonar equipments provide highly accurate ranges and bearings. They present information both visually and aurally. Both active and passive types of equipment are used.

Although specific sonars and related equipments are not covered in this chapter, basic principles of operations given herein are applicable to all sonar equipments.

SONAR SYSTEMS

Two general types of sonar systems are employed for the detection of targets. They are referred to as active and passive sonars.

Active sonars are capable of transmitting underwater sound pulses that strike targets and are returned in the form of echoes. Echoes returned indicate the range and bearing of the target.

Passive sonars do not transmit sound. They merely listen for sounds produced by the target to obtain accurate bearing and estimated range information.

Active sonar systems normally are associated with surface ships, whereas passive systems usually are associated with submarines. Newer surface ships, however, employ separate passive

systems in addition to their active sonars. Submarines, although still relying primarily on passive systems, also employ active sonars.

ACTIVE SONAR

A simplified active sonar system is shown in figure 6-1.

Active sonar systems are used to detect the presence of ships, analyze shoreline and bottom characteristics, and determine bottom depths. The basic system consists of a transmitter, one or more transducers, a receiver, and displays and controls of various sorts. The transmitter has a source of power and a means for modulating the basic power in a manner suitable for the particular application. In general, the basic transmitted power is frequency modulated as single pulses at a pulse repetition frequency (prf) dependent on the system range.

The transmitter power is converted from electrical to acoustic energy by means of the transducer for transmission of the sonar signal into the water. Received signals or echoes are reconverted by the same transducer (or by a different transducer in some sonar systems) from acoustic back to electrical energy. The received signal from the transducer is processed in a receiver, where various amplification, demodulation, and comparison operations are performed. The output of the receiver, in the form for proper presentation of target data, is fed to display and control units. The displays include aural types, such as loudspeakers and earphones, and visual types, including oscilloscopes, (CRT) cathode ray tubes, graphic recorders, and indicator lamps.

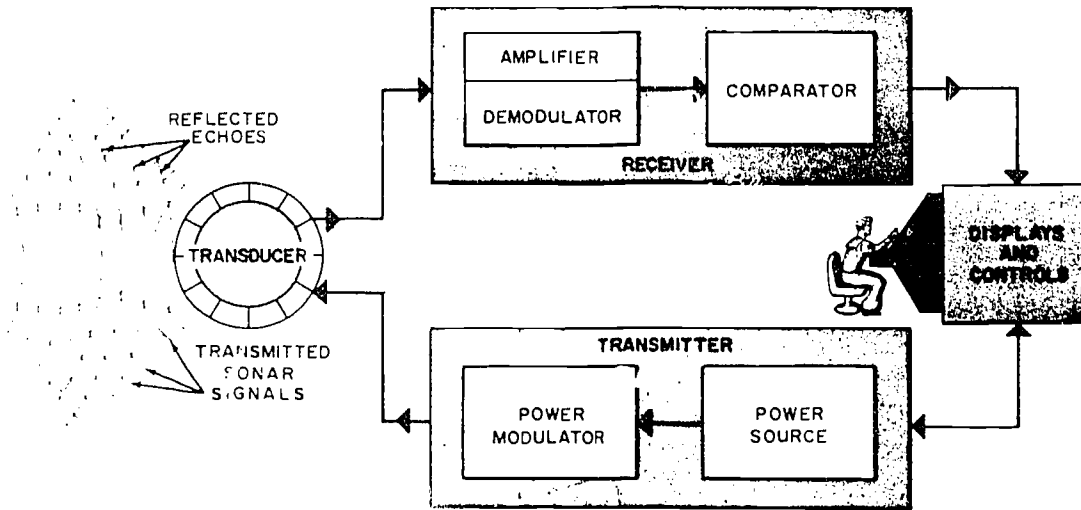

71.135

Figure 6-1.—Simplified active sonar system.

Searchlight Sonar (Directional)

Early active sonars utilized the searchlight principle for transmitting sounds. Like the searchlight, the transducer had to be trained to a particular bearing to transmit sound on that bearing. The sound beam was narrow in bearing width (about 5°), consequently the echoes were received from only a small sector of the surrounding sea. An arrangement of this type was necessary at that time because sufficient power for omnidirectional transmission could not be generated. The scanning sonars in widespread use today develop tremendous power—enough to be transmitted 360° in azimuth simultaneously.

Late modifications to active sonars allow the selection of directionally transmitted sonic pulses, somewhat related in principle to the earlier searchlight sonars. This feature, called rotating directional transmission, is discussed later.

The main disadvantage of the searchlight type of sonar was the length of time required to scan the area around the ship. Search procedures called for the operator to transmit, listen for echoes, train the transducer to a new bearing, transmit, listen, and so on, first on one side of

the ship, then the other. It was possible for a submarine to slip by undetected on the port side, for example, while the operator was searching on the starboard side. Moreover, maintaining contact with a target that had a rapidly changing bearing required a high degree of proficiency on the part of the operator. Another disadvantage was that searchlight equipment had only an audio presentation, whereas today's scanning sonars provide both a video and an audio presentation.

Scanning Sonar

Modern submarines and ASW ships are equipped with scanning sonar, which transmits sound pulses of high energy in all directions simultaneously. One of the features of scanning sonar is a cathode ray tube (CRT) display of all underwater objects detected in the area surrounding the ship. Target echoes appear as bright spots on the CRT, similar to the display of a radar's PPI.

Some of the data that you may learn from the CRT presentation are as follows:

1. The size of the target may be estimated from the size of the echo. Don't rely too heavily

on this feature, though, because echo appearance depends on such factors as target aspect, range, and equipment performance.

2. The distance of the echo from the center of the CRT represents range to the object from your ship when the CRT is used in the ship center display (SCD) mode.

3. True bearing of the object can be determined directly on the scope.

4. Target movement can be determined from its scope presentation. Fixed objects such as reefs and sunken ships will move in a direction parallel to your ship's movement and in the opposite direction. Moving objects may have motion in any direction with respect to own ship.

5. The wake of a submarine often can be seen. By examining the wake, you may be able to establish a submarine's heading even before its movement can be determined by tracking.

6. Submarines that are too far away for detection by echo ranging may yet emit enough noise to be detected. Under these conditions, a small segment of the scope appears to be filled with a rippling pattern. The general direction of the noise source can be ascertained by taking a bearing to the center of the noise pattern.

TRANSDUCERS

Knowledge of the design and function of the transducer is the key to understanding the principles of sonar, whether of the scanning or the searchlight type.

A device for converting one form of energy to another is a transducer. In sonar the acoustic energy of the sound waves is converted to mechanical energy in the form of oscillation of the molecules of the medium through which the sound travels. These oscillations cause a synchronous variation in pressure of the medium. The signals generated or received by the electronic circuits in sonar equipment are in the form of electrical energy. The sonar transducer acts as the link between the water and the electronic circuits of the sonar equipment and converts the electrical energy to acoustical energy and vice versa.

There are physical phenomena which exhibit the ability to change electrical to mechanical energy and mechanical to electrical energy, and which are employed in sonar transducers. These are the electrostrictive, the piezoelectric and the magnetostrictive effects. Materials exhibiting electrostrictive and piezoelectric properties are generally of crystalline or ceramic nature. They change dimensions when subjected to an electric field and develop a voltage potential between two opposite faces when mechanically stressed. Materials exhibiting the magnetostrictive effect change dimensions when subjected to a magnetic field and change magnetic permeability when subjected to mechanical stress. This change in permeability changes the intensity of any magnetic field in the presence of the material.

Variation in the strength of the electric or magnetic field at a frequency in the acoustic spectrum will cause acoustic waves to be generated by such material. When the transducers are placed in water, such acoustic waves can then be propagated from the material to the center. When sound waves impinge upon such material after propagation from the water, the mechanical stress resulting from the pressure variations will cause variations in the field strength (electric or magnetic) which in turn generate electric signals in suitable circuits.

Magnetostrictive Process

Magnetostriction is a process whereby changes occur in metals when they are subjected to a magnetic field. Depending on the material and the strength of the magnetic field, some materials will expand and some will contract, but independently of the direction of the applied field. Nickel is the most commonly used material in magnetostrictive transducers because it exhibits a very large magnetostrictive effect. Nickel contracts in a magnetic field to an extent largely proportional to the intensity of the field.

The nickel elements in transducers are generally one-half wavelength long and are supported at the central node so that the maximum amplitude of vibration takes place at the ends. In one type of transducer, the elements are nickel tubes. To increase the area of the active face in contact with the water in

In this design, a series of tubes or rods are attached to a diaphragm. The diaphragm becomes the active face of the transducer. The dimension of the tubes and the diaphragm plate is designed to make the transducer mechanically resonant at the operating frequency for maximum efficiency.

Because the nickel contracts for either direction of magnetic field, an applied a.c. sinusoidal field will cause the nickel to contract for each half of the a.c. cycle, resulting in a frequency of induced vibration twice that of the applied field. In a transducer, the sinusoidal magnetic field is obtained by winding coils around nickel rods, tubes, or stamped elements (stamped and stacked in various shapes), and impressing a current at the desired sonar signal frequency through the coil.

It is generally desired that the vibration and the resulting acoustic signal be of the same frequency as the electric signal applied to the coils. This is accomplished by superimposing a large d.c. polarizing magnetic field on the nickel elements by means of a d.c. polarizing current through the coil or directly by permanent magnets. If the d.c. field is larger than the a.c. signal field, then the resulting magnetic field will always be in one direction, with its magnitude varying with the a.c. signal. The change in nickel element length will thus be synchronous with the a.c. signal.

A d.c. polarizing field is also needed for application of the converse magnetostrictive effect. If the nickel element is subjected to varying longitudinal mechanical forces (acoustic pressure waves), the resulting stresses change the magnetic permeability of the nickel. If a d.c. magnetic field is present, the permeability changes will cause corresponding changes in the magnetic field intensity. These field changes will in turn induce a varying voltage in the coil wound around the nickel element which will vary proportionally with the impinging acoustic waves. Without the ambient d.c. polarizing field, no voltages will be induced in the coils.

In the searchlight or directional type of transducer, several hundred nickel tubes are arranged in a circle and mounted on one side of

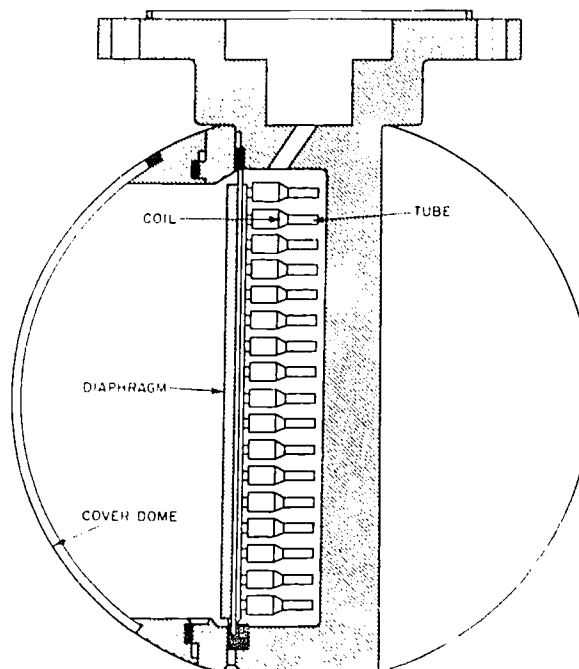

71.48

Figure 6-2.—Searchlight magnetostrictive transducer.

a metal plate called a diaphragm. Each tube is wrapped with a coil of wire to prevent frequency doubling. When an alternating current is applied to the coil, the tubes shorten and lengthen at the rate of the alternating current. Each tube is polarized by a constant magnetic field, usually supplied by a permanent magnet. During one half cycle of the applied signal, the a.c. voltage and the polarizing field add; during the next half cycle, they oppose each other, and the magnetic field is always in only one direction. The contractions of the tubes thus are fixed to the a.c. frequency.

As the tubes contract and expand, the diaphragm vibrates and produces an acoustic signal of the same frequency as the applied alternating current. A magnetostrictive transducer used in searchlight sonars is shown in figure 6-2.

Transducers employed with some scanning sonars also operate on the principle of magnetostriction. Instead of nickel tubes,

however, the transducer elements have nickel laminations pressed in a thermoplastic material. Each element contains a permanent magnet for polarizing the nickel. Several elements are mounted vertically to form 1 stave, and 48 vertical staves are arranged circularly to form the transducer. A scanning transducer is shown in figure 6-3. An exploded view of a portion of a stave is seen in figure 6-4.

Many types of operational scanning sonar transducers are magnetostrictive. Except for variations in dimensions, they are similar in design. The type shown in figure 6-3 is a cylindrical unit approximately 19 inches in diameter and 27 inches long, and has an operating frequency of 20 kHz.



71.49

Figure 6-3.—Scanning magnetostrictive transducer.

Electrically, the magnetostrictive scanning sonar unit acts as two independent transducers housed in a common container. One of the independent units is the search section. The other is the maintenance of close contact (MCC) section, located above the search elements.

The search section is made up of 48 vertical staves. Each stave consists of nickel laminations and a polarizing magnet. Electrically, the staves are independent of one another.

As its name implies, the MCC section is used to maintain contact on a close-in submarine. The MCC elements transmit in a delayed sequence from the top down, causing a phase delay of the sound beam, which results in the top of the beam bending down toward the delayed portion of the beam. The effect resembles refraction. Transmission is at a downward angle of approximately 30°.

Because the elements are so placed that they can cover a 360° area, there is no need to rotate the transducer in scanning sonar. Such an arrangement provides video coverage simultaneously on all bearings. Audio coverage is afforded by training a cursor to the desired bearing. Most present-day magnetostrictive transducers are built along the same general lines. Physical dimensions vary according to the operating frequency and power output desired.

Piezoelectric Process

The piezoelectric effect, which is a form of electrostriction, is the electric polarization produced by mechanical strain in certain classes of crystals. The polarization and the electric potential induced by it is proportional to the strain and changes sign with it. In the converse piezoelectric effect, an electric potential across the crystal face produces a mechanical deformation proportional to the induced electric polarization and of the same sign. The magnitude of this effect varies for crystals of different materials and for the different axes of the crystal.

Materials most commonly used for sonar transducers have included quartz, tourmaline, Rochelle salt (sodium potassium tartrate), ammonium dihydrogen phosphate (ADP), and

INTRODUCTION TO SONAR

lithium sulphate. Suitable large quartz crystals are difficult to obtain. Most crystal transducers use Rochelle salt and ADP because they exhibit a strong piezoelectric effect and are easily grown to the desired sizes. Because Rochelle salt cannot tolerate high temperatures to which it may be exposed during use or storage (it will disintegrate from internally generated heat if used to transmit high power for any length of time), it has generally been displaced by ADP and lithium sulphate. Because Rochelle salt has the strongest piezoelectric effect, it is still used in listening transducers and for low-power

applications. Tourmaline is used for calibration transducers because it is relatively insensitive to temperature changes.

A crystal transducer is constructed by cementing or mounting a stack of quarter-wave crystals to a heavy steel backing resonator plate also one-quarter wave-length thick. The assembly is mechanically resonant at the operating frequency with a node at the interface of the plate and crystals, and maximum amplitude at the free end of the crystals.

Since both Rochelle salt and ADP are soluble in water, the crystal assembly using these

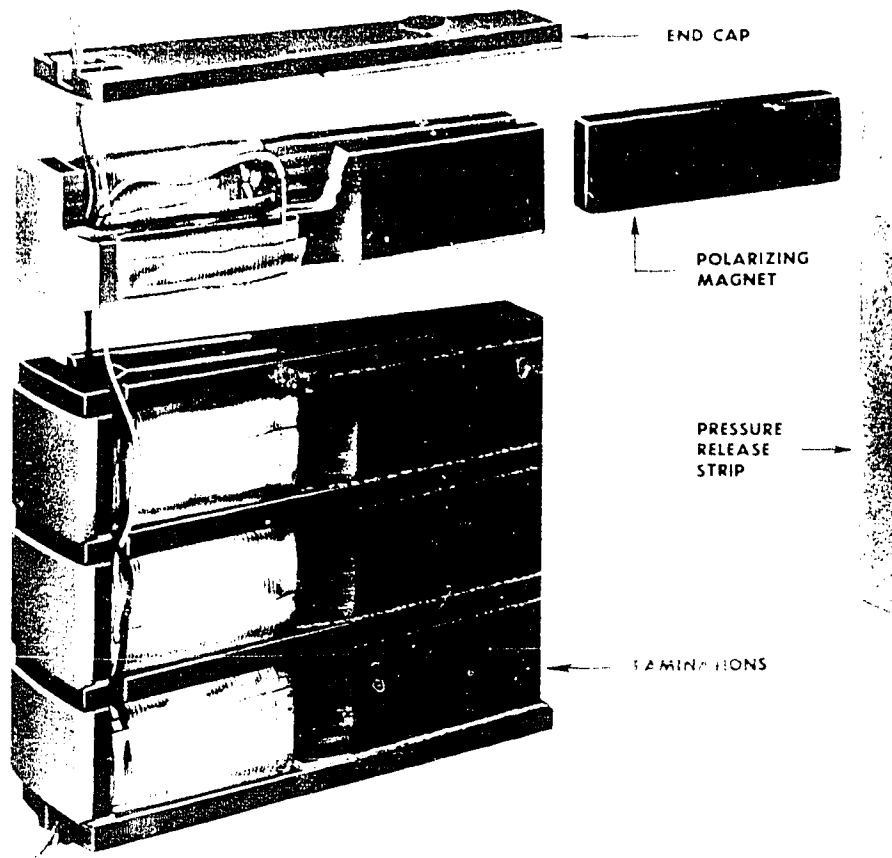

95

Figure 6-4.—Exploded view of one spinning sonar transducer stack.

71.50

materials is a sealed enclosure. To permit sound propagation, the enclosure must be filled with a thoroughly dehydrated liquid. Castor oil is commonly used because the velocity of sound in it is almost the same as that in seawater. Sound propagation from the castor oil to the seawater is via a thin metal diaphragm forming the face of the transducer assembly, shown in figure 6-5, or through a diaphragm of Rho-C rubber (i.e., rubber which has a "c" acoustic resistance equal to that of the water).

When used for listening, the maximum electric signal is produced by the crystals if the frequency of the received sound is the same as the resonant frequency of the transducer.

Electrostrictive Process

When an electric field is applied across a dielectric material, the material is deformed. This phenomenon, in which a change in dimensions is called

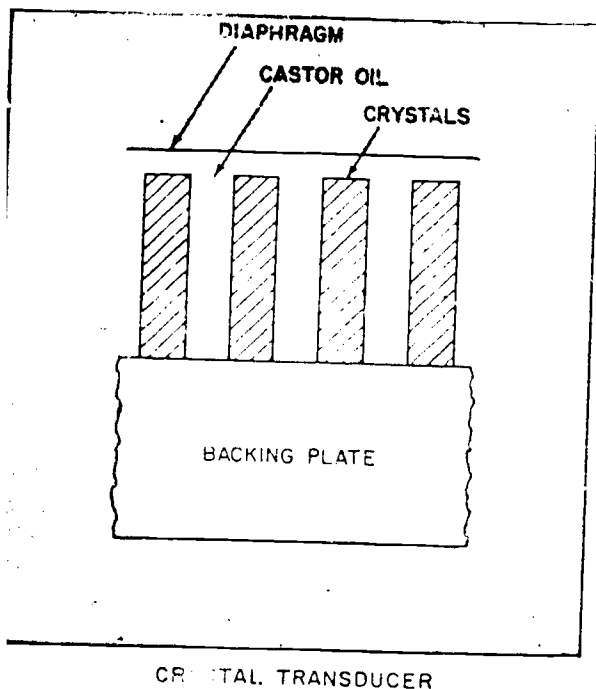

Figure 6-5.—Crystal transducer.

71.136

electrostriction and is independent of the direction (sign) of the electric field and proportional to the square of the field intensity. In the crystal transducers, the electrostrictive effect is present but much smaller than the piezoelectric effect and so is ignored. However, with barium titanate, a ceramic, the electrostrictive effect is large in comparison with the piezoelectric effect.

Ceramic for transducers has the advantage over crystals in that the ceramic can be molded to any desired shape. This property is particularly desirable for making cylindrical scanning or omnidirectional transducers. The converse electrostriction, the change in electric potentials when the material is stressed, takes place only when a constant polarization potential is present. The a.c. sonar signal is thus superimposed on the larger d.c. polarization, and the material dimension will vary directly with the magnitude of the resultant potential. The polarization of electrostrictive materials is thus analogous to the magnetic polarization required for magnetostrictive materials. Without the polarization, mechanical stresses will not produce an electric potential.

Nearly all transducers now being built are of the ceramic type. Ceramic compounds have high sensitivity, high stability with changing temperature and pressure, and relatively low costs.

MODERN ACTIVE SONAR THEORY

The theory of modern active sonar operation may best be understood by breaking it down into three basic functions: transmission, reception, and presentation. A block diagram of a representative sonar system is seen in figure 6-6. The diagram shows only the system's major units and main signal paths.

Transmission

Transmission of the sound pulse is initiated in the control-indicator, which is comprised of the receiver, audio and video channels, control circuits, and keying circuits. Pulse length is also

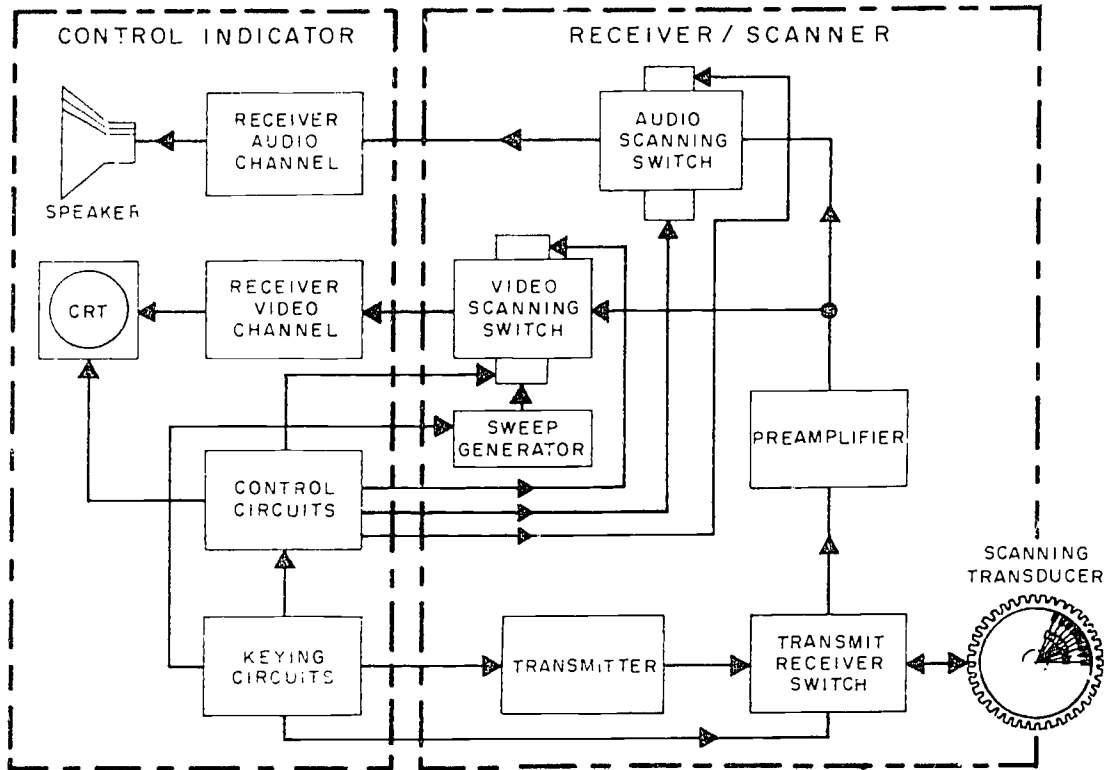

71.137

Figure 6-6.—Basic active sonar system block diagram.

determined at the control-indicator by the sonar operator. The keying pulse from the control-indicator triggers the transmitter oscillator in the receiver-scanning system assembly and actuates the transmit-receive switch in the audiofrequency (af) amplifier. In the receiver-scanner the pulse is modulated to the equipment operating frequency, amplified, and delivered to the sonar transmitter where it is further amplified to the power level required for transmission.

The output of the sonar transmitter is fed to the transmit-receive switch in the af amplifier, then to the transducer transfer switch where selection is made between NORMAL or MCC operation. The signal then goes to the transducer where it is converted to acoustical energy and propagated into the water. The shape of the transmitted signal resembles that of a hollow

cylinder (or sphere, depending on the shape of the transducer), which expands in diameter as it travels outward. The thickness of the cylinder walls depends on the pulse length selected by the operator. (See fig. 6-7.)

Reception

If the transmitted sound wave strikes an object having sufficient reflective characteristics, a small portion of the signal is returned to the transducer. In the transducer, the acoustic signal is converted to an electrical signal by the piezoelectric effect of the receiving staves. Each of the 48 staves has its own preamplifier, located in the af amplifier. After preamplification, the signal is sent to the video and audio-scanning switches in the receiver-scanning switch assembly.

The video-scanning switch rotates continuously, thereby sampling noise signals and echoes from all bearings. The audio-scanning switch is positioned to any bearing selected by the sonar operator. Signals from the scanning switches are fed to the receiver section of the receiver-scanner where they are converted to suitable frequencies and amplified for presentation.

Presentation

For the returning echo to be of any value, it must be presented in such a manner that the sonar operator can interpret the information it represents. The echo is presented to the operator both visibly and audibly.

The manually positioned audio-scanning switch feeds the signal to the audio portion of the receiver, which is of the superheterodyne type. Incorporated in the receiver audio circuits is a control for eliminating the effect of own ship's speed on the reverberation pitch. This control is called the own doppler nullifier (ODN). It removes own ship's doppler effect from target echoes, greatly aiding the operator in target classification. From the receiver the audio signal is sent to a headset position at the control-indicator and can also be fed to loudspeakers.

After the output of the video-scanning switch is processed in the video portion of the receiver, it is displayed at the control-indicator on a cathode-ray tube. The sweep on the CRT is a spiral scan, which is synchronized with the video scanning switch. (See fig. 6-8.)

One method of obtaining a spiral scan is to rotate the field of the deflection coils around the CRT, simultaneously applying a sawtooth voltage to the coils to cause displacement of the sweep with each succeeding rotation of the coil. For clarity of explanation, the coil yoke is mechanically connected to the video-scanning switch. As the video scanner and deflection coil rotate, the sawtooth voltage causes the sweep to spiral outward from the center of the scope at a linear rate. On reaching the scope's outer edge,

full deflection is achieved and the sweep is then cut off.

Rotation of the scanner is at such a speed that you don't see a spiral sweep but what appears to be an expanding circular sweep. An echo is seen on the scope as a brightening of the sweep at a distance from the scope center and in a direction corresponding to the target's range and bearing.

During the interval between the end of one sweep and the beginning of the next, the cursor is electronically produced on the scope. Because of the persistency of the CRT, the target echo remains visible for a short time, allowing the operator to determine accurately the target's range and bearing. Bisecting the echo with the cursor gives the bearing of the target. By adjusting the length of the cursor so that its tip touches the echo, the target's range is determined.

Also located on the sonar control-indicator are various switches and controls. Their purpose is to give a better target presentation. These switches and controls, together with complete operating procedures, are explained in the manufacturer's technical manual supplied with each sonar system.

Rotating Directional Transmission

Conventional scanning sonars formerly were of the type just discussed: that is, only

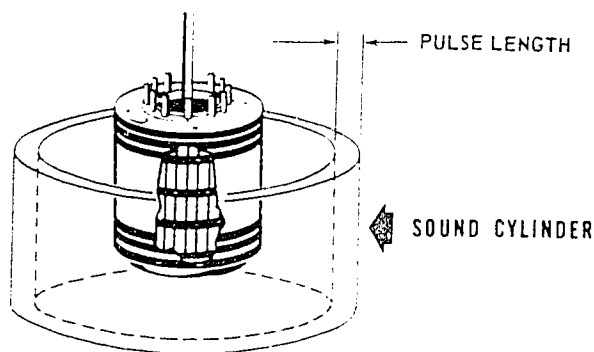

71.52
Figure 6-7.—Pulse length determines thickness of sound cylinder.

INTRODUCTION TO SONAR

omnidirectional transmission was possible. Modern sonars have an operating feature called rotating directional transmission (RDT), which operates on a principle similar to the searchlight type of transmission. The RDT provides greater transmitted power than the conventional scanning type, affording improved sensitivity and detection range.

At any instant of RDT, the signal is the resultant of phased excitation of several adjacent transducer staves, resulting in a source level improvement that is characteristic of directional transmission. Excitation of the transducer staves is caused by the output of a transmit scanner, which operates much like the video-scanning switch of a conventional scanning sonar. Transmission is accomplished in a sector (up to 300° wide) which is centered on the bow or on a

selected bearing, depending on the type of operation chosen by the operator at the control unit.

PASSIVE SONAR

Passive sonar, as its name implies, depends entirely on the target's noise as the sound source instead of the returned echoes of a transmitted signal. Target detection is achieved at great ranges through the use of highly sensitive hydrophones.

Although passive sonar is usually associated with submarines, many surface ships now have a passive system that utilizes their active sonar transducers. During the interval between sound pulse transmissions, the transducer acts as a hydrophone, allowing the sonar operator to monitor a broader frequency spectrum than

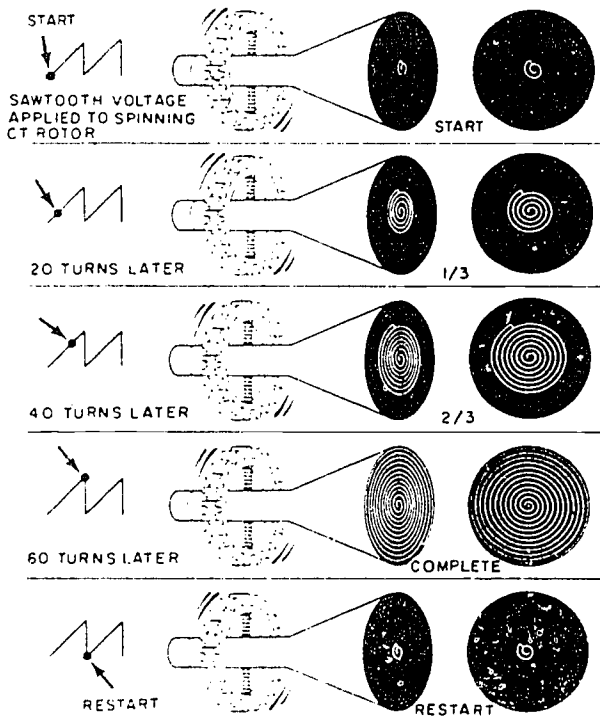

A STEP-BY-STEP GENERATION OF SPIRAL SCAN

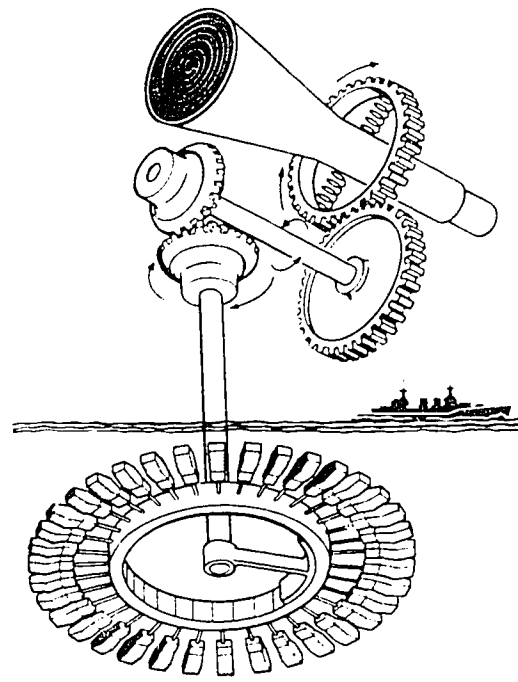

B SYNCHRONIZING THE SWEEP WITH THE SCANNING SWITCH

Figure 6-8.—Generation of spiral scan.

71.121

normally is possible. Passive reception does not interfere with the reception of pulse echoes. During transmission, however, the passive feature is interrupted.

Hydrophones

A hydrophone is a device used to listen for underwater sounds. In operation it is similar to

the transducer of active sonar equipment when converting sound energy to electrical energy. Two general types of hydrophones may be employed—electrostrictive and magnetostrictive. Modern hydrophones are of the electrostrictive type, consisting of ceramic elements that operate on the piezoelectric principle. When the elements are struck by a sound wave, the vibrations set up are converted to an electrical signal, amplified, and displayed at the operating console.

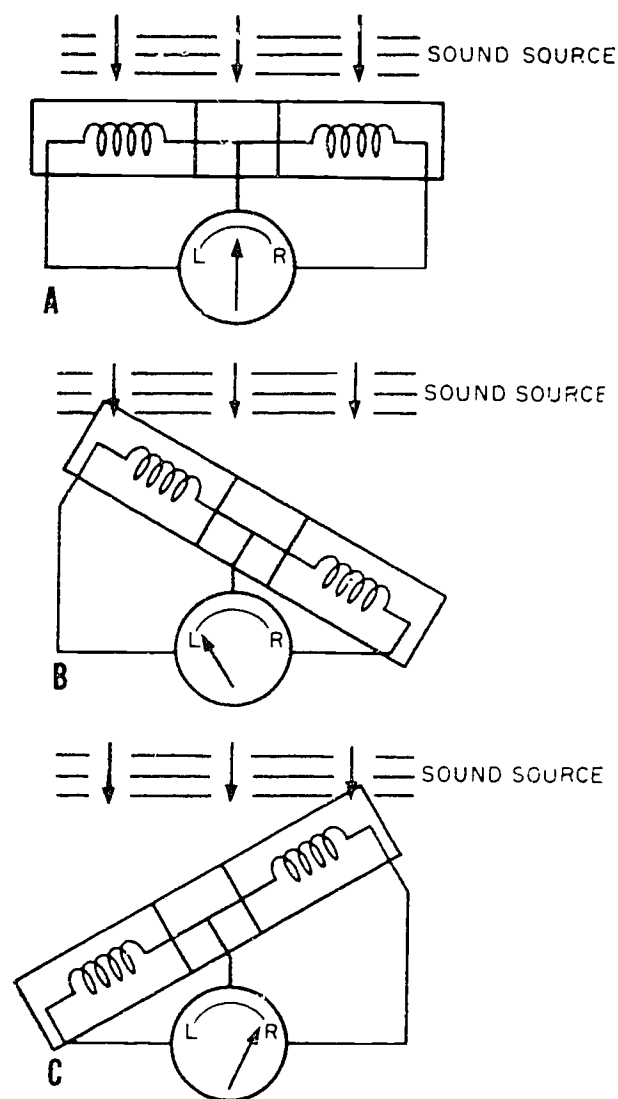

Figure 6-9.—Operation of the BDI.

71.54

SINGLE-LINE HYDROPHONE.--Knowledge of the single-line type of hydrophone, although it is not in general use today, will aid you in understanding how modern hydrophones operate.

A typical early type uses the magnetostrictive effect for sound detection. The hydrophone, which is trainable through 360° , is a line type whose nickel tubes are arranged horizontally in a line. It is divided electrically into right and left halves.

Weak signals from the hydrophone are fed to an audio amplifier, then to bandpass filters that remove undesired frequencies from the detected sound.

Accurate bearing is determined by training the hydrophone back and forth across the direction of the sound source. Outputs of the right and left halves of the hydrophone are fed to a bearing deviation indicator (BDI). Any phase difference between the right and left signals causes the meter to deflect.

Operation of the BDI is diagrammed in figure 6-9. In part A of the illustration, the hydrophone is on target. Signals in both halves (right and left) produce a phase difference equal to zero. No deflection is indicated by the meter needle. In part B, the hydrophone is trained off the target to the right, and the meter needle is deflected in the "train left" direction. The bearing deviation indication (BDI) of the meter informs the operator that he must train (push the needle to the left) left to obtain a phase difference of zero. The hydrophone in part C is trained to a position left of the target. A right train is necessary to obtain the desired bearing.

INTRODUCTION TO SONAR

The majority of passive sonar systems are equipped with the automatic target follower (ATF) feature. With the ATF feature, right and left signals are fed back into the training system, causing the hydrophone to follow the target automatically.

HYDROPHONE ARRAY.—Modern passive sonars utilize a hydrophone array, which is installed in many configurations. The conformal array is curved around the submarine's hull, with an open end aft. The circular array consists of a number of hydrophones arranged vertically in a circle and mounted in or under the submarine's bow. The line array consists of several hydrophones mounted along the horizontal axis of the submarine. Some of the newer passive sonars utilize a spherical array and in some cases a towed array. For more information on arrays, refer to *Sonar Technician S 3 & 2*, NAVEDTRA 10132, current series.

MODERN PASSIVE SONAR THEORY

The theory of modern passive sonar consists of two basic steps: reception and presentation. Figure 6-10 is a simplified block diagram of an array type of passive sonar. The array cannot be trained physically. Instead, a compensator switch is added that, in effect, trains the system electronically.

Reception

Signals received in an array type of passive sonar system are converted to electrical energy

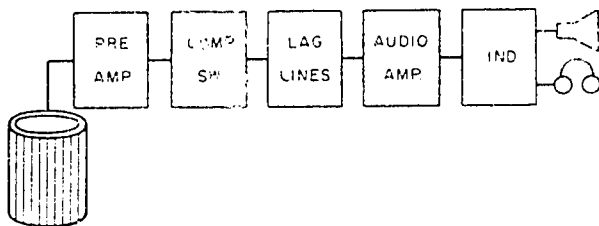

71.55

Figure 6-10.—Block diagram of an array-type passive sonar.

101

96

and then are fed to a preamplifier to be amplified to a usable level. There is one preamplifier for each hydrophone in the array. The output from each preamplifier is connected to a slipring in the compensator switch. The slipring couples the preamplifier output to a rotor plate.

One side of the rotor plate consists of an equal number of brushes and sliprings, each brush riding on a slipring. On the other side of the rotor plate, a set of brushes is arranged in a scale model of the hydrophone array. These latter brushes couple the rotor plate output to the stator plate. The stator plate has two sets of bars inlaid on the plate, one set on each half of the plate. Brushes on the rotor facing the stator plate make contact with the bars as the rotor is trained, and the signals present on the brushes are picked off by the bars. Half of the brushes on the rotor plate are always in contact with the stator plate, thereby utilizing half of the array at any given time. The center of the stator plate, being the reference point, makes it possible to determine the exact bearing of the target.

The arrangement of the hydrophones causes the signals to be out of phase with each other at the output of the preamplifiers. For the signals to be usable, they must be placed in phase with each other; hence, it is necessary to delay the signal. Each bar in the stator plate is connected to lag lines. The purpose of lag lines is to delay the first received signals a proportional amount until the last received signals can catch up.

Once the signals are in phase with each other, they are additive. As a result we have a strong signal to feed to the audio amplifier. There the signal is amplified and then is fed to an indicator.

Presentation

The console illustrated in figure 6-11 is representative of the indicators used with some types of array sonars. Target indications are presented continuously on a paper recorder and a CRT. They also are given audibly. The CRT is not located on the console itself, but is a part of a separate unit—an azimuth indicator (fig. 6-12).

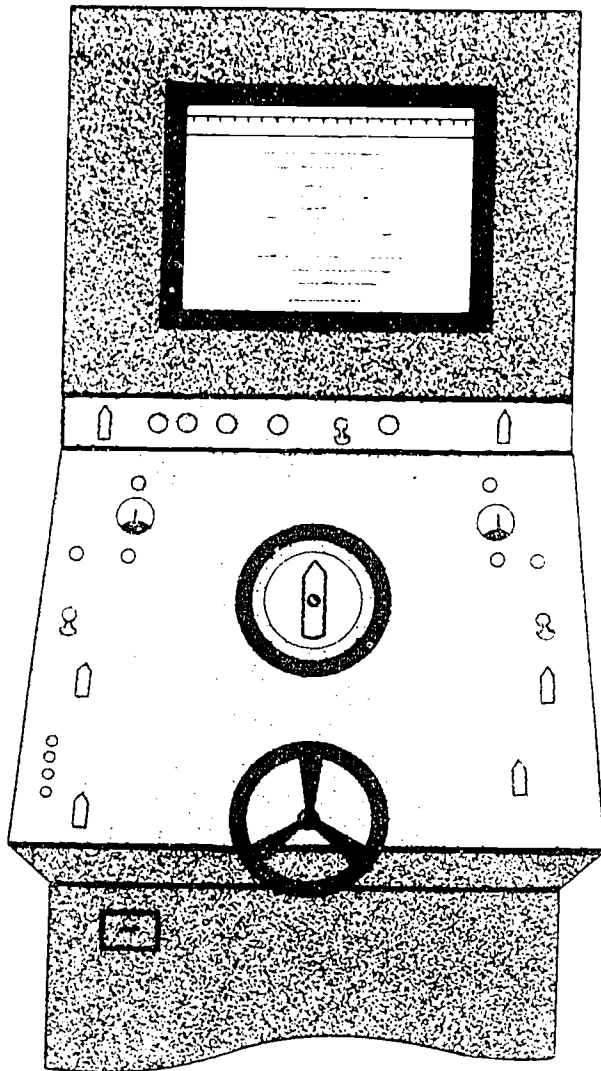

35.9
Figure 6-11.—Console of an array-type passive sonar.

The paper recorder (on the upper portion of the console) plots the bearing of all noise. Operating in synchronization with the paper recorder is the CRT. It indicates the location of all noise-producing targets by inward deflections of the circular sweep. An audio channel, provided with each azimuth indicator, permits listening (with the aid of an external speaker) to this continuously scanning beam.

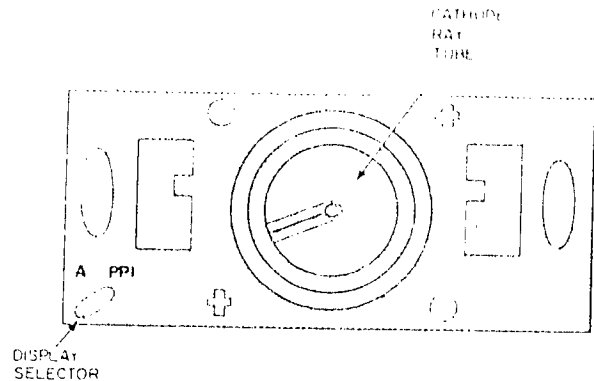

35.10
Figure 6-12.—Azimuth indicator of an array-type passive sonar.

More detailed information on passive sonar systems is contained in *Sonar Technician S 3 & 2*, NAVEDTRA 10132. Also consult the manufacturer's technical manual supplied with each equipment.

VARIABLE DEPTH SONAR (VDS)

As you recall from chapter 3 of this manual, oceanographic conditions frequently are such that there are layers of water with widely varying temperatures. Where these layers meet (layer depth), much of a transmitted sound beam is either reflected or sharply bent (refracted). Submarines operating beneath the layer depth may escape detection because the sound does not reach them or because the returning echo is greatly weakened or mushy. The VDS overcomes this disadvantage because it can be lowered beneath the layer depth, thus improving detection capabilities previously limited by the fixed, hull-mounted sonar.

Older VDS sets consist of a towed transducer operating in conjunction with a shipboard-installed, hull-mounted sonar set. The union is accomplished by providing a transducer within a hydrodynamic towed vehicle, plus a crane-type hoist for lowering, towing, and raising the vehicle (fig. 6-13). The towed

transducer is connected electrically to the ship through a cable extending through the center of the tow cable. A switching mechanism in the sonar set permits use of either the hull-mounted transducer or the towed-transducer, or both simultaneously.

A later type of VDS (not shown) is a sonar set complete within itself. Because it can be made to operate independently of other sonar systems, it is known as the independent variable depth sonar (IVDS).

DIPPING SONAR

Sonar equipment called "dipping sonar" can be used by rotary-wing aircraft (helicopters) to detect submerged submarines. Because it isn't practical to drag sonar equipment through the water at the minimum flying speeds of fixed-wing aircraft, only aircraft that can hover or move at low speeds are suited for sonar detection.

Because of the limited weight-carrying and power-producing characteristics of aircraft, high-powered azimuth-type sonar is not carried by aircraft. The equipment is of the "searchlight" type which pings on one bearing at a time, must be trained to the required bearing to detect a target, and presents only an audible echo without video presentation. In spite of these limitations, airborne sonar gear is capable of excellent results because it can be transported from one location to another at a much higher speed than that of any surface vessel and because, although such aircraft as helicopters are noisy, they produce little water-conducted noise. (Most dipping sonar presently used in helicopters is capable of scanning 360° and also of narrowing the search to a selected bearing.)

In a helicopter, the dip or dunking sonar equipment, except for a ball-shaped transducer housing the 500-foot cable from which it is suspended, is located in the helicopter fuselage. When the helicopter has reached a location where the presence of a submarine is suspected,

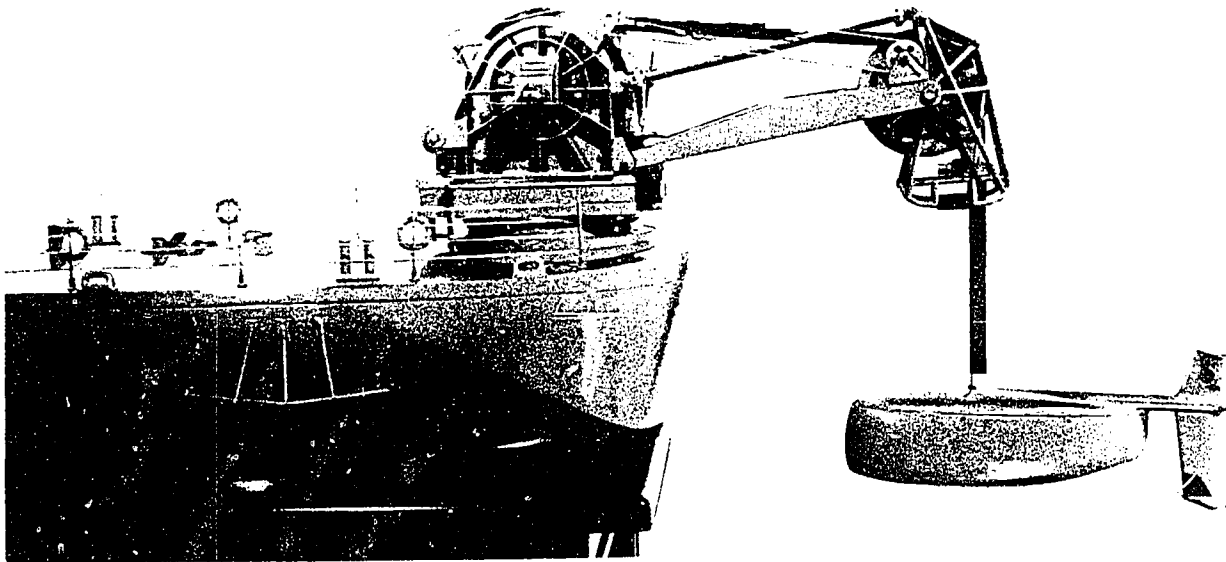

103

51.63

Figure 6-13.—VDS towed vehicle ready for lowering.

it descends to 10 to 20 feet above the water, and the sonar ball is lowered to about 400 feet below the surface. After searching, the helicopter hauls in the cable. After the cable has been retracted, the helicopter can go to another location. When the submarine is detected and located, the helicopter can "vector in" other aircraft and ASW vessels for the attack or can itself attack if properly armed.

The search procedure can be completed in a few minutes (especially if the search doesn't encompass the full 360° in azimuth), and the helicopter can be up and away. Present types of submarines have no effective countermeasures against helicopters. This search technique is much more difficult in heavy weather although improvements in this respect are being made

continually. Figure 6-14 shows a helicopter with sonar submerged, searching.

SONOBUOYS

Radio sonobuoys are small expendable floating hydrophone units whose output is radio-broadcast by a small transmitter in the sonobuoy. They are generally dropped to the sea surface by fixed-wing aircraft in the area where enemy submarines are expected to be. Usually more than one is dropped at a time, in a circular pattern around the contact area (as determined by other detection data). An experienced operator, by comparing its pitch (for doppler) as received by each sonobuoy, can estimate the present location and direction of movement of the target. After two to four hours, a soluble plug in the sonobuoy dissolves and allows the

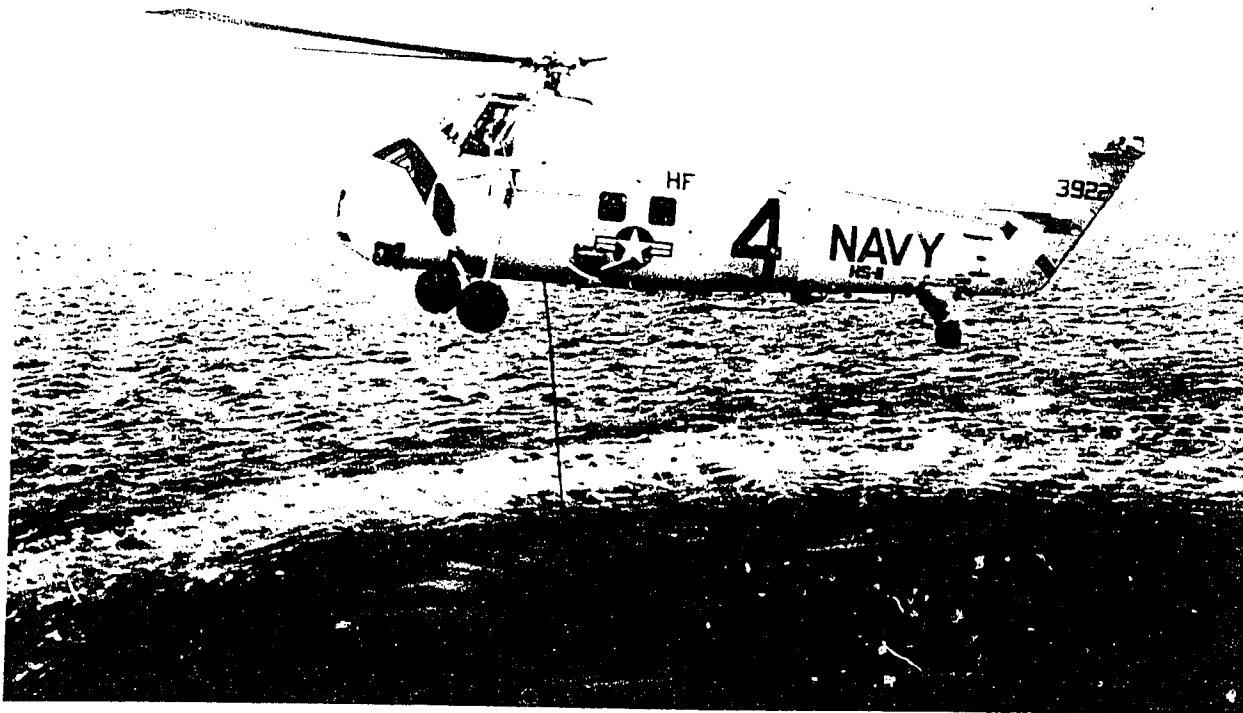
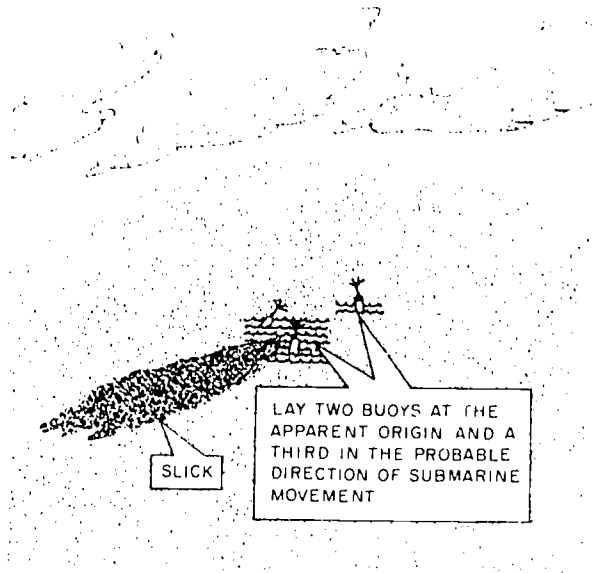

Figure 6-14.—Dip sonar in use by helicopter.

3.115



110.106

Figure 6-15.—Radio sonobuoys used to locate submerged submarines.

unit to sink. While afloat, the sonobuoy indicates its position visually (by releasing red dye into the water or by keeping a lamp lit) and by radar.

Figure 6-15 shows diagrammatically how one type of sonobuoy pattern is initiated by an aircraft in response to surface indication of the presence of a submerged submarine (in this case, the oil slick from a submarine that has been damaged). The buoys are planted where they will continue to pick up the submarine's sound as it proceeds underwater. A frequent pattern is a circle of buoys about the area (called the datum) in which the submarine contact is expected.

**DEPTH SOUNDER
(FATHOMETER)**

The use of sound is a common method of measuring water depth. A sound pulse, directed toward the bottom, is transmitted, and its echo is received. The time between pulse transmission and echo reception is measured and, based on

the speed of sound in water, the depth is thereby determined. Such an echo sounding device is known as a sonar sounding set called a fathometer or a depth sounder. Basically the fathometer is a navigational instrument; but, because it operates on the sonar principle, it usually is given to the Sonar Technician for upkeep.

One type depth sounder used aboard ships and submarines is the AN/UQN-1 sonar sounding set, shown in figure 6-16. Several models of the set are in use.

The AN/UQN-1 depth sounder employs the hot stylus and sensitized paper method of recording depths. It also has a visual scope presentation for shallow depths. This depth sounder is a compact unit, capable of giving

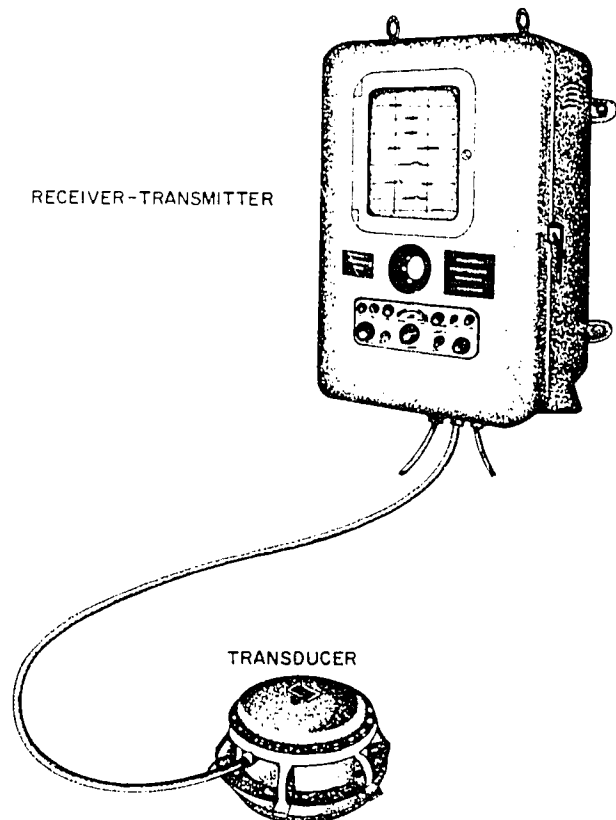

62.9

Figure 6-16.—Depth sounding equipment.

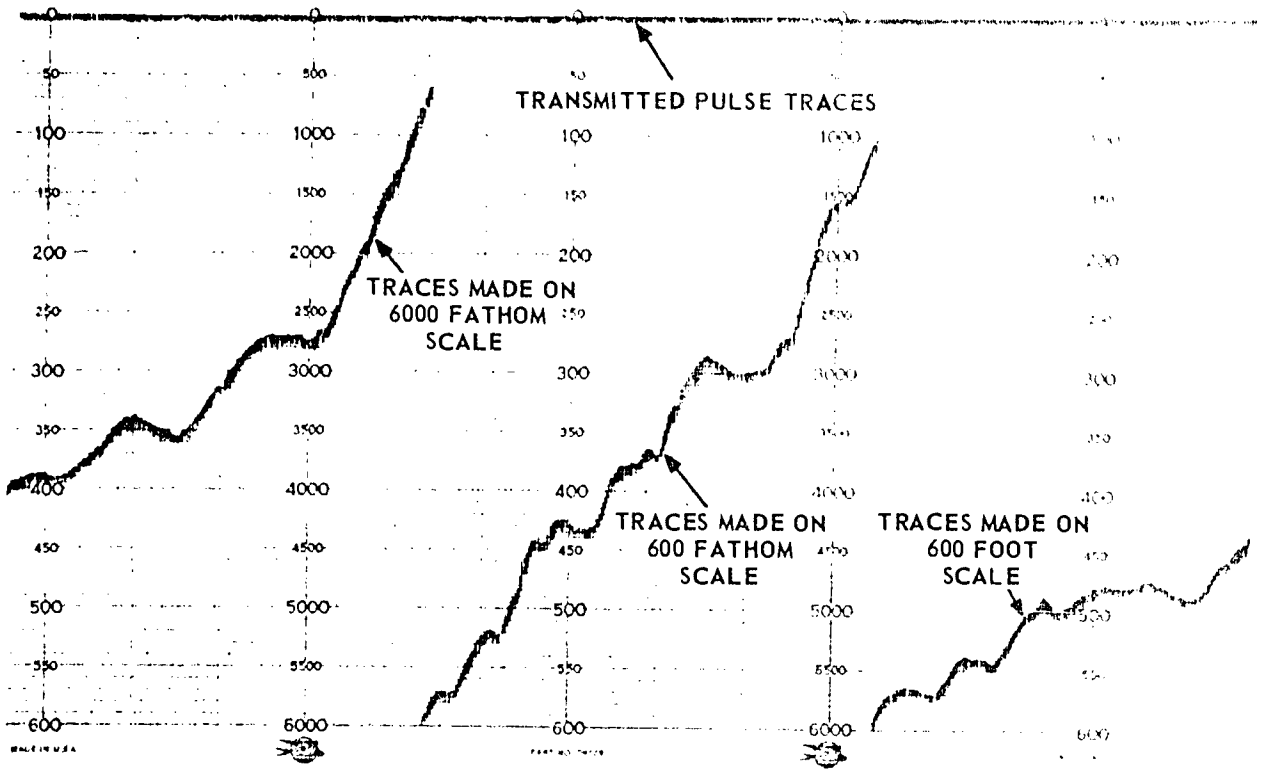

Figure 6-17.—Depth recording showing a steady decrease in depth.

62.10

accurate readings at a wide range of depths—from about 5 feet to 6000 fathoms. Three recorder ranges are provided on the AN/UQN-1. They are 0 to 600 feet, 0 to 600 fathoms, and 0 to 6000 fathoms. The CRT ranges are 0 to 100 feet and 0 to 100 fathoms. The equipment may be keyed manually or automatically. (NOTE: All depths are measured from the ship's keel, not the water's surface.)

Two styluses are used, but they are spaced so that only one stylus records at a time. When the depth sounder records, a stylus starts down the recorder chart simultaneously with the transmission pulse. The stylus moves at a constant velocity and marks the paper twice—once at the top of the chart, when the pulse is transmitted, and again on the depth indication when the echo returns. A depth recording made by a depth sounder of this type is seen in figure 6-17.

The recording illustrated was made from a ship sailing over a sea with steadily decreasing depth. The first part of the trace was recorded on the 6000-fathom scale. Inasmuch as the paper moves from right to left, you can see in the section of the paper shown that the depth decreased from 4000 to 600 fathoms. (Later depth information is to the right of the paper.) When depth was about 600 fathoms, the scale was shifted to the 600-fathom setting. (See how shifting makes use again of the entire width of the paper.) Because depth decreased still further, the scale was shifted to the 600-foot setting when a depth of about 100 fathoms was recorded.

The marking on the paper is downward (stylus motion is downward) in alternate rows printed from 0 to 600 and 0 to 6000. Marking the chart paper in this manner allows the same paper to be used for all recorder settings. You

must check which scale the equipment is recording on to make sure whether the marking is in thousands of fathoms, hundreds of fathoms, or hundreds of feet.

Be sure the range scale in use is greater than the water depth. Otherwise, a false depth indication (or no indication) will result, depending on the position of the styluses at the time of echo return. If water depth actually is 120 feet, for instance, and you have selected the 100-foot range scale, a depth of 20 feet will be indicated.

Other false indications are multiple echoes and reverberations, both of which usually are caused by too high a gain setting. Multiple echoes are the result of the transmitted pulse being reflected back and forth several times between the bottom and the ship's keel. In shallow water a solid line may be recorded, making it impossible to read the depth. Both multiple echoes and reverberation effects can be reduced by decreasing the gain.

Visual indication is supplied by a circular sweep on the face of a CRT. Transmitted pulse and returning echo mark the sweep trace radially. The visual indicator, pointing to a depth of 82 feet or fathoms (depending on the scale setting) is shown in figure 6-18.

Operational Procedure

Following is a brief discussion on normal operation, security operation, and shutdown procedures. Refer to figure 6-19 while reading this description.

NORMAL OPERATION.—For simplicity, it may be assumed that there is only one normal way of operating the depth sounder. Deviations may be considered as expedients for conserving electrical energy, time, or paper, or for maintaining sonar security.

1. Move power switch to **STANDBY**, wait about 30 seconds, then throw the switch to **ON**. This procedure prolongs the life of the keyer tube by allowing the filament to heat before applying plate voltage.

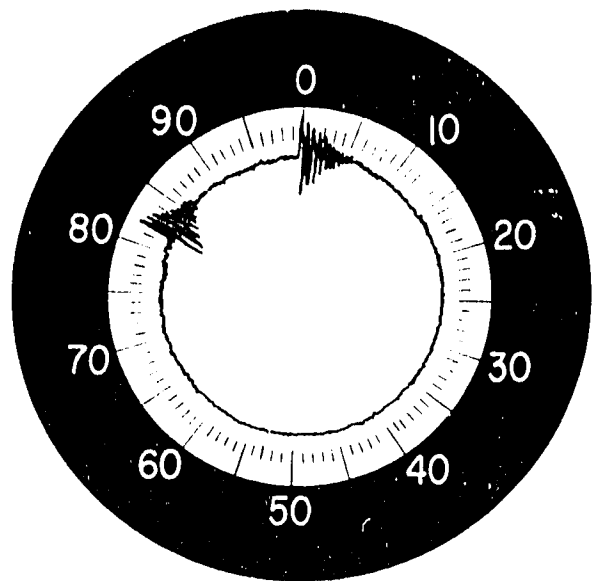

71.57
Figure 6-18.—Visual depth indicator.

2. On the range switch, select the proper range scale. On the indicator the scale is either 100 feet or 100 fathoms. On the recorder the scale is 600 feet, 600 fathoms, or 6000 fathoms.

3. Set the ping switch to **AUTOMATIC**.

4. Turn the gain control clockwise until a suitable echo mark is obtained.

5. Observe that both styluses attached to the revolving belt mark the paper from the zero line to 5 feet.

6. Check to see that the proper range marking is indicated on the top of the paper.

7. Depress marker button. Observe that a straight line is drawn down the full length of the paper. This line should be straight from top to bottom, otherwise the stylus is out of adjustment.

SECURITY OPERATION.—If it is not desired to place pulsed energy in the water periodically, the depth sounder may be operated as for normal operation, except that the ping switch is triggered downward to **SINGLE PING**, then is released. The circuitry is arranged to

pulse the first time the keying contacts operate after triggering and then to release immediately. The ping switch may be held down as long as desired without damage. The result is exactly the same as if this switch were in the AUTOMATIC position.

SHUTDOWN. Put the ping switch in the OFF position. Throw the power switch to the

OFF position (center). This action disconnects both sides of the 115-volt, 60 Hz supply from the equipment (except the service outlet).

Routine Maintenance

Routine maintenance as used here applies to functions, besides operation, that should be performed by the operator. When the operator

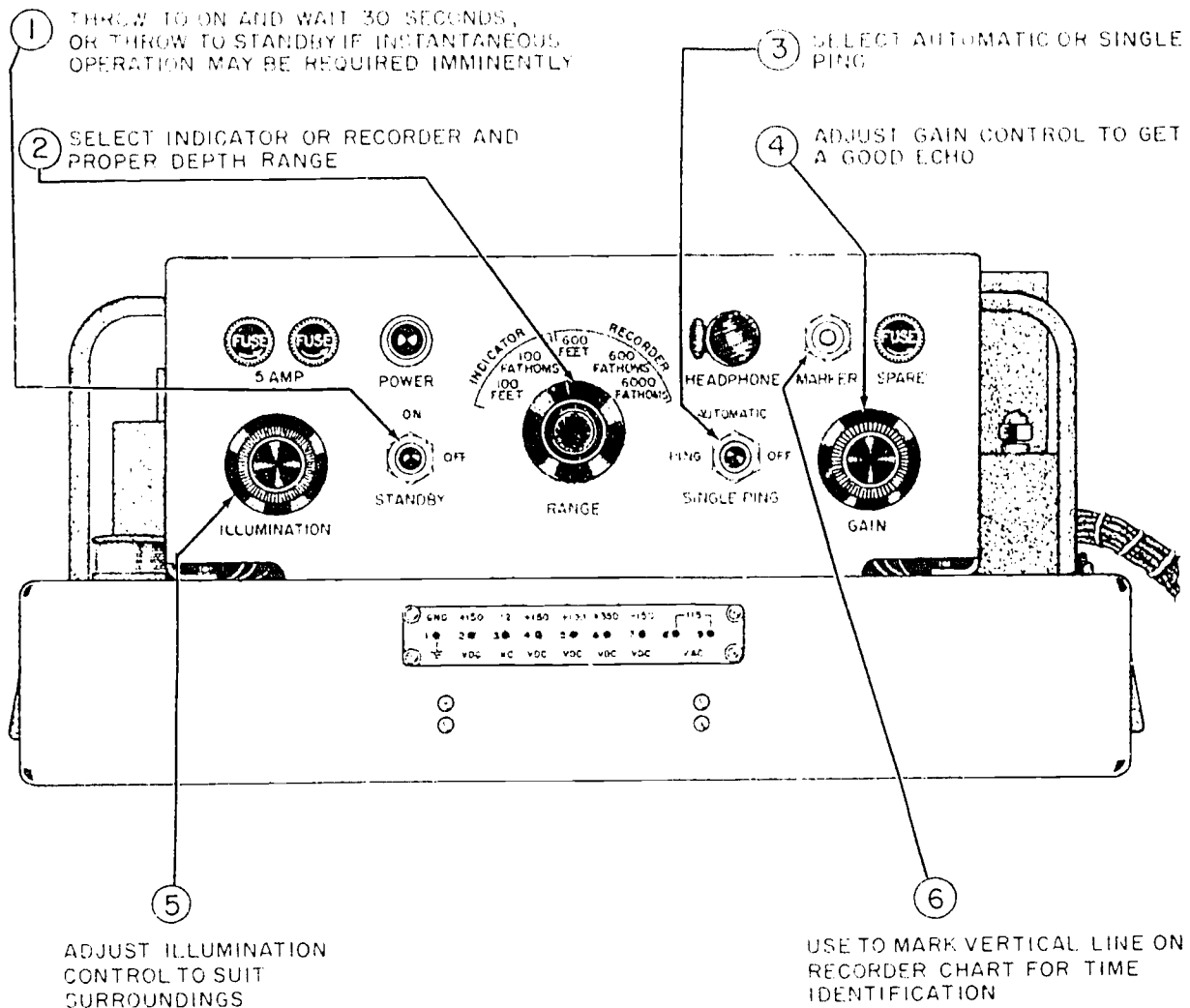

Figure 6-19.—Depth sounder control panel.

71.58

INTRODUCTION TO SONAR

checks out depth sounder equipment before a run, he should be prepared (if necessary) to make minor adjustments and replace lamps, tubes, styluses, or paper. Moreover, he should be satisfied that the equipment will render continuous satisfactory performance during the anticipated operating interval.

The manufacturer's technical manual that accompanies the particular depth sounder aboard your ship lists a step-by-step procedure for accomplishing minor adjustments, replacing parts, and satisfying preventive maintenance requirements.

TAPE RECORDER

Sonar Technicians, particularly aboard submarines, must be able to make recordings of sonar echoes and of other sounds detected by the transducer or hydrophone. Such recordings are valuable aids in classifying sounds (determining the nature and/or source). All ships and submarines are supplied with the necessary equipment to make such recordings. The most common installation is the AN/UNQ-7 recorder-reproducer sound set, familiarly known as a tape recorder.

The AN/UNQ-7 tape recorder is more sophisticated than many commercial types. It is a two-track recorder and reproducer, and is responsive to all frequencies in the audible range. Both tracks may be recorded either simultaneously or independently. Normally, track B is used to record signals directly from the sonar equipment. Track A is used for recording voice information.

When a recording reproduced by the equipment is played back, both tracks can be heard, or only one track, each channel having its own volume control. In short, the AN/UNQ-7 acts as a combination of two separate recorders that are capable of being coupled to allow superimposing two audio information channels upon each other. Figure 6-20 shows the front panel of the recorder. Later models, namely the -7B, -7C, -7D, and -7E are transistorized and have a somewhat different appearance, but their operating characteristics are the same as the basic model.

Originally the AN/UNQ-7 had recording speeds of 3-3/4 and 7-1/2 inches per second (ips). Field changes permitted an additional speed of 15 ips. All subsequent models, beginning with the AN/UNQ-7A, have the 15 ips feature built in. In general, the faster the recording speed, the more faithful is the sound reproduction.

The standard reel is 7 inches in diameter, holding 1200 feet of 1/4-inch tape. At a recording speed of 15 ips, 1200 feet of tape will last about 15 minutes.

Operating Principles

Magnetic tape consists of finely ground iron-oxide particles deposited upon a plastic backing (tape). The particles, too small to be seen with the naked eye, are deposited in such a way that they are allowed to magnetically move or line up in an orderly fashion as a result of some force applied to them. The force having

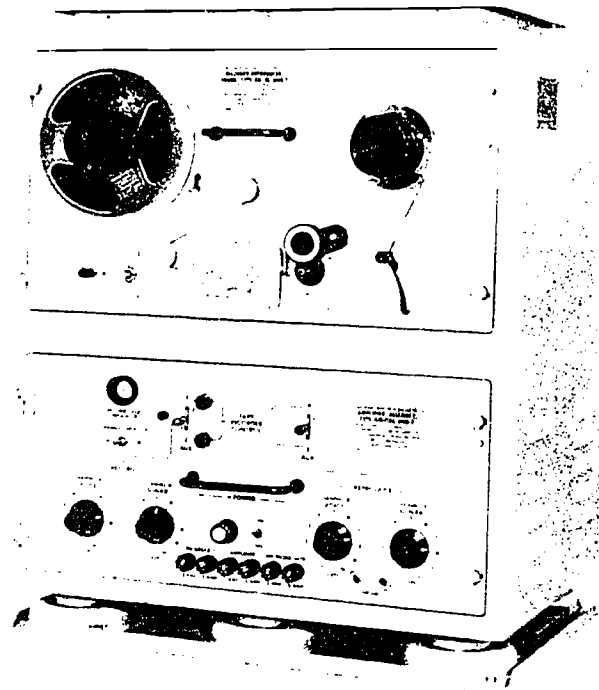

109

Figure 6-20.—Tape recorder AN/UNQ-7.

7.54

such an effect on the iron-oxide particles is a magnetic field. This magnetic field can be caused by a common magnet or by a temporary electromagnetic field. It results from passing an electrical current through a coil of wire.

Magnetic Heads

A microphone contains a magnetic device that is capable of producing electrical energy representative of the sounds spoken into it. In a tape recorder, the microphone-produced electrical pattern is fed to a wire coil, causing a magnetic field which represents the pattern. The coil is wound on a core that has a gap in one side. Because the magnetic field is most intense at the gap, that is where the signal is placed on the tape. The narrower the gap and the sharper the gap edges, the better is the high-frequency response. Figure 6-21 shows a typical magnetic head. The magnetic tape passes over the head, and the electrical pattern is reproduced upon the tape in the form of regular patterns of iron-oxide particles that magnetically line up in accordance with the signal passed through the coil.

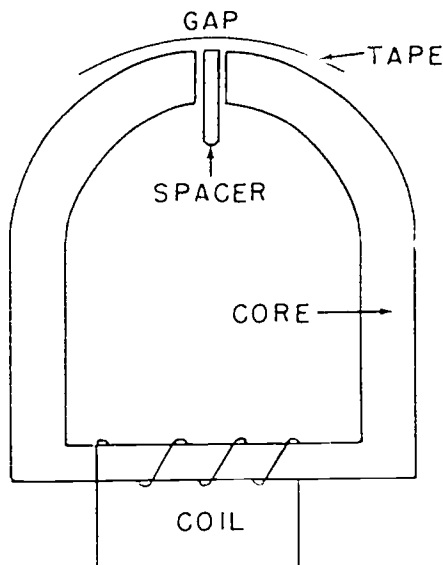

71.122

Figure 6-21.—Typical magnetic head.

The recorder has three heads. The device in the recorder about which the magnetic field is produced by the microphone is called the recording head. Another head, called the erase head, eliminates the magnetic pattern from the particles on the tape. A third head is for playback of the recorded signal and is called the reproduction head. The three heads are contained in a single housing.

RECORDING HEAD.—The recording head is composed of a highly permeable material, which means that the core is easily magnetized and just as easily demagnetized, by a current passing through the coil. High permeability is a necessity for the magnetic field to follow the fluctuations of the signal to be impressed on the tape.

In reality, the signal cannot be put “as is” directly onto the tape. It must be mixed with another signal for strength and linearity; that is, for consistent form throughout the signal band. The bias signal with which the original signal is mixed is of very high frequency—too high to be heard. Electrically, it has unchanging, steady-strength characteristics. The a.c. bias assures better acceptance by the tape of the signal to be recorded and helps reduce distortion of strong signals.

ERASE HEAD.—Tape passes from the erase head to the recording head, and then to the reproduction head (in that order). The erase head demagnetizes both channels simultaneously. It is unnecessary to erase a tape individually before it is re-recorded because, when a tape is being used for recording, the erase head is energized so that a new recording cannot be ruined by superimposing it over an older one. Thus, tapes having recordings that no longer are needed for retention can be used directly. The machine simply is set to record; the old tape is put on; and, after it passes the erase head, it is “cleaned” of the earlier recording. It next passes the recording head, which puts a new magnetic pattern on it.

REPRODUCTION HEAD.—The reproduction head, which is next in line, is similar to the recording head in construction. That is, it has a broken ring of permeable

material wound with wire coils. When the recorded tape passes over the gap, the permeable material is affected by changes in the tape's magnetic field, and an electric current is induced in the coils surrounding the ring. The induced signal is amplified and fed to phone jacks for audible presentation.

Operating the Equipment

The top half of the tape recorder, as seen in figure 6-20, is the actual recorder and reproducer. The lower portion is the amplifier section. It includes controls and indicators that directly affect the recording and playback of the tapes.

Each recording track has a separate channel. On the equipment they are labeled channels A and B. Channel A is used for voice recording and reproduction; channel B, for sonar information. Both channels have separate controls for recording and reproduction. The recording controls are to the left of the amplifier section. Playback controls are at the right of the amplifier section.

THREADING TAPE.—The roll of magnetic tape to be used for recording purposes is placed on the left reel-hold assembly on the upper section of the recorder. It is placed in such a way that, when the equipment is in operation (recording or reproducing), the reel rotates in a counterclockwise direction, and the magnetic tape leaves the reel from the bottom.

Other parts are on the upper section to guide the tape and to pull it through the head device. When the tape unwinds from the left reel, it is threaded around the guiding assemblies, fed through the head assembly, around the capstan which actually pulls the tape through), and then it is taken up by the right reel. A pictorial diagram of the path followed by the tape from reel to reel is printed on the face of the head assembly. By adhering to the diagram, you will have no difficulty threading the equipment properly.

RECORDING.—After the tape is threaded, the tape recorder is energized by turning the power switch to the ON position. You must wait for a short warmup period.

Next, select the speed at which recording is desired. As mentioned earlier, there is a choice of 3-3/4, 7-1/2, or 15 inches per second. Select the faster speed for critical recordings during which the pitch of the echo may have an important part in later evaluation. A recording made at a higher speed can be studied more completely by reproducing it at the lower speed. (An 800-Hz tone, recorded at 7-1/2 inches per second, is heard at 400 Hz when reproduced at 3-3/4 inches per second.) Hence, recordings that may require later analysis should be made at the higher speed. The disadvantage of the higher recording speed is that the tape is used twice as fast as when operating at the next slower speed. Information on speeds to use for recording and playback are contained in the technical manual supplied with each recorder.

Although the higher speed provides the highest quality reproduction, differences in recordings made at each speed are not detected easily. Only when a critical analysis of the recording is made does the faster speed prove its worth over the slower one.

The recording level is selected next, and each channel's level must be adjusted individually. An indicator on the amplifier assembly is labeled **RECORD LEVEL INDICATOR**. Directly below it is a two-position toggle switch labeled **CHANNEL SELECTOR**. The positions of the switch are marked A and B, each representing a channel. Set the toggle switch to either channel, and observe the vertical amplitude on the face of the indicator. The record level controls, below the **CHANNEL SELECTOR** switch, are marked for channels A and B. Adjust the level control for the channel chosen until the signal peaks (shown in the level indicator) occupy the space between the upper and lower horizontal lines. Next, select the other position on the switch and make the same adjustments for the other channel. The equipment is now ready to record on both channels.

To start the recording process, an unlabeled button to the right of the record level indicator is held to the left, and the tape recorder control (record section) is moved up to the No. 1 position. A light (indicator No. 1) glows as the equipment begins to record.

The unlabeled button is called the record safety interlock switch. Its function is to prevent accidental or inadvertent recording. To record, you must place the record switch in the No. 1 position and simultaneously turn the record safety interlock switch to the left.

To stop recording, set the record switch to the neutral (middle) position. To start recording again, move the safety interlock once more to the left as the record switch is returned to the No. 1 position.

Another position of the record switch is labeled AUX (for auxiliary). This position is provided for use if an auxiliary recorder-reproducer is added to the system.

RECORDING FROM REMOTE LOCATION.—A device that allows some control of the assembly from remote locations is included with the tape recorder. A single operating control and two indicating lamps (labeled STANDBY and RECORD) are on the remote control unit. The single operating control is a two-position toggle switch that parallels the record switch on the amplifier section. Preliminary adjustments, such as tape threading and level control, must be set before using the remote control unit. The standby light indicates that power has been applied and that tape is threaded. It does not signify selection of the proper speed nor adjustment of the level controls. It does not light when no power is applied, when the tape is threaded improperly, nor when the equipment is used to reproduce a previously recorded tape.

The positions of the toggle switch are STANDBY and RECORD. The standby position corresponds to the neutral position of the record switch on the recorder proper. The record position takes precedence at both locations, meaning that, if RECORD is selected on the remote control unit, the equipment will record even though the record switch on the equipment proper is in neutral. If RECORD is selected on the instrument proper but STANDBY is set on the remote control unit, the equipment will record again. Thus, a tape being reproduced on the recorder proper can be ruined (by the

automatic erasure process during recording) if the switch at the remote control unit is set to the record position during playback. Consequently, the switch on the remote control unit must never be moved from the standby position unless the standby light is glowing.

When the machine is recording, the RECORD light on the remote control unit glows. When approximately 5 minutes of recording time, at 7½ ips, remains on the tape, the RECORD lamp flashes to warn that the end of the reel is approaching. If the recorder cuts out (this feature is automatic when the tape reel is exhausted), the RECORD light goes out. When the tape recorder returns to a standby condition, the STANDBY light glows again.

REPRODUCING.—To play a recording, thread the tape, turn on the power switch, allow for warmup, and choose the tape speed.

Next, place the REPRODUCE switch in the No. 1 position (it has the same positions as the RECORD switch). This setting actuates tape motion, and both channels are reproduced simultaneously.

Finally, adjust the reproduce level controls for both channels to the desired output of each of the headphones (if used) or the loudspeaker.

To stop the playback, simply return the reproduce switch to the neutral (middle) position. This stoppage may occur at will throughout the run of the reel. The equipment returns to the standby condition whenever the neutral position is selected. As in the recording mode, the tape motion stops automatically when the end of the reel is reached.

Remember that the switch on the remote control unit must not be set to record during the reproduction mode of operation. Otherwise, the recording will be ruined.

Other Uses

The tape recorder allows simultaneous recording and reproducing of sounds. By this

INTRODUCTION TO SONAR

means, you can monitor what is being recorded as it is recorded. Steps to set the equipment to this mode of operation are included in the equipment instruction book, Technical Manual, Recorder-Reproducer Set, Sound, AN/UNQ-7, NAVSHIPS 365-2471.

A switch on the upper section of the instrument allows rapid rewind and fast forward operation. Instructions and procedures for using the switch, as well as those for erasing and splicing the tape, are also included in the instruction book.

CHAPTER 7

BASIC FIRE CONTROL

Although the overall objective of all Sonar Technicians is to aid in destroying enemy submarines, the manner in which the task is accomplished varies with the individual branch of the rating. The shipboard Sonar Technician, for example, tries to maintain continuous contact and aggressively enters the submarine/ship duel, using every available means to hold contact. The submariner has a tendency to sneak up on the target, gathering attack information from the noises produced by the target itself, perhaps making one sonar transmission just before firing. In each instance, the ultimate goal of the antisubmarine unit is destruction of the enemy submarine. The system by which information is collected and translated into weapon firing data (including positioning of weapon launchers) is called fire control.

UNDERWATER FIRE CONTROL

Fire control is defined as the technique by which weapons are directed to a selected target. It consists of the material, personnel, methods, communications, and organization necessary to destroy the enemy. Underwater fire control includes all of the foregoing components, with the added difficulty that the selected target is a submarine, capable of moving in three dimensions—in range, bearing, and depth.

REPRESENTATIVE UNDERWATER FIRE CONTROL SYSTEM

Because many operational aspects of specific fire control systems are classified, this section describes in general terms the functions of what may be considered a representative underwater

FCS. The discussion following does not apply specifically to all FCSs on all ships; the aim is to describe the main elements of most systems so that you will understand their functions and how they work together.

The basic fire control attack problem consists of analyzing target motion from sensor inputs, determining future target position, selecting the optimum weapon, and generating launching orders to deliver the weapon and destroy the target. Weapon selection is determined from target data and the computed fire control solution. Various units of the FCS are: (1) a position indicator to allow for command control of weapon selection and firing, (2) a stabilization computer to stabilize launcher and sonar during the attack problem, (3) one or more position indicators to allow testing, setting and monitoring of a selected weapon and to act as a compatibility link between gun fire control radar and the attack console, and (4) the attack console, the central data processing center of the FCS.

Attack Console

The attack console is a computer in the data processing center of the FCS. In addition to receiving target data from sonar, it may be able to act on target bearing and range from missile or gun FC radars.

The console receives information such as (1) own ship's course and speed, and (2) target range, relative bearing, depth, course, and speed. There may be other inputs, depending upon the type of weapon to be launched; most inputs are generated electronically, while others may be inserted manually. The console displays the

INTRODUCTION TO SONAR

attack problem on the console geographic plotter section, combining target data with ballistic's and own ship's motion to provide (depending on the weapon to be employed)--

1. Generated data for sonar tracking and position keeping.
2. Launcher train and elevation orders.
3. Missile or torpedo set-in orders.
4. Range and bearing for torpedo attacks.
5. Director designation for in-flight tracking.

From received target motion quantities, the console computes aided sonar bearing and range tracking information and sends it to sonar. If sonar loses contact, the operator places the console in the position-keeping mode, and attack problem computations continue from the last observed target range, bearing, course, and speed values already entered into the computer.

Depending on what the inputs to the computer are and the weapon(s) to be controlled, the console solves the attack problem and transmits to the weapon the firing signal and the stabilized weapon train angle. It also transmits to the bridge the course to steer for the attack. (More precisely, it puts out corrections to own ship's course.)

Stabilization Computer

The stabilization computer receives roll and pitch data from the ship's gyrocompass, target bearing from sonar, and apparent depression angle from the attack console. From these quantities the computer generates stabilized sonar train and depression orders and transmits them to sonar. Input and output stabilization data are displayed on dial indicators on the front panel of the computer.

Position Indicator

A position indicator on the bridge provides command with an indication of the source of contact (sonar or radar): a continuous display of own ship, target, and weapon tactical

information; an indication of firing readiness; and for some weapons a control by which the commanding officer approves the payload selection. For the last, unless command activates the "approved" control, the attack console cannot generate a firing command.

Relay Transmitters

In general, relay transmitters receive input data at a particular frequency, then convert it to a different frequency (operating voltage) for transmission to other equipments. There are many types of relay transmitters, depending on the purpose for which utilized. This brief discussion, of course, is concerned only with FCS relay transmitters.

One type of relay transmitter tests, programs, and monitors the ignition and separation assembly data of a selected missile. After the missile is selected, the transmitter tests the power supply, thrust cutoff velocity time channel, and airframe separation time channel to ensure missile readiness for firing. If missile check results are unsatisfactory, another missile must be selected.

A second type makes the attack console compatible with gun or missile FCSs and weapon direction equipment. This transmitter is used during (1) missile or target tracking and (2) missile designation. For the former, the transmitter converts single-speed synchro target or missile bearing data into two-speed synchro signals for transmission to the attack console. When the transmitter is utilized for missile designation, water entry point quantities and airframe separation time are received by synchro transmissions from the attack console. Designated missile elevation is set in manually at the relay transmitter.

WEAPONS

Some of the antisubmarine (A/S) weapons controlled by underwater fire control equipment and used by ships and submarines against enemy submarines are described in the topics that follow. The discussion also points out some of the problems that must be overcome by the

underwater fire control system to realize success. Since these weapons were presented in chapter 2 of this manual, the discussion is brief. Not all weapons are discussed because of the nature of their classification.

SURFACE A/S WEAPONS

Aboard ship, several kinds of antisubmarine weapons are available. The principal one is the ASROC utilizing torpedo or depth charge payload. Also included are one of two types of above water torpedo tubes—the Mk 32 triple mount (see fig. 7-1), or the Mk 32 superstructure-mounted double mount (see fig. 7-2).

Homing torpedoes are of two types—active and passive. The active type transmits sound pulses and homes on the echoes reflected from the target. The passive type is guided to the target by noise emanating from the target itself.

Early antisubmarine torpedoes had two serious drawbacks. First, the endurance or active period was relatively short—a matter of minutes. Second, their speed capability, compared with

speeds of many modern submarines, was slow, and they could be outrun by submarines. These drawbacks have been eliminated for the most part in modern high-speed torpedoes. The newer torpedo also is quite maneuverable, in contrast to the submarine, and has a tighter turning circle. Except for attempting to delude the torpedo with a decoy-type device, one of the best defenses the submarine skipper can provide against a modern antisubmarine torpedo is to call for all available power in an effort to clear the area at maximum speed. Even then, modern torpedoes are normally faster than the submarine. But, inasmuch as the primary mission of an A/S escort vessel is to prevent the submarine from making an attack, causing the submarine to evade a torpedo and run from the area would accomplish the escort's mission.

When conducting an antisubmarine torpedo attack the ship must maneuver into a favorable launching position. A typical homing torpedo runs in helical patterns while seeking a submarine. Once contact with the submarine is achieved, the torpedo steers toward the target. If contact is lost, the torpedo searches for a short time in the general direction in which it is running, then resumes a helical search pattern if

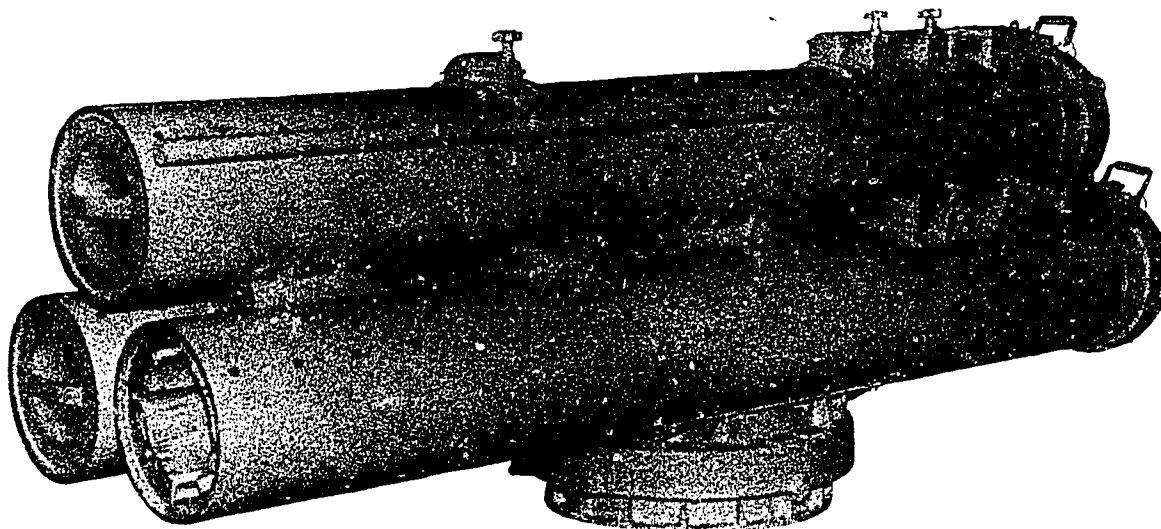

Figure 7-1.—Mk 32 torpedo tube.

3.129

INTRODUCTION TO SONAR

contact is not regained. Some types have a passive capability in conjunction with their active feature which enables them to detect a submarine that is beyond their active acoustic range.

The shipboard antisubmarine rocket, known as ASROC, was discussed in chapter 2 of this manual.

SUBMARINE A/S WEAPONS

Today's submarine has a choice of many types of torpedoes, each designed for a specific purpose. The three main classes of torpedoes are straight-running, acoustic-homing, and wire-guided.

Although the straight-running contact torpedoes are useful in certain tactical situations, they are not considered effective as antisubmarine weapons. These torpedoes are used chiefly against surface targets at fairly short ranges. They are noisy and thus are detected easily, but they are difficult to counter because of their high speed.

Acoustic-homing torpedoes available to submarines have features for homing passively or actively, and for combining the two.

Wire-guided torpedoes are a variation of the acoustic-homing torpedo. They are guided to the target submarine's vicinity by signals sent over the wire by the launching submarine. After the target is acquired by the torpedo, it homes on

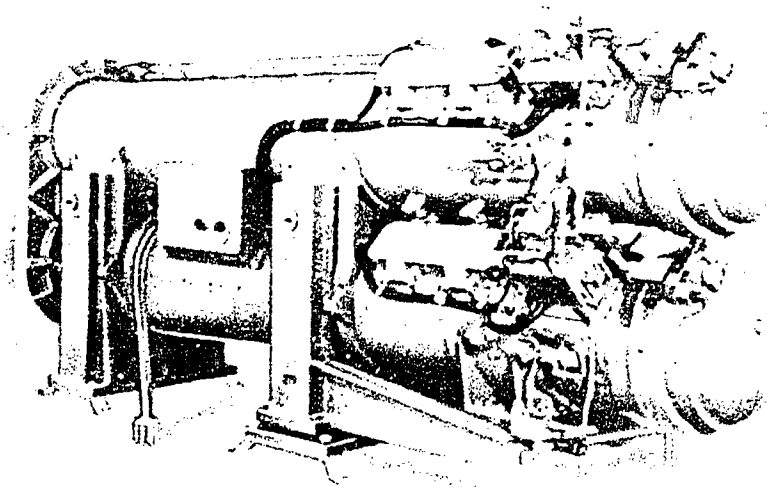

117

Figure 7-2.—View of Mk 32 Mod 9 surface vessel torpedo.

3.129

112

the target without further guidance from the launching submarine.

The submarine also has a rocket-propelled weapon, containing a nuclear warhead called SUBROC, which was described in chapter 2.

DETECTION-TO-DESTRUCTION PHASES

Theoretically, the fire control problem begins when a target is detected and ends with its destruction. In practice, though, the fire control problem starts well after initial detection. It commences after the initial classification and when target tracking is ordered.

Like all other fire control systems (antiaircraft, surface-to-surface, and the like), the antisubmarine fire control system solves the problem in the following stages: (1) tracking the target (2) analyzing target motion and (3) computing ballistic solution.

Detecting a submarine is no easy matter. Neither is it a simple task, once a submarine contact is established, to carry out the successive phases mentioned here. Although fire control systems are capable of performing complicated tasks, such as predicting future positions, submarine hunting is subject to errors caused by human judgment. Training in proper operation of the equipment for maximum ASW effectiveness is a must for Sonar Technicians.

Because the same equipment often is used in detecting a submarine as in tracking it, detection is considered as a phase even though, in the strictest sense, it may not be a part of the problem.

DETECTION PHASE

A submarine may be detected in several ways, the most positive being visual sighting. If the submarine is seen to dive, classification is evident; there is no question about the positive nature of the contact.

Detection also can be made by radar. If a radar contact suddenly disappears, there is a good chance that the echo was the return from a

surfaced submarine and that the disappearance was caused by diving. If sonar contact also is held, it can be assumed the contact is a submarine. Most surface-search radars can receive a radar indication from a periscope. Hence, it is possible to track a submarine that is operating completely submerged except for its periscope. The radar method goes hand in hand with visual detection because radar frequently provides the first indication, directing eyes to the location of the periscope, snorkel, sail, or hull of the submarine.

The sonar equipment aboard your ship or submarine is designed to detect and track the submarine and feed computing devices with tactical data to achieve the destruction phase of the problem.

TRACKING PHASE

After detection, the contact must be tracked. Aboard a submarine, a graphic display of target bearings is made during this phase. From information furnished by this display, target motion is established. Normally, the submarine uses only passive sonar for tracking because active sonar may disclose the presence and even the location of the tracker.

Shipboard Sonar Technicians track the target with both active and passive sonars, including LAMPS employing sonobuoys, and depend largely upon the strength and quality of the echo of the transmitted pulse for target information. Antisubmarine ships have fire control systems that incorporate automatic tracking features. Once the contact is established firmly, the automatic devices keep the sonar on the target and compute the course to be steered so that the ship will arrive at the best firing position for the weapons selected for use.

Basically, establishment of relative rates of target motion is all that is desired from the tracking phase of the problem. The tracking phase sets up the pattern for the next phase—target motion analysis. It is from the relative rates that actual target motion is determined.

TARGET MOTION ANALYSIS PHASE

The target motion analysis phase is a dynamic problem because both the attacking unit and the target usually are in motion continuously, and all related factors change constantly. As a result of the target motion analysis phase, we can establish the true motion components of the target (course and speed). There are several ways of arriving at a course and speed solution.

The target's true course and speed can be established on the NC-2 plotter maintained in CIC by Operations Specialists from information supplied by automatic inputs from sonar. The NC-2 utilizes own ship's course and speed inputs to cause a lighted "bug" to follow own ship's movements. Sonar target true bearing and range input cause a different colored "bug" to move to the indicated position. Target course and speed are then determined by the NC-2 plotter. The NC-2 plot aids the CIC officer in conning the ship, when CIC has control of the attack, and supplies search arcs to the sonar operators whenever contact is lost.

The target's true course and speed can also be established on the dead-reckoning tracer (DRT) plot maintained in CIC by OSs from information supplied by the sonar operators over sound-powered telephone circuits. The DRT utilizes own ship's course and speed inputs to cause a lighted "bug" to follow own ship's movements. Sonar target ranges and true bearings are plotted from the bug, thus establishing the submarine's position. Course and speed are then determined by the DRT plotter.

Target true course and speed also can be read from dials on the attack console.

On the surface ships the underwater fire control systems usually have to compute a horizontal sonar range from the measured slant range and estimated target depth information. This computation is necessary because the fire control system solves for target course and speed in the horizontal plane on the surface in which the ship operates. Slant range is transmitted to the attack console from the sonar console. Depth is set manually into the fire control system.

The attacking submarine may use different methods to determine true direction of target motion. One method is by direct observation, when possible, of the angles on the bow. Angle on the bow was discussed in chapter 5.

BALLISTIC SOLUTION PHASE

It is difficult to say when one phase of solving a fire control problem ends and another begins. One phase usually overlaps another; often they are concurrent. The start of the ballistic solution phase, for example, practically coincides with that of the tracking phase. An antiaircraft fire control system presently in use provides a solution in only 2 seconds once the target is acquired by radar. Yet, during that time, the target is tracked, its motion is analyzed, and the ballistic solution is computed. Most underwater fire control systems, however, take longer to develop a solution. The reason is that certain inaccuracies in target information are inherent in underwater sound. Additionally, range limitations of the weapons require the attacking unit to be within a specific distance to launch nontrainable weapons, and within a specific area to fire its trainable weapons.

After determining the target's course, speed, and estimated depth, two items must be considered to complete the problem. One is whether or not we need to close the target. The other is when to fire.

If the target needs to be closed, keep in mind that you don't want to alert the submarine if at all possible. Also remember that the farther you stay away from an enemy submarine, the less chance he has to shoot at you.

The second consideration—when to fire—is a decision made by the commanding officer after the fire control computer has reached a solution. Many factors are included in the FCS solution. Due to the classification of many of these factors, they are not discussed in this manual. More detailed information may be found in STS 3 & 2, NET 10132-C, and STG 3 & 2, NET 10131-D.

DESTRUCTION PHASE

Destruction of the target is the ultimate goal of the submarine hunter. During this phase the

computed ballistic solution is used so that the ordnance may effectively be fired on the target. Although the surface ship's primary A/S weapon is the homing torpedo, whether fired from a tube or ASROC, the methods of submarine destruction by surface ships are many and varied. Included are ramming, hull-rupturing, near misses by torpedoes, complete destruction by atomic depth charge, or any action which forces the submarine to the surface where it can be sunk by surface gunfire. Submarines, of course, use their A/S torpedoes on their submarine targets. In short, the destructive phase includes action on the part of the attacking unit that leads to a kill—directly or indirectly.

FUNDAMENTAL PROBLEM

The fundamental problem of fire control is to deliver fire on the selected target. A direct hit is not required with some weapons. An atomic depth charge, for example, can cause the destruction of a submarine if the charge explodes close enough to it. All attacks are made with the intention of hitting the target but, with some weapons, a near-miss is good enough.

Solving the fundamental problem is no easy matter. The difficulty is due to such factors as target speed, maneuvers, and range and speed of the weapon, all of which play important roles in delivering fire on the selected target. The solution to the problem varies greatly with given situations. A duck hunter, for example, "leads" the duck along the path of flight. If the hunter aimed directly at the duck as he fired, the shot would pass through the area at which he aimed: but, because the duck is moving, it no longer would be at that spot when the shot reached there. Consequently, the hunter makes an estimate of the future position of the duck, aims for that spot, and fires his gun. If he estimates correctly, both the shot and the duck will arrive simultaneously at the predicted position. The fire control problem is similar to the duck hunter's problem but on a much larger scale.

REFERENCE PLANES

Assume that a gun, rigidly fixed to a ship's deck, fires, while the deck is level, and its

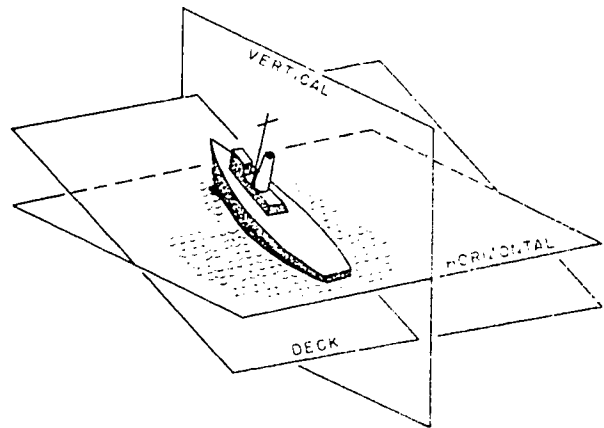

71.123

Figure 7-3.—Reference planes.

projectile hits the target. The same gun, if fired at a time other than when the deck is level, will miss the target. If the gun is free to train (rotate) and elevate, however, compensation can be made for the ship's roll and pitch. The gun then will remain reasonably steady, thus improving the chances of hitting the target, regardless of the ship's motion. A fire control system, in conjunction with a stable element, attempts to make the necessary adjustments to keep the weapon steady.

Deviations from the level attitude are measured by a gyromechanism (the stable element), which transmits to a computer in the fire control system signals that indicate variation of the position of the deck with respect to the horizontal.

Based on signals from the stable element, the fire control system computes values of train and elevation for the weapons launchers to compensate for deviation from the level attitude. The various attitudes are measured with reference to flat, two-dimensional surfaces called planes. (See fig. 7-3.) An underwater fire control system computes solutions in the horizontal, deck, and vertical planes.

Horizontal Plane

A horizontal plane is tangent to the surface of the Earth. Visualize this condition by laying a

INTRODUCTION TO SONAR

playing card or an orange. The card represents the horizontal plane; the orange symbolizes the Earth; and the point of contact between the two is the point of tangency. Every plane parallel to the horizontal plane is likewise a horizontal plane.

Deck Plane

The deck plane represents the level of the ship's gun mounts. (References to guns include similar weapons systems.) When the ship is level, the horizontal and deck planes coincide; but, when the ship rolls and pitches, the deck plane deviates from the horizontal. The stable element measures the amount of angular deviation and transmits the information to the fire control system. The fire control computer compensates for deck tilt by computing a solution in the horizontal plane, then makes train and elevation corrections. In effect, the system brings the deck plane back to the horizontal.

Vertical Plane

A vertical plane is perpendicular to the horizontal plane and is the reference from which bearings are measured. Relative bearing, for example, is measured in the horizontal plane clockwise from the vertical plane through own ship's centerline to the vertical plane through the line of sight.

The system of planes makes possible the design and construction of mechanical and electronic equipment to solve the fire control problem. These lines and planes are imaginary extensions of some characteristic of the ship or target.

FIRE CONTROL NOMENCLATURE

Fire control nomenclature provides a brief and accurate means of expressing quantities that otherwise would require extended descriptions. Although all underwater fire control systems use basically the same fire control symbols, each system has a few symbols that are unique. The entire nomenclature is too lengthy and detailed for inclusion in this text, but a brief explanation

of the basic system is provided so that you may better understand the meaning and purpose of the fire control quantities and their symbols.

Ordnance pamphlet OP 1700 has established and standardized the nomenclature used in describing fire control problems and their solutions for the control of guns, underwater weapons, and missiles. Volume 1 contains the nomenclature for the quantities applicable to solutions of the gun fire control problem. Volume 2 covers the nomenclature for underwater related quantities. Volume 3 has the standard nomenclature for missile related quantities.

The geometrical quantities used in naval fire control are those quantities involved in the mathematical solution of the general fire control problem. Hence, the geometrical quantities fall into certain main classes of quantities. Each of the main classes of quantities is represented by a class name. In each class, other geometrical quantities, besides the basic quantity, are expressed by applying modifiers to the basic quantity. The modifiers express the way in which the quantity is measured.

To illustrate, a class of quantities for expressing present target position is linear distance between own ship and the target. This class of quantities is called ranges. The basic geometrical quantity in this class is the linear distance between own ship and the target, measured along the line of sight. It is expressed by the capital letter R. Another quantity in this class is the linear distance between own ship and the target, measured in the deck plane. This quantity is symbolized by applying the modifier d (meaning measured in the deck plane) to the basic range quantity R, forming quantity Rd.

The nomenclature assigned to represent the basic geometrical quantity in each class and the letters and numerals used as modifiers are listed (as mentioned previously) in the three volumes of OP 1700. Extracts of Volume 2 of OP 1700 (Underwater Fire Control Nomenclature) are contained in *Sonar Technician G 3 & 2*.

SONAR POSITION QUANTITIES

When a target echo is received by a sonar transducer, the target actually is not at the position indicated on the sonarscope but at

some other location. This difference in target positions is due to curvature of the sound beam and to target movement during echo return time.

The determination of actual target position requires the application of corrections to the sonar measurements. These corrections, which are computed in the underwater fire control system, consist of two position quantities: apparent target position and past target position. (Target course and speed are basically produced by this information.) Sonar position quantities are illustrated in figure 7-4.

Two class quantities, range (R) and bearing (B), are shown, together with the modifiers necessary to express the appropriate measurement. Quantities related to apparent target position are represented by the lowercase letter a ; those related to past target position use the letter p . The modifier h means the measurement is in the horizontal plane; the modifier v refers to the vertical plane.

Apparent Target Position

Apparent target position is the point from which the sonar echo appears to come. It differs

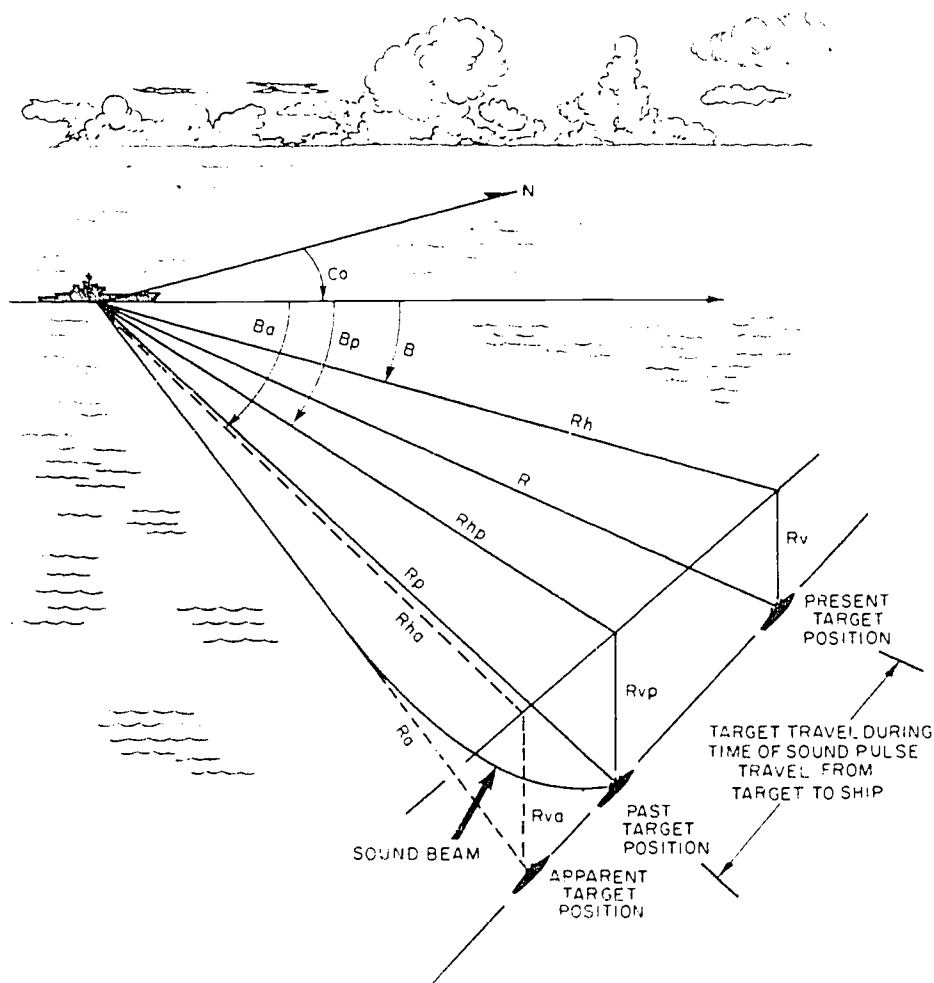

Figure 7-4.—Sonar position quantities.

71.124

INTRODUCTION TO SONAR

from present target position because of refraction of the sound beam and because of target travel during the time required for the echo to return to own ship. The dotted lines in figure 7-4 represent apparent position measurements. The quantity B_a is apparent target relative bearing, and R_{ha} is apparent target range measured in the horizontal plane.

Past Target Position

Past target position is the location of the target when struck by the sound beam. In other words, it is the position from which the sonar echo actually comes. Past target position differs from apparent target position because of refraction of the sound beam. It differs from present target position because of target movement during the time it takes the sound pulse to return to own ship.

Present Target Position

Present target position is where the target actually is located when the sonar echo reaches own ship. It represents the distance traveled by the target during the time it takes the sound pulse to return to own ship from the target. As shown in figure 7-4, quantity B is the target's relative bearing at the time the echo is received.

Target depth (R_{vua}) and slant range (R_a) are combined to give horizontal range to past target position (R_{hp}). R_a is computed with other quantities to give present target position ($c(R_a)$) for use in the weapons system.

EQUIPMENT

An underwater fire control system usually is designed to operate with a particular weapon system although efforts are made to make the system compatible with future weapons. One modern fire control system may be used with several weapon types. Regardless of the system, it serves only one purpose: the destruction of enemy submarines.

After target position is determined, the basic problem for the system is to predict future target position, calculate the required attack course and firing time, and transmit the data to weapons and control stations.

Because most underwater FCSs are of a classified nature, they cannot be included in this text. Certain concepts are discussed, however, to give you some basic knowledge of how a FCS operates.

Electromechanical Devices

Electromechanical devices combine two different types of action—electrical and

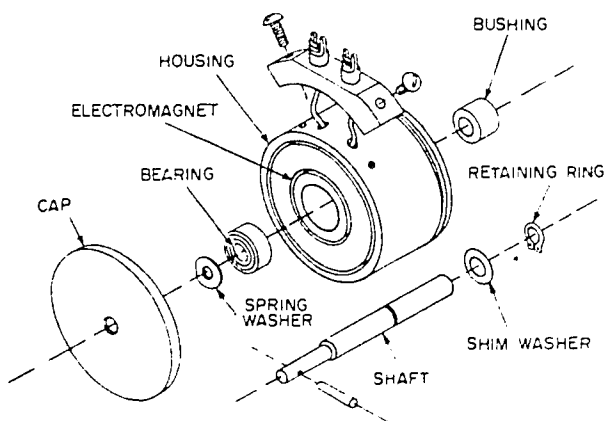

71.59

Figure 7-5.—Magnetic brake—exploded view.

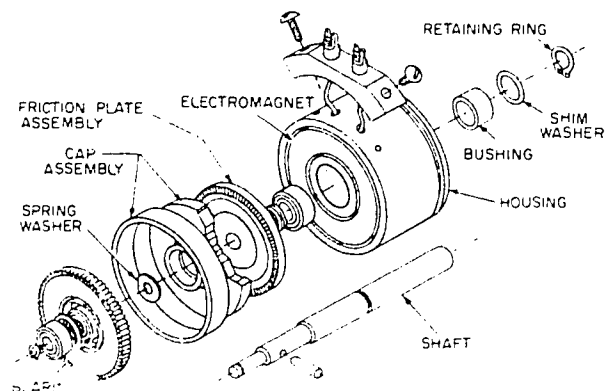

71.60

Figure 7-6.—Magnetic clutch—exploded view.

123

mechanical. These devices, such as the magnetic brake and magnetic clutch, have wide usage and application in fire control computing components.

The magnetic brake can stop and hold a shaft at a given value when certain conditions are met. The magnetic brake is used to prevent a line of gearing from turning. When the current is off, no magnetic action takes place. In figure 7-5, (an exploded view of a magnetic brake), notice that the spring washer holds the cap away from the electromagnet, thus allowing the shaft to turn freely. When the current is turned on, the electromagnet exerts a force great enough to overcome the effect of the spring washer and pulls the cap tight against the electromagnet, thereby locking the shaft in place.

An electromagnetic clutch is used to engage and disengage a line of gearing. An exploded view of a magnetic clutch is shown in figure 7-6. When current is fed to the electromagnet, the friction plate assembly and cap assembly are in contact with each other, and the output line transmits input rotation. When current to the electromagnet is cut off, the friction plate assembly and cap assembly separate by spring action, losing contact with each other. The output line does not rotate or transmit any input to the clutch when these components are separated.

Electrical Resolver

Another device that should be considered here (although it is an electrical assembly—not electromechanical) is the electrical resolver. The resolver is a computing device and functions much like a transformer. It is capable of separating an electrical input vector into two right angle components. The resolver has a stator and a rotor, each part consisting of two separate coils wound at right angles to each other. Voltages induced on the stator coils by excitation of the rotor coils depend upon the displacement of the rotor with respect to the electrical zero reference axis of the resolver. In solving for a single vector, only one of the stator coils is connected electrically and represented on

a schematic. Figure 7-7 shows the schematic symbol of an electrical resolver.

When the resolver is zeroed electrically, the rotor coil clamped to the stator coil is called the cosine coil. The other rotor coil, at right angles to it, is called the sine coil. As the rotor rotates from 0° to 360° , the voltage induced across the cosine coil follows the cosine function of the excitation voltage. Similarly, the voltage induced across the sine coil follows the sine function of the excitation voltage.

SCHEMATIC IDENTIFICATION OF SYSTEM COMPONENTS

In the maintenance publications for fire control systems, the devices described in this section are identified by standardized symbols. The identifying symbols and their abbreviations for system components are reproduced in figure 7-8. Usage of some of the component symbols in a sectional diagram may be seen in figure 7-9.

UNDERWATER FIRE CONTROL SYSTEMS

A modern fire control system is tailored to the requirements of a particular weapon system. Aboard submarines, the weapon is either a torpedo or the SUBROC. Aboard surface ships, the weapon is either a torpedo or the ASROC. Regardless of the type of FCS used, each one has the same purpose—to direct the weapon to the target.

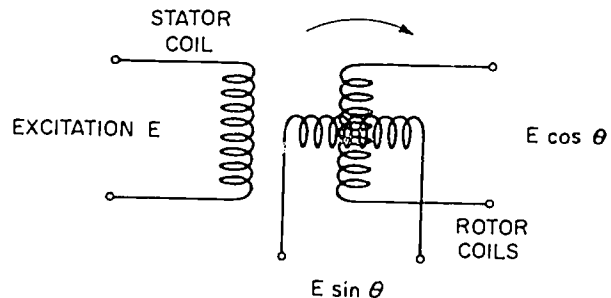

12.105

Figure 7-7.—Electrical resolver—schematic symbol.

INTRODUCTION TO SONAR

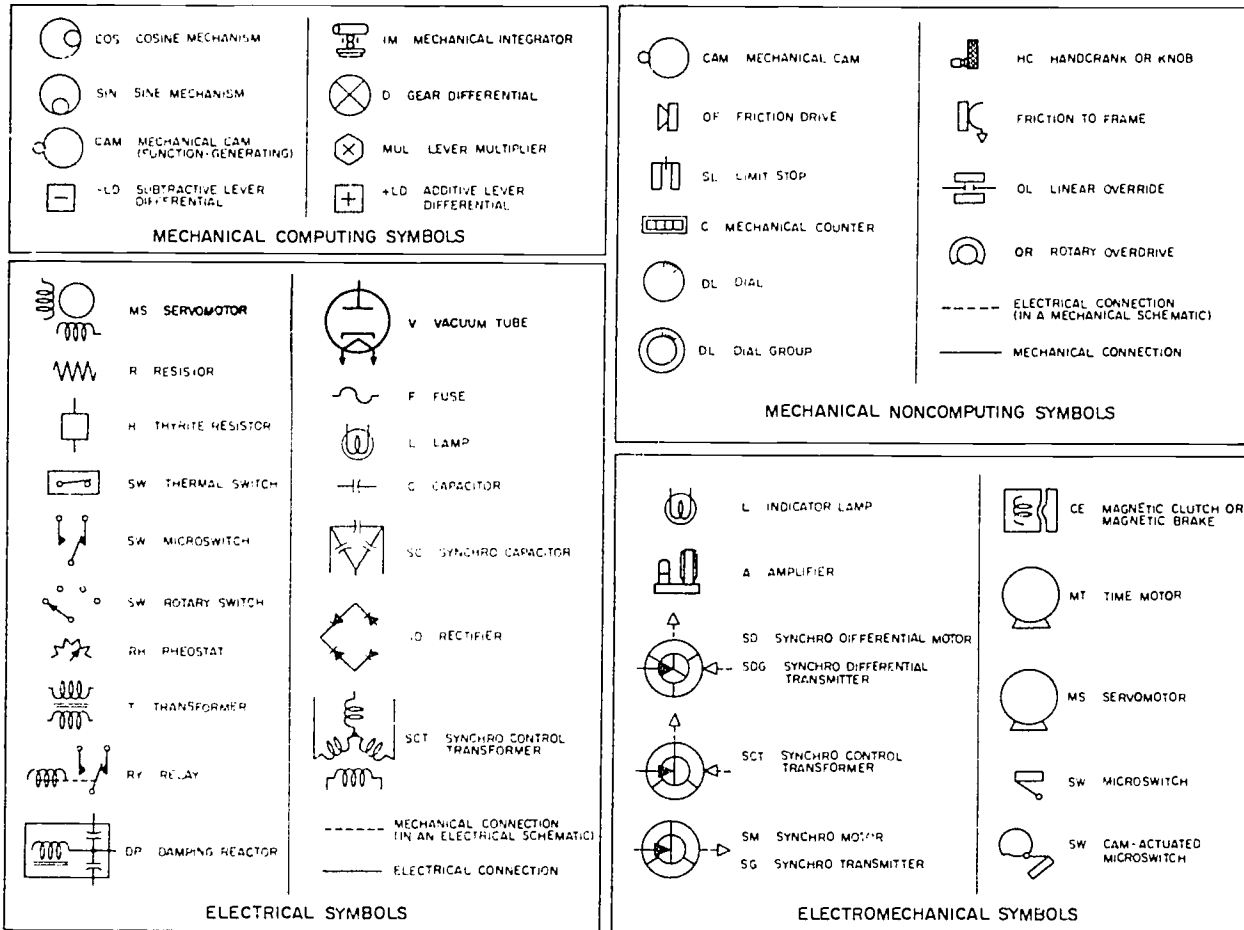

Figure 7-8.—Identifying symbols and their abbreviations.

13.5

Surface Ship System

A shipboard underwater fire control system (the Mk 114 UBFC) is illustrated in figure 7-10. The system performs the following functions:

1. Integrates associated fire control equipment with own ship's components.
2. Receives target position information from sonar or radar and combines it with own ship's and ballistic's data to produce weapon orders.
3. Provides aided tracking and position-keeping information back to the sonar.

A detailed discussion of the complete Mk 114 UBFC is contained in *Sonar Technician G 3 & 2, NET 10131-D*. It is recommended that you refer to the STG publication after completing this manual.

Submarine System

When a submarine is on the surface, the fire control problem is essentially the same as a surface ship's. However, when the submarine is below the surface the fire control problem becomes much more complicated. Figure 7-11 shows a representative submarine fire control system (the Mk 113 FCS).

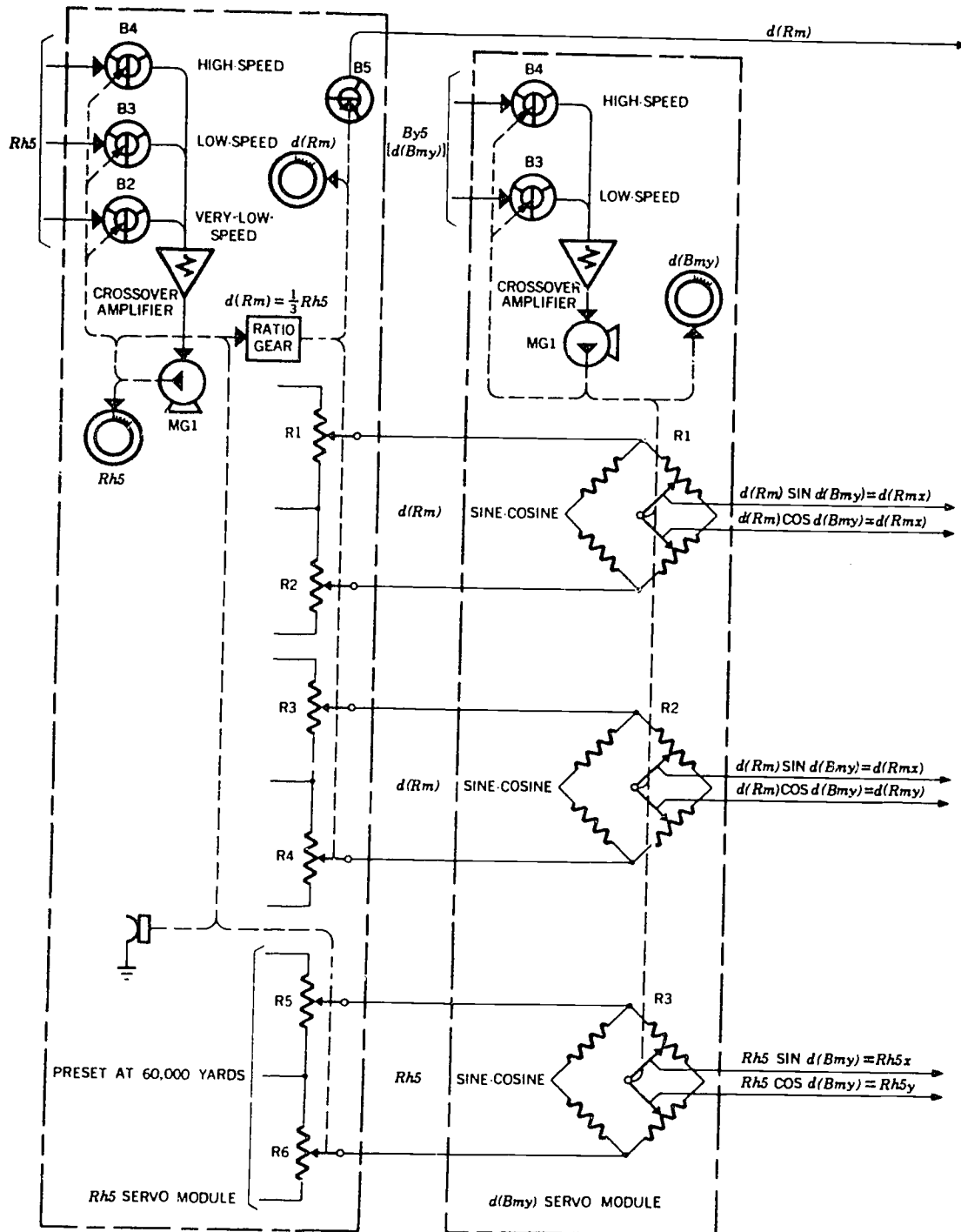
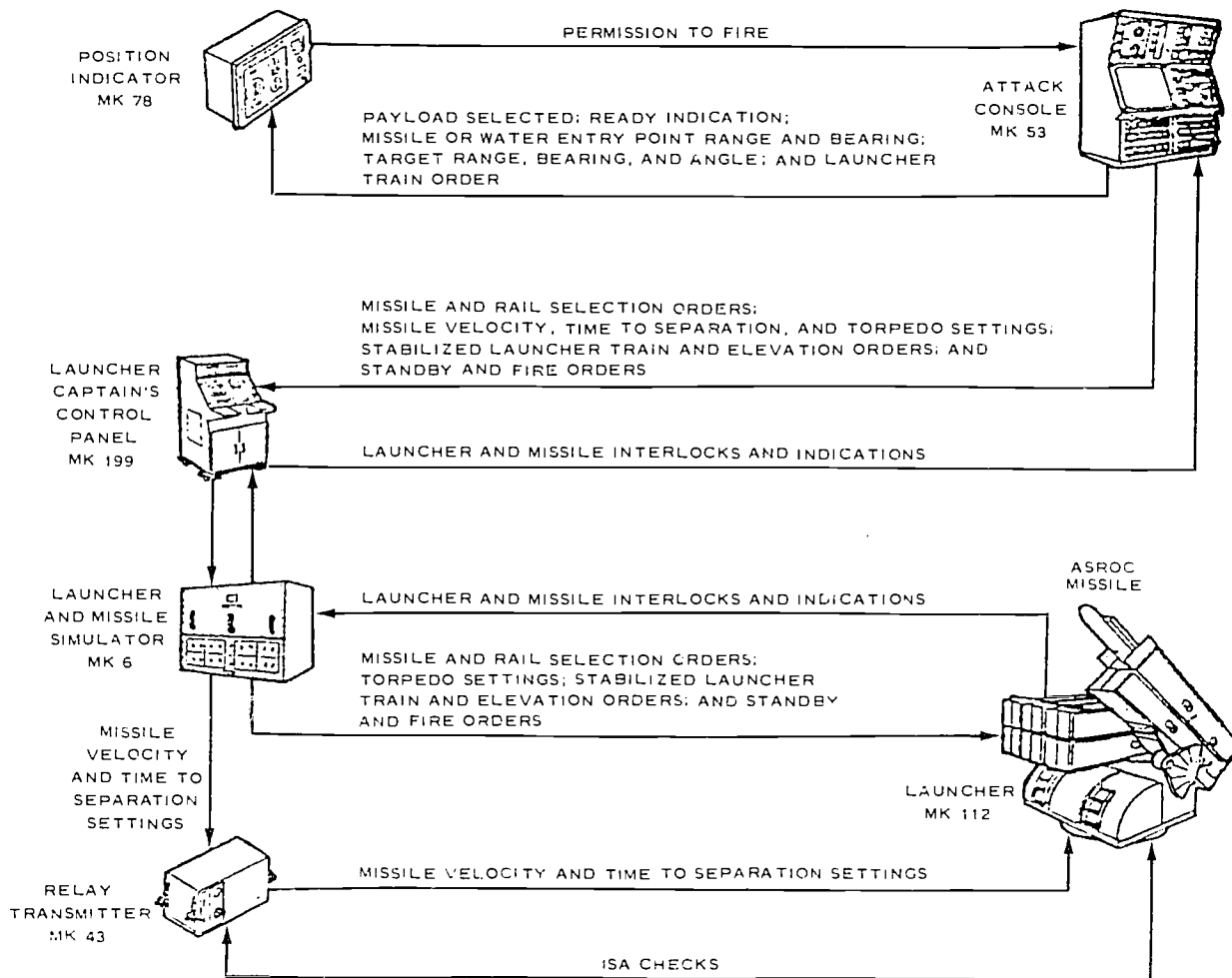

Figure 7-9.—Rhs and d(Bmy) schematic diagram relay transmitter Mk 44.

71.131

INTRODUCTION TO SONAR



71.132

Figure 7-10.—Mk 114 underwater ballistics fire control system.

The Mk 113 FCS provides solutions for launching the SUBROC missile and many different mods of torpedoes. Due to the classification of this subject, it will not be discussed any further in this manual; the Mk 113 FCS is discussed in detail in *Sonar Technician S 3 & 2*. NET 10132-C.

FIRE CONTROL SYSTEM TESTS

Certain transmission, computing, and rate tests must be performed to ascertain that the fire control solution is correct and that values are received correctly at remote stations. Also,

frequent operation of a system exercises servosystems, power drives, and computing networks, thereby bringing attention to any existing trouble.

Transmission Tests

Transmission tests are held to check the accuracy of automatically controlled devices at remote stations and to check their response to changing signals. When running these tests, the first step is to establish voice communications between stations. Next, the man at the transmitting station must read the exact output

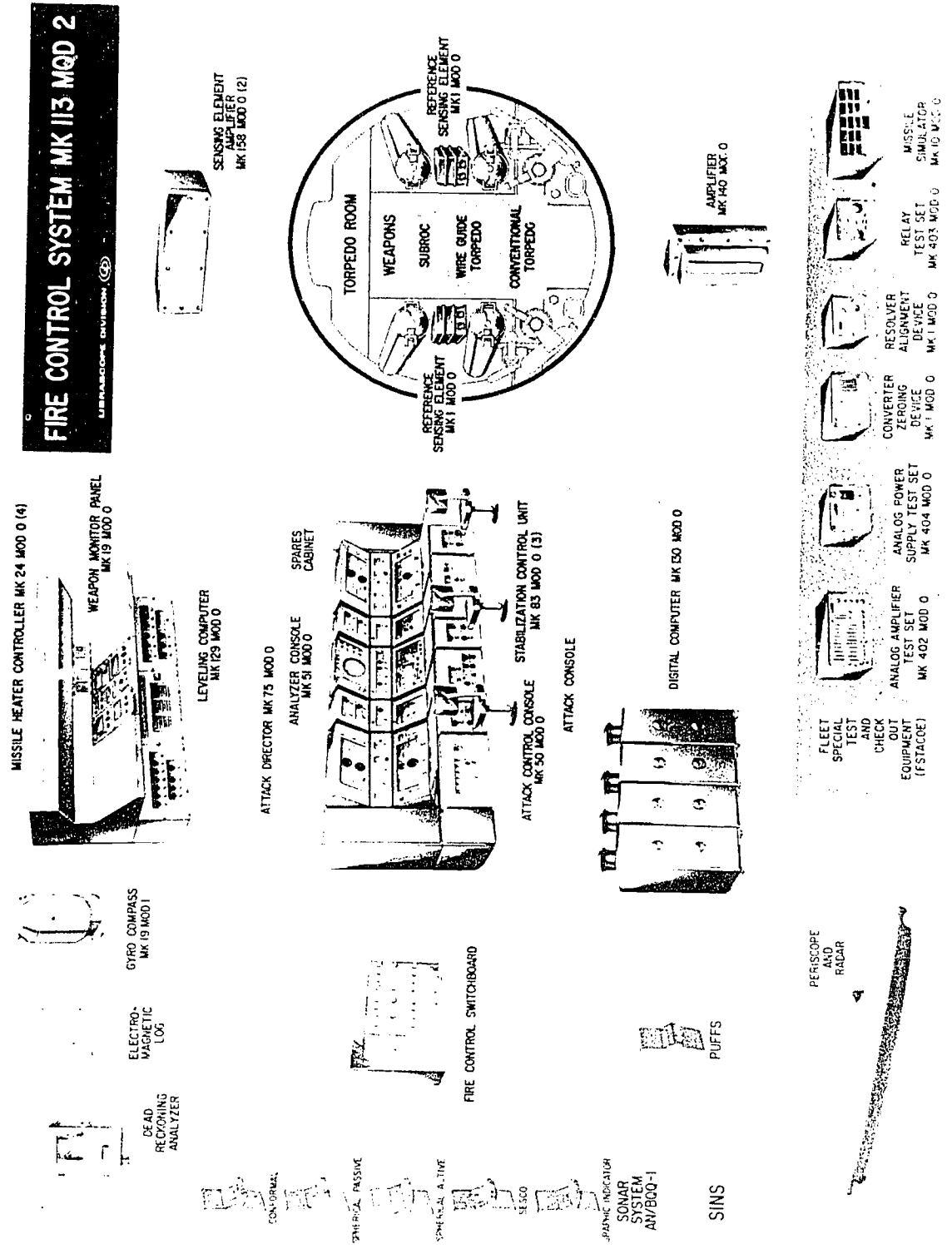

141.173

Figure 7-11.—Mk 113 fire control system.

123
128

INTRODUCTION TO SONAR

value of the quantity being checked. In turn, the man at the receiving station must adjust the receiver to correspond to the reading from the transmitting station.

Computing Tests

As sonar tracks a moving target, constantly changing inputs are fed to the computer. Instantaneous values of these inputs are used by the computer to solve ballistic computations and predict future target positions. The computer's solution is, therefore, based on an infinite number of static (still) problems. As relative motion rates are integrated with time to generate computer changes in target position, the problem becomes dynamic. To test the computer's accuracy, consequently, both static and dynamic tests are run.

STATIC TESTS.—Static tests check the overall operation of the computing system in a standstill condition. In this type of test, appropriate test values are inserted manually, and the problem is stopped at a fixed point. Input test quantities are thus of a constant value and produce fixed answers which do not change with time. These fixed answers indicate whether the static portion of the fire control equipment is performing properly.

DYNAMIC TESTS.—Dynamic tests are run to check the computer's generation of bearing and range for specified time intervals against a mathematical solution whose answer contains correct amounts of change in quantities for like conditions. During the test, fixed values are assigned to relative motion rates by manually setting inputs to the relative motion group. The time system of the computer is then moved,

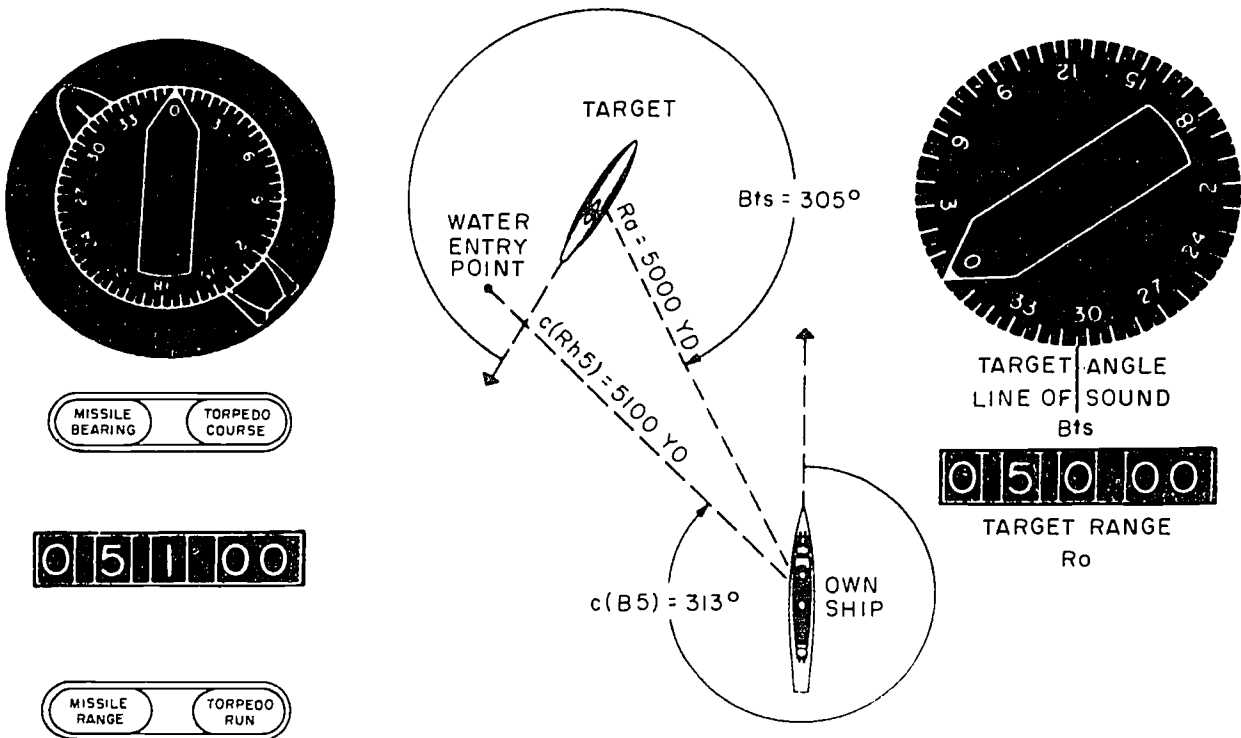

129

Figure 7-12.—Missile and target dial and counter functions.

71.133

either manually or by the time motor, an amount equal to the test interval. Readings are then taken to ensure correctness of the solution.

Rate Tests

Rate control tests check the functioning of the rate control system. Mechanisms of this system correct values, such as target angle and target speed, so that computer target motion rates agree with actual rates of the target. In other words, this test determines the time required for the computer to arrive at correct relative motion rates. Time required must be small, but smoothness of tracking must also be considered. The rate control system is a compromise between these two factors.

Rate control tests consist of tracking a hypothetical motionless target with the computer set for a selected sensitivity of rate error detection. Sensitivity is controlled by the time constant input to the rate control system. Initially a large error is introduced and the time motor is started. Time required to reduce the error by a preselected percentage is timed by a stopwatch. This stopwatch reading is a measure of the actual time constant or sensitivity of the system. It is compared against the theoretical value for the test.

Each fire control system is provided with a set of tests to determine the operating accuracy. Some are daily tests, some are weekly tests, and some are monthly tests. Refer to the specific OD or OP for each individual fire control system test.

INTERPRETING DIAL READINGS

Sonar Technicians must be able to interpret and sometimes interpolate sonar and fire control equipment dial settings. Information to be read from these dials includes such values as range, target angle, true bearing, relative bearing, and many other fire control values. Normally two types of dials are used: disc dials and ring dials.

A disc dial is simply a flat, circular plate secured to a shaft and inscribed with values of the function it serves. A ring dial is circular-shaped also, but has a hollow center to permit placing a disc dial within it. An example of the use of these dials is shown in figure 7-12.

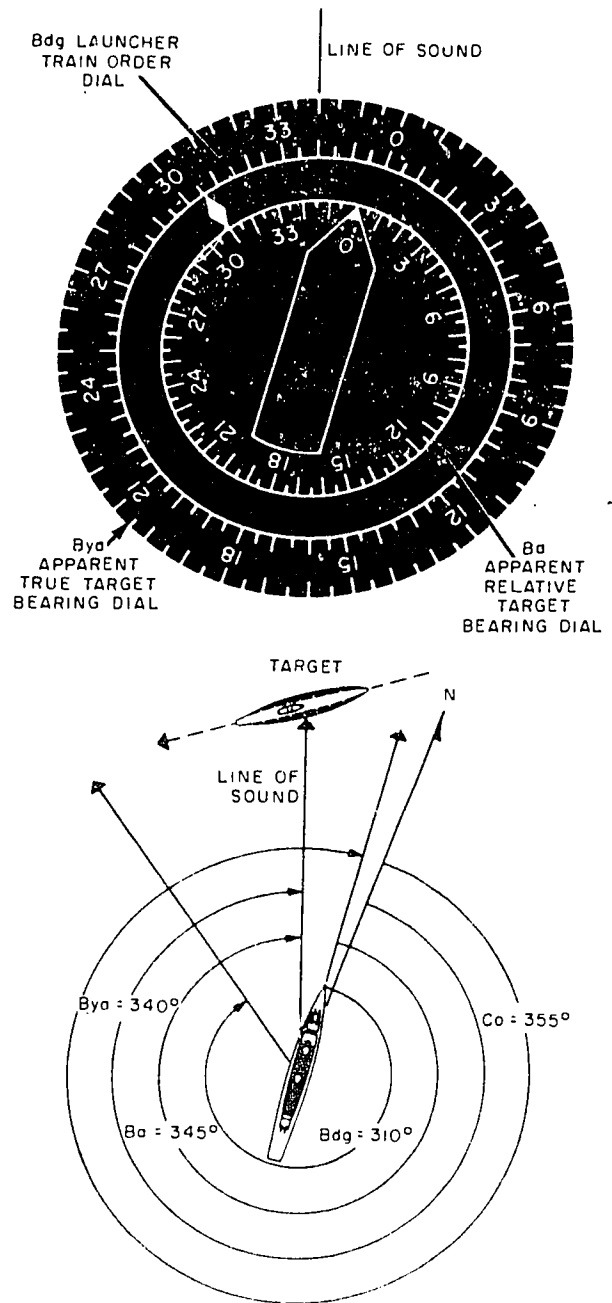

71.134

Figure 7-13.—Own ship dial group functions.

INTRODUCTION TO SONAR

The dial group on the left shows the relative water entry point bearing $c(B5)$ of an ASROC missile. The dial is read on the inner dial against the line index on the missile of the outer dial. The $c(B5)$ shown in this case is approximately 313° .

The dial on the right shows the target angle (Bts) of the target being tracked. Target angle is read against the line of sound index. The Bts shown in this case is 305° .

Figure 7-13 shows the more complex own ship's dial group. This group includes three concentrically mounted dials: an inner dial, an intermediate dial, and an outer dial. The inner dial displays apparent relative target bearing Ba when read with reference to the LINE OF SOUND index. The inner dial is graduated in 5° increments and is numbered in 30° increments from 0° to 360° . The Ba value is 345° . Areas indicating bearings where own ship superstructure would interfere with missile firing are indicated on the inner dial as UNSAFE. Own ship's outline is also inscribed on the inner dial.

The intermediate dial of own ship's dial group contains a diamond index which indicates launcher train order Bdg' values when read against the inner dial. The Bdg' value is 310° . The Bdg' index, when read with reference to the inner dial, indicates launcher train order with respect to own ship's bow. The intermediate dial

also indicates whether the selected weapon will clear the superstructure when fired.

The outer dial of own ship's dial group displays apparent true target bearing Bya values when read with reference to the LINE OF SOUND index. The outer dial is graduated in 5° increments and is numbered in 30° increments from 0° to 360° . Own ship's course (not received as an input) can be interpreted by the position of the bow of own ship inscribed on the inner dial against the graduations on the outer dial. This interpretation is possible because the equation for Co is: $Co = Bya - Ba$. The Co value shown in figure 7-13 is 355° .

The dials just discussed are only a few of the many that you must be able to interpret. Of particular importance is the ability to interpolate (to "read between the lines") and to note direction of change of dial readings. Our discussion of the fire control problem, and of the equipment used to solve the problem, was necessarily restricted to fundamentals. Computer mechanisms fire control nomenclature, and antisubmarine weapons were only briefly covered, serving to acquaint you with the problems involved in making attacks on enemy submarines. You need to study many technical manuals and other training courses to fully comprehend the duties of a Sonar Technician.

CHAPTER 8

COMMUNICATIONS

The essential factor in communication between two persons is that the language they use be understandable to both. Not only must one person be able to express himself clearly, but the other person must be able to comprehend what is communicated.

Realizing that many problems are encountered in communications, the Navy has adopted standard methods and practices to minimize errors and misunderstandings in message transmittal and reception. Many of these standard procedures are used by other allied services. They are invaluable in conducting joint international operations. The phonetic alphabet has been adopted by all allied forces for combined operations.

In this chapter you will become acquainted with some of the internal and external communication systems used aboard ship. Additionally, you will learn correct operating procedures for radiotelephone and underwater telephone communications. Because the phonetic alphabet and sound-powered (S/P) telephone procedures are covered in *Basic Military Requirements*, NAVEDTRA 10054, they are not included in this text.

INTERNAL COMMUNICATIONS

Most Navy personnel, regardless of rate, are familiar with internal communications. Sonar Technicians, especially, have occasion to use several types of systems available for transmitting sonar information. It is almost impossible to conduct attacks on enemy submarines or ships without some method of internal communications. On a destroyer, sonar control may be located below decks, on the

bridge level, or in some other section of the ship (depending on the type and class of ship). Because it is remote from the bridge, some means of communication must be established between the bridge and sonar control. This requisite is accomplished by utilizing one or more of the internal communication systems. Shipboard circuits include MC (loudspeakers) circuits, sound-powered phones, and automatic devices. These devices are remote indicators and are used to transmit bearing and range information, weapon status, and many other types of data needed by other stations.

When sonar contact is made, the bridge usually is informed over an MC system. By this method, all stations concerned are alerted, and sound-powered phones are then manned to eliminate excessive noise levels caused by the constant use of loudspeakers. The ASW officer is directed to make the attack. Although most of the information flow is conducted on the sound-powered phones, the information is backed up by automatic electromechanical devices so all stations are aware of the progress of the attack.

SOUND-POWERED PHONES

The shipboard voice communication system used most extensively is the S/P telephone network. It consists of primary battle circuits JA to JZ, with auxiliary and supplemental circuits for use if a primary circuit is damaged. The degree to which these circuits are manned varies. Few circuits are used under normal peacetime cruising conditions. During general quarters, when all battle stations are manned, all circuits may be used.

INTRODUCTION TO SONAR

Of primary concern to the Sonar Technician are the JA, JP, and JS circuits. The JA, the captain's battle circuit, is used for transmitting orders to key control stations and for exchanging vital information with those stations. Weapons control information is passed over the 8JP circuit. The other S/P circuit you will probably man is the 6IJS. It normally is used as a one-way system to provide contact range and bearing and other data to UB plot, CIC, and the bridge. The IJS circuit is the main antisubmarine attack team control circuit. It connects the bridge, CIC, and sonar control, and is used primarily for conning orders when sonar or CIC has control of an attack. Normally, the IJS is manned by officers in charge of the various stations.

Circuit discipline must be maintained at all times when you are wearing phones. Personal conversations with friends on the same circuit may cause a delay in the transmission of vital information, resulting in a delayed or missed attack. With the high speeds of modern submarines, such a delay could result in the loss of your ship or the ship you are trying to protect.

MC SYSTEMS

Although sound-powered phones are the most common means of internal communications, there are other methods, one of which is the MC (shipboard announcing) system. The MC system is an electronic speaker-type system, similar to an office-to-office intercommunication system, and is designed to provide amplified voice communication.

Sonar and CIC underway watch stations usually are not fully manned under normal cruising conditions aboard ASW ships. When a sonar contact is gained, the 29MC (sonar control and information) is used to alert CIC, UB plot, and the bridge. Contact information (such as ranges, bearings, and doppler reports) is passed over this circuit until the contact is classified as nonsubmarine or until ASW stations can be fully manned. Submarines utilize the 27MC (sonar and radar control) system.

Another communication system found aboard most ships and submarines is the 21MC (captain's command system). It is a two-way system, with each intercommunicating unit capable of calling either 10 or 20 stations, depending on the type of ship in which it is installed. The essential components are a reproducer, amplifier, and controls necessary for operation. The reproducer acts as a microphone in the calling unit and as a loudspeaker in the unit called. Amplification takes place in the calling unit. The controls consist of the talk switch, pushbutton assembly, busy light, call light, volume and dimmer controls, and a microphone or handset jackbox.

To operate the 21MC, depress the pushbutton of the station desired. If the station is busy, the red BUSY light will flash. If the BUSY light does not flash, depress the TALK switch and speak directly into the speaker grill. Release the TALK switch to listen. When your conversation is completed, depress the release button at the far left end of the row of station buttons to remove your intercom unit from the circuit. When you are called, the CALL light illuminates. It is unnecessary to depress the button of the station calling; merely use the TALK switch as described herein.

Despite its many advantages, when the MC system is used, the noise level is increased greatly. This condition occurs because of its speaker-type output and the fact that it picks up background noise from the transmitting station. Because of the high noise level generated by operating the 21MC, it should be used only when absolutely necessary.

REMOTE INDICATORS

The fastest means of communicating information is to transfer it electrically. Through the use of electromechanical and electronic repeaters, sonar information is displayed at remote locations aboard ships and submarines without delay.

One type of display, an electronic azimuth-range indicator, shows bearing and range of a contact on a cathode ray tube. It duplicates audio and video information present at the sonar operator's console.

Another type of remote indicator displays sonar information electromechanically. Contact range and bearing are shown by counters similar to an automobile's mileage indicator. There are many other electromechanical transmitters used to display sonar information. The most commonly used are the Mk 78 position indicator and the Mk 44 relay transmitter used with the ASROC weapon system.

As you can see, electrical/electronic repeaters reduce the time required to transmit information, eliminate noise-producing transmissions, and reduce the volume of traffic over S/P telephone circuits.

EXTERNAL COMMUNICATIONS

During antisubmarine operations (and, for that matter, all operations), it is imperative that communications between ASW units, such as ships and aircraft, be conducted smoothly and efficiently, and be free of confusion insofar as practicable. If a faulty microphone switch of a sound-powered phone frequently cuts out, this common failure can prevent vital information from getting through just as effectively as if it were not reported at all.

Poorly trained or inattentive operators can cause confusion, delay, and mistakes, and may even create a dangerous situation.

RADIOTELEPHONE

Radiotelephone (R/T), commonly called voice radio, is a rapid means of exchanging information between ships, aircraft, and submarines. Voice radio usually is amplitude modulated. A continuous-wave radiofrequency carrier has an audio signal impressed upon it, varying its amplitude in accordance with the audio variations. A handset or a carbon microphone is used to key the transmitter.

Although voice radio is a fast means of communication, speed without accuracy is more than worthless—it can be dangerous. When ships are operating together at high speeds and in close formation, a mistake or a delay in communications can cause a collision.

In antisubmarine operations, voice radio is used to exchange contact and tactical information between the CICs and bridges of the ships participating in the operation. The captain or the OOD mans the bridge radio circuit, used primarily to exchange tactical information. The CIC officer and the Operation Specialist handle the combat information (CI) net to exchange contact information between CICs. Contact information between CICs is evaluated by the CIC evaluator, and pertinent information is relayed to the captain and OOD on the bridge by use of sound-powered phones.

Because radiotelephone procedures are used with the underwater telephone and because Sonar Technicians may be assigned CIC watches during normal cruising conditions, it is necessary for you to be familiar with proper radiotelephone procedures.

RADIOTELEPHONE PROCEDURES

When you use a radiotelephone, your speech must be clear and slow. Speak the message by natural phrases not in stilted, word-by-word fashion. Use a normal tone; don't shout. Pronounce each word clearly and distinctly, pausing at intervals. Think about what you are going to say, then say it. Keep the message as brief as possible.

Heading

The basic format of a military message consists of the heading, text, and ending. The message form is in plaindress, abbreviated plaindress, or codress. Codress is an encrypted message, with which a Sonar Technician normally is not concerned. Plaindress is used for radiotelegraph and teletype communications, as well as for radiotelephone administrative messages. A plaindress message usually has a complex heading, consisting of call, transmission instructions, precedence, date-time group, address, and other elements. The type of radiotelephone message you will use most, however, is the abbreviated plaindress, in which the heading includes only the station called and the station calling. In some instances, after communications are established, the heading

contains only the station calling. An example of a typical heading is: BRASSPLATE -THIS IS ESKIMO.

Text

The text of the message is the basic thought or idea the originator wishes to communicate. It follows the heading, and is separated from it by the word BREAK. Quite often radiotelephone messages, particularly those of a tactical nature, are coded. There are several reasons for coding messages. The first is obvious: so that the enemy will not know your intentions. If, for instance, you were ordered in plain language to commence a sonar listening sweep and the message was intercepted by an enemy submarine, he could rig for silent running to reduce his noise output to a minimum, making your job all the more difficult. If the message is sent in code, however, chances of interpretation by the enemy are reduced even though he should intercept it. Another purpose is brevity. The less time on the air, the better (for both security and practical reasons).

Signal codes are contained in communication publications known as signal books (of which there are several), each having a particular application. One signal book consists of two letters, or a combination of letters and numerals, that usually are used for tactical signals. (Members of NATO use this book, as well as the standard phonetic alphabet, for combined operations.) As an example, a certain two-letter and a numeral signal tells all ships to make oil fog and smoke. From his signal book, the captain of an Italian ship can read and understand the meaning of the signal as quickly as the captain of a U.S. Navy destroyer. Two letters and a numeral thus overcome the language barrier and make a brief message as well.

Another means of reducing transmission time and providing a degree of security is through the use of brevity code words. In general, these code words are used to convey contact and related information. Communications publication ACP 165 contains the operational brevity code.

At the end of the text, the word BREAK is used again to separate the text from the ending.

Ending

The ending of a radiotelephone message consists of one of two words--OVER or OUT. When OVER is used, the sender is telling the receiver to go ahead and transmit, or "This is the end of my transmission to you and a response is necessary." With the use of OUT, the sender in effect is telling the receiver: "This is the end of my transmission to you and no response is required." In motion pictures and television productions, you are likely to see military personnel say "Over and out," but there is never a need for their combined use in this manner.

CALL SIGNS

In radiotelephone procedure, ships have call signs that are common, easily pronounced words or expressions. The radiotelephone call sign of one ship, for example, is BLUE STAR; another is BEANSTALK; still another is EL TORO. All U.S. Navy ships are assigned a voice call sign. If you need to know the voice call sign of any Navy ship, you can find it in the communication publication JANAP 119.

PROWORDS

Radiotelephone procedure also requires the use of standard procedural words called prowords. Although prowords are not code words as such, they say a great deal with the utmost brevity. The words OVER and OUT, mentioned earlier, are prowords. Besides OVER and OUT, two other prowords that are never used together are ROGER and WILCO. ROGER is used as a receipt. It merely means that you have received the message—not that you understand it or will carry out any orders contained in it. WILCO is the answer to the proword ACKNOWLEDGE and means that you will comply with any instructions or orders contained in the message. For this reason, the proword WILCO must never be used without specific permission from a person having the authority to grant such permission. This person is usually the commanding officer of your ship.

Following is a list of the more common prowords, the meaning and usage of which you

Chapter 8--COMMUNICATIONS

should memorize. This list is not as complete as the lists in communication publications. It consists mainly of the prowords you are most likely to hear and use on the underwater telephone. Should you be interested in seeing a more complete list of prowords, check NTP-4 or ACP 125.

<u>Proword</u>	<u>Meaning</u>
ALL AFTER	All after.
ALL BEFORE	All before.
BREAK	The text is separate at this point. Do not confuse the separated portions.
CORRECTION	An error in my transmission has been made. I now correct it.
DISREGARD	This entire transmission is in error. Disregard it.
THIS TRANSMISSION	
FIGURES	Figures or numerals follow.
FROM	This message is originated by _____.
I SAY AGAIN	I repeat the entire transmission (or portions indicated).
I SPELL	I shall spell the next word with the standard phonetic alphabet.
OUT	This is the end of my transmission. No receipt is required.
OVER	Go ahead with your transmission at this time. (Or, this is the end of my transmission for which a response is required.)

<u>Proword</u>	<u>Meaning</u>
ROGER	I have received your last transmission satisfactorily.
SAY AGAIN	Repeat all (or portions indicated) of your message.
THAT IS	You have repeated my message or have given information correctly.
CORRECT	
THIS IS	This message is from _____.
TIME	What follows is the time or date-time group of this message.
TO	This message is for action by and is directed to _____.
WAIT	I must pause for a few seconds.
WAIT OUT	I must pause for longer than a few seconds.
WILCO	I have received and understood your message, and you have the assurance of the command that it will be complied with. (This type of answer requires CO's permission.)
WORD AFTER	The word after (word) is _____.
(word)	
WORD BEFORE	The word before (word) is _____.
(word)	
WRONG	Your last transmission was incorrect. The correct version follows.

INTRODUCTION TO SONAR

INTERNATIONAL MORSE CODE

The international Morse code is a telegraphic alphabet, which is another way of saying that it is a dot and dash communication system. The code is pronounced by saying "dit" and "dah," not "dot" and "dash," so forget about dots and dashes and think only in terms of dits and dahs. The group of dits and dahs representing each character must be made as one unit, with a clear break between each dit and dah, and a much more distinct break between character.

Never try to identify a character by counting dits and dahs. Don't let yourself get into this habit. It's a temptation at first, but you won't be able to count fast enough when the code speed picks up. Learn sound patterns instead. To understand what this requirement means, rap out the pattern beginning "Shave and a haircut." You recognize this ditty from its characteristic rhythm, not because it has a certain number of beats in it. You must learn code the same way. Each character has its own distinctive sound pattern. With study and drill, you will learn to recognize each pattern as fast as you now recognize "Shave and a haircut." The accent always falls on dahs, and you should pronounce each rhythmical combination with that rule in mind. Go through the alphabet several times to get the feel of the sound of the dit-dah combinations.

THE CODE

In the pronunciation guide for the sounds of the characters in the accompanying list, the sounds are written out phonetically insofar as possible. The short sound "dit" actually takes on the sound "di." The "i" is very short and the "t" is dropped.

<u>Letter</u>	<u>Pronunciation</u>
A	di-DAH
B	DAH-di-di-dit
C	DAH-di-DAH-dit
D	DAH-di-dit

<u>Letter</u>	<u>Pronunciation</u>
E	dit
F	di-di-DAH-dit
G	DAH-DAH-dit
H	di-di-di-dit
I	di-dit
J	di-DAH-DAH-DAH
K	DAH-di-DAH
L	di-DAH-di-dit
M	DAH-DAH
N	DAH-dit
O	DAH-DAH-DAH
P	di-DAH-DAH-dit
Q	DAH-DAH-di-DAH
R	di-DAH-dit
S	di-di-dit
T	DAH
U	di-di-DAH
V	di-di-di-DAH
W	di-DAH-DAH
X	DAH-di-di-DAH
Y	DAH-di-DAH-DAH
*Z	DAH-DAH-di-dit

*ZULU is written as Z to avoid confusion with the number 2.

Chapter 8—COMMUNICATIONS

<u>Number</u>	<u>Pronunciation</u>	<u>Short Sounds</u>	<u>Practice Words</u>
1	di-DAH-DAH-DAH-DAH	T DAH	MINE, TIME, MAINE, TEAM
2	di-di-DAH-DAH-DAH	A di-DAH	AIM, NITE, TAME, TEA, MATE
3	di-di-di-DAH-DAH	I di-dit	TAME, NAME, MITE, MIAMI
4	di-di-di-di-DAH	M DAH-DAH	MAMA, MEAN, MAN, MAT, EMIT
5	di-di-di-di-dit	N DAH-Dit	MINT, MANE, TAN, ITEM, TINT
6	DAH-di-di-di-dit	<u>Medium Sounds</u>	<u>Practice Words</u>
7	DAH-DAH-di-di-dit	D DAH-di-dit	MUST, SAME, MAMA, SUIT, AUTO
8	DAH-DAH-DAH-di-dit	G DAH-DAH-dit	MUSS, OUST, MUSE, MUTE, ATOM
9	DAH-DAH-DAH-DAH-dit	K DAH-di-DAH	TAUT, MASS, MAST, SUET, SAM, WIND
**0	DAH-DAH-DAH-DAH-DAH-	O DAH-DAH-DAH	SEA, TUM, SAW, OAT, SUE, SAT, WED
Study and Practice		R di-DAH-dit	SUM, MUD, IOU, USE, SEAM, DARK
<p>If you have any trouble learning code, the following method may be helpful. Go through the three groupings of short, medium, and long sounds with their accompanying practice words. Make up words of your own if you wish further practice. Speak the practice words in code. Say "TEE: DAH dit dit: MINE" DAH-DAH-di-dit DAH-dit dit."</p> <p>If you can speak words rapidly and distinctly in code, you'll have an easy time of it when you learn to receive code, because the spoken code and transmitted code sounds are similar. Practice the figures in even groups: 11, 22, 33, 44, 55, 66, 77, 88, 99, etc. Learn each letter by overall sound. Never count the dits and dahs.</p>		S di-di-dit	GEORGE, DOWN, KIND, SORT, MASK
<u>Short Sounds</u>	<u>Practice Words</u>	U di-di-DAH	WORK, GROW, URGE, TUG, PULL
E dit	TEE, ATE, EAT, TEA, MEAT, MEET	W di-DAH-DAH	WIGS, WORN, WET, WAKE, WALL
		<u>Long Sounds</u>	<u>Practice Words</u>
**Zero is written as Ø to avoid confusion with the letter O.		B DAH-di-di-dit	BAT, BALL, BEAT, GLIB, GAB, JAB

INTRODUCTION TO SONAR

<u>Long Sounds</u>	<u>Practice Words</u>
C DAH-di-DAH-dit	CUT, CAM, COAT, CODE, CALF
F di-di-DAH-dit	FIVE, FAT, FUSS, FEET, EFFECT
H di-di-di-dit	ACHE, HUSH, HAVE, HOLD, HOT
J di-DAH-DAH-DAH	JERK, JIM, JAR, JAM, JAB
L di-DAH-di-dit	LIKE, LAG, JELLY, LOVE, LATE
P di-DAH-DAH-dit	PUSH, PAIR, POLE, PART, HAPPY
Q DAH-DAH-di-DAH	QUAY, QUEBEC, QUEEN, QUIZ, QUIT
V di-di-di-DAH	VIM, VERY, VETCH, VAT, EVE
X DAH-di-di-DAH	WAX, XRAY, LYNX, SIX, EXAM
Y DAH-di-DAH-DAH	YOUNG, YOKE, YAK, JERKY, YAM
Z DAH-DAH-di-dit	ZERO, BUZZ, FIZZLE, QUILL, LYNX

The only way to learn code is by practice—continual practice. The value of practice cannot be overemphasized as you will learn when you test yourself, with the help of your shipmates, to find out how well you have developed your skill through practicing by yourself.

If you have carried out the commendations made up to this point, you are ready to receive code transmitted to you on a

handkey. The ship or station to which you are attached has a practice handkey you can use.

Find a Radioman who will key code groups to you to help you in your training. The sound produced by keying an oscillator resembles the sound of code from the sonar transmitter.

After you learn the sound of each character at a slow rate of speed, it is not difficult to reduce the time between characters and thus to copy at a much faster speed. But don't strive for speed before accuracy. Be a competent operator. Make every transmission and reception accurately. Accuracy is much easier if you learn the fundamentals well. Some code practice exercises that will help you are included for your convenience.

CODE PRACTICE

1. EEE TTT AAA NNN III SSS HHH RRR
 MMM OOO EEE TTT AAA NNN III SSS
 SSS HHH MMM RRR OOO EEE TTT III
 TTT EEE TTT III NNN SSS OOO AAA
 NNN EEE AAA NNN TTT OOO III SSS
2. UUU VVV DDD BBB KKK CCC WWW JJJ
 PPP UUU VVV DDD BBB KKK CCC WWW
 JJJ PPP VVV UUU BBB CCC KKK WWW
 DDD KKK BBB CCC WWW UUU VVV JJJ
 CCC WWW KKK PPP DDD VVV JJJ UUU
3. RRR LLL FFF GGG ZZZ XXX YYY QQQ
 RRR LLL FFF GGG QQQ ZZZ YYY RRR
 QQQ GGG ZZZ LLL YYY RRR FFF LLL
 YYY QQQ RRR XXX ZZZ YYY LLL GGG
 LLL QQQ YYY UUU ZZZ XXX RRR LLL
4. 111 222 333 444 555 666 777 888
 999 ~~888~~ 111 222 333 444 555 666
 777 888 999 ~~888~~ 123 456 789 ~~888~~
 113 344 225 577 668 ~~888~~ 992 228
 123 456 789 ~~888~~ 345 678 ~~888~~ 599
5. V U I Y O Z C X G P S L E J P Q X Z R I F C V B
 W F E D S H Q Z A L K F B V P S T U O T M E G Y
 Z X V E G H I W S L H M U A E V U A E W Q G H V
 C I X Z L N P Y U E V U W S X E D C R F V T G B
 Y H N U J M I F O L P Q A Z W S X E D C R F V T

Chapter 8—COMMUNICATIONS

CODE PRACTICE

6. E 8 Y 7 B 6 X 1 S Ø 2 2 A 3 C 5 S 4 I 2 F u 1 F
 5 D B Q 4 T 6 U 9 Q 2 E Ø S 5 U 1 Y G 2 J 4 S 3
 E 5 T 7 Z 8 K 6 M 9 R 1 A 2 R S 7 W 8 E 9 R 2 A
 3 Z 3 X 6 U 8 B 7 C 6 T E 8 Y 7 B 6 Y Ø F 1 W 4
 F 1 A 7 I 5 R 8 S Ø M 6 C 2 K 3 A 9 Z 3 Z 6 D 2

7. WI AN TY SX EC LV OD OZ SP TZ EC NU VA EH LM DQ
 BM ZS CD QA IU SD PQ OW IE UR YT LA KS JD HF GM
 ZN XB CV QZ WX EC RV TB YN UM IL OP AE SR DT FY
 HU JI KO LO ZS XD CF VG BH NJ MK SW XE CR VT BY
 NU MI LO PS DO FI GY BU IN JU HA XR TV TV YB NU

8. DE FT BY 72 VA 54 98 IM BT BT 11 34 66 CV VF TG
 62 84 QA WS RP 64 2Ø BY 77 GY AA YF UH IJ VD BK
 K 99 25 56 83 25 LA KS JD CY BU IN EB QV QV ZZ
 22 ØØ TT 75 44 VY 53 VS CW MC WH 66 FS SS ER EE
 26 CG PL IA LE FG QY 85 RI 39 NF JE SI 25 37 AP

9. WNT AGR DTS ELY BFC UZX REH KCE HIJ AQE RNG TCV
 EPL ZSW QAH SHL GBT VRT GUK GYO DCN XSD ZAU YER
 DLN ARG VNB EDX HWS UTA RHI KTZ HBY ALK RDC TOC
 ESX IUP PEJ NYH GHT DFR VED SWN VBT XEZ RDA FUD
 NYH OLX RWH MKY ATA NWS RGU SKZ KDG OKL OIX GLM

CODE PRACTICE

10. OLVHM YBLUR XOHIZ OVICT FINXC
 XSHTY VIZNT UBLMQ ABLBE JNCYZ
 BZWCN JNCDO TLZKL ABDEF ZVNUW
 KFREQ LMXMV NHUWQ RNVUT KUXFC
 DEHLY HEDIP AZQWI ZYSKO IQAWM

11. NWZIH ZXCKA DHTGW WNLIP WBUOX
 ADXFR JIQCA UTHAV NCBRF DSEDC
 XVHRW QIMNJ FSTRO TNBLU JHKNI
 OPJUY RGBNS VCXTR JTUBD CGPHS
 VXH7G 2J19Y TX3S6 T148P BTØZX

PROSIGNS

Procedural signals, called prosigns, are used by radiotelegraph operators for the same reason that prowords are used by radiotelephone talkers. Most prowords have an equivalent prosign, which, in several instances, is an abbreviation of the proword. You will notice in the accompanying list of prosigns that some of them are overscored. Overscoring means that the letters are to be sent as one character; that is, without the normal pause between letters.

<u>Prosign</u>	<u>Proword</u>	<u>Meaning</u>	<u>Remarks</u>
AA.....	ALL AFTER.....	All after	} Used to identify portions of a transmission when requesting a repetition.
AB.....	ALL BEFORE.....	All before	
WA.....	WORD AFTER.....	Word after	
WB.....	WORD BEFORE.....	Word before	
K.....	OVER.....	Go ahead and transmit.	} Every transmission ends with one or the other of these prosigns.
<u>AR</u>	OUT.....	End of transmission; no reply expected or desired.	
<u>AS</u>	WAIT.....	I must pause for a few seconds.	
<u>AS</u> <u>AR</u>	WAIT OUT.....	I must pause longer than a few seconds.	
<u>BT</u>	BREAK.....	Long break.....	Separates text of message from heading and ending.

INTRODUCTION TO SONAR

<u>Prosign</u>	<u>Proword</u>	<u>Meaning</u>	<u>Remarks</u>
II.....		Separative.....	Used for all other separations in messages. Write it as a short dash.
DE.....	FROM.....	From	
EEEEEEEE	CORRECTION.....	I just made..... an error.	Corrected version is sent immediately.
EEEEEEE	\overline{AR}	DISREGARD THIS TRANSMISSION	
\overline{IMI}	SAY AGAIN.....	Repeat	
R.....	ROGER.....	I have received all of your last trans- mission.	

Sending

Your ability to send code depends mainly on two considerations. First, you must know the correct sound of the character you are attempting to transmit. Second, you must know the correct method for keying. Practicing the code aloud, as well as receiving it by oscillator, should give you a good knowledge of code sound. The proper method for keying is your next concern.

Probably the first key you'll encounter is the unshielded telegraph key, normally used on practice oscillators on shipboard and on station circuits. The key must be adjusted properly before you can transmit clear-cut characters. A handkey, with parts labeled, is shown in figure 8-1.

A spring tension screw, behind the key button, controls the amount of upward tension on the key. The tension desired varies with operators. Too much tension forces the key button up before the dahs are completely formed; spacing between characters is irregular, and dits are not clearly defined. If the spring tension is very weak, characters run together and the space between characters is too short.

The gap between the contacts, regulated by the space adjusting screw at the back of the key, should be set at 1/16 for beginners. This

measurement does not apply to every key and operator; it is a matter of personal preference. Some operators like a closed key, others an open key. "Closed" and "open" are terms for a short and long gap. As the student progresses, further gap adjustment may be made to suit his sending speed. Contacts that are too close have an effect similar to weak spring tension. Contacts that are spaced too far have the same effect as too much spring tension.

The final adjustment of the key is the sidewise alignment of the contact points. This alignment is controlled by the trunnion screws at either side of the key. If they are too tight, the key lever binds. If they are too loose, the contacts have sidewise play. Usually, when the sidewise alignment is correct, no further adjustment is required.

From the beginning you should learn the correct way to grasp the key. The following instructions, in the order listed, constitute the proper procedure for becoming a proficient operator: Do not hold the key tightly, but let your fingers rest lightly on the key knob. Your thumb rests against the side; your forefinger rests on top of the key; your third finger is bent and relaxed with the remaining two fingers.

Speed and accuracy of transmission depend, to a large extent, on acquiring the proper movements of your wrist and hand while

operating the key. To close the key, your wrist moves upward and your hand rocks downward toward your fingertips. To open the key, these two movements are reversed—your wrist comes down and your hand rocks back. A dah should be about three times as long as a dit.

Conditions of the water have a bearing on the speed at which you will be able to transmit. At times you can transmit rapidly and your signals will be clearly audible. Other times you may have to go very slowly, otherwise your dits and dahs cannot be distinguished by the receiving operator.

UNDERWATER COMMUNICATIONS

For many reasons it is necessary for a ship and a submerged submarine to communicate with each other. Of paramount importance is the safety of the submarine and its crew. During exercise periods, the ship can advise the submarine when it is safe to surface. Should an emergency arise aboard the submarine, the ship can be so informed. Exercises can be started and stopped, or one in progress can be modified, by using the underwater telephone. Attack accuracy can be signaled by the submarine to the attacking ship. Sonar Technicians must be

proficient in radiotelephone procedures because those techniques are used for underwater voice communication. When CW (radiotelegraph) is used, you must be able to send and receive Morse code without causing delay or misunderstanding.

The most widely used underwater telephone installation is the AN/WQC-2 (and modification) sonar set, commonly called SEATALK. Although intended for use by sonar control personnel, some installations provide remote voice operation from the bridge. The WQC-2 operates at frequencies that are compatible with all other existing underwater telephone units. Figure 8-2 shows the front panel controls of the AN/WQC-2. As can be seen in figure 8-2, the AN/WQC-2 has all of the capabilities of the older AN/UQC-1 (fig. 8-3), with many modifications for better transmission and reception.

The range of transmission varies with water conditions, local noise level, and reverberation effects. Under normal sonar conditions, however, communication between ships should be possible at ranges comparable to those of the UQC-1. Under the same conditions, submarines achieve a greater range. If the submarines are operating in a sound channel, the communication range may be many miles greater than that achieved by surface ships.

Local noise, caused by ship's movement through the water, machinery, screws, etc., can reduce the range to less than half the normal range. Severe reverberation effects may also cause a reduction in range, but you can overcome them by speaking slowly, pausing after each word to let the echoes die out. At very short ranges, it may be impossible to reduce the receiving gain to a comfortable speaker output level. Then, you must speak softly, holding the microphone away from your lips.

VOICE PROCEDURE

As mentioned earlier, you will use the same voice procedures for underwater voice communication as for radiotelephone transmissions. In other words, you call the station for which you have a message, identify yourself, send your message, and end the transmission with either OVER or OUT.

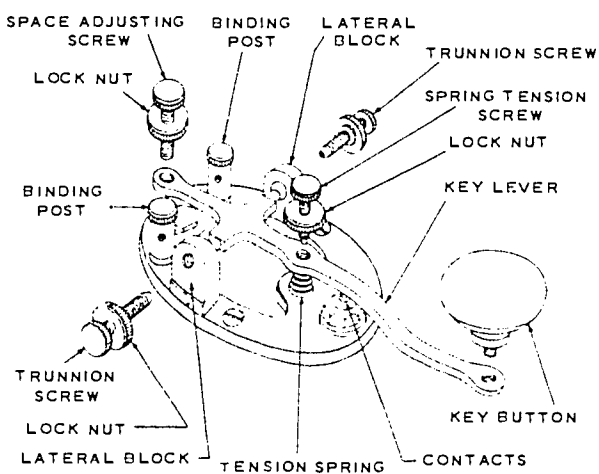

76.8A

Figure 8-1.—Handkey.

INTRODUCTION TO SONAR

Calling and Answering

Here is an example of a call from a submarine (call sign COPY CAT) to an ASW ship (call sign SHARK FIN). Dashes shown are not actually sent but indicate pauses the operator makes so that his transmission can be understood more easily.

SHARK FIN—THIS IS COPY CAT—OVER.
COPY CAT—THIS IS SHARK FIN—OVER.

With communication established, COPY CAT sends his message:

SHARK FIN—THIS—IS COPY CAT—
BREAK—AM AT EXERCISE DEPTH.
READY FOR COMEX—BREAK—
OVER.

SHARK FIN gives a receipt, using an abbreviated call:

THIS IS SHARK FIN—ROGER—OUT.

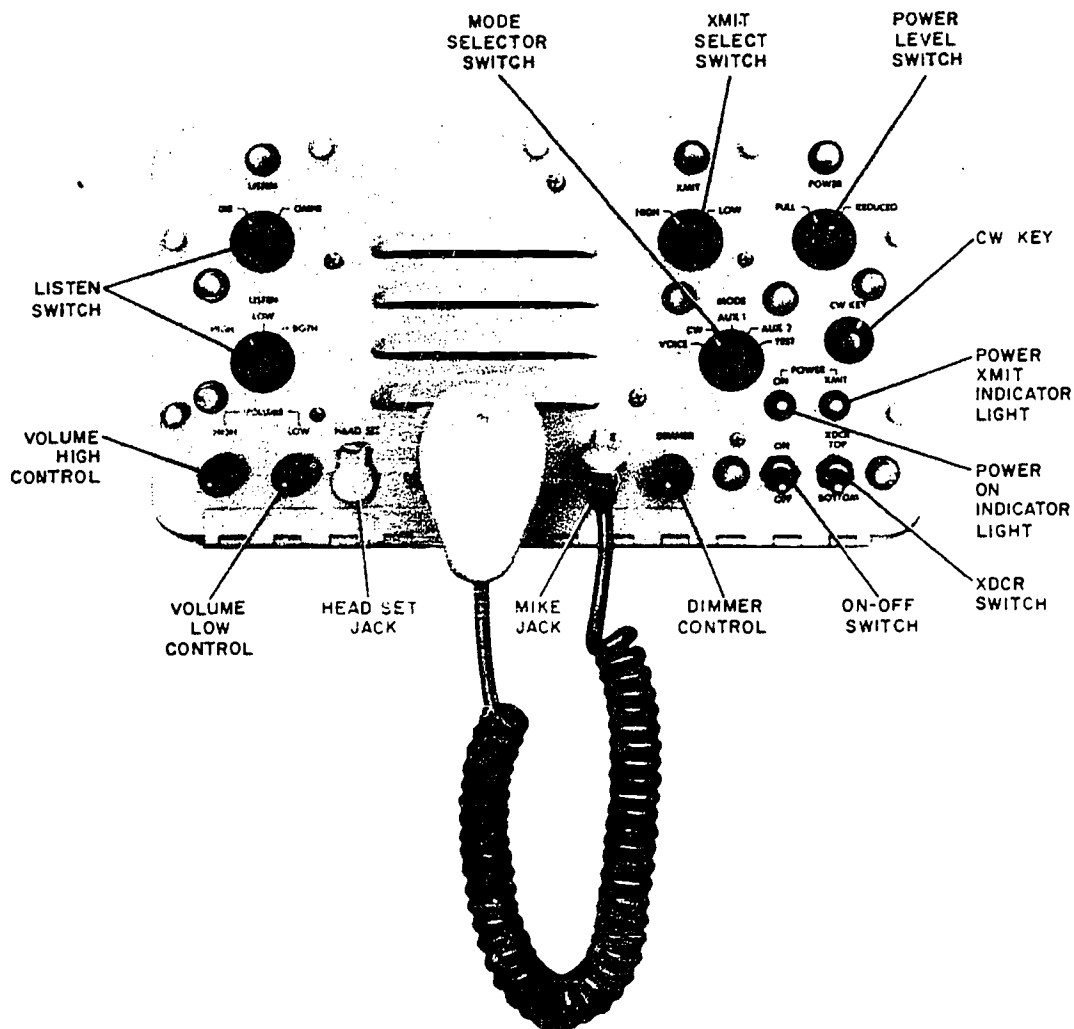

Figure 8-2.—AN/WQC-2 front panel controls.

141.296

Following is an example of a related series of messages between ships conducting an ASW exercise.

SEA POWER—THIS IS TOP HAT—
BREAK—STANDBY MY “BASSET”
PORT—2 MIN.—BREAK—OVER.

TOP HAT—THIS IS SEA POWER—
BREAK—ROGER—WILL REMAIN
CLEAR OF YOU UNTIL
COMPLETION YOUR ATTACK—
OVER.

THIS IS TOP HAT—ROGER—OUT.

Correcting an Error

If you make an error in transmission, send the proword CORRECTION immediately. Go back to the last correctly sent word, repeat it, and continue with the correct version. Example:

COPY CAT—THIS IS SHARK FIN—
BREAK—ROGER YOUR YELLOW—
ALL HERE—CORRECTION—ALL
CLEAR TO COME TO PERISCOPE
DEPTH—BREAK—OVER.

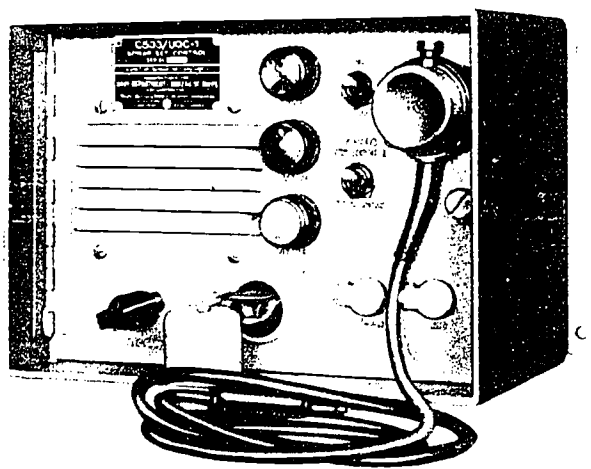

71.71

Figure 8-3.—AN/UQC-1 control unit.

Waits

When an operator finds it necessary to delay transmission momentarily, he sends the proword WAIT. If the delay is for longer than a few moments, the transmission is WAIT OUT. A new call is made when communication is resumed.

Repetitions

The request for a repetition is SAY AGAIN, not “Repeat.” Used alone, SAY AGAIN means “Repeat all of your last transmission.” Followed by identification data, it means “Repeat the indicated portion of your transmission.” The answer to SAY AGAIN is I SAY AGAIN, followed by the repetition requested. For example, COPY CAT asks SHARK FIN to repeat all of his last transmission and SHARK FIN complies.

THIS IS COPY CAT—SAY AGAIN—OVER.

THIS IS SHARK FIN—I SAY
AGAIN—BREAK—ROGER YOUR
YELLOW—ALL CLEAR TO COME TO
PERISCOPE DEPTH—BREAK—OVER.

If COPY CAT missed only the word DEPTHS, he would frame his request as follows:

THIS IS COPY CAT—SAY AGAIN—WORD
AFTER PERISCOPE—BREAK—OVER.

When COPY CAT has the complete message, he sends a receipt.

Canceling a Message

To cancel a message in progress, cease sending immediately and transmit the proword DISREGARD THIS TRANSMISSION. Example: SHARK FIN’S operator begins a message, then is ordered to delay it.

COPY CAT—THIS IS SHARK FIN—
BREAK—TAKE STATION MY PORT—
DISREGARD THIS TRANSMISSION—
BREAK—OVER.

INTRODUCTION TO SONAR

Once a message is received for, it cannot be canceled by means of the proword **DISREGARD THIS TRANSMISSION**. Instead, a new message must be sent.

SUBMARINE COMMUNICATION METHODS

The AN/WQC underwater telephone is the submerged submarine's primary means of communicating with surface ships. For this reason, during exercise periods, ships are required to man the WQC continuously. In addition to its required use for safety purposes, the WQC is used throughout an exercise by ships and submarines for sending attack signals, obtaining range checks, transmitting sonar short signals, and for several other purposes. Subject to equipment limitations, keyed sonar is the secondary means of underwater communications. Many submarine sonars do not have CW capability.

Emergency communication equipment carried by a submarine include a radio and a telephone. The radio is battery-powered and floats to the surface upon release through the signal ejector. Once on the surface, it automatically transmits on emergency radiofrequencies.

The emergency telephone, designated AN/BQC-1A,B,C, is also battery-powered and is portable. It has the same voice frequency characteristics as SEATALK, with a range of about 5000 yards. The usual installation provides one set in the forward escape compartment and one set in the aft escape compartment. In addition to its voice

transmission capability, the AN/BQC can emit a 24.26 kHz continuous tone for homing purposes. The AN/BQC-1B and C also provide a 9.58 kHz tone for homing.

Submarine rescue vessels have equipment capable of detecting and homing on the tone. With all batteries in good condition, 72 hours of continuous tone transmission are possible. Range of the homing signal is 2000 to 5000 yards.

Colored flares and smoke signals afford another means of communication. Black or green signals are used by the submarine to indicate the simulated firing of torpedoes and to mark her position. A yellow flare or smoke signifies the submarine intends to surface. Ships must then clear the area and keep other shipping away. A designated ship notifies the submarine that the signal was sighted and informs him when it is safe to surface. A red flare denotes trouble. It means the submarine is carrying out emergency surfacing procedures. If the flares are repeated or if the submarine fails to surface within a reasonable length of time, it can be assumed he is disabled and requires immediate assistance. You must make every effort to maintain sonar contact and establish communications by any means possible, but preferably by voice.

Detailed pyrotechnic, sonar, and explosive signal information is contained in FXP 1. All Sonar Technicians must become familiar with the signals in that publication. The rescue of a disabled submarine's crew could depend on your ability to establish and maintain reliable communications.

CHAPTER 9

TEST EQUIPMENT; TEST METHODS; MAINTENANCE

Sonar Technicians must assist in the upkeep and repair of the sonar equipment aboard their ship or station. Consequently, you must become familiar with the types of test equipment, test methods, and safety precautions to be observed when using or working on electronic equipment. Naturally, a knowledge of electronics is required also. Information related to the electronics field can be found in *Basic Electricity*, NAVEDTRA 10086, and *Basic Electronics*, Vol. I and II, NAVEDTRA 10087. Information on the selection, care, and use of hand and portable power tools is contained in *Tools and Their Uses*, NAVEDTRA 10085.

SAFETY

Maintaining electrical and electronic equipment is a dangerous business. Every year, lives are lost aboard ship due to electric shock; and, in most instances, death could have been avoided by observing appropriate safety precautions.

Most people treat with extreme caution a circuit containing several thousand volts, but act with indifference toward the common household current. Yet, 115 volts a.c. is the prime cause of death from electric shock. Cases have been recorded of fatal shocks from such equipment as portable drills and grinders, fans, movie projectors, and even coffee pots. You must continually be alert when working with electricity, and you must follow strictly all pertinent safety precautions.

Although some safety practices are given in this chapter, you should become familiar with the safety instructions contained in the following publications: *NAVSEA Technical*

Manual, Chapter 9670; *Handbook of Test Methods and Practices*, NAVSHIPS 0967-000-0130; *Safety Precautions for Shore Activities*, NAVSO P-2455; and *Navy Safety Precautions for Forces Afloat*, OPNAVINST 5100.19.

GENERAL SAFETY PRECAUTIONS

Whenever possible, deenergize the main power input to any equipment before you work on it. Remember, though, that there still may be power in the equipment from such external sources as synchros, remote indicator circuits, and instrument heater elements. When you open the switch in the main supply (or any other power switch), indicate the switch is open by attaching to it a tag reading "THIS CIRCUIT WAS ORDERED OPEN FOR REPAIRS AND SHALL NOT BE CLOSED EXCEPT BY DIRECT ORDER OF (your name, or name of person in charge of repairs)."

If you must work on an energized circuit, observe the following safety precautions.

1. Never work alone. Have another man, qualified in first aid for electric shock, present at all times. He should also be instructed in how to secure the power.

2. Use insulating rubber matting. The matting must be kept clean and dry. Wear rubber gloves, if possible, and use insulated tools. Remove rings and watches.

3. Use only one hand whenever possible. Keep the other hand behind you or in your pocket.

4. Do not indiscriminately stick your hand into an enclosure.

INTRODUCTION TO SONAR

5. Have ample illumination.
6. Never short out, tamper with, or bypass an interlock.

Before working on a deenergized component, discharge all capacitors in the unit. A capacitor is a device for temporarily storing electrical energy. Successive small charges are built up in the capacitor for later release. Sonar transmitting equipments utilize this feature by building up electrical energy in the equipment's capacitor bank between each ping. A trigger pulse then releases the energy in a single high-powered pulse. Nearly all types of electronic equipment use capacitors of varying sizes and types. Normally, the larger the capacitor, the higher the electrical charge it will hold for a greater length of time. On many electronic equipments, charges upwards of 14,000 volts are present. Usually, such large charges are discharged by mechanical means when the equipment is opened. Many other capacitors, however, must be discharged manually by the man working on the circuit.

To drain capacitor charges, the device you will use is the shorting bar, shown in figure 9-1. The shorting bar usually consists of a copper rod which has an insulated grip on one end. A heavy braided cable is soldered to the rod near the grip. On the free end of the cable is a battery clip. When using the shorting bar, first secure power to the equipment, clamp the cable clip firmly to the frame or other good ground, then discharge each capacitor by holding the insulated handgrip and touching the terminals of the capacitors with the copper rod. Always ground the capacitor at least twice because the capacitor's charge may not be completely drained by one application of the shorting bar.

Practically all electronic equipments have a metal grounding strap connecting the equipment chassis to the ship's hull. The purpose of the grounding strap is to place the equipment's frame and the hull at the same electrical potential, thus permitting personnel to touch the equipment without danger of receiving an electric shock. As you know, a difference in potential is what causes current to flow. If a component should develop a short to the chassis, the short-circuited power will bleed off to ground through the strap. If there is a faulty

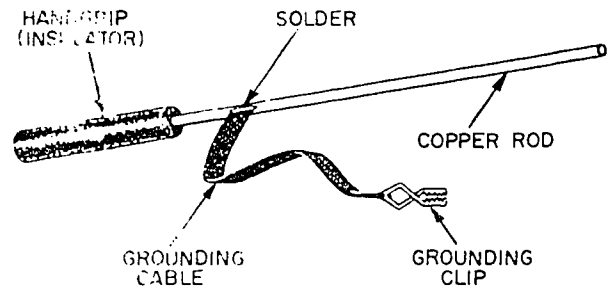

Figure 9-1.—Shorting bar.

1.1

or open ground strap connection, however, a potential difference is established. Should you then come in contact with the equipment, you become the ground strap. In other words, the current passes from the equipment through you to ground, resulting in an electric shock—possibly a fatal one. You must ensure, therefore, that all ground connections are tight and free of foreign matter, such as dirt, grease, or paint, that might interfere with the required metal-to-metal contact at the ground connection points.

Fuses are another source of potential danger to the careless Sonar Technician. The purpose of a fuse is to protect electric circuits and components. A fuse blows because more current than the fuse can handle tries to pass through it. The cause of the current overload may be a momentary surge in ship's power, or it may be a short circuit. Whatever the cause, two precautions must be observed when replacing fuses. First, use a fuse puller, even if power is secured. (Although it is desirable to secure power to the affected circuit, it is not always necessary or practical to do so.) If you use a screwdriver, pliers, or your bare fingers, you may receive a severe electric shock if you contact adjacent live circuits. Second, always replace a fuse with one having the same rating. Substituting a higher rated fuse may cause serious damage to the equipment. If the circuit does not burn out, dangerous potentials may exist that normally would not be present, thus endangering servicing personnel.

Cathode ray tubes (CRTs) are used in all sonar equipment. They are of rugged

construction and normally have a long life. They do require replacement from time to time, however, and a few precautions must be observed in handling them. A CRT must be handled gently to prevent breaking it and to avoid displacing its internal elements. Always place a CRT face down on cushioning material. If the tube is broken, don't handle the glass with bare hands because the tube's inner surface is coated with a toxic material. Gloves and special face masks are available to personnel handling CRTs.

SAFETY WITH POWER TOOLS

Hazards associated with the use of portable electric power tools include electric shock, bruises, cuts, falls, particles in the eyes, explosions, and the like. All Sonar Technicians should become familiar with the safety practices contained in *NAVSEA Technical Manual*, Chapter 9600, Section II. Following are some of the general safety precautions you should observe when working with power tools.

1. Ensure that the tools are grounded in accordance with articles 60-25 through 60-27 and 60-29 of the *NAVSEA Technical Manual*.
2. Avoid, if possible, using spliced cables.
3. Carefully inspect the cord and plug. If the cord is frayed or the plug appears damaged, replace them.
4. If an extension cord is used, connect the cord of the power tool into the extension cord, then connect the extension cord into the power receptacle. When your work is finished, unplug the extension cord from the power receptacle, then unplug the cord of the power tool.
5. Wear safety goggles for protection against particles that might strike your eyes.
6. Make sure the cables do not present a tripping hazard.

GROUNDING TEST EQUIPMENT

Equipment that measures electrical values of component parts must never assume a ground level different from that of the chassis of the

component. One reason is that measurement of an electrical value of a component, by an equipment having its own ground level value, could reflect the difference in potential between the component and the test equipment. Another reason is that, if the ground level of the test equipment differs from that of the component being measured, a condition of electrical hazard may result, and maintenance personnel may be shocked.

Externally powered equipment, such as a tube tester, is grounded to the frame of the ship through a standard three-wire electrical cord and plug. A firm connection to the power receptacle is all that is needed to ground such equipment so that it will be safe to the touch. Other equipment--perhaps older or repaired test equipment--may not be equipped with the three-wire cord. If it is not so equipped, the test equipment should be grounded, with a separate cable running from its chassis or housing to the frame. Always check to see that the ground connection is firm and that it is sufficient to take any electrical load supplied to it.

ELECTRIC SHOCK

Electric shock is a jarring, shaking sensation. You may feel as though someone hit you with a sledge hammer. Although usually associated with high voltage, fatal shocks often are received from 115 volts or less. If your skin resistance (which varies) becomes low enough, a current of 100 milliamperes (.100 ampere) at 115 volts, sustained for only a couple of seconds, is sufficient to cause death.

Symptoms and Effects

The victim of an electric shock is very pale; his skin is cold and clammy. His breathing (if he is breathing) is irregular, shallow, and rapid. He may sweat profusely, and his eye pupils will be dilated. In some cases he will be unconscious and have an extremely weak pulse, or no pulse. In severe cases he will have no heartbeat. Vital organs in the path of the current may be damaged (usually due to heat) and nerves paralyzed.

INTRODUCTION TO SONAR

Rescue and Treatment

The first thing to do for a victim of electric shock is to remove him from contact with the circuit. The best method is to open the switch if you can do so without too much delay. If an ax is handy and the power cable is accessible, the cable can be cut, assuming that it would take too long to find the proper switch. If there are no ready means for cutting the power, use any dry nonconducting material to pull the man free; a belt, clothing, a piece of line, a wooden stick, or a sound-powered phone cord. Be extremely careful that you don't become a victim yourself.

The treatment to give a shock victim depends on his condition—whether he is breathing or not. The following care is prescribed when the man is breathing.

1. Lay victim on his back, with his head lower than his feet. Loosen the clothing about his neck and abdomen so he can breathe freely. Keep him warm, but not hot. **SUMMON MEDICAL AID.**
2. Keep the man still. Electric shock weakens the heart, and any muscular activity on his part may cause the heart to stop functioning.
3. Normally, no liquids should be given. Never give stimulants nor sedatives.
4. If the necessary materials are available, apply a small amount of Vaseline to his burns, and cover them with a sterile dressing to prevent infection.

Resuscitation

If the shock victim is not breathing, immediate efforts must be made to revive him even though he may appear to be dead. (Victims of severe electric shock sometimes appear as though rigor mortis has set in.) The effort must be continued until medical personnel can take over or until a competent person declares the victim to be dead. Speed in beginning artificial respiration is of the utmost importance. Figure 9-2 shows that the victim's best chance of survival depends on beginning resuscitation within 5 minutes.

The mouth-to-mouth method of artificial respiration is preferred. Next in preference is the back-pressure, arm-lift method. Detailed information on administering artificial respiration can be found in *Standard First Aid Training Course*, NAVEDTRA 10081. Whichever method you use, the important objective is to start immediately.

TEST EQUIPMENT

Electrical equipment is designed to operate at certain efficiency levels. Technical instruction books, and sheets containing optimum performance data—such as voltages and resistances—are prepared for each Navy equipment. The instructions are intended to aid the technician in maintaining the equipment.

As a Sonar Technician, you will work with many different types of test equipment. This chapter discusses some of the basic equipments such as multimeter, oscilloscope, signal generator, frequency counter, and transistor tester. If these test equipments do not sound basic to you, keep in mind that as sonar technology becomes more complicated, sonar equipment becomes more sophisticated. It follows, then, that test equipment used to maintain the sonar equipment must become more sophisticated also.

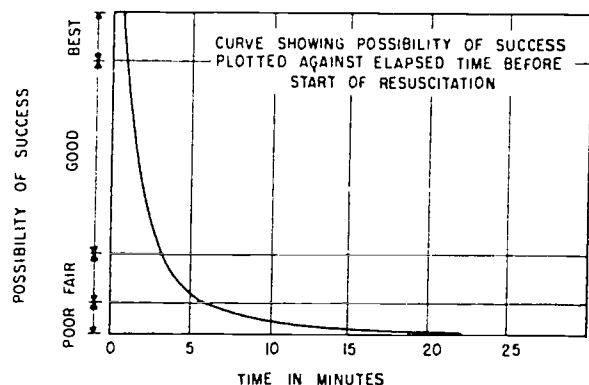

71.101

Figure 9-2.—Importance of speed in commencing artificial respiration.

MULTIMETER

The multimeter is a multipurpose meter that can measure resistances, a.c. and d.c. voltages, and d.c. milliamps. Its versatility and portability eliminate the need for carrying several meters for test purposes. The usual precautions must be observed when making resistance and voltage measurements. When measuring d.c. voltage, proper polarity must be observed. The face of the instrument has separate graduated scales to indicate the three values that can be measured. Be sure you read the proper scale. Figure 9-3 shows the front view of one of the most common multimeters used in today's Navy, the AN/PSM-4D. Figure 9-4 shows another

multimeter used in the Navy today, the electronic multimeter ME-6D/U. As a Sonar Technician, you will become familiar with these meters.

OSCILLOSCOPE

The oscilloscope is one of the most valuable pieces of test equipment available to the Sonar Technician. With the oscilloscope you can determine a signal's frequency, pulse width, and amplitude; measure voltages and phase relations; and observe signal waveforms. The latter use is particularly helpful since many technical manuals include (in their servicing block diagrams) waveforms at various test points.

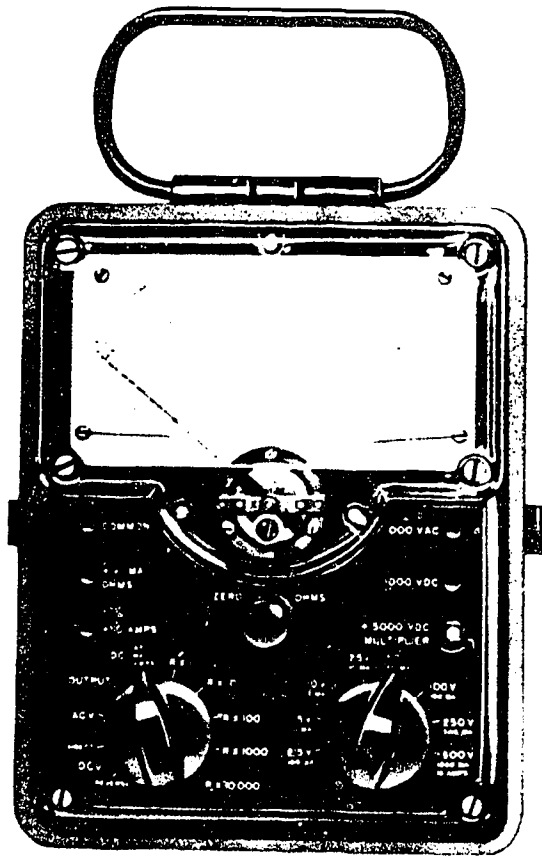

4.133

Figure 9-3.—Multimeter AN/PSM-4D front view.

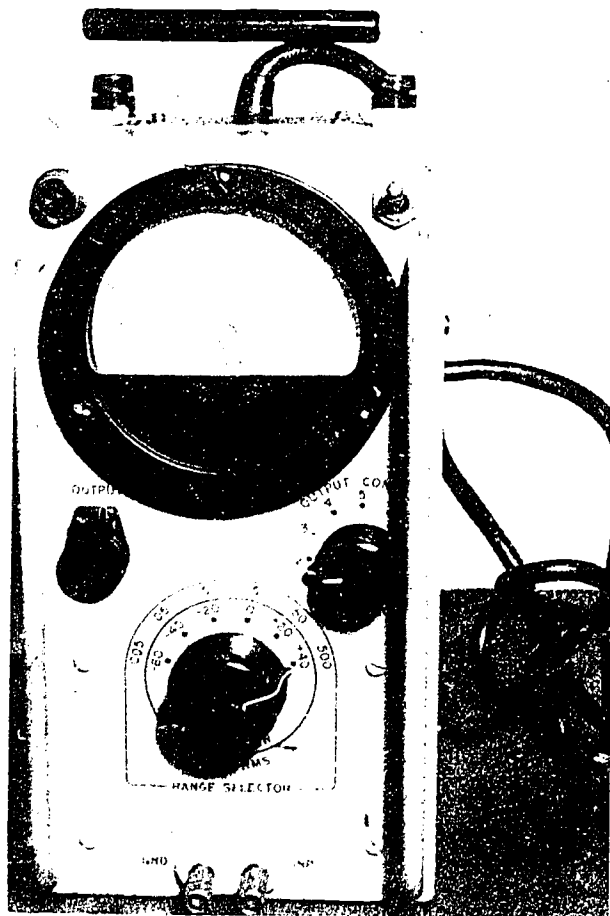

4.133

Figure 9-4.—Electronic multimeter ME-6D/U.

INTRODUCTION TO SONAR

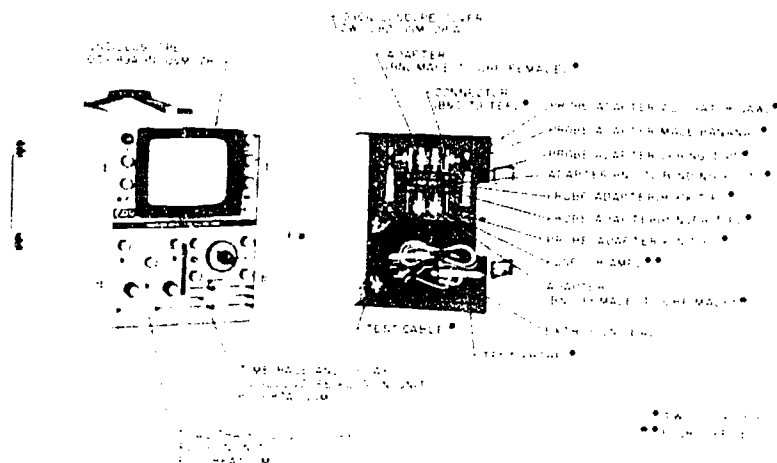

Figure 9-5.—Typical oscilloscope, AN/USM-281.

71.130

The oscilloscope (fig. 9-5) consists of a cathode ray tube, vertical and horizontal beam deflecting circuits, sawtooth voltage sweep circuits, and necessary power supplies. The signal to be observed (a sine wave, for instance) is applied to the vertical deflection plates. If that were the only signal applied, all you would see on the scope would be a straight, vertical line. To have the sweep conform to the sine wave voltage on the vertical deflection plates, a sawtooth (linearly increasing) voltage is applied simultaneously to the horizontal deflection plates. The result is that the sweep moves across the scope at a uniform rate, following the fluctuations of the signal applied to the vertical plates. When the sawtooth signal reaches its cutoff point, the sweep returns rapidly to its starting point to await the next sawtooth signal. The measurement of frequency, calibration, and other special situations requires the use of a synchroscope, which is an oscilloscope with special circuits added, such as sweep triggers and marker generators. The sweep commences only when a signal is received.

SIGNAL GENERATORS

In the maintenance of electronic equipment, it is often necessary to employ standard sources

of a.c. energy, both audiofrequency and radio frequency. These sources are called signal generators. They are used in testing and aligning transmitters, receivers, and amplifiers; they are also used when troubleshooting various electronic devices and sometimes when measuring frequency.

The principal function of a signal generator is the production of an alternating voltage of the desired frequency and amplitude which has the necessary modulation for the test or measurement concerned. It is very important that the amplitude of the generated signal be correct. In many generators, output meters are included in the equipment so that the output may be adjusted and maintained at a standard level over a wide range of frequencies.

When using the generator, the output test signal is coupled into the circuit being tested, and its progress through the equipment is traced by the use of high-impedance indicating devices such as vacuum tube voltmeters or oscilloscopes. In many signal generators, calibrated networks of resistors, called attenuators, are provided. These are used to regulate the voltage of the output signal and also provide correct impedance values for matching the input impedance of the circuit under test. Accurately

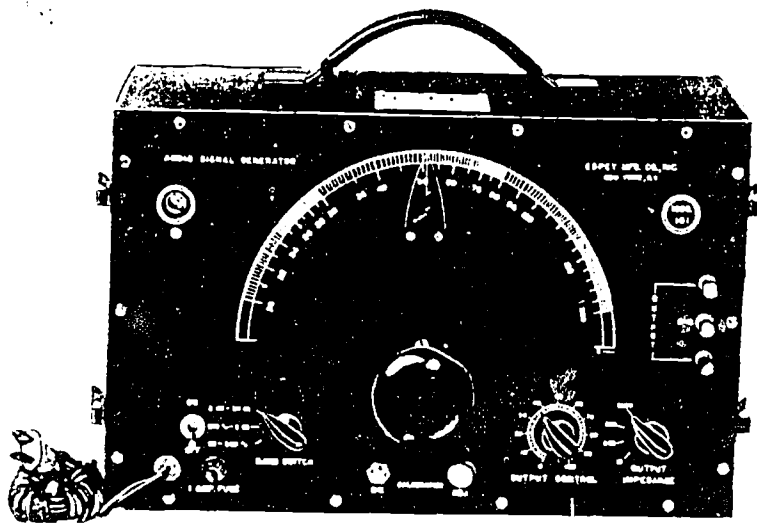

Figure 9-6.—Signal Generator.

71.131

calibrated attenuators are used since the signal strength must be regulated to avoid overloading the circuit receiving the signal. Figure 9-6 is a typical signal generator.

FREQUENCY COUNTER

The AN/USM-207 (fig. 9-7) is a portable, solid-state electronic counter for precisely measuring and displaying on an 8-digit numerical readout the frequency and period of a cyclic electrical signal, the frequency ratio of two signals, the time interval between two points on the same or different signals, and the total number of electrical impulses (totalizing). The counter also provides the following types of output signals:

1. Standard signals from 0.1 Hz to 10 MHz in decade steps derived from a 1 MHz frequency standard, frequency dividers, and a frequency multiplier.
2. Input signals divided in frequency by factors from 10 to 10^8 by a frequency divider.
3. Digital data of the measurement in four-line binary-coded-decimal form with decimal point and control signals for operation of printers, data recorders, or control devices.

TRANSISTOR TESTER

Laboratory transistor test sets are used in experimental work to test all characteristics of transistors. For maintenance and repair, however, it is not necessary to check all of the transistor parameters. A check of two or three performance characteristics is usually sufficient to determine whether a transistor needs to be replaced. Two of the most important parameters used for transistor testing are the transistor current gain (Beta) and the collector leakage or reverse current (I_{co}). These are discussed in *Basic Electronics, Vol. 1*, NAVEDTRA 10087-C.

Semiconductor test set AN/USM-206A (fig. 9-8) is a rugged field type tester designed to test transistors and semiconductor diodes. The set will measure the Beta of a transistor, the resistance appearing at the electrodes and the reverse current of a transistor or semiconductor diode, a shorted or open condition of a diode, the forward trans-conductance of a field effect transistor, and the condition of its own batteries.

TEST METHODS

When a piece of sonar equipment breaks down, it may be your job to locate the trouble

INTRODUCTION TO SONAR

and restore the faulty circuit to its proper operating condition. The means by which you find the faulty component is called troubleshooting, which consists of logical testing methods. Troubleshooting aids include troubleshooting charts, servicing diagrams, and voltage and resistance charts.

Troubleshooting charts list various equipment malfunctions, the probable cause of each, and the necessary corrective action. Servicing diagrams show test points, desired waveforms, proper voltages and other related servicing information. Voltage and resistance charts show the normal voltage and resistance values at the pins of connectors and tube sockets.

Although much of the equipment you are required to maintain is quite complex, the job is

much easier if broken into successive, logical steps. Figure 9-9 shows a general troubleshooting procedure. Steps 1 through 5 are followed in locating the trouble. Steps 6 and 7 are carried out in making repairs. Sometimes steps 2, 3, 4, and 5 may be eliminated, but never steps 6 and 7.

TERMINAL DESIGNATIONS

When carrying out your troubleshooting procedures, you will find that many test points are located on terminal boards. Wiring diagrams, which aid you in tracing a circuit from one unit to another, indicate the terminal connections of each circuit in each unit. You must understand, therefore, the system used for marking terminal boards and conductors as set forth in *Dictionary*

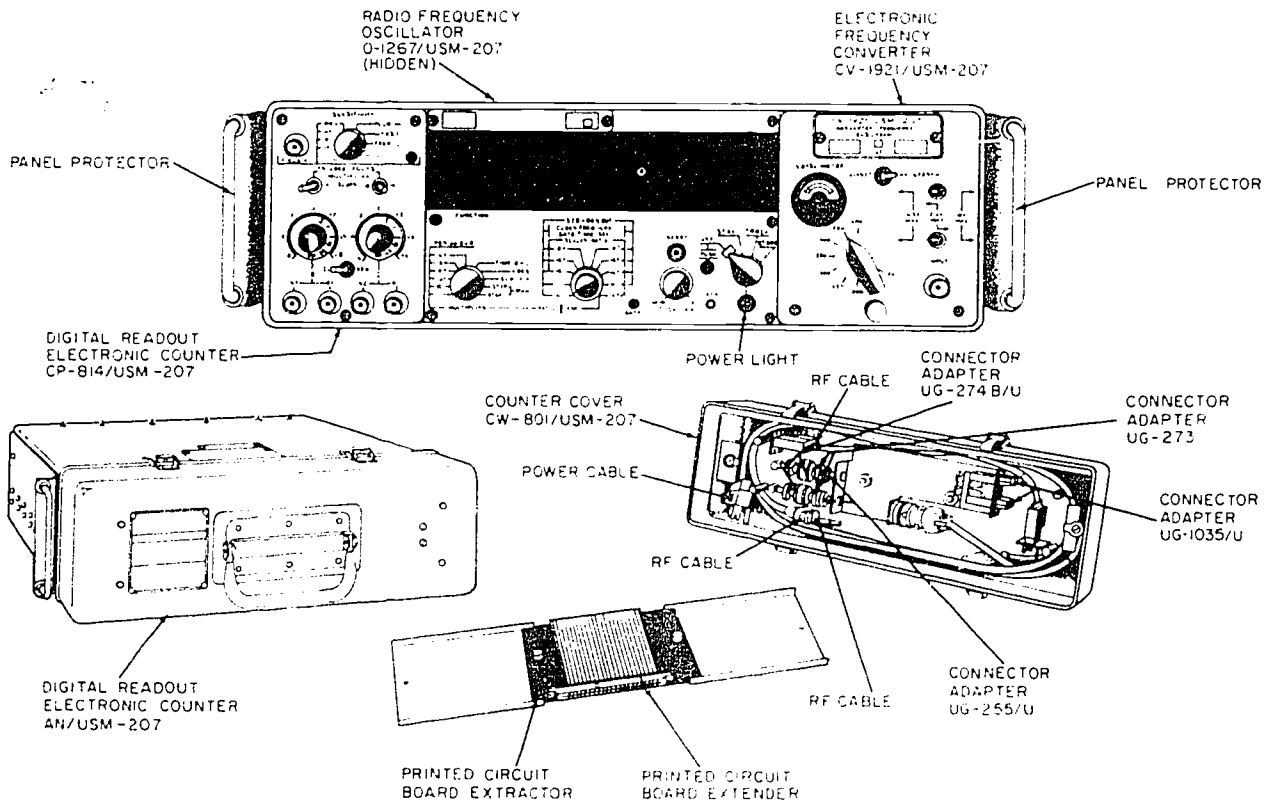

Figure 9-7.—Digital readout electronic counter AN/USM-207.

162.7

of Standard Terminal Designations for Electronic Equipment, NAVSEA 900,186.

Terminal Boards

Terminal boards are marked with a three- or four-digit number preceded by the letters TB. The first one or two digits of the TB number represent the unit number in the equipment. This number is assigned in a logical order. The last two digits represent the terminal board number in a unit, starting with 01, 02, 03, etc. Thus, terminal board TB 1003 indicates the 3rd

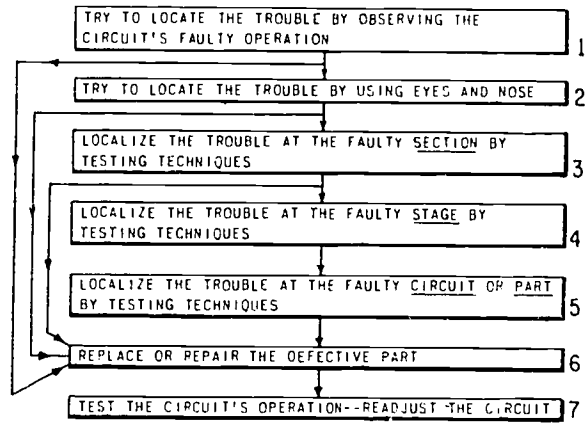

12.259

Figure 9-9.—Troubleshooting procedure.

terminal board in the 10th unit of the equipment.

Terminal Markings

Markings of terminals on terminal boards indicate a specific function for the following circuits: (1) common primary power circuits, (2) ground terminals, (3) common servo and synchro circuits, (4) video circuits, (5) trigger circuits, and (6) audio circuits. The breakdown of these categories into specific functions, with the terminal designation of each, is listed in NAVSEA 900,186. They are called rigidly assigned designations.

Terminals whose functions do not fall under the categories listed are assigned designations in accordance with NAVSEA 900,186. Only terminals that are connected together externally have exactly the same designation within any given equipment.

Conductor Marking

On the conductor lead, at the end near the point of connection to a terminal post, spaghetti sleeving is used as a marking material and insulator. The sleeving is engraved with indelible

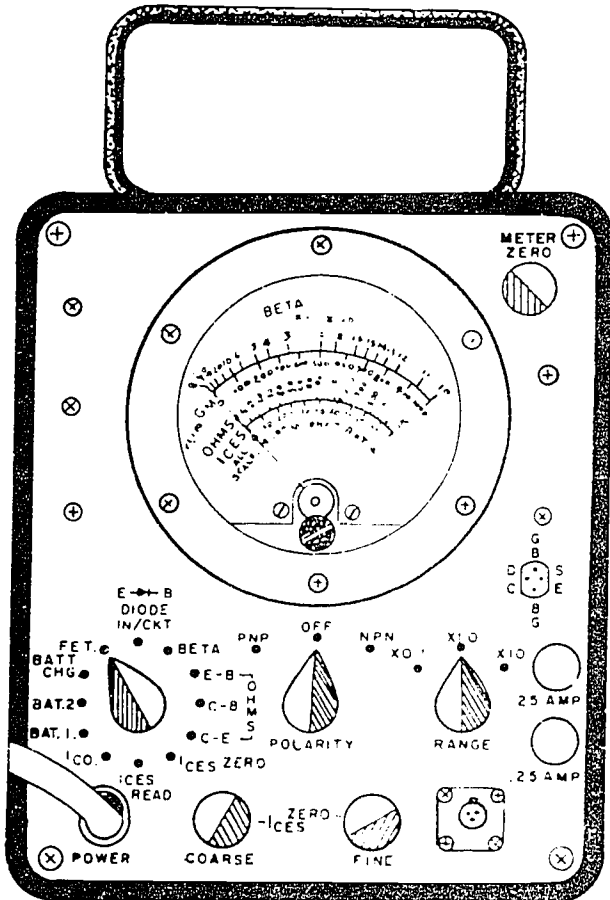

162.121

Figure 9-8.—Semiconductor test set AN/USM-206A.

ink or branded with identifying numbers and letters by a varitype machine, and slid over the conductor.

The order of marking is such that the first appearing set of numbers and letters, reading from left to right, is the designation corresponding to the terminal to which that end of the wire is connected. Following the terminal designation is a dash and then the number (without TB) of the terminal board to which the other end of the conductor is attached. There is another dash and the designation of the particular terminal to which the other end of the wire is connected.

Figure 9-10 shows how terminal boards, terminals, and conductors are marked. The lower portion of the illustration, for example, shows a conductor running from terminal 2A on TB101 to terminal 7B on TB401. The spaghetti sleeve on the conductor attached to TB101 is marked 2A-401-7B, indicating the other end of the conductor is attached to terminal 7B on TB401. The sleeve at terminal 7B of TB401 is marked 7B-101-2A, indicating the other end of the conductor is attached to terminal 2A on TB101. If you must remove a conductor from a terminal, the first set of letters and numbers tells you to which terminal it must be reconnected.

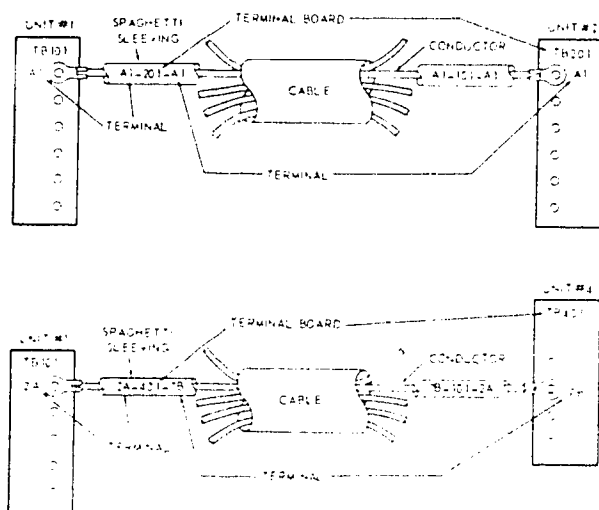

70.9

Figure 9-10.—Conductor and terminal markings.

Cable Marking

When doing maintenance or repair work, you may have to trace a cable from one section of the ship to another, examining the cable for damage that might be the cause of equipment breakdown. Cables are identified by metal tags that give information on the cable's use. Tags are attached to the cable as close as practicable to each terminal connection, on both sides of decks and bulkheads, and at intervals of about 50 feet. Formerly, colored tags were used to classify the necessity of the cable, and you may still see some of them. Red indicates a vital circuit, yellow a semivital circuit, and gray a nonvital circuit.

The cable designation information is a combination of letters and numbers, consisting of a service letter, circuit letters, and cable numbers. A typical cable designation is R-SK3. The service letter (R) means the cable supplies electronic equipment; the circuit letters (SK) denote scanning sonar; and the number (3) means it is the third cable in the scanning sonar circuit. A complete list of cable designations may be found in chapter 9600 of *NAVSEA Technical Manual*.

RESISTORS

A resistor is a device used to limit current flow. It is of either the fixed or variable type. Resistors are tested with an ohmmeter after the resistor is disconnected from the circuit. This action prevents damage to the meter from circuit voltage and ensures that only the resistor being tested gives a reading on the meter. Before conducting the test, set the meter to the proper scale, touch the ends of the meter test leads together, and adjust the meter to obtain a zero reading.

Fixed Resistors

Fixed resistors may be made of wire, wound on a core and coated with ceramic, or they may be made of carbon. They have either axial or radial leads, and a wattage rating according to the amount of heat they dissipate. In general,

carbon resistors are rated 1/2 to 2 watts. Wire-wound resistors usually are rated above 2 watts.

Resistance value is indicated by colored markings on the resistor. The standard color

code given in table 9-1 is used to interpret the resistor markings. You can easily memorize the color code.

A resistor always has three (sometimes four) resistance value indicators. Two methods are used to color code fixed resistors. In figure 9-11, the axial-lead type is shown to the left; the radial-lead type is shown on the right. Resistance value is determined as follows: Color A indicates the first significant figure; color B indicates the second significant figure; color C gives the multiplier (number of zeros); and color D is the percentage of tolerance. If there is no fourth color, the tolerance is 20%. Assume that an axial-lead and a radial-lead resistor each have the following color code marking: A--red, B--green, C--orange, and D--gold. Referring to table 9-1, you find that the first significant figure is 2, the second significant figure is 5, and the multiplier is 1000 (three zeros). The resistance value is 25,000 ohms, or 25K as it sometimes is marked on a schematic diagram. The tolerance is 5%.

A fixed resistor is tested by placing an ohmmeter lead on each resistor lead. For the resistor used in our example, a reading of 24K to 26K would be acceptable.

Low-power, wire-wound resistors have axial leads and are color coded similar to the regular axial-lead resistor, except that band A is double width.

Table 9-1.--Standard Color Code for Resistors

Color	Significant figure or number of zeros	Decimal multiplier	Resistance tolerance
Black	0	---	Percent ±
Brown	1	---	---
Red	2	---	---
Orange	3	---	---
Yellow	4	---	---
Green	5	---	---
Blue	6	---	---
Violet	7	---	---
Gray	8	---	---
White	9	---	---
Gold	---	0.1	5(J)*
Silver	---	---	10(K)*
No color . . .	---	---	20(M)*

*Symbol designation alternate for color.

20.373

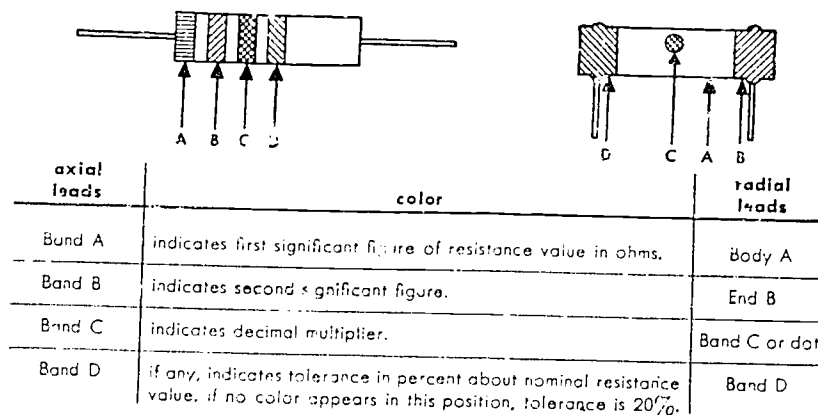

Note: Low-power insulated wire-wound resistors have axial leads and are color coded similar to the left-hand figure above except that band A is double width.

Figure 9-11.--Color code for axial-lead and radial-lead fixed resistors.

20.374

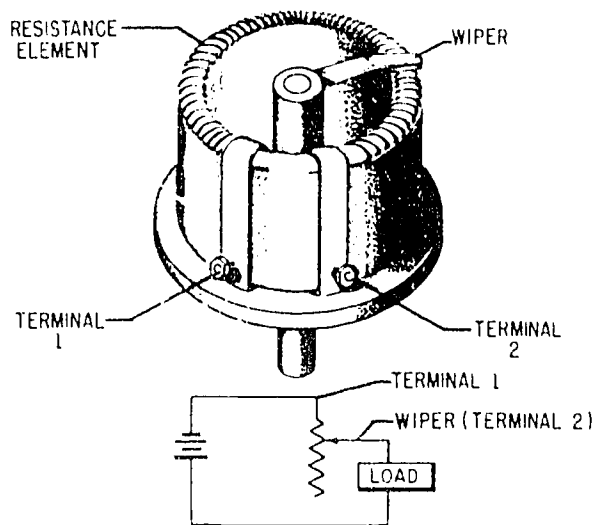

Figure 9-12.—Rheostat.

71.94

Variable Resistors

Variable resistors are of two general types: may be rheostats or potentiometers.

A rheostat normally is used to adjust the current in a circuit without opening the circuit. Some rheostats, however, are so constructed that the circuit may be opened also. In general, a rheostat has two terminals. One terminal is connected to one end of the resistance element; the other, to the sliding contact. As seen in figure 9-12, the resistance element is circular in shape and is made of resistance wire wound around an insulating form that usually is of a ceramic material. The resistance is decreased by rotating the wiper toward terminal 1.

To test a rheostat, you first must disconnect it from the circuit. An ohmmeter is used to measure the resistance between terminals 1 and 2 (refer to fig. 9-12), with the wiper rotated all the way to terminal 2. This action gives total resistance. Moving the wiper slowly back toward terminal 1 shows an ever-decreasing resistance until a reading of zero is obtained. If a reading of maximum shows on the meter during this phase of rotating the wiper toward terminal 1, it means the wiper is not making proper contact at that point.

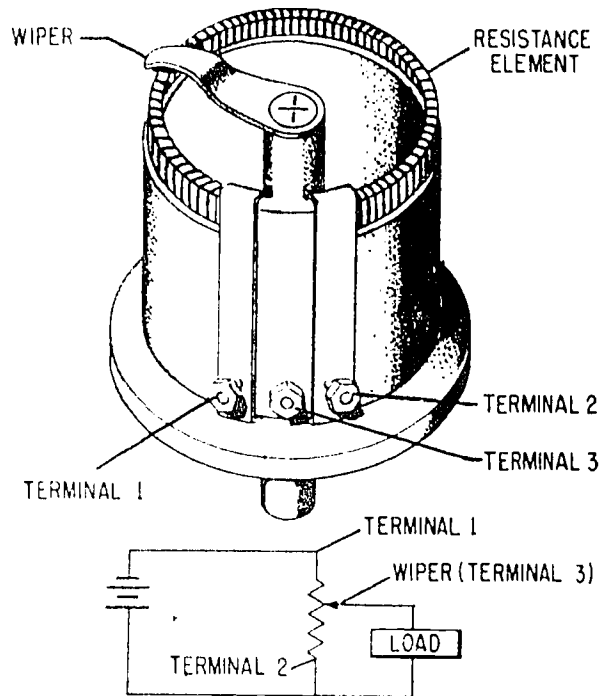

Figure 9-13.—Potentiometer.

33.75

The potentiometer (often called a "pot") is a control instrument used for varying the amount of voltage applied to an electrical device. The term "potentiometer" customarily refers to any adjustable resistor having three terminals, two of which are connected to the ends of the resistance element and the third to the wiper contact. The potentiometer is illustrated in figure 9-13. By positioning the sliding contact, any desired voltage within the range of the potentiometer may be selected and used where needed. As a rule, potentiometers are constructed to carry smaller currents than rheostats.

Potentiometers are measured in much the same way as rheostats. When disconnected from the circuit, they may be tested with an ohmmeter by measuring for total resistance between terminal 1 and 2. Applying one lead to terminal 3 and the other lead to either terminal 1 or 2 and moving the wiper results in a smoothly increasing or decreasing variation in resistance.

CAPACITORS

Many capacitors have their value printed on them, but some types use a color code system to indicate their value. The color code used is the same as that used for resistors, but the methods of marking the capacitors vary greatly. The method used for fixed mica capacitors is shown in figure 9-14.

A black dot in the upper left corner signifies that the capacitor has a mica dielectric. The center dot in the upper row indicates the first significant figure, and the upper right dot indicates the second significant figure of the capacitance value in micromicrofarads ($\mu\mu f$). The right dot in the lower row indicates the decimal multiplier that determines the number of zeros to be added to the right of the two significant figures. The center dot (lower row) specifies the tolerance, which is the possible deviation of the actual capacitor value from that given by its dot markings. The left dot on the lower row deals with temperature coefficients and applications.

By way of explanation, a capacitor with upper-row dots colored black, red, and green (reading from left to right, according to the directional indicator) would mean a mica capacitor with the significant figures 2 and 5.

The lower row of dots (reading from right to left) are brown, red, and red. The brown dot requires the addition of one zero to the value 25, giving the result as $250 \mu\mu f$. The red center dot indicates that the actual capacitor value may be greater or smaller than the $250 \mu\mu f$ by plus or minus 2 percent. The left red dot means it is a bypass or silver mica capacitor. Some mica capacitors have only three dots, indicating the first and second significant figures and the multiplier. Their tolerance is 20 percent, and they have a 500-volt rating. Try reading some of the values of the mica capacitors you see in electronic equipment when they are exposed to view. Learning to read capacitor values is a matter of practice, much like reading resistor values.

Electrolytic Capacitors

Electrolytic capacitors are used where a large amount of capacitance is required. As the name implies, electrolytic capacitors contain an electrolyte. This electrolyte can be in the form of either a liquid (wet electrolytic capacitor) or a paste (dry electrolytic capacitor). Wet electrolytic capacitors are no longer in popular use due to the care needed to prevent spilling of the electrolyte.

Dry electrolytic capacitors consist essentially of two metal plates between which is placed the

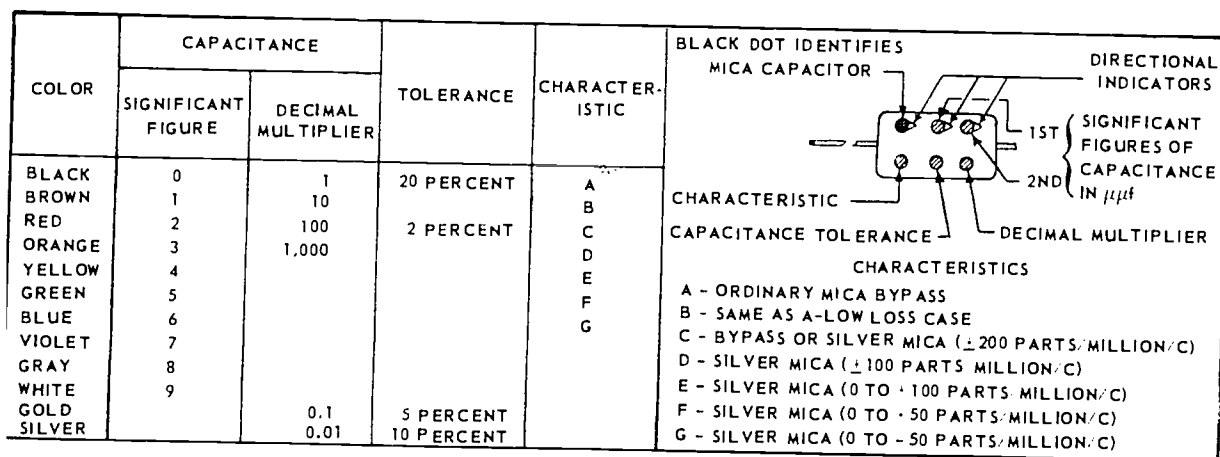
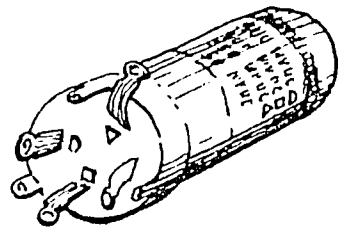
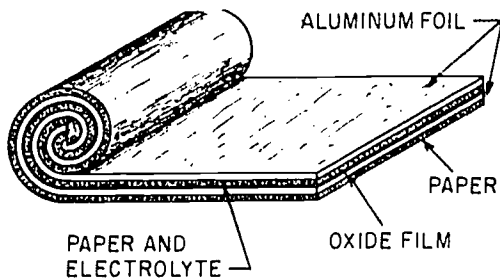

Figure 9-14.—Color code for fixed mica capacitors.

20.376



236.216

Figure 9-15.—Construction of an electrolytic capacitor.

electrolyte. In most cases the capacitor is housed in a cylindrical aluminum container which acts as the negative terminal of the capacitor (fig. 9-15). The positive terminal (or terminals if the capacitor is of the multisection type) is in the form of a lug on the bottom end of the container. The size and voltage rating of the capacitor is generally printed on the side of the aluminum case.

Capacitance measurements are usually accomplished by either a bridge-type or a reactance-type capacitance meter. For accuracy, the former equipment is comparable to the resistance bridge, and the latter instrument is comparable to the ohmmeter. Capacitance tolerances vary even more widely than resistance tolerances, being dependent upon the type of capacitor, the value of the capacitance, and the voltage rating. The results of capacitance tests must be evaluated to determine whether a particular capacitor will fulfill the requirements of the circuit in which it is used. The power factor of a capacitor is important because it is an indication of the various losses attributable to the dielectric, such as current leakage and

dielectrical absorption. Current leakage is of considerable importance, especially in electrolytic capacitors. The measurement of capacitance is very simple; however, you must make the important decision of whether to reject or continue to use a certain capacitor after it has been tested. A common test equipment used for testing capacitors, the ZM-11A/U, is shown in figure 9-16.

MAINTENANCE

Any piece of machinery or precision equipment requires some type of care to keep it running efficiently. Proper upkeep of an automobile, for example, includes changing the oil at certain mileage intervals. The windshield must be kept clean; headlights and brakes must be adjusted now and then; and an occasional engine tuneup must be obtained. Sonar equipment also requires periodic upkeep, but in more detail and at more regular intervals than does an automobile. Aboard your ship or submarine, you will assist in carrying out scheduled maintenance on the equipment to which you are assigned.

Various publications are available to assist you in carrying out a maintenance program. The manufacturer's technical manual for each piece of equipment is an invaluable aid. These books describe the components of the equipment, operating standards, and required maintenance. Other publications include the *NAVSEA Technical Manual* and *Electronic Information Bulletins (EIBs)*.

TYPES OF MAINTENANCE

Maintenance is divided into three categories, according to complexity and purpose. The three types of maintenance are operational, preventive, and corrective.

At first glance it may seem that preventive and operational maintenance are synonymous, but there is a good deal of difference between the two. Operational maintenance is confined to tasks that can be performed by an operator while he is on watch, and usually is further confined to one component, such as the sonar

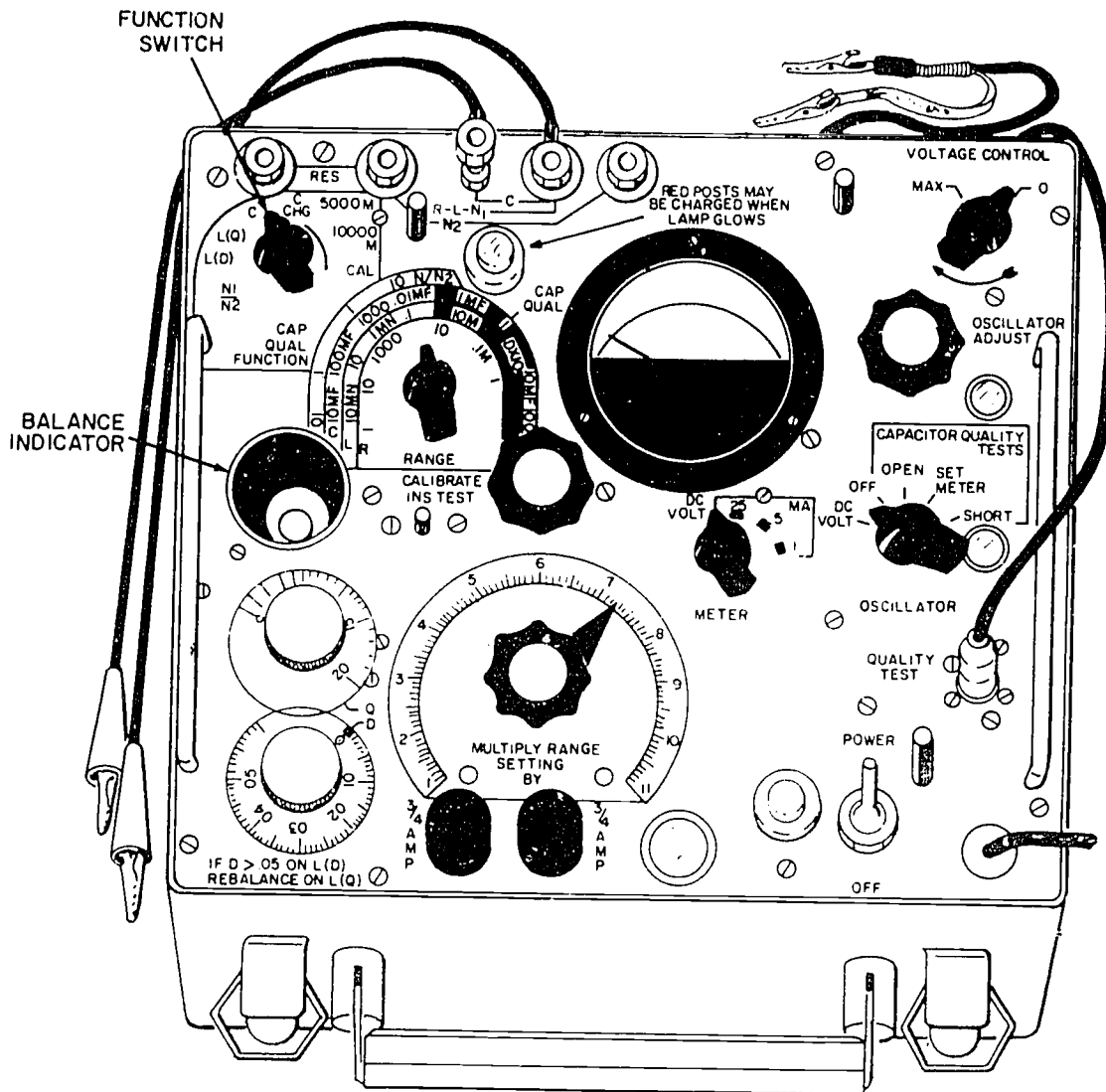

Figure 9-16.—Capacitance-inductance-resistance bridge ZM-11A/U.

1.68

console. Preventive maintenance is a systematic program covering the entire sonar system and requires several men to carry out.

The Navy's operational and preventive maintenance program formerly was called POMSEE. Ships and stations today, however, utilize a program known as the Standard Navy Maintenance and Material Management System, more familiarly called the 3-M System, which will be discussed later in the chapter.

Operational Maintenance

Operational maintenance is the elementary upkeep performed by the operator to keep his equipment in good operating condition. It consists mainly of proper operation of the equipment, such as starting, stopping, calibrating, and manipulating controls in the prescribed manner. At times, operational maintenance may also include inspection,

INTRODUCTION TO SONAR

cleaning, and lubrication of equipment, and replacement of minor parts, such as indicator lamps.

Preventive Maintenance

Preventive maintenance is intended to forestall equipment failure. Besides testing, discussed previously, this chapter comprises inspection, cleaning, and lubrication. If no high degree of technical skill or internal alignment is required, it also includes minor adjustments and replacement of minor deteriorated parts which, if left uncorrected, might lead to equipment malfunction or part failure.

INSPECTION.--All electronic equipment should be inspected daily for such defects as broken meter glasses, loose control knobs, burned-out indicator lights, loose cable connections, and the many small items that may be checked with or without the equipment actually being energized. On units that utilize ventilation for cooling, the intake and outlet areas should be inspected to see that they are free of obstructions.

Many items should be inspected daily, weekly, and monthly to help maintain the equipment in serviceable condition. In some instances these routine checks include electrical measurements to check individual units for malfunctioning circuitry. Technical manuals furnished by the manufacturer include lists of checks to be conducted at regular intervals and the desired reading or measurement required for peak performance of the specific equipment.

CLEANING.--Cleaning is an important part of preventive maintenance. External surfaces of electronic units and the surrounding spaces should be cleaned daily. This daily routine reduces the amount of dirt and dust that enters the equipment through circulating air blower intakes. Some dust and dirt naturally will work their way in; hence, the interiors of units should be cleaned carefully, at least once a week, with a soft cloth. If possible, a vacuum cleaner should be used. Avoid using blowers, bellows, or cleaning solvents, because they tend to push or wash dirt into inaccessible corners. Air filters should be cleaned at least once a week. Climate

and operating conditions may require cleaning more often. Overheating due to clogged air filters often is a prime cause of equipment failure. Neglect in cleaning filters is, therefore, inexcusable.

Generators must be given a careful cleanliness check while the equipment is inoperative. Brushes and commutators should be cleaned frequently. Be careful not to blow or brush carbon dust and other foreign matter into the windings or bearings. When cleaning generators, ensure that the brushes slide freely in their holder and exert proper pressure on the slipping or commutator surface.

LUBRICATION.--Electronic gear has many parts--such as motors, hoists, gears, and springs--that require regular lubrication. The manufacturer's technical manual should be followed to ascertain where, how often, and how much lubrication is needed. Use caution when lubricating the parts of any piece of equipment, and follow the instructions in the book pertaining to the individual type of equipment. Too much lubrication can be just as harmful as too little.

Corrective Maintenance

Corrective maintenance, another name for repair, is necessary only after equipment failure. Corrective maintenance usually calls for replacement of internal parts or alignment of electronic components requiring technically trained personnel. Some of this work is performed by operating personnel while assisting the technician. As you advance in rate, you will perform more highly technical maintenance on your own.

MAINTENANCE AND MATERIAL MANAGEMENT SYSTEM

Reliability of electronic equipment depends on the quality of the preventive and operational maintenance received by the equipment. As equipment becomes more complex, the maintenance problem becomes ever greater.

In the past, many programs evolved that often were uncoordinated and sometimes

unworkable. The lack of well-trained technicians, together with the large number of reports required by some programs, seriously hampered the maintenance effort. Overloaded systems commands, moreover, could not properly correlate the mass of information in the reports.

To alleviate these conditions, the Standard Navy Maintenance and Material Management (3-M) System was implemented. The 3-M System replaces all other maintenance programs. It prescribes standard maintenance procedures, provides a feedback report system that enables the program to be updated, and corrects errors and deficiencies.

Procedures for managing and reporting the maintenance program are contained in *Ship's Maintenance and Material Management (3-M) Manual*, OPNAVINST 4790.4.

Basic elements of the 3-M System are the Planned Maintenance Subsystem (PMS) and the Maintenance Data Collection Subsystem (MDCS). The PMS provides a uniform system of planned preventive maintenance. The MDCS provides a means of collecting necessary maintenance and supply data, in a form suitable for machine processing. A man-hour accounting system also is used aboard repair ships and tenders in conjunction with the MDCS. As a third class petty officer, you will be concerned with the Planned Maintenance Subsystem and certain portions of the Maintenance Data Collection Subsystem. The degree of equipment readiness, effectiveness, and reliability depends on how well you perform the required maintenance.

Planned Maintenance Subsystem

Preventive maintenance, when properly carried out, reduces casualties and associated costs and equipment downtime required for major repairs. The PMS is designed to simplify maintenance procedures (insofar as possible) by defining the maintenance required, scheduling its performance, describing the tools and methods to be used, and providing for the detection and prevention of impending casualties.

In establishing minimum equipment maintenance requirements, the *NAVSEA Technical Manual*, manufacturers' technical manuals, and other applicable publications are reviewed critically. If planned maintenance requirements are found to be unrealistic or unclear, they are modified or completely revised before incorporation into the PMS.

It is possible that the planned maintenance specified in the PMS may differ from that prescribed in other documents. Should some variance become apparent, remember that, insofar as preventive maintenance is concerned, the PMS supersedes and takes precedence over existing requirements set forth in various technical publications.

PLANNED MAINTENANCE SUBSYSTEM MANUAL.—A master *Planned Maintenance Subsystem Manual* (OPNAV 43PI) is tailored to each ship. It contains minimum planned maintenance requirements for each maintainable component installed in that particular ship. Normally, appropriate sections (engineering, electronics, weapons, etc.) of the master manual are kept in the office of the department concerned. Respective sections are used by department heads in planning and scheduling all maintenance requirements in their departments.

The departmental PMS manual contains a section for each division or maintenance group within a department. Each divisional section includes a table of contents and a maintenance index page (MIP) for each system, subsystem, or component. Applicable portions of the PMS manual are kept in the working space for the equipment to which they pertain. These portions serve as a ready reference to the required planned maintenance. Each MIP contains a brief description of maintenance requirements and the frequency with which they are to be effected.

The frequency code is: D—daily, W—weekly, M—monthly, Q—quarterly, S—semiannually, A—annually, C—overhaul cycle, and R—situation requirement. Frequency codes for daily, weekly, monthly, quarterly, semiannual, and annual planned maintenance actions are self-explanatory. Code C designates certain planned maintenance actions performed in a

INTRODUCTION TO SONAR

SYSTEM/SUBSYSTEM OR COMPONENT	REFERENCE PUBLICATIONS	DATE			
Main Circulating Pump		15 June 1968			
<small>CONFIRMATION: THESE MAINTENANCE REQUIREMENTS ARE APPLICABLE TO EQUIPMENT IN WHICH THE FOLLOWING CHANGES HAVE BEEN ACCOMPLISHED:</small>					
SYSCOM MRC CONTROL NO.	MAINTENANCE REQUIREMENT	PERIODICITY CODE	SKILL LEVEL	MAN HOURS	RELAYED MAINTENANCE
84 5078 W	1. Sample and inspect lube oil. 2. Lubricate the speed limiting governor. 3. Turn pump several revolutions by hand; if steam is available, turn by steam.	W-1	MM3	0.5	None
66 5079 M	1. Test speed limiting governor.	M-1	MM1 FN	0.2 0.2	None
35 7998 Q	1. Clean pump and renew oil. 2. Clean lube oil filter.	Q-1	MM3 FN	0.5 1.5	None
68 P778 Q	1. Test spring-loaded exhaust valve by steam.	Q-2	MM2 FN	0.2 0.2	W-1
A4 4830 Q	1. Inspect reduction gears.	Q-3	MM1	0.5	None
65 4079 O	1. Renew stuffing box packing.	O-4	MM3	1.0	None
84 5082 A	1. Sound and tighten foundation bolts. 2. Inspect and clean steam strainer.	A-1	MM3	1.0	None
85 5083 C	1. Inspect internal water lubricated bearing and journal for condition. Measure bearing and propeller clearances.	C-1	MM1 2FN	12.0 24.0	Q-4
95 D045 C	1. Inspect carbon packing for wear.	C-2	MM2 FN	2.0 2.0	None
16 5510 C	1. Clean, inspect, and preserve exterior of turbine casing.	C-3	MM2 FN	1.0 1.0	C-2
MAINTENANCE INDEX PAGE OPNAV FORM 4700.3 (A) (REV. 4-71)		SYSCOM MIP CONTROL NUMBER E-5/76-68			

Figure 9-17.—Example of a hull mechanical or electrical equipment MIP.

98.176

specified quarter (i.e., once) during the operational cycle between shipyard overhauls. Code R identifies planned maintenance actions that are to be performed before getting underway, after a specified number of hours of operation, or to meet other requirements that arise only during specific situations.

Figure 9-17 shows a typical maintenance index page. Information entered on the MIP includes the system or component, a short description of each maintenance requirement, maintenance frequency code plus a consecutive number starting with numeral 1 for each frequency code assigned, rate(s) recommended to perform the maintenance, average time required to perform the maintenance, and related maintenance requirements. Related maintenance represents additional planned maintenance that can be completed before, in conjunction with, or immediately after a scheduled maintenance.

Shipboard application of the PMS varies slightly from one ship to another. Clarification is required, therefore, of information found on MIPs regarding rates recommended to perform maintenance and the average time required for the task. Actually, maintenance tasks are performed by personnel available and capable, regardless of the rate listed on the MIP. As listed on the MIP, average time required does not consider time required to assemble necessary tools and materials, to obtain permission to secure equipment, nor to clean the area and put away tools upon conclusion of a task. Always remember, however, that no maintenance is complete until all tools and equipment are put away and the area is cleaned.

SCHEDULING PLANNED MAINTENANCE.—For each division or maintenance group, a cycle schedule that provides a visual display of planned maintenance requirements (based on the operational cycle of the ship between shipyard overhauls) is exhibited in the departmental office. Information supplied on a cycle schedule for any particular division or maintenance group includes the MIP number from the PMS manual, a listing of all equipment within that particular group for which planned maintenance is

required, and the specific quarter in which the semiannual, annual, and overhaul cycle planned maintenance actions are to be performed. A cycle schedule also lists quarterly and situation requirement planned maintenance actions that must be scheduled, as well as monthly planned maintenance requirements.

Cycle schedules are utilized by department heads, in conjunction with their division officers and leading petty officers, to prepare quarterly planned maintenance schedules. A quarterly schedule is displayed in a holder, known as the maintenance control board, adjacent to the cycle schedule to which it pertains. A quarterly schedule gives a visual display of the ship's employment schedule and the planned maintenance to be performed during that particular quarter. A quarterly schedule has 13 columns, 1 for each week in the quarter, for scheduling maintenance throughout a 3-month period.

At the end of each week, the leading petty officer of a division or maintenance group updates the quarterly schedule by crossing out (with an X) the preventive maintenance performed. If a planned maintenance action is not completed during the week it is scheduled, the leading petty officer circles the action on the quarterly schedule. Uncompleted maintenance is then rescheduled for another week within the same quarter.

At the close of each quarter, the applicable quarterly schedule is removed from its holder and retained on board as a record of the planned maintenance completed. This record may be discarded at the beginning of the second quarter after the next shipyard overhaul.

A quarterly schedule also is used by a leading petty officer to arrange a weekly planned maintenance schedule for posting in an appropriate workspace. The weekly schedule of planned maintenance should not be considered as the total of all work for a given week. This weekly work covers only scheduled planned maintenance and is in addition to other routine work, upkeep, and corrective maintenance to be accomplished. The weekly schedule provides a list of components in the working area, appropriate page number of the PMS manual,

INTRODUCTION TO SONAR

and spaces for the leading PO to use in assigning planned maintenance tasks to specified personnel. Daily and weekly planned maintenance actions are preprinted on the forms, and the other maintenance actions are written in by the leading PO as required. When the leading PO is assured that a maintenance task is completed, he crosses out the maintenance requirement number on the weekly schedule. If for some reason a task cannot be completed on the day scheduled, the leading petty officer circles the maintenance requirement number and reschedules it for another day. Current status of scheduled maintenance is readily available by looking at the weekly schedule.

MAINTENANCE REQUIREMENT CARD.—A maintenance requirement card (MRC) is a 5 by 8 inch card on which a planned maintenance task is defined sufficiently to enable assigned personnel to perform the task. (See fig. 9-18.) A master set of MRCs is maintained in the departmental office. Cards applicable to the equipment for which Sonar Technicians are responsible are maintained in the workspace. If a card in the workspace becomes lost or mutilated, a new card may be made from the master set and can be used until a feedback report is sent in and a new card obtain 1.

A maintenance requirement card is one of the principal components of the PMS with which Sonar Technicians are concerned. Suppose that on a Monday morning an individual looks at the weekly schedule and finds that he is assigned the maintenance action identified as M-14. The weekly schedule indicates that this particular maintenance action is listed on page SO-9 of the PMS manual. The MRC that describes the task assigned is identified by the number combination SO-9, M-14 in the upper right corner. In preparation for performing the assigned task, MRC number SO-9, M-14 is selected from the set of cards in the workspace. An MRC identifies each component; gives the rate and time required to perform the maintenance; gives a brief description of maintenance required; cites safety precautions to be observed; and lists tools, parts, and materials needed to accomplish the task.

SYSTEM SO-9	COMPONENT ELECTRICAL ASSIGNMENT	NMC CODE E-14
SUBSYSTEM ELECTRICAL	RELATED MAINTENANCE None	DATES E-14 E-14
MAINTENANCE REQUIREMENT DESCRIPTION 1. Inspect and adjust electrical assignments.		TOTAL M.H. E-14 E-14 ELAPSED TIME E-14
SAFETY PRECAUTIONS 1. Observe standard safety precautions listed in the Safety Summary of OP 433 (PMS-SMS), Volume 1.		
TOOLS, PARTS, MATERIALS, TEST EQUIPMENT 1. MSA-880000-8-4 2. MSA-880000-8-7		
PROCEDURE 1. Inspect and adjust electrical assignments. 2. Inspect and adjust electrical assignments. 3. Inspect and adjust electrical assignments. 4. Inspect and adjust electrical assignments. 5. Inspect and adjust electrical assignments.		
MAINTENANCE REQUIREMENT CARD (MRC) OPNAV FORM 4790/7B (REV. 11-68)		

98.176
Figure 9-18.—MRC card.

This information is given to enable personnel to be completely ready to perform all prescribed maintenance before actually working on equipment authorized. The procedure described on the MRC is standardized and is the best known method of performing that particular task. For purposes of time conservation, any related maintenance requirement included on the MRC should be done at the same time or in conjunction with the assigned task.

FEEDBACK REPORT.—A PMS feedback report, OPNAV FORM 4790/7B (fig. 9-19) is

Chapter 9—TEST EQUIPMENT; TEST METHODS; MAINTENANCE

SEE INSTRUCTIONS ON BACK OF GREEN PAGE FROM (SHIP NAME AND HULL NUMBER)		REPORT SYMBOL: OPNAV 4790 4 011 1 August 1972
BROOKE (DEG-1)		DATE
TO		
<input type="checkbox"/> NAVY MAINTENANCE MANAGEMENT FIELD OFFICE (Category A)		
<input checked="" type="checkbox"/> TYPE COMMANDER (Category B)		
SUBJECT: PLANNED MAINTENANCE SUB-SYSTEM FEEDBACK REPORT		
SYSTEM SUB-SYSTEM OR COMPONENT: Compensating System (relief valves)		
SYSTEM MRC CONTROL NUMBER P-37/1-C8	SYSTEM MRC CONTROL NUMBER C8 P776 Q	
DESCRIPTION OF PROBLEM		
CATEGORY A		CATEGORY B
<input type="checkbox"/> SHIP/MRC/EGL REPLACEMENT		<input checked="" type="checkbox"/> TECHNICAL
<input type="checkbox"/> EQUIPMENT ADDITION		<input type="checkbox"/> TYCOM ASSISTANCE
<input type="checkbox"/> EQUIPMENT DELETION		<input type="checkbox"/> OTHER (Specify)
<input type="checkbox"/> CHANGE TO EQUIPMENT		
REMARKS		
Before testing setting on relief valve, we need calibration steps for Leslie-Matic controller. This step in procedure is not contained on the present MRC. This ship does not have any pub or Tech Manual as to the steps that should be taken in checking the Leslie-Matic controller for accuracy.		
ORIGINATOR H. Grant	WORK CENTER CODE EB14	
DEPARTMENT HEAD R. Kline	JMW COORDINATOR H. Noll	
TYCOM <input checked="" type="checkbox"/> CONCISE <input type="checkbox"/> DO NOT CONCISE	<input type="checkbox"/> TAKES ACTION	<input type="checkbox"/> PASSES FOR ACTION
SIGNATURE W. Wood	DATE 2 Aug 1972	
OPNAV 4790 7B (6 73)	ACTION COPY	PAGE _____ OF _____

98.176

Figure 9-19.—PMS feedback report.

designed for reporting any discrepancies or suggested improvements in the PMS as installed aboard ship. This report is to be filled out by the man who discovers a discrepancy or suggests an improvement. It is signed by a designee of the commanding officer and is mailed via the type commander to an appropriate field office listed on the reverse side of the originator's copy of the form.

When submitting a feedback report, be sure it is filled out completely and legibly. If the

purpose of submitting a feedback report is to correct a discrepancy, for example, on a maintenance requirement card, be sure the discrepancy is clearly identified and the recommended change is correct and readily understood. Instructions for preparing the report are listed on the back of the form.

Maintenance Data Collection Subsystem

The Maintenance Data Collection Subsystem is intended to provide a means of recording maintenance actions in substantial detail so that a variety of information may be collected concerning maintenance actions and performance of equipment. In addition to the foregoing information, MDCS furnishes data on initial discovery of a malfunction, how equipment malfunctioned, how many man-hours were expended on its repair, equipment involved, repair parts and materials used, delays incurred, reasons for delay, and the technical speciality or work center that performed the maintenance.

In recording maintenance actions, codes must be used to convert information to a language that can be read by automatic data processing machines. Codes are listed in the equipment identification code (EIC) manual. Third class petty officers are required to prepare numerous maintenance forms, using appropriate EICs. These forms are sent to a data processing center where coded information is punched onto cards, which then are machine processed to produce various reports for use in maintenance and material management.

Reports coming from the automatic data processing machines are accurate and useful only if information is entered clearly and correctly on maintenance forms. All codes supplied on the forms must therefore be accurate and clearly written.

The MDCS requires that coded entries be made on OPNAV Form 4790/2k, Ship's Maintenance Action Form. Detailed descriptions and instructions for this form are contained in Volume II of the 3-M manual, OPNAVINST 4790.3.

CHAPTER 10

SECURITY

The security of the United States in general and of naval operations in particular depends greatly upon the success attained in safeguarding classified information. It is of paramount importance that everyone responsible for the security of classified information preserve a balanced and commonsense outlook toward the subject.

As a Sonar Technician you will hear a great deal about the security of classified material because you will have access to and utilize classified information every day. For this reason, all activities brief newly arrived Sonar Technicians in security and require them to sign a statement attesting to the fact that they have received the briefing and understand the content. Further, as a part of each command's security program, you will be required to read and indicate your understanding of several of the most important national laws and regulations related to security.

Maintaining the security of classified material, however, requires more than a briefing, a regulation, or a law. Security will only be as effective as you make it; there is no one to whom you can transfer your responsibility for protecting this information. The security of classified material is not an extra job; it is a basic part of your assignment just as is operating electronic equipment. You must be security conscious to the point that you automatically exercise proper discretion in the discharge of your duties and do not think of security of information as something separate and apart from other matters. In this way, security of classified information becomes a natural element of every task and not an additionally imposed burden.

Security is more than a matter of being careful; it requires both study and practice.

Thorough understanding of this chapter will not provide full knowledge of all the finer points concerning security, but it will provide you with a good fundamental background upon which security is built.

PURPOSE OF THE SECURITY PROGRAM

The security program deals basically with the safeguarding of information that could, in the hands of unauthorized personnel, be used to the detriment of the United States. Classified information may be compromised through careless talk, improper handling, and various other ways. Some of the ways in which military personnel may accidentally give away vital information are discussed in *Basic Military Requirements*, NAVEDTRA 10054 (current series).

SECURITY PRINCIPLES

The Department of Defense security formula is based on the premise of circulation control; i.e., the control of dissemination of classified information. According to this policy, knowledge or possession of classified defense information is permitted only to persons whose official duties require access in the interest of promoting national defense and only if they are determined to be trustworthy.

DEFINITIONS

The following definitions are taken from *Department of the Navy Information Security Program Regulation*, OPNAVINST 5510.1E.

ACCESS

The ability and opportunity to obtain knowledge or possession of classified information.

ALIEN

Any person not a citizen or a national of the United States.

CLASSIFICATION

The determination that official information requires, in the interest of national security, a specific degree of protection against unauthorized disclosure, coupled with a designation signifying that such a determination has been made.

CLASSIFICATION GUIDE

An instruction indicating the classification, downgrading, and declassification guidance that may be assigned to subjects within a specific area of defense activity.

CLASSIFIED INFORMATION

Official information which has been determined to require, in the interest of national security, protection against unauthorized disclosure and which has been so designated.

CLASSIFIED MATERIAL

Any matter, document, product, or substance on or in which classified information is recorded or embodied.

CLASSIFIER

An individual who does either of the following:

1. Determine that official information, not known by him to be already classified, currently requires, in the interest of national security, a specific degree of protection against unauthorized disclosure and, having the authority to do so, designates that official

information as Top Secret, Secret, or Confidential.

2. Determines that official information is in substance the same as information known by him to be already classified by the government as Top Secret, Secret, or Confidential and designates it accordingly.

CLEARANCE

An administrative determination by competent authority that an individual is eligible for access to classified information of a specific classification category.

COMPETENT AUTHORITY— COMMANDING OFFICER

For the purposes of this chapter, the terms “competent authority” and “commanding officer” are synonymous. These terms are intended to include “commander,” “officer in charge,” “naval representative,” “director,” “inspector,” and any other title assigned to an individual, military or civilian, who, through command status, position, or administrative jurisdiction, is qualified to assume responsibility and to render a decision with regard to a specific question under consideration.

COMPROMISE

The known or suspected exposure of classified information or material to an unauthorized person.

Compromise, when evaluated for reporting purposes, shall be described as follows:

1. Confirmed—compromise is considered confirmed when conclusive evidence exists that classified material was compromised.

2. Suspected—compromise is suspected when evidence exists beyond a reasonable doubt that classified material has been subjected to compromise.

3. Remote—compromise is considered remote when, after the conduct of an initial inquiry, there exists strong evidence indicating there was minimal risk of the material getting into the public domain or minimal risk that the

INTRODUCTION TO SONAR

circumstances of the unauthorized disclosure could reasonably be expected to damage the national security.

CUSTODIAN

An individual who has possession of or is otherwise charged with the responsibility for safeguarding and accounting for classified information.

DECLASSIFICATION

The determination that classified information no longer requires, in the interest of national security, any degree of protection against unauthorized disclosure, coupled with a removal or cancellation of the classification designation.

DOCUMENT

Any recorded information, regardless of its physical form or characteristics, including, without limitation, written or printed material; data processing cards and tapes; maps and charts; paintings; drawings; engravings; sketches; working notes and papers; reproductions of such things by any means or process; and sound, voice, or electronic recordings in any form.

DOWNGRADE

To determine that classified information requires, in the interest of national security, a lower degree of protection against unauthorized disclosure than currently provided, coupled with a changing of the classification designation to reflect such lower degree.

FORMERLY RESTRICTED DATA

Information removed from the Restricted Data category upon determination jointly by the Atomic Energy Commission and Department of Defense that such information relates primarily to the military utilization of atomic weapons and that such information can be adequately safeguarded as classified defense information. Such information is, however, treated the same as Restricted Data for purposes of foreign dissemination.

MARKING

Thy physical act of indicating on classified material the assigned classification, changes in classification, downgrading and declassification instructions, and any limitations on the use thereof.

NEED TO KNOW

The necessity for access to, or knowledge or possession of classified information to carry out official military or other governmental duties. Responsibility for determining whether a person's duties require that he possess or have access to classified information and whether he is authorized to receive it rests upon the possessor of the classified information and not upon the prospective recipient.

RESTRICTED DATA

All data (information) covering (1) design, manufacture, or utilization of atomic weapons; (2) the production of special nuclear material; or (3) the use of special nuclear material in the production of energy, but not to include data declassified or removed from the Restricted Data category pursuant to Section 142 of the Atomic Energy Act. (See Section 11y, Atomic Energy Act of 1954, as amended, and "Formerly Restricted Data.")

SECURITY

A protected condition of classified information which prevents unauthorized persons from obtaining information of direct or indirect military value. This condition results from the establishment and maintenance of protective measures which ensure a state of inviolability from hostile acts or influence.

UPGRADE

To determine that certain classified information requires, in the interest of national security, a higher degree of protection against unauthorized disclosure than currently provided, coupled with a changing of the classification designation to reflect such higher degree.

CLASSIFICATION CATEGORIES

Official information that requires protection in the interest of national defense is placed into one of three categories: Top Secret, Secret, or Confidential. Following are examples and definitions of each category.

TOP SECRET

The Top Secret classification is limited to defense information or material requiring the highest degree of protection. It is applied only to information or material the defense aspect of which is paramount, and the unauthorized disclosure of which could reasonably be expected to cause **EXCEPTIONALLY GRAVE DAMAGE** to the Nation, such as—

1. A war, an armed attack against the United States or her allies, or a break in diplomatic relations that would affect the defense of the United States.
2. The unauthorized disclosure of military or defense plans, intelligence operations, or scientific or technological developments vital to the national defense.

SECRET

The Secret classification is limited to defense information or material the unauthorized disclosure of which could reasonably be expected to cause **SERIOUS DAMAGE** to the Nation, such as—

1. Jeopardizing the international relationships of the United States.
2. Endangering the effectiveness of a program or policy of vital importance to the national defense.
3. Compromising important military or defense plans, or scientific developments important to national defense.
4. Revealing important intelligence operations.

CONFIDENTIAL

The use of the Confidential classification is limited to defense information or material the

unauthorized disclosure of which could reasonably be expected to cause damage to the National security, such as—

1. Operational and battle reports that contain information of value to the enemy.
2. Intelligence reports.
3. Military radiofrequency and call sign allocations that are especially important or are changed frequently for security reasons.
4. Devices and material relating to communication security.
5. Information that reveals strength of our land, air, or naval forces in the United States and overseas areas, identity or composition of units, or detailed information relating to their equipment.
6. Documents and manuals containing technical information used for training, maintenance, and inspection of classified munitions of war.
7. Operational and tactical doctrine.
8. Research, development, production, and procurement of munitions of war.
9. Mobilization plans.
10. Personnel security investigations and other investigations, such as courts of inquiry, which require protection against unauthorized disclosure.
11. Matters and documents of a personal or disciplinary nature which, if disclosed, could be prejudicial to the discipline and morale of the armed forces.
12. Documents used in connection with procurement, selection, or promotion of military personnel, the disclosure of which could violate the integrity of the competitive system.

NOTE: Official information of the type described in paragraphs 10, 11, and 12 above is classified Confidential only if its unauthorized disclosure could be prejudicial to the defense interests of the Nation. If such information does not relate strictly to defense, it must be safeguarded by other means than the Confidential classification.

ACCOUNTABILITY

A continuous chain of receipts for Top Secret material is maintained. In addition, a

INTRODUCTION TO SONAR

disclosure record form is attached to each document that circulates within a command or activity, and each person having knowledge of its contents signs the form.

Each command establishes administrative procedures for recording Secret material originated and received, and maintains a receipting system for Secret matter distributed or routed within the command.

Each command also maintains a system that ensures accountability for all Confidential material originated or received.

PHYSICAL SECURITY

Physical security has to do with safeguarding classified information by physical means. It includes the designation of security areas, stowage, custody, accountability, transmission, dissemination, and ultimate disposition or destruction. In other words, here we are concerned with methods of preventing unauthorized persons from obtaining physical custody of classified material.

SECURITY AREAS

Spaces containing classified matter are known as security areas. These security (or sensitive) areas have varying degrees of security interest, depending upon the purpose and the nature of the work and information or materials concerned. Consequently, the restrictions, controls, and protective measures required vary according to the degree of security importance. To meet different levels of security sensitivity, there are three types of security areas; all areas are clearly marked by signs reading "SECURITY AREA - KEEP OUT. AUTHORIZED PERSONNEL ONLY."

Exclusion Area

Spaces requiring the strictest control of access are designated exclusion areas. They contain classified matter of such nature that, for all practical purposes, admittance to the area permits access to the material.

An exclusion area is fully enclosed by a perimeter barrier of solid construction. Exits and entrances are guarded, or secured and alarm protected; and only those persons whose duties require access and who possess appropriate security clearances are authorized to enter.

Limited Area

A limited area is one in which the uncontrolled movement of personnel permits access to the classified information therein. Within the area, access may be prevented by escort and other internal controls.

The area is enclosed by a clearly defined perimeter barrier. Entrances and exits are either guarded, controlled by attendants to check personal identification, or under alarm protection.

Operating and maintenance personnel who require freedom of movement within a limited area must have a proper security clearance. The commanding officer may, however, authorize entrance of persons who do not have clearances. In such instances, escorts or attendants, and other security precautions must be used to prevent access to classified information located within the area. Sonar is designated as a limited area.

Controlled Area

A controlled area does not contain classified information. It serves as a buffer zone to provide greater administrative control and protection for the limited or exclusion areas. Thus, passageways or spaces surrounding or adjacent to limited or exclusion areas may be designated controlled areas.

Controlled areas require personnel identification and control systems adequate to limit admittance to those having bona fide need for access to the area.

STOWAGE

Stowage refers to the manner in which classified material is protected by physical and/or mechanical means. The degree of

protection necessary depends on the classification, quantity, and scope of the material.

A numerical evaluation system has been developed for determining the relationship between the security interest and level of protection required. The system is outlined in chapter 5 and appendix H of OPNAVINST 5510.1E.

The keys or combinations to safes and lockers containing classified material are made available only to persons whose duties require access to them. The keys or combinations must be changed at least every 12 months. They also must be changed when any person having knowledge of them is transferred from the organization, and when the keys or combinations are suspected of being compromised.

Any time you find a safe or cabinet containing classified material unlocked and unattended by assigned persons, be sure to report the condition immediately to the watch officer. Do not touch the container or contents, but guard them until the officer arrives. The watch officer then assumes responsibility for such further actions as locking the safe, recalling the responsible persons, and reporting the security violation to the commanding officer.

PROPER HANDLING

Each individual in sonar must take every precaution to prevent intentional or casual access to classified information by unauthorized persons. When classified publications are removed from storage for working purposes, they must be covered or placed face down when not in use. If sonar must be vacated, all classified material must be properly protected. Rough drafts, carbon paper, worksheets, and similar items containing classified information should be placed in a burn bag after each has served its purpose.

At the end of each watch, all classified material that must be passed from watch to watch is inventoried properly and custody is transferred to the relieving watch officer and watch supervisor. All other classified matter must be locked up. Wastebaskets should be checked to ensure no classified trash has

mistakenly been placed in the wastebaskets. Classified trash must be placed in burn bags and the bags must be properly stowed until destroyed according to your command's policy.

Vaults, safes, or lockers used for stowage of classified matter must always be kept locked when not under the supervision of authorized personnel. Always rotate the dial of all combination locks at least four complete turns when securing safes, files, and cabinets. If the dial is only given a quick twist, it may be possible to open the lock merely by turning the dial in the opposite direction. Always make sure that all drawers of safes and file cabinets are held firmly in the locked position. Prior to removal of any furniture from a security area, always check closely for classified material in hidden areas of each desk, safe, or cabinet.

SECURITY CLEARANCES

PERSONNEL CONTROL

An important element of physical security is personnel control. No person is permitted access to classified material unless he previously has been granted a security clearance by his commanding officer. Every clearance above Confidential is based on a national agency check (NAC), a background investigation (BI), or both.

An NAC consists of the investigation of files and records of a number of agencies including the FBI, ONI, and BUPERS. A background investigation, which includes an NAC, inquires into the loyalty, integrity, and reputation of the person being investigated.

A personnel security clearance is an administrative determination that an individual is eligible, from a security standpoint, for access to classified information of the same or lower category as the clearance being granted. A certificate of clearance does not in itself constitute authority for access to classified information. It is merely a determination of eligibility for access. Classified information is made available to appropriately cleared persons only when it is necessary in the interest of national defense, when the individual requires the information to carry out his assigned duties, when there is no other source of the same

INTRODUCTION TO SONAR

classified information available to him, and when he is capable both physically and mentally of providing the degree of protection that the information requires.

The following is a list of personal acts of varying degrees of seriousness which, if committed in the past or present, can cause the denial or revocation of a personal security clearance.

1. Commission of any act of sabotage, espionage, treason, or sedition; conspiring with or aiding or abetting another to commit or attempt to commit any act of sabotage, espionage, treason, or sedition.

2. Establishment or continuation of a sympathetic association with a saboteur, spy, traitor, seditionist, anarchist, revolutionist, espionage or other secret agent or representative of a foreign nation, or any representative of a foreign nation whose interests are inimical to the interests of the United States.

3. Advocacy of use of force of violence to overthrow the government of the United States, or the alteration of the form of government of the United States by unconstitutional means.

4. Membership in or affiliation or sympathetic association with any foreign or domestic organization, association, movement, group, or combination of persons which is totalitarian, Fascist, Communist, subversive, or which has adopted a policy of advocating or approving the commission of acts of force or violence to deny other persons their rights under the Constitution of the United States.

5. Actions which serve the interests of another government in preference to the interests of the United States.

6. Failure or refusal to sign a loyalty certificate, pleading protection of the Fifth Amendment or of Article 31 Uniform Code of Military Justice, or refusal to completely answer questions contained in required security forms or personal history statements.

7. Any deliberate misrepresentation, falsification, or omission of material fact.

8. Participation in the activities of an organization established as a "front" for an organization referred to above, when one's personal views were sympathetic to the subversive purposes of such organization.

9. Participation in the activities of an organization, with knowledge that it had been infiltrated by members of subversive groups.

10. Sympathetic interest in totalitarian, Fascist, Communist, or similar subversive movements.

11. Currently maintaining a close, continuing association with a person who has engaged in activities or associations of the types referred to above.

12. The uncovering of any facts which furnish reason to believe that the individual may be subjected to coercion, influence, or pressure which may cause him to act contrary to the best interests of national security.

13. Willful violation or disregard of security regulations.

14. Intentional unauthorized disclosure of classified information to any person.

15. Any criminal, infamous, dishonest, immoral, or notoriously disgraceful conduct; habitual use of intoxicants to excess; drug addiction; or sexual perversion.

16. Acts of a reckless, irresponsible or wanton nature which indicate poor judgment and instability.

17. Any excessive indebtedness, recurring financial difficulties, unexplained affluence, or repetitive absences without leave.

18. All other behavior, activities, or associations which tend to show that the person is not reliable or trustworthy.

19. Any illness, including any mental condition, of a nature which, in the opinion of competent medical authority, may cause significant defect in the judgment or reliability of the individual.

COMPROMISE

No one in the Navy is authorized to handle any classified material except that required in the performance of duty. All other persons are unauthorized, regardless of rank, duties, or clearance.

If it is known—or even suspected—that classified material is lost or passed into the hands of some unauthorized person, the matter is said to be compromised. The seriousness of the compromise depends on the nature of the

material and the extent to which the unauthorized person may divulge or make use of what he learns. Never fail to report a compromise that comes to your attention.

DISCIPLINARY ACTION FOR SECURITY VIOLATIONS

Any person who is found to be responsible for the loss, unauthorized disclosure, or possible compromise of classified information, and any person who violates security regulations shall be promptly and adequately disciplined, regardless of rank or rate, or position. Disciplinary action may include trial by court-martial. Persons found guilty of loss of classified material through gross neglect may be fined \$10,000 or imprisoned for not more than 10 years or both.

PERSONAL CENSORSHIP

Personal censorship is the most difficult part of security. Each individual, through indiscreet or boastful conversation, personal letters, and discussions of classified information in nonsecure spaces, is capable of doing grave damage to the security of our country. Personal discussion of official affairs with families or friends, or even careless talk, while on duty in the presence of persons not authorized to receive certain information, is dangerous and must be avoided. There is only one safe policy for you to follow when off duty—don't discuss classified matters with anyone, not even family or close friends. Usually the desire to impress others with the importance of one's job is quite strong. Divulging classified information is an unwise way of trying to impress anyone, particularly when by doing so a man may be endangering his country and many lives.

Loose talk in public places is even more dangerous. Conversation in restaurants, hotel lobbies, airports, elevators, taverns, and other public places can be overheard easily. Foreign agents are trained scientifically to collect from such conversations particles of seemingly harmless information. Once pieced together and analyzed, these "innocent" bits of talk

sometimes reveal military information of incalculable value.

Mail likewise is subject to interception by an enemy. The following topics must not be mentioned in personal correspondence:

1. Location, identity, or movement of ships or aircraft.
2. Forces, weapons, military installations, or plans of the United States or her allies.
3. Casualties to personnel or material by enemy action.
4. Employment of any naval or military unit of the United States or her allies.
5. Criticism of equipment or morale of the United States or her allies.

Personal censorship also extends to telephone conversations. Telephone wires can be tapped, and conversations can be overheard at the switchboard and other points along the circuit. Never discuss classified information over a telephone. A guide to personal conduct is presented at the end of this chapter.

RESTRAINT ON REPRODUCTION

Those portions of documents and materials which contain Top Secret information shall not be reproduced without the consent of the originating activity or higher authority. All other classified material shall be reproduced sparingly in the minimum number of copies; and any stated prohibition against reproduction shall be strictly observed. The following restrictive measures apply to reproduction equipment and to the reproduction of classified material:

1. The number of copies of documents containing classified information shall be kept to a minimum to decrease the risk of compromise and reduce storage costs.
2. Officials, by position title, authorized to approve the reproduction of Top Secret and Secret material shall be designated. These designated officials will carefully review the

INTRODUCTION TO SONAR

need for reproductions with a view toward minimizing classified reproductions consistent with operational requirements and reproduction prohibitions imposed by the material originator or higher authority.

3. Specific reproduction equipment shall be designated for the reproduction of classified material; reproduction of classified material shall be restricted to equipment so designated. Rules, to minimize human error inherent in the reproduction of classified material, will be posted on or near the designated equipment.

4. Appropriate warning notices prohibiting reproduction of classified material shall be posted on equipment used only for the reproduction of unclassified material.

5. If the designated equipment involves reproduction processes using extremely sensitive reproduction paper, such paper shall be used and stored in a manner to preclude image transfer of classified information.

a. When thermal copy paper is used to reproduce documents upon which classified information has been recorded, only Type 1 (back coated) thermal copy paper shall be used.

b. When slip sheets are placed between the diazo process film sheets in the reproduction process of classified information, the slip sheets should be handled as classified waste.

6. All copies of classified documents reproduced for any purpose, including those incorporated in a working paper, are subject to the same controls prescribed for the document from which the reproduction is made.

7. Samples, waste, or overruns resulting from the reproduction process shall be safeguarded according to the classification of the information involved and shall be destroyed promptly as classified waste.

8. When classified material is reproduced, the reproduced material shall be marked with the classification and other special markings which appear on the original material from which copies are reproduced.

DISSEMINATION POLICY

Components shall establish procedures for the dissemination of classified material originated or received by them, subject to specific rules established by higher authority and by OPNAVINST 5510.1 series. As a further limit on dissemination, the originating official or activity may prescribe specific restrictions on a classified document or on its text when security considerations make them necessary.

A General Guide

It is not possible to provide each individual with a complete list of do's and don'ts as far as security is concerned. There are, however, two rules of thumb which will usually help in answering the questions "Should I do this?" or "Should I say this?"

1. Could spies or traitors possibly learn anything from this?
2. Could this possibly help spies or traitors verify something that they already have ideas about or have guessed?

If there is the slightest possibility that the answer to either of these two questions might be "Yes," "Probably," or even "Possibly," the action should not be taken or the statement should not be made. One of the personal restrictions that working with classified material requires of an individual is that conduct and speech must always be guarded. The goal of the security program is to train military and civilian personnel to the point that whenever and however a topic comes up which has even the most remote bearing on classified information, the employees will automatically become alert, watchful, and on their guard against security slips.

The following list may be used as a general guide to answering the many questions that may be asked concerning security information.

1. You may disclose the command you work for by simply stating that you work for the Department of the Navy at the address to which you are assigned. Using utmost discretion,

you may give the official address of your command, your general job title, your grade and salary, and length of service, if required. If any further information is desired by persons or firms with whom you may be dealing, instruct them to request such information by letter addressed to your commanding officer.

2. When replying to questions by anyone (including your immediate family), concerning the nature of your assignment, you should state that your work is classified and that the law prevents you from revealing the type of work in which you are engaged.

3. Caution your family not to discuss your assignment with others. They should simply state that they do not know what your duties are. Remember, the less your family knows about your job, the less likely they are to unwittingly reveal information of value to foreign intelligence.

4. If a complete stranger is overly persistent in questioning you about your job, simply inform him that you do not care to discuss the subject further. Quiz him as to his name, address, and purpose of his inquiry. He will probably drop the subject. You may leave his presence, if circumstances permit, or change the subject. In all cases, report the facts and circumstances to your commanding officer.

5. Classified matters may only be discussed, outside your assigned ship or station, in other secure government spaces and then only if it is necessary to effect official business. First determine the clearance status of the other party and his need to know in conjunction with that business. The information will be limited to that which is necessary to carry on official business.

6. You may associate with non-citizens on a close social basis. However, any contact other than official with personnel from Communist-controlled countries should be reported to your commanding officer immediately. Meetings with other foreign nationals need not be reported.

7. There may be restrictions on going overseas after leaving your present assignment, either for a new assignment or privately. The specific restrictions are dependent upon the type of classified information to which you may have had access and the area of the world to which you wish to go. The length of time the

restriction is imposed depends upon the assignment that you held. Certain other restrictions are imposed on private overseas travel by the State Department. When leaving your present assignment, you will be informed as to what restrictions apply, if any.

8. There are also security requirements concerning vacation or business travel abroad. Your commanding officer will assure that you are given a defensive security briefing to alert you to be on guard against exploitation by others whose interests may be inimical to those of the United States, prior to travel under the following conditions.

a. Travel to or through Communist-controlled countries for any purposes.

b. Attendance at international, scientific, technical, engineering, or other professional meetings in any country outside the United States where it can be anticipated that Communist-controlled representatives will participate or be in attendance.

9. Generally speaking, nothing may be written or said for public consumption about the status, mission, composition, organization, or function of the command that you are presently assigned to or the results that it obtains. Of course, certain information may be printed for public consumption, but only the commanding officer or his designated representative may release such information.

10. Upon learning of what appears to be a security violation by the press, radio, television, or any other means normally available to the public, bring it to the attention of your security officer or commanding officer. State the facts: what, when, where, how, and by whom. If it is printed material, submit a copy or an actual clipping of the material. Include the identification of the periodical, the author, and/or the photographer.

11. From time to time you may wonder why you are required to be so security conscious when the news media seems to be telling everything. This is understandable. However, always remember that just because certain items appear in periodicals, newspapers, or on the air, it does not necessarily mean that their publication was authorized nor does it mean

INTRODUCTION TO SONAR

that the information is factual. Frequently, such releases are the educated guesses of the author. Do not deny, affirm, or comment on such material; it will only aid in establishing as fact that which, before, was only suspected.

12. When separated from the Navy, you must continue to be security conscious, especially when applying for a job. During your job interview, you may state that you were assigned to a particular command, along with your general job title. Under no circumstances may you include Department of Defense classified information. It is recommended that, prior to your separation, you write a complete job description of your duties and responsibilities. Take your resume to your division officer for his advice, assistance, and clearance.

As a Sonar Technician you will have access to large amounts of classified material, which sometimes makes life aboard ship very tedious. The majority of your shipmates do not have security clearances or even a need to know. You can not, of course, give them any classified

information. Be ever mindful of where you are, even when you are talking to other Sonar Technicians. Security information can only be discussed in sonar or the few other secure spaces aboard ship. Discussion of security information is forbidden in any of the other spaces aboard ship, such as the mess hall or your berthing compartment.

The above list does not cover every circumstance which may arise. Should a situation arise which is not covered in this chapter, no statement should be made. Report the situation to your superior and an appropriate answer will be given for future guidance.

You alone are responsible for any violation of security that you may deliberately or unintentionally commit. You are urged to become fully acquainted with the contents of the Department of the Navy Information Security Program Regulation, OPNAVINST 5510.1E. Moreover, you must always vigilantly guard against violating the trust which has been placed in you. To relax security, even for a moment, may invite disaster.

APPENDIX I

GLOSSARY

ABSORPTION: Loss of energy that is turned into heat.

ACOUSTIC: Pertaining to sound or the study of sound.

ACTIVE SONAR: An apparatus that radiates and receives information from returning echoes.

ADVANCE: After rudder is applied, the distance continued along original course until on the new course.

AFTERNOON EFFECT: The daytime heating of the surface water which results in a reduction of sonar ranges usually in the afternoon.

AMBIENT NOISE: The naturally occurring noise in the sea and the noise resulting from man's activity but excluding self-noise and reverberation.

AOB (Angle on the Bow): The angle formed between an imaginary line drawn from a target's stern through its bow and outward, and a second line between the target and own ship. Angle is measured from 000° to 180° both port and starboard. Clockwise down starboard side and counterclockwise down port side.

ARRAY: A group of hydrophones arranged to provide the desired directional characteristics.

ASROC: Antisubmarine rocket.

ASW (Antisubmarine Warfare): Operations conducted against submarines, their supporting forces and bases.

BATHYTHERMOGRAPH: A device that automatically plots a graph showing temperature as a function of depth when lowered into the sea.

BEARING: The direction of an object from an observer, measured clockwise from a reference point.

BEARING DRIFT: Bearing cursor is trained back and forth across the target to check for the bearing width, and the target is classified. The operator then places the cursor in the center of the target pip. The cursor shows direction of sound reception. Its length indicates range when the cursor line is adjusted to touch the target echo. With the ship headed for the target on a steady course, and at a constant speed, with the cursor bisecting the echo, any change in target bearing results from target movement. If the target moves to the right, the operator must train his cursor to the right in order to remain on target, reporting "Bearing drift right." If the target moves to the left, he must train his cursor to the left to remain on target, and reports "Bearing drift left."

BOTTOM BOUNCE: That form of sound transmission in which sound rays strike the bottom, in deep water, at relatively steep angles, and are reflected toward the surface.

CAVITATION: The formation of local cavities (bubbles) in a liquid as a result of the reduction of total pressure. This pressure reduction may result from a negative pressure produced by rarefaction or from the reduction of pressure by hydrodynamic flow such as is produced by high speed movement of an underwater propeller.

INTRODUCTION TO SONAR

CIC (Combat Information Center): The tactical command center of the ship.

COMPRESSION: In wave motion, the forcing together of the medium's molecules. See **RAREFACTION**.

COUNTERMEASURES: Devices and/or techniques intended to impair the operational effectiveness of enemy activity.

CRT: Cathode ray tube.

CW (Continuous Wave): The on-off keying of a carrier frequency of a transmitter in such a way as to form a code that can be translated into a readable intelligence.

db (dB): Abbreviation for decibel.

DECIBEL: A value that expresses the comparison of sounds of two different intensities. This value is defined as 10 times the common logarithm of the ratio of the two sound intensities.

DECK PLANE: The deck plane represents the level of the ship's gun mounts. (References to guns include similar weapons systems.) When the ship is level, the horizontal and deck planes coincide, but when the ship rolls and pitches, the deck plane deviates from the horizontal. The stable element measures the amount of angular deviation and transmits the information to the fire control system. The fire control computer compensates for deck tilt by computing a solution in the horizontal plane, then makes train and elevation corrections. What the system does, in effect, is bring the deck plane back to the horizontal.

DENSITY: The mass per unit volume. Example: salt water—30 parts/1000.

DIPPING SONAR: Used by helicopters. Lowered from the helicopter for searching and retracted for flight.

DIRECT PATH: Sound waves that travel in direct paths at whatever angle they left the source.

DIVERGENCE: Energy loss caused by spreading in all directions.

DOPPLER EFFECT: If there is a relative movement between a wave source and a reflecting surface, the frequency of the waves returning to the source will differ from that used in the original emission. This is known as doppler effect. In active sonar sets, the effect of source movement is allowed for automatically and so the change in frequency indicates relative movement of the reflector along the source/reflector line.

DYNAMIC TESTS: Dynamic tests are run to check the computer's generation of bearing and range for specified time intervals against a mathematical solution whose answer contains correct amounts of change in quantities for like conditions. During the test, fixed values are assigned to relative motion rates by manually setting inputs to the relative motion group. The time system of the computer is then moved, either manually or by the time motor, an amount equal to the test interval. Readings are then taken to ensure correctness of the solution.

ECHO: That portion of the energy reflected to the receiver from the target.

ELECTROSTRICTIVE: A mechanical deformation caused by the application of an electric field.

ESM (Electronic Warfare Support Measures): Concerns electronic emissions and countermeasures.

FATHOMETER: A direct reading device for determining water depth by reflecting sonic or ultrasonic waves from the ocean bottom.

FBM: Fleet Ballistic Missile Submarine. (SSBN)

FCS: Fire Control System.

FIRE CONTROL: The technique for delivering fire on a selected target.

Appendix I—GLOSSARY

- FLOW NOISE:** The noise produced by water movement past the transducer, hydrophone array housing, or the hull of a moving ship or submarine, or by the vertical movement of a sonobuoy in the sea.
- FREQUENCY:** Rate of vibration of a sound source. Determines the pitch of a sound.
- GRADIENT, NEGATIVE:** When the temperature of the water decreases with depth, it has a negative temperature gradient.
- GRADIENT, POSITIVE:** When the temperature of the water increases with depth, it has a positive temperature gradient.
- HERTZ:** A unit of frequency equal to one cycle per second.
- HORIZONTAL PLANE:** A horizontal plane is tangent to the surface of the earth. Visualize this condition by laying a playing card on an orange. The card represents the horizontal plane, the orange symbolizes the earth, and the point of contact between the two is the point of tangency. Every plane parallel to the horizontal plane is likewise a horizontal plane.
- HORIZONTAL RANGE:** Range from own ship to target measured in the horizontal plane.
- ISOBALLAST CURVES (Lines):** Precalculated lines appearing on recorder charts. Indicates buoyancy (used on submarines).
- ISOTHERMAL LAYER:** A layer of water in which there is no appreciable change of temperature with depth.
- ISOVELOCITY LAYER:** A layer of water in which there is no appreciable change of sound velocity with depth.
- kHz (Kilohertz):** A prefix representing 10^3 or 1000.
- LAYER DEPTH:** The depth from the surface of the sea to the top of the first significant negative thermocline.
- LAYER EFFECT:** Partial protection from echo ranging and listening detection when below layer depth.
- MAD (Magnetic Anomalous Detectors):** Equipment capable of detecting slight distortions in the earth's magnetic field. In the U.S. Navy, used exclusively by aircraft.
- MAGNETOSTRICTIVE (ION) PROCESS:** Changes in metal caused by being subjected to a magnetic field.
- MC:** Shipboard announcing and intercommunications system circuit.
- MDCS:** Maintenance Data Collection Subsystem.
- mHz (Megahertz):** Prefix denoting 10^6 or 1,000,000.
- MICROPASCAL:** The standard unit of measure in all sonar computations for sonar sound pressure level. Replaces the microbar.
- MIP:** Maintenance Index Page (3-M system).
- MRC:** Maintenance Requirement Card (3-M system).
- MULTIMETER:** Several instruments or instrument circuits combined in a single enclosure and used in measuring two or more electrical quantities in a circuit.
- OCEANOGRAPHY or OCEANOGRAPHIC:** Branch of science dealing with the ocean; pertaining to the ocean.
- PASSIVE SONAR:** An apparatus that receives energy generated from another source.
- PIEZOELECTRIC:** The property of certain crystals which produce voltage when subjected to a mechanical stress.
- PMS:** Planned Maintenance Subsystem.
- QUENCHING:** The reduction in underwater sound transmission or reception resulting from

INTRODUCTION TO SONAR

absorption and scattering of sound energy by air bubbles entrapped around the sonar dome.

RANGE: The distance of an object from an observer.

RAREFACTION: In wave motion, when the vibration is inward, a rarefaction or region of reduced pressure is produced.

RATE TESTS: Tests of own ship and target rate mechanisms by having certain components generate movement for a certain time frame.

RDT: Rotating directional transmission.

REFLECTION, SOUND: Sound rays transmitted in the sea eventually reach either the surface or the bottom. Since these boundaries are abrupt and very different in sound transmitting properties from the water, sound energy along a ray path striking these boundaries will be returned (reflected) to the water.

REFRACTION, SOUND: The bending or curving of sound ray that results when the ray passes from a region of one sound velocity to a region of a different velocity. The amount of ray bending depends on the amount of difference between sound velocities.

RELATIVE BEARING: The angle between ships head and an object measured in a clockwise direction.

RELATIVE MOTION: The apparent movement of an object in relation to another object.

REVERBERATION: The combined sound of many small echoes returned to the hydrophone by reflection from the surface, at the bottom, and particles in the water.

R/T: Radio Telephone.

SCANNING SONAR: Sonar that transmits sound pulses in all directions simultaneously.

SCATTERING: Reflection losses from particles suspended in the water.

SONAR: Acronym for **S**ound **N**avigation **A**nd **R**anging. Apparatus or technique of obtaining information regarding objects or events underwater.

SONIC: Within the audible range of the human ear.

SONOBUOY: Small floating buoy with an attached hydrophone and a radio transmitter that relays underwater sounds picked up by the hydrophone to ASW units.

SOUND CHANNEL: Condition when two layers of water with near equal temperatures produce a sound channel. Sound between the two layers is refracted by the layers, stays between them, and travels for great distances.

S/P: Sound powered. Example: Sound-powered phones. Shipboard system using voice to activate circuits. (No batteries or external power.)

SSXBT (Submarine Expendable BT): Temperature versus depth plot to 2500 feet.

STATIC TEST: A test using fixed inputs with the problem stopped at a fixed point. Outputs (or answers) are also fixed.

SUBROC: Submarine-installed weapon system designed as defense against high-speed nuclear-powered submarines.

SUBSONIC (Infrasonic): A frequency below the audio range.

TARGET ANGLE: The relative bearing of the surface ship from the target.

TARGET ASPECT: The relative position of the submarine with respect to the sound beam.

THERMAL NOISE: A very low level noise produced by molecular movement in the sea.

THERMISTER: A solid state, semi-conducting device whose resistance varies with temperature.

THERMOCLINE: A region of relatively rapid decrease in temperature.

Appendix I--GLOSSARY

3-M SYSTEM: Maintenance and Material Management system.

TRANSDUCER: A device used to convert electrical energy to mechanical energy.

TRANSFER: After rudder is applied, the distance moved at right angles to the original course during the turn.

TRUE BEARING: The angle from north to the line of sight, measured clockwise through 360°.

TRUE MOTION: The movement of an object across the earth, using true (geographic) north as the reference point.

TURN COUNTING: Counting revolutions of a contact's propellers to determine its speed or the type of ship.

UB PLOT: Underwater Battery Plot. Fire control equipment installed here.

UBFCS (UBWCS): Underwater Battery Fire Control System. Example: Mk 114 FCS.

ULTRASONIC: Having a frequency above the audible sound.

VARIABLE DEPTH SONAR (VDS): The term is normally used to describe a sonar whose transducer is towed beneath its parent ship with the object of improving sonar detection ranges. Helicopter and submarine sonars, though

variable depth, are not usually included in this category.

VELOCITY: A vector quantity that includes both magnitude (speed) and direction in relation to a given frame of reference.

VERTICAL PLANE: A vertical plane is perpendicular to the horizontal plane, and is the reference from which bearings are measured. Relative bearing, for example, is measured in the horizontal plane clockwise from the vertical plane through own ship's centerline to the vertical plane through the line of sight. The system of planes makes possible the design and construction of mechanical and electronic equipment to solve the fire control problem. These lines and planes are imaginary extensions of some characteristic of the ship or target, or of the relation in space between them.

WAVELENGTH: The distance between points of corresponding phase of two consecutive cycles.

WIRE-GUIDED TORPEDO: Torpedo linked to the ship by a wire through which ship can transmit guidance and command signals to the torpedo and the torpedo can transmit status signals to the ship.

XBT (Expendable Bathythermograph): A device that automatically plots a graph showing temperature as a function of depth when lowered into the sea.

INDEX

A

Access, 163
Accountability, 165
Active sonar, 85-87
Advancement examination, 11
Advancement, how to qualify for, 11-14
Aircraft, 32-34
 antisubmarine aircraft, 34
 patrol planes, 34
Aircraft, antisubmarine, 34
Aircraft carrier (CV), 25
Alien, 163
Allied communication publications, 10
Ambient noise, 41-44
Antisubmarine aircraft, 34
Antisubmarine armament, 29-32
 ASROC, 30
 torpedoes, 30-32
Antisubmarine units, 24-29
 aircraft carrier (CV), 25
 destroyer (DD), 25
 frigate (FF), 26
 guided-missile cruiser (CG) (CGN), 29
 guided-missile destroyer (DDG), 25
 guided-missile frigate (FFG), 26-29
Appendix I—Glossary, 173-177
Armament, antisubmarine, 29-32
Armament, submarine, 19-24
ASROC, 30
ASW, history and development of, 15-34
Attack submarines (SSN), 19

B

Ballistic solution phase, 114
Basic fire control, 109-126
Bathymograph, 58-70
Bathymograph logs, 70

Bathymograph (SSBXT) submarine
 expendable, 62
Bathymograph system surface ship
 expendable, 62-64
Bathymograph systems submarine, 59-62
Bearing drift, 80
Bearings, 72-78
 converting true and relative bearings,
 76-78
 gyro failure, 75
 relative bearings, 73
 stern line indicator, 74
 true bearings, 73
Bearings and motion, 71-84
Bearings relative, 73
Bearings, true, 73

C

Call signs, 130
Capacitors, 153
Carrier, aircraft (CV), 25
Categories, classification, 165
Censorship, personal, 169
Characteristics of sound, 39
Classification, 163
Classification categories, 165
 confidential, 165
 secret, 165
 top secret, 165
Classification guide, 163
Classified information, 163
Classifier, 163
Clearance, 163
Clearances, security, 167
Code, 132-134
Code practice, 134-137
 prosigns, 135-137

INDEX

- Communications, 127-140
Communications, external, 129-132
Communications, internal, 127-129
Communications, underwater, 137-140
Competent authority—commanding officer, 163
Compromise, 163, 168
Computing target angle, 81-84
Confidential, 165
Control, personnel, 167
Converting true and relative bearings, 76-78
Cruiser, guided-missile, (CG) (CGN), 29
Custodian, 164
- D**
- Daily heating, 65-70
Data, restricted, 164
Declassification, 164
Deep water sound propagation, 51-53
Definitions, 162-165
 access, 163
 alien, 163
 classification, 163
 classification guide, 163
 classified information, 163
 classified material, 163
 classifier, 163
 clearance, 163
 competent authority—commanding officer, 163
 compromise, 163
 custodian, 164
 declassification, 164
 document, 164
 downgrade, 164
 formerly restricted data, 164
 marking, 164
 need to know, 164
 restricted data, 164
 security, 164
 upgrade, 164
Depth sounder (fathometer) 100-104
Depth-sound speed measuring set AN/BQH-1A, 59-62
Designation, terminal, 148-150
Destroyer, (DD), 25
Destroyer, guided-missile (DDG), 25
Destruction phase, 114
Detection phase, 113
Detection-to-destruction phases, 113-115
 ballistic solution phase, 114
 destruction phase, 114
 detection phase, 113
 target motion analysis phase, 114
 tracking phase, 113
Development and history of ASW, 15-34
Dipping sonar, 98
Disciplinary action for security violations, 169
Dissemination policy, 170-172
Document, 164
Doppler and reverberations, 53
Doppler and target aspect, 80
Doppler effect, 53-55
 doppler and reverberations, 53
 doppler reports, 54
Doppler/no doppler, 55
Doppler reports, 54
Downgrade, 164
- E**
- Echo strength, 56
Echoes from false targets, 56
Echoes, interpreting, 55-57
Effects of temperature, 58
 temperature layers, 58
EIBs and EIMBs, 8
EIMBs and EIBs, 8
Electric shock, 143
Enlisted rating structure, 2
 sonar technician rating, 2
Equipment, 118
Equipment, test, 144-147
Examination, advancement, 11
External communications, 129
 call signs, 130
 prowords, 130-132
 radiotelephone, 129
 radiotelephone procedures, 129
- F**
- Fire control, basic, 109-126
Fire control nomenclature, 116
Fire control system, representative underwater, 109
Fire control system tests, 122-125
Fire control systems, underwater, 119-122

INTRODUCTION TO SONAR

Fire control, underwater, 109
Fleet ballistic missile submarines (SSBN), 19
Fleet Ballistic missile system, 21-23
Formerly restricted data, 164
Frequency counter, 147
Frigate (FF), 26
Frigate, guided-missile (FFG), 26-29
Fundamental problem, 115-126
 equipment, 118
 fire control nomenclature, 116
 fire control system tests, 122-125
 interpreting dial readings, 125
 reference planes, 115
 schematic identification of system components, 119
 sonar position quantities, 116-118
 underwater fire control systems, 119-122

G

General safety precautions, 141-143
Generators, signal, 146
Glossary, Appendix I, 173-177
Gradient, negative, 65
Gradient, positive, 65
Grounding test equipment, 143
Guided-missile cruiser (CG) (CGN), 29
Guided-missile destroyer (DDG), 25
Guided-missile frigate (FFG), 26-29
Gyro failure, 75

H

History and development of ASW, 15-34
How to qualify for advancement, 11-14

I

Indicator stern line, 74
Indicators remote, 128
Information, classified, 163
Information sonar, 71
Internal communications, 127-129
 MC systems, 128
 remote indicators, 128
 sound-powered phones, 127
International morse code, 132-134
 the code, 132-134

Interpreting dial readings, 125
Interpreting echoes, 55-57
 doppler/no doppler, 55
 echo strength, 56
 echoes from false targets, 56
Isothermal layer, 66

K

Keeping up with new developments, 3

L

Leadership responsibilities, 2
Logs, bathythermograph, 70

M

Maintenance, 154-161
 maintenance and material management system, 156-161
 types of maintenance, 154-156
Maintenance and material management system, 156-161
Maintenance; test equipment; test methods, 141-161
Maintenance, types of, 154-156
Management system maintenance and material, 156-161
Manufacturer's technical manual, 8
Marking, 164
Material and maintenance management system, 156-161
MC systems, 128
Measurement of sound, 40
Methods, submarine communication, 140
Methods, test, 147-154
Mines, 21
Missile system, fleet ballistic, 21-23
Missile system, SUBROC, 23
Modern active sonar theory, 91-94
Modern passive sonar theory, 96
Morse code, international, 132-134
Motion, 78
 advance and transfer, 78-80
 bearing drift, 80
 doppler and target aspect, 80
 relative motion, 78
 true motion, 78

INDEX

- Motion and bearings, 71-84
Motion, relative, 78
Motion, true, 78
Multimeter, 145
- N
- NATO/Allied tactical doctrine publications, 10
NAVEDTRA publications, 8
NAVSEA (formerly NAVSHIPS) publications, 8
Negative gradient, 65
Noise, 40
Noise, ambient, 41-44
Nomenclature, fire control, 116
- O
- Operation, 64
Oscilloscope, 145
- P
- Passive sonar, 94-96
Patrol plane, 34
Personal censorship, 169
Personnel control, 167
Phase, ballistic solution, 114
Phase, destruction, 114
Phase, detection, 113
Phase, target motion analysis, 114
Phase, tracking, 113
Phases, detection-to-destruction, 113-115
Phones, sound-powered, 127
Physical security, 166
 proper handling, 167
 security areas, 166
 stowage, 166
Physics of sound, 35-57
 ambient noise, 41-44
 characteristics of sound, 39
 measurement of sound, 40
 noise, 40
 quenching, 47
 reflections, 45
 refraction, 46
 requirements for sound, 35-37
 reverberations, 46
 sound waves, 37-39
 transmission losses, 44
 underwater sound, 45
- Planes, reference, 115
Policy dissemination, 170-172
Positive gradient, 65
Power tools, safety with, 143
Practice, code, 134-137
Principles of sonar, 85-108
Principles, security, 162
Problem, fundamental, 115-126
Procedure, voice, 137-140
Procedures, radiotelephone, 129
Propagation of sound in the sea, 47-53
 deep water sound propagation, 51-53
 structural conditions, 47
Proper handling, 167
Prosigns, 135-137
Prowords, 130-132
Publications, allied communication, 10
Publications, NATO/Allied tactical doctrine, 10
Publications, NAVEDTRA, 8
Publications, NAVSEA (formerly NAVSHIPS), 8
Publications promulgated by CNO, 8
Publications promulgated by COMNAVCOMM, 9
Publications, U.S. Communication, 10
Publications, U.S. Navy tactical doctrine, 9
Purpose of the security program, 162
- Q
- Quenching, 47
- R
- Radiotelephone, 129
Radiotelephone procedures, 129
Rating, sonar technician, 2
Rating structure, enlisted, 2
Reading XBT recorder traces, 64-70
 daily heating, 67-70
 isothermal layer, 66
 negative gradient, 65
 positive gradient, 65
 XBT trace marking, 70
Reference planes, 115
Reflections, 45
Refraction, 46
Relative bearings, 73
Relative motion, 78

INTRODUCTION TO SONAR

Remote indicators, 128
Report everything you hear, 57
Representative underwater fire control system, 109
Reproduction or restraint, 169
Requirements for locating submarines, 71
 sonar information, 71
Requirements for sound, 35-37
Resistors, 150-153
Responsibilities and rewards of advancement, 2-5
Responsibilities, leadership, 2
Restraint on reproduction, 169
Restricted data, 164
Restricted data, formerly, 164
Reverberations, 46
Reverberations and doppler, 53
Rewards and responsibilities of advancement, 2-5
 keeping up with new developments, 3
 leadership responsibilities, 2
 working with others, 3-5

S

Safety, 141-144
 electric shock, 143
 general safety precautions, 141-143
 grounding test equipment, 143
 safety with power tools, 143
Safety precautions, general, 141-143
Safety with power tools, 143
Schematic identification of system components, 119
Secret, 165
Security, 162-172
Security areas, 166
Security clearances, 167
 personnel control, 167
Security, physical, 166
Security principles, 162
Security program, purpose of, 162
Security violations, disciplinary action for, 169
Shock, electric, 143
Signal generators, 146
Sonar, active, 85-87
Sonar dipping, 98
Sonar information, 71
Sonar, passive, 94-96

Sonar position quantities, 116-118
Sonar, principles of, 85-108
Sonar systems, 85-108
 active sonar, 85-87
 depth sounder (fathometer), 100-104
 dipping sonar, 98
 modern active sonar theory, 91-94
 modern passive sonar theory, 96
 passive sonar, 94-96
 sonobuoys, 99
 tape recorder, 104-108
 transducers, 87-91
 variable depth sonar (VDS), 97
Sonar technician, 1-14
Sonar technician rating, 2
Sonar theory, modern active, 91-94
Sonar theory, modern passive, 96
Sonar variable depth (VDS), 97
Sonobuoys, 99
Sound, characteristics of, 39
Sound in the sea, propagation of, 47-53
Sound, measurement of, 40
Sound, physics of, 35-57
Sound propagation, deep water, 51-53
Sound pulse, underwater, 44
Sound, requirements for, 35-37
Sound waves, 37-39
Sound-powered phones, 127
Stern line indicator, 74
Stowage, 166
Structural conditions, 47
Studying for the test, 5-11
 Allied communication publications, 10
 EIBs and EIMBs, 8
 manufacturer's technical manual, 8
 NATO/Allied tactical doctrine publications, 10
 NAVEDTRA publications, 8
 NAVSEA (formerly NAVSHIPS) publications, 8
 publications promulgated by CNO, 8
 publications promulgated by COMNAVCOMM, 9
 U.S. communications publication, 10
 U.S. Navy tactical doctrine publications, 9
Submarine, 15-19
 attack submarines (SSN), 19
 fleet ballistic missile submarines (SSBN), 19
 general description, 17-19
 history and development, 15-17

INDEX

- Submarine armament, 19-24
fleet ballistic missile system, 21-23
mines, 21
SUBROC missile system, 23
torpedoes, 20
- Submarine A/S weapons, 112
- Submarine bathythermograph systems, 59-62
depth-sound speed measuring set
AN/BQH-1A, 59-62
submarine expendable bathythermograph
(SSXBT), 62
- Submarine communication methods, 140
- Submarine expendable bathythermograph
(SSXBT), 62
- Submarines, requirements for locating, 71
- Submarines (SSBN), fleet ballistic missile, 19
- Submarines (SSN), attack, 19
- SUBROC missile system, 23
- Surface A/S weapons, 111
- Surface ship expendable bathythermograph
system, 62-64
operation, 64
- System, bathythermograph surface ship
expendable, 62-64
- System components, schematic identification of,
119-122
- System tests, fire control, 122-125
- Systems, MC, 128
- Systems, sonar, 85-108
- Systems, underwater fire control, 119-122
- T
- Tape recorder, 104-108
- Target and doppler aspect, 80
- Target angle, computing, 81-84
- Target motion analysis phase, 114
- Technical manual, manufacturer's, 8
- Technician, sonar, 1-14
- Temperature, effects of, 58
- Temperature layers, 58
- Terminal designations, 148-150
- Test equipment, 144-147
frequency counter, 147
multimeter, 145
- Test equipment (Continued)
oscilloscope, 145
signal generators, 146
transistor tester, 147
- Test equipment grounding, 143
- Test equipment; test methods; maintenance,
141-161
- Test methods, 147-154
capacitors, 153
resistors, 150-153
terminal designations, 148-150
- Test methods; test equipment; maintenance,
141-161
- Test, studying for, 5-11
- Tester, transistor, 147
- Top secret, 165
- Torpedoes, 20, 30-32
tracking phase, 113
- Transducers, 87-91
- Transistor tester, 147
- Transmission losses, 44
- True and relative bearings, converting, 76-78
- True bearings, 73
- True motion, 78
- Types of maintenance, 154-156
- U
- Underwater communications, 137-140
submarine communications methods, 140
voice procedure, 137-140
- Underwater fire control, 109
representative underwater fire control
system, 109
- Underwater fire control systems, 119-122
- Underwater sound pulse, 44
- Units, antisubmarine, 24-29
- Upgrade, 164
- U.S. communication publication, 10
- U.S. Navy tactical doctrine publications, 9
- V
- Variable depth sonar (VDS), 77
- Voice procedure, 137-140

INTRODUCTION TO SONAR

	W	
Waves, sound, 37-39		Weapons, surface A/S, 111
Weapons, 110-113		Working with others, 3-5
submarine A/S weapons, 112		
surface A/S weapons, 111		X
Weapons, submarine A/S, 112		XBT recorder traces, reading, 64-70
		XBT trace marking, 70

OCCUPATIONAL STANDARDS

		Covered in Assignment or Bibliography	
Sonar Technician Third Class (Surface) & (Submarine)		STG	STS
<u>14 ELECTRONICS MAINTENANCE</u>			
14617	Identify underwater fire control symbols	4	—
14676	Identify standard electronic component color coding system	5	5
14963	Perform operational tests and make external adjustments on equipment	NT 10131	NT 10132
<u>18 TEST EQUIPMENT</u>			
18133	Operate general purpose test equipment	5	5
<u>22 SENSOR OPERATIONS</u>			
22232	Identify sounds produced by surface ships, torpedoes, submarines, evasion devices, sonar transmissions, marine life, and natural phenomena	2	2
22233	Interpret passive/active sonar recorder traces	NT 10131	NT 10132
22234	Identify LOFAR contacts	NS 0967 340-4020	NS 0967 340-4020
22235	Operate sonar sensors for detection and classification of sonar contacts	4	4
22238	Distinguish the characteristics, functions and effects of controlled jamming and evasive devices on sonar operations	NT 10131	NT 10132
22240	Determine range predictions	2	

		Covered in Assignment or Bibliography	
Sonar Technician Third Class (Surface) & (Submarine)		STG	STS
<u>22 SENSOR OPERATIONS (Continued)</u>			
22241	Prepare and interpret sonar messages	2	2
22242	Interpret acoustic conditions to determine best submarine conditions to avoid detection	2	2
22243	Classify and record contacts	NT 10131	NT 10132
22244	Determine: A. True and relative bearings B. Range actions C. Target angle, target aspect and Doppler D. True and relative motion and target course	3	3
22256	Construct and interpret the following sonar plots: A. Time bearing (Barnard) plot B. Relative motion (Lynch) plot C. Sonar navigational (Strip) plot D. Time/Range plot	---	NT 10132
22260	Locate primary/secondary and casualty power circuits	NT 10131	NT 10132
22263	Recognize major equipment malfunctions during sensor operations	NT 10131	NT 10132
22802	Operate tape recorder	6	6
22804	Operate bathythermograph	4	4
22806	Operate the underwater fire control system including dial reading and positioning operational controls to predetermined values	NT 10131	---
<u>24 ELECTRICAL MAINTENANCE</u>			
24526	Inspect and clean commutators and slipping assemblies; inspect and replace brushes	5	5
24571	Inspect, clean, and tighten or replace stylus	NS 0967 000 0130	NS 0967 000 0130
<u>28 TECHNICAL DRAWINGS</u>			
28080	Identify electronic components on schematics and trace major signal flow	NT 10087	NT 10087

		Covered in Assignment or Bibliography	
		STG	STS
Sonar Technician Third Class (Surface) & (Submarine)			
<u>51 MAINTENANCE PLANNING AND QUALITY ASSURANCE</u>			
51011	Complete maintenance data forms for: A. Completed maintenance actions (MAF) B. Deferred maintenance actions C. Work requests	OPNAV INST 4790.4	OPNAV INST 4790.4
51026	Use maintenance requirement cards (MRC)	OPNAV INST 4790.4	OPNAV INST 4790.4
<u>86 COMMUNICATIONS</u>			
86088	Operate underwater telephone	5	5
86099	Operate exterior communications facilities associated with sonar operations	4	4
<u>87 NAVIGATION AND TACTICAL SUPPORT</u>			
87221	Operate fathometer	3	3
<u>92 ELECTROMECHANICAL MAINTENANCE</u>			
92091	Inspect, clean and lubricate electromechanical equipment	NS 0967 000 0130	NS 0967 000 0130
<u>94 MECHANICAL MAINTENANCE</u>			
94764	Use and maintain handtools and portable power tools	5	5

INTRODUCTION TO SONAR

NAVEDTRA 10130-C

Prepared by the Naval Education and Training Program Development Center, Pensacola, Florida

Your NRCC contains a set of assignments and self-scoring answer sheets (packaged separately). The Rate Training Manual, Introduction to Sonar, NAVEDTRA 10130-C, is your textbook for the NRCC. If an errata sheet comes with the NRCC, make all indicated changes or corrections. Do not change or correct the textbook or assignments in any other way.

HOW TO COMPLETE THIS COURSE SUCCESSFULLY

Study the textbook pages given at the beginning of each assignment before trying to answer the items. Pay attention to tables and illustrations as they contain a lot of information. Making your own drawings can help you understand the subject matter. Also, read the learning objectives that precede the sets of items. The learning objectives and items are based on the subject matter or study material in the textbook. The objectives tell you what you should be able to do by studying assigned textual material and answering the items.

At this point you should be ready to answer the items in the assignment. Read each item carefully. Select the BEST ANSWER for each item, consulting your textbook when necessary. Be sure to select the BEST ANSWER from the subject matter in the textbook. You may discuss difficult points in the course with others. However, the answer you select must be your own. Use only the self-scoring answer sheet designated for your assignment. Follow the scoring directions given on the answer sheet itself and elsewhere in this course.

Your NRCC will be administered by your command or, in the case of small commands, by the Naval Education and Training Program Development Center. No matter who administers your course you can complete it successfully by earning grades that average 3.2 or

higher. If you are on active duty, the average of your grades in all assignments must be at least 3.2. If you are NOT on active duty, the average of your grades in all assignments of each creditable unit must be at least 3.2. The unit breakdown of the course, if any, is shown later under Naval Reserve Retirement Credit.

WHEN YOUR COURSE IS ADMINISTERED BY LOCAL COMMAND

As soon as you have finished an assignment, submit the completed self-scoring answer sheet to the officer designated to administer it. He will check the accuracy of your score and discuss with you the items that you do not understand. You may wish to record your score on the assignment itself since the self-scoring answer sheet is not returned.

If you are completing this NRCC to become eligible to take the fleetwide advancement examination, follow a schedule that will enable you to complete all assignments in time. Your schedule should call for the completion of at least one assignment per month.

Although you complete the course successfully, the Naval Education and Training Program Development Center will not issue you a letter of satisfactory completion. Your command will make a note in your service record, giving you credit for your work.

WHEN YOUR COURSE IS ADMINISTERED BY THE NAVAL EDUCATION AND TRAINING PROGRAM DEVELOPMENT CENTER

After finishing an assignment, go on to the next. Retain each completed self-scoring answer sheet until you finish all the assignments in a unit (or in the course if it is not divided into units). Using the envelopes provided,

mail your self-scored answer sheets to the Naval Education and Training Program Development Center where the scores will be verified and recorded. Make sure all blanks at the top of each answer sheet are filled in. Unless you furnish all the information required, it will be impossible to give you credit for your work. You may wish to record your scores on the assignments since the self-scoring answer sheets are not returned.

The Naval Education and Training Program Development Center will issue a letter of satisfactory completion to certify successful completion of the course (or a creditable unit of the course). To receive a course-completion letter, follow the directions given on the course-completion form in the back of this NRCC.

You may keep the textbook and assignments for this course. Return them only in the event you disenroll from the course or otherwise fail to complete the course. Directions for returning the textbook and assignments are given on the book-return form in the back of this NRCC.

PREPARING FOR YOUR ADVANCEMENT EXAMINATION

Your examination for advancement is based on the Manual of Navy Enlisted Manpower and Personnel Classification and Occupational Standards (NAVPERS 18068-D). The sources of questions in this examination are given in the Bibliography for Advancement Study (NAVEDTRA 10052). Since your NRCC and textbook are among the sources listed in this bibliography, be sure to study both in preparing to take your advancement examination. The standards for your rating may have changed since your course and textbook were printed, so refer to the latest editions of NAVPERS 18068-D and NAVEDTRA 10052.

NAVAL RESERVE RETIREMENT CREDIT

The course is evaluated at 10 Naval Reserve retirement points, which will be credited upon satisfactory completion of the entire course. These points are creditable to personnel eligible to receive them under current directives governing the retirement of Naval Reserve personnel. Credit cannot be given again for this course if the student has previously received credit for completing another Introduction to Sonar NRCC or ECC.

COURSE OBJECTIVE

While completing this course, the student will demonstrate his understanding of the course materials by correctly answering items on the following: procedures for advancement to the petty officer level and the duties and responsibilities of the STG and STS 3&2; major sound propagation factors and terms used; types of ASW attacks, stations and communications; on board methods and components, and functions, of passive and active sonars; operational capabilities and characteristics of auxiliary sonar equipment; duties and qualities of a sonar watchstander; basic introduction to integrated fire control systems; evaluation and classification of sonar targets; identification of evasive maneuvers and countermeasures devices; maintenance, testing, and calibration methods and procedures; and personnel responsibility for security of classified material.

While working on this nonresident career course, you may refer freely to the text. You may seek advice and instruction from others on problems arising in the course, but the solutions submitted must be the result of your own work and decisions. You are prohibited from referring to or copying the solutions of others, or giving completed solutions to anyone else taking the same course.

Naval nonresident career courses may include a variety of items -- multiple-choice, true-false matching, etc. The items are not grouped by type; regardless of type, they are presented in the same general sequence as the textbook material upon which they are based. This presentation is designed to preserve continuity of thought, permitting step-by-step development of ideas. Some courses use many types of items, others only a few. The student can readily identify the type of each item (and the action required of him) through inspection of the samples given below.

MULTIPLE-CHOICE ITEMS

Each item contains several alternatives, one of which provides the best answer to the item. Select the best alternative and erase the appropriate box on the answer sheet.

SAMPLE

- s-1. The first person to be appointed Secretary of Defense under the National Security Act of 1947 was
1. George Marshall
 2. James Forrestal
 3. Chester Nimitz
 4. William Halsey

The erasure of a correct answer is indicated in this way on the answer sheet

	1	2	3	4
	T	F		
s-1		C		

TRUE-FALSE ITEMS

Determine if the statement is true or false. If any part of the statement is false the statement is to be considered false. Erase the appropriate box on the answer sheet as indicated below.

SAMPLE

- s-2. Any naval officer is authorized to correspond officially with a bureau of the Navy Department without his commanding officer's endorsement.

The erasure of a correct answer is also indicated in this way on the answer sheet:

	1	2	3	4
	T	F		
s-2		CC		

MATCHING ITEMS

Each set of items consists of two columns, each listing words, phrases or sentences. The task is to select the item in column B which is the best match for the item in column A that is being considered. Specific instructions are given with each set of items. Select the numbers identifying the answers and erase the appropriate boxes on the answer sheet.

SAMPLE

In items s-3 through s-6, match the name of the shipboard officer in column A by selecting from column B the name of the department in which the officer functions.

A. Officers

B. Departments

- | | |
|-------------------------------|---------------------------|
| s-3. Damage Control Assistant | 1. Operations Department |
| s-4. CIC Officer | 2. Engineering Department |
| s-5. Assistant for Disbursing | 3. Supply Department |
| s-6. Communications Officer | |

The erasure of a correct answer is indicated in this way on the answer sheet

	1	2	3	4
	T	F		
s-3		C		
s-4	C			
s-5			C	
s-6	C			

How To Score Your Immediate Knowledge of Results (IKOR) Answer Sheets

	1	2	3	4
	T	F		
1		C	6	1
2	C	9	9	2
3			C	
4	CC	12		1

Total the number of incorrect erasures (those that show page numbers) for each item and place in the blank space at the end of each item.

Sample only

Number of boxes erased incorrectly	0-2	3-7	8-
Your score	4.0	3.9	3.8

Now TOTAL the column(s) of incorrect erasures and find your score in the Table at the bottom of EACH answer sheet.

NOTICE: If, on erasing, a page number appears, review text (starting on that page) and erase again until "C", "CC", or "CCC" appears. For courses administered by the Center, the maximum number of points (or incorrect erasures) will be deducted from each item which does NOT have a "C", "CC", or "CCC" uncovered (i.e., 3 pts. for four choice items, 2 pts. for three choice items, and 1 pt. for T/F items).

Assignment 1

The Sonar Technician; History and Development; Physics of Sound

Textbook, NAVEDTRA 10130-C: Pages 1 thru 40

In this course you will demonstrate that learning has taken place by correctly answering training items. The mere physical act of indicating a choice on an answer sheet is not in itself important; it is the mental achievement, in whatever form it may take, prior to the physical act that is important and toward which nonresident career course learning objectives are directed. The selection of the correct choice for a course training item indicates that you have fulfilled, at least in part, the stated objective(s).

The accomplishment of certain objectives, for example, a physical act such as drafting a memo, cannot readily be determined by means of objective type course items; however, you can demonstrate by means of answers to training items that you have acquired the requisite knowledge to perform the physical act. The accomplishment of certain other learning objectives, for example, the mental acts of comparing, recognizing, evaluating, choosing, selecting, etc., may be readily demonstrated in a course by indicating the correct answers to training items.

The comprehensive objective for this course has already been given. It states the purpose of the course in terms of what you will be able to do as you complete the course.

The detailed objectives in each assignment state what you should accomplish as you progress through the course. They may appear singly or in clusters of closely related objectives, as appropriate; they are followed by items which will enable you to indicate your accomplishment.

All objectives in this course are learning objectives and items are teaching items. They point out important things, they assist in learning, and they should enable you to do a better job for the Navy.

This self-study course is only one part of the total Navy training program; by its very nature it can take you only part of the way to a training goal. Practical experience, schools, selected reading, and the desire to accomplish are also necessary to round out a fully meaningful training program.

Learning Objective: Acquaint the new ST with the basics of the ST rating.

- 1-1. How does the U. S. prepare itself to meet a potential submarine threat?
1. Conducts antisubmarine warfare (ASW) exercise.
 2. Revises ASW tactics.
 3. Evaluates new equipment.
 4. Does all of the above.
- 1-2. Nuclear submarines are advantageous in ASW operations because they can
1. screen the area for surface ships
 2. select the best depth for operations
 3. conduct operations over wide ocean areas
 4. accomplish either 2 or 3 above
- 1-3. Which of the following would be considered a general rating?
1. STG2
 2. STS3
 3. STSC
 4. STCM
- 1-4. Which of the following equipments is not normally maintained by an STS?
1. Fire control
 2. Active sonar
 3. Passive sonar
 4. Oceanographic

1

Learning Objective: Explain the rewards of being an ST, the methods of advancement, and the sources of information for study.

- 1-5. What type of ship would an STG most likely be sent aboard after he attends "A" school?
1. Destroyer tender
 2. Destroyer
 3. Minesweeper
 4. Submarine
- 1-6. Which of the following are considered advantages of advancement?
1. Higher pay
 2. Greater prestige
 3. Getting ahead in chosen career
 4. All the above
- 1-7. Which of the following publications should you use when studying the Military Requirements for Advancement to PO3?
1. NAVEDTRA 10052
 2. NAVEDTRA 10061
 3. NAVEDTRA 10056
 4. NAVEDTRA 10130
- 1-8. You can keep abreast of new developments that affect you, your work, and the Navy by being able to
1. find up-to-date information and check that which pertains to your specialty
 2. collect personal copies of appropriate technical manuals
 3. complete all correspondence courses that pertain to your rating
 4. complete all correspondence courses that pertain to the deck group
- 1-9. Which of the following is the basic purpose of all communication?
1. Knowledge of own language
 2. Understanding
 3. Effective leadership
 4. All of the above
- Use the following alternatives for items 1-10 and 1-11.
1. NAVEDTRA 1414/1
 2. NAVEDTRA 10052
 3. NAVEDTRA 10061
 4. NAVPERS 18068
- 1-10. Which publication contains a list of study material for advancement examinations?
- 1-11. In what publication will you find an up-to-date list of the qualifications for advancement?
- 1-12. Which of the following publications come under cognizance of COMNAVCOMM?
1. ACPs
 2. DNCs
 3. JANAPs
 4. All of the above
- Use the following alternatives for items 1-13 thru 1-16.
1. NWP O
 2. NWIP 1-4
 3. NWIP 11-20
 4. NWP 16
- 1-13. Which publication establishes the basic operational communications doctrine?
- 1-14. Which publication provides guidance for the operation of a COMTAC library?
- 1-15. Which publication lists the missions and characteristics of U.S. Navy ships?
- 1-16. Which publication contains experimental tactics and procedures?
- Use the following alternatives for items 1-17 thru 1-20.
1. ATP 1
 2. FXP 1
 3. ATP 28 (USN ADDENDUM)
 4. AXP 1
- 1-17. Which publication establishes tactics and procedures for conducting submarine exercises?
- 1-18. Which publication contains the basic concepts and principals of ASW operations?
- 1-19. Which publication establishes tactics and procedures for evaluating Allied antisubmarine exercises?
- 1-20. Which publication contains basic maneuvering instructions?

- 1-21. Which of the following actions, if any, is taken when an outdated question is found on an advancement examination?
1. The old correct answer is counted.
 2. All four answers are counted correct.
 3. All four answers are counted wrong.
 4. None of the above are done.
- 1-22. What is the purpose of the profile sheet?
1. To verify your advancement
 2. To compare overall examination performance
 3. To point out weak areas
 4. To assign a numerical grade for each section
- 1-23. How many months must an active duty STGSN serve to be eligible for STG3?
1. 4
 2. 6
 3. 12
 4. 18
- 1-24. In what grade does an inactive duty Sonar Technician require selection board approval for advancement?
1. E-4
 2. E-5
 3. E-6
 4. E-7
- 1-25. After you pass the written examination, what other factor will limit advancement?
1. Rating quotas
 2. Time in grade
 3. Practical factors
 4. Duty stations
-
- Learning Objective: Provide the new ST with the background of ASW and submarine.
-
- 1-26. It is necessary for a Sonar Technician to be thoroughly familiar with the capabilities of enemy submarines in order to
1. detect them easier
 2. hold contact after detection
 3. aid in hunt and destroy operations
 4. do all of the above
- 1-27. A submarine was first used as an offensive weapon during what war?
1. Spanish-American War
 2. American Revolutionary War
 3. WW I
 4. WW II
- 1-28. The submarine's greatest advantage is that
1. it is very difficult to sink
 2. it has more potent weapons
 3. its crew is smaller than a surface ship's
 4. it can operate beneath the surface of the ocean where detection is difficult
- 1-29. Which of the following statements correctly describes the origins of sonar?
1. A device called ASDIC was first developed by America and was later improved by Britain and renamed sonar.
 2. A device called a sound fathometer was first developed by Britain and was designed for A/S use by America and renamed sonar.
 3. A device called ASDIC was first developed by Britain and was later improved by America and renamed sonar.
 4. A device called a sound fathometer was first developed by America and was redesigned for A/S use by Britain and renamed sonar.
- 1-30. The Skipjack differs from other nuclear submarines primarily in its
1. hull design
 2. ability to carry ballistic missiles
 3. type of propulsion plant
 4. cruising range
- 1-31. Which of the following groups of submarine classes is arranged in order of increasing displacement?
1. X-1, Seahound, Shrimp
 2. Shrimp, X-1, Seahound
 3. X-1, Shrimp, Seahound
 4. Seahound, X-1, Shrimp
- 1-32. Which of the following is the main limitation to a modern submarine's ability to stay submerged at sea?
1. Fuel shortage
 2. Equipment failures
 3. Navigation errors
 4. Human endurance and supply space

1-33. Which of the following submarines was created to act as a nuclear deterrent to a general war?

1. Guppy II
2. SSBN
3. SSN fast attack (conventional hull)
4. SSN fast attack (albacore hull)

1-34. The primary mission of the attack submarine is

1. ASW
2. barrier patrol
3. avoiding detection
4. launching missiles

Learning Objective: Provide the new ST with knowledge of the different types of torpedoes and mines.

-
- Use the following alternatives for items 1-35 thru 1-38:
 1. Wire-guided
 2. Straight-running
 3. Active acoustic
 4. Passive acoustic

1-35. Which torpedo sends out pulses of sound and homes on echoes that return from the target?

1-36. Which torpedo may be guided throughout its run by signals from the launching ship?

1-37. Which torpedo uses preset values to intercept a target?

1-38. Which torpedo depends upon target noise for guidance?

1-39. When secrecy is required for laying mines, what delivery means is used?

1. Aircraft
2. Surface craft
3. Submarines
4. Minelayers

1-40. All of the following mines may be programmed to allow several ships to pass before exploding except

1. acoustic
2. magnetic
3. pressure
4. contact

Learning Objective: Acquaint the new ST with the different types of missiles used in the Navy and the types of launching platforms used.

1-41. Which missile will contain multiple warheads?

1. Point defense
2. Polaris A3
3. ASROC
4. SUBROC

1-42. The SUBROC is which of the following types of missiles?

1. Underwater-to-surface
2. Surface-to-surface
3. Surface-to-air
4. Underwater-to-air-to-underwater

1-43. Which submarine-launched ASW weapon uses an inertial guidance system?

1. Mk 45 torpedo
2. ASTOR
3. SUBROC
4. ASROC

1-44. At what point is guidance to the SUBROC missile terminated?

1. 30 seconds after launch
2. When the guidance wire breaks
3. At a predetermined height
4. At a preset depth

1-45. Which of the following is/are the principal function/functions of the destroyer?

1. Operating offensively against surface ships
2. Operating defensively against submarines
3. Defending against air attack
4. All of the above

1-46. Several postwar Forrest Sherman class destroyers have been converted to DDGs by

1. replacing the #2 gun mount with a TARTAR missile launcher
2. replacing the #1 gun mount with a TARTAR missile launcher
3. replacing the after TARTAR missile launcher with a REGULAS missile launcher
4. replacing the ASROC launcher with a SPARROW missile launcher

- 1-47. The USS BELKNAP (CG26) displaces how many tons?
 1. 2200
 2. 4700
 3. 5400
 4. 6700
- 1-48. The ASROC missile can deliver which of the following payloads?
 1. Depth charge
 2. Torpedo
 3. Either 1 or 2 above
 4. Wire-guided torpedo
- Judge questions 1-49 thru 1-51 True or False.
- 1-49. The SUBROC missile with a torpedo payload uses parachute stabilization.
- 1-50. The SUBROC missile with a depth charge payload uses either parachute stabilization or fin stabilization.
- 1-51. There are five principal ways to launch a torpedo.
- 1-52. Which of the following is an advantage of the Mk 46 torpedo over the Mk 44 torpedo?
 1. Improved propulsive power
 2. Greater cargo
 3. Greater speed
 4. All of the above
- 1-53. How does MAD (magnetic anomaly detection) equipment detect submarines?
 1. By measuring exhaust trail gases
 2. By measuring variations in the Earth's magnetic lines of force
 3. By active sonar transmission
 4. By measuring total magnetism of the submarine
- 1-54. The Navy's newest fixed-wing ASW aircraft is the
 1. S2-F
 2. P-3
 3. SH-2F
 4. S-3A
-
- Learning Objective: Define the elements of and the requirements for sound.
-
- 1-55. Whether a wave is transverse or longitudinal depends on the wave's
 1. components of motion
 2. frequency
 3. amplitude
 4. wavelength
- 1-56. Sound waves vary in length according to their
 1. amplitude
 2. intensity
 3. frequency
 4. strength
- 1-57. The upper limit of sound vibration that can be detected by the average ear is about
 1. 10,000 vibrations per second
 2. 15,000 vibrations per second
 3. 25,000 vibrations per second
 4. 40,000 vibrations per second
- 1-58. Sound waves cannot travel through a
 1. gas
 2. liquid
 3. solid
 4. vacuum
- 1-59. The sounds transmitted by the modern sonar equipment of the 1970's fall within the range designated
 1. sonic
 2. subsonic
 3. ultrasonic
 4. supersonic
- 1-60. Sonar equipment is designed to convert returning echoes to a base frequency of 800 Hz because an 800-Hz note
 1. can be reproduced easily
 2. is louder than other audible sounds
 3. travels farther than other audible sounds
 4. is the most pleasing to the average human ear over long periods

- 1-61. How much of an increase or decrease in sound intensity or total power must take place before it can be detected by the human ear?
1. 1/4
 2. 1/3
 3. 1/2
 4. 3/4
- 1-62. Which of the following functions is best performed by the human ear?
1. Discrimination between sounds of changing intensity
 2. Detecting changes at low frequency
 3. Detecting changes at high frequency
 4. Discriminating between sounds of varying pitch
- Judge items 1-63 thru 1-65 True/False.
- 1-63. The backward movement of a transducer causes an area of low pressure or a compression.
- 1-64. A wavelength is the distance from one point on a wave to the next point of similar compression.
- 1-65. A sound wave may travel great distances at a high rate of speed; however, the particles within the medium move very little.
- 1-66. Why does sound travel faster through water than through air?
1. Because air is denser than water
 2. Because water offers less resistance to waves than air
 3. Because the particles in water are closer together than the particles in air
 4. Because the particles in water are farther apart than the particles in air
- 1-67. If your sonar equipment has an operating frequency of kHz, it has a wavelength in 39°F seawater of
1. 0.37 ft
 2. 0.45 ft
 3. 0.76 ft
 4. 0.96 ft
- 1-68. The pitch of sound may be raised by
1. increasing the amplitude of the vibrations
 2. decreasing the amplitude of the vibrations
 3. decreasing the rate of vibrations
 4. increasing the rate of vibrations
-
- Learning Objective: Explain the mathematical principles of sound measurement.
-
- 1-69. What is the third harmonic of a 1600-Hz tone?
1. 3200 Hz
 2. 4800 Hz
 3. 6400 Hz
 4. 8000 Hz
- 1-70. Your sonar equipment has suffered a loss of 9 decibels in source level. How much of the original power does your equipment have left?
1. 12.5%
 2. 15.0%
 3. 25.0%
 4. 50.0%
- 1-71. Which method is most practical to use for increasing the range of your sonar equipment?
1. Increasing the source level
 2. Increasing the receiver sensitivity
 3. Reducing the local noise
 4. Reducing the source level

Assignment 2

Physics of Sound (continued); Bathythermograph

Textbook, NAVEDTRA 10130-C: Pages 41 thru 70

Learning Objective: Define the various noise sources and the types of noise they emit.

- 2-1. The following three sources of noise in water--molecular motion, wind on the sea's surface, and sea lift--are types of
1. flow noise
 2. ambient noise
 3. thermal noise
 4. surface agitation noise
- 2-2. Which of the following noises is the result of molecular motion in the medium caused by temperature?
1. Thermal
 2. Biological
 3. Flow
 4. Propulsion
- 2-3. Which of the following is a more reliable measure of expected ambient noise?
1. Windspeed
 2. Sea state
 3. Surface temperature
 4. Time of day
- 2-4. Which of the following noises that may be produced in a surface ship decreases the ability of the surface ship to detect underwater targets but, because it is not radiated appreciably, has little effect on the ability of the target to detect the surface ship?
1. Flow noise
 2. Cavitation noise
 3. Main propulsion noise
 4. The rat-a-tat-tat of a chipping hammer
- 2-5. How does a change in flow noise from laminar to turbulent affect noise intensity?
1. Increases sharply
 2. Increases gradually
 3. Remains the same
 4. Decreases
- 2-6. Flow noise and cavitation noise are both produced by the movement of an object through water. One way they differ is that cavitation noise occurs
1. as soon as the object starts to move
 2. before flow noise occurs
 3. when the pressure around the moving object fluctuates
 4. when air bubbles form around the moving object
- 2-7. As a propeller rotates in water, it will at different speeds of rotation produce (A) sheet cavitation, (B) flow noise, and (C) tip cavitation. In what sequence will these three types of noise be produced?
1. B, A, C
 2. B, C, A
 3. C, A, B
 4. C, B, A
- 2-8. Your submarine commences cavitating at a depth of 100 feet when the speed exceeds 6 knots. What happens to the amplitude and frequency of the noise when the depth is increased to 200 feet and the speed remains the same?
1. Amplitude increases, frequency decreases
 2. Amplitude increases, frequency increases
 3. Amplitude decreases, frequency increases
 4. Amplitude decreases, frequency decreases

- 2-9. How does dynamic imbalance in machinery become a sonar noise problem?
1. Leakage currents are created.
 2. Static noises are fed into the receiver.
 3. Vibration is changed to acoustic energy.
 4. The imbalance causes flow noise.
- 2-10. What type of noise is made when the anchor windlass is used?
1. Surface agitation
 2. Thermal noise
 3. Ambient noise
 4. Self-noise
- 2-11. Which of the following is the most probable cause of a 60-Hz noise generated within the sonar equipment itself?
1. A badly balanced shaft
 2. Improperly shielded cable
 3. Portable power tools
 4. The fire and flushing pumps
- 2-12. Which types of marine life could be mistaken for hydroplane noise?
1. Whale
 2. Porpoise
 3. Seal
 4. Shrimp
- 2-13. When you hear a noise made by marine life that sounds similar to burning brush, the depth of the marine life is
1. less than 30 fathoms
 2. 100 fathoms or more
 3. 300 fathoms
 4. 1000 fathoms
- 2-14. Which of the following marine life produce a sound similar to that of someone hammering?
1. Porpoises
 2. Snapping shrimp
 3. Sperm whales
 4. Blackfish
- 2-15. Which of the following transmission losses is independent of frequency?
1. Attenuation
 2. Absorption
 3. Scattering
 4. Divergence
- 2-16. The attenuation (decrease in strength) of a sound beam is caused by the combined effects of
1. absorption and scattering
 2. absorption and reflection
 3. reflection and refraction
 4. refraction and scattering
- 2-17. Reflection of sound energy occurs anytime the sound medium changes in
1. thickness
 2. shape
 3. density
 4. temperature
- 2-18. What happens to sound energy that is transmitted from an underwater source when the sound reaches the surface of the water?
1. Most of it continues on into the air.
 2. All of it continues on into the air.
 3. Most of it is reflected downward into the water.
 4. All of it is reflected downward into the water.
- 2-19. In general, what kind of shallow bottom causes the least transmission loss?
1. Smooth sand
 2. Rough gravel
 3. Soft mud
 4. Rough rocks
- 2-20. When you transmit sound energy into the water, the many echoes you receive from sources such as the water mass, the surface, and the bottom of the sea, are called
1. reverberations
 2. refractions
 3. absorptions
 4. diversions

Learning Objective: Define and discuss the controlling factors of sound, their effects on the transmission of sound, and methods of recognizing the factors.

- 2-21. What causes volume reverberations?
1. Sound energy reradiated by small particles
 2. Surface and bottom reflections
 3. Marine life
 4. All of the above
- 2-22. Which of the following conditions will cause the highest reverberation levels?
1. Flat surface and deep water
 2. Flat surface and smooth bottom
 3. Rough surface and rocky bottom
 4. Rough surface and smooth bottom
- 2-23. Two things that happen to the sound beam when sound is transmitted into water are: (A) its cross sectional area becomes larger as the sound moves out from the source, and (B) its direction is affected by water pressure, salinity, and changes in temperature. What are each of these two effects called?
1. (A) scattering, (B) refraction
 2. (A) divergence, (B) refraction
 3. (A) scattering, (B) reflection
 4. (A) divergence, (B) reflection
- 2-24. When a beam of sound passes from one medium of high temperature into a medium of low temperature, the sound beam is
1. reflected
 2. refracted
 3. absorbed
 4. scattered
- 2-25. Which of the following sounds indicates that a sonar beam is being quenched?
1. Hollow booming
 2. Sharp pinging
 3. Shrill screech
 4. Dull thudding
- 2-26. What is the most important factor affecting the speed of sound in water?
1. Temperature
 2. Pressure
 3. Salinity
 4. Chemical composition
- 2-27. How is the speed of a sound wave traveling through water affected by water temperature and pressure?
1. Its speed increases when temperature increases and also when pressure increases.
 2. Its speed decreases when temperature increases and also when pressure increases.
 3. Its speed increases when temperature increases and decreases when pressure increases.
 4. Its speed decreases when temperature increases and increases when pressure increases.
- 2-28. Which factor controlling the speed of sound varies in direct proportion to the water depth?
1. Salinity
 2. Pressure
 3. Temperature
 4. Density
- 2-29. Which figure in the textbook shows the behavior of a sonar beam when it is influenced by water pressure only?
1. 3-15
 2. 3-16
 3. 3-17
 4. 3-18
- 2-30. Which figure in the textbook correctly shows the behavior of a sonar beam in water that has a continuous negative thermal gradient?
1. 3-15
 2. 3-16
 3. 3-17
 4. 3-18
- 2-31. A submarine using the layer effect for protection will find the most protection under conditions similar to those represented in the text book by figure
1. 3-15
 2. 3-16
 3. 3-17
 4. 3-18
- 2-32. Which, if any, of the following thermal gradients will produce layer depth at the depth of maximum temperature?
1. Positive
 2. Negative
 3. Isovelocity
 4. None of the above

- 2-33. Echo ranging in shallow water is difficult due to the sound being
1. scattered
 2. absorbed
 3. reflected
 4. refracted
- 2-34. What is the approximate depth of a submarine if it passes under a sonar beam so that contact is lost at 100 yards?
1. 100 ft
 2. 200 ft
 3. 300 ft
 4. 400 ft
- 2-35. In a layer of water that provides a sound channel, what is the relationship between the water temperatures at (A) the upper limit of the layer, (B) the lower limit of the layer, and (C) the axis of the layer?
1. A and B are the same, C is cooler than A and B
 2. A and B are the same, C is warmer than A and B
 3. A and C are the same, B is cooler than A and C
 4. A and C are the same, B is warmer than A and C
- 2-36. What condition must exist in order to have a convergence zone effect?
1. A negative gradient at the surface
 2. A sound channel axis between 350 fathoms and 500 fathoms
 3. A sound source in the sound channel axis
 4. A water depth of approximately 2000 fathoms
- 2-37. The principle by which an object's motion changes the pitch of a sound that comes from the object is called the
1. bounce principle
 2. frequency shift principle
 3. convergence principle
 4. doppler
- 2-38. Earlier in this assignment, the relationship between a sound's frequency, its velocity, and its wavelength was discussed. One version of their relationship ($F = \frac{V}{\lambda}$) applies very closely to the discussion on the effects of motion on sound. Compressing the sound wave is the same as shortening the sound's wavelength. What effect has an object's motion on the wavelength, and thus on the frequency of a sound that is coming from the object, if the object is moving away from you?
1. The wavelength increases and the frequency goes up.
 2. The wavelength increases and the frequency goes down.
 3. The wavelength decreases and the frequency goes up.
 4. The wavelength decreases and the frequency goes down.
- 2-39. Assume that you pick up a target on your sonar equipment. What may you decide about the target if the pitch of the echo is lower than the pitch of the reverberations?
1. The target is approaching your ship.
 2. The target is moving away from your ship.
 3. The target is maintaining the same position relative to your ship.
 4. The target is moving at constant speed.
- 2-40. A report of "Doppler moderate, up," indicates that a target is approaching your ship with a speed component of about
1. 2 knots
 2. 3 to 6 knots
 3. 7 to 9 knots
 4. 10 knots
- 2-41. Which of the following may give a sharp echo with doppler?
1. Kelp bed
 2. Fresh submarine wake
 3. Whale
 4. Riptide
- 2-42. A poor quality echo is reflected from a stern aspect target because
1. the target area is small
 2. the echo comes from multiple sources
 3. wake interference reduces the signal
 4. of all of the above factors

- 2-43. What action should you take when you hear unusual sounds while on watch?
1. Identify the sound, then report it.
 2. Report every unusual sound immediately.
 3. Report it only if it is a submarine.
 4. After a reasonable period for identification, make your report.

Learning Objective: Explain the effect of varying oceanographic conditions on the transmission of sound.

- 2-44. What single factor has the most pronounced effect on the speed of sound wave travel through water?
1. Depth of water
 2. Salinity of water
 3. Water temperature
 4. Water pressure
- 2-45. How will an increase in the water temperature from 73°F to 74°F affect the speed of sound passing through the water?
1. The speed of sound will increase approximately 6 feet per second.
 2. The speed of sound will increase approximately 2 feet per second.
 3. The speed of sound will decrease approximately 4 feet per second.
 4. The speed of sound will decrease approximately 12 feet per second.
- 2-46. What would be the relationship of temperature verses depth in a thermocline?
1. The temperature remains constant with depth.
 2. The temperature decreases with depth.
 3. The temperature varies erratically within the thermocline as depth increases.
 4. The temperature remains constant above and below the thermocline.
- 2-47. What are the two effects a thermocline has on sound energy that cause a sound beam's direction to be distorted?
1. Reflection and reverberations
 2. Convergence and refraction
 3. Convergence and reverberations
 4. Reflection and refraction

Learning Objective: Explain the bathythermographs currently used in the Navy, including their operational characteristics.

- 2-48. What is the sound velocity range of the AN/BQH-1A?
1. 4000 - 4800 fps
 2. 4200 - 5100 fps
 3. 4600 - 5100 fps
 4. 4800 - 5100 fps
- 2-49. A series of lines on the recorder chart of the AN/BQH-1A depth-sound speed measuring set aid a moving submarine in maintaining its trim. What are these lines called?
1. Isothermal
 2. Isometric
 3. Isoballast
 4. Isodynamic
- 2-50. Sensitivity of the velocity-measuring portion of the AN/BQH-1A is sufficient to indicate change in sound velocity of
1. 0.1 fps
 2. 1 fps
 3. 3 fps
 4. 5 fps
- 2-51. Two sound heads, one mounted on the keel and the other on the sail of a submarine, are used to get accurate information concerning changing thermal gradients affecting buoyancy during diving operations. Which sound head is used when the submarine is (A) ascending and (B) diving?
1. Both A and B, upper
 2. Both A and B, lower
 3. A lower, B, upper
 4. A upper, B lower
- 2-52. The AN/BQH-1A sonar set measures the velocity of sound in water by
1. correlating the several known factors
 2. timing a transmitted pulse between a transmitter and a receiver
 3. timing a transmitted pulse from another submarine
 4. determining echo intensity from a transmission

- 2-53. The depth scale of the AN/BQH-1A depth-sound speed measuring set is calibrated for a maximum depth of
1. 700 ft
 2. 800 ft
 3. 1500 ft
 4. 4800 ft
- 2-54. One precaution you take when you operate the BQH-1A depth-speed measuring set is to avoid
1. using the recorder unit
 2. energizing the lower sound head before the submarine is completely submerged
 3. energizing the upper sound head before the submarine is completely submerged
 4. selecting an overlapping depth scale
- 2-55. When you shift from one sound head of the BQH-1A depth-sound speed measuring set to another head, what information do you receive in addition to the velocity of sound?
1. Depth under the keel
 2. Distance to the surface
 3. Amount of radiated heat at the sound head in use
 4. Difference in depth between the two sound heads
- 2-56. One emergency feature of the AN/BQH-1A is that the
1. depth may be read if the sound needs fail
 2. sound velocity is always shown
 3. depth reading is always shown
 4. depth and velocity circuitry are combined
- 2-57. What is the maximum operating depth of the SSXBT?
1. 1000 ft
 2. 1500 ft
 3. 2000 ft
 4. 2500 ft
- 2-58. Approximately how much time is required to complete a temperature profile after launching the SSXBT down to its maximum operating depth?
1. 1 min
 2. 2 min
 3. 3 min
 4. 4 min
- 2-59. What actuates the release mechanism on the SSXBT, causing the probe to descend?
1. Atmospheric pressure
 2. Water pressure
 3. Commands from the launching ship
 4. A preset timer
- 2-60. What component of the surface ship expendable BT senses the changing temperatures?
1. Thermometer
 2. Sound head
 3. Thermistor
 4. Bourdon tube
- 2-61. The surface ship expendable BT recorder begins marking temperature when the
1. cannister is loaded into the launcher
 2. probe strikes the water
 3. wire unreels from the probe
 4. wire unreels from the cannister
- 2-62. What feature of the surface ship expendable BT allows a vertical descent of the probe?
1. Simultaneous unreeling of the wire from the cannister probe
 2. Spin stabilization of the probe
 3. The weight of the probe
 4. The speed of the probe
- 2-63. What is the maximum operating depth of the surface ship expendable BT?
1. 1000 ft
 2. 1500 ft
 3. 2000 ft
 4. 2500 ft
-
- Learning Objective: Discuss how information derived from the BT may be used in ASW work.
-
- 2-64. Which of the following temperature gradients will usually result in short target ranges?
1. Negative
 2. Positive
 3. Isothermal
 4. Mixed

2-65. Which of the following thermal gradients is usually observed in coastal waters?

1. Negative
2. Positive
3. Isothermal
4. Mixed

2-66. What causes the phenomenon known as afternoon effect?

1. Tides
2. The sun
3. Tradewinds
4. Waves

2-67. What will usually happen to the temperature of the water near the surface after the sun sets?

1. Positive gradients will become isothermal.
2. Negative gradients will become isothermal.
3. Negative gradients will become positive.
4. Positive gradients will become negative.

Assignment 3

Bearings and Motion; Principles of Sonar

Textbook, NAVEDTRA 10130-C: Pages 71 thru 102

Learning Objective: Provide the new ST with the basic mechanics of bearings and ranges.

- 3-1. Which of the following is used as a reference for computing true bearings?
1. North-south axis
 2. True north
 3. Geographic north
 4. Magnetic north
- 3-2. What information do you need to locate accurately an underwater object in relation to your ship?
1. The direction of true north
 2. A geographical reference point
 3. The object's direction and distance
 4. The depth of the water
- 3-3. Which of the following results may be obtained from a speedy determination of correct bearing and range?
1. A correct solution from the computer
 2. The exact target location
 3. A successful attack
 4. All of the above
- 3-4. How should you report a range of 2350 yards?
1. Range two thousand three hundred and fifty
 2. Range twenty three fifty
 3. Range two three five oh
 4. Range two three five zero

- 3-5. A comparison of the uses of true and relative bearings in sonar operating procedure reveals that
1. relative bearings are used as long as the ship's gyrocompass is operating properly
 2. relative bearings are used only when the ship's gyrocompass fails
 3. true bearings are used only when the ship's gyrocompass fails
 4. true bearings are used at all times, regardless of the condition of the ship's gyro compass

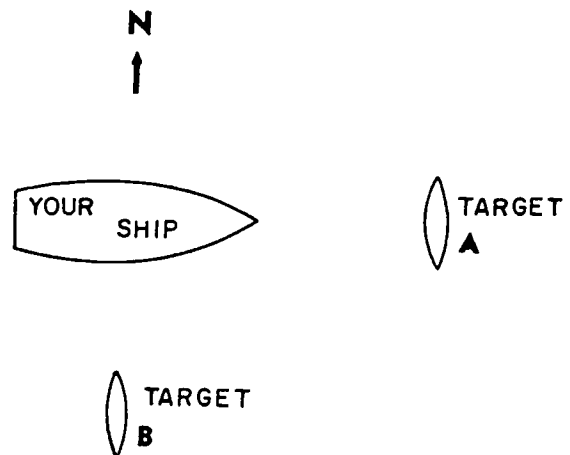

Figure 3A.--Bearings.

- 3-6. What is the true bearing of target A in figure 3A?
1. 000°
2. 090°
3. 180°
4. 270°

- 3-7. What is the true bearing of target B in figure 3A?
1. 000°
2. 090°
3. 180°
4. 270°

- 3-8. The relative bearing of target A in figure 3A is
1. 000°
2. 090°
3. 180°
4. 270°

- 3-9. The relative bearing of target B in figure 3A is
1. 000°
2. 090°
3. 180°
4. 270°

Learning Objective: Familiarize the new ST with types of bearing and range indicators.

Information for items 3-10 and 3-11: Bearing indicators like the one in figure 5-5 in your textbook are used to provide remote stations with true and relative sonar bearings. In these two items, the two dials on the indicator that move are referred to as dial A and dial B, dial A being the one that has the diamond indicator, and B being the inner dial--the one labeled Gyro-Compass Repeater.

- 3-10. How will the positions of the dials in figure 5-5 change to indicate that your ship is on course 045° and that your sonar is trained on the port beam?
1. Both A and B will move clockwise 90°.
2. Both A and B will move counterclockwise 90°.
3. A will move counterclockwise 135° and B will remain in its present position.
4. B will move clockwise 90° and A will remain in its present position.

- 3-11. How will the positions of the dials in figure 5-5 change to indicate that your ship is on course 315° and that your sonar is trained on your starboard beam?
1. B will move clockwise 90° and A will move clockwise 045°.
2. Both A and B will move counterclockwise 90°.
3. A will move counterclockwise 90° and B will remain in its present position.
4. B will move clockwise 90° and A will remain in its present position.

Learning Objective: Acquaint the new ST with the manipulation of bearings.

- 3-12. If your ship is on course 090° true when you make sonar contact at 180° true, what is the true bearing reading on your stern line indicator?
1. 000°
2. 090°
3. 180°
4. 270°

- 3-13. Your ship is on a heading of 180° true and alters course right to 270° true. What change occurs to the stern line indicator?
1. Rotates clockwise and stops on 270°
2. Rotates counterclockwise and stops on 090°
3. Rotates clockwise and stops on 090°
4. No change

- 3-14. If your ship's stern is 090° true when she suffers a gyrocompass casualty, what is the stern line indicator reading after the casualty?
1. 000° relative
2. 090° true
3. 180° relative
4. 270° true

- 3-15. If you are headed for a sonar contact at 135° true when a gyrocompass failure occurs, what must you do with the console cursor to remain on target?
1. Turn it left 45°.
2. Turn it left 135°.
3. Turn it right 45°.
4. Turn it right 135°.

- 3-16. What is the true bearing of a target if your ship is headed 270° true and the target bearing is 270° relative?
1. 000°
 2. 090°
 3. 180°
 4. 270°

- 3-17. Assume that a target is moving due east and that your destroyer is approaching it from the south. At a range of 700 yards, the target is due north of your ship and the conning officer orders a course of 045° to take a lead on the target. After the change in course, the cursor will be moved to show a relative bearing of the target of about
1. 000°
 2. 045°
 3. 180°
 4. 310°

- 3-18. Your ship is on course 253° true and the target bears 109° relative. What is the true target bearing?
1. 002°
 2. 107°
 3. 144°
 4. 182°

- 3-19. Your ship is on course 035° true and the target bears 334° true. What is the target's relative bearing?
1. 009°
 2. 119°
 3. 154°
 4. 299°

- 3-20. The relative motion of a target is the motion the target appears to have if you consider your ship as being
1. stopped (dead in the water)
 2. on course 000°
 3. on course 180°
 4. on course 090° or 270°

- 3-21. Your ship is on course 170° and you have the following bearing and range information on a submarine:

Time	Bearing	Range
0010	220°	8000
0015	215°	6750
0020	209°	5700
0025	200°	4800

What will your ship do in relation to the target?

1. Pass ahead
2. Pass astern
3. Pass over
4. Pass parallel

Learning Objective: Acquaint the new ST with advance and transfer.

- 3-22. What is the distance along the old course that a ship covers between the time that right rudder is applied and the time that the ship is steadied in its new course?

1. Drag
2. Cover
3. Transfer
4. Advance

- 3-23. The distance your ship moves at right angles to the original course after rudder is applied is called

1. transfer
2. advance
3. drift
4. set

- 3-24. The bearing drift of a target indicates the direction of target movement if your ship is on a steady course at a constant speed and the relative bearing to the target is approximately

1. 000°
2. 045°
3. 090°
4. 315°

Learning Objective: Point out to the new ST the relationship between bearings and doppler.

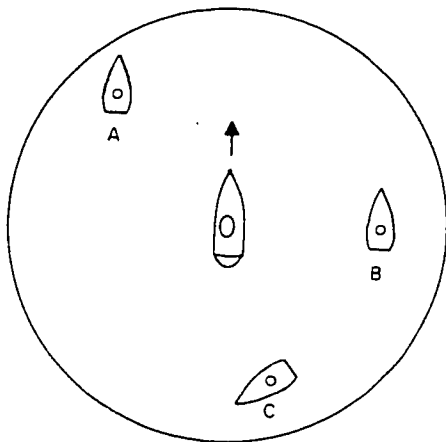

Figure 3B.--Aspect and Doppler.

● In figure 3B the submarine is in the center on course 000°, speed four knots.

- 3-25. What is the doppler and target aspect when your ship is at position "A"?
1. Up doppler, port bow aspect
 2. No doppler, port bow aspect
 3. Down doppler, starboard bow aspect
 4. No doppler, port beam aspect
- 3-26. What is the doppler and target aspect when your ship is stopped at position "B"?
1. Up doppler, starboard beam aspect
 2. Down doppler, starboard beam aspect
 3. No doppler, aspect undetermined
 4. No doppler, starboard quarter aspect
- 3-27. What is the sequence of doppler when your ship has circled the target clockwise from position "A" to "B" and has arrived at position "C"?
1. No, up, down
 2. Up, no, up
 3. No, no, down
 4. Up, no, down

- 3-28. Your ship is headed directly toward a target that has right bearing drift and up doppler. What is target aspect?
1. Port bow
 2. Starboard bow
 3. Direct bow
 4. Port beam

- 3-29. If you use the quadrant method of determining target aspect as shown in figure 5-13 of your textbook, a dotted line representing a port bow aspect will be located in quadrant
1. A
 2. B
 3. C
 4. D

- 3-30. Your ship is on course 195° true, the submarine bears 187° true, and the bearing is steady with up doppler. What maneuver has the submarine performed if the doppler changes to down and the bearing drifts left?
1. Turned right
 2. Turned left
 3. Turned right and stopped
 4. Turned left and backed down

- 3-31. To determine target angle, you must effectively put yourself on the target. You perform this operation in the target angle formula by applying 180° to
1. the target's true bearing
 2. the target's relative bearing
 3. own ship's course
 4. the target aspect

- 3-32. You are on a surface ship headed 000° and a submarine on your starboard beam is also headed 000°. How will you report target angle, and how will the submarine sonar operator report angle on the bow?
1. 090°, port 90
 2. 090°, starboard 90
 3. 270°, port 90
 4. 270°, starboard 90

- 3-33. Your contact is on course 275° true, bearing 176° true. What is the target angle?
1. 081°
 2. 099°
 3. 261°
 4. 289°

- 3-34. Your target is on course 334° and the target bearing is 135° . What is the target angle?
1. 161°
 2. 315°
 3. 341°
 4. 351°
- 3-35. Your submarine has a contact bearing 260° true on course 300° true. What is the angle on the bow?
1. 180° , starboard
 2. 160° , port
 3. 140° , port
 4. 140° , starboard

Learning Objective: Explain the basic principles of sonar, both active and passive.

- 3-36. What target information can be expected from passive sonar systems?
1. Estimated bearing and accurate range
 2. Accurate bearing and estimated range
 3. Accurate bearing and range
 4. Estimated bearing and range
- 3-37. What device is used to convert sound energy into electrical energy?
1. Transmitter
 2. Transducer
 3. Receiver
 4. Loudspeaker
- 3-38. The main function of modern sonar receivers is to provide signals for the
1. loudspeaker and for the video indicators
 2. microphone and for the loudspeaker
 3. transducer and for the video indicators
 4. transducer and for the microphone

- 3-39. What advantage does modern active sonar have over searchlight sonar?
1. The ability to maintain contact on a maneuvering target
 2. The ability to search quickly all around the ship
 3. The ability to see a 360° video presentation
 4. All of the above advantages

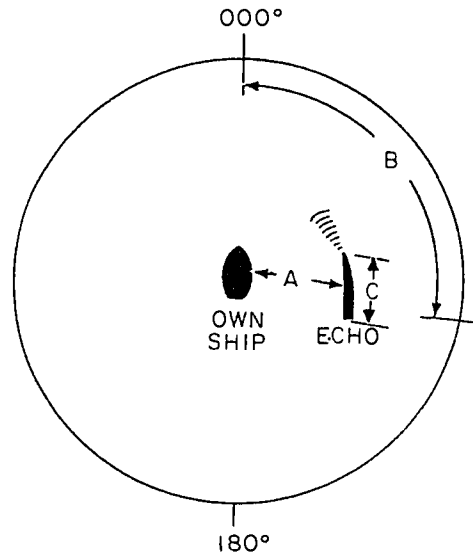

Figure 3C.--Sonar CRT display.

- Refer to figure 3C and use the following alternatives for items 3-40 thru 3-42.
1. Target motion
 2. Target distance
 3. Target bearing
 4. Target size
- 3-40. What target information is determined by dimension A?
- 3-41. What target information is represented by dimension B?
- 3-42. What target characteristic do you estimate from dimension C?

Learning Objective: Describe transducers and hydrophones and their functions.

- 3-43. The magnetostrictive process of signal conversion is caused by
1. changes in the dimension of metals placed in a magnetic field
 2. changes in the dimension of crystals placed in a magnetic field
 3. polarization of crystals
 4. polarization of ceramics
- 3-44. What is used to prevent frequency doubling in a magnetostrictive transducer?
1. Mica insulation
 2. Wire coils
 3. Castor oil
 4. Metal laminations
- 3-45. Magnetostrictive transducer elements used in scanning sonar are composed of
1. nickel tubes
 2. nickel laminations
 3. ammonium dihydrogen phosphate
 4. barium titanate
- 3-46. The maintenance of the close contact feature of the sonar unit causes the sound beam to
1. bend upward
 2. bend downward
 3. increase in power
 4. expand horizontally
- 3-47. What type of material is used in a piezoelectric transducer?
1. Magnets
 2. Nickel laminations
 3. Wire coils
 4. Crystals
- 3-48. Which of the following crystals is relatively insensitive to temperature changes?
1. ADP
 2. Rochelle salt
 3. Tourmaline
 4. Lithium sulphate
- 3-49. Electrostrictive transducer elements are composed of
1. nickel tubes
 2. nickel laminations
 3. ADP crystals
 4. ceramics

- 3-50. Electrostrictive transducer elements are polarized by using
1. permanent magnets
 2. laminated elements
 3. wire coils
 4. high voltage

Learning Objective: Discuss the modern active sonar theory, including transmission, reception, and presentation.

- Use the following alternatives for items 3-51 thru 3-53:
1. Control-indicator
 2. Receiver-scanner
 3. Transmitter
 4. Audiofrequency amplifier
- 3-51. What unit contains the circuitry that initiates and determines the length of the transmitted pulse?
- 3-52. In what unit is the transmitted pulse modulated to the operating frequency?
- 3-53. In which unit is the incoming echo signal strength increased before it reaches the scanning switches?
- Reverberations are used as the pitch reference for echo doppler discrimination. When your ship is moving, the change in wavelength caused by the ship's motion causes the reverberation pitch to be higher from the bow than from the beam or stern. The own ship's doppler nullifier (ODN) circuitry uses own ship's speed and sonar bearing inputs to correct this difference. When in use, the ODN circuitry causes the reverberations received by a ship in motion to be of the same pitch as those received by a ship that is drifting.
- 3-54. When your sonar equipment has ODN circuits, how will the frequency of an echo from a stopped submarine vary if you gain contact on your bow and pass it astern?
1. Change from high to low
 2. Change from low to high
 3. Increase steadily
 4. Remain the same

- 3-55. When a target echo shows at extreme range on the cathode ray tube of your sonar, what is the relative value of the sawtooth voltage?
1. Maximum
 2. Three-fourths
 3. One-half
 4. Minimum
- 3-56. When, during the sweep cycle, is the cursor produced on the scope?
1. During the first half
 2. During the second half
 3. Between sweeps
 4. Continuously

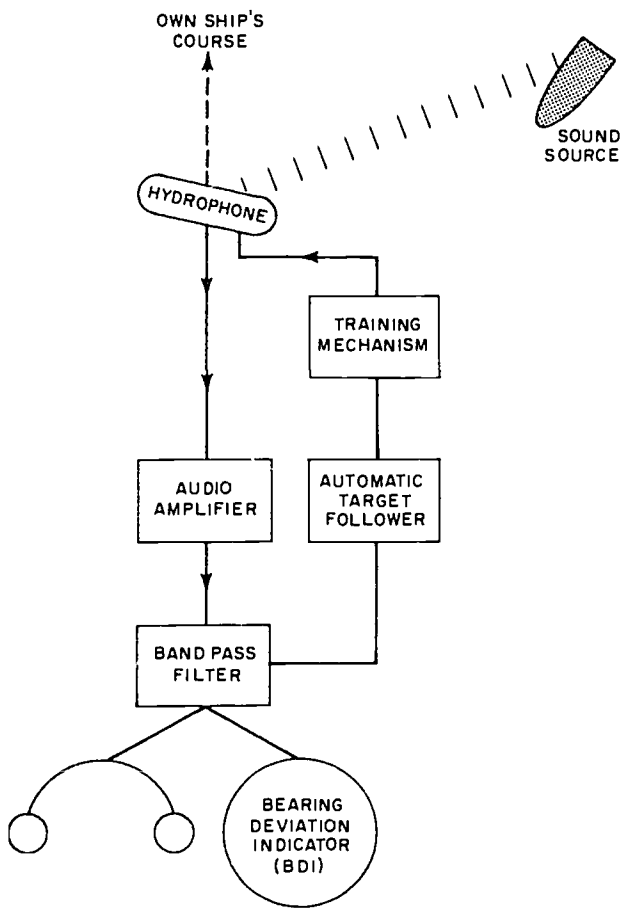

Figure 3D.--Single-line hydrophone system.

- 3-57. The sonar system shown in figure 3D is capable of accurately determining the sound source's
1. aspect
 2. range
 3. speed
 4. bearing
- 3-58. Which of the following items of information will be given by the bearing deviation indicator (BDI) of the sonar system in figure 3D?
1. Own ship's course must be changed to starboard for maximum signal reception.
 2. Hydrophone must be trained right for minimum phase difference.
 3. Hydrophone must be trained right for maximum phase difference.
 4. Hydrophone must be trained left for minimum phase difference.
- 3-59. In figure 3D, the automatic target follower (ATF) serves to relay
1. training signals to the RLI
 2. training signals to the training mechanism
 3. audible frequency target signals to the audio amplifier
 4. audible frequency target signals to the filter
- 3-60. What type of sonar is illustrated in figure 6-10 of the textbook?
1. Conformal passive array
 2. Circular passive array
 3. Cylindrical hydrophone array
 4. Single-line hydrophone
- 3-61. The compensator switch in an array type of passive sonar system provides a function most similar to that provided by a single-line hydrophone system's
1. RLI meter
 2. audio amplifier
 3. band pass filter
 4. training mechanism
- 3-62. What reference point is used in passive array sonar to determine target bearing?
1. Center of the rotor plate
 2. Center of the stator plate
 3. Center of the compensator switch
 4. Center transducer element

- 3-63. The purpose of the lag lines in the array sonar described in your textbook is to
1. delay the signal from the hydrophones farthest from the sound source
 2. speed up the signal from the hydrophones farthest from the sound source
 3. delay the signal from the hydrophones nearest to the sound source
 4. speed up the signal from the hydrophones nearest to the sound source
- 3-64. The audio amplifier input signal is strongest when the
1. output of the lag lines is in phase
 2. output of the lag lines is not in phase
 3. stator plate is centered
 4. preamplifier output is not in phase
- 3-65. Which of the following advantages do you have with variable depth sonar that you do not have with hull-mounted transducers?
1. Generally longer ranges
 2. More accurate classification
 3. Faster search speeds
 4. The ability to get below thermal layers
-
- Learning Objective: Discuss the depth sounder, including its use and operational characteristics.
-
- 3-66. For what purpose is the AN/UQN-1 designed, and what operating principle does it use?
1. To determine target depth by solving a right triangle formula, using slant range and depression angle
 2. To determine depth of the sea by bouncing sound pulses off the bottom of the sea
 3. To determine target bearing by monitoring target noise
 4. To record target range by marking chemically treated paper
- 3-67. On which of the five range scales on the AN/UQN-1 does the scope provide a visual presentation?
1. The 100 ft scale only
 2. The 100 ft and 100 fathom scales only
 3. The 100 fathom and 600 fathom scales only
 4. On all five scales
- 3-68. What depth is indicated by the last trace mark on the chart in figure 6-17 in your textbook?
1. 400 feet
 2. 430 feet
 3. 4000 feet
 4. 4300 feet
- 3-69. You are facing the chart on an AN/UQN-1 depth sounder. In what directions do the stylus and the paper travel?
- | | <u>Stylus</u> | <u>Paper</u> |
|---------|---------------|--------------|
| 1. Up | right | right |
| 2. Up | left | left |
| 3. Down | right | right |
| 4. Down | left | left |
- 3-70. Which of the following can be controlled by reducing the gain on the AN/UQN-1 depth sounder?
1. Solid line in shallow water
 2. Reverberations
 3. Multiple echoes
 4. All of the above
- 3-71. Before you place the AN/UQN-1 depth sounder in a transmitting mode of operation, you should allow it to warm up in standby for a minimum period of
1. 10 seconds
 2. 20 seconds
 3. 30 seconds
 4. 60 seconds
- 3-72. Depressing the mark button on the AN/UQN-1 depth sounder causes a
1. single pulse of sound energy to be transmitted
 2. bright spot to appear on the scope
 3. solid circle to appear around the scope's edge
 4. solid line to appear on the chart for record purposes
- 3-73. What are the two modes of sound transmission (keying) provided by the AN/UQN-1?
1. AUTOMATIC and SINGLE PING
 2. MARK and RECORD
 3. AUTOMATIC and MARK
 4. RECORD and SINGLE PING

Assignment 4

Principles of Sonar (continued); Basic Fire Control; Communications

Textbook, NAVEDTRA 10130-C: Pages 104 thru 136

Learning Objective: Discuss the tape recorder, including its use and operational characteristics.

- 4-1. What are the sound inputs to each of the tracks of the AN/UNQ-7?
1. Both tracks are fed underwater sound information.
 2. One track is connected to the sonar equipment; the other records sound from the sonar operator's station.
 3. Both tracks are fed information directly from the sonar equipment.
 4. Both tracks record sound from the sonar operator's station.
- 4-2. The purpose of the microphone in the AN/UNQ-7 tape recorder is to
1. transfer the electrical sound signals onto the tape
 2. convert the magnetic sound energy on the tape to electrical sound energy
 3. convert sound waves in the air to electrical sound energy
 4. increase the strength of the magnetic field on the tape
- 4-3. What is a material called that is capable of being made easily magnetic and is also able to lose its magnetism easily?
1. Antimagnetic
 2. Diffusible
 3. Permeable
 4. Sensitive
- 4-4. In what sequence does the magnetic tape in the AN/UNQ-7 pass the three magnetic heads during the RECORD mode of operation?
1. Erase, record, reproduce
 2. Erase, reproduce, record
 3. Reproduce, record, erase
 4. Reproduce, erase, record
- 4-5. What happens to the tape when the erase head of an AN/UNQ-7 recorder is energized?
1. The top track is erased and upon rewinding the bottom track is erased.
 2. Either the top or bottom track may be erased as selected.
 3. Either top or bottom or both tracks may be erased as selected.
 4. Both tracks are always erased simultaneously.
- 4-6. What is one reason that you should record critical sonar information at 15 inches per second when you are recording with the AN/UNQ-7?
1. To use as little tape as possible
 2. To permit later analysis at lower speeds
 3. To decrease the number of unwanted noises recorded
 4. To permit later analysis at higher speed
- 4-7. What tape speed should be used for a high-quality recording?
1. 3 3/4
 2. 7 1/2
 3. 15
 4. Any of the above

- 4-8. The record safety interlock switch on the AN/UNQ-7 prevents
1. obtaining an electrical shock while working on the recorder
 2. obtaining an electrical shock while threading the recorder
 3. accidental recording from the remote control unit
 4. accidental recording at the main unit
- 4-9. While you are playing a tape on the AN/UNQ-7 tape recorder, someone places the toggle switch on the remote control unit to RECORD. What will happen and why?
1. The tape will continue to play back because the record interlock is not engaged.
 2. The tape will continue to play back because reproduce takes precedence over record.
 3. The tape will be erased because the record interlock is engaged.
 4. The tape will be erased because record takes precedence over reproduce.
- 4-10. How is the operator at a remote control unit warned when there are 5 minutes or less of recording time remaining on the tape on the AN/UNQ-7 recorder?
1. The RECORD lamp goes out.
 2. The RECORD lamp flashes.
 3. The STANDBY lamp goes out.
 4. The STANDBY lamp flashes.

Learning Objective: Describe the major elements of a typical underwater fire control system.

- 4-11. Fire control systems are used to
1. maintain target contact by using echo ranging sonar equipment
 2. evaluate target-generated noise to maintain sonar contact
 3. maintain contact by use of active and passive sonar equipment
 4. collect and translate information into weapon firing data

- 4-12. Which of the following main elements of a fire control system receives target data from sonar?
1. Stabilization computer
 2. Attack console
 3. Positive indicator
 4. Relay transmitter

- 4-13. Which of the following puts out corrections to own ship's course?
1. Attack console
 2. Positive indicator
 3. Relay transmitter
 4. Stabilization computer

- 4-14. Which piece of equipment allows the commanding officer to approve the payload selection?
1. Attack console
 2. Position indicator
 3. Relay transmitter
 4. Stabilization computer

Learning Objective: Identify the ASW weapons used against submarines in today's Navy.

- 4-15. What is the main shipboard weapon currently used for action against submarines?
1. Stern dropped depth charge
 2. ASROC torpedo
 3. Mk 32 time launched torpedo
 4. Lamps delivered depth charge

- 4-16. Modern antisubmarine torpedoes are better than early models because the newer torpedoes
1. go faster
 2. go farther
 3. are more maneuverable
 4. have all of the above advantages

- 4-17. A typical torpedo runs in what type of pattern?
1. Circle right
 2. Circle left
 3. Helical
 4. Straight-running

- 4-18. All of the following torpedoes are suitable for antisubmarine work except
1. straight-running contact
 2. active acoustic-homing
 3. passive acoustic-homing
 4. wire-guided

Learning Objective: Describe the various phases used during the conduct of ASW.

- 4-19. Which of the following steps in the destruction of a target is not ordinarily considered a part of the fire control problem?
1. Target detection
 2. Target tracking
 3. Target movement analysis
 4. Ballistic computation
- 4-20. Both initial detection and tracking of a completely submerged submarine are commonly accomplished by
1. visual sighting
 2. search radar
 3. sonar equipment
 4. fire control computing equipment
- 4-21. Which of the following devices is most likely to be used by a submarine in tracking a surface target?
1. Sonobuoys
 2. Passive sonar
 3. Active sonar
 4. Magnetic equipment
- 4-22. The goal of the tracking phase of the fire control problem is to accurately determine the target's
1. rate of relative motion
 2. rate of descent
 3. course
 4. speed
- 4-23. A submarine's true course and speed is plotted on the dead-reckoning tracer by using information from
1. own ship's course
 2. own ship's speed
 3. sonar range and bearing
 4. all of the above sources

- 4-24. In analyzing target motion, the surface sonar fire control system must first combine sonar slant range with the target's known or estimated depth. By combining these two quantities, the system determines the
1. vertical range to the target
 2. horizontal range to the target
 3. target's course
 4. target's speed

- 4-25. Why is it desirable to stay as far away from an enemy submarine as possible and still maintain contact?
1. To obtain more accurate sonar information
 2. To obtain more accurate fire control solution
 3. To keep away from your own weapons
 4. To keep the enemy from shooting at you
- 4-26. Which of the following actions would be considered part of the destruction phase of an ASW attack?
1. Any indirect action forcing a submarine to surface
 2. The launching of an ASROC missile
 3. Use of the computed ballistic solution
 4. All of the above actions

Learning Objective: Point out the variables and fire control symbols used by fire control systems.

- 4-27. Which of the following variables would most likely cause a miss during an ASW attack?
1. Own ship's course and speed change
 2. Target course and speed change
 3. Own ship's roll and pitch
 4. Target's roll and pitch
- 4-28. The stable element is used in fire control to correct variation introduced by
1. changes in own ship's speed
 2. changes in own ship's heading
 3. own ship's roll and pitch
 4. changes in target bearing

- 4-29. In which of the following planes does the FC computer compute solutions?
1. Horizontal
 2. Vertical
 3. Deck
 4. All of the above
- 4-30. Which of the following references is used to measure the number of degrees between two vertical planes?
1. Relative bearing
 2. Roll
 3. Pitch
 4. Target depth
- 4-31. Detailed information on the new system for underwater fire control nomenclature is found in OP 1700, Volume
1. 1
 2. 2
 3. 3
 4. 4
- 4-32. Which FC symbol represents the unmodified (basic) range from your ship to the target?
1. Rp
 2. Rv
 3. Rh
 4. R
- 4-33. What quantity is the result of correcting sonar measurements?
1. Apparent target position
 2. Past target position
 3. Actual target position
 4. Future target position
- 4-34. The difference between past target position and apparent target position is caused by
1. sound beam refraction
 2. target movement
 3. parallax
 4. all of the above
- 4-35. After target course, position, and speed have been determined, which of the following functions must be performed by the fire control system?
1. Estimating where the target will be when the weapon is delivered
 2. Calculating what course to take and when to fire
 3. Sending all the required information to the control and weapon stations
 4. Performing all of the above functions
- 4-36. A magnetic brake uses electrical energy to
1. arrest or prevent movement of a rotating shaft
 2. resolve electrical vectors into line as components
 3. link two or more rotating shafts
 4. transform rotation speeds between shafts
- 4-37. Which of the following devices are basically similar in their design and construction but different in function?
1. Magnetic clutch and electrical resolver
 2. Magnetic brake and magnetic clutch
 3. Electrical resolver and magnetic brake
 4. Electrical resolver and mechanical integrator
- 4-38. Which trigonometric functions describe the output voltages produced by an electrical resolver as the rotor is turned?
1. Sine and cosine
 2. Tangent and cotangent
 3. Secant and cosecant
 4. Cosine and cotangent
-
- Learning Objective: Describe the types of tests used to maintain a modern FC computer.
-
- Use the following alternatives for items 4-39 thru 4-42:
 1. Transmission test
 2. Static test
 3. Dynamic test
 4. Rate test
- 4-39. What fire control system test is used to check the accuracy of a remote target angle indicator?
- 4-40. In what test would you manually insert target bearing and course to find target angle as a fixed value?
- 4-41. What test is used to check the accuracy of a computer time system?
- 4-42. What systems test is used to check the ability of a computer to correct an introduced error in a given time?

- 4-43. In figure 4-13 of your textbook, the diamond index on the intermediate ring dial of own ship's dial group indicates
1. own ship's course
 2. relative target bearing
 3. true target bearing
 4. launcher train order
- 4-44. By what method of internal communication do the bridge personnel receive initial sonar contact information?
1. Sound-powered phones
 2. Automatic indicator
 3. Voice tube
 4. MC system
- Use the following alternatives for items 4-45 thru 4-47:
1. 29MC
 2. 61JS
 3. 21MC
 4. 1JS
- 4-45. What is the designation of the antisubmarine attack team control circuit?
- 4-46. Which circuit is used to send contact information until ASW stations are fully manned?
- 4-47. What is the designation of the captain's command system?
- 4-48. Which of the following sound powered circuits is usually one way from sonar?
1. JA
 2. JP
 3. 1JS
 4. 61JS
- 4-49. What feature on some MC units can the operator make use of to avoid interfering with a circuit that is in use?
1. Cutout relay
 2. Flashing light signals
 3. Busy signal buzzers
 4. Monitor headsets
- 4-50. Compared to sound-powered circuits, MC circuits have the disadvantage of
1. providing fewer separate circuits
 2. increasing the general noise level
 3. permitting only one-way operation
 4. requiring central operator control
- 4-51. Target information for antisubmarine attacks is transmitted quickest by
1. sound-powered phones
 2. repeaters
 3. MC circuits
 4. voice tube
- 4-52. Video sonar information is displayed at a remote station by using
1. electro-mechanical repeaters
 2. dial display groups
 3. electronic azimuth-range indicators
 4. MC circuits
- 4-53. The main advantage of radiotelephone over other types of external communications is its greater
1. accuracy
 2. reliability
 3. security
 4. speed
- 4-54. Which of the following message forms is most used by Sonar Technicians?
1. Plaindress
 2. Abbreviated plaindress
 3. Codress
 4. Abbreviated codress
- 4-55. What element of a message follows the call?
1. Heading
 2. Text
 3. Ending
 4. Reply
- 4-56. Coded tactical signals are used to
1. overcome language barriers
 2. reduce chances of enemy interpretation
 3. use less time in transmission
 4. accomplish all of the above
- 4-57. What brevity code word is used to convey the meaning "This is the end of my message; no response is required"?
1. OVER
 2. BREAK
 3. OUT
 4. OVER and OUT

Learning Objective: Understand and make use of the International Morse Code.

- 4-58. You should learn the Morse code using "dit" and "dah" sounds instead of "dot" and "dash" sounds because using "dits" and "dahs", makes it easier for you to
1. separate each individual sound
 2. learn the sound patterns of each letter
 3. count the number of dits in each character
 4. count the beats in each character
- 4-59. Where does the accent usually fall in Morse code letters?
1. On the dit
 2. On the dah
 3. On the first sound
 4. On the last sound
- 4-60. Which of the following practices may help a student to memorize Morse code?
1. Writing the alphabet
 2. Speaking words in code
 3. Visualizing the dits and dahs
 4. Counting the dits and dahs individually
- 4-61. The Morse code sound is in the short sound group for all of the following letters except
1. S
 2. E
 3. N
 4. M
- 4-62. Which time interval should you decrease to increase your code practice speed?
1. Between characters
 2. For each character
 3. Between words
 4. For each word

Learning Objective: Understand the use of prosigns and proper radiotelegraph procedures.

- 4-63. The word "PROSIGN" stands for
1. the first sign
 2. procedure sign
 3. provisional signature
 4. promissory signature
- 4-64. What prosign is used to separate the message text from the ending?
1. AR
 2. BT
 3. II
 4. TR
- 4-65. What prosign is used to indicate the word "from"?
1. AB
 2. BT
 3. DE
 4. WA

● Information for items 4-66 thru 4-70. Suppose your ship (NTLY) is operating with her sister (NMTE) during an independent ship exercise (ISE) period. You have received permission to conduct a CW communication exercise with the sister ship over Gertrude. First you establish communication to see if the Sonar Technicians on the other ship are interested. These items refer to some of the messages you might transmit.

- 4-66. What is the first transmission you make?
1. NMTE DE NTLY K
 2. NMTE DE NTLY BT K
 3. NTLY DE NMTE K
 4. NTLY DE NMTE BT K
- 4-67. After you establish communication, your second message asking them if they are interested will be
1. NTLY DE DO YOU WISH COM DRILL THIS NET BT K
 2. DE NTLY BT DO YOU WISH COM DRILL THIS NET K
 3. NMTE NTLY DC YOU WISH COM DRILL THIS NET OVER
 4. DE NTLY BT DO YOU WISH COM DRILL THIS NET BT K
- 4-68. Which of the following is a correct reply from your sister ship?
1. DE NMTE BT AFFIRMATIVE BT K
 2. NMTE DE BT AFFIRMATIVE BT K
 3. NTLY NMTE BT AFFIRMATIVE BT K
 4. NTLY NMTE BT AFFIRMATIVE OVER

4-69. If, during the drill, you wished to pause for a few seconds to make an adjustment what prosign would you use?

1. AR
2. IMI
3. BT
4. AS

4-70. Later, to conclude the drill, which of the following messages do you send if you expect no reply?

1. NMTE BT THANKS FOR DRILL OUT
2. NMTE BT THANKS FOR DRILL AR
3. DE NTLY BT THANKS FOR DRILL
BT K
4. DE NTLY BT THANKS FOR DRILL
BT AR

Assignment 4

Communications (continued); Maintenance and Safety; Security

Textbook, NAVEDTRA 10130-C: Pages 136 thru 170

Learning Objective: Recognize prosigns and correct radio-telephone procedures.

- 5-1. The adjusting screws on the sides of an unshielded telegraph key are adjusted to
1. prevent the key's movement sideways
 2. prevent the key's movement up and down
 3. provide correct spring tension
 4. provide correct spacing between the contacts
- 5-2. All of the following are correct procedures for using a telegraph key except
1. grasping the key tightly
 2. resting your fingers lightly on the key knob
 3. placing your thumb against the side of the knob
 4. placing your forefinger on the key top
- 5-3. What communication procedure should you use when operating the underwater telephone?
1. Sound-powered phone procedure
 2. MC communication procedure
 3. Radiotelephone procedure
 4. Any of the preceding three procedures
- 5-4. Which of the following calls and endings illustrate proper radio-telephone calling procedure?
1. BLUEBIRD CALLING WALRUS - GO AHEAD WALRUS
 2. WALRUS - THIS IS BLUEBIRD - OVER
 3. WALRUS DE BLUEBIRD - KAY
 4. WALRUS - BLUEBIRD CALLING - OVER
- 5-5. You have received and understood WALRUS' last transmission. To acknowledge receipt, you should reply
1. ROGER - OVER
 2. ROGER WALRUS - OVER AND OUT
 3. OK WALRUS - BLUEBIRD IS OFF AND CLEAR
 4. THIS IS BLUEBIRD - ROGER - OUT
- 5-6. If you make an error in transmitting a message, you should identify the correct version with
1. SAY AGAIN
 2. CORRECTION
 3. BREAK
 4. DISREGARD THIS TRANSMISSION
- 5-7. Which of the following prowords should you send if a substantial delay is necessary during communication with another radio-telephone station?
1. WAIT
 2. STANDBY
 3. QRX
 4. WAIT OUT
- 5-8. You have just received a long message, the last few words of which were obscured by interference. Which of the following replies that you might use conforms to standard procedure?
1. ROGER - BUT REPEAT LAST TEN WORDS
 2. CORRECTION - SAY AGAIN
 3. SAY AGAIN - ALL AFTER AIRBORNE
 4. ROGER - REPEAT BACK LAST TEN WORDS

- 5-9. Which of the following submarine equipments is used for emergency underwater communications?
1. AN/BQC-1
 2. AN/WQC-1
 3. AN/UQC-1
 4. Radiotelephone

Learning Objective: Identify the various flares used for communications.

- Use the following alternatives for items 5-10 thru 5-12.
 1. Green
 2. White
 3. Red
 4. Yellow

- 5-10. What color of flare is used to indicate the submarine has simulated firing?
- 5-11. If a submarine intends to surface, he should fire what color of flare?
- 5-12. What color flare would NOT be used under normal conditions?
- 5-13. Which of the following publications contains detailed information about pyrotechnic signals?
1. ATP-1
 2. NWIP 1-4
 3. AXP-1
 4. FXP-1

Learning Objective: Describe the safety precautions to be observed when using or working on electrical or electronic equipment.

- 5-14. Which of the following voltages often is treated with indifference and is, therefore, the principal cause of electrical fatalities?
1. 600
 2. 440
 3. 220
 4. 115
- 5-15. An index of Navy safety precautions applicable to the operating forces afloat is contained in
1. NAVSEA Technical Manual
 2. NAVSEA 0967-000-0130
 3. NAVSO P-2455
 4. OPNAV NOTICE 5100.19

- 5-16. When you have disconnected and tagged the sonar equipment main power switch, which of the following circuits may still be energized?

1. Remote indicators
2. Heater elements
3. Synchros
4. All of the above circuits

- 5-17. When you go to close a switch you have previously tagged and find another OPEN tag on it, what should you do?

1. Close the switch, and remove your tag only.
2. Close the switch, and remove both tags.
3. Leave the switch open, but remove your tag.
4. Leave the switch open, and remove both tags.

- 5-18. When two people in the same space are working on energized circuits, which of the following qualifications should each have?

1. Ability to secure the power
2. Ability to give artificial respiration
3. Ability to perform first aid for shock
4. All of the above qualifications

- 5-19. Which of the following devices generally are used to discharge capacitors in deenergized equipment?

1. Grounding straps
2. Interlocks
3. Rubber gloves
4. Shorting bars

- 5-20. Electrical potential between equipment frames and the ship's hull is prevented by using

1. ground straps
2. shock mountings
3. interlocks
4. shorting bars

- 5-21. When replacing blown fuses, observe the following safety precaution(s)

1. Secure power when practical
2. Use only proper fuse puller
3. Replace fuse with one of same rating
4. All the above

- 5-22. What do you do to damaged power tool cords to make them safe?
1. Wrap with rubber tape.
 2. Wrap with friction tape.
 3. Shorten to remove the damaged section.
 4. Replace the cord.
- 5-23. Test equipment should be at the same ground level as the equipment being measured to prevent erroneous readings and
1. electrical hazards
 2. damage to test equipment
 3. damage to equipment being tested
 4. capacitive reactance
- 5-24. Tube testers and other portable, externally-powered test equipment are grounded to the ship's hull by the use of
1. grounding straps
 2. three wire electrical cords and connectors
 3. shorting bars
 4. probes
- 5-25. While you and STG3 Smith are working on the equipment, Smith makes contact with an electrical circuit and cannot let go. Nearby, a peacoat is lying on an aluminum chair and you are wearing a web belt. Which of these three articles might you use to remove Smith from the circuit if you could not easily secure main power?
1. The chair or the peacoat
 2. The chair or your web belt
 3. The peacoat or your web belt
 4. Any of the three articles
- 5-26. In the process of treating a person who is not breathing as a result of electrical shock, you might perform all the following acts except to
1. loosen his collar
 2. give him morphine
 3. give him artificial respiration
 4. cover him with a blanket
- 5-27. The most important factor when you administer artificial respiration is to
1. use the mouth-to-mouth method
 2. use the back pressure, arm lift method
 3. begin treatment immediately
 4. call a corpsman

Learning Objective: Explain the operation of the test equipment used in testing and troubleshooting sonar equipment.

- 5-28. What general purpose instrument may you use to avoid carrying several others?
1. Megohmmeter
 2. Multimeter
 3. Ohmmeter
 4. Voltmeter
- 5-29. Which of the following instruments may be used to measure frequency?
1. Multimeter
 2. Voltmeter
 3. Oscilloscope
 4. Megohmmeter
- 5-30. Transistors and diodes can be thoroughly checked by which of the following?
1. AN/URM-127
 2. AN/USM-206
 3. AN/USM-207
 4. AN/PSM-4D

Learning Objective: Describe the testing and troubleshooting procedures necessary for logical and accurate test and repair of sonar equipment.

- 5-31. At what step in the troubleshooting procedure in figure 9-9 of the textbook would you first use a multimeter?
1. One
 2. Two
 3. Three
 4. Four
- 5-32. Which of the following terminal board markings indicate the second board in the fourth unit of the equipment?
1. TB 1402
 2. TB 1420
 3. TB 402
 4. TB 420

- 5-33. What markings do you use on each end of a conductor that connects terminal E6 of board TB 802 to terminal C8 of board TB 202?
1. E6-202-C8/C8-802-E6
 2. C8-202-E6/E6-802-C8
 3. C8-202-E6/E6-202-C8
 4. C8-802-E6/E6-802-C8

- 5-34. Where do you attach cable identification tags?
1. Close to each terminal connection
 2. On the cable at 50 foot intervals
 3. On either side of decks and bulkheads
 4. At all of the above locations

- 5-35. Where do you find a complete list of cable designations?
1. Manufacturer's Technical Manuals
 2. Handbook of Test Methods and Practices
 3. Dictionary of Standard Terminal Designations for Electronic Equipment
 4. NAVSEA Technical Manual; Chapter 9600

- 5-36. A 100 ohm resistor with a silver band may vary in resistance within minimum and maximum values of
1. 95 and 105 ohms
 2. 90 and 110 ohms
 3. 85 and 115 ohms
 4. 80 and 120 ohms

- 5-37. What function does a rheostat normally perform in a circuit?
1. Voltage variation
 2. Current adjustment
 3. Open the circuit
 4. Close the circuit

- 5-38. A variable resistor intended for use as a rheostat may frequently be distinguished from one intended for use as a potentiometer by the
1. number of terminals
 2. color code marking
 3. type of knob
 4. length of the resistor element

- 5-39. The continuity of rheostats and potentiometers is usually tested by using a/an
1. ammeter
 2. voltmeter
 3. ohmmeter
 4. wattmeter

- 5-40. The principal use of a potentiometer in a circuit is to
1. vary voltage
 2. vary current
 3. open and close the circuit
 4. control motor speed

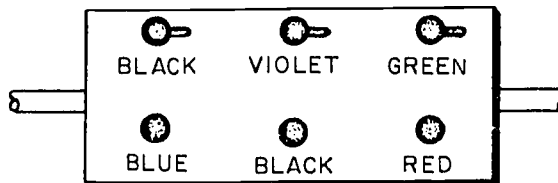

Figure 5A.—Fixed capacitor.

- Refer to figure 9-14 in your textbook and figure 5A in this course for items 5-41 thru 5-43.

- 5-41. What is the value in micro-microfarads of the capacitor shown in figure 5A?
1. 500
 2. 600
 3. 750
 4. 7,500
- 5-42. What is the minimum and maximum capacitance, in micromicrofarads, allowed for the capacitor shown in figure 5A?
1. 600 to 900
 2. 750 to 775
 3. 6,000 to 7,500
 4. 6,000 to 9,000
- 5-43. What dielectric is used in the capacitor shown in figure 5A?
1. Air
 2. Clay
 3. Mica
 4. Graphite
- 5-44. What tolerance is allowed for a capacitor that has three dot code markings?
1. 2%
 2. 5%
 3. 10%
 4. 20%

Learning Objective: Explain the types of maintenance and how each is used to keep sonar equipment operational.

- 5-45. Which of the following publications concerning equipment operating standards are used to assist in carrying out a maintenance program?
1. Manufacturer's Technical Manuals
 2. NAVSEA Technical Manual
 3. Electronic Information Bulletin
 4. 3-M Manual

In items 5-46 thru 5-49, select from column B the type of maintenance described in column A.

A. Work Performed	B. Type of Maintenance
5-46. The Sonar Technician on watch replaces an indicator lamp.	1. Operational 2. Preventive 3. Corrective
5-47. The sonar watch section cleans the air filters while the sonar gear is in a standby situation.	4. Operational or Preventive
5-48. A weak vacuum tube is replaced during a system check.	
5-49. The senior Sonar Technician adjusts a relay that has caused an equipment failure.	

- 5-50. The Standard Navy Maintenance and Material Management (3-M) System does which of the following?
1. Prescribes standard maintenance procedures
 2. Provides feedback for program updating
 3. Replaces all other maintenance programs
 4. All the above

- 5-51. A means of collecting maintenance and supply data in a form suitable for machine processing is provided by
1. PMS
 2. MDCS
 3. MIP
 4. OPNAVINST 4790.4

- 5-52. The MIP frequency code which identifies actions that arise only during specific situations is
1. A
 2. C
 3. R
 4. S

- 5-53. Who is responsible for updating the quarterly schedule?
1. Department head
 2. Division officer
 3. Leading petty officer
 4. 3-M coordinator

- 5-54. An MRC does NOT list which of the following?
1. Tools, parts and materials
 2. Brief description of maintenance required
 3. Safety precautions to be observed
 4. Location of equipment

- 5-55. Which form is designed for reporting discrepancies or suggested improvements in PMS?
1. OPNAV 4790/7B
 2. OPNAV 4790/2K
 3. OPNAVINST 4790.4
 4. All the above

Learning Objective: Be familiar with the definitions of the major elements of security.

- 5-56. What attitude should guide naval personnel in safeguarding classified information?
1. All personnel should refrain from disseminating information about security requirements.
 2. All personnel should make security of classified information a natural element in all tasks.
 3. All personnel should think of security as a function separate from their daily tasks.
 4. Only personnel with security clearances should concern themselves with security requirements.

- 5-57. An instruction indicating the classification, downgrading, and declassification guidance that may be assigned to subjects within a specific area of defense activity is defined as
1. classified information
 2. classification
 3. classification guide
 4. classified material
- 5-58. An individual who determines that official information is in substance the same as information known by him to be already classified by the government as Top Secret, Secret, or Confidential and designates it accordingly is known as a/an
1. competent authority
 2. commanding officer
 3. custodian
 4. classifier
- 5-59. Formerly Restricted Data is so designated by which of the following?
1. Atomic Energy Commission
 2. Department of Defense
 3. Both 1 and 2 above
 4. Secretary of the Navy
- 5-60. Into which of the following categories is classified information divided?
1. Secret, Confidential, and Restricted Data
 2. Top Secret, Secret, and For Official Use Only
 3. Confidential, Secret, and Top Secret
 4. Confidential, For Official Use Only, and Secret
- The following alternatives are for items 5-61 thru 5-66.
1. Secret
 2. Top Secret
 3. Confidential
 4. Restricted Data
- 5-61. What classification is assigned to material the unauthorized disclosure of which could result in exceptionally grave damage to the United States?
- 5-62. Which classification is applied to material of such a nature that its unauthorized disclosure could damage the Nation?
- 5-63. What classification is assigned to mobilization plans of the United States?
- 5-64. What classification is given to information which if disclosed could lead to a break in diplomatic relation affecting the defense of the United States?
- 5-65. Which classification is assigned to devices and material related to communication security?
- 5-66. Which classification is assigned to materials having a nature such that its unauthorized disclosure could be prejudicial to the defense interests of the United States?
- 5-67. According to the text, which of the following pieces of information is most likely to be classified as Secret?
1. Documents concerning disciplinary action, the knowledge of which is to be safeguarded
 2. Frequency and call sign allocations
 3. An important intelligence operation
 4. Security investigations of naval officers
-
- Learning Objective: Define the different types of security areas.
-
- 5-68. Which of the following has to do with "Physical Security"?
1. Transmission
 2. Destruction
 3. Custody
 4. All the above
- 5-69. An area which permits uncontrolled movement of personnel is known as
1. a limited area
 2. an exclusion area
 3. a controlled area
 4. any of the above

Learning Objective: State the requirements of maintaining security of keys and combinations.

- 5-70. When must the keys or combinations to safes or locks be changed?
1. Every 12 months
 2. When a person with knowledge of them is transferred
 3. When a compromise is suspected
 4. When any of the above occur
- 5-71. How many complete turns of a lock is required to secure a safe?
1. At least two
 2. At least three
 3. At least four
 4. At least five

Learning Objective: Be familiar with the parameters of "Personal Security."

- 5-72. Those persons who are entitled to have or know about classified material are those who have
1. the proper clearance
 2. achieved the rank of lieutenant
 3. a "need to know"
 4. both 1 and 3 above

- 5-73. Who, if anyone, in the Navy is allowed access to classified information by virtue of his rank?
1. Admirals
 2. Captains
 3. Both 1 and 2 above
 4. None

- 5-74. Which of the following topics must not be mentioned in personal letters?
1. Casualties to personnel or material by enemy action
 2. Location, identification, or movement of ships or aircraft
 3. Criticism of equipment or morale of the United States or her allies
 4. All of the above topics

- 5-75. When using thermal copy paper to reproduce classified information, what type thermal copy is used?
1. Front coated
 2. Back coated
 3. Uncoated
 4. Any of the above

COURSE DISENROLLMENT

All study materials must be returned. On disenrolling, fill out only the upper part of this page and attach it to the inside front cover of the textbook for this course. Mail your study materials to the Naval Education and Training Program Development Center (PDC).

PRINT CLEARLY

NAVEDTRA Number

10130-C

COURSE TITLE

INTRODUCTION TO SONAR

Name

Last

First

Middle

Rank/Rate

Designator

Social Security Number

COURSE COMPLETION

Letters of satisfactory completion are issued only to personnel whose courses are administered by the Naval Education and Training Program Development Center. On completing the course, fill out the lower part of this page and enclose it with your last set of self-scored answer sheets. Be sure mailing addresses are complete. Mail to the Naval Education and Training Program Development Center (PDC).

NAME

ZIP CODE

MY SERVICE RECORD IS HELD BY:

Activity

Address

ZIP CODE

Signature of enrollee

FINAL QUESTION: What did you think of this course? Of the text material used with the course? Comments and recommendations received from enrollees have been a major source of course improvement. You and your command are urged to submit your constructive criticisms and your recommendations. This tear-out form letter is provided for your convenience. Typewrite if possible, but legible handwriting is acceptable.

Date _____

From: _____

_____ ZIP CODE _____

To: Naval Education and Training Program Development Center (PDD3)
Building 923
Pensacola, Florida 32509

Subj: RTM/NRCC INTRODUCTION TO SONAR, NAVEDTRA 10130-C

1. The following comments are hereby submitted:

.....(Fold along dotted line and staple or tape).....

.....(Fold along dotted line and staple or tape).....

DEPARTMENT OF THE NAVY

NAVAL EDUCATION AND TRAINING PROGRAM
DEVELOPMENT CENTER (PDD 3)
PENSACOLA, FLORIDA 32509

OFFICIAL BUSINESS
PENALTY FOR PRIVATE USE, \$300

POSTAGE AND FEES PAID
DEPARTMENT OF THE NAVY
DOD-316



NAVAL EDUCATION AND TRAINING PROGRAM DEVELOPMENT CENTER (PDD 3)
BUILDING 923
PENSACOLA, FLORIDA 32509

233