

DOCUMENT RESUME

ED 127 190

SE 021 227

AUTHOR Sohre, Beverly, Ed.
 TITLE Parts and Pieces: MINNEMAST Coordinated Mathematics - Science Series, Unit 22.
 INSTITUTION Minnesota Univ., Minneapolis. Minnesota School Mathematics and Science Center.
 SPONS AGENCY National Science Foundation, Washington, D.C.
 PUB DATE 70
 NOTE 138p.; For related documents, see SE021201-234; Photographs may not reproduce well
 AVAILABLE FROM MINNEMAST, Minnemath Center, 720 Washington Ave., S.E., Minneapolis, MN 55414

EDRS PRICE MF-\$0.83 HC-\$7.35 Plus Postage.
 DESCRIPTORS *Curriculum Guides; Elementary Education; *Elementary School Mathematics; *Elementary School Science; Experimental Curriculum; Fractions; *Interdisciplinary Approach; Learning Activities; Mathematics Education; *Measurement; Primary Grades; Process Education; Science Education; Units of Study (Subject Fields)
 IDENTIFIERS *MINNEMAST; *Minnesota Mathematics and Science Teaching Project

ABSTRACT

This volume is the twenty-second in a series of 29 coordinated MINNEMAST units in mathematics and science for kindergarten and the primary grades. Intended for use by second-grade teachers, this unit guide provides a summary and overview of the unit, a list of materials needed, and descriptions of seven groups of lessons. The purposes and procedures for each activity are discussed. Examples of questions and discussion topics are given, and in several cases ditto masters, stories for reading aloud, and other instructional materials are included in the book. The distinction between counting measure and measure of amount is introduced in the first lesson. Subsequent lessons deal with the use of fractions in the measurement of weight, length, mag of angles, time and area. In the final section, rules for calculation with fractions are developed. (SD)

 * Documents acquired by ERIC include many informal unpublished *
 * materials not available from other sources. ERIC makes every effort *
 * to obtain the best copy available. Nevertheless, items of marginal *
 * reproducibility are often encountered and this affects the quality *
 * of the microfiche and hardcopy reproductions ERIC makes available *
 * via the ERIC Document Reproduction Service (EDRS). EDRS is not *
 * responsible for the quality of the original document. Reproductions *
 * supplied by EDRS are the best that can be made from the original. *

U.S. DEPARTMENT OF HEALTH,
EDUCATION & WELFARE
NATIONAL INSTITUTE OF
EDUCATION

THIS DOCUMENT HAS BEEN REPRO-
DUCED EXACTLY AS RECEIVED FROM
THE PERSON OR ORGANIZATION ORIGIN-
ATING IT. POINTS OF VIEW OR OPINIONS
STATED DO NOT NECESSARILY REPRESENT
OFFICIAL NATIONAL INSTITUTE OF
EDUCATION POSITION OR POLICY

ED127190

PARTS

AND

PIECES

22

MINNEMAST

2

21 227

ERIC
Full Text Provided by ERIC

KINDERGARTEN	1. WATCHING AND WONDERING
	2. CURVES AND SHAPES
	3. DESCRIBING AND CLASSIFYING
	4. USING OUR SENSES
	5. INTRODUCING MEASUREMENT
	6. NUMERATION
	7. INTRODUCING SYMMETRY
	8. OBSERVING PROPERTIES
FIRST GRADE	9. NUMBERS AND COUNTING
	10. DESCRIBING LOCATIONS
	11. INTRODUCING ADDITION AND SUBTRACTION
	12. MEASUREMENT WITH REFERENCE UNITS
	13. INTERPRETATIONS OF ADDITION AND SUBTRACTION
	14. EXPLORING SYMMETRICAL PATTERNS
	15. INVESTIGATING SYSTEMS
	16. NUMBERS AND MEASURING
SECOND GRADE	17. INTRODUCING MULTIPLICATION AND DIVISION
	18. SCALING AND REPRESENTATION
	19. COMPARING CHANGES
	20. USING LARGER NUMBERS
	21. ANGLES AND SPACE
	22. PARTS AND PIECES
	23. CONDITIONS AFFECTING LIFE
	24. CHANGE AND CALCULATIONS
	25. MULTIPLICATION AND MOTION
	26. WHAT ARE THINGS MADE OF?
	27. NUMBERS AND THEIR PROPERTIES
	28. MAPPING THE GLOBE
THIRD GRADE	29. NATURAL SYSTEMS

OTHER MINNEMAST PUBLICATIONS

The 29 coordinated units and several other publications are available from MINNEMAST on order. Other publications include:

STUDENT MANUALS for Grades 1, 2 and 3, and
printed TEACHING AIDS for Kindergarten and Grade 1.

LIVING THINGS IN FIELD AND CLASSROOM
(MINNEMAST Handbook for all grades)

ADVENTURES IN SCIENCE AND MATH
(Historical stories for teacher or student)

QUESTIONS AND ANSWERS ABOUT MINNEMAST
Sent free with price list on request

OVERVIEW
(Description of content of each publication)

MINNEMAST RECOMMENDATIONS FOR SCIENCE AND MATH IN THE INTERMEDIATE GRADES
(Suggestions for programs to succeed the MINNEMAST Curriculum in Grades 4, 5 and 6)

PARTS AND PIECES

UNIT 22



MINNESOTA MATHEMATICS AND SCIENCE TEACHING PROJECT
720 Washington Avenue S. E., Minneapolis, Minnesota 55455.

MINNEMAST

DIRECTOR

JAMES H. WERNTZ, JR.
Professor of Physics
University of Minnesota

ASSOCIATE DIRECTOR
FOR SCIENCE

ROGER S. JONES
Associate Professor of Physics
University of Minnesota

ASSOCIATE DIRECTOR
FOR RESEARCH AND EVALUATION

WELLS HIVELEY II
Associate Professor of Psychology
University of Minnesota

Except for the rights to materials reserved by others, the publisher and copyright owner hereby grants permission to domestic persons of the United States and Canada for use of this work without charge in English language publications in the United States and Canada after July 1, 1973, provided the publications incorporating materials covered by these copyrights contain acknowledgement of them and a statement that the publication is endorsed neither by the copyright owner nor the National Science Foundation. For conditions of use and permission to use materials contained herein for foreign publications or publications in other than the English language, application must be made to: Office of the University Attorney, University of Minnesota, Minneapolis, Minnesota 55455.

The Minnesota Mathematics and Science Teaching Project developed these materials under a grant from the National Science Foundation.

© 1970, University of Minnesota. All rights reserved.

PARTS AND PIECES

This unit was developed by MINNEMAST on the basis of the experiences of teachers who used an earlier trial version.

JEANNE BURSHEIM
Research Fellow
University of Minnesota

THOMAS R. POST
Associate Professor of Mathematics Education
Division of Elementary Education
University of Minnesota

PAUL C. REDIN
Assistant Professor of Mathematics
Bethel College and Seminary
St. Paul, Minnesota

ELAINE E. VOGT Writer

BEVERLY SOHRE Editor

SONIA FORSETH Art Director

JUDITH L. NORMAN Illustrator

CONTENTS

Materials List	vi
Introduction	1
Section 1. Two Kinds of Measure	5
Lesson 1 Amount Measure and Counting Measure	8
Section 2. Fractions and Weight	13
Lesson 2 Between Weights	16
Lesson 3 Weighing with a Standard Unit	24
Lesson 4 Fractional Units of Weight	29
Section 3. Fractions and Length	37
Lesson 5 Length — An Amount Measure	40
Lesson 6 Fractional Units of Length	44
Section 4. Fractions and the Mag of Angles	53
Lesson 7 Mag — An Amount Measure	56
Lesson 8 Fractional Units of Mag	63
Section 5. Fractions and Time	67
Lesson 9 Time — An Amount Measure	71
Lesson 10 Tenths of a Second	81
Section 6. Fractions and Area	87
Lesson 11 Area — An Amount Measure	90
Lesson 12 Fractional Parts of Sets	96
Section 7. Calculating with Fractions	103
Lesson 13 Adding Fractions	106
Lesson 14 Subtracting Fractions	111
Lesson 15 ^a Writing Addition Sentences	115
Lesson 16 Writing Subtraction Sentences	118
Lesson 17 Adding Fractions on the Number Line	121
Lesson 18 Subtracting Fractions on the Number Line	124
Appendix: Making a Beam Balance	128

Complete List of Materials for Unit 22

(Amounts based on a class of 30)

total number required to teach unit	item	lesson in which item is first used
30	**Student Manuals	1
9	*beam balance kits, each containing: 1 purple tinkertoy rod 1 green tinkertoy rod 2 red tinkertoy rods 1 blue tinkertoy rod 6 round tinkertoy joints 1 picture hook 12-inch piece of string 1 washer for bob 1 ruler 1 5" x 5" x 5" cardboard triangle 2 paper cups with small holes near the top 2 straightened paper clips masking tape	2
100	*extra cups	2
1	piece of clay equivalent in weight to 8 paper cups	2
30	*magnifiers	2
10	*Ping-Pong balls	2
	assorted small objects, such as pencils, erasers, paper clips, corks or coins	2
30	pencils	3
30 boxes	crayons	3
7 or 8	trays, each containing: *rubber ball, 1½" in diameter *Ping-Pong ball *cork *magnifier *marble *large nail *lead sinker *beam balance and cups	3

30	scissors	4.
1 or 2	blank transparencies	6
1	*china marking pen	6
30	***sets of Minnebars	6
30	*rulers	6
30	**clock protractors (from Unit 21)	7
1	overhead projector	7
1	transparency of clock face with fractions (provided with the lesson)	7
30	**fractional protractors	8
1	stop watch (borrow from principal or physical education teacher)	10
1	masking tape	10
30	*brass fasteners	10

*kit items as well as
**printed materials available from
Minnemath Center, 720 Washington Ave. S.E., Mpls., Minn. 55455
***available from The Judy Company,
310 North Second Street, Minneapolis, Minnesota 55401.

INTRODUCTION

This unit has been designed to teach children what fractions are and how to do simple computations with them. The teaching procedure follows Piaget's theory that, at this level, a number of physical concrete experiences should, wherever possible, precede work with abstractions such as mathematical equations. The unit places a high emphasis on understanding as compared to mechanical deftness and drill. The Teacher Background, which follows, gives the rationale underlying the lessons, and shows how these learnings fit into the child's mathematical education as a whole.

TEACHER BACKGROUND

Children in traditional math programs begin their studies with the whole or natural numbers. A set of rules for operating with these numbers is then presented to them, and they spend a good deal of time trying to become adept in the use of these rules. When some predetermined level of competency is attained by most of the students, a new "system" of numbers is introduced. (This is usually either the set of negative whole numbers or the rationals [fractions].) Little or no attempt is made to relate the new numbers to the numbers already studied. The process is then repeated, beginning with a new set of rules and followed by an appropriate amount of drill to entrench the new method firmly in the student's mind. The process continues until the student is convinced that mathematics consists of an endless series of unrelated parts. Experience shows him that success occurs when he can remember when to do what; it does not encourage him to see how each part fits into a larger picture of mathematics or how his present studies relate to what he has already learned. The connections between the various kinds of numbers and the similarities of their properties are largely ignored.

MINNEMAST writers believe that the student should be shown as much of that larger picture as he can comprehend at his present level. Why should students not be shown that natural numbers, integers and rational numbers are all components of

the larger set known as the real numbers? For your convenience, these components are shown in the following diagram:

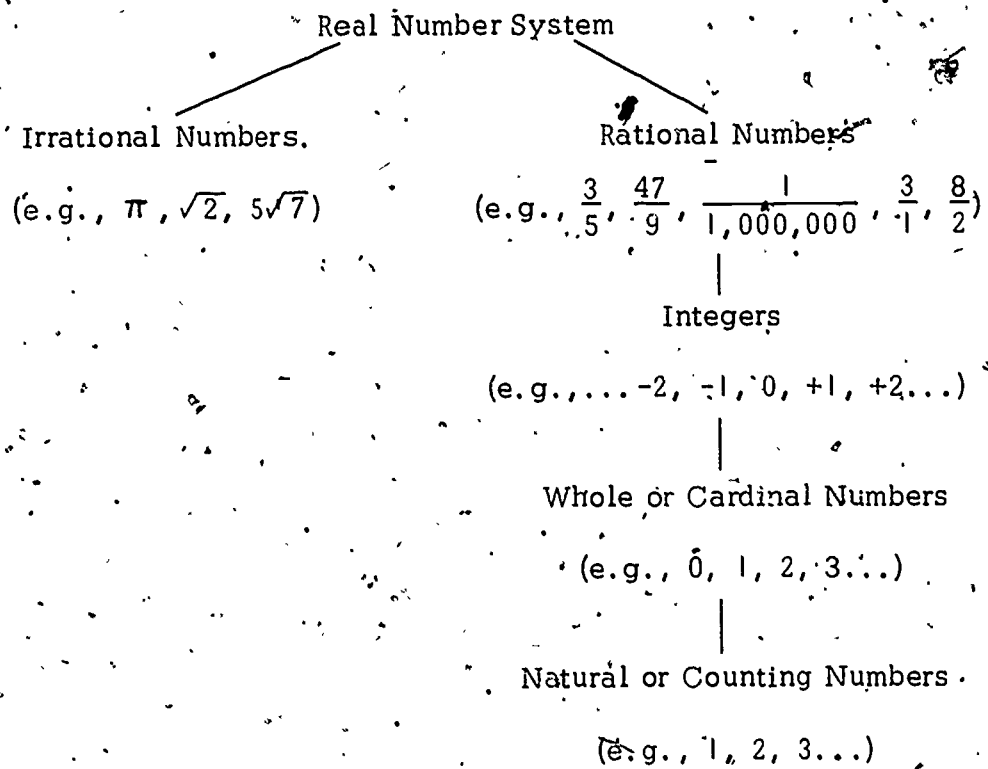

Study of the rational numbers composes most of the mathematical work in an elementary curriculum. The set of rational numbers is often depicted in a Venn diagram-like that shown below. Note that each subset includes the next smaller subset(s). For example, the rationals include all integers, whole and natural numbers. The integers include all whole and natural numbers. Thus:

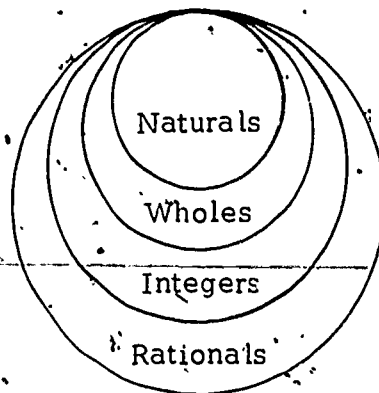

MINNEMAST attempts to alleviate the fragmented student view of mathematics by providing models that will remain adequate throughout the child's experience with the subject, even at high school and college levels. For this reason we emphasize the use of the number line. The real number system is defined as "the set of numbers that can be put in one to one correspondence with the points on a line." For this reason we believe the number line to be a most natural model.

In this unit we attempt to expand the student's understanding of the real number system by formally introducing him to the set of rational numbers. We try to have him develop the need for rational numbers by creating situations that demand a new kind of number. In other words, we present problems that cannot be solved if he uses only the whole numbers. Pilot testing of this unit has shown that children have no trouble in seeing the need for fractions and that they are capable of discussing the use of fractions intelligently.

What About Rational Numbers?

The rational numbers have a property not shared by any set of numbers thus far considered. This property is known as density. When we say that the rational numbers are dense, we simply mean that between any two rational numbers there is always one more.

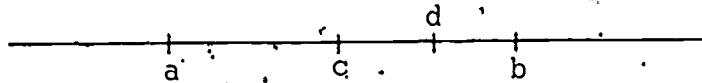

Thus if a and b are rational numbers there is another number c between a and b , where c is also a rational number. We then know that there is another rational number (say d) between c and b . For example, let $a = \frac{1}{4}$ and $b = \frac{3}{4}$. Then c , between them, might be $\frac{1}{2}$. Between $\frac{1}{4}$ and $\frac{1}{2}$ there are still more rational numbers. This process may be continued endlessly, indicating that the set of rational numbers between any two given rational numbers is itself an infinite set. The property of density certainly does not apply when one considers the set of whole numbers, for there is not another whole number between any two adjacent whole numbers. (Choose 5 and 6, for example.) In this unit, we do not develop the notion of density to this degree with the children, but are content if children understand that there are "many, many" points between any two points on the number line.

How Many or How Much?

To develop an intuitive concept of density in young children, we have introduced two distinct types of measure in this unit. "Counting Measure" refers to "how many" or the number of parts into which an object is divided. "Amount Measure" refers to "how much" or the overall quantity of material under consideration. It is when we want to describe an amount measure that we see the value of rational numbers. Amounts are "dense" in the same way that rational numbers are dense. Given two amount measures, we can always find a third amount measure that is between the other two. For example, if we are weighing cheese, there is an amount of cheese that has a weight between, say 4 ounces and $4\frac{1}{2}$ ounces.

Counting measures, however, are not dense. Consider two sets (A and B). Set A has five marbles and Set B has six marbles. It is not possible to find another set with a whole number of marbles between five marbles and six marbles. The marbles are therefore described by a "counting measure."

The concepts of weight, length, angle, time and area are developed in this unit as amount measures. It is our hope that through considering amount measure the children will gain an intuitive understanding of the density of the rational number system. Amount measures are frequently interpreted on the number line in order to reinforce the children's understanding of the density of rational numbers.

TWO KINDS OF MEASURE

SECTION I



"HOW MUCH OR HOW MANY?"



SECTION 1 TWO KINDS OF MEASURE

PURPOSE

- To introduce the children to the difference between an amount measure and a counting measure, in preparation for the work with fractions of which this unit consists.

COMMENTARY

There is only one lesson in this introductory section. The children should have no difficulty seeing the difference between an amount measure and a counting measure and in completing the worksheets. Each problem gives the children a choice between two sets, from which they must choose one as more desirable than the other. For example, Set A might consist of six very small candy bars. Set B might contain three large candy bars whose total content is greater than the combined small bars in Set A. Each child must decide whether he would prefer to have the greater number of candy bars (the counting measure) or the greater amount of candy (the amount measure). For each decision the child is required to explain his choice.

Lesson 1: AMOUNT MEASURE AND COUNTING MEASURE

The purposes of this lesson are:

- to have the children learn the difference between a counting measure, which tells "how many," and an amount measure, which tells "how much"
- to observe that on some occasions one prefers to use the counting measure but on other occasions the amount measure is more appropriate.

Counting measure is used when you are interested in how many members there are in a set. Amount measures, such as weight, volume, area and length, are used when you are interested in how much is in a set. For example, if you were buying a package of marbles, you would want to know how many marbles were in the package, not its weight or volume. But if you were buying a package of rice, you would not care how many grains of rice were in the package but rather how much the package weighed.

MATERIALS

- Worksheets 1 through 5 in the Student Manual

PROCEDURE

Activity A

Distribute the Student Manuals for this unit and ask the children to turn to Worksheet 1. Ask them to imagine that the candy in the sets is real and that they can choose either Set A or Set B. Say that both sets contain the same kind of candy. Then ask the children to make their choices and write in the answers to the questions on the worksheet.

Briefly discuss the children's reasons for choosing Set A or Set B candy bars. (Most children will probably choose Set B because it has more candy.)

Have the children do Worksheets 2, 3 and 4 on their own. Tell them that they should choose the set they would rather

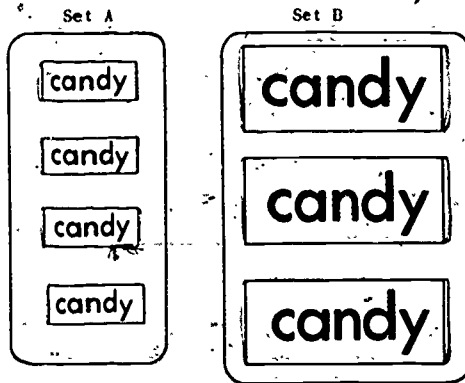

★ Which set of candy bars would you rather have? _____

★ Why? _____

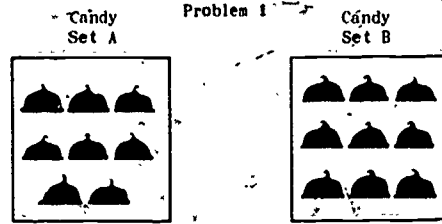
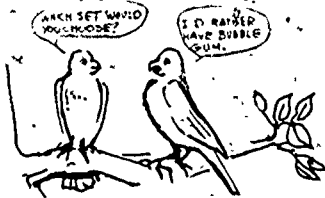

★ Which set would you rather have? _____

★ Why? _____

Problem 2

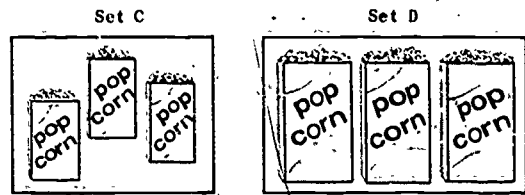

★ Which set would you rather have? _____

★ Why? _____

Problem 3

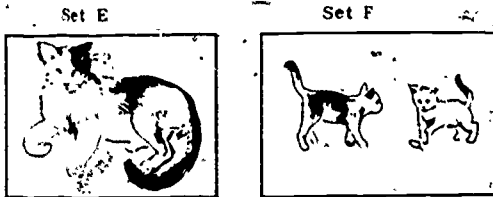

★ Which set would you rather have? _____

★ Why? _____

Problem 4

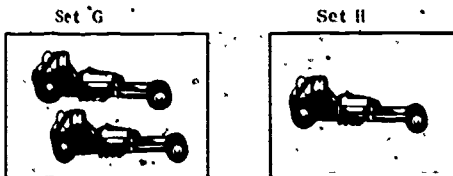

★ Which set would you rather have? _____

★ Why? _____

Problem 5

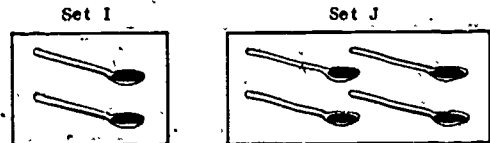

★ Which set of sour medicine would you rather have? _____

★ Why? _____

Problem 6

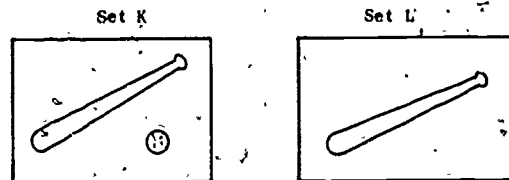

★ Which set would you rather have? _____

★ Why? _____

have in each problem, but you will expect them to be able to give a reason for their choice.

When the children have completed the worksheets, ask each child which set he chose and why. Accept all answers (even when children have chosen the smaller quantity), as long as the child can provide a reason for his choice. Some responses may be unexpected, such as "My mother would not let me have more than one cat," or "I don't like popcorn; it's too salty." Ask the children to think about how they made their decisions. Then provide the following information:

WHEN YOU WANTED TO KNOW HOW MANY, YOU USED A COUNTING MEASURE. WHEN YOU WANTED TO KNOW HOW MUCH, YOU USED AN AMOUNT MEASURE.

You might also wish to write this information on the chalkboard in some such form as this:

1. A counting measure is used when you want to know how many.
2. An amount measure is used when you want to know how much.

Be sure the children understand the meanings of counting measure and amount measure. Amount measures are measures such as length, weight and volume. As you teach this unit, use "how much" and "amount measure" interchangeably. Counting measures are used to refer to the number of objects in a set, or "how many."

Have the children turn to Worksheet 5, which contains examples of situations where one kind of measure or the other is preferred. Ask the children to imagine the following situations and to explain on the worksheet the reason for their choice and the kind of measure they used.

Situation 1 — Abercrombie is very fond of dogs. He likes them so much that sometimes after school he visits all the neighbors who own dogs, just so that he can play with them.

*1

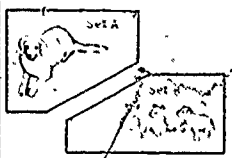

Which set would you choose? _____
Why? _____
What kind of measure did you use? _____

*2



Which set would you choose? _____
Why? _____
What kind of measure did you use? _____

*3

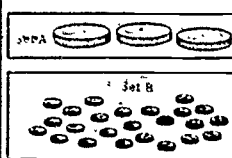

Which set would you choose? _____
Why? _____
What kind of measure did you use? _____

*4

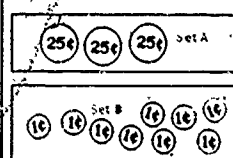

Which set would you choose? _____
Why? _____
What kind of measure did you use? _____

His father and mother have given him permission to keep either the large dog in Set A or the three small puppies in Set B. Which set do you think he will choose? Is he interested in using a counting measure or an amount measure? Why?

Situation 2 — Suppose it is a hot summer day and you and your friends are very thirsty. The bottles in each set contain your favorite kind of pop. Which set will you choose? Are you going to use a counting measure or an amount measure to help you decide? Why?

Situation 3 — Suppose you want to play a game of checkers with your friend. You know that it takes 24 checkers to play, so which set of checkers would you use, Set A or Set B? What type of

measure are you interested in here — the counting measure or the amount measure? Why?

Situation 4 — You are saving money to buy a new bicycle. Which set of money would you rather have, Set A or Set B? Which kind of measure would you use? Why?

But suppose you lost nine of your red checkers and you needed something to take their place. Would you choose Set A or Set B coins? Why? Which kind of measure would you use this time?

After you have gone through all the situations on Worksheet 5, summarize the activity.

SOMETIMES WE ARE INTERESTED IN HOW MANY THINGS ARE IN A SET. THEN WE USE A COUNTING MEASURE. AT OTHER TIMES WE DON'T CARE HOW MANY THINGS THERE ARE IN THE SET. WE JUST WANT TO KNOW HOW MUCH THERE IS, SO WE USE AN AMOUNT MEASURE, SUCH AS LENGTH OR WEIGHT OR VOLUME.





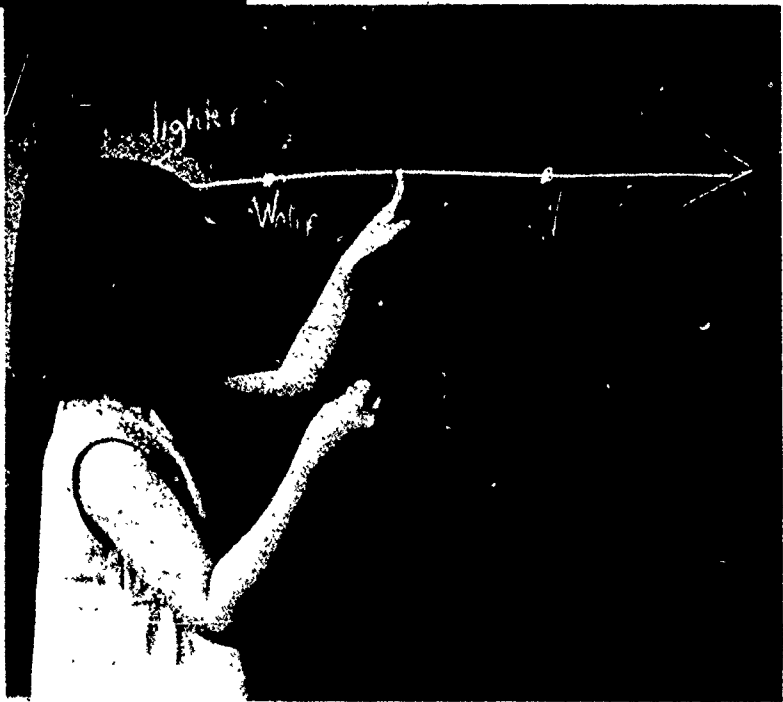

23

SECTION 2 FRACTIONS AND WEIGHT

PURPOSE

- To have the children begin work with weight — an amount measure — as a means of introducing them to several important properties of fractions.

COMMENTARY

In the three lessons of this section the children begin to acquire some insight into three important properties of fractions. These are:

1. That there are many (actually an infinite number of) fractional parts between any two whole units.
2. That there are many (infinitely many) fractions that denote the same amount or point. For example, $\frac{1}{2}$, $\frac{2}{4}$, $\frac{3}{6}$ and $\frac{4}{8}$ all designate the same point.
3. That fractional amounts can be represented and ordered on a number line from least to greatest.

In this section you will be using weight to teach these various properties of fractions. Working with a physical property such as weight prepares the children for the abstract computations with fractions in the final section of this unit. This should be a relatively easy and natural way to introduce the children to fractions since they have had a good deal of practice with the beam balance in previous MINNEMAST units.

In this section the children also review and use symbolic notation, especially the "appears to be the same as" (\doteq) symbol that is so necessary in measuring activities. The idea of measurement as an approximation to an ideal has been emphasized in all previous measurement units. The concept is reinforced here.

Lesson 2: BETWEEN WEIGHTS

The purposes of this lesson are:

- to have the children see that when they measure weight they are using an amount measure
- to show the children that dividing an object into parts affects the counting measure but not the total amount measure
- to have the children discover that there are objects whose weights are between the weights of two other objects.

In Activity A the children fill out two worksheets that show that when an object is broken apart, the counting measure changes but not the amount measure. With a beam balance that you have preassembled, the children demonstrate the same idea with a piece of clay. When broken into smaller pieces, the counting measure of the clay changes, but not the total weight. In this same activity the children are reminded that the "appears to be the same as" (\approx) symbol is used when measuring weight because an amount measurement such as weight cannot be measured with complete precision.

In Activity B the children use your demonstration beam balance to compare the weight of a Ping-Pong ball and a cork. They use the "greater than" ($>$) and "less than" ($<$) symbols for these weight comparisons. Worksheets 7 and 8 provide review and practice in using the symbols.

In Activity C each group of four children constructs one beam balance according to instruction guide sheets provided in the Student Manuals. They then use the balances to place small objects of different weights in order from lightest to heaviest. They record their findings on a line on Worksheet 9 and discover that between any two adjacent weights, there is always an intermediate weight.

MATERIALS

- Worksheets 6 through 9
- "Making Your Beam Balance" (instruction guide sheets in Student Manuals)
- 1 preassembled beam balance and 1 small piece of clay
 - for each group of four (Activity C) --
- 1 beam balance and 11 extra cups
- 1 magnifying glass
- 1 Ping-Pong ball
- assorted small objects, such as pencils, erasers, paper clips, corks or coins

PREPARATION

Assemble one beam balance before class. Use the instructions provided in the appendix to this manual or in the Student Manuals. Also have ready a ball of clay equivalent in weight to eight paper cups.

PROCEDURE

Activity A

Review the meanings of counting measure and amount measure. Remind the children that counting measure tells how many, while amount measure tells how much. Have the children turn to Worksheet 6 and write in their answers to the two problems. When they have finished, hold a discussion about the worksheet.

Worksheet 6
Unit 22

Name _____

* Did the counting measure change when the paper was cut? yes

* Did the amount measure change when the paper was cut? no

* Did the counting measure change when the apple was cut? yes

* Did the amount measure change when the apple was cut? no

They should observe that the counting measure changes when an object is cut apart. Then ask whether they think that the amount measure changes. There may be disagreement on this. The following demonstration should resolve this question.

Have the class gather in front of a demonstration table on which you have placed a beam balance, a ball of clay, and a supply of paper cups.

Ask a child to weigh the clay, using the paper cups as the standard unit of weight. You may have to remind him that the beam is considered balanced when the bob string hangs in the red area of the cardboard triangle. Record the measurements on the chalkboard:

Weight of clay = 8 paper cups (amount measure)

Number of pieces of clay = 1 piece (counting measure)

Ask the children if they remember what the "appears to be the same as" (\approx) symbol means. Remind them that this symbol is used because we can never be sure our amount measurements were made with complete accuracy, even with equipment more precise than the beam balance.

Now have a child break up the ball of clay that was just weighed and form several smaller balls. All the clay should be used, and the smaller balls should be returned to the cup on the beam balance.

As the child puts the clay balls into the cup, have him count them. Record the number of pieces (the counting measure) of clay on the chalkboard. Then ask the children what they think the weight of the clay balls will be. Write their predictions on the board and then have a child use paper cups to balance the beam. Record the weight (amount measure) of the clay in cup units. Have the children discuss the result. Be sure they understand that when the clay was broken up its counting measure was changed, but its amount measure (weight) remained the same. If necessary, lead the discussion with such questions as:

27

HOW MANY PIECES OF CLAY DID YOU WEIGH THE FIRST TIME?

WAS THE COUNTING MEASURE DIFFERENT AFTER YOU BROKE UP THE CLAY?

WAS THE WEIGHT DIFFERENT AFTER YOU BROKE UP THE CLAY?

DID THE AMOUNT MEASURE CHANGE?

DID YOU HAVE THE SAME AMOUNT OF CLAY BEFORE AND AFTER YOU BROKE IT UP?

Close the discussion with a final emphasis on the fact that weight is an amount measure — it tells how much.

Activity B

On the demonstration table, place a beam balance, a Ping-Pong ball and a cork. Ask the children to gather around the table and have them tell you which object they think weighs more — the ball or the cork. Then put the Ping-Pong ball in one cup of the beam balance and the cork in the other. Ask the children to look at the beam balance and tell you which of the two objects is heavier. When a child says that the Ping-Pong ball is heavier, ask how he can tell. (He will probably say that he knows the ball is heavier because the beam is lower on the side that holds the ball.) Then ask the children which object is lighter in weight, and how they can tell. (They should be able to say that the beam is higher on the side that holds the object of less weight — the cork.)

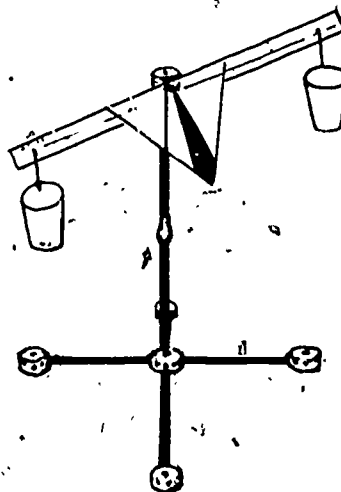

Write the following on the chalkboard:

Weight of Ping-Pong ball $>$ Weight of cork

Ask a volunteer to read what you have written. (The weight of the Ping-Pong ball is greater than the weight of the cork.) Be sure the class remembers the meaning of the greater than ($>$) sign. Remind them that the arrow always points toward the smaller measurement.

Then write:



Weight of cork $<$ Weight of Ping-Pong ball

Ask someone to read the sentence. (The weight of the cork is less than the weight of the Ping-Pong ball.) Reinforce the meaning of the less than ($<$) sign by saying, "The pointed end is always toward the smaller measurement."



Worksheet 7
Unit 22 Name _____

Place the correct symbol in each box.
Use $<$, $>$, or $=$.



The length of the sports car is less than the length of the truck.

Length of  Length of 

The length of the snake is greater than the length of the beetle.

Length of  Length of 



Tom's height appears to be the same as Bobo's height.

Height of  Height of 



Worksheet 8
Unit 22 Name _____

Place the correct symbol in each box.
Use $<$, $>$, or $=$.



The height of the tree is greater than the height of the house.

The weight of the ant is less than the weight of the elephant.

The length of the pencil appears to be the same as the length of the crayon.

Have the children return to their seats and look at Worksheets 7 and 8. Explain that on these worksheets they are going to compare two objects in each problem. Remind them that in each box they must use the greater than ($>$), less than ($<$), or appears to be the same as (\approx) symbols. Then have the children complete Worksheets 7 and 8. (Since these worksheets provide a review of the use of symbols the children have used in previous units, they probably will not need more practice than that provided on the worksheets. If it is evident that they do, give more chalkboard examples.)

Activity C

Divide the class into groups of four children to construct beam balances according to the guide sheets provided in their Student Manuals. Have your assembled balance on display so that the children can refer to it as a model.

Worksheet 9
Unit 22

Name _____

magnifying glass
 Ping-Pong ball

- Put in one cup of your beam balance.
Put in the other cup.
Which is heavier?
Use $>$, $<$, or \approx to write the answer in the box.

w_p	<input checked="" type="checkbox"/>	w_o
-------	-------------------------------------	-------
- Mark a point on the line to show the weight of .
Label it A.
Mark a point on the line to show the weight of .
Label it B.

- Take the out of the cup.
Choose some other object.
Put it in the cup.
Which object is heavier? magnifier
- Can you find a place for it on the line?
Mark the point and label it C.
- Choose another object. Weigh it. Mark a point on the line to show the weight of your object.
Label it D.

When the beam balances are completed, distribute a magnifier, a Ping-Pong ball and at least two other small objects to each group. Ask the children to turn to Worksheet 9. Explain that W is the abbreviation for weight. Tell the children they will be ordering the weights of the group's objects according to the instructions on the worksheet. Encourage them to devise their own system for doing this.

When most of the children have completed Step 4, stop them for a class discussion. Some children may have found it difficult to order those objects of unknown weight which weighed less than the heavy object (the magnifying glass.) In the discussion, the children should tell how they solved the ordering problem.

For example, a child might find that the weight of a coin is less than the weight of the magnifying glass. He would then compare its weight to that of the Ping-Pong ball. If the coin weighed more than the Ping-Pong ball, its point would fall between the two points already on the number line. If it weighed less than the Ping-Pong ball, its point would fall to the left of the other points.

The most obvious general procedure, after having compared the object of unknown weight with the heavier object, is to compare it with the next lighter object. If it is still lighter, it would be represented by a point to the left of the other two points on the line; if it is heavier than the lighter object, the point would go between the other points on the line.

When each group has a workable procedure, have the children return to their work areas, check the answers they already have, and finish ordering their assortment of objects by weight. Each group should order a minimum of four objects.

When the children are finished, hold a short discussion directed at developing the idea that for every two unequal lengths, there can be found a third weight that is between them. This discussion can be enlarged as follows:

Begin by drawing a line on the board. Label one end "lighter weights" and the other "heavier weights" as shown below. Select three objects of different weights (not necessarily the ones in the example) and mark and label points on the line to represent these objects.

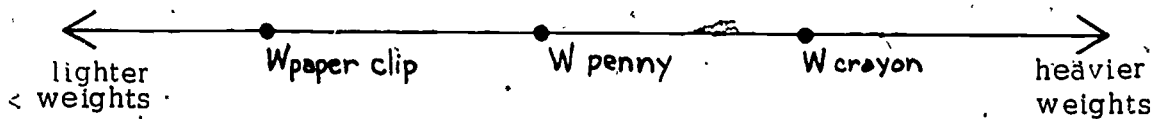

Point out to the class that the weight of the penny (or whatever between weight you have chosen) is between the weight of the paper clip and the crayon. Then ask the children if they think there is any object that has a weight between the

weight of the penny and the weight of the crayon. Have the children find several such objects. They should see that it is possible to have objects whose weights fit your specification.

Have the groups return to their beam balances and look on their trays or in their desks for any object with a weight that falls between the weight of any two adjacent objects on the line. Ask the children to mark these on your chalkboard line. Give help if necessary.

Lesson 3: WEIGHING WITH A STANDARD UNIT

The purposes of this lesson are:

- to have the children discover that the weights of many objects fall between two whole number units of weight
- to associate weight with the number line, and to show that many weights fall between two whole numbers
- to reinforce the idea of weight as an amount measure.

The children use their beam balances in this lesson to measure the weights of several objects. They use the weight of a paper cup as the standard unit. They find that often the weight is not an exact number of cups, but is between two numbers. The children mark on the number line the range within which the exact weight lies.

MATERIALS

- Worksheets 10, 11 and 12
- pencils
- crayons

-- for each group of four --

A tray and the following items from the second grade OMSI kit:

- rubber ball, one and one-half inches in diameter
- Ping-Pong ball
- cork
- magnifying glass
- marble
- large nail
- lead sinker
- beam balance and cups

PREPARATION

Before class, have a child help you arrange on trays the materials needed by each group. (This equipment will also be used in Lesson 4.)

PROCEDURE

Activity A

Have the class gather around a demonstration table, on which you have placed a beam balance and a tray of materials. Briefly review the results of Lesson 2, in which the children found that many objects have weights that are between the weights of two other objects. Show the class the set of objects on the tray. Then ask:

HOW COULD WE USE THIS BEAM BALANCE TO FIND OUT WHETHER THE RUBBER BALL OR THE MARBLE WEIGHS MORE? (Put the ball in the cup on one side of the balance and the marble in the other cup.)

Ask:

WHICH WEIGHS MORE, THE BALL OR THE MARBLE? (The ball.)

HOW MUCH MORE THAN THE MARBLE DOES THE BALL WEIGH? (We don't know.)

HOW CAN WE FIND OUT?

The children should remember using paper cups and paper clips as standard units of weight in their previous MINNE-MAST studies. If they do not, show the paper cups and ask if these could be used as standard units to weigh each object and then compare the weights.

Have a child weigh the rubber ball, using paper cups as standard weight units. The children should see that the weight of six paper cups is not enough to balance the ball, while seven cups weigh too much. This means that the

weight of the rubber ball is between six and seven cups.
Record this on the chalkboard as follows:

W of rubber ball $>$ W of 6 cups, and

W of rubber ball $<$ W of 7 cups.

Read the above as, "The weight of the rubber ball is greater than the weight of six cups and the weight of the rubber ball is less than the weight of seven cups."

Draw a number line on the chalkboard:

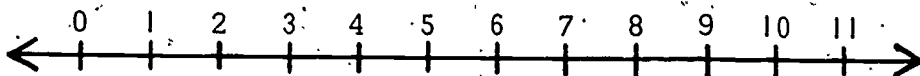

Explain that each one of the marks on the number line represents the weight of that number of paper cups. For example, point 2 represents the weight of two paper cups. (Actually it is the length of the segment from 0 to that mark.) Give a child a piece of red chalk and have him color the part of the number line that represents the weight of the rubber ball (the part of the line between, but not including points 6 and 7). The correct notation for this is:



Be sure the children understand that the point that represents the weight of the rubber ball is located in this portion of the line, but that they do not know exactly where.

Now ask a child to weigh the marble, using paper cups as standard units. (The marble will probably weigh between 3 and 4 cups.) Write the weight on the board:

W of the marble $>$ W of 3 cups, and

W of the marble $<$ W of 4 cups.

Read the above as, "The weight of the marble is greater than the weight of three cups, and the weight of the marble is less than the weight of four cups."

Have a student use brown chalk to mark the portion of the number line that represents the weight of the marble (the part between points 3 and 4). Again make sure the children understand that the point that represents the weight of the marble is located in this part of the number line. It is between three and four cups. Ask:

NOW CAN WE TELL HOW MUCH MORE THE BALL WEIGHS THAN THE MARBLE?

Using the number line, the children should be able to see that the rubber ball is at least four cups heavier than the marble. Some children may also notice that it is at most six cups heavier.

Activity B

Tell the children that they will all have a chance to weigh several objects. Organize the class into groups of four. Tell each group to take a tray of materials and a beam balance to their work area and begin weighing the objects on the tray. Ask them to record the results on Worksheets 10, 11 and 12.

When the children are finished, have them bring their worksheets to the demonstration table. Then draw a number line from 0 through

Worksheet 10 Unit 22		Name _____
<p>● stands for rubber ball. ○ stands for Pink-Pong ball.</p>		
<p>★1. Weigh the ●. Use paper cup units. Fill in the blanks.</p> <p>W of ● > W of <u>6</u> cups, and W of ● < W of <u>7</u> cups.</p> <p>W of ● is between W of <u>6</u> cups and W of <u>7</u> cups.</p> <p>Color the part of the number line that shows the W of ●.</p>		
<p>★2. Weigh the ○. Use paper cup units. Fill in the blanks.</p> <p>W of ○ > W of <u>0</u> cups, and W of ○ < W of <u>1</u> cups.</p> <p>W of ○ is between W of <u>0</u> cups and W of <u>1</u> cups.</p> <p>Color the part of the number line that shows the W of ○.</p>		

ρ stands for magnifying glass.
 α stands for cork.

★3. Weigh the ρ . Use paper cup units. Fill in the blanks.

W of ρ > W of 3 cups, and
W of ρ < W of 4 cups.

W of ρ is between W of 3 cups and W of 4 cups.

Color the part of the number line that shows the W of ρ .

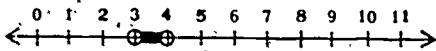

★4. Weigh the θ . Use paper cup units. Fill in the blanks.

W of θ > W of 0 cups, and
W of θ < W of 1 cups.

W of θ is between W of 0 cups and W of 1 cups.

Color the part of the number line that shows the W of θ .

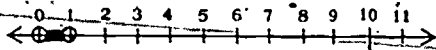

δ stands for sinker.
 Γ stands for nail.

★5. Weigh the δ . Use paper cup units. Fill in the blanks.

W of δ > W of 5 cups, and
W of δ < W of 6 cups.

W of δ is between W of 5 cups and W of 6 cups.

Color the part of the number line that shows the W of δ .

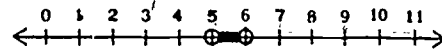

★6. Weigh the Γ . Use paper cup units. Fill in the blanks.

W of Γ > W of _____ cups, and
W of Γ < W of _____ cups.
W of Γ = W of 3 cups.

W of Γ is between W of _____ cups and W of _____ cups.

Color the part of the number line that shows the W of Γ .

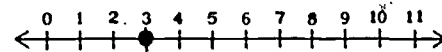

10 on the chalkboard. Ask the children to give you the weight of each object so that you or they can mark the weight on the chalkboard number line. If there are disagreements about the weight of any object, have it weighed again on your demonstration beam balance and mark the agreed-upon weight on the number line. Now emphasize the fact that the weight of only one object (the nail) appears to be the same as the weight of a whole number of paper cups.

Also point out again that weight is an amount measure. Say that if the children were using a counting measure on the number line, they would only be concerned with the points that are whole numbers. But, since they are using an amount measure — weight — they do not always have a number that is a whole number of standard units. There are many weights between two standard weights. Save the worksheets and equipment for the next lesson.

Lesson 4: FRACTIONAL UNITS OF WEIGHT

The purposes of this lesson are:

- to have the children see the need for fractional units of weight
- to review the meaning of fractional notation.

In this lesson, through discussion, demonstration and experimentation, the children should realize that one method of getting a more precise measure of weight is by using fractional parts of their standard weight.

MATERIALS

- completed Worksheets 10, 11 and 12 from Lesson 3
- Worksheet 13
- blue, green, yellow and brown crayons
 - for each group of four --
- tray of objects from previous lesson with pair of scissors added
- beam balance and extra cups

PREPARATION

Before class, add a pair of scissors to each tray prepared and used in Lesson 3.

PROCEDURE

Activity A

Have the children take out Worksheets 10, 11 and 12 and review the results of the previous lesson. Emphasize the fact that most of the weights the children recorded fell between two whole number units. Then ask:

DID ANY TWO OBJECTS WEIGH ABOUT THE SAME NUMBER

OF CUPS? (Yes. The Ping-Pong ball and the cork each weighed between 0 and 1 cups.) Remind the children that the marble, like the magnifying glass, weighed between 3 and 4 cups.

Ask the children to consider first the weights of the Ping-Pong ball and the cork.

DOES THE FACT THAT THE PING-PONG BALL AND THE CORK BOTH WEIGH BETWEEN ZERO AND ONE CUP MEAN THAT BOTH THESE OBJECTS WEIGH THE SAME? (Answers may vary.)

Ask the children how they can find out. A child will probably suggest weighing one against the other with the beam balance. Have him carry out this suggestion. When the children see that the objects do not weigh the same, have another child weigh the magnifying glass against the marble with the beam balance. The class will see that these two objects do not balance either, and are therefore not the same weight. Ask the children to look at the worksheets again, noting that from the marks on the number lines it is impossible to tell that the weights of the Ping-Pong ball and the cork are not the same, or that the weights of the magnifying glass and the marble are not the same. Ask:

CAN ANYONE THINK OF SOMETHING WE COULD DO TO A PAPER CUP THAT WOULD HELP US GET A MORE PRECISE MEASUREMENT OF OUR OBJECTS?

If no child suggests cutting or breaking a paper cup into smaller pieces, hold up a pair of scissors. Then cut a paper cup in half. (You can get fairly precise halves if you cut one side of the cup through the seam, then across the bottom and up the other side.)

Hold up one half of the cup. Ask what part of a whole cup this piece is. (It is one-half.) Have a child write $\frac{1}{2}$ on the chalkboard. Briefly discuss what the fraction means:

THE BOTTOM NUMBER TELLS US INTO HOW MANY EQUAL PARTS THE WHOLE UNIT IS DIVIDED.

THE TOP NUMBER TELLS US HOW MANY OF THOSE EQUAL PARTS WE HAVE.

To show the children that the two halves of the cup are of the same weight, weigh them against each other with the beam balance. If the two halves do not balance, discard them and cut another cup. You should be able to get two halves that balance almost perfectly. If the balance is slightly off, point this out to the children and use it as an example of the difficulty of dividing physical things with precision.

Draw a number line (0 through 5) on the chalkboard. Then, ask a student to weigh the marble on the beam balance, using cups and half-cups. (The marble will probably weigh between $3\frac{1}{2}$ and 4 cups.) Select another student to show the interval on the number line and have him label the point $3\frac{1}{2}$.

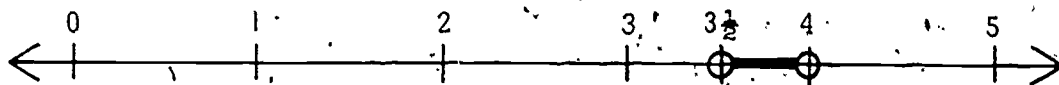

Tell the children that this measurement is more precise than the ones made only with whole cups, but that you would like them to make weight measurements that are even more precise than this. The children should suggest cutting a cup into smaller parts. Follow this suggestion by cutting a cup into fourths lengthwise as precisely as you can.

Ask the class what part of the weight of the whole cups each of these pieces represents. (Each represents one-fourth of the whole.) Write $\frac{1}{4}$ on the chalkboard and discuss the meaning of the notation. Then weigh four fourth-cups against one whole cup to show the weights are equivalent.

A child should also weigh two fourth-cups against one half-cup, so the class can see the equivalence relation. (If

there is a small imbalance, explain that it may be due to cutting errors.)

Now have a student weigh the marble using whole and fourth-cups. (The marble will probably weigh between $3\frac{3}{4}$ and 4 cups.) Draw another number line (0 through 5) on the chalkboard and ask the class where the weight of the marble could be represented on this line. Divide the line segment between 3 and 4 into four equal parts. Explain that each of these parts represents the weight of one fourth-cup. Have the class help you label the points between 3 and 4 with $\frac{1}{4}$, $\frac{2}{4}$, and $\frac{3}{4}$, as shown:

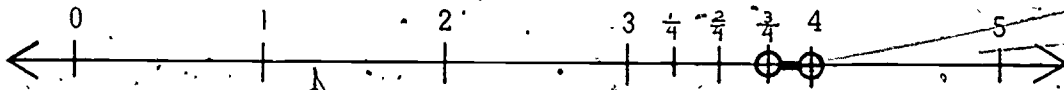

Then have a child show where the weight of the marble would fall. Next ask the class if there is another name for the fraction $\frac{2}{4}$. They should see that $\frac{1}{2}$ is another name for $\frac{2}{4}$. Write $\frac{1}{2}$ above $\frac{2}{4}$ on the number line. To emphasize the equivalence, ask:

DO $3\frac{1}{2}$ AND $3\frac{2}{4}$ REPRESENT THE WEIGHT OF THE SAME NUMBER OF CUPS?

Ask the class if the fourth-cups have given a more precise measure of the marble's weight. (Yes. The range of betweenness on the number line has been narrowed considerably.) Then ask:

HOW CAN WE FIND OUT WHETHER OR NOT THE MAGNIFYING GLASS ALSO WEIGHS BETWEEN $3\frac{3}{4}$ AND 4 CUPS?
(Weigh it, using whole cups, half-cups and fourth-cups.)

Tell the children that in the next activity they will use their beam balances to find the answer.

Activity B

Have the children form groups of four and take a tray of materials and a beam balance to their work areas. Ask them to

- stands for marble.
- ⌒ stands for magnifying glass.
- stands for cork.
- stands for Ping-Pong ball.

W● is between W $3\frac{3}{4}$ cups and W 4 cups.

W⌒ is between W $3\frac{1}{4}$ cups and W $3\frac{3}{4}$ cups.

W○ is between W 0 cups and W $\frac{1}{4}$ cups.

W○ is between W $\frac{1}{4}$ cups and W $\frac{3}{4}$ cups.

Color the part of the number line that shows each weight.

- Use brown for W●.
- Use yellow for W⌒.
- Use green for W○.
- Use blue for W○.

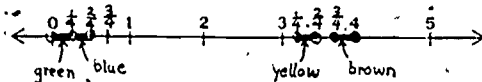

cut one of their extra cups into halves and another cup into fourths. (You may find it necessary to help some groups to insure accurate cutting.) The groups should then use their beam balances and their whole, half and fourth cups to find the information required to complete Worksheet 13:

When all the groups have completed Worksheet 13, discuss their results. The children should now be able to give you a more detailed description of the relation between the weights of the Ping-Pong ball and the cork. They should also describe more accurately the relation between the weights of the magnifying glass and the marble.

Ask the class the following questions:

HOW MANY COUNTING NUMBERS ARE THERE BETWEEN ONE AND TWO? (None.)

- Draw a number line (0 through 5) on the chalkboard and have a child color with chalk the part that is between 1 cup and 2 cups.

HOW MANY WEIGHTS ARE THERE BETWEEN ONE CUP AND TWO CUPS?

Call on several children for answers to this question. Their answers may vary. (Quite a few, very many, hundreds, etc.) On the number line mark several dots between 1 cup and 2 cups. The children should see that if each of these

dots represented a point, they could have many, many points between 1 cup and 2 cups. If each of these points represented a different weight, they could have many, many weights between 1 cup and 2 cups. To make this idea more clear, put two cups in one side of your beam balance and one cup in the other. Say:

IS THERE A COUNTING NUMBER BETWEEN THE ONE CUP ON THIS SIDE OF THE BALANCE AND THE TWO CUPS ON THIS OTHER SIDE? (No.)

To emphasize the point that there are no whole numbers between 1 and 2, but only fractions, do this demonstration: Tear an irregular piece from a paper cup and drop it in the side of the beam balance that has only one cup. Ask:

HAVE I ADDED ANOTHER WHOLE CUP TO THIS SIDE OF THE BALANCE? (No.)

HAVE I ADDED WEIGHT TO IT? (Yes, the beam is closer to being balanced than before.)

Repeat the procedure of tearing and adding pieces of the paper cup to the light side of the balance. Ask the children to watch and see if you add any whole cups. As you drop in the last piece, say:

NOW THE BEAM IS BALANCED AGAIN. WHY?

The children should be able to say that you have added a whole cup to the light side of the balance, even though you did so with a fractional part at a time. Make the point that there were no whole-cup units in between the weights of 1 and 2 cups.

From this experiment elicit two other ideas from the children: (1) that the beam is now balanced because each side has a weight of two whole-cup units in it, and (2) that tearing a cup affected its counting measure (number of pieces), but not its amount measure (total weight of all its pieces).

Conclude the lesson by having the children review the usefulness of fractional parts of a whole unit when dealing with an amount measure such as weight. You can do this by asking the children how many objects that they weighed required the use of fractions. (All except the nail.) You might also ask the children to show, on a number line, how much more precise their weight measurements became when they narrowed them down from whole units to halves, and then to fourths. Say that in the next lesson the class will be studying another amount measure — length — and they will see if fractional units are helpful in measuring that, too.

NOTE: Your class will not be using the beam balances again this year, so each group should disassemble theirs for storage in a plastic bag. The children should unhook the cups, remove the bob string, lift off the ruler (leaving the white and red triangle taped to it) and pull the tall rod from the base. They should also stack the uncut cups and place these in the bag. All of the objects that were weighed (the rubber ball, Ping-Pong ball, marble, sinker, etc.) should be put in the bag, too. This will greatly facilitate your preparation for Unit 16 next year.



SECTION 3 FRACTIONS AND LENGTH

PURPOSE

- To reinforce the learnings that were started in the weight lessons by having the children study another amount measure, length.

COMMENTARY

In the two lessons of this section the children see that length is an amount measure and that fractions are helpful in describing it more precisely, just as fractions were helpful in describing various weights.

The children use symbolic notation on their worksheets when comparing length measurements. The concept that there are many measurements between any two given ones is also reiterated.



Lesson 5: LENGTH — AN AMOUNT MEASURE

The purposes of this lesson are:

- to illustrate that length is an amount measure
- to show that there can be as many different lengths of objects as there are points on a number line
- to motivate the need for fractional parts of a whole number in order to describe length more accurately.

In this lesson the children see that length is also an amount measure and find that whole numbers are inadequate for describing it.

MATERIALS

- Worksheets 14 and 15
- scissors

PROCEDURE

Activity A

Have the children turn to Worksheet 14. Have them complete this worksheet either as a class or individually. Discuss the answers, stressing the idea that in this case they are interested in "how much" (an amount measure) — that is, the total length of the set of objects. You may want the children to think of other cases in which length is the measure to be

Worksheet 14
Unit 22

Name _____

★ Ethelbert likes candy. His favorite candy is licorice. The candy in Set A and Set B is licorice.

★ Which set of licorice do you think Ethelbert will choose, Set A or Set B? Set B

★ Why? It has more candy

Set A



counting measure = 5

Set B

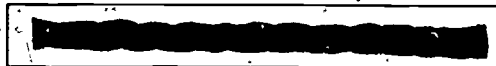

counting measure = 1

★ Is Ethelbert interested in the counting measure or the amount measure of the sets?

Amount Measure

★ Is length a counting measure or an amount measure?

Amount Measure

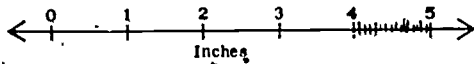

1. Cut out Strips A and B from the bottom of this page.
2. Measure L of A on the number line.
Then fill in the blanks:
L of A > 4 inches.
L of A < 5 inches.
3. Measure L of B on the number line.
Then fill in the blanks:
L of B > 4 inches.
L of B < 5 inches.
4. Are the lengths of A and B the same? No
5. Are their lengths between the same whole numbers?
yes
6. How many other strips can you cut that are between 4 and 5 inches in length? many
7. Try making some of these strips.
Mark the length of each strip on the number line.

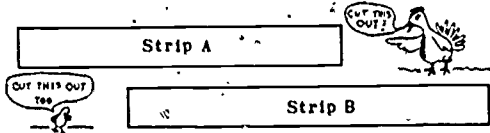

considered; for example in selecting a fishing line, scarf, hair ribbon, or kite string.

Have the children turn to Worksheet 15. Tell them that L is going to be used as the abbreviation for length, just as W was used for weight in previous lessons. Then you may need to review the use of the greater than (>) and less than (<) symbols. To do this draw a line $15\frac{1}{2}$ inches long on the chalkboard. Label it A. Have a child measure line A to see that it is between 15 and 16 inches. Then ask the class to help you use symbols to describe its length:

L of A > 15 inches, and

L of A < 16 inches

Have a child read the above: "The length of A is greater than fifteen inches and the length of A is less than sixteen inches."

See that each child has scissors for Worksheet 15. Ask the children to work in pairs and to feel free to compare answers with one another. Walk about, so that if disagreements arise, you can help the children reach a conclusion.

In answer to Question 6, the children are not expected to be able to anticipate the denseness of the possible lengths. (There are actually infinitely many lengths between the

integral units.) However, the children should be able to predict that there will be at least several possible lengths between 4 inches and 5 inches. After they actually make the strips, as required in Question 7, they should have a better idea of how very many there could be.

In Question 7, the children are asked to make strips with lengths between 4 inches and 5 inches. Provide blank paper and be sure that they understand that each strip should be of a different length. As much as possible, let the individual teams use their own methods for making these strips. When a pair of children think they have finished, encourage them to try to make one or two more strips, to emphasize the fact that there can always be more in-between lengths. The teams should record the lengths of their strips on the number line at the top of the worksheet by marking a point that corresponds with the length of each strip. Some children might create a variety of lengths by cutting successive pieces off the end of the five-inch strip. This is completely acceptable as long as they record each length on the number line as they go along.

In summary, ask the class the following questions:

HOW MANY WHOLE NUMBERS ARE THERE BETWEEN FOUR AND FIVE? (None.)

HOW MANY LENGTHS DID WE FIND BETWEEN FOUR INCHES AND FIVE INCHES? (Many.)

Draw a number line on the chalkboard and color the part that is between four inches and five inches. Then ask:

HOW MANY POINTS ARE THERE BETWEEN FOUR INCHES AND FIVE INCHES? (Very many.)

Discuss with the class the idea that if each of these points represented a different length, they could have many, many (infinitely many) lengths between four and five inches. This discussion should also be compared with the discussion of weight, in which the class found that there are many, many

weights between one cup and two cups. Then ask:

CAN WE DESCRIBE ALL POSSIBLE WEIGHTS USING ONLY WHOLE NUMBERS? (No.)

WHAT OTHER KINDS OF NUMBERS MIGHT WE ALSO USE? ($\frac{1}{2}$, $\frac{1}{4}$, etc.; fractions.)

The children should see that fractional parts of whole units are necessary in order to describe amount measures precisely.

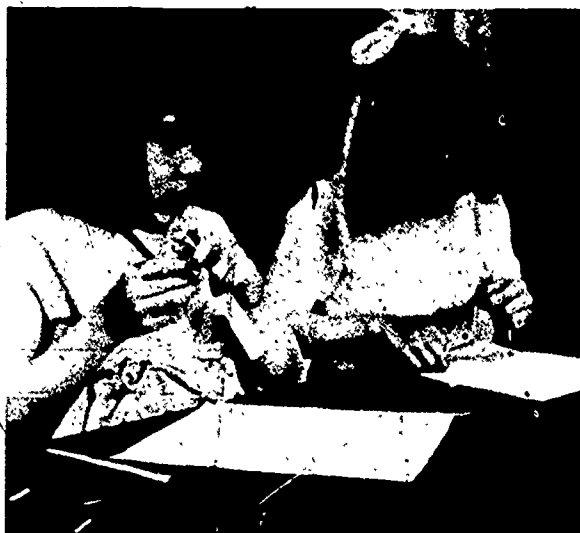

Lesson 6: FRACTIONAL UNITS OF LENGTH

The purposes of this lesson are:

- to have the children associate fractional units of length with the points between whole numbers on a number line
- to have them review the notion that equivalent fractions are different names for the same point on a number line.

The children systematically fold a paper strip into progressively smaller parts and name these lengths on a number line. The resulting fractions are related to Minnebars of corresponding length. The children then compare the various fractions to show that certain combinations of small fractions are equivalent to larger ones. Toward the end of the lesson the children learn about mixed fractions (numerals that represent some whole units and some partial units, such as $5\frac{3}{4}$).

MATERIALS .

- 1 transparency of Worksheet 16.
 - marking pen
- for each child --

- Worksheets 16 through 19
- scissors
- crayons
- set of Minnebars
- ruler and pencil

PREPARATION

After reading the lesson, make a transparency of your full-page copy of Worksheet 16, according to the instructions in Activity A.

52

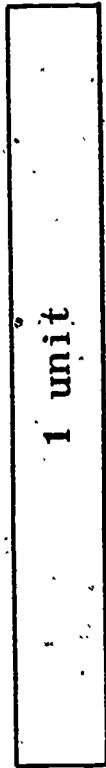

_____ bar $\hat{=}$ L of 1 unit

_____ bar $\hat{=}$ L of $\frac{1}{2}$ unit

_____ bar $\hat{=}$ L of $\frac{1}{4}$ unit

I like Minebars, don't you?



PROCEDURE

Activity A

Worksheet 16
Unit 22

Name _____

1 unit

1 of Dark blue bar = 1 of 1 unit

1 of Yellow bar = 1 of $\frac{1}{2}$ unit

1 of Red bar = 1 of $\frac{1}{4}$ unit

The numbers above

1 unit

Distribute a set of Minnebars to each student. Have the children remove Worksheet 16 from the Student Manuals. Ask them to cut carefully the strip marked "1 unit" from the worksheet. When they have done this, say that this strip will represent one unit of length in this activity. Then ask the children to find a Minnebar that has a length that appears to be the same as the length of the paper unit. (They should select the dark blue bar.) Then they should fill in the first sentence on the worksheet. They may use either a dark blue crayon or they may write out the words:

L of dark blue bar = L of 1 unit

Now ask the children to fold their 1-unit paper strips into two parts that appear equal in length. Then ask:

WHAT PART OF THE LENGTH OF OUR PAPER UNIT IS ON EACH SIDE OF THE FOLD? (One-half.)

Ask a child how he would write one-half on the board. ($\frac{1}{2}$.) Then ask the class what the two on the bottom tells. (It tells into how many equal parts the whole was divided.) Next ask what the top number tells. (It tells how many equal parts of the whole we are talking about.)

Now have the children find a Minnebar with a length that appears to be the same as that of a half unit. When they have found it (the yellow bar); they should check by placing two yellow bars next to the blue bar. Each yellow bar is one-half the length of the blue bar. This information should be filled in on the worksheet with appropriate crayon or writing:

L of yellow bar \doteq L of $\frac{1}{2}$ unit

When this is done, have each child fold his unit strip into four parts that appear to be of equal length. Ask what part of the length of one unit each of these four parts are. (Each is one-fourth.) Discuss the notation that would be used to designate each fourth ($\frac{1}{4}$). Then have the children try to find a Minnebar whose length appears to be the same as the length of a one-fourth unit. When they have decided on the red bar, have them check by placing four red bars next to the blue bar and record the result on the worksheet:

L of red bar \doteq L of $\frac{1}{4}$ unit

Demonstrate to the class how the strip could be divided into eight parts of equivalent length by folding a strip once more. Discuss with the children what part of the whole unit each of these would be. Write $\frac{1}{8}$ on the board and review the meaning of the notation.

Ask the children to put black Minnebars beside the blue one and see how they compare in length. They will see that the length of eight black bars appears to be the same as the length of one blue. Therefore, one black bar is one-eighth unit.

Now have the class place a blue bar on the number line on Worksheet 16 so that one end is lined up with zero. They should mark the point on the number line that corresponds to the length of the blue bar. Then ask the class:

WHAT NUMERAL SHOULD WE ASSIGN TO THE POINT? (1, because it is located one unit from zero.)

Have the children mark the point that is two units from zero.

Then have the class place a yellow bar on the number line so that one end is lined up with zero. They should mark the point on the number line that corresponds to the length of the yellow bar. Then ask:

WHAT NUMERAL SHOULD WE ASSIGN TO THIS POINT?
($\frac{1}{2}$, because the yellow bar is equal to one-half the length of one unit and this point is one-half unit from zero.)

Have the class place another yellow bar next to the first yellow bar. Ask them what this point should be labeled. ($\frac{2}{4}$, because it is two half-units from zero.) They should then place a third yellow bar on the number line and label the point that corresponds to three half-units.

Follow this same procedure with the red bars as you label fourths. Stress each time that the label for the point tells how far that point is from zero. A completed number line should look like the following:

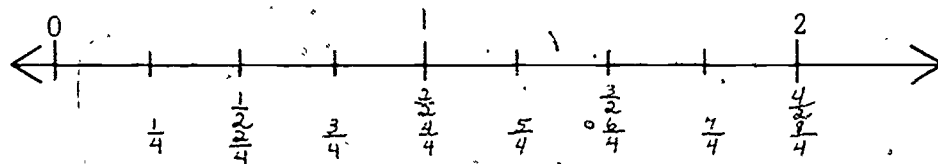

You may want to demonstrate to the class how eighths can be labeled on the number line. Mark your copy of Worksheet 16 with whole, half and fourth units. Make a transparency of it for the overhead projector. Place a black bar on the number line on the transparency. Mark this point and have the class label it. Place another black bar next to the first, mark this point and have the class name it. Repeat this procedure until your number line looks like the one on the next page.

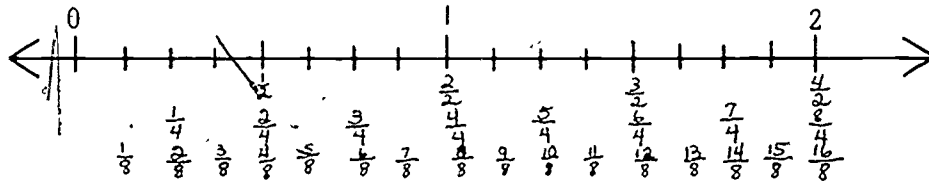

Ask:

HAVE WE NAMED ALL THE POINTS OR LENGTHS BETWEEN 0 AND 2? (No.)

If the class answers yes, put your finger on an unnamed point (say between $\frac{3}{8}$ and $\frac{4}{8}$) and ask for its name. When the children see that all points have not been named, ask:

HOW MANY MORE POINTS DO YOU THINK THERE ARE THAT COULD BE NAMED? (Many.)

Emphasize to the children that many, many points between 0 and 2 (or 0 and 1, or 1 and 2) can be named by fractions.

Activity B

Discuss with the class the notion of equivalent fractions. In this case, the term refers to several fractions that designate the same length. For example, one unit is equal in length to two halves, four fourths, and eight eighths. This can be represented by laying the bars representing these fractions next to the blue bar.

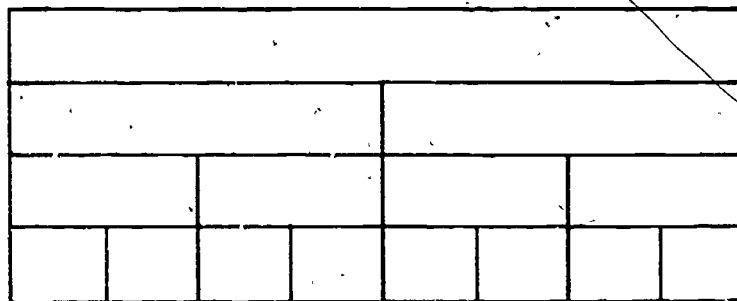

57

Name _____

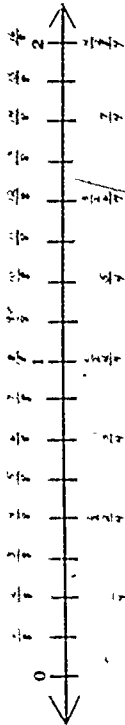

Measure the lengths of these Minibars using the number line.
If a length has more than one name, write down all its names.

- l. of pink bar = $\frac{3}{7}$ units
- l. of tan bar = $\frac{4}{7}$ units
- l. of dark green bar = $\frac{5}{7}$ units
- l. of aqua blue bar = $\frac{6}{7}$ units
- l. of light green bar = $1\frac{1}{7}$ units
- l. of yellow bar = $1\frac{2}{7}$ units
- l. of dark blue bar = $1\frac{3}{7}$ units
- l. of purple bar = $1\frac{4}{7}$ units
- l. of red bar = $1\frac{5}{7}$ units
- l. of black bar = $1\frac{6}{7}$ units
- l. of orange bar = 2 units

The children should see that these are just different ways of naming the same point on the number line and that these names all represent the same value.

Have the children complete Worksheet 17. When they are through, discuss their answers, introducing mixed fraction notation. For example, hold up a pink bar and ask how many units long it is. The children will probably say it is three half-units long. Draw a number line on the chalkboard and label it like the number line on Worksheet 17. Mark the point $\frac{3}{2}$ and show the children that another name for this point is $1\frac{1}{2}$ by drawing arrows as illustrated below. Then repeat the procedure with the tan and purple bars, stressing the mixed fraction names for each.

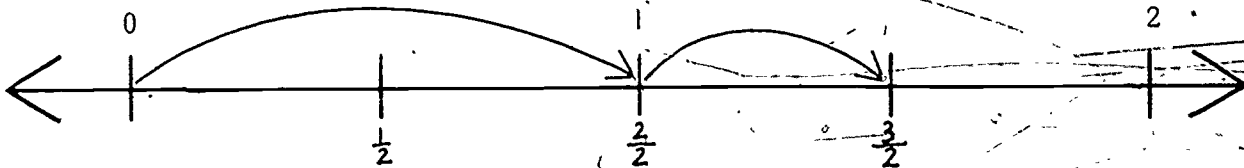

Now have the children do Worksheet 18. This serves as a review of the lesson and incidentally introduces the notation for mixed fractions. Give the children an opportunity to complete this worksheet independently. But if, as you walk about observing their work, you see that the children are having difficulty, ask the class to stop for a discussion of an example. Make this discussion brief. When the children

have finished the worksheet, discuss it with them, using a representation of the number line on the chalkboard.

Distribute a ruler to each child and have the class turn to Worksheet 19. Tell the children to use their rulers to draw lines of the lengths specified on the worksheet. If some children have trouble doing this, you may want to conclude this lesson by having them practice measuring the lengths of various objects in the room. Partners could check each other's work.

Worksheet 18
Unit 22

Name _____

1 unit = 1 inch

- How many inches is point 3 from 0? 3 inches
- Name point A with a numeral. $\frac{3}{2}$
Can you give it another name? yes
What is it? $\frac{3}{2}$
- Color red the point that is $2\frac{1}{2}$ inches from zero.
Label that point $2\frac{1}{2}$
- Color blue the point that is $5\frac{1}{4}$ inches from zero.
Label that point $5\frac{1}{4}$
- Color green the point that is $1\frac{1}{2}$ inches from zero.
Label that point $1\frac{1}{2}$
Can you give that point another name? yes
What is it? $\frac{3}{2}$
- Label the point that is $3\frac{3}{4}$ inches from zero.

Worksheet 19
Unit 22

Name _____

Use a ruler.

*Draw a line that is $2\frac{1}{2}$ inches long.

*Draw a line that is $5\frac{1}{2}$ inches long.

*Draw a line that is $\frac{3}{4}$ inches long.

*Draw a line that is $1\frac{1}{8}$ inches long.

MEASURE MEASURE, THAT'S ALL I DO.

ATURE

123

[Handwritten scribbles]

[Faint handwritten marks]

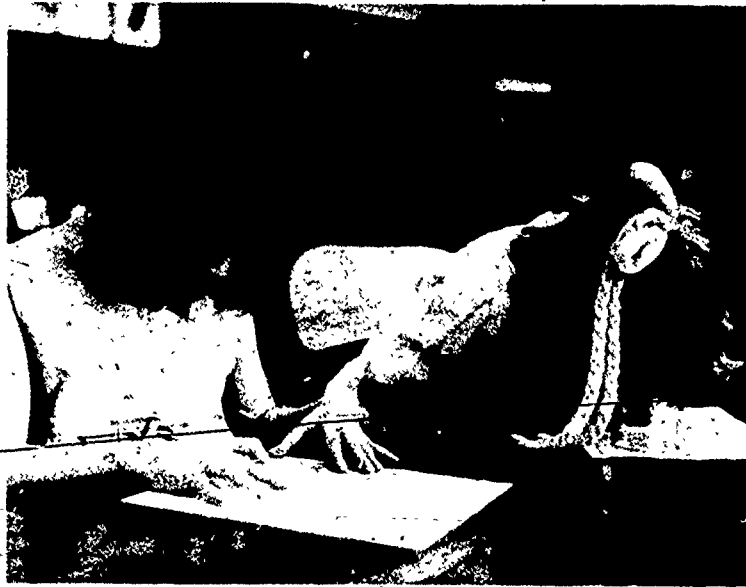

SECTION 4 FRACTIONS AND THE MAG OF ANGLES

PURPOSE

- To introduce the children to still another amount measure, mag of angles, in connection with their work with fractions.

COMMENTARY

In Unit 21 the children learned what an angle is, what the mag of an angle is, and how to measure mag with a clock protractor. In the two lessons of this section of Unit 22, the children review what they have learned about angles in Unit 21 and, at first, use the same clock protractors used in that unit. Then they go on to discover that their mag measurements can be more precise if they use fractions of an hour. They construct a model of one hour that is divided into halves, fourths and eighths. They are then given a new protractor that has these markings around the entire clock face.

The protractors used in these lessons are preparatory to the introduction of the standard degree protractor, which consists of 360 fractional parts or "degrees," and which is used in Unit 26 of the third grade. But the chief purpose here is to build toward the understanding that, as a measuring unit is divided into ever smaller fractional parts, it becomes possible to use it for increasingly precise measurements.

Lesson 7: MAG — AN AMOUNT MEASURE

The purposes of this lesson are:

- to illustrate that the mag of an angle is an amount measure
- to have the children see the need for fractions in describing the mag of an angle with more precision
- to associate the mags of angles with points on a number line
- to have students measure angles with protractors divided into halves, fourths and eighths.

In Unit 21, the children measured the mags of angles to the nearest hour or half-hour with a clock protractor. In this lesson the children attempt to measure several angles with their clock protractors and, in the process, realize that whole and half-number intervals are inadequate to describe these mags. This leads to an activity in which points between hour intervals are named with fractions.

MATERIALS

- 30 clock protractors (from Unit 21)
- Worksheets 20 through 22
- overhead projector
- transparency of clock face with fractions (provided with the lesson)

PROCEDURE

Briefly review angles and angle measurement with the class. The children should remember that an angle consists of two rays with a common origin. Discuss the meaning of the word "mag" as the measure of the amount of rotation from one ray of an angle to the other. The children should recall that any angle can have several different mags, depending on the direction in which it is rotated. Remind the class that the smallest mag of the angle is the one they will use, just as they did in Unit 21.

Unit 22

Clock Face with Fractions

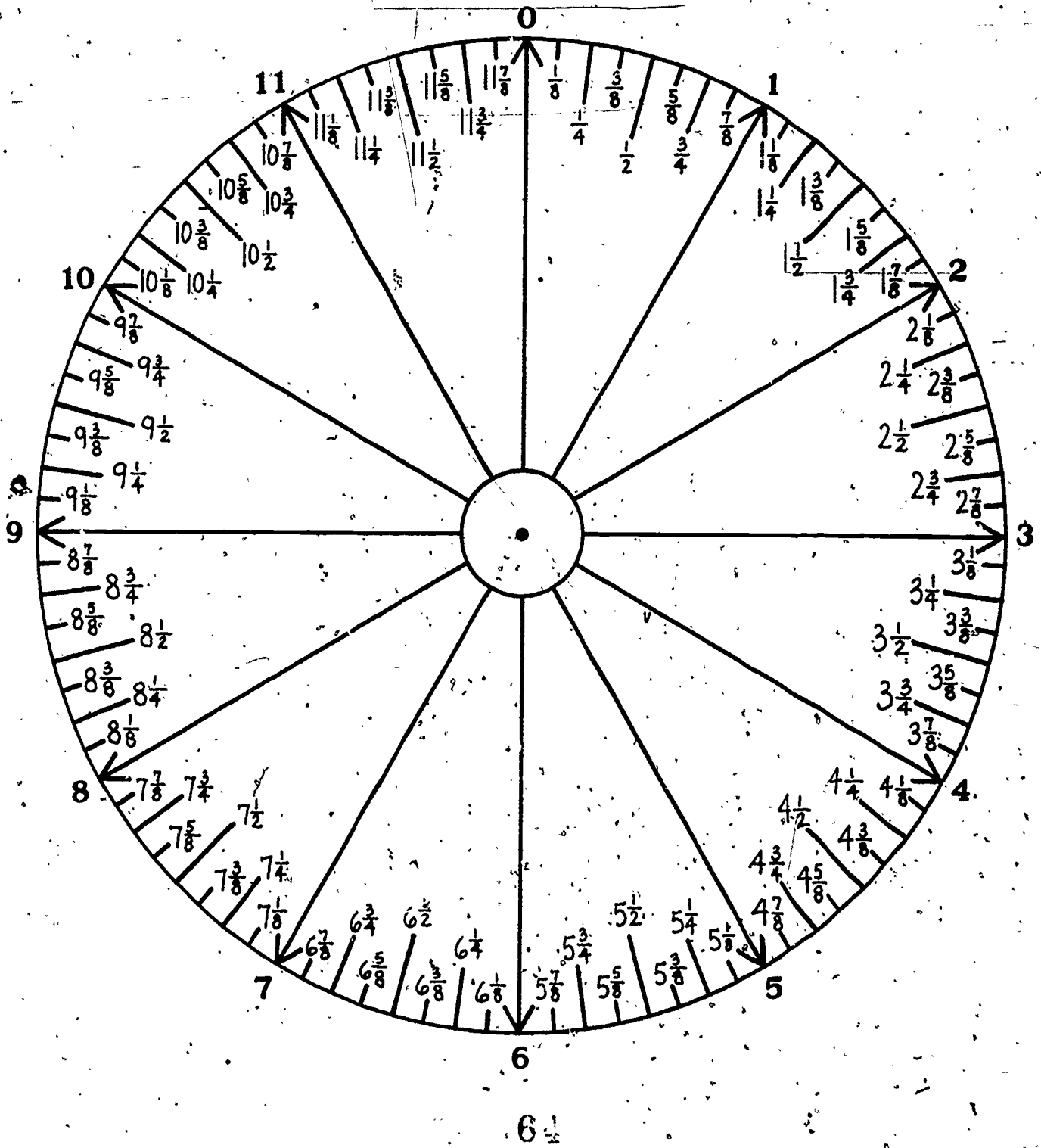

larger mag

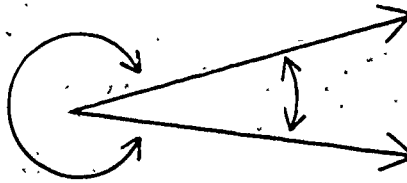

smaller mag

Ask the children if they remember what they used as the standard unit of mag. (The hour on the clock protractors.)

Depending on your class, you may want to discuss and demonstrate this simplified method of measuring the mag of an angle before the children start the worksheets. (For more detailed information, see Unit 21, Angles and Space, Lesson 5.)

Step 1. Place the center of the "clock" on the vertex of the angle.

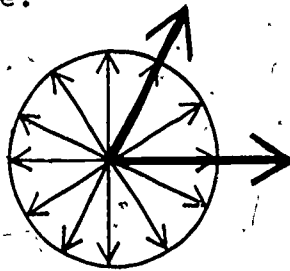

Step 2. Line up one of the clock's rays with one of the rays of the angle.

Step 3. Count the hours on the clock between the angle's two rays.

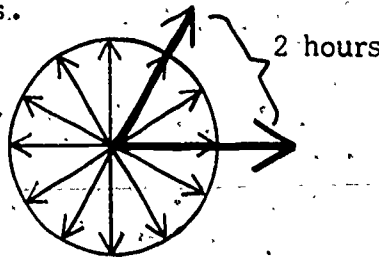

Show the children that the 2-hour mag measurement found in this example could be counted in either direction, clockwise or counterclockwise. (See diagram on the next page.)

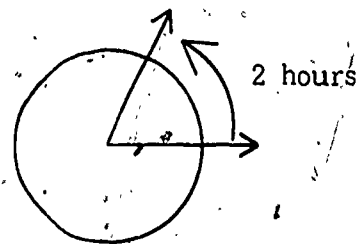
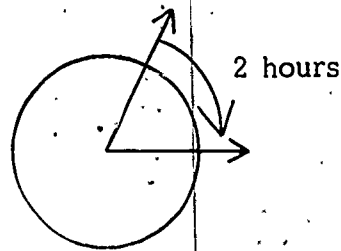

Use a chalkboard example to refresh the children's memories of the notation used in recording the mag of an angle. Draw an angle with a mag of four hours, for example. Have the children tell you what the notation should be. Then write it beside the angle, thus:

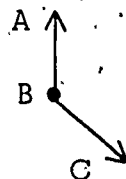

Mag of angle ABC = 4 hours

Have a child read what it says. (The mag of angle ABC appears to be the same as four hours.) Then ask:

HOW WOULD WE WRITE THE MAG OF AN ANGLE THAT FALLS BETWEEN FOUR AND FIVE HOURS?

Some children should remember the type of notation used with weight and length. If not, tell the children that the following notation will be used.

Mag of angle ABC $>$ 4 hours, and

Mag of angle ABC $<$ 5 hours

Write the notation on the chalkboard and read it to the children: "The mag of angle ABC is greater than four hours and the mag of angle ABC is less than five hours." Leave an example of the two notations on the chalkboard. Give a clock protractor to each child. Have the children open their manuals to Worksheet 20 and use their clock protractors to measure the mags of angles on the worksheet. Tell them you want their measurements to be as accurate as possible. When they have

completed the worksheet, discuss their answers. (All of the angle measurements are between one and two hours.) Ask:

CAN YOU DESCRIBE YOUR ANGLE MEASUREMENTS PRECISELY USING ONLY WHOLE NUMBER UNITS? (No.)

WHAT WILL YOU HAVE TO DO TO DESCRIBE YOUR MEASUREMENTS MORE PRECISELY? (Use fractions to name parts of the standard unit.)

DID WE EVER DO THIS BEFORE? (Yes, when we were describing other amount measures such as weight and length.)

IS THE MAG OF AN ANGLE A COUNTING MEASURE OR AN AMOUNT MEASURE? (An amount measure.) WHY? (Because it tells how much rotation there is between the two rays of an angle.)

Worksheet 20
Unit 22

Name _____

Measure each angle.
Then fill in the blanks.

	Mag of ABC > $\frac{1}{2}$ hours, and < $\frac{2}{2}$ hours
	Mag of DEF > $\frac{1}{2}$ hours, and < $\frac{2}{2}$ hours
	Mag of GHI > $\frac{1}{2}$ hours, and < $\frac{2}{2}$ hours
	Mag of JKL > $\frac{1}{2}$ hours, and < $\frac{2}{2}$ hours

Worksheet 21
Unit 22

Name _____

Have the children turn to Worksheet 21. Ask them to describe this worksheet. (It is an enlarged part of the clock protractor, the part between 0 hours and 1 hour.) Then ask:

CAN ANYONE THINK OF A WAY WE COULD DIVIDE THIS HOUR UNIT INTO HALVES? (Someone should remember from the last lesson the folding of the strip of paper into two equivalent parts.)

After tearing the worksheet out of their manuals, the children can fold the paper so that point 0 is lined up with point 1. They should put a pencil mark on the crease. Ask:

HOW SHOULD WE LABEL THIS POINT? ($\frac{1}{2}$.) WHY? (Because it is halfway between zero and one.)

Show this and the following steps on the chalkboard.

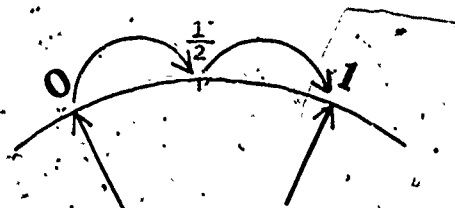

Now ask the children to divide the hour unit into fourths. They should mark at the creases and label the points. Have them follow the same procedure for eighths, if you feel they can do it. Some children may have difficulty folding their papers exactly into fourths or eighths, but at this time the main concern is to have them label these points and understand what each fraction means. A completed hour unit divided into parts and labeled with fractions would look like this:

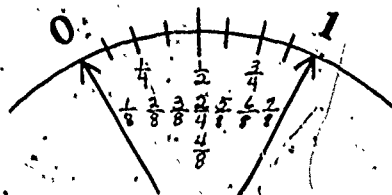

FRACTIONS AND TIME

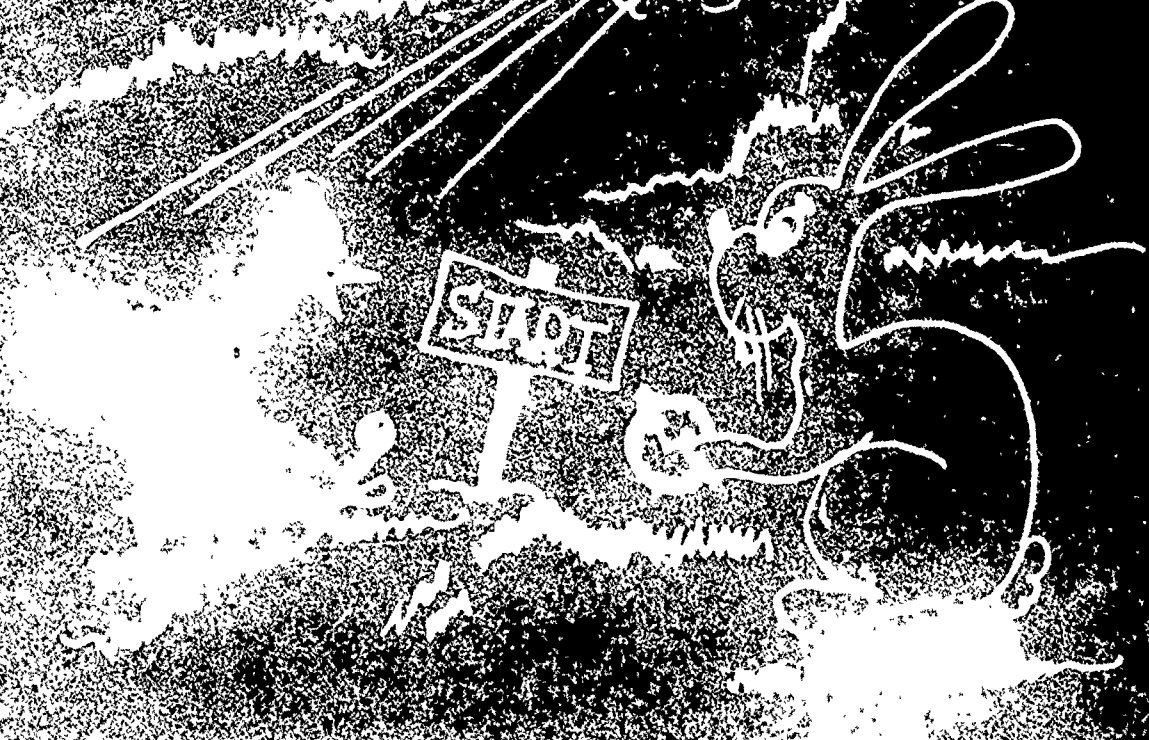
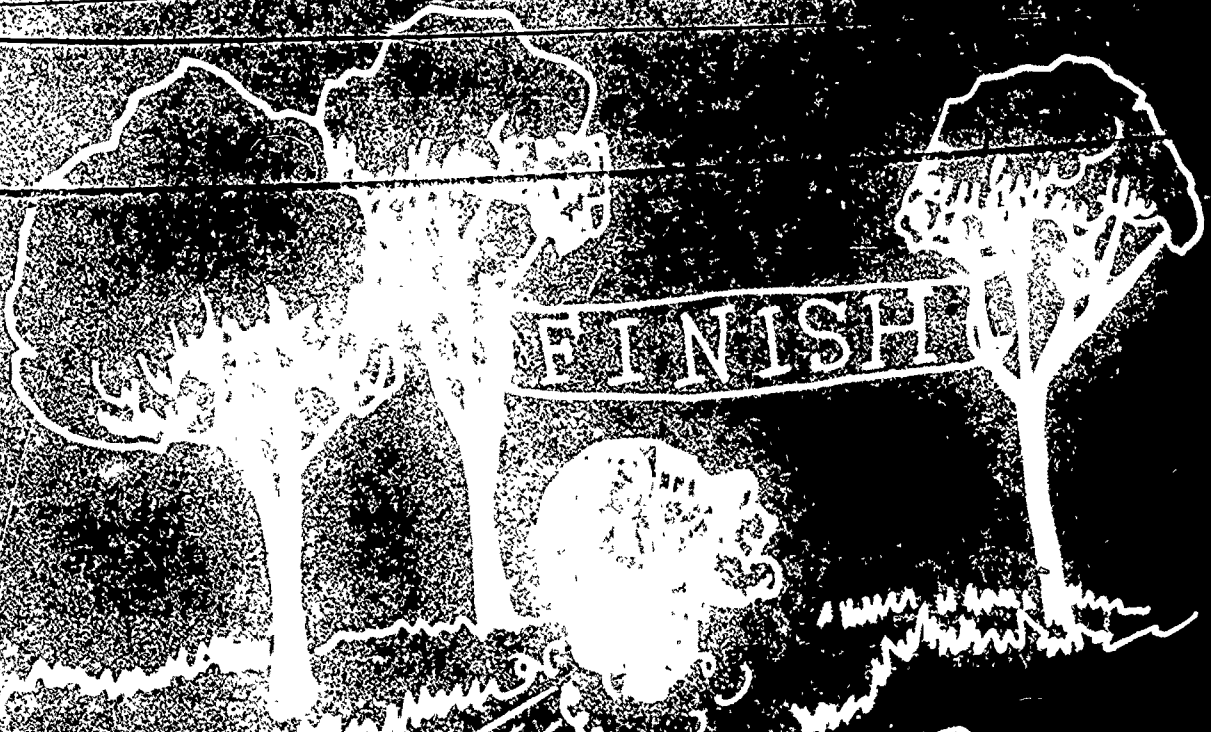

"HE RAN THAT IN A SPLIT SECOND!"

Continue labeling the marks through two on the clock. Use mixed numbers and discuss their meaning with the class. For example, $1\frac{1}{2}$ is one unit plus one-half unit from zero, or one and one-half units from zero. When you feel the children are ready, have them complete labeling the clock through four.

Use the overhead projector and the transparency of a completely labeled clock (provided with the lesson) to discuss the children's labeling of their partial clocks and the labeling pattern that is continued through the remaining hours.

Have the children save their copies of Worksheets 20 and 22 for the next lesson.



Lesson 8: FRACTIONAL UNITS OF MAG

The purposes of this lesson are:

- to provide practice in measuring angles
- to reinforce the idea that fractions are needed to describe the mag of an angle more precisely.

In this lesson the children practice naming points on a circular number line and later measure the angles with a new clock protractor that has fractional divisions.

MATERIALS

- Worksheets 20 and 22 from previous lesson
- Worksheets 23 through 27
- red and blue crayons
- fractional protractor for each child (included with printed materials for this unit)

PROCEDURE

Activity A

Have the children turn to Worksheet 23. Explain that they are to use fractions to determine the names for points R, P, S and K. Tell them they may refer to Worksheet 22 for help, if necessary. When the children have completed Worksheet 23, have them do Worksheets 24 and 25. Then have them check their answers using Worksheet 22 as a partial key.

Activity B

Distribute the fractional protractors to the children and have them compare these new protractors with the ones they used in the last lesson. Have the children measure the angles on Worksheet 26 with the new protractors. Then have them compare their measurements with those on Worksheet 20. The children should see that the mag of the angles on both

worksheets appear to be the same, but that their new protractor permitted them to get more precise measurements. Emphasize the fact that measurement of angles is an amount measure, and that in order to describe measurements of angles more precisely, it was necessary to use fractional parts of units.

If your class needs more practice in measuring angles, have them complete Worksheet 27. Then let the children draw and measure any angles they wish.

Worksheet 23
Unit 22

Name _____

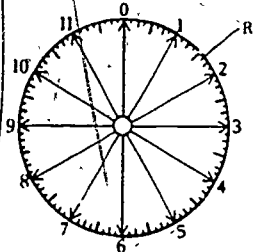
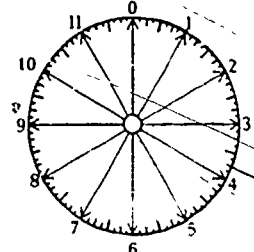
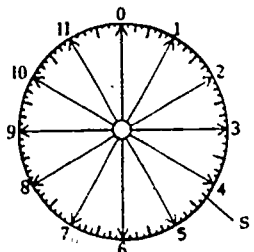
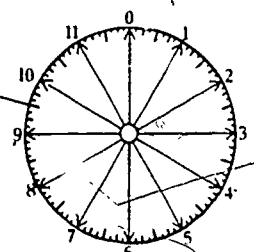
 <p>The fraction for Point R is $1\frac{1}{2}$.</p>	 <p>The fraction for Point P is $3\frac{3}{4}$.</p>
 <p>The fraction for Point S is $4\frac{1}{4}$.</p>	 <p>The fraction for Point K is $9\frac{1}{2}$.</p>

Worksheet 24
Unit 22

Name _____

You will need a red crayon and a blue crayon to do these problems.

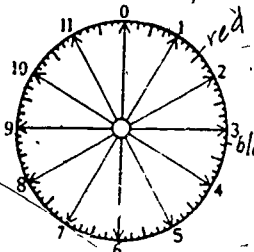
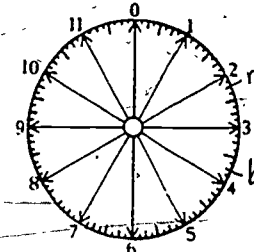
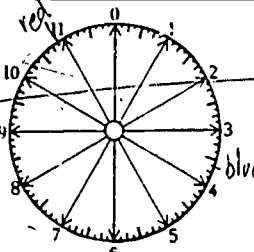
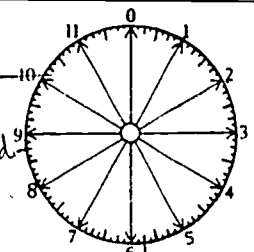
 <p>Color Point $1\frac{1}{2}$ <u>red</u>.</p> <p>Color Point $3\frac{1}{4}$ <u>blue</u>.</p>	 <p>Color Point $2\frac{1}{4}$ <u>red</u>.</p> <p>Color Point $3\frac{3}{4}$ <u>blue</u>.</p>
 <p>Color Point $10\frac{7}{8}$ <u>red</u>.</p> <p>Color Point $3\frac{5}{8}$ <u>blue</u>.</p>	 <p>Color Point $8\frac{3}{4}$ <u>red</u>.</p> <p>Color Point $5\frac{3}{4}$ <u>blue</u>.</p>

Worksheet 25

Unit 22

Name _____

Write the mags of the angles in the blanks.

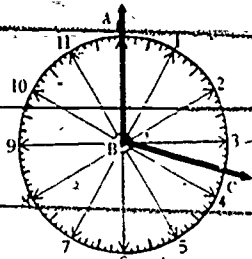

Mag of ABC = $3\frac{1}{2}$ hours.

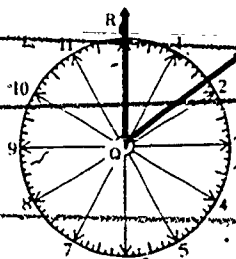

Mag of RQP = $1\frac{1}{4}$ hours.

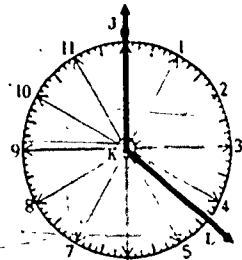

Mag of JKL = $4\frac{3}{8}$ hours.

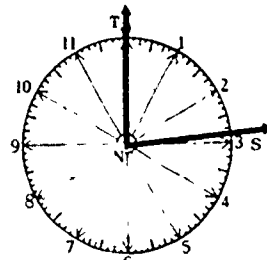

Mag of TNS = $2\frac{1}{4}$ hours.

Worksheet 26

Unit 22

Name _____

Measure each angle.

Then fill in the blanks.

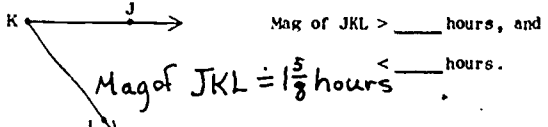
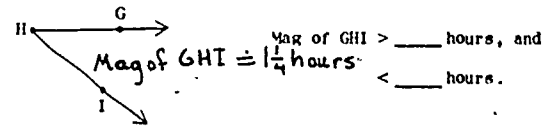
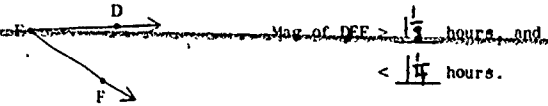
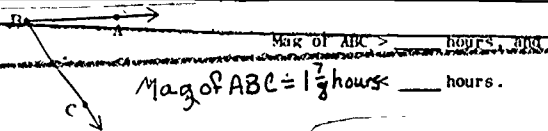

Worksheet 27

Unit 22

Name _____

Measure each angle.

Write your answers in the blanks.

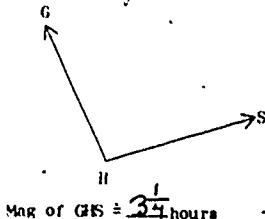
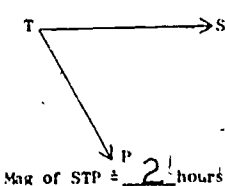
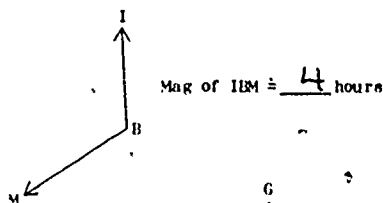
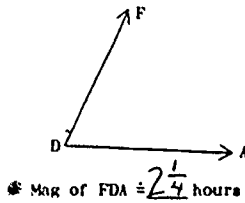
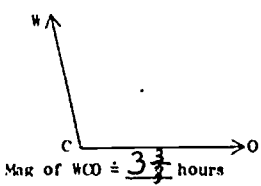

FRACTIONAL TIME SPLIT SECONDS

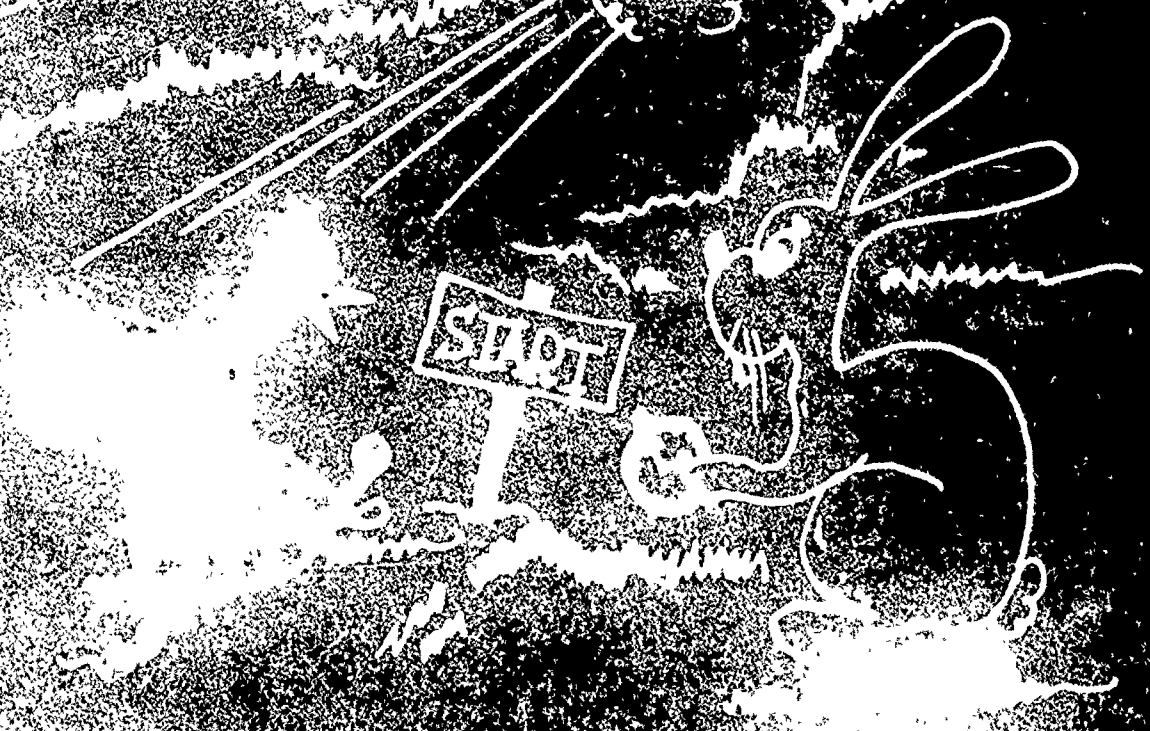
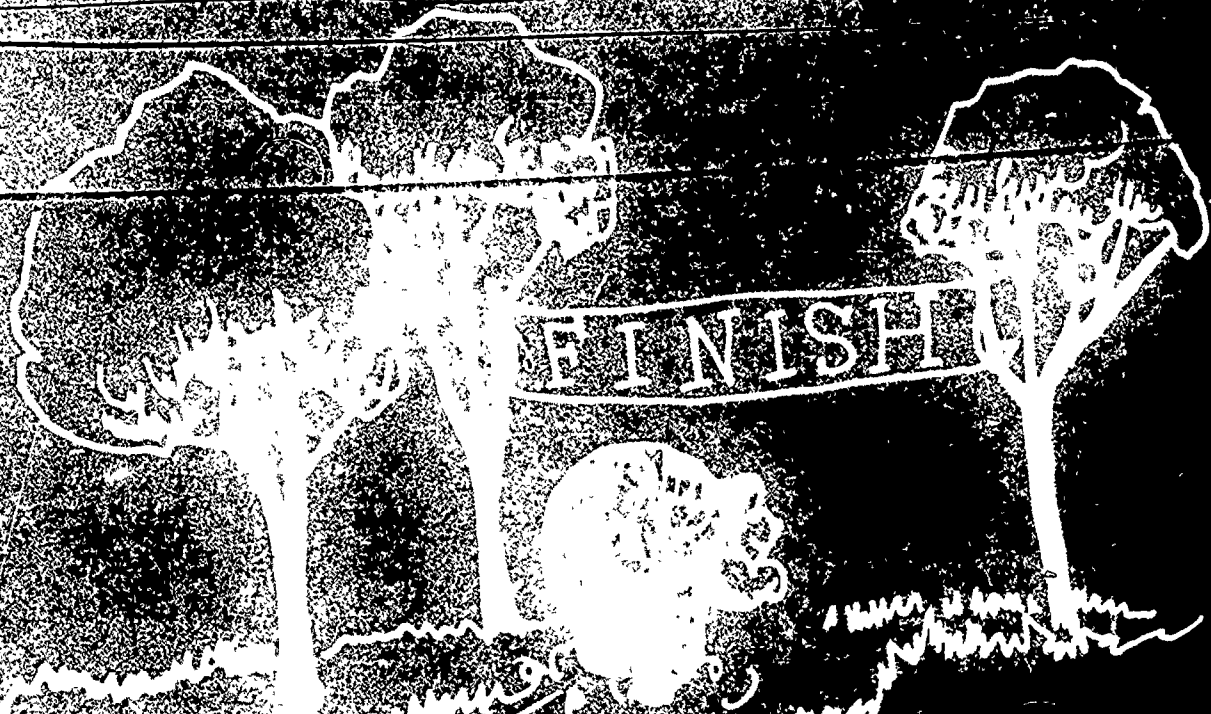

"HE RAN THAT IN A SPLIT SECOND!"



PURPOSE

- To have the children review what they have learned about amount measures in previous sections.
- To introduce the measurement of time as another type of amount measure.
- To improve understanding of the relations between various standard units of time.
- To reinforce the concept of the density of the rational numbers.
- To have the children discover the necessity and usefulness of the three hands (hour, minute and second) on a standard twelve-hour clock.

COMMENTARY

This section has two lessons. Lesson 9 provides a brief review of amount measures and of the usefulness of scaling, and then introduces the measurement of time as another kind of amount measure. By means of scaled-up lines on a Time Chart, the children use fractions to gain an understanding of the relations between five standard time units: day, hour, minute, second, and tenth-second. They learn that an hour is one twenty-fourth of a day; a minute is one sixtieth of an hour; a second is one sixtieth of a minute; and that a second can be subdivided into tenths of a second. Straight number lines are used, as well as a clock face, to reinforce the understandings.

In Lesson 10 the children construct a paper clock that has hour, minute and second hands on it. They come to see the need and use for each hand. Their measurements of durations are refined to tenths of a second.

When work with this section is concluded, the children should see that even such small fractions as those representing tenths of a second could be subdivided again and again. The

idea that, no matter how small a fractional unit may be, it can be partitioned into innumerable smaller ones, is important in understanding fractions. This concept (the density of rational numbers) should be emphasized repeatedly. The children are not expected to be able to say, "Rational numbers are dense," or "There is an infinite number of fractions," but they should be able to hypothesize that there are many many other fractions between any two they study.

Lesson 9: TIME — AN AMOUNT MEASURE

The purposes of this lesson are:

- to provide a brief review of counting and amount measures
- to introduce time as an amount measure
- to develop an understanding of the concept of the density of fractions.

In Activity A the children review the main concepts about amount measure by completing worksheets. The emphasis is on the idea that whole numbers are not always adequate for measuring amounts.

Activity B is a diversion from fractions, but it is necessary to prepare the children for the next activity. It is very brief, being merely a discussion of a worksheet cartoon that reminds the children what scaling-up is.

Scaling-up has been done with each unit of time on the worksheet used in Activity C. This worksheet, or Time Chart, enables the children to compare time lines that represent a day, hour, minute, and second. Relationships between the time units are emphasized. In the process, the children's comprehension of the density of points on a number line is increased.

MATERIALS

-- for each child --

- Worksheets 28 through 32
- magnifier
- ruler
- pencil

Worksheet 28
Unit 22

Name _____

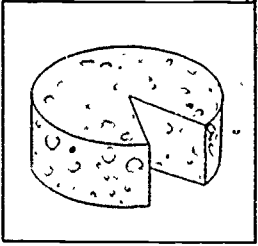

Set A

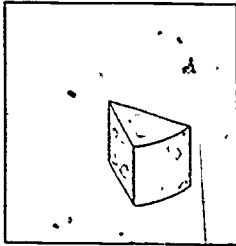

Set B

Is the number of things in Set A equal to the number of things in Set B? yes

Is the amount of cheese in Set A equal to the amount of cheese in Set B? no

Is the weight of Set A equal to the weight of Set B? no

Is weight a counting measure or an amount measure? amount measure

Could we use whole numbers to describe all weights? no

Besides whole numbers, what other kind of numbers do we need? fractions

Worksheet 29
Unit 22

Name _____

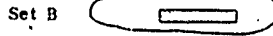
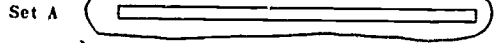

Are the counting measures of Set A and Set B equal? yes

Are the amount measures of Set A and Set B equal? no

Is length a counting measure or an amount measure? amount measure

Do whole numbers describe all lengths? no

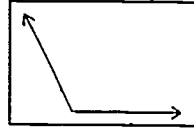

Set C

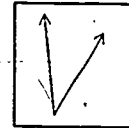

Set D

Is the mag of an angle a counting measure or an amount measure? amount

Besides whole numbers, what other kind of numbers did we need? fractions

Worksheet 30
Unit 22

Name _____

Ruby Robin flew for 5 hours.

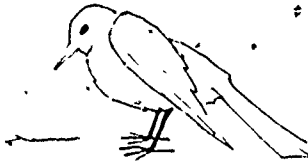

Rosie Robin flew for 1 hour.



Which bird flew for a longer time? Ruby

How much longer? 4 hours.

When a measure tells you how much, it is an amount measure.

PROCEDURE

Activity A

Have the children complete Worksheets 28, 29 and 30 as a class. Whenever necessary, refer to previous activities to refresh the children's memories. Throughout the discussion, emphasize the idea that to describe amount measures adequately, fractions as well as whole numbers are necessary.

The children should notice that each set on Worksheets 28 and 29 has a counting measure of one. Does this mean that the amount measure of each set is the same? Not necessarily; there may be several amount measures (such as volume, weight, area and length) that all describe a set. Therefore, on these worksheets, amount measures are shown that differ obviously for the two sets given on a sheet.

Worksheet 30 introduces the notion of time measurement as an amount measure. This idea will be emphasized in Activity C.

Activity B

Provide each child with a magnifying glass. Then have the children turn to Worksheet 31. The purpose of this worksheet is to remind the children what scaling up is, and does. (They will appreciate its usefulness more in Activity C.)

Ask the children to pretend that the detective in the cartoon has found a very old stone tablet of some kind. He thinks that the markings on the tablet may reveal something very interesting, but he has not been able to make out what they say. However, he hopes that there may be something he can figure out on the last line of the tablet.

Have the children look through their magnifiers at the same line the detective is examining. Ask them to describe what they see. (They will see a line segment labeled AB. They may note that it looks lumpy, and no separate points on the line can be seen.)

Now say that when the detective used a more powerful magnifier, he discovered that line segment AB was made up of a

number of equally spaced dots or points. He was very disappointed and said, "Why this doesn't help me at all!"

Conclude the discussion by eliciting from the children that using a magnifier is one means of scaling up something so that you can see it, and perhaps work with it, better. Say that you think they, at least, will see how useful and helpful scaling up can be when they do the next activity.

Activity C

This discussion activity is built around Worksheet 32, the Time Chart. Before class, look this chart over in a Student Manual. Keep in mind its two chief purposes:

- to have the children see how the various units of time measurement are related in terms of fractions, and
- to lead them to an understanding of the density of fractions.

From their own experience, the children are acquainted with such time terms as day, hour, minute and second. From previous MINNEMAST work in Units 12 and 19, they are also familiar with time lines like those used on the Time Chart. Therefore, the children should be able to contribute substantially to the discussion. The less familiar points that you will want to elicit, when working with the Time Chart, are listed at the top of page 76.

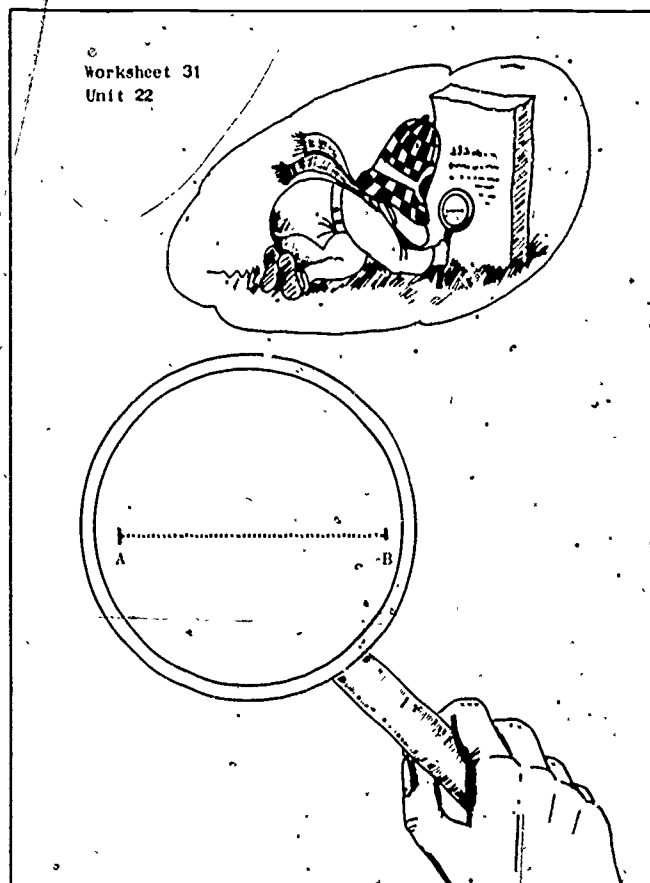

Time Chart

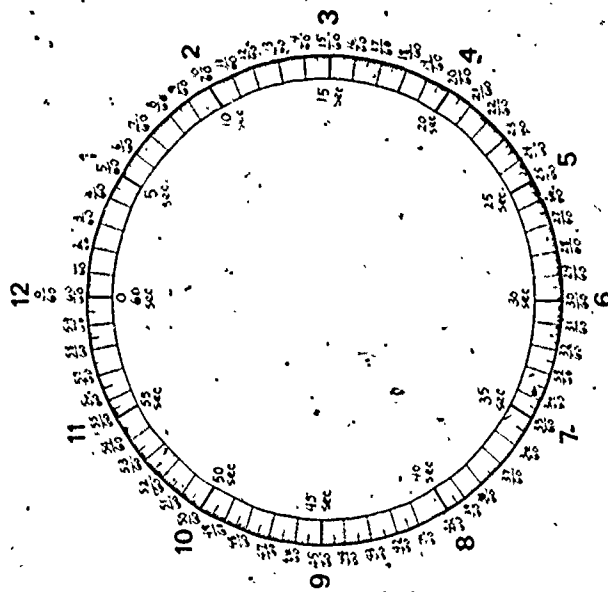
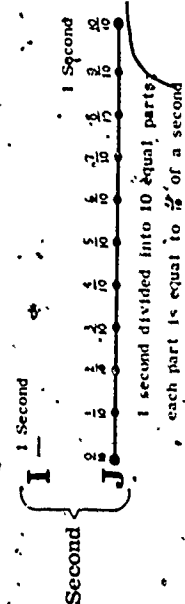
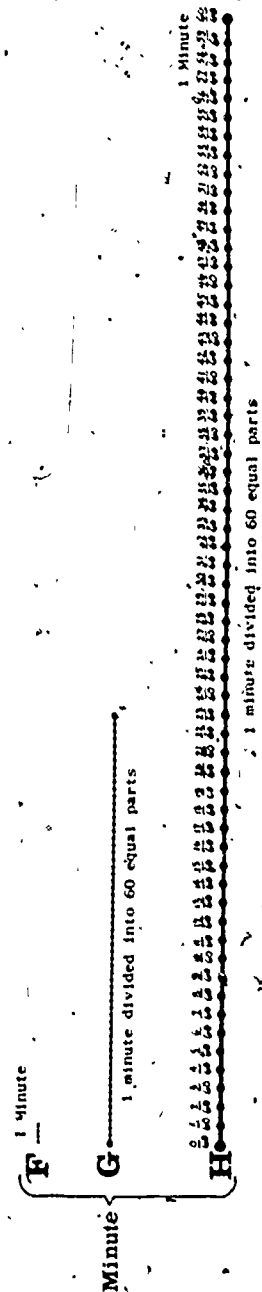
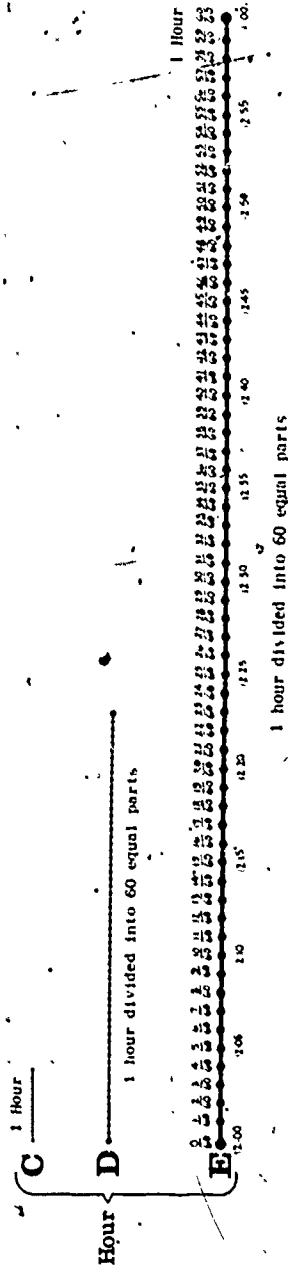
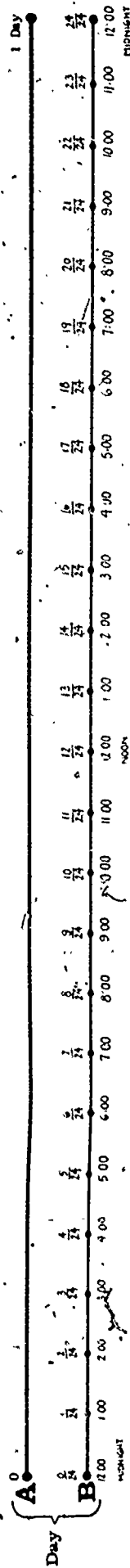

NOTE: Foldout Time Chart in Student Manual is larger and easier to read.

Points to elicit:

- that time is measured with an amount measure and fractions are necessary in using amount measures.
- that 1 day consists of 24 smaller equal fractional parts, each of which is 1 hour.
- that 1 hour consists of 60 still smaller equal fractional parts, each of which is 1 minute.
- that 1 minute consists of 60 even smaller equal fractional parts, each of which is 1 second.
- that 1 second consists of yet smaller equal fractional parts, each of which is a tenth of a second.
- that even so small a unit as one-tenth of a second could be subdivided again and again, and that this process could go on endlessly.

Each child will need a magnifying glass to examine time lines C, F and I, to see the need for scaling up. Each child should also have a pencil and a ruler. When these are provided, ask the children to turn to Worksheet 32 and unfold it.

Begin the activity by asking the children to identify the worksheet as a Time Chart consisting of number lines that are called "time lines." Ask if the number line around the clock face is also a time line. (Yes, but it's in the shape of a circle.)

Now tell the children that, as a class, they are going to discuss the time lines, one line at a time. Then take them through the following procedure, varying it wherever you see fit:

Time line A.

- Have this line identified as representing the duration of 1 day.
- What is missing from line A? What do we need to show on this line? (Fractional parts representing the hours.)

Time line B.

- Is this line the same length as line A? (Yes, it has not been scaled up.)
- How is it different from A? (It shows a duration of 1 day partitioned into 24 equal fractional parts. Each part represents 1 hour.)
- Have the children check a few of the 24 parts with a ruler to see if they are equal.
- With pencils, have each child mark off each fraction with a curved arrow and label it appropriately, like this:

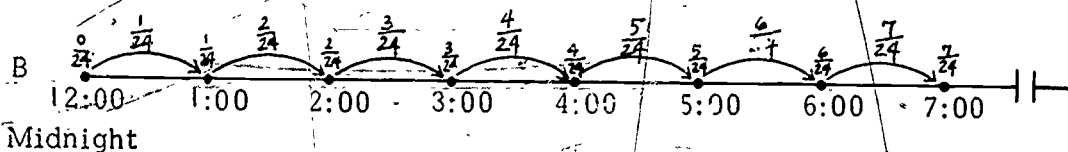

Elicit these relationships:

$$1 \text{ day} = 24 \text{ hours}$$

$$1 \text{ hour} = \frac{1}{24} \text{ day}$$

Direct attention to the numerals below line A. The children should see that each point on the line — each fraction from $\frac{0}{24}$ (midnight) to $\frac{24}{24}$ (midnight again) — represents a time that can be read on the clock face. They should note that:

The duration from $\frac{0}{24}$ to $\frac{12}{24}$ is only once around the clock and is therefore only $\frac{1}{2}$ day. The hours in this duration are called A.M. hours.

The duration from $\frac{12}{24}$ to $\frac{24}{24}$ is also once around the clock and represents the other $\frac{1}{2}$ day. This is the duration from noon to midnight, the P.M. hours of the day.

Give some practice in having the children associate the fractions above the line with clock time by asking what time it is at such durations as $\frac{7}{24}$ from $\frac{0}{24}$, $\frac{11}{24}$ from $\frac{0}{24}$ and so on.

8.

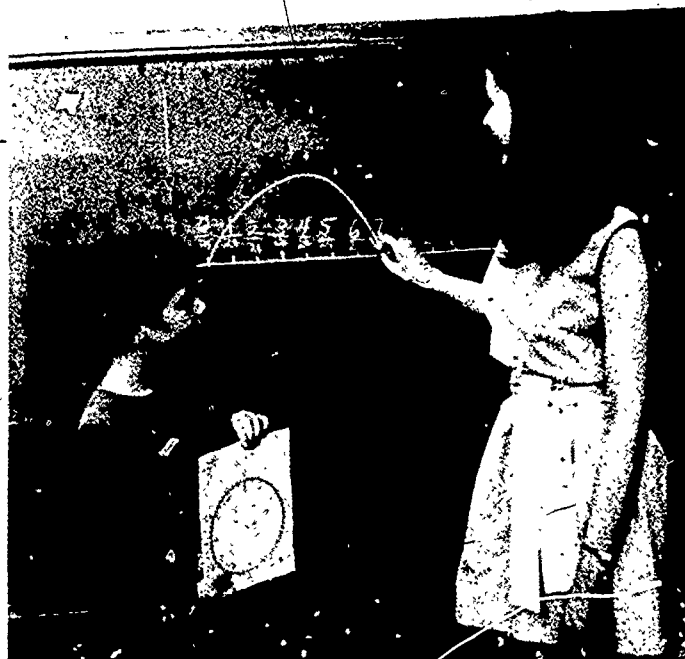

Time line C.

- Have the children use rulers to check the length of this line with the length of any hour on line B, and see if it has been scaled up or down. (No, it's the same length as any of the 24 hours represented on line B.)
- Have the children use magnifiers to see the need for scaling up in order to discern the fractional parts.

Time line D.

- What has happened here? (Line C has been scaled up. The separate points are visible.)
- Is there room now to write in the 60 fractional parts of this line? (No, it has to be scaled up more.)

Time line E.

- What is this line? (It's time line D scaled up so that the 60 equal fractional parts of an hour, the 60 minutes, could be seen better and be labeled.)
- It still represents only 1 hour, only $\frac{1}{24}$ of line B.
- Elicit these relationships:

$$1 \text{ hour} = 60 \text{ minutes}$$

$$1 \text{ minute} = \frac{1}{60} \text{ hour}$$

- Using the numerals under the line, the children should see that the duration represented for each $\frac{5}{60}$ hour represents a duration of 5 minutes.

Time lines F, G and H.

- Have the children examine and discuss each of these lines in the same manner as they did lines C, D and E. They should check to see that line F is the same length as $\frac{1}{60}$ of line E. Then they should see the need for scaling up, and so on.
- They should establish these relationships:

$$1 \text{ minute} = 60 \text{ seconds}$$

$$1 \text{ second} = \frac{1}{60} \text{ minute}$$

Time lines I and J.

- Have the children examine and discuss these lines in the same way they did the hour and minute lines.

- Elicit and emphasize the fact that line J could be scaled up still further to show even smaller partitionings of time units. Do this by asking the children into how many more fractional parts each $\frac{1}{10}$ second could be divided or by asking how long this process of partitioning could go on. Acceptable answers for this age group are, "We could go on partitioning forever and ever," or "We could find many, many more fractions in between these, if we scaled up more."

You might like to use the chalkboard to record the children's summary of the time relationships they have found. You might also wish to have them reiterate that time measurement is an amount measurement, and to discuss the value of scaling up.

Save copies of Worksheet 32 for the next lesson.

NOTE: The materials used in this activity and in the next lesson could be used to give the children practice in clock-reading skills. With their increased understanding of how the different time-measuring units relate to each other, the children's clock-readings should be more meaningful than the rote method used by many children to tell time.

However, clock-reading is not a purpose of this unit. Only you can decide whether your class should have this extra reinforcement at this point or not. If you would like to provide practice in clock-reading, see Lesson 11 (pages 57-61) of Unit 19. There you will find suggestions for helping the children distinguish between A.M. and P.M., and some ideas for worksheets. In fact, you may even discover that you have kept some worksheets for "use later in the year," as was suggested in Unit 19. These could be used now.

Lesson 10: TENTHS OF A SECOND

The purposes of the lesson are:

- to have the children discover the usefulness of measuring events of short duration
- to provide practice in making and recording such measurements
- to improve their understanding of the standard twelve-hour clock
- to learn that a standard unit of time, as well as a numeral, is necessary in specifying a duration:

The children discuss and see the necessity for fractions that represent very short durations of time. They learn to recognize and record these fractions. Then, with the help of a stop watch, they see and record the time taken by each of several runners to cover a short distance. The races are intentionally designed to be run in the classroom where it would be impractical to have more than one child running at a time. This sets up a need for the stop watch and for working with seconds and tenths of a second.

During this lesson the children cut out second, minute and hour hands from a worksheet and fasten them to a paper clock face. As they learn how each hand measures time in relation to the other hands, they see the necessity and economy of having three hands on the clock. (If there were only one hand, a twelve-hour clock would have 3600 equal fractional parts just to represent the minutes and seconds in one hour!) The ideas presented are closely associated with the density concepts of the previous lesson. In fact, all of the activities of this lesson are practical applications of the work the children did with the Time Chart.

MATERIALS

- 1 stop watch (borrow from principal or physical education teacher)

- masking tape
- for each child --
- Worksheet 32 from Lesson 9
- Worksheet 33
- 1 brass fastener
- scissors
- pencil

PREPARATION

Before class, place a strip of masking tape near the front of the room. This will be the starting line for the races the children will be running. In line with this, place another strip of tape at the back of the room. This will be the finish line. The distance between the start and finish lines should not be more than fifteen feet. The finish line should be located at a safe distance from the wall and from other obstructions.

PROCEDURE

Activity A

Ask the children to look at their Time Charts from the previous lesson and have them discuss whether or not such a small unit of time as one-tenth of a second is useful. They should be able to suggest a number of uses. For example: timing a snap of the fingers, timing a wink of the eye, timing the click of a camera shutter, deciding who won at track events, and deciding a close finish of any sort.

Have the children discuss the possibility of measuring time in even smaller units, such as those they might insert between the tenths of a second on time line J. The children should see that they can partition the tenths again and again, especially if they scaled up the line. However, they may not know of any need for such tiny time measurements, so you may wish to tell them that some scientists use special clocks that can measure a millionth, or even a decillionth, of a second. Such

clocks can measure a duration much much smaller than a wink of the eye or a snap of the fingers.

Now bring out the stop watch and show the children how it works. Explain that it is called a "stop" watch because it can be stopped at any point. Then direct their attention to the clock face on their Time Charts. Discuss the numerals found on the inner circle. Have the children compare the second intervals with those on time line H. Discuss the relationships between time line H and the circular number line on the clock face.

Next have the children turn to the clock face on Worksheet 33. Explain that this is a larger version of the clock on the Time Chart. Have them cut out the second hand and attach it to the center of the clock face with a brass fastener.

When the children have done this, explain that as you count off seconds, using the stop watch, you want them to rotate the second hand on their "clocks". They are to start with the second hand at zero. If you wish, you may count off the first ten and the last ten, giving the children a chance to set their second hands accordingly. When all the children have rotated the second hand once around their clocks, ask if they could express

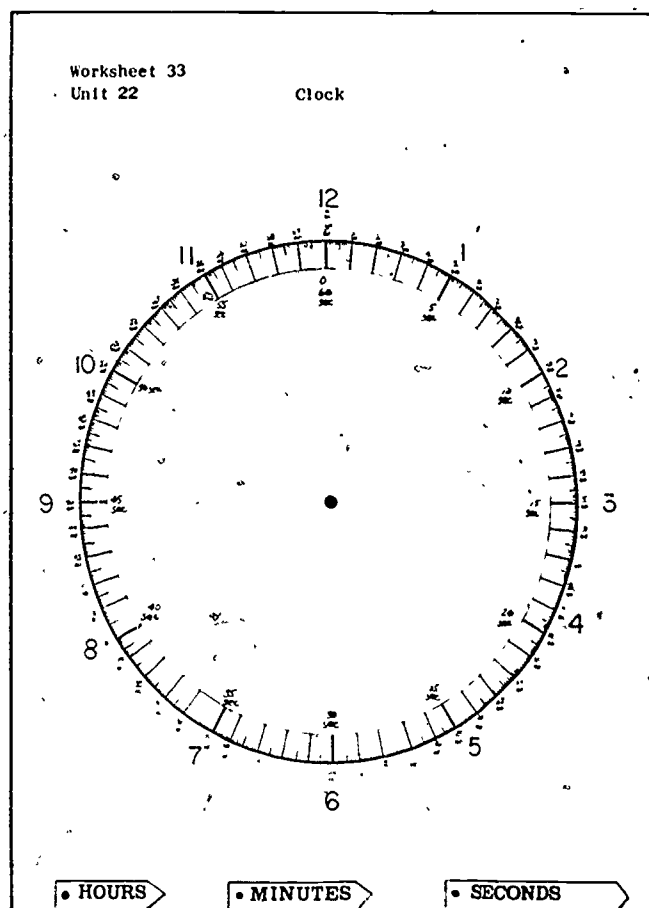

50

"sixty seconds" using a different standard time unit. They should see that one complete rotation of the second hand is equivalent to one minute. Have them check this on the Time Chart, if necessary.

Ask the children to rotate the second hand from zero to seven. Then ask them to move the hand to seven and three-tenths seconds. Check their work and have them discuss reasons for pointing the second hand as they did. They should see that each second is divided into ten equal parts, and that each of these parts represents one-tenth of a second. Give additional practice by having the children rotate the second hand to several other points, using seconds and tenths of seconds. They should now be able to record on their clocks any durations that will occur in connection with the races in the next activity.

Activity B

Show the children the start and finish lines on the classroom floor. Say that five children are going to run this distance, one at a time. You will use the stop watch to find out how long it takes each child to run this distance. Each student will then mark the runner's name next to the point on the clock that shows how many seconds and tenths of seconds it took for him to run the race.

Select five children to do the running. Place yourself near the finish line. When you say "Go" and start the watch, the first runner should run. Stop the watch as soon as he reaches the finish line. Have another child read the stop watch and tell the class how many seconds and tenths of seconds it took this first runner to run the race. (Be sure to hold the stop watch yourself at all times, as it is a precision instrument and can be easily damaged.) Each child should now record the name of this first runner near the appropriate point on his clock face. Continue this procedure for all five runners. When all five students have raced, have the children look at their clocks and tell you who won.

Depending on class interest, you may want to have other groups of children run the race, too.

Activity C

Ask the class why standard clocks (like their classroom clock) have more than one hand. What problems might there be if they had just a second hand, or just a minute hand, or just an hour hand? Encourage the children to look at their clock faces and Time Charts as you elicit and discuss these ideas:

- (1) If there were only a second hand on the clock, it would be very difficult to keep track of how many minutes or hours had gone by since zero.
- (2) If there were only a minute hand, each of the sixty units would represent one minute. To tell seconds, people would have to divide the minute units into sixty equal parts. The points would be so close together that they could not be seen.
- (3) If there were only an hour hand, each of the twelve hours would have to be divided into sixty equal parts to show the minutes, as on time line E. To show seconds, each of those minutes on time line E would have to be divided to sixty equal parts again. Obviously, a clock would have to be extremely large to show so many fractional parts. It would not be practical to have such large clocks.

Ask the children how this problem was solved. (By putting three hands on the clock: one to keep track of the hours, one to keep track of the minutes, and one to keep track of the seconds.)

Have the children now cut out the hour and minute hands from Worksheet 33 and fasten them in place. Ask them to put the hour hand beneath the minute hand and the second hand on top of the minute hand.

All hands should be pointed to zero. The children should rotate the second hand one complete revolution. When they have done this, they should move the minute hand to one minute. Have the children do this several times, or as many times as you think necessary.

Indicate that when the second hand completes sixty revolutions, the minute hand will have completed one full revolution, and the hour hand will be pointing to $\frac{1}{12}$. If you wish, discuss the relative speeds of these hands as demonstrated on the class clock — that is, each time the second hand makes one complete revolution the hour hand moves one-twelfth of a revolution. Do not dwell on the specific details of the relationships if the children are having difficulty in understanding them.

Tell the children to set their clocks to show "a duration of one." They will probably be confused and not know which clock hand to move. Ask why they can't decide. In the ensuing discussion, elicit and emphasize this idea: The numeral assigned to an amount measurement, such as the measurement of time, has no meaning unless one knows what unit of measure is being used. When speaking of a duration, it is necessary to specify the unit, thus: 1 hour, 1 minute, 1 second, 1 day, 1 month, 1 year, etc.

This concludes the work the children need to do with time measurement for the purpose of this unit. If you wish to provide more clock-reading activities, refer to the note at the end of Lesson 9.



3
Handwritten scribbles

Handwritten scribbles

Handwritten scribbles

Handwritten scribbles



SECTION 6 FRACTIONS AND AREA

PURPOSE.

- To introduce the measurement of area as an amount measure requiring the use of fractions.
- To have the children work with this new amount measure and associate their area measurements with points on the number line.
- To have the children devise and use a method for solving problems that involves fractional parts of sets.

COMMENTARY

The two lessons in this section consist mainly of having the children complete worksheets. In Lesson 11 some of the worksheets review previous work with fractions in measurements not connected with area. Then the children go on to do worksheets that require them to partition various geometric drawings into equal fractional parts and label the parts.

In Lesson 12 the children are given problems in story form. These stories, on their worksheets, require them to find a way to partition amount measures of various kinds. Then, on other worksheets, they put this method to use.

Lesson 11: AREA - AN AMOUNT MEASURE

The purposes of this lesson are:

- to develop the concept of area as an amount measure
- to compare area to other amount measures
- to associate area measurement with points on the number line
- to review basic notions of fractions in relation to the partitioning of a unit of measure.

In Activity A the children discover that the area of a two-dimensional figure (also considered to be a set) remains unchanged when the figure is divided into parts. This is in contrast to the counting measure of the same set which does change when subdivided. This lets the children see that area measurement possesses properties similar to other amount measures they have studied.

In Activity B the children complete a set of worksheets to review several basic notions of fractions in relation to the partitioning of a whole unit. Again, the amount measure being discussed (that of area) is associated with the number line.

MATERIALS

- Worksheets 34 through 40
- crayons
- scissors

PROCEDURE

Activity A.

Have the children tear Worksheet 34 from their Student Manuals. Ask them to cut Square A carefully from the bottom

of the worksheet. Then have them compare the area of Square A with that of Square B by placing A on B. Since there is no overlapping, and the squares appear to be the same size, they can be said to have the same area.

Establish the fact that each square is a set with a counting measure of one. Then ask:

IF YOU CUT UP THE SET, SQUARE A, WOULD YOU CHANGE THE COUNTING MEASURE OF YOUR SET? (Yes.)

WOULD YOU CHANGE THE AMOUNT MEASURE OF YOUR SET? (No.)

To show the children that the amount measure would not change, have them cut Square A on the dotted lines. When they have done this, ask:

WHAT IS THE COUNTING MEASURE OF SET A NOW? (Four.)

Reiterate the fact that the counting measure of the set has changed from one object to four objects. Then ask:

HAVE YOU CHANGED THE TOTAL AREA OF SET A? HOW CAN YOU TELL?

Let the children speculate. Encourage them to give reasons for their statements. Eventually some child will probably place the pieces of Square A on Square B to show that the total area of the four pieces appears to be the same as the area of Square B. Comparison by superposition is a valid method of comparing areas in which quantification is not necessary.

IS AREA AN AMOUNT MEASURE OR A COUNTING MEASURE? (An amount measure.)

Compare area to other amount measures such as weight and length. The children should remember that the total length of an object was unchanged if that object was cut up, i.e.:

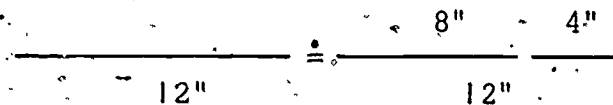

Name _____

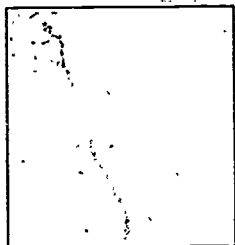

Square B

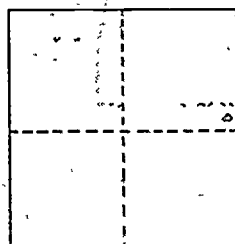

Square A



They should also recall that the same comparison can be made with weight measurements:

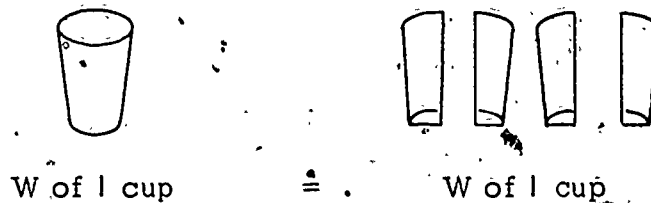

Briefly review the idea that fractional parts of units were needed to describe adequately the amount measures studied so far. Ask the children to speculate about whether fractional numbers will also be required to describe the amount measure of area adequately. Ask if it is possible to describe the area of a section of Square A using only whole numbers. (No.) Then say:

WHAT KIND OF NUMBER IS NEEDED TO DESCRIBE THE AREA OF ONE PIECE OF SQUARE A? (A fraction.)

WHAT FRACTION COULD WE GIVE TO EACH PIECE OF SQUARE A? (One-fourth.) WHY? (Because the whole unit was cut into four equal parts and each piece is one of those equal parts.)

Activity B

This activity involves a series of worksheets that review several of the basic ideas already considered in this unit. The examples on the worksheets are limited to fractional parts of a single whole. These basic ideas about fractions will be extended in the next lesson to include fractional parts of sets containing more than just one object.

The amount of help needed with Worksheets 35 through 40 will vary from child to child. You may want to introduce all the worksheets briefly and then give individual help where needed.

On Worksheet 35, the children should be able to determine whether or not a figure is labeled correctly. Notice that two of the figures are divided into equivalent parts, but labeled incorrectly. (There are five mislabelings altogether.)

Worksheet 35
Unit 22

Name _____

Put a red X on the figures that are not labeled correctly.

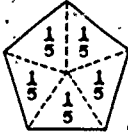
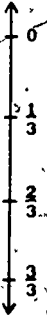
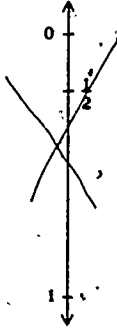
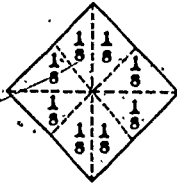
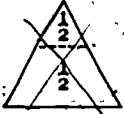
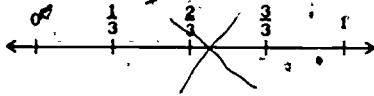
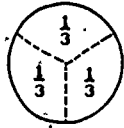

Worksheet 36
Unit 22

Name _____

What fractional part of each circle is shaded?
Write the fraction next to each circle.

Example:



$\frac{3}{5}$



$\frac{1}{5}$



$\frac{2}{5}$



$\frac{3}{4}$



$\frac{1}{3}$



$\frac{1}{2}$



$\frac{1}{4}$



$\frac{3}{3}$ or 1

On Worksheet 36, the children are required to write the fraction corresponding to the amount of shaded area on several circular shapes. They should have little trouble with this worksheet.

Worksheets 37 and 38 are designed to associate fractional units of area with points on a number line. When the children have finished these worksheets, discuss their answers. Worksheet 38 can be correctly colored in many different ways. Encourage diverse responses.

Worksheets 39 and 40 are to be done individually by the children. The children are then to check answers with a partner. If they cannot agree, they should consult you. These worksheets could be done during free time.

Circle the point on the number line that represents the shaded area of each drawing.

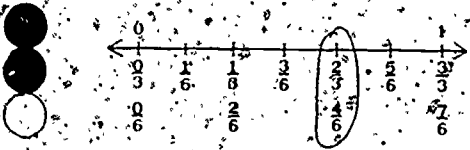
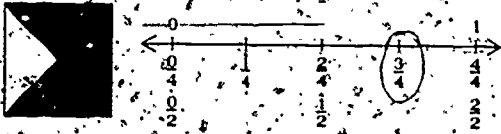
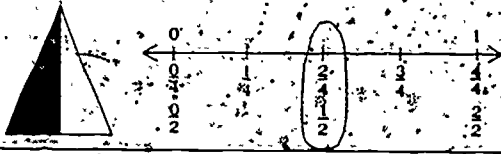

Label point A on each number line with a fraction. Color the area of each figure that matches the fraction you gave to point A.

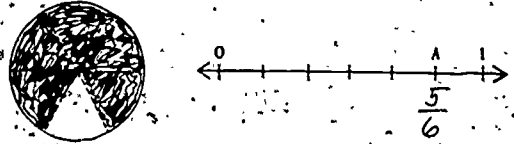
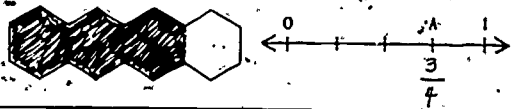
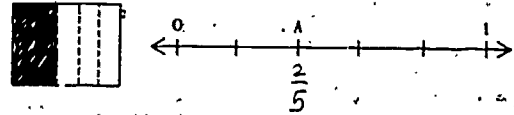
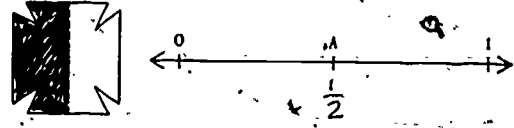

- Choose a partner.
- Color one part of the circle.
- How much of the circle did you color? $\frac{1}{3}$
- Find that point on the number line.

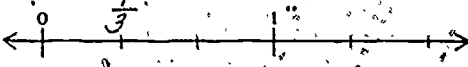
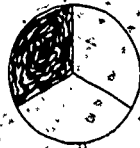

- Label the point.

- Color three parts of this circle.
- How much of the circle did you color? $\frac{3}{4}$
- Find that point on the number line.

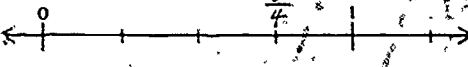

- Label the point.
- Do you and your partner have the same answers?

- Choose a partner.
- Label point A on the number line.

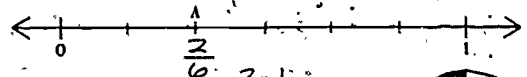

- What fraction did you write at point A? $\frac{2}{6}, \frac{1}{3}$
- Color that much of the circle.

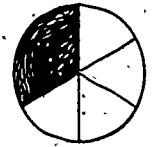

- Label point B on the number line.

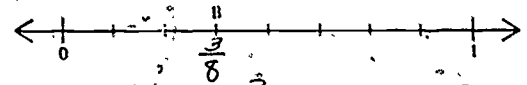

- What fraction did you write at point B? $\frac{3}{8}$
- Color that much of the circle.

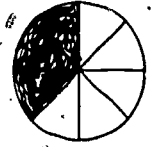

- Do you and your partner have the same answers?

Lesson 12: FRACTIONAL PARTS OF SETS

The purposes of this lesson are:

- to have the children devise a method for solving problems that involve fractional parts of sets
- to have them use this method for partitioning amount measures.

In Activity A the children are given some problems in story form. To find solutions to the problems they must find a way to partition an amount measure of one kind or another (weight, length, area, etc.) Worksheets in Activity B provide practice in using the method they have developed.

MATERIALS

- Worksheets 41 through 51
- pencils

PROCEDURE

Activity A

The worksheets used in this activity each pose a problem in story form. Depending on the ability of your class, you may wish to have children take turns reading the stories or you may wish to read them yourself as the children follow along in their Student Manuals

Begin with Worksheet 41. Read, or have it read, to the class. Then ask the children to devise a method for solving the problems on the worksheet. The following procedure can be used for solving problems of this type.

Problem: $\frac{3}{4}$ of 16 squares = how many squares?

Step 1 — With a mark, show the number of squares (16) on the number line.

Step 2 — Divide the units on the number line into 4 equal parts.

Step 3 — Determine the number that represents 3 of those 4 equal parts.

Step 4 — Conclude that $\frac{3}{4}$ of 16 = 12.
Therefore, $\frac{3}{4}$ of 16 squares = 12 squares.

The children can complete the rest of the worksheets in this activity in groups or you can do several more as a class activity and have the children work individually on the last few.

Activity B

The worksheets in this activity were designed to provide a reasonable indication of how well the children understand the basic notion of fractions. Have the children complete Worksheets 48 through 51. Encourage them to use the diagram and number lines provided to help them solve the equations. Worksheet 51 may prove difficult for some children. When the children have completed these worksheets, discuss their answers. You may want to use the flannel board and some cutouts during this discussion.

Worksheet 41
Unit 22

Name _____

The Block Family

Just for fun, pretend that once upon a time there was a family made of blocks. The members of the Block family all had bodies made of squares.

Papa Block was the largest. His body was made of 16 squares.

Mamma Block's body was $\frac{3}{4}$ the size of Papa's.

Junior Block's body was $\frac{1}{2}$ the size of Papa's.

Baby Block's body was $\frac{1}{4}$ the size of Papa's.

Remember that Papa's body = 16 squares. Mark that point on the number line on the next page.

Then use the number line to find out how many squares Mamma, Junior and Baby Block had.

Mamma's body = $\frac{3}{4}$ of Papa's body.
 $\frac{3}{4}$ of 16 squares = 12 squares.

Junior's body = $\frac{1}{2}$ of Papa's body.
 $\frac{1}{2}$ of 16 squares = 8 squares.

Baby's body = $\frac{1}{4}$ of Papa's body.
 $\frac{1}{4}$ of 16 squares = 4 squares.

Worksheet 41, page 2
Unit 22

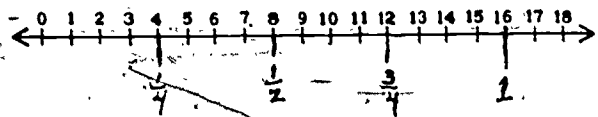

Find the body that belongs to each member of the Block family and mark the name under it.

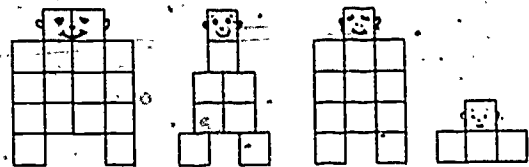

Papa Junior Mamma Baby

Drako, the Dragon (Length)

Drako, the dragon, was known far and wide for his great fire-shooting power and for his very bad temper.

When Drako was very angry, he would shoot fire from his mouth for a distance of 12 feet.

When he was only mildly angry, Drako would shoot fire for only two-thirds ($\frac{2}{3}$) of this distance.

Even when he was not angry at all, Drako was grumpy and would shoot fire one-fourth ($\frac{1}{4}$) as far as he would when he was very angry.

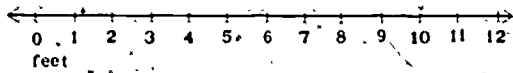

Use the number line to answer the questions on the next page.

When Drako was very angry, he shot fire 12 feet.

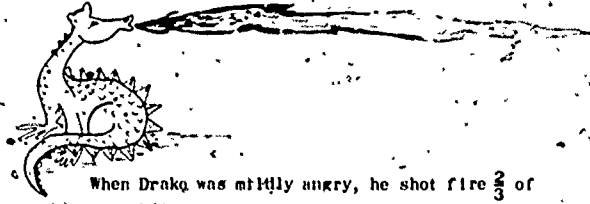

When Drako was mildly angry, he shot fire $\frac{2}{3}$ of his angry distance.

$\frac{2}{3}$ of 12 feet = 8 feet

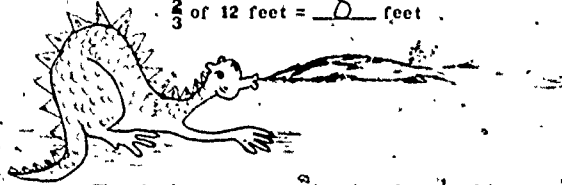

When Drako was grumpy, he shot fire $\frac{1}{4}$ of his angry distance.

$\frac{1}{4}$ of 12 feet = 3 feet

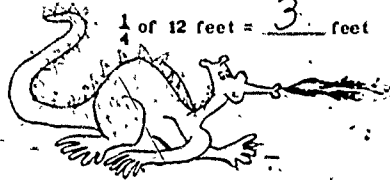

Griselda, the Glop (Length)

Griselda was a greedy glop. She was shaped just like a pancake and could spread out just like a pancake too.

Griselda ate everything she could. When she found a basket of berries and ate them all, the greedy little animal spread out until she was six inches wide.

When she found only a few small fish to eat, she was two-thirds ($\frac{2}{3}$) as wide.

When she found nothing to eat, she was only one-half ($\frac{1}{2}$) as wide as she was after eating all the berries. At times like that, Griselda felt very sorry for herself. Poor Griselda!

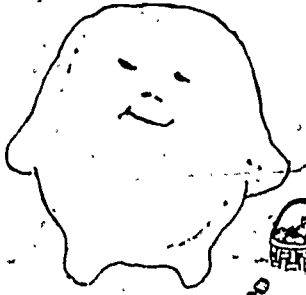

Greedy Griselda

Inches

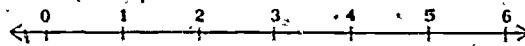

After she ate the berries, Griselda was 6 inches wide.

After she ate a few small fish, Griselda was $\frac{2}{3}$ as wide.

$\frac{2}{3}$ of 6 inches = 4 inches

After she had nothing at all to eat, Griselda was $\frac{1}{2}$ as wide.

$\frac{1}{2}$ of 6 inches = 3 inches

Slinky Slim, the Slithering Snake

Slinky Slim, a slithering snake, liked to eat funny fat little animals called frodes because they tasted so good to him. But one little frode, Fritzzy, saw the snake coming. He ran all around the pond where Slinky Slim was searching, to warn the other frodes:

"Run for your lives, Frodes." Fritzzy yelled, "or hide where Slinky Slim can't find you."

All the fat little frodes hid behind a big rock near the edge of the pond. They could see Slinky Slim, but he could not see them. How they laughed when a week went by, and Slinky Slim had not found a single frode to eat.

"Slinky Slim has lost one-fifth ($\frac{1}{5}$) of his weight this week. Goody, goody!" they laughed.

The next week, Slinky Slim lost another one-fifth ($\frac{1}{5}$) of what he used to weigh.

This time the happy little frodes had an extra-special celebration because Slinky Slim left to find a better hunting ground.



Slinky Slim weighed 5 pounds when the frodes hid behind the rock.

During the first week, Slinky lost $\frac{1}{5}$ pounds.

$\frac{1}{5}$ of 5 pounds = $\frac{1}{5}$ pounds.

During the second week, Slinky lost $\frac{1}{5}$ pounds.

$\frac{1}{5}$ of 5 pounds = $\frac{1}{5}$ pounds.

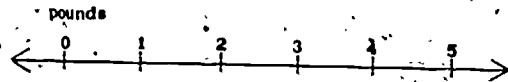

Sally, the Sailfish (Angle)

Sally, the sailfish, had the most beautiful dorsal fin of any of the fish in the ocean.

All the other fish were jealous of Sally's beautiful fin, especially because she was always bragging about the mag. of it.

Some of the other fish decided to have a beauty contest. The fish whose fin had the greatest mag would be the winner. They hoped to find a fish with a fin of greater mag than Sally's.

Did they find one? You will have to measure the mag of each fin to find out.

Here are the fins in the beauty contest.

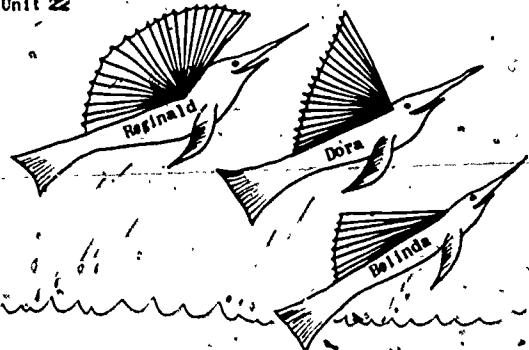
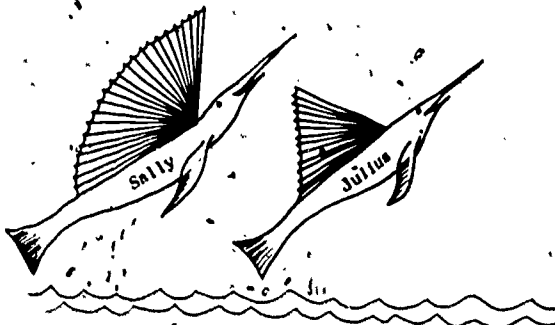

Mag of Sally's fin = $\frac{4}{5}$ hours

Mag of Julius' fin = $\frac{2}{5}$ hours

Mag of Reginald's fin = $\frac{5}{5}$ hours

Mag of Dora's fin = $\frac{3}{5}$ hours

Mag of Belinda's fin = $\frac{1}{5}$ hours

Which fin won? Reginald's

Sally's fin was what fractional part of Reginald's? $\frac{4}{5}$

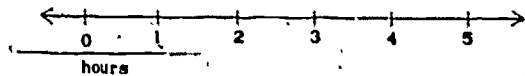

Frittery Fribble, a Frivolous Fish (Volume)

Frittery Fribble, a frivolous fish, lived in a deep, cool lake where the wind always seemed to be blowing.

The high waves made it hard for Frittery Fribble (who was lazy as well as frivolous) to do as much sun bathing as he liked. But one day he found a little creek that connected the deep lake to a shallow pond.

Frittery Fribble liked the warm sunny pond so well that he frittered and fribbled and frivoled in it for two whole weeks.

But each day he noticed that something strange was happening -- the pond was getting shallower and shallower. The sun was drying up the pond!

By the end of the first week, the pond had lost one-fourth ($\frac{1}{4}$) of its volume of water.

And by the end of the second week, the pond had lost another one-half ($\frac{1}{2}$) of the water it used to have.

Frittery decided he had had enough sun bathing for a while and should go home and visit his friends. But when he tried to swim out of the pond, he found that the creek had completely dried up. There was no way to swim home.



Frittery Fribble was frantic!

Then a very lucky thing happened. It started to rain. And it rained and it rained and it rained. Soon the creek was full of water again, and frivolous Frittery Fribble swam home.

After that, he was never again quite so foolish or frivolous, or so fond of sunbathing.

The pond had 40 gallons of water to start with.

10 gallons of water dried up during the first week.

$\frac{1}{4}$ of 40 gallons = 10 gallons

20 gallons of water dried up during the second week.

$\frac{1}{2}$ of 40 gallons = 20 gallons

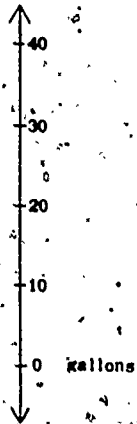

Mr. Ragfoot's Walk from Town (Time)

Mr. Ragfoot was carrying groceries home from town. The walk took him 4 hours, and he was very tired when he got home.

"What took you so long? Didn't you know I was in a hurry for the sugar? I wanted to bake cookies for you," Mrs. Ragfoot said.

"Carrying that bag of sugar was part of my trouble," Mr. Ragfoot said. "It slowed me down, and I had other troubles besides."

"I spent one-half ($\frac{1}{2}$) of the time walking up a very steep hill.

"Then a big white dog chased me for one-fourth ($\frac{1}{4}$) of the time, and I really had to go like the wind to keep him off my heels.

"When the dog went away, I got a thorn in my foot, and it has been there one-fourth ($\frac{1}{4}$) of the time."

Mrs. Ragfoot felt very sorry for her husband. She quickly removed the thorn and baked up a batch of cookies as fast as she could.

Then she sat down and began to wonder why her husband hadn't stopped to take the thorn out of his foot.



Next she began to wonder how many hours her husband had spent walking up the hill, how long he was chased by the dog, and how long he had the thorn in his foot. Will you help her figure it out?

Mr. Ragfoot walked 4 hours.

Mr. Ragfoot walked uphill for $\frac{1}{2}$ of 4 hours, or 2 hours.

Mr. Ragfoot was chased by a dog for $\frac{1}{4}$ of 4 hours, or 1 hour.

Mr. Ragfoot walked with a thorn in his foot for $\frac{1}{4}$ of 4 hours, or 1 hour.

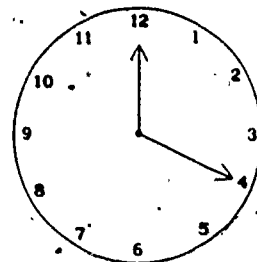

Worksheet 48
Unit 22

Name _____

Fill in the blanks.
If you need help, use the number lines.

$\frac{1}{2}$ of 8 pounds = 4 pounds

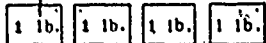
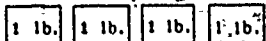

$\frac{1}{3}$ of 6 feet = 2 feet

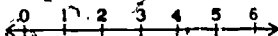
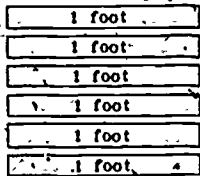

$\frac{1}{4}$ of 12 hours = 3 hours

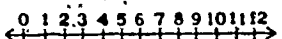
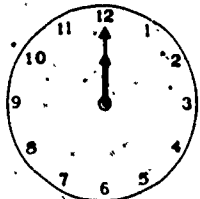

$\frac{1}{5}$ of 10 pints = 2 pints

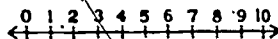
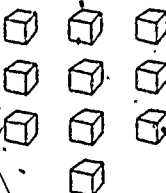

Worksheet 49
Unit 22

Name _____

Fill in the blanks.
If you need help, use the number lines.

$\frac{2}{3}$ of 6 degrees = 4 degrees

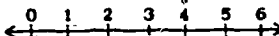

$\frac{3}{4}$ of 8 pounds = 6 pounds

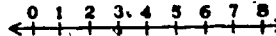
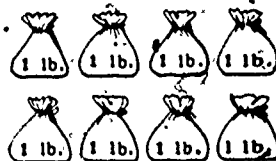

$\frac{5}{8}$ of 8 quarts = 5 quarts

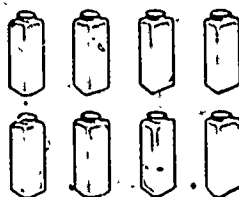

$\frac{5}{6}$ of 12 feet = 10 feet

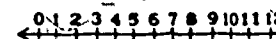
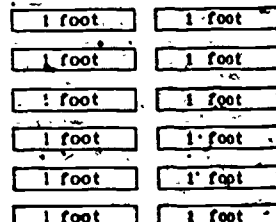

Worksheet 50
Unit 22

Name _____

Fill in the blanks.
If you need help, use the pictures.

$\frac{1}{2}$ of 10 = 5



$\frac{1}{3}$ of 9 = 3



$\frac{1}{4}$ of 4 = 1



$\frac{2}{3}$ of 12 = 8



$\frac{3}{4}$ of 16 = 12

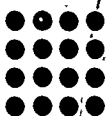

Worksheet 51
Unit 22

Name _____

Fill in the blanks.
If you need help, use the pictures.

$\frac{1}{3}$ of 10 = 3 $\frac{1}{3}$

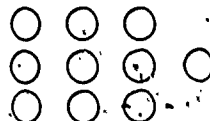

$\frac{1}{4}$ of 9 = 2 $\frac{1}{4}$

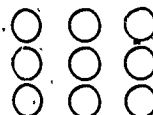

$\frac{1}{7}$ of 7 = 1 $\frac{1}{7}$

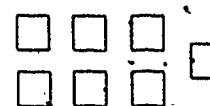

$\frac{1}{5}$ of 6 = 1 $\frac{1}{5}$

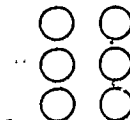

CALCULATING WITH FRACTIONS

SECTION 7

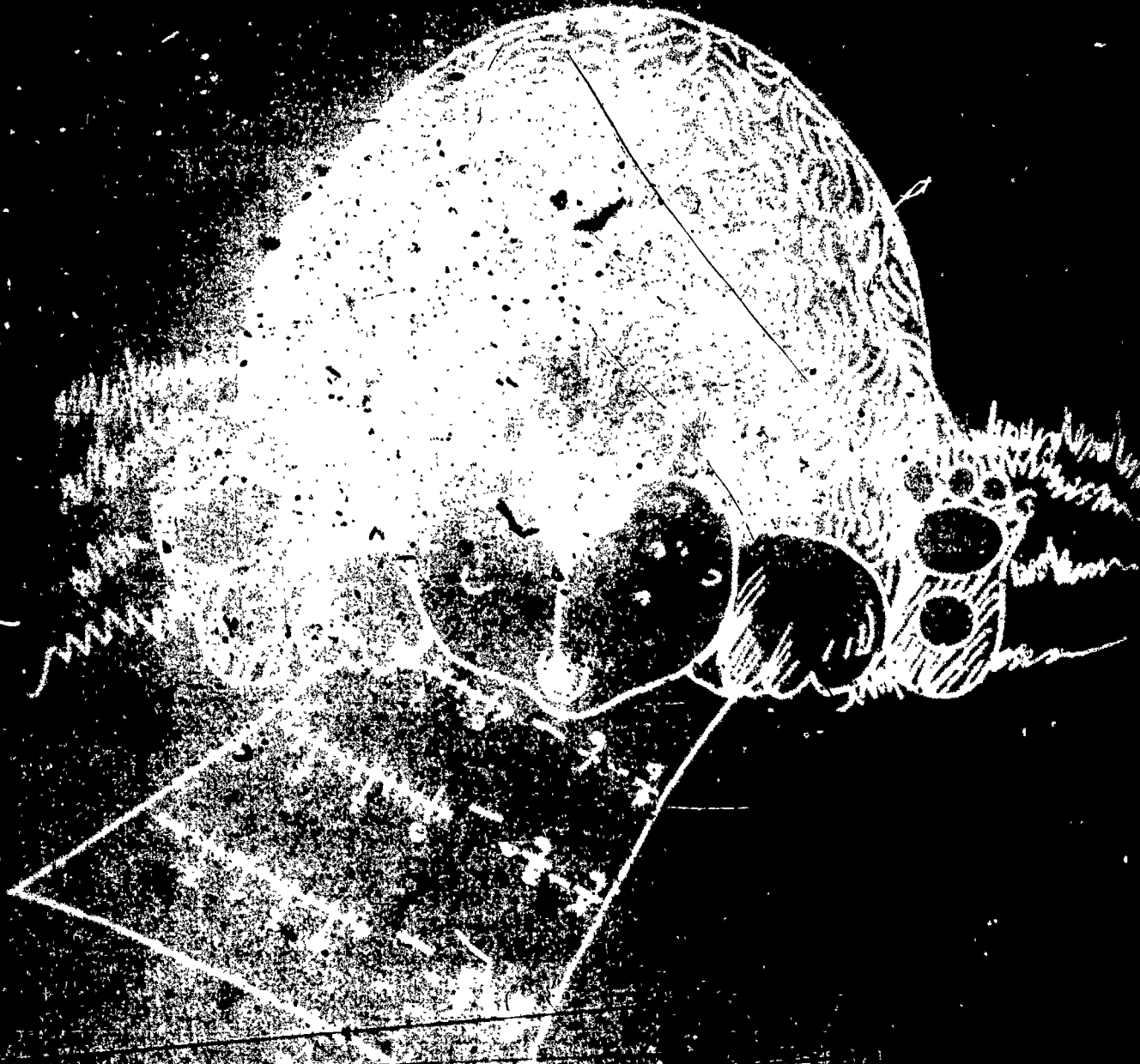

WHO WOULD SAY THAT I COULD DO THIS?

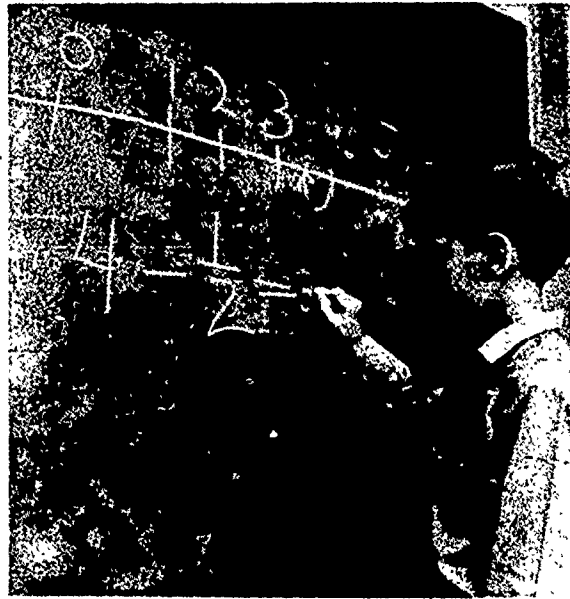

SECTION 7 CALCULATING WITH FRACTIONS

PURPOSE

- To have the children learn to add and subtract fractions.
- To have them reinforce these calculations with physical objects such as paper strips and Minnebars.
- To show the similarity between calculating with whole numbers and calculating with fractions, by having the children do the procedures on the number line.

COMMENTARY

By this time the children should be well aware that fractions are equal parts of whole units. They have had experience with this idea in dealing with five different amount measures: weight, length, mag of angles, time and area. All of these activities have required them to deal with physical objects and have given them the necessary understanding and background for doing the more abstract calculations presented here.

Even so, to make sure the children understand the connection between the physical procedures and the abstract calculations with fractions, physical embodiments such as Minnebars and paper strips are included here also. (The children need not use such aids unless they still need them.)

Lessons 17 and 18 provide work in adding and subtracting fractions on the number line. The children come to see that these processes are very much like adding or subtracting whole numbers. The only difference is that they must first subdivide whole units into appropriate fractional parts before doing their computations.

Lesson 13: ADDING FRACTIONS

The purpose of this lesson is:

- to introduce the children to the addition of fractions, using both counting and amount measures.

A story problem is the device used in this lesson to introduce the children to simple problems in which they add fractions.

MATERIALS

- Worksheets 52 through 55
- pencils
- crayons

PROCEDURE

Activity A

Have the children turn to Worksheet 52. Then tell them the following story problem:

Part I

Sam and Billy went to the store together one Saturday morning. Sam bought a bag of marbles and Billy bought a candy bar. Then they went back home to play with the marbles. Sam opened the bag and lined up his new set of marbles in a row. Then he counted them and found that he had eight marbles.

Draw eight circles on the chalkboard to represent the marbles. Then say that four of the marbles had stars on them. Draw stars on four of the chalkboard circles, and have the children do the same on their worksheet "marbles." Then ask:

WHAT FRACTIONAL PART OF THE SET OF EIGHT MARBLES HAD STARS? (Four eighths.)

Sam's Marbles

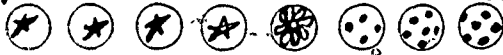

Billy's Candy Bar

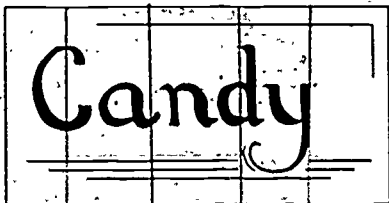

Sam Billy Sam

Color $\frac{1}{2}$ of the triangles red.

Color 1 white triangle blue.

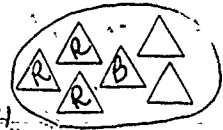

What fractional part of the $\frac{2}{3}, \frac{4}{6}$ triangles did you color?

Write an addition sentence that represents the fractional part of all the triangles that you colored

$$\frac{3}{6} + \frac{1}{6} = \frac{4}{6} = \frac{2}{3}$$

$\frac{1}{3}$ of this doughnut has chocolate frosting. Color it brown.

$\frac{1}{3}$ of this doughnut has orange frosting. Color it orange.



$\frac{1}{3}$ has no frosting. Don't color it.

If your friend didn't like frosting on doughnuts, what $\frac{1}{3}$ fractional part of this doughnut would he like?

If you ate all the parts with frosting, what $\frac{2}{3}$ fractional part of the doughnut would you eat?

Write an addition sentence to show how you decided what fractional part to eat.

$$\frac{1}{3} + \frac{1}{3} = \frac{2}{3}$$



$\frac{2}{6}$ of the flowers have 5 petals.

$\frac{1}{2}$ of the flowers have 6 petals.

$\frac{1}{6}$ of the flowers have 8 petals.

$\frac{5}{6}$ of the flowers do not have 8 petals.

None of the flowers have 3 petals.

What kind of measure were you using in this set?

amount measure

Color $\frac{1}{4}$ of the circle red.

Color $\frac{2}{4}$ of the circle green.

$\frac{1}{4}$ of the circle is not colored.

$\frac{3}{4}$ of the circle is not red.

$\frac{1}{2}$ of the circle is not green.

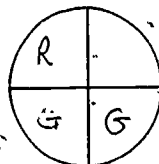

Put mushrooms on $\frac{1}{6}$ of this pizza.

Put hamburger on $\frac{2}{6}$ of this pizza.

Put onions on $\frac{2}{6}$ of this pizza.

Put cheese on $\frac{1}{6}$ of this pizza.

Would you eat this pizza? Yes

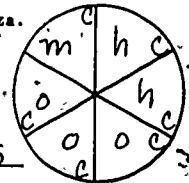

There are 7 members of this set.

Each member is $\frac{1}{7}$ of the set.

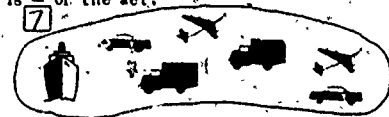

$\frac{4}{7}$ are trucks. $\frac{2}{7}$ are cars.

$\frac{4}{7}$ of these are made to go on highways.

$\frac{2}{7}$ of these can fly.

$\frac{1}{7}$ of these do not sail on water.

Write the notation ($\frac{4}{8}$) on the chalkboard. Then tell the children that one of Sam's marbles had a flower on it. Draw a flower on one of the remaining circles on the board and have the children do the same on their worksheets. Ask:

WHAT FRACTIONAL PART OF THE SET HAD FLOWERS ON IT?
(One eighth.)

Write the notation ($\frac{1}{8}$) on the board. Then say that the rest of the marbles had dots on them. Draw dots on the remaining three marbles, and have the children put dots on the unmarked marbles on their worksheets. Then tell the children that Sam asked Billy if he knew what fractional part of the set had dots, and which part had either stars or flowers. Pose these as separate questions, and write the fractions on the board as the children answer each question:

WHAT FRACTIONAL PART OF THE SET OF MARBLES HAD FLOWERS ON IT? (One eighth, written $\frac{1}{8}$.)

WHAT FRACTIONAL PART OF THE SET HAD EITHER STARS OR FLOWERS ON IT? (Five eighths, written $\frac{5}{8}$.)

Next ask the children to show you how they could write an addition sentence that would show a way to get the answer, $\frac{5}{8}$. If the children are not familiar with the method, suggest the following addition sentence:

$$\frac{4}{8} + \frac{1}{8} = \frac{5}{8}$$

Explain each part of the equation. The symbol $\frac{4}{8}$ represents the marbles with stars. The four tells the number of starred marbles and the eight tells how many marbles there are in the whole set. So by looking at the fraction $\frac{4}{8}$, the children can tell that four eighths of the marbles in the set have stars on them. The symbol $\frac{1}{8}$ represents the flowered marble. The + means that the two kinds of marbles are being combined or added together. The $\frac{5}{8}$ represents the total of the starred and the flowered marbles.

Point to the dotted marbles and ask the children what fractional part of the entire set of marbles is represented by the fraction, $\frac{3}{8}$. If the children seem to be having difficulty naming the fractions that various combinations of marbles make, go over this part of the activity again.

Then ask:

WHEN WE WERE TALKING ABOUT FRACTIONAL PARTS OF THIS SET, WHAT KIND OF MEASURE DID WE USE? (Counting measure.)

Part 2

After Sam and Billy had figured out everything they wanted to know about the marbles, Billy asked, "How about having a bite of my candy bar, Sam?"

"Fine," Sam said, and he took a bite that amounted to one fifth of the candy bar.

Ask the children what Billy and Sam could have done to the candy bar that would tell them how much Sam ate. Have them look at the bottom part of Worksheet 5.2 and make suggestions. If they do not think of dividing the drawing of the candy bar into five equal parts, draw a rectangle on the board and divide it thus:

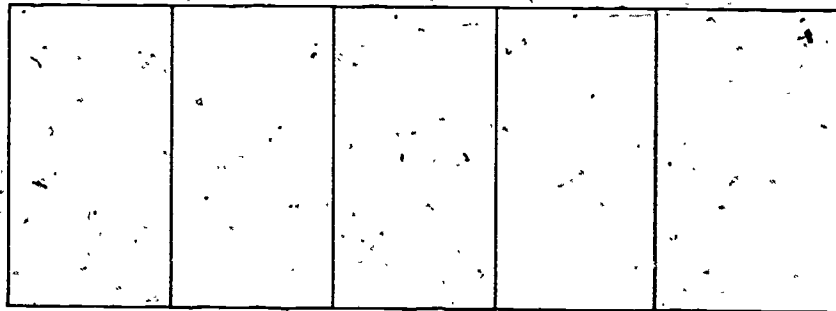

Then ask the children to divide the picture of the candy bar into five approximately equal parts. They may use rulers to do this, but the divisions do not have to be exact. Mainly

you want the children to understand that the lines represent a division of the candy bar into five equal parts. Say that Billy and Sam must have marked the candy bar in some such way to determine that Sam had eaten one fifth of it. Ask the children to color the part of their worksheet that represents the amount Sam ate.

Say that Billy then took a bite of the candy. His was a big bite — it was equal to two fifths of the original amount of candy. Have the children use another color to represent on their worksheets the amount that Billy ate.

Next say that Sam ate the rest of the candy. Have the children use the color they used for Sam's first bite to color the amount he ate this second time. When they have done this, tell the children that Billy and Sam then started wondering who had eaten the most candy. Ask the children to figure this out. Write the fractions and the equation on the board as they give the following information:

Billy ate $\frac{2}{5}$

Sam ate $\frac{1}{5} + \frac{2}{5}$ or $\frac{3}{5}$

Then ask:

WHAT KIND OF MEASURE ARE YOU USING WHEN YOU DIVIDE A CANDY BAR? (An amount measure; either weight or volume in this case.)

Activity B

The problems on Worksheets 53, 54 and 55 are similar to the ones that the class has just worked in Activity A. If the children seem to be having difficulty in adding fractions, you may want to do Worksheet 53 with them. Worksheets 54 and 55 should be completed by the children in their free time.

Lesson 14: SUBTRACTING FRACTIONS

The purpose of this lesson is:

- to introduce subtraction of fractions, using familiar situations.

Subtraction is presented in this lesson as a separation of a set of physical objects. The children learn to relate subtraction in fraction form with the physical separation by making an equation that describes the process.

MATERIALS

- Worksheets 56 through 59
- crayons

PROCEDURE

Tell the children that in this lesson they are going to learn how to subtract fractions. Then read or tell the following story problem to them:

Matt and his friends formed a club. They built a little clubhouse where they liked to meet to talk or play games. There were nine boys in this club.

One hot summer day, Matt's mother brought a watermelon and decided to treat all the boys in the club. She sent Matt to the clubhouse to round up his friends and bring them home. While Matt was gone, she cut the melon into nine equal pieces, one for each boy.

But when Matt came back, he brought only three of his friends with him. He explained that the five others had gone on a hike and would not be back that day. Then the four boys wondered if Matt's mother would let them

eat all nine pieces of the melon. They also wondered how much each of them would get if she did.

Let the class decide how much of the melon each of the four boys would get if Matt's mother decided to let them eat all nine pieces. Demonstrate on the chalkboard, if necessary, to arrive at the conclusion that each of the four boys would get two and one-fourth pieces of melon. Then say that Matt's mother decided that each boy would have only one piece—she was going to save the remainder for the family's supper.

Ask these questions:

COUNTING MATT AND HIS THREE FRIENDS, HOW MANY BOYS WERE THERE TO EAT WATERMELON? (4.)

IF THERE WERE NINE PIECES OF WATERMELON, WHAT FRACTIONAL PART OF THE MELON WOULD EACH BOY BE EATING? (One ninth, written $\frac{1}{9}$.)

WHEN THE BOYS ATE THEIR PIECES, WHAT FRACTIONAL PART OF THE MELON HAD THEY EATEN ALTOGETHER? (Four ninths, written $\frac{4}{9}$.)

Ask the children to turn to Worksheet 56 and color the number of pieces the boys ate. Then ask:

HOW MANY PIECES DID YOU COLOR? (4.)

WHAT FRACTIONAL PART OF THE MELON WAS LEFT FOR MATT'S FAMILY? (Five ninths, written $\frac{5}{9}$.)

HOW CAN WE WRITE A SUBTRACTION SENTENCE THAT SHOWS HOW WE GOT THAT ANSWER?

In all probability the children will merely count the uncolored pieces. Remind them that the entire melon can be represented by the fraction $\frac{9}{9}$, and that they should be trying to make up a sentence, using fractions, to show what happened. The result should be:

$$\frac{9}{9} - \frac{4}{9} = \frac{5}{9} \text{ or } \frac{1}{1} - \frac{4}{9} = \frac{5}{9} \text{ or } 1 - \frac{4}{9} = \frac{5}{9}$$

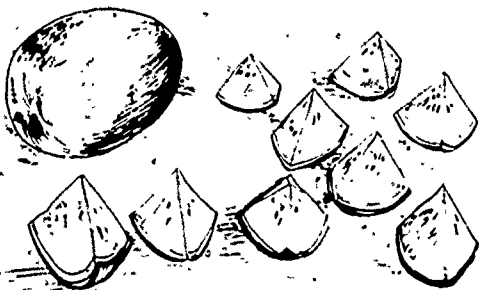

Each slice is what fractional part of the whole melon? $\frac{1}{9}$

In the whole melon there are 9 pieces.

How many boys were going to eat watermelon? 4

What fractional part of the melon did the boys eat? $\frac{4}{9}$

How much of the melon was left over? $\frac{5}{9}$

Write a subtraction sentence to show how much melon was left over.

$$\frac{9}{9} - \frac{4}{9} = \frac{5}{9}$$

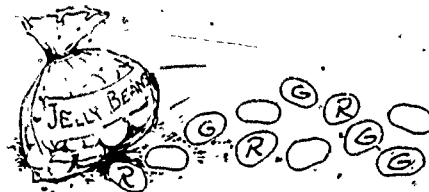

How many jelly beans does Sally have in all? 11

How many jelly beans did you color red? 3

How many jelly beans did you color green? 4

Write an addition sentence to show what fractional part of the jelly beans Sally ate or gave to her friends.

$$\frac{3}{11} + \frac{4}{11} = \frac{7}{11}$$

How many jelly beans did Sally have left? 4

Write a subtraction sentence to show what fraction Sally had left.

$$\frac{11}{11} - \frac{7}{11} = \frac{4}{11}$$

Now have the children turn to Worksheet 57. Say that a girl named Sally had a small bag in which there were eleven jelly beans. Ask what fractional part of the set each of these jelly beans is: ($\frac{1}{11}$.)

Then say that three of the jelly beans were red. They were cherry flavored. Since cherry was Sally's favorite flavor, she ate these right away. Have the children color three of the jelly beans on their worksheet red. Ask:

WHAT FRACTIONAL PART OF HER SET OF JELLY BEANS DID SALLY EAT? ($\frac{3}{11}$.)

Next tell the children that four of the jelly beans were green. They were lime flavored, and Sally did not care for them, so she gave these four away to friends. Have the children color four of the uncolored jelly beans green. Then ask:

HOW MANY OF THE JELLY BEANS DID SALLY EITHER EAT OR GIVE AWAY? (Seven.) WHAT FRACTIONAL PART OF ALL HER JELLY BEANS IS THAT? ($\frac{7}{11}$.)

Now ask the children to help you write an addition sentence to show how they got that answer. The result should be:

$$\frac{3}{11} + \frac{4}{11} = \frac{7}{11}$$

WHAT FRACTIONAL PART OF THE JELLY BEANS DID SALLY HAVE LEFT? ($\frac{4}{11}$.)

HOW CAN WE WRITE A SUBTRACTION SENTENCE TO SHOW HOW YOU FOUND THAT ANSWER?

$$\frac{11}{11} - \frac{7}{11} = \frac{4}{11} \quad \text{or} \quad 1 - \frac{7}{11} = \frac{4}{11}$$

Have the children next complete Worksheets 58 and 59. Note that alternate methods of solving the same problem are suggested by several of the questions on this worksheet. This is done so that children will realize that many problems can be solved in more than one way. This is an important concept and you should discuss alternate methods of solving problems as opportunities to do so arise.

Worksheet 58
Unit 22

Name _____

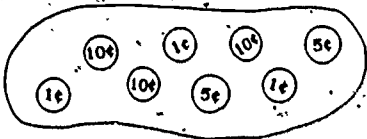

Count the coins. How many are there? 8

What fractional part of the set is pennies? $\frac{1}{8}$

What fractional part is nickels? $\frac{2}{8}$

Write an addition sentence to show what fractional part of the set is either pennies or nickels.

$$\frac{1}{8} + \frac{2}{8} = \frac{3}{8}$$

Write a subtraction sentence to show what fractional part of the set is either pennies or nickels.

$$\frac{8}{8} - \frac{5}{8} = \frac{3}{8}$$

How many of the coins are worth more than five cents? 3

What fractional part of the set of coins is dimes? $\frac{2}{8}$

Write a subtraction sentence to show how you got the answer.

$$\frac{8}{8} - \frac{5}{8} = \frac{3}{8}$$

Worksheet 59
Unit 22

Name _____

MRQRQQMARM

Count the letters in the set.

How many are there? 11

What fractional part of the set is R's? $\frac{4}{11}$

What fractional part is M's? $\frac{3}{11}$

What fractional part is either R's or M's? $\frac{7}{11}$

Write an addition sentence to show how to find the answer.

$$\frac{4}{11} + \frac{3}{11} = \frac{7}{11}$$

Now write a subtraction sentence to show how to find the answer.

$$\frac{11}{11} - \frac{4}{11} = \frac{7}{11} \quad \frac{8}{11} - \frac{1}{11} = \frac{7}{11}$$

What fractional part of the set is Q's? $\frac{3}{11}$

Write a subtraction sentence to show what fractional part of the set is not M's or R's.

$$\frac{11}{11} - \frac{4}{11} - \frac{3}{11} = \frac{4}{11}$$

Lesson 15: WRITING ADDITION SENTENCES

The purposes of this lesson are:

- to represent fractions physically using paper strips
- to provide more practice in adding fractions
- to write addition sentences for fractions.

MATERIALS

- scissors
- Worksheets 60, 61 and 62

PROCEDURE

Activity A

Have the children turn to Worksheet 60 in their Student Manuals and cut off a strip of squares (20 squares). Say that they should help figure out a way to select a strip of squares that will represent the fraction $\frac{5}{7}$.

WHAT DO WE NEED TO KNOW FIRST? (What size our unit will be.)

Suggest that they make the whole unit some size that is easy to divide into seven equal parts. Lead them to the idea that a convenient length for a whole unit would be seven squares long. Have them cut a unit of this length from the strip of paper squares and label it "1 unit."

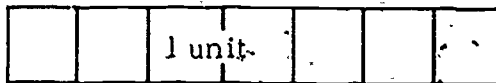
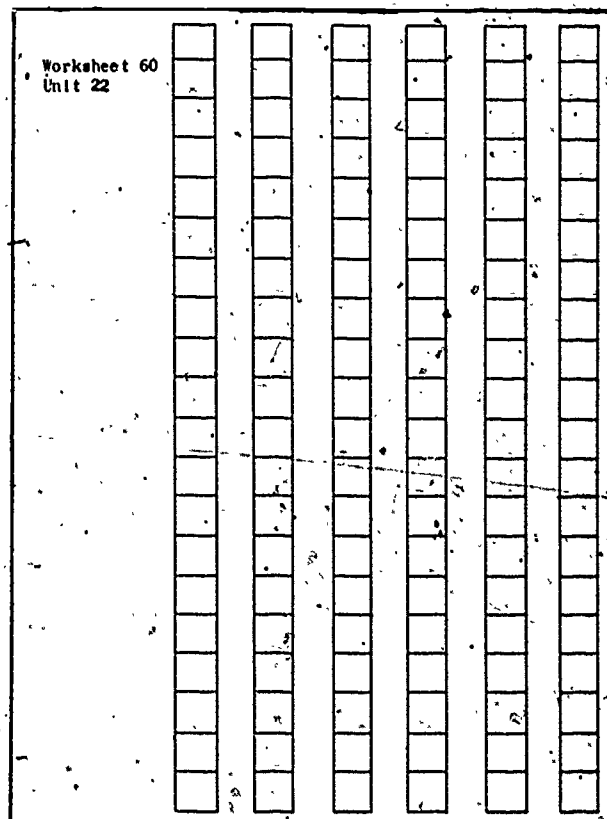

NOW THAT WE KNOW HOW LONG OUR WHOLE UNIT IS,
 COULD WE CUT A NEW STRIP THAT IS $\frac{5}{7}$ OF THIS UNIT?
 HOW MANY SQUARES WOULD IT BE? (5.)

Have the children cut a second strip that is five squares long. Emphasize the fact that the new strip represents $\frac{5}{7}$ because the unit is represented by seven equal parts and this strip is the same as five of these parts. Have the children compare the 1 unit strip to the $\frac{5}{7}$ unit strip by laying the smaller strip next to the larger one and comparing the strips, using one to one correspondence of squares.

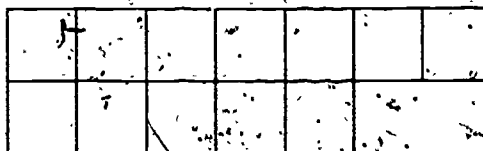

Now have the children cut a third strip of squares that represents $\frac{3}{7}$. Have them tell you why it represents this fraction. Ask them to lay the $\frac{3}{7}$ strip next to the 1 unit strip and compare the squares, using one to one correspondence.

Then ask:

WHAT FRACTION WOULD WE REPRESENT IF WE PUT THE $\frac{5}{7}$ STRIP AND THE $\frac{3}{7}$ STRIP END TO END?



Have the children put these strips end to end and compare them with the unit strip. Remind them that each square represents $\frac{1}{7}$. They can find the fractions represented by the two strips by counting the number of squares in both. Using this method, most of the children will probably answer $\frac{8}{7}$. Others may say that the two strips represent $1\frac{1}{7}$ because they noticed that the two strips were as long as the unit strip plus one more square.

Ask the class to suggest addition sentences that would represent the addition of the $\frac{5}{7}$ strip and the $\frac{3}{7}$ strip. They may suggest any of the following, all of which are correct:

$$\frac{5}{7} + \frac{3}{7} = \frac{8}{7} \quad \frac{3}{7} + \frac{5}{7} = \frac{8}{7} \quad \frac{5}{7} + \frac{3}{7} = 1\frac{1}{7} \quad \frac{3}{7} + \frac{5}{7} = 1\frac{1}{7}$$

Continue the activity until you are satisfied that the children understand the main ideas involved. Choose units that can be shown easily with strips of squares. Discuss several fractions with different denominators. For example, if the class wanted to represent the fraction $\frac{2}{5}$, a convenient unit to use would be five squares. If they wanted to show the fraction $\frac{3}{8}$, a convenient unit to use would be eight squares. Use some of the rest of the strips for other problems, but save a row or two for use in connection with Worksheet 61.

Activity B

Have the children complete Worksheets 61 and 62. Have them work in groups of three or four to do this.

Worksheet 61
Unit 22 Name _____



 This is our unit.

How many equal parts are there in the unit? 5

What fraction represents each of the parts? $\frac{1}{5}$

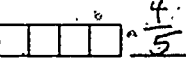

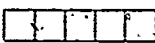
What fraction represents each of these strips?

①  $\frac{2}{5}$ ②  $\frac{4}{5}$

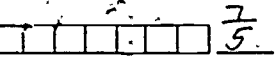
③  $\frac{5}{5}$ ④  $\frac{3}{5}$

⑤  $\frac{1}{5}$ ⑥  $\frac{7}{5}$

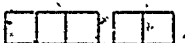
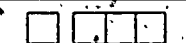
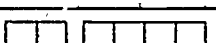
Add the strips and write the addition sentence that tells what you did.

 $\frac{3}{5} + \frac{2}{5} = \frac{5}{5}$	 $\frac{1}{5} + \frac{3}{5} = \frac{4}{5}$
 $\frac{2}{5} + \frac{4}{5} = \frac{6}{5}$	 $\frac{1}{5} + \frac{2}{5} = \frac{3}{5}$

Worksheet 62
Unit 22 Name _____

Represent the fraction $\frac{1}{6}$ with paper squares by following these steps.

- Choose a unit length and cut it out from the squares on Worksheet 60.
My unit has 6 squares.
- Now cut a strip of squares that represents $\frac{1}{6}$ of your unit. My $\frac{1}{6}$ strip has 1 square.

Cut out strips to represent these fractions:

$\frac{2}{6}$, $\frac{3}{6}$, $\frac{4}{6}$, $\frac{5}{6}$

Use your strips to complete these addition sentences.

$\frac{1}{6} + \frac{2}{6} = \frac{3}{6}$	$\frac{4}{6} + \frac{1}{6} = \frac{5}{6}$
$\frac{2}{6} + \frac{3}{6} = \frac{5}{6}$	$\frac{3}{6} + \frac{4}{6} = \frac{7}{6}$
$\frac{2}{6} + \frac{4}{6} = \frac{6}{6}$	$\frac{2}{6} + \frac{3}{6} = \frac{5}{6}$

Lesson 16: WRITING SUBTRACTION SENTENCES

The purposes of this lesson are:

- to have the children represent fractions physically by using paper strips.
- to provide them with practice in subtracting fractions
- to have them write subtraction sentences for fractions.

MATERIALS

- scissors
- Worksheets 63 through 66

PROCEDURE

Have the children turn to Worksheet 63 and cut off a strip of 20 squares. Ask the children if they could use these squares to represent a subtraction problem, for example, $1 - \frac{2}{5}$.

WHAT WILL WE HAVE TO DO FIRST? (Decide on a unit.)

HOW MANY SQUARES WOULD BE CONVENIENT? (Five squares.)

Have the children cut a strip of five squares and label it "1 unit." As the children cut the strips, make a drawing of the unit on the chalkboard. Then ask:

WHAT MUST WE DO NEXT? (Cut a strip representing $\frac{2}{5}$.)

Have the children cut a strip two squares long. Then develop with the class a method for showing what is done when $\frac{2}{5}$ of a unit strip is subtracted from the 1 unit strip. One method is to put the $\frac{2}{5}$ strip just under the 1 unit strip.

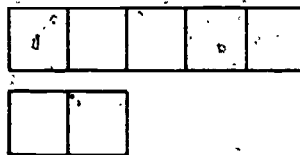

Worksheet 63
Unit 22

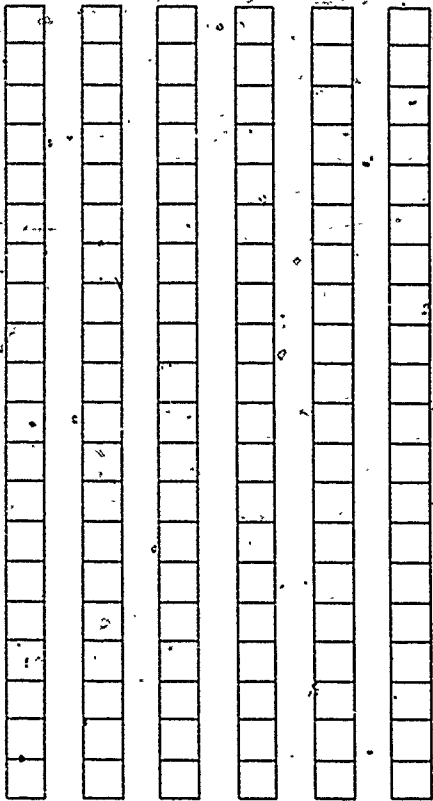

Worksheet 64
Unit 22

Name _____

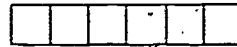

This is our 1 unit.

What fraction does each of the parts represent? $\frac{1}{6}$

Subtract.

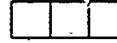
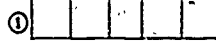

$$\frac{2}{6} - \frac{1}{6} = \frac{1}{6}$$



$$\frac{4}{6} - \frac{3}{6} = \frac{1}{6}$$

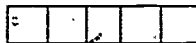
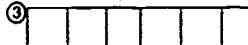

$$\frac{5}{6} - \frac{4}{6} = \frac{1}{6}$$



$$\frac{5}{6} - \frac{1}{6} = \frac{4}{6}$$



$$\frac{3}{6} - \frac{1}{6} = \frac{2}{6}$$

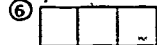

$$\frac{2}{6} - \frac{1}{6} = \frac{1}{6}$$

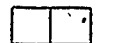
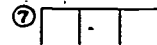

$$\frac{4}{6} - \frac{2}{6} = \frac{2}{6}$$

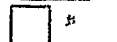
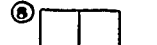

$$\frac{3}{6} - \frac{2}{6} = \frac{1}{6}$$

Worksheet 65
Unit 22

Name _____

Cut a unit to go with the fraction $\frac{1}{8}$. It has 8 squares. Now cut strips from Worksheet 63 to represent $\frac{1}{8}, \frac{2}{8}, \frac{3}{8}, \frac{4}{8}, \frac{5}{8}, \frac{6}{8}$ and $\frac{7}{8}$.

Use your strips to complete the following equations.

$$1 - \frac{5}{8} = \frac{3}{8}$$

$$\frac{5}{8} - \frac{2}{8} = \frac{3}{8}$$

$$\frac{7}{8} - \frac{2}{8} = \frac{5}{8}$$

$$1 - \frac{1}{8} = \frac{7}{8}$$

$$\frac{6}{8} - \frac{3}{8} = \frac{3}{8}$$

$$\frac{4}{8} - \frac{3}{8} = \frac{1}{8}$$

$$\frac{2}{8} - \frac{1}{8} = \frac{1}{8}$$

$$\frac{3}{8} - \frac{3}{8} = 0$$

$$1 - \frac{7}{8} = \frac{1}{8}$$

$$\frac{6}{8} - \frac{2}{8} = \frac{4}{8}, \frac{2}{4}, \frac{1}{2}$$

$$\frac{7}{8} - \frac{5}{8} = \frac{2}{8}, \frac{1}{4}$$

$$\frac{5}{8} - \frac{4}{8} = \frac{1}{8}$$

Worksheet 66
Unit 22

Name _____

Cut a unit to go with the fraction $\frac{1}{9}$. It has 9 squares. Now cut strips from Worksheet 63 to represent $\frac{1}{9}, \frac{2}{9}, \frac{3}{9}, \frac{4}{9}, \frac{5}{9}, \frac{6}{9}, \frac{7}{9}$ and $\frac{8}{9}$.

Complete the following equations. Use the paper strips only if you need them.

$$\frac{2}{9} + \frac{3}{9} = \frac{5}{9}$$

$$\frac{1}{9} + \frac{1}{9} = \frac{2}{9}$$

$$\frac{3}{9} - \frac{2}{9} = \frac{1}{9}$$

$$\frac{1}{9} - \frac{1}{9} = 0$$

$$1 + \frac{1}{9} = \frac{10}{9}$$

$$\frac{4}{9} + \frac{5}{9} = \frac{9}{9} \text{ or } 1$$

$$\frac{8}{9} - \frac{3}{9} = \frac{5}{9}$$

$$\frac{6}{9} - \frac{3}{9} = \frac{3}{9}$$

$$\frac{7}{9} + \frac{2}{9} = \frac{9}{9} \text{ or } 1$$

$$\frac{2}{9} + \frac{3}{9} = \frac{5}{9}$$

$$1 - \frac{4}{9} = \frac{5}{9}$$

$$\frac{2}{9} + 2 = \frac{20}{9}$$

Then compare the number of squares in the two strips using one to one correspondence. Ask:

HOW MANY MORE SQUARES ARE THERE IN THE 1 UNIT STRIP? (3.)

Have the children cut a strip equal to the $\frac{2}{5}$ unit strip from the 1 unit strip. Then ask them to write a subtraction sentence which tells what they have done:

$$1 - \frac{2}{5} = \frac{3}{5} \quad \text{or} \quad \frac{5}{5} - \frac{2}{5} = \frac{3}{5}$$

Have the children cut strips representing $\frac{4}{5}$, $\frac{5}{5}$, $\frac{6}{5}$ and $\frac{7}{5}$. Then have the class use the strips they have cut out to find new subtraction sentences. List these on the board as the children suggest them. They may include:

$$\frac{5}{5} - \frac{4}{5} = \frac{1}{5} \quad \frac{7}{5} - \frac{3}{5} = \frac{4}{5} \quad \frac{4}{5} - \frac{2}{5} = \frac{2}{5}$$

$$\frac{4}{5} - \frac{1}{5} = \frac{3}{5} \quad \frac{6}{5} - \frac{2}{5} = \frac{4}{5}$$

$$\frac{3}{5} - \frac{1}{5} = \frac{2}{5} \quad \frac{6}{5} - \frac{1}{5} = \frac{5}{5}$$

When you are satisfied that the children understand how to represent subtraction sentences with paper strips, have them complete Worksheets 64, 65 and 66.

Lesson 17: ADDING FRACTIONS ON THE NUMBER LINE

The purpose of this lesson is:

- to illustrate that addition of rational numbers can be done on the number line in the same way that integers are added on the number line.

In Units 11, 13, 16, 17 and 20, the children have used number lines to illustrate the addition, subtraction or multiplication of two numbers. When adding $3 + 5$, for example, they begin at zero and jump three places to the right, then jump five more places to the right. This corresponds to a single jump of eight. Because of the relationship that exists between the number line and the real number system, length can be used to clarify the children's ideas about number (length being concrete rather than abstract). For each length there is one and only one unique real number, and for each real number there is one and only one length on the number line. A length of three units joined to a length of five units is equivalent to a single length of eight units. Since these lengths correspond to unique real numbers we can conclude that $3 + 5 = 8$. In this lesson, the children review the addition of integers on the number line, and then use a similar procedure to add fractions and mixed numbers.

MATERIALS

- Worksheets 67 and 68

PROCEDURE

Activity A

To review the procedures the children have used to add whole numbers on a number line, sketch a number line labeled from zero through seven on the chalkboard. Ask someone to use it to add $2 + 3$. He may do it by making 2 one-unit jumps and then 3 one-unit jumps to the right, or by making 1 two-unit jump and then 1 three-unit jump to the right. (See diagram on the next page.)

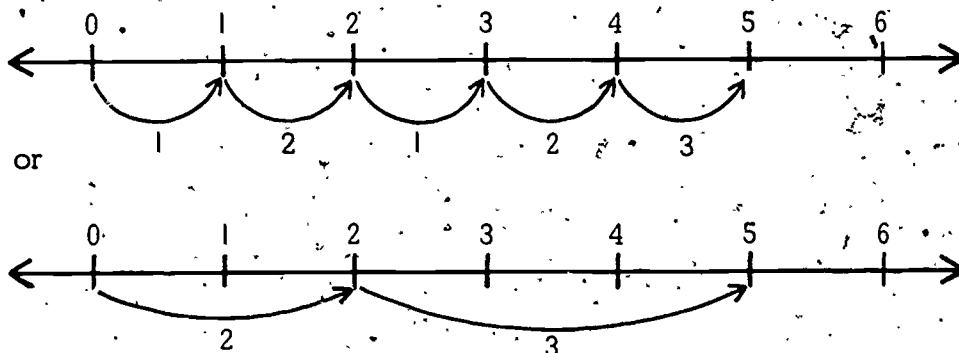

If your class needs practice in number line addition, have the children work several more addition problems with number lines at the chalkboard.

Then ask the class if they think they could also use a number line to add fractions. Draw a number line labeled zero through four and call on a child to try the following problem: $2 + \frac{3}{4}$. If he has trouble determining where $\frac{3}{4}$ falls between two and three, remind him that whole units must be divided into equal parts before a fraction of that whole can be represented. Have a child divide the distance between two and three on the number line into four equal parts. Then he can move three of those parts to the right, landing at $2\frac{3}{4}$.

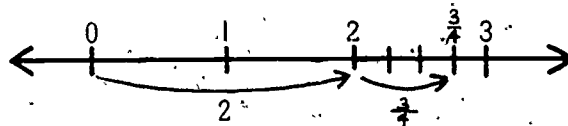

Draw a number line labeled zero to three and have a child add $\frac{4}{5} + \frac{3}{5}$ using it. He will have to divide the distance between zero and one into five equal parts, and the distance between one and two into five equal parts. Then he can move $\frac{4}{5}$ to the right of zero and $\frac{3}{5}$ more from that point.

Draw more number lines on the board and have volunteers demonstrate how to add the following problems:

$$\frac{1}{2} + 1\frac{1}{2} = ? \quad 2\frac{1}{2} + 1\frac{1}{2} = ? \quad 1\frac{1}{4} + 2\frac{2}{4} = ? \quad \frac{5}{3} + \frac{1}{3} = ?$$

You may have to help the children make the divisions between each whole number.

Activity B

Have the children do Worksheets 67 and 68.

Worksheet 67
Unit 22

Name _____

Use the number lines to help you complete these addition sentences.

$\frac{3}{8} + \frac{4}{8} = \frac{7}{8}$

$\frac{2}{5} + \frac{4}{5} = \frac{6}{5} \text{ or } 1\frac{1}{5}$

$\frac{2}{3} + \frac{2}{3} = \frac{4}{3} \text{ or } 1\frac{1}{3}$

$\frac{3}{4} + \frac{1}{4} = \frac{4}{4} \text{ or } 1$

$\frac{3}{6} + \frac{4}{6} = \frac{7}{6} \text{ or } 1\frac{1}{6}$

Worksheet 68
Unit 22

Name _____

Use the number lines to help you complete the following addition sentences.

$3 + \frac{2}{3} = 3\frac{2}{3}$

$7 + \frac{1}{3} = 7\frac{1}{3}$

$6 + \frac{1}{4} = 6\frac{1}{4}$

$1\frac{1}{2} + 5\frac{1}{2} = 7$

$2\frac{1}{3} + 3\frac{2}{3} = 6$

Lesson 18: SUBTRACTING FRACTIONS ON THE NUMBER LINE

The purpose of this lesson is:

- to illustrate the structural similarity that exists between subtracting whole numbers (integers) and fractional numbers (rational numbers) by using the number line.

This is the concluding lesson of the unit. After the children have completed the work given here, you may wish to have them recall some of the different kinds of amount measures they have used in previous sections.

MATERIALS

- Worksheets 69 and 70

PROCEDURE

Begin the lesson by conducting a review of the procedures the children have used to subtract whole numbers on the number line. Draw a number line labeled from zero through eight on the chalkboard. Ask a child to use this number line to subtract four from seven. He will start at the seven and may do the subtraction by marking one-unit moves to the left or by jumping all four units at once.

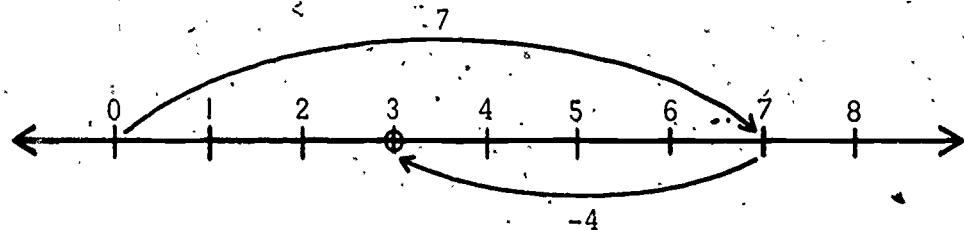
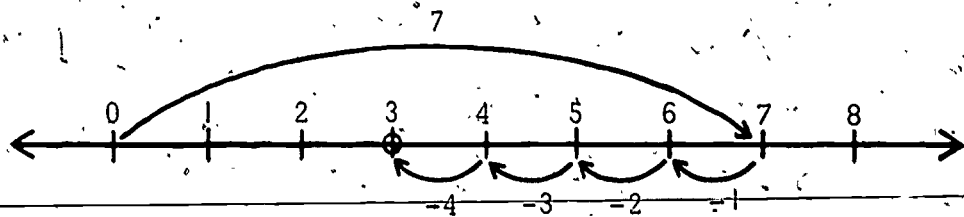

If your class needs more practice in number line subtraction, have the children work several more practice problems with number lines. Some suggested problems are:

$$8 - 3 = 5 \quad 5 - 1 = 4 \quad 4 - 2 = 2 \quad 6 - 5 = 1$$

$$9 - 3 = 6 \quad 7 - 2 = 5 \quad 8 - 2 = 6 \quad 2 - 2 = 0$$

Then ask the class if they think they could also use a number line to subtract fractions. Draw another number line labeled zero through eight and call on a child to solve the following problem.

$$7 - \frac{2}{3}$$

Remind the children that whole units must be divided into equal parts before we can show a fraction of that whole. Have the child divide the distance between seven and six into three equal parts. Ask the children how this will help them solve the subtraction sentence ($7 - \frac{2}{3} = ?$). They can now move two of those parts to the left, ending at $6\frac{1}{3}$.

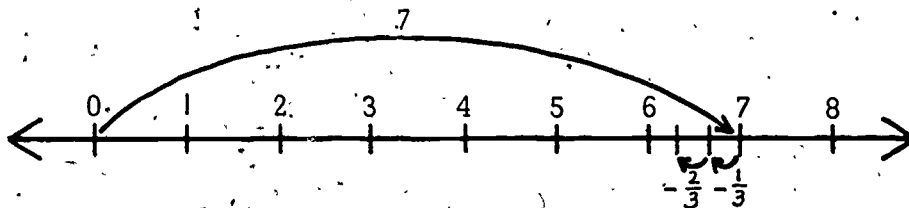

You may wish to have several children take turns doing subtraction problems on number lines at the chalkboard until you are sure that the children understand the procedure. Some examples you may want to use are:

$$5 - \frac{2}{8} \quad 4 - \frac{6}{7} \quad 8 - \frac{4}{5} \quad 3 - \frac{1}{2}$$

$$5 - \frac{3}{3} \quad 7 - \frac{5}{6} \quad 6 - \frac{3}{4} \quad 2 - \frac{1}{6}$$

Next, draw a number line (0 through 7) on the chalkboard and write a problem near the number line, as shown on the next page.

$$6 - \frac{5}{4} = ?$$

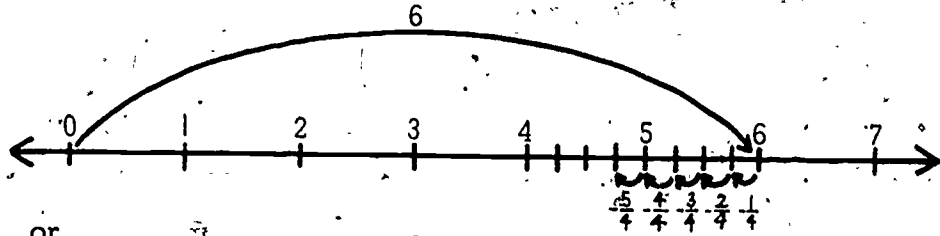

or

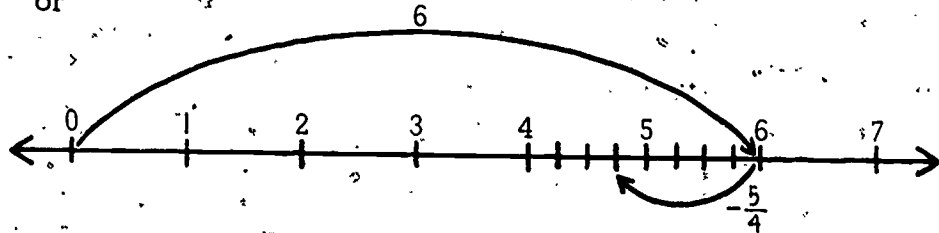

Call on a child to solve the problem at the board and ask him to explain what he is doing. First he will have to divide the units between six and five and between five and four into four equal parts each. Then he can move five of these parts to the left to get an answer of four and three-fourths. Encourage discussion of this procedure to make sure all the children understand it.

You may want the class to practice subtraction problems of this type. Some students could use number lines drawn on the chalkboard. Others could use number lines on their desks. Some suggested problems are:

$$6 - \frac{3}{2}$$

$$5 - \frac{7}{5}$$

$$7 - \frac{8}{5}$$

$$4 - \frac{4}{3}$$

$$2 - \frac{3}{2}$$

$$5 - \frac{6}{5}$$

$$6 - \frac{8}{7}$$

$$5 - \frac{8}{5}$$

Finally, draw a number line on the chalkboard labeled zero through five and write this problem next to it:

$$4 - 1\frac{1}{2} = ?$$

Have a child come to the board and solve the problem. First he will need to move one whole unit to the left. Then he must divide the whole unit between two and three into two equal parts and move one of these units to the left.

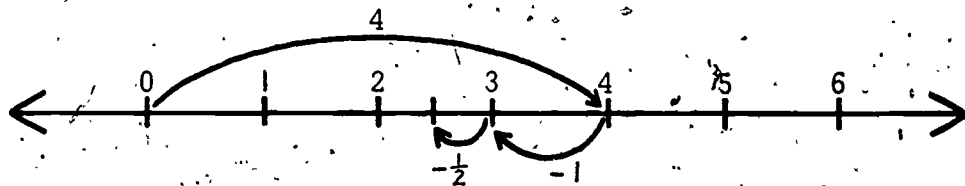

If more practice is necessary, offer the following problems:

$$5 - 3\frac{2}{3}$$

$$6 - 2\frac{1}{4}$$

$$7 - 4\frac{3}{5}$$

$$8 - 5\frac{3}{5}$$

Have the children complete Worksheets 69 and 70 individually or in small groups. Discuss solutions when they have finished.

Worksheet 69
Unit 22 Name _____

Subtract. Use the number line.

$5 - 2 = 3$

$4 - \frac{1}{2} = 3\frac{1}{2}$

$3 - \frac{2}{3} = 2\frac{1}{3}$

$2\frac{1}{2} - 1 = 1\frac{1}{2}$

$4\frac{1}{2} - 2\frac{1}{2} = 2$

Worksheet 70
Unit 22 Name _____

Subtract. Use the number line.

$\frac{2}{3} - \frac{1}{3} = \frac{1}{3}$

$\frac{5}{6} - \frac{3}{6} = \frac{2}{6}$

$\frac{7}{3} - \frac{2}{3} = \frac{5}{3}$

$\frac{5}{4} - \frac{3}{4} = \frac{2}{4}$

$\frac{1}{5} - \frac{1}{5} = 0$

Making a Beam Balance

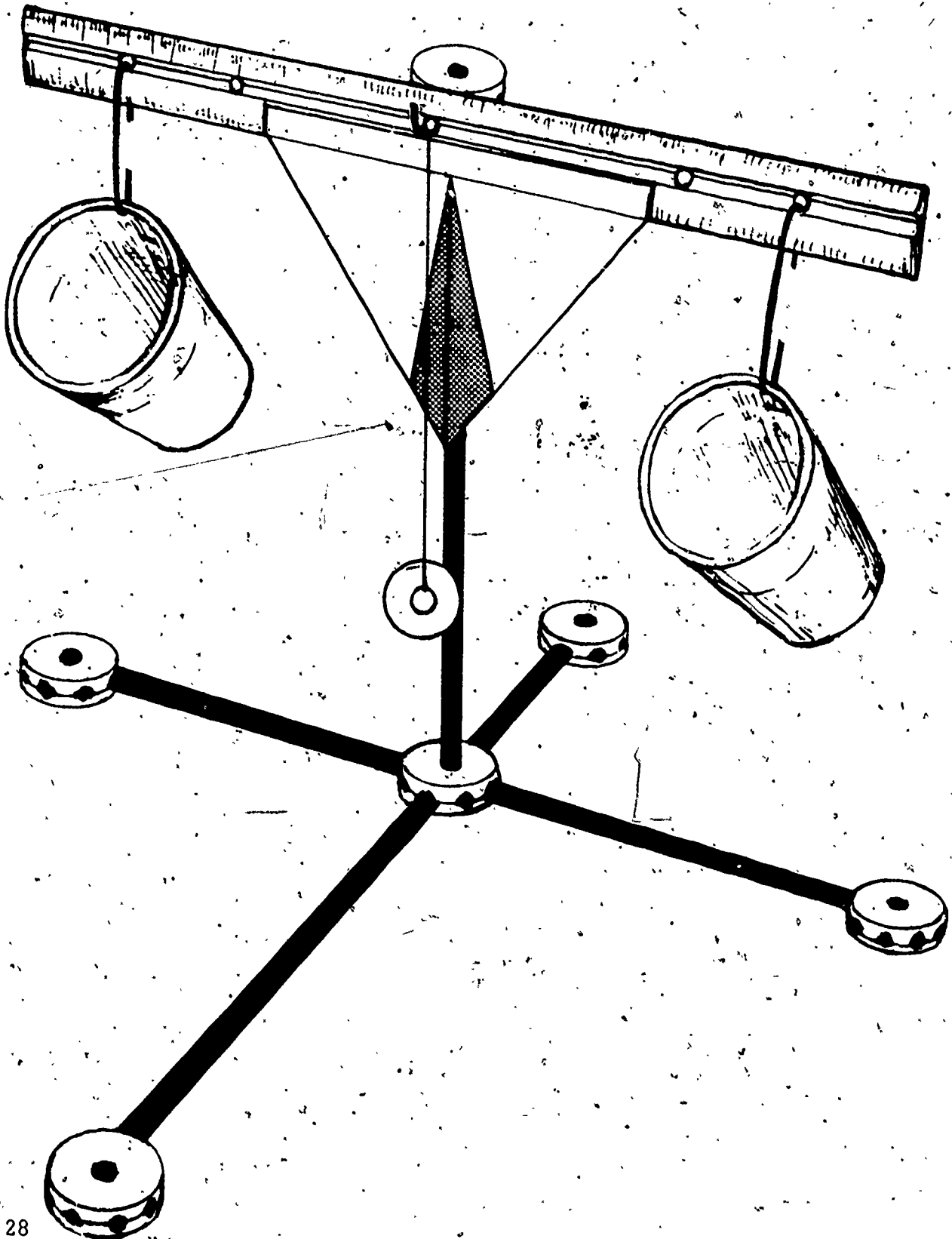

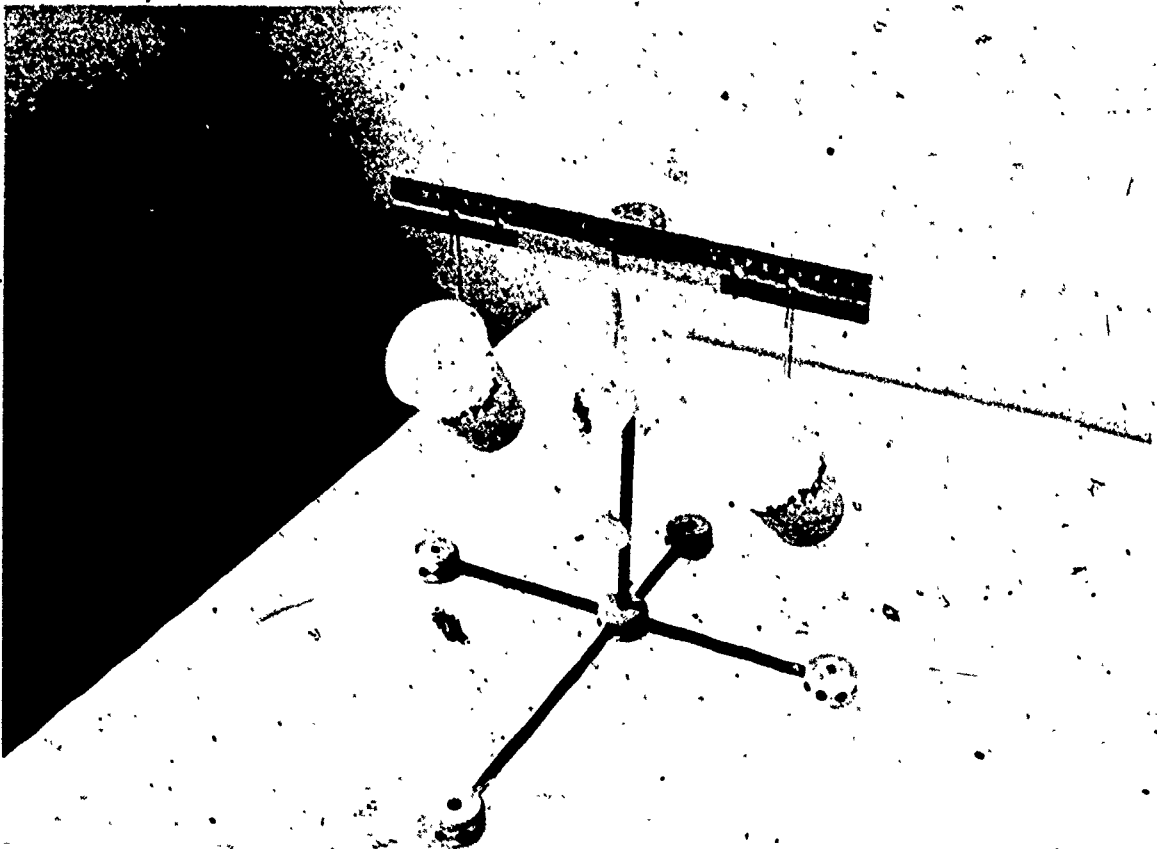
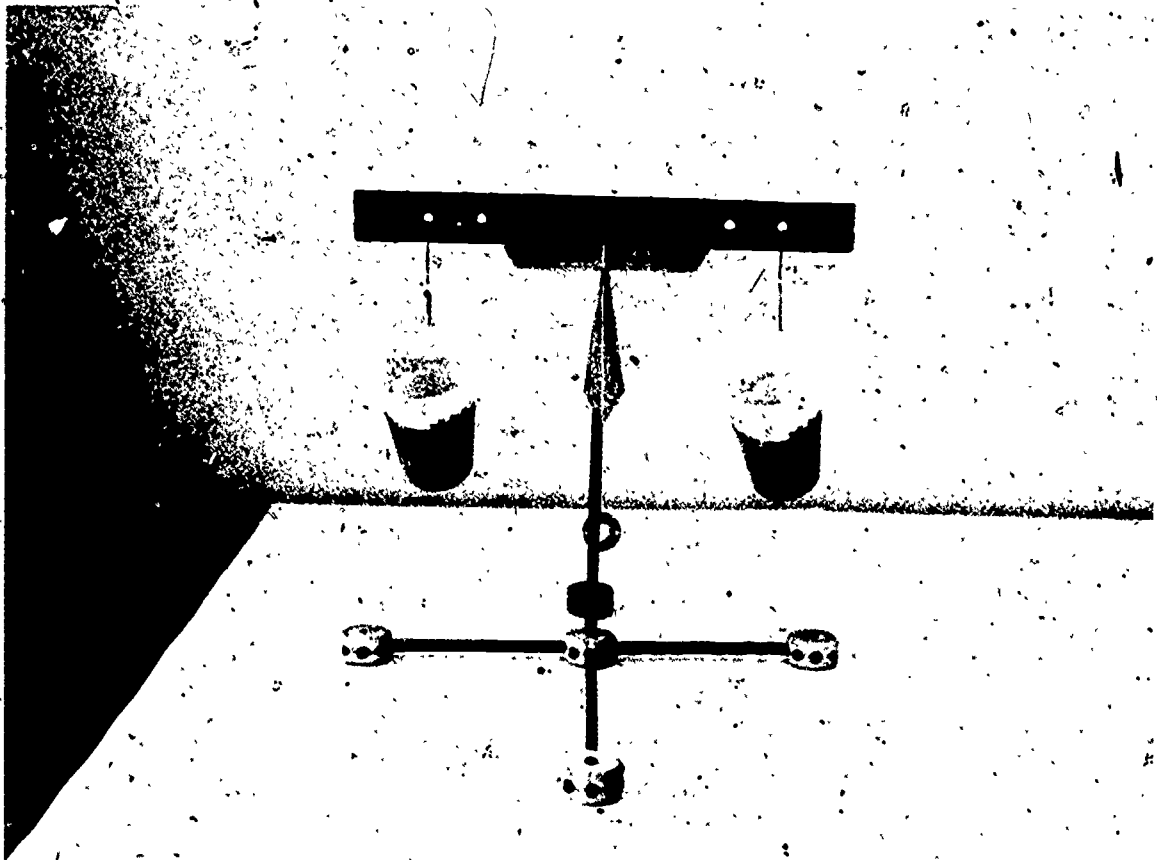

PARTS FOR BUILDING A BEAM BALANCE

Kit Items:

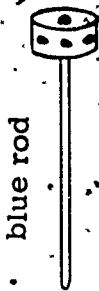

blue rod

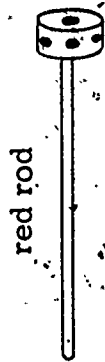

red rod

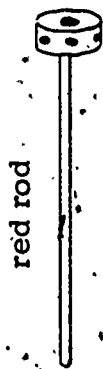

red rod

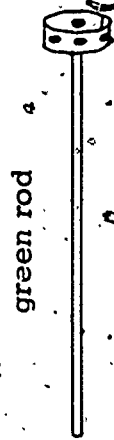

green rod

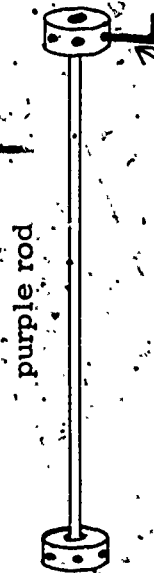

purple rod

picture hook

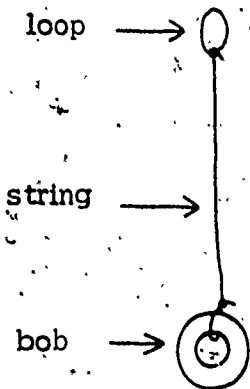

loop

string

bob

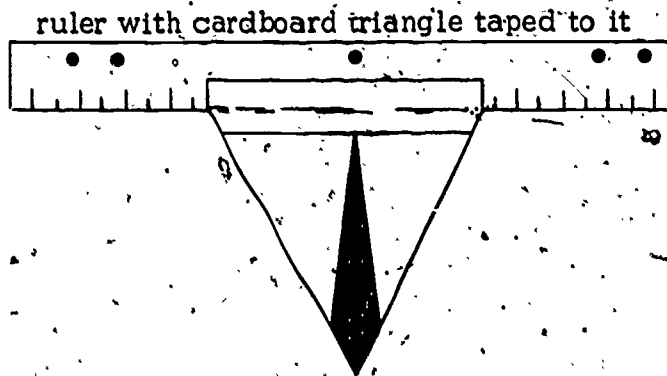

ruler with cardboard triangle taped to it

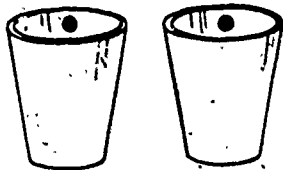

2 cups with small holes near opening



2 straightened paper clips

Steps in Putting Beam Balance Together:

Step 1. Put stand together.

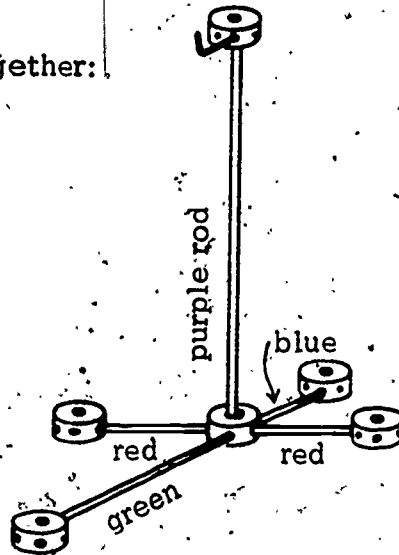

Step 2. Put balance arm on stand by slipping the center hole of the ruler over the picture hook.

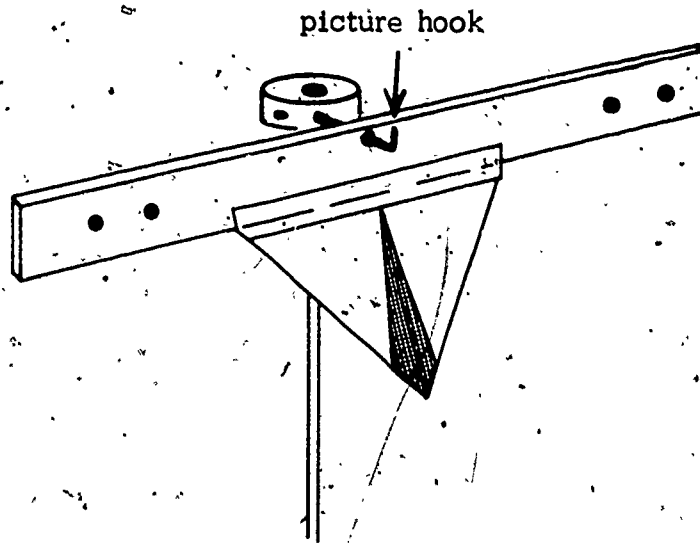

Step 3. Attach two cups to the balance arm.

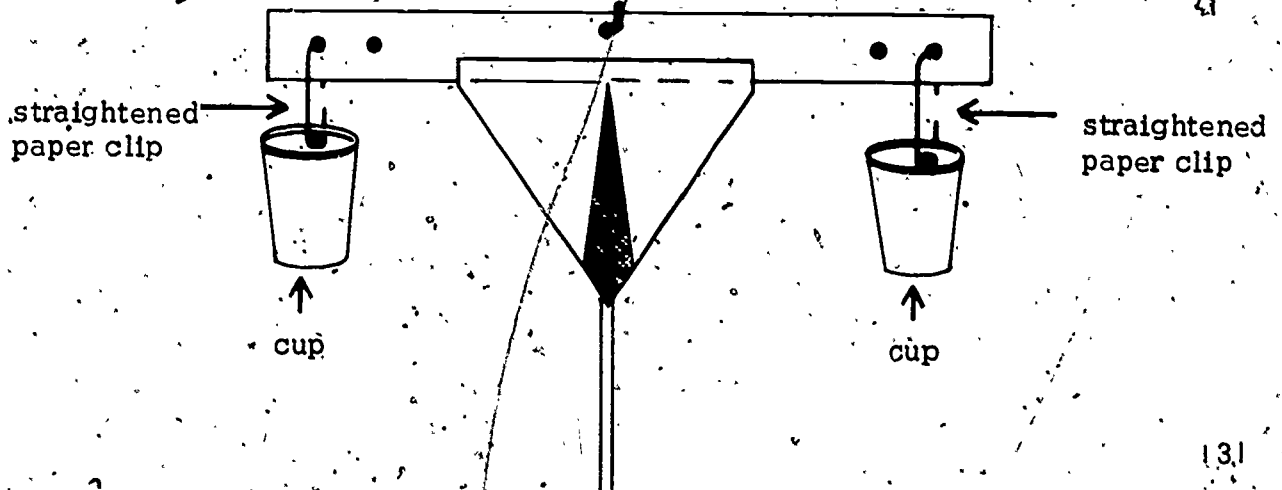

Step 4. Attach bob to the end of the picture hook. (Caution: Make sure the balance arm does not touch the string of the bob.)

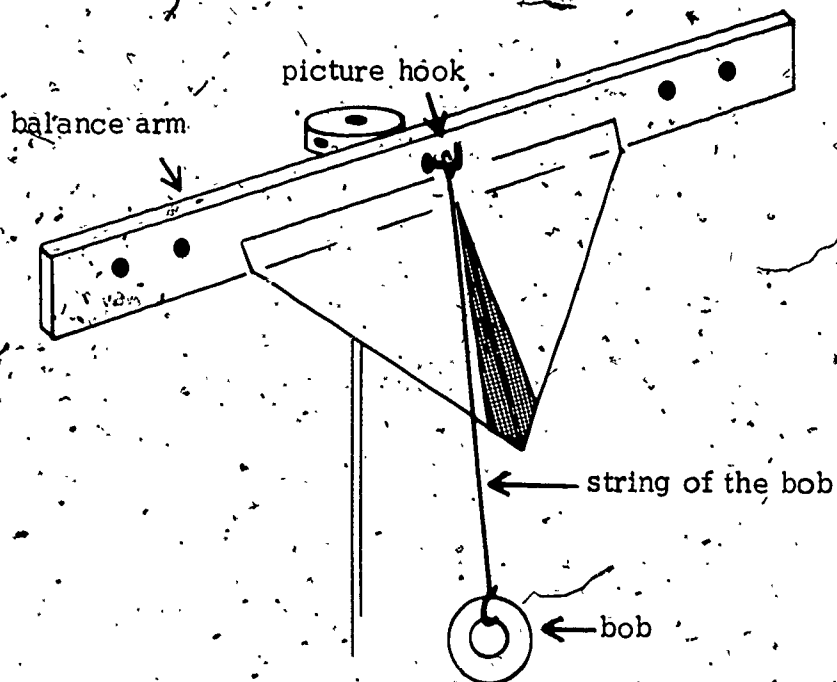

Step 5. Adjust the balance arm by putting masking tape on the end which is too light. When the beam is balanced, the bob string should be lined up with the center line of the red triangle.

