

DOCUMENT RESUME

ED 127 184

SE 021 221

AUTHOR Vogt, Elaine E., Ed.
 TITLE Numbers and Measuring; Learning With TOR: MINNEMAST
 Coordinated Mathematics - Science Series, Unit 16.
 INSTITUTION Minnesota Univ., Minneapolis. Minnesota School
 Mathematics and Science Center.
 SPONS AGENCY National Science Foundation, Washington, D.C.
 PUB DATE 71
 NOTE 159p.; For related documents, see SE021201-234;
 Photographs may not reproduce well
 AVAILABLE FROM MINNEMAST, Minnemath Center, 720 Washington Ave.,
 S.E., Minneapolis, MN 55414

EDRS PRICE MF-\$0.83 HC-\$8.69 Plus Postage.
 DESCRIPTORS *Curriculum Guides; Elementary Education; *Elementary
 School Mathematics; *Elementary School Science;
 Experimental Curriculum; Interdisciplinary Approach;
 Learning Activities; Mathematics Education;
 *Measurement; Number Concepts; *Number Systems;
 Primary Grades; Process Education; Science Education;
 Units of Study (Subject Fields)
 IDENTIFIERS *MINNEMAST; *Minnesota Mathematics and Science
 Teaching Project

ABSTRACT

This volume is the sixteenth in a series of 29 coordinated MINNEMAST units in mathematics and science for kindergarten and the primary grades. Intended for use by second-grade teachers, this unit guide provides a summary and overview of the unit, a list of materials needed, and descriptions of five groups of lessons. The purposes and procedures for each activity are discussed. Examples of questions and discussion topics are given, and in several cases ditto masters, stories for reading aloud, and other instructional materials are included in the book. This unit begins with a review of ordering concepts and then introduces linear measurement to the nearest half inch, measuring and adding fractional units, and measuring diameters and circumferences. Fourteen lessons are devoted to systems of numeration and place value. The measurement of weight, an introduction to negative numbers, and our monetary system are the subjects of other lesson sequences. (SD)

 * Documents acquired by ERIC include many informal unpublished *
 * materials not available from other sources. ERIC makes every effort *
 * to obtain the best copy available. Nevertheless, items of marginal *
 * reproducibility are often encountered and this affects the quality *
 * of the microfiche and hardcopy reproductions ERIC makes available *
 * via the ERIC Document Reproduction Service (EDRS). EDRS is not *
 * responsible for the quality of the original document. Reproductions *
 * supplied by EDRS are the best that can be made from the original. *

NUMBERS & MEASURING

04

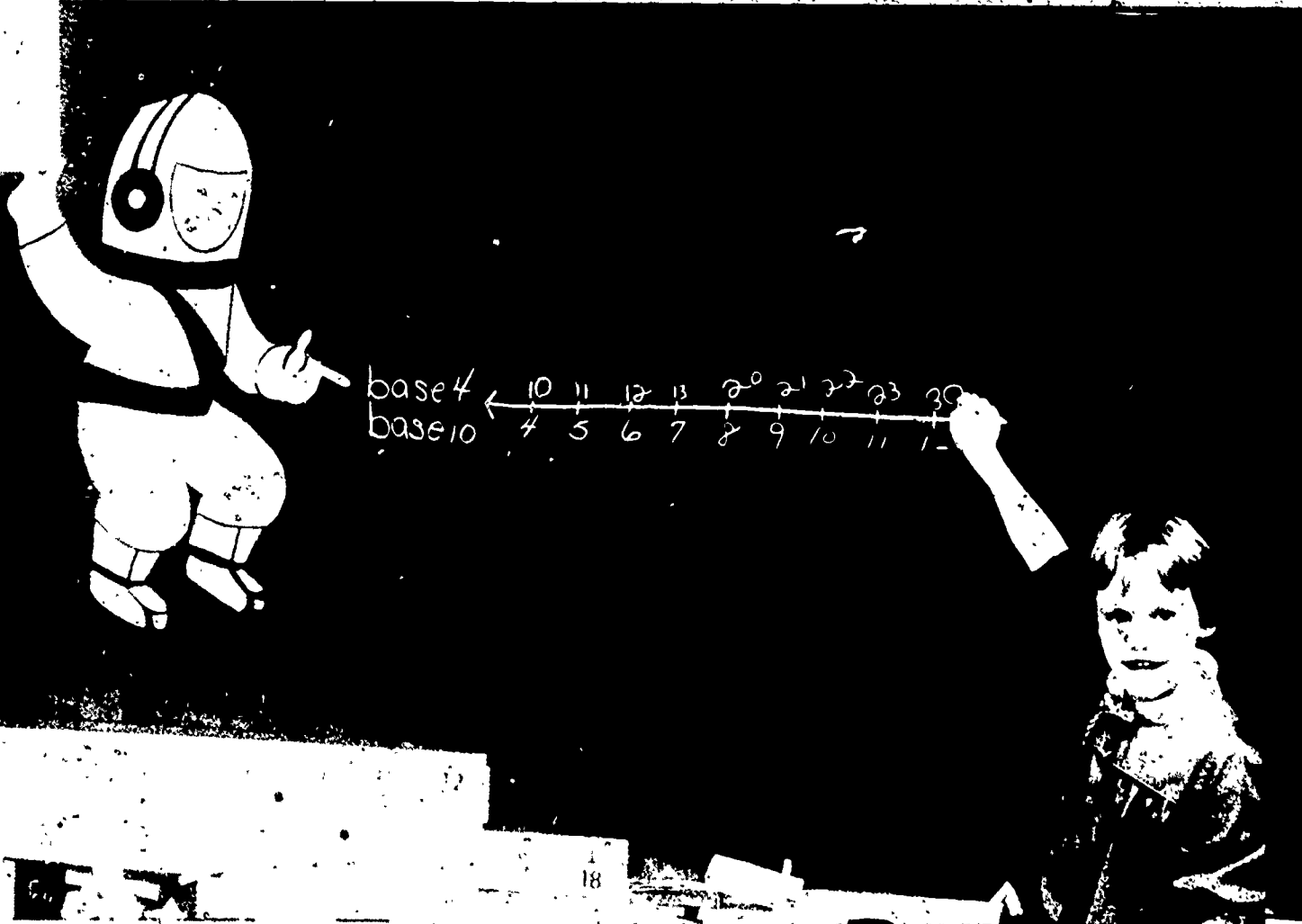

021 221

UNIT



2

MINNESOTA MATHEMATICS AND SCIENCE TEACHING PROJECT

KINDERGARTEN
FIRST GRADE
SECOND GRADE
THIRD GRADE

1. WATCHING AND WONDERING
2. CURVES AND SHAPES
3. DESCRIBING AND CLASSIFYING
4. USING OUR SENSES
5. INTRODUCING MEASUREMENT
6. NUMERATION
7. INTRODUCING SYMMETRY
8. OBSERVING PROPERTIES
9. NUMBERS AND COUNTING
10. DESCRIBING LOCATIONS
11. INTRODUCING ADDITION AND SUBTRACTION
12. MEASUREMENT WITH REFERENCE UNITS
13. INTERPRETATIONS OF ADDITION AND SUBTRACTION
14. EXPLORING SYMMETRICAL PATTERNS
15. INVESTIGATING SYSTEMS
- 16. NUMBERS AND MEASURING
17. INTRODUCING MULTIPLICATION AND DIVISION
18. SCALING AND REPRESENTATION
19. COMPARING CHANGES
20. USING LARGER NUMBERS
21. ANGLES AND SPACE
22. PARTS AND PIECES
23. CONDITIONS AFFECTING LIFE
24. CHANGE AND CALCULATIONS
25. MULTIPLICATION AND MOTION
26. WHAT ARE THINGS MADE OF?
27. NUMBERS AND THEIR PROPERTIES
28. MAPPING THE GLOBE
29. NATURAL SYSTEMS

OTHER MINNEMAST PUBLICATIONS

The 29 coordinated units and several other publications are available from MINNEMAST on order. Other publications include:

STUDENT MANUALS for Grades 1, 2 and 3, and printed TEACHING AIDS for Kindergarten and Grade 1.

LIVING THINGS IN FIELD AND CLASSROOM (MINNEMAST Handbook for all grades)

ADVENTURES IN SCIENCE AND MATH (Historical stories for teacher or student)

QUESTIONS AND ANSWERS ABOUT MINNEMAST Sent free with price list on request

OVERVIEW (Description of content of each publication)

MINNEMAST RECOMMENDATIONS FOR SCIENCE AND MATH IN THE INTERMEDIATE GRADES (Suggestions for programs to succeed the MINNEMAST Curriculum in Grades 4, 5 and 6)

NUMBERS & MEASURING

LEARNING
WITH TOR

UNIT **16**



MINNESOTA MATHEMATICS AND SCIENCE TEACHING PROJECT
720 Washington Avenue S.E., Minneapolis, Minnesota 55455

MINNEMAST

DIRECTOR

JAMES H. WERNTZ, JR.
Professor of Physics
University of Minnesota

ASSOCIATE DIRECTOR
FOR SCIENCE

ROGER S. JONES
Associate Professor of Physics
University of Minnesota

ASSOCIATE DIRECTOR
FOR RESEARCH AND EVALUATION

WELLS HIVELEY II
Associate Professor of Psychology
University of Minnesota

Except for the rights to materials reserved by others, the publisher and copyright owner hereby grants permission to domestic persons of the United States and Canada for use of this work without charge in English language publications in the United States and Canada after July 1, 1973, provided the publications incorporating materials covered by these copyrights contain acknowledgement of them and a statement that the publication is endorsed neither by the copyright owner nor the National Science Foundation. For conditions of use and permission to use materials contained herein for foreign publications or publications in other than the English language, application must be made to: Office of the University Attorney, University of Minnesota, Minneapolis, Minnesota 55455.

The Minnesota Mathematics and Science Teaching Project developed these materials under a grant from the National Science Foundation.

© 1968, University of Minnesota. All rights reserved.

Third Printing, 1971

NUMBERS & MEASURING

This unit was developed by MINNEMAST on the basis of experiences of the many teachers who taught an earlier version in their classrooms.

JAMES M. KRABY
Chairman, Mathematics and Science Departments
North Hennepin State Junior College

HOWARD T. STACKPOLE
Research Fellow
University of Minnesota

EDMUND C. BRAY
Assistant to Director
Curriculum Materials
Development

ELAINE E. VOGT
NANCY SUTTON
JANICE MANLEY
Editor
Assistant
Assistant

JACK KABAT
SONIA D. FORSETH
Art Director
Associate Art Director



CONTENTS

Materials List	vi
Introduction	1
Section 1. Measuring and Ordering	4
Lesson 1 A Review of Ordering	6
Lesson 2 Measuring to the Nearest Half Inch	23
Lesson 3 Measuring and Adding Fractional Units	26
Lesson 4 Diameters and Circumferences	32
Section 2. Numeration and Place Value	39
Lesson 5 Numbers vs. Numerals	41
Lesson 6 T Notation and Numerals to 99	43
Lesson 7 The Number Line	45
Lesson 8 Measuring with Two-Digit Numerals	49
Lesson 9 Adding Two-Digit Numerals on the Slide Rule	55
Lesson 10 The Abacus	57
Lesson 11 Adding and Subtracting with the Abacus	61
Lesson 12 The Numerals through 999	64
Lesson 13 Counting by Tens	69
Lesson 14 Tor's Number System — Base Four	75
Lesson 15 Tor's Base-Four Number Line	81
Lesson 16 The Base-Four Abacus	84
Lesson 17 Egyptian Numeration	87
Lesson 18 Roman Numeration	92
Section 3. Measuring Weight	97
Lesson 19 A New Property	99
Lesson 20 Using a Seesaw	105
Lesson 21 Building a Beam Balance	109
Lesson 22 Standard Weight and Variation	115
Lesson 23 Measuring Children's Weights	119
Lesson 24 Constructing a Rubber-Band Scale	123
Lesson 25 Experiments with a Beam Balance	129
Section 4. Negative Numbers	132
Lesson 26 Directions on the Number Line	133
Lesson 27 Negative Integers	135
Section 5. Teaching Tor to Use our Money (Lesson 28)	139

Complete List of Materials for Unit 16
(Numbers based on class size of 30.)

total number required to teach unit	item	lessons in which item is used
30	** Student Manuals	
1	** drawing of Tor	1, 14
5	flat, rectangular objects, 2 of the same length	1
30	* MINNEMAST rulers	1, 2, 3
30	scissors	1
1	number line, 0-100 (from addition slide rule)	2, 3, 7, 9
1	roll of masking tape	2, 4
3-4	circles, squares or strips of paper or flannel	3
10	*** sets of Minnebars	3, 14, 20
1	*** thin, square property block	3
1	tape measure or yardstick	3, 8
30	*** addition slide rules	3, 7, 9, 28
5	pieces of chalk: white, red, blue, yellow, orange	3, 8
6	sets of 5 cylinders: 1 six-oz. orange juice can; *1 Dry cell; *1 tube from MINNEMAST viscosity kit; 1 large, thick circular property block; 1 small, thick circular property block	3, 4
1	large cylinder, with length of yarn longer than its circumference	4
25	* 10" lengths of yarn	4
30	* rulers	4, 8, 13, 20
5	pens or crayons to mark yarn	4
1	United States flag	5
2000	* counters	6, 12, 13, 14
1	flannel board	6, 14
30	boxes of crayons	6, 8
30	red pens or pencils	7, 24
10	large books	8
30	* desk number lines, 0-25	8
5	* abaci	10, 11, 13, 16

1 each	transparencies of Worksheets 26, 29, 35 (optional)	11
150	*soft file cups (small paper cups)	12
20	trays or boxes large enough to hold 10 paper cups	12
5-10	pictures of Egypt and Rome (optional)	17, 18
2-3	*sets: Ping-Pong ball, rubber ball, ball of clay	19
2-3	sets: brick, *hard block, *soft block, closed box of similar size, etc.	19
2-3	sets: irregular stone, papier-mâché lump, *styrofoam	19
2-3	sets: 3 cups containing materials of 3 different densities	19
30	sets: *paper clip, crayon, ruler, scissors	19
110	*paper cups	20, 21, 22, 24
1	seesaw (or 6' x 8" x 2" plank balanced on a brick)	20
10	beam balances made from *balance kit and *Tinker toy special set (see list on p. 110)	21, 22, 24, 25
10	*rubber balls	22
2-3 each	scissors; *Ping-Pong balls	22
15 each	*1" paper clips, *corks	22, 24
10	*2" paper clips	22, 24
1 each	1" piece of chalk, 1" rubber eraser	22
1	scale to weigh children	23
10	2" x 14" strips of oak tag	24
10	rubber or elastic strings	24
10 each	8" Tinker toy rod, 3-1/4" Tinker toy rod, cylindrical connector	24
1	birthday candle, matches	25
10-12	objects, e.g., ice cubes, cotton, water, apple, sand, eggs, spring or elastic, clay, milk, pencil, chalk or crayon, bar of soap	25
30	** number lines, -15 to +15	27
	coins	28

*kit items as well as

**printed materials available from
Minnemath Center, 720 Washington Ave. S.E., Mpls., Minn. 55455

***available from The Judy Company,
310 North Second Street, Minneapolis, Minnesota 55401



INTRODUCTION

This unit is designed:

- To improve the child's ability to make quantitative measurements by giving him practice in measuring the properties of length and weight.
- To introduce the idea that measurements vary because of human error and imprecise measuring devices.
- To enlarge the child's comprehension of the real number system by extending his knowledge of numbers to 999, to fractions, and to negative integers.
- To explain the structure of the decimal place-value notation.
- To provide experience in calculating with denominate quantities (7 inches, 6 feet, 10 cents).

At this point in the MINNEMAST program, the child has had experience in comparing objects on the basis of simple properties and has started to study the real number system. In this unit we want him to learn to measure more accurately, using quantitative scales on rulers and balances. We also want him to learn more about the number system by examining some of the ways numbers are represented.

Previously the child made rather rough estimates of the properties of objects by comparing them two at a time (binary comparison). When determining the lengths of objects, he lined them up and arranged them in order by eye. When comparing weights of different objects, he judged their heaviness by hefting them in his hands. In this unit the child discovers that these simple binary comparisons do not give very accurate determinations of properties. He finds out that a ruler, or any such quantitative measuring device, gives more precise measurements. He also discovers the advantages to himself and others of this improved description of a property.

Length and weight are the two properties used to illustrate the need for quantitative measurement. The idea is that simple binary comparisons and subjective judgment do not

carefully describe certain kinds of properties. A more quantitative method is needed. The whole process of measurement is an attempt to extend the precision and accuracy of the human senses. Our eyes can judge length, but with a ruler we can measure it more precisely.

Measurement, then, is a tool we use for making more accurate and objective observations of the world. The better we can describe and analyze a thing, the better chance we have of understanding it, and measurement enables us to be quantitative in our descriptions. Thus measurement is a fundamental part of the scientific process, and the emphasis in this unit is on measurement rather than on length or weight per se.

In performing measurements, we always find a certain amount of variation in the results. Different people may get different answers, and no instrument is perfectly accurate. Therefore, in this unit we take up the subject of error and variation in measurement so that the child will have early experiences with the practical problems of making measurements.

In enlarging the child's view of the real number system, numbers up to 999 are introduced. Fractions and negative numbers are considered in a very rudimentary way, as are other mathematical ideas (the value of coins, the Egyptian method of representing numbers, etc.). Many of these extensions of the child's view of mathematics have important practical applications and will be emphasized in other units. But the emphasis here is on enlarging the meaning of the number concept. There is no wish to minimize, for example, the significance of fractions -- so essential in many kinds of calculations and measurements. But more important at this time than the child's ability to manipulate fractions is his realization that negative numbers, fractions, and numbers up to 999 (as well as the digits from 0 to 99 with which he is already familiar) are all part of the same set of real numbers.

Similarly, the base-four system of numeration is introduced only to clarify the decimal place-value system of notation we use for representing numbers. No emphasis at all should be placed on memorizing the base-four system. Also, all considerations of the subject, "number vs. numeral," are included only to help the children distinguish a number from the various

ways it can be represented. Some ways are useful for calculations, others for representing fractions, and still others for studying the properties of the numbers. It is precisely this flexibility of representation which needs emphasis. Once a child understands the concept and structure of numbers as distinct from the way they are represented, he can choose whichever symbols or systems of numeration best suit his purpose.

NOTES ON TEACHING THE UNIT

This coordinated unit should be taught during two class periods each day, and be completed in four or five weeks. However, you may wish to begin this unit before completing Unit 15, Investigating Systems. In that case it is suggested that you start teaching this unit in parallel with Unit 15, at any point you find convenient.

The first part of a continuing story, "Tor," appears at the beginning of Lesson 1. Tor is a very inquisitive little man from outer space. Teachers who have tried out this unit found the story highly motivating to the children. Children not only enjoyed pretending they were answering Tor's questions, but seemed to find it easier to explain things to him than to answer direct questions. You may use the Tor device as much as you see fit. For your convenience, a black and white figure of Tor is provided in the printed materials. This can be colored and mounted on cardboard by you or the children; or you may choose to draw your own figure of Tor or use one the children draw. In any case, make sure the figure has two-digit hands (only one thumb and one finger on each hand), as this is useful in introducing the lesson on base four.

Questions may arise about what "weight" is. To avoid long departures from the main subject of measurement, you can explain to the children -- quite simply -- that weight is the property of heaviness that all objects possess. We know that we are somewhat sensitive to this property because we can feel the weight of objects by holding them in our hands. Should some children be persistently curious about weight, they should not be discouraged, but should be told that the weight of an object is the pull on that object by the earth.

SECTION 1 MEASURING AND ORDERING

PURPOSE

- To review the proper use of the greater than ($>$), less than ($<$), equal to ($=$), and appears to be the same as (\approx) symbols.
- To help children see the advantage of using different units of measurement.
- To give practice in the use of measuring tools.
- To introduce the use of fractional units in measurement and to give practice in the addition of half units.

COMMENTARY

This section reviews and extends earlier measuring experiences and emphasizes determining length and recording it. The records then are used as a basis for review and practice in arithmetic.

The section consists of four lessons, each requiring about two class periods. A story is read to the children to introduce the activities of Lesson 1. The activities include a review of the symbols listed above, ordering by length, and counting by ones. Measurements in this lesson are made with the centimeter scale.

In Lesson 2 the symbols are used to record comparison of numbers. The children use rulers with an inch scale to measure objects to the nearest inch or half inch. This information is plotted on a number line.

An experiment in Lesson 3 involves using ordinal numbers (first, second, third, etc.), measuring distances, and recording data. The number line is used for the addition of half units of measurement.

Lesson 4 introduces two new measurements that can be made on circular objects. The children have opportunities to investigate the relationship between circumference and diameter.

Measurements are plotted on the number line and more experience with whole and half units is given.

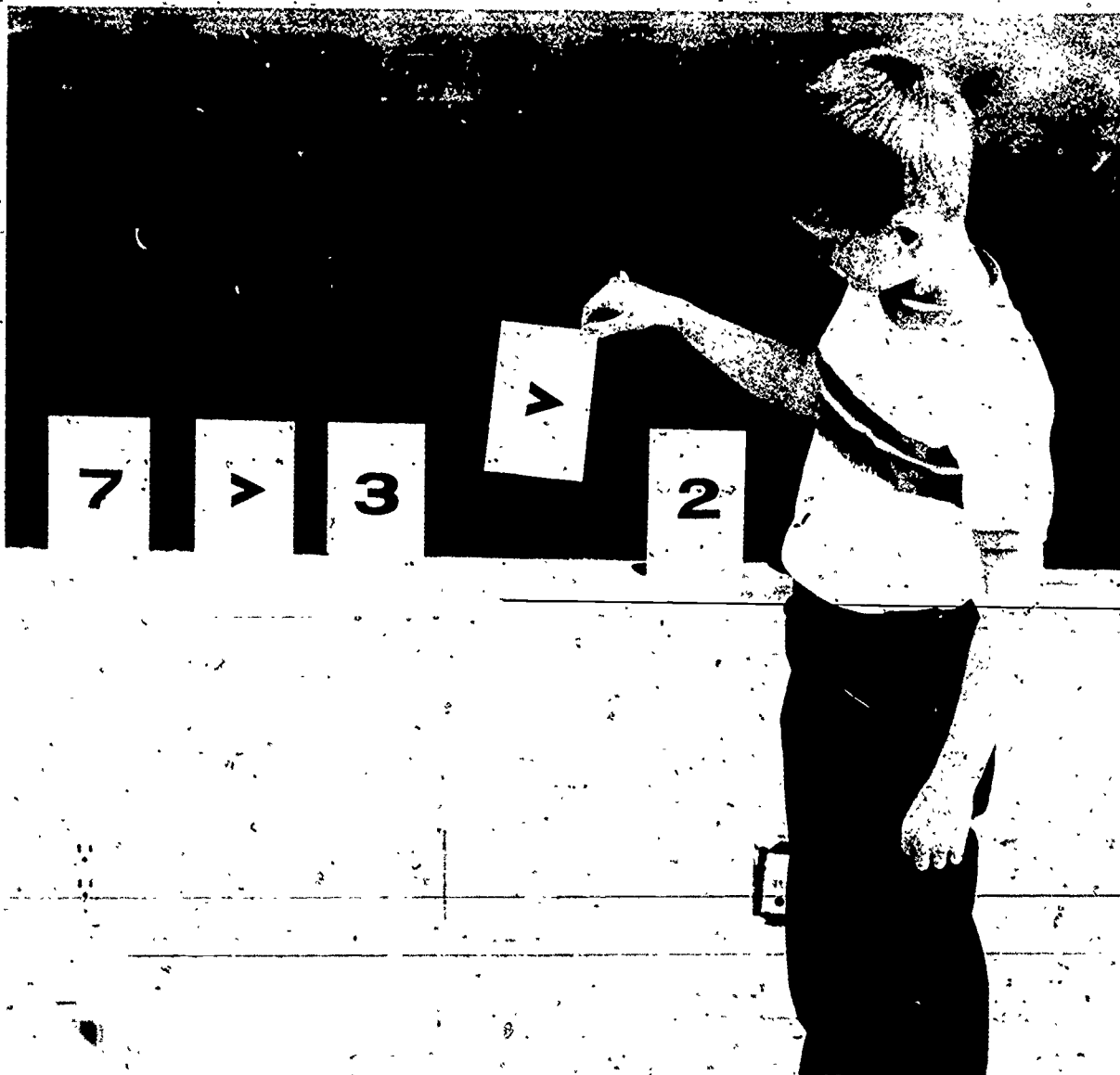

The boy in the photograph is using numeral and symbol cards to show that 7 is greater than 3 and 3 is greater than 2. If you wish to use cards in this way, they are easy to make, or you can borrow them from the first-grade supplies.

Lesson 1: A REVIEW OF ORDERING

A story introduces the activities of this lesson, which includes a review of the use of symbols, ordering by length, and counting. As in Unit 12, Measurement with Reference Units, length is defined as the measure of the longest dimension of an object.

Activity A reviews direct comparing of lengths and recording of the comparisons. You may want to remind the children that some objects can be compared for length, not only by lining up one end of each, but also by stacking objects appropriately -- the longest at the bottom. Try to guide the discussion so that the use of the symbols ($>$, $<$, \doteq) occurs naturally when the children are comparing the lengths of the various objects.

For Activities B and C, Worksheets 1-4 give individual practice in ordering the lengths of objects in two ways: by direct comparing and by measuring. Remind the children of the special ways the equality and approximation symbols are used.

The equality symbol ($=$) should be used to state the number of objects in a set of discrete objects, because the number is known to be precisely 3 and not 2 or 4. Example:

$$N_A = 3$$

This says, "The number of objects in Set A is exactly 3."

The approximation symbol (\doteq) should be used to state a measurement, because measurements are not precise. A measurement of 3 inches may be 2.999 or 3.001. Example:

$$L_A \doteq 3 \text{ inches}$$

This says, "The length of object A appears to be about 3 inches."

Activity D gives the children a review of the counting numbers from 0 to 99 (Worksheet 5).

MATERIALS

- story, "Tor," provided below
- drawing of Tor, provided in the printed materials
- 5 flat rectangular objects (boxes, rulers, books, etc.) --
2 of which are apparently of the same length
- MINNEMAST rulers, 1 per child
- Worksheets 1-5, in Student Manuals
- scissors for each child

PROCEDURE

Read the story, "Tor," to the children. Later, perhaps during art or free time, they can help you color and mount on cardboard the figure of Tor provided in the printed materials. The figure (or another drawn by you or a child) can be placed on the chalk tray during the activities.

TOR

The children in the second grade were sitting at their desks, quietly reading. Miss Johnson, their teacher, suddenly realized that the room was much too warm. Speaking softly to one of her students, she said, "Tommy, it's such a beautiful day, almost like summer. Would you open the windows, please?"

As Tommy was doing this, he looked up and saw a streak of bright white light high in the sky. Then the light came nearer. It looked more red than white. The streak seemed to point toward the school yard just below the windows.

"Miss Johnson," Tommy called out, "something's coming down out of the sky. I think it's going to land on our playground!"

Everyone rushed pell-mell to the windows. All hearts pounded with excitement as the red streak slowed down. Then it gave off green and purple puffs of smoke. Then it went beep, beep, pop, and landed -- without another sound -- right in the center of the school yard.

"It's a space ship! I just know it's a space ship!" Tommy exclaimed.

"My goodness, Tommy, I think you're right!" Miss Johnson sounded just as thrilled as the children.

"It looks just like a great big rubber ball!" Susan shouted.

"And it has red and white stripes like peppermint candy!" Mary said.

Tommy pointed to the space ship. "Oh, oh, a door is opening!"

And sure enough, one of the red stripes slid open, a ladder popped out, and a little man in a space suit climbed down the ladder to the ground. He looked up and waved to the children and Miss Johnson. Everyone waved back.

Then the little man raised his visor and called out, "Is this the Earth?" and the children all shouted back, "Yes, yes, it is!"

"Is this a school?"

"Yes, yes!"

"Good! I was hoping it was, but I couldn't be sure. May I come up for a visit?"

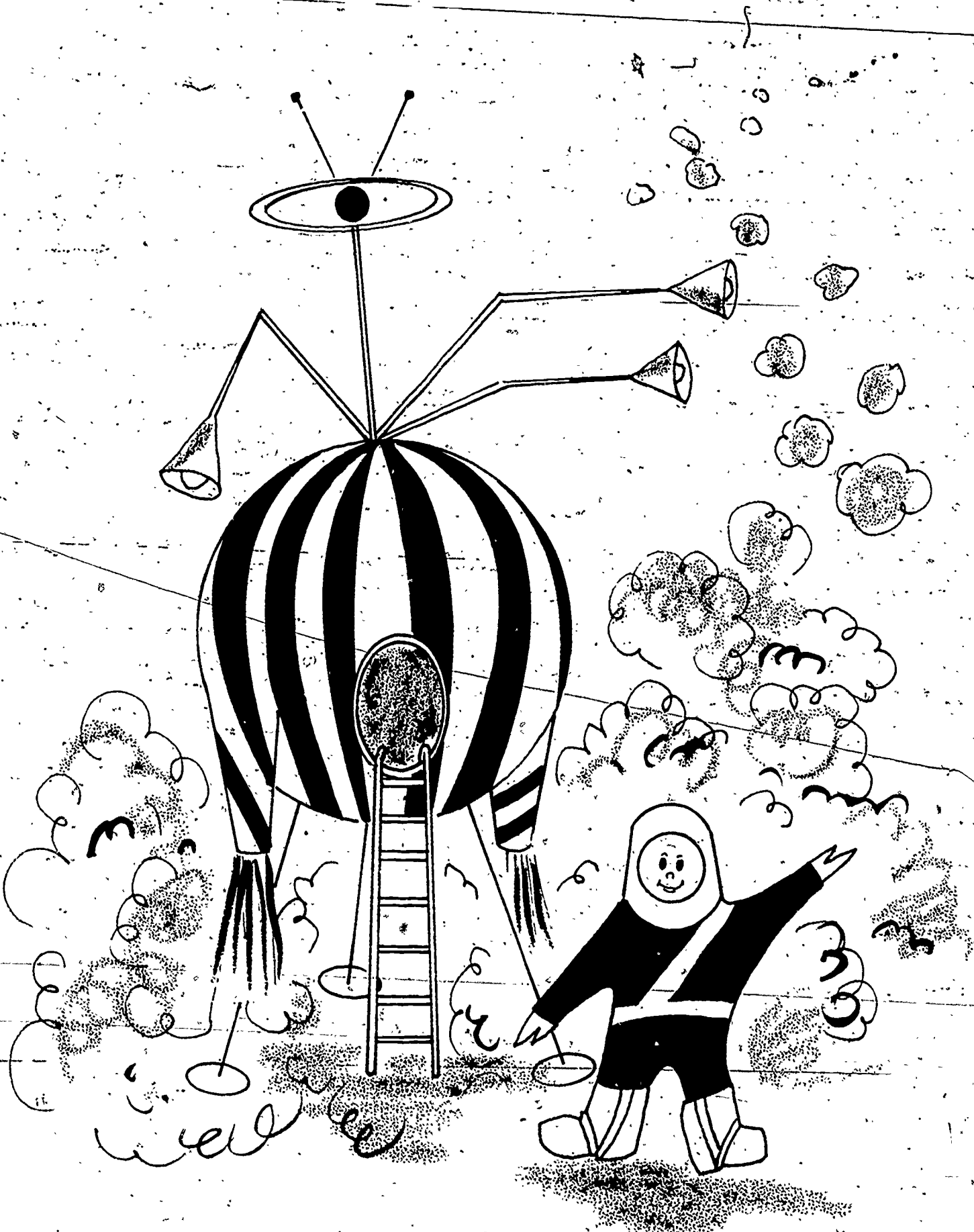

The children surrounded Miss Johnson, begging her to say yes. "He's very friendly -- he even waved to us," they reminded her.

Miss Johnson smiled. Then, leaning from the window a little, she called out, "We'll come down and show you the way to our room."

"Thank you very much, but that won't be necessary," the space man said. And before anyone had a chance to decide what to do next, he reached in a pocket of his space suit and took out a can.

"That looks like some kind of a spray can," Joe said.

And that is just what it turned out to be! The children and their teacher stared in amazement as the space man pointed the can at the ground and began to spray. As he sprayed down, he rose up, up, up, in the air. When he was just above the window sills, he sprayed away from the school and flew backwards through an open window right into the classroom. Then he stopped spraying and floated gently to the floor.

Now the children clustered around the space man. They admired his shiny blue suit and his bright red boots. When he took off his helmet, they were delighted to see a round, friendly face with rosy cheeks, and hair brushed to a neat point on top of his head. They noticed his hands -- he had hands that looked something like mittens, with just a thumb and one finger on each. And Tommy noticed that the space man was much shorter than anyone in the room, but, of course, he didn't say anything about that.

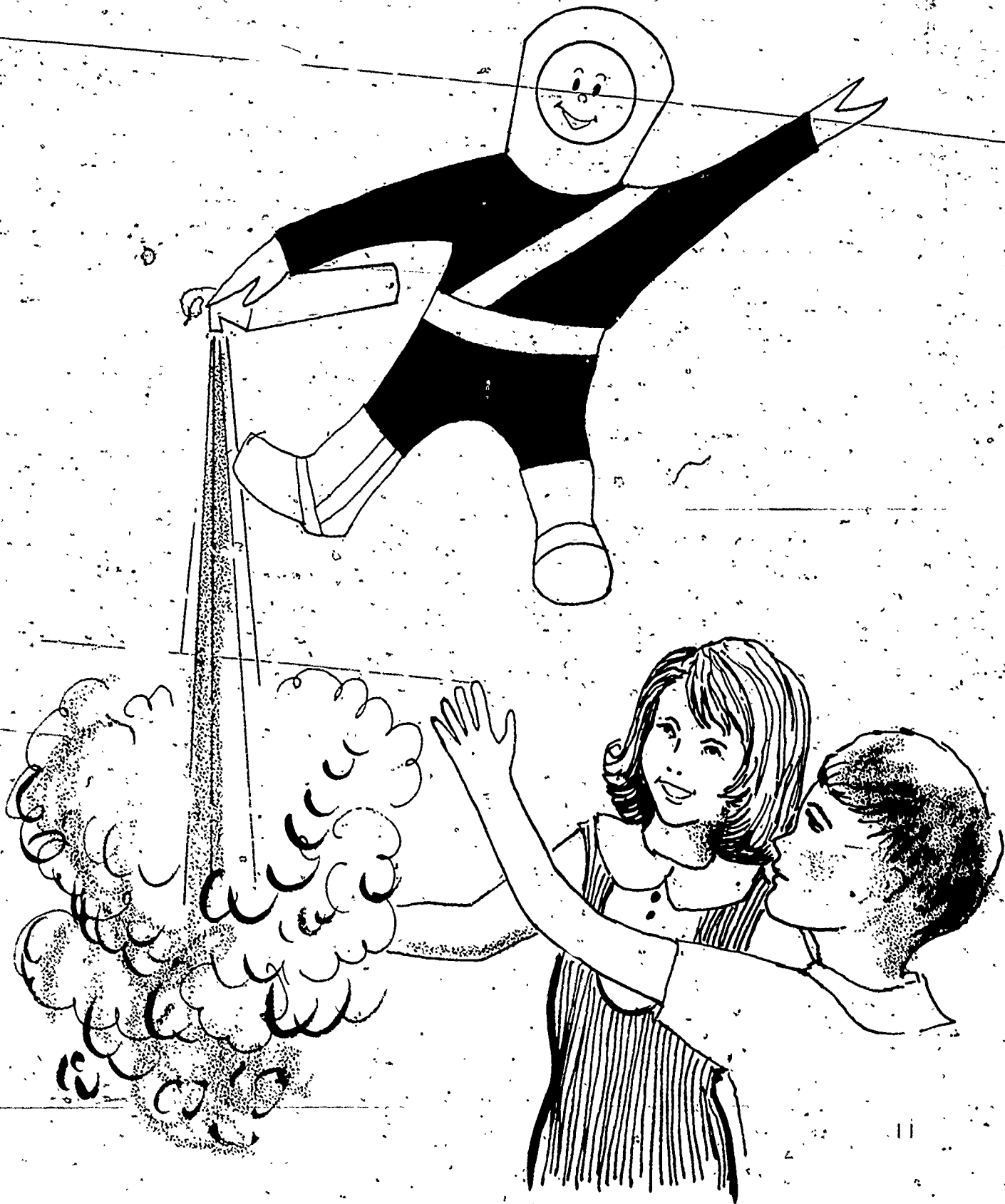

"Good morning, Earth people," the space man said. "I am Tor, from Titan. Titan is the largest moon of the planet Saturn. I can hardly believe that I have really found the Earth. Are you sure this is the Earth and that this is truly an Earth school?"

"Yes, Tor," the teacher answered. "This is a class in the second grade. I am Miss Johnson and these are my students."

"That's wonderful!" Tor said. "I could not have selected a better place to land. On Titan, many of us have been listening to your radio programs and so we have learned to speak your language. Now I have been sent to learn how to read all your written symbols, especially those you use in mathematics and science. Can I learn such things here?"

"Yes, we study all kinds of things like that," Miss Johnson said. "Today we are going to review some symbols we use when we compare the lengths of objects."

"Well, could I stay in this class and learn along with your students?" Tor asked.

Miss Johnson said, "Well, what do you think, children? Shall we let Tor stay and learn along with us? Will you be willing to explain things to him and try to find answers to his questions?"

Together the children all shouted, "Oh, yes, yes!" and "Tor, please stay!"



Tor practically jumped up and down for joy. "Oh, how lucky I am!" he exclaimed. "People on Titan said you might not like me -- that you might not be friendly at all. I was so afraid."

Then, to show how friendly they were, the children all surrounded Tor again and started asking questions. The questions came out in such a rush that Tor could hardly keep track of them.

Tommy asked, "How long did it take you to get here, Tor?" and Joe wanted to know how many miles Tor had traveled. Sally asked, "Where are you going to stay?" and Mary wanted to know what he liked to eat.

Miss Johnson rapped a pencil on the desk for order. When it was quiet in the room, Tor turned to Tommy. "It took a very long time for me to get here and I can tell you how much that is in my time -- it's segura ziggeraties -- but I really don't know how to figure anything in your time, so that answer will have to wait until I learn." Turning then to Joe, Tor said, "When I learn your units of measurement, I'll be able to tell you how far I traveled, but I certainly can't do that now." To Sally and Mary, he said, "You don't have to worry about where I will stay or what I will eat, because I will live in my spaceship, where I have everything that I need. After school you are all invited to come and inspect my ship, but right now I am very eager to start learning, because there's so very much I don't know."

Miss Johnson offered Tor her chair. Tor looked it over.

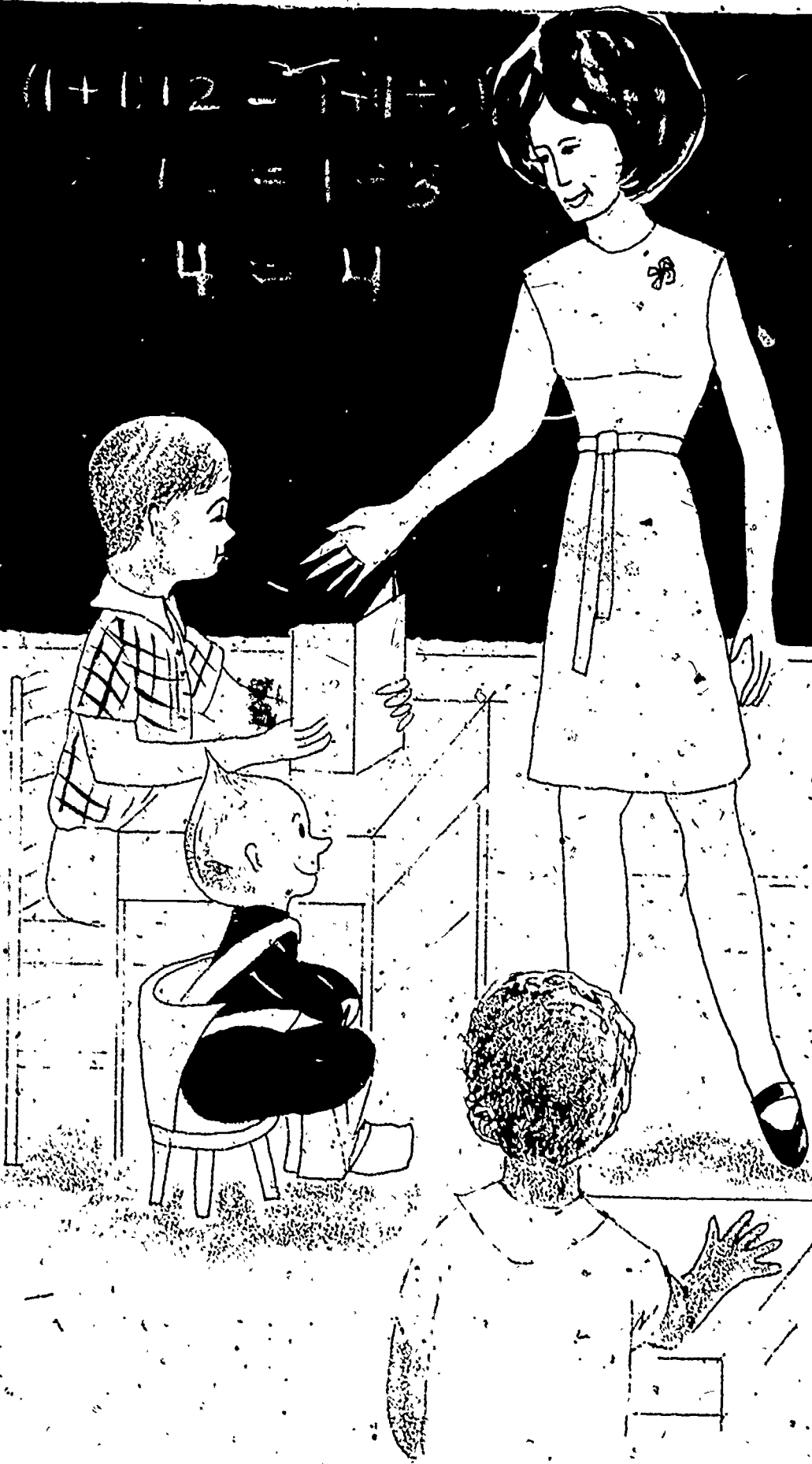

"It's much too tall for me, Miss Johnson," he said. "It would not be comfortable."

Miss Johnson sent Tommy to the kindergarten to fetch a smaller chair, but when Tor saw it, he said, "This chair is less tall than your chair, Miss Johnson, but it's still too tall for me."

"My," Sally said, "you are fussier than Goldilocks in the story of the three bears," but Tor wasn't listening. He sprayed himself out to his ship and back again, and when he came back he was carrying a little chair that he said was "just right." He put it beside Tommy's seat, announced, "I'm ready now," and sat down.

When Miss Johnson saw that Tor was comfortable, she put some objects on her desk and said, "Let's begin by showing our visitor how we make comparisons," and the lesson began.

.....

Activity A

Place five flat rectangular objects where the children can see them. (Remember that two of the objects should be of the same apparent length.) Ask one child to pick up any two objects (e.g., a book and a ruler) and hold them up for the class to see. The following questions assume that Tor is learning along with the children. Whether you use this pretense or not, guide the discussion to the property of length.

CAN YOU TELL TOR WHICH OF THE TWO OBJECTS HAS THE GREATER LENGTH? (The ruler.)

SHOW TOR HOW WE CHECK THE COMPARISON. (We place one object beside the other.)

HOW COULD WE RECORD THIS COMPARISON? (We could write, "The length of the ruler is greater than the length of the book.")

CAN ANYONE SHOW TOR A SHORTER WAY TO RECORD THE COMPARISON?

Write $L_R > L_B$ on the chalkboard.

CAN YOU TELL TOR WHAT THE L STANDS FOR? (Length.)

WHAT THE R STANDS FOR? (Ruler.)

WHAT THE B STANDS FOR? (Book.)

HOW DO WE READ THE SYMBOL? (Is greater than.)

NOW PLEASE READ THE WHOLE COMPARISON SENTENCE FOR TOR. (The length of the ruler is greater than the length of the book.)

Have another child compare and then record the relative lengths of two other objects. Repeat this several times until the greater than (>), the less than (<) and the approximation (\approx) symbols have all been used and discussed.

The children may enjoy recording a comparison of the lengths of the three chairs in the Tor story:

$$L_J > L_K > L_T$$

(The length of Miss Johnson's chair is greater than the length of the kindergarten chair, which is greater than the length of Tor's chair.)

They could also reverse this ordering, using the < symbol:

$$L_T < L_K < L_J$$

(The length of Tor's chair is less than the length of the kindergarten chair, which is less than the length of Miss Johnson's chair.)

If there are children in your class who have not had MINNE-MAST in first grade, they probably will need additional practice in using the symbols before going on to the next activity. Numeral and symbol cards may prove useful here (see photograph on page 5).

Activity B

Distribute the student manuals and have each child carefully cut out the six objects on Worksheet 1.

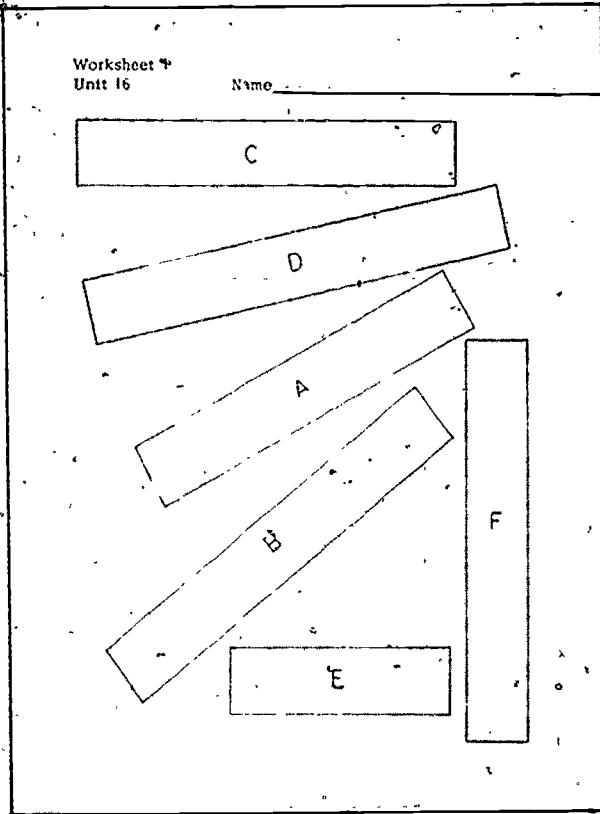

Tell the children they are to compare two of these paper strips at a time for the property of length, then fill in the proper symbols on Worksheet 2. Have one child make the first binary comparison of strips A and B, and record it on the board for the class and Tor. Then let the children work individually on the five other binary comparisons.

When they have completed the six statements, ask them to arrange their six paper strips in order on their desks. -- the shortest at the left. Then explain that in the general ordering on the last line of Worksheet 2, they are to fill in first the letter symbols or names of their strips (A for strip A, etc.) and then the correct relation symbols.

Have the children save their paper strips for use in Activity C and for Lesson 2.

Worksheet 2
Unit 16 Name _____

Compare the lengths of your paper strips, two at a time. In the blanks, write $<$, $>$ or $=$.

$l_A < l_B$
 $l_C < l_D$
 $l_E < l_F$
 $l_A < l_F$
 $l_B > l_E$
 $l_D > l_C$

Order all your paper strips by length on your desk. Fill in the name of each strip and $<$, $>$ or $=$.

$l_E < l_A < l_C = l_F < l_B < l_D$
 (or E) (or C)

Activity C

In this activity the children use their paper strips, a ruler with a centimeter scale, and two worksheets. Begin with a review of the proper uses of the equality ($=$) and approximation (\approx) symbols (for Tor, if you like).

Ask six children to come to the front of the room. Tell three to stand at the left and three at the right. Name one group "Set A" and the other "Set B."

HOW MANY MEMBERS DOES SET A HAVE? (3.)

Write $N_A = 3$ on the chalk board.

HOW MANY MEMBERS DOES SET B HAVE? (3.)

Write $N_B = 3$ on the chalk board.

IS THE NUMBER OF MEMBERS IN SET A EQUAL TO THE NUMBER OF MEMBERS IN SET B? (Yes.)

Write $N_A = N_B = 3$ on the chalk board.

NOW TELL TOR WHEN WE USE THE EQUAL-SIGN. (When two sets have an equal number of members, when we can count the members and see the equality.)

Add a member to Set A, then ask the same questions again. This time the final answer is that we cannot use the equal-sign because 4 is greater than 3. ($4 > 3$.)

Since $N_A = 4$ and $N_B = 3$, then $N_A > N_B$.

DO WE USE THE EQUAL-SIGN WHEN WE RECORD MEASUREMENTS OF LENGTH? (No, because measurements are not exact.)

TELL TOR WHAT SIGN WE USE. (We use \approx , the "appears to be the same as" symbol.)

Worksheet 3
Unit 16 Name _____

Measure each strip with a centimeter ruler and write the lengths in the blanks.

$L_A \doteq \underline{14}$ cm

$L_B \doteq \underline{16}$ cm

$L_C \doteq \underline{15}$ cm

$L_D \doteq \underline{17}$ cm

$L_E \doteq \underline{9}$ cm

$L_F \doteq \underline{15}$ cm

Order the measurements here. Start with the smallest.

$\underline{9}$ cm < $\underline{14}$ cm < $\underline{15}$ cm \doteq $\underline{15}$ cm < $\underline{16}$ cm < $\underline{17}$ cm

Now tell the children to show how they can check their previous ordering of the six paper strips. Have them use the centimeter scale on their rulers to measure each paper strip and then record the length of each strip with a numeral on Worksheet 3. Remind the children to line up one end of each strip with zero (which is not at the very end of a MINNEMAST ruler).

On the last line the children fill in the numerals representing the measurements -- starting with the smallest numeral. One (15) is already given in this ordering.

ARE YOUR NUMERALS IN COUNTING ORDER?

Check to see that the children place the smallest numeral on the left, the largest on the right.

Ask the children to compare this new ordering with the ordering on Worksheet 2. Ask one child to copy the first ordering on the chalk board and another child to put the second ordering directly below it.

Have the class check to see whether the two orderings are correct. Remind the children to use the list of binary comparisons ($L_A \doteq 14$ cm, etc.) on Worksheet 3 as a reference.

On Worksheet 4 the children record on the number line the name of each strip (its letter) at the numeral which represents the length of the strip. The length of C is already plotted for them.

Worksheet 4

Unit 16

Name _____

How many centimeters long is your A strip?

Mark an A at that point on this number line.

How many centimeters long is your B strip?

Mark a B at that point on this number line.

Do the same for the rest of your strips.

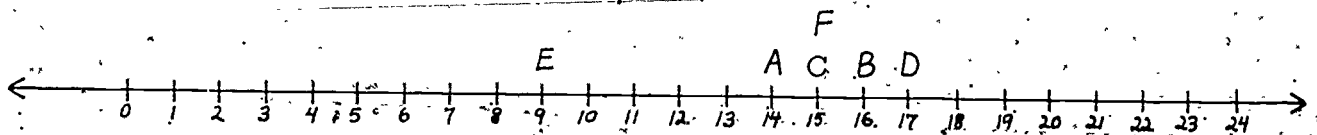

Activity D

This is a review of the counting numbers from 0 to 99. The children fill in the missing numerals on Worksheet 5.

Worksheet 5
Unit 16 Name _____

Start at 0 and work this way → across each row of squares. Fill each blank square with the next counting number.

0	1	2	3	4	5	6	7	8	9
10	11	12	13	14	15	16	17	18	19
20	21	22	23	24	25	26	27	28	29
30	31	32	33	34	35	36	37	38	39
40	41	42	43	44	45	46	47	48	49
50	51	52	53	54	55	56	57	58	59
60	61	62	63	64	65	66	67	68	69
70	71	72	73	74	75	76	77	78	79
80	81	82	83	84	85	86	87	88	89
90	91	92	93	94	95	96	97	98	99

Point out that some of the numerals the children put in order on Worksheet 3 are found on this worksheet, with some others. Read the directions with the class before the children start writing in the numerals. Remind them that each numeral is one more or one less than its neighbor. Tell them that they may refer to the number line if they wish.

Save the completed worksheets for correction and review in Lesson 2.

Lesson 2: MEASURING TO THE NEAREST HALF INCH

This lesson gives a review of the ordering of numerals and then introduces the measurement of length to the nearest half inch. The children record their measurements and plot them on number lines.

Earlier units emphasized the fact that measurements can never be perfectly accurate by having the children express their results in two ways:

- (1) They measured within an interval of length and recorded the measurement as

$$6 \text{ in.} < L_B < 7 \text{ in.} \quad (\text{Six inches is less than the length of object B, and the length of object B is less than seven inches.})$$

- (2) They made a simple approximation and recorded it as

$$L_B \approx 6 \text{ in.} \quad (\text{The length of object B appears to be about 6 inches.})$$

In this lesson the children again use the approximation symbol to express measurements to the nearest half inch:

$$L_B \approx 6 \text{ in.}$$

$$L_A \approx 5\frac{1}{2} \text{ in.}$$

Some children may need help in deciding whether a length is $6\frac{1}{2}$ or 7 inches long. Guide them to choose the closer reading. When a measurement appears to be midway between two readings, let the child choose the reading he prefers. Experience like this reinforces the idea that measurements are only approximations.

MATERIALS

- number line (0-100) taped on the chalk board
- -- for each child --
- Worksheets 5-7
- MINNEMAST ruler
- paper strips A, C, D and E from Lesson 1, or a set of four Minnebars (such as 1 pink, 1 gray, 1 purple, and 1 green) labeled A, C, D and E respectively
- 1 object of the child's choice, less than 7" in length

Activity A

Have the children review and correct Worksheet 5 for Tor.

Activity B

Worksheet 6	
Unit 6	Name _____
Fill in each blank with $>$, $<$ or $=$. Look at the number line or at Worksheet 5 if you wish.	
3 <u>></u> 6	1 <u><</u> 4
5 <u>></u> 2	3 <u>></u> 0
3 <u>=</u> 3	44 <u>></u> 27
2 <u>></u> 1	96 <u>></u> 69
14 <u>></u> 4	84 <u>></u> 37
23 <u><</u> 49	24 <u>=</u> 24
60 <u>></u> 32	15 <u><</u> 32

Ask the children to turn to Worksheet 6; and explain the instructions to them. Do one or two examples as a class exercise. Suggest that the children may use corrected Worksheet 5 and the number line on the board for reference. Ask the children to complete the rest of Worksheet 6 individually. As soon as possible after completion, check the answers with the class.

Activity C

Have the children take out their MINNEMAST rulers. See if they can tell Tom that the marks between the numerals on the inch scale indicate half inches. Then explain that they are going to measure the length of objects to the nearest half inch.

Have the children measure and record on Worksheet 7 the lengths of paper strips A, C, D and E (or Minnebars so labeled) and an object of their own choice -- not longer than seven inches.

Next have the children use number line 1 to plot the length of object A, and number line 2 to plot the length of object C.

Then, before plotting the length of object D, ask them to write in the numerals on number line 3. When the children have done this, direct them to mark off the inches and half inches on number lines 4 and 5, and to number these two lines. (A few children may need help in numbering or marking the number lines.) Then they are to plot the last two lengths.

Some children may feel frustrated at being required to measure only to the nearest half inch, when they are capable of measuring quarter inches. Since MINNEMAST rulers do not indicate quarter inches, these children should be permitted to work with other rulers and record their measurements on plain sheets of paper, but only after they have completed Worksheet 7 according to directions.

Save the completed worksheet for use in the next lesson.

Worksheet 7
Unit 17 Name _____

Objects	Length in inches
1. Object A	$\approx 5\frac{1}{2}$ "
2. Object C	≈ 6 "
3. Object D	$\approx 6\frac{1}{2}$ "
4. Object E	$\approx 3\frac{1}{2}$ "
5. Object I chose	≈ 7 " (many possible answers)

Record to nearest inch or half inch.

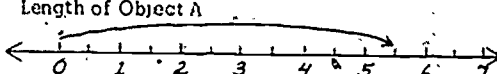
Length of Object A

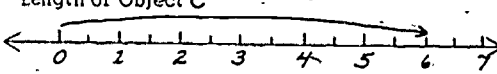
Length of Object C

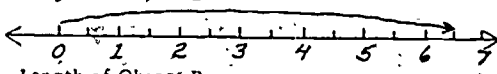
Length of Object D

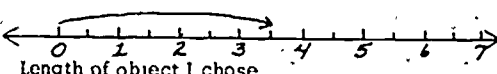
Length of Object E

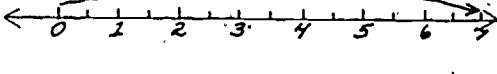
Length of object I chose.

Lesson 3: MEASURING AND ADDING FRACTIONAL UNITS

This lesson continues the work with fractional units, reviews the idea that two halves combine to make a whole, and gives practice in the use of ordinal numbers (first, second, third, etc.).

Activities include a worksheet on which lengths measured to the nearest half inch are added, as well as some sets of objects with whole and half members. An experiment where objects roll from an inclined plane to a level surface provides further opportunities for measuring to the nearest half inch.

The inclined plane can be constructed very simply with a property block and two rulers, as shown:

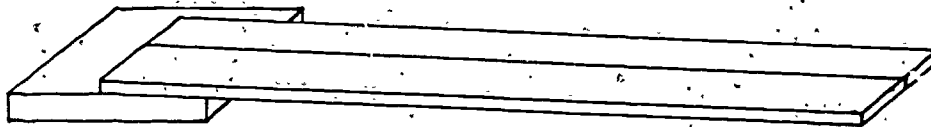

MATERIALS

- a few paper or flannel circles, squares and strips
- number line, 0-6, of very large units drawn on chalk board
- 1 number line tape (to 100)
- Minnebars
- 2 MINNEMAST rulers
- 1 thin square property block
- 1 tape measure or yardstick
- 1 addition slide rule
- 1 piece of white chalk, 1 red, 1 blue
- 4 or 5 cylindrical objects, such as: 6 oz. juice can, dry cell (D), empty viscosity tube without cover (from first-grade kit), large and small circular property blocks, crayons or pencils, small cars (size of Match-box Series) if children can bring them

- list of ordinal numbers on chalk board, as follows:

First	first	1st
Second	second	2nd
Third	third	3rd
Fourth	fourth	4th
Fifth	fifth	5th

- Worksheet 8 .

PROCEDURE

Activity A

To prepare the children for their individual work in adding fractional units (halves), review with them the idea that a whole is made up of two equal parts and that each of these two equal parts is one half of the whole. Demonstrate this with drawings on the board or by cutting paper strips, circles and squares in half, and fitting the halves together again. Pretend that a paper circle is a cookie, cut it in half and line up the halves like this:

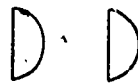

IF THESE TWO HALVES ARE TWO EQUAL PARTS OF A COOKIE, HOW MANY COOKIES WOULD I HAVE IF I ADDED THE TWO TOGETHER? ($\frac{1}{2} + \frac{1}{2} = 1$.)

Have a child check this by turning the second half "cookie" to fit the first:



Give as many similar examples as seem necessary for the children to understand that $\frac{1}{2} + \frac{1}{2} = 1$.

Now pretend that 2 paper squares and 3 half squares are cookies and half cookies, and arrange them like this:



HOW MANY COOKIES WOULD I HAVE IF I ADDED ALL THESE WHOLE AND HALF COOKIES?

($1 + \frac{1}{2} + 1 + \frac{1}{2} + \frac{1}{2} = 3\frac{1}{2}$.)

If children have trouble adding these, encourage them to fit as many halves into wholes as possible, and then count.

To review the addition of whole units of length, use a number line of six large units on the chalk board. In showing how to add 2 and 3, for example, draw first a curve from 0 to 2, then a curve from 2 to 5. The children should be able to see that the numeral at the end of the second curve is the sum of the two.

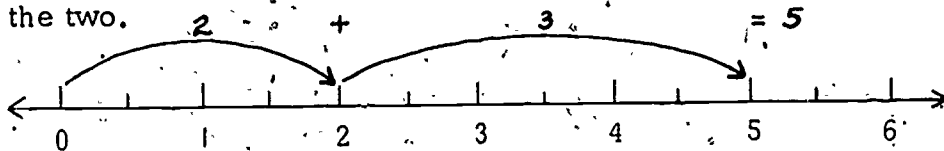

Have the children demonstrate, by marking off the solutions to such problems as $4 + 1$, $3 + 2$, $3 + 3$, etc.

Now use the same number line to have the class do a few examples where they add one length that is a whole number of units to a length that has a fraction ($2 + 3\frac{1}{2}$, $1\frac{1}{2} + 3$, $1 + 1\frac{1}{2}$, etc.).

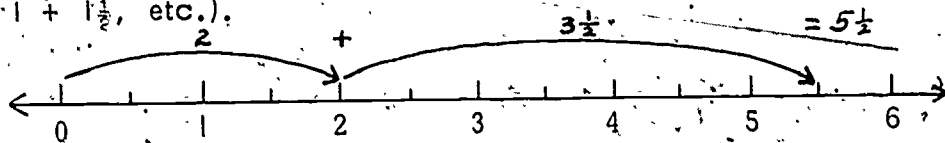

Finally, demonstrate the addition of two fractional lengths:

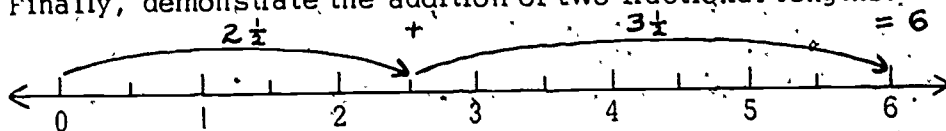

Have the children practice adding other fractional lengths on the number line until you feel sure they understand how to do it. For those having difficulty, provide pairs of Minnebars so that the children can measure each bar with a ruler, then place both together at the ruler's edge to read the result.

Activity B:

Remind the children that on Worksheet 7 they recorded the lengths of five objects to the nearest half inch. On Worksheet 8 they will use number lines to add the numbers which represent these lengths. Point out that the worksheet is not wide enough to hold a number line of twenty inches, but the marks will represent inches. In the first three problems the

children will be adding the number of inches and half inches. In the last four problems, they will be adding objects and halves of objects. Read the directions on the worksheet and have the children follow along. When you think they understand the procedure, have them complete the worksheet individually, with as little help as possible. In the class discussion that follows, let each child check and correct his results. There may be a little variation in the answers to problems 1 and 2, because some children may choose a reading a half unit different from others, but the answers to problem 3 should vary greatly. Ask about this:

Worksheet 8
Unit 16 Name _____

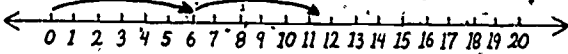
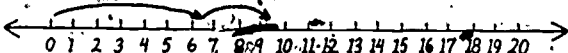
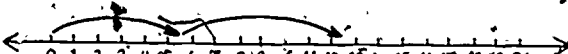
- Draw a curve to show the length of Object C. Add the length of Object A to it.

- Draw a curve to show the length of Object D. Add the length of Object E to it.

- Draw a curve to show the length of Object A. Add the length of your chosen object to it.

Add the cookies and half cookies in each row. Write the equation.

4. $\square\square\square + \square\square\square = 5\frac{1}{2}$	$2\frac{1}{2} + 3 = 5\frac{1}{2}$
5. $\square\square + \square\square\square\square = 5$	$1\frac{1}{2} + 3\frac{1}{2} = 5$
6. $\bigcirc\bigcirc\bigcirc\bigcirc + \bigcirc = 4\frac{1}{2}$	$4 + \frac{1}{2} = 4\frac{1}{2}$
7. $\bigcirc + \bigcirc + \bigcirc = 1\frac{1}{2}$	$\frac{1}{2} + \frac{1}{2} + \frac{1}{2} = 1\frac{1}{2}$

DO WE HAVE MANY DIFFERENT ANSWERS FOR PROBLEM 3? (Yes.)

WHY? (Because we chose many different objects to add to the length of object A.)

Some children may not see that the answer to problem 7 is $\frac{1}{2} + \frac{1}{2} + \frac{1}{2} = 1\frac{1}{2}$. If so, review the cutting and fitting together of the paper cookies. Elicit from the class that half an object remains half an object no matter how it is turned.

Activity C

This activity involves measuring the distances that cylindrical objects roll from an inclined slope and familiarizing the children with some of the ordinal numbers. The equipment consists of a long number line taped on the chalk board at a height where the children can easily reach it; two MINNEMAST rulers propped on a small, square property block; four or five cylindrical objects (marked A, B, C, D, etc.) to be used in each "race"; and one tape measure or yardstick. Since an object may roll six feet or more, even when gently released at the top of the slope, select a fairly large area where all children can see what happens. A location near the number line would probably be most convenient.

Introduce the activity by asking the children whether they have ever rolled toy cars downhill to see how far the cars would go. Say that today the class is going to roll some objects down a slope for the same reason.

Explain to the children that they are going to observe, measure and record the distance each object rolls after it comes off the slope. Tell them to think of the activity as a race to see which object will roll the farthest.

Then tell the children they will have a good opportunity to use some of the ordinal numbers they see on the chalk board. They can say that the object that goes the greatest distance is the winner -- it is first, another object will come out second in the amount of inches it travels, and so on.

For each race, assign four different children for these tasks:

1. To release the objects gently, one at a time, at the top of the slope.
2. To mark with chalk the spot on the floor where each object stops.
3. To measure to the nearest half inch the distance each object travels from the base of the slope.
4. To record each measurement on the number line, marking it with an A, a B, etc.

Have the children record with white chalk for the first race, red for the second, and blue for the third. Provide child 3 with a tape measure or yardstick. Help him if he has to add large numbers.

After each object has been rolled, and the distance marked, measured, and recorded, ask the children which object came in first, which second, etc. Use these ordinal numbers frequently and refer to them as ordinal numbers. The children will need to recognize the abbreviations (1st, 2nd, 3rd, 4th and 5th) for the worksheet in the next lesson, but they need not go beyond that now, as they will receive more practice with ordinal numbers in future lessons.

At the end of the first race, ask the children what would happen if the same experiment were repeated.

DO YOU THINK WE WOULD GET THE SAME RESULTS IF WE RACED THESE SAME OBJECTS AGAIN?

HOW CAN WE FIND OUT?

Erase the floor marks from the first race and have the class repeat the experiment with other participants. Ask whether the results are the same. Then ask whether the results would be the same for a third race, and let them conduct that.

If there is time, the children may enjoy racing the same objects from a slightly higher slope, or a different set of objects from the same slope, etc.



Lesson 4: DIAMETERS AND CIRCUMFERENCES

Measuring diameters and circumferences of cylindrical objects gives the children further practice in determining and recording lengths to the nearest half unit. The lesson also takes a first step toward developing in the children some appreciation of the relation between the diameter and the circumference of a circle.

In Activity A the children hold yarn around each of five cylinders, mark the yarn where it overlaps, then measure the marked segment of yarn to the nearest centimeter or half centimeter. They record these five measurements of circumference in Table A of Worksheet 9.

In Activity B the children draw an outline of one end of each cylinder and measure the diameters of these circular outlines with their rulers. They record -- to the nearest half centimeter -- the lengths of the five diameters in Table B of Worksheet 9. They also check the accuracy of the first diameter measurements by measuring another diameter of each circle.

Then each child selects the two measurements of just one object to plot on number lines. On a third number line he plots the length of the circumference of his selected object with a red crayon above the line, and repeated lengths of the diameter of the same object with a blue crayon below the line. He thus discovers that the circumference is approximately three times longer than the diameter of a circle (and/or cylinder).

For the purposes of this lesson, define diameter very simply as "the distance across a circle" and circumference as "the distance around a circle." Use the terms "diameter" and "circumference" as often as you can fit them in naturally, so that the children will begin to use them, too.

MATERIALS

- 1 rather large cylindrical object (such as a 3-lb. coffee can, canister or waste basket) and a piece of yarn slightly longer than its circumference
- Worksheet 9

-- for each group of five --

- 1 six-oz. juice can; 1 dry cell (D); 1 tube from viscosity kit; 1 large, thick, circular property block; 1 small, thick, circular property block. (In the order listed, label the objects: 1st, 2nd, 3rd, 4th, and 5th.)
- 25 pieces of yarn, each about 10" long
- 5 rulers with centimeter scale
- masking tape (optional)
- 5 crayons, soft lead pencils, or pens for marking the yarn

PROCEDURE

Activity A

Display a set of the five cylindrical objects that the groups of children are going to use, along with a ruler, a crayon or other marking tool, a sheet of paper, and a piece of yarn.

Explain that the five objects are cylindrically shaped, much like some of those the children used in the last lesson. Say that this time, instead of measuring how far the objects roll from a slope, the children are going to make measurements on the objects themselves.

Pick up two objects from the set.

CAN ANYONE SHOW US HOW WE COULD COMPARE THE CIRCUMFERENCES -- THE DISTANCES AROUND THE CURVED SURFACES -- OF THESE TWO OBJECTS?

Have the children come to the front of the room and try out whatever methods of comparing they suggest. Some children may remember that in kindergarten or first grade they put string or paper around each circular object, cut these at the point or line of overlap, and then compared the lengths of the strings or the pieces of paper.

If no child uses the yarn to mark off the distance around an object and the ruler to provide units of measurement, suggest that this be tried. If necessary, give a demonstration

of the procedure: Select a cylinder that is not in the children's set (e.g., a coffee can) and wrap a piece of yarn around it. Mark the two parts of the yarn at the point of overlap, and then measure the marked segment with the ruler.

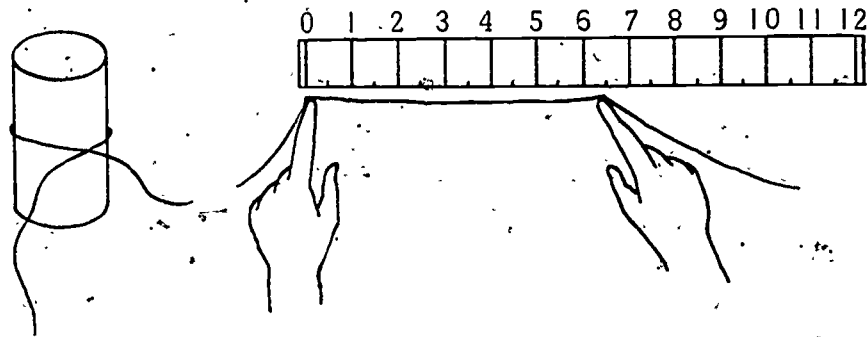

Have a few children try the method. Some may be dexterous enough to hold and measure a segment of yarn without marking it. Others may need to fasten the yarn to the cylinder with tape in order to do the marking. In any case, point out the importance of fitting the yarn closely around the object and of holding the yarn firmly in place until it is marked (or securing it firmly at the two appropriate places with fingers of both hands until it is measured).

Activity B

Have monitors distribute the sets of cylinders, yarn, etc. to the groups of children. Ask the children to take turns measuring the circumference of each object to the nearest half centimeter and to record the five measurements in Table A of Worksheet 9. The following remarks may be helpful:

USE A NEW PIECE OF YARN FOR EACH OBJECT, IF YOU ARE GOING TO MARK THE YARN. MAKE TWO MARKS ON THE YARN WHERE IT OVERLAPS. MEASURE THE DISTANCE BETWEEN THE TWO MARKS TO THE NEAREST CENTIMETER OR HALF CENTIMETER. IF THERE ARE NO HALF-CENTIMETER MARKS ON YOUR RULER, DECIDE FOR YOURSELVES WHERE THE HALF MARKS SHOULD BE.

If any member of a group is having difficulties, suggest that the other members assist him.

When all have finished filling in Table A of the worksheet, hold a discussion about the value of knowing how to measure the circumference of an object:

CAN YOU GIVE TOR ANY REASONS WHY IT MIGHT BE USEFUL TO KNOW HOW TO MEASURE THE CIRCUMFERENCE OF AN OBJECT?

Any child's reason is adequate for this discussion (finding a length of paper to cover an object, shopping for a new belt to surprise Daddy on his birthday, etc.).

Worksheet 9
Unit 16 Name _____

A Object Circumference		B Object Diameter	
1st	18 cm	Juice can	1st 5½ cm
2nd	11 cm	Dry cell	2nd 3 cm
3rd	10 cm	Tube	3rd 3 cm
4th	16½ cm	Large block	4th 5 cm
5th	8½ cm	Small block	5th 2½ cm

A Plot the circumference of your chosen object on number line A.

B Plot the diameter of chosen object on number line B.

C Plot the circumference of your chosen object again.

Now below the number line plot diameters of your chosen object over and over until you have just passed the end of the circumference.

Jumps taken to come near circumference 3

Activity C

Show the children how to draw the outline of one end of a cylinder by holding a large object (such as a wastebasket) against the chalk board and drawing around it with a piece of chalk.

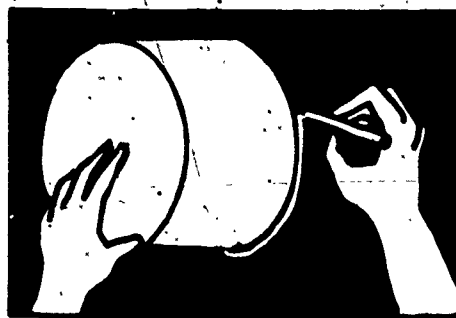

Then draw a straight line across the circle on the board and explain that this is one diameter (one line of greatest distance) of your circle. Measure this diameter with a yardstick or meterstick and record the measurement on the board.

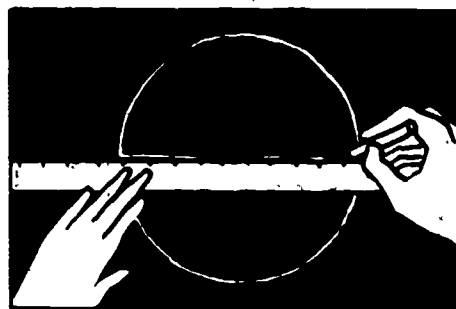

Next draw a vertical diameter of the circle, and measure and record it. Draw, measure and record a few more diameters until the children notice that all your diameter measurements are the same.

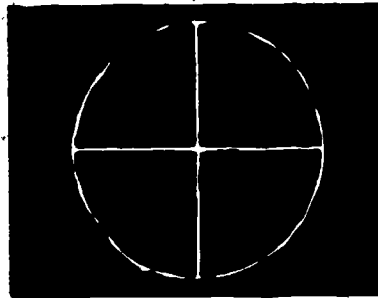

Now explain to the children that they are to draw outlines of each cylinder (in the group's set) on the back of Worksheet 8. They are to pass the objects around, so that all can be working at the same time. But before giving an object to the next child, they must write the ordinal number of the object (1st, 2nd, etc.) inside its circular outline:

Ask the children to draw their circles carefully, pressing down firmly on each object and keeping the pencil point as close to the object as they can. Tell them not to crowd the circles together on the paper, but to leave room for recording some measurements.

When all have neatly drawn and suitably labeled the five circles, ask the children to draw one diameter straight across each circle (horizontally). Then have them measure each diameter to the nearest centimeter or half centimeter and record each measurement near the appropriate circle. Ask how this measurement could be checked. When the children suggest checking it by drawing and measuring another diameter for each circle, ask them to draw an up-and-down (vertical) diameter in each, and to measure and record these near their first records. Check the results:

WHEN YOU MEASURED THE SECOND DIAMETER OF EACH CIRCLE, DID YOU GET THE SAME MEASUREMENT AS THE FIRST TIME?

If the two diameter measurements by the same child for the same circle vary by more than half a centimeter, check his paper to see whether either his circles or his diameters are too poorly drawn to be useful. If so, have him draw and measure others with your guidance. If his drawings are good enough, ask him to measure again more carefully. Children may have drawn circles of slightly varying diameter for the

same object so it is not necessary for all measurements in a group or in the class to agree, but each child should have -- for each of his own circles -- a fairly accurate measurement.

WHEN YOU ARE SATISFIED THAT YOU HAVE MEASURED THE DIAMETER OF EACH CIRCLE CAREFULLY, RECORD THE MEASUREMENTS CAREFULLY IN TABLE B OF WORKSHEET 9.

When the children have done this, ask them to discuss situations where the measurement of a diameter would be needed:

CAN YOU TELL FOR ANY REASONS WHY IT MIGHT BE USEFUL TO KNOW HOW TO MEASURE THE DIAMETER OF AN OBJECT?

Some of the answers previously given for the usefulness of circumference measurements are suitable here also, but the children may be able to think of others (e.g., fitting a rake or other tool with a new handle, finding a nut to fit a bolt, finding out whether a "round" tablecloth will cover a "round" table while the cloth is still folded in half).

Call attention to the number lines on Worksheet 9! Tell each child to choose one object from the five his group has and check to see which of his circles represent that object. Then he is to find, from his data tables, the length of the circumference of that object and plot it on number line A. On number line B, he is to plot the diameter of the circle.

Before the children work individually on number line C, demonstrate its use on a larger number line on the chalk board. Ask a child to give you the data for his circle -- its circumference and its diameter. Lay off the circumference above the number line and then lay off the diameter below the line. Starting from the end of that diameter, mark off an interval equal to another diameter. Continue marking off such intervals until one diameter interval goes beyond the end of the circumference.

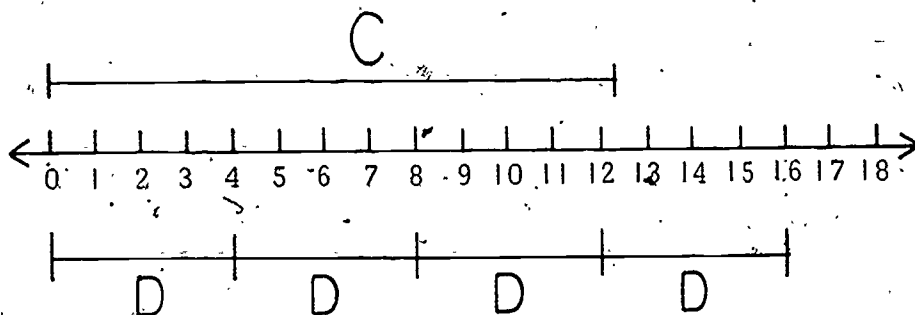

Ask the class to draw the circumference of the chosen object with red crayon above the number line C. Tell the children to try to find out how many diameter-length jumps fit into the circumference by drawing the diameters below the number line C in blue crayon. Then you might ask the following:

CAN YOU TELL FOR ANYTHING YOU NOTICE ABOUT THE CIRCUMFERENCE AND THE DIAMETER OF THE CIRCLES?
(There are about three diameters in a circumference.)

IF WE KNEW ONLY THE DIAMETER OF A CIRCLE, HOW COULD WE FIND ITS CIRCUMFERENCE? (We could lay off three diameters and get an idea of the circumference.)

If there is time, or if the children want to check into this further, they could make a number line on a sheet of paper, and mark off all the circumferences in Table A above the line, and all the diameters in Table B below the line. Or, using a different color of chalk for each object's measurements, you could demonstrate on a large number line on the board, all the data in the tables of Worksheet 9 as the children provide it.

Some children might like to measure cylindrical objects not used in class and report their findings. Suggested items are: kaleidoscope, piece of metal pipe, plastic or metal kitchen containers, drinking glasses, vases and jars.

SECTION 2 NUMERATION AND PLACE VALUE

PURPOSE

- To teach the use of numerals in representing the idea of number.
- To develop the child's understanding of the decimal place-value notation.
- To have the child recognize the correspondence between the real numbers and the points on a number line.
- To develop an understanding of the use of numbers in making measurements.
- To extend familiarity with the numbers up to 999.
- To give practice in addition and subtraction.

COMMENTARY

This section attempts to enlarge the child's understanding of the number concept and of the structure of the number system so that he will be able to manipulate numbers better in arithmetical operations. The child will also gain more insight into numbers by using them in making measurements.

Tor can be used to good advantage in this section. The children can pretend to teach him some of the number concepts they are studying. The fact that Tor has a total of only four fingers is useful in introducing base four.

There are thirteen lessons in this section. In Lesson 5 the children study the distinction between numbers and numerals. In Lesson 6 they study T notation (using the letter T to represent 10's), and numerals to 99. Lessons 7-9 use the number line, measurement, and the addition slide rule to provide practice in addition and subtraction of two-digit numbers and to help the children understand place value. The abacus illustrates place value in another way in Lessons 10 and 11. Work with the abacus also reinforces the groundwork that has already been laid for understanding

the standard addition algorithm (rule of procedure for solving a mathematical problem). Knowledge of the numbers is extended to 999 in Lesson 12, not only to enable the children to handle larger numbers, but also to demonstrate the generality of the decimal place-value notation. Lesson 13 gives practice in counting by tens.

Lessons 14-16 are concerned with the base four system of numeration. Lessons 17 and 18 present the Egyptian and Roman systems of numeration to emphasize the superiority of the decimal place-value notation.

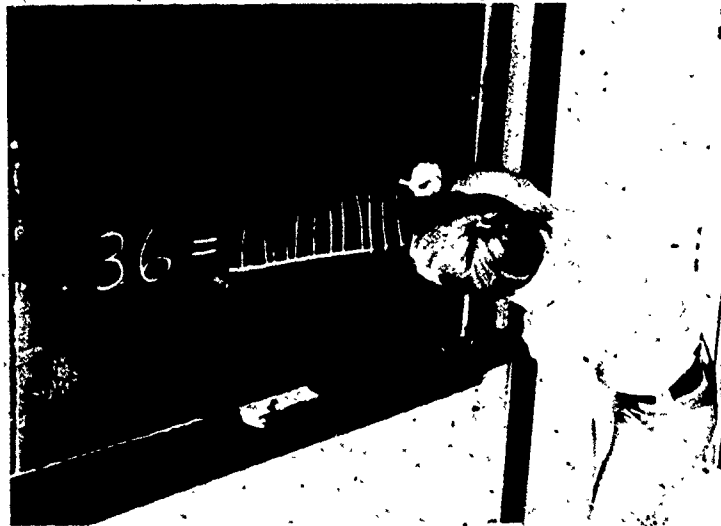

Lesson 5: NUMBERS VS. NUMERALS

The purpose of this lesson is to review the fact that numbers are mathematical ideas for which symbols can be written, and that these symbols are called numerals. The children are given further work with numbers to help them with their measurements and to prepare them better for their future work in mathematics and science.

MATERIALS

- pencils, counters, paper clips, etc.
- United States flag
- an apple (optional)

PROCEDURE

Activity A

Explain to the students that they are going to help teach Tor about our numeration system.

By the following procedure, demonstrate that numerals are symbols. Write on the chalkboard these ten numerals: 0, 1, 2, 3, 4, 5, 6, 7, 8, 9. Tell the children that Tor wants to know what these symbols represent. Have a child read them aloud for Tor. The following discussion will bring out the idea that numerals are symbols representing numbers and that numbers are ideas describing quantities.

Have the children arrange sets of five objects, (e.g: pencils, counters, paper clips, etc.) on their desks. Ask a question of Tor, such as, "Tor, how are these sets alike?" (They all contain 5 objects. They all can be represented by the numeral 5.) Write 5 on the chalkboard. Continue by having the children arrange sets of 7 objects on their desks. Again ask the question, "How are these sets alike?" (They can all be represented by the numeral 7.) Repeat, using sets of 4 objects, 8 objects, 3 objects, etc. Tell Tor and the children that "7," "8," etc. are the names we use for representing the number of members in each set.

Tor says, "I think I understand, but I'm not quite sure. Numerals are not numbers, but they stand for numbers."

CAN YOU SHOW TOR SOMETHING IN THIS ROOM THAT IS A SYMBOL FOR OUR COUNTRY? (The United States flag.)

IS THE UNITED STATES FLAG ACTUALLY OUR COUNTRY? (No, it's a symbol for our country.)

WHEN WE SEE THE FLAG, WE ARE REMINDED OF OUR COUNTRY. THE FLAG IS A SYMBOL OF OUR COUNTRY. WE THINK OF WHAT IT STANDS FOR WHEN WE GIVE OUR PLEDGE OF ALLEGIANCE.

Now print the word "apple" on the chalkboard. Ask the children to find an apple for Tor.

IS THERE AN APPLE ON THE CHALKBOARD? (No.)

THE WORD "APPLE" ISN'T VERY TASTY, IS IT? THE WORD ON THE BOARD IS JUST A SYMBOL FOR AN APPLE.

THE SYMBOLS 0, 1, 2, 3, 4, 5, 6, 7, 8, 9 WHICH WERE WRITTEN ON THE CHALK BOARD ARE CALLED NUMERALS. WE GIVE THEM NAMES: ZERO, ONE, TWO, THREE, FOUR, ETC. BUT THESE ARE NOT THE NUMBERS -- THEY ARE JUST THE SYMBOLS FOR THE NUMBERS.

Explain to the children that they learn many things about numbers by doing things with the symbols for numbers -- the numerals -- but numbers have properties that numerals do not. Tell them that by looking at the United States flag, they can see that our country has 50 states and 13 original colonies; but they can't know from the flag that Washington, D. C. is our capital or that the 4th of July is Independence Day. In the same way, explain that numerals help represent numbers, but they don't tell everything about them. Say that a large part of what we call "mathematics" is the study of the properties of numbers.

Tor says, "I think I understand now."

Lesson 6: T NOTATION AND NUMERALS TO 99

This lesson reviews the numbers from one to 99 and explains how we represent them. The decimal system of place-value notation is presented as a specific example of numeration.

MATERIALS

- counters and flannel board
- Worksheets 10-14, colored crayons

PROCEDURE

Write several two-digit numerals on the chalk board (e.g. 16, 34, 73). Explain that Tor has asked about these numerals. What does the "34" mean? Does it mean a three and a four?

Place 34 counters on the flannel board. Have one of the children divide the counters into as many sets or groups of ten counters as he can. (3 sets of 10 counters plus 4 left over.)

Have the children explain to Tor that we represent the 3 sets of 10 counters as 3 tens (or 3×10) or in a simpler form as 3T's. We can write a numeral for all 34 counters by using the operation of addition -- by adding the 3 tens to the 4 counters or $3T + 4$. A shorter name for $3T + 4$ would be 34. Therefore, when we write the numeral 34, the 3 represents the number of sets of ten, and the 4 represents the number of ones. This is called the decimal (base 10) place-value system of numerals. Repeat the above procedure with numerals such

as 47, 62, 13, etc., until the children are ready to do Worksheets 10-14. Read the instructions on the worksheets to them.

Worksheet 10

Unit 16

Name _____

Draw a closed curve around each set of ten. Record the number of tens (T's) and the number of ones left over. Write the shorter name for the sum.



$$\underline{3} \text{ T} + \underline{5} \text{ ones} = \underline{30} + \underline{5} = \underline{35}$$



$$\underline{6} \text{ T} + \underline{3} \text{ ones} = \underline{60} + \underline{3} = \underline{63}$$



$$\underline{1} \text{ T} + \underline{7} \text{ ones} = \underline{10} + \underline{7} = \underline{17}$$

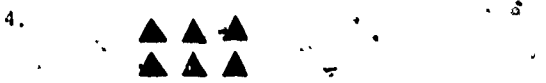

$$\underline{0} \text{ T} + \underline{6} \text{ ones} = \underline{0} + \underline{6} = \underline{6}$$

Worksheet 11
Unit 16

Name _____

Record the number of tens (T's) and the number of ones in the following numerals. Then write the number in the place-value chart.

16 Number of tens (T's) 1 T's Ones
Number of ones 6 1 6

34 Number of tens (T's) 3 T's Ones
Number of ones 4 3 4

93 Number of tens (T's) 9 T's Ones
Number of ones 3 9 3

82 Number of tens (T's) 8 T's Ones
Number of ones 2 8 2

42 Number of tens (T's) 4 T's Ones
Number of ones 2 4 2

Worksheet 12
Unit 16

Name _____

Start at zero and work this way → across each row. Fill in each square with the next counting number.

0	1	2	3	4	5	6	7	8	9
10	11	12	13	14	15	16	17	18	19
20	21	22	23	24	25	26	27	28	29
30	31	32	33	34	35	36	37	38	39
40	41	42	43	44	45	46	47	48	49
50	51	52	53	54	55	56	57	58	59
60	61	62	63	64	65	66	67	68	69
70	71	72	73	74	75	76	77	78	79
80	81	82	83	84	85	86	87	88	89
90	91	92	93	94	95	96	97	98	99

Worksheet 13
Unit 16

Name _____

Use Worksheet 12 to help you fill in the boxes.

What numeral follows?

16 ?	17	8 ?	9
32 ?	33	28 ?	29
93 ?	94	47 ?	48
46 ?	47	3 ?	4
54 ?	55	74 ?	75

Worksheet 14
Unit 16

Name _____

What numeral completes the number pattern?

Color the numerals on Worksheet 12 as directed.

- 0, 2, 4, 6, 8, 10 Color these red.
- 9, 12, 15, 18, 21, 24 Color these yellow.
- 25, 26, 27, 28, 29, 30 Color these green.
- 38, 41, 44, 47, 50, 53 Color these blue.
- 89, 91, 93, 95, 97, 99 Color these brown.

Lesson 7: THE NUMBER LINE

This lesson reviews and extends the concept of the number line which is seen as still another way of representing the numbers and of learning some of their properties. The addition slide rule (which is essentially two number lines) is also used. Most of the lesson should be done as a class activity.

MATERIALS

- number line (0-100) taped to chalk board
 -- for each child --
- addition slide rule
- red pen or pencil
- Worksheets 15 and 16

PROCEDURE

Draw or tape a number line on the chalk board. Suggest to the children that the number line could be used to help Tor understand more about our system of numeration. You might say, "Tor wants to know in what order we arrange our numerals." Ask such questions as:

IS THERE ANY WAY TOR CAN TELL WHICH NUMBER IS LARGER THAN ANOTHER -- BESIDES LOOKING AT THE NUMBER OF TENS AND ONES? (Yes, he can look at the number line to see which numeral is larger.)

HOW DOES THE NUMBER LINE TELL US WHICH NUMBER IS LARGER? (The numeral to the right of another numeral is always larger.)

THAT'S RIGHT. AS WE GO THIS WAY → ALONG THE NUMBER LINE, EACH NUMERAL IS ONE GREATER THAN THE PRECEDING ONE.

Activity A

Give each child an addition slide rule. Ask the children to describe it, eliciting that it consists of two number lines.

Ask for volunteers to demonstrate how it can be used to add two numbers. If no child remembers the procedure well enough -- from first grade -- to give a good demonstration, show the children how the two number lines of the slide rule are used.

WE ARE GOING TO ADD 3 TO 6 WITH THE ADDITION SLIDE RULE. WHERE SHOULD THE 6 BE PLACED ON THE LOWER LINE? (Straight below the zero on the upper number line.)

WHERE DO WE READ THE SUM OF 6 AND 3? (Straight down from the three of the upper line.)

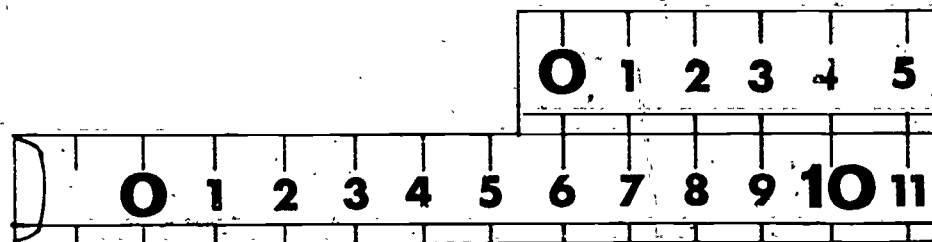

Have the children use the addition slide rule and then the number line on the chalk board to show how number lines are used to add numbers. Ask them to do such addition problems as $6 + 7$, $33 + 6$, $53 + 9$, $17 + 2$, etc. Continue giving addition problems until the children can use their slide rules easily.

The various rules for addition, which the children have been applying, are properties of numbers, but it is not necessary for the children to recognize this now. However, they should be able to state some of the ways (some of the rules) they have used to add numbers.

LET'S REVIEW FOR SOME OF THE WAYS WE ADDED NUMBERS. (We used the decimal notation to add tens and ones; we used one number line on the chalk board; we used two number lines on the addition slide rule.)

Have the children do Worksheet 15 (as a class activity, if necessary).

Worksheet 15		Name _____	
Unit 16			
Use your addition slide rule to add the following.			
$17 + 12 =$	<u>29</u>	$4 + 5 =$	<u>9</u>
$6 + 9 =$	<u>15</u>	$84 + 9 =$	<u>93</u>
$13 + 6 =$	<u>19</u>	$5 + 8 =$	<u>13</u>
$44 + 3 =$	<u>47</u>	$24 + 2 =$	<u>26</u>
$63 + 9 =$	<u>72</u>	$37 + 0 =$	<u>37</u>

Activity B

Tell the children that Tor would like to know what we call points on the number line that are between the numerals. Have some of the children come up and find points halfway between a pair of numerals on the chalk board number line (such as $4\frac{1}{2}$, $18\frac{1}{2}$, $23\frac{1}{2}$, etc.) The number line representation helps the children see that fractional numbers exist between the whole numbers. Explain that fractional numbers must not be very different from the integers since they are both represented by points on the number line.

Give the children red marking pens or pencils. Have them mark the half-units on their addition slide rules (on the upper tape only).

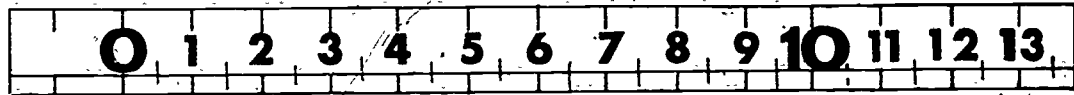

Red marks 

Demonstrate addition problems such as these:

$$5 + 2\frac{1}{2} = \underline{7\frac{1}{2}} \qquad 53 + 9\frac{1}{2} = \underline{62\frac{1}{2}}$$

$$17 + 3\frac{1}{2} = \underline{20\frac{1}{2}} \qquad 32 + 3\frac{1}{2} = \underline{35\frac{1}{2}}$$

Continue the class work until the children seem to understand. Then have them do Worksheet 16.

Worksheet 16
Unit 16

Name _____

Use your addition slide rule (with $\frac{1}{2}$'s marked) to add the following.

$$4 + 3\frac{1}{2} = \underline{7\frac{1}{2}} \qquad 3 + 9\frac{1}{2} = \underline{12\frac{1}{2}}$$

$$7\frac{1}{2} + 6 = \underline{13\frac{1}{2}} \qquad 9 + 6\frac{1}{2} = \underline{15\frac{1}{2}}$$

$$5\frac{1}{2} + 2 = \underline{7\frac{1}{2}} \qquad 16 + 2\frac{1}{2} = \underline{18\frac{1}{2}}$$

$$10 + 10\frac{1}{2} = \underline{20\frac{1}{2}} \qquad 15 + 2\frac{1}{2} = \underline{17\frac{1}{2}}$$

$$\frac{1}{2} + \frac{1}{2} = \underline{1} \qquad 6\frac{1}{2} + 21\frac{1}{2} = \underline{28}$$

Lesson 8: MEASURING WITH TWO-DIGIT NUMERALS

In addition to providing practice in measuring with two-digit numerals, this lesson builds the idea that numerals can be used to represent size. Concrete examples of length measurements are shown on the number line. This lesson also reinforces the concept of place value.

In Activity B the children learn the number of inches in a foot and the number of inches and feet in a yard. In order to determine the number of feet in a yard, standard 12-inch rulers are easy to use. If MINNEMAST rulers are used, allowance must be made for their extra length, either by overlapping the rulers or by arranging them in this way along the yardstick:

Method of comparing MINNEMAST rulers with a yardstick:

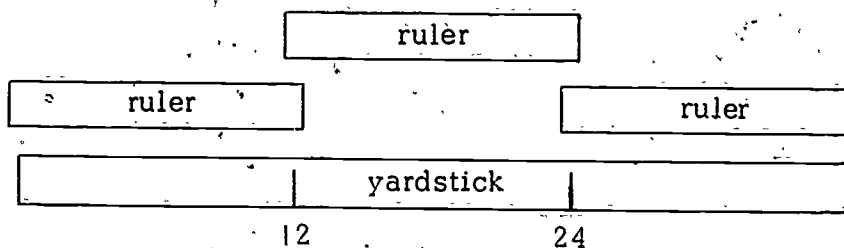

It is desirable for each group of children to have a yardstick and three rulers, but if this is not possible, either divide the class into larger groups or have the children take turns using the equipment. The number lines -- which the children use -- may be taped to their desks before the lesson begins.

MATERIALS

- number line (0-25) on the chalk board
- red, blue, yellow and orange chalk
- -- for each group --
- 1 standard 36" yardstick
- 3 standard 12" rulers
- 1 large book

-- for each child--

- 1 desk number line (0-25)
- red, blue, yellow and orange crayons
- Worksheets 17, 18, 19 and 20

PROCEDURE

Activity A

Write the following numerals on the chalk board -- in no particular order or position -- like this:

1 34 25 19 5
4 2 7 24 17
9

Mention that Tor is still puzzled by our numerals. He would like more information about 2's and 4's, for example. Indicating the appropriate numerals on the board, say that Tor wants to know whether 24 is the same as the sum of 2 and 4.

LET'S SEE IF WE CAN EXPLAIN TO TOR THE DIFFERENCE BETWEEN 2, 4, AND 24.

Draw a number line (0-25) on the chalk board. See that each child has a number line with the same number of units on his desk. Ask the children to locate and mark with a red crayon an X at these three points: 2, 4, and 24. Mark your chalk board number line at the same points with red chalk. Next, have each child use a ruler and a blue crayon to draw a line segment from 0 to 2; a yellow crayon to draw a line segment from 0 to 4; and a red crayon to draw a line segment from 0 to 24. Mark these on the chalk board also.

— red

— yellow

— blue

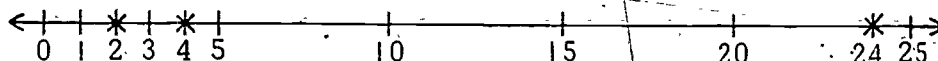

TELL WHICH LINE IS LONGEST. (The red line.)

WHICH LINE IS THE SHORTEST? (The blue line.)

Explain that the same two digits, (2 and 4) were used in all the parts of the example. Bring out the fact that the length represented by combining and writing 2 and 4 as 24 is significantly longer than a length of either 2 or 4. Then, above the red line on the chalk board, represent the sum of 2 and 4 with an orange line segment from 0 to 6.

IS THE LENGTH OF $2 + 4$ THE SAME AS THE LENGTH OF 24? (No.)

WHAT DOES 24 MEAN?

Answer this by writing $20 + 4$ on the chalk board.

WOULD THIS SUM, $20 + 4$, BE A WAY OF REPRESENTING 24? (Yes.)

CAN YOU THINK OF ANOTHER WAY TO WRITE 24?
($2T + 4$.)

Now tell the children that they are to think of the number line as having units which will represent inches: the numeral 24 will represent 24 inches, the 2 will be 2 inches, the 4 will be 4 inches, and so on.

On the chalk board write:

20 inches + 4 inches (or) $20'' + 4''$

If you use the shorter symbol (") for inches, make sure the children know what it is.

IS WHAT I HAVE WRITTEN A WAY OF REPRESENTING 24 INCHES? (Yes.)

TELL ME ANOTHER WAY TO WRITE 24 INCHES.
[(2T + 4) inches.]

Repeat the activity with another set of numerals, such as 1, 5, and 15. Then ask the children to do Worksheets 17 and 18. Give as much help as necessary.

Worksheet 17
Unit 16

Name _____

Complete the following equations:

$$\underline{24} \text{ inches} = (\underline{2} \text{ T} + \underline{4}) \text{ inches}$$

$$\underline{17} \text{ inches} = (\underline{1} \text{ T} + \underline{7}) \text{ inches}$$

$$\underline{21} \text{ inches} = (\underline{2} \text{ T} + \underline{1}) \text{ inches}$$

$$\underline{16} \text{ inches} = (\underline{1} \text{ T} + \underline{6}) \text{ inches}$$

$$\underline{9} \text{ inches} = (\underline{0} \text{ T} + \underline{9}) \text{ inches}$$

$$\underline{11} \text{ inches} = (\underline{1} \text{ T} + \underline{1}) \text{ inches}$$

Measure the following:

(Many possible answers)

Length of Desk $\hat{=}$ ___ inches = (___ T + ___) inches

Width of Desk $\hat{=}$ ___ inches = (___ T + ___) inches

Worksheet 18
Unit 16

Name _____

Complete the following equations:

$$\underline{18} \text{ inches} = (\underline{1} \text{ T} + \underline{8}) \text{ inches}$$

$$\underline{20} \text{ inches} = (\underline{2} \text{ T} + \underline{0}) \text{ inches}$$

$$\underline{7} \text{ inches} = (\underline{0} \text{ T} + \underline{7}) \text{ inches}$$

$$\underline{12} \text{ inches} = (\underline{1} \text{ T} + \underline{2}) \text{ inches}$$

$$\underline{4} \text{ inches} = (\underline{0} \text{ T} + \underline{4}) \text{ inches}$$

$$\underline{22} \text{ inches} = (\underline{2} \text{ T} + \underline{2}) \text{ inches}$$

Measure the following:

(Many possible answers)

Length of Book $\hat{=}$ ___ inches = ___ T + ___ inches

Width of Book $\hat{=}$ ___ inches = ___ T + ___ inches

Activity B

Divide the class into groups and provide each group with a yardstick and three 12-inch rulers. Identify the objects for the children. Then ask them to find out (for Tor) how

many inches there are in the yardstick and how many 12-inch rulers are equal to the yardstick.

CAN YOU TELL FOR ANOTHER NAME FOR YOUR 12-INCH RULER? (It's a one-foot ruler.)

Write 1 foot and 1 ft on the chalk board.

HOW MANY FEET ARE THERE IN ONE YARD? (3.)

Give the children enough time to use the rulers in various ways to find the answers to the problems. If MINNEMAST rulers are used, see if the children can devise their own methods of taking care of the overlap when measuring the rulers along the length of the yardstick. (One method is shown in the lesson commentary.)

Ask the children to do Worksheet 19. Tell them they may work together and use their rulers and yardsticks to find the answers. The starred worksheet problems involve concepts not yet presented in the MINNEMAST materials (adding 36 and 36, which involves carrying; using the fractional notation of one-third). Use your own judgment about whether your class should try these problems with your help, whether only advanced students should do the problems, or whether the problems should be omitted.

Worksheet 19
Unit 16

Name _____

Use your rulers to help complete the following:

$$\underline{12} \text{ inches} = \underline{1} \text{ foot}$$

$$\underline{24} \text{ inches} = \underline{2} \text{ feet}$$

$$\underline{36} \text{ inches} = \underline{3} \text{ feet}$$

$$\underline{36} \text{ inches} = \underline{1} \text{ yard}$$

$$\underline{72} \text{ inches} = \underline{2} \text{ yards*}$$

$$\underline{3} \text{ feet} = \underline{1} \text{ yard}$$

$$\underline{1} \text{ foot} = \underline{\frac{1}{3}} \text{ yard*}$$

Activity C

Draw a number line (0-25) on the chalk board. Refer to the units as representing inches. Draw an X through the point representing the numeral 16.

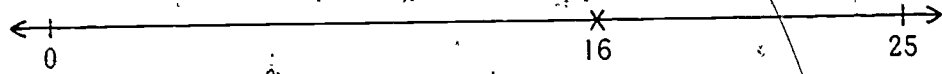

HOW MANY FEET ARE THERE FROM 0 TO 16?

Answers to the question may vary (close to one foot, greater than one foot, etc.). Give your answer by pointing out that one foot would represent a line from 0 to 12, with 4 inches remaining. Therefore, 16 inches = 12 inches + 4 inches, or 1 foot + 4 inches. Write this on the chalk board. Repeat the activity with a 21-inch example:

21 inches = 12 inches + 9 inches, or 1 foot + 9 inches

Have the children do Worksheet 20.

Worksheet 20
Unit 16. Name _____

Use your desk number line and a ruler to help answer the following.

16 inches = 1 foot + 4 inches

21 inches = 1 foot + 9 inches

8 inches = 0 foot + 8 inches

14 inches = 1 foot + 2 inches

25 inches = 2 feet + 1 inch

12 inches = 1 foot + 0 inches

Lesson 9: ADDING TWO-DIGIT NUMERALS ON THE SLIDE RULE

The children receive more practice in using the addition slide rule to solve problems on the worksheets which make up this lesson. A few problems deal with the addition of units of weight (pounds) to show that numerals can be used to represent and add quantities other than units of length.

MATERIALS

- number line (0-100) taped to the chalk board
- addition slide rules
- Worksheets 21, 22 and 23

PROCEDURE

Let the children work the problems on the worksheets independently, if they can. If they cannot, read the instructions to them, and discuss the problems carefully so that the children will see that addition is needed to solve them.

Emphasize again the fact that addition slide rules are merely movable number lines arranged in a very convenient way for finding sums. Demonstrate by having a few children check the answers obtained on the slide rule by using the number line on the chalk board. The children should realize that when they use only one number line they have to add the second numeral to the end of the first by counting off each one; when using the slide rule (two number lines) the sum can be found much more quickly.

Worksheet 21
Unit 16

Name _____

Use your addition slide rule.

1. Billy weighs 38 pounds. Billy's boots weigh 5 pounds. How many pounds do Billy and his boots weigh together?

$$\underline{38} \text{ pounds} + \underline{5} \text{ pounds} = \underline{43} \text{ pounds}$$

2. Barbara wanted to measure a 17 inch stick with her 12 inch ruler. She found that when she placed the ruler beside the stick, the ruler was too short. How many inches short was Barbara's ruler?

$$12 \text{ inches} + \underline{5} \text{ inches} = 17 \text{ inches}$$

3. Mike measured a 27 inch stick with a 12 inch ruler. He found that two lengths of the ruler were too short. How many inches short?

$$12 \text{ inches} + 12 \text{ inches} + \underline{3} = 27 \text{ inches}$$

Worksheet 22
Unit 16

Name _____

Use your addition slide rule.

1. Kathy weighs 47 pounds. Kathy's winter coat weighs 8 pounds. How much will Kathy and her coat weigh together?

$$\underline{47} \text{ pounds} + \underline{8} \text{ pounds} = \underline{55} \text{ pounds}$$

2. Sammy wants to show Tor his electric train. He has two tables, one 19 inches long and one 11 inches long. If he pushes the two tables together, how long could the train track be?

$$\underline{19} \text{ inches} + \underline{11} \text{ inches} = \underline{30} \text{ inches}$$

3. Sandra has two chairs. One chair is 12 inches wide. The other is 13 inches wide. Add the widths of the two chairs.

$$\underline{12} \text{ inches} + \underline{13} \text{ inches} = \underline{25} \text{ inches}$$

Worksheet 23
Unit 16

Name _____

Use your addition slide rule.

1. Becky has two pencils. One pencil is 5 inches long. The other is $2\frac{1}{2}$ inches long. Add the lengths of the two pencils.

$$\underline{5} \text{ inches} + \underline{2\frac{1}{2}} \text{ inches} = \underline{7\frac{1}{2}} \text{ inches}$$

2. Billy's book is $4\frac{1}{2}$ inches long. Sue's book is 7 inches long. How many inches longer is Sue's book than Billy's?

$$\underline{4\frac{1}{2}} \text{ inches} + \underline{2\frac{1}{2}} \text{ inches} = \underline{7} \text{ inches}$$

3. Sammy is $7\frac{1}{2}$ years old. Billy is $9\frac{1}{2}$ years old. How much older than Sammy is Billy?

$$\underline{7\frac{1}{2}} \text{ years} + \underline{2} \text{ years} = \underline{9\frac{1}{2}} \text{ years}$$

Lesson 10: THE ABACUS

This lesson is intended as a review of the use of the abacus, but to some children this convenient device for calculating may be unfamiliar. A nine-bead (per column) abacus shows the place-value property of the decimal system of numeration. The MINNEMAST abacus has columns for thousands, hundreds, tens and ones. In this lesson the children use the abacus to find sums less than 100, so they use only the two columns representing tens and ones. All parts of the lesson may be done as class work.

MATERIALS

- abaci (5 per class provided; 1 per child desirable)
- Worksheets 24 and 25



PROCEDURE

Activity A

Tell the children that Tor would like to know if there is a method of adding numerals without writing them or using a number line or slide rule. Discuss this with your class and lead one of the children to suggest using an abacus. If the children remember their work with the abacus from first grade, have one of them explain its use to Tor. If the children are not familiar with the abacus, explain its use as a calculating device. Demonstrate how the first column of beads on the right represents the number of ones and the second from the right represents the number of tens.

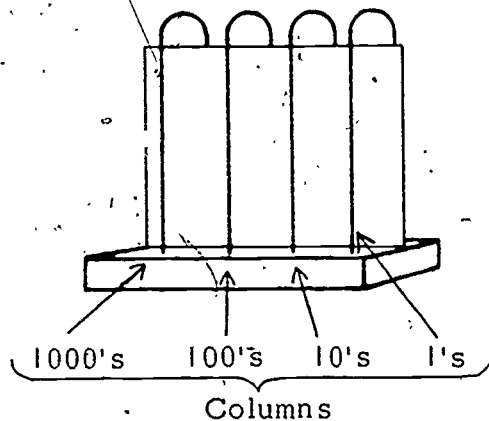

Show how the columns of the abacus have the same place value as the written numerals have. Give several examples, e.g:

The numeral 62 is represented on an abacus as

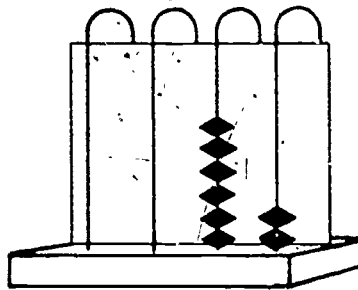

6 beads on the
10's column

2 beads on the
1's column

$$6 T + 2 = 62$$

To avoid confusion have the children label the two columns that they will be using in this lesson. Have them put tape at the base of the abacus and write 1 and T on the tape, as shown in the drawing.

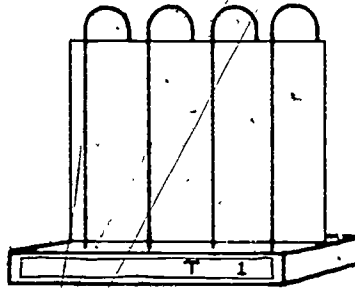

Make sure the children understand that they may use no more than nine beads in any column. The 1's column may represent numerals from 0 to 9, depending on the number of beads showing. When 10 is reached, the 9 beads are slid to the back of the column and replaced by 1 bead in the 10's column. When 20 is represented, there are 2 beads in the 10's column and no beads showing in the 1's column.

Activity B

Place an abacus where all the children can see it. Illustrate a numeral such as 72 on the abacus and have one of the children tell what number is represented by the beads. Change the number of beads and have a child tell what numeral it represents. Repeat this activity until you think the children understand the process.

Activity C

Write a numeral on your chalk board. Have the children record it on their abaci. Check to make sure the correct number of beads is in each column. Let the children take turns writing numerals on the chalk board and representing the numerals on their abaci. Then have them complete Worksheets 24 and 25.

After completing the worksheets, if some children want to use their abaci to represent hundreds and thousands, permit them to experiment on their own time.

Worksheet 24
Unit 16

Name _____

Write the numeral shown by the beads.

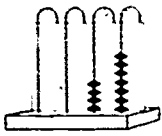

$$\underline{4} \text{ T's} + \underline{7} \text{ ones} = \underline{47}$$

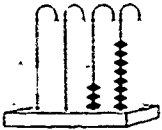

$$\underline{3} \text{ T's} + \underline{8} \text{ ones} = \underline{38}$$

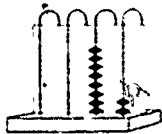

$$\underline{8} \text{ T's} + \underline{2} \text{ ones} = \underline{82}$$

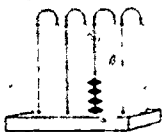

$$\underline{4} \text{ T's} + \underline{0} \text{ ones} = \underline{40}$$

Worksheet 25
Unit 16

Name _____

Draw on each abacus as many beads as you need to show the numeral.

7

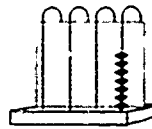

13

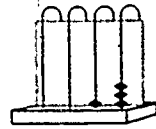

42

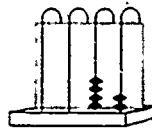

94

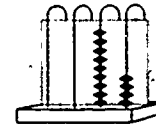

18

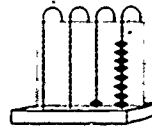

67

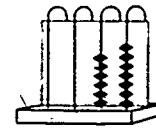

Lesson 11: ADDING AND SUBTRACTING WITH THE ABACUS

This lesson gives the children practice in adding and subtracting two-digit numerals with the abacus. If possible, provide each child with an abacus and prepare transparencies of the worksheets for use on an overhead projector. All of the lesson may be conducted with class participation, if you wish.

MATERIALS

- abaci (1 per child, if possible)
- Worksheets 26, 27, 28 and 29
- 1 transparency of each worksheet (optional)
- overhead projector (optional)

PROCEDURE

Activity A

Review with the children the use of the abacus. Elicit from them, or remind them, that the column at the extreme right shows the number of ones; the second column from the right shows the number of tens; etc. Emphasize again the place value of each column by representing numbers on the abacus and then in written numerals.

Provide each child or group of children with an abacus to use. Then project a transparency of Worksheet 26 and demonstrate the first problem. (If you have no projector, use the chalk board.) Carry out the addition on an abacus and write the answer on the chalkboard:

$$5 \text{ T} + 5 = 55$$

Help the children complete this worksheet, so that they can try to do Worksheet 27 independently. Encourage them to use the abacus to find the sums.

Worksheet 26
Unit 16

Name _____

What number is shown on this abacus? 23

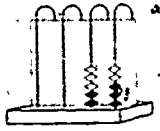

Add 32 to the abacus by drawing 3 beads on the ten's column and 2 beads on the one's column.

The new number is:

$$\underline{5} \text{ T} + \underline{5} = \underline{55}$$

What number is shown on this abacus? 34

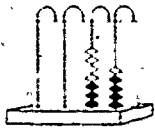

Add 41 to the abacus by drawing 4 beads on the ten's column and 1 bead on the one's column.

The new number is:

$$\underline{7} \text{ T} + \underline{5} = \underline{75}$$

What number is shown on this abacus? 72

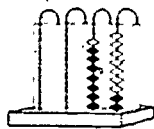

Add 17 to the abacus.

The new number is:

$$\underline{8} \text{ T} + \underline{9} = \underline{89}$$

Worksheet 27
Unit 16

Name _____

Add. Use your abacus to find the sum.

$$41 + 8 = \underline{49}$$

$$16 + 2 = \underline{18}$$

$$13 + 4 = \underline{17}$$

$$4 + 13 = \underline{17}$$

$$36 + 3 = \underline{39}$$

$$3 + 36 = \underline{39}$$

$$42 + 37 = \underline{79}$$

$$21 + 43 = \underline{64}$$

$$61 + 0 = \underline{61}$$

$$37 + 30 = \underline{67}$$

Activity B

Demonstrate the first problem of Worksheet 28. Show the children that to subtract, they need only flip the correct number of beads to the back of the abacus. Give examples such as $34 - 21$.

HOW CAN WE SUBTRACT 21 FROM 34 ON THE ABACUS?
(We remove 1 bead from the ones column and 2 beads from the tens column.)

Write the answer on the chalk board in numerals:

$$34 - 21 = 13$$

Have some children do subtraction problems for the class. Ask them to demonstrate both with the abacus and by writing each problem in numerals on the chalk board. Explain that on the worksheets subtraction is done by simply crossing out the specified number of beads in each column to represent flipping the beads.

Ask the children to try to complete Worksheets 28 and 29, but help them if they have difficulties.

Worksheet 28
Unit 16 Name _____

What number is shown on this abacus? 65

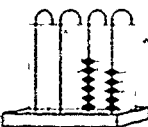

Cross out 3 beads in the one's column. Cross out 2 beads in the ten's column.

The new number is:
4 T + 2 = 42

What number is shown on this abacus? 46

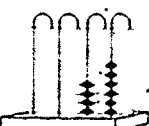

Cross out 4 beads in the one's column. Cross out 3 beads in the ten's column.

The new number is:
1 T + 2 = 12

What number is shown on this abacus? 47

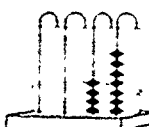

Subtract 17. Cross out the correct number of beads.

The new number is:
3 T + 0 = 30

Worksheet 29
Unit 16 Name _____

Subtract. Use your abacus.

$16 - 8 = \underline{8}$	$48 - 21 = \underline{27}$
$23 - 13 = \underline{10}$	$53 - 12 = \underline{41}$
$94 - 21 = \underline{73}$	$37 - 30 = \underline{7}$
$68 - 2 = \underline{66}$	$86 - 72 = \underline{14}$
$17 - 15 = \underline{2}$	$9 - 9 = \underline{0}$

Lesson 12: THE NUMERALS THROUGH 999

The children's conception of place value is here extended to the hundreds. This gives the class some idea of the larger quantities that numerals are used to represent. After completing the lesson, the children should have an understanding of numerals through 999.

This lesson follows closely the procedure given in first grade in Lesson 39 of Unit 11, Introducing Addition and Subtraction. Lesson 39 was an optional lesson. If it was taught to your class, perhaps the children will not need to spend much time on the concepts. However, new notation for hundreds is used in this unit, e.g: since 100 means 10 tens, $T \cdot T$ is used to represent 100; $3T \cdot T$ stands for 300. ($T \cdot T$ is an intermediate step towards the exponential notation, T^2 .)

If you feel that your class is ready for thousands, you may present that notation also. If the class is not ready, you may wish to let some children continue to the thousands. The notation for 1000 (10 hundreds) is represented by $T \cdot T \cdot T$. In T notation, 4752 is: $4T \cdot T \cdot T + 7T \cdot T + 5T + 2$.

MATERIALS

-- for each child --

- 5 or more paper cups
- Worksheets 30 through 34

-- for each group of 3 or 4 --

- pile of counters (various amounts for each group, but more than 200)
- 2 or more trays or boxes large enough to hold 10 paper cups

PROCEDURE

Activity A

Divide the class into groups of three or four children. Provide each child with five paper cups, and each group with a large pile of counters and two trays. Ask the children to take counters from the group's pile and put ten in each paper

cup. When the group has ten filled cups, one child should place them in a tray. Ask the children to tell you how many counters there are in a tray filled with ten cups each holding ten counters (100). Show them how to write this in T notation as T·T. Provide enough materials so that the groups will have three-digit results for problem 1 of Worksheet 30. Each group should end up with:

- at least 2 trays of 10 cups containing 10 counters each
- cups of 10 counters insufficient to fill a tray (0-9)
- single counters left over insufficient to fill a cup (0-9)

With help from the class, demonstrate on the chalk board how the children in a group are to record the number of counters the group has:

IF A GROUP HAS 2 TRAYS FULL OF 10 CUPS, 3 CUPS OF 10'S, AND 6 COUNTERS LEFT OVER, HOW WOULD WE FILL THE BOXES IN PROBLEM 1 OF WORKSHEET 30?

Write on the chalk board:

2	3	6
---	---	---

Then show how the blanks in the sentence under the boxes should be filled:

2 hundreds, 3 tens and 6 ones = 236

Have the children do problem 1 of Worksheet 30. If answers vary within a group, have the children check and correct each other.

For problem 2 of the worksheet, ask two groups to put all their trays, cups and odd counters together, and again see how many trays of ten filled cups they have, how many extra cups of tens, and how many ones are left over. Using all the counters from two groups, each child should record the results, as before.

1. Write in the boxes the number of counters your group has.

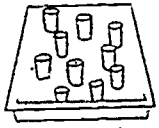
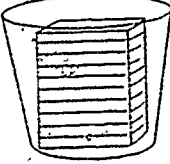
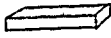
Number of trays	Number of cups	Number of ones
		
2	3	6

2 hundreds + 3 tens + 6 ones = 236

2. Combine your counters with those of another group. Write the number of counters in the new set.

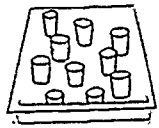
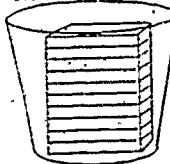
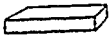
Number of trays	Number of cups	Number of ones
		
4	2	5

4 hundreds + 2 tens + 5 ones = 425

(Use the many possible answers to this worksheet.)

Next have the children complete Worksheets 31 and 32 by looking at the numerals given at the left. If any children have difficulty, remind them that T·T stands for 10 tens or 100. If you wish, have the class participate afterward in assembling the number of counters represented on the worksheets.

Conclude the activity by having the children do Worksheets 33 and 34.

Worksheet 31
Unit 16 Name _____

Fill in the blanks and boxes for each numeral.

342	Number of hundreds = <u>3</u> Number of tens = <u>4</u> Number of ones = <u>2</u>	T·T's T's Ones <table border="1"><tr><td>3</td><td>4</td><td>2</td></tr></table>	3	4	2
3	4	2			
516	Number of hundreds = <u>5</u> Number of tens = <u>1</u> Number of ones = <u>6</u>	T·T's T's Ones <table border="1"><tr><td>5</td><td>1</td><td>6</td></tr></table>	5	1	6
5	1	6			
73	Number of hundreds = <u>0</u> Number of tens = <u>7</u> Number of ones = <u>3</u>	T·T's T's Ones <table border="1"><tr><td>0</td><td>7</td><td>3</td></tr></table>	0	7	3
0	7	3			
407	Number of hundreds = <u>4</u> Number of tens = <u>0</u> Number of ones = <u>7</u>	T·T's T's Ones <table border="1"><tr><td>4</td><td>0</td><td>7</td></tr></table>	4	0	7
4	0	7			

Worksheet 32
Unit 16 Name _____

Fill in the blanks and boxes for each numeral.

794	Number of hundreds = <u>7</u> Number of tens = <u>9</u> Number of ones = <u>4</u>	T·T's T's Ones <table border="1"><tr><td>7</td><td>9</td><td>4</td></tr></table>	7	9	4
7	9	4			
32	Number of hundreds = <u>0</u> Number of tens = <u>3</u> Number of ones = <u>2</u>	T·T's T's Ones <table border="1"><tr><td>0</td><td>3</td><td>2</td></tr></table>	0	3	2
0	3	2			
347	Number of hundreds = <u>3</u> Number of tens = <u>4</u> Number of ones = <u>7</u>	T·T's T's Ones <table border="1"><tr><td>3</td><td>4</td><td>7</td></tr></table>	3	4	7
3	4	7			
8	Number of hundreds = <u>0</u> Number of tens = <u>0</u> Number of ones = <u>8</u>	T·T's T's Ones <table border="1"><tr><td>0</td><td>0</td><td>8</td></tr></table>	0	0	8
0	0	8			

Worksheet 33
Unit 16 Name _____

Fill in the blanks.

3 hundreds + 7 tens + 8 ones = 378

4 hundreds + 2 tens + 4 ones = 424

5 T·T + 6 T + 3 ones = 563

8 T·T + 9 T + 8 ones = 898

6 T·T + 3 T + 4 ones = 634

4 T·T + 4 T + 4 ones = 444

9 T·T + 3 T + 8 ones = 938

Worksheet 34
Unit 16 Name _____

Fill in the blanks.

549 = 5 hundreds + 4 tens + 9 ones.

210 = 2 hundreds + 1 tens + 0 ones.

832 = 8 T·T + 3 T + 2 ones.

592 = 5 T·T + 9 T + 2 ones.

821 = 8 T·T + 2 T + 1 ones.

463 = 4 T·T + 6 T + 3 ones.

617 = 6 T·T + 1 T + 7 ones.

Activity B

It is desirable for the children to know how to pronounce three-digit numerals correctly. Remind them not to use "and" between hundreds and tens:

WE SAY "FOUR HUNDRED SIXTY-TWO," NOT "FOUR HUNDRED AND SIXTY-TWO."

You may wish to write a few numerals on the chalk board and ask the children to pronounce them:

121 — One hundred twenty-one

369 — Three hundred sixty-nine, etc.

Activity C

Bring up some questions that require answers with three-digit numerals. Make up questions of your own or choose from the following:

1. How many pages are in this book?
2. How many words are on this page?
3. How many tiles are on the floor?
4. How many holes are in the pegboard?
5. How many seconds are there in two minutes?
6. How many days are in one year?
7. How much do some of the adults you know weigh?

Some of the answers to the above questions may be easy for the children to answer (questions 1, 6 and 7); others may require counting.

If you wish, you may go on to discuss questions that require answers with four-digit numerals, but this is entirely optional. Suggestions are:

1. How many seconds are there in an hour? (3600.)
2. How many miles wide is the United States? (This requires looking at a map and its scale, then measuring and converting the scale into miles.)

Lesson 13: COUNTING BY TENS

Motivation for the work with tens is provided by Worksheet 35 which shows the outlines of some houses, lots and streets on a grid where each unit of length represents ten feet. Activity A prepares the children to use the worksheet and to count by tens the lengths of the sides and perimeters of a few houses and lots.

The lesson begins with the consideration of a chalk line ten feet long, so that the children will understand how much length is represented by each side of the small squares on the grid. Then the children learn how directions are shown on a map. A transparency of Worksheet 35 would be most helpful to the discussion, if you have the equipment to make and project one.

In Activity B, the children complete Worksheet 35. Activity C makes use of counters to provide more practice in counting. By counting in various ways (by twos, threes, fives, tens, etc.) the children are led to see that counting by tens is more rapid and convenient than the other methods.

MATERIALS

- foot ruler
- Worksheet 35
- transparency of Worksheet 35 (optional)
- abaci (optional)
- 60 to 100 counters for each group of 5 or 6 children

PROCEDURE

Activity A

Draw a line ten feet long on the chalk board at a height the children can easily reach, or draw it on the floor. Have a few children measure the line with a foot ruler to determine that its length is ten feet. Now have the children turn to Worksheet 35 and explain to them that each side of the small square at the bottom of the worksheet represents (stands for) a length of ten feet. In a discussion, elicit that the ten-foot

line on the chalk board would be very difficult to use as a length on a worksheet, and therefore, maps use shorter units to represent longer ones. Make sure that the children understand that each small section of the grid stands for a length of ten feet:

Next ask the children to look at the compass directions at the lower right of Worksheet 35. Hold a discussion about the way they are represented on a map and see whether the children can tell you where north, south, east and west are on the paper. Then have the children write "N" or "North" at the top of the worksheet, "S" or "South" at the bottom, "W" or "West" at the left and "E" or "East" at the right. Explain that these directions will be handy when you ask them to count off the number of feet in the south side of a house, etc. (If you wish to spend some time here having the children learn the actual directions, you may do so, but -- unless the children are facing north at their desks -- this might take some time. For the purposes of this lesson it is only necessary that the children recognize how directions are usually indicated on a map.)

Explain that on the worksheet the regions with names printed in them will be called houses. Each house region is included in a larger region which will be called the house lot. That part of the lot which surrounds each house is shaded, so that the children can tell where the lot ends and the street or another lot begins. When two lots join, small white spaces show where each lot ends and another starts.

Have the children find Ash Street on their maps. Ask them to start at the west end of Ash Street, calling that point zero, then count by tens as they would on a number line. Remind them that in this case each mark on the line represents ten feet, so they should count along Ash Street by tens: zero, ten, twenty, thirty, forty, fifty and sixty feet.

Now ask the children to look at Jane's house, and ask how long each side of that house is. (Thirty feet.) Next ask what the perimeter -- distance around -- Jane's house is. The children may count by tens around the house to reach 120 feet for the length of the perimeter, or they may calculate $30 + 30 + 30 + 30$ on their fingers, or with an abacus, or with stacks of counters each containing 10 counters.

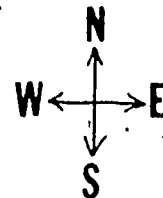
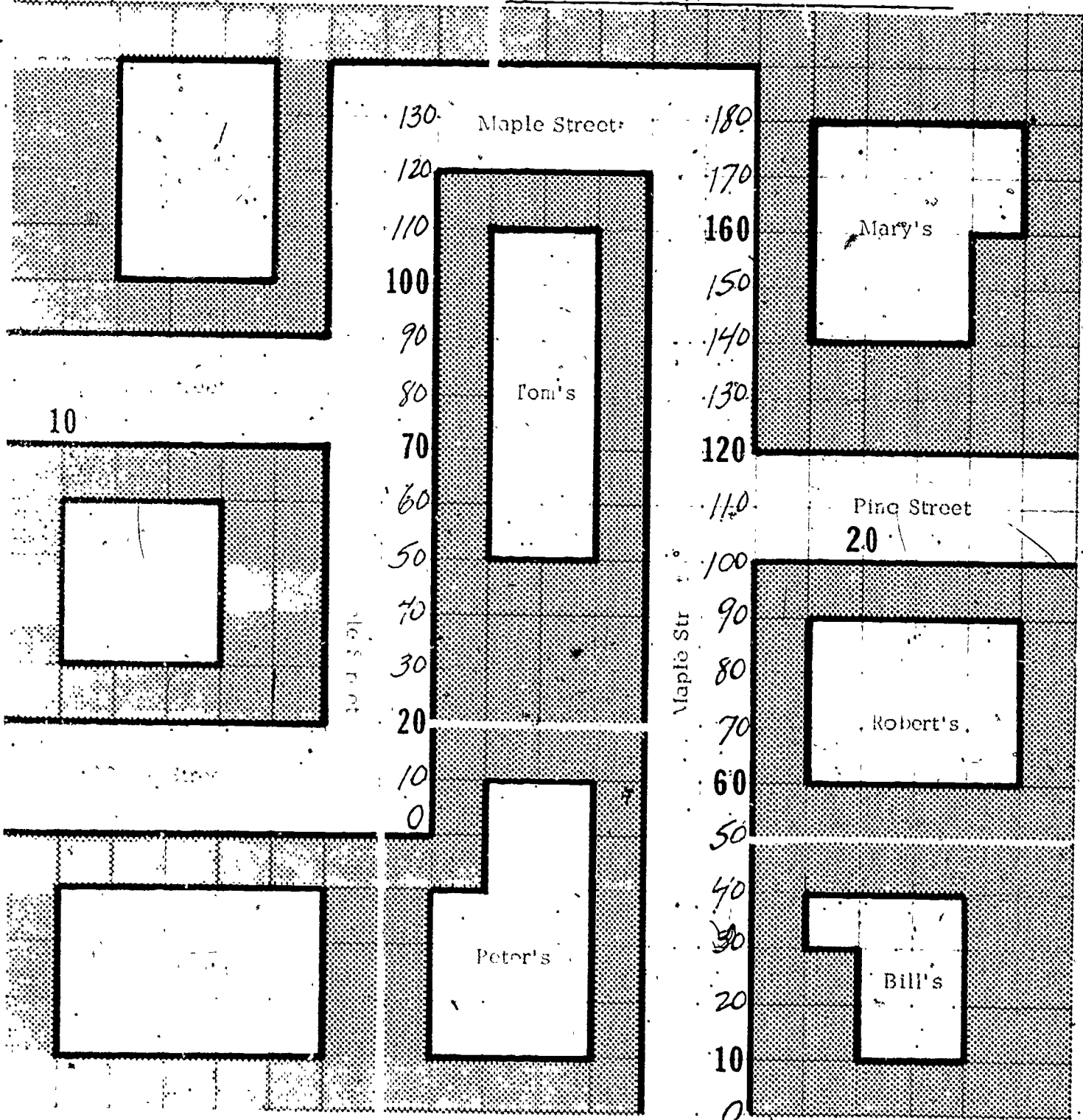

Next have the children find the length of the north side of Jane's lot (60 ft.). Then ask them to find something on the map to measure that would be the same in length as the north side of Jane's lot. (Ash Street or the south side of Mike's lot, for example.)

Continue with the following:

WHAT IS THE MEASUREMENT OF THE EAST SIDE OF JANE'S LOT? (Fifty feet.)

WHAT OTHER LENGTH IS THE SAME AS THAT OF THE EAST SIDE OF JANE'S LOT? (The north side or the south side of Kathy's house, for example.)

Ask the same kind of questions when you discuss Kathy's, Tom's and Robert's houses and lots. You need not discuss all the rectangular houses and lots if the children understand the procedure. When you think they do, direct their attention to Bill's house and lot.

WHAT IS DIFFERENT ABOUT BILL'S HOUSE? (It is not rectangular.)

HOW CAN WE MEASURE THE SOUTH SIDE OF IT?

Lead the children to measure both lines on the south side and add them. Then ask them to measure the north side.

WHAT DO YOU NOTICE ABOUT THE NORTH AND SOUTH MEASUREMENTS OF BILL'S HOUSE? (The sum of the lengths of the two parts of the south side equals the length of the north side.)

Repeat the procedure for the east and west side of Bill's house if it is necessary to insure understanding.

Ask the children to measure Bill's lot, then have them measure Mary's and Peter's houses and lots. Guide those who need help when they try to measure Peter's, Mike's and Mary's lots.

Activity B

Before proceeding with more work on the map, ask the class to think about and discuss whether it is important to learn to make measurements, and when they would need to use this skill.

Now ask the children to find the two parts of Maple Street that run in a north-south direction. Tell them to start at the south end of each part of Maple Street and write in the numerals at every point that represents ten more feet, so that they will have two separate ten-counting charts when they finish. Some numerals have been filled in to help them. Remind the children to start at zero and write that first.

When the class finishes the worksheet, correct the papers in a general discussion.

Activity C

This activity gives more practice in counting by tens. Divide your class into groups of five or six children and give each group a pile of counters (60 to 100 or so). Each child individually counts the number of counters in his group's pile, and secretly records the number on a slip of paper. (Encourage the children to think of various ways to arrange the counters -- in stacks or sets of twos, threes, fours, fives, tens, etc. The object here is to see whether the children will discover that counting by tens is more rapid and convenient.) After each child has secretly recorded his answer, he may push the counters into any arrangement he wishes for the next player. No child should tell what his count is until all have had a turn. Then, members of a group should compare and correct their answers.

Conclude the activity by asking the children to compare various ways of counting a certain number (e.g., 84) by twos, threes, fives, tens, etc. This will emphasize the method that is quickest and easiest (tens), if the children haven't already discovered it. For example:

84 counters

5, 10, 15, 20, 25, 30, 35, 40...80, 81, 82, 83, 84

vs.

10, 20, 30, 40...80, 81, 82, 83, 84

Lesson 14: TOR'S NUMBER SYSTEM -- BASE FOUR

This lesson is intended only to help the children achieve a better understanding of place value. It is not intended that they should master the concepts and ideas of the base-four numeration system. The purpose of having the children work with the base-four system, in which they group by fours, is to have them comprehend the place-value concept more easily as it applies to the decimal system, in which they group by tens.

MATERIALS

- picture of Tor on display
- flannel board
- counters for flannel board
- Minnebars
- Worksheets 36 and 37

PROCEDURE

Activity A

Ask the children to look at the picture of Tor. Ask whether the children think that the reason we count by tens is that we have ten fingers. Then see if the children can suggest what kind of a base for counting (how many numerals) Tor and his friends on Titan might use.

Say that Tor noticed that we write a T for ten, that we have ten fingers on our hands, and that we call our number system a base-ten numeration system, whereas on Titan, he and his friends each have a total of only four fingers (2 thumbs + 2 fingers = 4 fingers), so they use a base-four system. Say that Tor thinks his new friends on Earth would understand his number system best if they tried to use it a little, and he has suggested some ways for them to do so.

TORS BASE FOUR

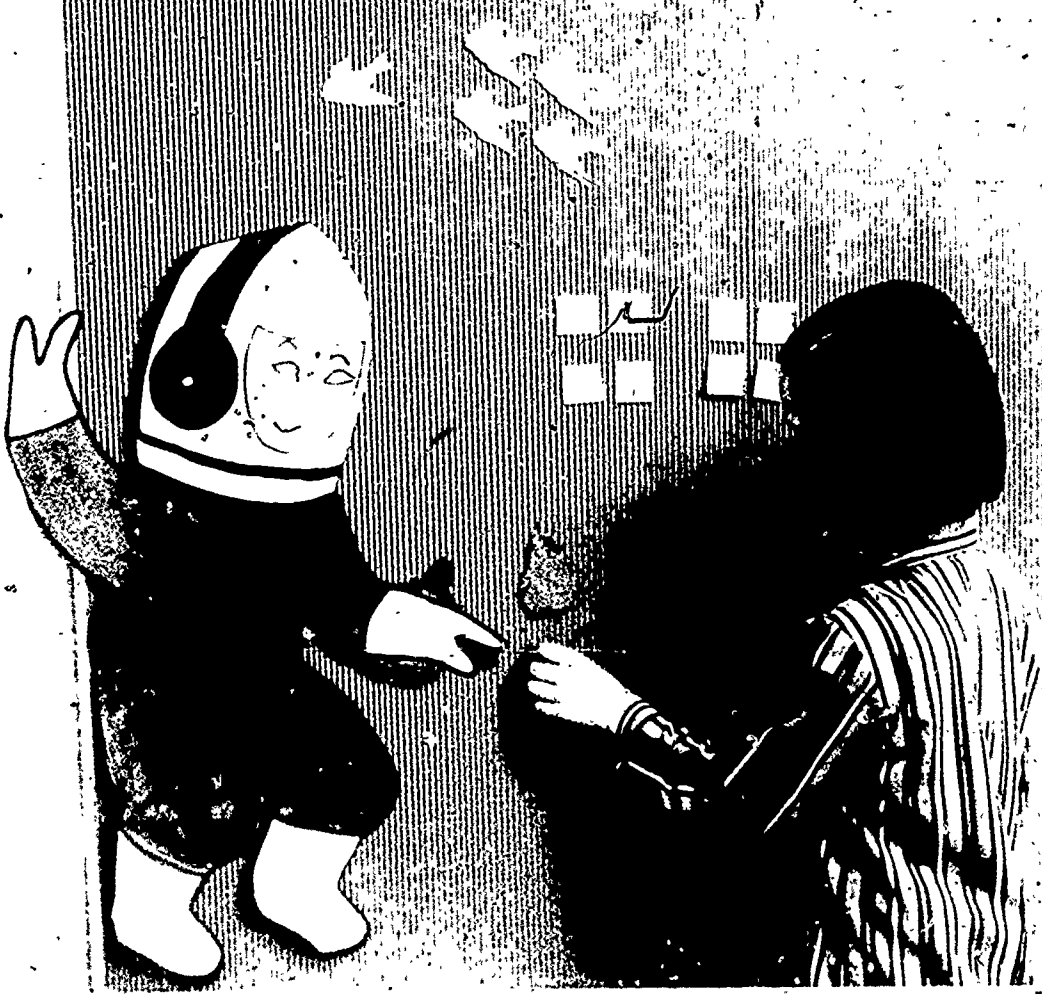

The photograph shows a child arranging objects on a bulletin board. Her sets represent the place values used in base 4.

Place 13 counters on the flannel board. Have a child separate the counters into groups or sets of four. (There will be one left over.)

$$\begin{array}{cccc} 0 & 0 & 0 & 0 \\ 0 & 0 & 0 & 0 \end{array} \quad 0$$

HOW MANY GROUPS OF FOUR ARE THERE? (3.)

HOW MANY ONES ARE LEFT OVER? (1.)

Tor says, "There are three 4's and one 1. In base four I would write this number as 31 (pronounced three-one). I would use the letter F to represent the fours place and write the expanded numeral as $3F + 1$."

Write " $3F + 1 = 31$ (base four)" on the chalk board.

Explain to the children that Tor uses completely different symbols on Titan to write his base-four numerals, but that you are using the base-ten symbols to write the base-four numerals, because the children already know these numerals.

Tell the children that Tor mentioned that in our base-ten system we use the numerals 0, 1, 2, 3, 4, 5, 6, 7, 8, and 9. He wants them to think about how many numerals they should use in base four and to say what they are. (0, 1, 2, and 3.)

YES, TOR SAYS THAT SINCE HE HAS ONLY FOUR FINGERS ALTOGETHER, HE NEEDS TO USE ONLY FOUR NUMERALS IN HIS BASE-FOUR SYSTEM. THE NUMERALS ARE 0, 1, 2, AND 3.

Suggest that Tor would like the children to repeat the example, this time with 11 counters on the flannel board, and then with 5. Have the children group the 11 counters into $2F + 3$, and the 5 counters into $1F + 1$.

Show the steps and notation for each example:

$$11 = 2F + 3 = 23$$

$$5 = 1F + 1 = 11$$

You can also explain the base-four system to the children with this analogy:

WHEN WE WORK WITH QUARTS OF WATER, WE COUNT 0 QUARTS, 1 QUART, 2 QUARTS, 3 QUARTS; BUT WHEN WE GET TO FOUR QUARTS, WE REMEMBER THAT 4 QUARTS EQUAL 1 GALLON. THEREFORE, INSTEAD OF SAYING 4 QUARTS, WE CAN SAY 1 GALLON.

Give this example:

$$7 \text{ quarts} = 4 \text{ quarts} + 3 \text{ quarts} = 1 \text{ gallon} + 3 \text{ quarts}$$

Conclude the activity by having the children do Worksheets 36 and 37.

Worksheet 36
Unit 16 Name _____

Draw a closed curve around each set of 4. Write the number of fours (F's) and the number of ones left over. Write the name in base 4 with numerals.

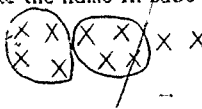
1. 
2 F's + 2 ones = 22 (base four)

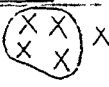
2. 
1 F's + 1 ones = 11 (base four)

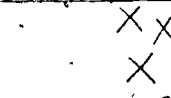
3. 
3 F's + 1 ones = 31 (base four)

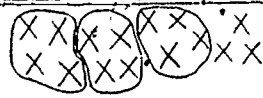
4. 
3 F's + 3 ones = 33 (base four)

Worksheet 37
Unit 16 Name _____

Record the number of fours (F's) in the base-four numerals below. Record the number of ones. Then write the number in the place-value chart.

Base four	Number of fours (F's)	Number of ones	F's	ones
33	3	3	3	3
21	2	1	2	1
32	3	2	3	2
10	1	0	1	0

Activity B

Divide the class into pairs of children and give each pair nine to fifteen 1-unit Minnebars and three 4-unit Minnebars. Ask the children how many 1-unit bars are equal to one 4-unit bar (4).

Say that Tor has thought of a game the children can play with the Minnebars. Child A of each pair should start out with any number of 1-unit bars he chooses, but the number must be between nine and fifteen. Child B should start out with all three of the 4-unit bars. Now Child A should exchange as many sets of four 1-unit bars as he can for 4-unit bars. When Child A has no more sets of four 1-unit bars to exchange, he should write down the number of 4-unit bars and the number of 1-unit bars he has. That record should describe what he has in base four.

Have two children demonstrate the game. Give Child A thirteen 1-unit bars to start with and Child B three 4-unit bars. When A is through exchanging sets of fours with B, he should have three 4-unit bars and one 1-unit bar. He should write down 31. Child B should check A's base-four numeral to see that it is correct. Show the process and the notation on the chalk board:

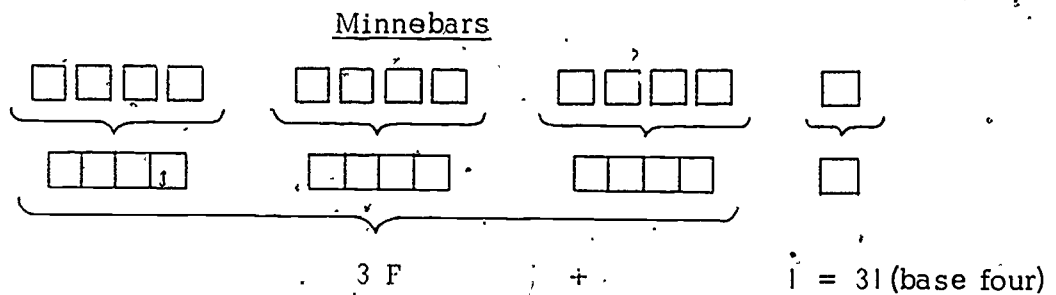

Now have all the pairs of children play the game. Tell the class that the children should reverse their roles after they have written down the result of a game and it has been checked by the other partner. Move about the room to give assistance where needed. Remind the children to write down their results in base 4. See that the children change the number of 1-unit Minnebars for each game, but always keep it within the limit of 9 to 15 bars.

Activity C (Optional)

To show the children the number of objects represented by the numeral 21 in base ten and by the same numeral in base four, use counters, or draw on the chalk board:

Set A, 21 (base 10)

0 0 0
0 0
0 0
0 0
0 0
0 0
0 0
0 0
0 0
0 0

Set B, 21 (base 4)

0 0 0
0 0
0 0
0 0

WHICH SET HAS THE GREATEST NUMBER OF MEMBERS?
(Set A; base 10.)

WHICH NUMERAL 21 -- BASE FOUR OR BASE TEN --
STANDS FOR THE GREATER NUMBER? (21, base 10.)

Repeat the procedure with comparisons of 13 (base 4) and 13 (base 10); 2 (base 4) and 2 (base 10); 12 (base 4) and 12 (base 10); 12 (base 4) and 6 (base 10); etc. (The last comparison will show the same number of objects -- 6 -- in each base.)

Lesson 15: TOR'S BASE-FOUR NUMBER LINE

This lesson compares base-four numeration with base-ten numeration by means of a number line. It also provides additional practice in writing base-four numerals.

MATERIALS

- Worksheets 38 and 39

PROCEDURE

Activity A

Draw a number line on the chalk board, with the numerals 0 through 15 labeled in the familiar (base 10) manner.

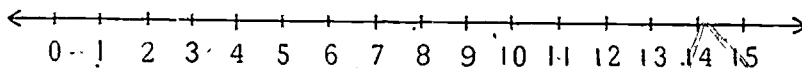

Remind the children that in our decimal system of numeration, when we come to the numeral ten, we run out of basic numerals (digits) and use a combination of 1 and 0 ($1T + 0 = 10$). The position or place of a digit tells its value. If it is at the extreme right, the position tells the number of ones. If it is second from the right, it tells the number of tens.

Now tell the children that they are going to help you label the number line in Tor's system, remembering that Tor can use only four digits (or basic symbols): 0, 1, 2, and 3. Label the first four corresponding points above the number line. Point out that when Tor gets to the point corresponding to our numeral for four, he has already run out of basic symbols and must use a combination of two symbols, namely 1 and 0 or 10 ($1F + 0$). Label 10 above our point four. Say that the one represents the number of fours, and the zero the number of ones. Then ask:

HOW SHOULD WE LABEL THE NEXT POINT IN TOR'S BASE-FOUR SYSTEM -- THE POINT THAT CORRESPONDS TO OUR NUMERAL FOR FIVE? ($1F + 1$ or 11 .)

Write in 11 above the 5 on the number line. Continue this process for:

$$6 = 1 F + 2, \text{ or } \underline{12}$$

$$11 = 2 F + 3, \text{ or } \underline{23}$$

$$7 = 1 F + 3, \text{ or } \underline{13}$$

$$12 = 3 F + 0, \text{ or } \underline{30}$$

$$8 = 2 F + 0, \text{ or } \underline{20}$$

$$13 = 3 F + 1, \text{ or } \underline{31}$$

$$9 = 2 F + 1, \text{ or } \underline{21}$$

$$14 = 3 F + 2, \text{ or } \underline{32}$$

$$10 = 2 F + 2, \text{ or } \underline{22}$$

$$15 = 3 F + 3, \text{ or } \underline{33}$$

The chalk board number line should now show the number line in base four and base ten, like this:

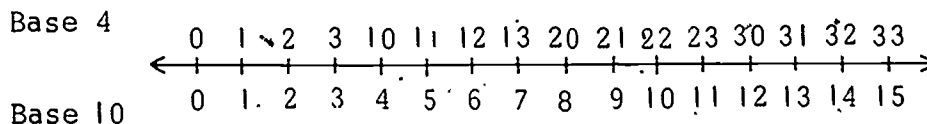

Worksheets 38 and 39 provide practice in writing base-four numerals. For Worksheet 38, remind the children that they can always check (or figure out) their answers by finding out how many fours and how many ones are in the base-ten numerals given below the number line.

For Worksheet 39, remind the children that they can use Worksheet 38 for reference. The children should enjoy noticing that:

$$4 = 10, \text{ in base four}$$

$$8 = 20, \text{ in base four}$$

$$12 = 30, \text{ in base four, etc.}$$

If the children seem to have much difficulty; use the worksheets as class activities. Put no importance at all on their memorizing or mastering the base-four system.

If your class is exceptionally bright, you might like to end the lesson by holding a discussion about other possible bases. Some children may know base two, where only zero and one

are used. Some others may like to speculate about what kind of a base Tor would have used if he had had six or eight fingers, etc.

Worksheet 38
Unit 16 Name _____

Label the number lines below with Tor's numerals. Write the base 1 numerals above the number lines. The numbers below the lines are base 10.

0 1 2 3 4
0 1 2 3 4

2 22 21 30 31
9 10 11 12 13

2 3 20
4 5 6 7 8

Worksheet 39
Unit 16 Name _____

Use Worksheet 38 to help you fill in Tor's counting numbers in the chart below. Write only numerals that are base four (Tor's base).

0	1	2	3
10	11	12	13
20	21	22	23
30	31	32	33

Lesson 16: THE BASE-FOUR ABACUS

This lesson gives the children practice in using the base-four abacus. It helps reinforce the idea of place value. The columns of MINNEMAST abaci are removable, so that many different bases can be represented on it; but for the purposes of this lesson remove all but three beads from each column.

MATERIALS

- abaci (with number of beads reduced to 3 per column)
- Worksheets 40 and 41

PROCEDURE

Activity A

Remove all but three beads from each ring (column) on the abaci. Mention to the class that Tor says this type of abacus can be used to work with his base-four number system.

CAN ANYONE TELL WHAT THE BEADS ON THE FIRST COLUMN ON THE RIGHT OF THE ABACUS STAND FOR? (The number of ones.)

WHAT DO THE BEADS ON THE SECOND COLUMN STAND FOR? (The number of fours.)

You may also wish to ask:

WHAT DO THE BEADS ON THE THIRD COLUMN FROM THE RIGHT REPRESENT? (The number of sixteens.)

THE BEADS ON THE FOURTH COLUMN FROM THE RIGHT? (The number of sixty-fours.)

Label your abacus and have the children label theirs with a 1 at the extreme right and an F for the next column.

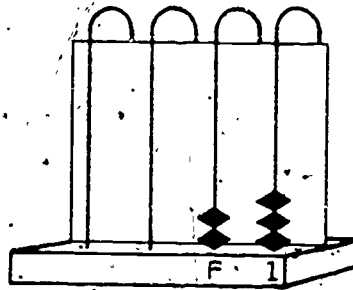

Show two beads on the fours column and three beads on the ones column. Write on the chalk board:

$$2 F + 3 = 23$$

(base four)

Alter the number of beads and ask the children to write sentences using this notation to describe the base-four numeral shown on the abacus. Continue by writing several base-four numerals on the chalk board and ask the children each to record these numerals on the abacus.

When the children have had this practice, ask them to complete Worksheets 40 and 41. Keep in mind that the children are working entirely in base four here -- they are not converting back to base ten. Therefore, although $3 F + 3$ (for example) might look as though the answer should be written 15, it should not, because in base four the second column refers to the number of fours, which is 3, and the first column refers to the number of ones, which in this case is also 3. If the worksheets prove too difficult for independent work, have the children do them as class activities.

Worksheet 40

Unit 16

Name _____

Write the base four numeral shown by the beads on each abacus.

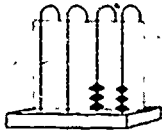

$$\underline{3} \text{ F} + \underline{3} \text{ ones} = \underline{33}$$

(Base 4)

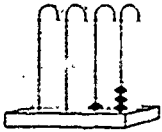

$$\underline{1} \text{ F} + \underline{3} \text{ ones} = \underline{13}$$

(Base 4)

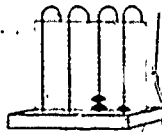

$$\underline{2} \text{ F} + \underline{1} \text{ ones} = \underline{21}$$

(Base 4)

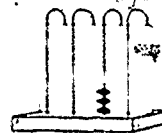

$$\underline{3} \text{ F} + \underline{0} \text{ ones} = \underline{30}$$

(Base 4)

Worksheet 41

Unit 16

Name _____

Draw on the abacus the beads you need to show the base 4 numeral.

33

Base 4

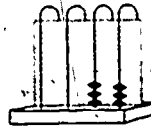

21

Base 4

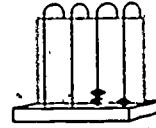

10

Base 4

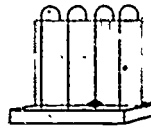

30

Base 4

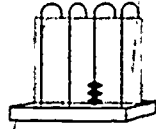

3

Base 4

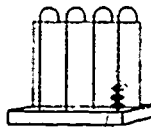

23

Base 4

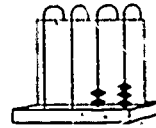

Lesson 14: RELATION BETWEEN STRUCTURE AND FUNCTION OF TEETH

In this lesson the children study their teeth and see how the different shapes are related to different functions. Experiments are performed using models to represent different kinds of teeth. The children then go on to review the other parts of their own eating system.

MATERIALS

-- for the class --

- table knife or ruler
- flat stone or block of wood
- Plasticene

-- for each child --

- pieces of apple, banana, or a few nut meats
- mirror

Activity A

Give the children mirrors and have them once again observe their teeth. Review the differences in shape between the biting teeth and the chewing teeth.

SUPPOSE YOUR FRONT TEETH WERE BROAD AND FLAT INSTEAD OF HAVING THIN EDGES. WOULD THEY BE BETTER FOR BITING OFF PIECES OF FOOD? HOW CAN WE FIND OUT?

At this point we introduce the idea of experimenting with a model. We use a stone and a knife to represent two types of teeth, to see how the teeth are adapted to do their special job.

IS THERE SOMETHING THAT HAS A THIN EDGE AND SOMETHING ELSE THAT IS BROAD AND FLAT THAT WE CAN USE FOR EXPERIMENTING TO SEE WHICH CUTS BETTER?

You should be prepared with materials that children might suggest as models, such as a table knife and a flat stone, or a ruler and a block of wood.

WHICH OF THESE IS MORE LIKE OUR FRONT TEETH? (The knife.)

IN WHAT WAY IS IT LIKE THE TEETH? (It has a thin, sharp edge.)

TOUCH YOUR FRONT TEETH TO FEEL THE EDGE.

Show the children two pieces of Plasticene of the same size, with which they can experiment to see which shape is better for cutting. Have one child cut the Plasticene with the knife and the other with the stone. The one who finishes first should hold up his two pieces. This will dramatize the difference in efficiency of the two shapes.

WHICH SHAPE IS BETTER FOR A BITING TOOTH? (The thin edge.)

Have the children use their mirrors to look at their biting teeth and see how much the edges resemble the edge of the knife.

YOUR FRONT TEETH BITE. WHAT HAVE YOU SEEN YOUR BACK TEETH DO? (They squash and grind the food.)

ARE YOUR BACK TEETH MORE LIKE THE KNIFE IN SHAPE OR MORE LIKE THE STONE? (Like the stone.)

HOW CAN WE FIND OUT WHICH SHAPE IS BETTER FOR SQUASHING AND GRINDING—A KNIFE OR A STONE? (Try them and see.)

Have one child use the edge of the knife and another the stone on pieces of apple, banana or nuts and show the results to the class.

The following question is especially important because it draws attention to the relation between the structure and function of an organ.

NOW WHO CAN TELL US HOW THE SHAPE OF TEETH HELPS THEM DO THEIR JOB BETTER? (Biting teeth are thin, which makes them better for cutting. Grinding

teeth are flat, which makes them better for grinding and squashing food.)

Activity B.

NOW TELL US WHAT OTHER PARTS OF YOUR BODY BESIDES YOUR TEETH YOU USE WHEN YOU EAT. (Lips, tongue. Children may also recall using their arms, fingers, fingernails, etc.)

Distribute another piece of apple to each of the children so that they can investigate the part the tongue plays in eating. Ask them to wait until you give them the signal to put their pieces of apple into their mouths. Then they are to take a bite and start chewing, but they are not to move their tongues while they chew. After an interval call "Freeze." Tell them that when you say "Melt," they may use their tongues while chewing, to see what difference the use of the tongue makes in eating. When they have finished eating, continue the discussion.

WHAT JOB DOES THE TONGUE DO WHEN WE EAT? (It pushes food onto the chewing teeth and then it pushes food to the back of the mouth so that we can swallow it.)

Have the children use their mirrors again to observe how the tongue moves.

WHAT PROPERTY DOES THE TONGUE HAVE THAT ENABLES IT TO DO ITS WORK? (It bends easily in many directions.)

WHAT DO YOUR LIPS DO TO HELP YOU EAT? (They keep the food from falling out of your mouth while you chew.)

WHAT PARTS OF YOUR BODY DID YOU DISCOVER TO BE IN YOUR SYSTEM FOR EATING? (Arms, hands, fingers, fingernails, biting teeth, chewing teeth, tongue, lips.)

Provide an opportunity for children to include other parts of the body in the eating system. Each child who does so should be asked to explain what function the part has. For example, someone might mention the eyes because they see the food, or the throat which is involved in swallowing.

Lesson 15: THE STORY OF PINTA

In a living organism it is obviously not possible for the children to test the necessity of different components of a system by removing them one at a time and observing whether the system still functions. To help them visualize the role of an individual part, the following story describes the difficulties a cat had when it lost the use of its tongue through an injury.

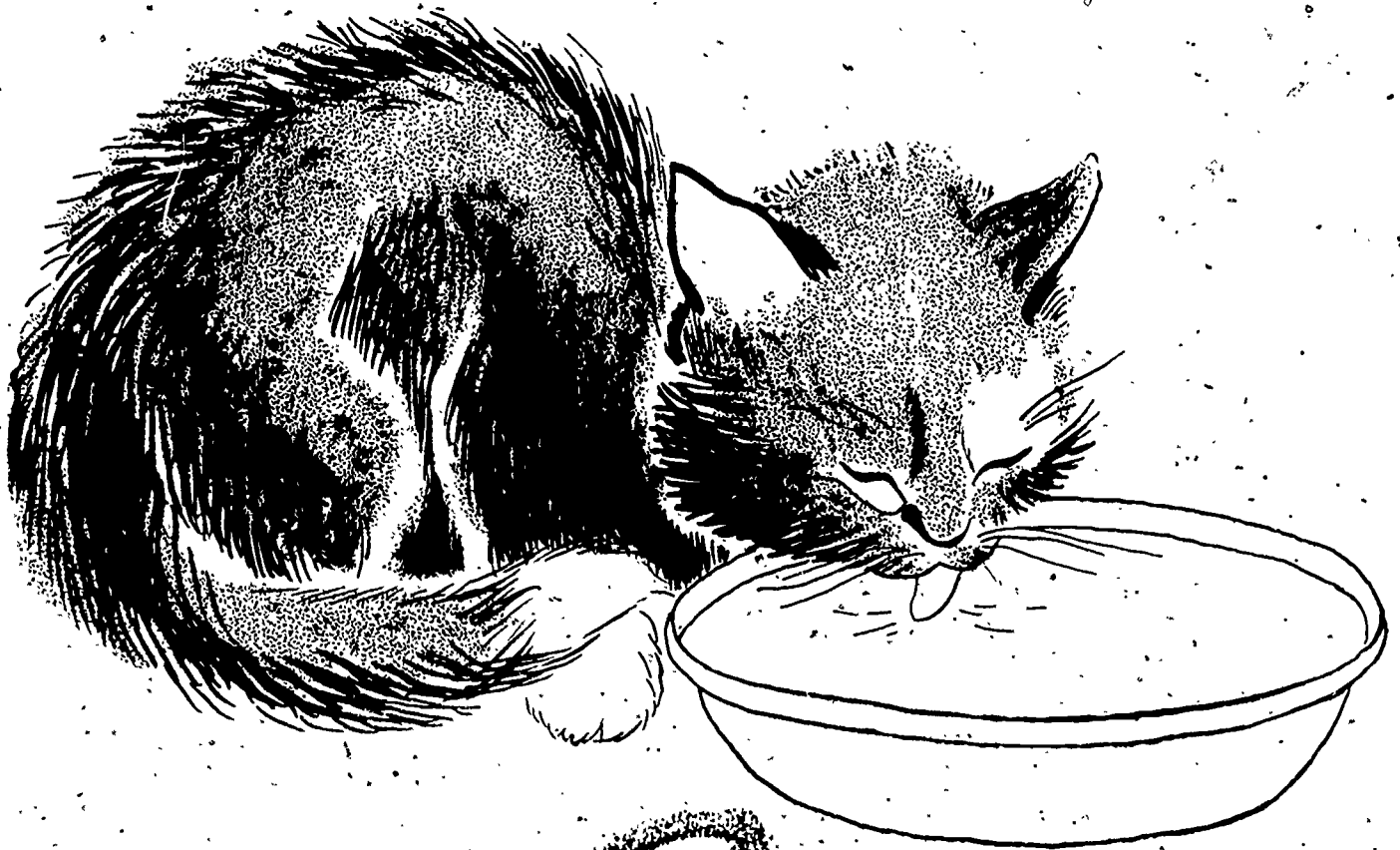

Pinta

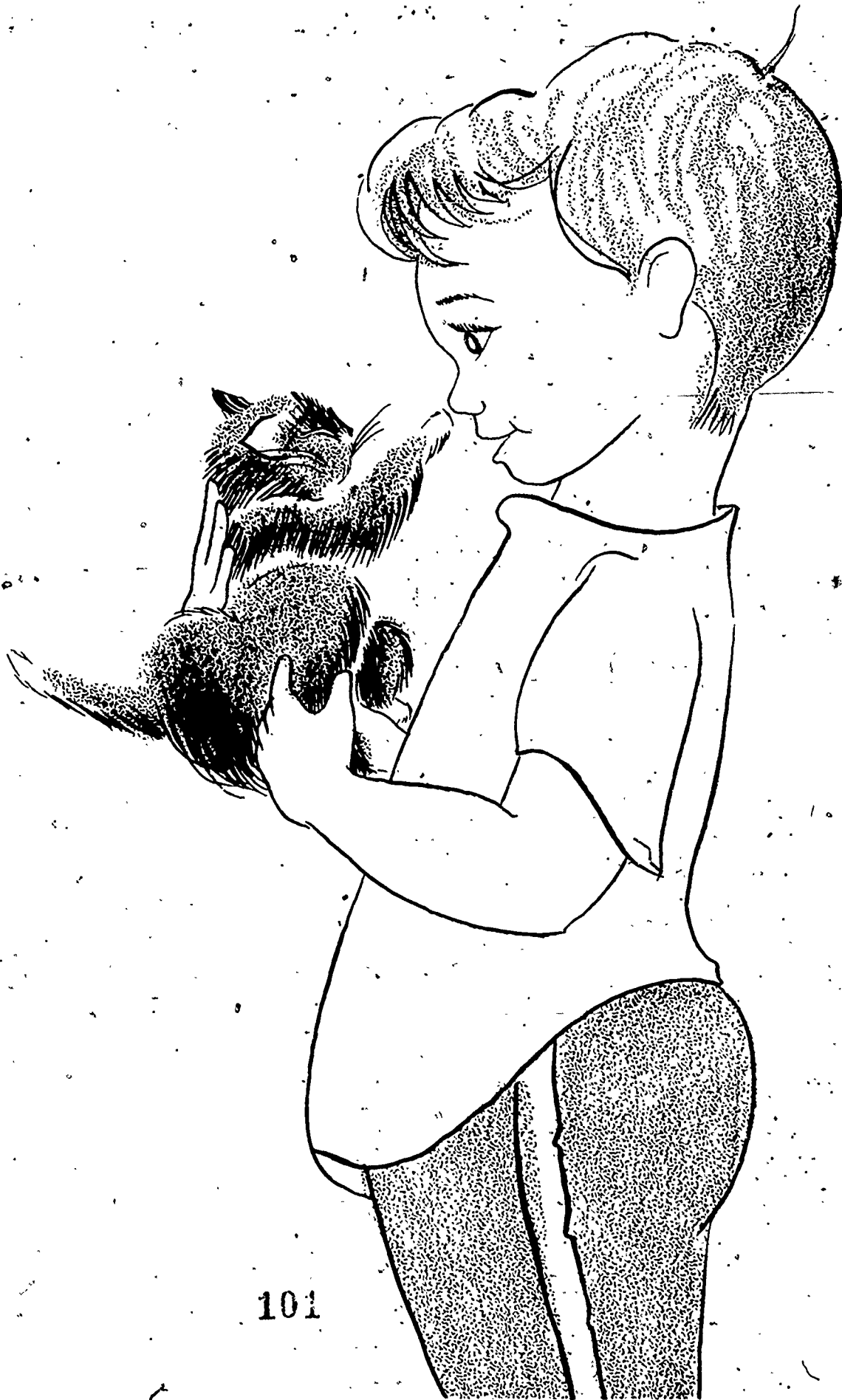

Pinta was a lovable, fat, little kitten when Frank got her for a birthday present. She had bright green eyes that were big and round. Her fur was jet black, except for her four snow-white feet and two white patches -- one over her left eye and one at the tip of her fuzzy tail. Frank thought she was the prettiest kitten in the world.

Pinta was very playful. She especially loved to play "catch the mouse" with Frank. She might be curled up and purring, or washing her face with one white paw, or licking her soft, round belly to keep it clean, but whenever Frank said, "Catch the mouse, Pinta," she would stop whatever she was doing.



Frank would drag a string with a piece of paper tied to the end across the floor in front of her. Pinta's muscles would bunch up as she got ready to pounce at the paper. She would crouch low on the ground and the white tip of her tail would twitch slowly. Her round green eyes would get narrow and fierce. She would sneak slowly along, following the paper Frank was pulling. Then suddenly she would spring, catch the paper with sharp claws, bite it with her pointed teeth and roll over and over on the floor. After pretending to eat the "mouse," she would wash herself with her long, pink tongue, as she always did after eating real food.

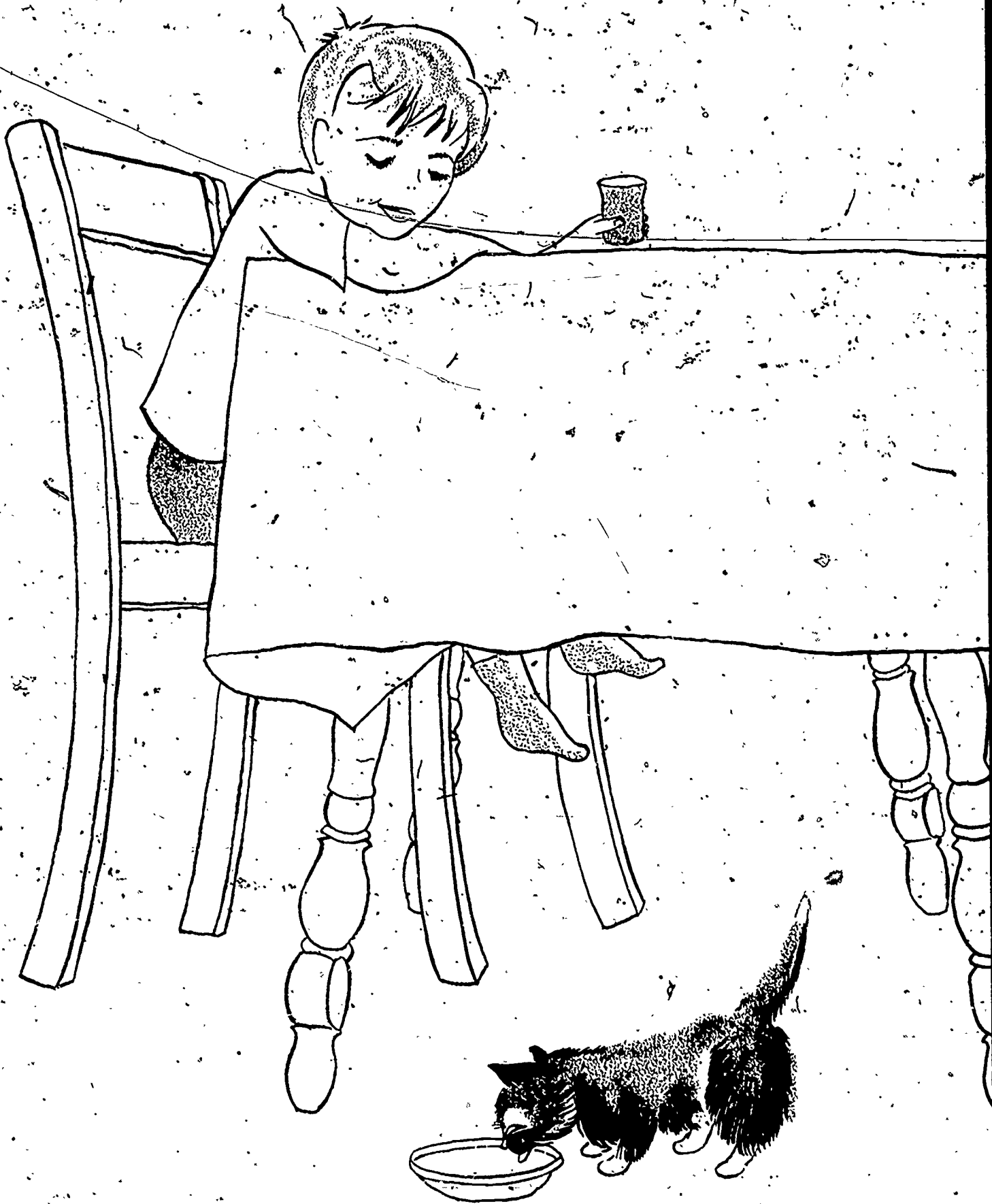



So that is what Frank did. He and the medicine dropper were very important parts of Pinta's eating system for the next week.

Pinta did not like being held on her back and fed with the dropper. Poor Pinta! Even though she did not have to move her burnt tongue to lap the milk, it still hurt her to swallow. For a few days, eating was very difficult.

Pinta had another difficulty too. She could not use her tongue to wash herself, and she began to look very shabby. She could not keep her coat glossy and clean without her tongue. She was not at all a happy kitten after her accident.

There was a game that Pinta often played when there was no one to stop her. It was like chasing the string, but it was very dangerous. Near Frank's bed a small lamp was connected to an electrical outlet. The lamp's electric cord hung down in a loop, just like the loop of string in the "catch the mouse" game. Pinta would tap the cord with one white paw to make it swing, and then she would pounce on the swinging electric cord and bite it.

One day an awful thing happened. Pinta pounced on the wire and bit right through the covering. And everyone knows how dangerous an electric cord is when the covering is gone. Pinta let out a terrible yowl!

Frank came running when he heard Pinta. Frank's mother and father came running, too. His father quickly pulled the plug out of the electrical outlet. When the electricity was disconnected they could pick Pinta up. They knew how badly Pinta must have burned her tongue. They called the veterinarian to tell him what had happened. "Pinta has burned her tongue," Frank told the veterinarian. "How will she eat now? She needs her tongue to lap up her milk."

"You will have to try to feed her with a medicine dropper," the veterinarian said.

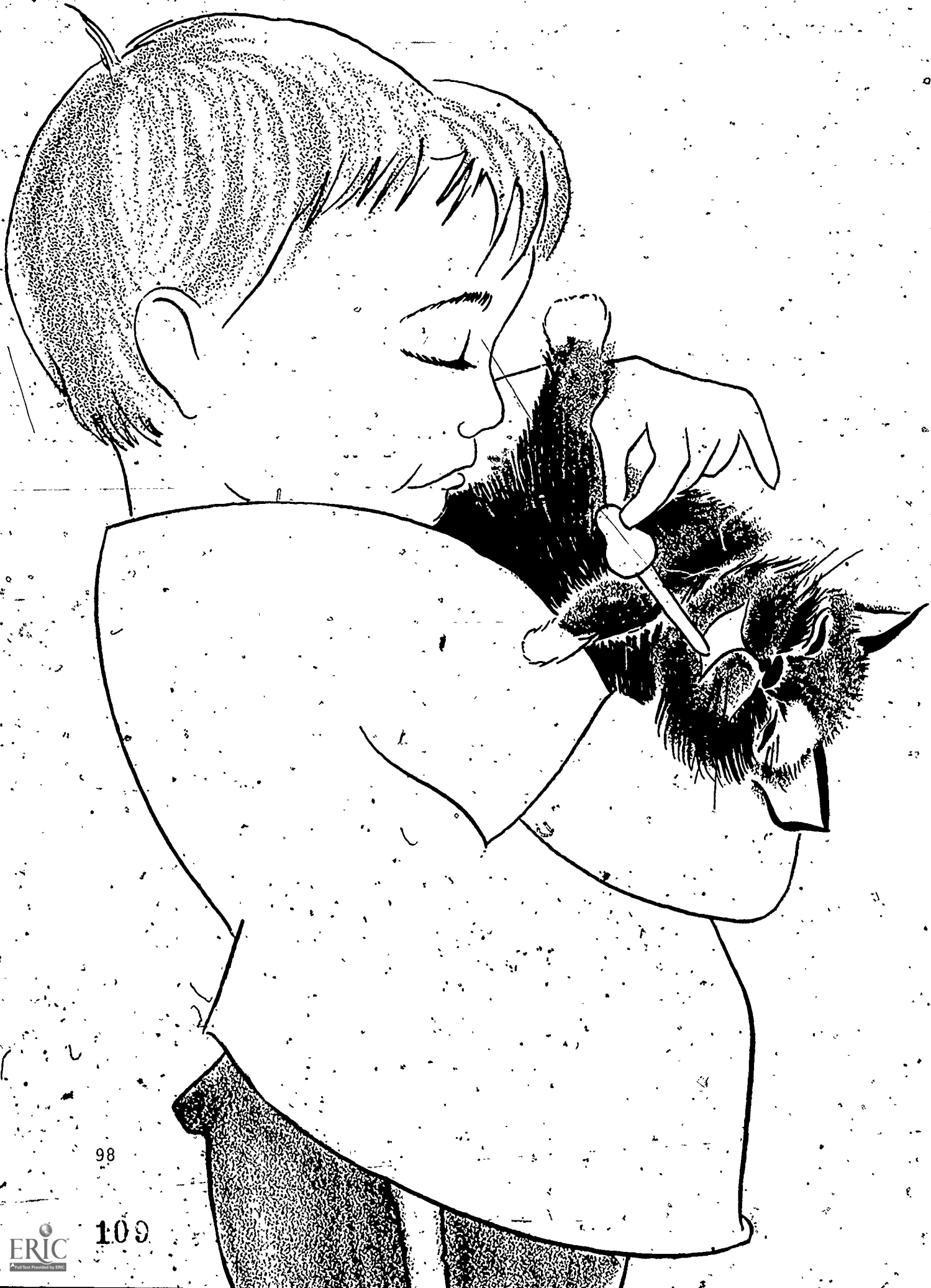

So that is what Frank did. He and the medicine dropper were very important parts of Pinta's eating system for the next week.

Pinta did not like being held on her back and fed with the dropper. Poor Pinta! Even though she did not have to move her burnt tongue to lap the milk, it still hurt her to swallow. For a few days, eating was very difficult.

Pinta had another difficulty too. She could not use her tongue to wash herself, and she began to look very shabby. She could not keep her coat glossy and clean without her tongue. She was not at all a happy kitten after her accident.

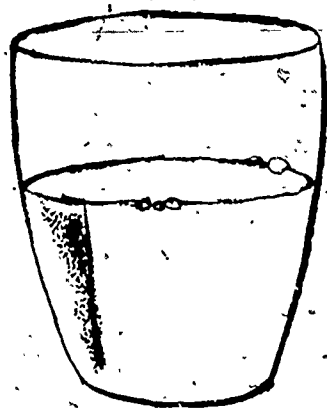

But one day when Frank was feeding her, she pushed away the medicine dropper and struggled out of his arms. She walked over to the glass of milk from which Frank had been filling the dropper. She poked her small black nose into the glass. Carefully and slowly, her pink tongue came out, reaching down toward the milk. Lap. The tongue disappeared into her mouth. Lap-lap. Then Pinta was lapping the milk as fast as she could. Her tongue was well; she could use her own system for eating again! She was so hungry that she ate for a long time without stopping.

Pinta keeps away from electric wires now. She knows how dangerous they can be, and so does Frank. And Frank knows how important a tongue is for a cat.

In the course of the discussion following the story, raise these questions:

PINTA'S TONGUE WAS PART OF HER EATING SYSTEM. WHAT WERE SOME OTHER PARTS OF THAT SYSTEM? (Lips, teeth. Some child may correctly say that Frank and the medicine dropper were part of the system after her injury. The children might also note that the parts of her body that she used to play "catch the mouse" were also components of her eating system.)

WHAT ELSE DID PINTA USE HER TONGUE FOR, BESIDES EATING? (For washing herself.)

WHAT WOULD HAPPEN TO A SQUIRREL IF HE LOST THE USE OF HIS TEETH? EXPLAIN WHY. (He would die, because the teeth play an indispensable role in his eating. He must be able to crack nuts, gnaw through twigs, etc.)

Lesson 16: INVESTIGATING EATING SYSTEMS OF OTHER ANIMALS

In the first part of this lesson, skulls of several animals will be studied. A set of skulls may be borrowed from your local museum. You will want skulls of an animal that eats only plants (e.g., cow, deer); of one that eats chiefly flesh (e.g., bobcat, fox, dog); and of one that has large gnawing teeth (e.g., beaver, squirrel). In case it proves impossible to obtain the skulls, we provide some photographs. But work with the photographs cannot compare with the actual experience of seeing and feeling the real teeth, so every effort should be made to get the skulls for this lesson.

After the children have studied the differences in skull and teeth structures, they are shown the film, Animals -- Ways They Eat. In this the children can actually see an animal's system at work as far as is possible in a film.

In the last activity in this lesson, the children summarize their experiences with eating systems by studying drawings of several animals and coloring those parts of the bodies that they consider to be components of the animals' eating systems.

MATERIALS

-- for the class --

- skulls as described above, or photos of skulls
- a chisel
- a piece of soft wood, such as pine
- Animals -- Ways They Eat, Encyclopedia Britannica Films. 16 mm, sound, 11 min.

-- for each child --

- mirror
- photographs of skulls (in Student Manual)
- drawings of animals (in Student Manual)

Activity A

SUPPOSE YOU HAD TO BITE THE BARK OFF A TREE OR CHEW THROUGH A LOG. WHAT KIND OF FRONT TEETH WOULD YOU NEED? (Large, strong, sharp teeth.)

WHICH ANIMAL BITES BARK OFF TREES AND OFTEN CHEWS THROUGH THICK BRANCHES? (The beaver.)

DOES THE BEAVER HAVE FRONT TEETH THAT ARE LARGE, STRONG AND SHARP? (Yes.)

In the discussion following this question, lead children to distinguish between something they themselves have actually seen and what they have only read about, heard about, or inferred. Most children will answer "Yes" to the question. Your response to this should be such questions as "How do you know? How close were you to the beaver when you saw his teeth? Suppose someone wanted to see and feel the teeth of a beaver. How could he do it without danger of being bitten?" Explain that when a beaver dies, the teeth remain in its skull. If you could get the skull of a beaver you could have a good look at its teeth without the danger of being bitten. Then present the skull to the class. If you must depend on the photograph, have the children study it on page 25 of their Student Manuals while you display the one supplied to you.



Skull of a Beaver

HERE IS A BEAVER SKULL. WE CAN HAVE A GOOD LOOK AT ITS TEETH.

Take the skull around to the children. Permit them not only to see the teeth at close range, but to feel the sharp edges of the biting teeth. If you are working with photographs, encourage the children to imagine how the teeth would feel.

HOW MANY LARGE BITING TEETH DOES THE ANIMAL HAVE?
(Four.)

WHAT PROPERTIES DO THESE TEETH HAVE? (They are larger than the other teeth. They are curved. They have sharp edges. They are thickest near the bone and are thinner toward the biting edge.)

If possible, show a chisel for comparison and demonstrate what a chisel does to wood.

WHAT OTHER KINDS OF TEETH DOES THE ANIMAL HAVE?
(Do not try for specific answers. The purpose of this question is to encourage the children to observe differences among the teeth.)

HOW MANY BACK TEETH DOES IT HAVE? (It is difficult to tell from the photograph how many of these teeth the beaver has. There are sixteen—eight uppers, four on each side; and eight lowers, four on each side.)

ARE THESE TEETH SYMMETRICALLY ARRANGED? (Yes. If you are using a skull, have a child do the mirror test if possible.)

WHAT ARE SOME OF THE PROPERTIES OF THESE TEETH?
(The teeth are very hard. Their sides are smooth but their grinding surfaces are rough.)

Let the children run their fingers across the grinding surfaces and discuss how the hard edges are related to the job these teeth do.

LET US COMPARE THE ANIMAL'S TEETH WITH HUMAN TEETH.

Have the children use mirrors to examine their own teeth for comparison with the skull or with photographs. Ask about resemblances and differences.

Next show the skull or photographs of a meat-eating animal (bobcat, fox, dog), but do not identify the animal immediately. (These appear on pages 26-27 of the Student Manual.)



Skull of a Bobcat



Skull of a Bobcat

LET'S LOOK AT THE TEETH OF A DIFFERENT ANIMAL. Hold up the skull if you have one, and add, I AM GOING TO BRING IT AROUND. YOU CAN NOT ONLY OBSERVE ITS TEETH, BUT YOU CAN PUT YOUR FINGER INTO ITS MOUTH AND FEEL THE TEETH.

WHICH ARE THE LARGEST TEETH? Have the children point to the teeth.

HOW MANY OF THESE LONG TEETH DO YOU SEE? (Usually four.)

WHAT DO YOU THINK THESE TEETH DO?

Here is an opportunity for the children to speculate and infer. If they say, "The teeth are for biting," ask, "If the teeth are for biting off a piece of food, shouldn't they be shaped like the biting teeth of a beaver or like our own biting teeth? Are they?" Have the children look and see that these teeth are not like our biting teeth. "Then what can they be for?" If no one answers, your next hint will elicit the answer.

I AM PLACING MY FINGERS BEHIND THESE LONG CURVED TEETH. (If you are using photos, substitute: IMAGINE PLACING YOUR FINGERS BEHIND THESE FOUR LARGE TEETH.)

IMAGINE MY FINGERS TO BE A LIVE MOUSE OR A LIVE BIRD JUST CAUGHT BY THIS ANIMAL. WHAT JOB DO YOU SEE THE BIG TEETH DOING? (They prevent the mouse or bird from escaping.)

THIS IS A SKULL OF A (name the animal). HOW DO YOU SUPPOSE THIS MEAT-EATER GETS ITS FOOD? (It probably catches animals.)

LOOK AT THESE TWO LARGE TEETH AGAIN. WHAT PROPERTIES HELP THEM HANG ON TO THE ANIMALS THE MEAT-EATER CATCHES? (They are long and curved to hold in a small animal. They are pointed and can stick into an animal that is larger than the mouth. They are big and strong so that even a strong animal cannot escape.)

LET'S LOOK AT THEM AGAIN AND FEEL THEM. WHAT PROPERTIES DO THE BACK TEETH HAVE? (The teeth are hard and pointed. They are white. They are shiny.)

WHY DO YOU SUPPOSE THESE BACK TEETH ARE DIFFERENT IN SHAPE FROM THE BACK TEETH OF A GNAWING ANIMAL OR FROM OUR BACK TEETH? (They have a different job to do.)

WHAT DO YOU THINK THEIR JOB IS? (Their job is to tear raw meat.)

HOW DO THE FRONT TEETH OF A MEAT-EATER RESEMBLE HUMAN TEETH?

Have the children make a direct comparison, using skulls, photographs and mirrors to note that in each the front teeth are chisel-shaped.

WHAT DO YOU THINK THE JOB OF THE FRONT TEETH IS?

(To bite off pieces of food.)

WHAT ARE THE DIFFERENT WAYS WE HAVE SEEN THAT TEETH ARE USED? (Gnawing, grinding, cutting, tearing.)

LOOKING AT THE KINDS OF TEETH THIS ANIMAL HAS, WHAT DO YOU THINK IT DOES TO ITS FOOD? (It tears and cuts it.)

Now display the skull or photographs of the plant-eating animal. (These appear on pages 28-29 of the Student Manual.)

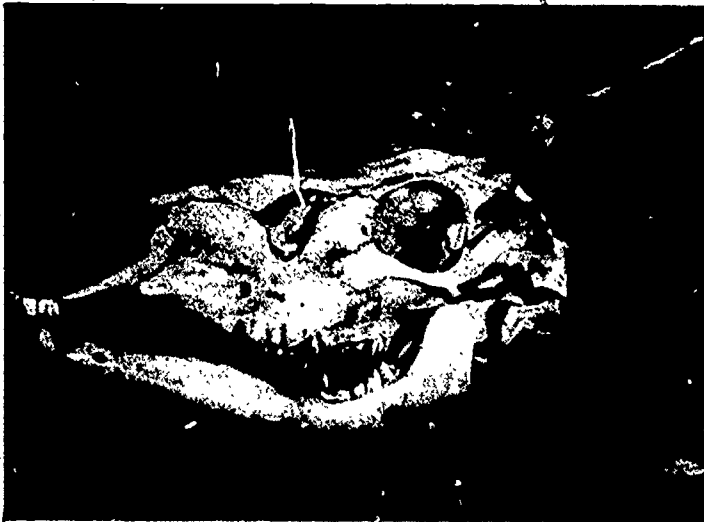

Skull of a White-tailed Deer

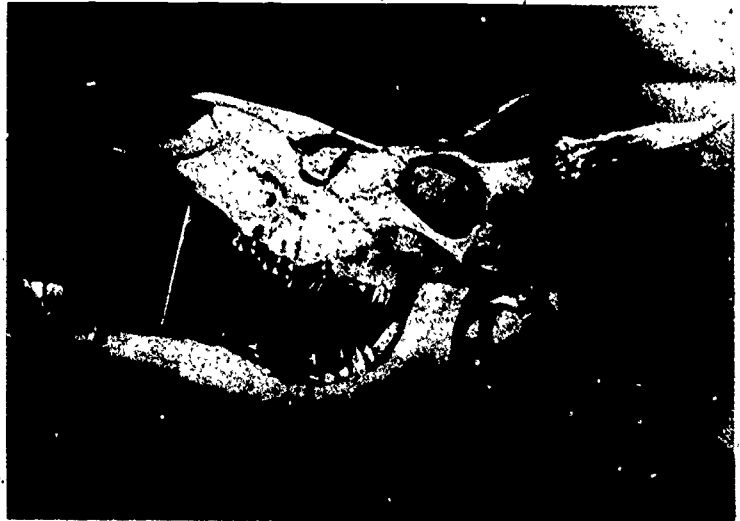

Skull of a White-tailed Deer

LET US LOOK AT THE TEETH OF STILL ANOTHER ANIMAL. THIS IS A SKULL OF A (cow, deer, moose). WHERE ARE MOST OF ITS TEETH—IN THE FRONT OF ITS MOUTH OR IN THE BACK? (In the back.)

ARE THE BACK TEETH SHAPED LIKE CUTTING TEETH OR LIKE TEETH THAT GRIND AND CRUSH FOOD? (Like grinding teeth.)

HOW MANY BITING TEETH DOES THE PLANT-EATER HAVE IN THE UPPER PART OF ITS MOUTH? (None.)

IN WHAT DIRECTION DO THE LOWER BITING TEETH POINT?
(They point forward.)

SINCE THE PLANT-EATER DOESN'T HAVE ANY UPPER BITING
TEETH, HOW DO YOU SUPPOSE IT BITES AND TEARS ITS
FOOD?

Encourage speculation, especially on the use of the tongue
in conjunction with front lower teeth. Point out to the chil-
dren that these are only speculations and that to find out the
answers they should actually observe the animals as they
eat. This is possible with a film.

Activity B

Animals — Ways They Eat shows the many ways that animals
of different kinds are adapted to get and eat their foods.
Many kinds of animals, living in different habitats and eat-
ing various kinds of foods, are shown. A number of close-up
scenes show the various body parts that are used by animals
to get and to eat their food.

After the children have seen the film, have them describe the
eating system of some of the animals.

Activity C

Worksheets 11-14 show pictures of a number of animals.
The children are to color only those parts of each animal that
are components of its eating system. Have the class work
together on the first animal, the elephant. Ask which parts
are involved and have the class color each as it is men-
tioned. Have the children continue with the other pictures
independently, and then review and compare the worksheets
after completion. If a child has colored an unusual part,
have him explain why he considers it to be part of the ani-
mal's eating system.

There may be some disagreement with respect to some part
a child may say is part of the system. If he can establish
some relation with eating, however remote, he is to be con-
sidered correct.

Worksheet 11
Unit 15

Name _____

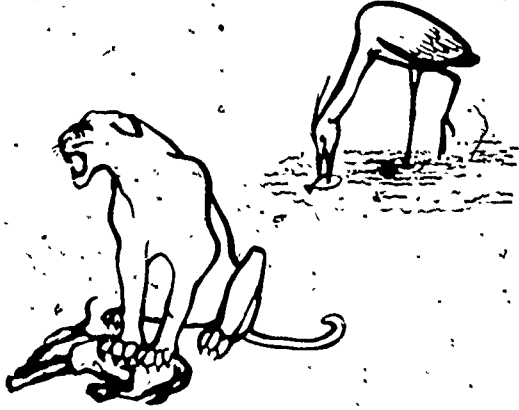
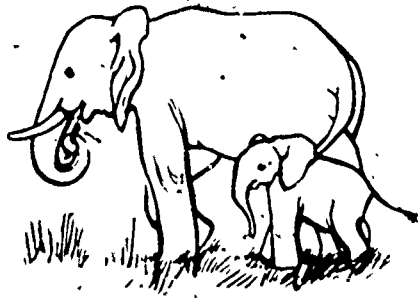

Worksheet 12
Unit 15

Name _____



Worksheet 13
Unit 15

Name _____

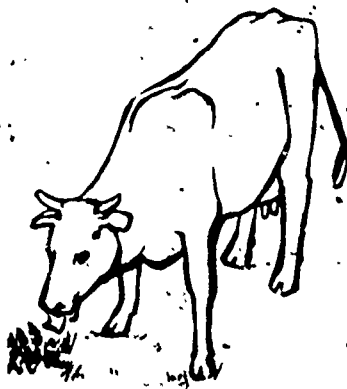

Worksheet 14
Unit 15

Name _____



SECTION 6 A BULB-LIGHTING SYSTEM (Lesson 17)

PURPOSE

- To start with a set of objects and to use them in devising a system.
- To determine the conditions necessary to a bulb-lighting system.
- To develop an experimental method for classifying objects according to whether or not they can serve as connectors in a bulb-lighting system.

COMMENTARY

In most of the previous sections of this unit the children were presented with phenomena which they investigated to determine what the essential components of the systems were. In this section they are given an assortment of objects from which they are to choose a subset that can serve as the components of a system that they themselves devise. (The lesson is built around a bulb-lighting system, but the children are likely to devise other interesting systems as well.)

This section can help you evaluate the children's grasp of the basic ideas of the whole unit. Do the children describe their systems in terms of the interrelation of the parts and in terms of an analysis of the phenomena? In classifying their objects, do they specifically test each one to see if it will work as a connector in the bulb-lighting system?

In any circuit for lighting the bulb, the basic requirement is that there be some continuous metal connection between one end of the flashlight cell and the metal tip of the bulb, and between the other end of the cell and the threaded portion of the bulb. Of course, you will not point this out to the children. Let them discover as much as they can for themselves.

Three Simple Systems

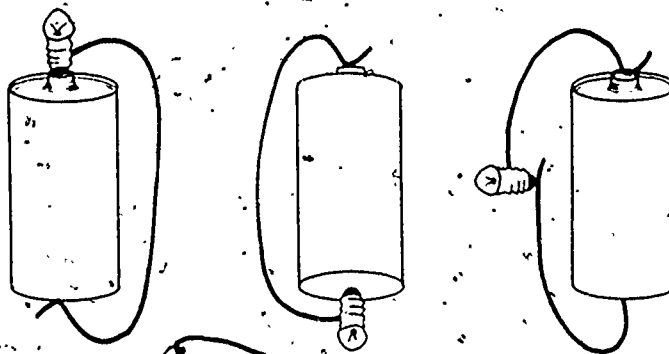

A Complex System

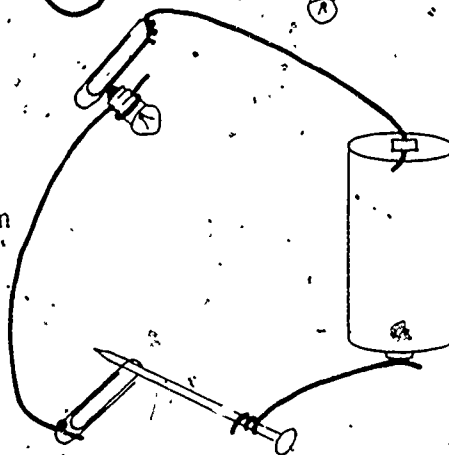

If a few children discover that the clothesline will close the circuit successfully, make sure that they realize that there is a wire through the center, and that the wire has to make contact at both ends in order to close the circuit. Let them demonstrate this to the class.

Limit the discussion during this lesson to the systems and to what objects will or will not work in them. Do not get involved in any attempt to explain why or how the systems work. Even the most elementary explanation of electrical effects is too involved for early grades.

MATERIALS

-- for each group of four children --

a tray or box containing four of each of the following items: . .

- flashlight cell -- 1.5 volt
- flashlight bulb -- 2.25 volt (all four in a soufflé cup)
- rubber band
- #20 spikes.

- masking tape, 6 in. strips placed on waxed paper

- string

short lengths (approximately 6 in.) of the following

- fine, bare copper wire

- soda straw

- fine plastic tubing

- insulated wire with insulation removed from 1/2 in. at each end

- plastic clothesline (wire-centered)

- paper strip, 1/2 in. wide

- magnetic tape

- ribbon

PROCEDURE

Activity A

Provide each group of four children with a tray or box of the materials listed above. Tell the children that each one is to choose a subset of three objects from the set of objects in his group's box. He is not to choose more than one of each kind of object for his subset; each subset should be made up of three different objects.

Have the children experiment with the objects they have chosen to see if they can discover a way to make something interesting happen. Allow adequate time for all to experiment. If children have problems in handling the various pieces of equipment, let two work together or suggest that some masking tape may be useful in making firm connections.

Ask the children to show some of the things they have discovered. One may have made a pendulum, another may have produced a sound by plucking a rubber band, etc. You should have allowed the experimentation period to continue until several children have devised systems in which a bulb is lit.

If no one in your class has found a way to light the bulb, direct them toward this problem as follows:

WHICH OBJECTS DO YOU THINK ARE NECESSARY FOR LIGHTING THE BULB? (Bulb, dry cell, wire.)

Children who did not select these three objects to work with should feel free to exchange those they did choose. If a child is having difficulty with the three objects, give a little more direction:

IF YOU TOUCH THE BULB TO ONE END OF THE CELL, HOW CAN YOU ALSO CONNECT IT TO THE OTHER END?

When all the children have devised a system in which their bulbs are lit, pose a new problem and give them time to work on it.

CAN YOU TAKE THE OBJECTS THAT ARE PART OF YOUR BULB-LIGHTING SYSTEM, ARRANGE THEM IN A DIFFERENT WAY, AND STILL GET THE BULB TO LIGHT?

Activity B

Have each group classify all the objects in the box into two subsets according to whether or not they can be used as part of a bulb-lighting system. The children should plan their own experimental methods for determining how to classify the objects. It is to be hoped that they will test each object in an orderly way. If a child notes that his classification can also be defined in terms of metal and non-metal, compliment him but do not attempt to guide the class to this interpretation.

Activity C

As another activity for small groups, have the children attempt to develop more complex arrangements of objects as bulb-lighting systems. (Some children may want to do this during their free time.) Such systems can be shown to the class, or if taped together, left on display. (Be sure that the systems on display are disconnected when not in use, to prevent the energy of the cells from being used up.)

Some child may discover that it is possible to design a system in which more than one bulb is lit. If several cells are included in one circuit it is possible that a bulb will be burned out, but otherwise there is no danger in any system which can be devised from the materials supplied.