

DOCUMENT RESUME

ED 124 718

CE 007 325

AUTHOR Arata, Barbara.  
 TITLE Exploring Fashion Design.  
 INSTITUTION Rutgers, The State Univ., New Brunswick, N.J.  
 CURRICULUM Lab.  
 SPONS AGENCY New Jersey State Dept. of Education, Trenton; Div. of Vocational Education.  
 REPORT NO VT-102-817  
 PUB DATE Mar 76  
 NOTE 103p.  
 AVAILABLE FROM Vocational-Technical Curriculum Laboratory, Rutgers--The State University, Building 4103--Kilmer Campus, New Brunswick, New Jersey 08903 (Catalog Number NT-196, \$2.50)

EDRS PRICE MF-\$0.83 HC-\$6.01 Plus Postage.  
 DESCRIPTORS Career Education; \*Career Exploration; \*Clothing Design; \*Clothing Instruction; \*Curriculum Guides; Grade 9; Grade 10; Home Economics Education; Manuals; \*Needle Trades; Seamstresses; Secondary Education; Sewing Machine Operators  
 IDENTIFIERS Apparel Industry.

ABSTRACT The purpose of the curriculum guide is to introduce the exploratory student to the fundamental skills and knowledge necessary for employment in the garment industry, from factory to design room. It was developed for a six or seven-week exploratory program for ninth or tenth grade students. The manual provides an introduction to the different areas that comprise fashion design. The units of the guide are: (1) introduction to textiles, (2) preparation of fabrics, (3) cutting and pressing, (4) the power sewing machine, (5) the single-needle lockstitch machine, (6) machine operation, (7) things to make, (8) measurements, (9) using a commercial pattern, (10) designing, and (11) sketching. Each lesson format includes a student objective, detailed information, and assignments. Pictures and diagrams illustrate the lessons. Included in the guide is a list of job opportunities in the garment industry with brief descriptions. (Author/NJ)

\*\*\*\*\*  
 \* Documents acquired by ERIC include many informal unpublished \*  
 \* materials not available from other sources. ERIC makes every effort \*  
 \* to obtain the best copy available. Nevertheless, items of marginal \*  
 \* reproducibility are often encountered and this affects the quality \*  
 \* of the microfiche and hardcopy reproductions ERIC makes available \*  
 \* via the ERIC Document Reproduction Service (EDRS). EDRS is not \*  
 \* responsible for the quality of the original document. Reproductions \*  
 \* supplied by EDRS are the best that can be made from the original. \*  
 \*\*\*\*\*

ED 124718

State of New Jersey  
Department of Education  
Division of Vocational Education

# EXPLORING FASHION DESIGN

Barbara Arata, Instructor

Neal B. Perkins, Superintendent  
Bergen County Vocational Technical Schools  
Hackensack, New Jersey

Vocational Technical  
Curriculum Laboratory  
Rutgers - The State University  
Building 4103 - Kilmer Campus  
New Brunswick, New Jersey

U.S. DEPARTMENT OF HEALTH,  
EDUCATION & WELFARE  
NATIONAL INSTITUTE OF  
EDUCATION

THIS DOCUMENT HAS BEEN REPRODUCED EXACTLY AS RECEIVED FROM THE PERSON OR ORGANIZATION ORIGINATING IT. POINTS OF VIEW OR OPINIONS STATED DO NOT NECESSARILY REPRESENT OFFICIAL NATIONAL INSTITUTE OF EDUCATION POSITION OR POLICY.

March 1976

ED 003 336

NEW JERSEY DEPARTMENT OF EDUCATION

FRED G. BURKE, COMMISSIONER

RALPH H. LATAILLE, DEPUTY COMMISSIONER

DIVISION OF VOCATIONAL EDUCATION

STEPHEN POLIACIK, ASSISTANT COMMISSIONER

BENJAMIN SHAPIRO, PROJECT DIRECTOR

CURRICULUM LABORATORY

RUTGERS THE STATE UNIVERSITY

BUILDING 4103 KILMER CAMPUS

NEW BRUNSWICK, NEW JERSEY

## TABLE OF CONTENTS

	Page
Introduction	1
Future Job Opportunities	iii
<b>UNIT I - INTRODUCTION TO TEXTILES</b>	
Lesson 1 - Kinds of Fibers	1
2 - Properties and Characteristics of Fibers	3
3 - Fibers and Their End Uses	5
4 - From Fiber to Fabric	8
5 - From Fabric to Finish	14
<b>UNIT II - PREPARATION OF FABRICS</b>	
Lesson 1 - Looking at Grain	16
2 - Straightening the Fabric	18
3 - Preparing Cotton Before Cutting	21
<b>UNIT III - CUTTING AND PRESSING</b>	
Lesson 1 - Tips for Cutting and Pressing	22
<b>UNIT IV - THE POWER SEWING MACHINE</b>	
Lesson 1 - General Information	23
2 - Rules of Safety	25
3 - Safety - Tools	26
4 - General Care of the Machine	27
<b>UNIT V - THE SINGLE-NEEDLE LOCKSTITCH MACHINE</b>	
Lesson 1 - The Lockstitch Machine	30
2 - The Singer 120U	31
3 - The Singer 331K	34
4 - The Bobbin	36
<b>UNIT VI - MACHINE OPERATIONS</b>	
Lesson 1 - Basic Machine Skills	38
2 - Sewing on Paper	39

Page

**UNIT VII - THINGS TO MAKE**

Lesson 1 - Making a Placemat	41
2 - Making an Apron	45

**UNIT VIII - MEASUREMENTS**

Lesson 1 - Introduction to Measuring	49
2 - Fractions of an Inch (Quarters)	51
3 - Fractions of an Inch (Eighths)	53
4 - From Inches to Centimeters	56

**UNIT IX - USING A COMMERCIAL PATTERN**

Lesson 1 - Body Measurements	58
2 - Figure Types	60
3 - The Pattern Size	63
4 - The Pattern Envelope	64
5 - The Cutting Layout Guide	69
6 - The Pattern Pieces	71
7 - Marking	75

**UNIT X - DESIGNING**

Lesson 1 - Thinking Design	78
----------------------------	----

**UNIT XI - SKETCHING**

Lesson 1 - The Croquis - Front View	80
2 - The Croquis - Back View	82

## INTRODUCTION

The purpose of this book is to introduce the exploratory student to the fundamental skills and knowledge necessary for working in the garment industry, from factory to design room. It was developed for a six or seven-week exploratory program for ninth or tenth grade students.

In teaching this course, it is important to give the student as much insight as possible into the world of fashion. Fashion design is the total of many areas and this manual is an introduction to the different areas. To emphasize this, the units are all in different colors. The different colors also emphasize the fact that this book is not designed for the usual sequential method of teaching.

This book gives the teacher the freedom of starting in any area and interrelating as many areas as are needed. Teaching in this manner will maintain the student's interest better. This constant flow from one area into another area points out to the student that, "you can't learn one without the other."

While using this book, the teacher can present to the student a more realistic view of what studying fashion design will be like. Fashion design is not just drawing pretty pictures, not just sewing, etc. This way the student will discover that you cannot study only those areas you like, but you must study all the areas for job success after graduation.

Study the chart of job opportunities that could be open to students who have finished the entire course of fashion design. As you teach these units, direct the student to the types of jobs that would be available with the skills and knowledge learned by these units. In the garment industry today, "skill" is the key word. The designer with a broader range of skill and knowledge has more doors open. The objective is to prepare those people who not only have ideas, but are able to use their skills and knowledge to execute them in order to keep their jobs.

# THE TREE OF SUCCESS

ON THE JOB TRAINING  
GOOD WORK HABITS

SHOP MATH

BASIC  
EDUCATION

SEWING  
SKILLS

GOOD CITIZENSHIP  
RIGHT ATTITUDE

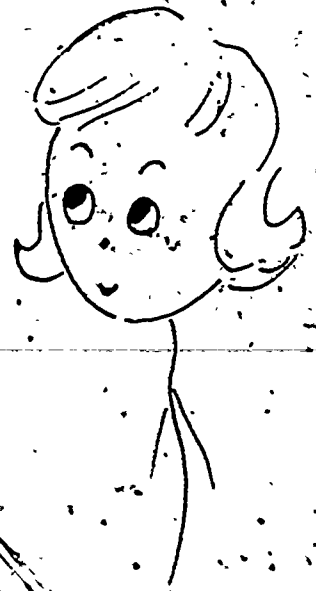



## FUTURE JOB OPPORTUNITIES

### Designing Room Occupations

- Assistant Designer:** Makes first pattern - usually from designer's sketch. Works closely with designer. Supervises samplehands.
- Design-Room Trainee:** General help in the design room. "Picking up Pins."
- Designer:** Designs new line of garments for every season. Sketches ideas, selects fabric and trimmings, and supervises all activities in the design room.
- Duplicate Cutter:** Cuts duplicates from original sample.
- Hand Cutter:** Cuts individual garments by hand.
- Patternmaker:** Develops master pattern from garment.
- Patternmaker Trainee:** Works with patternmaker to develop master pattern from garment.
- Samplehand/Samplemaker:** Sews first sample. Works with designer or assistant designer.
- Sketcher:** Sketches samples for production and showroom use.

### Sewing Room Occupations

- Draper:** Examines partially finished garment for fit and for sewing errors. Pins final details such as bows and flowers in place before garment is finished.
- Examiner/Inspector:** Examines or inspects finished garments for sewing errors.
- Folder:** Folds, pins, bags, tags, and boxes garments.
- Floor Girl or Boy:** Distributes and collects bundles of garment parts to and from workers in factory.
- Hand Sewer:** Hand sews all items such as hems, buttons, etc. Presses samples by hand.



**Sewing Machine Operator:** Sews on any standard or special sewing machine. May do one task repeatedly, or may do multiple job tasks.

**Retailing Occupations**

**Alteration Hand:** Alters ready-made garments to markings of fitter.

**Dressmaker:** Cuts and sews a complete garment for an individual customer.

**Fitter:** Pins and chalk marks adjustments on ready made garments to fit customers.

**Sales in Ladies Dept.:** Assists customers in choosing garments best suited for them.

**Sales in Fabric Dept.:** Assists customers in buying fabric and selecting types of fabric, yardage, trimmings, etc. Cuts fabric for customers.

UNIT I - INTRODUCTION TO TEXTILES

# UNIT I

## INTRODUCTION TO TEXTILES

### Kinds of Fibers

### Lesson 1

**Objective:** The student will be able to identify the two major groups of fibers.

**Information:** Fabric is cloth made of fibers. A fiber is a hair-like strand.

There are two major groups of fibers into which all fibers can be classified:

1. Natural Fibers come from animals or plants. Natural means coming from nature. The natural fibers are cotton, wool, silk and linen.
2. Man-Made Fibers are made from such things as coal, air, water, limestone, oil, natural gas, and salt.

The man-made group is divided into two classes:

- a. Cellulosic fibers — made from cellulose, the fibrous substance found in all forms of plant life. The cellulosic fibers are rayon, acetate and triacetate (arnel).
- b. Non-cellulosic fibers or synthetics — made entirely from chemical elements. The synthetics are listed in the Fiber Classification Chart on the next page. The most frequently used synthetics are polyester, nylon, acrylic and modacrylic.

### FIBER CLASSIFICATION CHART

	Fibers	Source
<b>NATURAL FIBERS</b>	Vegetable (plant) — Cotton	Cotton plant — cellulose
	Vegetable (plant) — Linen	Flax plant — cellulose
	Animal — Wool	Sheep — protein (keratin)
	Animal — Silk	Silkworm's cocoon — protein
	Mineral — Asbestos	Rocks — silicate of magnesium, calcium, and other minerals.
<b>MAN-MADE FIBERS (SYNTHETICS)</b>	<b>A. Natural Fiber (Cellulosic), Chemically Treated</b>	
	Rayon (Viscose or Cuprammonium)	Wood or cotton plant (cellulose)
	Acetate and Arnel	Wood or cotton plant (cellulose), acetyl
	<b>B. Fibers Made Purely From Chemical Elements (Non-Cellulosic)</b>	
	Nylon	Polyamide
Dacron	Polyester	
Orlon, Acrilan, Creslan	Acrylic	
Dynel	Modacrylic	
Saran	Vinylidene chloride	
Glass fibers (Fiberglas)	Glass	

Assignment:

1. The teacher will hand you small samples of fabrics, which are called swatches. In your notebooks or on separate sheets of paper, do the following:
  - a. At the top of one page write - NATURAL FIBERS, then on another page write - MAN-MADE FIBERS.
  - b. Look at the swatches and determine the fiber content of each fabric. Divide the swatches into the two major groups listed above.
  - c. Now break the major groups into classes.  
Natural fibers - determine which come from animal and which come from plant.  
Man-made fibers - determine which come from cellulose and which come from chemicals
  - d. The swatches are to be pasted on the pages according to group and class. Leave a column of empty space next to each swatch for writing information about the fabrics.

UNIT I  
INTRODUCTION TO TEXTILES

Properties and Characteristics of Fibers

Lesson 2

**Objective.** The student will be able to describe the properties and characteristics of different fibers.

**Information.** The properties and characteristics of fibers are those special qualities that affect the way fibers act under certain conditions; and make the fibers different from each other.

PHYSICAL PROPERTIES OF FIBERS

Fiber	Color	Texture	Luster	Length
COTTON	White, yellow-white to tan	Fluffy, soft	None	½" to 2½"
LINEN	Yellow-white to gray	Coarse, inelastic	Semi-bright	12" to 20"
WOOL	Yellow-white to black	Fuzzy, soft, springy	Dull	1" to 8"
SILK	White to tan	Smooth, soft, fine	Bright	1200' to 4000'
RAYON	White to yellow-white	Smooth, slick	Bright to dull	As desired
ACETATE	Light blue or white (can be solution dyed)	Smooth, slick	Bright to dull	As desired
NYLON	Translucent or ivory	Smooth, slick	Bright to dull	As desired
DACRON	White	Smooth, slick	Usually bright	As desired
ORLON	Ivory	Soft, fuzzy	Usually semidull	Usually ½" to 4"

Properties and Characteristics of Natural Fibers:

1. Cotton - withstands high temperatures well; absorbent; soft; comfortable. Little elasticity; shrinks.
2. Wool - wears well; resists creasing at low humidity; warmth without weight; naturally water repellent; pliable.
3. Silk - luxurious appearance; lustrous; drapes well; does not wrinkle easily; strong. Fiber is weakened when wet; perspiration will destroy silk.
4. Linen - crisp, cool, natural luster, durable; launders well; absorbent. Wrinkles easily.

## Properties and Characteristics of Man-Made Fibers:

1. Rayon - soft and pliable; takes dyes in vivid colors; does not pill (to pill means to form tiny balls on the fabric caused by rubbing). Does not wash well.
2. Acetate - high luster; drapable; soft; creases and pleats well. Does not wash well; cannot withstand high temperatures.
3. Triacetate - comfortable; high wrinkle resistance; colorfastness to washing and sunlight; dries quickly; pleats well. Arnel is its common name which is the licensed trademark for triacetate produced by the Celanese Corporation.
4. Polyester - strong; wrinkle resistant; colorfast to washing and sunlight; resistant to bagging, stretching and shrinking. It is one of the most popular fibers for blending.
5. Nylon - very strong; good stretch and recovery (as in hosiery); washes easily and dries quickly; lightweight, high-abrasion resistance. Blends well with other fibers.
6. Acrylic - wool-like (warmth without weight); resistance to shrinking and wrinkling; dries rapidly. Pilling may occur after garment is worn a while. Blends well with wool, rayon and cotton.
7. Modacrylic - bulky and crush resistant; resembles fur in appearance and warmth; flame resistant.

### Assignment:

Fill in more information regarding the swatches. Start with your first swatch by writing in the fabric name, which your teacher will help you do; then describe its properties and characteristics.

# UNIT I INTRODUCTION TO TEXTILES

## Fibers and Their End Uses

## Lesson 3

**Objective:** The student will be able to list some of the primary end uses of the different fibers.

**Information:** The properties and characteristics vary in each of the fibers. Some fibers will stand on their own while others will be blended together, in order to get the desired results for the end product.

No one fiber is capable of all the qualities that we require for every kind of job. Some fibers that are suitable for clothing cannot be used for home furnishing and so forth.

When we think of fibers, we think of fabric. When we think of fabric, we think of clothing. But clothing is only one area in the textile industry. Another area is home furnishings. Sheets, towels, pillowcases, curtains, carpets and upholstery are just a few of the products used in the home. And then we have industry - automobile manufacturers use huge quantities of fabrics and fibers for tires, upholstery and carpeting; conveyor belts that keep parts moving through factories are made of fabric.

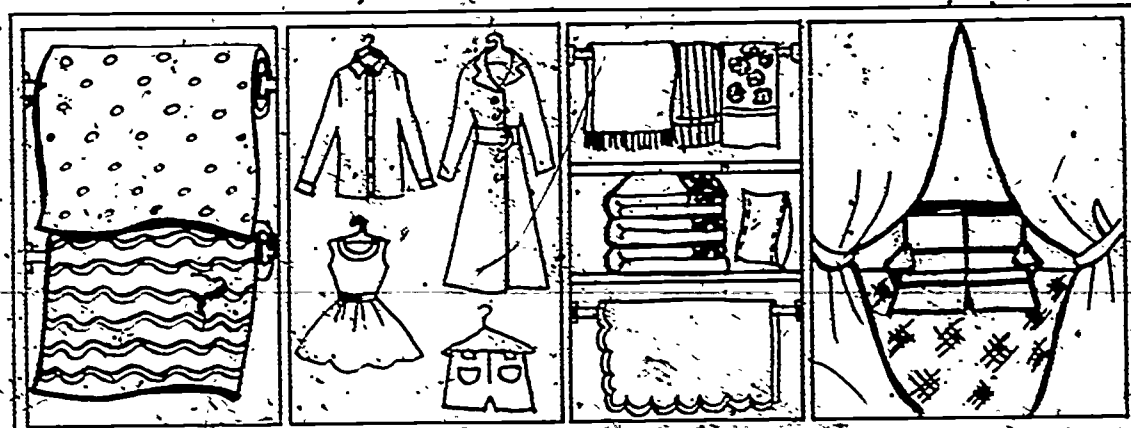

Yard Goods

Clothing

Linens

Home Furnishings

Textiles are used in thousands of products in many areas; clothing, industry, medicine and science are just a few of the areas where textiles are used.

### End Uses of Fibers

1. Cotton - Most widely used fiber throughout the world. The reasons are:
  - a. It can be grown easily and cheaply
  - b. It is cheap to produce
  - c. It has great versatility in the varieties of cloth it can be made into. It is used in clothing, upholstery, draperies, furniture, automobile tires, rugs, etc.



2. Wool - Most familiar fiber known to man. Its unique properties make it different from any other fiber. Everything about it is designed for protection from the elements. Its uses vary and include coats, suits, dresses, skirts, slacks, and sweaters.
3. Silk - Finest natural fiber known to man. It is the longest fiber known. When it is reeled from the silkworm's cocoon, it already is yarn; and therefore it needs very little done to it before it is woven into cloth. It is used for the more expensive men's and women's wearing apparel from evening to daytime to pajamas and accessories. Silk is also used for home furnishings.
4. Linen - One drawback is that its disadvantages could not be overcome; therefore it has never become a volume fabric making it costly to produce. It is the strongest natural fiber known to man and is used for summer wearing apparel such as dresses, suits, jackets and slacks. Good house linen is probably the best known use of linen.
5. Rayon - Two factors, versatility and economy, make it the most widely used man-made fiber in the United States. It was the first man-made fiber that could be made from a chemical treatment of cellulose. It is used in clothing (usually with other fibers), linen-like fabrics, blends with acetate for draperies and upholstery, and industrial use.
6. Acetate - Its three most pronounced characteristics, high luster, drapability, and body, are responsible for its extensive use in dressy fabrics. It is widely used in home furnishings for upholstery fabrics, draperies, curtains, shower curtains, and bedspreads. It is used in the more reasonably-priced clothing fields and is a favorite in lingerie.
7. Triacetate - Grew out of acetate. It is used for uniforms, sports clothes, dresses, and blouses. It is also used in fabrics for knits and lightweight blends for summer and travel wear. Triacetate and nylon blends are widely used in brushed sleepwear.
8. Polyester - Particularly popular as a polyester blend for summer dresses. Other popular uses of this fiber are clothing for the entire family including streetwear, sportswear, lingerie, curtains, draperies, bedspreads, bed sheets and carpeting. Industrial uses include sewing thread of polyester.
9. Nylon - Best known for its earliest and most common uses, hosiery and lingerie. It is used in skiwear, also widely used in home furnishings because of its durability. It is used as woven or knit clothing for the entire family. Industrial uses include nylon rope.

10. Acrylic - The fiber most like wool. It is important in the sweater market. Other uses include knit dresses, socks, slacks, pile fabrics, carpets, and blankets. One of its major end uses is winter coats.
11. Modacrylic - Resembles the acrylic fiber in characteristics and has many of the same end uses. It is frequently blended with another fiber to provide more flame resistance.

Assignment:

1. What are two important end uses for each of the different fibers?
2. Bring in 3 small samples of fabrics. Discuss what you think their end uses would be and why.

UNIT I  
INTRODUCTION TO TEXTILES

**Objective:** The student will be able to describe how fabric is made.

**Information:** There are several ways to make fabric from yarn:

- a. Weaving is the interlacing of two sets of yarns at right angles to each other.
- b. Knitting is a series of connecting loops made with needles.
- c. Other methods for non-woven fabrics use machines that apply combinations of heat, moisture and pressure, or heat, plastic and pressure.

Weaving is the most common way to make fabric from yarn. The machine for weaving is called a loom.

Raw fiber is first fluffed and cleaned; then it is formed into long, rope-like strands. The fiber goes through a series of machines that straighten and twist or spin the fibers into yarn. (Early man twisted and combed the fibers by hand to form yarn.)

Now we can begin weaving. First, there are the lengthwise yarns which are pulled tight and remain in a fixed position on the loom. This set of yarns does not move; they are called the *warp yarns*. The warp yarns are the strongest yarns. The crosswise yarns are the action threads that weave in and out of the warp yarns to form the fabric; they are called the *filling yarns* or the *woof*. The filling is not as strong as the warp. The filling yarn is carried by a shuttle, or by a tiny jet of water in the newer looms.

## LOOM

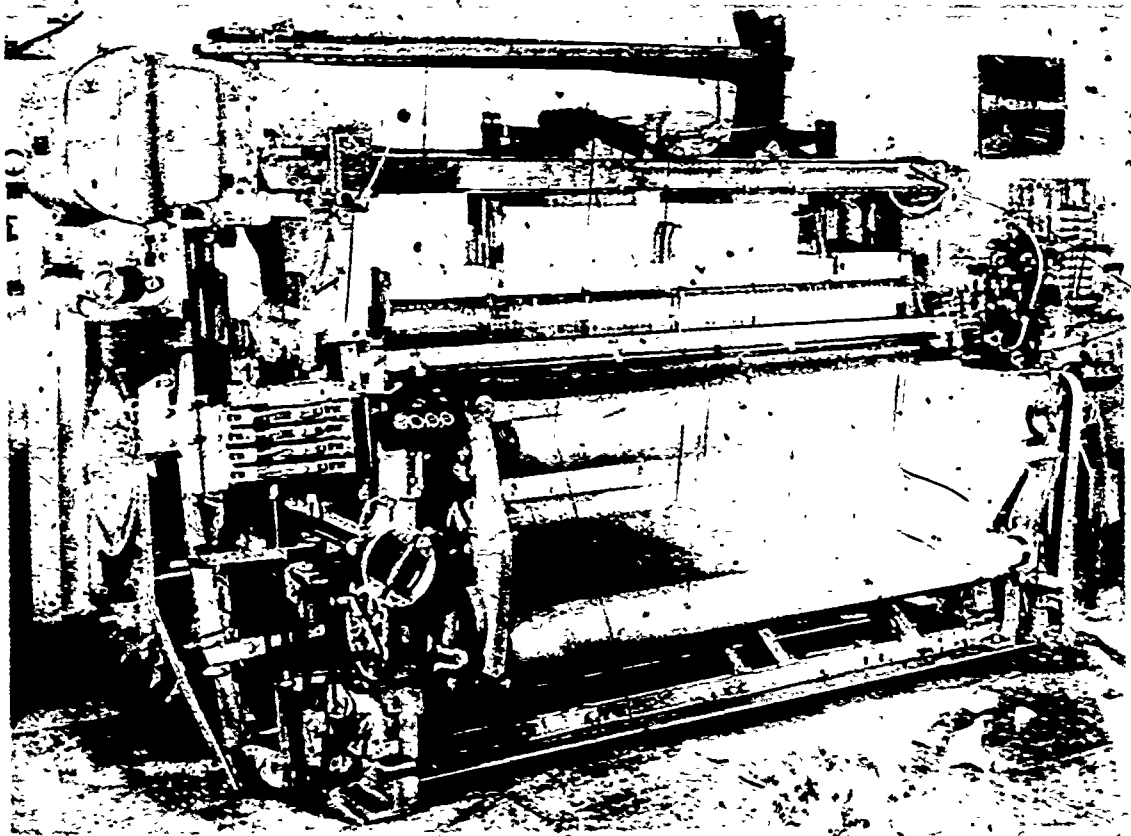

We know how weaving is done now, but what about centuries ago when man did not have modern technology. One of the earliest methods of weaving was done on a warp-weight loom. The warp yarns were suspended from a bar between two upright posts and weighted at the bottom in order to keep the warp yarns in a fixed position. They usually used another bar for the weight, and this is how the two-bar loom developed. Then they weaved the filling yarns in and out of the warp yarns by hand, which usually required two people. As our technology advanced, our looms advanced to where we are today with our shuttleless looms. In a shuttleless loom, the filling yarns are carried through the warp yarns by means of steel bands that are attached to wheels on each side of the loom.

There are three basic weaves:

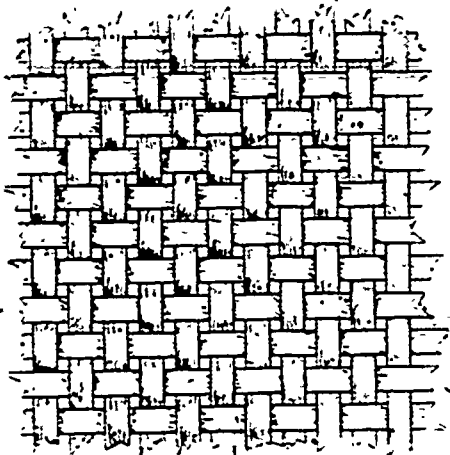

W  
A  
R  
P

Plain Weave — the simplest weave. Each filling yarn passes successively over and under each warp yarn.

F I L L I N G

Twill Weave — the strongest weave. The filling yarns go over and under two or more warp yarns at regular intervals; this produces a diagonal line in the cloth.

A diagonal line is a slanted line going from one corner to another corner as shown in illustration.

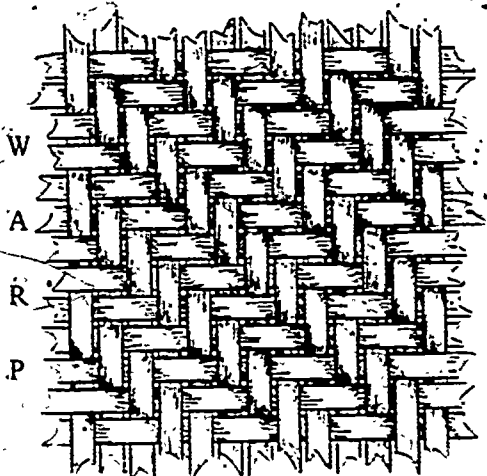

W  
A  
R  
P

F I L L I N G

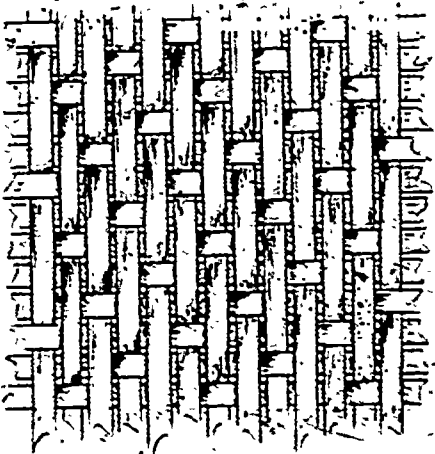

W  
A  
R  
P

Satin Weave — the irregular weave. Either the warp or the filling yarns pass over a number of yarns of the other set before interweaving. This produces a smooth, unbroken, lustrous surface.

Remember the satin weave as having few interlacings and long floats.

F I L L I N G



Knitting is another way to make fabric from yarn. The fibers are interlocked in a series of connecting loops so there is freedom of movement within the loops, which gives the fabric comfort stretch.

There are two basic groups of knits:

1. Warp Knits - Have stretch only in the width of the fabric. An example is tricot.
2. Weft Knits - Have stretch in both the width and the length of the fabric. Examples are single knits and double knits.
  - a. Single knits are made with one set of yarns, so the fabric is only one layer. They drape softly.
  - b. Double knits are made with two sets of yarns, so the fabric has two interlocked layers, which cannot be separated. They are firmer than single knits, but still flexible.

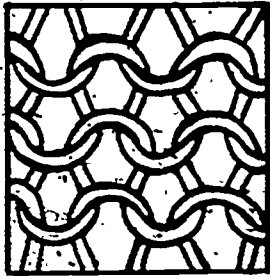

Single Knit



Double Knit



Tricot Knit

Knits will always be important in the world of fabrics. The reasons for their popularity are:

- a. elasticity (the ability to stretch and come back to its original shape.)
- b. comfort (it moves when you do.)
- c. soft look (great for body-hugging fits).



Knitting Machine



Now we come to our other methods of making fabric. Non-woven fabrics are produced directly from fibers. The methods are:

1. Felting — the matting together of fibers by heat, moisture, and pressure.
2. Bonding — the pressing of fibers into thin sheets or webs held together by adhesive or plastic.

**Assignment:**

1. Looking at the sample swatches you have, can you tell whether the fabric was made by weaving, knitting, or another method? After a class discussion, write in the method by which each fabric was made.
2. Your teacher will give you three swatches of fabrics. Using your pick glass and pick needle, try to decide which of the three basic weaves it was made by.

Your pick glass will magnify all the yarns for you so that you can see the weaving pattern. Your pick needle will help you separate the yarns.

3. Study the diagram of the plain weave and try to imitate what you see by using paper straws. Flatten out each straw, and lay about 20 straws side by side; these are your warp yarns. Now, fasten one end of each straw to a board using thumbtacks. To start weaving, interlace 20 more straws over and under the straws that are the warp yarns as in the diagram. If you would like to illustrate how plaids are woven, use different colored straws.

UNIT I  
INTRODUCTION TO TEXTILES

From Fabric to Finish

Lesson 5

**Objective:** The student will be able to list and define various finishes and special treatments done to fabrics.

**Information:** After the fabric has been woven, it is still unfinished. Now it must be bleached, dyed or printed before it is ready for use. It may also go through various finishing processes for one or more of the following reasons:

- a. improve its appearance and feel
- b. add a functional property not originally in the fiber or fabric, i.e., to make fabric water-repellent
- c. make it easy to care for
- d. make it wear better and longer.

Some of the minimum care finishes are:

1. Permanent Press – completely washable; requires no ironing.
2. Durable Press – completely washable; may need little ironing.
3. Base of Care – completely washable; does need little ironing.

Some of the special treatments are:

1. Waterproofing – water cannot pass through fabric.
2. Water-Repellent – causes fabric to shed water. Does not make fabric completely waterproof.
3. Stain-Resistant – most spills easily removed with water or cleaning fluid without leaving a ring.
4. Pre-Shrunk – helps keep fabric shrinkage to a minimum.
5. Flame-Retardant – prevents fabric from catching on fire.

Other special treatments that change the appearance and/or feel of fabrics are:

1. Brushing, napping, shearing, and sueding – gives fabric a fluffy nap or deep pile.
2. Embossing – gives fabric a design that is raised so that its surface is no longer smooth.

3. Moireing – gives fabric a wood-grained appearance.
4. Creping – gives fabric a textured surface.
5. Flocking – a design on the surface of the fabric. It is done by applying short, loose fibers onto the fabric with an adhesive.

In the area of fabric dyeing, generally, most fabrics are dyed *after* they are woven. The fabric is placed in large tubs or vats. Some fabrics are yarn dyed, which means that the yarn is dyed *before* weaving. This yarn-dyeing process is more expensive and is done when a plaid or geometric pattern is desired.

Some fabrics go through printing processes after they are dyed. One way of printing is called roller printing which is similar to printing on paper. Another way of printing is called screen printing in which a design on a stencil is placed on a thin cloth screen. The screen is laid over the cloth to be printed and color paste is added. The paste is forced through the holes in the screen which transfers the design to the cloth.

#### Assignment

1. By looking at and feeling your swatches, can you tell which of the fabrics have special finishes and treatments? If so, write which finish and/or treatment.
2. Have a class demonstration with the teacher's guidance on the process of screen printing.
3. Look at your swatches again. Can you tell which have been roller printed and which have been screen printed? Write in the correct process of printing next to the swatch.

UNIT II— PREPARATION OF FABRICS

## UNIT II PREPARATION OF FABRICS

### Looking at Grain

### Lesson 1

**Objective** The student will be able to look at a piece of fabric and point out the lengthwise grain, crosswise grain, and bias grain.

**Information.** Grain is the direction that threads run in fabric. It is important that we can tell one grain from another because all things are not always cut on the same grain. The fit, durability, and appearance of a garment depend largely on the grain on which it is cut.

The lengthwise grain runs in the same direction as the warp yarns, vertically (the long way). It runs parallel with the selvage. Generally, garments are cut on the lengthwise grain because it is the strongest grain. The garment will wear better and longer.

The crosswise grain runs in the same direction as the filling yarns (woof), horizontally (across the fabric). It runs from selvage to selvage. The crosswise grain is not as strong as the lengthwise grain. Garments are cut on this grain only when maximum strength is not needed, or for design purposes such as crosswise stripes.

The selvage is the finished edge of the fabric that is woven with stronger yarns. There is a selvage on both lengthwise edges of the fabric.

The lengthwise grain and the crosswise grain are both called the "straight of grain." So the arrow on a pattern will say "place on straight of grain." You must decide which grain is best for that particular design.

Bias is any diagonal on the fabric. The fabric will stretch somewhat when pulled on the bias.

True bias is the diagonal edge that is formed when the fabric is folded over so that the crosswise grain runs in the same direction as the lengthwise grain. Where bias has some stretch, true bias has the *maximum* stretch. For design purposes, some garments are cut on the true bias.

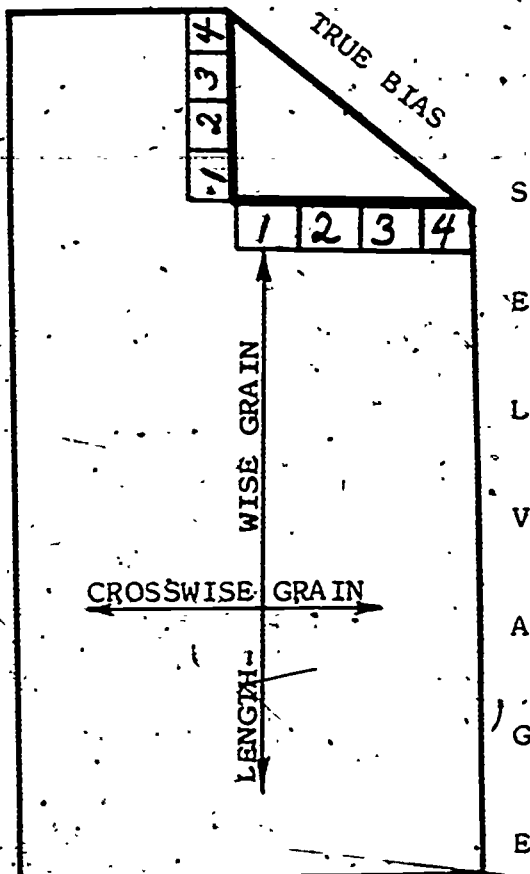

To check true bias, measure from the point out toward the edge of the fabric on either side of the point with a ruler, and see that your measurements are the same. If not, then you do not have true bias.

**Assignment:**

Soon you will be sewing your first project, an apron. But first, as you are learning, fabrics must be prepared before they can even be cut.

For your apron you need  $1\frac{1}{4}$  yards of fabric. It must be a woven fabric such as cotton or a cotton blend, 36" wide. *Do not* buy any plaids or prints that need to be matched. *Do* buy a solid color or a small print. (These choices are best for the beginner).

Your teacher will ask you to label the lengthwise grain, the crosswise grain, true bias, and the selvage. When you can do this, you are ready to go on.

UNIT II  
PREPARATION OF FABRICS

Straightening the Fabric

Lesson 2

**Objective:** The student will be able to make his/her fabric thread perfect.

**Information:** After the fabric has been woven, colored, printed, and put through any of the special processes we have already studied, it may not be straight anymore. Before you can cut fabric, the grain must be straight.

*When a single yarn or thread runs across the cut or torn edge from selvage to selvage you know that the fabric is thread perfect.*

There are three methods for making fabric thread perfect:

1. **Tearing** - Find the crosswise grain. Make a small cut with a pair of scissors through the selvage. Now tear the fabric; it will tear on the grain line. If the fabric does not tear easily, stop. If it does tear easily, go all the way across the fabric.

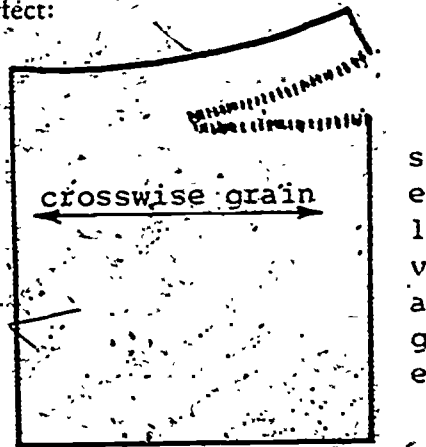

2. **Drawing a thread** - If the fabric will not tear, then try this method. Pick up a single yarn or thread on the crosswise grain (using a pin). Pull this thread all the way across the fabric. It will make a line, this is the grainline. Cut on this line.

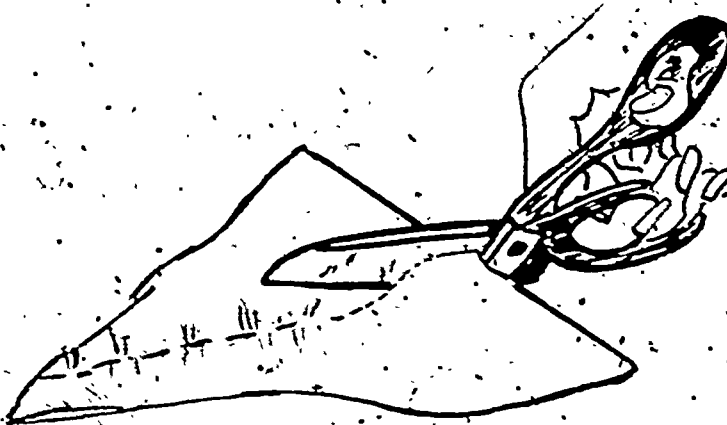



3. Cutting along a thread — If the fabric has a definite thread or rib, or a woven pattern like a plaid, cut along that line from selvage to selvage; it is the grainline.

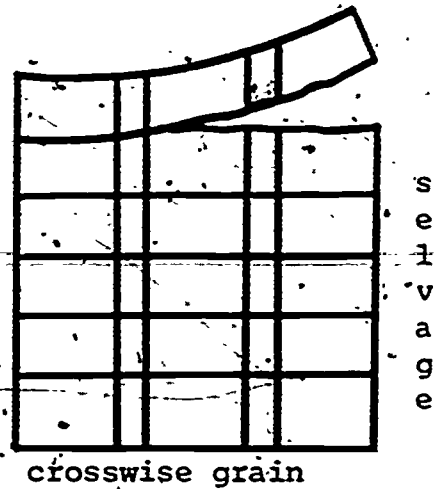

Use the best method for the type of fabric you have. Make fabric thread perfect on both crosswise ends. This is necessary for checking fabric grain.

In order to make sure your grain is straight (now that your fabric is thread perfect), fold the fabric in half lengthwise. Pin edges together and selvages together. Place the fabric at the edge of a table at the corner, or use the L-square. If it lies smooth and even with the table edges or L-square, the grain is straight. This is called *squaring fabric*.

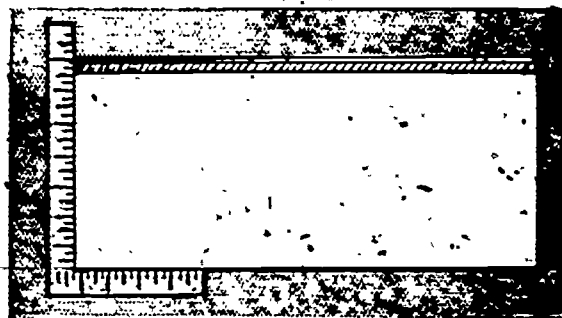

Some fabrics are permanently locked off-grain. The reason for this can be due to any of the finishes or special treatments given to the fabrics. These fabrics are not a good choice for beginners. The grain cannot be made thread perfect.

If the grain does not lie smooth and does not square up, try straightening it by stretching. Unpin and unfold the fabric. Take one end in one hand, the other end in the other hand. Pull gently but firmly. This will help straighten the crosswise grain. Pressing with a steam iron will also help straighten grain (except woolsens). In pressing, *never press on folds*. Pressing on folds will give you a crease that may not come out.

Assignment:

Take your apron fabric and make your fabric thread perfect, using one of the three methods. Then check your fabric grain, using the method above. If your fabric does not square up properly, your teacher will guide you as to what you should do.

## UNIT II PREPARATION OF FABRICS

### Preparing Cotton Before Cutting

### Lesson 3

**Objective.** The student will be able to shrink and straighten cotton fabric for cutting.

**Information.** The beginner should start off with a woven fabric that is easier to handle such as cotton or one of the cotton blends.

Most of the cotton blends will not need shrinking. However, some of your 100% cottons may need shrinking. Ask if it was preshrunk before the fabric is cut. Or try to find out for yourself by looking for this information on the manufacturer's label which is attached to the bolt of fabric. If it has not been preshrunk, buy  $\frac{1}{4}$  yard extra to allow for shrinkage.

For cotton blends that do not need shrinking, just use the steam pressing method for straightening grain. Fold fabric in half lengthwise with right sides together. First pin or baste selvages together, then pin or baste crosswise ends. Dampen the underside of the folded fabric with a sponge. The steam from the iron will dampen the topside of the fabric. Press along the lengthwise grain. If that does not work, press along the crosswise grain. Again remember, *do not press on the fold.*

For the shrinking/straightening method, fold fabric in half lengthwise with selvages pinned together. Clip along the selvege every 3 or 4 inches. Slant your seissors when you cut; do not clip past the edge of the selvege. Lay the folded fabric in warm water and let it soak. Do not wring the fabric. Let it drip; then lay it out on a flat surface to dry. While it is still wet, smooth out any noticeable wrinkles. This helps straighten the grain. Just before it dries, press it with a dry iron along the lengthwise grain. *Do not press the fold.*

#### Assignment:

You will now take your apron fabric and try to straighten the grain by stretching (as described in Lesson 2), steam pressing, or by the shrinking method if that is necessary. Now your fabric is ready to be cut.

**UNIT III – CUTTING AND PRESSING**

## UNIT III CUTTING AND PRESSING

### Tips for Cutting and Pressing

### Lesson 1

**Objective:** The student will be able to cut and press properly.

**Information.** Proper cutting means that all the edges are smooth and neat, all seam allowances are even, and the notches are cut in the right places. A notch helps you to match up pattern pieces. Always *press as you sew*.

#### Cutting:

Always cut with the right kind of scissors: use bent-handled shears with sharp blades.

To cut properly, one hand holds the shears and the other hand is placed flat down on the fabric to hold it in place. The shears move along with long, even strokes brushing lightly against the top of the table. Do not close blades completely after each cut. When cutting curves, use short, even strokes. *Never lift fabric off the table when cutting.*

Never use pinking or scalloping shears for cutting something out. They are used only for finishing seams.

Never use your fabric shears for cutting paper; it makes them dull.

#### Pressing:

Always press fabric before you sew it. Then as you sew, each seam and dart should be pressed. This gives the garment the professional, finished touch. At the end, the garment gets a final pressing.

Steam pressing can be done right on the fabric. Most pressing is done on the wrong side.

When pressing with a dry iron (without steam), use a pressing cloth. It helps prevent a shine on the right side of the fabric.

Use a press-and-lift motion when pressing. Always press with the grain of the fabric, from bottom to top.

Always test the iron on a scrap of fabric to make sure the iron is not too hot for it.

**UNIT-IV - THE POWER SEWING MACHINE**

## UNIT IV THE POWER SEWING MACHINE

### General Information

### Lesson 1

**Objective.** The student will have general knowledge of the power sewing machine.

**Information.** The power sewing machine is different from the home sewing machine because:

1. it is stronger
2. it is much faster
3. it is used in factories.

People who work on power sewing machines do not all have the same job titles. For example:

**OPERATOR** — Person who works on a power machine in a factory. The job may be doing one task over and over again or doing several tasks.

**SEAMSTRESS** — Person who works on a power machine in a hotel or hospital. The job is making repairs on uniforms, linens, etc.

**SAMPLEMAKER** — Person who works on a power machine in the manufacturer's (SAMPLEHAND) sample room. The job is sewing the first sample while working with the designer or the assistant designer.

**DRESSMAKER** — Person who works for a custom boutique or a private custom dressmaker. The job is cutting and sewing a complete garment for an individual customer.

These are just a few of the jobs that would be of interest to you. There are other jobs that require knowing how to sew on a power machine.

The machine has two parts: 1. The machine itself is called the head; 2. The table on which it rests.

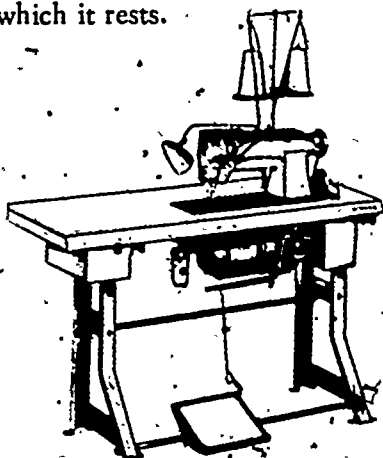

### THE POWER SEWING MACHINE

As your teacher shows you the parts, follow along by reading the information on the next page.



The picture on page 23 shows the thread stand which holds the thread and keeps it out of your way as you work.

On the floor is the treadle. When you step on it, the machine starts to go.

Under the table is the motor which gives the machine the power to sew.

On the left side under the table is a drawer. Tools are kept in this drawer.

On the right side under the table is a switch for turning the machine ON and OFF. SHUT THE MACHINE OFF WHENEVER YOU LEAVE IT.

The kneelift is hanging down under the table. It raises and lowers the presser foot.

Right behind the machine head is a light so you can see better.

**Assignment:**

Your teacher will number the different parts of the machine. Write down what each part is called and what it does.

UNIT IV  
THE POWER SEWING MACHINE

Rules of Safety

Lesson 2

**Objective:** The student will use the power sewing machine safely.

**Information:** POWER MACHINES ARE DANGEROUS.

The following rules should be obeyed at all times when operating a power machine:

1. Adjust the light position by holding onto the flexible neck rather than the metal cover over the bulb. The cover can get dangerously hot. The newer lights are safer; the metal covers do not become very hot. Turn light off when not at machine.
2. Turn the machine OFF when threading the machine, changing a needle, or leaving the machine. You might avoid an accident caused if you should step on the treadle.
3. Do not oil machine unless instructed to do so by teacher. When you do oil the machine, make sure it is turned OFF.
4. When sewing, do not go faster than you can control the machine. If you are sewing too fast, the needle might hit a pin and break. The needle could fly into your face.
5. Keep hands away from the moving needle. Keep your face back from the work area; your eyes are important.
6. Keep feet off treadle unless you are ready to sew.
7. Never run machine when it is threaded if the bobbin is in unless sewing on fabric. The threads will get all jammed up inside the machine.
8. Do not talk while operating the machine. Concentrate only on the task you are doing.

UNIT IV  
THE POWER SEWING MACHINE

Safety - Tools

Lesson 3

Objective: The student will handle tools carefully.

Information: SCISSORS ARE SHARP AND DANGEROUS.

Be on the safe side:

1. When handing scissors to another person, hold the scissors by their point.
2. Never point scissors at another person.
3. When you walk, do not hold scissors open or with the point turned in towards any part of your body. Do not run with scissors in your hand. Hold the scissors closed and with the point down towards the floor.
4. When you work at the machine, have your scissors point away from you and in a place where they cannot fall off the table.

You can never be too careful when working with power machines and tools. It is very foolish to ignore safety rules. No one wants to hire someone who does not have good sense about safety. In practicing safety, you also take better care of your fellow workers.

Safety is the key word, not only your own, but remember safety for others, too.

Assignment:

The teacher will assign each student a key safety rule to be stenciled on oaktag (hard paper) with poster paint. Each safety rule will be on a separate card as per example:

ALWAYS SHUT MACHINE OFF,  
EXCEPT WHEN SEWING.

UNIT IV  
THE POWER SEWING MACHINE

General Care of the Machine

Lesson 4

**Objective:** The student will know how to care for a power machine.

**Information.** Power machines and repair costs are expensive. Repair costs can be kept low if you take good care of the machine.

Take good care of a machine; keep it running well. If it doesn't seem to be running as well as it should, then have it checked immediately instead of waiting and causing more damage to the machine.

Make sure your attachments are right for the machine that you are working on. For example, not all bobbin cases are the same. You cannot use the same bobbin case for every power sewing machine.

Make sure you use the right needle for the machine. Every machine has a label with a number on it. This is the number of your needle. Also, the instruction manual (a small guide book that comes with every machine) will tell you which needle to use.

The instruction manual will tell you the right kind of thread to use. The machine will not sew properly with the wrong kind of thread.

Clean the machine regularly. Lift the head up and see if there are any caught threads or pieces of lint under the machine. You can use a brush for this. Wipe off the machine and table area before you start sewing in case there is any oil from the machine on it. You don't want your garment getting dirty from the machine before you even get it finished.

Cleaning the machine means cleaning the bobbin case. Do this with a small piece of wood (a match).

Make sure the machine is oiled regularly. If the machine is too dry, the parts rub together and wear out. Prevent repair costs; keep your machine oiled.

Every instruction manual or operator's guide tells you the type of oil to use; it has a picture that shows where to oil. Regular machines have red holes which are your oiling points. The self-oiling machine has a pan in the table under the machine head that you fill with oil. As the machine runs, the oil runs through it. The self-oiling machine has a gauge which show you how much oil is in the machine.

**UNIT V - THE SINGLE-NEEDLE LOCKSTITCH MACHINE**

Regular Machine

Arrows show oiling points.

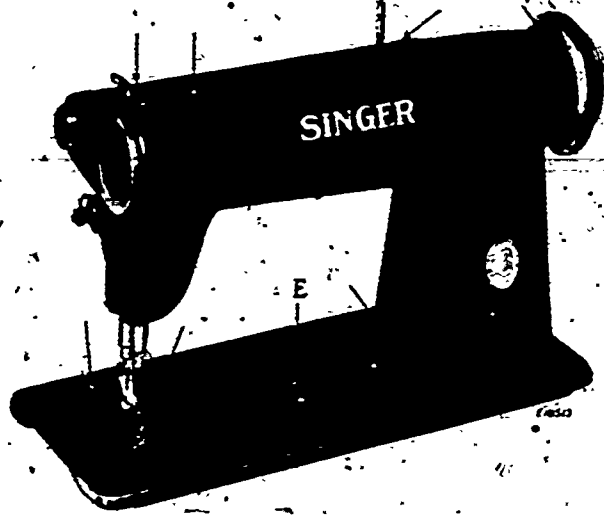

Showing the Eight Oiling Points on the Machine

Self-Oiling Machine

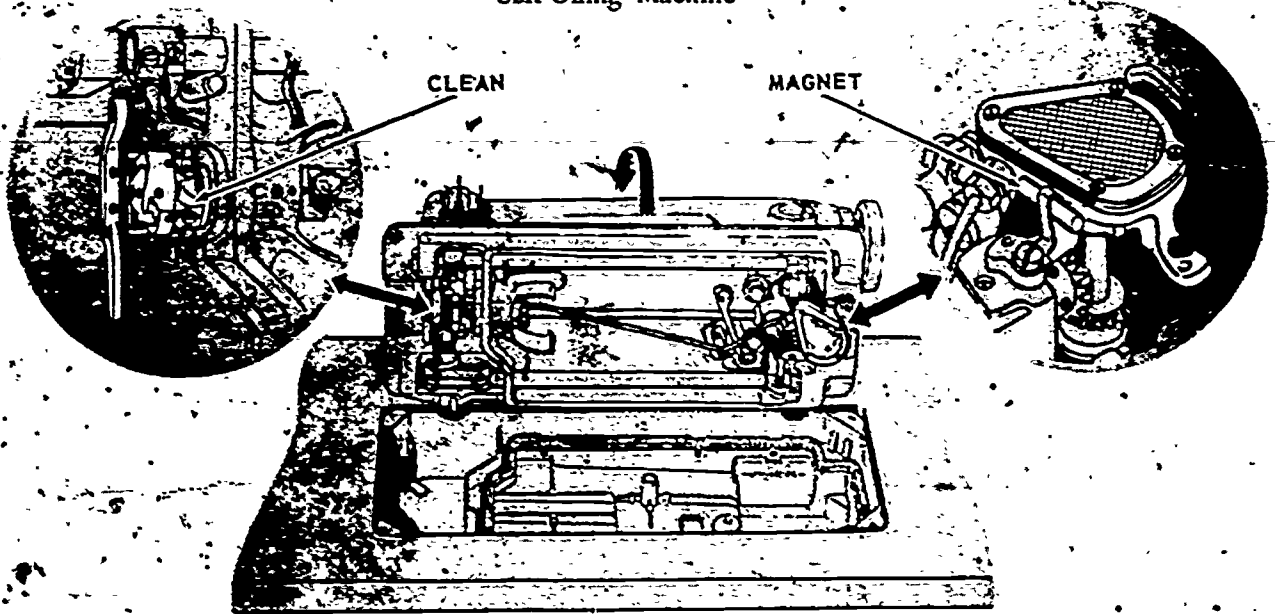



## Oil Running Through the Machine

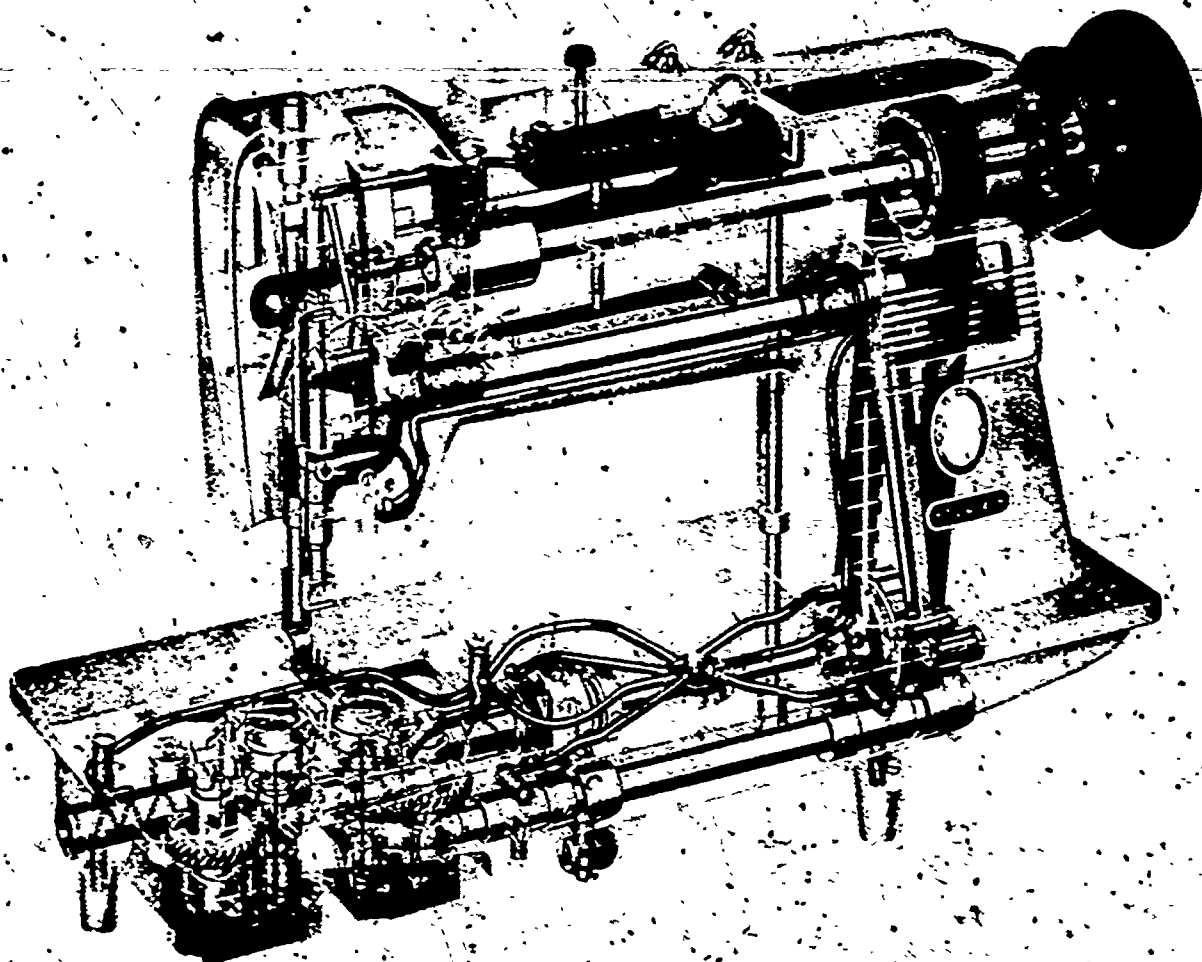

### Assignment:

1. What is the difference between oiling a regular machine such as the 331K, and oiling a self-oiling machine such as the 120U?
2. Demonstrate your ability to oil both types of machines.

UNIT V  
THE SINGLE-NEEDLE LOCKSTITCH MACHINE

The Lockstitch Machine

Lesson 1

**Objective:** The student will be able to describe what a single-needle lockstitch machine does.

**Information:** A single-needle lockstitch machine is the machine most used in the factory because it does all the straight sewing such as seams and darts; it sews the garment together.

It is called single-needle because that is what it has — one needle. It is called lockstitch because of the way the bobbin thread interlocks with the top thread that goes through the needle.

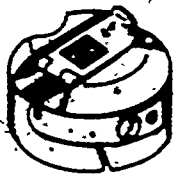

Bobbin Case

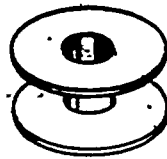

Bobbin



Lockstitch

The single-needle lockstitch machines that will be described in the following lessons are the 120U with the reverse lever and the 331K.

UNIT V  
THE SINGLE-NEEDLE LOCKSTITCH MACHINE

The Singer 120U

Lesson 2

- Objectives:
1. The student will be able to name the parts and what they do.
  2. The student will be able to thread the Singer 120U.

Information: The new Singer Sewing Machine Model 120U is used for straight-line, single-needle lock stitching in fabrics. It sews fabrics that are very fine and fabrics that are heavier – from lingerie to men's overcoating.

The thing that makes this new model different from the older models is that the 120U has a reverse lever which lets you sew backwards. Sewing backwards is called backtacking. You usually backtack at the beginning and end of a seam. It keeps the stitches from pulling out as you sew other parts of the garment together.

The other way to keep the stitches from pulling out at the beginning and ending of a seam is to tie the threads. But this takes longer and is not as strong.

To backtack, start sewing as usual. Sew about 5 stitches and push down on the reverse lever. Let go of the lever as soon as the needle is back at the place you started sewing. Then just go on sewing as usual.

An illustration of a Singer 120U machine is shown below with the names of its parts. There is also a guide on how to thread the machine.

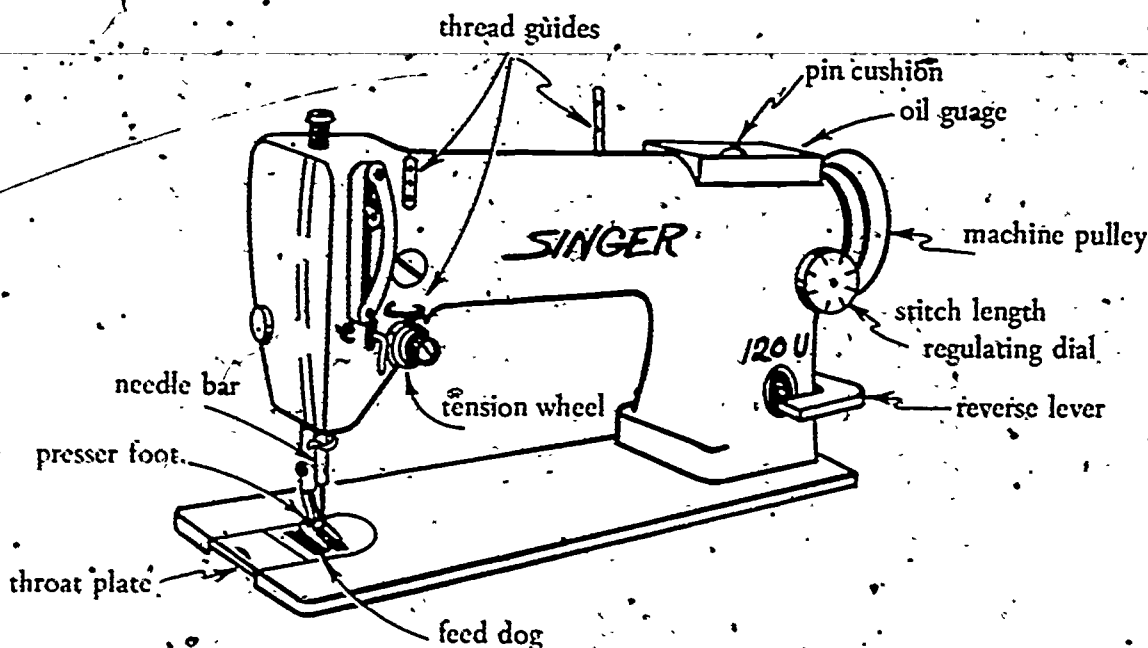

## Threading The Machine

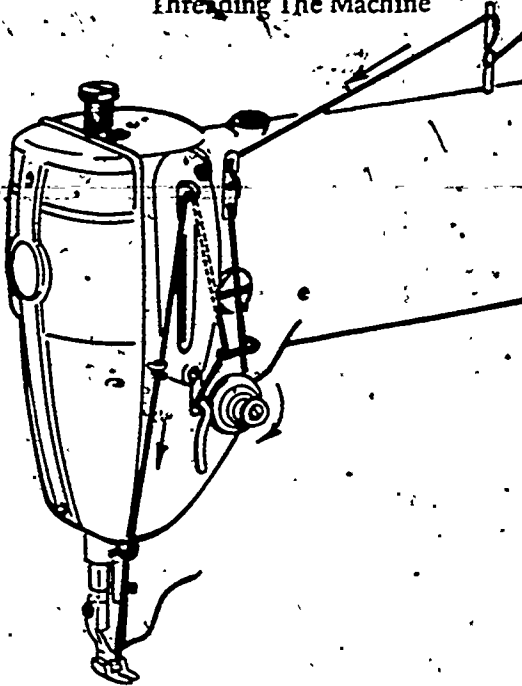

Now that we know the names of the different parts of the machine, we should know what each part does.

Pin cushion — holds pins so that you do not have pins all over the table.

Oil gage — shows what the oil level is in the machine.

Machine pulley — brings the needle up and down when turned *towards* you.

Stitch length regulating dial — makes the stitch larger or smaller. The higher the number, the larger the stitch. The smaller the number, the smaller the stitch. It goes from 1 to 5. One is the smallest stitch; five is the largest stitch. (Singer 120U machine).

Stitch changer — also makes the stitch larger or smaller. Instead of turning a dial, you raise or lower a lever. Raising the lever makes the stitch smaller; lowering the lever makes the stitch larger. (Singer 331K machine).

Reverse lever — Machine sews backwards when you press down on lever.

Tension wheel — regulates the amount of tension (tightens up the thread just enough so the stitches are perfect) on the needle thread. For more tension, turn wheel to the right. For less tension, turn wheel to the left. Tension can also be adjusted on the bobbin thread. There is a tiny screw on the bobbin case for adjusting the tension; you turn it just as described above.

Feed dog - holds the fabric in place from the bottom.

Presser foot - holds the fabric in place from the top.

Throat plate - holds the feed dog in place.

Needle bar - holds the needle in place. The needle bar should always be at its highest point (meaning right before the needle is ready to go down again) when inserting a needle and when leaving the machine.

UNIT V  
THE SINGLE-NEEDLE LOCKSTITCH MACHINE

The Singer 331K

Lesson 3

- Objectives.
1. The student will be able to describe the difference between the Singer 120U and the Singer 331K.
  2. The student will be able to thread the Singer 331K.

Information: The Singer Machine Model 331K is a heavy-duty sewing machine. Therefore, it is better suited for sewing heavy upholstery fabrics than the Singer 120U.

The newer model of the 331K line has a reverse lever enabling you to sew backward as well as forward.

The older models do not have the reverse levers. Therefore, you must backtack by hand using the machine; or you must tie the threads as mentioned in Lesson 2.

To backtack on the older model 331K, start sewing as usual. Sew about 5 stitches, then press against the kneelift (kneelift raises and lowers the presser foot so that you can move the fabric). Move the fabric towards you until the needle is back at the place where you started sewing. Then just go on sewing as usual.

Instead of a stitch length regulating dial like the 120U, the 331K has what is called a stitch changer. It is a lever that moves up and down for changing the stitch length rather than a dial that turns.

The bobbin case and bobbin for the 331K is not the same as the 120U bobbin case and bobbin. **NEVER USE THE SAME BOBBIN CASE AND BOBBIN FOR BOTH MACHINES.** It just won't work, and the machine may get jammed.

The threading guide for the machine is on the next page.



## Threading the Machine

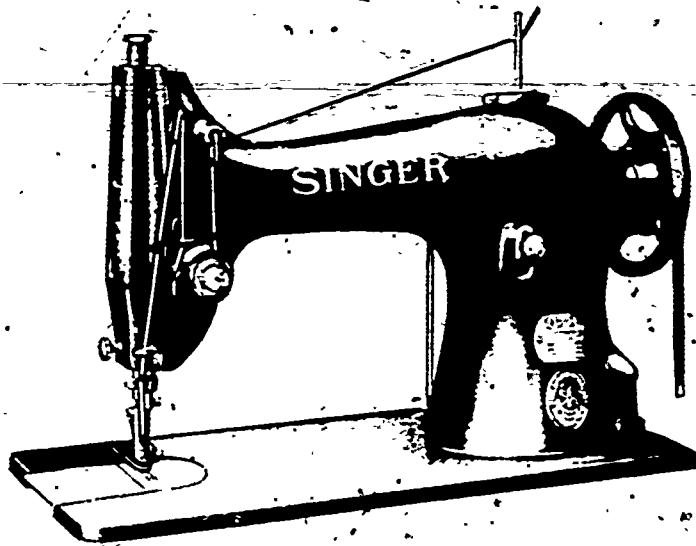

### Assignment:

1. What is a single-needle lockstitch machine?
2. Your teacher will hand you a drawing of a Singer sewing machine. Name the parts.
3. Thread the Singer 120U and the Singer 331K.
4. What makes the 120U different from the 331K?
5. Can you use the same bobbin case and bobbin for both machines?

UNIT V  
THE SINGLE-NEEDLE LOCKSTITCH MACHINE

The Bobbin

Lesson 4

**Objective:** The student will be able to wind a bobbin, insert the bobbin into the bobbin case, and put the bobbin case back into the machine.

**Information:** The bobbins and bobbin cases for the Singer 120U and the Singer 331K are different. The illustration below will show you why.

Singer 120U  
Bobbin and Bobbin Case

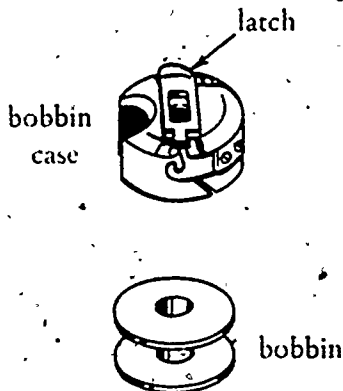

Singer 331K  
Bobbin and Bobbin Case

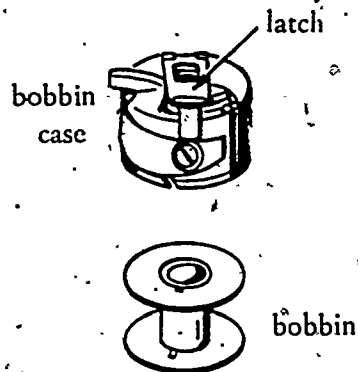

By looking at the bobbin cases, you can see that the 120U bobbin case has an opening; and the 331K bobbin case has a short extension. This is the important difference. Also they are different sizes.

If the bobbin cases are different sizes, then the bobbins must be different sizes too. The bobbin for the 120U is wider in diameter and narrower (notice the stem between the two discs) than the 331K bobbin.

Always wind the bobbin while you are sewing. If you don't, then you must unthread your needle and remove the bobbin case from the machine before you wind the bobbin, or the machine will jam.

### Winding the Bobbin

Press down to push pulley against belt

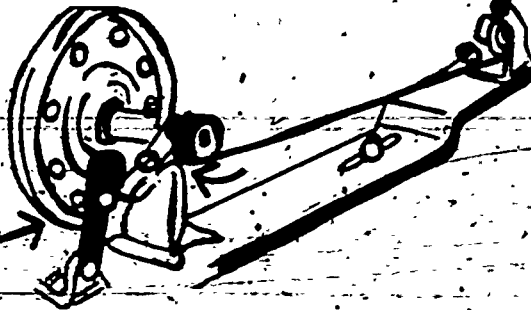

### Threading the Bobbin

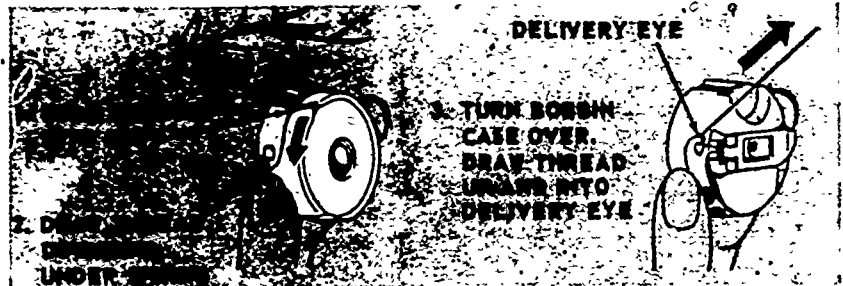

When you take the bobbin case out, open the latch and hold it. Let go of the latch, turn the case upside down, and the bobbin will fall out.

When putting the bobbin case into the machine, open the latch and hold it. Replace the bobbin case on the stud (the tiny metal rod sticking out), and let go of the latch. Press the bobbin case in further until you feel a "click."

### Assignment:

1. Your teacher will put two bobbins and two bobbin cases in front of you. Which case belongs to the Singer 120U and which to the 331K. Explain how you can tell the difference between the two bobbin cases.
2. You will wind a bobbin and insert the bobbin into the bobbin case and put the bobbin case back into the machine.

**UNIT VI – MACHINE OPERATIONS**

UNIT VI  
MACHINE OPERATIONS

Basic Machine Skills

Lesson 1

**Objective:** The student will be able to operate the power sewing machine.

**Information:** The key word to sewing on a power machine is *control*. Once you have learned how to control your machine, then you are ready to sew a garment.

Control means running the machine at a speed by which you can sew without difficulty. Do not worry about sewing fast as a beginner. Sew slowly at first and gain control over the machine. First control—then speed. You do not save time by sewing fast and making mistakes. The mistakes have to be ripped out and done over. Go slowly and sew it right the first time.

You have threaded the machine and are ready to sew. Now, switch the machine ON. Press your knee against the kneelift, so the presser foot will come up. Put what you are going to sew under the presser foot. Take your knee away from the kneelift. The presser foot will come down by itself and hold the fabric in place. Start with your needle in the fabric. Turn the machine pulley towards you and the needle will come down. At first, step on the foot treadle lightly until you get the feel of the machine. As you become sure of yourself, step on the foot treadle harder to make the machine go faster — *but always keep full control.*

*Never leave your machine without having your needle bar at its highest point; switching the machine and light OFF.*

UNIT VI  
MACHINE OPERATIONS

Sewing on Paper

Lesson 2

**Objectives:** The student will be able to sew straight, curved, and circular stitching: turn, square corners, and backtack.

**Information:** The best way to learn how to sew is by sewing on paper without threading the machine. Use a paper that is medium weight. Paper that is too thin, such as regular lined looseleaf paper, will tear too easily.



Sample #1

For Sample #1, use computer printout paper that is no longer useful and is going to be thrown out. (Ask the data processing class for it.)

It is good for practicing sewing straight lines as in Sample #1, because the lines are already there. The weight is right.

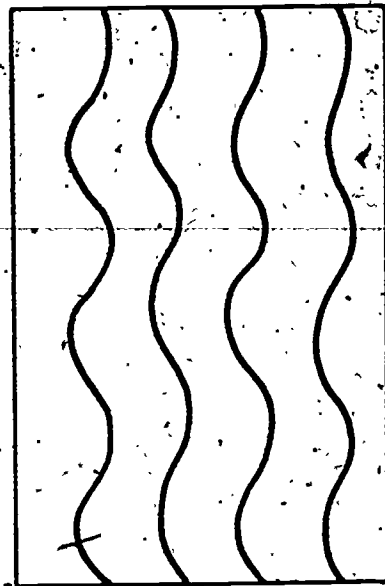

Sample #2

This sample has curved lines.

This sample has circular stitching. This is hard to sew -- go slowly.

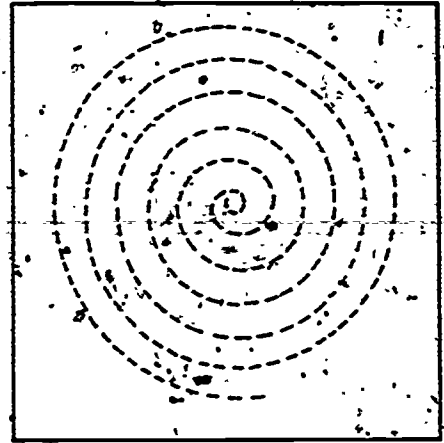

Sample #3

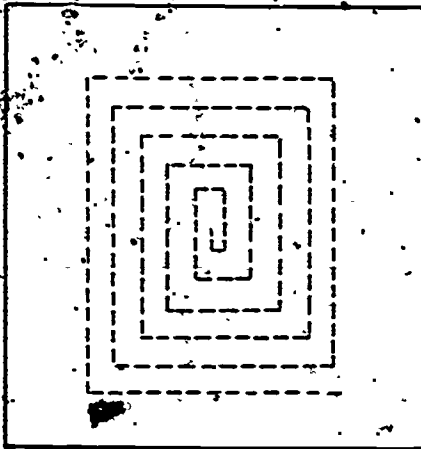

Sample #4

This sample teaches you to stop at the right spot.

It teaches you to make square corners.

To make a square corner:

1. When you come to the corner, the needle should be in the fabric.
2. Leave the needle in the fabric, lift the presser foot, and turn your work.
3. Do the same thing at each corner.

Assignment:

Your teacher will give you marked paper. Run the machine, following the lines. Number your papers so that you can see how you improve.



UNIT VII - THINGS TO MAKE

## UNIT VII THINGS TO MAKE

### Making a Placemat

### Lesson 1

**Objective.** The student will be able to make a placemat by following the instructions on a task detailing sheet.

**Information.** Place mats are sometimes used instead of a tablecloth on the table. Each person at the table has one in front of him.

To use a task detailing sheet, read it over completely, first. Then take each step in its order. After completing a step, put a check mark next to it. You will know where you left off when you go to work on it again. It is important to learn how to work from written instructions. Your employer may leave you a note and/or sketch explaining what he /she wants you to do that day. You will be expected to work it out for yourself. *You must learn to work on your own.* You will not always be able to go to someone for help.

The following illustrations are to help you understand the steps. Next to each illustration are the step numbers.

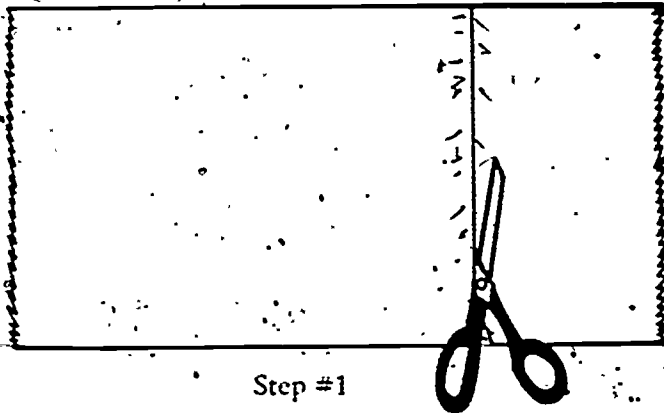

Step #1

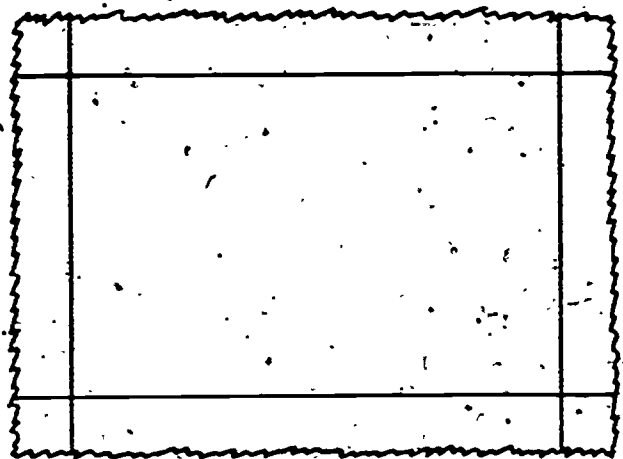

Steps #2, 3, 4 and 5

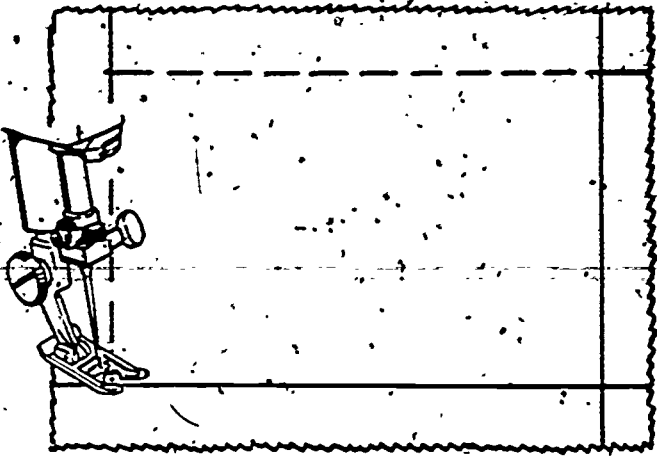

Step #6

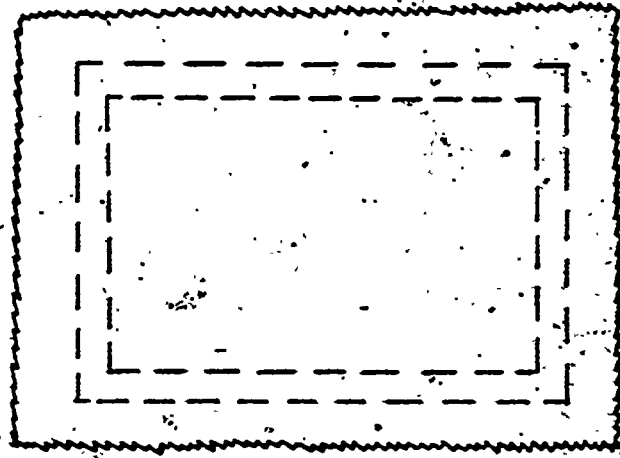

Step #7

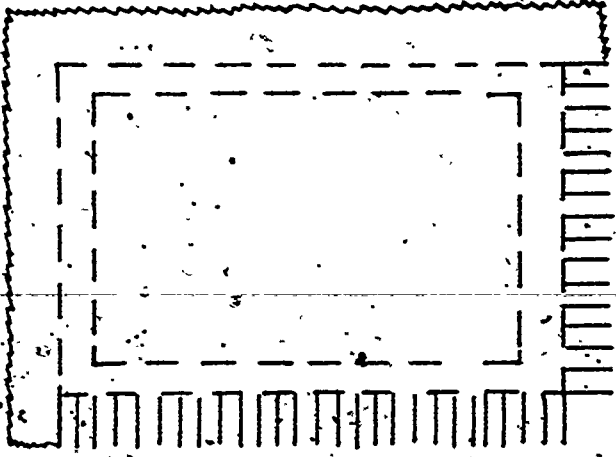

Step #8

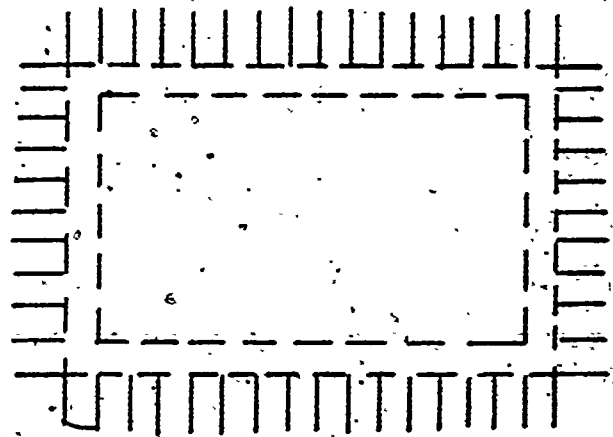

Step #9

**Assignment:**

Your teacher will give you fabric for the placemat. Look over the steps on the task detailing sheet and the illustrations that match the steps. Can you make the placemat following the written instructions only? Try. If you get stuck, find the illustration that matches that step and try to figure it out for yourself.

When the placemat is finished, attach it to the task detailing sheet with a paperclip. Put your name and date on the sheet. Hand it in to your teacher.

Name \_\_\_\_\_ Date \_\_\_\_\_ Completed \_\_\_\_\_  
Class \_\_\_\_\_ Grade \_\_\_\_\_

### Task Detailing Sheet

Task: Making a placemat.

Objective. The student will be able to make a placemat, given the measurements and fabric, using the proper tools and pressing equipment and either the Singer 120U or the Singer 331K sewing machine. All stitches will be the same, straight and with square corners.

#### Task Steps

1. Make fabric thread perfect so that you have a straight grain.
2. Measure piece of fabric 16 inches wide by 12 inches long.
3. Cut and press piece.
4. Measure 1 inch in from each edge; mark it.
5. Pull a thread on all 4 sides on the measured 1 inch line.
6. Machine stitch all 4 sides on lines; make square corners; and go beyond the beginning stitches 1 inch to fasten ends.
7. Machine stitch a second line of stitching one presser foot ( $\frac{1}{4}$  inch) inside the first line of stitching.
8. Pull threads out up to outside line of stitching.
9. Final pressing.

## UNIT VII THINGS TO MAKE:

### Making an Apron

### Lesson 2

**Objective.** The student will be able to make an apron by following the instructions on a task detailing sheet.

**Information.** Aprons are worn to protect our clothing from getting dirty when working at home or at our job.

This apron is simple enough for a beginner. It is a drawstring apron.

The materials needed: 1 yard of fabric, 36 inches wide and thread to match.

In this lesson the only visual aid (something you can look at) that you will get is the demonstration given by your teacher. She/He will go over each step and show you how it is done. After the demonstration is over, read the step again and try to remember how the instructor did it.

Stay stitching is machine stitching used to retain shape and prevent stretching. For example, it might be used around a neckline. The staystitch should be right next to the seamline, but in the seam allowance. When you finally stitch the seam, the staystitch will not show.

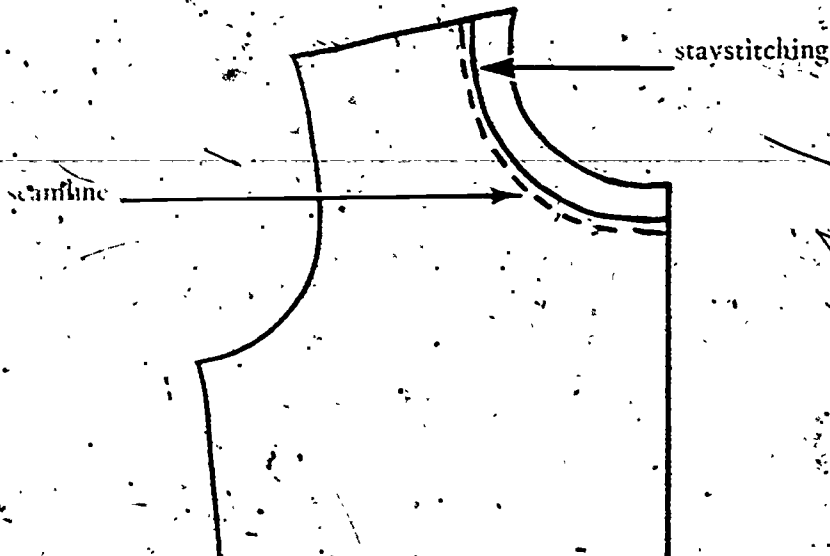

The other thing you will learn is the hemming stitch. This is done by hand with a needle and thread. Make a knot at one end of the thread. Work from right to left. Begin by inserting the needle under the hem edge. Pull the thread all the way through; the knot will keep it from pulling out. Now, pick up one or two fabric threads in the garment, and insert the needle under the hem edge about  $\frac{1}{4}$  inch beyond the point where you brought your needle up. You should not be able to see the stitch on the right side of the garment.

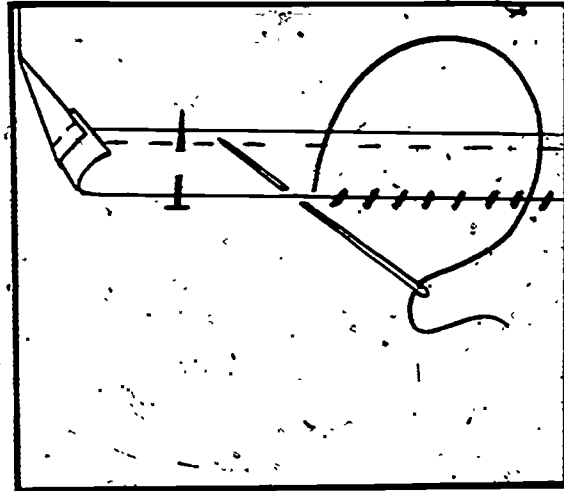

The hemming stitch is used on the belt of the apron.

To avoid pricking your finger with the needle, use a thimble when hand sewing. A thimble is a tiny metal or plastic cap that fits over the tip of your finger.

**Assignment:**

Your apron fabric has already been prepared; it is ready to work with. Follow the instructions on the task detailing sheet. Ask your teacher for help *only* when you really cannot figure something out for yourself.



Name \_\_\_\_\_

Date \_\_\_\_\_

Completed \_\_\_\_\_

Class \_\_\_\_\_

Grade \_\_\_\_\_

### Task Detailing Sheet

**Task:** Making a drawstring apron

**Objective:** The student will be able to make a drawstring apron with tool pockets, given the measurements and fabric, using the proper tools and pressing equipment and either the Singer 120U or the Singer 331K sewing machine. All stitches will be the same with straight lines and correct measurements.

#### Task Steps

1. Make fabric thread perfect.
2. Measure down from torn edge 19 inches and cut or tear. This is the body piece of the apron.
3. Pockets – measure down 11 inches and cut or tear.
4. Drawstring – measure down 6 inches and cut or tear.
5. Press each piece.
6. Staystitch  $\frac{1}{4}$  inch from all cut edges.
7. Trim crosswise threads on body piece when needed.
8. Turn a 2-inch hem at top of body piece and press.
9. Stitch  $\frac{1}{2}$  inch from cut edge of fabric and press.
10. Fold body piece into 4 equal parts and press folds.
11. Trim crosswise threads on pocket piece when necessary.
12. Turn a 2-inch hem at top of pocket piece and press.
13. Stitch  $\frac{1}{2}$  inch from cut edge and press.
14. Fold pocket piece into 4 equal parts and press folds.
15. Place right side of pockets to wrong side of body piece; match selvage edges and staystitching along bottom; stitch  $\frac{1}{2}$  inch seam (from cut edge); and join the two pieces.
16. Turn pocket piece to right side of body piece and press.

17. Stitch on crease lines of pockets, making 4 pockets; backtack the top edges of pockets to reinforce them (by machine).
18. Stitch selvage edges together to form ends of pockets; backtack them also.
19. Cut the 6-inch drawstring piece into two 3-inch pieces; join the 2 pieces; and make one long piece for the drawstring.
20. Staystitch  $\frac{1}{4}$  inch from cut edges.
21. Clean finish edges of drawstring piece by turning the ends  $\frac{1}{4}$  inch once and pressing; then turn it  $\frac{1}{4}$  inch again and press again.
22. Hem stitch by hand.
23. Press for final pressing.
24. Insert drawstring through hem at top of body piece.

UNIT VIII - MEASUREMENTS

## UNIT VIII MEASUREMENTS

### Introduction to Measuring

### Lesson 1

**Objective:** The student will be introduced to measuring.

**Information:** To make garments, you must know how to measure.

Exact measurements are important in making a garment, adjusting a pattern, or measuring fabric. If you need  $2\frac{1}{2}$  yards of fabric, and the salesperson cannot measure accurately, you may wind up with less fabric than you paid for. Not only did you lose money, but you may not have enough fabric to make the garment you want. And on the other hand, if the salesperson gives you more fabric than you paid for, then you were just lucky. But the salesperson won't be so lucky if he/she continues to "give" fabric away. When the salesperson's employer loses money, the salesperson may be out of a job. Why? Because he/she does not know how to measure! Don't let this happen to you.

In sewing, a tape measure, a ruler, or a yardstick can be used. They are used at different times depending on what it is you want to measure. These are all marked in inches.

Always read a tape measure, ruler, or yardstick from the end near the number 1.

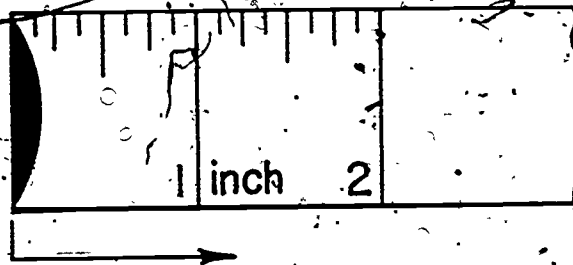

And every inch is divided into smaller parts called *fractions*. A fraction is a part of a whole thing. For example,  $1/2$  inch is a fraction of 1 inch.

The tape measure and yardstick are divided into eighths, quarters, and halves of an inch. If you know how to measure with a tape measure, then you know how to measure with a yardstick.

The ruler is generally divided into sixteenths, eighths, quarters and halves. This divides the ruler even more than the tape measure or yardstick.

A tape measure is a thin piece of cloth or plastic that is 60 inches long. It is used when measuring things that have form, such as when taking body measurements.

The ruler comes in different sizes: 6-inch, 12-inch and 15-inch rulers are generally used in sewing. It is used for making small measurements.

The yardstick is 36 inches long. It is used for making long straight lines.

Assignment:

1. You take body measurements with a \_\_\_\_\_
2. It is important to know how to \_\_\_\_\_
3. These measuring tools are all marked in \_\_\_\_\_
4. Every inch is divided into smaller parts called \_\_\_\_\_
5. The tape measure and yardstick are divided into \_\_\_\_\_, and \_\_\_\_\_
6. The ruler comes in different \_\_\_\_\_
7. For making long straight lines, use a \_\_\_\_\_
8. A \_\_\_\_\_ is used for making small measurements.

## UNIT VIII MEASUREMENTS

### Fractions of an Inch (Quarters)

### Lesson 2

**Objective:** The student will be able to measure in quarters of an inch.

**Information:** There are four  $\frac{1}{4}$ -inches in 1 inch. In fractions when the numerator (the top number) and the denominator (the bottom number) are the same, they equal a whole. For example:  $\frac{4}{4} = 1$

Let's study the tape measure and how it is divided into quarters.

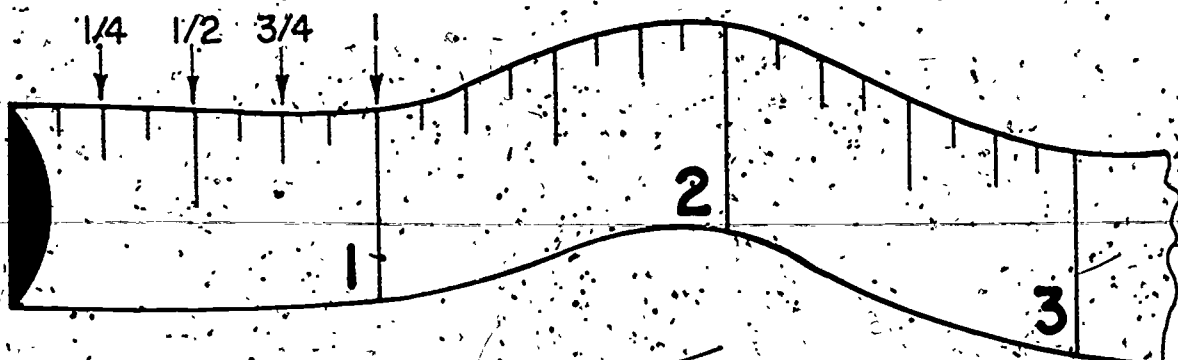

Measuring from the end of the tape:

1. The second line is the  $\frac{1}{4}$ -inch mark.
2. The fourth line is the  $\frac{1}{2}$ -inch mark.  $2 \times \frac{1}{4} = \frac{1}{2}$  inch or  $\frac{2}{4}$  inch =  $\frac{1}{2}$  inch.
3. The sixth line is the  $\frac{3}{4}$ -inch mark.  $3 \times \frac{1}{4} = \frac{3}{4}$  inch.
4. The eighth line is the 1-inch mark.  $4 \times \frac{1}{4} = 1$  inch, or  $\frac{4}{4} = 1$ .

*Only the numbers for the whole inches are printed on the tape measure.*

#### Assignment

1. How many quarter-inches in one-half inch?
2. How many  $\frac{1}{4}$ -inches in 1 inch?
3. How many  $\frac{1}{4}$ -inches in  $\frac{3}{4}$  inch?
4. What does  $\frac{2}{4}$  inches equal?

5. Which are the only numbers printed on the tape measure?

6. Where is the numerator?

7. Where is the denominator?

8. When the numerator and denominator are the same, what do they equal?



UNIT VIII  
MEASUREMENTS

Fractions of an Inch (Eighths)

Lesson 3

Objective: The student will be able to measure in eighths of an inch.

Information: There are eight  $\frac{1}{8}$ -inches in 1 inch.  $\frac{8}{8} = 1$

Let's study the tape measure and how it is divided into eighths.

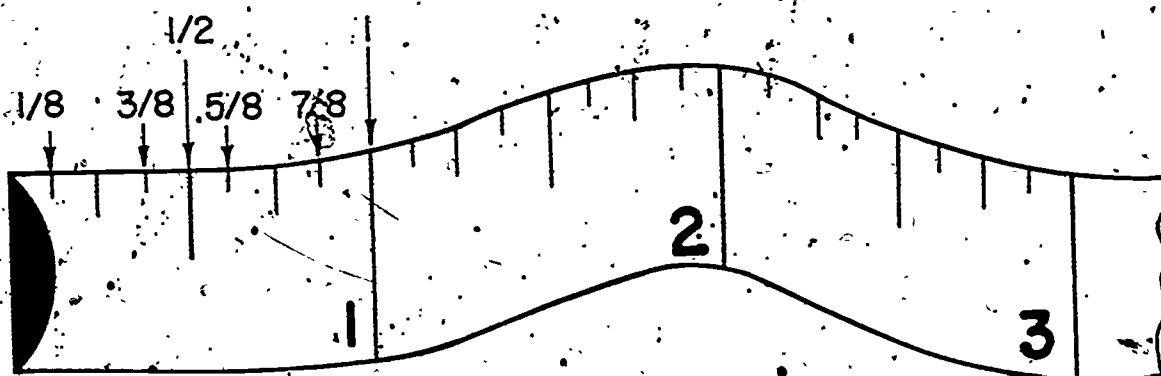

Measuring from the end of the tape:

1. The first line is the  $\frac{1}{8}$ -inch mark.
2. The second line is the  $\frac{1}{4}$ -inch mark.  $2 \times \frac{1}{8} = \frac{1}{4}$  inch, or  $\frac{2}{8}$  inch =  $\frac{1}{4}$  inch.
3. The third line is the  $\frac{3}{8}$ -inch mark.  $3 \times \frac{1}{8} = \frac{3}{8}$  inch.
4. The fourth line is the  $\frac{1}{2}$ -inch mark.  $4 \times \frac{1}{8} = \frac{1}{2}$  inch, or  $\frac{4}{8}$  inch =  $\frac{1}{2}$  inch.
5. The fifth line is the  $\frac{5}{8}$ -inch mark.  $5 \times \frac{1}{8} = \frac{5}{8}$  inch.
6. The sixth line is the  $\frac{3}{4}$ -inch mark.  $6 \times \frac{1}{8} = \frac{3}{4}$  inch, or  $\frac{6}{8}$  inch =  $\frac{3}{4}$  inch.
7. The seventh line is the  $\frac{7}{8}$ -inch mark.  $7 \times \frac{1}{8} = \frac{7}{8}$  inch.
8. The eighth line is the 1 inch mark.  $8 \times \frac{1}{8} = 1$  inch, or  $\frac{8}{8} = 1$ .

Think of it this way:

A whole is divided into halves. The halves are divided into quarters and the quarters are divided into eighths. The eighths are also divided into sixteenths, such as in the case of the ruler. The whole can be broken down even further, but it is not necessary for our purposes.

Measurements to learn:

$$36 \text{ inches} = 1 \text{ yard}$$

$$36 \text{ inches} = 3 \text{ feet}$$

$$12 \text{ inches} = 1 \text{ foot}$$

$$3 \text{ feet} = 1 \text{ yard}$$

$$4\frac{1}{2} \text{ inches} = \frac{1}{8} \text{ yard}$$

$$9 \text{ inches} = \frac{1}{4} \text{ yard}$$

$$12 \text{ inches} = \frac{1}{3} \text{ yard}$$

$$13\frac{1}{2} \text{ inches} = \frac{3}{8} \text{ yard}$$

$$18 \text{ inches} = \frac{1}{2} \text{ yard}$$

$$22\frac{1}{2} \text{ inches} = \frac{5}{8} \text{ yard}$$

$$24 \text{ inches} = \frac{2}{3} \text{ yard}$$

$$27 \text{ inches} = \frac{3}{4} \text{ yard}$$

$$31\frac{1}{2} \text{ inches} = \frac{7}{8} \text{ yard}$$

Assignment:

Your teacher will hand you a task-detailing sheet with a sketch of a tape measure. You are to name each mark on the tape measure by filling in the blanks. Also, answer the three questions at the end.

Task Detailing Sheet

Task: Marking in the fractions of an inch on the sketch below.

Objective: The student will be able to read and use a tape measure properly or any other measuring device that is divided into quarters and eighths.

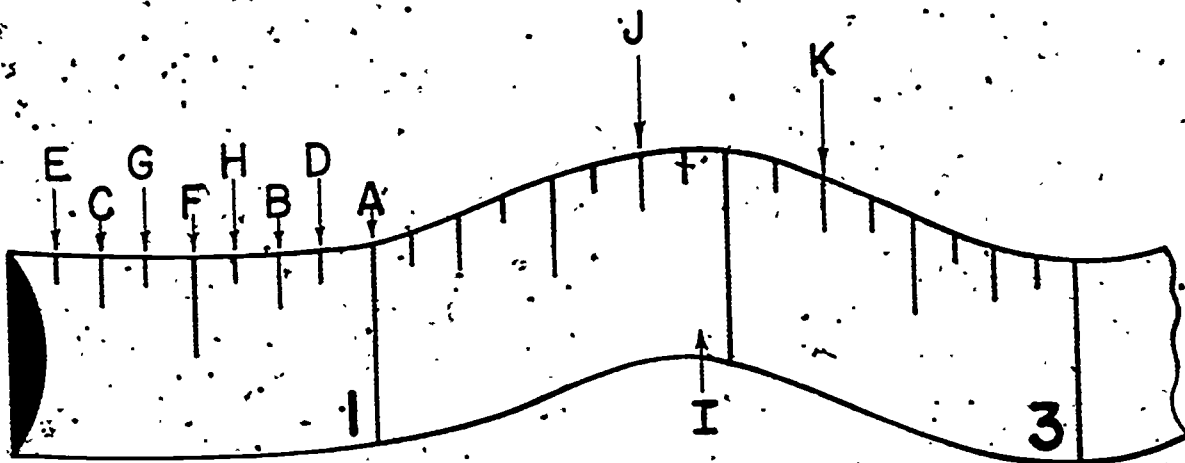

Fill in the blanks:

A \_\_\_\_\_ D \_\_\_\_\_ G \_\_\_\_\_ J \_\_\_\_\_  
 B \_\_\_\_\_ E \_\_\_\_\_ H \_\_\_\_\_ K \_\_\_\_\_  
 C \_\_\_\_\_ F \_\_\_\_\_ I \_\_\_\_\_

- In fractions, when the numerator and denominator are the same, such as  $\frac{4}{4}$ , the fraction equals a \_\_\_\_\_.
- A fraction is a \_\_\_\_\_ of a thing.
- The tape measure, yardstick, and ruler are all marked in \_\_\_\_\_.

## UNIT VIII MEASUREMENTS

### From Inches to Centimeters

### Lesson 4

**Objective.** The student will be able to state how many centimeters equal an inch.

**Information.** Long ago, there were no real standards for measuring things. The unit called the 'foot' actually comes from the typical length of a man's foot, which was one of the ways we measured. And from the typical length of both a man's forearm and hand, we developed the unit called the yard. Not every man has an average length foot, forearm, or hand. So this kind of measuring was not very accurate.

Can you imagine two countries trying to trade with one another and measuring the goods with feet and arms? And perhaps the other country did not measure the same way! Something had to be done. The Metric System was born.

The metric system is used in most of the countries in the world. Where we use inches, they use centimeters. Where we use yards, they use meters. Where we use miles, they use kilometers.

So to measure in centimeters instead of inches, we must know this: 2.54 centimeters = 1 inch. Some rulers will have inches on one side and centimeters on the other side. Did you ever wonder what all those lines on the other side of the ruler were for?

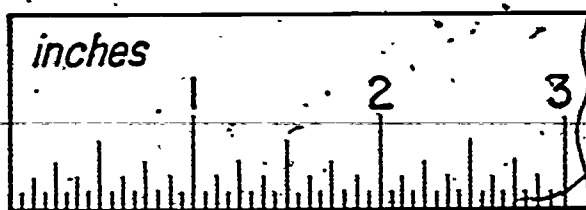

There are 16  $\frac{1}{16}$ -inches in 1 inch on a ruler. Count them.

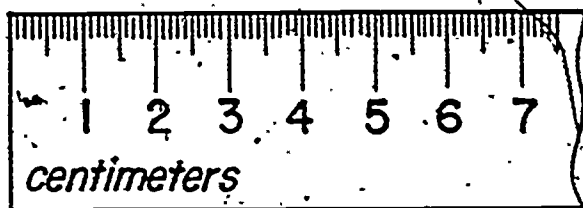

There are 10 millimeters in 1 centimeter. Count them.

If you want to know what something measures in centimeters, take the number of inches and multiply them by 2.54 and you will get your answer.

Clothing sizes are different with the metric system too. Look how clothing sizes in the metric system compare with our U.S. clothing sizes.

**UNIT IX – USING A COMMERCIAL PATTERN**

## CLOTHING SIZES MEN

HATS		SHIRTS	
U.S.	Metric	U.S.	Metric
6 <sup>1</sup> / <sub>2</sub>	52	13	33
6 <sup>7</sup> / <sub>8</sub>	54	14	35
7 <sup>1</sup> / <sub>8</sub>	56	15	37
7 <sup>1</sup> / <sub>2</sub>	58	16	40
7 <sup>3</sup> / <sub>4</sub>	60	17	42

SHOES		SOCKS	
U.S.	Metric	U.S.	Metric
6	38	9	23
7	40	10	25 <sup>1</sup> / <sub>2</sub>
8	41	11	28
9	43	11 <sup>1</sup> / <sub>2</sub>	29 <sup>1</sup> / <sub>4</sub>
10	44	12	30 <sup>1</sup> / <sub>2</sub>
11	45		
12	46		

## WOMEN

DRESSES			SHOES		
U.S.	English	French	U.S.	English	Metric
10	32	38	4	2	34
12	34	40	5	3	35
14	36	42	6	4	36
16	38	44	7	5	38
18	40	46	8	6	38 <sup>1</sup> / <sub>2</sub>
20	42	48	9	7	40
			10	8	41

HATS		STOCKINGS	
U.S.	Metric	U.S.	Metric
21	53	8	20 <sup>1</sup> / <sub>2</sub> size 0
22	56	9	21 <sup>1</sup> / <sub>2</sub> size 2
23	58	10	25 <sup>1</sup> / <sub>2</sub> size 4
24	61	11	27 <sup>1</sup> / <sub>2</sub> size 6
24 <sup>1</sup> / <sub>2</sub>	62		

### Assignment:

1. How did our measuring unit, the 'foot' come about?
2. Where is the metric system used?
3. How many centimeters equal one inch?
4. How many millimeters are in one centimeter?
5. What size clothing do you wear in the different measurement systems, i.e. U.S., French, English, or metric?

## UNIT IX USING A COMMERCIAL PATTERN

### Body Measurements

### Lesson 1

**Objective:** The student will be able to take body measurements accurately.

**Information:** In order to buy a pattern, you must first find out the pattern size. You must measure certain areas of the body to get the pattern size. Use the tape measure.

To help find your pattern size:

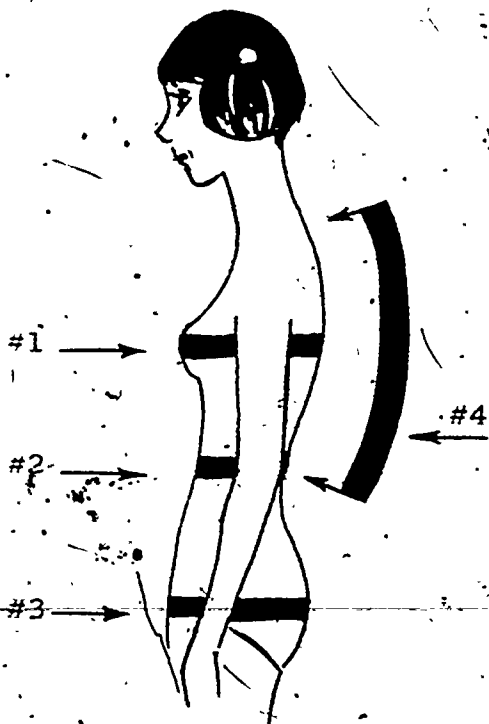

1. Bust — around the fullest part of the bust, straight across the back, and high under the arms.
2. Waist — at natural waistline.
3. Hips — around the largest part, 7" - 9" down from the waist.
4. Back waist length — from bone at back of neck to waistline.

When taking body measurements:

1. Wear undergarments that you will have on when you wear the garment you are making. Otherwise, it won't fit correctly.
2. Hold your finger in back of the tape measure so that your finger is in between the tape and the body. This gives a more accurate measurement. It



helps you make sure that you are not holding the tape measure too tightly or too loosely.

3. Tie a string or ribbon around the waist. It helps when measuring the back waist length.

**Assignment:**

Pair up with one of your classmates and take body measurements of each other. Write them down.

UNIT IX  
USING A COMMERCIAL PATTERN

Figure Types

Lesson 2

**Objective.** The student will be able to determine figure types knowing the height and body measurements of a person.

**Information:** You not only need body measurements to pick out the right pattern size, but you also need to know what figure type you are.

Your figure type depends on two things:

1. Height
2. Back waist length

If you find a figure type with the same height and back waist length as yours, then check the body measurements. If they are the same or close, then this is the pattern size to buy.

If you find two or more figure types that have the same bust, waist, and hip measurements as yours, check the back waist lengths. The one with the back waist length most like yours is the pattern size to buy.

If you find that your measurements do not fit any figure type, pick the one that is closest to your figure and height. The pattern will have to be adjusted in certain areas.

Pattern sizes and ready-to-wear clothes sizes are different. When you buy a pattern, look at the measurements — not at the size.

Charts of figure types are found in the back of pattern catalogs. Pattern catalogs show you the styles that are available. However, there is a chart on the next page so that you can find out right now what pattern size to buy.

<p>About 5'5" to 5'8"</p>	<p><b>MISSSES'</b></p> <p>Misses' patterns are designed for a well proportioned, and developed figure, about 5'5" to 5'8" without shoes.</p> <table border="1"> <tr> <td>Size</td> <td>6</td> <td>8</td> <td>10</td> <td>12</td> <td>14</td> <td>16</td> <td>18</td> </tr> <tr> <td>Bust</td> <td>30½</td> <td>31½</td> <td>32½</td> <td>34</td> <td>36</td> <td>38</td> <td>40</td> </tr> <tr> <td>Waist</td> <td>22</td> <td>23</td> <td>24</td> <td>25½</td> <td>27</td> <td>29</td> <td>31</td> </tr> <tr> <td>Hip</td> <td>32½</td> <td>33½</td> <td>34½</td> <td>36</td> <td>38</td> <td>40</td> <td>42</td> </tr> <tr> <td>Back Waist Length</td> <td>15½</td> <td>15¾</td> <td>16</td> <td>16½</td> <td>16¾</td> <td>17</td> <td></td> </tr> </table>	Size	6	8	10	12	14	16	18	Bust	30½	31½	32½	34	36	38	40	Waist	22	23	24	25½	27	29	31	Hip	32½	33½	34½	36	38	40	42	Back Waist Length	15½	15¾	16	16½	16¾	17		<p>About 5'5" to 5'8"</p>	<p><b>WOMEN'S</b></p> <p>Women's patterns are designed for the larger, more fully mature figure, about 5'5" to 5'8" without shoes.</p> <table border="1"> <tr> <td>Size</td> <td>38</td> <td>40</td> <td>42</td> <td>44</td> <td>46</td> <td>48</td> <td>50</td> </tr> <tr> <td>Bust</td> <td>42</td> <td>44</td> <td>46</td> <td>48</td> <td>50</td> <td>52</td> <td>54</td> </tr> <tr> <td>Waist</td> <td>34</td> <td>36</td> <td>38</td> <td>40½</td> <td>43</td> <td>45½</td> <td>48</td> </tr> <tr> <td>Hip</td> <td>44</td> <td>46</td> <td>48</td> <td>50</td> <td>52</td> <td>54</td> <td>56</td> </tr> <tr> <td>Back Waist Length</td> <td>17¼</td> <td>17¾</td> <td>17¾</td> <td>17¾</td> <td>17¾</td> <td>17¾</td> <td>18</td> </tr> </table>	Size	38	40	42	44	46	48	50	Bust	42	44	46	48	50	52	54	Waist	34	36	38	40½	43	45½	48	Hip	44	46	48	50	52	54	56	Back Waist Length	17¼	17¾	17¾	17¾	17¾	17¾	18
Size	6	8	10	12	14	16	18																																																																												
Bust	30½	31½	32½	34	36	38	40																																																																												
Waist	22	23	24	25½	27	29	31																																																																												
Hip	32½	33½	34½	36	38	40	42																																																																												
Back Waist Length	15½	15¾	16	16½	16¾	17																																																																													
Size	38	40	42	44	46	48	50																																																																												
Bust	42	44	46	48	50	52	54																																																																												
Waist	34	36	38	40½	43	45½	48																																																																												
Hip	44	46	48	50	52	54	56																																																																												
Back Waist Length	17¼	17¾	17¾	17¾	17¾	17¾	18																																																																												
<p>About 5'4" to 5'5"</p>	<p><b>JUNIOR</b></p> <p>Junior patterns are designed for a well proportioned, shorter waisted figure, about 5'4" to 5'5" without shoes.</p> <table border="1"> <tr> <td>Size</td> <td>5</td> <td>7</td> <td>9</td> <td>11</td> <td>13</td> <td>15</td> </tr> <tr> <td>Bust</td> <td>30</td> <td>31</td> <td>32</td> <td>33½</td> <td>35</td> <td>37</td> </tr> <tr> <td>Waist</td> <td>21½</td> <td>22½</td> <td>23½</td> <td>24½</td> <td>26</td> <td>28</td> </tr> <tr> <td>Hip</td> <td>32</td> <td>33</td> <td>34</td> <td>35½</td> <td>37</td> <td>39</td> </tr> <tr> <td>Back Waist Length</td> <td>15</td> <td>15¼</td> <td>15½</td> <td>15¾</td> <td>16</td> <td>16¼</td> </tr> </table>	Size	5	7	9	11	13	15	Bust	30	31	32	33½	35	37	Waist	21½	22½	23½	24½	26	28	Hip	32	33	34	35½	37	39	Back Waist Length	15	15¼	15½	15¾	16	16¼	<p>About 5'2" to 5'3"</p>	<p><b>HALF-SIZE</b></p> <p>Half-size patterns are for a fully developed figure with a short backwaist length, waist and hip are larger in proportion to bust than other figure types; about 5'2" to 5'3" without shoes.</p> <table border="1"> <tr> <td>Size</td> <td>10½</td> <td>12½</td> <td>14½</td> <td>16½</td> <td>18½</td> <td>20½</td> <td>22½</td> <td>24½</td> </tr> <tr> <td>Bust</td> <td>33</td> <td>35</td> <td>37</td> <td>39</td> <td>41</td> <td>43</td> <td>45</td> <td>47</td> </tr> <tr> <td>Waist</td> <td>26</td> <td>28</td> <td>30</td> <td>32</td> <td>34</td> <td>36½</td> <td>39</td> <td>41½</td> </tr> <tr> <td>Hip</td> <td>35</td> <td>37</td> <td>39</td> <td>41</td> <td>43</td> <td>45½</td> <td>48</td> <td>50½</td> </tr> <tr> <td>Back Waist Length</td> <td>15</td> <td>15¼</td> <td>15½</td> <td>15¾</td> <td>16</td> <td>16¼</td> <td>16½</td> <td>16¾</td> </tr> </table>	Size	10½	12½	14½	16½	18½	20½	22½	24½	Bust	33	35	37	39	41	43	45	47	Waist	26	28	30	32	34	36½	39	41½	Hip	35	37	39	41	43	45½	48	50½	Back Waist Length	15	15¼	15½	15¾	16	16¼	16½	16¾
Size	5	7	9	11	13	15																																																																													
Bust	30	31	32	33½	35	37																																																																													
Waist	21½	22½	23½	24½	26	28																																																																													
Hip	32	33	34	35½	37	39																																																																													
Back Waist Length	15	15¼	15½	15¾	16	16¼																																																																													
Size	10½	12½	14½	16½	18½	20½	22½	24½																																																																											
Bust	33	35	37	39	41	43	45	47																																																																											
Waist	26	28	30	32	34	36½	39	41½																																																																											
Hip	35	37	39	41	43	45½	48	50½																																																																											
Back Waist Length	15	15¼	15½	15¾	16	16¼	16½	16¾																																																																											
<p>About 5'1" to 5'3"</p>	<p><b>JUNIOR PETITE</b></p> <p>Junior Petite patterns are designed for a well proportioned petite figure, about 5' to 5'1" without shoes.</p> <table border="1"> <tr> <td>Size</td> <td>3JP</td> <td>5JP</td> <td>7JP</td> <td>9JP</td> <td>11JP</td> <td>13JP</td> </tr> <tr> <td>Bust</td> <td>30½</td> <td>31</td> <td>32</td> <td>33</td> <td>34</td> <td>35</td> </tr> <tr> <td>Waist</td> <td>22</td> <td>22½</td> <td>23½</td> <td>24½</td> <td>25½</td> <td>26½</td> </tr> <tr> <td>Hip</td> <td>31½</td> <td>32</td> <td>33</td> <td>34</td> <td>35</td> <td>36</td> </tr> <tr> <td>Back Waist Length</td> <td>14</td> <td>14¼</td> <td>14½</td> <td>14¾</td> <td>15</td> <td>15¼</td> </tr> </table>	Size	3JP	5JP	7JP	9JP	11JP	13JP	Bust	30½	31	32	33	34	35	Waist	22	22½	23½	24½	25½	26½	Hip	31½	32	33	34	35	36	Back Waist Length	14	14¼	14½	14¾	15	15¼	<p>About 5'1" to 5'3"</p>	<p><b>YOUNG JUNIOR/TEEN</b></p> <p>This new size range is designed for the developing pre-teen and teen figures, about 5'1" to 5'3" without shoes.</p> <table border="1"> <tr> <td>Size</td> <td>5/6</td> <td>7/8</td> <td>9/10</td> <td>11/12</td> <td>13/14</td> <td>15/16</td> </tr> <tr> <td>Bust</td> <td>28</td> <td>29</td> <td>30½</td> <td>32</td> <td>33½</td> <td>35</td> </tr> <tr> <td>Waist</td> <td>22</td> <td>23</td> <td>24</td> <td>25</td> <td>26</td> <td>27</td> </tr> <tr> <td>Hip</td> <td>31</td> <td>32</td> <td>33½</td> <td>35</td> <td>36½</td> <td>38</td> </tr> <tr> <td>Back Waist Length</td> <td>13½</td> <td>14</td> <td>14½</td> <td>15</td> <td>15½</td> <td>15¾</td> </tr> </table>	Size	5/6	7/8	9/10	11/12	13/14	15/16	Bust	28	29	30½	32	33½	35	Waist	22	23	24	25	26	27	Hip	31	32	33½	35	36½	38	Back Waist Length	13½	14	14½	15	15½	15¾										
Size	3JP	5JP	7JP	9JP	11JP	13JP																																																																													
Bust	30½	31	32	33	34	35																																																																													
Waist	22	22½	23½	24½	25½	26½																																																																													
Hip	31½	32	33	34	35	36																																																																													
Back Waist Length	14	14¼	14½	14¾	15	15¼																																																																													
Size	5/6	7/8	9/10	11/12	13/14	15/16																																																																													
Bust	28	29	30½	32	33½	35																																																																													
Waist	22	23	24	25	26	27																																																																													
Hip	31	32	33½	35	36½	38																																																																													
Back Waist Length	13½	14	14½	15	15½	15¾																																																																													

Assignment:

1. Taking all the information you have, try to determine what your figure type is.
2. Now taking your body measurements and figure type, try to determine what pattern size you should buy.

UNIT IX  
USING A COMMERCIAL PATTERN

The Pattern Size

Lesson 3

**Objective:** The student will be able to select the right pattern size for the right item.

**Information:** You know what your pattern size is. But the pattern may or may not be the best fit in all body areas. There may be times when you will have to buy a pattern size different from the size you usually buy. Here's why.

You do have an overall pattern size that you buy. But...

1. If you want to make a blouse, dress, suit, or coat, pick the size with the bust measurement closest to yours.
2. Pick skirt and pants pattern sizes by your waist measurement. If your hips are much larger than your waist, pick the size by your hip measurement and alter the waist.
3. If the pattern includes a wardrobe which includes a blouse, skirt, jacket, etc., choose the size by your bust measurement.
4. If your measurements are between two sizes, follow this rule: if you are small-boned, pick the smaller size; if you are large-boned, pick the larger size.

**Assignment:**

Start thinking about what you would like to make as your project garment. Discuss the possibilities with your teacher. Remember, you are a beginner. So, stick to your 'easy-to-sew' styles.

UNIT IX  
USING A COMMERCIAL PATTERN

The Pattern Envelope

Lesson 4

**Objective:** The student will be able to use the information on the pattern envelope to help her make a garment.

**Information:** A pattern has three main elements: 1.- the envelope; 2.- the Cutting and Sewing Direction Sheet; and 3.- the tissue pattern pieces. Let's take a look at the pattern envelope.

A picture of the front of a pattern envelope is on the next page. The letters point to the places of information on the envelope front. See below:

- A - The upper left-hand corner has the pattern size. Always check the size to make sure the salesperson gave you the right size. Patterns are not returnable!
- B - Each style sketched has a number below it. This is called a *view*. Circle the view you want to make.
- C - At the top of the envelope, for example, you may see "How to Sew", "For Knits only", etc. This is to guide you. Beginners should always buy "easy" patterns. Never try to make a garment out of a woven fabric with a "For Knits Only" pattern. Sometimes there is special information for one of the views, which is found below that sketch.

More information is available. Suggested fabrics are listed on the back. You can also get a feel for the type of fabric - soft or rigid. Looking at the sketches on the envelope front may also show you if you can match your special stripe or print with your selected view.

The Envelope Front

# 6228 Simplicity \$1.00

IN S.A. & CANADA  
1.10

Size 10  
Bust 32 1/2"  
Miss.





There is a picture of the envelope back on the next page. It also has letters pointing to the places of information on the envelope back. See below:

- A - The box in the upper right corner gives advice on buying special fabrics. It shows if extra fabric is needed and which fabrics are unsuitable for the design.
- B - Gives the body measurements on which the patterns are sized. These are *not* the exact measurements of this pattern. Remember, patterns must have ease added into them.
- C - The number of pieces in the pattern is shown in the upper left corner under the pattern number.
- D - Shows back views of the pattern pieces (showing the back of the garment).
- E - A yardage chart showing how much fabric is needed for the different views, fabric widths, and pattern sizes. It also lists yardages for linings and interfacings if any.
- F - This section describes the construction and design details of the garment.
- G - Now, we have a list of suggested fabrics for each view. This guides you so that you can see what types of fabrics will and won't work for this design.
- H - Look at the list of sewing notions needed to make the garment. Buy them along with your fabric. It saves time and you can match the color correctly.
- I - Here are the finished garment measurements. They include the width of lower edge (hem), finished back length (neck to waist), etc. They guide you in pattern alterations you need to make.

The Envelope Back

**MISSES' BLOUSE AND SCARF.**

Metric Conversion Chart—Give on enclosed direction sheet.

Extra fabric is needed to match plaids, stripes or one-way designs.

STANDARD BODY MEASUREMENT	Bust	Waist	Hip	Back neck to waist	Length
32½"	34	36	40	16	40
34"	36	38	42	17	42
36"	38	40	44	18	44
38"	40	42	46	19	46
40"	42	44	48	20	48
42"	44	46	50	21	50
44"	46	48	52	22	52
46"	48	50	54	23	54
48"	50	52	56	24	56
50"	52	54	58	25	58
52"	54	56	60	26	60
54"	56	58	62	27	62
56"	58	60	64	28	64
58"	60	62	66	29	66
60"	62	64	68	30	68

**Fabric required** — Sizes 10 12 14 16 18

View	Blouse and Scarf	Even bias design or plain fabric	Yds.
View 1	35" or 36" without nap	3¾	4
View 2	44" or 45" without nap	2¼	2¾
View 3	35" or 36" without nap	3¼	3¾
View 1 or 2	25" fabric	½	½
View 3	32" or 36" fabric	½	½
View 1 or 2	Blouse interfacing	Woven or non-woven fabric	½
View 3	Blouse and Scarf	35" or 36" without nap	3¾
View 1 or 2	Blouse interfacing	¾ yard 25", 32", 35" or 36" woven or non-woven fabric.	2½

**Garment Measurements**

Finished back length of blouse: 24½, 24¾, 25, 25¼, 25½ ins.

Sewing notions: Thread. View 1 or 2: Seven ¾" buttons, Six ½" buttons. View 3: Seven ¾" buttons.

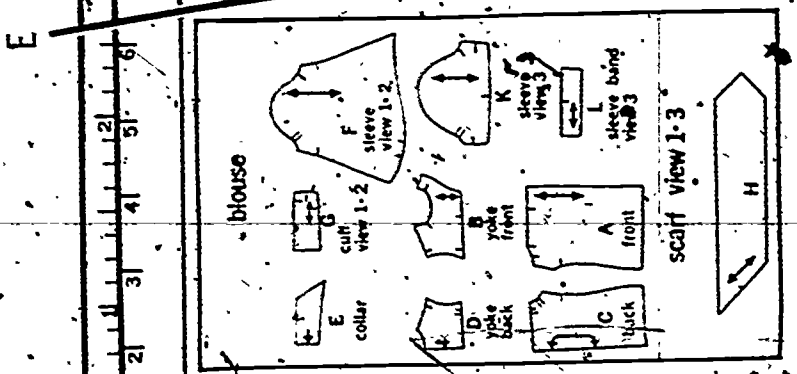

**MISSES' BLOUSE AND SCARF:** The blouse V. 1, 2 & 3—with front and back yokes has high round neckline, shirt type collar and front button closing. V. 1 & 2 have long set-in sleeves gathered to buttoned cuffs; V. 3 has short set-in sleeves gathered to sleeve bands. The bias-scarf V. 1 & 3 is made of same fabric as the blouse.

**Suggested fabrics:** Printed silk, surah, shantung, crepe, jersey, challis, chambray, leno, dotted swiss, gingham, flannel, light-weight wool, wool flannel, matte jersey, double knit. View 1 also in even bias design fabric.

**6228**  
10 PIECES GIVEN

CHINA (Inches) MEASURE C/ms

Using the yardage chart on the envelope back, you will find out how much fabric to buy. Follow below and mark your envelope accordingly:

1. Mark the view you wish to make, i.e. View 2.
2. Mark your size, i.e. size 10.
3. Mark the width of the fabric you intend to buy, i.e. 44".
4. Draw a line *across* the fabric width. Draw another line *down* from your pattern size. Circle the number where the two lines meet. This is the amount of fabric you need to buy.
5. Check to see if you need any interfacing, lining, etc. Using the same method as above, you will find how much you need to buy.

On the yardage chart next to the fabric widths, you will find the words "with nap" and/or "without nap". This means any nap, pile, or one-way fabric where all the pattern pieces must be laid facing in the same direction. This requires buying extra fabric of  $\frac{3}{8}$  to  $\frac{3}{4}$  of a yard depending on the fabric width.

Simple definition for nap    Soft, short threads covering a fabric; going in one direction only. An example of a napped fabric is Corduroy.

Assignment:

1. Using your own pattern envelope, describe what information the envelope front gives you.
2. Using your pattern, describe what information the envelope back gives you.
3. Taking what you have learned in Lesson 4, how much fabric do you need to make the garment? Show how to figure this out.
4. Besides your fabric, is there anything else you need? How do you know this?

UNIT IX  
USING A COMMERCIAL PATTERN

The Cutting Layout Guide

Lesson 5

**Objective.** The student will be able to use the cutting layout guide. Each pattern comes with a "Cutting and Sewing Direction Sheet." A cutting layout guide is included.

**Information.** By using the cutting layout guide, you save time and fabric. There is no figuring on your part; just follow the layout diagram. Pattern companies figure all of this out for you.

The direction sheet has sketches of all the views. Under each sketch, it tells how many and which pattern pieces are needed for that view. Each pattern piece has a letter on it.

Take out only those pattern pieces needed to make the garment. Put your name on each piece so that there is no confusion. Put the rest of the pieces not being used back into the envelope. Put your name on the envelope.

How to pick out the correct cutting layout:

1. Find the *view* you wish to make and circle it.
2. Under the view, the layouts are listed according to size and fabric width. Choose the one in the *size* of your pattern.
3. It must also have the same *width* of your fabric.

If you have a napped fabric, circle the picture for "with nap."

Now, look at the picture of the cutting layout section from the direction sheet. Study the circled layout. Fold the fabric with the wrong side facing you (the right sides of fabric should be inside).

Locate the fold and selvage edges on the layout. Make sure your fabric is facing the same way. Otherwise you will lay the pieces out all wrong.

Pick out the correct cutting layout:

1. The *view* you are making.
2. In the *size* of your pattern, and
3. The *width* of your fabric.

Pick the picture for "with nap" if you are using napped or one-way material.

Circle the correct picture.

1  
2  
3

**Cutting Layouts**

**View 1 DRESS WITH OR WITHOUT COLLAR**

NOTE: For Dress Without Collar, omit Belt (optional) - Cut a straight strip of fabric, 1-3/4" wide and the waist measurement plus 5".

**PLAID OR PLAIN FABRIC**

Fabric With or Without Nap  
Sizes 9, 10, 11, 12 - 35" - 36"

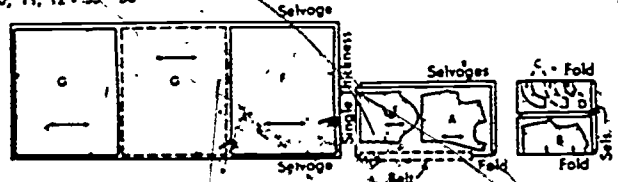

Fabric With or Without Nap  
Sizes 13, 14, 16 - 35" - 36"

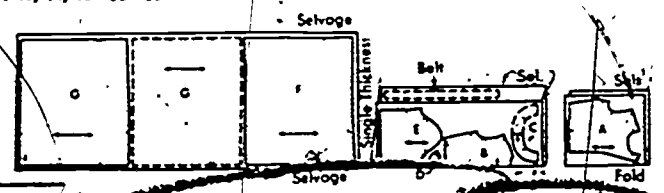

**PLAIN FABRIC**

Fabric Without Nap  
Sizes 9, 10, 11, 12, 14 - 44"  
45"

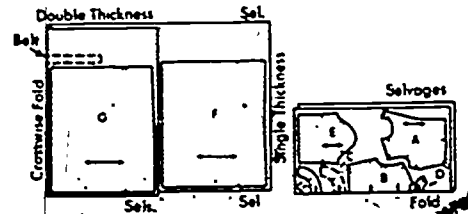

Fabric Without Nap  
Sizes 13, 16 - 44"

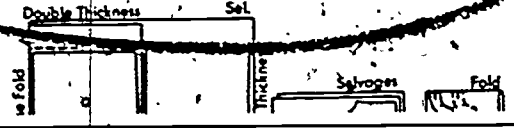

**Assignment:**

1. Using your own pattern, pick out the correct cutting layout for it.
2. Prepare your fabric for cutting.
3. What side of the fabric should be on the outside facing you?

UNIT IX  
USING A COMMERCIAL PATTERN

The Pattern Pieces

Lesson 6

**Objective.** The student will be able to read and understand the markings printed on all pattern pieces.

**Information;** Each pattern piece has markings. These markings are there to help you with the cutting, marking, and sewing of your garment.

Each pattern piece has the following identification markings:

1. Pattern number
2. Pattern size
3. Identification letter
4. View number
5. Name of the piece and whether it is front or back.

Other identification markings you may find are:

1. A double line with the words, "lengthen or shorten here," for those pattern pieces that may need this alteration.
2. Center front and center back are clearly marked.
3. The waistline is usually marked on the back pattern piece; sometimes it is marked on the front pattern piece.
4. The line arrowheads tell you what grain to place the pattern on. For example:

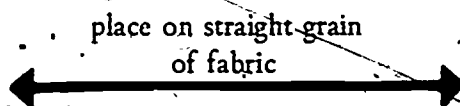

The straight grain of fabric is either the lengthwise grain or the crosswise grain. Generally, garments are cut on the *lengthwise grain*.

A bracketed grainline means the pattern edge has to be placed exactly on the fold of the fabric. For example:

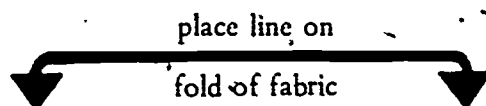

5. Cutting lines are the heavy solid outside lines on the pattern. Sometimes these cutting lines are found inside the pattern piece also. In these instances, the lines may indicate a shorter hemline for one of the views (the garment may come in two lengths) or a lining from another piece.

There are also construction markings which help you to sew the garment together. Some patterns will have all of the markings; some patterns will not have all of the markings. It depends on the design details of that style. Below are some of the markings you may find. See the sketch on the next page for the matching letters.

- A - Dots are aids for matching seams and other parts of the garment.
- B - The broken line is the stitching line (seamline). You sew right on that line. It is usually  $5/8$ " wide.
- C - The v-shaped symbols along the cutting line are called notches. They help you join pattern pieces.
- D - The arrowheads on the seamline show you the direction to sew the seam so that the fabric grain does not get pulled out of shape.
- E - The two broken lines that come to a point are called darts. The solid line in the center of the dart is for folding.
- F - We know the solid line outside the pattern is the cutting line. But the solid lines inside the pattern can mean different things such as hemlines, fold lines, pocket placement, etc.

There are other construction markings, but at this stage you need not worry about them. As you become a more experienced sewer, you will learn the other construction markings.



A Blouse Front

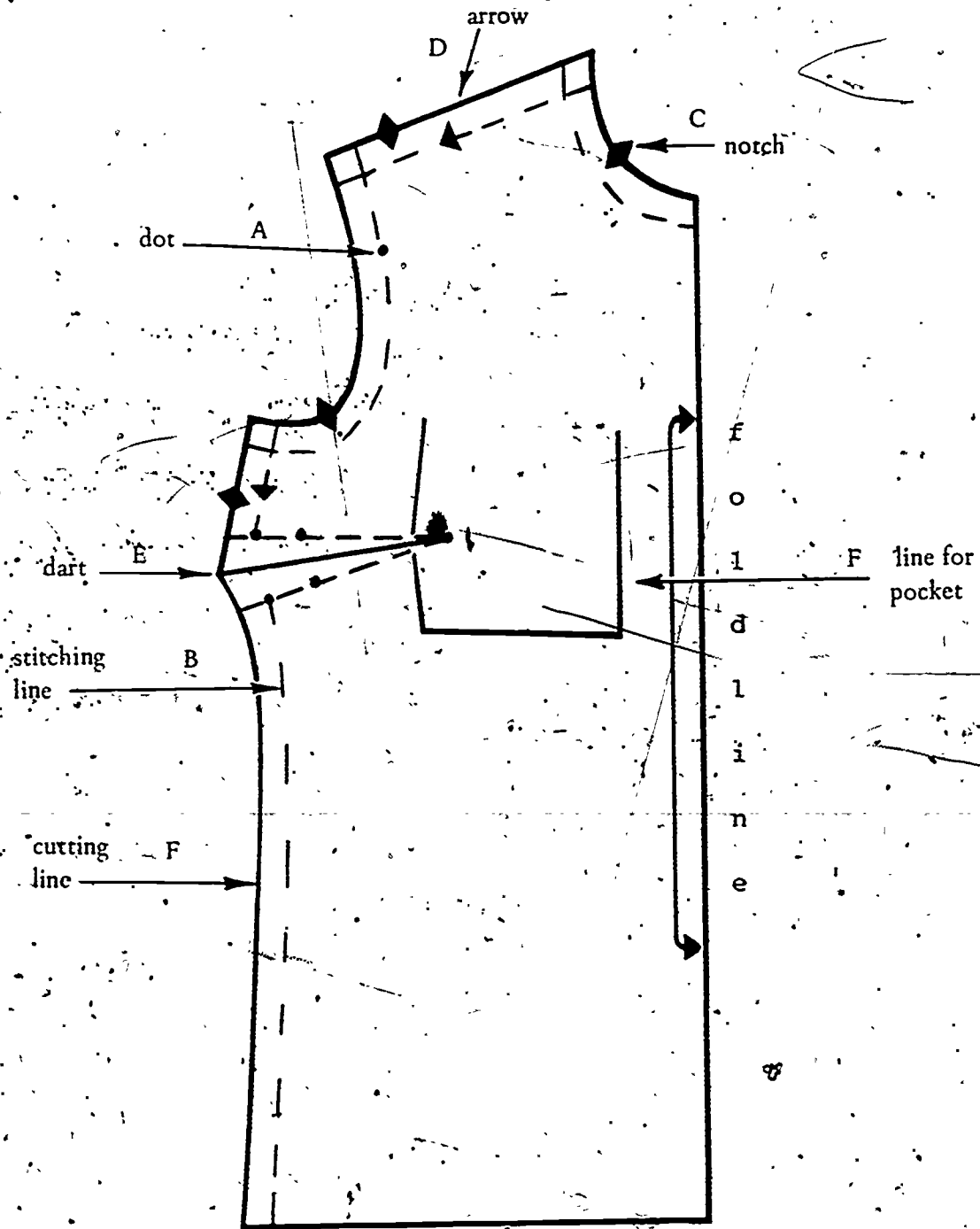

Study your own pattern pieces that you will soon be laying out on fabric and cutting. Are the markings clear to you?

Always make a 'trial' layout - that is, lay out all the pattern pieces you need to make the garment to make sure they all fit according to the grain. Then pin them into place.

The excess paper around the pattern will fall away as you cut. After each piece is cut, fold in and put it aside.

Assignment:

Lay out your pattern pieces and have your teacher check them. After it is checked by your teacher, pin the pattern pieces onto the fabric. Make sure you measure your straight grainlines. Let your teacher check it over. If it is O.K., cut out the pattern pieces.

1. Name the 5 identification markings that are *always* on each pattern piece.
2. A double line shows the point where you can \_\_\_\_\_ of \_\_\_\_\_ the pattern piece.
3. The waistline is usually marked on the \_\_\_\_\_ pattern piece.
4. A straight line arrowhead means "place on \_\_\_\_\_ of fabric."
5. A bracketed grainline means "place line on \_\_\_\_\_ of fabric."
6. The heavy solid outside lines on the pattern are the \_\_\_\_\_.
7. \_\_\_\_\_ markings help you sew the garment together.
8. Dots are aids for matching \_\_\_\_\_.
9. The broken line is the \_\_\_\_\_.
10. The v-shaped symbols are called \_\_\_\_\_.
11. The \_\_\_\_\_ show you the direction to sew the seam in.
12. The two broken lines that come to a point form a \_\_\_\_\_.
13. Solid lines inside the pattern can mean different things: for example, \_\_\_\_\_.

UNIT IX  
USING A COMMERCIAL PATTERN

Marking

Lesson 7

**Objective:** The student will be able to mark the fabric according to the construction symbols on the pattern pieces.

**Information:** In order to know where to make that dart, sew that seam, etc., it is necessary to transfer the construction symbols from the pattern to the wrong side of the fabric. *This is why we keep the right sides of the fabric inside.* This is called marking.

Always mark accurately and neatly; it is your guide for sewing your garment together. If the marking is sloppy, the sewing will be sloppy. Take the time out to mark carefully in the beginning, and you'll save time and energy later on when you're sewing.

It is usually not necessary to mark straight seamlines, but beginners should mark *all lines*. This way you cannot make a mistake.

There are several methods of marking:

1. **Tracing Paper and Wheel** - It is the easiest, fastest and most accurate way of marking for most fabrics. It is also called *dressmaker's paper*.
2. **Chalk and Pins** - Stick straight pins right down through pattern and fabric on the lines to be marked. Turn fabric over so that the points of the pins face up. Mark a dot wherever there is a pin sticking up. Turn fabric back over again so that the pattern side faces up. Remove the pattern carefully so that you do not pull out the pins. Again, mark a dot wherever there is a pin sticking up. Mark with chalk and ruler. After marking is done, remove pins.
3. **Tailor's Tacks** - It is the best method for marking bulky, spongy fabrics. You need a needle and cotton thread for making tailor's tacks.

Learn more about these methods of marking by the illustrations below.

*Here is how you mark with dressmaker's paper:*

1. The color of the paper should be close to the color of the cloth.

2. To mark double fabric:

Place a paper right side up, under bottom fabric.

Place second paper, right side down, between the pattern and the fabric.

3. To mark single fabric:

Place sheet facing wrong side of fabric.

4. Push tracing wheel over the lines.

5. Press enough to mark lightly.

6. Use a ruler for straight lines.

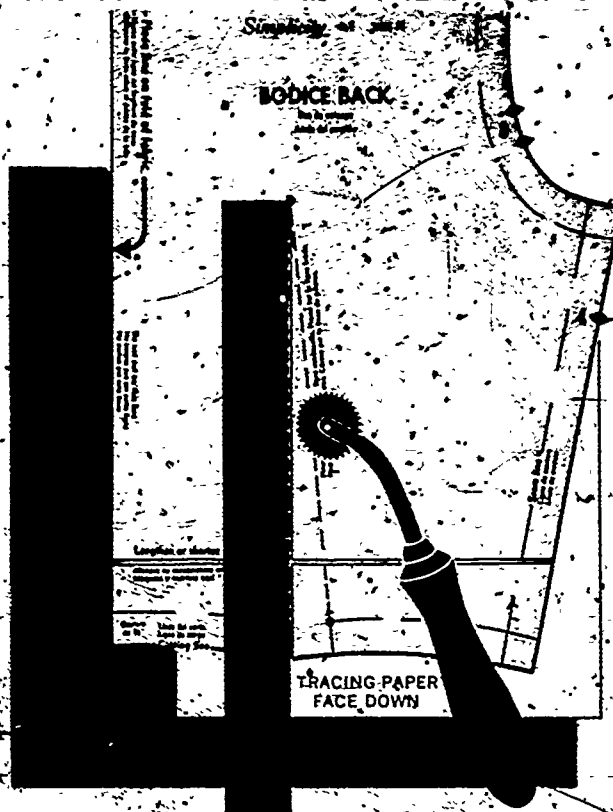

Here is how to make tailor's tacks:

1. Double thread, no knot.
2. Keep fabric and pattern pinned together.
3. Make a small stitch, going through all thicknesses. Leave ends of thread sticking out about 1 inch.
4. Make another stitch on top of the first stitch.
5. Leave a loop in the thread.
6. Cut off the thread about 1 inch from stitch.
7. Carefully remove the pattern piece.
8. Carefully lift the top piece of fabric.
9. Cut the threads between the two pieces of fabric.
10. Now you have a tailor's tack on each piece.

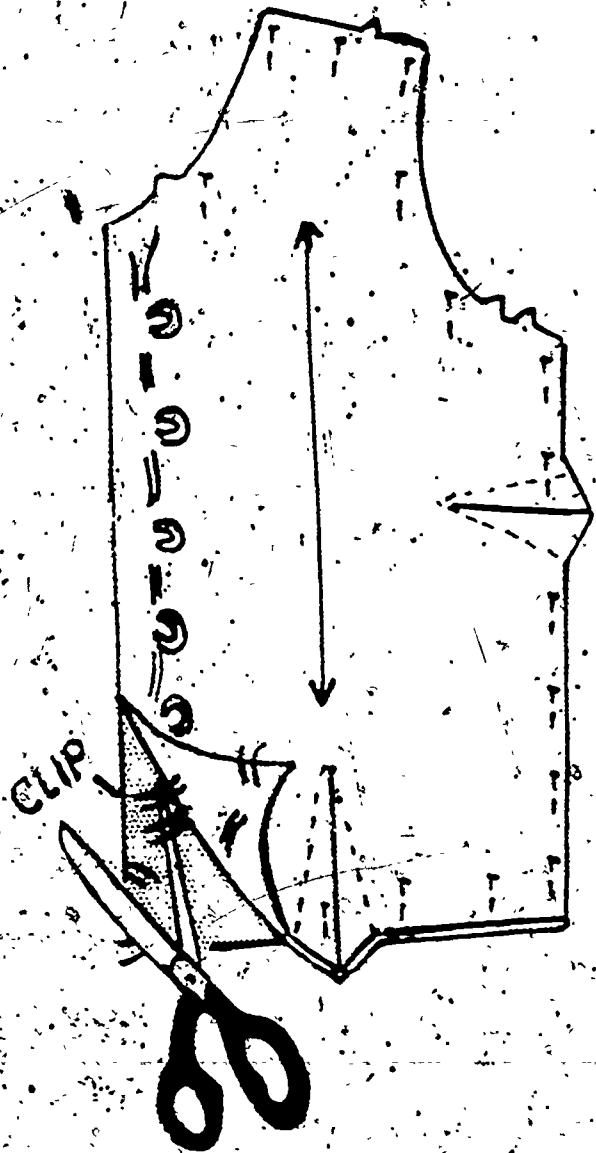

Assignment:

1. Take your pattern pieces and mark them accordingly. Leave pattern pieces pinned on until all of them have been marked properly.
2. Demonstrate how to make a tailor's tack.

UNIT X - DESIGNING

## UNIT X DESIGNING

### Thinking Design

### Lesson 1

**Objective:** The student will be able to identify the sources they can draw on to think in terms of designing a line of garments.

**Information:** The designer must create a new line of garments for each of the seasons - Spring, Summer, Fall (Back to School) and Holiday-Resort; that's four lines a year.

It is not an easy job to think of new and exciting things. No sooner does one line end than the new line must begin. The designer must be constantly aware of what is happening in fashion, fabrics, trims, accessories, and the mood of the country at the moment. From all these sources that he/she uses for inspiration, the designer creates his/her line of garments.

Now is the time for you to start thinking as a designer. Here are some of the places to look for inspiration:

1. Look in all the fashion magazines. See what the trend is. For instance, are the clothes romantic looking; are they sporty looking, etc.?
2. Look at the fabrics and the colors favored for that season. A fabric may give you the idea you need for a design. Some designers work this way.
3. What accessories are popular for that season? Are boots big news? Are they carrying handbags, shoulder bags, clutch bags, etc.? Are they wearing narrow belts, wide belts, or no belts? What kind of jewelry is popular? All these things can inspire your designs.
4. Look at costume books. Some part of an elaborate costume may inspire a whole line of garments. It may be a kind of collar, a neckline, a shape, etc. Look at the different periods of time and what they wore then. Fashion goes in cycles. Some of the old styles become fashionable again after many years.
5. What is happening around us? Is it the super space age? Perhaps you should design something that looks futuristic. Is the country feeling patriotic? Let loose with the stars, etc. Is the mood nostalgic - say from the 30's era. Design something that Joan Crawford would have worn, etc.

There are many different approaches to design. Some designers would not use any of the above sources to help them design their garments. But ideas are not pulled out of a top hat. Everyone uses something as a source of inspiration.



You may see something that gives you an idea. Then the ideas just keep coming. Other times, you will find the road slow and hard. It really doesn't matter how you design that line of garments; it's the end result that counts. **DO THEY LIKE IT AND WILL THEY BUY IT?**

**Assignment:**

1. Look through the latest fashion magazines. What are the latest trends in fashion?
2. Your teacher will assign you a season. Design a line of six garments.
3. What other sources do you use for getting ideas to design?

**UNIT XI - SKETCHING**

## UNIT XI SKETCHING

### The Croquis - Front View

Lesson 1

**Objective:** The students will be able to sketch their ideas by using the croquis.

**Information:** Designers make rough sketches. It is usually a pencil sketch that shows construction and style details so that an assistant can work from it. The croquis is the basic working figure to use - front and back views. The sketch may have swatches of fabric stapled to it and any other special information needed.

How to make a croquis, front view:

1. Draw a 4½-inch vertical line (C) and mark it off into half inches. See sketch on next page. Step 1.
2. At the first half-inch mark, draw a horizontal line (across). This will be the shoulder line. Make it 1" wide (½" on each side of the vertical line). Connect points A and B to the point C, forming a triangle. See sketch on next page. Step 1.
3. The bust is sketched at the second half-inch mark. See sketch on next page. Step 2.
4. Make a short curved line somewhat below the third mark for a waistline. Step 2.
5. Start the curve of the hips slightly below the waist. Curve out slightly below the waistline, but do not curve out too far beyond the lines of the triangle. Have the lines meet at C. See Step 2.
6. You can draw in the neckline and arms as in Step 2.

Heads, hands and feet are not necessary in this sketch. The details of the garment are important. They should be sketched in clearly.

# CROQUIS - FRONT VIEW

Step 1

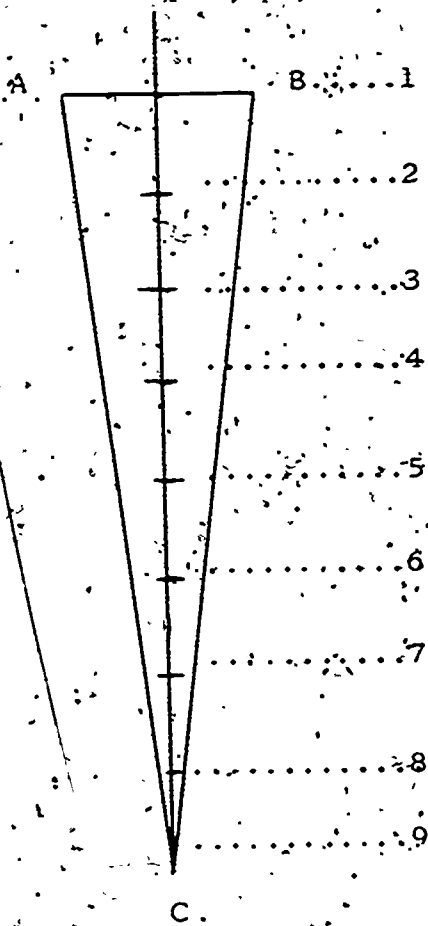

Step 2

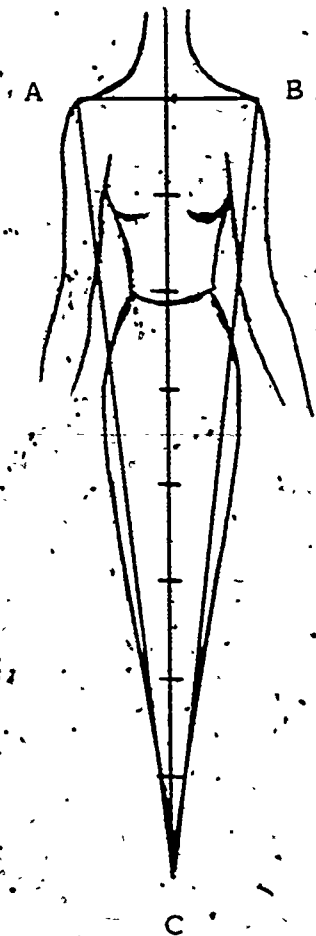

Now that you have your basic working figure, the croquis, you can start sketching garments. Just take tracing paper and place it over the croquis and sketch. Just move the paper along as you sketch your garments.

Assignment:

1. Draw the croquis.
2. Start sketching some simple garments using tracing paper and pencils.

## UNIT XI SKETCHING

### The Croquis - Back View

Lesson 2

**Objective:** The student will be able to sketch the back view of the garment.

**Information.** While it is important to see the front of a garment, it is just as important to see what the back of the garment looks like. Most garments close in the back. Or some garments have the styling detail in the back of the garment rather than in the front.

How to make a croquis, back view:

1. Draw a 4½-inch vertical line (F) and mark it off into half inches. (see sketch on next page, Step 1).
2. At the first half-inch mark, draw a horizontal line (across). This will be the shoulder line. Make it 1" wide (½" on each side of the vertical line). Connect points D and E to point F, forming a triangle, as you did, in the front view.
3. Make a short curved line somewhat below the third mark for the back of the waistline. Step 2.
4. Taper the sides of the back of the body from the second mark to meet the sides of the waistline. Step 2.
5. Start the curve of the hips slightly below the waist; curve out slightly beyond the lines of the triangle. Step 2.
6. Draw a curved line somewhat below the fourth mark. This represents the end of the back hips. Step 2.
7. You can draw in the neckline and arms as in Step 2.

# CROQUIS - BACK VIEW

Step 1

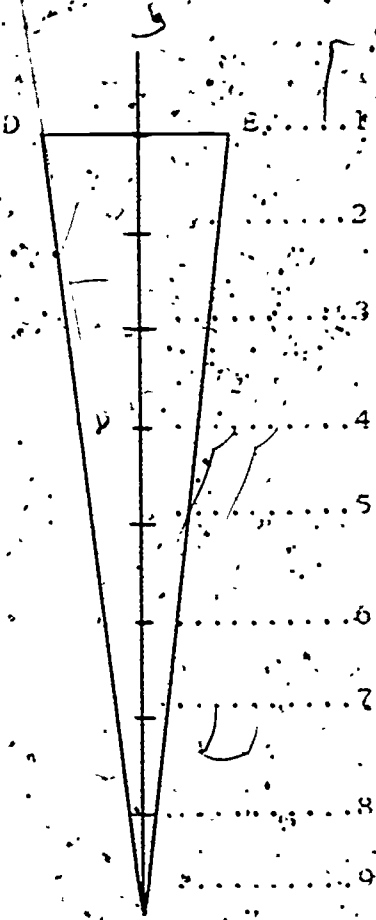

Step 2

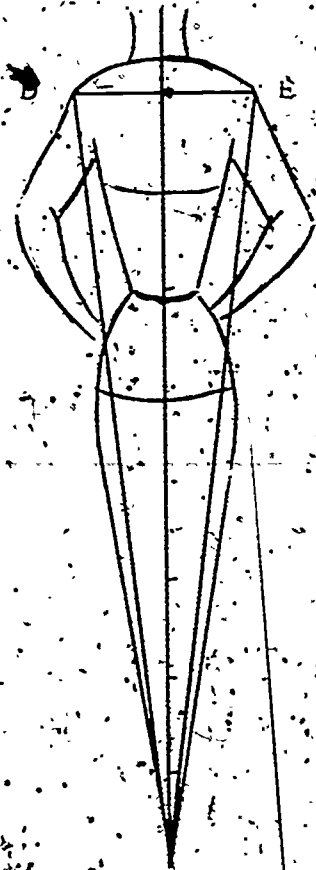

Now you can sketch both the front of your garment and the back.

Assignment:

1. Draw the croquis.
2. Sketch back views of all the garments you have already done.