

DOCUMENT RESUME

ED 121 588

SE 020 458

AUTHOR Fuller, Robert G., Ed.; And Others
TITLE Study Modules for Calculus-Based General Physics. [Includes Modules 31-34: Inductance; Wave Properties of Light; Interference; and Introduction to Quantum Physics].

INSTITUTION Nebraska Univ., Lincoln.
SPONS AGENCY National Science Foundation, Washington, D.C.
PUB DATE 75
NOTE 83p.; Prepared at a College Faculty Workshop (University of Colorado, Boulder, June 23-July 11, 1975); Directions for the CBP modules are found in SE 020 448; Related documents are SE 020 449-461

AVAILABLE FROM University of Nebraska, CBP Workshop, Behlen Laboratory of Physics, Lincoln, Nebraska 68588 (entire set of 42 modules, \$15.00)

ZDRS PRICE MF-\$0.83 HC-\$4.67 Plus Postage
DESCRIPTORS *Calculus; College Science; *Course Descriptions; Electricity; Higher Education; Individualized Curriculum; Instructional Materials; Light; Optics; *Physics; *Programed Instruction; Science Education; Undergraduate Study

IDENTIFIERS Keller Plan; *Personalized System of Instruction; PSI

ABSTRACT

This is part of a series of 41 Calculus Based Physics (CBP) modules totaling about 1,000 Pages. The modules include study guides, practice tests, and mastery tests for a full-year individualized courses in calculus-based physics based on the Personalized System of Instruction (PSI). The units are not intended to be used without outside materials; references to specific sections in four elementary physics textbooks appear in the modules. Specific modules included in this document are: Module 31--Inductance, Module 32--Wave Properties of Light, Module 33--Interference, and Module 34--Introduction to Quantum Physics. (CP)

 * Documents acquired by ERIC include many informal unpublished *
 * materials not available from other sources. ERIC makes every effort *
 * to obtain the best copy available. Nevertheless, items of marginal *
 * reproducibility are often encountered and this affects the quality *
 * of the microfiche and hardcopy reproductions ERIC makes available *
 * via the ERIC Document Reproduction Service (EDRS). EDRS is not *
 * responsible for the quality of the original document. Reproductions *
 * supplied by EDRS are the best that can be made from the original. *

STUDY MODULES FOR CALCULUS-BASED GENERAL PHYSICS*

THIS DOCUMENT HAS BEEN REPRODUCED EXACTLY AS RECEIVED FROM THE PERSON OR ORGANIZATION ORIGINATING IT. POINTS OF VIEW OR OPINIONS STATED DO NOT NECESSARILY REPRESENT OFFICIAL NATIONAL INSTITUTE OF EDUCATION POSITION OR POLICY.

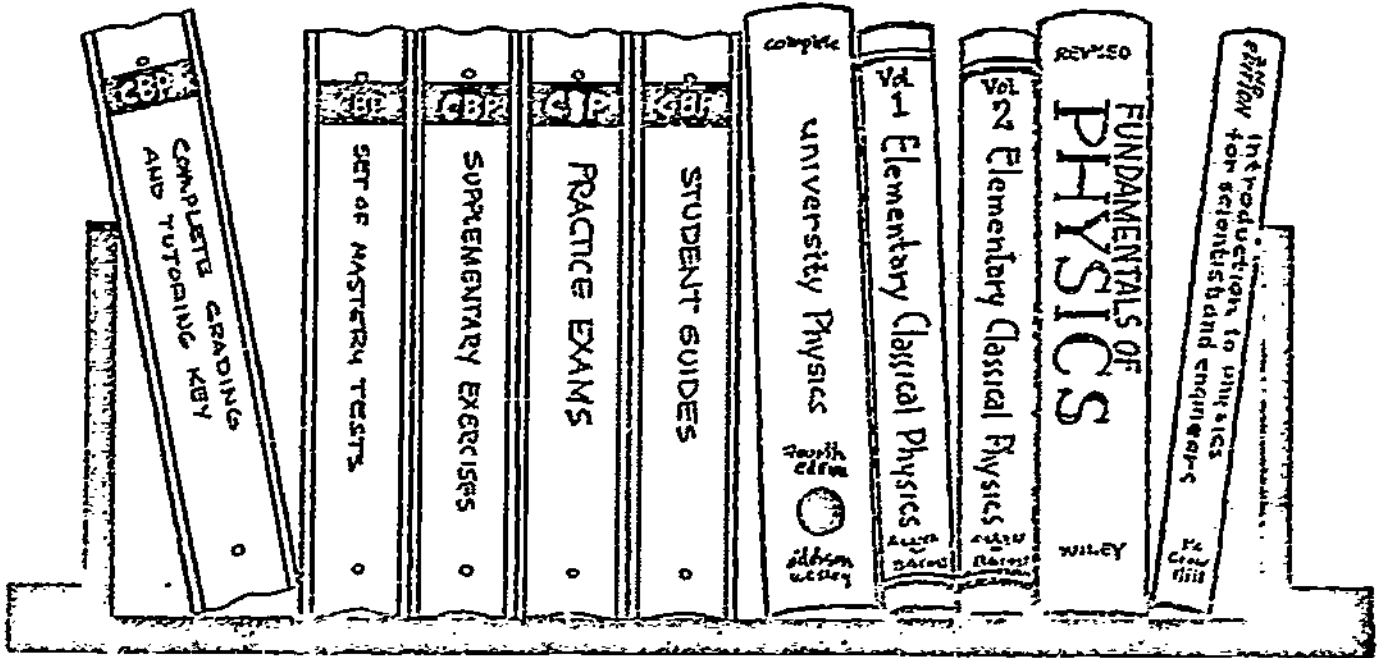

PERMISSION TO REPRODUCE THIS COPY-
RIGHTED MATERIAL HAS BEEN GRANTED BY

Robert G. Fuller
CBP Workshop

CBP Workshop
Behlen Laboratory of Physics
University of Nebraska
Lincoln, NE 68508

TO ERIC AND ORGANIZATIONS OPERATING
UNDER AGREEMENTS WITH THE NATIONAL IN-
STITUTE OF EDUCATION. FURTHER REPRO-
DUCTION OUTSIDE THE ERIC SYSTEM RE-
QUIRES PERMISSION OF THE COPYRIGHT
OWNER.

*Supported by The National Science Foundation



Comments

These modules were prepared by fifteen college physics professors for use in self-paced, mastery-oriented, student-tutored, calculus-based general physics courses. This style of teaching offers students a personalized system of instruction (PSI), in which they increase their knowledge of physics and experience a positive learning environment. We hope our efforts in preparing these modules will enable you to try and enjoy teaching physics using PSI.

Robert G. Fuller
Director
College Faculty Workshop

MODULE AUTHORS

OWEN ANDERSON	Bucknell University
STEPHEN BAKER	Rice University
VAN BLEUMEL	Worcester Polytechnic Institute
FERNAND BRUNSCHWIG	Empire State College
DAVID JOSEPH	University of Nebraska - Lincoln
ROBERT KARPLUS	University of California - Berkeley
MICHAEL KOLONEY	Rose Hulman Institute of Technology
JACK MUNSEE	California State University - Long Beach
GARY NEWBY	Boise State University
IVOR NEWSHAM	Olivet Nazarene College
WILLIAM SNOW	University of Missouri - Rolla
WILLARD SPERRY	Central Washington State College
ROBERT SWANSON	University of California - San Diego
JAMES TANNER	Georgia Institute of Technology
DAVID WINCH	Kalamazoo College

These modules were prepared by the module authors at a College Faculty Workshop held at the University of Colorado - Boulder, from June 23 to July 11, 1975.

Workshop Staff

Allert A. Bartlett	University of Colorado
Thomas C. Campbell	Illinois Central College
Harold Q. Fuller	University of Missouri - Rolla

Calculus-Based Physics (CBP) Modules Production Staff

Robert G. Fuller	Editor
Thomas C. Campbell	Assistant Editor
William D. Snow	Illustrator
Catherine A. Caffrey	Production Editor

Copyright CBP Workshop
University of Nebraska - Lincoln, 1975
Reproduction Rights Granted

COMMENT TO USERS

In the upper right-hand corner of each Mastery Test you will find the "pass" and "recycle" terms and a row of numbers "1 2 3 ..." to facilitate the grading of the tests. We intend that you indicate the weakness of a student who is asked to recycle on the test by putting a circle around the number of the learning objective that the student did not satisfy. This procedure will enable you easily to identify the learning objectives that are causing your students difficulty.

COMMENT TO USERS

It is conventional practice to provide several review modules per semester or quarter, as confidence builders, learning opportunities, and to consolidate what has been learned. You the instructor should write these modules yourself, in terms of the particular weaknesses and needs of your students. Thus, we have not supplied review modules as such with the CBP Modules. However, fifteen sample review tests were written during the Workshop and are available for your use as guides. Please send \$1.00 to CBP Modules, Behlen Lab of Physics, University of Nebraska - Lincoln, Nebraska 68588.

FINIS

This printing has completed the initial CBP project. We hope that you are finding the materials helpful in your teaching. Revision of the modules is being planned for the Summer of 1976. We therefore solicit your comments, suggestions, and/or corrections for the revised edition. Please write or call

CBP WORKSHOP
Behlen Laboratory of Physics
University of Nebraska
Lincoln, NE 68588

Phone (402) 472-2790
(402) 472-2742

INDUCTANCE

INTRODUCTION

Anyone who has ever grabbed an automobile spark-plug wire at the wrong place, with the engine running, has an appreciation of the ability of a changing current in (part of) a coil of wire to induce an emf in the coil. What happens is that the breaker contacts open, suddenly interrupting the current, and causing a sudden large change in the magnetic field through the coil; according to Faraday's law, this results in a (large) induced emf. In general, the production of an emf in a coil by a changing magnetic field due to a current in that same coil is called self-induction; and the ability of a coil to produce an emf in this way is commonly measured by its self-inductance L , usually called more briefly its inductance. A coil used in this way is more formally called an inductor.

The transmission of electric signals by television, radio, and telephone depends on time-varying currents and fields to represent the appearance of pictures and the sound of voices; and so, as you can well imagine, capacitors and inductors play an important role in the circuits of such devices. You already know that a capacitor can store energy; so can an inductor. If an inductor carrying a current is connected to a resistor, its energy is dissipated as heat in the resistor, much as for a charged capacitor. But now suppose you connect it instead to a capacitor; the inductor will try to give its energy to the capacitor - and vice versa - but the initial energy is not quickly dissipated from the electrical circuit. What do you suppose happens? If you do not already know, can you guess, before studying this module?

PREREQUISITES

Before you begin this module, you should be able to:

Location of
Prerequisite Content

*Use Ampère's law to calculate \vec{B} inside toroids and long solenoids (needed for Objective 1 of this module)	Ampère's Law Module
*Relate the emf induced in such toroids and solenoids to the time rate of change of \vec{B} or ϕ_B (needed for Objective 1 of this module)	Faraday's Law Module
*Find the power dissipated by a resistor (needed for Objective 2 of this module)	Ohm's Law Module
*Add voltages around an RC circuit to verify the exponential time dependences of the current and voltage (needed for Objective 2 of this module)	Direct-Current Circuits Module
*Find the energy stored in a capacitor (needed for Objective 3 of this module)	Capacitors Module
*Relate the motion of a mechanical oscillator to the mathematical expression for its displacement (needed for Objective 3 of this module)	Simple Harmonic Motion Module

LEARNING OBJECTIVES

After you have mastered the content of this module, you will be able to:

1. Inductance - Apply the definition of inductance, Ampère's law, and Faraday's Law to toroids and long solenoids to (a) find the inductance L ; and (b) relate the induced emf to the rate of change of current or flux.
2. LR circuits - Determine currents, voltages, stored energies, and power dissipations in simple LR circuits. (This includes adding up voltages around the circuit to find a differential equation and determine the time dependence.)
3. LC circuits - Determine charges, voltages, currents, and stored energies in simple LC circuits. (This includes using the principle of energy conservation to find maximum values, as well as to obtain a differential equation and determine the time dependence.)

TEXT: Frederick J. Bueche, Introduction to Physics for Scientists and Engineers (McGraw-Hill, New York, 1975), second edition

SUGGESTED STUDY PROCEDURE

Read the General Comments on the following pages of this study guide, along with Sections 25.3 through 25.5 and 27.8 in your text; but the part of Section 25.5 after Eq. (25.7), and Cases 2 and 3 of Section 27.8 (including Illustration 27.8) are optional, for the purposes of this module. Optional: Read Section 25.2. Recommended: Read Sections 34-1 through 34-3 in Halliday and Resnick (HR)* or Section 34-1 in Weidner and Sells (WS),* for further discussion of electromagnetic oscillations.

Although this is not explicit in the text, Bueche assumes the self-inductance L to be defined as the proportionality factor between the current and the flux:

$$N\phi = Li. \quad (B1)$$

When there is no ferromagnetic material near the coil, ϕ is proportional to i , and L is thus constant. Differentiation then yields $L(di/dt) = N(d\phi/dt)$, which by Faraday's law is just the induced emf $-\mathcal{E}$. Therefore, as in Eq. (25.2),

$$\mathcal{E} = -L(di/dt). \quad (B2)$$

Equations (B1) and (B2) are equivalent for coils that do not have ferromagnetic cores, as will be the case in the problems of this module. You will find that Eq. (B1) is sometimes more convenient to use than Eq. (B2).

BUECHE

Objective Number	Readings	Problems with Solutions		Assigned Problems Study Guide	Additional Problems
		Study Guide	Text		
1	Sec. 25.3	A	Illus. ^a 25.2	F, G	Chap. 25: Quest. ^a 2, 11
2	General Comment 1; Secs. 25.4, 25.5 thru Eq. (25.7)	B, C		H, I	Chap. 25: Probs. 12, 13
3	General Comment 2; Sec. 27.8; HR*; Secs. 34-1 thru 34-3; or WS*; Sec. 34-1	D, E		J, K	L

^aIllus. = Illustration(s). Quest. = Question(s).

*HR = David Halliday and Robert Resnick, Fundamentals of Physics (Wiley, New York, 1970; revised printing, 1974).

WS = Richard T. Weidner and Robert L. Sells, Elementary Classical Physics (Allyn and Bacon, Boston, 1973), second edition, Vol. 2.

TEXT: David Halliday and Robert Resnick, Fundamentals of Physics (Wiley, New York, 1970; revised printing, 1974)

SUGGESTED STUDY PROCEDURE

Read the General Comments on the following pages of this study guide, along with Sections 32-1 through 32-4, and 34-1 through 34-3 in your text.

HALLIDAY AND RESNICK

Objective Number	Readings	Problems with Solutions		Assigned Problems	Additional Problems
		Study Guide	Text		
1	Secs. 32-1, 32-2	A	Chap. 32, Ex. ^a 1	F, G	Chap. 32: Probs. 1, 2, 5, 9, 10(a), 11(b), Quest. ^a 4
2	General Comment 1; Secs. 32-3, 32-4	B, C	Chap. 32, Ex. 2, 3, 4	H, I	Chap. 32: Probs. 11(a), 12 thru 25, Quest. 7 thru 11
3	General Comment 2; Secs. 34-1, 34-2, 34-3	D, E	Chap. 34, Ex. 1, 2, 3	J, K	L; Chap. 34: Probs. 1 thru 17

^aEx. = Example(s). Quest. = Question(s).

TEXT: Francis Weston Sears and Mark W. Zemansky, University Physics (Addison-Wesley, Reading, Mass., 1970), fourth edition

SUGGESTED STUDY PROCEDURE

Read the General Comments on the following pages of this study guide, along with Sections 33-9 through 33-12 in your text; but the latter part of Section 33-10, on p. 477, is optional for the purposes of this module. Optional: Read Section 33-8. Recommended: Read Sections 34-1 through 34-3 in Halliday and Resnick (HR)* or Section 34-1 in Weidner and Sells (WS)* for further discussion of electromagnetic oscillations.

SEARS AND ZEMANSKY

Objective Number	Readings	Problems with Solutions		Assigned Problems	Additional Problems
		Study Guide	Text	Study Guide	
1	Sec. 33-9	A	Example in Sec. 33-9	F, G	33-12, 33-20, 33-21
2	General Comment 1; Secs. 33-10, 33-11	B, C		H, I	33-30 thru 33-34
3	General Comment 2; Sec. 33-12; HR*: Secs. 34-1, 34-2, 34-3; or WS*: Sec. 34-1	D, E		J, K	L; 33-35

*HR = David Halliday and Robert Resnick, Fundamentals of Physics (Wiley, New York, 1970; revised printing, 1974).

WS = Richard T. Weidner and Robert L. Sells, Elementary Classical Physics (Allyn and Bacon, Boston, 1973), second edition, Vol. 2.

TEXT: Richard T. Weidner and Robert L. Sells, Elementary Classical Physics (Allyn and Bacon, Boston, 1973), second edition, Vol. 2

SUGGESTED STUDY PROCEDURE

Read the General Comments on the following pages of this study guide, along with Sections 32-1 through 32-3 and 34-1 in your text.

There is a typographical error in Eq. (34-7); the second-to-last term should read $(Q_m \cos \omega t)^2 / 2C$.

WEIDNER AND SELLS

Objective Number	Readings	Problems with Solutions		Assigned Problems	Additional Problems
		Study Guide	Text	Study Guide	
1	Sec. 32-1	A	Ex. ^a 32-1	F, G	32-12(a)
2	General Comment 1; Secs. 32-2, 32-3	B, C	Ex. 32-2	H, I	32-2, 32-5 thru 32-11, 32-12(b), 32-13
3	General Comment 2; Sec. 34-1	D, E		J, K	L; 34-1

^aEx. = Example(s).

GENERAL COMMENTS1. LR Circuits

Suppose you are given the circuit shown in Figure 1. Before the switch is closed, the current is zero. When the switch is closed, the current starts to rise - but only at a finite rate; since the inductor will not allow any sudden change in the current. [The induced emf $-L(di/dt)$ would be infinite!] Furthermore, the current will not rise indefinitely, because of the opposing voltage $V_R = -Ri$ across the resistor. Therefore, the behavior of the current has the appearance of Figure 2. Since the emf induced in L vanishes as the current approaches its final, unchanging, value i_0 , we see that

$$i_0 = V_B/R. \quad (1)$$

Next, adding voltages around the circuit, much as you did in the module Direct-Current Circuits for circuits containing only resistors and batteries, leads to the equation

$$V_B - Ri - L(di/dt) = 0. \quad (2)$$

This "differential equation" gives a mathematical description of the behavior of the current i after the switch is closed.

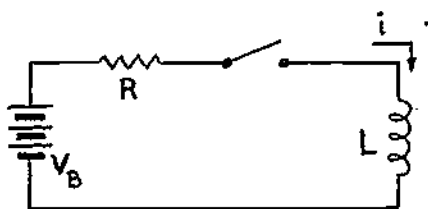

Figure 1

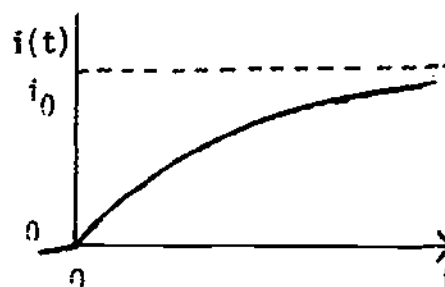

Figure 2

Another possibility is the circuit shown in Figure 3. Initially, the switch is closed; and we imagine that the current i has reached its steady-state value, so that the emf induced in L is zero. Therefore, the voltage difference across R is zero, and the current through the inductor is

$$i_0 = V_B/R_1 \quad (3)$$

while the switch is closed. When the switch is opened, the emf induced in the inductor again prevents any instantaneous change in i ; its initial value is

therefore just i_0 . The current now flows through the only path open to it, namely, through R ; as a result, the resistor R heats up. Evidently, this supply of heat is not unlimited (or we would use it to heat houses!); the current must fall toward zero, as in Figure 4. Incidentally, since the resistor does heat up, we have seen that an inductor stores energy when a current is flowing through it.

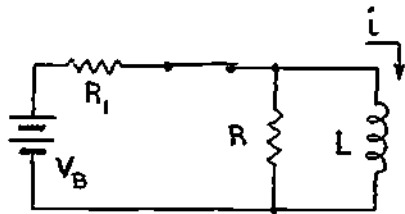
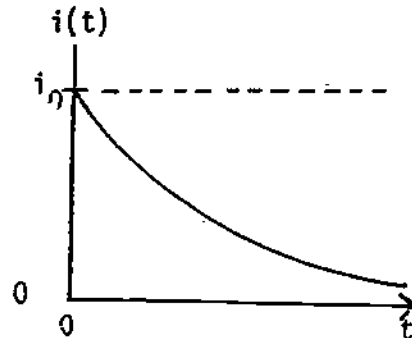

Figure 3

Figure 4



Figures 2 and 4 should recall to mind the behavior of the charge and current in the RC circuits that you studied in the module Direct-Current Circuits. A synopsis of the results for such circuits is presented in Figure 5. If you look back, you will find, for example, that the voltage across the capacitor obeys the

Figure 5: RC Circuits ($\tau = RC$)

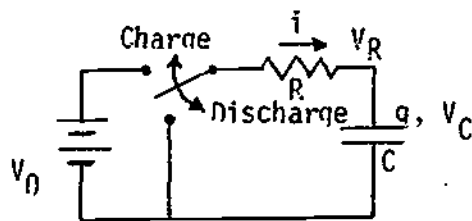

Note proportionalities:

$$V_C = q/C; \quad V_R = Ri.$$

Switch is moved at $t = 0$.

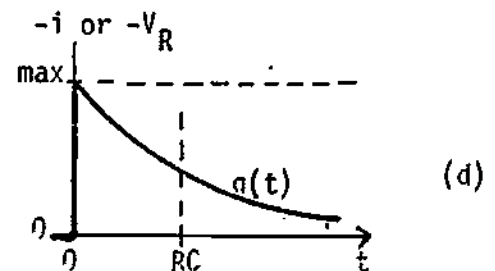
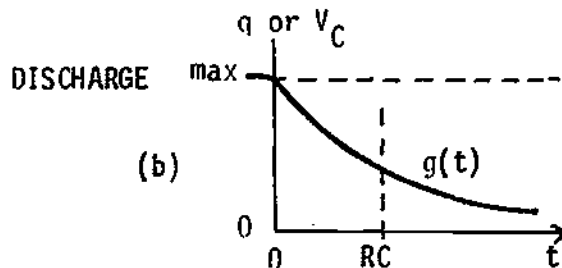
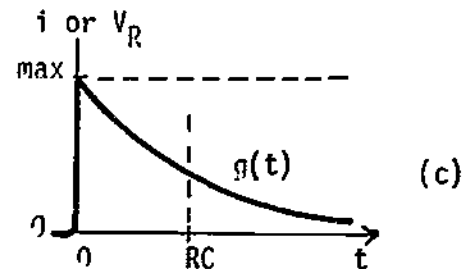
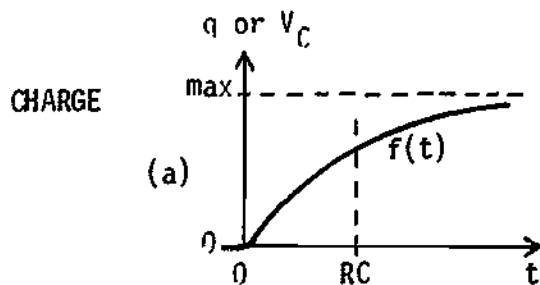

equation

$$V_C = V_B[1 - e^{-t/\tau}] \quad (\text{where } \tau = RC) \quad (4)$$

when the switch is moved to the "charge" position, and

$$V_C = V_B e^{-t/\tau} \quad (5)$$

when the switch is moved back to "discharge" after the capacitor has become fully charged. In fact, all the quantities indicated in Figure 5 can be expressed as

$$y = \text{const} \times f(t) \quad \text{or} \quad y = \text{const} \times g(t), \quad (6)$$

$$\text{where } f(t) = 1 - e^{-t/\tau} \quad \text{and} \quad g(t) = e^{-t/\tau}. \quad (7)$$

Note that $f(0) = 0$ and $f(\infty) = 1$, $g(0) = 1$ and $g(\infty) = 0$.

In each case, "const" is just the maximum value of the quantity in question, which is either the limiting value for large times, or the initial value at $t = 0$.

Of course, we are not really interested in re-solving RC circuits in this module! The point of all this is that we need to find the solution of the differential equation (2). The similarity between Figures 2 and 5(a) - both curves rise from zero to an asymptotic value - suggests that we "try" a solution similar to Eq. (4). (Actually, if you checked the differential equations, you would find that they are similar, too.) That is, we set

$$i(t) = Af(t) = A(1 - e^{-t/\tau}), \quad (8)$$

where the constant A is determined by the condition, from Eq. (1), that

$$i(\infty) = i_0 = V_B/R = A(1 - 0) = A. \quad (9)$$

Substitution of the expression (8) into the differential equation (2) leads to

$$0 = V_B - RA(1 - e^{-t/\tau}) - L(A/\tau)e^{-t/\tau} = V_B - V_B + (V_B - LV_B/R\tau)e^{-t/\tau}, \quad (10)$$

when the value $A = V_B/R$ is inserted, from Eq. (9). This equation is satisfied if and only if

$$\tau = R/L. \quad (11)$$

With these particular values, Eq. (8) becomes

$$i(t) = (V_B/R)(1 - e^{-t/\tau}); \quad (12)$$

we have found the needed solution to Eq. (1), for the current $i(t)$ in the circuit of Figure 1! (It can also be shown that this solution is unique.)

Other LR circuit problems can be analyzed in this same way; as above, the steps are:

- (a) Determine the qualitative behavior of the current as a function of time, including its maximum value.
- (b) Add voltages around the circuit to find the appropriate differential equation.
- (c) "Try" a solution to (b) of the form $Af(t)$ or $Ag(t)$, where $f(t)$ and $g(t)$ are defined in Eq. (7), depending on whether (a) was increasing or decreasing. [The constant A is equal to the maximum value found in part (a).] The resulting equation gives the correct value of τ .

Once you know $i(t)$, it is a relatively simple matter to find any other quantity, such as the voltage across the resistor, $V_R = Ri$, or the induced emf $\mathcal{E}_L = -di/dt$. A summary of the results for typical LR circuits is presented in Figure 6.

Figure 6: LR Circuits ($\tau = L/R$)

Note proportionalities: $\mathcal{E}_L = -L(di/dt)$;
 $V_R = Ri$. Switch is moved at $t = 0$.

ENERGIZE (Corresponds to "Charge")

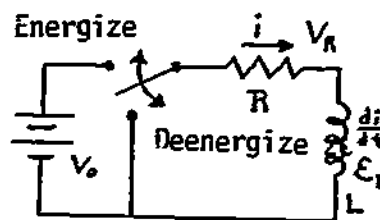
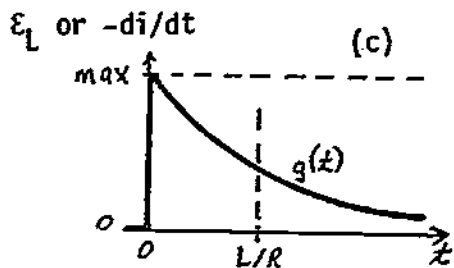
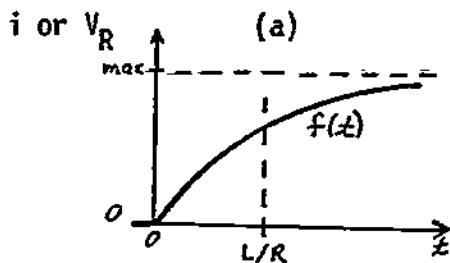

DEENERGIZE (Corresponds to "Discharge")

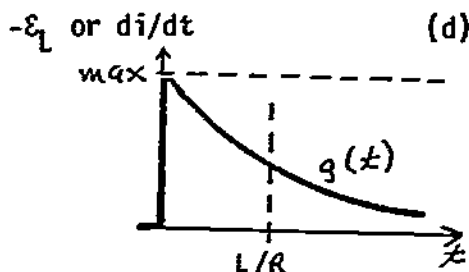
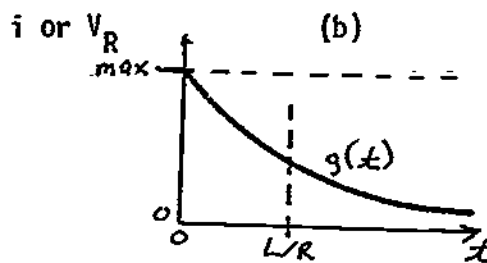

2. LC Circuits

As the term "LC" implies, we are assuming idealized inductors and capacitors, with negligible resistive or other dissipative effects; the circuit shown in Figure 7 is constructed from such idealized components. With the switch in position a, the capacitor acquires the charge

$$q_0 = CV_B \tag{13}$$

As you learned in the module Capacitors, this implies that an amount of energy

$$U_C = (1/2)(q_0^2/C) = U_0 \tag{14}$$

is stored in the capacitor.

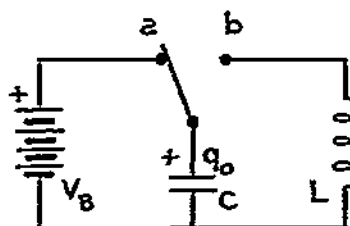

Figure 7

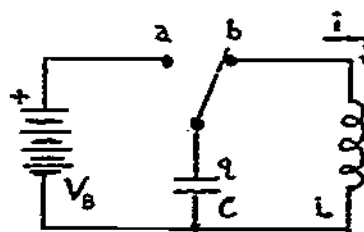

Figure 8

When the switch is moved to position b as in Figure 8, positive charge starts to flow from the upper plate of C through L. Eventually, the capacitor becomes discharged ($q = 0$), at which time

$$U_C = 0. \quad (15)$$

But the energy U_0 that was originally stored in the capacitor must have gone somewhere. It could not have been converted to internal ("heat") energy, since there are no resistors in the circuit; therefore it must have gone into the inductor. That is, the current must have the value $i = i_0$ such that the energy stored in the inductor is

$$U_L = (1/2)Li_0^2 = U_0. \quad (16)$$

Of course, the inductor will not let the current stop abruptly; the capacitor thus proceeds to charge up again, but with negative charge on the top plate. The current does stop, however, when all the energy has been transferred back to the capacitor, i.e., when

$$U_C = U_0 \text{ and } U_L = 0. \quad (17)$$

Next, the potential difference across the charged capacitor plates again starts a current flowing through the inductor, but in the opposite direction from before - and so on.

Thus, there is a continual transfer of energy back and forth between the capacitor and the inductor, in such a way that the total energy is constant:

$$U_C(t) + U_L(t) = U_0. \quad (18)$$

See Figure 9. This transfer of energy back and forth is very nicely portrayed by the upper circular diagram on p. 10 [Fig. 11(a)].

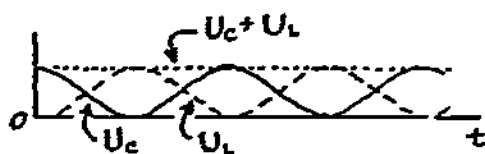

Figure 9

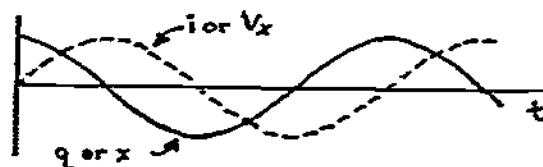

Figure 10

The lower circular diagram [Fig. 11(b)] shows the analogous situation in a mechanical oscillator; the spring potential energy is the analog of U_c , and the kinetic energy of the moving mass is the analog of U_L . The oscillation of the positive charge between the upper and lower plates of C is very similar to the back and forth motion of the mass in the mechanical case; in fact, we can represent the charge q and the displacement x (or the current i and the velocity v_x) by the same graph, as in Figure 10, provided we match up the amplitudes, frequencies, and phases.

The curves in Figure 10 were drawn to be sinusoidal; how can we check this claimed behavior? Simple enough:

(a) Write the equation of energy conservation:

$$(1/2)q^2/C + (1/2)Li^2 = U_0.$$

(b) Differentiate with respect to time:

$$(1/C)q(dq/dt) + Li(di/dt) = 0.$$

(c) Use $i = dq/dt$, cancel a factor, and rearrange:

$$LC(d^2q/dt^2) + q = 0. \quad (19)$$

Another differential equation! But do not despair; we are merely going to check the claimed sinusoidal behavior - thus we set

$$q(t) = q_m \cos(\omega t + \phi), \quad (20)$$

(where q_m , ω , and ϕ are constants to be determined) and substitute this expression into Eq. (19) to see whether or not it is a solution. The substitution leads to

$$-LC\omega^2 q_m \cos(\omega t + \phi) + q_m \cos(\omega t + \phi) = 0, \quad (21)$$

Figures 11(a) and (b) visualize the energy transfer that occurs during one cycle of an electrical oscillator [Figure 11(a)] and of a mechanical oscillator [Figure 11(b)]. Note the amazingly similar behavior of these apparently dissimilar devices.

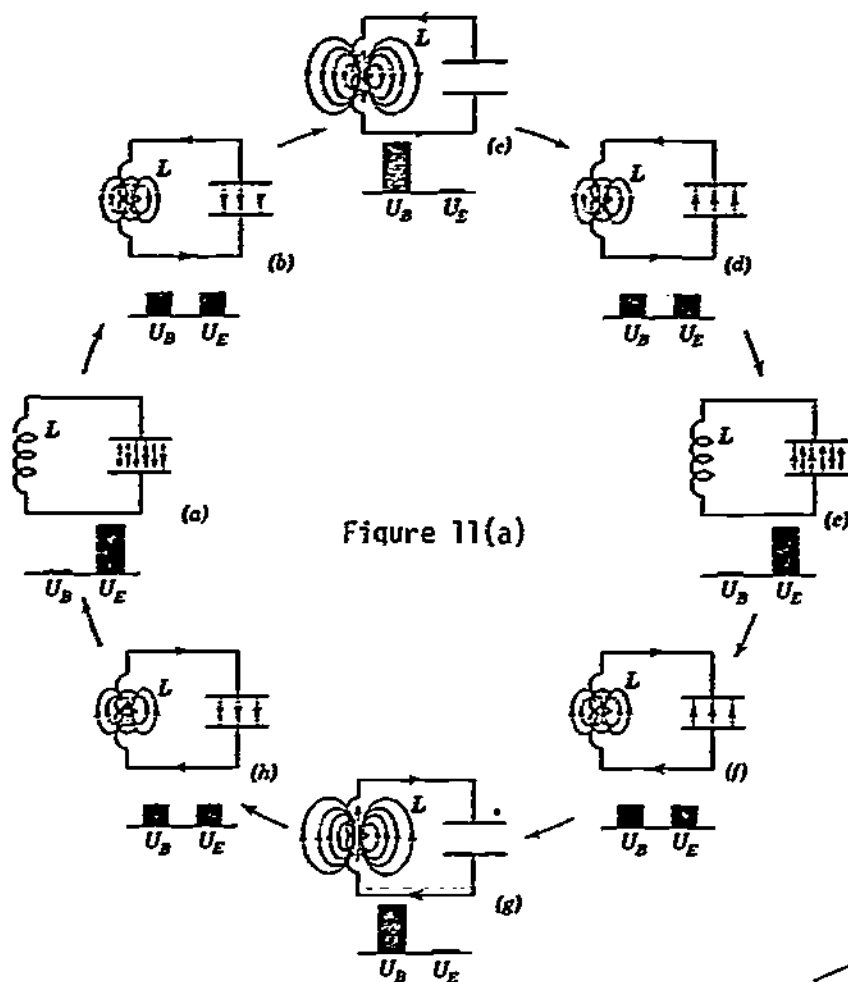

Figure 11(a)

The diagrams on this page [Figures 11(a) and 11(b)] have been reprinted from Fundamentals of Physics, by David Halliday and Robert Resnick (Wiley, New York, 1970; revised printing, 1974), with permission of the publisher. In the text they are Figures 34-1 and 7-4, respectively.

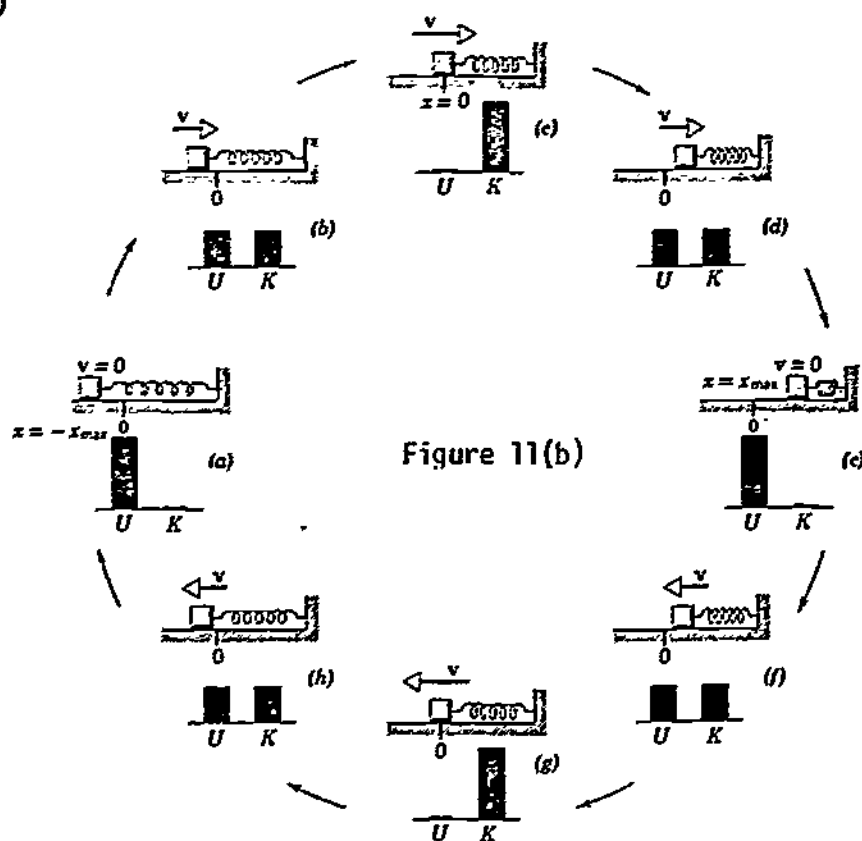

Figure 11(b)

which is satisfied provided

$$\omega = \sqrt{1/LC}. \quad (22)$$

The sinusoidal behavior (20) is thus verified, and we have found the frequency

$$f = \omega/2\pi = (1/2\pi)\sqrt{1/LC}. \quad (23)$$

As in the mechanical case, the values of q_0 and ϕ are determined by initial conditions. For example, if the switch in Figure 7 is moved to b at $t = 0$, then

$$q(t = 0) = CV_B \quad \text{and} \quad dq/dt(t = 0) = 0; \quad (24)$$

applying these conditions to Eq. (20) yields

$$q_m = CV_B \quad \text{and} \quad \phi = 0. \quad (25)$$

ADDITIONAL LEARNING MATERIALS

Auxilliary Reading

Stanley Williams, Kenneth Brownstein, and Robert Gray, Student Study Guide with Programmed Problems to Accompany Fundamentals of Physics and Physics, Parts I and II, by David Halliday and Robert Resnick (Wiley, New York, 1970).

Objective 1: Sections 31-1 and 31-2;

Objective 2: Sections 31-4 and 31-7 through 31-9;

Objective 3: Section 33-1.

Various Texts

Frederick J. Bueche, Introduction to Physics for Scientists and Engineers (McGraw-Hill, New York, 1975), second edition: Sections 25.3 through 25.5 and 27.8.

David Halliday and Robert Resnick, Fundamentals of Physics (Wiley, New York, 1970; revised printing, 1974): Sections 32-1 through 32-4 and 34-1 through 34-3.

Francis Weston Sears and Mark W. Zemansky, University Physics (Addison-Wesley, Reading, Mass., 1970), fourth edition: Sections 33-9 through 33-12.

Richard T. Weidner and Robert L. Sells, Elementary Classical Physics (Allyn and Bacon, Boston, 1973), second edition, Vol. 2: Sections 32-1 through 32-3 and 34-1.

PROBLEM SET WITH SOLUTIONS

- A(1). An inductor in Figure 12 has been wound on a long cylindrical form with a square cross section measuring 1.00 cm by 1.00 cm. The winding has been painted over, so that it is impossible to count the turns; however, you are able to determine that the flux through the center is 1.00 μT when the current is 4.0 A.

- (a) Apply Ampère's law (indicate your path) to find the number of turns per meter.
 (b) If the inductance is $200 \mu\text{H}$, about how long is the winding? Neglect the spreading of the magnetic lines of force at the ends.
 (c) If a potential difference of 1.00 mV is applied between the ends of the inductor, at what rate does the current increase, as long as the resistance of the inductor can be neglected?

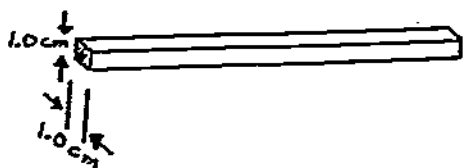

Figure 12

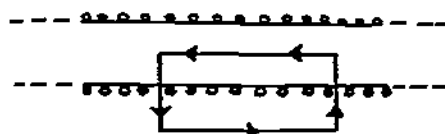

Figure 13

Solution

(a) Applying Ampère's law to the rectangular path in Figure 13 yields

$$\oint \vec{B} \cdot d\vec{\ell} = \mu_0 N' i,$$

where ℓ is the length of the rectangle, B is the strength of the magnetic field, N' is the number of turns enclosed by the rectangle, and i is the current in each. Since B is the quotient of flux and area, the number of turns per unit length is

$$n = \frac{N'}{\ell} = \frac{B}{\mu_0 i} = \frac{1.00 \times 10^{-6} \text{ turns}}{(4\pi \times 10^{-7})(4.0)(1.00 \times 10^{-4}) \text{ m}} = 1.99 \times 10^3 \text{ turns/m.}$$

(b) Since the total number of turns is $N = Li/\phi_B$, the length must be

$$\frac{N}{n} = \frac{Li}{\phi_B n} = \frac{(2.00 \times 10^{-4})(4.0)}{(1.00 \times 10^{-6})(1.99 \times 10^3)} \text{ m} = 0.40 \text{ m.}$$

(c) Since $|\mathcal{E}| = L(di/dt)$,

$$\frac{di}{dt} = \frac{|\mathcal{E}|}{L} = \frac{1.00 \times 10^{-3} \text{ A}}{2.00 \times 10^{-4} \text{ s}} = 5.0 \text{ A/s.}$$

- B(2). (a) After switch S in Figure 14 has been closed for a long time, what is the current through the inductor?
 (b) The switch is then opened at time $t = 0$. What is the voltage across resistor A at a later time t ? Verify your answer.
 (c) How much energy is dissipated in resistor A between time $t = 0$ and $t = \infty$?

Figure 14

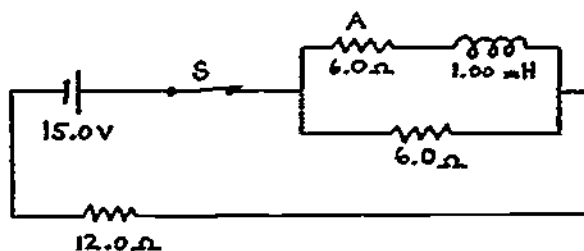
Solution

(a) The presence of the inductor can be neglected, since $di/dt = 0$. The series-parallel combination of resistors has an effective resistance of 15.0Ω ; the total current is thus 1.00 A , and the current through the inductor is 0.50 A .

(b) Adding voltages around the small loop yields

$$-Ri - Ri - L(di/dt) = 0 \quad \text{or} \quad di/dt = -(2R/L)i.$$

This differential equation is satisfied by $i = i_0 e^{-2Rt/L}$; and we must have $i_0 = 0.50 \text{ A}$ to get $i(0) = 0.50 \text{ A}$, as required by part (a). Therefore

$$i = (0.50 \text{ A})e^{-1.20 \times 10^4 t \text{ s}}.$$

(c) At $t = 0$, the energy stored in the inductor is $(1/2)Li_0^2$. This energy will be dissipated in the two resistors; and since the resistances are equal, half must clearly go to each. Thus $(1/4)Li_0^2 = 6.2 \times 10^{-5} \text{ J}$ is dissipated in resistor A.

C(2). Find the voltage $V_R(t)$ across the resistor R in the circuit of Figure 3 (General Comments) when the switch is opened after having been closed a long time.

Solution

Step (a), finding the qualitative behavior, has already been done in Figure 4 above: $i(t)$ is a decreasing function, and must therefore be proportional to $g(t)$. Also, we found that its maximum value, which occurs at $t = 0$, is just

$$i(0) = i_0 = V_B/R_1.$$

[See Eq. (3) and the text immediately following.] Step (b): Adding up voltages around the circuit (with the switch open) yields the differential equation

$$-Ri - L(di/dt) = 0. \quad (*)$$

Step (c): Setting

$$i(t) = Ag(t) = Ae^{-t/\tau}, \quad \text{with } A = V_B/R_1$$

to satisfy $i(0) = V_B/R_1$, and substituting these expressions into (*) yields

$$-RAe^{-t/\tau} + (LA/\tau)e^{-t/\tau} = 0.$$

This is satisfied by the choice $\tau = L/R$, so that

$$i(t) = (V_B/R_1)e^{-Rt/L} \quad \text{and} \quad V_R(t) = Ri(t) = (RV_B/R_1)e^{-Rt/L}.$$

Figure 15

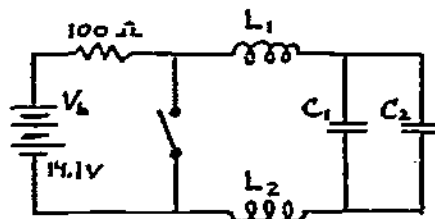

D(3). In the circuit shown in Figure 15, $C_1 = C_2 = 50 \mu\text{F}$, $L_1 = L_2 = 1.80 \text{ mH}$, and the resistance of the inductors is negligible.

(a) Find the energies stored in each of the capacitors and inductors, given that the switch has been open a long time.

(b) The switch is now closed; write down the energy-conservation equation that applies now. Do this directly; do not combine capacitors and inductors.

(c) Use (b) to derive a "differential equation" and show that the current in the circuit can be written in the form $i = i_0 \sin \omega t$. Derive the value of ω .

Solution

(a) The current is zero, and the potential difference V_B appears across each capacitor. Thus the energies stored in C_1 , C_2 , L_1 , and L_2 are $(1/2)C_1V_B^2 = 5.0 \text{ mJ}$, the same, 0, and 0, respectively.

$$(b) \quad (1/2)L_1 i^2 + (1/2)L_2 i^2 + \frac{(1/2)q_1^2}{C_1} + \frac{(1/2)q_2^2}{C_2} = U_0 \quad (= \text{sum of energies above}).$$

(c) First, let us set $L_1 = L_2 \equiv L$, and $C_1 = C_2 \equiv C$. We note that i is the derivative of the total charge $q = q_1 + q_2$; and $q_1 = q_2$. It will thus be convenient to replace q_1 and q_2 by $(1/2)q$. The energy equation is now

$$Li^2 + q^2/4C = U_0.$$

Differentiating this and replacing i by dq/dt yields

$$2L \frac{dq}{dt} \frac{d^2q}{dt^2} + \frac{1}{2C} q \frac{dq}{dt} = 0 \quad \text{or} \quad 4LC \frac{d^2q}{dt^2} + q = 0.$$

This is the desired differential equation. The expression $q = q_0 \cos(\omega t + \phi)$ satisfies this, provided $\omega = \sqrt{1/4LC}$ - just try it and see. Differentiating that expression yields

$$i = -\omega q_0 \sin(\omega t + \phi) = i_0 \sin(\omega t + \phi),$$

where $i_0 = -\omega q_0$. Finally, we must have $\phi = 0$ to get $i = 0$ at $t = 0$.

E(3). The inductors in the circuit shown in Figure 16 have negligible resistance. The switch has been closed a long time.

(a) Find the energies stored in the inductors and in the capacitor.

(b) The switch is now opened, at $t = 0$. Use energy conservation to determine the differential equation for the charge in the capacitor.

(c) Write an expression for the charge as a function of time for $t > 0$, and show that it satisfies the differential equation. Evaluate all parameters (such as ω) that occur in this expression.

(d) Find the voltage across the capacitor at $t = \pi\sqrt{2CL_1}/6$.

Figure 16

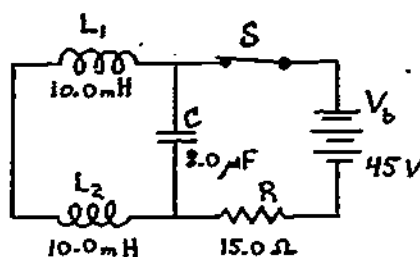

Solution

(a) The current through L_1 is V_b/R ; thus the energy stored in it is $(1/2)L_1 i^2 = L_1 V_b^2 / 2R^2 = 45 \text{ mJ}$. The same is true of L_2 . There is no voltage across C ; there is thus no energy stored in it.

(b) The current is the same in L_1 and L_2 ; call it i . Thus the total energy is

$$(1/2)L_1 i^2 + (1/2)L_2 i^2 + \frac{(1/2)q^2}{C} = Li^2 + \frac{(1/2)q^2}{C} = U_0,$$

where $L = L_1 = L_2$ and $(1/2)U_0$ is the energy calculated in (a). Differentiating with respect to time and replacing i by dq/dt yields

$$2L \left(\frac{dq}{dt} \right) \left(\frac{d^2q}{dt^2} \right) + \left(\frac{q}{C} \right) \left(\frac{dq}{dt} \right) = 0 \quad \text{or} \quad 2LC \left(\frac{d^2q}{dt^2} \right) + q = 0.$$

(c) $q = q_0 \sin \omega t$. (We have already arranged the phase to make $q = 0$ at $t = 0$.) The second derivative of this is $-\omega^2 q_0 \sin \omega t$; thus the differential equation is satisfied provided $\omega = 1/\sqrt{2LC} = 2.50 \times 10^3$ rad/s. The derivative of the expression for q is $i = \omega q_0 \cos \omega t$, which becomes ωq_0 at $t = 0$. But this must be the same as the current before the switch was opened, which was found in part (a) to be V_b/R ; we therefore have $q_0 = V_b/R\omega = 1.20$ mC.

Alternate evaluation of q_0 : When $i = 0$, $q = q_0$; at this time all the energy resides in the capacitor. Therefore by energy conservation, $U_0 = q_0^2/2C$, or $q_0 = \sqrt{2U_0C}$, where from part (a), $U_0 = 90$ mJ.

(d) $V = q/C = (q_0/C) \sin \omega t \rightarrow q_0/2C = 75$ V at the given time.

Figure 17

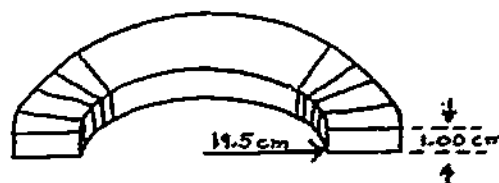

Problems

- F(1). A toroidal inductor as in Figure 17 having 1000 turns is wound on a form with an inner radius $r_0 = 19.5$ cm and square cross section of base and height equal to 1.00 cm.
- Find the \vec{B} field inside the inductor as a function of the radius r from the toroid's center and the current i . Indicate the path you used when applying Ampère's law.
 - Find the inductance of the inductor. You may neglect the variation of \vec{B} with radius inside the windings.
 - What is the induced emf when a current through the winding is increasing at 10.0 A/s?
- G(1). You are winding an inductor on a cylindrical form with a rectangular cross section measuring 1.00 cm by 2.00 cm, as in Figure 18. The wire you are using allows you to get 10 turns per centimeter. Assume that you will wind an inductor long enough that the spreading of the lines of force at the ends can be neglected, as a good enough approximation.
- Find the flux ϕ through a turn near the center, as a function of the current i . Use Ampère's law, and indicate the path you have chosen.
 - Approximately how long a winding do you need for an inductance of 150 μH ?
 - At what rate $d\phi/dt$ will the flux increase when a potential difference of 3.00 mV is applied across the inductor?

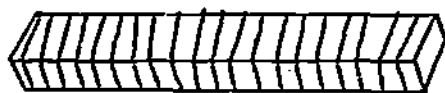

Figure 18

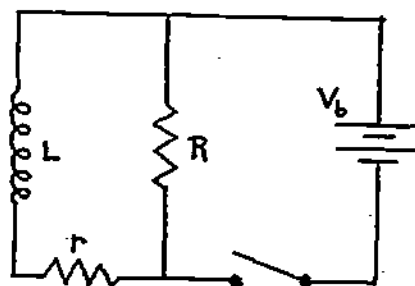

Figure 19

- H(2). In Figure 19 an inductor (with inductance L and resistance r) and a resistor R in parallel are connected to a battery until the currents reach steady values. Then the switch leading to the battery is suddenly opened.
- Express the following four currents in terms of V_b , L , R , and r :
 - through the inductor before the switch is opened;
 - through the inductor immediately after the switch is opened;
 - through the resistor R before the switch is opened;
 - through the resistor R immediately after the switch is opened.
 - What emf appears across the resistor R immediately after the battery is disconnected?
 - What is the exponential time dependence of the current after the switch is opened? Derive the differential equation for the current, and use it to verify your answer. Sketch this behavior as a function of time.
 - Compute the total energy dissipated.

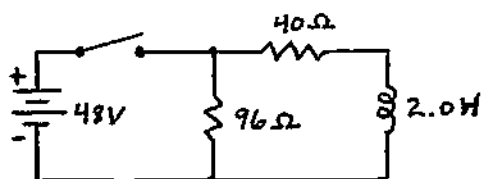

Figure 20

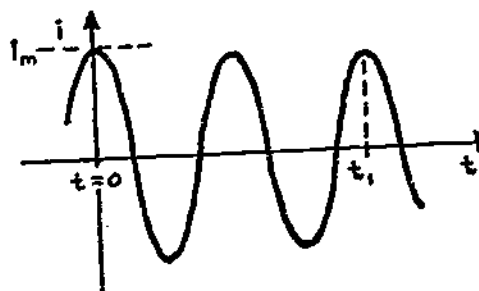

Figure 21

- I(2). The switch in Figure 20 has been open a long time; it is now closed. The resistance of the inductor is negligible.
- Sketch the time dependence of the current through the inductor.
 - What is the current through the $40\text{-}\Omega$ resistor 0.0200 s later?
 - How much energy is stored in the inductor at this instant?
 - If you come back the next day, how much power do you find being dissipated by the $40\text{-}\Omega$ resistor?

- J(3). An oscilloscope connected to plot the current through the inductor in an LC circuit as a function of time produces the trace shown in Figure 21. Note that the current is a maximum at $t = 0$; you are able to determine that this maximum current is $i_m = 10.0 \text{ mA}$. Also, you find that the time t_1 is 4.0 ms . The capacitor in this circuit has a capacitance of $0.200 \text{ }\mu\text{F}$.
- Neglecting the slow decrease of amplitude of the oscillations caused by energy losses, how long does it take for the current to drop from i_m to $(1/2)i_m$?
 - How large is L ?
 - Again neglecting energy losses, use energy conservation to find the maximum value V_m of the potential across the capacitor.

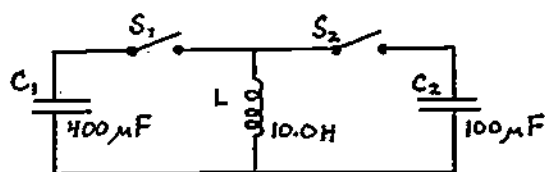

Figure 22

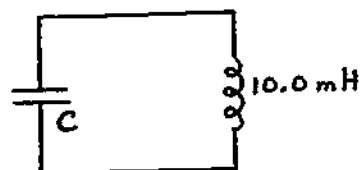

Figure 23

- K(3). Initially, C_1 in Figure 22 is charged to a potential of 100 V .
- Describe how you can manipulate switches S_1 and S_2 to charge C_2 to a potential larger than 100 V . (If you act fast enough!)
 - What is the largest potential you can obtain this way?
 - How long after you close S_2 should you open it again?
- L(3). The circuit shown in Figure 23 is oscillating at the frequency $f = 5.0 \times 10^4 \text{ Hz}$. At the instant $t = 0$, there is a current $i = 0.0100 \text{ A}$ flowing through the inductor, but no charge on the capacitor plates.
- Find the capacitance C .
 - Use energy conservation to find q_{max} and V_{max} for the capacitor.
 - Find the current in the inductor at $t = 2.50 \times 10^{-6} \text{ s}$.
 - Use energy conservation to derive a differential equation involving q , and from that derive the expression for f that you used in part (a).

Figure 24

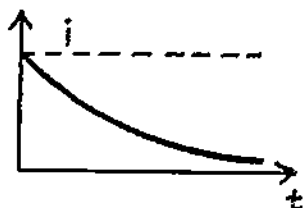
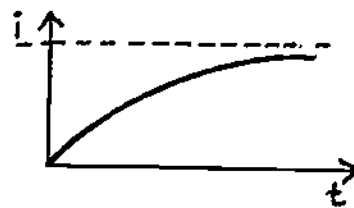

Figure 25



Solutions

F(1). (a) $(2.00 \times 10^{-4} \text{ Wb/A m})i/r$. (b) $1.00 \times 10^{-4} \text{ H}$. (c) 1.00 mV .

G(1). (a) $(2.50 \times 10^{-7} \text{ Wb/A})i$. (b) 0.60 m . (c) $5.0 \text{ } \mu\text{Wb/s}$.

H(2). (a)(i) V_b/r ; (ii) V_b/r ; (iii) V_b/R ; (iv) V_b/r . (b) $V_b R/r$.

(c) $i = i_0 e^{-(R+r)t/L}$. Adding emfs around the circuit yields $-L(di/dt) = -(R+r)i = 0$; substituting the expression for i yields $[L(R+r)/L - (R+r)]i_0 e^{-(R+r)t/L} = 0$.

See Figure 24. (d) $LV_b^2/2r^2$.

I(2). (a) See Figure 25. (b) 0.40 A . (c) 0.160 J . (d) 58 W .

J(3). (a) 0.330 ms . (b) 0.51 H . (c) 15.9 V .

K(3). (a) Close S_1 ; wait until all the energy is in L ; close S_2 and open S_1 ; wait until all the energy is in C_2 ; open S_2 . (b) 200 V . (c) $1/4 \text{ cycle} = 0.050 \text{ s}$.

L(3). (a) $1.01 \times 10^{-9} \text{ F}$. (b) $3.2 \times 10^{-8} \text{ } \zeta$, 31 V . (c) 7.1 mA .

(d) $\frac{1}{2}(q^2/C) + \frac{1}{2}Li^2 = 0$.

Differentiate and set $i = dq/dt$ to get $q + LC(d^2q/dt^2) = 0$; $q = q_0 \sin \omega t$ satisfies this provided $\omega^2 = LC$, or $f = 1/2\pi\sqrt{LC}$.

PRACTICE TEST

1. The toroidal inductor in Figure 26 consists of 2000 turns wound on a form with an average (principal) radius $r_0 = 20.0 \text{ cm}$. The cross section of the winding is somewhat unusual: an isosceles triangle with base $b = 1.00 \text{ cm}$ and height $h = 1.00 \text{ cm}$.

(a) Choose an appropriate path (indicate what it is), and use Ampère's law to find \vec{B} for points inside the winding as a function of the distance r from the center C and of the current i in the windings.

(b) Find the inductance of this toroid, neglecting the variation of \vec{B} with r for points inside the winding.

(c) What is the induced emf when the flux through the toroid is increasing at the rate $d\phi/dt = 3.00 \text{ } \mu\text{Wb/s}$?

Practice Test Answers

1. (a) Use a path with radius r , inside the toroid; $B = (4.0 \times 10^{-4} \text{ Wb/A m})(i/r)$.
 (b) $200 \mu\text{H}$. (c) 6.0 mV .

2. (a) 23.4 W . (b) The differential equation is $di/dt + (4.0 \text{ s})i = 0$, which is satisfied by $i = i_0 e^{-4.0t \text{ s}}$. (c) 0.33 A . (d) 0.71 J .

3. (a) 106 Hz . (b) 0.180 A . (c) Energy conservation reads $(1/2)(q^2/C) + (1/2)Li^2 = U_0$; upon differentiation and simplification, this becomes $q + LC(di^2/dt^2) = 0$.
 (d) The expression given has its maximum at $t = 0$, as it should; substituting it into the differential equation yields $q_0 \cos \omega t - \omega^2 LC \cos \omega t$, which is satisfied provided $\omega = \sqrt{1/LC}$.

3. The switch in Figure 28 has been open a long time; it is now closed.
 (a) What is the frequency of oscillation?
 (b) What is the maximum current in the inductor?
 (c) Use energy conservation to derive a differential equation for the charge on the capacitor.
 (d) Use your result (c) to show that the charge can be expressed in the form $q = q_0 \cos \omega t$, assuming the switch was closed at $t = 0$.
2. (a) The switch in Figure 27 has been closed a long time. What is the power dissipated by the $65\text{-}\Omega$ resistor? The resistance of the inductors is negligible.
 (b) The switch is now opened. Add voltages to determine the time dependence of the current.
 (c) What will the current through the inductors be after 0.150 s ?
 (d) How much energy will be stored in the two inductors together at that instant?

Figure 26

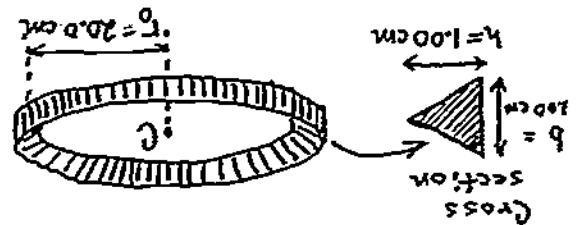

Figure 27

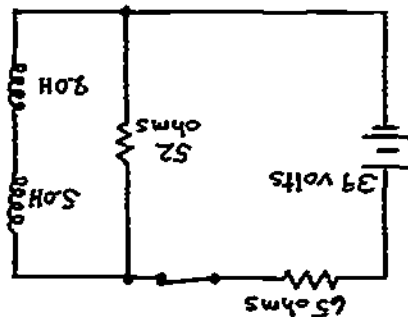
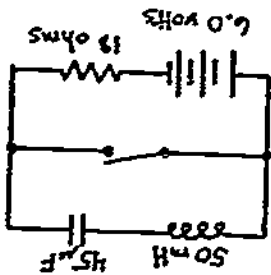

Figure 28



INDUCTANCE

Date _____

Mastery Test Form A

pass	recycle
1	2
	3

Name _____

Tutor _____

- The inductor in Figure 1 is wound on a toroidal form with average (principal) radius $r_0 = 20.0$ cm. The cross section of the toroid is an ellipse of height $2a = 1.00$ cm and width $2b = 2.00$ cm. There are 400 turns around the toroid. Recall that the area of an ellipse is equal to πab , where a and b are the large and small radii, respectively.
 - Use Ampère's law to express \vec{B} inside the toroid as a function of the current i in each turn and of the radius r from the center C of the toroid. Indicate the path you used.
 - Find the inductance of this toroid. (Neglect the variation of \vec{B} with r inside the toroid.)
 - At a certain instant of time, the current through this inductor is increasing at the rate $di/dt = 2.00$ A/s. What is the induced emf?

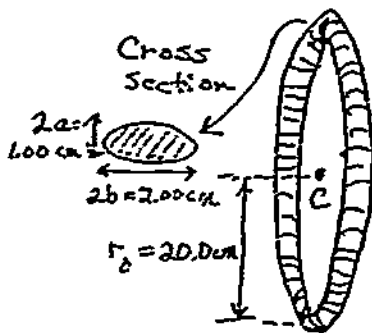

Figure 1

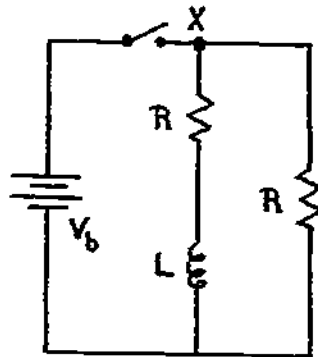

Figure 2

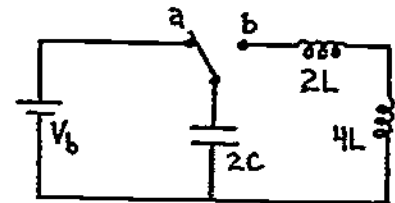

Figure 3

- For the circuit shown in Figure 2:
 - State the current at point X immediately after the switch is closed at $t = 0$ s.
 - Find the energy stored after a very long time of operation.
 - Find the current as a function of time at point X after the switch is opened at $t = t_0$, when the circuits have been operating for a long time. Show that your answer is correct by adding voltages around the appropriate path.
- The inductors in Figure 3 have negligible resistance. The switch is moved from a to b at time $t = 0$ s. Answer the following in terms of L , C , V_b , t , and constants:
 - Use energy conservation to determine the differential equation for the charge on the capacitor.
 - Write an expression for the charge as a function of time for $t \geq 0$ s.
 - Show that this expression satisfies the differential equation.
 - Evaluate all the parameters (such as ω) that occur in your expression for part (b).
 - Find the voltage across the capacitor at $t = (1/2)\pi\sqrt{3LC}$.
 - How much energy is stored in the "4L" inductor at that time?

INDUCTANCE

Date _____

Mastery Test Form B

pass recycle

1 2 3

Name _____ Tutor _____

- A solenoid 1.00 m long is wound with a double layer of thin copper wire allowing 1000 turns/m in each layer. The radius of the solenoid is 3.00 cm.

 - Find the inductance. Indicate the path you use when applying Ampère's law.
 - What voltage must be applied to cause the current to increase at the rate of 5.0 A/s?
- The switch in Figure 1 has been closed a long time. It is now opened. Assume the inductors have negligible resistance.

 - Add voltages to find a differential equation for the current through the 51-Ω resistor, and sketch it. [Hint: Since the voltages across the two inductors are the same, $L_1(di_1/dt) = -\mathcal{E}_1 = -\mathcal{E}_2 = L_2(di_2/dt)$, which can be integrated to yield $L_1i_1 = L_2i_2$ at all instants of time.]
 - What is the current through the 51-Ω resistor 0.75 s after the switch is opened?
 - At what rate is energy being dissipated in the 51-Ω resistor at this instant?
- In Figure 2, $t = 0$, $q = 2.00 \mu\text{C}$ and $i = 0$.

 - What is q_{max} ? What is V_{max} across the capacitor? Use energy conservation to find i_{max} .
 - At what frequency f does this circuit oscillate?
 - Write down expressions for q and i at any instant of time. (Give numerical values for all constants that appear in these equations.)
 - Use energy conservation to obtain a differential equation involving q ; and use this to verify the expression for q that you wrote in part (c).

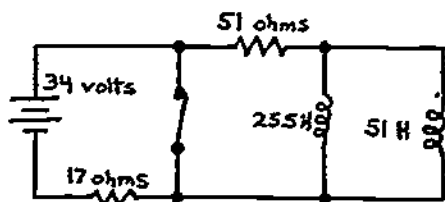

Figure 1

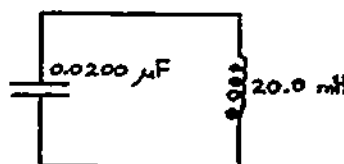

Figure 2

INDUCTANCE

Date _____

Mastery Test Form C

pass recycle

1 2 3

Name _____

Tutor _____

- An inductor is wound on a toroidal form with circular cross section of radius $r = 1.50$ cm. The radius of the toroid to the center of the cross section is 30.0 cm; it has 2000 turns of wire.
 - Find the inductance. (Be sure to indicate the path you use when applying Ampère's law.)
 - If there is an induced emf of $10.0 \mu\text{V}$, at what rate is the flux increasing through the toroid?
- The switch in Figure 1 is closed at $t = 0$ s, after having been open a long time. Assume the inductors have negligible resistance.
 - Add voltages around the appropriate loop to determine the exponential time dependence of the current.
 - What is the current flowing through the inductors at $t = 0.50$ s?
 - How much energy is dissipated in the $35\text{-}\Omega$ resistor from the time the switch is closed until the next day?

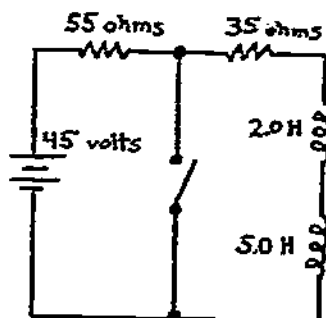

Figure 1

- After the circuit in Figure 2 has reached the steady state, switch S is closed. Calculate the following for the LC circuit:
 - the frequency of oscillation;
 - the energy in the circuit; and
 - the maximum current in the inductor.
 - Write the appropriate energy-conservation equation, differentiate it, and simplify to obtain a "differential equation" for the charge. Use this equation to verify the expression for frequency that you used in part (a).

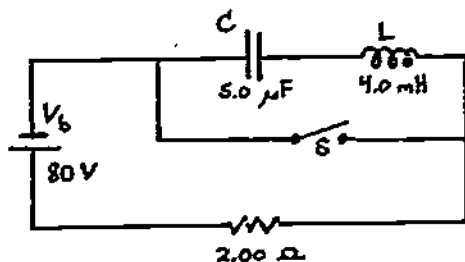

Figure 2

MASTERY TEST GRADING KEY - Form A

1. What To Look For: (a) Make sure student indicates path used, and really applies Ampere's law.

S Solution: (a) The easiest path is a circle of radius r , inside the toroid. Ampere's law gives $2\pi rB = \mu_0 ni$, so

$$B = \frac{\mu_0 ni}{2\pi r} = \frac{(4\pi \times 10^{-7})(400)}{2\pi} \text{ W/A m} \left(\frac{i}{r}\right) = (8.0 \times 10^{-5} \text{ W/A m}) \left(\frac{i}{r}\right).$$

$$(b) L = \frac{N\phi}{i} = \frac{NBA}{i} = \frac{(400)(8.0 \times 10^{-5})(0.50 \times 10^{-4}) \text{ H}}{(0.20)} = 8.0 \times 10^{-6} \text{ H}.$$

$$(c) |\mathcal{E}| = L(di/dt) = (8.0 \times 10^{-6})(2.00) \text{ V} = 16.0 \mu\text{V}.$$

2. What To Look For: (c) Check that student derives the differential equation.

Solution: (a) V_b/R (no current through L).

(b) The current in the inductor is V_b/R , thus the energy is $(\frac{1}{2})(LV_b^2/R^2)$.

(c) The current will have a decreasing exponential dependence on t :

$$i = i_0 e^{-2R(t - t_0)/L},$$

Adding voltages: $-Ri - Ri - L(di/dt) = 0$, or $di/dt + (2R/L)i = 0$. Substituting the expression for i :

$$(-2R/L + 2R/L)i_0 e^{-2R(t - t_0)/L} = 0.$$

3. Solution: (a) $(\frac{1}{2})\frac{q^2}{2C} + \frac{1}{2}(2L)i^2 + \frac{1}{2}(4L)i^2 = V_0 (= \frac{1}{2}V_b^2/C)$ or $\frac{q^2}{2C} + 6Li^2 = V_0$.
Differentiate:

$$(q/C)(dq/dt) + 12Li(di/dt) = 0 \text{ or } d^2q/dt^2 + (1/12LC)q = 0.$$

(b) $q = q_0 \cos \omega t$ where $q_0 = 2CV_b$ and $\omega = \sqrt{1/12LC}$.

(c) Substituting (b) into the O.E. yields $-\omega^2 q_0 \cos \omega t + (1/12LC)q = 0$.

(d) Already done above; note $q(0) = 2CV_b$.

(e) $T = 2\pi/\omega = 2\omega\sqrt{12LC}$, so $\frac{t}{T} = 1/8$ period; $V = \frac{q}{2C} = \frac{q_0 \cos(\pi/4)}{2C} = \frac{V_b}{\sqrt{2}}$.

(f) $|i| = |dq/dt| = \omega q_0 \sin \omega t = \frac{1/\sqrt{12LC}(2CV_b)}{\sqrt{2}} = V_b \sqrt{C/6L}$. So Energy = $\frac{1}{2}(4L)i^2 = \frac{1}{3}CV_b^2$.

MASTERY TEST GRADING KEY - Form B

1. What To Look For: (a) Check path and actual use of Ampère's law.

Solution: (a) See Figure 36. Only the "top" of the rectangle gives a contribution to the integral. $\oint \mathbf{B} = \mu_0 n \mathbf{i}$, where n = turns/m.

$$L = \frac{N\Phi}{i} = \frac{N\pi r^2 B}{i} = (n)(\pi r^2)\mu_0 n = \pi\mu_0 r^2 n^2$$

$$= \pi(4\pi \times 10^{-7})(3.00 \times 10^{-2})^2(1.00)(2.00 \times 10^3)^2 = 14.2 \text{ mH.}$$

(b) $|\mathcal{E}| = L(di/dt) = 71 \text{ mV.}$

2. Solution: (a) $L_1 i_1 = L_2 i_2$, $i_1 = (\frac{L_2}{L_1 + L_2})i$ and $i_2 = (\frac{L_1}{L_1 + L_2})i$, where $i = i_1 + i_2$. Adding emfs around one loop yields

$$-R_1 i - R_2 i - \frac{L_1 L_2}{L_1 + L_2} \left(\frac{di}{dt}\right) + v_b = 0,$$

which reduces to $+(4.0/A)i + (1.00 \text{ s/A})(di/dt) = 2.00$.

(b) Since we need a rising exponential, we write $i = i_0(1 - e^{-at})$ and substitute this into the O.E. (see Figure 37):

$$4i_0(1 - e^{-at}) + ai_0 e^{-at} = 2.$$

In the limit $t \rightarrow \infty$, this requires $i_0 = 0.50 \text{ A}$; this leaves us with $-2e^{-at} + (1/2)ae^{-at} = 0$, which requires that $a = 4.0/\text{s}$. Thus

$$i = (0.50 \text{ A})(1 - e^{-4.0t \text{ s}}). \text{ When } t = 0.75 \text{ s, } i = (0.50 \text{ A})(1 - e^{-3.00}) = 0.48 \text{ A.}$$

(c) $P = i^2 R = 11.8 \text{ W}$ (11.4 W if a more accurate value of i is used).

Figure 36

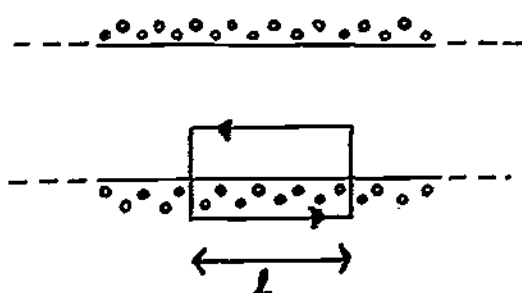

Figure 37



INDUCTANCE

3. Solution: (a) $q_{\max} = 2.00 \mu\text{C}$; $V_{\max} = q_{\max}/C = 100 \text{ V}$. $(1/2)Li_{\max}^2 = (1/2)(q_{\max}^2/C)$,

or

$$i_{\max} = q_{\max}/\sqrt{LC} = \frac{2.00 \times 10^{-6}}{[(2.00 \times 10^{-8})(0.0200)]^{1/2}} = 0.100 \text{ A}.$$

(b) $f = \omega/2\pi = (1/2\pi)\sqrt{LC} = (1/4\pi) \times 10^{-5} = 8.0 \times 10^3 \text{ Hz}$.

(c) $q = q_{\max} \cos \omega t$, where $\omega = 5.0 \times 10^4/\text{s}$;

$$i = \frac{dq}{dt} = -\omega q_{\max} \sin \omega t = -i_{\max} \sin \omega t.$$

q_{\max} and i_{\max} were evaluated in (a).

(d) $(1/2)Li^2 + (1/2)(q^2/C) = V_0$ (Energy conservation). Differentiate:

$Li(di/dt) = (q/C)(dq/dt) = 0$. Simplify: $LC(d^2q/dt^2) + q = 0$. Substitute expression for q , from (c): $(-\omega^2 LCq_{\max})(\cos \omega t) = 0$, provided $\omega = 1/\sqrt{LC}$.

MASTERY TEST GRADING KEY - Form C

1. What To Look For: (a) Check path and actual use of Ampère's law.

Solution: (a) The best path is a circle of radius $R = 30.0$ cm, inside the toroid. Then Ampère's law gives us

$$2\pi RB = \mu_0 Ni, \text{ or } B = \mu_0 Ni / 2\pi R.$$

$$L = \frac{N\phi}{i} = \frac{N\pi r^2 B}{i} = \frac{\mu_0 N^2 r^2}{2R} = \frac{(4\pi \times 10^{-7})(2000)^2 (1.5 \times 10^{-2})^2}{2(0.30)} \text{ H} = 1.88 \text{ mH}.$$

- (b) $10.0 \mu\text{V} = |\mathcal{E}| = N(d\phi/dt)$; therefore,

$$\frac{d\phi}{dt} = \frac{|\mathcal{E}|}{N} = \frac{(10.0 \times 10^{-6})}{2000} = 5.0 \times 10^{-9} \text{ W/s}.$$

2. Solution: (a) $-iR - L_1(di/dt) - L_2(di/dt) = 0$ or $(5.0/s)i + di/dt = 0$;

thus $i = i_0 e^{-5.0t/s}$.

- (b) $i_0 = V_b / (R + R') = 0.50 \text{ A}$; thus at $t = 0.50 \text{ s}$, $i = 0.50e^{-2.50} \text{ A} = 0.041 \text{ A}$.

- (c) $(1/2)Li_0^2 = 3.5(0.50)^2 = 0.88 \text{ J}$.

3. Solution: (a) $f = 1/2\pi\sqrt{LC} = 1.13 \times 10^3 \text{ Hz}$.

- (b) $(1/2)V_b^2 C = 16.0 \text{ mJ} (= V_0)$.

- (c) $(1/2)Li_{\text{max}}^2 = V_0$, or

$$i_{\text{max}} = \sqrt{2V_0/L} = \sqrt{32 \text{ mJ}/4.0 \text{ mH}} = \sqrt{8.0} = 2.80 \text{ A}.$$

- (d) $(1/2)Li^2 + q^2/C = V_0$ by energy conservation.

Differentiate: $Li(di/dt) + (q/C)(dq/dt) = 0$.

Simplify: $LC(d^2q/dt^2) + q = 0$. The expression $q = q_0 \cos \omega t$ satisfies

$$-LC\omega^2 q_0 \cos \omega t + q_0 \cos \omega t = 0,$$

i.e., if $\omega = \sqrt{1/LC}$. And, of course, $f = \omega/2\pi$.

WAVE PROPERTIES OF LIGHT

INTRODUCTION

How do Polaroid sunglasses reduce glare? What evidence is there for an expanding universe? You will learn the answer to these two questions by considering some properties of light. Gamma rays, x rays, light (ultraviolet, visible, and infrared) and radio waves are all forms of electromagnetic radiation and therefore share the same basic properties as mentioned in this module and the module Maxwell's Predictions. The basic difference among these types of electromagnetic radiation is their wavelengths or frequencies.

PREREQUISITES

Before you begin this module, you should be able to:	Location of Prerequisite Content
*Calculate the cross product of two vectors (needed for Objective 1 of this module)	Vector Multiplication Module
*Define energy and power (needed for Objective 1 of this module)	Work and Energy Module
*Define momentum (needed for Objective 2 of this module)	Impulse and Momentum Module
*Solve problems using Newton's second law (needed for Objective 2 of this module)	Newton's Laws Module
*Solve problems using the relations among the properties of electromagnetic waves (needed for Objectives 1 through 3 of this module)	Maxwell's Predictions Module

LEARNING OBJECTIVES

After you have mastered the content of this module, you will be able to:

1. Poynting vector - Write the defining equation for the Poynting vector $\vec{S} = (1/\mu_0)(\vec{E} \times \vec{B})$, and apply this definition with $|\vec{E}| = c|\vec{B}|$ and the fact that \vec{E} is perpendicular to \vec{B} to determine the power, Poynting vector, electric field, and magnetic field of an electromagnetic wave.
2. Radiation momentum - Write the equation that relates radiation momentum to the radiation energy, and use this equation to calculate the momentum trans-

ferred or forced on an object for cases of total absorption or total reflection.

3. Polarization - Write the polarization equation $I = I_0 \cos^2 \theta$, and apply it to solve problems involving the intensity of light transmitted by a polarizing material.
4. Doppler effect - Write and apply the equation that describes the observed frequency when a source of electromagnetic radiation and an observer are either approaching or receding from each other.

GENERAL COMMENTS

This module attempts to relate some apparently abstract properties of electromagnetic radiation to situations that you have experienced. The warmth of the Sun on your skin is the result of energy that has been released from the nuclear "burning" of hydrogen in the Sun and transported across 1.50×10^{11} m to Earth in the form of electromagnetic radiation. This experience can be quantified by the use of the Poynting vector, which gives the magnitude and direction of this energy transfer. The Poynting vector is the power per unit area transmitted by the electromagnetic field. We do not feel the momentum associated with radiation because its impulse is too small.

Sunlight reflected from objects tends to be plane polarized. Your Polaroid sunglasses have their polarization axis perpendicular to the polarization axis of the reflected light and thereby reduce glare. Police radar uses the frequency change, or Doppler effect, produced by reflection from a moving object. One must be careful to distinguish between the Doppler effects for sound and for light. Only one equation is necessary for the Doppler effect for light, namely,

$$\nu = \nu_s \left(\frac{1 + v/c}{1 - v/c} \right)^{1/2} = \nu_s \left(\frac{1 + v/c}{(1 - v^2/c^2)^{1/2}} \right),$$

where ν_s is the frequency of the source; ν is the observed frequency; v is the relative speed of approach between the source and the observer, where v is positive if the source and the observer are approaching each other and negative if they are receding; and c is the speed of light.

The order of the subject material in this module is not important. Texts differ in the order and emphasis given each subject. Therefore, it is not necessary to study the objectives in the listed order, except that the radiation momentum is usually defined in terms of the Poynting vector.

TEXT: Frederick J. Bueche, Introduction to Physics for Scientists and Engineers (McGraw-Hill, New York, 1975), second edition

SUGGESTED STUDY PROCEDURE

First read the General Comments. Your text describes the concepts in the objectives in various chapters. Section 29.3 in Chapter 29 treats the average value of the Poynting vector; its instantaneous value can be written in vector form as $\vec{S} = (\vec{E} \times \vec{B})/\mu_0$. The text briefly treats radiation momentum on p. 626, and therefore it is essential to work Problems B and F. The concept of radiation pressure follows directly from the Poynting vector.

Bueche lets you derive the polarization expression $I = I_0 \cos^2 \theta$ in Problem 21 of Chapter 33. You should work Problems C and G. Your text only treats the Doppler effect for sound. Interestingly, the expression for the Doppler effect for light is simpler than that for sound. Only one equation is necessary for light:

$$v = v_s \left(\frac{1 + v/c}{1 - v/c} \right)^{1/2}$$

(see General Comments), and this depends only on the relative velocity of approach or recession. When you have worked Problems E through H and 7 through 9 in Chapter 29, and 21 in Chapter 33, take the Practice Test.

BUECHE

Objective Number	Readings	Problems with Solutions		Assigned Problems	
		Study Guide	Text	Study Guide	Text
1	Sec. 29.3 *	A	Illus. ^a 29.1	E	Chap. 29, Probs. 7, 8, 9
2	p. 626	B		F	Chap. 29, Quest. ^a 5
3	Secs. 33.8, 33.9, 33.10	C		G	Chap. 33, Prob. 21
4	General Comments	D		H	

^aIllus. = Illustration(s). Quest. = Question(s).

STUDY GUIDE: Wave Properties of Light

3(HR 1)

TEXT: David Halliday and Robert Resnick, Fundamentals of Physics (Wiley, New York, 1970; revised printing, 1974)

SUGGESTED STUDY PROCEDURE

First read the General Comments. Your text treats the concepts in the same order as the objectives. Read all of Chapter 35, work Problems A through H and the text problems, and take the Practice Test before attempting a Mastery Test.

HALLIDAY AND RESNICK

Objective Number	Readings	Problems with Solutions		Assigned Problems	
		Study Guide	Text (Chap. 35)	Study Guide	Text (Chap. 35)
1	Sec. 35-4	A	Ex. ^a 1	E	11, 13, 17
2	Sec. 35-5	B	Ex. 2	F	27, 28, 30
3	Sec. 35-6 [Eq. (35-15)]	C		G	35, 36
4	Secs. 35-9, 35-10 [Eqs. (35-17), (35-2D)]	D	Ex. 6	H	44, 45, 47, 48

^aEx. = Example(s).

TEXT: Francis Weston Sears and Mark W. Zemansky, University Physics (Addison-Wesley, Reading, Mass., 1970), fourth edition

SUGGESTED STUDY PROCEDURE

First read the General Comments. For Objective 1, the Poynting vector, Eq. (36-9), may be written as $S = (1/\mu_0)(\vec{E} \times \vec{B})$ using $H = \vec{B}/\mu_0$. Your text defines a momentum density, which can be shown to be equivalent to momentum $p = (\text{energy per unit area} \times \text{unit time})/c = U/c$ (for total absorption).

Your text has a very extensive treatment on polarization, but Sections 42-1 and 42-5 alone cover Objective 3. Sears and Zemansky treat the Doppler effect for both sound and light, but this module is concerned only with the Doppler effect in light.

Study Problems A through D before working the Assigned Problems and taking the Practice Test.

SEARS AND ZEMANSKY

Objective Number	Readings	Problems with Solutions		Assigned Problems		Additional Problems
		Study Guide	Text	Study Guide	Text	
1	Sec. 36-3	A	Example on p. 522	E	36-5, 36-6	
2	Sec. 36-3	B		F		
3	Secs. 42-1 to 42-11	C		G	42-7, 42-12	
4	Sec. 23-9	D		H		23-12, ^a 23-13, ^a 23-15 ^a

^aThese problems are for sound only.

TEXT: Richard T. Weidner and Robert L. Sells, Elementary Classical Physics (Allyn and Bacon, Boston, 1973), second edition, Vol. 2

SUGGESTED STUDY PROCEDURE

First read the General Comments. Your text uses the symbol \vec{I} for the Poynting vector, but since most texts use the symbol \vec{S} our Problems and Tests use the symbol \vec{S} . Section 40-3 with the Examples 40-1 and 40-2 is the most important part of the reading for Objective 3.

Study Problems A through D before working the Assigned Problems and taking the Practice Test.

WEIDNER AND SELLS

Objective Number	Readings	Problems with Solutions		Assigned Problems	
		Study Guide	Text	Study Guide	Text
1	Sec. 35-4 [Eqs. (35-26), (35-18)]	A		E	35-3, 35-5
2	Sec. 35-5	B		F	35-5, 35-8
3	Secs. 40-1 to 40-5	C	Ex. ^a 40-1, 40-2	G	40-3, 40-4
4	Sec. 35-10	D		H	35-21, 35-23, 35-24

^aEx. = Example(s).

PROBLEM SET WITH SOLUTIONS

- A(1). A plane radio wave is propagating in free space along the positive z axis with $\vec{E} = E_0 \sin(\omega t - kz)\hat{i}$. Find (a) the expression for the magnetic field as a function of t and z; and (b) the Poynting vector as a function of t and z.

Solution

- (a) $|\vec{E}| = c|\vec{B}|$, $|\vec{B}| = |\vec{E}|/c = (E_0/c) \sin(\omega t - kz)$ with \vec{B} along \hat{j} ,
 $\vec{B} = (E_0/c) \sin(\omega t - kz)\hat{j}$.
- (b) $\vec{S} = (1/\mu_0)(\vec{E} \times \vec{B}) = (1/\mu_0)E_0 \sin(\omega t - kz)\hat{i} \times (E_0/c) \sin(\omega t - kz)\hat{j}$
 $= (1/\mu_0)cE^2 \sin^2(\omega t - kz)\hat{k}$.

- B(2). A parallel beam of electromagnetic radiation with energy flux $S = 10.0 \text{ W/cm}^2$ is incident normally on a perfectly reflecting mirror of 1.00 cm^2 area for 1000 s.
- (a) What is the momentum transferred to the mirror?
 (b) What is the average force acting on the mirror?

Solution

- (a) $p = 2U/c$, where U is energy = $S \times t \times A$.

$$p = \frac{2StA}{c} = \frac{2(10.0 \text{ W/cm}^2)(1000 \text{ s})(1.00 \text{ cm}^2)}{3.00 \times 10^8 \text{ m/s}} = \frac{2.00 \times 10^4 \text{ W s}}{3.00 \times 10^8 \text{ m/s}}$$

$$= 6.7 \times 10^{-5} \frac{\text{J}}{\text{m/s}} = 6.7 \times 10^{-5} \text{ kg m/s}.$$

- (b) $F = p/t = (6.7 \times 10^{-5})/(1000) = 6.7 \times 10^{-8} \text{ N}$ (small force).

- C(3). A beam of unpolarized light shines on the three polarizers in Figure 1. The lines indicate the axes of transmission of the polarizers. Find the intensity of light (in terms of I_0) at points A, B, and C.

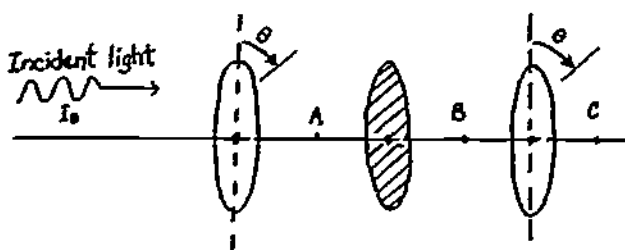

Figure 1

Solution

At point A there is a reduction in intensity caused by the transmission of only the components of E at θ and the light is plane polarized:

$$I_A = I_0/2.$$

At point B there is a reduction of the intensity by

$$I_B = (I_0 \cos^2 \theta)/2.$$

At point C the intensity is

$$I_C = I_B \cos^2 \theta = I_0(\cos^2 \theta)(\cos^2 \theta)/2 = (I_0 \cos^4 \theta)/2.$$

D(4). A characteristic hydrogen line from a distant galaxy is measured on Earth to have a reduction in frequency of 25% compared to the same hydrogen line on Earth. What is the radial velocity of this galaxy with respect to Earth?

Solution

Doppler effect:

$$v = v_s \frac{1 + v/c}{[1 - (v/c)^2]^{1/2}}, \quad \frac{v}{v_s} = \frac{3}{4} = \frac{1 + v/c}{[1 - (v/c)^2]^{1/2}}.$$

Let $v/c = x$. Then

$$\frac{3}{4} = \frac{1 + x}{(1 - x^2)^{1/2}}, \quad \frac{9}{16} = \frac{(1 + x)^2}{1 - x^2} = \frac{(1 + x)^2}{(1 - x)(1 + x)} = \frac{1 + x}{1 - x},$$

$$\frac{9}{16} - \left(\frac{9}{16}\right)x = 1 + x, \quad -\frac{7}{16} = \left(\frac{25}{16}\right)x, \quad x = -\frac{7}{25} = \frac{v}{c} = -0.280.$$

Thus $v = -8.4 \times 10^7$ m/s away from Earth. (Galaxy is receding.)

Problems

- E(1). The time-average value of the Poynting vector at $v = 0$ is $\vec{S}_{av} = S_{av} \hat{j}$. Find
 (a) the maximum values of the electric and magnetic fields; and
 (b) their plane of oscillation.
- F(2). Calculate the force due to solar radiation on a 10.0-m^2 , perfectly absorbing panel above Earth's atmosphere. The plane of the panel is perpendicular to the Sun's radiation, and the solar constant is 1400 W/m^2 . (The solar constant is the power per unit area from the Sun above Earth's atmosphere.)

- G(3). A beam of unpolarized light is incident on two crossed polarizers, i.e., the first one has its direction of polarization vertical, the second one has its direction horizontal. A third polarizer is placed between the other two. Neglecting partial absorption of the transmitted component, what fraction of an incident unpolarized beam is transmitted through the whole system if the middle polarizer has its direction of polarization:
- vertical?
 - 45° to the vertical?
 - horizontal?
- H(4). Police use radar to measure the speed of automobiles. What is the relative difference between the transmitted and received frequencies $(\nu - \nu_s)/\nu_s$ for an automobile approaching at a speed of 30.0 m/s?

Solutions

E(1). (a) Since $[\int_0^T \sin^2(\omega t) dt] / \int_0^T dt = 1/2$,

$$S_{av} = (E_0 B_0 / \mu_0) \{ [\int_0^T \sin^2(\omega t) dt] / \int_0^T dt \} = E_0 B_0 / 2\mu_0.$$

But $B_0 = E_0/c$ and $E_0 = \sqrt{2c\mu_0 S_{av}}$, thus

$$B_0 = \sqrt{2\mu_0 S_{av}} / c.$$

(b) \vec{E} and \vec{B} are in the xz plane perpendicular to \vec{z} .

F(2). 4.7×10^{-5} N. Total reflection would give twice this amount.

G(3). (a) 0. (b) 1/8. (c) 0.

H(4). $(\nu - \nu_s) / \nu_s = 2 \times 10^{-7}$.

PRACTICE TEST

A laser emits a narrow beam of light with an average power of 10^{-2} W over a cross-sectional area of $5.0 \times 10^{-6} \text{ m}^2$.

1. Find the maximum electric and magnetic fields in the beam.
2. What force would this beam exert on a completely absorbing surface perpendicular to the beam?
3. If the laser is plane polarized, what must be the angle between the polarization axes of a polarizing sheet and the polarization axes of the laser if the transmitted light is to be 25% of the incident intensity?
4. What would be the relative frequency difference $(\nu - \nu_s)/\nu_s$ of this laser as measured by a spaceship receding from the laser at $3.00 \times 10^4 \text{ m/s}$?

1. $E = 1.20 \times 10^3 \text{ V/m}$, $B = 4.1 \times 10^{-6} \text{ T}$.
2. $F_p = (1/3) \times 10^{-10} \text{ N}$.
3. $\theta = 60^\circ$.
4. -10^{-4} .

Practice Test Answers

WAVE PROPERTIES OF LIGHT

Date _____

Mastery Test Form A

pass recycle

1 2 3 4

Name _____ Tutor _____

1. The electric field component of a radio wave is $\vec{E} = E_0 \sin(\omega t - kz)\hat{i}$.
 - (a) Find the expression for the magnetic field component of this wave.
 - (b) Find the instantaneous and average values of the Poynting vector.
 - (c) Find the average force exerted by the wave on a completely reflecting surface in the xy plane with an area of A.
 - (d) What is the relative frequency difference $(\nu - \nu_s)/\nu_s$ measured by a receiver aboard an airplane traveling toward the source of the wave at 3.00×10^2 m/s?

2. A beam of unpolarized light is transmitted successively through three polaroids whose axes are 30° , 60° , and 30° , respectively. What is the transmitted intensity after each polarizer?

HAVE PROPERTIES OF LIGHT

Date _____

Mastery Test Form B

pass recycle

1 2 3 4

Name _____ Tutor _____

1. A radio station radiates at a power of $5.0 \times 10^4 \text{ W}$. Assume that the radiation is isotropic over a hemisphere with the transmitter at the center.
 - (a) Find the magnitude of the Poynting vector at a distance of 10^3 m .
 - (b) Find the magnitude of the electric and magnetic fields associated with this radiation at a distance of 10^3 m .
 - (c) What is the average pressure on this hemisphere with radius 10^3 m (assume it is perfectly absorbing)?
 - (d) What is the relative frequency $(\nu - \nu_s)/\nu_s$ measured by a rocket receiving this signal as it recedes from Earth at a speed of 10^8 m/s ?

2. Three polarizers are placed in a beam of unpolarized light. Calculate the intensity of the light after each of the following polarizers if the initial intensity is I_0 . The polarization axis of each polarizer is vertical, 30° to vertical, and 60° to vertical, respectively.

WAVE PROPERTIES OF LIGHT

Date _____

Mastery Test Form C

pass recycle

1 2 3 4

Name _____ Tutor _____

1. The electromagnetic radiation from a light bulb exerts a force of 4.0×10^{13} N on a completely absorbing surface with an area of 10^{-4} m², perpendicular to the direction of radiation. Find:
 - (a) the momentum transferred to this area during a 10.0-s interval;
 - (b) the average value of the Poynting vector at this surface;
 - (c) the maximum values of the electric and magnetic fields associated with this radiation at this surface.

2. The "H_γ" radiation observed on Earth caused by hydrogen gas in a distant nebula has been "red-shifted" to a frequency of 4.87×10^{14} Hz. If the same spectrum line measured at rest on Earth is 6.91×10^{14} Hz, how rapidly is the nebula traveling away from Earth?

3. Plane-polarized light with its axis of polarization in a vertical direction is incident on a polarizer with its axis of polarization at 45° with respect to the vertical. Find the ratio of incident to transmitted intensity on light due to the polarizer.

MASTERY TEST GRADING KEY - Form A

1. What To Look For: (a) Direction of \vec{B} . (b) $S_{av} = E_0 B_0 / 2\mu_0$. (c) Use of Newton's second law, S is power/unit area. (d) Positive sign for v/c when approaching.

Solution: (a) $|\vec{B}| = |\vec{E}|/c$ and \vec{B} is in the \hat{j} direction.

$$\vec{B} = (E_0/c) \sin(\omega t - kz) \hat{j}.$$

$$(b) \vec{S} = (\vec{E} \times \vec{B})/\mu_0 = (E_0^2/c\mu_0) \sin^2(\omega t - kz) \hat{k},$$

$$S_{av} = E_0^2/2c\mu_0.$$

$$(c) F = \Delta p/\Delta t,$$

$$\Delta p = 2U_{av}/c \text{ and } \Delta p/\Delta t = 2U_{av}/(c \Delta t)$$

with $U_{av} = S_{av} A \Delta t$. Therefore

$$F_{av} = 2S_{av} A \Delta t/\Delta t c = 2S_{av} A/c.$$

$$(d) v = v_s \left(\frac{1 + v/c}{(1 - v^2/c^2)^{1/2}} \right), v/c = 10^{-4}, \text{ therefore } (1 - v^2/c^2)^{1/2} = 1$$

$$\text{and } (v - v_s)/v_s = v/c = 10^{-6}.$$

2. What To Look For: θ is angle between axes of successive polaroids and intensity incident on the second polaroid is intensity transmitted by first polaroid.

Solution: After first polaroid: $I_1 = I_0/2$. After second polaroid:

$$I_2 = I_1 \cos^2 \theta = I_0/2 \cos^2 30^\circ = 3I_0/8.$$

After third polaroid:

$$I_3 = I_2 \cos^2 \theta = 3I_0/8 \cos^2 30^\circ = (9/32)I_0.$$

MASTERY TEST. GRADING KEY - Form B

1. What To Look For: (a) Relationship between power, energy, and the Poynting vector. (b) $B_0 = E_0/c$; correct equation for S_{av} . Correct units. (c) Newton's law.

$$P = U/t = SA/t.$$

- (d) Negative sign for v because of recession.

Solution: (a) $P = E/t = 5.0 \times 10^4 \text{ W}$. $S = E/tA = P/A$.

$$S = P/2\pi r^2 = (5.0 \times 10^4 \text{ W})/(2\pi \times 10^6 \text{ m}) = 7.96 \times 10^{-3} \text{ W/m}^2.$$

(b) Since $S_{av} = E_0^2/2\mu_0 c$,

$$E_0 = \sqrt{2\mu_0 S_{av} c} = [2(4\pi \times 10^{-7} \text{ N s}^2/\text{C}^2)(7.96 \times 10^{-3} \text{ W/m}^2)(3.00 \times 10^8 \text{ m/s})]^{1/2}$$

$$E_0 = \sqrt{6} \text{ N/C} \quad \text{and} \quad B_0 = \sqrt{2/3} \times 10^{-8} \text{ T}.$$

(c) $\frac{F}{A} = \frac{\Delta p}{\Delta t} = \frac{U}{2c \Delta t} = \frac{SA}{2cA} = \frac{7.96 \times 10^{-3} \text{ W/m}^2}{2(3.00 \times 10^8 \text{ m/s})} = 1.33 \times 10^{-11} \text{ N/m}^2.$

(d) $v = v_s \left(\frac{1 + v/c}{[1 - (v/c)^2]^{1/2}} \right)$ for recession at $v = -10^4 \text{ m/s}$ and $\sqrt{1 - v^2/c^2} = 1$.

$$\frac{v - v_s}{v_s} = \frac{-10^4 \text{ m/s}}{3.00 \times 10^8 \text{ m/s}} = \frac{-10^{-4}}{3}.$$

2. What To Look For: First polarizer transmits only the vertical components. θ is the relative angle between polaroids.

Solution: I_0 incident on first. $I_0/2$ transmitted by first.

$$(I_0/2) \cos^2 30^\circ = 3I_0/8 \quad \text{transmitted by second.}$$

$$(I_0/8) \cos^2 30^\circ = 9I_0/32 \quad \text{transmitted by third.}$$

MASTERY TEST GRADING KEY - Form C

1. What To Look For: (a) Newton's second law. (b) Relationship among power, energy, and the Poynting vector. Units. (c) Units.

Solution: (a) $F = \Delta p / \Delta t$. Therefore, $\Delta p = F \Delta t = (4)(10) = 4.0 \times 10^{-12} \text{ kg m/s}$.

(b) $F = \Delta p / \Delta t = U / 2c \Delta t = P / 2c = S_{\text{av}} A / 2c$. Therefore,

$$S_{\text{av}} = F 2c / A = (4.0 \times 10^{-13} \text{ N}) 2(3.00 \times 10^8 \text{ m/s}) / (10^{-4} \text{ m}^2) = 2.40 \text{ W/m}^2.$$

(c) $S_{\text{av}} = E_0^2 / 2\mu_0 c$. Therefore, $E_0 = \sqrt{2\mu_0 c S_{\text{av}}} = \sqrt{2(4\pi \times 10^{-7})(3.00 \times 10^8) 2.40}$,

$$E_0 = 42.5 \text{ N/C}. \quad B_0 = E_0 / c = 1.42 \times 10^{-8} \text{ T}.$$

2. Solution: Receding:

$$v = v_s \left(\frac{1 - v/c}{1 + v/c} \right)^{1/2}. \quad \text{Let } x = v/c. \text{ Then } v = v_s \left(\frac{1 - x}{1 + x} \right)^{1/2} \text{ and } v/v_s = 3/4.$$

$$\text{Therefore, } 1 - x = \frac{9}{16}(1 + x) \text{ or } x = 7/25.$$

3. Solution: $I = I_0 \cos^2 45^\circ$. $I = I_0/2$.

INTERFERENCE

INTRODUCTION

You may have observed the sound from your radio fade in and out as you listened to some distant station. Or perhaps you have sat in a "dead" seat in a poorly designed concert hall where, despite the fact that no physical object is between you and the performer, the sound is distorted and weak. Perhaps you have held two fingers close together and looked with one eye through the narrow slit separating the fingers and observed those mysterious black lines in and parallel to the slit. These and many other similar phenomena result from the interference of two or more waves of the same frequency. This module will provide you with the basis for understanding such phenomena in terms of a wave model.

PREREQUISITES

Before you begin this module,
you should be able to:

Location of
Prerequisite Content

*Add vectors (needed for Objective 3 of
this module)

Dimensions and Vector
Addition Module

*Use the wave properties of light in solving
problems (needed for Objectives 1 through
4 of this module)

Wave Properties
of Light
Module

LEARNING OBJECTIVES

After you have mastered the content of this module, you will be able to:

1. Coherent sources - List the conditions necessary for two sources to be coherent, and apply these conditions so as to determine if two sources are coherent.
2. Interference maxima and minima - Calculate the location of amplitude maxima and minima given the positions, frequency, and relative phase of two coherent sources and the propagation speed of the wave.
3. Intensity patterns - Calculate relative intensities at various points in interference patterns resulting from two coherent sources.
4. Thin films - Relate the index of refraction n and thickness t of a thin film to maxima and minima of reflected and transmitted light (wavelength λ) and solve associated problems using this relationship among n , t , and λ .

TEXT: Frederick J. Bueche, Introduction to Physics for Scientists and Engineers (McGraw-Hill, New York, 1975), second edition

SUGGESTED STUDY PROCEDURE

Your readings are from Chapter 31. Read Section 31.1, study Problems A and B, and work Problem F. Then read Sections 31.3 and 31.4. You might also read Section 31.2, particularly if you have not completed the module Sound. Then study Problem C and Illustrations 31.1 and 31.2 before working Problems G, H, and I. Next read Section 31.5, study Problem D and Illustration 31.3. Work Problems J and K. Read Sections 31.9 and 31.10, and study Problem E, before working Problem L. Although you are not required to do so, you may enjoy reading Sections 31.7 and 31.8.

Try the Practice Test, and work some Additional Problems if necessary, before attempting a Mastery Test.

BUECHE

Objective Number	Readings	Problems with Solutions		Assigned Problems	Additional Problems (Chap. 31)
		Study Guide	Text	Study Guide	
1	Sec. 31.1	A, B		F	Quest. ^a 11, 14
2	Sec. 31.4	C	Illus. ^a 31.1, 31.2	G, H, I	Quest. 4, Probs. 1, 5, 6
3	Secs. 31.3, 31.5	D	Illus. 31.3	J, K	Probs. 3, 7, 8
4	Secs. 31.9, 31.10	E		L	Quest. 5, 8, Probs. 9, 10, 11, 15, 21

^aIllus. = Illustration(s). Quest. = Question(s).

TEXT: David Halliday and Robert Resnick, Fundamentals of Physics (Wiley, New York, 1970; revised printing, 1974)

SUGGESTED STUDY PROCEDURE

Your readings are from Chapter 37. Read Sections 37-1 and 37-2. Pay particular attention to the discussion on pp. 707 and 708. If you do not understand the phase argument relative to Figure 37-6, reread Section 36-4 in Chapter 36. Notice that Eqs. (37-1) and (37-2) are exact for Figure 37-6 and approximate (but very accurate for $D \gg d$) for Figure 37-5. Read Section 37-3. This is an excellent discussion of coherent and incoherent sources. Then study Problems A, B, and C, and work Problems F through I. Read Section 37-4, study Problem D and Example 2, and work Problems J and K. Then read Section 37-5, and study Examples 3 and 4 and Problem E before working Problem L. Even though you are not required to, you might enjoy reading Section 37-6, which describes the interferometer.

Take the Practice Test, and work some Additional Problems if necessary, before trying a Mastery Test.

HALLIDAY AND RESNICK

Objective Number	Readings	Problems with Solutions		Assigned Problems	Additional Problems (Chap. 37)
		Study Guide	Text	Study Guide	
1	Sec. 37-3	A, B		F	Quest. ^a 3, 5
2	Sec. 37-2	C	Ex. ^a 1	G, H, I	Quest. 7, Probs. 1, 5, 9, 17, 19
3	Sec. 37-4	D	Ex. 2	J, K	Probs. 2, 5
4	Sec. 37-5	E	Ex. 3, 4	L	Quest. 9, 10, Probs. 27, 29, 31, 37

^aEx. = Example(s). Quest. = Question(s).

TEXT: Francis Weston Sears and Mark W. Zemansky, University Physics (Addison-Wesley, Reading, Mass., 1970), fourth edition

SUGGESTED STUDY PROCEDURE

Your readings are from Chapter 41. First read Section 41-1, an excellent discussion of coherence and interference. Study it carefully. Then study Problems A and B before working Problem F. Read Section 41-2. You may omit the last paragraph if you wish. Then study Problem C and work Problems G, H, and I. Read Section 41-3, study Problem D and work Problems J and K. Next read Sections 41-4 through 41-6, study Problem E, and work Problem L. Section 41-7 is an interesting discussion of energy conservation and interference, definitely worth reading. You may also find Sections 41-8 and 41-9 interesting even though they are not required.

Take the Practice Test, and work some Additional Problems if necessary, before attempting a Mastery Test.

SEARS AND ZEMANSKY

Objective Number	Readings	Problems with Solutions	Assigned Problems	Additional Problems
		Study Guide	Study Guide	
1	Sec. 41-1	A, B	F	
2	Sec. 41-2	C	G, H, I	41-1
3	Sec. 41-3	D	J, K	41-3
4	Secs. 41-4, 41-5, 41-6	E	L	41-5, 41-9, 41-10, 41-12, 41-13

TEXT: Richard T. Weidner and Robert L. Sells, Elementary Classical Physics (Allyn and Bacon, Boston, 1973), second edition, Vol. 2

SUGGESTED STUDY PROCEDURE

Your readings are from Chapter 38. Read Section 38-5, study Problems A and B, and work Problem F. Then read Sections 38-1, 38-2, 38-3, and 38-6, and study Problems C and D, before working Problems G through K. Next read Sections 38-4 and 38-7, study Problem E, and work Problem L. You may find Section 38-8 enjoyable to read.

Take the Practice Test, and work some Additional Problems if necessary, before attempting a Mastery Test.

WEIDNER AND SELLS

Objective Number	Readings	Problems with Solutions	Assigned Problems	Additional Problems
		Study Guide	Study Guide	
1	Sec. 38-5	A, B	F	
2	Secs. 38-2, 38-6	C	G, H, I	38-3, 38-5, 38-7, 38-16, 38-19
3	Sec. 38-3	D	J, K	
4	Secs. 38-4, 38-7	E	L	38-20, 38-21

PROBLEM SET WITH SOLUTIONS

A(1). List the conditions that must be satisfied if two sources are to be coherent.

Solution

The two sources must have a relative phase that does not change with time. Note that this implies that if the two are producing periodic signals, the two frequencies must be identical. (Why?)

B(1). Signals from two sources superpose at point P to give complete destructive interference. Are the two sources coherent? Why?

Solution

Yes. Complete destructive interference of two signals requires that the two signals have the same amplitude and be oppositely directed at each instant, i.e., be out of phase by π . This constant phase difference of the received signals requires the sources to have a fixed phase difference, i.e., to be coherent.

C(2). In Figure 1, S_1 and S_2 are identical (in-phase) sources emitting transverse (perpendicular to the paper) waves of frequency ν and wavelength λ . Determine the positions of all maxima and minima along the line OX.

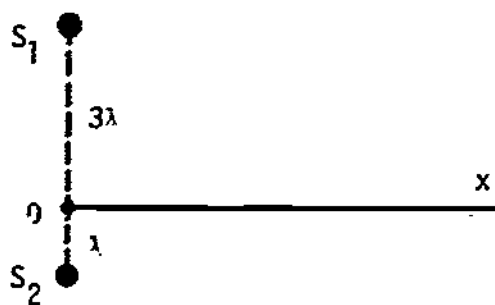

Figure 1

Solution

The pathlength difference ΔL as shown in Figure 2 is

$$\Delta L = L_1 - L_2 = \sqrt{x^2 + 9\lambda^2} - \sqrt{x^2 + \lambda^2}.$$

For maxima, $\Delta L = n\lambda$; for minima, $\Delta L = (n + 1/2)\lambda$, where n is a nonnegative integer. We treat both cases by writing $\Delta L = \alpha\lambda$, and determine x in terms of α , i.e.,

$$\sqrt{x^2 + 9\lambda^2} - \sqrt{x^2 + \lambda^2} = \alpha\lambda.$$

Solving for x gives us (after discarding negative solutions)

$$x = [\sqrt{(16 - \alpha^2)(4 - \alpha^2)}/2\alpha]\lambda.$$

Maxima: $\alpha = 1$, $x_1 = (\sqrt{15} \cdot 3/2)\lambda = (3/2)\sqrt{5}\lambda \approx 3.4\lambda$.

$\alpha = 2$, $x_2 = 0$.

Minima: $\alpha = 1/2, \quad x_{1/2} = (\sqrt{63 \times 15/4})\lambda = (3/4)\sqrt{105}\lambda \approx 7.7\lambda.$

$$\alpha = 3/2, \quad x_{3/2} = (\sqrt{55 \times 7/12})\lambda = (\sqrt{385/12})\lambda \approx 1.69\lambda.$$

The locations of these maxima and minima are shown in Figure 3 with the pathlength difference shown below the location. Note: The result given for x has answers for $\alpha \geq 4$. Clearly, these cannot be acceptable solutions since the maximum value for $L_2 - L_1$ is 2λ ($\alpha = 2$) at $x = 0$. The solutions for $\alpha \geq 4$ are extraneous values introduced in the process of solving for x .

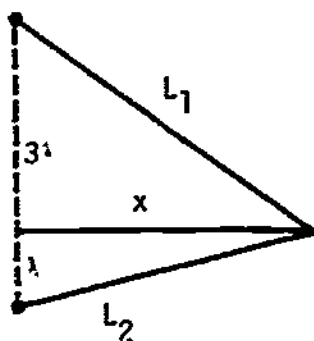

Figure 2

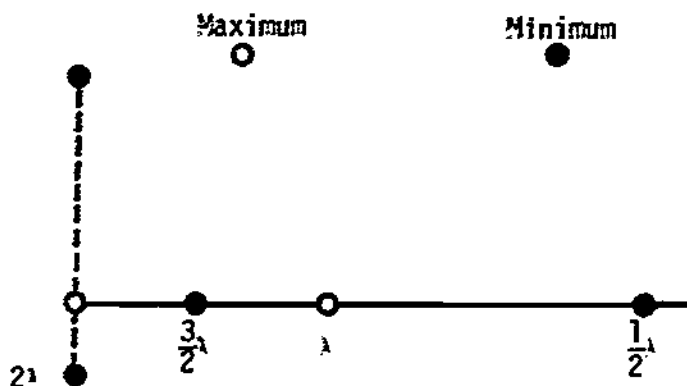

Figure 3

- D(3). The width of one of the slits in a double-slit experiment is increased so that the amplitude of the light from that slit is increased by 50%. Determine the ratio of the intensity at a minimum to that of a maximum. Compare this to the result for equal slits.

Solution

The resultant amplitudes at the maximum where the two signals are in phase and at the minimum where the two are out of phase by π rad are shown in Figure 4. Since intensity is proportional to the square of the amplitude,

$$\frac{I_{\min}}{I_{\max}} = \left(\frac{E_{\min}}{E_{\max}} \right)^2 = \left(\frac{0.50}{2.50} \right)^2 = \frac{1}{25} = 0.040.$$

For identical slits the two equal signals (out of phase by π rad) exactly cancel at a minimum, and

$$I_{\min}/I_{\max} = 0 \quad (\text{equal width slits}).$$

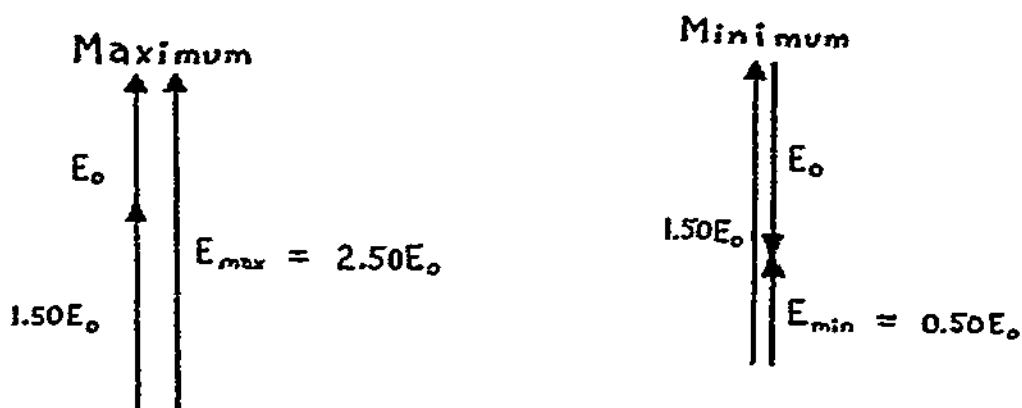

Figure 4

E(4). Light of wavelength 530 nm (5300 Å) is incident normally on an oil film ($n = 1.20$). Calculate the two smallest thicknesses of the film such that a person viewing reflected light would think the film had disappeared.

Solution

See Figure 5. Wavelength in the film is $\lambda_f = \lambda/n$. The distance traveled in the film is $2t$. The phase change is π at the upper surface. If the two reflected rays are to interfere destructively, the phase difference must equal $(2m + 1)\pi$, $m = 0, 1, \dots$

Total phase difference = phase difference due to different pathlengths + phase difference due to phase change upon reflection

$$= 2\pi\left(\frac{2t}{\lambda/n}\right) + \pi = \frac{4\pi nt}{\lambda} + \pi.$$

Therefore, for destructive interference,

$$4\pi nt/\lambda + \pi = (2m + 1)\pi \text{ or } t_n = m\lambda/2n,$$

$$t_1 = \lambda/2n = (530 \text{ nm})/2(1.20) = 220 \text{ nm}, \quad t_2 = \lambda/n = (530 \text{ nm})/1.20 = 440 \text{ nm}.$$

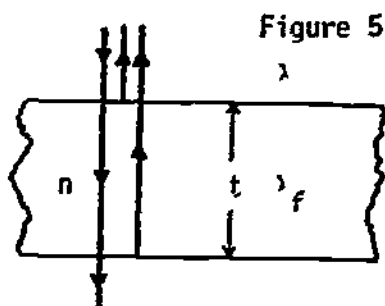

Figure 5

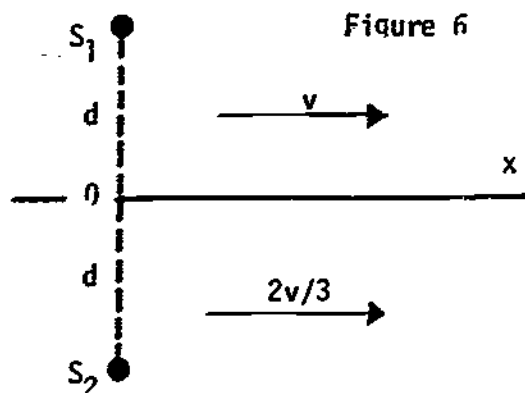

Figure 6

Problems

- F(1). Consider the two coherent sources of Problem B.
 (a) If the amplitude of one source is doubled with no other changes occurring, are the two still coherent?
 (b) Is complete destructive interference still observed at point P? Explain.
- G(2). (a) Would the transverse disturbances at the two maxima [$x = 0$, $x = (3/2)\sqrt{5}\lambda$] of Problem C have equal amplitudes?
 (b) Would the two minima of Problem C be complete destructive interference?
- H(2). In Figure 6, S_1 and S_2 are identical sources emitting transverse (perpendicular to the paper) waves of frequency ν . S_1 is immersed in a medium that propagates waves with a speed v , whereas the propagation speed in the medium surrounding S_2 is $2v/3$. The line OX represents a boundary between the two media. Determine the location of maxima and minima along OX if $d = v/\nu$.
- I(2). Light of wavelength 510 nm (5100 \AA) used in a double-slit (Young's) experiment produces interference fringes separated by 0.250 cm on a screen 0.50 m from the double slit. Calculate the slit separation.
- J(3). Repeat Problem D for the case where the wider slit contributes a signal with twice the amplitude of the smaller slit.
- K(3). For the conditions of Problem J, consider a point in the interference halfway between a maximum and an adjacent minimum. Calculate the ratio of the intensity at this point to that at the maximum. Compare this to the equal-width slit result.
- L(4). Work Problem E for the case where the oil film is deposited on a flat, glass ($n = 1.50$) surface.

Solutions

- F(1). (a) Yes. Changing the amplitude of one source does not change the phase relationship between the two.
 (b) Not complete destructive interference. The two signals still arrive at point P oppositely directed at each instant; but one amplitude is always twice the other so that some disturbance is now observed at P.
- G(2). (a) No. Hint: The amplitude of any real wave decreases with distance from its source. In fact, if this effect had been considered carefully, it would have caused a change in the positions of the maxima and minima found in Problem C.
 (b) No. Same as part (a).
- H(2). See Figure 7. Maxima: $x_n = (v/\nu)\sqrt{4n^2 - 1} = d\sqrt{4n^2 - 1}$,
Minima: $x_n - 1/2 = (2v/\nu)\sqrt{n(n - 1)} = 2d\sqrt{n(n - 1)}$, where $n = 1, 2, \dots$

For $n \gg 1$, $x_n \approx 2nd$ and $x_{n-1/2} = (2n-1)d$.

I(2). $1.00 \times 10^{-4} \text{ m} = 0.0100 \text{ cm} = 0.100 \text{ mm}$.

J(3). $1/9 = 0.111$.

K(3). $5/9 \approx 0.56$, D.50.

L(4). 110 nm, 330 nm.

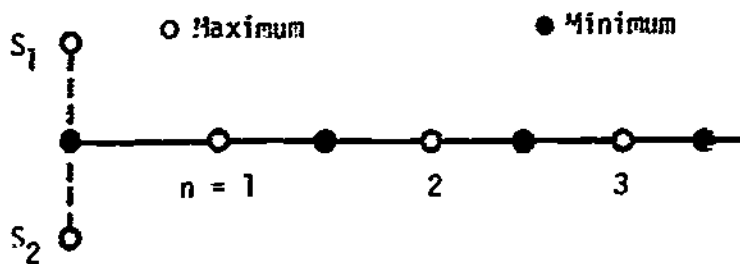

Figure 7

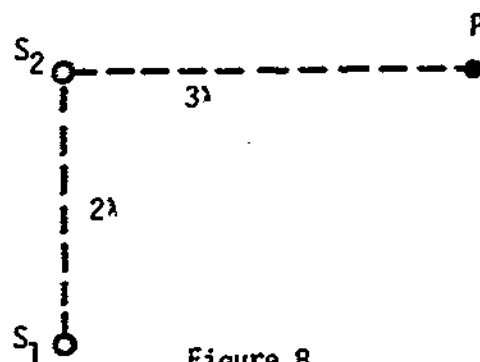

Figure 8

PRACTICE TEST

- (a) List the condition(s) necessary for two sources to be coherent.
(b) Two speakers are driven by different audio-oscillators. Is it possible for these two to be coherent sources? Explain.
- A double-slit arrangement (slit separation = 0.100 mm) is used to determine the wavelength of a monochromatic beam of light. Adjacent bright fringes are separated by 0.61 cm on a screen 1.00 m away. Calculate the wavelength.
- In Figure 8, S_1 and S_2 are in-phase coherent sources of transverse (perpendicular to the paper) disturbances. The S_1 to S_2 amplitude ratio at point P is 0.80. Determine the ratio of the intensity of the disturbance at point P to that at point P if S_1 is turned off.
- Determine the smallest nonzero value for the thickness of a film ($n = 1.40$) that transmits all of the 620-nm-wavelength light that strikes the film perpendicularly.

- 220 nm.
- 0.65.
- 610 nm.

- (a) Phase difference between two fixed in time.
(b) Yes, provided two oscillators are finely tuned. Even then thermal drifts introduce slowly varying phase.

INTERFERENCE

Date _____

Mastery Test Form A

pass recycle

1 2 3 4

Name _____ Tutor _____

- (a) List the condition(s) necessary for two sources to be coherent.
 (b) Are wavelengths of radiation from two coherent sources necessarily the same? Explain.
- Light of 560 nm wavelength is used in a double-slit (Young's) experiment with the slit separation equal to 0.150 mm. Calculate the distance between adjacent dark fringes on a screen 0.80 m away.
- In Figure 1, S_1 and S_2 are two identical coherent speakers. The intensity of the disturbance at P is the same when both sources are on as when only S_1 or S_2 is on. What can you conclude about the phase difference between S_1 and S_2 ?
- Two perfectly flat plates of glass are separated by an air film. When the plates are illuminated at normal incidence by either violet light ($\lambda = 450$ nm) or yellow light ($\lambda = 600$ nm) there is no reflection. What is the minimum (nonzero) thickness of the air gap?

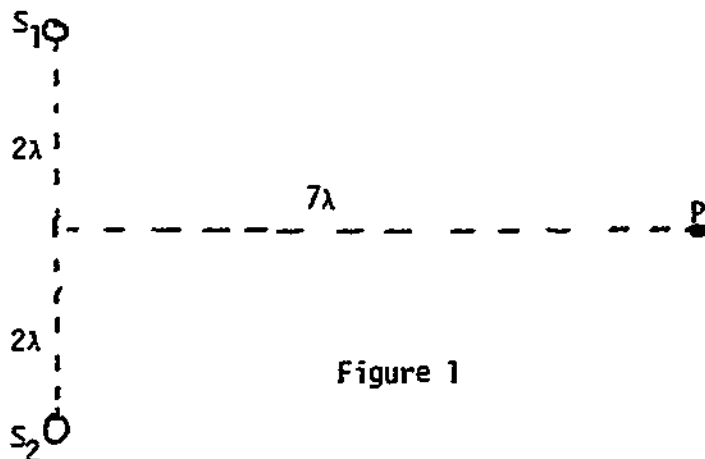

Figure 1

INTERFERENCE

Date _____

Mastery Test Form B

pass		recycle	
1	2	3	4

Name _____ Tutor _____

1. (a) List the condition(s) necessary for two sources to be coherent.
 (b) Can two sources that emit at different power rates be coherent? Explain.
2. Light of 480 nm wavelength is used in a double-slit (Young's) experiment, and adjacent dark fringes are separated by 2.00 mm on a screen 1.20 m away. Calculate the distance between the two slits.
3. Light from two in-phase coherent sources arrives at a point with equal amplitudes. The distances from the point to the two sources differ by $\lambda/6$. Calculate the ratio of the intensity of the light at the point with both sources to the intensity at that point with one source.
4. A lens with an index of refraction of 1.70 is coated with a film ($n = 1.40$). Calculate the minimum (nonzero) thickness of the film if wavelengths $\lambda_1 = 450$ nm and $\lambda_2 = 550$ nm are to enter the lens at normal incidence with no reflection.

INTERFERENCE

Date _____

Mastery Test Form C

pass recycle

1 2 3 4

Name _____ Tutor _____

1. (a) List the condition(s) necessary for two sources to be coherent.
 (b) Can two sources of different frequencies be coherent? Explain.
2. Light of 520 nm wavelength is used in a double-slit (Young's) experiment (slit separation = 0.45 mm). Adjacent dark fringes separated by 2.10 mm are observed on a screen. Determine the slit-to-screen distance.
3. Light from two in-phase coherent sources produces an interference pattern on a screen S ($R \gg d$), as shown in Figure 1. The intensity at a minimum is observed to be $1/7$ that at an adjacent maximum. Determine the ratio of the amplitudes of the two signals.
4. Two square (2.00×2.00 cm) pieces of plane glass are laid one upon the other on a table. A thin strip of metal is placed between them at one edge so that a thin wedge of air is formed. The plates are illuminated by light ($\lambda = 650$ nm) at normal incidence. Interference fringes are observed to be separated by 0.48 mm. Determine the thickness of the metal strip.

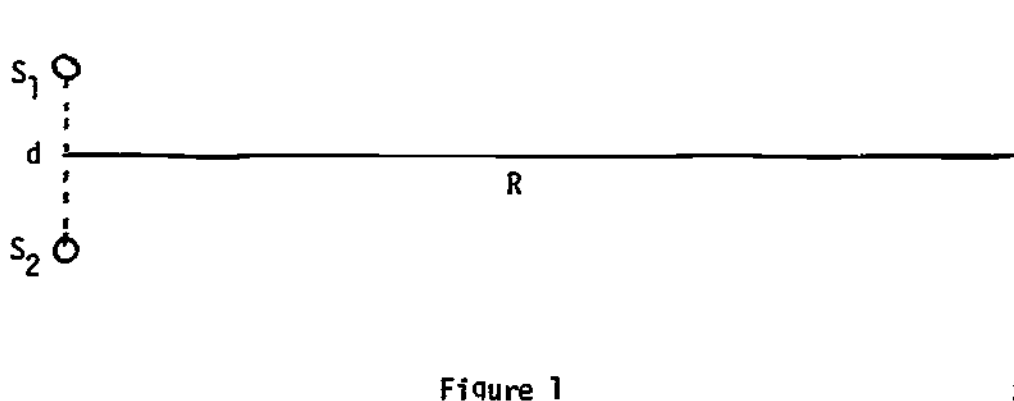

Figure 1

MASTERY TEST GRADING KEY - Form A

1. What To Look For: (a) Correct answer. (b) Accept "yes" if well justified.

Solution: (a) Phase difference between the two does not change. (b) Yes, if immersed in same medium. No, if in different media with different speeds, i.e., $\lambda = u/v$.

2. What To Look For: Correct answer.

Solution: $\lambda/d = \Delta x/R$,

$$\Delta x = \lambda R/d = 3.00 \text{ mm} = 3.00 \times 10^{-3} \text{ m.}$$

3. What To Look For: Correct answer. Diagram showing addition of vectors.

Solution: See Figure 11. If $E = E_0$, then $\theta = 60^\circ = \pi/3$, and the phase difference

$$\phi = \pi - \pi/3 = 2\pi/3 \text{ or } \phi' = 2\pi - \phi = 4\pi/3.$$

4. What To Look For: Correct answer. Student must show evidence on how he determined m .

Solution: See Figure 12. For reflection cancellation:

$$(2t/\lambda)2\pi + \pi = (2m + 1)\pi \text{ or } 2t = m\lambda.$$

The minimum t for smallest m such that

$$m\lambda_2 = (m + 1)\lambda_1, \quad m(\lambda_2 - \lambda_1) = \lambda_1,$$

so

$$m = \lambda_1/(\lambda_2 - \lambda_1) = 450/150 = 3.$$

Therefore

$$t = m\lambda_2/2 = 3(600)/2 = 900 \text{ nm.}$$

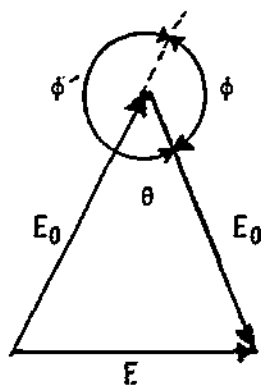

Figure 11

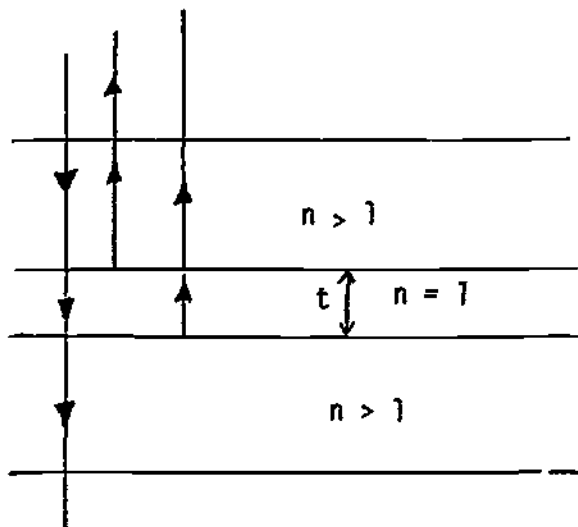

Figure 12

MASTERY TEST GRADING KEY - Form B

1. What To Look For: (a) Correct answer. (b) Correct answer with justification.

Solution: (a) Phase difference between two constant in time. (b) Yes. Power depends upon frequency ν and amplitude. Two coherent sources (same ν) can have different amplitude and hence different power.

2. What To Look For: Correct answer.

Solution: $\lambda/d = \Delta x/R,$

$$\Delta x = \lambda R/d = 0.290 \text{ mm} = 2.90 \times 10^{-4} \text{ m.}$$

3. What To Look For: See that phase ϕ is determined correctly. Check to see vector diagram. Correct answer.

Solution: See Figure 13. $\phi = 2\pi \frac{\lambda/6}{\lambda} = \frac{\pi}{3}.$

$$E_m^2 = E_0^2 + E_0^2 + 2E_0^2 \cos(\pi/3) = 3E_0^2. \quad I_m/I_0 = 3E_0^2/4E_0^2 = 3/4.$$

4. What To Look For: Correct answer. Student shows evidence how he determined m.

Solution: See Figure 14. Destructive interference:

$$2\pi(2nt/\lambda) = (2m + 1)\pi \quad \text{or} \quad 4nt = (2m + 1)\lambda.$$

Minimum t for smallest m such that

$$(2m + 1)\lambda_2 = (2m + 3)\lambda_1, \quad 2m(\lambda_2 - \lambda_1) = 3\lambda_1 - \lambda_2,$$

$$m = (3\lambda_1 - \lambda_2)/2(\lambda_2 - \lambda_1) = 800/200 = 4.$$

Therefore

$$t = 9\lambda_2/4n = 9(550)/4(1.4) = 880 \text{ nm.}$$

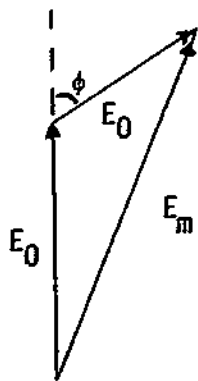

Figure 13

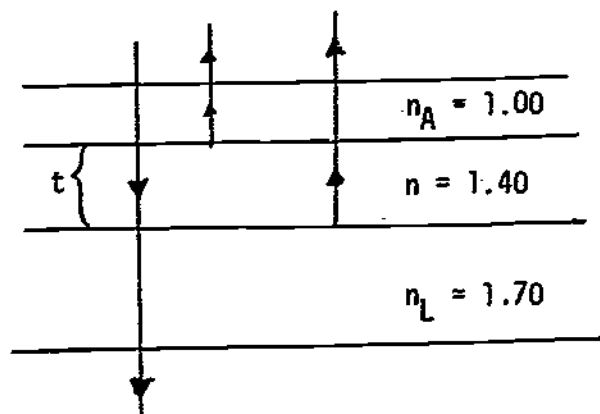

Figure 14

MASTERY TEST GRADING KEY - Form C

1. What To Look For: (a) Correct answer. (b) Correct answer with justification.

Solution: (a) Phase difference between two does not change. (b) No. Impossible to keep phase constant if two periods are different.

2. What To Look For: Correct answer.

Solution: $\lambda/d = \Delta x/R,$

$$R = (d \Delta x)/\lambda = 1.80 \text{ m.}$$

3. What To Look For: Correct answer.

Solution: See Figure 15. $[(1 - \alpha)E_0/(1 + \alpha)E_0]^2 = 1/7,$

$$(1 - \alpha)/(1 + \alpha) = 1/\sqrt{7}, \quad \sqrt{7} - 1 = (\sqrt{7} + 1)\alpha,$$

$$\alpha = (\sqrt{7} - 1)/(\sqrt{7} + 1) = 0.45 \text{ or } 1/\alpha = 2.20.$$

4. What To Look For: Correct answer. Ask how student obtained relationship between d and λ if it's not clear from his work.

Solution: See Figure 16. $\frac{\lambda/2}{\ell} = \theta = \frac{d}{L},$

$$d = \lambda L/2\ell = 1.38 \times 10^{-5} \text{ m.}$$

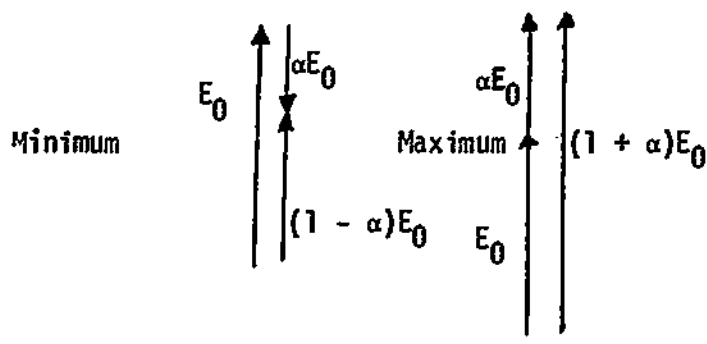

Figure 15

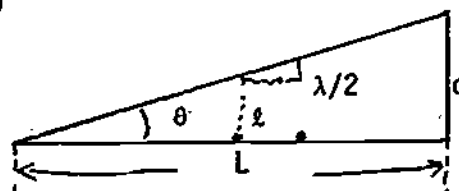

Figure 16

STUDY GUIDE

INTRODUCTION TO QUANTUM PHYSICS

INTRODUCTION

You have probably encountered a system known as an "electric eye," which senses light from an artificial source or the sun. This information is used to open doors, count pedestrians or auto traffic, turn on lights at sunset, read holes in punched cards, and for a host of other applications. Most of these devices are based on the photoelectric effect, which is the light-induced emission of electrons from atoms.

The photoelectric effect completely baffled physicists at the time of its discovery. Einstein's explanation of this process, which won the Nobel Prize in 1921, was a major part of the twentieth-century revolution in physics known as the quantum theory. In this module we shall study the photoelectric and Compton effects, the processes that clearly demonstrate that the energy and momentum in electromagnetic waves are transferred as discrete entities called photons.

PREREQUISITES

Before you begin this module, you should be able to:

Location of
Prerequisite Content

*Find wavelength, given wave speed and frequency (needed for Objectives 1 through 3 of this module)

Traveling Waves
Module

*Solve problems using conservation of energy (needed for Objective 2 of this module)

Conservation of
Energy Module

*Solve problems involving elastic collisions (needed for Objective 3 of this module)

Collisions
Module

*Relate the wavelength of electromagnetic waves to the type of radiation, and relate energy flux to energy density in the wave (needed for Objectives 1 through 3 of this module)

Maxwell's
Predictions
Module

LEARNING OBJECTIVES

After you have mastered the content of this module, you will be able to:

1. Quantum relations - Use the Planck-Einstein-de Broglie relations to relate the energy or momentum of a photon to the frequency or wavelength of the associated electromagnetic wave.

2. Photoelectric effect - Use conservation of energy and the quantum relations to solve problems involving photoelectric emission of electrons from metals. The relevant physical quantities are the frequency of the light, the work function of the metal, and the maximum kinetic energy of the emitted electrons.
3. Compton effect - Use conservation of energy and momentum as expressed by the Compton formula to calculate the energy or momentum of the outgoing particles in the collision of a photon with an electron at rest.

GENERAL COMMENTS

At the beginning of the twentieth century, there was a growing number of phenomena for which there was no description consistent with the physics we have studied in the preceding modules. A modification of classical physics was in order. The ideas we discuss here were developed in the first years of this century by Planck, Einstein, and de Broglie as each tried to understand these new phenomena. Their conclusions can be summarized as follows:

All energy propagates as waves. When energy or momentum is transferred between the wave and a source or absorber, the energy E and momentum p are in discrete amounts related to the frequency f and wavelength λ by the relations

$$E = hf \quad \text{and} \quad p = h/\lambda$$

where Planck's constant $h = 6.63 \times 10^{-34}$ J s. These discrete amounts of energy and momentum are called quanta; the quantum of electromagnetic radiation is called a photon. When the frequency is low and the number of photons involved very large, we use the language of classical waves. If the number of photons is small, like one, then we use the language of particle mechanics to describe the process.

The experiments that most clearly demonstrate the existence of photons are the photoelectric effect and the Compton effect. In the photoelectric effect, light incident on an atom or group of atoms may result in the ejection of an electron. The relation between the kinetic energy of the electron and the frequency of the incident light is found to be

$$hf = \phi + E,$$

which is just the conservation of energy. The energy of the absorbed photon, hf , is equal to ϕ (work function or ionization energy, the energy needed to remove an electron from an atom), plus E , the kinetic energy of the ejected electron. For single atoms, the kinetic energy given above is the energy of the ejected electron. For a solid, it is an upper bound, since the electron may lose some of its kinetic energy to other atoms as it leaves the solid. ϕ is typically of the order of 1.60×10^{-19} J, also known as an electron volt.

The Compton effect is the elastic scattering of a photon from an electron at rest. Since the photon transfers some of its energy and momentum to the electron in the collision, energy and momentum conservation together with the quantum relations require that the wave frequency must decrease and the wavelength must increase. The increase of wavelength for scattering of the photon through an angle θ from an electron of mass m is

$$\lambda' - \lambda = (h/mc)(1 - \cos \theta).$$

Notice that for $\theta = 0$ (no scattering) the photon wavelength is unchanged. As θ increases, more energy is transferred to the electron, thus energy conservation requires a larger increase in photon wavelength; when the photon bounces straight back, the wavelength change is $2h/mc = 4.85 \times 10^{-12}$ m. It follows that the wavelength shift is easily observed only for x rays (short wavelength, high photon energy) incident on electrons. Since there are no targets consisting of free electrons at rest, Compton-effect experiments are usually done by scattering from electrons found in atoms. In this case, a correction, usually negligible, must be made for the binding energy.

TEXT: Frederick J. Bueche, Introduction to Physics for Scientists and Engineers (McGraw-Hill, New York, 1975), second edition

SUGGESTED STUDY PROCEDURE

Read the General Comments for an overview of the material of this module. Skip the discussion of blackbody radiation at the beginning of Chapter 35. Although it is historically correct that the ideas of quantum physics began with Planck's explanation of blackbody radiation, the physical ideas involved in this phenomenon are very complex and are often presented incorrectly.

Objective 1 is introduced in the context of discussing Objectives 2 and 3. As you read the suggested pages for each objective, work through the Illustrations. Then study Problems A, B, and C, and work the Assigned Problems. This should give you enough practice to understand the objectives and to work the Practice Test.

BUECHE

Objective Number	Readings	Problems with Solutions		Assigned Problems		Additional Problems (Chap. 35)
		Study Guide	Text	Study Guide	Text (Chap. 35)	
1	Secs. 35.3, 35.4	A		D	10	
2	Sec. 35.3	B	Illus. ^a 35.2, 35.3	E	9, 11	12
3	Sec. 35.4	C	Illus. 35.4	F	15, 16	

^aIllus. = Illustration(s).

TEXT: David Halliday and Robert Resnick, Fundamentals of Physics (Wiley, New York, 1970; revised printing, 1974)

SUGGESTED STUDY PROCEDURE

Read the General Comments for an overview of the material of this module. Skip the discussion of blackbody radiation at the beginning of Chapter 39. Although it is historically correct that the ideas of quantum physics began with Planck's explanation of blackbody radiation, the physical ideas involved in this phenomenon are very complex and are often presented incorrectly.

Objective 1 is introduced in the context of discussing Objectives 2 and 3. As you read the suggested pages for each objective, work through the Examples. Then study Problems A, B, and C, and work the Assigned Problems. This should give you enough practice to understand the objectives and to work the Practice Test.

HALLIDAY AND RESNICK

Objective Number	Readings	Problems with Solutions		Assigned Problems		Additional Problems (Chap. 39)
		Study Guide	Text (Chap. 39)	Study Guide	Text (Chap. 39)	
1	Secs. 39-4, 39-5, 39-6	A		D	15	
2	Secs. 39-4, 39-5	B	Ex. ^a 2, 3	E	17, 19, 21	16, 18, 20, 22
3	Sec. 39-6	C	Ex. 4	F	25, 27	24, 26, 28

^aEx. = Example(s).

TEXT: Francis Weston Sears and Mark W. Zemansky, University Physics (Addison-Wesley, Reading, Mass., 1970), fourth edition

SUGGESTED STUDY PROCEDURE

Read the General Comments for an overview of the material of this module. Sears and Zemansky discuss the photoelectric effect only briefly, the Compton effect not at all. For this reason, we suggest that you include another text in your reading, following the Table below. For each Objective, read the text, study the respective Problem with Solution and examples, then work the corresponding Assigned Problems. Try the Practice Test before taking a Mastery Test.

SEARS AND ZEMANSKY

Objective Number	Readings	Problems with Solutions		Assigned Problems		Additional Problems
		Study Guide	Text	Study	Text	
1	Sec. 43-4	A		D	43-15	
2	Sec. 43-4	B		E	43-5, 43-7 43-9, 43-11	43-6, 43-8, 43-10, 43-12

Frederick J. BUECHE, Introduction to Physics for Scientists and Engineers (McGraw-Hill, New York, 1975), second edition

2	Sec. 35.3	B	Illus. ^a 35.2, 35.3	E	Chap. 35, Probs. 9, 11	Chap. 35, Prob. 12
3	Sec. 35.4	C	Illus. 35.4	F	Chap. 35, Probs. 15, 16	

David HALLIDAY and Robert RESNICK, Fundamentals of Physics (Wiley, New York, 1970; revised printing, 1974)

2	Secs. 39-4, 39-5	B	Ex. ^a 2, 3	E	Chap. 39, Probs. 17, 19, 21	Chap. 39, Probs. 16, 18, 20, 22
3	Sec. 39.6	C	Ex. 4	F	Chap. 39, Probs. 25, 27	Chap. 39, Probs. 24, 26, 28

^aIllus. = Illustration(s). Ex. = Example(s).

STUDY GUIDE: Quantum Physics

4(W5 1)

TEXT: Richard T. Weidner and Robert L. Sells, Elementary Classical Physics (Allyn and Bacon, Boston, 1973), second edition, Vols. 1 and 2

SUGGESTED STUDY PROCEDURE

Since your text does not cover quantum physics, you may ask your instructor for a corresponding Study Guide if you have access to one of the following texts.

Frederick J. Bueche, Introduction to Physics for Scientists and Engineers (McGraw-Hill, New York, 1975), second edition

David Halliday and Robert Resnick, Fundamentals of Physics (Wiley, New York, 1970; revised printing, 1974)

PROBLEM SET WITH SOLUTIONS

A(1). An FM radio station broadcasts electromagnetic waves with $f = 10^8$ Hz,
 $\lambda = 3.00$ m.

(a) What energy and momentum is carried by one photon?

(b) If the radiated power is 10^4 W, how many photons are emitted per second?

Solution

$$(a) E = hf = (6.63 \times 10^{-34} \text{ J s})(10^8 \text{ s}^{-1}) = 6.63 \times 10^{-26} \text{ J.}$$

$$P = h/\lambda = (6.63 \times 10^{-34} \text{ J s})/(3.00 \text{ m}) = 2.21 \times 10^{-34} \text{ kg m/s.}$$

(b) $P = RE$, where R is the rate of photon emission.

$$R = \frac{P}{E} = \frac{10^4 \text{ J/s}}{6.63 \times 10^{-26} \text{ J/photon}} = 1.51 \times 10^{29} \text{ photons/s.}$$

Thus, it is very difficult to see individual photons.

B(2). When light of wavelength 4500 \AA ($1 \text{ \AA} = 10^{-10} \text{ m}$) falls on a metal plate, electrons are emitted with a maximum kinetic energy of $1.20 \text{ eV} = 1.6 \times 10^{-19} \text{ J}$.

(a) What is the work function ϕ for the plate?

(b) What is the longest wavelength light that can cause photoemission from this plate?

Solution

(a) Photoelectric equation (energy conservation):

$$hf = \phi + E, \quad f\lambda = c,$$

$$\phi = h\left(\frac{c}{\lambda}\right) - E = (6.63 \times 10^{-34} \text{ J s})\left(\frac{3.00 \times 10^8 \text{ m/s}}{4.5 \times 10^{-7} \text{ m}}\right) - (1.92 \times 10^{-19} \text{ J})$$

$$= 2.49 \times 10^{-19} \text{ J} = 1.56 \text{ eV.}$$

(b) The energy of the emitted electron must be at least equal to zero for emission to occur:

$$hf \geq \phi, \quad hc/\lambda \geq \phi,$$

$$\lambda \geq \frac{hc}{\phi} = \frac{(6.63 \times 10^{-34} \text{ J s})(3.00 \times 10^8 \text{ m/s})}{1.56 \times 10^{-19} \text{ J}}, \quad \lambda_{\text{max}} = 1.28 \times 10^{-6} \text{ m} = 12800 \text{ \AA}.$$

C(3). Electromagnetic waves (photons) of wavelength 0.050 \AA are scattered 60° from electrons at rest.

- (a) What is the wavelength of the scattered photon?
 (b) What is the kinetic energy of the recoil electron?

Solution

(a) $\lambda' = \lambda + (h/mc)(1 - \cos \theta)$ (Compton formula),

$$\begin{aligned}\lambda' &= 0.05 \text{ \AA} + \left(\frac{6.63 \times 10^{-34} \text{ J s}}{(9.11 \times 10^{-31} \text{ kg})(3.00 \times 10^8 \text{ m/s})} \right) (1 - \cos 60^\circ) \\ &= 0.05 \text{ \AA} + (1.21 \times 10^{-12} \text{ m}) = 0.062 \text{ \AA}.\end{aligned}$$

(b) By energy conservation: $hc/\lambda = hc/\lambda' + E$,

$$E = hc(1/\lambda - 1/\lambda'),$$

$$\begin{aligned}E &= (6.63 \times 10^{-34} \text{ J s})(3.00 \times 10^8) \left(\frac{1}{5.0 \times 10^{-12} \text{ m}} - \frac{1}{6.2 \times 10^{-12} \text{ m}} \right) \\ &= 7.7 \times 10^{-15} \text{ J} = 48 \text{ 000 eV} = 48 \text{ keV}.\end{aligned}$$

Problems

D(1). A photon with $E = 1.00 \text{ J}$ would be easily observable as a single particle. What are the frequency and wavelength of the electromagnetic wave?

E(2). A certain metal surface has a threshold wavelength for photoemission of λ_0 . If the incident wavelength is $\lambda_0/2$, electrons of maximum kinetic energy 1.40 eV ($1 \text{ eV} = 1.6 \times 10^{-19} \text{ J}$) are emitted.

- (a) What is λ_0 ?
 (b) What is the work function ϕ ?

F(3). You have a detector that detects photons scattered 90° from a copper target. You detect photons with $\lambda_1 = 0.0300 \text{ \AA}$ and $\lambda_2 = 0.054 \text{ \AA}$.

- (a) Why are there two different wavelengths in the scattered radiation?
 (b) What is the wavelength of the incident radiation?
 (c) What is the kinetic energy of the recoil electron?

Solutions

$$D(1). \quad f = E/h = (1.00 \text{ J}) / (6.63 \times 10^{-34} \text{ J s}) = 1.51 \times 10^{33} \text{ Hz.}$$

$$\lambda = c/f = (3.00 \times 10^8 \text{ m/s}) / (1.51 \times 10^{33} \text{ s}^{-1}) = 1.99 \times 10^{-25} \text{ m.}$$

It would evidently be very difficult to observe interference phenomena with such short waves, since there are no known detectors with sufficient spatial resolution.

E(2). (a) At threshold, electrons have zero energy:

$$hc/\lambda_0 = \phi.$$

For the shorter wavelength,

$$2hc/\lambda_0 = \phi + E.$$

Subtract the first equation from the second: $hc/\lambda_0 = E$,

$$\lambda_0 = \frac{hc}{E} = \frac{(6.63 \times 10^{-34} \text{ J s})(3.00 \times 10^8 \text{ m/s})}{1.4(1.6 \times 10^{-19} \text{ J})} = 8.88 \times 10^{-7} \text{ m} = 8880 \text{ \AA}.$$

$$(b) \quad \phi = hc/\lambda_0 = E = 1.40 \text{ eV.}$$

F(3). (a) The target contains electrons and copper nuclei of mass $M = 1.055 \times 10^{-25} \text{ kg}$. For electrons:

$$\Delta\lambda = h/mc = 0.0240 \text{ \AA}, \quad \Delta\lambda = \lambda' - \lambda.$$

For scattering from copper nuclei:

$$\Delta\lambda = h/Mc = 2.10 \times 10^{-7} \text{ \AA} \quad (\text{negligible shift}).$$

Thus, the 0.030- \AA photons are scattered 90° from copper nuclei, and the 0.054- \AA photons are scattered 90° from electrons.

(b) $\lambda_{\text{inc}} = 0.030 \text{ \AA}$ [to two significant figures, actually slightly less - see part (a)].

(c) Use energy conservation: $hc/\lambda = hc/\lambda' + E$,

$$E = hc\left(\frac{1}{\lambda} - \frac{1}{\lambda'}\right) = (6.63 \times 10^{-34} \text{ J s})(3.00 \times 10^8) \left(\frac{1}{3.00 \times 10^{-12} \text{ m}} - \frac{1}{5.4 \times 10^{-12} \text{ m}}\right)$$

$$= 2.95 \times 10^{-14} \text{ J} = 184 \text{ keV.}$$

PRACTICE TEST

1. The work function ϕ of tungsten metal is 4.6 eV ($1 \text{ eV} = 1.60 \times 10^{-19} \text{ J}$).
- (a) What is the threshold wavelength for photoemission from tungsten?
- (b) If light of wavelength 2200 Å ($1 \text{ Å} = 10^{-10} \text{ m}$) falls on a tungsten surface, what is the maximum kinetic energy (in electron volts) of the emitted electrons?
2. Photons of wavelength $\lambda = 0.040 \text{ Å}$ are Compton (elastically) scattered from electrons.
- (a) What is the energy of the photon?
- (b) The recoil electron has a kinetic energy of $1.40 \times 10^5 \text{ eV}$. What was the scattering angle θ of the photon? ($h = 6.63 \times 10^{-34} \text{ J s}$; $m_e = 9.11 \times 10^{-31} \text{ kg}$.)

Practice Test Answers

1. (a) 2730 Å. (b) 1.10 eV.

2. (a) $5.0 \times 10^{-14} \text{ J}$ or 311 keV. (b) $\cos \theta = -0.34$, $\theta = 110^\circ$.

INTRODUCTION TO QUANTUM PHYSICS

Date _____

Mastery Test Form A

pass recycle

1 2 3

Name _____ Tutor _____

1. Light of wavelength 350 nm shines on a metal surface whose work function is 1.80 eV ($1 \text{ eV} = 1.6 \times 10^{-19} \text{ J}$). The light intensity is $1.80 \times 10^3 \text{ W/m}^2$.
 - (a) What is the maximum kinetic energy of the emitted photoelectrons?
 - (b) If the intensity of the light were doubled, what would be the maximum kinetic energy of the electrons?
 - (c) If the wavelength of the incident light were doubled, what would be the kinetic energy of the emitted electrons?

2. Photons scattered backwards ($\theta = 180^\circ$) from electrons at rest are observed to have a wavelength of 0.069 \AA ($1 \text{ \AA} = 10^{-10} \text{ m}$). ($h = 6.63 \times 10^{-34} \text{ J}$; $m_e = 9.11 \times 10^{-31} \text{ kg}$.)
 - (a) What is the wavelength of an incident photon?
 - (b) What is the kinetic energy of a recoiling electron?

INTRODUCTION TO QUANTUM PHYSICS

Date _____

Mastery Test Form B

pass recycle

1 2 3

Name _____

Tutor _____

1. Light of wavelength 450 nm shines on a metal surface. The emitted electrons are seen to have a maximum kinetic energy of 0.80 eV ($1 \text{ eV} = 1.6 \times 10^{-19} \text{ J}$; these electrons need a retarding potential of 0.80 V to stop them).
 - (a) What is the work function of the metal?
 - (b) What is the longest wavelength that would produce emitted electrons?

2. A photon is scattered backwards ($\theta = 180^\circ$) from an electron at rest. The electron recoils with a kinetic energy of 10^5 eV ($1.6 \times 10^{-14} \text{ J}$) ($h = 6.63 \times 10^{-34} \text{ J}$; $m_e = 9.11 \times 10^{-31} \text{ kg}$).
 - (a) What is the energy of the incident photon?
 - (b) If the photon energy were doubled, what would be the change in wavelength for backward scattering ($\theta = 180^\circ$)?

INTRODUCTION TO QUANTUM PHYSICS

Date _____

Mastery Test Form C

pass recycle

1 2 3

Name _____

Tutor _____

$$h = 6.63 \times 10^{-34} \text{ J s.}$$

$$m_e = 9.11 \times 10^{-31} \text{ kg.}$$

1. You want to build a photoelectric source using light of $\lambda = 440 \text{ nm}$. You have a choice of the following materials as emitters:

Metal	ϕ
Lithium	2.30 eV
Zinc	3.6 eV
Tungsten	4.5 eV

- (a) Which material(s) will not work at all?
 (b) Which material produces the most energetic electrons? What is their energy?
2. You have a source of photons of wavelength $\lambda = 0.0200 \text{ \AA}$ ($1 \text{ \AA} = 10^{-10} \text{ m}$). You want to produce $\lambda = 0.040 \text{ \AA}$ photons by Compton scattering from free electrons at rest; you propose to identify the $\lambda = 0.040 \text{ \AA}$ photons by measuring the energy of the recoil electron.
- (a) What is the required scattering angle?
 (b) What is the kinetic energy of the recoil electron?

MASTERY TEST GRADING KEY - Form A

1. What To Look For: Photoelectric equation. Consistent units. (c) The electron energy does not scale linearly with photon wavelength or energy. In this case, nothing comes out.

Solution: $hc/\lambda = \phi + E,$

$$E = \frac{hc}{\lambda} - \phi = \frac{6.63 \times 10^{-34} \text{ J s}}{3.5 \times 10^{-7} \text{ m}} \frac{3.00 \times 10^8 \text{ m/s}}{1.60 \times 10^{-19} \text{ J/eV}} - 1.80 \text{ eV}$$

$$= 3.55 \text{ eV} - 1.80 \text{ eV} = 1.75 \text{ eV} = 2.80 \times 10^{-19} \text{ J.}$$

(b) Same as part (a), K.E. does not depend on intensity.

(c) $E = hc/2\lambda - \phi = 1.775 \text{ eV} - 1.80 \text{ eV}$. Ugh! Not enough energy to knock out an electron. No electrons emitted.

2. What To Look For: (a) Compton formula. $\theta = 180^\circ$. $h/mc = 0.0243 \text{ \AA}$. Solve for λ .
(b) Energy conservation. Consistent units.

Solution: (a) $\lambda' - \lambda = (h/mc)(1 - \cos \theta) = 2h/mc.$

$$\lambda = \lambda' - 2h/mc = 0.069 \text{ \AA} - 0.049 \text{ \AA} = 0.0200 \text{ \AA}.$$

(b) $hc/\lambda = hc/\lambda' + E,$

$$E = hc\left(\frac{1}{\lambda} - \frac{1}{\lambda'}\right) = (6.63 \times 10^{-34} \text{ J s})(3.00 \times 10^8 \text{ m/s})$$

$$\times \left(\frac{1}{2.00 \times 10^{-12} \text{ m}} - \frac{1}{6.9 \times 10^{-12} \text{ m}}\right)$$

$$= 7.1 \times 10^{-14} \text{ J} = 4.4 \times 10^5 \text{ eV.}$$

MASTERY TEST GRADING KEY - Form B

1. What To Look For: Photoelectric equation. Convert wavelength to frequency. Use consistent energy units. Set $E = 0$ in photoelectric equation. Convert electron volts to joules or vice versa.

Solution: (a) $hf = \phi + E$, $f = c/\lambda$.

$$\phi = \frac{hc}{\lambda} - E = \frac{(6.63 \times 10^{-34})(3.00 \times 10^8)}{(4.5 \times 10^{-7})(1.60 \times 10^{-19})} - 0.80 \text{ eV} = (2.76 - 0.80) \text{ eV} = 1.96 \text{ eV}.$$

(b) At threshold: $hc/\lambda = \phi$,

$$\lambda = \frac{hc}{\phi} = \frac{(6.63 \times 10^{-34} \text{ J s})(3.00 \times 10^8 \text{ m/s})}{(1.96 \text{ eV})(1.60 \times 10^{-19} \text{ J/eV})}$$

$$= 6.3 \times 10^{-7} \text{ m} = 6.3 \times 10^3 \text{ \AA} = 630 \text{ nm}.$$

2. What To Look For: Compton equation. Conservation of energy. Correct substitution. Multiplication by $\lambda(\lambda + 2h/mc)$. Solution of quadratic equation. Reject negative answer.

Solution: (a) $\lambda' - \lambda = (h/mc)(1 - \cos \theta) = 2h/mc$.

$$\lambda' = \lambda + 2h/mc, \quad hc/\lambda - hc/\lambda' = E, \quad 1/\lambda - 1/\lambda' = E/hc.$$

$$\frac{1}{\lambda} - \frac{1}{\lambda + 2h/mc} = \frac{E}{hc}, \quad \lambda + \frac{2h}{mc} - \lambda = \left(\frac{E}{hc}\right)\lambda\left(\lambda + \frac{2h}{mc}\right), \quad \lambda^2 + \left(\frac{2h}{mc}\right)\lambda - \frac{2h^2}{mE} = 0,$$

$$\lambda = \left[-\frac{2h}{mc} \pm \left(\frac{4h^2}{m^2c^2} + \frac{8h^2}{mE} \right)^{1/2} \right] \left(\frac{1}{2} \right) = -\left(\frac{h}{mc} \right) \left[1 \pm \left(1 + \frac{2mc^2}{E} \right)^{1/2} \right]$$

$$= 0.0243 \text{ \AA} \left[\left(1 + \frac{1.02 \text{ MeV}}{0.100 \text{ MeV}} \right)^{1/2} - 1 \right] = 0.057 \text{ \AA}.$$

$$E = \frac{hc}{\lambda} = \frac{(6.63 \times 10^{-34} \text{ J s})(3.00 \times 10^8 \text{ m/s})}{5.7 \times 10^{-12} \text{ m}} = 3.5 \times 10^{-14} \text{ J} = 2.20 \times 10^5 \text{ eV}.$$

(b) $\lambda' - \lambda$ does not depend on λ . $\lambda' - \lambda = 0.049 \text{ \AA}$.

MASTERY TEST GRADING KEY - Form C

1. What To Look For: Calculate energy of photon. Compare with work function. Use photoelectric equation to find electron energy. If negative, no emission.

Solution:

$$\frac{hc}{\lambda} = \frac{(6.63 \times 10^{-34})(3.00 \times 10^8)}{4.4 \times 10^{-7}} = 4.52 \times 10^{-19} \text{ J} = 2.83 \text{ eV.}$$

Metal	ϕ	E_{elec}
Lithium:	2.3 eV	0.53 eV
Zinc:	3.6 eV	No
Tungsten:	4.5 eV	No

$hc/\lambda = \phi + E_{\text{elec}}$. (a) Zinc, tungsten won't work. (b) Lithium produces most energetic electrons: $E_{\text{elec}} = 0.53 \text{ eV}$.

2. What To Look For: Compton formula. Solve for $\cos \theta$. Conservation of energy.

Solution: (a) $\lambda' - \lambda = (h/mc)(1 - \cos \theta)$.

$$\frac{h}{mc} = \frac{6.63 \times 10^{-34} \text{ J s}}{(9.11 \times 10^{-31} \text{ kg})(3.00 \times 10^8 \text{ m/s})} = 2.43 \times 10^{-12} \text{ m} = 0.0243 \text{ \AA.}$$

$$\frac{\lambda' - \lambda}{h/mc} = 1 - \cos \theta, \quad \cos \theta = 1 - \frac{\lambda' - \lambda}{h/mc} = 1 - \frac{0.040 - 0.0200}{0.0243} = 0.177.$$

Thus, $\theta = 80^\circ$.

(b) $hc/\lambda = hc/\lambda' + E$.

$$E = hc\left(\frac{1}{\lambda} - \frac{1}{\lambda'}\right) = (6.63 \times 10^{-34} \text{ J s})(3.00 \times 10^8 \text{ m/s})$$

$$\times \left[\frac{1}{2.00 \times 10^{-12} \text{ m}} - \frac{1}{4.0 \times 10^{-12} \text{ m}} \right] = 5.0 \times 10^{-14} \text{ J} = 3.10 \times 10^5 \text{ eV.}$$