

DOCUMENT RESUME

ED 117 331

CE 005 898

AUTHOR Bernardeau, Christine; And Others
 TITLE U.S. Armed Forces Minority Officer Procurement. Technical Report No. 75-23.
 INSTITUTION Human Resources Research Organization, Alexandria, Va.
 SPONS AGENCY Department of Defense, Washington, D.C. Manpower Requirements and Analysis.
 REPORT NO HumRRO-TR-75-23
 PUB DATE Oct 75
 NOTE 87p.

EDRS PRICE MF-\$0.83 HC-\$4.67 Plus Postage
 DESCRIPTORS *Armed Forces; Demography; Employment Patterns; Manpower Utilization; Military Personnel; *Minority Groups; Models; *Officer Personnel; *Recruitment; Simulation; Socioeconomic Influences; Tables (Data)

ABSTRACT

Findings regarding minority officer procurement in the Armed Forces are analyzed in terms of concepts and standards regarding minority officer representation and of methods for achieving minority representation goals. Chapter 1, Concepts and Standards of Representation, discusses sociopolitical and socioeconomic criteria subdivided through the use of basic demographic variables. Chapter 2, Minority Officer Representation: Status and Objectives, presents a statistical analysis of the current composition of the officer corps in terms of end strengths, loss patterns, and accession patterns with a summary of objectives set by each Service. Chapter 3, Simulation Models, describes Army sources of procurement, compares them with other Services, and discusses simulated methods for achieving Army minority officer goals. The analysis is supplemented by 4 charts, 7 graphs, and 46 tables. Major findings indicate: a lack of coordinated Department of Defense policy regarding minority officer accession; no significant educational gap between minority and white officers; minority officers are in predominantly lower ranks, with lower loss rates; minority officer accession percentages are increasing for the Navy, Air Force, and the Marine Corps, with Army accession variable; and the Army simulation model of officer sources of procurement indicates that the Army can reach any procurement level it defines. (LH)

 * Documents acquired by ERIC include many informal unpublished *
 * materials not available from other sources. ERIC makes every effort *
 * to obtain the best copy available. Nevertheless, items of marginal *
 * reproducibility are often encountered and this affects the quality *
 * of the microfiche and hardcopy reproductions ERIC makes available *
 * via the ERIC Document Reproduction Service (EDRS). EDRS is not *
 * responsible for the quality of the original document. Reproductions *
 * supplied by EDRS are the best that can be made from the original. *

Technical
Report

75-23

HumRRO-TR-75-23

HumRRO

DEC 5 1975

CE

U.S. Armed Forces Minority Officer Procurement

Christine Bernardeau, Richard Eisenman, and
Agnes Purcell

U.S. DEPARTMENT OF HEALTH
EDUCATION & WELFARE
NATIONAL INSTITUTE OF
EDUCATION

THIS DOCUMENT HAS BEEN REPRODUCED EXACTLY AS RECEIVED FROM THE PERSON OR ORGANIZATION ORIGINATING IT. POINTS OF VIEW OR OPINIONS STATED DO NOT NECESSARILY REPRESENT OFFICIAL NATIONAL INSTITUTE OF EDUCATION POSITION OR POLICY.

HUMAN RESOURCES RESEARCH ORGANIZATION
300 North Washington Street • Alexandria, Virginia 22314

Approved for public release; distribution unlimited.

October 1975

Prepared for
Department of Defense
Manpower Requirements and Analysis
The Pentagon
Washington, D.C. 20301

ED 117 331

CE 005 897

The Human Resources Research Organization (HumRRO) is a nonprofit corporation established in 1969 to conduct research in the field of training and education. It is a continuation of The George Washington University Human Resources Research Office. HumRRO's general purpose is to improve human performance, particularly in organizational settings, through behavioral and social science research, development, and consultation.

The contents of this report do not necessarily represent the official opinion or policy of the sponsor of the HumRRO research.

Published
October 1975
by

HUMAN RESOURCES RESEARCH ORGANIZATION
300 North Washington Street
Alexandria, Virginia 22314

Unclassified

SECURITY CLASSIFICATION OF THIS PAGE (When Data Entered)

REPORT DOCUMENTATION PAGE		READ INSTRUCTIONS BEFORE COMPLETING FORM
1. REPORT NUMBER HumRRO-TR-75-23	2. GOVT ACCESSION NO.	3. RECIPIENT'S CATALOG NUMBER
4. TITLE (and Subtitle) U.S. ARMED FORCES MINORITY OFFICER PROCUREMENT		5. TYPE OF REPORT & PERIOD COVERED Technical Report
		6. PERFORMING ORG. REPORT NUMBER Technical Report 75-23
7. AUTHOR(S) Christine Bernardeau, Richard Eisenman, and Agnes Purcell		8. CONTRACT OR GRANT NUMBER(S) MDA 903-75-C-0128
9. PERFORMING ORGANIZATION NAME AND ADDRESS Human Resources Research Organization (HumRRO) 300 North Washington Street Alexandria, Virginia 22314		10. PROGRAM ELEMENT PROJECT TASK AREA & WORK UNIT NUMBERS
11. CONTROLLING OFFICE NAME AND ADDRESS Department of Defense Manpower Requirements and Analysis The Pentagon/Washington, D.C. 20301		12. REPORT DATE October 1975
		13. NUMBER OF PAGES 84
14. MONITORING AGENCY NAME & ADDRESS (if different from Controlling Office)		15. SECURITY CLASS. (of this report) Unclassified
		15a. DECLASSIFICATION/DOWNGRADING SCHEDULE
16. DISTRIBUTION STATEMENT (of this Report) Approved for public release; distribution unlimited.		
17. DISTRIBUTION STATEMENT (of the abstract entered in Block 20, if different from Report)		
18. SUPPLEMENTARY NOTES Research performed by HumRRO Eastern Division under Project DRAMA.		
19. KEY WORDS (Use the terms and identify by block number) Accessions Army Affirmative Actions Manpower Minority officers Officers Procurement Race		
20. ABSTRACT (Use the terms and identify by block number) This report discusses (a) different concepts of minority officer representation in the Armed Forces and their correlative standards, (b) a method to achieve the Army minority officer goals. The perception of the amount of minority representation in the officer ranks depends upon the standard chosen. Minority officer end strength analysis discloses that (a) there is (Continued)		

DD FORM 1473 1 JAN 73 EDITION OF NOV 65 IS OBSOLETE

Unclassified

SECURITY CLASSIFICATION OF THIS PAGE (When Data Entered)

Unclassified

SECURITY CLASSIFICATION OF THIS PAGE (When Data Entered)

20. ABSTRACT (Continued)

no significant gap in educational attainment between white and minority officers and there is an upward trend toward better education among all officers; (b) minority officers are crowded in lower ranks; and (c) ROTC and OCS play important roles in building minority officer strength. Minority officer loss analysis discloses that there are smaller minority officer loss rates than white loss rates. Minority officer accession percentages have increased since FY1970 for the Navy, the Air Force, and the Marine Corps, while the Army minority officer accession shows yearly variation. The Army simulation model of officer procurement sources proves Army ability to reach any level of minority officer representation it defines; (b) the Army "Affirmative Actions Plan" (AAP) goals in both procurement program enrollment and accession will overshoot the AAP CY1985 minority officer end strength goals, but the desired minority officer composition by source of procurement will not be met; (c) Army officer force projections, with no increase in minority officer accession rates after 1978, can be expected to reach the AAP CY1985 minority officer end strength goals without major difficulties.

Unclassified

SECURITY CLASSIFICATION OF THIS PAGE (When Data Entered)

EXECUTIVE SUMMARY

The purpose of this report is to present (a) a discussion of different concepts of minority officer representation in the Armed Forces and their correlative standards, (b) a description of the Armed Forces status with regard to minority representation in the officer ranks, and (c) a method to achieve the Army minority officer goals.

The major findings may be summarized as follows:

(1) The statement of minority representation in the officer ranks might range from 3.1% Blacks and 2.7% "Others," if the standard chosen is the racial-ethnic distribution among 'Managers' in the Labor Force, to 11.1% Blacks and 5.6% "Others," if the standard chosen is the racial-ethnic distribution in the general population.

(2) Minority officer end strength analysis discloses that (a) there is no significant gap in educational attainment between white and minority officers and there is an upward trend toward better education among all officers; (b) minority officers are crowded in lower ranks and as rank goes up minority officer representation goes down; and (c) ROTC plays a very important role in building minority officer strength in the Army and the Air Force, while OCS does the same for the Navy and Marine Corps.

(3) Minority officer loss analysis discloses that (a) on the whole, minority officer loss rates are smaller than white loss rates; (b) minority officers have a higher propensity to leave the Services in the first four years of service than do Whites in the Navy, the Air Force, and Marine Corps; and (c) the highest loss rate occurs among physicians and dentists for both white and minority officers.

(4) Minority officer accession percentages have constantly increased since FY1970 for the Navy, the Air Force, and the Marine Corps, while the Army minority officer accession shows variation from year to year.

(5) The wide variation of minority officer representation objectives in the various Services demonstrates the lack of a coordinated Department of Defense policy. Army minority officer objectives are 10.0% Blacks and 5.0% "Others" for CY1985, the Navy chose 6.0% Blacks and 2.0% "Others" in FY1980, while the Air Force goal is set at 5.6% minority officers in FY1980. The Marine Corps intends to access a minimum of 100 minority officers per year.

(6) The Army simulation model of officer sources of procurement proves that (a) the capability of the Army to reach any level of minority officer representation it defines, (b) the Army "Affirmative Actions Plan" (AAP) goals in both procurement program enrollment and accession will overshoot the AAP CY1985 minority officer end strength goals, but the desired minority officer composition by source of procurement will not be met; (c) Army officer force projections, with no increases in minority officer accession rates after 1978, can be expected to reach the AAP CY1985 minority officer end strength goals without major difficulties. However, physician and dentist accessions and end strength remain a problem for whites and minorities as well.

CONTENTS

	Page
Introduction	9
Chapter	
1 Concepts and Standards of Representation	11
Socio-Political Criteria	11
Population Distribution	11
Equality Perception	12
Socio-Economic Criteria	14
Population Distribution	14
Liberal Representation Based on Current Requirements	17
2 Minority Officer Representation: Status and Objectives	18
Status	18
End Strength Minority Officer Representation in the Armed Forces ..	18
Minority Officer Losses During FY1974	34
Minority Officer Accessions	38
Objectives	43
3 Simulation Models	48
Officer Procurement Patterns as a Framework to Simulation Models	48
Army Manpower Pools and Procurement Programs: Army	
Flow-Chart FY1974	48
Similarities and Differences Between the Services' Flow-Charts	50
Modeling Army Procurement	54
Minority Enrollments and Graduation in the Army Officer	
Procurement Programs	54
Simulation Models	59
References	89
Bibliography	90

LIST OF ILLUSTRATIONS

Chart	
1	Minority Male Manpower Pools and Officer Accessions, by Procurement Program, Army Active Duty FY1974
2	Minority Male Manpower Pools and Officer Accessions, by Procurement Program, Navy Active Duty, FY1974
3	Minority Male Manpower Pools and Officer Accessions, by Procurement Program, Marine Corps, Active Duty, FY1974
4	Minority Male Manpower Pools and Officer Accessions, by Procurement Program, Air Force Active Duty, FY1974

LIST OF ILLUSTRATIONS (Continued)

Graph	Page
1 DoD FY1972 Officer Inventory, by Race and Source of Procurement	19
2 DoD FY1974 Officer Inventory by Race and Source of Procurement	20
3 DoD FY1974 White Officers Inventory, by Services and Sources of Procurement	30
4 DoD FY1974 Spanish Officers Inventory, by Services and Sources of Procurement	31
5 DoD FY1974 Black Officers Inventory, by Services and Sources of Procurement	32
6 DoD FY1974 "Other" Officers Inventory, by Services and Sources of Procurement	33
7 Total Army Minority Officer Force FY1978	70

LIST OF TABLES

Table	Page
1 Distribution of Minority Groups in the Population: Census 1970	12
2 Ratio of Officers to Enlistees: All Services	13
3 Ethnic Groups Participation in Selected Occupation Fields in the Experienced Civilian Labor Force: Census 1970	14
4a Years of School Completed by Men and Women, 16 Years and Over: Census 1970	15
4b Years of School Completed by Men, 16 Years and Over: Census 1970	15
5a Years of School Completed by Men, 16-34 Years Old: Census 1970	16
5b Years of School Completed by Men, 16-34 Years Old: March 1974	16
6 Distribution of the Undergraduate Racial-Ethnic Enrollment: 1972	17
7 Representation of Minority Officers, by Occupational Areas and Services-FY1974	21
8 Distribution of Educational Attainment of White and Minority Officers, End Strength-FY1974	22
9 Educational Attainment in the Armed Forces, Officers End Strength: FY1972-1974	22
10 Officer Racial-Ethnic Distribution, by Rank and Service: FY1974	24
11 Rank Distribution Among White Officers and Minority Officers: FY1974	25
12 Racial-Ethnic Officer Distribution, by Source of Procurement, End Strength: Army FY1974	26
13 Racial-Ethnic Officer Distribution, by Source of Procurement, End Strength: Navy FY1974	27
14 Racial-Ethnic Officer Distribution, by Source of Procurement, End Strength: Marine Corps FY1974	28
15 Racial-Ethnic Officer Distribution, by Source of Procurement, End Strength: Air Force FY1974	28
16 Racial-Ethnic Officer Distribution, by Source of Procurement, End Strength: DoD, FY1974	29

LIST OF TABLES (Continued)

Table		Page
17	Officer Loss Rates, by Occupational Area, by Race and by Service: FY1974	34
18	Losses of Officers 26-31 Years Old, by Service: FY1974	35
19	Officer Losses, by Length of Service: FY1974 (First 4 Years of Service)	36
20	Officer Racial-Ethnic Loss Rates, by Source of Procurement, Army: FY1974	36
21	Officer Racial-Ethnic Loss Rates, by Source of Procurement, Navy: FY1974	37
22	Officer Racial-Ethnic Loss Rates, by Source of Procurement, Marine Corps: FY1974	37
23	Officer Racial-Ethnic Loss Rates, by Source of Procurement, Air Force: FY1974	38
24	Minority Officer Accessions, by Source of Procurement: Army	39
25	Minority Officer Accessions, by Source of Procurement: Navy	40
26	Minority Officer Accessions, by Source of Procurement: Marine Corps	41
27	Minority Officer Accessions, by Source of Procurement: Air Force	42
28	Trends in Educational Attainment, Bachelor's Degree or Higher: Male Officers' Accession	43
29	Army Minority Officer Goals	44
30	Navy Minority Officer Goals	45
31	Minority Officer Representation in the Armed Forces, FY1974	46
32	Military Academy Enrollment and Graduation: Army	55
33	Percentage of Military Academy Graduation to the Total Enrollment: Army	56
34	Distribution of Entrance and Graduation, by Ethnic Groups: Military Academy	57
35	Racial-Ethnic Enrollment in ROTC Programs, by Year of Program: Men	58
36	Army Minority Participation in ROTC Scholarship Program: FY1974 and FY1975	59
37	End Strength Projection Numbers: FY1980	60
38	Linear Estimation of the Army Officer Force	60
39a	Projected Accession and End Strength, First Application: "Saturated Favorable" Projection	64
39b	Projected Accession and End Strength, First Application: "Saturated Least Favorable" Projection	66
40a	Projected Accession and End Strength, Second Application: "Actual Favorable" Projection	72
40b	Projected Accession and End Strength, Second Application: "Actual Least Favorable" Projection	75
41	Input Needed in Officer Procurement Programs: "Actual Favorable" Projection	78
42	Projected Accession and End Strength, Second Application: AAP "Desired" Projection	79
43	AAP "Desired" and "Actual Favorable" Accession Projections for Physicians and Dentists, and "Other" Sources of Procurement	82
44	Additional Minority Accession Needed Between AAP "Desired" Projection and the "Actual Favorable" Projection	83
45	Input Needed in Officer Procurement Program (AAP Goals)	84
46	Accession Needed to Reach 10% Black Officers and 4% "Other" Minority Officers in 1985, "Reversed" Projection	85

**U.S. Armed Forces
Minority Officer Procurement**

INTRODUCTION

James R. Schlesinger, Secretary of Defense, observed in his *Annual Defense Department Report FY1976 and FY1977* that "Minority Officer participation remains a challenge to the officer procurement programs of the Services."¹ The same issue is addressed more directly in the Department of the Army Affirmative Actions Plan (draft) (AAP), which reports that the Army "continues to experience an acute shortage of minority officers" and that "there is a need to increase representation in the 'Other' minority categories."² It also indicates that "the Army does not have an accurate picture of what its other minority population really is" and "this inhibits programs directed toward 'other minorities'."³

It is clear that present levels of minority officer representation in the Armed Forces pose a serious problem. The obvious solution is to lay out a comprehensive plan for minority participation in the Armed Forces.

The Services do not have a clear picture of their minority officer composition in general and their "Other" minority officer composition in particular. This leads to three questions. The first is: What does "minority" mean and what constitutes an "acceptable" level of minority participation in the Armed Forces? After definition of what minority and representation mean, there is basis for answering the second question: What is the present level of minority officer participation? The last question is: Given the actual minority officer participation, what is the most efficient method to achieve the desired representation?

The report is divided into three chapters, which address the three questions. The first chapter discusses different concepts of representation and presents their correlative standards. Chapter 2 describes the actual status of the Armed Forces and their objectives with regard to minority representation. Chapter 3 analyzes accession flows in two steps. First, all the Services' officer procurement programs are summarized on flow charts connecting the qualified candidates pools to the various officer procurement programs, and into the active officer force structure. Second, simulation models which were designed on the basis of the Army chart have been projected under several hypotheses.

¹ James R. Schlesinger, Secretary of Defense. *Annual Defense Department Report FY1976 and FY1977*, Department of Defense, Washington, 1974. This report does not address minority representation, but does address representation of women.

² U.S. Department of the Army. "Affirmative Actions Plan" (draft), p. 10, 1975.

³ *Ibid.*, p. 7.

Chapter 1

CONCEPTS AND STANDARDS OF REPRESENTATION

In FY1974, 4.6% of the officers on active duty were members of minority groups.¹ When compared to the percentage of minority groups in the general population, this figure seems very low and immediately raises the question: What should the minority officer representation in the Armed Forces be? At present, an acceptable definition of the ideal minority representation in the officer forces has not been formulated. An attempt will be made in this chapter to isolate and clarify the issues critical to an adequate definition and to suggest several alternative definitions that are responsive to those issues.

To begin with, a definition of "minority group" is in order. The phrase is intended to identify a population that differs measurably from the general population in racial-ethnic status. Here racial-ethnic status refers to both morphologic characteristics and cultural background. The overlapping of these two notions, race and ethnicity, makes the problem of classification complex. Each race may be divided into several distinctive ethnic groups, while one entire ethnic group might include one, two, or all three races. The racial-ethnic classifications selected for the purposes of this report are as follows: Blacks, Persons of Spanish Origin² (Mexicans, Cubans, Puerto Ricans, South Americans, and others of Spanish origin, whether they are Caucasian, Negroid, or Mongoloid), Orientals (specifically, Japanese, Chinese, and Filipinos), and American Indians.

The concepts of representation to be presented here are divided into socio-economic and socio-political criteria, and subdivided through the use of demographic variables. Thus, basic demographic variables, such as age and sex, and elementary indications of social organizations, such as nationality, race or color, language, education, labor force status, and occupation, will be used to arrive at standards of representation.

SOCIO-POLITICAL CRITERIA

Population Distribution

In the General Population (Table 1)

One standard of representation would consist of the percentage of each racial-ethnic group in the population. The latest data available on the racial-ethnic composition of the general population according to the categories cited are from the 1970 Census.³

¹ Data provided by the Manpower Research and Data Analysis Center (MARDAC), Officer Master File, 1974.

² Persons of Spanish origin might be of any race: 93.3% are Caucasians, 5.0% are Negroid; 1.7% other ethnic race (U.S. Bureau of the Census. "Persons of Spanish Origin," *Census of Population, 1970, Subject Reports, Final Report PC (2)-1C*, U.S. Government Printing Office, Washington, 1973). Therefore, the Spanish group is recounted in the racial group in Census Bureau information. ~~This recounting~~ contributes negligibly to the other minority groups. In DoD information, the Spanish are not recounted.

³ More recent data are available for Blacks, persons of Spanish origin, and a third category that regroups American Indians, Orientals, and any other small groups not mentioned above.

Blacks represent 11.1% of the population, American Indians 0.4%, Persons of Spanish Origin 4.5%, and Orientals 0.7%. Socio-political subcategories might be used as a substitute for the global percentage of each racial-ethnic group in the population: (a) racial-ethnic group percentage with age control, (b) the same racial-ethnic group with sex control, (c) the same group with both age and sex controls. These controls would result in very little change in the standard.

Table 1

Distribution of Minority Groups in the Population:
Census 1970
(Percent)

Minority Group	Men	Women	Total
Blacks			
All ages	10.8	11.3	11.1
16-34	10.5	11.6	11.1
Spanish Origin			
All ages	4.5	4.4	4.5
16-34	4.8	5.0	4.9
Orientals ^a			
All ages	0.7	0.6	0.7
16-34	0.7	0.5	0.7
American Indians			
All ages	0.4	0.4	0.4
16-34	0.4	0.4	0.4

^aJapanese, Chinese, and Filipinos are grouped together as Orientals.

Source: U.S. Census Bureau, Census 1970.

In the Armed Forces (Table 2)

The size of the officer strength is roughly determined by the size of the enlisted strength. A ratio of officer strength to enlisted strength could be the standard for each minority group. Under this standard, any manipulation in the minority enlisted representation produces a change in the desirable minority officer representation, and the whole question of representation is carried over to the enlisted ranks.

One of the possible standards is one officer to seven enlisted personnel in each racial-ethnic group in the Army; in the Navy this ratio would be 1 to 7.3 in the Marine Corps 1 to 9.5, and in the Air Force 1 to 4.6.

Equality Perception

In the General Population

The equality perceived by each racial-ethnic group might be the source of another concept of representation. Unfortunately, no measure of this factor is readily available.

Table 2

Ratio of Officers to Enlistees: All Services

Population	Army		Navy		Marine Corps		Air Force	
	O/E ^a	Percent Enlistees (men)	O/E	Percent Enlistees (men)	O/E	Percent Enlistees (men)	O/E	Percent Enlistees (men)
Black	1/33	27.3	1/52	11.1	1/74	16.3	1/29	21.6
"Other"	1/20	2.0	1/83	1.1	1/34	1.3	1/7	1.3
All Races	1/7	100.0	1/7.3	100.0	1/9.5	100.0	1/4.6	100.0
All Races Projection O/E								
FY 1980	1/8.5		1/8.7		1/10.7		1/5.3	

^aO/E: Officer/Enlistee

Sources: Manpower Research and Data Analysis Center (MARDAC), Officer and Enlistee Master Files FY1974.

Projection FY1980 given by the Services.

National minority leaders might have a perception of their appropriate participation in the officer ranks of the Armed Forces. Enlistees and officers from both white and minority groups might also have some idea of the needed representation in their Service. Yet to obtain any kind of standards, a survey would be necessary among (a) the different racial-ethnic leaders and (b) the Armed Forces.

In the Armed Forces - Leadership

Leadership is crucial in any social organization and especially in the Armed Forces, since national defense depends so much upon the manner in which the Services are led. What would be the ideal minority leadership at different levels of command? Given the same percentage of minority personnel in units and given the same tasks, what level of minority officers is best? At present there is little information.

One way to explore such a standard might be by empirical experimentation. Statistical procedures might even indicate the threshold beyond which officers from a given racial-ethnic group would improve the output of the unit. Types of minority and non-minority officers could be selected so that they were as similar as possible in their physical and intellectual potentials. We could evaluate the extent to which effectiveness depends upon minority leadership, both absolutely and in relation to other variables such as education and motivation.

A theoretical approach could be developed along with the empirical approach. For example, one might postulate that the chances of having at least one minority officer among any *ten* officers should be at least 95%. Then the proportion, P , of minority officers should satisfy the equation $1-(1-p)^{10} = .95$, so that $p = .26\%$; for a 95% chance for at least one minority officer among *twenty* we would have $p = .14\%$; etc.

Such analyses could be undertaken for operational units as well as for occupational categories.

SOCIO-ECONOMIC CRITERIA

Population Distribution

Professional Categories (Table 3)

The civilian labor force is divided into four occupational categories—White Collar, Blue Collar, Service Workers, and Farm Workers. This concept could be utilized to determine several standards of representation. One standard is to match the kind of work which is done by officers, at the same salary level, with professional categories in the labor force.

Table 3

**Ethnic Groups Participation in Selected Occupation Fields
In the Experienced Civilian Labor Force: Census 1970**

Minority Group	White Collar			Professional			Managers		
	Men	Women	Total	Men	Women	Total	Men	Women	Total
Black	4.0	6.5	5.4	3.5	8.3	5.4	2.3	4.4	3.1
Spanish Origin ^a	2.4	2.4	2.4	2.1	1.8	2.0	1.9	2.0	2.0
Oriental	0.8	0.2	0.8	1.2	1.0	1.1	0.6	0.8	0.7
American Indian	0.1	0.2	0.1	0.2	0.2	0.2	0.1	0.2	0.1
Total Minority	7.3	9.3	8.7	7.0	11.3	8.7	4.8	7.3	5.9

^aPersons of Spanish origin could be of any race. (See note page 11) Thus all persons included here are also included in the race categories.

Source U.S. Census Bureau, Census 1970, Occupational Characteristics (Table 11).

Three criteria might be used. First, the distribution of racial-ethnic groups among white collar workers could be taken as a standard. In this case, minority officer participation would be 5.4% Black officers, 2.4% Spanish officers, and 0.8% Orientals. A major difficulty here is that the white collar category covers a wider spectrum of work types and salary levels than is covered by the officer category.

Two alternate standards might be the racial-ethnic composition of subgroups within the white collar category. The two subgroups are (a) the professional category, which includes such professions as architects, engineers, lawyers, and health professions, and (b) managers and administrators. These categories narrow down the differences between white collar and officers' type of work and level of salary. However, these categories also narrow down the percentage of representation of each racial-ethnic group because of a low number of minority persons in highly qualified professional categories. If "Professional" percentage is chosen as a standard, there would be 5.4% black officers, 2.0% Spanish, 1.1% Oriental, and 0.2% American Indian. The diminution of the standard is more visible if "Managers" is taken as standard. The percentages are as follows: 3.1% Black, 2.0% Spanish, 0.7% Oriental officers, and 0.1% American Indians. The same three demographic subcriteria described for the first concept—that is, racial-ethnic group percentage with age control (16-34 years old), the same racial-ethnic group with sex control (men only), the same group with both controls (sex and age)—might be utilized as suitable variables.

Level of Education (Tables 4-6)

The theoretical level of education required for an officer's commission is a Bachelor's degree. One standard of representation is the percentage of each racial-ethnic group in the Bachelor degree population.

The standards could then be 4.0% Blacks, 1.6% Spanish, 1.4% Orientals, and 0.1% American Indians, if the whole population, male and female, is taken into consideration (Table 4a). If the standards are restricted to the male population (Table 4b), the percentages of Bachelor's degree holders are then smaller for Blacks (2.9%).

Table 4a
Years of School Completed by Men and Women 16 Years and Over:
Census 1970

Minority Group	High School Only		1 to 3 Years College		4 or more Years College		Population 16 and Over	
	Number	Percent	Number	Percent	Number	Percent	Number	Percent
Blacks	3,274,262	7.7	957,636	6.9	508,622	4.0	14,015,283	11.1
Spanish Origin ^a	1,245,659	2.9	394,790	2.8	200,619	1.6	5,450,833	4.3
Orientals	208,312	0.7	157,779	1.1	173,433	1.4	974,339	0.8
Indians	106,661	0.2	36,048	0.3	13,550	0.1	452,938	0.4
Total Minority	4,906,894	11.6	1,548,253	11.1	896,224	7.0	20,893,393	16.5
Total Population	42,457,479	100.0	13,937,337	100.0	12,779,333	100.0	126,802,541	100.0

Table 4b
Years of School Completed by Men 16 Years and Over:
Census 1970

Blacks	410,875	7.9	435,270	12.8	215,988	2.9	6,449,469	10.8
Spanish Origin ^a	559,742	3.1	219,370	6.4	124,014	1.6	2,624,016	4.4
Japanese	64,735	0.4	34,335	1.0	37,295	0.5	194,980	0.3
Chinese	32,910	0.2	28,125	0.8	40,955	0.5	163,893	0.3
Filipinos	27,099	0.1	16,765	0.5	18,208	0.2	125,756	0.2
Indians	49,689	0.3	18,277	0.5	7,689	0.1	219,672	0.4
Total Minority	2,145,050	12.0	752,142	22.0	444,149	5.9	9,777,786	16.4
All Races	17,906,561	100.0	3,412,174	100.0	7,502,220	100.0	59,516,384	100.0

^aPersons of Spanish origin can be of any race, they are also included in other race categories.

Source: U.S. Census Bureau, Census 1970.

Table 5 (a and b) shows the percentage restricted to men 16-34 years old. An alternate standard which might be substituted is the actual percentage of each racial-ethnic group in the enrollment of four-year colleges (Table 6), then the standards are much higher than the preceding ones, 8.4% Blacks, 2.4% Spanish, 1.0% Orientals, and 0.6% Indians.

Queues

Another possible concept is to follow as closely as possible the distribution of each racial-ethnic group in any suitable pool. This pool could be the Bachelor's degree

Table 5a
 -Years of School Completed by Men 16-34 Years Old:
 Census 1970

Minority Group	High School Only		1 to 3 Years College		4 or More Years College		Population 16-and Over	
	Number	Percent	Number	Percent	Number	Percent	Number	Percent
Blacks	900,671	11.1	270,125	9.4	88,656	3.2	2,945,914	14.9
Spanish ^a	358,701	4.4	142,766	5.0	53,751	1.9	1,341,422	6.8
Orientals	53,845	0.7	52,402	1.8	47,410	1.7	205,648	1.0
Indians	31,998	0.4	11,619	0.4	3,708	0.1	112,691	0.6
Total Minority	1,345,215	16.6	476,912	16.6	193,525	6.9	4,811,323	23.3
Total Population	8,118,301	100.0	2,868,092	100.0	2,806,114	100.0	19,814,417	100.0

Table 5b
 Years of School Completed by Men 16-34 Years Old:
 March 1974

Blacks	1,706,000	10.6	447,000	7.4	168,000	3.3	3,317,000	10.8
Spanish ^a	440,000	4.1	216,000	3.5	77,000	1.8	1,640,000	5.3
Orientals								
Indians								
Others ^b	124,000	1.1	132,000	2.2	132,000	3.1	503,000	1.6
Total Minority	1,706,000	15.8	795,000	13.1	377,000	8.9	5,460,000	17.7
Total Population	10,792,000	100.0	6,076,000	100.0	4,254,000	100.0	30,822,000	100.0

^aPersons of Spanish origin can be of any race, they are also included in other race categories

^bOthers does not include white.

Source: U.S. Census Bureau, Census 1970.

Table 6

**Distribution of the Undergraduate
Racial-Ethnic Enrollment: 1972**

Minority Group	Percent of Total Population Enrolled
Black	8.4
Spanish ^a	2.4
Oriental	1.0
Indian	0.6

^aPersons of Spanish origin might be of any race; they are included in other categories.

Source: Racial and ethnic enrollment data from Institutions of Higher Education, HEW Office for Civil Rights OCR - 74-13

population, and the corresponding standard, the racial-ethnic percentage in the Bachelor's degree group year, by year. This concept would lead to a changing standard for the accession of minority officers in the Armed Forces. It would reflect at any one time the actual rate of integration in the socio-economic system, and would allow a smooth transition between the desirable representation and the supply and the demand from both sources—the Armed Forces and the Civilian labor forces. The equilibrium would be met without overbidding and without changing the quality requirements.

This standard could be further controlled according to *propensity* to seek commissions among minority groups, both within the enlisted force and within society.

Liberal Representation Based on Current Requirements

The last alternative concept might be to allow the percentage of minority officers to find its own level. As stated by William K. Brehm before the Senate Armed Services Committee, "the response of the American public to military service [will] determine what [minority] representation will be" within the Services. In the extreme case of this concept, no standards would be set, no policy would be generated, and no special advertisements toward minority groups would be needed. Here, the percentage of minority representation would fluctuate according to the economic situation. The ongoing O&D policy could be interpreted as a "floating" standard, but assisted by monitoring (e.g., through the OASD(EO)) and by planning equal promotion opportunity.

¹ William K. Brehm. Statement of Assistant Secretary of Defense (Manpower and Reserve Affairs) before the Senate Armed Forces Committee, February 24, 1975, p. 39.

Chapter 2

MINORITY OFFICER REPRESENTATION: STATUS AND OBJECTIVES

This chapter provides a statistical analysis of present racial composition of the Armed Forces officer corps, along with a summary of the objectives set by each Service for minority representation within those corps. As has been indicated, in FY1974, 4.6%¹ of the officers on active duty were members of minority groups. Of these minority groups, 2.7% were Blacks, 1.3% Spanish, and 0.6% "Others" (Graphs 1 and 2). The overall participation of minority officers among the four Services varies widely. One out of 15 officers (6.7%) is a minority member in the Army, one out of 40 (2.5%) is in the Navy, and one out of 24 in both the Air Force (4.0%) and the Marine Corps (4.0%).

STATUS

The discussion is divided into three sections: (a) an analysis of minority officer representation in the Armed Forces with respect to end strength; (b) an analysis of the different loss patterns which exist for each Service, and (c) an analysis of the accession patterns for each branch. In the first and second section the analysis is performed in terms of five variables: (a) DoD occupational area, (b) educational level, (c) age distribution, (d) rank, and (e) source of procurement and length of service.² The third section consists of a trend analysis by source of procurement and educational level.

End Strength Minority Officer Representation in the Armed Forces

Occupational Area (Table 7)

The eight Department of Defense occupational areas are as follows: 1) General Officers, 2) Tactical Operations Officers, 3) Intelligence Officers, 4) Engineering and Maintenance Officers, 5) Scientist and Professional Officers, 6) Medical Officers, 7) Administrators, and 8) Supply, Procurement and Allied Officers. As indicated in Table 7, representation in each occupational area varies widely among the Services.

In each of the Services minority officers are underrepresented among General Officers when their participation is compared to the overall percentage of minority officers. In the Army, minority personnel comprise 6.7% of all officers, yet constitute only 4.2% of General Officers. For the Navy, these figures are 2.5% versus 1.3%. For the Air Force, the percentages are 4.0% versus 2.1%, while for the Marine Corps they are 4.1% versus 0.7%.

The representation of minority personnel among Medical Officers is rather good for the Navy and the Air Force, 3.2% for the former (0.7% higher than the overall representation percentage) and 5.0% for the latter (1.0% higher than its total representation). The Marine Corps does not have its own Medical Corps, but relies on the Navy.

¹ A gain of 0.7 percentage points over a period of two years.

² The raw data were provided by the Manpower Research and Data Analysis Center (MARDAC).

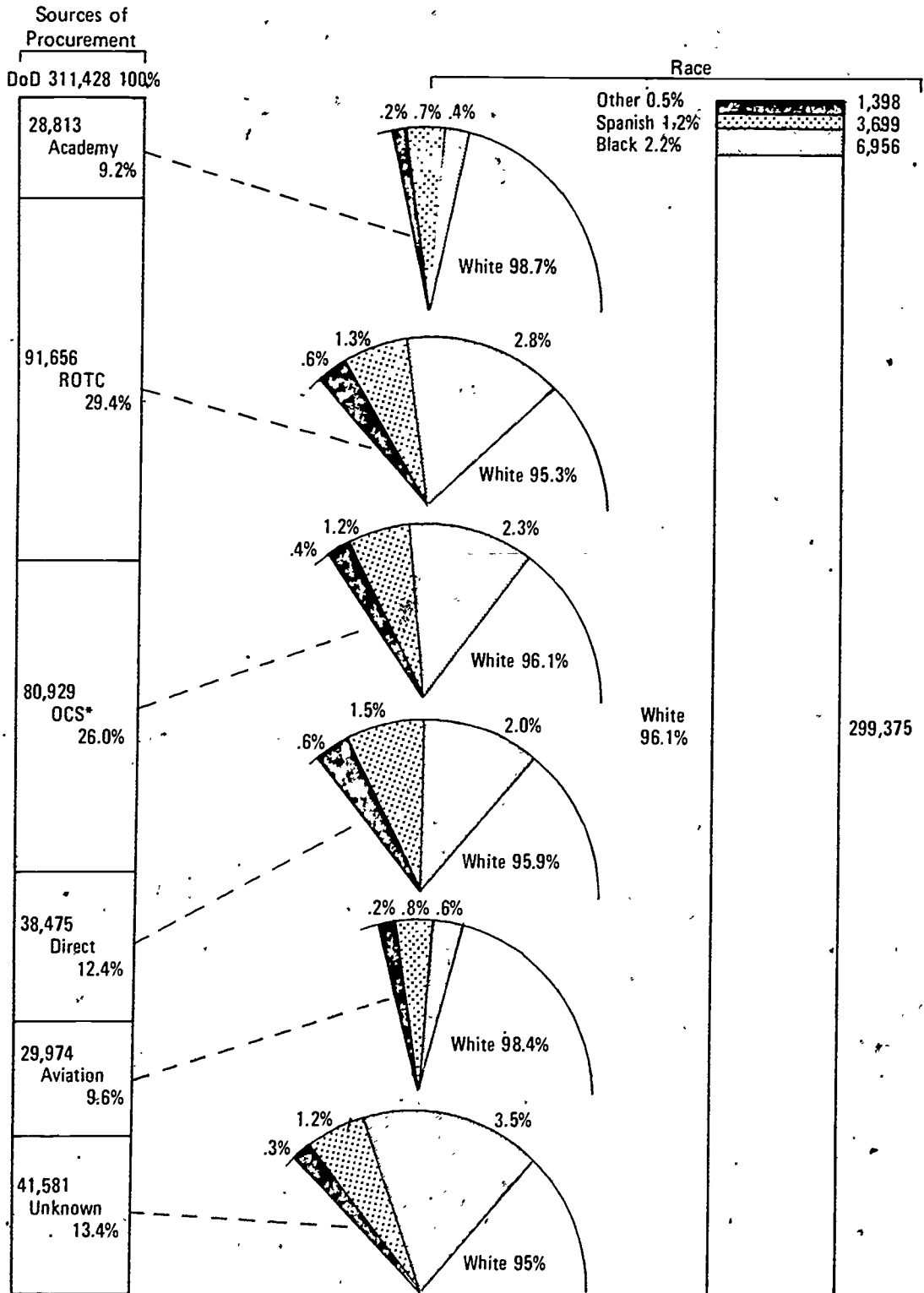

Source: MARDAC, Officer Master File, FY1972

* Officer Candidate School, Officer Candidate Class, Officer Training School

Graph 1. DoD FY1972 Officer Inventory, by Race and Source of Procurement

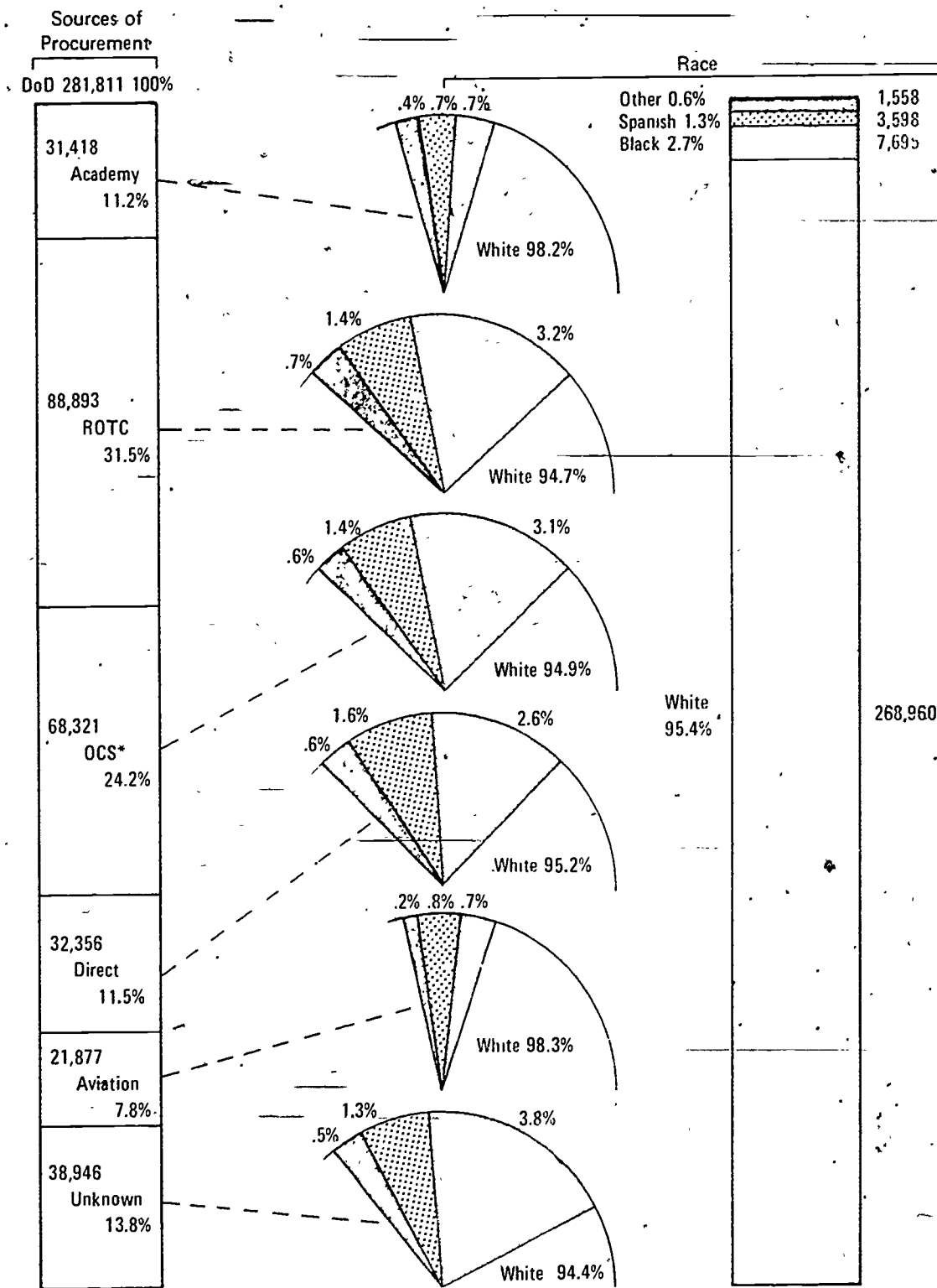

Source MARDAC Officer Master File, FY1974.

*Officer Candidate School, Officer Candidate Class, Officer Training School

Graph 2. DoD FY1974 Officer Inventory, by Race and Source of Procurement

Table 7

**Representation of Minority Officers, by Occupational
Areas and Services: FY1974**
(Percent)

Occupational Area	Army	Navy	Marine Corps	Air Force
General Officers	4.2	1.3	0.7	2.1
Tactical Operations Officers	6.4	1.8	3.2	2.6
Intelligence Officers	6.0	2.4	8.6	4.9
Engineering and Maintenance Officers	7.9	2.1	5.4	5.0
Scientist and Professional Officers	4.7	2.0	0.0	4.7
Medical Officers	5.4	3.2	0.0	5.0
Administrators	8.3	2.8	7.2	5.1
Supply, Procurement, and Allied Officers	9.0	2.6	8.5	5.6
All Officers	6.7	2.5	4.1	4.0

For the Army, the minority Medical Officer percentage of 5.4% is 1.3% lower than its overall minority officer representation.

Among Intelligence Officers, minority officers are very well represented in the Marine Corps (8.6%) and the Air Force (4.9%), while in the two other Services they have attained almost the same percentage as the overall percent.

Among Scientists and Professionals, minority officer participation is above average in the Air Force (4.7%) though somewhat below average in the Army (4.7%) and the Navy (2.0%). The Marine Corps does not have a Scientist and Professional Officers Corps.

The only two categories in which minority officers are very well represented in every Service are "Supply Procurement and Allied Officers" and "Administrative Officers," where the respective percentages are 9.3% and 9.1% for the Army; 2.8% and 2.6% for the Navy; 7.2% and 8.5% for the Marine Corps, and 5.1% and 5.6% for the Air Force.

Educational Level (Tables 8-9)

A comparison of the educational attainment among white officers and minority officers demonstrates that in FY1974 there is no significant gap between the two groups. The only noticeable difference exists in the Marine Corps, where 75.5% of white officers versus 67.6% of minority officers are college graduates. Navy and Army minority officers are slightly less educated than their counterpart white officers (80.3% versus 85.0% for the Navy and 81.4% versus 83.6% for the Army), but this is reversed in the Air Force where 92.3% of minority officers versus 90.6% of white officers are college graduates.

Comparison of the educational levels between FY1972 and FY1974 indicates an upward trend toward better education among officers. This is most obvious among Marine Corps officers, as 66.3% were college graduates in FY1972 while 75.2% were graduates in FY1974. In the Army, the percentage of black officers who were college graduates gained 7.1% over a period of two years, achieving a total percentage of 82.6% college graduates in FY1974. During the same period, the percentage of white officers

Table 8

**Distribution of Educational Attainment of White and Minority Officers
End Strength: FY1974
(Percent)**

Education	Army		Navy		Marine Corps		Air Force	
	White	Minority	White	Minority	White	Minority	White	Minority
High School Incomplete	0.0	0.0	0.0	0.0	0.2	0.1	0.0	0.0
High School Graduate	1.9	2.8	2.8	2.7	11.4	18.4	2.0	1.3
1-2 Years College	10.8	13.1	5.1	4.5	8.2	9.2	3.5	2.0
3-4 Years College	0.0	0.0	2.7	4.0	3.4	3.2	1.6	1.5
College Graduate	83.6	81.4	85.0	80.3	75.5	67.6	90.6	92.3
Total	100.0	100.0	100.0	100.0	100.0	100.0	100.0	100.0

Source: Manpower Research and Data Analysis Center (MARDAC), Officer Master File.

exhibited a gain of 7.3% to achieve a total percentage of 83.6%. In the Navy, there is a noticeable increase in the percentage of white officers with a college degree (a gain of 2.3%), while college graduates among Spanish officers diminishes slightly (0.9%). In the Air Force, the increase in college graduates is general, the percentage of whites with a degree increases by 3.6%; Spanish 3.5%; Blacks 1.9%, and "Others" 1%¹ (Table 9).

Table 9

Educational Attainment in the Armed Forces, Officers End Strength: FY72-FY74

Population	Percent Having Bachelor's Degree or Higher							
	Army		Navy		Marine Corps		Air Force	
	1972	1974	1972	1974	1972	1974	1972	1974
Whites	76.3	83.6	82.7	85.0	66.8	75.5	87.0	90.6
Blacks	75.3	82.4	80.8	80.3	41.3	67.1	91.2	93.1
Spanish	68.0	76.4	78.3	77.3	58.3	65.9	86.8	90.3
Malayans	0.0	0.0	79.6	91.4	80.0	71.4	0.0	0.0
Others	83.6	87.1	0.0	70.3	77.4	77.5	91.9	92.9
Total	76.2	83.5	86.0	84.9	66.3	75.2	87.1	90.6

Source: MARDAC, Officer Master File.

¹This entails a sharp diminution of officers who have only a high school degree or 1 to 3 years of college and very soon will permit attaining the goal of 100% college graduates among officers in the Air Force.

Age Distribution

The age distribution analysis provides one indicator of recent officer accession policies in the four Services, since a comparison of age distribution within white and minority officer end strengths is a direct reflection of accession rates. This is especially true for the first age group: 22 to 26 years old. Respectively, 44% and 46% of minority officers in the Navy and the Marine Corps are 22 to 26 years old, while 29% of white officers for the Navy and 33% for the Marine Corps are in this group. This disparity is not found in the Air Force, where white and minority officer age distributions are not significantly different. Thus, Air Force accession rates for white and minorities were either similar in the recent years or were compensated by losses. For the Army, the image of white and minority officers' age distribution is not as clear as it is for the other Services. Minority officer representation equals white officers between 22 and 26 years old and between 44 and 46 years old. However, they are slightly underrepresented in the age group 27 to 29 years old (14% minority versus 17% white officers) and between 47 and 55 years old (2.5% versus 3.9%), while they are overrepresented in the age group 32 to 42 years old (41.5% versus 34.1%).

Rank Distribution Among Minority Officers

Rank distribution is reported for two separate analyses. First, rank distribution of white and minority officers in each rank is compared to the overall minority officer percentage in each Service. Second, rank distribution among white officers is compared to rank distribution among minority officers.

Minority Representation by Rank (Table 10). On the whole, the present level of minority officer representation which exists in the Armed Forces is crowded in the lower ranks. This is demonstrated by an analysis of rank distribution which shows that as rank goes up minority participation goes down. A partial exception to this rule is the Army, which maintains through the rank of Lieutenant Colonel a slightly higher percentage than its overall minority percentage. Yet there are no minority officers above O-8, Major General for the Army and Rear Admiral (upper half) in the Navy. No minority officers have attained a rank above Brigadier General in the Air Force and none above Colonel in the Marine Corps.

The effort to increase overall minority participation in the Navy and Marine Corps officers' ranks during FY1974, which is observable in the age distribution analysis is also highly visible in rank distribution. The rank of O-1 exhibits a fairly high concentration of minority officers for both Services (more than double their overall percentage—5.2% for the Navy and 8.2% for the Marine Corps). A similar inflation of the proportion of minority officers in the rank of 2nd Lieutenant is apparent in the Air Force. However, based on the age distribution analysis, this would seem to indicate a slower advancement rate for minority officers rather than a recent effort to increase minority participation.

Rank Distribution Among White and Minority Officers (Table 11). A parallel analysis of rank distribution among white and minority officers for each Service most notably reinforces the statement made in the preceding paragraph, since the proportion of minority officers is obviously much higher than the proportion of white officers in lower ranks and much lower in higher ranks. As may be obtained from Table 11, the percentage of minority officers in the rank of 2nd Lieutenant or Ensign is more than twice as high as the percentage for white officers in the Navy and Marine Corps, and nearly twice as high in the Air Force. Also of interest is that there is a very high concentration of Captains in the four Services: 35 to 38% of white and minority officers in the Army and Air Force, and around 25 to 28% for the Navy and Marine Corps. This concentration of minorities in the rank of Captain could be the opportunity to smooth out the distributional gap in higher ranks between white and minority personnel.

Table 10

Officer Racial-Ethnic Distribution, by Rank and Service: FY 1974
(Percent)

Rank	White	Black	Spanish	Other	Total Minority	Total
Army Rank						
Second Lieutenant	93.0	4.0	2.3	0.7	7.0	100.0
First Lieutenant	93.4	4.2	1.6	0.8	6.6	100.0
Captain	93.5	4.4	1.6	0.5	6.5	100.0
Major	92.8	5.1	1.5	0.6	7.2	100.0
Lieutenant Colonel	92.4	5.5	1.4	0.6	7.5	100.0
Colonel	96.3	2.2	1.0	0.4	3.7	100.0
Brigadier General	94.9	4.2	0.8	0.0	5.0	100.0
Major General	98.9	1.1	0.0	0.0	1.1	100.0
Lieutenant General	100.0	0.0	0.0	0.0	0.0	100.0
General	100.0	0.0	0.0	0.0	0.0	100.0
Overall Percent	93.3	4.5	1.6	0.6	6.7	100.0
Navy Rank						
Ensign	94.1	3.1	1.3	0.9	5.2	100.0
Lieutenant Junior Grade	96.7	1.8	0.9	0.7	3.3	100.0
Lieutenant	98.2	0.8	0.7	0.3	1.8	100.0
Lieutenant Commander	98.3	0.6	0.8	0.3	1.7	100.0
Commander	98.3	0.5	0.8	0.3	1.6	100.0
Captain	98.7	0.4	0.7	0.2	1.3	100.0
Rear Admiral (lower half)	99.3	0.7	0.0	0.0	0.7	100.0
Rear Admiral (upper half)	99.1	0.0	0.9	0.0	0.9	100.0
Vice Admiral	100.0	0.0	0.0	0.0	0.0	100.0
Admiral	100.0	0.0	0.0	0.0	0.0	100.0
Overall Percent	97.5	1.2	0.8	0.4	2.5	100.0
Marine Corps Rank						
Second Lieutenant	91.8	5.5	1.8	0.9	8.2	100.0
First Lieutenant	95.3	2.7	1.5	0.4	4.7	100.0
Captain	96.5	1.9	1.3	0.2	3.4	100.0
Major	98.0	0.4	1.3	0.2	1.9	100.0
Lieutenant Colonel	98.7	0.3	0.9	0.1	1.3	100.0
Colonel	99.3	0.0	0.5	0.2	0.7	100.0
Brigadier General	100.0	0.0	0.0	0.0	0.0	100.0
Major General	100.0	0.0	0.0	0.0	0.0	100.0
Lieutenant General	100.0	0.0	0.0	0.0	0.0	100.0
General	100.0	0.0	0.0	0.0	0.0	100.0
Overall Percent	95.9	2.3	1.4	0.3	4.1	100.0

(Continued)

Table 10 (Continued)

Officer Racial-Ethnic Distribution, by Rank and Service: FY 1974
(Percent)

Rank	White	Black	Spanish	Other	Total Minority	Total
Air Force Rank						
Second Lieutenant	93.1	4.6	1.5	0.8	6.9	100.0
First Lieutenant	96.3	1.9	1.3	0.4	3.7	100.0
Captain	95.7	2.2	1.3	0.7	4.2	100.0
Major	96.5	1.8	1.1	0.5	3.5	100.0
Lieutenant Colonel	97.1	1.4	0.9	0.6	2.9	100.0
Colonel	97.4	1.2	1.0	0.3	2.5	100.0
Brigadier General	98.0	1.0	0.0	0.0	1.0	100.0
Major General	100.0	0.0	0.0	0.0	0.0	100.0
Lieutenant General	97.3	0.3	0.0	0.0	0.0	100.0
General	100.0	0.0	0.0	0.0	0.0	100.0
Overall Percent	95.9	2.2	1.2	0.6	4.0	100.0

Source: MARDAC, Officer Master File

Table 11

Rank Distribution Among White Officers and Minority Officers: FY 1974
(Percent)

Rank	Army		Navy		Marine Corps		Air Force	
	White	Minority	White	Minority	White	Minority	White	Minority
0.1	13.5	14.3	14.6	31.4	18.7	39.2	12.0	20.9
0.2	13.1	12.9	18.0	24.2	22.4	25.7	12.7	11.4
0.3	35.0	34.1	24.8	17.6	28.7	23.7	36.7	38.5
0.4	19.3	21.0	23.2	15.4	17.3	8.0	19.7	16.7
0.5	12.5	14.2	12.6	8.0	8.8	2.8	12.7	8.9
0.6	5.8	3.1	6.1	3.2	3.5	0.6	5.5	3.4
0.7	0.2	0.2	0.2	0	0.2	0	0.1	0
0.8	0.2	0	0.1	0	0.1	0	0.1	0
0.9	0	0	0	0	0	0	0	0
0.10	0	0	0	0	0	0	0	0
Total	100.0	100.0	100.0	100.0	100.0	100.0	100.0	100.0

Minority Officer Representation by Source of Procurement, End Strength
(Tables 12-16, Graphs 3-6)

A major difference exists between the Services in the way in which they procure and retain their officers. ROTC plays a very important role in building minority officer strength in the Army and Air Force, while OCS does the same for the Navy and Marine Corps. For the Army, about 40% of the black officers, 37% of Spanish officers, and 42% of "Other" officers were procured through ROTC. These percentages range similarly between 44% of black officers and 53% of "Other" officers in the Air Force. More than half of the Navy black officers and more than 40% of the black officers in the Marine Corps were procured through OCS programs. Service-wide, 50% to 80% of minority officer end strength was procured through ROTC and OCS, compared to 40% to 70% of white officers.

When the minority officer pattern of procurement is compared with the white officer pattern, the main difference is the very small percentage of minority officers procured through the Service Academies. This difference is most critical in the Navy, since 18% of white officers went through the Naval Academy versus only 3.9% of black officers. The Academies provide 7-11% of white officers for the three other Services compared to 2-5% of black officers. This point is of particular interest since there are very few minority officers in the higher rank, and since the Service Academies produce the majority of Generals.

Table 12

**Racial-Ethnic Officer Distribution, by Source of Procurement, End Strength:
Army FY1974**

Source of Procurement	White		Black		Spanish		"Other"		Total	
	Number	Percent	Number	Percent	Number	Percent	Number	Percent	Number	Percent
Academy	9,711	11.5	92	2.3	76	5.1	41	7.9	9,920	10.9
ROTC Scholarship	4,806		175		82		36		5,099	
ROTC Non-Scholarship	22,349		1,435		466		183		24,433	
ROTC Total	27,155	32.0	1,610	39.7	548	37.0	219	42.1	29,532	32.5
OCS Direct										
Procurement	2,431		48		31		15		2,525	
OCS In-Service	8,059		657		188		37		8,941	
OCS Total	10,490	12.4	705	17.4	219	14.8	52	10.0	11,466	12.6
Direct Appointment	4,163		90		85		31		4,369	
"Others"	10,794		369		222		54		11,439	
Direct Total	14,957	17.6	459	11.3	307	20.7	85	16.3	15,808	17.4
Aviation Training	0		0		0		0		0	
Unknown	22,508	26.5	1,193	29.3	330	22.3	123	23.7	24,154	26.6
Total	84,821	100.0	4,059	100.0	1,480	100.0	520	100.0	90,880	100.0
Percent Distribution		93.3		4.5		1.6		0.6		100.0

Source: MARDAC, Officer Master File.

Table 13
Racial-Ethnic Officer Distribution, by, Source of Procurement, End Strength: Navy FY 1974

Source of Procurement	White		Black		Spanish		Malayan		"Other"		Total	
	Number	Percent	Number	Percent	Number	Percent	Number	Percent	Number	Percent	Number	Percent
	Academy	11,040	18.0	30	3.9	66	12.0	16	7.6	14	17.3	11,166
ROTC Scholarship	7,483		30		43		25		8		7,589	
ROTC Non-Scholarship	2,016		32		15		11		0		2,074	
ROTC Total	9,499	15.4	62	8.1	58	11.0	36	17.1	8	9.9	9,663	15.3
OCS Direct Procurement	13,087		352		140		96		21		13,696	
OCS In-Service												
"Others"	2,802		47		33		4		3		2,889	
OCS Total	15,889	25.8	399	52.3	173	32.9	100	47.6	24	29.6	16,585	26.3
Direct Appointment	4,276		41		37		31		12		4,397	
Direct Total	4,276	7.0	41	5.4	37	7.0	31	14.8	12	14.8	4,397	7.0
Aviation Training	9,238	15.0	70	9.2	71	13.5	6	2.8	5	6.2	9,390	14.9
Unknown	11,581	18.8	161	21.1	121	23.0	21	10.0	18	22.2	11,902	18.8
Total	61,523	100.0	763	100.0	526	100.0	210	100.0	81	100.0	63,103	100.0
Percent Distribution	97.5		1.2		0.8		0.3		0.2		100.0	

Source: MARDAC, Officer Master File.

Table 14

**Racial Ethnic Officer Distribution, by Source of Procurement, End Strength:
Marine Corps FY1974**

Source of Procurement	White		Black		Spanish		"Other"		Total	
	Number	Percent	Number	Percent	Number	Percent	Number	Percent	Number	Percent
Academy	1,250	7.5	22	5.4	14	5.8	2	2.9	1,288	7.4
ROTC Scholarship	352		10		2		0		364	
ROTC Non-Scholarship	5,235		75		64		21		5,395	
ROTC Total	5,587	33.4	85	21.0	66	27.4	21	30.0	5,759	33.1
OCS Direct										
Procurement	4,202		105		52		18		4,377	
OCS In-Service	2,145		54		41		8		2,248	
OCS Total	6,347	38.0	159	39.3	93	38.6	26	37.1	6,625	38.0
Direct Appointment										
Direct Total										
Aviation Training	880	5.3	5	1.2	13	5.4			898	5.2
Unknown	2,636	15.8	134	33.1	55	22.8	21	30.0	2,846	16.3
Total	16,700	100.0	405	100.0	241	100.0	70	100.0	17,416	100.0
Percent Distribution	95.9		4.5		1.4		0.4		100.0	

Source: MARDAC, Officer Master File.

Table 15

**Racial-Ethnic Officer Distribution, by Source of Procurement, End Strength:
Air Force FY1974**

Source of Procurement	White		Black		Spanish		"Other"		Total	
	Number	Percent	Number	Percent	Number	Percent	Number	Percent	Number	Percent
Academy	8,862	8.4	78	3.2	70	5.2	34	5.0	9,044	8.2
ROTC Scholarship	6,637		143		74		34		6,888	
ROTC Non-Scholarship	35,304		950		470		327		37,051	
ROTC Total	41,941	39.6	1,093	44.3	544	40.3	361	53.3	43,939	39.8
OCS Direct										
Procurement										
OCS In-Service										
OCS OTS	32,109		887		468		181		33,645	
OCS Total	32,109	30.3	887	35.9	468	34.6	181	26.7	33,645	30.5
Direct Appointment	4,274		62		53		17		4,406	
"Others"	7,310		267		117		51		7,745	
Direct Total	11,584	10.3	329	13.3	170	12.6	68	10.1	12,151	11.0
Aviation Training	11,378	10.7	80	3.3	99	7.3	32	4.9	11,589	10.5
Unknown	42		1				1		44	
Total	105,916	100.0	2,468	100.0	1,351	100.0	677	100.0	110,412	100.0
Percent Distribution	96.0		2.2		1.2		0.6		100.0	

Table 16

**Racial-Ethnic Officer Distribution, by Source of Procurement, End Strength:
DoD FY1974**

Source of Procurement	White		Black		Spanish		"Other"		Total	
	Number	Percent	Number	Percent	Number	Percent	Number	Percent	Number	Percent
Academy	30,863	11.5	222	2.9	226	6.3	107	6.9	31,418	11.3
ROTC Scholarship	19,278		358		201		103		19,940	
ROTC Non-Scholarship	64,904		2,492		1,015		542		68,953	
ROTC Total	84,182	31.3	2,840	37.0	1,216	33.8	645	41.4	88,893	31.5
OCS Direct										
Procurement	19,720		505		223		150		20,598	
OCS In-Service	10,204		711		229		45		11,196	
"Other"	39,011		934		501		188		36,534	
OCS Total	64,835	24.1	2,150	27.9	953	26.5	383	24.6	68,321	24.2
Direct Appointment	12,713		103		175		91		13,082	
"Other"	18,104		636		339		105		13,184	
Direct Total	30,817	11.4	829	10.8	514	14.3	196	12.6	32,356	11.5
Aviation Training	21,496	8.0	155	2.0	183	5.1	43	2.7	21,877	7.8
Unknown	36,767	13.7	1,489	19.4	506	14.0	184	11.8	38,946	13.8
Total	268,960	100.0	7,695	100.0	3,598	100.0	1,558	100.0	281,811	100.0
Percent Distribution		95.4		2.7		1.3		0.6		100.0

Services
DoD 268,960 100%

Sources of Procurement DoD

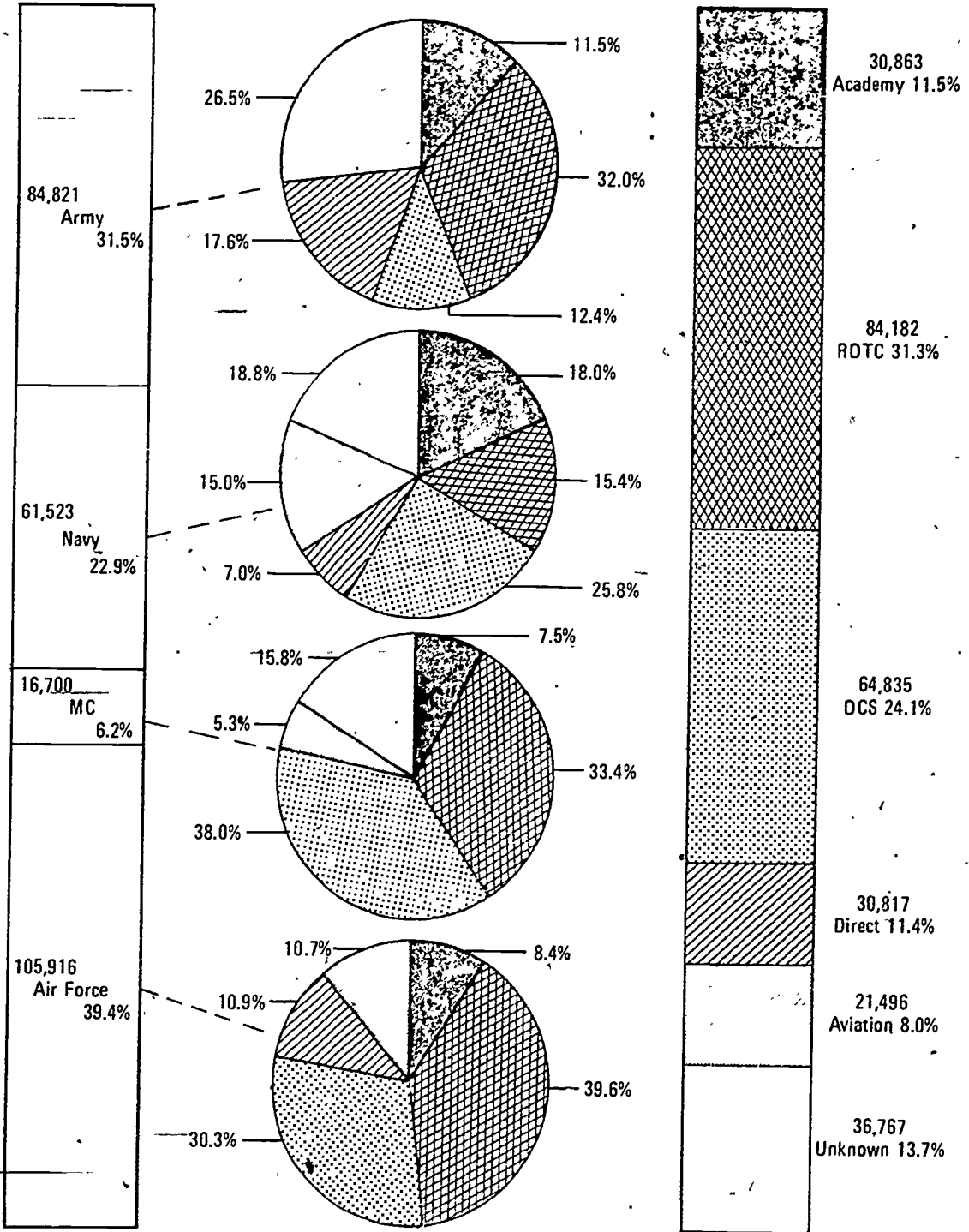

Source: MARDAC Officer Master File, FY1974

Graph 3 DoD FY1974 White Officers Inventory, by Services and Sources of Procurement

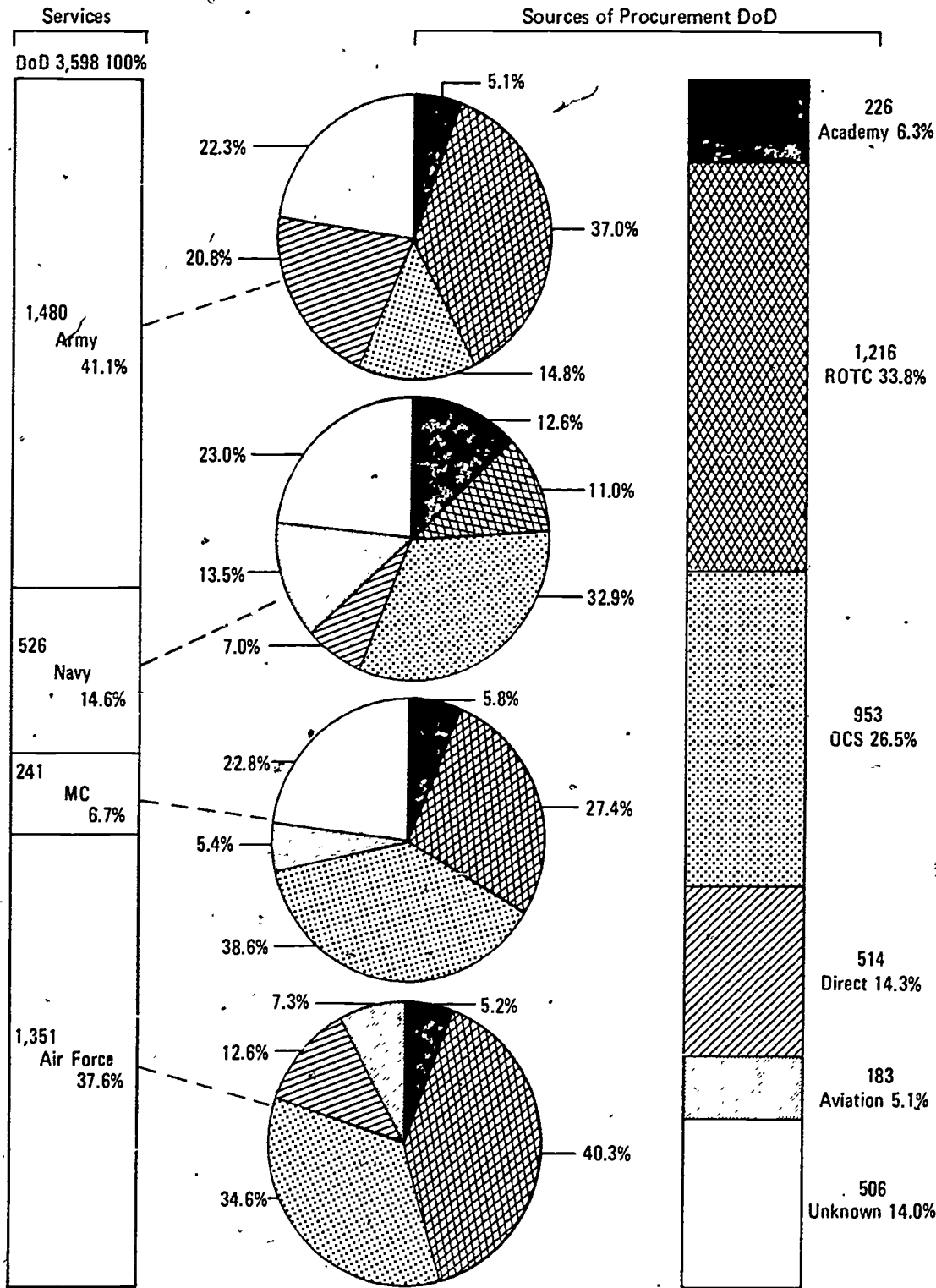

Source: MARDAC Officer Master File, FY1974

Graph 4. DoD FY1974 Spanish Officers Inventory, by Services and Sources of Procurement

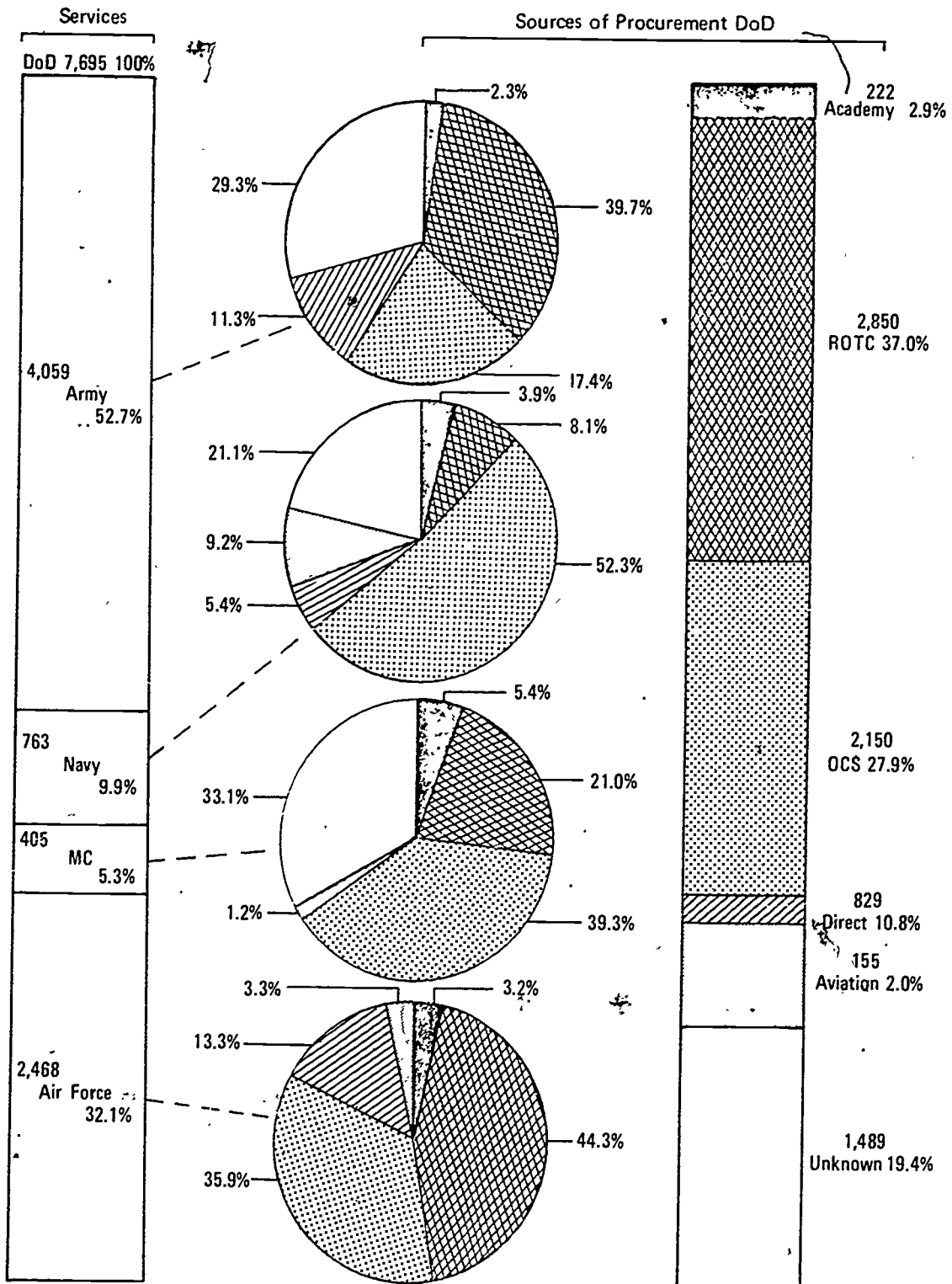

Source. MARDAC Officer Master File, FY1974

Graph 5. DoD FY1974 Black Officers Inventory, by Services and Sources of Procurement

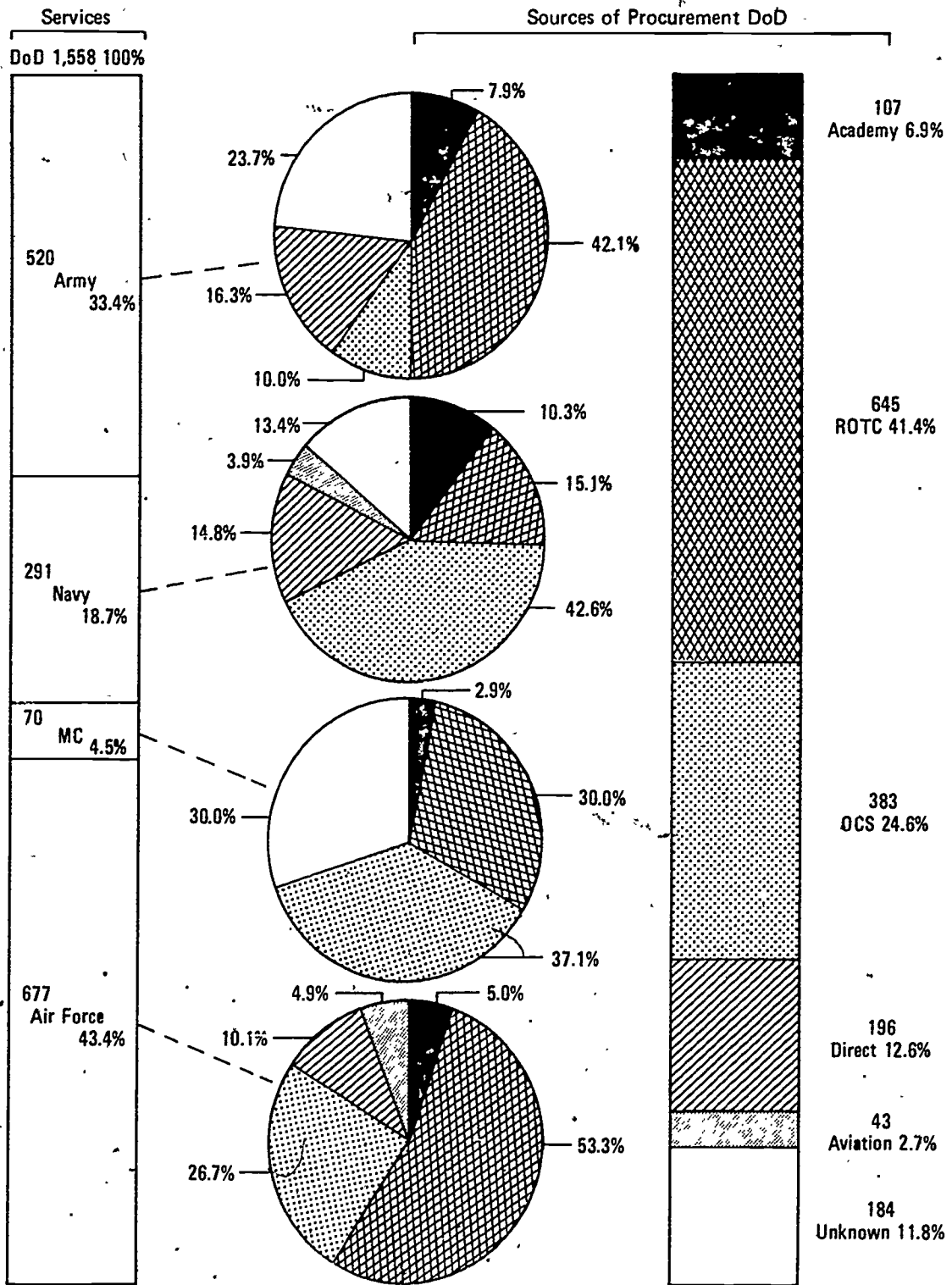

Source: MARDAC Officer Master File, FY1974

Graph 6: DoD FY1974 "Other" Officers Inventory, by Services and Sources of Procurement

Minority Officer Losses During FY1974

Minority officer losses represent 3.7% of the Army officer losses; 1.3% of the Navy Officer losses, 2.2% of the Marine Corps losses, and 2.0% of the Air Force losses. The following loss analysis is almost parallel to the end strength analysis. It stresses the main points in losses in occupational areas, age distribution, length of service, and source of procurement.

Occupational Areas (Table 17)

In the Navy and in the Air Force the highest loss rate is among Medical officers, white and minority as well. In the Navy, the percentage of white Medical officers who

Table 17

Officer Loss Rates, by Occupational Area, by Race, and by Service: FY1974

Occupational Area	Army		Navy		Marine Corps		Air Force	
	White	Minority	White	Minority	White	Minority	White	Minority
General Officers								
Number	85	2	386	1	123	0	282	2
Percent	12.5	8.0	13.5	8.0	16.0		20.0	12.0
Tactical Operations Officer								
Number	6826	310	1371	11	1628	21	4941	53
Percent	14.5	13.0	9.0	8.0	12.5	9.0	9.0	6.0
Intelligence Officers								
Number	840	340	187	2	20	1	335	8
Percent	19.0	67.0	11.5	9.5	11.0	14.0	9.0	7.0
Engineering and Maintenance Officers								
Number	1753	76	1661	21	174	5	1471	52
Percent	16.0	10.0	13.0	12.0	11.5	8.0	9.0	8.0
Scientists and Professionals								
Number	708	10	586	6	90	0	828	17
Percent	15.0	6.0	13.0	10.0	26.0		6.0	5.0
Medical Officers								
Number	3548	60	2474	28	0	0	2575	63
Percent	25.0	13.0	26.0	15.0			22.0	16.0
Administrators								
Number	2146	101	1595	24	152	7	1456	47
Percent	17.0	12.0	13.0	10.0	14.0	12.5	11.0	7.0
Supply, Procurement, and Allied Officers								
Number	717	46	578	9	207	8	652	17
Percent	12.0	10.0	14.0	12.0	14.0	8.0	10.5	7.0
Unknown	87	4	604	21	196	17	39	5
Total								
Number	16,710	639	9,442	123	2,590	59	12,579	264
Percent	16.5	14.0	13.0	10.0	13.0	11.0	11.0	8.0

leave the Service each year is 26% versus 15% for minority, while in the Air Force the white loss rate is 22% versus 12.5% for blacks. One possible explanation of the variance between white and minority officer loss rates might be offered. It is possible that many minority Medical officers are recently acceded and since they are still under their Service obligation, this makes minority Medical officer loss rate artificially low. In the Army and the Marine Corps, the highest minority loss rate is among Intelligence officers—16% for the former and 14% for the latter.

Age Distribution (Table 18)

Between 40% and 50% of officer losses are among officers 26 to 31 years old. The proportion of these losses among minority officers in this age bracket is around 17% for the Navy, the Army, and the Marine Corps, and 10% for the Air Force. The corresponding white loss proportion is 24% for the Army, 20% for the Marine Corps, 18% for the Navy, and 14% for the Air Force. The Navy is the only Service which has an equal loss rate between white and minority officers in the same cohort group.

Table 18
Losses of Officers 26-31 Years Old, by Service: FY1974
(Percent)

Population	Army		Navy		Marine Corps		Air Force	
	1	2	1	2	1	2	1	2
White	52.0	24.0	48.0	18.0	50.0	20.0	47.0	14.0
Minority	38.0	16.0	57.0	17.0	42.0	15.0	43.0	10.0

Legend: 1—Percent of 26-31-year-old officer losses to the total losses.
2—Percent of 26-31-year-old officer losses to 26-31 year old officers (white or minority) end strength.

Length of Service (Table 19)

Minority officer losses during the first four years of service account for between a fifth and a half of minority losses.

In the Navy, proportionally, minority losses (58.0%) are more than double white officer losses (28.0%) during the same period of time. For the Air Force and Marine Corps, these percentages are nearly equal for white and minority officers. The white Army officers are the only ones who have a higher proportional loss during the first four years of service. For all Services, white officer loss rates vary between 2% to 8% of white officer strength, versus 2% to 6% for minority officers.

Source of Procurement (Tables 20-23)

The highest loss rate in the Army appears to be among officers accessed by "Direct Appointment" (Physicians/Dentists)—38% white officers and 22% minority officers. This high loss rate is directly connected to professional activity, and corroborates the occupational area loss analysis.

The second highest loss rate is among officers who were accessed through OCS programs. This particular point is interesting with regard to minority Army officer losses

Table 19

Officer Losses, by Length of Service: FY1974
(First 4 Years of Service)

Population	Army			Navy			Marine Corps			Air Force		
	1	2	3	1	2	3	1	2	3	1	2	3
White	47.0	21.0	8.0	28.0	13.0	4.0	17.0	8.0	2.0	28.0	10.0	3.0
Minority	35.0	12.0	5.0	58.0	12.0	6.0	20.0	4.0	2.0	31.0	6.0	2.0
Black	24.0	10.0	3.0	58.0	11.0	5.0	20.0	4.0	2.0	26.0	4.0	2.0
"Other"	55.0	19.0	8.0	58.0	14.0	7.0	25.0	4.0	2.0	44.0	14.0	5.0

Legend: 1—Percent of first 4 year officer losses to the total losses.
 2—Percent of first 4 year officer losses to the first 4 year officer strength (white or minority).
 3—Percent of first 4 year officer losses to the officer strength (white or minority)

Source: MARDAC, Officer Master File.

Table 20

Officer Racial-Ethnic Loss Rates, by Source of Procurement, Army:
FY1974
(Percentage)

Source of Procurement	White	Total Minority	Black	Other
Academy	5.0	2.0	3.0	0.0
ROTC Scholarship	8.0	6.0	7.0	0.0
ROTC NonScholarship	16.0	11.0	10.0	14.0
OCS	29.0	23.0	21.0	7.0
Direct Appointments Physicians/Dentists	38.0	22.0	16.0	35.0
Direct Appointment. "Others"	19.0	11.0	10.0	16.0
Aviation Training	0.0	0.0	0.0	0.0
Total	16.0	12.0	12.0	15.0

Source: MARDAC, Officer Master File.

Table 21

**Officer Racial-Ethnic Loss Rates, by Source of Procurement, Navy:
FY1974
(Percentage)**

Source of Procurement	White	Total Minority	Black	Other
Academy	6.0	8.0	3.0	12.0
ROTC Scholarship	9.0	9.0	9.0	8.0
ROTC NonScholarship	19.0	12.0	8.0	21.0
OCS Direct Procurement	14.0	11.0	10.0	13.0
OCS In-Service	0.0	0.0	0.0	0.0
OCS-OTS	13.0	14.0	14.0	12.0
Direct Appointments Physicians/Dentists	42.0	18.0	18.0	19.0
Direct Appointment. "Others"	0.0	0.0	0.0	0.0
Aviation Training	12.0	8.0	9.0	0.0
Total	13.0	10.0	9.0	13.0

Source: MARDAC, Officer Master File.

Table 22

**Officer Racial-Ethnic Loss Rates, by Source of Procurement, Air Force:
FY1974
(Percentage)**

Source of Procurement	White	Total Minority	Black	Other
Academy	5.0	2.0	2.0	0.0
ROTC Scholarship	7.0	5.0	5.0	6.0
ROTC NonScholarship	7.0	8.0	8.0	8.0
OCS/OTS	9.0	5.0	4.0	9.0
Direct Appointments Physicians/Dentists	28.0	26.0	16.0	48.0
Direct Appointment. "Others"	14.0	10.0	9.0	13.0
Aviation Training	19.0	14.5	14.0	16.0
Total	11.0	8.0	7.0	10.0

Source: MARDAC, Officer Master File.

Table 23

**Officer Racial-Ethnic Loss Rates, by Source of Procurement,
Marine Corps: FY1974
(Percentage)**

Source of Procurement	White	Total Minority	Black	Other
Academy	5.0	4.0	4.0	0.0
ROTC Scholarship	12.0	17.0	20.0	0.0
ROTC NonScholarship	12.0	7.0	8.0	0.0
OCS Direct Procurement	18.0	16.0	15.0	22.0
OCS In-Service	10.0	6.0	7.0	0.0
Aviation Training	12.0	0.0	0.0	0.0
Total	13.0	11.0	11.0	10.0

Source: MARDAC, Officer Master File.

for two reasons. First, minority Army *career* officers are procured primarily from ROTC and not OCS programs.¹ Thus, the high loss rate among OCS officers does not significantly affect the minority career force. Second, high losses from OCS indicate that OCS should be used as a source of procurement for Army minority officers only as a last resort. The Physician and Dentist loss rate is similar in the Navy with 42% white and 18% minority officer losses. The highest loss rate for the Marine Corps officers is from officers procured through OCC, 18% white and 16% minority officers. Losses from Air Force direct appointments of Physicians and Dentists are highest proportionally for that service also, with a loss of 28% white and 26% minority officers.

In conclusion, three important points from the preceding analysis of minority officer losses should be stressed. First, minority loss rates are smaller than white loss rates. Second, minority officers have a higher propensity to leave the Services in the first four years of service than whites, in the Navy, Marine Corps and the Air Force. Third, the highest loss rate occurs among Physicians and Dentists for both white and minority officers.

Minority Officer Accessions (Tables 24-28)

This discussion consists of a trend analysis of officer accessions from FY1970 to FY1974, by source of procurement and educational level. The analysis does not include Spanish-origin officers among minority officers, since the OASD reports from which the information was gathered record Spanish-origin officer accessions with white officer accessions.

¹This is based on the MARDAC Officer File and minority force projections by source of procurement and length of service.

Table 24

Minority Officer Accessions, by Source of Procurement: Army

Source of Procurement	Accessions ^a									
	FY1970		FY1971		FY1972		FY1973		FY1974	
	No.	%	No.	%	No.	%	No.	%	No.	%
Military Academy	1	0.1	3	0.4	8	1.0	37	4.0	39	4.9
ROTC Non-Scholarship	187	1.3	253	2.7	104	2.4	157	3.8	84	3.3
ROTC Scholarship	14	1.3	48	4.6	28	2.6	28	2.8	22	1.8
Other College Programs	-	-	-	-	-	-	-	-	-	-
Reservists	6	0.8	7	1.2	10	1.6	8	2.7	5	1.0
OCS from Civilian Life	28	0.8	37	1.9	4	0.5	14	1.9	3	2.9
OCS from Active Military	119	2.1	40	4.4	18	6.1	45	14.9	35	16.6
OCS from College Programs	-	-	-	-	-	-	-	-	-	-
Other O.C. Programs	-	-	-	-	-	-	-	-	-	-
Temporary Officer Direct from Ranks	11	0.5	10	1.3	2	1.7	3	7.5	3	15.8
Other	-	-	-	-	-	-	4	12.9	3	14.3
Physicians	30	1.0	63	2.7	16	0.6	32	1.7	25	1.8
Other Medical Specialists	2	0.8	7	2.7	1	0.5	3	5.7	3	2.3
Senior Medical Students	-	-	1	2.4	-	-	1	2.4	2	3.3
Other Direct from Civilian Life	4	0.7	4	0.8	7	3.0	15	3.8	15	3.5
Program Not Reported	5	1.3	3	0.8	13	3.0	11	14.9	5	7.9
Total Commissioned Officers	407	1.3	476	2.5	211	1.8	358	3.6	244	3.3

^aPercent column indicates percentage of the total accession by program.

Source. Cumulative Report of Officer Procurement and Officer Candidate Accession by Program
RCS:DD-M(Q)1107, Office of the Assistant Secretary of Defense (OASD).

Table 25

Minority Officer Accessions, by Source of Procurement: Navy

Source of Procurement	Accessions ^a									
	FY1970		FY1971		FY1972		FY1973		FY1974	
	No.	%	No.	%	No.	%	No.	%	No.	%
Military Academy	8	1.0	4	0.5	9	1.1	9	1.2	6	0.7
ROTC Non-Scholarship	13	1.0	11	1.5	9	1.5	1	0.6	6	2.1
ROTC Scholarship	4	0.4	2	0.2	11	1.2	17	2.2	19	2.0
Other College Programs	6	0.7	4	0.6	6	0.9	28	4.3	4	1.0
Reservists	2	0.4	2	0.4	1	0.3	1	0.4	1	0.5
OCS from Civilian Life	58	1.3	94	3.3	119	4.0	140	7.7	75	5.3
OCS from Active Military	-	-	-	-	-	-	-	-	-	-
OCS from College Programs	4	1.9	4	1.6	2	0.6	4	1.5	6	2.4
Other O.C. Programs	-	-	-	-	-	-	-	-	-	-
Temporary Officer Direct from Ranks	2	3.6	-	-	-	-	-	-	-	-
Other	2	6.4	-	-	1	2.2	-	-	-	-
Physicians	31	1.7	20	1.4	19	1.0	18	1.6	8	3.5
Other Medical Specialists	4	2.8	7	3.3	2	0.7	13	4.7	6	2.7
Senior Medical Students	4	1.6	2	0.7	1	0.5	10	8.1	2	5.7
Other Direct from Civilian Life	2	0.9	-	-	4	1.1	4	0.9	8	3.3
Program Not Reported	-	-	-	-	-	-	-	-	-	-
Total Commissioned Officers	140	1.2	150	1.7	184	2.0	245	3.7	141	2.8

^aPercent column indicates percentage of the total accession by program.

Source: Cumulative Report of Officer Procurement and Officer Candidate Accession by Program
RCS-DD-M(Q)1107, Office of the Assistant Secretary of Defense (OASD).

Table 26

Minority Officer Accessions, by Source of Procurement: Marine Corps

Source of Procurement	Accessions ^a									
	FY1970		FY1971		FY1972		FY1973		FY1974	
	No.	%	No.	%	No.	%	No.	%	No.	%
Military Academy	3	2.8	1	0.8	8	3.3	4	2.8	3	3.3
ROTC Non-Scholarship	2	3.4	2	6.9	2	5.9	3	14.3	4	16.7
ROTC Scholarship	2	2.1	3	3.5	3	3.1	4	3.3	10	5.9
Other College Programs	9	1.1	8	1.1	21	4.1	14	2.3	27	4.5
Reservists	1	1.0	1	0.9	1	2.7	—	—	—	—
OCS from Civilian Life	27	2.1	14	1.8	36	4.7	49	5.8	51	8.0
OCS from Active Military	10	2.7	1	1.5	2	2.6	5	6.6	1	1.7
OCS from College Programs	—	—	—	—	2	15.4	—	—	1	4.0
Other OC Programs	—	—	—	—	—	—	—	—	—	—
Temporary Officer Direct from Ranks	15	11.4	2	8.0	—	—	21	10.0	11	10.7
Other	—	—	1	4.0	—	—	—	—	—	—
Physicians	—	—	—	—	—	—	—	—	—	—
Other Medical Specialists	—	—	—	—	—	—	—	—	—	—
Senior Medical Students	—	—	—	—	—	—	—	—	—	—
Other Direct from Civilian Life	—	—	—	—	—	—	—	—	—	3.6
Program Not Reported	—	—	—	—	—	—	—	—	—	—
Total Commissioned Officers	69	2.3	33	1.7	75	4.4	100	4.9	109	6.1

^aPercent column indicates percentage of the total accession by program.

Source: Cumulative Report of Officer Procurement and Officer Candidate Accession by Program
RCS:DD-M(Q) 1107, Office of the Assistant Secretary of Defense (OASD).

Table 27

Minority Officer Accessions, by Source of Procurement: Air Force

Source of Procurement	Accessions ^a									
	FY1970		FY1971		FY1972		FY1973		FY1974	
	No.	%	No.	%	No.	%	No.	%	No.	%
Military Academy	8	1.0	6	0.9	11	1.7	17	2.0	16	2.0
ROTC Non-Scholarship	72	1.6	94	2.4	51	1.7	65	2.6	53	3.7
ROTC Scholarship	-	-	8	2.0	13	1.4	37	2.2	37	2.5
Other College Programs	-	-	-	-	-	-	-	-	-	-
Reservists	3	1.7	-	-	4	2.4	14	10.0	1	2.1
OCS from Civilian Life	17	0.4	31	1.0	31	1.1	122	5.9	83	6.3
OCS from Active Military	-	-	-	-	-	-	-	-	-	-
OCS from College Programs	13	2.2	14	2.4	20	3.2	22	3.3	112	16.7
Other OC Programs	-	-	-	-	-	-	-	-	-	-
Temporary Officer Direct from Ranks	-	-	-	-	-	-	-	-	-	-
Other	-	-	-	-	-	-	-	-	-	-
Physicians	15	.9	11	0.7	6	0.4	8	0.5	9	0.7
Other Medical Specialists	8	2.5	2	0.5	12	4.1	8	2.7	43	9.9
Senior Medical Students	-	-	-	-	-	-	-	-	-	-
Other Direct from Civilian Life	1	1.6	1	2.6	-	-	4	11.8	-	-
Program Not Reported	-	-	-	-	-	-	-	-	-	-
Total Commissioned Officers	137	1.1	167	1.5	148	1.4	297	3.1	354	4.8

^aPercent column indicates percentage of the total accession by program.

Source: Cumulative Report of Officer Procurement and Officer Candidate Accession by Program
RCS:DD-M(Q)1107, Office of the Assistant Secretary of Defense (OASD).

Table 28

**Trends in Educational Attainment, Bachelor's Degree or Higher:
Male Officers' Accession
(Percent)**

Service	FY1970	FY1971	FY1972	FY1973	FY1974
Army	49.4	77.8	76.4	68.0	51.4
Navy	98.3	90.4	68.2	73.9	61.8
Marine Corps	71.2	51.7	64.0	59.1	68.3
Air Force	99.1	99.4	99.2	99.1	97.1

Source: Cumulative Report of Officer Procurement by Educational Attainment, Office of the Assistant Secretary of Defense, OASD-RCSSD-M(Q)1107. (No racial breakdown available.)

The percentage of minority officer accessions has constantly increased since FY1970 for the Marine Corps, the Air Force, and the Navy, except during FY1974 for the Navy. Army minority officer accessions show variations from year to year. Despite improvement, minority accessions still represent a small percentage of total accessions (Tables 24-27). In FY1974 those percentages were 3.3% for the Army, 2.8% for the Navy, 6.1% for the Marine Corps, and 4.8% for the Air Force.

In FY1974 more than half of Navy minority officer accessions and 48% of Marine Corps minority officer accessions came through OCS programs. This is consistent with the end strength analysis (first subsection) which indicated that almost half of black officers were procured through OCS for both Services.

Meanwhile the Army acceded 34% of the minority officers in FY1974 through ROTC non-scholarship. The number and percentage of minority officers acceded through West Point was increased sharply, from 0.2% in FY1970 to 16% in FY1974.

The apparent trend in educational attainment seems to be toward a decrease in college graduate accessions. This trend seems to be extremely inconsistent with the end strength analysis previously reported. The end strength analysis (Table 8) reported an increase of college graduates between FY1972 and FY1974 while Table 28 shows a net decrease not only between FY1972 and FY1974, but between FY1970 and FY1974 as well.¹

Objectives (Tables 29-31)

The preceding section analyzed in some detail the status of minority representation in the Armed Forces in FY1974. This second part is devoted to the Services' respective objectives with regard to minority representation.

Table 29 shows a series of minority goals defined in the "Affirmative Actions Plan" (draft) of the Department of the Army. This plan sets a series of "planning targets, arranged in timetable format to facilitate a management effort."² This is a detailed and well organized plan in which: first, end strength goals are specified; second, yearly

¹ It appears that the Services' accession bookkeeping might have an important shortcoming. This hypothesis is based on the fact that the percent of "Unknown" level of education seems to rise year after year rather than, to decrease.

² "Affirmative Actions Plan," p. 2.

Table 29

Army Minority Officer Goals

Goal ^a	CY75	CY76	CY77	CY78	CY79	CY85
1. Active duty commissioned/warrant officer end strength goal (Regular and USAR)							
5.0% Black; 2.0% other; 1.5% female	X						
5.5% Black; 2.5% other; 2.0% female		X					
6.0% Black; 3.0% other; 2.5% female			X				
7.0% Black; 3.5% other; 3.0% female				X			
8.0% Black; 4.0% other; 3.5% female					X		
10.0% Black; 5.0% other; 6.0% female							X
2. Yearly commissioning goal for professional branches ^b							
10% Black; 3% other; 1% female	X	X					
11% Black; 3% other; 2% female			X	X			
12% Black; 4% other; 4% female					X		
13% Black; 5% other; 7% female							X
3. Increase male minority group OCS, ROTC, and USMA enrollment							
a. OCS: 15% Black; 4% other	X						
—18% Black; 4% other		X	X	X	X		X
b. ROTC: 17% Black; 4% other	X						
19% Black; 6% other		X	X	X	X		X
c. USMA: 5.0% Black; 4% other	X						
5.5% Black; 4% other		X					
6.0% Black; 5% other			X				
6.5% Black; 5% other				X			
7.0% Black; 6% other					X		
13.0% Black; 6% other							X
d. USMAPS: 14.5% Black; 7% other	X	X					
15.0% Black; 7% other			X	X	X		
16.0% Black; 7% other							X
4. Increase minority student participation in the Army ROTC scholarship program							
Achieve by CY79 a percentage of scholarship participation among male minority students enrolled in ROTC that is not less than the percentage of ROTC scholarship participants among the general population.	X	X	X	X	X		X

^aIn all cases in this plan, the word "other" means Spanish descent, American Indian and other ethnic categories as approved by the Office of the Secretary of Defense.

^bProfessional branches Judge Advocate General Corps, Medical Corps, Dental Corps, Veterinary Corps, Army Nurse Corps, Army Medical Specialist Corps and Chaplains Corps.

Source: "Affirmative Actions Plan" (Draft), 1975, Department of the Army.

commissioning goals for professional branches are set up; third, yearly enlistment goals, by source of procurement, are defined. As an example, 15% minority officers is the target for CY1985. This is approximately the percentage of minorities in the general population in FY1970.

Navy goals are presented in Table 30.¹ The Navy sets up 6.0% as its goal for black officers end strength and 2.0% for the "Other" minority officers. This corresponds to the proportion of minority men 16-34 years old who had a Bachelor's degree in FY1974. Special goals have been set up by source of procurement. The Air Force goal with regard to minority representation, 5.6% in FY1980, seems to be based on minority distribution among the Bachelor's degree population during FY1970. The Marine Corps has not set up a percentage, but rather a minimum 100 minority officer accessions per year.²

Table 30 -

Navy Minority Officer Goals
(Percent) -

Other	Black	"Other"
1. Male Accessions		
USNA, NROTC	12.0	6.0
OCS, ROC, AVROC	6.0	2.0
AOC, NFOC	6.0	2.0
Male/Female Accessions		
DC	2.0	1.0
MC	6.0	3.0
MSC, NC	4.0	1.0
JAG	2.0	2.0
2. End Strength	6.0	2.0

Source: Naval Equal Opportunity Program (5 Dec 1973),
Department of the Navy.

The gap between the actual percentage during FY1974 and the different goals in each Service seems to be large (Table 31). Further, the wide variation between the Services in their minority representation goals, as described previously, demonstrates the lack of a coordinated overall DoD policy. The difference between the actual minority percentages and the future goals in each Service does, however, reflect a recent change in the Services' minority orientation. Nevertheless, it has yet to be proven: (1) that yearly minority enrollment goals for procurement programs and yearly commissioning goals defined by each Service actually lead to the overall percentage objective of minority representation implied by these future goals, and (2) that minority enrollment goals for procurement programs and yearly commissioning goals can be met, considering the supply

¹ U.S. Department of the Navy. *Navy Equal Opportunity Program*, 5 Dec. 1973.

² Minority objectives data for the Air Force and Marine Corps were provided by the respective Service.

Table 31
Minority Officer Representation in the Armed Forces, FY1974

Category	Army			Navy			Marine Corps			Air Force										
	White	Black	Spanish	White	Black	Spanish	White	Black	Spanish	White	Black	Spanish								
	Total	Minority	"Other"	Total	Minority	"Other"	Total	Minority	"Other"	Total	Minority	"Other"								
Inventories	93.3	4.5	1.6	0.6	6.7	97.6	1.2	0.8	0.4	2.4	95.9	2.3	1.4	0.4	4.1	95.9	2.2	1.2	0.6	4.0
Accessions ^a	96.7	2.8	-	0.5	3.3	97.2	2.0	-	0.8	2.8	93.9	5.1	-	1.0	6.1	95.2	4.8	-	-	4.8 ^b
Losses ^a	96.3	2.1	-	0.5	3.7	98.7	0.8	-	0.4	1.3	97.7	1.9	-	0.2	2.2	97.9	1.4	-	0.6	2.0

^a Does not include persons of Spanish origin.

^b Black only.

Source: Inventories and Losses—MARDAC, Officer Master File.

Accessions—Cumulative Report of Officer Procurement and Officer Candidate Accession RCS: DD-M(O)1107.

in minority manpower pools. These questions will be examined in the following chapter for the Army. The Army is the only Service able to provide a data base in the detail needed to accurately model the yearly goals by program enrollment, by specific source of procurement, and by the overall minority representation objective.¹

Two possible ways exist to build better minority representation in the Armed Forces. The first is to drastically reduce minority losses through remedial policy change; the second is to increase minority 'accession' through existing procurement programs. Since minority loss rates are already very low, the first procedure will take a long time to achieve any significant increase in minority representation in the Armed Forces. Thus, the only practical possibility is to increase minority participation through accessions. This prospect is discussed in the following chapter, which focuses specifically on the problem of increasing minority officer representation in the Army.

¹The data were collected from the Army procurement programs and the Army Equal Opportunity Office.

Chapter 3

SIMULATION MODELS

From the analyses reported in Chapters 1 and 2, it appears that: (a) the Services are well below their desired minority officer objectives; (b) the most effective method of rapidly building minority officer strengths among the Services is by increasing accessions through existing procurement programs; and (c) the Army is the only service able to provide sufficient information to design a coherent model of its sources of procurement. Thus, the major focus in this chapter will be on the Army sources.

In the first part of this discussion, Army sources of procurement are described in order to illustrate the elements of a service procurement system. Following the Army description, the similarities and differences between the other Services' sources of procurement are described. In the second part, the Army procurement system is simulated in order to determine (a) what level of minority representation the Army could reach, (b) whether the Army AAP could produce minority officer participation at the level desired, and (c) whether minority manpower pools can support the increased Army officer participation contemplated by that plan.

OFFICER PROCUREMENT PATTERNS AS A FRAMEWORK TO SIMULATION MODELS

Officer procurement patterns consist of military manpower pools, officer procurement programs, and the pathways between the pools and the programs. This is discussed in the following subsection for the Army. The Services' procurement patterns are compared in the second subsection.

Army Manpower Pools and Procurement Programs: Army Flow-Chart FY1974 (Chart 1)

Chart 1 is divided into three lengthwise parts. On the left side of the chart are pools from which candidates for officer programs can be drawn. In the middle of the chart, officer procurement programs are shown. On the right side, Minority Officer Strength is represented.

On the top left of the chart, the box entitled "Minority Men Population" represents minority men who are 16-24 years old, not enrolled in college, and not enlisted in the Army. This box is divided into the population not enrolled in any educational program and the population still enrolled in some form of school. The population not enrolled is further divided into four levels of educational attainment: (a) non high school graduates, (b) high school graduates, (c) some college, and (d) college graduates. The population still enrolled in school is also divided into four categories: (a) minority men enrolled below high school, (b) minority men in high school who are going to drop out, (c) minority men who are going to graduate from high school but are not going to enroll in college, and (d) minority men who are going to graduate from high school and enroll in college.

The next four boxes on the left of the chart represent the minority male population at different levels of college and years of college. The last box on the bottom left of the

16-24 Minority Men Population

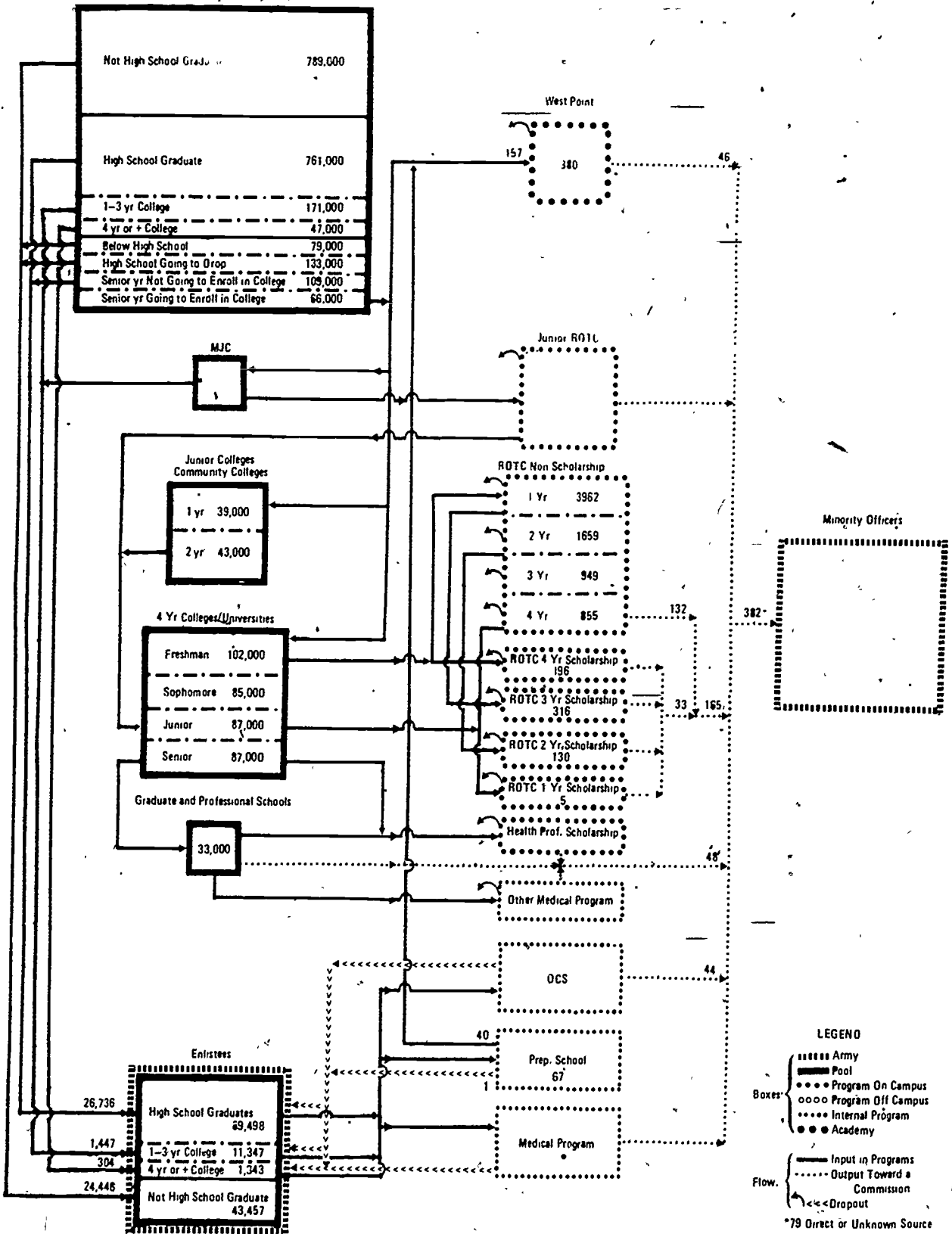

Chart 1: Minority Male Manpower Pools and Officer Accessions, by Procurement Program, Army Active Duty, FY1974

chart represents the enlisted ranks from which minority officer candidates can be drawn. This box, like the first one described, is also divided into four levels of education. The numbers found in each box represent the actual population having the characteristics specified in the box or its subdivision.

Between boxes, arcs are drawn which simulate the different paths that a potential officer candidate might take. For example, a senior in high school, who is about to enroll in college, has four alternatives available to him if he wants to become an officer. He can apply to: (a) West Point (U.S. Military Academy, USMA) (in which case, he would have applied the year before; (b) a Military Junior College (MJC);¹ (c) a junior college; or (d) a four-year college.

From each of these four alternatives, there is a path that can be followed whenever the candidate is at a certain level. Suppose the potential candidate has chosen to enroll in a four-year college. Then, as a freshman, he has three basic choices: (a) apply to a ROTC non-scholarship program, (b) apply to a ROTC scholarship program, or (c) postpone his choice for one or two years. Later he will have the same choices again.

Numbers on arcs to the left of the boxes represent input flows during FY1974.

The procurement programs which may lead to a commission are represented by boxes in the middle of the chart. These are divided into three categories for the Army. On the top of the page is West Point (USMA) which is followed by "on-campus programs," Junior ROTC (which very seldom leads directly to a commission), ROTC scholarship programs, ROTC non-scholarship programs, and Health Professional Programs. The remaining boxes represent internal programs (viz., Other Medical Programs, Officer Candidate School (OCS), Preparatory School to West Point, and Medical Programs). Numbers in the boxes indicate minority enrollment in the programs.²

Arcs entering boxes from the left indicate input flows from the qualified pools. Arcs and arrows leaving from the left of the boxes indicate either dropouts from the programs or input from one program into another, such as candidates to West Point coming from Preparatory School.³ The arcs leaving from the right side of the boxes mean that the program leads to a commission. The arcs terminate in the last box, in the right side of the chart: Minority Officer End Strength. Numbers near the arrows on the arcs leaving program boxes indicate numbers of officers commissioned from that program during FY1974.⁴

Similarities and Differences Between the Services' Flow-Charts (Charts 1-4)

Several differences exist between the flow-charts for the various services. First, while ROTC non-scholarship and scholarship programs exist in each service, the Army ROTC scholarship program exhibits much more flexibility. Army scholarships can be of any length, one to four years, while in the other services the choice is limited to two- and four-year scholarships.

Second, it appears that the Army does not have any "off-campus programs," while the Navy has three—Officer Candidate School (OCS), Aviation Reserve Officer Candidate (AVROC), Reserve Officer Candidate (ROC); the Marine Corps has two—Platoon Leader

¹ Military Junior Colleges are private colleges whose educational programs go from High School to two year college level. They offer Junior ROTC programs.

² Whenever the data were available.

³ Very few numbers are available here, simply because statistics are not kept on this basis.

⁴ Since there are slight discrepancies between MARDAC data and the OASD Cumulative Report of Officer Procurement and Officer Candidate Accession, and since the following simulation model utilizes as data framework statistics gathered by MARDAC, the accession numbers on the flow-chart are MARDAC data.

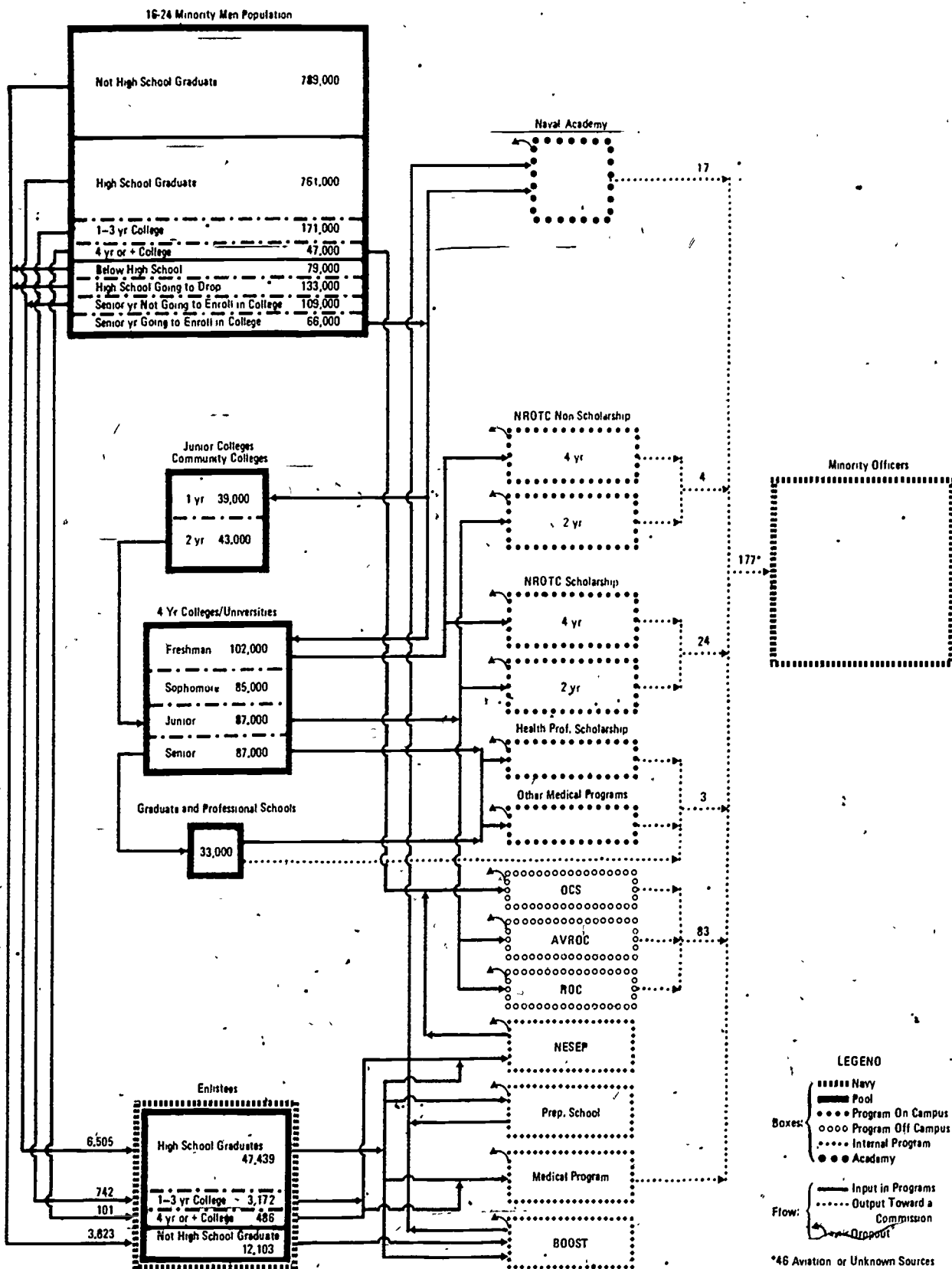

Chart 2. Minority Male Manpower Pools and Officer Accessions, by Procurement Program, Navy Active Duty, FY1974

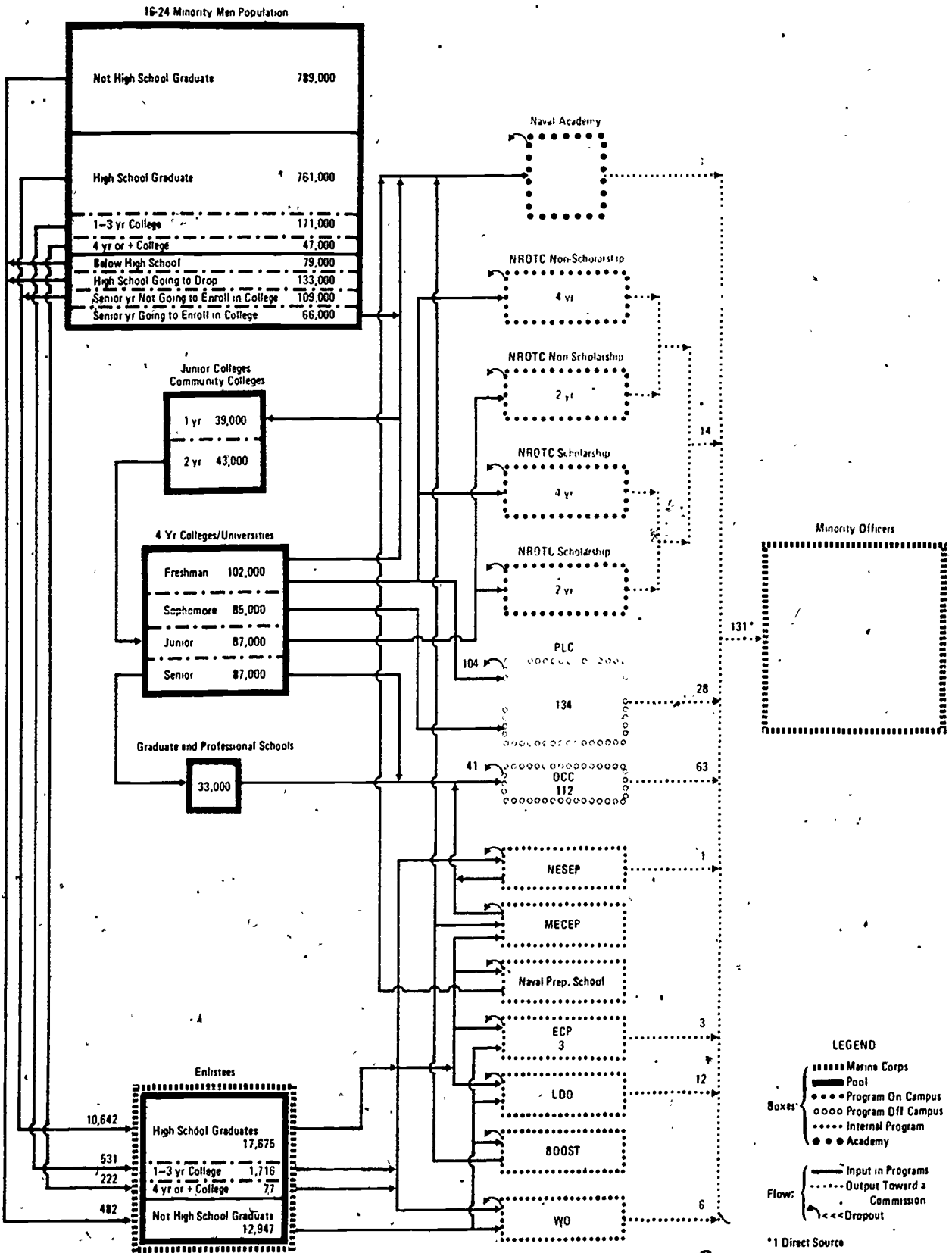

Chart 3. Minority Male Manpower Pools and Officer Accessions, by Procurement Program, Marine Corps Active Duty, FY1974

16-24 Minority Men Population

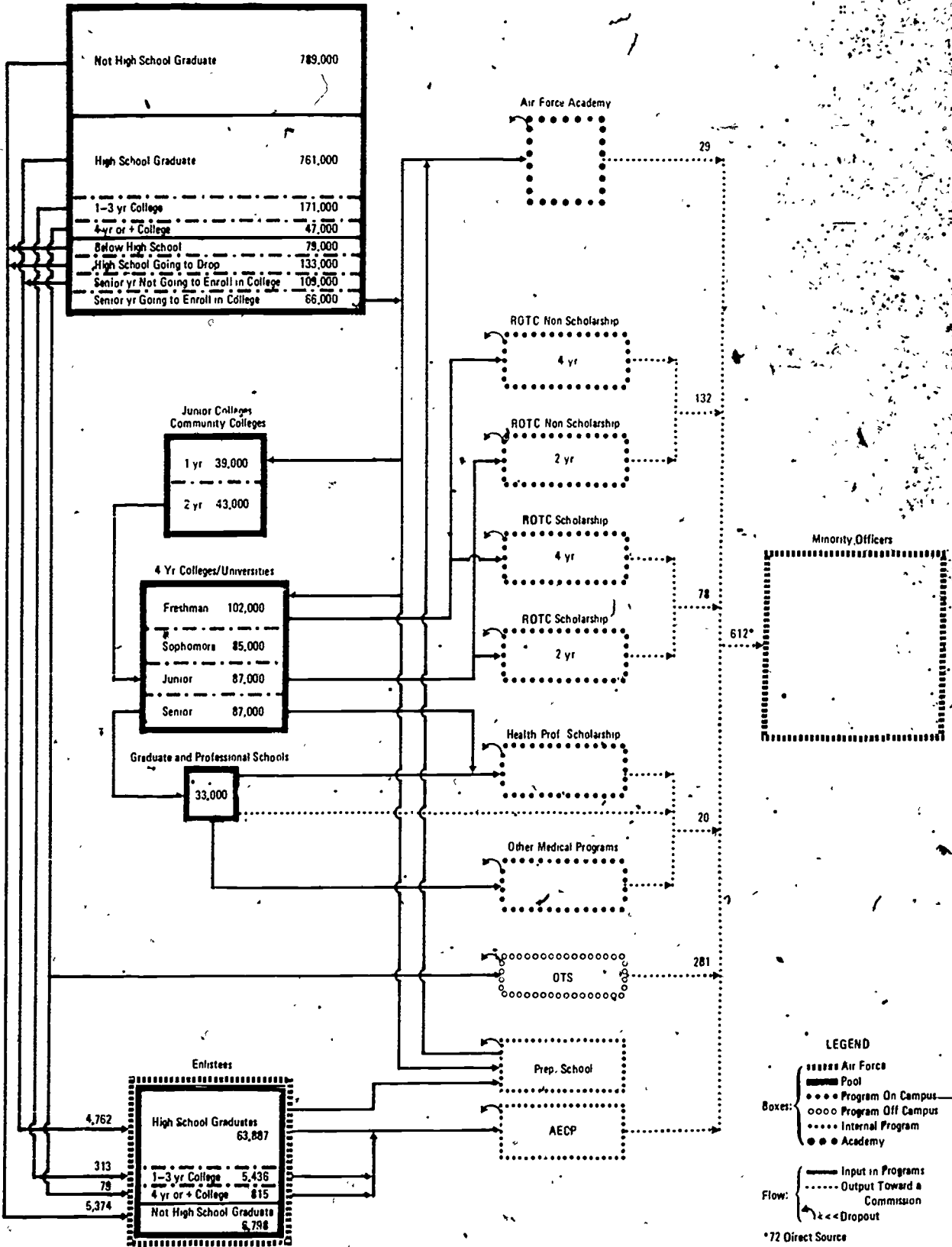

Chart 4. Minority Male Manpower Pools and Officer Accessions, by Procurement Program, Air Force Active Duty, FY1974

Class (PLC), and Officer Candidate Class (OCC); and the Air Force has Officer Training School (OTS).

Third, the Army OCS program, similar in principle to the Navy OCS, the Marine Corps OCC, and the Air Force OTS, recruits its candidates among enlisted men, while the three other Services recruit candidates from the college population.

Fourth, the proliferation of internal programs in the Marine Corps should be noted. The Marine Corps offers seven different programs which might allow minority enlistees to obtain a commission. However, of the seven programs, only three lead to a direct commission: (a) the Enlisted Commissioning Program (ECP), (b) the Limited Duty Officer (LDO), and (c) the Warrant Officer Program (WO). The four other programs are more appropriately considered educational programs. These include the Marine Corps Enlisted Commissioning Education Program (MECEP), the Navy Enlisted Scientific Educational Program (NESEP), the Broadened Opportunity for Officer Selection and Training (BOOST), and the Naval Preparatory School. The last three programs are common to the Navy.

MODELING ARMY PROCUREMENT

This section is divided into two parts. The first presents information on the officer procurement programs with regard to minority enrollees, and the corresponding AAP goals. The second discusses the results of the Army simulation models.

Minority Enrollments and Graduation in the Army Officer Procurement Programs (Tables 32-36)

Before further presentation of the Army models, information on minority enrollment, drop-outs, and graduation from the U.S. Military Academy (USMA) and ROTC will be exhibited and compared to the Army Affirmative Action Plan goals.

First, a close look at the Academy minority participation (Tables 32 through 34) discloses that minority participation is still very low (Table 34), but it is gradually growing to a projected 10.9% in FY1978. Second, a comparison between racial-ethnic entrance distribution and graduation distribution shows a slightly higher percentage for minority graduations over white graduations (Table 33). This means that minority candidates are less likely to drop out than their white counterparts. The Army black enrollment goal for the USMA, as stated in the Army Affirmative Action Plan, will be reached for FY1977 and "Other" enrollment will be only 0.9% below its goal. But for 1978¹, black enrollment is expected to be 5.6% (Table 34) while the goal is 6.5%. However, during the same year, "Other" enrollment is projected as meeting its goal. This data analysis demonstrates the capability of the Army to reach its short-term Academy minority enrollment goals.

The corresponding ROTC enrollment percentages in FY1974, 16.2% for Blacks and 4.7% for "Other," are very close to the CY1975 goals, 17% for Blacks and 4% for "Other" (Table 35). On the other hand, the ROTC scholarship participation goal among minority male students is still very far from the CY1979 goal. During FY1974 the ratio of black ROTC scholarships to black ROTC total enrollment was 8.9%, for the "Other" it was 13.4% (Table 36). These figures are to be compared with a goal of 20.3% in CY1979.

¹Goals and accessions are not in the same year frame. Goals are specified in Calendar Year, and accessions in Fiscal Year.

Table 32

Military Academy Enrollment and Graduation: Army

Population	Class '73		Class '74		Class '75		Class '76		Class '77		Class '78	
	Enter	Graduate	Enter	Graduate	Enter	Graduate	Enter	Graduate	Enter	Graduate	Enter	Graduate
	Projection as of 31 Dec 1974											
White	1376	903	1308	790	1253	809	1265	812	1233	935	1278	1104
Black	45	24	40	24	54	36	52	35	82	56	81	77
American Indian	2	2	4	2	3	2	7	1	7	4	2	2
Chinese	1	1	1	1	0	0	4	4	6	5	5	4
Guamanian	1	1	1	1	0	0	0	0	0	0	3	3
Hawaiian	2	2	1	1	1	1	0	0	2	2	2	1
Japanese	2	2	5	4	12	11	21	16	12	10	11	8
Malayan/Filipino	2	2	2	2	3	3	4	4	3	3	9	9
Mexican American	4	4	6	5	9	7	16	13	16	11	24	20
Puerto Rican	2	2	5	3	2	1	6	3	5	4	11	9
Latin American	1	1	0	0	2	1	0	0	6	6	6	5
Other	0	0	0	0	0	0	0	0	0	0	3	3
Total Minority	62	41	65	43	86	62	110	76	139	101	157	141
Total	1438	944	1373	833	1339	871	1375	888	1373	1036	1435	1245

Source: Office of the Director of Institutional Research, USMA; Personnel Officer, USCC.

Table 33

Percentage of Military Academy Graduation to the Total Enrollment: Army

Population	Class '73	Class '74	Prójection as of 31 Dec 1974			
			Class '75	Class '76	Class '77	Class '78
White	65.6	60.4	64.6	64.2	75.8	86.4
Black	53.3	60.0	66.7	67.3	68.3	95.1
American Indian	100.0	50.0	66.7	14.3	57.1	100.0
Chinese	100.0	100.0	0	100.0	83.3	80.0
Guamanian	100.0	100.0	0	0	0	100.0
Hawaiian	100.0	100.0	100.0	0	100.0	50.0
Japanese	100.0	80.0	91.7	76.2	83.3	72.7
Malayan/Filipino	100.0	100.0	100.0	100.0	100.0	100.0
Mexican American	100.0	83.3	77.8	81.2	68.7	83.3
Puerto Rican	100.0	60.0	50.0	50.0	80.0	81.8
Latin American	100.0	0	50.0	0	100.0	83.3
Other	0	0	0	0	0	100.0
Total Minority	66.1	66.1	72.1	69.1	72.7	83.8
Total	65.6	60.7	65.0	64.6	75.5	86.7

Source: Office of the Director of Institutional Research, USMA, Personnel Officer, USCC

Table 34

Distribution of Entrance and Graduation, by Ethnic Groups: Military Academy
(Percentage)

Ethnic Group	Projection as of 31 Dec 1974											
	Class '73		Class '74		Class '75		Class '76		Class '77		Class '78	
	Enter	Graduate	Enter	Graduate	Enter	Graduate	Enter	Graduate	Enter	Graduate	Enter	Graduate
White	95.7	95.7	95.3	94.8	93.6	92.9	92.0	91.4	89.9	90.2	89.1	88.7
Black	3.1	2.5	2.9	2.9	4.0	4.1	3.8	3.9	6.0	5.4	5.6	6.2
American Indian	0.1	0.2	0.3	0.2	0.2	0.2	0.5	0.1	0.5	0.4	0.1	0.2
Chinese	0.07	0.1	0.07	0.1	0	0	0.3	0.4	0.4	0.5	0.3	0.3
Guamanian	0.07	0.1	0.07	0.1	0	0	0	0	0	0	0.2	0.2
Hawaiian	0.1	0.2	0.07	0.1	0.07	0.07	0	0	0.1	0.2	0.1	0.08
Japanese	0.1	0.2	0.04	0.5	0.9	1.3	1.5	1.8	0.9	1.0	0.8	0.6
Malayan Filipino	0.1	0.2	0.1	0.2	0.2	0.3	0.3	0.4	0.2	0.3	0.6	0.7
Mexican American	0.3	0.4	0.4	0.6	0.7	0.8	1.2	1.5	1.2	1.1	1.7	1.6
Puerto Rican	0.1	0.2	0.4	0.4	0.1	0.1	0.4	0.3	0.4	0.4	0.8	0.7
Latin American	0.07	0.1	0	0	0.1	0.1	0	0	0.4	0.6	0.4	0.4
Other	0	0	0	0	0	0	0	0	0	0	0.2	0.2
Total Minority	4.3	4.3	4.7	5.2	6.4	7.1	8.0	8.5	10.1	9.7	10.9	11.3
Total	100.0	100.0	100.0	100.0	100.0	100.0	100.0	100.0	100.0	100.0	100.0	100.0

Source: Office of the Director of Institutional Research, USMA; Personnel Officer, USCC

Table 35

Racial-Ethnic Enrollment in ROTC Programs, by Years of Program: Men

Years of Program	White	Black	Hispanic Spanish	Puerto Ricans	Filipino	Hawaiian	Indian	Other	Total Minority	Total
1972-73										
Opening										
4 years 1	14,125	2,902	210	286	11	10	26	107	3,552	17,677
2	7,854	1,446	128	126	4	8	3	80	1,795	9,649
3	4,604	568	91	55	9	6	2	47	778	5,382
4	5,242	497	72	68	5	5	6	64	717	5,959
2 years 3	966	123	18	19	4	8	2	8	182	1,148
4	1,153	65	20	11	1	1	1	15	114	1,267
Total	33,944	5,601	539	565	34	38	40	321	7,138	41,082
Percent										
Distribution	82.6	13.6	1.3	1.4	0	0	0	0.8	17.4	100.0
Closing										
4 years 1	10,397	2,245	156	264	7	11	15	80	2,778	13,175
2	6,007	1,258	96	97	6	7	2	58	1,524	7,531
3	4,339	541	81	45	7	11	4	39	728	5,067
4	4,859	483	59	54	6	6	6	58	672	5,531
2 years 3	820	111	19	13	5	8	2	13	171	991
4	1,001	56	18	8	1	2	1	11	97	1,098
Total	27,423	4,694	429	481	32	45	30	259	5,970	33,393
Percent										
Distribution	82.1	14.1	1.3	1.4	0	0	0	0.8	17.9	100.0
1973-74										
Opening										
4 years 1	9,739	2,390	171	284	8	8	35	84	2,980	12,719
2	5,035	1,226	83	130	3	8	6	53	1,509	6,544
3	3,666	553	67	85	5	5	4	39	758	4,424
4	4,060	507	87	42	8	7	4	45	700	4,760
2 years 3	603	110	22	36	5	5	2	11	191	734
4	722	101	21	13	4	1	2	13	155	877
Total	23,825	4,887	451	590	33	34	53	245	6,293	30,118
Percent										
Distribution	79.1	16.2	1.5	1.9	0.1	0.1	0.2	0.8	20.9	100.0

Source: Army Equal Opportunity Office

Table 36

Army Minority Participation in ROTC Scholarship Program: FY1974 and FY1975

Fiscal Year	Black		Spanish		"Other"		Total Minority		Total
	Number	Percent	Number	Percent	Number	Percent	Number	Percent	Number
1974									
1 yr	1	1.2	2	2.4	2	2.4	5	5.8	86
2 yr	107	10.7	13	1.3	10	1.0	130	13.0	1,000
3 yr	266	15.2	37	2.1	13	0.7	316	18.0	1,750
4 yr	80	2.2	54	1.5	62	1.7	196	5.3	3,664
Total	454	7.0	106	1.6	87	1.3	647	9.9	6,500
1975 (before revision)									
1 yr	0	0	0	0	0	0	0	0	0
2 yr	101	10.4	21	2.2	15	1.6	137	14.1	972
3 yr	269	15.8	45	2.7	15	0.9	329	19.7	1,698
4 yr	66	1.9	43	1.3	49	1.4	158	4.6	3,433
Total	436	7.1	109	1.8	79	1.3	624	10.2	6,104

Source: Army Equal Opportunity Office.

The CY1975 commissioning goal for professional branches—Judge Advocate General Corps (JAG), Medical Corps (MC), Dental Corps (DC), Veterinary Corps (VC), and Army Specialist Corps and Chaplains Corps—is set at 10% for Blacks and 3% for "Other". This goal seems very far from being reached for Blacks, since black accession for these professional branches was only 1.9% in FY1974.

Simulation Models

The results of the Army simulation models are presented in this part. The primary function of a simulation model is to simplify, by means of a set of equations containing variables, numerical constants and constraints, the complexity of a given system, in such a way that it accounts for the critical variables within the system, while permitting an easy comprehension and a flexible manipulation of the relationships between variables. The value of a simulation model, its strength and weakness depend on the accuracy and the texture of the data.

The major problems inherent to simulation modeling are (a) choosing at which level of detail the simulation is to be performed and (b) testing the cogency of the hypotheses utilized in the simulation. This subsection describes the approaches used to solve these problems in the present study and reports the results of the application of models which simulate the Army officer procurement system.

Hypotheses (Tables 37 and 38)

As seen in Chapter 2, the major minority representation problem is the lack of minority officers in specific occupational areas and in higher ranks (which is a function of two variables—minority input and length of service). Thus, the level of the Army simulation models is determined by the following three sets of variables. (a) sources of

procurement, (b) length of service¹, and (c) racial-ethnic groups—Whites, Blacks, Spanish, and Others.

Army simulation models are based on the flow chart described previously. They project white and minority forces through 1985. The force sizes given are those at the end of June of each year. Several hypotheses underlie the force projections and each of these is treated below:

Estimation of the Force Size Year by Year Through 1985. (Hypothesis No. 1) FY1980 projection numbers were obtained for officers and enlistees (Table 37) from the Services. A linear estimation of the force size (officers and enlistees) was then calculated between FY1974 and FY1980 (Table 38). Estimates for the years after FY1980 were based on the hypothesis that the force size will remain constant at the FY1980 level since the preceding projection would have produced substantial diminution of the officer strength.

Table 37

End Strength Projection Numbers:
FY1980

Personnel	Army	Navy	Marine Corps	Air Force
<u>Officers</u>				
Men	75,442	54,165	16,479	91,180
Women	5,868	4,150	385	5,820
Total	81,310	61,685	16,864	97,000
<u>Enlisted</u>				
Men	638,500	457,015	176,836	481,180
Women	56,200	20,000	2,200	78,240
Total	694,700	477,015	179,536	489,000

Source: Services.

Table 38

Linear Estimation of the Army
Officer Force

Fiscal Year	Force Size
1974	90,880
1975	88,307
1976	85,734
1977	83,161
1978	80,588
1979	78,015
1980	75,442

¹The first two sets of variables were chosen because of the correlation of sources of procurement and occupational areas, and the high loss rate during the first four years of service.

Loss Rates. (Hypothesis No. 2) Hypotheses were needed to estimate two different loss rates:

(1) Force loss rates were computed on the basis of MARDAC data for FY1974, by race, sources of procurement, and length of service. Assumptions were made that the preceding loss rates will remain equal through 1985 or that there will not be any major modification in their magnitudes.

(2) Attrition rates by procurement programs were based on the backup study made by the Services for the *Military Manpower Training Report for FY1975*.¹ Assumptions were made that they will be constant through 1985 and that there were no major differentiations in attrition rates between white and minority candidates.

Level of Educational Attainment. (Hypothesis No. 3) The estimation of educational attainment level breakdown for the male population, 16-24 years old, is based on several hypotheses. The most critical are as follows: First, the population enrolled in college (by year of college) and not enrolled (by level of educational attainment) was based on data collected in October 1973² and projected forward, assuming that minority behaviors with regard to educational attainment will stay constant through 1985. The same assumption was made to estimate High School dropouts and High School graduates enrolling in college. These assumptions entail a slight underestimation of the number of minority High School graduates and a slight overestimation of minority High School graduates going to college, since High School graduation is increasing and college enrollment is decreasing proportionately among minority groups.³

Simulation Runs

Three applications of the Army simulation model have been designed. The first application projects racial composition of the officer force from 1978 through 1985, based upon maximum possible minority accession. In this application minority accessions are related to numbers of available minority personnel in the pools in such a way that every possible minority candidate, qualified mentally and physically and favorable toward entering the Army, is introduced into a procurement program. This provides the upper limits of the racial composition in the Army Officer Corps and shows that however minority representation is defined, the system is capable of producing enough minority men to meet the standard implied by that definition. This first application is called the Saturated projection.

The second application is divided into two parts. The first part takes the actual officer composition of the Army and projects the force as the system is now. This projection is called the Actual projection. The second part consists of taking the Army AAP enrollment and accession goals by year to see whether these specific goals could possibly be met.

The third application takes the overall Army goals for minority representation in 1985 and reverses the model to produce the accessions required from 1978. This gives the racial accession composition necessary to meet the CY1985 Army goals. It is called the Reversed projection. The results of the Reversed projection, when compared to the Actual projection, will indicate the necessary operational steps by year and by sources of procurement, to reach the overall AAP goals.

¹Department of Defense, *Military Manpower Training Report for FY1975*, March 1974.

²U.S. Bureau of the Census. "Social and Economic Characteristics of Students. October 1973," *Current Population Reports*, Series P-20, No. 272, U.S. Government Printing Office, Washington, 1974.

³See *Employment of High School Graduates and Dropouts*, October 1973 Special Labor Force Report 168, U.S. Department of Labor, Bureau of Labor Statistics, 1974.

For the first two applications of the Army model, bounds of the Army officers pools are delimited, first, to men who are qualified, physically and mentally,¹ and second, to those who are either favorable to enter the Army or would seriously consider entering the Army.² These latter variables delineate upper and lower limits between which the future racial officer composition of the Army might fluctuate, depending upon exterior factors, such as economic and/or political conditions. Projections based on pools of candidates who say they might enter the Army are called Favorable, and projections based on pools of candidates who say they would consider entering the Army are termed Least Favorable.

The primary differences between the Favorable and the Least Favorable simulation models consist of a severe diminution of the available pool size. This is, of course, reflected in the officer accession numbers and in the officer force size by year. Because there are no other major differences between the Favorable projection and the Least Favorable projection, the results of the Least Favorable are not presented in as much detail as the Favorable projection results. In the following, each of the applications described will be utilized to respond to specific problems.

The first application will demonstrate that the Army is capable of reaching whatever minority officer end strength goal is defined. The second application will indicate what level of minority representation end strengths and accessions the Army will probably reach in 1978, determine whether the Army yearly commissioning and enrollment goals are consistent with the CY1985 end strength goal of the Affirmative Action Plan, and ascertain whether the preceding commissioning and enrollment goals are feasible with regard to the availability of minority pools. The third application will specify the minimum number of enrollees in particular procurement programs, and the minority accessions needed in order to meet the overall AAP goals by 1985.

First Application: Saturated Projection (Tables 39a, 39b). The Saturated projection demonstrates the Army capability of reaching any minority representation goals. Despite the fiction of the Saturated simulation model, it reveals that a sufficient number of minority young men, qualified both mentally and physically, exist in the general population who could be drawn into specific officer commissioning programs (Tables 39a, b).

Two Saturated projections have been made: one Favorable projection and the other Least Favorable. The level of the officer minority end strength and the level of the total force vary following the two types of projections as just seen. In consequence, Army minority officer representation could be between almost half and a little over a quarter the size of the officer corps in 1985.

However, in projecting this level of minority representation, two important observations should be made. First, the upper limit of minority representation requires the officer force size to enlarge gradually by 1979 to a level 2.9% above the FY1979

¹This estimation is based on Bernard D. Karpinos, "Applicants for Enlistment. Result of Examination for Military Service," HumRRO Special Report SR-ED-75-5, April 1975.

²The data for these estimations come from *Attitudes and Motivation Toward Enlistment in the U.S. Army*, conducted for N.W. Ayer and Son, Inc., and the U.S. Army, Opinion Research Corporation, Princeton, N.J., April 1974. The objectives of the study were to (a) measure the attitudes, motivations and plans of young men (17-21 years old) with respect to military service in general, enlistment in the Army in particular, and (b) identify that group of young men who may be considered to be quality prospects for the Army and measure their attitudes and motivation toward enlistment. The interviews were conducted during the period November 30, 1973 to January 7, 1974 on non-college young men (17-21 years old, not attending college full time) and on college young men (19-21 years old, attending a junior college or senior college).

Table 39b
Projected Accession and End Strength,
First Application: "Saturated Least Favorable" Projection

Source	1979			1980			1981			1982		
	White	Black	Total Minority	White	Black	Total Minority	White	Black	Total Minority	White	Black	Total Minority
Academy												
No.	726	51	819	468	371	479	456	364	464	460	362	461
%	88.6	6.2	100.0	49.4	39.2	100.0	49.6	39.6	100.0	49.9	39.3	100.0
ROTC												
No.	1850	649	2669	2046	523	2769	2046	532	619	2062	538	685
%	69.3	24.3	100.0	75.5	19.3	100.0	75.1	19.5	100.0	75.1	19.6	100.0
Physicians and Dentists												
No.	64	8	76	60	7	71	60	7	71	60	8	72
%	84.2	10.5	100.0	84.5	9.9	100.0	84.5	9.9	100.0	83.3	11.1	100.0
AAP%		12.4	4.0									
OCS												
No.	0	858	1001	0	858	1001	0	858	1001	0	858	1001
%		85.7	100.0		85.7	100.0		85.7	100.0		85.7	100.0
"Other"												
No.	106	12	142	100	13	119	100	13	119	100	12	118
%	74.6	8.4	100.0	84.0	10.9	100.0	84.0	10.9	100.0	84.0	10.9	100.0
AAP%		12.4	4.0									
Total												
No.	2746	1578	388	2674	1772	401	2662	1774	400	2682	1778	399
%	58.3	33.5	100.0	55.2	36.6	100.0	55.0	36.7	100.0	55.2	36.6	100.0
Total End Strength												
No.	62335	6993	2023	57638	8185	2238	52949	9261	1419	49506	10238	2574
%	87.4	9.8	100.0	84.7	12.0	100.0	81.9	14.3	100.0	79.4	16.4	100.0
AAP%												
Projected Force												
No.			78,015			75,442			75,442			75,442
Ratio ^b			91.5			90.2			85.7			82.6

^a"Other" includes Spanish accessions.

^bRatio: Total End Strength
Projected Force

Source	1983			1984			1985					
	White	Black	"Other"	White	Black	"Other"	White	Black	"Other"	Total	Minority	Total
Academy												
No.	459	361	101	460	358	102	460	358	102	460	460	920
%	49.8	39.2	11.0	50.0	38.9	11.1	50.0	38.9	11.1	50.0	50.0	100.0
ROTC												
No.	2060	543	151	2029	539	153	692	539	153	692	692	2660
%	74.8	19.7	5.5	74.6	19.8	5.6	25.4	100.0	74.0	20.3	5.7	26.0
Physicians and Dentists												
No.	60	8	4	64	8	4	12	8	4	12	12	76
%	83.3	11.1	5.6	84.2	10.5	5.3	15.8	100.0	84.2	10.5	5.3	15.8
AAP%												
OCS												
No.	0	858	143	0	858	143	1001	1001	0	858	143	1001
%		85.7	14.3		85.7	14.3	100.0	100.0		85.7	14.3	100.0
"Other"												
No.	100	12	6	106	12	6	18	12	106	12	6	124
%	84.7	10.2	5.0	85.5	9.7	4.8	14.5	100.0	85.5	9.7	4.8	14.5
AAP%												
Total												
No.	2679	1782	405	2659	1775	408	2183	4842	2598	1775	408	2183
%	55.0	36.6	8.3	54.9	36.7	8.4	45.1	100.0	54.3	37.1	8.6	45.7
Total End Strength												
No.	46895	11032	2732	44619	11730	2876	14606	59225	42589	12324	3002	15326
%	77.3	18.2	4.5	75.3	19.8	4.9	24.7	100.0	73.5	21.3	5.0	26.3
AAP%												
Projected Force												
No.			75,442			75,442						75,442
Ratio			80.4			78.5						76.8

projected force, and by 1985 to 5.6% above the projected force,¹ while the lower limit of minority representation requires force sizes which are smaller than those projected for 1978 through 1985. Second, whichever pool is used, two important sources of procurement will fall short of officer accessions for both white and minority. They are Physicians and Dentists Direct Appointment, and "Other" Direct Appointment which regroups accessions for the Judge Advocate General Corps (JAG), the Veterinary Corps, the Army Specialist Corps, and the Chaplain Corps.

Both sources of procurement recruit candidates from Bachelor's degree or first professional degree pools. The sizes of the pools, though reasonably large, are drastically reduced when limited to the Bachelor's and the first professional graduates who are either favorable or would seriously consider entering the Army.² Because of this reduction in these highly qualified pools, even in the most Favorable Projection Physicians and Dentist accessions attain only 79% of the annual need, which is based upon 1972-1974 accession data.³ The size of the Physicians and Dental Corps, both white and minority, then reaches a little over half of their need in 1978, and just 61% in 1985, presuming that the need stabilizes at the level of 1978.⁴

The Least Favorable Projection generates dramatically low figures not only for Physician and Dentist accessions and end strengths in particular, but for the other sources of procurement as well. Physician and Dentist accession in this case cannot be higher than 5.0% of the Army need, and the Medical and Dental Corps attain a mere 9% of the medical force needed in 1985, assuming that the need stays equal through 1985. This is a crucial problem, even if the estimation of the considered pools is fairly conservative.

Second Application (Tables 40-45). The second application is divided into two parts: the Actual Projection and AAP Desired Projection.

(1) Actual Projection. Based on present enrollment and accession rates, and according to the Favorable Projection, the yearly minority end strength will be reached as projected by the Affirmative Actions Plan of the Department of the Army every year through 1985, except for CY1979, which will be 0.5% lower than desired. However, even if the overall minority participation goal is reached, desired minority representation goals will not be achieved (a) at the level of racial composition of Army end strength, and (b) at the level of sources of procurement with respect to both accessions and end strength. Concerning the former shortfall, the gap between "Other" representation in the Actual Projection and Army AAP goals is increasing from 0.1% in FY1976 to 1.6% in 1985. In the case of the latter shortfall, neither the desired number nor the racial percentage goal will be reached for minority physicians and dentists.

The possibility of Army success in meeting these objectives is severely limited by an overall health professional procurement problem. As projected by the Health Personnel All-Volunteer Force Task Force, the Medical and Dental Corps forces

¹ See the first hypothesis, p. 60.

² This reduction is the combination of two factors. The first one is the age of the graduates and the second is the fact that they are college graduates. This explanation of the reduction is obtained from *Attitudes and Motivation Toward Enlistment in the U.S. Army*, which reports that (a) the older you are the less likely you are willing to enter the Army, and (b) the male population enrolled in college is less likely to enter the Army than the male high school graduate population. Though the second factor is given without race differentiation, it seems reasonable that minority Bachelor's and/or first professional degrees follow the same pattern as the general bachelor's and/or first professional degree. Two arguments lend credence to this assumption. First, there is no reason why minority graduates' behaviors should substantially differ from white graduates' behavior, especially in those highly technical professions and, second, the strong market demand for technically trained minority persons reduces the actual minority pool size.

³ MARDAC, Officer Master File.

⁴ Need. 6459, for each year between 1976-78. Figures obtained from *Health Personnel All Volunteer Task Force, Phase II Report*, October 1973. No racial breakdown is available.

for FY1977 and FY1978 will reach only 54% of its required level.¹ Assuming that the requirement for medical and dental corps force sizes will remain stable through 1985, the corresponding projected force will reach, at best, 66% of its level in 1985. The "Other" sources of procurement goals which regroup—Judge Advocate General Corps (JAG), Veterinary Corps (VC), Army Specialist Corps, and Chaplain Corps—are never met and are so far from the goal that it seems unreasonable to think that they will ever be reached.

An important point which should be stressed is that in order to meet the preceding overall minority participation goals, the officer force size has to be a little larger than the desired end strength force projected by the Army.² The total officer force size must be increased by 2 to 3% over the desired force. This necessary increase is reflected in Tables 40a and 40b. In order to meet the overall minority percentage projected by the Actual Favorable simulation model—that is, 15.5% minority officers in 1985—Table 40a, indicates needed yearly accession by sources of procurement and racial mix.³

Table 41 discloses the necessary input in three specific officer procurement programs (viz., USMA, ROTC, and OCS) in order to meet the preceding racial mix in accessions. Input numbers for USMA and ROTC refer to the first year of either program. Inputs in these programs are reflected as accessions four years later, while OCS input figures are reflected as accessions during the same year. Attrition rates of each program are, of course, taken into account. For example, in order to arrive at the specific racial breakdown of Academy officer accession for 1980—820 Whites, 51 Blacks, and 51 "Others" (Table 40)—it is necessary to enroll 1246 Whites, 87 Blacks, and 76 "Others" as freshmen in West Point in FY1976 (Table 41), while in order to commission 993 officers from OCS in 1981, 1439 are needed as input into the OCS program during 1981.

(2) AAP Desired Projection. Two major points have been demonstrated in the preceding section. First, the Army can reach any kind of minority force representation defined, though the desired racial mix among minority officers and sources of procurement described in the AAP will not be met. Second, based on the current procurement program enrollments until 1978 and thereafter on constant 1978 accession rates, the overall Army AAP minority officer end strength goals will be attained. Now it will be illustrated that by CY1985 the Army Affirmative Actions Plan produces minority force proportionally much larger than is needed to meet AAP end strength minority goals.

To do this the AAP minority accession goals (Table 29) are used as an input into the Desired projection simulation model. The result is a 1985 minority officer projected end strength which overshoots the AAP overall minority goals, but still does not produce the desired racial mix in the officer force stated in the AAP. Following AAP enrollment and accession goals, 1985 minority officer strength will be comprised of 13.3% black officers and 4.5% of "Other" minority officers, instead of 10.0% black and 5.0% "Other" minority officers as contemplated by AAP end strength goals. The numbers of accessions needed to follow the AAP minority accession goals, year by year, are

¹ *Ibid.*

² FY1980 Army End Strength projection given by the Army, for the assumptions on the officer force size between FY1980 and FY1985 see the first hypothesis, p. 60.

³ As a sample, Graph 7, "Total Army Minority Officer Force FY 1978" gives the size of the Army Minority Officer Force by source of procurement and length of service. Graphs of this type are available for each fiscal year for the *Actual Favorable* and *Least Favorable* Projections of the Second Application. Detailed tables by race, length of service, and source of procurement are available for the first two applications by fiscal year.

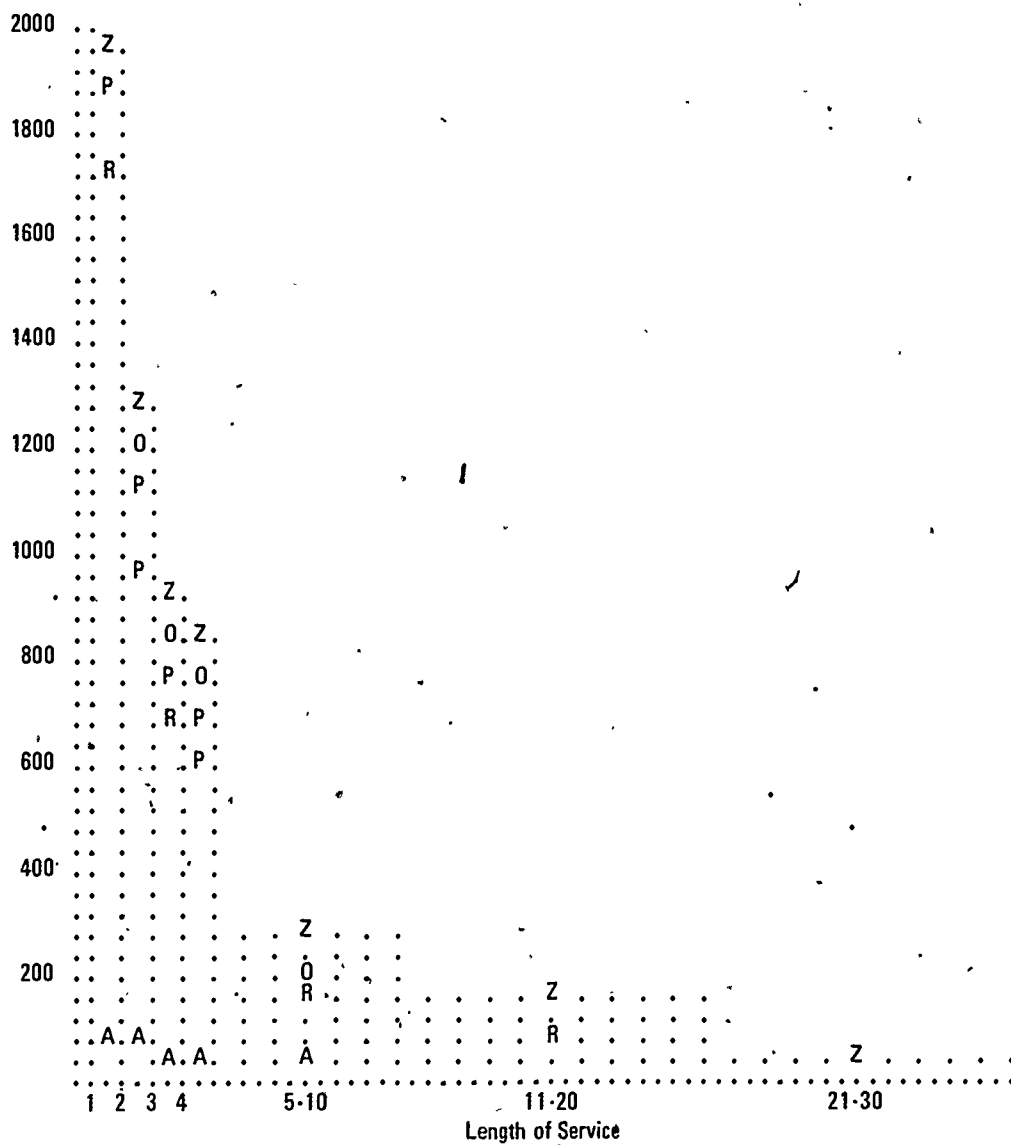

Source of Procurement Codes:

- A = Academy
- R = ROTC
- P = Health Professionals
- O = OCS
- V = Aviation Training
- Z = Other source or unknown

Graph 7: Total Army Minority Officer Force, FY1978

Table 40b (Continued)

Source	1980			1981			1982			1983		
	White	Black	Total "Other" Minority Total	White	Black	Total "Other" Minority Total	White	Black	Total "Other" Minority Total	White	Black	Total "Other" Minority Total
Academy No.	820	51	102	820	51	102	820	51	102	820	51	102
%	88.9	5.5	11.1	88.9	5.5	11.1	88.9	5.5	11.1	88.9	5.5	11.1
ROTC No.	1908	640	800	1908	640	805	1925	655	820	1923	660	830
%	70.5	23.5	29.5	70.3	23.6	29.7	70.1	23.4	29.9	69.9	24.0	30.1
Physicians and Dentists No.	60	7	4	60	7	4	60	8	4	60	8	4
%	84.5	9.9	5.6	84.5	9.9	5.6	84.5	9.9	5.6	83.3	11.1	5.5
AAAP												
OCS No.	914	75	12	914	75	12	905	75	12	905	75	12
%	91.4	7.4	1.2	91.4	7.4	1.2	91.4	7.4	1.2	91.2	7.6	1.2
"Other" No.	100	13	5	100	13	3	100	12	3	100	12	2
%	84.7	11.0	4.2	86.2	11.2	2.6	86.2	11.2	2.6	87.7	10.5	1.8
AAAP												
Total No.	3802	786	232	3802	786	235	3810	801	235	3808	806	239
%	78.9	16.3	4.8	78.8	16.3	4.9	78.6	16.5	5.3	78.4	16.6	4.9
Total End Strength No.	59660	6439	1919	56012	6560	1935	53231	6674	1959	51115	6833	2010
%	87.7	9.5	2.8	86.8	10.2	3.0	86.0	10.8	3.2	85.2	11.4	3.4
AAAP												
Projected Force No.			75,442			75,442			75,442			75,442
Ratio			90.2			85.5			82.0			79.5

Table 41

Input Needed in Officer Procurement Programs:^a Actual Favorable Projection

	Academy					ROTC ^b					OCS ^c										
	White	Spanish	Black	Other	Total	White	Spanish	Black	Other	Total	White	Spanish	Black	Other	Total	White	Spanish	Black	Other	Total	
1976	1246	41	87	35	163	1409	10417	683	3570	188	4441	14858	1324	0	109	17	126	0	0	0	1450
1977	1246	41	87	35	163	1409	"	"	"	"	"	1328	0	0	109	17	126	0	0	0	1451
1978	1248	41	87	35	163	1409	"	"	"	"	"	"	0	0	0	0	0	0	0	0	0
1979	"	"	"	"	"	"	"	"	"	"	"	"	0	0	0	0	0	0	0	0	0
1980	"	"	"	"	"	"	"	"	"	"	"	"	0	0	0	0	0	0	0	0	0
1981	"	"	"	"	"	"	"	"	"	"	"	"	0	0	0	0	0	0	0	0	0
1982	"	"	"	"	"	"	"	"	"	"	"	1315	0	0	107	17	124	0	0	0	1439
1983	"	"	"	"	"	"	"	"	"	"	"	861	0	71	12	83	0	0	0	0	944
1984	"	"	"	"	"	"	"	"	"	"	"	513	0	42	7	49	0	0	0	0	562
1985	"	"	"	"	"	"	"	"	"	"	"	514	0	48	7	55	0	0	0	0	569
												650	0	54	9	63	0	0	0	0	713

^aAcademy and ROTC are 4-year programs while OCS is a 5-week program.

^bAcademy and ROTC accession rates are assumed to be constant through 1985, on the level of 1978; therefore, enrollments numbers are constant for both programs.

^cThe OCS program is used as a filler program, limited to 1000 accessions per year.

presented in Table 42. Compared to the accessions projected by the Actual Favorable model, it appears that the Army will have some difficulties meeting the AAP enrollment and accession goals because the particular pools from which candidates might be drawn into the corresponding officer procurement programs are not large enough, especially for physicians and dentists (Table 43) and 'other' sources of procurement. Table 44 compares the level of both Actual Favorable and AAP projected accessions. Table 45 provides the minority and white input in three specific officer procurement programs required to meet the AAP goals.

Third Application: Reversed Projection (Table 46). The first application, Saturated projection, was based on a fictitious hypothesis, viz., that every possible candidate, qualified mentally and physically, and willing to enter the Army does enroll in one or another officer procurement program. The second application, Actual projection, was just the projection of the present model of sources of procurement. The third application, Reversed projection, is entirely theoretical. However it does bring two major points. First, it gives the minimum number of white and minority yearly officer accessions, in terms of the total number and sources of procurement. Second, it reinforces the results projected by the Actual Favorable model presented as the second application of the Army simulation model of the officer sources of procurement.

The Reversed projection has been designed as follows. First, it takes the officer force size, estimated following Hypothesis No. 1,¹ and utilizes the overall AAP minority officer end strength goals to structure the 1985 end force strength as desired by the AAP. Second, it takes the FY1978 officer force size projected by the Actual Favorable projection as an arrival point. Third, it reverses the model between these two given years and displays, year by year, the racial accession as a total number and by sources of procurement.² Table 45 presents the minority accessions needed to achieve the overall minority participation goal for the officer corps by 1985—10.0% Blacks and 5.0% "Others". As seen in Table 46, the total minority accession projected by the Reversed model is very similar to the total minority accession projected by the Actual Favorable model, which is based on the available manpower pools. The Reversed projection is thus a proof of the cogency of the Actual Favorable projection as a plan for meeting the AAP overall minority officer representation goals.

Conclusion

From the preceding analysis the following conclusions may be drawn.

First, the Army minority officer end strength can be at almost any level the Department of the Army chooses, with one major reservation. This reservation is that the desired racial accession mixture and procurement source strength cannot be met.

Second, the AAP minority procurement program enrollment and accession goals will exceed the CY1985 overall minority objectives, but still not attain the desired racial mix among minority officers. It will encounter serious problems in its execution, especially in meeting "direct" sources of procurement goals, both physicians and dentists, and other "direct" sources of procurement which include JAG, VC, Army Specialists Corps, and Chaplains Corps.

Third, based on current enrollment figures in officer procurement programs until 1978 and on constant 1978 accession rates and racial mix, the minority force projected arrives at the desired AAP overall minority goals. However, the racial mix among

¹ See p. 60.

² Officer procurement program accession rates for each race were assumed to be equal to the total racial accession rates within a given year.

Table 42
Projected Accession and End Strength,
Second Application: AAP "Desired" Projection

Source	1979			1980			1981			1982		
	White	Black	"Other" ^a Minority Total	White	Black	"Other" ^a Minority Total	White	Black	"Other" ^a Minority Total	White	Black	"Other" ^a Minority Total
Academy												
No.	1042	84	72	532	43	37	80	612	893	72	62	134
%	87.0	7.0	6.0	86.9	7.0	6.0	13.1	100.0	87.0	7.0	6.0	13.1
ROTC												
No.	3642	923	291	1860	471	149	620	2480	3121	791	250	1041
%	75.0	19.0	6.0	75.0	19.0	6.0	25.0	100.0	75.0	19.0	6.0	25.0
Physicians and Dentists												
No.	1760	251	84	899	128	43	171	1070	1508	215	72	287
%	84.0	12.0	4.0	84.0	12.0	4.0	16.0	100.0	84.0	12.0	4.0	16.0
AAP%	12.0	4.0	4.0									
OCS												
No.	372	86	19	190	44	10	54	243	319	74	16	90
%	78.0	18.0	4.0	78.1	18.1	4.1	22.2	100.0	78.0	18.1	3.9	22.0
"Other"												
No.	2058	294	98	1050	150	50	200	1250	1763	251	83	334
%	84.0	12.0	4.0	84.0	12.0	4.0	16.0	100.0	84.1	12.0	4.0	16.0
AAP%												
Total												
No.	8674	1638	564	4531	836	289	1125	5655	7604	1403	483	1886
%	80.1	14.8	5.1	80.1	14.8	5.1	19.9	100.0	80.1	14.8	5.1	19.9
Total End Strength												
No.	68463	7053	2473	65552	7325	2542	9867	75418	64733	7956	2742	10698
%	87.8	9.0	3.1	86.9	9.7	3.4	13.1	100.0	85.8	10.6	3.6	14.2
AAP%	8.0	4.0	4.0									
Projected Force												
No.			78,015									
Ratio ^b			99.9									
			75,442									
			99.9									
			75,442									
			99.9									

^a"Other" includes Spanish accessions.

^bRatio: Total End Strength / Projected Force

Table 43

**AAP "Desired" and "Actual Favorable" Accession Projections for
Physicians and Dentists, and "Other" Sources of Procurement**

Year	Physicians and Dentists				"Other" Sources of Procurement ^a			
	White		Minority		White		Minority	
	AAP	"Actual Favorable"	AAP	"Actual Favorable"	AAP	"Actual Favorable"	AAP	"Actual Favorable"
1979	1760	935	335	173	2058	1221	307	20
1980	889	924	171	179	1050	1058	250	44
1981	1508	909	287	175	1763	1521	331	86
1982	1508	900	287	176	1763	1500	334	81
1983	1405	895	268	176	1643	1485	312	77
1984	1417	958	270	195	1656	1582	314	80
1985	1409	945	309	192	1647	1555	361	80

^aJAG, VC, Army Specialists Corps, and Chaplains Corps.

Source: AAP "Desired" and "Actual Favorable" projections.

Table 44

Additional Minority Accession Needed Between AAP "Desired" Projection and the "Actual Favorable" Projection

Source of Procurement	1979			1980			1981			1982			1983			1984			1985		
	1	2	3	1	2	3	1	2	3	1	2	3	1	2	3	1	2	3	1	2	3
Academy	156	93	63	80	102	-22	134	102	32	134	102	32	124	102	22	125	102	23	128	102	26
ROTC	1214	1083	131	620	1106	-486	1041	1106	65	1040	1106	-66	970	1106	-136	978	1106	-128	996	1106	-10
Physicians and Dentists	335	173	162	171	179	-8	287	175	112	287	176	111	268	176	92	270	195	75	309	192	117
OCS	105	0	105	54	0	54	90	86	4	90	57	33	84	34	50	84	38	46	86	43	43
"Other" ^a	392	20	372	200	44	156	334	86	248	334	81	253	312	77	235	314	80	234	361	80	281
Total	2202	1369	833	1125	1431	-306	1886	1555	331	1885	1522	363	1757	1495	262	1771	1521	250	1880	1523	357

^a"Other" source of procurement: JAG, VC, Army Specialists Corps, and Chaplains Corps.

Legend: 1-AAP "Desired" Projection
2-"Favorable" Projection
3-Desired minus Favorable

Table 45

Input Needed in Officer Procurement Programs (AAP Goals)

Year	Academy			ROTC			OCS		
	White	Black	Total ^a "Other" ^a Minority	White	Black	Total "Other" ^a Minority	White	Black	Total "Other" ^a Minority
1976	809	65	56	7221	1892	598	2478	9699	
1977	1358	109	75	8727	3174	1004	4178	12905	
1978	1398	109	94	12531	3173	1004	4177	16708	
1979	1265	102	87	11679	2960	935	3895	15574	691
1980	1274	102	88	11775	2984	944	3928	15703	152
1981	1298	105	90	11996	3040	960	4000	15996	79
1982									130
1983									130
1984									122
1985									122
									125
									567

^a"Other"--Spanish candidates are included here.

Source: "Affirmative Actions Plan" (draft), Department of the Army.

Enrollment goals in officer procurement programs and accession goals.

Table 46

Accessions Needed to Reach 10% Black Officers and 5% "Other" Minority Officers in 1985, "Reversed" Projection

Year	Academy			ROTC			OCS			Physicians and Dentists			"Other" b			Total								
	White	Black	"Other" c	White	Black	"Other"	White	Black	"Other"	White	Black	"Other"	White	Black	"Other"	White	Black	"Other"						
1985	646	104	64	2621	423	262	3306	257	41	25	323	1131	182	113	1426	1316	212	132	1660	5971	962	596	7529	
1984	651	101	62	2642	413	251	3306	259	40	24	323	1140	178	108	1426	1327	207	126	1660	6019	939	571	7529	
1983	656	99	59	2663	402	240	3305	261	39	23	323	1149	173	103	1425	1337	202	121	1660	6066	915	546	7527	
1982	661	96	56	2684	392	229	3305	263	38	22	323	1158	169	99	1426	1348	197	115	1660	6114	892	521	7527	
1981	666	94	54	2704	381	219	3304	265	37	21	323	1167	164	94	1425	1358	191	110	1659	6160	867	498	7525	
1980	671	91	51	2725	371	208	3304	267	36	20	323	1175	160	89	1424	1368	186	104	1658	6206	844	472	7522	
1979	700	92	50	2839	373	204	3416	278	36	20	324	1225	161	88	1424	1426	187	102	1715	6468	849	464	7781	

^aSpanish accessions are included in "Other".

^b"Other" source of procurement includes: JAG, VC, Army Specialists Corps, and Chaplains Corps.

minority officers is still not met, and medical and dental and other accessions are still very low.

Finally, perhaps the most important finding of this study is that in the Actual Favorable case it will not be very difficult to reach the CY1985 AAP goals of 15.0% of minority officer representation in the Army Officer Corps. The accessions needed to reach these goals, which are presented in Table 40a, not only allow minority officer representation to reach this point but also allow the officer force size to reach approximately the force size for 1985 projected by the Army.¹

¹The force size is projected by the Army by year until 1980, thereafter projected as level.

REFERENCES

- Brehm, William K. Statement of Assistant Secretary of Defense (Manpower and Reserve Affairs) Before the Senate Armed Forces Committee, February 24, 1975.
- Department of Defense. *Military Manpower Training Report for FY1976*, March 1975.
- Department of Defense. *Military Manpower Training Report for FY1975*, March 1974.
- Department of Defense, Office of the Assistant Secretary of Defense (Health and Environment), *Health Personnel All Volunteer Task Force, Phase II Report*, October 1973.
- Karpinos, Bernard D. "Applicants for Enlistment: Result of Examination for Military Service," HumRRO Special Report SR-ED-75-5, April 1975.
- Opinion Research Corporation. *Attitudes and Motivation Toward Enlistment in the U.S. Army*, Opinion Research Corporation, Princeton, New Jersey, April 1974.
- Schlesinger, James R., Secretary of Defense. *Annual Defense Department Report, FY1976 and FY1977*, Department of Defense, Washington, 1974.
- U.S. Bureau of the Census. "Social and Economic Characteristics of Students: October, 1973," *Current Population Reports*, Series P-20, No. 272, U.S. Government Printing Office, Washington, 1974.
- U.S. Bureau of the Census. "Persons of Spanish Origin," *Census of Population: 1970*, Subject Reports, Final Report PC(2)-1C, U.S. Government Printing Office, Washington, 1973.
- U.S. Department of the Army. "Affirmative Actions Plan" (draft), 1975.
- U.S. Department of Labor, Bureau of Labor Statistics. *Employment of High School Graduates and Dropouts, October 1973*, Special Labor Force Report 168, 1974.
- U.S. Department of the Navy. *Navy Equal Opportunity Program*, December 1973.

BIBLIOGRAPHY

- Frankel, Martin M. and Beamer, J. Fred. *Projection of Educational Statistics to 1982-83*, DHEW Publication No. (OE)74-11105, Office of Education, National Center for Educational Statistics, U.S. Government Printing Office, 1974.
- U.S. Bureau of the Census. "Social and Economic Characteristics of Students: October 1974," *Current Population Reports*, Series P-20, No. 278, School Enrollment, U.S. Government Printing Office, Washington, February 1975.
- U.S. Bureau of the Census. "Projections of the Population of the United States by Age and by Sex, 1975-2000 With Extensions of Total Population to 2025" (Advance Report), *Current Population Reports*, Series P-25, No. 541, Population Estimates and Projections, U.S. Government Printing Office, Washington, February 1975.
- U.S. Bureau of the Census. "Population of the United States, Trends and Prospects: 1950-1990," *Current Population Reports*, Series P-23, No. 49, Special Studies, U.S. Government Printing Office, Washington, May 1974.
- U.S. Bureau of the Census. "Estimates of the Population of the United States, by Age, Sex, and Race: July 1, 1974 and April 1, 1970," *Current Population Reports*, Series P-25, No. 529, Population Estimates and Projections, U.S. Government Printing Office, Washington, September 1974.
- U.S. Bureau of the Census. "Educational Attainment in the United States: March 1973 and 1974," *Current Population Reports*, Series P-20, No. 274, Population Characteristics, U.S. Government Printing Office, Washington, 1974.
- U.S. Bureau of the Census. *Census of Population: 1970, Volume I, Characteristics of Population*, U.S. Government Printing Office, Washington, 1973.
- U.S. Bureau of the Census. "Projections of School and College Enrollment: 1971-2000," *Current Population Reports*, Series P-25, No. 473, Population Estimates and Projections, U.S. Government Printing Office, Washington, January 1972.
- U.S. Bureau of the Census. "Projection of the Population of the United States, by Age and Sex, 1970-2020," *Current Population Reports*, Series P-25, No. 470, U.S. Government Printing Office, Washington, November 1971.
- U.S. Department of Health, Education, and Welfare. *Racial and Ethnic Enrollment Data From Institutions of Higher Education*, Office for Civil Rights OCR-74-113, Fall 1972.

HUMAN RESOURCES RESEARCH ORGANIZATION

300 North Washington Street • Alexandria, Virginia 22314

President
Executive Vice President
Executive Officer
Vice President & Treasurer

Dr. Meredith P. Crawford
Dr. William A. McClelland
Mr. Saul Lavisky
Mr. Charles W. Smith

RESEARCH DIVISIONS

HumRRO Eastern Division
300 North Washington Street
Alexandria, Virginia 22314

Dr. J. Daniel Lyons
Vice President & Director

HumRRO Central Division
400 Plaza Building
Pace Blvd. at Fairfield Drive
Pensacola, Florida 32505

Dr. Wallace W. Prophet
Vice President & Director

Louisville Research Office
1939 Goldsmith Lane
Louisville, Kentucky 40218

Mr. William C. Osborn
Office Director

Columbus Research Office
Suite 23, 2601 Cross Country Drive
Columbus, Georgia 31906

Dr. Joseph A. Olmstead
Office Director

Pensacola Research Office
400 Plaza Building
Pace Blvd. at Fairfield Drive
Pensacola, Florida 32505

Dr. Paul W. Caro
Office Director

HumRRO Western Division
27857 Berwick Drive
Carmel, California 93921

Dr. Howard H. McFann
Vice President & Director

El Paso Research Office
P.O. Box 6057
Fort Bliss, Texas 79916

Dr. Robert D. Baldwin
Office Director