

DOCUMENT RESUME

ED 116 933

88

SE 019 994

AUTHOR  
TITLE

Mahaffey, Michael L.; McKillip, William D.  
Career Oriented Mathematics, Student's Manual.  
[Includes Scale; Apprenticeship: Learning to be a  
Cement Mason; Textiles; Being Self-Employed:  
Harvesting and Sale of Pulpwood; and Lumber Yard  
Employee.]

INSTITUTION  
SPONS AGENCY

Berrien County Schools, Nashville, Ga.  
Bureau of School Systems (DHEW/OE), Washington, D.C.;  
Georgia State Dept. of Education, Atlanta.

PUB DATE  
NOTE

[75]  
116p.; For the accompanying teacher's manual, see SE  
019 993. Other documents in this series include SE  
019 991 and 992

AVAILABLE FROM

Berrien County Board of Education, Title III, P.O.  
Box 473, Nashville, Georgia 31639 (1-4 copies, \$4.00  
ea., 5-9, \$3.75 ea., 10-30, \$3.50 ea., 31 or more,  
\$3.25 ea., payment must accompany orders; Teacher  
Manual included with order of 30 Student Manuals)

EDRS PRICE  
DESCRIPTORS

MF-\$0.76 HC-\$5.70 Plus Postage  
\*Basic Skills; \*Career Education; Curriculum;  
Education; Geometry; Instruction; \*Instructional  
Materials; \*Mathematical Applications; Mathematics;  
Measurement; Motivation; Secondary Education;  
\*Secondary School Mathematics; Textbooks

IDENTIFIERS

\*Career Oriented Mathematics; Elementary Secondary  
Education Act Title III; ESEA Title III; University  
of Georgia

ABSTRACT

This volume includes student manuals for five units  
in the Career Oriented Mathematics Program, which was developed to  
improve mathematical abilities and attitudes of secondary students by  
presenting the material in a job-relevant context. The units are  
titled: (1) Scale, (2) Apprenticeship: Learning to be a Cement Mason,  
(3) Textiles, (4) Being Self-Employed: Harvesting and Sale of  
Pulpwood, and (5) Lumber Yard Employee. The manuals are consumable,  
most pages containing problems and accompanying diagrams or necessary  
data. The mathematical content of the units is basic computation and  
elementary geometry. (SD)

\*\*\*\*\*  
\* Documents acquired by ERIC include many informal unpublished \*  
\* materials not available from other sources. ERIC makes every effort \*  
\* to obtain the best copy available. Nevertheless, items of marginal \*  
\* reproducibility are often encountered and this affects the quality \*  
\* of the microfiche and hardcopy reproductions ERIC makes available \*  
\* via the ERIC Document Reproduction Service (EDRS). EDRS is not \*  
\* responsible for the quality of the original document. Reproductions \*  
\* supplied by EDRS are the best that can be made from the original. \*  
\*\*\*\*\*

U S DEPARTMENT OF HEALTH,  
EDUCATION & WELFARE  
NATIONAL INSTITUTE OF  
EDUCATION

THIS DOCUMENT HAS BEEN REPRO-  
DUCED EXACTLY AS RECEIVED FROM  
THE PERSON OR ORGANIZATION ORIGIN-  
ATING IT. POINTS OF VIEW OR OPINIONS  
STATED DO NOT NECESSARILY REPRESENT  
OFFICIAL NATIONAL INSTITUTE OF  
EDUCATION POSITION OR POLICY.

ED116933

CAREER ORIENTED

MATHEMATICS

119 994

ERIC  
Full Text Provided by ERIC

208

FOREWORD

This Career Oriented Mathematics Curriculum was prepared through a contractual agreement between the Berrien County Board of Education and Dr. Michael L. Mahaffey and Dr. William D. McKillip of the University of Georgia. Funding for this effort was provided by a grant from the Georgia State Department of Education, ESEA Title III.

Lossie L. Gaskins, Superintendent  
Berrien County Schools

Larry C. Manning, Director  
Title III

CONTENTS

Scale . . . . .	2
Apprenticeship: Learning to Be a Cement Mason . . . . .	25
Textiles . . . . .	54
Being Self-Employed: Harvesting and Sale of Pulpwood . . . . .	67
Lumber Yard Employee . . . . .	90

STUDENT'S MANUAL

SCALE

### General Instruction

There are three units pertaining to measurement; (1) Scale Drawing; (2) Measurement, and (3) Area & Perimetric. These units should be taught in this order to have the best effect. There is an appendix to follow the third unit, it contains optional activities related to measurement and a review assignment dealing with all three units. This assignment can be used in its entirety or in parts as each specific unit is completed. You may wish to use this as a test or review for the measurement lessons.

## 1. Scale

You have heard the term scale used in many different ways. For example, you may have built a "scale model" or made a "scale drawing". What do you think meant when we use the word "scale" in these ways.

One way of thinking about the word scale, is that it is a picture or model that looks exactly like the real object. Only the size may be bigger or smaller. For example in the following figure B is a scale drawing of A. Why?

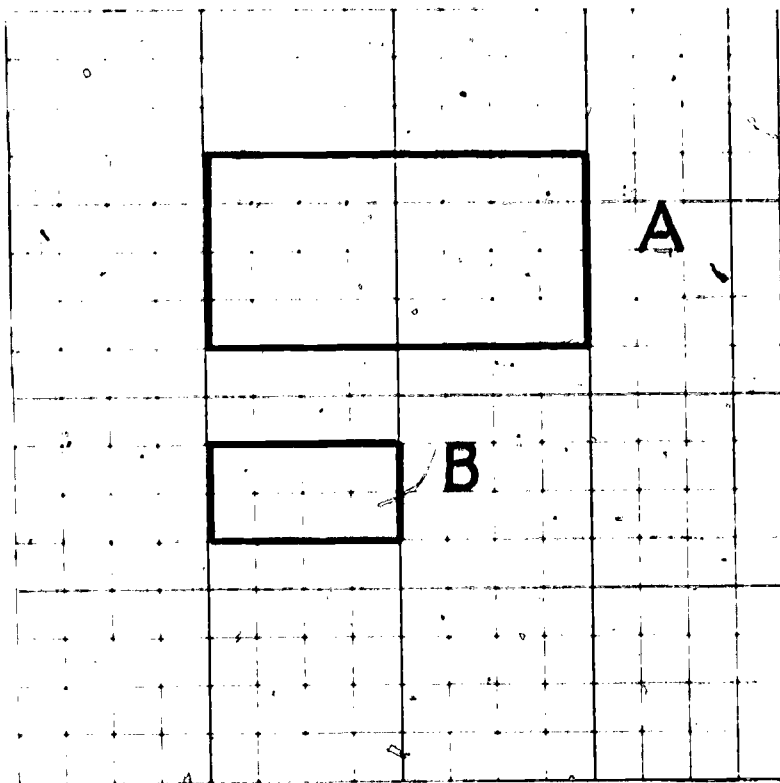

## 2. Determining the Scale

To determine the scale of a model or a drawing is usually fairly easy. All we have to do is find out how the scale figure compares to the original, is it the same size, smaller, or larger. Then we find how much it has changed. Lets take a few examples to make

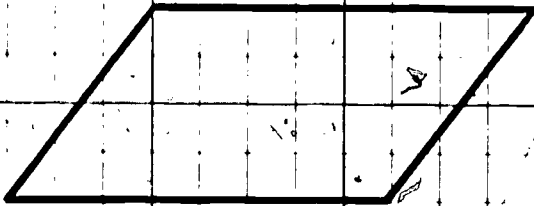
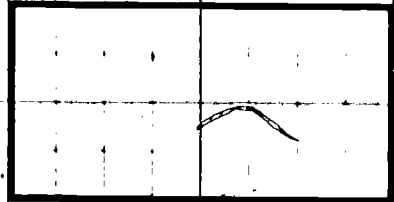
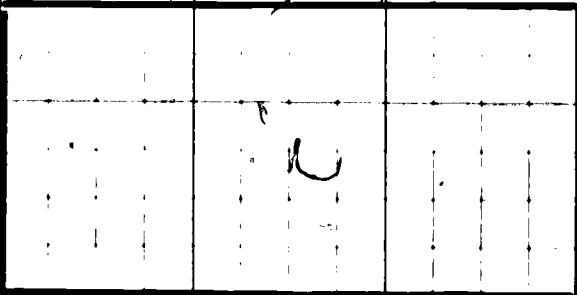
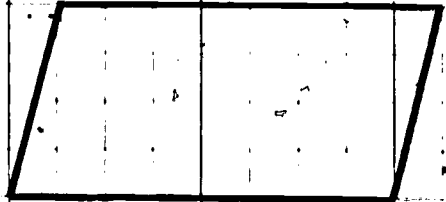
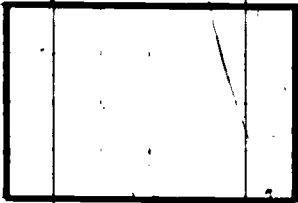
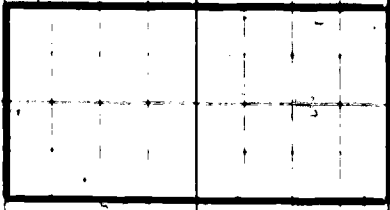

WORKSHEET NUMBER 2

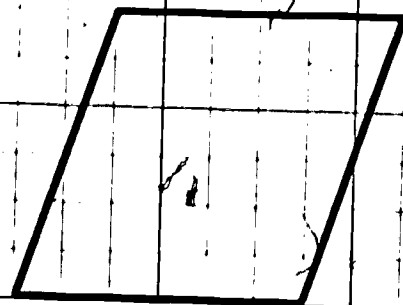
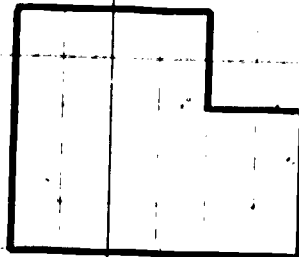
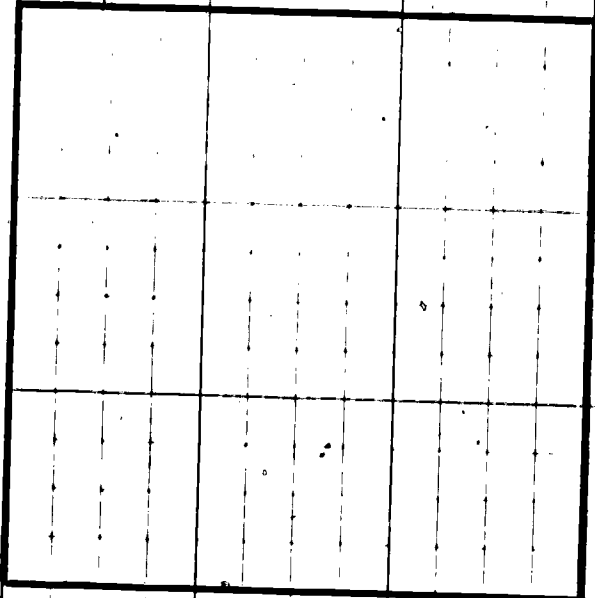
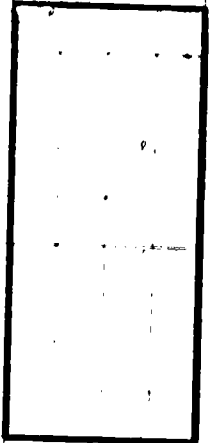
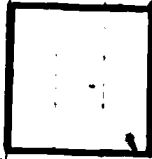
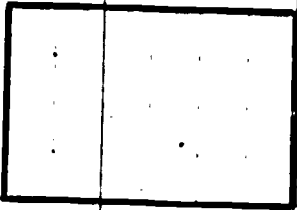



LESSON NUMBER 1

Determine which of the figures below the line are a scale drawing of the figure at the left. Then state what the scale is for these drawings.

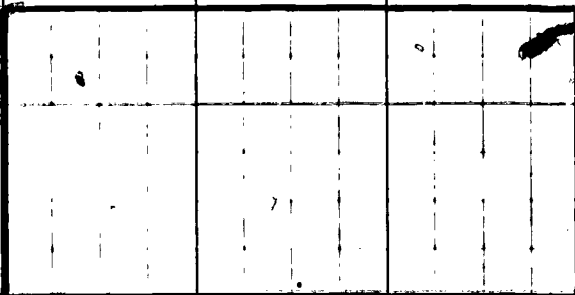
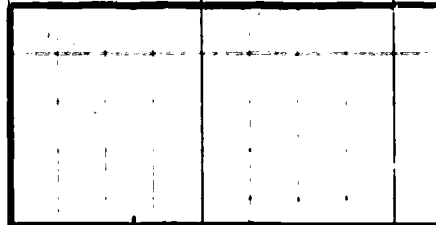
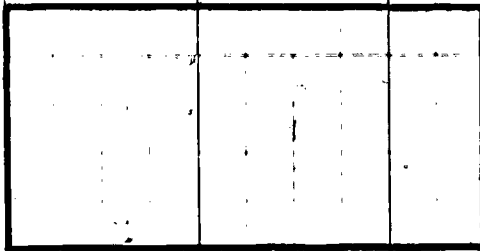
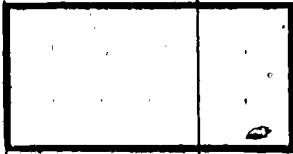

this clear.

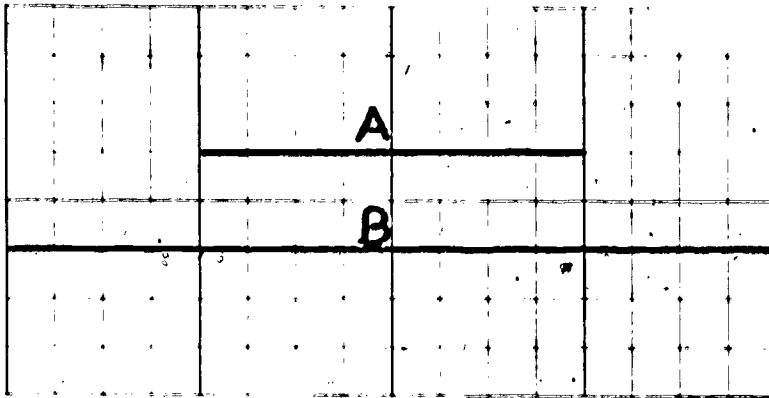

"B" is a scale drawing of "A": Is the scale "larger" or "smaller?" It's larger, of course. "A" 2 units long or we can say that for every "Unit" in "A" there are 2 "units" in "B" or a scale of 1 to 2. Now look at the following:

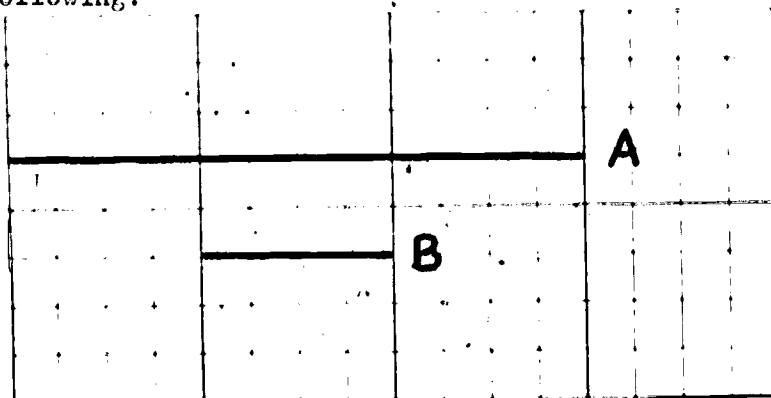

What would you say the scale would be this time? Remember its getting smaller.

Let's go for another example. In the figure that follows "B" is a scale drawing of "A".

What do you think the scale is for this drawing?

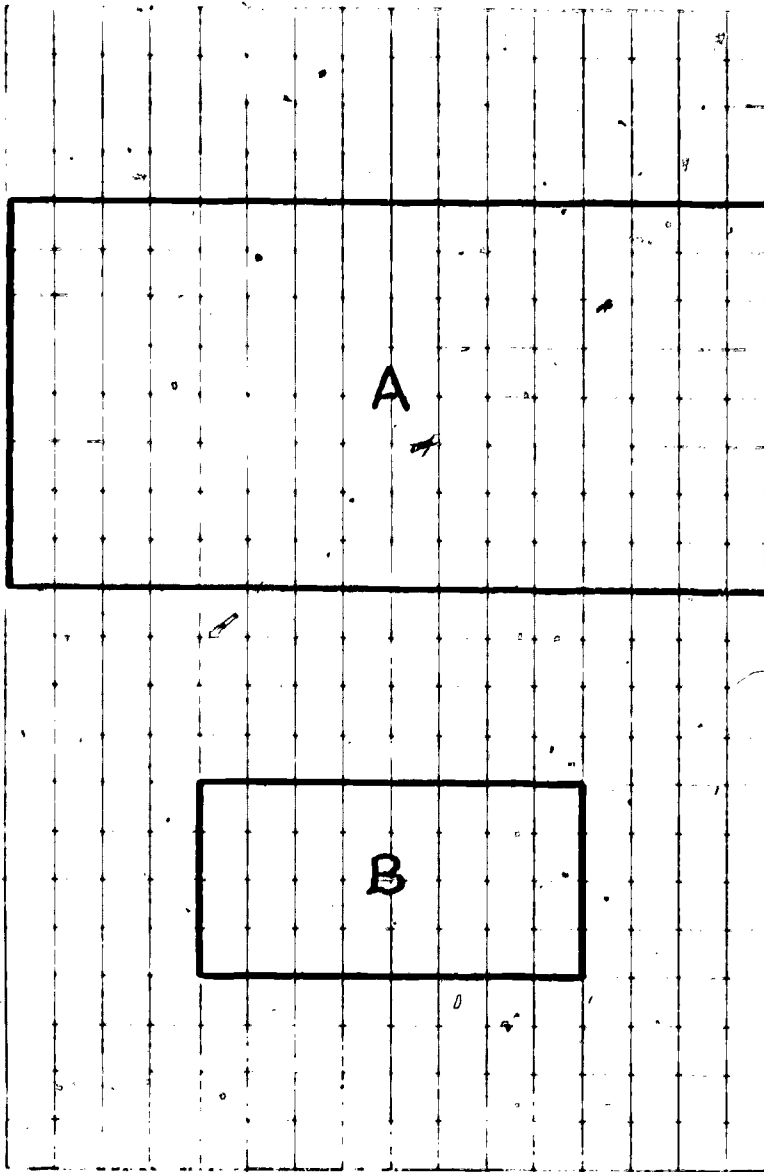

3. Drawing to a given scale.

Class discussion will be used to complete this lesson.

WORKSHEET NUMBER 3

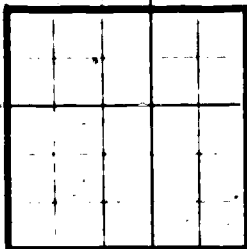
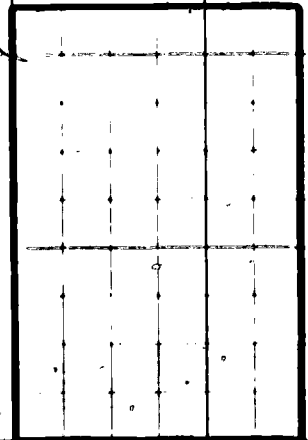
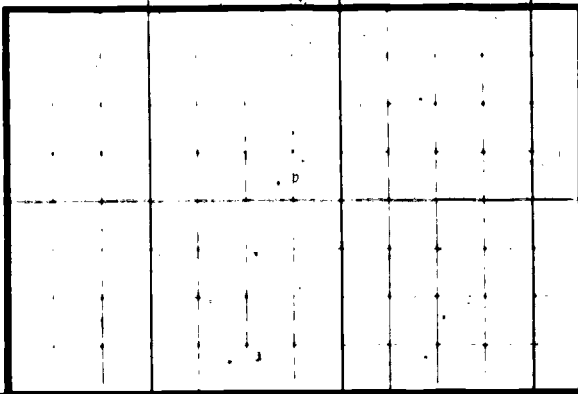
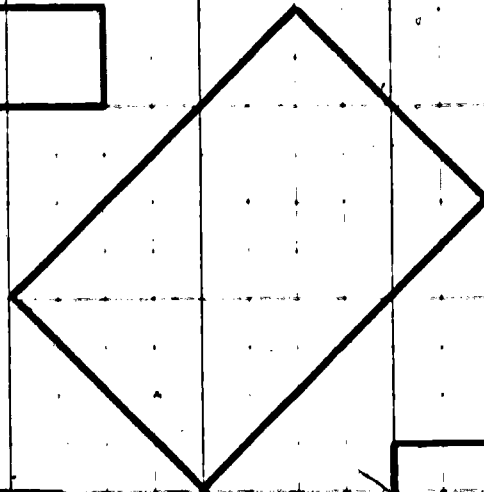
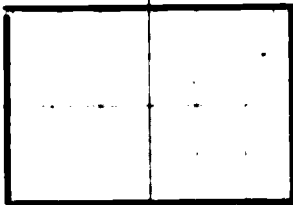
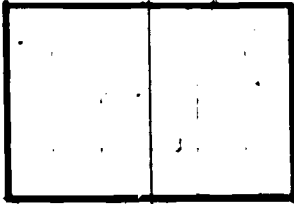

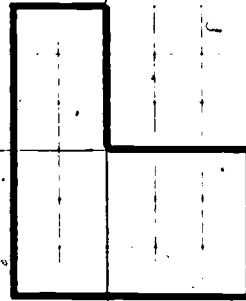
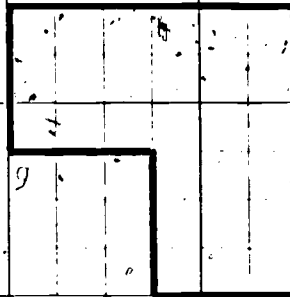
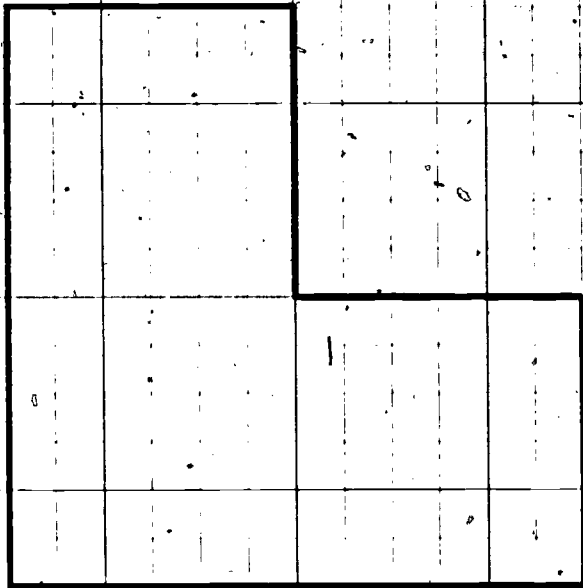
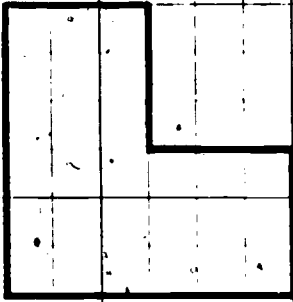

WORKSHEET NUMBER 5

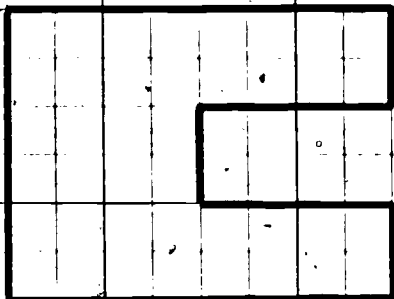

Make copies 1 to 2, 1 to 1,  
1 to 1/2, and 1 to 1 1/2.

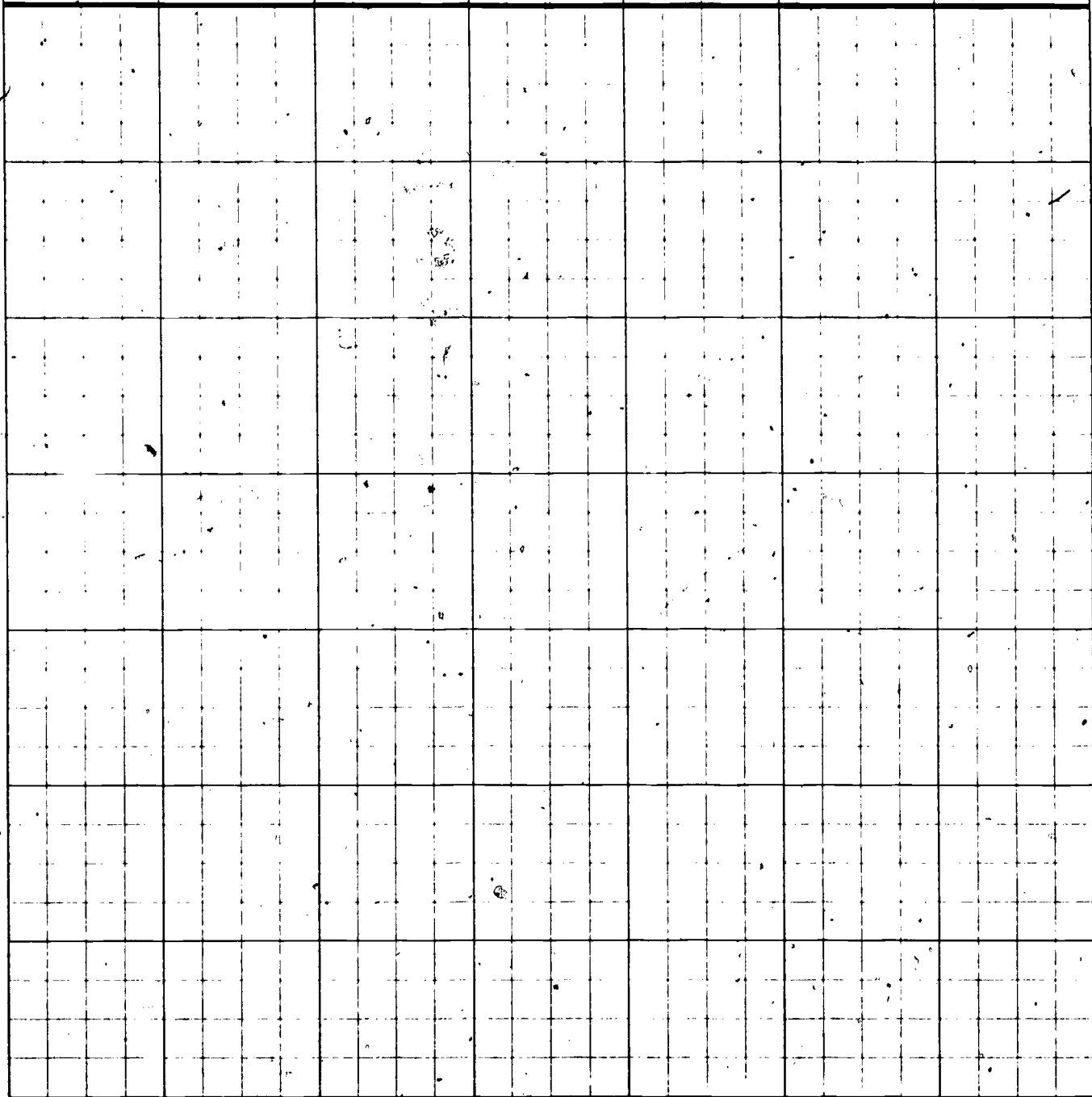

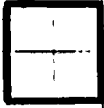

1 to 2

Make copies as indicated by each figure.

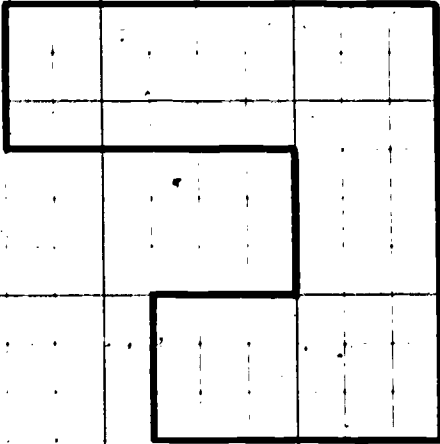

1 to 1/3

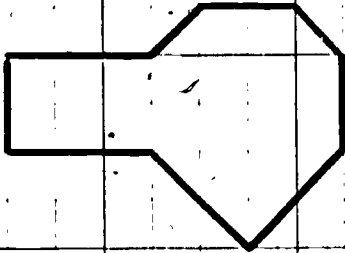

1 to 2

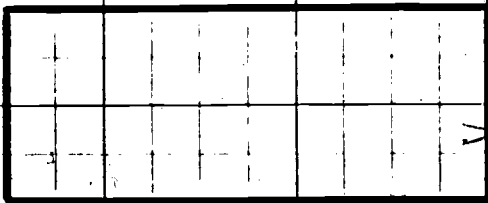

1 to 1/2

4. Exploration

5. Summary & Review.



APPENDIX

Review Lesson

1. Use a ruler to measure the lengths of each of these lines.

\_\_\_\_\_

nearest in. \_\_\_\_\_; nearest  $\frac{1}{2}$  in. \_\_\_\_\_; nearest  $\frac{1}{4}$  in. \_\_\_\_\_

\_\_\_\_\_

Nearest in. \_\_\_\_\_; nearest  $\frac{1}{2}$  in. \_\_\_\_\_; nearest  $\frac{1}{4}$  in. \_\_\_\_\_

2. Which of the figures are "scale drawings" of figure A? What is the scale in each case?

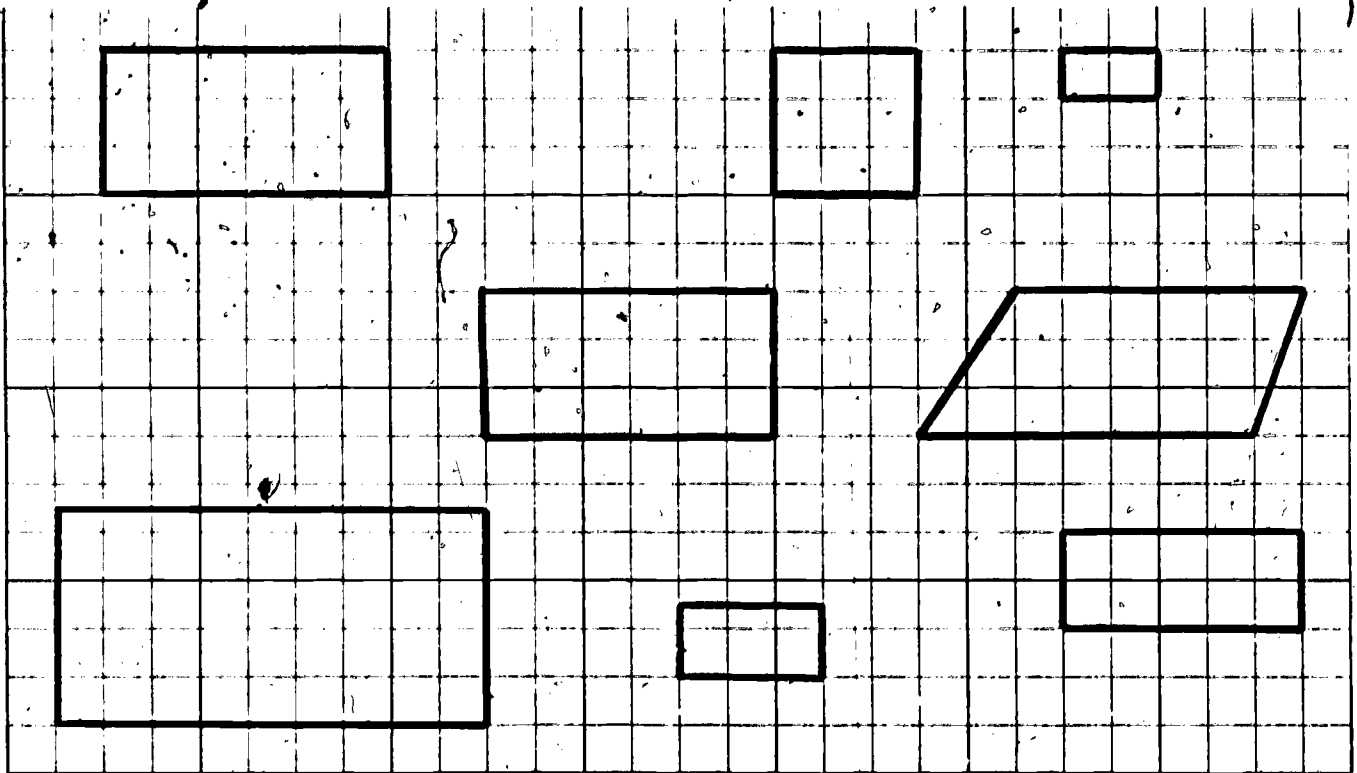

3.

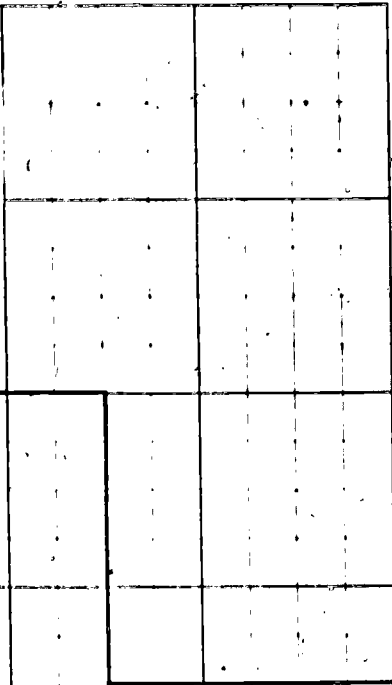

Make 2 scale drawings of this figure. Make one scale drawing to a scale of 1 to 1/2, and the other to a scale of 1 to 1/3.

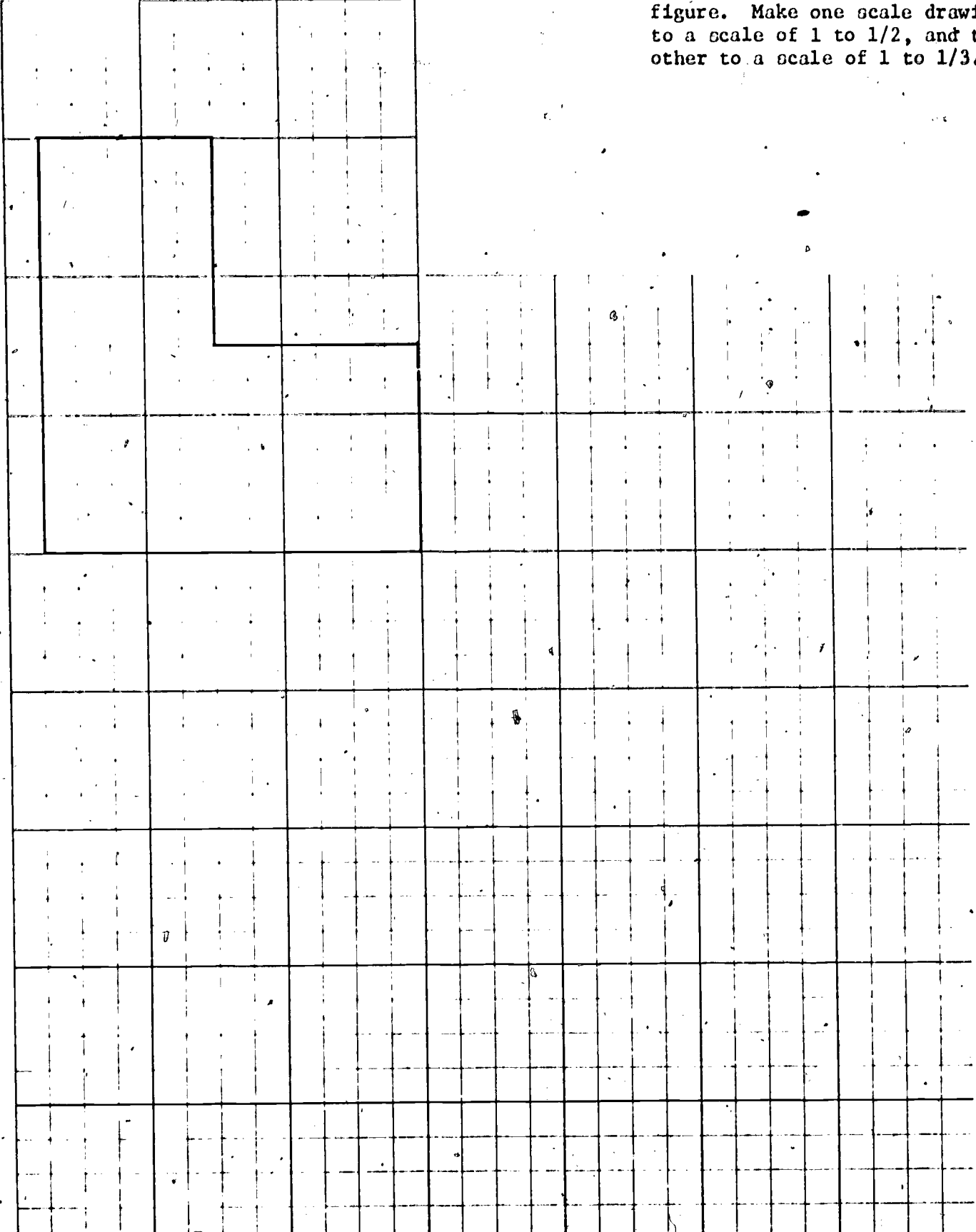

4. A land developer made these measurements on an irregular plot of ground.

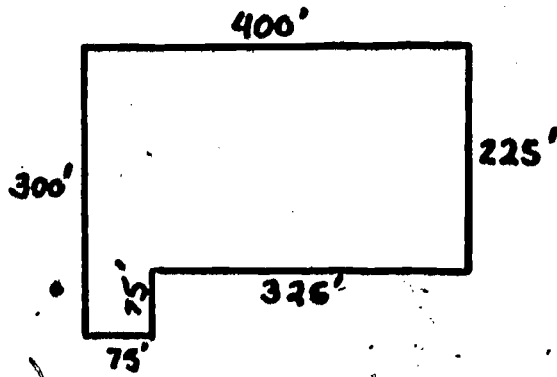

In a scale drawing he draws the 400 foot side 16 inches long. What scale is he using?

1 inch = \_\_\_\_\_ feet

How long will the other lines in his drawing be?

325 feet = \_\_\_\_\_ inches

225 feet = \_\_\_\_\_ inches

300 feet = \_\_\_\_\_ inches

75 feet = \_\_\_\_\_ inches

5. What is the area of each of these figures?

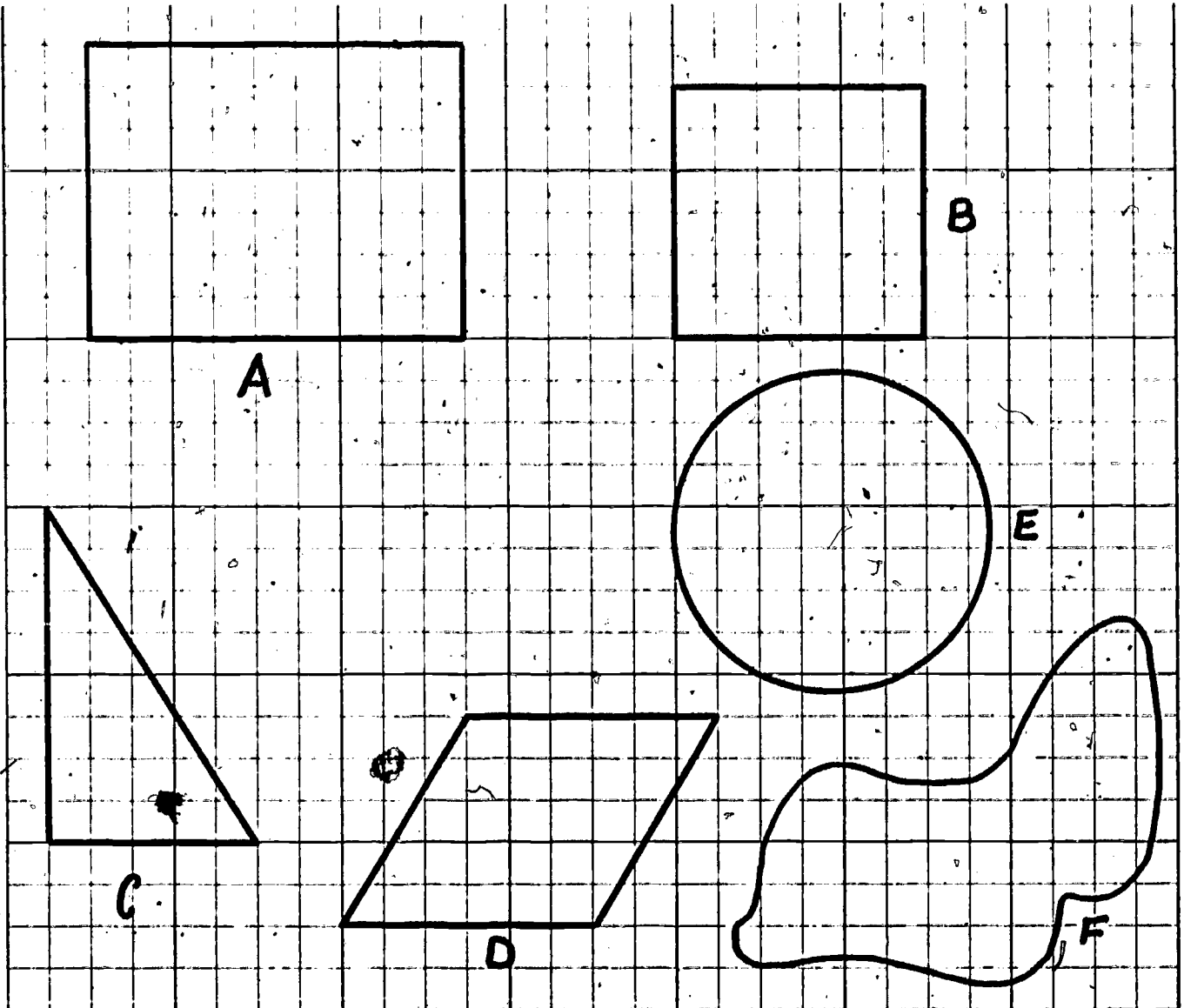

6. What is the area of each of these figures?

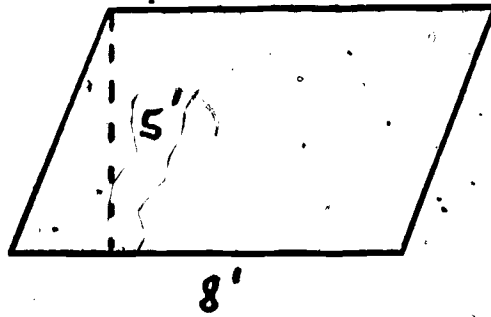
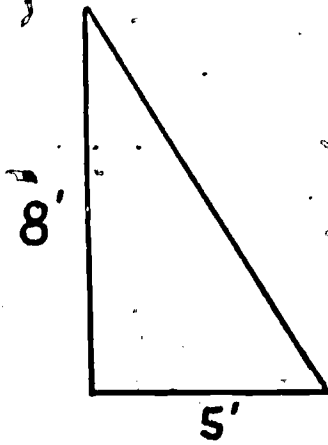
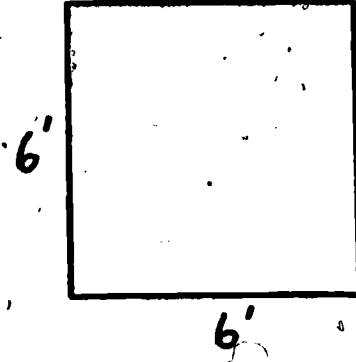
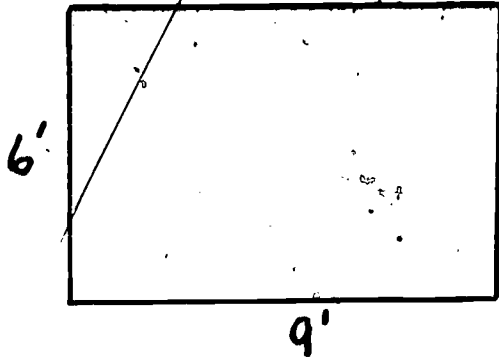

SUGGESTED OPTIONAL ACTIVITIES

Topic: Layout and Construction

Activity 1.

Objectives:

The students will divide into groups of 3 to 6; the groups will meet to plan their construction project.

Materials:

Notebook paper and pencils.

Procedure:

Begin with a talk on the place of this project in the unit. Emphasize that this project is like a real job and uses their previous learning in the unit. Stress the importance of mature cooperation in the work to be done. Students should be encouraged to form groups in which they will work well, not necessarily with their best friends.

Hand out the Project Organization Sheet to all students and go over the things they must do. Each student should keep his Project Organization Sheet for the time the project runs.

Now direct the students to form groups. You observe the groups as they form and sit with the group you judge will have the greatest difficulty getting organized. When they are organized and working, move to other groups to assist them. Remember, this project is to be the students' own; they must provide the leadership and effort. Expect some to do more than others but be firm with students who are not participating. Encourage student leadership.

Students should use the remainder of the period to measure the thing they are going to build and to record the measurements on a rough drawing in preparation for making a scale drawing.

Assignment:

Get the measurements needed to make scale drawings for the project.

Class Periods 2, 3, and 4. (More or fewer days at the discretion of the teacher.)

Objective:

To complete the scale drawing and collect the material for construction.

Materials:

When the students have planned the construction, they should have a good idea of the material they need and should be collecting it.

Procedure:

Each class period should start with a short group meeting. Topics to be discussed are (1) What materials have been obtained; what still needs to be collected, (2) How are the scale drawings coming (What needs to be done today.

Then the group members begin whatever tasks they have to do. You should circulate around the room. Particularly, talk with students who are not participating. A student who really does not have anything to do on the project may study.

When a group is finished with the scale drawings you should check them and approve them for construction. If the scale drawings are not correct or not adequate they should be done correctly before construction begins.

Class Periods 5, 6, 7, 8, 9, 10. (More or fewer days at the discretion of the teacher.)

Objective:

To construct a scale model based on the scale drawings just completed.

Materials:

Each group will have its own list of materials and should have collected them.

Procedure:

Permit groups to work at their own pace. Encourage creativity and freedom of expression.



This is the last activity in this unit. Try to arrange for public display of these projects and the scale drawings.

Topic: Scale Drawing

Activity 2.

Problem: Make scale drawing of the school yard.

Procedure: Work in teams of 2 or 4. Locate the boundaries of the school yard. Pick a scale. Go from one corner to the next. Each time shoot angles to key points. One member of your team can go to the next corner with a pole so you can sight him. Measure the distances and draw them to scale.

Activity 3.

Problem: Plan a sprinkling water system for the school yard.

Procedure: Make a scale sketch of the school yard (see Job Cards 5 and 6A). Plan the location of the water pipes which will be buried in the ground and determine where to place sprinklers. Calculate how many feet of water pipe you will need.

Activity 4.

Problem: Plan a swimming pool.

Procedure: Locate a good spot for a swimming pool. Make a scale drawing of the pool and calculate how much room it will take. Make sure it will fit.

PROJECT ORGANIZATION SHEET

Group members:

---

---

---

---

---

Construction Project

- 1) Trailer
- 2) Classroom
- 3) Steel frame building
- 4) Small house
- 5) Other \_\_\_\_\_  
\_\_\_\_\_  
\_\_\_\_\_

(Select one):

Steps in construction:

- 1) Collect measurements of the real thing.
- 2) Decide on a scale. What scale will your group use? \_\_\_\_\_
- 3) Make scale drawings (note need for floor, all exterior and interior walls, roof).
- 5) Decide on material to be used to construct model; obtain material.
- 6) Assign exterior construction, interior construction and detail to group members.
- 7) Begin construction.

STUDENT'S MANUAL

APPRENTICESHIP: LEARNING  
TO BE A CEMENT MASON

**Apprenticeship: Learning  
To Be A Cement Mason**

**1. Apprentice Program**

Sam Jackson wanted to enter the building trades and thought he would do well in cement work. He liked outdoor work and he had done some cement work with his father and enjoyed it. How important is it to like the work you do? Do many people you know like their work? How does "liking the job" compare in importance to the pay from that job?

He learned that a journeyman cement mason working in Atlanta earned \$7.35 per hour. An apprentice earns \$3.67 per hour to start and advances as follows:

Time on Job	%	Hourly Rate
0-6 Months	50%	\$3.67
6-12 Months	55%	
1-1 1/2 Years	65%	
1 1/2 - 2 Years	75%	
2 - 2 1/2 Years	85%	
2 1/2 - 3 Years	95%	
3 or More Years	100%	

Complete the table. The percent figure is the percent of the pay of a journeyman cement mason, \$7.35 per hour.

Sam found out that there is a waiting list for entry into the Plasterers and Cement Mason's Union Apprenticeship program. He wrote for information and had his name put on the list. He would receive \$50.00 per week for 6 weeks while going to apprentice school and then go through 3 years of "OJT," On the Job Training, at the pay scale shown above.

Would you do what Sam is going to do? What are the advantages and disadvantages? What is the purpose of an apprentice program?

## 2. Constructing Cement Forms

Sam began his first day of "OJT," On the Job Training, with a small cement contractor. He worked alongside the owner and a journeyman cement mason. A "journeyman" is a skilled worker who has completed training for his trade. The contractor was himself a journeyman mason.

The job they were doing was to pour a driveway and the slab for a garage. The blue print looked like the next page. Convert the dimensions given on the blue print to feet. The scale is 1 inch = 16 feet.

Sam was to figure how much wood they needed to construct the forms. They would need to form up the drive, the garage and the extra circular part separately. The "perimeter" of a shape is the distance around it. Calculate the perimeter of the driveway and the garage.

Now calculate the perimeter of this part:

It is part of a circle.

What is the distance around a circle? The circumference (distance around) a circle is close to 3.14 times the diameter.

The diameter is \_\_\_\_\_, so the circumference is \_\_\_\_\_.

However, only 1/4 of that is actually part of the job because that piece is a quarter circle. Now, what is the perimeter of that part?

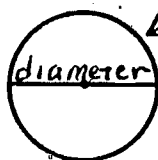

Circumference is distance around

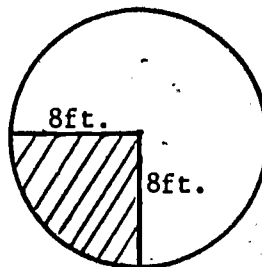

Now, find the perimeter of the shaded figures on the blue print.

DIAMETER =  $6\frac{1}{2}$  ft.

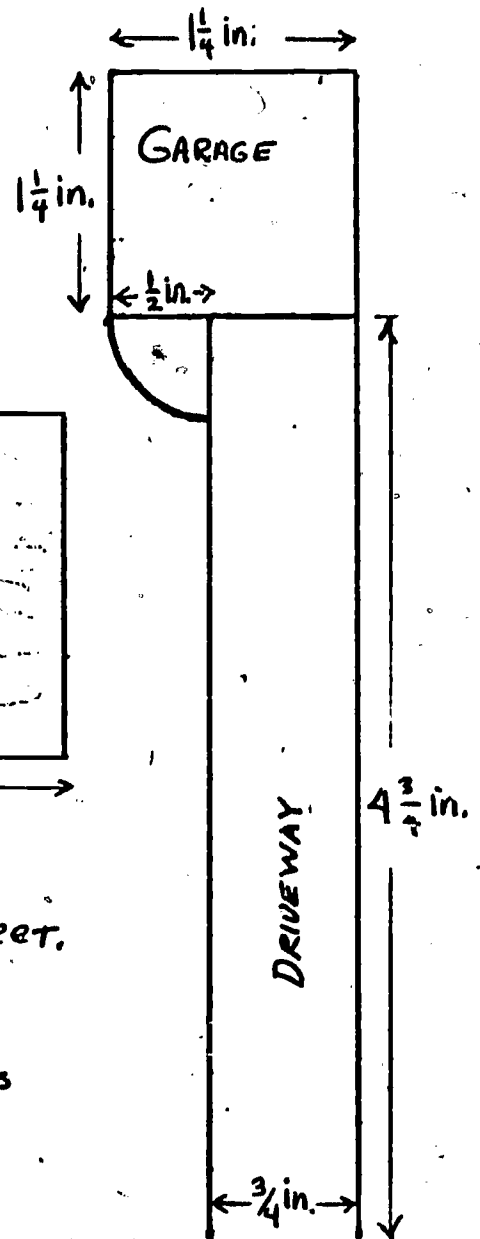
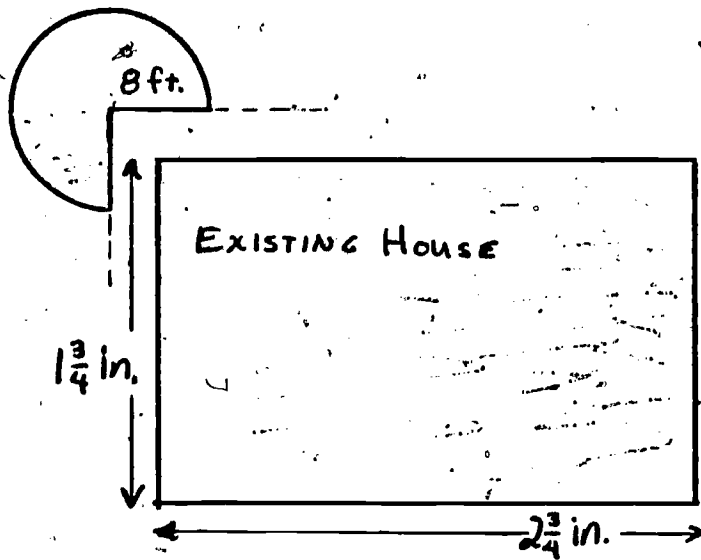
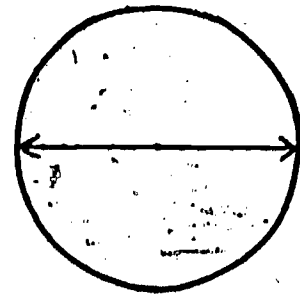
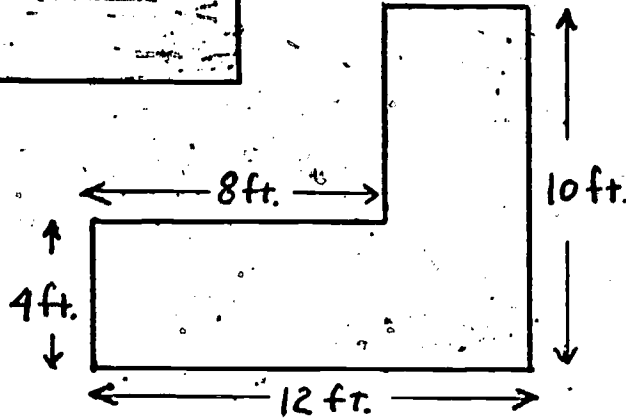
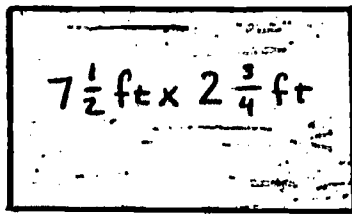

Scale: 1 inch = 16 feet.

DRIVEWAY AND GARAGE TO BE 4" SLABS OF FINISHED CONCRETE.

STREET

**MISSION INCREDIBLE:**

This is your mission, should you choose to accept it. Phone your local cement dealer, the people who have the "cement mixer trucks." Ask them how they sell concrete and the cost of concrete. Go to a local hardware or building supply store where they sell "sacrete" products and find the cost of a sack of concrete mix. How much concrete will one sack make? Bring this information back to class.

Most concrete company sell concrete by the "yard" meaning one cubic yard. Construct, in one corner of the classroom a "cubic yard." It is a cube which is one yard long, wide and high.

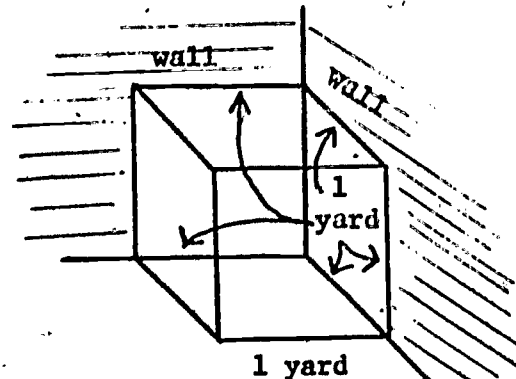

Call a cement work contractor or a general contractor and ask him how much a cement finisher charges to finish a driveway. Many charge "by the foot." What does that mean?

3. Volume: Dimensions in the same units

When the forms were set, the contractor decided that there was time to pour the slab for the garage. Sam was to figure how much cement, in cubic yards, was needed to pour the slab. Sam needed to review the way to find the volume of an object. Let's look at an object 3 inches wide, 5 inches long and 4 inches high.

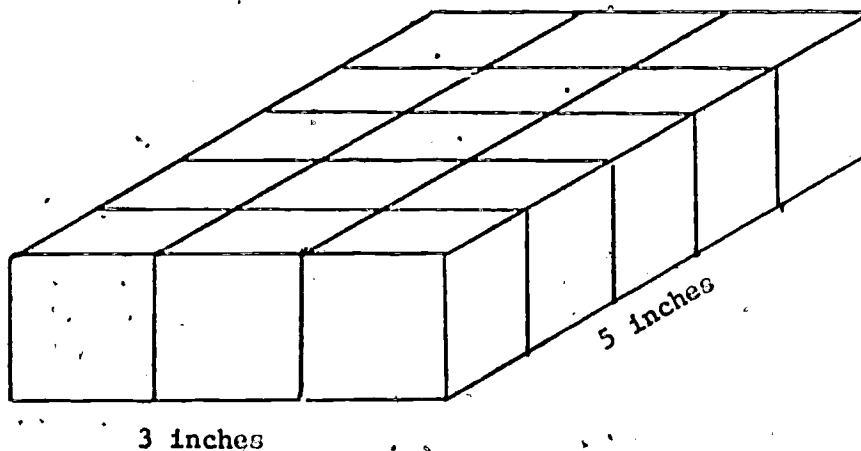

How many "cubic inches" are in this first layer?

How can you find this?

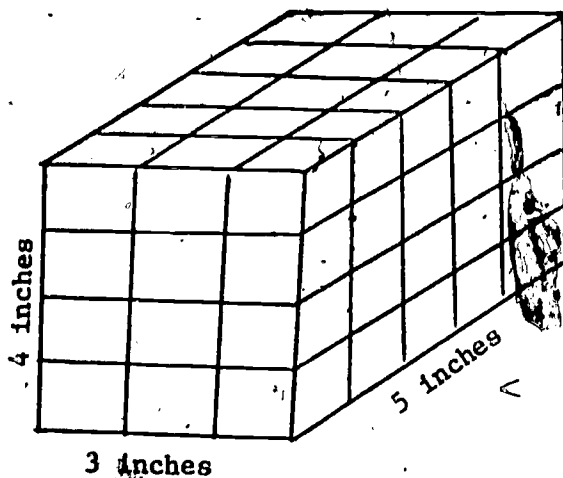



How many blocks are in each layer? How many blocks are in all four layers? How can you find the number of blocks in the whole shape?

Problems: Find the number of cubic units in each of these shapes.

	Length	Width	Height	Volume
1.	7 in.	4 in.	6 in.	_____
2.	12 in.	5 in.	8 in.	_____
3.	6 in.	6 in.	15 in.	_____
4.	8 1/2ft.	5 1/2ft.	4 ft.	_____
5.	6 2/3ft.	1 1/2ft.	8 ft.	_____
6.	12 3/4ft.	5 ft.	1/2 ft.	_____
7.	2 1/5 ft.	1 3/4ft.	8 ft.	_____
8.	13.2 in.	5.1 in.	7.4 in.	_____
9.	18.5 in.	6.2 in.	5.7 in.	_____
10.	8.4 in.	3.5 in.	.5 in.	_____

4. Dimensions in volume: mixed units.

Now, let's look at some problems like the slab of cement. Most of the time a slab of cement will be given, length and width in feet, depth in inches, and the volume needed in cubic yards. Remove the last page from this unit cut out the figure and fold it up and tape it as the teacher directs. This is how a slab of cement 1 yard x 1 yard x 4 inches would actually look.

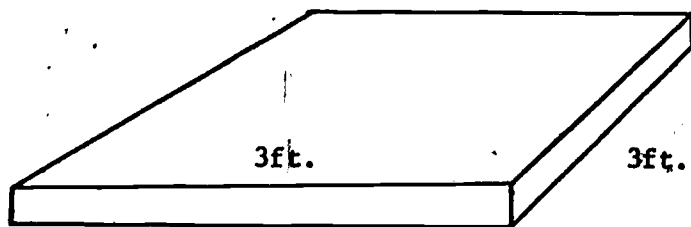

Sam had to work this problem without a model of the slab. He said:

$$\begin{aligned}
 V &= l \times w \times h \\
 &= 12 \text{ ft.} \times 12 \text{ ft.} \times 4 \text{ in.} \\
 &= 4 \text{ yds.} \times 4 \text{ yds.} \times \frac{1}{9} \text{ yard} \\
 &= \frac{16}{9} \text{ cubic yards} \\
 &= 1\frac{7}{9} \text{ cubic yards}
 \end{aligned}$$

Problems. Find the volume in cubic yards of each of these slabs. Follow the form above. Construct these shapes from the solids you made if you want.

	l	w	h	Vol.
1.	12 ft.	9 ft.	4 in.	_____
2.	15 ft.	6 ft.	6 in.	_____
3.	30 ft.	12 ft.	4 in.	_____
4.	$22\frac{1}{2}$ ft.	12 ft.	6 in.	_____
5.	51 ft.	36 ft.	9 in.	_____
6.	12 ft.	10 ft.	4 in.	_____
7.	28 ft.	15 ft.	6 in.	_____
8.	120 ft.	84 ft.	9 in.	_____

### 5. Cost of Concrete

Sam was ready now to find out how many "yards" of concrete would be needed for the floor of the garage. The garage is 20 ft. x 20 ft. and 4 inches thick. Find the number of cubic yards required.

---

### It's A Rip Off

---

Drawing a figure without lifting your pencil or tracing over a line you have drawn is easy sometimes ... and hard sometimes.

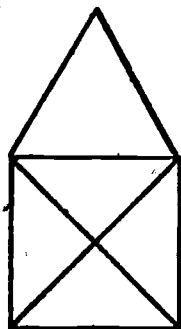

(Easy)

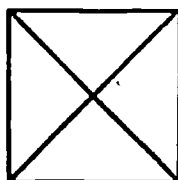

(Hard)

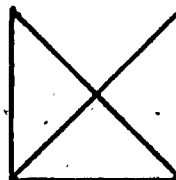

( ? )

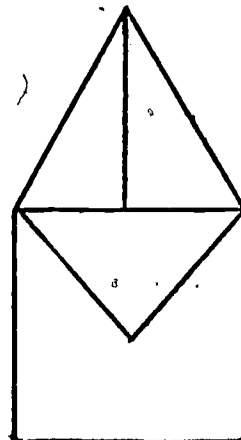

( ? )

Sam's calculations gave him the "exact" answer, but, to be safe, he should order a little more than he needs. Why?

If you were Sam, how much concrete would you order? \_\_\_\_\_

How much would that much concrete cost? You may use the cost per cubic yard which the local concrete companies charge or ask your teacher for a cost figure.

For each of the concrete shapes (problems 1-8 in the last lesson) find the volume of concrete you would order and the cost. Use whatever price you have been using.

	Vol.	Order Vol.	Cost
1.	_____	_____	_____
2.	_____	_____	_____
3.	_____	_____	_____
4.	_____	_____	_____
5.	_____	_____	_____
6.	_____	_____	_____
7.	_____	_____	_____
8.	_____	_____	_____

6. Review of Area Formulas.

Find the areas of these figures.

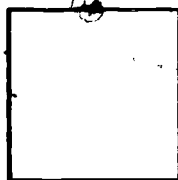

6 in.

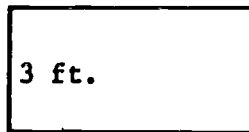

3 ft.

8 ft.

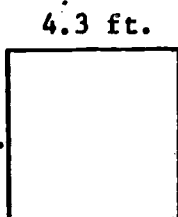

4.3 ft.

4.3 ft.

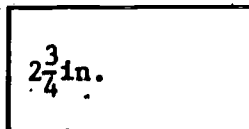

$2\frac{3}{4}$  in.

$9\frac{2}{3}$  in.

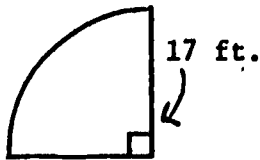
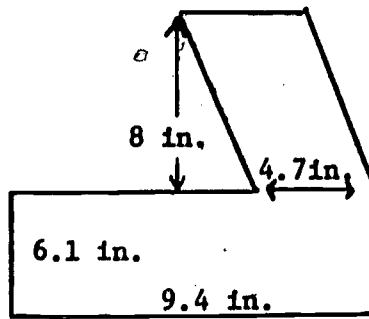
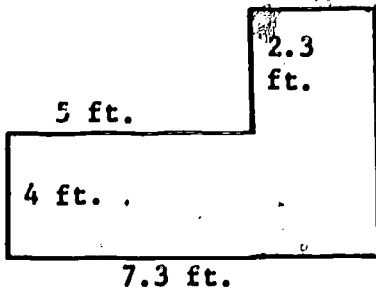
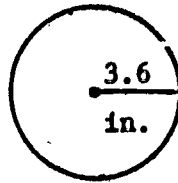
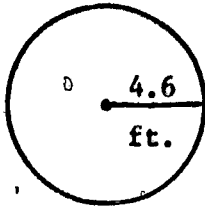
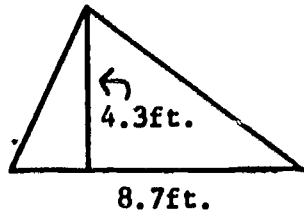
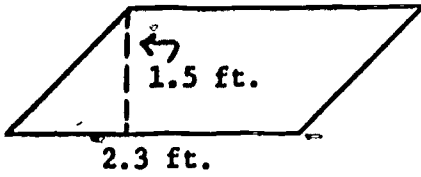

7. Three Volume Formulas.

Carefully take the last 3 pages from this unit and construct the models on those pages. There are three different, but related volume formulas for these 3 shapes.

#1

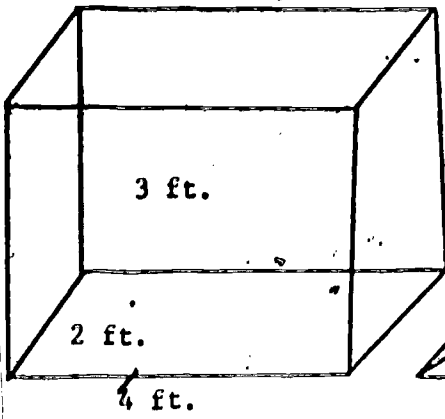

$$V = A \times h$$

#2

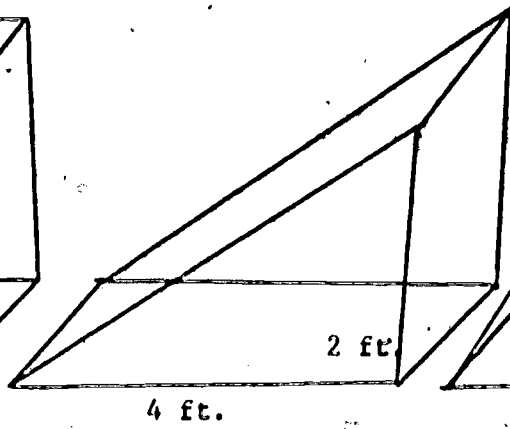

$$V = \frac{1}{2} \times A \times h$$

#3

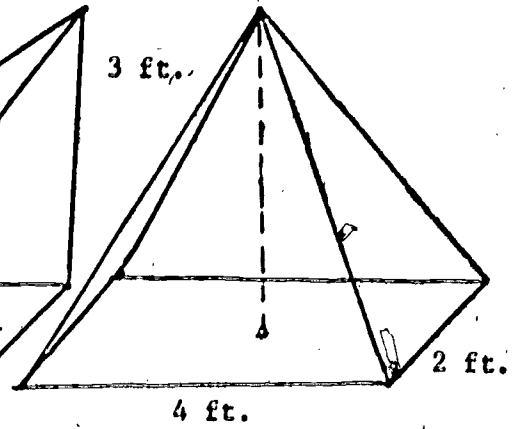

$$V = \frac{1}{3} \times A \times h$$

In each case the volume is found using the area of the base and the height. If the figure is a "rectangular solid" the volume is area  $\times$  height. If the figure rises from a base to a line, shaped like a wedge, the volume is  $\frac{1}{2} \times$  Area  $\times$  height. If the figure rises to a point, the volume is  $\frac{1}{3} \times$  Area  $\times$  height. Calculate the volume of each of these three models you have constructed.

1.  $V = A \times h = \underline{\quad} \times \underline{\quad} = \underline{\quad}$

2.  $V = \frac{1}{2} \times A \times h = \underline{\quad} \times \underline{\quad} \times \underline{\quad} = \underline{\quad}$

3.  $V = \frac{1}{3} \times A \times h = \underline{\quad} \times \underline{\quad} \times \underline{\quad} = \underline{\quad}$

Find the volume of each of these. First choose the proper formula.

#1

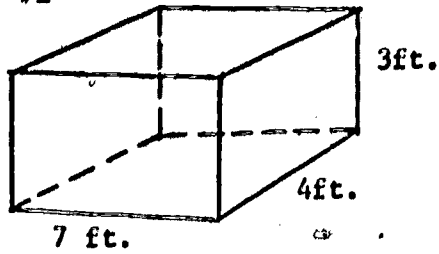

#4

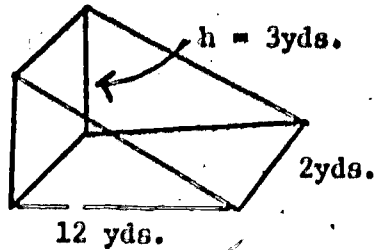

#2

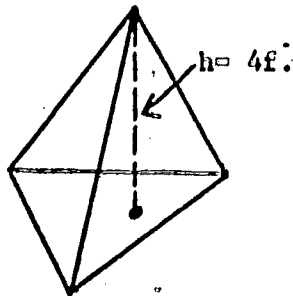

A of base =  
18 sq.ft.

#5

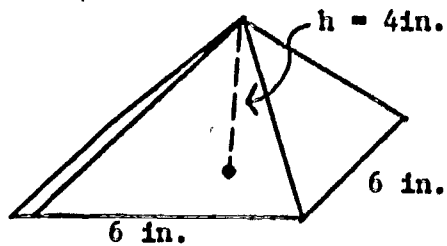

#3

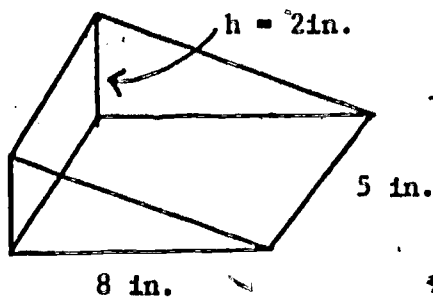

#6

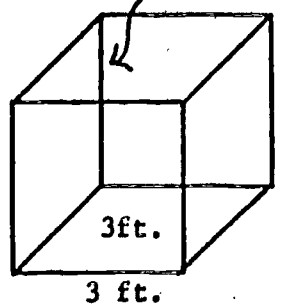

It's A Rip Off

Look at your model wedge this way:

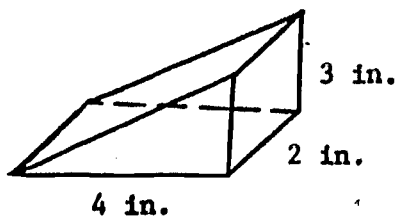

V = \_\_\_\_\_

Now look at the wedge this way:

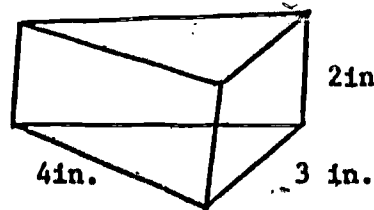

V = \_\_\_\_\_

Is the formula the same?

Is the volume the same?

## 8. Plane Surfaces.

When the cement was delivered and poured into the forms, Sam helped the journeyman cement mason level it. Then the journeyman used a float and trowel to produce a smooth surface.

Making a surface flat and level is very important, as you might guess. A flat level surface is called a plane. When the forms were set, the contractor was careful to see that the sides were parallel, like this:

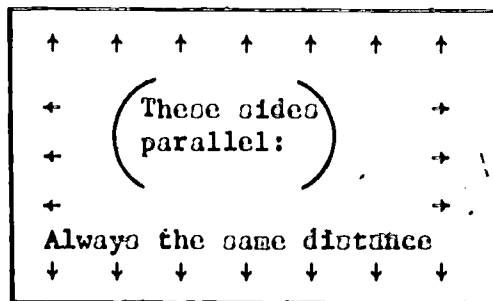

Two lines, or two sides of the form are parallel if they are always the same distance apart, like straight railroad tracks.

When two sides of the form are parallel a straight board resting on the forms will smooth the cement into a level flat surface.

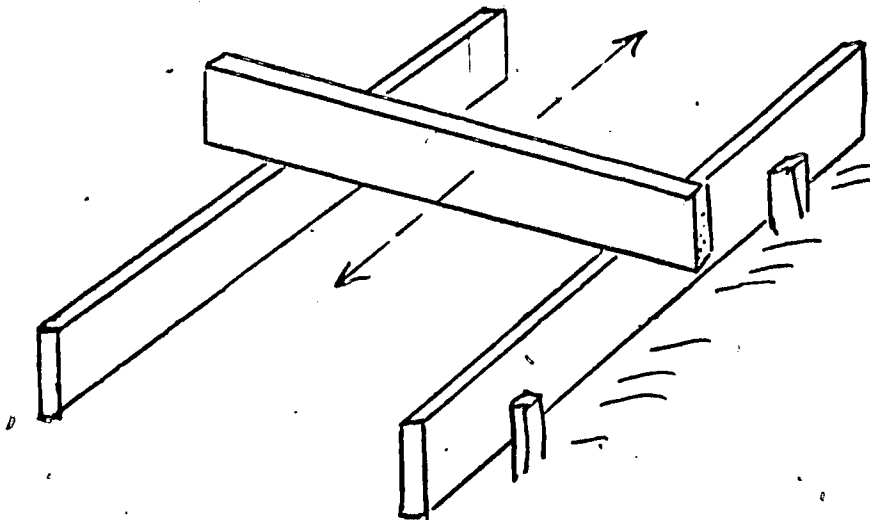

### MISSION INCREDIBLE

This is your mission, should you choose to accept it: to make a model to show the class how concrete is leveled in forms.

Obtain the following materials: a large shallow box, 10 feet of wood about 1 in. x  $\frac{1}{2}$  in., glue, dry sand (a shoe box full is enough). Make it like this:

Glue an 18 in. x 12 in. rectangle of wood to the bottom of the box.

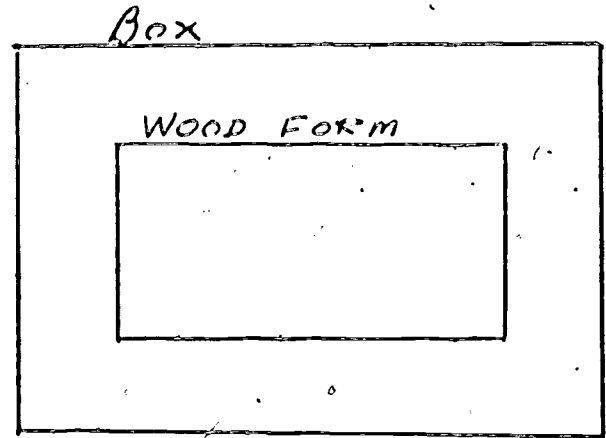

Use remaining wood for a "leveling plank."

LOOKS LIKE  
THIS

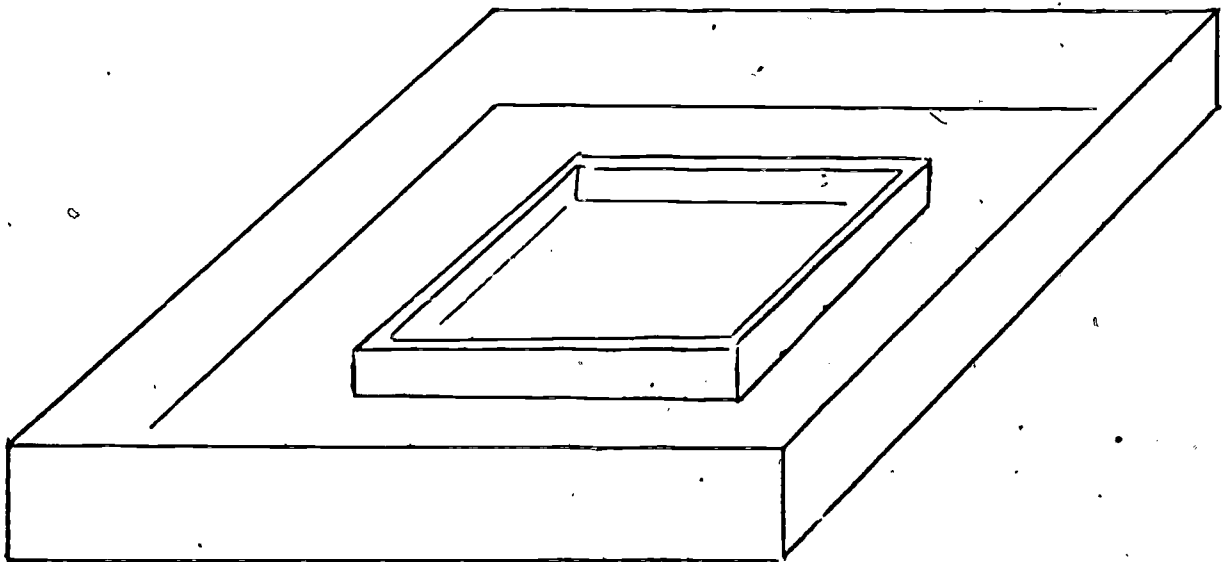



It's A Grump (Round off all decimals to the nearest hundredth.)

1.  $35 \times 97 =$
2.  $23.4 + 6.8 + 19.3 =$
3.  $437.8 \div 12.4 =$
4.  $2\frac{1}{2} + 5\frac{2}{3} =$
5.  $9.68 \times 5.41 =$
6.  $2\frac{3}{4} - 1\frac{1}{5} =$
7.  $14\frac{1}{2} \times 1\frac{3}{4} =$
8.  $7 \times 9.3 \times 42 =$
9.  $5\frac{2}{5} - 1\frac{1}{2} =$
10.  $43.7 \div 129.1 =$

9. Cost of Cement Finishing

When the concrete has been leveled, the journeyman uses the float and trowel to produce a smooth surface. When the contractor is estimating the cost of the job he figures from 12 to 15 cents per square foot for cement finishing. Go back to the blue print and figure the cost of finishing the concrete driveway and garage floor. Use \_\_\_\_\_ per square foot as the cost.

	Area	Cost
Garage Floor		
Quarter Circle 		
Driveway		

Calculate the area of each of these shapes and then the cost of finishing them if they were poured in concrete.



21 ft.

14 ft.

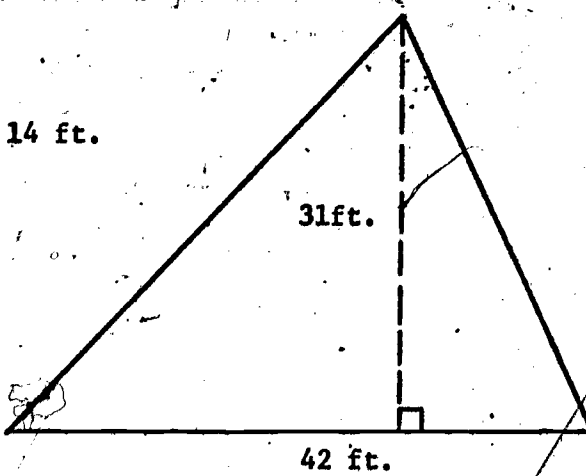

31ft.

42 ft.

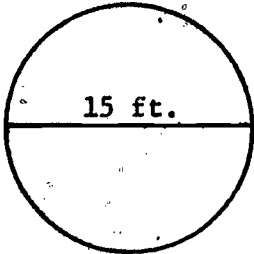

15 ft.

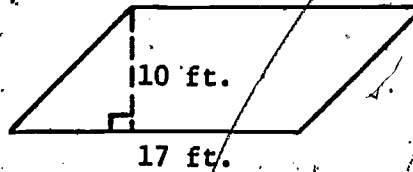

10 ft.

17 ft.

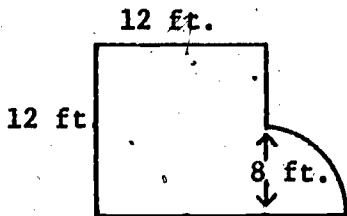

12 ft.

12 ft

8 ft.

#### 10. Foundation For A House

Sam's next job was to pour a foundation, a "footing," for a small house. The shape of the house was marked with stakes on the ground and the excavation was done by a man using a power shovel. Why is so much more work done by power equipment now? Some people say that using power equipment cuts down on jobs. What do you think?

The foundation of the house was to be constructed following the blue print (next page). When the forms are constructed the volume must be determined approximately in cubic yards. To figure the volume, imagine cutting the foundation into blocks.

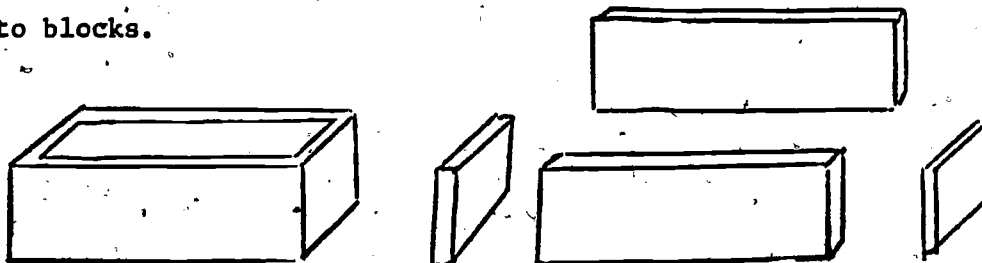

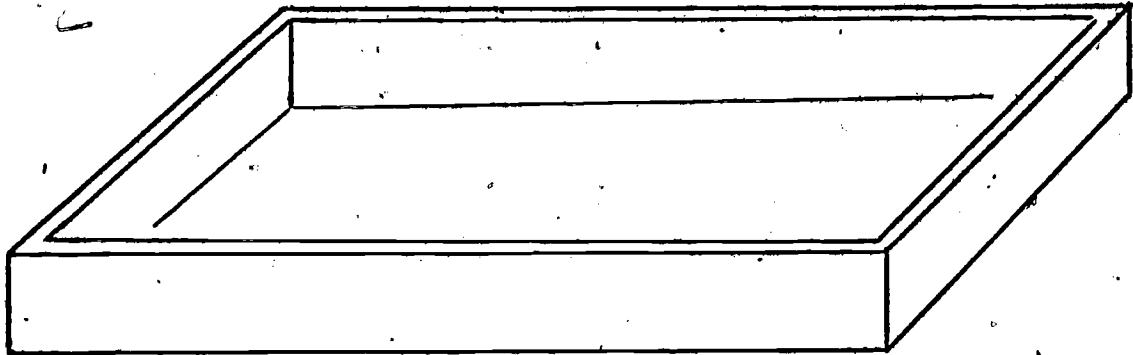

SKETCH

BLUEPRINT

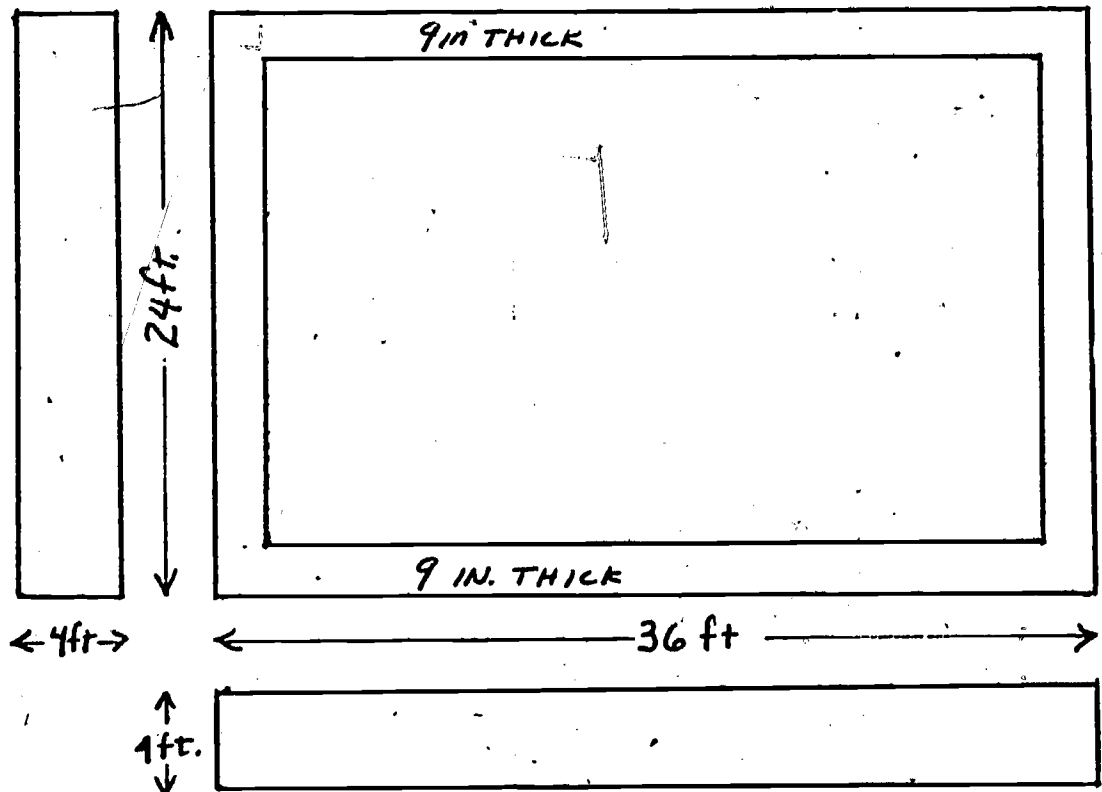

SCALE: 1 in = 8 FEET  
DO NOT SCALE THICKNESS.

What are the dimensions of each block?

Short side: l = \_\_\_\_\_ w = \_\_\_\_\_ h = \_\_\_\_\_

Long side: l = \_\_\_\_\_ w = \_\_\_\_\_ h = \_\_\_\_\_

Now calculate the volume in cubic yards of concrete needed to fill the cement form. Would you order exactly that amount? How much concrete would you order? How much would that much concrete cost?

---

Here are three more foundations. Find the volume of each one in cubic yards and estimate the quantity of concrete you would order for each one.

~~~~~It's A Rip Off~~~~~

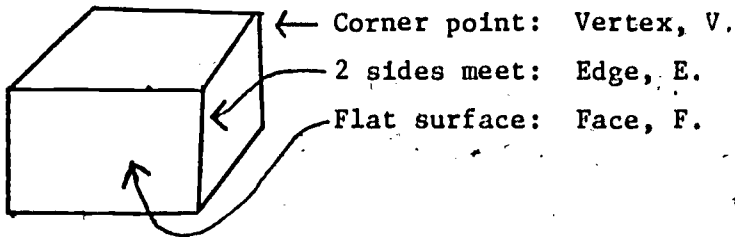

What do you know about that?  
 Try some other solids!

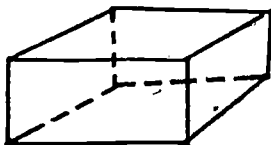

$F + V - E =$  \_\_\_\_\_

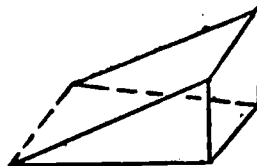

$F + V - E =$  \_\_\_\_\_

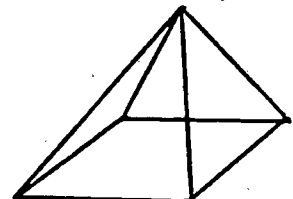

$F + V - E =$  \_\_\_\_\_

G.R.U.M.P.

$$\begin{array}{r} 3\frac{3}{5} \\ - 1\frac{7}{10} \\ \hline \end{array}$$

$$\begin{array}{r} 4\frac{2}{3} \\ + 1\frac{3}{4} \\ \hline \end{array}$$

$$2\frac{3}{5} \times 1\frac{1}{2} =$$

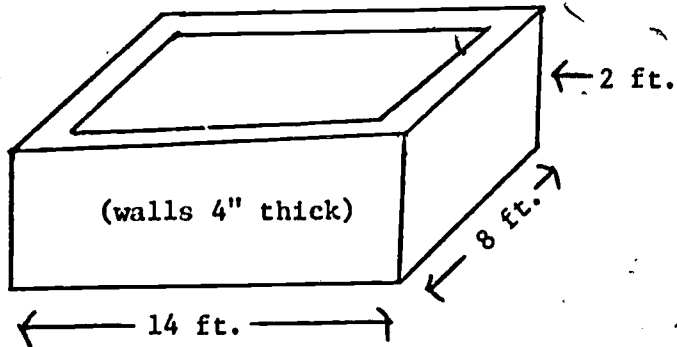
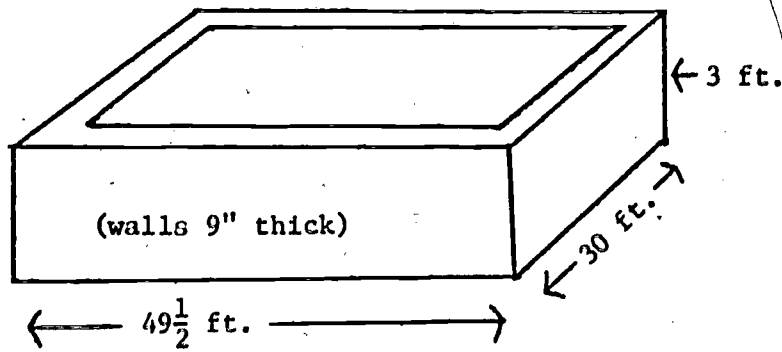
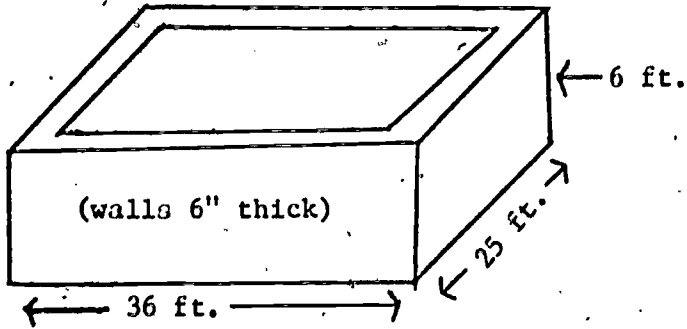

**MISSION INCREDIBLE**

This is your mission, if you choose to accept it: You are a cement contractor and you are bidding on the cement work for a new subdivision. There will be 10 houses but the cement work for each will be the same. Prepare your estimate as follows. This job will take about 20 days, one working month.

1. Concrete \_\_\_\_\_ yards @ \_\_\_\_\_ per yard: \_\_\_\_\_
  2. Labor (unskilled) \$100 per house: \_\_\_\_\_
  3. Labor (cement finisher) \_\_\_\_\_ per foot: \_\_\_\_\_
  4. Profit \_\_\_\_\_%
- Total Bid \_\_\_\_\_

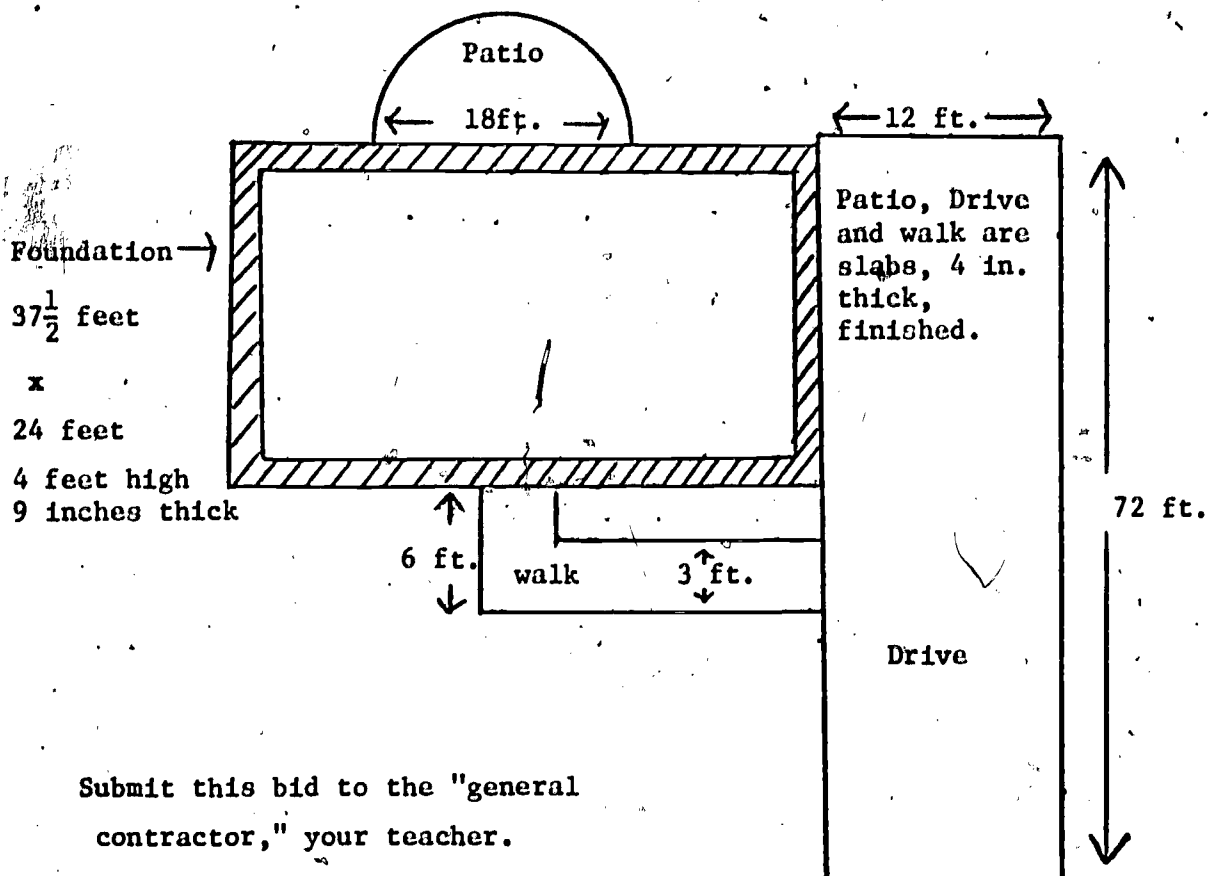

Submit this bid to the "general contractor," your teacher.

### 11. Opening The Sealed Bids

Several bids have been received from cement contractors for the work on the new subdivision. At this time the general contractor will now open the bids and award the contract.

What is the purpose of having "bids" for a job? Why are these bids kept secret?

When each bid has been opened and the bids listed on the board, work out the "cost" for each item.

Cost for concrete \_\_\_\_\_  
Cost for unskilled labor \_\_\_\_\_  
Cost for finishing \_\_\_\_\_  
Total Cost \_\_\_\_\_

How do the bids compare to the total cost? Are any bids actually below cost? How did that happen?

What percent profit is reasonable for this job? Remember that the contractor will work one month on this job and take a big risk! What should he make in "profit" for this?

Consider cost, the contractors salary, and profit, what is a "best" bid?

GRUMP

|              |               |
|--------------|---------------|
| 43.2         | 19.73         |
| <u>x 1.4</u> | <u>- 4.94</u> |

3.7 / 296.82

### 12. Volume of Foundations Which Are Not Level.

Sam found that pouring a foundation for a house on a hill was different! The volume of concrete needed was not as easy to figure. Of course the

house has to be level ...

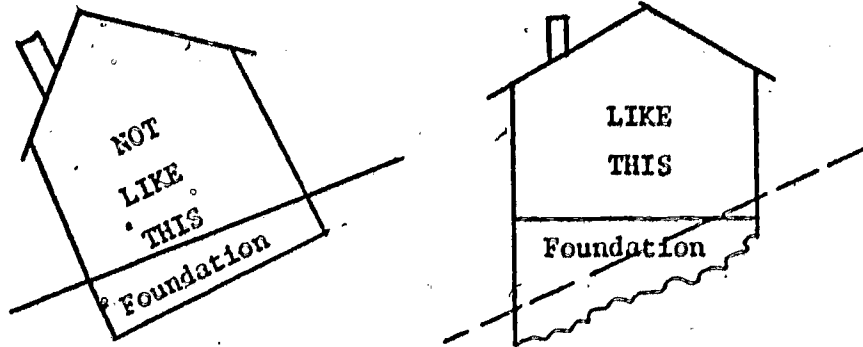

The foundation for this house might look like this

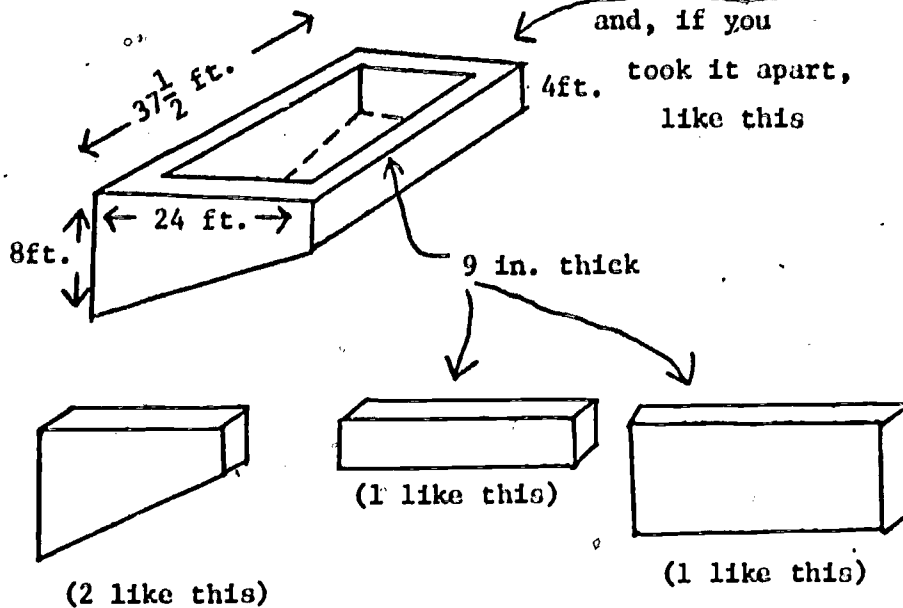

Sam found that the volume of the end blocks (  ) was hard to calculate. Then he found that he could think of it like this:

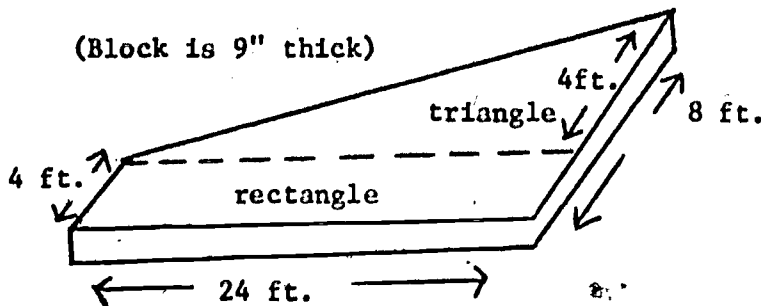



Then the volume formula  $V = Ah$  (area  $\times$  height) could be used. The area could be divided into a rectangle and a triangle. Calculate the area of the rectangle:

Now, the area of the triangle:

Total area: \_\_\_\_\_

height : \_\_\_\_\_

Volume =  $A \times h$

Volume in cubic yards = \_\_\_\_\_

Now complete the calculations for the other sides:

Short Side

$$V = l \times w \times h =$$

Tall Side

$$V = l \times w \times h =$$

Two Slanted sides

Total:

GRUMP

|               |                |             |
|---------------|----------------|-------------|
| 421           | 8,356          | 29          |
| 3596          | <u>- 2,178</u> | <u>x 43</u> |
| 285           |                |             |
| 37            |                |             |
| <u>+ 9571</u> |                |             |

437  $\overline{) 27,968}$

49

47

Here is one more hillside foundation:

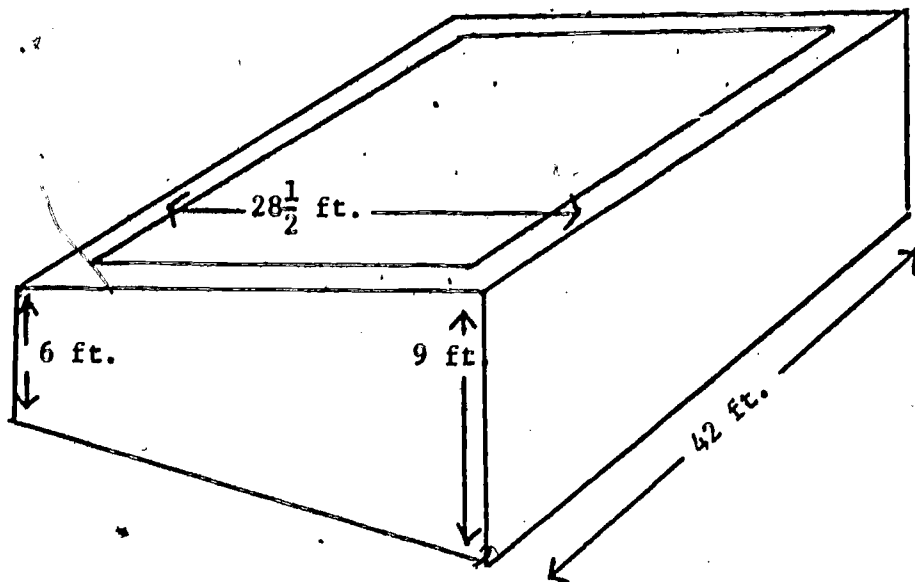

All blocks are 9" thick. Find

Volume: \_\_\_\_\_

Volume to be ordered: \_\_\_\_\_

Cost: \_\_\_\_\_

13. Small Job Work.

Sam does small jobs when he has spare time or when business is slow. For most of these jobs he buys bags of concrete mix and mixes it himself. What did your "mission incredible" team find out about the cost of bags of concrete mix? \_\_\_\_\_

How does the cost of concrete in bags compare to the cost of concrete delivered by truck?

Cost in bags \_\_\_\_\_

Cost from truck \_\_\_\_\_

(Is there any other reason for preferring the concrete be delivered by truck?)

Sam charged \$25.00 to make a base for a bird bath. The base is shown here:

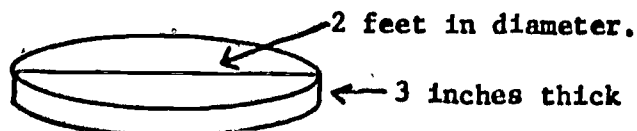

For this job he provided the concrete, which he mixed himself from a bag. How much concrete did he need and what was his profit for that job?

He charged \$35.00 for patching some cement stairs. Patching work does not use much concrete, but it takes a long time. He used  $1/2$  bag of concrete mix and worked 4 hours on the job. How much did he make per hour?

GRUMP

$$3\frac{4}{5} \times 1\frac{2}{3} = \underline{\hspace{2cm}}$$

$$5\frac{1}{2} \div 2\frac{1}{2} = \underline{\hspace{2cm}}$$

$$\begin{array}{r} 3\frac{3}{4} \\ + 2\frac{1}{5} \\ \hline \end{array} \qquad \begin{array}{r} 5\frac{1}{3} \\ - 2\frac{3}{5} \\ \hline \end{array}$$

#### 14. Summary

How did Sam get started in his trade?

He had to go to Atlanta and be an apprentice for 3 years. Why?

What are the advantages of spending a long apprenticeship learning a trade? What are the disadvantages?

What will Sam earn as an apprentice? "Could you earn more in a "regular job?" What does Sam expect to earn eventually?

When Sam finished his apprenticeship he could stay in a large city or he could move back to his home town. Which would you do?

Would you do what Sam did?

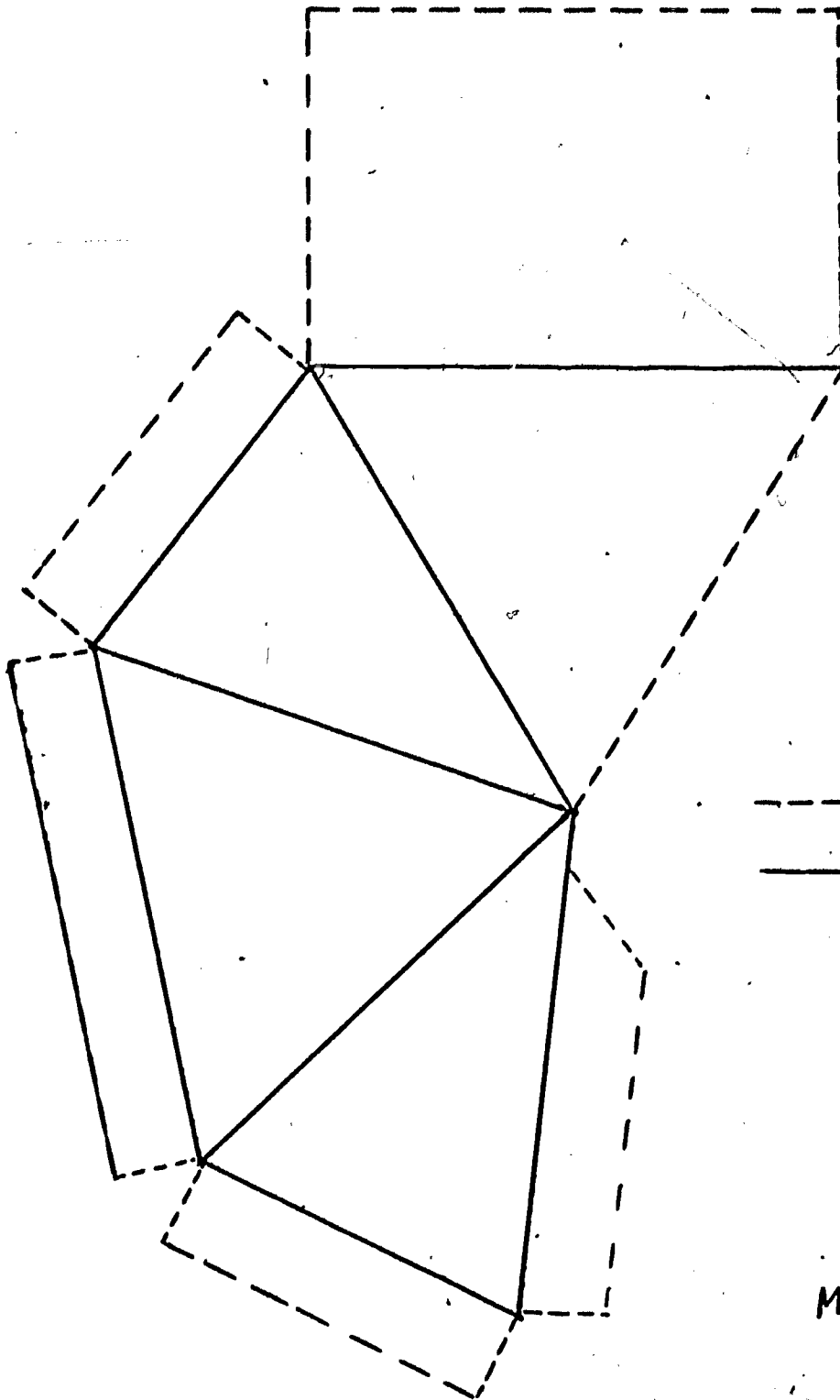

--- CUT  
 — FOLD

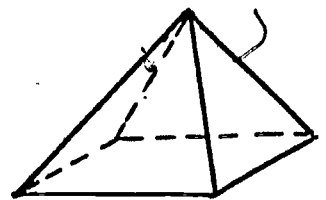

MAKES ONE LIKE THIS

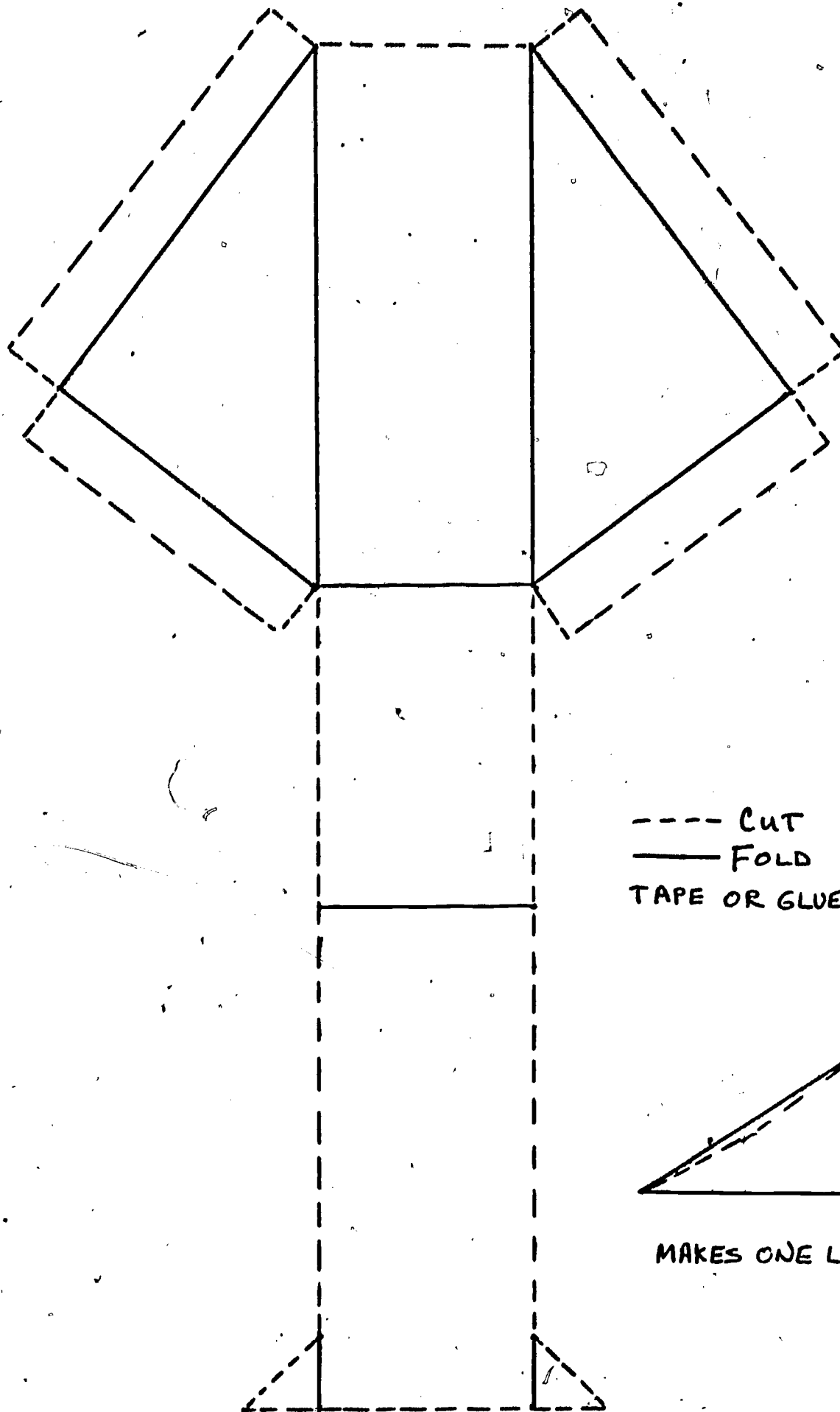

- - - - CUT  
 ——— FOLD  
 TAPE OR GLUE

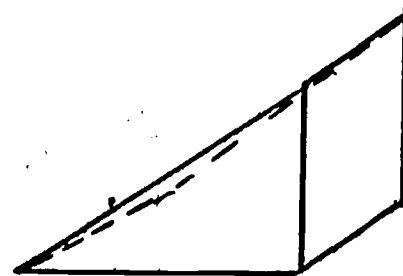

MAKES ONE LIKE THIS

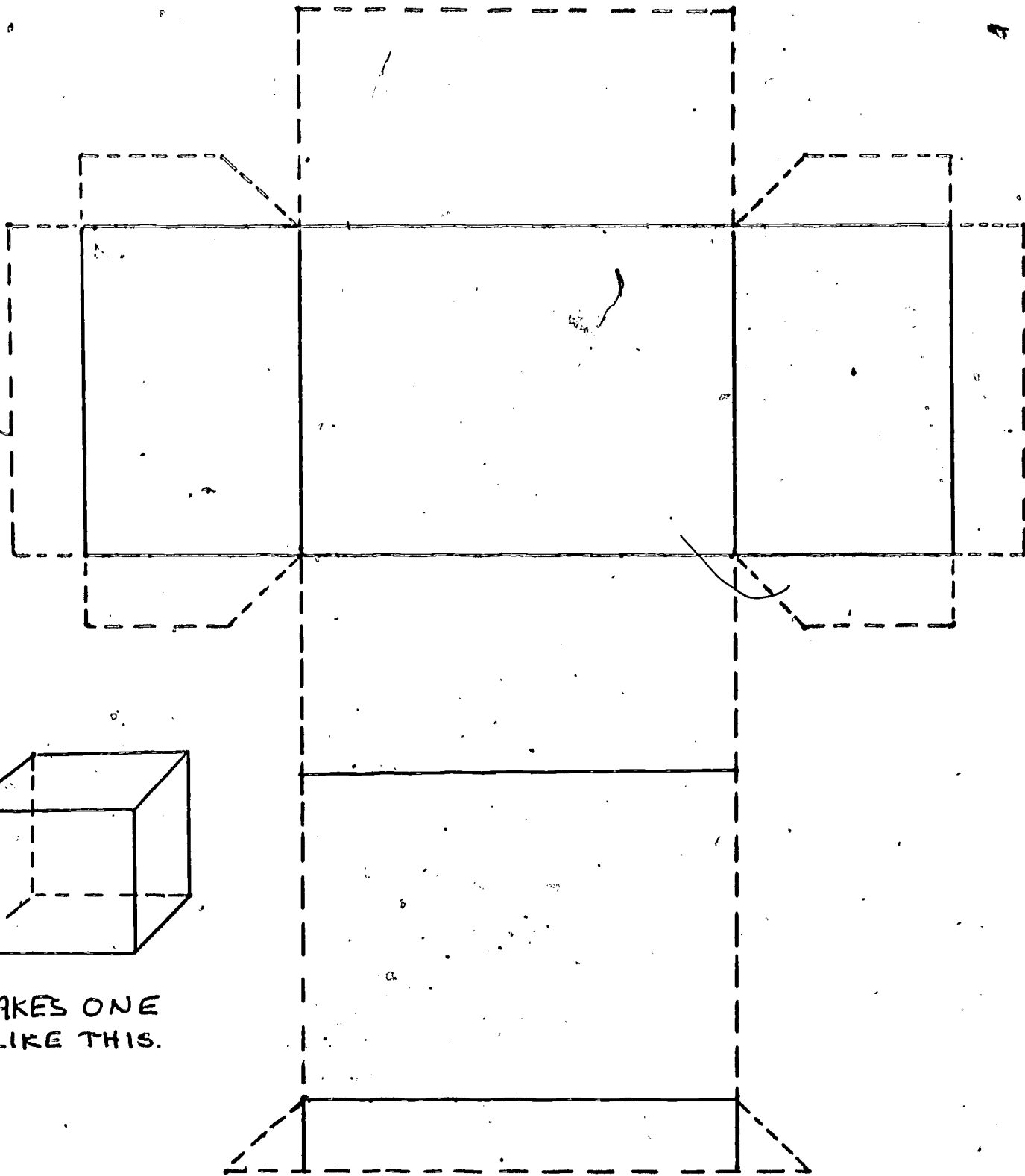

MAKES ONE  
LIKE THIS.

TO CONSTRUCT THIS MODEL, CUT ALONG  
DOTTED LINES AND FOLD ALONG SOLID  
LINES. GLUE OR TAPE TO FORM A BOX.

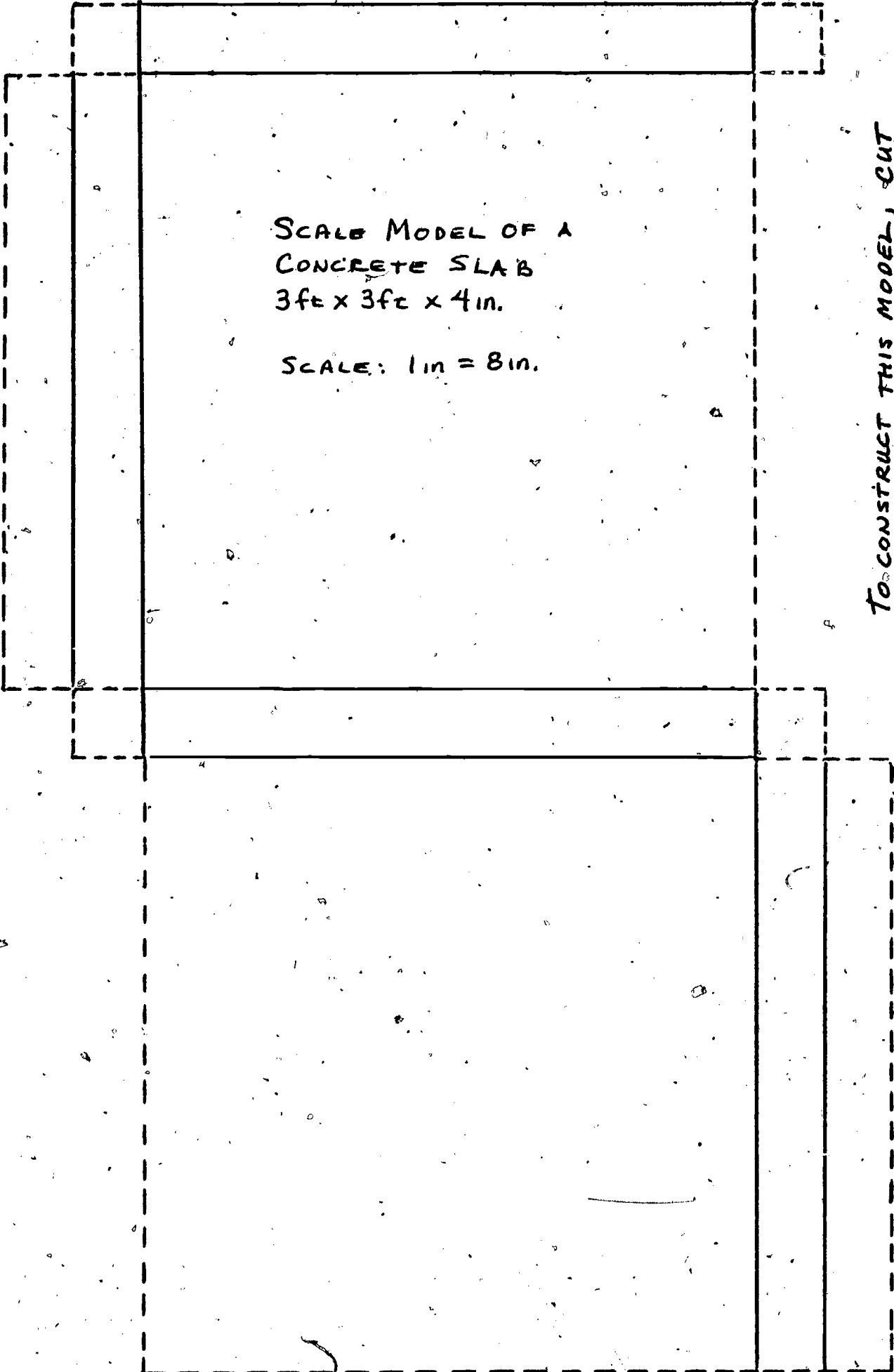

SCALE MODEL OF A  
CONCRETE SLAB  
3fe x 3fe x 4in.

SCALE: 1in = 8in.

TO CONSTRUCT THIS MODEL, CUT  
ALONG DOTTED LINES AND FOLD  
ALONG SOLID LINES. GLUE OR  
TAPE TO FORM A BOX.

STUDENT'S MANUAL

TEXTILES



## Textile Employee

Zelda Miller

### 1. Discussion of Job

When Zelda graduated from high school she decided to find a job in a textile mill. She had several different types to select from in her area. For example there was a rug mill, mens' clothing and a ladies' clothing mills in the area. She wanted to pick the one that she felt the most about so she went to work at a factory that made ladies sports wear. This particular factory produced pant-suits, dresses and other casual wear. What kind of experiences could Zelda have had in school and at home that would have prepared her for this type of work?

The manager told Zelda she could get the job without experience, since they would train her to do the task she was hired to do. What advantages would there be in having experience?

GRUMP

$$2.14 + 33.69 + 78.31 + .79 = \underline{\hspace{2cm}}$$

$$\begin{array}{r} 56.7 \\ \times 32 \\ \hline \end{array} \quad \frac{7}{8} \times 2\frac{1}{2} =$$

$$1.6 \quad 272 \quad 3\frac{1}{2} + \frac{3}{4} =$$

### 2. Beginning the Job

Zelda began her job as a sewing machine operator. She found out that every body operating a machine did a different part of the outfit being made. For example, one person just sewed on a sleeve, one did the collar, one the lining and so on. Why do you think

## MISSION INCREDIBLE

This is your assignment, should you choose to accept it. There are several mills in your area. Get a group of 2 or 3 students together and visit a mill. You will have to get permission to do this. Also, you would need to call the manager for an appointment. You are to find out the following information:

- a) What do they make?
- b) Do they pay by piece work?
- c) Do they have quotas?
- d) What are the salaries of the employee?
- e) What are some of the jobs available?
- f) What kind of experience is helpful?

After gathering this information you should report this to your fellow students.

they did it this way, rather than have one person do the whole outfit. Zelda's task was to sew on the sleeves. Zelda was told how her salary would be figured. The manager said she would be paid \$2.10 an hour, plus they would pay her "piece work". This meant she would get paid her regular salary, plus so much per item over her quota. A quota is the number of items that an employee is expected to complete within an allotted time. Zelda's quota is 500 items per week. This means Zelda is required to finish the 500 items before she would start on piece work. Lets look at an example of what one week might look like. Zelda worked a 40 hour week and sewed 600 items what would her salary be for the week? As she gets better at her job, Zelda can increase her weekly salary. In each of the following find out what her weekly pay would be, remember her quota is 500 items.

1. Zelda produced 624 items the second week. What would her pay for the week be?
2. The third week she produced 735 items, what was her total pay?
3. The fourth week Zelda missed a day of work. She worked 32 hours and produced 550 items what was her pay?
4. One week Zelda worked a regular 40 hour week and was paid \$100. What was her piece work pay? How many items did she have to do for this extra amount.
5. How many items would she need to complete to earn \$25.00 extra. (Hint, don't forget she has to make her quota first.)

---

IT'S A RIP OFF!

---

Each of the following patterns are made-up of six squares. If you are only allowed to cut on the solid lines (not the dotted), how many of these patterns could be folded so they make a cube.

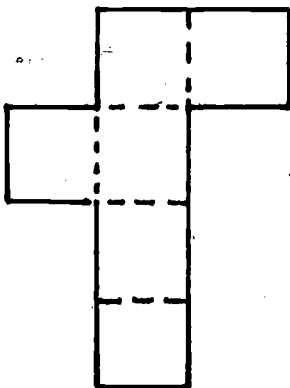
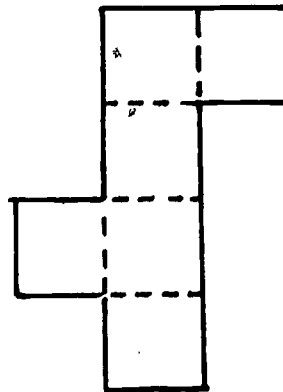
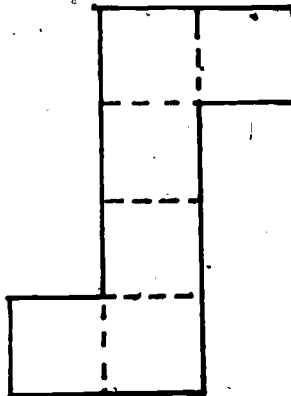
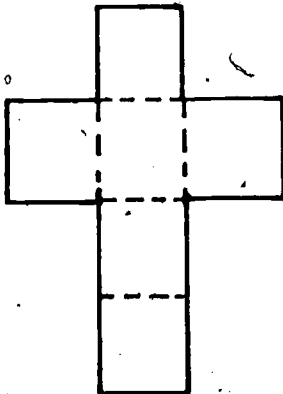
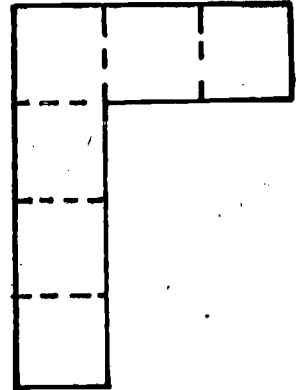
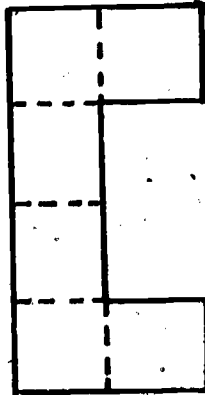
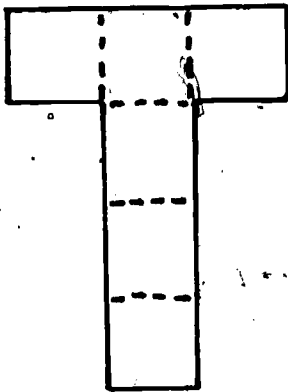

### 3. Setting the Seam Gauge

One of the most important parts of sewing is the proper setting of the seam gauge. This gauge determines how far in the stitching will be on the material. If the gauge is set at the wrong place the size of the garment will not be correct and this would cause the item to be wasted.

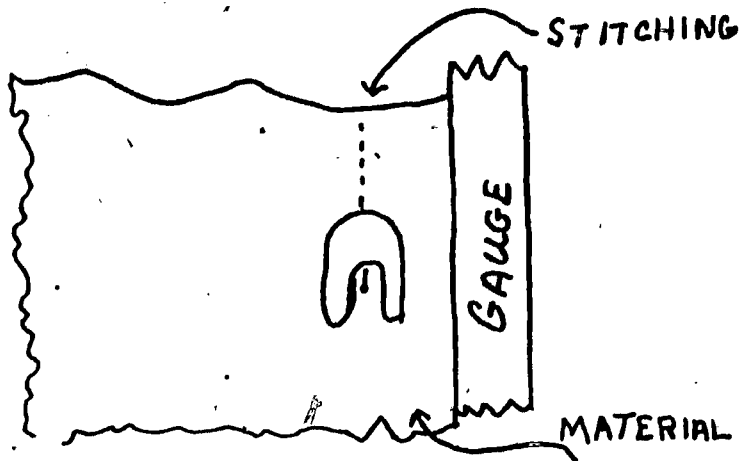

This gauge is varied to make the garment the correct size. The gauge will usually vary from  $\frac{1}{2}$ " for large sizes to  $1 \frac{1}{4}$ " for smaller sizes. Therefore, it is necessary for a machine operator to be able to read a ruler to the nearest sixteenth of an inch.

Zelda was told that she was to set the gauge as accurately as she could. Do you think she could have been exact in the measurements?

Measure the following line segment to the nearest inch.



Now that you have discussed the above problem measure the following line segments to the nearest inch.

a.



ans. \_\_\_\_\_

61

b.  ans. \_\_\_\_\_  
\_\_\_\_\_

c.  ans. \_\_\_\_\_  
\_\_\_\_\_

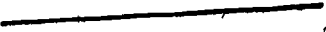
d.  ans. \_\_\_\_\_  
\_\_\_\_\_

**Problems:**

In each of the following problems measure the line segment to the nearest unit indicated. Also, give the fractional part of your measurement could be off (possible error.)

**Example:**

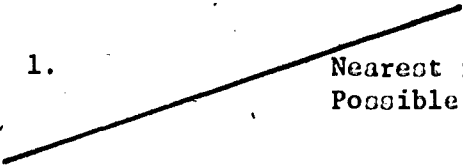
1.  Nearest inch 3"  
Possible error 1/2"

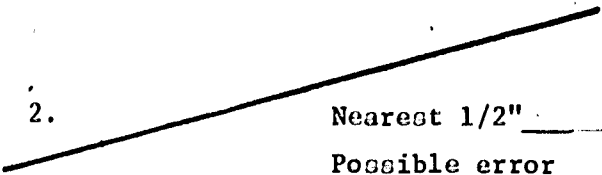
2.  Nearest 1/2" \_\_\_\_\_  
Possible error \_\_\_\_\_

3.  Nearest 1/4" \_\_\_\_\_  
Possible error \_\_\_\_\_

4.  Nearest 1/8" \_\_\_\_\_  
Possible error \_\_\_\_\_

5.  Nearest 1/16" \_\_\_\_\_  
Possible error \_\_\_\_\_

6.  Nearest 1/2" \_\_\_\_\_  
Possible error \_\_\_\_\_

#### 4. Pattern Cutter and Marker

Before any sewing can be done it is necessary for someone to lay out the desired pattern and to make sure it is cut properly. This particular job can pay as high as \$6.00 an hour. Can you think of any reasons why this job should pay so much more than that of a sewing machine operator. It is the responsibility of the "pattern marker" to select the material from stock and to lay out the pattern with the least amount of waste as possible. This is so that as many garments as possible can be obtained from a roll of material.

Material comes in large rolls and is measured in terms of linear yards. The smallest unit of measure used varies, but is usually  $\frac{1}{8}$  of a yard or  $\frac{1}{10}$  of a yard. The width of the material is also in standard widths. These are usually 36", 44" and 60". Thus, when selecting material you have to think of two measurements, what width do you need and how long. For example if a pattern calls for  $3 \frac{1}{8}$  yards of 44 inch material it would look like this:

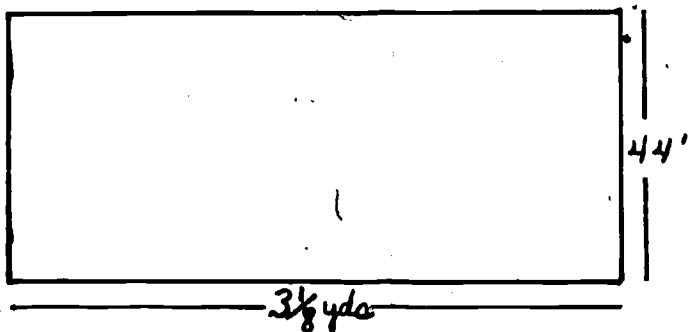

Of course in a clothing mill the cutter does not just work with just one outfit at a time. He will lay out an entire roll of material on a large cutting table before he lays

out the pattern. An illustration of the material lay out follows:

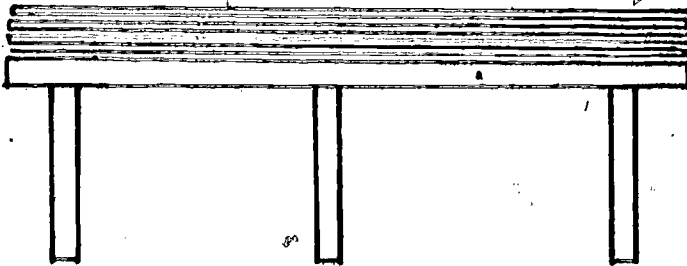

Once he has layed out the material he would roll out the pattern on top of the material, mark the pattern and then cut through all of the material at once. As you can see, he would be cutting out a large number of outfits at one time.

Look back at this illustration above and find out how many lanier yards of material there are in the layout (there are 7 layers of material, 45 feet each).

If a pattern called for 3 yards of this material, how many outfits would you get from this layout?

Problems:

In each of the following problems we will use the same table as in the illustration (45' long).

1. If the pattern cutter layed out 12 layers of material and each dress required  $3 \frac{1}{2}$  yards of material, how many dresses can he get in this situation?
2. There were 15 layers of material on the table. Each pant suit required 4 yards, how many pant suits can be obtained?



3. Find the number of layers of material, if the cutter had layed out 270 yards of material.
4. If 81 yards of material had been layed out and an outfit required  $3 \frac{1}{8}$  yards, how many can be cut. Would there be any waste?
5. How many outfits, requiring  $4 \frac{1}{4}$  yards each, can be cut from 320 yards of material. Would there be any waste?

---

IT'S A RIP OFF

---

Look at the addition problem below. Replace each of the  with the same digit, so the sum is correct.

$$\begin{array}{r}
 3, \square 5 2 \\
 1, 0 7 \square \\
 5, 4 \square 2 \\
 \hline
 \square 7 3 \square \\
 1 \square, 9 2 \square
 \end{array}$$

## 5. Cost of Garments

When a company sells a garment they must take into account what it cost them to make it. This includes wages payed to workers, over head (rent, lights, heat, etc.) and the cost of material. For example, a dress takes  $4 \frac{1}{8}$  yards of material and the material cost \$3.28 a yard. The material cost for the dress is:

$$\$3.28 \times 4 \frac{1}{8} = \frac{\$3.28}{1} \times \frac{33}{8} = \frac{108.24}{8} = \$13.58$$

What would the material cost for a pair of pants, if the pants require  $3 \frac{1}{4}$  yards of material costing \$2.75 per yard?

Can you think of any thing else that would go into the cost of making clothing? Now that you have discussed some of the items that add to the cost of making clothes, find the cost of each of the following pieces of wearing apparel.

1. To make a pair of men's pants it requires the following:

3  $\frac{1}{4}$  yards of material at \$2.40 per yard

1 zipper at 50¢

3 buttons, 5¢ each

Find the total cost of material.

2. The material required for a ladies blouse is:

2  $\frac{1}{2}$  yards of material at \$1.75 per yard

6 buttons at 3 for 10¢

1  $\frac{1}{2}$  yards of interfacing 50¢ per yard

Find the cost of materials.

3. A ladies pant suit requires

1 zipper 42¢

6  $\frac{1}{2}$  yards of material at \$2.15 per yard

3  $\frac{1}{2}$  yards of lining at \$1.15 per yard

2 yards of interfacing at 50¢ per yard

What is the total cost of material?

### Mission Incredible

This is your assignment, should you choose to accept it. You are to bring a pattern from home or go to a "sewing center" and look at a pattern and answer the following.

- a) How much material does it require?
- b) What other items are needed to finish the article of clothing?
- c) Find out the price of materials.
- d) Compute the cost of making the garment.

Bring back this information to class and share your results. How does the cost compare to buying the articles in a store?

## 6. Waste

There are several ways that waste of material can occur, but one of the most costly is to use material too wide for the pattern. For example, if the pattern calls for 44 inch material and the cutter uses 60 inch material, he is wasting a strip of material 16" wide.

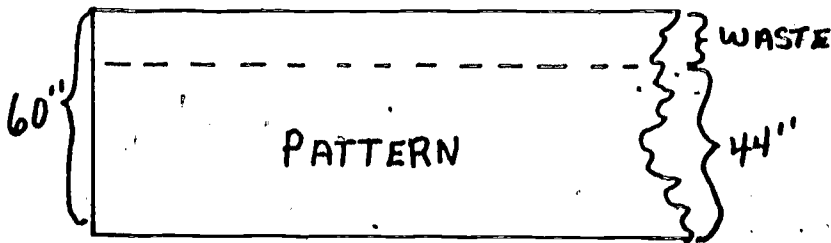

Can you find out how many square feet of material he would waste if the piece he is cutting is 45 feet long?

### Example 2

If the material is 44 inches wide and the pattern called for 36 inch, what would be the number of square feet wasted on a piece 80 feet long?

### Problems:

Find the number of square feet of waste in each of the following

|   | Pattern width | Material width | Material length |
|---|---------------|----------------|-----------------|
| 1 | 44"           | 60"            | 150ft           |
| 2 | 36"           | 44"            | 210ft           |
| 3 | 36"           | 60"            | 110ft           |
| 4 | 36"           | 44"            | 500ft           |

5. If the material, in each of the above, cost 60¢ a square foot, what is the cost of the waste in each of the four problems?

STUDENT'S MANUAL

BEING SELF-EMPLOYED:  
HARVESTING AND SALE OF PULPWOOD

Being Self-Employed:  
Harvesting and Sale of Pulpwood.

Mike Stewart

1. Beginning to Learn The Business

When Mike Stewart left high school he went to work for a pulpwood producer. A pulpwood producer is a man who cuts wood in the forest and transports it to a pulpwood yard. He may work with two other men or he may have several crews working at the same time. When he brings his pulpwood to the yard he will sell it to a dealer who delivers it to a paper mill.

Mike earned \$1.75 per hour cutting and loading pulpwood in the forest. He went with Mr. Sams each day in his truck and cut down trees, trimmed the branches and stacked them on the truck using a "big stick loader". Mike liked this job because he liked to operate machinery and work out doors. He always felt good in the woods. Would you like this kind of job? Mike thought that he might make more money if he ran the crew, rather than working for someone else. What would Mike gain by going into business for himself? What would he lose?

If Mike decides to go into the pulpwood business for himself, what should he know about the business? Discuss this and make a list of the things you think Mike should know.

---

---

---

---

---

---

---

---

GRUMP

|       |         |
|-------|---------|
| 435   | 3,407   |
| 3,297 | - 1,988 |
| 85    |         |
| + 651 |         |

259 / 85,961

|      |
|------|
| 238  |
| x 47 |

## 2. Harvesting By The Cord

Mike began to watch the business very closely. He knew that he would need all the knowledge and all the experience he could get to make a profit when he went into business for himself. "If a man with money meets a man with experience, the man with the experience gets the money and the man with the money gets the experience."

He observed that wood is measured by a unit called a cord. One cord of wood is a stack 4 feet high, 4 feet wide and 8 feet long. The wood is in the form of round logs.

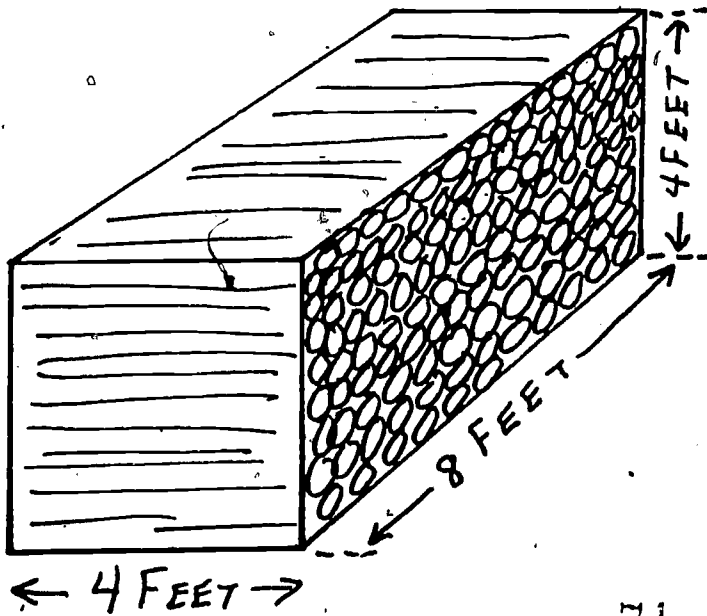

ONE CORD

71

69

Of course, you wouldn't find a cord stacked this neatly most of the time. This is just to give you the idea. How many cubic feet are in the dimensions of a cord?

How many cords of wood are in each of these stacks?

1. A stack 4 feet high, 8 feet long and 6 feet wide.
2. A stack 6 feet high, 12 feet long and 4 feet wide.
3. A stack cut for fireplace wood: 5 feet high, 10 feet long and 18 inches wide.
4. A stack of long logs: the logs are 10 feet long and they are stacked in a pile 6 feet wide and 4 feet high.
5. A stack 12 feet long, 5 1/2 feet wide and 3 feet high.
6. A stack 10 feet long, 4 feet wide and 2 1/2 feet high.



### 3. Units for Cutting and Sale

When cutting trees in the woods Mike was told to cut logs 5 feet 3 inches long. Mike said "Wouldn't it be easier to figure cords if we cut the logs 4 feet long?" Mr. Sams said, "It would be but we can't sell our wood unless we cut it 5 feet 3 inches long. The wood dealer would not buy it any other length." Can you guess why pulpwood is all cut in 5 foot 3 inch lengths? What reasons could there be for this? Think of the places you have seen wood stacked. What is done with it?

A cord is a stack of wood which is 4 ft. x 4 ft. x 8 ft. How many cords in a stack which is 4 feet high, 5 feet 3 inches wide and 8 feet long?

(Remember The Answer)

In some areas, wood is sold by the "unit".

A unit is a pile 4 feet x 5 ft. 3 in. x 8 ft.

It is like a cord, except of course it is larger than a cord. How much bigger is a "unit" than a cord? What could you use as a "multiplying factor" to change units to cords?

How would you change cords to units?

Wood is also sold by the ton, by the unit, by the cord and by the "cunit". A ton is 2,000 lb., a unit is a pile 4' x 5'3" x 8', a cord you already know, and a cunit is 100 cubic feet. This varies widely from place to place.

MISSION. INCREDIBLE

1. This is your assignment, should you choose to accept it. A cord of wood is not all wood. There are air spaces around the logs which are not filled with wood. Find the volume of wood and the volume of air in a stacked cord of wood.

Volume of a cord \_\_\_\_\_

Volume of wood \_\_\_\_\_

Volume of air \_\_\_\_\_

Suggestion: Assume a cord is made of all the same size sticks, round and stacked like this

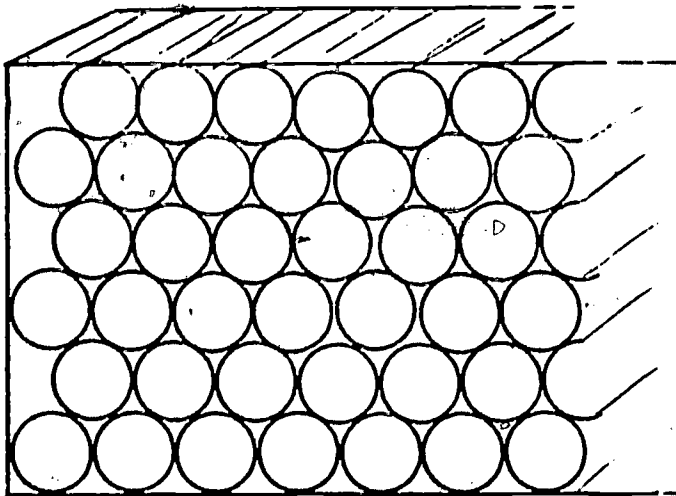

2. Collect enough small sticks to make a "scale model" of a cord of wood. You might make your model 1 foot long by 6 inches high by 6 inches wide. Bring this for display in class.

One unit of pine pulpwood is equal to 7,022 lb. What is the weight of a cunit of pulpwood? What is the weight of a cord of pulpwood. What is the weight of a ton of pulpwood.

GRUMP

$$\begin{array}{r} 2\frac{3}{4} \\ + 5\frac{5}{6} \\ \hline \end{array} \qquad \begin{array}{r} 4\frac{2}{3} \\ - 1\frac{4}{5} \\ \hline \end{array}$$

$$3\frac{2}{5} \times 1\frac{1}{2} =$$

$$4\frac{2}{3} + 1\frac{3}{5} =$$

#### 4. How Much Is Your Wood Worth?

When Mike went with Mr. Sams to the pulp-  
yard he watched the man measure the wood while  
it was on the truck. The bed of the truck was  
16 feet long the the wood was piled about 6  
feet high.



The wood was cut to the standard 5 foot 3  
inch length. The man at the wood yard did  
some calculations on an old envelope on the  
hood of the truck. He turned to Mike and  
said "How many cords do you reckon this is,  
Mike?" Mike said "I have it figured to

about \_\_\_\_\_." Can you fill in the number of cords for Mike? Work it out.

Mr. Sams showed Mike the ticket and the check when he came out of the office. Look at the ticket on the next page. Look now!

Have you examined the form? What questions would you want to ask about the ticket? List your questions here.

---

---

---

---

---

Mr. Sams gets \$33.00 per cord before deductions. This figure will vary widely from place to place. Close to a mill where wood is scarce a producer may get more than this. In the mountains of North Georgia where there is plenty of wood and no mills a producer may get much less. Calculate the pay, at \$33.00 per cord for the following loads. All the wood in these loads is cut 5'3" long.

1. A truck 18 feet long loaded 4 feet high.
2. A truck 12 feet long loaded 4 feet high.
3. A truck 20 feet long loaded 5 feet high.
4. A truck 16 feet long loaded 8 feet high.
5. A truck 20 feet long loaded 6 feet high.

Stumpage  
 Name J. J. Manning  
 Rate 18 / cord

VALDOSTA PULPWOOD YARD  
 Rt. 4, Box 297  
 Valdosta, Georgia

Producer Mc. L. Sams  
 Cords: 3.9 x \$33.

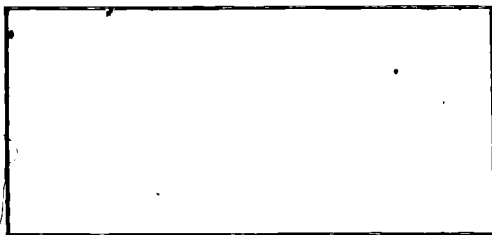

|            |                 |
|------------|-----------------|
| Total      | <u>\$128.70</u> |
| Stumpage   | <u>70.20</u>    |
| Truck      | <u>7.80</u>     |
| Saw        | <u>1.95</u>     |
| Account    | <u>- 0 -</u>    |
| Total Ded. | <u>79.95</u>    |
| Paid       | <u>48.75</u>    |

VALDOSTA PULPWOOD YARD  
 Rt. 4, Box 297  
 Valdosta, Georgia

VALDOSTA CENTRAL BANK  
April 12, 1974

Pay To The Order Of. L. Sams \$ 48.75  
 Exactly Forty eight and 75/100 dollars

XXX SAMPLE XXXXXXXXXXXXXXXXXXXXXXXXXXXXXXXXXX

096-082-04-00

It's A Rip Off

Do these addition problems: When you see a pattern or a short cut, stop adding and use the short cut!

1 = \_\_\_\_\_

1 + 3 = \_\_\_\_\_

1 + 3 + 5 = \_\_\_\_\_

1 + 3 + 5 + 7 = \_\_\_\_\_

1 + 3 + 5 + 7 + 9 = \_\_\_\_\_

1 + 3 + 5 + 7 + 9 + 11 = \_\_\_\_\_

1 + 3 + 5 + 7 + 9 + 11 + 13 = \_\_\_\_\_

1 + 3 + 5 + ... (50 odd numbers) ... + 99 = \_\_\_\_\_

Doggone!



77

## 5. Financing Truck and Saw

Mike wondered about the deductions for truck and saw on the Pulpwood Receipt. Mr. Sams explained that he bought the truck and the saws he was using on "time". The credit was arranged so that the payment was deducted from the money he was paid for the wood.

"How much do they take out?", Mike asked. Mr. Sams explained that they take a certain amount per cord of wood he sells. Using the pulpwood receipt, calculate the deduction for each cord of wood for the saw and the deduction for the truck.

Mr. Sams Paid \$225.00 for each of the 3 saws they use on the job. He put 25% down and the remainder is being deducted from his earnings at the rate you figured above. How many cords will Mr. Sams have to cut to pay for the saws at that rate?

Mr. Sams paid \$2,400.00 for a used truck when he went into the business. How many cords of wood will he have to cut to pay for the truck?

GRUMP

$$43 + 982 + 1,256 + 85 + 273 = \underline{\hspace{2cm}}$$

$$43,072 - 9889 = \underline{\hspace{2cm}}$$

$$2,437 \times 198 = \underline{\hspace{2cm}}$$

$$2,946 \div 157 = \underline{\hspace{2cm}}$$

### MISSION INCREDIBLE

Here is your mission, should you choose to accept it. You and 1 or 2 friends check the yellow pages under saws and list several places in your town where chain saws are sold. Visit one of these places and, when the salesman is not busy, explain to him that you are studying the pulpwood business and would like to look at a good chain saw.

Plan the questions you want to ask about it. Bring the information back to class. Here are some questions you might ask:

How much does it cost?

If you can't pay it all, can it be financed?

How long will it last in steady use?

What safety features does it have?

6 & 7. Stumpage, Acres

"Stumpage" is the money paid to the owner of the land on which the wood is growing. Stumpage is very different in different sections of the country and even in different parts of the state. In Georgia it may vary from less than \$9.00 per cord to more than \$30.00 per cord. Try to think of reasons why the price paid for this basic resource should vary so much in Georgia. Discuss. List your reasons:

---

---

---

---

---

---

---

---

As Mike and Mr. Sams worked on various jobs, Mike learned about the economics of growing the wood, as well as harvesting it. Mike was told by a tree farmer that most "planted" forest land would produce 10 to 15 cords per acre, more or less, depending on the land. Mike wasn't too clear about acres so he looked it up. You look up the definition of acre and write it here?

---

---

---

---

Now, you know what an acre is compared to a square foot. How big is an acre compared to a square



mile? Is it larger or smaller than a square mile?

How many acres in one square mile?

Calculate the number of acres in each of the following areas.

1. 475 feet x 850 feet
  - a. Estimate \_\_\_\_\_
  - b. Answer \_\_\_\_\_
2. 2,570 feet x 1,400 feet
  - a. Estimate \_\_\_\_\_
  - b. Answer \_\_\_\_\_
3. 1,500 feet x 950 feet
  - a. Estimate \_\_\_\_\_
  - b. Answer \_\_\_\_\_
4. 350 feet x 1,975 feet
  - a. Estimate \_\_\_\_\_
  - b. Answer \_\_\_\_\_
5. 2,750 feet x 1,750 feet
  - a. Estimate \_\_\_\_\_
  - b. Answer \_\_\_\_\_

Calculate the value, to the owner, of standing timber. Take 10 acres at 12 cords per acre and \$18.00 per cord "stumpage."

Calculate the value of the standing timber to the owner, in each of these problems:

1. A stand of 15 acres with 14 cords per acre and \$18.00 stumpage.
2. A stand of 30 acres averaging 9 cords per acre and \$12.50 stumpage.
3. A stand of  $11\frac{1}{2}$  acres with 14 cords per acre and \$21.50 stumpage.

GRUMP

|                      |                      |
|----------------------|----------------------|
| 34.95                | 39.604               |
| 2.78                 | <u>- 12.937</u>      |
| 16.4                 |                      |
| 3.75                 |                      |
| <u>+ 14.0</u>        |                      |
| 3.62 / <u>19.487</u> | 43.5<br><u>x .19</u> |

8 & 9. How Much Can You Make?

Mike is beginning to get an idea of how wood is cut, measured, and sold. He knows how much it will bring in the pulpwood yard and how much the owner of the land gets. But how much, he wonders, can you earn by steady work as a pulpwood producer?

He looks at it this way: Take a week's work in harvesting pulpwood, deduct expenses, and let's see what's left. That would be my profit if I were a pulpwood producer. Mike kept track of the deliveries Mr. Samo made to the pulpwood yard during one week:

| <u>day</u> | <u>loads</u> | <u>ords</u>   |
|------------|--------------|---------------|
| Monday     | 2            | 3.4, 3.8      |
| Tuesday    | 3            | 3.2, 3.6, 2.9 |
| Wednesday  | 2            | 3.7, 4.1      |
| Thursday   | 3            | 3.6, 2.9, 3.7 |

Go back and look at the pulpwood receipt on page 75. Use that form to figure out how much money Mr. Sams will make on each load.

If 3 or 4 people get together in a group and these problems you will get done faster.

Cash after Deductions:

|              |     |       |
|--------------|-----|-------|
| Monday       | 3.4 | _____ |
|              | 3.8 | _____ |
| Tuesday      | 3.2 | _____ |
|              | 3.6 | _____ |
|              | 2.9 | _____ |
| Wednesday    | 3.7 | _____ |
|              | 4.1 | _____ |
| Thursday     | 3.6 | _____ |
|              | 2.9 | _____ |
|              | 3.7 | _____ |
| Week's Total |     | ===== |

Now we know how much Mr. Sams get when he sold the wood he had cut. What expenses are already paid for him?

\_\_\_\_\_

\_\_\_\_\_

\_\_\_\_\_

What other expenses does Mr. Sams have in doing business? Estimate how much each expense you think of will cost him.

\_\_\_\_\_

\_\_\_\_\_

\_\_\_\_\_

How much did Mr. Sams earn that week?  
Could he make that much at a regular job?

GRUMP

$$35.2 + 47.9 + 296.83 + 46. + 0.39 = \underline{\hspace{2cm}}$$

$$29.61 \times 3.4 = \underline{\hspace{2cm}}$$

$$304.7 - 197.34 = \underline{\hspace{2cm}}$$

$$43.79 \div 296.1 = \underline{\hspace{2cm}}$$

#### 10. Growing Wood: Cords Per Acre

Mike knew how much the owner of the land got for stumpage: \$18.00 per cord. But he did not know how much money a man could make from an acre of land planted in trees or how long it would take to grow them.

When he looked up this information he found that "wild land" will grow from 1/2 to 1 cord per acre per year, depending on soil, water, and climate. A plantation or tree farm which is planted and managed will grow from 1 to 2 cords per acre per year. Again, this will depend on soil, water and climate. A stand of pine will grow in 20 years, or sometimes less. After 20 years, how many cords of wood would you get from an acre of wild land?

Least expected:                     

Most expected:                     

After 20 years, how many cords would you get from an acre of land in a planted and managed forest?

Least expected:                     

Most expected:                     

A farmer plants 20 acres in trees, which he expects to harvest in 20 years. At \$18.00 per cord stumpage how much can he expect to get for

his wood in 20 years?

Most expected: \_\_\_\_\_

Least expected: \_\_\_\_\_

How much did he make per acre per year for the time his land was used to grow the trees?

Most expected: \_\_\_\_\_

Least expected: \_\_\_\_\_

### GRUMP

42% of 9,375 = \_\_\_\_\_

14 is \_\_\_\_\_% of 56.

28% of a number is 14.

What is the number? \_\_\_\_\_

### 11. Finding Wood: Estimating the height of a tree

One of the things that Mr. Sams needs to do to keep his business going is to find land owners who have wood and want to sell it. He will then estimate how much wood a man has on his land and how long it will take to harvest it. What will tell you how much wood a man has on his land? What would you need to know to estimate?

There are several easy ways to get an estimate of the height of an object. One of them is by shadow measurement.

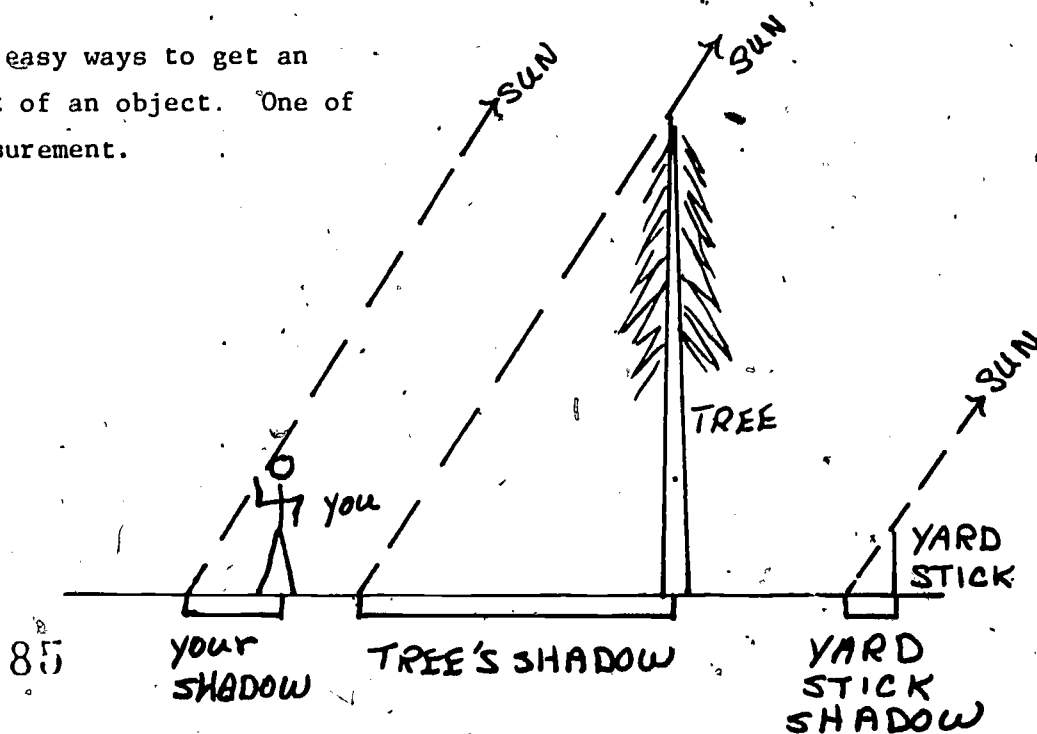

Objects and their shadows at any particular time, form the same fraction so,

$$\frac{\text{Your Height}}{\text{Your Shadow}} = \frac{\text{Tree Height}}{\text{Tree Shadow}}$$

or, if you have a yard stick,

$$\frac{\text{Yard Stick}}{\text{Yard Stick Shadow}} = \frac{\text{Tree Height}}{\text{Tree Shadow}}$$

Let's invent one for practice: you are 5'5" tall.

You measure your shadow and find it is 3'4" long.

You measure the shadow of a tree and find it is

28 feet long. How tall is the tree?

Solving the same kind of problem is easier and more accurate with a yard stick. Try this one: The shadow of the yard stick was 48 inches long at the time the shadow of the tree was 76 feet. How tall is the tree?

### MISSION INCREDIBLE

Choose some prominent land marks around town and around your school. Church towers, trees, the school chimney, etc., would all be good. Measure their heights using shadow measurement. For a building you may have to estimate part of the shadow length. Make a bulletin board display showing these heights on a graph like the one below.

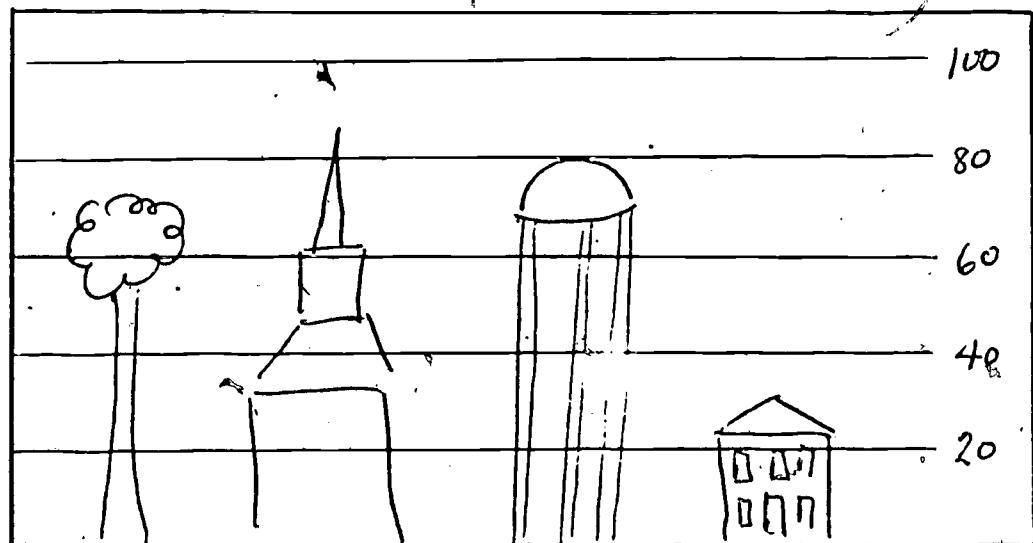

Work these problems:

1. My height: 5'10"  
My Shadow: 4'2"  
Tree's Shadow: 47 feet.
  
2. My height: 5'2"  
My Shadow: 7'6"  
Tree's Shadow: 91 feet.
  
3. My height: 6'  
My Shadow: 4'4"  
Tree Shadow: 61 feet.
  
4. Yard Stick's Shadow: 30"  
Tree's Shadow: 42 feet.
  
5. Yard Stick's Shadow: 39"  
Tree's Shadow: 21 feet.

12. Estimating Working Time

Mr. Sams has located a stand of trees which the owner wants to sell. This is a large irregular area shown on page 20. Mr. Sams inspects the property and estimates the height of the trees. After looking the property over he thinks that there are about 15 cords per acre on this land. "Mike," he asks, "about how many acres do you think there are in this area?" Mike said, "Well, I can't figure it very close because of that creek, but I can get a good estimate. Look at drawing #1 on page 20. Can you estimate the number of acres on this land? Try it now. Work in groups if you wish. The drawings on page are drawn to scale 1 inch = 200 feet.

Now... how many acres do you think are in the first property? How many cords of wood will come out of that forest?

acres: \_\_\_\_\_ cords: \_\_\_\_\_



#1

HOUSE AND  
BARN

THIS LOT WILL  
YIELD ABOUT 15  
CORDS PER ACRE

1" = 200'

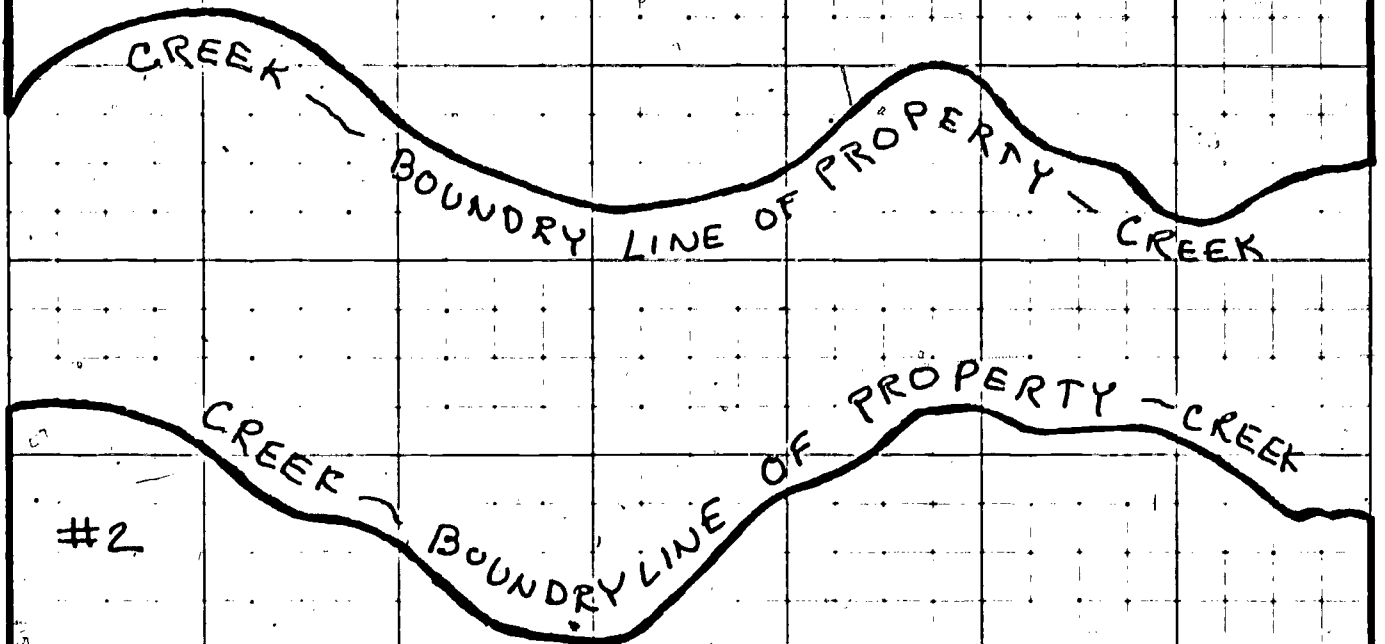

#2

THIS LOT WILL YIELD  
ABOUT 11 CORDS PER  
ACRE

1" = 200'

HOUSE  
AND  
YARD

CULTIVATED

Look back to the information contained in lessons 8 and 9. How long will it take Mr. Sams and his crew to harvest the wood on this land? How much will the owner of the land get for his wood and how much will Mr. Sams earn? Get together in a group to work out the answers to these questions. Use a calculator if one is available.

(If you need more space, work on the backs of pages.)

13. A Chance to be "Self-Employed."

Mike now has an opportunity to become a pulpwood producer himself. He can harvest the wood in lot #2, pictured on the last page. It is not as good a stand of trees but should yield about 11 cords per acre. Should Mike do it? How long will it take him to get the wood out of that lot?

How much will he make if he pays two helpers each  
\$1.75 per hour and works 48 hours per week?

14. Summary and Discussion

What do you think about the pulpwood business?

Would you do what Mike did, learn the business  
and buy a truck to get into it?

STUDENT'S MANUAL

LUMBER YARD EMPLOYEE

## Lumber Yard Employee

Frank Johnson

### 1. Discussion of Job

Frank has been hired to work in a lumber yard. His job requires him to wait on customers, fill orders, and make out the bills for the orders. On his first day on the job Frank found out there were a lot of things he didn't know about selling lumber. He found out that there were many different ways of pricing different products. For example, nails are sold by the pound. Can you think of any other ways that items in a lumber yard would be priced? Make a list in the space on the right of other ways you think items may be priced.

After you have completed your list, you will have a chance to discuss this in class.

When a product is priced it is usually stated like the following:

Common Nails...\$.30 per pound

House paint....\$5.95 per gallon

When pricing a product, the price is usually given for "one unit" like gallon, pound, foot. What would it cost a customer to purchase 5 gallons of paint at the above price? (Don't forget to add the tax)

### 2. Lumber Yard Price List

When Frank began work the manager gave him a price list to help him make out the sales slips for the customer. When Frank looked at the list he saw several words and terms that he didn't know. Are there any that you do not understand?

The manager told Frank he would not be expected to know all the new terms right away. He could learn them as he went along on his new job.

What other jobs could he do in the lumber yard besides filling orders?

3. Making Out Sale Receipt

Frank was given the following order to fill.

| BUILDER SUPPLY CO. |                     |           |  |
|--------------------|---------------------|-----------|--|
| #                  | Description         | Unit Cost |  |
| 6 lb.              | Common Nails        |           |  |
| 2 lb.              | Finish nails        |           |  |
| 9                  | 3/4 x 4 x 8 Plywood |           |  |
|                    |                     |           |  |
|                    |                     |           |  |
|                    | Total               |           |  |
|                    | Tax (3%)            |           |  |
|                    | Total               |           |  |

Once Frank had loaded the order on the man's truck he had to figure out the cost of the order. (Use your price list to complete the sales receipt).

First, he found out that the common nails were how much per pound? a per pound.

How much would the six pound of nail cost?

b

The finish nails cost how much per pound?

c Then the 2 pounds costs how much? d

Finally, the plywood costs e per sheet and the 9 sheets would cost          in all.

What was the total cost of the building materials? f. Frank then completed the receipt by figuring the 3% tax and adding it to the cost of the materials. What total should he have gotten?

Using the price list on the next page, find the cost of each of the following orders.

BUILDERS SUPPLY CO.

| #      | Description        | Unit Cost |  |
|--------|--------------------|-----------|--|
| 4 lbs. | common nails       |           |  |
| 12     | 1/4x4x8 AC plywood |           |  |
|        |                    |           |  |
|        |                    |           |  |
|        |                    |           |  |
|        |                    |           |  |
|        |                    |           |  |
|        |                    |           |  |
|        | Total              |           |  |
|        | Tax (3%)           |           |  |
|        | Total              |           |  |

BUILDERS SUPPLY CO.

| #      | Description        | Unit Cost |  |
|--------|--------------------|-----------|--|
| 5 gal. | White paint        |           |  |
| 4 lbs. | Finish Nail        |           |  |
| 15     | 3/4x4x8 AD plywood |           |  |
|        |                    |           |  |
|        |                    |           |  |
|        |                    |           |  |
|        |                    |           |  |
|        |                    |           |  |
|        | Total              |           |  |
|        | Tax (3%)           |           |  |
|        | Total              |           |  |

BUILDERS SUPPLY CO.

| #      | Description        | Unit Cost |  |
|--------|--------------------|-----------|--|
| 4      | 3/4x4x8 AC plywood |           |  |
| 8      | 1/4x4x8 AC plywood |           |  |
| 3 lbs. | Box nails          |           |  |
|        |                    |           |  |
|        |                    |           |  |
|        |                    |           |  |
|        |                    |           |  |
|        |                    |           |  |
|        | Total              |           |  |
|        | Tax (3%)           |           |  |
|        | Total              |           |  |

BUILDERS SUPPLY CO.

| #  | Description        | Unit Cost |  |
|----|--------------------|-----------|--|
| 14 | 3/4x4x8 AD plywood |           |  |
|    |                    |           |  |
|    |                    |           |  |
|    |                    |           |  |
|    |                    |           |  |
|    |                    |           |  |
|    |                    |           |  |
|    |                    |           |  |
|    | Total              |           |  |
|    | Tax (3%)           |           |  |
|    | Total              |           |  |

### MISSION INCREDIBLE

This is your mission, should you choose to accept it. Go to your local lumber dealer and ask for information on the price of materials sold in his lumber yard. Once you have obtained these prices, make a chart to be put up in the classroom so everyone can see what the different items would cost. (Get as many different prices as you can)



#### 4. Linear Feet

Frank was loading the truck for a delivery one day when he saw an item he didn't understand. The order asked for "100 linear feet of 2x4's." Frank decided that he better ask his boss before he loaded the wrong thing. Mr. Wood gave him the following examples to look at. Can you tell what "linear feet" means?

- a) a 2 x 4 x 12 feet has 12 linear feet
- b) a 2 x 4 x 24 feet has 24 linear feet
- c) a 2 x 4 x 14 feet has 14 linear feet

Frank looked at the examples and said, "You mean linear feet is just the same as the regular length of the board?" Mr. Wood said that's right, can you tell me how many linear feet there are in 3 - 2 x 4 x 12 feet? Frank said there must be 36 linear feet all together. Was Frank right?

Mr. Wood told Frank that the lumber only came in special lengths. The boards would be 8 feet, 10 feet, 12 feet, 14 feet, 16 feet, 18 feet, 20 feet, 22 feet and 24 feet in length. He also said they sometimes were longer but he didn't keep them in stock. What length do you think the next board would be?

Frank went back to load the truck and put the following 2 x 4's on the truck.

5 - 2 x 4 x 8 feet

5 - 2 x 4 x 12 feet

Did he have 100 linear feet of 2 x 4's on the truck?

Is there any other way Frank could have gotten 100 linear feet of 2 x 4's on the load?

Frank filled the following orders, find out how many linear feet of lumber went out in each order.

a) 8 - 2 x 4 x 12 feet  
7 - 2 x 4 x 16 feet  
12 - 2 x 4 x 10 feet

b) 20 - 1 x 4 x 16 feet  
30 - 1 x 4 x 8 feet

c) 25 - 1 x 12 x 14 feet

d) 20 - 1 x 12 x 14 feet  
8 - 1 x 12 x 16 feet

5. Board Feet (For 1 inch lumber)  
After sending out an order one day, Mr. Wood

called Frank into his office. He told Frank there had been a mistake in filling the order. The order called for 50 board feet of 2 x 6's and there was only half enough sent. Frank said he had put 50 linear feet of 2 x 6's on the truck, wasn't that the same thing. He was told there was a difference between board feet and linear feet. Mr. Wood said he would explain the differences to Frank.

Let's start at the beginning. One board foot means we have a piece of wood 1 inch thick x 12 inches wide and 1 foot long. Here's a picture of what one board foot of lumber would look like.

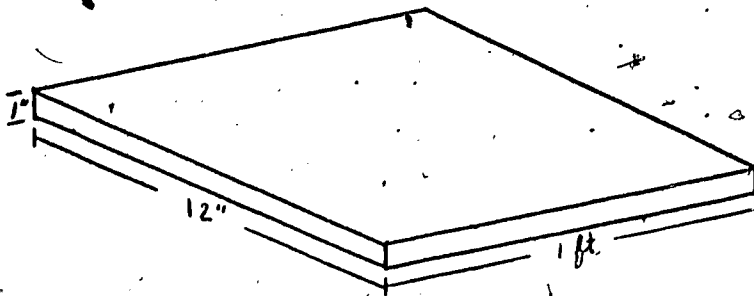

How many board feet would there be in a board 1" x 12" x 7 feet? Frank said, isn't this the same as the linear feet? Mr. Wood said it was in this case; but he would give another example. Let's look at a board 1" x 6" x 12".

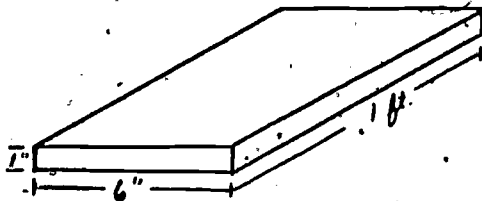

This board is 1 linear foot long, but it is not one board foot. Why?

Let's see if we can put together pieces of 1 x 6 so it will make a board foot. Can you think of how this could be done. Discuss your idea's in class before going on.

Did anyone try to do it like the picture below

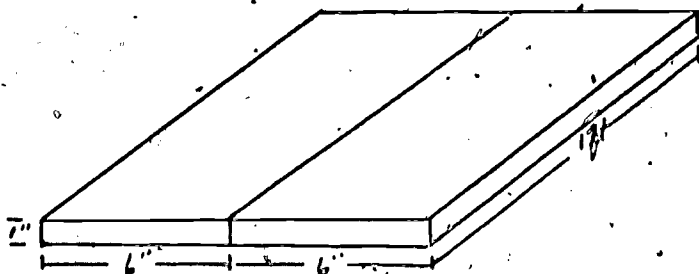

If you take 2 - 1 x 6 x 12" and put them together, they will make a board 1" x 12" x 12". Is this 1 board foot? Frank said he thought he had the idea for 1 x 6's. How about if I take a 1" x 6" x 4 ft. (he made a drawing) and put it together like this.

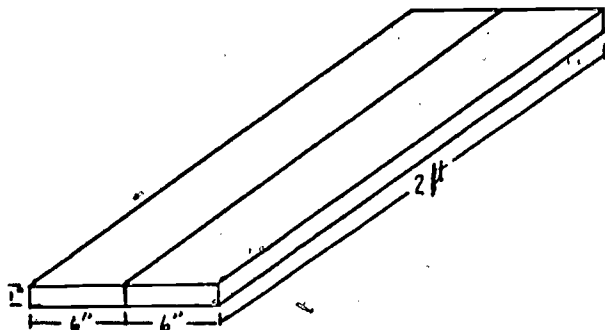

Wouldn't this give me 2 board feet of lumber? Mr. Wood told him that was correct. Frank said all he did was to think of cutting the board into two equal parts and putting them together.

Problems: Find the number of board feet in each of the following:

|    | <u>No. of Board</u> | <u>Size</u>    | <u>Board feet</u> |
|----|---------------------|----------------|-------------------|
| 1. | 2                   | 1"x12"x10 feet | _____             |
| 2. | 1                   | 1"x6"x14 feet  | _____             |
| 3. | 5                   | 1"x6"x14 feet  | _____             |
| 4. | 1                   | 1 x6 x20 feet  | _____             |
| 5. | 1                   | 1 x6 x8 feet   | _____             |

6. Board Feet (For 1 inch lumber con't)

Frank decided that if he could figure board feet for 1" x 12" and 1" x 6" boards he should be able to do the same thing for 1" x 4" boards. He figured it like this.

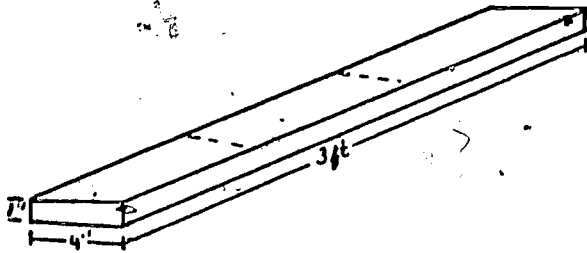

If I take a board 1" x 4" x 3 feet, I can cut it into 3 pieces, 1 foot long and put them together to make 1 board foot (1" x 12" x 1 foot). He tried

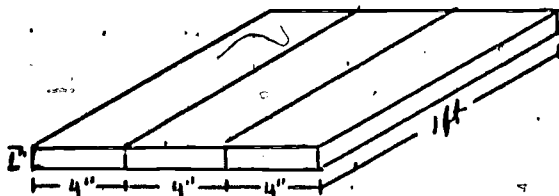

this same method for a board 1" x 4" x 6 feet.

How many board feet did he find?

Problems: Find the board feet in each of the following.

|    | <u>No. of Boards</u> |                 | <u>Board feet</u> |
|----|----------------------|-----------------|-------------------|
| 1. | 1                    | 1"x12"x12 feet  | _____             |
| 2. | 1                    | 1 x 6 x 12 feet | _____             |
| 3. | 1                    | 1 x 4 x 12 feet | _____             |
| 4. | 2.                   | 1"x12"x18 feet  | _____             |
| 5. | 2                    | 1"x6"x18 feet   | _____             |
| 6. | 2                    | 1"x4"x18 feet   | _____             |

Frank looked at some problems he had worked (see following list) and decided there was an easier way to find the number of board, without making a drawing.

| <u>Size</u>        | <u>Board feet</u> |
|--------------------|-------------------|
| 1" x 12" x 6 feet  | 6 board feet      |
| 1" x 12" x 18 feet | 18 board feet     |
| 1" x 6" x 6 feet   | 3 board feet      |
| 1" x 6" x 16 feet  | 8 board feet      |
| 1" x 4" x 6 feet   | 2 board feet      |
| 1" x 4" x 9 feet   | 3 board feet      |

What do you think Frank had come up with?

Problem: Find the number of board feet in each of the following.

|    | <u>No. of boards</u> | <u>Size</u>     | <u>Board feet</u> |
|----|----------------------|-----------------|-------------------|
| 1. | 2                    | 1 x 4 x 6 feet  | _____             |
| 2. | 10                   | 1 x 6 x 12 feet | _____             |
| 3. | 1                    | 1 x 2 x 12 feet | _____             |
| 4. | 18                   | 1 x 12 x 8 feet | _____             |
| 5. | 4                    | 1 x 2 x 10 feet | _____             |
| 6. | 4-4                  | 1 x 6 x 8 feet  | _____             |

7. Board Feet (For 1 inch lumber cont'd)

Frank figures since he could find the board feet for 1 x 2's, 1 x 4's, 1 x 6's and 1 x 12's, he should be able to do the same for 1 x 8's. He decided to work just like he did for the other widths. "I'll just imagine cutting the board and make a piece 1" x 12" x 1 foot and see what happens." The following drawings show how he did his work.

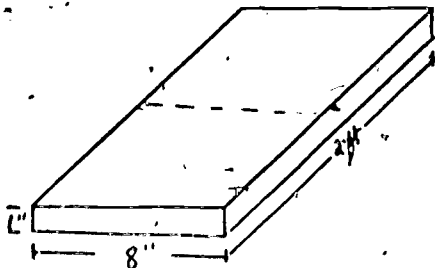

Frank started with a board, 1" x 8" x 2 feet and cut it into 1 foot lengths.

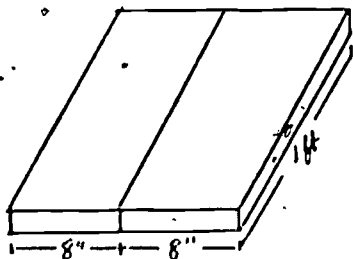

This gave him a piece 1" x 16" x 1 foot.

Step 3. Frank figures that if he could get a piece 1" x 12" x 1 foot (1 board foot) he would try for 2 board feet. So he took 1" x 8" x 3 feet and cut it like the following drawing and then put them together

---

It's A Rip Off

(1) Write down a three digit number where the hundreds digit is larger than the ones digit. Example 842

(2) Reverse the digits and subtract

$$\begin{array}{r} 842 \\ - 248 \\ \hline 594 \end{array}$$

(3) Reverse the digits and add

$$\begin{array}{r} 594 \\ + 495 \\ \hline 1,089 \end{array}$$

(4) What did you get?

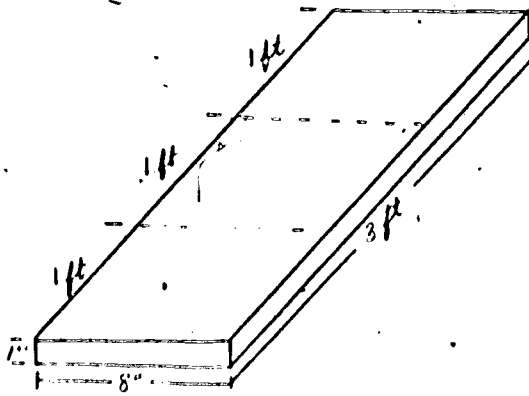

like the drawing below.

Step 4.

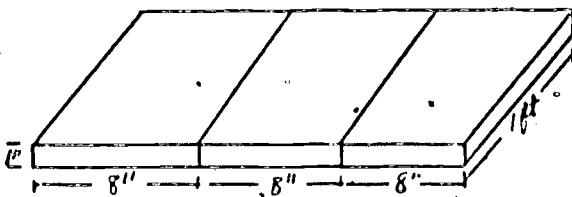

Frank thought, "I've got a board 1" x 12" x 2 feet, that's the same as 2 board feet. It takes a 1" x 8" x 3 feet to make 2 board feet." What do you think Frank tried next?

Frank decided there must be some sort of patterns for 1 x 8's. He didn't want to have to keep putting pieces of board together to work out board feet for a 1 x 8. He kept the following table to see if he could find the pattern.

| <u>Size</u> | <u>Board Feet</u> |
|-------------|-------------------|
| 1 x 8 x 3   | 2                 |
| 1 x 8 x 6   | 4                 |
| 1 x 8 x 9   | 6                 |
| 1 x 8 x 12  | 8                 |



(cont'd)

| <u>Size</u> | <u>Board Feet</u> |
|-------------|-------------------|
| 1 x 8 x 15  | _____             |
| 1 x 8 x 18  | _____             |
| 1 x 8 x 21  | _____             |

Can you finish the table and find the pattern?

Remember: for 1 x 2's you took  $1/2 \times$  length.

1 x 4's you took  $1/3 \times$  length

1 x 6's you took  $1/2 \times$  length

Maybe there's a fraction you can multiply times the length for 1 x 8's.

Problems:

Find the number of board feet in each of the following:

|    | <u>No. of Boards</u> | <u>Size</u> | <u>Board Feet</u> |
|----|----------------------|-------------|-------------------|
| 1. | 4                    | 1 x 6 x 12  | _____             |
| 2. | 2                    | 1 x 8 x 12  | _____             |
| 3. | 2                    | 1 x 3 x 14  | _____             |
| 4. | 9                    | 1 x 4 x 12  | _____             |

It's a Grump

$$\begin{array}{r} 4.75 \\ \times 23 \\ \hline \end{array}$$

$$\begin{array}{r} 37.52 \\ \times 36 \\ \hline \end{array}$$

$$\begin{array}{r} 15.65 \\ \times 7.46 \\ \hline \end{array}$$

$$\begin{array}{r} .75 \\ \times .5 \\ \hline \end{array}$$

$$\begin{array}{r} 88 \\ \times .9 \\ \hline \end{array}$$

$$\begin{array}{r} 36 \\ \times .17 \\ \hline \end{array}$$

8. Pricing lumber by the board foot

Mr. Wood asked Frank to complete the inventory sheet on the following page. Mr. Wood needed to know how many dollars worth of lumber he had in stock. He told Frank that he had completed the count of the lumber but did not have it priced yet. This was to be Frank's job.

Complete the inventory sheet by finding the number of board feet and the total cost.

Use your price list to find the correct price for the lumber. Remember you're using board feet. You'll find an example worked on the top of the next page.

Problem Set:

Example: 12 - 1" x 8" x 18 feet (common pine)

Step 1: Board feet in one 1 x 8 x 18 is

$$\frac{2}{3} \times \frac{18}{1} = \frac{36}{3} = 12 \text{ board feet}$$

Step 2: Since there are 12 boards the total board feet is

$$\begin{array}{r} 12 \\ \times 12 \\ \hline 24 \\ \hline 12 \\ \hline 144 \text{ board feet} \end{array}$$

Step 3: The price of 1 x 8 common is \$.48 a board foot. So the total cost is

$$\begin{array}{r} 144 \\ \times .48 \\ \hline 1152 \\ \hline 576 \\ \hline \$69.12 \end{array}$$

| No. of Boards | Size of Board            | No. of Board ft. | Price per Board foot | Total Cost |
|---------------|--------------------------|------------------|----------------------|------------|
| 12            | 1"x8"x18' (common pine)  | 144              | 48                   | \$ 69.12   |
| 15            | 1"x6"x12' (common pine)  |                  |                      |            |
| 50            | 1"x12"x10' (common pine) |                  |                      |            |
| 25            | 1"x4"x20' (common pine)  |                  |                      |            |
| 20            | 1"x8"x12' (common pine)  |                  |                      |            |
| 14            | 1"x10"x12' (common pine) |                  |                      |            |

9. Board Feet (For 2 inch lumber)

A board foot has been defined to be a board  
1" x 12" x 1 foot.

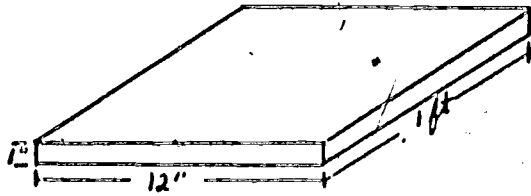

How many board feet would there be in a board  
2" x 12" x 1 foot? Would it be the same as a 1 inch  
board?

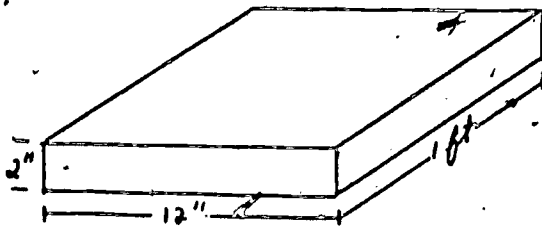

Discuss your solution with the class. Now try to find  
how many board feet there are in a board 2" x 6" x 1 foot.

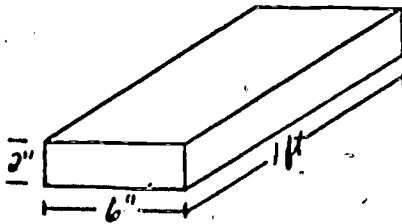

Look at the table on the following page and see if you  
can discover a way of finding the board feet in a 2"  
board.

Now, that you have studied the table complete the  
last four entries in each column. Can you explain how  
to find the board feet for a 2 inch board?

| Size               | Board Feet | Size               | Board Feet |
|--------------------|------------|--------------------|------------|
| 1" x 12" x 8 feet  | 8          | 2" x 12" x 8 feet  | 16         |
| 1" x 12" x 16 feet | 16         | 2" x 12" x 16 feet | 32         |
| 1" x 6" x 10 feet  | 5          | 2" x 6" x 10 feet  | 10         |
| 1" x 6" x 18 feet  | 9          | 2" x 6" x 18 feet  | 18         |
| 1" x 4" x 12 feet  | 4          | 2" x 4" x 12 feet  | 8          |
| 1" x 4" x 18 feet  | 6          | 2" x 4" x 18 feet  | 12         |
| 1" x 8" x 12 feet  | 8          | 2" x 8" x 12 feet  | 16         |
| 1" x 8" x 24 feet  | 16         | 2" x 8" x 24 feet  | 32         |
| 1" x 6" x 14 feet  | _____      | 2" x 6" x 14 feet  | _____      |
| 1" x 12" x 8 feet  | _____      | 2" x 12" x 8 feet  | _____      |
| 1" x 8" x 6 feet   | _____      | 2" x 8" x 6 feet   | _____      |
| 1" x 4 x 15 feet   | _____      | 2 x 4 x 15 feet    | _____      |

**Problem:**

Don't get fooled in working the following problems. Some are 1 inch boards and some are 2 inch boards. Find the number of board feet in each of the following:

| No. of Boards | Size              | Board Feet |
|---------------|-------------------|------------|
| 1. 2          | 1" x 6" x 12 ft.  | _____      |
| 2. 4          | 2" x 6" x 12 ft.  | _____      |
| 3. 8          | 2" x 12" x 16 ft. | _____      |
| 4. 1          | 2" x 8" x 12 ft.  | _____      |
| 5. 15         | 2" x 4 x 12 ft.   | _____      |

It's A Grump

$$\begin{array}{r}
 487 \\
 982 \\
 17 \\
 + 624 \\
 \hline
 \end{array}$$

$$37 \overline{) 4,672}$$

$$12\frac{1}{2} \times \frac{2}{3}$$

$$\begin{array}{r}
 4\frac{1}{2} \\
 - 2\frac{1}{4} \\
 \hline
 \end{array}$$

10. Selling cut lumber.

Frank found out it was possible for a customer to get lumber cut to size. This caused some problems when it came to finding out how much to charge for the materials. For example, one day Frank sold a piece of  $3/4$  inch AC plywood that was 2 feet by 3 feet.

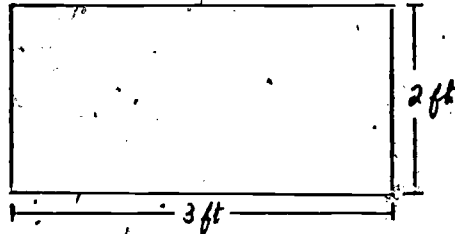

How do you think Frank could find out what it should cost?  
Stop --- Let's see if the class can come up with the answer.

A customer came into the lumber yard and wanted an estimate of what it would cost for the lumber to build a dog house. He gave Frank the following list of materials. Using your price list and what you have learned find the cost of the materials needed for the project.

MATERIALS LIST FOR DOG HOUSE

2 pieces 1/2" x 2 ft. x 3 ft. AC plywood  
2 pieces 1/2 x 2 ft. x 2 ft. AC plywood  
2 pieces 1/2 x 1 1/2 ft. x 3 ft. AC plywood  
1 piece 3/4 x 2 ft. x 3 ft. AC plywood  
2 lbs. Box nails  
2 qts. White paint

11. Keeping a running inventory.

Another responsibility that Frank was given was keeping a "running" inventory. This means that he must keep track of the lumber that is in stock. Frank was told he should check the inventory once every two weeks. Why do you think it would be important to make this kind of check?

The first time Frank took the inventory he counted all the lumber. However, he found this took too long. He thought maybe he could come up with a way to save himself some work.

Can you come up with a way that Frank could save time in taking his inventory?

Frank decides he could just measure the stack of lumber and then figure out how many pieces there was in the stack. Here's a situation Frank worked out. A stack of plywood was 30 inches high and each piece was 1/2 inch thick. So Frank said he would work it as follows.

$$30 \div \frac{1}{2} = \frac{30}{1} \times \frac{2}{1} = 60$$

This told Frank there were 60 pieces of 1/2" plywood in the stack. Why?

Problem:

Frank measured another stack of plywood and found it was 60 inches high. If each piece was 3/4 inch thick, how many pieces were there in the stack?

There was one thing that caused Frank some problems. He found that lumber wasn't always measured by what he thought it should. For example, a 1" x 4" board was really 3/4" x 3 1/2", a 1" x 6" board was really 3/4" x 5 1/2", and a 2" x 4" was really 1 1/2" x 3 1/2". What do you think the measurements of a 2" x 6" board would be?

Using the list given to you, solve the following:

Problem:

1. How many 2 x 4 are there in a stack 60 inches high?
2. How many pieces of 1/4" plywood are there in a stack

48 inches high?

3. How many 2 x 6 are there in 4 stacks, if each stack is 24 inches high?

How many 1 x 8 are there in 12 stacks, if each stack is 72 inches high?

5. How many pieces of  $\frac{5}{8}$ " plywood are there in a stack 45 inches high?



## 12. Putting Down a Sub-Floor

In most houses a sub-floor is put down before the finish flooring is put in. A sub-floor is just what's under your wood or tile floors. Usually a carpenter will use  $\frac{1}{2}$ " plywood for this job.

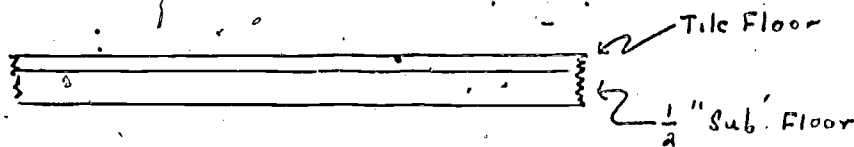

Example:

If we wanted to put a sub-floor in a room that looked like the following drawing, how many pieces of  $\frac{1}{2}$ " plywood would be needed?

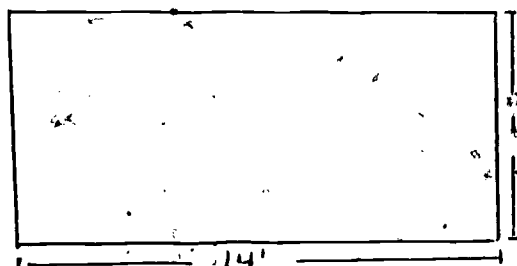

Problems:

In each of the following, find the number of sheet of  $\frac{1}{2}$ " x 4' x 8' plywood will be needed to cover each floor and what its cost will be.

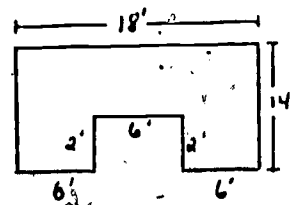
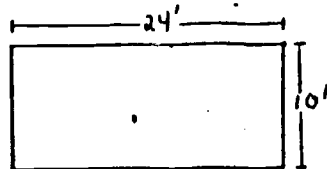
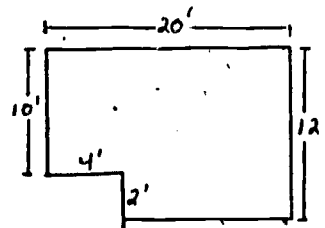
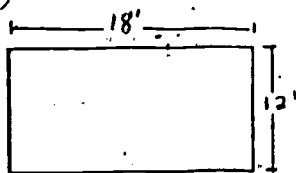

13. Discounts.

If a contractor buys a large amount of lumber he will sometimes receive a discount on his purchase. This discount will vary from lumber yard to lumber yard. You might want to call your local dealer and find out if he gives discounts and how much. For our problem we will give a discount of 15% off of the total purchase. This means you must first find the total cost of an order and then take off 15% to find the cost to the contractor. This price after discount is called the net cost.

Find the net cost of the following order, use the price list given to you to figure the cost of each item.

| BUILDERS SUPPLY COMPANY |                         |           |  |
|-------------------------|-------------------------|-----------|--|
| #                       | Description             | Unit Cost |  |
| 25                      | 1/2 x 4 x 8 AC plywood  |           |  |
| 100                     | 2 x 4 x 16 spruce       |           |  |
| 20                      | 1 x 12 x 12 yellow pine |           |  |
| 20 lbs.                 | common nails            |           |  |
| 10                      | 2 x 10 x 12 yellow pine |           |  |
|                         | TOTAL                   |           |  |
|                         | DISCOUNT 15%            |           |  |
|                         | NET COST                |           |  |

14. Summary and Discussion

What do you think of the job?

## ACTUAL LUMBER MEASUREMENTS

| DESCRIPTION | ACTUAL MEASUREMENT                      |
|-------------|-----------------------------------------|
| 2 x 4       | $1\frac{1}{2}'' \times 3\frac{1}{2}''$  |
| 2 x 6       | $1\frac{1}{2}'' \times 5\frac{1}{2}''$  |
| 2 x 8       | $1\frac{1}{2}'' \times 7\frac{1}{2}''$  |
| 2 x 10      | $1\frac{1}{2}'' \times 9\frac{1}{2}''$  |
| 2 x 12      | $1\frac{1}{2}'' \times 11\frac{1}{2}''$ |
| 1 x 4       | $3\frac{3}{4}'' \times 3\frac{1}{2}''$  |
| 1 x 6       | $3\frac{3}{4}'' \times 5\frac{1}{2}''$  |
| 1 x 8       | $3\frac{3}{4}'' \times 7\frac{1}{2}''$  |
| 1 x 10      | $3\frac{3}{4}'' \times 9\frac{1}{2}''$  |
| 1 x 12      | $3\frac{3}{4}'' \times 11\frac{1}{2}''$ |
| 4 x 4       | $3\frac{1}{2}'' \times 3\frac{1}{2}''$  |
| 4 x 6       | $3\frac{1}{2}'' \times 5\frac{1}{2}''$  |
| 4 x 8       | $3\frac{1}{2}'' \times 7\frac{1}{2}''$  |

Plywood is always the same size as the description, for example a piece of plywood  $1\frac{1}{2}'' \times 4' \times 8'$  is actually  $1\frac{1}{2}$  inch by 4 feet x 8 feet.

| <u>Description</u>               | <u>Price</u>      |
|----------------------------------|-------------------|
| 2 x 4 Spruce                     | 20¢ Linear feet   |
| 2 x 6 #2 yellow pine             | 31¢ Linear feet   |
| 2 x 8 #2 yellow pine             | 39¢ Linear feet   |
| 2 x 10 #2 yellow pine            | 58¢ Linear feet   |
| 2 x 12 #2 yellow pine            | 70¢ Linear feet   |
|                                  |                   |
| 1 x 4 common yellow pine         | 16¢ Linear feet   |
| 1 x 6 common yellow pine         | 24¢ Linear feet   |
| 1 x 8 common yellow pine         | 32¢ Linear feet   |
| 1 x 10 common yellow pine        | 41¢ Linear feet   |
| 1 x 12 common yellow pine        | 53¢ Linear feet   |
|                                  |                   |
| $\frac{3}{4}$ x 4 x 8 AD plywood | \$14.75 per sheet |
| $\frac{3}{4}$ x 4 x 8 AC plywood | \$15.52 per sheet |
| $\frac{1}{2}$ x 4 x 8 AC plywood | \$13.75 per sheet |
|                                  |                   |
| $\frac{1}{4}$ x 4 x 8 AC plywood |                   |
|                                  |                   |
| Paint (white)                    | \$3.25 per gallon |
|                                  | \$1.25 per quart  |
| Paint (colors)                   | \$4.25 per gallon |
|                                  | \$2.10 per quart  |
|                                  |                   |
| Common Nails                     | 30¢ per pound     |
| Finish Nails                     | 35¢ per pound     |
| Box Nails                        | 35¢ per pound     |