

DOCUMENT RESUME

ED 116 805

PS 008 287

AUTHOR Maurer, Daphne; Salapatek, Philip  
 TITLE Developmental Changes in the Scanning of Faces by Infants.  
 PUB DATE Apr 75  
 NOTE 19p.; A preliminary version of this paper was presented at the Biennial Meeting of the Society for Research in Child Development (Denver, Colorado, April 10-13, 1975); Not available in hard copy due to marginal reproducibility of original document

EDRS PRICE MF-\$0.76 Plus Postage. HC Not Available from EDRS.  
 DESCRIPTORS Age Differences; \*Discrimination Learning; \*Eye Fixations; \*Infants; \*Mothers; Physical Characteristics; \*Stranger Reactions; Visual Perception  
 IDENTIFIERS \*Eye Contact

ABSTRACT

This study investigated the way 12 infants, aged 1 month and 2 months, scanned the still and expressionless faces of their mothers, of strange women, and of strange men. Each infant was placed in a padded head-restraining cradle under a half-silvered mirror which was angled at 45 degrees to enable the child to view an adult's face at an optical distance of 48 cm. Infant eye fixation was recorded on videotape by corneal photography and replays were used to score the fixations of duration greater than 2 seconds on eight facial features: hairline, chin, right eye, left eye, nose, mouth, right ear and left ear. Data indicated that at 1 month of age infants fixated away from faces most of the time, looked at their mothers' faces even less often than at the strangers' faces, and looked at a limited portion of the facial perimeter. In contrast, 2-month-olds fixated the faces most of the time, looked at more facial features, and were more likely to look at internal features--especially the eyes. These results suggest that infants as young as 1 month old can discriminate their mothers' faces from strangers' faces, a discrimination which is probably based on differences in hairline and chin. Possible bias in results across the two age levels may be due to the use of motionless expressionless faces, which have been avoided by 1-month-old infants in other studies: results are compared to those obtained for infant scanning of inanimate two-dimensional shapes. (GO)

\*\*\*\*\*  
 \* Documents acquired by ERIC include many informal unpublished \*  
 \* materials not available from other sources. ERIC makes every effort \*  
 \* to obtain the best copy available. Nevertheless, items of marginal \*  
 \* reproducibility are often encountered and this affects the quality \*  
 \* of the microfiche and hardcopy reproductions ERIC makes available \*  
 \* via the ERIC Document Reproduction Service (EDRS). EDRS is not \*  
 \* responsible for the quality of the original document. Reproductions \*  
 \* supplied by EDRS are the best that can be made from the original. \*  
 \*\*\*\*\*

ED116805

U.S. DEPARTMENT OF HEALTH  
EDUCATION & WELFARE  
NATIONAL INSTITUTE OF  
EDUCATION  
DOCUMENT HAS BEEN REPRODUCED  
FOR THE NATIONAL INSTITUTE OF  
PERSONNEL AND HUMAN RESOURCES  
FROM THE NATIONAL INSTITUTE OF  
EDUCATION. THE NATIONAL INSTITUTE  
OF PERSONNEL AND HUMAN RESOURCES  
DOES NOT NECESSARILY REPRESENT  
THE NATIONAL INSTITUTE OF  
EDUCATION'S POLICY.

Developmental Changes in the Scanning of Faces by Infants

Daphne Maurer

McMaster University

Philip Salapatek

University of Minnesota

BEST COPY AVAILABLE

ED 116 805

Running head: Scanning of Faces by Infants

2

00002

## Abstract

Six one-month-old infants and six two-month-old infants each viewed three faces (his mother's, a strange woman's, and a strange man's) while his eye movements were recorded by corneal photography. The one-month-olds fixated away from the faces most of the time, and they looked at their mothers even less often than at the strangers. When they did fixate a face, they usually chose a limited portion of the perimeter. By contrast, two-month-olds fixated the faces most of the time, looked at more features, and were more likely to look at internal features, especially the eyes. This scanning resembles that reported previously for two-dimensional shapes, although in some respects it appears unique to faces.

00003

## Developmental Changes in the Scanning of Faces by Infants

The human face is a very interesting stimulus for young infants. Newborns will look at a face-like stimulus in preference to a colored disk (Fantz, 1963, 1965), a bullseye (Fantz, 1963), a die (Stechler, 1964), newsprint (Fantz, 1963, 1965), a red square (Fantz, 1967), or a lighted orange globe (Fantz, 1967), and infants older than two months will smile at a face-like stimulus (Spitz & Wolf, 1946). Yet there is reason to believe that the face is interesting to infants younger than ten weeks not because it is a face, but because it is a complex object: They will smile just as often at a face with its features distorted or a face lacking a mouth (Ahrens, 1954; Spitz & Wolf, 1946); they will look just as long at a face with scrambled features (Fantz, 1965, 1966, 1970; Hershenson, Kessen & Munsinger, 1967); and the time they spend looking at a face-like stimulus depends not on its realism but on its amount of contour (Haaf, 1974).

Consequently, infants may scan a face much the same way as they scan two-dimensional shapes. If so, then infants less than two months old should fixate only a limited portion of the face, usually a section of the perimeter (Kessen, Salapatek & Haith, 1972; Nelson & Kessen, 1969; Salapatek, 1975; Salapatek & Kessen, 1966, 1973; Salapatek, Note 6, Note 7). Only infants two months and older should scan broadly and look at the details inside the face (Salapatek, 1975).

Donnee (1972, Note 4) found some support for these predictions in a study of how infants scan a color photograph of a strange woman. One-month-olds looked longest at the edge of the face, while two-month-olds

looked longest at the features inside, lingering especially on the eyes.<sup>1</sup> Although Donnee claimed one-month-olds did not show "limited contour scanning," in fact her one-month-olds fixated significantly fewer parts of the face than her two-month-olds.

But unlike photographs or two-dimensional shapes, real human faces are three-dimensional, a factor which affects other aspects of infants' visual behavior (Fantz, 1965, 1966, 1967, 1970; Fantz & Nevis, 1967). Also, some faces may be familiar, and familiarity by itself affects infants' visual behavior (Milewski, 1975; Hunter & Ames, Note 5). For these reasons, the scanning of any real face, but especially of the mother's face, may differ from the scanning previously observed of unfamiliar two-dimensional shapes and of a photographed stranger.

The study reported here investigated how the infant of one and two months scans three real human faces: his mother's, a strange woman's, and a strange man's.<sup>2</sup>

#### Method

##### Subjects

The subjects were 12 full-term infants born at the Hospital of the University of Pennsylvania. Six were approximately 1 month old ( $\bar{X}$  = 32.5 days, range 28-43 days; 3 males, 3 females), and six were approximately 2 months old ( $\bar{X}$  = 64.5 days, range 59-71 days; 5 males, 1 female). Six of the subjects were black, five were white, and one was oriental.

##### Apparatus

The apparatus was similar to one described by Haith (1969). Each infant lay in a padded, head-restraining cradle under a half-silvered mirror, which was angled at 45° so he could see the reflected face of an adult sitting behind and slightly above him (Figure 1). The adult's

face was optically about 48 cm from the infant's eyes, and was illuminated by two, 3-inch (7.6 cm) fresnel spotlights with 75 watt lamps, placed about 45° toward the sides and 60 cm away. The harshness and heat of the lamps were reduced by double layers of cineroid. Black cotton duck provided a featureless backdrop. A television camera behind the mirror monitored the adult's face.

Mounted above the mirror and aimed at the infant's right eye were four infrared reference lamps and a second television camera. The reference lamps were Bausch and Lomb Nicholas microscope illuminators, each fitted with a Corning 7-69 filter and a filter made from three sheets of Polaroid Type HN-7 rotated with respect to one another until they transmitted no light visible to an adult. Most of the light transmitted was between 1000 and 1150 nm. The camera was a Shibaden HV14 equipped with a Resistron Epic vidicon tube sensitive enough to infrared light that it detected the corneal reflections of the four reference lamps. To illuminate the pupil, another Bausch and Lomb illuminator with a Corning 7-69 filter was aimed at the eye from the side.

Both cameras were connected to a special effects generator, which allowed periodic sampling of the picture from the first camera without losing all of the picture from the second. The special effects generator was connected to a videotape recorder, which in turn was connected to monitors. A microphone next to the infant's head transmitted all sounds in the room onto the audio track of the videotape recorder.

#### Procedure

Each baby was placed in the padded cradle under the mirror and positioned so his right eye was centered in the field of the camera. His mother was positioned behind him, and an experimenter noted the location of her head. All the faces were presented at this location.

During these preparations and during the approximately 30 seconds between trials, a black curtain hid the adult's face. To keep the infant alert during these periods, the mirror was made transparent by turning on a light behind it, thereby letting him see light fixtures, a television camera, wires, etc.

Each baby viewed three faces in an order randomized across subjects: his mother's, a strange white man's, and a strange white woman's. (Four men and two women served as the strangers.) The adults were instructed to remain still and expressionless, and subsequent replays of the videotapes showed they did. Each face was presented until an experimenter watching a monitor judged that the infant's pupil and reflections were recorded clearly for 75 seconds.

An experimenter held a pacifier in the baby's mouth and kept the baby's eye in the field of the camera. If the baby fell asleep or began to cry, the experimenter or, if necessary, the mother roused or comforted him. Then the baby was placed back in the apparatus and the trial was continued. Every infant completed the procedure.

### Results

#### Data Reduction

As a subject changed his fixation, the corneal reflections of the reference lamps systematically changed their positions relative to the center of the pupil (see Maurer, 1975, for a detailed explanation). A scorer replayed the videotape for each infant and judged from the reflections when the infant looked at a face, and which of eight features he fixated. These features were the hairline, chin, right eye, left eye, nose, mouth, right ear and left ear. Only fixations longer than 2 seconds were scored. The scorer did not know the age of any subject he was scoring.

00007

To validate this procedure, an adult took the infant's position in the apparatus, and the scorer judged from the television monitor which feature the adult was fixating. The scorer was correct 95% of the time.

### Scanning

Although both age groups shifted from one feature to another about as often, the two-month-olds fixated a greater number of different features. Thus, an analysis of variance on the number of times during each trial that the eye shifted from one feature to another showed no effect of age or category of face (i.e., mother/strange man/strange woman), and no interaction between age and category. However, on the average, two-month-olds fixated 2.7 different features during each trial, while one-month-olds fixated only 1.7. An analysis of variance on the number of different features fixated per trial showed a significant effect of age,  $F(1, 10) = 3.80$ ,  $p < .05$ , but no effect of category of face and no interaction between age and category.

### Features Fixated

Fixations off the face. A surprising result was that 59% of the one-month-olds' fixations were off the face entirely. By contrast, only 11% of the two-month-olds' fixations were off the face. An analysis of variance on the percentage of fixations during each trial which were off the face showed that the two age groups differed significantly,  $F(1, 10) = 19.89$ ,  $p < .01$ , with no effect of category of face.

However, there was a significant interaction between category of face and age,  $F(2, 20) = 6.09$ ,  $p < .01$ . Only among the one-month-olds did category affect the percentage of fixations off the face,  $F(2, 20) = 6.09$ ,  $p < .01$ : One-month-olds looked at their mothers' faces less often than either strange face. In fact, they looked at their mothers' faces less often in 11 of the 12 comparisons.



Fixations on the face. Subsequent analyses were restricted to fixations on the face. The percentages of these fixations on different features were compared. Since the percentages in no case varied with category of face, they were averaged across categories for each subject.

All six one-month-olds, but only two of the two-month-olds, fixated the perimeter more often than the inside of the face ( $p = .05$ , Fisher test<sup>3</sup>). While looking at the perimeter, the infants of both ages were more likely to fixate the chin and hairline than the ears, one month:  $T = 0$ ,  $p = .05$ ; two months:  $T = 0$ ,  $p = .05$ , Wilcoxon test of matched pairs. They were as likely to look at the chin as the hairline.

Analyses inside the face were restricted to infants who directed more than 25% of their fixations there. Infants were less likely to fixate the nose than the eyes,  $T = 0$ ,  $p = .02$ , or the mouth,  $T = 0$ ,  $p = .01$ , Wilcoxon test of matched pairs.<sup>4</sup> In fact, no subject ever fixated the nose. The two-month-olds fixated the eyes more than the one-month-olds,  $U = 2$ ,  $p = .03$ , Mann-Whitney test<sup>3</sup>, and tended to fixate the eyes more than the mouth: The 4 of 6 two-month-olds who looked inside the faces fixated the eyes more than the mouth on all 12 of their trials.

#### Discussion

In at least one respect this scanning of faces resembles the scanning previously reported of two-dimensional shapes (Salapatek, 1975, Note 6, Note 7): limited scanning of the perimeter at one month and more extended scanning at two months. Although one-month-olds did change their region of fixation almost as often as two-month-olds, they did not fixate as many regions of the face on any trial. This finding resembles Donnee's report (1972, Note 4) that one-month-olds enter fewer zones of a photographed face than older infants. It is hardly surprising since most of the time one-month-olds did not fixate the faces at all.

The findings that two-month-olds were more likely than one-month-olds to fixate inside the faces, and especially more likely to fixate the eyes, are similar to findings reported by Donnee (Note 4) for a photograph and tentatively by Bergman et al. (Note 2) for real faces. One simple explanation is that two-month-olds are more likely to look inside any object and, once inside, they select the feature with the highest contrast. This explanation is consistent with Salapatek's (1975, Note 6) finding that two-month-olds are more likely than one-month-olds to look at a feature inside a square or circle.

A different interpretation is that eyes have acquired some special meaning for infants by the time they are two months old, perhaps because mothers like and work hard to elicit eye-to-eye contact (Robson, 1967). This interpretation is consistent with the findings that by this age infants look longer at a face if the eyes are open (Ames, Note 1), and smile at a face if and only if it contains two eyes (Ahrens, 1954).

Another result also suggests that infants respond differently to faces and two-dimensional shapes: One-month-olds fixated away from the faces most of the time, while infants of this age will spend long periods of time looking at two-dimensional shapes (Salapatek, 1975, Note 6). This result seems strange, but is corroborated by Donnee (1972, Note 4): She reports that her one-month-old subjects fixated the "exterior" of her photographed face more than 90% of the time, and an examination of her plots shows that much of this time was spent far from the faces.

One possible explanation is that from the one-month-olds' point of view the faces were incongruously silent, stationary, and expressionless. Others (Carpenter & Stechler, Note 3; Tronick, Adamson, Wise, Als & Brazelton, Note 8) have found that one-month-olds, but often not two-

month-olds, avoid looking at manikins, unresponsive faces, and several other stimuli which should seem incongruous to an infant. Apparently the one-month-olds in this study found the faces incongruous, but perhaps the two-month-olds did not because they had seen faces in a greater variety of poses.

If this reasoning is correct, then each one-month-old should have seen his mother's face as more incongruous than the strangers' faces, since when viewing his mother he would have had the greatest expectations for movement, expression, etc. Consequently, he should have looked away from his mother's face more often than he looked away from the strangers' faces, which in fact he did.

Whatever the reason, the results imply that infants as young as one month can discriminate their mothers' faces from strangers' faces. The discrimination is probably based on differences in the hairline or chin, since one-month-olds rarely looked elsewhere, and since in two-dimensional shapes they appear to recognize changes only along the border (Milewski, 1975).

## Reference Notes

1. Ames, E. Personal communication, 1975.
2. Bergman, T., Haith, M., & Mann, L. Development of eye contact and facial scanning in infants. Paper presented at the meetings of the Society for Research in Child Development, Minneapolis, Minnesota, April 1971.
3. Carpenter, G., & Stechler, G. Effects of stimulus movement on attention in early infancy. Paper presented at the meetings of the Society for Research in Child Development, Santa Monica, California, March 1969.
4. Donnee, L. Infants' developmental scanning patterns to face and non-face stimuli under various auditory conditions. Paper presented at the meetings of the Society for Research in Child Development, Philadelphia, Pennsylvania, March 1973.
5. Hunter, M., & Ames, E. Visual habituation and preference for novelty in five-week-old infants. Paper presented at the meetings of the Society for Research in Child Development, Denver, Colorado, April 1975.
6. Salapatek, P. The visual investigation of geometric pattern by the one and two month old infant. Paper presented at the meetings of the American Association for the Advancement of Science, Boston, Massachusetts, December 1969.
7. Salapatek, P. Visual investigation of geometric form by the human infant. Paper presented at the meetings of the Society for Research in Child Development, Philadelphia, Pennsylvania, March 1973.
8. Tronick, E., Adamson, L., Wise, S., Als, H., & Brazelton, T. The infant's response to entrapment between contradictory messages in face to face interaction. Paper presented at the meetings of the Society for Research in Child Development, Denver, Colorado, April 1975.

## References

- Ahrens, R. [Contributions on the development of physiognomy and mimicry recognition] Zeitschrift für Experimentelle und Angewandte Psychologie, 1954, 2, 412-454.
- Donnée, L. The development of infants' scanning patterns to face and face-like stimuli under various auditory conditions. Unpublished doctoral dissertation, Harvard University, 1972.
- Fantz, R. Pattern vision in newborn infants. Science, 1963, 140, 296-297.
- Fantz, R. Visual perceptual development from birth as shown by pattern selectivity. Annals of the New York Academy of Science, 1965, 118, 793-814.
- Fantz, R. Pattern discrimination and selective attention as determinants of perceptual development from birth. In A. Kidd & J. Rivoire (Eds.), Perceptual Development in Children. New York: International Universities Press, 1966, Pp. 143-173.
- Fantz, R.. Visual perception and experience in early infancy: A look at the hidden side of behavioral development. In H. Stevenson, E. Hess & H. Rheingold (Eds.), Early Behavior: Comparative and Developmental Approaches. New York: Wiley, 1967. Pp. 181-224.
- Fantz, R. Visual perception and experience in infancy: Issues and approaches. In B. Lindsay & F. Young (Eds.), Early Experience and Visual Information Processing in Perceptual and Reading Disorders. Washington, D.C.: National Academy of Sciences, 1970, Pp. 351-381.
- Fantz, R., & Nevis, S. The predictive value of changes in visual preferences in early infancy. In J. Hellmuth (Ed.), The Exceptional Infant. Vol. 1. The Normal Infant. Seattle: Special Child Publications, 1967. Pp. 351-413.

- Haaf, R. Complexity and facial resemblance as determinants of response to face-like stimuli by 5- and 10-week-old infants. Journal of Experimental Child Psychology, 1974, 18, 480-487.
- Haith, M. Infrared television recording and measurement of ocular behavior in the human infant. American Psychologist, 1969, 24, 279-283.
- Hershenson, M., Kessen, W., & Munsinger, H. Ocular orientation in the human newborn infant: A close look at some positive and negative results. In W. Wathen-Dunn (Ed.), Models for the Perception of Speech and Visual Form. Cambridge, Massachusetts: MIT Press, 1967. Pp. 282-290.
- Kessen, W., Salapatek, P., & Haith, M. The visual response of the human newborn to linear contour. Journal of Experimental Child Psychology, 1972, 13, 9-20.
- Milewski, A. Infants' discrimination of internal and external visual pattern elements. Unpublished doctoral dissertation, Brown University, 1975.
- Nelson, K., & Kessen, W. Visual scanning by human newborns: Responses to a complete triangle, to sides only, and to corners only. Proceedings of the 78th Annual Convention of the American Psychological Association, 1969.
- Robson, K. The role of eye-to-eye contact in maternal-infant attachment. Journal of Child Psychology and Psychiatry, 1967, 8, 13-25.
- Salapatek, P. Visual scanning of geometric figures by the human newborn. Journal of Comparative and Physiological Psychology, 1968, 66, 247-258.
- Salapatek, P. Pattern perception in early infancy. In L. Cohen & P. Salapatek (Eds.), Infant Perception: From Sensation to Cognition. Vol. 1.: Basic Visual Processes, in press.

Salapatek, P., & Kessen, W. Visual scanning of triangles by the human newborn. Journal of Experimental Child Psychology, 1966, 3, 155-167.

Salapatek, P., & Kessen, W. Prolonged investigation of a plane geometric triangle by the human newborn. Journal of Experimental Child Psychology, 1973, 15, 22-29.

Spitz, R., & Wolf, K. The smiling response: A contribution to the ontogenesis of social relations. Genetic Psychology Monographs, 1946, 34, 57-125.

Stechler, G. Newborn attention as affected by medication during labor. Science, 1964, 144, 315-317.

00015

## Footnotes

A preliminary version of this paper was presented at the April 1975 meetings of the Society for Research in Child Development. This research was supported by United States Grants HD-03405 and HD-07317, and by Canadian National Research Council Grant 1797. The authors wish to thank Bob Carr, Morris Moscovitch, David Atkins, and Joann McMenamin who acted as strangers; Bonita Trumbule who helped collect the data; and Debby Kay who helped to analyze it. Requests for reprints should be sent to Daphne Maurer, Department of Psychology, McMaster University, Hamilton, Ontario, Canada.



<sup>1</sup>Donnee also reported that ten-week-olds return to scanning the edges of faces, but there is no information available on how 10-week olds scan two-dimensional shapes. Also, her data are confounded by her definition of "the border of the face," which included the area around the mouth.

<sup>2</sup>Bergman, Haich & Mann (Note 2) reported preliminary findings on how infants scan real faces. Their results resemble those of Donnee in some respects (e.g., older infants' were more likely to look inside the faces), but complete analyses have not been reported.

<sup>3</sup>One-tailed test since this result had been predicted. All other tests are two-tailed except where indicated.

<sup>4</sup>Since some infants rarely looked inside the faces, the n was too small to analyze each group separately.

Figure Captions

Figure 1. Schematic of the apparatus.

00018

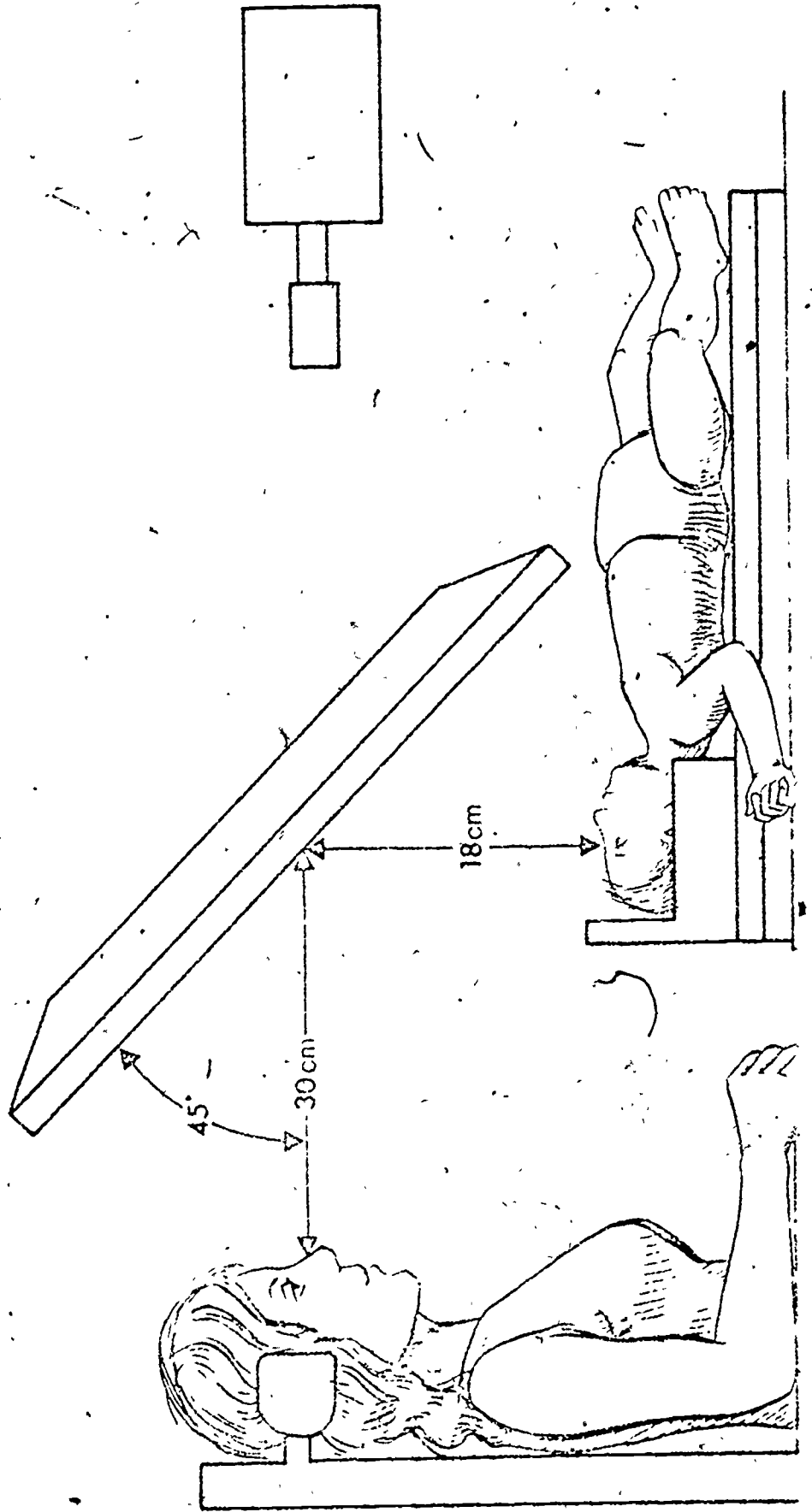
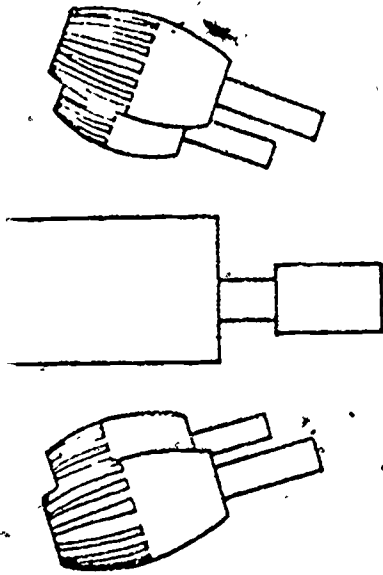

00019