

## DOCUMENT RESUME

ED 116 006

CE 005 915

AUTHOR Rich, William; Wood, Eugene  
 TITLE Agricultural Production: Program Planning Guide: Volume 1.  
 INSTITUTION Southern Illinois Univ., Carbondale. Dept. of Agricultural Industries.  
 SPONS AGENCY Illinois Professional and Curriculum Development Unit for Vocational and Technical Education, Springfield.  
 PUB DATE 30 Jun 75  
 NOTE 157p.; For Volumes 2-7, see CE 005 916-921  
 EDRS PRICE MF-\$0.76 HC-\$8.24 Plus Postage  
 DESCRIPTORS \*Agricultural Education; Agricultural Machinery Occupations; \*Agricultural Occupations; \*Agricultural Production; Animal Science; Behavioral Objectives; \*Course Content; \*Curriculum Guides; Farm Management; Lesson Plans; Occupational Clusters; Occupational Information; Plant Science; Post Secondary Education; Program Planning; Resource Guides; Secondary Education; Unit Plan; Units of Study (Subject Fields)

## ABSTRACT

The program planning guide for agricultural production was written to assist Applied Biological and Agricultural Occupations (ABAO) teachers in enriching existing programs and/or to provide the basis for expansion of offerings to include additional materials for the cluster areas of animal science, plant science, farm mechanics, and farm business management. Each guide includes the following components: an introduction (brief discussion of the subject matter); sample job titles and cluster areas (major job titles, D.O.T. numbers, O.E. numbers, and information about salaries, educational requirements, and career advancement opportunities); competencies for cluster areas and for job titles, stated as behavioral objectives; a core course outline (a representative sample of how a curriculum should be constructed, including references); sample teaching plans designed for one to five days in length (comprising cluster areas, unit titles, problem areas, a brief introduction, student performance objectives, a detailed outline of instructional content, learning activities, special materials and equipment, and student references). Also included are: specific and selected references; a brief description of school facilities; lists of equipment, supplies, and audiovisual materials; and a partial list of ways to increase teacher competencies. (BP)

NOV 20 1975

ED116006

funded by:  
Illinois Office of Education  
in cooperation with:  
Southern Illinois University / Carbondale

U S DEPARTMENT OF HEALTH,  
EDUCATION & WELFARE  
NATIONAL INSTITUTE OF  
EDUCATION

THIS DOCUMENT HAS BEEN REPRO-  
DUCED EXACTLY AS RECEIVED FROM  
THE PERSON OR ORGANIZATION ORIGIN-  
ATING IT. POINTS OF VIEW OR OPINIONS  
STATED DO NOT NECESSARILY REPRESENT  
OFFICIAL NATIONAL INSTITUTE OF  
EDUCATION POSITION OR POLICY.

CL0...

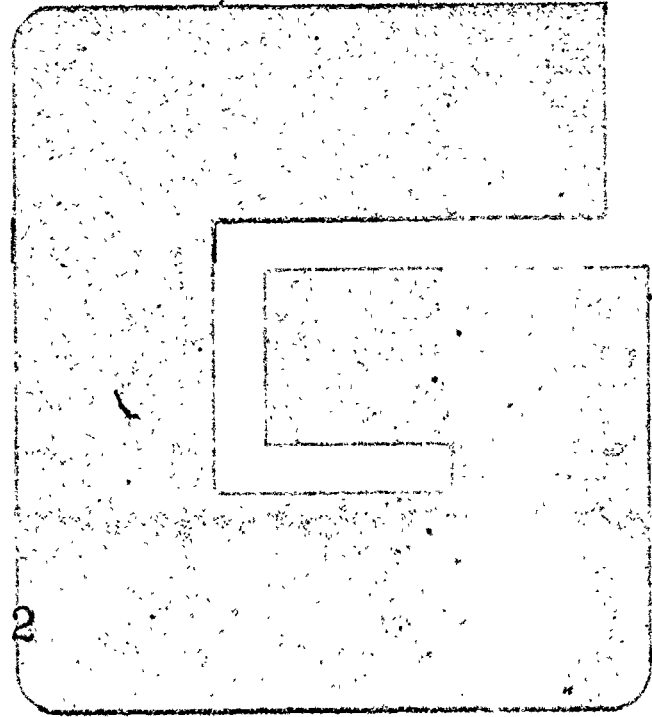

Volume I

PROGRAM PLANNING GUIDE IN AGRICULTURAL PRODUCTION

Guide Author

Mr. William Rich  
Lake Land College

and

Dr. Eugene Wood  
Southern Illinois University

Project Director

Dr. Thomas R. Stitt  
Southern Illinois University

Project Title

Development of Teachers' Guide and Students' Instructional  
Materials for Seven Selected Applied Biological and  
Agricultural Occupation Related Areas (PCB-A5-031)

Produced as a result of a contractual agreement managed by:

Professional and Curriculum Development Unit  
Board of Vocational Education and Rehabilitation  
Division of Vocational and Technical Education

in cooperation with:

Agricultural Industries Department  
School of Agriculture  
Southern Illinois University  
Carbondale, IL 62901

Date

U  
June 30, 1975

TABLE OF CONTENTS

General Introduction . . . . . 1

Introduction to Agricultural Production  
Occupational Program Planning Guide . . . . . 7

Sample Cluster Areas and Job Titles . . . . . 10

Sample Job Descriptions . . . . . 11

Competencies for Cluster Areas . . . . . 16

Competencies for Job Titles . . . . . 28

Core Course Outline for Agricultural Production . . . . . 89

Exemplary Teaching Plans . . . . . 102

References . . . . . 144

    Specific References . . . . . 144

    Selected References for More Information . . . . . 148

School Facilities, Equipment, and Supplies . . . . . 149

    Facilities . . . . . 149

    Equipment . . . . . 149

    Supplies . . . . . 150

Audio Visual Sources and Materials . . . . . 151

Teachers' Competencies and Training Available . . . . . 153

## INTRODUCTION

The Program Planning Guides were written to assist the Applied Biological and Agricultural Occupations teacher in enriching the existing programs and/or to provide the basis for expansion of offerings to include an additional agricultural cluster area. For example, the current offering may be Agricultural Production with Agricultural Mechanics, and Agricultural Supplies and Services is to be added to the offering.

These guides are the result of a funded project coordinated by the Professional and Curriculum Development Unit, Division of Vocational and Technical Education, Board of Vocational Education and Rehabilitation in cooperation with the Agricultural Industries Department, Southern Illinois University, Carbondale, during the FY 1975. The project was entitled "Development of Teachers' Guide and Student Instructional Materials for Seven Selected ABAO (Applied Biological and Agricultural Occupations) Related Areas." The seven ABAO areas selected include:

1. Agricultural Production - O.E. Code 01.0100
2. Agricultural Supplies and Services - O.E. Code 01.0200
3. Agricultural Mechanics - O.E. Code 01.0300

4. Agricultural Products - O.E. Code 01.0400
5. Ornamental Horticulture. - O.E. Code 01.0500
6. Agricultural Resources - O.E. Code 01.0600
7. Forestry - O.E. Code 01.0700

Major division, cluster area, and job titles were written with O.E. numbers, and only an occasional reference to D.O.T. The O.E. code was selected in that teachers in Illinois classify all of their students under this system.

The provisions of the SIU/C-DVTE project provided an opportunity for participation from throughout the Illinois Applied Biological and Agricultural Occupations staff. Each member contributed in his unique way, and they represent each of the four institutions which train DVTE staff, V.A.S., and ABAO teachers in community colleges and high schools.

The projects activities were coordinated by a Steering Committee. All major decisions on content, format, job titles, and final draft approval were the responsibility of the steering committee. They spent considerable time and effort in reviewing these guides. The steering committee was composed of the following members:

<u>Name</u>	<u>ABAO Project Contribution</u>
Mr. Lonnie Hart Assistant Coordinator DVTE Springfield, IL 62706	Chairman-Steering Committee
Mr. G. D. Coil Head Consultant, ABAO-DVTE Springfield, IL 62706	Steering Committee

<u>Name</u>	<u>ABAO Project Contribution</u>
Mr. Allan Utech Consultant, ABAO-DVTE Springfield, IL 62706	Steering Committee
Dr. Ed Breese Agriculture Department Western Illinois University Macomb, IL 61455	Steering Committee
Mr. P. E. Cross ABAO Instructor McLeansboro Community Unit McLeansboro, IL 62859	Steering Committee
Mr. Kyle Wittler Coordinator, Ag Business Parkland College 2400 West Bradley Champaign, IL 61820	Steering Committee
Dr. John Matthews Head Vocational Agriculture Service 434 Mumford Hall University of Illinois Urbana, IL 61801	Steering Committee

The project staff in alphabetical order are as follows:

<u>Name</u>	<u>ABAO Project Contribution</u>
Dr. Benton K. Bristol Associate Professor Department of Agriculture Illinois State University Normal, IL 61761	Agricultural Mechanics Guide Author
Dr. William A. Doerr Assistant Professor and Assistant Dean School of Agriculture Southern Illinois University at Carbondale Carbondale, IL 62901	Forestry Guide Co-Author
Mr. Carl German Graduate Student Agriculture Education Southern Illinois Univeristy at Carbondale Carbondale, IL 62901	Agricultural Resources Co- Author

<u>Name</u>	<u>ABAO Project Contribution</u>
Dr. L. R. Hilterbrand Division Chairman Agriculture Resources Shawnee College Road Ullin, IL 62992	Agricultural Resources Guide Co-Author
Mr. Michael Marks ABAO Teacher Farina LaGrove Community Unit Farina, IL 62838	Agricultural Supply and Service Guide Co-Author
Mr. B. L. Rich Division Chairman Agriculture Department Lake Land College Mattoon, IL 61938	Co-Author of Agricultural Production
Mr. Sam Robb ABAO Instructor Pinckneyville Community Unit Pinckneyville, IL 62274	Agricultural Projects Guide Co-Author
Mr. Roger Ross Applied Biological and Agriculture Occupations New Lenox, IL 60451	Ornamental Horticulture Co-Author
Dr. Thomas Stitt Professor Agricultural Industries Department Southern Illinois University at Carbondale Carbondale, IL 62901	Project Director, Agricultural Resources, Ornamental Horti- culture, and Forestry Co- Author
Dr. Richard Welton Assistant Professor Agricultural Industries Department Southern Illinois University at Carbondale Carbondale, IL 62901	Agriculture Supply and Service and Agriculture Products Guides Co-Author
Dr. Eugene Wood Professor and Chairman Agricultural Industries Department Southern Illinois University at Carbondale Carbondale, IL 62901	Agricultural Production Guide Author and Principal Investigator of Project



Each guide includes the following component parts.

Introduction Unique consideration for the subject matter area.

Sample Job Titles and Cluster Areas This includes information about salary, education requirements and career advancement opportunities. These job titles and cluster areas are coordinated with a brochure entitled "Applied Biological and Agricultural Occupations Career Directory" published by the Division of Vocational and Technical Education, 1035 Outer Park Drive, Springfield, IL.

Competencies for Cluster Areas and Competencies for Job Titles The competencies, stated in measurable terms, are presented by cluster areas and job titles.

Core Course Outline The core course outline is a representative sample of how a curriculum could be constructed to present the program.

Exemplary Teaching Plans This is a section which incorporates teaching plans for selected units in the outline. Their function is to provide sample plans which the ABAO teacher may follow in developing his respective units.

Reference The references are coded into the teaching plan and listed with their source in the reference section.

School Facilities, Equipment, and Supplies This provides the ABAO teacher with a source for major items which will be required to operate the program.

Audio Visual Materials This is a listing of currently available visual materials for use in teaching the respective subject matter areas.

Teachers Competencies and Training Available This is a brief review of sources where the teacher could secure additional skills to assist in delivering a quality program.

These Program Planning Guides were prepared to improve the quality and increase the scope of Applied Biological and Agricultural Occupations offerings available in Illinois. The Guides can only be successful with your review, adaptation, adoption, and implementation.

## INTRODUCTION TO AGRICULTURAL PRODUCTION

Agricultural Production has as its main function the production of food and/or fiber. For purpose of this program planning guide four cluster areas were identified in agricultural production and representative job titles listed under each cluster area. O.E. codes and D.O.T. numbers are included in the guide to assist the instructor in locating more information on a cluster area or job title.

The areas identified were:

- I. Animal Science
  - A. Swine Producer-breeder
  - B. Beef Producer-breeder
  - C. Specialty animal raiser
- II. Plant Science
  - A. Cereal grain producer
  - B. Oil crop producer
  - C. Forage crop producer
  - D. Specialty crop producer
- III. Farm Mechanics
  - A. Machine and Equipment operator
- IV. Farm Business Management
  - A. Tenant farmer

A list of competencies was developed for each cluster area and job title, and stated in measurable terms. The cluster objectives are broad based and the job title objectives were written more specific to include competencies the student

should master for entry level employment. The competency lists are not meant to be complete, but representative of student needs. The instructor should use his advisory committee and area farmers and businessmen to expand the competency lists and tailor them to meet the individual student needs.

The evaluation procedures used in the behavioral objectives are examples of those that can be used. It is essential, however, that the student know what is expected of him and the level of accomplishment he is expected to attain. The teacher should choose the evaluation method appropriate to the situation.

A core course outline with selected references was developed from the most commonly identified cluster area and job title competencies. The instructor can apply the core course outline to the particular enterprise or job title that meets the needs of his students. References listed are by no means complete. Hopefully the instructor will supplement the reference list for both himself and the student.

Detailed teaching plans were developed as examples in each of the cluster areas. They are designed to be from one to five days in length. The instructor should select the areas of the core course outline that will be used and complete the development of detailed teaching plans.

The materials developed in this program planning guide has had input from students and has been reviewed by the Agriculture Division staff at Lake Land College. No attempt

was made to be original in all materials; any material that met a need was included.

Of great value in determining competencies and content included in the program planning guide were curriculum guides and instructional materials from Ohio, Oklahoma, Iowa, Arizona and Illinois. Special credit is due Dr. Paul E. Hemp for his publication, Using Behavioral Objectives in Applied Biological and Agricultural Occupations Programs, University of Illinois and Vocational Agriculture Service at the University of Illinois.

## SAMPLE CLUSTER AREAS AND JOB TITLES

The cluster areas and job titles included in this guide are:

### Animal Science

Swine Producer-Breeder

Beef Producer-Breeder

Specialty Animal Raiser

### Plant Science

Cereal Grain Producer

Oil Crop Producer

Forage Crop Producer

Specialty Crop Producer

### Farm Mechanics

Machine and Equipment Operator

### Farm Business Management

Tenant Farmer

SAMPLE JOB DESCRIPTIONS

MAJOR JOB TITLE: Swine Production-Breeder  
D.O.T. NUMBER: 413.181  
O.E. NUMBER: 01.01010104  
LOCATION: May be self-employed, employed by a farm manager, land owner, tenant farmer, or may manage swine operation for a purebred swine producer or a commercial swine producer. Breeds and raises swine for sale as meat or to other breeders.  
SALARY: Beginning salary for high school graduate with no experience is \$5,500 to \$7,000 per year. Fringe benefits often include meat, utilities, and profit sharing. \$2.50-\$3.00 per hour.  
EDUCATION: High school diploma usually required. Two-year degree from a community college is desirable. B.S. Degree can be obtained.  
CAREER ADVANCEMENT: Hired labor  
Supervisor  
Manager  
Owner

MAJOR JOB TITLE: Beef Producer-Breeder  
D.O.T. NUMBER: 413.181  
O.E. NUMBER: 01.01010102  
LOCATION: May be self-employed, employed by a farm manager, land owner, tenant farmer, or may manage a beef operation for a purebred beef producer or a commercial beef producer. Breeds and raises cattle.  
SALARY: Beginning salary for high school graduate with no experience is \$5,500 to \$7,000 per year. Fringe benefits often include meat, utilities, and profit sharing. \$2.50-\$3.00/hour.

**EDUCATION:** High school diploma usually required. Two-year degree from a community college is desirable. B.S. Degree can be obtained.

**CAREER ADVANCEMENT:** Hired labor  
Supervisor  
Manager  
Owner

**MAJOR JOB TITLE:** Specialty Animal Raiser

**D.O.T. NUMBER:** 419.181

**O.E. NUMBER:** 01.01010199

**LOCATION:** May be self-employed or employed by a commercial specialty animal raiser, laboratory animal producer, or veterinary clinic.

**SALARY:** Beginning salary for high school graduate with no experience is \$2.25 to \$2.75 per hour.

**EDUCATION:** High school diploma is usually required. Some community colleges offer a two-year program training in animal specialties.

**CAREER ADVANCEMENT:** Hired labor  
Supervisor  
Manager  
Owner

**MAJOR JOB TITLE:** Cereal Grain Producer

**D.O.T. NUMBER:** 401.181

**O.E. NUMBER:** 01.01020101

**LOCATION:** May be self-employed, employed by a farm manager, land owner, tenant farmer or may manage a crop program for individuals. Plants, cultivates, and harvests cereal grain for sale.

**SALARY:** Beginning salary for high school graduates with no experience is \$5,500 to \$7,000 per year. Fringe benefits often include meat, utilities, and profit sharing. \$2.50-\$3.00/hour.



**EDUCATION:** High school diploma usually required. Two-year degree from a community college is desirable. B.S. Degree can be obtained.

**CAREER ADVANCEMENT:** Hired labor  
Supervisor  
Manager  
Owner

**MAJOR JOB TITLE:** Oil Crop Producer

**D.O.T. NUMBER:** 401.181

**O.E. NUMBER:** 01.01020104

**LOCATION:** May be self-employed, employed by a farm manager, land owner, tenant farmer or may manage a crop program for individuals. Plants, cultivates, and harvests oil crop for sale.

**SALARY:** Beginning salary for high school graduates with no experience is \$5,500 to \$7,000 per year. Fringe benefits often include meat, utilities, and profit sharing. \$2.50-\$3.00/hour.

**EDUCATION:** High school diploma usually required. Two-year degree from a community college is desirable. B.S. Degree can be obtained.

**CAREER ADVANCEMENT:** Hired labor  
Supervisor  
Manager  
Owner

**MAJOR JOB TITLE:** Forage Crop Producer

**D.O.T. NUMBER:** 405.181

**O.E. NUMBER:** 01.01020103

**LOCATION:** May be self-employed, employed by a farm manager, land owner, tenant farmer or may manage a crop program for individuals. Raise forage crops to be used as hay.

**SALARY:** Beginning salary for a high school graduate with no experience is \$5,500 to \$7,000 per year. Fringe benefits often include meat, utilities, and profit sharing. \$2.50-\$3.00/hour.

**EDUCATION:** High school diploma is usually required. Two-year degree from a community college is desirable. B.S. Degree can be obtained.

**CAREER ADVANCEMENT:** Hired labor  
Supervisor  
Manager  
Owner

**MAJOR JOB TITLE:** Specialty Crop Grower .

**D.O.T. NUMBER:** 409.883

**O. E. NUMBER:** 01.0103

**LOCATION:** May be self-employed by a farm manager, land owner, tenant farmer or may manage a crop program for individuals. Raises various kinds of crops for sale.

**SALARY:** Beginning salary for a high school graduate with no experience is \$5,500 to \$7,000 per year. Fringe benefits often include meat, utilities, and profit sharing.

**EDUCATION:** High school diploma usually required. Two-year degree from a community college is desirable. B.S. Degree can be obtained.

**CAREER ADVANCEMENT:** Hired labor  
Supervisor  
Manager  
Owner

**MAJOR JOB TITLE:** Machine and Equipment Operator

**D.O.T. NUMBER:** 409.883

**O.E. NUMBER:** 01.0103

**LOCATION:** May be self-employed, employed by a farm manager, land owner, or a tenant farmer. Drives and controls farm equipment to till soil and to plant, cultivate, and harvest crop.

**SALARY:** Beginning salary for high school graduates with no experience is \$5,500 to \$7,000 per year. Fringe benefits often include meat, utilities, and profit sharing. \$2.50-\$3.00 per hour.

**EDUCATION:** High school diploma is usually required. Two-year degree from a community college is desirable. B.S. Degree can be obtained in Agricultural Mechanics.

**CAREER ADVANCEMENT:** Hired labor  
Supervisor  
Manager  
Owner

**MAJOR JOB TITLE:** Tenant Farmer

**D.O.T. NUMBER:** 409.181

**O.E. NUMBER:** 01.0104

**LOCATION:** May be self-employed, employed by a farm manager, land owner. Plants, cultivates, and harvests crops on land rented from another. Determines inputs for production and share returns with owner.

**SALARY:** Beginning salary for high school graduate is usually an hourly wage of \$2.50 to \$3.00. As advancement is made, the pay is share of the crop.

**EDUCATION:** High school diploma is usually required. Two-year degree from a community college is desirable. B.S. Degree can be obtained.

**CAREER ADVANCEMENT:** Hired labor  
Hired hand  
Tenant farmer

## COMPETENCIES FOR CLUSTER AREAS

### I. Agricultural Production

#### A. Animal Science

##### 1. Selection

The student will be able to:

- EE a. From a group of livestock within one species, distinguish those animals that are superior according to a phenotype or type selection process as determined by market demands.
- EE b. Given the production testing data of a group of animals within one species, determine those animals that are superior based on the evaluation of their past and present breeding records of animal performance.

##### 2. Feeding and Nutrition

The student will be able to:

- EE a. Given a specific type of livestock of known weight, sex, and reproductive purpose, list the nutrient requirements of that livestock according to recommendations of the National Research Council or similar publications.
- EE b. Orally or in writing, list the six basic food nutrients and explain a minimum of two major functions that each serves in the animal body as described in a reference of standards such as those of the National Academy of Sciences.
- EE c. From a list of the ingredients found in a ration of either home or commercial origin or a combination of these two, indicate,

KEY: EE-ESSENTIAL for ENTRY  
DA-DESIRABLE for ADVANCEMENT

orally or in writing, the nutritive value of the feedstuffs as given by a feed composition table.

- EE d. When given a list containing several feeds, both home grown and commercial and the cost of each along with a specific class of animals to feed, design a least-cost balanced ration for that group of animals so that it is appropriate for the animal's weight, sex, age, and productive purpose to the instructor's satisfaction.
- DA e. Interpret label information on feed additives well enough so that he can either follow feeding procedures or explain them to insure the safe use of the additives to animal and consumers according to F.D.A. requirements.
- EE f. Using livestock or slides and pictures, identify:
- (1) Deficiency symptoms of vitamins and recommend preventative measures to insure that his livestock does not become affected.
  - (2) Deficiency symptoms of minerals likely to be deficient and recommend preventative measures to insure that his livestock does not become affected.

Evaluation will be made against a recognized standard test.

### 3. Breeding and Management

The student will be able to:

- EE a. For each type of livestock commonly produced in the area, describe the typical signs of estrus and appropriate methods of determining the onset of the heat period of the females to the satisfaction of the instructor.
- EE b. From a diagram, photograph, or specimen of livestock, identify the different organs that comprise the reproductive tracts and explain the major functions of each as described by a standard reference on the subject.

- EE c. When given a newborn animal, perform management tasks necessary to increase the animal's chances for survival as described in a standard reference text.
- DA d. When given the breeding female of a certain animal species, determine when it is to the student's advantage to use the breeding male for natural insemination of his females or to use artificial insemination to insure the greatest productive efficiency. Conclusion must meet with approval of the agriculture instructor.
- EE e. When given a properly restrained animal, perform the following tasks to conform to accepted procedures outlined in a standard reference book:
- (1) Castration
  - (2) Dehorning
  - (3) Tattooing
  - (4) Earnotching
  - (5) Vaccination
  - (6) Intramuscular injections

#### 4. Animal Health

The student will be able to:

- EE a. When given a list of diseases of livestock, outline a preventative control program using recognized references for the given diseases, such that the possibility of disease can be reduced or eliminated in a given herd of livestock. Conclusions must match recommendations of a local veterinarian.
- EE b. When given a listing of parasites which may infest livestock, outline a preventative control program using recognized references for the given parasites, such that parasite infestation can be reduced or eliminated in a given herd of livestock. Program must agree with the recommendations of the local veterinarian.

## 5. Housing Equipment

The student will be able to:

- EE a. When given the number and type of livestock for a proposed production program and with the use of references, determine a type and size of building appropriate in regards to maintenance, economy of construction, efficient environmental conditions for the animal, and efficient livestock and materials handling. Recommendations must meet housing standards of extension specialist.

## 6. Marketing

The student will be able to:

- DA a. When given supply and demand schedules and number of livestock to be sold, determine the price and total return expected by constructing supply/demand curves to the satisfaction of the instructor.
- EE b. Through market reports for a five-year period for a given livestock species, determine the cyclic pattern for prices and the most feasible time for marketing the animal according to recognized reference material.
- EE c. When given a group of animals of varying species and their intended use, determine the market grade(s) most appropriate for the animals according to conformation, finish, and quality verified by a marketing specialist.
- EE d. When given a list of available markets in the local area and a number of animals to be marketed, determine the most appropriate method to use considering services offered, selling costs, competition, and returns. Answers must gain 80% acceptance by classmates.
- EE e. When given animals ready for shipment, demonstrate the handling procedures and/or processes needed to avoid or reduce shrinkage, bruises, crippling, and/or death loss according to specifications of the instructor.

## B. Plant Science

### 1. Plant Development

The student will be able to:

- EE a. When given a mature plant seed, identify all of the labeled parts and explain their functions according to a standard reference text.
- EE b. Trace the above and below ground plant development on a diagram by weekly intervals according to standard reference texts.

### 2. Variety Selection and Seeding Practices

The student will be able to:

- EE a. When provided with information regarding the moisture content of a soil, the kind of crop seed to be planted, determine the depth to plant the seed to insure a high germination. The decision should be made according to approved agronomic research data.
- EE b. When provided with information concerning the crop to be grown and the conditions under which it is to be grown, specify the optimum planting date, rate, and depth according to approved agronomic research data.

### 3. Seedbed Preparation

The student will be able to:

- EE a. For a given soil type, soil condition, and crop seed, select the tillage practice that will produce soil conditions providing 90% or more germination of viable seed.
- EE b. When given information regarding the physical properties of the soil and the crop to be grown, determine the tillage practices to use, based on yield and effects on the soil, according to tillage research information and to the satisfaction of the teacher.



- DA c. Using information providing the optimum planting dates for a crop, determine the tillage practices that can be accomplished in the time available under normal weather conditions according to weather and implement time-use data.

#### 4. Fertility

The student will be able to:

- EE a. When given a crop to be grown, determine the amounts of nutrients required at a specified yield of the crop according to recognized agronomic standards.
- DA b. Identify from plants with visually detectable nutrient deficiencies which nutrient(s) are deficient in the growing crop plants to the extent that a diagnosis of the present fertility practice can be made and corrections applied for future use, according to agronomy standards for the area.
- EE c. Using the needed soil sampling equipment, collect a representative soil sample of a field and prepare for testing in a manner and in accordance with recommendations prescribed by the agriculture teacher.

#### 5. Weed Control

The student will be able to:

- EE a. When given a situation of a weedy field, identify the major weeds common to the area and describe well enough to classify them according to reproductive characteristics as well as type and degree of harmful effects. The solutions must be 95% accurate.
- EE b. When given a specific weed problem and crop rotation plan, outline and recommend an effective biological, cultural, or chemical control program which will control anticipated weed problems to the satisfaction of the teacher.
- EE c. When given various commonly used herbicides, demonstrate the recommended procedure for safety precautions for safe application of herbicides according to the Custom Spray Operator's Manual.

## 6. Insect and Disease Control

The student will be able to:

- EE a. Using live plants, preserved specimens of plants, or colored photographs of plants affected with diseases common in the local area, identify the diseases with 90% accuracy.
- EE b. For diseases of crops in the area, explain the recommended procedures to prevent or keep the diseases in check to the satisfaction of the instructor.
- EE c. Given plant specimens damaged by insects, recognize the source of the damage, either on sight or by using selected references, for the insects that commonly cause significant economic losses in the area. The student will attain 95% accuracy.
- EE d. Given specific insect problems, determine recommended biological and cultural methods of control that are practical to use for each insect and growing crop according to current reference materials.

## 7. Harvesting and Storage

The student will be able to:

- EE a. When given a farm crop to be harvested, determine the stage of maturity at which the crop should be harvested to realize the greatest yield in quality and quantity according to a standard text.
- EE b. When given a specific farm crop, determine the moisture content of the crop within two percent through visual examination of the crop or by using devices designed to measure moisture content of the specific farm crop.
- DA c. When given the type of crop(s), the expected volume or amount of crop to be stored, and sufficient references, determine the type and size of facilities needed to provide storage for farm crops such that the quality of the crops will be maintained at an optimum level of quality. The answer must conform to the recommendations of the agriculture teacher.

## 8. Marketing

The student will be able to:

- DA a. Given supply and demand schedules and the bushels, pounds, or other appropriate measures of farm crops to be sold, determine the price and total return expected by constructing and interpreting supply/demand curves to the satisfaction of the instructor.
- EE b. Through market reports for a five-year period for a given farm crop, determine the cyclic pattern for prices and the most feasible time for marketing the given crop, considering the cyclic pattern and the supply and demand for the particular crop to the satisfaction of the instructor.
- EE c. When given a specific farm crop and the criteria for grading the crop, determine the market grade according to U.S.D.A. grading standards with 95% accuracy.

## C. Farm Mechanics\*

## 1. Tillage Operations

The student will be able to:

- EE a. When provided with information concerning the size and type of farm operation, the type of soil, equipment, manpower, and money available, select the tillage machinery needed for the desired type of tillage to prepare a satisfactory seedbed for good seed germination and/or control of weeds to the satisfaction of the instructor.
- EE b. When provided with various types of tillage machinery, operate the machinery in a safe manner and prepare a satisfactory seedbed for good seed germination and/or control of weeds as recommended by the operator's manual.

\* Refer to Agricultural Mechanics Program Planning Guide for more information.

- DA c. When given various types of tillage machinery that have been in operation in the field, perform the necessary maintenance to insure their proper operation as recommended by the operator's manual.

## 2. Planting Operations

The student will be able to:

- EE a. Provided with information concerning the size and type of farm operations, and the equipment, manpower, and money available, select the planting equipment needed to provide efficient as well as economical planting to the satisfaction of the instructor.
- EE b. Provided with equipment for planting, operate the planter to provide the desired rate of seed or plants, fertilizer, and herbicides per acre for the desired germination, stand, and weed control as recommended by the operator's manual.
- DA c. Given equipment for planting, perform the necessary maintenance to insure its proper operation as recommended in the operator's manual.

## 3. Fertilizing and Spraying Operations

The student will be able to:

- EE a. When provided with information concerning the size and type of farm operation, the type of soil, equipment, manpower, and money available, select fertilizer, weed, insect, and/or disease control machinery needed to maximize crop production.
- EE b. When provided with machinery for fertilization, weed, insect, and/or disease control, operate such machinery in a safe manner and provide the desired fertilizer application, weed, insect, and/or disease control as recommended in the operator's manual.
- DA c. When given machinery for fertilization, weed, insect, and/or disease control, perform the necessary maintenance to insure their proper operation as recommended in the operator's manual.

#### 4. ~~Harvesting Operations~~

The student will be able to:

- EE a. Provided with information concerning the size and type of farm operation, and the equipment, manpower, and money available, select the harvesting equipment needed for the given operation to the satisfaction of the instructor.
- EE b. Provided with equipment for harvesting, operate the equipment in a way that is safe and will minimize crop losses as recommended in the operator's manual.

#### 5. Power Unit

The student will be able to:

- EE a. When given maintenance and service jobs involving tractors and other machinery, determine and use all safety practices according to recommendations of safety specialists and to the satisfaction of the instructor.
- DA b. When given the problem of making minor repairs or replacement of parts on the ignition, cooling, fuel, lubrication, or other systems of farm power equipment, determine procedures to follow, and select the most suitable repair or replacement materials, according to recommendations as provided in the operator's manual and service manual.

#### D. Farm Business Management

##### 1. Farm Planning

The student will be able to:

- EE a. Given information concerning the available land, labor, capital, and management, plan a program that will maximize losses for a particular farm that is consistent with family and operator objectives. The plan must conform to recommendations of a professional farm planner.
- EE b. When provided with information concerning soils, rainfall, topography, and management practices, plan a crop rotation that

will conserve soil according to recommendations of a soil scientist.

- DA c. When given data relating to farm costs and returns, explain why labor efficiency is important to the satisfaction of the agriculture instructor.

## 2. Records and Analysis

The student will be able to:

- EE a. When given a particular farming operation and current value of items, take inventory and record these items in a record book according to recommended procedures and to the satisfaction of the instructor.
- EE b. When given a list of receipts and expenditures from a farm business, correctly enter the receipts and expenditures in the appropriate section of a farm account book with 100% accuracy.
- EE c. When given the records of a farming operation, complete a farm business summary or profit and loss statement to the satisfaction of the agriculture instructor.
- DA d. When given a complete set of farm records, calculate measures of the farm business from summarized data that will be useful in studying the farm business to the satisfaction of the instructor.

## 3. Farm Budgeting

The student will be able to:

- EE a. When given data concerning a farming operation, set up a complete budget for a farming operation, including both crop and livestock production, using procedures from a recognized text on budgeting.
- EE b. When given a specific type and size of farming operation, accurately work out an operating budget for a specific year showing cash income and cash expenses for the farm business by the month to the satisfaction of the instructor.

#### 4. Financial Management

The student will be able to:

- EE a. List the major sources of farm production and farm real estate credit available and give distinguishing information about each type of agency using a recognized reference text.
- EE b. When given data with regard to a farmer's character, net worth, past results, and new plan, present a case to a lending agency for obtaining the necessary credit to the satisfaction of the instructor.

#### 5. Leasing and Risk Management

The student will be able to:

- EE a. Explain how insurance works and why it is possible to protect oneself against large, unknown losses, such as the loss of an entire farm through liability, to the satisfaction of the instructor.
- EE b. Given a farm situation with crops and livestock, plan the kinds of insurance and the approximate amounts to have to provide adequate economical protection according to recognized insurance standards.
- DA c. When given a specific farm situation, explain the major legal precautions to take with regard to property within the state to the satisfaction of the instructor.

COMPETENCIES FOR JOB TITLES

I. Agricultural Production

A. Animal Science

Swine Producer-Breeder

1. Selecting swine

EE a. When shown a picture or actual specimen of a hog, the student will be able to identify the following parts with 100% accuracy:

- (1) Neck
- (2) Ham
- (3) Toes
- (4) Pastern
- (5) Dewclaw
- (6) Knee
- (7) Jowl
- (8) Hock
- (9) Head
- (10) Shoulder
- (11) Chest floor
- (12) Rump
- (13) Side
- (14) Loin

KEY: EE-ESSENTIAL for ENTRY  
DA-DESIRABLE for ADVANCEMENT



- EE b. Using the shape of the ears, head, face, body, color and body markings, and leg characteristics as bases of identification, the student will be able to identify the following breeds with 100% accuracy:
- (1) Berkshire
  - (2) Chester White
  - (3) Duroc
  - (4) Hereford
  - (5) Hampshire
  - (6) Poland China
  - (7) Spotted Poland
  - (8) Tamworth
  - (9) Yorkshire
- DA c. When shown actual specimen or pictures of purebred swine showing inherited defects, the student will be able to identify the following defects with 90% accuracy:
- (1) Inverted teats
  - (2) Cryptorchidism
  - (3) Screw tails
  - (4) Hair whorls (swirls)
  - (5) Defective ears
  - (6) Odd-shaped toes
  - (7) Ruptures
  - (8) Atresia ani
- EE d. Given a group of young animals and the production records of their parents, the student will be able to select high-quality breeding stock. His decisions will be based on size of litter farrowed and weaned, weight at weaning time, and rate of gain of the pigs. His selection will be in agreement with the choices of the Agricultural Occupations teacher.

DA e. Given two examples of feeder pigs, the student will be able to compare them based on the following factors:

- (1) Health
- (2) Type
- (3) Price
- (4) Size in relation to age
- (5) Uniformity
- (6) Grade

Answers must agree with the swine specialists recommendations.

DA f. Given a ring of four purebred animals, the student will be able to use these items in describing the differences among the animals to the satisfaction of the instructor:

- (1) Larger
- (2) Longer
- (3) More rugged
- (4) Balanced
- (5) Wider chest
- (6) Higher tail setting
- (7) Cleaner
- (8) Heavier muscled
- (9) Heavier boned
- (10) Thicker ham
- (11) Better turn of topline
- (12) Better flare to rump and bulge to ham
- (13) More prominent underline

DA g. Given a problem situation including information about available labor, available facilities, available capital, potential markets, and extra costs of purebred production, the student will choose either a

~~purebred system or a grade system of hog~~  
production. His choice will be evaluated  
on the basis of maximum profit by the  
agriculture instructor.

## 2. Feeding and Nutrition

EE a. Given a tag from any feed bag, the student  
will be able to identify the following  
items with 100% accuracy:

- (1) Name, brand, trademark
- (2) Analysis or chemical composition
- (3) Net weight
- (4) Name and address of manufacturer
- (5) Name and amount of feed additives
- (6) Name and amount of feedstuffs

EE b. Given the following list of swine feeds,  
the student will be able to classify the  
feeds in one of the five major nutritive  
groups (protein, carbohydrates, vitamins,  
minerals, and fats) with 100% accuracy:

- (1) Corn
- (2) Soybean oil meal
- (3) Wheat
- (4) Ground limestone
- (5) Fish meal
- (6) Cottonseed meal
- (7) Alfalfa meal
- (8) Steam bone meal
- (9) Alfalfa
- (10) Ladino clover
- (11) Lespedeza
- (12) Bromegrass

- DA c. The student will be able to list the essential vitamins, minerals, and antibiotics of a daily ration for a 100 lb. pig according to NRC standards.
- EE d. Given a ration balancing problem, including information on the percentage of desired crude protein and amount of feed, the student will be able to calculate the amount of corn and soybean meal needed using the Pearson square method.
- DA e. The student will be able to explain the economic advantages and disadvantages of the following methods of feeding to the satisfaction of the Agricultural Occupations teacher:
- (1) Hand feeding
  - (2) Self-feeding
  - (3) Creep feeding
  - (4) Limit feeding
- DA f. The student will be able to prepare a feeding program for sows under the following situations based on swine specialists' recommendations:
- (1) Flushing period
  - (2) Gestation period
  - (3) Farrowing time
  - (4) Lactating period
  - (5) Drying-up period
- DA g. The student will be able to design a feeding program for swine under the following situations which will be in agreement with the recommendations of a swine specialist:
- (1) Starting ration
  - (2) Growing ration
  - (3) Finishing ration

- DA h. Given a problem situation including information on commercial feed prices, commercial mixing costs, delivery charges, and home mixing costs, the student will be able to calculate the economic advantage or disadvantage in mixing feed rations on the farm to the satisfaction of the agriculture instructor.
- DA i. The student will be able to list the functions of five antibiotics used in swine feeds with 100% accuracy.
- DA j. Given the following minerals, the student will be able to list the deficiency symptoms of each with 90% accuracy:
- (1) Salt
  - (2) Calcium
  - (3) Phosphorus
  - (4) Iodine
  - (5) Iron
  - (6) Copper
  - (7) Zinc
  - (8) Magnesium
  - (9) Manganese
  - (10) Potassium
- DA k. Given the following vitamins used in swine feeding, the student will be able to list or state the functions and sources of each to the satisfaction of the instructor:
- (1) Vitamin A
  - (2) Vitamin D
  - (3) Thiamine
  - (4) Pyredozine
  - (5) Riboflavin

(6) Niacin

(7) Panthothenic Acid

(8) Vitamin B-12

DA 1. The student will be able to list or state the deficiency symptoms of the following according to a standard reference text:

(1) Vitamin A

(2) Vitamin B

(3) Thiamine

(4) Riboflavin

(5) Niacin

(6) Panthothenic Acid

(7) Vitamin B-12

(8) Pyridoxine

DA m. Given the following feeds, the student will prepare a list showing the five feeds which are the best sources of carbohydrates, fats, protein, minerals, and vitamins according to feeding standards provided:

(1) Corn

(2) Oats

(3) Wheat

(4) Cottonseed meal

(5) Linseed meal

(6) Alfalfa meal

(7) Sun-cured hay

(8) Fish meal

(9) Meat and bone meal

(10) Tankage

(11) Blood meal

(12) Wheat bran

### 3. Breeding and Management

- EE a. Given two separate drawings of the male and female reproductive organs of swine, the student will be able to label the parts indicated on the hand-out chart with 90% accuracy.
- DA b. The student will be able to illustrate or explain the following systems of breeding swine to the satisfaction of the instructor:
- (1) Inbreeding
  - (2) Linebreeding
  - (3) Upgrading
  - (4) Crossbreeding
  - (5) Backcross
- EE c. Given breeding dates of ten different sows and a gestation table, the student will be able to calculate the expected farrowing date of each sow with 100% accuracy.
- EE d. Given a group of swine of which some are in heat, the student will be able to identify the in-heat sows and list external signs of estrus to the satisfaction of the instructor.
- DA e. The student will be able to list the advantages and disadvantages of the pen system of breeding and the lot system of breeding. His answer will be evaluated on the basis of the amount of labor required and probable conception rates.
- EE f. Given ten ear-notched pigs and the marking system used, the student will be able to identify the individual pigs by their number with 100% accuracy.
- DA g. The student will be able to develop, keep, and maintain accurately the following swine records:
- (1) Breeding records
  - (2) Production records

- (3) Feed records
- (4) Labor records
- (5) Pedigree and herd records
- (6) Budget record.
- (7) Financial statement record
- (8) Daily activities record
- (9) Efficiency records
- (10) Inventory records (opening & closing)

These records must conform to the standards recommended by the instructor.

DA h. Given a complete swine production record, the student will be able to analyze the records to determine the following information:

- (1) Net profit or loss
- (2) Average daily gain
- (3) Feed cost per 100 lbs. of gain
- (4) Returns per 100# feed fed

The obtained figures must be the same as those computed by the instructor.

DA i. Given a hog or pig and an animal thermometer, the student will be able to demonstrate how to take the body temperature of the animal. He will not incur injury to the pig or the thermometer and his temperature reading will agree with that taken by a veterinarian or teacher.

EE j. Given a group of sows about to farrow, the student will be able to prepare an outline of the following approved practices to prepare them for the farrowing house:

- (1) Isolation of the pregnant sows from the herd
- (2) Cleaning the pregnant animal
- (3) Preparation for the farrowing house



which includes guard rail, bedding, temperature, and ventilation

(4) Sanitation practices

The resulting outline of activities should conform to the recommendations of a swine specialist.

EE k. The student will be able to prepare a time schedule of baby pig management practices which includes the following activities that conform to the recommendations of a swine specialist:

- (1) Ear notching
- (2) Oral iron treatment
- (3) Clipping needle teeth
- (4) Vaccination
- (5) Creep feeding
- (6) Castrating boar pigs
- (7) Weaning
- (8) Docking

DA l. The student will be able to explain the merits of the pasture and confinement systems of finishing hogs. His explanation will include differences in land, labor, and building requirements and sanitation factors to the satisfaction of the instructor.

DA m. Given a problem situation including information and location of farm, land, labor, and capital available, the student will be able to select a swine production system from the following list which will give the greatest net profit according to FBFM records:

- (1) Feeder pig production
- (2) Farrow to finish
- (3) Finishing feeder pigs

EE n. Given the proper tools the student will be able to demonstrate proper technique

for the following operations to the satisfaction of his instructor:

- (1) Ear notching
- (2) Clipping needle teeth
- (3) Iron shots
- (4) Docking tails
- (5) Castrating boar pigs

#### 4. Animal health

DA a. Given colored slides or actual specimens of animals exhibiting symptoms of each of the following diseases, the student will be able to identify the symptoms of each disease with 100% accuracy:

- (1) Atrophic rhinitis
- (2) Swine dysentery
- (3) Edema disease
- (4) Pig scours
- (5) Erysipelas
- (6) Pneumonia
- (7) Foot and mouth disease
- (8) Hog influenza
- (9) Swine pox
- (10) Mastitis-metritis-agalactia complex

EE b. Given the preceding list of diseases, the student will be able to recommend preventative and control measures for each disease which will be in agreement with those of the local veterinarian.

DA c. Given specimens of the following parasites, the student will be able to identify each by common name and recommend preventative and control measures that correspond to those of the local veterinarian:

- (1) Ascarids
- (2) Blowfly
- (3) Thread worm
- (4) Kidney worm
- (5) Lice
- (6) Tungworm
- (7) Whipworm
- (8) Mites
- (9) Ringworm
- (10) Screwworm

#### 5. Housing and equipment

EE a. The student will be able to identify from slides or actual examples the following types of swine equipment with 100% accuracy:

- (1) Ear notchers
- (2) Vaccination syringes
- (3) Tool for clipping needle teeth
- (4) Tool for castrating
- (5) Sprinklers
- (6) Pig brooders
- (7) Heat lamps
- (8) Self-feeder
- (9) Wallow
- (10) Breeding crate
- (11) Ringers
- (12) Farrowing crates

- DA b. Given the equipment listed in item "a", the student will be able to develop a storage and maintenance system for the tools. His plan will be evaluated on the basis of sanitation, labor efficiency, care of the equipment, and cost of construction.
- DA c. Given a problem involving production of 24 litters of feeder pigs a year, the student will be able to compare the advantages and disadvantages of portable and central houses. Conclusions will be evaluated upon housing cost per pig, amount of labor per pig and net returns per pig.

## 6. Marketing

- DA a. Using the last four weekly average market prices of hogs and corn, the student will be able to compute the hog-corn ratios of each week with 100% accuracy.
- DA b. Given 10 examples of the liveweight and carcass weight of a market hog, the student will be able to calculate the dressing percentage with 90% accuracy.
- EE c. Given a market hog and back fat probe, the student will be able to measure back fat thickness at three different locations of the animal's body. The obtained readings should be in agreement with those obtained by the instructor.
- EE d. Given a problem situation, the student will be able to select a marketplace based on the following factors:
- (1) Distance
  - (2) Transportation problems
  - (3) Shrinkage
  - (4) Methods of grading
  - (5) Handling and selling charges
  - (6) Dependability
  - (7) Price quotations
  - (8) Marketing services available

His selection will be judged on economy of marketing by the instructor.

- EE e. The student will be able to prepare a written outline of precautions to prevent bruises, crippling, and death losses during transportation of hogs. His recommendations will be in agreement with those of a live-stock marketing agent.

### Beef Producer-Breeder

#### 1. Selecting beef

- EE a. From a chart showing the parts of a steer, the student will be able to name the following parts with 100% accuracy:

- (1) Muzzle
- (2) Nostril
- (3) Jaw
- (4) Dewlap
- (5) Shoulder vein
- (6) Top of shoulder
- (7) Heart girth
- (8) Knee
- (9) Dewclaw
- (10) Crops
- (11) Ribs
- (12) Loin
- (13) Hock
- (14) Cod
- (15) Rear flank

- EE b. Using pictures provided by breed associations, the student will be able to recognize the following breeds with 100% accuracy:
- (1) Angus
  - (2) Hereford
  - (3) Shorthorn
  - (4) Simmental
  - (5) Charolais
  - (6) Limousin
  - (7) Maine-Anjou
  - (8) Gelbvieh
  - (9) Brangus
- EE c. The student will be able to prepare a paper explaining the following defects that may be found in cattle according to breed association standards:
- (1) Cryptorchidism
  - (2) Off-type
  - (3) Ridgling
  - (4) Rupture
  - (5) Sickle hocked
  - (6) Tie
- EE d. Given a ring of four heifers, the student will be able to rank the animals acceptable to the agricultural occupations instructor based on the following points:
- (1) General appearance
  - (2) Form
  - (3) Finish
  - (4) Quality
  - (5) Constitution
  - (6) Breed and sex character

## 2. Feeding and nutrition

EE a. Given two feed bag tags, the student will be able to compare them for their feeding value based on the following:

- (1) Crude protein
- (2) Feed additives
- (3) Mineral content
- (4) Vitamin level

Evaluation will be based upon the most economical feed.

EE b. Given the following list of beef feeds, the student will be able to classify the feeds in one of the five major nutritive groups (protein, carbohydrates, vitamins, minerals, and fats):

- (1) Corn
- (2) Soybean oil meal
- (3) Wheat
- (4) Ground limestone
- (5) Steamed bone meal
- (6) Fish meal
- (7) Cottonseed meal
- (8) Alfalfa meal
- (9) Corn silage
- (10) Haylage
- (11) Alfalfa
- (12) Orchard grass

DA c. The student will be able to list the essential vitamins, minerals, and antibiotics of a daily ration for the following classes of animals according to NRC standards:

- (1) Beef cow

- (2) Beef heifer
  - (3) 450-pound calf
  - (4) 900-pound market animal
  - (5) Beef bull
- EE d. Given a ration balancing problem, including information on the feeds to be used, percentage of crude protein and amount of feed, the student will be able to calculate a ration using the Pearson square method with 100% accuracy.
- EE e. The student will be able to prepare a feeding program for the beef breeding herd under the following situations based on beef specialists recommendations:
- (1) Wintering bred heifers
  - (2) Wintering bred cows
  - (3) Cows nursing calves
  - (4) Breeding bull
- EE f. The student will be able to design a feeding program for market cattle under the following situations which will be in agreement with the recommendations of a beef specialist:
- (1) Grain fed drylot
  - (2) Silage fed drylot
  - (3) Pasture fed-grain finish
- DA g. The student will be able to list the functions of five antibiotics from a list of 10 that are commonly used in cattle feed with 100% accuracy.
- DA h. Given the following minerals, the student will be able to list the deficiency symptoms with 90% accuracy:
- (1) Salt
  - (2) Calcium
  - (3) Phosphorus



- (4) Iodine
- (5) Iron
- (6) Copper
- (7) Zinc
- (8) Magnesium
- (9) Manganese
- (10) Potassium

DA i. Given the following vitamins used in cattle feeding, the student will be able to list or state the function and source of each to the satisfaction of the instructor:

- (1) Carotene
- (2) Vitamin A
- (3) Thiamine
- (4) Riboflavin
- (5) Niacin
- (6) Pantothenic acid

DA j. Given a problem situation including information of silage costs, conventional bale costs and large package hay system costs, the student will be able to make comparisons to establish the most suitable system of hay handling for his beef raising system. Conclusion will be judged on a least-cost feeding program.

### 3. Breeding and management

EE a. Given two separate drawings of the male and female reproductive organs of beef, the student will be able to label the parts indicated on the hand-out chart provided with 90% accuracy.

EE b. The student will be able to illustrate or explain the following systems of breeding beef to the satisfaction of the instructor:

- (1) Inbreeding
- (2) Linebreeding

- (3) Upgrading
  - (4) Crossbreeding
  - (5) Backcross
  - (6) A. I. (Artificial Insemination)
- EE c. Given breeding dates for 10 different cows and a gestation table, the student will be able to calculate the expected calving date of each cow with 100% accuracy.
- EE d. Given a group of cows of which some are in heat, the student will be able to identify the in-heat cows and list external signs of estrus with 90% accuracy.
- DA e. The student will be able to make comparisons between using A. I. and using a bull to settle cows. His answer will be evaluated on the basis of:
- (1) Economics
  - (2) Conception rate
  - (3) Quality of calf
  - (4) Convenience
- DA f. The student will be able to develop, keep, and maintain accurately the following beef records:
- (1) Breeding records
  - (2) Production records
  - (3) Feed records
  - (4) Labor records
  - (5) Pedigree & herd records
  - (6) Budget records
  - (7) Financial statement records
  - (8) Daily activity record
  - (9) Efficiency records
  - (10) Inventory records

These records must conform to standards established by the agricultural occupations instructor.

DA g. Given a complete beef production record, the student will be able to analyze the records to determine the following information:

- (1) Net profit or loss
- (2) Average daily gain
- (3) Feed cost per 100 lbs. gain
- (4) Returns per \$100 feed fed

The obtained figures must be the same as those computed by the teacher.

EE h. Given a group of 10 cows about to calve, the student will be able to prepare an outline of the following approved practices to prepare them for calving:

- (1) Isolation of pregnant animal from herd
- (2) Cleaning the pregnant animal
- (3) Preparation of the calving barn
- (4) Sanitation procedures

DA i. For the home farm situation the student will be able to analyze the following systems of beef production and choose the most profitable plan for his farm:

- (1) Beef cow, calf sold
- (2) Beef cow, calf fed
- (3) Short fed market animals
- (4) Long fed market animals

Results will be evaluated against FBFM records.

EE j. Given the correct tools, the student will be able to demonstrate proper technique for the following operations to the satisfaction of his employer or peers:

- (1) Ear tagging
- (2) Castrating
- (3) Dehorning
- (4) Hoof trimming
- (5) Injection
- (6) Clipping

#### 4. Animal health

EE a. Given specimens of the following parasites, the student will be able to identify each by common names and recommend preventative and control measures that correspond to those of the local veterinarian:

- (1) lice
- (2) Mites
- (3) Ringworm
- (4) Face fly
- (5) Lung worms
- (6) Stomach worms
- (7) Blow fly
- (8) Screw worm

EE b. The student will be able to develop a chart of ten common diseases in beef using the following categories. Information on the chart will be judged against recommendations of the local veterinarian:

- (1) Disease
- (2) Symptoms
- (3) Class of animals affected
- (4) Control measures
- (5) Prevention measures

## 5. Housing and equipment

DA a. Given a problem involving production of 40 calves per year, the student will be able to compare advantages and disadvantages of pasture and drylot production and reach a conclusion correct for his farm based on cost per calf, labor per calf, net return per calf and convenience.

EE b. From reading assignments the student will be able to list the advantages and disadvantages of the following types of fences:

- (1) Barbed wire
- (2) Electric wire
- (3) Woven wire
- (4) Board fence
- (5) Pipe or metal fence

EE c. Given a problem situation, the student will be able to design adequate housing based on the following:

- (1) Space per animal
- (2) Waterers required
- (3) Feeder space
- (4) Lighting needs
- (5) Manure disposal system
- (6) Ventilation needs

Answers must conform to recommendations of the beef specialist.

## 6. Marketing

EE a. Given a problem situation, the student will be able to select a marketplace based on the following factors:

- (1) Distance
- (2) Transportation problems
- (3) Shrinkage

- (4) Methods of grading
- (5) Handling and selling charges
- (6) Dependability
- (7) Price quotations
- (8) Marketing services available

His selection will be judged on economy of marketing by the instructor.

- EE b. Given necessary information on 10 market animals, the student will be able to compute grade and yield data with 100% accuracy.
- EE c. From livestock market reports the student will be able to graph the cash and future prices for feeder cattle and market cattle by the week for six months to the satisfaction of the instructor.
- DA d. From reading assignments the student will be able to state the important provisions of the following laws affecting cattle marketing:
- (1) Meat Inspection Act
  - (2) Food, Drug, and Cosmetic Act
  - (3) 28-Hour Law in Rail Shipment
  - (4) Copper-Volsted Act
  - (5) Robinson-Patman Act

### Specialty Animal Raiser

#### 1. Selection

- EE a. Given five live animals, the student will be able to identify the breeds according to industry standards or official breed pictures with 100% accuracy.

- EE b. From a handout chart the student will be able to correctly name the listed parts of the animal with 100% accuracy.
- EE c. Given a ring of four animals and their production records, the student will be able to rank the animals according to industry standards on the following:
- (1) Conformation
  - (2) Growth rate
  - (3) Production capability
  - (4) Color

## 2. Feeding and nutrition

- EE a. The student will be able to, from class handouts, draw the digestive system of the animal and describe the digestive process with 95% accuracy.
- EE b. From reading assignments, the student will be able to develop a chart listing the nutrient requirements (protein, carbohydrates, vitamins, minerals, and antibiotics) for the animal species according to its productive purpose. The answer will be judged against industry standards.
- EE c. The student will be able to assemble a list of feeds that will meet the nutritive requirements outlined in letter "b" above from information found in Morrison's Feed and Feed Handbook with 100% accuracy.
- EE d. Given a ration balancing problem including information on the feeds to be used, percentage of crude protein and amount of feed, the student will be able to calculate a ration using the Pearson Square method with 100% accuracy.
- EE e. With information from reference materials, the student will be able to design a year-round feeding program for the animal to be raised. The plan will be evaluated against feeding programs in use by producers.

## 3. Breeding and management

- EE a. Given drawings of the male and female reproductive organs of the species, the student will be able to label the indicated parts with 90% accuracy.
- EE b. Given breeding dates for 10 different animals in the species, the student will be able to calculate the expected birth date of the young with 100% accuracy.
- EE c. Given a group of animals of which some are in heat, the student will be able to determine which animals are in heat and list external signs of estrus to the instructor's satisfaction.
- DA d. The student will be able to develop, keep and maintain accurately records with the following items:
- (1) Breeding records
  - (2) Production records
  - (3) Feed records
  - (4) Labor records
  - (5) Pedigree records
  - (6) Budget records
  - (7) Financial statements
  - (8) Daily activity records
  - (9) Efficiency records
  - (10) Inventory records.
- DA e. From the records in letter "d", the student will be able to analyze the records to determine the following:
- (1) Profit or loss
  - (2) Average daily gain
  - (3) Feed cost per 100 pound produced
  - (4) Returns per 100# feed fed



The analysis must conform to those of the instructor.

EE f. From reading material, the student will be able to prepare a time schedule for management of the newborn and young animal which will include the following practices:

- (1) Identification
- (2) Medication
- (3) Vaccination
- (4) Weaning
- (5) Supplemental feeding
- (6) Clipping, docking, castration, etc.

#### 4. Animal health

EE a. From U.S.D.A. bulletins, the student will be able to summarize the common diseases that could affect the animal and develop a chart showing symptoms, treatment and control. The project will be evaluated based on local veterinarian recommendations.

EE b. From trade magazines, the student will be able to collect pictures of five internal parasites that commonly are found on the specialty animal and develop recommendations for treatment of the condition. Answers must conform to instructor recommendations.

#### 5. Housing and equipment

EE a. Given a problem situation, the student will be able to design adequate housing and equipment recommendations for the year-round operation of the specialty animal enterprise taking the following into consideration:

- (1) Space requirements
- (2) Waterers needed
- (3) Feeder space needed
- (4) Lighting needs

- (5) Ventilation needs
- (6) Manure disposal needs
- (7) Operator comfort
- (8) Animal comfort

Recommendations must conform to standards in use in the industry.

## 6. Marketing

EE a. From industry market reports, the student will be able to graph the market price for the specialty animal by the week for a six month period. The graph must be to the satisfaction of the instructor.

EE b. Given a problem situation, the student will be able to select a market for the animal or animal products based on the following factors:

- (1) Distance
- (2) Transportation problems
- (3) Shrinkage
- (4) Methods of grading
- (5) Handling and selling charges
- (6) Dependability
- (7) Price quotations
- (8) Marketing services available

The student's selection will be judged on the economy of marketing by the instructor.

EE c. From reference material, the student will be able to prepare a written outline of precautions to prevent bruises, crippling, and death losses during transportation of the animal or animal product. His recommendations will be in agreement with those of a livestock marketing agent.

## B. Plant Science

## Cereal Grain Producer (Corn)

## 1. Plant development

- EE a. Given a mature seed, the student will be able to identify the following parts and explain the functions of each part with 100% accuracy:
- (1) Pericarp
  - (2) Endosperm
  - (3) Embryo
  - (4) Coleoptile
- 
- (5) Scutellum
  - (6) Plumule
  - (7) Radicle
  - (8) Tip cap
- EA b. The student will be able to draw and label the parts of a corn plant at the following stages of the life cycle with 100% accuracy:
- (1) Seed in soil
  - (2) Germinating and emerging seed
  - (3) Two-week old corn plant
  - (4) Mature corn plant showing roots, stalk, corn ear, tassel, leaves, and silk
- DA c. Using a corn plant or pictures of a corn plant, the student will be able to explain to a class of his peers the process of pollination and fertilization. The student will be able to answer correctly at least one-half of the questions raised by his classmates.
- EE d. From class notes the student will be able to set up a growth calendar for corn that will show the development of the plant by one week intervals from planting until harvest and using the following columns:

- (1) Date
- (2) Stage of development
- (3) Root development
- (4) Leaf development
- (5) Ear development
- (6) Growing point
- (7) Moisture needs
- (8) Nutrient needs

## 2. Variety selection and seeding practices

EE a. From a list of ten popular corn hybrids grown locally, the student will be able to select four hybrids and describe the main characteristics of each based on the following:

- (1) Standability
- (2) Yield potential
- (3) Disease resistance
- (4) Growing degree days
- (5) Height
- (6) Herbicide tolerance

Recommendations must conform to those of a seed specialist.

- EE b. Given the label from a seed corn bag, the student will be able to explain in his own words each of the items listed on the tag to the instructor's satisfaction.
- EE c. Given figures for plant population at harvest for a desired yield per acre, percent barren stalks, and field losses due to disease, cultivation, etc., the student will calculate the rate of planting needed per acre to the satisfaction of the instructor.

- EE d. When presented with a simulated problem which includes a description of important field and crop variables, the student will be able to make sound management decisions regarding rate of planting, depth of planting, and time of planting. His answer will correspond to corn specialist's recommendations.
- DA e. From class handouts the student will be able to develop a list of factors favoring early planting of corn. The list must correspond to the instructor's recommendations.

### 3. Seedbed preparation

- EE a. The student will be able to demonstrate the "balling" method of judging soil moisture according to the steps recommended by a soil expert.
- DA b. The student will be able to describe a system of minimum tillage and to compare costs per acre of minimum tillage operations and conventional tillage operations to the satisfaction of the instructor.
- EE c. Given actual field conditions or descriptive data on various degrees of wetness, weed or other crop growth and various soil conditions, the student will be able to recommend a practical tillage plan and tell why he favors the proposed plan. He must gain 80% approval of his classmates.

### 4. Fertility

- EE a. Given the results of soil tests and desired yields, the student will be able to prepare a well-balanced fertilizer application program which includes the following:
- (1) Kinds of fertilizers to apply
  - (2) When to apply
  - (3) Methods of application
  - (4) Rate of application
  - (5) Cost to be involved

The program should be in agreement with the recommendations of a fertility expert.

- EE b. Given price and analysis figures, the student will be able to calculate the cost per pound of actual nitrogen for each of the following fertilizers with 100% accuracy:
- (1) Ammonium nitrate
  - (2) Ammonium sulfate
  - (3) Urea
  - (4) Anhydrous ammonia
  - (5) 28% solution
- 
- EE c. Given sample sacks of fertilizers with different analysis, the student will be able to analyze the information on the sack, and compute the number of pounds of nitrogen, phosphorus, and potassium with 100% accuracy.
- EE d. Given actual corn plant specimens or pictures of specimens exhibiting deficiency symptoms for primary elements and micro-nutrients, the student will be able to identify deficiencies of nitrogen, phosphorus, potassium, boron, chlorine, cobalt, copper, iron, manganese, molybdenum, and zinc. The identification must be 90% accurate.
5. Weed control
- DA a. The student will be able to distinguish between pre-emergence and post-emergence herbicide applications and to explain how each type of treatment reacts to given weed control to the satisfaction of the instructor.
- EE b. The student will be able to discuss verbally or in writing the purposes of field cultivation and to indicate the effects of cultivation on plant growth, soil moisture, and weed control to the satisfaction of the instructor.
- EE c. Given colored slides and/or actual specimens of the following weeds, the student

will be able to give the common name and list one recommended herbicide and cultural practice to control each: (100% accuracy is required.)

- (1) Yellow nutsedge
- (2) Giant foxtail
- (3) Yellow foxtail
- (4) Johnson grass
- (5) Common milkweed
- (6) Wild sweet potato
- (7) Pigweed
- (8) Smartweed
- (9) Quack grass
- (10) Canada thistle
- (11) Wild cucumber
- (12) Field bindweed
- (13) Climbing milkweed
- (14) Velvet leaf
- (15) Morning glory

- EE d. Given the band width and row spacing in inches and rate of broadcast in gallons per acre, the student will be able to compute the band rate and recommend at least three types of spray nozzles to use. Student's recommendations must agree with those of the instructor.
- EE e. The student will be able to recognize effects of herbicide carryover and to identify and discuss the factors causing carryover. Factors listed will be judged against class notes.

6. Insect and disease control

- EE a. Given a certain field situation involving disease infestation, the student will identify the affected parts or plants,

give the common name of the disease, and recommend one fungicide and one cultural practice to control each disease: (The student will attain 90% accuracy.)

- (1) Stewart's disease
  - (2) Corn mosaic
  - (3) Corn rust
  - (4) Seedling blight
  - (5) Corn ear rots
  - (6) Corn smut
  - (7) Corn bacterial wilt
- 
- (8) Stalk rot
  - (9) Crazy top
  - (10) Northern & Southern leaf blight

EE b. When confronted with color slides or actual specimens of the following insect pests, the student will identify them by stating the common name, scientific name, feeding habit, most destructive stage of life, and recommend one chemical and one management practice to control each with 90% accuracy:

- (1) Seed corn beetle
- (2) Corn root aphids
- (3) Corn root worm
- (4) Corn ear worm
- (5) Stalk borer
- (6) Grasshopper
- (7) Thief ant
- (8) Grape colaspis
- (9) Seed corn maggot
- (10) Wire worm
- (11) Corn bill bug



- (12) Chinch bug
- (13) Corn flea beetle
- (14) Fall army worm
- (15) Corn borer
- (16) Black cut worm
- (17) White grub

- EE c. Given a list of agricultural chemicals, the student will be able to classify them in terms of their pollution potential and their toxic effects to man and other animals according to the Custom Spray Operator's Manual.
- EE d. The student will be able to relate either verbally or in writing the necessary safety precautions that should be used in handling and storing agricultural chemicals. The student's recommendations should conform to those of a weed specialist.

#### 7. Harvesting and storing

- EE a. The student will be able to calculate field loss behind a harvesting machine. His performance will be evaluated in terms of calculations made by the agriculture teacher or engineering specialist.
- EE b. The student will be able to determine when to harvest corn for drying, for storage as ear corn, and for storage as shelled corn. His performance will be judged by comparing his decisions to those made by a panel of successful farmers.
- DA c. The student will be able to estimate yields in a given field within a ten percent error range of the actual yield. The method will be prescribed by the agriculture instructor and checked by him.
- EE d. The student will be able to calculate the cost of storing a given amount of corn on the farm for a specified period of time. Figures will be compared with FBFM records for accuracy.

## 8. Marketing

- EE a. Given monthly corn prices, shrinkage, storage costs, and other facts, the student will be able to show whether sale at harvest or sale of corn later in the season would be more profitable. His decision should be in agreement with the opinion of a marketing agent.
- DA b. The student will be able to calculate the shrinkage in percentage and bushels for a given batch of corn when dried from 25.5% moisture down to 15.5%. Accuracy must be 100% when checked against minery tables.
- EE c. Given a common model of an electric moisture tester, the student will be able to run three tests and obtain essentially the same readings as an experienced tester gets.
- DA d. The student will be able to illustrate how a hedging operation works and to explain how hedging can be used to minimize risks. The illustration and explanation should be in agreement with those in reliable references on marketing agricultural products.
- EE e. When given a 500 gram sample of corn, the student will be able to assign the sample the proper U.S.D.A. grade based on:
- (1) Moisture
  - (2) Test weight
  - (3) Foreign material
  - (4) Heat damaged kernels
- The grade must agree with that of the local grain elevator operator.

Oil Crop Producer (Soybean Producer)

EE a. Given a mature seed, the student will be able to identify the following parts and explain their function with 100% accuracy:

- (1) Testa
- (2) Radicle
- (3) Embryo
- (4) Coleoptile

EE b. From class notes the student will be able to draw and label the parts of the soybean plant at the following stages of the life cycle with 100% accuracy:

- (1) Emergence
- (2) Two leaf stage
- (3) First trifoliolate leaf
- (4) Full bloom

EE c. From reference material the student will be able to prepare a paper on the soybean plant indicating the following:

- (1) Day length requirement
- (2) Degree days
- (3) Rainfall needed
- (4) Temperature requirement
- (5) Frost-free growing days

Answers must conform to a standard reference text.

EE d. Using a real plant or soybean picture, the student will be able to explain to his peers the development of the soybean plant from emergence to maturity and to correctly answer one-half of the questions raised by classmates.

## 2. Variety selection and seeding practices

EE a. The student will be able to make a comparison between public varieties, private

varieties, blends and hybrids and select the most suitable seed for his farming situation. His decision must conform to recommendations of seed specialists.

- EE b. Given the label from a soybean seed bag, the student will be able to explain in his own words each of the items listed on the tag to the instructor's satisfaction.
- EE c. When presented with a problem situation which includes a description of important field and crop variables, the student will be able to make sound management decisions regarding rate of planting, depth of planting, and time of planting. His answer must conform to soybean specialist's recommendations.
- EE d. Given seed size, germination percent, and expected pre-harvest plant losses, the student will be able to calculate a planting rate in seeds per foot to give a harvest population of six soybean plants per foot. His conclusion must be verified by the instructor.

### 3. Seedbed preparation

- EE a. The student will develop criteria for determining when soil moisture is correct for tillage operations in soybean seedbed preparation. The student will use assigned references and develop a list of 10 guidelines that conform to standards set by the instructor.
- DA b. The student will be able to write a comparison between minimum tillage and conventional tillage considering cost per acre, effect on yield of soybeans and special machines required. Conclusions must agree with District Soil Conservationist's recommendations.
- EE c. Given a certain field situation, the student will write a comprehensive plan of how to prepare the seedbed which includes a list of farm implements to use, sequence, schedule, and frequency of each operation, labor requirements, and estimated cost of production. The student's plan must conform to recommendations of the instructor.

## 4. Fertility

- EE a. Given a certain field situation, the student will be able to draw a map of the field and indicate points where soil samples should be collected. He will collect samples and prepare them for testing using the approved practices commonly recommended by soil scientists.
- EE b. Given five soil samples, the student will be able to conduct tests for acidity, phosphorus, and potassium. His results should agree with test results obtained by an official testing laboratory for at least 12 of the 15 samples.
- EE c. Given information on soil test levels, previous crop grown, expected yield, and variety to be planted, the student will be able to design a fertility program for a soybean field that conforms to recommendations of the agricultural occupations teacher.
- EE d. Using slides of deficiency symptoms showing in soybeans, the student will be able to identify the cause of the deficiency symptom and recommend corrective action with 90% accuracy.

## 5. Weed control

- EE a. From class notes the student will be able to develop a list of ten broadleaf and ten grass weeds that are considered serious pests in the local area. He will make a mounted collection of these weed samples and identify them with 90% accuracy.
- EE b. Given the following list of herbicides, the student will prepare a table showing the weeds each control, methods of application, rate of application per acre, and time of application:
- (1) Amiben
  - (2) Lorox
  - (3) Lasso
  - (4) Sencor
  - (5) Treflan

(6) Cobex

(7) Alanap

(8) Vernam

The weed control table should be in agreement with recommendations of a weed control specialist.

DA c. The student will be able to distinguish between pre-plant and pre-emergence herbicide applications and to explain how each type of treatment reacts to given weed control to the satisfaction of the instructor.

EE d. The student, using class notes, will be able to explain the factors affecting herbicide drift and to list the preventative measures that should be taken to prevent excessive drift. Answers must conform to recommendations of a weed specialist.

6. Insect and disease control

EE a. The student will be able to distinguish between the purposes of insecticides and fungicides. He will list five insecticide chemicals and five fungicide chemicals and name one insect and one disease that could be controlled with each chemical. The student's listing must correspond to label information.

EE b. Given a certain field situation concerning disease infestation, the student will identify the affected parts or plants, give the common name of the disease, and recommend either a cultural or chemical control practice for each disease. The student will attain 90% accuracy.

EE c. When confronted with slides of the following soybean insects, the student will identify them by stating the common name, feeding habits, most destructive stage of life, and recommend a cultural or chemical control measure for each with 90% accuracy:

(1) Grasshopper

(2) Cut worm

- (3) Leafhopper
- (4) Army worm
- (5) Flea beetle
- (6) Green clover worm

EE d. Given a list of ten adapted soybean varieties, the student will be able to find and report the resistance of each variety to disease and insect damage. The student's results must conform to the recommendations of a soybean specialist.

#### 7. Harvesting and storing

EE a. Given a specific problem, the student will be able to calculate the cost of storing a given amount of soybeans for a specified period of time. His calculations must correspond to the answer determined by the teacher.

EE b. The student will be able to calculate field losses behind a combine. His performance will be evaluated in terms of calculations made by the agriculture instructor.

#### 8. Marketing

EE a. From grain market reports the student will be able to chart the weekly cash and futures soybean prices on a graph for a six-month period to the satisfaction of the instructor.

EE b. Using class handout material, the student will discover guidelines that can be used for profitable soybean marketing. The student must present six guidelines to the satisfaction of his peers.

EE c. When provided with six soybean samples and a moisture tester, the student will be able to determine the moisture content of the samples within .5%.

DA d. From class handouts the student will be able to draw a comparison between the domestic price of soybeans and the volume of soybeans exported. The comparison will be judged against the instructor's observations.

EE e. When given a 500 gram sample of soybeans, the student will be able to assign the sample the proper U.S.D.A. grade based on:

- (1) Moisture
- (2) Test weight
- (3) Foreign material
- (4) Splits

The grade must agree with that of the local grain elevator operator.

#### Forage Crop Producer

##### 1. Plant Development

EE a. From a handout chart showing the parts of a mature grass and legume seed the student will be able to identify all parts shown with 100% accuracy.

DA b. Using a real alfalfa plant the student will be able to explain to a class of his peers the process of pollination and fertilization. The student will be able to correctly answer at least one half of the questions raised by classmates.

EE c. By diagram, the student will be able to demonstrate the functional differences between the roots development of a grass plant and legume plant at eight weeks of age. The answer must conform to diagrams in the text materials.

DA d. With the aid of references the student will be able to outline a 10 step program for pasture management of forage crops that will increase the animal unit carrying capacity to its maximum potential. Program evaluation will be based on S.C.C. recommendations for pasture improvement.



## 2. Variety selection and seeding practices

- EE a. Given a legume sample and inoculant, the student will be able to demonstrate the proper procedure for inoculating the sample. The procedure must be judged correct by the agriculture teacher.
- EE b. Without the aid of references the student will be able to identify ten grasses and ten legume seed samples with 100% accuracy from a list provided by the instructor.
- EE c. From the list of adapted forage crop varieties the student will be able to select three grasses and three legumes and rank them on the following characteristics:
- (1) Yield potential
  - (2) Disease tolerance
  - (3) Drought resistance
  - (4) Standability
  - (5) Insect tolerance
  - (6) Feed value

Recommendations must match those of a forage specialist.

- EE d. When presented with a forage field problem which includes field conditions and crop goals, the student will be able to make sound management decisions regarding rate of planting, depth of planting and time of planting. His answer will correspond to forage specialist recommendations.

## 3. Seedbed preparation

- EE a. The student will be able to describe an ideal seedbed for forages. He will use class notes and reference material to recommend tillage operations needed to achieve a good seedbed for the following situations:
- (1) Field planted in wheat
  - (2) Soybean stubble

(3) Grass sod land

(4) Field of corn stalks

Recommendations must gain approval of classmates.

#### 4. Fertility

EE a. Given the results of soil tests and the desired yield, the student will be able to prepare a build-up and maintenance fertilizer application program which includes the following:

(1) Kinds of fertilizer to apply

(2) When to apply

(3) Method of application

(4) Rate of application

(5) Cost of program per acre

The program must be in agreement with a specialist in fertility.

DA b. When shown slides of the following nutrition deficiency symptoms in forages the student will be able to identify the deficiency cause with 90% accuracy.

(1) Nitrogen

(2) Phosphorus

(3) Potassium

(4) Manganese

(5) Calcium

(6) Boron

(7) Zinc

(8) Copper

#### 5. Weed control

EE a. Given colored slides and/or specimens of the following weeds, the student will be able to give the common name and list one cultural or chemical control measure with

100% accuracy:

- (1) Giant foxtail
- (2) Yellow foxtail
- (3) Chickweed
- (4) Bull nettle
- (5) Canada thistle
- (6) Johnsongrass
- (7) Quackgrass

6. Insect and disease control

EE a. Given a specific field problem concerning disease infestation, the student will identify five diseases using plant parts and recommend either a cultural or chemical control practice for each disease. The student will attain 90% accuracy.

EE b. From a list of forage crop insects given in class the student will identify 10 insects, give their common name and specify which of the following control measures would be most suitable.

- (1) Tillage practices
- (2) Crop rotation
- (3) Insecticides

The student will attain 100% accuracy.

DA c. From field observation the student will be able to estimate the losses in tons per acre of forage from a severe infestation of alfalfa weevil. His conclusion must conform to the estimate of a forage specialist.

7. Harvesting and storage

EE a. Using reading assignments as a guide the student will be able to develop a harvesting schedule for legumes and grasses that will maximize the feed value per acre on the students home farm. His recommendations

will be compared with the recommendations in the Agronomy Handbook.

- DA b. Given a specific field situation, the student will be able to recite the advantages of ensiling a forage crop versus harvesting it as a hay crop for feeding purposes. He must be able to answer satisfactorily all questions raised by classmates.

## 8. Marketing

- EE a. When confronted with five forage crop samples the student will be able to rank them on the following characteristics with 90% accuracy.
- (1) Aroma
  - (2) Color
  - (3) Feed value
  - (4) Weed infestation
  - (5) Stem-leaf ratio
  - (6) Storage potential
- DA b. Through class discussion the student will be able to list and describe the five potential methods of marketing a forage crop from the farm. The conclusions must agree with the recommendations of the Agricultural Occupations instructor.

## Specialty Crop Producer

### 1. Plant development

- EE a. Given a mature seed, the student will be able to name the parts and give the function of each part with 100% accuracy.

- EE b. Using a real plant or colored slide the student will be able to explain to his peers the development of the plant from emergence to maturity and to correctly answer one half of the questions raised by classmates.

## 2. Variety selection and seeding practices

- EE a. From a list of adapted varieties the student will be able to select four varieties most suitable for his farm and rank them on the following characteristics:

- (1) Yield potential
- (2) Disease resistance
- (3) Insect resistance
- (4) Drought tolerance
- (5) Desirability of produce
- (6) Temperature tolerance

Recommendation must be able to be verified by an extension specialist.

- EE b. When presented with a home farm problem which includes relevant field and crop information, the student will be able to make sound management decisions regarding rate of planting, depth of planting, time of planting and immediate post planting care. His answers must conform to the recommendations of a crop specialist.

## 3. Seedbed preparation

- EE a. When given a specific field problem the student will be able to write a comprehensive plan of how to prepare the seedbed which includes:

- (1) Farm implements to use
- (2) Sequence of operation
- (3) Schedule of operation
- (4) Frequency of operation
- (5) Labor requirements

◊ (6) Estimated cost

Recommendations shall conform to industry standards.

4. Fertility

EE a. Given the results of soil tests and desired yields, the student will be able to prepare a well balanced fertilizer application program which includes the following:

- (1) Kinds of fertilizer to apply
- (2) When to apply
- (3) Methods of application
- (4) Rate of application
- (5) Cost to be involved

The program should be in agreement with the recommendations of a fertilizer expert.

DA b. When confronted with colored slides showing ten nutritive deficiency symptoms the student will be able to identify the specific cause and recommend corrective action with 100% accuracy.

5. Weed control

EE a. From assigned readings the student will be able to develop a list of ten broad-leaf and ten grass weeds that are considered serious pests in the local area. He will make a mounted collection of the weed representatives and identify them with 90% accuracy.

EE b. The student will be able to discuss verbally the purposes of field cultivation and to indicate the effects of cultivation on plant growth, soil moisture, and weed control to the satisfaction of the instructor.

EE c. Using the weed collection in letter "a", the student will be able to develop herbicide recommendations for each weed to give control. Recommendations must agree with the custom spray operation manual.

## 6. Insect and disease control

- EE a. The student will be able to distinguish between the purpose of insecticides and fungicides. He will list five insecticides and five fungicides and develop a list of insects and diseases that can be controlled with each chemical. Recommendations of the spray operator manual will be used as a check.
- DA b. The student will be able to assess insect and disease damage on his own crop using reading material as a basis. His estimation must conform to that of the instructor.

## 7. Harvesting and storage

- EE a. Using reading assignments as a guide the student will be able to develop a harvesting schedule for the crop that will maximize the returns and give the highest nutritive from the crop; the schedule must meet the approval of the agriculture teacher.
- DA b. From interviews with specialists the student will be able to design a storage program that will give the highest quality crop with the lowest cost. The conclusions must gain acceptance of 70% of the class.

## 8. Marketing

- EE a. Using class handout material or reading assignments the student will discover guidelines that can be used for profitable crop marketing. The student must present six guidelines to the satisfaction of his peers.
- DA b. Through class discussion the student will be able to list and describe five potential methods of marketing a specialty crop from the farm using the following criteria:
- (1) Price per unit
  - (2) Transportation
  - (3) Grading system
  - (4) Marketing services offered

- (5) Distance to market
- (6) Handling and selling charge
- (7) Dependability
- (8) Price quotations

The conclusions must agree with the recommendations of the Agriculture Occupations instructor.

### C. Farm Mechanics

#### Machine and Equipment Operator\*

##### 1. Tillage operations

EE a. When confronted with commonly used models of the following farm implements, the student will describe and demonstrate how and when they are properly used by the local farmers:

- (1) Chisel plow
- (2) Moldboard plow
- (3) Field cultivator
- (4) Disc plow
- (5) Cultipacker
- (6) Rotary tiller
- (7) Disk
- (8) Spike-tooth harrow
- (9) Spring-tooth harrow

Student performance must be judged adequate by the teacher.

EE b. When confronted with colored slides, or actual specimens of each of the following

\* Refer to Agricultural Mechanics Program Planning Guide for more information.



farm implements, the student will be able to identify the parts of:

- (1) Moldboard plow
  - (a) Moldboard
  - (b) Frog
  - (c) Shean
  - (d) Heal
  - (e) Landside
- (2) Disk plow
  - (a) Land wheel axle
  - (b) Furrow wheel
  - (c) Pullbar bracket
  - (d) Disk
- (3) Disk harrow
  - (a) Gangs
  - (b) Disk blades
- (4) Spike-tooth harrow
  - (a) Tooth
  - (b) Crossbars or frames

The student will attain 100% accuracy.

- EE c. The student will be able to plow a 40-acre field on his own and perform the necessary tillage operations to prepare a suitable seedbed. In so doing, the student will demonstrate proficiency in the following jobs:
- (1) Servicing and starting a tractor
  - (2) Driving a tractor
  - (3) Hitching or mounting plows, disks, and harrows to the tractor
  - (4) Adjusting and servicing the implements listed in letter "a".
- EE d. Given a commonly used model of a row crop cultivator, the student will be able to identify the following parts with 90% accuracy:
- (1) Depth wheels
  - (2) Row spacing adjustment

- (3) Shovels
- (4) Parallel rigs
- (5) Adjustable cross bars
- (6) Lifting device

DA c. Given a row crop cultivator in need of adjustment, the student will be able to make the necessary adjustments and will test the cultivator in the field. His adjustments will be evaluated by a farmer and the teacher.

## 2. Planting operations

EE a. Given a corn planter, the student will be able to adjust or calibrate it to drop 22,000 kernels per acre at a speed of four miles per hour. The steps used in calibration should be according to the recommendations of the manufacturer.

DA b. Given a corn planter with the following three operational difficulties, the student will trace it to the possible causes and make necessary adjustments according to the recommendations of the manufacturer:

- (1) Too heavy planting
- (2) Missing hill or dropping unevenly
- (3) Stringing corn

EE c. The student will be able to plant a field of soybeans according to specifications provided by his employer or teacher. Using a modern tractor-planter outfit, the student will service the tractor and make necessary field adjustments on the planter in order to achieve the proper rate and depth of planting specified by his employer or teacher.

EE d. Given a specific field problem, the student will be able to adjust a small grain drill to the following specifications using the operator manual:

- (1) Seeding 90 lbs. per acre
- (2) Planting 1 inch deep

(3) Row width of 7 inches

DA e. Having a correctly adjusted planter, the student will be able to demonstrate the proper technique for starting and maintaining straight rows when planting a field of grain. The student will jointly evaluate the job with his instructor upon completion.

### 3. Spraying operations

DA a. Given the swath width and speed of application, the student will be able to calculate the number of hours it will take him to spray a 40-acre corn field which is square in shape. The answer should be correct to one decimal place.

EE b. Given a common model of a power sprayer, the student will be able to identify 95% of the following parts:

- (1) Tank
- (2) Pressure regulator
- (3) Return or by pass valve
- (4) Filter or strainer
- (5) Nozzles
- (6) Shut off valve
- (7) Agitator

EE c. Given commonly used sprayer equipment, the student will be able to demonstrate its operation according to the recommendations of the manufacturer.

DA d. Given a common model of power sprayer, the student will be able to demonstrate how to clean it and prepare it for winter storage according to the recommendations of the manufacturer.

EE e. Given a common model of power sprayer set at 35 psi with the tank filled with water, the student will be able to calibrate it in the field to determine the number of gallons per acre for the desired concentrate

of pesticide according to instructions given in the operator's manual.

#### 4. Fertilizing operation

- EE a. Given a fertilizer spreader buggy, the student will be able to demonstrate the proper calibration of the machine to evenly spread a swath 40 feet wide, applying 400 pounds per acre and traveling 6 miles per hour. His setting must agree with the fertilizer dealer's recommendation.
- EE b. Using a fertilizer buggy, the student will be able to demonstrate safe loading, transporting, and unloading techniques to the satisfaction of the agriculture teacher.
- DA c. Upon completion of the spreader use, the student will be able to repair and prepare it for winter storage to the satisfaction of his employer.
- EE d. Given a starter fertilizer attachment on a corn planter, the student will be able to calibrate it for rate of application and depth according to the manufacturer's instructions.
- EE e. The student will be able to demonstrate the proper technique for transferring anhydrous ammonia from the nurse tank to the applicator tank using a rig on the student's farm. Technique will be one approved by the National Fertilizer Institute.

#### 5. Harvesting operations

- EE a. The student will be able to lubricate and adjust a corn picker, corn combine, and picker-sheller following the recommendations listed in the owner's manual.
- EE b. The student will be able to operate a corn picker, a corn combine, and a picker-sheller using approved safety precautions. The student performance will be evaluated by a farm operator or an agricultural mechanics teacher.
- DA c. The student will be able to prepare a corn picker, a corn combine, and a picker

sheller for winter storage following the procedures outlined in the owner's manual.

- EE d. In a field situation the student will be able to make the following adjustments on a soybean combine according to the operator's manual:
- (1) Reel speed
  - (2) Concave adjustment
  - (3) Cylinder speed
  - (4) Sieve adjustment
  - (5) Air flow
  - (6) Forward speed
- EE e. The student will be able to assist in harvesting 20 acres of a forage hay crop by demonstrating safe operation of the following equipment:
- (1) Mower
  - (2) Hay conditioner
  - (3) Rake
  - (4) Baler
  - (5) Ensilage chopper
  - (6) Hay stacker

Performance will be evaluated by the employer or agriculture teacher.

## 6. Power units

- EE a. Given a matched set of spark plugs to the power unit, the student will be able to gap the plugs within 1/1000 of an inch specified by the operator's manual and properly install them in the engine. The work will conform to standards set by the agriculture teacher.
- EE b. The student will be able to remove and replace an old battery from a vehicle without incurring injury to himself, the

vehicle, the battery, or the battery mount. He will use a battery carrier and practice safety regulations provided by the instructor.

- EE c. The student will be able to check tire inflation. He will use a tire gauge and manual of correct tire inflations according to size and load. His readings will be within one pound of the instructor's recommendations.
- DA d. Given a "fixed" tractor engine, the student will be able to trouble shoot the problem and get the engine running following the procedures listed:
- (1) Check fuel supply
  - (2) Check ignition
  - (3) Check air supply
  - (4) Check compression
  - (5) Check carburetor setting

Check-out procedure must follow plan approved in the mechanics textbook.

- EE e. Given a tractor engine in need of engine lubrication servicing, the student will be able to:
- (1) Drain oil from engine
  - (2) Select proper oil to put into engine
  - (3) Refill oil reservoir to correct level
  - (4) Remove and replace engine oil filter

These operations will be in accordance with the operator's manual.

#### D. Farm Business Management

##### Tenant Farmer

##### 1. Farm planning

- EE a. Using forms provided by the instructor the student will be able to complete an inventory of the following resources on his home farm:

- (1) Land
- (2) Labor
- (3) Capital
- (4) Management

Student results must be satisfactory to the farm operator.

- DA b. The student will be able to calculate the labor and capital inputs for a given acreage of corn, soybeans and forage crop and to calculate expected yield, labor and management earnings and net profit for each crop. His answers should be the same as those obtained by the instructor.
- EE c. Given the home farm operation the student will be able to establish a crop rotation for the farm using the following factors that will be within the allowable soil loss standards established by the S.C.S.:
- (1) Rainfall factor
  - (2) Erodability factor
  - (3) Length and steepness of slope
  - (4) Cropping-management factor
  - (5) Erosion control practice
- DA d. The student will be able to establish realistic standards and goals for the following efficiency factors:
- (1) Cost of producing a bushel of grain
  - (2) Machinery cost per acre
  - (3) Labor and management wage per acre
  - (4) Yield in bushels per acre
  - (5) Total fixed costs
  - (6) Total variable costs

The goals established by the student should be judged attainable and satisfactory by the instructor.

- EE e. Given a problem situation including information about available labor, available facilities, available capital, potential markets and operation preferences the student will be able to select a livestock enterprise most suitable for his home farm situation. The student's selection must receive 80 percent acceptance from his classmates.
- EE f. Using a specific livestock enterprise, the student will be able to determine the most satisfactory system of management based on the following factors:
- (1) Pasture and feed
  - (2) Labor
  - (3) Facilities
  - (4) Capital
  - (5) Operator preference
- The student's conclusions must receive 80% acceptance from his classmates.
- DA g. When given data regarding production, amount of labor used, and labor costs, calculate measures of labor efficiency with 95% accuracy.
- DA h. When given a situation where hired labor is involved, explain what procedures to use in dealing with workers to get them to accomplish more per worker. The student's recommendations must gain acceptance of a local farm manager.
- DA i. Given the home farm situation the student will be able to select needed power and machinery for the farm in order to schedule for the farm. The student's answer must conform to the farm management manual recommendations.
- EE j. From class notes and reading assignments the student will be able to select needed power and machinery for the farm in order to schedule all jobs within available time. The student's recommendations must conform to the suggestions of a farm machinery specialist.



DA k. The student will be able to calculate power and machinery costs for the home farm livestock system using forms provided by the instructor. The student's conclusions must be in general agreement with FBFM record results.

2. Records and analysis

EE a. When given a particular farming operation and current value of items, the student will be able to take inventory and record these items in a record book according to recommended procedures and to the satisfaction of the instructor.

EE b. When given the items to be included in a depreciation schedule for a farming operation the student will be able to set up a depreciation schedule and correctly calculate depreciation by two methods prescribed by the instructor with 100% accuracy.

EE c. When given a list of receipts from a farm business, the student will be able to correctly enter the receipts in the appropriate section of a farm account book according to instructor guidelines with 100% accuracy.

EE d. The student will be able to, when given a list of expenditures, correctly enter expenditures in the appropriate section of a farm account book with 100% accuracy.

EE e. The student will be able to accurately total columns in a farm account book and make appropriate accuracy checks to the satisfaction of the agricultural occupations teacher.

EE f. When given the records of a farming operation, the student will be able to complete a farm business summary or profit and loss statement with 95% accuracy.

DA g. When given a complete set of farm records, the student will be able to calculate the following measures of efficiency with 95% accuracy.

(1) Value of crop production per acre

- (2) Returns per 100# of feed fed
- (3) Pounds of feed fed per pound of gain
- (4) Value of production per man
- (5) Labor cost per acre
- (6) Machinery and equipment cost per acre
- (7) Building cost per acre
- (8) Fertilizer cost per acre

DA .h. From record comparisons, the student will be able to identify the strong and weak parts of the farm business to the satisfaction of the instructor.

### 3. Farm budgeting

- EE a. When given data concerning a farming operation, the student will be able to set up a complete farm budget for the farming operation, including both livestock and crop production. The student solution must meet recommendations of the agriculture instructor.
- EE b. When given a specific size and type of farming operation, the student will be able to work out a cash flow for a specific year showing cash income and cash expenses by month for the farm business. The results must meet guidelines established by the agriculture teacher.

### 4. Financial management

- EE a. From class notes the student will be able to list the major sources of farm production and farm real estate credit available and give distinguishing information about each type of agency. The information must be acceptable to 90% of the student's peers.
- EE b. When given the necessary data that accompanies five loans, the student will be able to calculate the amount and percent of interest charged with 95% accuracy.
- EE c. When given amortization tables of intermediate-term loans and payment tables for

real estate loans the student will be able to calculate:

- (1) Total interest paid over life of the loan
- (2) Total payment of principal and interest in any one year of the loan

The student will attain 100% accuracy.

- EE d. When given data with regard to a farmer's character, net worth, past records and a new farm plan, the student will be able to present a case to a lending agency for obtaining the necessary credit. The presentation will be judged acceptable to a local farm lender.

#### 5. Leasing and risk management

- EE a. When given a farm tenancy situation the student will be able to explain the following precautions that will give maximum protection to both landlord and tenant:

- (1) Legal precautions relating to farm leases
  - (a) Requirements of written lease
  - (b) Lease termination under written lease
  - (c) Lease termination under verbal agreement
- (2) Right tenants have in removing improvements
- (3) Legal consequences of abandonment

The student explanation must conform to recommendations of a local attorney.

- EE b. When given a farm situation, the student will be able to explain the major legal precautions with regard to pollution regulations as they affect farmers according to current standards of the Environmental Protection Agency. Student's recommendations must meet the approval of the Agricultural Occupations instructor.

EE c. From reading assignments the students will be able to explain with 95% accuracy what hazards are insured against and the types of coverages available through:

- (1) Fire insurance
- (2) Crop insurance
- (3) Automobile insurance
- (4) Health insurance
- (5) Accident insurance
- (6) Disability insurance

EE d. The student will be able to define the advantages, disadvantages and appropriate situations for the following kinds of life insurance:

- (1) Term insurance
- (2) Ordinary life insurance
- (3) Limited pay insurance
- (4) Endowment insurance

Definitions will be evaluated against recommendations of a local insurance agency manager with 95% accuracy.

CORE COURSE OUTLINE FOR AGRICULTURAL PRODUCTION

<u>Course Outline</u>	<u>Reference Code</u>	<u>Reference</u>
I. Agricultural Production		
A. Animal Science		
1. Selection		
a. Parts of the animal	SR	V.A.S. Booklet <u>Judging Beef Cattle, Swine, and Sheep (4)</u>
b. Breeds of animals	SR	V.A.S. <u>Slidefilm Selecting Beef Breeding Animals (1 av)</u>
c. Defects of animals	SR	V.A.S. <u>Breeds of Beef Cattle (1)</u>
d. Livestock terms	SR	V.A.S. <u>Breeds of Swine (2)</u>
e. Production records	SR	V.A.S. <u>Slidefilm Breeds of Beef Cattle (2 av)</u>
f. Livestock evaluation	SR	V.A.S. <u>Slidefilm Breeds of Swine (3 av)</u>
2. Feeding and nutrition		
a. Digestive system	SR	V.A.S. <u>Improving Animals through Breeding (3)</u>
	SR	(3) (4)
	SR	V.A.S. <u>Slide set Aberdeen-Angus Judging Classes (9 av)</u>
	SR	V.A.S. <u>General Facts on Livestock Feeding (5)</u>
	SR	V.A.S. <u>Slidefilm Digestion in Swine (6 av)</u>

KEY: TR-TEACHER REFERENCE  
 SR-STUDENT REFERENCE

<u>Course Outline</u>	<u>Reference Code</u>	<u>Reference</u>
b. Function of nutrients	SR	(5)
c. Nutrient requirements	SR	(5)
d. Nutrient value of feeds	SR	(5)
	SR	V.A.S. <u>Silage as an Animal Feed</u> (8)
e. Balancing rations	SR	V.A.S. <u>Buying and Feeding Beef Cattle</u> (9)
	SR	V.A.S. <u>Feeds and Feeding Swine</u> (10)
f. Feed tag information		
g. Feeding programs	SR	(9) (10)
h. Least cost rations	SR	(8) (9) (10)
i. Deficiency symptoms	SR	<u>Ensminger Stockman's Handbook</u> (17)
j. Feed additives	SR	V.A.S. <u>Feed Additives</u> (7)
3. Breeding and management		
a. Reproductive organs	SR	(17)
b. Estrus cycles	SR	(17)
c. Gestation tables	SR	(17)
d. Systems of breeding	SR	(3)
	SR	V.A.S. <u>Artificially Inseminating Livestock</u> (11)
	SR	V.A.S. <u>Systems of Swine Breeding</u> (12)
e. Care and management	SR	V.A.S. <u>Caring for the Sow and Litter at Farrowing Time</u> (13)

<u>Course Outline</u>	<u>Reference Code</u>	<u>Reference</u>
f. Care and management of growing animals		
g. Care and management of finishing animals		
h. Production systems	SR	V.A.S. Caring for the Swine Herd during Breeding and Gestation (14)
	SR	V.A.S. The Swine Enterprise (15)
i. Records	SR	(17)
j. Special skills	SR	V.A.S. Castrating, Docking, and Dehorning (16)
k. Animal identification		
A. Animal health		
a. Losses from diseases	SR	(17)
b. Disease identification and symptoms	SR	(17)
c. Prevention and control of disease	SR	(17)
d. Losses from parasites	SR	(17)
e. Parasite identification and control	SR	(17)
f. Prevention and control of parasites	SR	(17)
	SR	Agricultural Extension Service, University of Illinois Illinois Custom Spray Operator's Manual (32)

<u>Course Outline</u>	<u>Reference Code</u>	<u>Reference</u>
5. Housing and equipment		
a. Production alternatives	SR	Extension Agricultural Engineer, Urbana, Illinois Swine Handbook, Housing and Equipment (18). Extension Agricultural Engineer, Urbana, Illinois Beef Handbook, Housing and Equipment (19)
b. Building selection	SR	(18) (19)
c. <u>Ventilation (environmental control)</u>	SR	(18) (19)
d. Waste disposal	SR	(18) (19)
e. Fencing	SR	(18)
f. Handling equipment	SR	(18) (19)
g. Feeding equipment	SR	V.A.S. Slidefilm <u>Cattle Handling Facilities</u> (8 av) (18) (19)
6. Marketing		
a. Supply/demand	SR	(17)
b. Cyclic patterns	SR	(17)
c. Price movements	SR	V.A.S. What Factors Affect Prices of Agricultural Products (20) (17)
d. Market classes and grades	SR	(17)
	SR	V.A.S. Slidefilm <u>Appraising Market Hogs for Carcass Merit</u> (5 av)
	SR	V.A.S. Slidefilm <u>U.S.D.A. Swine and Pork Carcass Grades</u> (4 av)



<u>Course Outline</u>	<u>Reference Code</u>	<u>Reference</u>
e. Marketing methods	SR	(17)
f. Preventing animal losses	SR	(17)
	SR	<u>V.A.S. Slidefilm Preventing Transportation Losses of Livestock (7 av)</u>
g. Regulations		
B. Plant Science		
1. Plant development	SR	Aldrich and Leng <u>Modern Corn Production (21)</u>
	SR	Scott and Leng <u>Modern Soybean Production (22)</u>
a. Seed and plant parts		
b. Pollination and fertilization		
c. Growth and development	SR	<u>V.A.S. Illinois Agronomy Handbook (23)</u>
2. Variety selection and seeding practices	SR	(21) (22)
a. Seed and plant identification		
b. Selecting a variety	SR	(23)
	SR	<u>V.A.S. Slidefilm Producing Hybrid Seed Corn (21 av)</u>
c. Interpreting seed bag labels		
d. Planting, rates, depth, and dates	SR	(21) (22) (23)
	SR	<u>V.A.S. Slidefilm Planting Corn (10 av)</u>
e. Inoculation	SR	<u>V.A.S. Inoculation of Legumes (24)</u>
3. Seedbed preparation	SR	(21) (22)
a. Crop seedbed needs	SR	(23)



<u>Course Outline</u>	<u>Reference Code</u>	<u>Reference</u>
b. Implements to use and sequence of operations		
c. Erosion control	SR (23) SR	<u>V.A.S. Minimum Tillage (25)</u>
d. Soil compaction and water retention	SR	(23) (25)
4.. Fertility	SR	(21) (22)
a. Collecting soil samples	SR	<u>V.A.S. Collecting and Preparing Soil Samples for Testing (26)</u>
	SR	<u>V.A.S. Slidefilm Collecting and Preparing Soil Samples for Testing (19 av)</u>
b. Running soil tests	SR SR SR	<u>V.A.S. pH Test for Soil Acidity (29)</u> <u>V.A.S. Testing Soils for Phosphorus (30)</u> <u>V.A.S. Determining Available Potassium in the Soil (31)</u>
	SR	<u>V.A.S. Slidefilm Using the pH Meter in Testing Soils for Acidity (20 av)</u>
c. Soil test interpretation	SR	(23)
d. Nutrient functions and crop needs		
e. Sources of nutrients		
f. Rate and method of application	SR	(23)
g. Deficiency symptoms	SR	<u>V.A.S. Hunger Signs in Crops (27)</u>
h. Safe handling of fertilizer	SR	<u>V.A.S. Handling and Using Agricultural Chemicals Safely (28)</u>

<u>Course Outline</u>	<u>Reference Code</u>	<u>Reference</u>
5. Weed control	SR	(21) (22)
a. Crop losses from weeds	SR	Agricultural Extension Service, University of Illinois Storing and Drying Corn (33)
	SR	<u>V.A.S. Slidefilm The Wicked World of Weeds (18 av)</u>
b. Weed identification.	SR	V.A.S. Slidefilm Identification of Weed Seedlings, Broadleaves (16 av)
	SR	<u>V.A.S. Slidefilm Identification of Weed Seedlings, Grasses (17 av)</u>
c. Chemical and cultural control	SR	(32)
d. Pre- and post-emergence application	SR	(32)
	SR	<u>V.A.S. Slidefilm Using Pre-emergence Herbicides (22 av)</u>
e. Band and broadcast application	SR	(32)
f. Herbicide injury and carryover	SR	(32)
	SR	<u>V.A.S. Slidefilm Recognizing Herbicide Injury (15 av)</u>
g. Safe use of herbicides	SR	(32)
6. Insect and disease control	SR	(21) (22)
a. Losses from insects and disease	SR	(32)
	SR	V.A.S. Slidefilm Diseases of Soybeans (11 av)
	SR	<u>V.A.S. Slidefilm Corn Diseases in Illinois (12 av)</u>
b. Disease symptoms	SR	V.A.S. Slidefilm Diseases of Wheat (14 av)
	SR	<u>V.A.S. Slide set Diseases of Alfalfa (23 av)</u>
c. Cultural and chemical control	SR	(32)
	SR	<u>V.A.S. Slide set Diseases of Clovers (24 av)</u>

<u>Course Outline</u>	<u>Reference Code</u>	<u>Reference</u>
d. Insect identification and crop damage	SR	(32)
e. Cultural and chemical control	SR	(32)
f. Pesticide safety	SR	(21) (22)
7. Harvesting and storing		
a. Estimating yields		
b. Harvesting methods		
c. Estimating field losses		
d. Storage systems		
8. Marketing	SR	(21) (22)
a. Supply/demand		
b. Price movements		
c. Grading grain	SR	V.A.S. Slidefilm Determining Market Grades of Corn (13 av)
d. Marketing methods		
e. Marketing guidelines		
f. Using the futures market		
C. Farm Mechanics		
1. Tillage operations	SR	John Deere Tillage (34)

<u>Course Outline</u>	<u>Reference Code</u>	<u>Reference</u>
a. Selecting equipment		
b. Parts		
c. Operation		
d. Adjustment		
e. Maintenance		
2. Planting operations	SR	John Deere <u>Planting</u> (35)
a. Selecting equipment		
b. Parts		
c. Operation		
d. Calibration	SR	V.A.S. Slidefilm <u>Calibrating a Granular Applicator</u> (26 av)
e. Maintenance		
3. Spraying operations	SR	John Deere <u>Mowing and Spraying Equipment</u> (36)
a. Selecting equipment		
b. Parts		
c. Operation		
d. Calibration	SR	(26 av)
e. Maintenance	SR	V.A.S. Slidefilm <u>Calibrating Field Sprayers</u> (25 av)

<u>Course Outline</u>	<u>Reference Code</u>	<u>Reference</u>
4. Fertilizer operations		
a. Selecting equipment		
b. Parts		
c. Operation		
d. Calibration	SR	(26 av)
e. Maintenance		
5. Harvesting operations		
a. Selecting equipment		
b. Parts		
c. Operation		
d. Adjustment		
e. Maintenance		
6. Power unit		
a. Safety	SR	John Deere Fuels, Lubricants, and Coolants (38)
b. Operation	SR	<u>John Deere Preventative Maintenance (39)</u>
c. Care of tires		
d. Care of battery		
e. Engine lubrication		

<u>Course Outline</u>	<u>Reference Code</u>	<u>Reference</u>
f. Cooling system		
D. Farm Business Management		
1. Farm planning	SR	Herbst <u>Farm Management, Principles, Budgets (40)</u>
a. Resource inventory		
b. Kinds and amounts of crops to produce		
c. Planning livestock for the farm	SR	V.A.S. <u>Slidefilm Plan the Livestock System and Estimate Fertility Costs (32 av)</u>
d. Choosing the system of livestock management		
e. Meeting labor needs		
f. Making decisions about power and machinery		
g. Farmstead arrangement and building justification		
2. Records and analysis	SR	(40)
a. Record keeping systems	SR	V.A.S. <u>Slidefilm Starting to Keep Records (28 av)</u>
b. Completing the farm records	SR	V.A.S. <u>Slidefilm Keeping Records Up-to-Date (29 av)</u>
	SR	V.A.S. <u>Slidefilm Summarizing and Analyzing Records (30 av)</u>
c. Enterprise analysis	SR	V.A.S. <u>Slidefilm Increasing Earnings Through Farm Records (31 av)</u>

d.	Profit and loss statement		
e.	Financial statement		
3.	Farm budgeting		
a.	Data to use		
b.	Procedures		
c.	Complete budget		
d.	Partial budget		
e.	Cash flow		
f.	Linear planning		
4.	Financial management	SR	V.A.S. <u>Law for the Farmer (41)</u>
a.	Sources and cost of using credit	SR	V.A.S. <u>Determining Credit Needs on the Farm (43)</u>
b.	Use of credit to increase earning	SR	V.A.S. <u>Sources of Farm Credit (44)</u>
c.	Becoming a good credit risk	SR	Murray and Nelson <u>Agriculture Finance (45)</u>
5.	Leasing and risk management		
a.	Types of leases	SR	(41)
		SR	V.A.S. <u>Slidefilm The Illinois Crop-Share Cash Farm Lease (27 av)</u>
b.	Insurance protection	SR	(45)
		SR	V.A.S. <u>Slidefilm Insurance in the Farm Business (33 av)</u>



<u>Course Outline</u>	<u>Reference Code</u>	<u>Reference</u>
c. Farm law	SR	(40)
d. Pollution regulations	SR	(41)

## EXEMPLARY TEACHING PLANS

### I. Agricultural Production

#### A. Animal Science

UNIT: 2. Feeding and Nutrition

PROBLEM AREA: b. Function of Nutrients

### TEACHING PLAN

I. INTRODUCTION: An imbalance of nutrients in a ration is usually inefficient and often results in high feed costs in relation to the nutritional benefits to the animal. A deficiency of one or more of the nutrients may impair normal growth or production, while an excess of one or more of the nutrients is often wasteful and, in some cases, toxic to the animal.

### II. STUDENT PERFORMANCE OBJECTIVES:

The student will be able to:

- A. Orally or in writing list the six basic food nutrients and explain a minimum of two major functions that each serves in the animal body as described in a reference of standards such as those of the National Academy of Sciences.
- B. Given the following list of feeds, classify the feeds into one of the six major nutritive groups with 100 per cent accuracy:
  1. Corn
  2. Soybean oil meal
  3. Wheat
  4. Ground limestone
  5. Steamed bone meal
  6. Fish meal
  7. Cottonseed meal
  8. Alfalfa meal
  9. Corn silage
  10. Haylage
  11. Alfalfa
  12. Orchard grass

### III. OUTLINE OF INSTRUCTIONAL CONTENT:

- A. Nutrient -- A compound or group of compounds having similar chemical composition that aids in the support of life.
- B. Major uses of food and water in an animal's body
1. Body maintenance
  2. Body growth
  3. Production
    - a. Eggs
    - b. Milk
    - c. Wool
    - d. Meat
  4. Reproduction
- C. Food nutrients and their function in the body
1. Protein compounds
    - a. Essential for life
    - b. CHO and N
    - c. Made up of amino acids
    - d. Concentrated in reproductive parts of plants and in growing portions
    - e. In animals is protoplasm and cell walls
    - f. Greater part of muscles, internal organs, cartilage and connective tissue, skin, hair, feathers, and horns
    - g. Functions
      - (1) Essential for repair and growth of body
      - (2) Essential for fetal development in pregnant animals
      - (3) Used in milk production
      - (4) Serves as source of energy and body fat
    - h. Sources
      - (1) Meat scraps, tankage and packing house by-products
      - (2) Leguminous seeds
      - (3) Oil-bearing seeds
      - (4) Cereal by-products
      - (5) Legume hay
  2. Carbohydrates
    - a. 3/4 of all dry matter in plants
    - b. Chief source of energy and heat in feed
    - c. Composed of CHO
    - d. Includes sugars, starches, and cellulose
    - e. Formed by CO<sub>2</sub> entering plant through stomata on lower leaf surface and joins with water

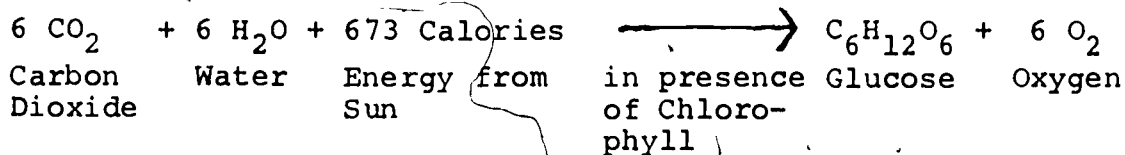

- f. Functions
    - (1) Principal source of energy
    - (2) Converted into fats and stored in the body
  - g. Sources
    - (1) Cereal grains
    - (2) Root crops
    - (3) Legume seeds
    - (4) Hay and pasture
3. Fats
- a. Rich in C and H; poor in O
  - b. -2.25 times as much energy in equal amount of fat as carbohydrates
  - c. Occurs in all plants, but in smaller amounts than carbohydrates
  - d. Functions
    - (1) Fuel for liberation of energy
    - (2) Excess is stored in body and acts as a reserve
  - e. Sources
    - (1) Oily seeds
    - (2) Corn and cereal grains
4. Minerals
- a. No part of animal or plant life is free of mineral matter
  - b. Animals contain higher amounts than do plants
  - c. Mineral elements necessary for growth:
    - (1) Potassium
    - (2) Calcium
    - (3) Magnesium
    - (4) Iron
    - (5) Oxygen
    - (6) Phosphorus
    - (7) Sulfur
    - (8) Sodium
    - (9) Chlorine
    - (10) Iodine
  - d. Functions
    - (1) Regulated body processes
    - (2) Formation and repair of bones, protein tissue and body tissues
  - e. Sources
    - (1) Mineral supplements
    - (2) Di calcium phosphate
    - (3) Ground limestone
    - (4) Steamed bone meal
5. Vitamins
- a. Organic in nature
  - b. Designated by letter of alphabet or chemical compound
  - c. Indispensable to life but does not become a part of the essential structure of any tissue
  - d. Vitamins of practical importance



- (1) Fat soluble
  - (a) A
  - (b) D
  - (c) E
  - (d) K
- (2) Water soluble
  - (a) B complex
  - (b) C
- e. Functions
  - (1) Promotes growth and stimulates appetite
  - (2) Assists in reproduction and lactation
  - (3) Aids in utilization of food nutrients
- f. Sources
  - (1) Vitamin supplements
  - (2) Sunshine
  - (3) Grains
  - (4) Forage crops
  - (5) Digestive system

#### 6. Water

- a. Largest single constituent of all living things
- b. Runs 70 - 80 per cent of total weight
- c. Dry grain has 8 - 15 per cent water
- d. Composed of hydrogen and oxygen
- e. Functions
  - (1) Carries nutrients in plants and animals
  - (2) Dissolves nutrients
  - (3) Controls body temperature
  - (4) Enables plants and animals to hold their shape
- f. Sources
  - (1) Feedstuffs
  - (2) Watering system

#### IV. POSSIBLE STUDENT LEARNING ACTIVITIES:

- A. Have students bring samples of feed sources of each nutrient from their home farm and feed stores. Put together an exhibit of sources of feed nutrients and their functions.
- B. Have students make a magazine report on a topic dealing with one of the food nutrients.
- C. Assign students to find the average amount of water that common farm animals need per day.

#### V. SPECIAL MATERIALS AND EQUIPMENT:

- A. Display area for food nutrient exhibit
- B. Several samples of hard-to-find sources of nutrients such as vitamins

C. Collections of feed bag tags

VI. STUDENT REFERENCES:

A. V.A.S. 1013 General Facts on Livestock Feeding

B. V.A.S. 1018 Minerals for Livestock

C. Stockman's Handbook, Ensminger, Interstate, Danville, Illinois.

## I. Agricultural Production

## A. Animal Science

UNIT: 3. Breeding and Management

PROBLEM AREA: b: Estrus Cycles

## TEACHING PLAN

I. INTRODUCTION: There is a limited period of time, several hours, during the estrus period when breeding will result in much higher conception rates than if breeding is done sooner or later, even though the female is still in the estrus period.

II. STUDENT PERFORMANCE OBJECTIVES:

The student will be able to:

- A. Given a group of females of which some are in heat, identify the in-heat females and list external signs of estrus with 90 per cent accuracy.
- B. For each type of livestock commonly produced in the area, describe the typical signs of estrus and appropriate methods of determining the onset of the heat period of the females to the satisfaction of the instructor.

III. OUTLINE OF INSTRUCTIONAL CONTENT:

- A. Estrus cycle
  - 1. Regularly occurring cycle in female animals that regulated the production of egg cells essential for reproduction.
  - 2. At one point in the cycle, called the heat period, ovulation takes place; that is, an egg is shed from the ovary and is available for fertilization.
  - 3. Females ovulate continuously within the estrus cycle. The estrus cycle contains a period of ovulation and a period when no eggs are ovulated.
- B. Timing of estrus cycle functions
  - 1. Length of estrus cycle
    - a. Cattle -- 21 day average -- 19-23 day range
    - b. Hogs -- 21 day average -- 18-24 day range
  - 2. Length of heat period
    - a. Cattle -- 16-20 hours average -- 6-30 hours range

- b. Hogs -- 48-72 hours average -- 24-120 hours range
  - 3. Time of ovulation
    - a. Cattle -- 14 hours after end of heat
    - b. Hogs -- 2nd day of heat
  - 4. Life of egg after ovulation
    - a. Cattle -- 20 hours
    - b. Hogs -- 20-24 hours
- C. Visual indicators of estrus
  - 1. Cattle
    - a. Will stand to be mounted and try to mount other animals
    - b. Will be nervous and active
    - c. Vulva may be swollen and a discharge may appear
  - 2. Hogs
    - a. Will mount other sows
    - b. Vulva swells with slight mucous discharge
    - c. General nervous reactions
- D. Timing of breeding
  - 1. In order for fertilization to occur, the male sperm must unite with the female egg
  - 2. Egg stays alive for a limited period of time
  - 3. Sperm usually lives for about four hours
  - 4. If the female were bred at the wrong time, it is possible that no egg would be present or that by the time the egg was ovulated the sperm may have died

#### IV. POSSIBLE STUDENT LEARNING ACTIVITIES:

- A. Take a field trip to a local sale barn or livestock market and have students observe animals in heat.
- B. Collect information on heat indicators for livestock now on the market.
- C. Secure a reproductive tract from slaughter house and try to determine stage of estrus.

#### V. SPECIAL MATERIALS AND EQUIPMENT:

- A. Provide samples of commercial livestock heat indicators.
- B. Dissecting kits for reproductive tract examination

#### VI. STUDENT REFERENCE:

- A. Stockman's Handbook, Ensminger, Interstate, Danville, Illinois.



## I. Agricultural Production

## B. Plant Science

UNIT: 5. Weed Control

PROBLEM AREA: f. Herbicide Injury and Carryover

## TEACHING PLAN

I. INTRODUCTION: Herbicides can be very beneficial for controlling weeds if used properly. Knowledge of crop tolerance to herbicides and how to control drift will aid the student in reducing crop injury.

II. STUDENT PERFORMANCE OBJECTIVES:

The student will be able to:

- A. Recognize effects of herbicide carryover and to identify and discuss the factors causing the carryover. Factors listed will be judged against class notes.
- B. Using class notes, explain the factors affecting herbicide drift and list preventative measures that should be taken to prevent excessive drift. Answers must conform to recommendations of a weed specialist.

III. OUTLINE OF INSTRUCTIONAL CONTENT:

- A. Recognizing herbicide injury
  - 1. Check all suspects
    - a. Disease symptoms and herbicide injury are often confused. Soybean mosaic and 2,4-D damage are look-alikes. Soybean seedling blights are often mistaken for Aatrex injury.
    - b. Determine crop treatments used both last year and this year
    - c. Is there a pattern to the injury?
      - (1) Spillage
      - (2) Overlaps
      - (3) Speed change
    - d. Herbicide injury most likely to occur on thin, shallow, low organic matter content soils
  - 2. Causes of herbicide injury
    - a. Usage of herbicides of poor or close crop tolerance
    - b. Residual carryover of herbicides from last season
    - c. Drift from nearby herbicide application

3. Crop tolerance to pre-emergence herbicides
    - a. Corn
      - (1) Aatrex -- Good
      - (2) Bladex -- Good-Fair
      - (3) Lasso -- Good
      - (4) Lasso and Atrazine -- Good
      - (5) Sutan -- Fair-Good
      - (6) Sutan and Atrazine -- Good
    - b. Soybeans
      - (1) Amiben -- Fair-Good
      - (2) Lasso -- Good
      - (3) Lasso and Lorox -- Fair
      - (4) Sencor and Lexone -- Fair
      - (5) Treflan -- Fair-Good
  4. Crop tolerance to post-emergence herbicides
    - a. Corn
      - (1) Aatrex and oil -- Fair-Good
      - (2) Banuel -- Good-Fair
      - (3) 2, 4-D -- Fair-Good
      - (4) Bladex -- Fair-Good
    - b. Soybeans
      - (1) Basagram -- Fair-Good
      - (2) Tenoran -- Fair
      - (3) 2, 4-D -- Fair
  5. Residual carryover injury
    - a. Atrazine has sometimes persisted in soil damage to soybeans, legumes, and small grains planted the following year
    - b. Treflan carryover may cause injury to oats and corn
  6. Herbicide drift
    - a. Post-emergence application of herbicides applied can produce injury to nearby susceptible crops such as soybeans
    - b. Wind direction and speed as well as temperature affect the amount of drift and the degree of injury
- B. Reducing herbicide injury
1. Crop tolerance of herbicide
    - a. Choose a herbicide of best crop tolerance that will control the weeds
    - b. Choose the correct rate for the soil type
    - c. Check equipment and replace worn nozzles
    - d. Calibrate and make accurate application
    - e. Apply at the proper time and growth stage
    - f. Use drop pipes or leaf lifters where prescribed
  2. Carryover or residual herbicides
    - a. Match the herbicide program and crop rotation program
    - b. Use herbicides of shorter persistence that will control weeds

- c. Use mixtures or combinations of herbicides to reduce the rate of persistent herbicides
  - d. Apply a persistent herbicide accurately
  - e. Band apply persistent herbicides
  - f. Plow rather than disk after a persistent herbicide
  - g. Apply a persistent herbicide as early as possible
3. Drift of herbicides
- a. Watch wind speed and direction when applying post-emergence herbicides
  - b. Check the location of nearby susceptible crops before application
  - c. Use the proper formulation to reduce volatility
  - d. Be very cautious with aerial application
  - e. Increase average drop size and reduce mist
    - (1) Use a lower pressure and reduce mist spray
    - (2) Use higher spray volume
    - (3) Use spray thickeners

IV. POSSIBLE STUDENT LEARNING ACTIVITIES:

- A. Collect pictures of herbicide damage and prepare a display for the classroom.
- B. With the use of a sprayer, determine the spray pattern under boom heights of 24 inches and 48 inches. Also check the pattern under 25 psi and 50 psi.

V. SPECIAL MATERIALS AND EQUIPMENT:

- A. Farm sprayer and water supply

VI. STUDENT REFERENCES:

- A. V.A.S. 4045 Handling and Using Agricultural Chemicals Safely
- B. Custom Spray Operator's Manual, Current Edition, University of Illinois

## I. Agricultural Production

## B. Plant Science

UNIT: 4. FertilityPROBLEM AREA: a. Collecting Soil Samples

## TEACHING PLAN

I. INTRODUCTION: Fertility needs are, to a large extent, determined by the crop to be grown, the yield goal of the crop, available nutrients in the soil, amount and kind of manure applied, and the previous crop grown on the field. An accurate soil test is dependent on a very small amount of soil representing as much as four acres. A poor job of collecting samples will mean a poor soil test.

II. STUDENT PERFORMANCE OBJECTIVES:

The student will be able to:

A. Given a certain field situation, draw a map of the field and indicate points where soil samples will be collected. He will collect samples and prepare them for testing using the approved practices commonly recommended by soil scientists.

III. OUTLINE OF INSTRUCTIONAL CONTENT:

## A. Field Sampling\*

1. Start for the field to collect soil samples only after you understand the importance of sampling and how to do it. Over a period of years, a farmer is likely to invest several thousand dollars on the basis of results obtained from soil tests in a 40-acre field. It is easily possible to make hundreds of dollars for an extra hour spent in careful sampling and recording the location of each sample. The best laboratory test in the world made on samples that are carelessly taken are not only worthless but may lead you to spend thousands of dollars for plant nutrients that you don't need while you neglect

\*These directions and Soil Test Form B are a courtesy of Vocational Agriculture Service, 424 Mumford Hall, Urbana, Illinois.

- to buy nutrients that your fields lack.
2. When the soil finally gets into the test tube in the laboratory, about 1 teaspoonful is going to represent 2 to 5 acres. It had better be the right teaspoonful!
- B. Materials you will need
1. A supply of at least 11 small paper sacks (for a 40-acre field)
  2. A basket or box for carrying the samples
  3. A pan or bucket for mixing the small samples
  4. A trowel, spade, or auger to dig the samples
- C. Plan where to sample and how many samples to take
1. Fields that appear to have only one kind of soil and where recent past cropping and fertilizer and limestone treatments have been the same throughout. You may follow a regular pattern as indicated on the diagram.
    - a. For a 10-acre field take 4 samples at locations corresponding to 1, 2, 6, and 7 on the diagram for a 20-acre field.
    - b. Each sample shown by a number on the diagram is a mixture of 5 small samples taken within a square rod at the places shown by the x marks. The reason for taking these 5 small samples is to make certain that the whole sample does not come from within a band of fertilizer applied in the previous year.
    - c. Eleven samples are suggested for a 40-acre field, 7 for 20 acres, and 4 for 10 acres in order to outline areas with different fertility status due to unseen soil differences or differences in previous fertilizer or limestone applications or cropping systems.
  2. Fields that have different kinds of soil, that have problem areas, or that have been cropped, fertilized, or limed differently in the past 5 to 10 years
    - a. The same general suggestions apply as outlined under the above group, but you will want to take enough additional samples to fully represent the different conditions within the field. This is a matter of judgment, but remember that a few extra samples take little time or money but may give a much better picture of the fertility status of the field. Fields are sampled only once in 4 to 8 years. Don't gamble on short cuts to a good sampling job.

D. Take the samples and record the location of each sample and outline low spots, knolls, draws, etc., on the map

1. This information is needed to help you or the person who interprets the tests arrive at the proper treatment. If you plan to treat according to soil tests, then you must know where each sample came from.

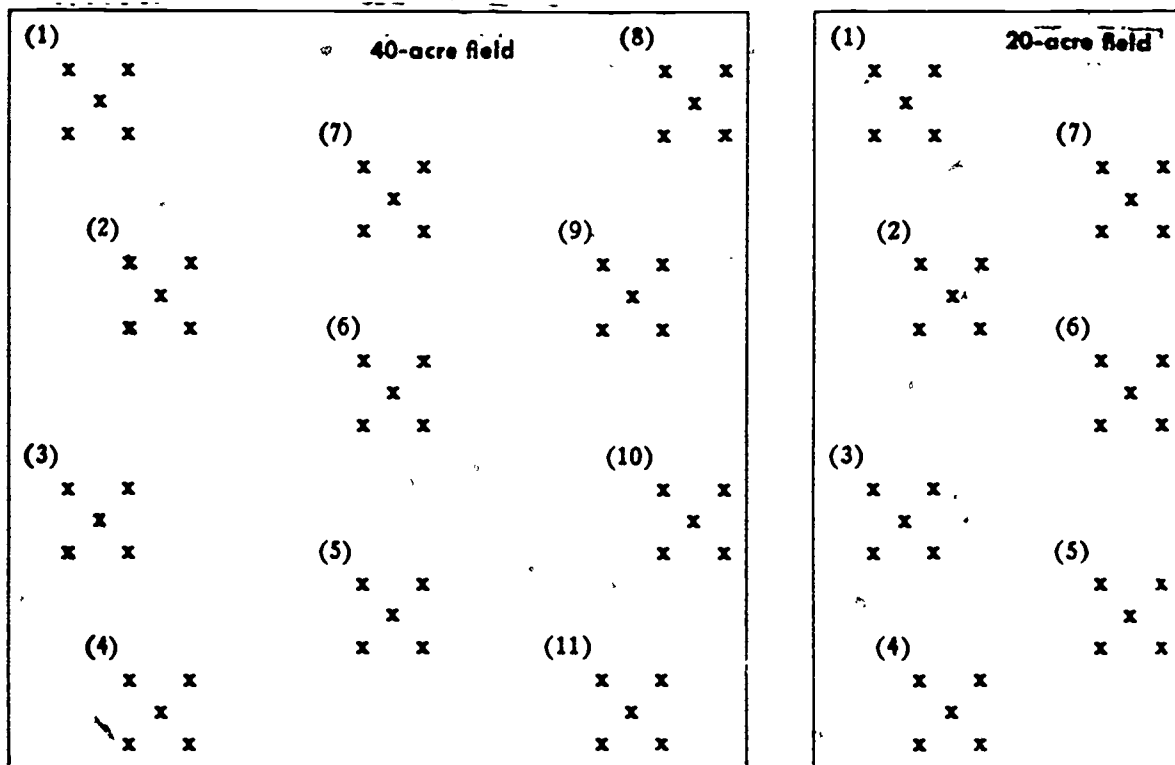

E. Prepare the samples for testing

1. Let the samples air-dry with the tops of the containers open for several days. Don't rush the drying process by placing samples on a stove or radiator. This will produce misleading test results.
2. Break up clods and lumps so the soil will pass through ordinary window screen. The samples are ready for testing.

F. Fill out the Information Sheet, Soil Test Form B

1. This form lists the cropping history, previous fertilizer, lime, and manure treatments, and other information to supplement the information supplied by the soil tests and thus lead to more sound fertility suggestions. The soil test is

an important tool in diagnosing fertility needs and in suggesting treatments but it should never be the only tool. Here is an illustration to prove the point. If you apply limestone according to the results of a soil test and then retest within two years, the second test will show a considerable limestone requirement even though there is enough in the soil for high yields of legumes. The soil test by itself in this case is misleading.

G. Mail or take the samples to the laboratory

IV. POSSIBLE STUDENT LEARNING ACTIVITIES:

- A. Have students each map out a field on their farm, indicate where samples are to be taken. They should collect the samples, bring them into the laboratory and prepare them for testing.
- B. Have extension agent or soil test laboratory personnel speak to class on procedures for collecting soil samples and preparing them for testing.
- C. Have students prepare a display for board of proper equipment and procedures for collecting samples. Make arrangements with local bank or agricultural business to put the display on exhibit.

V. SPECIAL MATERIALS AND EQUIPMENT:

- A. Tools necessary for sample collection
  - 1. Spade
  - 2. Auger
  - 3. Probe
  - 4. Mixing pan
  - 5. Sacks
- B. Mortar and pestule or soil grinder

VI. STUDENT REFERENCES:

- A. V.A.S. 4001 Collecting and Preparing Soil Samples for Testing
- B. Illinois Agronomy Handbook, University of Illinois, Champaign, Illinois

# REQUEST FOR TESTING SERVICE, INFORMATION SHEET

(To accompany soil samples)

DATE \_\_\_\_\_

	Township _____	Tests Desired:
County _____	Section _____ Qtr. _____	pH _____
	Field _____	P <sub>1</sub> _____
	Acres _____	P <sub>2</sub> _____
	Samples _____	K _____

TENANT \_\_\_\_\_ ADDRESS \_\_\_\_\_

OWNER \_\_\_\_\_ ADDRESS \_\_\_\_\_

In order that the results of the tests may be properly analyzed and interpreted, the following information should be submitted with the samples from each field:

1. Kind of soil: sandy \_\_\_\_\_ silt loam \_\_\_\_\_ clay \_\_\_\_\_, muck \_\_\_\_\_
  2. Is drainage good \_\_\_\_\_ fair \_\_\_\_\_ poor \_\_\_\_\_?
  3. Is the field level \_\_\_\_\_ gently rolling \_\_\_\_\_ rolling \_\_\_\_\_ steep \_\_\_\_\_?
  4. Has the field been limed? \_\_\_\_\_ About when? \_\_\_\_\_ Amount per acre \_\_\_\_\_
  5. Has rock phosphate been applied? \_\_\_\_\_ About when? \_\_\_\_\_ Amount per acre \_\_\_\_\_
  6. Has superphosphate been applied? \_\_\_\_\_ About when? \_\_\_\_\_ Amount per acre \_\_\_\_\_
  7. Has potash been applied? \_\_\_\_\_? About when? \_\_\_\_\_ Amount per acre \_\_\_\_\_
  8. Has manure been applied in the past 4 years? \_\_\_\_\_ When? \_\_\_\_\_ Amount per acre \_\_\_\_\_
  9. Has mixed fertilizer been applied in the past 2 years? \_\_\_\_\_ When? \_\_\_\_\_
- Amount per acre \_\_\_\_\_ Formula \_\_\_\_\_ Crop \_\_\_\_\_
10. Crop grown last year \_\_\_\_\_ yield \_\_\_\_\_; 2 years ago \_\_\_\_\_ yield \_\_\_\_\_  
Crop to be grown this year \_\_\_\_\_, next year \_\_\_\_\_
  11. How do you use your legume crop? Plowdown \_\_\_\_\_ hay \_\_\_\_\_ silage \_\_\_\_\_ green chop \_\_\_\_\_
  12. How deep do you plow? \_\_\_\_\_
  13. Are there any special problems? \_\_\_\_\_

### MAP OF THIS FIELD (Number the sample locations)

Top of map is north

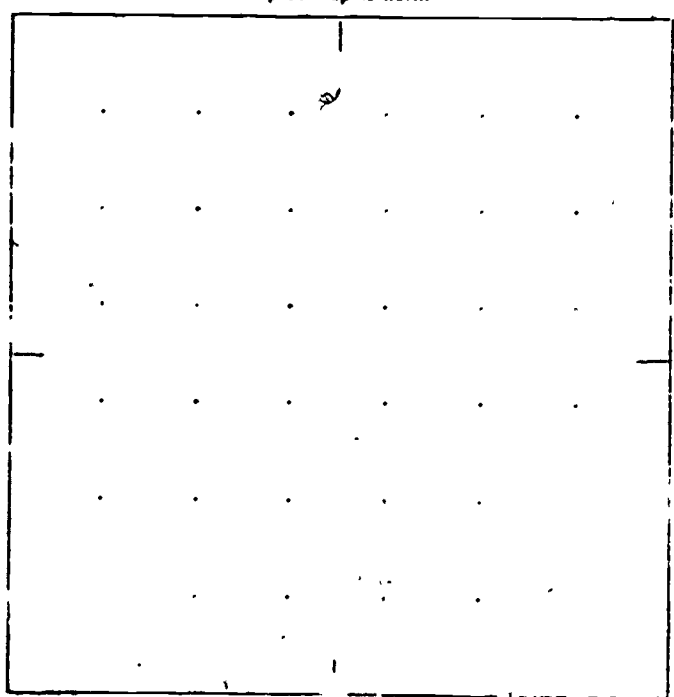



## DRAW MAP OF FARM

(Number each field)

Top of map is north

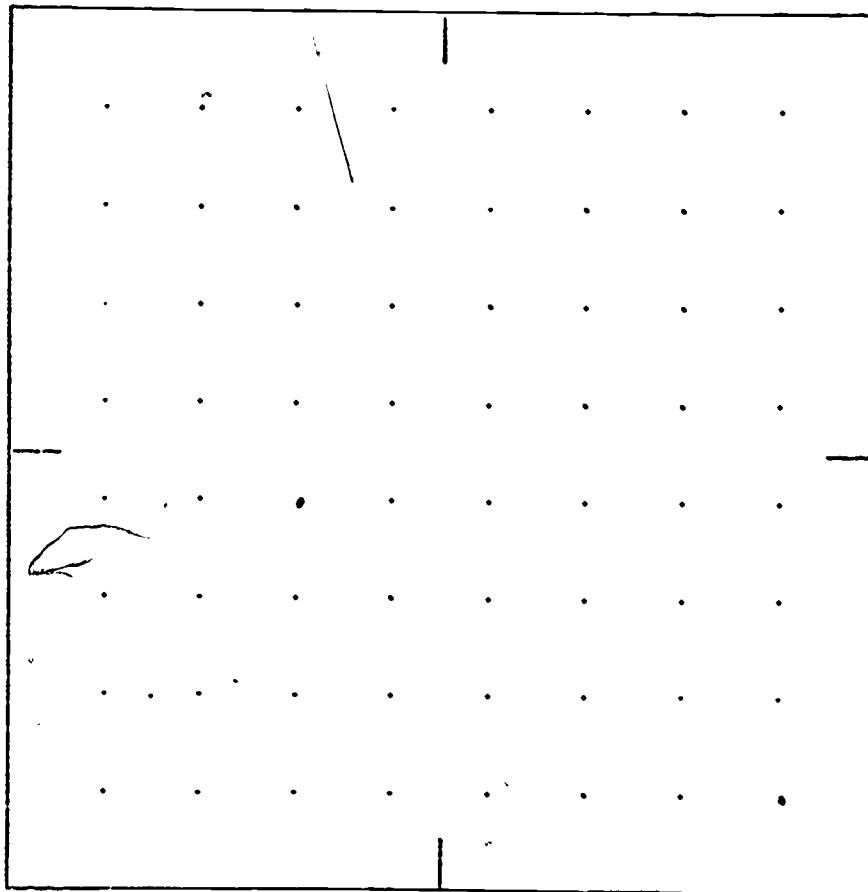

south

### WHAT TESTS SHOULD BE MADE ON MY SAMPLES?

**$P_2$  Test:** This test measures both available phosphorus and phosphorus in rock phosphate, but does not show the amount in each form. It gives you the basis for deciding whether to apply rock phosphate and, if so, how much to add. You must have it to qualify for ACP practice payment.

**$P_1$  Test:** This test shows available phosphorus and is the guide to the amount of soluble phosphorus that may be applied for crops in the next 2 to 4 years. It does not measure the phosphorus still in the form of rock phosphate. It does not qualify you for ACP payment.

**Costs:** The extra cost for both tests is less than 10 cents per acre.

**Our Recommendation:** We recommend that you have both tests run unless:

- Your only purpose is to qualify for ACP payment for rock phosphate. In that case the  $P_2$  test is all that is needed.
- Your only purpose is to determine available phosphorus as a guide to a fertilizer-program of only soluble sources of phosphorus (superphosphate, mixed fertilizers, and blends using other than rock phosphate). In that case, run  $P_1$ .

Cooperative Extension Work in Agriculture and Home Economics  
University of Illinois College of Agriculture and the United States  
Department of Agriculture cooperating. Louis B. Howard, Director.  
Acts approved by Congress May 8 and June 30, 1914

Reproduced for classroom teaching purposes with permission of the Cooperative Extension Service.

1178

## I. Agricultural Production

## C. Farm Mechanics

UNIT: 6. Power Unit

PROBLEM AREA: e. Engine Lubrication

## TEACHING PLAN

I. INTRODUCTION: Servicing the farm tractor lubrication system is vital to the operation of the power unit. Today's high performance engines operate with very close tolerances and under extremely severe conditions. Downtime and expensive repairs can be minimized.

II. STUDENT PERFORMANCE OBJECTIVES:

The student will be able to:

- A. When given the problem of servicing the engine lubrication system, correctly perform the following operations in accordance with the operator's manual:
1. Drain oil from engine
  2. Select proper oil for engine type
  3. Refill oil reservoir to correct level
  4. Remove and replace the engine oil filter

III. OUTLINE OF INSTRUCTIONAL CONTENT:

## A. Terms and definitions

1. Friction--the resistance to movement between any two objects placed in contact with each other
2. Viscosity--a measure of the ability of an oil to flow
3. Oil pan--a cover on the bottom of the engine providing a reservoir for the engine oil
4. Oil filter--a device used to strain the engine oil thus removing abrasive particles

## B. Purposes of lubrication system

1. Lubricates moving parts to minimize power loss from friction
2. Acts as a cooling agent to remove heat from engine parts
3. Forms a seal between piston rings and cylinder walls
4. Acts as a cleaning agent
5. Absorbs shock between bearings and other parts

- C. Conditions that affect oil change intervals
1. Engine design
  2. Kind of fuel used
  3. Oil capacity in relation to the size and horsepower of the engine
  4. Load temperature under which the tractor operates
  5. Dirt conditions under which the tractor operates
- D. Filter assemblies
1. Filter bowl held in position with a through bolt
  2. Filter cartridge held in place with cap and through bolt
  3. "Spin-on" double filters with their own outer shells
- E. Selecting engine oils
1. Use reputable brands of oil of the proper viscosity and service ratings as outlined in the operator's manual (NOTE: If the manufacturer has a special oil which does a better job, use only that oil in your engine.)
  2. Drain and change oil at recommended intervals (NOTE: For exact intervals, see the machine operator's manual. Always drain out oil while it is hot and before the sludge settles.)
  3. Select only oils which have been performance tested
  4. Oils carrying a similar MIL specification can be mixed even though obtained from different suppliers
  5. Bring the engine up to normal operating temperature each time it is used (NOTE: This will help reduce engine wear.)
  6. Keep oil containers covered, sealed, and protected to prevent contamination by dirt or water
- F. Storing and handling engine oils
1. Store oil inside whenever possible in clean closed cabinets or rooms (NOTE: It is best to keep oil relatively warm in the winter.)
  2. If stored outside, lay oil barrels on their sides; if they cannot be laid on their sides, tilt them slightly (NOTE: Turn the barrel so that the bung is at the high side, away from any water which collects.)
  3. Keep oil bungs drawn tight
  4. Rinse oil containers and funnels in solvent after use (NOTE: Cover them to keep out dirt, or store them upside down.)
  5. When adding oil, clean all dirt from around the filter cap before removing it (NOTE: Do the same before unscrewing an oil filter or a filter cap.)

# Types of Filter Assemblies

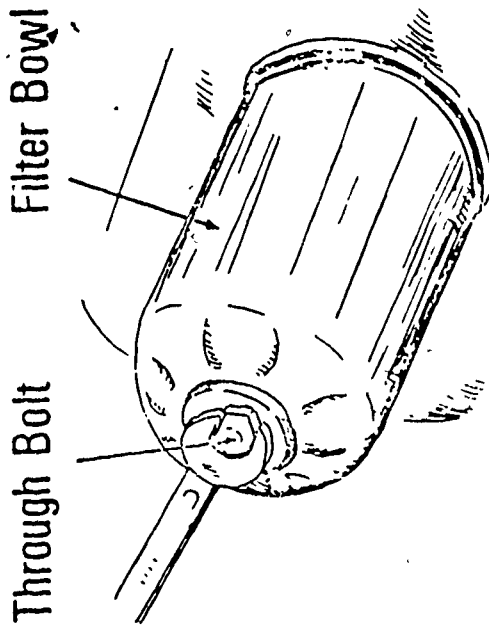

FILTER BOWL

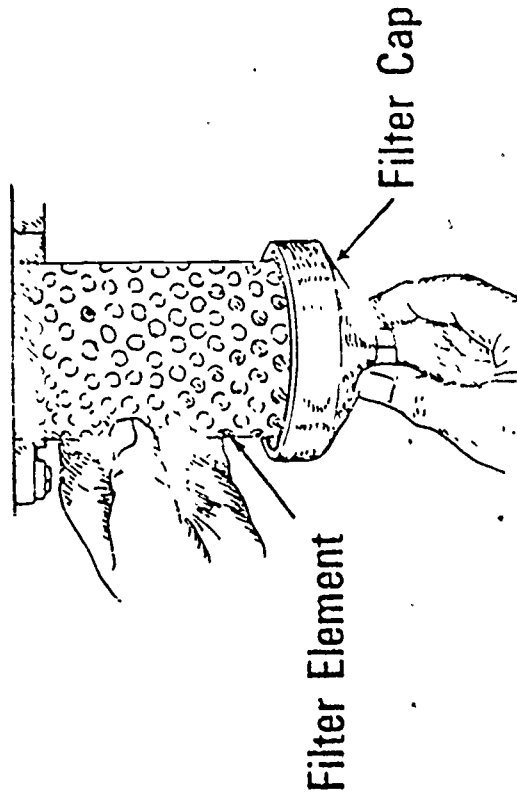

FILTER CARTRIDGE

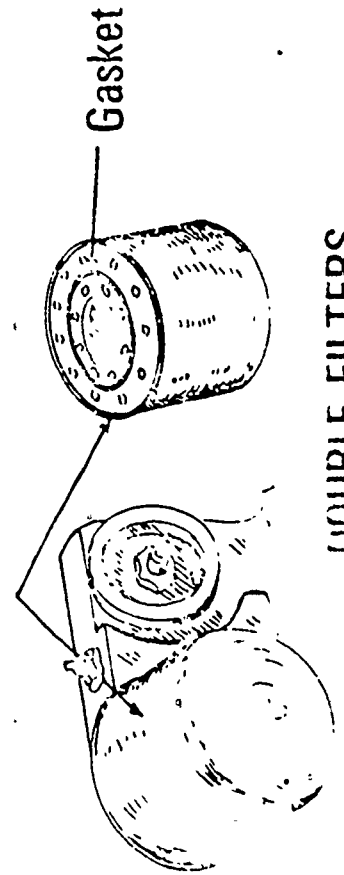

DOUBLE FILTERS

# Purposes of Lubricants

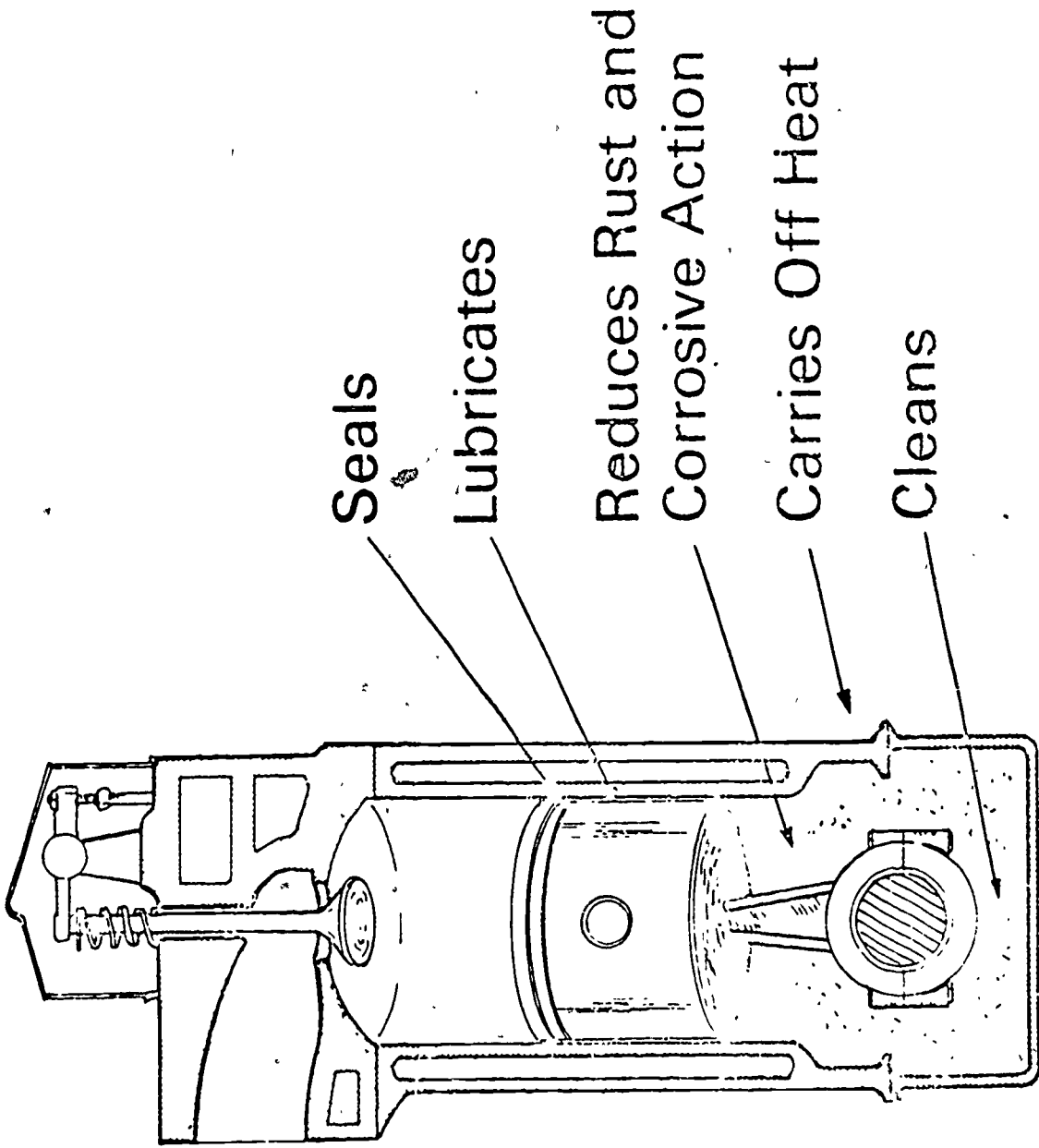

## JOB SHEET #1 -- CHANGING CRANKCASE OIL

- I. Tools and materials needed
  - a. Wrench for drain plug
  - b. Clean rags
  - c. Container for old oil
  - d. New oil of grade and type recommended for your tractor
- II. Procedure
  - a. Operate engine until thoroughly heated (NOTE: Oil will drain more completely while hot; more of the contaminants are removed while the oil is still agitated. If crankcase is drained while oil is cold, some of the more highly contaminated oil may remain in the engine.)
  - b. Remove drain plug (clean if of magnetic type) (NOTE: Use a wrench that fits the drain plug, not a pair of pliers. Pliers will gradually round off the corners of the plug until it will be difficult to either remove or tighten it.)
  - c. Allow crankcase to drain for several minutes (NOTE: This allows time for oil to drain from various parts of the engine. This is important in order to remove as much dirt laden oil as possible. If it is time for an oil filter change, remove the filter while oil is being drained.)
  - d. Replace drain plug (NOTE: If drain plug is equipped with a gasket, be sure it is in place on the drain plug. Tighten the plug. (Do not overtighten or cross thread.) If filter element was removed, install a new one. Follow procedures in Job Sheet #2.)
  - e. Refill crankcase with new oil (NOTE: Be extra careful that the tops of oil cans are thoroughly clean. Check the funnel, or any containers you may be using, to make certain they are free of dirt. No amount of filtering will completely take the place of the care you use when you refill with new oil.) One to three extra quarts will probably be needed, if you changed oil filters, to recharge the new filter. Check the operator's manual for the requirements of your tractor. Use the viscosity and type of oil recommended in your operator's manual.
  - f. Start engine and operate it for a few minutes at a low rpm (revolutions per minute) (NOTE: This gives the oil an opportunity to fill the oil filter and establish a true level on the dip stick. Also check the pressure gauge to make certain the oil pump is working properly.)
  - g. Check for oil leaks (NOTE: Observe area around drain plug and around filter element if filter was changed.)
  - h. Check oil level on dip stick (NOTE: If oil is not to the "full" line, add until it reaches that level. Do not overfill, this increases oil consumption and causes oil foaming.)
  - i. Store used oil in a drum or small closed container

## JOB SHEET #2 -- REPLACING AN OIL FILTER

- I. Tools and materials needed
  - a. New filter cartridge
  - b. Clean rags
  - c. Container to catch waste oil
  - d. Wrenches, if needed to loosen or tighten filter cap or bowl
  - e. Cleaning solvent -- Kerosene or diesel fuel
  
- II. Procedure
  - a. Find location of oil filter
  - b. Wipe dirt from filter and from around filter area
  - c. Remove drain plug (if provided) from base of filter and catch oil in a jar
  - d. Loosen filter bowl or cover and remove
  - e. Remove old filter cartridge and discard it (NOTE: Do not try to clean the old filter element (unless it is the old style screen type). Abrasives embedded in filter material are difficult or impossible to remove.)
  - f. Clean inside of filter bowl and base with kerosene or diesel fuel (NOTE: This is to remove dirt deposits. Use a clean cloth and clean solvent solutions.)
  - g. Replace and tighten drain plug (if one was removed)
  - h. Install new gasket, if supplied with filter (NOTE: New gaskets are usually supplied with new filters. However, if a new gasket is not available, examine the old one. It may still be usable. With a "spin-on" type of filter you can reduce the chance of damaging the gasket by first applying a slight amount of crankcase oil or grease to the gasket before the filter is screwed into position.)
  - i. Install new filter unit (NOTE: If your replacement cartridge is the type that is installed in a filter bowl, rotate the element slightly to help it become sealed. Do not apply much pressure because the seals can be easily damaged. If you have a "spin-on" filter that uses a rubber gasket, turn the filter on until the gasket contacts the base, then tighten no more than one-half turn. This keeps from over tightening which distorts the gasket and causes leaks.)
  - j. Replace filter bowl (if of that type) and tighten in place (NOTE: Tighten just enough to form a seal. Too much tightening damages the gaskets.)
  - k. Operate engine and check for leakage around filter (NOTE: This is important. A small leak can cause enough oil loss to damage your engine.)
  - l. Check oil level and add oil if needed (NOTE: Most filter elements require about one additional quart to recharge them. However some require more, even as much as three quarts.)

IV. POSSIBLE STUDENT LEARNING ACTIVITIES:

- A. Take a field trip to the home farm of one of the students and have a team of students demonstrate the proper technique for changing oil and filter.
- B. Demonstrate proper procedure for changing oil and filter on a laboratory engine in the farm shop.
- D. Invite a representative for a local fuel and oil supplier to come to the classroom and discuss oil classifications.

V. SPECIAL MATERIALS AND EQUIPMENT:

- A. Tools to service the lubrication system
  - 1. Wrench for drain plug and filter
  - 2. Container for old oil
  - 3. Clean rags
  - 4. New oil of proper grade and type
  - 5. New cartridge

VI. STUDENT REFERENCES:

- A. Fundamentals of Service, Fuels, Lubrications, and Coolants, Moline, Illinois: John Deere Service Publication.



## I. Agricultural Production

## C. Farm Mechanics

UNIT: 6. Power UnitsPROBLEM AREA: d. Care of Battery

## TEACHING PLAN

- I. INTRODUCTION: The battery is the heart of the power unit to get it started, operate lights and accessories and for efficient operation. The battery will give years of satisfactory service if it is properly cared for.
- II. STUDENT PERFORMANCE OBJECTIVES:
- The student will be able to:
- A. Remove and replace an old battery from a vehicle without incurring injury to himself, the vehicle, the battery, or the mount. He will use a battery carrier and practice safety regulations provided by the instructor.
- B. Given the proper tools, take a hydrometer reading on a battery, and determine if it checks out in the range specified with 100 per cent accuracy.
- III. OUTLINE OF INSTRUCTIONAL CONTENT:
- A. Terms associated with:
1. Battery construction
    - a. Plates--Store active materials which bring about the chemical reaction to provide electricity
    - b. Separators--Insulate the negative plates from the positive plates
    - c. Electrolyte--Solution of water and sulphuric acid
    - d. Cell--Consists of plates of two different materials immersed in an electrolyte solution that reacts chemically to produce electricity
    - e. Battery case--Holds the cells and electrolyte to make up the completed battery
    - f. Vent caps--Close the opening in each cell cover and provide a vent to allow gases to escape
    - g. Positive post--The larger of the two battery posts
    - h. Negative post--The smaller of the two battery posts

# Battery Construction

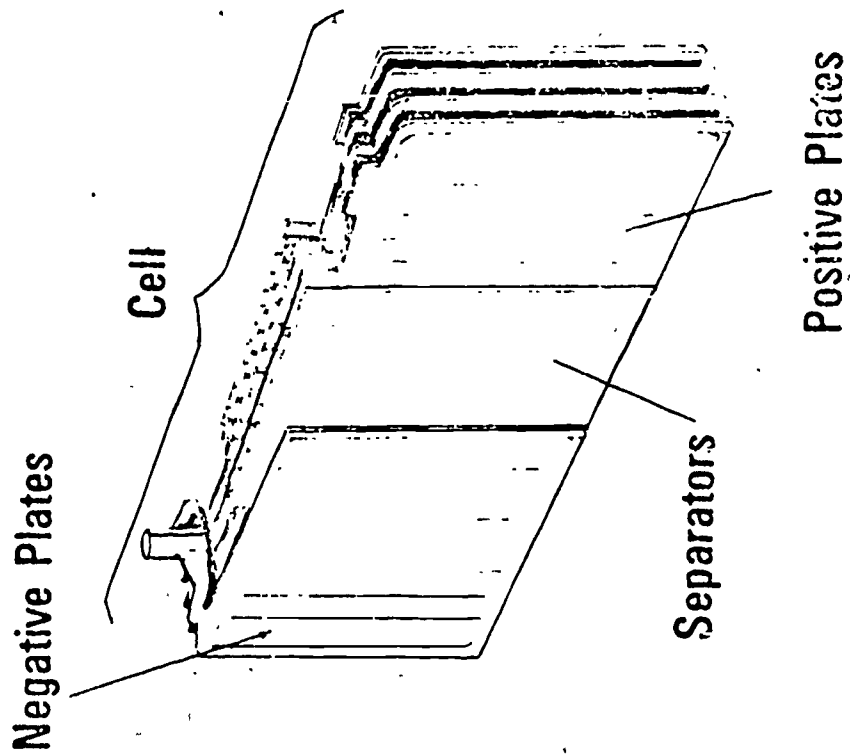
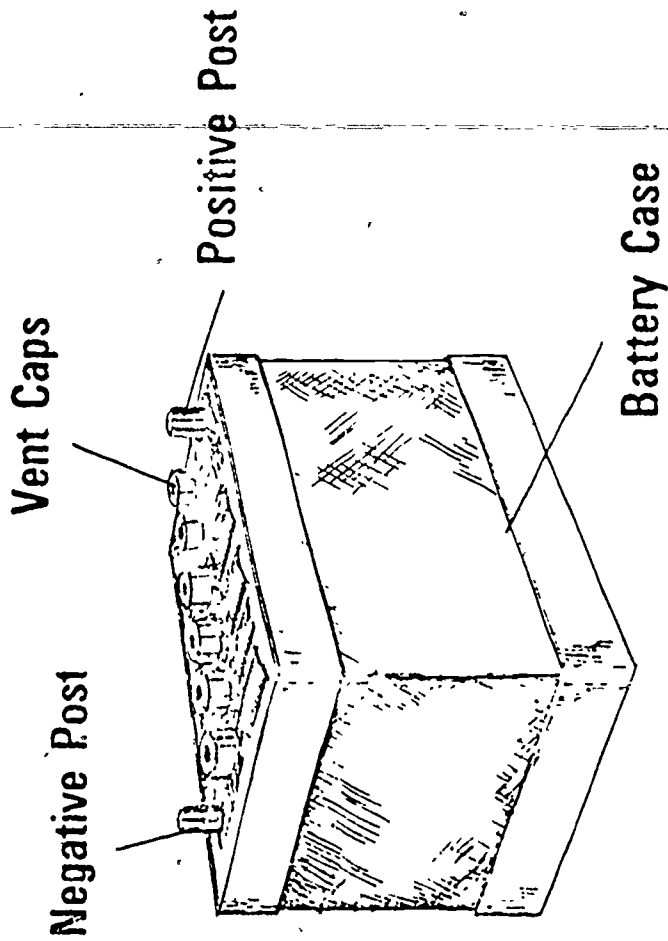

## 2. Battery testing

- a. Specific gravity--The weight of a solution compared to distilled water that has a reading of 1.000
- b. Hydrometer--An instrument which measures specific gravity of the electrolyte

## B. Functions of a battery

1. To supply current for starting the engine
2. To supply current when the demand exceeds the output of the charging system
3. To stabilize the voltage in the system during operation

## C. Battery safety

1. Battery electrolyte must not be allowed to spill or come in contact with clothing, skin, eye, or car paint
2. Flames or sparks must be kept away from a battery as the gases given off by a battery are very explosive
3. Avoid shorting or grounding the battery during service or removal

## JOB SHEET #1 -- REMOVE, CLEAN, SERVICE, AND REPLACE A BATTERY

## I. Tools and equipment

- a. Bristle brush
- b. Wire brush
- c. Screwdriver
- d. Battery clamp puller
- e. Combination end wrenches, 7/16" - 9/16"
- f. Battery cable spreader
- g. Baking soda and water solution -- (two tablespoons of baking soda to one pint of water)
- h. Battery anti-corrosion paste
- i. Battery post and cable cleaner
- j. Battery lift strap

## II. Procedure

- a. Disconnect battery cables from the battery posts (NOTE: Always disconnect the grounded battery cable first to avoid short circuits.)
- b. Remove the battery hold-down
- c. Remove the battery from the machine (NOTE: Use a suitable battery lift strap to lift the battery from the battery tray.)
- d. Inspect the battery tray for dirt or corrosion (NOTE: Clean with baking soda and water as required.)
- e. Check battery cables for worn or frayed insulation

- f. Clean battery cable clamps and battery posts (NOTE: Battery posts and inside of battery cable clamps must be clean and bright.)
- g. Remove the loose dirt and corrosion particles from top of battery
- h. Brush soda water solution on battery, battery posts, clamps, and battery hold-down (NOTE: Keep water and soda from entering the battery through the vent holes in the vent caps.)
- i. Wash away residue with clean water (NOTE: Remove all residue that may have lodged around battery, frame, or parts of the vehicle.)
- j. Dry the battery and battery cables with a clean cloth
- k. Set the battery into place using a lift strap (NOTE: Position the battery to allow for correct battery cable attachment.)
- l. Install the battery hold-down clamp or strap and tighten securely
- m. Reconnect battery cables to the battery posts (NOTE: Always reconnect the power cable first and the ground cable last.)
- n. Tighten the battery cable clamps securely (NOTE: Use care to avoid twisting the battery cable posts.)
- o. Spread a coating of battery anti-corrosion paste over the cable clamps and terminals
- p. Remove vent caps and check electrolyte level in all cells
- q. Add water if necessary to bring electrolyte up to proper level (NOTE: Do not overfill.)

#### JOB SHEET #2 -- CHECK A BATTERY WITH A HYDROMETER

- I. Tools and equipment
  - a. Shop towels
  - b. Hydrometer
- II. Procedure
  - a. Remove vent caps from battery
  - b. Insert the hydrometer into the first cell
  - c. Squeeze the rubber bulb to draw electrolyte into the hydrometer to suspend the float (NOTE: If the electrolyte level is too low, add water, charge for one hour, and recheck.)
  - d. Make sure the float is not bumping the top of the hydrometer tube or sticking to the side of the tube
  - e. Take reading at eye level (NOTE: Write down reading for each cell.)
  - f. Squeeze bulb to return electrolyte to cell
  - g. Repeat for other cells
  - h. Adjust the readings for temperature (NOTE: Add four

gravity points (0.004) to the reading for every 10°F. above 80°. Subtract four gravity points (0.004) for each 10° below 80°F.)

- i. Specific gravity should read from 1.215 to 1.270 (corrected for 80°F. electrolyte temperature)
- j. The variation in readings between cells should be no more than 0.050
- k. If the readings are not within the above mentioned range, further testing will be required
- l. Replace vent caps upon completion of test

#### IV. POSSIBLE STUDENT LEARNING ACTIVITIES:

- A. Secure an old battery and prepare a cut-away model for instructional use.
- B. Purchase the proper tools for handling and servicing a battery for the home farm shop.
- C. Student-team prepare a demonstration for class on servicing a battery.

#### V. SPECIAL MATERIALS AND EQUIPMENT:

- A. Tools to service a battery
  1. Lift strap
  2. Wire brush
  3. Screwdriver
  4. Battery clamp puller
  5. Combination end wrenches 7/16" - 9/16"
  6. Baking soda and water solution
  7. Battery post and cable cleaner
  8. Bristle brush
  9. Hydrometer
  10. Clean rags

#### VI. STUDENT REFERENCES:

- A. Fundamentals of Service Electrical Systems Manual, Moline, Illinois, John Deere and Company

## I. Agricultural Production

## D. Farm Business Management

UNIT: 5. Leasing and Risk ManagementPROBLEM AREA: b. Insurance Protection

## TEACHING PLAN

I. INTRODUCTION: Insurance makes it possible for a person to protect himself against large unknown losses by making annual contributions into a fund. Young farmers and others who cannot stand the risk of a large loss out of their own pocket can shift this risk by purchasing insurance. Nearly everyone insures their life, home, automobile, and other personal property. In addition, farmers usually insure their crops and livestock.

II. STUDENT PERFORMANCE OBJECTIVES:

The student will be able to:

- A. Explain how insurance works and why it is possible to protect oneself against large, unknown losses such as the loss of an entire farm through liability to the satisfaction of the instructor.
- B. Given a farm situation with crops and livestock, plan the kinds of insurance and the appropriate amounts to have to provide adequate economical protection according to recognized insurance standards.
- C. From reading assignments the student will be able to explain with 95% accuracy what hazards are insured against and the types of coverage available through:
  1. Fire insurance
  2. Crop insurance
  3. Automobile insurance
  4. Health insurance
  5. Accident insurance
  6. Disability insurance
- D. The student will be able to define the advantages, disadvantages, and appropriate situations for the following kinds of life insurance:
  1. Term
  2. Ordinary life
  3. Limited pay life
  4. Endowment

Definitions will be evaluated against recommendations of a local insurance agency manager with 95% accuracy.

### III. OUTLINE OF INSTRUCTIONAL CONTENT:

#### A. Terms and definitions

1. Annuity--A contract that provides an income for a specified period of time such as a number of years or for life
2. Application--A statement of information made by a person applying for insurance (NOTE: This becomes part of the policy.)
3. Automatic premium loan--A provision authorizing the premium to be subtracted from policy cash values if not paid by the end of the grace period
4. Beneficiary--Person named in the policy to receive proceeds at death of insured
5. Cash value--Amount available in cash upon voluntary termination of policy before death
6. Convertible--Term insurance exchanged at option of policyholder without evidence of insurability for another insurance plan
7. Disability benefit (waiver of premium)--The provision added to life insurance to pay premiums if totally and permanently disabled
8. Double indemnity--An accidental death benefit to pay double face amount in case of death by accident
9. Endowment insurance--Insurance payable to the insured if living on maturity date or death prior to maturity
10. Face amount--Amount stated on the face of the policy that will be paid in case of death or at maturity
11. Grace period--A period (usually 31 days) following the premium due date during which a premium may be paid without a penalty (NOTE: This applies only to life insurance where stated and sometimes to health insurance.)
12. Group insurance--Insurance which is usually issued without a medical examination on a group of persons under a single master contract
13. Lapsed policy--A policy terminated for nonpayment of premium
14. Policy--Document stating terms of contract that is issued to policyholder by the company
15. Policy Dividend--A refund of part of the premium on participating policies plus interest
16. Policy loan--Cash loaned on the cash value of policy at a specified interest rate
17. Premium--The payment or consideration one makes as a policyholder in agreement with the policy for insurance

18. Insurance--Spreads the risk of one person's misfortune among a large number of persons
19. Family income life insurance--A combination of permanent life insurance and decreasing term insurance
20. Homeowner's policy--A combination of several coverages or protections in one policy regarding home, personal property, and liability insurance
21. Credit insurance--Written through lending institutions on lives of borrowers (NOTE: Most credit insurance is decreasing term policies in which the amount of insurance is equal to the unpaid portion of the mortgage.)
22. Permanent life insurance--Includes straight life, limited pay, and endowment
23. Term life insurance--Give protection for a stated period of time and at the end of term is the termination of contract
24. Liability--When one is negligent and therefore liable for injury or damage caused to someone else (NOTE: Liability insurance protects one from claims made by other people and provides defense in the event of a groundless suit. Liability limits should be equal to assets.)

B. Types of liability insurance

1. Public liability--Protects policyholder from lawsuits by members of the public who suffer property or bodily injury caused by his negligence (NOTE: This would apply to auto liability and farmer's comprehensive liability.)
2. Employer's liability--Protects employer when he is liable for on-the-job accidents caused by his negligence (NOTE: This covers loss of time, medical care, bodily injury, sickness, and death.)
3. Workmen's compensation--Pays the employee's medical expense regardless of who is negligent
4. Farmer's comprehensive liability--Similar to public liability but is designed specifically for farmers

C. Basic automobile coverages

1. Bodily injury liability--Protects the policyholder financially if he or a member of his family injures someone while operating his vehicle (NOTE: State law requires everyone to have liability insurance.)
2. Property damage liability--Protects the policyholder financially if he or a member of his family damages someone's automobile or other property (NOTE: Most policies also offer liability protection for one if driving a borrowed car, or if loaning one's car to someone else.)



- 3.. Medical reimbursement--Pays for any medical, dental, hospital, nursing, or funeral expenses incurred as the result of an auto or truck accident involving the insured vehicle regardless of fault
  4. Comprehensive physical damage--Insures auto against glass breakage, fire, theft, and all weather elements
  5. Collision--Insurance pays for damage to one's car regardless of the burden of negligence (NOTE: Deductible choice ranges from \$10 to \$250.)
  6. Protection against the uninsured motorist--Coverage for holder to recover loss for bodily injury caused by a person having no liability insurance
- D. Interpretation of a 10-20-5 automobile policy
1. Ten indicates insured person is protected against damages up to \$10,000 for one person
  2. Twenty means insured person is protected against damages up to \$20,000 for two or more persons injured in one accident (NOTE: This is not in addition to the \$10,000 protection for one person.)
  3. The five indicates insured person is protected against property damage to others up to \$5,000 (NOTE: It costs very little to raise liability limits. 100-300-100 costs as little as \$10.00 more per year than 10-20-5.)
- E. Factors to consider when determining types of automobile coverages to buy
1. Liability insurance should be purchased for every licensed vehicle
  2. Liability limits should be the same on all vehicles (NOTE: Minimum liability limits should be equal to one's assets.)
  3. It is advisable to carry medical insurance on every vehicle (NOTE: Medical payments cover passengers as well as the one insured and family.)
  4. Consider dropping comprehensive and collision insurance when:
    - a. The car is paid for and there is no bank note
    - b. One can afford to repair the car from personal funds
    - c. One can do without the automobile if destroyed
    - d. The value of car is not more than the cost of comprehensive and collision premiums
 (NOTE: All these factors should be considered and applied to each individual circumstance.)
- F. Items that influence automobile insurance premiums
1. Number of basic coverages one carries
  2. Area one lives in
  3. Value and size of automobile
  4. Age
  5. Sex (NOTE: Boys' rates are higher than girls'.)

6. Marital status
7. Distance one drives to work
8. Use of car--business or pleasure
9. Driving habits of individuals
10. Claims paid on policy during past three-year period
11. Rates must be similar for equal risks
12. Cost of repairs (NOTE: Rates are set by each insurance company, and the insurance commission regulates these rates.)

G. Ways to save on automobile insurance

1. Safe driver discount (NOTE: Some companies give a ten to twenty percent discount on basic premiums to those with a three-year record of no involvement in accidents where they were at fault or convicted of traffic violations.)
2. Driver education discount (NOTE: Discount varies from company to company, but the course must meet national standards and be successfully completed.)
3. Two or more cars discount

H. Types of property insurance

1. Fire and extended coverage--Protects dwellings, farm buildings, and personal property against the perils of fire, lightning, wind, hail, explosion, riot, and civil commotion (NOTE: Property does not have to be owner occupied.)
2. Homeowners--A package policy generally for town property that insures the dwelling, additional private structures, personal property such as household goods, and comprehensive personal liability; to qualify for this policy, the dwelling must be owner occupied (NOTE: Homeowners insured against damage from fire, and extended coverage described in item "1", plus theft, vehicle damage, falling objects, weight of ice and snow, freezing of plumbing system, and hot water heater rupture.)
3. Farm owners--Same as homeowners plus optional coverages of farm barns and buildings, machinery, grain, hay, livestock, tools and equipment, and employer's liability

I. Items that influence cost of property insurance

1. Amount of protection
2. Type of construction (wood or brick)
3. Location
4. Distance from fire department
5. Period of time covered

J. Basic rules for buying property insurance

1. Do not insure if financially able to do without or to replace with personal funds or if a loss would not hamper the farm operation

2. Insure if there is a loan against property under personal ownership
  3. Write enough coverage to replace the loss
- K. Crop hail and federal crop insurance
1. Crop hail
    - a. An insurance company policy that protects against loss by hail or fire; optional coverage is loss by wind
    - b. The amount of loss payable is the amount of insurance multiplied by the percentage of damage
    - c. Damage percentage is determined by sampling methods that are agreeable to both parties
  2. Federal crop insurance
    - a. Provides "all risk" crop investment insurance
    - b. Does not insure profit for the farmer or cover avoidable losses such as those caused by neglect or poor farming practices
    - c. Pays up to the guaranteed yield (NOTE: If actual yield is as much as guarantee then no payment is made regardless of extent of loss.)
- L. Kind of life insurance policies
1. Term insurance
    - a. Covers the stated number of years or term that the policy is in effect
    - b. Usually does not accumulate any cash value
    - c. Insurance protection ends when the stated term expires
    - d. Used for business insurance protection, creditor's risk, and general family protection
    - e. For the time contracted, it is the cheapest form of life insurance
    - f. Chances of death increase with age, therefore policy rates are higher for each succeeding period
    - g. No guarantee of renewal
    - h. Group insurance is usually term insurance
  2. Straight life insurance (whole life or ordinary life)
    - a. Provides lifetime protection
    - b. Most widely used of all permanent life insurance
    - c. Costs less annually than any other kind of lifetime protection
    - d. Premiums are paid throughout the policyholder's lifetime
    - e. Policy accumulates a cash value
    - f. Policyholder may borrow the cash value of his policy
  3. Limited payment life insurance
    - a. Provides lifetime protection

- b. Premiums are paid only during a specified period of time
  - c. Fewer premiums are necessary so each one is larger
  - d. Accumulate cash value
  - e. Twenty year, or thirty year pay, or paid up at 65 are examples of limited payment life insurance (NOTE: Anyone having above average income for a few years might consider this type of insurance.)
4. Endowment insurance
- a. Policy puts emphasis on savings more than any other life insurance
  - b. Purpose is to accumulate a certain amount of money in a specified period, while providing life insurance
  - c. If policy holder lives, whole amount of policy is paid to him when endowment comes due
  - d. If policyholder dies before the period has elapsed, the full amount of the policy is paid to the beneficiary
  - e. Expensive form of insurance protection
  - f. Suits those who wish money for educating children or during retirement
- M. Instances when family income life insurance is needed most
- (NOTE: Combination of permanent life and decreasing term insurance.)
1. When there are small children to be reared or educated
  2. While policyholder is paying off mortgage
- EXAMPLE: The chart below illustrates a common form of family income policy (NOTE: If the policy shown had been in effect for fifteen years, the beneficiary would receive monthly income payments for the remaining five years of the policy.)

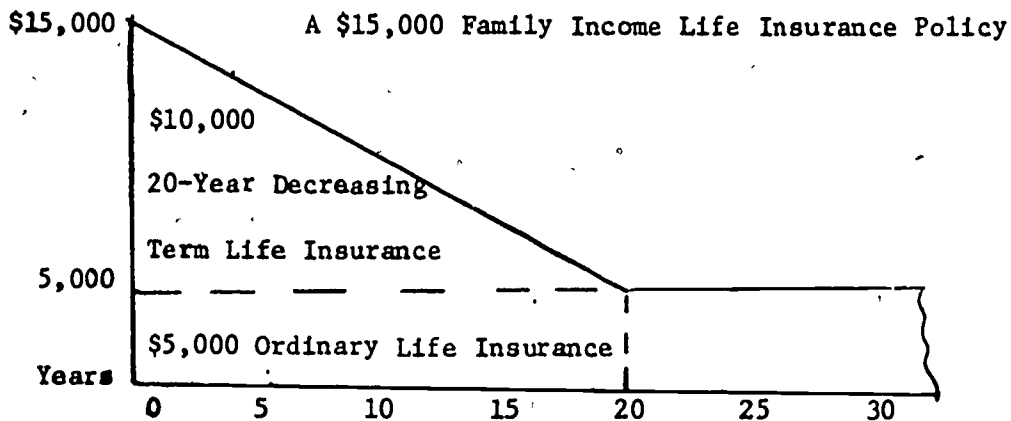

- N. Factors that determine amount of life insurance needed
1. Family's income and net worth
  2. Size of the family
  3. Age and sex of the children
  4. Skills and abilities of the wife and older children
  5. Indebtedness of the family
  6. Long-time goals including college education for the children (NOTE: A qualified insurance agent is able to program one's insurance needs. Know the insurance agent and have confidence in him. There is usually a need for revision of your insurance needs.)
- O. Kinds of health insurance
1. Hospital-surgical-medical
    - a. Known as first dollar coverage with a small deductible clause EXAMPLE: \$20, \$50, or \$100 deductible
    - b. Usually has specified limits on room and board, hospital special charges, surgery, and out patient care
  2. Major medical
    - a. Pays for expenses associated with a catastrophe and has a large deductible clause of from \$100 to \$1,000 but has a large benefit limit EXAMPLE: \$10,000 to \$20,000
    - b. Usually covers most all expenses over the deductible with possibly a limit on room, board, and surgery
    - c. Has larger benefit period than hospital-surgical-medical EXAMPLE: Three years
    - d. Major medical usually pays 80% for eligible expenses for the first one to five thousand dollars and 100% thereafter until maximum benefits are reached
  3. Disability income
    - a. Pays a stated amount while a person is disabled because of injury or illness
    - b. Deductibles on disability income are called waiting periods (NOTE: This is the period between the start of disability and beginning of payment.)
    - c. Has different combinations of waiting periods (NOTE: Example: 0/0 means no waiting period for accident or sickness, 30/90 means 30 days waiting period for accidents and 90 days waiting period for sickness.)
    - d. Variations in length of benefit periods may be purchased EXAMPLE: Life time benefits for accidents and five year benefit for sickness

e. Usually there are smaller benefits for partial disability

(NOTE: The hospital-surgical-medical, major medical, and disability income policies can be purchased in group plans, individual plans, and family plans. Many employers of larger firms provide group plans for employees.)

IV. POSSIBLE STUDENT LEARNING ACTIVITIES:

- A. Invite local insurance agency manager to meet with class and answer questions about insurance.
- B. Have students bring either their own or policies from home and figure out coverage provided by the policy.
- C. Conduct a telephone interview with a person who has recently suffered a covered loss and get his comments.
- D. Have class figure a problem on how many years of premiums it would take to equal the value of a tractor.

V. SPECIAL MATERIALS AND EQUIPMENT:

- A. Slide film projector
- B. Examples of different types of policies

VI. STUDENT REFERENCES:

- A. Insurance in the Farm Business #380A Filmstrip from V.A.S.
- B. Handbook of Life Insurance, Institute of Life Insurance, 277 Park Avenue, New York, New York 10017
- C. Your Social Security, Superintendent of Documents, U.S. Government Printing Office, Washington, D.C. 20402, 1970.

## I. Agricultural Production

## D. Farm Business Management

UNIT: 4. Financial Management

PROBLEM AREA: a. Sources and Cost of Using Credit

## TEACHING PLAN

I. INTRODUCTION: The capital requirements of modern agriculture are rapidly increasing. If young farmers are to compete, they will have to have a source of credit that is dependable and large enough to meet their needs. The credit must be of the right kind and at a cost that is fair.

II. STUDENT PERFORMANCE OBJECTIVES:

The student will be able to:

- A. List major sources of farm production and farm real estate credit available and give distinguishing information about each type of agency using a recognized reference text.
- B. When given the necessary data that accompanies five loans, calculate:
1. Total interest paid over life of the loan
  2. Total payment of principal and interest in any one year of the loan
- The student will attain 100% accuracy.

III. OUTLINE OF INSTRUCTIONAL CONTENT:

- A. Terms and definitions
1. Appraisal--A fair market value given on personal property
  2. Collateral--Livestock, land, and other personal property used to secure the loan
  3. Amortized--Regular schedule of payment of the loan
  4. Interest rate--Percentage charged for the use of money
  5. Maturity--Date the loan is to be paid in full
  6. Mortgages--A written claim listing the collateral to secure the loan
  7. Principal--Amount of money borrowed



## B. Types of loans

1. Long-term loans
  - a. Extend from five to thirty years or more
  - b. Used for such purposes as the purchase of farms, for farm improvements, for major repairs, and other purposes
2. Intermediate loans
  - a. Extend for periods of one to five years
  - b. Used for purchase of machinery and equipment, the purchase of breeding herds and flocks, and construction or major repair of farm buildings
3. Short-term loans
  - a. Extend for periods up to one year
  - b. Used for such items as fertilizer, feed or seed, or to pay other current operating expenses

## C. Types of interest

1. Compound interest--Interest calculated at regular intervals and added to the principal (compound interest is the same for savings as borrowing)  
EXAMPLE: Compound interest on a \$100.00 loan with interest at 1% per month

PERIOD	BEGINNING BALANCE	CHART INTEREST	ENDING BALANCE
a. 1st Mo.	\$100.00	\$1.00	\$101.00
b. 2nd Mo.	101.00	1.01	102.00
c. 3rd Mo.	102.00	1.02	103.03
d. 4th Mo.	103.03	1.03	104.06

2. Simple interest--Product of the principal, the time in years, and the annual rate of interest  
EXAMPLE: Interest on \$1,200.00 for one year with the rate of interest at 6% per annum equals \$72.00
3. Discount interest--Interest is deducted from principal at time loan is made  
EXAMPLE: (1) \$1,200.00 loan for one year discounted at 6%  
(2) Borrower would receive: \$1,200.00 - \$72.00 = \$1,128.00  
(3) \$1,200.00 would be paid at the end of the year  
(NOTE: True annual interest would be 6.38%.)
4. Add-on-interest--Interest is calculated on the beginning balance and then added to principal to obtain the amount to be repaid in equal periodic installments  
EXAMPLE: (1) \$1,200.00 installment plan loan @ 6% interest to be repaid in 12 equal monthly payments



$$(2) \quad \$1,200.00 \times 6\% = \$72.00$$

$$(3) \quad \$1,200.00 \div \$72.00 = \$1,272 \div 12$$

months = \$106.00 payment

(NOTE: Interest is being paid on unowed money, true annual rate is 11.07%.)

- D. Factors that determine rate of interest
1. Cost of money in the money market
  2. Service cost of making records, keeping records, and collecting loans
  3. Risk of loss

E. Calculating interest rates

Total of Finance Charges	X	No. of Payments	X	<u>1</u>	=	True Annual
1/2 Original Loan		No. of Years		No. of Payments Plus 1		Rate of Interest

EXAMPLE: A farmer borrowed \$8,000.00 which cost him \$400.00 for 24 months. What was his interest rate?

$$\frac{400}{4,000} \times \frac{24}{2} \times \frac{1}{25} = 4.8\% \text{ Interest}$$

F. Advantages and disadvantages of credit sources

1. Commercial banks
  - a. Advantages
    - (1) Convenience of borrowing
    - (2) Know personal needs
    - (3) Loan approved quickly
    - (4) Loans on more diversified items
    - (5) Will make character loans
  - b. Disadvantages
    - (1) Interest rate usually higher
    - (2) Short-term loans
    - (3) Will not loan as much on land as some agencies
2. Individuals
  - a. Advantages
    - (1) Low rate of interest
    - (2) Immediate loan
    - (3) Greater possibility to negotiate the payment or interest of loan
  - b. Disadvantages
    - (1) Not dependable
    - (2) Usually short-term credit
3. Federal land banks
  - a. Advantages
    - (1) Usually have low interest rates on long-term loans
    - (2) Long-term loan (20-40 year)

- (3) More understanding on economic conditions
- b. Disadvantages
  - (1) Complicated loan procedure
  - (2) Borrower has to buy shares
  - (3) Usually appraised value is low
  - (4) Limited funds to be loaned
- 4. Production credit association
  - a. Advantages
    - (1) Low interest rate
    - (2) Unlimited funds
    - (3) Pay interest only on amount of time used
    - (4) Keeps better records
  - b. Disadvantages
    - (1) Borrower has to buy shares
    - (2) Short-term loans
    - (3) Not conveniently located
- 5. Farmer's home administration
  - a. Advantages
    - (1) Makes loans to individuals who do not qualify for other loans
    - (2) Short, intermediate, and long-term loans
    - (3) Reasonable rates and terms on loans
    - (4) Advice, assistance, and supervision given by supervisor
  - b. Disadvantages
    - (1) Not intended as a permanent source of financing
    - (2) Borrowers expected to refinance when suitable commercial sources are available
    - (3) Secure loans only on larger acreages
- 6. Insurance companies
  - a. Advantages
    - (1) Long-term mortgages
    - (2) Low interest rates
    - (3) Not any limits on size of loan except for self-imposed limits
  - b. Disadvantages
    - (1) First mortgage loans
    - (2) Some states prohibit short-term loans
    - (3) Selective about areas where loans are made
    - (4) Can not pay loan back all at once
- 7. Merchants and dealers
  - a. Advantages
    - (1) Easier for poor risk persons
    - (2) Convenient for farmer
    - (3) Immediate loan
    - (4) Loan can be made for large percent of value
    - (5) Repayment schedule may be designed for individual
  - b. Disadvantages
    - (1) Interest is higher

- (2) May have different form of credit arrangement for various customers (This could be an advantage.)

- G. Factors to consider in choosing a source of credit
1. Amount of the loan
  2. Rate of interest
  3. Length of loan period
  4. Repayment schedules
  5. Size of payments
  6. Reliability of lending agents

IV. POSSIBLE STUDENT LEARNING ACTIVITIES:

- A. Invite representative of local credit institution to meet with class and discuss credit sources.
- B. Have student determine type of credit he would need if he were to expand his farming operation.
- C. Figure what it would cost to finance a new 100 horsepower tractor if paid out in three years.

V. SPECIAL MATERIALS AND EQUIPMENT:

- A. Slide film projector
- B. Amortization tables

VI. STUDENT REFERENCES:

- A. V.A.S. Unit 2025a, Determining Credit Needs on the Farm
- B. V.A.S. Unit 2027a, Sources of Farm Credit
- C. Nelson, Aaron G., and William G. Murrery, Agriculture Finance, Ames, Iowa, Iowa State University Press, 1967

## REFERENCES

### Specific References

- I. Agricultural Production
  - A. Animal Science Cluster Area
    1. Breeds of Beef Cattle V.A.S. 1024A. Urbana, Illinois: Vocational Agriculture Service, University of Illinois.
    2. Breeds of Swine V.A.S. 1045. Urbana, Illinois: Vocational Agriculture Service, University of Illinois.
    3. Improving Animals through Breeding V.A.S. 1009. Urbana, Illinois: Vocational Agriculture Service, University of Illinois.
    4. Judging Beef Cattle, Swine, and Sheep Booklet. Urbana, Illinois: Vocational Agriculture Service, University of Illinois.
    5. General Facts on Livestock Feeding V.A.S. 1013. Urbana, Illinois: Vocational Agriculture Service, University of Illinois.
    6. Minerals for Livestock V.A.S. 1018. Urbana, Illinois: Vocational Agriculture Service, University of Illinois.
    7. Feed Additives V.A.S. 1038. Urbana, Illinois: Vocational Agriculture Service, University of Illinois.
    8. Silage as an Animal Feed V.A.S. 1043. Urbana, Illinois: Vocational Agriculture Service, University of Illinois.
    9. Buying and Feeding Beef Cattle V.A.S. 1012. Urbana, Illinois: Vocational Agriculture Service, University of Illinois.
    10. Feeds and Feeding Swine V.A.S. 1036. Urbana, Illinois: Vocational Agriculture Service, University of Illinois.
    11. Artificially Inseminating Livestock V.A.S. 1002G. Urbana, Illinois: Vocational Agriculture Service, University of Illinois.
    12. Systems of Swine Breeding V.A.S. 1039. Urbana, Illinois: Vocational Agriculture Service, University of Illinois.

13. Caring for the Sow and Litter at Farrowing Time V.A.S. 1037. Urbana, Illinois: Vocational Agriculture Service, University of Illinois.
14. Caring for the Swine Herd During Breeding and Gestation V.A.S. 1034. Urbana, Illinois: Vocational Agriculture Service, University of Illinois.
15. The Swine Enterprise V.A.S. 1029. Urbana, Illinois: Vocational Agriculture Service, University of Illinois.
16. Castrating, Docking, and Dehorning V.A.S. 1032. Urbana, Illinois: Vocational Agriculture Service, University of Illinois.
17. Stockman's Handbook, Ensminger. Danville, Illinois: The Interstate Printers and Publishers.
18. Swine Handbook, Housing and Equipment Extension Agricultural Engineer, Urbana, Illinois: University of Illinois.
19. Beef Handbook, Housing and Equipment Extension Agricultural Engineer, Urbana, Illinois: University of Illinois.
20. What Factors Affect Prices of Agricultural Products V.A.S. 6009. Urbana, Illinois: Vocational Agriculture Service, University of Illinois.

#### B. Plant Science Cluster Area

21. Modern Corn Production, Aldrich and Leng. Cincinnati, Ohio: F and W Publishing Company.
22. Modern Soybean Production, Scott and Leng. Cincinnati, Ohio: F and W Publishing Company.
23. Illinois Agronomy Handbook. Urbana, Illinois: Vocational Agriculture Service, University of Illinois.
24. Innocation of Legumes V.A.S. 4022. Urbana, Illinois: Vocational Agriculture Service, University of Illinois.
25. Minimum Tillage V.A.S. 4041. Urbana, Illinois: Vocational Agriculture Service, University of Illinois.
26. Collecting and Preparing Soil Samples for Testing V.A.S. 4001. Urbana, Illinois: Vocational Agriculture Service, University of Illinois.
27. Hunger Signs in Crops V.A.S. 4011a. Urbana, Illinois: Vocational Agriculture Service, University of Illinois.

28. Handling and Using Agricultural Chemicals Safely V.A.S. 4045. Urbana, Illinois: Vocational Agriculture Service, University of Illinois.
  29. pH Test for Soil Acidity V.A.S. 4002a. Urbana, Illinois: Vocational Agriculture Service, University of Illinois.
  30. Testing Soils for Phosphorus V.A.S. 4003g. Urbana, Illinois: Vocational Agriculture Service, University of Illinois.
  31. Determining Available Potassium in the Soil V.A.S. 4004g. Urbana, Illinois: Vocational Agriculture Service, University of Illinois.
  32. Illinois Custom Spray Operator's Manual. Urbana, Illinois: Agricultural Extension Service, University of Illinois.
  33. Storing and Drying Corn V.A.S. 4044. Urbana, Illinois: Agricultural Extension Service, University of Illinois.
- C. Farm Mechanics Cluster Area
34. Tillage. Moline, Illinois: John Deere Service Publications.
  35. Planting. Moline, Illinois: John Deere Service Publications.
  36. Mowing and Spraying Equipment. Moline, Illinois: John Deere Service Publications.
  37. Combine Harvesting. Moline, Illinois: John Deere Service Publications.
  38. Fuels, Lubricants, and Coolants. Moline, Illinois: John Deere Service Publications.
  39. Preventative Maintenance. Moline, Illinois: John Deere Service Publications.
- D. Farm Business Management Cluster Area
40. Farm Management, Principles, Budgets, Herbst. Champaign, Illinois: Stipes Publishing Company.
  41. Law for the Farmer V.A.S. 2018B. Urbana, Illinois: Vocational Agriculture Service, University of Illinois.
  42. Agriculture and the Environmental Protection Agency AE 4264. Urbana, Illinois: Department of Agriculture Economics, University of Illinois.

43. Determining Credit Needs on the Farm V.A.S. 2025a. Urbana, Illinois: Vocational Agriculture Service, University of Illinois.
44. Sources of Farm Credit V.A.S. 2027a. Urbana, Illinois: Vocational Agriculture Service, University of Illinois.
45. Agriculture Finance, Murray and Nelson. Ames, Iowa: Iowa State University Press.

Selected References for More Information

- A. New Instructional Materials for Agricultural Education. Urbana, Illinois; Printed by Vocational Agriculture Service for American Vocation Association.

This publication is published annually by the Curriculum Materials Committee of the Agricultural Education Division of the American Vocational Association. Its purpose is to inform educators of current agricultural curriculum materials that are available to them.

- B. Teaching Materials Catalog. Urbana, Illinois: Vocational Agriculture Service, University of Illinois.

This publication lists teaching materials available, developed primarily for use in agriculture classes at the secondary, post-secondary and adult levels.

- C. Books for Agriculture. Danville, Illinois: The Interstate Printers and Publishers, Inc.

This catalog gives a brief description of materials available to the agriculture teacher for use in classes and shops.

- D. Fundamentals of Service. Moline, Illinois: John Deere Service Publications.

A catalog of manuals and visuals that are useful in classroom instruction involving power and machinery.



## SCHOOL FACILITIES, EQUIPMENT, AND SUPPLIES

### Facilities

A clean comfortable classroom, well lighted and equipped, is a prerequisite to a successful program in Agricultural Production. The farm shop should be large enough to accommodate an on-going program and adequately equipped with tools and machines for high quality instruction.

In addition, the instructor should have available the following instructional aids:

1. Slide film projector
2. Slide projector
3. 16mm film projector
4. Overhead projector and pens
5. Acetate overlay material
6. Tape recorder

### Equipment

Listed below are samples of equipment and materials to keep on inventory:

<u>ITEM</u>	<u>SOURCE</u>
1. Up-dated reference books	Publishing Company
2. Current agriculture magazines	Publishing Company
3. Slide films	Vocational Agriculture Service
4. Current bulletins and circulars	Extension Service
5. Agriculture releases	Vocational Agriculture Service
6. Charts on animal parts	Supply Catalog
7. Gestation tables	Supply Catalog
8. Livestock equipment	Supply Catalog or Local Supplier
a. Ear notchers	
b. Syringe and needles	
c. Castrating knife	
d. Tattoo outfit	
e. Needle teeth clippers	
f. Hoof trimmers	
9. Pictures of deficiency symptoms in animal nutrition	Supply Catalog
10. Pictures of crop disease specimens	Supply Catalog
11. Pictures of livestock parasites	Supply Catalog
12. Crop seed samples	Vocational Agriculture Service

<u>ITEM</u>	<u>SOURCE</u>
13. Soil test equipment	Supply Catalog
14. Weed seed samples	Vocational Agriculture Service
15. Weed mounts	Supply Catalog
16. Insect specimens and slides	Supply Catalog
17. Grain sieves	Supply Catalog
18. Moisture tester	Supply Catalog

### Supplies

Following are samples of supplies that are expendable but essential:

<u>ITEM</u>	<u>SOURCE</u>
1. Breed pictures	Breed Associations
2. Judging pictures	Breed Associations
3. Livestock judging rings	Local Community
4. Grain judging rings	Local Community
5. Feed samples	Local Community
6. Feed tag samples	Local Community
7. Feed additive bag tags	Local Community
8. Plant specimens	Local Community
9. Planting flats for germination	Supply Catalog
10. Fertilizer samples	Local Community
11. Sample herbicide containers	Local Community
12. Record book samples	Local Community
13. Profit and loss statement	Vocational Agriculture Service
14. Financial statements	Vocational Agriculture Service
15. Cash flow forms	Vocational Agriculture Service
16. Budget forms	Vocational Agriculture Service
17. Examples of farm leases	Local Community
18. Examples of bank notes	Local Community

In addition to the items listed, the Agriculture Occupations instructor should identify several centers throughout the school district so that community resources can be utilized. Examples include:

1. Sites for field trips
2. Class speakers
3. Judging animal rings
4. Machinery adjustment

## AUDIO VISUAL SOURCES AND MATERIALS

Source: Vocational Agriculture Service, 434 Mumford Hall,  
University of Illinois, Urbana, Illinois 61801.

### I. Agricultural Production

#### A. Animal Science Cluster

##### Slidefilms

- 1 av. Selecting Beef Breeding Animals V.A.S. 100A
- 2 av. Breeds of Beef Cattle V.A.S. 102
- 3 av. Breeds of Swine V.A.S. 164A
- 4 av. U.S.D.A. Swine and Pork Carcass Grades V.A.S. 168
- 5 av. Appraising Market Hogs for Carcass Merit V.A.S. 169
- 6 av. Digestion in Swine V.A.S. 170
- 7 av. Preventing Transportation Losses of Livestock V.A.S. 186A
- 8 av. Cattle Handling Facilities V.A.S. 187

##### Slide Set

- 9 av. Aberdeen-Angus Judging Classes V.A.S. S103

#### B. Crop Science Cluster

##### Slidefilms

- 10 av. Planting Corn V.A.S. 731A
- 11 av. Diseases of Soybeans V.A.S. 747A
- 12 av. Corn Diseases in Illinois V.A.S. 732
- 13 av. Determining Market Grades of Corn V.A.S. 733
- 14 av. Diseases of Wheat V.A.S. 773
- 15 av. Recognizing Herbicide Injury V.A.S. 798
- 16 av. Identification of Weed Seedlings, Broadleaves V.A.S. 800-801
- 17 av. Identification of Weed Seedlings, Grasses V.A.S. 803
- 18 av. The Wicked World of Weeds V.A.S. 811
- 19 av. Collecting and Preparing Soil Samples for Testing V.A.S. 703-64
- 20 av. Using the pH Meter in Testing Soils for Acidity V.A.S. 704-63
- 21 av. Producing Hybrid Seed Corn V.A.S. 730A
- 22 av. Using Pre-emergence Herbicides V.A.S. 797

##### Slide Sets

- 23 av. Diseases of Alfalfa V.A.S. S749
- 24 av. Diseases of Clovers V.A.S. S750

## C. Farm Mechanics Cluster

## Slidefilms

- 25 av. Calibrating Field Sprayers V.A.S. 442
- 26 av. Calibrating a Granular Applicator V.A.S. 443

## D. Farm Business Management Cluster

## Slidefilms

- 27 av. The Illinois Crop-Share Cash Farm Lease V.A.S. 340-65
- 28 av. Starting to Keep Records V.A.S. 350A
- 29 av. Keeping Records Up-To-Date V.A.S. 351A
- 30 av. Summarizing and Analyzing Records V.A.S. 352A
- 31 av. Increasing Earnings Through Farm Records V.A.S. 353
- 32 av. Plan the Livestock System and Estimate Fertility  
Costs V.A.S. 372
- 33 av. Insurance in the Farm Business V.A.S. 380A

## TEACHERS' COMPETENCIES AND TRAINING AVAILABLE

Several opportunities exist for instructors in Agricultural Production to upgrade themselves to keep up with the dynamic field in which they work. Following is a partial listing of ways to increase teacher competencies:

1. Attend inservice workshops held during the annual Agricultural Occupations Teacher Conference in June.
2. Request area community college, four-year institutions, Division of Vocational and Technical Education, Illinois Vocational Association, Vocational Agriculture Service, and industry to conduct workshops in your special interest area.
3. Attend state-wide meetings such as:
  - a. Custom Spray Operator school
  - b. Feed and Grain Dealer's conference
  - c. Swine Day at university
  - d. Beef Day at university
  - e. Agronomy Day at university.
4. Attend area meetings conducted by Extension Service.
5. Enroll in course work at university either on campus or extramural.