

DOCUMENT RESUME

ED 115 509

SE 019 983

AUTHOR Booker, Edward; And Others
TITLE Chemistry - Part III, An Introduction to Organic Chemistry: Teacher's Curriculum Guide for the Thirteen-College Curriculum Program.
INSTITUTION Institute for Services to Education, Inc., Washington, D.C.
SPONS AGENCY National Inst. of Education (DHEW), Washington, D.C.
BUREAU NO BR-7-0867
PUB DATE 71
CONTRACT OEC-0-8-070867-0001
NOTE 86p.; Appendix material from ED 084 936; For related documents, see SE 019 980-982

EDRS PRICE MF-\$0.76 HC-\$4.43 Plus Postage
DESCRIPTORS *Chemistry; *College Science; Curriculum; Curriculum Development; *Disadvantaged Youth; Higher Education; Instructional Materials; Negro Colleges; *Organic Chemistry; Physical Sciences; Science Education; *Teaching Guides
IDENTIFIERS Thirteen College Curriculum Program

ABSTRACT

This booklet is a teacher's manual in a series of booklets that make up the core of a Physical Science course designed for the freshman year of college and used by teachers in the Thirteen College Curriculum Program. This program is a curriculum revision project in support of 13 predominantly Negro colleges and reflects educational research in the area of disadvantaged youth. This unit covers the fundamentals of organic chemistry, beginning with a discussion of ionic and covalent bonding. Exercises using molecular models are used to illustrate the geometry of basic organic molecules and the structural similarities of organic compounds in the same chemical classes. The kinds of bonds in a given molecule are related to chemical properties and chemical activity. A card game which reveals some important rules of organic chemistry is utilized. Experiments are also provided for some of the major concepts.
(MLH)

* Documents acquired by ERIC include many informal unpublished *
* materials not available from other sources. ERIC makes every effort *
* to obtain the best copy available. Nevertheless, items of marginal *
* reproducibility are often encountered and this affects the quality *
* of the microfiche and hardcopy reproductions ERIC makes available *
* via the ERIC Document Reproduction Service (EDRS). EDRS is not *
* responsible for the quality of the original document. Reproductions *
* supplied by EDRS are the best that can be made from the original. *

ATING IT. POINTS OF VIEW OR OPINIONS
STATED DO NOT NECESSARILY REPRESENT
OFFICIAL NATIONAL INSTITUTE OF
EDUCATION POSITION OR POLICY.

FD115509

"PERMISSION TO REPRODUCE THIS COPY-
RIGHTED MATERIAL HAS BEEN GRANTED BY
ISE"

TO ERIC AND ORGANIZATIONS OPERATING
UNDER AGREEMENTS WITH THE NATIONAL IN-
STITUTE OF EDUCATION, FURTHER REPRO-
DUCTION OUTSIDE THE ERIC SYSTEM RE-
QUIRES PERMISSION OF THE COPYRIGHT
OWNER."

010 983



CHEMISTRY - PART III
An Introduction to Organic Chemistry

TEACHER'S CURRICULUM GUIDE
for the
Thirteen-College Curriculum Program

contributors

Edward Booker, D.Ed.
Assistant Professor of Chemistry
Texas Southern University
Houston, Texas

Vallie Guthrie, M.S.
Instructor of Physical Science
North Carolina A.&T. State University
Greensboro, North Carolina

Leroy Colquitt, Ph.D.
Senior Program Associate
Physical Science
Institute for Services To Education
Washington, D. C.

Dorothy Harris, M.S.
Director of TCCP
Bennett College
Greensboro, North Carolina

Melvin Gadson, M.S.
Instructor of Chemistry
Florida A.&M. University
Tallahassee, Florida

Dennis Holloway, M.S.
Instructor of Chemistry
& Physical Science
Jackson State College
Jackson, Mississippi

editors

Leroy Colquitt, Ph.D.
Senior Program Associate
Physical Science
Institute for Services to Education
Washington, D. C.

Ralph W. Turner, Ph.D.
Director, Basic Studies
Professor of Chemistry
Florida A.&M. University
Tallahassee, Florida

Copyright © 1971 by the Institute for Services to Education, 2001 S Street, N. W., Washington, D. C. 20009. No part of this material may be reproduced in any form whatsoever without the express written consent of the Curriculum Resources Group.

ABOUT THE INSTITUTE FOR SERVICES TO EDUCATION

The Institute for Services to Education was incorporated as a non-profit organization in 1965 and received a basic grant from the Carnegie Corporation of New York. The organization is founded on the principle that education today requires a fresh examination of what is worth teaching and how to teach it. ISE undertakes a variety of educational tasks, working cooperatively with other educational institutions, under grants from government agencies and private foundations. ISE is a catalyst for change. It does not just produce educational materials or techniques that are innovative; it develops, in cooperations with teachers and administrators, procedures for effective installation of successful materials and techniques in the colleges.

ISE is headed by Dr. Elias Blake, Jr., a former teacher and is staffed by college teachers with experience in working with disadvantaged youth and Black youth in educational settings both in predominantly Black and predominantly white colleges and schools.

ISE's Board of Directors consists of persons in the higher education system with histories of involvement in curriculum change. The Board members are:

Vernon Alden	Chairman of the Board, The Boston Company, Boston, Massachusetts
Herman Branson	President, Lincoln University
Kingman Brewster, Jr.	President, Yale University
Donald Brown	The Center for Research on Learning and Teaching, University of Michigan
Arthur P. Davis	Graduate Professor in English, Howard University
Carl J. Dolce	Dean, School of Education, North Carolina State University
Alexander Heard	Chancellor, Vanderbilt University
Vivian Henderson	President, Clark College
Martin Jenkins	Director, Urban Affairs, ACE
Samuel Nabrit	Executive Director, Southern Fellowship Fund, Atlanta, Georgia
Arthur Singer	Vice President, Sloan Foundation, New York, New York
Otis Singletary	President, University of Kentucky
C. Vann Woodward	Professor of History, Yale University
Stephen Wright	Vice President of the Board, CEEB
Jerrold Zacharias	Professor of Physics, Massachusetts Institute of Technology

ABOUT THE THIRTEEN-COLLEGE CURRICULUM PROGRAM

From 1967 to the present, ISE has been working cooperatively with the Thirteen-College Consortium in developing the Thirteen-College Curriculum Program. The Thirteen-College Curriculum Program is an educational experiment that includes developing new curricular materials for the entire freshman year of college in the areas of English, mathematics, social science, physical science, and biology and two sophomore year courses, humanities and philosophy. The program is designed to reduce the attrition rate of entering freshmen through well thought-out, new curricular materials, new teaching styles, and new faculty arrangements for instruction. In addition, the program seeks to alter the educational pattern of the institutions involved by changing blocks of courses rather than by developing single courses. In this sense, the Thirteen-College Curriculum Program is viewed not only as a curriculum program with a consistent set of academic goals for the separate courses, but also as a vehicle to produce new and pertinent educational changes within the consortium institutions. At ISE, the program is directed by Dr. Frederick S. Humphries, Vice-President. The curricular developments for the specific courses and evaluation of the program are provided by the following persons:

<u>Course</u>	<u>ISE STAFF</u>
English	Miss Joan Murrell, Senior Program Associate Miss Carolyn Fitchett, Program Associate Mr. Sloan Williams, Program Associate Miss Tiveeda Williams, Research Assistant
Social Science	Miss Ernestine Brown, Secretary Dr. George King, Senior Program Associate Dr. William J. Massie Jr., Program Associate Miss Nancy Seymour, Research Assistant
Mathematics	Miss Gloria Lowe, Secretary Dr. Beauregard Stubblefield, Senior Program Associate Mr. Bernis Barnes, Program Associate Dr. Phillip McNeil, Program Associate Dr. Walter Talbot, Consultant
Physical Science	Mrs. Debrah Johnson, Secretary Dr. Leroy Colquitt, Senior Program Associate Dr. Roosevelt Calbert, Program Associate Dr. Ralph W. Turner, Consultant Mr. Arny Daniel, Consultant Miss LuCinda Johnson, Secretary Mrs. Cynthia Paige, Secretary

ABOUT THE THIRTEEN-COLLEGE CURRICULUM PROGRAM

<u>Course</u>	<u>ISE Staff</u>
Biology	Dr. Charles Goolsby, Senior Program Associate Mr. Dan Obasun, Program Associate Dr. Paul Brown, Consultant
Humanities	Mr. Clifford Johnson, Senior Program Associate Mr. Roger Dickerson, Program Associate Mr. Keopapetse Kgositsile, Program Associate Miss Marquerite Willett, Secretary
Philosophy	Dr. Conrad Snowden, Senior Program Associate Dr. Henry Olela, Program Associate Miss Valerie Simms, Program Associate Miss Judith Burke, Research Assistant Miss Faith Halper, Secretary
Evaluation	Dr. Thomas Parmeter, Senior Research Associate Dr. Joseph Turner, Senior Research Associate Mr. John Faxio, Research Assistant Mrs. Judith Rogers, Secretary

In addition, Miss Patricia Parrish serves as general editor of the curriculum materials as well as an Administrative Assistant to the Director. Mrs. Joan Cooke is Secretary to the Director.

The curriculum staff is assisted in the generation of new educational ideas and teaching strategies by teachers in the participating colleges and outside consultants. Each of the curriculum areas has its own advisory committee, with members drawn from distinguished scholars in the field but outside the program.

The number of colleges participating in the program has grown from the original thirteen of 1967 to nineteen in 1970. The original thirteen colleges are:

Alabama A and M University
Bennett College
Bishop College
Clark College
Florida A and M University
Jackson State College
Lincoln University

Huntsville, Alabama
Greensboro, North Carolina
Dallas, Texas
Atlanta, Georgia
Tallahassee, Florida
Jackson, Mississippi
Lincoln University, Pennsylvania

Norfolk State College
 North Carolina A and T State
 University
 Southern University
 Talladega College
 Tennessee State University
 Voorhees College

Norfolk, Virginia

Greensboro, North Carolina
 Baton Rouge, Louisiana
 Talladega, Alabama
 Nashville, Tennessee
 Denmark, South Carolina

A fourteenth college joined this consortium in 1968, although it is still called the Thirteen-College Consortium. The fourteenth member is

Mary Holmes Junior College

West Point, Mississippi

In 1971, five more colleges joined the effort although linking up as a separate consortium. The members of the Five-College Consortium are:

Elizabeth City State University
 Langston University
 Southern University at
 Shreveport
 Saint Augustine's College
 Texas Southern University

Elizabeth City, North Carolina
 Langston, Oklahoma

Shreveport, Louisiana
 Raleigh, North Carolina
 Houston, Texas

The Thirteen-College Curriculum Program has been supported by grants from:

The Office of Education, Title III, Division of College Support
 The Office of Education, Bureau of Research
 The National Science Foundation, Division of the Undergraduate
 Education
 The Ford Foundation
 The Carnegie Corporation
 The ESSO Foundation

Thirteen College Consortium
Physical Science Teachers

	1967-68	1968-69	1969-70	1970-71
Alabama A & M:	Army Daniels	Army Daniels	Army Daniels	Army Daniels
Bennett:	Perry Mack	Perry Mack	Dorothy Harris	Dorothy Harris
Bishop:	Burtis Robinson	Burtis Robinson	Burtis Robinson	Burtis Robinson
Clark:	Arthur Hannah	Arthur Hannah	Arthur Hannah	Arthur Hannah
Florida A & M:	Ralph Turner	Lewis Allen	Robert Flakes	Melvin Gadson
Jackson State:	Dennis Holloway	Dennis Holloway	Dennis Holloway	Dennis Holloway
Lincoln:	Sabinus Christensen	Sabinus Christensen	Julian McCreary	Julian McCreary
Mary Holmes:	-----	Thomas Wirth	Thomas Wirth	William Royal
Norfolk State:	Melvin Smith	Melvin Smith	Leon Ragland	Leon Ragland
North Carolina State:	Curtis Higgenbotham	Vallie Guthrie	Vallie Guthrie	Vallie Guthrie
Southern:	Thomas Wirth	Charles Osborne	Charles Osborne	-----
Talladega:	Harban Singh	Harban Singh	Aleyamma George	Aleyamma George
Tennessee State:	Berry Hempstead	Berry Hempstead	Wil Cumming	Wil Cumming
Voorhees:	Bernie Dingle	Bernie Dingle	Bernie Dingle	Donald Volz

Five College Consortium
Physical Science Teachers

1970-71

Elizabeth City State College

Kumar Chatterjie

Langston University

Jimmie White

Saint Augustine's College

Ramesh Mathur

Southern University
at Shreveport

Margaret Knighton

Texas Southern University

Edward Booker

Eight College Consortium
Physical Science Teachers

1971-72

Alcorn A. & M. College	Newtie Boyd
Bethune-Cookman College	Walter Floyd
Grambling College	Thomas Williams
Jarvis Christian College	Adell Mills
Lemoyne-Owen College	Charles Phillips
Southern University at New Orleans	Charles Scott
University of Maryland (Eastern Shore)	Leon Punsalan
Virginia Union University	James Pennessy

PREFACE

This booklet is one of a series of seven that make up up the core of a course in Physical Science designed and used by teachers in the twenty-seven colleges participating in the Thirteen-College Curriculum Program.

The course has several unique features. Especially important is its balanced emphasis on effective teaching methodology and basic concepts in the physical sciences. The two are closely woven into the fabric of the course. Consequently, in order that a teacher gain maximum use of these materials which were designed especially for the TCCP course it is essential that he understands the purposes it was designed to serve and the style and techniques chosen to accomplish them.

Course Objectives

The basic goal of the course is to make clear the nature of science as an enterprise and illustrate by numerous examples how science really proceeds. Exercises are chosen according to their potential to bring students into working contact with the essential aspects of the scientific experience. In these experiences the students develop concrete ideas about the operational meaning of, and the association between observation, experiment, measurement, hypothesis, theory, the nature of evidence, test, modification, formulating questions, accuracy of language, the role and value of schematic language in general and mathematics as an appropriate language in particular, the role of the observer, prediction, and the residual mystery of unanswered questions.

Secondly we strive to develop an appreciation for the features of science that distinguishes it from the other major disciplines, namely, the ability to establish a clear and testible criterion for the value of concepts and the role of experimentation as the sole criterion for the scientific truth. "Facts" and theories are never presented without a description; at least, of the experiments which support them.

By the use of a judicious choice of problems in the course we seek to divulge the peculiar nature of physical science that distinguishes it from other sciences. The course stresses the use of mathematics as a major analytical tool and the use of numerical patterns to describe physical phenomena.

Finally we are concerned with developing an appreciation for the value of "rigor" as a quality measure of a scientific study. A natural part of this is an exposure to the development of the analytical tools and skills to deal with scientific problems.

Pedagogical Priorities

High on our list of priorities in the course is the requirement that a substantial amount of learning take place in the classroom. Attention is given to creating learning situations where students collect information firsthand, consider its implications, and draw conclusions all within the same class period. The classrooms learning experiences are constructed so that they closely approximate real life situations where one has to search for clues and insights from a variety of sources, from

reference materials, the teacher, as well as other students.

The student must acquire the habit of weighing carefully the value of the information obtained from each.

Because of the variety of learning styles among the students, a mechanism is established for generating a variety of models of information integration. By encouraging students to actively participate in classroom exercises and develop ideas from the evidence that is presented for class inspection, the students themselves provide a range of models of learners. Students are encouraged to seek information from one another and teach themselves while the teacher supervises. This setting generates a number of dramatic experiences in a process of vital intellectual interaction.

The role of the teacher in the classrooms described above differs from that in a more traditional lecture oriented classroom where he is the central figure in the classroom and the prime source of information. In the settings described above the teacher becomes a coordinator. It is his responsibility to assist the students in seeking information and judging the value of what they find. He asks students the questions he would ask himself when he is in search of answers to crucial questions, displays the criteria he uses to reach conclusions, and thus allows the students themselves to make the crucial steps in the learning process. In order to be effective in this role, a teacher must accept as legitimate a wider base of student experiences, priorities, intellectual styles, and range of abilities.

It has been our experience that if these things are given proper

attention, students develop an attitude about learning, where the learner is active, aggressive, and effective.

The Scope and Structure of the Course

The course is based upon five topics:

1. The Nature of Physical Science
2. Light
3. Inorganic and Organic Chemistry
4. Conservation principles
5. Gas Laws and Kinetic Theory

Each unit is self-contained, starting with a fundamental concept and developing in a spiral fashion through a hierarchy of levels. Each level contains the development of at least one fundamental idea from empirical data obtained in the laboratory, the demonstration of the utility of the concept, and a natural termination point that permits a study to end at a variety of levels always with a sense of completion. By virtue of their self-containment, a given unit may be interchanged in a course sequence with almost any other; consequently, a teacher may construct his course around the sequence of units that best suits his own interests and the background of his students.

FORMAT OF THE UNIT

This booklet has been designed to serve as a guide to assist the teacher in creating a successful classroom in a laboratory oriented course. As such it contains a number of hints, suggestions, and procedural instructions. When questions are presented in the text as a part of the development of a concept, answers are also given. These special features of the unit are unique to the teacher's version and do not appear in the companion student workbook.

There is a basic uniformity to the structure of each chapter. Each chapter is built around experimental activities that are designed to develop one or more fundamental physical concepts. The structure of the chapters are usually divided into four parts. First, to set the stage, we suggest a discussion session with the class to examine their initial ideas and attitudes about the problem to be studied and to establish a base of reference with which to compare the ideas that are developed in the course of the investigation. Secondly, we move to establish the rationale for beginning a particular experiment - or set of experiments - and design the experiment. Thirdly, experiments are carried out, data gathered, and the search for physical patterns begins. Once these patterns are identified and a useful description is constructed we move to an examination of its applications and implications.

INTRODUCTION TO ORGANIC CHEMISTRY

17

xiii / xiv

CONTENTS

	<u>Page</u>
Chapter I. GENERAL INTRODUCTION	1
Chapter II. THE CHEMICAL BOND	
A. The Structure of the Atom	4
B. The Ionic Bond	4
C. The Covalent Bond	5
1. Brief Summary	5
2. Detailed Study	5
3. The Notion of Shared Electrons	13
4. Covalent Bonding in a Nutshell	15
Chapter III. THE PATTERNS OF ORGANIC CHEMISTRY	
A. Introduction.....	16
B. A Study With Molecular Models	17
C. Extracting Patterns From Experimental Data	20
1. Chemical Classes	21
2. Patterns Within a Chemical Class	22
3. Regularities Among Chemical Formulas of Compounds Within a Class	22
4. Molecular Structural Similarities of Compounds Within Chemical Classes	24
D. A Short Summary of Information on the Hydrocarbon Classes	26
E. Problems	29
F. "Organic Rummy" a Chemistry Card Game	32
Chapter IV. THE ROLE OF THE CHEMICAL BOND IN DETERMINING CHEMICAL PROPERTIES	
A. Introduction	38
B. Developing a New Rule	
1. Gathering Evidence	39

	<u>Page</u>
2. Stating the Rule	40
3. Applying the Rule	40
4. Interpreting the Rule	42
C. Chemical Activity	
1. The Concept.....	43
2. An Experimental Study	43
D. Isomers	50
E. Experimental Determination of a Molecular Structure	53
F. Problems	55
G. Organic Chemistry Data	57
APPENDIX	65

I. GENERAL INTRODUCTION

Most of the compounds considered in the unit "Chemistry Part I" are classified as inorganic compounds and their chemistry comprises a major division of the field of chemistry. Another major branch of chemistry involves the study of a class of compounds called organic compounds. These two classes of compounds are antithetical, for every known compound falls into either one or the other class. Consequently, a well rounded study of the principles of chemistry is not complete without a consideration of both.

A precise and unerring definition that distinguishes them has been hard to come by; chemists pursued the matter for centuries. The first attempts to construct a classification scheme that distinguishes between them was based on a study of living tissue. All living tissue contains substances whose chemistry differs from that of non-living matter. The substances found in living matter were called organic and those in non-living matter, inorganic. The implications of this rule were extended and it was postulated that all organic compounds are the products of living organisms. The rule was a good rule of thumb; but the generalization was too broad; it was disproven in 1828. Wöhler produced urea, an organic compound, in the laboratory by evaporating an aqueous solution of an inorganic salt called ammonium acetate. Since then millions of other compounds have been produced from non-living matter and identified as organic compounds.

Although organic compounds are not solely the product of life, they are vital to life on this planet. Without organic compounds, the earth would be somewhat like the barren surface of the moon. All life would disappear. We would lose the essentials for sustaining life: our food, our medicine, and our clothes. In the table below are listed some of the more familiar organic substances. Of the substances listed, some - such as benzene, phenol, wood alcohol, and acetic acid are pure compounds, while others - such as fats, proteins, coal tar, and petroleum - are complex mixtures.

TABLE I

SOURCE	ORGANIC COMPOUND OR MIXTURE
Animals	fat, proteins
Plants	starch, cellulose
Coal (destructive distillation)	coal tar, benzene, phenol, naphthalene
Wood (destructive distillation)	wood alcohol, acetone, acetic acid
Petroleum (fractional distillation)	cleaner's naphtha, gasoline, kerosene, mineral oil, vaseline
Fermentation processes	ethyl alcohol, acetone, butyl alcohol

Steps leading to a more exact understanding of these compounds were made as a result of the advanced techniques and insights of modern chemistry. One of these steps was the recognition that the element carbon is a prime ingredient of organic compounds. But this is not the distinguishing characteristic, for some inorganic compounds also contain carbon. Organic compounds are classified as a special group for the most fundamental reason possible, namely, because their patterns of chemical combination (i.e. their laws of macroscopic chemistry) are different from those of inorganic compounds. The scheme used to describe the laws of chemical combination for inorganic compounds simply does not apply to organic compounds.

As we recall, the law describing the combination patterns of elements as they form organic compounds is based on the fact that a numerical value can be assigned to each element to represent its 'combination tendency' with other elements. A simple accounting procedure can be set up that enables us to use the numbers to predict which elements will combine to form compounds. It is important that each element behaves so consistently that we can use a single valence (sometimes two, but rarely more) for an element. As a consequence, any two elements combine with one another to form only one or two distinct compounds.

For organic compounds this is not so. Hydrogen alone combines with carbon to form such an innumerable variety of organic compounds that these compounds comprise a special class worthy of its own study. They form an indeterminate number of compounds. In each one the relative valence of the two elements is different. There is no more dramatic way that these compounds may announce the inadequacy of a valence scheme to describe their behavior.

II. THE CHEMICAL BOND

A. THE STRUCTURE OF THE ATOM

What is the key to a scheme that describes the chemistry of organic compounds? How do we find it? In order to gain some insight, we study the details of the mechanism for the chemical bond, for it determines the patterns with which atoms combine.

We begin with a brief study of the structure of the atom and the details of the bond for inorganic compounds.

Basic Features of the Atom

1. Atoms are made up of a nucleus containing positively charged particles called protons surrounded with an equal number of negatively charged particles called electrons. Because the atom contains an equal number of positive and negative charges, it is said to have a "net or neutral" charge.
2. Electrons are bonded to the nucleus of the atom by electrical forces.
3. The electrons are in constant motion about the nucleus.
4. The principles of quantum mechanics require the motion of two electrons to become correlated when they are brought sufficiently near each other.

B. THE IONIC BOND

The ionic bond is responsible for the patterns displayed by the inorganic compounds. It is the simplest type of chemical bond and the easiest to understand. This bond is accomplished by an exchange of electrons between two atoms. Each atom is composed of equal amounts of negative and positive charge. If an electron is transferred from one atom to the other, a charge imbalance is created between the originally neutrally charged atoms. The atom receiving the electron has an excess negative charge and the atom losing the electron has an excess positive charge and the electrical force is

created that binds the atoms together.

In a word "Electron Transfer" is the key to ionic bonding.

C. THE COVALENT BOND

1. Brief Summary

The covalent bond which holds organic compounds together is a little more complicated. The electrical forces between the electrons of one atom and the nucleus of an adjacent atom also play an important role in the covalent bond. However, the electrons that create a covalent bond between atoms are not permanently transferred from one atom to another but are equally 'shared' between the atoms. Moreover, while the ionic bond depends solely on the effects of electrical forces, the covalent bond incorporates an additional and very unusual mechanism. This mechanism has no counterpart in the world of everyday things because it is a quantum effect and thus, restricted to behavior of matter on an atomic scale. The effects of this unusual phenomenon, nonetheless, can be given an interpretation in terms of everyday phenomena that makes it a little less mysterious.

All of the complicated details of the process aside, "electron sharing" is the key to the covalent bond.

2. Detailed Study

The first question we must answer is "How may atoms, which have a net neutral charge, attract one another?". As we have seen above, the covalent bond is accomplished without a permanent transfer of charges which leaves atoms (or ions as they are called when they lose or gain electrons) charged. One would think that two atoms that have a net

neutral charge could not attract one another because the electrical forces acting on the negative and positive charge of an atom would cancel. We find, however, this is not so. Close inspection shows the strength of the electrical forces depend on the separation between the charged particles. If the charged particles of an atom are appropriately arranged a force results which may be either attractive or repulsive, depending on the spatial arrangement of the charges. As an illustration of how this occurs, consider figure 1 in which we represent two atoms each, composed of a single electron and a singly charged positive nucleus. To analyze the electrical forces between these two atoms we employ Coulomb's law of electrostatics which states that the magnitude of the force of attraction (or repulsion) between two charges is proportional to the product of the magnitude of the charges and inversely proportional to the square of the distance between the charges. Attraction occurs between two bodies of unlike charges and repulsion occurs between two bodies of like charge. Mathematically the law is represented by the equation

$$F \propto \frac{q_1 q_2}{r^2}$$

where F is the magnitude force of attraction (or repulsion), q_1 is the magnitude of total electrical charge on one body, q_2 is the magnitude of the total electrical charge on the other, and r is the distance between the charged bodies.

Figure 1 - Forces Between Two Adjacent, Neutral Atoms

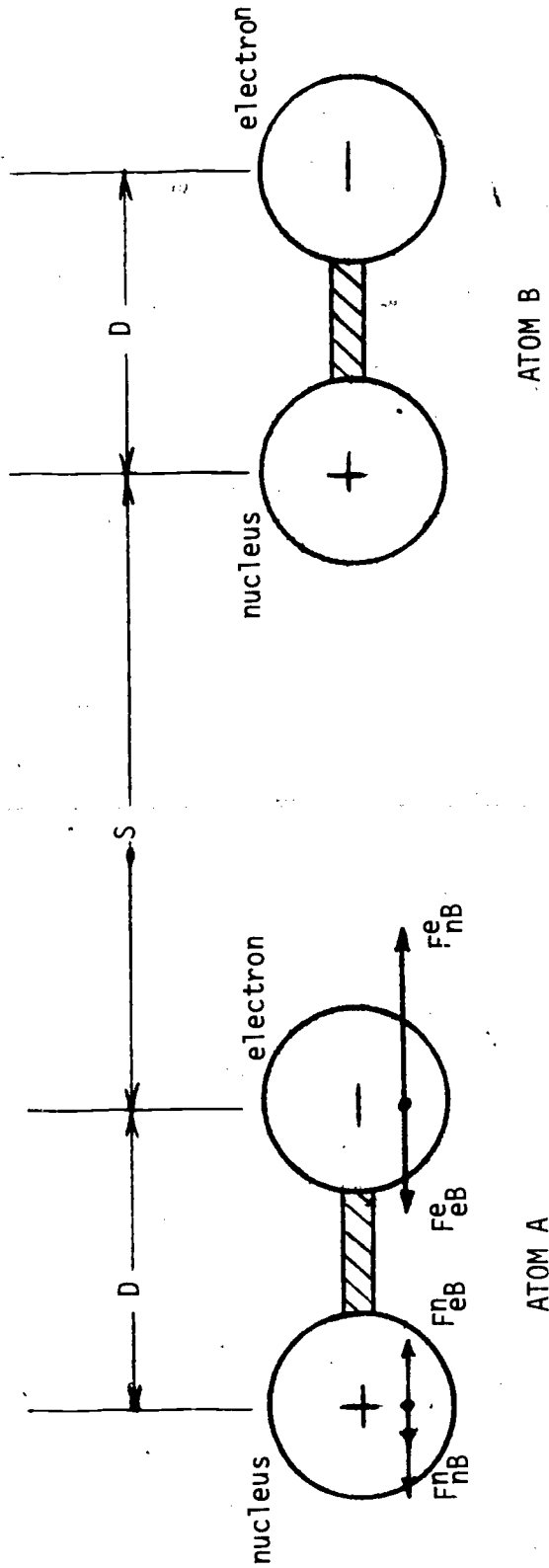

F_{nB}^e represents the force of nucleus B on electron A
 F_{eB}^e represents the force of electron B on electron A
 F_{nB}^n represents the force of nucleus B on nucleus A
 F_{eB}^n represents the force of electron B on nucleus A

In figure 1 we have diagrammed the forces acting on each charged particle within the atoms due to the charged particles within the adjacent atom. [There is a force of attraction between the two oppositely charged particles of an atom but that is so strong that it binds them together. We represent its effects by drawing a double line between the electron and its nucleus to indicate that they remain together because of this internal force.] The length and direction of the arrows above represent the magnitude and direction of the electrical force on the electron and nucleus of atom A caused by the individual charges within atom B. The symbols used to designate these forces describe the source of the forces. For example, the symbol F_{eB}^e represents the force on the electron of atom A by the electron on atom B.

Because the magnitude of the charges on the electrons and nuclei of the atoms represented above are the same (only the sign of the charges differ), we may ignore them as a constant factor in comparing the magnitudes of the forces described above. We need consider only the effects of the different separations between the charges.

Because the nucleus of atom B is closer to the electron of atom A than is the electron of atom B, the force of attraction by the nucleus on electron B is larger than the force of repulsion of the electron of atom B on the electron on atom A.

Mathematically we may express this by the inequality

$$F_{nB}^e > F_{eB}^e$$

The total force acting on the electron is $F_{nB}^e - F_{eB}^e$.

In a similar fashion we may conclude that the force of repulsion on the nucleus of atom B is larger than the force of attraction on nucleus A by the electron on atom B, or mathematically,

$$F_{nB}^n > F_{eB}^n$$

the total force acting on the nucleus is $F_{nB}^n - F_{eB}^n$.

Because of the direction in which the forces act, the electron on atom A is attracted to atom B, while the nucleus of atom A is repelled away from atom B.

In order to decide whether the total force acting on atom A is attractive or repulsive we must compare the magnitude of the forces $F_{nB}^e - F_{eB}^e$

and $F_{nB}^n - F_{eB}^n$.

To do this, we must consult the formula

which gives the precise magnitude of these forces, namely the mathematical expression for Coulombs Law.

The easiest way to compare the differences between these forces is to draw a graph which represents the magnitude of the force between two charged objects as a function of the distance between them as shown in figure 2 .

As is indicated in figure 2, the length of the vertical arrows

represent the electrical forces F_{nB}^e, F_{eB}^e , etc. The magnitude of

the force , $(F_{nB}^e - F_{eB}^e)$ is represented by the difference in the length

of the first two adjacent vertical lines and the magnitude of the force

$$F_{nB}^n - F_{eB}^n$$

is represented by the difference in length of the se-

cond and third vertical lines.

Figure 2
Graphical Representation of Coulombs Law
the Force Between Two Charged Particles

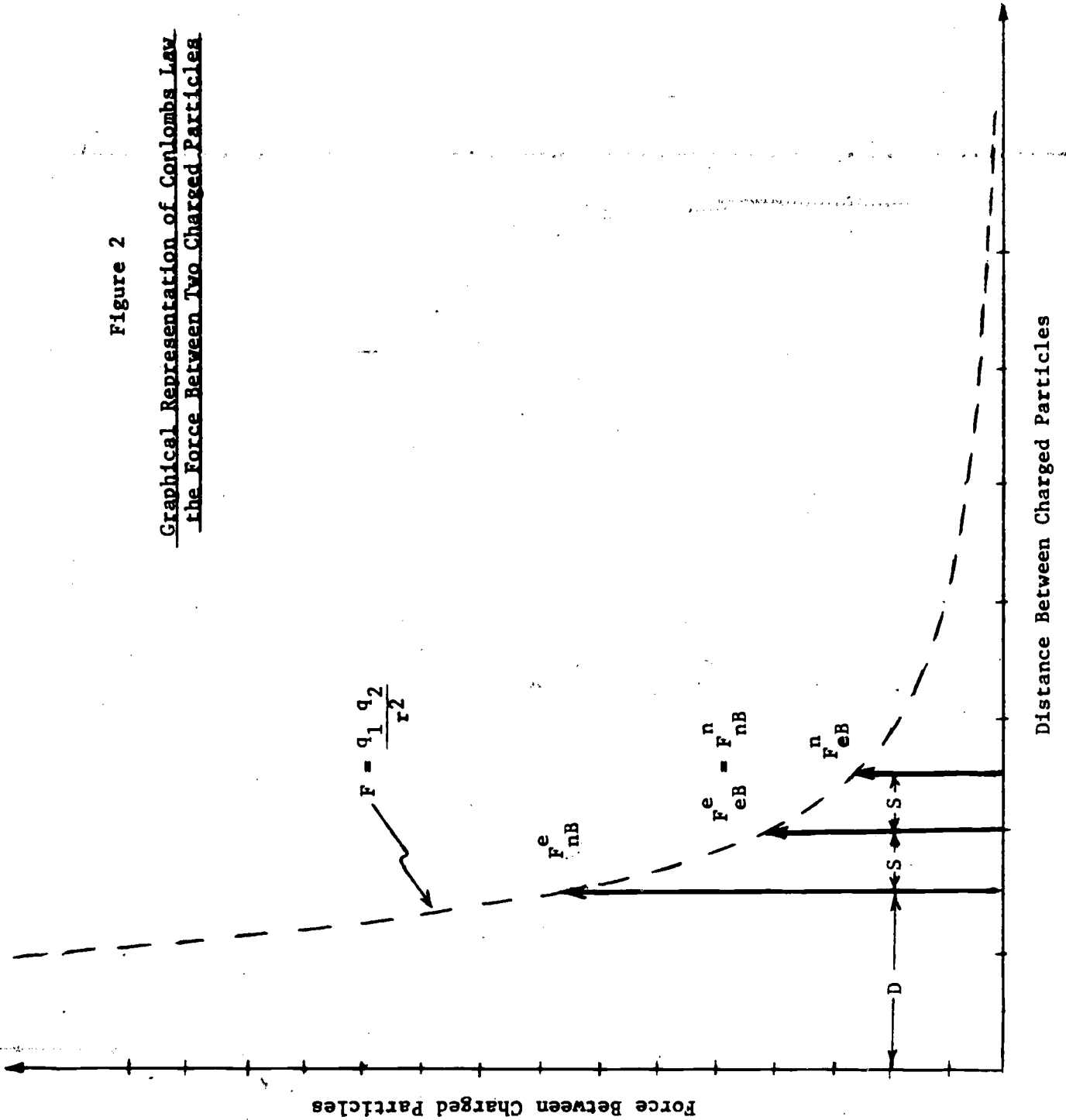

Because the vertical lines representing the forces are equally spaced, we can easily see that $F_{nB}^e - F_{eB}^e > F_{nB}^n - F_{eB}^n$. Use of the geometrical principle tells us that because the vertical lines are equally spaced, the difference between their lengths would be equal if the tops of the lines could be connected by a straight line. But since the line connecting the tops bend upward we may conclude that $F_{nB}^e - F_{eB}^e > F_{nB}^n - F_{eB}^n$. Thus we see that the force of attraction on the electron is greater than the force of repulsion on the nucleus. Hence, the net force on atom A by the charges on atom B namely

$$\left(F_{nB}^e - F_{eB}^e \right) - \left(F_{nB}^n - F_{eB}^n \right)$$

is attractive.

Analysis similar to that used above may be employed to determine the total forces acting between neutrally charged systems with various orientations. In figure 3 we illustrate various relative positions that charged systems may take with respect to one another and show the direction of the resulting forces.

It is clear from the results of the preceding problem, how two objects with an equal balance of electrical charge may have attractive electrical forces between them if their electrical charges are appropriately arranged. Moreover we see that the force can be repulsive as well as attractive. It would be reasonable to guess that atoms covalently bound assume an arrangement similar to one of those above. Unfortunately the nature of the covalent bond is not so simple; there is an additional complication. In the situation represented above the charged particles must remain fixed in the positions shown if there is to be a net electrical force between them. However,

Figure 3 - Electrical Forces Between Adjacent Atoms as a Function of The Electrons' Position

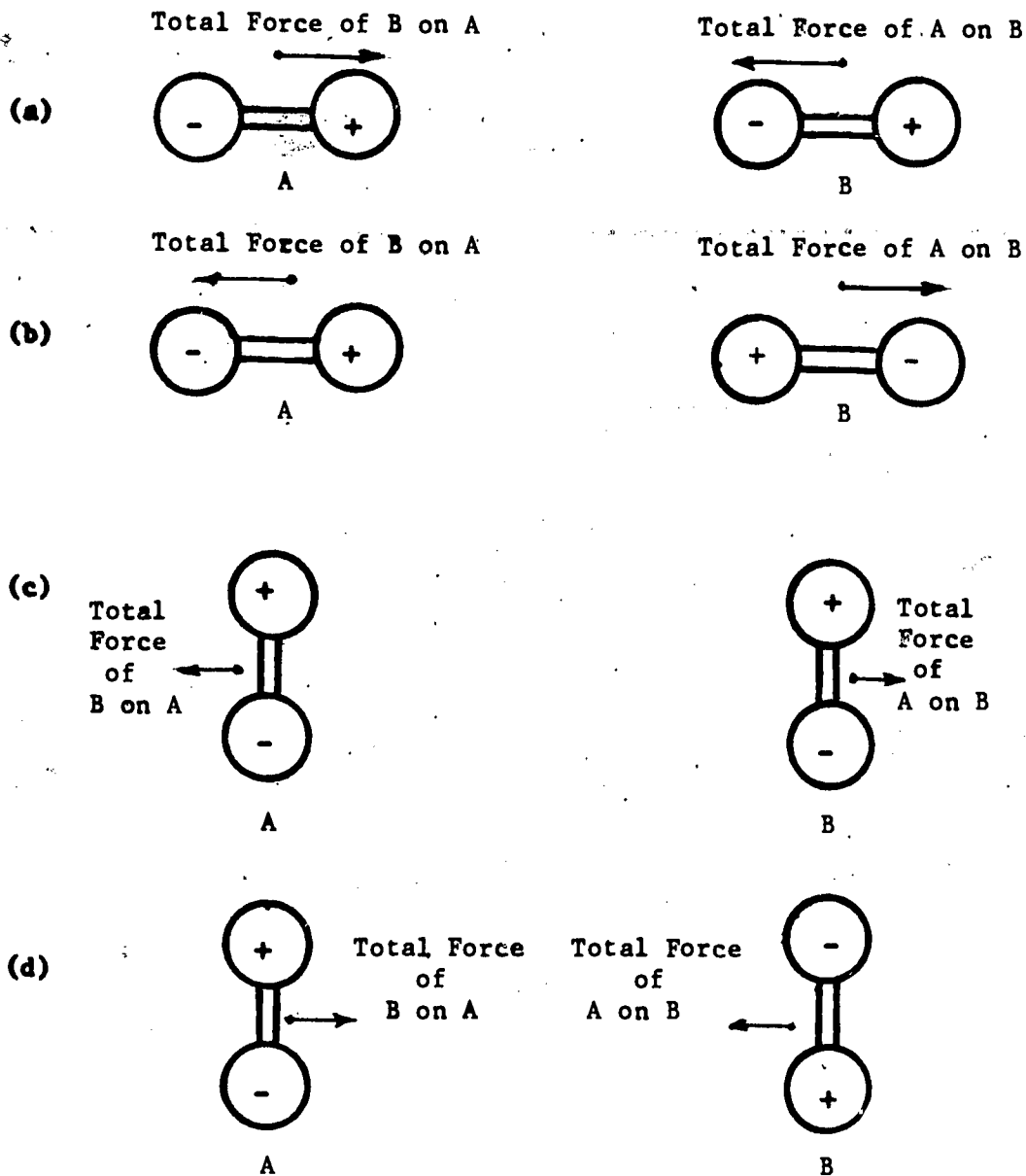

In (a) and (d) of figure 3 the total electrical forces are attractive, while forces between the system in (b) and (c) are repulsive. Whether the two atoms attract or repel them is a matter of the charge arrangement.

the negatively charged particles of an atom, the electrons, do not remain fixed but move in orbits around the positively charged nucleus. In order that there will always be a net attractive force between the two atoms, the electrons of both atoms must adjust themselves as they move around their nucleus so that they always maintain an arrangement that results in a net attractive force. To see how this is possible, consider figure 4 which represents the orientation of the electrons of two adjacent atoms at four different times as the electrons travel around their own nucleus.

An analysis of the electron forces on the components of each atom shows that in each of the arrangements shown in figure 4, there is a net force of attraction between the two atoms. Hence, in order for the systems to be correctly arranged at all times so that there is an attractive force between them in spite of the motion of their electrons, the motion of the electrons must be synchronized.

3. The Notion of Shared Electrons

The correlated motion of the electrons about their nuclei is the basic ingredient in the phenomenon of covalent bonding. However, to complete our model, we must consider an additional factor, one which leads to the notion that electrons are shared between two atoms that are covalently bound.

Because of the net attractive forces of the adjacent atom on an electron when it is between the two nuclei, it moves closer to the neighboring nucleus. But because of the effects of its motion about its own nucleus it soon swings back to the opposite side of its own nucleus. Similarly the electron of the other atom swings closer to the nucleus of the adjoining atom when it is between the two nuclei. As a result, the orbits of the electron become more egg shaped than circular. They spend as much time near one nucleus

Figure 4 - Successive Stages of the Position of the Electrons Around Two Adjacent Atoms Bound By Attractive Electrical Forces

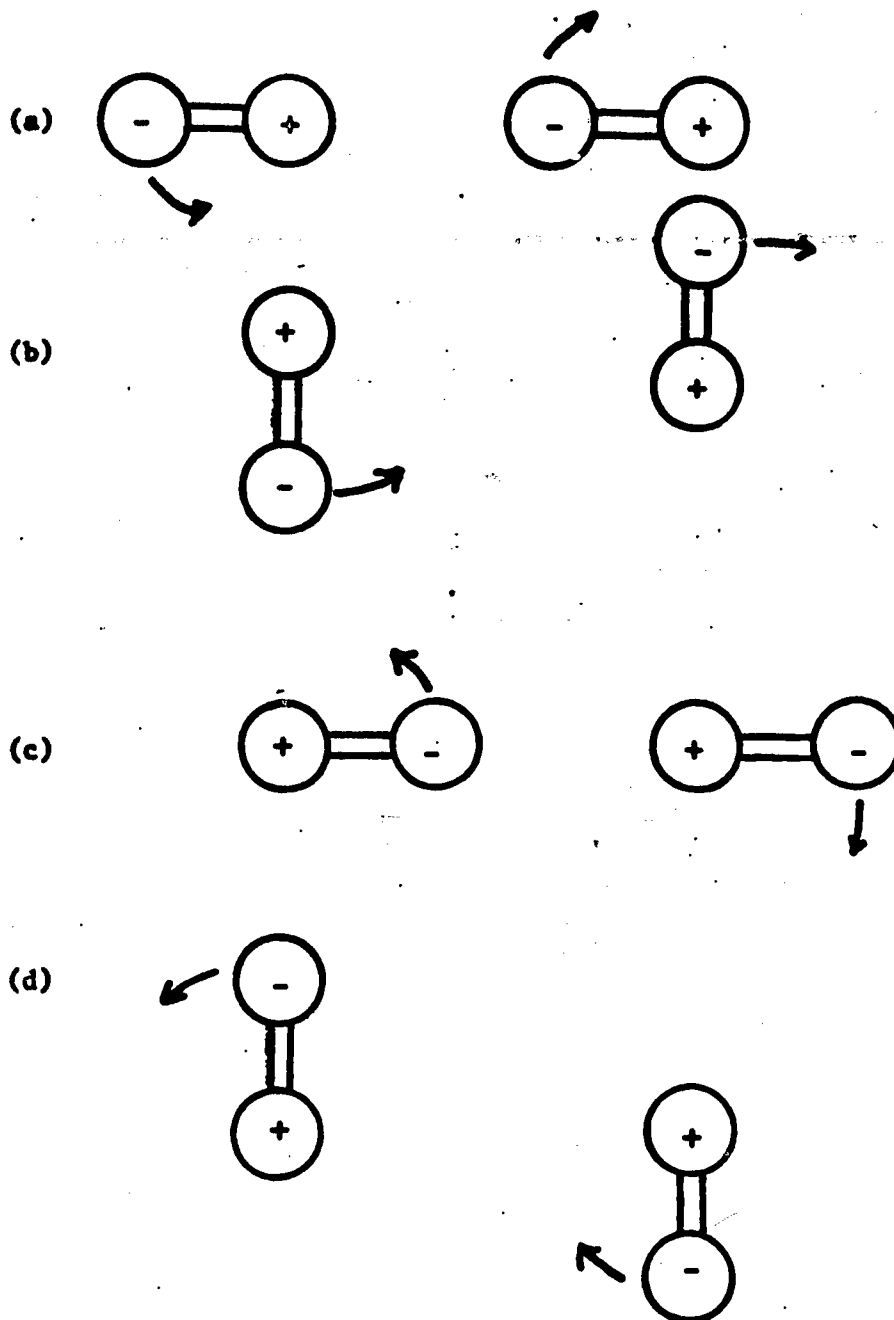

The four figures above represent successive stages of the motion of the electrons around their nuclei. At each stage the total electrical force between them is attractive.

as near the other and it becomes convenient to describe them as being "shared" between the two atoms.

4. Covalent Bonding in a Nutshell

A simplified picture of covalent bonding would be that the electron arrangement between two atoms switches back and forth between the arrangements shown below

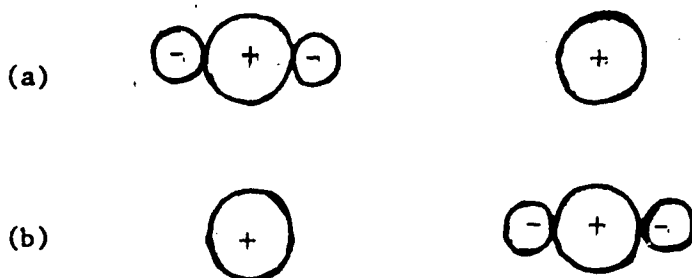

Each of the arrangements above resembles an ionic bonding arrangement. But the fact that the electrons are in the next instance transferred to the other nucleus reverses the ownership of the electrons while still maintaining an arrangement of attraction. We may say that the bonding is due to a cooperative sharing of electrons.

III. THE PATTERNS OF ORGANIC CHEMISTRY

A. INTRODUCTION

One of the wonders of the law that describes the patterns of inorganic chemistry is its simplicity. Although the formation of a compound is the result of complicated interactions between atoms, only the simplest aspects of the physical phenomenon are reflected in the law. For example, as we have seen, the ionic bond is created as a result of forces between the electrically charged constituents of atoms. Although the details of the process are complicated the net effect is simple. Electrons are transferred from one atom to another creating a charged imbalance and, hence, an electrical force to bind the atoms together. The valences that we assign atoms to represent their combining tendency turns out to be simply a measure of the number of electrons lost or gained in the transfer process. The fact that the total valence of an ionic compound is zero is a reflection of the fact that the number of electrons lost by one atom equals the number of electrons gained by the other. Thus, the simplicity of the statement of the law is a reflection of the existence of a simple description for the physical mechanism responsible for the bonding process.

We may expect that the same is true for organic compounds. If there is a simple law that describes the patterns with which elements combine to form organic compounds, it must bear a direct relation to a simple, accurate description of the organic bond. The study in chapter II, showed that the covalent bond does have a simple interpretation, it is formed as the result of two atoms sharing electrons.

In this chapter we exploit this simple interpretation of the covalent bond to establish a law that describes the patterns of organic chemistry. To simplify our study we restrict ourselves to an investigation of the simplest class of organic compounds, the hydrocarbons, which are composed of only hydrogen and carbon. In the light of what we learned about the covalent bond we will assume that an organic molecule composed of hydrogen and carbon atoms is formed according to the following rules:

1. Instead of transferring its electrons, the carbon atom will share its four electrons with neighboring atoms. The four electrons are used because the carbon atom has a tendency to lose or gain four electrons in forming ionic compounds. We assume this number is significant for organic compounds as well.
2. Instead of transferring its electron, the hydrogen atom will share its one electron with neighboring carbon atoms. One electron is used because the hydrogen atom tends to lose one electron in forming ionic compounds.
3. We will maintain a faith in nature's preference for order and regularity and require that the models we construct have a structural symmetry.

B. A STUDY WITH MOLECULAR MODELS

We will search for the patterns of chemical combinations in organic compounds by using the rules cited above to generate mechanical models of organic molecules. It is not important that the model bear a close resemblance to the molecule it represents; for we will be concerned only with the broad features of the molecule such as the ratio of carbon and hydrogen atoms that it contains. The value of our rules depend on whether or not they can be used to predict the patterns with which atoms combine to form compounds.

EXPERIMENT I -A STUDY OF MOLECULAR MODELS OF THE HYDROCARBONS

EQUIPMENT: Five 3/4" diameter styrofoam balls.
 Twelve 1/2" diameter styrofoam balls,
 One box of tooth picks.
 One set of organic information cards.

PROCEDURE: Using the rules below, construct as many models of molecules
 as you can containing:

- (a) one carbon atom
- (b) two carbon atoms
- (c) three carbon atoms.

Rules for Constructing Models

- (i) Each carbon atom (represented by 3/4" balls) is connected to its neighbors by four bonds (tooth picks). It can have up to four neighbors in satisfying this rule.
- (ii) Each hydrogen atom (represented by 1/2" balls) is connected to its neighbors by one bond (tooth pick).
- (iii) The molecular model must contain at least one of each type of atom.
- (iv) The molecular model must have an overall symmetry.

When a model is constructed obeying these rules, draw a picture of the structure and record the chemical formula that represents it. In order to check whether your models represents (have the same number of hydrogen and carbon atoms as) a real compound, a reference source containing listings of the chemical formulas of the hydrocarbons should be consulted. In addition to the chemical formula of the hydrocarbons the reference should contain information about the compounds such as their names and some of their chemical properties. The ISE Organic Compound Information Cards are recommended for this purpose. These cards contain the following information for each hydrocarbon molecule with up to five carbon atoms:

- (i) The chemical formula
- (ii) The name of the compound, if it exists.

Some of the hydrogen-carbon combinations that satisfy the rules for a valid model do not represent existing compounds under

ordinary laboratory conditions such as:

$$\begin{array}{c} \text{H} & & & & \text{H} \\ & \diagdown & & & / \\ & \text{C} = \text{C} = \text{C} = \text{C} & & & \\ & / & & & \diagdown \\ \text{H} & & & & \text{H} \end{array}$$

These compounds and the fact that they do not exist should be recorded also.

- (iii) Important properties or uses.

Each time you discover a molecular model that represents a real hydrocarbon molecule, record all of the information about the compound contained on the information card.

Carry out your investigation in steps. Find all of the molecules with one carbon atom first. When these have been exhausted construct all of the models you can with two carbon atoms, etc.

C. EXTRACTING PATTERNS FROM EXPERIMENTAL DATA

Given the experimental data you collected in the above experiment, you are in a position to begin looking for patterns among them. We shall be searching for regularities in the molecular structure and chemical properties of these compounds that enable us to predict:

- a. the existence of other compounds.
- b. the way they behave in chemical reactions.

For this is the purpose of chemical laws.

To assist us, we have collected three types of information:

- a. information on their molecular structure
- b. some of their chemical reactions
- c. the nomenclature scheme chemists use to designate them

By and large the nomenclature scheme may be treated on the same basis as the data on their chemical properties. Chemists often devise systems to name compounds that reflect their chemical properties. Thus we may treat all of the data above as if it were empirical data obtained in the laboratory given to us by professional chemists who have performed experiments. For example, once discovering a new compound we could ask a chemist to do experiments and determine some of the chemical properties of the compound and give us the chemical equation describing his results. In this way we would obtain the chemical formulas given on the information cards. Similarly we could ask him to perform other experiments that would enable him to classify the compounds according to some scheme. After he does this he would likely name the compounds to reflect similarities in their chemical properties. Thus we would obtain the names of the compounds as we have them on the information cards. Our problem now is to relate this information to

the structural properties of these compounds and search for patterns among them.

1. Chemical classes

Assuming that chemists have given the compounds names with some scheme in mind, we begin a search for a pattern among these names. A comparison of the endings of the names of the compounds shows that all the compounds found in either -ane, -ene, or -yne.

PROBLEM 1: List all of the reaction equations for the hydrocarbons found so far. Substitute names for the chemical formulas in the reaction equation.

For example, the equation:

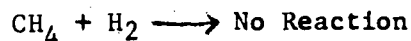

reads:

Methane + Hydrogen yields ~~no~~ reaction

Since we are searching for similarities among compounds with the same endings in their names, it may be helpful to rewrite the chemical reaction equations once more, this time omitting the prefixes. Search for a pattern among the results.

The results of the problem described above leads to the following general properties:

-ane + hydrogen \longrightarrow No Reaction

-ene + hydrogen \longrightarrow -ane

-yne + hydrogen \longrightarrow -ene

This confirms the fact that all compounds whose name end in -ane have similar chemical properties, similarly for compounds whose name end with -ene

and -yne. Hence we have shown there is some similarity in their behavior, and thus a reason for grouping compounds with the same name ending in the same class. These classes are called alkanes, alkenes, and alkynes, respectively.

2. Patterns within a chemical class

PROBLEM 2: List the compounds within the same class vertically in order of increasing number of carbon atoms and label them with their names. What patterns do you notice in the use of prefixes?

The result of this problem shows that the prefixes are either meth-, eth-, prop-, but-, or pent-. Careful examination of these show that:

- (i) those with only one carbon atom have the prefix, meth-
- (ii) those with two carbon atoms have the prefix eth-
- (iii) those with three carbon atoms have the prefix prop-, etc.

3. Regularities Among Chemical Formulas of Compounds Within a Class.

PROBLEMS 3: Assuming a valence of +1 for hydrogen, compute the valence for carbon in all of the compounds found. Assuming a valence of -4 for carbon, compute what the valence must be for hydrogen in all of the compounds found. Discuss the value of a valence as an aid in predicting the occurrence of these compounds.

The results of this problem illustrate the failure of the concept of valence to account for the combination patterns of hydrogen and carbon when they form organic compounds.

PROBLEM 4: List the chemical formula of the compounds of the alkane class in order of increasing number of carbon atoms. Construct an ordered pair of numbers from the formulas of each to represent the number of carbon and hydrogen atoms in each compound. Search for a relation between pairs of succeeding numbers. Use this pattern to predict the formulas for the next largest alkane compound. For example, let us assume the formula for methane, ethane, and propane are:

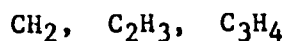

(Note: These are not the correct formulas for these compounds. We are using them merely as an example.)

According to the instructions above we would then form pairs of numbers of carbon and hydrogen atoms in each compound, thus obtaining:

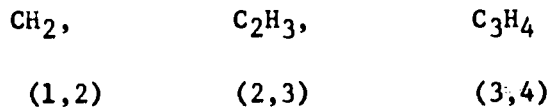

These pairs of numbers have a very simple relationship namely, that the number of hydrogen atoms is always 1 more than the number of carbon atoms. Hence, an (hypothetical) alkane with four carbon atoms would have the formula C_4H_5 if this pattern were the same for all compounds in the alkane class.

Repeat the above process for the alkenes.

Repeat the above process for the alkynes.

The results of the above problem, show that:

The fourth alkane should be C_4H_{10}

The third alkene should be C_4H_8

The third alkyne should be C_4H_6

PROBLEM 5: Predict the names for each of the compounds with four carbon atoms you found above. Experimentally, check the validity of your theoretical predictions by consulting the information cards.

PROBLEM 6: After identifying the chemical formula for the fourth alkane, the third alkene, and the third alkyne, add these to the series of formula and try to construct a general mathematical formula that relates the number of carbon atoms to the number of hydrogen atoms, so that once the number of carbon atoms is known, we can predict the number of hydrogen atoms that will combine with it. For example, in the hypothetical series given above in problem 4 each term in the series:

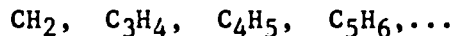

may be represented by the formula:



This is a mathematical way of saying that for each of the compounds in this series the number of hydrogen atoms is always one more than the number of carbon atoms.

The results of this problem shows that the correct general formula for the alkanes is $\text{C}_N\text{H}_{2N+2}$.

PROBLEM 7: Repeat the process described in problem 6 to find the general chemical formulas representing compounds of the alkene class.

Find the general chemical formula for alkynes.

The results of these studies show that the general formula for the alkene is: C_nH_{2n} and C_nH_{2n-2} for the alkynes.

PROBLEM 8: Using these general formulas, predict the name and chemical formula of the:

alkane with 5 carbon atoms

alkene with 5 carbon atoms

alkyne with 5 carbon atoms

Check your results experimentally by consulting the information cards.

4. Molecular Structural Similarities of Compounds within Chemical Classes.

According to the patterns discussed above, there are two features common to compounds within the same class.

- (a) They have similar chemical reactions.
- (b) The number of hydrogen atoms and the number of carbon atoms in a given compound is related in a way that can be described by a mathematical formula.

It would be useful if we could identify other structural similarities among compounds in the same chemical class, since geometry and structure has been the key that has enabled us to make progress so far.

PROBLEM 9: Study the models representing the molecular structure of the alkanes, alkenes, and alkynes. Search for structural similarities within chemical classes and differences between chemical classes.

The result of this study shows that the distinguishing features of these compounds are found in the structure of their carbon-carbon bonds. The alkanes have only one bond connecting their carbon atoms to one another.

The alkenes have one double bond connecting a pair of carbon atoms and the

rest are connected to one another by single bonds. The alkynes have one triple bond connecting a pair of carbon atoms, with only single bonds bridging the rest.

This result is a natural, mathematical consequence of the numbers involved in the rules governing the construction of a model. Given those geometric rules and the requirement that carbon atoms have 4 bonds and hydrogen 1, the general formulas $C_N H_{2N+2}$, $C_N H_{2N}$, and $C_N H_{2N-2}$ relating compounds with only one bond between carbon atoms, two between one pair of C atoms, and three bonds between another pair of C atoms is a mathematical law; no other relation is possible.

After completing the above study, it is reasonable to ask, "How closely do our models resemble real molecules?" Have we generated the correct patterns purely out of luck? Or is the fact that our model generates the correct numerical patterns to describe the combination of hydrogen-carbon atoms an indication that our model contains most of the essential features of real molecules? We can answer this only by appealing to further study.

Experimental evidence obtained by chemists shows that the patterns are no accident and the alkanes do share one electron between carbon atoms, the alkenes share two electrons between a pair of carbon atoms, and the alkynes share three electrons between a pair of carbon atoms. Our faith in the model as an accurate representation of real organic molecules is vindicated.

D. A SHORT SUMMARY OF INFORMATION ON
THE HYDROCARBON CLASSES

Table II - Some Alkanes

Name	Molecular Formula	Graphic Representation
Methane	CH_4	$\begin{array}{c} \text{H} \\ \\ \text{H} - \text{C} - \text{H} \\ \\ \text{H} \end{array}$
Ethane	C_2H_6	$\begin{array}{c} \text{H} \quad \text{H} \\ \quad \\ \text{H} - \text{C} - \text{C} - \text{H} \\ \quad \\ \text{H} \quad \text{H} \end{array}$
Propane	C_3H_8	$\begin{array}{c} \text{H} \quad \text{H} \quad \text{H} \\ \quad \quad \\ \text{H} - \text{C} - \text{C} - \text{C} - \text{H} \\ \quad \quad \\ \text{H} \quad \text{H} \quad \text{H} \end{array}$
Butane	C_4H_{10}	$\begin{array}{c} \text{H} \quad \text{H} \quad \text{H} \quad \text{H} \\ \quad \quad \quad \\ \text{H} - \text{C} - \text{C} - \text{C} - \text{C} - \text{H} \\ \quad \quad \quad \\ \text{H} \quad \text{H} \quad \text{H} \quad \text{H} \end{array}$
Pentane	C_5H_{12}	$\begin{array}{c} \text{H} \quad \text{H} \quad \text{H} \quad \text{H} \quad \text{H} \\ \quad \quad \quad \quad \\ \text{H} - \text{C} - \text{C} - \text{C} - \text{C} - \text{C} - \text{H} \\ \quad \quad \quad \quad \\ \text{H} \quad \text{H} \quad \text{H} \quad \text{H} \quad \text{H} \end{array}$

Table IV - Some Alkynes

Name	Molecular Formula	Graphic Representation
Ethyne	$\begin{matrix} C & H \\ 2 & 2 \end{matrix}$	$H - C \equiv C - H$
Propyne	$\begin{matrix} C & H \\ 3 & 4 \end{matrix}$	$\begin{array}{ccccccc} & & H & & & & \\ & & & & & & \\ H & - & C & - & C & \equiv & C & - & H \\ & & & & & & \\ & & H & & & & \end{array}$
Butyne -1	$\begin{matrix} C & H \\ 4 & 6 \end{matrix}$	$\begin{array}{ccccccccccc} & & H & & H & & & & & & \\ & & & & & & & & & & \\ H & - & C & - & C & - & C & \equiv & C & - & H \\ & & & & & & & & & & \\ & & H & & H & & & & & & \end{array}$
Pentyne -1	$\begin{matrix} C & H \\ 5 & 8 \end{matrix}$	$\begin{array}{ccccccccccc} & & H & & H & & H & & & & \\ & & & & & & & & & & \\ H & - & C & - & C & - & C & - & C & \equiv & C & - & H \\ & & & & & & & & & & \\ & & H & & H & & H & & & & \end{array}$
.	.	.
.	.	.
.	.	.

E. PROBLEMS

1. Group the following compounds into alkanes, alkenes, alkynes:

(a)

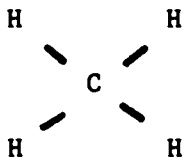

(b)

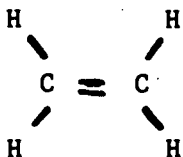

(c)

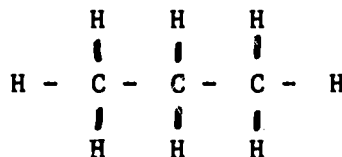

(d)

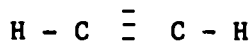

(e)

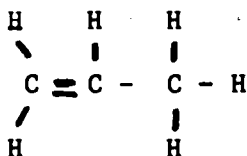

(f)

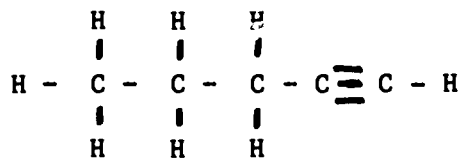

2. Name the following compounds:

(a)

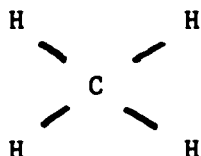

(b)

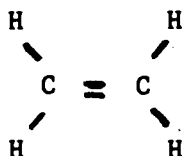

(c)

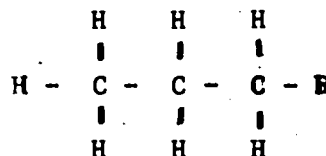

(d)

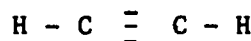

(e)

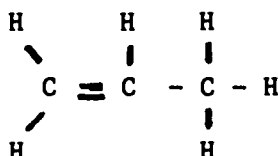

(f)

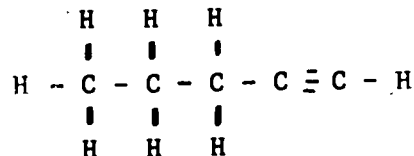

3. Which of the following compounds obeys bonding rules that are not consistent with that found in the hydrocarbons?

(a)



(b)

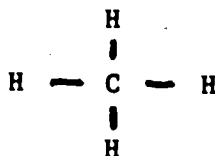

(c)

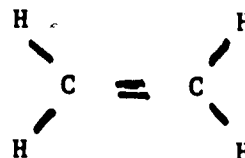

(d)

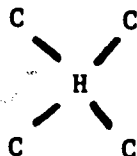

(e)

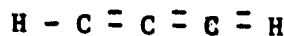

(f)

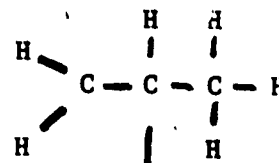

(g)



(h)

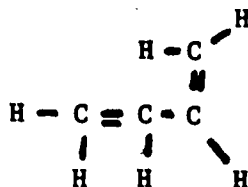

(i)

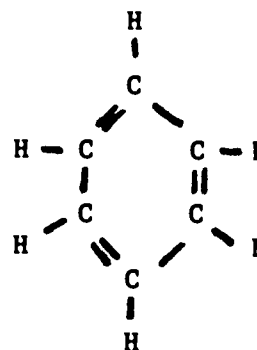

4. Give the chemical formulas for the compounds whose structural formulas are given in problem # 1.

5. Give the structural formulas for the following compounds.

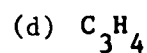
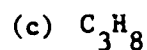
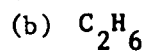
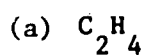

6. Identify the hydrocarbon class to which the following compounds belong:

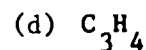
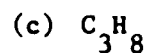
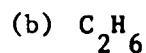
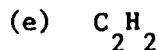
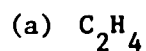

7. Name each of the compounds listed below

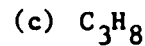
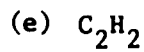
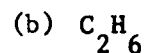
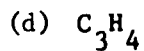
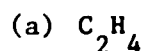

8. Complete the following reaction equations

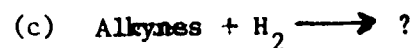
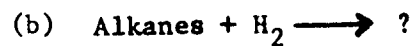

F. "ORGANIC RUMMY"a CHEMISTRY CARD GAME

As a means of engaging students in a practice of some of the important rules of organic chemistry, a card game has been devised and is described below. The main features are:

- (a) Students are given a chance to display their knowledge of organic chemistry and at the same time learn more.
- (b) They are able to engage in a creative exchange of scientific ideas in a friendly spirit of competition usually reserved only for professional scientists.

DESCRIPTION OF THE CARDS

A deck of "ORGANIC RUMMY" CARDS contains different kinds of cards.

Each is shown below



(a)

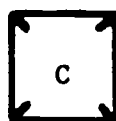

(b)



(c)

Each card represents an atom, and an arrangement of bonds.

By arranging a proper set of these cards it is possible to construct representations of hydrocarbon molecules. A few of these arrangements are shown below:

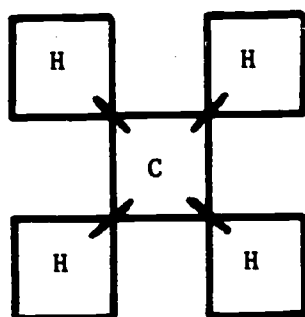
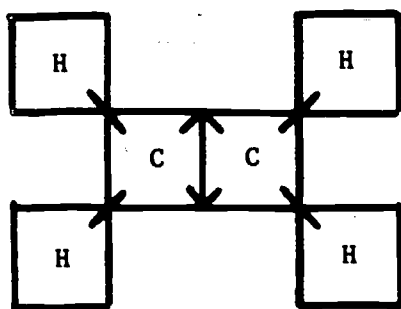
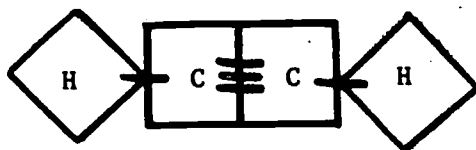
methane (CH_4)ethene (C_2H_4)ethyne (C_2H_2)

OBJECT OF THE GAME

The object of the game is for each player to arrange his cards to represent molecules which will enable him to total the most number of points. The rules for points are given below.

RULES

1. Each player is dealt 7 cards to begin the game.
2. A single deck contains 90 cards. Any number of players may play. If more than four players are engaged in a game, two decks should be combined.
3. The player to the left of the dealer begins the play. He may either "spread" a compound [i.e. arrange his cards on the table face up, so that they represent a valid hydrocarbon compound] or he may pass his chance to "spread" and instead draw a card from the deck [placed face down in the center of the table] in an attempt to improve his hand.
4. Each player receives a fixed point value for his compound spread according to the scheme given below.
5. In addition to the base point value of his spread a player has a chance to total extra points by identifying pertinent facts about the compound his spread represents. Specifically he is given the following points for identifying the features:

(a) chemical class	5 points
(b) name	10 points
(c) chemical formula	5 points
(d) some property or use	5 points
(e) one of its chemical reactions	10 points

Ex mpel:

Spread I

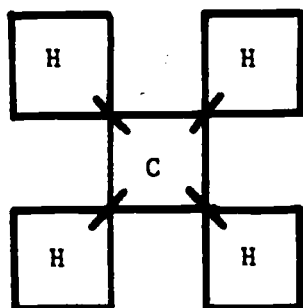

20 - carbon atoms

5 - Class (alkane)

10 - Name (methane)

5 - Formula (CH_4)

5 - (property) Gas at room temperature

5 - Reaction ($\text{CH}_4 + \text{H}_2 \longrightarrow$ No Reaction)

Total score = 50 points

Spread II

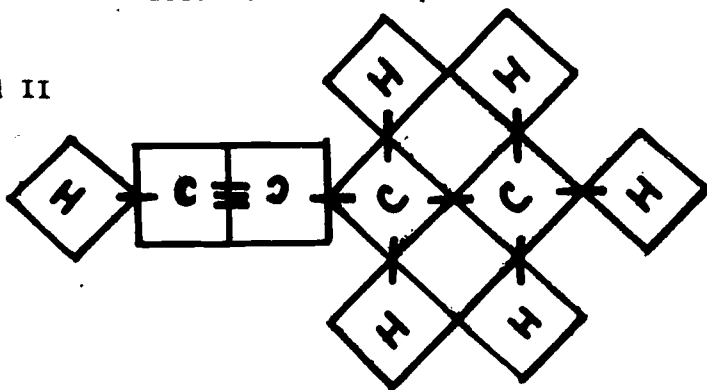

80 - Carbons Atoms

5 - Class (Alkyne)

10 - Name (Butyne)

5 - Formula (C_4H_6)

0 - Property?

10 - Reaction: Butyne $+ 2\text{H}_2 \longrightarrow$ Butane

Total score = 110

6. When spreading his compound each player must record all identification information on a sheet of paper to accompany the spread. All information is subject to scrutiny by other players. On questions of the validity of identification of information the "Handbook of Chemistry and Physics" should be consulted.
7. After spreading a compound, the player then draws from the deck numbers of cards equal to those he spread to replenish his hand.
8. The game is complete when:
 - (a) a player has spread all his cards and there are no more available in the deck. This player goes "out" and the game ends.
 - (b) the deck is exhausted and each player after having a chance to make a spread from the remaining cards in his hand can spread no more.
9. At the end of the game, each player totals the number of cards in his hand and multiplies by 5, then subtracts this score from his game total as a penalty.
10. If a player has gone "out" to end the game, he multiplies his last spread score by two, as a bonus.
11. The player with the highest score at the end of the game wins.

Variations

There are many possible variations to these rules. Players may couple to play partners and design features in the rules that enable them to benefit from one another's card strength. Rules may be designed to approximate the "contract" playing of bridge or pinochle. Even a game of "Organic Solitaire" can be designed. Students should be invited to try their imagination at constructing some of these variations.

Bonus Cards

In order to increase the frequency with which compounds with large molecular structures are introduced into the game, a group of bonus cards are added to the deck. The cards contain representations of fragments of large molecules. Several are shown below.

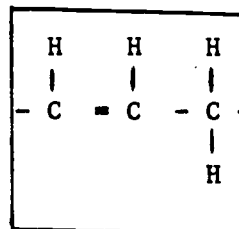
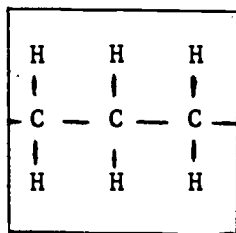

These cards are used along with other cards to complete a molecular structure.

For example, the three-card spread below represents a molecule of propane.

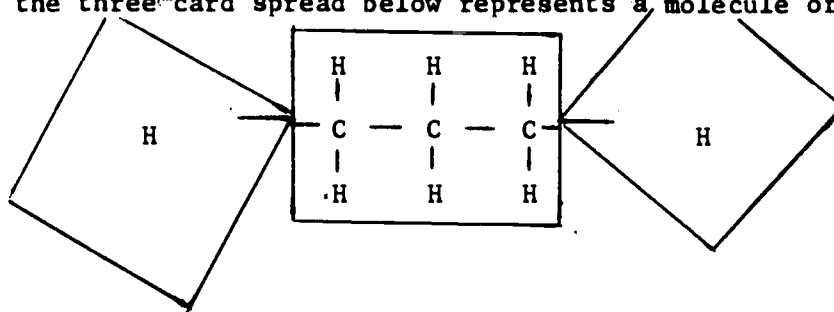

IV. THE ROLE OF THE CHEMICAL BOND
IN DETERMINING CHEMICAL PROPERTIES

A. INTRODUCTION

The spatial configurations of its covalent bonds is a pivotal property of the organic molecule. We have built a model on this principle that has been very effective in assisting us in deciphering codes and relations hidden among laws of organic chemistry.

In this section we will rely on our molecular model to help us understand the role of the chemical bond in determining the outcome of chemical reactions. The model we have developed enables us to determine possible outcomes of chemical reactions. It remains, however, for us to identify the properties of molecules that determine the probable outcome of chemical reactions. For example, by using the rules of covalent bonding to rearrange the bonding patterns alone, we can predict several possibilities, but we cannot predict which one occurs in the laboratory.

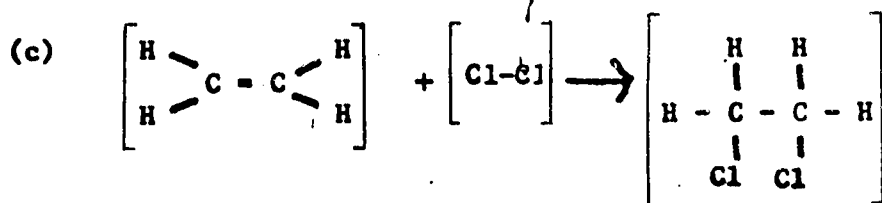
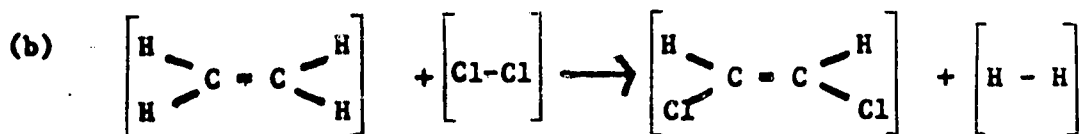
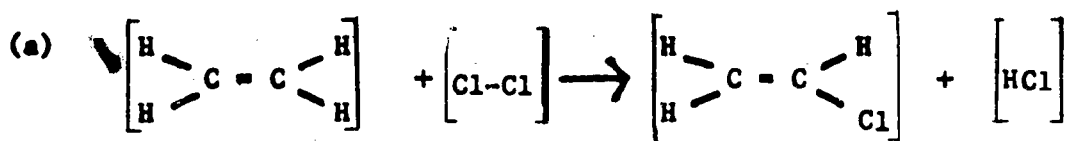

Each of the three reactions is theoretically possible, i.e. they satisfy our fundamental rules for covalent bonding. But they are all different and they do not occur with equal probability. Usually only one occurs under normal laboratory conditions. Nature chooses which by evoking some new rule, for all three equations obey all the rules we have discovered so far. The object of this chapter is to find that rule. To do this, we must resort to reviewing additional and some new experimental evidence.

B. DEVELOPING A NEW RULE

1. Gathering Evidence

It is reasonable to begin by reviewing the set of reaction equations we have acquired so far about the compounds. For convenience we have listed all of these below:

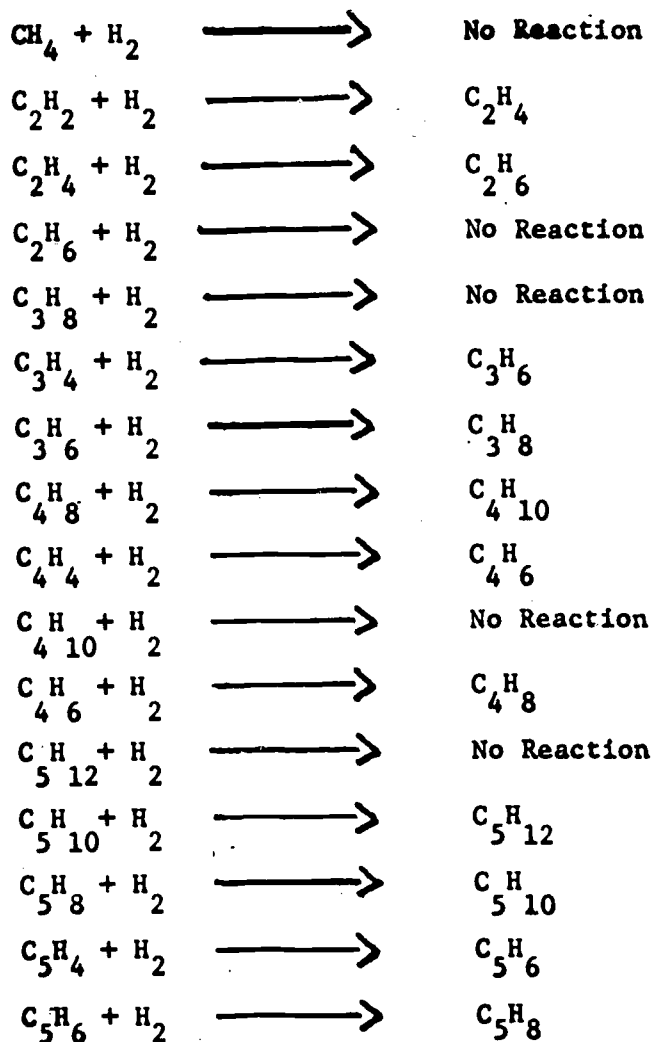

PROBLEM: Draw the structural equivalent of each of the equations listed and search for patterns of similarity among them.

Analysis: An analysis of this problem shows several trends.

- Whenever there are only single bonds connecting carbon atoms within a hydrocarbon molecule, it does not react with hydrogen.
- The net effect of the reaction between the two molecules, when one is a hydrocarbon and the other is hydrogen, is to absorb the hydrogen molecule into the hydrocarbon forming a double-bonded pair of carbon atoms.
- In each case, when a reaction occurs, the hydrogen molecule is absorbed by breaking one of the bonds between a double bonded pair of carbon atoms.

2. Stating the Rule

PROBLEM: Construct a rule that sums up these effects so that someone who does not know the results could predict them using your rule.

Analysis: One simple statement of the rule would be "The bond between two carbon atoms with the highest number of bonds loses one bond and readjusts to absorb the new molecule(s) in a chemical reaction."

3. Applying the Rule

PROBLEM: Apply your rule to predict the outcome of the reaction.

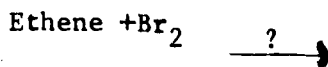

In order to apply it to the equation Ethene + Br₂ we convert it to structural form, thus:

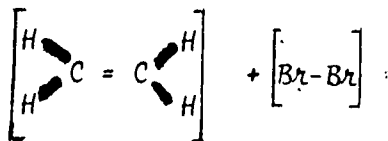

The rule requires us to break one of the center bonds to form the molecule

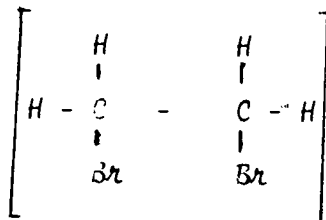

Thus the rule gives us the correct result:

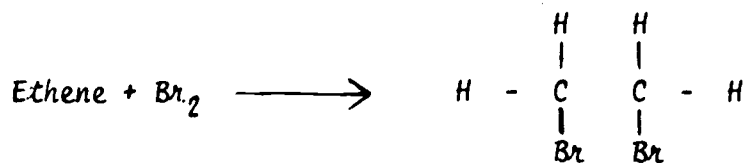

It is important to note that there are other possibilities. Following the original covalent bonding model rules only, we also obtain the reactions:

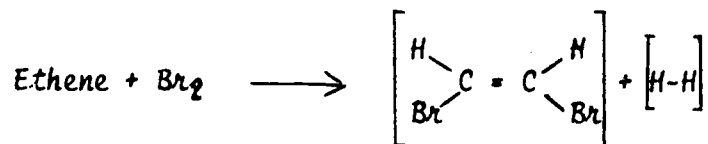

or

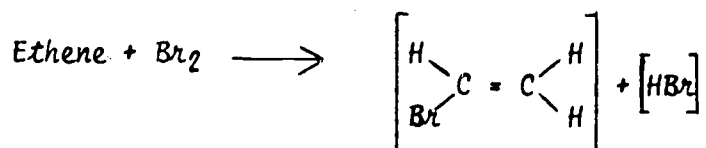

These reactions are less probable.

PROBLEM: Use the covalent bond model and the new rule devised above to predict the reaction products in the reactions shown below:

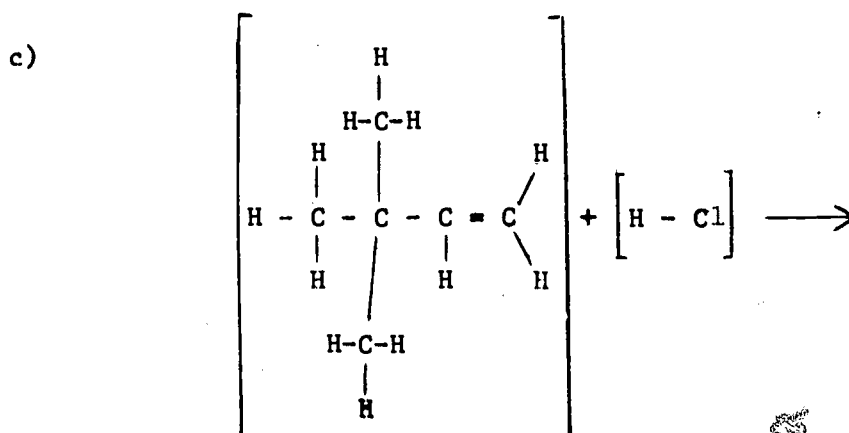
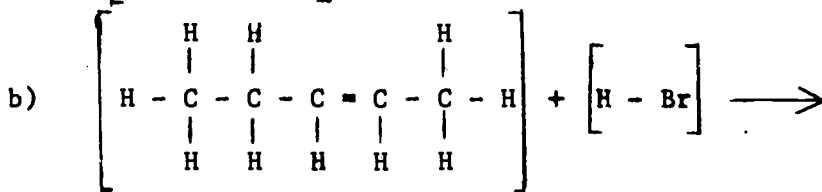
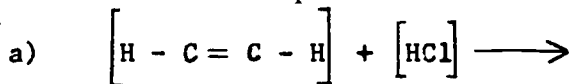

Analysis: The correct solution to these problems is obtained by following the simple rule cited above. All we need do is find the highest multiple carbon-carbon, break one of these and insert the atoms of the other reactant molecule. For example the solution to problem a is:

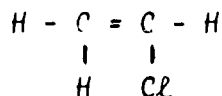

4. Interpreting the Rule

The rule we have developed has proven to be a very useful one. If we were to make a simple interpretation of these results, we could postulate that during chemical reactions between organic molecules, the weakest covalent bond breaks and is made available for accepting new atoms!

This is an intriguing interpretation, but the fact that a bond between the two carbon atoms that share the most bonds is the one to break implies it is the weakest. Such an interpretation runs counter to our intuition. It would seem more natural for two atoms that share the most electrons to have the strongest bond. This would be true if the bonds did not interact with one another. But because of the electrical nature of the bonds, this is not the case. One can demonstrate this effect using mechanical models. In section F of Chapter IV a physical model is described that illustrates this. That model is based on the use of magnetic instead of electrical forces but the principle is the same.

PROBLEM: Construct a model of the ethyne, ethene, and ethane molecules and indicate the spatial distribution of their electrical charges. Review the magnetic model in section F. Construct a similar model based on electrical forces to predict the relative strength of the carbon-carbon bonds in these molecules.

Use your model to explain why it is reasonable that carbon molecules are not found to be composed of two carbon atoms (i.e., C₂). Note that this structure is consistent with our rules which state that the carbon atom must share four electrons with neighboring atoms.

C. CHEMICAL ACTIVITY

1. The Concept

One of the fundamental ideas introduced in our study of inorganic compounds was that of the relative activity of elements. Chemical activity was defined as a measure of the tendency of an atom to break old bonds and form new ones. This concept, along with an empirical measure of chemical activity, is useful in enabling us to predict the results of chemical reactions. A similar concept can be introduced which will enable us to relate the reaction properties of organic compounds. In general terms, chemical activity is a measure of the ease with which chemical bonds are broken. This can be verified experimentally.

PROBLEM: On the basis of the previous sections predict the relative chemical activities of ethane, ethene, and ethyne. List them in order of increasing chemical activity.

2. An Experimental Study

A study of chemical reactions in inorganic chemistry shows that the greater the difference in the activities of elements, the greater the amount of heat that is given off in a reaction between them. We proceed to see if this principle may be extended to organic compounds. A reasonable study to make in order to compare the properties of compounds with different activities is to have each react with the same compound and measure the temperature of each reaction.

Experiment II - The Relative Activities of Methane, Ethene, and Ethyne

Equipment: Cannisters containing samples of methane, ethene, and ethyne are available in a "Demonstrator Kit" from the local gas company for a small fee.

Objective

The purpose of this experiment is to compare the activities of each of these compounds by comparing the temperature of its flame.

Procedure

1. Connect each cannister to a bunsen burner and ignite the gases.
2. Using tongs, heat a pyrex test tube in the ethyne flame until it melts. Record the heating time so that each heating operation can be fairly compared. It is well known that the duration of heating affects the results.
3. Heat another pyrex tube in the ethene flame until it melts. Record the heating time needed to melt.
4. Heat a third pyrex tube in the methane flame. Double or triple the time held in the ethene flame as a demonstration that the pyrex does not melt in the methane flame.
5. Repeat the demonstration using three iron nails.

These results are summarized in table V.

Table V

COMPARISON OF BURNING TEMPERATURE
OF SOME HYDROCARBONS BY HEATING TEST MATERIAL

FLAME COMPOUND	TEST MATERIAL	EFFECT on test material	Heating Time
methane	pyrex	None	
ethene	pyrex	Melts	
ethyne	pyrex	Melts	
methane	Iron	None	
ethene	Iron	None	
ethyne	Iron	Melts	

Analysis

The first step in analyzing our experimental results is to write chemical equations for the burning reaction. The common phenomena of burning is basically the result of a substance combining with oxygen at high temperatures and giving off heat. This heat in turn maintains a higher temperature. More oxygen combines with more material and the reaction sustains itself.

PROBLEM:

Draw the structural equivalent of each of the burning reactions below, and predict the reaction products and show that there are at least two possibilities of reaction products.



[Note: Oxygen atoms form covalent bonds with one another to form molecules with the formula O_2 .]

These problems may be solved by utilizing the nomenclature scheme for these compounds and the rules of covalent bonding. For example, using the nomenclature rule the equation:



translates to its structural equivalent given below.

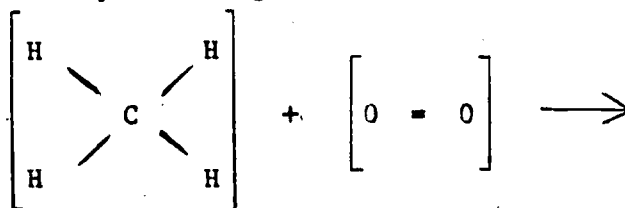

If the carbon combines with the oxygen; there are several possibilities, two of which are:

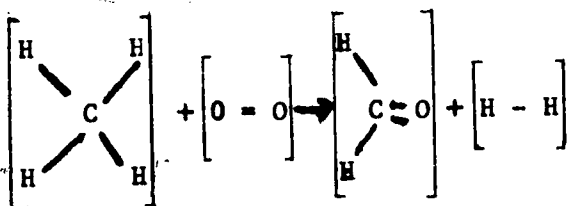

and

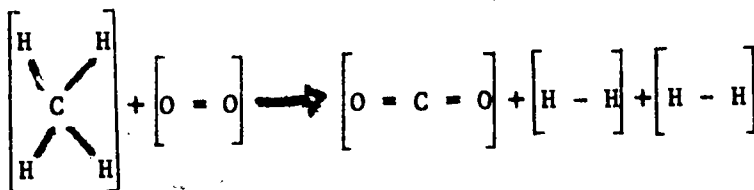

It turns out that in the second case, there is a further reduction; the hydrogen molecules are freed and other oxygen molecules combine to form water so that the total reaction is usually written as:

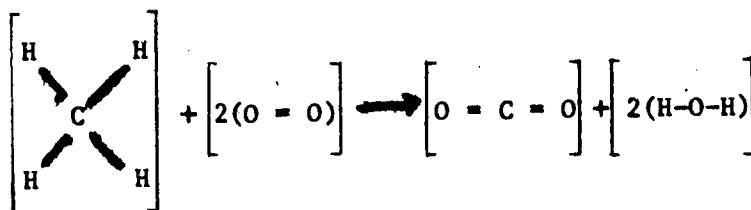

There are even more possibilities for the reactions involving ethane, ethene, and ethyne. This is another practical illustration of the need for other laws regarding chemical reactions if we are to be able to make reasonable and

accurate predictions about their outcome.

In this instance we rely on empirical evidence. The results of chemical analysis of these reactions shows that the major products are CO_2 and water. Thus, the correct solutions to the equations are:

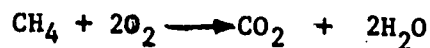
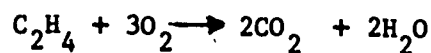

There is a major ingredient missing from these equations, i.e. the amount of heat liberated in the process. We provide this by analyzing the data from the heating demonstration.

Problem:

Using the information from the melting experiments, order the three reactions in terms of increasing amounts of heat liberated.

The result shows that the heat of the ethyne reaction is greater than that of the ethene reaction which in turn is greater than that of the methane reaction. To accommodate this information we modify the equations representing the burning reactions to read:

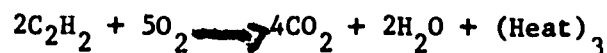
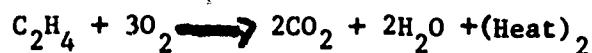
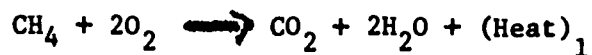

where

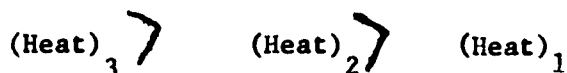

Since the reaction products are the same in each case, it is reasonable to attribute the difference in heat between them to the difference in their initial products. Thus, if we associate heat liberated with chemical activity, we have evidence to confirm our earlier prediction i.e. that ethyne is more active than ethene which is more active than ethane.

D. ISOMERS

As further evidence of the important role properties such as the strength of the chemical bond play in determining the chemical properties of the compound, it is instructive to compare the properties of a special set of compounds that are related in a unique way. These are compounds which have the same chemical formula but have different molecular structure. Two or more chemical compounds related in this way are called isomers. For some compounds such as methane, ethane and propane there is only one possible arrangement of carbon and hydrogen atoms that will satisfy the valence rules. Butane, on the other hand, may have its four carbon atoms and ten hydrogen atoms arranged in two different ways:

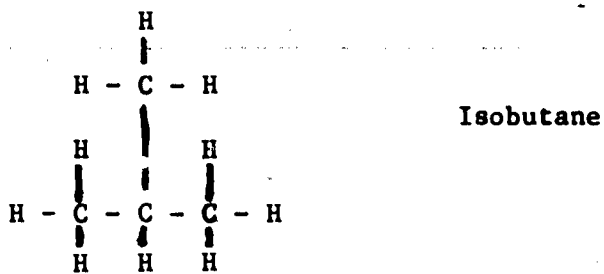
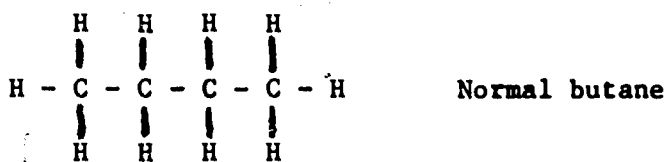

Although these compounds have the same chemical formula, C_4H_{10} , they have different chemical and physical properties. For example, the boiling point of isobutane is 10°C , while that of normal butane is -1°C .

The fundamental concept of isomerism is that two identical sets of

atoms ordered in different structural arrangements may have different chemical and physical properties. Although this may seem difficult to understand at first, further thought shows this result is consistent with the following concepts :

- (a) The chemical properties of a compound are determined by the relative ease with which various chemical bonds are broken.
- (b) There are electrical interactions between bonds. Different bonds have different strengths.
- (c) The strength of a given chemical bond in a molecule is dependent on the total structure of that molecule.

The total strength of a given bond is dependent not just on its immediate environment but the total structural arrangement of the molecule. Consider an analogous structure problem with bricks and mortar. If we give ten different men 1000 bricks and cement and have each build a structure using all of the bricks, the strength of each structure, and hence the strength of its weakest bond, is determined by its overall architecture. Certain designs will collapse under a given weight more easily than others. This is a basic principle of architectural design. The same principle holds in the architecture of molecular design, only the bricks and the mortar differ.

It is difficult to predict the precise differences in properties of two isomers, given just the structural difference in the molecules. The chemical properties of a system is dependent in a complicated way on its electronic structure. We may expect only that the compounds should have different macroscopic properties.

There are innumerable ways in which two molecules may differ

and still remain isomers of one another. Chemists have found it convenient to classify some of the differences

(a) *Structural Isomerism*

Compounds are structural isomers when they are composed of the same number of types of atoms but have different molecular structures and hence, different chemical properties. Butane (C_4H_{10}) has a skeleton consisting of four carbon atoms which may be arranged in two ways:

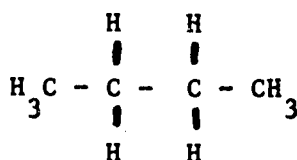

n-butane

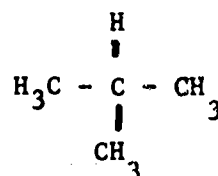

isobutane

(b) *Geometrical Isomerism*

Some hydrocarbons, mainly the alkenes, exhibit a type of stereoisomerism. Two-Butene exists in two configurationally different forms: the Cis form is the arrangement in which the two methyl groups, CH_3 , are on the same side of the double bond. In the trans form, the methyl groups are on the opposite sides of the double bond.

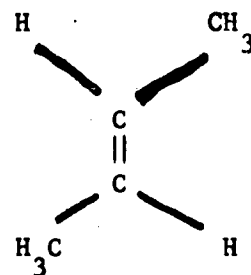
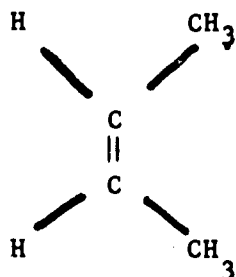

One is a twisted form of the other.

(c) *Optical Isomers*

Some isomers are mirror images of one another. Though at first glance they may appear to be identical, they are not. They are related to one another as the right hand is to the left.

The mirror image of an object is not always different from the original. For example, the mirror image of a perfectly spherical unmarked ball is an identical perfectly spherical unmarked ball. In order for an object's mirror image to be different from the object itself its top must be distinct from its bottom and its left different from its right. Indeed, anything whose mirror image is different from the original is said to have the property of "handedness".

But what is the difference in chemical and physical properties of such two closely related class of molecules? Surely all of the chemical and physical properties are the same. The only properties or phenomena that distinguish between them are those that reflect a property of handedness; and these are few. One important one is the interaction with polarized light (light that has a handedness). Consequently, these isomers are also called "optical" isomers.

E. EXPERIMENTAL DETERMINATION OF A MOLECULAR STRUCTURE

In this chapter we have placed a great deal of importance on the geometrical structure of the molecules of organic compounds. If we know the molecular structure of a molecule, we are able to predict something about its chemical and physical properties. Consequently, the molecular structure of a compound contains the code for one of its most essential properties.

But molecules are too small to be seen. How does one determine its shape? As an illustration of how chemist solve such a problem, instead of hydrocarbons let us use some more reactive substances that contain oxygen. We choose two that have the molecular formula C_2H_6O . Suppose we have two samples, one is the liquid ethyl alcohol; the other is a gas named dimethyl ether. The covalent valence rules permit two possible structures for C_2H_6O :

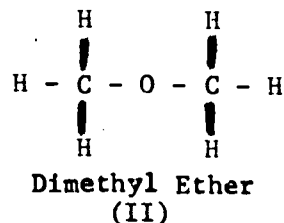
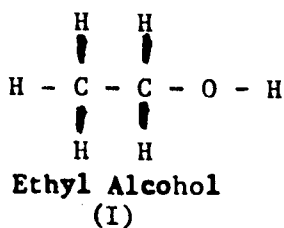

How do we distinguish between them? Our problem is to match these structures with the properties of the two substances. A chemist would proceed by studying the chemical properties of the two samples. Suppose he finds that clean sodium metal reacts vigorously with one, giving hydrogen gas and the compound $\text{C}_2\text{H}_5\text{ONa}$. Since only one sodium atom is absorbed into a molecule, replacing a hydrogen atom we must assume that the hydrogen it replaced occupied a unique position. Otherwise several sodium atoms would have replaced the several positions occupied by the several equivalent hydrogen atoms. This suggests that this sample of $\text{C}_2\text{H}_6\text{O}$ has the structure indicated in figure (I) above. Secondly this first sample is found to react with HCl to give water. In this reaction an O and an H atom have been replaced by a Cl atom, which suggest that the O and H were together in the original molecule. This reinforces the conclusion that our sample is ethyl alcohol.

We need to go no further to assign the first of the above formulas to ethyl alcohol, so the second must represent dimethyl ether.

Many simple examples of this sort give the organic chemist a backlog of information which enables him to handle more difficult problems. By investigating the properties of a substance, an organic chemist can make a good guess at the formula, and then narrow down the possibilities with information obtained from other experiments.

F. PROBLEMS

1. Complete the following reaction equations

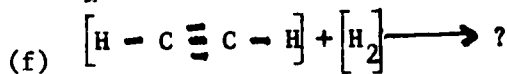
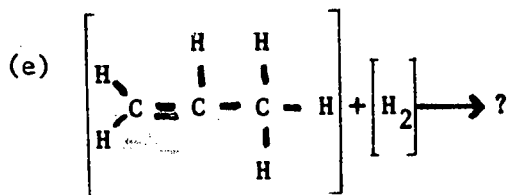
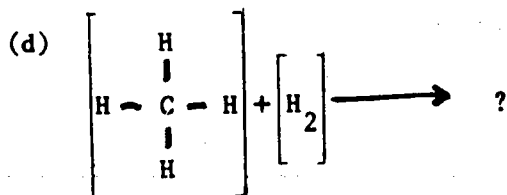
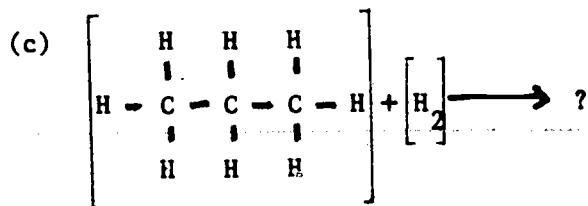
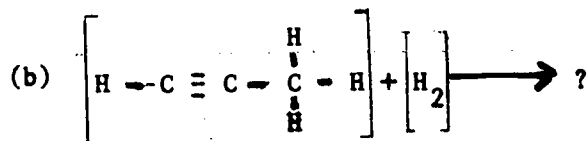
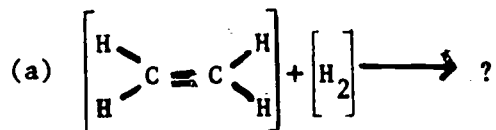

2. Complete the following reaction equations:



3. Using the fact that oxygen requires two bonds to join a covalent compound, give the structural equation equivalent of the following reactions:

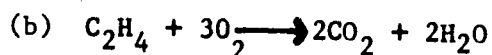
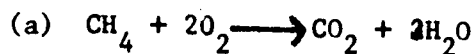

4. Using the fact that chlorine requires one bond to join a covalent compound (chlorine gas is represented by Cl_2) predict the results of the following reactions by giving the equation in structural form

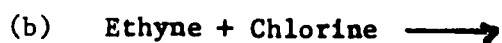
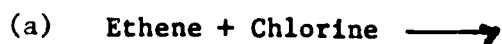

The general chemical formulas for the alkanes, alkenes, and alkynes

are C_nH_{2n} , $\text{C}_n\text{H}_{2n+2}$ and $\text{C}_n\text{H}_{2n-2}$.

5. Write the structural formula for a simple representation of each of these classes, for example methane, ethene, ethyne. Then transcribe the structural formula into a chemical formula. Having done this you will have the chemical formula for an alkane, an alkene, and an alkyne. Compare these formulae with the general formula above and identify which class each general formula represents.

Group the following into hydrocarbon classes, i.e., (alkanes, alkenes, etc.)

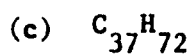
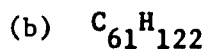
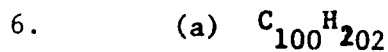

G. Organic Chemistry Data

Chemical Formula: CH_4

Name: Methane



Structural Formula:

Properties: Gas at Room Temperature. Natural Gas found below ground. Used in domestic heating.

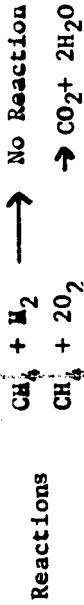

Chemical Formula: C_2H_4

Name: Ethene



Structural Formula:

Properties: Gas at room temperature, polymerized to give polyethylene.

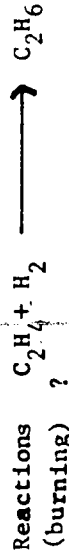

Chemical Formula: C_2H_2

Name: Ethyne



Properties: Gas At Room Temperature (Common Name used in welding Acetylene)

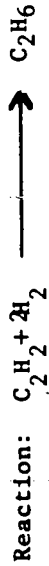

Chemical Formula: C_2H_6

Name: Ethane

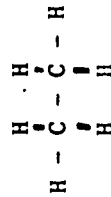

Properties: Gas at Room Temperature

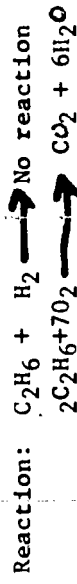



Chemical Formula:

Name: Propane

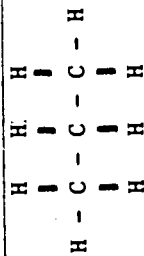

Structural Formula:

Properties: Gas at Room Temperature.
Commercial use: Fuel for cigarette lighter, domestic heating.

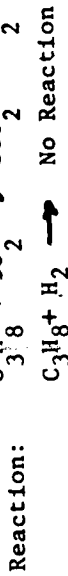

Reaction:



Chemical Formula:

Name: Propene

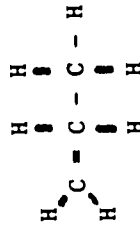

Structural Formula:

Properties: gas at room temperature Polymerized to make "polypropylene".

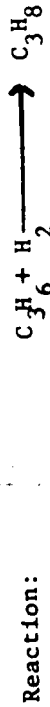

Reaction:



Chemical Formula:

Name: Propyne

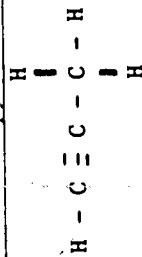

Structural Formula:

Properties:



Reaction:



Chemical Formula:

Name: Propadiene



Structural formula:

Does not exist under ordinary laboratory conditions

Properties:

Reaction:



Chemical Formula:

Name: Butene -1

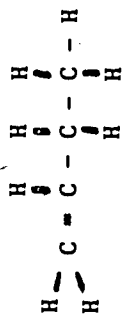

Structural Formula:

Properties:



Chemical Formula:

Name: 1 - But - 3 - yne

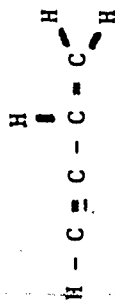

Structural Formula:

Properties: liquid at room temperature. Commercial use: used in preparation of "neoprene" rubber.

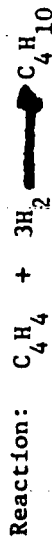



Chemical Formula:

Name: Butane

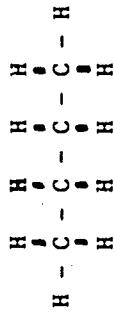

Structural Formula:

Properties: Gas at Room Temperature.
 Commercial use: Domestic heat & cigarette lighter fuel

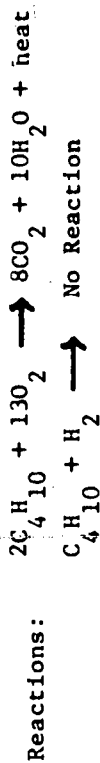

Chemical Formula: C_4H_6

Name: Butadiene - 1,2

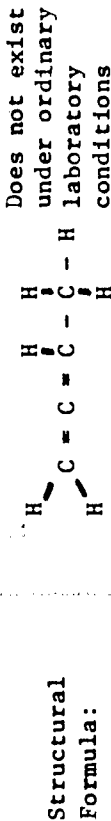

Chemical Formula:

Name: Butatriene

Does not exist under ordinary laboratory conditions.

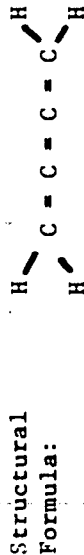

Properties

Reactions

61



Chemical Formula:

Name: 1,3 Butadiene

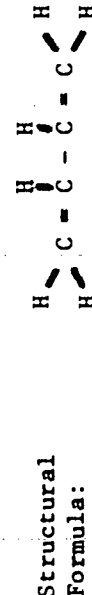

Properties: gas at room temperature. Commercial use: Polymerized to give synthetic rubbers. Intermediate in manufacture of nylon.



Chemical Formula: C_5H_{12}

Name: Pentane

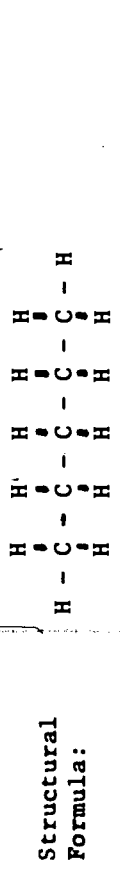

Properties: liquid at room temperature. Commercial use: additive to blended gasolines.



Chemical Formula: C_5H_8

Name: Pentadiene - 1,2

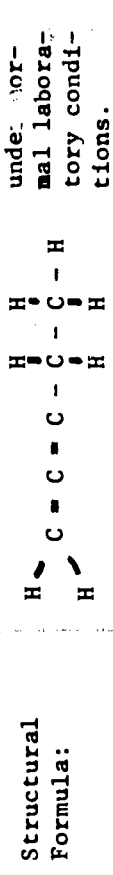

Does not exist under normal laboratory conditions.

Properties:

Reaction:

Chemical Formula: C_5H_{10}

Name: Pentene - 1

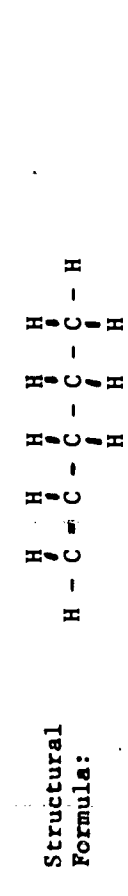

Properties: liquid at room temperature



Chemical Formula: C_5H_8

Name: Pentadiene - 1,3

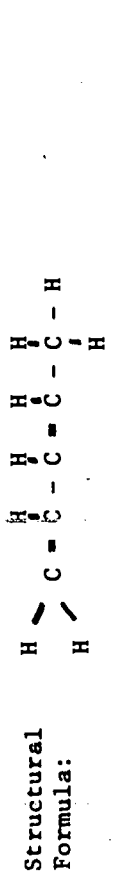

Properties: liquid at room temperature



Chemical Formula: C_5H_4

Name: Pentadiyne -1,3

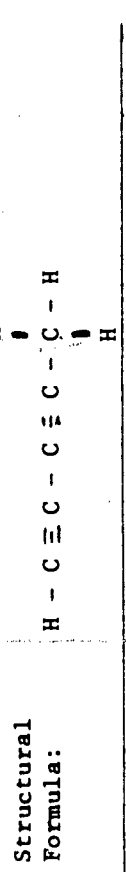

Properties: liquid at room temperature

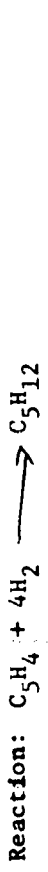

Chemical Formula: C_5H_6

Name: 1 - Pentyne, 3 - ene

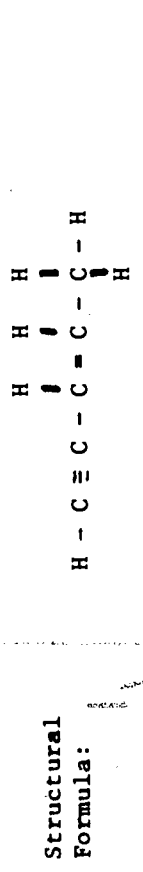

Properties: liquid at room temperature



Chemical Formula: C_5H_4

Name: 1, 4 Penta diyne

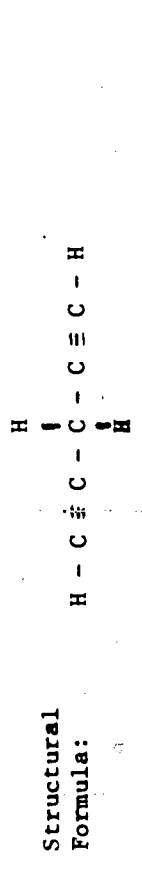

Properties: liquid at room temperature

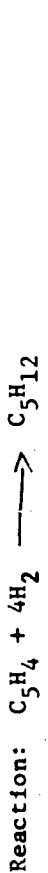

Chemical Formula: C_5H_8

Name: 2-Methyl - 1,3 - butadiene

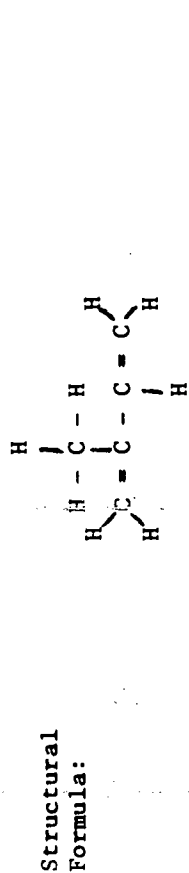

Properties: liquid at room temperature. Commercial use: Polymerized to give natural rubber used in tires.



APPENDIX

MAGNETIC MODEL OF COVALENTLY BOUND MOLECULE

Using steels balls and toroidal magnets, one can construct a model of an organic molecule which demonstrates two important features:

- (a) Two objects that do not normally attract one another can be bonded together through their mutual attraction for a third object.
- (b) As a result of a repulsive force between bonds, the most stable spatial arrangement of the bonds connected to a single object is one in which the bonds are widely separated.

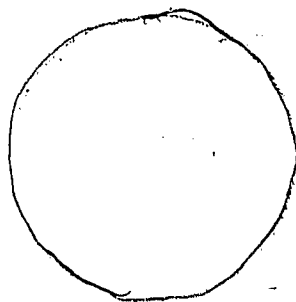
Equipment:

One large steel ball
(represents carbon atom)

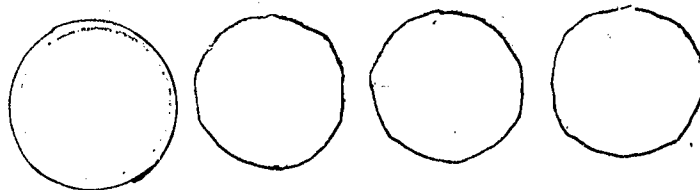

Four small steel balls, each
represents a hydrogen atom.

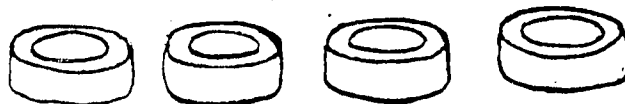

Four toroidal magnets from child's
toy to represent 'bonds'

Figure 1A

Demonstration of the Bonding Principle

Place the large and small ball into contact showing they do not "bind" together. Then using magnet show it will act as a bond between the balls as shown below in Figure 2A .

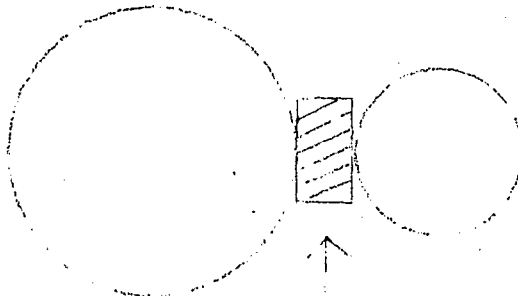

MAGNET

Figure 2A

Demonstration of the instability of close spatial groups of interacting bonds

Construct a model of methane by binding four small balls to the large one using the four magnets as shown below.



[Note: Arrange the same pole for all magnets to be pointing in the same direction, either toward the center of the sphere or outwards].

Figure 3A

Bring all four small balls and their bonds together into as small an area on the surface of the large ball as possible, holding them in contact. This arrangement is unstable because when they are released they move apart under the force of the mutual repulsion of the bonds.