

DOCUMENT RESUME

ED 114 622

CE 005 487

AUTHOR Diehl, Donald W.; Penner, Wayman R.
 TITLE Commercial Carpentry: Instructional Units.
 INST-BBB08691;BBB12485
 INSTITUTION Associated General Contractors of America,
 Washington, D.C.; Oklahoma State Dept. of Vocational
 and Technical Education, Stillwater. Curriculum and^o
 Instructional Materials Center.
 PUB DATE 74
 NOTE 1,166p.
 AVAILABLE FROM Oklahoma State Dept. of Vocational and Technical
 Education, Curriculum and Instructional Materials
 Center, 1515 West Sixth Street, Stillwater Oklahoma
 74074 (\$20.00); Associated General Contractors of
 America, 1957 E Street, N.W., Washington, D.C. 20006
 (\$20.00)

EDRS PRICE MF-\$2.02 Plus Postage. HC Not Available from EDRS.
 DESCRIPTORS Building Trades; *Carpenters; *Construction
 (Process); Course Content; *Curriculum Guides;
 Evaluation Criteria; *Instructional Materials; Job
 Application; Leadership Qualities; Learning
 Activities; Post Secondary Education; Safety
 Education; Secondary Education; Student Evaluation;
 *Tests; Trade and Industrial Education; Unit Plan

ABSTRACT

The guide contains 11 sections, each consisting of one or more units of instruction in commercial carpentry. The sections cover the following: introduction (orientation, safety, and applying for a job), leadership, related information (lumber, measuring, and fasteners), power and hand tools, blueprint reading, site preparation and layout, forming, framing, exterior finish, interior wall finish, and interior trim. Each unit is based on behavioral objectives stated in two forms: terminal objectives stating the subject matter to be covered, and specific objectives stating the necessary student performance. Suggested teacher and student activities, information sheets providing the essential content, reference lists, and tests with answers are included for each unit. Many of the units also contain transparency masters, student handout sheets, job sheets designed to teach skills, and assignment sheets (with answers) providing paper and pencil activities. Illustrations are numerous throughout the guide. Progress sheets after each section can be used by students and teacher to record test results and acceptable performance of skills outlined in the job sheets. (Author/MS)

ED114622

U S DEPARTMENT OF HEALTH,
EDUCATION & WELFARE
NATIONAL INSTITUTE OF
EDUCATION

THIS DOCUMENT HAS BEEN REPRO-
DUCED EXACTLY AS RECEIVED FROM
THE PERSON OR ORGANIZATION ORIGIN-
ATING IT. POINTS OF VIEW OR OPINIONS
STATED DO NOT NECESSARILY REPRESENT
OFFICIAL NATIONAL INSTITUTE OF
EDUCATION POSITION OR POLICY

PERMISSION TO REPRODUCE THIS
COPYRIGHTED MATERIAL BY MICRO-
FICHE ONLY HAS BEEN GRANTED BY

Okl. State Dept. of
Voc Tech Ed.

TO ERIC AND ORGANIZATIONS OPERAT-
ING UNDER AGREEMENTS WITH THE NA-
TIONAL INSTITUTE OF EDUCATION.
FURTHER REPRODUCTION OUTSIDE
THE ERIC SYSTEM REQUIRES PERMIS-
SION OF THE COPYRIGHT OWNER.

COMMERCIAL CARPENTRY

Instructional Units

Donald W. Diehl
Construction Superintendent
Ringland-Johnson-Crowley Company
Des Moines, Iowa

Wayman R. Penner
Curriculum Specialist
Trade and Industrial Education
State Department of Vocational and Technical Education
Stillwater, Oklahoma

Developed as a cooperative project by the
Associated General Contractors of America,
Paul E. Emerick, Chairman, Manpower and Training Committee

and

Oklahoma State Department of Vocational and Technical Education
Leslie Fisher, Chairman
Francis Tuttle, Director
Ronald Meek, Coordinator, Curriculum and Instructional
Materials Center

1974

CE 005 487

2/3

COPYRIGHT 1974

Associated General Contractors of America
and the Oklahoma State Department of Vo-Tech Education,
Curriculum and Instructional Materials Center

Edited by
State Department of Vocational and Technical Education
Stillwater, Oklahoma

Distributed by

Associated General Contractors of America
1957 E Street, N.W., Washington, D.C. 20006
and the
Curriculum and Instructional Materials Center, Oklahoma State
Department of Vo-Tech Education
Stillwater, Oklahoma 74074

TABLE OF CONTENTS

Section A--Introduction

Unit I	Orientation
Unit II	Safety
Unit III	Applying for a Job

Section B--Leadership

Unit I	Parliamentary Procedure and Public Speaking
Unit II	Becoming a Good Leader

Section C--Related Information

Unit I	Lumber
Unit II	Measuring
Unit III	Fasteners

Section D--Tools

Unit I	Hand Tools
Unit II	Power Tools

Section E--Blueprint Reading

Unit I	Blueprint Reading
--------	-------------------

Section F--Site

Unit I	Site Preparation
Unit II	Site Layout

Section G--Forming

Unit I	Introduction to Forming
Unit II	Footing Forms
Unit III	Edge Forms on Grade
Unit IV	Wall Forms
Unit V	On Grade Curb Forms

Unit VI	Vertical Piers and Columns
Unit VII	Horizontal Beam Forms
Unit VIII	Above Grade Slab Systems
Unit IX	Fireproof Encasement Forms
Unit X	Stair Forms
Unit XI	Bridge Deck Forms

Section H--Framing

Unit I	Floor and Sill Framing
Unit II	Wall and Partition Framing
Unit III	Roof Framing
Unit IV	Trusses
Unit V	Structural Timber Construction
Unit VI	Fireproof Masonry and Metal Stud Construction

Section I--Exterior Finish

Unit I	Exterior Wall Coverings and Trim
--------	----------------------------------

Section J--Interior Wall Finish

Unit I	Dry Wall
--------	----------

Section K--Interior Trim

Unit I	Stair Construction
Unit II	Door Hanging and Trim
Unit III	Cabinet and Fixture Installation
Unit IV	Paneling

FOREWORD

In 1972, the Associated General Contractors of America met with representatives of the Oklahoma Curriculum and Instructional Materials Center to discuss the possibility of developing, as a cooperative project, a course of instruction that would be especially designed for training the carpenter who will make his career in industrial and commercial construction.

This publication is the result of those original discussions. It is the product of close coordination between general contractors, men that actually work in construction, and vocational-technical educators. It represents a conscious effort to meld the practical experience of personnel from the world of construction with the best instructional methods available from the world of education.

The trainers of construction craftsmen are faced with the challenge of providing thorough, and modern training to the backbone of the building industry - its workforce. The purpose of this manual is to assist carpentry teachers in providing a uniformly high caliber of thorough instruction to their student craftsmen. This publication should be supplemented by each instructor's own methods and materials. The information in the manual may be adapted to coincide with local conditions that dictate modification in content or method.

Dr. Francis T. Tuttle, Director
Oklahoma State Department of
Vocational and Technical Education

Paul E. Emerick, Chairman
Manpower and Training Committee
Associated General Contractors of America

PREFACE

The need for instructional material to be used in training the commercial carpenter has for many years been felt by contractors and by those responsible for the training of carpenters. The Associated General Contractors of America with the cooperation and support of the Oklahoma State Department of Vocational Technical Education, Curriculum Center have accepted the challenge to produce a manual for use in training the commercial carpenter in those areas in which he is expected to be proficient.

Instructional material in this manual is written in terms of student performance using measurable behavioral objectives. This is an innovative approach to teaching that accents and augments the teaching learning process. Criterion referenced evaluation instruments provide for a uniform measurement of student progress.

Carpentry instructors throughout the world are faced with the challenge of providing students with the skill and related information necessary to meet the demands of a changing profession. Competition for jobs is greater than ever, therefore, the carpenter must be better trained and better equipped to find and retain meaningful employment.

The purpose of this manual is to assist carpentry instructors in improving instruction throughout the industry. This publication should be supplemented by each instructor's methods and materials. Any information in this manual that does not concur with the instructor's course of study can very easily be modified to meet his needs.

Donald W. Diehl

Wayman R. Penner

ABOUT THE AUTHORS

Donald W. Diehl was born in 1910 in Iowa City, Iowa. His father, a building contractor, started Don's carpentry training at an early age. Although his formal education ended in the tenth grade, Don later completed various courses associated with carpentry through correspondence and night school. This independent study continued through the years with numerous hours spent in the library to research projects and procedures.

In 1937, he joined the United Brotherhood of Carpenters and Joiners of America, Local Union #308 in Cedar Rapids, Iowa. Don held the rate of Chief Carpenter in the U.S. Navy during WW II and after his discharge, he served as a Field Representative for the U.S. Dept. of Labor, Bureau of Apprenticeship. Upon leaving the Bureau of Apprenticeship, he returned to construction and was employed by Ringland-Johnson Crowley Co. of Des Moines, Iowa, the company he has remained with for nineteen years. Don is presently classified as a Superintendent, a position he earned after working at all levels of construction. He is a member in good standing in the Carpenters Local #106 Des Moines, Iowa, and for the development of this commercial carpentry manual, his forty three years of experience were loaned to the Associated General Contractors of America. During this period, he served as a member of the staff of the Oklahoma State Department of Vocational-Technical Education, Curriculum and Instructional Materials Center.

Wayman R. Penner was born in 1935 in Okeene, Oklahoma and completed his formal education at Corn, Oklahoma. After serving in the U.S. Navy, he earned a B.S. Degree in Industrial Arts Education from Southwestern State College, Weatherford, Oklahoma and taught in the Tulsa Public School System as a cabinetmaking instructor and later as supervisor of Adult Vocational Education. During this time, he earned a M.S. Degree in Trade and Industrial Education from Oklahoma State University, Stillwater, Oklahoma. Wayman has worked for six years in residential construction and as a cabinet contractor. In 1970, he was awarded a U.S. Office of Education Grant to pursue a doctoral degree at Oklahoma State University. Upon completion of the degree, he was employed by the Oklahoma State Department of Vocational Technical Education as a curriculum specialist. Wayman has authored an article entitled "Nature and Scope of Adult Vocational Teacher Education Characteristics" and a "Residential Carpentry" curriculum manual. He is presently coordinating the development of further curriculum materials for the division of Trade and Industrial Education.

ACKNOWLEDGEMENTS

Appreciation is expressed to the many individuals and companies who gave of their time and knowledge in the preparation of this manual.

Ad Hoc Committee Members and Staff Representatives of the Associated General Contractors who contributed to the Curriculum and Instructional Materials Center Project

Chairman, AGC
Manpower and Training Committee

Ad Hoc Committee
Chairman

Mr. Paul E. Emerick
Paul B. Emerick Co.
Portland, Oregon

Dean Weaver
Weaver Construction Co.
Denver, Colorado

Committee Members

Mr. Irving deMilt, Director
Manpower & Training Division
AGC of America, Inc.
Washington, DC

John E. Hinkson
Constr. Training School
St. Louis, Missouri

Mr. H. Pratt Farnsworth
Pratt Farnsworth Inc.
Metairie, Louisiana

Timothy R. McCarthy
McCarthy Bros. Constr. Co.
St. Louis, Missouri

Robert B. Fay
Joseph B. Fay Co.
Pittsburgh, Pennsylvania

Duke Nielsen
AGC/Colo. Bldrs. Chapter
Denver, Colorado

Tom. E. Gajda
CAP of Indianapolis &
Central Indiana
Indianapolis, Indiana

Mr. W. L. Pemberton
Gamble Const. Co.
St. Louis, Missouri

Arthur A. Prado
West. Pa. Hvy & Hwy CIAP
Fund
Pittsburgh, Pennsylvania

We are grateful to the following companies for their efforts to assist us in the development of this instructional manual.

Frank Paxton Lumber Co., Des Moines, Iowa
Gates & Sons Inc., Denver, Colorado
Universal Form Clamp Co., Chicago, Illinois
Metal Forms Corporation, Milwaukee, Wisconsin

Strickland Systems Inc., Jacksonville, Florida
(MFG) Molded Fiber Glass Concrete Forms Co., Ashtabula, Ohio
Con-Form Equipment Corporation, Elk Grove Village, Illinois
American Plywood Association, Dallas, Texas
Kermit Ingham Lumber Co., Stillwater, Oklahoma
Automated Building Components, Inc., Miami, Florida.

Gratitude is expressed to Beth Parker for editing, to Nancy Skach and Barbara Reed for assistance with research, and Jennifer Norton, and the Communications Center for typing.

Special appreciation to Ron Meek, Coordinator, Dr. Irene Clements and Bob Patton, Assistant Coordinators, Bob Rea, Media Graphics Designer, Susan Bell and Dean Clark, Illustrators, Sandy Lamirand, Audiovisual Clerk, Teresa Robertson, Phyllis Evicks, and Cheryl Sieber, Secretaries, for their help and encouragement, and Ron Wilkerson and Paul Newlin, for their photographic expertise.

Our sincere thanks to:

Mr. Jack Hall, Bill Bontrager, and other personnel of the Weitz Company Inc. of Des Moines, Iowa, for their assistance in developing the job sheet on Slip Forms.

Mr. Arthur Prado and other personnel of the Western Pennsylvania Heavy and Highway Construction Industry Advancement Program of Pittsburgh, Pennsylvania, for their assistance in developing the unit on Bridge Deck Forms.

Mr. Paul E. Emerick of the Paul B. Emerick Co. of Portland, Oregon, for his assistance in developing the unit on Structural Timber Construction.

Mr. Claire Seeliger of the Dolese Ready-Mixed Concrete Co., Stillwater, Oklahoma, for providing our photographer with a simulated slump test for the Introduction to Forming unit.

The H.W. Hackleman Construction Co., Stillwater, Oklahoma, for permitting us to photograph various forming applications on a construction site.

Mr. Gordon Sukow of the Frank Paxton Lumber Co., Des Moines, Iowa, for his assistance in securing information vital to this manual.

USE OF THIS PUBLICATION

Instructional Units

Commercial Carpentry curriculum includes eleven sections. Each section consists of one or more units of instruction. Each instructional unit includes behavioral objectives, suggested activities for teacher and students, information sheets, assignment sheets, job sheets, visual aids, tests, and answers to the test. Units are planned for more than one lesson or class period of instruction.

Careful study of each instructional unit by the teacher will help him determine:

- A. The amount of material that can be covered in each class period.
- B. The skills which must be demonstrated.
 1. Supplies needed
 2. Equipment needed
 3. Amount of practice needed
 4. Amount of class time needed for demonstrations
- C. Supplementary materials such as pamphlets and filmstrips that must be ordered.
- D. Resource people that must be contacted.

Objectives

Each unit of instruction is based on behavioral objectives. These objectives state the goals of the course thus providing a sense of direction and accomplishment for the student.

Behavioral objectives are stated in two forms: Terminal Objectives stating the subject matter to be covered in a unit of instruction; Specific Objectives stating the student performance necessary to reach the terminal objective.

Since the objectives of the unit provide direction for the teaching-learning process, it is important for the teacher and students to have a common understanding of the intent of the objectives. A limited number of performance terms have been used in the objectives for this curriculum to assist in promoting the effectiveness of the communication among all individuals using the materials.

Following is a list of performance terms and their synonyms which were used in this material:

<u>Name</u>	<u>Identify</u>	<u>Describe</u>
Label	Select	Define
List in writing	Mark	Discuss in writing
List orally	Point out	Discuss orally
Letter	Pick out	Interpret
Record	Choose	Tell how
Repeat	Locate	Tell what
Give		Explain

Order

Arrange
Sequence
List in order
Classify
Divide
Isolate
Sort

Distinguish

Discriminate

Construct

Draw
Make
Build
Design
Formulate
Reproduce
Transcribe
Reduce
Increase
Figure
Cost

Demonstrate

Show your work
Show procedure
Perform an experiment
Perform the steps
Operate
Remove
Replace
Turn off/on
(Dis) assemble
(Dis) connect

Reading of the objectives by the student should be followed by a class discussion to answer any questions concerning performance requirements for each instructional unit.

Teachers should feel free to add objectives which will fit the material to the needs of his students and community. When a teacher adds objectives, he should remember to supply the needed information, assignment and/or job sheets, and criterion tests.

Suggested Activities

Each unit of instruction has a Suggested Activities sheet outlining steps to follow in accomplishing specific objectives. The activities are listed according to whether they are the responsibility of the instructor or the student.

Instructor: Duties of the instructor will vary according to the particular unit; however, for best use of the material they should include the following: provide students with objective sheet, information sheets, assignment sheets, and job sheets; preview filmstrips, make transparencies, and arrange for resource materials and people; discuss terminal and specific objectives and information sheets; give test. Teachers are encouraged to use any additional instructional activities and teaching methods to aid students in accomplishing the objectives.

Students: Student activities are listed which will help the student to achieve the objectives for the unit.

Information Sheets

Information sheets provide content essential for meeting the cognitive (knowledge) objectives of the unit. The teacher will find that information sheets serve as an excellent guide for presenting the background knowledges necessary to develop the skills specified in the terminal objective.

Students should read the information sheets before the information is discussed in class. Students may take additional notes on the information sheets.

Transparency Masters

Transparency masters provide information in a special way. The students may see as well as hear the material being presented, thus reinforcing the learning process. Transparencies may present new information or they may reinforce information presented in the information sheets. They are particularly effective for such activities as learning and locating the parts of a machine.

Transparencies should be made and placed in the notebook where they will be immediately available for use. Transparencies direct the class's attention to the topic of discussion. They should be left on the screen only when topics shown are under discussion. (NOTE: Stand away from the overhead projector when discussing transparency material. The noise of the projector may cause the teacher to speak too loudly.)

Job Sheets

Job sheets are an important segment of each unit. The instructor should be able to and in most situations should demonstrate the skills outlined in the job sheets. Procedures outlined in the job sheets give direction to the skill being taught and allow both student and teacher to check student progress toward the accomplishment of the skill. Job sheets provide a ready outline for a student to follow if he has missed a demonstration. Job sheets also furnish potential employers with a picture of the skills being taught and the performances he might reasonable expect from a person who has had this training.

Assignment Sheets

Assignment sheets give direction to study and furnish practice for paper and pencil activities to develop the knowledges which are necessary prerequisites to skill development. These may be given to the student for completion in class or used for homework assignments. Answer sheets are provided which may be used by the student and/or teacher for checking student progress.

Test and Evaluation

Paper-pencil and performance tests have been constructed to measure student achievement of each objective listed in the unit of instruction. Individual test items may be pulled out and used as a short test to determine student achievement of a particular objective. This kind of testing may be used as a daily quiz and will help the teacher spot difficulties being encountered by students in their efforts to accomplish the terminal objective. Test items for objectives added by the teacher should be constructed and added to the test. Progress sheets are provided for student and teacher to record acceptable performance of skills outlined in job sheets.

Test Answers

Test answers are provided for each unit. These may be used by the teacher and/or student for checking student achievement of the objectives.

ORIENTATION
UNIT I

TERMINAL OBJECTIVE

After completion of this unit, the student should be able to list places of employment and facts concerning the occupational outlook for carpenters. He should be able to list student requirements and steps involved in commercial construction. He should complete a personal information sheet. This knowledge will be evidenced by scoring eighty-five percent on the unit test.

SPECIFIC OBJECTIVES

After completion of this unit, the student should be able to:

1. List three facts concerning the occupational outlook for carpentry.
2. Name five employment opportunities for carpenters.
3. List six student requirements for the carpentry program.
4. Name six major skills involved in carpentry.
5. Demonstrate the ability to complete a personal information sheet.

ORIENTATION
UNIT I

SUGGESTED ACTIVITIES

- I. Instructor:
 - A. Provide students with objective sheet.
 - B. Provide students with information and assignment sheets.
 - C. Discuss terminal and specific objectives.
 - D. Discuss information and assignment sheets.
 - E. Give test.
- II. Student:
 - A. Read objective sheet.
 - B. Study information sheet.
 - C. Complete assignment sheet.
 - D. Take test.

INSTRUCTIONAL MATERIALS

- I. Included in this unit:
 - A. Objective sheet
 - B. Information sheet
 - C. Assignment Sheet #1--Personal Information Sheet
 - D. Test
 - E. Answers to test
- II. Reference--*Occupational Outlook Handbook*, 1970-71 edition. U.S. Department of Labor, Bureau of Labor Statistics, Bulletin No. 1650.

ORIENTATION
UNIT I

INFORMATION SHEET

- I. Occupational outlook
 - A. Job opportunities result each year from the need to replace experienced carpenters who retire or die
 - B. The number of new houses being constructed each year requires more carpenters to construct and maintain them
 - C. Specialization has created more job opportunities and more desirable working conditions
- II. Employment opportunities
 - A. Independent and union affiliated residential building contractors
 - B. Independent and union affiliated commercial contractors
 - C. Building maintenance for large office buildings or corporations
 - D. Pre-fab shops
 - E. Lumber yards as handy man
- III. Student requirements for the carpentry program
 - A. Operate all power tools correctly
 - B. Be safety conscious and follow safety regulations
 - C. Take instructions readily and follow directions
 - D. Be a good citizen
 - E. Control temper at all times
 - F. Display enthusiasm about work
 - G. Exhibit pride in the carpentry trade
 - H. Practice conservation of materials and man-hours
 - I. Be punctual

INFORMATION SHEET

IV. Major skills involved in carpentry

- A. Blueprint reading
- B. Measuring
- C. Use of hand tools
- D. Use of power tools
- E. Making material estimates
- F. Erecting a building

ORIENTATION
UNIT I

ASSIGNMENT SHEET #1--PERSONAL INFORMATION SHEET

NAME _____ CLASS _____

HOME ADDRESS _____

HOME PHONE _____

PARENT'S NAME (or guardian) _____

PARENT'S OCCUPATION _____

PARENT'S BUSINESS PHONE _____

WHERE CAN YOUR PARENTS BE REACHED IN CASE OF AN EMERGENCY? _____

FAMILY DOCTOR _____

LIST SHOP COURSES YOU HAVE HAD _____

TRADE EXPERIENCE _____

NAME OF INSURANCE COMPANY _____

ORIENTATION
UNIT I

TEST

1. List three facts concerning the occupational outlook for carpentry.
 - a.
 - b.
 - c.
2. Name five employment opportunities for carpenters.
 - a.
 - b.
 - c.
 - d.
 - e.
3. List six student requirements for the carpentry program.
 - a.
 - b.
 - c.
 - d.
 - e.
 - f.
4. Name six major skills involved in carpentry.
 - a.
 - b.
 - c.
 - d.
 - e.
 - f.

5. Demonstrate the ability to complete a personal information sheet.

ORIENTATION
UNIT I

ANSWERS TO TEST

1.
 - a. Job opportunities result each year from the need to replace experienced mechanics who retire or die
 - b. The number of new houses being constructed each year requires more carpenters to construct and maintain them
 - c. Specialization has created more job opportunities and more desirable working conditions
2.
 - a. Independent and union affiliated residential building contractors
 - b. Independent and union affiliated commercial contractors
 - c. Building maintenance for large office buildings or corporations
 - d. Pre-fab shops
 - e. Lumber yards as handy man
3.
 - a. Operate all power tools correctly
 - b. Be safety conscious and follow safety regulations
 - c. Take instructions readily and follow directions
 - d. Be a good citizen
 - e. Control temper at all times
 - f. Display enthusiasm about work
 - g. Exhibit pride in the carpentry trade
 - h. Practices conservation of materials and man-hours
 - i. Be punctual
4.
 - a. Blueprint reading
 - b. Measuring
 - c. Use of hand tools
 - d. Use of power tools
 - e. Making material estimates
 - f. Erecting a building

5. Performance skills will be evaluated according to the criteria listed on the progress chart.

**SAFETY
UNIT II****TERMINAL OBJECTIVE**

After completion of this unit, the student should be able to recognize unsafe situations and be able to state rules for shop and personal safety. He should be able to select the correct fire extinguisher for the classes of fire and match the safety color code with statements of its use. The student should be willing to sign the safety pledge form and should make at least 90 percent on the unit test.

SPECIFIC OBJECTIVES

After completion of this unit, the student should be able to:

1. Define the terms safety, accident, and first aid.
2. Match the six colors of the safety color code with statements of their use.
3. List five rules for personal safety.
4. List eight rules for general safety.
5. List five methods used to maintain a clean and orderly work area.
6. Match the three classes of fire with statements defining each class.
7. List the three components of the fire triangle.
8. Select from a list of fire extinguishers the types best suited to extinguish each class of fire.
9. Indicate a willingness to work safely by subscribing to the student safety pledge form.

SAFETY
UNIT II

SUGGESTED ACTIVITIES

I. Instructor:

- A. Provide students with objective sheet.
- B. Provide students with information sheet and the safety pledge form.

(NOTE: It is recommended the student be taught the ten or thirty hour construction safety and health training course.)

- C. Make transparencies.
- D. Discuss terminal and specific objectives.
- E. Discuss information sheet.
- F. Give test.

II. Student:

- A. Read objective sheet.
- B. Study information sheet.
- C. Complete the safety pledge form.
- D. Take test.

INSTRUCTIONAL MATERIALS

I. Included in this unit:

- A. Objective sheet
- B. Information sheet
- C. Transparency masters:
 - 1. TM 1--The Fire Triangle
 - 2. TM 2--Types of Fire Extinguishers
- D. Assignment Sheet #1--Student Safety Pledge Form
- E. Test
- F. Answers to test

II. References:

- A. Kidde Portable Extinguishers. *The ABC's of Fire Protection*. Belleville, New Jersey: Walter Kidde and Company, Inc.
- B. U.S. Department of Health, Education, and Welfare, Office of Education. *An Accident Prevention Program for School Shops and Laboratories*. Department of Vocational Education, Pennsylvania State University, 1967.
- C. Department of Labor. *Federal Register*. Vol. 36. Number 105. Part II. May 29, 1971.
- D. Department of Education, Division of Vocational Education, State of New Jersey. *Safety Practices and Procedures in School Shops*. Trenton, New Jersey: New Jersey State Department of Vocational Education.
- E. Manual of Accident Prevention in Construction, The Associated General Contractors of America, 1971.

SAFETY
UNIT II

INFORMATION SHEET

- I. Terms and definitions
 - A. Safety--State or condition of being safe; freedom from danger, risk, or injury
 - B. Accident--Includes any suddenly occurring, unintentional event which causes injury or property damage
 - C. First aid--Immediate, temporary care given to the victim of an accident or sudden illness until the services of a physician can be obtained
- II. Colors and application of the safety color code
 - A. Federal safety red--The basic color for the identification of:
 1. Fire protection equipment and apparatus
 2. Portable containers of flammable liquids
 3. Emergency stop bars, stop buttons, and emergency electrical stop switches on machinery
 - B. Federal safety yellow--The basic color for designating:
 1. Caution and for marking physical hazards
 2. Waste containers for explosive or combustible materials
 3. Caution against starting, using, or moving equipment under repair
 4. Identification of the starting point or power source of machinery
 - C. Federal safety orange--The basic color for designating:
 1. Dangerous parts of machines
 2. Safety starter buttons
 3. The exposed parts (edges only) of pulleys, gears, rollers, cutting devices, and power jaws
 - D. Federal safety purple--The basic color for designating radiation hazards.
 - E. Federal safety green--The basic color for designating:
 1. Safety

INFORMATION SHEET

2. Location of first aid equipment

(NOTE: This applies to equipment other than fire fighting equipment.)

F. Federal safety black and white--(used individually or in combination) The basic colors for designating:

1. Traffic flow
2. Housekeeping purposes

III. Personal safety rules

- A. Wear clothing appropriate to the instructional activity being performed
- B. Confine long hair before operating rotating equipment
- C. Always wear safety glasses; use suitable helmets and goggles for welding
- D. Remove ties when working around machine tools or rotating equipment
- E. Remove rings and other jewelry when working
- F. Conduct yourself in a manner conducive to safe practices
- G. Use soap and water frequently as a method of preventing skin diseases

IV. General safety rules

- A. Keep all hand tools sharp, clean, and in safe working order
- B. Report any defective tools, machines, or other equipment to the supervisor
(NOTE: In this unit, the term supervisor refers to the foreman, superintendent or instructor that is in charge of the work area.)
- C. Retain all guards and safety devices except with the specific authorization of the supervisor
- D. Operate a hazardous machine only after receiving instruction on how to operate the machine safely
- E. Report all accidents to the supervisor regardless of nature or severity
- F. Operator turns off power and makes certain the machine has stopped running before leaving
- G. Make sure all guards and barriers are in place and adjusted properly before starting a machine tool

INFORMATION SHEET

- H. Disconnect the power from machine tools before performing the maintenance task of oiling or cleaning
 - I. Use a solvent only after determining its properties, what kind of work it has to do, and how to use it
 - J. Use correct, properly fitting wrenches for nuts, bolts, and objects to be turned or held
 - K. Keep the work area floor clear of scraps and litter
 - L. Clean up any spilled liquids immediately
 - M. Oily rags or oily waste should be stored in metal containers
 - N.³ Clean the chips from a machine with a brush--not with a rag or the bare hands
 - O. Do not use compressed air to clean your person or clothing
 - P. Use only approved scaffolding
- V. Methods used to maintain a clean and orderly work area
- A. Arrange machinery and equipment to permit safe, efficient work practices and ease in cleaning
 - B. Stack materials and supplies safely or store in proper place
 - C. Store tools and accessories safely in cabinets, on racks, or in other suitable devices
 - D. Clear working areas and work benches of debris and other hazards
 - E. Clean and free floors from obstructions and slippery substances
 - F. Free aisles, traffic areas, and exits of materials and other debris
 - G. Dispose of combustible materials properly or store in approved containers
 - H. Store oily rags in self-closing or spring-lid metal containers
 - I. Know the proper procedures to follow in keeping the work area clean and orderly
 - J. Keep sufficient brooms, brushes, and other housekeeping equipment readily available
- VI. Classes of fires
- A. Class A--Fires that occur in ordinary combustible materials such as wood, rags, and rubbish

INFORMATION SHEET

- B. Class B--Fires that occur with flammable liquids, such as gasoline, oil, grease, paints, and thinners
- C. Class C--Fires that occur in or near electrical equipment such as motors, switchboards, and electrical wiring

VII. Three components of the fire triangle (Transparency 1)

- A. Fuel--Any combustible material
- B. Heat--Enough to raise the fuel to its ignition temperature
- C. Oxygen--Necessary to sustain combustion

(NOTE: To produce fire these three elements are necessary and must be present at the same time. If any one of the three is missing, a fire cannot be started or, with the removal of any of them, the fire will be extinguished.)

VIII. Types of fire extinguishers (Transparency 2)

- A. Pressurized water--Operates usually by squeezing a handle or trigger; used on Class A fires
- B. Soda acid--Operates by turning extinguisher upside down; used on Class A fires
- C. Carbon dioxide (CO_2)--Operates usually by squeezing handle or trigger; used on Class B and C fires
- D. Dry chemical--Operates usually by squeezing a handle, trigger, or lever; used on Class B and C fires
- E. Foam--Operates by turning extinguisher upside down; used on Class A and B fires

The Fire Triangle

To produce fire, three things must be present at the same time.

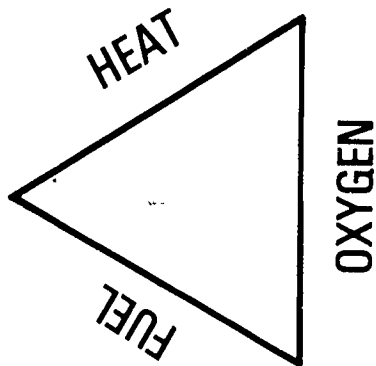

If any one of the three is missing, a fire cannot be started or, with the removal of any one, the fire will be extinguished.

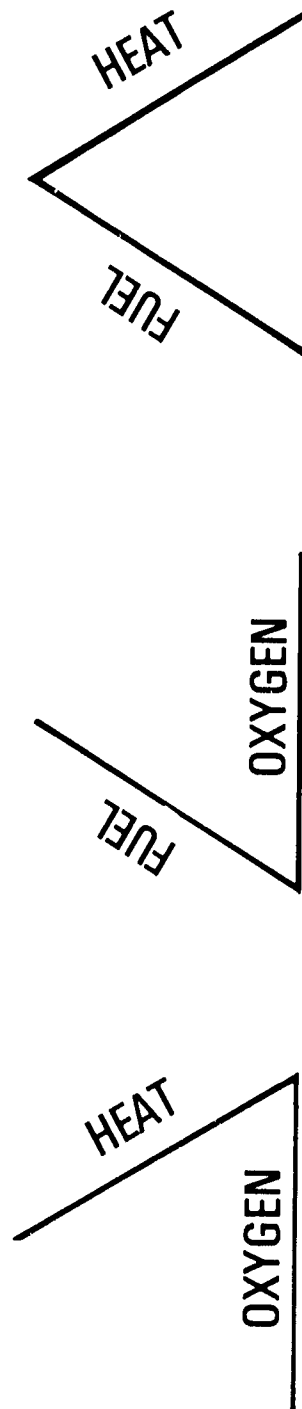

Types of Fire Extinguishers



Pressurized
Water

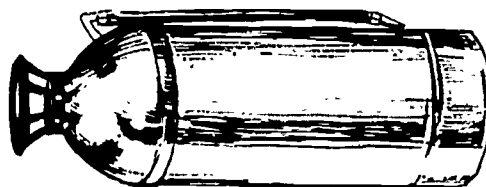

Soda-Acid

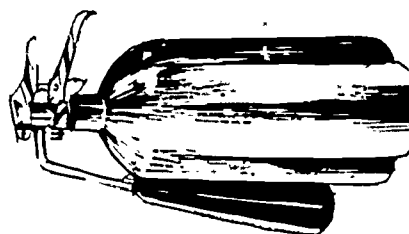

Carbon
Dioxide

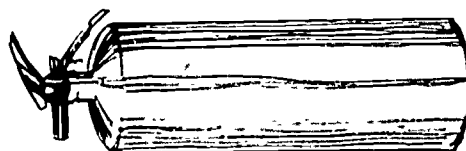

Dry
Chemical

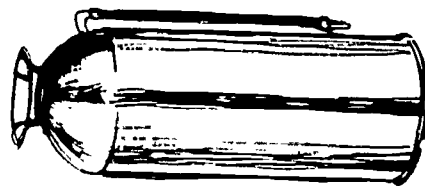

Foam

SAFETY
UNIT II

ASSIGNMENT SHEET #1--STUDENT SAFETY PLEDGE FORM

_____, who is enrolled in Vocational _____
 _____, will as a part of his shop experience, operate machines,
 providing that his parent or guardian gives written permission.

It is understood that each student will be given proper instruction, both in the use of the equipment and in correct safety procedures concerning it, before being allowed to operate it himself. The student must assume responsibility for following safe practices, and we therefore ask that he subscribe to the following safety pledge.

1. I promise to follow all safety rules for the shop.
2. I promise never to use a machine without first having permission from the instructor.
3. I will not ask permission to use a particular machine unless I have been instructed in its use, and have made 100% on the safety test for that machine.
4. I will report any accident or injury to the teacher immediately.

Date _____ Student's signature _____

I hereby give my consent to allow my son to operate all machines and equipment necessary in carrying out the requirements of the course in which he is enrolled.

Date _____ Parent's signature _____

Parents are cordially invited to visit the shop to inspect the machines and to see them in operation.

SAFETY
UNIT II

TEST

1. Define the following terms.
 - a. Safety--
 - b. Accident--
 - c. First aid--

2. Match the following colors of the safety color code with the correct statements of their use.

_____ a. Designates caution	1. Green
_____ b. Used to identify the location of fire fighting equipment	2. White
_____ c. Designates the location of safety and first aid equipment	3. Orange
_____ d. Designates dangerous parts of equipment which may cut, crush, shock, or otherwise injure	4. Purple
_____ e. Designates caution against starting equipment while it is being worked on or against the use of defective equipment	5. Black
_____ f. Designates traffic flow	6. Red
_____ g. Designates radiation hazards	7. Yellow

3. List five personal safety rules.
 - a.
 - b.
 - c.
 - d.
 - e.

4. List eight rules for general safety.
 - a.
 - b.
 - c.
 - d.
 - e.
 - f.
 - g.
 - h.

5. List five methods used to maintain a clean and orderly work area.
 - a.
 - b.
 - c.
 - d.
 - e.

6. Match the classes of fire with the correct statement defining each class.

<u> </u> a. Fires that occur with flammable liquids such as gasoline, oil, or grease	1. Class A
<u> </u> b. Fires that occur in ordinary combustible materials such as wood, rags, and rubbish	2. Class B
<u> </u> c. Fires that occur in or near electrical equipment such as motors, switchboards, and electrical wiring	3. Class C
	4. Class D

7. List the three components of the fire triangle.
 - a.
 - b.
 - c.

8. Write the number or numbers of the fire extinguisher best suited to extinguish each class of fire.

- | | |
|---|--------------------------------------|
| _____ a. Fires that occur with flammable liquids such as gasoline, oil, or grease | 1. Pressurized water |
| _____ b. Fires that occur in or near electrical equipment such as motors, switchboards, and electrical wiring | 2. Carbon dioxide (CO ²) |
| _____ c. Fires that occur in ordinary combustible materials such as wood, rags, and rubbish | 3. Dry chemical |
| | 4. Soda acid |
| | 5. Foam |

SAFETY
UNIT II

ANSWERS TO TEST

1.
 - a. State or condition of being safe; freedom from danger, risk, or injury
 - b. Includes any suddenly occurring, unintentional event which causes injury or property damage
 - c. Immediate, temporary care given the victim of an accident or sudden illness until the services of a physician can be obtained
2.
 - a. 7
 - b. 6
 - c. 1
 - d. 3
 - e. 7
 - f. 2 and 5
 - g. 4
3. Any five of the following:
 - a. Wear shop clothing appropriate to the instructional activity being performed
 - b. Confine long hair before operating rotating equipment
 - c. Always wear safety glasses; use suitable helmets and goggles for welding
 - d. Remove ties when working around machine tools or rotating equipment
 - e. Remove rings and other jewelry when working
 - f. Conduct yourself in a manner conducive to safe practices
 - g. Use soap and water frequently as a method of preventing skin diseases
4. Any eight of the following:
 - a. Keep all hand tools sharp, clean, and in safe working order
 - b. Report any defective tools, machines, or other equipment to the supervisor

- c. Retain all guards and safety devices except with the specific authorization of the supervisor
 - d. Operate a hazardous machine only after receiving instruction on how to operate the machine safely
 - e. Report all accidents to the supervisor regardless of nature or severity
 - f. Operator turns off power and makes certain the machine has stopped running before leaving
 - g. Make sure all guards and barriers are in place and adjusted properly before starting a machine tool
 - h. Disconnect the power from machine tools before performing the maintenance task of oiling or cleaning
 - i. Use a solvent only after determining its properties, what kind of work it has to do, and how to use it
 - j. Use correct properly fitting wrenches for nuts, bolts, and objects to be turned or held
 - k. Keep the work area clear of scraps and litter
 - l. Clean up any spilled liquids immediately
 - m. Oily rags or oily waste should be stored in metal containers
 - n. Clean the chips from a machine with a brush-not with a rag or the bare hands
 - o. Do not use compressed air to clean your person or clothing
 - p. Use only approved scaffolding
5. Any five of the following:
- a. Arrange machinery and equipment to permit safe, efficient work practices and ease in cleaning
 - b. Stack materials and supplies safely or store in proper place
 - c. Store tools and accessories safely in cabinets, on racks, or in other suitable devices
 - d. Clear working areas and work benches of debris and other hazards
 - e. Clean and free floors from obstructions and slippery substances
 - f. Free aisles, traffic areas, and exits of materials and other debris
 - g. Dispose of combustible materials properly or store in approved containers

- h. Store oily rags in self-closing or spring-lid metal containers
 - i. Know the proper procedures to follow in keeping the area clean and orderly
 - j. Keep sufficient brooms, brushes, and other housekeeping equipment readily available
- 6.
- a. 2
 - b. 1
 - c. 3
- 7.
- a. Fuel
 - b. Heat
 - c. Oxygen
- 8.
- a. 2, 3, and 5
 - b. 2 and 3
 - c. 1, 4, and 5

APPLYING FOR A JOB
UNIT III

TERMINAL OBJECTIVE

After completion of this unit, the student should be able to locate a job opening, make formal application, and effectively interview for a job. This knowledge will be evidenced through demonstration and by scoring eighty-five percent on the unit test.

SPECIFIC OBJECTIVES

After completion of this unit, the student should be able to:

1. Match terms associated with a job application to the correct definition.
2. List four means of locating job openings.
3. List three methods of applying for a job.
4. Select ten items of information that may be asked on an application.
5. Select from a list the attributes or attitudes an employer looks for during a personal interview.
6. Identify examples of proper conduct during the job interview.
7. Demonstrate the ability to:
 - a. Write a letter of application for a carpentry job.
 - b. Make an appointment by phone for a carpentry job interview.
 - c. Write a resume.
 - d. Complete an application form for a job as a carpenter.
 - e. Write a follow-up letter after an interview for a carpentry job.

APPLYING FOR A JOB
UNIT III

SUGGESTED ACTIVITIES

- I. Instructor:
 - A. Provide students with objective sheet.
 - B. Provide students with information, assignment, and handout sheets.
 - C. Make transparencies.
 - D. Discuss terminal and specific objectives.
 - E. Discuss information sheet.
 - F. Discuss assignment sheets and handouts.
 - G. Give test.
- II. Student:
 - A. Read objective sheet.
 - B. Study information sheet.
 - C. Complete assignment sheets.
 - D. Take test.

INSTRUCTIONAL MATERIALS

- I. Included in this unit:
 - A. Objective sheet
 - B. Information sheet
 - C. Transparency masters
 1. TM 1--Attitudes
 2. TM 2--Take Time To Be On Time
 3. TM 3--Appropriate Dress

D. Assignment sheets

1. Assignment Sheet #1--Write a Letter of Application
2. Assignment Sheet #2--Complete an Application
3. Assignment Sheet #3--Prepare a Resume
4. Assignment Sheet #4--Write a Follow-Up Letter

E. Student handouts

1. Student Handout #1--Application for Employment
2. Student Handout #2--Dear Kid
3. Student Handout #3--Sample Letter of Application
4. Student Handout #4--Sample Resume
5. Student Handout #5--Sample Follow-Up Letter

F. Test

G. Answers to test

II. References:

- A. Blackledge - Blackledge - Keily. *You and Your Job*. Dallas, Texas: South-Western Publishing Company, 1967.
- B. Milburn, Paul M. *How to Get a Job*. Shawnee, Oklahoma: Gordon Cooper Area Vocational Technical School, 1967.
- C. Moynihan - Moynihan - Daeger. *You and Your Job--How to Get It*. Chicago, Illinois: J. G. Ferguson Publishing Company, 1968.
- D. Wood - McKeena. *The Receptionist*. Dallas, Texas: Gregg Division, McGraw-Hill Book Company, 1966.

APPLYING FOR A JOB
UNIT III

INFORMATION SHEET

- I. Terms and definitions
 - A. Awards--Recognition received for outstanding achievement
 - B. Extra-curricular activities--The clubs, organizations, and social or church groups in which one participates
 - C. Fringe benefits--The extras provided by an employer such as paid vacations, sick leave, and insurance protection
 - D. Qualifications--The experience, education, and physical characteristics which suit a person to a job
 - E. Resume--A brief typed summary of one's qualifications and experience that is used in applying for a job
 - F. Vocational preparation--Any vocational courses and skills one has learned in high school or through work experience
- II. Means of locating a job opening
 - A. Classified ads
 1. Newspapers
 2. Magazines
 - B. Employment offices
 1. Department of labor
 2. Private
 - C. Local labor union business office
 - D. School officials
 1. Teacher
 2. Counselor
 3. Principal
- III. Methods of applying for a job
 - A. Letter
 - B. Telephone
 - C. In person

INFORMATION SHEET

IV. Information that may be asked on an application (Student Handout #1)

- A. Name and address
- B. Phone number
- C. Social Security Number
- D. Personal information
 - 1. Age
 - 2. Sex
 - 3. Height
 - 4. Weight
 - 5. Physical limitations
- E. Education
 - 1. Elementary
 - 2. High school
 - 3. College
 - 4. Other
- F. Experience (Including military)
- G. Next of kin
- H. Previous employers
- I. Reason for leaving last job
- J. Type of job for which one is applying
- K. References
- L. Resume (optional)

V. Personal attributes or attitudes (Transparency 1)

- A. Enthusiasm and interest
- B. Dedication and dependability
- C. Alertness, quickness of mind

INFORMATION SHEET

- D. Honesty and integrity
 - E. Desire to work
 - F. Desire to help others
 - G. Desire to improve one's self
- VI. Proper conduct during the interview (Transparencies 2 and 3; Student Handout #2)
- A. Greet interviewer with a warm smile
 - B. Call interviewer by name (Mr., Mrs., or Miss Jones)
 - C. Introduce self
 - D. Shake interviewer's hand firmly
 - E. Be seated only after interviewer has asked
 - F. Sit and stand erect; do not lean against the wall, a chair, or the desk
 - G. Do not put a hat or coat on the interviewer's desk
 - H. Let the interviewer take the lead in the conversation
 - I. Answer questions completely
 - J. Be polite and courteous
 - 1. Do not interrupt
 - 2. Say "Yes, sir" or "No, sir"
 - K. Have resume and examples of work available for quick reference
 - L. Make an extra effort to express one's self clearly and distinctly
 - 1. Take time to think through every answer
 - 2. Use proper grammar
 - 3. Do not swear
 - 4. Avoid use of slang
 - 5. Try to understand the interviewer's position
 - 6. Look the interviewer in the eye
 - M. Be sincere and enthusiastic

INFORMATION SHEET

- N. Avoid irritating or distracting habits:
 - 1. Smoking, chewing gum, eating candy
 - 2. Giggling or squirming in chair
 - 3. Finger tapping and/or swinging a crossed leg
 - O. Do not try to flatter the interviewer
 - P. Tell the truth about qualifications and experiences
 - Q. Speak well of former employers and associates
 - R. Be positive
 - S. Accept competition gracefully
 - T. Watch for a sign that the interview is over
 - U. Thank interviewer for his time
 - V. Leave promptly at completion of interview
- VII. Writing a letter of application (Student Handout #3)
- A. Make sure the letter meets the standards below:
 - 1. Attractive form
 - 2. Logical arrangement of information
 - 3. Free from smudges or typographical errors
 - 4. Free from spelling or grammatical errors
 - 5. Brief and to the point--Leave the details for the resume
 - 6. Positive in tone
 - 7. Clearly expressed ideas
 - B. The following information should be included in a letter of application
 - 1. Type of position for which one is applying
 - 2. Reason interested in position and firm
 - 3. Ways one's training meets the employer's needs
 - 4. Explanation of personal qualifications
 - 5. Mention of resume

INFORMATION SHEET

6. Request for interview

(NOTE: Be sure to include an address and a phone number where you can be reached.)

VIII. Making an appointment by phone for an interview

A. Steps to follow in making an appointment

1. Plan what to say before calling
2. State one's name and reason for calling

(NOTE: Remember that the receptionist is there to help you. Keep her on your side.)

3. Ask when would be the best time to come for an interview
(NOTE: Do not ask over the phone how much the job pays.)
4. Record the day, time, and place for the interview
5. Thank the receptionist for her help

(NOTE: Be polite and courteous. Remember that this is your first contact with the firm. Make that first impression a good one.)

IX. Preparing a resume (Student Handout #4)

A. Standards for a resume

1. Logically organized
2. Neatly typed
3. Error free
4. In outline form
5. Limited to one page if possible
6. Honest listing of qualifications and experience

B. Information to include in a resume

1. Name, address, and phone number
2. Recent photograph
3. Personal data
 - a. Birth date
 - b. Age, height, and weight

INFORMATION SHEET

- c. Physical limitations
- d. Marital status
- e. Hobbies
- 4. Education
 - a. Schools attended
 - b. Dates of attendance
 - c. Major field of study
 - d. Awards and activities
- 5. Job preferences
- 6. Experience
 - a. Name and address of company
 - b. Length of time worked
 - c. Brief description of duties and responsibilities
 - d. Special training programs or courses
- 7. References (usually three)

(NOTE: Be sure to obtain permission before naming someone as a reference.)

X. Writing a follow-up letter (Student Handout #5)

A. Make sure this letter meets the following standards:

- 1. Error free
- 2. Clean, neat, and arranged attractively
- 3. Free from spelling, punctuation, and grammatical errors
- 4. Sent within a day or two after the interview

B. Points to include in a follow-up letter

- 1. An expression of appreciation for the interviewer's time and interest
- 2. A summary of personal qualifications and interest in the position

(NOTE: Make this last bid for the job a prime example of your excellent work habits. Make the letter as clean, neat, and well worded as possible.)

Attitudes

Enthusiasm, Interest, Dedication, Dependability,
Alertness, Quickness of mind, Honesty, Integrity,

Desire to work, Desire to help others,

Desire to improve one's self

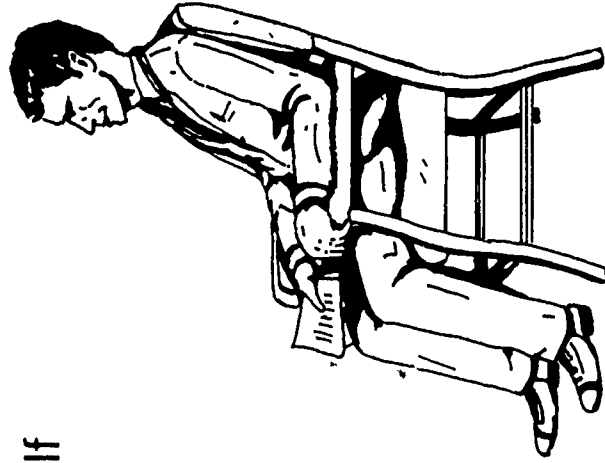
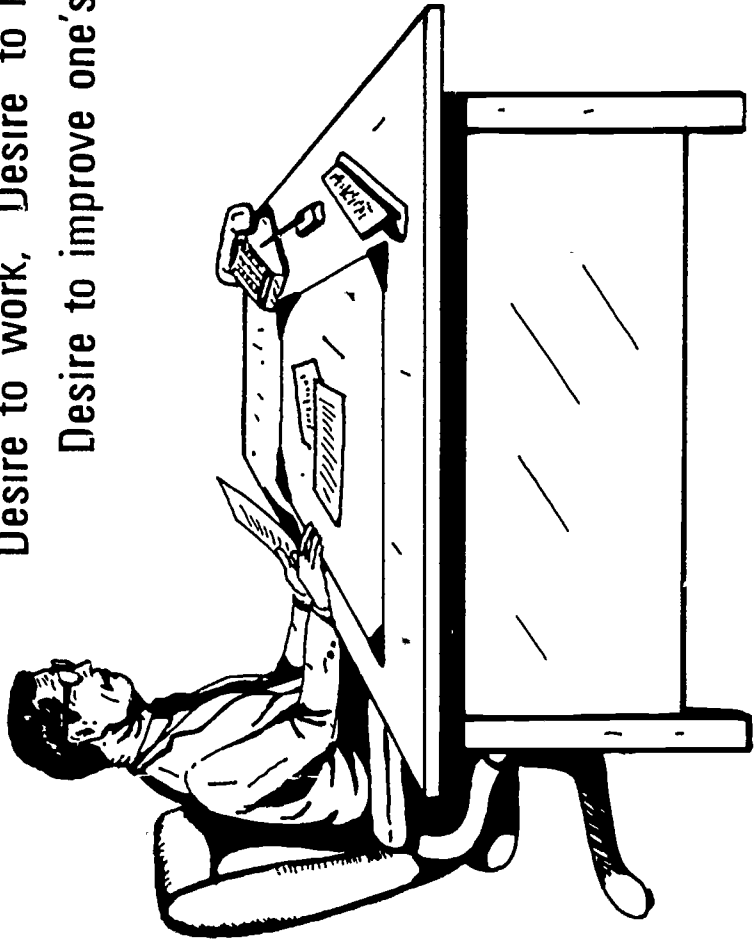

Take the Time to be on Time

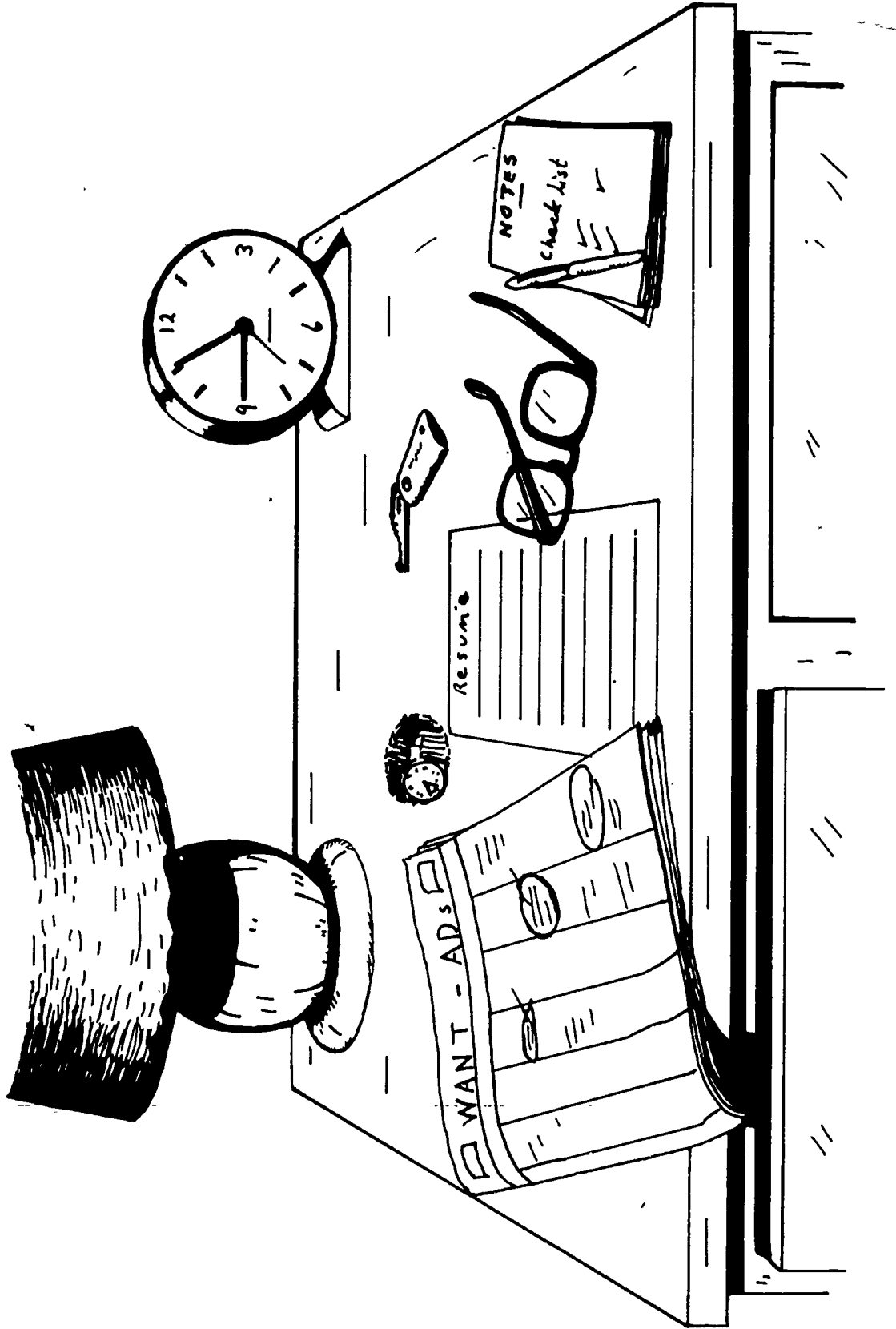

Appropriate Dress

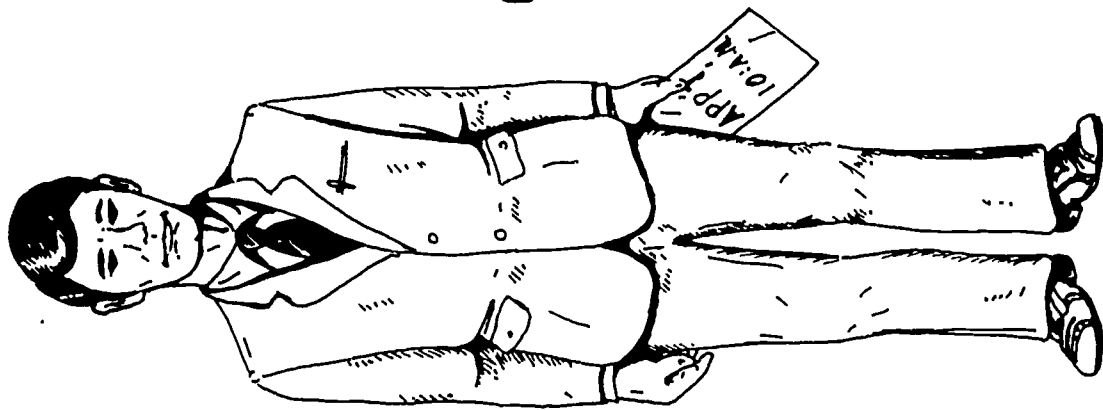

Hair-neat?

Friendly?

Clean shave?

Clean and neat clothes?

Pen and paper?

On time?

Shoes shined?

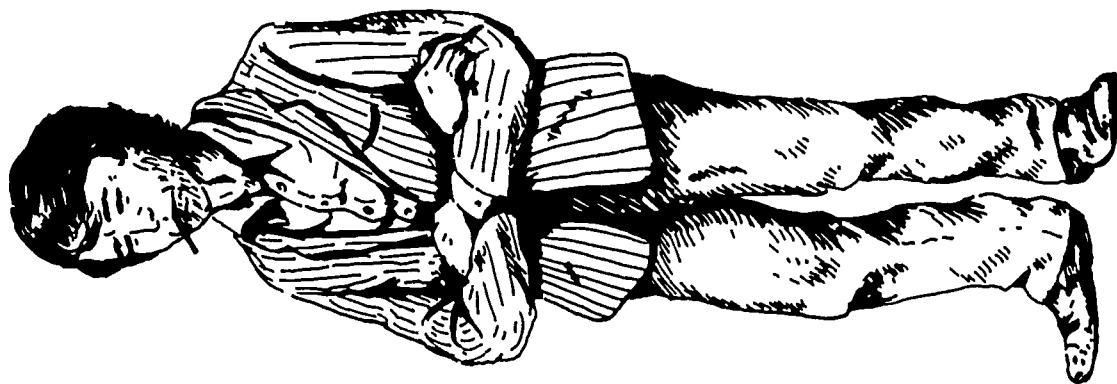

APPLYING FOR A JOB
UNIT III

ASSIGNMENT SHEET #1--WRITE A LETTER
OF APPLICATION

Directions:

- A. Write a letter of application to a prospective employer of carpenters. Use the sample letter in Handout #3 as a guide in composing the letter.
- B. Make sure the letter meets the standards outlined in the information sheet.

APPLYING FOR A JOB
UNIT III

ASSIGNMENT SHEET #2--COMPLETE AN APPLICATION

Directions:

View this form (Handout #1) as an application for employment as a carpenter. Fill in the required information being as honest and realistic as possible.

APPLYING FOR A JOB
UNIT III

ASSIGNMENT SHEET #3--PREPARE A RESUME

Directions:

- A. Write a resume to be included with a letter of application. Use the example in Handout #4 as a guide.
- B. Make sure this resume meets the standards outlined in the information sheet.

APPLYING FOR A JOB
UNIT III

ASSIGNMENT SHEET #4--WRITE A FOLLOW-UP LETTER

Directions:

- A. Write a follow-up letter to the prospective carpentry employer used in Assignment Sheet #1. Use the sample letter in Handout #5 as a guide in composing the letter.
- B. Make sure this letter meets the standards outlined in the information sheet.

APPLYING FOR A JOB UNIT III STUDENT HANDOUT #1

APPLICATION FOR EMPLOYMENT

Do not print

Date _____ Position applied for _____

Name _____ Height _____ Weight _____ Age _____

Address _____ Telephone No. _____
 (Street or RFD) (City) (State)

Previous address _____ Social Security No. _____

Birthdate _____ Birthplace _____
 (Month) (Day) (Year) (City) (State)

CHECK ALL THAT APPLY:

- Female
- Male
- Single
- Married
- Widowed
- Divorced
- Separated
- Own home
- Rent
- Board
- Live (Parents)
- With (Relatives)
- Purchasing home

Number and age of dependents: _____

Relationship of dependents: _____

Business or occupations of father: _____

(or Husband) _____

Interested in: Temporary work _____ Full-time _____ Part-time _____ Saturday only _____

Salary expected: _____

Are you responsible for your entire support? _____ Others who are dependent on you for _____

their support: Number _____ Ages _____

Nature of any physical defects _____

Recent illnesses _____

Date of last physical examination _____

EDUCATION	Circle grade completed	Name of School	Location	Major Subject	Year Graduated
Elementary	1 2 3 4 5 6 7 8				
High	1 2 3 4				
Business or Vocational	1 2 3 4				
College or University	1 2 3 4 5 6				
Night or Correspondence	1 2 3 4				

Give details of any other educational training _____

STUDENT HANDOUT #1

What are your hobbies? _____

In case of illness or emergency, notify Name _____

Address _____

Relationship _____ Telephone _____

Why do you feel qualified for the position for which you are applying?

PREVIOUS EMPLOYMENT
 (Last employment first)

From	To	Name & address of employer	Department-position duties salary	Reason for Leaving
Month	Month			
Year	Year			
Month	Month			
Year	Year			
Month	Month			
Year	Year			
Month	Month			
Year	Year			

PERSONAL REFERENCES

(Do not give names of relatives or former employers)

Name	Address	Occupation
1.		
2.		
3.		

Do Not Write In Space Below

Interviewed by: Personality _____
 Attitude _____
 Ambition and initiative _____

Other remarks: Calmness _____
 Physical qualities _____
 Intelligence _____
 Leadership _____
 Appearance and grooming _____
 Work best suited for _____

APPLYING FOR A JOB
UNIT III

STUDENT HANDOUT #2--DEAR KID

Dear Kid:

Today you asked me for a job. From the look of your shoulders as you walked out, I suspect you've been turned down before, and maybe you believe by now that kids out of high school can't find work.

But, I hired a teen-ager today. You saw him. He was the one with the polished shoes and a necktie. What was so special about him? Not experience, neither of you had any. It was his attitude that put him on the payroll instead of you. Attitude son. ATTITUDE. He wanted that job badly enough to shuck the leather jacket, get a haircut, and look in the phone book to find out what this company makes. He did his best to impress me. That's where he edged you out.

You see, Kid, people who hire people aren't "with" a lot of things and we have some Stone Age ideas about who owes whom a living. Maybe that makes us prehistoric, but there's nothing wrong with the checks we sign, and if you want one you'd better tune to our wave length.

Ever hear of "empathy?" It's the trick of seeing the other fellow's side of things. I couldn't have cared less that you're behind in your car payments. That's your problem and the president's. What I needed was someone who'd go out in the plant, keep his eyes open, and work for me like he'd work for himself. If you have even the vaguest idea of what I'm trying to say, let it show the next time you ask for a job. You'll be head and shoulders over the rest.

Look kid. The only time jobs grew on trees was while most of the manpower was wearing G.I.'s and pulling K.P. For all the rest of history you've had to get a job like you get a girl: "Case" the situation, wear a clean shirt, and try to appear reasonably willing.

Maybe jobs aren't as plentiful right now, but a lot of us can remember when master craftsmen walked the streets. By comparison you don't know the meaning of "scarce."

You may not believe it, but all around you employers are looking for young men smart enough to go after a job in the old-fashioned way. When they find one, they can't wait to unload some of their worries on him.

For both our sakes, get eager, will you?

APPLYING FOR A JOB
UNIT IIISTUDENT HANDOUT #3--SAMPLE LETTER
OF APPLICATION

Mr. John Jones
Personnel Director
Jones Construction Company
Box 19
Anywhere, U.S.A. 77704

Dear Mr. Jones:

Please consider me for the job of rough framing carpenter that you advertised in the Daily Chronicle.

The skills I have learned in my high school vocational carpentry courses should qualify me for this job. I have had experience in all of the basic skills required in residential construction including the safe use of power tools.

I will be graduating from high school in May, and I would like to become a carpenter. A more complete description of my qualifications is given in the enclosed resume.

May I come for an interview any time at your convenience? I can be reached by phone at 377-3303 after 3:30 p.m. or by mail at 774 East Adams Street, Anywhere, U.S.A. 77704.

Sincerely yours,

James F. Smith

Encl. 1

APPLYING FOR A JOB
UNIT III

STUDENT HANDOUT #4--SAMPLE RESUME

Name: James L. Smith
Address: 774 E. Adams St., Anywhere, U.S.A. 77704
Telephone: 377-3303

Age: 18 years
Height: 6' - 1"
Weight: 180 pounds
Health: Excellent
Marital Status: Single

Education: Expect to graduate from high school May 1973

Subjects Studied:

Vocational carpentry--2 years (1080 hours)
Algebra--2 semesters
Geometry--2 semesters
Basic drafting--2 semesters
Industrial arts wood working--2 semesters

Student activities:

President, Senior class
President, VICA
Treasurer, Baptist youth fellowship
Carpentry contest, 1st place State, 3rd place National

Work experience:

Carpenter's helper, Jones Construction Co., Summer 1972
Vocational Carpentry Class 1972-73, all phases of construction.
Mr. Sammy Slavedriver, Instructor.

References:

Mr. Sammy Slavedriver
Vocational Carpentry Instructor
Anywhere High School
Anywhere, U.S.A. 77704

Mr. John Naildriver
Construction Foreman
Jones Construction Company
2330 Lake Shore Drive
Anywhere, U.S.A. 77704

Mr. Jimmie Smith
Youth Director
Park View Baptist Church
711 Fellowship Circle
Anywhere, U.S.A. 77704

Date compiled _____

Signature _____

APPLYING FOR A JOB
UNIT III

STUDENT HANDOUT #5--SAMPLE FOLLOW-UP LETTER

Mr. John Jones
Personnel Director
Jones Construction Company
Box 19
Anywhere, U.S.A. 77704

Dear Mr. Jones:

Thank you for interviewing me for the rough framing carpenter job in your firm. I feel that working for Jones Construction Company would be enjoyable and that I could do the general rough framing work that the job requires. I hope that I will have the opportunity to prove my worth.

The application form you gave me is enclosed.

I will be available for work May 15. You may call me at my home after 3:30 p.m. The number is 377-3303.

Sincerely yours,

James L. Smith

encl.

APPLYING FOR A JOB
UNIT III

TEST

1. Match the terms associated with a job application to the correct definition.

- | | |
|--|---|
| <p>_____ a. A brief typed summary of one's qualifications and experiences that is used in applying for a job</p> <p>_____ b. The extras provided by an employer such as paid vacations, sick leave, and insurance protection</p> <p>_____ c. Recognition received for outstanding achievement</p> <p>_____ d. The experience, education, and physical characteristics which suit a person to a job</p> <p>_____ e. Any vocational courses and skills one has learned in high school or through work experience</p> <p>_____ f. The clubs, organizations, and social or church groups in which one participates</p> | <p>1. Awards</p> <p>2. Extra-curricular activities</p> <p>3. Fringe benefits</p> <p>4. Qualifications</p> <p>5. Resume</p> <p>6. Vocational preparation</p> |
|--|---|

2. List four means of locating job openings.

- a.
- b.
- c.
- d.

3. List three methods of applying for a job.

- a.
- b.
- c.

4. Select ten items of information that may be asked for on an application.

- | | |
|----------|---|
| _____ a. | 1. Race |
| _____ b. | 2. Name and address |
| _____ c. | 3. Phone number |
| _____ d. | 4. Shoe size |
| _____ e. | 5. Age |
| _____ f. | 6. Education |
| _____ g. | 7. Number of brothers and sisters |
| _____ h. | 8. Experience |
| _____ i. | 9. Next of kin |
| _____ j. | 10. Make and model of car |
| | 11. Previous employers |
| | 12. Reason for leaving last job |
| | 13. Are you left or right handed |
| | 14. Type of job for which one is applying |
| | 15. References |

5. Select seven personal attributes or attitudes that an employer looks for.

- | | |
|----------|----------------------------------|
| _____ a. | 1. Alertness |
| _____ b. | 2. Long wavy hair |
| _____ c. | 3. Dedication and dependability |
| _____ d. | 4. Enthusiasm and interest |
| _____ e. | 5. New car |
| _____ f. | 6. Honesty and integrity |
| _____ g. | 7. Desire to work |
| | 8. Beard |
| | 9. Flashy clothes |
| | 10. Desire to help others |
| | 11. Desire to improve one's self |

6. Identify ten examples of proper conduct during an interview.

- | | |
|----------|---|
| _____ a. | 1. Arrive five minutes late. Gives the impression that one is busy. |
| _____ b. | 2. Sit and stand erect |
| _____ c. | 3. Call interviewer by his or her first name |
| _____ d. | 4. Answer questions completely |
| _____ e. | 5. Put a hat or coat on the interviewer's desk |
| _____ f. | 6. Greet interviewer with a warm smile |
| _____ g. | 7. Sit down immediately upon entering the room |
| _____ h. | 8. Shake the interviewer's hand firmly |
| _____ i. | 9. Be polite and courteous |
| _____ j. | 10. Use all of the cute slang expressions |
| | 11. Look the interviewer in the eye |
| | 12. Be sincere and enthusiastic |
| | 13. Thank the interviewer for his time |
| | 14. Chain smoke (gives the impression of being a real "he man") |
| | 15. Speak well of former employees |
| | 16. Flatter the interviewer |
| | 17. Leave promptly at completion of interview |

7. Demonstrate the ability to:

- a. Write a letter of application for a carpentry job.
- b. Make an appointment by phone for a carpentry job interview.
- c. Write a resume:
- d. Complete an application form for a job as a carpenter.
- e. Write a follow-up letter after an interview for a carpentry job.

(NOTE: If this has not been accomplished prior to the test, ask your instructor when the above activities should be completed.)

APPLYING FOR A JOB
UNIT III

ANSWERS TO TEST

1.
 - a. 5
 - b. 3
 - c. 1
 - d. 4
 - e. 6
 - f. 2
2.
 - a. Classified ads
 - b. Employment offices
 - c. Local labor union business office
 - d. School officials
3.
 - a. Letter
 - b. Telephone
 - c. In person
4.
 - a. 2
 - b. 3
 - c. 5
 - d. 6
 - e. 8
 - f. 9
 - g. 11
 - h. 12
 - i. 14
 - j. 15

- 5. a. 1
- b. 3
- c. 4
- d. 6
- e. 7
- f. 10
- g. 11

- 6. a. 2
- b. 4
- c. 6
- d. 8
- e. 9
- f. 11
- g. 12
- h. 13
- i. 15
- j. 17

- 7. Performance skills will be evaluated according to the criteria listed on the progress chart.

Carpentry

PROGRESS CHART

Section A
Introduction

68

Student's Name	Unit I Orientation			Unit II Safety			Unit III Applying for a Job			Job
	1	2	3	1	2	3	1	2	3	
1										
2										
3										
4										
5										
6										
7										
8										
9										

2
3
4
5
6
7
8
9
10
11
12
13
14
15
16
17
18
19
20

69

Accuracy
85% Correct

90% Correct

85% Correct

PARLIAMENTARY PROCEDURE AND PUBLIC SPEAKING
UNIT I

TERMINAL OBJECTIVE

After completion of this unit, the student should be able to apply principles of parliamentary procedure and list characteristics of a good chairman. He should be able to match types of motions with their purpose and list characteristics of motions used in conducting a meeting. He should be able to list purposes of a speech, characteristics of a speech, and write and deliver a speech. This knowledge will be evidenced through demonstration and by scoring eight-five percent on the unit test.

SPECIFIC OBJECTIVES

After completion of this unit, the student should be able to:

1. List two principles upon which parliamentary procedure is based.
2. List three characteristics of a good chairman.
3. Match the types of motions with the appropriate definition.
4. Write the order of business for a meeting.
5. Write the characteristics of the kinds of motions used in conducting a meeting.
6. List three purposes for making a speech.
7. Write the outline most speeches follow.
8. List the three "ups" of speech delivery.
9. Demonstrate the ability to:
 - a. Use parliamentary procedure correctly.
 - b. Write and deliver a three to five minute speech.

PARLIAMENTARY PROCEDURE AND PUBLIC SPEAKING
UNIT I

SUGGESTED ACTIVITIES

I. Instructor:

- A. Provide students with objective sheet.
- B. Provide students with information sheet.
- C. Discuss terminal and specific objectives.
- D. Have students conduct a business meeting using correct parliamentary procedure.
- E. Have students give speeches.
- F. Give test.

II. Student:

- A. Read objective sheet.
- B. Study information sheet.
- C. Participate in discussion in business meetings and serve as chairman at least once.
- D. Write and deliver a speech.
- E. Take test.

INSTRUCTIONAL MATERIALS

I. Included in this unit:

- A. Objective sheet
- B. Information sheet
- C. Test
- D. Answers to test

II. References:

- A. Gray, Jarrell D. *Parliamentary Guide for Vocational Industrial Club of America*. Texas Association Inc., Henington Publishing Company, Wolfe City, Texas.
- B. Sturgis, Alice F. *Parliamentary Procedure*. New York, New York: McGraw-Hill Book Company, Inc.

III. Additional materials:

- A. "Workbook of Parliamentary Guide for Vocational Industrial Clubs of America," Vocational Industrial Clubs of America, Oklahoma Association. State Department of Vocational and Technical Education, 1515 West Sixth Street, Stillwater, Oklahoma 74074 (15¢). Teachers Key to Workbook, free.
- B. Jarrell D. Gray. *Parliamentary Guide for Vocational Industrial Clubs of America*. Texas Association, Inc. (35¢). Order from: Dr. Jarrell D. Gray, Box 717, Commerce, Texas 75428.

PARLIAMENTARY PROCEDURE AND PUBLIC SPEAKING
UNIT I

INFORMATION SHEET

- I. Principles upon which parliamentary procedure is based
 - A. The right of the majority to rule
 - B. The right of the minority to be heard and protected
- II. Characteristics of a chairman
 - A. Be impartial
 - B. Inspire confidence in the members
 - C. Provide leadership
- III. Types of motions
 - A. Main motion
 1. Main idea before the group
 2. Only one main motion before the meeting
 - B. Amendments--Change a main motion
 - C. Motion to reconsider--Close debate
 - D. Motion to adjourn--End the meeting
 - E. Questions of privilege--Protect rights and comforts of members
 - F. Privileged motion
 1. Must be disposed of immediately
 2. Kinds of privileged motions
 - a. Adjournment
 - b. Call for orders of the day
 - c. Fix time of next meeting
 - G. Rising to a point of order--Belief of error in procedure
 - H. Appeals--Dissatisfaction with a decision of the chair

INFORMATION SHEET

- IV. Order of business for a meeting
 - A. Opening ceremony
 - B. Minutes of previous meeting
 - C. Unfinished or old business
 - D. Committee reports
 - E. New business
 - F. Closing ceremony
 - G. Entertainment, recreation, refreshments
- V. Table of motions and rules that apply to motions (Extra sheet)
- VI. Purposes for making a speech
 - A. To inform
 - B. To entertain
 - C. To persuade
- VII. Speech outline
 - A. Introduction
 - B. Discussion
 - C. Conclusion
- VIII. Three "ups" of speech delivery
 - A. Stand up (avoid leaning on podium)
 - B. Speak up
 - C. Shut up (short conclusion)

INFORMATION SHEET

V. Table of Motions and Rules That Apply to Motions

Motions	May Interrupt Speaker	Required Second	Debatable	Vote Required	Motion That May Apply
A. Privileged					
1. To fix time	No	Yes	Limited	Maj.	Amend, Reconsider
2. To adjourn	No	Yes	No	Maj.	None
3. To take a recess	No	Yes	Limited	Maj.	Amend
4. Question of privilege	Yes	No	No	Chmn.rules	All
5. Call for order of day	Yes	No	No	None	None
B. Incidental					
1. Point of order	Yes	No	No or Maj.	Chmn.rules	None
2. Appeal	Yes	Yes	Yes	Maj.	All except amend
3. Suspend rules	No	Yes	No	2/3	None
4. Withdraw a motion	No	No	No	Maj.	Reconsider
5. Parliamentary inquiry	Yes	No	No or Maj.	Chmn.rules	None
6. Object to consider	Yes	No	No	2/3	All
7. Call for division of the house	Yes	No	No	Maj.	All
8. To call for a division of a question	No	Yes	No	Maj.	All
C. Subsidiary					
1. Lay on table	No	Yes	No	Maj.	None
2. Previous question	No	Yes	No	2/3	Reconsider
3. Refer to committee	No	Yes	Yes	Maj.	Amend, Recon., Prev. Ques.
4. Amend	No	Yes	Yes	Maj.	Amend, Recon., Prev. Ques.
5. Postpone indefinitely	No	Yes	Yes	Maj.	Limit Deb., Prev. Ques., Recon.
D. Main Motions					
1. General main motion	No	Yes	Yes	Maj.	All
2. Specific main motion	No	Yes	No	Maj.	None
a. To take from table	Yes	Yes	Yes	Maj.	Lim. Deb., Prev. Ques., Table
b. To reconsider	No	Yes	Yes	Maj.	All
c. To adopt a resolution	No	Yes	Limited	Maj.	Amend, Reconsider
d. To adjourn	No	Yes	Yes	Gen.,Maj., Spec. 2/3	All
e. To create order of day	No	Yes	Yes	Maj.	Amend, Recon., Prev. Ques., Lim. Deb.
f. To amend	No	Yes	Yes	Maj.	Amend, Recon., Prev. Ques., Lim. Deb.

PARLIAMENTARY PROCEDURE AND PUBLIC SPEAKING .
UNIT I

TEST

1. List two principles upon which parliamentary procedure is based.
 - a.
 - b.
2. List three characteristics of a good chairman.
 - a.
 - b.
 - c.
3. Match the types of motions with the appropriate definition.
 - a. _____ Main motion
 - b. _____ Amendment
 - c. _____ Adjournment
 - d. _____ To reconsider
 - e. _____ Point of order
 1. To end meeting
 2. To close debate
 3. Must be disposed of immediately
 4. Main idea before the group
 5. To change the main idea
 6. Used when the chair has made an error
4. Write the first three items in the order of business for a meeting.
 - a.
 - b.
 - c.

5. Write the characteristics of motions by filling in the blanks in the following table.

	Second Required	Debatable	Amendable	Vote Required
a. Main motion				
b. Amendment				
c. Adjournment				
d. Lay on table				
e. Point of order				

6. List three purposes for making a speech.

- a.
- b.
- c.

7. Write the outline form that most speeches follow.

- a.
- b.
- c.

8. List the three "ups" of speech delivery.

- a.
- b.
- c.

9. The student should demonstrate the ability to perform the following, to the satisfaction of the instructor.

- a. Use parliamentary procedure correctly.
- b. Write and deliver a three to five minute speech.

77

PARLIAMENTARY PROCEDURE AND PUBLIC SPEAKING
UNIT I

ANSWERS TO TEST

1.
 - a. The right of the majority to rule
 - b. The right of the minority to be heard and protected
2.
 - a. Be impartial
 - b. Inspire confidence in the members
 - c. Provide leadership
3.
 - a. 4
 - b. 5
 - c. 1
 - d. 2
 - e. 6
4.
 - a. Opening ceremony
 - b. Minutes of previous meeting
 - c. Unfinished or old business
5.

a.	Main motion	Yes	Yes	Yes	Majority
b.	Amendment	Yes	Yes	Yes	Majority
c.	Adjournment	Yes	No	No	Majority
d.	Lay on table	Yes	No	No	Majority
e.	Point of order	No	No	No	None
6.
 - a. To inform
 - b. To entertain
 - c. To persuade
7.
 - a. Introduction
 - b. Discussion
 - c. Conclusion

8.
 - a. Stand up (avoiding leaning on podium)
 - b. Speak up
 - c. Shut up (short conclusion)
9. Performance skills will be evaluated according to the criteria listed on the progress chart.

BECOMING A GOOD LEADER
UNIT II

TERMINAL OBJECTIVE

After completion of this unit, the student should be able to name characteristics of a good leader. He should be able to develop himself into a good leader and demonstrate his ability to lead others. He should take a Personality Self-Rating Scale to determine how he rates as a leader. This knowledge will be evidenced through demonstration and by scoring eighty-five percent on the unit test.

SPECIFIC OBJECTIVES

After completion of this unit, the student should be able to:

1. Define leadership.
2. Name five characteristics of a good leader.
3. Discuss in a short paragraph why he wants to become a good leader.
4. Name four steps he must take in order to become a good leader.
5. Name five values of having leadership ability.
6. Identify himself as a leader by taking the Personality Self-Rating Scale.
7. Identify some leaders within his community and list three factors that identify each as a leader.

BECOMING A GOOD LEADER
UNIT II

SUGGESTED ACTIVITIES

1. Instructor:
 - A. Provide students with objective sheet.
 - B. Provide students with information sheet.
 - C. Discuss terminal and specific objectives.
 - D. Discuss information and assignment sheets.
 - E. Help evaluate the student according to the Personality Self-Rating Scale.
 - F. Give test.
- II. Student:
 - A. Read objective sheet.
 - B. Study information sheet.
 - C. Demonstrate the ability to accomplish the procedures outlined in the assignment sheets.
 - D. Take test.

INSTRUCTIONAL MATERIALS

- I. Included in this unit:
 - A. Objective sheet
 - B. Information sheet
 - C. Assignment sheets
 1. Assignment Sheet #1-Personality Self-Rating Scale
 2. Assignment Sheet #2-Identifying Leaders Within Your Community
 - D. Test
 - E. Answers to test

II. References:

- A. *Official Manual*. Future Farmers of America. Alexandria, Virginia, 1971.
- B. Gray, Jarrell D. and J. R. Jackson. *Leadership Training and Parliamentary Procedure for FFA*. Englewood Cliffs, New Jersey: Prentice-Hall, Inc., 1958.
- C. *Animal Science*. Missouri State Department of Education, Agricultural Education Section, University of Missouri, Columbia, Missouri.

BECOMING A GOOD LEADER
UNIT II

INFORMATION SHEET

- I. Leadership-The combination of qualities which inspires confidence, draws others toward the leader, and causes them to follow
- II. Characteristics of a good leader
 - A. Preparedness-Know leadership takes work as well as practice
 - B. Group-mindedness-Regard yourself as a part of the group. Say "we" instead of "I"; do not try to run the crowd. Instead, be guided by the crowd's wishes
 - C. Consideration for others-Be understanding and friendly
 - D. Poise-Don't let irritations bother you
 - E. Humility-Be confident, but not cocky; do not be afraid to reveal you do not know everything
 - F. Hard work-Do not ask anyone to do something that you would not be willing to do yourself
 - G. Responsibility-Live up to your work and duties
 - H. Cooperativeness-Know how to work with others and enjoy working with them
 - I. Happiness-Enjoy life; the simple things as well as the big
 - J. Imagination-Help the persons in your group to learn and grow through the activities
 - K. Preciseness-Be able to express yourself effectively
 - L. Pride-Take pride in what you do; take pride in being a leader, but earn it
 - M. Neatness-Always be neat in dress and personal appearance
 - N. Courtesy-The words "please" and "thank you" pay dividends; use them often
 - O. Understanding-Know members' opinions and be ready to meet changing situations
 - P. Ambition-Set goals and make them high, but be sure to reach them

INFORMATION SHEET

- Q. Open-mindedness-Take advice, but do your own thinking
 - R. Curiosity-Analyze all the facts before you draw conclusions
 - S. Energy-Do your best at all times; plan to make the most effective use of your time
- III. Reasons to become a good leader
- A. Self-satisfaction
 - B. Leadership needed in all fields
 - C. Challenge to learn
 - D. Creates respect for others
 - E. Aids in maturity
- IV. Steps in becoming a good leader
- A. Leaders are made, not born
 - B. Study qualities of a good leader
 - C. Evaluate weak and strong points of yourself
 - D. Become a good follower
 - E. Develop a plan for training yourself as a leader
- V. Values of having leadership ability
- A. Education
 - B. Respect
 - C. Advancement in an occupation
 - D. Financial betterment
 - E. Pride
 - F. Security

BECOMING A GOOD LEADER
UNIT II

ASSIGNMENT SHEET #1 - PERSONALITY SELF-RATING SCALE

Circle the appropriate number following each trait. Four is outstanding, three is above average, two is average, one is poor. Total your score below.

- | | | |
|-----|--|---------|
| 1. | Do I maintain a well-groomed appearance? | 1 2 3 4 |
| 2. | Do I have a pleasing voice? | 1 2 3 4 |
| 3. | Is my posture alert and poised? | 1 2 3 4 |
| 4. | Is my disposition cheerful? | 1 2 3 4 |
| 5. | Do I make friends easily? | 1 2 3 4 |
| 6. | Do I exert a positive leadership? | 1 2 3 4 |
| 7. | Am I generally thoughtful of the feelings of others? | 1 2 3 4 |
| 8. | Is my enthusiasm sincere and contagious? | 1 2 3 4 |
| 9. | Do I persevere until I achieve success? | 1 2 3 4 |
| 10. | Am I sincere in my interest in other people? | 1 2 3 4 |
| 11. | Am I ambitious to get ahead? | 1 2 3 4 |
| 12. | Do I get along well with others? | 1 2 3 4 |
| 13. | Do I react constructively to criticism? | 1 2 3 4 |
| 14. | Do I remember names and faces? | 1 2 3 4 |
| 15. | Am I punctual on all occasions? | 1 2 3 4 |
| 16. | Do I have and evidence a spirit of cooperation? | 1 2 3 4 |
| 17. | Am I free from prejudice? | 1 2 3 4 |
| 18. | Do I know how people react in most situations? | 1 2 3 4 |
| 19. | Am I generally a good listener? | 1 2 3 4 |
| 20. | Do I refuse to allow what other people say hurt me? | 1 2 3 4 |
| 21. | Can I criticize without giving offense? | 1 2 3 4 |

ASSIGNMENT SHEET #1

- | | | |
|-----|--|---------|
| 22. | Do I usually like people for what they are,
or do I wait to see if they like me? | 1 2 3 4 |
| 23. | Do I enjoy being part of a group? | 1 2 3 4 |
| 24. | Am I reliable? | 1 2 3 4 |
| 25. | Can I adapt myself to all situations? | 1 2 3 4 |
| 26. | Am I easily discouraged? | 1 2 3 4 |
| 27. | Do I apply myself to the problems of each day? | 1 2 3 4 |
| 28. | Can I make a decision quickly and accurately? | 1 2 3 4 |
| 29. | Am I loyal to my superiors and associates? | 1 2 3 4 |
| 30. | Do I try to get the other fellow's point of view? | 1 2 3 4 |
| 31. | Am I neat and clean in my work as well as my
personal appearance? | 1 2 3 4 |
| 32. | Do I know where I make my mistakes, and do I
admit them? | 1 2 3 4 |
| 33. | Am I looking for opportunities to serve others better? | 1 2 3 4 |
| 34. | Am I following a systematic plan for improvement
and advancement? | 1 2 3 4 |
| 35. | Can I accept honors and advancements and yet keep
my feet on the ground? | 1 2 3 4 |
| 36. | Am I playing the game of life honestly and fairly
with myself, my fellow members, and others with
whom I work? | 1 2 3 4 |

Total Score _____

BECOMING A GOOD LEADER
UNIT II

EVALUATION OF ASSIGNMENT SHEET #1

Now to evaluate your scores--If your score totaled over 100, your personality rating is definitely superior and if you have been honest with yourself, you are among the people who are most likely to succeed. 90 - 100 is above average. 75 - 90 is average. Below 75 shows plenty of room for improvement. How did you rate?

BECOMING A GOOD LEADER
UNIT II

ASSIGNMENT SHEET #2 - IDENTIFYING LEADERS WITHIN YOUR COMMUNITY

Identify three individuals in your local community which appear to you as good leaders. After you have identified the leaders, list three factors that identify them as such.

NAME	LEADERSHIP QUALITIES
1. _____	a. _____
	b. _____
	c. _____
2. _____	a. _____
	b. _____
	c. _____
3. _____	a. _____
	b. _____
	c. _____

BECOMING A GOOD LEADER
UNIT II
TEST

1. Define leadership.
2. Name five characteristics of a good leader.
 - a.
 - b.
 - c.
 - d.
 - e.
3. Discuss in a short paragraph why you want to become a good leader.

4. What are four steps to follow in becoming a good leader?
 - a.
 - b.
 - c.
 - d.
5. Name five values of having leadership ability.
 - a.
 - b.
 - c.
 - d.
 - e.

BECOMING A GOOD LEADER
UNIT II

ANSWERS TO TEST

1. Leadership--The combination of qualities which inspires confidence, draws others toward the leader, and causes them to follow.
2. Any five of the following
 - a. Preparedness
 - b. Group-mindedness
 - c. Consideration for others
 - d. Poise
 - e. Humility
 - f. Hard work
 - g. Responsibility
 - h. Cooperativeness
 - i. Happiness
 - j. Imagination
 - k. Preciseness
 - l. Pride
 - m. Neatness
 - n. Courtesy
 - o. Understanding
 - p. Ambition
 - q. Open-mindedness
 - r. Curiosity
 - s. Energy
3. Discussion should include the following
 - a. Leadership needed in all fields
 - b. Challenge to learn

- c. Creates respect for others
 - d. Aids in maturity
 - e. Self-satisfaction
 - f. Other items that instructor felt was necessary
4. Any four of the following
- a. Leaders are made, not born
 - b. Study qualities of a good leader
 - c. Evaluate weak and strong points of yourself
 - d. Become a good follower
 - e. Develop a plan for training yourself as a leader
5. Any five of the following
- a. Education
 - b. Respect
 - c. Advancement in an occupation
 - d. Financial betterment
 - e. Pride
 - f. Security

Carpentry

PROGRESS CHART

22

Section B
Leadership

Student's Name	Unit I Parliamentary Procedure			Unit II Becoming a Good Leader			Job	Unit Test	Unit Test
	1	2	3	1	2	3			
1									
2									
3									
4									
5									
6									
7									
8									
9									

2 3 4 5 6 7 8 9 10 11 12 13 14 15 16 17 18 19 20

Accuracy
85% Correct

85% Correct

LUMBER UNIT I

TERMINAL OBJECTIVE

After completion of this unit the student should be able to match the types of lumber to their grades and write a bill of materials for ordering lumber. He should be able to list the two methods for drying lumber, identify the common defects in lumber, and compute board feet and cost. This knowledge will be evidenced through demonstration and by scoring eighty-five percent on the unit test.

SPECIFIC OBJECTIVES

1. Match the type of lumber to their grades.
2. List the common grades of fir plywood by face veneer.
3. Write a bill of materials for ordering lumber.
4. List the two major methods of sawing lumber.
5. List the two methods for drying lumber.
6. Identify six common lumber defects.
7. Compute board feet and cost.

LUMBER UNIT I

SUGGESTED ACTIVITIES

- I. Instructor:
 - A. Provide students with objective sheet.
 - B. Provide students with information sheet and student handouts.
 - C. Prepare transparencies.
 - D. Discuss terminal and specific objectives.
 - E. Discuss information sheet.
 - F. Provide students with assignment sheets.
 - G. Demonstrate and discuss steps outlined in assignment sheets.
 - H. Give test.
- II. Student:
 - A. Read objective sheet.
 - B. Study information sheet.
 - C. Demonstrate the ability to complete the assignment sheets.
 - D. Take test.

INSTRUCTIONAL MATERIALS

- I. Included in this unit:
 - A. Objective sheet
 - B. Information sheet
 - C. Transparency masters
 1. TM 1--Lumber Grading
 2. TM 2--Methods of Sawing Lumber
 3. TM 3--Lumber Defects

D. Student handouts

1. Student Handout #1--Veneers Used in Fir Plywood
2. Student Handout #2--Plywood Grades and Grade Trademarks

E. Assignment sheets

1. Assignment Sheet #1--Compute Board Feet
2. Assignment Sheet #2--Compute Board Feet
3. Assignment Sheet #3--Compute the Cost of Materials

F. Answers to assignment sheets

G. Test

H. Answers to test

II. References

- A. Burbahn, Walter E. *Fundamentals of Carpentry*. Fourth Edition, vol. 1, Chicago, Illinois: American Technical Society, 1967.
- B. Feirer, John L. *Cabinetmaking and Millwork*. Peoria, Illinois: Charles A. Bennett Company Inc., 1967.
- C. Feirer, John L. *Woodworking for Industry*. Peoria, Illinois: Charles A. Bennett Company Inc., 1971.
- D. Hackett, Donald F. and Patrick E. Spielman. *Modern Wood Technology*. Milwaukee, Wisconsin: The Bruce Publishing Company, 1968.
- E. Wagner, Willis H. *Modern Carpentry*. Homewood, Illinois: Goodheart-Willcox Company Inc., 1969.

LUMBER
UNIT I

INFORMATION SHEET

I. Lumber grading

A. Softwood grades (Transparency 1)

(NOTE: Softwood grades are commonly called yard lumber.)

1. Boards--One to 1 1/2 inches thick, 2 inches and wider

a. Finish grades

- 1) B and better
- 2) C select
- 3) D select

b. Common grades

- 1) No. 1 common
- 2) No. 2 common
- 3) No. 3 common
- 4) No. 4 common

2. Framing grades--Dimension and timber

(NOTE: Dimension lumber is two to five inches thick, two inches and wider. Timbers are five inches and thicker, five inches and wider.)

a. West Coast Douglas Fir

- 1) Select
- 2) Construction
- 3) Standard
- 4) Utility
- 5) Economy

b. Southern Pine

- 1) No. 1
- 2) No. 2
- 3) No. 3

INFORMATION SHEET

II. Standard Fir plywood grades

(NOTE: See Student Handout #1.)

A. Interior by face veneer

1. AA
2. AB
3. AC
4. BB
5. BC
6. CC
7. CD

B. Exterior by face veneer

(NOTE: See Student Handout #2.)

1. AA
2. AB
3. AD
4. BB
5. BD
6. CD
7. BB Plyform
8. HDO Plyform

III. Ordering lumber

A. Lumber measurements as a purchasing unit

1. Board foot--Strip lumber, boards, dimension lumber, structural timbers, and shop lumber
2. Square foot--Plywood, particle board, and hardboard
3. Lineal foot--Moulding and trim

INFORMATION SHEET

B. Specifications

1. Number of pieces

2. Thickness

a. Lumber sold by the board foot

(NOTE: One-half inch and thicker is designated as the next full inch, for example: three-fourths inch is listed as one inch.)

b. Lumber sold by the square foot

(NOTE: The exact thickness must be specified.)

c. Material sold by the lineal foot

(NOTE: The exact dimensions must be given.)

3. Width

a. The width of softwood lumber sold by the board foot is specified in even inches

Example: 2", 4", 6", 8", 10", 12"

b. The exact width of lumber sold by the square foot must be specified; this material is usually produced in four foot widths, unless special ordered

4. Length

(NOTE: The length of softwood lumber sold by the board foot is specified in even feet usually up to twenty-four feet.)

5. Grade

6. Kind of lumber

7. Face preparation

(NOTE: Yard lumber is generally surfaced on four sides and crosscut to length.)

INFORMATION SHEET

Examples for ordering lumber:

1. Yard lumber

	<i>Number of pieces</i>	<i>Thickness</i>	<i>Width</i>	<i>Length</i>	<i>Grade</i>	<i>Species</i>	<i>Drying</i>
a.	6	2"	4"	14'	utility,	fir,	KD
b.	4	1"	8"	16'	economy,	fir,	KD

2. Plywood

	<i>Number of pieces</i>	<i>Thickness</i>	<i>Width</i>	<i>Length</i>	<i>Grade</i>	<i>Species</i>
a.	4 sheets	3/4"	4'	8'	AB,	Fir, INT.
b.	2 sheets	1/4"	4'	8'	AC,	Fir, EXT.

IV. Two major methods used in sawing lumber (Transparency 2)

- A. Quarter sawed
- B. Plain or flat sawed

V. Methods of drying lumber

- A. Air dried
- B. Kiln dried

INFORMATION SHEET

VI. Common defects in lumber (Transparency 3)

(NOTE: A, B, C, and D are referred to as warp.)

A. Crook

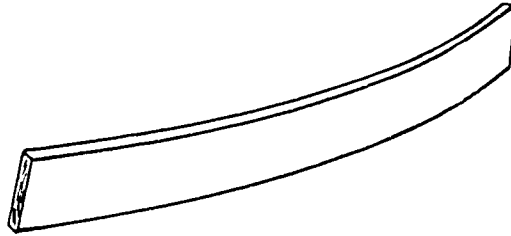

B. Bow

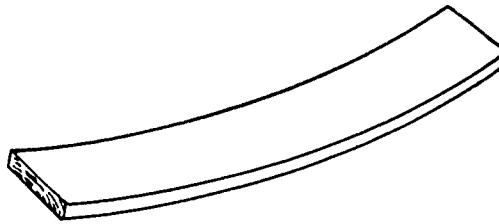

C. Cup

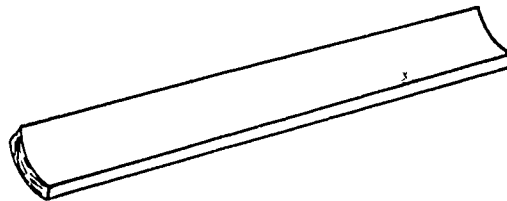

D. Twist or wind

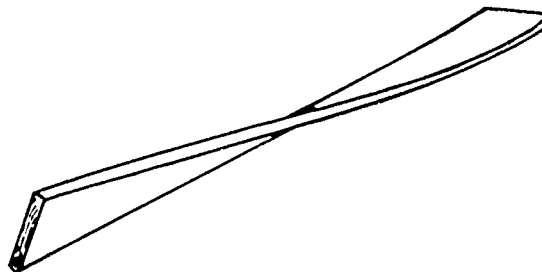

INFORMATION SHEET

E. Knot

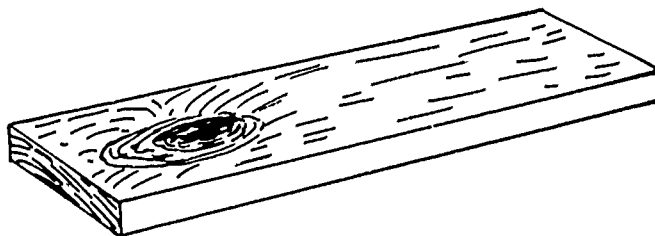

F. Check

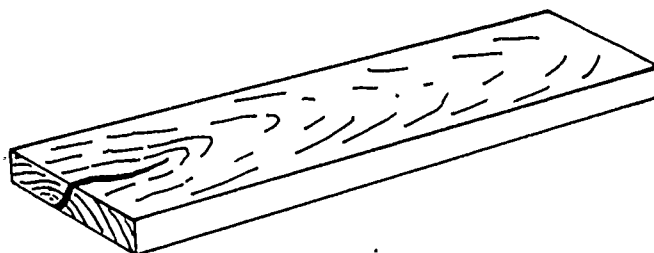

VII. Computing board feet and cost

- A. A board foot is 1 inch thick, 12 inches wide, and 1 foot long or the equivalent 1" x 12" x 1'
- B. Allowing "N" to mean number of pieces, "T" to mean "thickness in inches", "W" to mean "width in inches", and "L" to mean "length in feet," the formula may be written

$$\frac{N \times T \times W \times L}{12} = \text{board feet}$$

- C. Lumber sizes used in figuring board feet are the nominal sizes, lumber less than 1" thick is figured as 1 inch

Example: A piece 1/2" x 12" x 12" is considered as one board foot. Lengths are usually in even feet under twenty-four feet; lumber over twenty-four feet can be obtained upon specification.

INFORMATION SHEET

D. Unit of measure for lumber is board foot

(NOTE: Each of the illustrations is one board foot.)

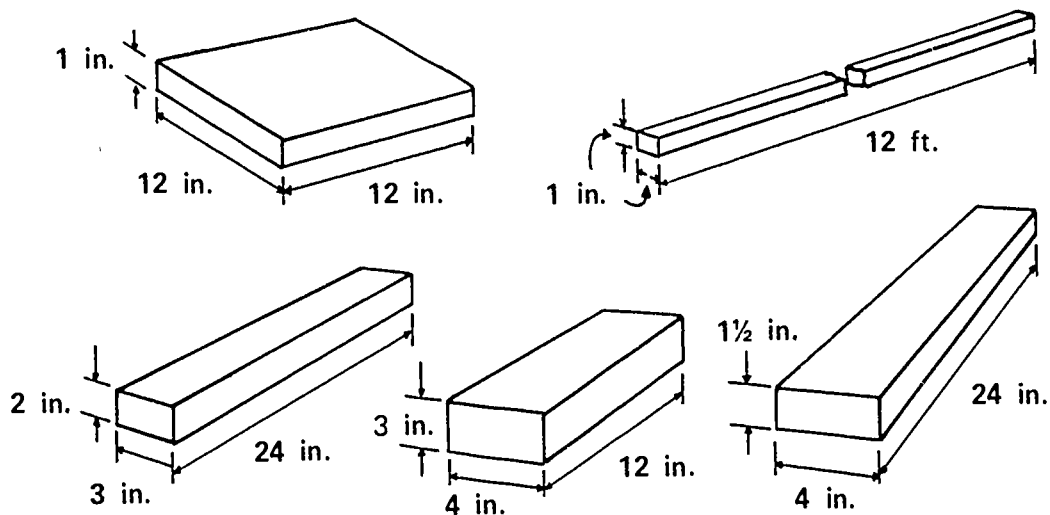

E. Pricing of lumber

1. Per board foot
2. Per 100 board feet
3. Per 1000 board feet

(NOTE: Per hundred board feet is abbreviated as "per C.")

(NOTE: Per thousand board feet is abbreviated as "per M.")

(NOTE: Fractional board feet are not computed but are rounded up to the nearest full board foot.)

1. $1 \frac{1}{3}$ board feet is called 2 board feet
2. $1 \frac{1}{2}$ board feet is called 2 board feet
3. $1 \frac{3}{4}$ board feet is called 2 board feet
4. $1 \frac{1}{2}$ board feet is called 2 board feet

Lumber Grading

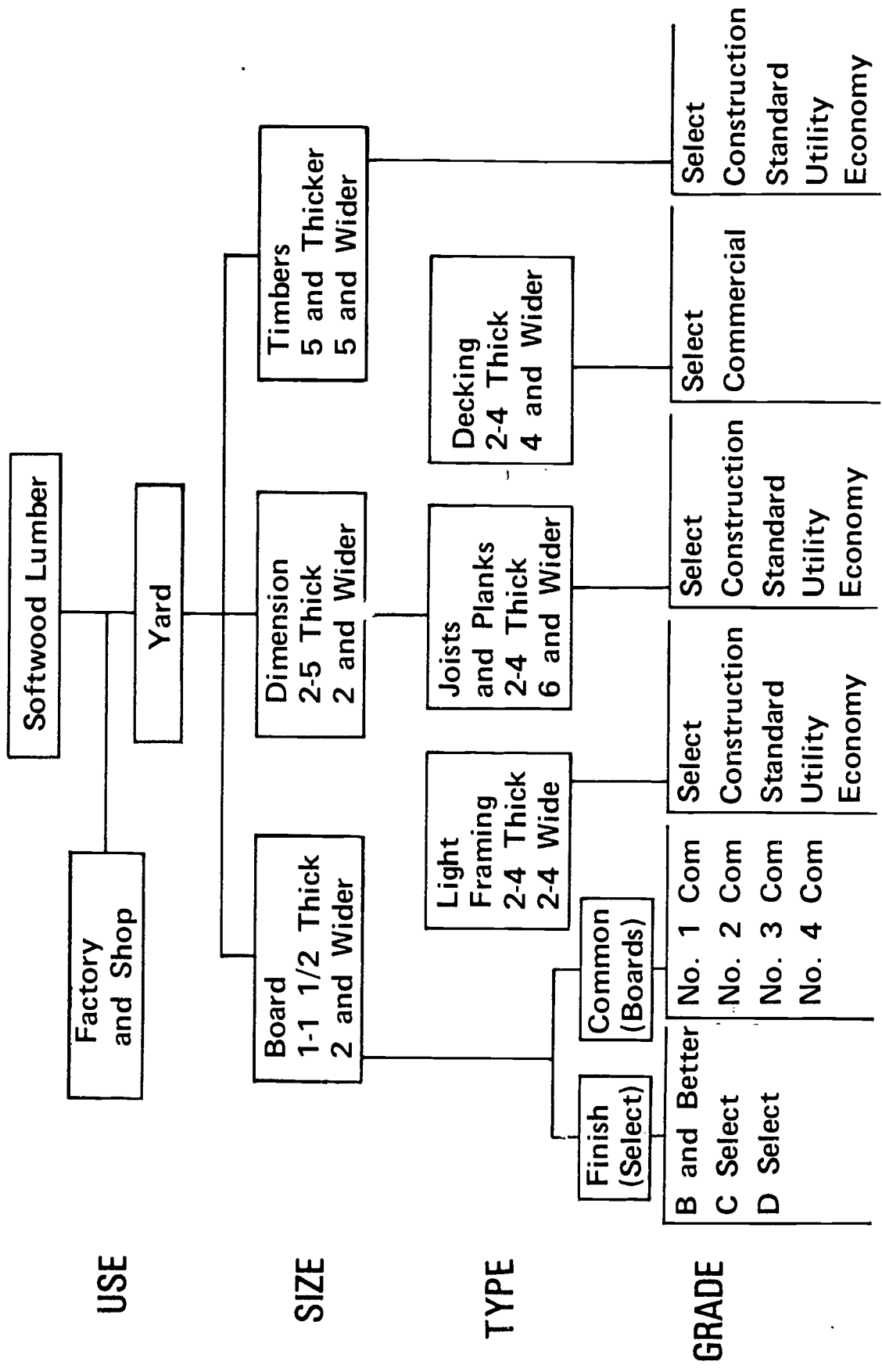

USE

SIZE

TYPE

GRADE

Methods of Sawing Lumber

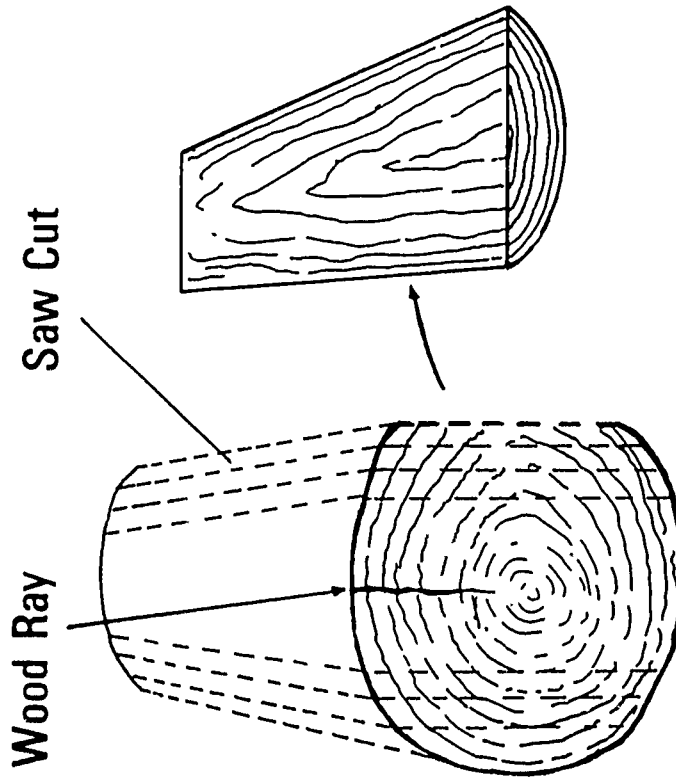

PLAIN SAWED (Flat)

Cut Tangent to Annual Rings

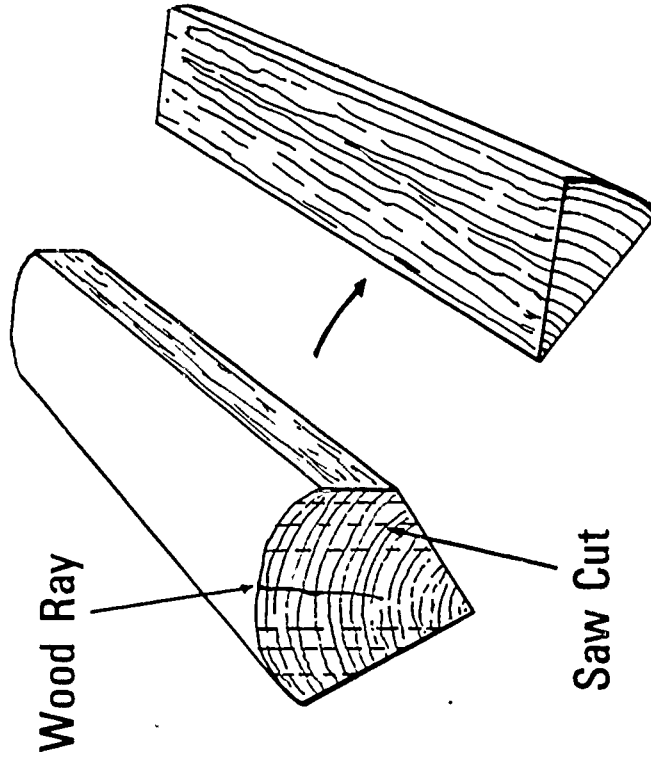

QUARTER SAWED

Lumber Defects

KINDS of WARP

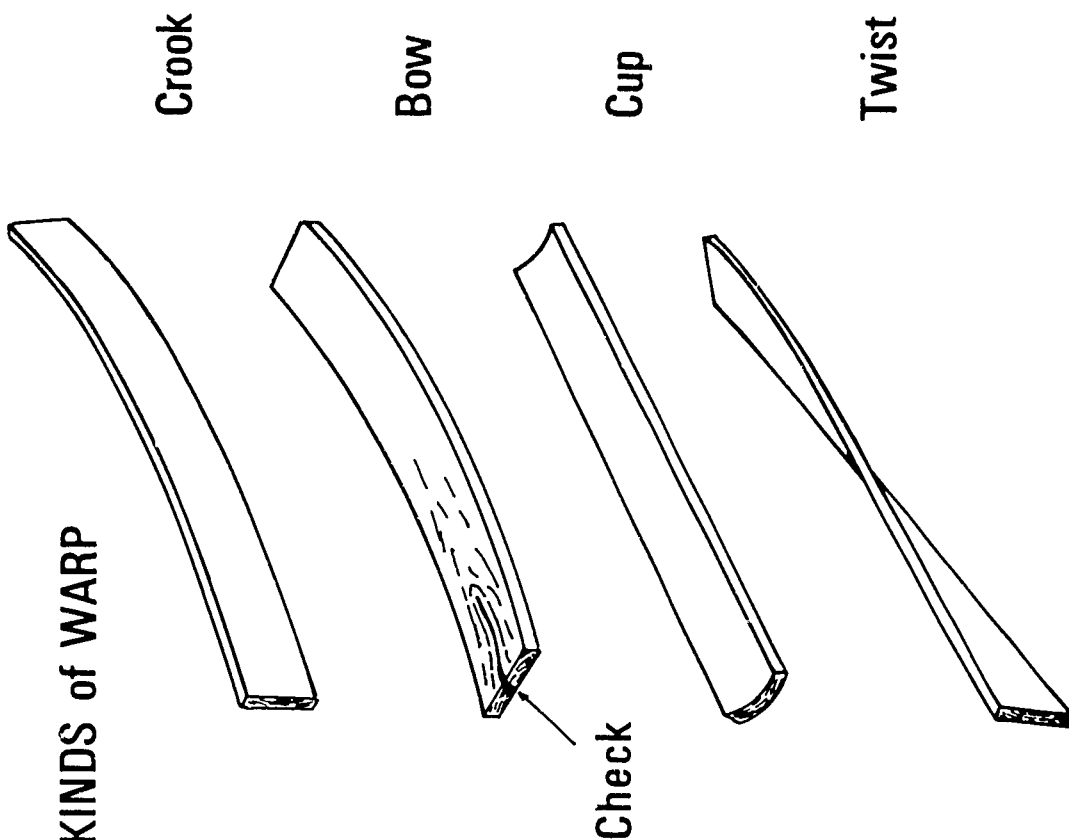

KINDS of Knots

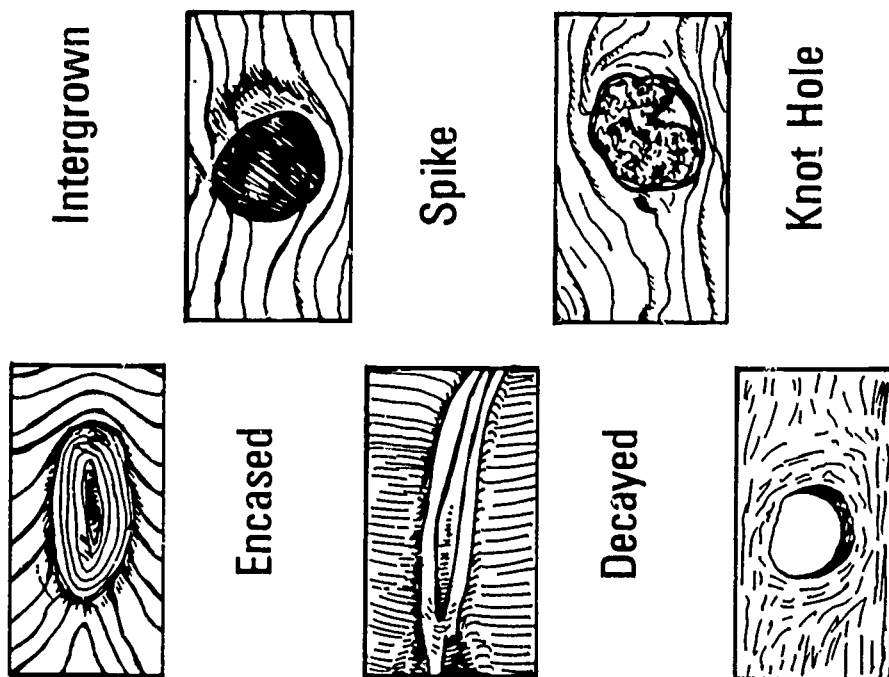

LUMBER
UNIT I

STUDENT HANDOUT #1--VENEERS USED IN FIR PLYWOOD

1. N--Intended for natural finish; select all heart wood free from all open defects; may contain few repairs if well matched
2. A--Smooth, paintable, well jointed; permits neatly made repairs
3. B--Relatively smooth, permits circular repair plugs, small tight knots
4. C--Minimum veneer permitted in exterior-type; knotholes up to 1", splits, tight knots, shims, and sanding defects
5. C--(Plugged) Improved C
6. D--Permits knots and knotholes to 2 1/2" in width and 1/2" larger under certain specified limits; limited splits permitted

MINIMUM BENDING RADII

Plywood Thickness (in.)	Across the Grain (ft.)	Parallel to Grain (ft.)
1/4	2	5
5/16	2	6
3/8	3	8
1/2	6	12
5/8	8	16
3/4	12	20

LUMBER
UNIT I

STUDENT HAND OUT #2--PLYWOOD GRADES AND GRADE TRADEMARKS

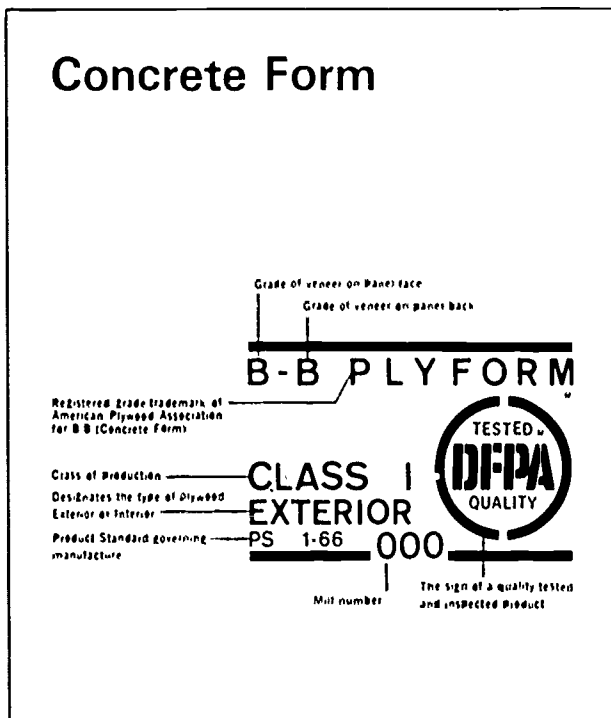

Grade-Use Guide for Concrete Forms*

Use these terms when you specify plywood	DESCRIPTION	Typical Grade-trademarks	VENEER GRADE	
			Faces	Inner Plys
B-B PLYFORM Class I & II** DFPA	Specifically manufactured for concrete forms. Many reuses. Smooth, solid surfaces. Edge-sealed. Mill-oiled unless otherwise specified.		B	C
High Density Overlay PLYFORM Class I & II** DFPA	Hard, semi-opaque resin-fiber overlay, heat-fused to panel faces. Smooth surface resists abrasion. Up to 200 reuses. Edge-sealed. Light oiling recommended between pours.		B	C Plugged
STRUCTURAL I PLYFORM** DFPA	Especially designed for engineered applications. All Group 1 species. Stronger and stiffer than PLYFORM Class I and II. Recommended for high pressures where face grain is parallel to supports. Also available with High Density Overlay faces.		B	C or C Plugged
Special Overlays, proprietary panels and Medium Density Overlay plywood specifically designed for concrete forming**	Produce a smooth uniform concrete surface. Generally mill treated with form release agent. Check with manufacturer for design specifications, proper use, and surface treatment recommendations for greatest number of reuses.			

*Commonly available in 5/8" and 3/4" panel thicknesses (4'x8' size).
**Check dealer for availability in your area.

LUMBER
UNIT I

ASSIGNMENT SHEET #1--COMPUTE BOARD FEET

Compute the total board feet in each of the problems listed below.

Formula:
$$\frac{N \times T \times W \times L}{12}$$

N = Number of pieces

T = Thickness in inches

W Width in inches

L Length in feet

1. 1 - 1" x 10" x 10' =
2. 1 - 1" x 4" x 14' =
3. 1 - 2" x 6" x 8' =
4. 1 - 2" x 8" x 10' =
5. 2 - 2" x 4" x 8'
6. 5 - 1" x 8" x 8' =
7. 10 - 4" x 6" x 10'
8. 1 - 2" x 4" x 18' =
9. 100 - 2" x 12" x 24' =
10. 30 - 1" x 2" x 6' =

LUMBER
UNIT 1

ASSIGNMENT SHEET # 2--COMPUTE BOARD FEET

Compute the total board feet for each of the pieces of lumber.

1. _____

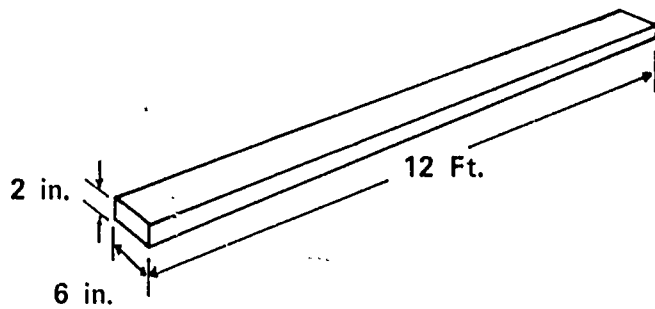

2. _____

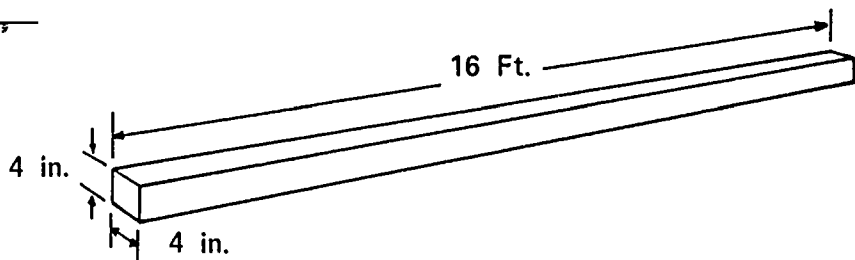

3. _____

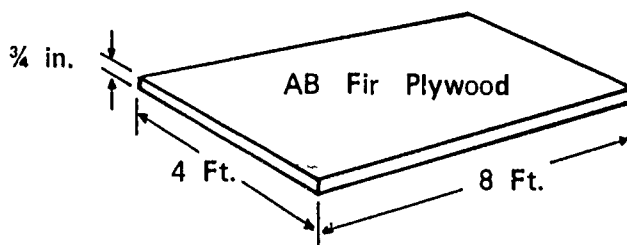

4. _____

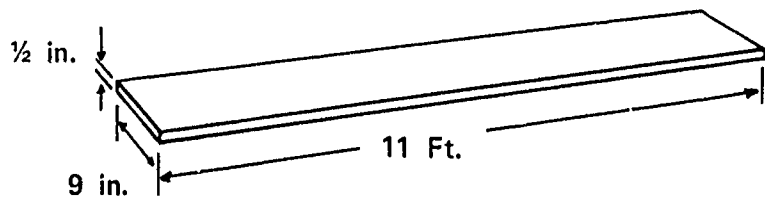

FAS, Walnut, KD, S4S

LUMBER
UNIT IASSIGNMENT SHEET #3--COMPUTE THE COST
OF MATERIALS

Compute the cost for each of the lumber orders listed below.

1. 10 - 2" x 4" x 12', utility, fir, price \$16.00 per 100 (C) board feet.

Answer: \$ _____

2. 30 - 1" x 6" x 16', #2, Yellow Pine, price \$200.00 per 1000 (M) board feet.

Answer: \$ _____

3. 40 - 1" x 12" x 14', #2, White Pine, price \$.30 per board foot.

Answer: \$ _____

4. 100 feet, casing, White Pine, price \$16.00 per (C).

Answer: \$ _____

LUMBER
UNIT I

ANSWERS TO ASSIGNMENT SHEETS

Assignment Sheet #1

1. 8 board feet
2. 5 board feet
3. 8 board feet
4. 13 board feet
5. 11 board feet
6. 27 board feet
7. 200 board feet
8. 12 board feet
9. 4,800 board feet
10. 30 board feet

Assignment Sheet #2

1. 1 board foot
2. 22 board feet
3. 32 square feet
4. 8 board feet

Assignment Sheet #3

1. \$12.80
2. \$48.00
3. \$168.00
4. \$16.00

LUMBER
UNIT I

TEST

1. Match the type of lumber to the grades for that type of lumber.
- | | |
|--|---|
| _____ a. Finish grades (Boards) | 1. Select; construction; standard; utility; economy |
| _____ b. Common grades (Boards) | 2. B and better; C select; D select |
| _____ c. Light framing, 2" to 4" thick; 2" to 4" wide | 3. No. 1 common; No. 2 common; No. 3 common; No. 4 common |
| _____ d. Joists and planks, 2" to 4" thick; 6" and wider | |
| _____ e. Timbers, 5" and thicker; 5" and wider | |
2. List the common grades for softwood plywood by face veneer.
- | Interior | Softwood | Exterior |
|----------|----------|----------|
| a. | | a. |
| b. | | b. |
| c. | | c. |
| d. | | d. |
| e. | | e. |
| f. | | f. |
3. Write a bill of materials for ordering the following lumber using the proper sequence, abbreviations, and terms. The materials are: ten boards, one inch thick, fourteen feet long and ten inches wide; number two common grade, White Pine lumber, kiln dried.

4. List the two major methods of sawing lumber.

a.

b.

5. List the two methods of drying lumber.

a.

b.

6. Identify the six lumber defects in the illustrations.

a. _____



b. _____



c. _____



d. _____



e. _____



f. _____

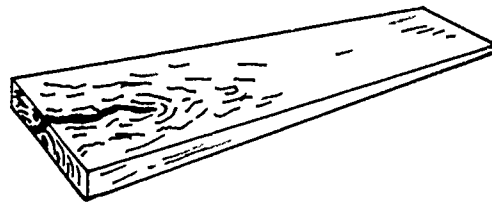

7. Compute the number of board feet and cost in the following bill of materials:
40 - 2" x 6" x 16', utility, Yellow Pine, KD, S4S at \$270.00 per M.

- a. Board feet--
- b. Cost--

LUMBER
UNIT I

ANSWERS TO TEST

1.
 - a. 2
 - b. 3
 - c. 1
 - d. 1
 - e. 1

2.

Interior	Softwood	Exterior
AA		AA
AB		AB
AD		AC
BB		BB
BD		BC
CD		CC

3. a. 10 - 1" x 10" x 14', No. 2 common, White Pine, KD
4.
 - a. Quarter sawed
 - b. Plain or flat sawed
5.
 - a. Air dried
 - b. Kiln dried
6.
 - a. Crook
 - b. Bow
 - c. Cup
 - d. Twist or wind
 - e. Knot
 - f. Check
7.
 - a. 640 board feet
 - b. \$172.80

MEASURING UNIT II

TERMINAL OBJECTIVE

After completion of this unit, the student should be able to define measuring terms and identify the basic tools used in measuring. He should be able to read a rule in feet, inches, and fractions of inches down to one-sixteenth of an inch. This knowledge will be evidenced through demonstration and by scoring eighty-five percent on the unit test.

SPECIFIC OBJECTIVES

After completion of this unit, the student should be able to:

1. Match terms associated with measuring to a list of definitions.
2. Identify five basic tools used by the carpenter in measuring.
3. Read a rule to the nearest one-sixteenth of an inch.
4. Demonstrate the ability to perform the following measuring skills:
 - a. Measure objects to the nearest sixteenth of an inch when given pictures of objects and a measuring instrument.
 - b. Draw lines and objects to specified dimensions.

MEASURING UNIT II

SUGGESTED ACTIVITIES

- I. Instructor:
 - A. Provide students with objective sheet.
 - B. Provide students with information and assignment sheets.
 - C. Make transparencies.
 - D. Discuss terminal and specific objectives.
 - E. Discuss information and assignment sheets.
 - F. Give test.
- II. Student:
 - A. Read objective sheet.
 - B. Study information sheet.
 - C. Complete assignment sheets.
 - D. Take test

INSTRUCTIONAL MATERIALS

- I. Included in this unit:
 - A. Objective sheet
 - B. Information sheet
 - C. Transparency masters
 1. TM 1--Measuring Tools
 2. TM 2--Graduations on a Rule
 3. TM 3--Reading the Eighths Rule
 4. TM 4--Reading the Sixteenths Rule
 - D. Assignment sheets
 1. Assignment Sheet #1--Reading a Rule
 2. Assignment Sheet #2--Measuring Objects
 3. Assignment Sheet #3--Drawing Lines and Objects

E. Answers to assignment sheets

F. Test

G. Answers to test

II. References:

A. McDonnell, Leo P. *Hand Woodworking Tools*. Albany, New York: Delmar Publishers, 1962.

B. Division of Stanley Works, Educational Department. *Stanley Tool Guide*. New Britain, Connecticut: Stanley Tools, 1972.

MEASURING
UNIT II

INFORMATION SHEET

- I. Terms and definitions
 - A. Measuring--The setting of limits or bounds according to a pre-determined standard
 - B. Inch--The smallest whole unit of lineal measure commonly used in carpentry
 - C. Foot--A unit of measure consisting of twelve equal parts called inches
 - D. Fraction--One or more equal parts of a whole
Example: $1/2$, $1/4$, $3/8$, $5/16$
 - E. Rule--An instrument that is graduated in whole units and fractions of units and used in measuring
 - F. Dimension--The number of full units and fractions of units between two points
 - G. Modular--Standardized units or dimensions for flexibility and variety in use
- II. Basic measuring tools (Transparency 1)
 - A. Bench rule
 - B. Framing square
 - C. Steel tape
 - D. Folding rule
 - E. Combination square
 - F. Mason's modular rule
- III. Reading a rule (Transparencies 2, 3, and 4)
 - A. All rules read similarly

(NOTE: Some rules are graduated with more divisions per inch than others, and layout tapes are marked sixteen inches on center.)

INFORMATION SHEET

B. Procedures for reading

1. Determine the number of graduations per inch
 - a. Locate small figure at the "0" end of rule which designates the divisions per inch
 - b. Count the divisions in one inch
 - c. Gain skill in determining the divisions through practice
2. Determine inches and fractions of an inch
 - a. Count the graduations in that fraction of an inch beyond the last full inch

Example:

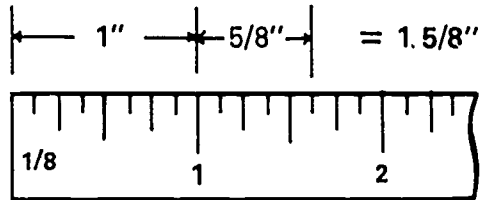

- b. Add the fraction to the last full inch

(NOTE: In the above example, the total amount equals one and five-eighths inch.)
3. Reduce the fraction if possible
4. Determine the feet and add the inches and fraction of an inch to obtain a correct measurement

Example:

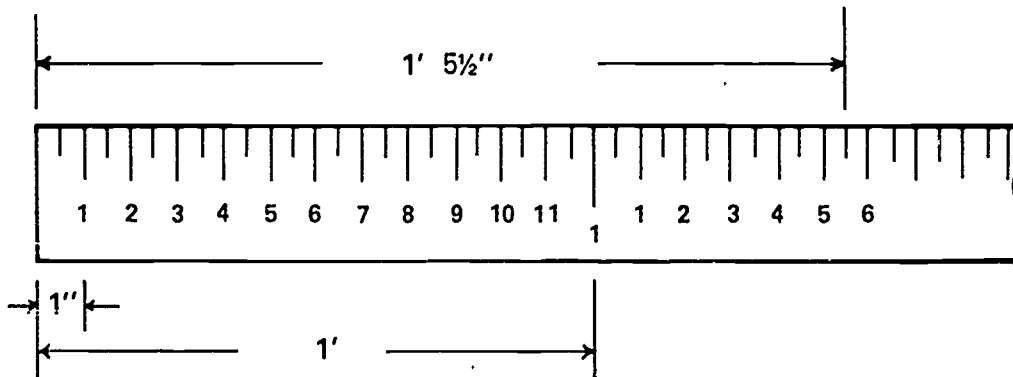

Measuring Tools

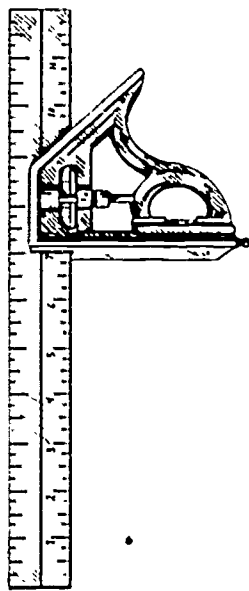

Combination Square

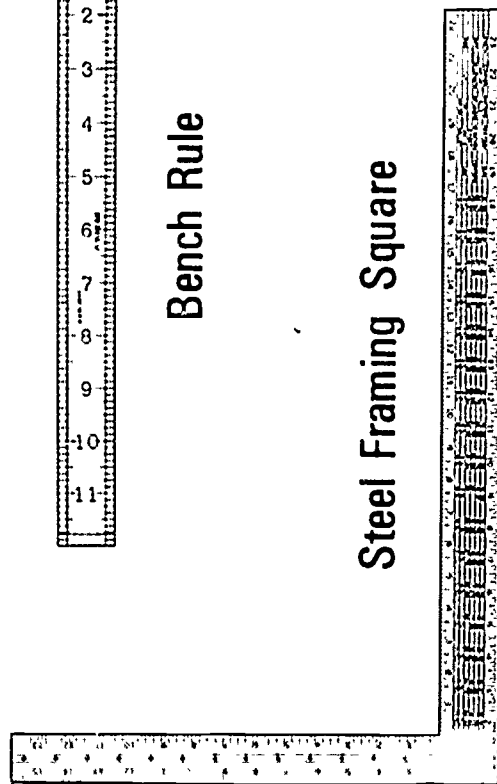

Steel Framing Square

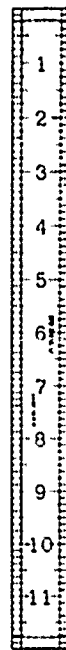

Bench Rule

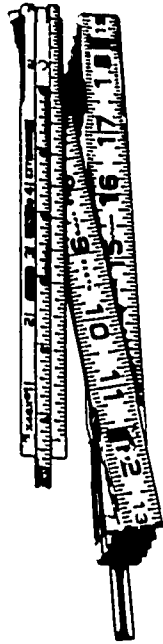

Folding Rule

Mason's
Modular Rule

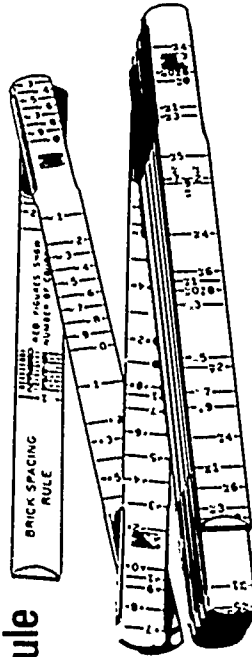

Steel Tapes

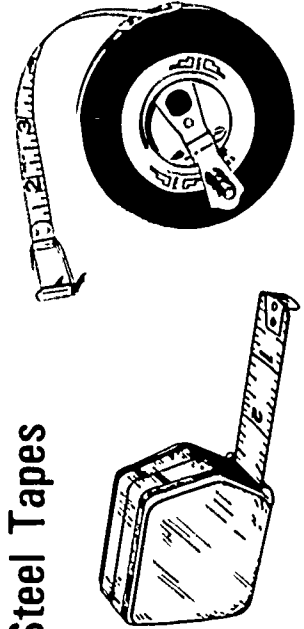

Graduations on a Rule

Halves

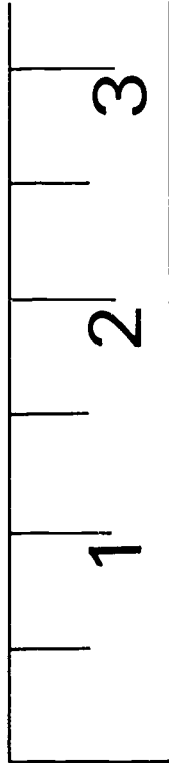

Quarters

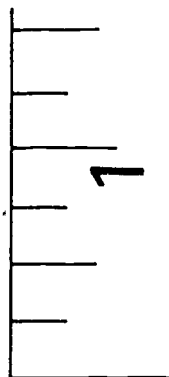

Eighths

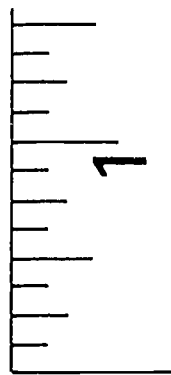

Sixteenths

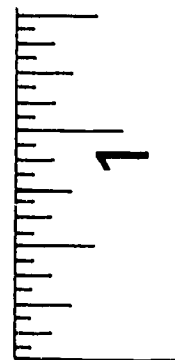

Thirty-Seconds

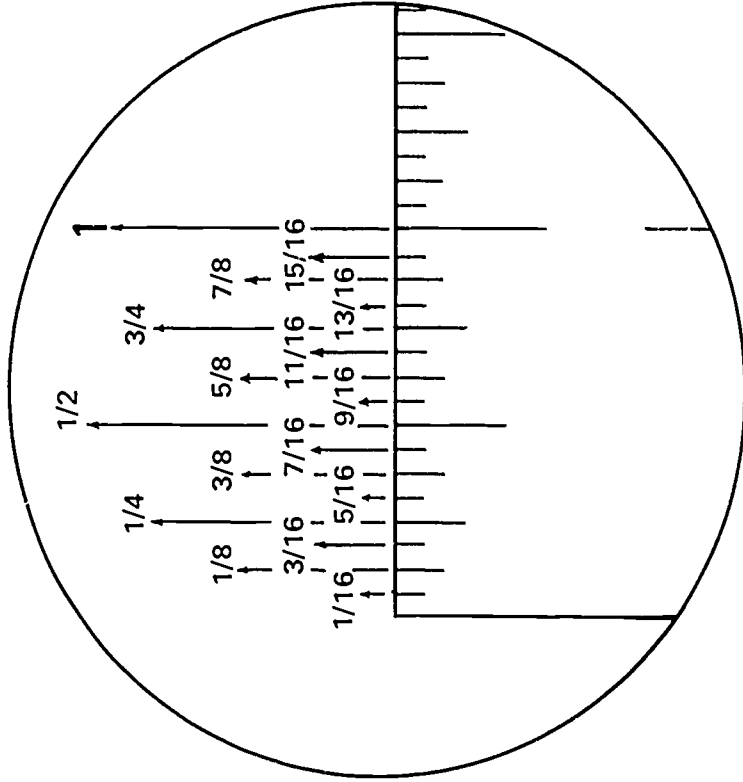

Graduations Applied to a Rule

Reading the Eighths Rule

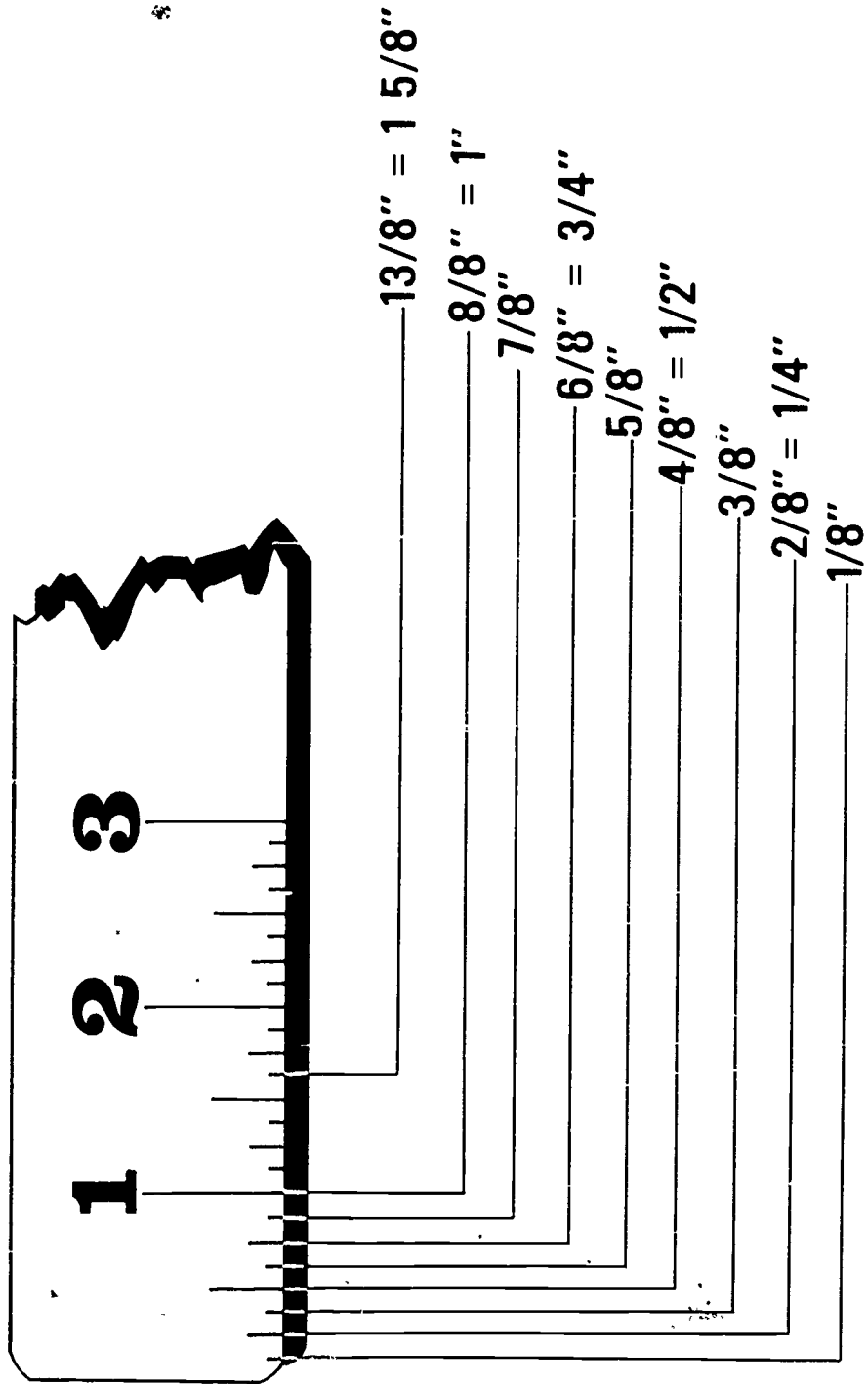

Reading the Sixteenths Rule

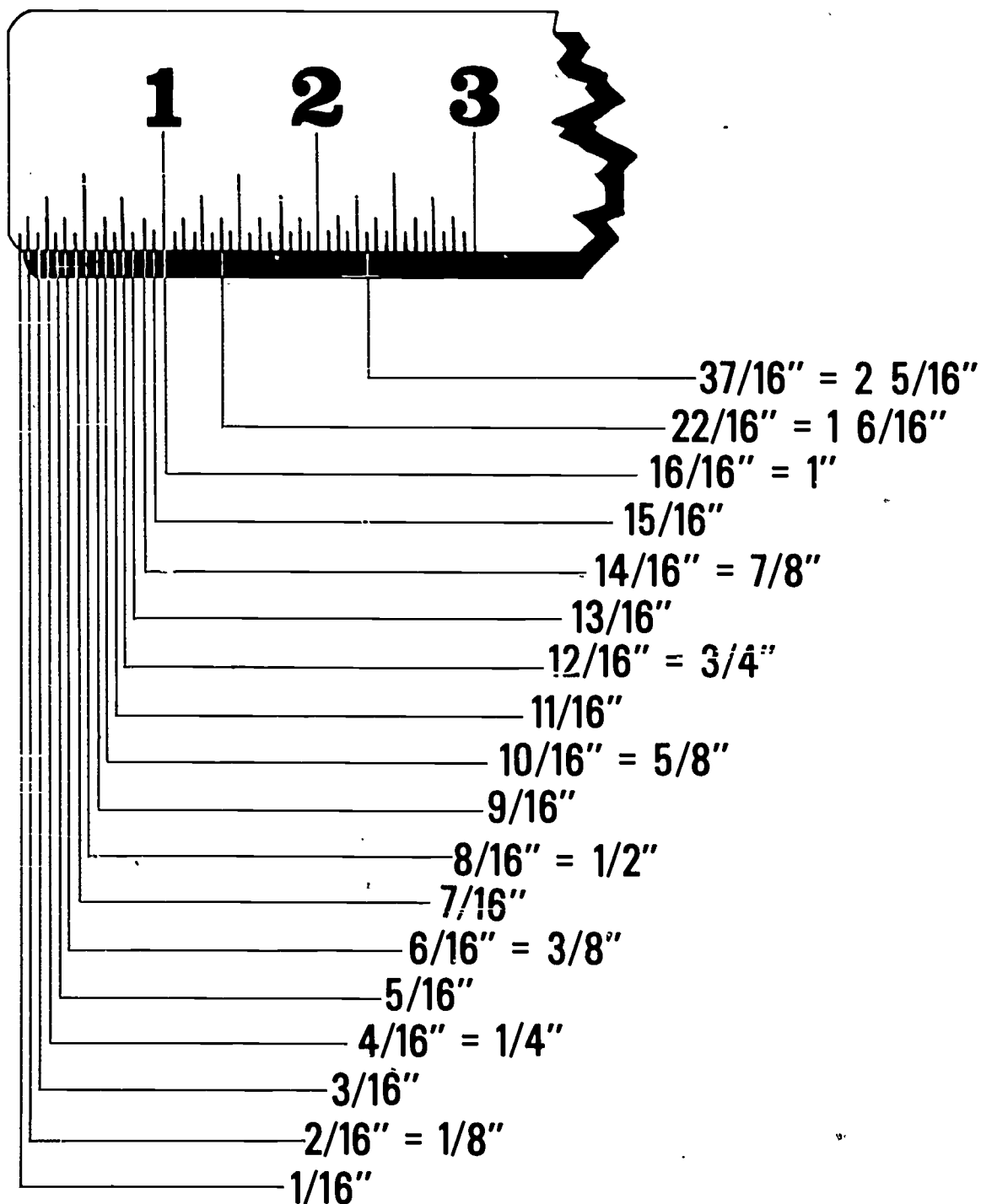

MEASURING
UNIT II

ASSIGNMENT SHEET #1--READING A RULE

1. Use the drawing below and read the rule to the nearest one-fourth inch.

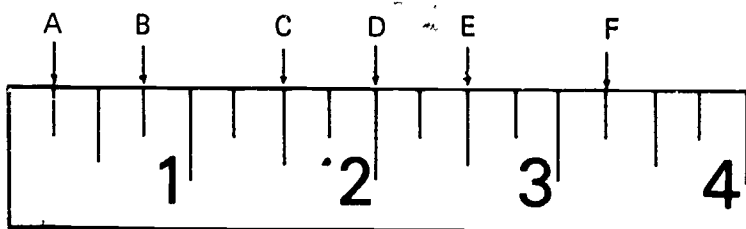

- a. 0-A _____
- b. 0-B _____
- c. 0-C _____
- d. 0-D _____
- e. 0-E _____
- f. 0-F _____
2. Use the drawing below and read the rule to the nearest one-eighth inch.

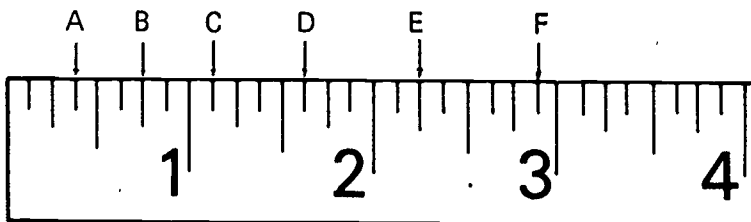

- a. 0-A _____
- b. 0-B _____
- c. 0-C _____
- d. 0-D _____
- e. 0-E _____
- f. 0-F _____

ASSIGNMENT SHEET #1

3. Use the drawing below and read the rule to the nearest one-sixteenth inch.

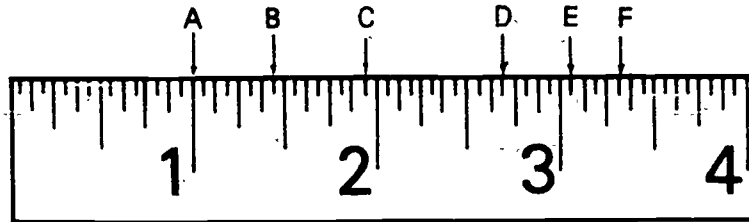

- a. 0-A _____
b. 0-B _____
c. 0-C _____
d. 0-D _____
e. 0-E _____
f. 0-F _____

MEASURING
UNIT II

ASSIGNMENT SHEET #2-MEASURING OBJECTS

Using a rule with one-sixteenth inch graduations, measure the following objects.

1.

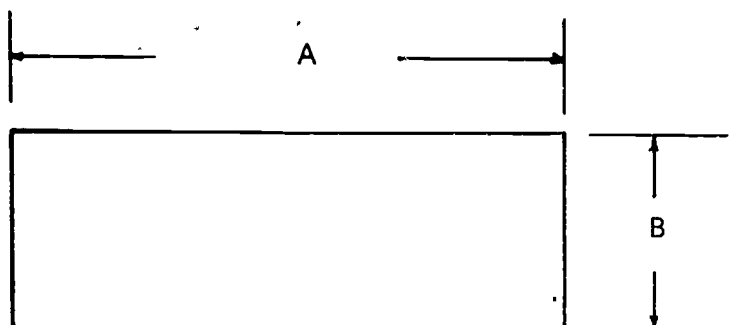

a. Length _____

b. Height _____

2.

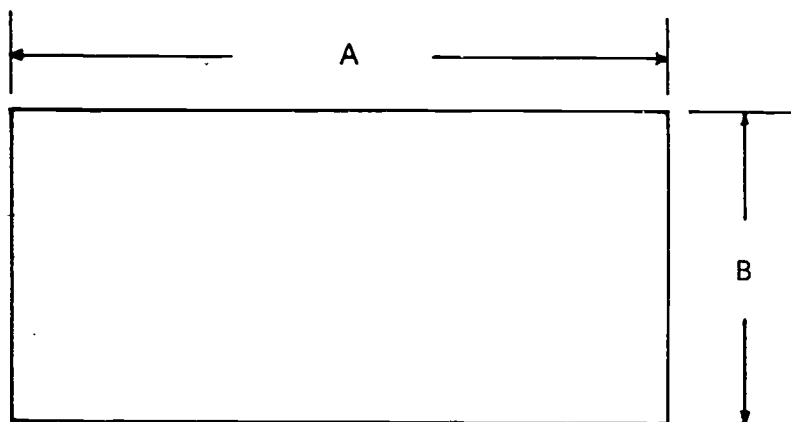

a. Length _____

b. Height _____

ASSIGNMENT SHEET #2

3.

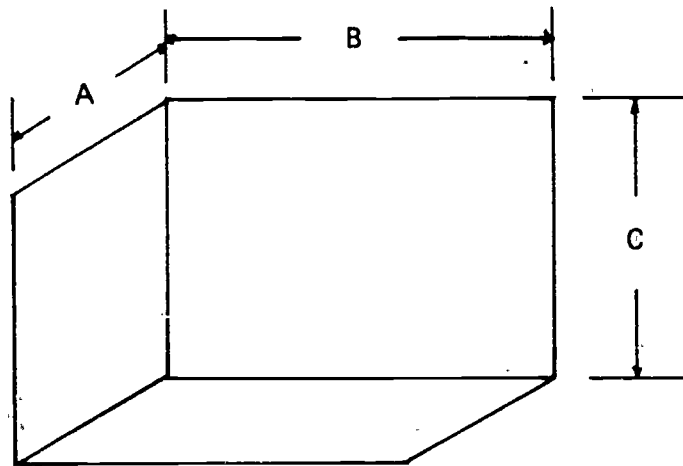

- a. Width _____
- b. Length _____
- c. Height _____

4.

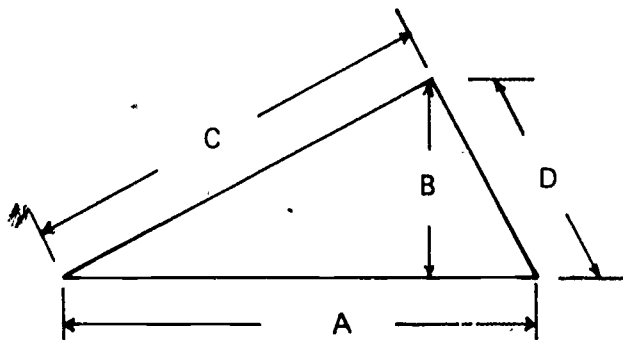

- a. Base _____
- b. Height _____
- c. Slope #1 _____
- d. Slope #2 _____

MEASURING
UNIT II

ASSIGNMENT SHEET #3-DRAWING LINES AND OBJECTS

Using a rule with one-sixteenth inch graduations, draw the following lines and objects to the given dimensions.

1. Draw straight lines to the following lengths:
 - a. $3 \frac{3}{4}$ inches
 - b. $2 \frac{1}{16}$ inches
 - c. $3 \frac{10}{16}$ inches
 - d. $\frac{5}{4}$ inch
 - e. $2 \frac{5}{8}$ inches
2. Draw a rectangle with a height of one and seven-eighths inches and a length of two and three-sixteenths inches.

ASSIGNMENT SHEET #3

3. Draw a triangle with a base length of two and one-half inches a height of one and one-half inches and one slope of two and one-eighths inches.

MEASURING
UNIT II

ANSWERS TO ASSIGNMENT SHEETS

Assignment Sheet #1

1.
 - a. $\frac{1}{4}$ inch
 - b. $\frac{3}{4}$ inch
 - c. $1 \frac{1}{2}$ inches
 - d. 2 inches
 - e. $2 \frac{1}{2}$ inches
 - f. $3 \frac{1}{4}$ inches
2.
 - a. $\frac{3}{8}$ inch
 - b. $\frac{3}{4}$ inch
 - c. $1 \frac{1}{8}$ inches
 - d. $1 \frac{5}{8}$ inches
 - e. $2 \frac{1}{4}$ inches
 - f. $2 \frac{7}{8}$ inches
3.
 - a. 1 inch
 - b. $1 \frac{7}{16}$ inches
 - c. $1 \frac{15}{16}$ inches
 - d. $2 \frac{11}{16}$ inches
 - e. $3 \frac{1}{16}$ inches
 - f. $3 \frac{5}{16}$ inches

Assignment Sheet #2

1.
 - a. 3 inches
 - b. 1 inch
2.
 - a. $3 \frac{9}{16}$ inches
 - b. $1 \frac{5}{8}$ inches

- 3. a. 1 inch
- b. $2 \frac{1}{8}$ inches
- c. $1 \frac{7}{16}$ inches
- 4. a. $2 \frac{9}{16}$ inches
- b. $1 \frac{1}{16}$ inches
- c. $2 \frac{1}{4}$ inches
- d. $1 \frac{3}{16}$ inches

Assignment Sheet #3

- 1. a. $3 \frac{3}{4}$ inches _____
- b. $2 \frac{1}{16}$ inches _____
- c. $3 \frac{5}{8}$ inches _____
- d. $1 \frac{1}{4}$ inches _____
- e. $2 \frac{5}{8}$ inches _____

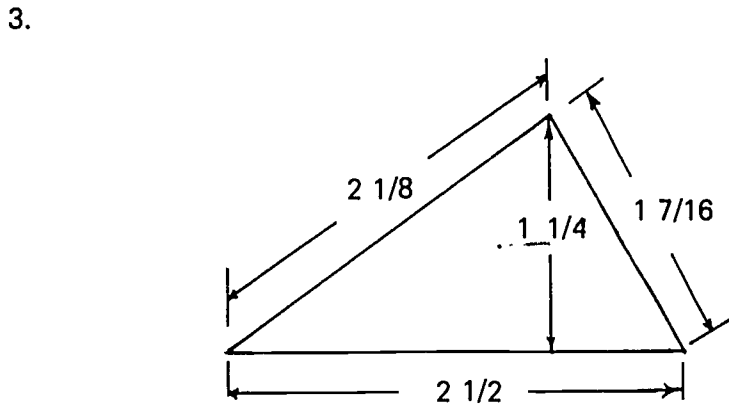
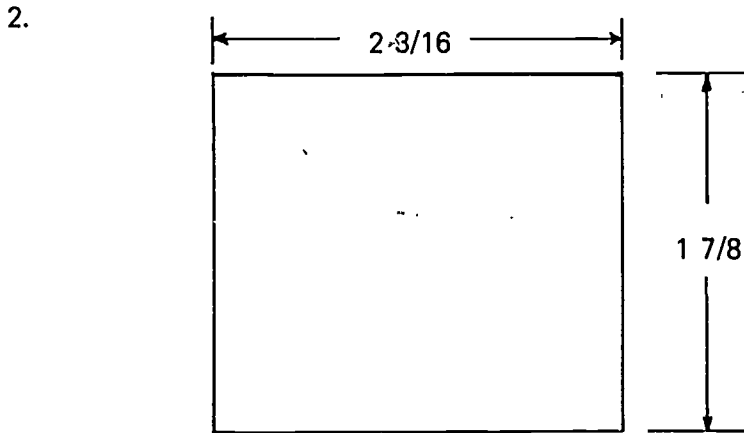

MEASURING
UNIT II

TEST

1. Match the following measuring terms to the correct definitions.

- | | |
|--|--------------|
| _____ a. The setting of limits or bounds according to a pre-determined standard | 1. Measuring |
| _____ b. The smallest whole unit of lineal measure commonly used in carpentry | 2. Rule |
| _____ c. A unit of measure consisting of twelve equal parts called inches | 3. Modular |
| _____ d. One or more equal parts of a whole | 4. Dimension |
| _____ e. An instrument that is graduated in whole units and fractions of units and used in measuring | 5. Inch |
| _____ f. The number of full units and fractions of units between two points | 6. Fraction |
| _____ g. Standardized units or dimensions for flexibility and variety in use | 7. Foot |

2. Identify the following measuring tools by placing the correct members in the blanks provided.

- _____ a. Bench rule
- _____ b. Framing square
- _____ c. Steel tape
- _____ d. Folding rule
- _____ e. Combination square
- _____ f. Mason's modular rule

1.



2.

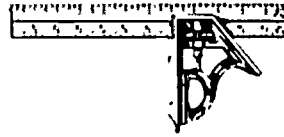

4.

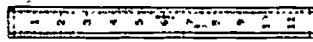

3.



5.

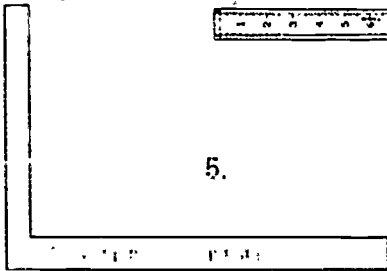

6.

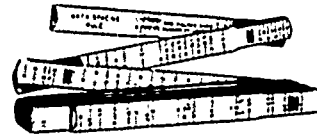

3. Read the rule pictured below to the nearest one-sixteenth of an inch.

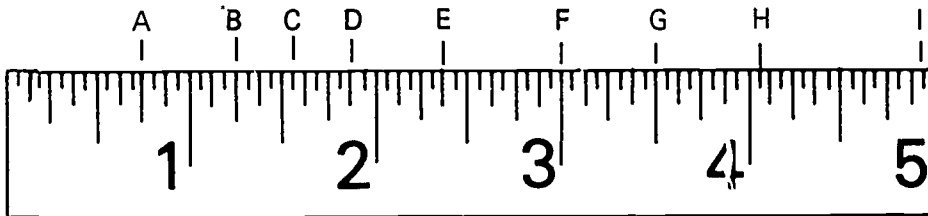

- | | |
|-----------------|-----------------|
| _____ a. 0 to A | _____ f. 0 to F |
| _____ b. 0 to B | _____ g. 0 to G |
| _____ c. 0 to C | _____ h. 0 to H |
| _____ d. 0 to D | _____ i. 0 to I |
| _____ e. 0 to E | |

4. Measure the following objects to the nearest one-sixteenth of an inch.

a.

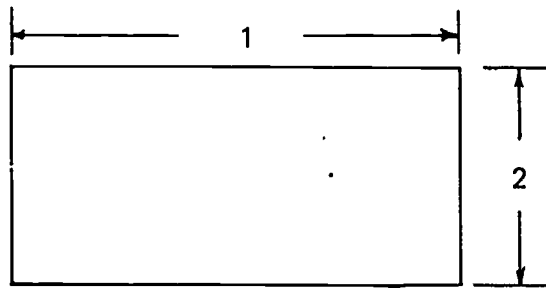

- _____ 1)
- _____ 2)

b.

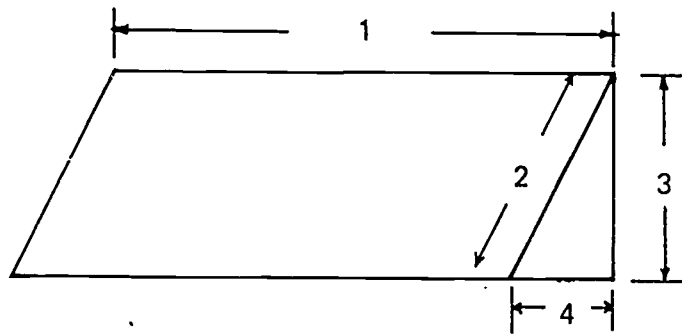

- _____ 1)
- _____ 2)
- _____ 3)
- _____ 4)

5. Draw objects to the specified dimensions.

a. Draw a $1 \frac{7}{8}$ inch square.

b. Draw a rectangle $1 \frac{5}{8} \times 2 \frac{1}{4}$ inches.

c. Draw a triangle with a base line of 2 inches, a height of $\frac{7}{8}$ inch, and one slope of $\frac{15}{16}$ inch.

MEASURING
UNIT II

ANSWERS TO TEST

1.
 - a. 1
 - b. 5
 - c. 7
 - d. 6
 - e. 2
 - f. 4
 - g. 3
2.
 - a. 4
 - b. 5
 - c. 3
 - d. 1
 - e. 2
 - f. 6
3.
 - a. $\frac{3}{4}$ inch
 - b. $1 \frac{1}{8}$ inch
 - c. $\frac{9}{16}$ inch
 - d. $1 \frac{7}{8}$ inches
 - e. $2 \frac{3}{8}$ inches
 - f. 3 inches
 - g. $3 \frac{1}{2}$ inches
 - h. $4 \frac{1}{16}$ inches
 - i. $4 \frac{15}{16}$ inches
4.
 - a. 1) $2 \frac{7}{16}$ inches
 - 2) $1 \frac{1}{8}$ inches

- b. 1) $2 \frac{3}{4}$ inches
- 2) $1 \frac{3}{16}$ inches
- 3) $1 \frac{1}{16}$ inches
- 4) $\frac{9}{16}$ inch

5. a.

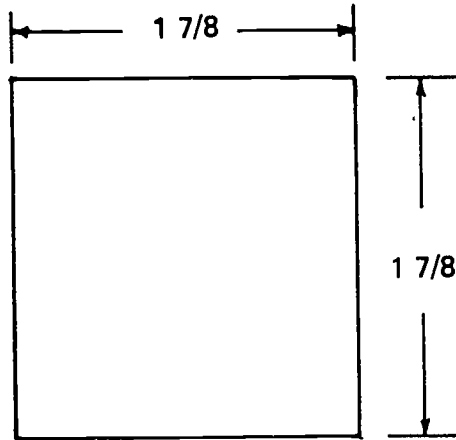

b.

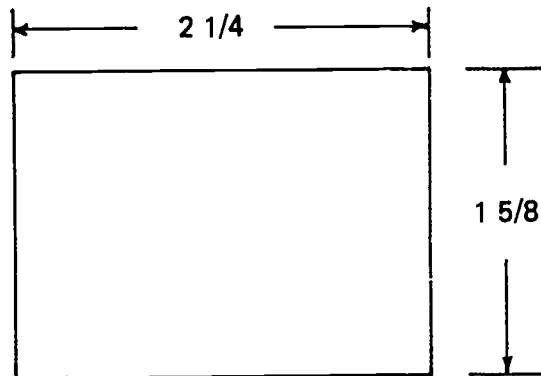

c.

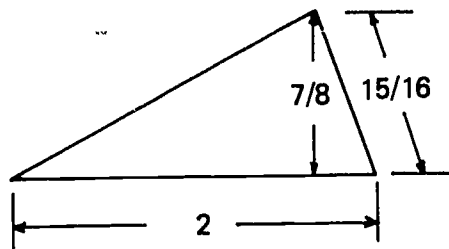

FASTENERS UNIT III

TERMINAL OBJECTIVE

After completion of this unit, the student should be able to define fasteners and anchors and identify the lengths of nails. He should be able to name the coatings and materials used for nails, and the types of connections made with screws, and identify the various kinds of screws and bolts. He should also be able to name the types of glue and define two kinds of adhesives. This knowledge will be evidenced by scoring eighty-five percent on the unit test.

SPECIFIC OBJECTIVES

After completing this unit, the student should be able to:

1. Define fastener as used in building construction.
2. Define anchor as used in building construction.
3. Identify the length and penny weight of four nails used most often in construction.
4. Name two coatings for nails.
5. Name two materials used to manufacture nails.
6. Identify five types of screw heads.
7. Identify three types of screws.
8. Name five types of connections made with screws.
9. Identify six types of bolts.
10. Name three kinds of glue.
11. Define epoxy resins.
12. Define contact cement.

FASTENERS
UNIT III

SUGGESTED ACTIVITIES

- I. Instructor:
 - A. Provide students with objective sheet.
 - B. Provide students with information sheet.
 - C. Make transparencies.
 - D. Discuss terminal and specific objectives.
 - E. Discuss information sheet.
 - F. Give test.
- II. Student:
 - A. Read objective sheet.
 - B. Study information sheet.
 - C. Take test.

INSTRUCTIONAL MATERIALS

- I. Included in this unit:
 - A. Objective sheet
 - B. Information sheet
 - C. Transparency masters
 1. TM 1--Anchors
 2. TM 2--Nails
 3. TM 3--Types of Screws
 4. TM 4--Types of Bolts
 - D. Test
 - E. Answers to test

II. References:

- A. Burke, Arthur E., J. Ralph Dalzell, and Gilbert Townsend. *Architectural and Building Trades Dictionary*. Chicago, Illinois: American Technical Society, 1955.
- B. Feirer, John L. *Woodworking for Industry*. Peoria, Illinois: Charles A. Bennett Company, Inc.

FASTENERS
UNIT III

INFORMATION SHEET

- I. Fastener in building construction--Any device such as a nail, screw, or bolt used to hold adjacent members together
- II. Anchor in building construction--Any device used to give stability to one part of the structure by securing it to a more stable part of the structure (Transparency 1)
- III. Lengths of nails used most often in construction (Transparency 2)

Penny Size	Length In Inches For Common, Box, And Finish
2d	1
3d	1 1/4
4d	1 1/2
5d	1 3/4
*6d	2
<hr/>	
7d	2 1/4
*8d	2 1/2
<hr/>	
9d	2 3/4
10d	3
12d	3 1/4
*16d	3 1/2
<hr/>	
*20d	4
<hr/>	
30d	4 1/2
40d	5
50d	5 1/2
60d	6

* Sizes most often used in construction

- IV. Coatings for nails
 - A. Cement
 - B. Galvanized
- V. Materials used to manufacture nails
 - A. Steel
 - B. Aluminum

INFORMATION SHEET

VI. Types of screw heads

A. Flat head



B. Round head



C. Oval head



D. Pan head



E. Hex head

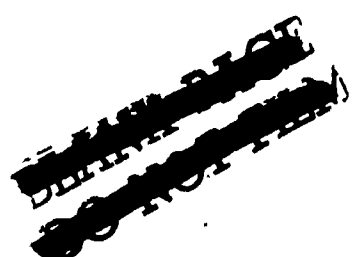

VII. Types of screws (Transparency 3)

A. Wood

B. Metal

C. Combination

VIII. Types of connections made with screws

(NOTE: See Transparency 1.)

A. Wood to wood

INFORMATION SHEET

- B. Metal to wood
 - C. Metal to metal (light metal)
 - D. Wood to concrete or masonry
 - E. Metal to concrete or masonry
- IX. Types of bolts (Transparency 4)
- A. Toggle
 - B. Coil
 - C. Stove
 - D. Carriage
 - E. Machine
 - F. Anchor
- X. Kinds of glue
- A. Waterproof
(NOTE: Recommended for the most severe exposure such as exterior and marine use.)
 - B. Water-resistant
(NOTE: Recommended for exterior exposure in which there will be some protection from the elements.)
 - C. Low water-resistant
(NOTE: Recommended for interior only.)
- XI. Epoxy resins--A two part adhesive
- (NOTE: When mixed together, a chemical action takes place which provides an ideal adhesive material for joining almost any material.)
- (CAUTION: Use extreme care when mixing. Do not get material on skin.)
- XII. Contact cement--A neoprene-based resin; a rubber type adhesive
- (NOTE: The adhesive is applied to both surfaces and allowed to dry, and then the surfaces are brought together. The bond is immediate. Its main use is glueing plastic laminate to backing material.)
- (CAUTION: Use extreme care when mixing. Do not get material on skin.)

Anchors



Drive Anchors



Wood Screw Lead Anchors



Plastic Screw Anchors



Machine Screw Anchors



Lag Screw Shields



Double Expansion Bolt Shields

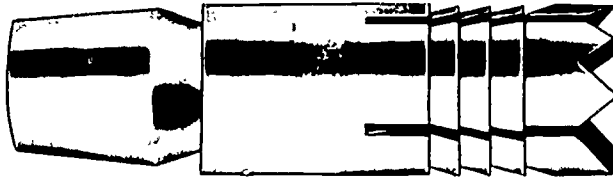

Self-Drilling Anchor

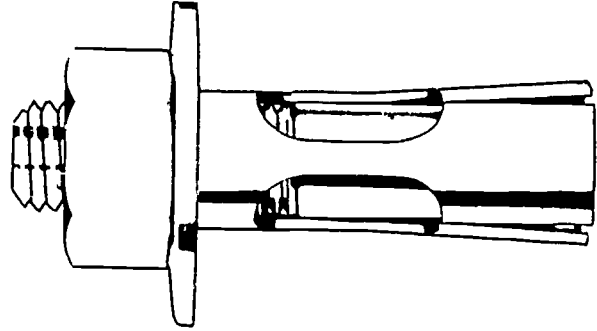

Bolt and Anchor Unit

Nails

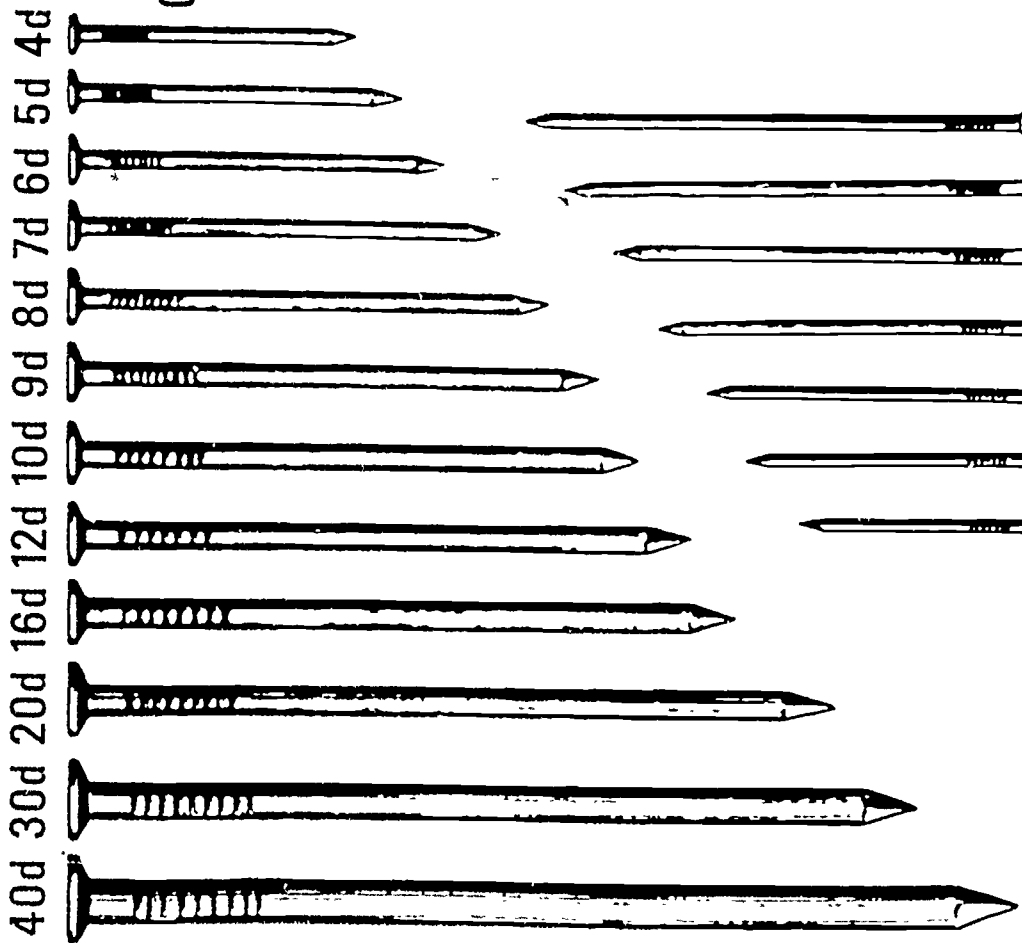

Common Nails

Box Nails, Smooth; Barbed
4d 5d 6d 7d 8d 9d 10d 12d 16d

Casing Nails
10d 7d 3d

Finishing Nails
3d 4d 5d 6d 7d 8d 9d

Finishing Nails

Types of Screws

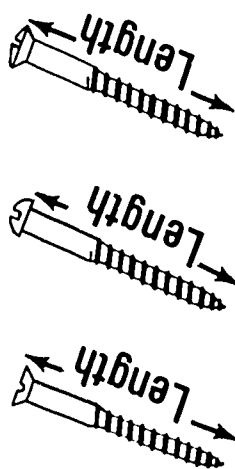

Lag Screw

Determine Screw Shank Sizes
by Comparison Below

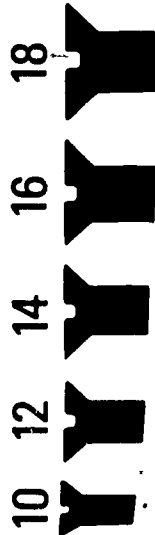
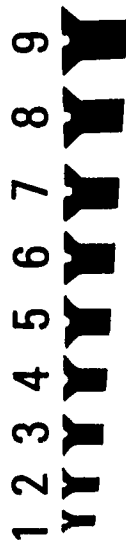

Wood Screws

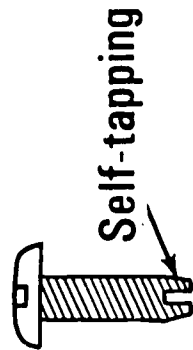
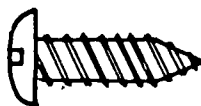

Metal Screws

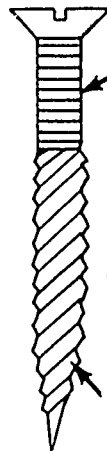

Wood Thread

Machine Thread

Combination Screw

Types of Bolts



Spring Wing
Toggle Bolt

Coil Bolt



Screw Anchor



Bolt



The Assembly

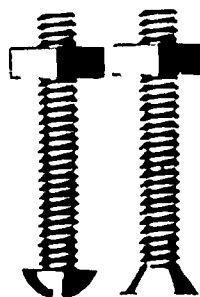

Stove Bolts



Carriage Bolt



Machine Bolts



Anchor Bolt

FASTENERS
UNIT III

TEST

1. Define fastener as used in building construction.
2. Define anchor as used in building construction.
3. Identify the length and penny weight of four nails used most often in building construction.

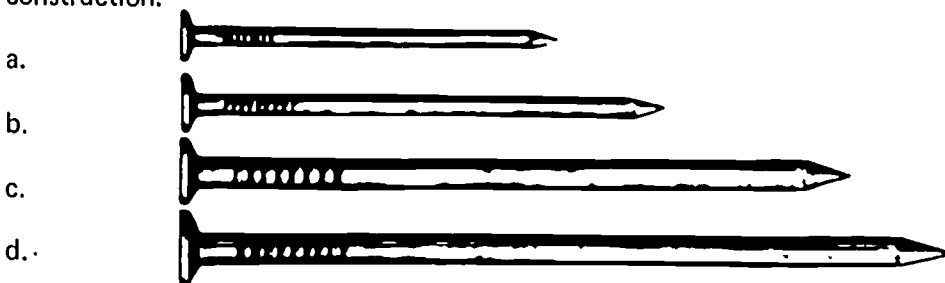

4. Name two coatings for nails.
 - a.
 - b.
5. Name two materials used to manufacture nails.
 - a.
 - b.
6. Identify five types of screw heads.

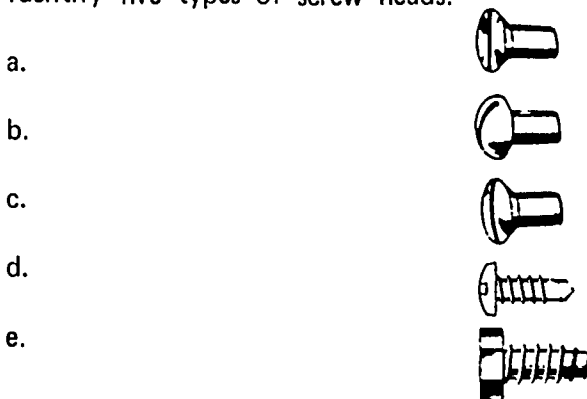

7. Identify three types of screws.

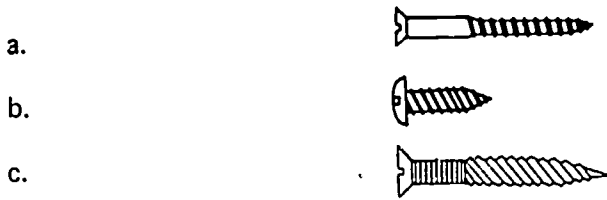

8. Name five types of connections made with screws.

- a.
- b.
- c.
- d.
- e.

9. Identify six types of bolts.

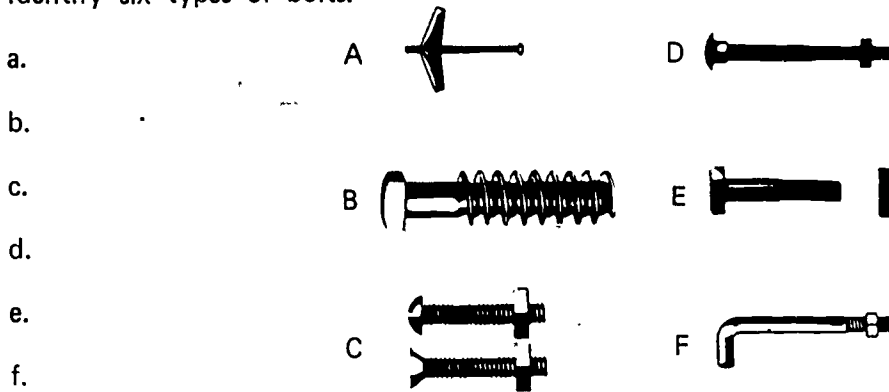

10. Name three kinds of glue.

- a.
- b.
- c.

11. Define epoxy resins.

12. Define contact cement.

FASTENERS
UNIT III

ANSWERS TO TEST

1. Any device such as a screw, nail, or bolt used to hold adjacent members together
2. Any device used to give stability to one part of the structure by securing it to a more stable part of the structure

(NOTE: Answers to questions 3 and 4 may be given in any order.)

3.
 - a. 6d 2"
 - b. 8d 2 1/2"
 - c. 16d 3 1/2"
 - d. 20d 4"
4.
 - a. Cement
 - b. Galvanized
5.
 - a. Steel
 - b. Aluminum
6.
 - a. Flat
 - b. Round
 - c. Oval
 - d. Pan
 - e. Hex
7.
 - a. Wood
 - b. Metal
 - c. Combination
8.
 - a. Wood to wood
 - b. Metal to wood
 - c. Metal to metal (light metal)

- d. Wood to concrete or masonry
- e. Metal to concrete or masonry
- 9.
 - a. Toggle
 - b. Coil
 - c. Stove
 - d. Carriage
 - e. Machine
 - f. Anchor
- 10.
 - a. Waterproof
 - b. Water-resistant
 - c. Low water-resistant
- 11. A two part adhesive
- 12. A neoprene-based resin; a rubber type adhesive

Carpentry

PROGRESS CHART

154

Section C
Related Information

Student's Name	Unit I Lumber			Unit II Measuring			Unit III Fasteners			Job	Unit Test
	1	2	3	1	2	3	1	2	3		
1											
2											
3											
4											
5											
6											
7											
8											
9											
10											

HAND TOOLS UNIT I

TERMINAL OBJECTIVE

After completion of this unit, the student should be able to list the basic rules concerning the care and safe use of hand tools. He should be able to identify tools common to the carpentry trade, state their intended use, and demonstrate the safe and correct use for each. This knowledge will be evidenced through demonstration and by scoring eighty-five percent on the unit test.

SPECIFIC OBJECTIVES

After completion of this unit, the student should be able to:

1. List four basic rules concerning the care of hand tools.
2. List five basic rules concerning the use of hand tools.
3. Identify two types of planes and write a use for each.
4. Identify three types of squares and write a use for each.
5. Identify six types of handsaws and write a use for each.
6. Identify four types of hammers and write a use for each.
7. Identify two types of screwdrivers.
8. Identify four types of pliers.
9. Identify five types of clamps.
10. Identify five types of leveling and/or plumbing instruments.
11. Identify four types of wrenches.
12. Identify three types of boring tools and three types of drilling tools, and state the name of each.
13. Identify four types of files by shape.
14. Identify two types of knives.
15. Identify three types of ladders.
16. Identify three types of measuring instruments.
17. Identify twenty-one miscellaneous tools.
18. Demonstrate the ability to use each tool safely and according to the recommended use.

HAND TOOLS UNIT I

SUGGESTED ACTIVITIES

- I. Instructor
 - A. Provide students with objective sheet.
 - B. Provide students with information sheet.
 - C. Make transparencies.
 - D. Discuss terminal and specific objectives.
 - E. Discuss information sheet.
 - F. Provide display of tools.
 - G. Demonstrate the use of each tool.
 - H. Give test.
- II. Student
 - A. Read objectives.
 - B. Study information sheet.
 - C. Practice using each tool after receiving instructions from the instructor on the correct use of the tool.
 - D. Take test.

INSTRUCTIONAL MATERIAL

- I. Included in this unit:
 - A. Objectives
 - B. Information sheet
 - C. Transparency masters
 1. TM 1--Types of Planes
 2. TM 2--Types of Squares
 3. TM 3--Types of Handsaws
 4. TM 4--Types of Hammers

5. TM 5--Types of Screwdrivers and Pliers
6. TM 6--Types of Clamps
7. TM 7--Types of Levels and Wrenches
8. TM 8--Types of Drilling and Boring Tools
9. TM 9--Types of Files and Knives
10. TM 10--Types of Ladders and Measuring Instruments
11. TM 11--Types of Miscellaneous Tools
12. TM 12--Types of Miscellaneous Tools (continued)
13. TM 13--Types of Miscellaneous Tools (continued)

D. Test

E. Answers to test

II. References:

- A. Association of General Contractors. *Task analysis of Residential Carpentry*. Denver, Colorado. 1972.
- B. Hammond, James J., Edward T. Donnelly, Walter F. Harrod, and Norman A. Rayner. *Woodworking Technology*. Bloomington, Illinois: McKnight and McKnight Publishing Company, 1966.
- C. Wagner, Willis H. *Modern Carpentry*. Homewood, Illinois: Goodheart-Willcox Company Inc., 1969.

HAND TOOLS
UNIT I

INFORMATION SHEET

- I. Basic rules concerning the care of hand tools
 - A. Keep tools sharp
 - B. Protect the cutting edge of tools when carrying or storing
 - C. Keep tools dry and lightly oiled when not in use
 - D. Use tools only for the purpose for which they were intended
- II. Basic rules concerning the safe use of hand tools
 - A. Use the right tool for the job
 - B. Do not use dull or broken tools
 - C. Be sure that tool handles are in good condition and securely fastened to the body of the tool
 - D. Do not throw tools
 - E. Keep fingers away from edges of cutting tools and work away from your body
- III. Identification of wood working planes and their uses
 - A. Jack plane
 1. Identification
 - a. Fourteen inches long
 - b. Two inches wide
 2. Use--General purposes
 - B. Block plane
 1. Identification
 - a. Four to 6 inches long
 - b. One and three-eighths to 1 and 5/8 inches wide
 2. Use--Small jobs on trim or end grain

INFORMATION SHEET

IV. Identification of squares and their uses

A. Framing square (rafter square)

1. Identification
 - a. Twenty-four inch blade
 - b. Sixteen inch tongue
 - c. Rafter and brace tables stamped on blade
2. Use--General framing procedures for layout of walls, partitions, rafters, braces, and stairs

B. Combination square

1. Identification
 - a. Twelve inch blade
 - b. Adjustable handle
(NOTE: The handle usually contains a leveling bubble and a scribe.)
 - c. Handle 90° and 45° side
2. Use
 - a. General purpose squaring, measuring, and leveling
 - b. Forty-five degree miter marking instrument

C. Sliding T bevel

1. Identification
 - a. Solid steel or wood handle
 - b. Adjustable blade
(NOTE: The blade is usually six inches long and may be folded into handle for storage.)
2. Use
 - a. Measure or transfer angles from 0° to 180°
 - b. Test or check a miter cut

INFORMATION SHEET

V. Identification of handsaws and their uses

A. Crosscut saw

1. Identification

- a. Twenty to 26 inches
in length
- b. Four to 12 points per inch
- c. Teeth filed at an angle across
their face

(NOTE: The teeth resemble knife edges.)

2. Use--Cuts across the grain of wood

(NOTE: A twenty-two inch ten point saw is good for general use.)

B. Rip saw

1. Identification

- a. Twenty to 28 inches in
length
- b. Five to 7 points per inch
- c. Teeth filed square across face

(NOTE: The teeth resemble chisle points.)

2. Use--Cuts with the grain of wood

(NOTE: A twenty-six inch five and one-half point saw is good for general use.)

C. Back saw (Miter box saw)

1. Identification

- a. Twelve to 28 inches in
length
- b. Eleven points per inch

INFORMATION SHEET

- c. Fine teeth
- d. Thin blade

(NOTE: It has a heavy metal band across the back to strengthen the thin blade.)

- 2. Use--Makes fine cuts for joinery and for use in a miter box

D. Coping saw

- 1. Identification--U-shaped saw frame

(NOTE: The U-shaped saw frame permits 4 5/8 or 6 1/2 inch deep cuts.)

- 2. Use
 - a. Cuts curves
 - b. Shapes ends of molding for joints and for scroll work

E. Compass saw

- 1. Identification
 - a. Twelve to 14 inches in length
 - b. Tapered blade
- 2. Use
 - a. Cuts gentle curves
 - b. Cuts inside corners

F. Hack saw

- 1. Identification
 - a. U-shaped saw frame
 - b. Handle
- 2. Use--Cuts all types of metal fasteners, hardware, and metal parts

INFORMATION SHEET

VI. Identification of hammers and their uses

A. Claw hammers (curved claw)

1. Identification
 - a. Curved claw
 - b. Wood, fiberglass, or steel handles
 - c. Sizes 13 to 20 ounces
2. Use--Driving and drawing nails

(NOTE: The thirteen ounce hammer is considered a finishing hammer and the sixteen ounce hammer is a general purpose hammer.)

B. Claw hammer (straight claw)

1. Identification
 - a. Straight claw
 - b. Sizes 16 to 20 ounces
2. Use--Driving nails

C. Sledge hammer

1. Identification
 - a. Large hammer
 - b. Balanced head with two identical faces
 - c. Sizes 2 to 20 pounds
2. Use--Driving stakes

D. Half hatchet

1. Identification
 - a. Short handle
 - b. Sharp surface on one-half of head
 - c. Hammer surface on one-half of head
(NOTE: This is for driving nails.)
 - d. Slot on side of blade
(NOTE: This is for pulling or drawing nails.)

INFORMATION SHEET

- 2. Use
 - a. Sharpening stakes
 - b. Trimming framing members
 - c. Nailing

VII. Types of screwdrivers

- A. Common
- B. Phillips

VIII. Types of pliers

- A. Combination slip joint
- B. Needle nose
- C. Side cutting (lineman's)
- D. Channel lock

IX. Types of clamps

- A. Bar
- B. Hand screw
- C. "C"
- D. Spring
- E. Band

X. Types of leveling and plumbing instruments

- A. Carpenter's level
- B. Torpedo level
- C. Line level
- D. Builder's level
- E. Plumb bob

INFORMATION SHEET

- XI. Types of wrenches
 - A. Box end
 - B. Open end
 - C. Combination
 - D. Adjustable

- XII. Types of boring and drilling tools
 - A. Boring tools
 - 1. Carpenter's brace
 - 2. Auger bit
 - 3. Flat bit
 - B. Drilling tools
 - 1. Hand drill
 - 2. Twist drill
 - 3. Push drill

- XIII. Types of files
 - A. Flat
 - B. Half round
 - C. Round
 - D. Triangular or three corner

- XIV. Types of knives
 - A. Utility
 - B. Putty

- XV. Types of ladders
 - A. Extension
 - B. Step
 - C. Single

INFORMATION SHEET

XVI. Types of measuring instruments

- A. Bench rule
- B. Folding rule
- C. Steel tape

XVII. Miscellaneous tools (Transparencies 11, 12, and 13)

- A. Chalk line and reel
- B. Pry bar (crow bar)
- C. Wood chisels
- D. Dividers
- E. Tin snips
- F. Nail set
- G. Bolt cutter
- H. Nail claw
- I. Square point shovel
- J. Round point shovel
- K. Sharp shooter
- L. Sand scoop
- M. Push broom
- N. Hand broom
- O. Bench brush
- P. Star drill
- Q. Miter box and saw
- R. Cold chisel
- S. Point
- T. Reversible ratchet
- U. Socket

Types of Planes

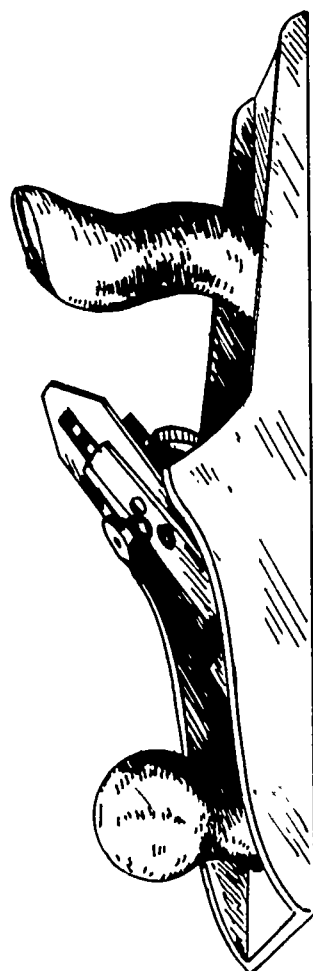

Jack Plane

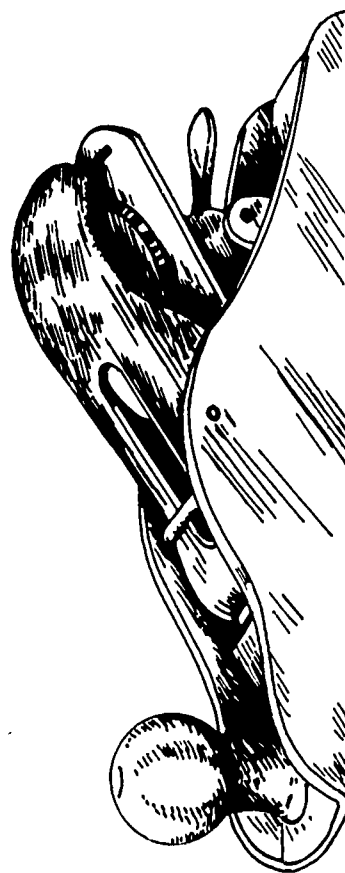

Block Plane

Types of Squares

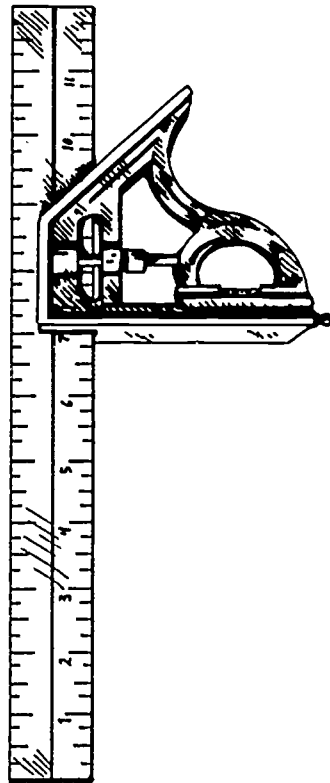

Combination Square

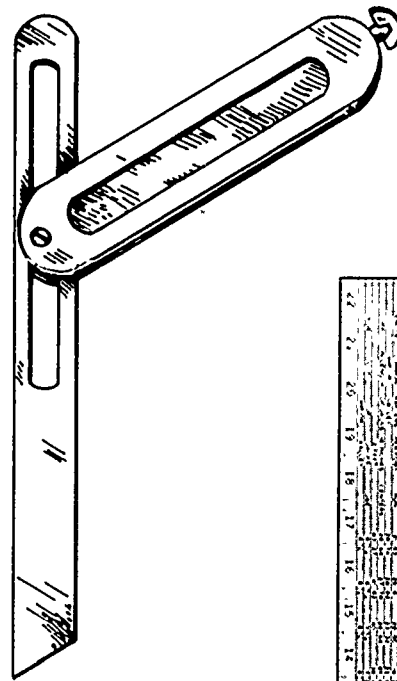

Sliding T-Bevel

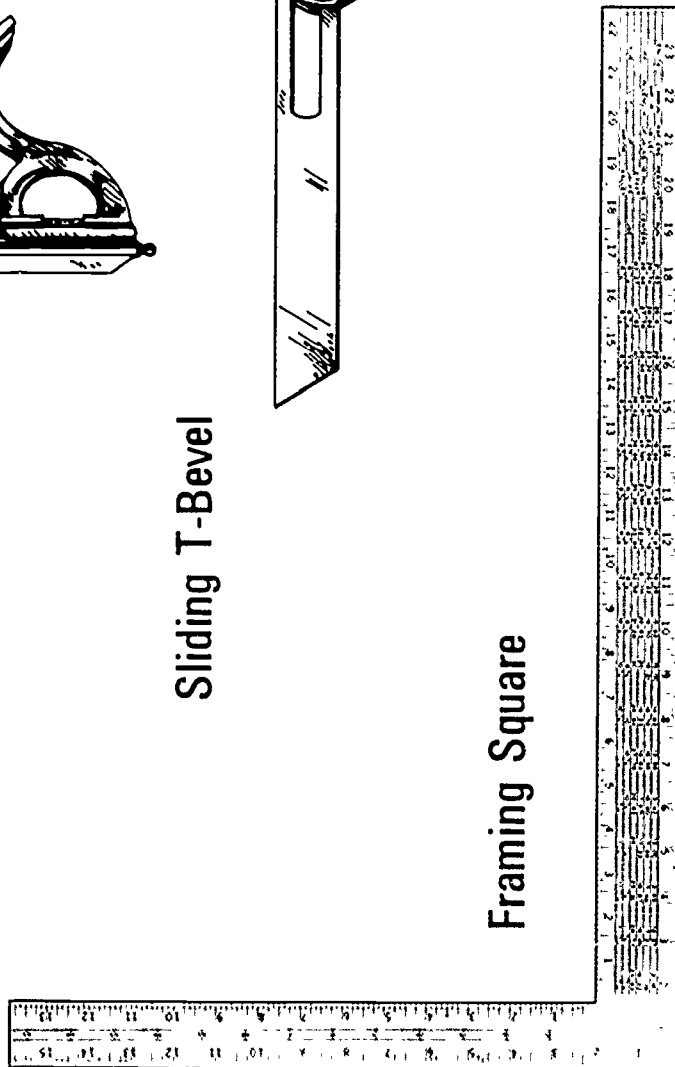

Framing Square

Types of Handsaws

BACK SAW

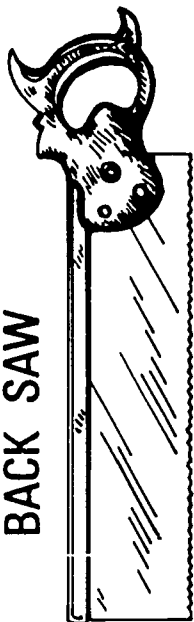

COMPASS SAW



HACK SAW

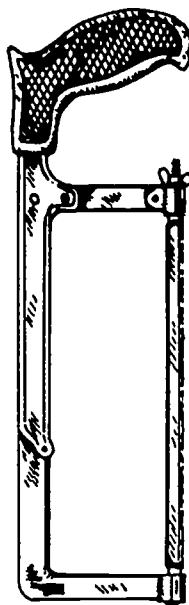

COPING SAW

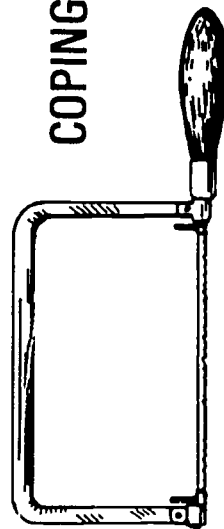

CROSSCUT SAW

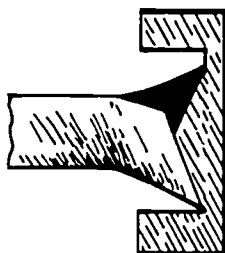
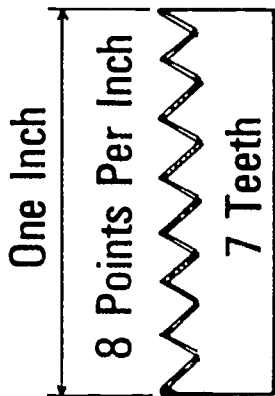

RIP SAW

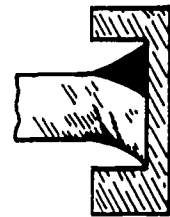
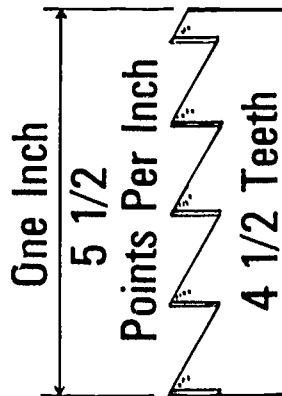

Types of Hammers



Curved Claw

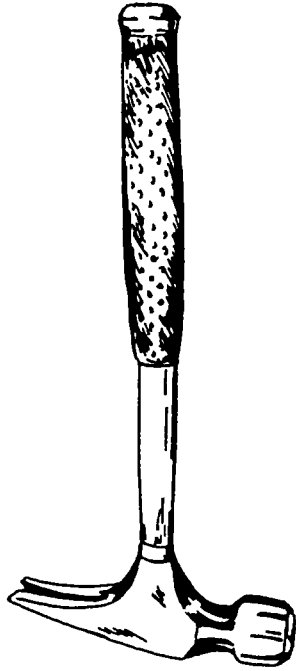

Straight Claw

CLAW HAMMERS

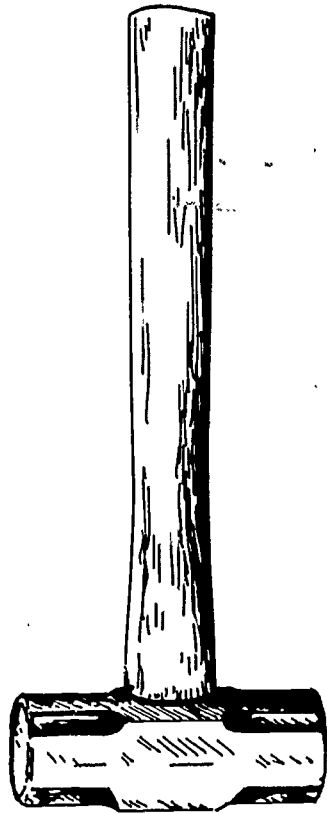

Sledge

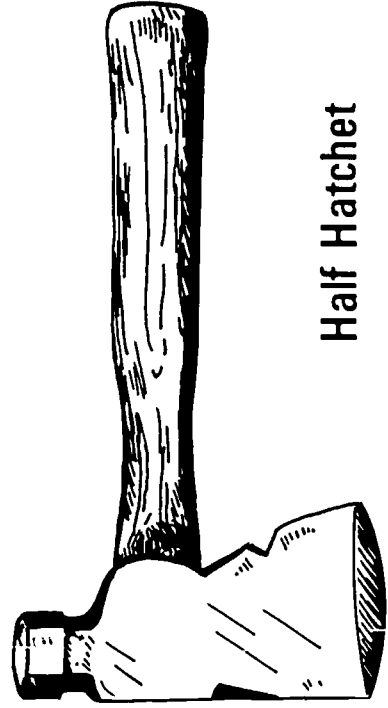

Half Hatchet

Types of Screwdrivers and Pliers

SCREWDRIVERS

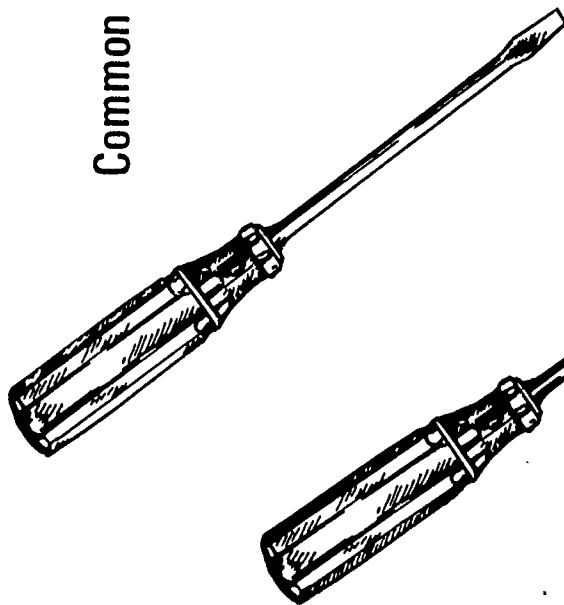

Common

Phillips

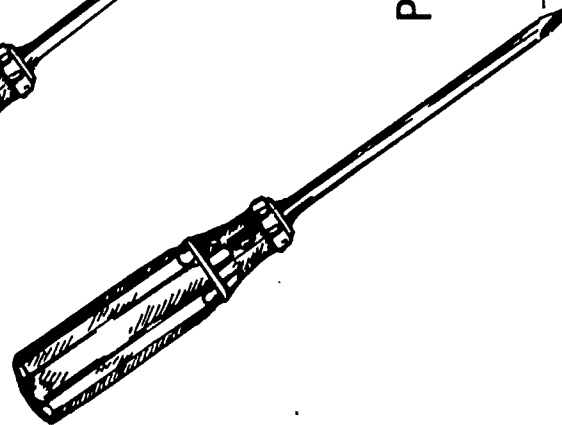

PLIERS



Linemen's Side Cutting



Needle Nose



Combination Slip-Joint

Channellock

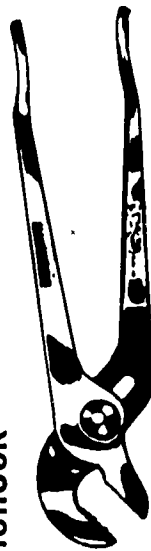

Types of Clamps

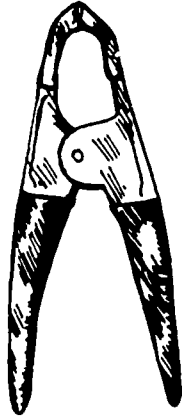

Spring

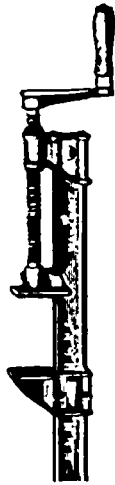

Bar

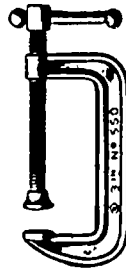

"C"

Hand Screw

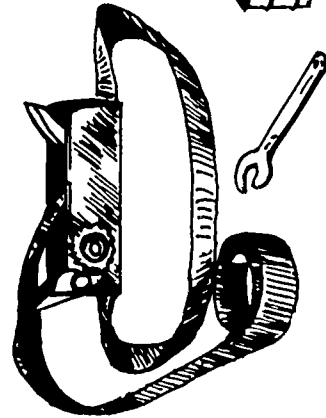
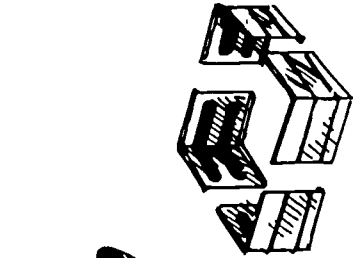
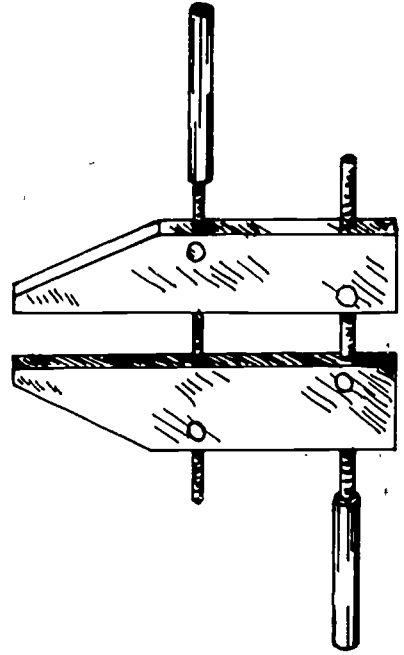

Band

Types of Levels and Wrenches

LEVELS



Carpenter's

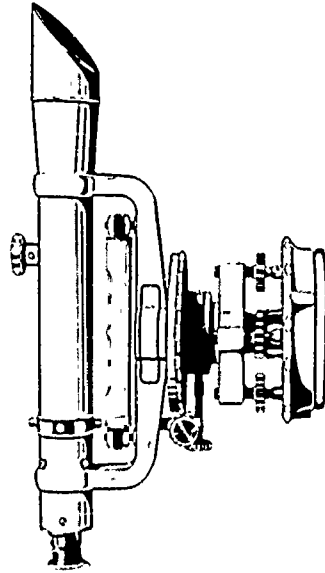

Builder's



Torpedo



Line

WRENCHES

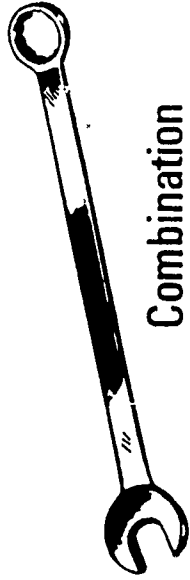

Combination



Adjustable

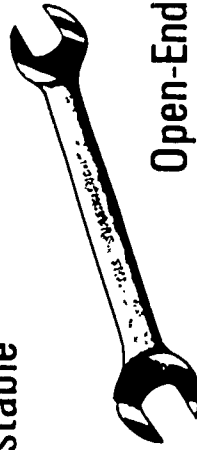

Open-End



Box-End

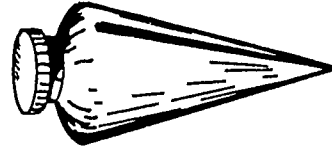

Plumb Bob

Types of Drilling and Boring Tools

BORING TOOLS

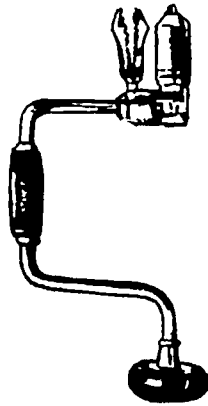

Carpenter Brace

DRILLING TOOLS



Hand Drill

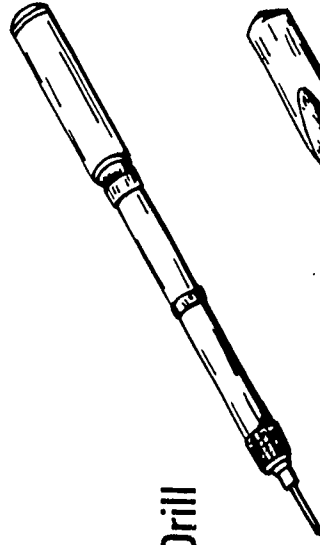

Push Drill

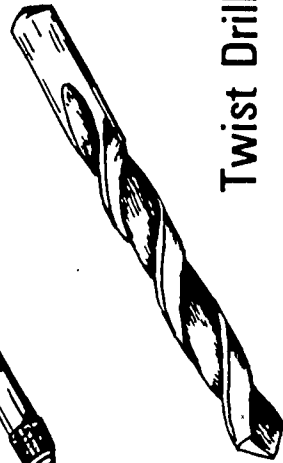

Twist Drill

Auger Bit

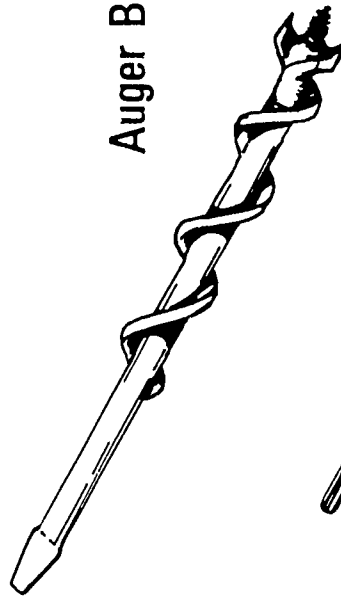

Flat Bit
(Speed Bit)

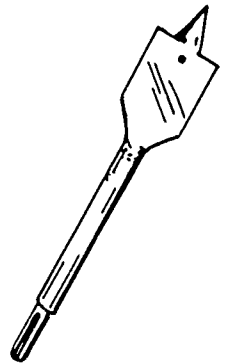

Types of Files and Knives

FILES



Half-Round Wood



Flat Wood



Triangular Wood



Round Wood

KNIVES

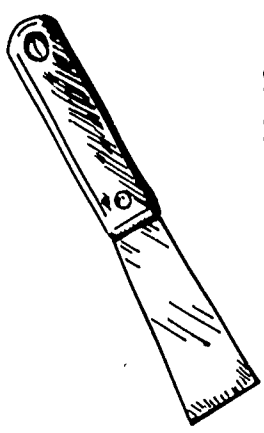

Putty Knife

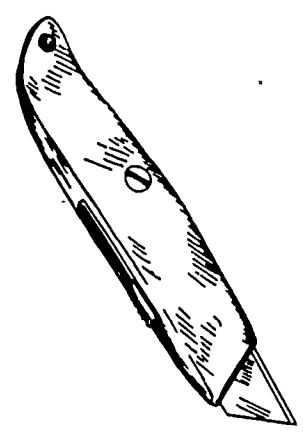

Utility Knife

Types of Ladders and Measuring Instruments

LADDERS

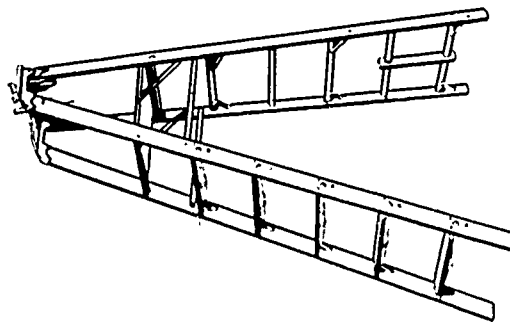

Step-Ladder

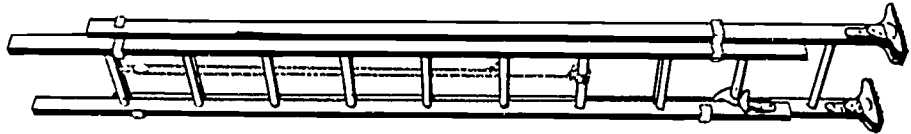

Extension Ladder

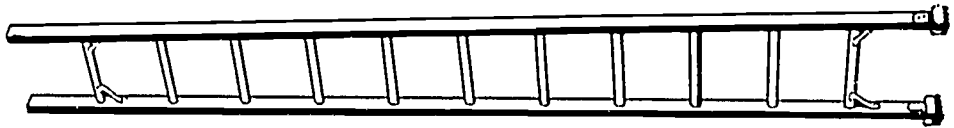

Single Ladder

Non-Skid

MEASURING INSTRUMENTS

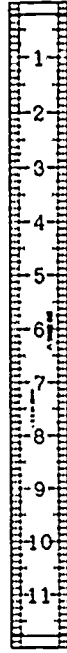

Bench Rule

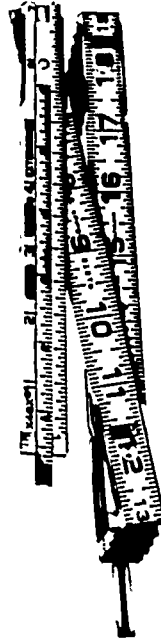

Folding Rule

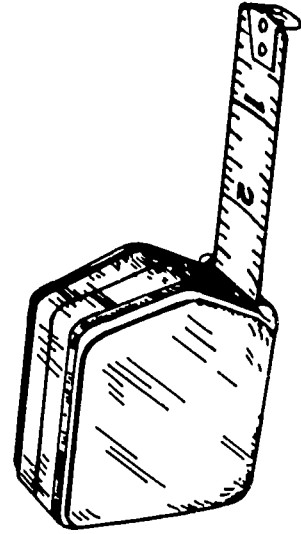

Steel Tape

Types of Miscellaneous Tools

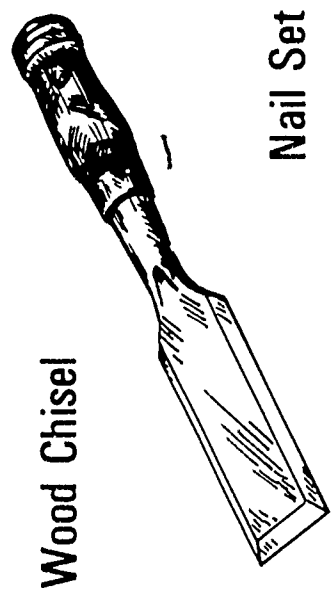

Wood Chisel

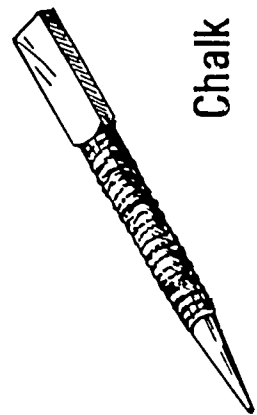

Nail Set

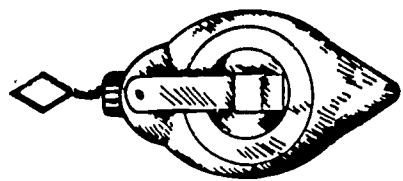

Chalk Line and Reel

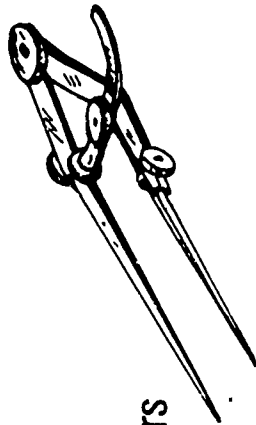

Dividers

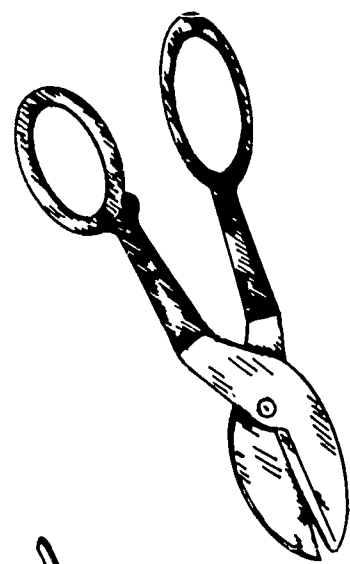

Tin Snips

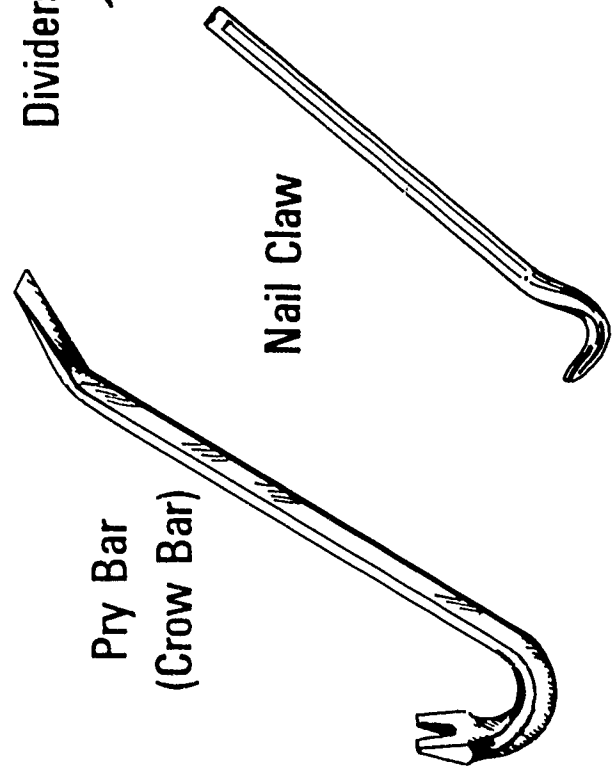

Pry Bar
(Crow Bar)

Nail Claw

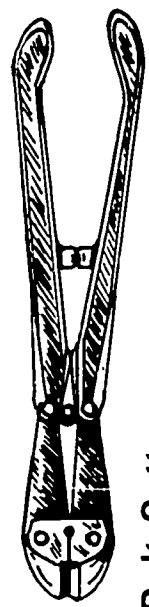

Bolt Cutter

177

Types of Miscellaneous Tools

(Continued)

Long Handle
Square Point Shovel



Long Handle
Round Point Shovel

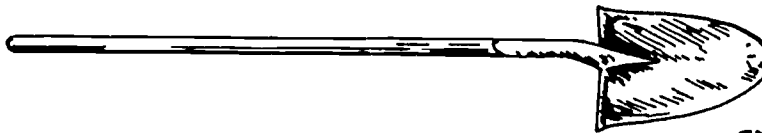

Sand Scoop

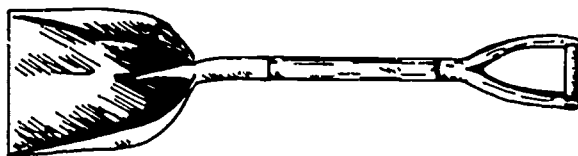

Sharp Shooter

Bench Brush

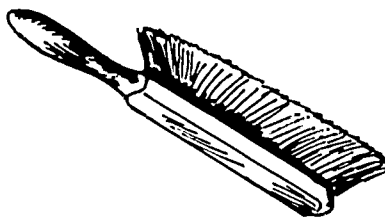

Push Broom

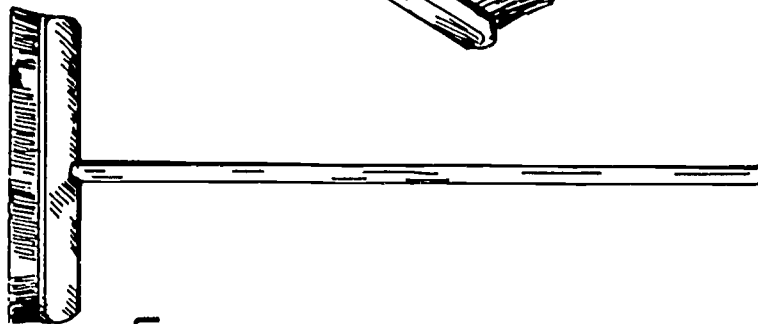

Hand Broom

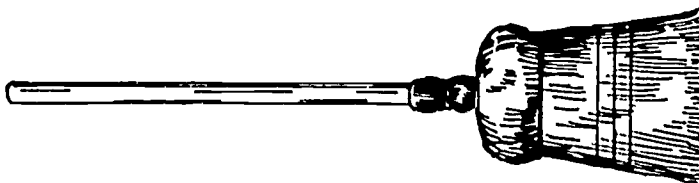

Types of Miscellaneous Tools

(Continued)

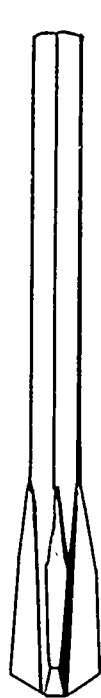

Star Drill



Cold Chisel



Point

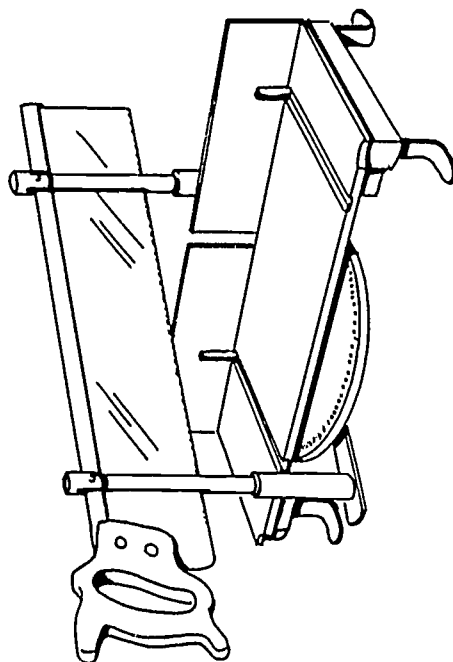

Miter Box and Saw

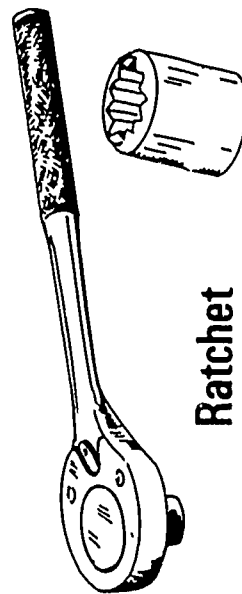

Ratchet

Socket

HAND TOOLS
UNIT I

TEST

1. List four basic rules concerning the care of hand tools.
 - a.
 - b.
 - c.
 - d.
2. List five basic rules concerning the use of hand tools.
 - a.
 - b.
 - c.
 - d.
 - e.
3. Identify two types of planes and write a use for each.
 - a. Identification:
Use:
 - b. Identification:
Use:

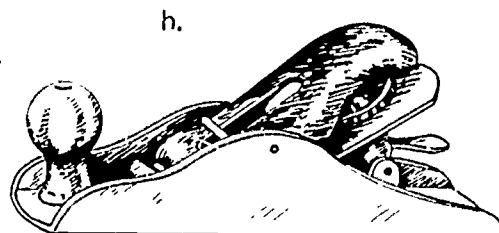
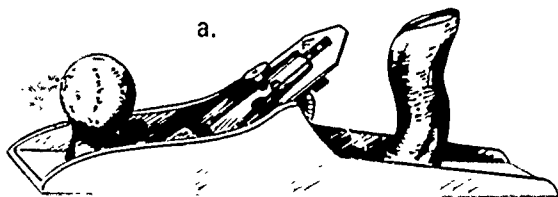

4. Identify three types of squares and write a use for each.

a. Identification:

Use:

b. Identification:

Use:

c. Identification:

Use:

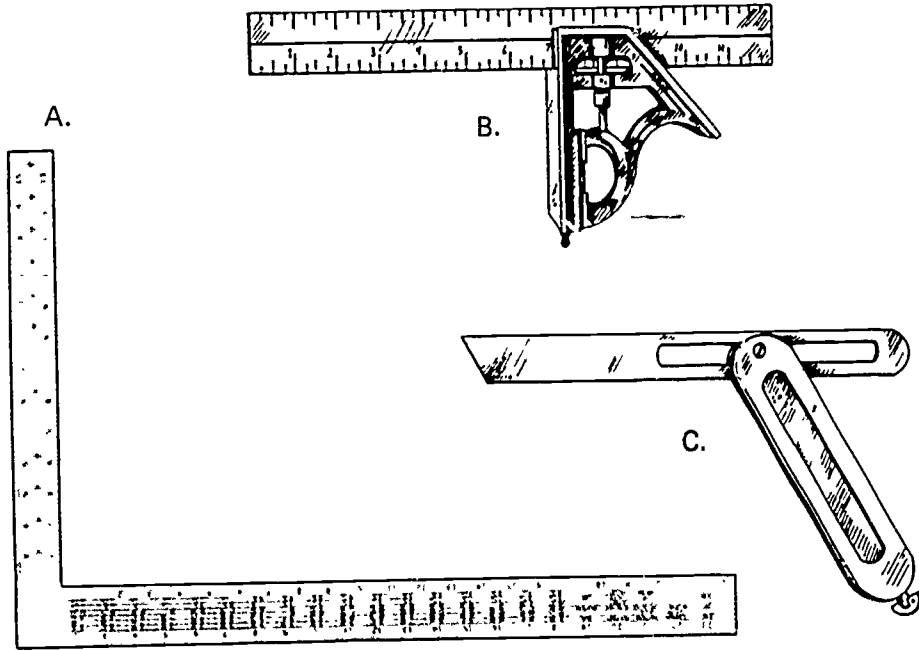

5. Identify six types of handsaws and write a use for each.

a. Identification:

Use:

b. Identification:

Use:

c. Identification:

Use:

d. Identification:

Use:

e. Identification:

Use:

f. Identification:

Use:

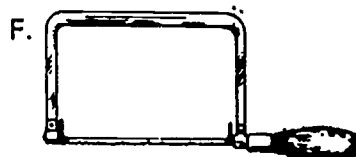
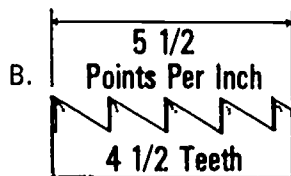
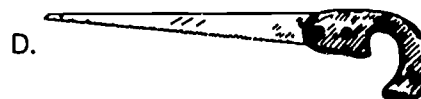
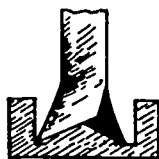
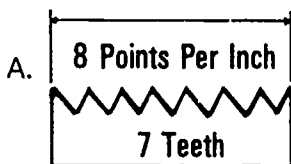
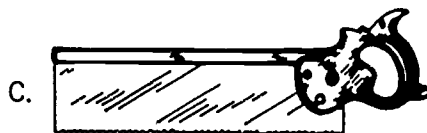
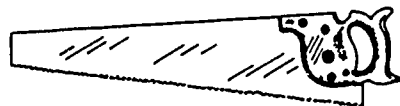

6. Identify four types of hammers and write a use for each.

a. Identification:

Use:

b. Identification:

Use:

c. Identification:

Use:

d. Identification:

Use:

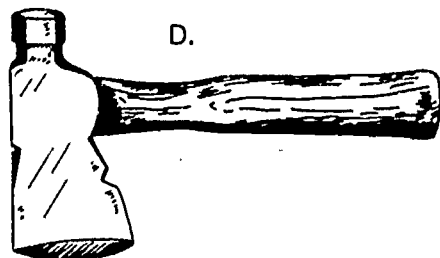
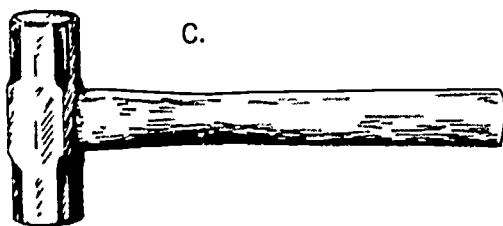
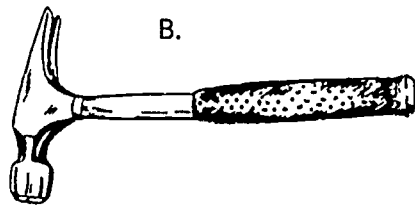
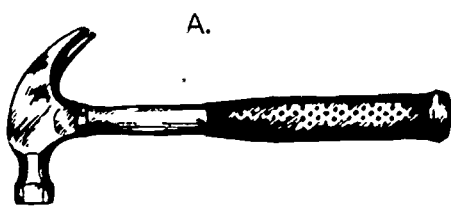

7. Identify two types of screwdrivers.

a. _____

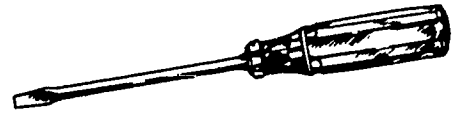

b. _____



8. Identify four types of pliers.

a. _____



b. _____



c. _____



d. _____

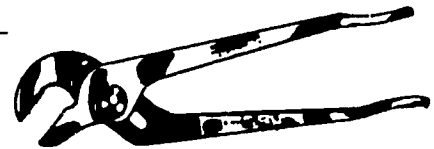

9. Identify five types of clamps.

a. _____



b. _____

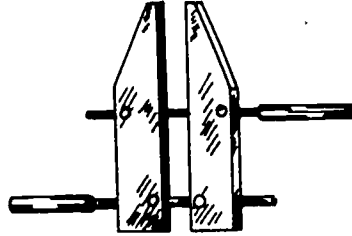

c. _____

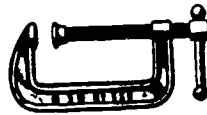

d. _____

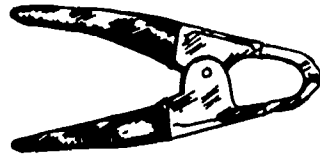

e. _____

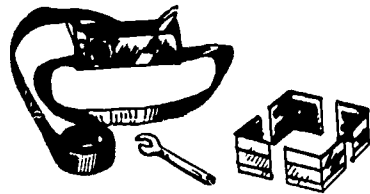

10. Identify five types of leveling or plumbing instruments.

a. _____



b. _____



c. _____



d. _____

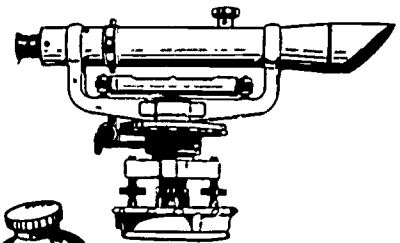

e. _____



11. Identify four types of wrenches.

a. _____



b. _____



c. _____



d. _____

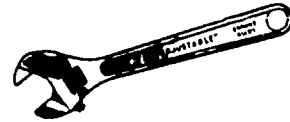

12. Identify the three types of boring and three types of drilling tools and state the name of each beside the corresponding letter.

a. Boring tools

1) () _____

2) () _____

3) () _____

b. Drilling tools

1) () _____

2) () _____

3) () _____

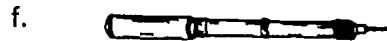
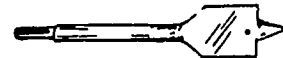
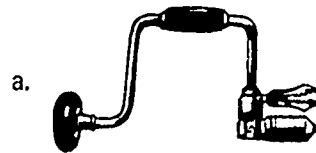

13. Identify four types of files.

a. _____



b. _____



c. _____



d. _____



14. Identify two types of knives.

a. _____

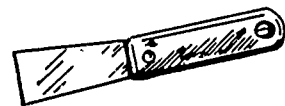

b. _____

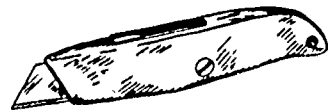

15. Identify three types of ladders.

a. _____



b. _____

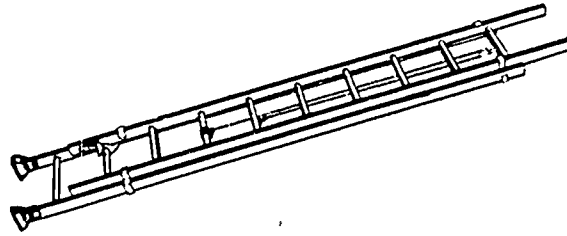

c. _____

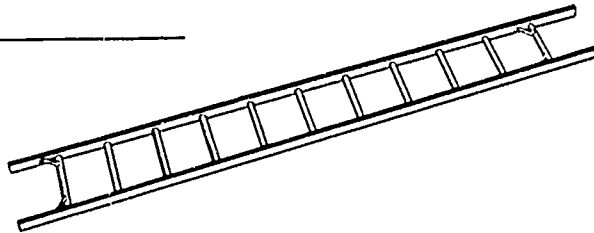

16. Identify three types of measuring instruments.

a. _____

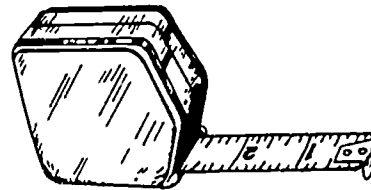

b. _____

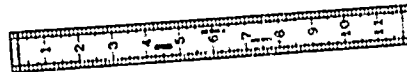

c. _____



17. Identify twenty-one miscellaneous tools.

a. _____



b. _____

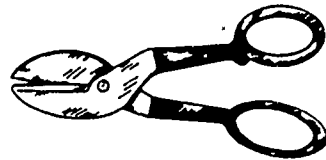

c. _____



d. _____



e. _____

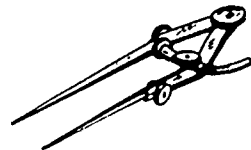

f. _____

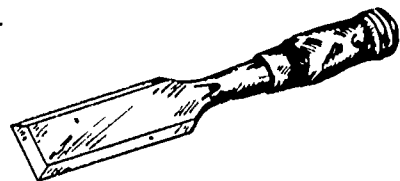

g. _____

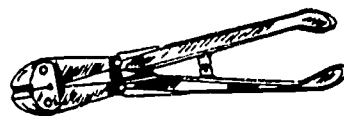

h. _____



i. _____

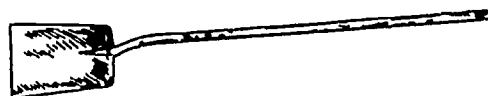

j. _____



k. _____



l. _____



m. _____



n. _____

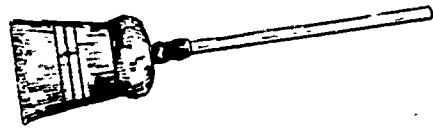

o. _____



p. _____

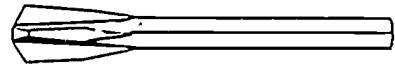

q. _____

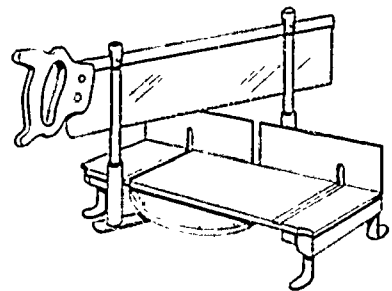

r. _____

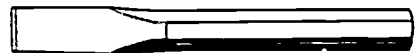

s. _____

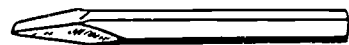

t. _____



u. _____



18. Demonstrate the ability to use each tool safely and according to the recommended use.

HAND TOOLS
UNIT I

ANSWERS TO TEST

1.
 - a. Keep tools sharp
 - b. Protect the cutting edge of tools when carrying or storing
 - c. Keep tools dry and lightly oiled when not in use
 - d. Use tools only for the purpose for which they were intended
2.
 - a. Use the right tool for the job
 - b. Do not use dull or broken tools
 - c. Be sure that tool handles are in good condition and securely fastened to the body of the tool
 - d. Do not throw tools
 - e. Keep fingers away from edges of cutting tools and work away from your body
3.
 - a. Jack plane
General purposes
 - b. Block plane
Small jobs on trim or end grain
4.
 - a. Framing square
General framing procedures for layout of walls, partitions, rafters, braces, and stairs
 - b. Combination square
General purpose squaring, measuring, leveling, or 45° miter marking instrument
 - c. Sliding T bevel
Measure or transfer any angle from 0° to 180° or to test or check a miter cut
5.
 - a. Crosscut saw
Cuts across the grain of wood
 - b. Rip saw
Cuts with the grain of wood
 - c. Back saw (miter box saw)
Makes fine cuts for joinery and for use in a miter box

- d. Coping saw
Cuts curves or shapes the ends of molding for joints and for scroll work
 - e. Compass saw
Cuts gentle curves or inside corners
 - f. Hack saw
Cuts all types of metal fasteners, hardware, and metal parts
- 6.
- a. Claw hammer (curved claw)
Driving and drawing nails
 - b. Claw hammer (straight claw)
Driving nails
 - c. Sledge hammer
Driving stakes
 - d. Half hatchet
Sharpening stakes, trimming framing members, and nailing
- 7.
- a. Common
 - b. Phillips
- 8.
- a. Combination slip joint
 - b. Needle nose
 - c. Side cutting (lineman's)
 - d. Channel lock
- 9.
- a. Bar
 - b. Hand screw
 - c. "C"
 - d. Spring
 - e. Band
- 10.
- a. Carpenter's level
 - b. Torpedo level

- c. Line level
 - d. Builder's level
 - e. Plumb bob
- 11.
- a. Box end
 - b. Open end
 - c. Combination
 - d. Adjustable
- 12.
- a. Boring tools
 - 1) (a) carpenter's brace
 - 2) (c) flat bit (speed bit)
 - 3) (d) auger bit
 - b. Drilling tools
 - 1) (b) hand drill
 - 2) (e) twist drill
 - 3) (f) push drill
- 13.
- a. Flat
 - b. Half round
 - c. Triangular (three corner)
 - d. Round
- 14.
- a. Putty
 - b. Utility
- 15.
- a. Step
 - b. Extension
 - c. Single
- 16.
- a. Steel tape
 - b. Bench rule
 - c. Folding rule

17.
 - a. Chalk line and reel
 - b. Tin snips
 - c. Pry bar (crow bar)
 - d. Nail set
 - e. Dividers
 - f. Wood chisel
 - g. Bolt cutter
 - h. Nail claw
 - i. Square point shovel
 - j. Round point shovel
 - k. Sharp shooter
 - l. Sand scoop
 - m. Push broom
 - n. Hand broom
 - o. Bench brush
 - p. Star drill
 - q. Miter box and saw
 - r. Cold chisel
 - s. Point
 - t. Reversible ratchet
 - u. Socket

18. Performance skills will be evaluated to the satisfaction of the instructor.

POWER TOOLS
UNIT II

TERMINAL OBJECTIVE

After completion of this unit, the student should be able to identify the common power woodworking machines and tools. He should be able to match a list of uses to the machine and complete the safety rules for each machine. This knowledge will be evidenced by scoring one hundred percent on the unit test.

SPECIFIC OBJECTIVES

After completion of this unit, the student should be able to:

1. Identify nineteen power tools used by the carpenter.
2. Match a list of operations or jobs to the power tools.
3. Complete ten general safety rules concerning power tools.
4. Complete safety rules for seventeen power tools.
 - a. Electric handsaw
 - b. Saber and reciprocating saws
 - c. Table saw
 - d. Radial arm saw
 - e. Jointer
 - f. Surfacer
 - g. Portable router and power plane
 - h. Spindle shaper
 - i. Electric hand drill; hammer drill
 - j. Power nailer
 - k. Portable belt sander
 - l. Motorized miter box
 - m. Powder actuated

- n. Drywall screwdriver
 - o. Band saw
5. Identify the accessories used with power tools.
 6. Demonstrate the proper use of each power tool according to the approved procedure.

L: 199

POWER TOOLS
UNIT II

SUGGESTED ACTIVITIES

- I. Instructor:
 - A. Provide students with objective sheet.
 - B. Provide students with information sheet.
 - C. Make transparencies.
 - D. Discuss terminal and specific objectives.
 - E. Discuss information sheet.
 - F. Give test.
- II. Student:
 - A. Read objective sheet.
 - B. Study information sheet.
 - C. Take test.

INSTRUCTIONAL MATERIALS

- I. Included in this unit:
 - A. Objective sheet
 - B. Information sheet
 - C. Transparency masters
 1. TM 1--Power Tools (Stationary)
 2. TM 2--Power Tools (Portable)
 3. TM 3--Power Tools (Portable and stationary)
 4. TM 4--Power Tools Accessories
 - D. Test
 - E. Answers to test

200
~~11/11~~

II. References:

- A. Feirer, John L. *Woodworking for Industry*. Peoria, Illinois: Charles Bennett Company, Inc., 1971.
- B. Groneman, Chris H. and Everett R. Galzener. *Technical Woodworking*. St. Louis, Missouri: McGraw-Hill Book Company, 1966.
- C. Hjorth, Herman and William F. Holtrop. *Operation of Modern Woodworking Machines*. New York: The Bruce Publishing Company, 1966.
- D. Wagner, Willis H. *Modern Carpentry*. Homewood, Illinois: Goodheart-Willcox, 1969.

POWER TOOLS
UNIT II

INFORMATION SHEET

- I. Power tools (Transparencies 1, 2, and 3)
 - A. Electric handsaw
 - B. Saber saw
 - C. Reciprocating saw
 - D. Table saw
 - E. Radial arm saw
 - F. Motorized miter box
 - G. Jointer
 - H. Surfacer
 - I. Portable router
 - J. Portable power plane
 - K. Spindle shaper
 - L. Electric hand drill
 - M. Power nailer
 - N. Portable belt sander
 - O. Powder actuated tool
 - P. Rotary hammer
 - Q. Hammer drill
 - R. Drywall screwdriver
 - S. Band saw
- II. Basic operations of power tools
 - A. Electric handsaw
 1. Crosscutting
 2. Ripping

INFORMATION SHEET

3. Mitering
4. Beveling
- B. Saber and reciprocating saws
 1. Cutting curved or irregular objects
 2. Crosscutting
 3. Ripping
 4. Internal cutting
- C. Table saw
 1. Ripping
 2. Crosscutting
 3. Mitering
 4. Rabbeting
 5. Dadoing
- D. Radial arm saw
 1. Ripping
 2. Crosscutting
 3. Mitering
 4. Rabbeting
 5. Dadoing
 6. Compound mitering
- E. Motorized miter box
 1. Crosscutting
 2. Mitering
- F. Jointer
 1. Edge planing
 2. Rabbeting

INFORMATION SHEET

3. Chamfering
 4. Beveling
 5. Tapering
 6. Face planing
- G. Surfacer
1. Face planing
 2. Planing to uniform thickness
- H. Portable router
1. Edge shaping
 2. Rabbeting
 3. Grooving, fluting, and reeding
 4. Trimming laminates
- I. Portable power plane
1. Face planing
 2. Edge planing
 3. Chamfering
 4. Beveling
- J. Spindle shaper
1. Edge shaping
 2. Shaping molding
 3. Grooving, fluting, and reeding
- K. Electric hand drill
1. Drilling and boring
 2. Driving screws
- L. Power nailer--Driving nails

INFORMATION SHEET

- M. Portable belt sander
 - 1. Face sanding
 - 2. Edge sanding
 - N. Powder actuated tool
 - 1. Driving threaded studs in concrete or steel
 - 2. Fastening wood to concrete or steel
 - 3. Fastening steel to steel
 - O. Rotary hammer
 - 1. Drilling in concrete
 - 2. Chipping concrete
 - 3. Tamping (dry pack)
 - P. Hammer drill
 - 1. Drilling holes in masonry or concrete
 - 2. Drilling holes (same as electric drill)
 - Q. Drywall screwdriver
 - 1. Driving screws in metal studs
 - 2. Driving screws in sheet rock
 - R. Band saw--Saw curved lines and circles
- III. General safety rules
- A. Always wear goggles when using a power tool
 - B. Lift and carry heavy and/or bulky objects safely
 - C. Do not jostle a person operating a power tool
 - D. Do not look around or attempt to carry on a conversation while operating a power tool
 - E. Wear appropriate clothing for the job
 - F. Make sure all tools are properly grounded before using

INFORMATION SHEET

- G. Assume a safe and comfortable position before using a power tool
 - H. Use a power tool only for its intended use
 - I. Do not use a dull or broken tool
 - J. Do not throw waste material in the work area
- IV. Safety rules for specific power tools
- A. Electric handsaw
 1. Be familiar with the correct operations and adjustments of the saw before attempting to use it
 2. Allow saw to gain maximum speed before starting the cut
 3. Be sure the automatic guard is free and retractable
(CAUTION: Do not lock guard in the retracted position.)
 4. Keep a firm grip on the saw at all times
 5. Keep electric cord in the clear to avoid cutting
 6. Check stock for nails and screws before cutting
 7. Set blade only deep enough to cut through the material
 8. Lay the saw down on its side after finishing the cut
 9. Use electric cords of sufficient size to service saw
 10. Do not stand in water while using the saw
 11. Check safety ground and be sure it is fastened to the saw
 - B. Saber and reciprocating saws
 1. Keep fingers away from blade
 2. Turn off motor immediately after finishing the cut
 3. Disconnect cord or turn off master switch before replacing a blade or making adjustments
 4. Make sure your hands and feet are dry before using these saws
 5. Be sure tool is properly grounded

INFORMATION SHEET

C. Table saw

1. The guard must be kept down over the saw while the machine is being used
2. Do not stand directly in line with the blade
3. The saw must not project more than one-eighth inch above the stock being cut
4. Never reach across the saw blade
5. When ripping long stock, the operator should secure help to support the stock as it leans the table
6. Make all adjustments on the machine with the power off and blade stopped
7. Use the push stick for all ripping less than four inches
8. Do not cut stock to length using the miter gauge and rip fence without first clamping on a stop block for clearance
9. Ripping without the rip fence and crosscutting without the miter gauge is FORBIDDEN
10. Be sure the tilted saw will clear before turning on machine when cutting angles
11. Always get a straight edge on the stock before ripping
12. Do not rip cylindrical stock on a circular saw
13. Extra care must be taken to hold a board when using a dado or molding head
14. Do not use the saw with a dull, cracked, or wrong kind of blade

D. Radial arm saw

1. Make sure saw has attained maximum speed before starting the cut
2. When crosscutting heavy stock, do not let the saw feed too fast; the saw will have a tendency to feed itself
3. Make sure the saw is set at the proper depth before turning on the machine

INFORMATION SHEET

4. Stand to the side of the line of sawing operation when ripping
5. Do not feed or pull stock too fast when ripping as this will jam the saw
6. Use only a sharp and properly set blade
7. Use the proper blade for the job to be done
8. When ripping always use the anti-kick-back guard
9. Do not stop blade by forcing scrap stock into blade
10. When ripping on the radial saw, follow the same safety rules set up for the table saw
11. When ripping on the radial saw, be certain to feed the material against the direction of the blade rotation

E. Jointer

1. A guard must be kept over knives at all times while operating jointer
2. The depth of the cut must be adjusted before the power is turned on
3. The jointer must not be used for stock less than twelve inches long
4. A push stick or push block must be used when jointing narrow or flat pieces of stock
5. The jointer must not be used for strips less than one inch wide
6. The clamping screws on the fence must be screwed down securely so that the fence cannot slip while in use
7. Do not start the cut until the machine has come up to maximum speed
8. Keep fingers as high as possible on the stock and never drag the thumb at back of the board
9. Avoid taking cuts deeper than one-eighth inch; too deep a cut sometimes causes "kickbacks"
10. In passing work over the jointer, change position of the hands so they will never be directly over the knives

INFORMATION SHEET

11. Follow through with the stock and allow the guard to return to the closed position
12. Do not attempt to plane discs or other pieces that cannot be held securely against the fence
13. Keep your eyes on your work; do not look around or engage in conversation while using the jointer

F. Surfacers

1. Become familiar with the stop switch, elevating handwheel, and brake (if any) so that the machine can be stopped quickly
2. Check the wood for defects such as large knots that might cause the board to split under pressure
3. Never surface painted or varnished stock; in fact, used lumber of any kind should not be surfaced
4. Make sure that the board to be surfaced has one true face
5. The shortest board that should be run through the machine should be two inches longer than the distance between the infeed and outfeed rolls
6. Always stand to one side of the table, never directly in line with the stock
7. Try to determine grain direction and feed into the machine so that the cutting will be done with the grain
8. As the feed rolls take hold of the stock, allow the machine to do the work; take your hands off the board
9. If a board gets stuck in the machine, lower the bed and turn off the machine
10. Never stoop down to watch a board being surfaced
11. Be especially careful of your fingers when surfacing a short board; sometimes the infeed rolls will tip the board up and then down quickly so that the fingers get pinched between the table top and the stock
12. If the stock is long, get help to feed the stock and take it off as it leaves the machine

INFORMATION SHEET

G. Portable router and power plane

1. Make all adjustments on the router and/or planer with the plug pulled
2. Keep both hands in their proper location on the router and/or planer
3. Keep a firm grip on the tool being used
4. Always use a door jack when routing for hinges or planing edges of a door; never have another person hold the door for you
5. Wear safety goggles when routing and/or planing
6. Always use jigs and guides with the router; never route or plow free hand
7. Do not attempt to remove too much material with one cut

H. Spindle shaper

1. Whenever possible, install the cutter so the bottom of the stock is shaped; in this way, the stock will cover most of the cutter and act as a guard
2. Make sure the cutter is locked securely to the spindle
3. Always position the left fence so that it will support the work that has passed the cutters
4. Adjust the spindle for correct height and lock in position; rotate the spindle by hand to make sure it clears all guards or fences
5. Check the direction of rotation by snapping the switch on and off; watch as the cutters come to rest; **ALWAYS FEED AGAINST THE CUTTING EDGE**; some shapers have a reversing switch so that the spindle can be rotated either clockwise or counter-clockwise
6. Examine the stock carefully for defects before cutting; never cut through a loose knot or stock that is cracked or split
7. Hold the stock down and against the fence with the hands on top of the material, -yet out of range of the cutters
8. Use all guards, jigs, and clamping devices whenever possible
9. Always use a depth collar when shaping irregular work; put a guide pin in the table to start the cutting

INFORMATION SHEET

10. Do not set spring hold-down clips too tightly against the work; use just enough tension to hold the work against the fence
 11. When depth collars and a guide pin are used for contour work, the operator must swing the work into the cutters; it is a good idea to keep the stock in motion in the direction of feed
 12. Never shape a piece shorter than ten inches
- I. Electric hand drill; hammer drill
1. Never use a tool that is not properly grounded
 2. Never attempt to use a hand auger bit; use only drills and bits designed for the tool
 3. Wear safety goggles
 4. Never try to stop the tool by taking hold of the chuck after the power is off
 5. On deep cuts, back out often to clean out the hole
 6. Always remove the chuck key before turning on the power
- J. Power nailer
1. Use only nails or fasteners that were designed for the gun
 2. Do not discharge nailer except when actually nailing
 3. Keep hands and body away from the discharge area of nailer
- K. Portable belt sander
1. Keep power cord away from belt of sander
 2. Hold sander firmly with both hands
 3. Do not wear loose fitting clothes while sanding
 4. Be sure sander has stopped running before turning loose
 5. Keep fingers away from revolving belt

INFORMATION SHEET

L. Motorized miter box

1. Disconnect power before making adjustments or changing the blade
2. Keep blade sharp
3. Do not attempt to cut stock that is too thick or too wide
4. Secure a helper to hold the end of long stock
5. Keep guards in place at all times
6. Use miter box only for intended use

M. Powder actuated tool

1. Take training program available from tool manufacturer; do not use powder actuated tool unless certified
2. Use the proper size pin and load
3. Never hold the end of the barrel against any part of the body
4. Do not hold hand on back of material in line with barrel
5. Wear safety goggles
6. Do not shoot close to edge of concrete

N. Drywall screwdriver

1. Never place screw point against your body
2. Never hold hand back of screw when driving in light metal

O. Band saw

1. Never saw with guards removed
2. Use proper size blade to avoid breaking

V. Accessories used with power tools (Transparency 4)

- A. Drive pin
- B. Threaded stud
- C. Percussion carbide-tipped drill

INFORMATION SHEET

- D. Concrete chisel
- E. Bull point
- F. Masonry drill
- G. Tamper
- H. Miter saw blade
- I. Combination saw blade
- J. Rip saw blade
- K. Crosscut saw blade

Power Tools (STATIONARY)

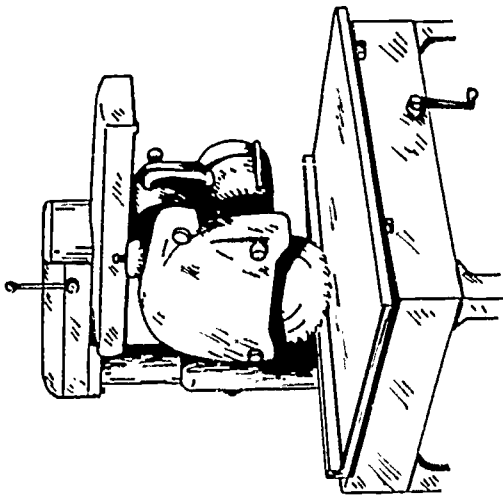

Radial Arm Saw

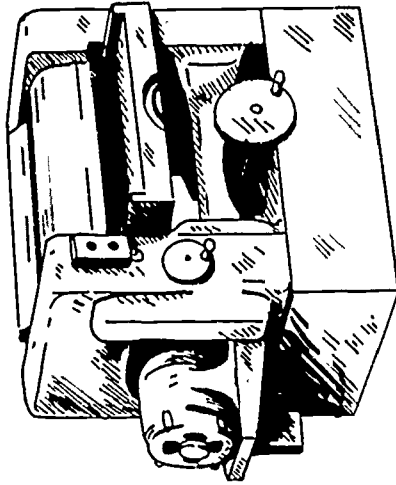

Surfer

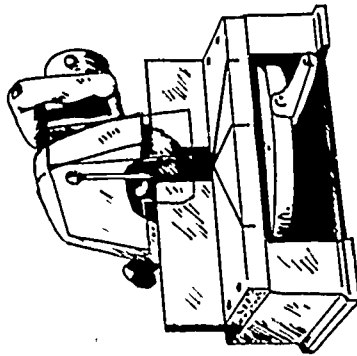

Motorized Miter Box

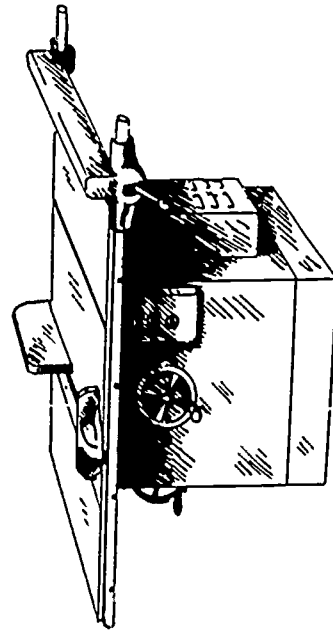
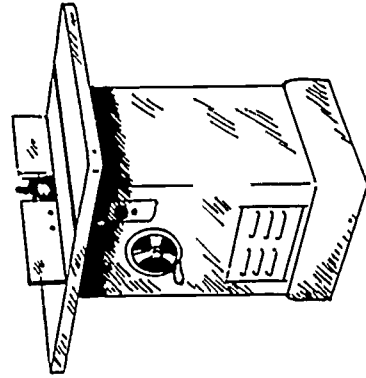
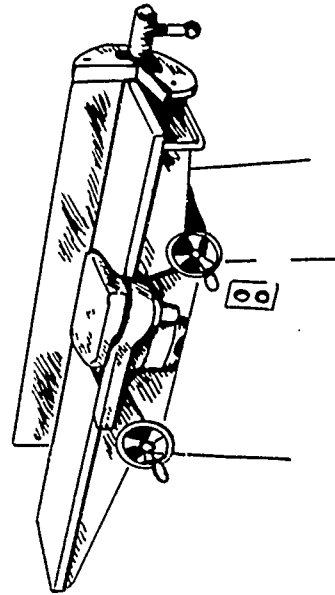

Table Saw



Spindle Shaper



Jointer

Power Tools (PORTABLE)

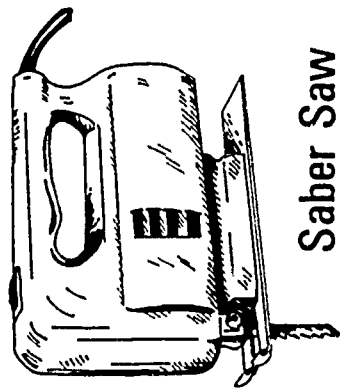

Saber Saw

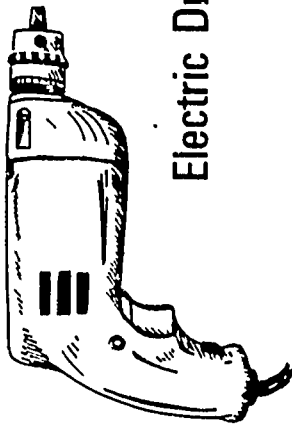

Electric Drill

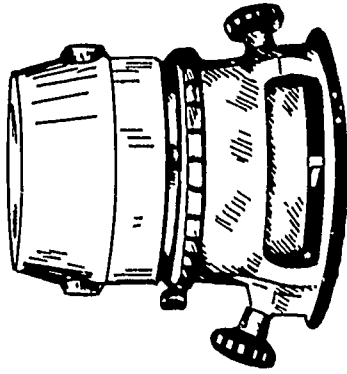

Router

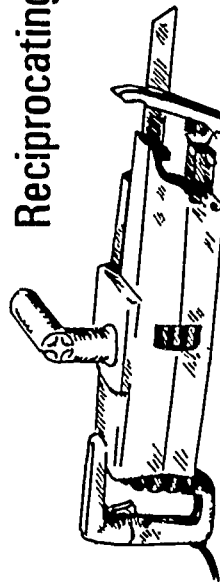

Reciprocating Saw

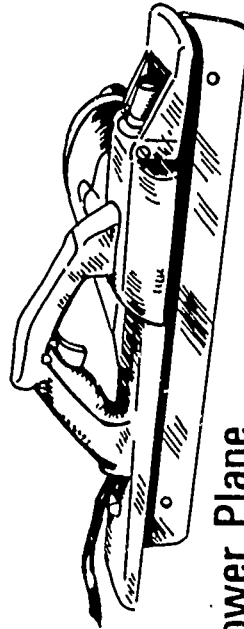

Power Plane

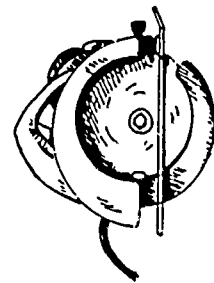

Electric Handsaw

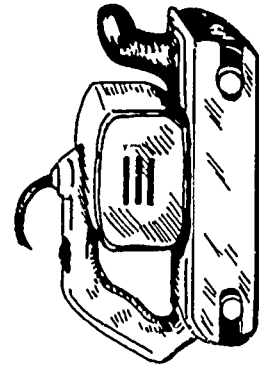

Belt Sander

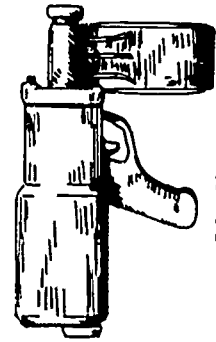

Power Nailer

Power Tools

(Portable and Stationary)

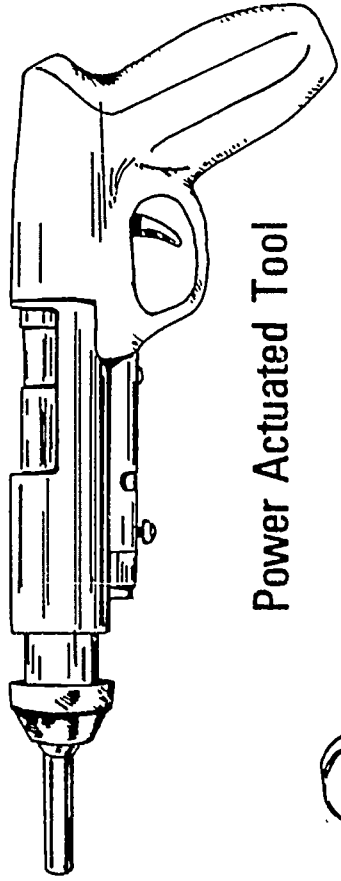

Power Actuated Tool

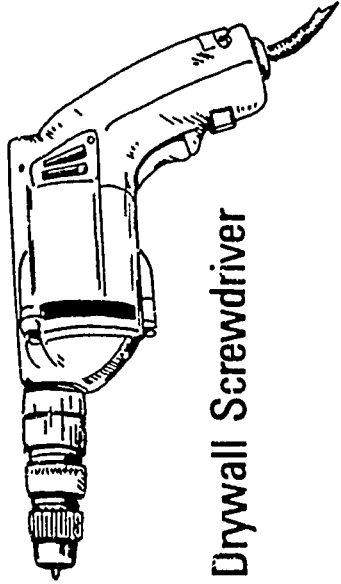

Drywall Screwdriver

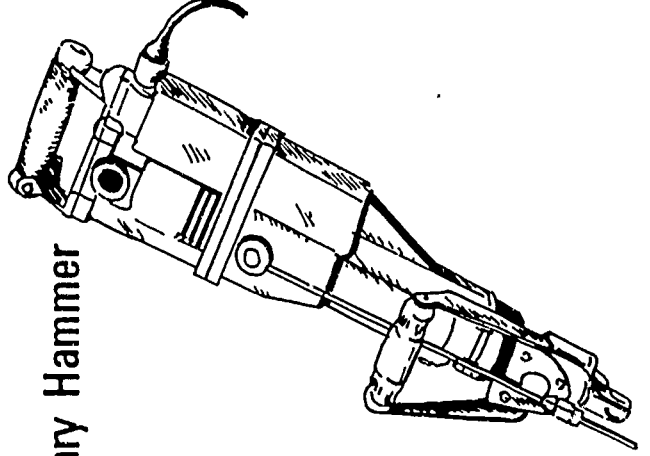

Rotary Hammer

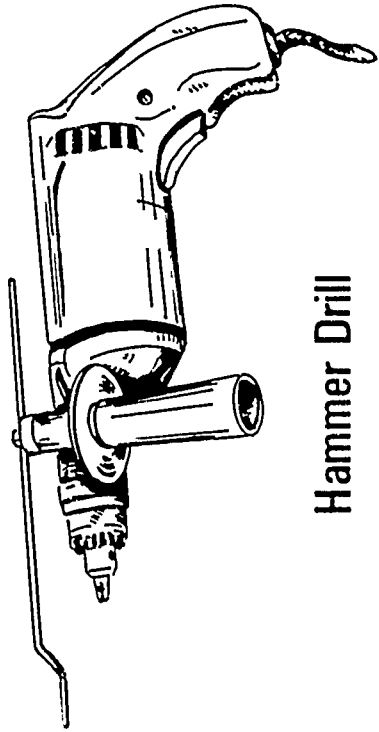

Hammer Drill

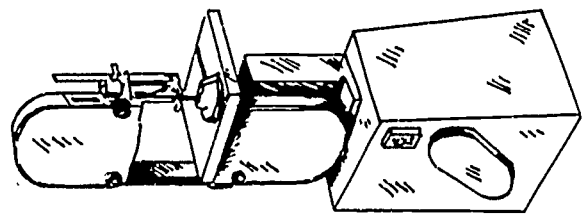

Band Saw

Power Tools Accessories



Drive Pin



Threaded Stud



Percussion Carbide-Tipped Drill



Bull Point

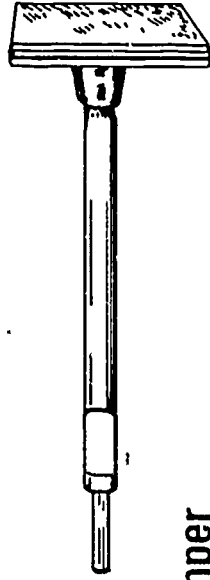

Tamper



Concrete Chisel



Masonry Drill

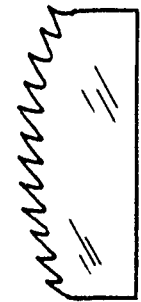

Cross-Cut

BLADES



Chisel-Tooth Combination

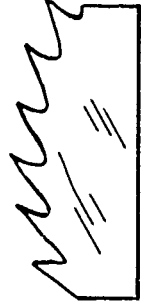

Rip



Miter

POWER TOOLS
UNIT II

TEST

1. Identify the following power tools.

a. _____

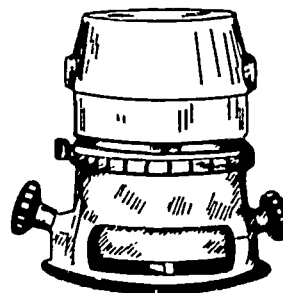

b. _____

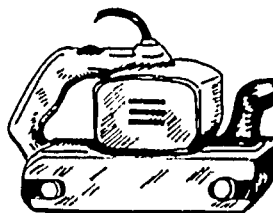

c. _____

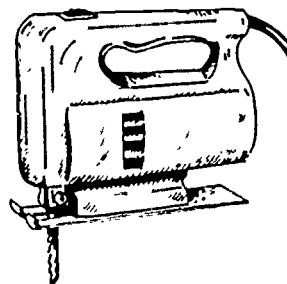

d. _____

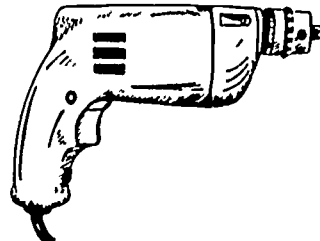

e. _____

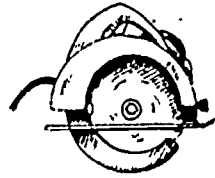

f. _____

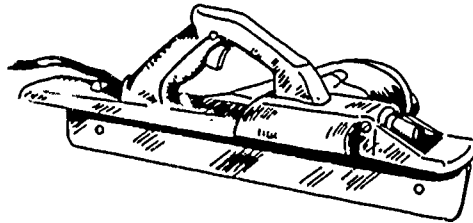

g. _____

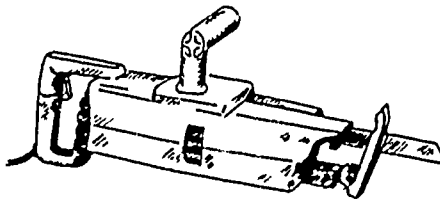

h. _____

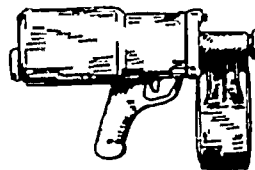

i. _____

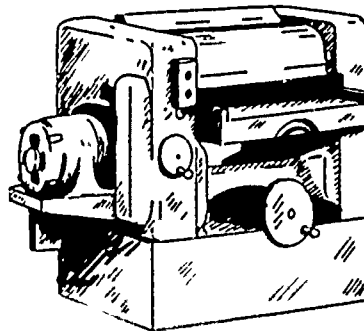

j. _____

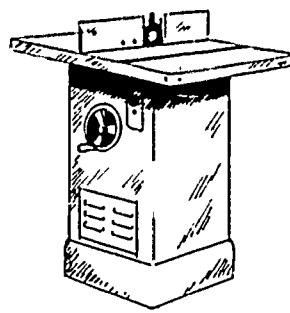

k. _____

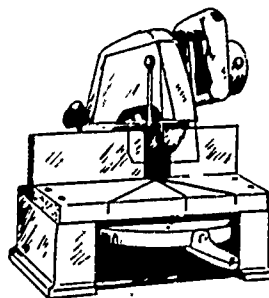

l. _____

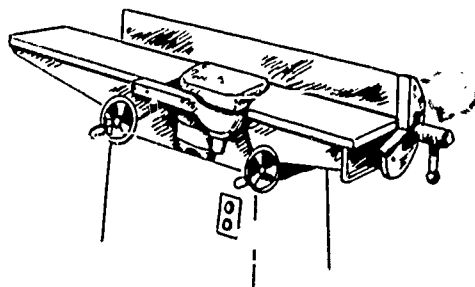

m. _____

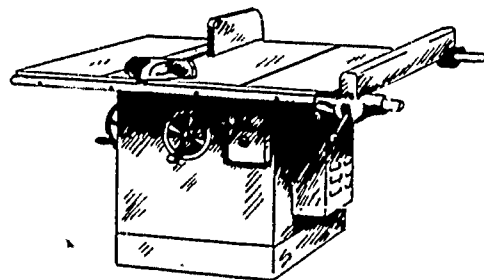

n. _____

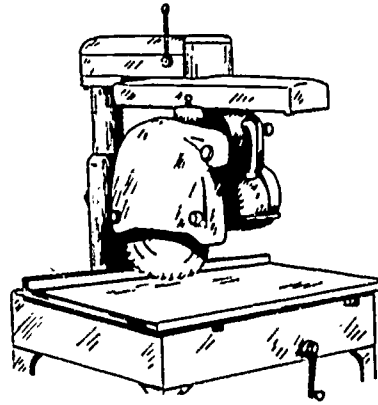

o. _____

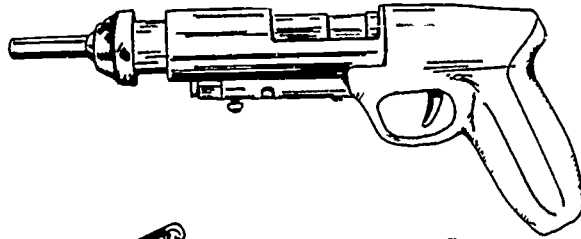

p. _____

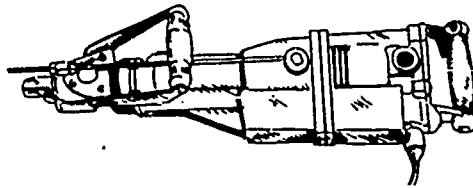

q. _____

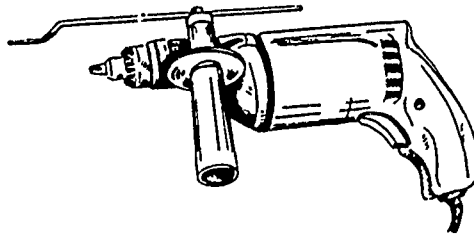

r. _____

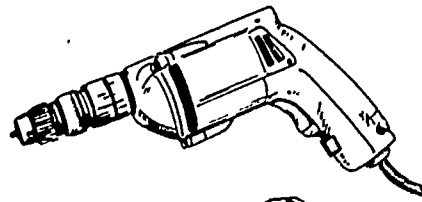

s. _____

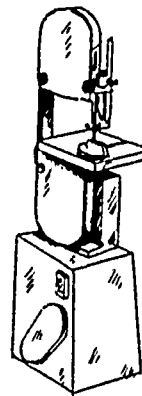

2. Match the operations or jobs on the right to the power tools.

- | | | | |
|----------|---------------------------------|-----|-------------------------------------|
| _____ a. | Electric handsaw | 1. | Crosscutting |
| _____ b. | Saber saw and reciprocating saw | 2. | Ripping |
| _____ c. | Table saw | 3. | Mitering |
| _____ d. | Radial arm saw | 4. | Beveling |
| _____ e. | Motorized miter box | 5. | Cutting curved or irregular objects |
| _____ f. | Jointer | 6. | Internal cutting |
| _____ g. | Surfacer | 7. | Rabbeting |
| _____ h. | Portable router | 8. | Dadoing |
| _____ i. | Portable power plane | 9. | Compound mitering |
| _____ j. | Spindle shaper | 10. | Edge planing |
| _____ k. | Electric hand drill | 11. | Chamfering |
| _____ l. | Power nailer | 12. | Tapering |
| _____ m. | Portable belt sander | 13. | Face planing |
| _____ n. | Drywall screwdriver | 14. | Planing to uniform thickness |
| _____ o. | Hammer drill | 15. | Edge shaping |
| _____ p. | Powder actuated drill | 16. | Shaping molding |
| _____ q. | Rotary hammer | 17. | Grooving, fluting, and reeding |
| _____ r. | Band saw | 18. | Drilling and boring |
| | | 19. | Driving screws |
| | | 20. | Driving nails |
| | | 21. | Face sanding |
| | | 22. | Edge sanding |
| | | 23. | Trimming laminates |
| | | 24. | Fastening wood to concrete or steel |
| | | 25. | Cutting curved lines and circles |

- 26. Driving screws in metal studs or sheet rock
- 27. Drilling or chipping concrete
- 28. Drilling holes in concrete

3. Complete ten general rules.

- a. Always wear _____ when using a power tool.
- b. _____ and _____ heavy and/or bulky objects safely.
- c. Do not _____ a person operating a power tool.
- d. Do not _____ or attempt to carry on a _____ while operating a power tool.
- e. Wear appropriate _____ for the job.
- f. Make sure that all power tools are properly _____ before using.
- g. Assume a _____ and _____ position before using a power tool.
- h. Use a power tool only for its _____ use.
- i. Do not use a _____ or _____ tool.
- j. Do not throw _____ in the work area.

4. Complete the following safety rules for seventeen power tools.

- a. Electric handsaw
 - 1) Be familiar with the _____ operations and adjustments of the saw before attempting to use it.
 - 2) Allow saw to gain _____ speed before starting the cut.
 - 3) Be sure the automatic guard is _____ and _____.
 - 4) Keep a _____ grip on the saw at all times.

- 5) Keep electric cord in the _____ to avoid cutting.
- 6) Check stock for _____ and _____ before cutting.
- 7) Set blade only _____ to cut through the material.
- 8) Lay the saw down _____ after finishing the cut.
- 9) Use electric cords of _____ to service saw.
- 10) Do not stand in _____ while using the saw.
- 11) Check the _____ and be sure it is _____ to the saw.

b. Saber and reciprocating saws

- 1) Keep _____ away from blade.
- 2) Turn off _____ immediately after finishing the cut.
- 3) Disconnect cord or turn off master switch before _____ a blade or making _____.
- 4) Make sure your hands and feet are _____ before using these saws.
- 5) Be sure tool is properly _____.

c. Table saw

- 1) The guard must be kept down over the _____ while the machine is being used.
- 2) Do not stand directly _____ with the blade.
- 3) Saw must not project more than _____ above the stock being cut.
- 4) Never reach _____ the saw blade.
- 5) When ripping long stock, the operator should secure _____ to support the _____ as it leaves the table.
- 6) Make all _____ on the machine with the power _____ and the _____ stopped.

- 7) Use the _____ for all ripping less than four inches.
- 8) Do not cut stock to length using the miter gauge and rip fence without first clamping on a _____ for clearance.
- 9) Ripping without the _____ and crosscutting without the _____ is FORBIDDEN.
- 10) Be sure the _____ saw will clear before turning on machine when cutting angles.
- 11) Always get a straight edge on the stock before _____ any stock.
- 12) Do not rip _____ stock on a circular saw.
- 13) Extra care must be taken to hold a board when using a _____ or _____ head.
- 14) Do not use the saw with a _____, _____ or _____ of blade.

d. Radial arm saw

- 1) Make sure the saw has attained _____ speed before starting the cut.
- 2) When _____ heavy stock, do not let the saw feed too fast; the saw will have a tendency to feed itself.
- 3) Make sure the saw is set at the proper _____ before turning on the machine.
- 4) Stand to the _____ of the line of the sawing operation when _____.
- 5) Do not _____ or _____ the stock too fast when ripping as this will jam the saw.
- 6) Use only a _____ and properly _____ blade.
- 7) Use the _____ blade for the job to be done.
- 8) When _____ always use the anti-kick-back guard.
- 9) Do not _____ blade by forcing scrap stock into blade.

- 10) When _____ on the radial saw, follow the same safety rules set up for the table saw.
- 11) When ripping on the radial saw, be certain to feed the material _____ the direction of the blade rotation.

e. Jointer

- 1) The guard must be kept over _____ at all times while operating jointer.
- 2) The _____ of cut must be adjusted before power is turned on.
- 3) The jointer must not be used for stock less than _____ long.
- 4) A _____ or _____ must be used when jointing narrow or flat pieces of stock.
- 5) The jointer must not be used for strips less than _____ wide.
- 6) The clamping screws on the fence must be screwed down _____ so that the fence cannot slip while in use.
- 7) Do not start the cut until the machine has come up to _____ speed.
- 8) Keep _____ as high as possible on the stock and never drag the _____ at the back of the board.
- 9) Avoid taking cuts deeper than _____; too deep a cut sometimes causes "kickbacks".
- 10) In passing work over the jointer, change position of the hands so they will never be _____ over the knives.
- 11) Follow through with the stock and allow the guard to return to the _____ position.
- 12) Do not attempt to plane _____ or other pieces that cannot be held securely against the fence.
- 13) Keep your eyes on your _____. Do not look around or engage in _____ while using the jointer.

f. Surfacer

- 1) Become familiar with the _____ switch, _____ hand wheel, and _____ so that the machine can be stopped quickly.

- 2) Check the wood for defects such as large knots that might cause the board to _____ under pressure.
- 3) Never surface _____ or _____ stock. In fact _____ lumber of any kind should not be surfaced.
- 4) Make sure that the board to be surfaced has one _____ face.
- 5) The shortest board that should be run through the machine should be _____ longer than the distance between the infeed and outfeed rolls.
- 6) Always stand to _____ of the table, never _____ in line with the stock.
- 7) Try to determine grain _____ and feed into the machine so that the cutting will be done _____ the grain.
- 8) As the feed rolls take hold of the stock, allow the machine to do the work; take your _____ off the board.
- 9) If a board gets stuck in the machine, _____ the bed and _____ off the machine.
- 10) Never stoop down to _____ a board being surfaced.
- 11) Be especially careful of your _____ when surfacing a short board; sometimes the infeed rolls will tip the board up and then down quickly so that the _____ get pinched between the table top and the stock.
- 12) If the stock is long get help to _____ the stock and _____ as it leaves the machine.

g. Portable router and power plane

- 1) Make all adjustments on the router and/or planer with the plug _____.
- 2) Keep both hands in their proper _____ on the router and/or planer.
- 3) Keep a _____ grip on the tool being used.

- 4) Always use a _____ when routing for hinges or planing edges of a door; never have another _____ hold the door for you.
- 5) Wear _____ when routing and/or planing.
- 6) Always use _____ and _____ with the router; never _____ or _____ free hand.
- 7) Do not attempt to _____ too much material with one cut.

h. Spindle shaper

- 1) Whenever possible, install the cutter so the _____ of the stock is shaped; in this way, the stock will cover most of the _____ and act as a _____.
- 2) Make sure the _____ is locked securely to the spindle.
- 3) Always position the _____ fence so that it will support the work that has passed the cutters.
- 4) Adjust the _____ for correct height and lock in position; rotate the spindle by hand to make sure it clears all _____ or _____.
- 5) Check the _____ of rotation by snapping the switch on and off; watch as the cutters come to rest; ALWAYS FEED _____ THE CUTTING EDGE; some shapers have a reversing switch so that the spindle can be rotated either clockwise or counter-clockwise.
- 6) Examine the stock carefully for _____ before cutting; never cut through a loose _____ or stock that is _____ or _____.
- 7) Hold the stock _____ and _____ the fence with the hands on top of the material, yet out of range of the cutters.
- 8) Use all _____, _____ and _____ devices whenever possible.
- 9) Always use a _____ when shaping irregular work; put a _____ in the table to start the cutting.

- 10) Do not set spring hold-down clips too _____ against the work; use just enough tension to _____ the work against the fence.
- 11) When depth collars and a guide pin are used for contour work, the operator must swing the work into the _____; it is a good idea to keep the stock in _____ in the direction of feed.
- 12) Never shape a piece shorter than _____.

i. Electric hand drill; hammer drill

- 1) Never use a tool that is not properly _____.
- 2) Never attempt to use a hand auger bit; use only _____ and _____ designed for machine use.
- 3) Wear safety _____.
- 4) Never try to stop the tool by taking hold of the _____ after the power is off.
- 5) On deep cuts, _____ often to clean out the hole.
- 6) Always remove the _____ before turning on the power.

j. Power nailer

1. Use only nails or fasteners that were _____ for the gun.
- 2) Do not _____ nailer except when actually nailing.
- 3) Keep _____ and _____ away from discharge area of nailer.

k. Portable belt sander

- 1) Keep power cord away from _____ of sander.
- 2) Hold sander firmly with _____ hands.
- 3) Do not wear _____ fitting clothes while sanding.
- 4) Be sure sander has stopped running before _____ loose.
- 5) Keep _____ away from revolving belt.

l. Motorized miter box

- 1) Disconnect power before making _____ or _____ the blade.
- 2) Keep blade _____.
- 3) Do not attempt to cut stock that is too _____ or too _____.
- 4) Secure a helper to hold the end of _____ stock.
- 5) Keep _____ in place at all times.
- 6) Use miter box only for _____ use.

m. Powder actuated tool

- 1) Take training program available from _____.
Do not use powder actuated tool unless _____.
- 2) Use the proper size _____ and load.
- 3) Never hold the end of the _____ against any part of the body.
- 4) Do not hold hand _____ of material in line with the barrel.
- 5) Wear _____.
- 6) Do not shoot _____ to the _____ of concrete.

n. Drywall screwdriver

- 1) Never place _____ against your body.
- 2) Never hold _____ back of _____ when driving in light metal.

o. Band saw

- 1) Never saw with _____ removed.
- 2) Use proper _____ to avoid breaking.

5. Identify the following power tool accessories.

- a. _____
- b. _____
- c. _____
- d. _____
- e. _____
- f. _____
- g. _____
- h. _____
- i. _____
- j. _____
- k. _____

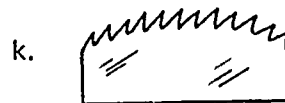
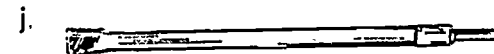
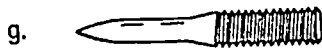
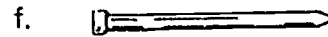

6. Demonstrate the proper use of each power tool according to the approved procedure.

POWER TOOLS
UNIT II

ANSWERS TO TEST

1.
 - a. Portable router
 - b. Portable belt sander
 - c. Saber saw
 - d. Electric hand drill
 - e. Electric handsaw
 - f. Portable power plane
 - g. Reciprocating saw
 - h. Power nailer
 - i. Surfacers
 - j. Spindle shaper
 - k. Motorized miter box
 - l. Jointer
 - m. Table saw
 - n. Radial arm saw
 - c. Powder actuated tool
 - p. Rotary hammer
 - q. Hammer drill
 - r. Drywall screwdriver
 - s. Band saw
2.
 - a. 1, 2, 3, 4
 - b. 1, 2, 5, 6
 - c. 1, 2, 3, 7, 8
 - d. 1, 2, 3, 7, 8, 9

- e. 1, 3
 - f. 4, 7, 10, 11, 12, 13
 - g. 13, 14
 - h. 7, 15, 17, 23
 - i. 4, 10, 11, 13
 - j. 15, 16, 17
 - k. 18, 19
 - l. 20
 - m. 21, 22
 - n. 26
 - o. 28
 - p. 24
 - q. 27
 - r. 25
- 3.
- a. Goggles
 - b. Lift, carry
 - c. Jostle
 - d. Look around, conversation
 - e. Clothing
 - f. Grounded
 - g. Safe, comfortable
 - h. Intended
 - i. Dull, broken
 - j. Waste material
- 4.
- a.
 - 1) Correct
 - 2) Maximum
 - 3) Free, retractable

- 4) Firm
 - 5) Clear
 - 6) Nails, screws
 - 7) Deep enough
 - 8) On its side
 - 9) Sufficient size
 - 10) Water
 - 11) Safety ground; fastened
- b.
- 1) Fingers
 - 2) Motor
 - 3) Replacing, adjustments
 - 4) Dry
 - 5) Grounded
- c.
- 1) Saw
 - 2) In line
 - 3) One-eighth inch
 - 4) Across
 - 5) Help, stock
 - 6) Adjustments, off, blade
 - 7) Push stick
 - 8) Step block
 - 9) Rip fence, miter gauge
 - 10) Tilted
 - 11) Ripping
 - 12) Cylindrical
 - 13) Dado, molding
 - 14) Dull, cracked, wrong kind

- d.
 - 1) Maximum
 - 2) Crosscutting
 - 3) Depth
 - 4) Side, ripping
 - 5) Feed, pull
 - 6) Sharp, set
 - 7) Proper
 - 8) Ripping
 - 9) Stop
 - 10) Ripping
 - 11) Against
- e.
 - 1) Knives
 - 2) Depth
 - 3) Twelve inches
 - 4) Push stick, push block
 - 5) One inch
 - 6) Securely
 - 7) Maximum
 - 8) Fingers, thumb
 - 9) One-eighth inch
 - 10) Directly
 - 11) Closed
 - 12) Discs
 - 13) Work, conversation
- f.
 - 1) Stop, elevating, brake
 - 2) Split
 - 3) Painted, varnished, used

- 4) True
 - 5) Two inches
 - 6) One side, directly
 - 7) Direction, with
 - 8) Hands
 - 9) Lower, turn
 - 10) Watch
 - 11) Fingers, fingers
 - 12) Feed, take it off
- g.
- 1) Pulled
 - 2) Location
 - 3) Firm
 - 4) Door jack, person
 - 5) Safety goggles
 - 6) Jigs, guides, route, plow
 - 7) Remove
- h.
- 1) Bottom, cutter, guard
 - 2) Cutter
 - 3) Left
 - 4) Spindle, guards, fences
 - 5) Direction, against
 - 6) Defects, knot, cracked, split
 - 7) Down, against
 - 8) Guards, jigs, clamping
 - 9) Depth collar, guide pin
 - 10) Tightly, hold

- 11) Cutters, motion
- 12) Ten inches
- i.
 - 1) Grounded
 - 2) Drills, bits
 - 3) Goggles
 - 4) Chuck
 - 5) Back out
 - 6) Chuck key
- j.
 - 1) Designed
 - 2) Discharge
 - 3) Hands, body
- k.
 - 1) Belt
 - 2) Both
 - 3) Loose
 - 4) Turning
 - 5) Fingers
- l.
 - 1) Adjustments, changing
 - 2) Sharp
 - 3) Thick, wide
 - 4) Long
 - 5) Guards
 - 6) Intended
- m.
 - 1) Tool manufacturer; certified
 - 2) Pin
 - 3) Barrel
 - 4) On back

- 5) Safety goggles
 - 6) Close; edge
 - n.
 - 1) Screw point
 - 2) Hand; screw
 - o.
 - 1) Top guard
 - 2) Size blade
- 5.
- a. Miter saw blade
 - b. Rip saw blade
 - c. Combination saw blade
 - d. Percussion carbide-tipped drill
 - e. Tamper
 - f. Drive pin
 - g. Threaded stud
 - h. Masonry drill
 - i. Bull point
 - j. Concrete chisel
 - k. Crosscut saw blade
6. Performance skills will be evaluated according to the criteria listed on the progress chart.

Carpentry

PROGRESS CHART

Section D Tools	Unit I Hand Tools			Unit II Power Tools																
	1	2	3	1	2	3	4	5	6	7	8	9	10	11	12	13	14	15	16	
	Unit Test	Electric Handsaw	Saber and Reciprocating Saws	Table Saw	Radial Arm Saw	Jointer	Surfacer	Portable Router & Power Plane	Spindle Shaper & Power Plane	Electric Hand and Hammer Drill	Power Nailers	Portable Belt Sander	Motorized Miter Box	Power Actuated Drywall Screwdriver	Band Saw	Job	Unit Test	Student's Name		
1																				
2																				
3																				
4																				
5																				
6																				
7																				
8																				
9																				
10																				

2

3

4

5

6

7

8

9

10

11

12

13

14

15

16

17

18

19

20

Accuracy
85% Correct

100% Correct

100% Correct

100% Correct

100% Correct

100% Correct

100% Correct

100% Correct

100% Correct

100% Correct

100% Correct

100% Correct

100% Correct

100% Correct

100% Correct

100% Correct

100% Correct

100% Correct

100% Correct

BLUEPRINT READING UNIT I

TERMINAL OBJECTIVE

After completion of this unit, the student should be able to define terms associated with blueprint reading and identify the alphabet of lines and drawing symbols. He should be able to measure scaled lines, list items included in a set of specifications, and extract specific information from a set of specifications. This knowledge will be evidenced by scoring eighty-five percent on the unit test.

SPECIFIC OBJECTIVES

After completion of this unit, the student should be able to:

1. Match terms associated with blueprint reading to a list of definitions.
2. Identify five types of architectural drawings.
3. Identify the eight types of lines included in the alphabet of lines.
4. Match the names of drawing symbols to a picture of the symbol.
5. Read an architect's scale.
6. List eleven major items that should be included in a set of specifications.
7. Extract specific information from a prepared set of building specifications.

BLUEPRINT READING UNIT I

SUGGESTED ACTIVITIES

- I. Instructor:
 - A. Provide students with objective sheet.
 - B. Provide students with information and assignment sheets.
 - C. Make transparencies.
 - D. Discuss terminal and specific objectives.
 - E. Discuss information and assignment sheets.
 - F. Give test.
- II. Student:
 - A. Read objective sheet.
 - B. Study information sheet.
 - C. Complete assignment sheets.
 - D. Take test.

INSTRUCTIONAL MATERIALS

- I. Included in this unit:
 - A. Objective sheet
 - B. Information sheet
 - C. Transparency masters
 1. TM 1--Plot plan
 2. TM 2--Foundation Plan
 3. TM 3--Floor Plan
 4. TM 4--Elevations
 5. TM 5--Details

6. TM 6--Alphabet of Lines
7. TM 7--Alphabet of Lines (Continued)
8. TM 8--Floor Plan Symbols
9. TM 9--Electrical Symbols
10. TM 10--Sectioning Symbols
11. TM 11--Architect's Scale
12. TM 12--Comparison of Solid Objects
13. TM 13--Door Schedule
14. TM 14--Schedule of Hardware

D. Assignment sheets

1. Assignment Sheet #1--Read the Architect's Scale at Full Scale or (12" = 12")
2. Assignment Sheet #2--Read the Architect's Scale at Half Scale or (6" = 12")
3. Assignment Sheet #3--Read the Architect's Scale At One-Fourth Scale Or (3" = 12")
4. Assignment Sheet #4--Read the Architect's Scale At One-Eighth Scale Or (1 1/2" = 12")

E. Answers to assignment sheets

F. Test

G. Answers to test

II. References:

- A. French, Thomas E. and Charles J. Vierch. *Engineering Drawing*. New York: McGraw-Hill, 1966.
- B. Hartman, William J. *Basic Drafting*. Stillwater, Oklahoma: State Department of Vocational and Technical Education, 1972.
- C. Hepler, Donald E. and Paul I. Wallach. *Architectural Drafting and Design*. New York: McGraw-Hill, 1971.
- D. Hornung, William J. *Architectural Drafting*. Englewood, New Jersey: Prentice Hall, 1949.

BLUEPRINT READING
UNIT I

INFORMATION SHEET

- I. Terms and definitions
 - A. Alphabet of lines--A set of conventional symbols covering all the lines needed to depict an object as to size and shape
 - B. Architect's scale--A rule divided into proportional feet and inches; a fraction of an inch is proportionally equal to one foot
Examples: $1/8$, $1/4$, $3/8$, $1/2$, $3/4$, $1\ 1/2$, and 3 inches to the foot
 - C. Architectural drawings--A graphic representation shown with lines and symbols
 - D. Structural drawing--Plans showing the structural components of the building
 - E. Mechanical drawing--Plans showing the plumbing and heating layout
 - F. Electrical drawing--Plans showing the electrical installation
 - G. Shop drawing--Detailed information of specific items
 - H. Blueprint--A copy of the original detailed drawing
 - I. Detail--A drawing that gives complete detailed information for an element of construction
 - J. Dimensions--The arrangement of lines and symbols to indicate the actual size for constructing the object that is represented
 - K. Elevation--Drawings representing the front, sides, or rear face of a structure and usually made as though the observer were looking straight at it
 - L. Plan--In architecture, a diagram showing a horizontal view of a structure such as floor plans and sectional plans
 - M. Scale drawing--A drawing made to size either proportionally larger or smaller than the actual size of the object represented
 - N. Section--A drawing of an object that has been cut to show internal construction
 - O. Specifications--A detailed set of written instructions which explains the drawing, describes material and equipment used in the structure as to quality and types, and becomes part of the contract
 - P. Symbol--An arbitrary sign that has been standardized and is used to represent an object, quality, or method

INFORMATION SHEET

II. Types of architectural drawings (Transparencies 1, 2, 3, 4, and 5)

A. Plot plan--Characteristics include:

1. The location of the structure on the site
2. Finished and existing grade contours
3. Property lines
4. Utilities
5. Location of existing conditions

(NOTE: This would include trees, buildings, or other structures.)

B. Foundation plan--Characteristics include: The location and size of footings, grade beams, foundation walls, stemwalls, and piers

C. Floor plan--Characteristics include:

1. Outside walls including the location and dimensions of all exterior openings
2. The type of construction through the use of symbols
3. The location of interior walls and partitions
4. Location and swing of doors
5. Stairways
6. The location of cabinets and other built-ins

D. Elevation--Characteristics include: Grade lines, floor heights, window size, roof line, or other dimensions

(NOTE: Elevations are shown for all faces of the structure.)

E. Details--Characteristics include:

(NOTE: These drawings are primarily used to depict details of construction that are too small or not shown in sufficient detail on the plan or elevation drawings. They may be full size or to a larger scale than the plan, elevation, or sectional view.)

1. Windows
2. Mill work
3. Ornamental iron

INFORMATION SHEET







4. Doors (Interior and exterior)
5. Built-ins
6. Door frames
7. Stairs
8. Walls and partitions

(NOTE: Sections are used freely on these drawings.)

III. Alphabet of lines (Transparencies 6 and 7)

- A. Object lines ()-- Show the main outline of the structure including exterior walls, interior partitions, porches, patios, driveways, and interior walls

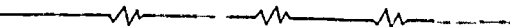
(NOTE: These lines should be the outstanding lines on the drawing.)











- B. Dimension lines ()-- Thin unbroken lines which designate dimensions
- C. Extension lines ()-- Extend, but do not touch, the object lines and permit dimension lines to be drawn between them
- D. Hidden lines ()-- Short dashes used to show lines that are not visible from that view
- E. Center lines ()-- A series of short and long dashes used to designate centers and provide a reference point for dimensioning
- F. Section lines ()-- Heavy lines consisting of a series of one long and two short dashes with arrows at each end pointing away from the area that is cut away for the purpose of sectioning
- G. Break lines ()-- Used when an area cannot or should not be drawn entirely
- H. Leaders ()-- Used to connect a note or dimension to a part of the building

INFORMATION SHEET

IV. Symbols (Transparencies 8, 9, 10)

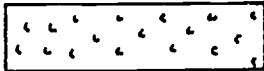

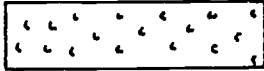

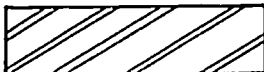
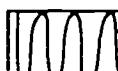

(NOTE: Check architect's drawings for symbols.)

A. Floor plan

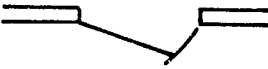

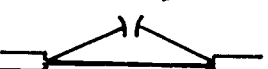



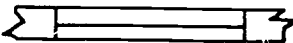

- | | | | |
|-----|--|--|----------------|
| 1. | Wood (rough) |  | |
| 2. | Wood (finished) |  | |
| 3. | Brick |  | |
| 4. | Firebrick |  | |
| 5. | Concrete |  | ← Conc Block |
| 6. | Sand, plaster, cement, gypsum board |  | |
| 7. | Tile--Hollow,
Terra-Cotta |  | ← Glazed |
| 8. | Cinders |  | |
| 9. | Earth |  | |
| 10. | Gravel |  | With Sand |
| 11. | Structural
Steel or iron |  | |
| 12. | Insulation |  | Loose
Solid |
| 13. | Flashing, termite
barrier, water-
proofing |  | |
| 14. | Brick veneer |  | |
| 15. | Arch--Cased
opening |  | |

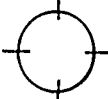
247







INFORMATION SHEET

- 16. Outside door 
- 17. Inside door 
- 18. Double-acting door 
- 19. Casement window 
- 20. Double-hung window 
- 21. Telephone outlet 
- 22. Floor drain 
- 23. Glass 

B. Electrical

- 1. Lighting outlet 
- 2. Ceiling lighting outlet for recessed fixture (Outline shows shape of fixture.) 
- 3. Duplex convenience outlet 
- 4. Duplex convenience outlet for grounding-type plugs 
- 5. Weatherproof convenience outlet 
- 6. Combination switch and convenience outlet 
- 7. Range outlet 
- 8. Junction box 
- 9. Bell-ringing transformer 

INFORMATION SHEET

- 10. Bell 
- 11. Service panel 
- 12. Distribution panel 
- 13. Switch leg indication; connects outlets with control points 
- 14. Low-voltage relay system wiring 
- 15. Special-purpose outlet; use subscript letters to indicate function; DW-Dishwasher, D.F.-Drinking Fountain, etc. 

- 16. Single-pole switch **S**
- 17. Three-way switch **S₃**
- 18. Four-way switch **S₄**

C. Sectioning

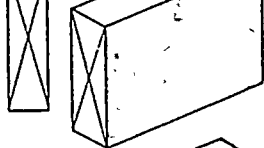
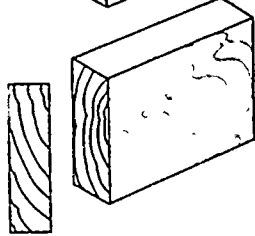
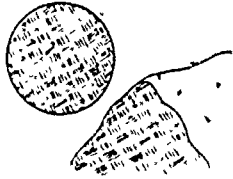
- 1. Rough lumber 
- 2. Finished lumber 
- 3. Earth 

INFORMATION SHEET

4. Concrete

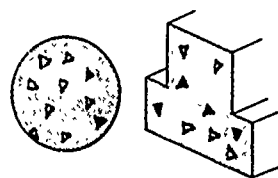

5. Metal

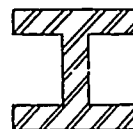

D. Mechanical

1. Supply duct section



2. Exhaust, return, or outside air duct section



3. Supply outlet; ceiling diffuser

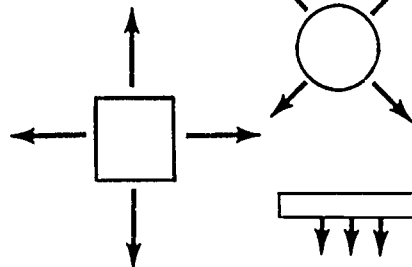

4. Supply outlet; ceiling diffuser

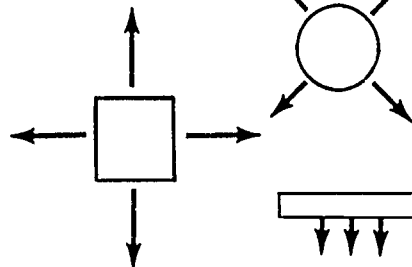

5. Linear diffuser

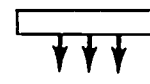

6. Recessed radiator

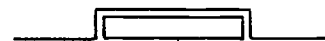

7. Enclosed radiator

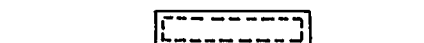

8. Unit heater



9. Louver opening

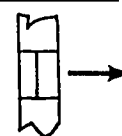

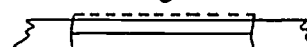

10. Intake louvers



11. Water heater

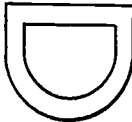

INFORMATION SHEET

- | | | |
|-----|------------------|---|
| 12. | Water closet |  |
| 13. | Wash fountain |  |
| 14. | Lavatory |  |
| 15. | Cold water | — — — — — |
| 16. | Hot water | — — — — — |
| 17. | Fire line | — F — F — F |
| 18. | Gas-low pressure | — G — G — G |
| 19. | Vent | - - - - - |

V. The architect's scale (Transparencies 11 and 12)

A. Rules for reading a scale

1. Select proper scale ratio
2. Scale should lay flat on the surface being measured
3. Double check all measurements
4. Practice measuring from the center of one line to the center of the next line
5. Do not use a scale where dimensions are available

B. Common scales to which plans are drawn

1. 12" = 1' - 0" (full scale)
2. 6" = 1' - 0" (one-half scale)
3. 3" = 1' - 0" (one-fourth scale)
4. 1/2" = 1' - 0"
5. 1/4" = 1' - 0"
6. 1/8" = 1' - 0"

INFORMATION SHEET

C. Interpret graduations on the architect's scale

1. The sixteenth scale

- a. 16 - 16ths make one inch



- b. 8 - 8ths make one inch; 2 - 1/16" make 1/8"

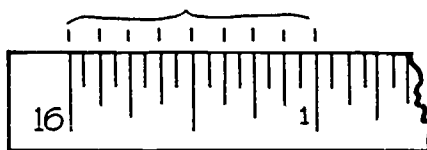

- c. 4 - 4ths make one inch; 4 - 1/16" make 1/4"

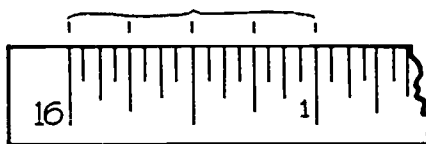

- d. 2 - 1/2ves make one inch; 8 - 1/16" make 1/2"



- e. For 1/32" increments there are two 1/32" in one 1/16" and two 1/16" in one 1/8"

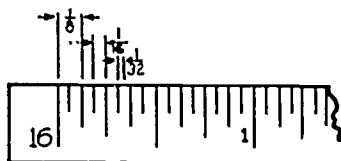

- f. Dimensions are read in this order

- 1) Feet marked thus (')
- 2) Inches marked thus (")
- 3) Fractions of an inch

INFORMATION SHEET

- g. Practice reading the following dimensions in inches and $1/16''$ (full scale)

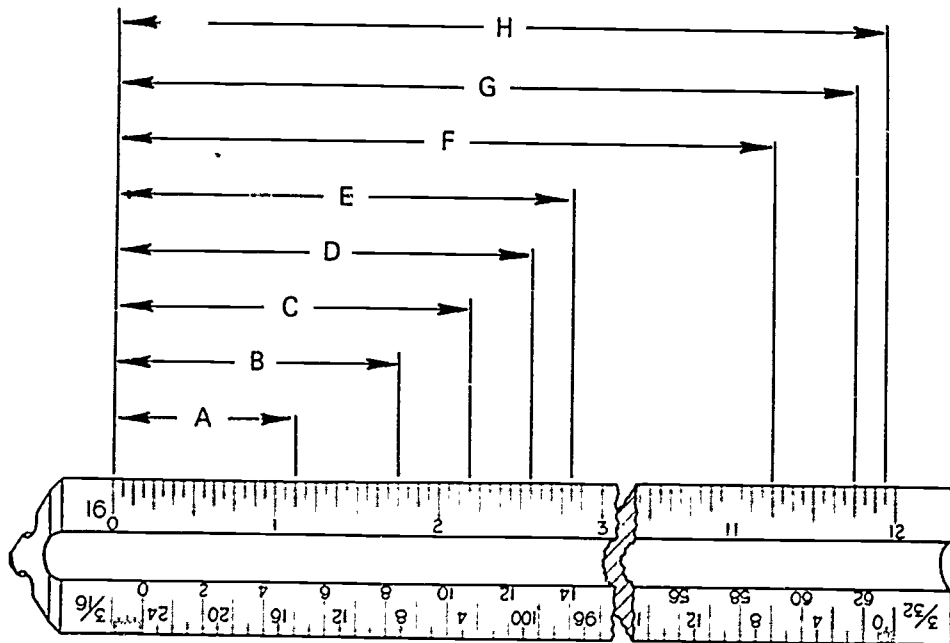

- 1) $A = 1'' + 2/16'' = 1 \frac{2}{16}''$ or $1 \frac{1}{8}''$
- 2) $B = 1'' + 12/16'' = 1 \frac{12}{16}''$ or $1 \frac{3}{4}''$
- 3) $C = 2'' + 3/16'' = 2 \frac{3}{16}''$
- 4) $D = 2'' + 9/16'' = 2 \frac{9}{16}''$
- 5) $E = 2'' + 13/16'' = 2 \frac{13}{16}''$
- 6) $F = 11'' + 4/16'' = 11 \frac{4}{16}''$ or $11 \frac{1}{4}''$
- 7) $G = 11'' + 12/16'' = 11 \frac{12}{16}''$ or $11 \frac{3}{4}''$
- 8) $H = 11'' + 15/16'' = 11 \frac{15}{16}''$

INFORMATION SHEET

h. One-half scale or 6" represents 12"

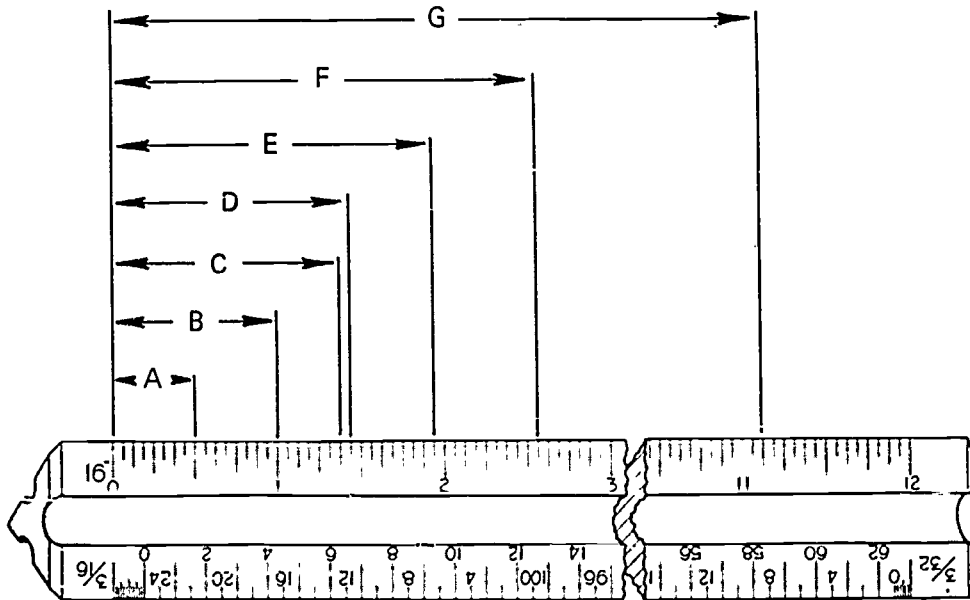
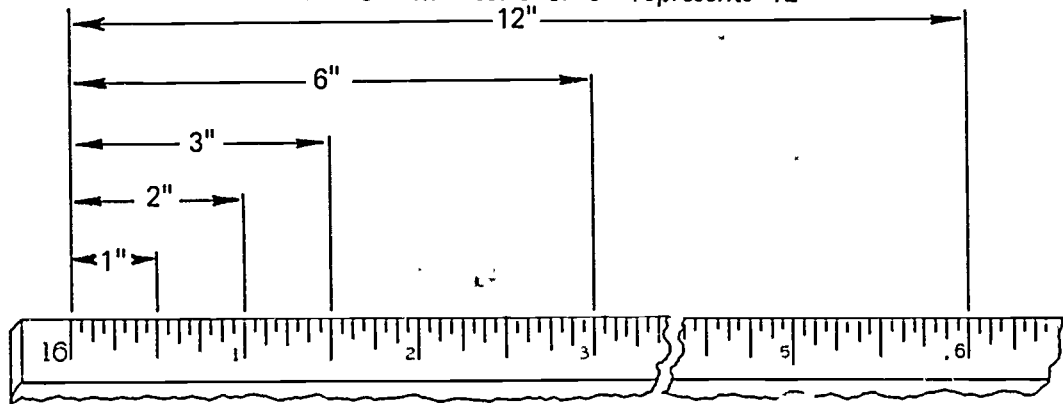

At half scale the 1/16" graduations each represent 1/8"

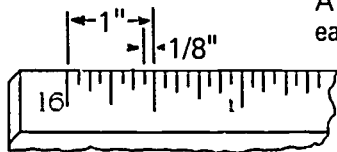

- 1) $A = 8/8" = 1"$
- 2) $B = 16/8" = 2"$
- 3) $C = 2" + 6/8" = 2 \frac{6}{8}"$ or $2 \frac{3}{4}"$
- 4) $D = 2" + 7/8" = 2 \frac{7}{8}"$
- 5) $E = 3" + 7/8" = 3 \frac{7}{8}"$
- 6) $F = 5" + 1/8" = 5 \frac{1}{8}"$
- 7) $G = 22" + 2/8" = 22 \frac{2}{8}"$ or $22 \frac{1}{4}"$

INFORMATION SHEET

i. One-fourth scale or $3'' = 12''$

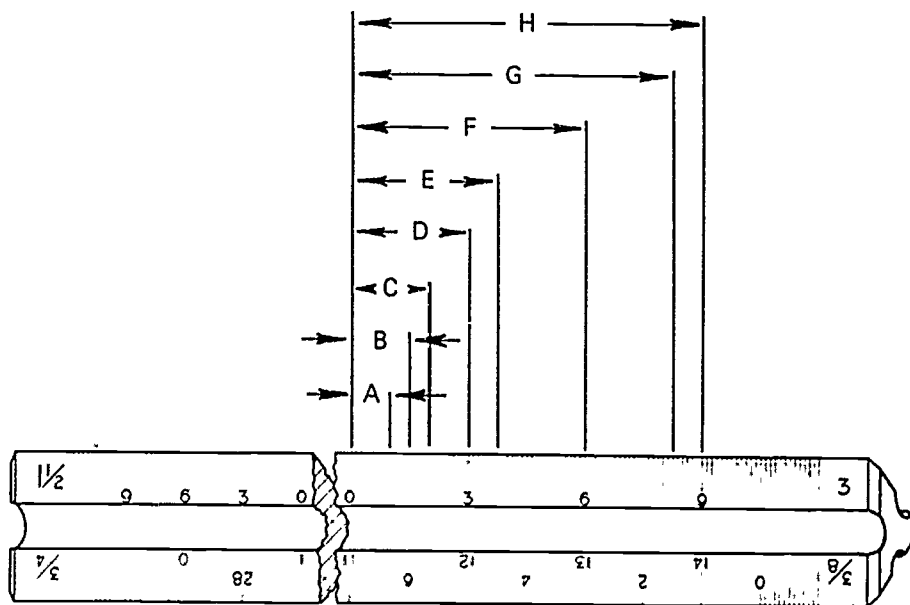
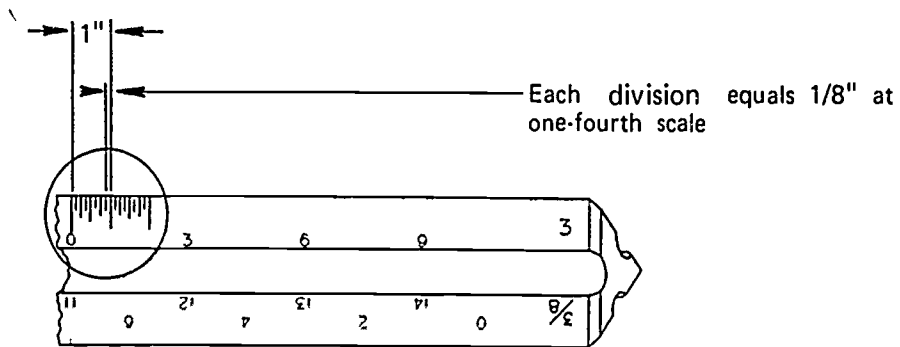
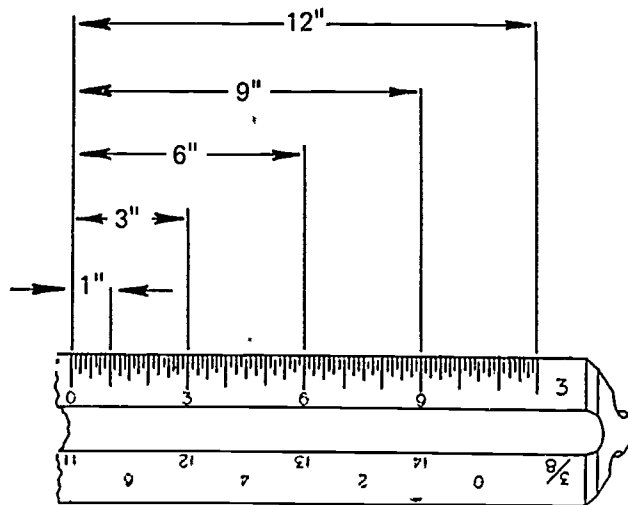

INFORMATION SHEET

- 1) A = 8 graduations 1"
- 2) B = $1'' + 4/8'' = 1 \frac{4}{8}$ or $1 \frac{1}{2}''$
- 3) C $1'' + 8/8'' = 1 \frac{8}{8}''$ or 2"
- 4) D = The number 3 = 3"
- 5) E $3'' + 6/8'' = 3 \frac{6}{8}''$ or $3 \frac{3}{4}''$
- 6) F The number 6 indicates = 6"
- 7) G = $8 + 2/8'' = 8 \frac{2}{8}''$ or $8 \frac{1}{4}''$
- 8) H The number 9 indicates = 9"

INFORMATION SHEET

j. Reading the one-eighth scale or 1 1/2" represents 12"

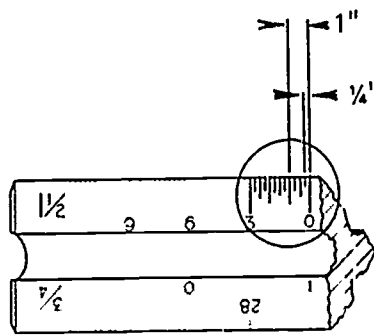
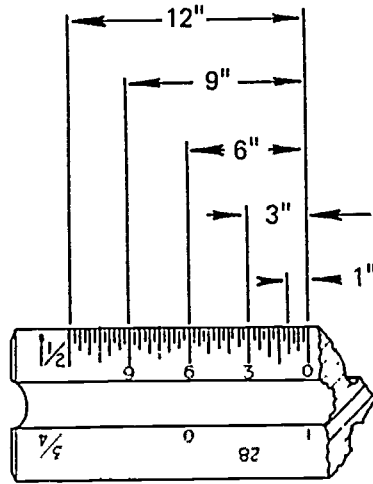

This is one inch at 1/8" scale graduated into spaces that represent 1/4"

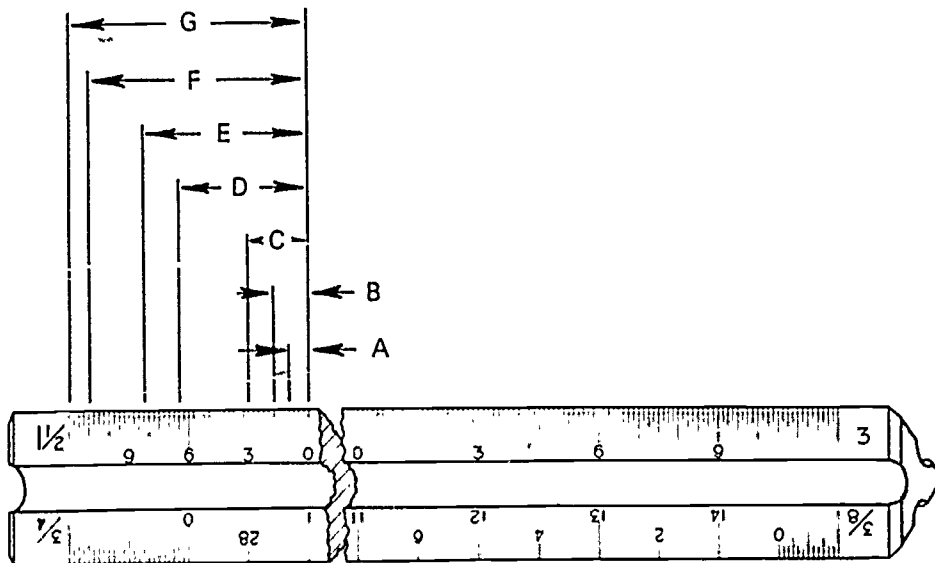

INFORMATION SHEET

- 1) A = 8 graduations = 1"
- 2) B $1" + 3/4" = 1 \ 3/4"$
- 3) C = The number 3 represents 3"
- 4) D = $6" + 2/4"$ $6 \ 2/4"$ or $6 \ 1/2"$
- 5) E = $8 + 1/4" = 8 \ 1/4"$
- 6) F = 2" past 9 represents 11"
- 7) G $1 \ 1/2"$ represents 12"

VI. Items included in a set of specifications

- A. Sizes
- B. Types and quality of building materials
- C. Methods of construction
- D. General requirements
- E. Owner's name and address
- F. Architect's name and address
- G. Location of new structure
- H. Completion date
- I. Contractor's bid form
- J. Guarantees
- K. Insurance requirements

VII. Specifications and schedules (Transparencies 13 and 14)

(NOTE: Schedules serve two basic purposes:

1. Conserve space on the drawing
2. Includes all information needed to order materials or to do the job.)

INFORMATION SHEET

A. Door schedule information

1. Size
 - a. Width
 - b. Height
 - c. Thickness
2. Design
3. Hardware
4. Head detail
5. Jamb detail
6. Remarks
7. Sill detail
8. Material

B. Schedule of hardware

1. Door number
2. Hardware set number
3. Quantity
4. Type
5. Catalog number

C. Room finish schedule

D. Column schedule

E. Beam schedule

Plot Plan

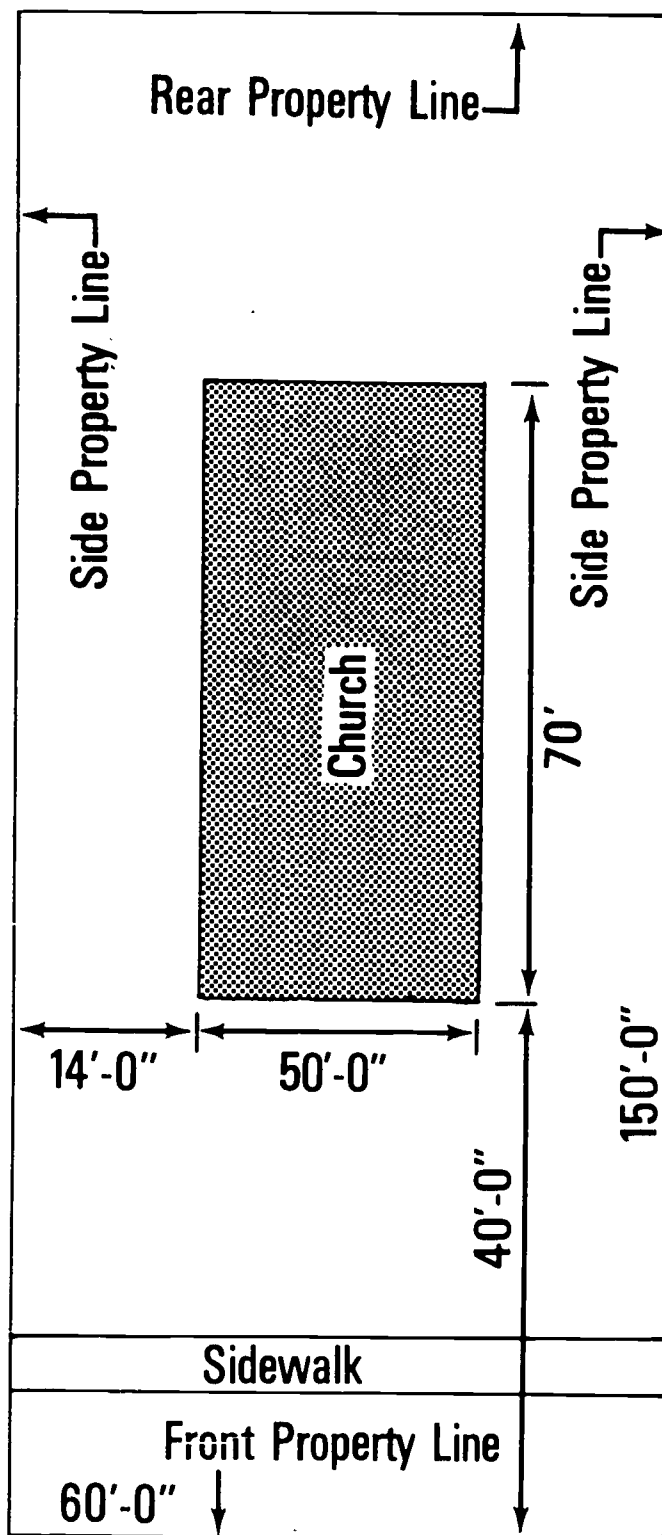

Foundation Plan

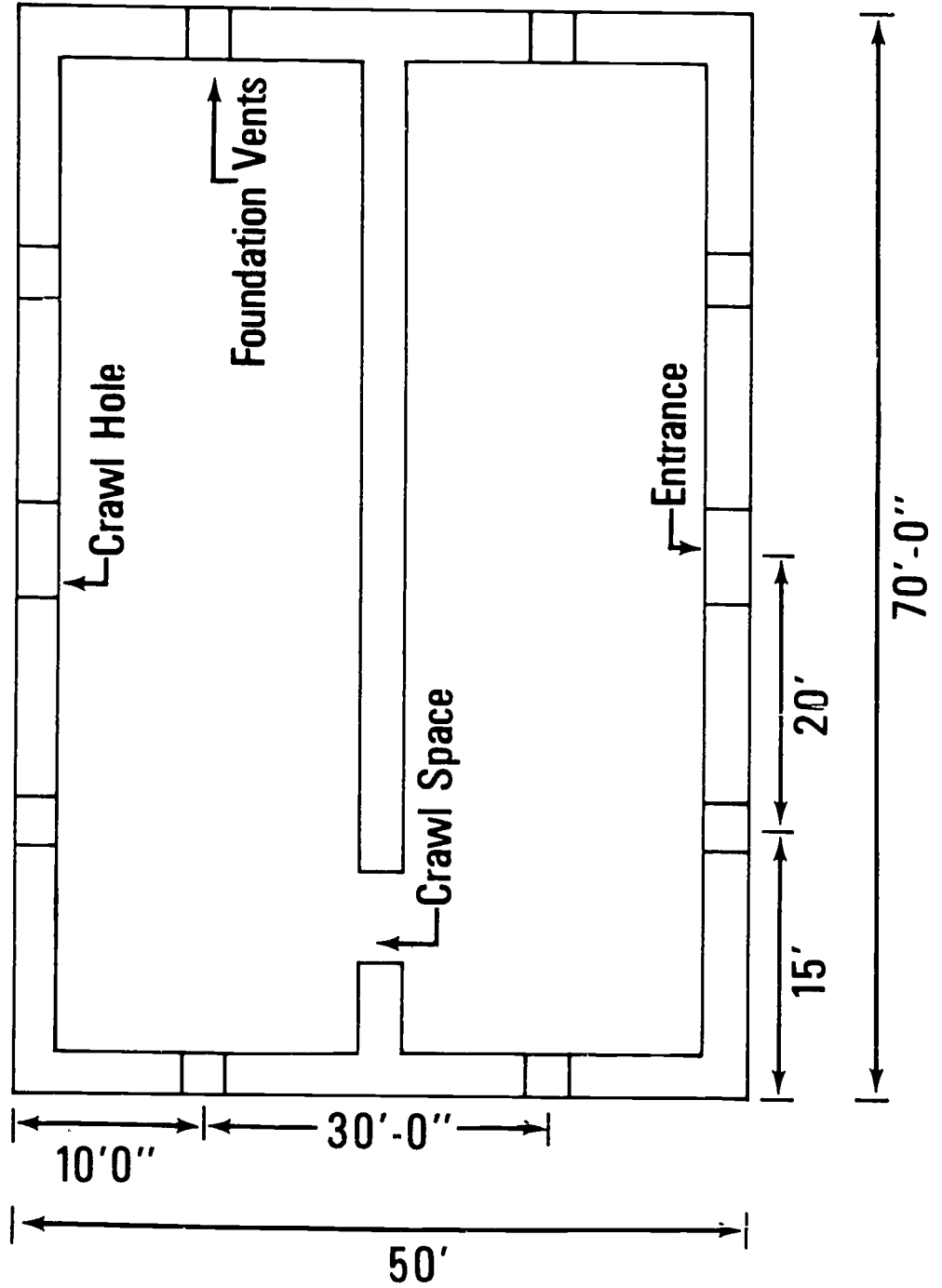

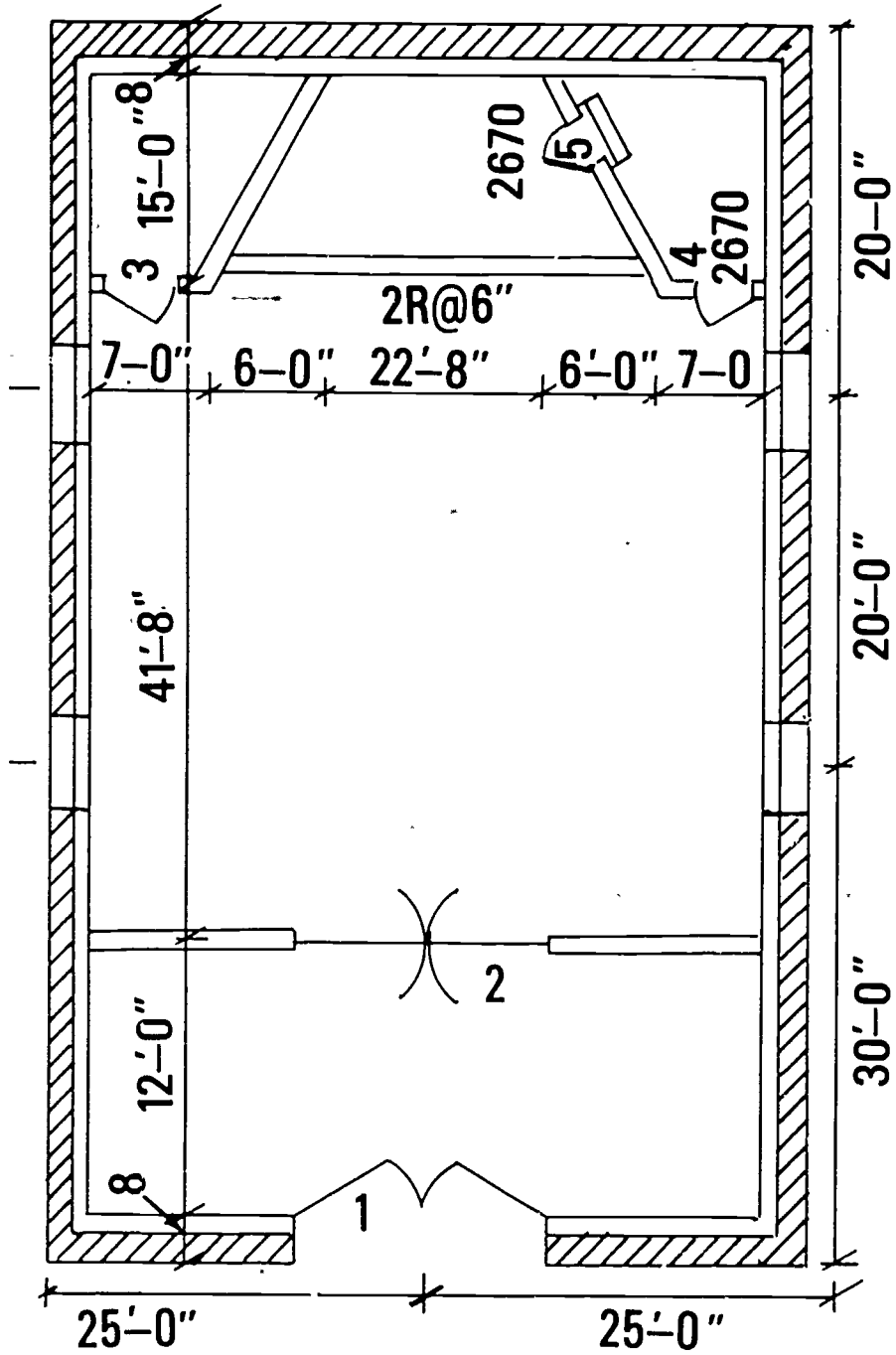

Floor Plan

262

Elevations

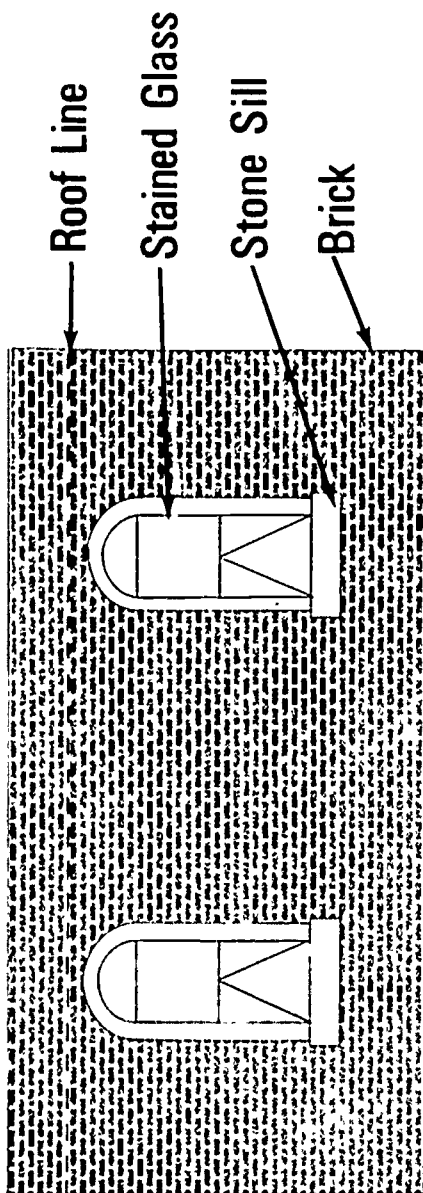

RIGHT SIDE (Left Side Similar)

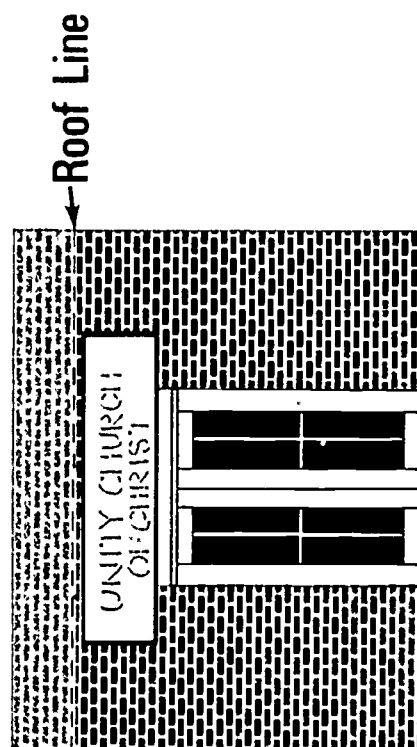

FRONT

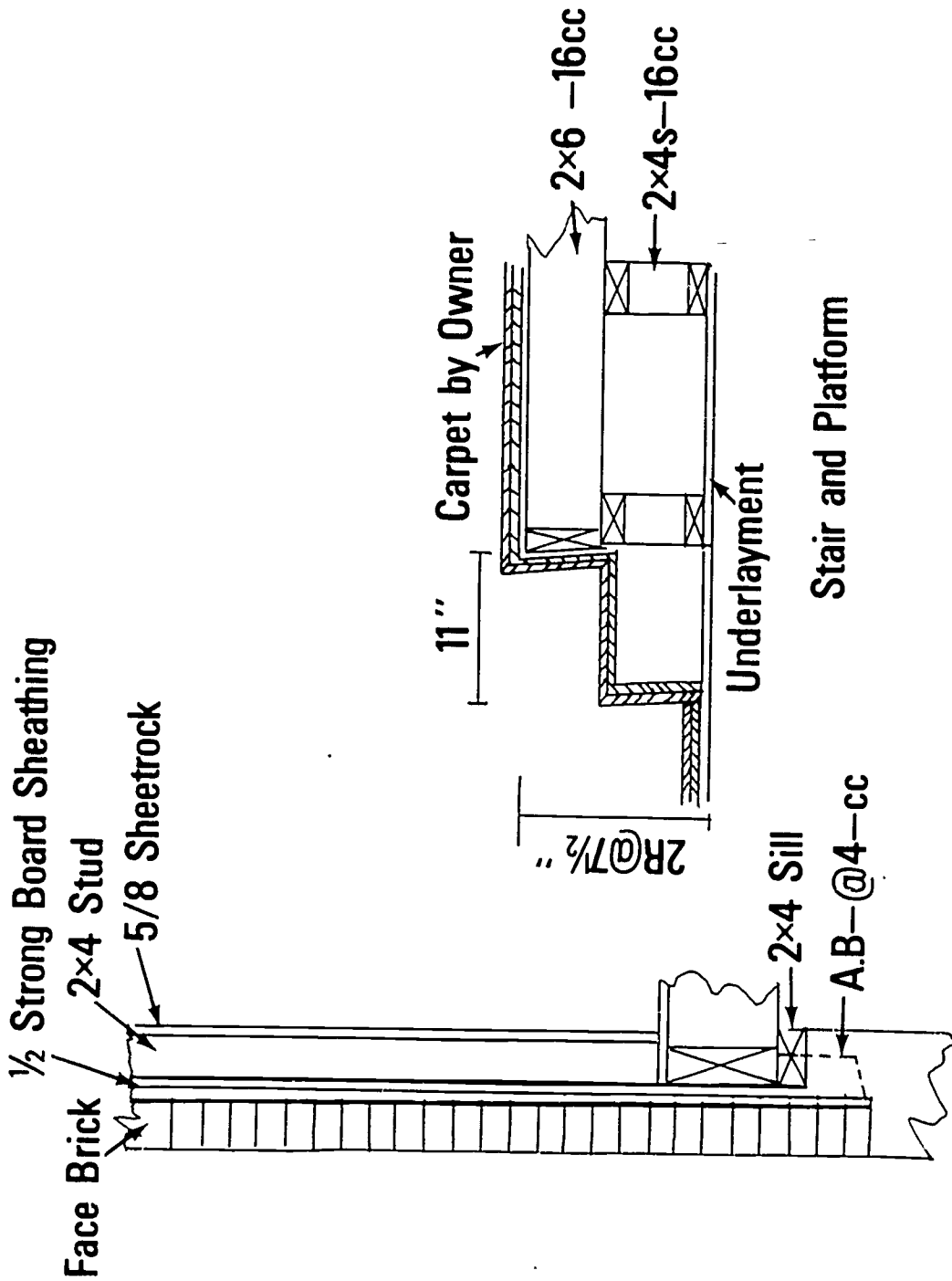









Scale 1"=1'-0"

Details

Typical Exterior Wall

Alphabet of Lines

Object Line	
Dimension Line	
Extension Line	
Hidden Line	
Center Line	
Section Line	
Break Line-Long	
Break Line-Short	
Leader	



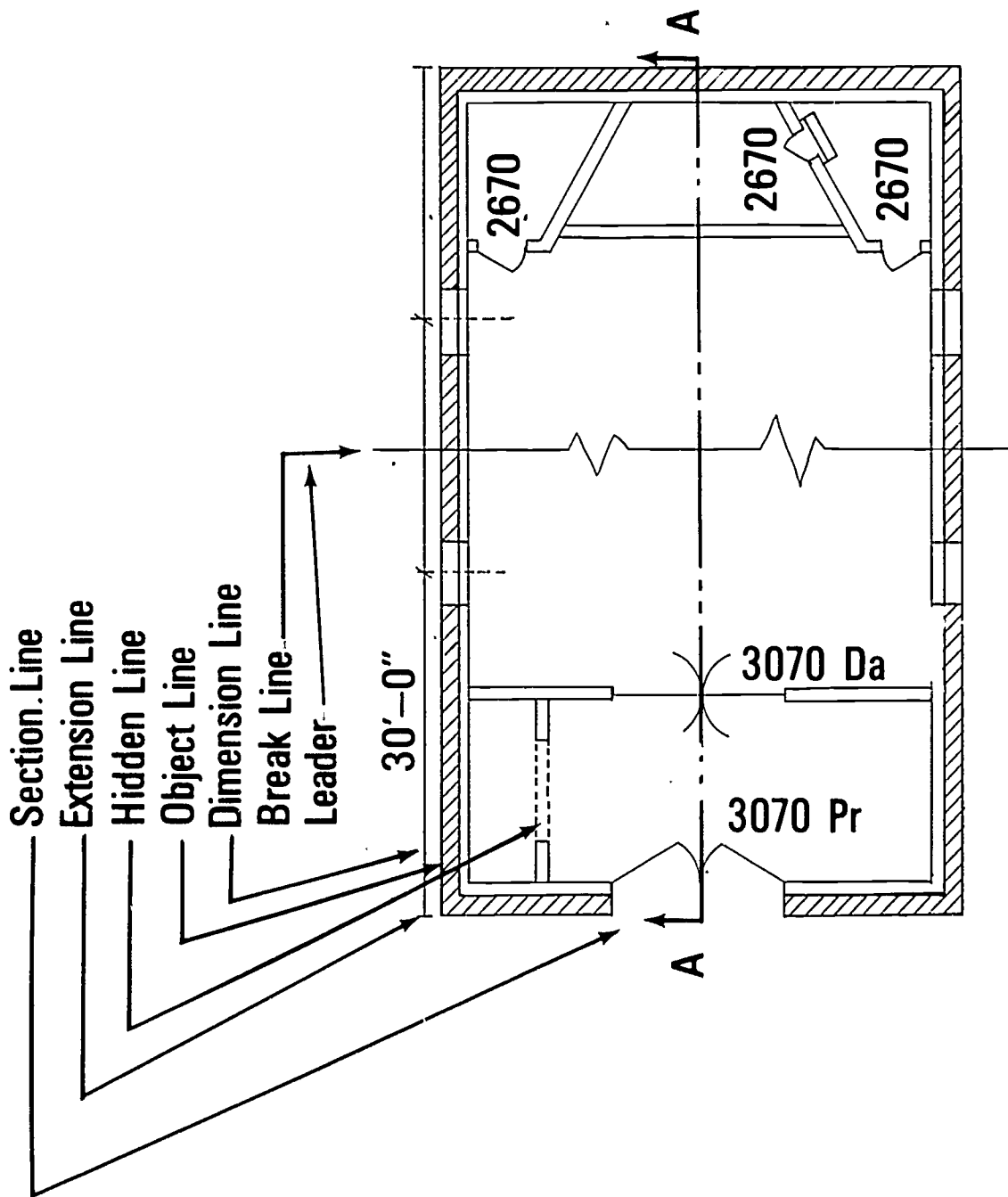







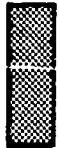

Alphabet of Lines (Continued)

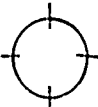

Floor Plan Symbols

	Wood-Rough		Cinders
	Wood-Finished		Earth
	Brick		Gravel With Sand
	Firebrick		Structural Steel or Iron
	Concrete Conc Block		Insulation Loose Solid
	Sand, Plaster, Cement		Flashing, Termite Barrier, Water-Proofing
	Tile-Hollow, Glazed Terra-Cotta		Brick Veneer
	Outside Door		Arch-Cased Opening
	Inside Door		Casement Window
	Double-Acting Door		Double-Hung Window
	Glass (Sheet & Plate)		Floor Drain
			Telephone Jack

Electrical Symbols

	Service Panel		Range Outlet
	Distribution Panel		Special-Purpose Outlet.
----	Switch Leg Indication. Connects outlets with control points.	WH	Use subscript letters to indicate function. DW-Dishwasher, DF-Drinking Fountain
----	Low-Voltage Relay System Wiring		Lighting Outlet
	Bell-Ringing Transformer		Ceiling Lighting Outlet for recessed fixture (Outline shows shape of fixture.)
	Junction Box	S	Single-Pole Switch
	Bell	S ₃	Three-Way Switch
	Duplex Convenience Outlet for Grounding -Type Plugs	S ₄	Four-Way Switch
	Weatherproof Convenience Outlet		Duplex Convenience Outlet
	Combination Switch and Convenience Outlet		

Sectioning Symbols

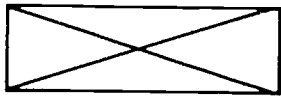

Rough Lumber

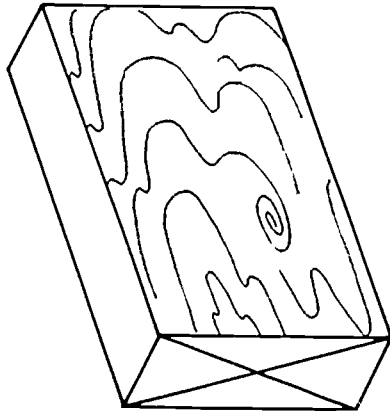

Finished Lumber

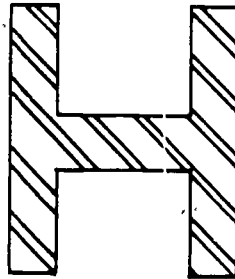
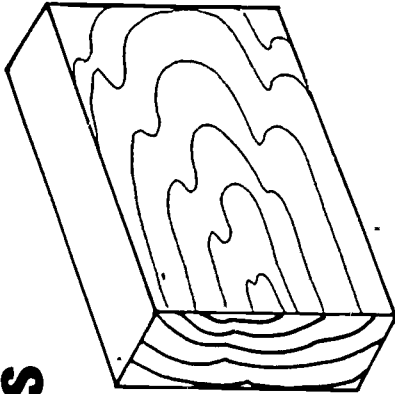

Metal

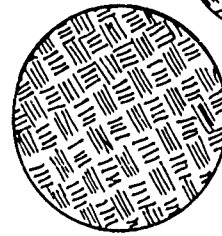

Earth

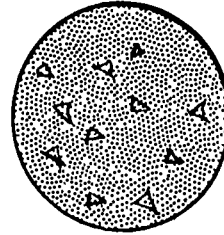
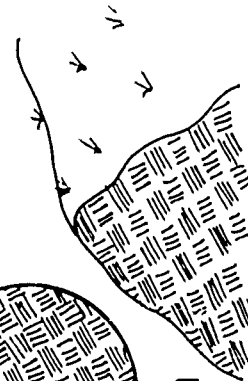

Concrete

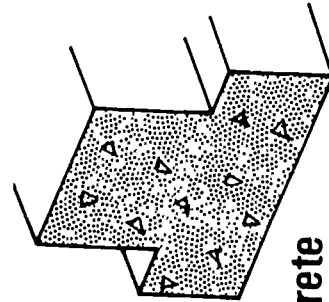

Architect's Scale

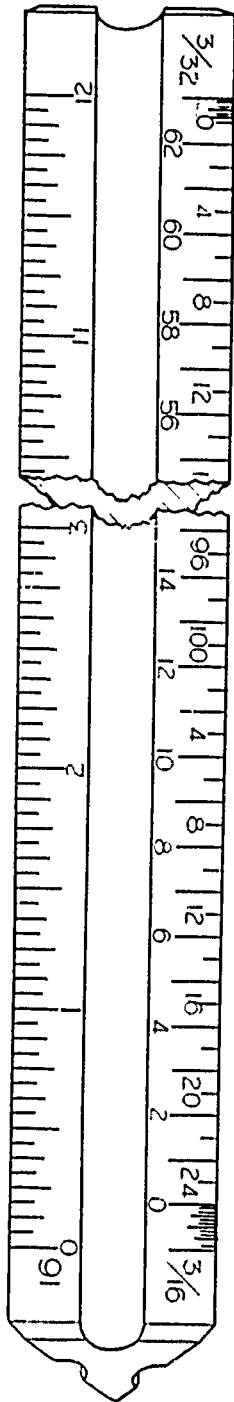

This is how the Architect's Scale should look.

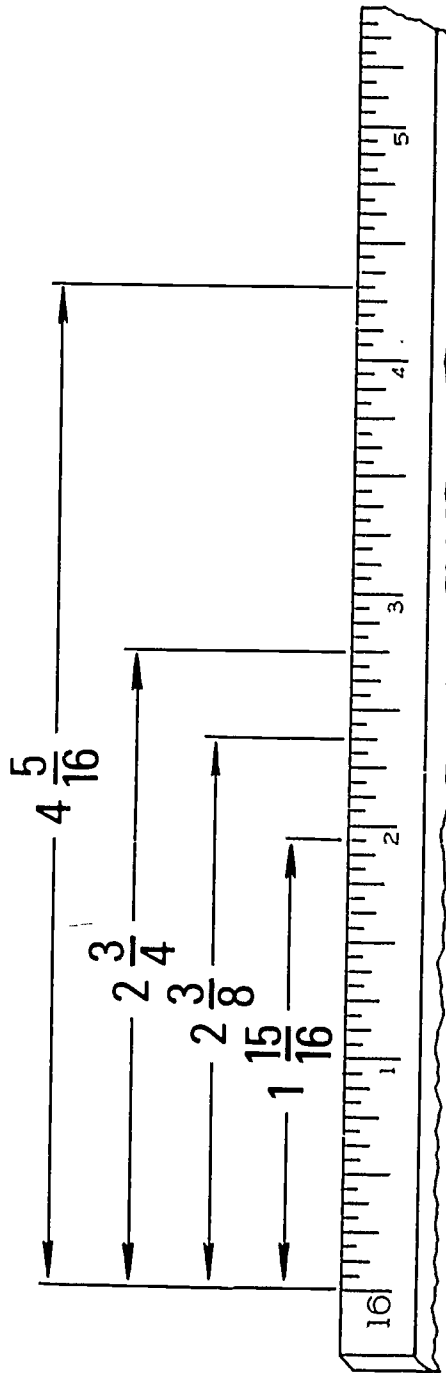

Measurements at Scale of 12" = 1'-0"

Comparison of Solid Objects

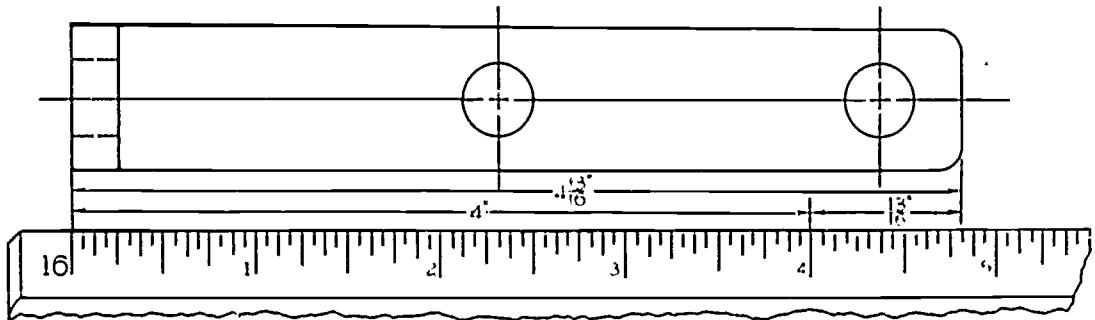

Full Scale 12" = 1'-0"

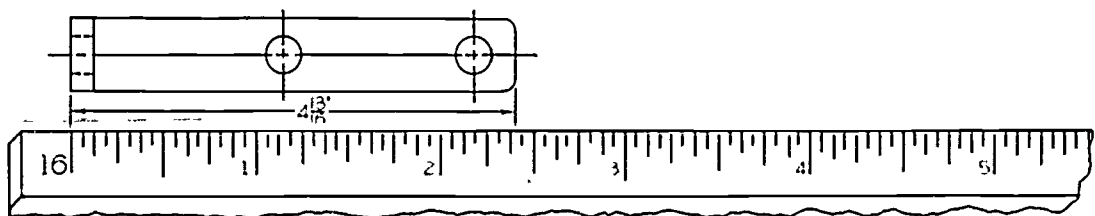

Half Scale 6" = 1'-0"

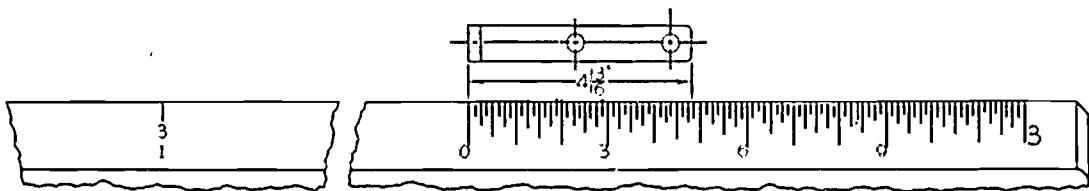

One-Fourth Scale 3" = 1'-0"

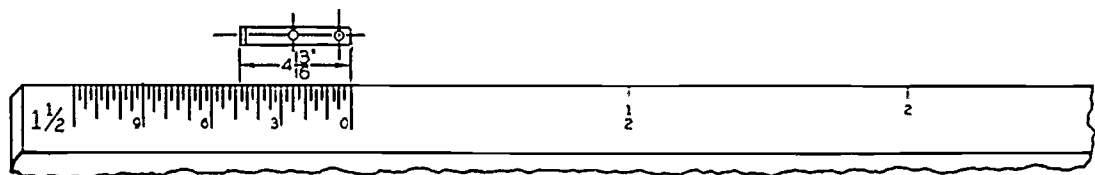

One-Eighth Scale $1 \frac{1}{2}$ " = 1'-0"

Door Schedule

No.	Size	Material	Design	Hardware	Head	Jamb	Sill	Remarks
101	3070x1¾ Pr	Oak	A	2	3/9	4/9	10/9	Threshold
102	3070x1¾ Pr	Oak	A	1	3/9	4/9	11/9	
103	2668x1½	Oak	B	3	3/9	4/9	11/9	
104	2668x1½	Oak	B	3	3/9	4/9	12/9	
105	2068x1½	Oak	B	3	3/9	4/9	12/9	

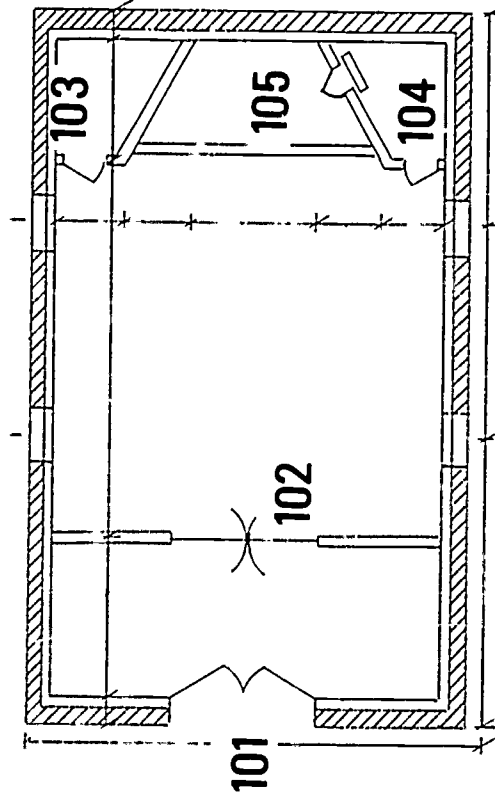

Door Schedule

Door No.	Hardware Set	Owners Number
101	2	1
102	1	2
103	3	3
104	3	4
105	3	5

Set 1

Pr of D.A. Vestibule to Chapel

2 Pr	Spring Hinges	3029- USP-8
1	Exten. Flush Bolt	C457B10×12
4	Floor Stops	446B10
4	Push Plates	39-6X16-US10

Set 2

Pr Exterior to Vestibule

3 Pr	Butts	BB1193-US10-4½×4½ NRP
2	Door Closers	C-RA-X-DB
2	Exit Device	8827 × 8858E0 × US10
1	Threshold	3151-A
1 Set	Weather Strip	332 AR (Lip & Sides)
1 Pr	Astragal	305 BN

Set 3

Storage to Chapel

1½ Pr	Butts	1279-US10-4×4
1	Lockset	HCE-131DL×US10
1	Door Closer	C-RA×DB

Hardware Schedule

BLUEPRINT READING
UNIT I

ASSIGNMENT SHEET #1--READ THE ARCHITECT'S SCALE
AT FULL SCALE OR (12" = 12")

Read the measurements shown below at full scale by reading the distance from "0" at left to points indicated on the scale with letters.

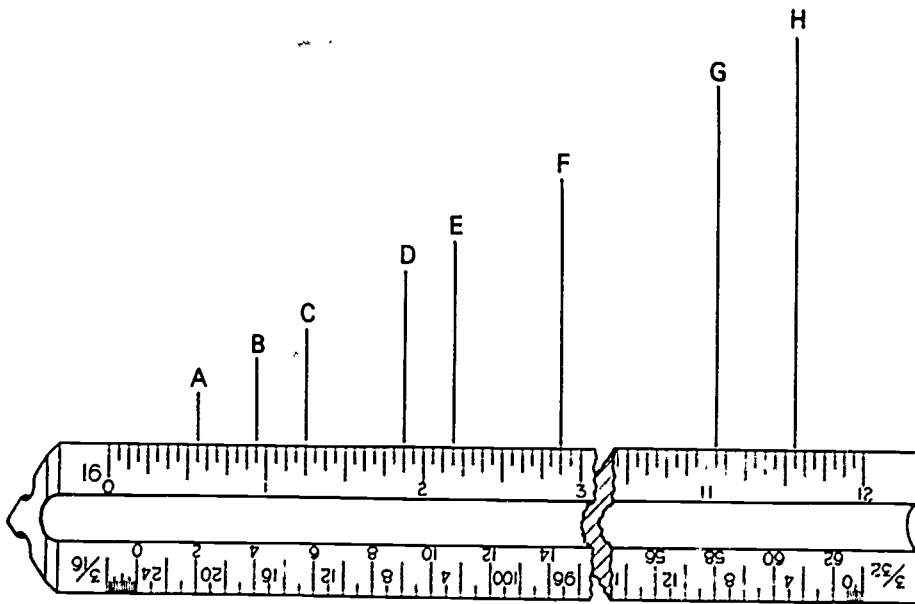

1. A =
2. B =
3. C =
4. D =
5. E =
6. F =
7. G =
8. H =

BLUEPRINT READING
UNIT I

ASSIGNMENT SHEET #2--READ THE ARCHITECT'S SCALE
AT HALF SCALE OR (6" = 12")

Read the measurements shown below at half scale by reading the distance from "0" at left to points indicated on the scale with letters.

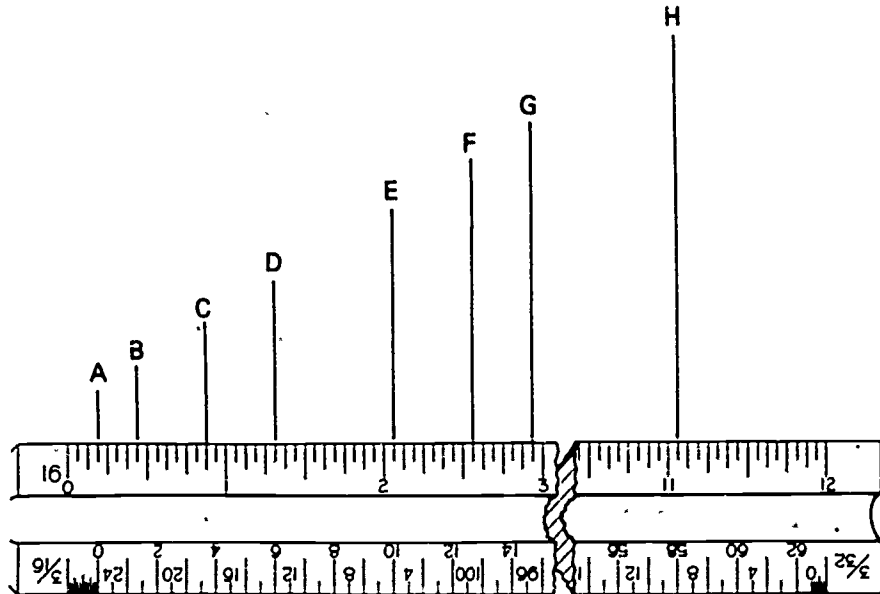

1. A =
2. B =
3. C =
4. D =
5. E =
6. F =
7. G =
8. H =

BLUEPRINT READING
UNIT I

ASSIGNMENT SHEET #3--READ THE ARCHITECT'S SCALE
AT ONE-FOURTH SCALE OR (3" = 12")

Read the measurements shown below at half scale by reading the distance from "0" at left to points indicated on the scale with letters.

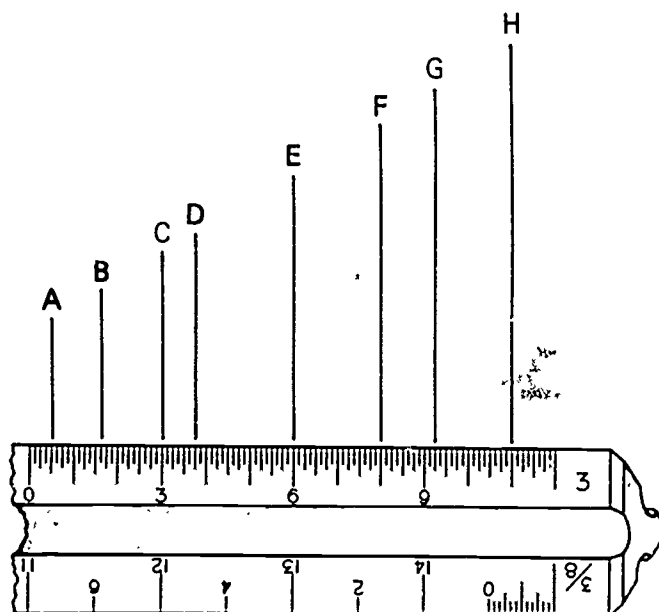

1. A =
2. B =
3. C =
4. D =
5. E =
6. F =
7. G =
8. H =

BLUEPRINT READING
UNIT I

ASSIGNMENT SHEET #4--READ THE ARCHITECT'S SCALE
AT ONE-EIGHTH SCALE OR ($1 \frac{1}{2}'' = 12''$)

Read measurements shown below at half scale by reading the distance from "0" at right to points indicated on the scale with letters.

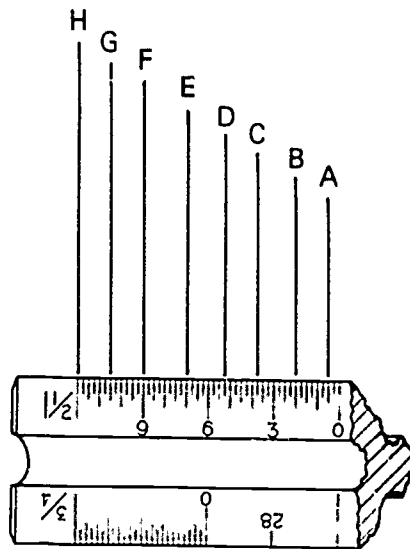

1. A =
2. B =
3. C =
4. D =
5. E =
6. F =
7. G =
8. H =

BLUEPRINT READING
UNIT I

ANSWERS TO ASSIGNMENT SHEETS

Assignment Sheet #1

1. $9/16''$
2. $15/16''$
3. $1\ 1/4''$
4. $1\ 7/8''$
5. $2\ 3/16''$
6. $2\ 7/8''$
7. $11\ 1/16''$
8. $11\ 9/16''$

Assignment Sheet #2

1. $3/8''$
2. $7/8''$
3. $1\ 3/4''$
4. $2\ 5/8''$
5. $4\ 1/8''$
6. $5\ 1/8''$
7. $5\ 7/8''$
8. $22\ 1/8''$

Assignment Sheet #3

1. $1/2''$
2. $1\ 5/8''$
3. $3''$

4. 3 3/4"
5. 6"
6. 8"
7. 9 1/4"
8. 11"

Assignment Sheet #4

1. 1/2"
2. 2"
3. 3 3/4"
4. 5 1/4"
5. 7"
6. 9"
7. 10 1/2"
8. 12"

BLUEPRINT READING
UNIT I

TEST

1. Match the following terms to the correct definition.

- | | |
|---|---------------------------|
| _____ a. A drawing of an object that has been cut to show internal construction | 1. Alphabet of lines |
| _____ b. Plans showing the structural components of the building | 2. Architect's scale |
| _____ c. A detailed set of written instructions which explains the drawing, describes material and equipment used in the structure as to quality and type, and becomes part of the contract | 3. Architectural drawings |
| _____ d. An arbitrary sign that has been standardized and is used to represent an object, quality, or method | 4. Blueprint |
| _____ e. Plans showing the plumbing and heating layout | 5. Structural drawing |
| _____ f. A graphic representation shown with lines and symbols | 6. Detail |
| _____ g. A drawing that gives complete detailed information for an element of construction | 7. Dimensions |
| _____ h. A set of conventional symbols covering all the lines needed to depict an object as to size and shape | 8. Elevation |
| | 9. Plan |
| | 10. Scale Drawing |
| | 11. Section |
| | 12. Specification |
| | 13. Symbol |
| | 14. Electrical drawing |
| | 15. Mechanical drawing |
| | 16. Shop drawing |

- _____ i. The arrangement of lines and symbols to indicate the actual size for constructing the object that is represented
- _____ j. In architecture, a diagram showing a horizontal view of a structures such as floor plans and sectional plans
- _____ k. A rule divided into proportional feet and inches; a fraction of an inch is proportionally equal to one foot
- _____ l. Drawings representing the front, sides, or rear fact of a structure and usually made as though the observer were looking straight at it
- _____ m. A copy of the original detailed drawing
- _____ n. A drawing made to a size either proportionally larger or smaller than the actual size of the object represented
- _____ o. Plans showing the electrical installation
- _____ p. Plans showing detailed information of specific items

2. Identify the five types of architectural drawings pictured below.

- a. _____
- b. _____
- c. _____
- d. _____
- e. _____

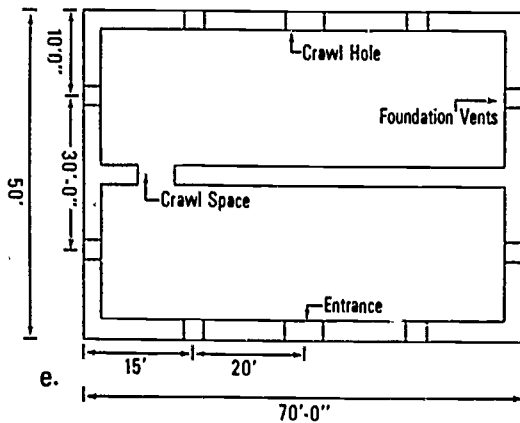
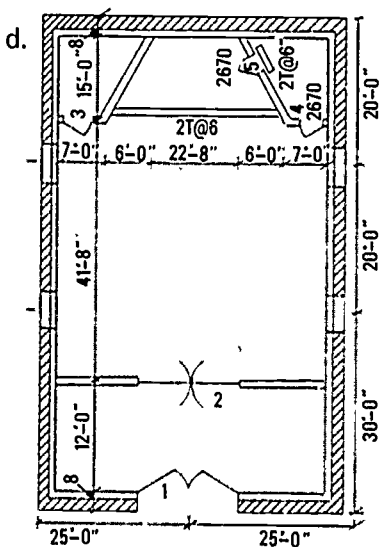
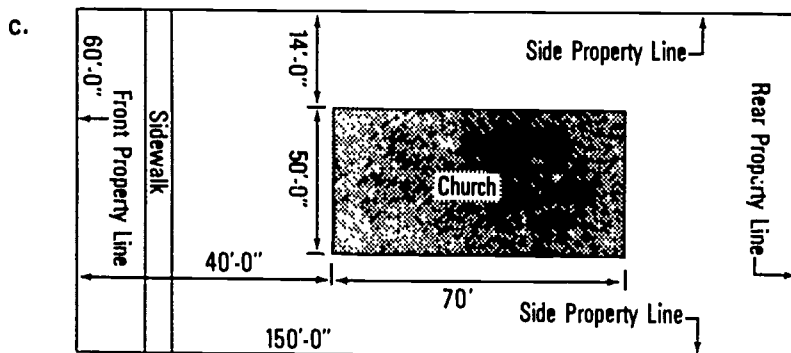
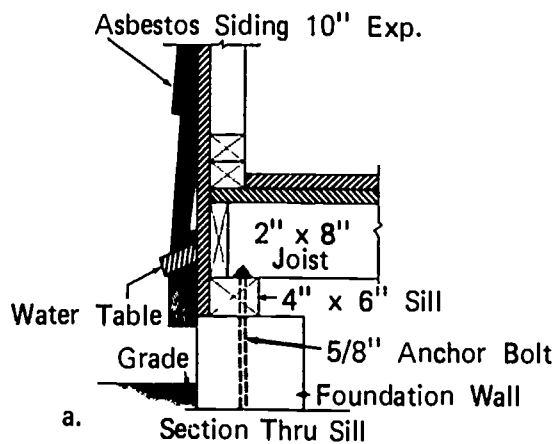

3. Identify the types of lines shown below.

- a. _____
- b. _____
- c. _____
- d. _____
- e. _____
- f. _____
- g. _____
- h. _____

4. Match the name of the drawing symbols to the pictures of the symbols.

a. Floor plan

- | | | |
|-----------|--|---|
| _____ 1) | | a) Brick veneer |
| _____ 2) | | b) Arch-Cased opening |
| _____ 3) | | c) Casement window |
| _____ 4) | | d) Cinders |
| _____ 5) | | e) Earth |
| _____ 6) | | f) Gravel |
| _____ 7) | | g) Double-hung window |
| _____ 8) | | h) Telephone outlet |
| _____ 9) | | i) Structural steel or iron |
| _____ 10) | | j) Insulation |
| _____ 11) | | k) Flashing, termite barrier, waterproofing |
| _____ 12) | | l) Tile-Hollow, Terra-Cotta |
| _____ 13) | | m) Outside door |
| _____ 14) | | n) Inside door |
| _____ 15) | | o) Double-acting door |
| _____ 16) | | |

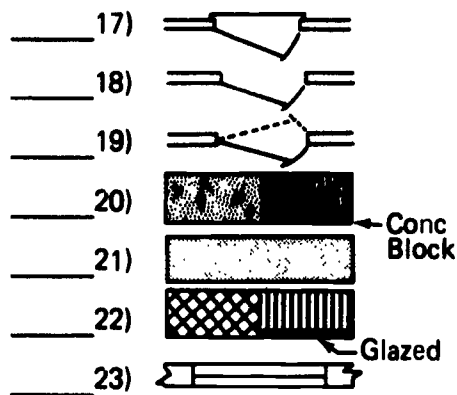

- p) Wood (rough)
- q) Wood (finished)
- r) Brick
- s) Firebrick
- t) Concrete
- u) Sand, plaster, cement, gypsum board
- v) Floor drain
- w) Glass

b. Electrical

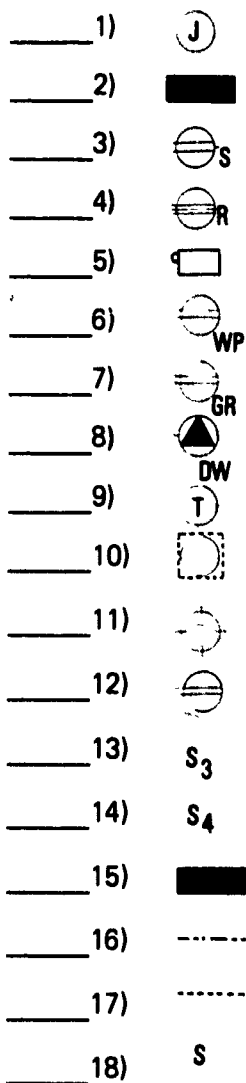

- a) Low-voltage relay system wiring
- b) Switch leg indication; connects outlets with control points
- c) Single-pole switch
- d) Junction box
- e) Service panel
- f) Combination switch and convenience outlet
- g) Range outlet
- h) Bell
- i) Distribution panel
- j) Weatherproof convenience outlet
- k) Duplex convenience outlet for grounding-type plugs
- l) Special-purpose outlet; use subscript letters to indicate function; WH-Water heater, D.F.-Drinking fountain, etc.
- m) Duplex convenience outlet

- n) Three-way switch
- o) Four-way switch
- p) Bell-ringing transformer
- q) Ceiling lighting outlet for recessed fixture (Outline shows shape of fixture.)
- r) Lighting outlet

c. Sectional

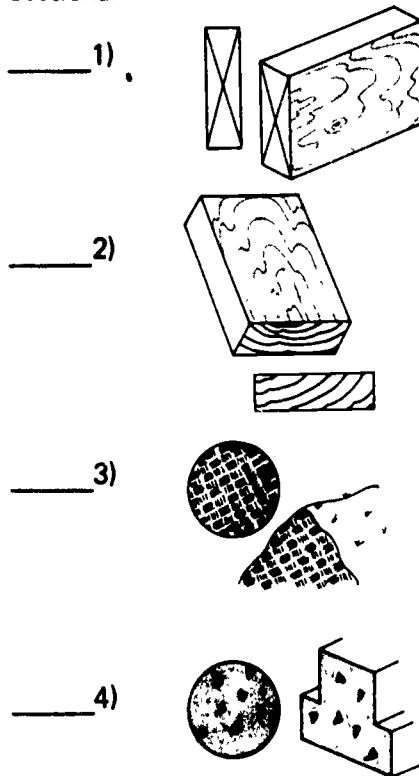





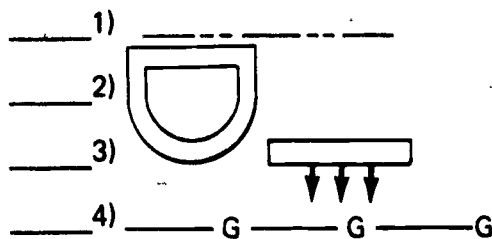







- a) Earth
- b) Concrete
- c) Rough lumber
- d) Finished lumber

d. Mechanical

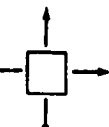

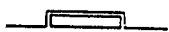
- a) Supply duct section
- b) Exhaust, return, or outside air duct section
- c) Supply outlet; ceiling diffuser

- | | | |
|-----------|---|------------------------------------|
| 5) _____ | _____ | d) Supply outlet; ceiling diffuser |
| 6) _____ | _____ | e) Linear diffuser |
| 7) _____ |  | f) Recessed radiator |
| 8) _____ |  | g) Enclosed radiator |
| 9) _____ |  | h) Unit heater |
| 10) _____ |  | i) Louver opening |
| 11) _____ |  | j) Intake louvers |
| 12) _____ |  | k) Water heater |
| 13) _____ |  | l) Water closet |
| 14) _____ |  | m) Wash fountain |
| 15) _____ |  | n) Lavatory |
| 16) _____ |  | o) Cold water |
| 17) _____ |  | p) Hot water |
| 18) _____ |  | q) Fire line |
| 19) _____ | | r) Gas-low pressure |
| | | s) Vent |

5. Read the measurements at the following scales.

a. _____

b. _____

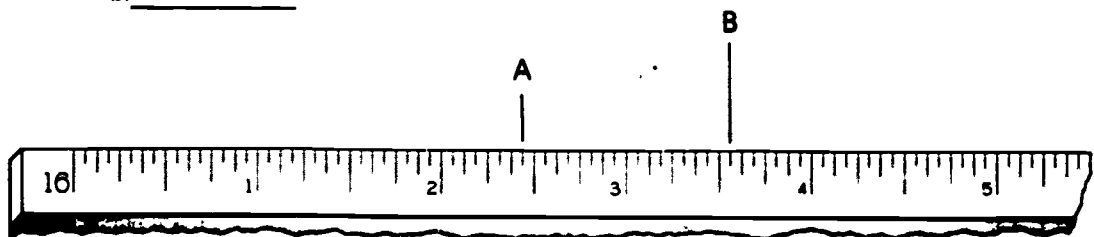

Full Scale (12" = 12")

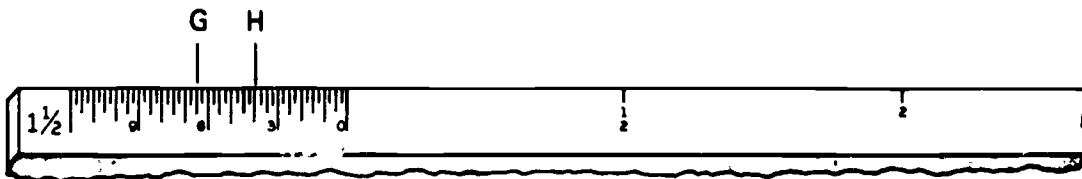
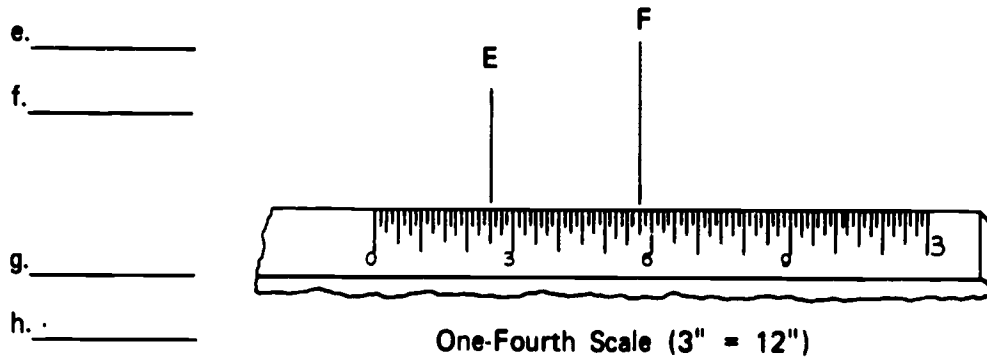
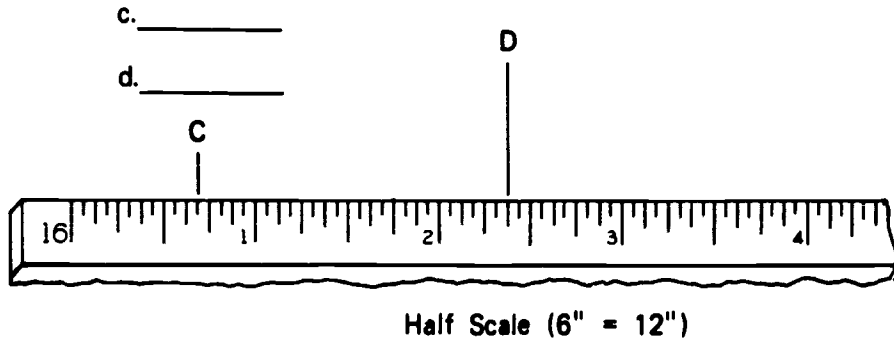

6. List eleven major items that are included in a set of specifications.

- a.
- b.
- c.
- d.
- e.
- f.
- g.
- h.
- i.
- j.
- k.

7. From the floor plan and schedules attached on the following pages, extract the following information.

a. Front entrance door specifications

- 1) Size
- 2) Material
- 3) ~~Design~~ Design
- 4) Hardware
- 5) Head
- 6) Jamb
- 7) Sill
- 8) Remarks

b. Hardware by set number

- 1) Set 1
 - a.
 - b.
 - c.
 - d.
- 2) Set 2
 - a.
 - b.
 - c.
 - d.
 - e.
 - f.
- 3) Set 3
 - a)
 - b)
 - c)

a. Door Schedule

No.	Size	Material	Design	Hardware	Head	Jamb	Sill	Remarks
101	3070x1¾ Pr	Oak	A	2	3/9	4/9	10/9	Threshold
102	3070x1¾ Pr	Oak	A	1	3/9	4/9	11/9	
103	2668x1½	Oak	B	3	3/9	4/9	11/9	
104	2668x1½	Oak	B	3	3/9	4/9	12/9	
105	2068x1½	Oak	B	3	3/9	4/9	12/9	

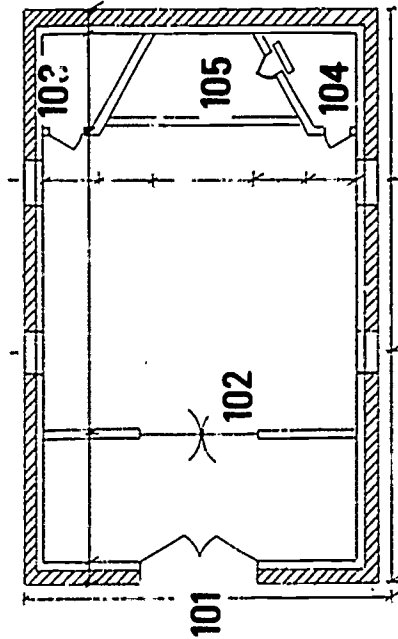

Door Schedule

b. Schedule of hardware

<u>Door No.</u>	<u>Hardware Set</u>	<u>Owners Number</u>
101	2	1
102	1	2
103	3	3
104	3	4
105	3	5

1) Set 1--Pr of D.A. vestibule to chapel

2 pr.	Spring hinges	3029 USP--8"
1	Exten. flush bolt	C457B10 x 12"
4	Floor stops	446B10
4	Push plate	39--6 x 16--US10

2) Set 2--Pair exterior to vestibule

3 pr.	Butts	BB1193--US10--4 1/2 x 4 1/2 NRP
2	Door closers	C--RA x DB
1 set	Exit device	8827 x 8858EO x US10
1	Threshold	3151-A
1 set	Weather strip	332AR (top and sides)
1 pr.	Astragal	305BN

3) Set 3--Storage to chapel

1 1/2 pr.	Butts	1279-US10--4 x 4
1	Lockset	HCE-131DL x US10
1	Door closer	C-RA x DB

BLUEPRINT READING
UNIT I

ANSWERS TO TEST

1.
 - a. 11
 - b. 5
 - c. 12
 - d. 13
 - e. 15
 - f. 3
 - g. 6
 - h. 1
 - i. 7
 - j. 9
 - k. 2
 - l. 8
 - m. 4
 - n. 10
 - o. 14
 - p. 16
2.
 - a. Details
 - b. Front elevation
 - c. Plot plan .
 - d. Floor plan
 - e. Foundation plan
3.
 - a. Object line
 - b. Dimension line

- c. Extension line
- d. Hidden line
- e. Center line
- f. Section line
- g. Break lines
- h. Leader

- 4. a. 1) d
- 2) e
- 3) f
- 4) i
- 5) b
- 6) c
- 7) g
- 8) j
- 9) k
- 10) a
- 11) h
- 12) v
- 13) p
- 14) q
- 15) r
- 16) s
- 17) m
- 18) n
- 19) o
- 20) t

- 21) u
22) l
23) w
- b. 1) d
2) e
3) f
4) g
5) h
6) j
7) k
8) l
9) p
10) q
11) r
12) m
13) n
14) o
15) i
16) a
17) b
18) c
- c. 1) c
2) d
3) a
4) b
- d. 1) p
2) n

- 3) e
- 4) r
- 5) s
- 6) o
- 7) l
- 8) j
- 9) m
- 10) k
- 11) q
- 12) c or d
- 13) g
- 14) b
- 15) h
- 16) d or c
- 17) i
- 18) f
- 19) a

- 5. a. $2 \frac{7}{16}$ "
- b. $3 \frac{9}{16}$ "
- c. $1 \frac{3}{8}$ "
- d. $4 \frac{3}{4}$ "
- e. $2 \frac{1}{2}$ "
- f. $5 \frac{3}{4}$ "
- g. $6 \frac{1}{2}$ "
- h. 4"

- 6. a. Sizes
- b. Types and quality of building materials
- c. Methods of construction

- d. General requirements
 - e. Owner's name and address
 - f. Architect's name and address
 - g. Location of new structure
 - h. Completion date
 - i. Contractor's bid form
 - j. Guarantees
 - k. Insurance requirements
7. a. 1) Size--3070 x 1 3/4" pr.
- 2) Material--Oak
- 3) Design--A'
- 4) Hardware--2
- 5) Head--3/9
- 6) Jamb--4/9
- 7) Sill--10/9
- 8) Remarks--Threshold
- b. 1) Set 1
- | | | | |
|----|-------|-------------------|--------------------|
| a. | 2 pr. | Spring hinges | 3029 USP - 8" |
| b. | 1 | Exten. Flush bolt | C457B10 x 12" |
| c. | 4 | Floor stops | 446B10 |
| d. | 4 | Push plate | 39 - 6 x 16 - US10 |
- 2) Set 2
- | | | | |
|----|-------|--------------|--------------------------------------|
| a. | 3 pr. | Butts | BB1193 - US10 -
4 1/2 x 4 1/2 NRP |
| b. | 2 | Door closers | C - RA x DB |
| c. | 1 set | Exit device | 8827 x 8858ED x US10 |
| d. | 1 | Threshold | 3151 - A |

- e. 1 set Weather strip 332AR (top and sides)
 - f. 1 pr. Astragal 305 BN
- 3) Set 3
- a. 1 1/2 pr. Butts 1279 - US10 - 4 x 4
 - b. 1 Lockset HCE - 121DL x US10
 - c. 1 Door closer C - RA x DB

Carpentry

PROGRESS CHART

2027

Section E
Blueprint Reading

Student's Name	Unit I Blueprint Reading								Job	Unit Test
	1	2	3	4	5	6	7	8		
1										
2										
3										
4										
5										
6										
7										
8										
9										
10										

3

4

5

6

7

8

9

10

11

12

13

14

15

16

17

18

19

20

8672

Accuracy
85% Correct

SITE PREPARATION UNIT I

TERMINAL OBJECTIVE

After completion of this unit, the student should be able to define terms associated with site preparation. He should be able to identify service locations from a plot plan, use this information in planning the location of a building on a site, and shoot grade with a builder's level. This knowledge will be evidenced through demonstration and by scoring eighty-five percent on the unit test.

SPECIFIC OBJECTIVES

After completion of this unit, the student should be able to:

1. Match terms associated with site preparation to a list of definitions.
2. List three factors that affect the location of a building on a site.
3. Identify the parts of the builder's level.
4. Distinguish between the vertical cross hair and the horizontal cross hair on the builder's level.
5. Identify the parts of the leveling rod.
6. Name four common errors that contribute to incorrect measurement.
7. List six rules to follow in providing care of the level.
8. Demonstrate the ability to:
 - a. Set up and adjust the builder's level.
 - b. Read the leveling rod.
 - c. Perform different types of leveling jobs selected by the instructor.

SITE PREPARATION UNIT I

SUGGESTED ACTIVITIES

- I. Instructor:
 - A. Provide students with objective sheet.
 - B. Provide students with information, assignment, and job sheets.
 - C. Make transparencies.
 - D. Discuss terminal and specific objectives.
 - E. Discuss information and assignment sheets.
 - F. Demonstrate and discuss procedures outlined in the job sheet.
 - G. Give test.
- II. Student:
 - A. Read objective sheet.
 - B. Study information sheet.
 - C. Complete assignment sheet.
 - D. Demonstrate the ability to accomplish the procedures outlined in the job sheet.
 - E. Take test.

INSTRUCTIONAL MATERIALS

- I. Included in this unit:
 - A. Objective sheet
 - B. Information sheet
 - C. Transparency masters
 1. TM 1--Parts of the Builder's Level
 2. TM 2--Self Reading Rods
 3. TM 3--Parts of the Leveling Rod
 4. TM 4--Reading the Rod

- D. Assignment Sheet #1--Reading the Self-Reading Rod
- E. Answers to assignment sheet
- F. Job Sheet #1--Set Up and Adjust the Builder's Level
- G. Test
- H. Answers to test

II. References:

- A. Burke, Arthur E., Ralph Dalzell, and Gilbert Townsend. *Architectural and Building Trades Dictionary*. Chicago, Illinois: American Technical Society, 1955.
- B. Durbahn, Walter E. and Elmer W. Sundberg. *Fundamentals of Carpentry*. Third Edition. Chicago, Illinois: American Technical Society, 1963.
- C. Hepler, Donald E. and Paul L. Wallach. *Architectural Drafting and Design*. New York: McGraw-Hill, 1953.
- D. Lair, E. A. *Carpentry For the Building Trades*. New York: McGraw-Hill, 1953.
- E. Smith, Ronald C. *Principles and Practices of Heavy Construction*. New Jersey: Prentice Hall, 1970.

SITE PREPARATION
UNIT I

INFORMATION SHEET

I. Terms and definitions

- A. Bench mark--A metal or stone marker placed in the ground by a surveyor with the elevation indicated on it; this is the reference point for determining grades and elevations in the area

(NOTE: The curb is sometimes used.)

- B. Building permit--An agreement between the builder and a city that specifies the type, quality, and extent of construction to be done
- C. Builder's level--An instrument consisting of a telescope, leveling bubble, and tripod used primarily for establishing grade levels
- D. Excavate--To remove soil for a footing or to establish a uniform grade
- E. Fall--Pertaining to the slope of a line such as inches of fall per foot of run

Example: 1" fall per 1' of run

- F. Fill--Soil or other substance used to raise the grade level
- G. Grade line--The level of the ground at the building line
- H. Grade stake--A stake driven into the ground that locates the finished level of the ground at that point

(NOTE: Read from the bench mark.)

- I. Leveling rod--A rod used in leveling with the builder's level and usually graduated in tenths and hundredths of a foot
- J. Site--A plot of ground on which a building is to be erected

II. Factors that affect the location of a building on a site

A. Ordinances

1. Distance from street
2. Distance from rear property line
3. Distance from side property lines

INFORMATION SHEET

B. Services

1. Electricity--Location of service entrance
2. Sewer
 - a. Location
 - b. Depth of sewer line in relation to grade level
3. Gas--Distance to service entrance

C. Contour of land

1. Flat
2. Rolling
3. Sloping

III. Parts of the builder's level (Transparency 1)

- A. Eye piece
- B. Focusing screw
- C. Sun shade
- D. Leveling bubble
- E. Clamp
- F. Slow motion screw
- G. Leveling head
- H. Headplate
- I. Leveling screw
- J. Tripod
- K. Leg thumb nuts
- L. Telescope barrel

INFORMATION SHEET

- IV. Cross hairs on the level
 - A. Vertical--Indicates direction
 - B. Horizontal--Indicates flat plane
 - C. Cross of the two--Designates line of sight
- V. Parts of the leveling rod (Transparencies 2, 3, and 4)
 - A. Target face--Red and white disc on rod used for certain types of readings
 - B. Target clamp--Holds the target in place
 - C. Vernier scale--Enables reading to the nearest thousandths of a foot
- VI. Common errors in measurement
 - A. Tape not pulled tight enough
 - B. Tape not in proper alignment
 - C. Plumb bob not used when measuring on a slope
 - D. Reading or recording wrong numbers
- VII. Care of the builder's level
 - A. Protect against shock and vibration during transport
 - B. Keep in box when not in use
 - C. Place lens and tripod cap in box after removing from instrument
 - D. Attach instrument to tripod securely and carefully before moving tripod
(NOTE: Never force screws or other moving parts of an instrument.)
 - E. Always use the sunshade regardless of the weather
 - F. Clean lens with soft tissue
(CAUTION: Do not clean with fingers or rough cloth and do not remove lenses.)

Parts of the Builder's Level

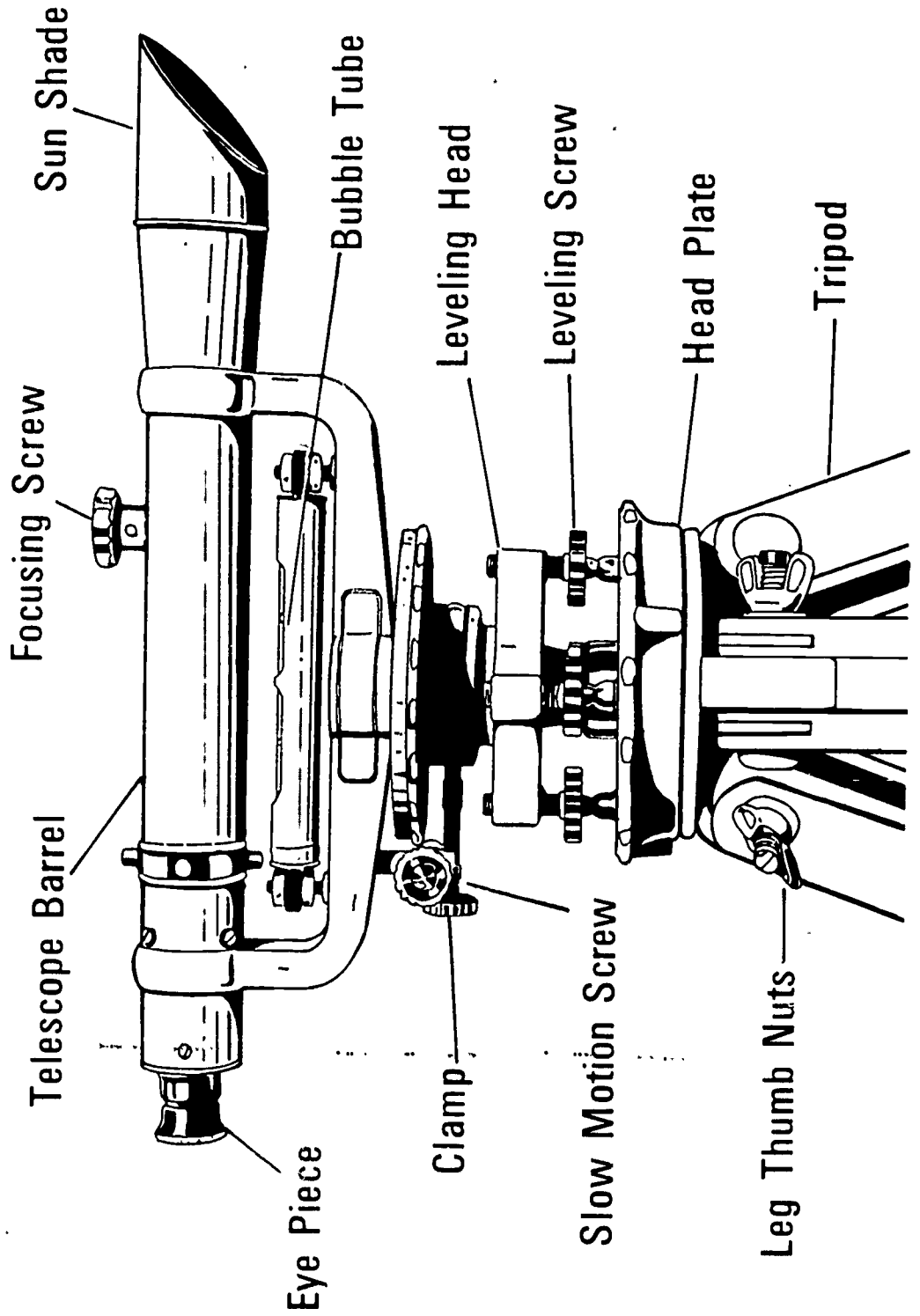

Self-Reading Rods

Direct
↓
Reading



Elevation
or
"Linker" Rod

Positive
↑
Reading



Philadelphia
or
"Philly" Rod

Parts of the Leveling Rod

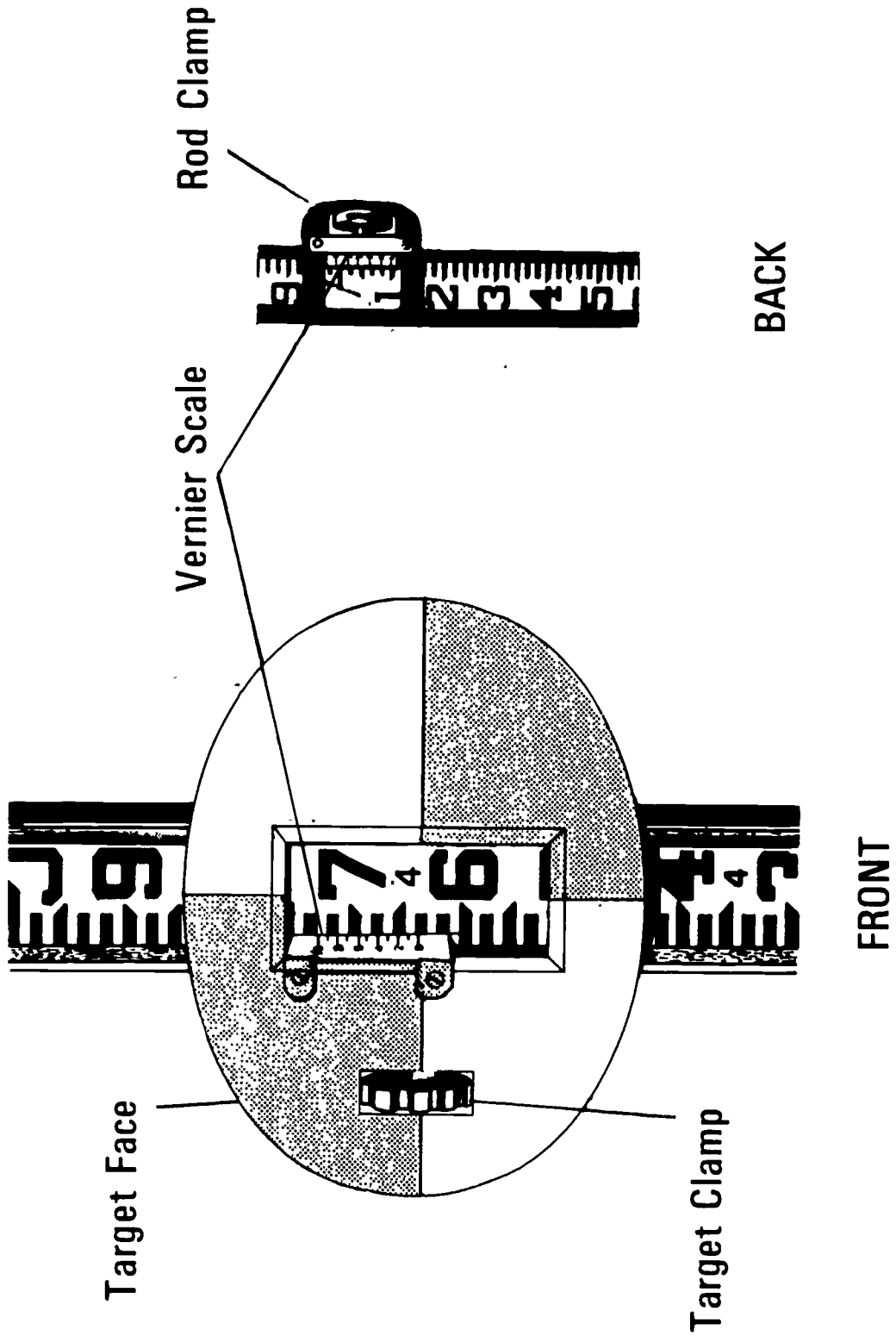

307

Reading the Rod

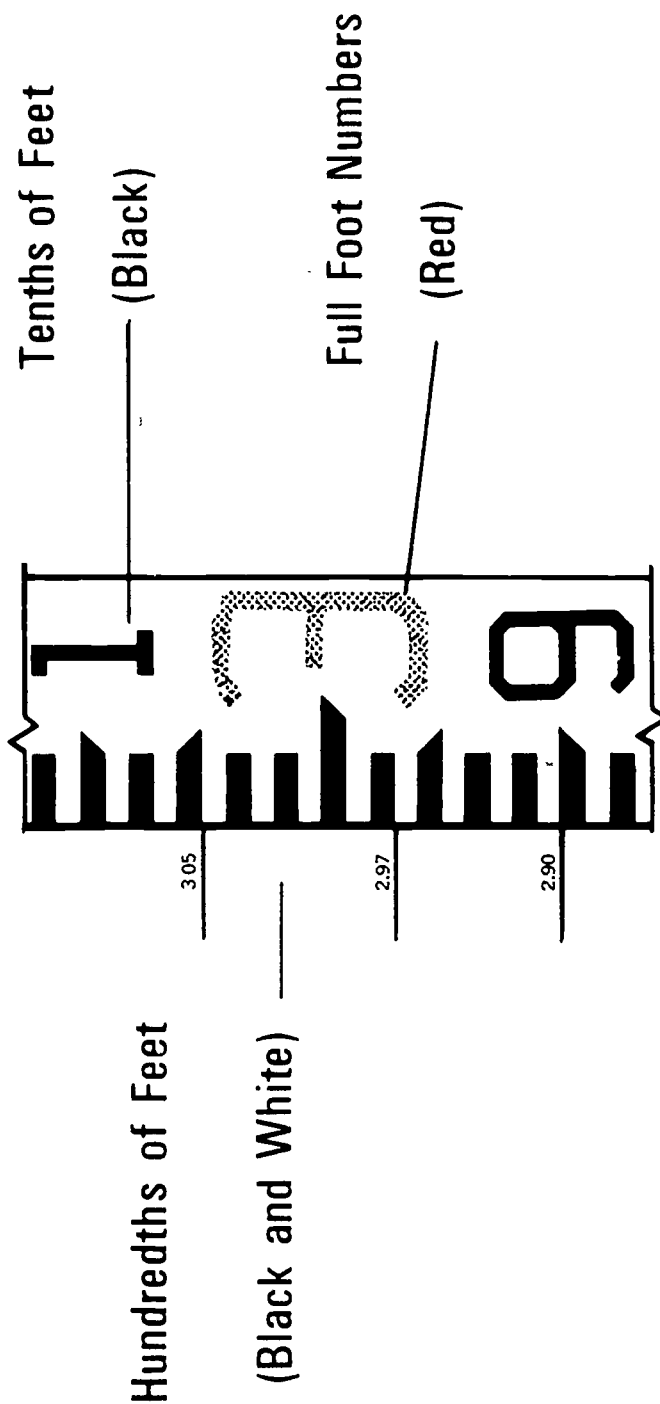

NOTE: Vernier scale reads thousandths of feet

SITE PREPARATION
UNIT I

ASSIGNMENT SHEET #1--READ THE SELF-READING ROD

Read each of the illustrations below and record your results in the blank provided.

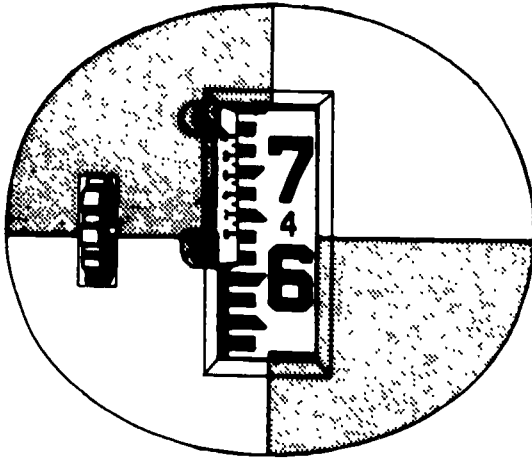

a. _____

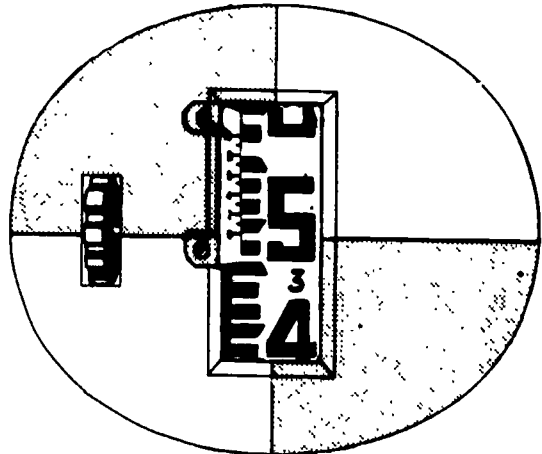

b. _____

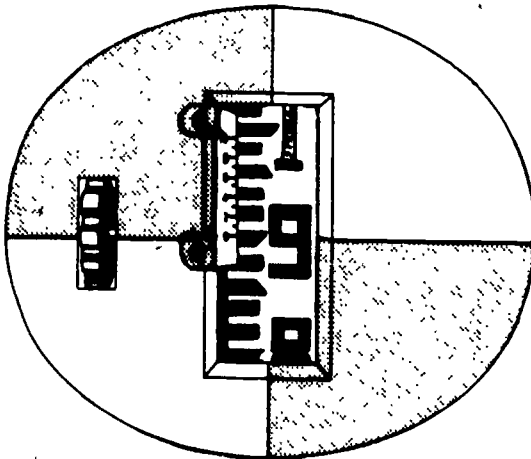

c. _____

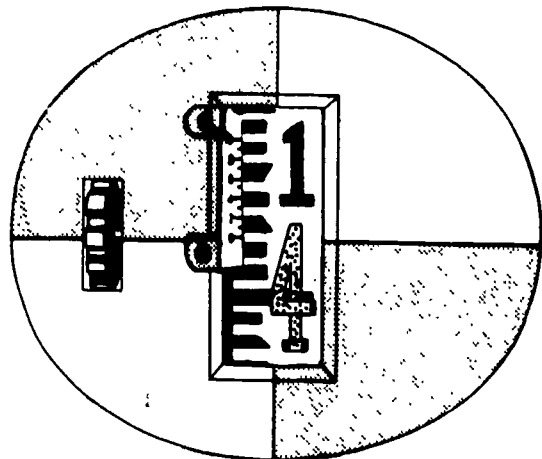

d. _____

SITE PREPARATION
UNIT I

ANSWERS TO ASSIGNMENT SHEET

1.
 - a. 4.64
 - b. 3.48
 - c. .90
 - d. 4.05

SITE PREPARATION
UNIT IJOB SHEET #1--SET UP AND ADJUST
THE BUILDER'S LEVEL

- I. Tools and equipment
 - A. Instrument
 - B. Tripod
- II. Procedures
 - A. Grasp the two legs of the tripod that are nearest you and set the leg shoes in the ground about three feet apart



- B. Swing third leg out to form a triangle
(NOTE: If the ground is not level, you may have to change position of tripod in order to keep headplate level.)
- C. Tighten leg thumb nuts
- D. Check headplate to see if it is level

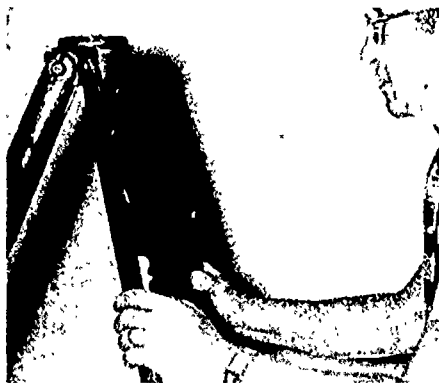

JOB SHEET #1

- E. Remove instrument from carrying case by lifting the level bar

(CAUTION: Never grasp the telescope barrel while removing instrument from carrying case.)



- F. Attach instrument to headplate by screwing it down

(CAUTION: Keep a firm grip on instrument until it is securely in position on tripod.)



- G. Remove dust cap from front lens

(NOTE: The dust cap should be kept in place in order to protect the lens from dust or scratches.)

- H. Attach sun shade to the instrument

- I. Align telescope barrel directly over one pair of leveling screws

(NOTE: The leveling screws will be used just as the name indicates to level the instrument.)

JOB SHEET #1



- J. By rotating screws under the barrel, bring bubble to the center of the leveling tube

(NOTE: Move your thumbs in opposite directions.)



- K. Check bubble to see if centered
- L. Turn instrument clockwise through 90 degrees to align with the other pair of leveling screws



JOB SHEET #1

- M. Bring bubble to center of marks by rotating leveling screws
- N. Turn instrument clockwise through 90 degrees to bring it parallel with first pair of leveling screws
- O. Again center bubble
- P. Turn instrument clockwise through 90 degrees to bring it parallel with second pair of leveling screws
- Q. Again center bubble

(NOTE: Bubble should stay in center regardless of what direction the telescope is pointing.)

- R. Focus cross hairs so that they appear sharp and clear

(NOTE: Focusing is accomplished by looking through the eye piece and by turning the eye piece ring until the cross hairs become sharp and clear.)

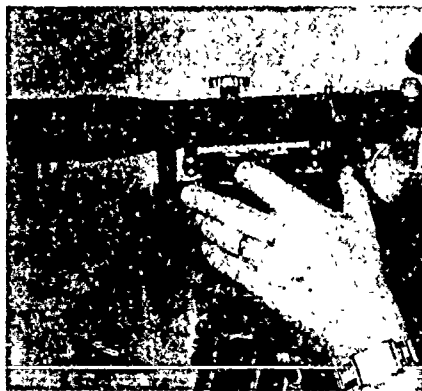

- S. Cross hairs should now be focused, but the target may not be in focus
- T. By rotating the focus screw, bring target into sharp focus

(NOTE: When cross hairs and target are in sharp focus, you should be able to read a rod accurately.)



SITE PREPARATION
UNIT I

TEST

1. Match the terms associated with site preparation to the list of definitions.

- | | |
|---|--------------------|
| _____ a. A rod used in leveling with the builder's level and usually graduated in tenths and hundredths of a foot | 1. Bench mark |
| _____ b. A plot of ground on which a building is to be erected | 2. Building permit |
| _____ c. An instrument consisting of a telescope, leveling bubble, and tripod used primarily for establishing grade levels | 3. Builder's level |
| _____ d. Pertaining to the slope of a line such as inches of fall per foot of run | 4. Excavate |
| _____ e. Soil or other substance used to raise the grade level | 5. Fall |
| _____ f. A metal or stone marker placed in the ground by a surveyor with the elevation indicated on it; this is the reference point for determining grades and elevations in the area | 6. Fill |
| _____ g. To remove soil for a footing or to establish a uniform grade | 7. Grade line |
| _____ h. The level of the ground at the building line | 8. Grade stake |
| _____ i. An agreement between the builder and a city that specifies the type, quality, and extent of construction to be done | 9. Leveling rod |
| _____ j. A stake driven into the ground that locates the finished level of the ground at that point | 10. Site |

2. List three factors that affect the location of a building on a site.

a. _____

b. _____

c. _____

3. Identify the parts of the builder's level.

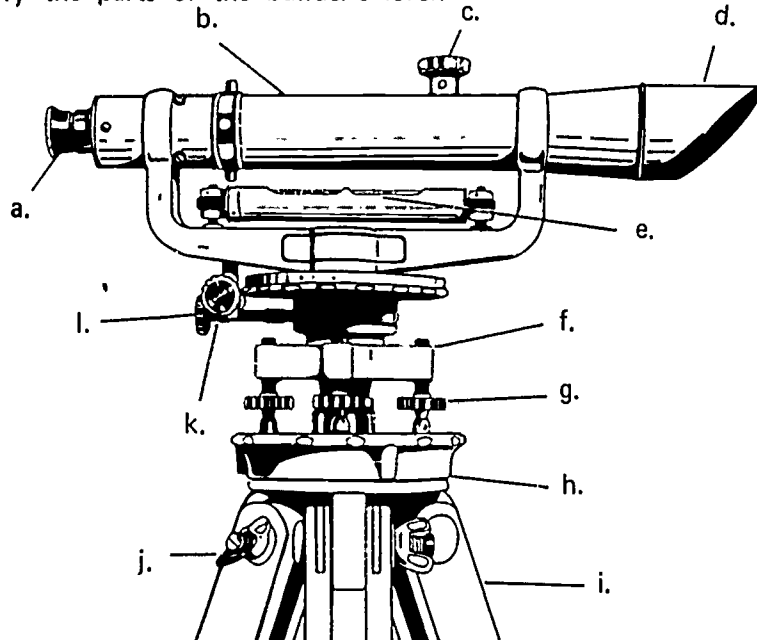

a.

b.

c.

d.

e.

f.

g.

h.

i.

j.

k.

l.

4. Using the drawing below, place an "X" on the line which indicates the vertical cross hair.

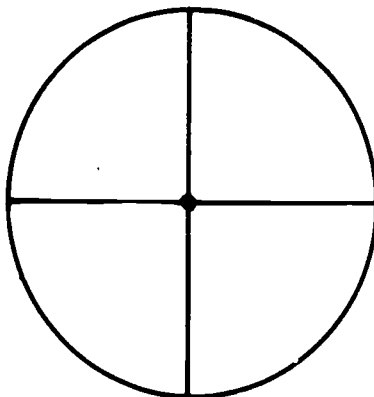

5. Identify the parts of the leveling rod.

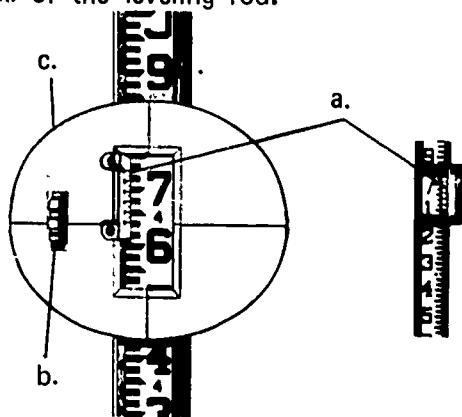

- a.
b.
c.
6. Name four common errors that contribute to incorrect measurement.
- a.
b.
c.
d.
7. Name six rules to follow in providing care of the level.
- a.
b.
c.
d.
e.

8. What are the readings on the drawings below?

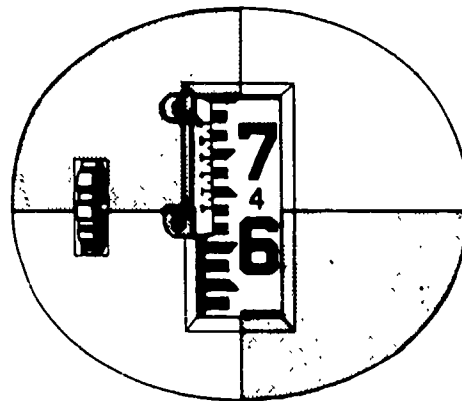
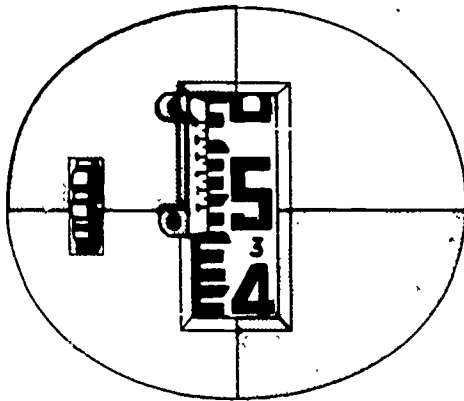

a. _____ b. _____

9. Demonstrate the ability to:

- a. Set up and adjust the builder's level.
- b. Read the leveling rod.
- c. Perform different types of leveling jobs selected by the instructor.

(NOTE: If this has not been accomplished prior to the test, ask the instructor when the above activities should be completed.)

SITE PREPARATION
UNIT I

ANSWERS TO TEST

1.
 - a. 9
 - b. 10
 - c. 3
 - d. 5
 - e. 6
 - f. 1
 - g. 4
 - h. 7
 - i. 2
 - j. 8
2.
 - a. Ordinances
 - b. Services
 - c. Contour of land
3.
 - a. Eye piece
 - b. Telescope barrel
 - c. Focusing screw
 - d. Sun shade
 - e. Bubble tube
 - f. Leveling head
 - g. Leveling screw
 - h. Headplate
 - i. Tripod

- j. Leg thumb screw
 - k. Slow motion screw
 - l. Clamp
- 4.

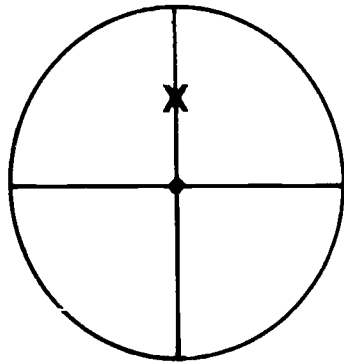

- 5.
 - a. Vernier scale
 - b. Target clamp
 - c. Target face
- 6.
 - a. Tape not pulled tight enough
 - b. Tape not in proper alignment
 - c. Plumb bob not used when measuring on a slope
 - d. Reading or recording wrong numbers
- 7.
 - a. Protect against shock and vibration during transport
 - b. Keep in box when not in use
 - c. Place lens and tripod cap in box after removing from instrument
 - d. Attach instrument to tripod securely and carefully before moving tripod
 - e. Always use the sunshade regardless of the weather
 - f. Clean lens with soft tissue
- 8.
 - a. 3.48
 - b. 4.64
- 9. Performance skills will be evaluated to the satisfaction of the instructor.

SITE LAYOUT UNIT II

TERMINAL OBJECTIVE

After completion of this unit, the student should be able to define terms associated with site layout and list factors that affect the layout. He should also be able to locate building lines from available datum, erect batter boards, and layout and square a building. This knowledge will be evidenced through demonstration and by scoring eighty-five percent on the unit test.

SPECIFIC OBJECTIVES

After completion of this unit, the student should be able to:

1. Match eight layout terms to their definitions.
2. List four factors that are pertinent to the site layout.
3. Locate the building lines on a plot plan from a set of datum.
4. Describe two methods for squaring a corner.
5. State the purpose of batter boards.
6. Demonstrate the ability to:
 - a. Erect batter boards.
 - b. Lay out a building using batter boards.
 - c. Square a building layout.
 - 1) Using the 3-4-5 rule or a multiple thereof.
 - 2) Using the diagonal method.

SITE LAYOUT
UNIT II

SUGGESTED ACTIVITIES

- I. Instructor:
 - A. Provide students with objective sheet.
 - B. Provide students with information, assignment, and job sheets.
 - C. Make transparencies.
 - D. Discuss terminal and specific objectives.
 - E. Discuss information and assignment sheets.
 - F. Demonstrate and discuss procedures outlined in the job sheet.
 - G. Give test.
- II. Student:
 - A. Read objective sheet.
 - B. Study information sheet.
 - C. Complete assignment sheet.
 - D. Demonstrate the ability to accomplish the procedures outlined in the job sheet.
 - E. Take test.

INSTRUCTIONAL MATERIALS

- I. Included in this unit:
 - A. Objective sheet
 - B. Information sheet
 - C. Transparency masters
 1. TM 1--Plot Plan
 2. TM 2--Squaring a Building
 3. TM 3--Batter Boards
 - D. Assignment Sheet #1--Building Layout

- E. Answers to assignment sheet
- F. Job Sheet #1--Erect Batter Boards and Locate Building Lines
- G. Test
- H. Answers to test

II. References:

- A. Burke, Arthur E., Ralph J. Dalzell, and Gilbert Townsend. *Architectural and Building Trades Dictionary*. Chicago, Illinois: American Technical Society, 1955.
- B. Durbahn, Walter E. and Elmer W. Sundberg. *Fundamentals of Carpentry*, Third Edition. Chicago, Illinois: American Technical Society, 1963.
- C. Lair, E. A. *Carpentry for the Building Trades*. St. Louis, Missouri: McGraw-Hill, 1953.
- D. Smith, Ronald C. *Principals and Practices of Heavy Construction*. New Jersey: Prentice Hall, 1970.

323

SITE LAYOUT
UNIT II

INFORMATION SHEET

- I. Terms and definitions
 - A. Batter boards--A temporary framework used to assist in locating corners when laying out a foundation
 - B. Bench mark--A metal or stone marker placed in the ground by the surveyor with the elevation indicated on it

(NOTE: This is the reference point for determining grades and elevations in the area although the curb is sometimes used.)
 - C. Builder's level--An instrument consisting of a telescope, leveling bubble, and tripod used primarily for establishing grade levels
 - D. Datum--Information used as a basis for calculating or measuring
 - E. Excavating--Removing soil for a footing or to establish a uniform grade
 - F. Footing--An enlargement at the lower end of a foundation wall, pier, or column to distribute the load
 - G. Grade line--The level of the ground at the building line
 - H. Grade stake--A stake driven into the ground that locates the finished level of the ground at that point
 - I. Leveling rod--A graduated rod used with the builder's level in leveling

(NOTE: This rod is usually graduated in tenths and in hundredths of a foot.)
 - J. Property lines--The boundaries of a lot or plot of ground
 - K. Plot plan--A drawing used to show the location and size of all buildings, driveways, sidewalks, and patios on the lot
- II. Factors pertinent to site layout
 - A. Local regulations
 1. Set back from front property line
 2. Proximity to side property lines

INFORMATION SHEET

- B. Location of services
 - 1. Sewerage
 - 2. Electricity
 - 3. Gas
- C. Existing trees and shrubs
- D. The shape of the terrain
 - 1. Flat
 - 2. Rolling
 - 3. Sloping

III. Datum used in laying out building lines (Transparency 1)

- A. Dimensions of property
- B. Set-back
 - 1. From curb
 - 2. From sidewalk
 - 3. From property line
- C. Distance from side boundaries
- D. Distance from rear of property
- E. Easements
- F. Building size
 - 1. Length
 - 2. Width
- G. Grade and location of bench mark
- H. Orientation of building on lot
 - 1. Square
 - 2. Diagonal

L- 325

INFORMATION SHEET

IV. Methods of squaring a building (Transparency 2)

A. The 3-4-5 rule

(NOTE: Any multiple of the 3-4-5 rule may be used depending on the size of the building, such as: 6-8-10, 12-16-20, 24-32-40, etc.)

B. The diagonal method

V. Purpose of batter boards--To provide a place of attachment for the string or twine used to locate building lines during excavation and construction (Transparency 3)

Plot Plan

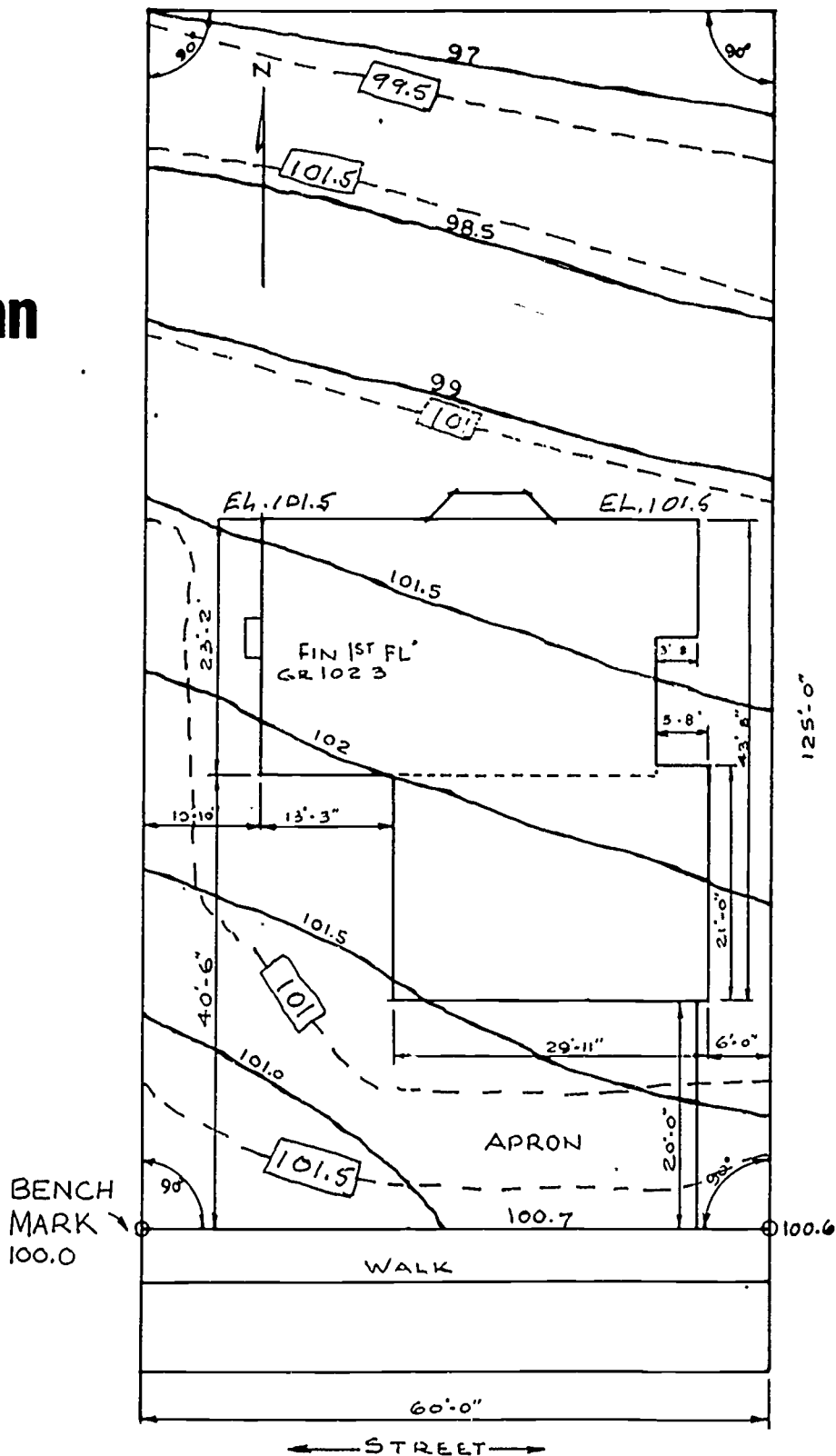

Existing Grade _____

Finish Grade _____

327

TM 1

Squaring a Building

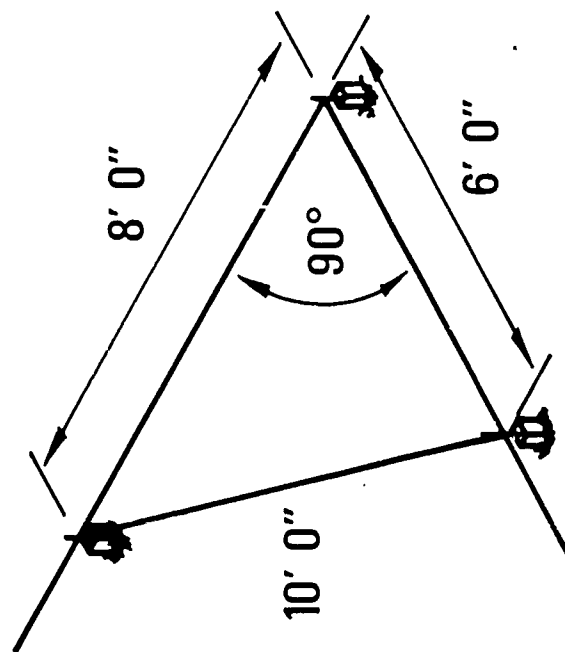

THE 3-4-5 RULE

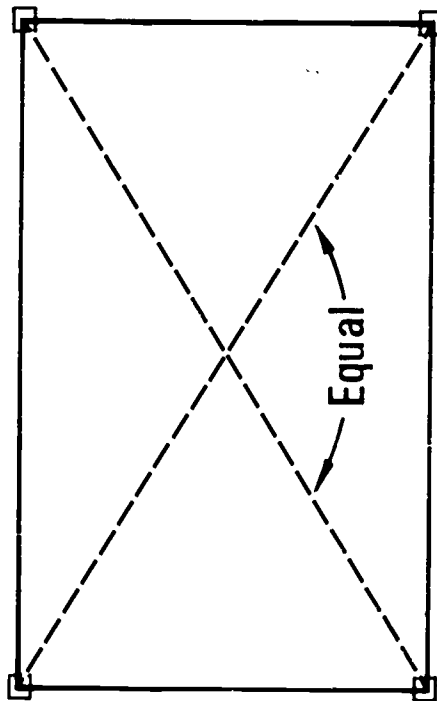

THE DIAGONAL METHOD

Batter Boards

SETTING UP BUILDING LINES

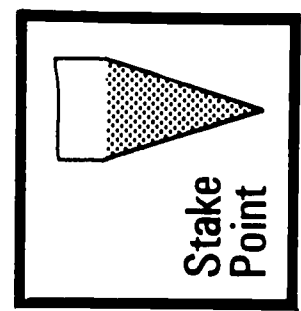
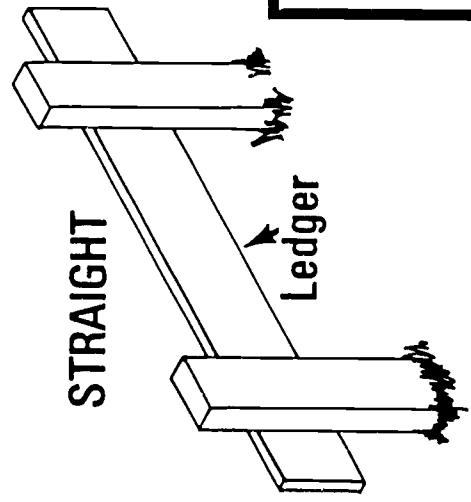
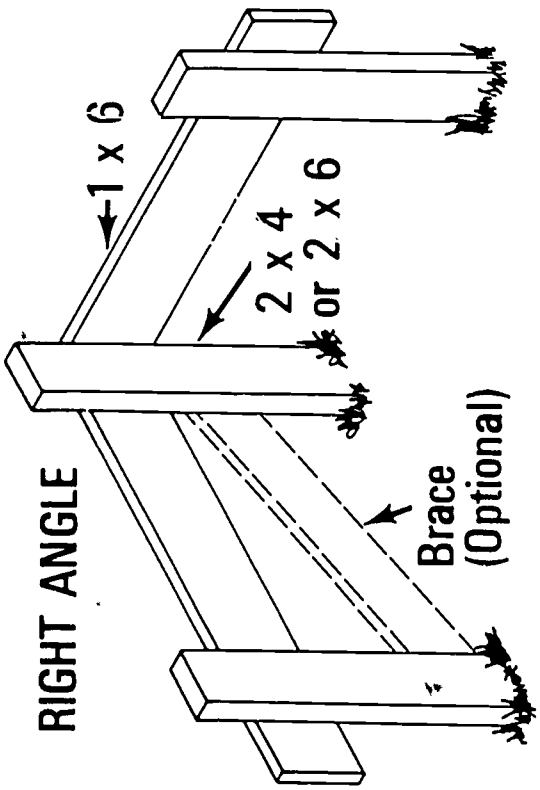
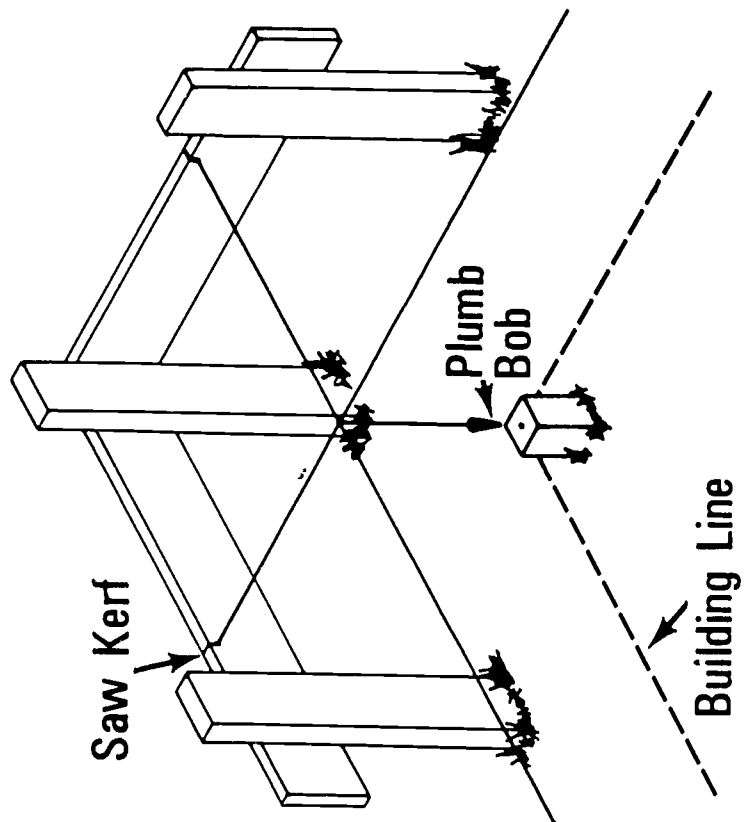

SITE LAYOUT
UNIT II

ASSIGNMENT SHEET #1--BUILDING LAYOUT

Using the following datum, locate the building lines of given dimensions on the plot using a scale of $1/32" = 1' 0"$.

1. Sidewalk (minimum)
 - a. 4' wide
 - b. 6' from curb
2. Building lines (minimum)
 - a. Front--30' from sidewalk
 - b. Sides--5'
 - c. Rear--30'
3. Easements--10' at rear for alley
4. Building size
 - a. Length 60'
 - b. Width 32'
5. Grade (minimum) at building line 101.0
6. Orientation--Front of building parallel to street and centered between side boundaries

ASSIGNMENT SHEET #1

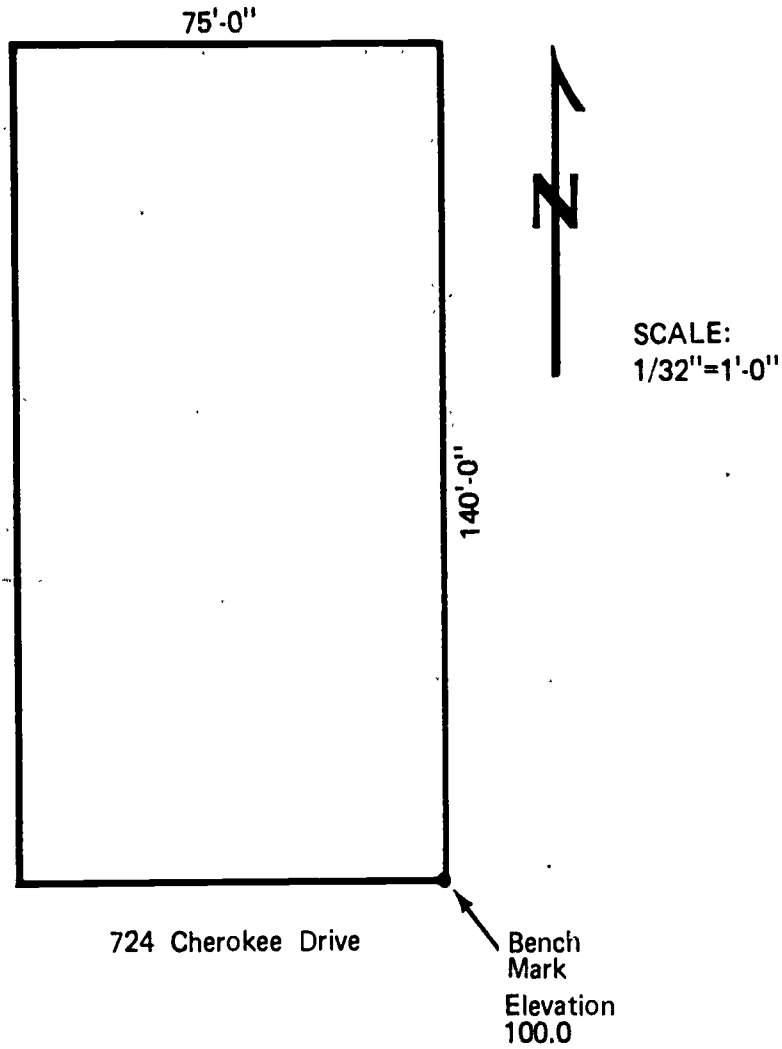

Use curb as
bench mark
at southeast
corner of
property.

SITE LAYOUT
UNIT II

ANSWERS TO ASSIGNMENT SHEET #1

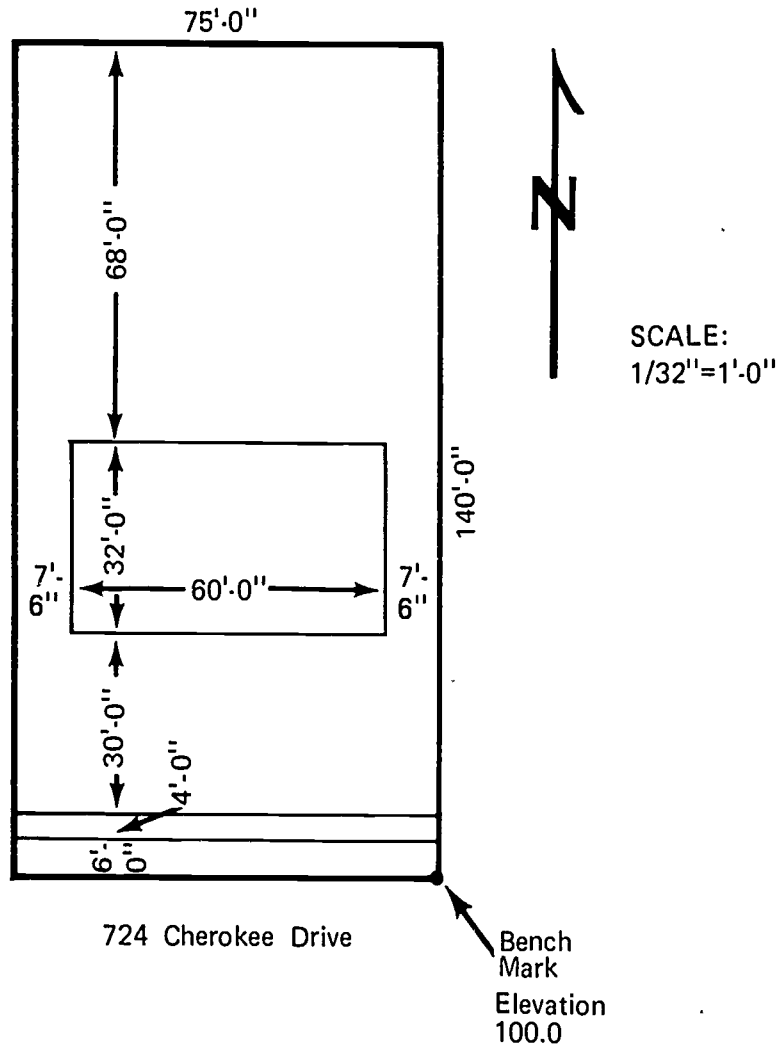

Use curb as
bench mark
at southeast
corner of
property.

SITE LAYOUT UNIT II

JOB SHEET #1--ERECT BATTER BOARDS AND LOCATE BUILDING LINES

I. Tools and materials needed

A. Tools

1. Sledge hammer
2. Claw hammer
3. Handsaw (crosscut)
4. Electric handsaw (if electricity is available on site)
5. Builder's level (if available)
6. Plumb bob
7. Heavy cord or twine

B. Materials

1. Batter board stakes 2" x 4" x 3'
2. Ledger boards 1" x 6" x 6'
3. Braces (if necessary) 1" x 4" x 6'
4. Nails 8d box
5. Corner stakes 2" x 2" x 1'

II. Procedure

A. Cut material to size

1. Batter board stakes (Figure 1)

FIGURE 1 1. Batter board stakes

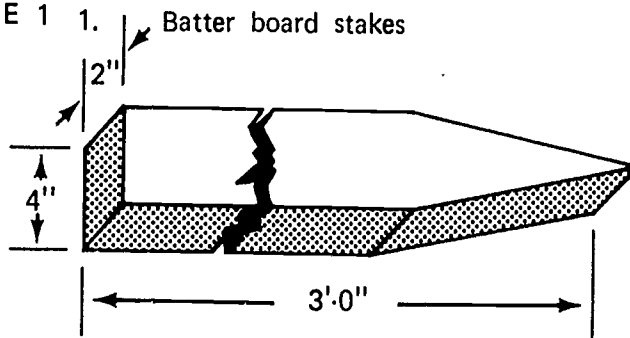

JOB SHEET #1

2. Ledger boards (Figure 2)

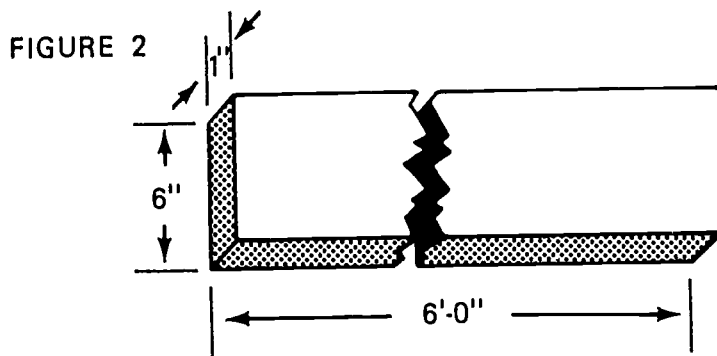

3. Braces (Figure 3)

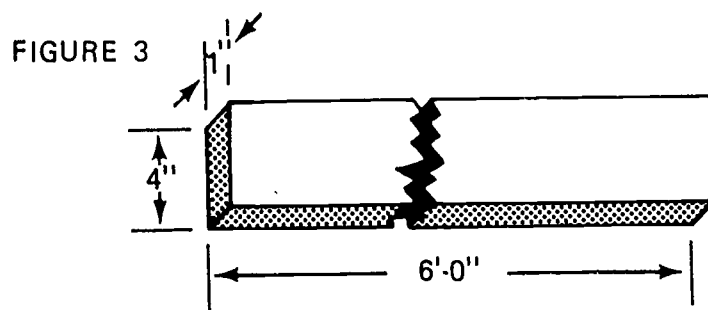

4. Corner stakes (Figure 4)

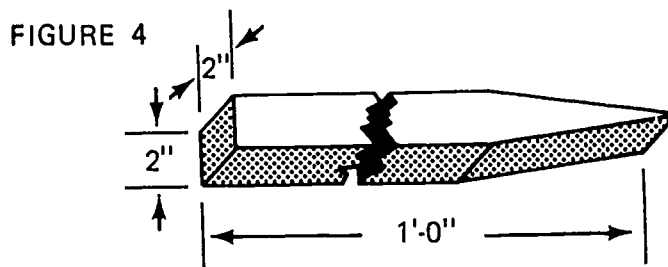

B. Locate property boundary markers

1. Stretch a string along all boundaries
2. Leave string in place until exact building lines have been located on batter boards

(NOTE: See Diagram A)

JOB SHEET #1

DIAGRAM A

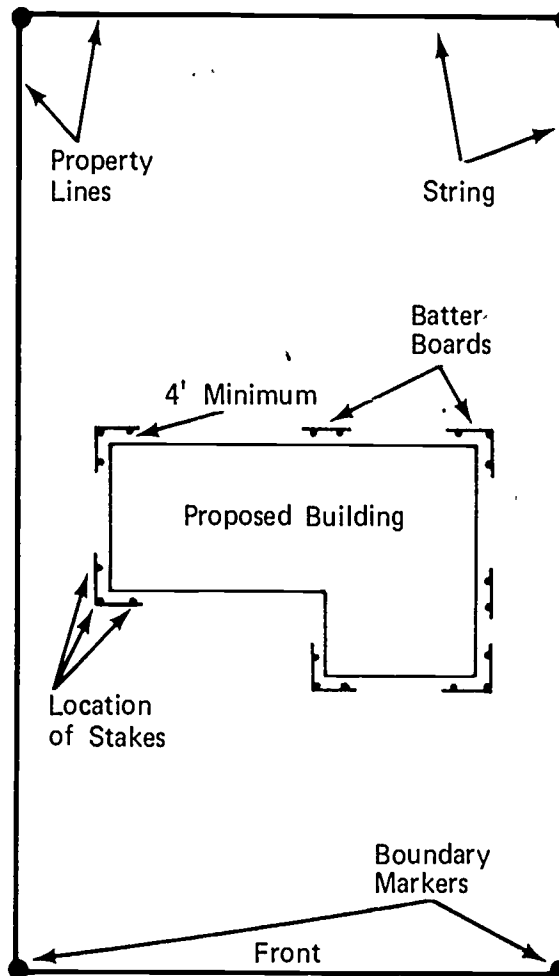

C. Locate approximate building lines on lot inside boundary lines

D. Erect batter boards

1. Drive batter board stakes at the corners of the building lines
 - a. Place stakes a minimum of four feet outside building lines

(NOTE: When setting batter board for large structures, set them back as far as possible, usually 20', to leave work room around the excavation for heavy equipment.)

JOB SHEET #1

- b. Use the builder's level to locate the top of all batter at the same elevation

(NOTE: Use the 2" x 4" x 3' stakes, see Diagram A.)

- 2. Attach ledger boards to stakes

(NOTE: Use the 1" x 6" x 6' boards, see Diagram B.)

DIAGRAM B

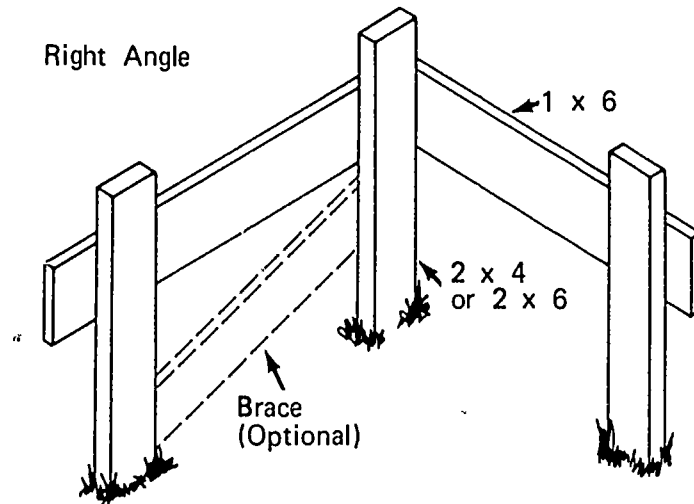

When the soil is loose or the stakes must be higher than 3 feet, braces should be used.

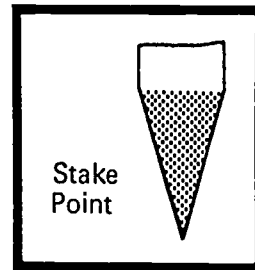
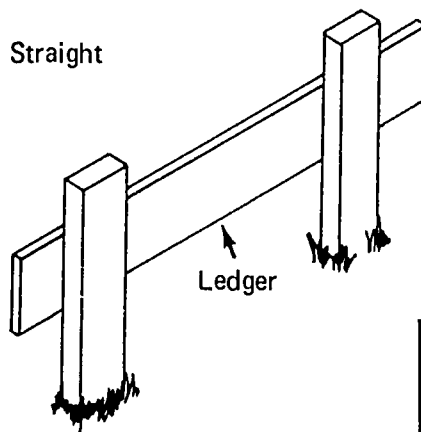

JOB SHEET #1

E. Locate building lines

1. Measure from property lines, as outlined by string, to the ledger boards and make a pencil mark on the ledger board

(NOTE: See Diagram C. Offset line hubs are sometimes set at line locations below the batter board.)

DIAGRAM C

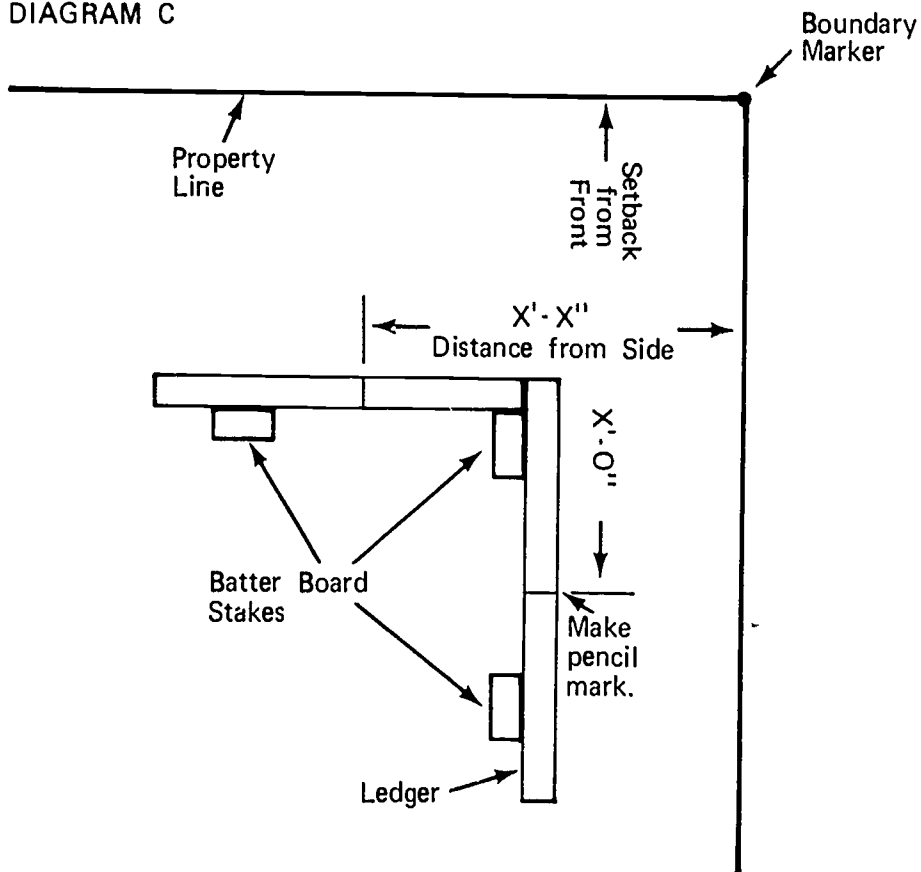

337

JOB SHEET #1

2. Attach string between points on ledger boards to locate building lines

(NOTE: See Diagram D.)

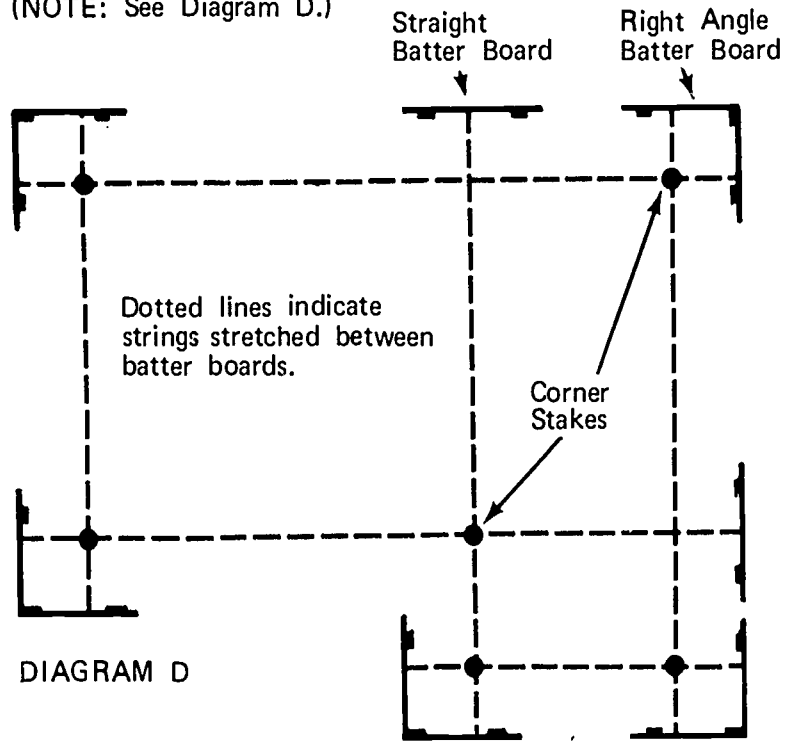

DIAGRAM D

JOB SHEET #1

3. Square the corners of the building lines

(NOTE: Shift the string on the ledger boards until corners are square.)

- a. Diagonal method

(NOTE: See Diagram E.)

DIAGRAM E

Diagonals of a square or rectangle will be equal in length.

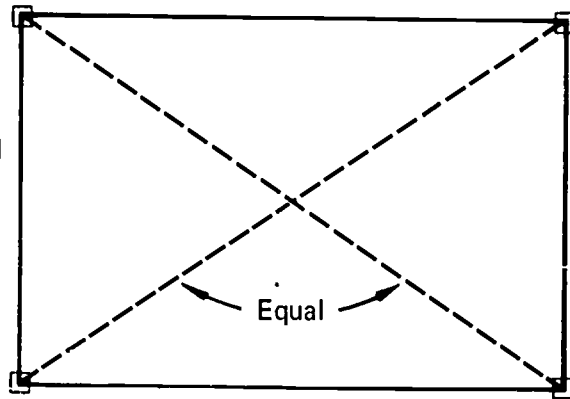

- b. The 3-4-5 rule

(NOTE: Any multiple of 3-4-5 may be used such as 6-8-10, 9-12-15, or 12-16-20.)

(NOTE: See Diagram F.)

DIAGRAM F

Using the 6-8-10 method to lay out or check a right angle.

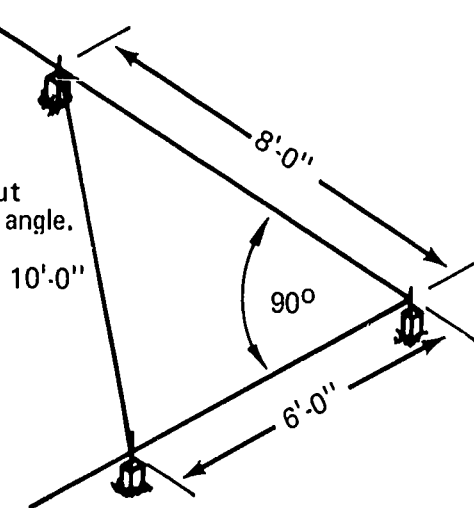

JOB SHEET #1

- c. After the exact location of lines are established, saw a kerf in each ledger board at the exact location to keep string from shifting

(NOTE: See Diagram G.)

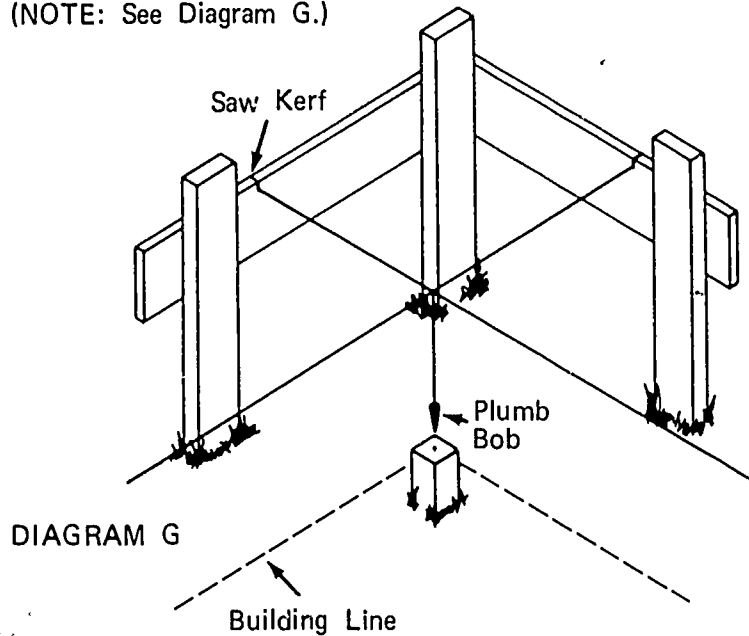

- F. Locate and drive corner stakes at building lines to establish grade
1. Plumb down from the intersection of the string at each corner of the building lines
 2. Drive a corner stake at this location

(NOTE: See Diagram G.)

- a. Use plumb bob to locate the position of the stake
- b. Use builder's level to establish grade
- c. Drive a nail in the top of each stake to locate the exact point of intersection

- G. Remove the string from around property lines

SITE LAYOUT
UNIT II

TEST

1. Match the following list of layout terms to the correct definitions.

- | | |
|--|--------------------|
| _____ a. Removing soil for a footing or to establish a uniform grade | 1. Batter boards |
| _____ b. An enlargement at the lower end of a foundation wall, pier, or column to distribute the load | 2. Bench mark |
| _____ c. A metal or stone marker placed in the ground by the surveyor with the elevation indicated on it | 3. Builder's level |
| _____ d. A drawing used to show the location and size of all buildings, driveways, sidewalks, and patios on the lot | 4. Datum |
| _____ e. A temporary framework used to assist in locating corners when laying out a foundation | 5. Excavating |
| _____ f. The boundaries of a lot or plot of ground | 6. Footing |
| _____ g. Information used as a basis for calculating or measuring | 7. Grade line |
| _____ h. The level of the ground at the building line | 8. Grade stake |
| _____ i. A graduated rod used with the builder's level in leveling | 9. Leveling rod |
| _____ j. An instrument consisting of a telescope, leveling bubble, and tripod used primarily for establishing grade levels | 10. Property lines |
| _____ k. A stake driven into the ground that locates the finished level of the ground at that point | 11. Plot plan |

2. List four factors that are pertinent to the site layout.
 - a.
 - b.
 - c.
 - d.

3. Locate the building lines on the plot plan given on the next page from the datum given below.
 - A. Sidewalk
 1. Four feet wide
 2. Six feet from curb
 3. Four inches thick
 - B. Building lines
 1. Front set back--30 feet from back of sidewalk
 2. Sides--Set in 5 feet
 3. Rear--Set in 30 feet
 - C. Easements--Ten feet at rear for alley
 - D. Building dimensions
 1. Front length--68 feet
 2. Width--32 feet
 - E. Orientation--Front of building parallel to the street and centered between the side boundaries

PLOT PLAN

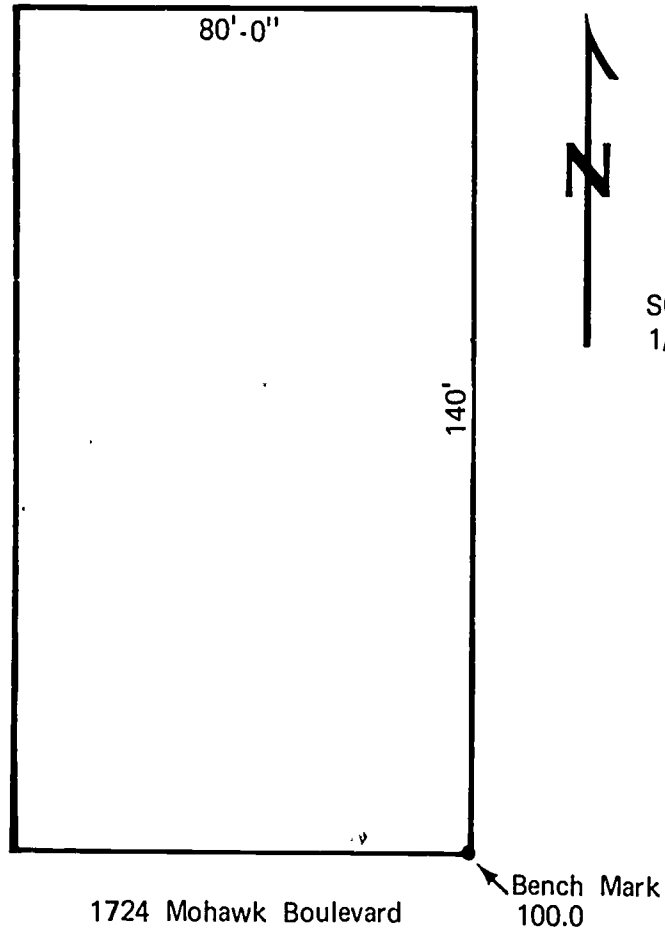

4. Describe two methods of squaring a building. (Use a diagram or sketch.)

a.

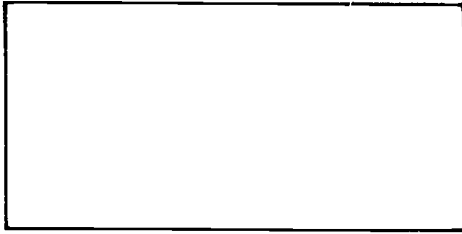

b.

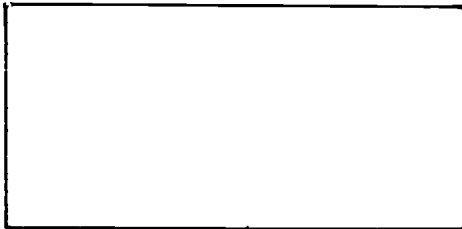

5. State the purpose of batter boards.

6. Demonstrate the ability to:

- a. Erect batter boards.
- b. Layout a building using batter boards.
- c. Square a building layout.
 - 1) Using the 3-4-5 rule or a multiple thereof.
 - 2) Using the diagonal method.

(NOTE: If this has not been accomplished prior to the test, ask the instructor when the above activities should be completed.)

SITE LAYOUT
UNIT II

ANSWERS TO TEST

1.
 - a. 5
 - b. 6
 - c. 2
 - d. 11
 - e. 1
 - f. 10
 - g. 4
 - h. 7
 - i. 9
 - j. 3
 - k. 8
2.
 - a. Local regulations
 - b. Location of services
 - c. Existing trees and shrubs
 - d. The shape of the terrain
3. (Answer shown on next page)

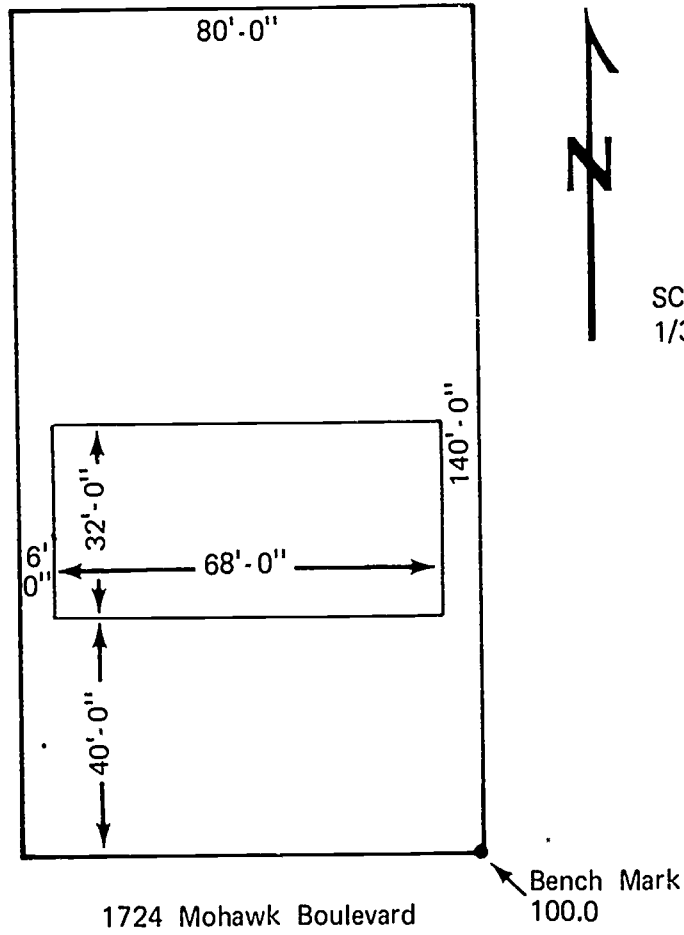

4. a. The 3-4-5 rule

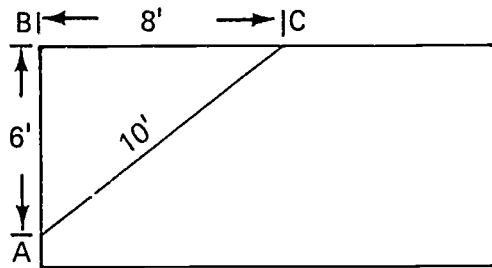

If the building is square the diagonal measurement A-C will be 10 feet.

b. The diagonal method

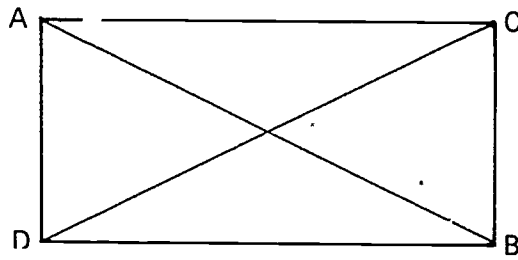

If the building is square the diagonal lines A-B and C-D will be the same length.

5. To provide a place of attachment for the string or twine used to locate building lines during excavation and construction.
6. Performance skills will be evaluated according to the criteria listed on the progress chart.

Carpentry

PROGRESS CHART

Job	Unit I Site Preparation				Unit II Site Layout				
	1	2	3	4	1	2	3	4	5
	Unit Test	Set Up & Adjust the Bidr's. Level	Read Leveling Rod	Perform Leveling Jobs	Unit Test	Erect Batter Boards For a Structure 50'X50'	Lay Out Building Lines For a Structure 50' X 50'	Square a Structure 50' X 50' (Diagonal Method)	Square a Structure (3-4-5 Rule)
1									
2									
3									
4									
5									
6									
7									
8									
9									

248

Section F
Site

Student's Name

2

3

4

5

6

7

8

9

10

11

12

13

14

15

16

17

18

19

20

Accuracy

85% Correct

Within 1/100 of a Foot @ 50'

Within 1/100 of a Foot @ 50'

Within 1/100 of a Foot @ 50'

85% Correct

Within 4' of Bldg. Lines

Ledger Bds. Within 1/100' of Same Elev.

Within 1/2" of Exact Side

In-Set & Front Set Back

Within 3/8" of Being Square

Within 3/8" of Being Square

INTRODUCTION TO FORMING UNIT I

TERMINAL OBJECTIVE

After completion of this unit, the student should be able to define wall form terms, write the purpose of forms, name the external factors that affect form design, and explain their effect on form design. He should be able to identify the parts and types of forms. This knowledge will be evidenced by scoring eighty-five percent on the unit test.

SPECIFIC OBJECTIVES

After completion of this unit, the student should be able to:

1. Match terms associated with wall forming to the correct definition.
2. Write the purpose of forms.
3. List seven external factors that affect form design.
4. Write the effects of external factors on form design.
5. Identify the parts of a form.
6. Identify three types of forms.

INTRODUCTION TO FORMING UNIT I

SUGGESTED ACTIVITIES

- I. Instructor:
 - A. Provide students with objective sheet.
 - B. Provide students with information sheet.
 - C. Make transparencies.
 - D. Discuss terminal and specific objectives.
 - E. Discuss information sheet.
 - F. Give test.
- II. Student:
 - A. Read objective sheet.
 - B. Study information sheet.
 - C. Take test.

INSTRUCTIONAL MATERIALS

- I. Included in this unit:
 - A. Objective sheet
 - B. Information sheet
 - C. Transparency masters
 1. TM 1--Slump Cone
 2. TM 2--Parts of a Form
 3. TM 3--Form Ties
 4. TM 4--Form Ties (Continued)
 5. TM 5--Panelized Forms
 6. TM 6--Built-in-Place Forms
 7. TM 7--Patented Forms

D. Test

E. Answers to test

II. References:

- A. Burke, Arthur E., J. Ralph Dalzell, and Gilbert Townsend. *Architectural and Building Trades Dictionary*.
- B. Smith, Ronald C. *Principles and Practices of Heavy Construction and Principles and Practices of Heavy Construction*. Prentice Hall Inc., 1970 and 1967.
- C. Peurifoy, R. L. *Formwork for Concrete Structures*. McGraw-Hill Inc., 1964.

INTRODUCTION TO FORMING
UNIT I

INFORMATION SHEET

- I. Terms and definitions
 - A. Brace--A piece of wood or other material that directs, resists, or supports weight or pressure
 - B. Cleat--A strip of wood or metal fastened across a form for temporary positioning or to replace a form tie
 - C. Duplex nail--A double headed nail used in forming and designed for easy removal
 - D. Footing--An enlarged area at the base of a wall or another object used to distribute the weight of the superstructure
 - E. Form tie--A wire or metal crosstie used to hold the pressure of wet concrete and maintain the proper wall thickness
 - F. Foundation--That portion of a wall upon which the building rests
 - G. Grade point--The level of the finished concrete in a form
 - H. Key--A beveled strip of wood or metal placed on the form where future pours occur
 - I. Key way--A groove left in the concrete by removal of the key
 - J. Monolithic pour--A continuous mass of concrete cast as a single piece
 - K. Scab--A piece of material nailed across a splice to strengthen and hold it together
 - L. Sheathing--Wide boards, plywood, or metal that make up the face of the form
 - M. Spreader--A block of wood that is used to hold the sides of the form apart and is removed as the concrete is poured; it may also be an integral part of the form tie
 - N. Spacer block--A block of wood or other material used as a spacer at offsets in a form
 - O. Stake--Small boards or steel bars sharpened on one end and driven into the ground to support a form
 - P. Dowel--A short piece of steel bar inserted through a bulkhead to tie the adjoining pours together

INFORMATION SHEET

- Q. Bulkhead--A board placed in a form to cut off the concrete pour
 - R. Hopper--A receptacle, usually funnel shaped, open or with a gate at the bottom
 - S. Vibrator--A power tool used to consolidate concrete
 - T. Power buggy--A machine used to transport concrete from the mixer to the pour site
 - U. Form oil--Paraffin oil or other manufactured product used on a form to prevent adhesion of concrete to the form
 - V. Water stop--A rubber, neoprene or some composition material used to prevent passage of water through a joint
 - W. Reinforcing bars--Steel bars used to strengthen concrete walls or beams; called rebars
- (NOTE: Rebar numbers are based on the number of 1/8 inches included in the nominal diameter of the bar. A #4 bar is 4/8 or 1/2 inch in diameter.)
- II. Purpose of a form--To hold the wet concrete to the desired shape until it has set
 - III. External factors that affect form design (Transparency 1)
 - A. Slump--Reflects the consistency of the concrete as shown by a slump test

(NOTE: To make a slump test, stand on the ears of the cone and fill the cone in three equal lifts, rodding each lift twenty-five times with a five-eighths inch bullet nosed rod. Level off the top by rolling the rod on top of the cone. Remove the cone gently and set it alongside the slumped concrete and measure slump as shown.)

 - B. Rate of pour--The vertical feet per hour of concrete placed within a form
 - C. Temperature--The air temperature at the time of pouring

(NOTE: At low air temperatures, the temperature of the concrete is also considered.)

 - D. Vibration--A method of consolidation of concrete within a form
 - E. Method of placement--Discharge directly out of truck, crane with concrete bucket, power buggies, and pump
 - F. Size of form--Height, width, and length
 - G. Type of concrete finishes
 - 1. Architectural
 - 2. Structural

INFORMATION SHEET

IV. Effect of external factors on form design

- A. Slump--The greater the slump, the longer it takes concrete to set, therefore, the pressure remains on the form for a longer period of time
- B. Rate of pour--The feet of concrete depth poured in one hour
- C. Temperature--Effects the rate at which hydration (set) of concrete occurs; the higher the temperature, the faster concrete sets

(NOTE: With a rate of pour of four feet per hour at 70°, the maximum pressure on the form is 550# per square feet. Using the same rate of pour at 50°, the maximum pressure increases to 750 p.s.f.)

- D. Vibration--Power vibration can cause pressure to increase thirty-five percent

(NOTE: Hand spading has very little effect on pressure.)

- E. Method of placement--Concrete weighs 150 pounds per cubic foot; the impact of this weight on concrete already placed causes an increase in pressure on the forms; the greater the height of the drop and the mass of concrete, the greater the pressure increase

(NOTE: High free drops of concrete causes aggregate separation.)

- F. Size of form--Thickness and length of the wall are used to figure the rate of pour; height and width have no bearing on pressure on forms, except for method of placement

(NOTE: For a given rate of fill, the pressure will be the same on a four inch wide wall as it is on a twelve inch wide wall.)

G. Types of concrete finishes

1. Architectural concrete--Will be exposed in the finished areas of the structure; forms will be designed to give a minimum of deflection and leakage; the concrete surface may be smooth, rough, incised, sculptured, sandblasted, bushhammered, or many other finishes
2. Structural concrete--Will not be exposed in the finished areas of the structure, so some deflection and leakage is permissible

V. Parts of a form (Transparencies 2, 3, and 4)

- A. Sheathing
- B. Brace
- C. Stake

INFORMATION SHEET

- D. Spreader
 - E. Cleat
 - F. Form tie
 - G. Waler
 - H. Stud
 - I. Strongback
 - J. Sole plate
 - K. Bottom plate
 - L. Top plate
 - M. Bulkhead
 - N. Scab
 - O. Key
 - P. Rustication strip
 - Q. Chamfer strip
- VI. Types of forms (Transparencies 5, 6, and 7)
- A. Panelized--Wood
 - B. Built-in-place--Wood
 - C. Patented--All metal, all wood, a combination of wood and metal, or fiberglass

Slump Cone

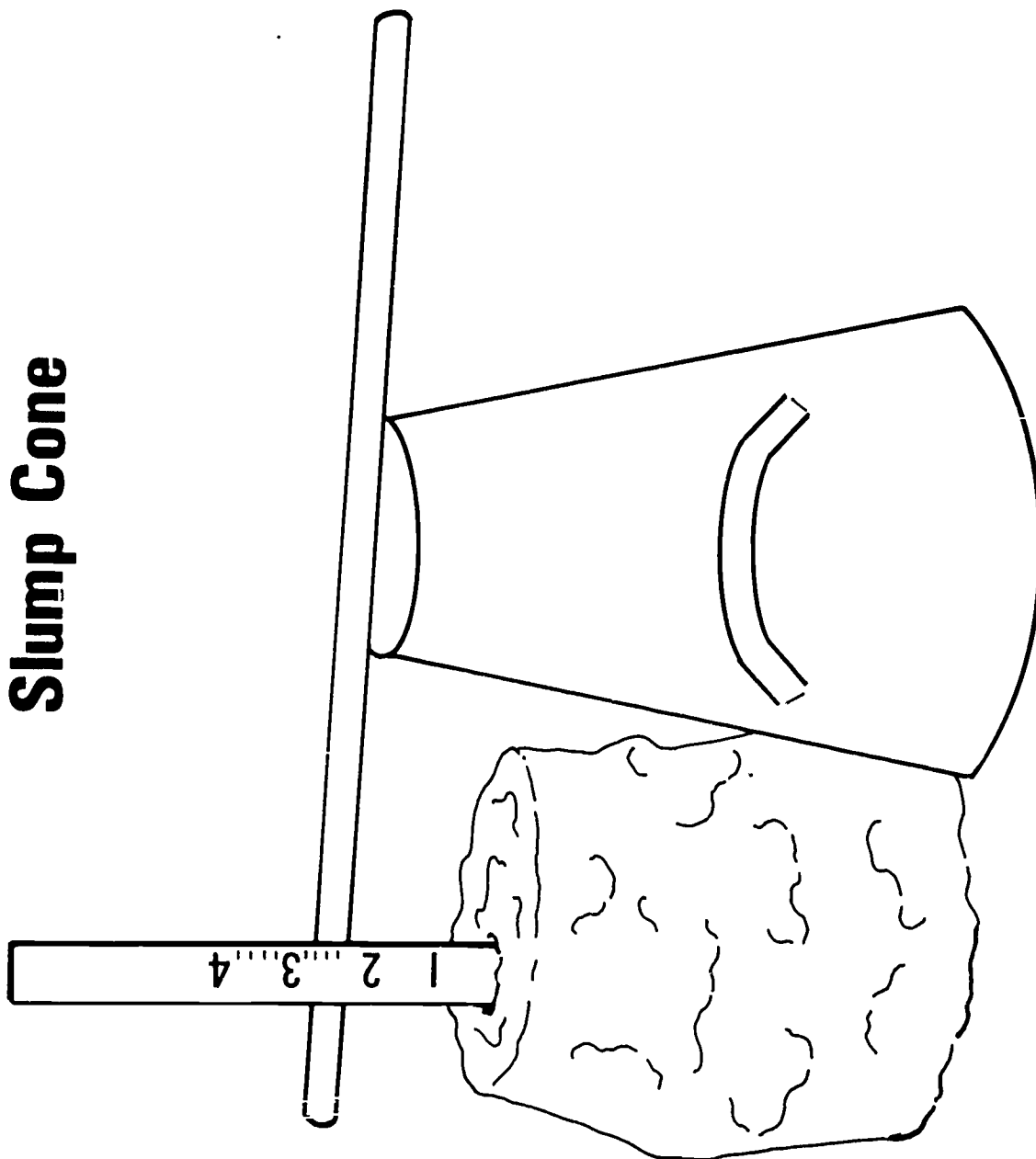

Parts of a Form

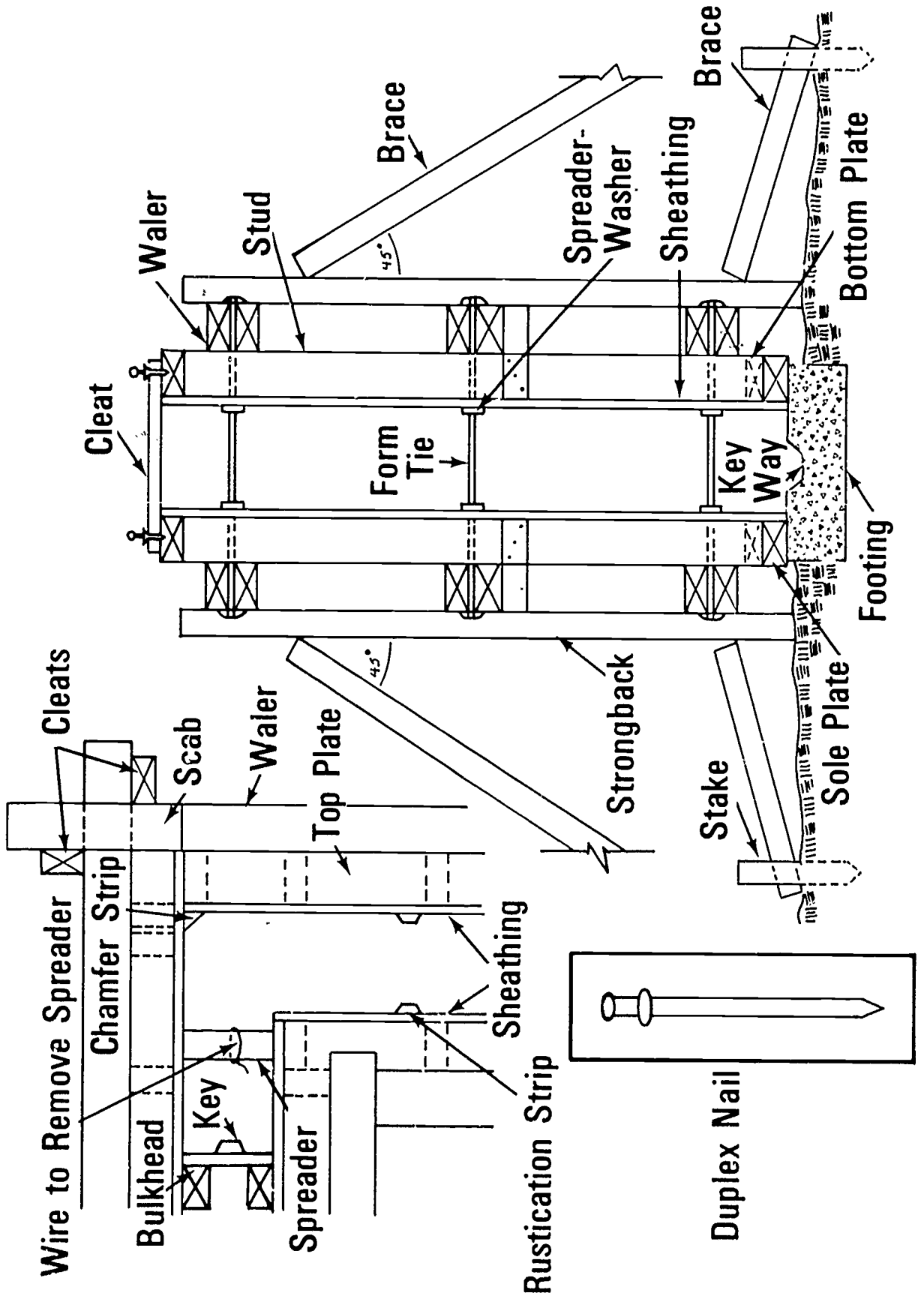

Form Ties

SHE BOLT ASSEMBLY

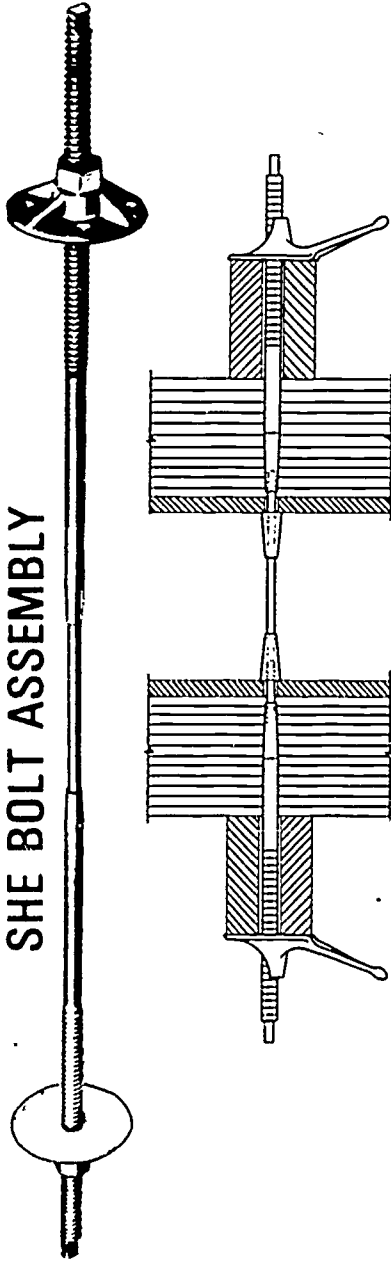

The Nut Washer Assembly consists of Two Outside Rods and Two Nut Washers

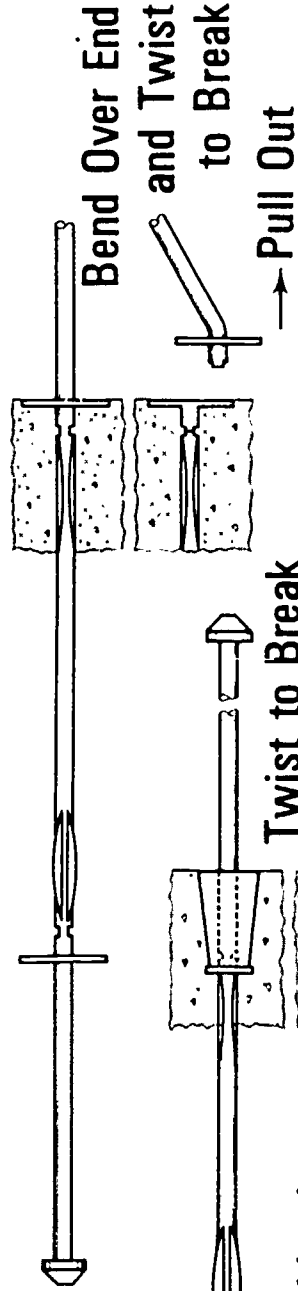
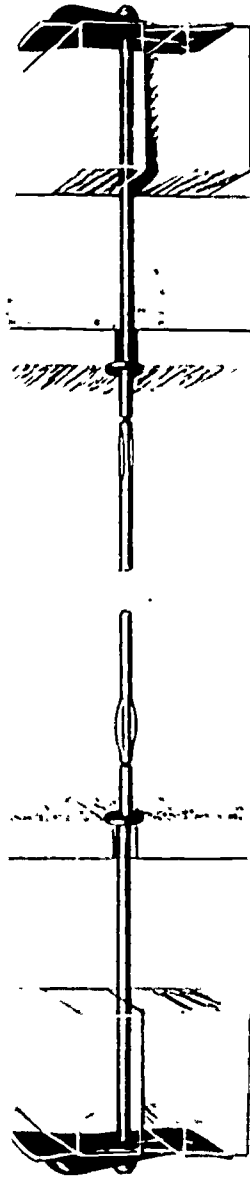

Bend Over End and Twist to Break

Pull Out

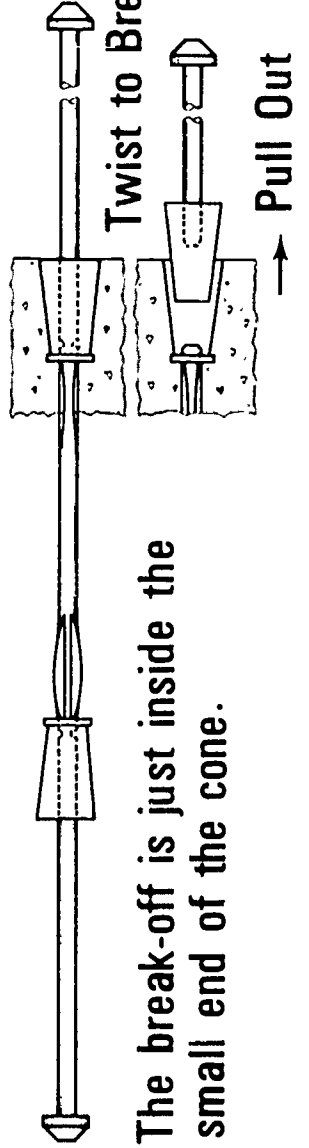

The break-off is just inside the small end of the cone.

Pull Out

Form Ties (CONTINUED)

WATERSEAL COIL TIE

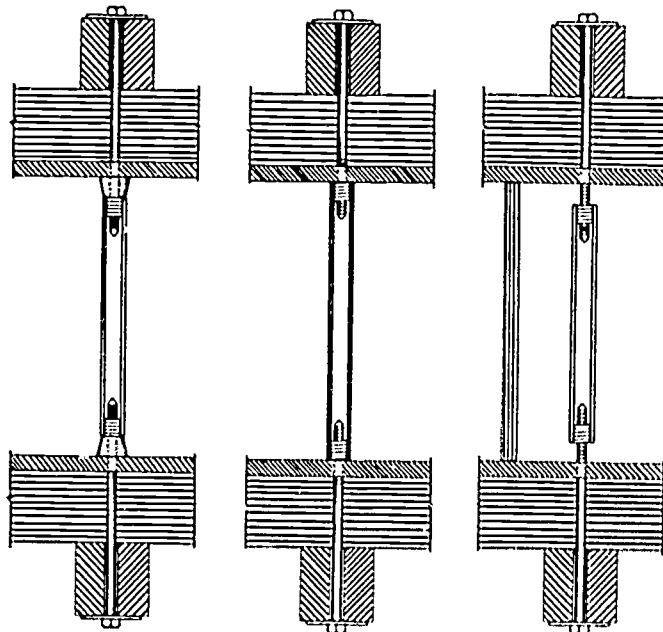
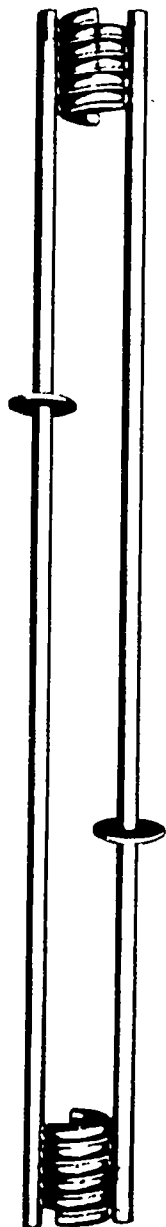

COIL TIE with
SPREADER CONE

COIL TIE as
SPREADER and TIE

COIL TIE with
SEPARATE SPREADER

Form Clamps (Buttons)
Used with Plain Round
Mild Steel Rods

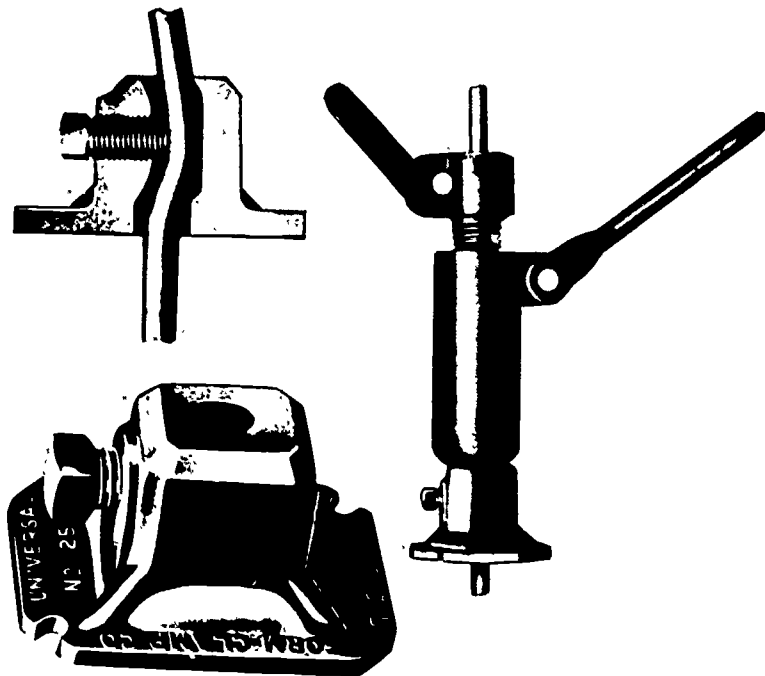

Panelized Forms



Built-in-Place Forms

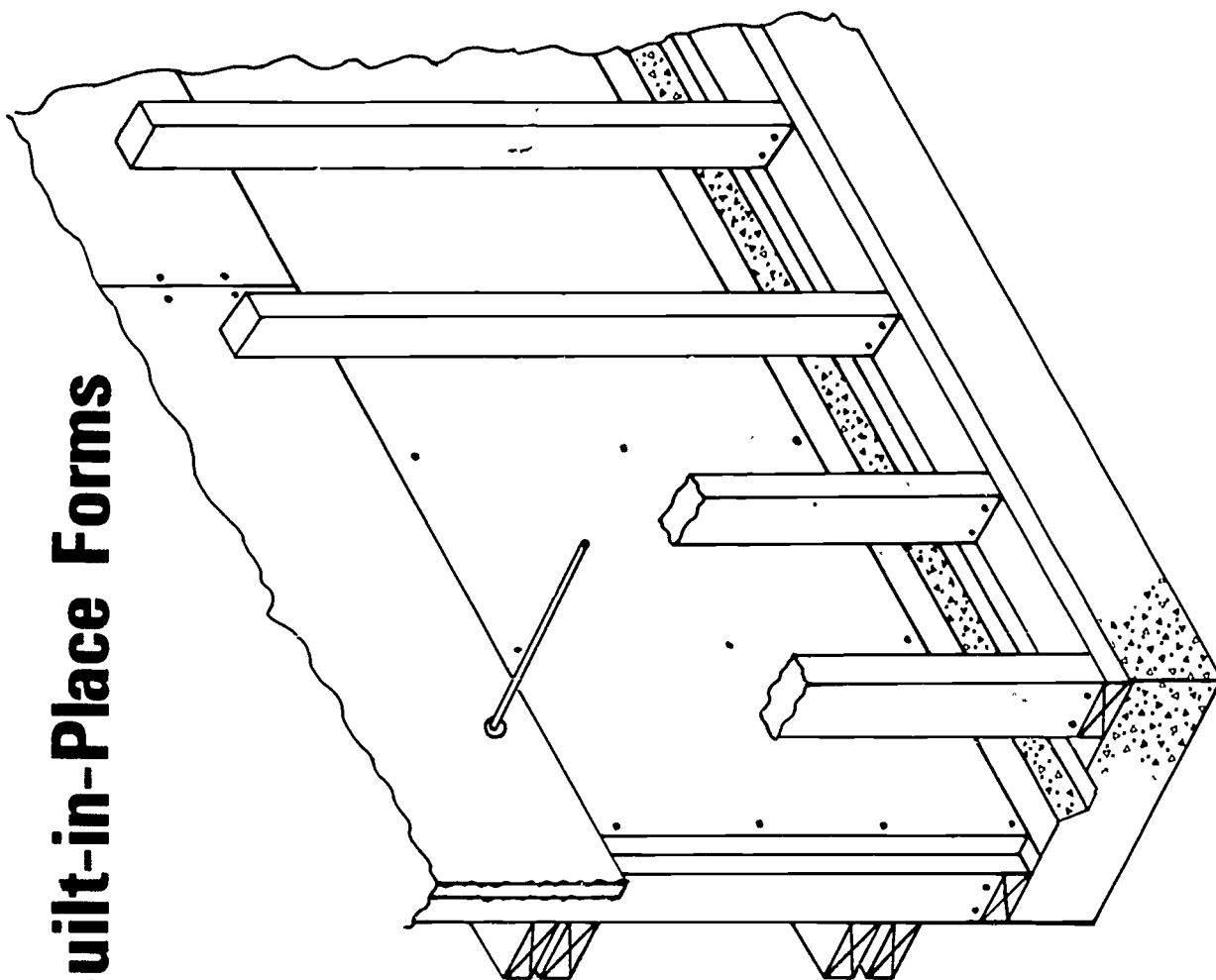

Patented Forms

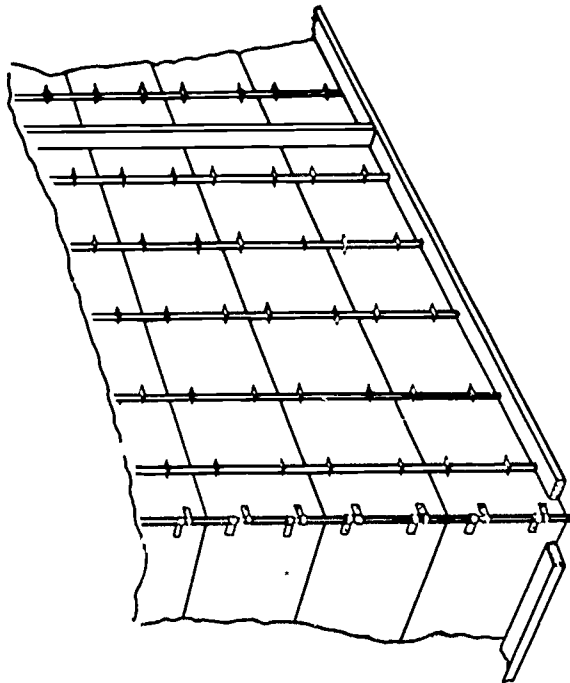

Wood

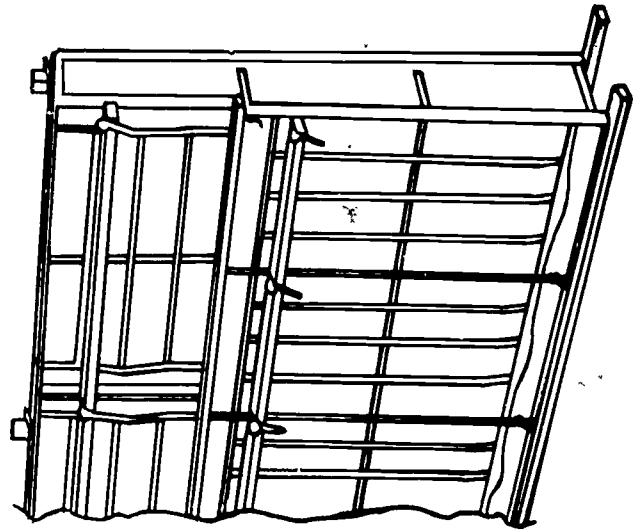

Metal

INTRODUCTION TO FORMING
UNIT I

TEST

1. Match the terms on the right with the correct definition.

- | | |
|---|----------------------|
| _____ a. A wire or metal crosstie used to hold the pressure of wet concrete and maintain the proper wall thickness | 1. Brace |
| _____ b. A beveled strip of wood or metal placed on the form where future pours occur | 2. Cleat |
| _____ c. A block of wood or other material used as a spacer at offsets in a form | 3. Duplex nail |
| _____ d. Wide boards, plywood, or metal that make up the face of the form | 4. Footing |
| _____ e. A short piece of steel bar inserted through a bulkhead to tie adjoining pours together | 5. Form tie |
| _____ f. A piece of material nailed across a splice to strengthen and hold it together | 6. Foundation |
| _____ g. A board placed in a form to cut off the concrete pour | 7. Grade point |
| _____ h. Small boards or steel bars sharpened on one end and driven into the ground to support a form | 8. Key |
| _____ i. A block of wood that is used to hold the sides of the form apart and is removed as the concrete is poured, it may also be an integral part of the form tie | 9. Key way |
| _____ j. A machine used to transport concrete from the mixer to the the pour site | 10. Monolithic pour |
| | 11. Scab |
| | 12. Sheathing |
| | 13. Spreader |
| | 14. Spacer block |
| | 15. Stake |
| | 16. Dowel |
| | 17. Bulkhead |
| | 18. Hopper |
| | 19. Vibrator |
| | 20. Power buggy |
| | 21. Form oil |
| | 22. Water stop |
| | 23. Reinforcing bars |

- _____ k. A power tool used to consolidate concrete
- _____ l. The level of the finished concrete in a form
- _____ m. A receptacle, usually funnel shaped, open or with a gate at the bottom
- _____ n. A continuous mass of concrete cast as a single piece
- _____ o. That portion of a wall upon which the building rests
- _____ p. A groove left in the concrete by removal of the key
- _____ q. Paraffin oil or other manufactured product used on a form to prevent adhesion of concrete to the form
- _____ r. A double headed nail used in forming and designed for easy removal
- _____ s. A piece of wood or other material that directs, resists, or supports weight or pressure
- _____ t. A strip of wood or metal fastened across a form for temporary positioning or to replace a form tie
- _____ u. An enlarged area at the base of a wall or another object used to distribute the weight of the superstructure
- _____ v. Steel bars used to strengthen concrete walls or beams; called rebars
- _____ w. A rubber, neoprene or some composition material used to prevent passage of water through a joint

2. Write the purpose of forms.

3. List seven external factors that affect form design.

a.

b.

c.

d.

e.

f.

g.

1)

2)

4. Write the effects on form design caused by each external factor you have named in question number three.

a.

b.

c.

d.

e.

f.

g.

5. Identify the seventeen parts of a form.

- a.
- b.
- c.
- d.
- e.
- f.
- g.
- h.
- i.
- j.
- k.
- l.
- m.
- n.
- o.
- p.
- q.

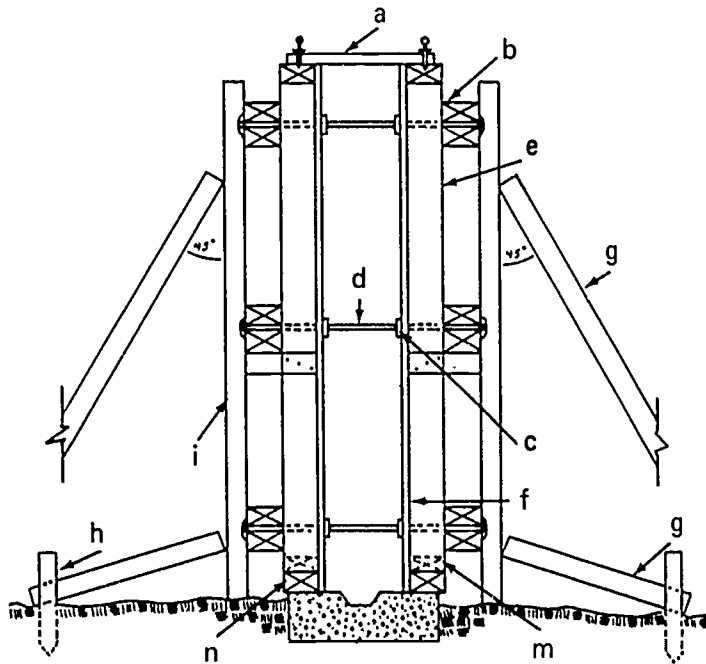
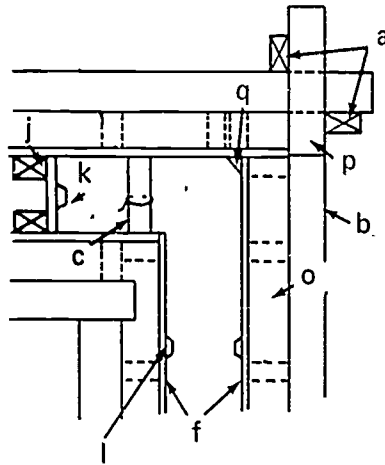

6. Identify three types of forms. Place the correct number(s) in the blanks given.

- _____ a. Panelized
- _____ b. Built-in-place
- _____ c. Patented

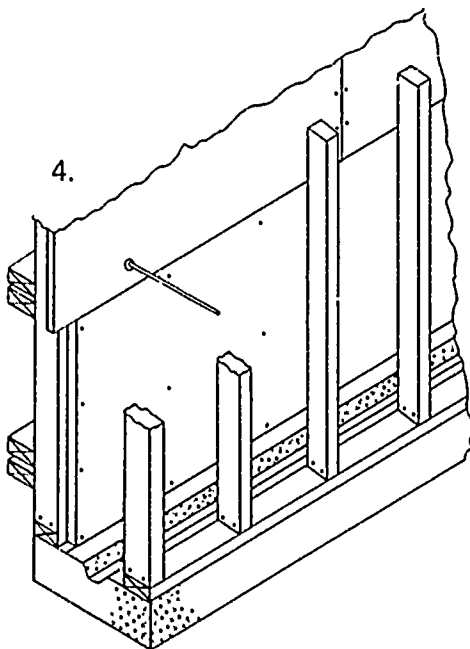
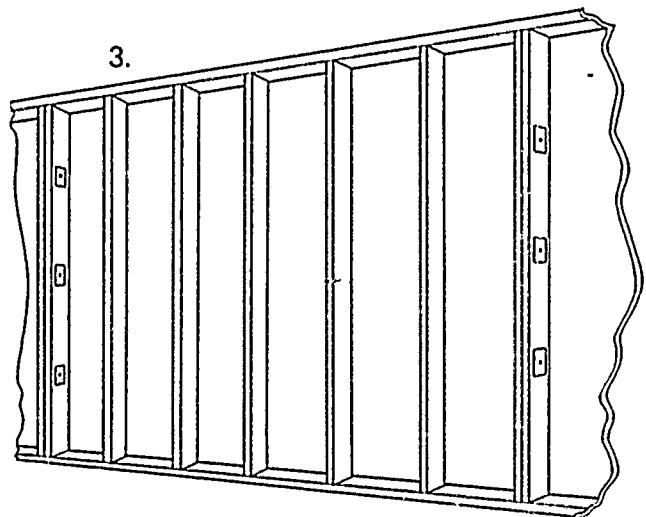
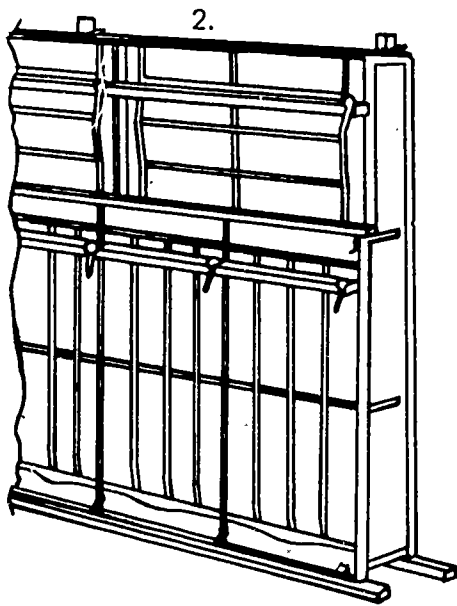
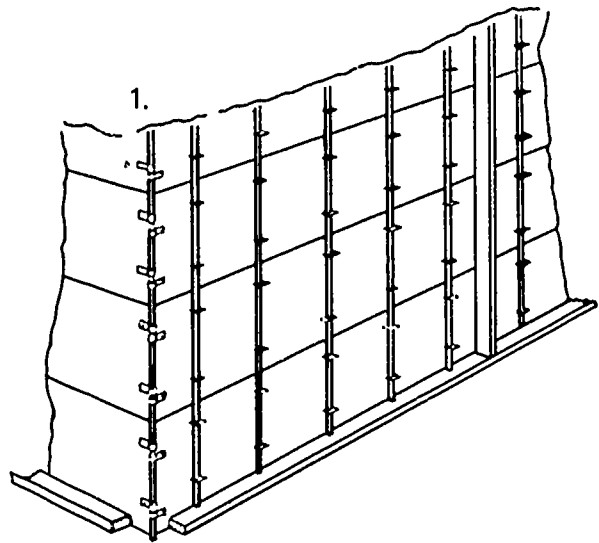

INTRODUCTION TO FORMING
UNIT I

ANSWERS TO TEST

1. a. 5
- b. 8
- c. 14
- d. 12
- e. 16
- f. 11
- g. 17
- h. 15
- i. 13
- j. 20
- k. 19
- l. 7
- m. 18
- n. 10
- o. 6
- p. 9
- q. 21
- r. 3
- s. 1
- t. 2
- u. 4
- v. 23
- w. 22

2. To hold wet concrete to the desired shape until it has set
3. The following answers may be given in any order.
 - a. Slump
 - b. Temperature
 - c. Rate of pour
 - d. Vibration
 - e. Method of placement
 - f. Size of form
 - g. Types of concrete finishes
 - 1) Architectural
 - 2) Structural
4. The following answers may be given in any order.
 - a. Slump--The greater the slump, the longer it takes concrete to set, therefore, the pressure remains on the form for a longer period of time
 - b. Temperature--Effects the rate at which hydration (set) of concrete occurs; the higher the temperature, the faster concrete sets
 - c. Rate of pour--The feet of concrete depth poured in one hour
 - d. Vibration--Power vibration can cause pressure to increase thirty-five percent
 - e. Method of placement--Concrete weighs 150# per cu. ft.; the impact of this weight on concrete already placed causes an increase in pressure on the forms; the greater the height of the drop and the mass of concrete, the greater the pressure increase
 - f. Size of form--Thickness and length of the wall are used to figure the rate of pour; height and width have no bearing on pressure or forms, except for method of placement
 - g. Types of concrete finishes
 - 1) Architectural concrete--Will be exposed in the finished areas of the structure; forms will be designed to give a minimum of deflection and leakage; the concrete surface may be smooth, rough, incised, sculptured, sandblasted, bushhammered, or many other finishes

- 2) Structural concrete-Will not be exposed in the finished areas of the structure, so some deflection and leakage is permissible
- 5.
- a. Cleats
 - b. Waler
 - c. Spreader
 - d. Form tie
 - e. Stud
 - f. Sheathing
 - g. Brace
 - h. Stake
 - i. Strongback
 - j. Bulkhead
 - k. Key
 - l. Rustication strip
 - m. Bottom plate
 - n. Sole plate
 - o. Top plate
 - p. Scab
 - q. Chamfer strip
- 6.
- a. 3
 - b. 4
 - c. 1 or 2

FOOTING FORMS
UNIT II

TERMINAL OBJECTIVE

After completing this unit, the student should be able to define footing form terms. He should be able to identify six styles of footings. He should be able to construct three types of footing forms and strip a pier footing form. This knowledge will be evidenced through demonstration and by scoring eighty-five percent on the unit test.

..

SPECIFIC OBJECTIVES

After completion of this unit, the student should be able to:

1. Match a list of footing form terms to a list of definitions.
2. Write the purpose of forms.
3. Identify the parts of a form.
4. Identify six styles of footing.
5. Name two methods of form construction.
6. Demonstrate the ability to:
 - a. Construct and set forms for a continuous footing.
 - b. Construct and set forms for a pile cap.
 - c. Construct and set a pier footing form.
 - d. Strip a pier footing form and prepare it for erection at another location.

FOOTING FORMS
UNIT II

SUGGESTED ACTIVITIES

I. Instructor:

- A. Provide students with objective sheet.
- B. Provide students with information and job sheets.
- C. Make transparencies.
- D. Discuss terminal and specific objectives.
- E. Discuss information sheet.
- F. Demonstrate and discuss procedures outlined in job sheets.
- G. Give test.

II. Student:

- A. Read objective sheet.
- B. Study information sheet.
- C. Demonstrate the ability to accomplish the procedures outlined in the job sheets.
- D. Take test.

INSTRUCTIONAL MATERIALS

I. Included in this unit:

- A. Objective sheet
- B. Information sheet
- C. Transparency masters
 1. TM 1--Parts of a Form
 2. TM 2--Continuous Footing
 3. TM 3--Pile Cap
 4. TM 4--Pier Footing

5. TM 5--Grade Beam
6. TM 6--Grillage Footing
7. TM 7--Stepped Continuous Footing
8. TM 8--Built On Site
9. TM 9--Patented Forms

D. Plan sheets (Included in Job Sheet #1)

1. Plan Sheet #1--Plot Plan
2. Plan Sheet #2--Foundation Plan
3. Plan Sheet #3--Batter Board Layout

E. Job sheets

1. Job Sheet #1--Construct and Set Forms for a Continuous Footing
2. Job Sheet #2--Construct and Set Forms for a Pile Cap
3. Job Sheet #3--Construct and Set Forms for a Pier Footing
4. Job Sheet #4--Strip Pier Footing Forms and Prepare Them for Erection at Another Location

F. Test

G. Answers to test

II. References:

- A. Waugh, Hebert R. and Nelson L. Burbank. *Building Terms and Definitions*. New York: Simmons-Boardman Publishing Corp.
- B. Smith, Ronald C. *Principles and Practices of Heavy Construction*. Prentice-Hall Inc., 1970 and 1967.
- C. Peurifoy, R. L. *Framework for Concrete Structures*. McGraw-Hill Inc., 1964.
- D. *Concrete Form Construction*. Albany, New York: Delmar Publishers.

FOOTING FORMS
UNIT II

INFORMATION SHEET

- I. Terms and definitions
 - A. Brace--A piece of wood or other material that directs, resists, or supports weight or pressure
 - B. Cleat--A strip of wood or metal fastened across a form for temporary positioning or to replace a form tie
 - C. Duplex nail--A double headed nail used in forming and designed for easy removal
 - D. Footing--An enlarged area at the base of a wall or another object used to distribute the weight of the superstructure
 - E. Form tie--A wire or metal crosstie used to hold the pressure of wet concrete and maintain the proper wall thickness
 - F. Foundation--That portion of a wall upon which the building rests
 - G. Grade point--The level of the finished concrete in a form
 - H. Key--A beveled strip of wood or metal placed on the form where future pours occur
 - I. Key way--A groove left in the concrete by removal of the key
 - J. Monolithic pour--A continuous mass of concrete cast as a single piece
 - K. Scab--A piece of material nailed across a splice to strengthen and hold it together
 - L. Sheathing--Wide boards, plywood, or metal that make up the face of the form
 - M. Spreader--A block of wood that is used to hold the sides of the form apart, and is removed as the concrete is poured; it may also be an integral part of the form tie
 - N. Spacer block--A block of wood or other material used as a spacer at offsets in a form
 - O. Stake--Small boards or steel bars sharpened on one end and driven into the ground to support a form
 - P. Dowel--A short piece of steel bar inserted through a bulkhead to tie adjoining pours together
 - Q. Bulkhead--A board placed in a form to cut off the concrete pour

INFORMATION SHEET

- R. Form oil--Paraffin oil or other manufactured product used on a form to prevent adhesion of the concrete to the form
 - S. Boil board--A wide board placed around the bottom of a form to keep the concrete from rising up around the form
 - T. Strip form--The process of removing a form after the concrete has set
 - U. Power buggy--A machine used to transport concrete from the mixer to the pour site
 - V. Vibrator--A power tool used to consolidate concrete
 - W. Hopper--A receptacle usually funnel shaped, open, or with a gate at the bottom
 - X. H. I.--The vertical distance from the bench mark to the line of sight of the instrument
- II. Purpose of a form--To hold wet concrete to the desired shape until it has set
- III. Parts of a form (Transparency 1)
- A. Sheathing
 - B. Brace
 - C. Stake
 - D. Spreader
 - E. Cleat
 - F. Form tie
 - G. Waler
 - H. Stud
 - I. Sole plate
 - J. Bottom plate
 - K. Top plate
 - L. Scab
- IV. Styles of footings (Transparencies 2, 3, 4, 5, 6, and 7)
- A. Continuous
 - B. Pile caps
 - C. Pier

INFORMATION SHEET

- D. Grade beam
 - E. Grillage
 - F. Stepped footing (continuous)
- V. Methods of form construction (Transparencies 8 and 9)
- A. Built on site
 - B. Patented

Parts of a Form

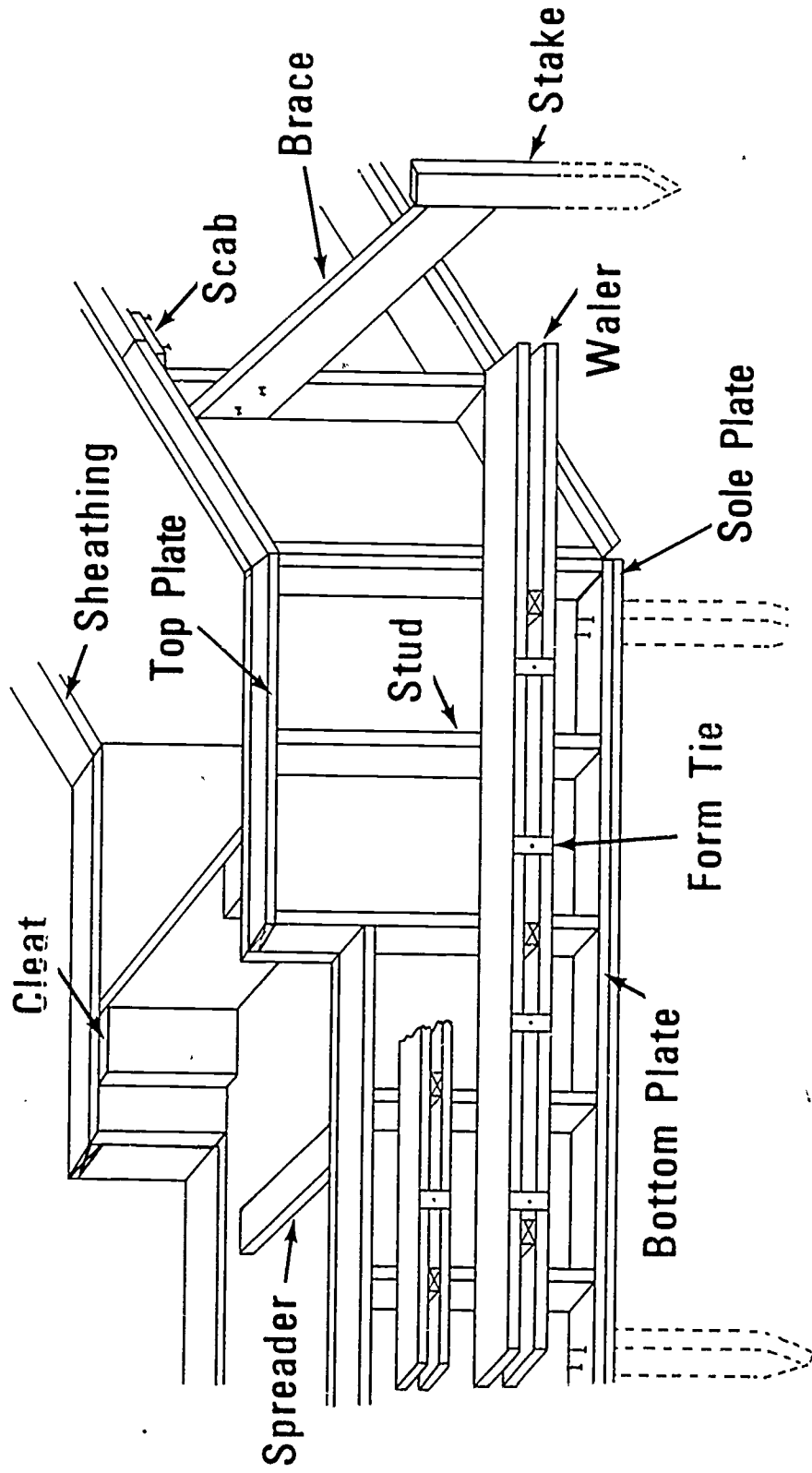

Continuous Footing

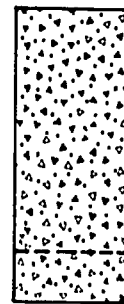
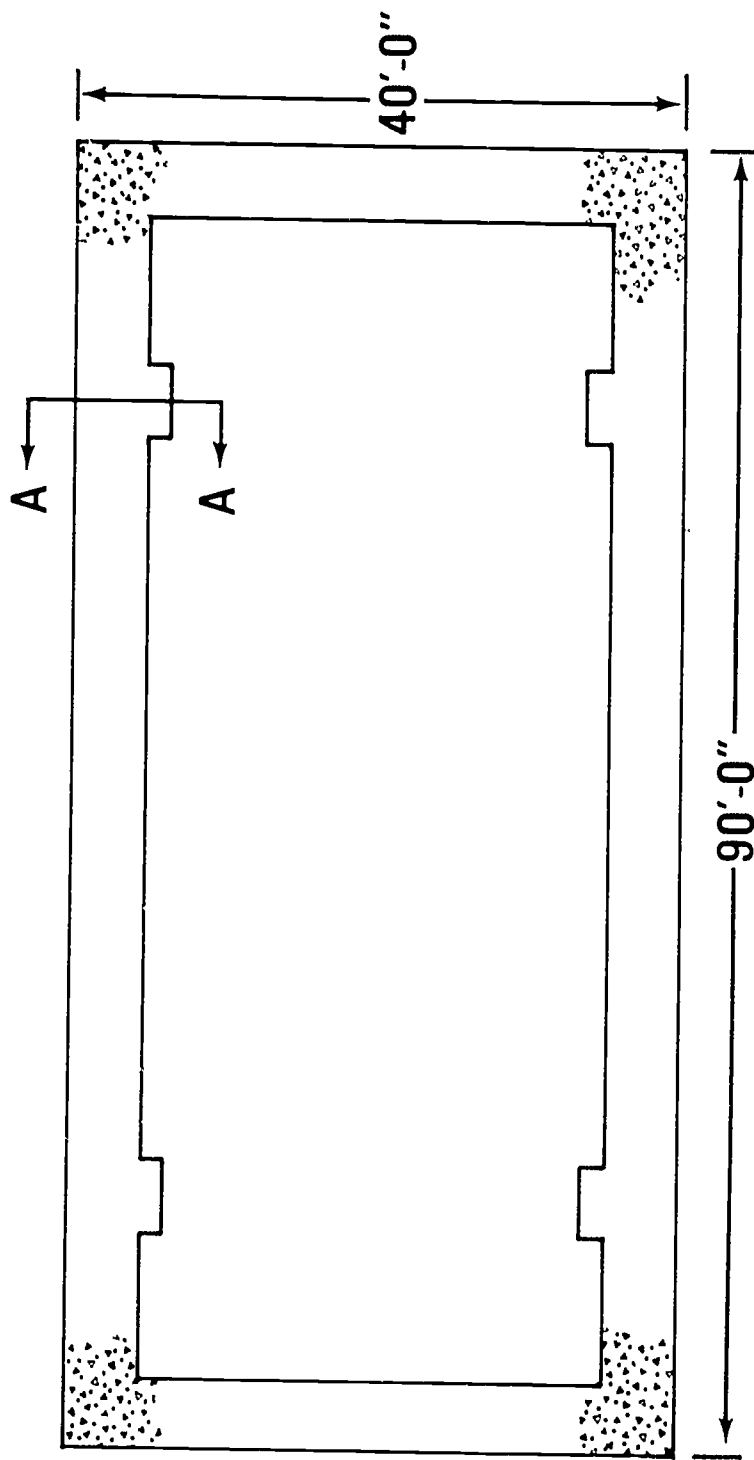

Section AA

Pile Cap

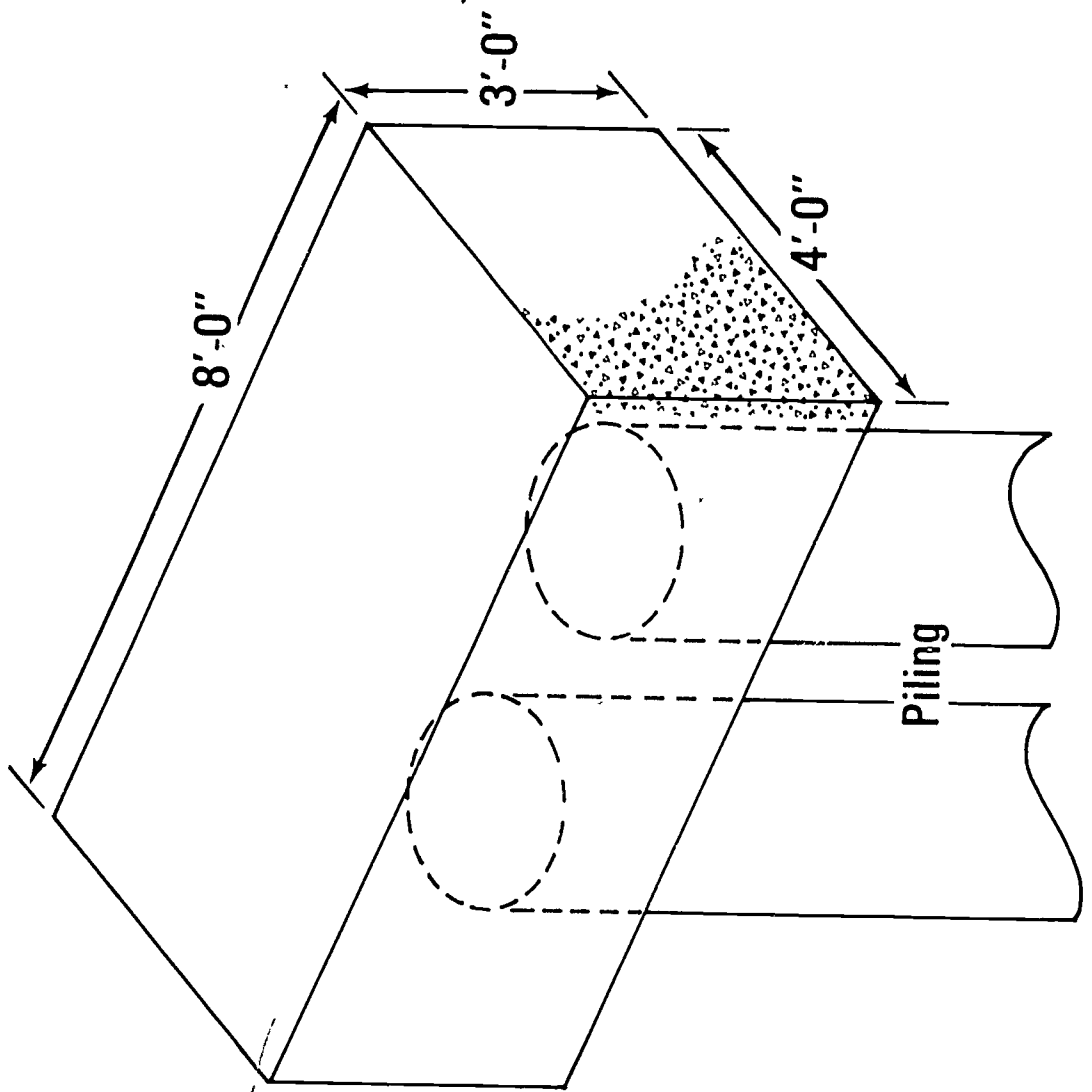

Pier Footing

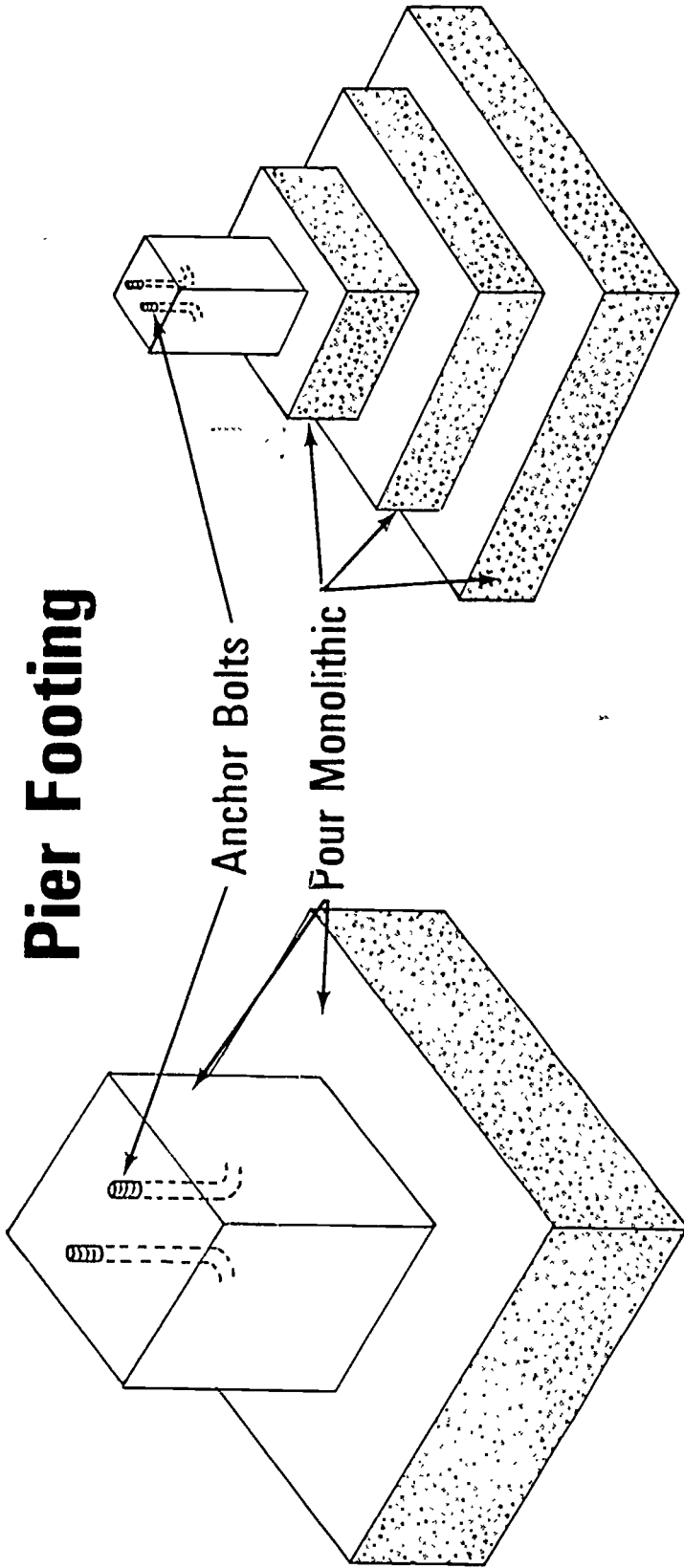

STEPPED PIER FOOTING

PAD PIER FOOTING

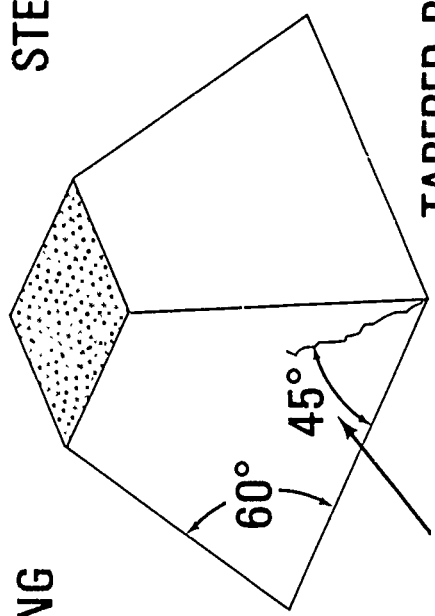

TAPERED PIER FOOTING

Angle of Shear

Grade Beam

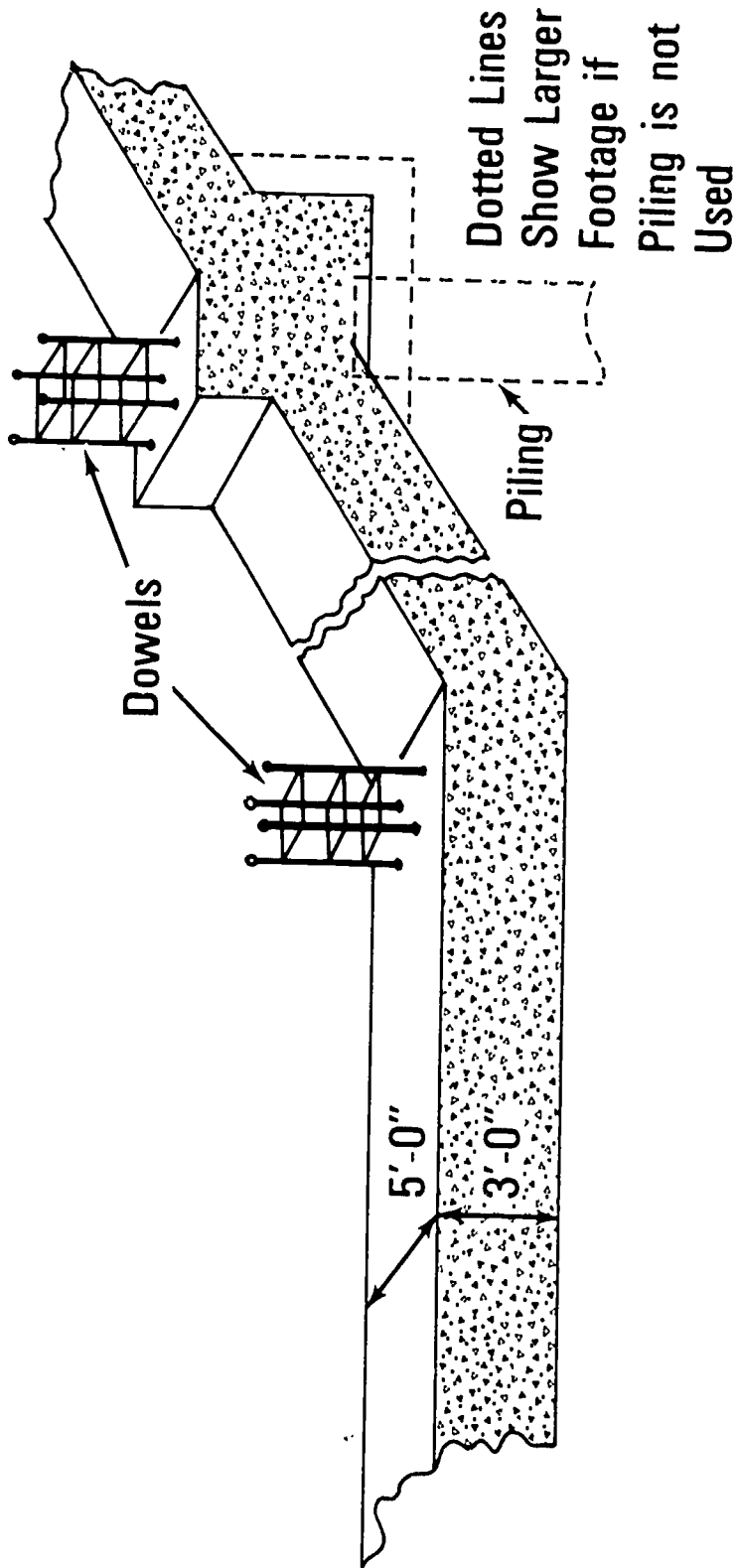

Grillage Footing

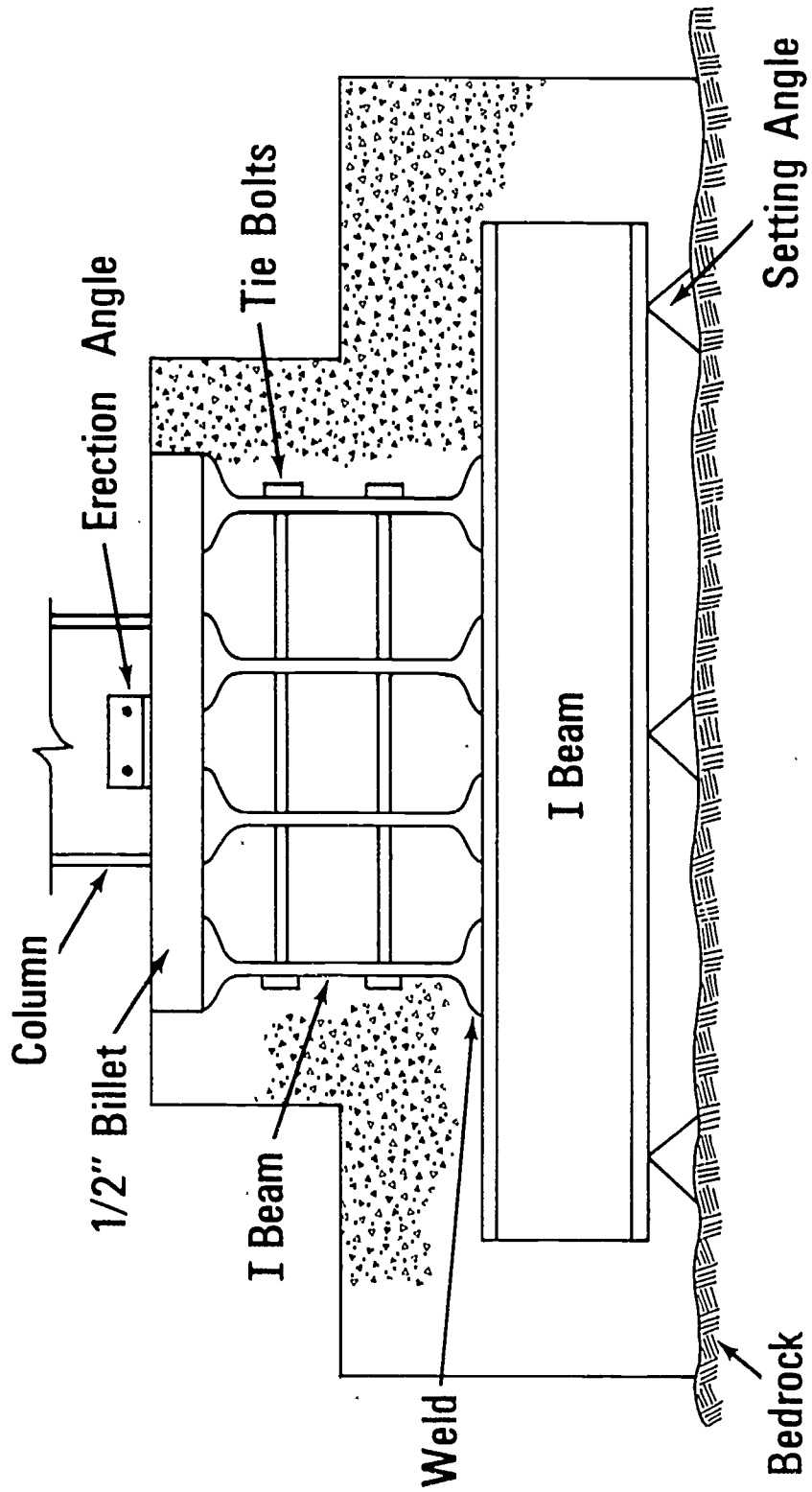

Stepped Continuous Footing

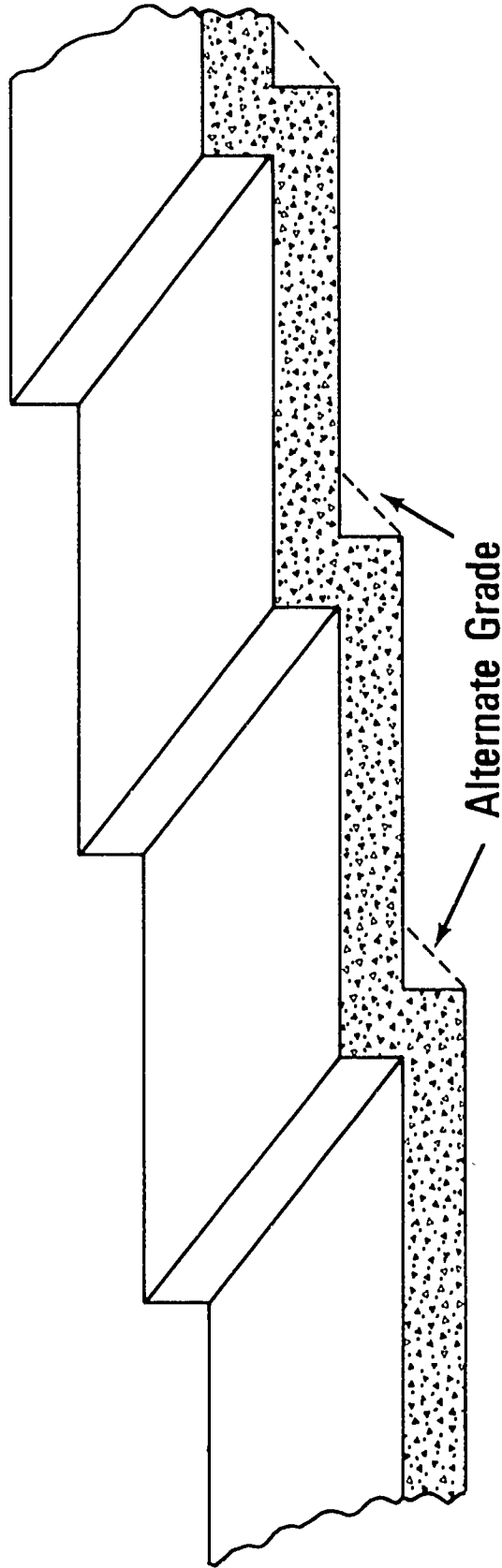

Built on Site

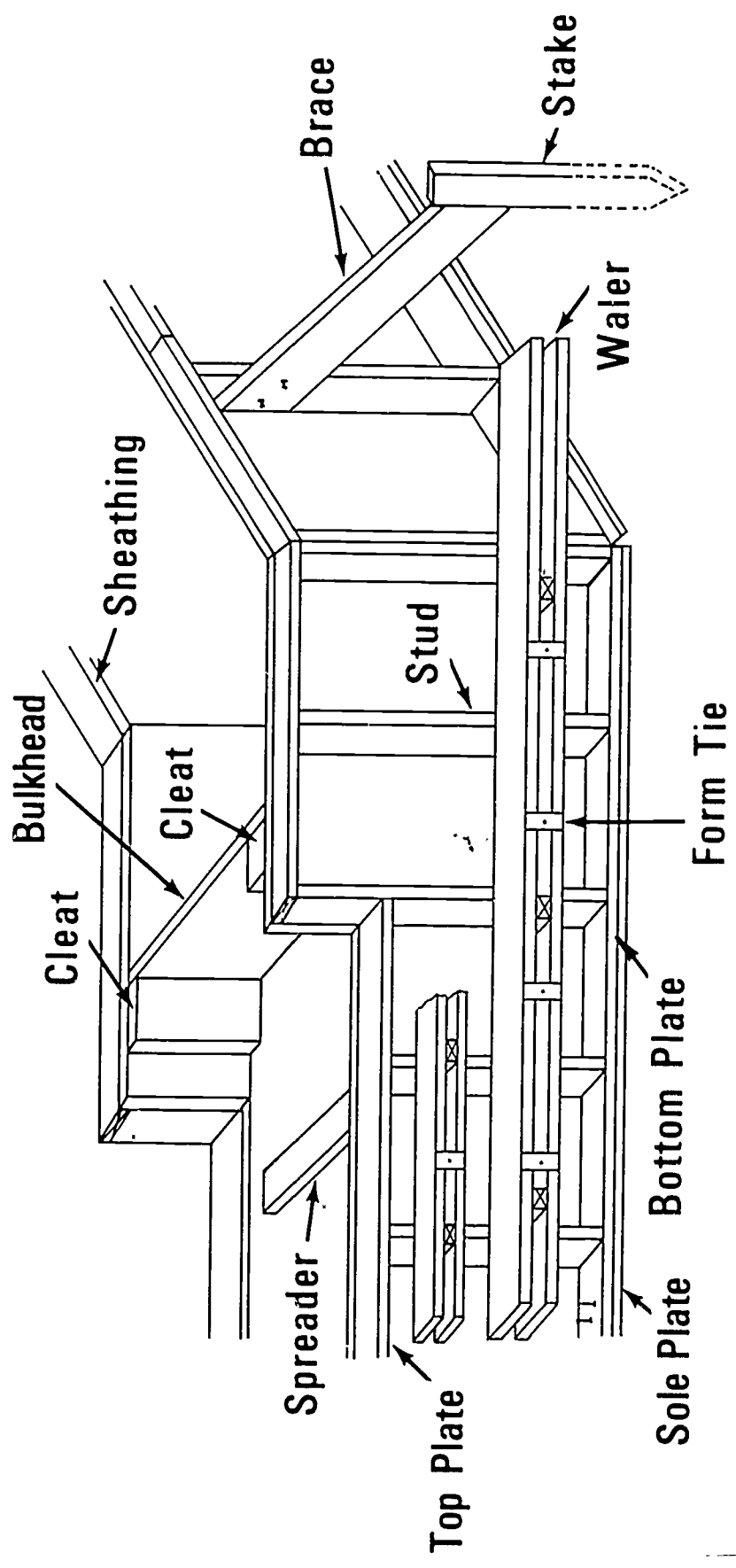

Patented Forms

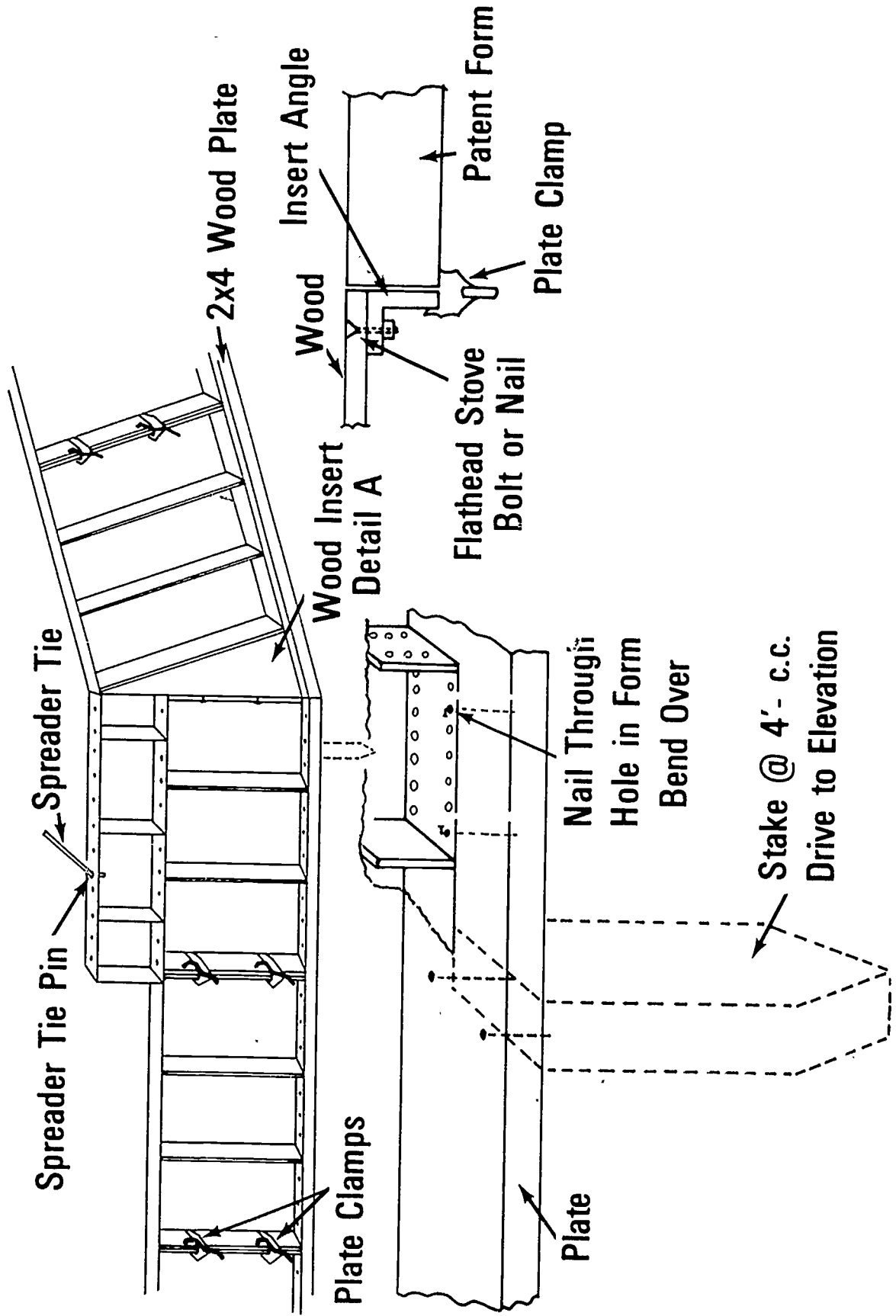

FOOTING FORMS
UNIT IIJOB SHEET #1--CONSTRUCT AND SET FORMS
FOR A CONTINUOUS FOOTING

I. Tools, materials, and plans needed

A. Tools

1. Electric handsaw
2. Crosscut handsaw
3. Claw hammer (16 ounce or larger)
4. Sledge hammer
5. 100 foot tape measure
6. Twelve or sixteen foot tape measure
7. Level (hand)
8. String
9. Builder's level

B. Materials

1. Stakes
2. Sheathing boards
3. Spreaders
4. Duplex nails
 - a. 8d
 - b. 16d
5. Form oil

C. Plans

1. Plot Plan Sheet #1
2. Foundation Plan Sheet #2
3. Batter Board Layout Plan Sheet #3

PLOT PLAN SHEET #1

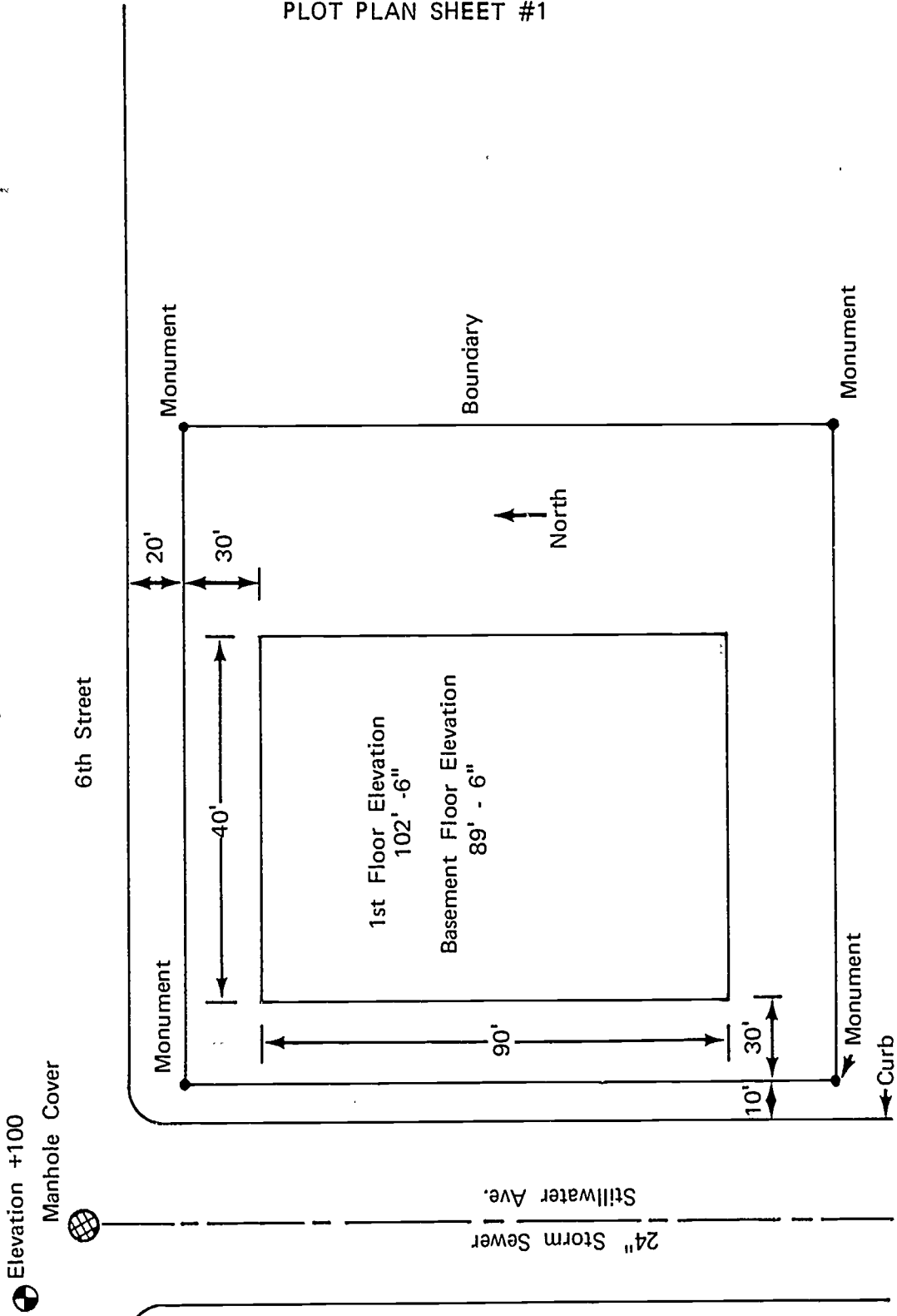

FOUNDATION PLAN SHEET #2

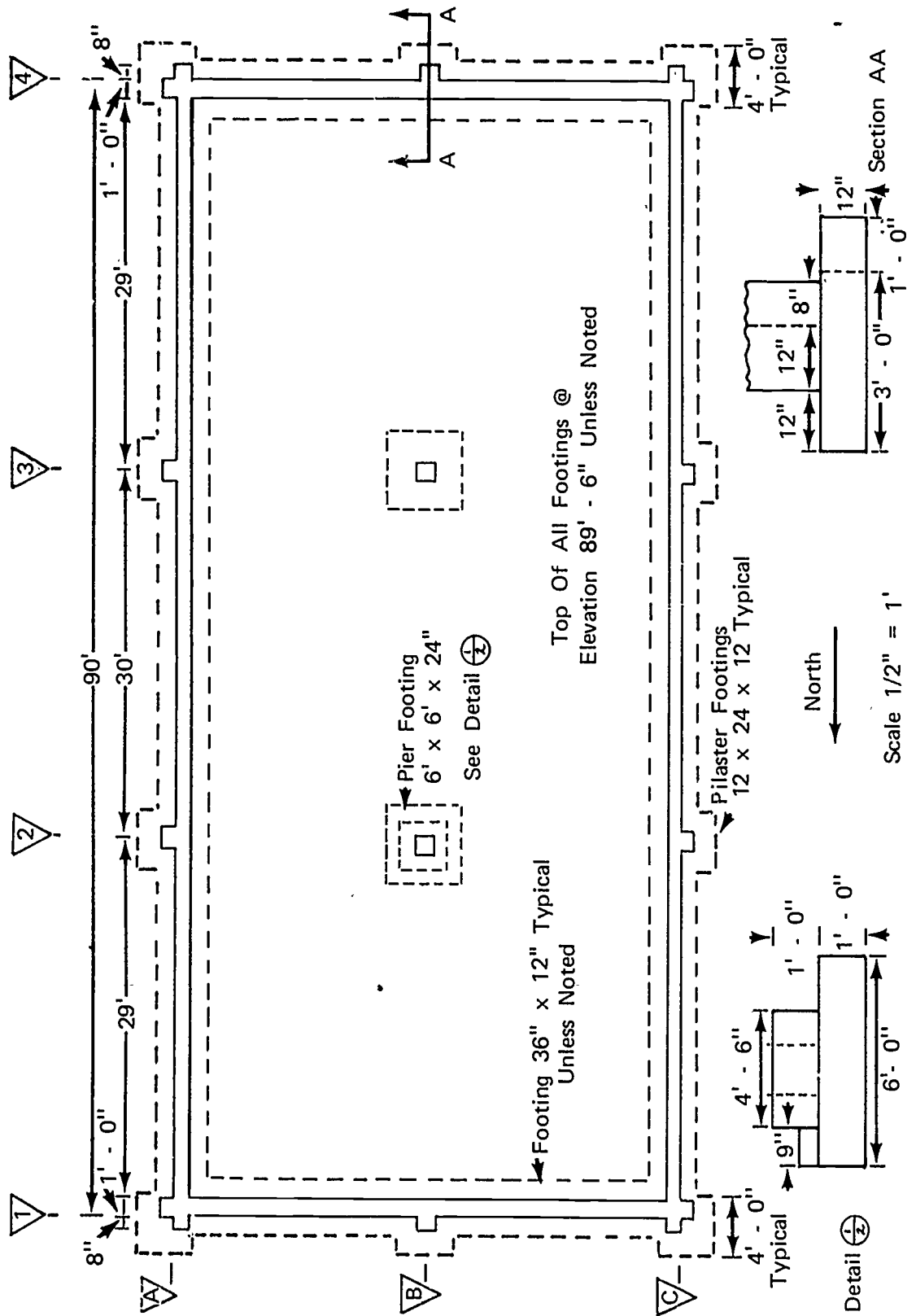

BATTER BOARD LAYOUT PLAN SHEET #3

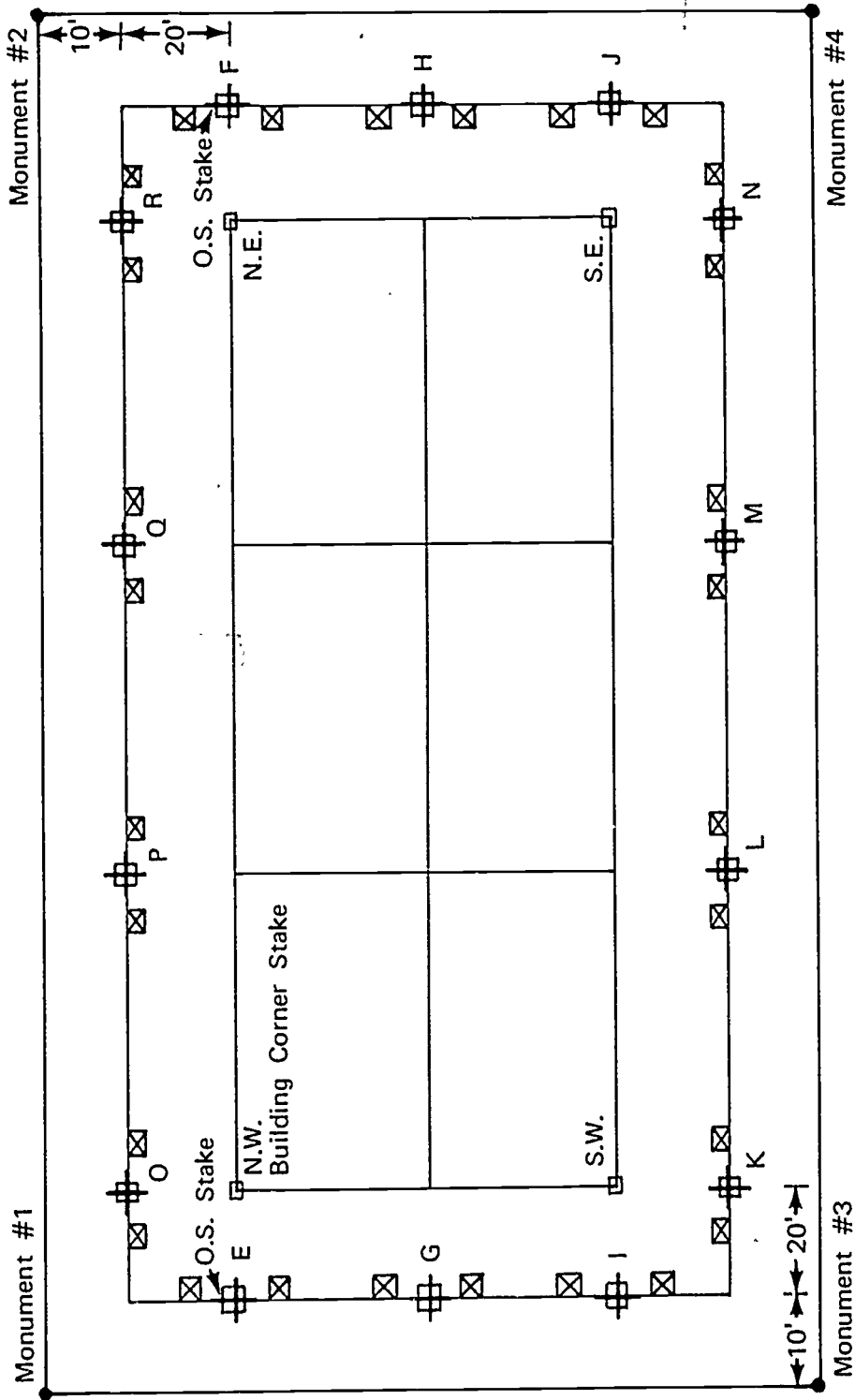

North →

O.S. Stake = Offset Stake

JOB SHEET #1

II. Procedure

- A. Locate the markings on the batter boards that indicate the building lines; secure the string in the kerfs and pull the lines taut (Figure 1)

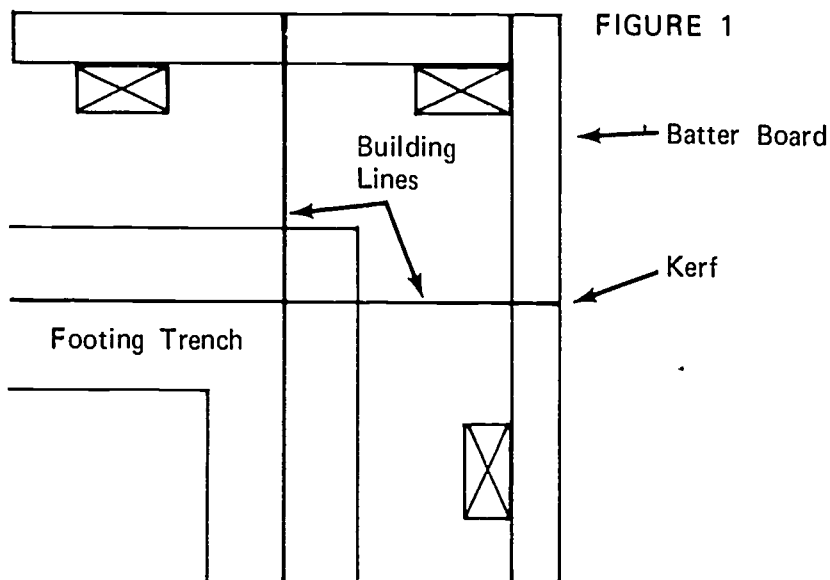

- B. From the intersection of the two lines, drop a plumb bob to point A to locate the building corner; drive a corner stake at this location, and drive a nail in top of it at the exact point where the plumb bob touches it (Figure 2)

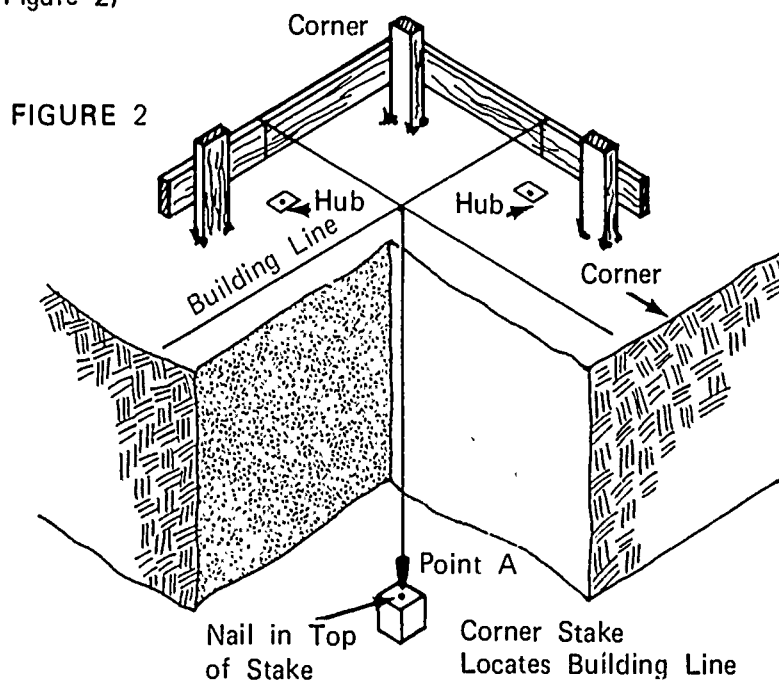

JOB SHEET #1

C. Transfer bench mark to bottom of excavation

1. Set up builder's level
2. Establish H.I. from bench mark

(NOTE: See Plan Sheet #1--Plot plan.)

3. Assuming an H.I. of $103' - 6''$, from the plot plan we find the basement floor elevation is $89' - 6''$ from $103' - 6''$ which is $14' - 0''$; this is the figure we should read on the leveling rod; however, the rod is only $12'$ long, so we will drive a stake in the bank reading $11' - 6''$ on the leveling rod, this will be at elevation $92' - 0''$ (Figure 3)

FIGURE 3

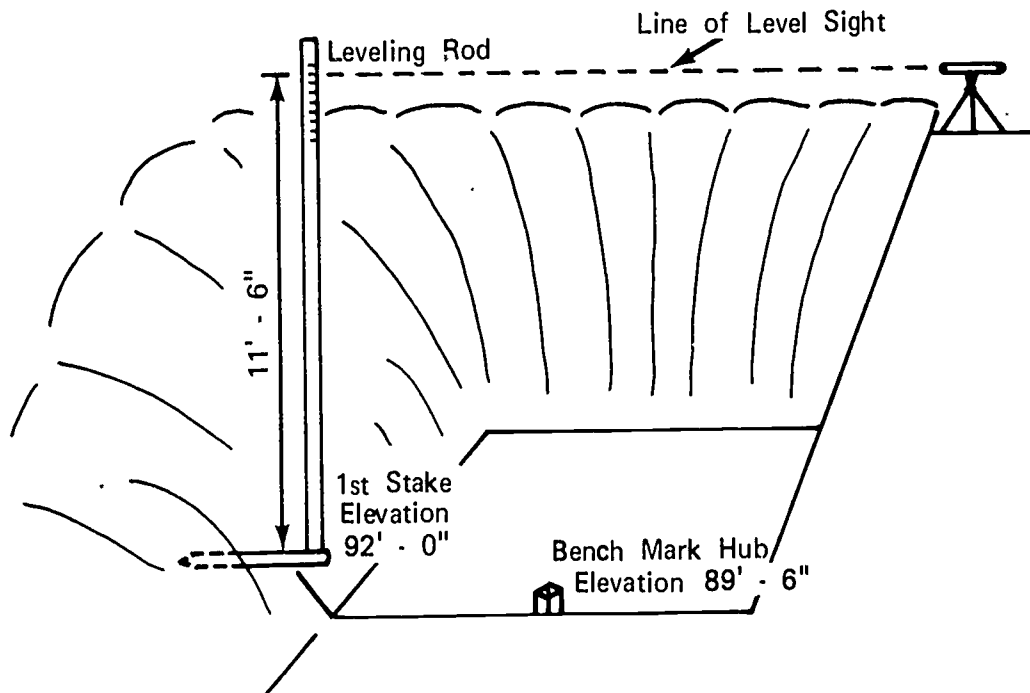

4. Move the instrument to the bottom of the excavation and set it up

JOB SHEET #1

5. Pick up H.I. from stake @ elevation 92' - 0" and set another hub inside the footing line with the top of the stake @ elevation 89' - 6" (Figure 4)

(NOTE: The bench mark hub should be placed in a central location and out of the areas of traffic.)

FIGURE 4

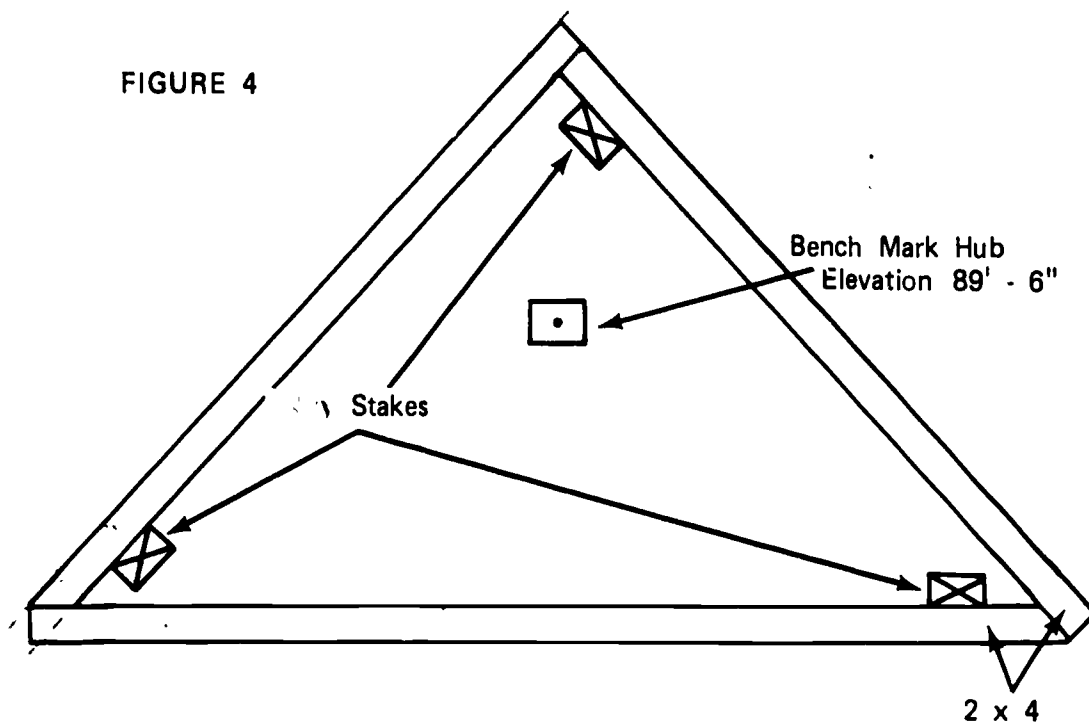

JOB SHEET #1

- D. Repeat step B at all corners
- E. Measure from the building corner stakes to the inside of the footing plus the thickness of the sheathing board, locate and drive the corner form stakes, and leave the top of the stakes one to two inches above the grade point (Figure 5)

(NOTE: See foundation plan. This dimension should be 24" plus 1 1/2" for sheathing equals 25 1/2".)

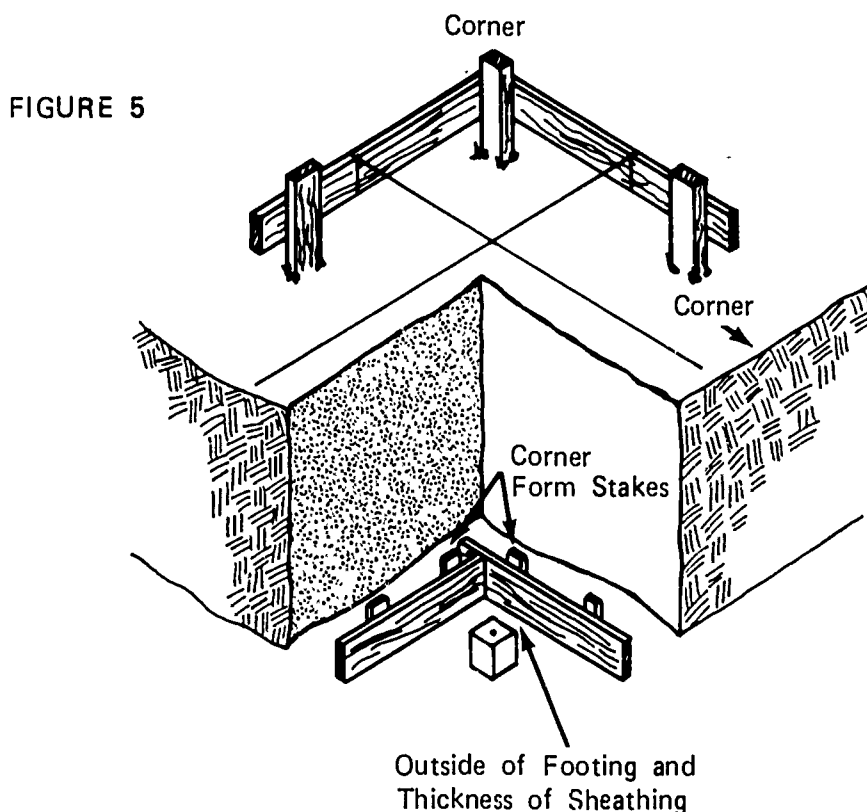

- (NOTE: Use the builder's level to locate the grade point. See Figure 3.)
- F. Stretch a string between the corner stakes one inch above the grade point
- G. Drive intermediate stakes at about four foot intervals
- H. Place sheathing boards in position and nail them to the stake one inch below the string
- (NOTE: Form oil must be applied before installation.)
- I. Cut a spreader the width of the footing to locate the position for the outside stakes

(NOTE: Remember to allow for the thickness of the sheathing when locating stakes. See Figure 6.)

JOB SHEET #1

FIGURE 6

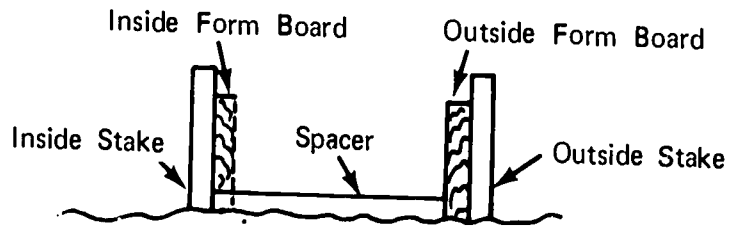

- J. Lay out all pilaster footings on inside form
(NOTE: See foundation plan for dimensions.)
- K. Drive stakes as indicated in Figure 7 and attach outside sheathing boards to the stakes
(NOTE: Level across the top of the sheathing boards to locate the grade point for the outside form.)

FIGURE 7

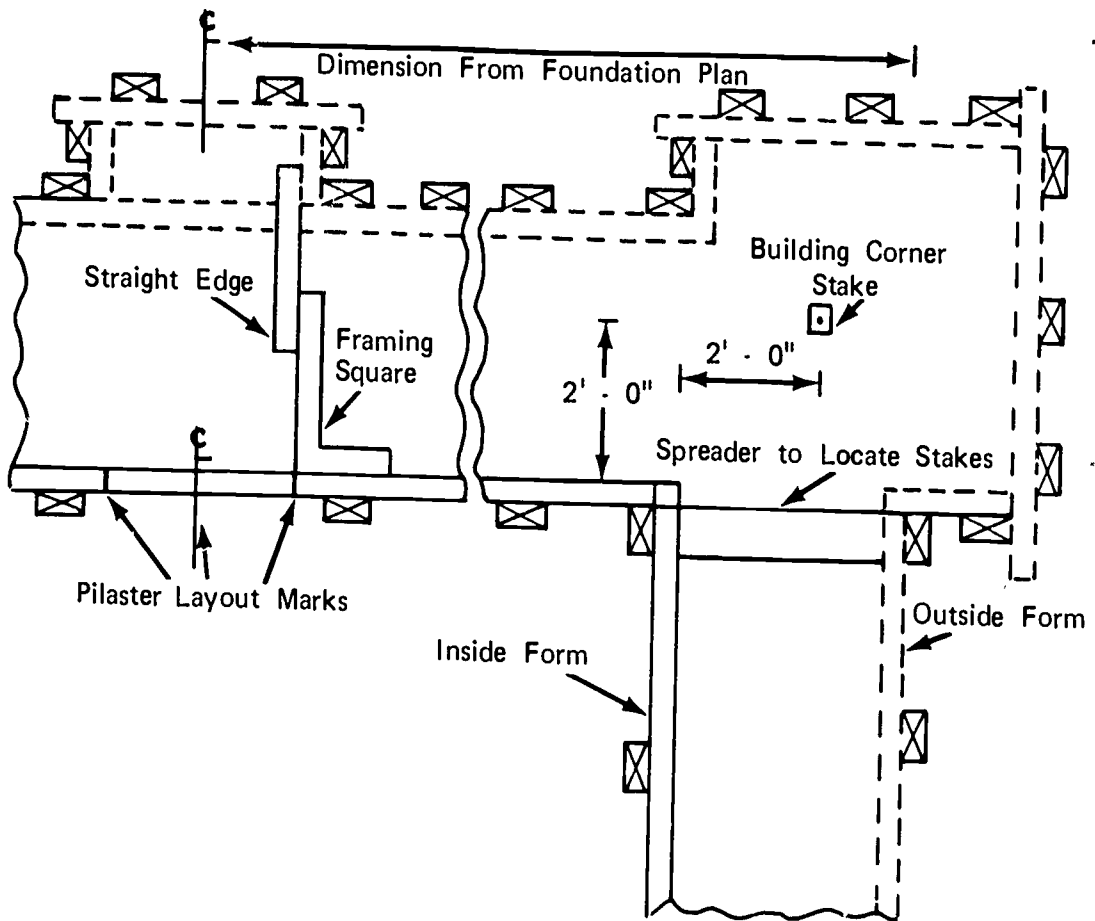

JOB SHEET #1

- L. Nail cleats across top of form (Figure 8)

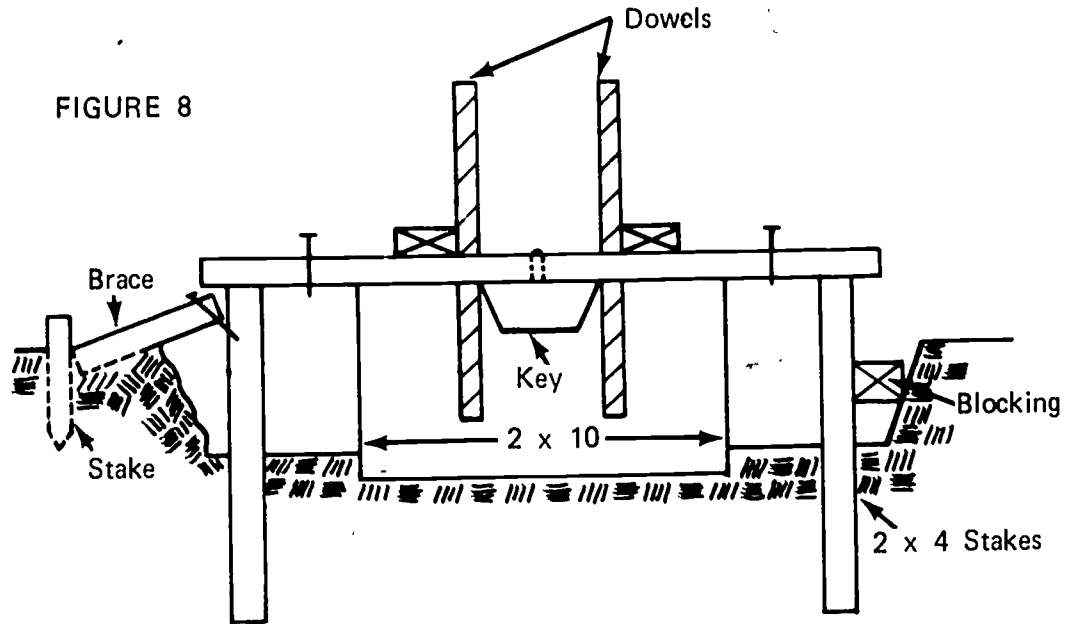

(NOTE: If dowels are used, a 2" x 4" may be nailed across the cleats to support them. For ease of pouring, dowels and key way may be installed after concrete is in place.)

- M. The forms may be aligned by bracing or blocking (See Figure 8.)

FOOTING FORMS
UNIT IIJOB SHEET #2--CONSTRUCT AND SET FORMS
FOR A PILE CAP

I. Tools and materials needed

A. Tools

1. Electric handsaw
2. Crosscut handsaw
3. Claw hammer (16 oz. or larger)
4. Sledge hammer
5. 100 foot steel tape measure
6. Twelve or sixteen foot tape measure
7. Level (hand)
8. Builder's level
9. Electric drill
10. Chalk line
11. Wrench (Ten inch adjustable)

B. Materials

1. Stakes
2. Sheathing
3. Spreaders
4. Form ties
5. 2 x 4's or 2 x 6's for:
 - a. Braces
 - b. Studs
 - c. Plates
 - d. Walers

JOB SHEET #2

6. Nails
 - a. 8D duplex
 - b. 16D duplex
 - c. 6D Common
 - d. 16D Common
 - e. 8D Common
7. Form oil

II. Procedure

- A. Determine the size of the form (Figure 1)

⊕ = Center Line

FIGURE 1

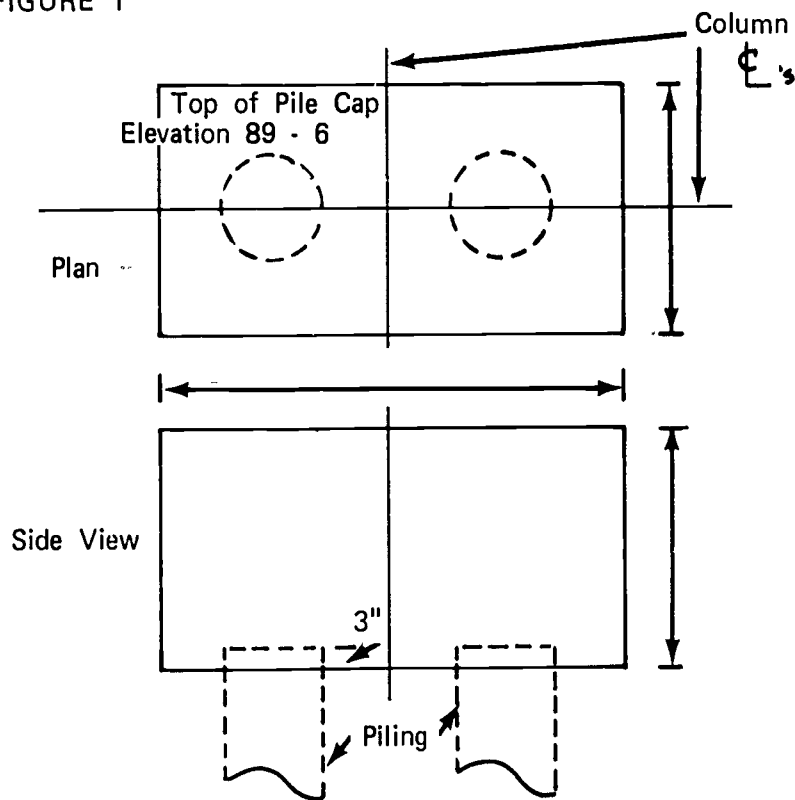

JOB SHEET #2

- B. Make material cut list (Figure 2)

FIGURE 2

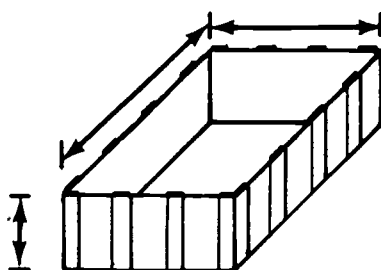

- C. Build forms

1. Using cut list as a guide, cut studs and sheathing to length and width

(NOTE: It is not absolutely necessary to rip plywood to width; form can be set and the grade line marked by driving nails into the sheathing. See Figure 3.)

FIGURE 3

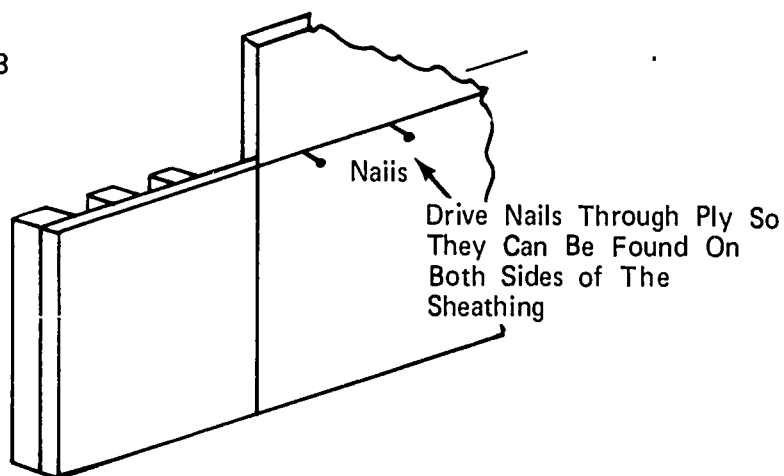

2. Lay out stud spacing (Figure 4)
 - a. Lay out the first and last stud on all four panels

(NOTE: Refer to corner detail for stud overhang of specific panel.)

JOB SHEET #2

- b. Divide the remaining distance into equal spaces not exceeding 16" on center

(NOTE: Place an X (witness mark) on the side of this layout line on which the stud will be placed.)

FIGURE 4

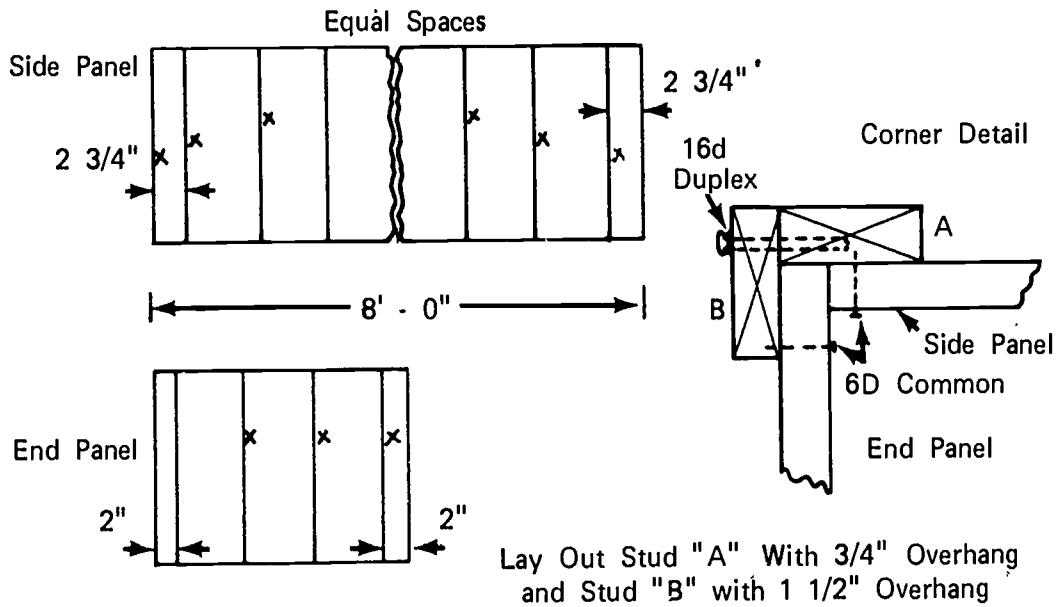

3. Nail sheathing to studs of the four panels (Figure 5).

(NOTE: The nailing pattern, shown in Figure 5, is sufficient for one or two pours. If the forms are used on more than two, they should be nailed at one foot centers.)

FIGURE 5

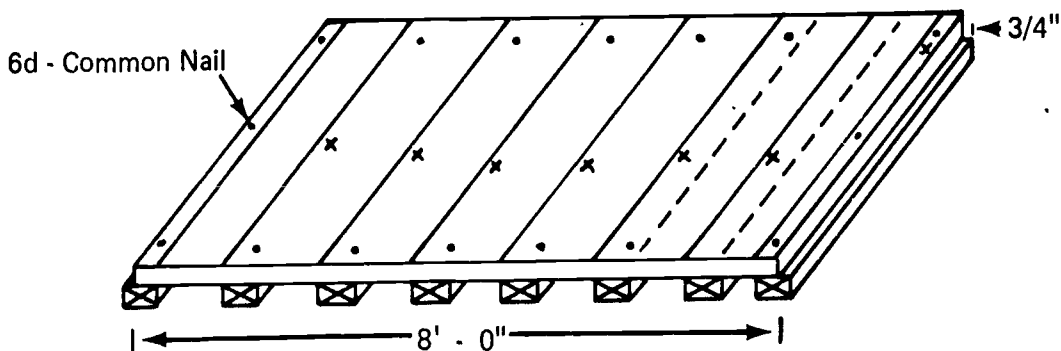

JOB SHEET #2

4. Drill the form tie holes (if used) (Figure 6)

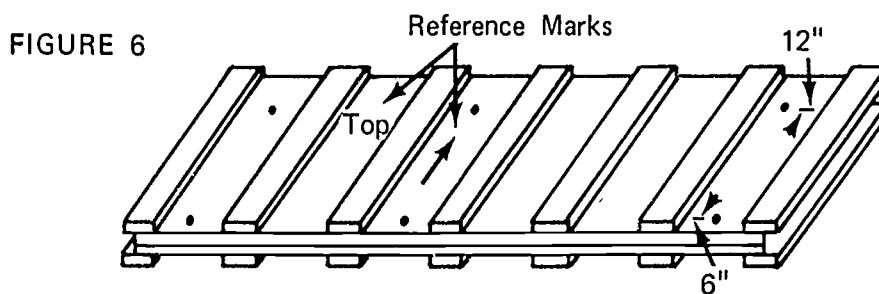

(NOTE: Scribe a line for horizontal location, so the ties will line up with the slot in the waler.) (Figure 7)

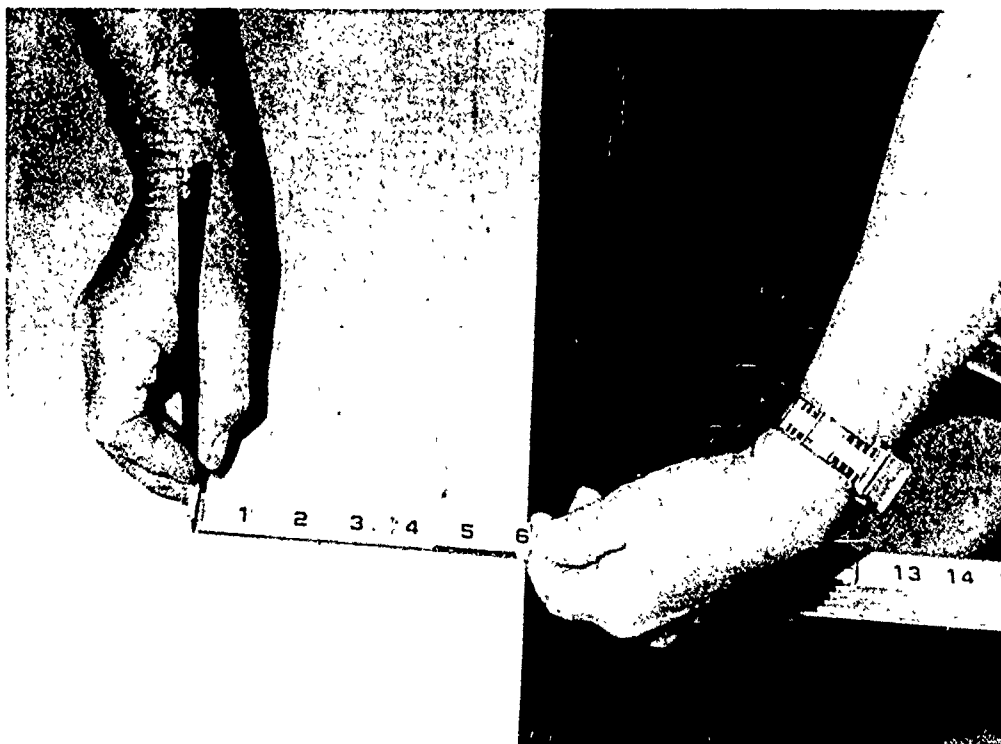

5. Set panels in excavation surrounding piles
(NOTE: Orient panels with reference marks.)

JOB SHEET #2

6. Nail panels together at the corners (Figure 8)

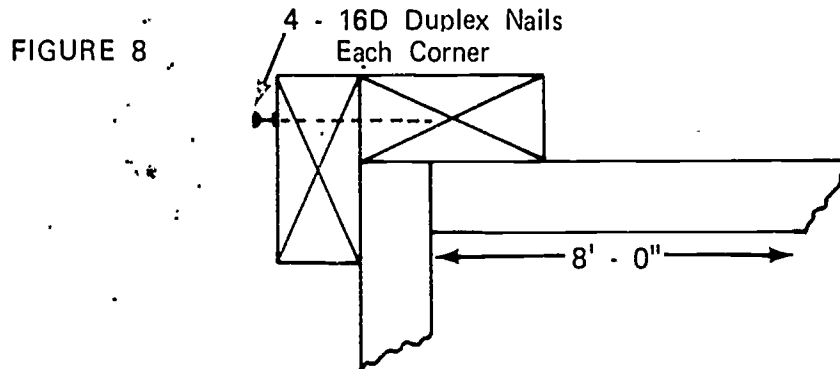

7. Locate the center of the four sides and square a mark across the top of the sheathing (Figure 9)

FIGURE 9

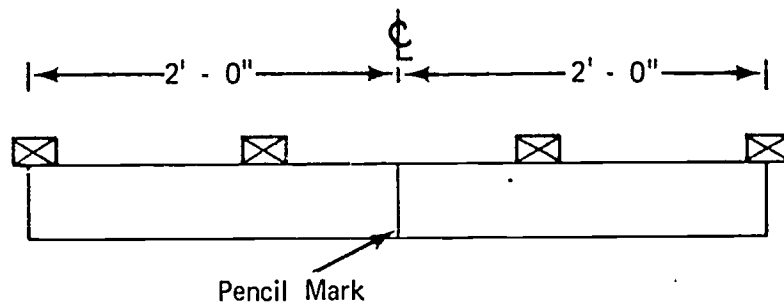

End Panel Shown

8. Set column center line stakes (Figure 10)
- a. Attach lines to the previously set batter boards AB and CD

JOB SHEET #2

- b. Locate stakes number 1, 2, 3, and 4 with a plumb bob hung from these lines

(NOTE: After stakes are driven, locate exact point of plumb bob on stake and drive a nail in the top of the stake at this location.)

FIGURE 10

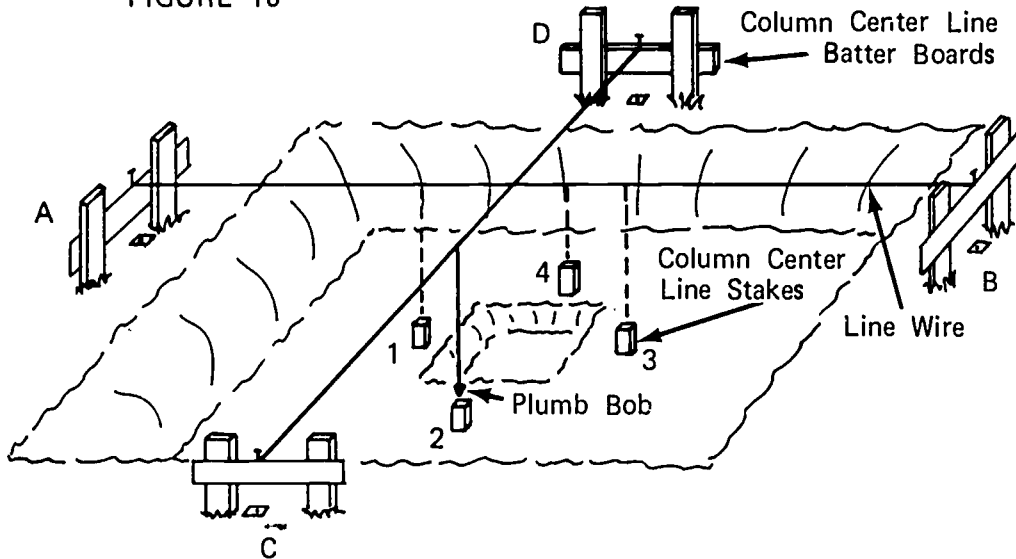

9. Secure line to nail in column center line stakes 1, 2, 3, and 4, pull the line taut (Figure 11)

FIGURE 11

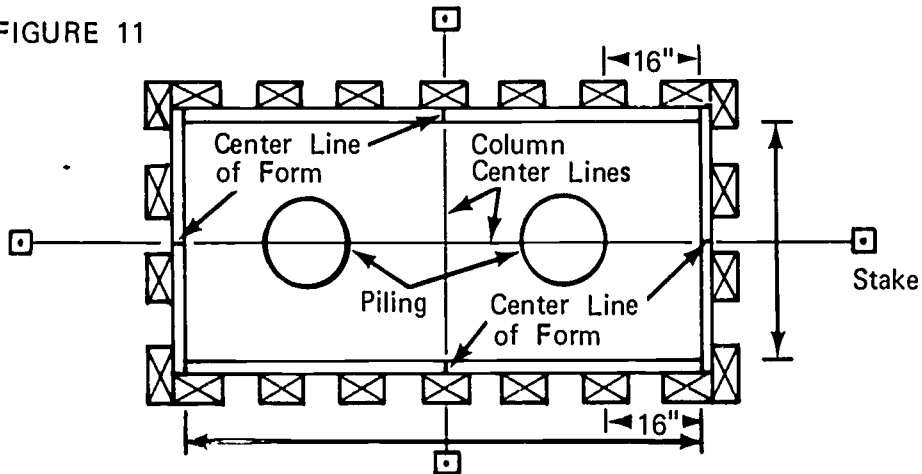

JOB SHEET #2

10. Line up, from center line, marks with column center lines (See Figure 11.)
11. Drive stakes at corners of form to hold it in position
12. Bring form to grade by blocking up and nailing to stake (Figure 12)

FIGURE 12

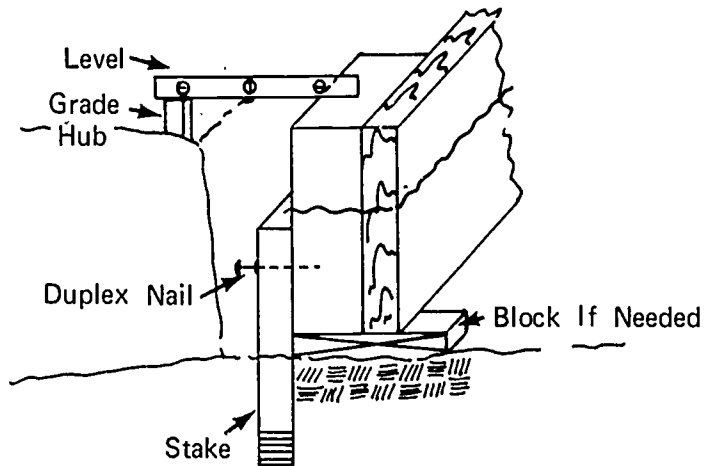

(NOTE: Form oil must be applied before rebar installation.)

13. Install form ties
14. Install walers

(NOTE: If form ties are not used, walers may be 2 x 4, or larger and should be nailed flat against the form.)
15. Cut spreaders to width of form; place at top and bottom of the form under the center line mark
16. Install buttons on form ties on one side and one end of the form
17. Install buttons on form ties on the opposite sides; pull form tight against spreaders and secure buttons

JOB SHEET #2

18. Install form without ties (Figure 13)

(NOTE: All procedures are the same except for drilling tie holes, installing the ties, and the type of waler used.)

FIGURE 13

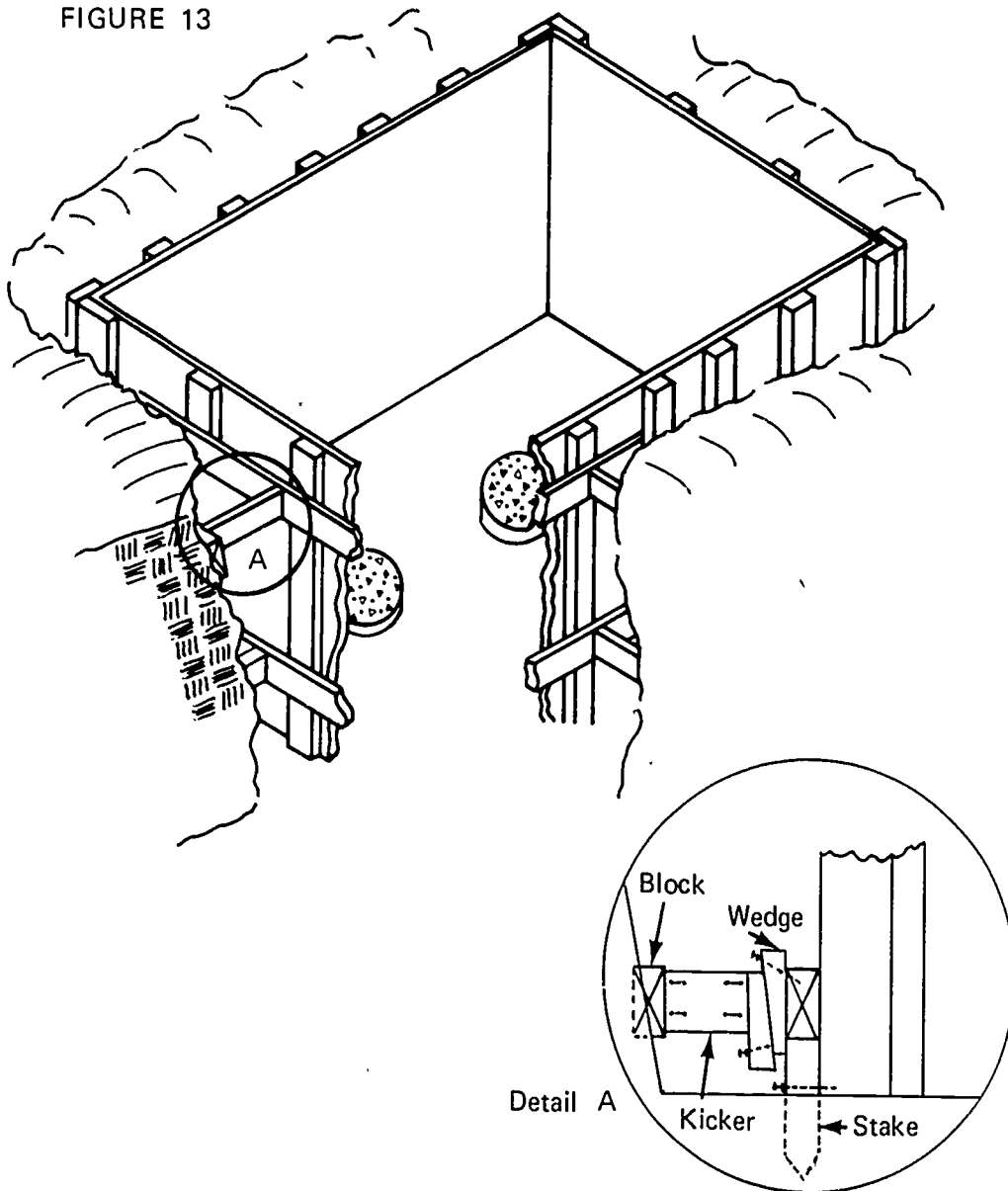

- a. Smooth off spot on bank for block
- b. Place block on smooth spot and measure from face of block to face of waler to secure kicker length
- c. Cut kicker

JOB SHEET #2

- d. Install kicker and block as shown in detail "A", Figure 13
- e. Install kickers at top and bottom walers, spaced horizontally as needed

(NOTE: Nail kickers securely so they do not vibrate out.)

406

FORMING
UNIT IIJOB SHEET #3--CONSTRUCT AND SET FORMS
FOR A PIER FOOTING

A. Tools

1. Electric handsaw
2. Crosscut handsaw
3. Claw hammer (16 oz. or larger)
4. Sledge hammer
5. 100 foot steel tape measure
6. Twelve or sixteen foot tape measure
7. Level
8. Builder's level
9. Electric drill
10. Chalk line
11. Wrench (Ten inch adjustable)
12. String line or wire

B. Materials

1. Stakes
2. Sheathing
 - a. 3/4" plywood
 - b. 2 x 10
3. Spreaders
4. Form ties
5. 2 x 4's or 2 x 6's for:
 - a. Braces
 - b. Studs
 - c. Hanger
6. Nails
 - a. 8D duplex
 - b. 16D duplex

JOB SHEET #3

- c. 6D common
- d. 16D common
- e. 8D common
- 7. Form oil
- 8. Column clamps

II. Procedure

- A. Determine the size of the form (Figure 1)

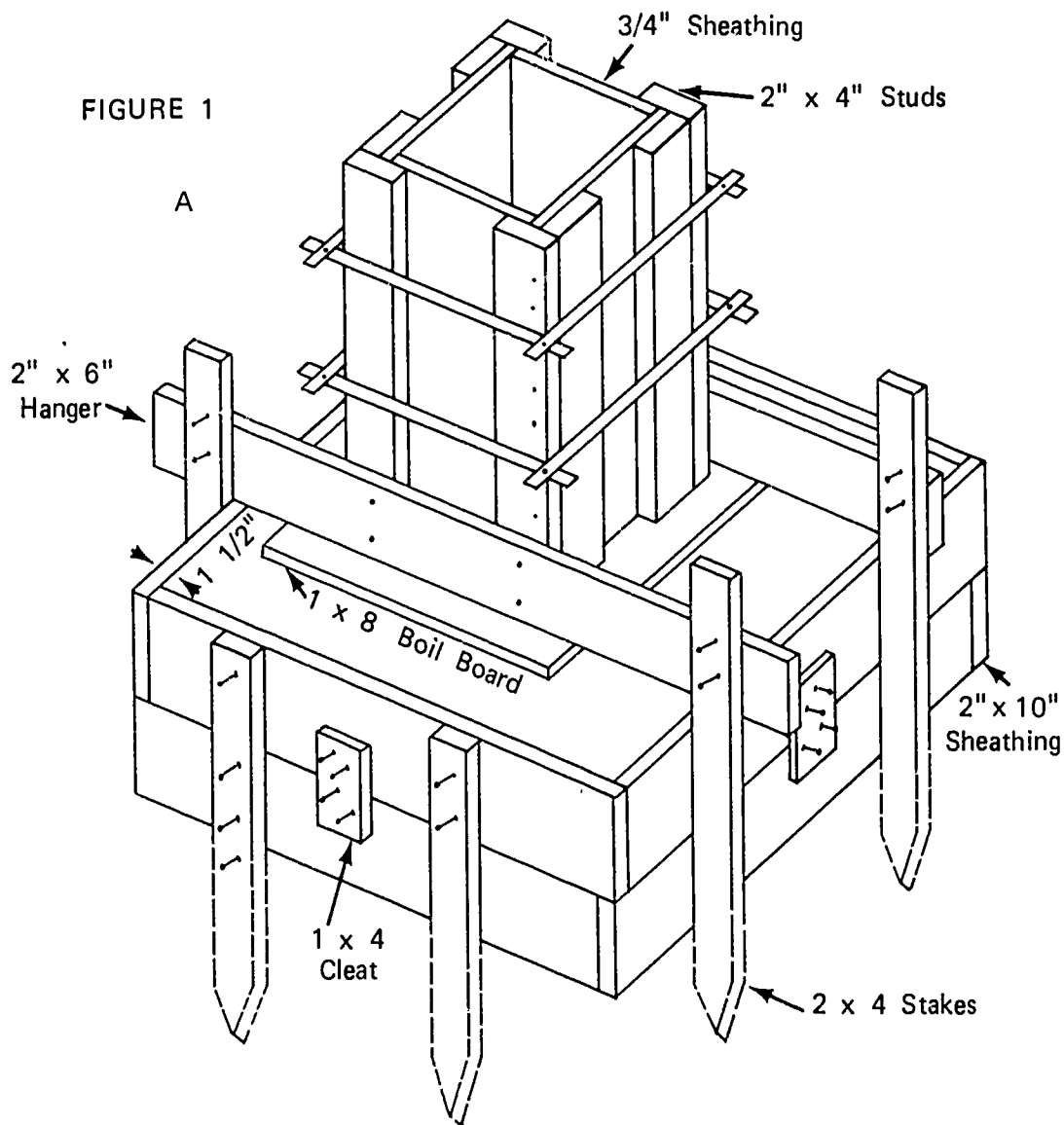

JOB SHEET #3

FIGURE 1

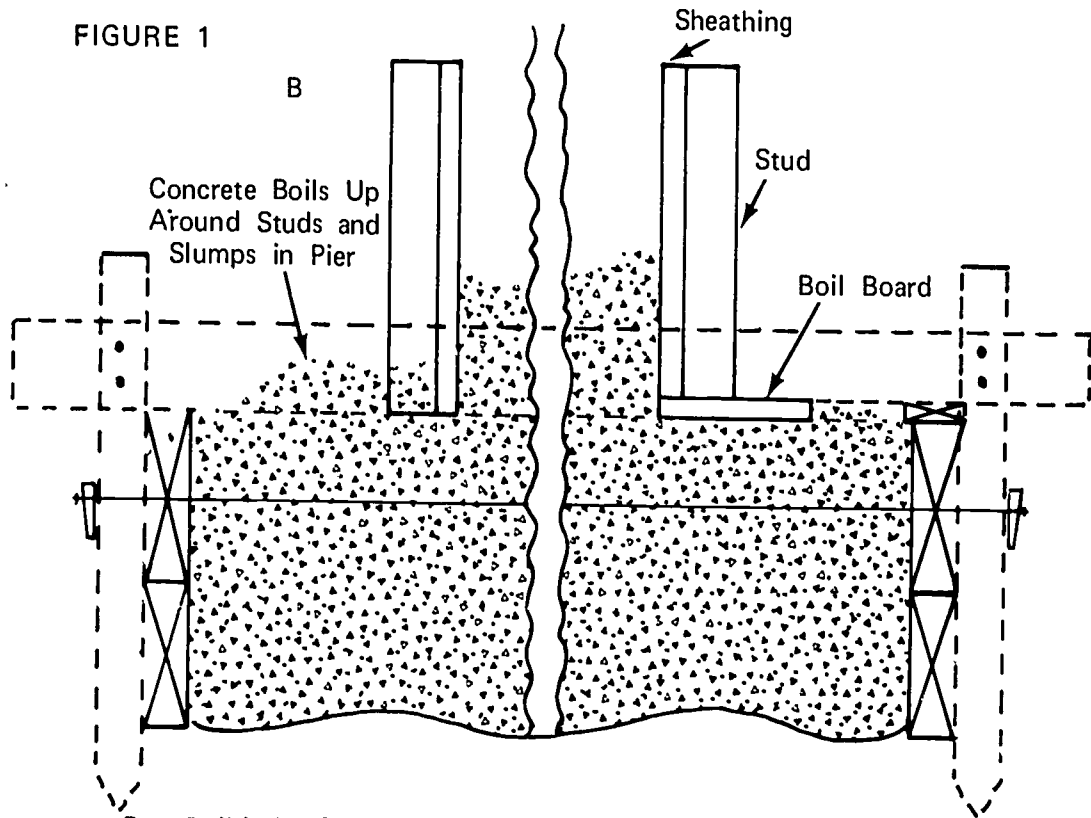

B. Build the forms

1. Make a material cut list (See Figure 1A.)
2. Cut material to size using the material cut list
3. Build the bottom form (Figure 2)

FIGURE 2

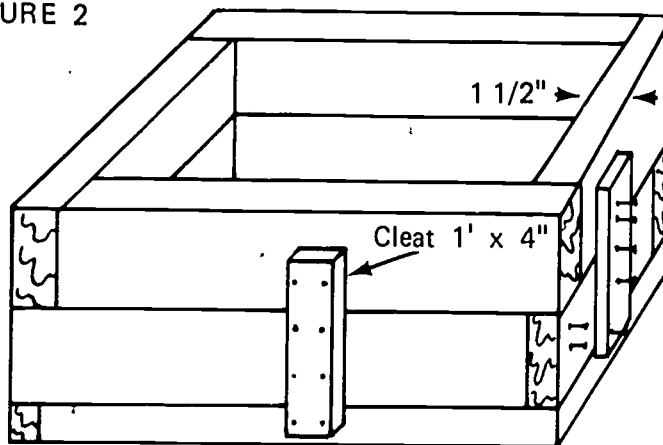

JOB SHEET #3

- Build the pier form panels (Figure 3)

FIGURE 3

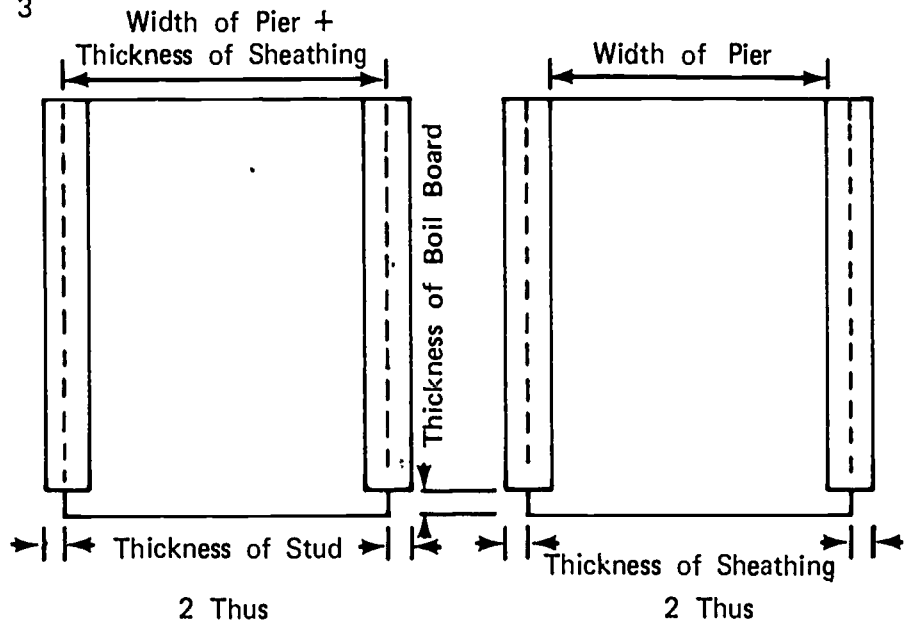

- Nail the panels together (Figure 4)

FIGURE 4

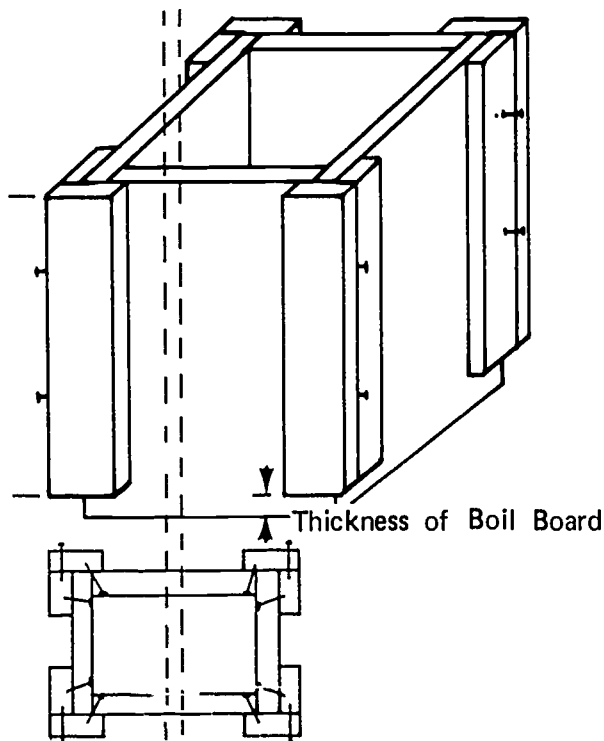

- Coat both forms with form oil

JOB SHEET #3

C. Locate and set column center line stakes (Figure 5)

FIGURE 5

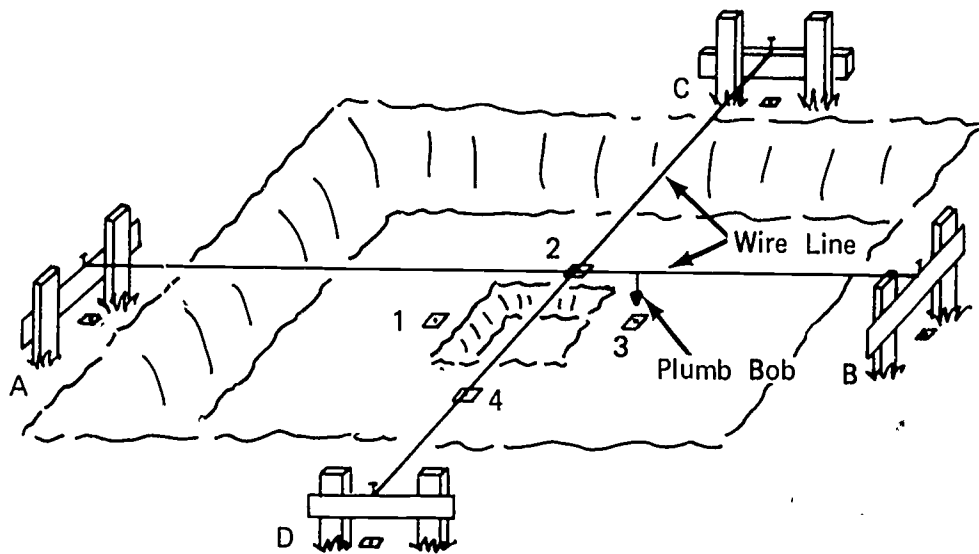

1. Stretch a line from stakes A-B and C-D
2. Establish center line stakes number 1, 2, 3, and 4 using a plumb bob

JOB SHEET #3

D. Set the form

1. Set bottom form section in excavation
2. Mark center line on all four sides of the form (Figure 6)

FIGURE 6

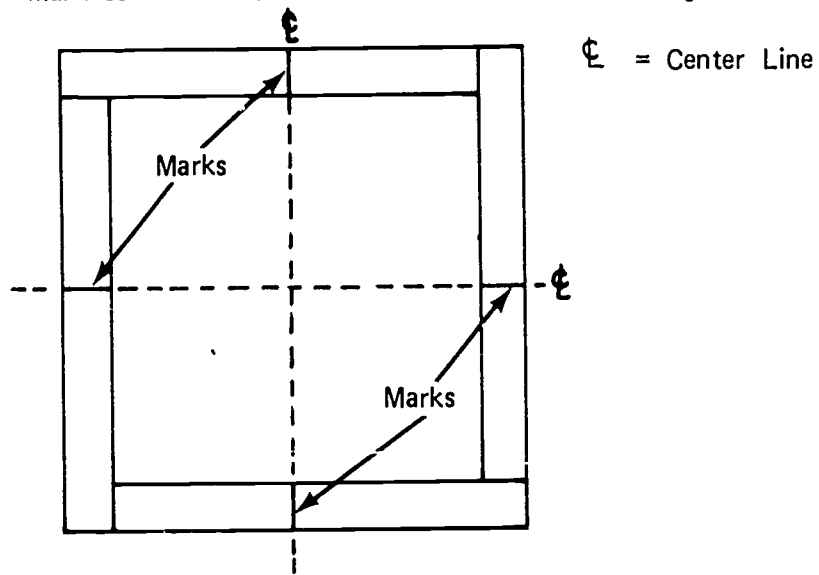

3. Stretch a line between stakes 1-3 and 2-4, pull it taut (See Figure 5.)
4. Locate form with center line marks directly under column center lines using a plumb bob or hand level (Figure 7)

FIGURE 7

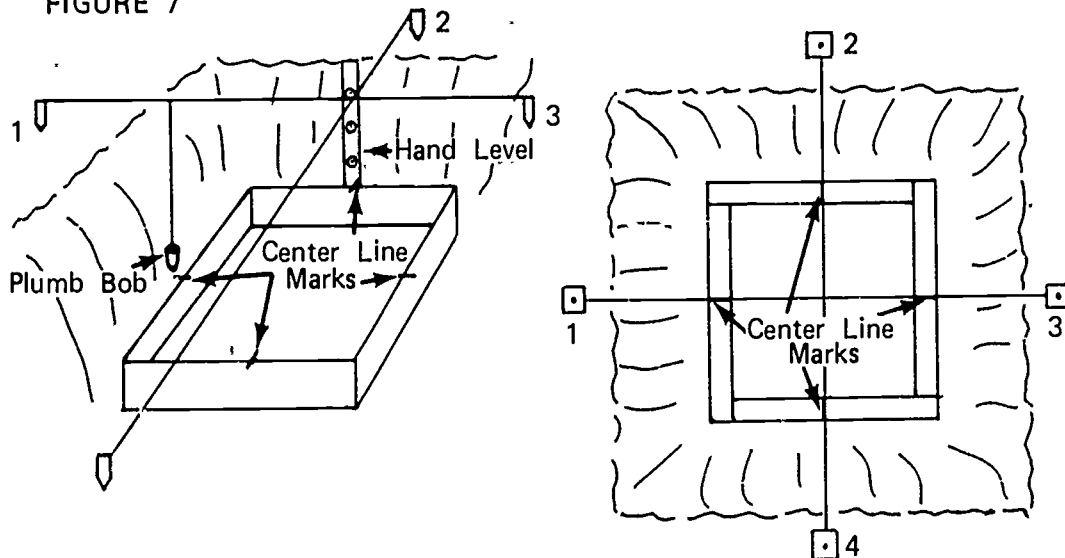

5. Drive stake at four corners of the form

JOB SHEET #3

6. Block up to grade and nail to stakes (Figure 8)

(NOTE: Use builder's level and leveling rod to establish grade from bench mark to the corners of the form.)

FIGURE 8

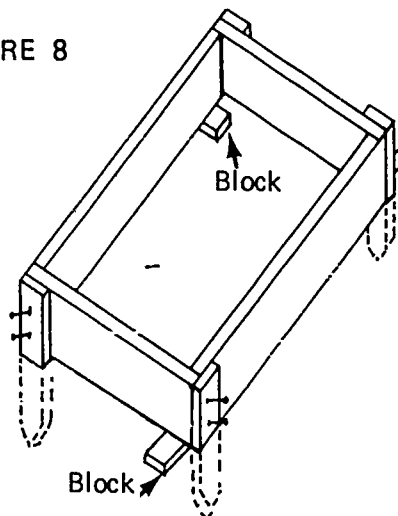

7. Turn pier panel upside down and install boil boards and hangers (Figure 9)

FIGURE 9

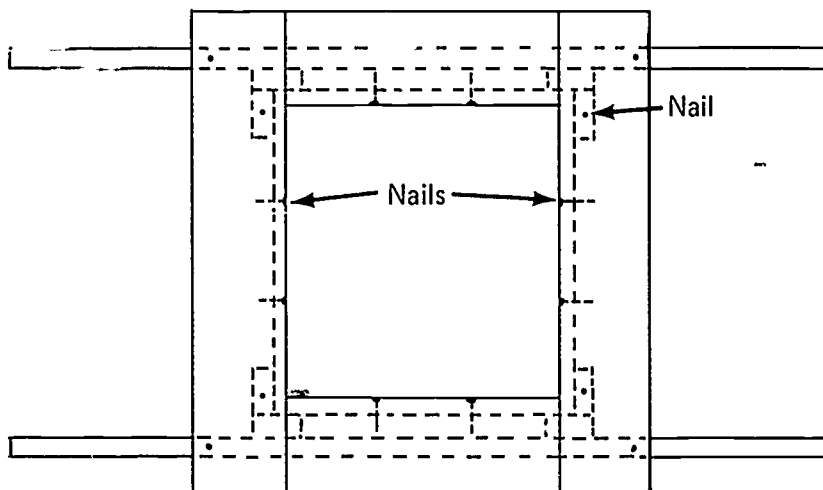

(NOTE: Install hanger so it is parallel to the short boil boards.)

JOB SHEET #3

8. Set pier form on bottom form and position it approximately on the column center line marks (Figure 10)

(NOTE: Raise hangers. Place a block between it and the lower form at the four points the hanger sets on the form and tack the block in place.)

FIGURE 10

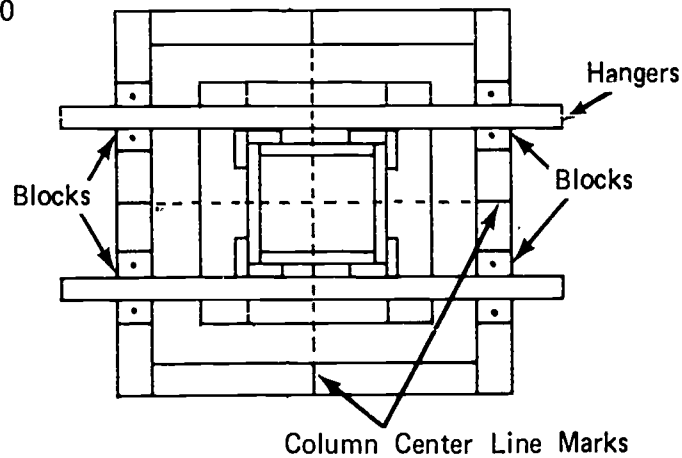

9. Mark the center of the sides of the pier form on the top of the sheathing (Figure 11)

FIGURE 11

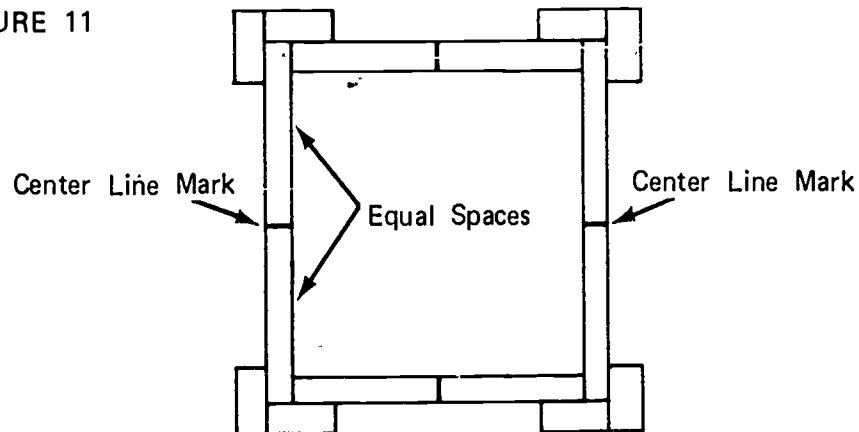

10. Plumb down from column center line to the marks on the top of the pier
(NOTE: This is the same as setting the bottom form in Figure 6.)

JOB SHEET #3

11. Nail hangers to bottom form
12. Drive stakes along the side of the form and the hanger
13. Check alignment of pier; if it is still okay, nail stakes to hangers (See Figure 1A.)
14. Install column clamps

(NOTE: Position one on top of hanger and one six inches from the top of the pier form. See Figure 1. If piers are over two feet high, more clamps will be needed.)

15. Brace or use kicker on the bottom form (Figure 12)

FIGURE 12

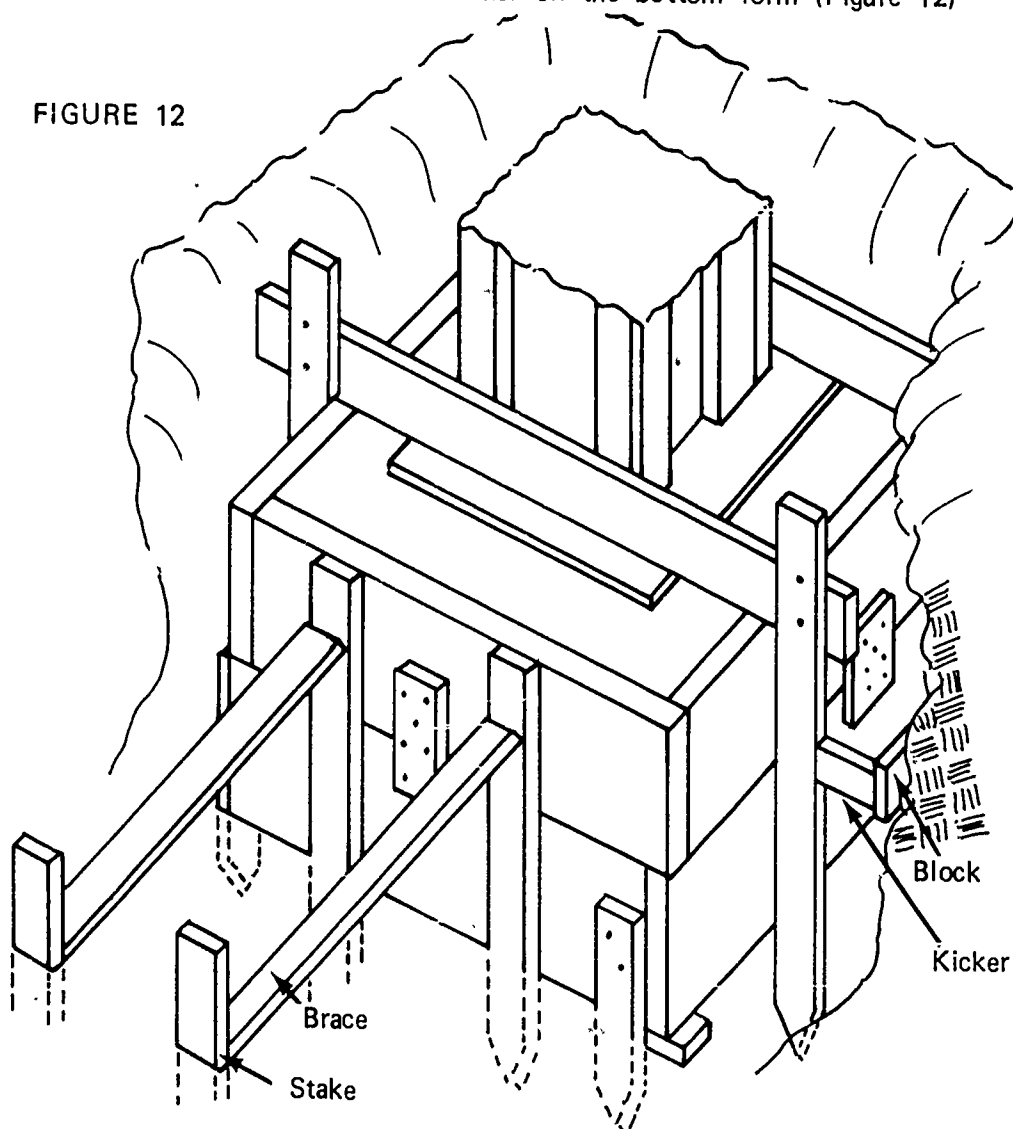

JOB SHEET #3

D. Build and set bolt template (Figure 13)

FIGURE 13

Bolt Setting Template

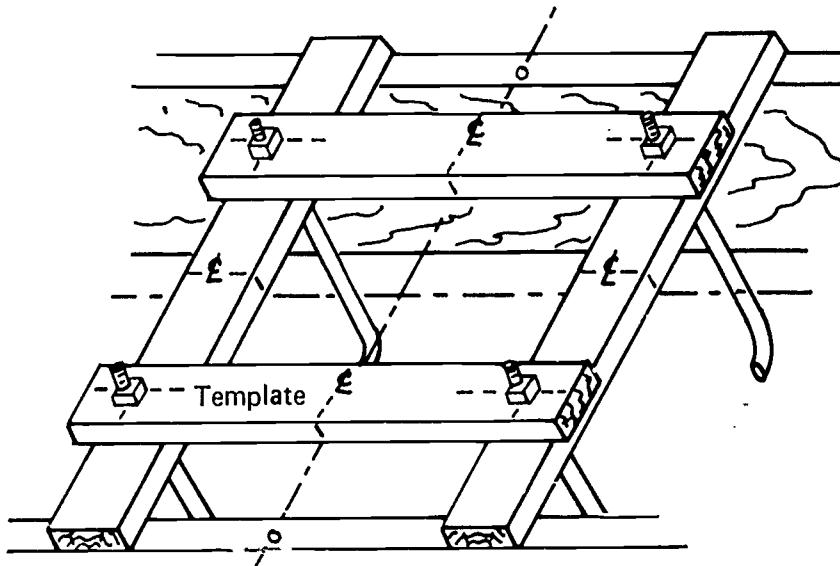

1. Cut two pieces of 1 x 3 long enough to reach across the top of the pier form
2. Cut two pieces three inches longer than the center line spacing of the bolts

JOB SHEET #3

3. Make a center line mark across the four pieces (Figure 14)

FIGURE 14

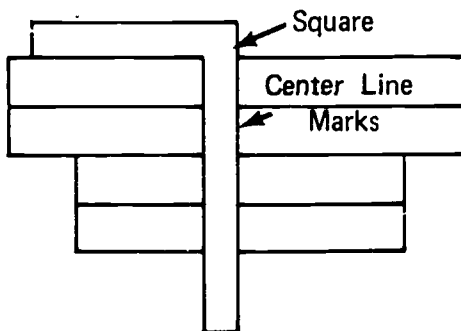

4. Lay out the bolt spacing on the length of the two short boards; cross these lines with a center line mark on the width (Figure 15)

(NOTE: Accuracy is of the utmost importance in all bolt layout.)

FIGURE 15

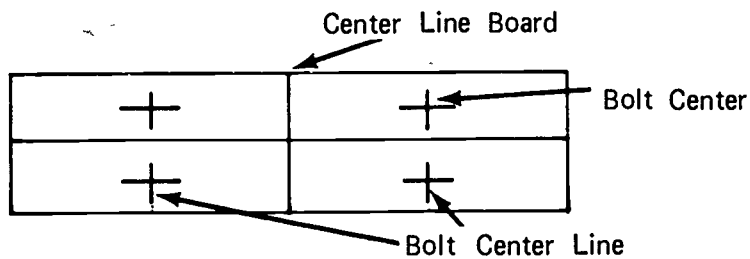

JOB SHEET #3

5. Nail the four pieces together (Figure 16)

(NOTE: Check template for square and bolt centers for distance before nailing securely.)

FIGURE 16

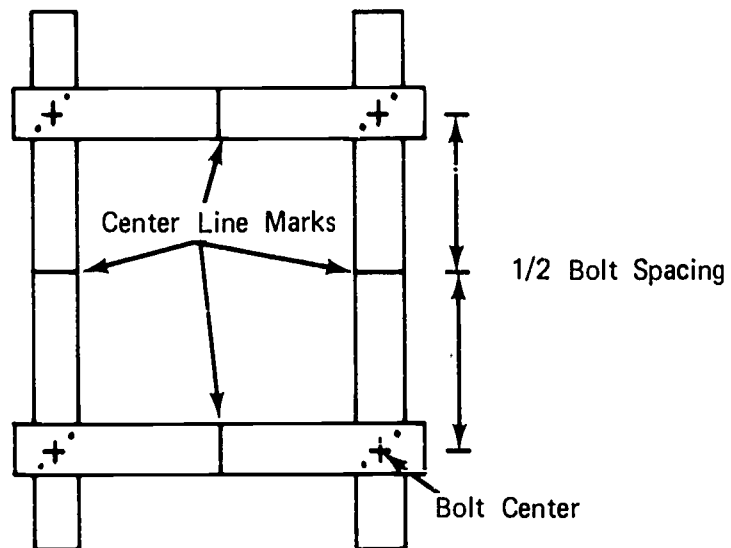

6. Drill holes at crosses marking bolt center

(NOTE: Holes should not be more than one-sixteenth larger than the bolt.)

JOB SHEET #3

7. Set template on pier form use a square to locate it on the column center lines; nail securely to form (Figure 17)

(NOTE: Recheck bolts for location and plumb after concrete is poured.)

FIGURE 17

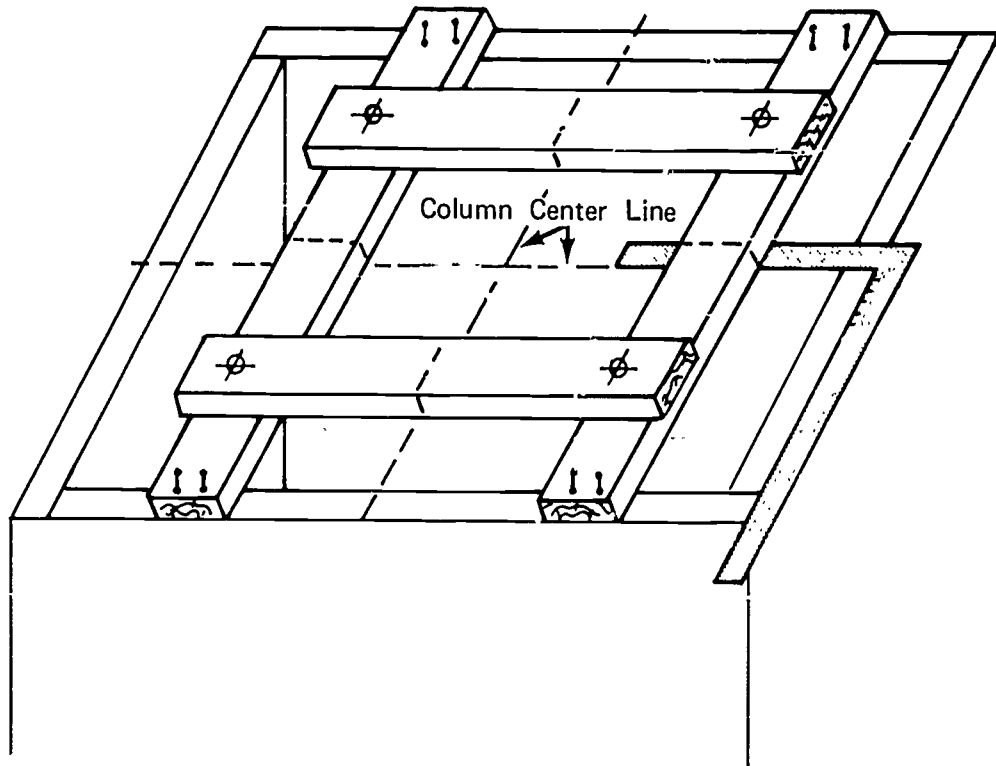

FOOTING FORMS UNIT II

JOB SHEET #4--STRIP PIER FORMS AND PREPARE THEM FOR ERECTION AT ANOTHER LOCATION

I. Tools and materials needed

A. Tools

1. Wrecking bar
2. Claw hammer (16 oz. or larger)
3. Large brush or spray can

B. Materials--Form oil

II. Procedure

A. Stripping forms

(NOTE: Remove in the reverse order of setting.)

1. Remove braces, kickers, and cleats on bottom form
2. Remove column clamps
3. Remove hangers

(NOTE: Care should be taken not to damage the form parts any more than necessary so that they may be reused.)

4. Remove pier form
 - a. Remove the duplex nails from 2 corners of the form
 - b. Pry this side from the pier
(CAUTION: Do not pry against the green concrete.)
 - c. Remove the remaining three sides as one unit (Figure 1)

FIGURE 1

Pry Out —
Hit Here To Loosen Back Side

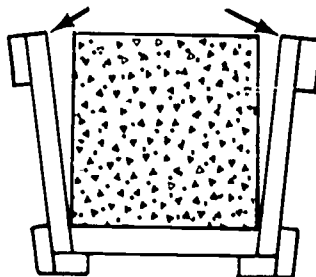

5. Remove the duplex nails from one corner of the bottom forms
6. Spread forms apart at this corner and remove in one unit

JOB SHEET #4

B. Prepare for erection at next location

1. Re-nail single pier panel to three panel sections
(NOTE: If boil board was damaged, replace it.)
2. Attach hangers
3. Re-nail corner of bottom form sections
4. Coat inside of forms with form oil
5. Transfer all parts to next location

FOOTING FORMS
UNIT II

TEST

1. Match the following list of footing forming terms to the list of definitions.

- | | |
|---|---------------------|
| _____ a. A wire or metal cross tie used to hold the pressure of wet concrete and maintain the proper wall thickness | 1. Brace |
| _____ b. A beveled strip of wood or metal placed on the form where future pours occur | 2. Cleat |
| _____ c. A block of wood or other material used as a spacer at offsets in a form | 3. Duplex nail |
| _____ d. Wide boards, plywood, or metal that make up the face of the form | 4. Footing |
| _____ e. A short piece of steel bar inserted through a bulkhead to tie adjoining pours together | 5. Form tie |
| _____ f. A piece of material nailed across a splice to strengthen and hold it together | 6. Foundation |
| _____ g. A board placed in a form to cut off the concrete pour | 7. Grade point |
| _____ h. Small boards or steel bars sharpened on one end and driven into the ground to support a form | 8. Key |
| _____ i. A block of wood that is used to hold the sides of the form apart and is removed as the concrete is poured; it may also be an integral part of a form tie | 9. Key way |
| _____ j. A machine used to transport concrete from the mixer to the pour site | 10. Monolithic pour |
| _____ k. A power tool used to consolidate concrete | 11. Scab |
| | 12. Sheathing |
| | 13. Spreader |
| | 14. Spacer block |
| | 15. Stake |
| | 16. Dowel |
| | 17. Bulkhead |
| | 18. Hopper |
| | 19. Vibrator |
| | 20. Power buggy |
| | 21. Form oil |
| | 22. Boil board |
| | 23. Strip form |
| | 24. H. I. |

- _____ l. The level of the finished concrete in a form
- _____ m. A receptacle usually funnel shaped, open, or with a gate at the bottom
- _____ n. A continuous mass of concrete cast as a single piece
- _____ o. That portion of a wall upon which the building rests
- _____ p. A groove left in the concrete by removal of the key
- _____ q. Paraffin oil or other manufactured product used on a form to prevent adhesion of concrete to the form
- _____ r. A double headed nail used in forming and designed for easy removal
- _____ s. A piece of wood or other material that directs, resists, or supports weight or pressure
- _____ t. A strip of wood or metal fastened across a form for temporary positioning or to replace a form tie
- _____ u. An enlarged area at the base of a wall or other object to distribute the weight of the superstructure
- _____ v. The process of removing a form after the concrete has set
- _____ w. A wide board placed around the bottom of a form to keep the concrete from rising up around the form
- _____ x. The vertical distance from the bench mark to the line of sight of the instrument

2. Write the purpose of forms.

3. Identify ten parts of a footing form by placing the correct number in the blanks provided.

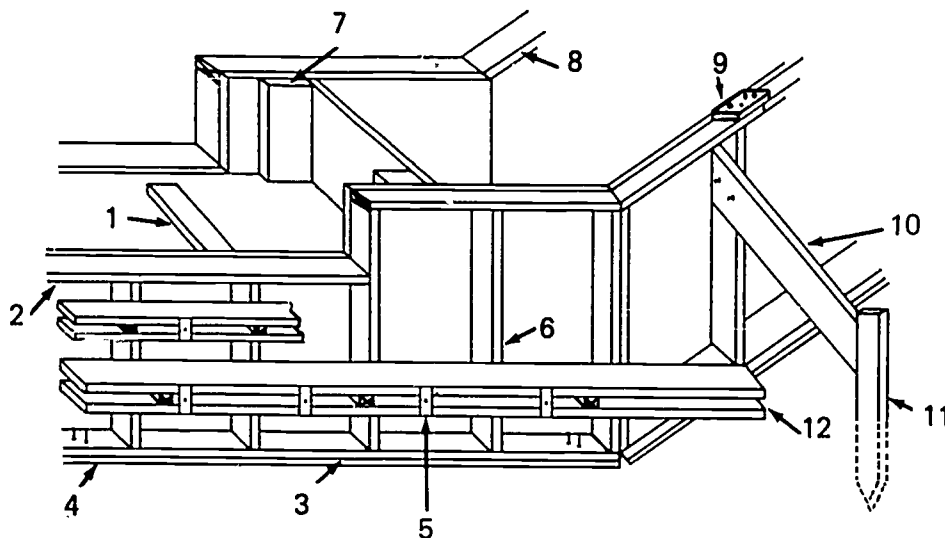

- ___ a. Cleat
- ___ b. Spreader
- ___ c. Stud
- ___ d. Form tie
- ___ e. Sole plate
- ___ f. Stake
- ___ g. Bottom plate
- ___ h. Waler
- ___ i. Brace
- ___ j. Top plate
- ___ k. Sheathing
- ___ l. Scab

4. Identify the six styles of footing by placing the correct number in the blanks.

- ___ a. Continuous
 - ___ b. Pile cap
- (Illustrations are given on the next three pages.)

- ___ c. Pier
- ___ d. Grade beam
- ___ e. Grillage
- ___ f. Stepped footing (continuous)

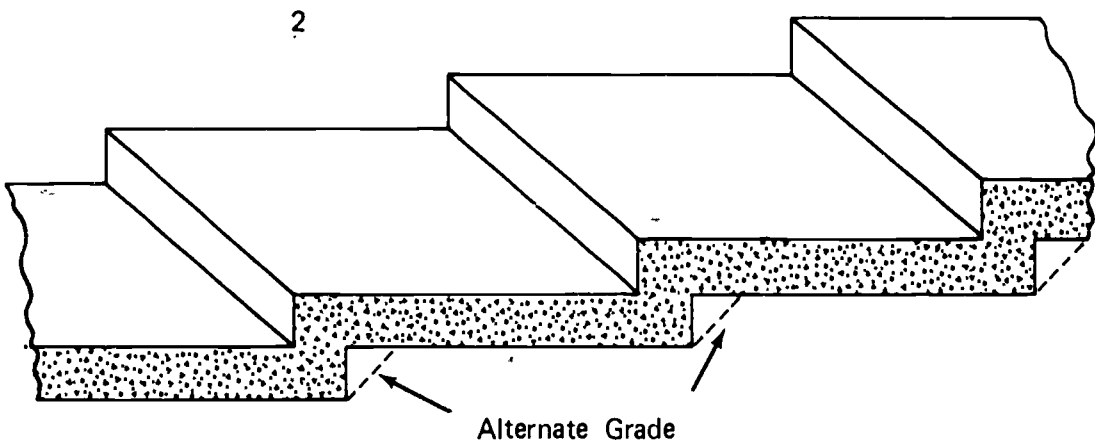
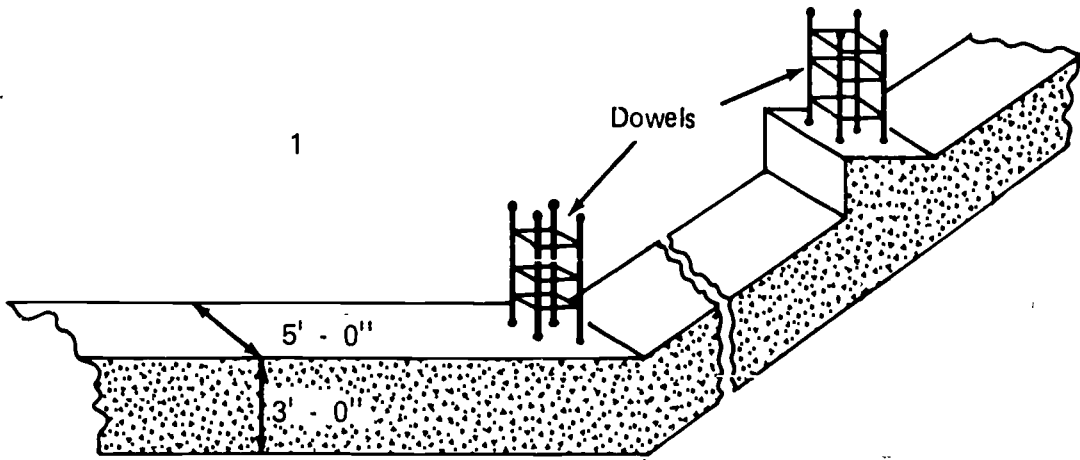

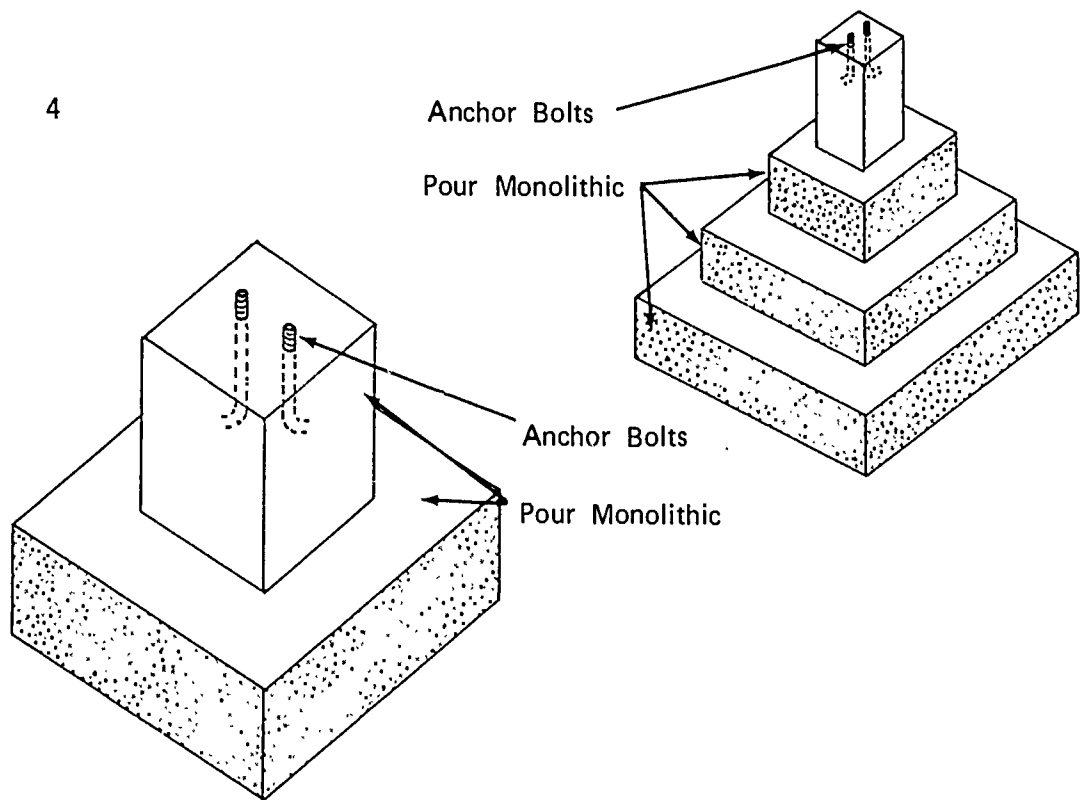
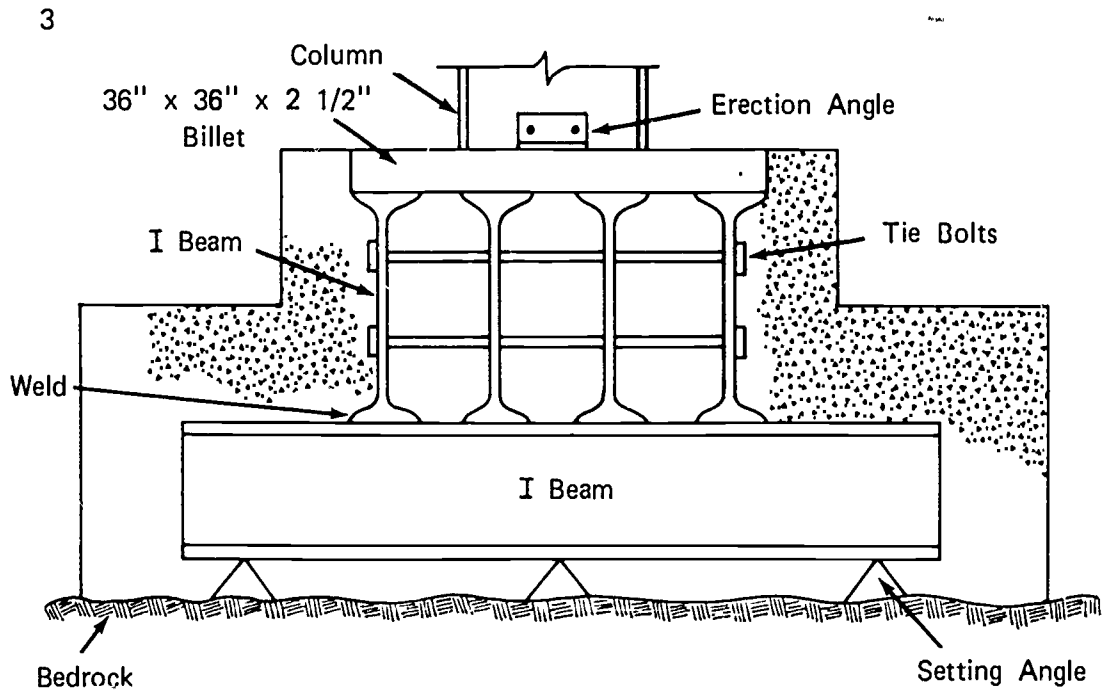

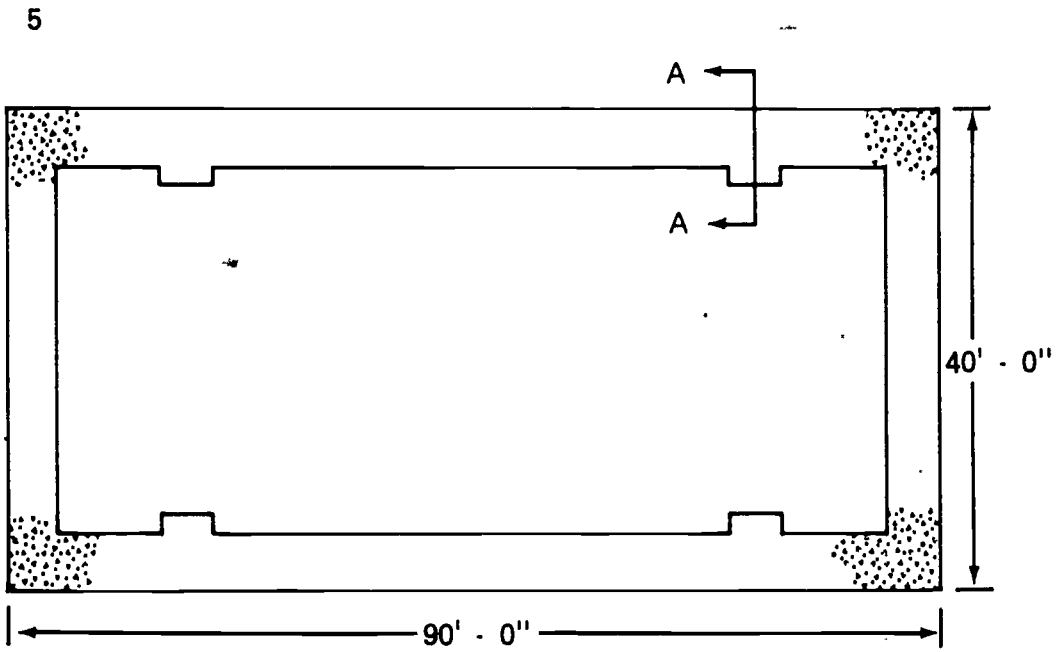

Section AA

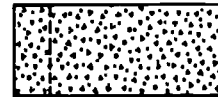

6

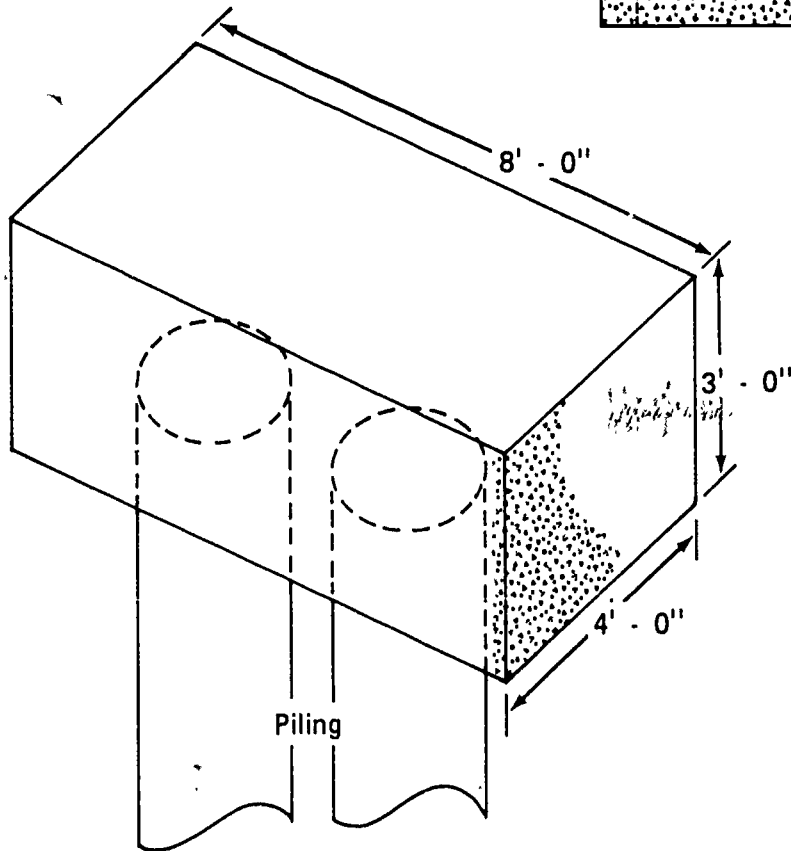

5. Name two methods of form construction.
 - a.
 - b.
6. Demonstrate the ability to:
 - a. Construct and set forms for a continuous footing.
 - b. Construct and set forms for a pile cap.
 - c. Construct and set a pier footing form.
 - d. Strip a pier footing form and prepare it for erection at another location.

(NOTE: If this has not been accomplished prior to the test, ask the instructor when the above activities should be completed.)

FOOTING FORMS
UNIT II

ANSWERS TO TEST

1. a. 5
b. 8
c. 14
d. 12
e. 16
f. 11
g. 17
h. 15
i. 13
j. 20
k. 19
l. 7
m. 18
n. 10
o. 6
p. 9
q. 21
r. 3
s. 1
t. 2
u. 4
v. 23
w. 22
x. 24

2. To hold wet concrete to the desired shape until it has set
3. Any ten of the following:
 - a. 7
 - b. 1
 - c. 6
 - d. 5
 - e. 4
 - f. 11
 - g. 3
 - h. 12
 - i. 10
 - j. 2
 - k. ~~8~~ 8
 - l. 9
4.
 - a. 5
 - b. 6
 - c. 4
 - d. 1
 - e. 3
 - f. 2
5.
 - a. Built on site
 - b. Patented
6. Performance skills will be evaluated according to the criteria listed on the progress chart.

EDGE FORMS ON GRADE UNIT III

TERMINAL OBJECTIVES

After completion of this unit, the student should be able to define wall form terms. He should be able to identify the parts of edge forms, name types of pours on which edge forms are used, and name three types of edge forms. He should be able to construct edge forms. This knowledge will be evidenced through demonstration and by scoring eighty-five percent on the unit test.

SPECIFIC OBJECTIVES

1. Match a list of form terms to the correct definitions.
2. Identify the parts of a form.
3. Name five types of pours on which edge forms are used.
4. Name three types of edge forms.
5. Demonstrate the ability to:
 - a. Construct edge forms for a floor without foundation walls.
 - b. Construct edge forms for a floor with foundation walls.
 - c. Construct edge forms for a stoop.

EDGE FORMS ON GRADE UNIT III

SUGGESTED ACTIVITIES

I. Instructor:

- A. Provide students with objective sheet.
- B. Provide students with information and job sheets.
- C. Make transparencies.
- D. Discuss terminal and specific objectives.
- E. Discuss information sheet.
- F. Demonstrate and discuss procedures outlined in job sheets.
- G. Give test.

II. Student:

- A. Read objective sheet.
- B. Study information sheet.
- C. Demonstrate the ability to accomplish the procedures outlined in the job sheets.
- D. Take test.

INSTRUCTIONAL MATERIALS

I. Included in this unit:

- A. Objective sheet
- B. Information sheet
- C. Transparency masters
 1. TM 1--Edge Form Without Wall
 2. TM 2--Edge Form With Wall
 3. TM 3--Types of Pours Using Edge Forms
 4. TM 4--Types of Pours Using Edge Forms (Continued)

5. TM 5--Types of Forms
6. TM 6--Types of Forms (Continued)

D. Job Sheets

1. Job Sheet #1--Construct Edge Forms for a Slab on Grade Without Foundation
2. Job Sheet #2--Construct Forms For a Slab on Grade With Foundation
3. Job Sheet #3--Construct Edge Forms For a Stoop

E. Test

F. Answers to test

II. References:

- A. Burke, Arthur E., J. Ralph Dalzell, and Gilbert Townsend. *Architectural and Building Trades Dictionary*. Chicago, Illinois: American Technical Society, 1955.
- B. Smith, Ronald C. *Principles and Practices of Heavy Construction*. Englewood Cliffs, New Jersey: Prentice Hall Inc. 1967.
- C. Peurifoy, R. L. *Formwork for Concrete Structures*. McGraw Hill Inc., 1964.
- D. *Concrete Form Construction*. Albany, New York: Delmar Publications.

EDGE FORMS ON GRADE
UNIT III

INFORMATION SHEET

- I. Terms and definitions
 - A. Edge form--A low form placed at the perimeter of a slab
 - B. Brace--A piece of wood or other material that directs, resists, or supports weight or pressure
 - C. Duplex nail--A double headed nail used in forming and designed for easy removal
 - D. Foundation--That portion of a wall including the footing upon which the building rests
 - E. Grade point--The level of the finished concrete in a form
 - F. Monolithic pour--A continuous mass of concrete cast as a single piece
 - G. Sheathing--Wood or metal that makes up the face of the form
 - H. Stake--Small boards or steel bars sharpened on one end and driven into the ground to help support a form
 - I. Expansion joint--A pre-formed piece of fibrous or asphaltic material used to separate units of concrete to prevent cracking due to expansion
 - J. Slab--A section of concrete larger in its horizontal dimensions than it is in thickness
 - K. Screed--A guide for leveling the surface
- II. Parts of an edge form (Transparencies 1 and 2)
 - A. Stake
 - B. Sheathing
 - C. Brace
 - D. Scab
 - E. Duplex nail
 - F. Block
 - G. Supports

INFORMATION SHEET

- H. Kicker
- I. Ties
- III. Types of pours using edge forms (Transparencies 3 and 4)
 - A. Floor with foundation
 - B. Floor without foundation
 - C. Stoop
 - D. Driveway
 - E. Sidewalk
- IV. Types of forms (Transparencies 5 and 6)
 - A. Wood
 - B. Metal
 - C. Combination of wood and metal

Edge Form Without Wall

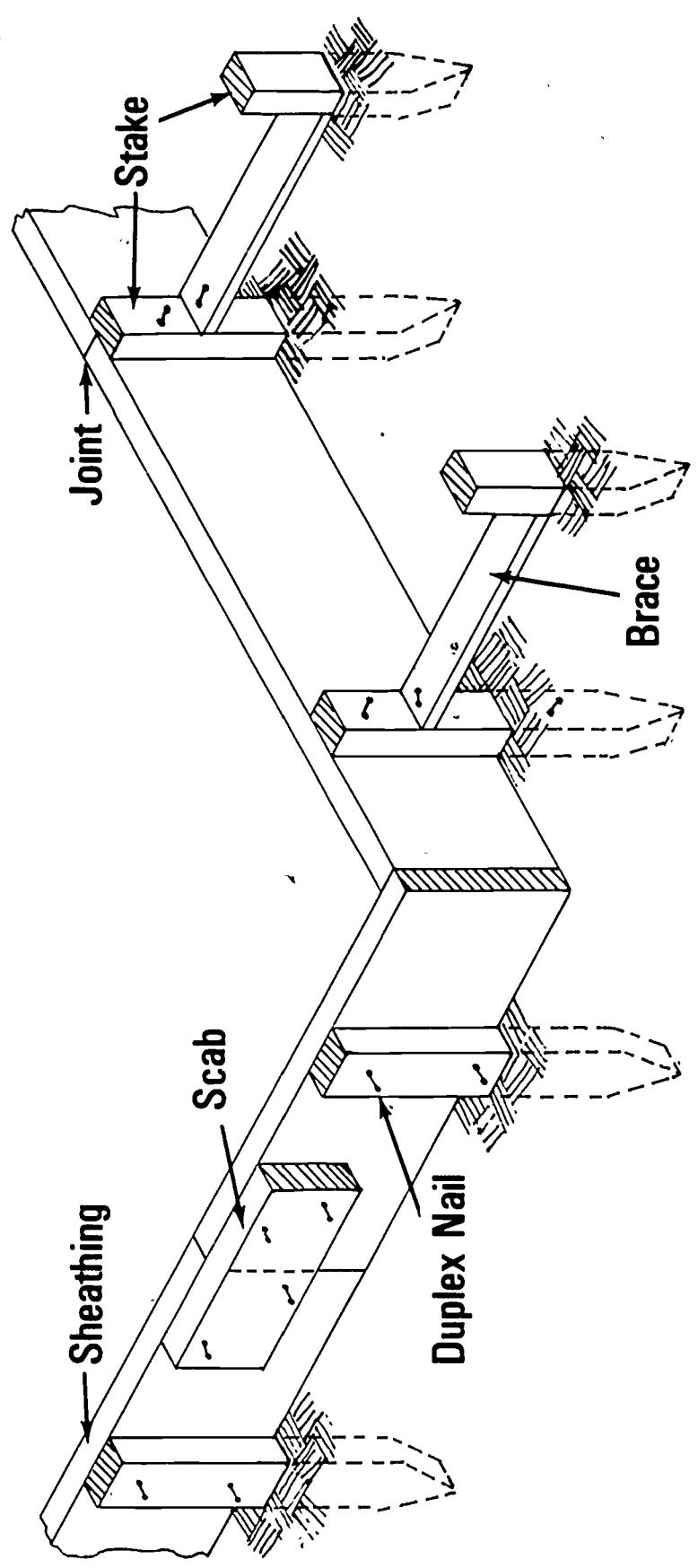

Edge Form With Wall

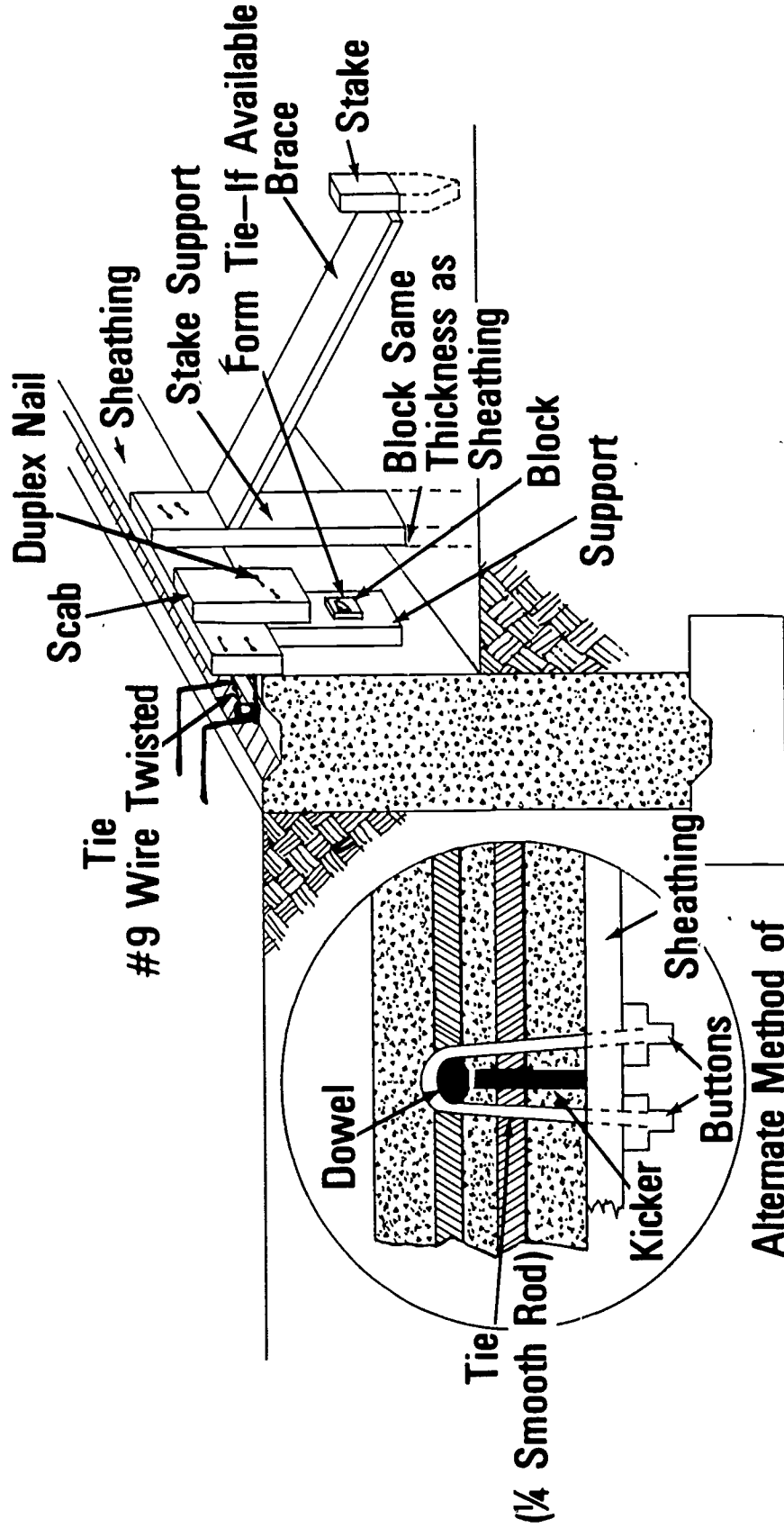

Alternate Method of Tying Form to Wall

Types Of Pours Using Edge Forms

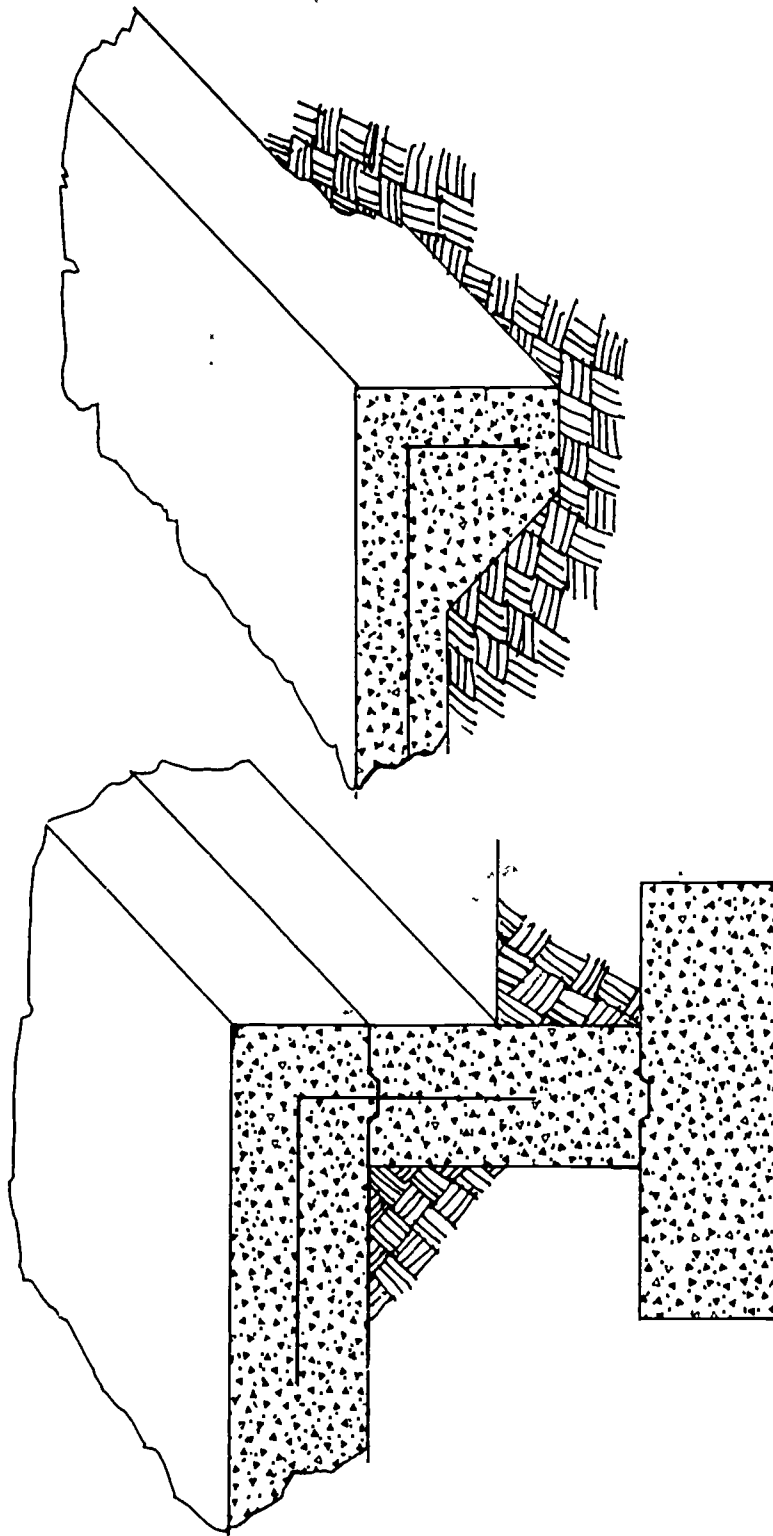

(a) Floor With Foundation

(b) Floor Without Foundation

Types Of Pours Using Edge Forms

(Continued)

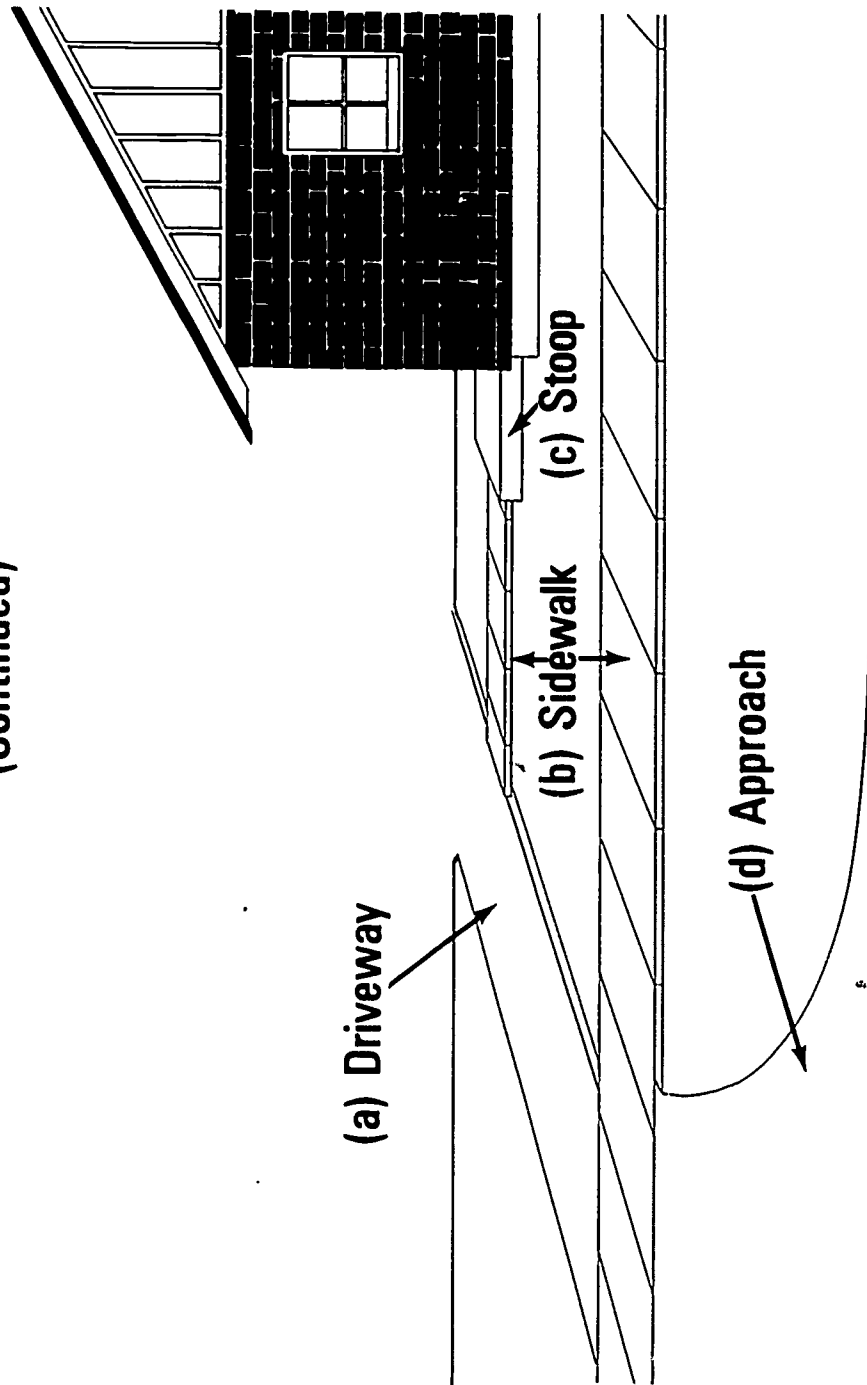

Types Of Forms

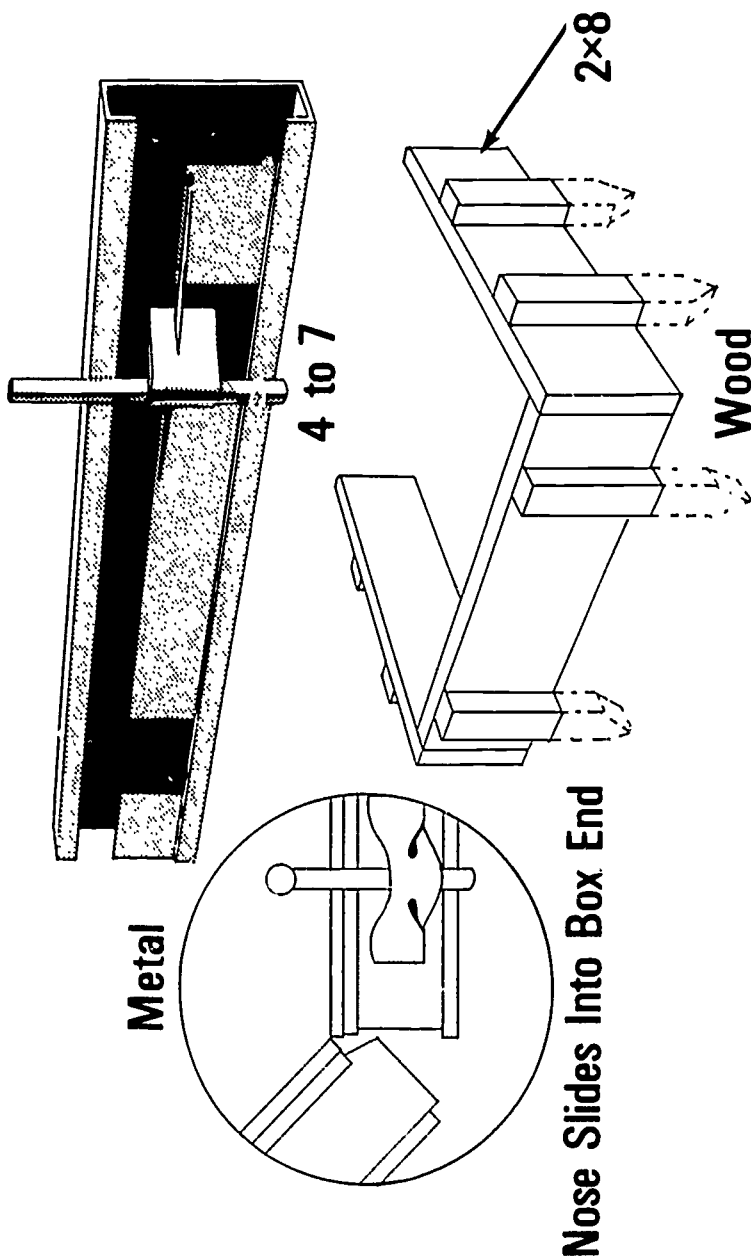

Types Of Forms

(Continued)

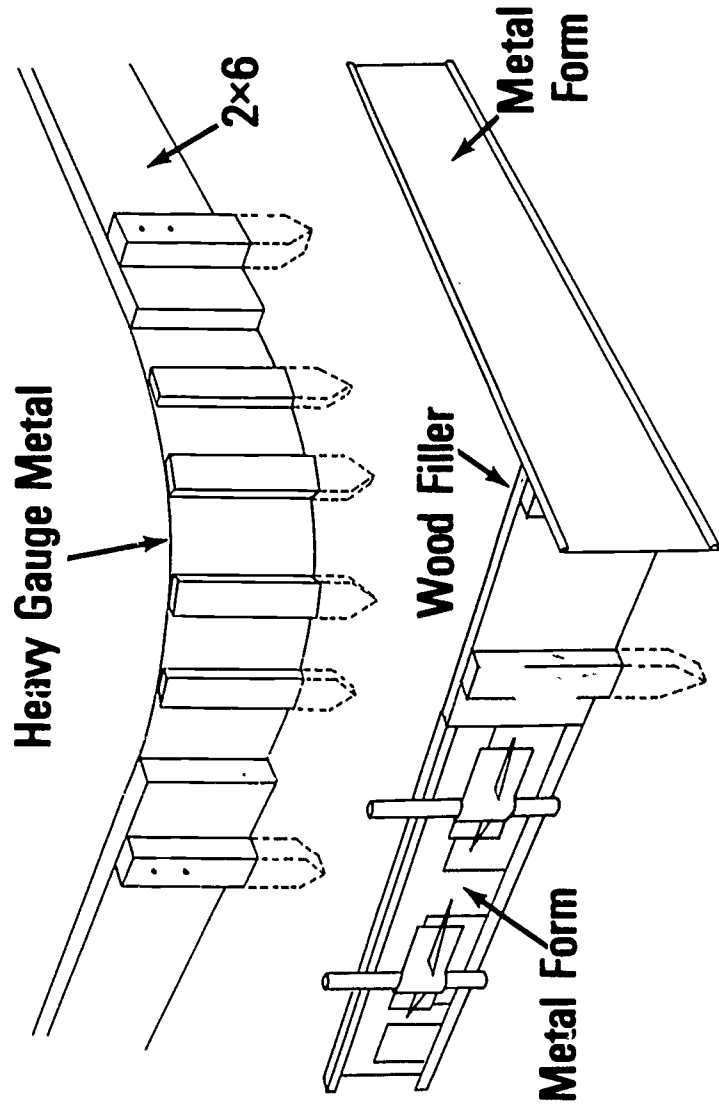

Combination Metal & Wood

EDGE FORMS ON GRADE
UNIT III

JOB SHEET #1--CONSTRUCT EDGE FORMS FOR A SLAB
ON GRADE WITHOUT FOUNDATION

I. Tools and materials needed

A. Tools

1. Sledge hammer
2. Claw hammer (16 ounce or larger)
3. Electric handsaw
4. Crosscut handsaw
5. 100 foot tape measure
6. Twelve or sixteen foot tape measure
7. Level (hand)
8. Chalkline and reel
9. Builder's level

B. Materials

1. Stakes
2. 2 x 10's for sheathing
3. Nails
 - a. 16d Duplex
 - b. 8d Duplex

II. Procedure

- A. Secure line to batter boards establishing four sides of the building

JOB SHEET #1

- B. Attach plumb bob to line intersections (Figure 1)

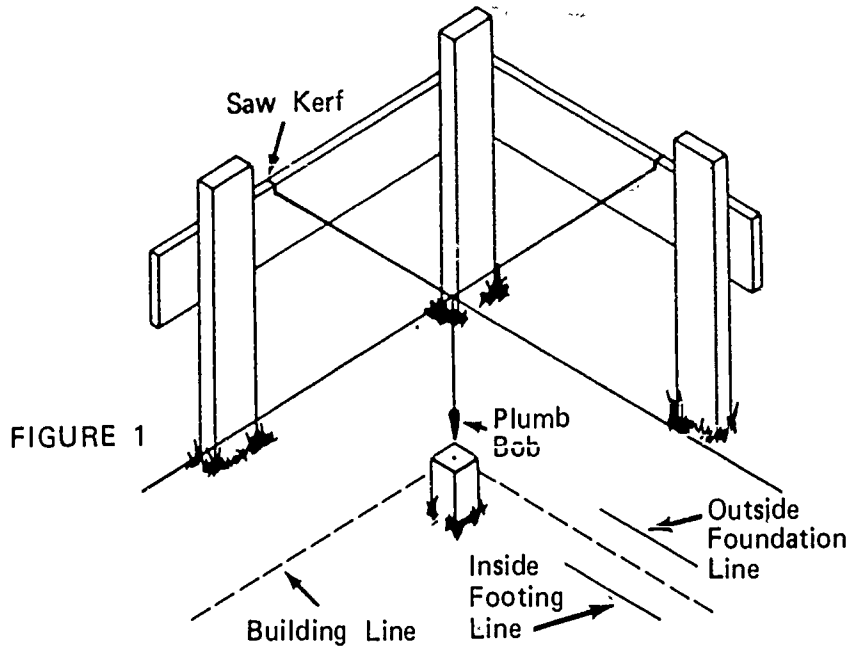

- C. Drive corner form stakes

(NOTE: Drive stakes outside the building corner the thickness of the sheathing. See Figure 1.)

(NOTE: Stakes should be long enough to reach below the edge thickness of the slab.)

- D. Repeat steps B and C on the other three corners

JOB SHEET #1

- E. Stretch a line between corner stakes, and drive the intermediate stakes (Figure 2)

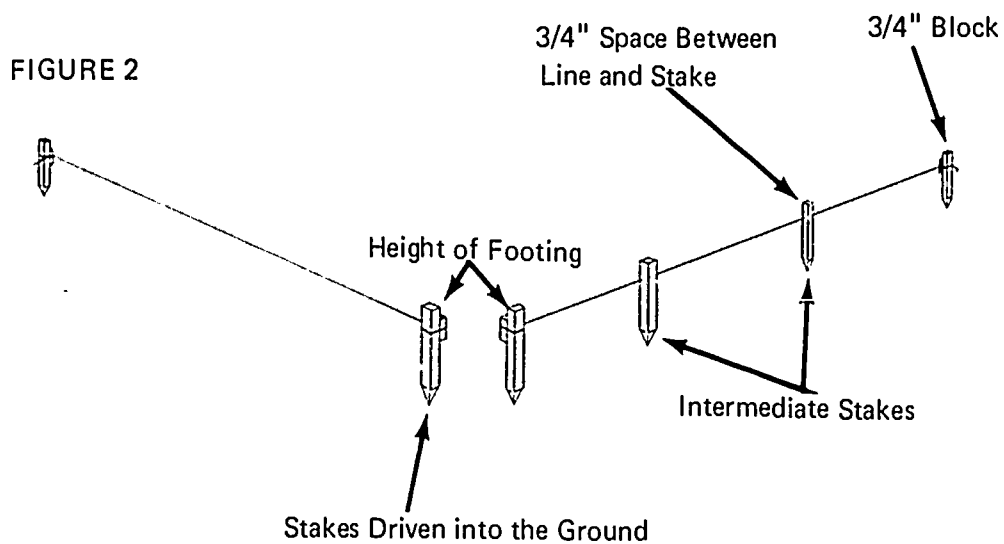

- F. Establish the grade elevation on all corner stakes
- G. Secure a line 3/4 inch above mark to gauge height of sheathing
(NOTE: Material of any thickness may be used for a gauge block.)
- H. Nail sheathing to stakes using a 3/4" gauge block (Figure 3)
(NOTE: Sight line to be sure it has not sagged.)

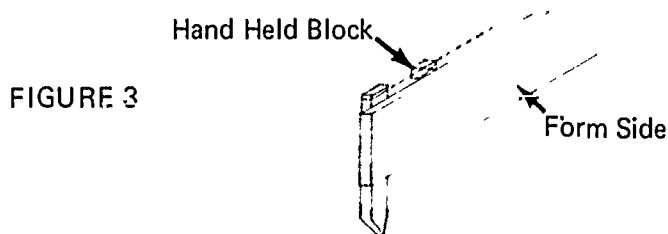

JOB SHEET #1

I. Tie all corners together as shown (Figure 4)

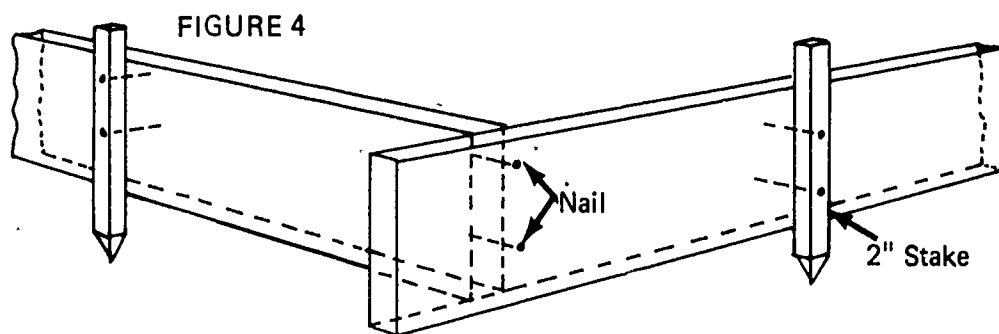

J. Brace the forms by one of the methods shown (Figure 5)

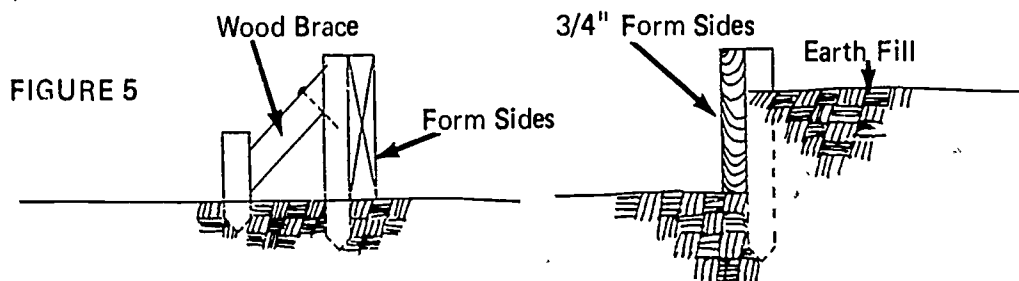

JOB SHEET #1

K. Make grade board as shown (Figures 6A and 6B)

(NOTE: On wide buildings, it will be necessary to set a temporary screed. See Figure 6B.)

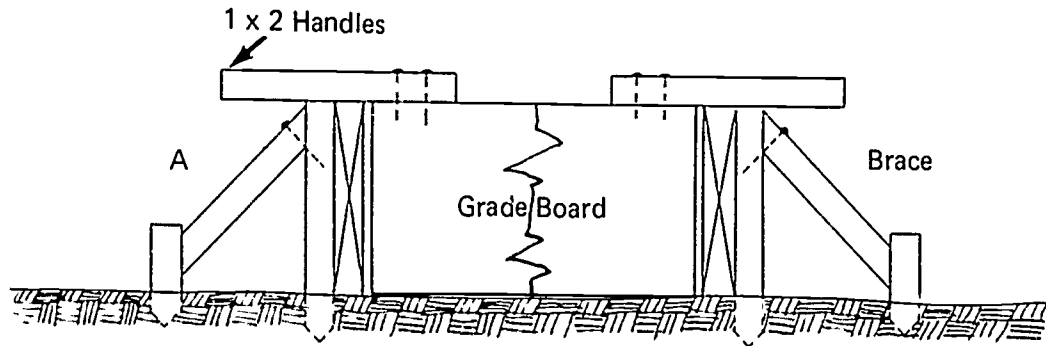
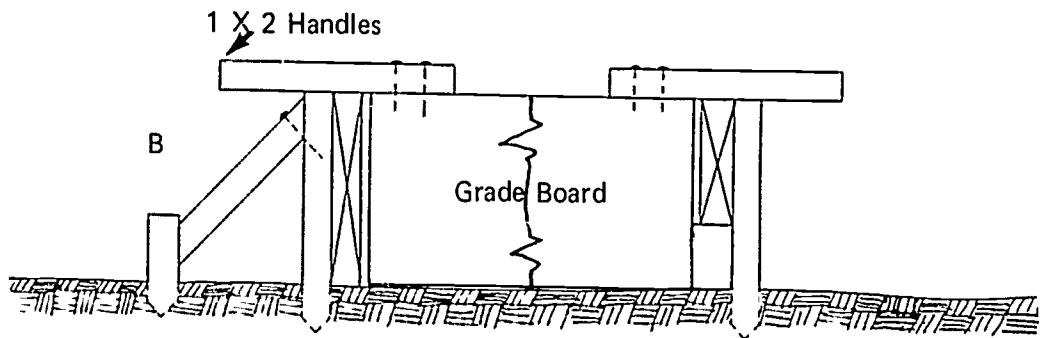

FIGURE 6



EDGE FORMS ON GRADE
UNIT IIIJOB SHEET #2--CONSTRUCT FORMS FOR A SLAB
ON GRADE WITH FOUNDATION

I. Tools and materials needed

A. Tools

1. Sledge hammer
2. Claw hammer (16 ounce or larger)
3. Electric handsaw
4. Crosscut handsaw
5. 100 foot tape measure
6. Twelve or sixteen foot tape measure
7. Level (hand)
8. String line
9. Chalkline
10. Builder's level

B. Materials

1. Stakes
2. Sheathing
3. Nails
 - a. 16d Duplex
 - b. 8d Duplex
4. #9 annealed wire

II. Procedure

- A. Lay sheathing on top of the wall or on the ground

(NOTE: This is to establish location of support stakes.)

JOB SHEET #2

- B. Drive support stakes at ends of each sheathing board (Figure 1)

(NOTE: Place a spacer block between the stake and the wall, hold the stake tight against the spacer block while driving. When driven, the top of the stake should be above the finish slab grade.)

FIGURE 1

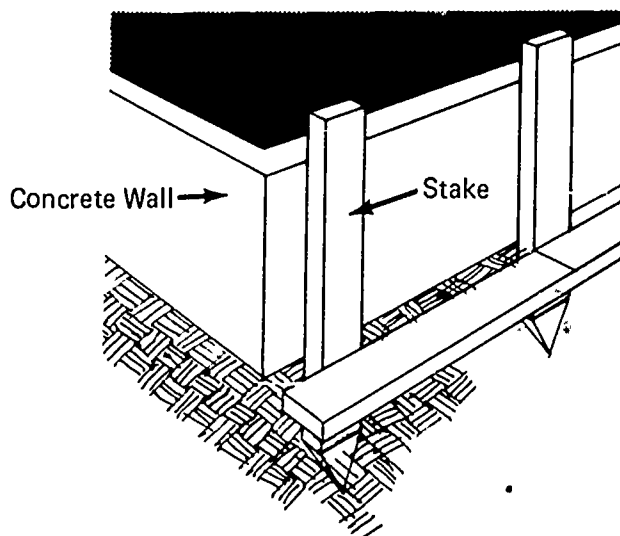

- C. Establish grade on support stakes

(NOTE: Use the builder's level and establish the grade from the bench mark.)

- D. Nail sheathing to stakes (Figure 2)

(NOTE: Drive a nail on the inside of the sheathing, a little less than the height of the grade mark on the stake and the foundation. Set sheathing in position, raise sheathing to grade mark, and nail.)

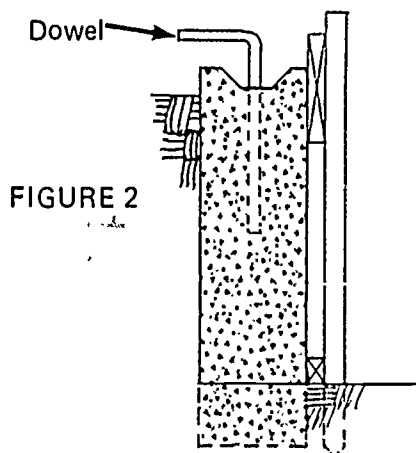

JOB SHEET #2

- E. Drive intermediate stakes
- F. Secure sheathing tight against the wall (Figures 3A and 3B)

(NOTE: Figures 3A and 3B show alternate methods of holding the form against the wall and plumb. There could be situations where they would both be used on the same form.)

- 1. Brace

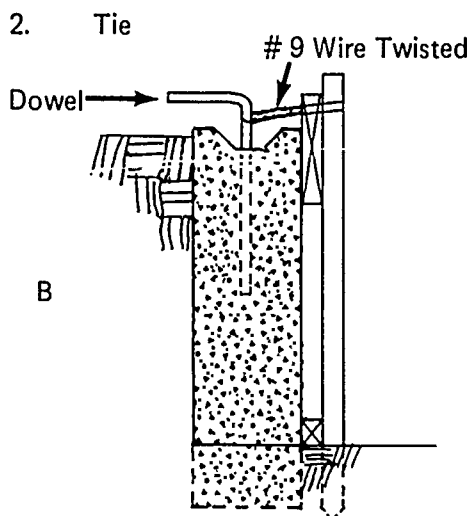
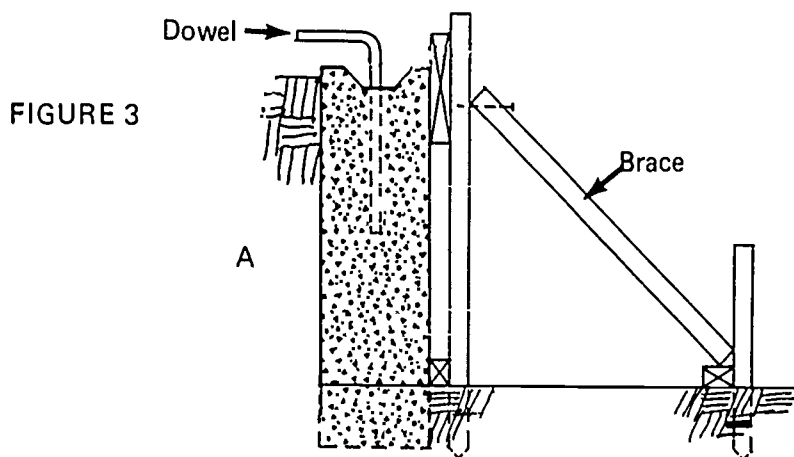

- G. Cut stakes off flush with top of the edge form on surfaces the straight edge will be pulled

EDGE FORMS ON GRADE
UNIT III

JOB SHEET #3--CONSTRUCT EDGE FORMS FOR A STOOP

I. Tools and materials needed

A. Tools

1. Sledge hammer
2. Claw hammer (16 ounce or larger)
3. Electric handsaw
4. Crosscut handsaw
5. 100 foot tape measure
6. Twelve or sixteen foot tape measure
7. Level (hand)
8. Chalkline and reel
9. Builder's level

B. Materials

1. Stakes
2. 2 x 6 for sheathing
3. Nails
 - a. 6d box
 - b. 8d Duplex

II. Procedure

- A. Establish a grade line using the builder's level

(NOTE: Stoops should slope from the building.)

JOB SHEET #3

- B. Drive corner and radius stakes, stretch a line between corner stakes, and drive the intermediate stakes (Figure 1)

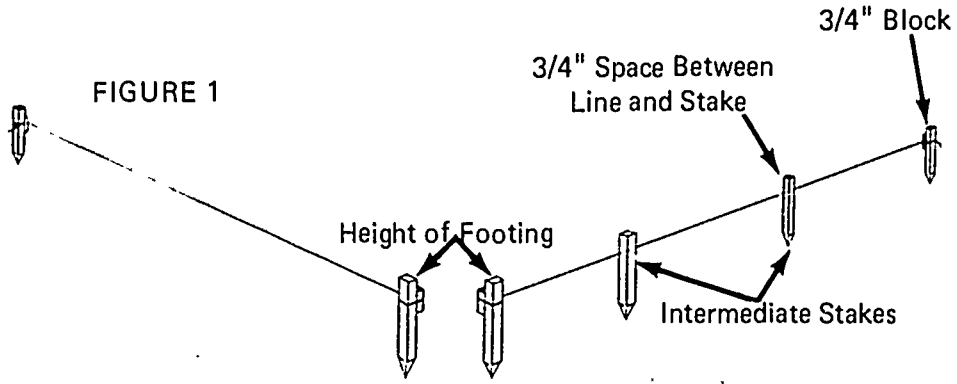

Stakes Driven into the Ground

- C. Nail 2 x 4 sheathing to stakes (Figure 2).

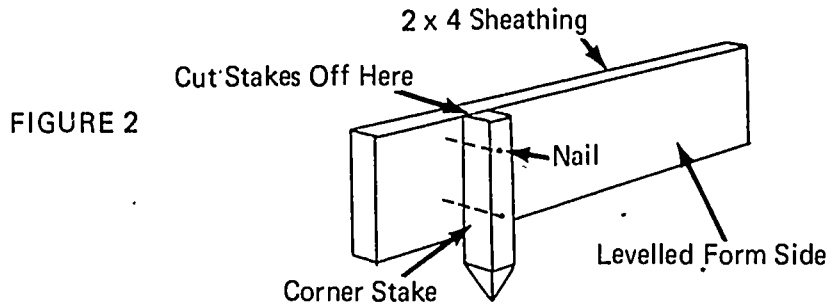

JOB SHEET #3

D. Tie the corners together as illustrated (Figure 3)

FIGURE 3

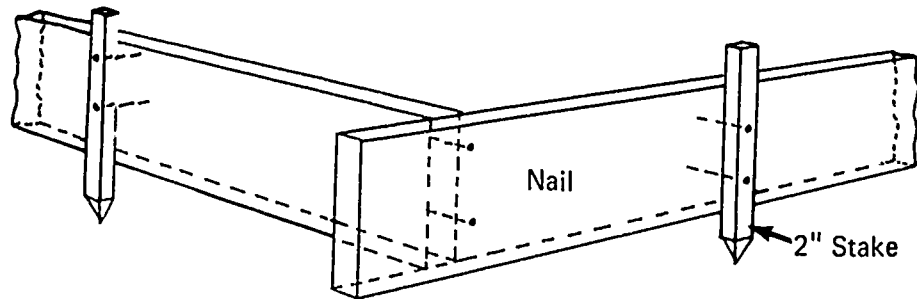

E. Set forms for curved sections (Figure 4)

1. Cut 1/4 inch hardboard into strips the thickness of the concrete
2. Hook tape on nail in radius stake
3. Drive stakes on radius line (Figure 4)

(NOTE: Set stake back the thickness of the hardboard. With this radius, we will use two thicknesses, 1/2 inch with staggered joints.)

Note: Set Stakes Back the
Thickness of the Hardboard

FIGURE 4

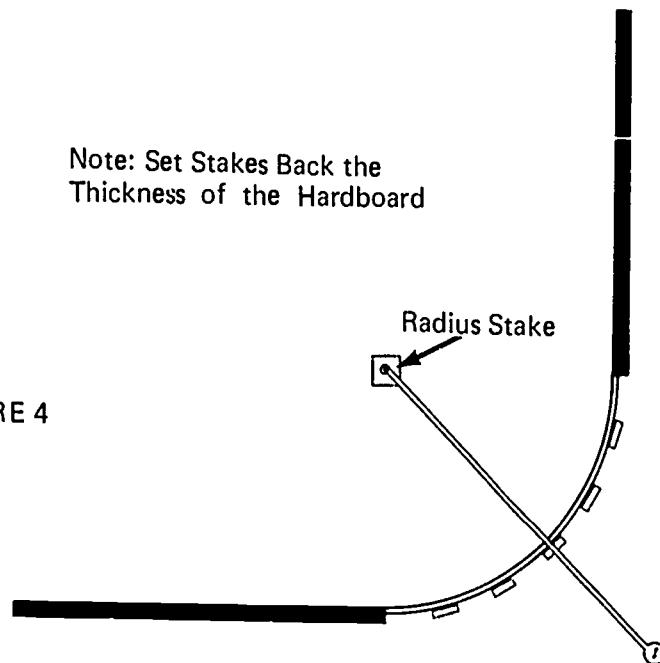

JOB SHEET #3

4. Nail hardboard to stakes
 - a. Hold the two pieces of hardboard flush on top and start nailing at one end
 - b. Proceed to add pieces and nail to stakes until curve is complete

(NOTE: If joints miss stakes, drive another stake.)

- F. Brace the forms by one of the methods shown (Figure 5)

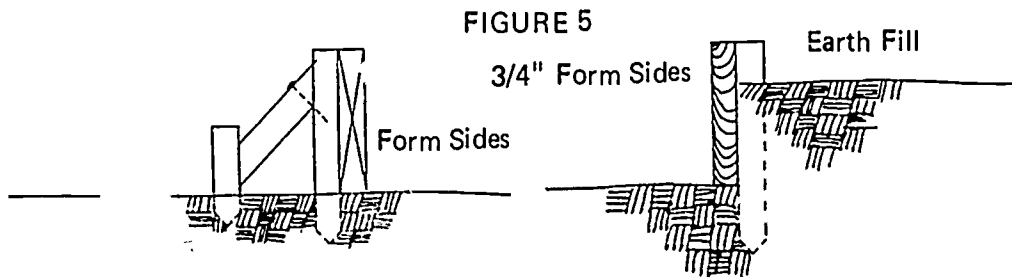

EDGE FORMS ON GRADE
UNIT III

TEST

1. Match the terms on the right with the correct definitions.

- | | |
|--|--------------------|
| _____ a. A low form placed at the perimeter of a slab | 1. Stake |
| _____ b. A piece of wood or other material that directs, resists, or supports weight or pressure | 2. Sheathing |
| _____ c. A double headed nail used in forming and designed for easy removal | 3. Slab |
| _____ d. That portion of a wall including the footing upon which the building rests | 4. Brace |
| _____ e. The level of the finished concrete in a form | 5. Expansion joint |
| _____ f. A continuous mass of concrete cast as a single piece | 6. Duplex nail |
| _____ g. Wood or metal that makes up the face of the form | 7. Monolithic pour |
| _____ h. Small boards or steel bars sharpened on one end and driven into the ground to help support the form | 8. Edge form |
| _____ i. A pre-formed piece of fibrous or asphaltic material used to separate units of concrete to prevent cracking due to expansion | 9. Foundation |
| _____ j. A section of concrete larger in its horizontal dimensions than it is in thickness | 10. Grade point |
| _____ k. A guide for leveling the surface | 11. Screed |

2. Identify the nine parts of a form by placing the correct number in the blanks provided.

- _____ a. Stake
- _____ b. Sheathing
- _____ c. Brace
- _____ d. Scab
- _____ e. Duplex nail
- _____ f. Block
- _____ g. Support
- _____ h. Kicker
- _____ i. Tie

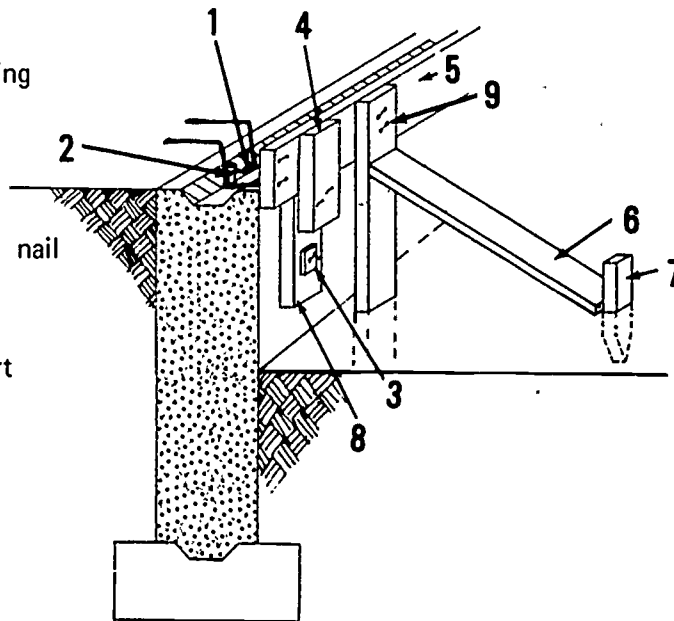

3. Name five types of pours on which edge forms are used.

- a.
- b.
- c.
- d.
- e.

4. Name three types of edge forms.

- a.
- b.
- c.

5. Demonstrate the ability to construct:

- a. Edge forms for a floor without foundation walls.
- b. Edge forms for a floor with foundation walls.
- c. Edge forms for a stoop.

EDGE FORMS ON GRADE
UNIT III

ANSWERS TO TEST

1.
 - a. 8
 - b. 4
 - c. 6
 - d. 9
 - e. 10
 - f. 7
 - g. 2
 - h. 1
 - i. 5
 - j. 3
 - k. 11
2.
 - a. 7
 - b. 5
 - c. 6
 - d. 4
 - e. 9
 - f. 3
 - g. 8
 - h. 2
 - i. 1
3.
 - a. Floor with foundation
 - b. Floor without foundation
 - c. Driveway
 - d. Sidewalk
 - e. Stoops

4.
 - a. Wood
 - b. Metal
 - c. Combination of wood and metal
5. Performance skills will be evaluated according to the criteria on the progress chart.

WALL FORMS UNIT IV

TERMINAL OBJECTIVES

After completion of this unit, the student should be able to define wall form terms, identify the parts of a form, and determine the width and quantity of panels needed to complete a form. He should be able to name the types of material used to build forms and the types of forms built from the materials. He should also be able to list the advantages of gang and panel forms over built in place or erected in place forms and to list the reasons built or erected in place forms might be used. He should also be able to construct various types of forms for walls. This knowledge will be evidenced through demonstration and by scoring eighty-five percent on the unit test.

SPECIFIC OBJECTIVES

1. Match terms associated with wall forming to the correct definitions.
2. Identify the parts of a form.
3. Estimate the material needed to build a form.
4. Estimate the width of panels and the required number of each.
5. Name materials which are used to construct forms.
6. Name six types of forms.
7. List four advantages of gang and panel forms over built in place or erected in place forms.
8. List four reasons why built in place or erected in place forms might be used.
9. Demonstrate the ability to construct:
 - a. Straight wall with patented forms.
 - b. Battered wall gang forms.
 - c. Circular wall forms.
 - d. Panel forms.
 - e. Slip forms.
 - f. Remove forms and prepare for storage.

WALL FORMS
UNIT IV

SUGGESTED ACTIVITIES

I. Instructor:

- A. Provide students with objective sheet.
- B. Provide students with information, assignment, and job sheets.
- C. Make transparencies.
- D. Discuss terminal and specific objectives.
- E. Discuss information and assignment sheets.
- F. Demonstrate and discuss procedures outlined in job sheets.
- G. Give test.

II. Student:

- A. Read objective sheet.
- B. Study information sheet.
- C. Complete assignment sheets.
- D. Demonstrate the ability to accomplish the procedures outlined in the job sheets.
- E. Take test.

INSTRUCTIONAL MATERIALS

I. Included in this unit:

- A. Objective sheet
- B. Information sheet
- C. Transparency masters
 1. TM 1--Parts of a Form
 2. TM 2--Plan of Foundation
 3. TM 3--Section A of Foundation Plan
 4. TM 4--Section B of Foundation Plan
 5. TM 5--Typical Pilaster Form

6. TM 6--Panel Layout and Sizes
7. TM 7--Patented Form Panels
8. TM 8--Job Built Panel Form
9. TM 9--Built in Place Wood Form
10. TM 10--Erected in Place Patented Form
11. TM 11--Gang Forms
12. TM 12--Liquid Head Form
13. TM 13--Plate Girder Forms

D. Assignment sheets

1. Assignment Sheet #1--Material Estimating
2. Assignment Sheet #2--Estimate Size and Quantity of Panels

E. Answers to assignment sheets

F. Job sheets

1. Job Sheet #1--Straight Wall Patented Forms
2. Job Sheet #2--Gang Forms for a Battered Wall
3. Job Sheet #3--Circular Wall Forms Built in Place
4. Job Sheet #4--Panel Forms
5. Job Sheet #5--
6. Job Sheet #6--Remove Forms and Prepare for Storage

G. Test

H. Answers to test

II. References:

- A. Burke, Arthur E., J. Ralph Dalzell, and Gilbert Townsend. *Architectural and Building Trades Dictionary*. Chicago, Illinois: American Technical Society, 1955.
- B. Smith, Ronald C. *Principles and Practices of Heavy Construction*. Englewood Cliffs, New Jersey: Prentice Hall, Inc., 1970.
- C. Peurifoy, R.L. *Formwork for Concrete Structures*. McGraw-Hill, Inc., 1964.
- D. *Concrete Form Construction*. Albany, New York: Delmar Publications.

WALL FORMS
UNIT IV

INFORMATION SHEET

- I. Terms and definitions
 - A. Brace--A piece of wood or other material that directs, resists, or supports weight or pressure
 - B. Cleat--A strip of wood or metal fastened across a form for temporary positioning or to replace a form tie
 - C. Duplex nail--A double headed nail used in forming and designed for easy removal
 - D. Footing--An enlarged area at the base of a wall or other object to distribute the weight of the superstructure
 - E. Form tie--A wire or metal crosstie used to hold the pressure of wet concrete and maintain the proper wall thickness
 - F. Foundation--That portion of a wall upon which the building rests
 - G. Grade point--The level of the finished concrete in a form
 - H. Key--A beveled piece of wood or metal placed in a form where future pours occur
 - I. Key way--A groove left in the concrete by removal of the key
 - J. Monolithic pour--A continuous mass of concrete cast as a single piece
 - K. Scab--A piece of material nailed across a splice to strengthen and hold the two pieces together
 - L. Sheathing--Wide boards, plywood, or metal that make up the face of the form
 - M. Spreader--A piece of wood that is used to hold the sides of the form apart and is removed as the concrete is poured; it may also be an integral part of the form tie
 - N. Spacer block--A block of wood or other material used as a spacer at offsets in form
 - O. Stake--Small boards or steel bars sharpened at one end and driven into the ground to support the form
 - P. Dowel--A short piece of steel bar used to tie adjoining pours together
 - Q. Bulkhead--A board placed in a form to cut off the concrete pour

INFORMATION SHEET

R. Form oil--Paraffin oil or other manufactured product used on a form to prevent adhesion of the concrete to the form

S. Panel--A single section of patented or job built form

II. Parts of a form (Transparency 1)

A. Sheathing

B. Brace

C. Stake

D. Spreader

E. Cleat

F. Form tie

G. Waler

H. Stud

I. Strongback

J. Sole plate

K. Bottom plate

L. Top plate

M. Spreader washer

N. Scab

O. Key

P. Bulkhead

Q. Spacer block

III. Material estimating

A. Studs

1. Determine length needed from height of wall

462

INFORMATION SHEET

2. Determine number needed
 - a. For 16" on center
 - 1) Multiply the length of the form by three-fourths
 - 2) Add one stud for each corner and one for each panel
 - 3) Add four studs for each pilaster

(CAUTION: Figure two sides of forms.)
 - b. For 2' on center
 - 1) Multiply the length of the form by one-half
 - 2) Add one stud for each corner, one for each panel, and four for each pilaster

B. Sheathing

1. Plywood--Square feet or number of pieces
(NOTE: Either 3/4" x 4' x 8' or 3/4" x 4' x 12' may be used.)
 - a. Calculate the square foot area
 - b. For 4' x 8' plywood, divide the square foot areas by thirty-two round up to the next whole number to determine number of pieces
 - c. For 4' x 12' plywood, divide the square foot area by forty-eight and round up to the next whole number to determine number of pieces
2. Lumber--Board feet
 - a. Calculate the square foot area of the forms
 - b. Calculate the material that must be allowed for waste by using the following table and add to the square foot area

Material	Percentage
1 x 6 - Tongued and Grooved	20
1 x 8 - Tongued and Grooved	15
1 x 6 - Square Edge	12
1 x 8 - Square Edge	10

INFORMATION SHEET

C. Plates (2" x 4" or 2" x 6")

(NOTE: Plate material is usually ordered in sixteen foot lengths.)

1. Determine length of forms
2. Multiply the length by four

(NOTE: If a sole plate is used, multiply by six.)

3. Divide the total lineal footage by 16 to get the number of pieces needed

D. Walers

(NOTE: Waler material is usually ordered in sixteen foot lengths.)

1. Calculate the number of walers by using the following table

50° Temperature					For 3/4" Sheathing, 2x4 Studs, Double 2x6 Wales	70° Temperature				
2"	3"	4"	5"	6"		Rate of Pour (Vertical Feet Per Hour)				
21"	18"	18"	16"	15"	Stud spacing for safe value of sheathing Wale spacing for safe value of studs Tie spacing for safe value of wales	24"	21"	18"	18"	18"
30"	27"	24"	24"	24"		33"	30"	27"	27"	24"
48"	42"	39"	33"	27"		48"	48"	45"	39"	39"

5000# TIES.

(NOTE: Wall height divided by waler spacing equals the number of walers.)

2. Determine the total length of the forms (inside and outside)
3. Multiply the total length of the forms by two
4. Multiply by the number of walers
5. Add two feet for each pilaster

(NOTE: This is lineal feet of material needed.)

6. Divide the total lineal feet by sixteen to get the total number of pieces needed

INFORMATION SHEET

E. Waler--Spacer blocks and supports--Lineal feet

(NOTE: Spacer blocks and supports are usually 1" x 4" material spaced four feet on center.)

1. Divide the total lineal feet of waler material by two
2. Divide by four to get the number of lineal feet of 1 x 4's needed

(NOTE: One lineal foot of 1" x 4" will cut one spacer three and one-half inches long and one support eight and one-half inches long.)

F. Braces (2 x 4's - 16') Quantity and length

(NOTE: Braces are normally only used on one side of a form.)

1. Determine length of brace
(NOTE: Brace should be not less than a forty-five degree angle to the form.)
2. Determine length of form to be braced
3. Divide by the brace spacing to get the number of braces needed; add one brace for end

G. Stakes--Lineal feet or ready made--One for each brace

(NOTE: Length will be determined by soil conditions.)

H. Form ties

(NOTE: Form ties are ordered by quantity needed. Give breaking strength, stud, sheathing, and waler width, and wall thickness.)

1. Determine the tie spacing by using the following table

50° Temperature					For 3/4" Sheathing, 2x4 Studs, Double 2x6 Wales	70° Temperature				
2"	3"	4"	5"	6"		Rate of Pour (Vertical Feet Per Hour)				
21"	18"	18"	16"	15"	Stud spacing for safe value of sheathing Wale spacing for safe value of studs Tie spacing for safe value of wales	24"	21"	18"	18"	18"
30"	27"	24"	24"	24"		33"	30"	27"	27"	24"
48"	42"	39"	33"	27"		48"	48"	45"	39"	39"

5000# TIES.

INFORMATION SHEET

2. Determine the length of the form
 3. Divide by the tie spacing to determine the number of ties per horizontal row
 4. Multiply by the number of walers, as determined in D-1, for the total number of ties needed
- I. Form tie clamps--Multiply the number of ties by two
- IV. Estimate width and number of panels
- A. Panel sizes are determined by
1. Ability to handle at the building and erection site
 2. Plan dimensions
 3. Cutting materials with the least amount of waste
- B. Determine sections of wall that will take identical panels (Transparency 2)
1. Pilaster spacing, north and south wall
 2. East and west walls and the returns to the first pilaster
- C. Panel sizes for sections "A" (Transparency 3)
1. Main panels sixteen feet long
(NOTE: Form plywood can be purchased in 4' x 8' or 4' x 12' sheets. Either of these sizes would build a 16' long panel without waste. Panels could be 4', 8', or 16' wide.)
 2. Filler panel sizes--Determined by distance between pilasters minus the thickness of the sheathing on the pilaster form
 3. Location of inside panels
 - a. Tie holes in panel "A" must line up with tie holes in panel "B"
 - b. Panel "A" will be three-fourths inch to the right of the left side of the pilaster
- D. Panel sizes section "B" (Transparency 4)
1. The inside end wall will be made up of three panels, one main panel, and two fillers
(NOTE: Two 16' main panels can not be used because of tie spacing.)

INFORMATION SHEET

2. Locate main panel to line up with tie holes in outside panel k or m
3. Filler panel sizes will be: a-9' - 0 3/4" and b-6' - 11 1/4"

(NOTE: These two panels total 16' and can be built without cut waste by using the salvage from the first panel to build the second.)

$$\begin{array}{r} 16' - 0'' \\ -6' - 11 \frac{1}{4}'' \\ \hline \text{Panel a } 9' - 0 \frac{3}{4}'' \end{array}$$

$$\begin{array}{r} 16' - 0'' \\ -9' - 0 \frac{3}{4}'' \\ \hline \text{Panel b } 6' - 11 \frac{1}{4}'' \end{array}$$

4. Panel c will be 13' - 8 1/2"

$$\begin{array}{r} 15' - 0'' \\ -0' - 11 \frac{1}{4}'' \\ \hline 14' - 0 \frac{3}{4}'' \\ - \quad 4 \frac{1}{4}'' \\ \hline 13' - 8 \frac{1}{2}'' \end{array}$$

5. Panel d will be 15' - 7"

$$\begin{array}{r} 15' - 11 \frac{1}{4}'' \\ - \quad 4 \frac{1}{4}'' \\ \hline 15' - 7'' \end{array}$$

(NOTE: Panels c and e will be the same size as panels d and f.)

6. Panel g will be

- a. Stud frame 15' - 3 1/2"

$$\begin{array}{r} 15' - 0'' \\ + \quad 4 \frac{1}{4}'' \\ \hline 15' - 4 \frac{1}{4}'' \\ - \quad 3/4'' \\ \hline 15' - 3 \frac{1}{2}'' \end{array}$$

- b. Sheathing--14' - 11 1/4"

$$\begin{array}{r} 15' - 3 \frac{1}{2}'' \\ -0' - 4 \frac{1}{4}'' \\ \hline 14' - 11 \frac{1}{4}'' \end{array}$$

(NOTE: Panels g, h, i, and j will all be the same size. Make h and i left hand panels and g and j right hand panels.)

INFORMATION SHEET

E. Pilaster panels (Transparency 5)--Sections A and B

1. Side panels will be 1' - 0"

(NOTE: This will be sheathing only.)

2. Face panel will be 2' - 8 1/2"

$$\begin{array}{r} 2' - 0'' \\ + \quad 8 \frac{1}{2} \\ \hline 2' - 8 \frac{1}{2}'' \end{array} \qquad \begin{array}{r} 4 \frac{1}{4}'' \\ + \quad 4 \frac{1}{4}'' \\ \hline 8 \frac{1}{2}'' \end{array}$$

F. Quantity of panel of each side needed to erect the foundation forms (Transparency 6)

1. 18--16' - 0"
2. 4--13' - 10 1/2"
3. 2--15' - 3 1/2" R
4. 2--15' - 3 1/2" L
5. 2--13' - 8 1/2" L
6. 2--15' - 7" R
7. 2--9' - 0 3/4" L
8. 2--6' - 11 1/4" R
9. 8--2' - 8 1/2"
10. 16--1' - 0" Sheathing only

V. Materials used to construct forms

- A. Wood
- B. Steel
- C. Fiberglass

VI. Types of forms constructed (Transparencies 7, 8, 9, 10, 11, 12, and 13)

A. Panel

1. Patented
2. Job built

INFORMATION SHEET

- B. Built in place (Wood)
 - C. Erected in place (Patented)
 - D. Gang
 - 1. Wood-Job built
 - 2. Patented panel
 - E. Liquid head
 - F. Plate girder
- VII. Potential advantages of gang and panel forms over built in place or erected in place forms
- A. Faster erection
 - B. Faster stripping
 - C. More reuses of form material
 - D. Cleaner site
- VIII. Reasons why built in place or erected in place forms might be used
- A. Accessibility of site
 - B. Availability of crane

Parts of a Form

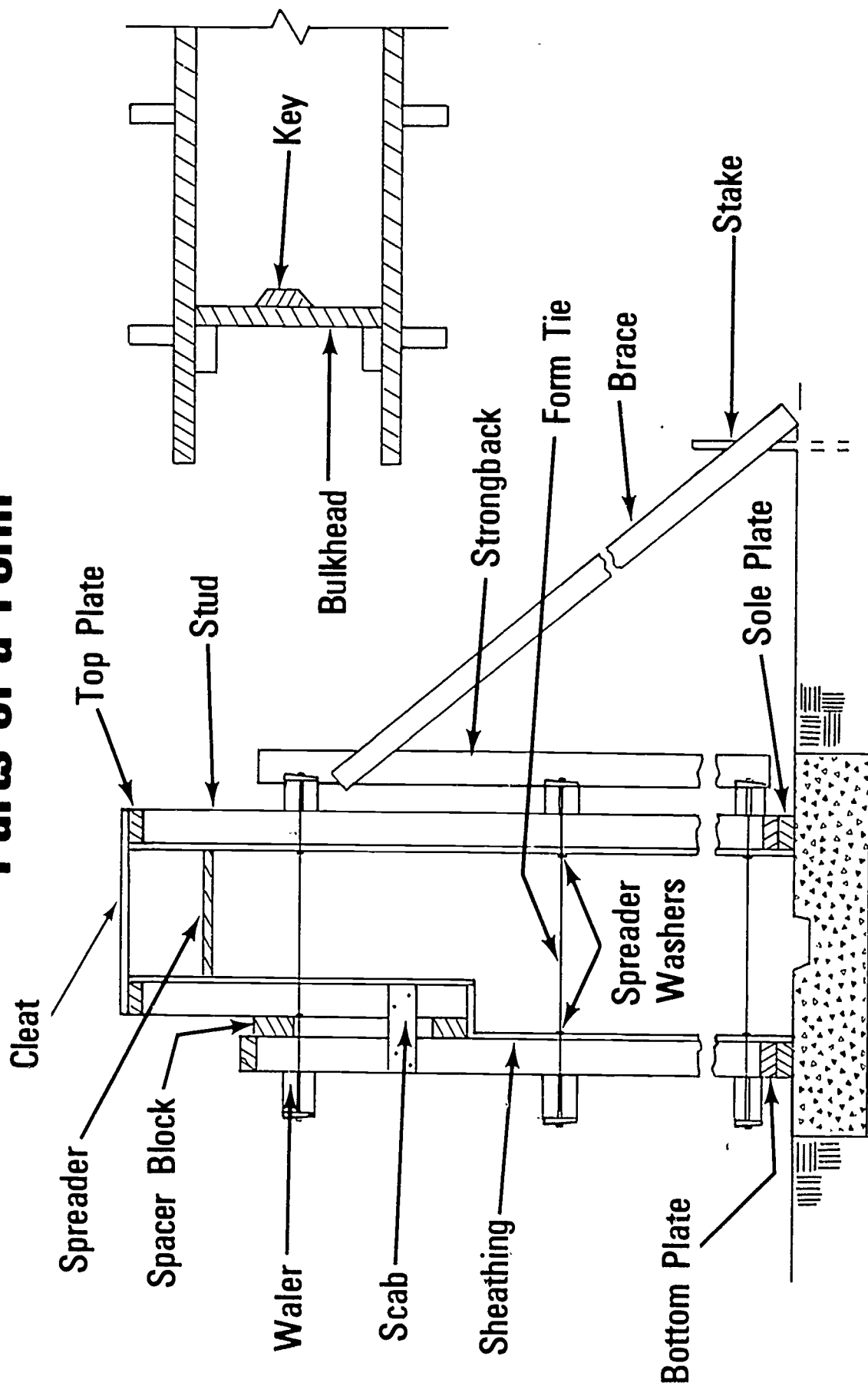

Plan of Foundation

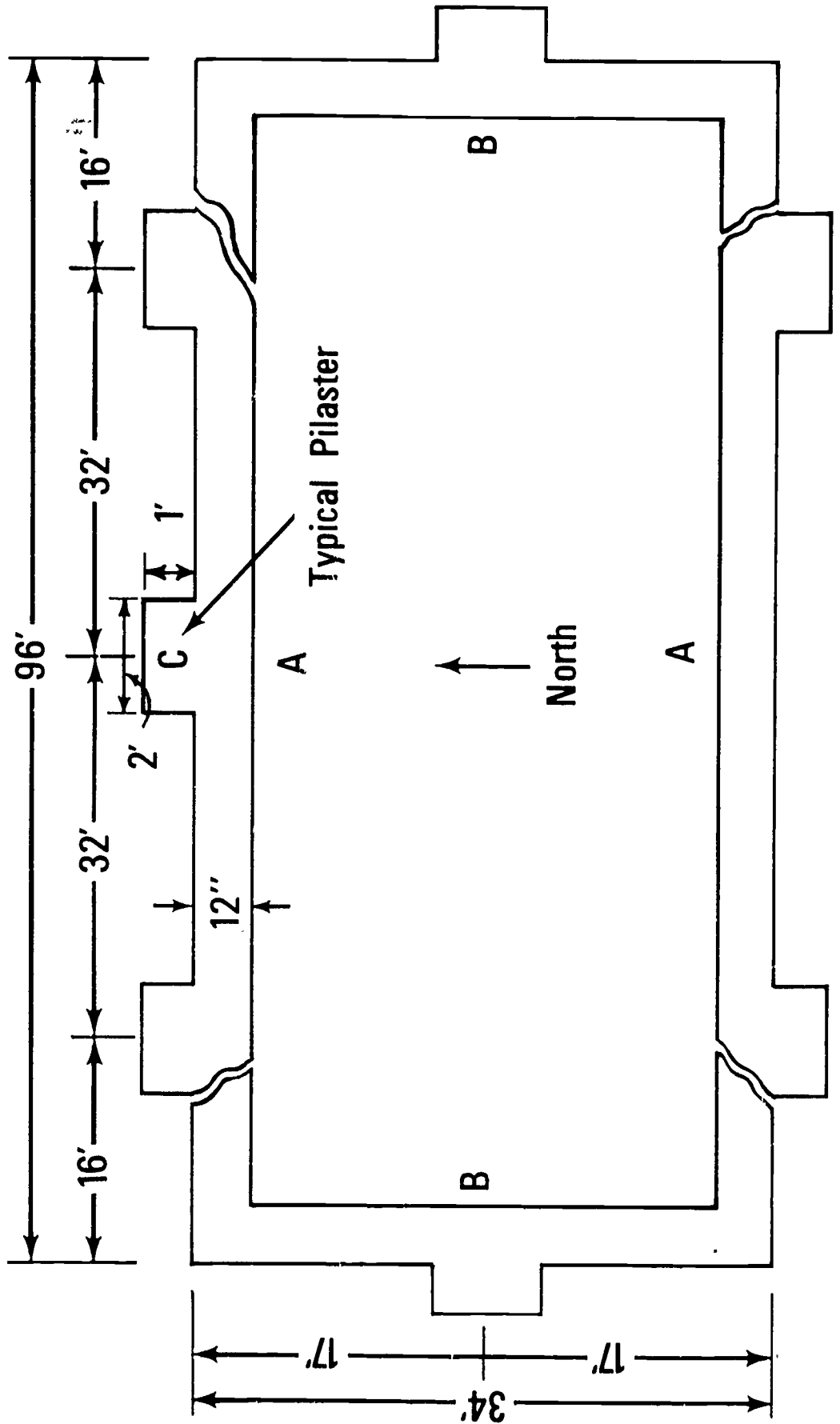

124

Section A of Foundation Plan

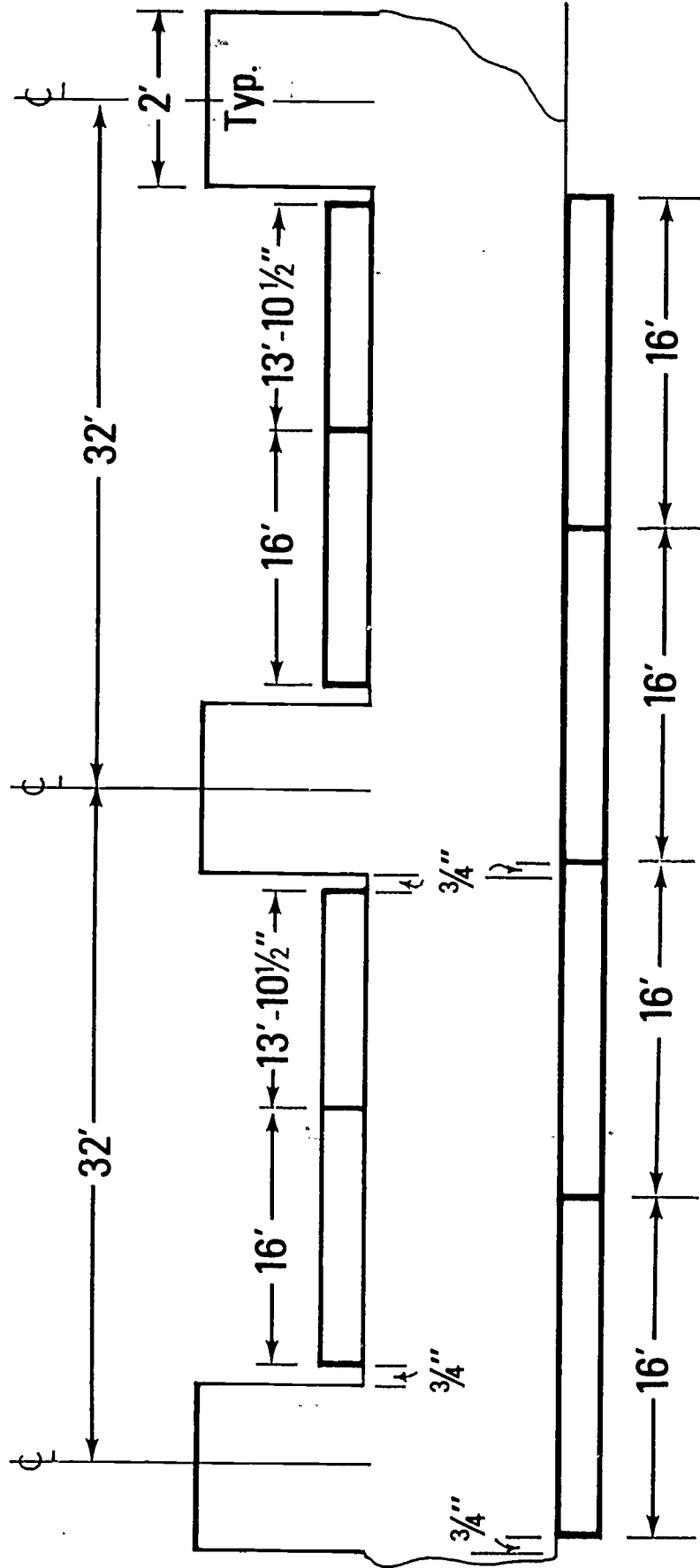

Section B of Foundation Plan

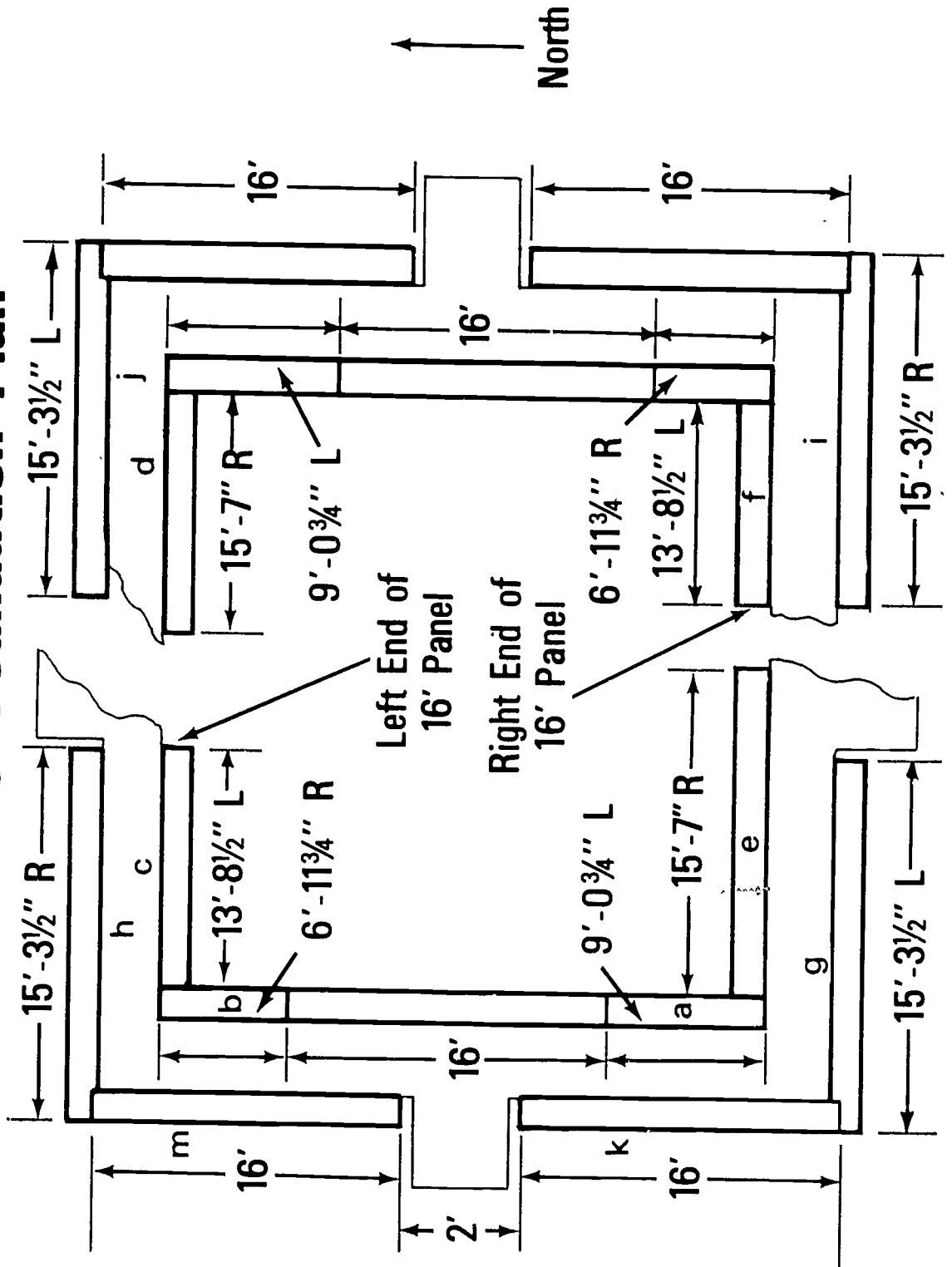

Typical Pilaster Form

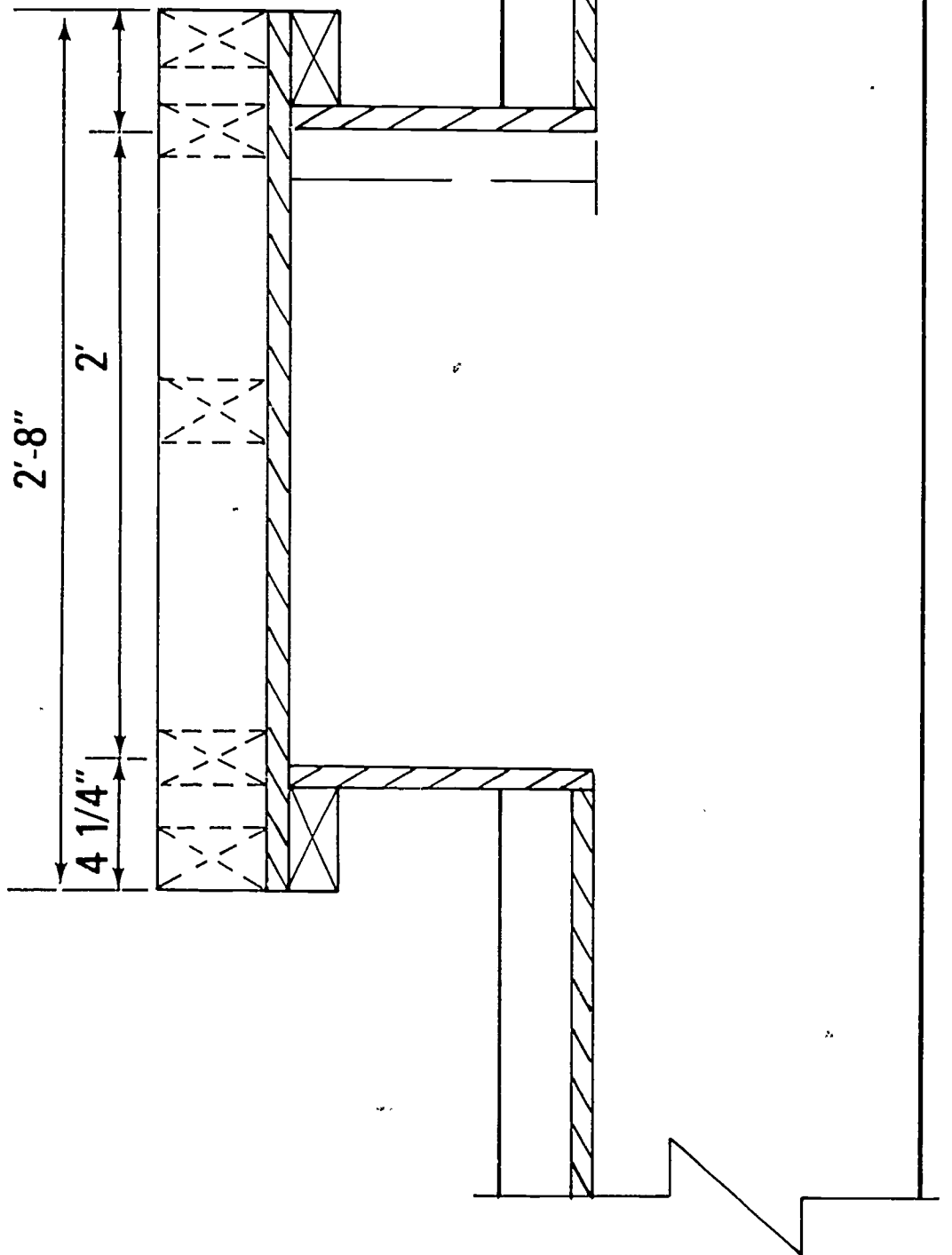

Panel Layout and Sizes

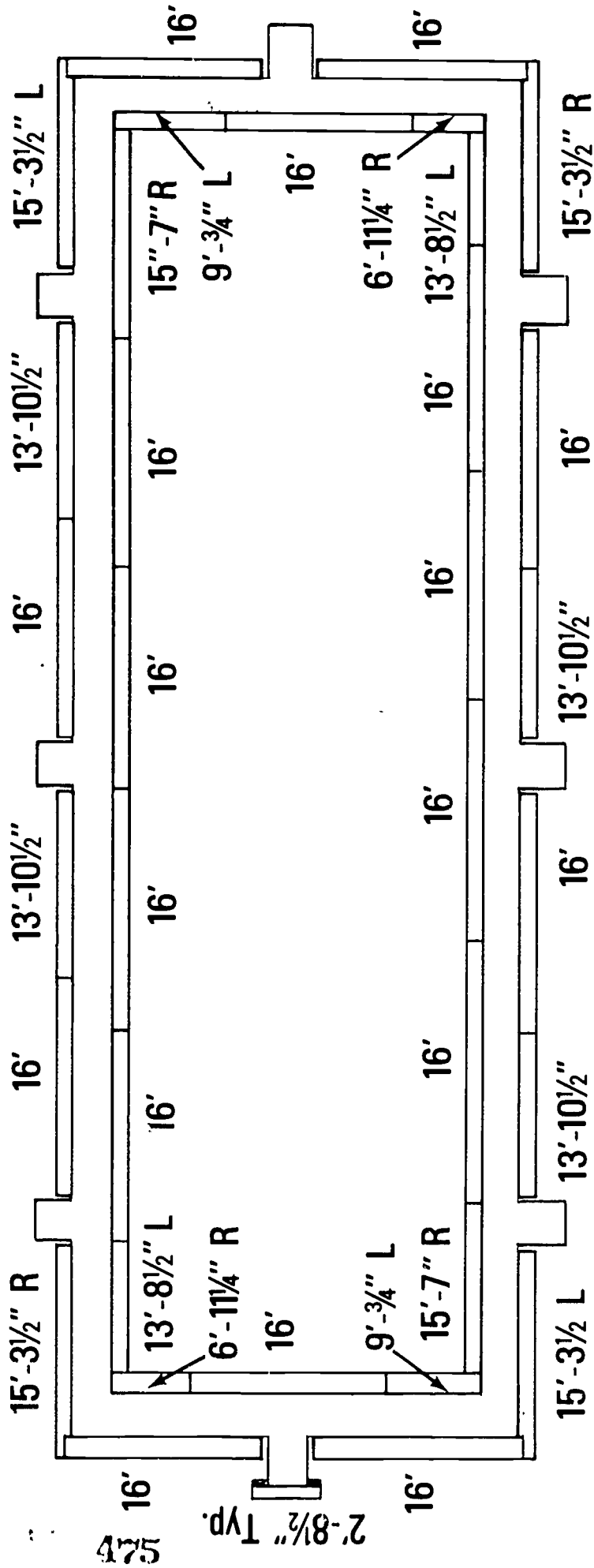

525 2'-8 1/2" Typ.

Patented Form Panels

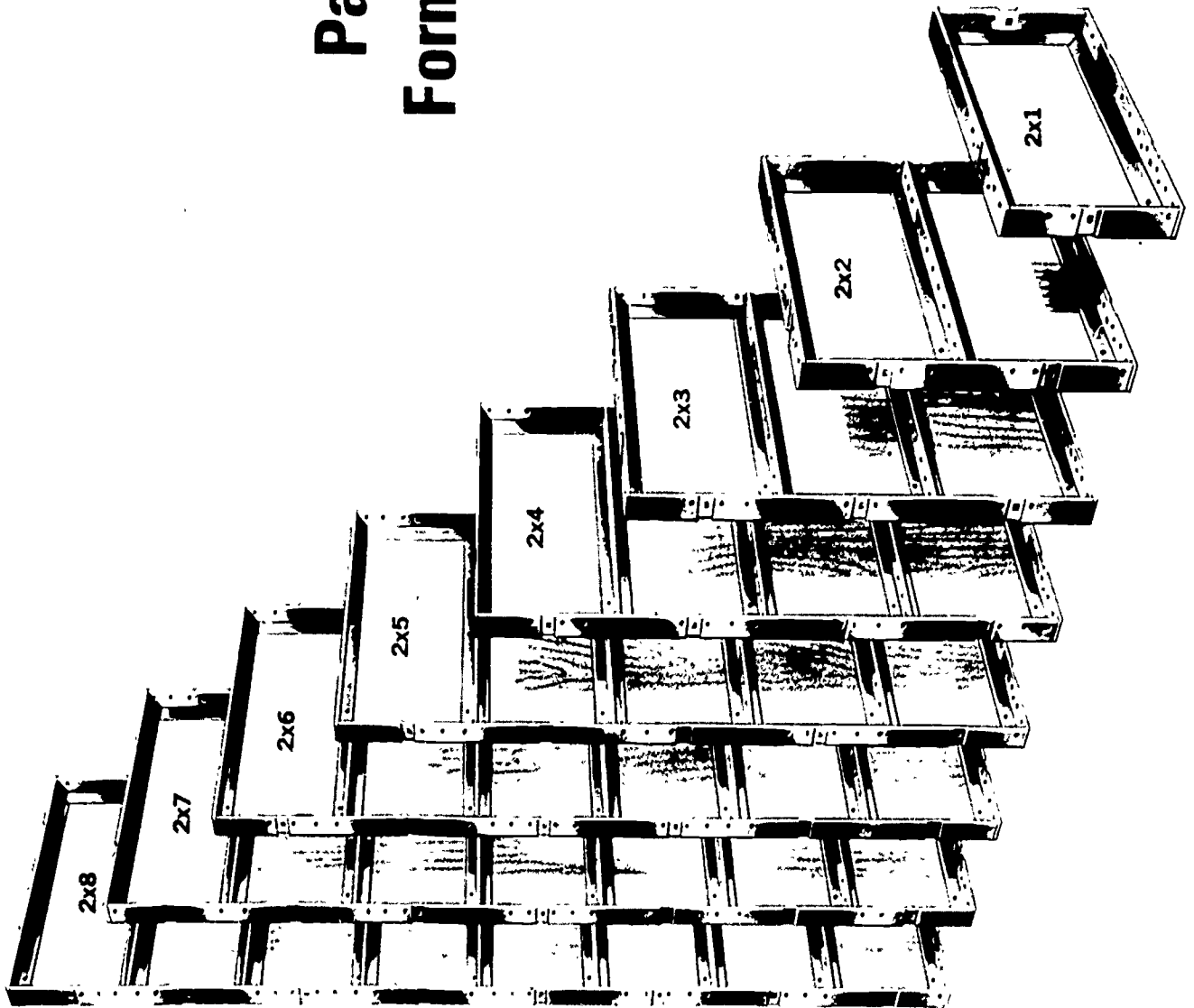

Job Built Panel Form

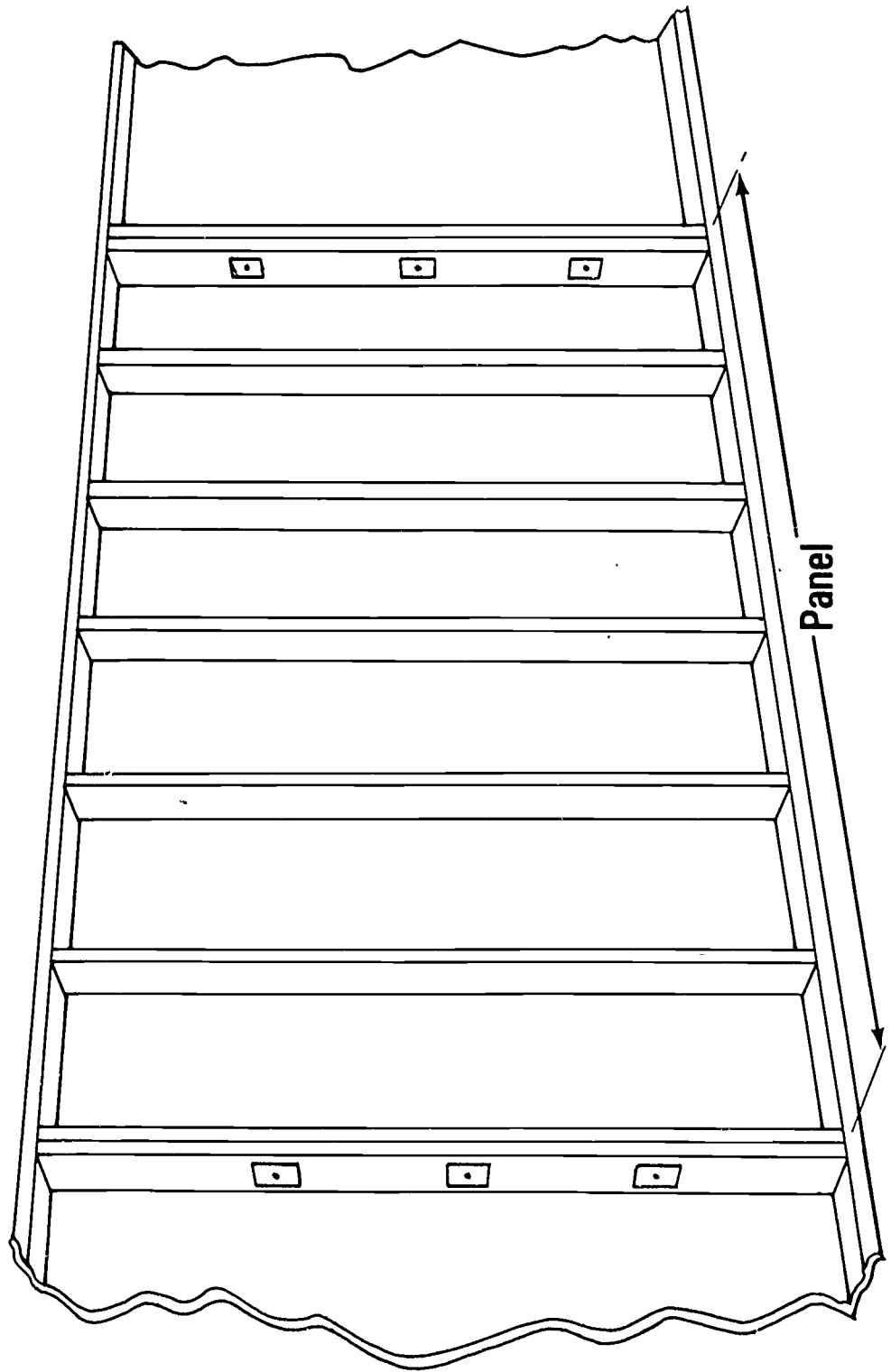

Built in Place Wood Form

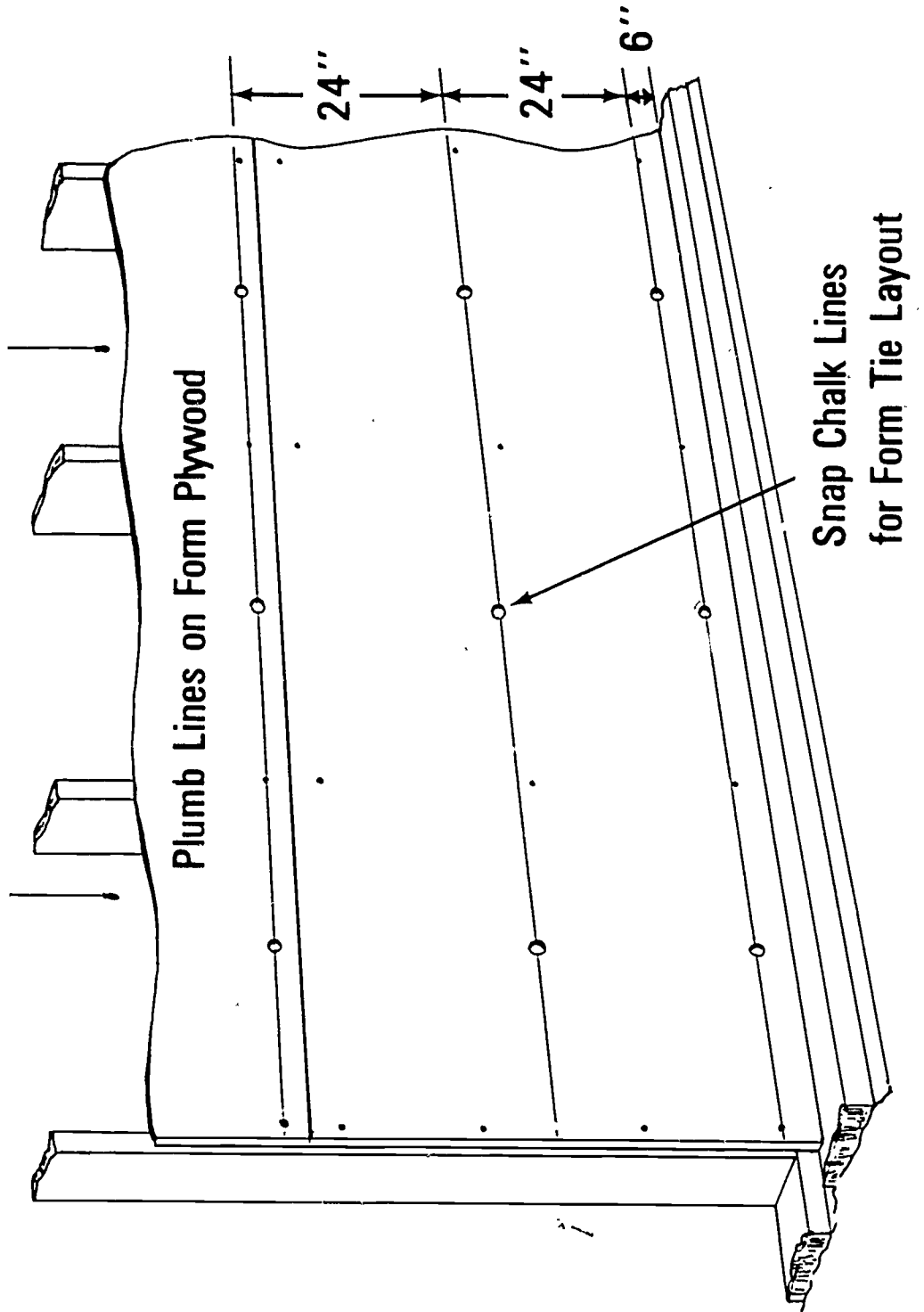

Erected-In-Place Patented Form

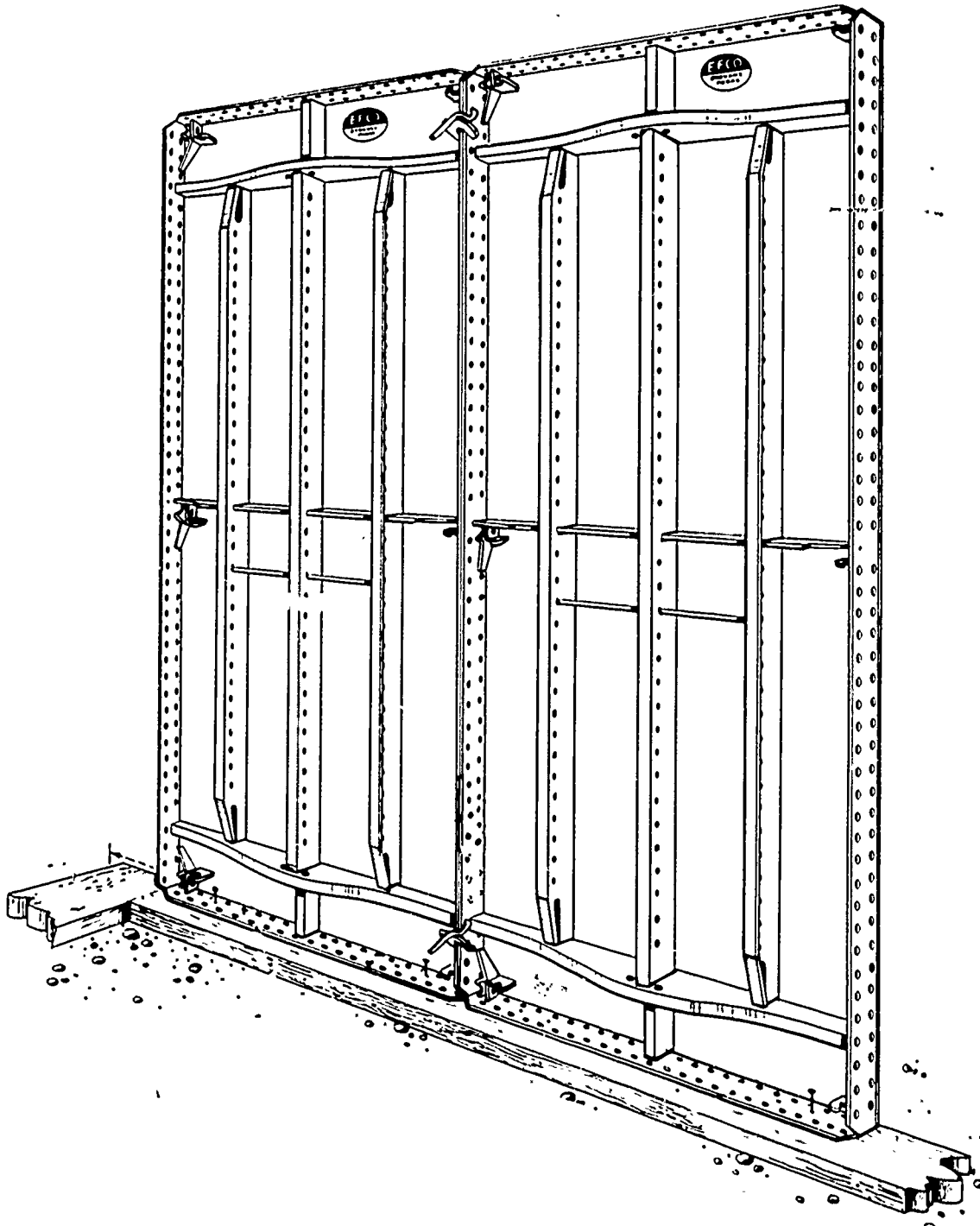

Gang Forms

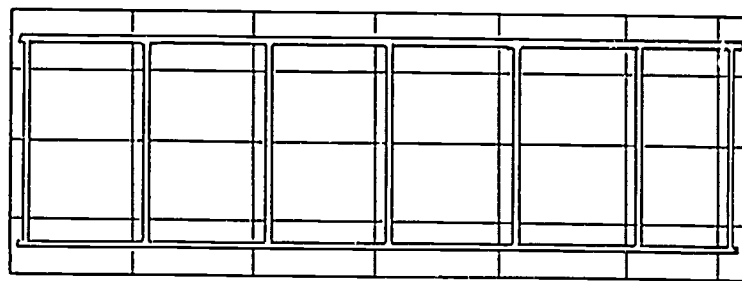
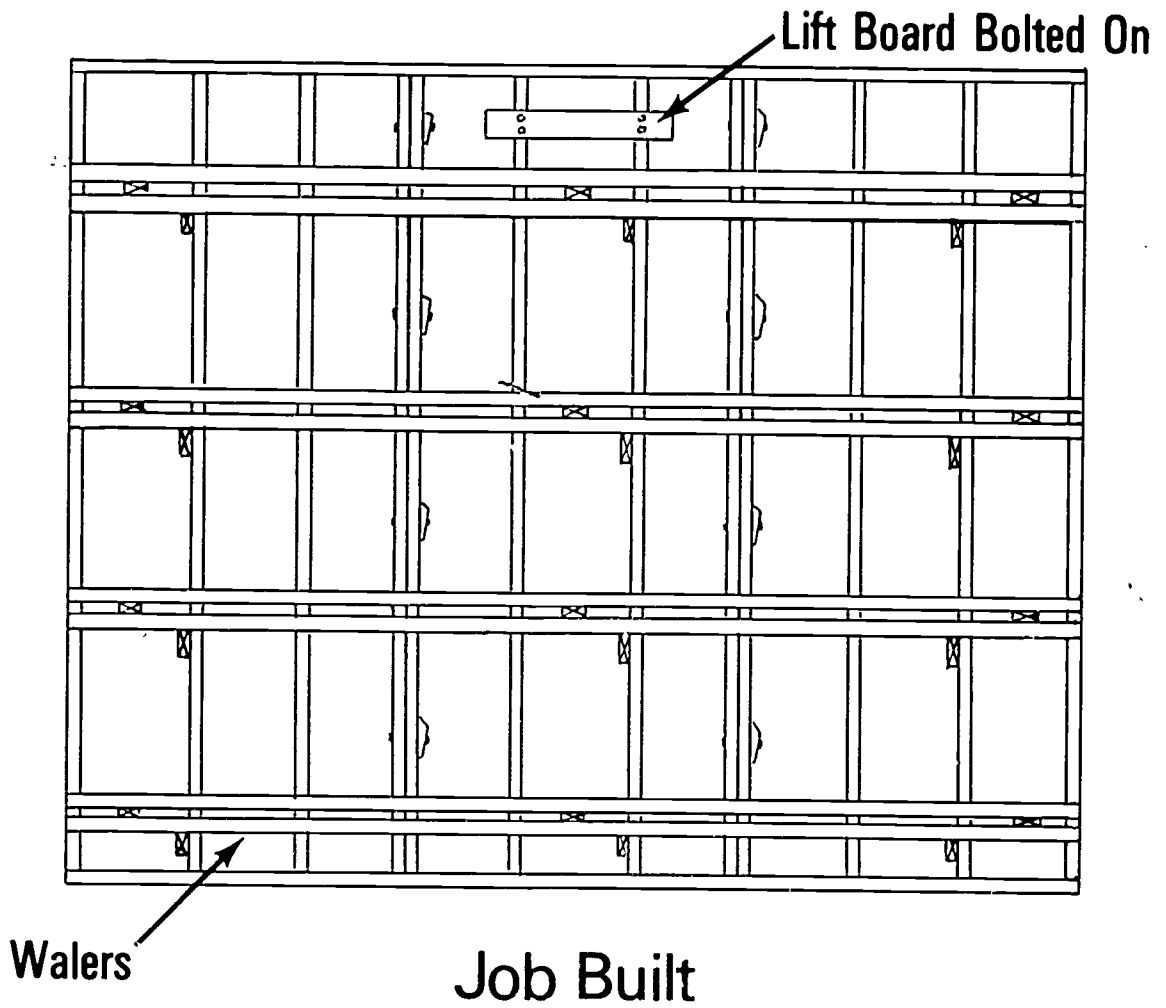

Patented Panel

Liquid Head Form

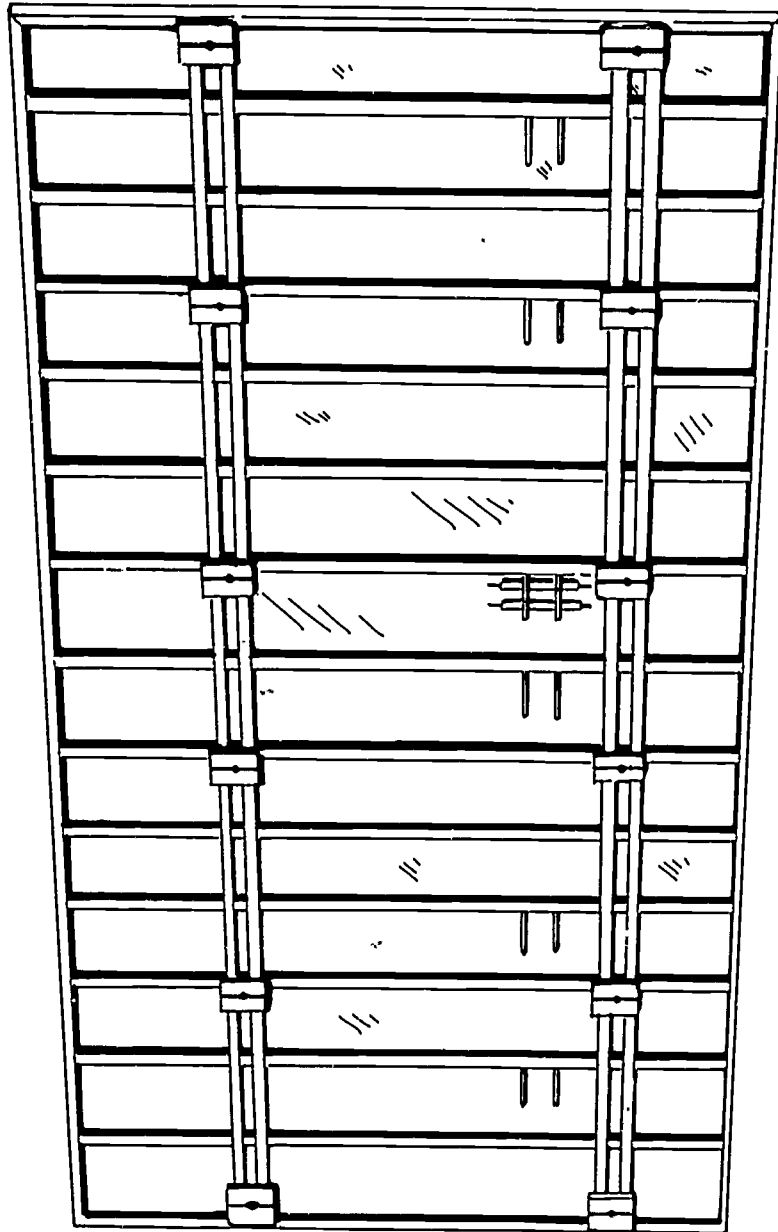
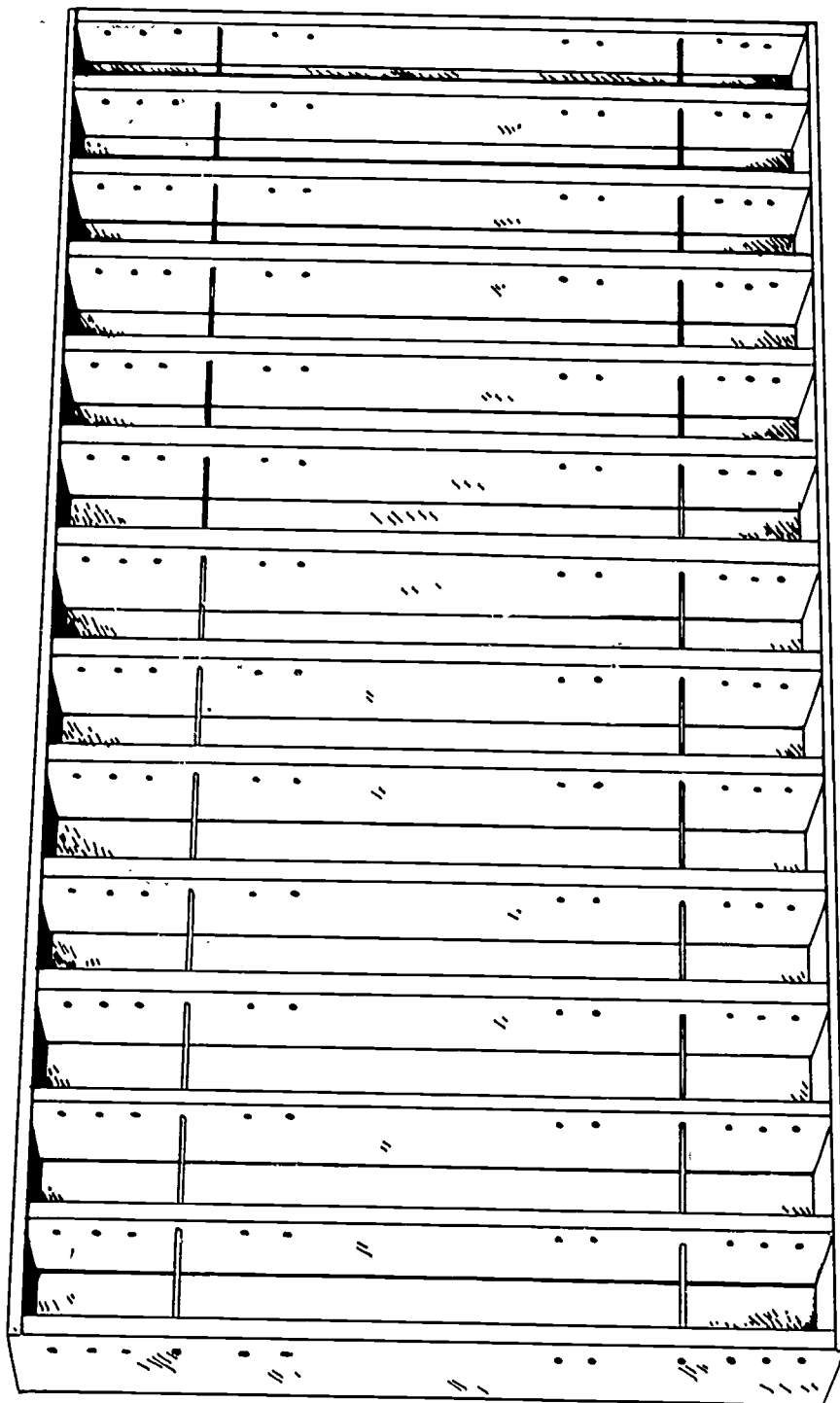

Plate Girder Forms



WALL FORMS UNIT IV

ASSIGNMENT SHEET #1-MATERIAL ESTIMATING

Using the information sheet, estimate the material needed to build form for the section of wall shown below.

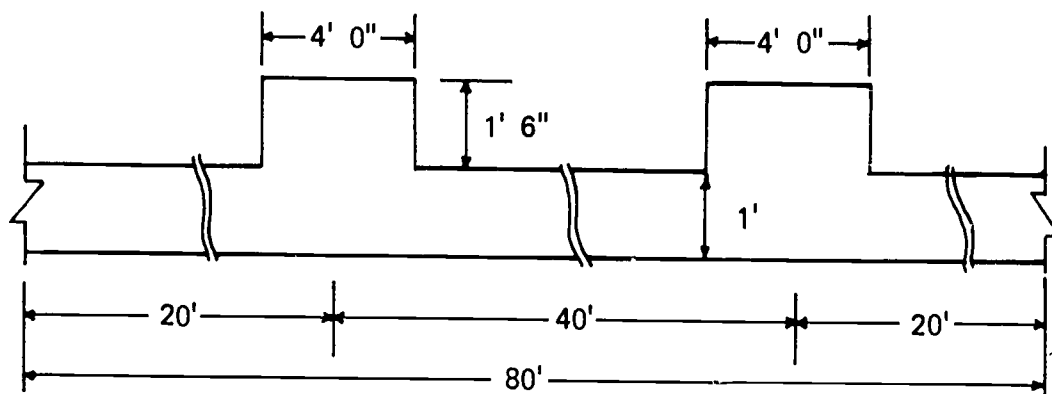

1. Studs (2 x 4)
2. Sheathing (plywood)
3. Plates (2 x 4)
4. Walers (2 x 4)
5. Waler spacer block and supports (1 x 4)
6. Braces (2 x 4)
7. Stakes (2" x 4" x 3')
8. Form ties
 - a. Wall
 - b. Pilaster
9. Form tie clamps

WALL FORMS
UNIT IV

ASSIGNMENT SHEET #2--ESTIMATE SIZE AND QUANTITY OF PANELS

Using the information sheet, estimate the size and quantity of panels needed to form the wall section shown below.

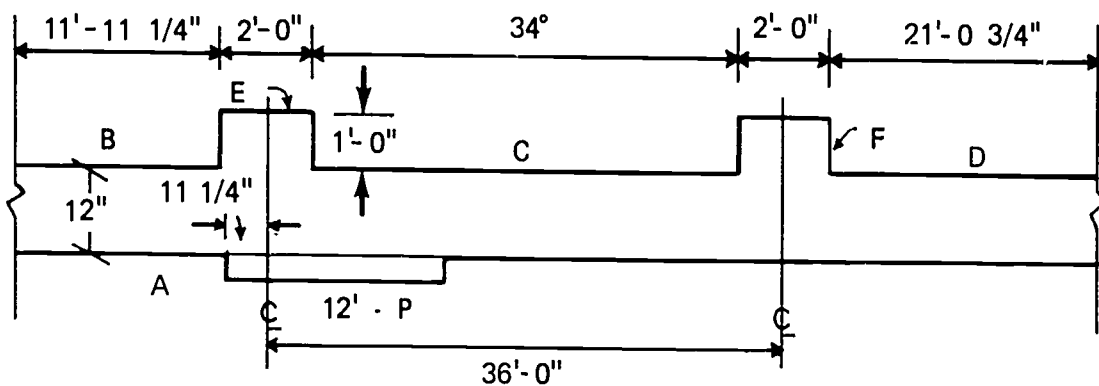

(NOTE: Assume tie spacing horizontal @ 2' c.c. Main panels 12' wide starting location of panel shown.)

1. Wall A

Main panels	Q	W
Filler panels	Q	W
2. Wall B

Main panels	Q	W
Filler panels	Q	W
3. Wall C

Main panels	Q	W
Filler panels	Q	W
4. Wall D

Main panels	Q	W
Filler panels	Q	W
5. Pilasters E and F

Face panels	Q	W
Side panels	Q	W

WALL FORMS
UNIT IV

ANSWERS TO ASSIGNMENT SHEETS

Assignment Sheet #1

1. 132--2" x 4" - 12'
2. 64 pc--4" x 8' plywood
3. 20--2" x 4" - 16'
4. 123--2" x 4" - 16'
5. 246 lin ft. (1 x 4)
6. 21--2" x 4" - 14'
7. 21--2" x 4" - 3'
8. 204--1' - 0"
36--26
9. 480

Assignment Sheet #2

1. 6--12' - 0"
0--0
2. 0--0
1--11' - 10 1/2"
3. 2--12' - 0"
1--9' - 10 1/2"
4. 1--12' - 0"
1--10' - 0 3/4"
5. 2--2' - 8 1/2"
4--1' - 0"

WALL FORMS
UNIT IV

JOB SHEET #1--STRAIGHT WALL PATENTED FORMS

I. Tools and materials needed

A. Tools

1. Electric handsaw
2. Crosscut handsaw
3. Claw hammer (16 oz. or larger)
4. Sledge hammer
5. 100' tape measure
6. Tape measure (12' or 16')
7. Level (hand)
8. Builder's level
9. Electric drill
10. Chalk line
11. All special tools supplied by the form manufacturer
12. Plumb bob

B. Materials

1. Stakes
2. 2 x 4 or 2 x 6 for
 - a. Braces
 - b. Plates
 - c. Strong backs
3. Patented forms and accessories

(NOTE: No two companies make the same type of form ties, panel clamps, aligner clamps, or panels. When a particular type is selected, that system must be referred to for all accessories and installation instructions.)

JOB SHEET #1

II. Procedure

A. Transfer the building corners from the batter boards to the footing
(NOTE: Use plumb bob.)

B. Snap a chalk line on the footing on the side set first

(NOTE: Either side may be set first. Figure 1 shows inside set first.) (Figure 1)

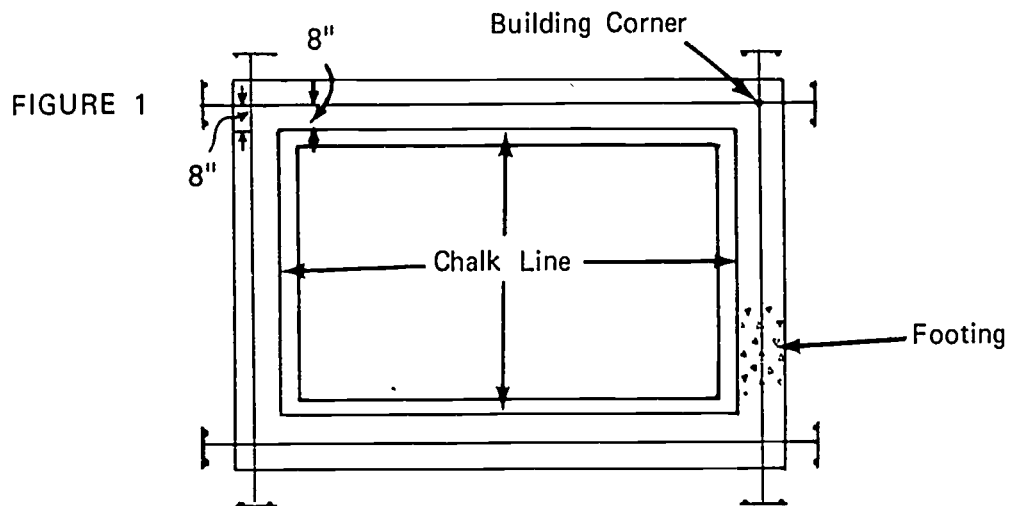

C. Secure 2 x 4 plates to footing using either 2 1/2" concrete nails or powder actuated tool with 2 1/2" pins (Figure 2)

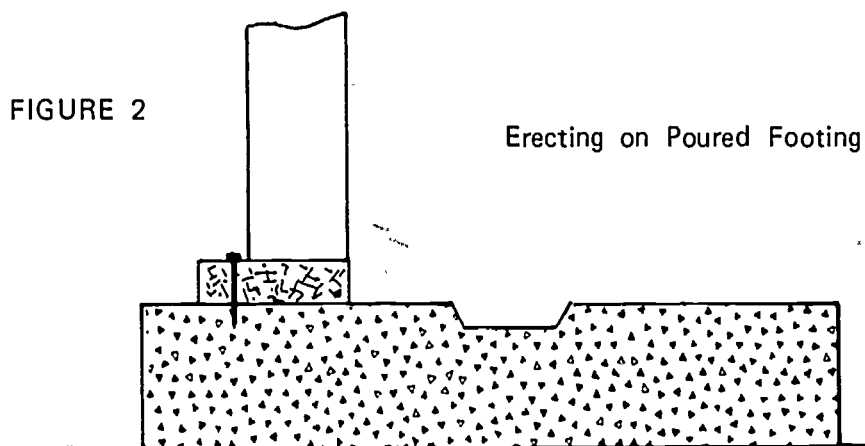

JOB SHEET #1

(NOTE: If erecting without footing, drive stakes to support plate as shown in Figure 3.)

FIGURE 3

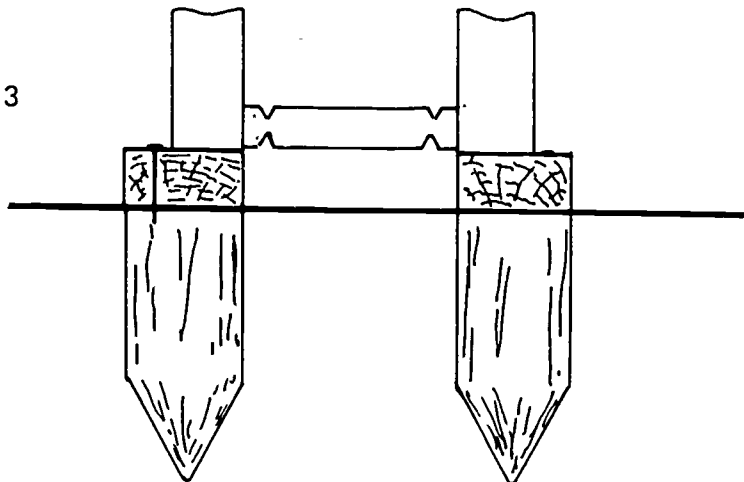

Erecting on Dirt Without Footing

- D. Lay out location of panels at corner (Figure 4)

(NOTE: Panels must be directly opposite each other. Figure 4 shows an inside corner panel. There are many others used by patent forms manufacturers. Consult the manufacturer's literature for specific corner layout.)

FIGURE 4

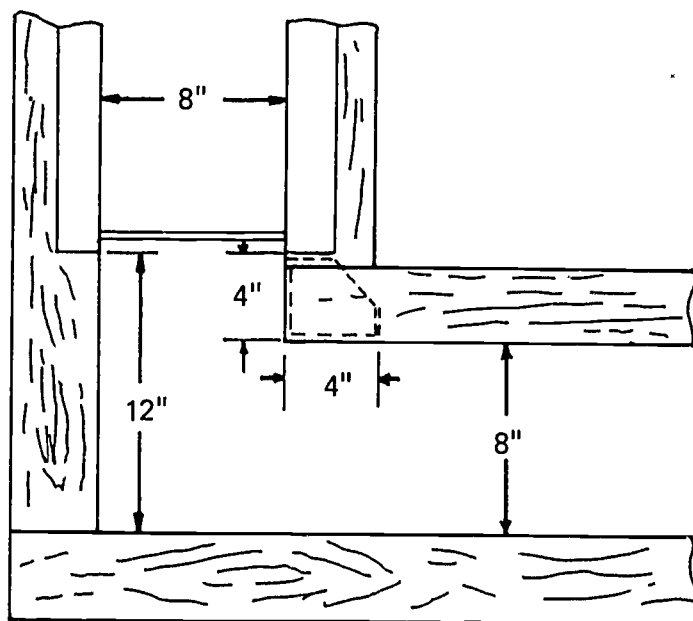

JOB SHEET #1

- E. Nail a form panel to the base plate in the nail holes provided at both ends of the plate (Figure 5)

FIGURE 5

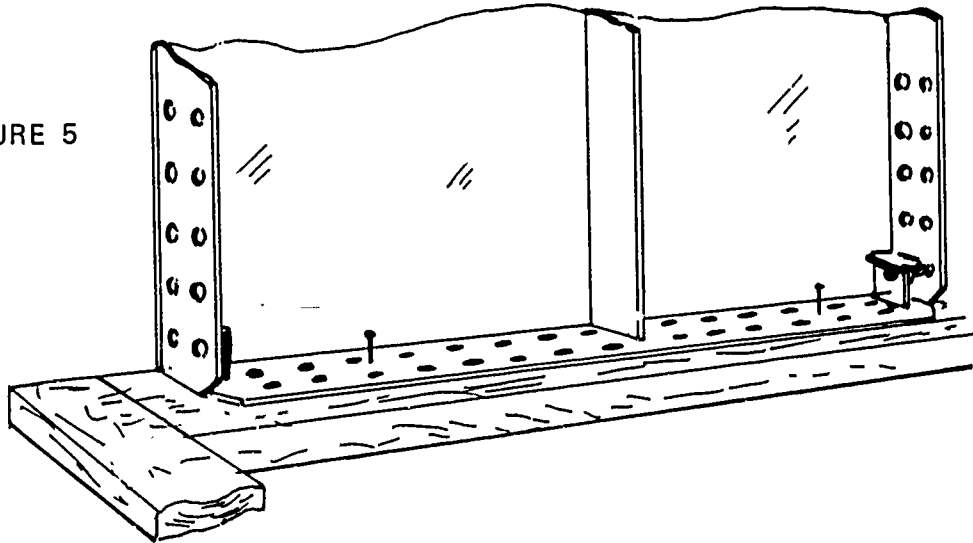

- F. Set the adjacent form panel in place and install clamp (Figure 6)

FIGURE 6

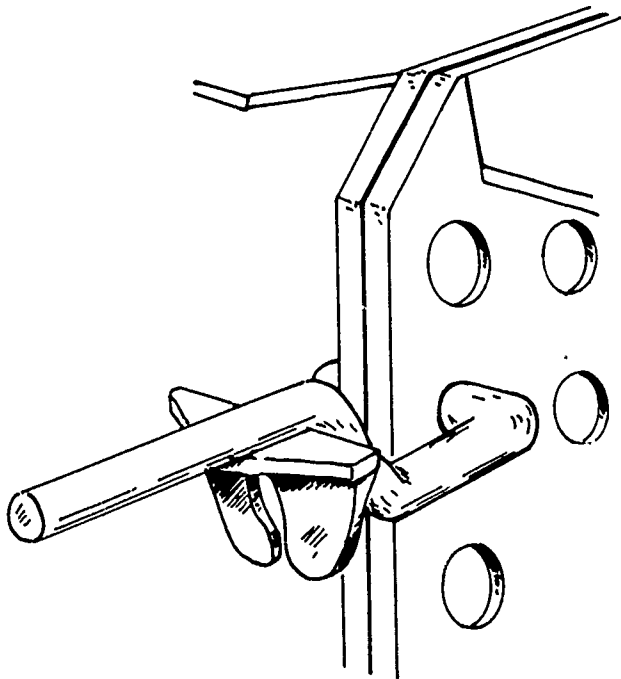

JOB SHEET #1

- G. Push the panel into alignment with the base plate and nail (Figure 7)

FIGURE 7

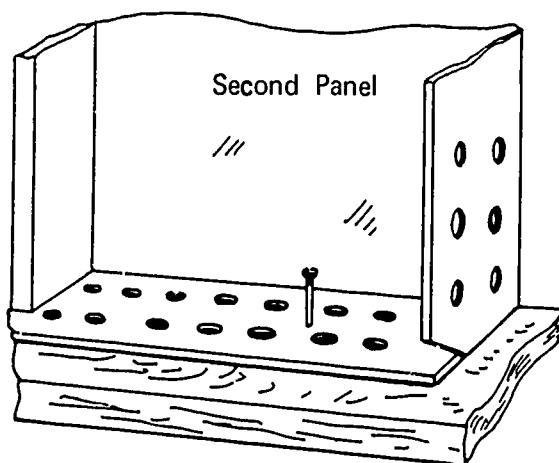

- H. Repeat steps F and G to continue erection on the first row
 I. Set up remaining rows and secure to adjoining panels (Figure 8)

(NOTE: Temporary braces will be installed when the panels are stacked to a height that there is danger of them falling over.)

FIGURE 8

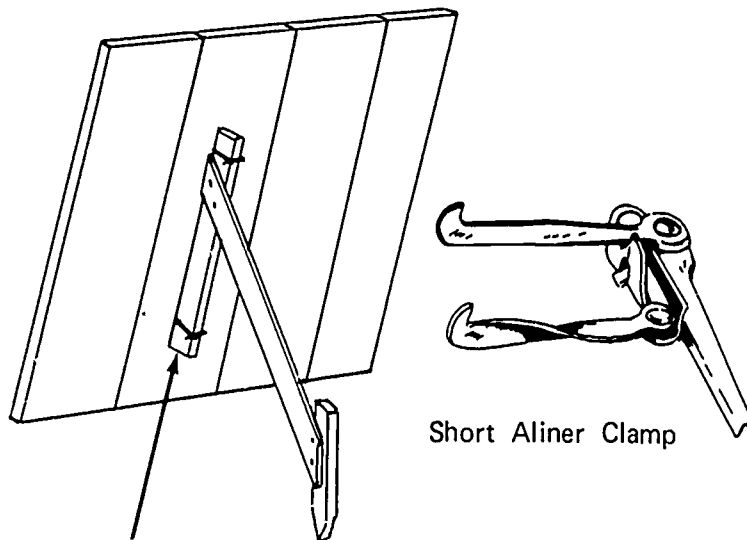

2 x 4 Clamped to Form With Aligner Clamp

- J. Install aligners (strongbacks if used)

JOB SHEET #1

- K. Install braces and align top of form

(NOTE: This alignment can be made by sighting or plumbing with a hand level.)

- L. Build and install all sleeves pockets, offsets, or blockouts needed in the finished wall

(NOTE: Form oils must be applied before rebar are installed.)

- M. Set plates for opposite side (Figure 9)

FIGURE 9

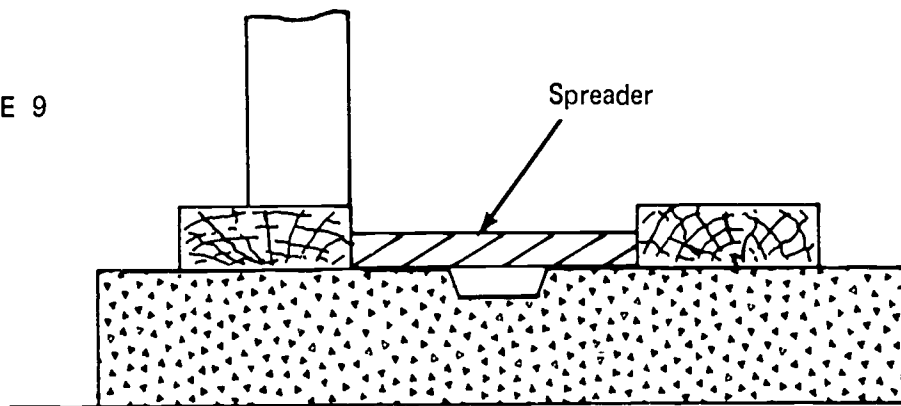

- N. Install form ties

(NOTE: Some form systems install ties when erecting the first side of the form.)

- O. Erect second side of form following the same procedures outlined in steps E to I inclusive (Figure 10)

(NOTE: Erection can start any place along the wall. Be sure panels opposite each other are the same size.)

FIGURE 10

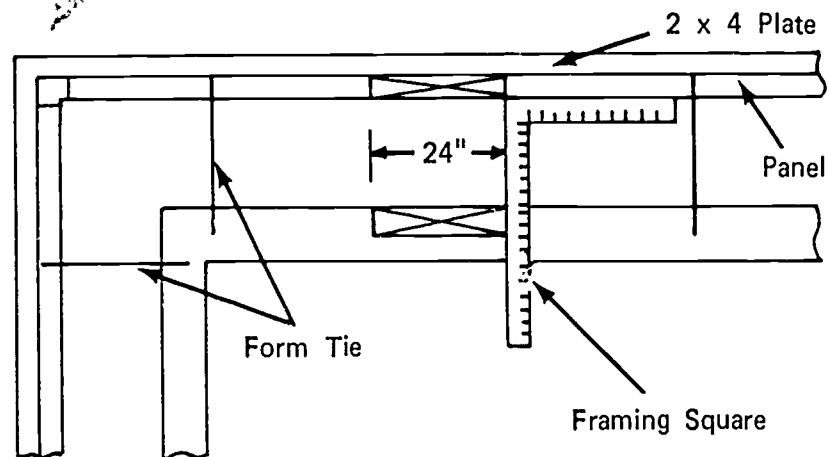

JOB SHEET #1

P. Establish the concrete grade

1. Grade board (Figure 11)

(NOTE: This method may be used if most of the panels are the same height and level on top.)

FIGURE 11

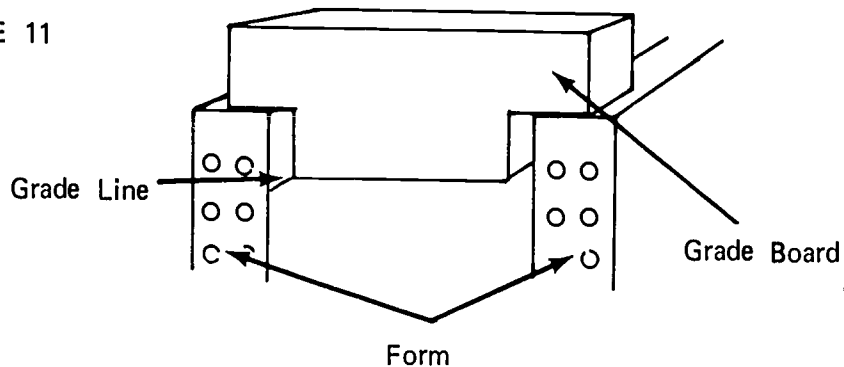

2. Grade strip

- a. Measure from top of form or establish elevation points with builder's level
- b. Snap a chalk line to mark grade (Figure 12)

FIGURE 12

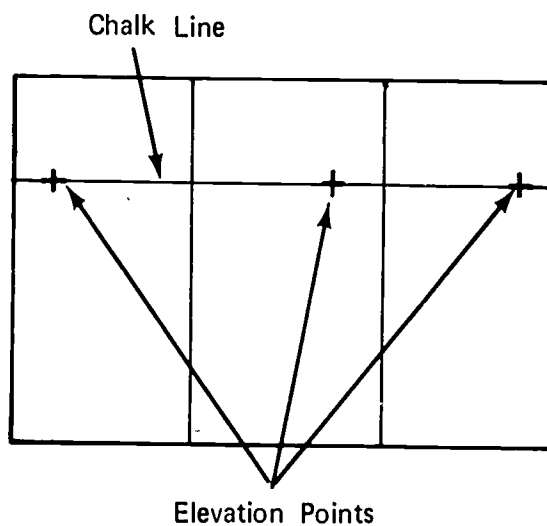

JOB SHEET #1

- c. Attach grade strip (Figure 13)--Drill 3/16" hole through form and nail strip with 6d duplex from the back side of the form

FIGURE 13

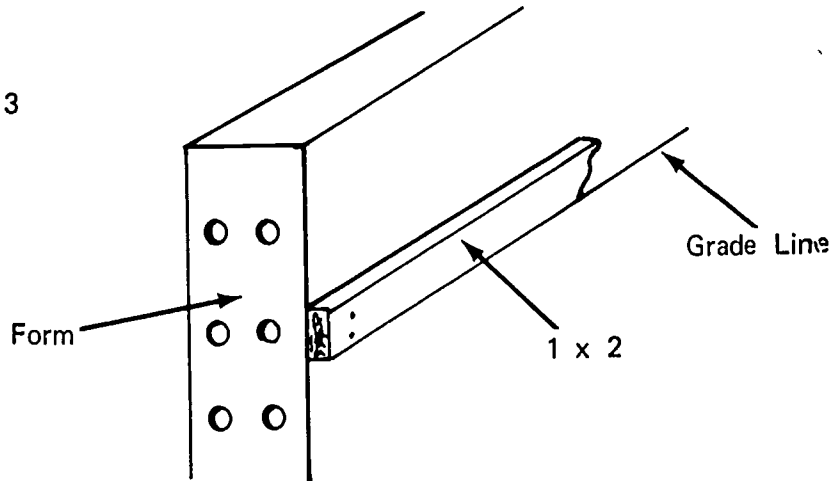

(NOTE: Nail to panel if wood sheathing is used on form system.) (See Figure 13.)

- Q. Recheck form alignment (Figure 14)

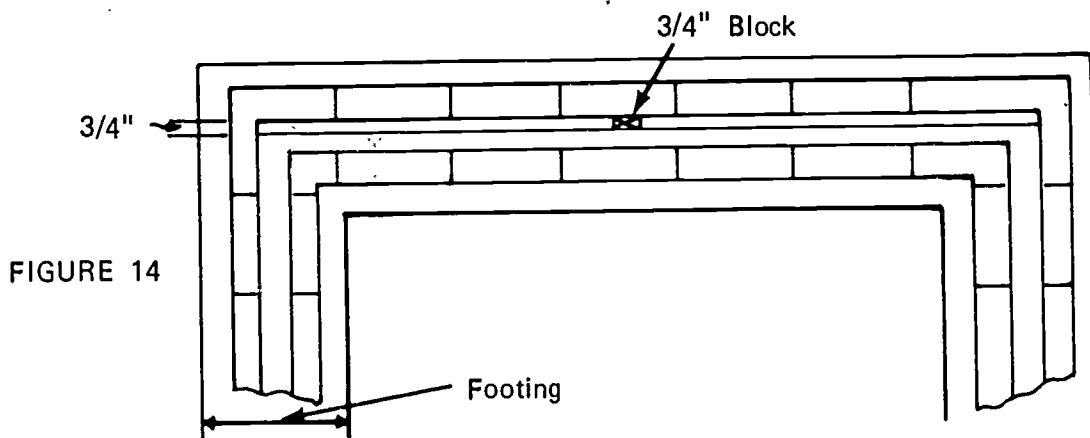

FIGURE 14

1. Secure line to top of form 3/4" out from face of form; draw taut
2. Use a 3/4" hand held block to check alignment at intermediate points
3. Adjust braces to secure alignment

WALL FORMS
UNIT IV

JOB SHEET #2--GANG FORMS FOR A BATTERED WALL

I. Tools and materials needed

A. Tools

1. Electric handsaw
2. Crosscut handsaw
3. Claw hammer (16 or 24 ounce)
4. Sledge hammer
5. 100' tape measure
6. Tape measure (12' or 16')
7. Level (hand)
8. Builder's level
9. Electric drill
10. Chalk line
11. Powder actuated tool

B. Materials

1. Stakes
2. Plates and braces--2 x 4's or 2 x 6's
3. Panels
4. Form ties
5. Walers
6. Waler brackets

II. Procedure

- A. Locate wall line on footings
- B. Snap a chalk line on the footing at the plumb side of the wall
- C. Nail sole plates to footings

JOB SHEET #2

(NOTE: Use 2 1/2" concrete nails or powder actuated driver with 2 1/2" pins.) (Figure 1)

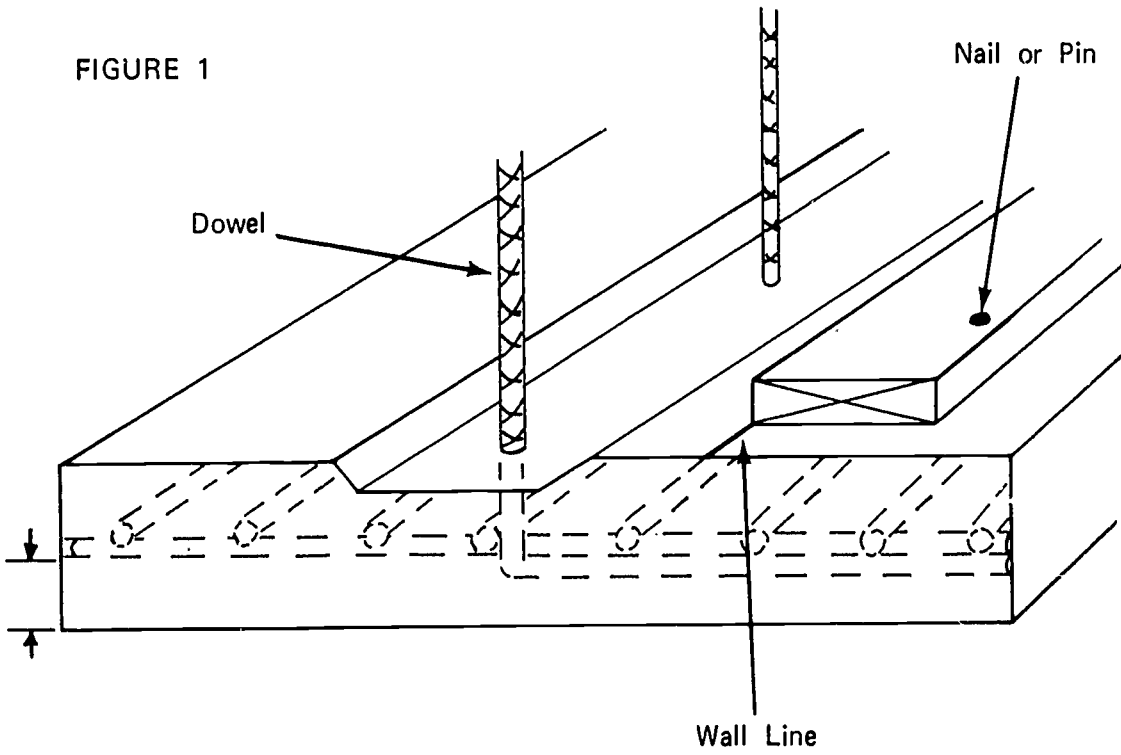

JOB SHEET #2

D. Build gang form

1. Level stringers of two inches or thicker material long enough to accommodate gang form (Figure 2)

(NOTE: The bed may be on the ground or on horses.)

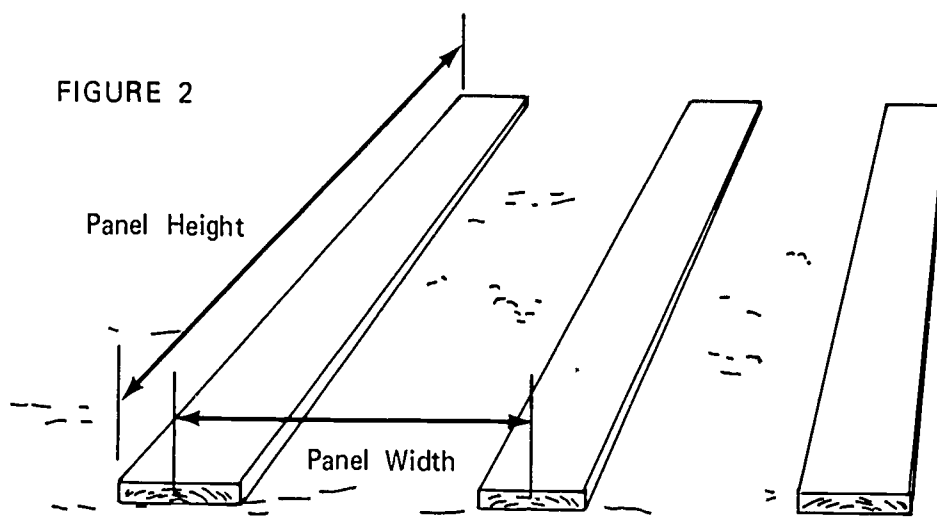

2. Lay panels on bed, face down
3. Bolt panels together with machine bolts or panel lock bolts (Figure 3)

FIGURE 3

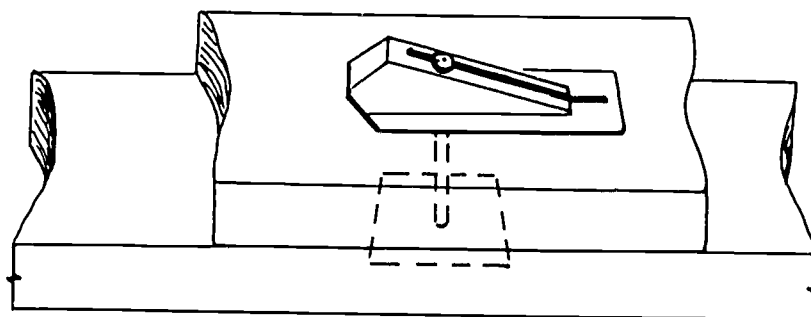

Panel Lock Bolt

JOB SHEET #2

4. Attach waler support brackets (Figures 4a, 4b, and 4c)

(NOTE: Supports 4b and 4c are nailed to the stud; 4a requires a drilled hole in the stud.)

FIGURE 4

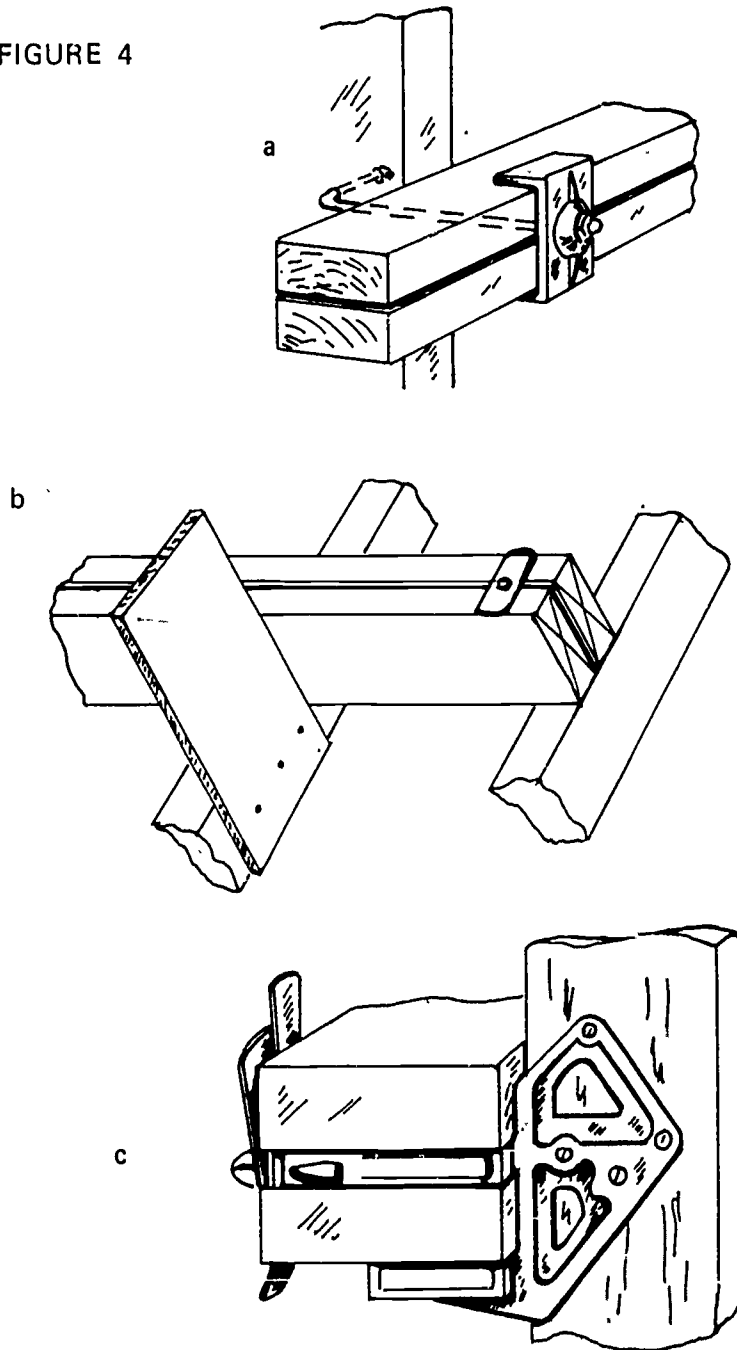

JOB SHEET #2

5. Install walers and strong backs (Figure 5)

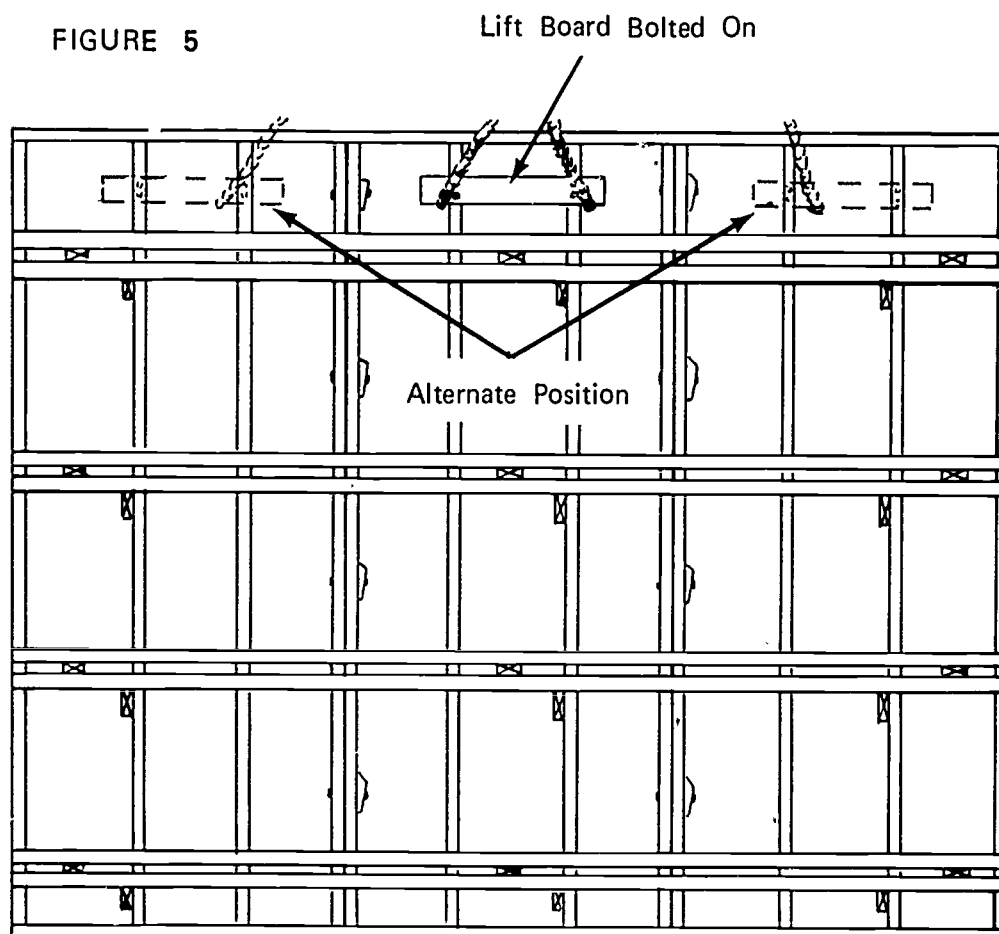

6. Install lifting board as shown in Figure 5

(NOTE: Position of lifting board is determined by length of panel.
For long panels, two are recommended.)

JOB SHEET #2

7. Lift panel off bed

(NOTE: A crane or boom truck may be used. Panels may be stored or set as their building progresses.)

8. Build all panels needed for job

(NOTE: Several factors are used to determine the number of panels needed. They are: length of pour, length of wall, erection time, and the length of time form must remain on wall after it is poured.)

E. Erect first side of form

1. Place first panel on sole plate
2. Line face of form with wall line (Figures 6a and 6b)

FIGURE 6

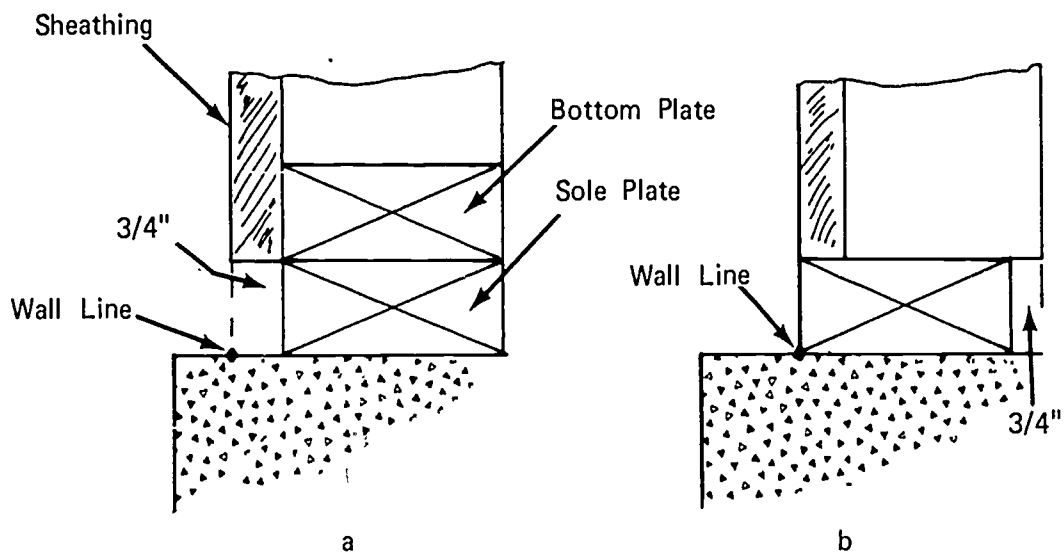

3. Nail bottom plate to sole plate

(NOTE: Use 16d duplex nails.)

JOB SHEET #2

4. Brace and plumb panel at both ends (Figure 7)

(NOTE: Do not cover panel bolt holes.)

FIGURE 7

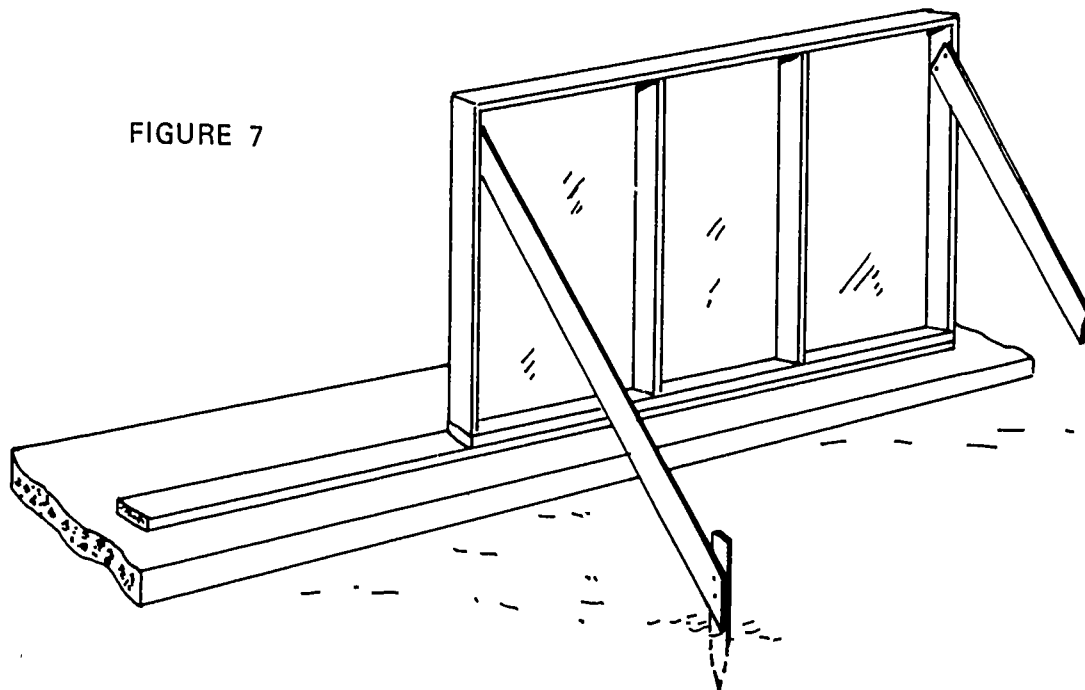

5. Set adjacent gang form
6. Bolt to first gang form
(NOTE: Use panel lock bolts as shown in Figure 3.)
7. Line face end with wall line and nail to sole plate
8. Plumb and brace free end
9. Repeat steps 5, 6, 7, and 8 to continue erection

JOB SHEET #2

F. Build and install bulkheads

1. Build bulkhead to height and shape of wall (Figure 8)

(NOTE: Blocks should be nailed over slots after rebar are installed.)

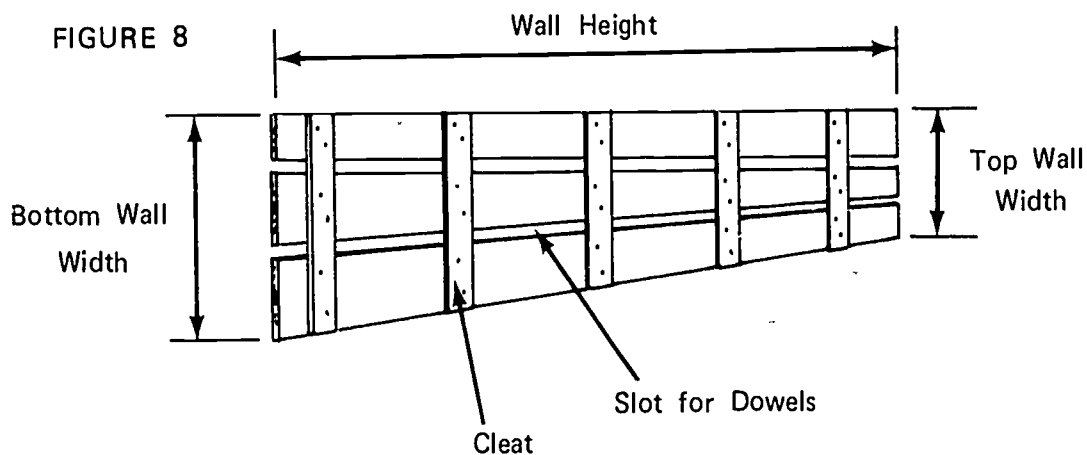

2. Nail kicker to form at bulkhead location on both ends of form (Figure 9)

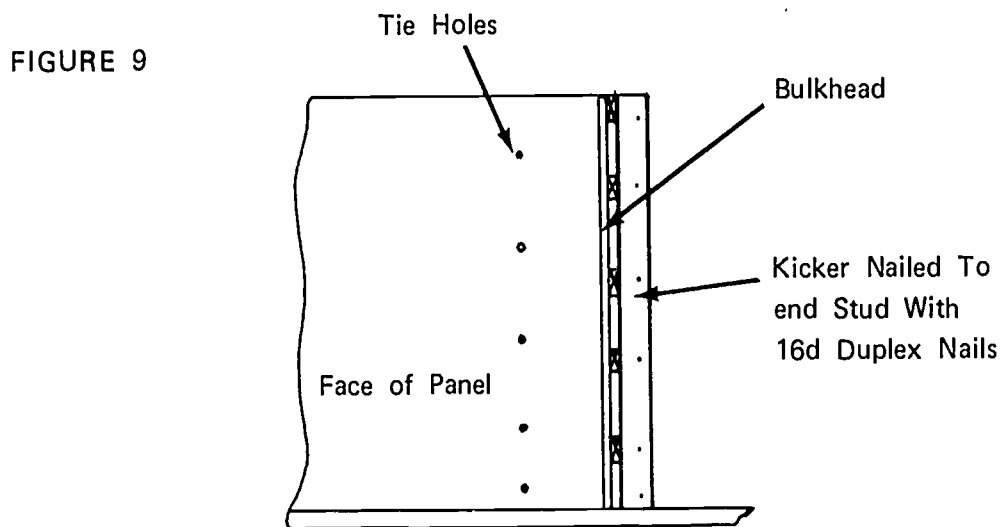

JOB SHEET #2

3. Set bulkhead against kicker and nail (Figure 10)
(NOTE: Install bulkheads at both ends of form.)

FIGURE 10

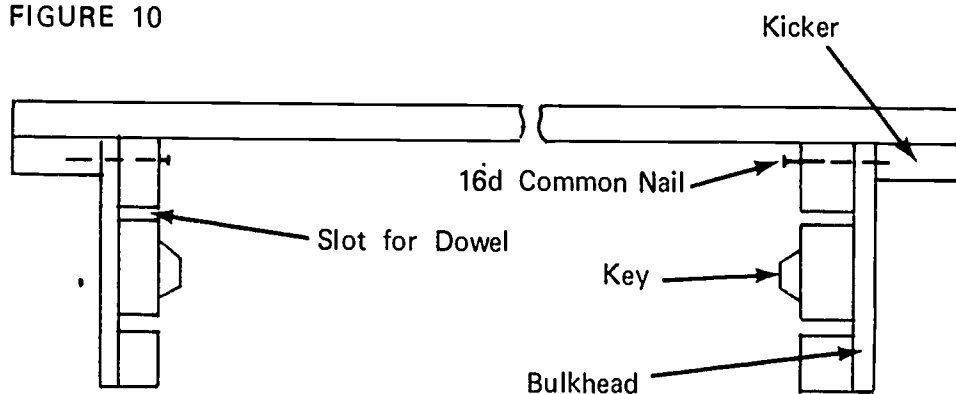

- G. Set second side of forms

(NOTE: Form oil must be applied before rebar are installed.)

1. Set sole plate (Figure 11)

(NOTE: Use spreader and secure plate as was opposite plate.)

FIGURE 11

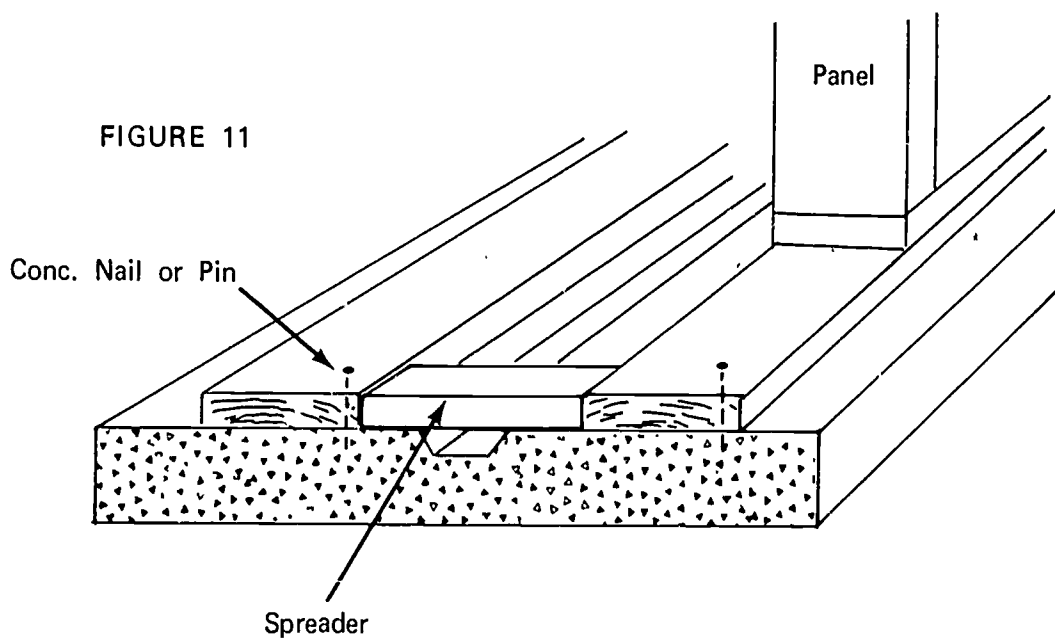

2. Nail bulkhead kicker on first gang form to correspond with opposite sides

JOB SHEET #2

- Stand first gang form on sole plate (Figure 12)

(NOTE: Position form square across from the opposite form. Tack spreaders to form.)

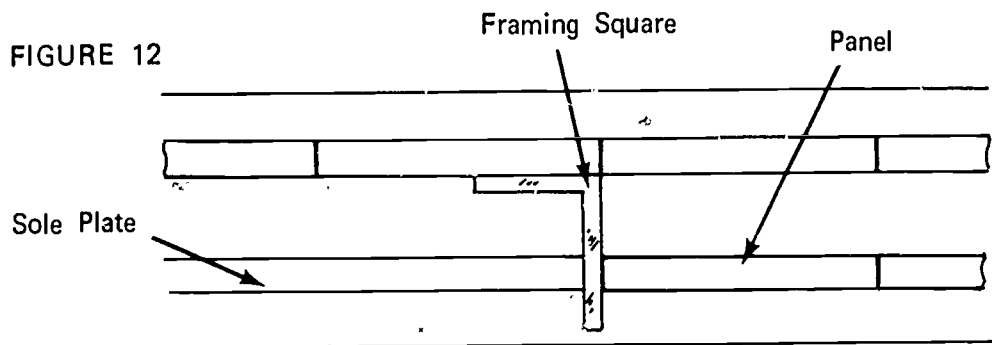

- Place on wall line and nail to sole plate
- Nail a cleat across both ends of the form to hold it in place (Figure 13)

(NOTE: Maintain correct wall thickness at lead end. The back end is against bulkhead. Braces may not be needed on this side.)

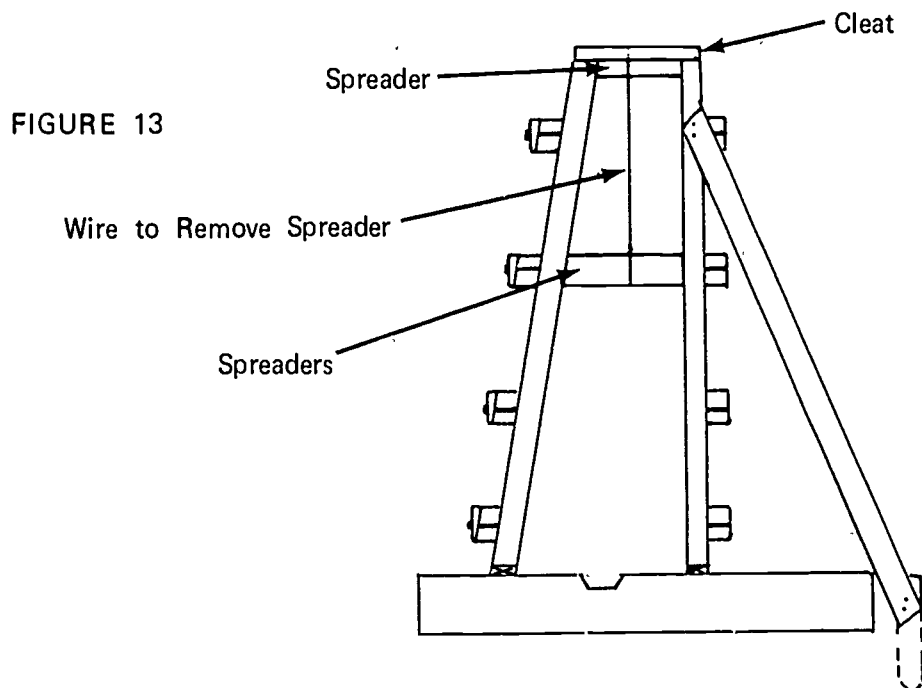

JOB SHEET #2

6. Set adjacent gang form
7. Bolt to first gang form
(NOTE: Use panel lock bolts as shown in Figure 3.)
8. Nail cleat across top of form at free end as shown in Figure 6
9. Repeat steps 5, 6, and 7 to continue erection

H. Install form ties

1. Assemble form ties (Figure 14)

(IMPORTANT: Threaded rod should be screwed into outside rod for full thread.)

FIGURE 14

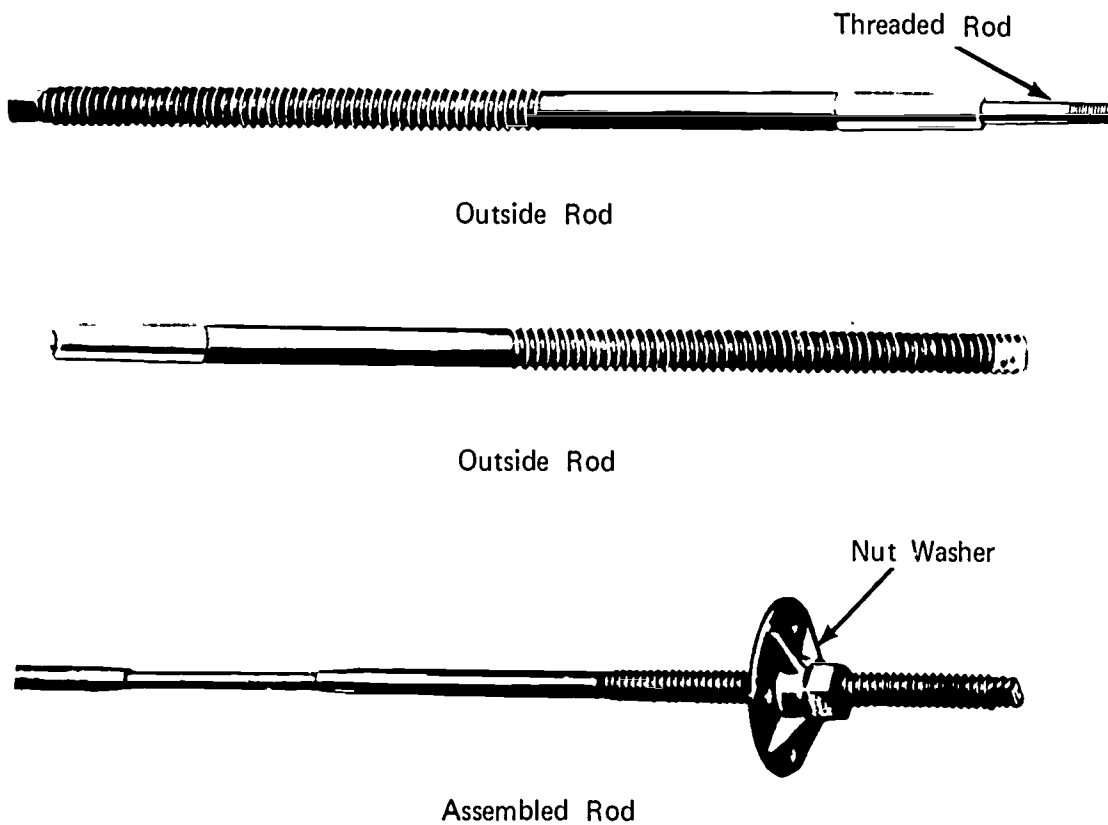

JOB SHEET #2

2. Place form tie assembly through forms from the plumb side (Figure 15)

(NOTE: Tack nut washer to stud so washer will remain against water while the opposite side nut is being installed.)

FIGURE 15

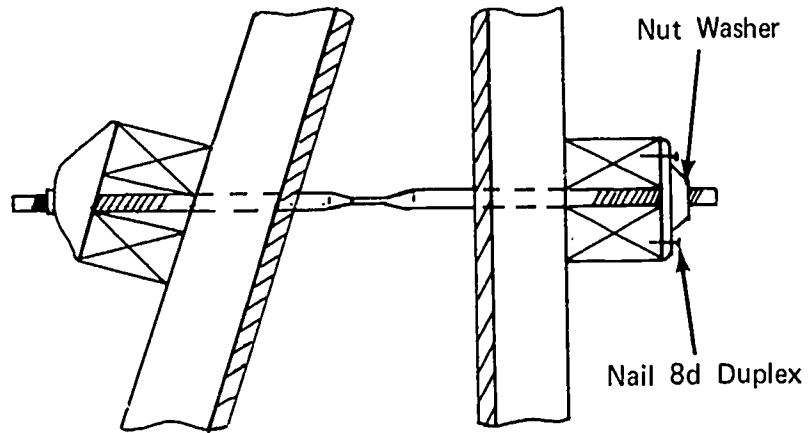

3. Install opposite side washer over tie and tack to water (Figure 16)

(NOTE: Either type washer may be used.)

FIGURE 16

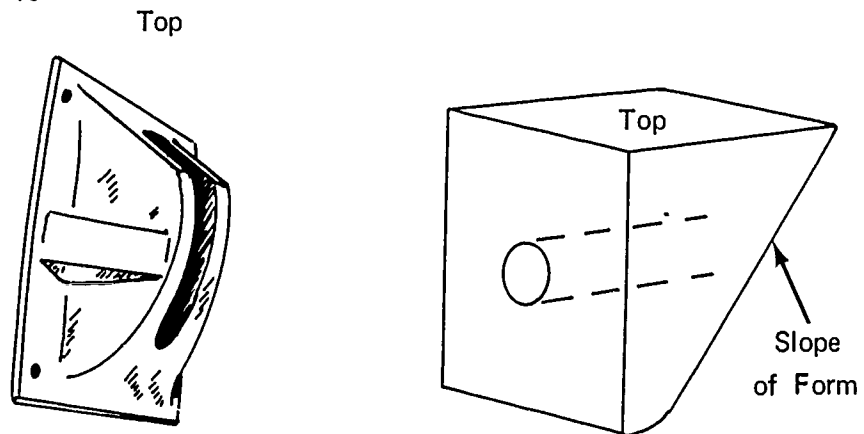

a Malleable Batter Washer

b Wood Washer

JOB SHEET #2

4. Install nut on all ties (Figure 17)

(NOTE: Use wing nut with malleable washer and nut washer with wood washer.)

FIGURE 17

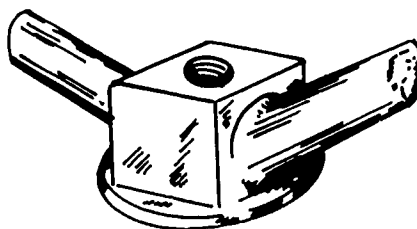

a Wing Nut



b Nut Washer

5. Tighten all nuts in the order shown (Figure 18)

(NOTE: Nuts should be pulled up snug, but avoid pulling spreaders into sheathing by drawing nuts too tight. Vertical end rows at bulkhead can be drawn tight; this will help hold the bulkhead.)

FIGURE 18

Tightening Sequence

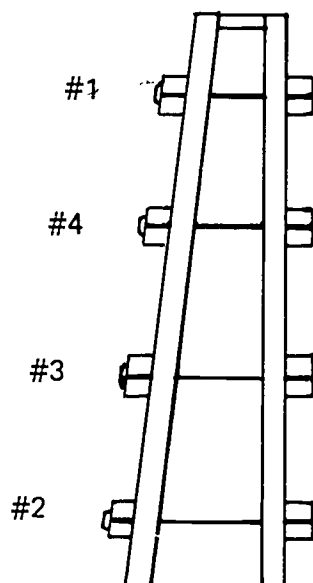

JOB SHEET #2

- I. Install additional support for bulkhead (if needed) (Figure 19)

(NOTE: The pressure on the bulkhead is the same as on the form.)

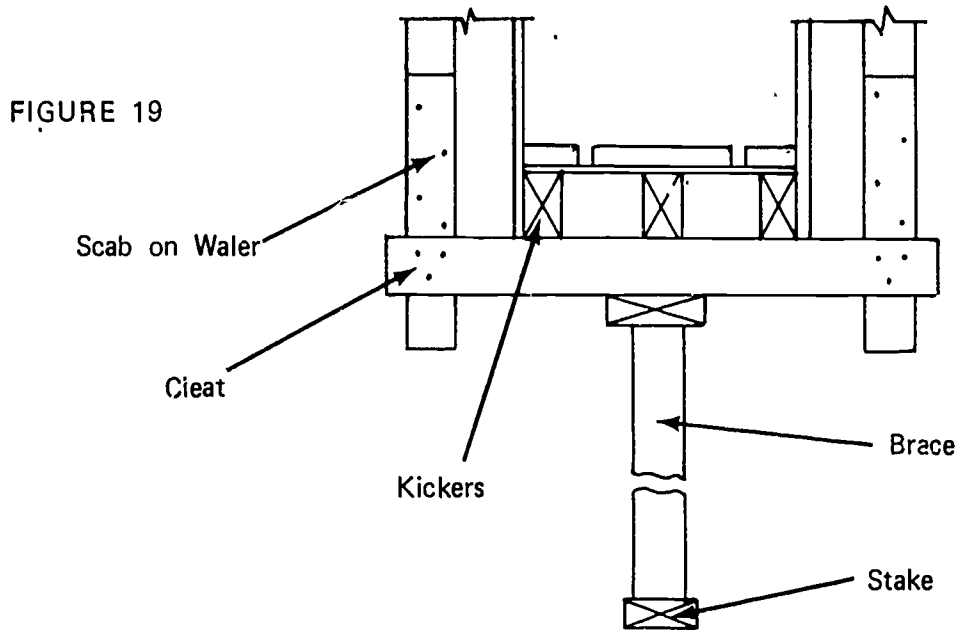

- J. Nail scabs over all water joints (Figure 20)

FIGURE 20

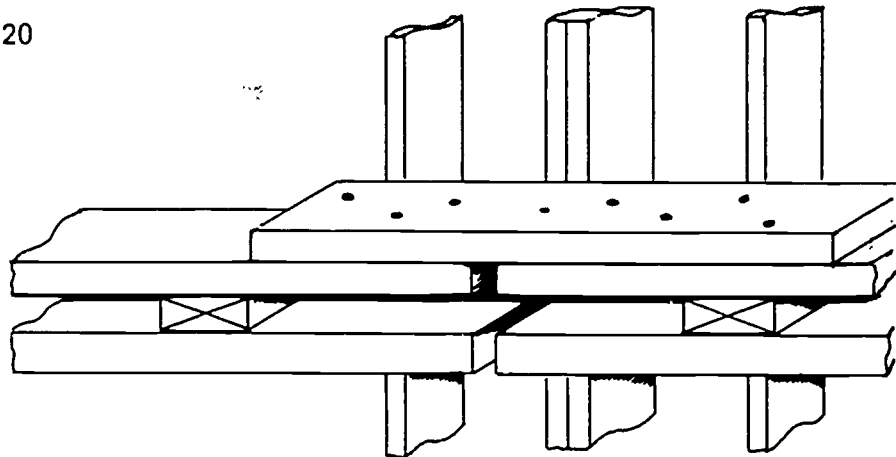

WALL FORMING
UNIT IV

JOB SHEET #3--CIRCULAR WALL FORMS BUILT IN PLACE

I. Tools and materials needed

A. Tools

1. Electric handsaw
2. Crosscut handsaw
3. Claw hammer (16 ounce or larger)
4. Sledge hammer
5. 100 foot steel tape measure
6. Twelve or sixteen foot tape measure
7. Level (hand)
8. Builder's level
9. Electric drill
10. Chalk line
11. Wrench (Ten inch adjustable)

B. Materials

1. Stakes
2. Sheathing
3. Spreaders
4. Form ties
5. 2 x 4's or 2 x 6's for
 - a. Braces
 - b. Studs

JOB SHEET #3

6. Nails
 - a. 8d duplex
 - b. 16d duplex
 - c. 6d common
 - d. 16d common
 - e. 8d common
7. 2 x 12--For segmental template ring
8. 1 x 4's

II. Procedure

- A. Determine height of wall and radius from plan
- B. Measure radius from center point to lay out circumference of wall
(NOTE: Lay out both inside and outside wall lines.)
- C. Lay out segmental template (Figure 1)

FIGURE 1

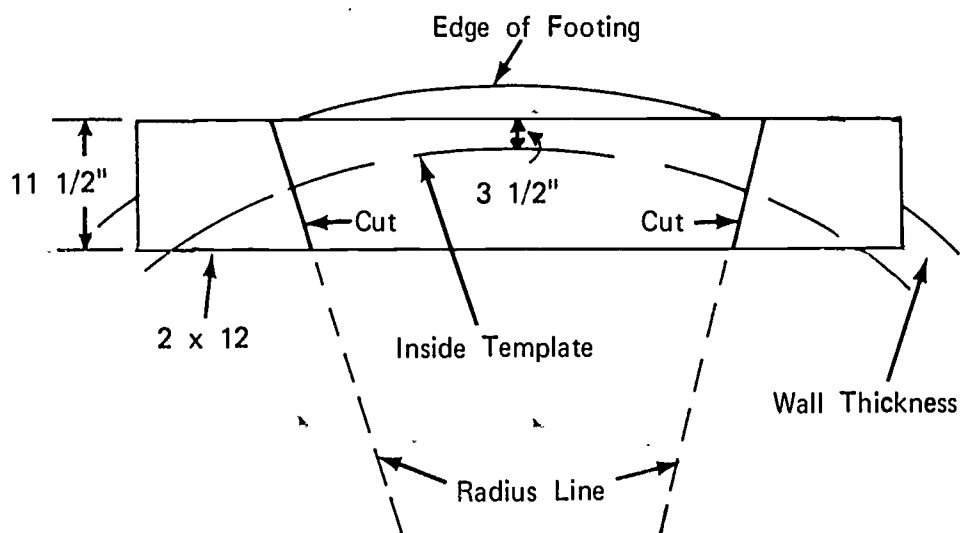

JOB SHEET #3

- D. Secure base templates to footing
(Figure 2)

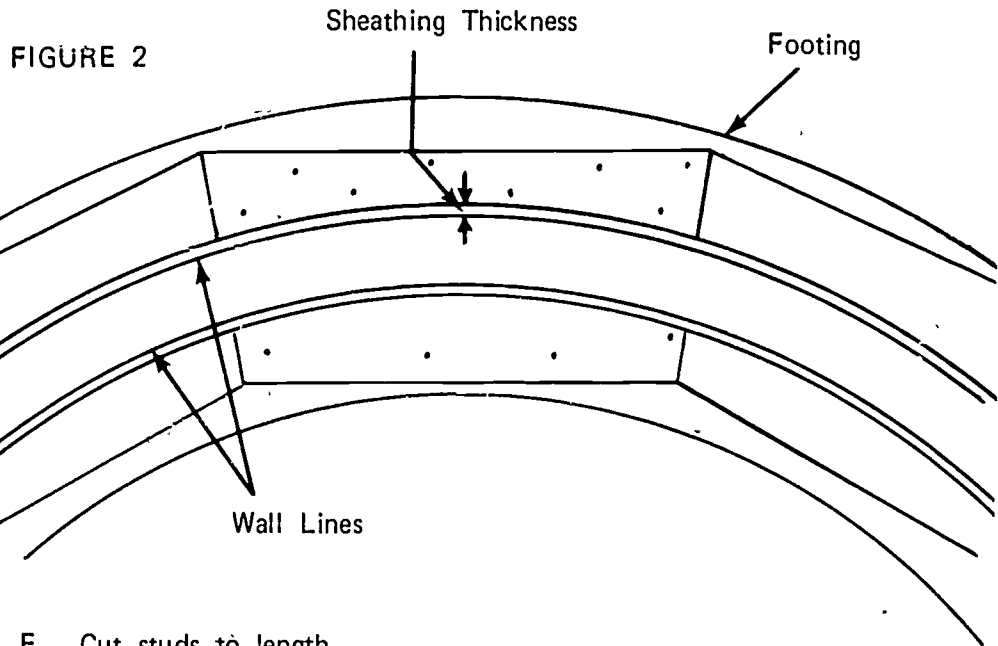

- E. Cut studs to length
 - F. Lay out stud spacing on both templates (Figure 3)
- (NOTE: Set inside form first.)

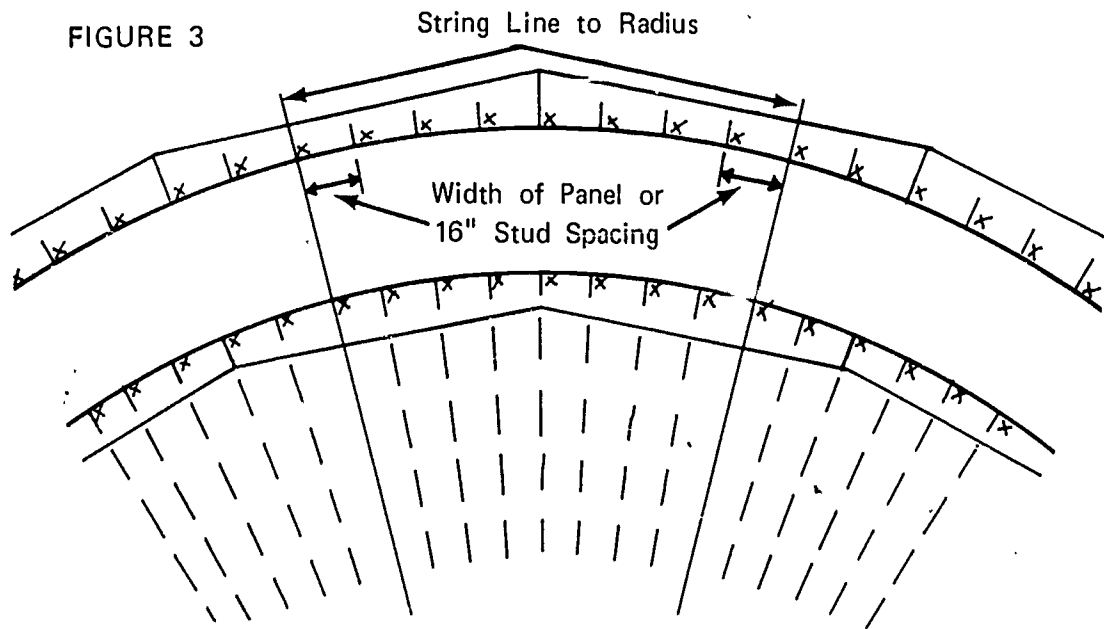

JOB SHEET #3

- G. Tack upper segmental templates to base plate and transfer stud layout (Figure 4)

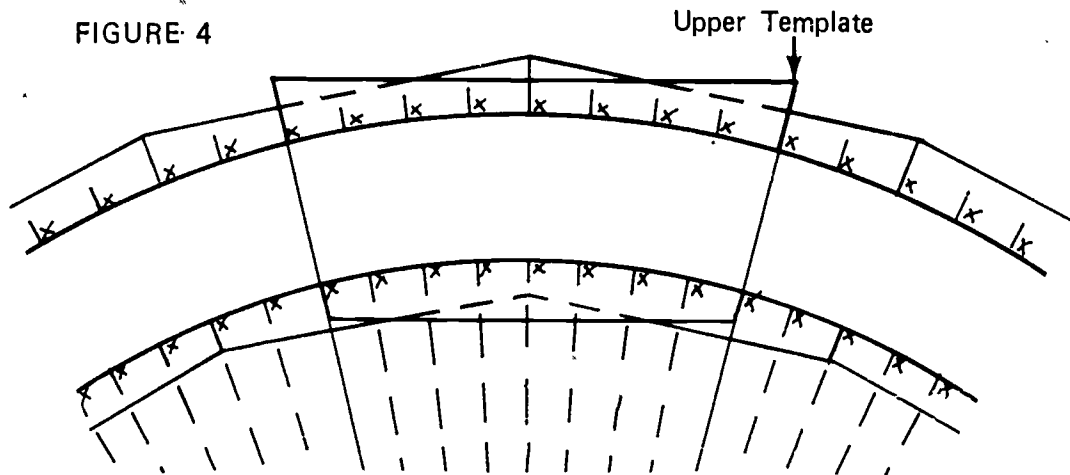

- H. Nail two studs to an upper segment of template (Figure 5)

(NOTE: Stagger segment joints.)

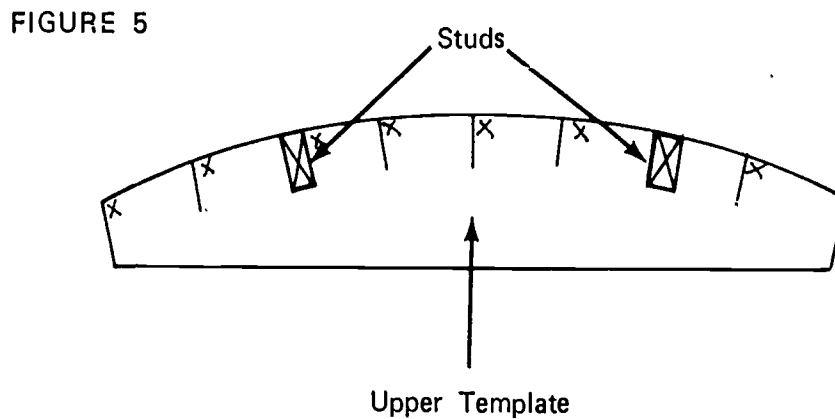

JOB SHEET #3

- I. Stand unit in position, then plumb and brace (Figure 6)

FIGURE 6

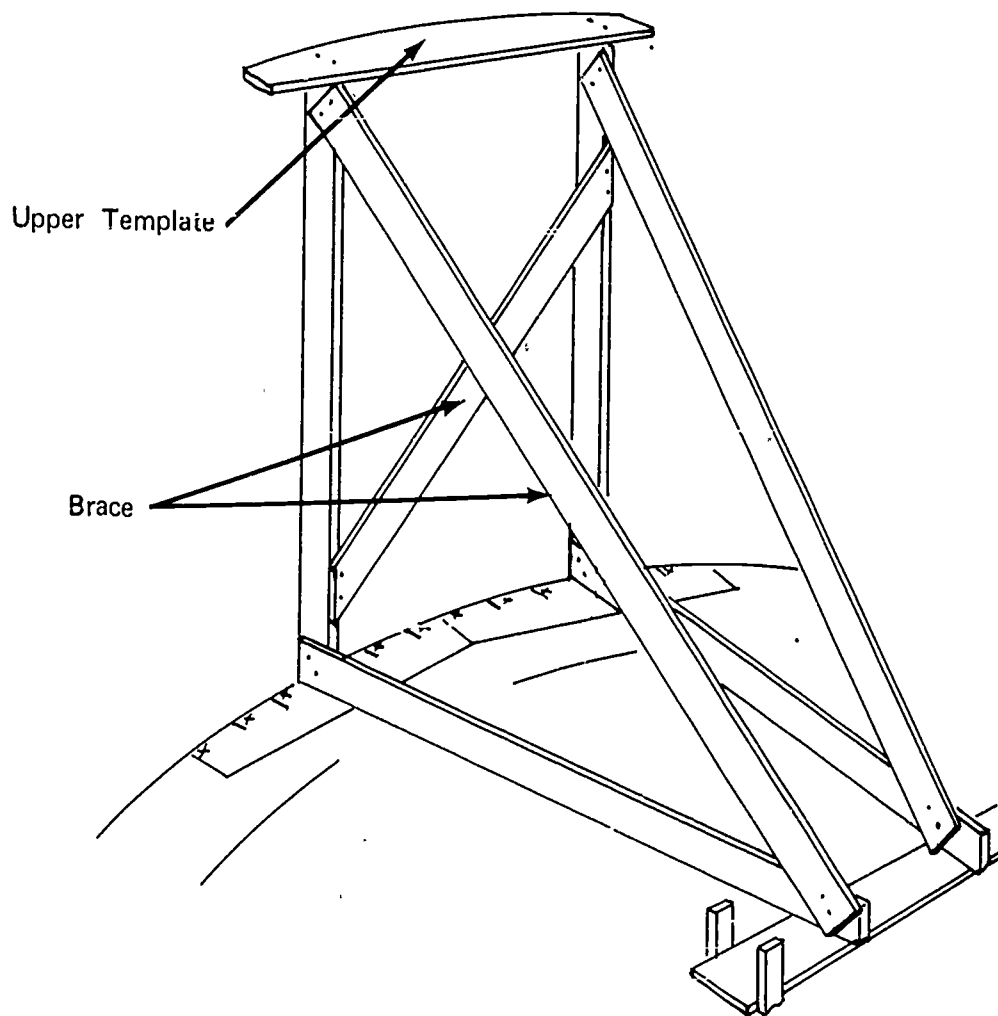

- J. Nail intermediate studs to upper and lower templates
- K. Continue erection as outlined in steps H, I, and J
- L. Nail scabs across joints of upper template

(NOTE: This may be done as erection progresses around the circle.)

JOB SHEET #3

M. Nail on sheathing (Figure 7)

(NOTE: Sheathing may be plywood or 1" x 6" boards. If an architectural finish is desired, cover the 1" x 6" board with thin ply or hardboard.)

FIGURE 7

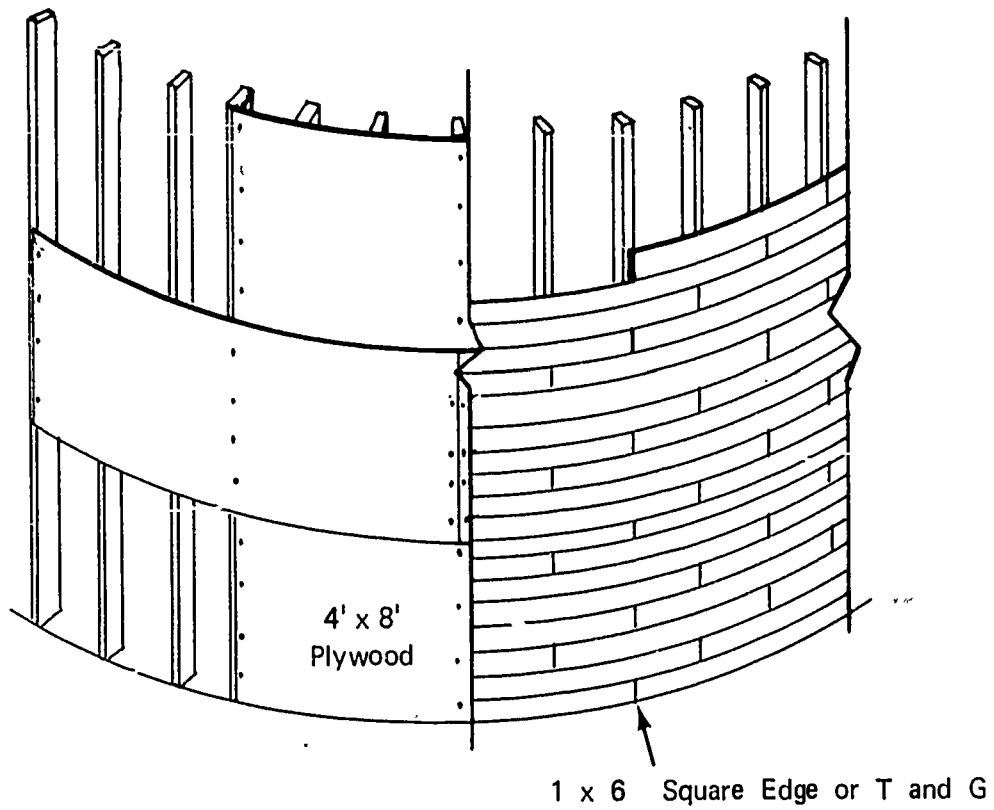

JOB SHEET #3

- N. Install inside walers (Figure 8)

(NOTE: Use the thickest material that springs to the circumference for walers. A double thickness of one inch material may be used.)

FIGURE 8

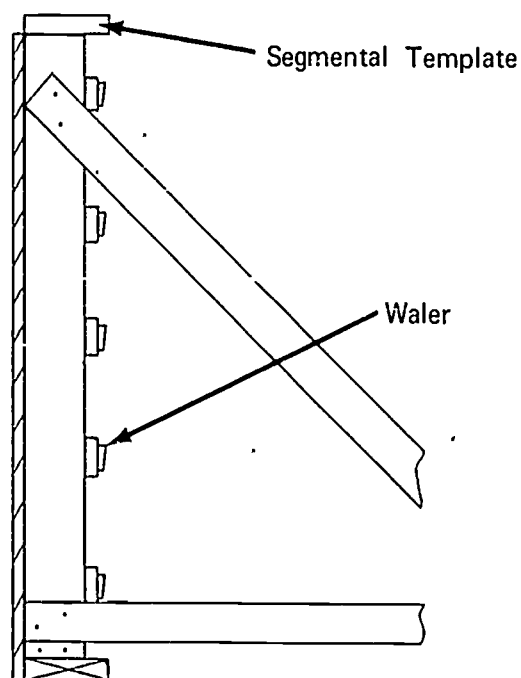

- O. Drill holes for form ties

(NOTE: Place ties as close to studs as possible.)

- P. Build and install all pockets, sleeves, or other blockouts needed in the finished wall

(NOTE: Reinforcing bars, if called for, will be installed at this time.)

- Q. Place form ties through inside wall and waler; secure with tie holder

- R. Sheath and stud outside form

(NOTE: Prebuilt panels may be used for outside sheathing. Narrow vertical panels work best. The width of the panels should be in direct relationship to the stud spacing.)

1. Attach studs to each panel

JOB SHEET #3

2. Drill tie holes

(NOTE: Make sure tie holes line up with inside form on radius line.)

3. Stand panel up and thread in ties
4. Nail upper template to studs
5. Nail cleat across the top to hold panels vertical (Figure 9)

(NOTE: After a number of panels have been erected, waler may be installed and tie holders secured to ties.)

FIGURE 9

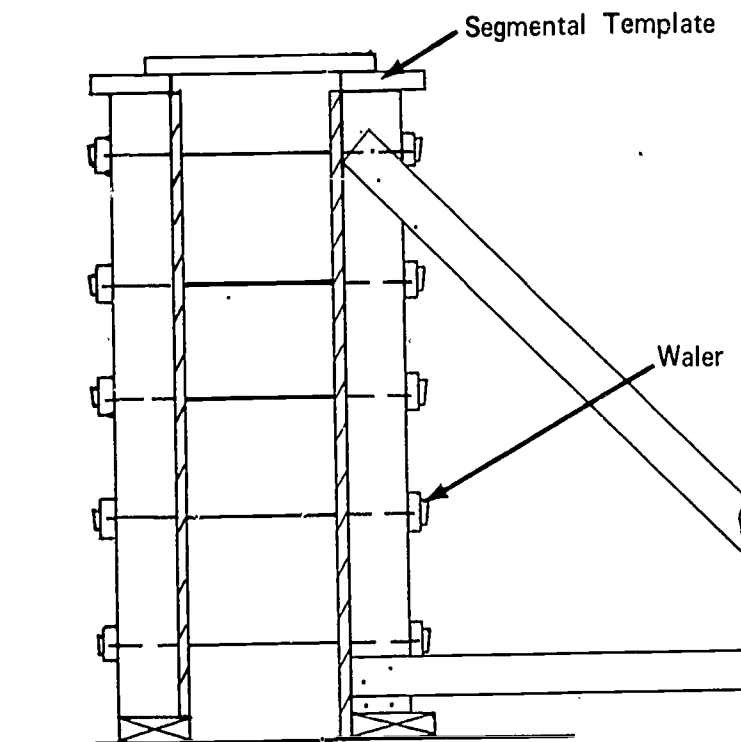

- S. Continue erection as outlined in steps 1 through 5 inclusive

WALL FORMS
UNIT IV

JOB SHEET #4--PANEL FORMS

I. Tools and materials needed

A. Tools

1. Electric handsaw
2. Crosscut handsaw
3. Claw hammer (16 or larger)
4. Sledge hammer
5. 100' tape measure
6. Tape measure (12' or 16')
7. Level (hand)
8. Builder's level
9. Electric drill
10. Chalk line
11. Power nailer

B. Materials

1. Stakes
2. Studs and plate--2 x 4's or 2 x 6's
3. Sheathing--Plyform
4. Plank--2 x 10 (for jig table)
5. Form ties and holders for
 - a. Walls
 - b. Pilasters

JOB SHEET #4

II. Procedure

- A. Determine height, width, and quantity of panels needed
- B., Build a jig table (Figure 1)

FIGURE 1

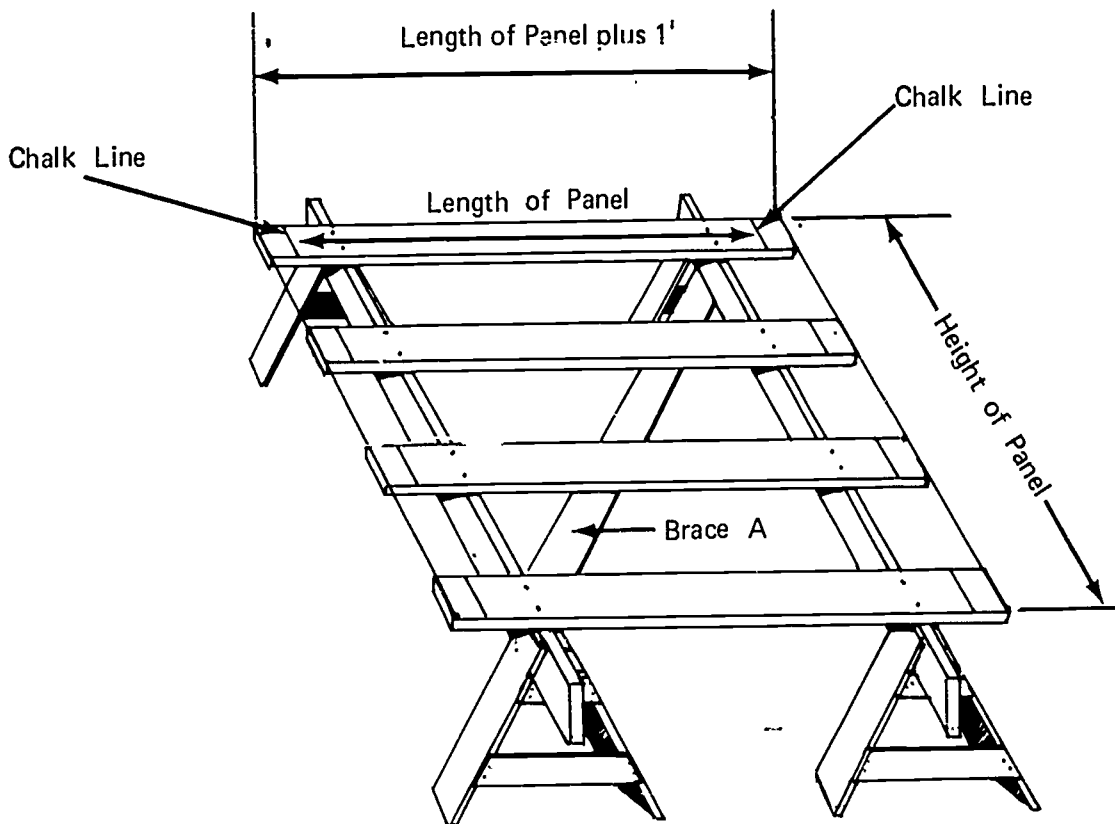

1. Secure or build horses a convenient work height (usually two feet)
2. Lay plank across the horses and nail
(NOTE: The platform should be a little larger than the panel.)
3. Check for square and nail brace A

JOB SHEET #4

- Lay out stud spacing on both outside planks (Figure 2)

FIGURE 2

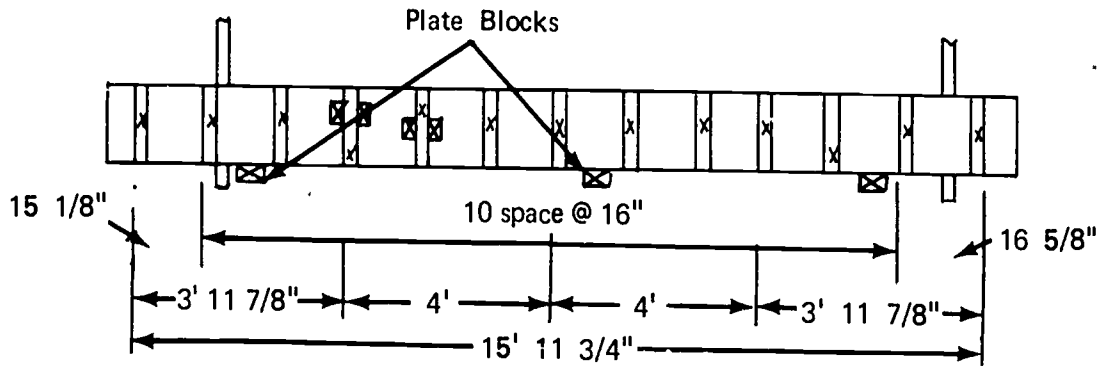

- Nail jig blocks to platform, one on each side of stud layout (Figure 3)

FIGURE 3

Width of Stud

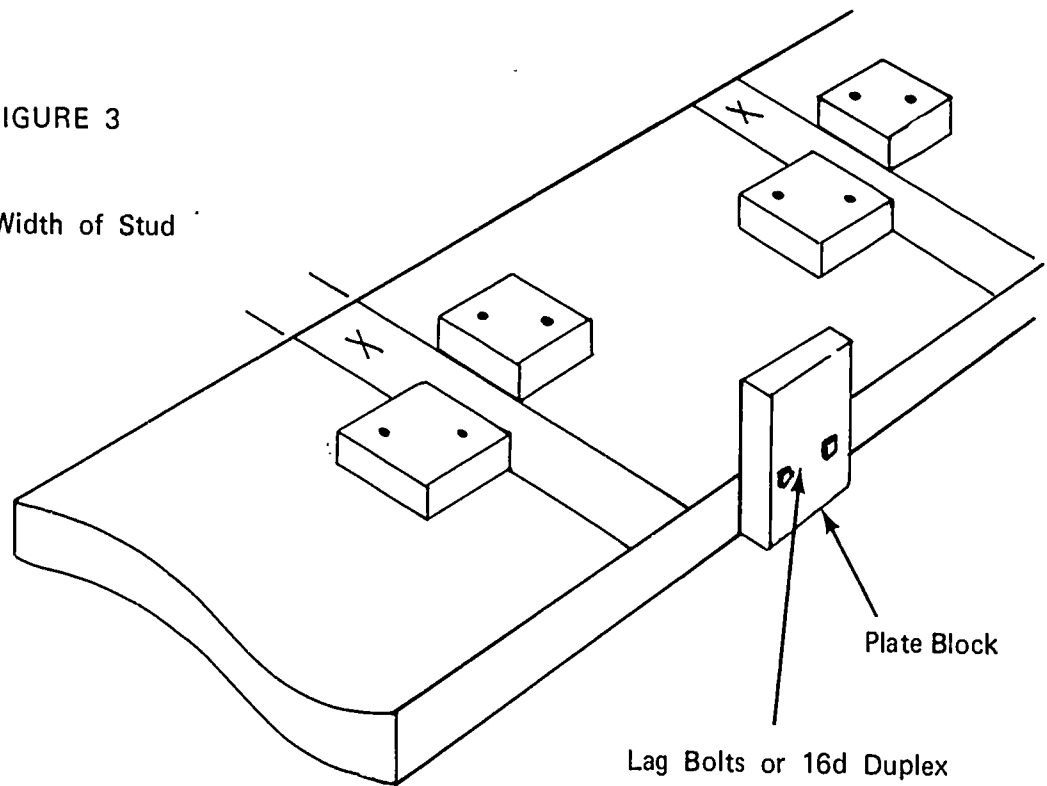

JOB SHEET #4

6. Nail or bolt plate blocks on one edge plank
(NOTE: The jig is now ready to use.)

C. Build panels

1. Cut plates and studs to correct length
(NOTE: Accuracy is very important in all phases of panel building.)
2. Make template for panel lock bolt holes (Figure 4)

FIGURE 4

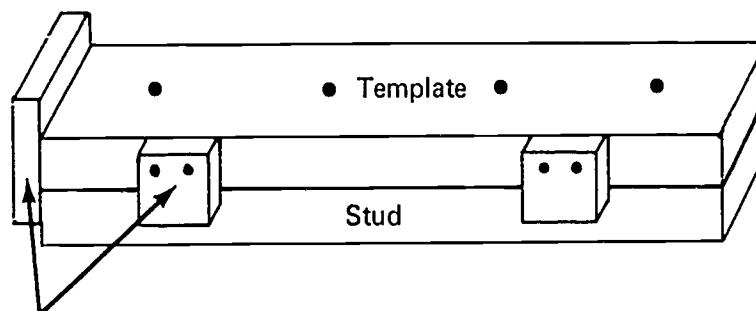

Blocks to Line Template With Stud

Stud Width

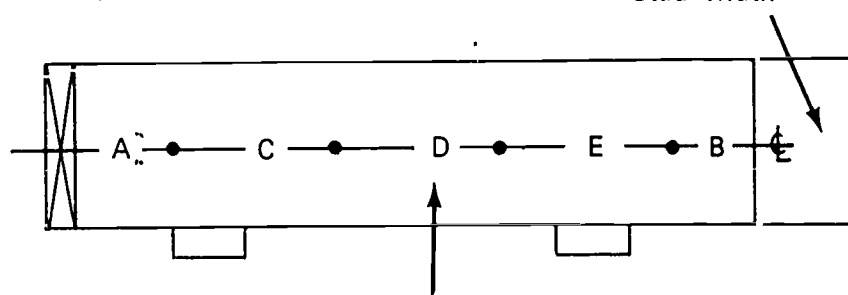

Make Spaces A and B Equal Distance From the End of the Stud.
Make Spaces C, D, and E Equal Distance From the End of the Stud.

3. Drill panel lock bolt holes in end studs
(NOTE: Pick straight studs.)
4. Place stud in jig
(IMPORTANT: Place pre-drilled studs at panel ends.)
5. Nail plates to studs
6. Pull plate down against plate blocks

JOB SHEET #4

7. Sheath panel (Figure 5)

(NOTE: Plywood may be installed vertically.)

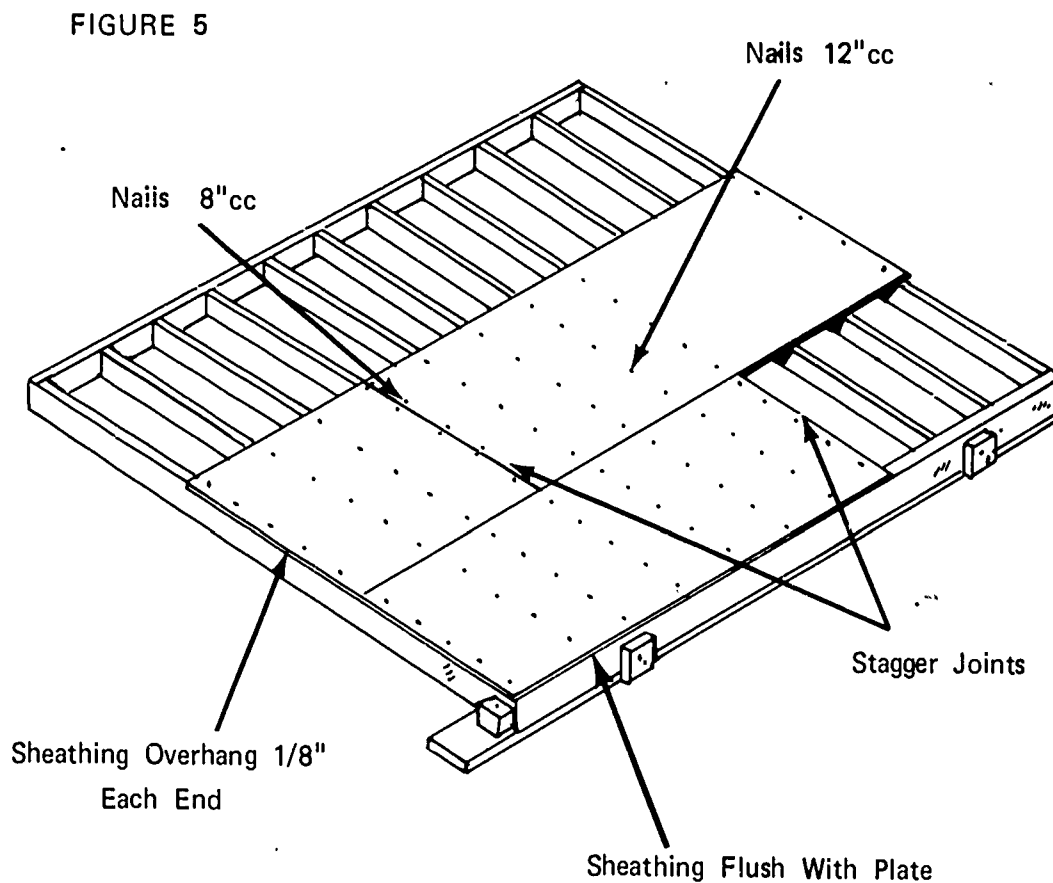

- a. Tack first sheet with 1/8" overhang on ends and flush with bottom plate
- b. Tack all sheets on panel; check fit
- c. Nail securely as shown in Figure 5

(NOTE: Use cement coated, ring shank, or other types of nails with good holding power.)

JOB SHEET #4

8. Determine tie spacing vertically and horizontally; use table below (Figure 6)

FIGURE 6

At 50° Temperature				For 3/4" Sheathing, 2x4 Studs, Double 2x4 Wales	At 70° Temperature			
2'	3'	4'	5'		Rate of Pour (Vertical Feet per Hour)	2'	3'	4'
21"	18"	18"	16"	Stud spacing for safe value of sheathing	24"	21"	18"	18"
30"	27"	24"	24"	Wale spacing for safe value of studs	33"	30"	27"	27"
30"	24"	24"	18"	Tie spacing for safe value of wales	36"	30"	27"	24"

3,000# Ties

(NOTE: Table calls for stud spacing of 18". When using ply, it is recommended the 16" spacing be used to avoid waste. The spacings can be less than the spacing shown, but should never be greater.)

9. Make tie spacing template (Figure 7)

(NOTE: Horizontal and vertical spacings can be laid out on the same template.)

FIGURE 7

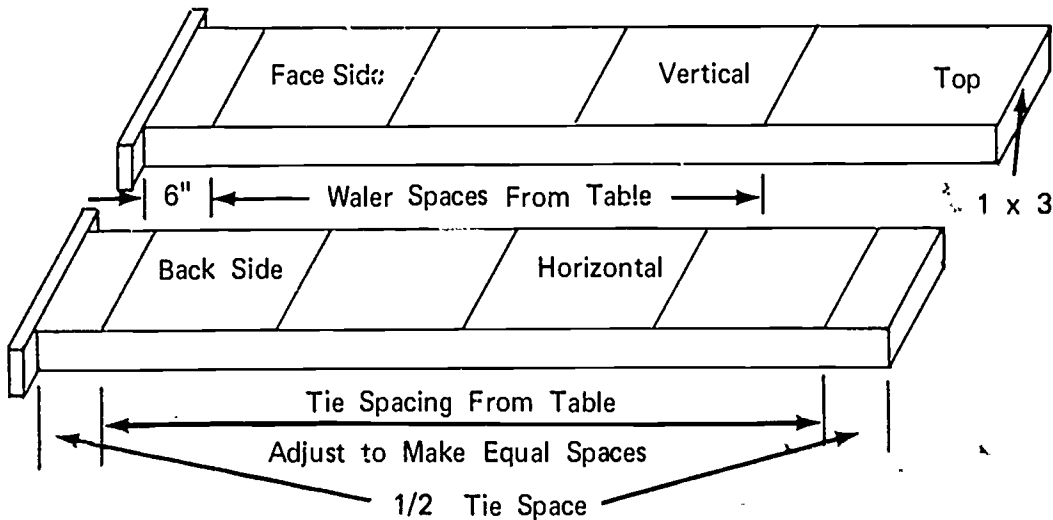

(IMPORTANT: Mark sides of template clearly to avoid error and speed up layout.)

JOB SHEET #4

10. Mark tie spacing from template on four sides of the panel (Figure 8)

FIGURE 8

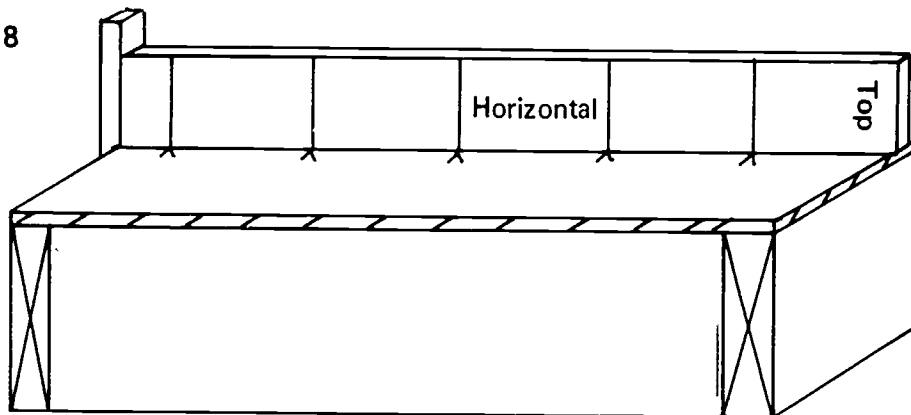

11. Snap chalk lines to connect all vertical and horizontal points (Figure 9)

FIGURE 9

Chalk Lines

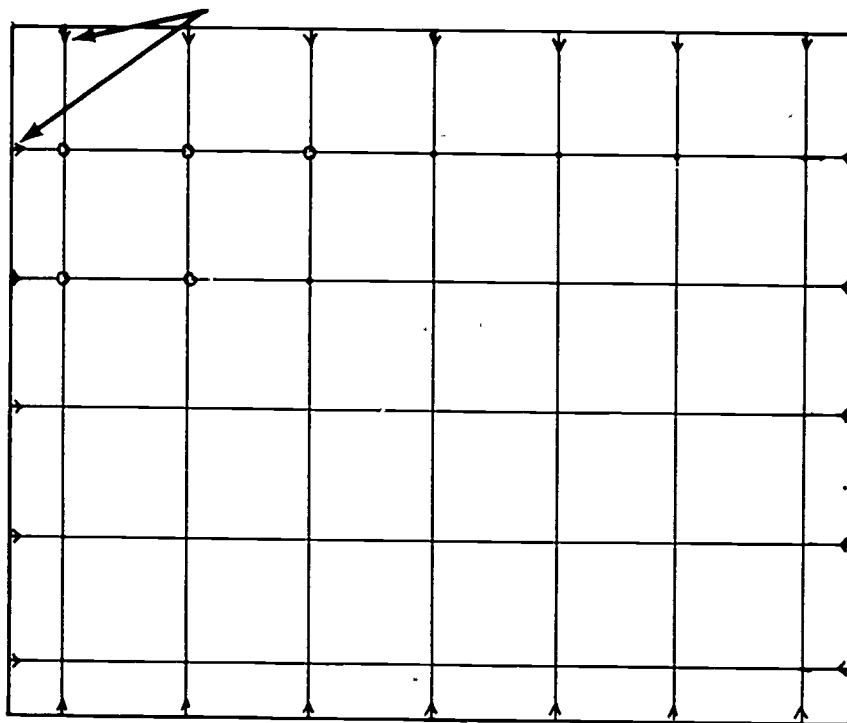

JOB SHEET #4

12. Drill tie holes at all points where chalk lines cross

(NOTE: Size of hole is determined by size of tie. Tie should fit hole snug to avoid loss of mortar.)

13. Build the required number of main filler and pilaster panels

D. Locate and set sole plates

1. Transfer building lines from the batter boards

(NOTE: Use plumb bob.)

- a. For setting on footings, establish corners and snap a chalk line on the footing at the wall line
- b. For setting without footings, drive stakes to support sole plate and panels (Figure 10)

FIGURE 10

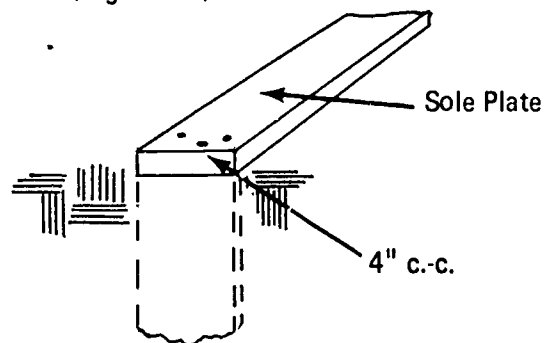

2. Set sole plates (Figure 11)

(NOTE: Sole plates may be set on the wall line as in Figure 11a or 3/4\"

FIGURE 11

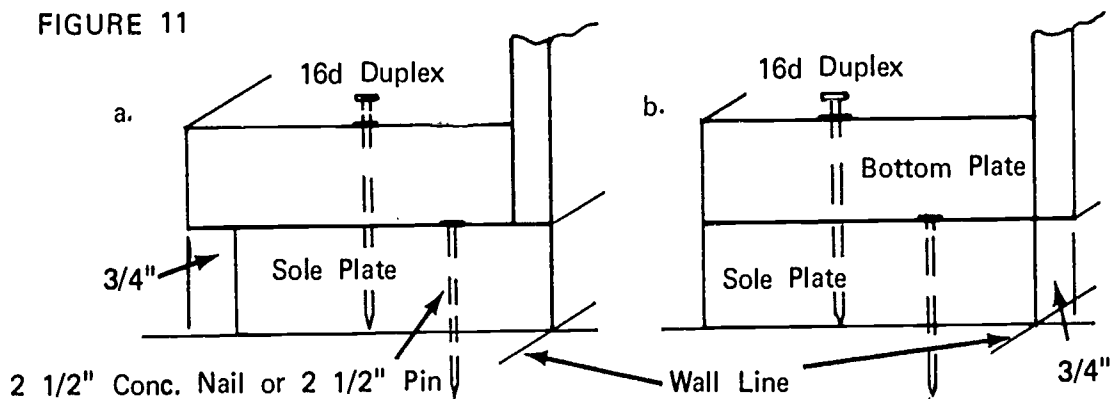

JOB SHEET #4

E. Erect first side panels

1. Establish location of first panel

(NOTE: This will assure that tie holes in the two sides are lined up and that filler panels will fit.)

2. Place the first panel on the wall line and secure to sole plate as shown in Figures 11a or 11b

(NOTE: Attach temporary brace to hold panel plumb.)

3. Set the adjacent panel in place and secure to first panel with panel lock bolts (Figure 12)

(NOTE: If panel lock bolts are not available, use machine bolts with washers.)

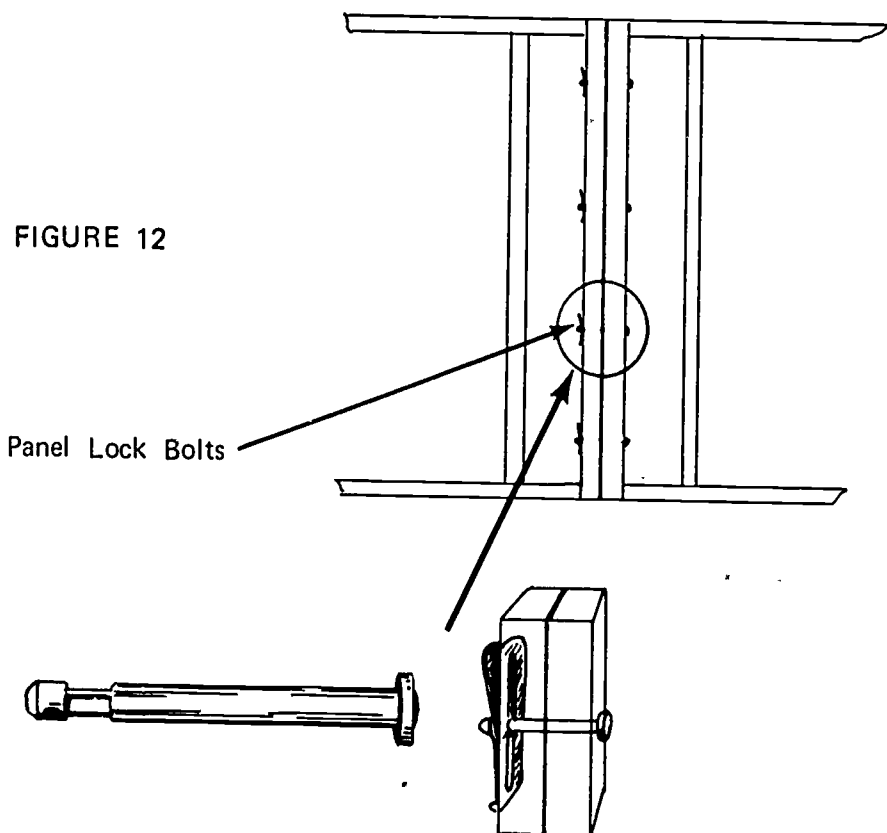

4. Line bottom of panel and nail to sole plate as shown in Figures 11a or 11b
5. Repeat steps 1, 2, 3, and 4 to continue erection

JOB SHEET #4

6. Erect pilaster panels
 - a. Erect main or filler panel on each side of the pilaster opening
 - b. Nail pilaster side panels to face panel (Figure 13)

FIGURE 13

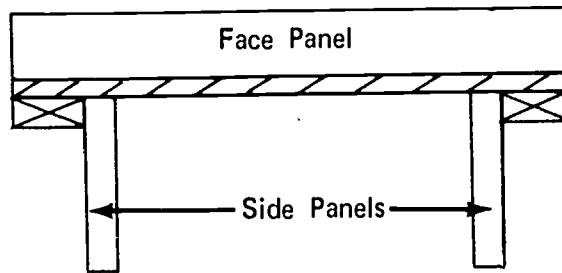

- c. Stand pilaster form in place and nail side panels to wall panels (Figure 14)

(NOTE: Make points "a" flush.)

FIGURE 14

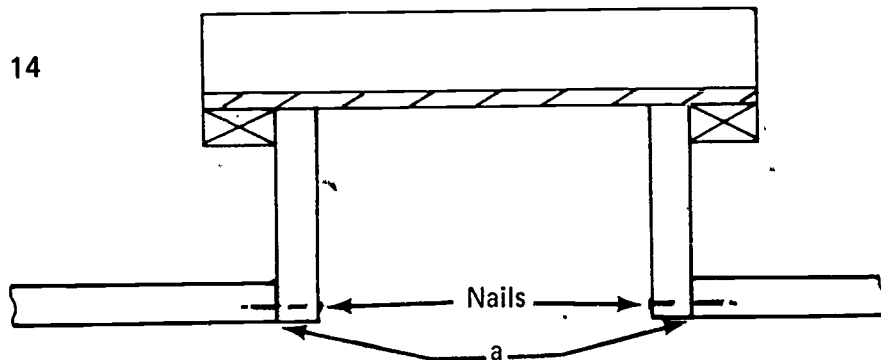

7. Install waler blocks or brackets (Figure 15a and 15b)

(NOTE: Be sure horizontal tie holes line with waler slot.)
8. Set walers on supports and tack to stud as shown in figures 15a or 15b
9. Place ties through form and waler; secure with tie holder

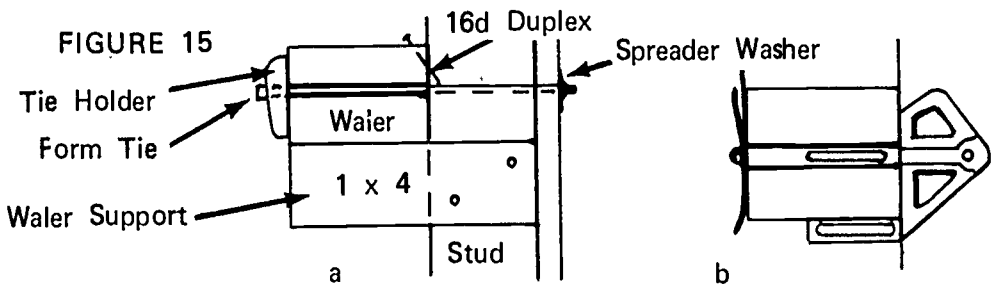

JOB SHEET #4

10. Install waler and brace pilaster (Figure 16)

FIGURE 16

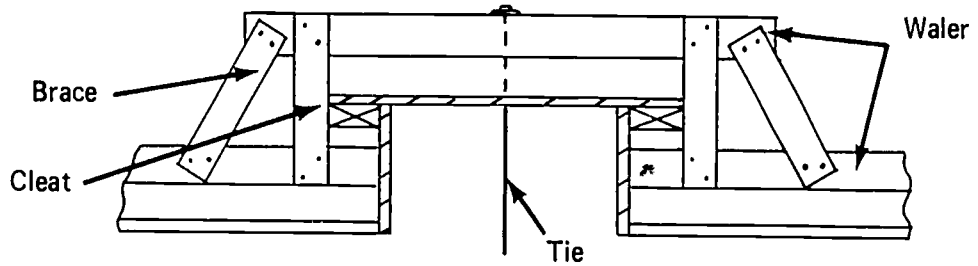

11. Install all sleeves pockets or blockouts (Figure 17)
(NOTE: Form oil must be applied before rebar are installed.)

FIGURE 17

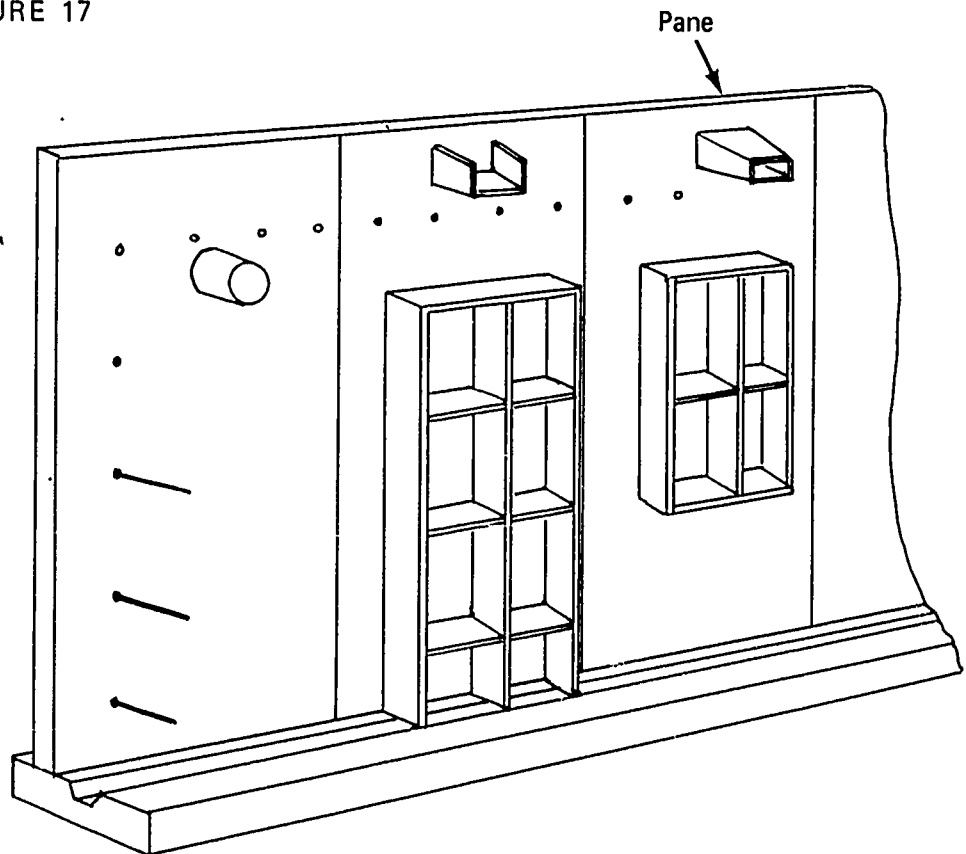

JOB SHEET #4

F. Erect second side panels

1. Stand panel on sole plate and when positioned tack to sole plate (Figure 18)

(NOTE: Thread ties through pre-drilled holes by setting panel on sole plate and tipping into place. A notched 1 x 2 will assist in lining up the ties with the holes.)

FIGURE 18

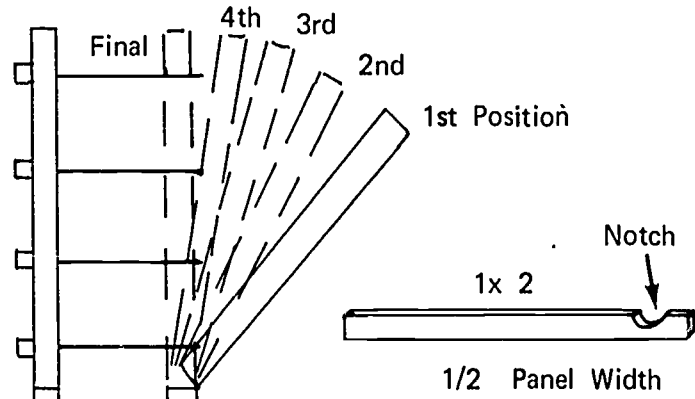

2. Place a short waler over one of the upper ties and secure panel with tie holder
3. Repeat steps 1 and 2 to continue erection
4. Install waler supports as shown in figures 15a or 15b
5. Set walers on supports, place tie holders on ties, and tighten

G. Align forms (Figure 19)

(NOTE: Align form with braces placed as needed along form.)

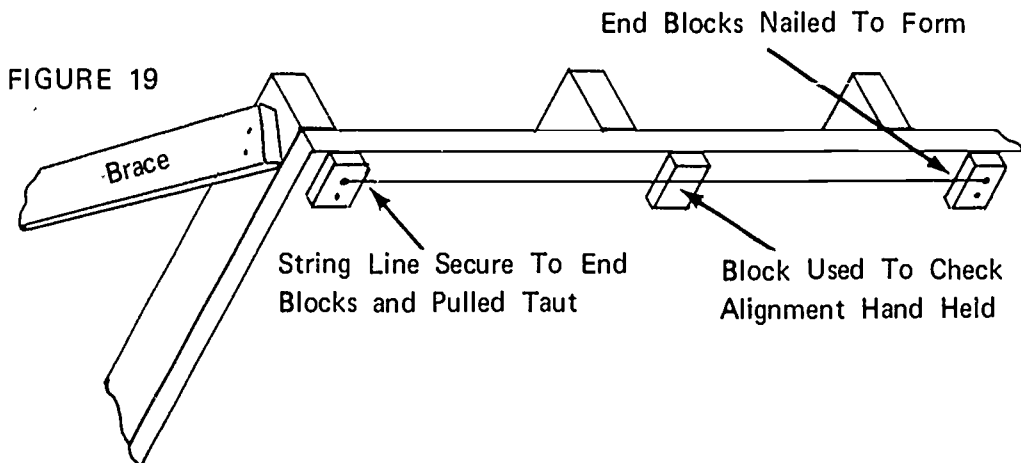

WALL FORMS
UNIT IV

JOB SHEET #5--SLIP FORMS

I. Tools and materials needed

A. Tools

1. Electric handsaw
2. Crosscut handsaw
3. Claw hammer 16
4. 100'--tape measure
5. Measuring tape (12' or 16')
6. Level (hand)
7. Electric drill and bits
8. Plumb bob
9. Builder's level

B. Materials

1. Hanger and tie rods--5/8 inch
2. Yokes--3 x 12's
3. Walsers--2 x 8's (3 top - 2 bottom)
4. Truss cords--2 x 10's
5. Truss web--2 x 6's
6. Scaffold hangers--2 x 4's
7. Guard rails--2 x 6 and 2 x 4's
8. Joist--2 x 8's
9. Jacks and jack rod
10. Water levels
11. Sheathing--3/4" plyform or 1 x 6 T & G
12. Decking--1 x 6"--8" or 10"
13. Pump and control panel

JOB SHEET #5

II. Procedure

A. Build form panels (Figure 1)

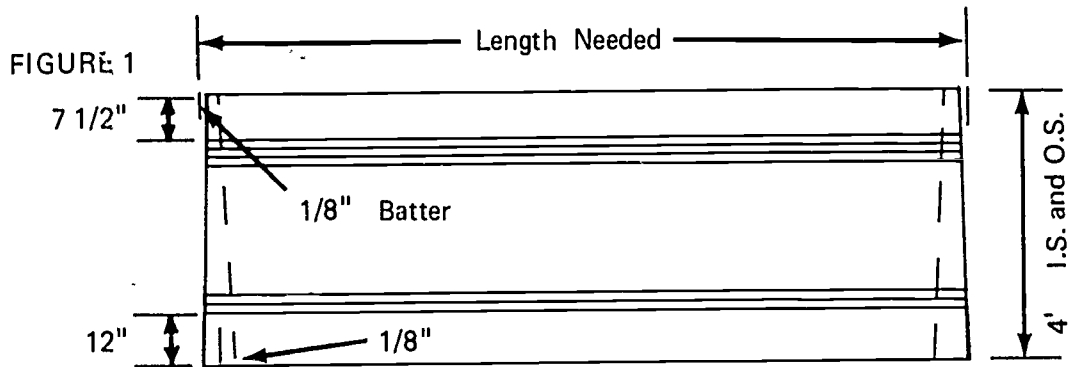

(NOTE: Inside form is shown in dotted lines. Batter outside forms 1/8" on both ends. For inside forms, batter opposite direction to make form 1/4" wider at the bottom.)

1. Cut plywood to size

(NOTE: Grain will run vertically.)

2. Fabricate walers

(NOTE: Do not use spacers as for a wall form, nail them tight to each other using 16D Common Nails. Use three ply top two ply bottom walers.)

3. Drill holes for hanger rods (Figure 2)

(NOTE: Hanger rods will be installed at each lifting yoke.)

FIGURE 2

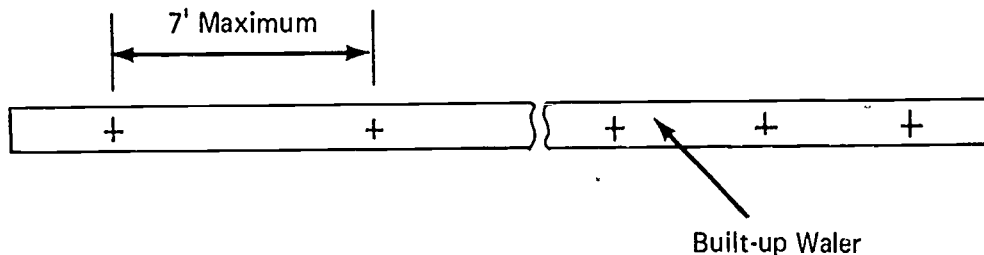

4. Nail plyform sheathing to walers

(NOTE: See Figure 1 for waler spacing.)

JOB SHEET #5

B. Build yokes (Figure 3)

(NOTE: A vertical rebar template may be secured to the higher outside leg of the yoke and deck handrail.)

FIGURE 3

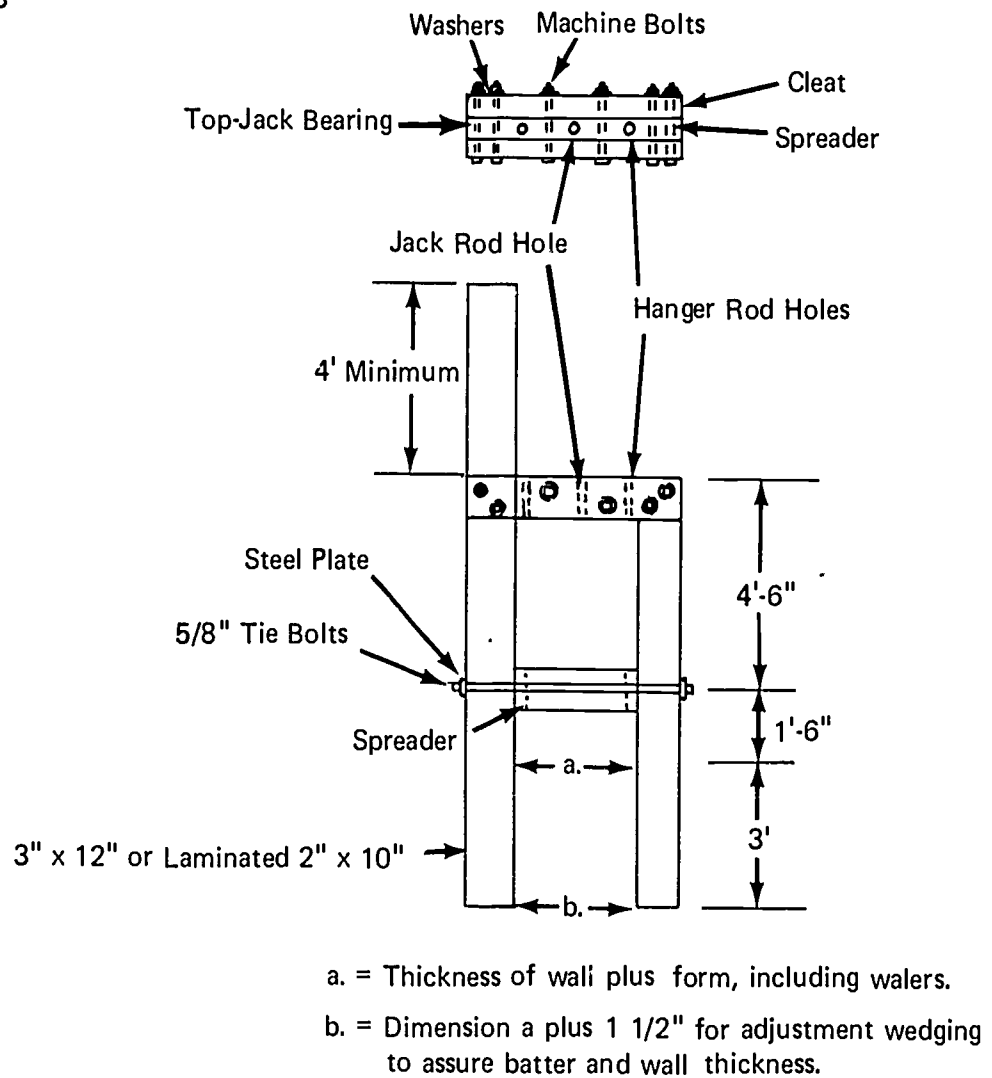

1. Lay out and cut material to size
2. Drill hanger bolt and jack rod holes in spreaders

(NOTE: Locate holes accurately.)

3. Assemble yoke as shown in Figure 3

JOB SHEET #5

C. Build scaffold hangers (Figure 4)

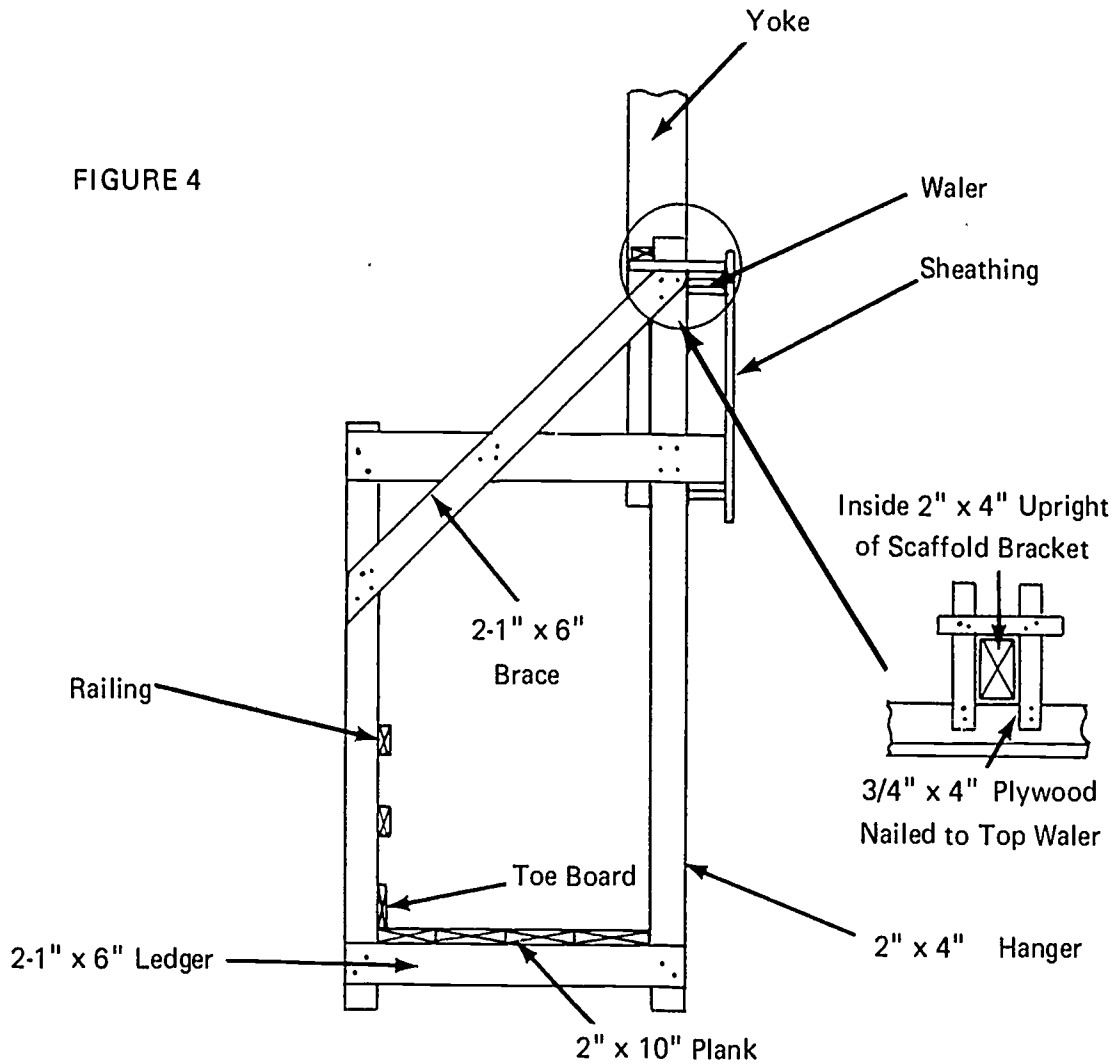

(NOTE: Plank and nails shall be installed after scaffold hangers are mounted on form. Inside scaffold hanger is made very similarly or hung from cable. See Figure 7.)

1. Lay out and cut material to length
2. Tack unit together
3. Drill bolt holes
4. Install bolts

(NOTE: Be sure to use flat washers on both ends of bolts.)

JOB SHEET #5

D. Build working platform truss (Figure 5)

FIGURE 5

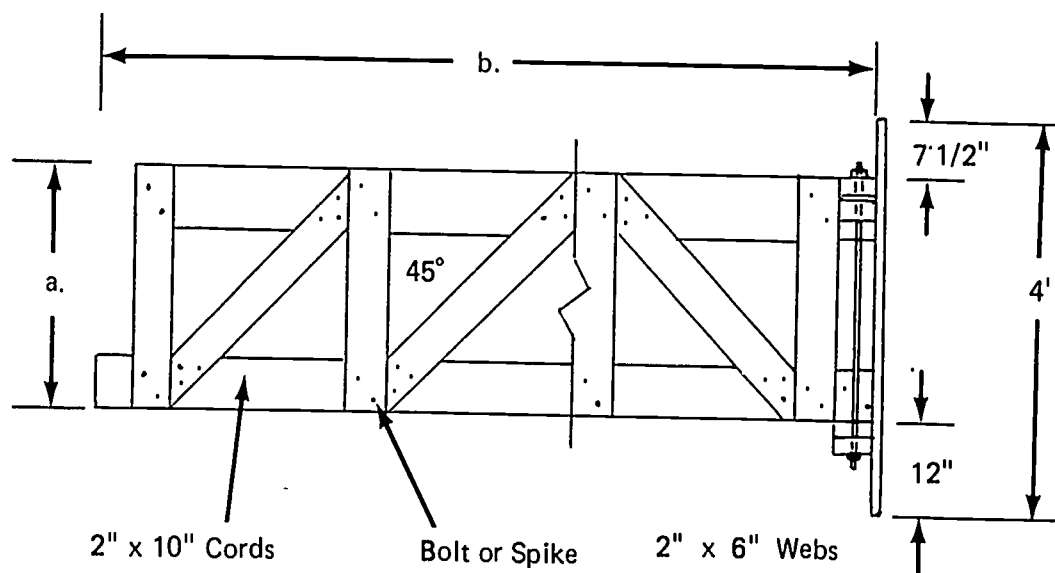

- a. Distance from top of bottom waler to top of upper waler.
- b. Sheathing to sheathing minus one inch.

1. Lay out and cut material to length

(NOTE: Length of truss and total height of pour will determine truss component sizes and method of fabrication.)

2. Assemble truss as shown in Figure 5

(NOTE: Webs will be nailed or bolted to chords. Also, there are other methods of building the truss. Follow the shop drawing details.)

JOB SHEET #5

E. Erect inside forms and trusses

1. Snap chalkline on footing to establish wall line
2. Set inside forms on three sides

(NOTE: Forms must be oiled before setting.) (Figure 6)

FIGURE 6

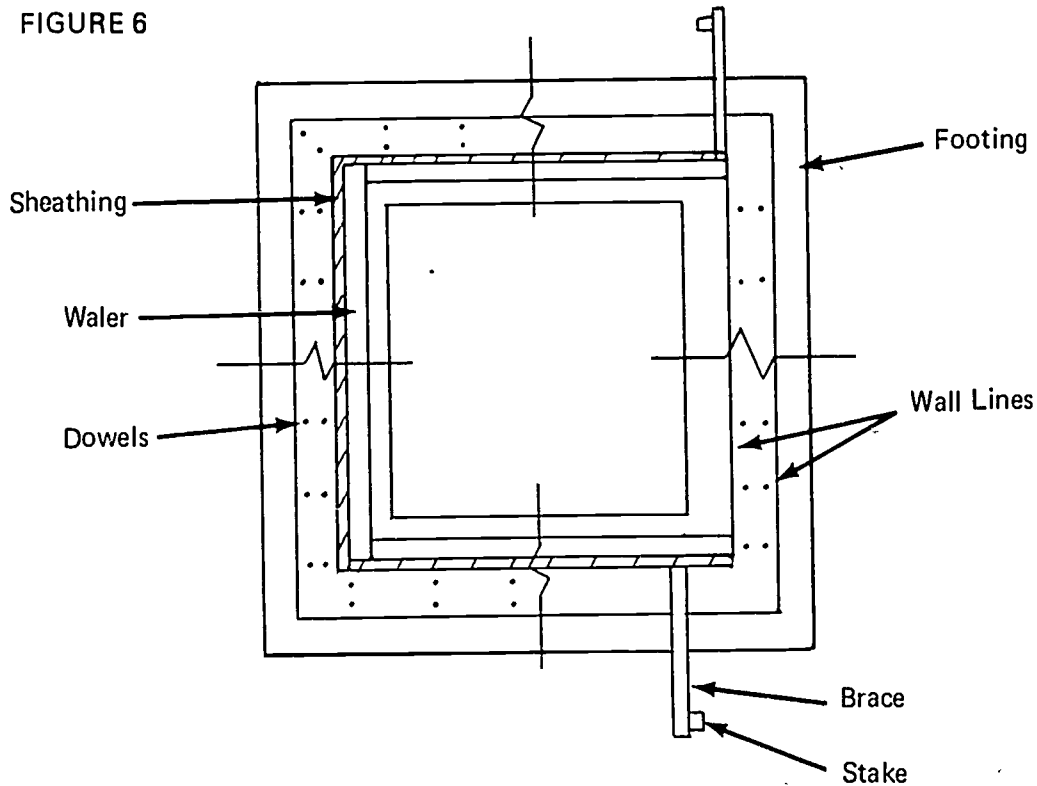

3. Install trusses
 - a. Set truss on waler of end form
 - b. Nail temporary leg to free end of truss to hold it level
(NOTE: This is to hold the truss level until the next form is set.)
 - c. Secure truss to waler
(NOTE: See Figure 5.)
4. Set end form

JOB SHEET #5

5. Check batter and alignment of form and secure trusses to walers
- F. Erect outside form and yokes

(NOTE: Rebars can be more easily installed prior to erecting outside form.)
(Figure 7)

FIGURE 7

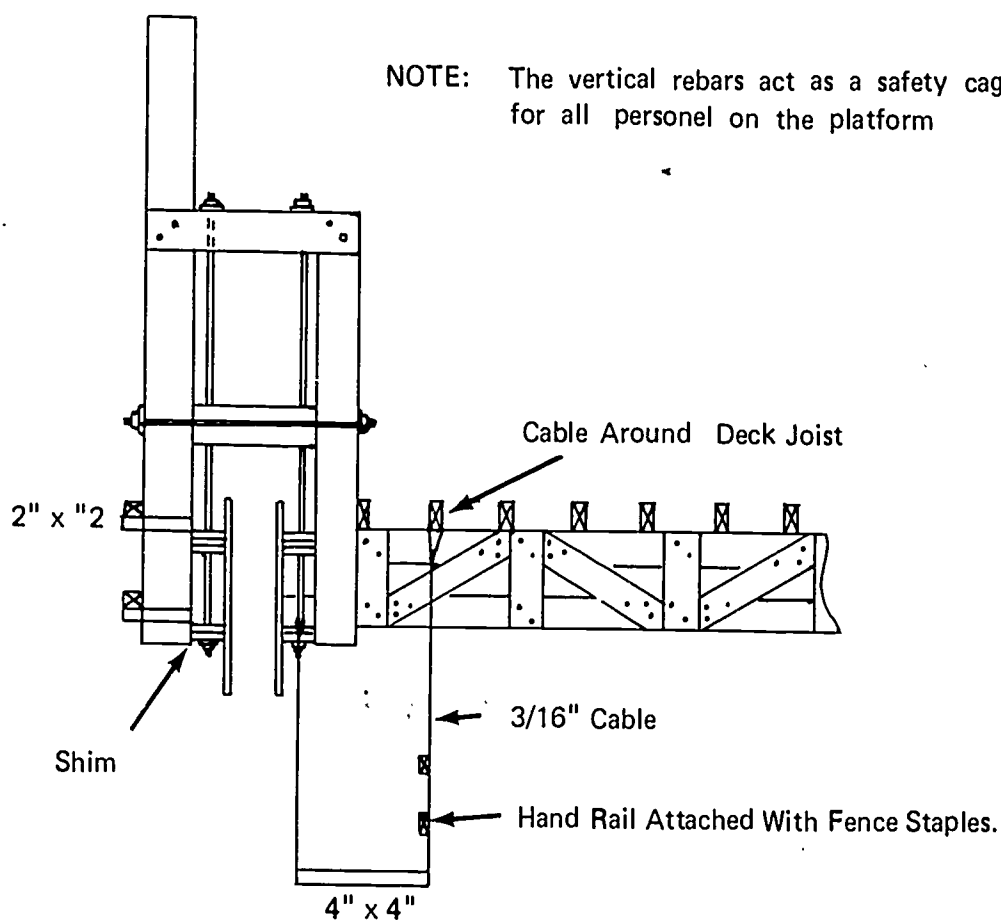

1. Stand forms in position
2. Nail together at corners
3. Install yokes

JOB SHEET #5

4. Secure yokes to walers of inside and outside form
 - a. Nail 2 x 2 to waler
 - b. Check batter and spacing between forms for wall thickness
 - c. Wood shim between waler and yoke or yoke and back 2 x 2 as required

G. Install hanger and jack rods

1. Thread hanger rods through hole in yoke and walers
(NOTE: Use a plate washer on top and bottom of rod.)
2. Secure nut on bottom of rod
(NOTE: Use double nut or lock washer so vibration does not loosen nuts.)
3. Thread jack rods through holes in yoke
(NOTE: Make sure rod is seated on footing and plumb.)

H. Install deck joist and decking (Figure 8)

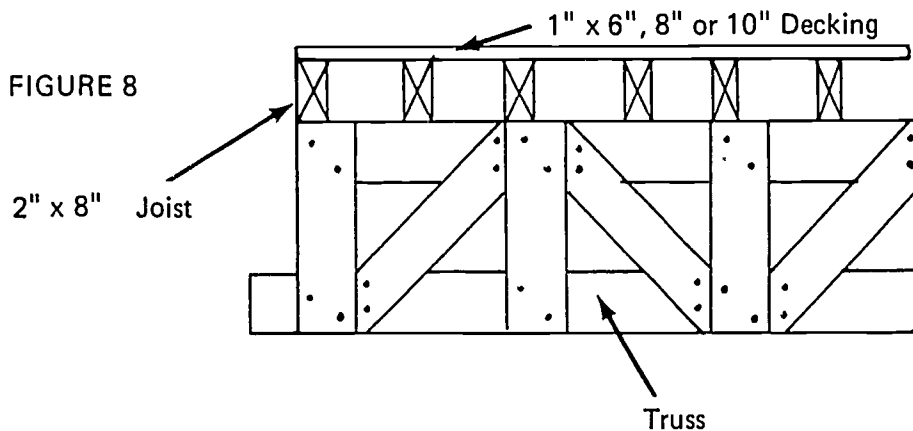

1. Install joist
(NOTE: Align side of form parallel to truss before installing joist.)
2. Lay decking
(NOTE: Leave holes in deck for access to inside scaffold, build a guard rail around hole.)

JOB SHEET #5

- I. Install jacks, pump, and control panel
 1. Place jacks on jack rod
 2. Set control panel and pump in a central location
 3. Connect pump hoses to jacks
- J. install water level and elevation measuring tape
 1. Set up builder's level
 2. Establish H.I. from bench mark
 3. Level forms with wood supports from slab to bottom walers at each yoke
 4. Measure an elevation from deck at each yoke where water level and tape will be referenced (Figure 9)

FIGURE 9

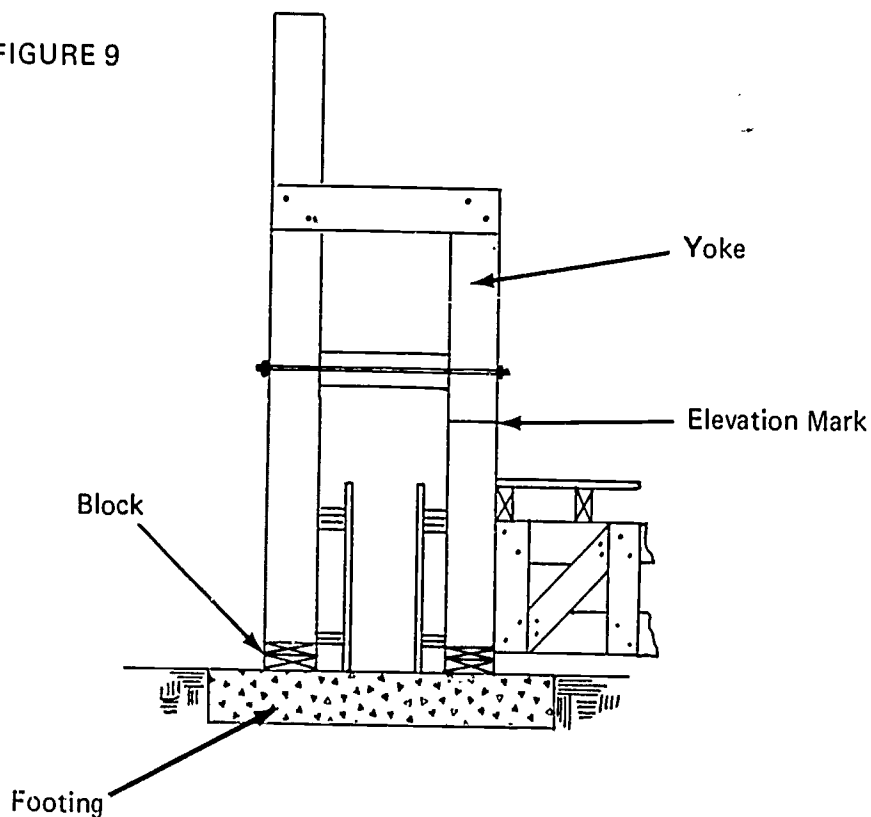

JOB SHEET #5

5. Secure water level to yoke (Figure 10)

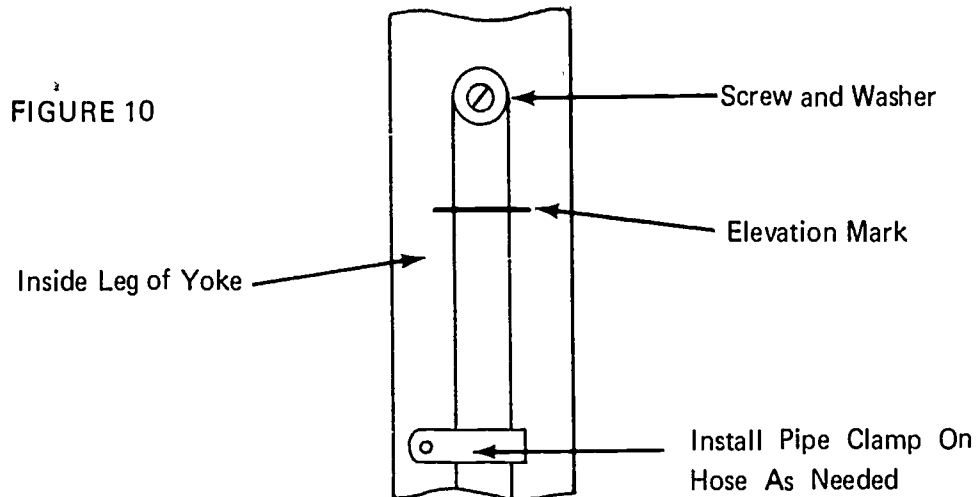

(NOTE: If water switch is not used, connect other end of hose to another yoke.)

6. Secure measuring tape
- Level over from elevation mark to rebar or lifting rod
 - Attach tape to rod or rebar

(NOTE: Be sure measurement on tape corresponds with known elevation of mark.)

- Attach tape reel to yoke spreader

(IMPORTANT: Keep tape taut.)

7. Secure plumb bob and line reel to platform; place plumb reference mark on footing

(NOTE: An alternate method of plumbing the wall is with a prismatic transit with a permanent reference target on footing slab and bottom of form, or measure distance at bottom and shoot top distance to face of wall.)

- K. Install scaffold hangers, rail, and plank

- Stand O.S. scaffold hanger against walers as shown in Figure 4
- Install rail

(NOTE: The scaffold may be enclosed with chicken wire mesh for safety from falling tools of finishers.)

JOB SHEET #5

3. Install plank platform

(NOTE: As the slip form raises, the walers will pick up the 1 x 6 hangers which can be nailed or bolted to the walers.)

4. Secure toe boards to uprights

5. Hang inside scaffold from joist as shown in Figure 7

(NOTE: Diagonal 1 x 6 braces can be nailed from scaffold plank to joist to stop sway.)

- L. Install splash board on top of outside form

(NOTE: Splash board may be 1 x 8 board or 1/4" plywood.)

WALL FORMS
UNIT IV

JOB SHEET #6--REMOVE FORMS AND PREPARE FOR STORAGE

(NOTE: The part of this job sheet about preparation for storage is only applicable if prefabricated forms are used.)

I. Tools and materials needed

A. Tools

1. Wrecking bar (crow bar)
2. Claw hammer (16 ounce)
3. Wire cutter
4. Large paint brush

B. Materials--Preservative

II. Procedure

A. Removing forms

(NOTE: Remove in reverse order form installation.)

1. Remove braces

(NOTE: Care should be taken not to damage the lumber any more than necessary so that it may be reused.)

2. Loosen or cut the ties
3. Pull all nails holding the form sections together
4. Strip the forms from the green concrete

(NOTE: Be very careful as you strip the forms as the concrete is still green and can be chipped or damaged very easily at this stage.)

(CAUTION: Do not pry against green concrete.)

5. Remove all nails from forms that are not to be reused; remove only those nails from prefabricated forms that were used to join panels

JOB SHEET #6

B. Prepare forms for storage

1. Clean the dried concrete from the face of the forms
2. Coat all form surfaces with form oil
3. Stack the form panels face-to-face on a level surface
4. If they are to remain outside, cover them with a sheet of plastic

WALL FORMS UNIT IV

TEST

1. Match the terms on the right with the correct definitions.

- | | |
|--|--------------------|
| _____ a. A piece of wood or other material that directs, resists, or supports weight or pressure | 1. Scab |
| _____ b. A strip of wood or metal fastened across a form for temporary positioning or to replace a form tie | 2. Key |
| _____ c. A double headed nail used in forming and designed for easy removal | 3. Spacer block |
| _____ d. An enlarged area at the base of a wall or other object to distribute the weight of the superstructure | 4. Dowel |
| _____ e. A wire or metal crosstie used to hold the pressure of wet concrete and maintain the proper wall thickness | 5. Monolithic pour |
| _____ f. That portion of a wall upon which the building rests | 6. Dupiex nail |
| _____ g. The level of the finished concrete in a form | 7. Bulkhead |
| _____ h. A beveled piece of wood or metal placed in a form where future pours occur | 8. Spreader |
| _____ i. A groove left in the concrete by removal of the key | 9. Foundation |
| _____ j. A continuous mass of concrete cast as a single piece | 10. Sheathing |
| | 11. Grade point |
| | 12. Form tie |
| | 13. Cleat |
| | 14. Footing |
| | 15. Form oil |
| | 16. Key way |
| | 17. Panel |
| | 18. Brace |
| | 19. Stake |

- _____k. A piece of material nailed across a splice to strengthen and hold the two pieces together .
- _____l. Wide boards, plywood, or metal that make up the face of the form
- _____m. A piece of wood that is used to hold the sides of the form apart and is removed as the concrete is poured; it may also be an integral part of a form tie
- _____n. A block of wood or other material used as a spacer at offsets in a form
- _____o. Small boards or steel bars sharpened at one end and driven into the ground to support the form
- _____p. A short piece of steel bar used to tie adjoining pours together
- _____q. A board placed in a form to cut off the concrete pour
- _____r. Paraffin oil or other manufactured product used on a form to prevent adhesion of the concrete to the form
- _____s. A single section of patented or job built form

2. Identify fifteen parts of a form.

- a.
- b.
- c.
- d.
- e.
- f.

- g.
- h.
- i.
- j.
- k.
- l.
- m.
- n.
- o.

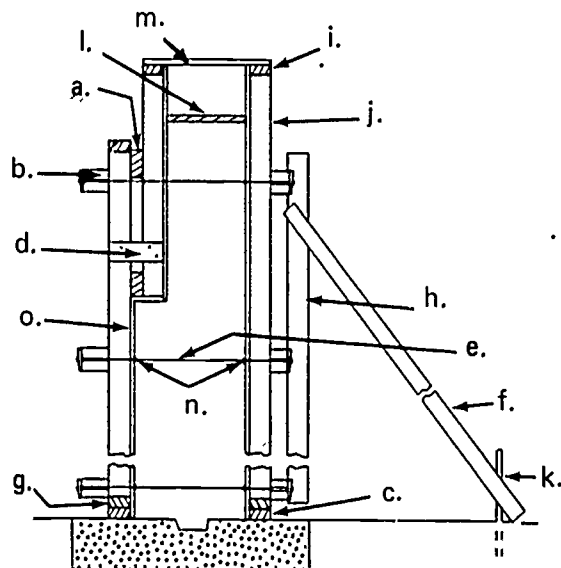

3. Estimate the material needed to build forms for the section of wall shown below.

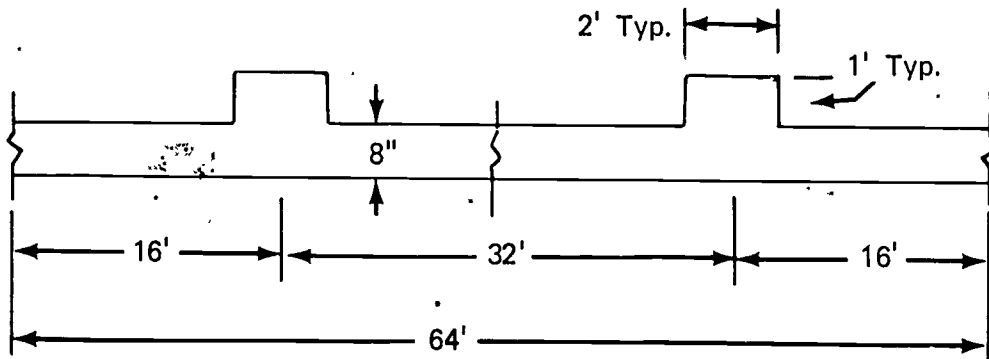

Facts given:

- Wall 12' high
- Tie and waler spacing 2'cc
- Brace 44' cc one side only with 3' stakes
- No sole plate required

- a. Studs (quantity and length) Q _____ L _____
- b. Sheathing (sq. ft.) _____
- c. Plates (lineal ft.) _____
- d. Walers (lineal ft.) _____
- e. Waler spacing blocks and supports (lineal ft.) _____
- f. Braces (quantity and length) Q _____ L _____
- g. Stakes (quantity) _____

h. Ties (quantity and length)

Wall Q _____ L _____

Pilasters Q _____ L _____

i. Form tie clamps (quantity) _____

4. Estimate the width and quantity of panels needed to form the wall section shown below.

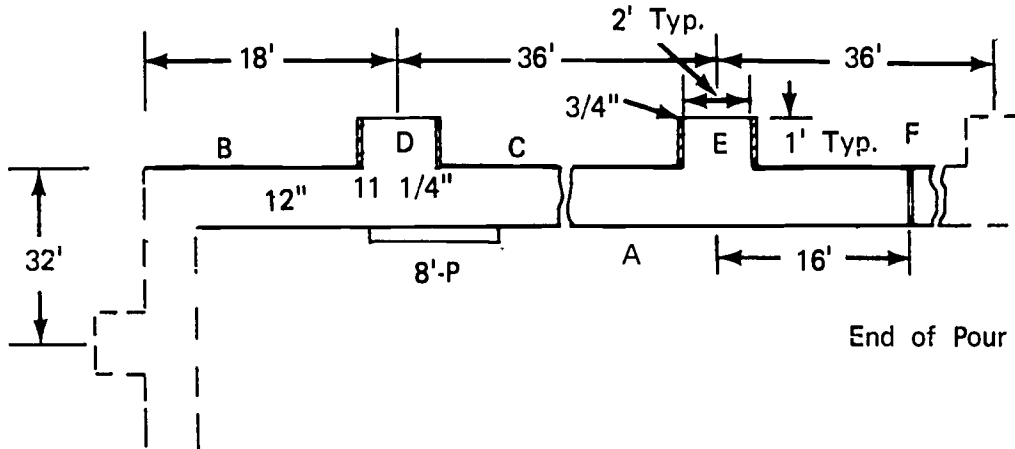

- (NOTE: Assume:
- a. Horizontal tie spacing is 2' cc
 - b. Main panel is 8' 0"
 - c. Starting location of a main panel
 - d. No single panel is under 2' 0" wide)

	Width	No.
a. Wall A		
Main panels		
Filler panels		
b. Wall B		
Main panels		
Filler panels		
c. Wall C		
Main panels		
Filler panels		

Width No.

- d. Wall F
 - Main panels
 - Filler panels
- e. Pilaster D and E
 - Face panels
 - Side panels

- 5. Name three materials used to build forms.
 - a.
 - b.
 - c.
- 6. Name six types of forms constructed.
 - a.
 - b.
 - c.
 - d.
 - e.
 - f.
- 7. List four advantages of gang and panel forms over built in place or erected in place forms.
 - a.
 - b.
 - c.
 - d.
- 8. List two reasons why built in or erected in place forms might be used.
 - a.
 - b.

9. Demonstrate the ability to construct:
 - a. Straight wall with patented forms.
 - b. Battered wall gang forms.
 - c. Circular wall forms.
 - d. Panel forms.
 - e. Slip forms.
 - f. Remove forms and prepare for storage.

WALL FORMS
UNIT IV

ANSWERS TO TEST

1.
 - a. 18
 - b. 13
 - c. 6
 - d. 14
 - e. 12
 - f. 9
 - g. 11
 - h. 2
 - i. 16
 - j. 5
 - k. 1
 - l. 10
 - m. 8
 - n. 3
 - o. 19
 - p. 4
 - q. 7
 - r. 15
 - s. 17
2.
 - a. Spacer block
 - b. Waler
 - c. Sole plate
 - d. Scab

- e. Form tie
 - f. Brace
 - g. Bottom plate
 - h. Strongback
 - i. Top plate
 - j. Stud
 - k. Stake
 - l. Spreader
 - m. Cleat
 - n. Sprader washer
 - o. Sheathing
- 3.
- a. 108--2" x 4" - 12'
 - b. 51 sheets 4' x 8' ply
 - c. 17--2" x 4" - 16'
 - d. 99--2" x 4" - 16'
 - e. 198--Lineal feet
 - f. 16--2" x 4" - 14'
 - g. 16--2" x 4" - 3'
 - h. 180--18" wall ties
12--20"
 - i. 384 tie clamps
- 4.
- | | Width | No. |
|----|--------------|-----|
| a. | 8' | 8 |
| | 7' - 8 1/2" | 1 |
| b. | 8' | 1 |
| | 8' - 11 3/4" | 1 |
| c. | 8' | 4 |
| | 1' 10 1/2" | 1 |

- | | | |
|----|-----------|---|
| d. | 8' | 2 |
| | 0 | 0 |
| e. | 2' 8 1/2" | 2 |
| | 1' 0" | 4 |
5. a. Wood
- b. Steel
- c. Fiberglass
6. Students may give the answers below in any order.
- a. Erect in place
- b. Gang
- c. Panel
- d. Liquid head
- e. Plate girder
- f. Built in place
7. Students may give the answers below in any order.
- a. Faster erection
- b. Faster stripping
- c. More reuses of form material
- d. Cleaner site
8. Students may give the answers below in any order.
- a. Accessibility of site
- b. Availability of crane
9. Performance skills will be evaluated according to the criteria listed on the progress chart.

ON GRADE CURB FORMS UNIT V

TERMINAL OBJECTIVE

After completion of this unit, the student should be able to define on grade curb forming terms. He should also be able to identify various types of curbs and median barriers and methods of constructing their forms. He should also be able to construct forms for a curb and gutter. This knowledge will be evidenced through demonstration and by scoring eighty-five percent on the unit test.

SPECIFIC OBJECTIVES

After completion of this unit, the student should be able to:

1. Match a list of forming terms to a list of definitions.
2. Identify types of curbs or curbs and gutters.
3. Name two methods of forming curbs and gutters or median barriers.
4. Identify four types of median forms.
5. Demonstrate the ability to construct a curb and gutter form.

ON GRADE CURB FORMS
UNIT V

SUGGESTED ACTIVITIES

I. Instructor:

- A. Provide students with objective sheet.
- B. Provide students with information and job sheets.
- C. Make transparencies.
- D. Discuss terminal and specific objectives.
- E. Discuss information sheet.
- F. Demonstrate and discuss procedures outlined in job sheet.
- G. Give test.

II. Student:

- A. Read objective sheet.
- B. Study information sheet.
- C. Demonstrate the ability to accomplish the procedures outlined in the job sheet.
- D. Take test.

INSTRUCTIONAL MATERIALS

I. Included in this unit:

- A. Objective sheet
- B. Information sheet
- C. Transparency masters
 - 1. TM 1--Curbs and Curb and Gutter Forms
 - 2. TM 2--Radius Curb and Gutter Forms
 - 3. TM 3--Radius and Serpentine Forms
 - 4. TM 4--Manufactured Curb and Gutter Form
 - 5. TM 5--Manufactured Median Barrier Form

6. TM 6--Job Built Curb and Gutter Forms
7. TM 7--Job Built Straight Curb with Trench
8. TM 8--Job Built Median Barrier Form
9. TM 9--Types of Median Barriers

E. Job Sheet #1--Build a Curb and Gutter Form

F. Test

G. Answers to test

- II. Reference: Burke, Arthur E., J. Ralph Dalzell, and Gilbert Townsend. *Architectural and Building Trades Dictionary*. Chicago, Illinois: American Technical Society, 1955.

ON GRADE CURB FORMS
UNIT V

INFORMATION SHEET

I. Terms and definitions

- A. Brace--A piece of wood or other material that directs, resists, or supports weight or pressure
- B. Cleat--A strip of wood or metal fastened across a form for temporary positioning or to replace a form tie
- C. Form tie--A wire or metal cross-tie used to hold the pressure of wet concrete and maintain the proper wall thickness
- D. Monolithic pour--A continuous mass of concrete cast as a single piece
- E. Spreader--A block of wood that is used to hold the sides of a form apart and is removed as the concrete is poured; it may also be an integral part of the form tie
- F. Mule--A template used to shape the profile of a curb and gutter
- G. Stake--Small boards or steel bars pointed on one end and driven into the ground to support a form
- H. Division plate--A thin steel plate placed between the forms to provide full depth joints in a curb and gutter
- I. Skeleton division plate--A thin steel plate placed between the forms to provide partial depth scoring in curbs and gutters
- J. Median barrier--A barrier placed between two lanes of highway
- K. Subgrade--The earth or rock grade on which concrete is poured

II. Types of curbs or curb and gutters (Transparencies 1, 2, and 3)

- A. Straight face vertical
- B. Straight face battered
- C. Single radius vertical
- D. Single radius battered
- E. Double radius vertical

INFORMATION SHEET

- F. Double radius battered
 - G. Roll curb and gutter
 - H. Highway gutter
 - I. Straight curb
 - J. Partially battered curb
 - K. Fully battered curb
 - L. Radius curb and gutter
 - M. Serpentine curb
- III. Methods of forming curbs and gutters or median barriers (Transparencies 4, 5, 6, 7, and 8)
- A. Manufactured forms
 - B. Job built forms
- IV. Types of median forms (Transparency 9)
- A. Set on slab
 - B. Set on subgrade
 - C. One side barrier
 - D. Road surfaces at different elevations

Curbs and Curb and Gutter Forms

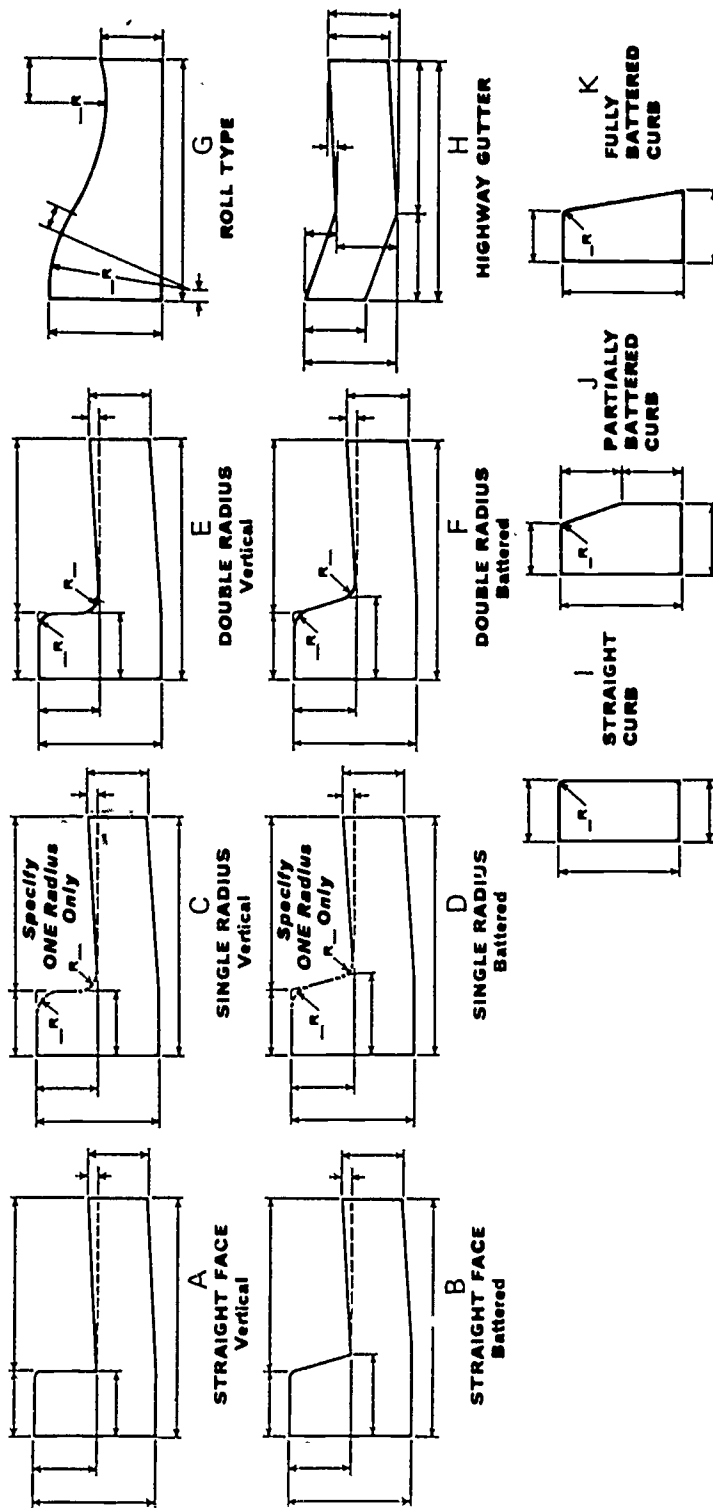

Radius Curb and Gutter Forms

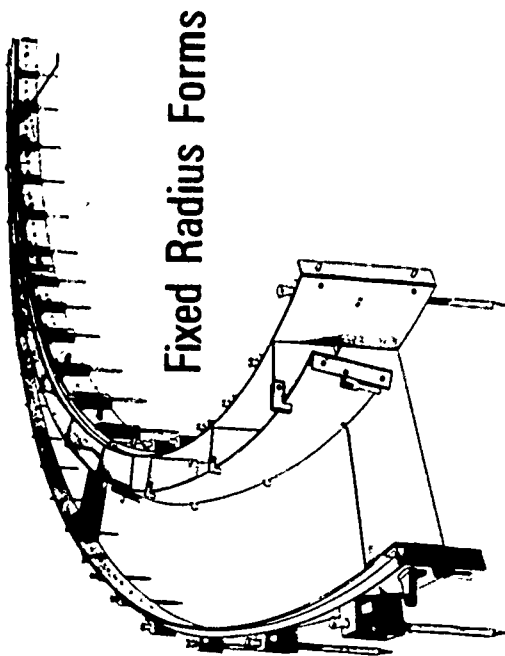

Fixed Radius Forms

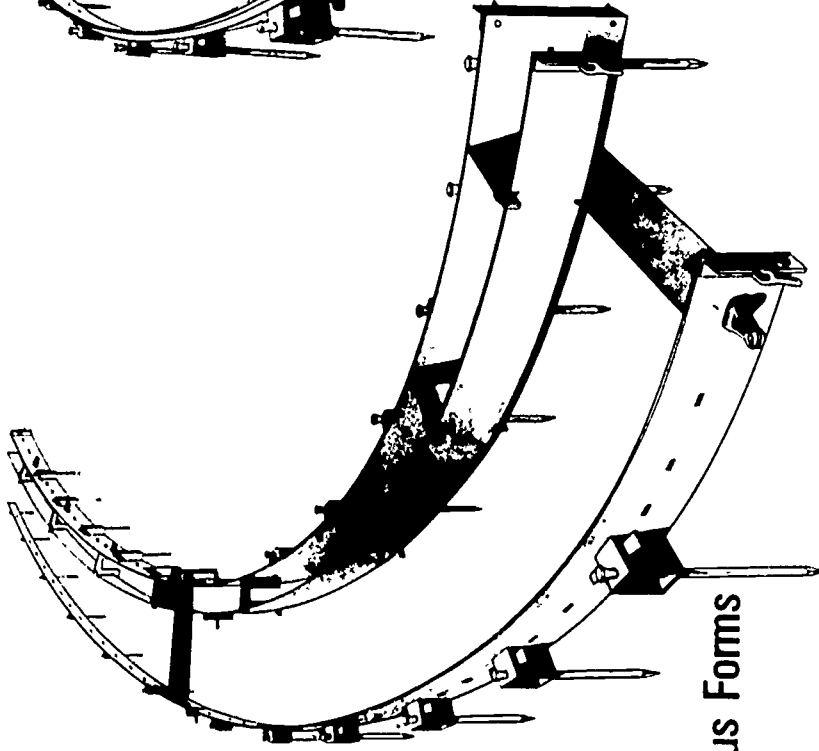

Flexible Radius Forms

Radius & Serpentine Form

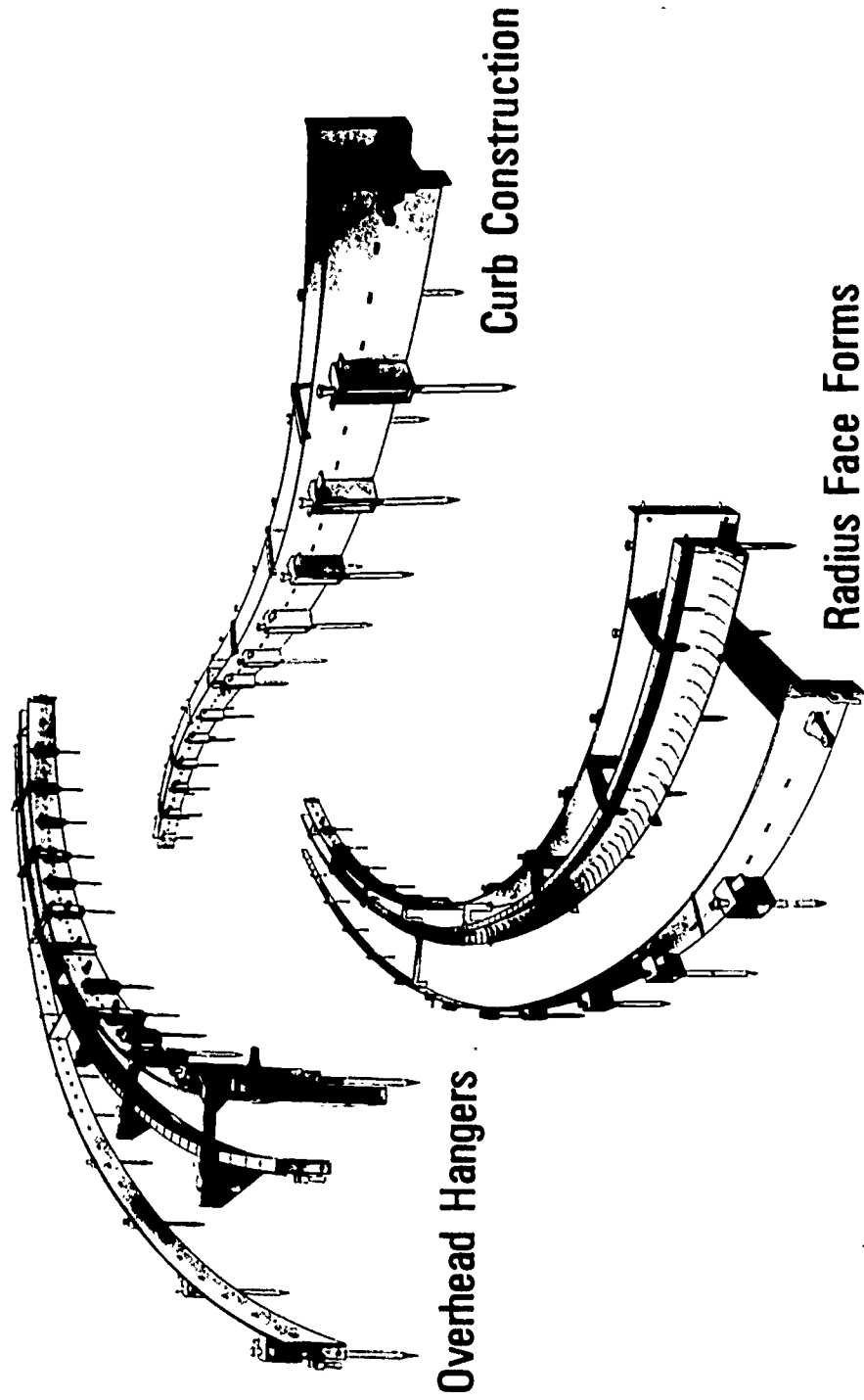

Manufactured Curb and Gutter Form

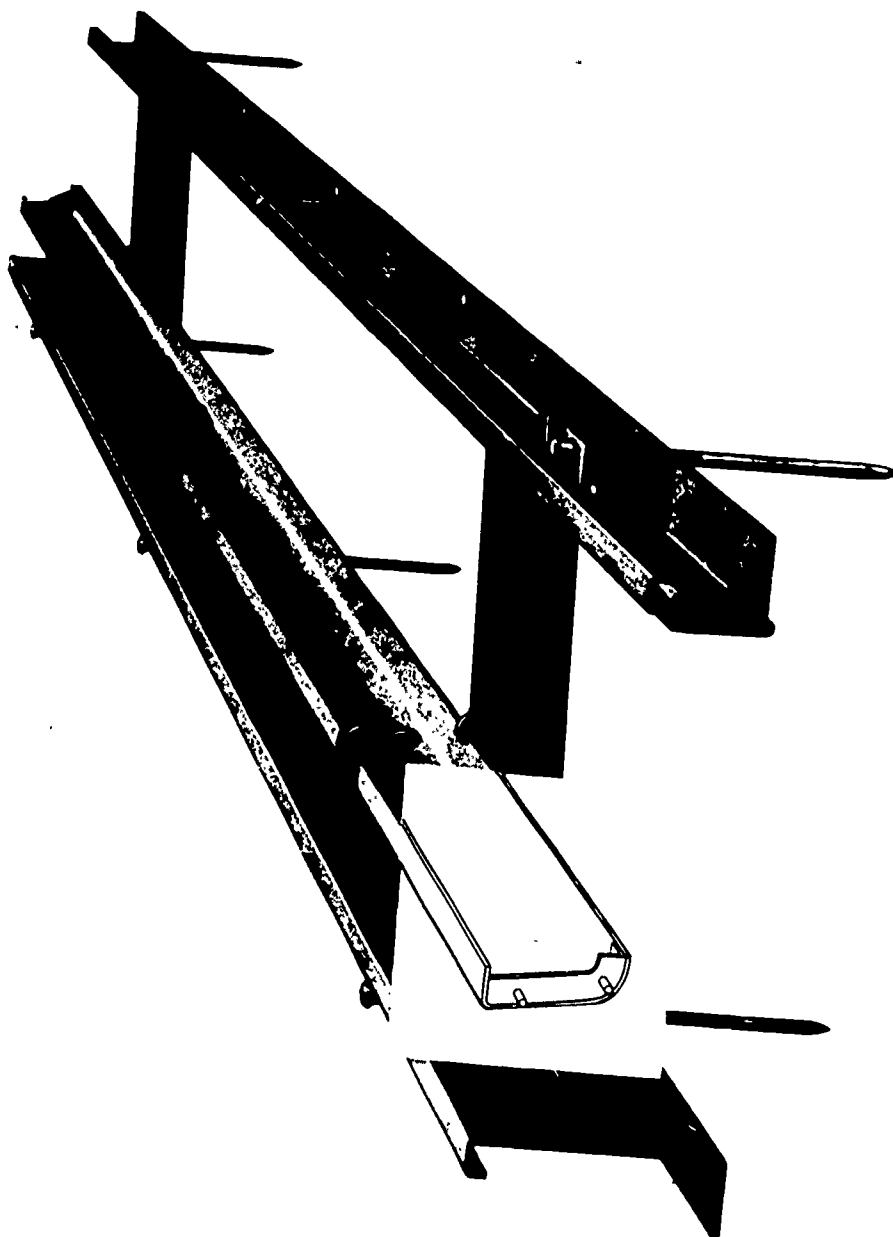

558

Manufactured Median Barrier Form

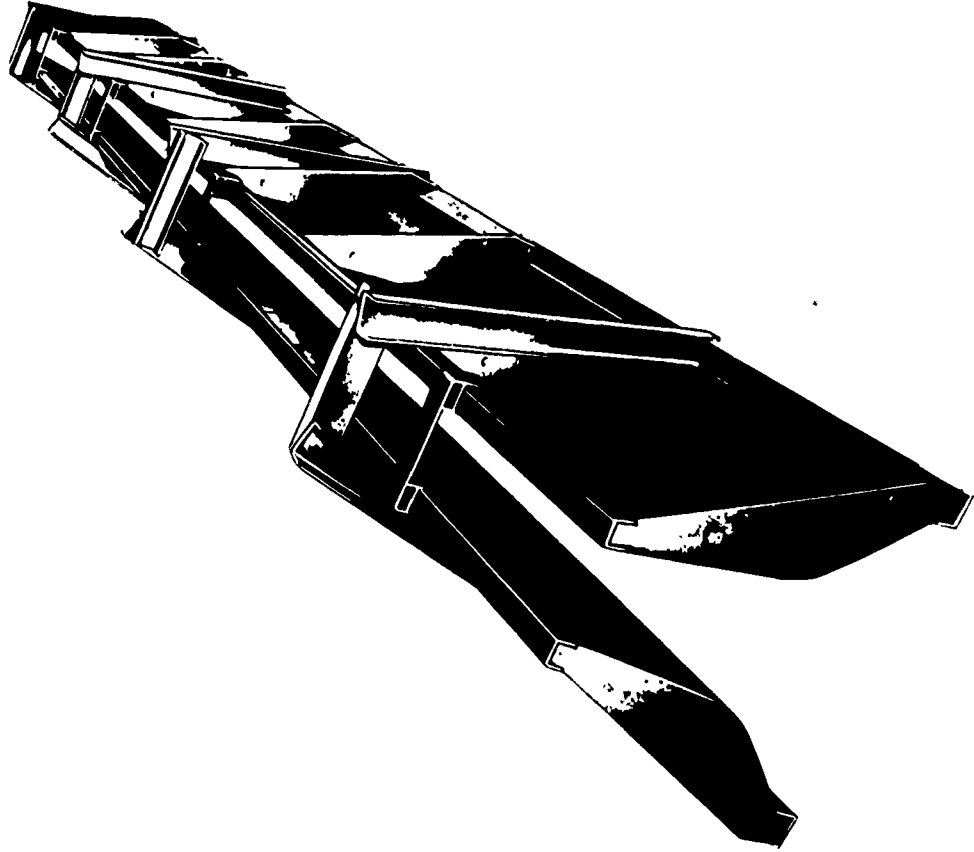

559

TM 5

Job Built Curb and Gutter Forms

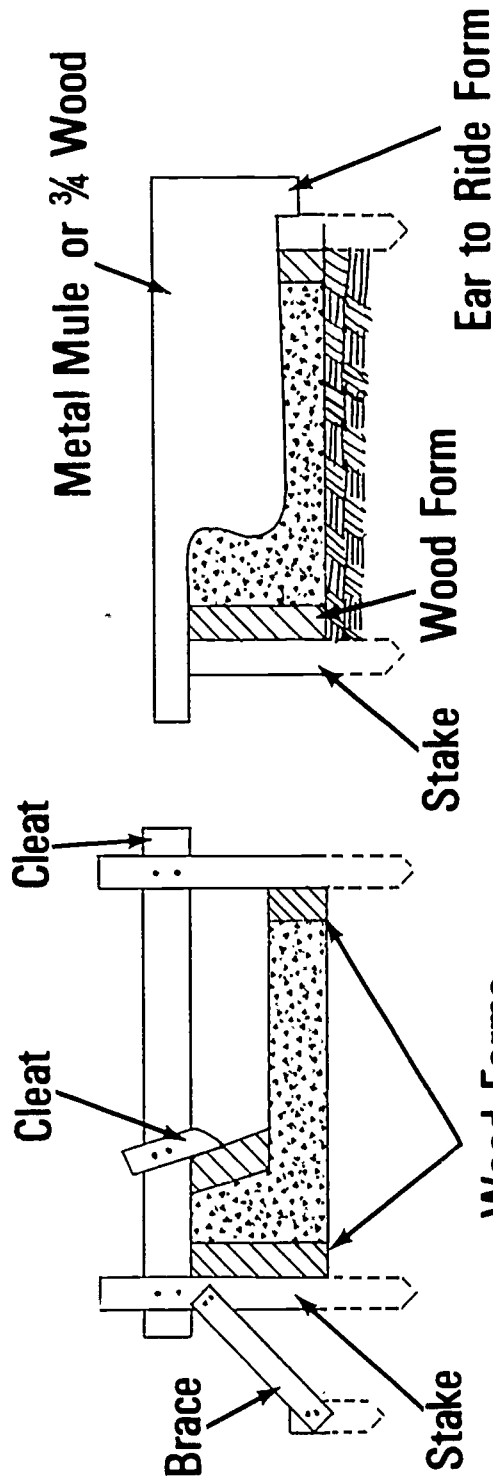

Curb & Gutter Formed Curb

Curb & Gutter Mule Formed Curb

Job Built Straight Curb With Trench

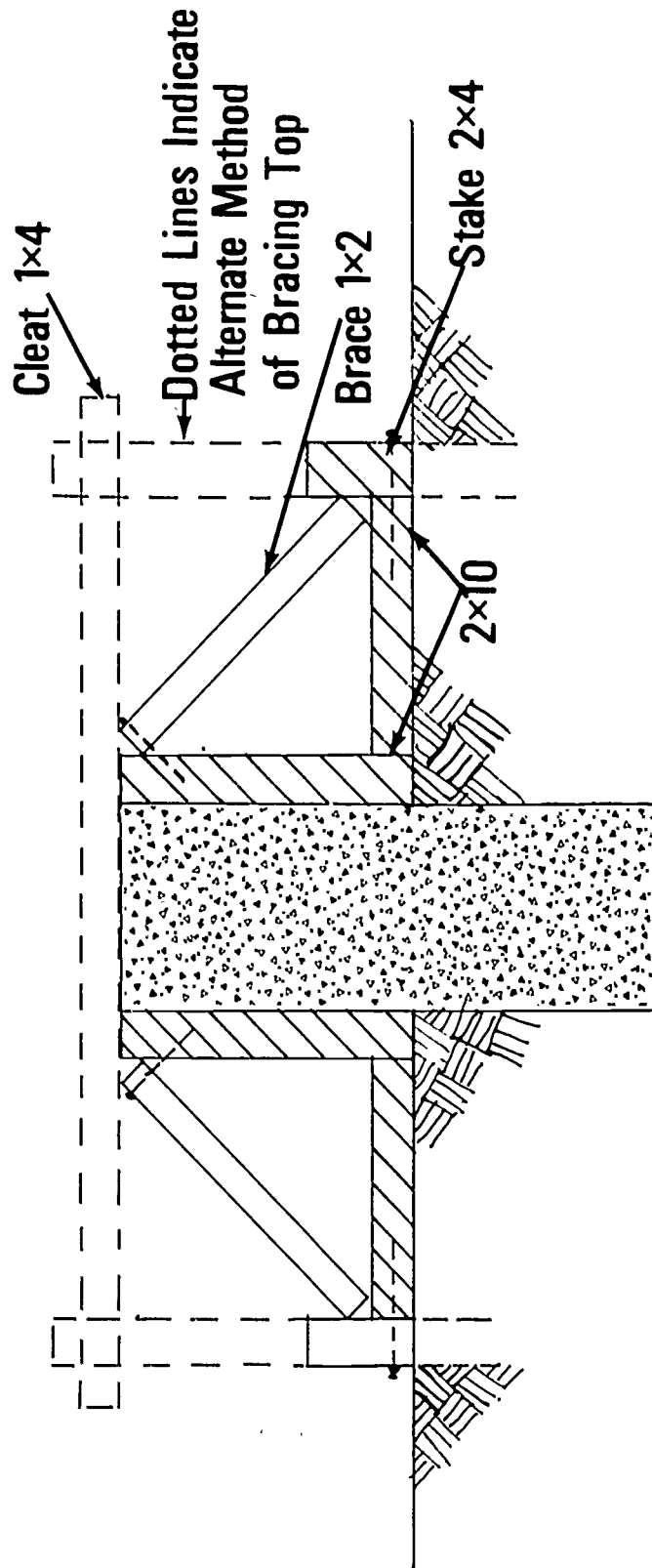

561

Job Built Median Barrier Form

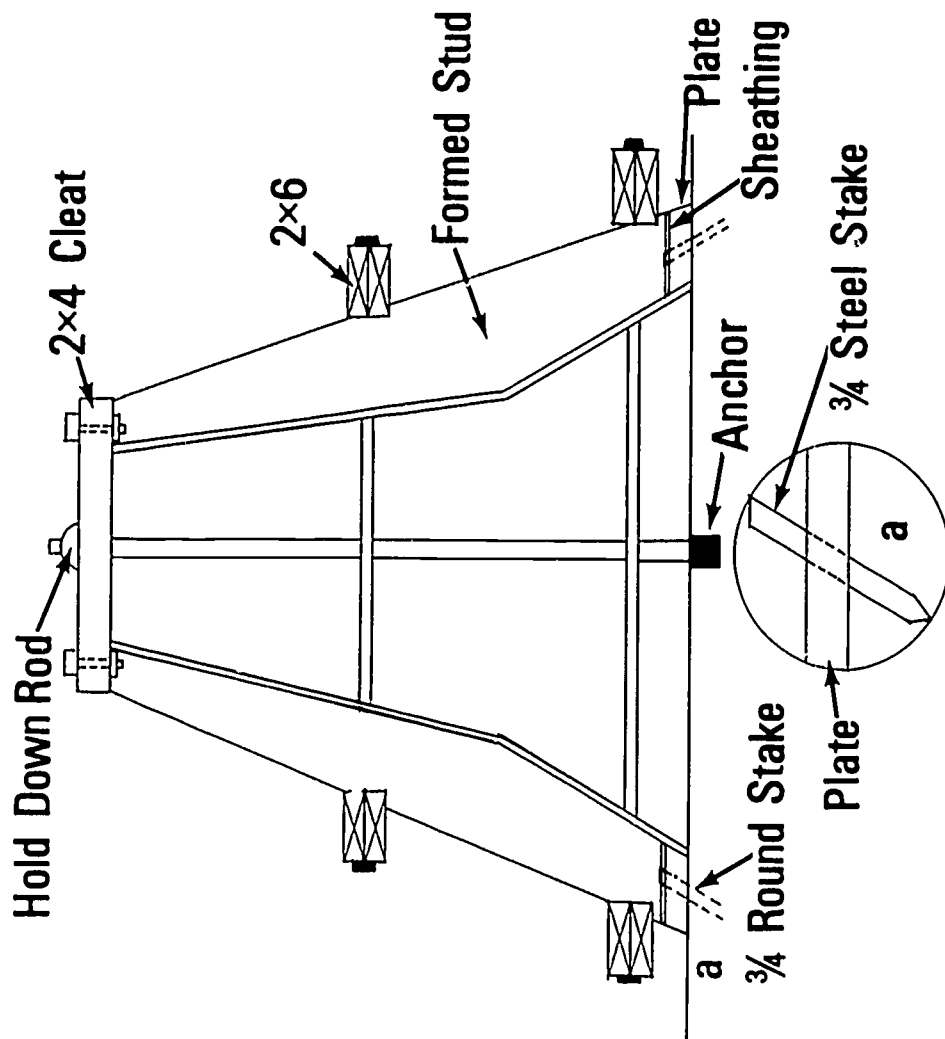

Types of Median Barriers

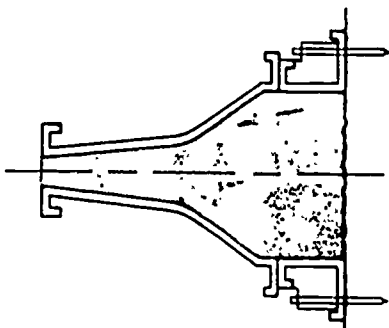

Set on Subgrade
B

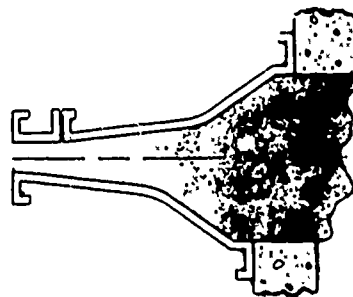

Road Surfaces at
Different Elevations
D

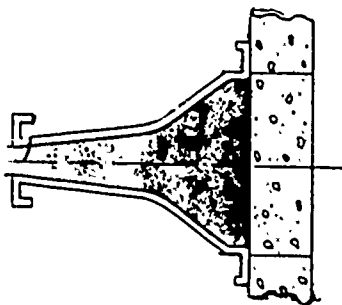

Set on Slab
A

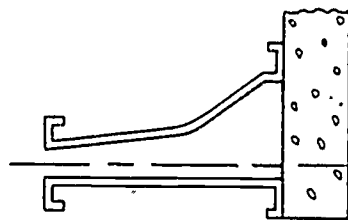

One Side Barrier
C

ON GRADE CURB FORMS
UNIT V

JOB SHEET #1--BUILD A CURB AND GUTTER FORM

I. Tools and materials needed

A. Tools

1. Sledge hammer
2. Claw hammer (16 ounce or larger)
3. Electric handsaw
4. Crosscut handsaw
5. 100 foot measuring tape
6. 12 or 16 foot measuring tape
7. Level (hand)
8. String line
9. Builder's level

B. Materials

1. Stakes
2. Sheathing--2 x 10
3. Nails
 - a. 16d duplex
 - b. 8d duplex

JOB SHEET #1

II. Procedure

A. Establish outside line of curb (Figure 1)

(NOTE: Prior to excavation, offset line and grade stakes have been placed on each side of the road. Check these stakes for offset and elevation.)

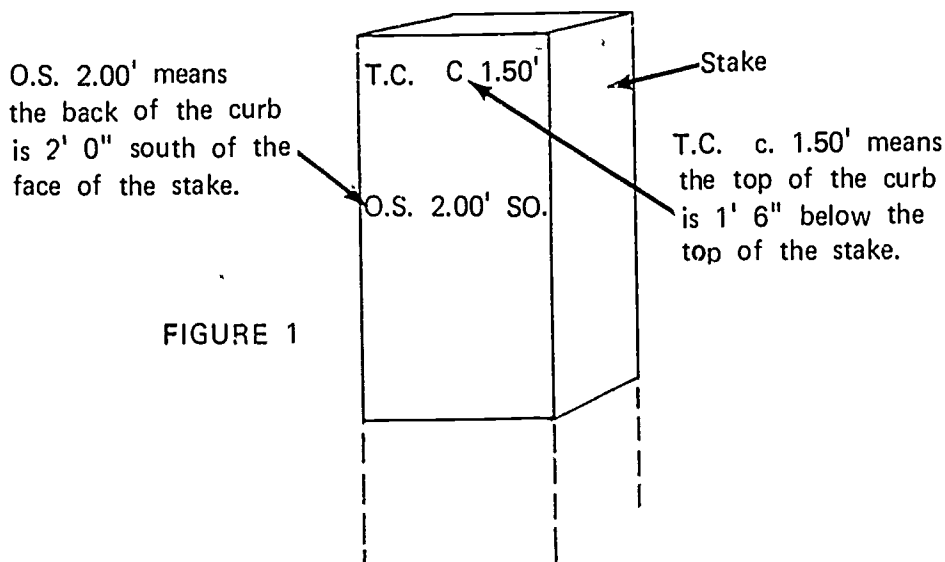

FIGURE 1

B. Measure over from offset stake to determine form stake location (Figure 2)

(NOTE: Deduct thickness of the form material from the offset dimension.)

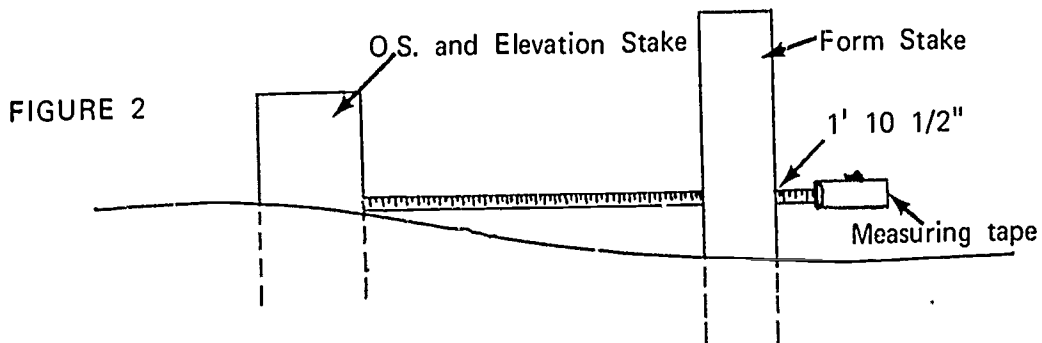
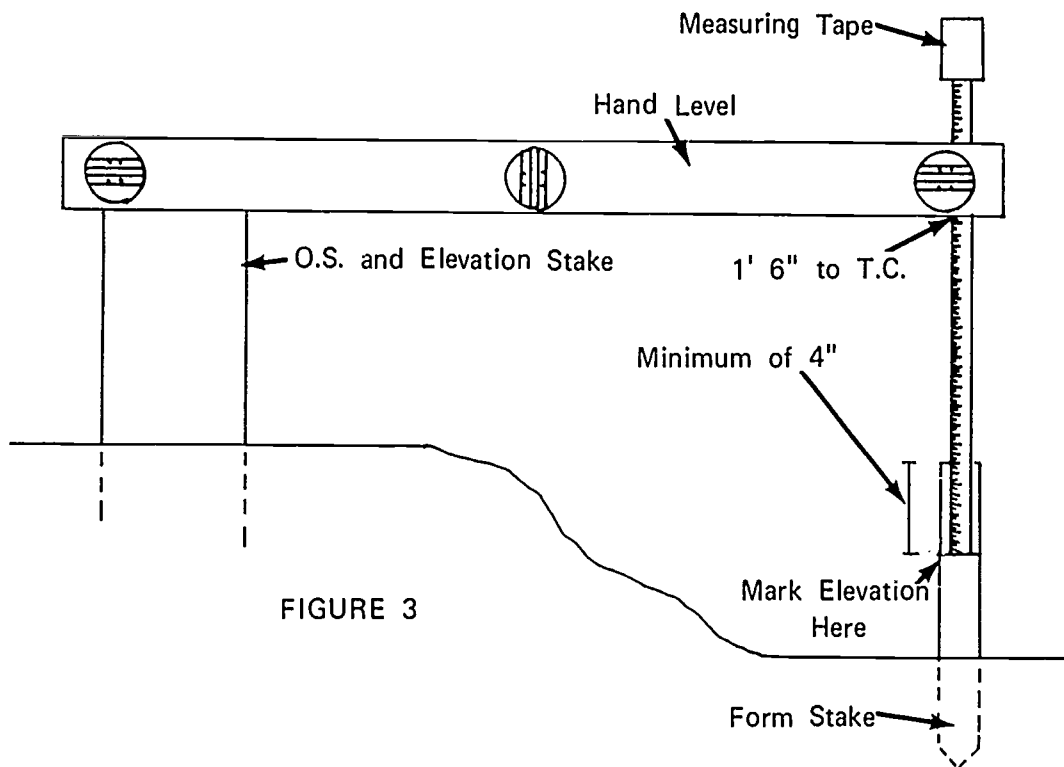

FIGURE 2

JOB SHEET #1

C. Check stakes for elevation as they are driven (Figure 3)

(NOTE: After stake is driven, place pencil mark on elevation of T.C.)



D. Drive stakes opposite each offset stake as shown in Figure 3

(NOTE: Offset stakes are usually set every twenty feet.)

E. Lay form material end to end along line of curb

JOB SHEET #1

- F. Attach line to stakes at elevation and drive intermediate stakes; mark elevation of T.C. on stakes (Figure 4)

(NOTE: Intermediate stake spacing can vary, but a stake must be driven at the joint of each length of form material.)

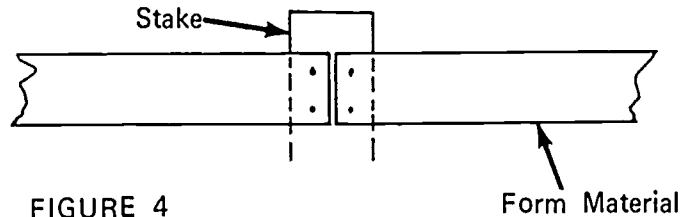

FIGURE 4

Form Material

- G. Nail form material to stakes

- H. Set opposite side stakes using spreader for location (Figure 5)

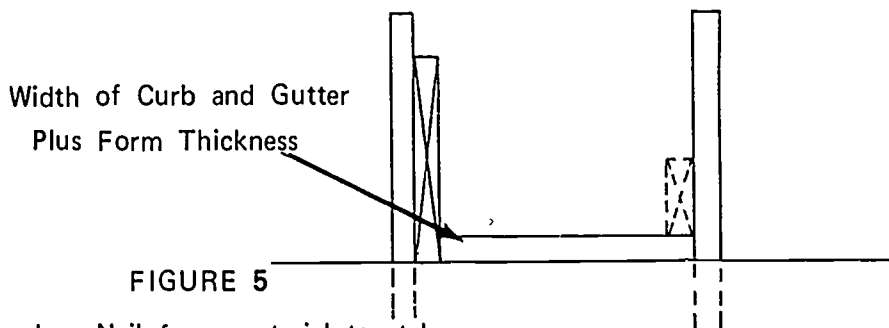

FIGURE 5

- I. Nail form material to stakes

- J. Nail a cleat across the stakes to support inside curb form; mark face of curb plus form on cleat (Figure 6)

(NOTE: The inside form may be suspended on stakes driven into the ground if this is permissible. This is a much faster installation.)

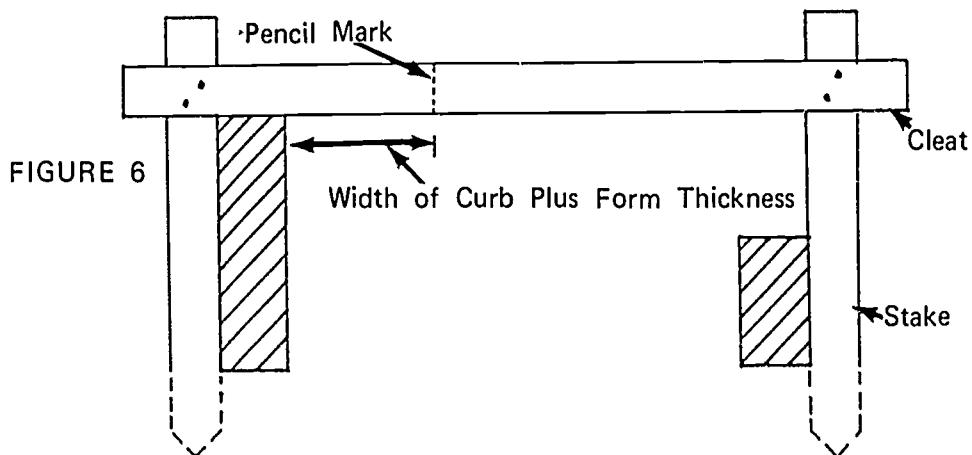

FIGURE 6

JOB SHEET #1

K. Lay curb face forms on cleats and lay out hanger location (Figure 7)

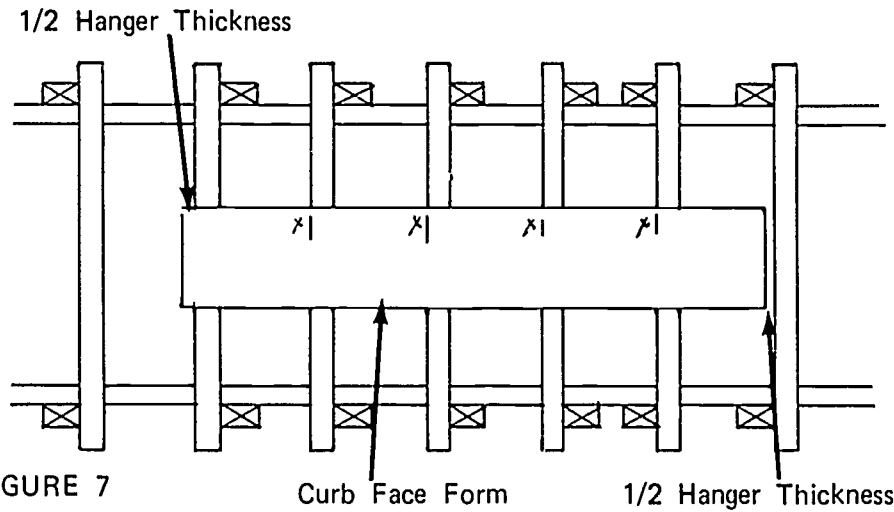

FIGURE 7

Curb Face Form

1/2 Hanger Thickness

L. Nail hangers to face form

M. Nail hangers to cleat (Figure 8)

(NOTE: All cleats and hangers should be nailed with duplex nails for easy removal.)

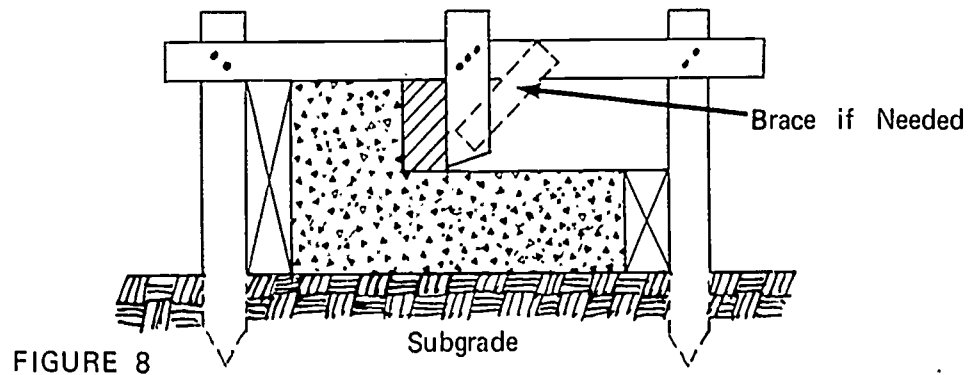

FIGURE 8

Subgrade

Brace if Needed

JOB SHEET #1

N. Repeat steps K, L, and M to complete forms

O. If forms need aligning, install braces (Figure 9)

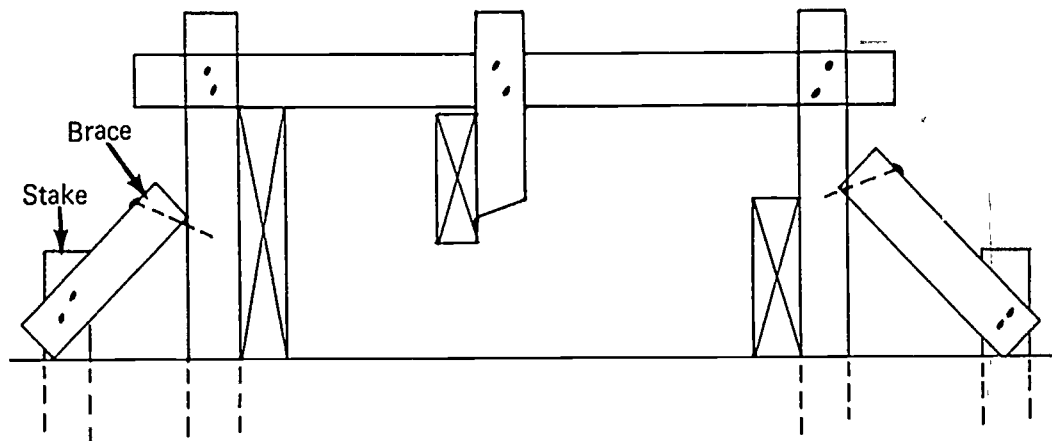

FIGURE 9

ON GRADE CURB FORMS
UNIT V

TEST

1. Match the terms on the right with the correct definitions.

- | | |
|---|----------------------------|
| _____ a. A piece of wood or other material that directs, resists, or supports weight or pressure | 1. Division plate |
| _____ b. A strip of wood or metal fastened across a form for temporary positioning or to replace a form tie | 2. Stake |
| _____ c. A wire or metal crosstie used to hold the pressure of wet concrete and maintain the proper wall thickness | 3. Median barrier |
| _____ d. A continuous mass of concrete cast as a single piece | 4. Brace |
| _____ e. A block of wood that is used to hold the sides of a form apart and is removed as the concrete is poured; it may also be an integral part of the form tie | 5. Subgrade |
| _____ f. A template used to shape the profile of a curb and gutter | 6. Skeleton division plate |
| _____ g. Small boards or steel bars pointed on one end and driven into the ground to support a form | 7. Cleat |
| _____ h. A thin steel plate placed between the forms to provide full depth joints in a curb and gutter | 8. Monolithic pour |
| _____ i. A thin steel plate placed between the forms to provide partial depth scoring in curbs and gutters | 9. Mule |
| | 10. Form tie |
| | 11. Spreader |

- ___ j. A barrier placed between two lanes of highway
- ___ k. The earth or rock grade on which concrete is poured

2. Identify the thirteen types of curbs and curbs and gutters illustrated below.

- ___ a. Partially battered curb
- ___ b. Highway gutter
- ___ c. Double radius battered
- ___ d. Single radius vertical
- ___ e. Straight face vertical
- ___ f. Single radius battered
- ___ g. Radius curb and gutter
- ___ h. Roll curb and gutter
- ___ i. Serpentine curb
- ___ j. Fully battered curb
- ___ k. Straight curb
- ___ l. Double radius vertical
- ___ m. Straight face battered

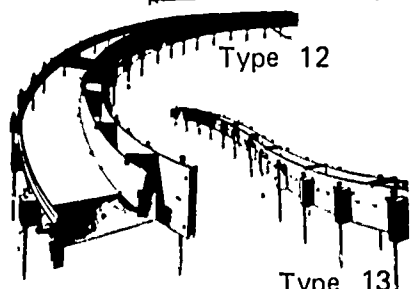
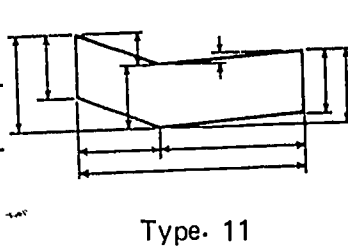
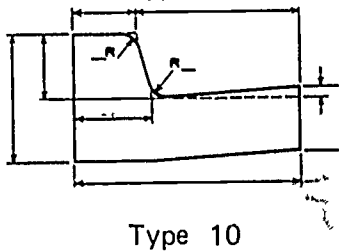
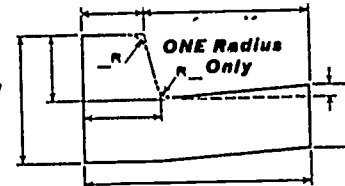
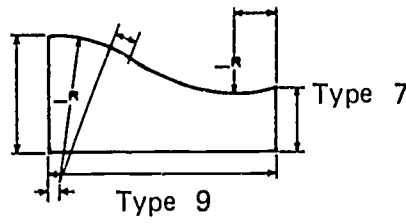
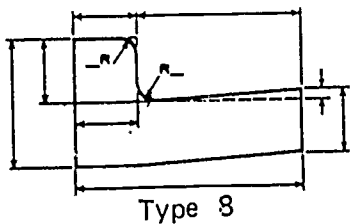
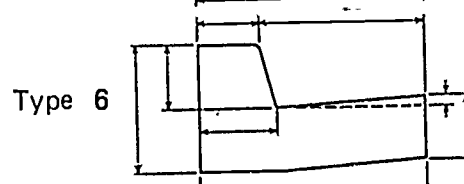
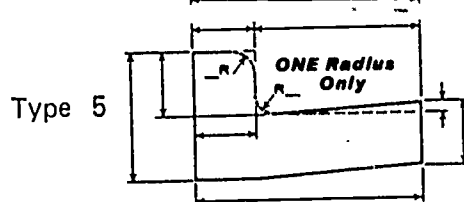
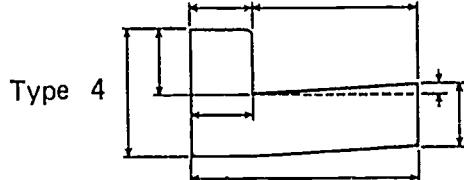
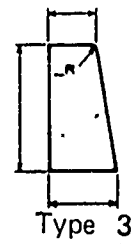
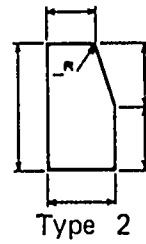
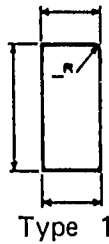

3. Name two methods of forming curbs or curbs and gutters or median barriers.

a.

b.

4. Identify the four types of median forms illustrated below. Place the correct number in the blanks provided below.

_____ a. Set on slab

_____ b. Set on subgrade

_____ c. One side barrier

_____ d. Road surfaces at different elevations

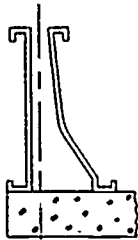

1

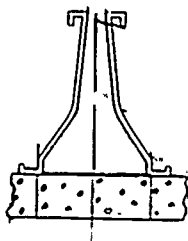

2

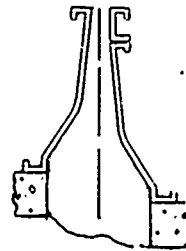

3

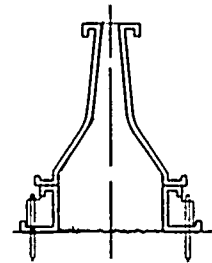

4

5. Demonstrate the ability to construct a curb and gutter form.

ON GRADE CURB FORMS
UNIT V

ANSWERS TO TEST

1.
 - a. 4
 - b. 7
 - c. 10
 - d. 8
 - e. 11
 - f. 9
 - g. 2
 - h. 1
 - i. 6
 - j. 3
 - k. 5
2.
 - a. 2
 - b. 11
 - c. 10
 - d. 5
 - e. 4
 - f. 7
 - g. 12
 - h. 9
 - i. 13
 - j. 3
 - k. 1
 - l. 8
 - m. 6

3.
 - a. Job built
 - b. Manufactured
4.
 - a. 2
 - b. 4
 - c. 1
 - d. 3
5. Performance skills will be evaluated according to the criteria on the progress chart.

VERTICAL PIERS AND COLUMNS
UNIT VI

TERMINAL OBJECTIVE

Upon completion of this unit, the student should be able to define column forming terms. He should be able to identify column shapes, types of columns, and materials used to construct column forms. He should also be able to name methods of column form construction and identify types of column corners. This knowledge will be evidenced by scoring eighty-five percent on the unit test.

SPECIFIC OBJECTIVES

After completing this unit, the student should be able to:

1. Match a list of forming terms to the correct definitions.
2. Identify six column shapes.
3. Name two types of column finishes.
4. Name four materials normally used for column forms.
5. Name two methods of column form construction.
6. Identify three types of column corners.
7. Demonstrate the ability to:
 - a. Construct a form for a round fluted column.
 - b. Construct a form for a square column.

VERTICAL PIERS AND COLUMNS
UNIT VI

SUGGESTED ACTIVITIES

- I. Instructor:
 - A. Provide students with objective sheet.
 - B. Provide students with information and job sheets.
 - C. Make transparencies.
 - D. Discuss terminal and specific objectives.
 - E. Discuss information sheet.
 - F. Demonstrate and discuss procedures outlined in job sheets.
 - G. Give test
- II. Student:
 - A. Read objective sheet.
 - B. Study information sheet.
 - C. Demonstrate the ability to accomplish the procedures outlined in the job sheet.
 - D. Take test.

INSTRUCTIONAL MATERIALS

- I. Included in this unit:
 - A. Objective sheet
 - B. Information sheet
 - C. Transparency masters
 1. TM 1--Column Shapes
 2. TM 2--Column Form Material
 3. TM 3--Job Built Square Column Form

4. TM 4--Manufactured Panel Square Column Form
5. TM 5--Job Built L-Shaped Column Form
6. TM 6--Manufactured Panels L-Shaped Column Form
7. TM 7--Types of Column Corners

D. Job sheets

1. Job Sheet #1--Construct Forms for a Round Fluted Column
2. Job Sheet #2--Construct Forms for a Square Column

E. Test

F. Answers to test

II. References:

- A. Burke, Arthur E., J. Ralph Dalzell, and Gilbert Townsend. *Architectural and Building Trades Dictionary*. Chicago, Illinois: American Technical Society, 1955.
- B. Smith, Ronald C. *Principles and Practices of Heavy Construction*. Englewood Cliffs, New Jersey: Prentice Hall, Inc., 1970.
- C. Peurifoy, R.L. *Form Work for Concrete Structures*. New York: McGraw-Hill Book Company, 1964.

VERTICAL PIERS AND COLUMNS
UNIT VI

INFORMATION SHEET

- I. Terms and definitions
 - A. Footing--An enlarged area at the base of a wall or another object used to distribute the weight of the superstructure
 - B. Column clamp--A manufactured device surrounding a column form to hold the pressure exerted by wet concrete
 - C. Yoke--A job built device surrounding a column form to hold the pressure exerted by wet concrete
 - D. Sheathing--Wide boards, plywood, or metal that makes up the face of a form
 - E. Capital--An enlarged area at the top of a column
 - F. Grade point--The level of finished concrete in a form
 - G. Pier--A slender support for an arch or a supporting section of wall between two openings
 - H. Column--A vertical shaft of many shapes designed to support the structure above
 - I. Staves--Vertical sheathing in a circular column form
- II. Column shapes (Transparency 1)
 - A. L-shaped
 - B. Square
 - C. Rectangular
 - D. Round
 - E. Tapered
 - F. Fluted
 - G. Captaled
- III. Types of column finishes
 - A. Architectural
 - B. Structural

INFORMATION SHEET

- IV. Materials used for column forms (Transparency 2)
 - A. Wood
 - B. Metal
 - C. Fiber (paper)
 - D. Molded fiber glass
- V. Methods of form construction (Transparencies 3, 4, 5, and 6)
 - A. Job built
 - B. Manufactured panels
- VI. Types of column corners (Transparency 7)
 - A. Chamfer (vinyl or wood)
 - B. Radius (vinyl)
 - C. Square

Column Shapes

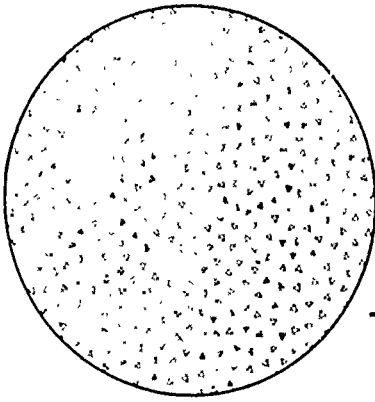

Round

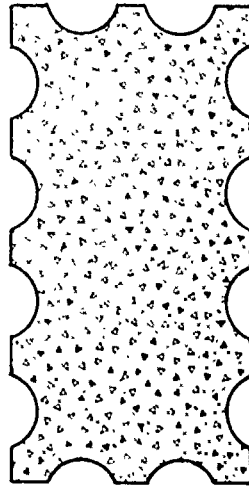

Fluted

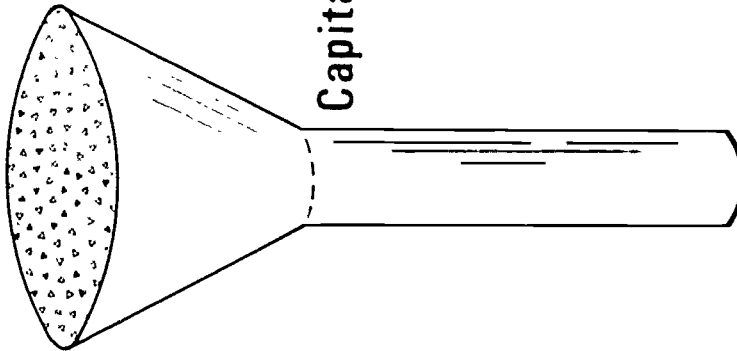

Capitaled



Tapered

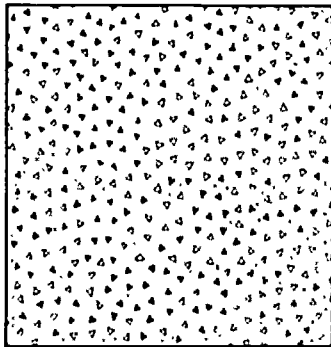

Square

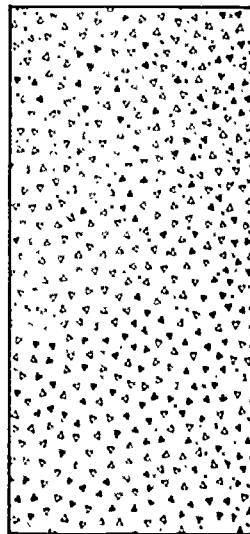

Rectangular

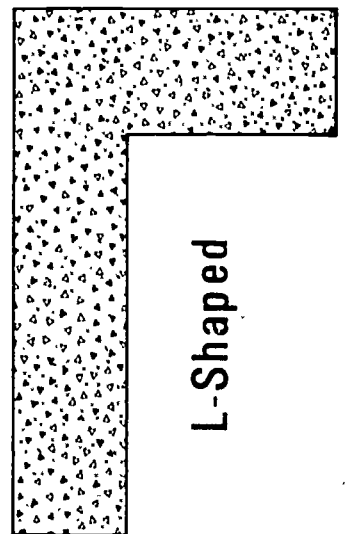

L-Shaped

Column Form Material

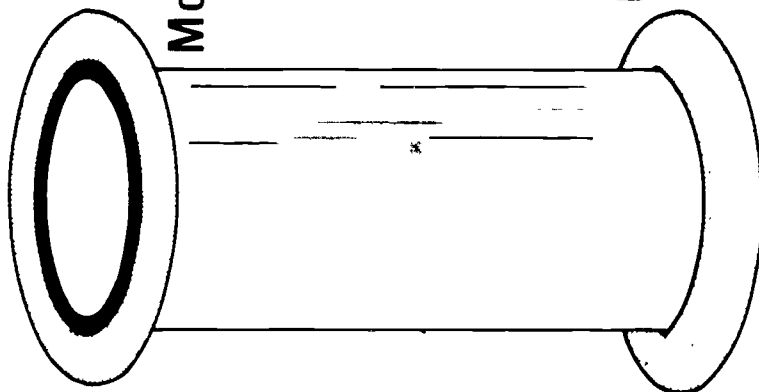

Molded Fiber Glass

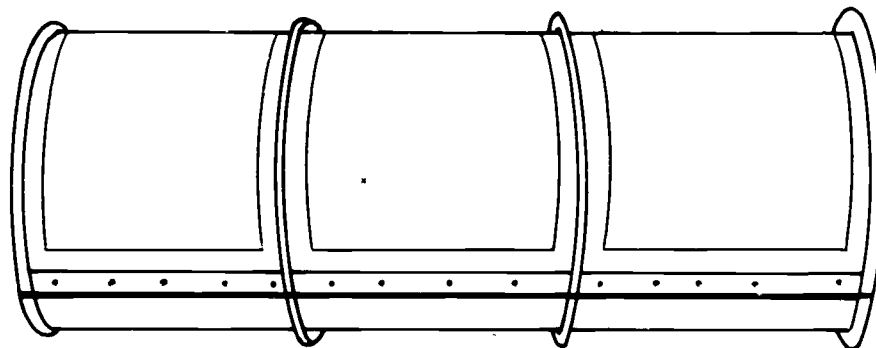

Steel

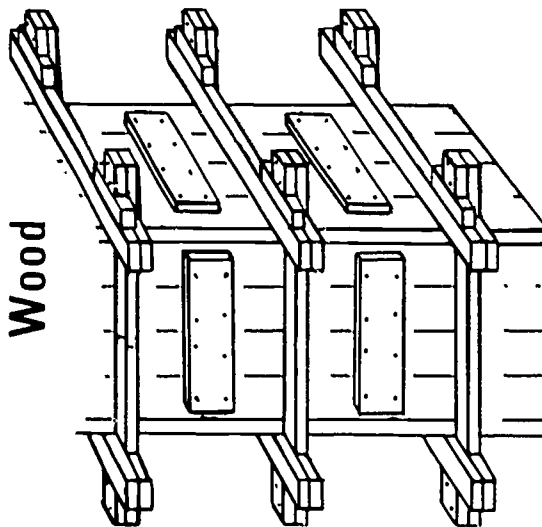

Wood

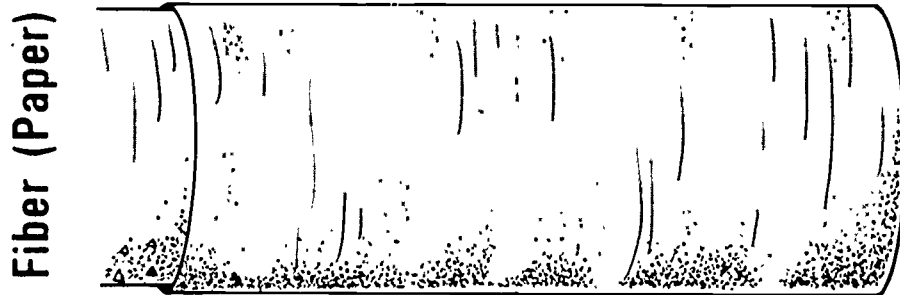

Fiber (Paper)

Job Built Square Column Form

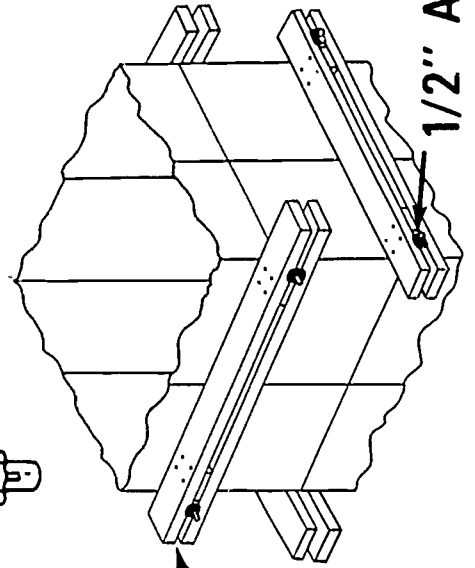
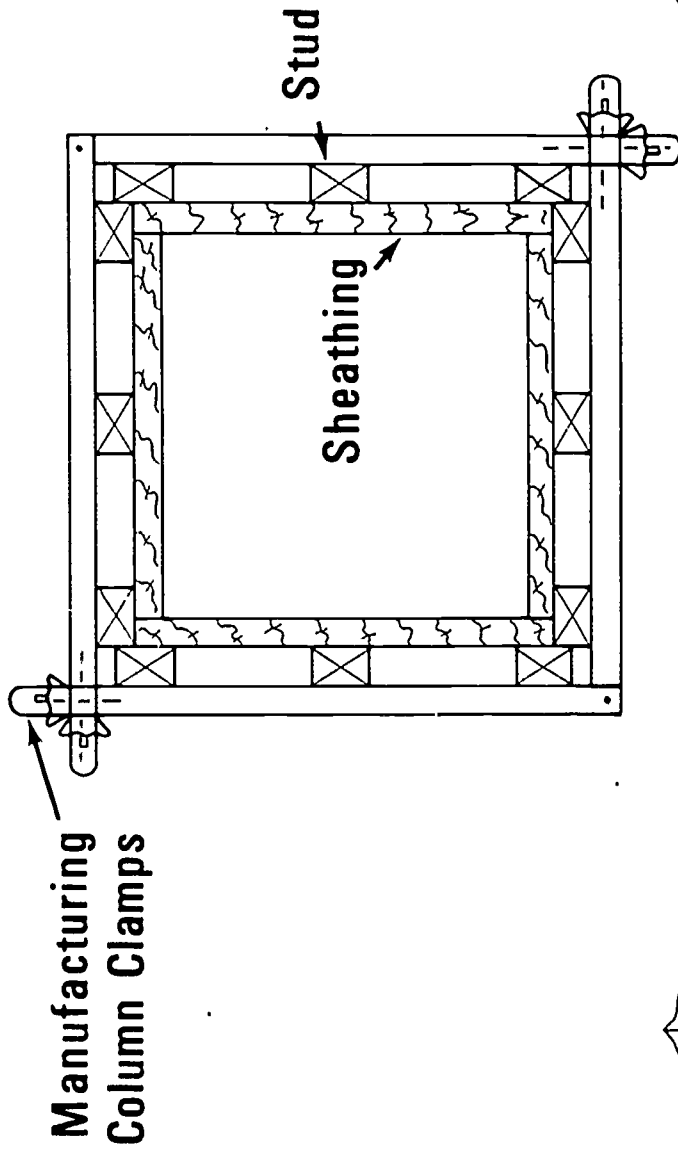

A

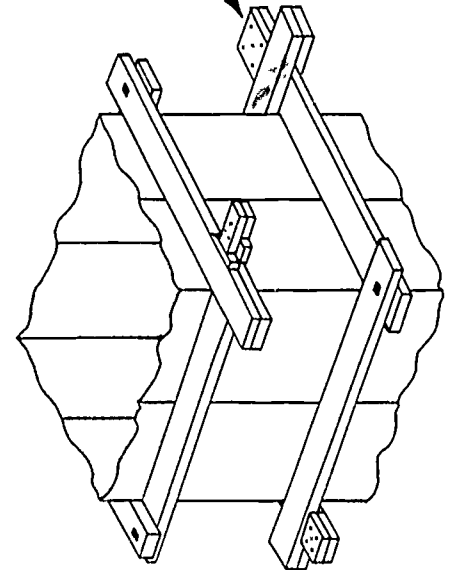

B

C 1/2" All Thread Rod or Form Ties

Manufactured Panel Square Column Form

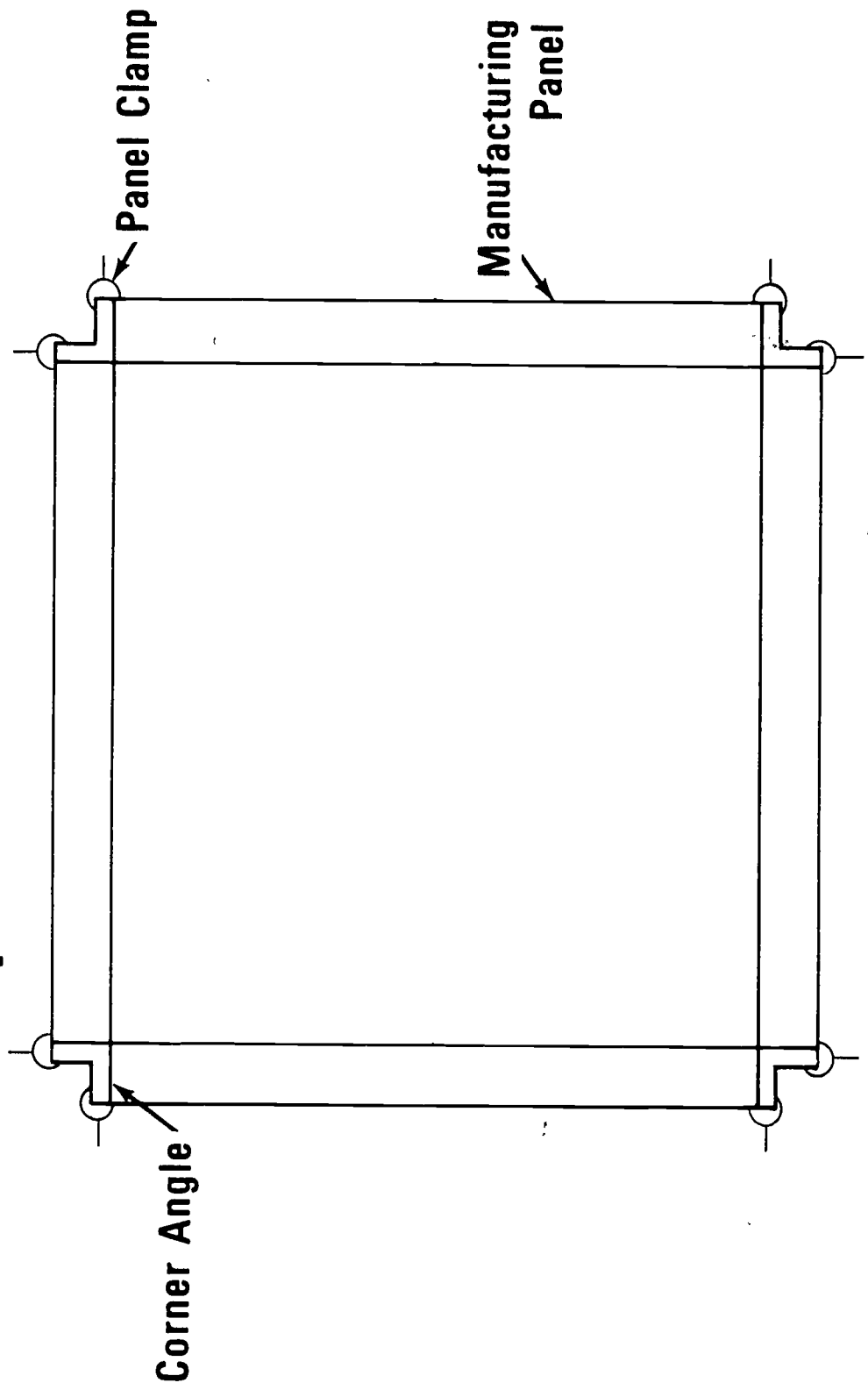

Job Built L-Shaped Column Form

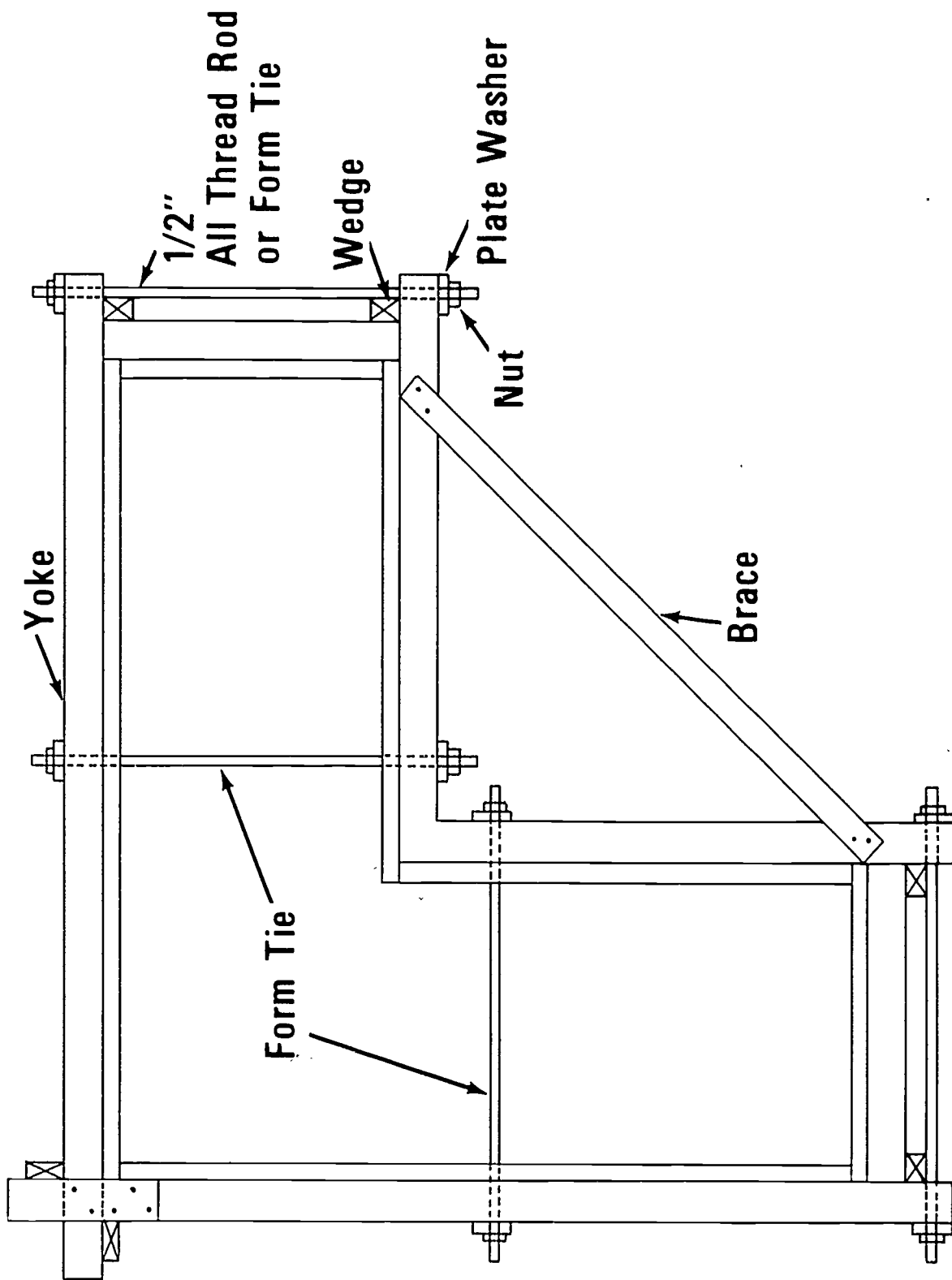

Manufactured Panels L-Shaped Column Form

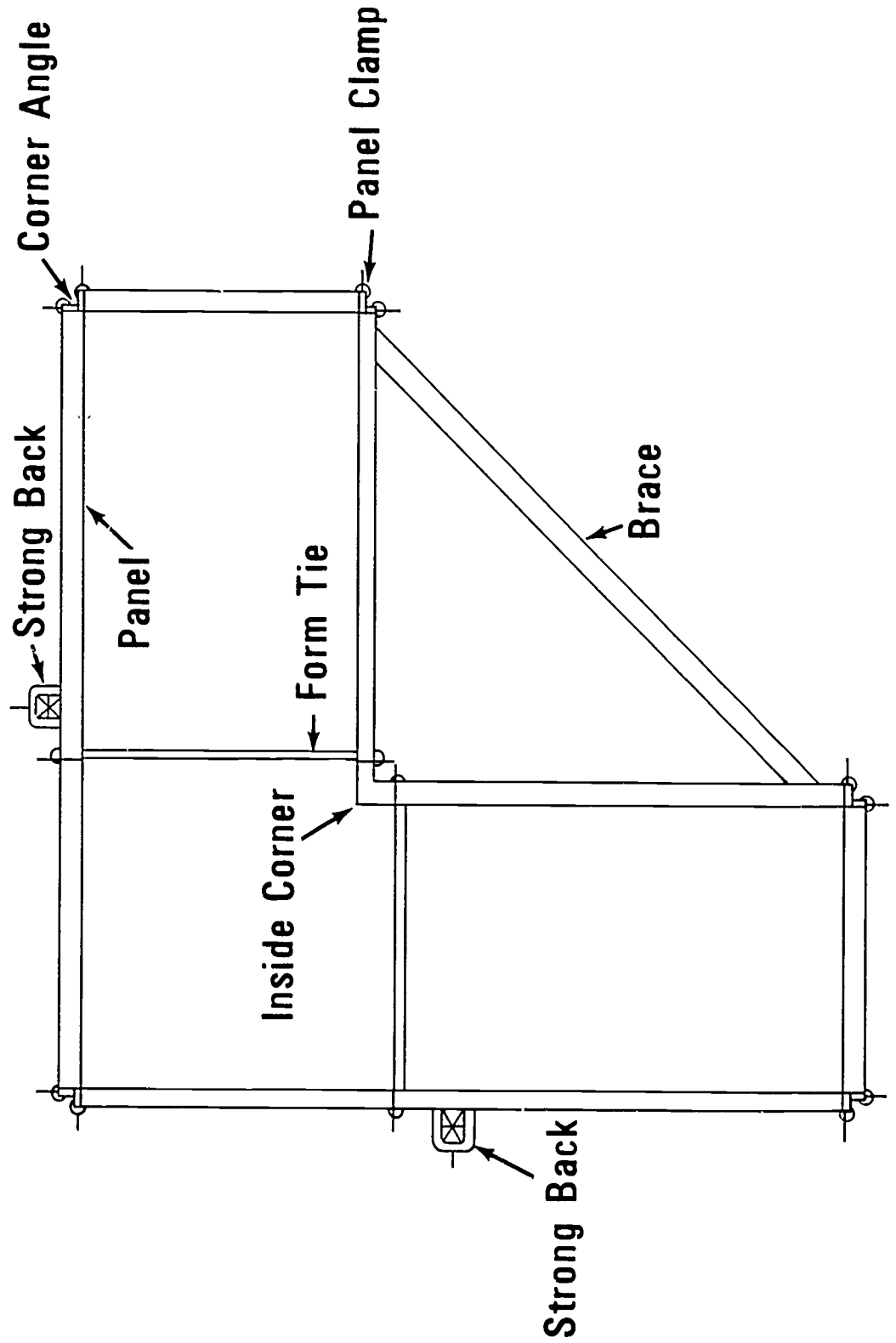

Types of Column Corners

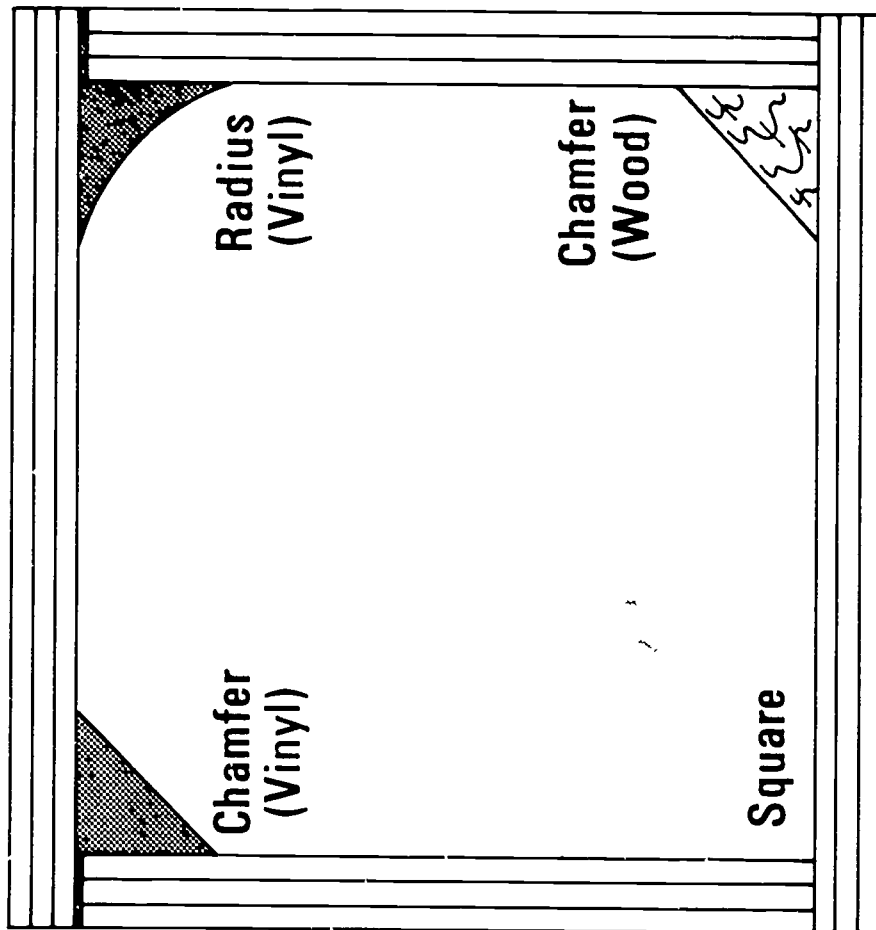

.VERTICAL PIERS AND COLUMNS
UNIT VI

JOB SHEET #1--CONSTRUCT FORMS FOR A ROUND FLUTED COLUMN

I. Tools and materials needed

A. Tools

1. Electric handsaw
2. Crosscut handsaw
3. Claw hammer (16 ounce or larger)
4. Tape measure (12 or 16 foot)
5. Level (hand)
6. 100 foot tape measure
7. Chalk line and reel
8. Transit level
9. Band saw or saber saw

B. Materials

1. Staves (1" x 2")
2. Segments (3/4" plywood)
3. Studs (2 x 6's)
4. Setting template (2" x 4")
5. Steel strapping
6. Half round wood (flutes)
7. Form oil

II. Procedure

A. Build forms

1. Lay out full size pattern on the floor or on a piece of plywood (Figure 1)

(NOTE: Diameter line will be the line on which the two halves of the form join. Place stud at each end of the half form.)

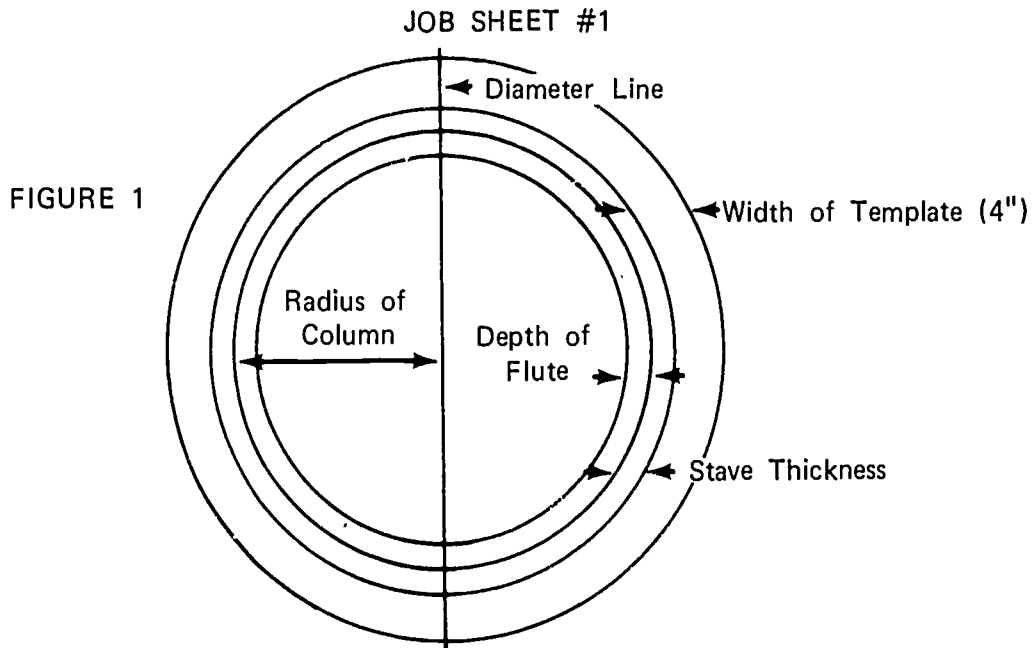

FIGURE 1

2. Divide quarter section of circle into equal segments (Figure 2)

(NOTE: The length of the segments is determined by the width and grain of the material used. The grain of the material should be as near parallel to the form surface as possible.)

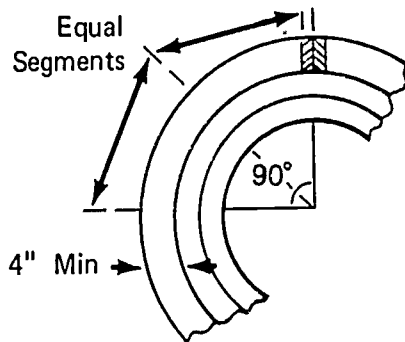

FIGURE 2

3. Lay template material on pattern and lay out segmental pattern (Figure 3)

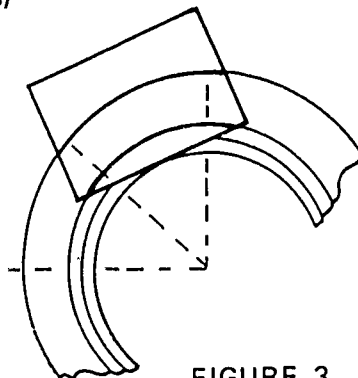
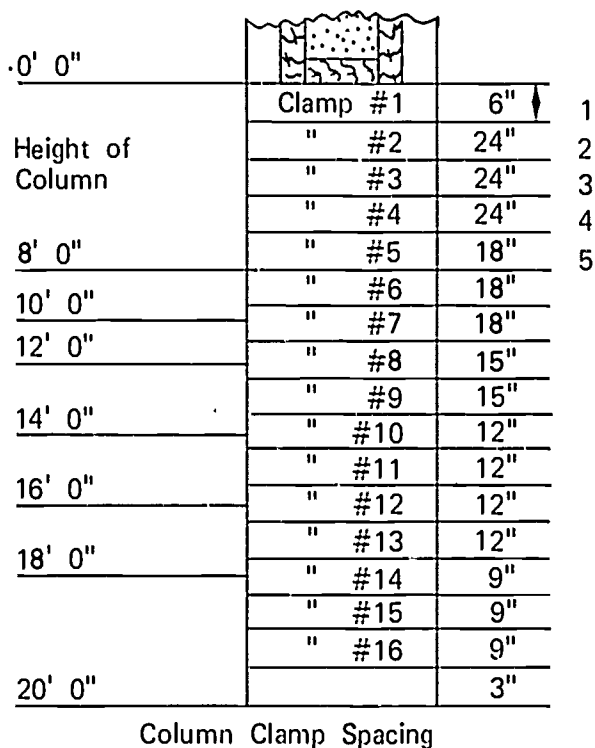



FIGURE 3

JOB SHEET #1

4. Determine number of segments needed (Figure 4)

(NOTE: Check column clamp spacing schedule for segmental ring spacing. Using the eight foot column height as an example, there would be five segmental templates needed. Labor can be saved by using steel strapping at intermediate locations.)



0' 0"			
Height of Column	Clamp #1	6"	1
	" #2	24"	2
	" #3	24"	3
	" #4	24"	4
	" #5	18"	5
8' 0"	" #6	18"	
10' 0"	" #7	18"	
12' 0"	" #8	15"	
14' 0"	" #9	15"	
16' 0"	" #10	12"	
16' 0"	" #11	12"	
18' 0"	" #12	12"	
18' 0"	" #13	12"	
20' 0"	" #14	9"	
	" #15	9"	
	" #16	9"	
20' 0"		3"	

Column Clamp Spacing

FIGURE 4

5. Cut required number of segments

(IMPORTANT: Mark the first segment PATTERN and use it for layout of remaining segment.)

JOB SHEET #1

6. Cut studs to length; notch and drill bolt holes (Figure 5)

(NOTE: Notches should be placed at clamp spacing as determined from the schedule. Bolt spacing should be at approximately two feet center to center. Be sure all studs are notched and drilled in identical location.)

FIGURE 5

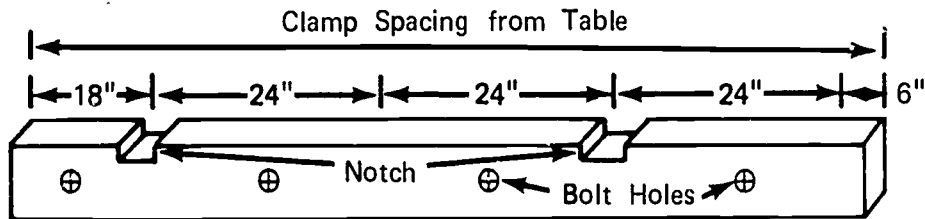

7. Nail segments together to form a half circle (Figure 6)

(NOTE: Stagger joints by starting second layer using one-half of the segment.)

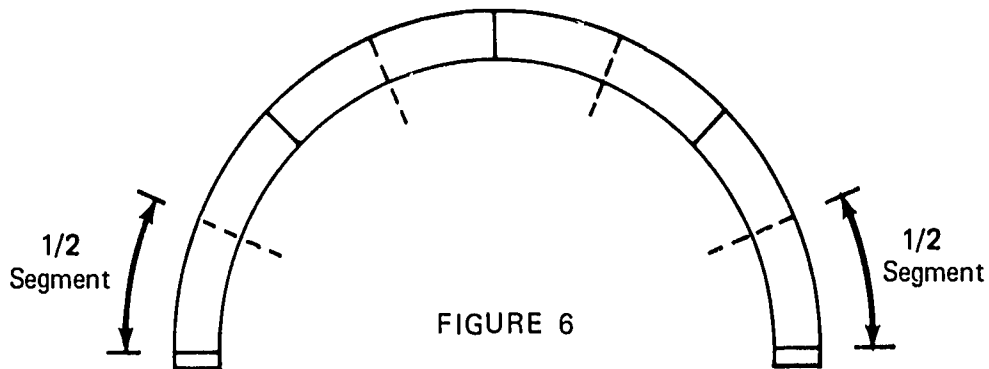

FIGURE 6

JOB SHEET #1

8. Attach segments to studs (Figure 7)

(NOTE: Use light pre-drilled angle iron and screws.)

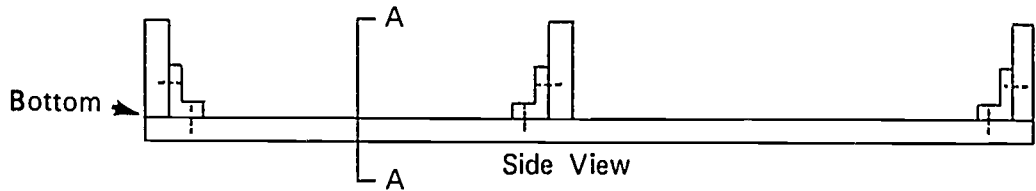
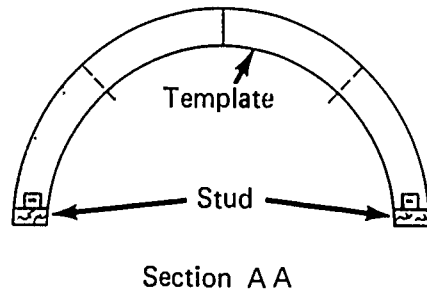

FIGURE 7



9. Nail staves to segments (Figure 8)

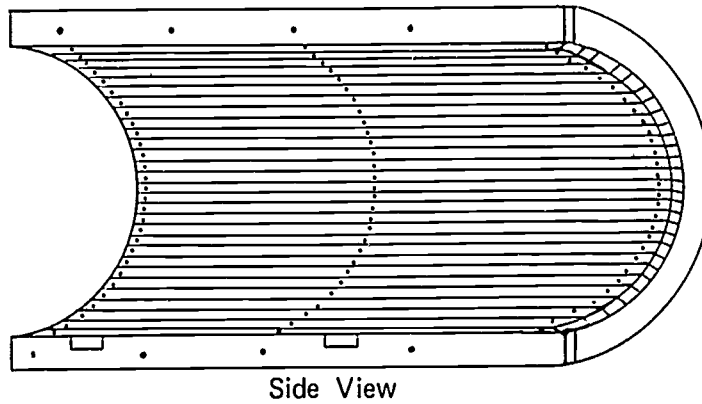
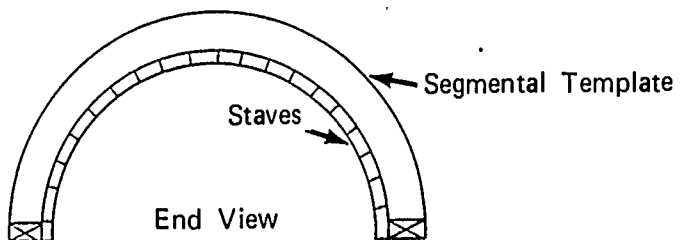

FIGURE 8



JOB SHEET #1

10. Nail half round wood to staves (Figure 9)

(NOTE: On the job, the size and spacing of the flutes are taken from the architect's plans.)

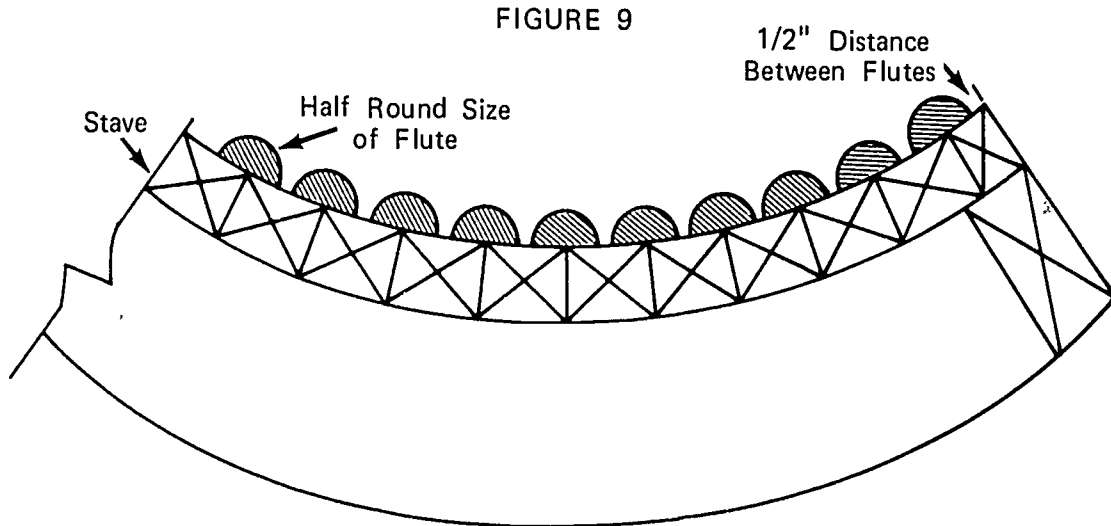

11. Apply liberal coat of form oil to form

(NOTE: This column has an architectural surface. Be sure the form oil is of the non-staining type.)

B. Set forms

1. Establish center line of column both directions (Figure 10)

(NOTE: Center lines may be established with a string line. Snap a chalk line in the column area.)

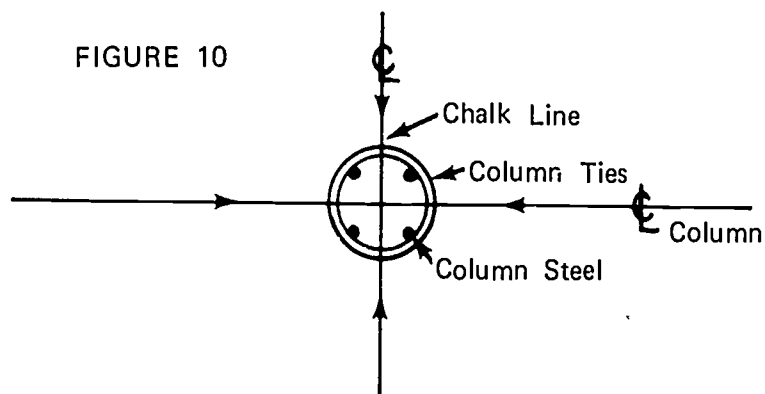

JOB SHEET #1

2. Locate the outside of the form and nail template blocks to the floor (Figure 1.1)

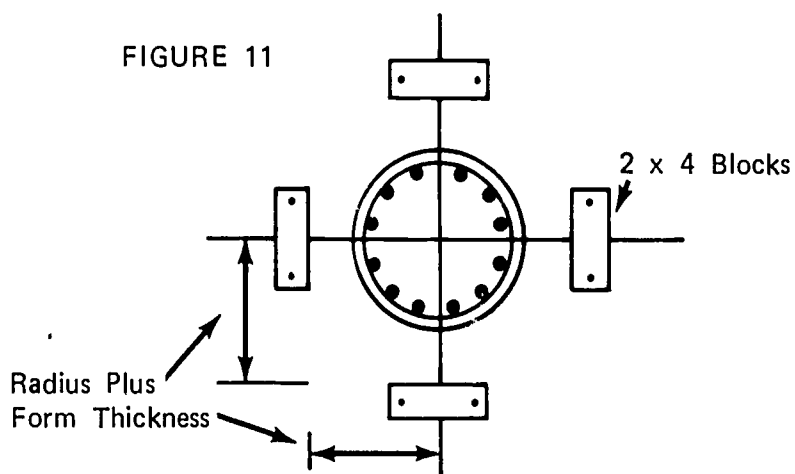

3. Set form halves in position inside the floor templates (Figure 12)

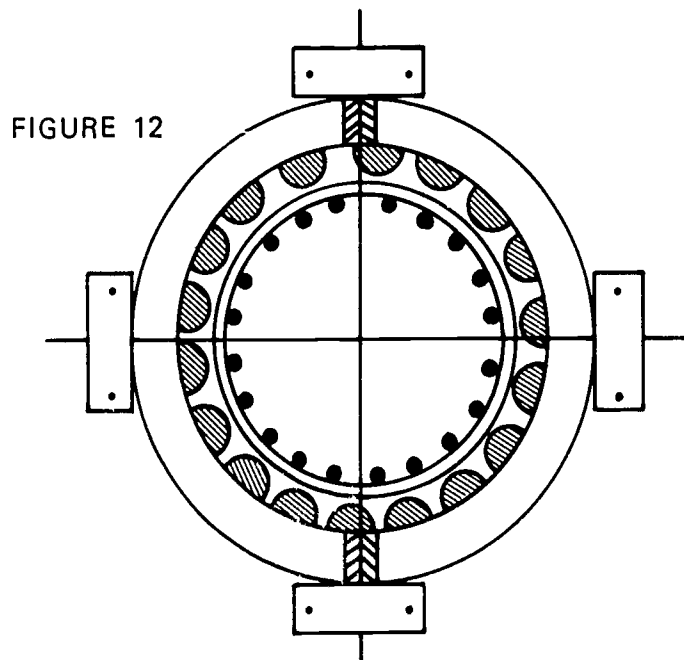

JOB SHEET #1

4. Bolt sections together (Figure 13)

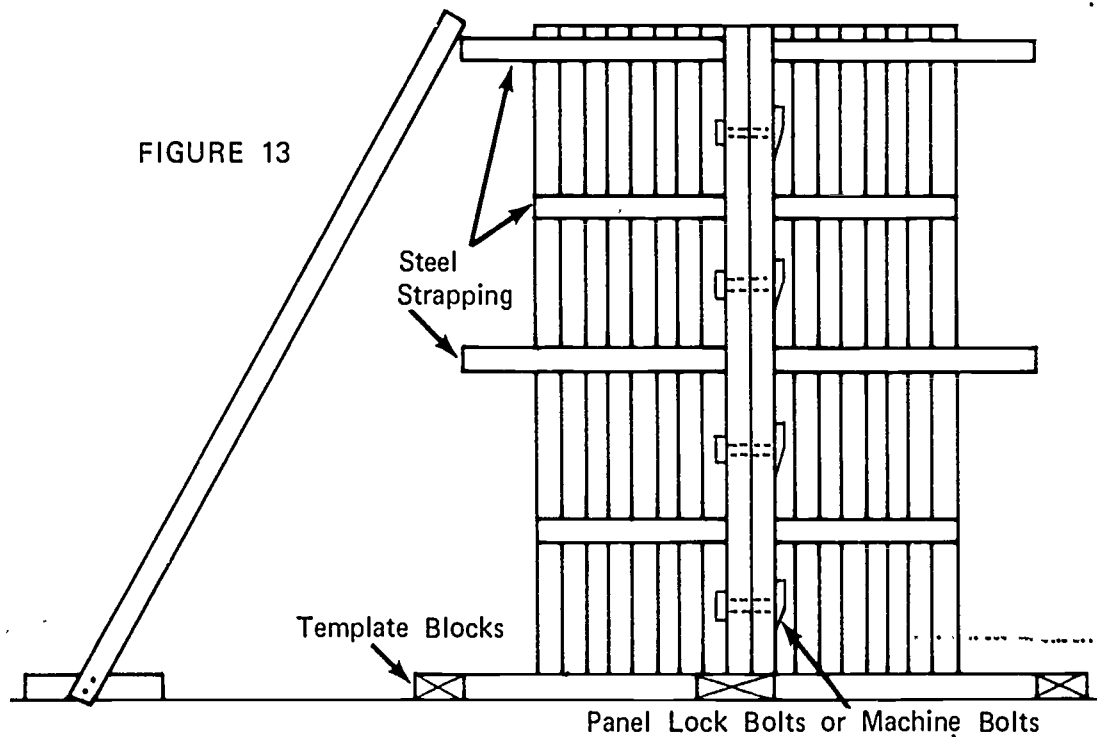

5. Place blocks under form and install steel strapping around template rings

(NOTE: Form should be blocked up high enough to install strapping on bottom segmental template.)

6. Thread strapping through notches in studs and tighten
7. Brace form plumb as shown in Figure 13

(NOTE: Two braces placed at quarter sections of the form should be sufficient.)

VERTICAL PIERS AND COLUMNS
UNIT VI

JOB SHEET #2--CONSTRUCT FORMS FOR A SQUARE COLUMN

I. Tools and materials needed

A. Tools

1. Hammer (16 oz. or larger)
2. Handsaw (crosscut)
3. Electric handsaw
4. String line
5. Electric drill

B. Materials

1. Sheathing-Plywood
2. Studs--2 x 4's
3. Column clamps

II. Procedure

- A. Determine size of column
- B. Cut column sides to size (Figure 1)

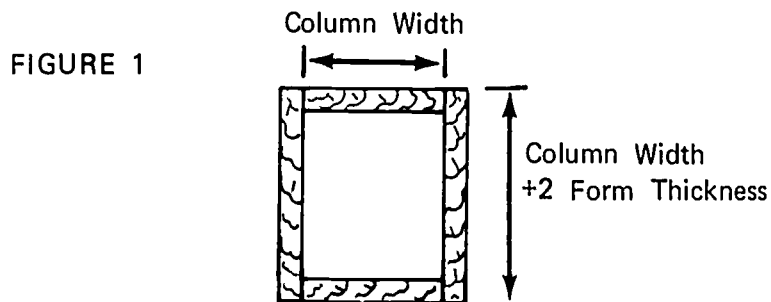

C. Cut column studs

(NOTE: Studs will be the same length as the beam side.)

JOB SHEET #2

D. Assemble column sides (Figure 2)

FIGURE 2

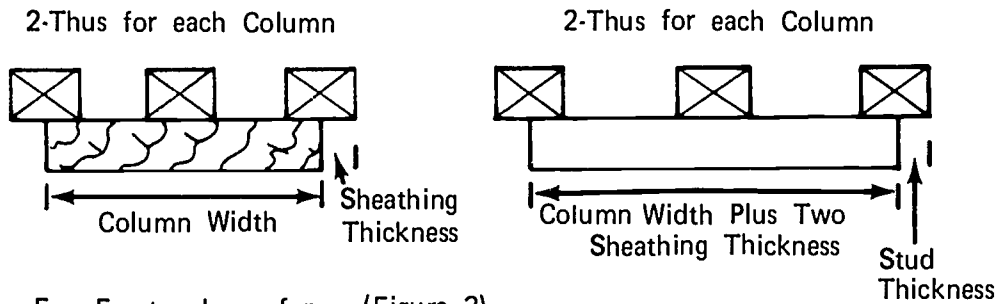

E. Erect column forms (Figure 3)

FIGURE 3

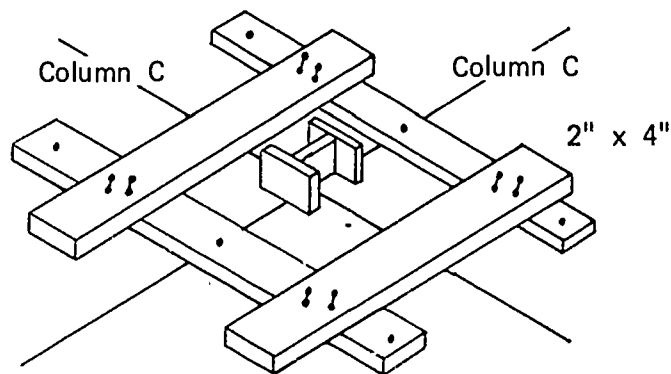

1. Coat forms with form oil
2. Lay out column center lines
3. Nail column template to floor

(NOTE: Template should be the same size as the outside of the column form.)

JOB SHEET #2

- Determine column clamp spacing (Figure 4)

FIGURE 4



0' 0"	Clamp #1	6"	1
Height of Column	" #2	24"	2
	" #3	24"	3
	" #4	24"	4
8' 0"	" #5	18"	5
10' 0"	" #6	18"	
12' 0"	" #7	18"	
14' 0"	" #8	15"	
	" #9	15"	
16' 0"	" #10	12"	
	" #11	12"	
18' 0"	" #12	12"	
	" #13	12"	
20' 0"	" #14	9"	
	" #15	9"	
	" #16	9"	
		3"	

Column Clamp Spacing

- Lay out template for column clamp spacing
- Stand opposing column sides in template and nail corner studs
(NOTE: Use duplex nails.)
- Stand the other two sides in template and nail as in step 6
- Stand template at column corners and mark column clamp locations on corner studs
- Drive a 16d duplex nail at each mark (Figures 5a and 5b)

(NOTE: These nails serve to support the clamps during installation. Check the type of clamp being used for side locations of nails.)

FIGURE 5

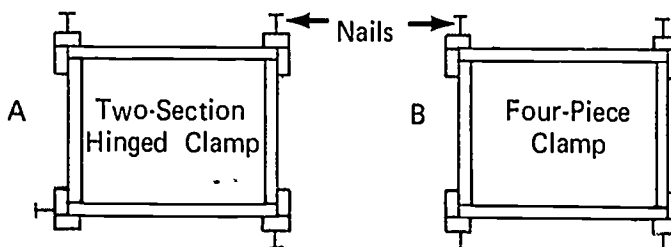

JOB SHEET #2

10. Lay sections of column clamps on nails and secure wedges
11. Brace form plumb in both directions

VERTICAL PIERS AND COLUMNS
UNIT VI

TEST

1. Match the following list of column forming terms to the correct definitions.

- | | |
|---|-----------------|
| _____ a. An enlarged area at the base of a wall or another object used to distribute the weight of the superstructure | 1. Pier |
| _____ b. A manufactured device surrounding a column form to hold the pressure exerted by wet concrete | 2. Capital |
| _____ c. The level of finished concrete in a form | 3. Column |
| _____ d. Wide boards, plywood, or metal that makes up the face of a form | 4. Staves |
| _____ e. An enlarged area at the top of a column | 5. Footing |
| _____ f. A job built devise surrounding a column to hold the pressure exerted by wet concrete | 6. Sheathing |
| _____ g. A slender support for an arch or a supporting section of wall between two openings | 7. Yoke |
| _____ h. A vertical shaft of many shapes designed to support the structure above | 8. Grade point |
| _____ i. Vertical sheathing in a circular column form | 9. Column clamp |

II. Identify the following column shapes.

- a.
- b.
- c.
- d.

e.

f.

g.

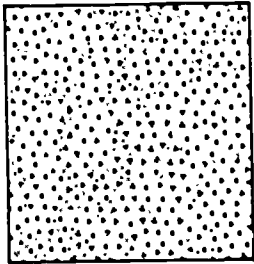

a.

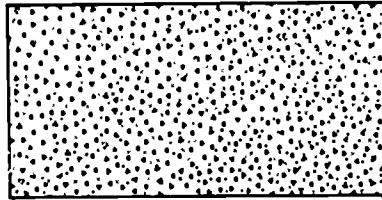

b.

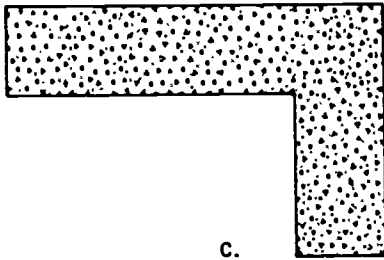

c.

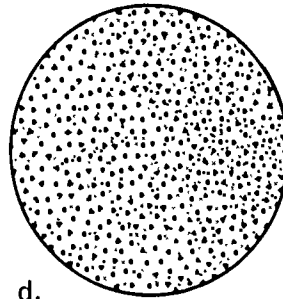

d.

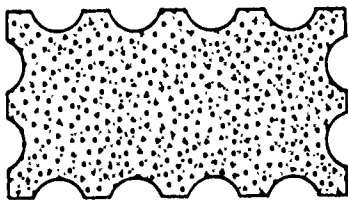

e.



f.

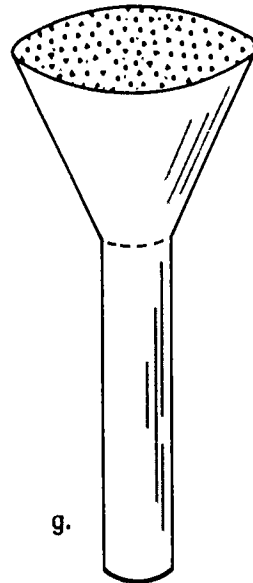

g.

3. Name two types of column finishes.
 - a.
 - b.
4. Name four materials normally used for column forms.
 - a.
 - b.
 - c.
 - d.
5. Name two methods of column form construction.
 - a.
 - b.
6. Identify three types of column corners.
 - a.
 - b.
 - c.

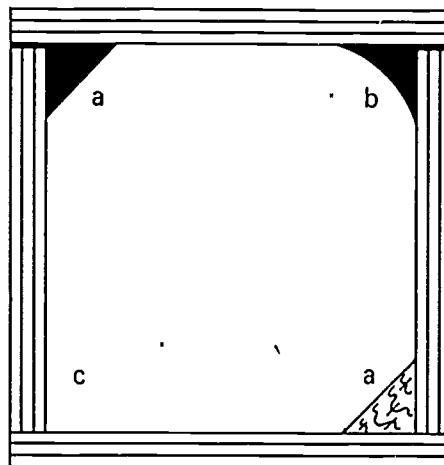

7. Demonstrate the ability to:
 - a. Construct a form for a round fluted column.
 - b. Construct a form for a square column.

(NOTE: If this has not been accomplished prior to the test, ask the instructor when the above activities should be completed.)

VERTICAL PIERS AND COLUMNS
UNIT VI

ANSWERS TO TEST

1.
 - a. 5
 - b. 9
 - c. 8
 - d. 6
 - e. 2
 - f. 7
 - g. 1
 - h. 3
 - i. 4
2.
 - a. Square
 - b. Rectangular
 - c. L-shaped
 - d. Round
 - e. Fluted
 - f. Tapered
 - g. Capitaled
3.
 - a. Architectural
 - b. Structural
4. The following answers may be given in any order.
 - a. Wood
 - b. Metal
 - c. Fiber (paper)
 - d. Molded fiber glass
5.
 - a. Job built
 - b. Manufactured panels

6. The following answers may be given in any order.
 - a. Chamfer (vinyl or wood)
 - b. Radius (vinyl)
 - c. Square
7. Performance skills will be evaluated according to the criteria on the progress chart.

HORIZONTAL BEAM FORMS UNIT VII

TERMINAL OBJECTIVE

After completion of this unit, the student should be able to define beam form terms and identify the parts of a beam form. He should be able to name the various types of beams and materials used to build their forms. He should also be able to identify methods of shoring and name one type of beam form that does not require shoring. This knowledge will be evidenced through demonstration and by scoring eighty-five percent on the unit test.

SPECIFIC OBJECTIVES

Upon completion of this unit, the student should be able to:

1. Match a list of forming terms to the correct definitions.
2. Identify the parts of a beam form.
3. Name four types of beams.
4. Name three materials used to manufacture beam forms.
5. Name four methods of shoring a beam.
6. Name one type of beam form that does not require intermediate shoring.
7. Demonstrate the ability to:
 - a. Construct a spandrel beam form.
 - b. Construct an interior beam form.
 - c. Construct an inverted beam form post-tensioned.

HORIZONTAL BEAM FORMS UNIT VII

SUGGESTED ACTIVITIES

I. Instructor:

- A. Provide students with objective sheet.
- B. Provide students with information and job sheets.
- C. Make transparencies.
- D. Discuss terminal and specific objectives.
- E. Discuss information sheet.
- F. Demonstrate and discuss procedures outlined in job sheets.
- G. Give test.

II. Student:

- A. Read objective sheet.
- B. Study information sheet.
- C. Demonstrate the ability to accomplish the procedures outlined in the job sheets.
- D. Take test.

INSTRUCTIONAL MATERIALS

I. Included in this unit:

- A. Objective sheet
- B. Information sheet
- C. Transparency masters
 1. TM 1--Parts of Beam Forming
 2. TM 2--Types of Beams
 3. TM 3--Wood T Shore With Wedges
 4. TM 4--Wood T Shore With Manufactured Clamps

5. TM 5--Patented Shore
6. TM 6--Patented Shore Scaffold
7. TM 7--A Beam Without Intermediate Shoring

D. Job sheets

1. Job Sheet #1--Spandrel Beam Form
2. Job Sheet #2--interior Beam Form
3. Job Sheet #3--Inverted Beam Form Post-Tensioned

E. Test

F. Answers 'to test

II. References:

- A. Burke, Arthur E., J. Ralph Dalzell, and Gilbert Townsend. *Architectural and Building Trades Dictionary*. Chicago, Illinois: American Technical Society, 1955.
- B. Smith, Ronald C. *Principles and Practices of Heavy Construction*. Englewood Cliffs, New Jersey: Prentice Hall, Inc., 1970.
- C. PCI--Slide Lecture No. 4. *Post-Tensioned Prestressed Concrete*. Prestressed Concrete Institute, 20 North Wacker Drive, Chicago, Illinois 60606.

HORIZONTAL BEAM FORMS UNIT VII

INFORMATION SHEET

- I. Terms and definitions
 - A. Brace--A piece of wood or other material that directs, resists, or supports weight or pressure
 - B. Nail point tie--A form tie with one end bent 90° and pointed
 - C. Scab--A piece of material nailed across a splice to strengthen and hold it together
 - D. Spreader--A piece of wood that is used to hold the sides of the forms apart and is removed as the concrete is poured; it may also be an integral part of a form tie
 - E. Cleat--A strip of wood or metal fastened across a form for temporary positioning or to replace a form tie
 - F. Shore--A prop placed against or beneath an object for support
 - G. Shore head--A horizontal timber placed across a shore and braced square
 - H. Beam bottom--That part of the beam form which supports the vertical pressure
 - I. Kicker--A piece of material used to resist horizontal pressure
 - J. Spandrel beam--A beam in the space between the window head and the sill of the window in the story above
 - K. Stringer--A piece of heavy material placed across several shores; a horizontal or inclined supporting member
 - L. Tendon--A single or multi-strand of high tensile wire or a rod used to stress concrete
 - M. Post-tensioning--A process of introducing internal stresses after the concrete has reached a predetermined strength
 - N. Mud sill--A horizontal timber laid directly on the ground to support a frame structure
 - O. Form oil--Paraffin oil or other manufactured product used on a form to prevent adhesion of concrete to the form
 - P. Ribbon--A horizontal board used to hold shores in alignment and to resist lateral movement

INFORMATION SHEET

- Q. Wedge--A tapered piece of wood or metal
 - R. Beam side--A stud frame and sheathing section which comprises the vertical section of a beam form
- II. Parts of beam or girder forming (Transparency 1)
- A. Top plate
 - B. Stud
 - C. Sheathing
 - D. Beam side
 - E. Beam bottom
 - F. Bottom plate
 - G. Kicker
 - H. Stringer
 - I. Shore head
 - J. Brace
 - K. Ribbon
 - L. Shore
 - M. Wedge
 - N. Mud sill
- III. Types of beams (Transparency 2)
- A. Spandrel
 - B. Interior
 - C. Inverted
- IV. Materials used to construct beam forms
- A. Wood
 - B. Metal
 - C. Molded fiber glass

608

INFORMATION SHEET

- V. Methods of shoring beams (Transparencies 3, 4, 5, and 6)
 - A. Wood T shores with wedges
 - B. Wood T shores with manufactured clamps
 - C. Patented shores
 - D. Patented shore scaffold
- VI. Type of beam form that does not require intermediate shoring-Plate girder (Transparency 7)

Parts of Beam Forming

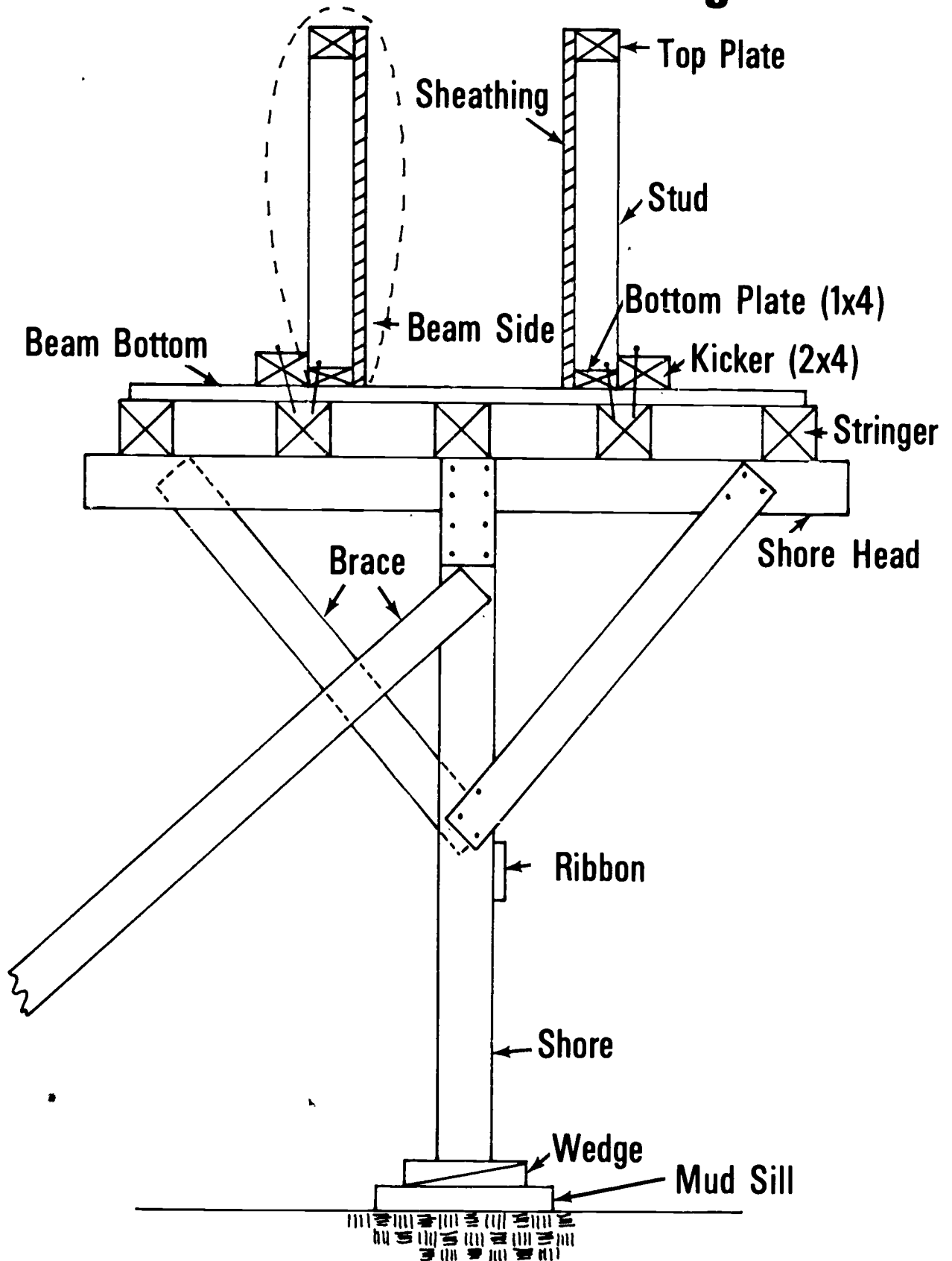

Types of Beams

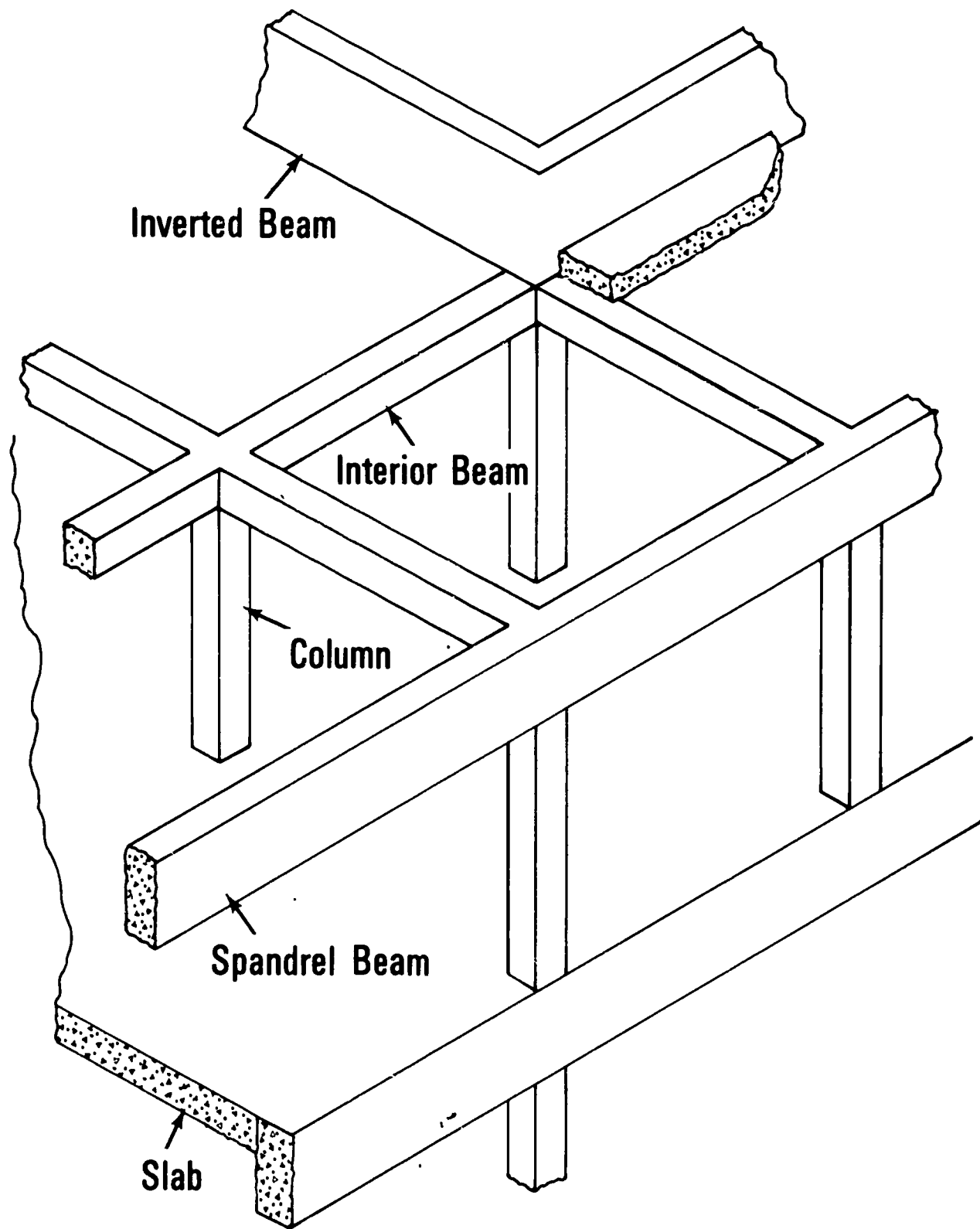

Wood T Shore with Wedges

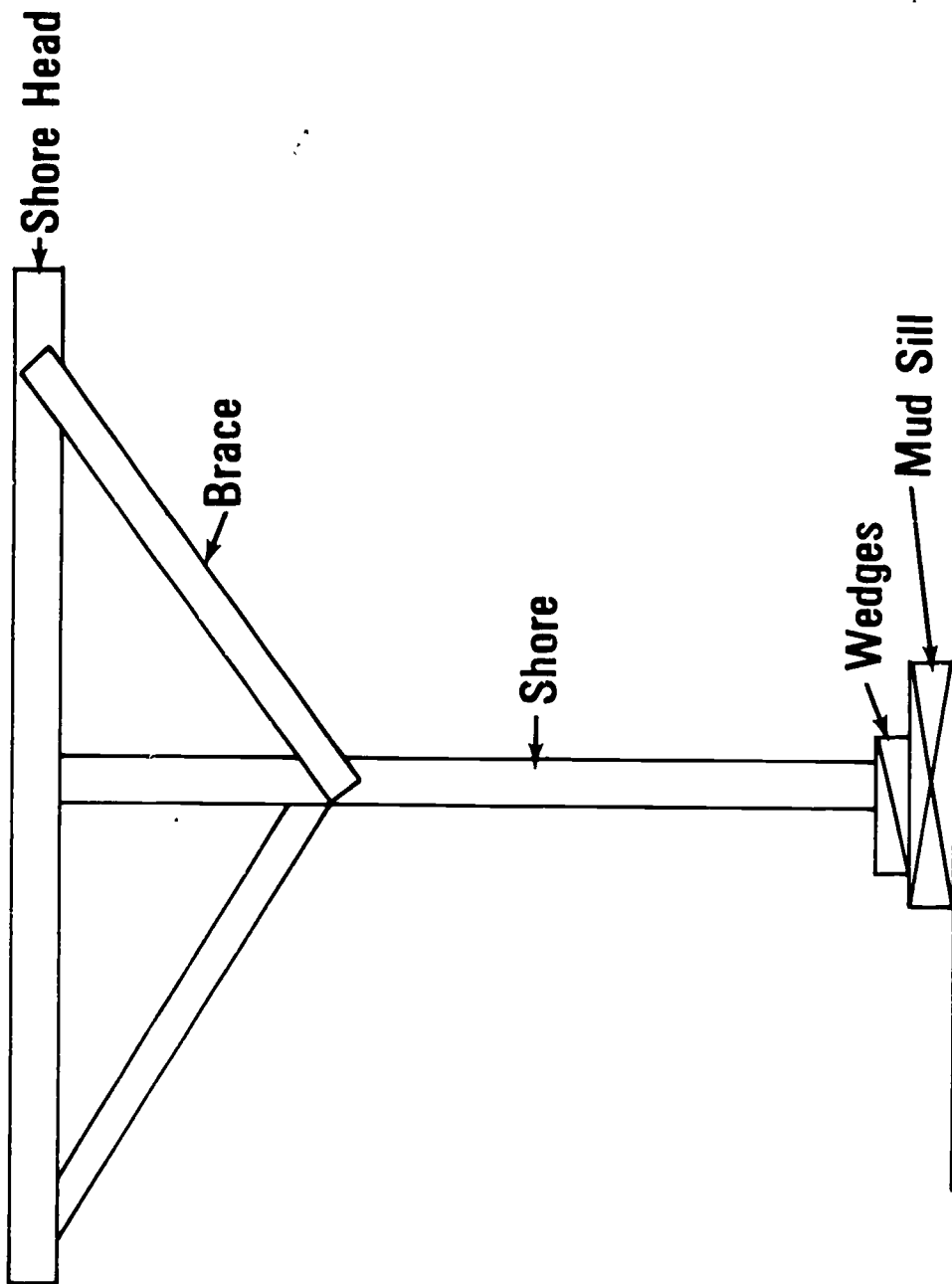

Wood T Shore with Manufactured Clamps

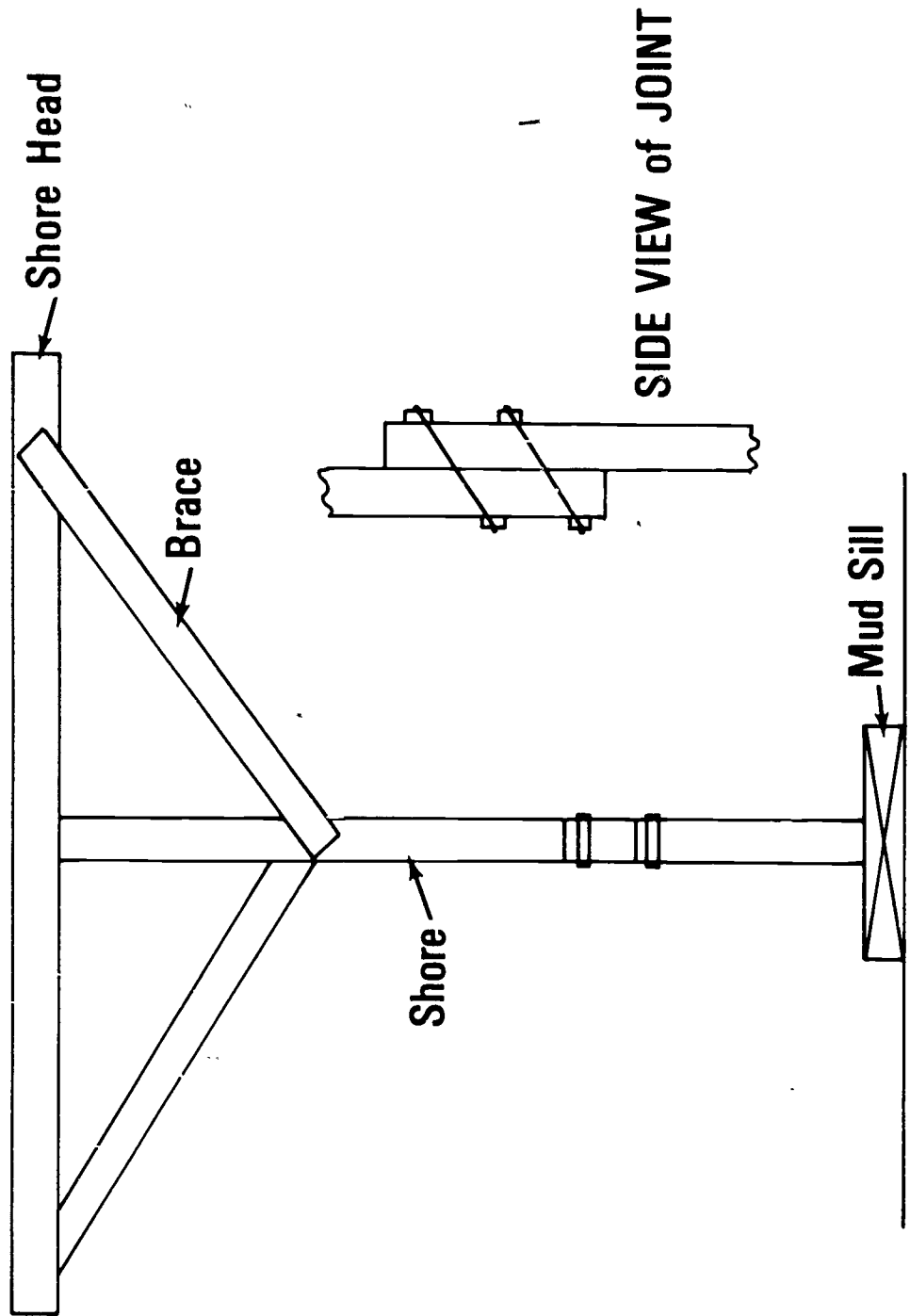

Patented Shore

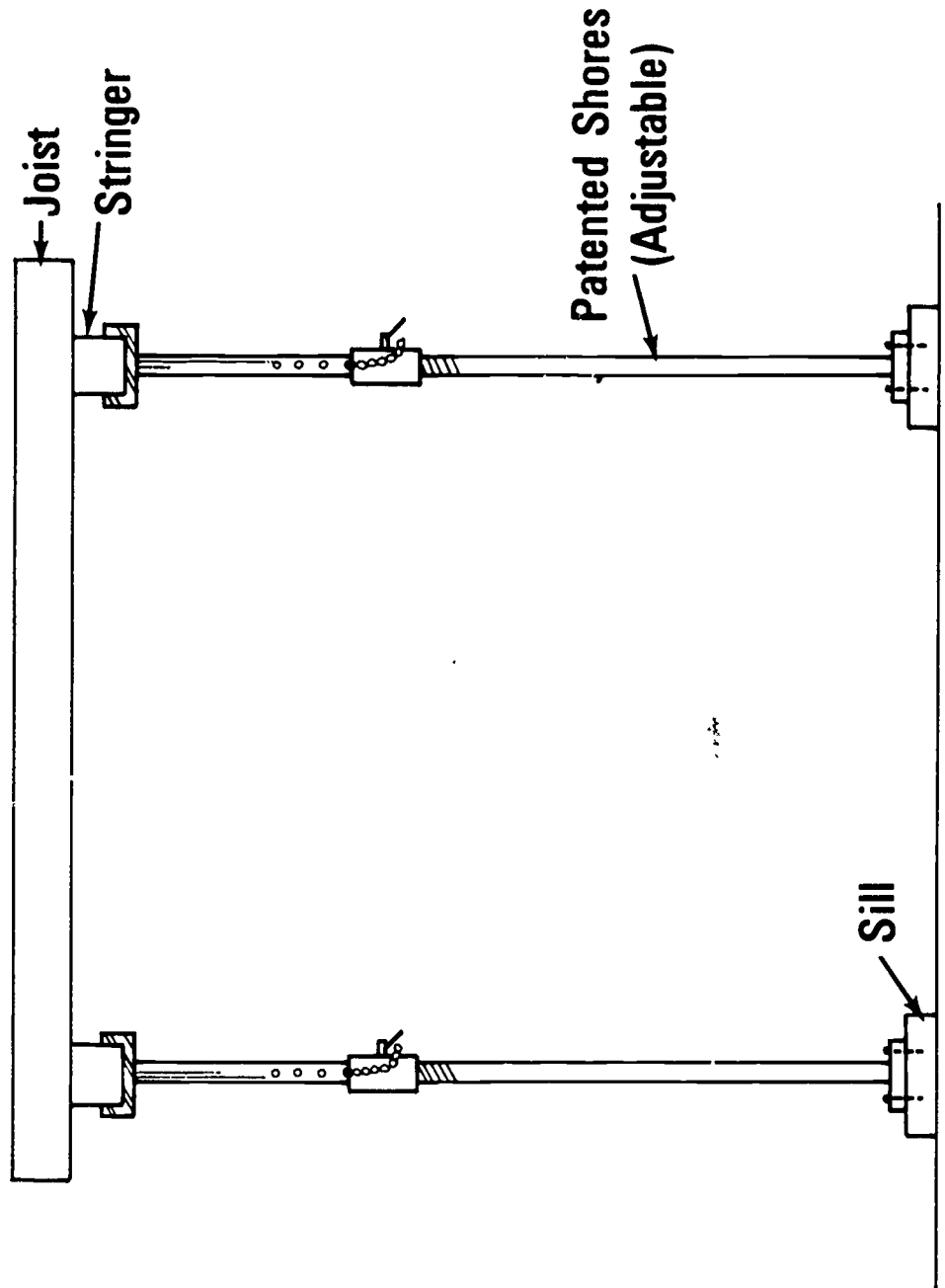

Patented Shore Scaffold

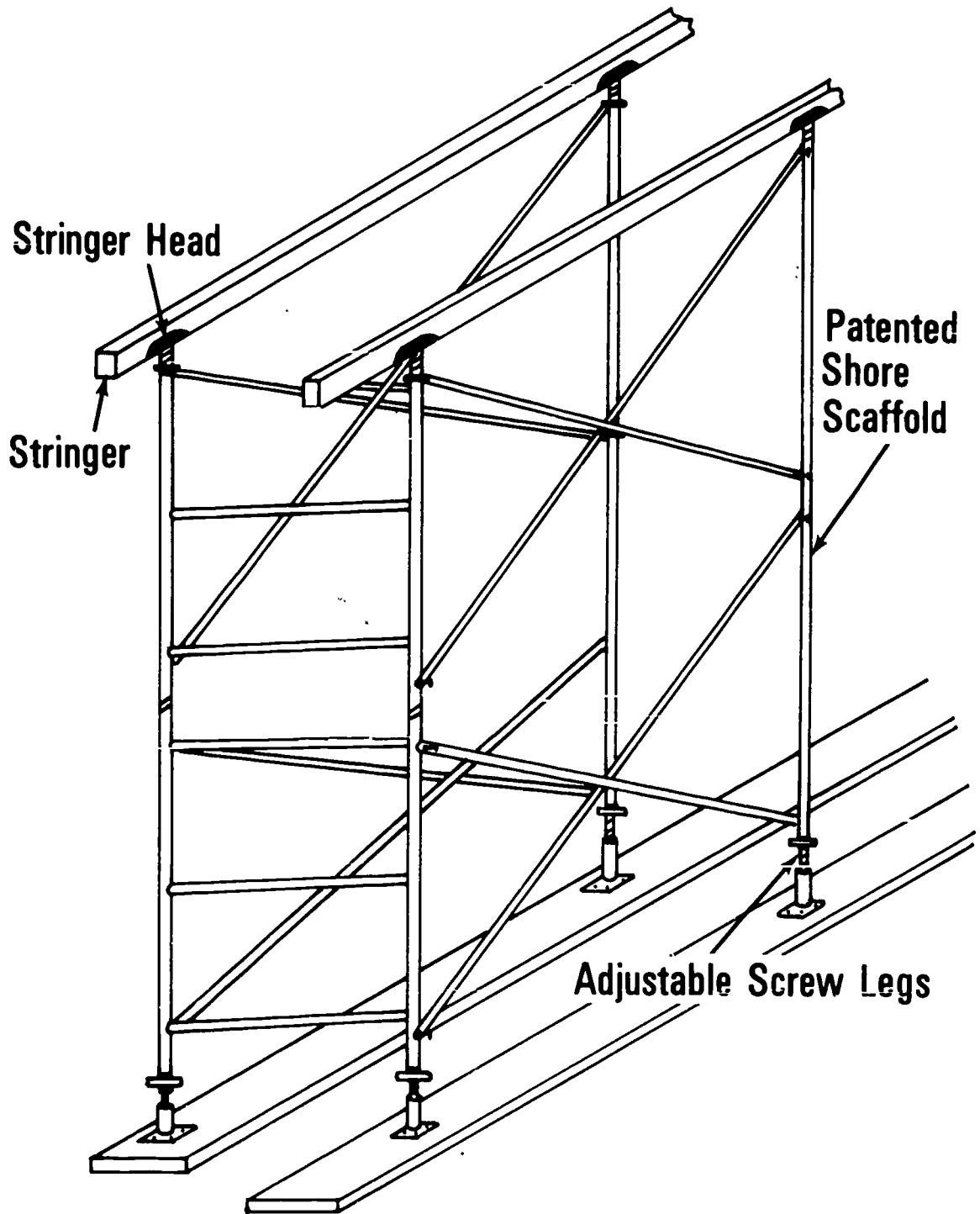

A Beam without Intermediate Shoring

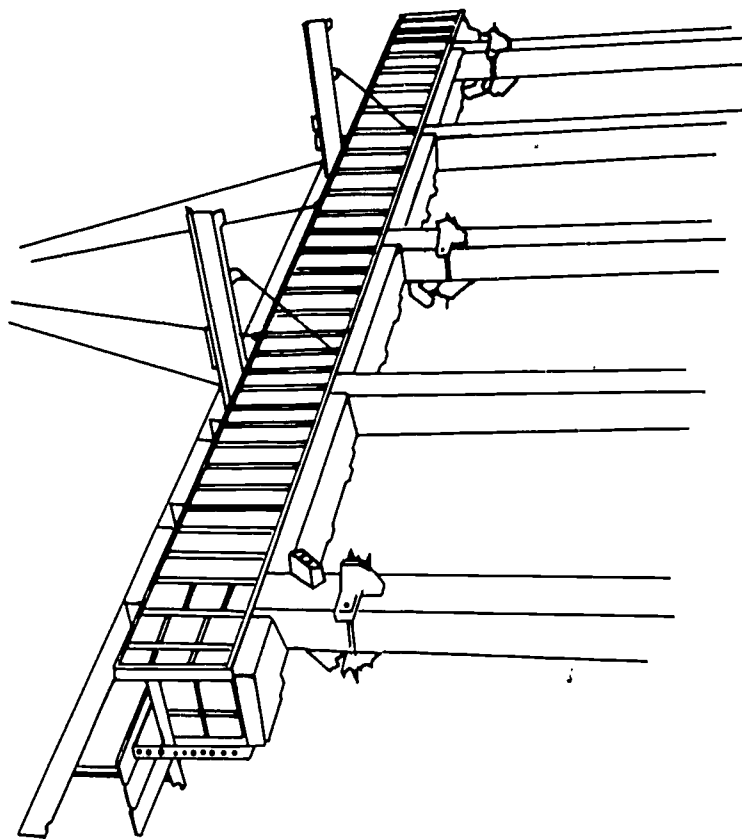

PLATE GIRDER FORM

HORIZONTAL BEAM FORMS
UNIT VII

JOB SHEET #1-SPANDREL BEAM FORM

I. Tools and materials needed

A. Tools

1. Claw hammer (16 oz. or larger)
2. Handsaw (Crosscut)
3. Electric handsaw
4. Plumb bob
5. Level (hand)
6. String line
7. Electric drill (1/4" or 3/8")
8. Drill bits

B. Materials

1. Nail point ties
2. Sheathing-Plywood
3. Studs, upper plates, kickers, and walers--2 x 4's
4. Shores--4 x 4's or larger
5. Stringers--4 x 4's or 4 x 6's
6. Sills--2 x 10's or larger
7. Shore clamps
8. Bottom plate and braces--1 x 4's
9. Form ties

II. Procedure

A. Determine beam size

(NOTE: On the job, this information will be secured from the structural plans and beam schedule.)

JOB SHEET #1

C. Drill form tie holes

1. Figure waler and ties spacing from table below (Figure 3)

FIGURE 3

At 50° Temperature				For 3/4" Sheathing, 2x4 Studs, Double 2x4 Wales	At 70° Temperature			
2'	3'	4'	5'		2'	3'	4'	5'
				Rate of Pour (Vertical Feet per Hour)				
21"	18"	18"	16"	Stud Spacing for Safe Value of Sheathing	24"	21"	18"	18"
30"	27"	24"	24"	Wale Spacing for Safe Value of Studs	33"	30"	27"	27"
30"	24"	24"	18"	Tie Spacing for Safe Value of Wales	36"	30"	27"	24"

2. Lay out and drill form tie holes using spacing obtained from the table (Figure 4)

(NOTE: Top row of ties should be the height of the inside form plus deck thickness.)

FIGURE 4

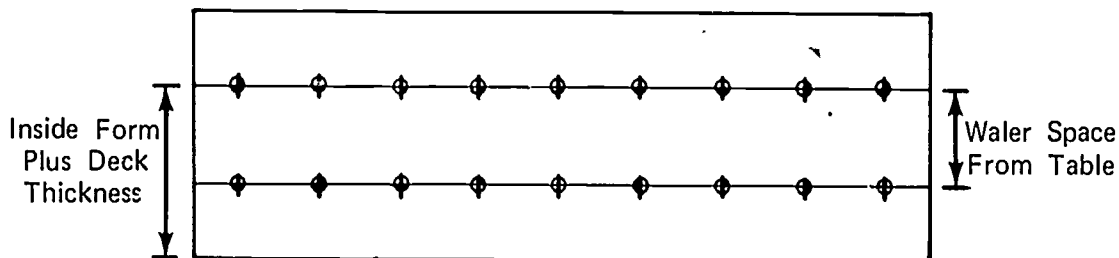

3. Drill form tie holes and use the first beam side drilled for a pattern

(NOTE: The inside beam side will only have one row of tie holes.)

D. Build T shores

1. Cut 4 x 4's to length

(NOTE: Shore pieces must be cut to have a minimum of 2' 0" lap.)

JOB SHEET #1

2. Lay shore heads at end of shores and at a right angle to the shore (Figure 5)

(NOTE: Shore head should be off center of the shore to facilitate installation and bracing of outer beam side.)

FIGURE 5

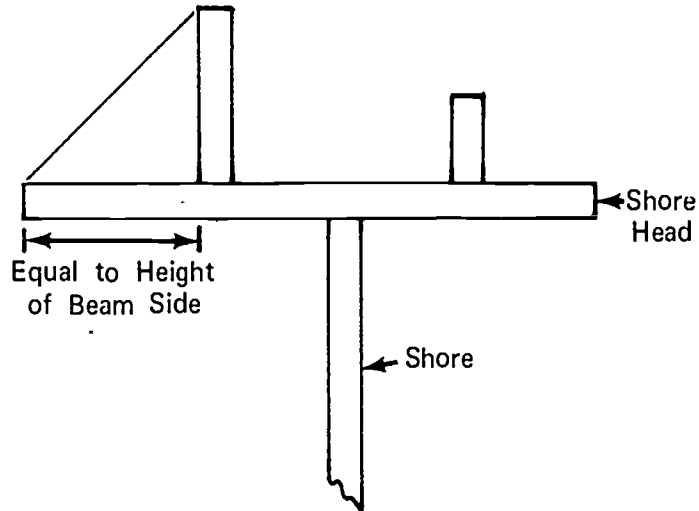

3. Square shore head on shore and nail scab across joint (Figure 6)

(NOTE: Use 2 x 4 scab and 16d duplex nails.)

FIGURE 6

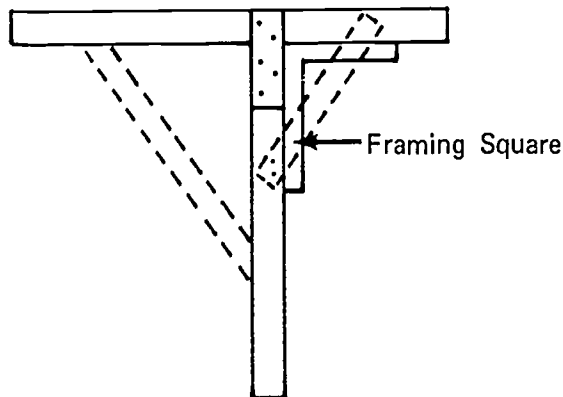

4. Install braces as shown by dotted lines in Figure 6

(NOTE: Check relationship of shore head and shore with framing square.)

JOB SHEET #1

5. Join the two pieces of shore with patented clamps (Figure 7)

(NOTE: Check for approximate shore length and tack clamps.)

FIGURE 7

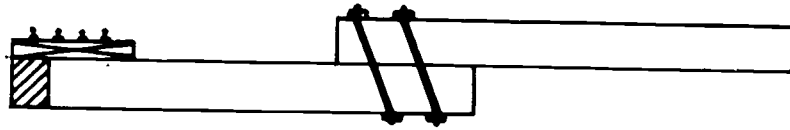

E. Erect shores and beam form

1. Lay mud sills on center line of beam (Figure 8)

(NOTE: If ground is not stable, cross another line of mud sill at shore locations.)

FIGURE 8

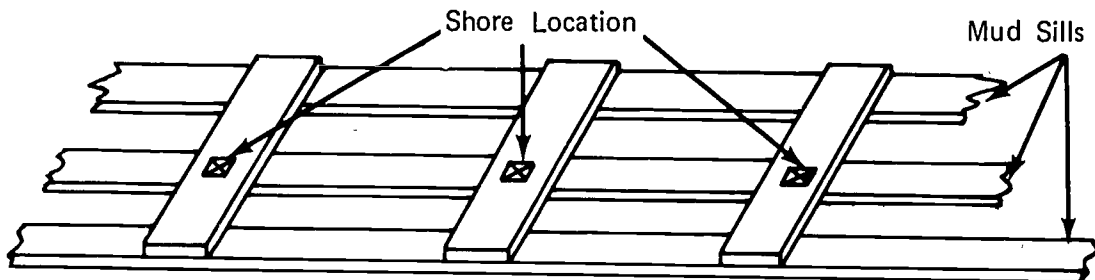

2. Nail stringer to two shore heads directly over shore

(NOTE: The shore at the column end should be held back approximately one foot from the end of the stringer. The other shore should have the stringer end centered on the shore head.)

3. Stand assembled unit upright on mud sills and brace plumb in both directions

(NOTE: When setting upper floors, use a single sill at the beam center line. This will permit anchorage of the base of the shore.)

4. Proceed with steps 2 and 3 until entire length of beam is shored

JOB SHEET #1

5. Install remaining stringers (Figures 9a and 9b)

(NOTE: Side stringers should be installed at beam edges and in position to receive nails through kicker. Stringers do not have to be cut as they can be lapped on the shore head.)

FIGURE 9

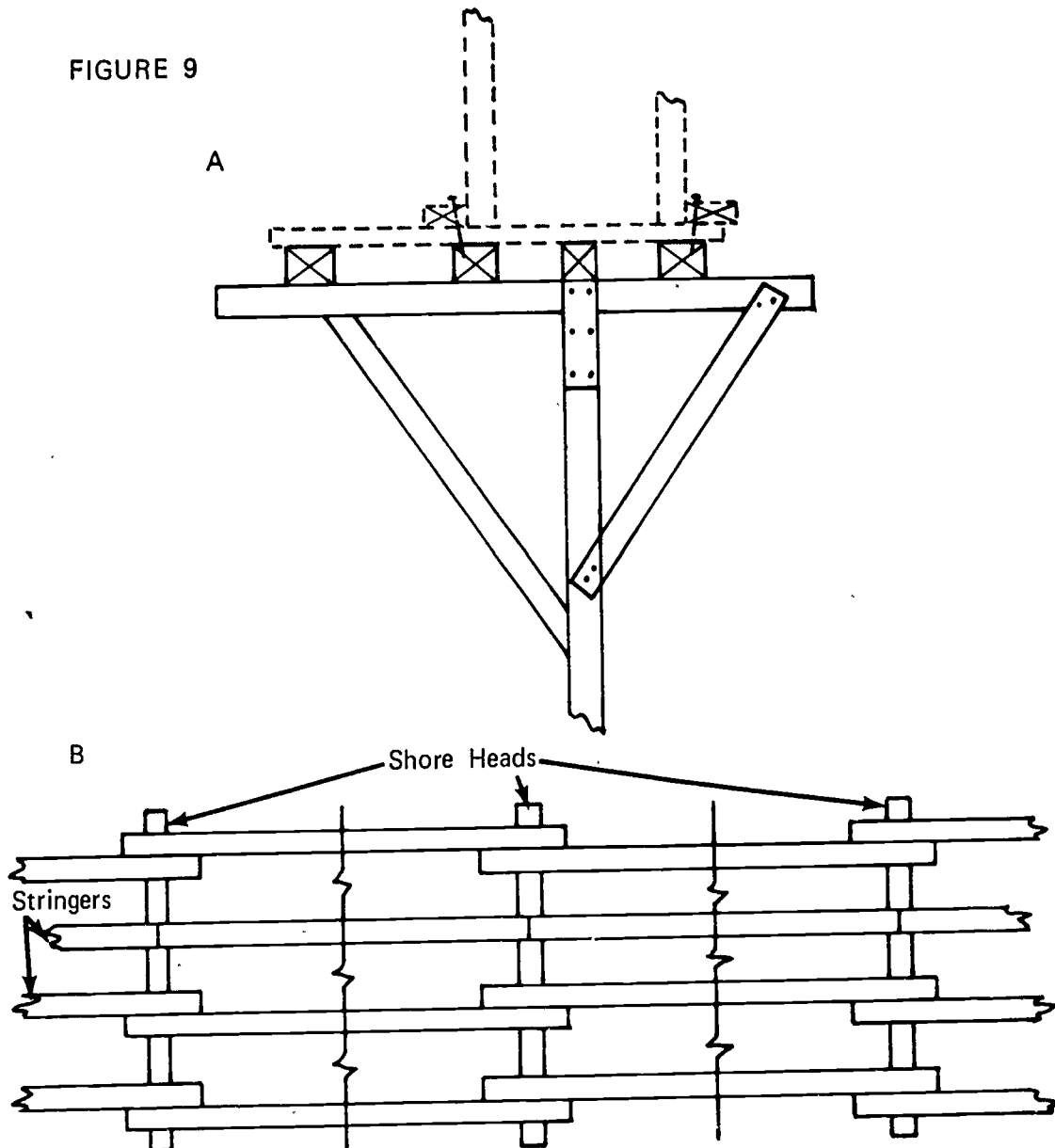

6. Nail plywood to the stringers the entire length of the beam
7. Snap chalk lines on the plywood locating both sides of the beam

JOB SHEET #1

8. Stand beam sides on plywood and nail through plywood to stringer

(NOTE: If stringers were lapped as shown in Figure 9b, short stringers which cross at least two shore heads might have to be added to facilitate nailing of the form or kicker.)

9. Brace to approximate line by plumbing beam side with a hand level

(NOTE: If spreader ties are used, be sure to install them after the first beam side is set.)

- F. Install kickers

(NOTE: Kickers may be installed prior to beam side installation if it is more convenient to do so.)

- G. Install walers on the rows of ties below the row of nail point ties at this time

- H. Secure all form tie heads

- I. Install and secure row of nail point ties and align beam side (Figure 10)

(NOTE: This row of ties are installed after the deck is installed on top of the inner beam side. Use string line to align top of beam side.)

FIGURE 10

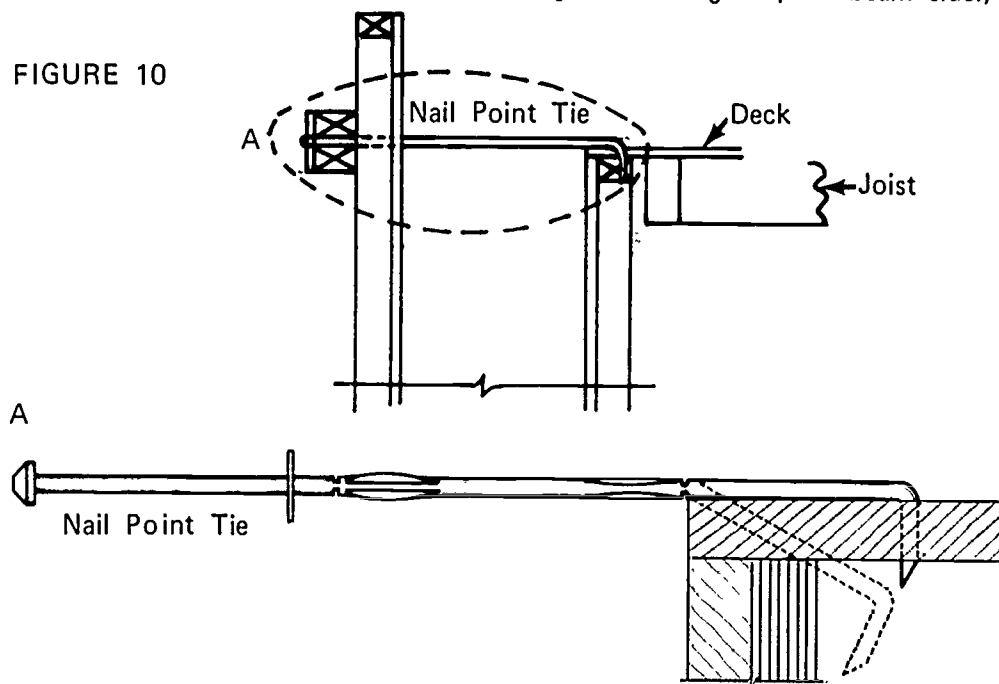

JOB SHEET #1

J. Install supplemental shore head supports (Figure 11)

(NOTE: This is generally necessary only on the second floor and above.)

FIGURE 11

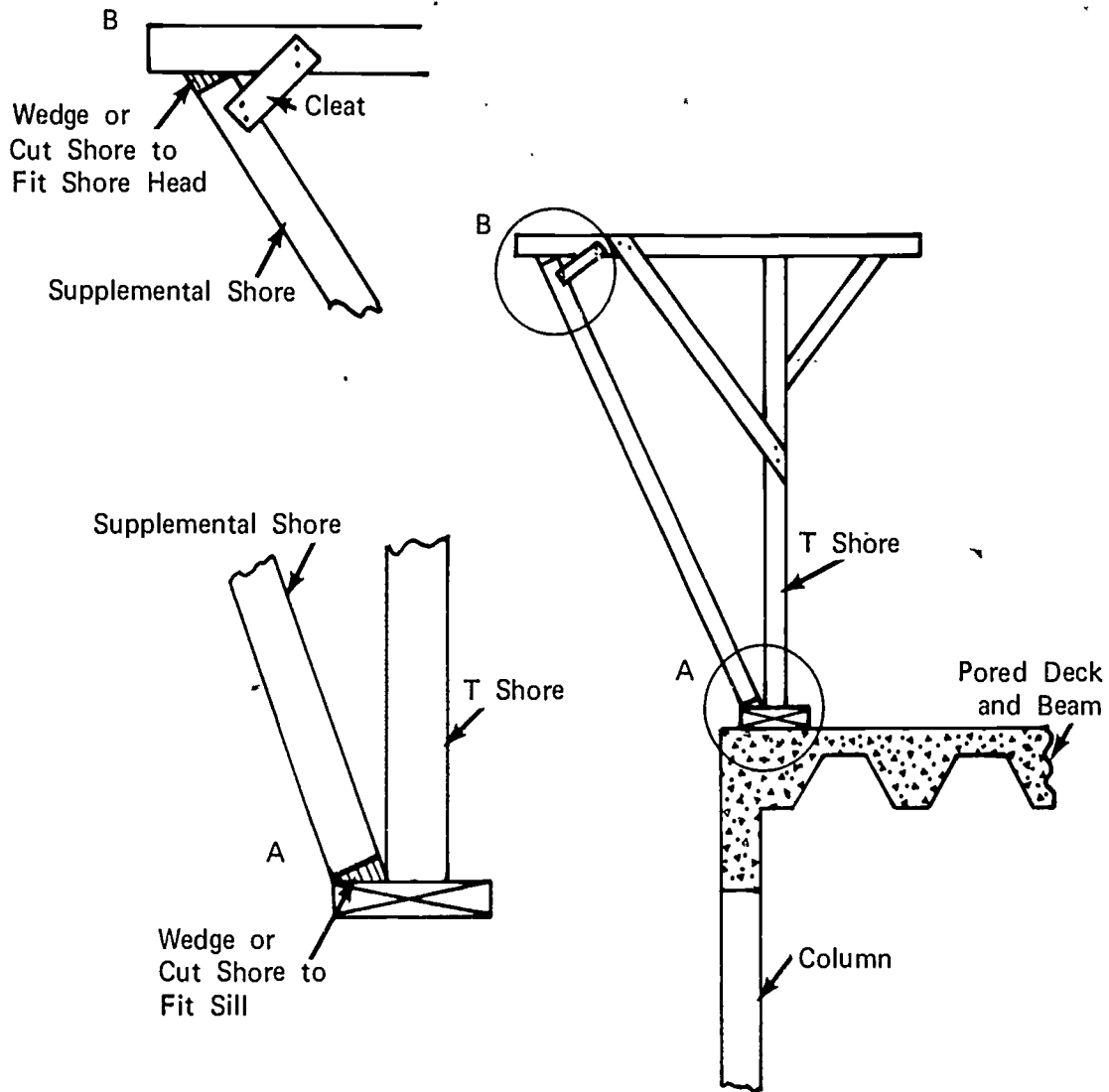

HORIZONTAL BEAM FORMS
UNIT VII

JOB SHEET #2--INTERIOR BEAM FORM

I. Tools and materials needed

A. Tools

1. Claw hammer (16 ounce or larger)
2. Handsaw (Crosscut)
3. Electric handsaw
4. Plumb bob
5. Level (hand)
6. String line

B. Materials

1. Sheathing--Plywood
2. Kickers--2 x 4's
3. Shores--Patented
4. Sills--2 x 8's or larger
5. Beam bottom--2 x 10's

II. Procedure

A. Determine beam size

(NOTE: On the job, this information will be secured from the structural plans and beam schedule.)

JOB SHEET #2

- B. Cut plywood to width for beam sides (Figure 1)

(NOTE: When figuring beam side widths, be sure to add beam bottom thickness and deduct decking thickness.)

FIGURE 1

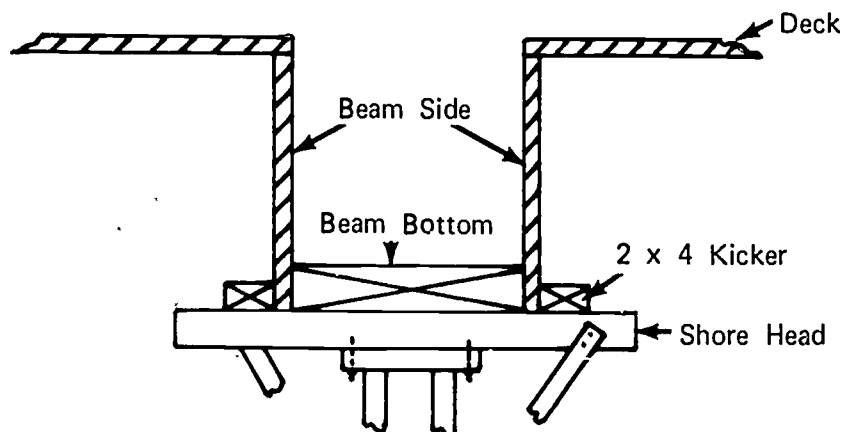

- C. Build beam bottom

1. Cut filler piece to correct width (Figure 2)

(NOTE: Figure correct width of material to rip with the least waste. It is better to cut two pieces from one piece if the waste is less. Straight material should be used.)

FIGURE 2

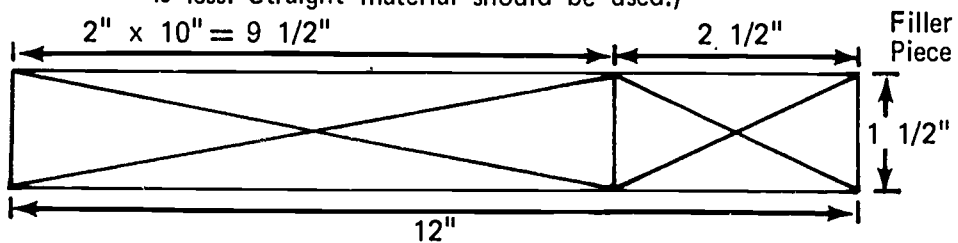

(NOTE: If a 2" x 4" was used to cut the 2 1/2" piece there would be 1" waste, if two pieces 2 1/2" wide are cut from a 2" x 6" there would be less than 1/2" waste.)

JOB SHEET #2

2. Cleat the pieces together (Figure 3)

(NOTE: Space cleats to miss shore location.)

FIGURE 3

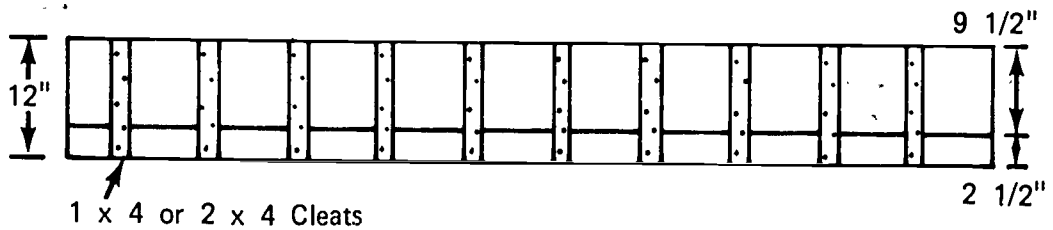

D. Build T shores

1. Cut shore heads

(NOTE: If braces are needed on beam side, shore heads will have to be long enough to receive the bottom end of the brace.)

2. Nail shore head to shore (Figure 4)

FIGURE 4

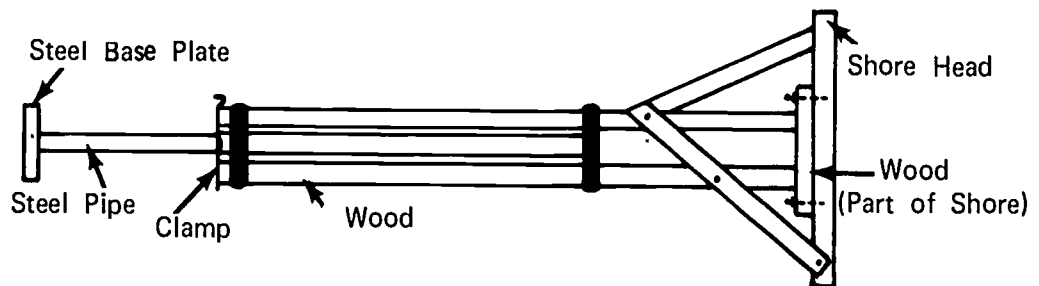

3. Install shore head braces

(NOTE: Make sure bottom of the brace does not interfere with upper pipe guide when shores are adjusted to height.)

E. Erect shores, beam bottom, and beam sides

1. Lay sill pieces on the deck at beam center line
2. Nail beam bottom to two T shores

(NOTE: The shore at the column should be held back approximately one foot from the end of the beam bottom. The other end of the beam bottom will be centered on the shore head.)

JOB SHEET #2

3. Stand the assembly upright on the sill and brace plumb in both directions

(NOTE: If beam bottom is too heavy to handle as outlined in steps 2 and 3, erect T shores individually then install beam bottom.)

4. Erect intermediate shores
5. Nail beam sides to beam bottom

(NOTE: Nailing should be held to a minimum. Nailing that is done should be between shore heads. In this location, the nails help hold the concrete pressure on the beam bottom.)

6. Nail continuous kicker to shore heads (Figure 5)

(NOTE: Kicker should be nailed tight against beam side. Use draw nails if necessary.)

FIGURE 5

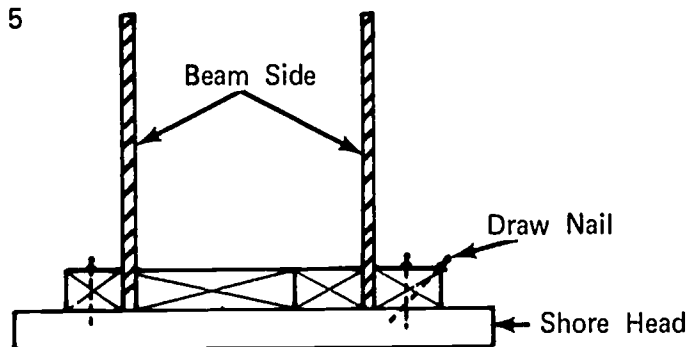

7. Plumb, align, and install kicker at top of beam sides after slab decking has been installed

HORIZONTAL BEAM FORMS
UNIT VII

JOB SHEET #3--INVERTED BEAM FORM POST-TENSIONED

I. Tools and materials needed

A. Tools

1. Claw hammer (16 oz. or larger)
2. Handsaw (Crosscut)
3. Electric handsaw
4. Plumb bob
5. Level (hand)
6. String line
7. Electric drill (1/4" or 3/8")
8. Drill bits

B. Materials

1. Sheathing--Plywood
2. Studs, upper plates, kickers, and walers--2 x 4's
3. Shores--Patented scaffold
4. Stringers--4 x 4's or 4 x 6's
5. Sills--2 x 10's
6. Form ties with spreader washers
7. Form supports--1/2" thin wall conduit; 1/4" allthread rod
8. Bottom plates--1 x 4's

II. Procedure

- A. Secure material
- B. Determine beam size

(NOTE: On the job, this information will be secured from the structural plans and beam schedule.)

JOB SHEET #3

C. Fabricate beam sides

1. Cut plywood to proper width
2. Cut studs and plates to length (Figure 1)

(NOTE: Beam side heights differ by the thickness of the slab.)

FIGURE 1

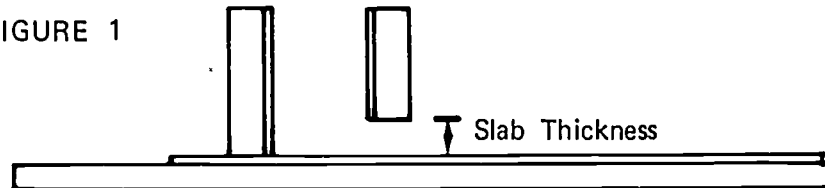

3. Lay out stud spacing on plates (Figure 2)

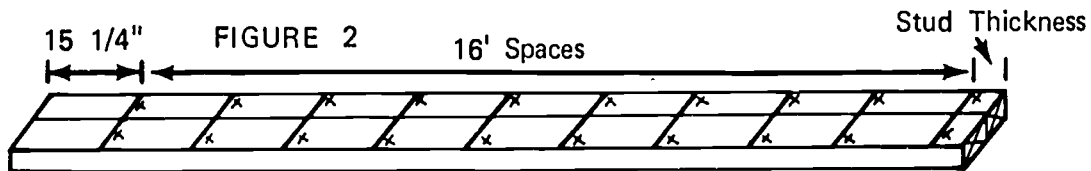

4. Nail studs to plate (Figures 3a and 3b)

(NOTE: A 1" plate is used on the bottom so the studs will bear against the kicker.) (See Figure 3b.)

FIGURE 3

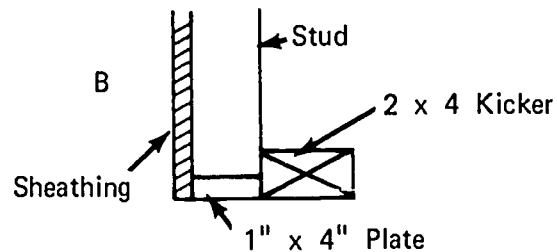
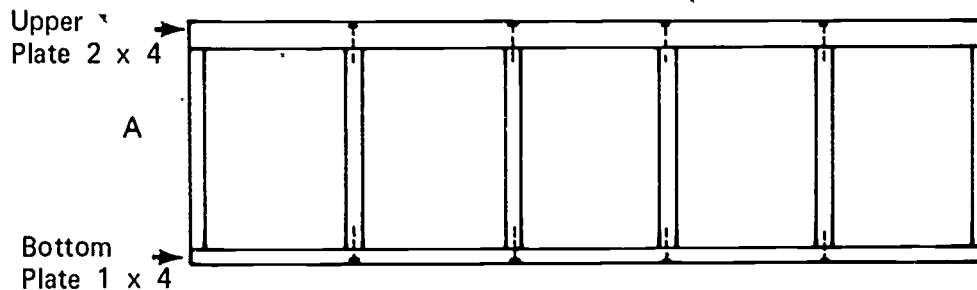

5. Nail sheathing to stud frame

(NOTE: Sheathing should be flush with all four edges of stud frame.)

6. Build required number of beam sides following steps 1 to 5, inclusive

JOB SHEET #3

D. Drill form tie holes

1. Figure waler and tie spacing from table below (Figure 4)

FIGURE 4

At 50° Temperature				For 3/4" Sheathing, 2x4 Studs, Double 2x4 Wales	At 70° Temperature			
2'	3'	4'	5'		2'	3'	4'	5'
				Rate of Pour (Vertical Feet per Hour)				
21"	18"	18"	16"	Stud Spacing for Safe Value of Sheathing	24"	21"	18"	18"
30"	27"	24"	24"	Wale Spacing for Safe Value of Studs	33"	30"	27"	27"
30"	24"	24"	18"	Tie Spacing for Safe Value of Wales	36"	30"	27"	24"

2. Lay out and drill form tie holes using spacing obtained from the table (Figure 5)

(NOTE: Bottom row of ties should be slab thickness plus six inches.)

FIGURE 5

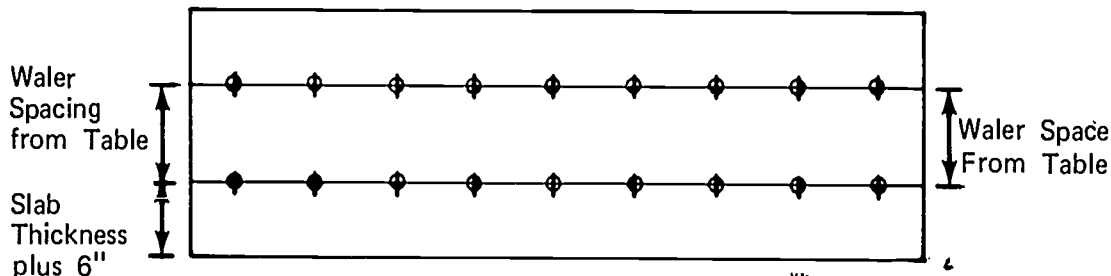

3. Drill form tie holes in inside and outer beam side using the first beam side drilled for a pattern

E. Erect scaffold

(NOTE: The patent scaffold will actually shore the slab deck which is on the same level as the beam bottom.)

1. Lay sill pieces on the deck

(NOTE: Sill locations should be one-half the frame width each side of the column center line.)

JOB SHEET #3

2. Set two adjustable screws in approximate final location
(NOTE: Final location is one foot from column face.)
3. Attach screw legs to scaffold
(NOTE: Screw legs must have base plates.)
4. Stand scaffold upright and attach two braces (Figure 6)
(NOTE: Lean the scaffold and secure the top section of brace first.)

FIGURE 6

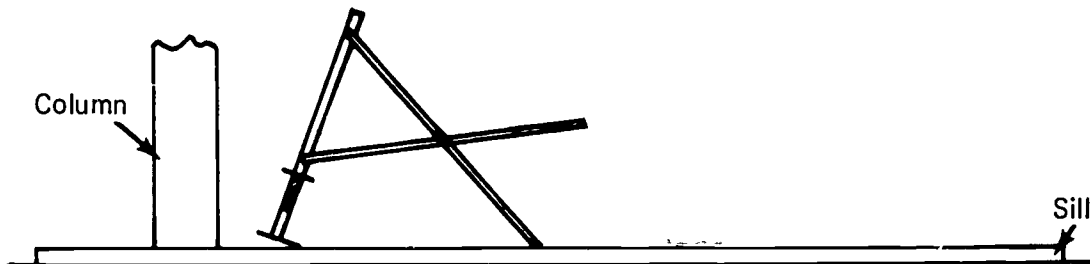

5. Attach second frame by raising brace until it aligns with pins on frame
(NOTE: If wing nuts are used to attach braces, catch only enough threads to hold the nut on for they will have to be removed to install the next brace.)
6. Install braces to last frame set
7. Set next frame with screw legs installed
8. Repeat steps 6 and 7 to continue erection
9. Place coupling pins in top of scaffold frame
(NOTE: Some patented scaffolds have a small bottom end which slips inside the top of the lower frame, therefore, coupling pins are not used.)
10. Place plank on top of first row of frames
11. Set second row of frames on pins
12. Attach braces

JOB SHEET #3

13. Continue to set frames as outlined in steps 9, 10, 11, and 12 until the desired height is reached
14. Install "U" head screw jack on all frame posts (Figure 7)

FIGURE 7

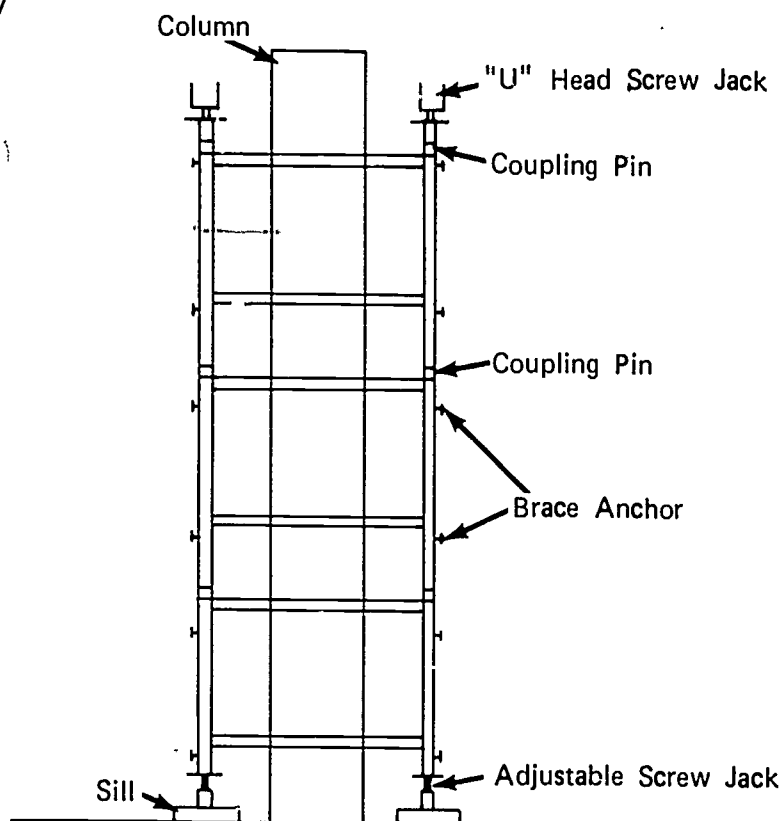

JOB SHEET #3

F. Install stringers, joist, and decking

1. Lay stringers in U head screw jack (Figure 8)

(NOTE: If stringers are not as wide as head, block from both sides so stringer is centered.)

FIGURE 8

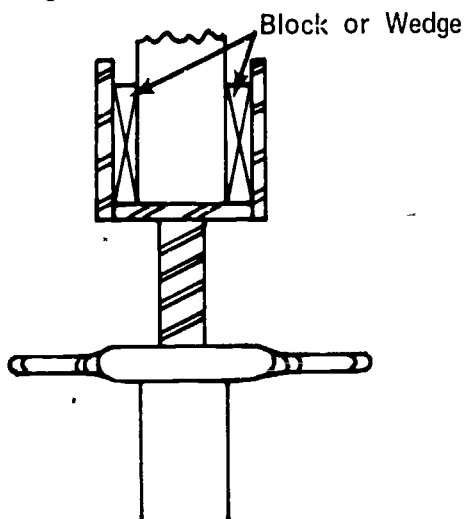

2. Lay joist across stringers and nail in place

(NOTE: Project joist past the stringer at not more than four foot intervals to facilitate beam side bracing.)

3. Nail plywood to joist

G. Install beam sides

1. Snap chalk line on deck locating face of beam

(NOTE: Refer to Figure 1.)

2. Set widest beam side on deck
3. Line beam side with chalk line and nail to joist
4. Install kicker tight against beam side
5. Brace beam side plumb

H. Make form supports

1. Cut conduit into lengths equal to the slab thickness

(NOTE: If form is heavy, deduct the thickness of two three-eighths inch washers from the slab thickness to determine conduit length.)

JOB SHEET #3

2. Cut 1/4" allthread rod to length (Figure 9)

(NOTE: The length of allthread needed is determined by the thickness of the slab, the deck, and the plate plus one and one-half inches for nuts and washers.)

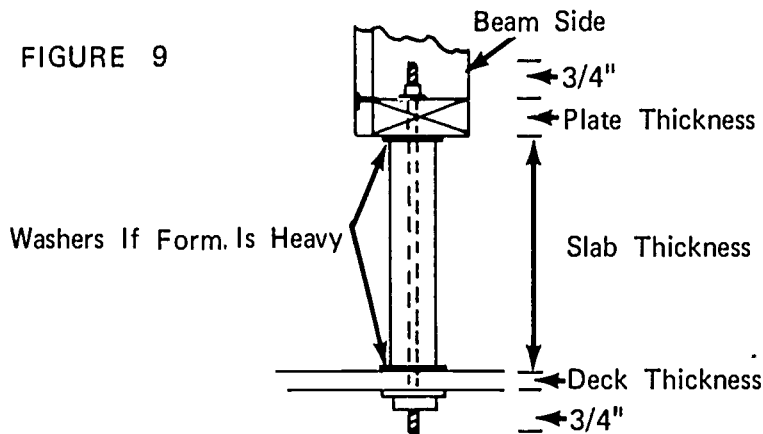

- I. Build and install bulkheads at both ends of beam (Figure 10)

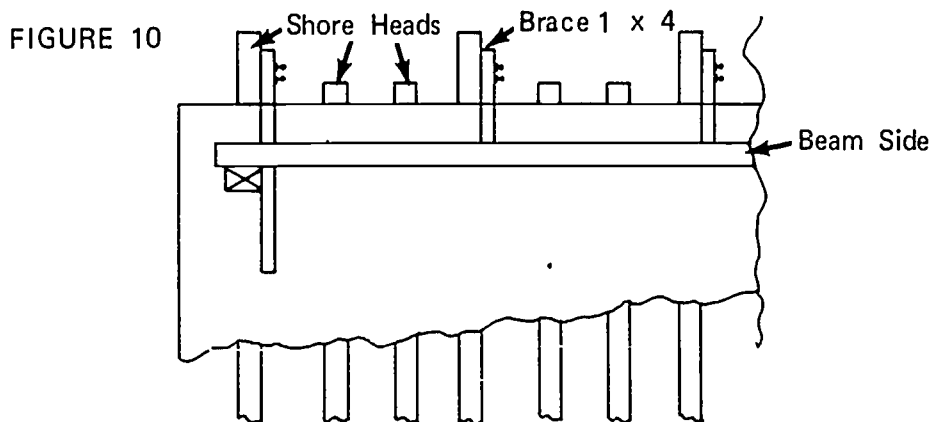

- J. Drill holes in bulkhead for post tensioning anchors

(NOTE: Form oil must be applied before installation of post-tensioning tendons and rebar. Location of the anchors will be shown on the plan or shop drawing.)

- K. Install walers

(NOTE: Make sure walers are centered on tie holes. Place form ties through form and waler and secure head.)

- L. Erect inner beam side

1. Tack a temporary support to the stud on the inner beam side

(NOTE: Leg should extend below the beam side a distance equal to the slab thickness plus one-fourth inch.)

JOB SHEET #3

2. Rest the form on the supports and guide form ties through holes in beam side

(NOTE: Nail a cleat across the top of the forms to hold it upright.)

3. Push form against spreader washers and drill holes for permanent supports

(NOTE: Use a long bit so hole in plate and deck can be drilled at the same time.)

4. Install walers and secure tie heads

M. Install permanent beam side supports

1. Screw nut on one end of allthread rod
2. Place washer on rod and insert in the hole of the plate
3. Hold conduit under the plate and insert rod through it and the deck
4. Screw nuts on rod under the deck

(NOTE: These supports also serve to keep the form from floating when the concrete is poured.)

5. Remove temporary supports

N. Post-tensioning is completed after the concrete has reached the designed strength

(NOTE: Beam bottom must be left in place until beam is post-tensioned.)

HORIZONTAL BEAM FORMS
UNIT VII

TEST

1. Match the list of forming terms on the right to the list of definitions.

- | | |
|--|---------------------|
| _____ a. A piece of wood or other material that directs, resists, or supports weight or pressure | 1. Ribbon |
| _____ b. A form tie with one end bent 90° and pointed | 2. Mud sill |
| _____ c. A piece of material nailed across a splice to strengthen and hold it together | 3. Beam side |
| _____ d. A piece of wood that is used to hold the sides of the forms apart and is removed as the concrete is poured; it may also be an integral part of a form tie | 4. Form oil |
| _____ e. A strip of wood or metal fastened across a form for temporary positioning or to replace a form tie | 5. Wedge |
| _____ f. A prop placed against or beneath an object for support | 6. Stringer |
| _____ g. A horizontal timber placed across a shore and braced square | 7. Kicker |
| _____ h. That part of a beam form which supports the vertical pressure | 8. Shore head |
| _____ i. A piece of material used to resist horizontal pressure | 9. Beam bottom |
| _____ j. A beam in the space between the window head and the sill of the window in story above | 10. Spandrel beam |
| | 11. Cleat |
| | 12. Scab |
| | 13. Shore |
| | 14. Nail point tie |
| | 15. Brace |
| | 16. Tendon |
| | 17. Post-tensioning |
| | 18. Spreader |

- _____ k. A piece of heavy material placed across several shores; a horizontal or inclined supporting member
- _____ l. A single or multi-strand of high tensile wire or a rod used to stress concrete
- _____ m. A process of introducing internal stresses after the concrete has reached a predetermined strength
- _____ n. A horizontal timber laid directly on the ground to support a frame structure
- _____ o. Paraffin oil or other manufactured product used on a form to stop adhesion of concrete to the form
- _____ p. A horizontal board used to hold shores in alignment and to resist lateral movement
- _____ q. A tapered piece of wood or metal
- _____ r. A stud frame and sheathing section which comprises the vertical section of a beam form

2. Identify fourteen parts of beam forming. Place the correct number in the blanks provided.

- _____ a. Top plate
- _____ b. Stud
- _____ c. Sheathing
- _____ d. Beam side
- _____ e. Beam bottom
- _____ f. Bottom plate
- _____ g. Kicker
- _____ h. Stringer
- _____ i. Shore head
- _____ j. Brace
- _____ k. Ribbon
- _____ l. Shore
- _____ m. Wedge
- _____ n. Mud sill

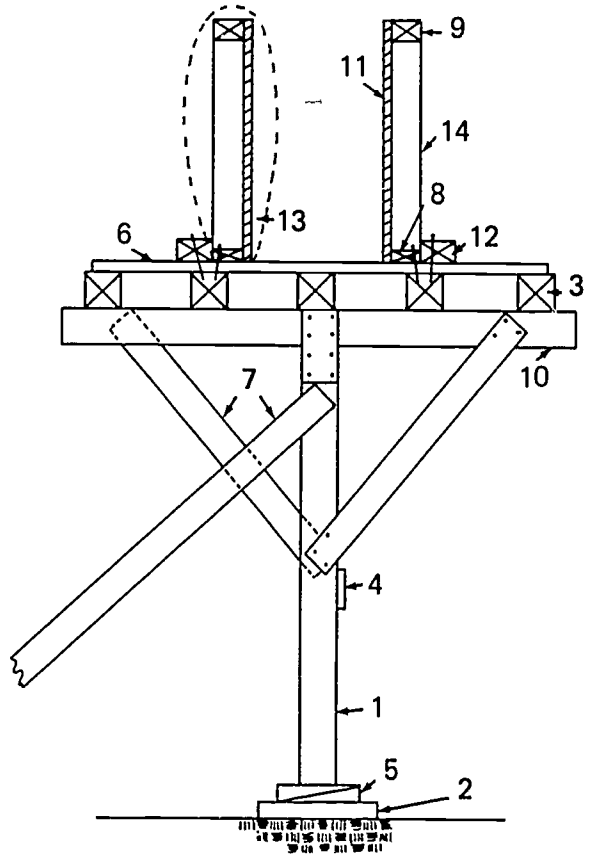

3. Name three types of beams.

- a.
- b.
- c.

4. Name three materials used to construct beam forms.

- a.
- b.
- c.

5. Name four methods of shoring beams.

- a.
- b.

- c.
- d.
- 6. Name one type of beam form that does not require intermediate shoring.
- 7. Demonstrate the ability to:
 - a. Construct a spandrel beam form.
 - b. Construct an interior beam form.
 - c. Construct an inverted beam form post-tensioned.

HORIZONTAL BEAM FORMS
UNIT VII

ANSWERS TO TEST

1.
 - a. 15
 - b. 14
 - c. 12
 - d. 18
 - e. 11
 - f. 13
 - g. 8
 - h. 9
 - i. 7
 - j. 10
 - k. 6
 - l. 16
 - m. 17
 - n. 2
 - o. 4
 - p. 1
 - q. 5
 - r. 3
2.
 - a. 9
 - b. 14
 - c. 11
 - d. 13
 - e. 6

- f. 8
 - g. 12
 - h. 3
 - i. 10
 - j. 7
 - k. 4
 - l. 1
 - m. 5
 - n. 2
3. The following answers may be given in any order.
- a. Spandrel
 - b. Interior
 - c. Inverted
4. The following answers may be given in any order.
- a. Wood
 - b. Metal
 - c. Molded fiber glass
5. The following answers may be given in any order.
- a. Wood T shore with wedges
 - b. Wood T shore with manufactured clamps
 - c. Patented shores
 - d. Patented shore scaffold
6. Plate girder
7. Performance skills will be evaluated according to the criteria on the progress chart.

ABOVE GRADE SLAB SYSTEMS UNIT VIII

TERMINAL OBJECTIVE

After completion of this unit, the student should be able to define terms associated with above grade slab systems. He should be able to identify parts of a slab form and the types of slabs. The student should be able to list the materials used to manufacture pans and void tubes and to name the types of manufactured exposed void forms. He should also be able to construct and strip slab forms. This knowledge will be evidenced through demonstration and by scoring eighty-five percent on the unit test.

SPECIFIC OBJECTIVES

After completion of this unit, the student should be able to:

1. Match a list of forming terms to the correct definitions.
2. Identify the parts of a slab forming system.
3. Identify three types of slabs.
4. Name the types of slabs that can be post-tensioned.
5. List three materials used to manufacture pans and domes.
6. List two materials used to manufacture void tubes.
7. Name four types of manufactured exposed void forms.
8. Name a slab forming system in which large sections of forms are moved intact to another pour location.
9. Demonstrate the ability to:
 - a. Construct forms for a two-way joist system.
 - b. Construct forms for a one-way joist system.
 - c. Construct flying forms for a flat slab.
 - d. Strip a two-way joist form system.
 - e. Set concealed void tubes.

ABOVE GRADE SLAB SYSTEMS
UNIT VIII

SUGGESTED ACTIVITIES

- I. Instructor:
 - A. Provide students with objective sheet.
 - B. Provide students with information and job sheets.
 - C. Make transparencies.
 - D. Discuss terminal and specific objectives.
 - E. Discuss information sheet.
 - F. Demonstrate and discuss procedures outlined in job sheets.
 - G. Give test.
- II. Student:
 - A. Read objective sheet.
 - B. Study information sheet.
 - C. Demonstrate the ability to accomplish the procedures outlined in the job sheets.
 - D. Take test.

INSTRUCTIONAL MATERIALS

- I. Included in this unit:
 - A. Objective sheet
 - B. Information sheet
 - C. Transparency masters
 1. TM 1--Parts of a Slab Forming System
 2. TM 2--One-Way Joist
 3. TM 3--Two-Way Joist
 4. TM 4--Flat Slab

5. TM 5--Steel or Molded Fiber Glass Form
6. TM 6--Molded Wood Fiber Form
7. TM 7--Adjustable and Flange Pans
8. TM 8--Long Forms and Domes
9. TM 9--Flying Form

D. Job Sheets

1. Job Sheet #1--Construct Forms for a Two-Way Joist System
2. Job Sheet #2--Construct Forms for a One-Way Joist System
3. Job Sheet #3--Construct Forms for a Flat Slab (Post-Tensioned)
4. Job Sheet #4--Strip a Two-Way Joist System
5. Job Sheet #5--Set Concealed Void Tubes

E. Test

F. Answers to test

II. References:

- A. Burke, Arthur E. and J. Ralph Dalzell, and Gilvert Townsend. *Architectural and Building Trades Dictionary*. Chicago, Illinois: American Technical Society, 1955.
- B. Durbahn, Walter E. and Elmer W. Sundberg. *Fundamentals of Carpentry*. Third Edition. Chicago, Illinois: American Technical Society, 1963.
- C. Wagner, Willis H. *Modern Carpentry*. Homewood, Illinois: Goodheart-Willcox, 1969.

ABOVE GRADE SLAB SYSTEMS
UNIT VIII

INFORMATION SHEET

I. Terms and definitions

- A. Brace--A piece of wood or other material that directs, resists, or supports weight or pressure
- B. Scab--A piece of material nailed across a splice to strengthen and hold it together
- C. Shore--A prop placed against or beneath an object for support
- D. Kicker--A piece of material used to resist horizontal pressure
- E. Stringer--A piece of heavy material placed across several shores; a horizontal or inclined supporting member
- F. Tendon--A single or multi-strand of high tensile wire or a rod used to stress concrete
- G. Post-tensioning--A process of introducing internal stresses after concrete has reached a predetermined strength
- H. Form oil--Paraffin oil or other manufactured product applied to a form to prevent adhesion of concrete to the form
- I. Ribbon--A horizontal board used to hold shores in alignment and to restrict lateral movement
- J. Wedge--A tapered piece of wood or metal
- K. Pan--A single section of manufactured form used to mold exposed voids in a one-way joist system
- L. Void tube--A manufactured tube of metal or fiber used to create concealed voids in slabs
- M. Open centering--Framing for pans and domes comprised of joist soffit forms and headers
- N. Deck--The horizontal sheathing that supports the wet concrete
- O. Dome--A manufactured product which forms an exposed void in a waffle slab system
- P. Waffle--The design of a slab which is poured on domes; also, a two-way joist system
- Q. Flying forms--A system whereby a large section of slab forms is removed with a crane and moved to the next pour location

INFORMATION SHEET

- II. Parts of a slab forming system (Transparency 1)
 - A. Shore
 - B. Joist soffit form
 - C. Header
 - D. Deck
 - E. Stringer
 - F. Dome
 - G. Pan
 - H. Wedge
 - I. End cap
- III. Types of slabs (Transparencies 2, 3, and 4)
 - A. One-way joist
 - B. Two-way joist (waffle)
 - C. Flat slab
- IV. All types of slabs can be post-tensioned
- V. Materials used to manufacture pans and domes (Transparencies 5 and 6)
 - A. Molded fiber glass
 - B. Steel
 - C. Molded fiber (wood or paper)
- VI. Materials used to manufacture void tubes
 - A. Steel
 - B. Fiber (paper)
- VII. Types of manufactured exposed void forms (Transparencies 7 and 8)
 - A. Adjustable form
 - B. Flange form
 - C. Long form
 - D. Dome form
- VIII. Slab forming system in which large sections of forms are moved intact to another pour location--A flying form (Transparency 9)

Parts of a Slab Forming System

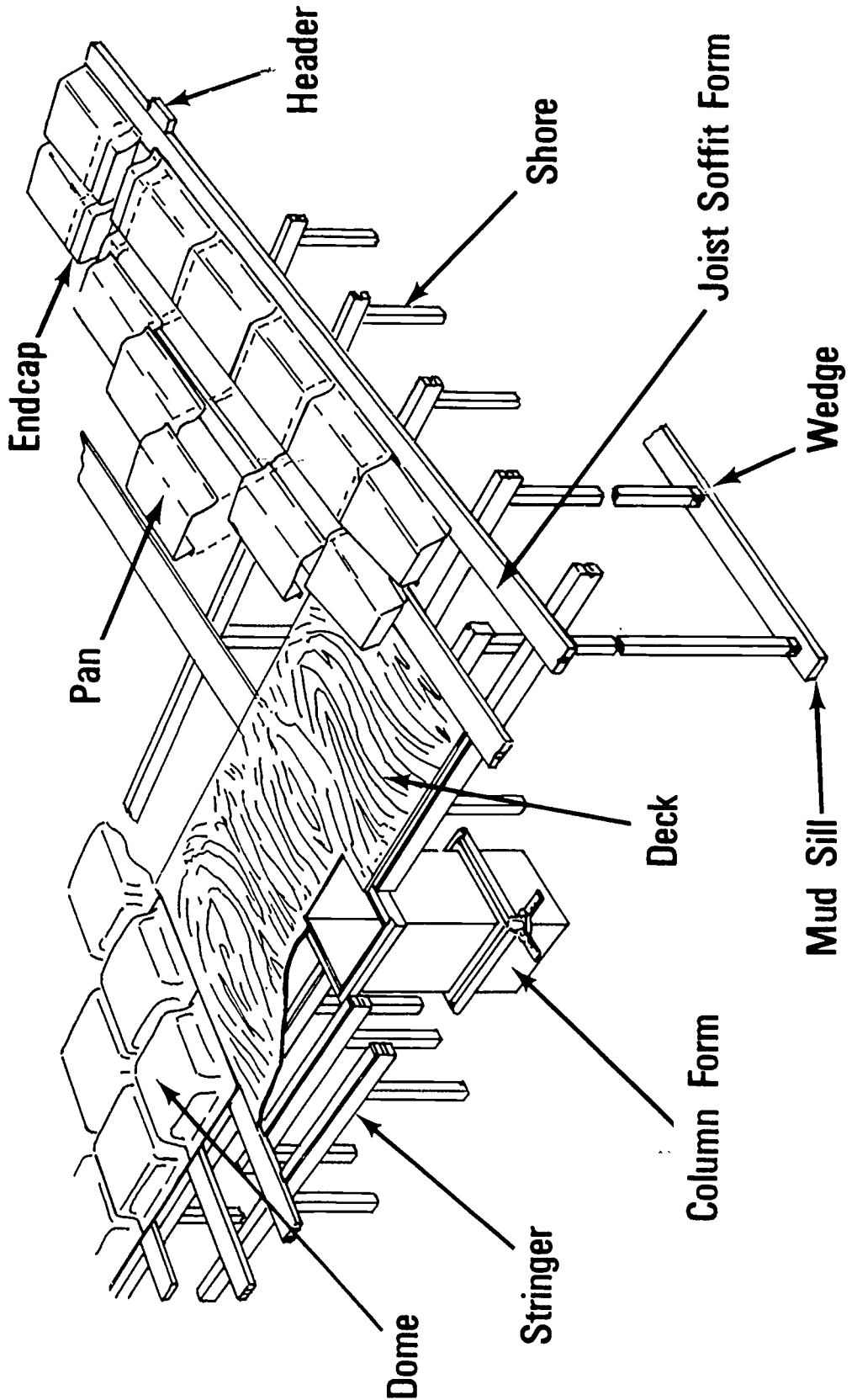

648

One-Way Joist

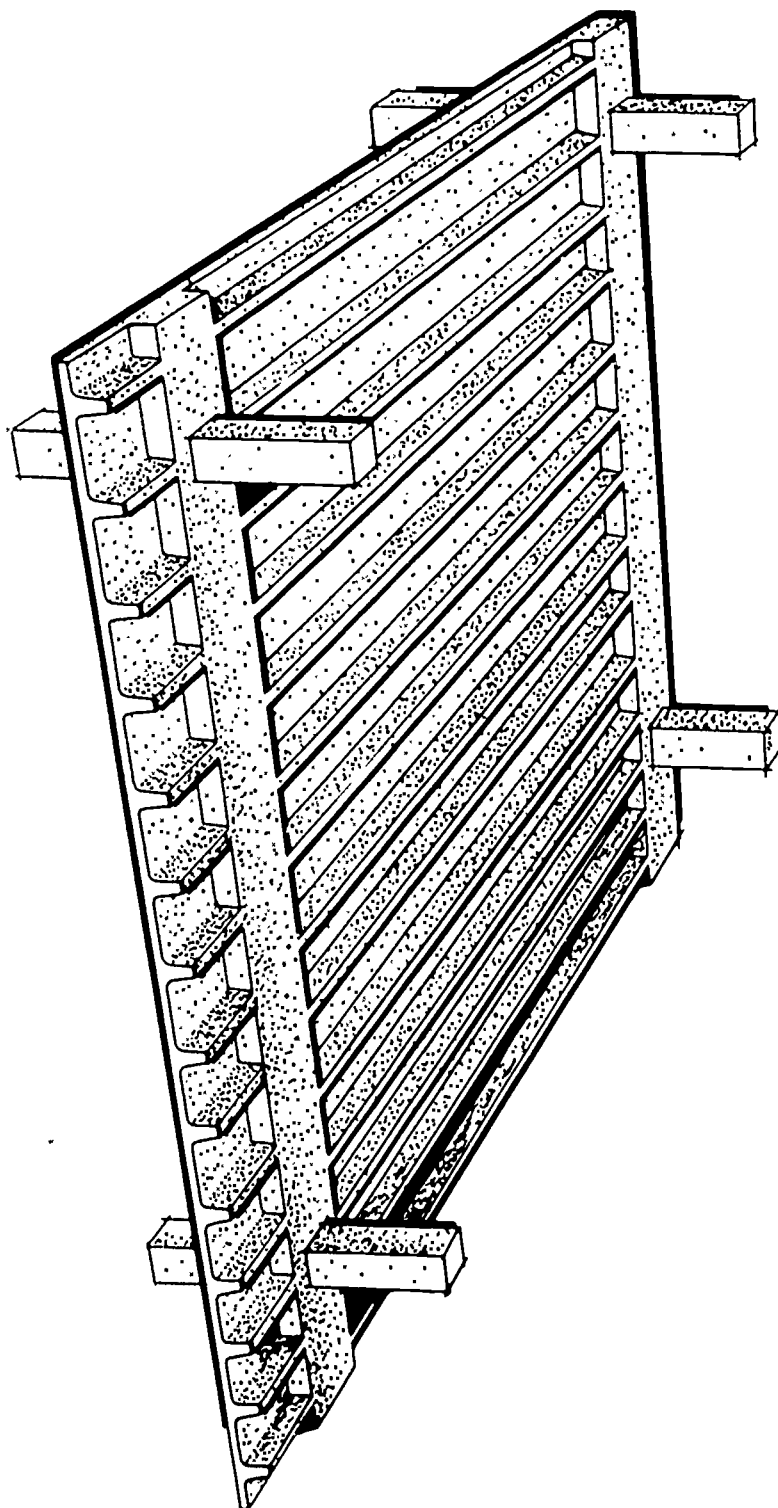

649

Two-Way Joist

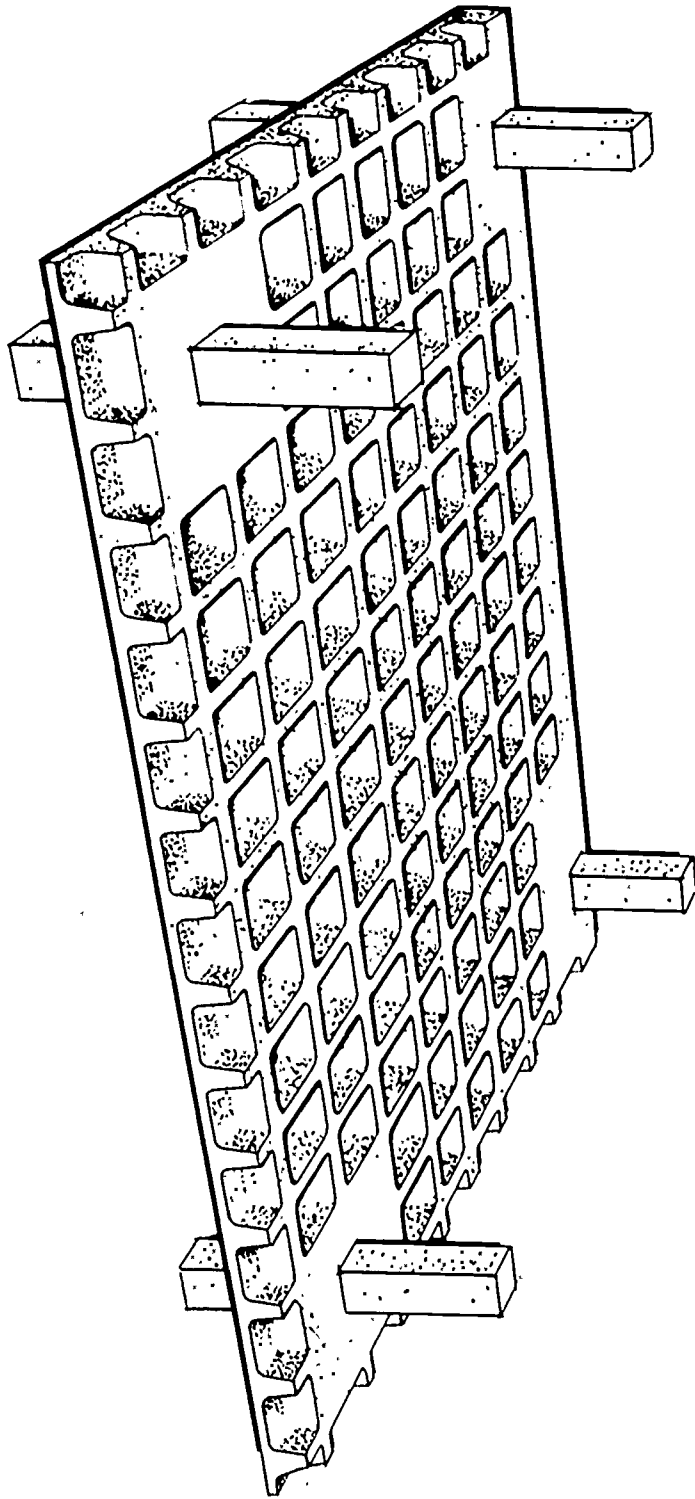

Flat Slab

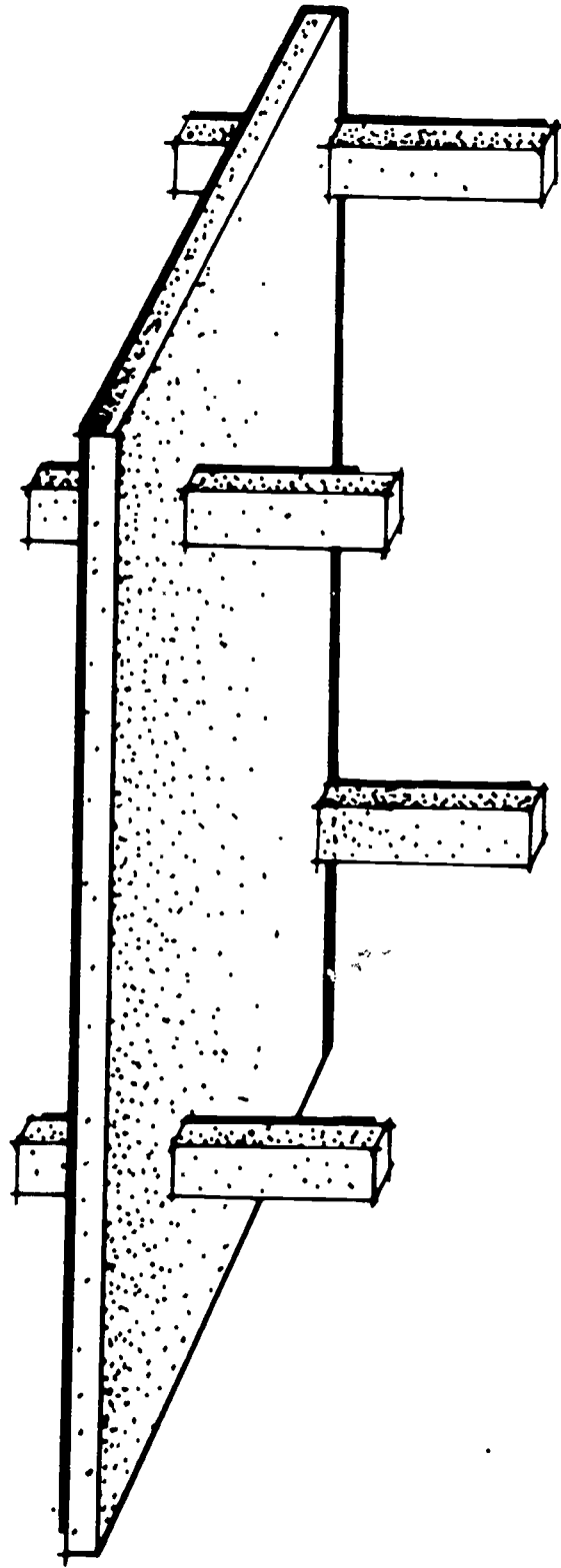

Steel or Molded Fiber Glass Form

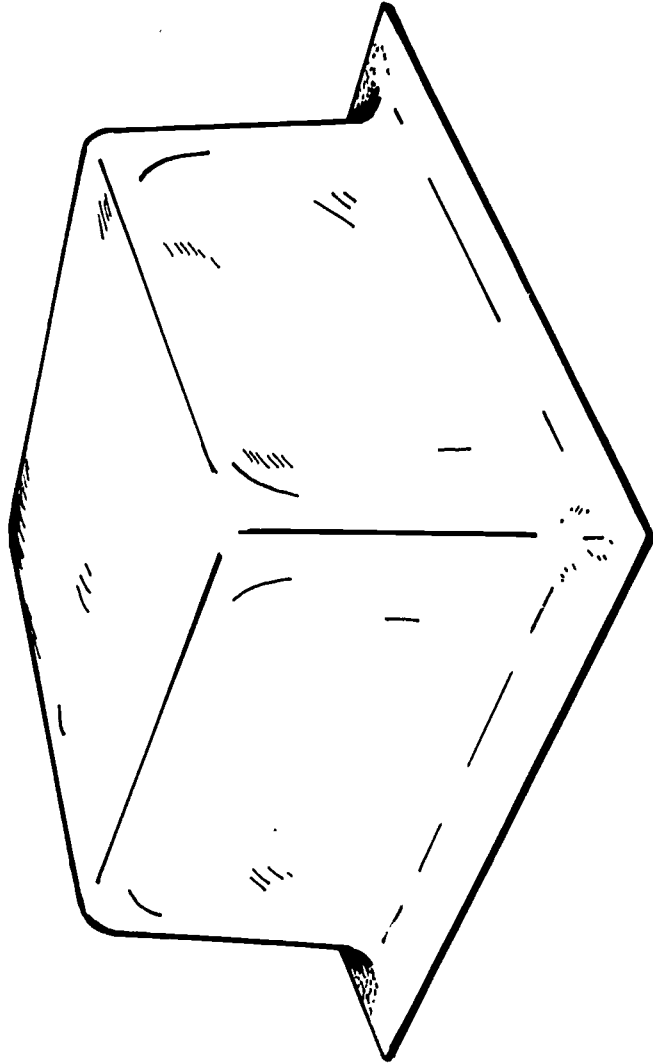

652

T/M 5

Molded Wood Fiber Form

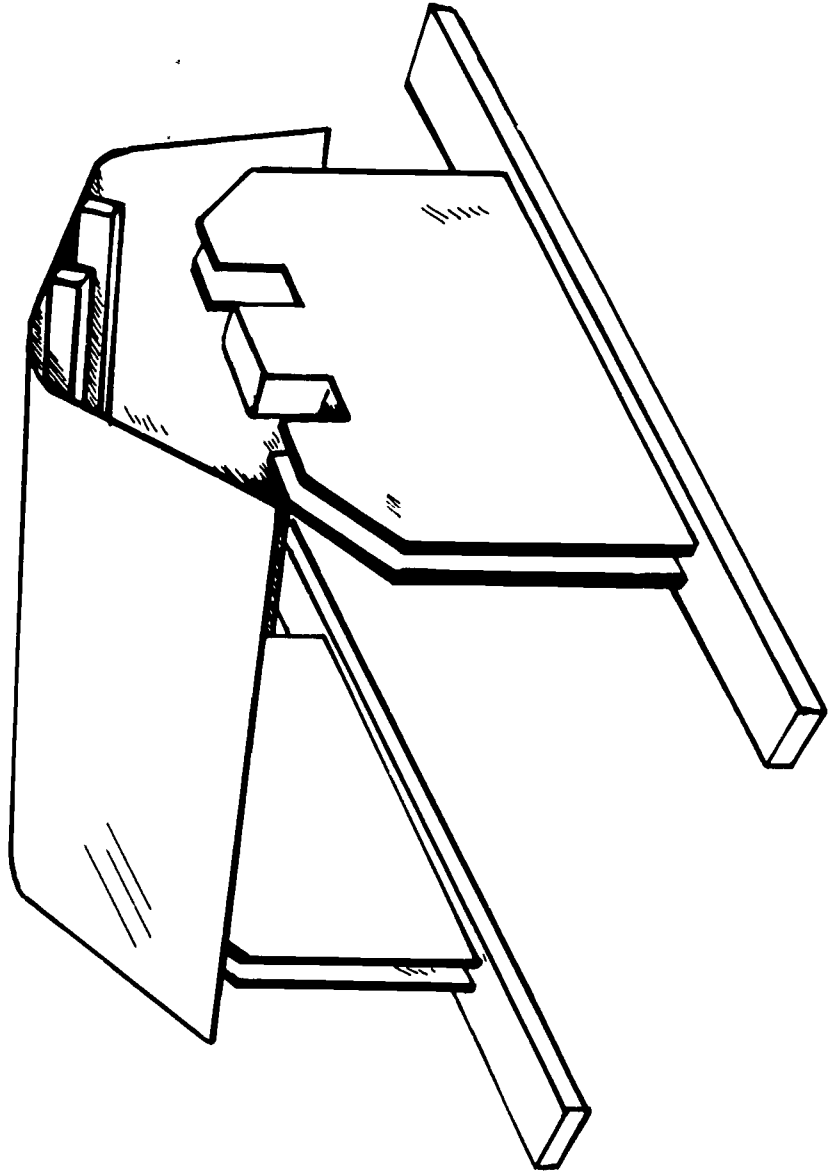

Adjustable and Flange Pans

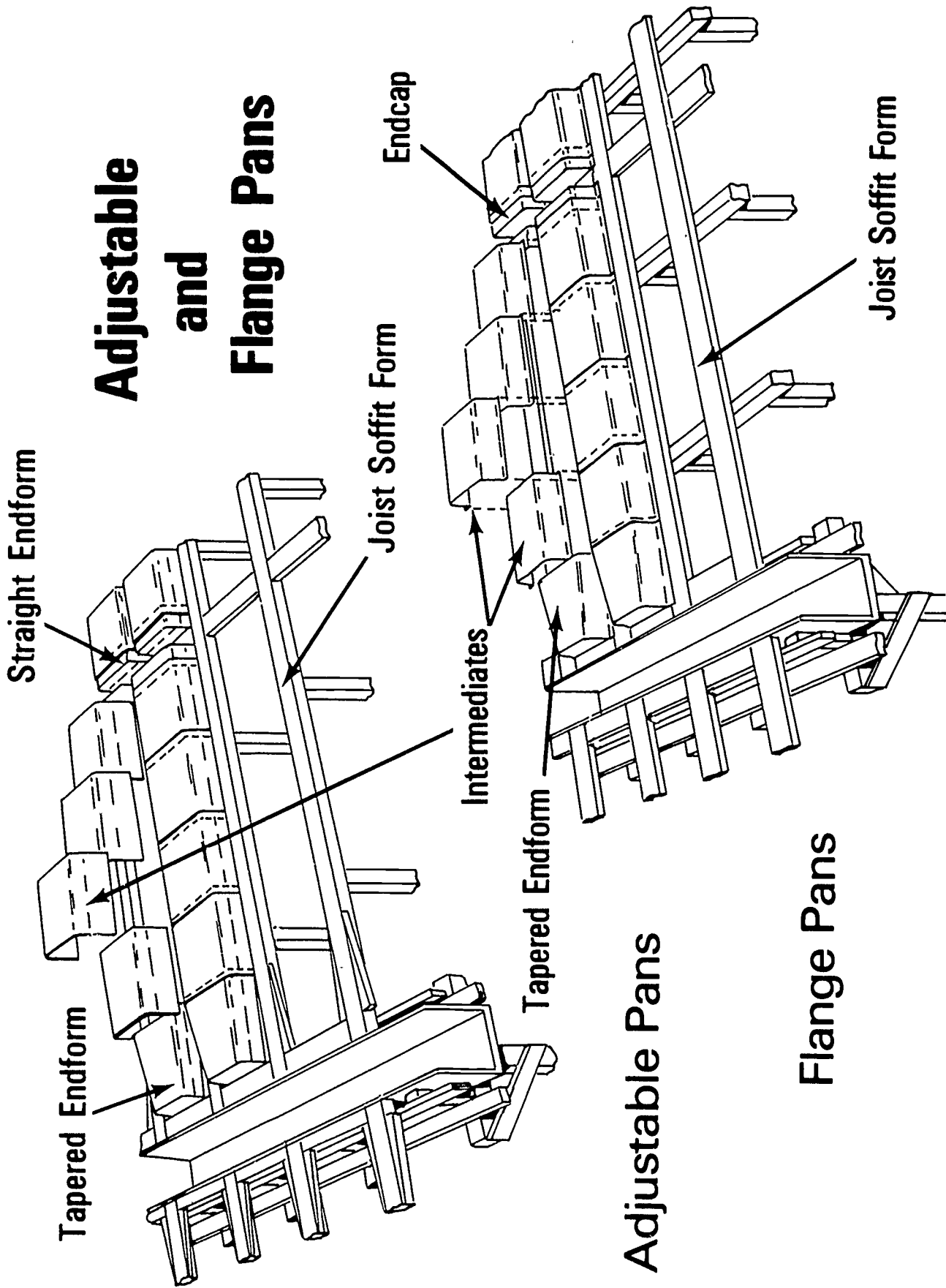

Adjustable Pans

Flange Pans

Long Forms and Domes

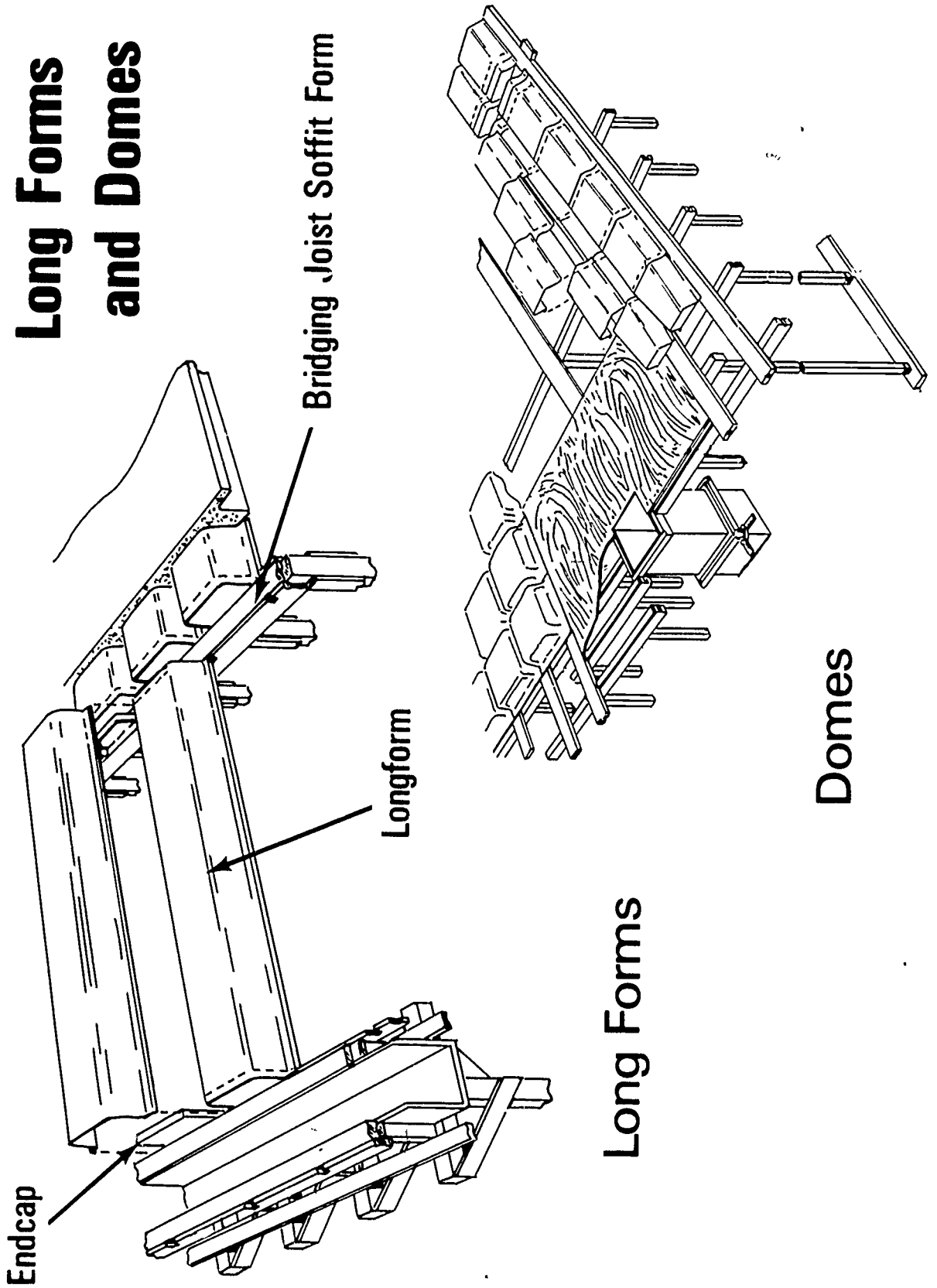

Long Forms

Domes

Flying Form

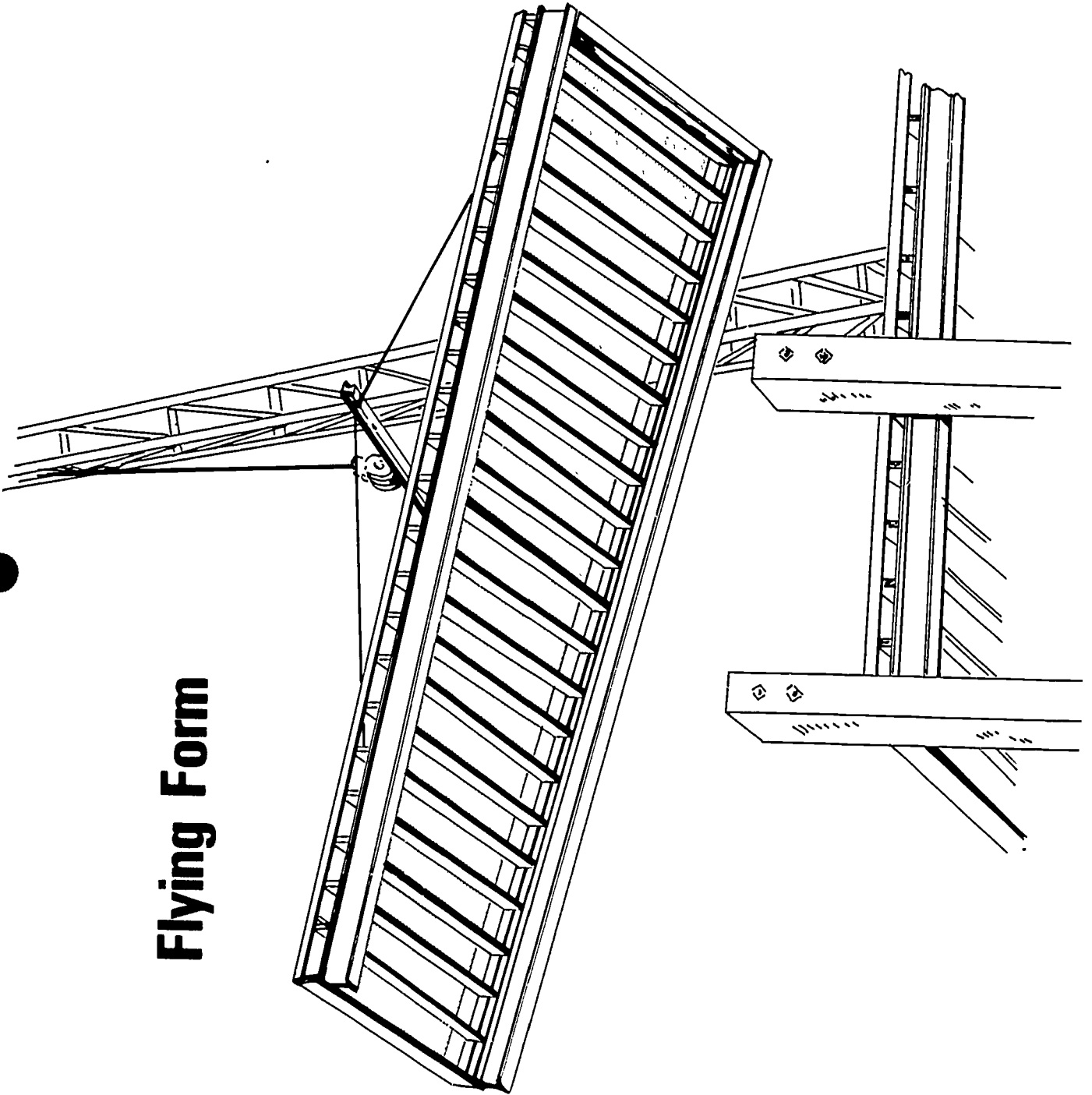

656

ABOVE GRADE SLAB SYSTEMS
UNIT VIII

JOB SHEET #1--CONSTRUCT FORMS FOR A TWO-WAY
JOIST SYSTEM

(NOTE: The shoring system used in this job sheet may be used on any type slab. A solid plywood decking may also be installed.)

I. Tools and materials needed

A. Tools

1. Claw hammer (16 oz. or larger)
2. Handsaw (Crosscut)
3. Electric handsaw
4. Level (hand)
5. Chalk line
6. Builder's level

B. Materials

1. Sills--2 x 8's or larger
2. Shore frames (scaffold)
3. Dome forms
4. Joist soffit form--2 x 8's or 2 x 10's
5. Deck--Plywood
6. Horizontal shores
7. Dome nails--Check manufacturer's specifications
8. Stringers--4 x 6's

II. Procedure

A. Erect shore frames

1. Lay sill pieces on deck

(NOTE: Sill locations should be one-half the frame width each side of the column center line.)

JOB SHEET #1

2. Set adjustable screw legs in approximate final location
(NOTE: Final location is one foot from column face.)
3. Attach screw legs to scaffold
(NOTE: Screw legs must have base plates.)
4. Stand frame upright and attach two X braces (Figure 1)
(NOTE: Lean top of frame and secure top brace first.)

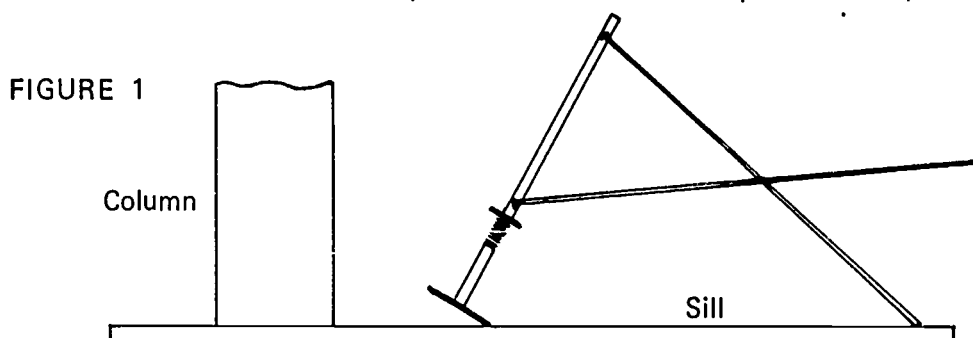

5. Attach second frame by raising brace until it aligns with stud on frame
(NOTE: If wing nuts are used to attach braces, catch only enough threads to hold the nut on; as they will have to be removed to attach the next brace.)
6. Attach braces to the frame set last
7. Attach next frame to braces
8. Repeat steps 6 and 7 to continue erection
9. Place coupling pins in top of frame legs
(NOTE: Some patented scaffolds have a small bottom end which slips inside the lower frame; therefore, coupling pins are not used.)
10. Place scaffold plank on top of frames
11. Set frame for second row on pins
12. Attach braces
13. Set second frame and secure braces
14. Repeat steps 9 through 13 inclusive to continue erection

JOB SHEET #1

15. Install U head screw jacks on all frame posts (Figure 2)

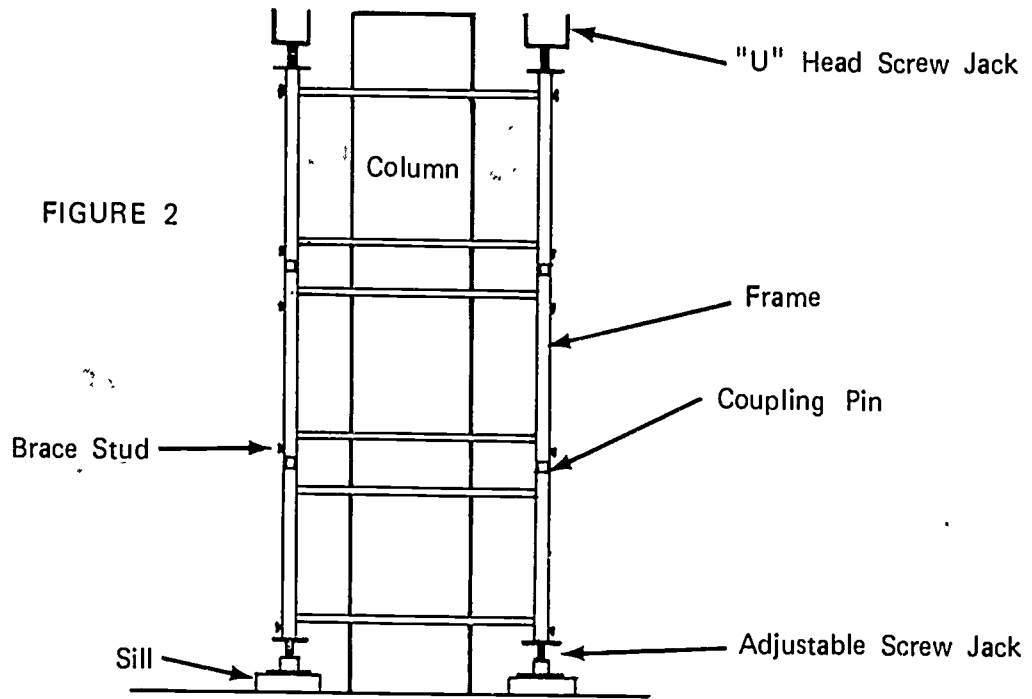

B. Install stringers

1. Lay stringers in U head (Figure 3)

(NOTE: If stringers are not as wide as the U head, block both sides so stringer is centered.)

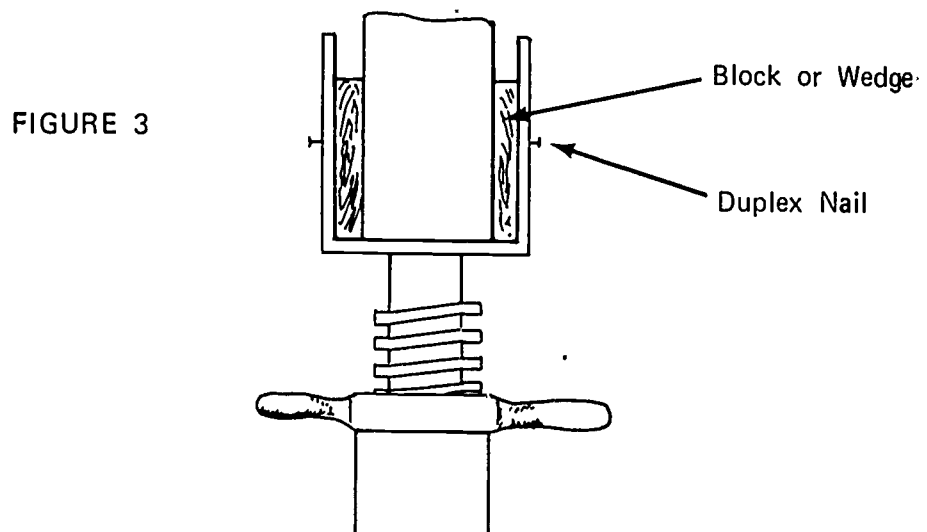

JOB SHEET #1

2. Nail stringers to U head

(NOTE: U heads are predrilled. Use duplex nails.)

- C. Set up shore scaffold on next column line as outlined in A and B

- D. Install horizontal shores

1. Make jig for adjusting shores
(Figure 4)

(NOTE: A light template with blocks nailed one each end may also be used to adjust the shores.)

FIGURE 4

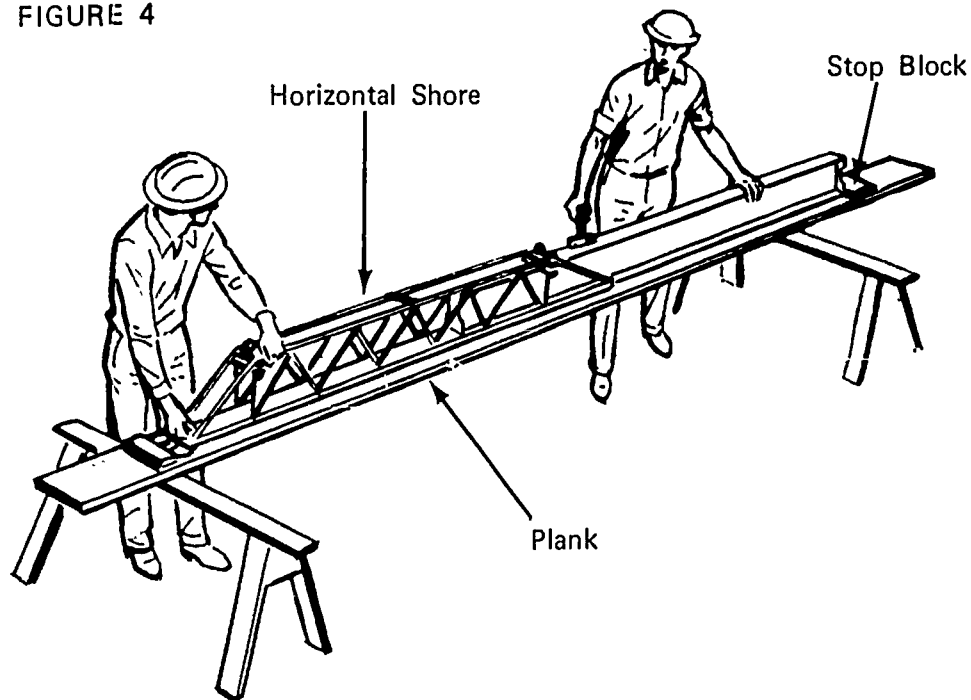

2. Adjust horizontal shores to proper length and lock tight
3. Lay out center line of structural joist on the stringer

(NOTE: Determine joist spacing from structural plans.)

JOB SHEET #1

4. Set horizontal shores (Figures 5a and 5b)

(NOTE: Center shore on layout mark. Shores can be set from above or below.)

FIGURE 5a

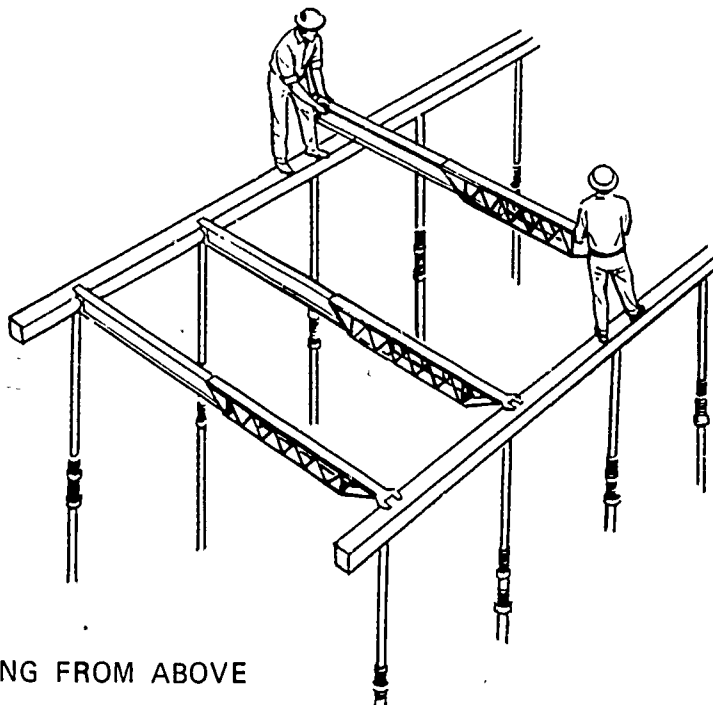
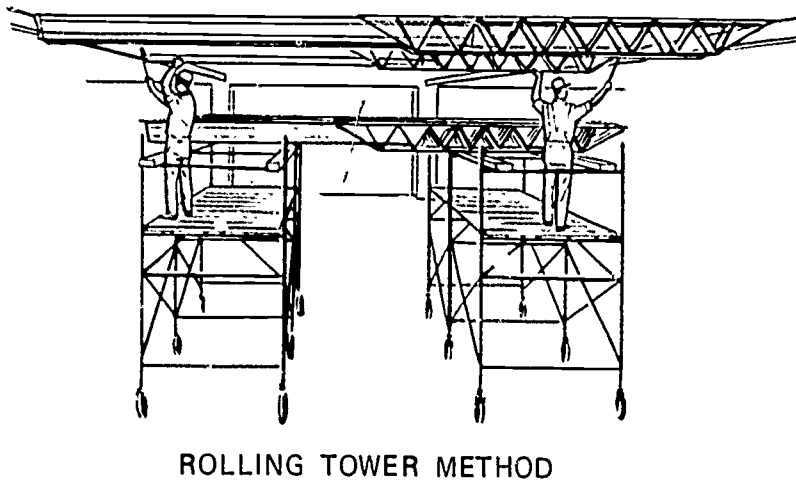

FIGURE 5b



JOB SHEET #1

E. Install beam soffit

1. Lay one inch thick material on top of horizontal shores
2. Nail plywood to one inch strips (Figure 6)

(NOTE: Horizontal shores might have to be set closer together in the beam area. Let plywood extend past side of beam to support one flange of the dome.)

FIGURE 6

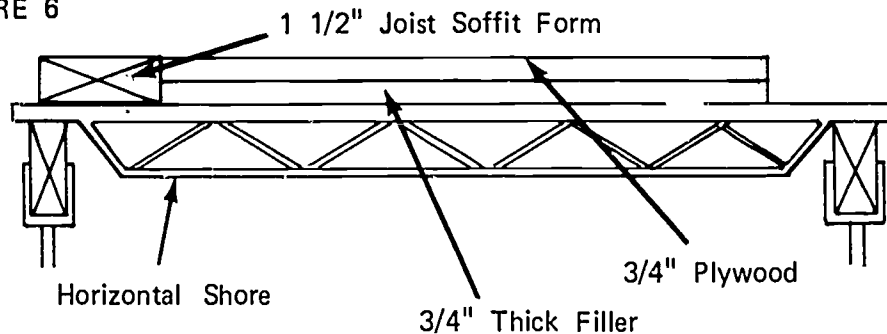

F. Install domes

1. Snap chalk line on ply at sides of beam
2. Lay plank across horizontal shores at joist center lines
3. Measure from column center line to edge of first dome and place pencil mark at this point
4. Set first dome (Figure 7)

(NOTE: Align dome flange with chalk line on one edge and place pencil mark at adjoining edge.)

FIGURE 7

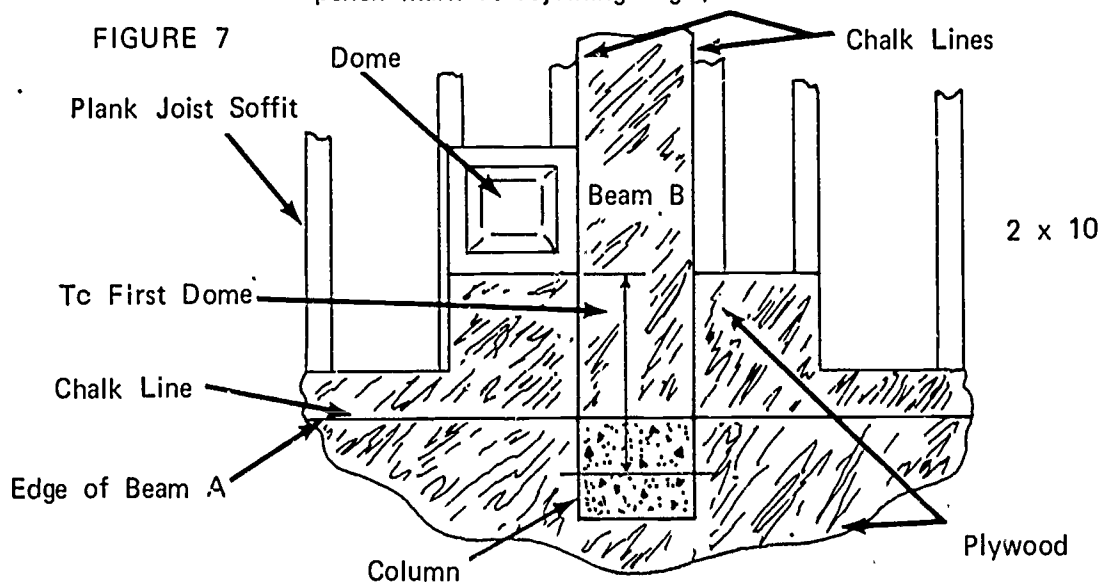

JOB SHEET #1

5. Set second dome on chalk line and against first pan; nail to plywood and joist bottom form

(NOTE: Check manufacturer's specifications for nailing and header instructions.)

6. Repeat step number 5 to set all domes in this row
7. Set second row of domes against the flange and in line with flange joints of first row

(NOTE: An additional dome might be added to this line to bring it to the side of beam A in Figure 7.)

8. Repeat step number 7 to continue setting remaining rows of domes
9. Coat entire form surface with form oil

(NOTE: Form oil must be applied before rebar are installed.)

G. Install perimeter beam side

1. Build spandrel beam side

(NOTE: The height of the beam side will be equal to the height of the dome plus the thickness of the slab.)

2. Coat form surface with form oil
3. Snap a chalk line on the plywood at the outside of the beam
4. Nail beam side kicker to deck
5. Stand beam side on deck and nail to kicker
6. Brace beam side (Figure 8)

(NOTE: Stretch string line over blocks to align top of form.)

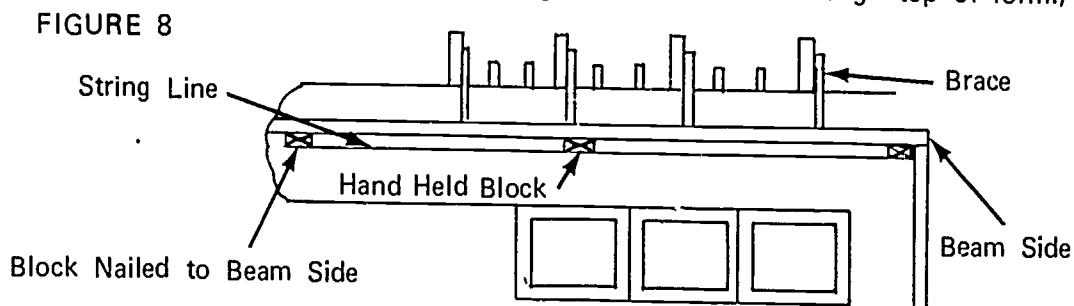

JOB SHEET #1

H. Check elevation of deck

1. Set up instrument on floor below
2. Establish HI of instrument
3. Make story pole correspond with elevation of bottom of beam bottom plywood
4. Adjust upper or lower screw legs to obtain correct elevation at beams (Figure 9)

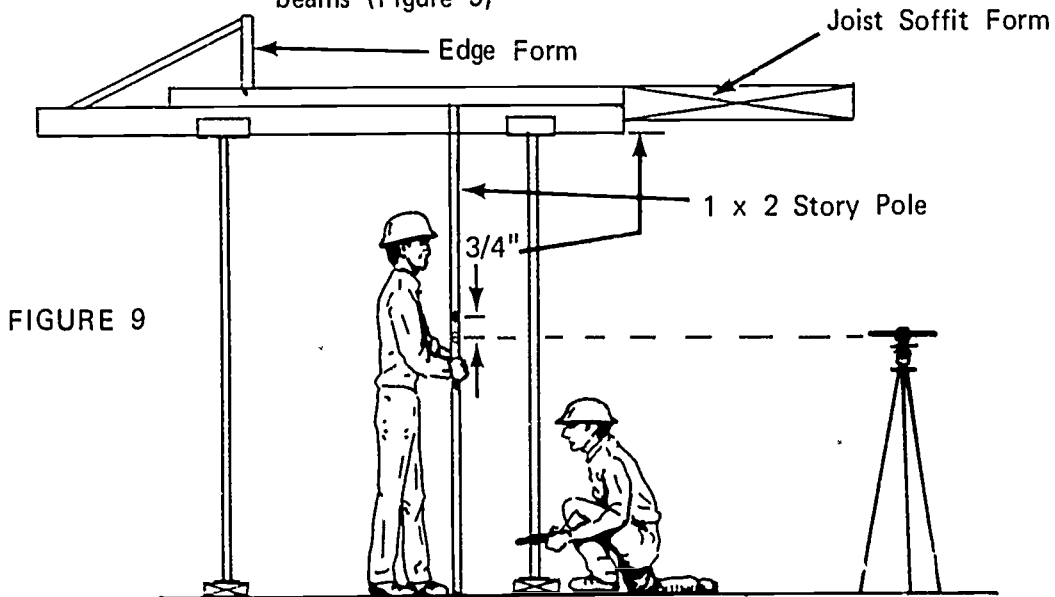

5. Check intermediate towers

(NOTE: Place mark 3/4" above deck mark to check joist form.)

I. Install bulkhead

(NOTE: If entire floor can not be poured at one time, bulkhead must be installed. If location is not given in the plans or specifications, check with your superior for permissible location.)

1. Place a 2 x 4 under the wire mesh on the end of pour
2. Screw 2 x 4 to pans

(NOTE: Check dome supplier for permissible anchorage.)

3. Lay 2 x 4 on top of mesh and first 2 x 4
4. Wedge upper 2 x 4 to proper elevation

JOB SHEET #1

5. Cut tapered pieces of plywood for joist area (Figure 10)
(NOTE: Make one piece and use it for a pattern.)

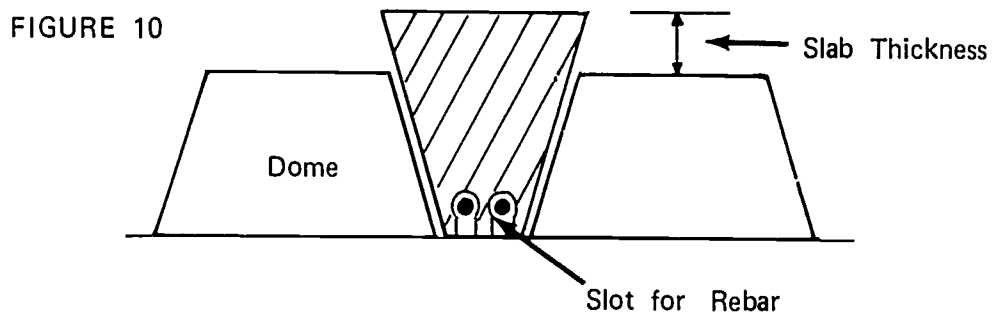

6. Nail plywood pieces to upper 2 x 4's
7. Brace bottom of plywood bulkhead (Figure 11)

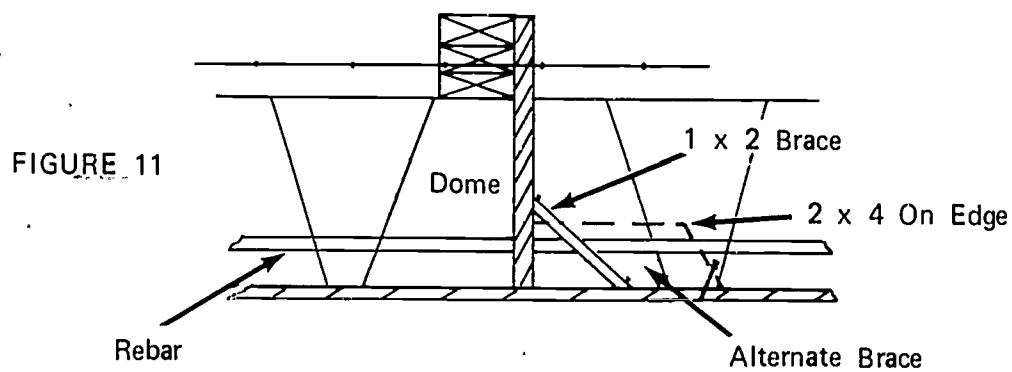

ABOVE GRADE SLAB SYSTEMS
UNIT VIIIJOB SHEET #2--CONSTRUCT FORMS FOR A ONE-WAY
JOIST SYSTEM

I. Tools and materials needed

A. Tools

1. Claw hammer (16 oz. or larger)
2. Handsaw (crosscut)
3. Electric handsaw
4. Level (hand)
5. Chalk line

B. Materials

1. Sills--2 x 8's or larger
2. Shores--Patented
3. Long forms
4. Joist soffit form--2 x 6's or 2 x 8's
5. Deck--Plywood
6. Joist--2 x 10's
7. Shore head--4 x 6's

JOB SHEET #2

II. Procedures

A. Erect shores and joist

1. Lay sills on deck (Figure 1)

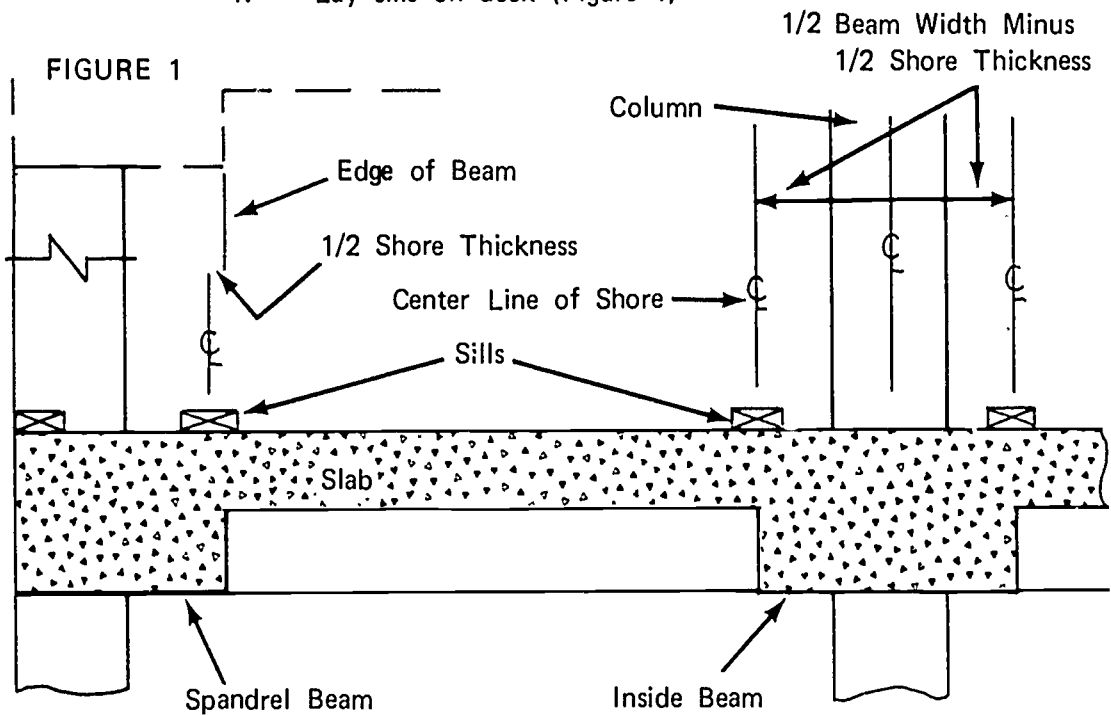

2. Secure two shores to shore head (Figures 2a and 2b)

(NOTE: Shores center lines should correspond with sill center line.)

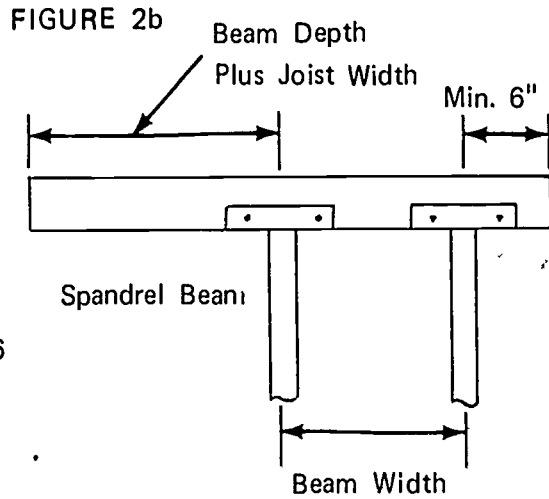
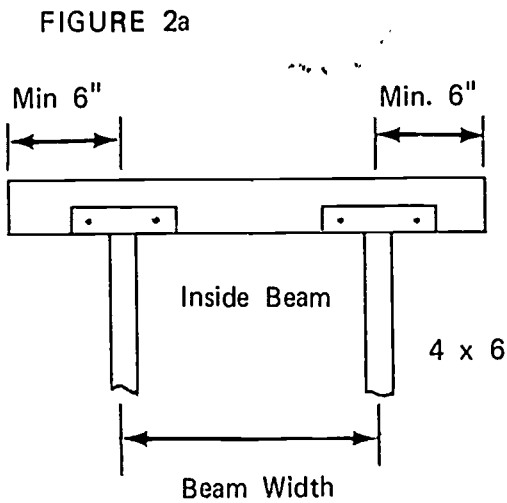

JOB SHEET #2

3. Stand first shore unit upright and brace it plumb in both directions

(NOTE: Set first unit one foot from the column. Nail base plates to the sill.)

4. Stand second unit upright at the end of the joist and brace it plumb in both directions

5. Nail center joist to shore heads

6. Snap a chalk line on shore heads at both sides of the beam

7. Nail remaining joists to shore heads

(NOTE: Nail edge joist accurately on the inside of the chalk line.)

8. Install bridging joist bottom forms

(NOTE: Bridging joists are placed at the end of long forms which are not adjacent to beams.)

- a. Frame stringers to exact width of bridging joist (Figure 3)

(NOTE: Stringer may be ripped or a filler added to attain correct width. It may also be laminated.)

FIGURE 3

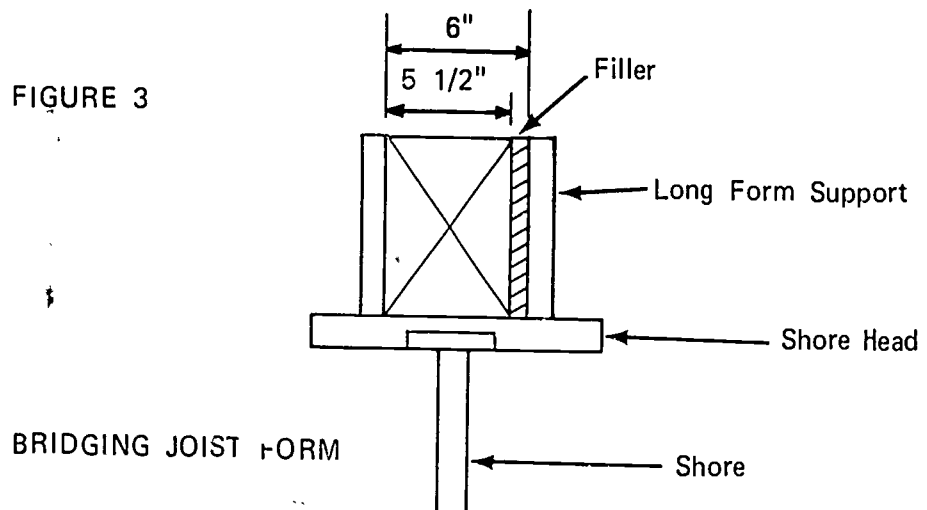

- b. Secure short shore heads to single shore (See Figure 3.)

- c. Stand T shores on sill and brace plumb in both directions

(NOTE: Shores will be placed to support each end of the stringer.)

JOB SHEET #2

- d. Nail stringer to shore heads
- e. Install intermediate shores
- f. Repeat steps a through e inclusive to continue erection of all bridging joist bottoms

B. Notch all long form supports and install the ones at the bridging joist

1. Notch material to receive flange on long form (Figure 4)

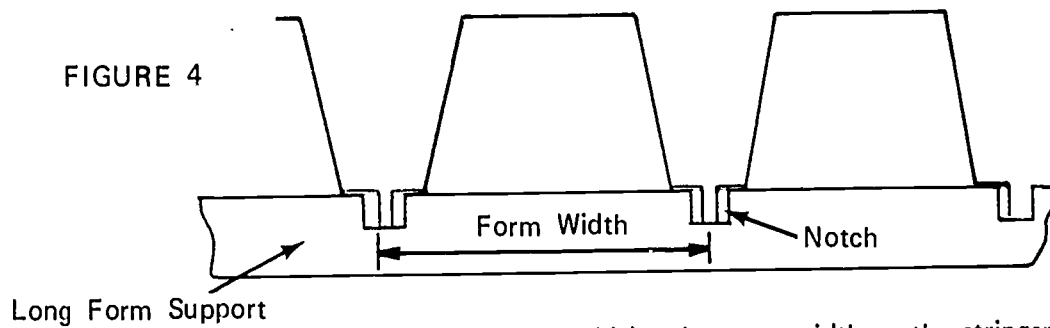

(NOTE: Material should be the same width as the stringer. See Figure 3.)

2. Nail long form support to stringer as shown in Figure 3

C. Install beam soffit form material and long form supports

1. Fabricate plywood to exact width of beam (Figure 5)

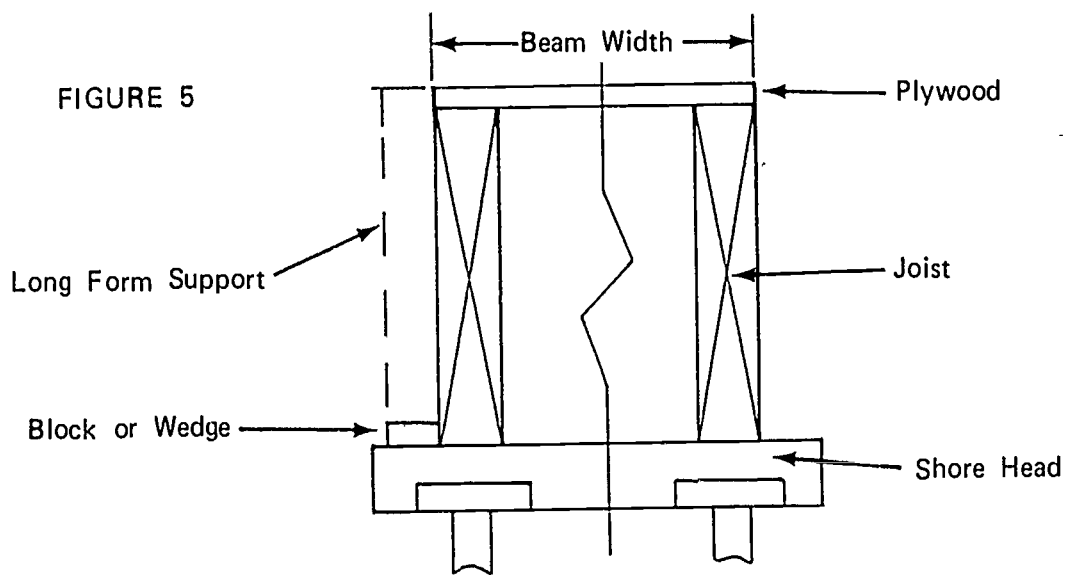

JOB SHEET #2

2. Nail plywood to joist
3. Nail long form supports to joist

(NOTE: If necessary, block long form support as shown in Figure 5 to bring top flush with plywood.)

- D. Install long forms (Figure 6)

FIGURE 6

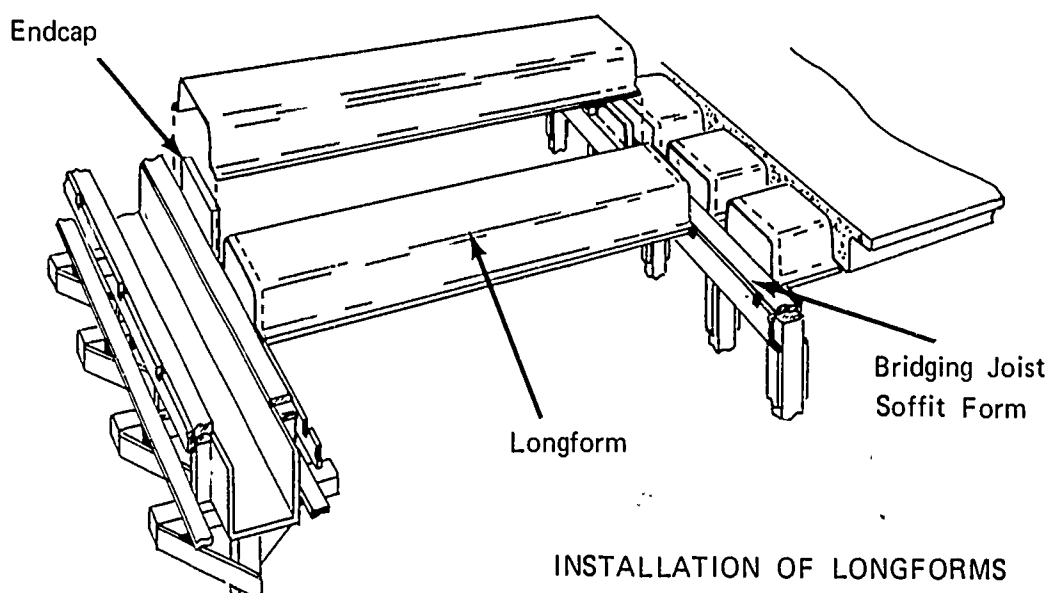

1. Nail end caps to supports
 2. Set long form over end cap
 3. Nail flange to form support
- (NOTE: Follow manufacturer's installation instructions.)
4. Repeat steps 1, 2, and 3 to continue setting remainder of long forms

- E. Apply form oil to all surfaces exposed to concrete

(NOTE: Rebar shall be installed after form oil has been applied.)

670

~~669~~

ABOVE GRADE SLAB SYSTEMS
UNIT VIII

JOB SHEET #3--CONSTRUCT FORMS FOR A FLAT SLAB (POST-TENSIONED)

(NOTE: Concealed void slab forms are constructed very similarly. Any type of shoring may be used.)

I. Tools and materials needed

A. Tools

1. Claw hammer (16 oz. or larger)
2. Handsaw (crosscut)
3. Electric handsaw
4. Chalk line
5. Builder's transit

B. Materials

1. Deck--Plywood
2. Horizontal shores
3. Shores--Patented type that attaches to columns
4. I beam ledgers
5. Joist (2 x 8's or 2 x 10's)
6. Void tubes with end caps
7. Void tube tie downs

II. Procedure

A. Build form section

1. Determine exact width of form section

(NOTE: Form section might be slightly smaller than distance between columns. Follow shore manufacturer's recommendations.)

2. Lay I beam ledgers on a level base

(NOTE: I beams will be parallel to each other.)

3. Lay horizontal shores on I beam ledgers and secure to ledgers

(NOTE: Use manufactured clips or bolts as recommended.)

JOB SHEET #3

4. Square unit using the diagonal method (Figure 1)

(NOTE: X bracing might be added to hold unit square and for rigidity.)

FIGURE 1

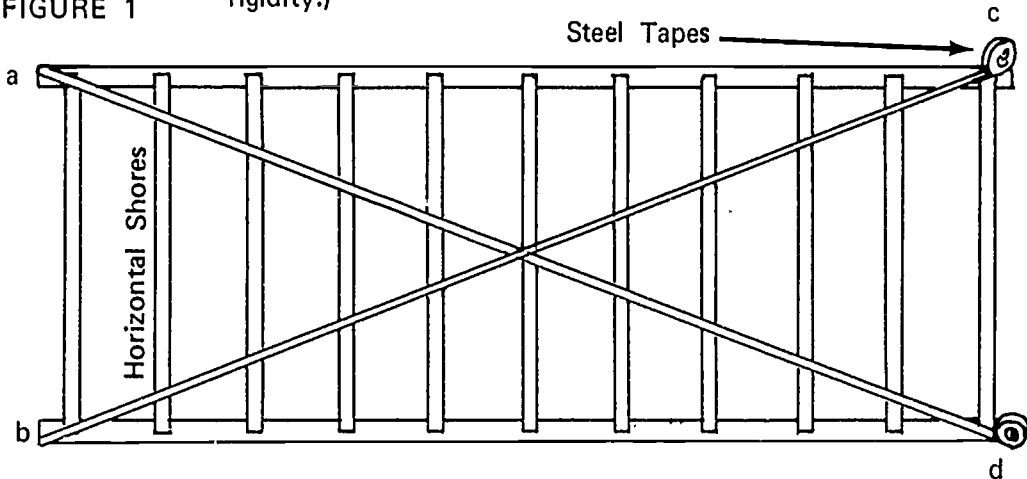

(NOTE: I beam ledgers a-c and b-d must be parallel. Hook tape at point a and read at point d. Repeat process at points b and c. The two readings should be the same. If not, slide either ledger to correct reading.) (See Figure 1)

5. Secure joist to horizontal shores

(NOTE: Use manufactured clips or bolts. Check manufacturer's recommendations.)

6. Nail decking to joist (Figure 2)

(NOTE: Plywood is held back at edge joist to catch beam bottom plywood.)

FIGURE 2

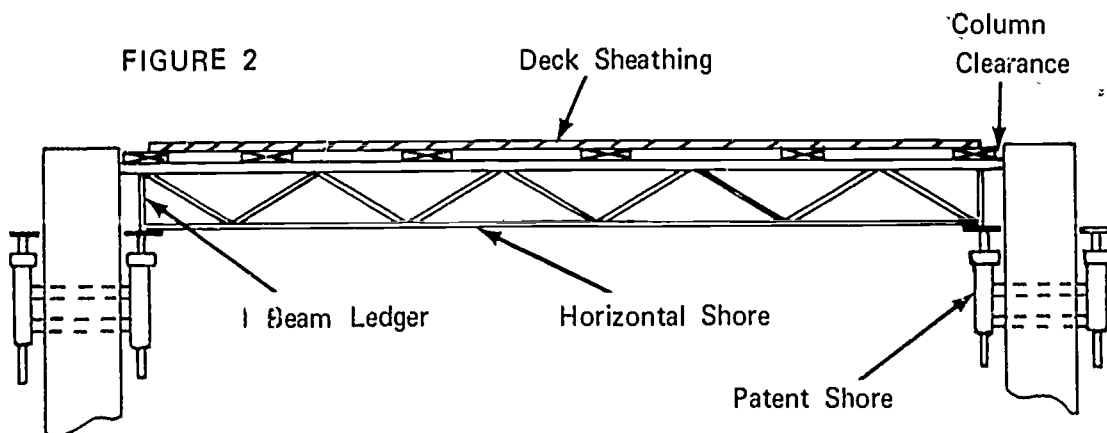

JOB SHEET #3

7. Repeat steps 2 to 6 inclusive to build required number of form sections
- B. Attach patented shores to columns or wall
- (NOTE: Pipe sleeves should have been placed in the proper location to receive shore bolts when the columns or wall was poured.)
- C. Adjust shore top plate to proper elevation (Figure 3)
- (NOTE: This can be done by measuring distance "a", shorehead extension from body of shore, "b" the distance from the plate to the top of the column, or "c" with a builder's level as shown in Figure 3.)

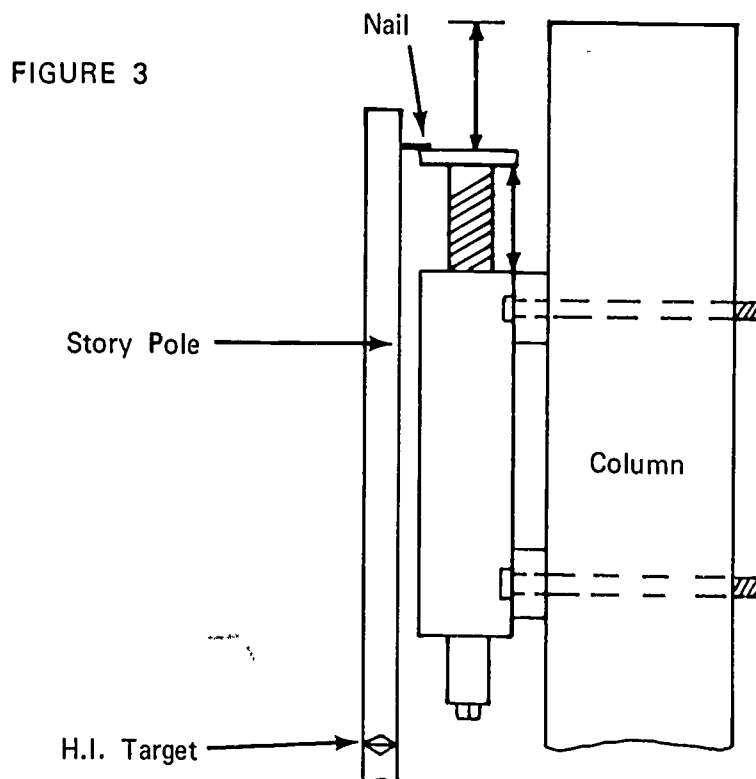

JOB SHEET #3

D. Set form sections on shores

(NOTE: Use crane to pick form section.) (Figure 4)

FIGURE 4



E. Install beam bottom plywood (Figure 5)

(NOTE: This is done after adjacent sections are set.)

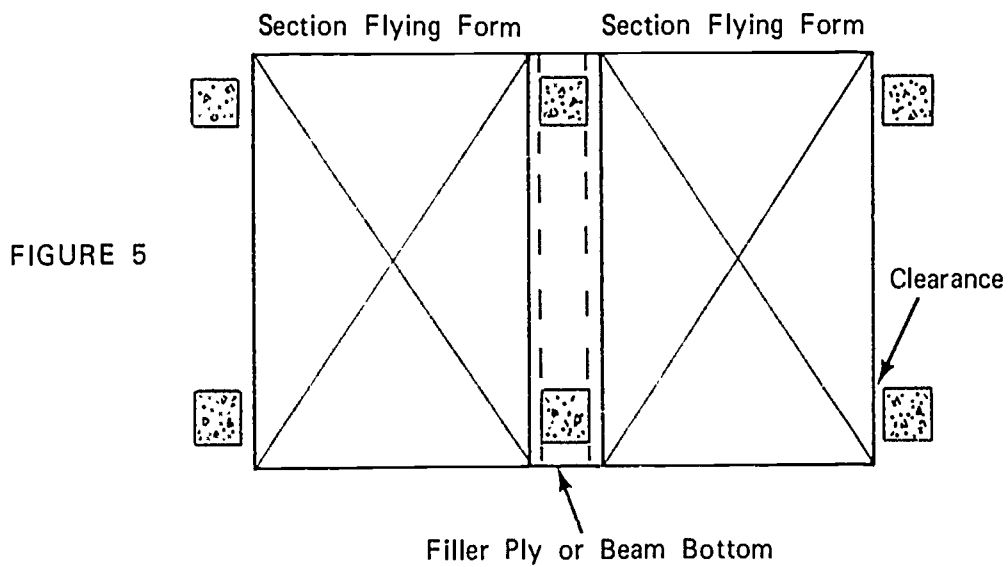

JOB SHEET #3

F. Install edge form

(NOTE: This is done after all form sections are set.)

1. Cut form material to proper width

2. Drill anchor bolt and tendon holes

(NOTE: Check anchor supplier's details for hole spacings.)

3. Mark points on the deck indicating the outside of the form

4. Snap a chalk line between those points

5. Nail form kicker to deck

6. Nail edge form to kicker

7. Align and brace

8. Apply form oil to all surfaces which will come in contact with concrete (Figure 6)

(NOTE: Form oil must be applied before tendons, tendon anchors, and rebars are installed.)

FIGURE 6

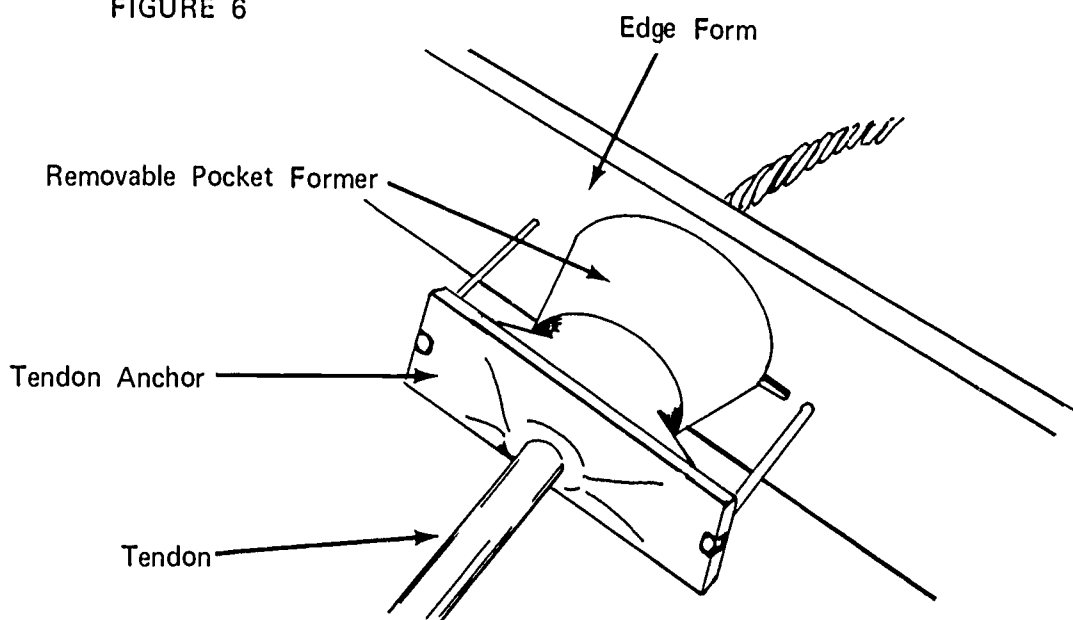

JOB SHEET #3

G. Move form to next pour location (Figure 7)

FIGURE 7

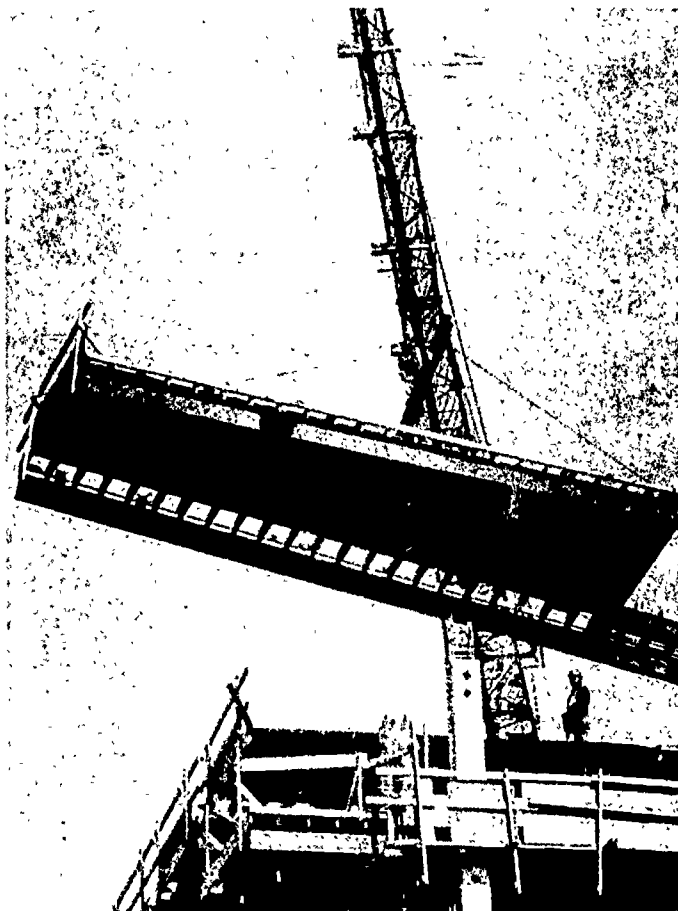

1. Lower shore adjustments until I beam ledger is resting on roller
(NOTE: Care should be exercised when lowering forms to avoid binding against columns. Be sure filler prices at columns are removed.)
2. Roll outside of building
3. Attach crane spreaders to form
4. Swing form clear of building and move it to next location
5. Repeat steps B, C, D, E, and F to continue erection

ABOVE GRADE SLAB SYSTEMS
UNIT VIII

JOB SHEET #4--STRIP A TWO-WAY JOIST SYSTEM

(NOTE: Steel dome systems are stripped very similarly.)

I. Tools needed

- A. Hammer (16 oz. or larger)
- B. Wrecking bar (24 inch or larger)
- C. Air compressor (100 to 125 psi.)
- D. Air hose
- E. Air gun (Furnished by dome manufacturer)

II. Procedure

- A. Lower shore scaffold by loosening either upper or lower screws.
(NOTE: This should only be done after concrete has reached its design stripping strength.)
- B. Loosen horizontal shore lock bolt
- C. Insert wrecking bar between the stringer and the end plate
- D. Telescope shore until it clears stringer
- E. Lower shore with other end still on stringer and tighten lock nut
(CAUTION: This will prevent further telescoping and potential injury.)
- F. Insert wrecking bar between stringer and end plate and pry out second end of horizontal shore
- G. Repeat steps B to F inclusive to continue removing horizontal shores
(CAUTION: Centering of joist bottoms might be loosened during this period. Watch for loose members and remove them immediately.)
- H. Strip all remaining joist bottoms forms and beam bottom forms
- I. Remove domes
 1. Blow out domes with air gun

(NOTE: Never pry on flange of dome forms. Domes have special valves in top for insertion of air gun.)

JOB SHEET #4

2. If dome does not pop out, look for these problems
 - a. Air not going through stripping valve--Center punch stripping plug with nail or sharp rod and try to blow out again
 - b. Attachment to dome top--Make sure rivets or pins have been pulled or that special attachment fastenings are loose
 - c. Excessive grout leakage under flange--Chip concrete away with a hammer
 - d. Concrete encrusted forms do not strip well--Do not let them get that way

J. Clean domes

1. Scrub domes with burlap saturated with form oil
(NOTE: Follow manufacturer's recommendation as to type of form oil.)
2. Scrape off any concrete not removed by the scrubbing
3. Coat scraped area with form oil
4. Make a neat pile of the forms
(NOTE: Do not throw domes, this could damage the flange. Follow manufacturer's recommendation for stacking.)

ABOVE GRADE SLAB FORM SYSTEMS
UNIT VIII

JOB SHEET #5-SET CONCEALED VOID TUBES

I. Tools and materials needed

A. Tools

1. Hammer (16 oz. or larger)
2. Chalk line
3. Electric drill (1/4" or 3/8")
4. Pliers (Side cutters)
6. Drill bit (1/4")

B. Material

1. Void tubes
2. End caps
3. Tie down spacers
4. Wire (#12 annealed)

II. Procedure

A. Drill holes for tie down wires

(NOTE: Deck has been erected as for a flat slab.)

1. Determine suggested spacing of tie downs from table (Figure 1)

FIGURE 1

It is suggested that tie-downs be spaced as follows:

6" - 11" O.D. . . .	5' on center	18.7" - 24.8" O.D. . .	3' on center
12" - 18.7" O.D. . .	4' on center	24.8" - 36.9" O.D. . .	2' on center

JOB SHEET #5

2. Locate first tie down

(NOTE: The first row of tie downs should be not over one-half the table spacing from the end of the tube.)

3. Lay out all spacing along the length and at each end of the void tube
4. Snap a chalk line to join layout points
5. Locate and snap a chalk line at center line of first joist
6. Lay fabricated spacer alongside chalk line with points at center line of joist.) (Figure 2)

FIGURE 2

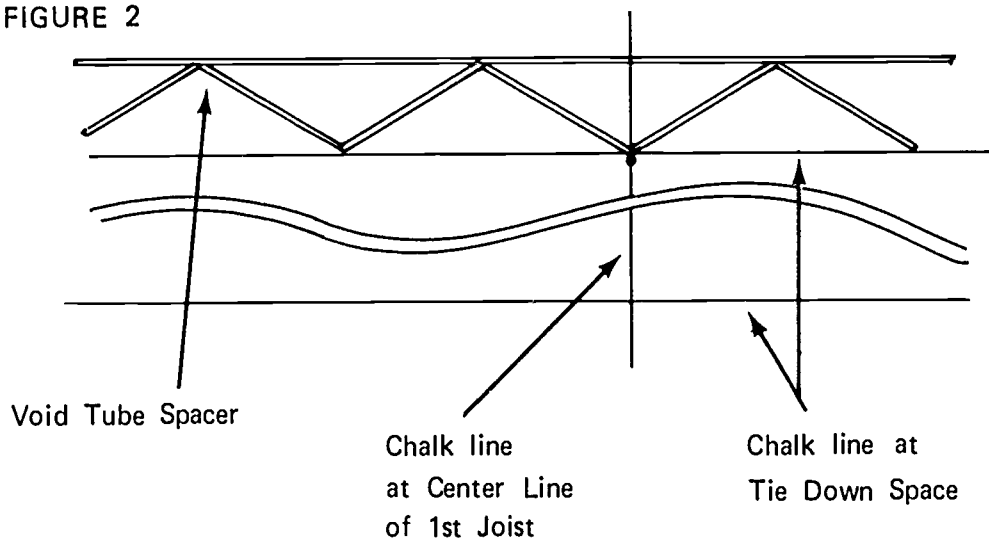

7. Drill holes through deck at points of fabricated spacer
8. Repeat steps 6 and 7 to drill remaining holes

(NOTE: Bottom rebar shall be installed at this time.)

JOB SHEET #5

B. Set and anchor void tubes

1. Attach end closures to void tubes (Figure 3)

FIGURE 3

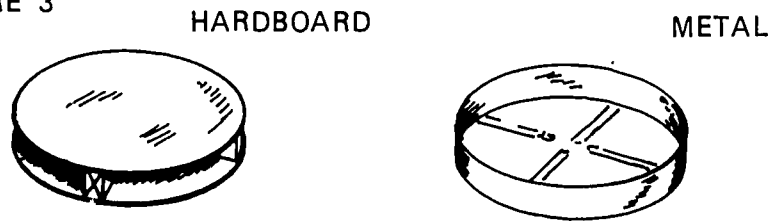

End closures can be made of wood or obtained from the manufacturer.

2. Lay void tubes on rebars
3. Install spacer on void tubes (Figure 4)

FIGURE 4

DETAILS OF A METHOD FOR SPACING AND TIE-DOWN

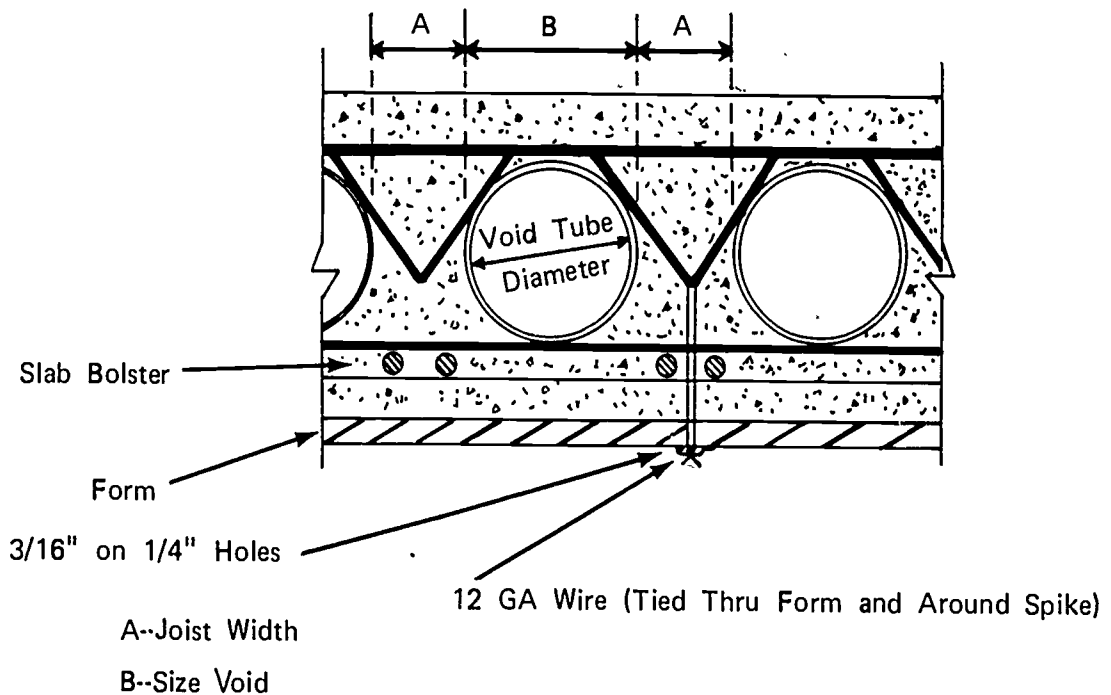

3. Cut wire to proper length

(NOTE: See Figure 4 which illustrated tie wire installation.)

JOB SHEET #5

4. Secure tie down spacers with pre-cut wire as shown in Figure 4

(NOTE: Tie down wire is looped over tie down spacer and both ends are inserted in pre-drilled hole in the deck and secured to a duplex nail driven into the under side of the deck.)

ABOVE GRADE SLAB SYSTEMS
UNIT VIII

TEST

1. Match the list of forming terms on the right to the correct definitions.

- | | |
|---|---------------------|
| _____ a. A piece of wood or other material that directs, resists, or supports weight or pressure | 1. Flying forms |
| _____ b. A piece of material nailed across a splice to strengthen and hold it together | 2. Void tube |
| _____ c. A prop placed against or beneath an object for support | 3. Dorne |
| _____ d. A piece of material used to resist horizontal pressure | 4. Open centering |
| _____ e. A piece of heavy material placed across several shores; a horizontal or inclined supporting member | 5. Waffel |
| _____ f. A single or multi-strand of high tensil wire or a rod used to stress concrete | 6. Stringer |
| _____ g. A process of introducing internal stresses after concrete has reached a predetermined strength | 7. Wedge |
| _____ h. Paraffin oil or other manufactured product applied to a form to prevent adhesion of concrete to the form | 8. Deck |
| _____ i. A horizontal board used to hold shores in alignment and to restrict lateral movement | 9. Par |
| _____ j. A tapered piece of wood or metal | 10. Brace |
| _____ k. A single section of manufactured form used to mold exposed voids in a one-way joist system | 11. Ribbon |
| _____ l. A manufactured tube of metal or fiber used to create concealed voids in slabs | 12. Scab |
| | 13. Post-tensioning |
| | 14. Kicker |
| | 15. Tendon |
| | 16. Form oil |
| | 17. Shore |

- _____ m. Framing for pans and domes comprised of joist soffit forms and headers
- _____ n. The horizontal sheathing that supports the wet concrete
- _____ o. A manufactured product which forms an exposed void in a waffle slab system
- _____ p. The design of a slab which is poured on domes; also, a two-way joist system
- _____ q. A system whereby a large section of slab forms is removed with a crane and flown to the next pour location

2. Identify nine parts of slab forming systems by placing the correct numbers in the blanks below.

- | | |
|----------------------------|------------------|
| _____ a. Shore | _____ f. Dome |
| _____ b. Joist soffit form | _____ g. Pan |
| _____ c. Header | _____ h. Wedge |
| _____ d. Deck | _____ i. End cap |
| _____ e. Stringer | |

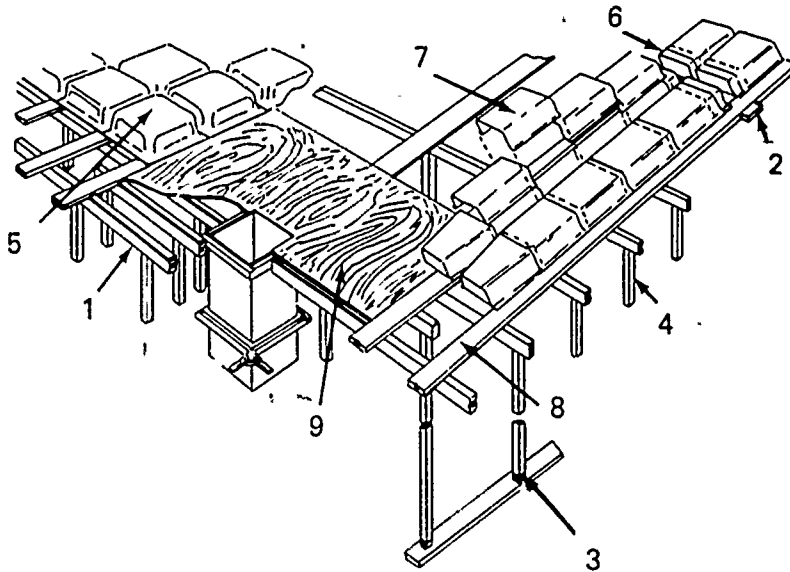

3. Identify the three types of slabs pictured below.

a.

b.

c.

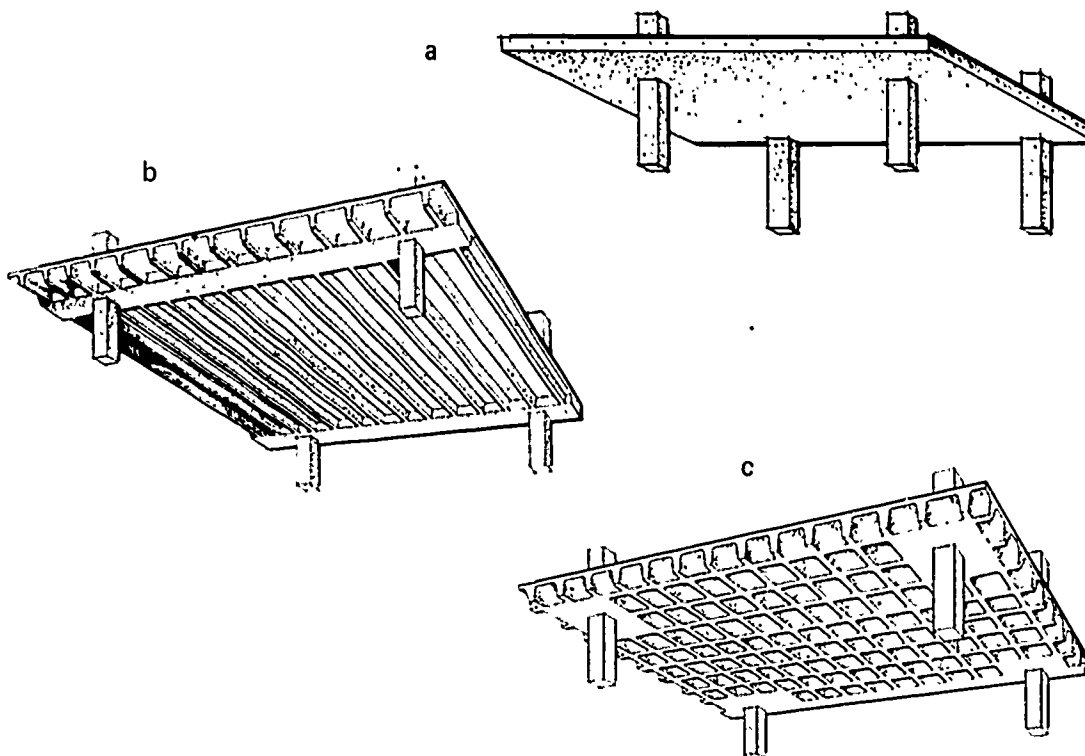

4. Name the types of slabs that can be post-tensioned.

5. List three materials used to manufacture pans and domes.

a.

b.

c.

6. List two materials used to manufacture void tubes.

a.

b.

ABOVE GRADE SLAB SYSTEMS
UNIT VIII

ANSWERS TO TEST

1.
 - a. 10
 - b. 12
 - c. 17
 - d. 14
 - e. 6
 - f. 15
 - g. 13
 - h. 16
 - i. 11
 - j. 7
 - k. 9
 - l. 2
 - m. 4
 - n. 8
 - o. 3
 - p. 5
 - q. 1
2.
 - a. 4
 - b. 8
 - c. 2
 - d. 9
 - e. 1
 - f. 5

- g. 7
 - h. 3
 - i. 6
3. a. Flat slab
b. One-way joist
c. Two-way joist (waffle)
4. All types of slabs may be post-tensioned
5. The following answers may be given in any order.
- a. Molded fiber glass
 - b. Steel
 - c. Molded fiber (wood or paper)
6. The following answers may be given in any order.
- a. Steel
 - b. Fiber (paper)
7. The following answers may be given in any order.
- a. Adjustable form
 - b. Flange form
 - c. Long form
 - d. Dome form
8. Flying form slab system
9. Performance skills will be evaluated according to the criteria listed on the progress chart

FIREPROOF ENCASUREMENT FORMS UNIT IX

TERMINAL OBJECTIVES

After completion of this unit, the student should be able to define beam and column form terms, define the term fireproof encasement, and write the purpose of it. He should be able to identify the parts of a form and tell what the major differences are between fireproof encasement and structural concrete forms. He should also be able to construct column, beam, and slab forms for fireproof encasement. This knowledge will be evidenced through demonstration and by scoring eighty-five percent on the unit test.

SPECIFIC OBJECTIVES

After completion of this unit, the student should be able to:

1. Define beam form terms.
2. Define the term fireproof encasement.
3. Write the purpose of fireproof encasement.
4. List two pieces of special hardware used to erect fireproof encasement forms.
5. Name the parts of a form.
6. List two major differences in the erection of fireproof encasement forms and structural concrete forms.
7. Demonstrate the ability to construct fireproof encasement forms for columns and beams.

FIREPROOF ENCASMENT FORMS UNIT IX

SUGGESTED ACTIVITIES

- I. Instructor:
 - A. Provide students with objective sheet.
 - B. Provide students with information and job sheets.
 - C. Make transparencies.
 - D. Discuss terminal and specific objectives.
 - E. Discuss information sheet.
 - F. Demonstrate and discuss procedures outlined in job sheet.
 - G. Give test.
- II. Student:
 - A. Read objective sheet.
 - B. Study information sheet.
 - C. Demonstrate the ability to accomplish the procedures outlined in the job sheet.
 - D. Take test.

INSTRUCTIONAL MATERIALS

- I. Included in this unit:
 - A. Objective sheet
 - B. Information sheet
 - C. Transparency masters
 1. TM 1--Beam Hanger and Joist Soffit
 2. TM 2--Parts of a Form
 - D. Job Sheet #1--Column and Beam Forms
 - E. Test
 - F. Answers to test

II. References:

- A. Burke, Arthur E., J. Ralph Dalzell, and Gilbert Townsend. *Architectural and Building Trades Dictionary*. Chicago, Illinois: American Technical Society, 1955.
- B. Smith, Ronald C. *Principles and Practices of Heavy Construction*. Englewood Cliffs, New Jersey: Prentice Hall, Inc., 1967.

691

~~684~~

FIREPROOF ENCASUREMENT FORMS
UNIT IX

INFORMATION SHEET

- I. Terms and definitions
 - A. Brace--A piece of wood or other material that directs, resists, or supports weight or pressure
 - B. Beam bottom--That part of a beam form which supports the vertical pressure
 - C. Beam side--A stud frame and sheathing section which comprises the vertical section of a beam form
 - D. Monolithic pour--A continuous mass of concrete cast as a single piece
 - E. Beam hanger--A steel hanger which supports the beam and slab forms
 - F. Soffit spacer--A piece of metal used to hold the beam bottom a predetermined distance from the structural steel
 - G. Ledger--A horizontal board nailed to a form to support intersecting horizontal members
 - H. Stringer--A piece of material placed across several shores; a horizontal or inclined supporting member
 - I. Form oil--Paraffin oil or other manufactured product used on a form to prevent adhesion of concrete to the form
- II. Fireproof encasement--The structural steel members are encased in concrete
- III. Purpose of fireproof encasement--To protect the structural steel against deterioration caused by overheating
- IV. Special hardware used to erect fireproof encasement forms (Transparency 1)
 - A. Beam--hangers
 - B. Soffit spacers
- V. Parts of a form (Transparency 2)
 - A. Beam side
 - B. Beam hanger
 - C. Decking
 - D. Joist
 - E. Stringer

INFORMATION SHEET

F. Column clamp

G. Ledger

H. Ledger support leg

I. Kicker

J. Beam bottom

K. Beam hanger wedge

L. Soffit spacer

VI. Major differences between erection of fireproof encasement forms and structural concrete forms

A. Through ties can not be used on fireproof encasement forms

B. Shores do not have to be used to support beam and slab forms for fireproof encasement

Beam Hanger and Joist Soffit

Made in 1" to 4" lengths as required.

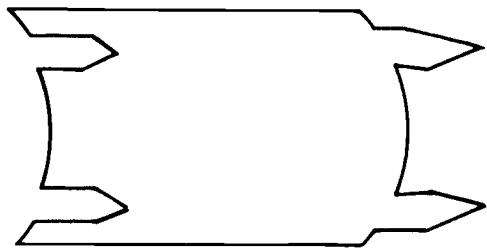

Soffit Spacer

Available in these sizes:
1 1/2"; 2"; 3".
They can also be furnished in heights over 3".

No. C-18 No. C-20

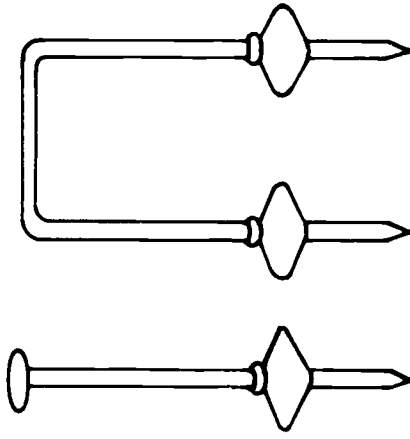

Single and Double Spacers

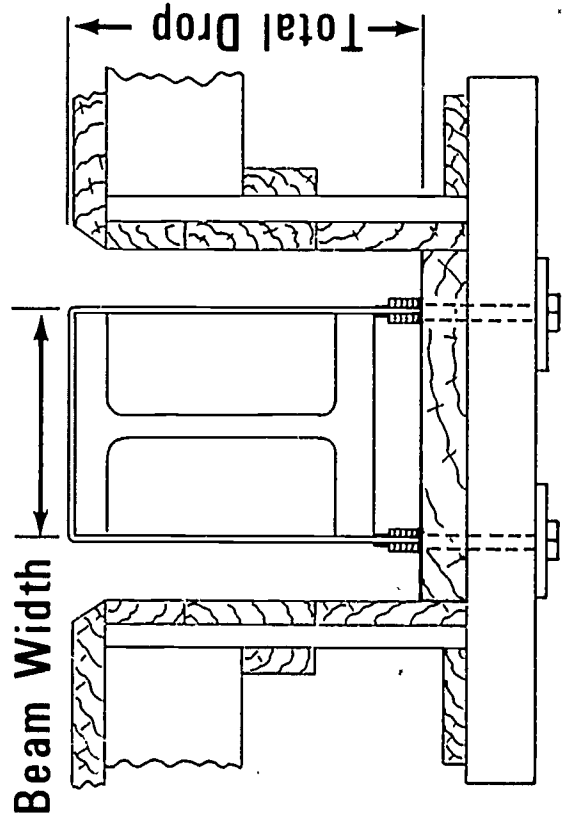

Same construction as standard coil tie.
Working loads per side: 3000 lbs. for 1/2", 7500 lbs. for 3/4" and 10,000 lbs. for 1". Ordering: Give beam width, diameter and total drop.

Parts of a Form

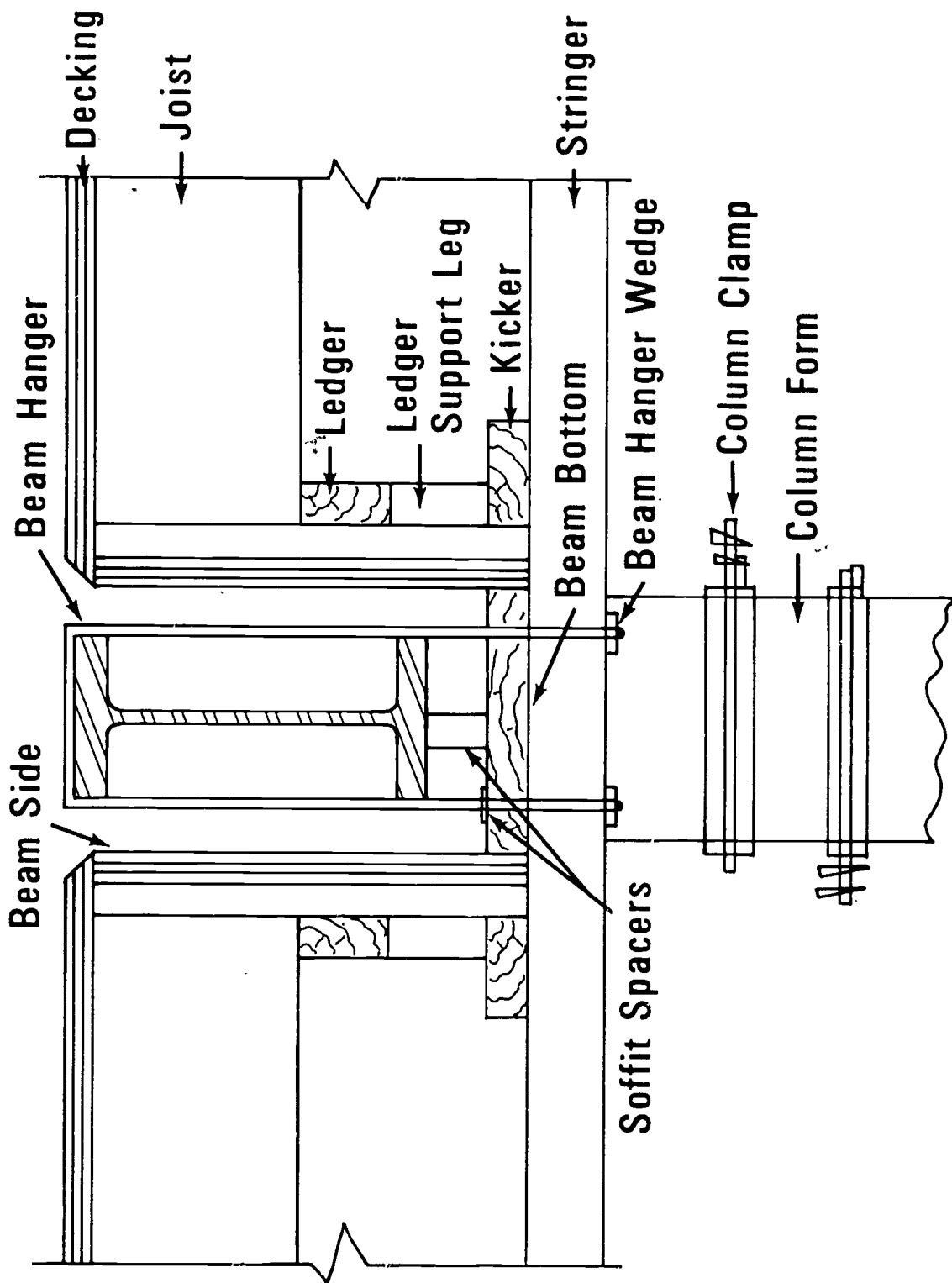

FIREPROOF ENCASEMENT FORMS
UNIT IX

JOB SHEET #1--COLUMN AND BEAM FORMS

(NOTE: Forms for structural concrete columns and beams are constructed very similarly.)

I. Tools and materials needed

A. Tools

1. Hammer (16 oz. or larger)
2. Handsaw (crosscut)
3. Electric handsaw
4. String line
5. Electric drill
6. Drill bits (size of hanger)

B. Material

1. Sheathing--Plywood
2. Stringers--4 x 4's
3. Beam bottom--2" thick material
4. Studs, top plates, and kickers--2 x 4's
5. Bottom plates and cleats--1 x 4's
6. Soffit spacers
7. Column clamps
8. Ledgers--2 x 6's
9. Ledger support legs--2 x 4's

II. Procedures

- A. Secure material
- B. Determine size of beams and columns
- C. Cut material to size
 1. Cut stringers to length

(NOTE: Stringer should extend past beam forms on each side to support deck and beam side kicker.)

JOB SHEET #1

2. Cut column plywood to size (Figure 1)

(NOTE: The height of the column form will be the distance from the floor to the underside of the decking.)

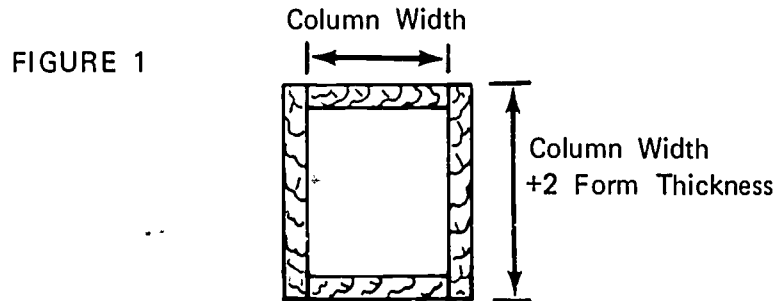

3. Cut out beam pocket in column side (Figure 2)

(NOTE: The size of the beam pocket should show the beam bottom and beam sides to extend to the inside of the column form.)

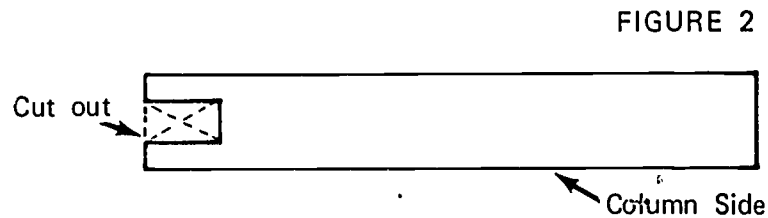

4. Cut beam plywood to size (Figure 3)

(NOTE: Beam side should set on the stringer and the decking should set on the beam side.)

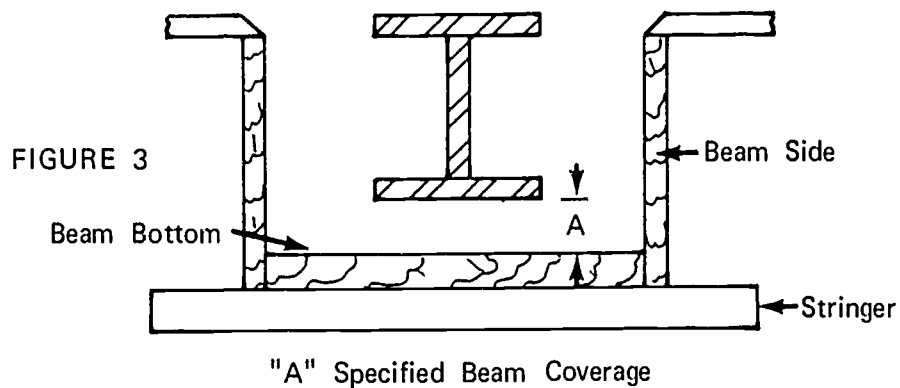

JOB SHEET #1

5. Cut column studs

(NOTE: Column studs will be the same length as the beam sides.)

6. Cut beam studs

(NOTE: Beam studs will be the height of the beam side minus the top and bottom plates.)

D. Assemble column and beam sides

1. Assemble the column sides (Figure 4)

FIGURE 4

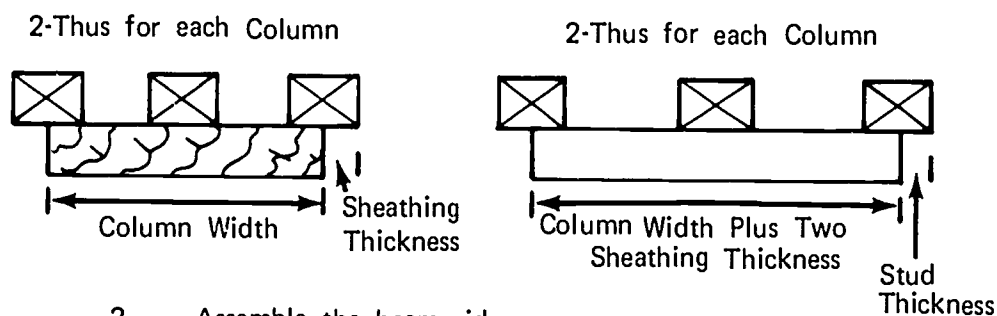

2. Assemble the beam sides

- a. Lay out stud spacing on plate
- b. Nail studs to plates
- c. Nail sheathing to studs

E. Build beam bottom (Figure 5)

1. Cut filler piece to correct width

FIGURE 5

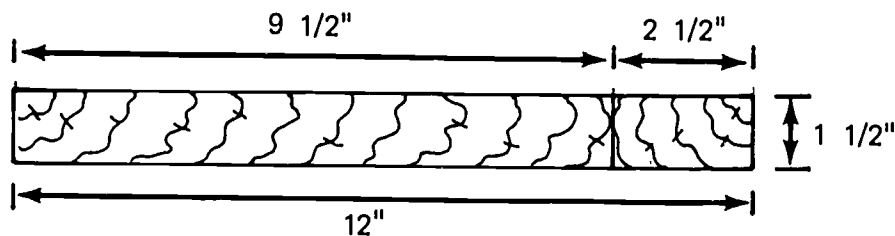

(NOTE: If a 2 x 4 was used to cut the 2 1/2" piece, there would be 1" waste. Two pieces 2 1/2" wide can be cut from a 2 x 6 with less than 1/2" waste for the two pieces.)

JOB SHEET #1

2. Cleat the pieces together (Figure 6)

(NOTE: Space cleats to miss beam hanger location.)

FIGURE 6

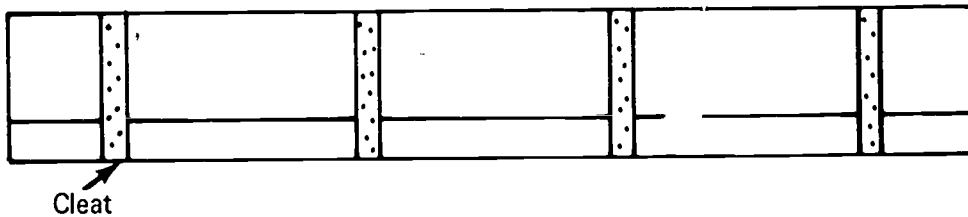

3. Drill holes for hangers in beam bottom
4. Drill holes in stringer to match cross spacing in beam bottom

F. Coat all forms with form oil

G. Erect column forms

(NOTE: If any type of reinforcing is called for, it should be installed on columns and beams before forms are erected.)

1. Lay out column center lines
2. Nail column template to floor (Figure 7)

(NOTE: Template should be size of outside of column form.)

FIGURE 7

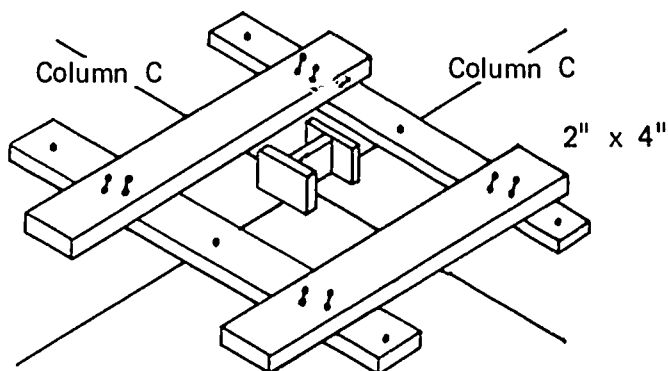

JOB SHEET #1

- Determine column clamp spacing (Figure 8)

(NOTE: Raise bottom spacing to clear template.)

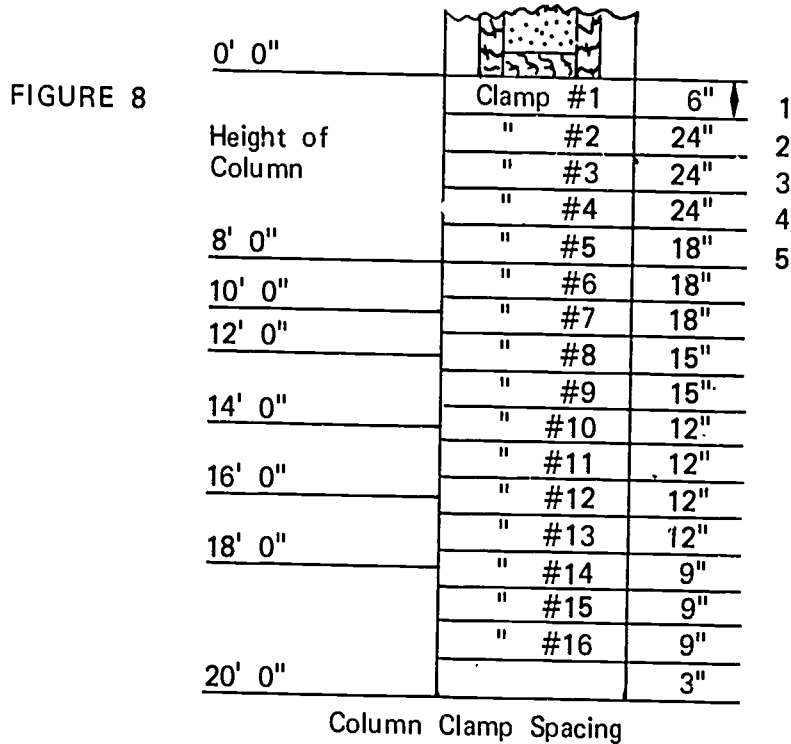

- Lay out template for column clamp spacing
- Stand opposing columns sides in template and nail corner studs
(NOTE: Use duplex nails.)
- Stand the other two sides in template and nail as in B
- Stand template at column corners and mark clamp locations on corner studs
- Drive a 16d nail at each mark (Figures 9a and 9b)

(NOTE: These nails serve to support the clamp during installation. Check type of clamp being used for side location of nails.)

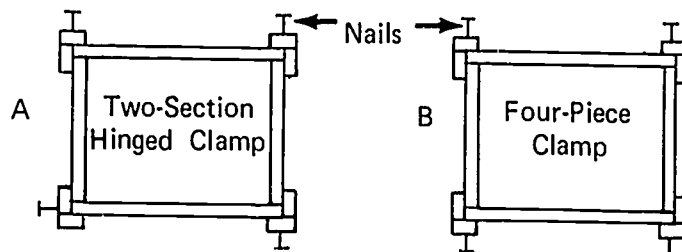

JOB SHEET #1

9. Lay sections of column clamp on column and secure wedges (Figure 10)

FIGURE 10

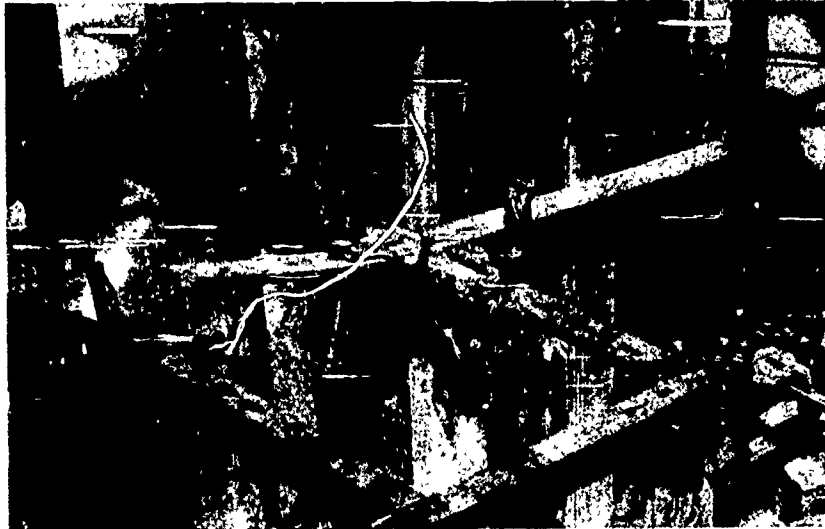

10. Place a wood spacing block between the stud beam and form to hold it plumb

H. Hang beam bottoms

1. Place beam hanger over steel beam close to end of first section of beam bottom
2. Nail a stringer to beam bottom
(NOTE: This should be on the end away from the column. Line up holes for hanger.)
3. Drive soffit spacers into beam bottom
4. Insert on end of the beam bottom into pocket cut out in column side
5. Raise the other end and insert beam hanger in pre-drilled holes
6. Install and secure wedges (Figure 11)

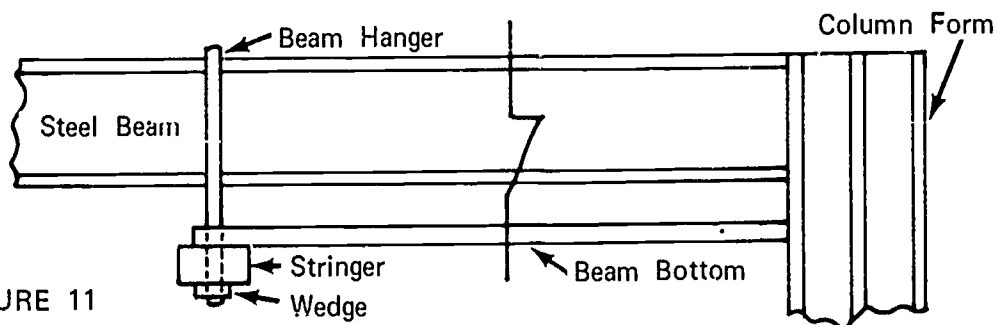

FIGURE 11

JOB SHEET #1

7. Install intermediate beam hangers
8. Repeat steps 1 through 7 to continue erection

(NOTE: The first end of the beam bottom will rest on the stringer instead of the column form.)

- I. Install beam sides, kicker, and ledger (Figure 12)

FIGURE 12

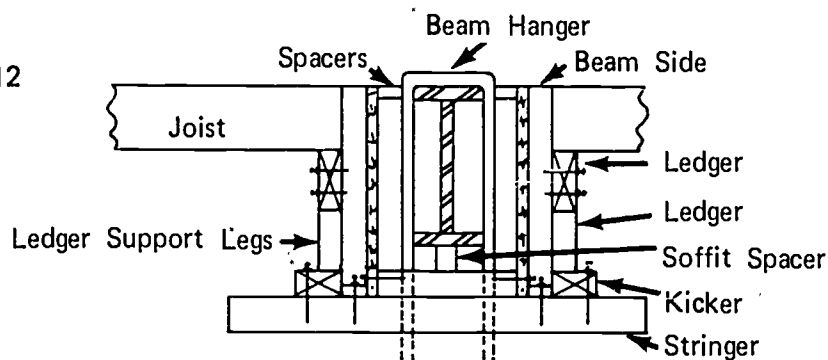

1. Nail beam side to stringer and beam bottom
2. Nail continuous kicker to stringer
3. Nail ledger to studs

(NOTE: Ledger is located to place the top of the joist flush with the top of the beam side.)

4. Cut ledger support legs to length and nail to studs
5. Align top of beam
 - a. Cleat across the beam sides to establish correct width
 - b. Insert correct length spacer between form and flange of beam to align

(NOTE: The forms are now ready to receive joist and decking for a flat slab.)

FIREPROOF ENCASUREMENT FORMS
UNIT IX

TEST

1. Match the following list of beam and column form terms to the correct definitions.

- | | |
|--|--------------------|
| _____ a. A piece of wood or other material that directs, resists, or supports weight or pressure | 1. Soffit spacer |
| _____ b. That part of a beam form which supports the vertical pressure | 2. Monolithic pour |
| _____ c. A stud frame and sheathing section which comprises the vertical section of a beam form | 3. Brace |
| _____ d. A continuous mass of concrete cast as a single piece | 4. Stringer |
| _____ e. A steel hanger which supports the beam and slab forms | 5. Beam side |
| _____ f. A piece of metal used to hold the beam bottom a predetermined distance from the structural steel | 6. Ledger |
| _____ g. A horizontal board nailed to a form to support intersecting horizontal members | 7. Form oil |
| _____ h. A piece of material placed across several shores; a horizontal or inclined supporting member | 8. Beam hanger |
| _____ i. Paraffin oil or other manufactured product used on a form to prevent adhesion of concrete to the form | 9. Beam bottom |

2. Define the term fireproof encasement.
3. Write the purpose of fireproof encasement.
4. List two pieces of special hardware used to erect fireproof encasement forms.
- a.
- b.

5. Identify twelve parts of the form illustrated below by placing the appropriate numbers in the blanks below.

- ____ a. Beam side
 ____ b. Beam hanger
 ____ c. Decking
 ____ d. Joist
 ____ e. Stringer
 ____ f. Column clamp
 ____ g. Ledger
 ____ h. Ledger support leg
 ____ i. Kicker
 ____ j. Beam bottom
 ____ k. Beam hanger wedge
 ____ l. Soffit spacer

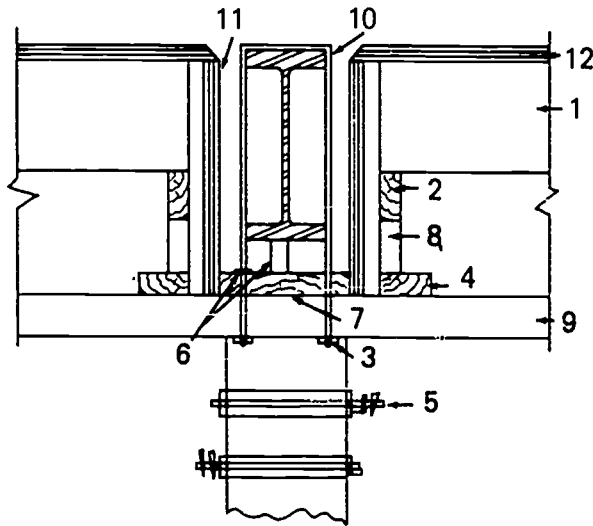

6. List two major differences between the erection of fireproof encasement forms and structural concrete forms.

- a.
b.

7. Demonstrate the ability to construct fireproof encasement forms for columns and beams.

(NOTE: If this has not been accomplished prior to the test, ask the instructor when the above activity should be completed.)

FIREPROOF ENCASUREMENT FORMS
UNIT IX

ANSWERS TO TEST

1.
 - a. 3
 - b. 9
 - c. 5
 - d. 2
 - e. 8
 - f. 1
 - g. 6
 - h. 4
 - i. 7
2. The structural steel members are encased in concrete
3. To protect structural steel against deterioration caused by overheating
4. The following answers may be given in any order.
 - a. Beam hangers
 - b. Soffit spacers
5.
 - a. 11
 - b. 10
 - c. 12
 - d. 1
 - e. 9
 - f. 5
 - g. 2
 - h. 8
 - i. 4
 - j. 7

- k. 3
 - l. 6
6. The following answers may be given in any order.
- a. Through ties can not be used on fireproof encasement forms
 - b. Shores do not have to be used to support beam and slab forms for fireproof encasement
7. Performance skills will be evaluated according to the criteria listed on the progress chart.

BRUNNEN
REPRODUCTION
PROHIBITED

STAIR FORMS UNIT X

TERMINAL OBJECTIVE

Upon completion of this unit, the student should be able to define stair forming terms and identify the parts of a stair form. He should be able to name the types of stairs and identify stair plan shapes. He should also be able to detail stair forms and construct them. This knowledge will be evidenced by demonstration and by scoring eighty-five percent on the unit test.

SPECIFIC OBJECTIVES

After completion of this unit, the student should be able to:

1. Match a list of stair forming terms to a list of definitions.
2. Identify the parts of a stair form.
3. Name two types of concrete stairs.
4. Identify five stair plan shapes.
5. Name two types of stair slabs.
6. Draw one sectional detail of stair forms for each type of stair slab.
7. Demonstrate the ability to construct forms for:
 - a. Suspended slab stairs.
 - b. Slab on earth stairs.
 - c. Short flights of stairs.

STAIR FORMS
UNIT X

SUGGESTED ACTIVITIES

I. Instructor:

- A. Provide students with objective sheet.
- B. Provide students with information and job sheets.
- C. Make transparencies.
- D. Discuss terminal and specific objectives.
- E. Discuss information sheet.
- F. Demonstrate and discuss procedures outlined in job sheets.
- G. Give test.

II. Student:

- A. Read objective sheet.
- B. Study information sheet.
- C. Demonstrate the ability to accomplish the procedures outlined in the job sheets.
- D. Take test.

INSTRUCTIONAL MATERIALS

I. Included in this unit:

- A. Objective sheet
- B. Information sheet
- C. Transparency masters
 1. TM 1--Parts of a Stair Form
 2. TM 2--Types of Stairs
 3. TM 3--Stair Plan Shapes
 4. TM 4--Stair Plan Shapes (Continued)
 5. TM 5--Types of Stair Slabs

6. TM 6--Suspended Slab Stair Forms
7. TM 7--Suspended Slab Stair Forms (Continued)
8. TM 8--Earth Supported Stair Slab Forms

D. Job sheets

1. Job Sheet #1--Forms for Suspended Stairs
2. Job Sheet #2--Forms for Stairs on Earth
3. Job Sheet #3--Forms for Short Flights of Stairs

E. Test

F. Answers to test

II. References:

- A. Burke, Arthur E., J. Ralph Dalzell, and Gilbert Townsend. *Architectural and Building Trades Dictionary*. Chicago, Illinois: American Technical Society, 1955.
- B. *Concrete Form Construction*. Albany, New York: Delmar Publishers.

STAIR FORMS
UNIT X

INFORMATION SHEET

I. Terms and definitions

- A. Brace--A piece of wood or other material that directs, restricts, or supports weight or pressure
- B. Key--A beveled piece of wood or metal placed in a form where future pours occur
- C. Scab--A piece of wood or metal secured across a splice to strengthen and hold the two pieces together
- D. Decking--Wide boards, plywood, or metal that make up the horizontal face of a form
- E. Stake--Small boards or steel bars sharpened at one end and driven into the ground to support the form
- F. Form oil--Paraffin oil or a manufactured product used on a form to prevent adhesion of the concrete to the form
- G. Horse--An inclined supporting member of a stair form or stair
- H. Landing--A platform between flights of stairs
- I. Stair rise--The distance from the floor to the top of a landing or to the floor above
- J. Riser--The vertical part of a stair step
- K. Stair run--The horizontal distance between the first riser and the face of the platform or stair opening above
- L. Tread--The horizontal part of a stair step
- M. Pitch board--A wood block used to lay out or support treads and risers
- N. Batter--The forward inclination of a riser
- O. Bent--A framework designed to carry lateral as well as vertical loads
- P. Stairwell--A compartment extending vertically through the building and in which stairs are placed
- Q. Framing square gauge--A device attached to a framing square to secure accuracy when laying out material

INFORMATION SHEET

- R. Kicker--In construction, a piece of wood or other material secured to a fixed object or wedged against an object to support weight or pressure
 - S. Bulkhead--A vertical board placed in a form to cut off the concrete pour
 - T. Spreader--A piece of wood or metal used to hold the sides of a form apart until the concrete is poured
- II. The parts of a stair form (Transparency 1)
- A. Horse
 - B. Joist
 - C. Block
 - D. Riser form
 - E. Side form
 - F. Sheathing
 - G. Edge forms
 - H. Brace
 - I. Stringer
 - J. Shore
 - K. Wedge
 - L. Sill
 - M. Scab
 - N. Kicker
 - O. Bulkhead
 - P. Spreader
- III. Types of stairs (Transparency 2)
- A. Rough
 - B. Finished

INFORMATION SHEET

IV. Stair plan shapes (Transparencies 3 and 4)

- A. Straight flight
- B. Straight flight with landing
- C. Ninety degree change stair with landing
- D. Ninety degree stair with winders
- E. Stair with landing returning 180°

V. Types of stair slabs (Transparency 5)

- A. Suspended
- B. Earth supported

VI. Details of stair forms for each type of slab (Transparencies 6, 7, and 8)

- A. Suspended
- B. Earth supported

Parts of a Stair Form

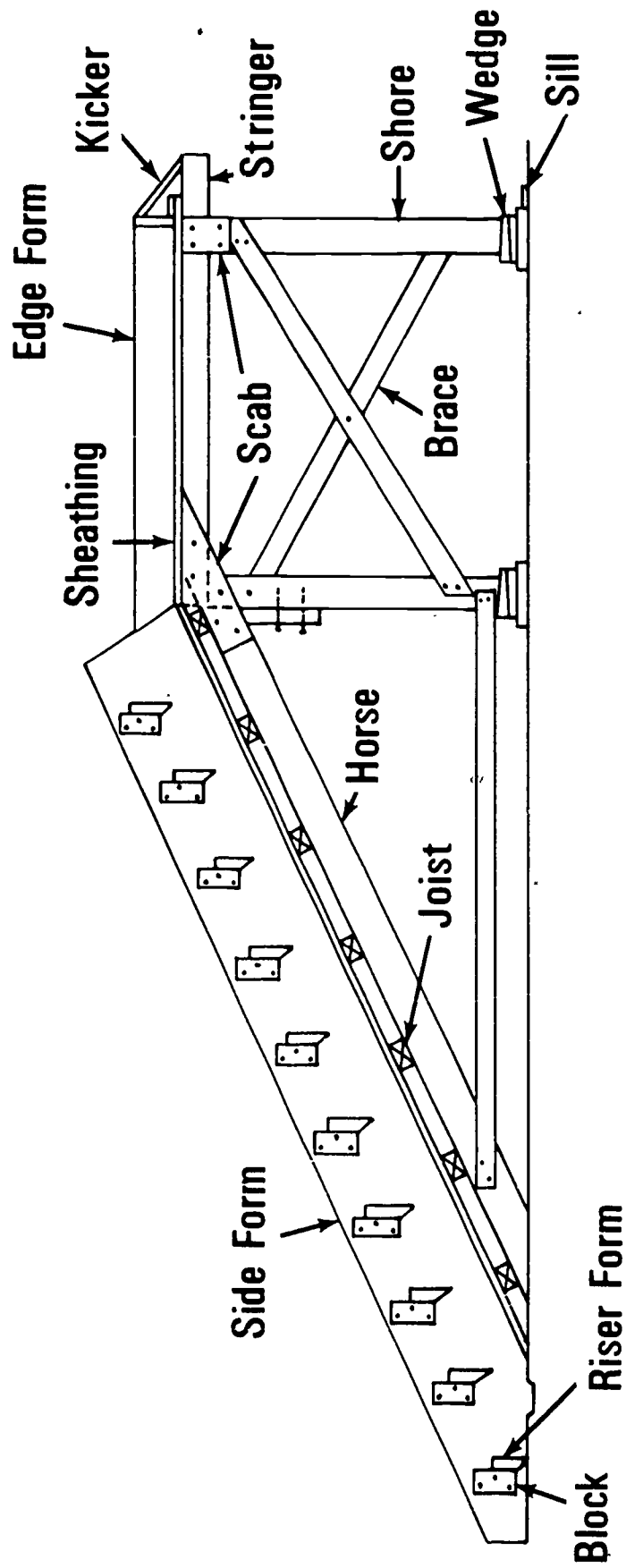

Types of Stairs

ROUGH STAIR

(Not a Monolithic Pour)

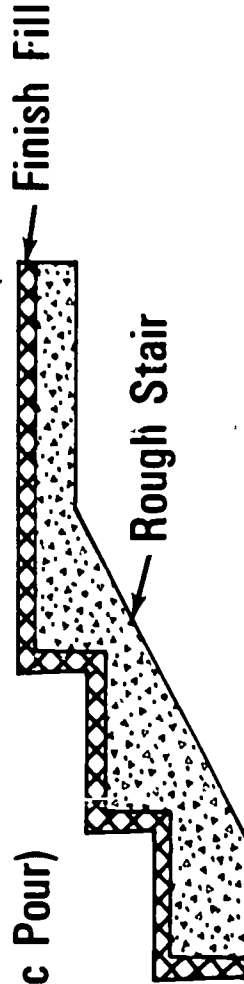

(Note: Finish Fill may be Terrazzo, Concrete, Ceramic Tile, Stone or other similar materials.)

FINISHED STAIR (Monolithic Pour)

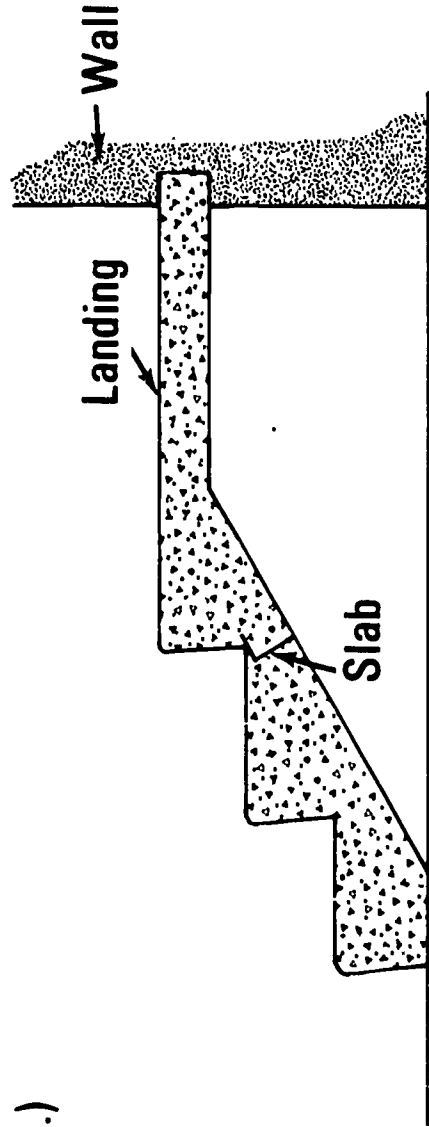

Stair Plan Shapes

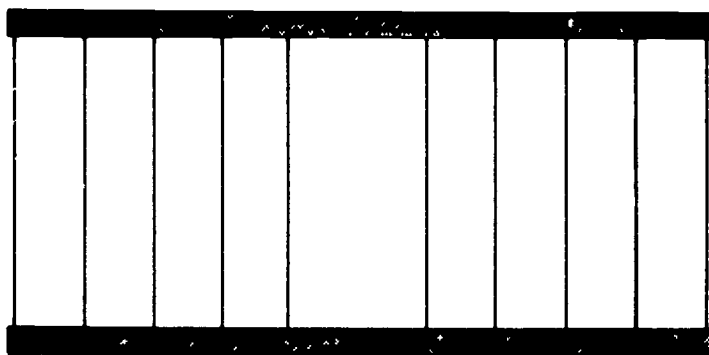

**STRAIGHT FLIGHT
WITH LANDING**

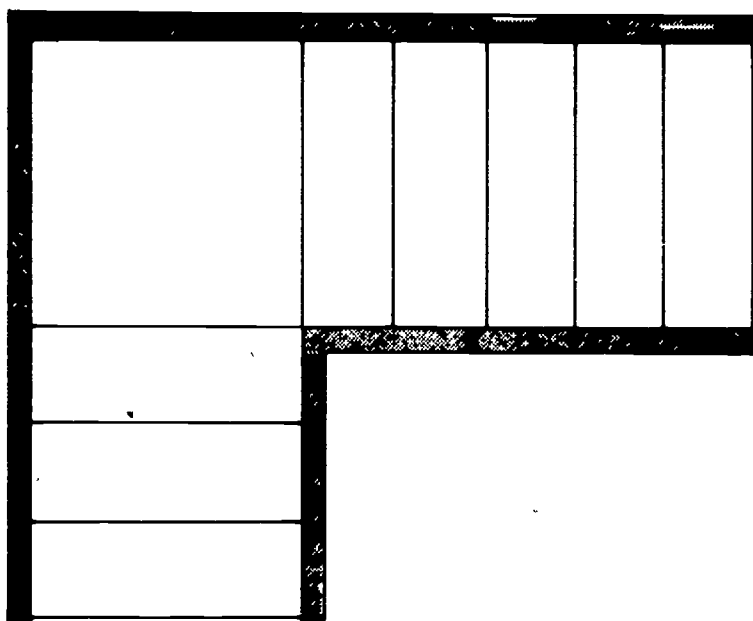

**90° FLIGHTS
WITH LANDING**

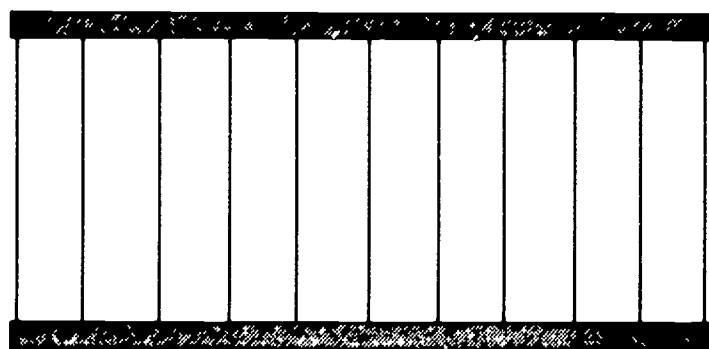

STRAIGHT FLIGHT

Stair Plan Shapes

(CONTINUED)

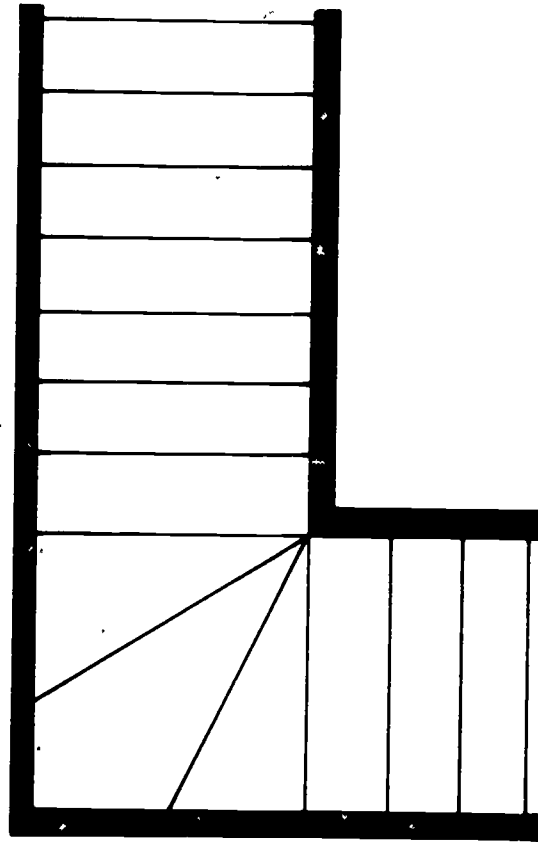

90° FLIGHTS WITH WINDERS

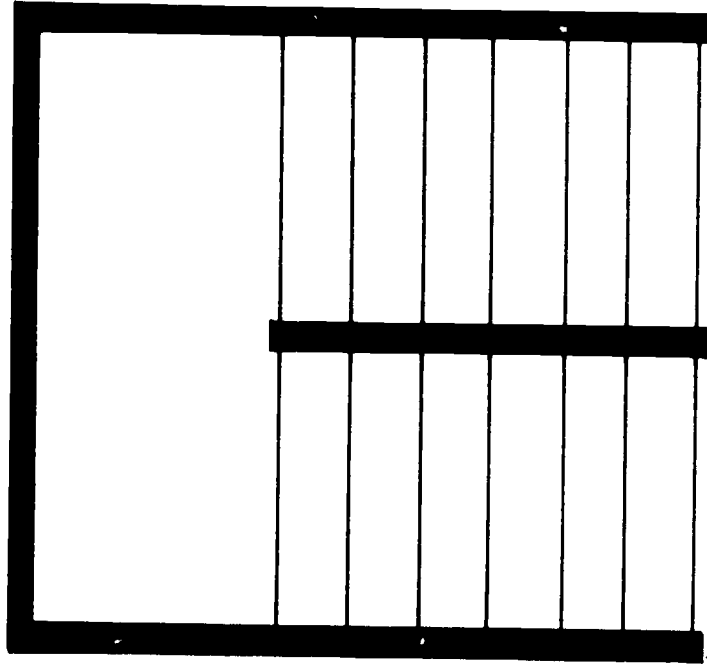

180° FLIGHTS WITH LANDING

Types of Stair Slabs

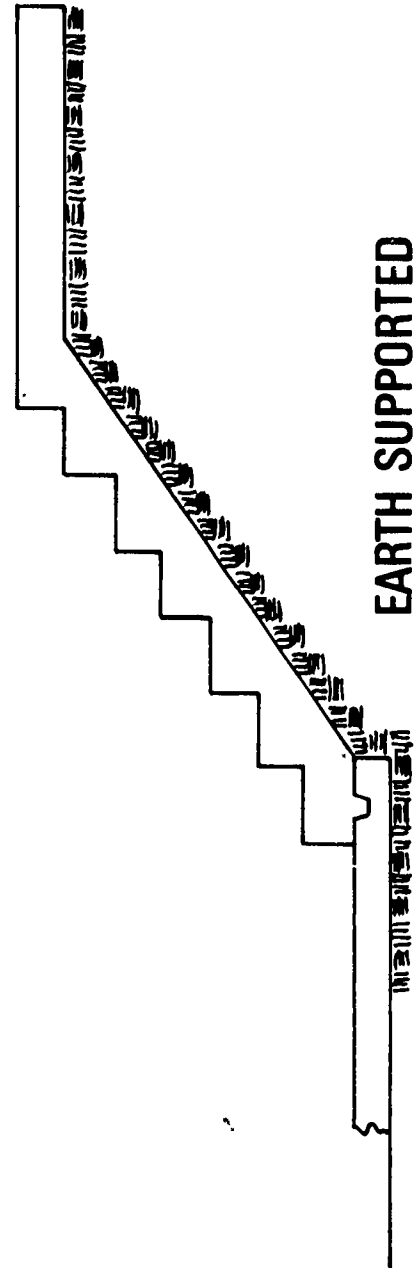
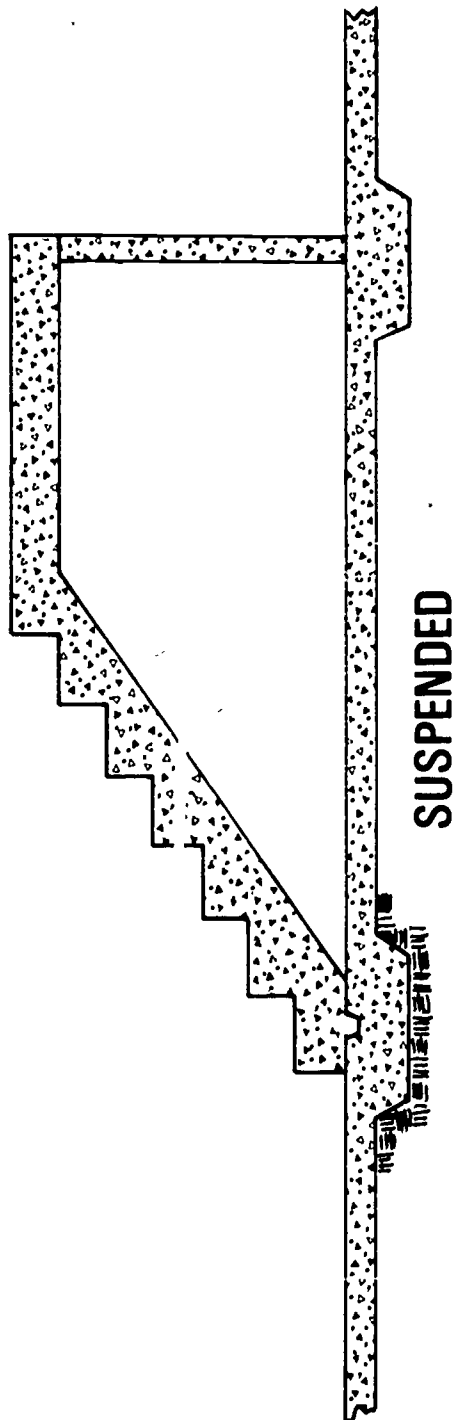

Suspended Slab Stair Forms

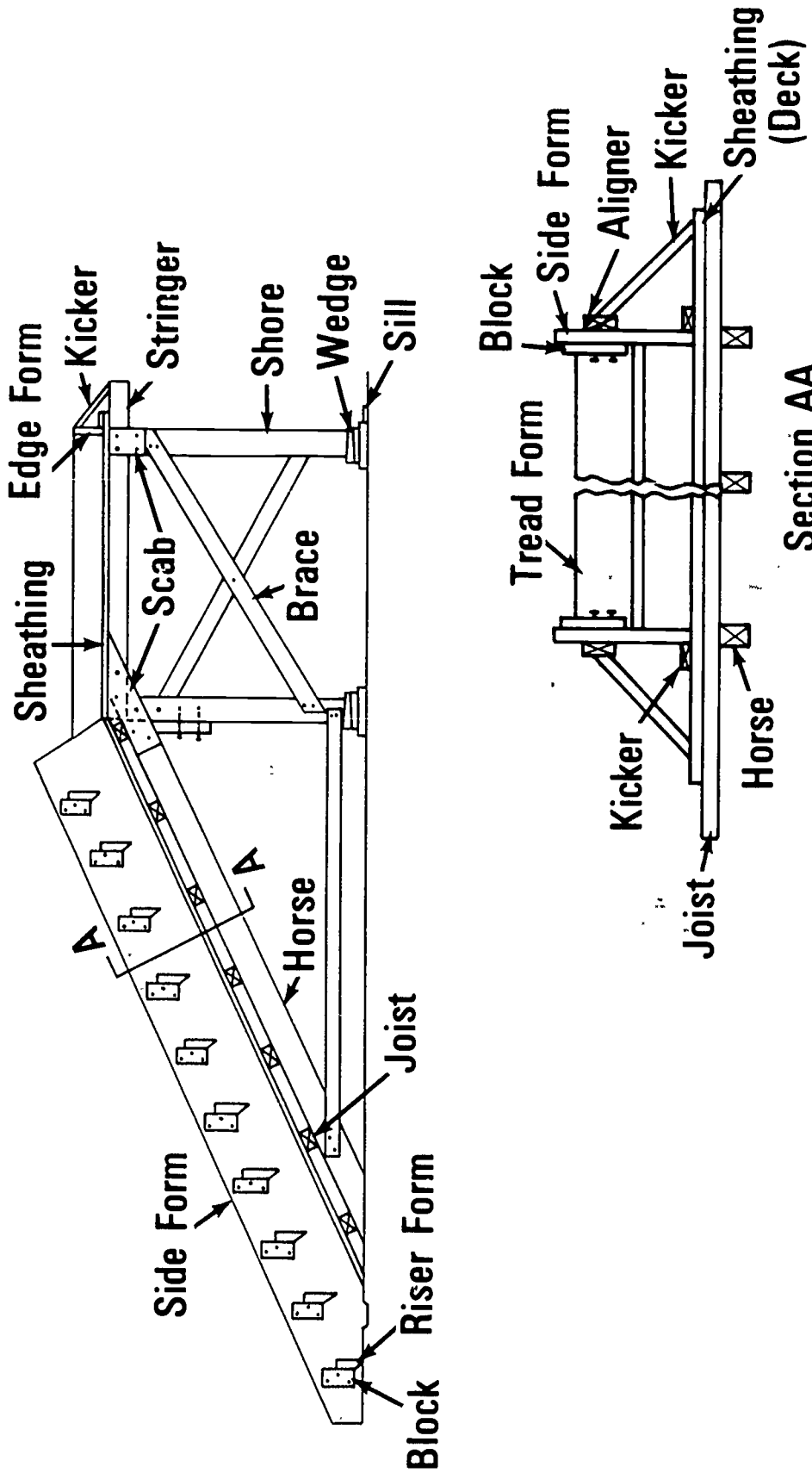

FORMS FOR STAIRS OPEN ON THE SIDES

Suspended Slab Stair Forms

(CONTINUED)

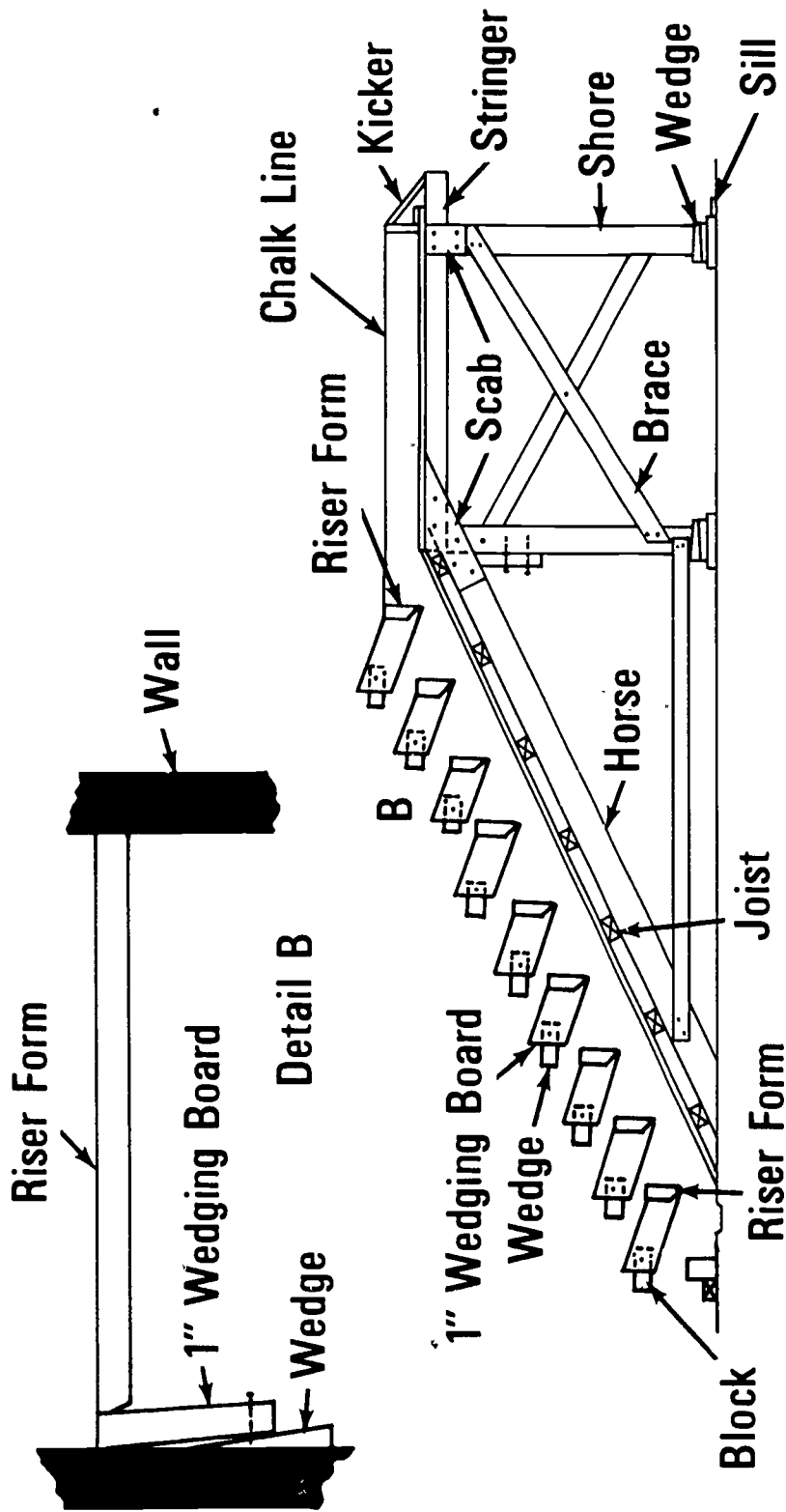

FORMS FOR STAIR BETWEEN WALLS

Earth Supported Stair Slab Forms

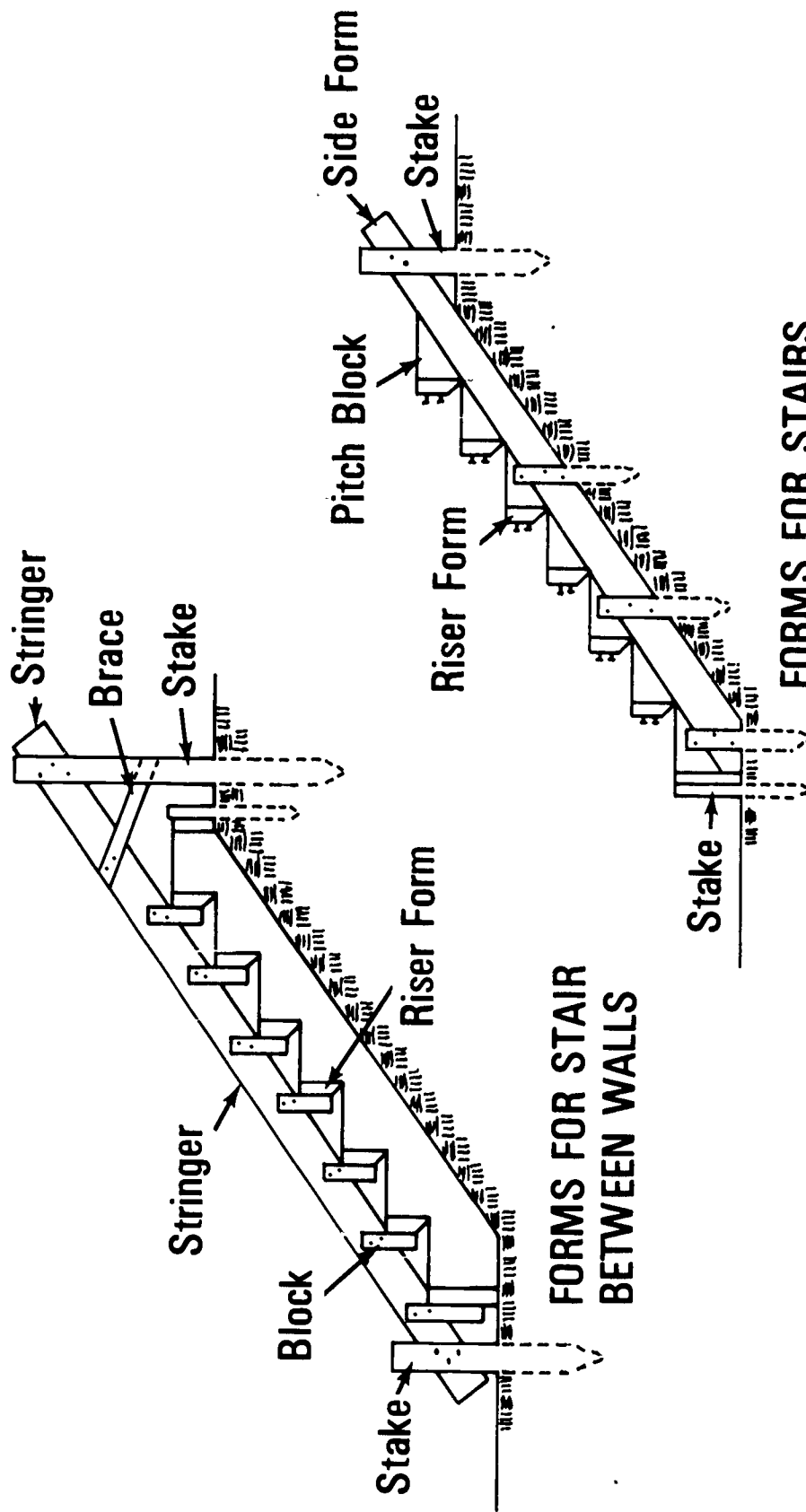

**FORMS FOR STAIR
BETWEEN WALLS**

**FORMS FOR STAIRS
OPEN ON THE SIDES**

STAIR FORMS
UNIT X

JOB SHEET #1--FORMS FOR SUSPENDED STAIRS

(NOTE: These forms are for stairs open at the sides.)

I. Tools and materials needed

A. Tools

1. Hammer (16 oz. or larger)
2. Handsaw (Crosscut)
3. Electric handsaw
4. Level (hand)
5. Builder's level
6. Framing square
7. Tape measure (12' or 16')
8. Framing square gauges

B. Materials

1. Side forms and decking--Plywood
2. Stakes, aligners, and blocks--2 x 4's
3. Braces--1 x 4's
4. Shores, horses, joist, and stringers--4 x 4's
5. Wedges--1 1/2" x 4" x 10"
6. Risers--2 x 8's

II. Procedure

A. Make a pitch board (Figure 1)

1. Place gauges on square to correspond to rise and run of a stair unit

JOB SHEET #1

- Place square on a thin board; mark and cut as shown in Figure 1

FIGURE 1

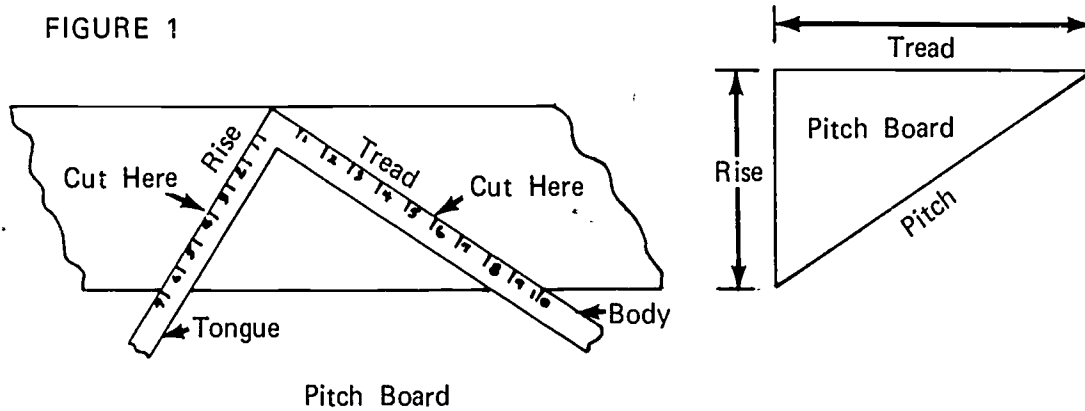

- Cut material to size (Figure 2)

FIGURE 2

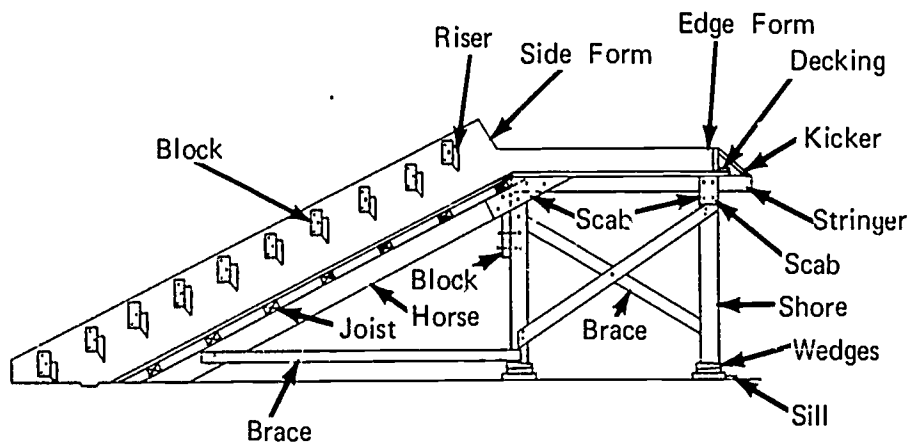

- Shores

(NOTE: Deduct decking, stringer, sill, and wedge thicknesses from the bottom of slab height to obtain shore length.)

JOB SHEET #1

2. Stringers

(NOTE: Stringers should project past the platform a distance equal to the height of the edge form.)

3. Cut side forms to width

(NOTE: Use the pitch board. Measure the step and slab thickness on a line 90° to the pitch, and at the intersection of the tread and riser, add two inches to determine width.)

4. Frame beam sides

(NOTE: Measure length of pitch on pitch board, multiply by the number of treads, and add one foot to determine length.)

5. Cut joist to length

(NOTE: Joist length will be the width of the slab plus the height of two side forms.)

6. Cut edge forms

(NOTE: Edge form width will be the same as the slab thickness.)

7. Cut horse scabs

(NOTE: Lay pitch board on material with the pitch side flush with the bottom and cut on the tread side.)

8. Cut horse blocks

(NOTE: Lay pitch board on edge of material with the pitch side flush with the bottom and cut on the riser side.)

JOB SHEET #1

9. Size riser forms (Figure 3)

(NOTE: When pouring a rough stair, it is not necessary to cut the bottom of the riser form at a 45° angle.)

- a. Cut to riser height
- b. Cut to stair width
- c. Cut 45° bevel on bottom edge

FIGURE 3

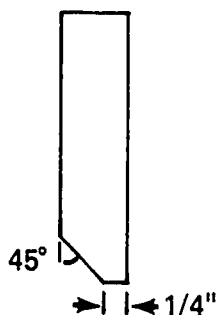

C. Lay out beam sides (Figure 4)

(NOTE: Two beams sides are needed, one right hand and one left hand.)

FIGURE 4

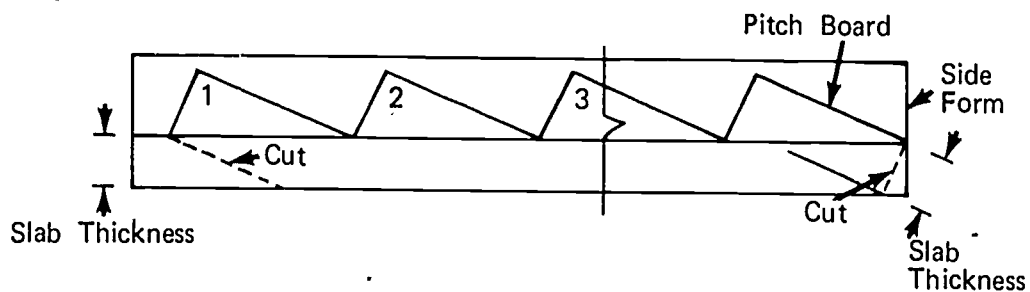

1. Scribe a pencil line on the form equal to the thickness of the slab
 2. Lay pitch side of pitch board on line and mark tread and riser position #1 as illustrated in Figure 4
 3. Move pitch board to position #2 and mark tread and riser
- (NOTE: Intersect all lines accurately. Use a sharp pencil.)
4. Repeat step 3 to lay out step number 3 and all other steps in the flight
 5. Lay out and cut ears as shown by dotted lines

JOB SHEET #1

D. Lay out and cut horses

1. Determine length (Figure 5)

FIGURE 5

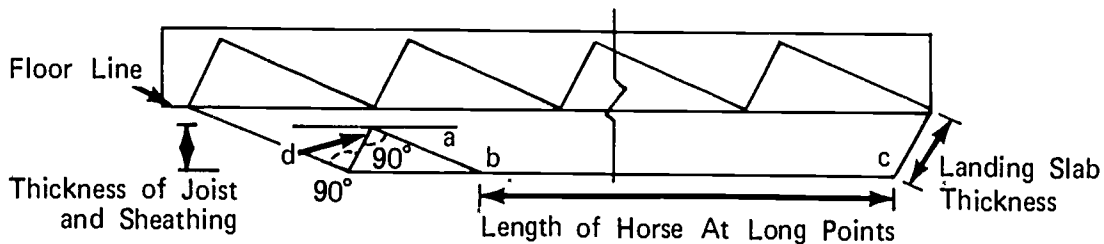

- a. Scribe a line equal to the thickness of the joist and sheathing establishing line "a"
- b. Square from intersection of floor line and bottom of side form to intersect with line "a"
- c. Square from this line to make point "b" intersect with the bottom edge of the form
- d. Measure from point "b" to point "c" to determine length of horse
- e. Lay out this length on horse

(NOTE: These are the long points of the horse.)

- f. Lay out top and bottom cuts (Figure 6)

FIGURE 6

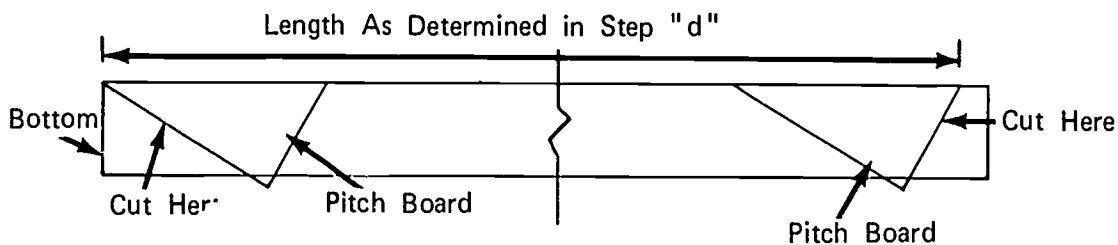

- g. Cut on lines as shown in Figure 5

JOB SHEET #1

E. Erect shores and stringers

1. Nail two shores to each stringer and X brace (Figure 7)

FIGURE 7

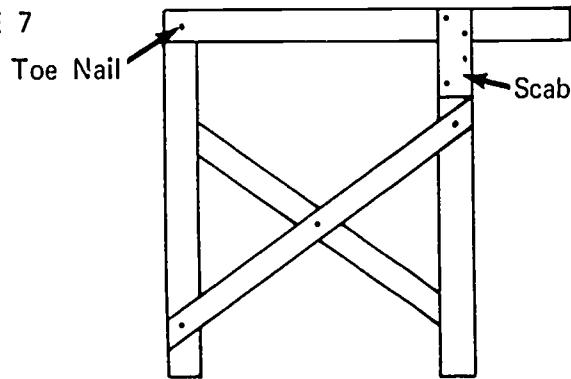

(NOTE: Place a block the thickness of the shore between braces to nail crossing point.)

2. Lay sills on floor at location of shores
3. Tack wedges to sill at shore locations
4. Stand end shore bents upright, tack spacer board across the top, and X brace
5. Install intermediate shore bents

F. Install horses

1. Tack top of the horse to shore

(NOTE: Measure length of line "d" (Figure 5) from top of decking to determine location.)

2. Nail cleat across horse, stringer, and shore
3. Repeat steps 1 and 2 to complete erection

G. Nail joist to horses

(NOTE: Space as needed and allow a uniform overhang on each side.)

H. Nail decking to joist and stringers

(NOTE: Use a minimum of nails to hold decking in place.)

I. Lay out sides of stair and landing

(NOTE: Drop a plumb bob from edge of stair hole to establish lines.)

JOB SHEET #1

J. Install side forms and edge forms

(NOTE: Form oil must be applied before rebar is installed.)

1. Nail a continuous kicker to deck

(NOTE: Kicker will be placed the thickness of the riser forms back of layout lines.)

2. Stand forms upright on the deck and nail to the kicker

K. Install riser form

(NOTE: Hold riser form on riser layout line and nail through form side with duplex nails.)

L. Install aligner and brace beam sides (Figure 8)

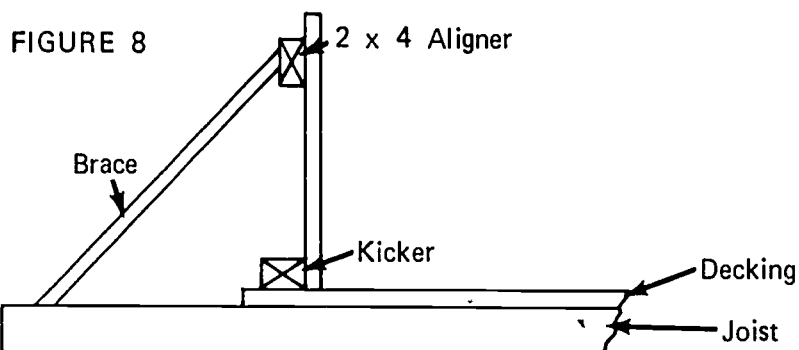

M. Install blocks at risers

(NOTE: Blocks are not needed if the tread form material is thick solid lumber.)

STAIR FORMS
UNIT X

JOB SHEET #2--FORMS FOR STAIRS ON EARTH

I. Tools and materials needed

A. Tools

1. Hammer (16 oz. or larger)
2. Handsaw (crosscut)
3. Electric handsaw
4. Sledge
5. Framing square gauges
6. Level (hand)
7. Builder's level
8. Framing square
9. Tape measure--12' or 16'

B. Materials

1. Side forms--Plywood
2. Stakes--2 x 4's
3. Aligners--2 x 4's
4. Risers--2 x 8's
5. Blocks--2 x 4's
6. Braces--1 x 4's

II. Procedures

A. Determining width and length of side form (Figure 1)

1. The form width will be the slab thickness plus the riser height and two inches

JOB SHEET #2

2. The form length will be the length on the pitch of one step times the number of steps in the flight; add one foot for overhang

FIGURE 1

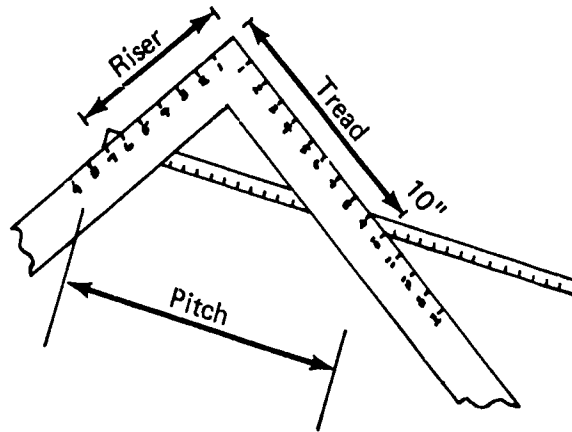

- B. Cut form side to size

(NOTE: Form sides may also be made from 1" x 6" or wider boards cleated together.)

- C. Lay out side forms (Figure 2)

FIGURE 2

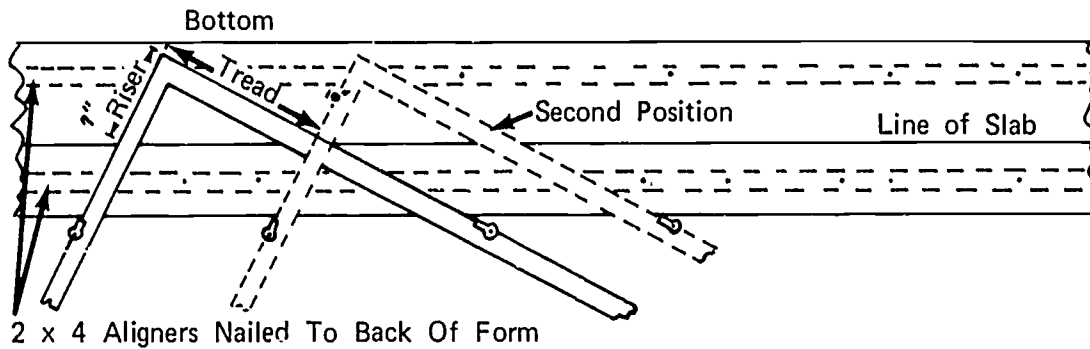

1. Gauge a line equal to the slab thickness on the form side
2. Lay framing square on form with riser height and tread width on slab line

JOB SHEET #2

3. Attach framing square gauges
4. Mark tread and riser on form
5. Move square to next step and lay out tread and riser

(NOTE: Use a sharp pencil and follow line intersections accurately.)

6. Repeat step 5 to complete layout
7. Lay out opposite side form following steps 1 to 6 inclusive

(NOTE: There will be two form sides. The forms will be laid out for right and left hand sides.)

8. Nail aligners to form sides

D. Nail riser support blocks to form sides (Figure 3)

FIGURE 3

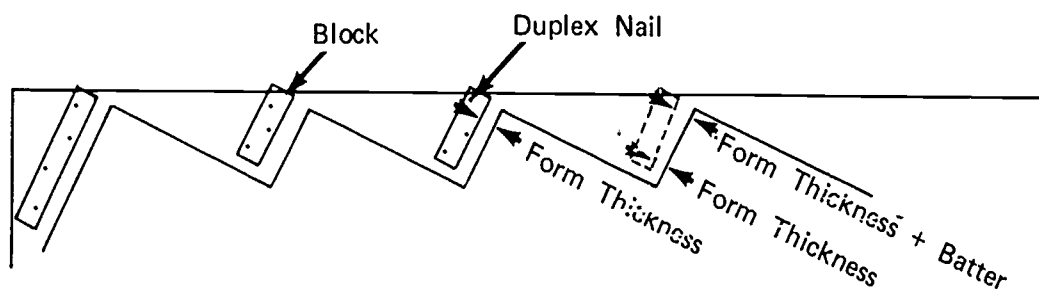

(NOTE: For battered riser, add batter dimension to tread length as shown on right hand riser.)

730

1030

JOB SHEET #2

- E. Set grade stakes at top and bottom of flight (Figure 4)

(NOTE: Use builder's level to establish grade from bench mark.)

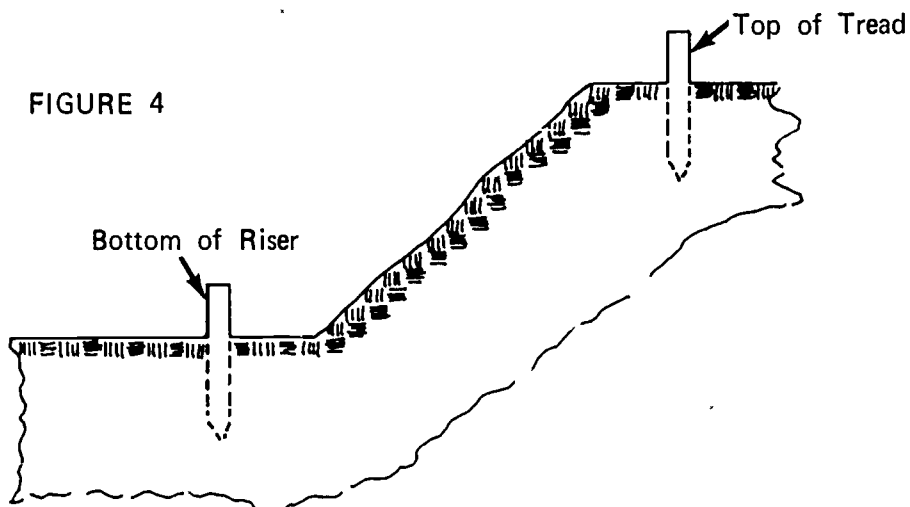

- F. Drive side form support stakes

(NOTE: Allow for sheathing and aligners when driving stakes.)

- G. Set form sides

1. Set form side against stakes
2. Level over from bottom grade stake to bottom of first riser; adjust form and nail to stake
3. Level over from top grade stake to top tread line; adjust form and nail to stake
4. Nail form to intermediate stakes
5. Repeat steps 1 to 4 inclusive to continue erection

JOB SHEET #2

H. Size riser forms (Figure 5)

1. Cut form material to length
2. Cut riser forms to width
3. Cut bottom of riser form to 45° angle

FIGURE 5

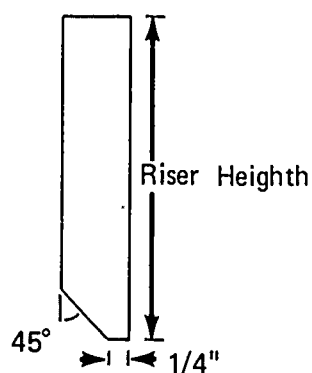

I. Install riser forms

1. Place riser form in position with top of form flush with tread line and against block
2. Nail riser forms from back side of side form using duplex nails
3. Repeat steps 1 and 2 to continue installation

(NOTE: If bottom landing slab is not poured at this time, a filler piece the thickness of the slab will have to be installed under the bottom riser form.)

STAIR FORMS
UNIT X

JOB SHEET #3--FORMS FOR SHORT FLIGHTS OF STAIRS

I. Tools and materials needed

A. Tools

1. Hammer (16 oz. or larger)
2. Handsaw (crosscut)
3. Electric handsaw
4. Sledge
5. Framing square gauges
6. Framing square
7. Level (hand)
8. Electric drill and bits

B. Materials

1. Side forms--Plywood
2. Stakes and stiffener--2 x 4's
3. Risers--2 x 8's
4. Braces--1 x 4's
5. Spreaders--1/2" conduit
6. Ties--Allthread or smooth rod

JOB SHEET #3

II. Procedure

- A. Determine width and length of side form (Figure 1)

(NOTE: Forms should be at least 4" wider than rise and run.)

FIGURE 1

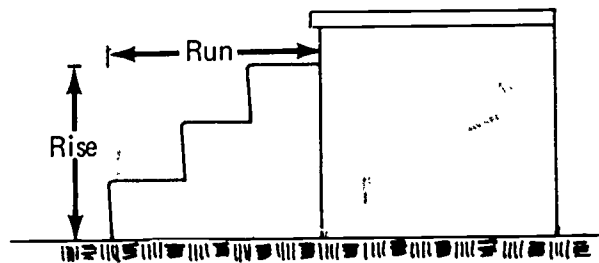

- B. Cut forms to size
C. Lay out steps on both forms (Figure 2)

(NOTE: Make a right and left hand layout.)

FIGURE 2

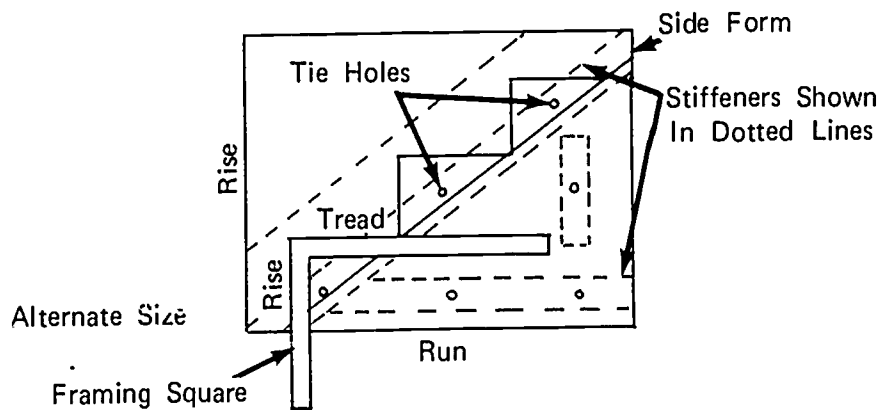

- D. Drill tie holes in pattern shown in Figure 2

(NOTE: Place forms back to back and drill both at the same time.)

JOB SHEET #3

E. Attach stiffeners to back side of forms centered on tie holes and drill tie holes in stiffeners

F. Cut spreaders and ties to length

1. Spreaders shall be as long as the stair is wide
2. Cut threaded rod (allthread) the width of the stairs plus two form thicknesses and lengths for nuts and washers on each end

(NOTE: Add one inch for tie projection.)

G. Size riser forms (Figure 3)

FIGURE 3

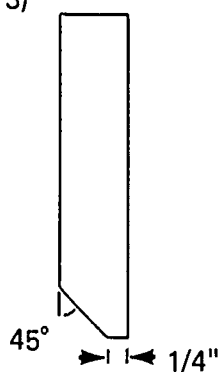

1. Lay out batter of riser on side form to determine exact width
2. Cut riser form to width
3. Cut riser form to length

(NOTE: Riser form length will be the same as the stair width.)

4. Cut 45° angle on face of tread

(NOTE: See Figure 3.)

H. Assemble side forms

1. Stand side forms on level surface
2. Place ties through spacer and holes in both forms and secure with nut and washer

(NOTE: One nut and washer should be placed on the allthread rod before it is installed.)

3. Snug up nuts to hold forms together

JOB SHEET #3

- I. Set form in pour location

(NOTE: Check for level across top of riser form and plumb side forms.)

1. Drive stakes at outside of form sides
2. Raise to level position both directions and nail to stakes

- J. Place fill dirt or form under slab (Figure 4)

(NOTE: If a form is used, it should be set before the side forms are set. Steps should be doveled at the top and rest on a footing.)

FIGURE 4

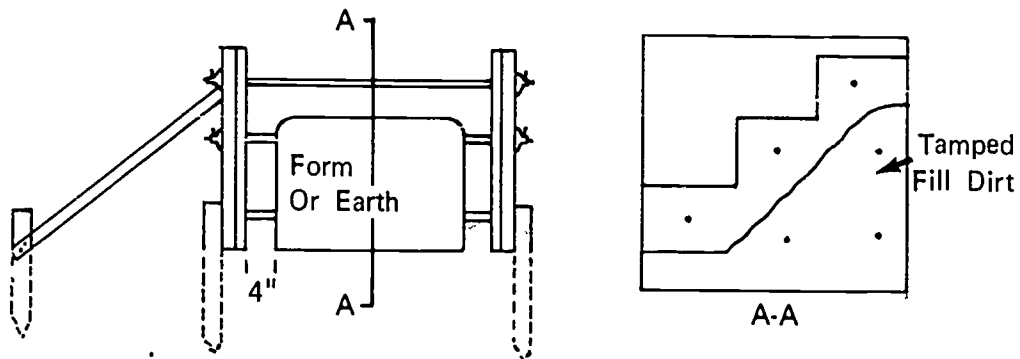

- K. Place brace as shown in Figure 4

(NOTE: Very little bracing is needed on this type of form. This type of form may be used in many situations.)

STAIR FORMS
UNIT X

TEST

1. Match the list of forming terms on the right to the correct definitions.

- | | |
|--|-------------------------|
| _____ a. A piece of wood or other material that directs, restricts, or supports weight or pressure | 1. Stairwell |
| _____ b. A-beveled piece of wood or metal placed in a form where future pours occur | 2. Batter |
| _____ c. A piece of wood or metal secured across a splice to strengthen and hold the two pieces together | 3. Spreader |
| _____ d. Wide boards, plywood, or metal that make up the horizontal face of the form | 4. Framing square gauge |
| _____ e. Small boards or steel bars sharpened at one end and driven into the ground to support the form | 5. Bulkhead |
| _____ f. Paraffin oil or a manufactured product used on a form to prevent adhesion of the concrete to the form | 6. Bent |
| _____ g. An inclined supporting member of a stair form or stair | 7. Tread |
| _____ h. A platform between flights of stairs | 8. Stair rise |
| _____ i. The distance from the floor to the top of a landing or to the floor above | 9. Form oil |
| _____ j. The vertical part of a stair step | 10. Pitch board |
| _____ k. The horizontal distance between the first riser and the face of the platform or stair opening above | 11. Riser |
| _____ l. The horizontal part of a stair step | 12. Horse |
| | 13. Kicker |
| | 14. Key |
| | 15. Stake |
| | 16. Scab |
| | 17. Brace |
| | 18. Decking |
| | 19. Landing |
| | 20. Stair run |

- _____ m. A wood block used to lay out or support treads and risers
- _____ n. The forward inclination of a riser
- _____ o. A framework designed to carry lateral as well as vertical loads
- _____ p. A compartment extending vertically through a building and in which stairs are placed
- _____ q. A device attached to a framing square to secure accuracy when laying out material
- _____ r. In construction, a piece of wood or other material secured to a fixed object or wedged against an object to support weight or pressure
- _____ s. A vertical board placed in a form to cut off the concrete pour
- _____ t. A piece of wood or metal used to hold the sides of a form apart until the concrete is poured

2. Identify fourteen parts of a stair form by placing the correct numbers in the blanks below.

- _____ a. Horse
- _____ b. Joist
- _____ c. Block
- _____ d. Riser form
- _____ e. Side form
- _____ f. Sheathing
- _____ g. Edge form
- _____ h. Brace
- _____ i. Stringer
- _____ j. Shore
- _____ k. Wedge
- _____ l. Sill
- _____ m. Scab
- _____ n. Kicker

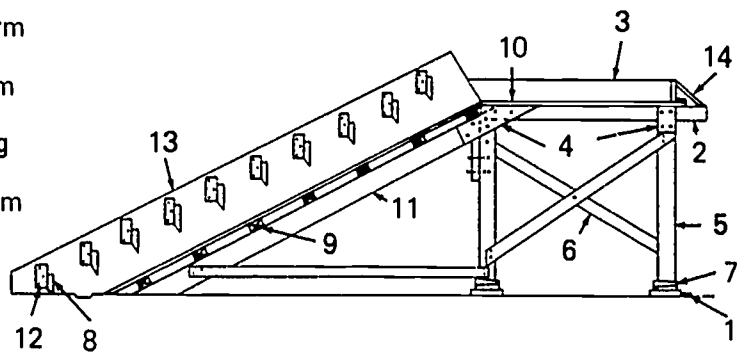

(NOTE: Since bulkheads and spreaders are used only occasionally, they are not shown on the illustration given.)

3. Name two types of concrete stairs.

a.

b.

4. Identify the five stair plan shapes.

_____ a. Straight flight

_____ b. Straight flight with landing

_____ c. Ninety degree change stair with landing

_____ d. Ninety degree stair with winders

_____ e. Stair with landing returning 180°

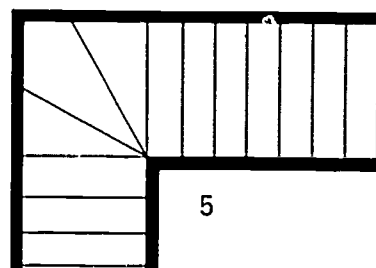
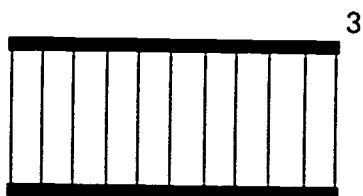
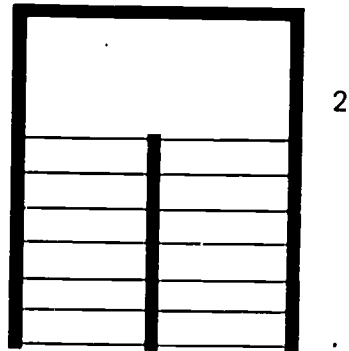
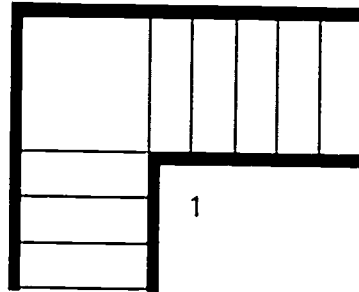

5. Name two types of stair slabs.

a.

b.

6. Draw a simple detail for each type of slab.

a.

b.

7. Demonstrate the ability to construct forms for:

a. Suspended slab stairs.

b. Slab on earth stairs.

c. Short flights of stairs.

(NOTE: If this has not been accomplished prior to the test, ask the instructor when the above activity should be completed.)

STAIR FORMS
UNIT X

ANSWERS TO TEST

1.
 - a. 17
 - b. 14
 - c. 16
 - d. 18
 - e. 15
 - f. 9
 - g. 12
 - h. 19
 - i. 8
 - j. 11
 - k. 20
 - l. 7
 - m. 10
 - n. 2
 - o. 6
 - p. 1
 - q. 4
 - r. 13
 - s. 5
 - t. 3
2.
 - a. 11
 - b. 9
 - c. 12

- d. 8
- e. 13
- f. 10
- g. 3
- h. 6
- i. 2
- j. 5
- k. 7
- l. 1
- m. 4
- n. 14

3. The following answers may be given in any order.

- a. Rough
- b. Finished

4. a. 3

- b. 4
- c. 1
- d. 5
- e. 2

5. The following answers may be given in any order.

- a. Suspended
- b. Earth supported

6. Evaluated to the satisfaction of the instructor.

7. Performance skills will be evaluated according to the criteria listed on the progress chart.

BRIDGE DECK FORMS
UNIT XI

TERMINAL OBJECTIVE

After completion of this unit, the student should be able to define bridge form terms, identify the parts of a form, and name methods of supporting deck forms and types of bridges receiving reinforced concrete decks. He should also be able to construct forms for a bridge deck. This knowledge will be evidenced through demonstration and by scoring eighty-five percent on the unit test.

SPECIFIC OBJECTIVES

After completion of this unit, the student should be able to:

1. Define bridge deck form terms.
2. Identify the parts of a bridge deck form.
3. Name three methods of supporting deck forms.
4. Name four types of bridges that use reinforced concrete slabs.
5. Demonstrate the ability to construct forms for a bridge deck.

BRIDGE DECK FORMS
UNIT XI

SUGGESTED ACTIVITIES

I. Instructor:

- A. Provide students with objective sheet.
- B. Provide students with information and job sheets.
- C. Make transparencies.
- D. Discuss terminal and specific objectives.
- E. Discuss information sheet.
- F. Demonstrate and discuss procedures outlined in job sheet.
- G. Give test.

II. Student:

- A. Read objective sheet.
- B. Study information sheet.
- C. Demonstrate the ability to accomplish the procedures outlined in the job sheet.
- D. Take test.

INSTRUCTIONAL MATERIALS

I. Included in this unit:

- A. Objective sheet
- B. Information sheet
- C. Transparency masters
 1. TM 1--Parts of a Bridge Deck Form
 2. TM 2--Methods of Supporting Bridge Deck Forms
 3. TM 3--Methods of Supporting Bridge Deck Forms (Continued)
 4. TM 4--Types of Bridges That Have Reinforced Concrete Slabs
 5. TM 5--Types of Bridges That Have Reinforced Concrete Slabs (Continued)

D. Job Sheet #1--Construct Forms for a Bridge Deck

E. Test

F. Answers to test

II. References:

- A. Burke, Arthur E., J. Ralph Dalzell, and Gilbert Townsend. *Architectural and Building Trades Dictionary*. Chicago, Illinois: American Technical Society, 1955.
- B. Smith, Ronald C. *Principles and Practices of Heavy Construction*. Englewood Cliffs, New Jersey: Prentice Hall, Inc., 1970.

BRIDGE DECK FORMS
UNIT XI

INFORMATION SHEET

I. Terms and definitions

- A. Bracket--A braced frame used to support deck overhang
- B. Coil bolt--A bolt with coarse threads made to fit the helix coil of coil ties and anchors
- C. Needle beam--A horizontal support member set on shores or hung
- D. Monolithic pour--A continuous mass of concrete cast as a single piece
- E. Brace--A piece of wood or other material that directs, resists, or supports weight or pressure
- F. Scab--A piece of wood or metal secured across a joint to strengthen and hold the two pieces together
- G. Bulkhead--A board placed in a form to cut off the concrete pour
- H. Sheathing--Wide boards, plywood, or metal that make up the face of the form
- I. Form oil--Paraffin oil or a manufactured product used on a form to prevent adhesion of the concrete to the form
- J. Edge form--A low form placed at the perimeter of a slab
- K. Expansion joint--A pre-formed piece of fibrous or asphaltic material used to separate units of concrete to prevent cracking due to expansion and contraction
- L. Slab--A section of concrete larger in its horizontal dimensions than it is in thickness
- M. Deck--The horizontal sheathing that supports the wet concrete
- N. Expansion dam--Part of the bridge that lets it expand and contract with temperature change
- O. Scuppers--A steel catch basin located on the low point of the bridge slab which is designed to drain water off the bridge slab
- P. Curb--Raised edge designed to keep cars on roadway
- Q. Median barrier--A wall projecting from the deck dividing opposite lanes of traffic

INFORMATION SHEET

- R. Backwall--A wall that receives the roadway and connects it to the bridge slab through the expansion joint
 - S. Diaphragm--The steel spacer beams at intervals on long girders
(NOTE: The diaphragm is perpendicular to the long girders and also supports the concrete at construction joints in the slab.)
 - T. Screed--A strip of wood or metal used as a guide for leveling or grading a concrete slab
 - U. Drip groove--A groove in any soffit where the undersurface is exposed to weather; it is designed to keep water from running back on the soffit
 - V. Parapet--A longitudinal walk above the surface of the deck which serves as a barrier throughout the length of a bridge
- II. Parts of a bridge deck form(Transparency I)
- A. Brace
 - B. Edge form--Parapet
 - C. Bracket (Job built or manufactured)
 - D. Decking
 - E. Wood filler
 - F. Stringer
 - G. Joist
 - H. Duplex nails
 - I. Supports
 - J. Cleat
 - K. Steel hangers
 - L. Allthread rod (with speed thread)
 - M. Washers & nuts
 - N. Chamfer--Refers to a beveled^d corner which is formed in concrete work by placing a three-cornered piece of wood (cant strip or skew back) in the form center
 - O. Drip groove--Notch in concrete to keep water off beams

INFORMATION SHEET

- III. Methods of supporting overhanging deck forms (Transparencies 2 and 3)
 - A. Bracket and hanger
 - B. Needle beam
 - C. Leg supports
- IV. Types of bridges that use reinforced concrete slabs (Transparencies 4 and 5)
 - A. Reinforced concrete slab
 - B. Reinforced concrete T beam
 - C. Steel I beam
 - D. Pre-cast concrete beam

Parts of a Bridge Deck Form

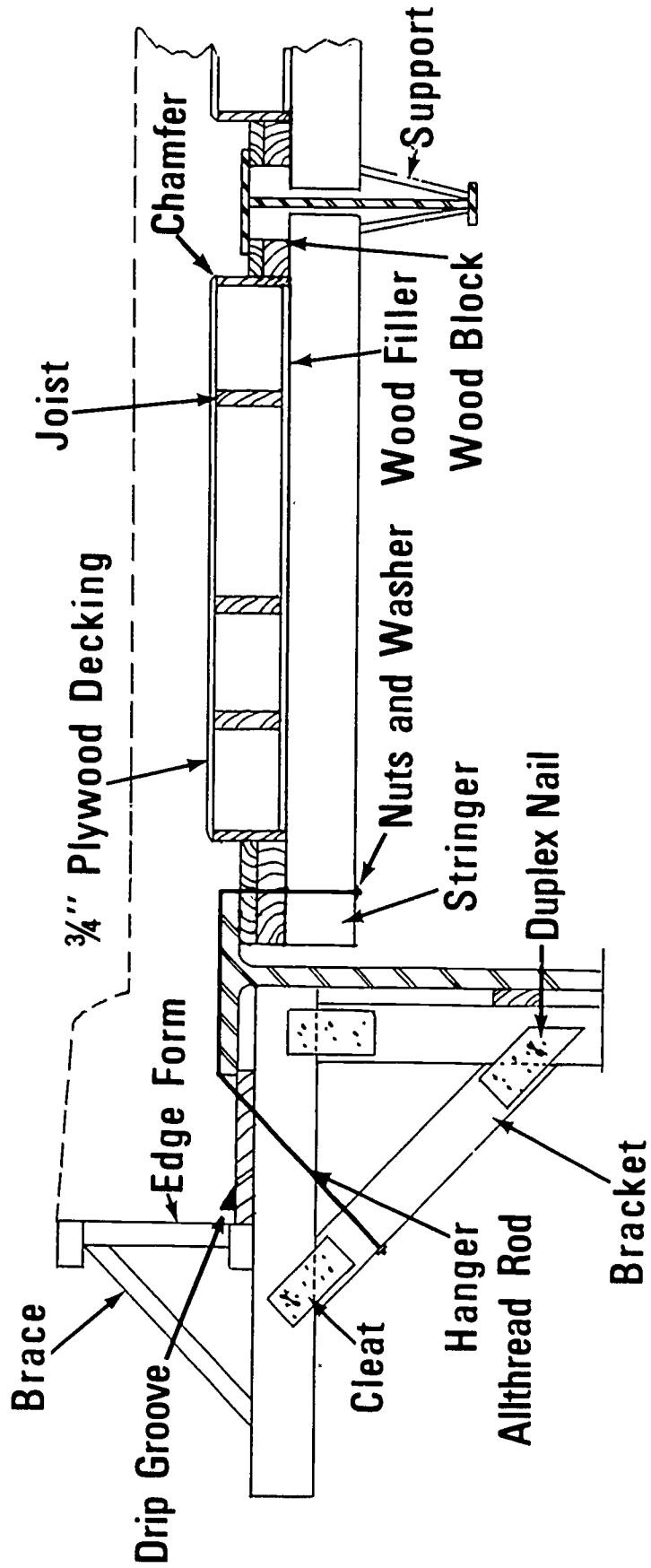

BRACKET AND HANGER

Methods of Supporting Bridge Deck Forms

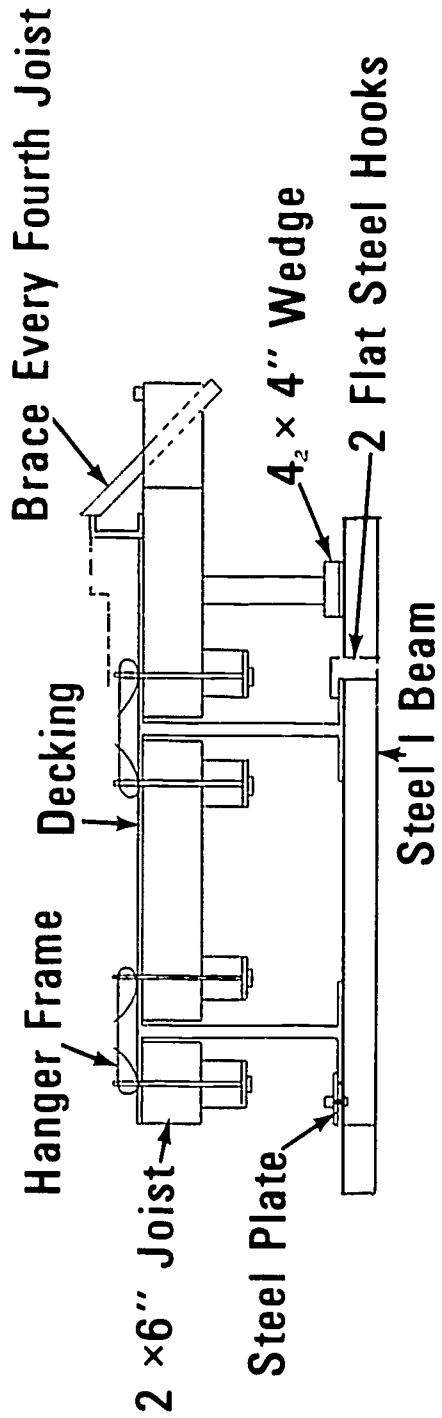
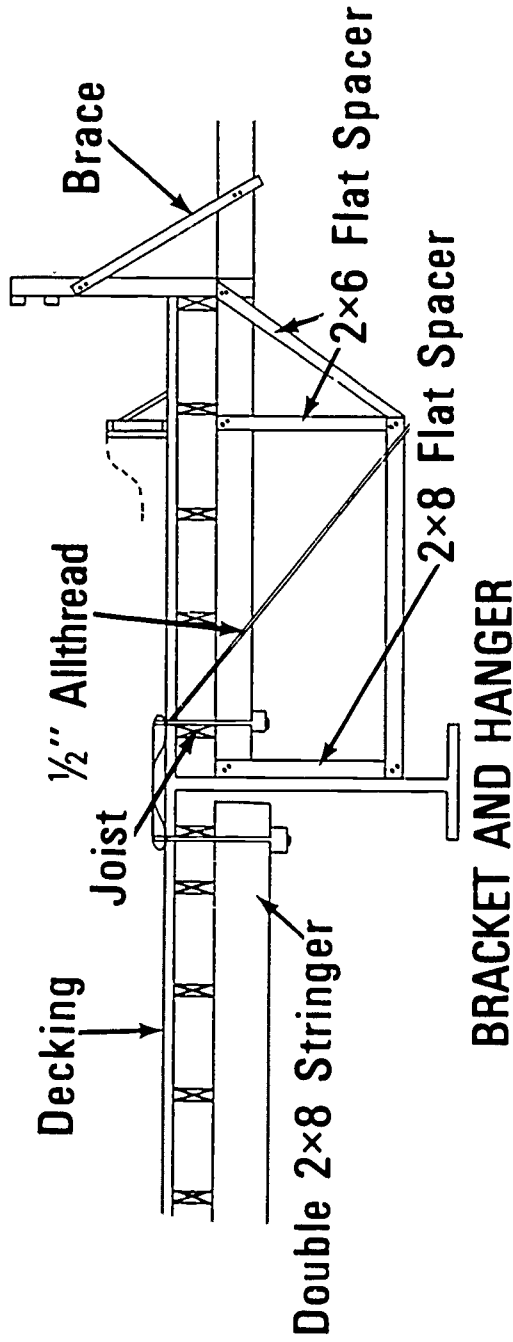

NEEDLE BEAM

Methods of Supporting Bridge Deck Forms

(Continued)

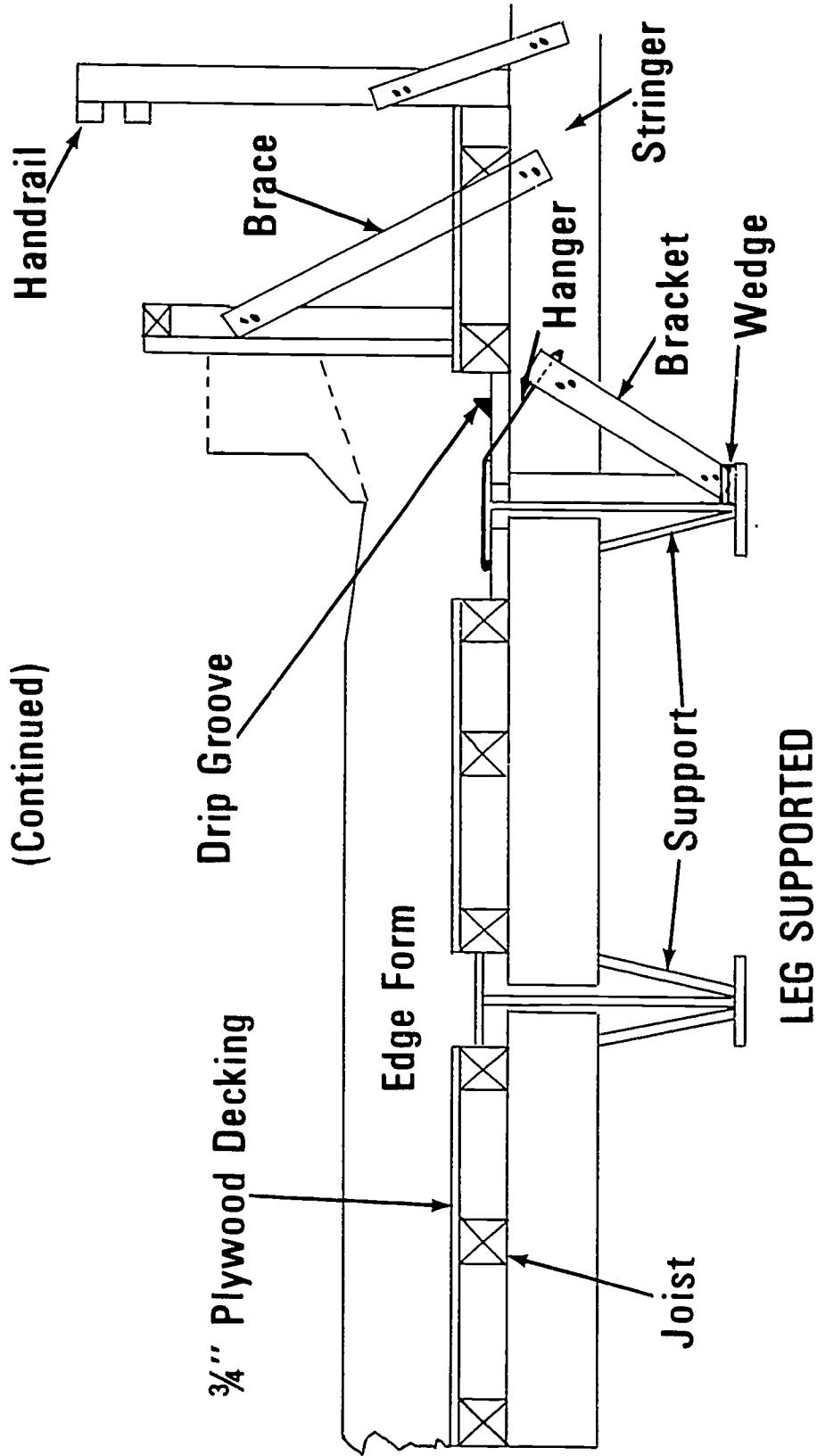

Types of Bridges That Have Reinforced Concrete Slabs

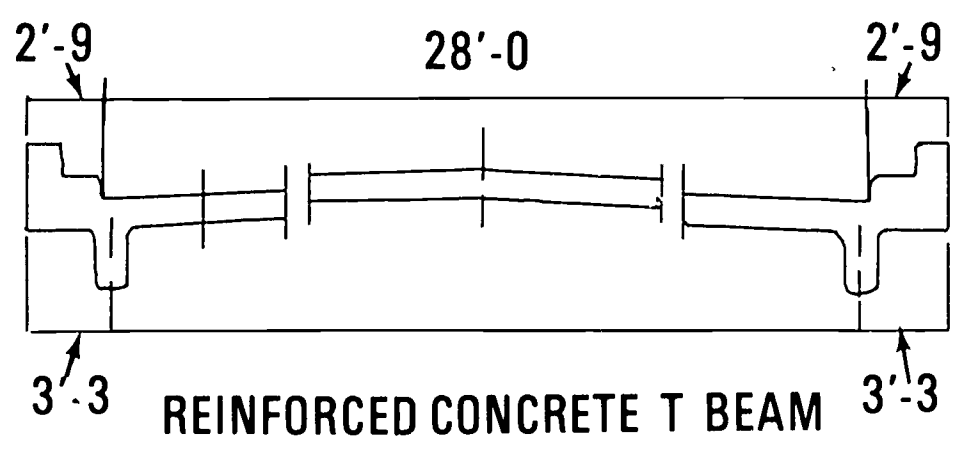
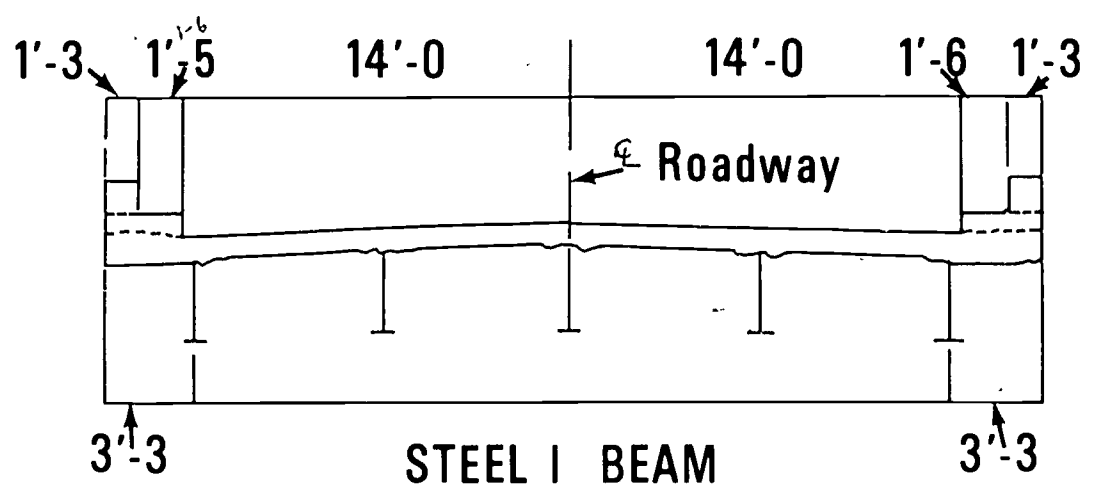
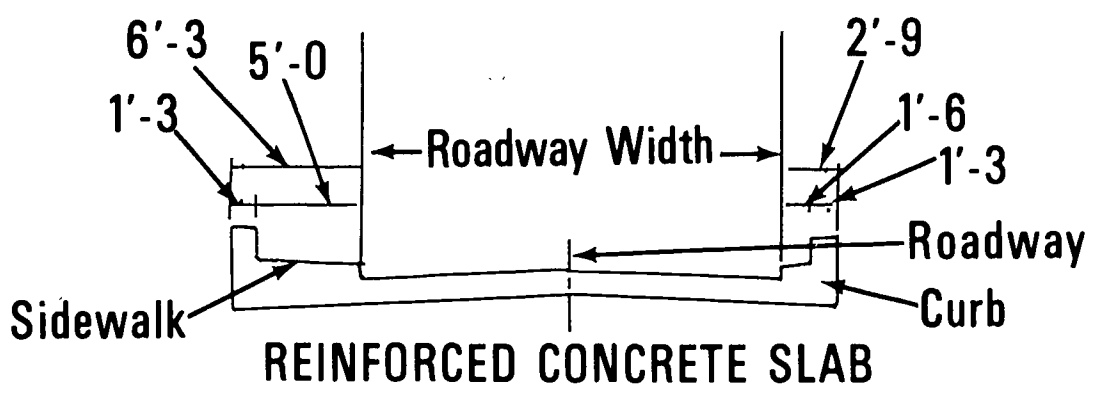

Types of Bridges That Have Reinforced Concrete Slabs

(Continued)

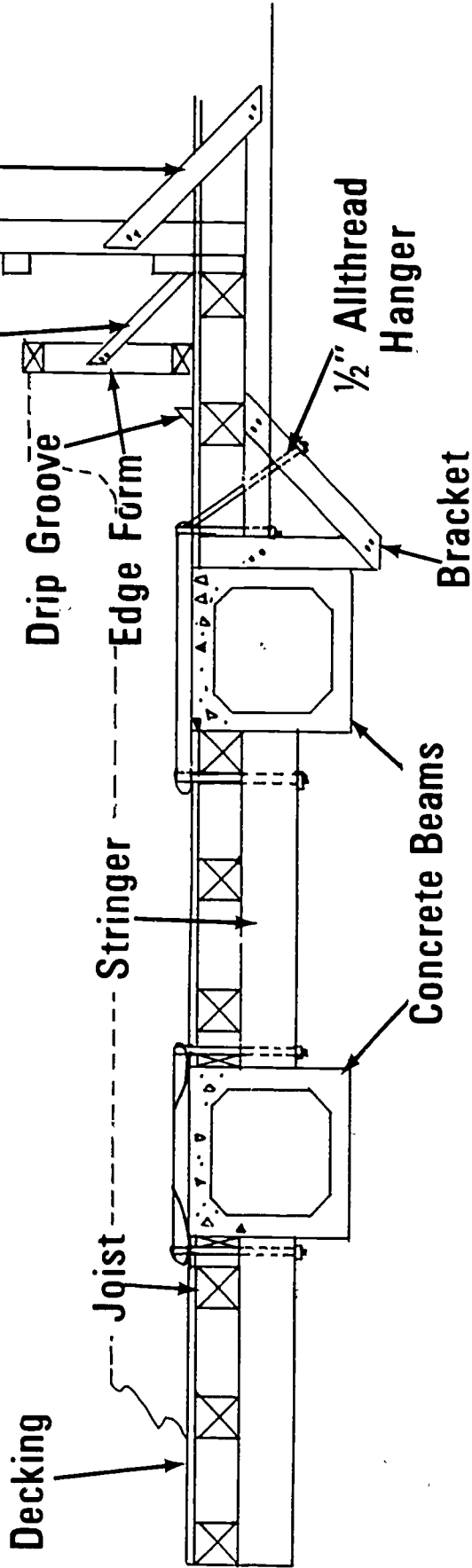

PRE-CAST CONCRETE BEAM

BRIDGE DECK FORMS
UNIT XI

JOB SHEET #1--CONSTRUCT FORMS FOR A BRIDGE DECK

I. Tools and materials needed

A. Tools

1. Ripping hammer (16 oz. or larger)
2. Handsaw
3. Electric handsaw and spare blades
4. Level (hand)
5. Wrecking bar
6. Chalk box
7. Wood chisel
8. 12" combination square
9. Utility knife for cutting expansion joint material

B. Materials

1. Brackets (Job built or manufactured)
2. Supports
3. Decking (Plywood or sheeting)
4. Joist (2 x 6)
5. Edge form or parapet
6. Stringer or whaler
7. Soffit
8. Brace
9. Hangers (To fit beam size)
10. 4 x 4 x 1/4" washers
11. 1/2 form bolts

JOB SHEET #1

12. 1/2 allthread with speed thread
13. Nuts
14. Plastic sleeves for bolts
15. Expansion joint material
16. Water stop
17. 6 penny nails-16 penny double head

II. Procedure

A. Size material

1. Cut stringer material to length and nail together with 3/4" spacers
2. Size plywood to proper width
3. Cut joist to correct length
4. Cut soffit to length and notch for bolts at proper spacing

B. Build brackets

1. Build template to conform with bracket shape
2. Cut material to correct length and size
3. Set material in template and nail or bolt
4. Build parapet forms
5. Cut chamfer for exposed edges
6. Cut drip groove

C. Erect deck supports and decking

1. Lay out hanger position on bridge beams
2. Assemble bolts, washers, and beam hangers with nuts
3. Place assembled hangers on bridge beams
4. Hang stringers on bolts in hangers with nuts

JOB SHEET #1

5. Place joist and plywood or sheeting--if plywood, nail at edge and ends

(NOTE: Do not over nail because it is difficult to strip. Allow space for soffit form at beam.)

6. Bring deck to grade
7. Place soffit form, wedge or block, to grade and nail
8. Hang brackets (Follow steps at D)

D. Erect brackets and decking

1. Hang bracket
2. Set to proper grade
3. Lay soffit form in place
4. Lay joist
5. Brace joist to keep from rolling
6. Lay plywood
7. Lay walkway and erect railing

E. Install edge forms and/or parapet

1. Locate and strike parapet line
2. Nail chamfer to line
3. Set parapet form to line (Nail with double head 16)
4. Brace top to line
5. Nail chamfer at top grade

F. Install bridge drain, flashing joints, and expansion dams

(NOTE: Bridge drains are set to line and grade simultaneously with steel on a steel girder.)

1. Cut hole in deck (drain size) at proper location
2. Place drain to line and 1/2" below deck grade to collect water

(NOTE: Flashing and expansion joint material usually go together. The flashing is installed about 2" below grade and there is a groove about 3/4" wide and 3/4" deep. This groove is filled with an epoxy or tar to keep the water from joint. Expansion dams are steel. The top is set to roadway grade.)

BRIDGE DECK FORMS
UNIT XI

TEST

1. Match the list of forming terms to the correct definition.

- | | |
|--|---------------------|
| _____ a. A brace frame used to support deck overhang | 1. Parapet |
| _____ b. A bolt with course threads made to fit the helix coil of coil ties and anchors | 2. Diaphragm |
| _____ c. A horizontal support member set on shores or hung | 3. Median barrier |
| _____ d. A continuous mass of concrete cast as a single piece | 4. Drip groove |
| _____ e. A piece of wood or other material that directs, resists, or supports weight or pressure | 5. Backwall |
| _____ f. A piece of wood or metal secured across a joint to strengthen and hold the two pieces together | 6. Screed |
| _____ g. A board placed in a form to cut off the concrete pour | 7. Expansion dam |
| _____ h. Wide boards, plywood, or metal that make up the face of the form | 8. Expansion joint |
| _____ i. Paraffin oil or a manufactured product used on a form to prevent adhesion of the concrete to the form | 9. Curb |
| _____ j. A low form placed at the perimeter of a slab | 10. Deck |
| _____ k. A pre-formed piece of fibrous or asphaltic material used to separate units of concrete to prevent cracking due to expansion and contraction | 11. Scuppers |
| | 12. Sheathing |
| | 13. Slab |
| | 14. Form oil |
| | 15. Brace |
| | 16. Needle beam |
| | 17. Bulkhead |
| | 18. Monolithic pour |
| | 19. Scab |
| | 20. Coil bolt |
| | 21. Edge form |
| | 22. Bracket |

- _____ l. A section of concrete larger in its horizontal dimensions than it is in thickness
- _____ m. The horizontal sheathing that supports wet concrete
- _____ n. Part of a bridge that lets it expand and contract with temperature change
- _____ o. A steel catch basin located on the low point of the bridge slab which is designed to drain water off the bridge slab
- _____ p. Raised edge designed to keep cars on the roadway
- _____ q. A wall projecting from the deck dividing opposite lanes of traffic
- _____ r. A wall that receives the roadway and connects it to the bridge slab through the expansion joint
- _____ s. A steel spacer beam at intervals on long guiders
- _____ t. A strip of wood or metal used as a guide for leveling or grading a concrete slab
- _____ u. A groove in any soffit where the undersurface is exposed to the weather; it is designed to keep the water from running back on the soffit
- _____ v. A longitudinal walk above the surface of the deck which serves as a barrier throughout the length of the bridge

2. Identify the parts of a deck form.

- _____ a. Brace
- _____ b. Edge form-Parapet
- _____ c. Bracket
- _____ d. Decking
- _____ e. Wood filler
- _____ f. Stringer
- _____ g. Joist
- _____ h. Duplex nail
- _____ i. Supports
- _____ j. Cleat
- _____ k. Steel hangers
- _____ l. Allthread rod (with speed thread)
- _____ m. Washer and nut
- _____ n. Chamfer
- _____ o. Drip groove

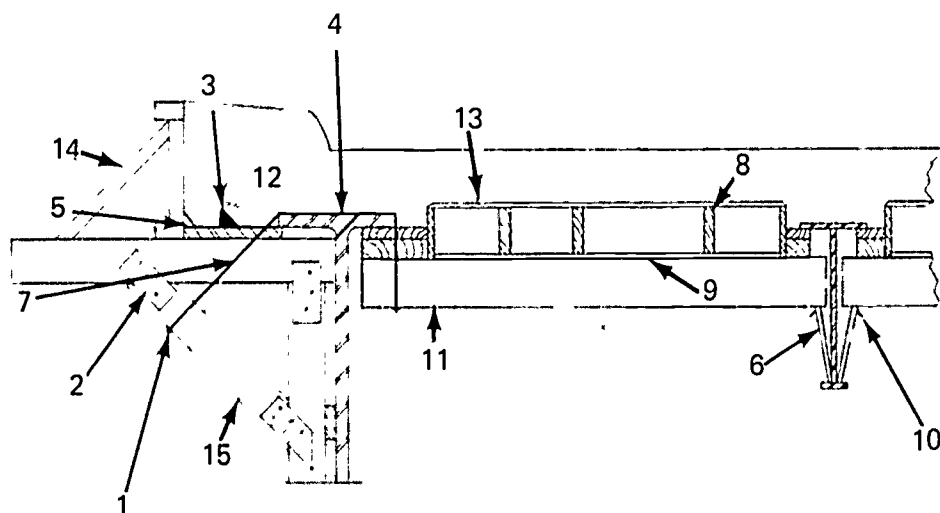

3. Name three methods of supporting overhanging deck forms.
 - a.
 - b.
 - c.
4. Name four types of bridges that use reinforced concrete slabs.
 - a.
 - b.
 - c.
 - d.
5. Demonstrate the ability to construct forms for a bridge deck.

(NOTE: If this has not been accomplished prior to the test, ask the instructor when the above activity should be completed.)

BRIDGE DECK FORMS
UNIT XI

ANSWERS TO TEST

1. a. 22
- b. 20
- c. 16
- d. 18
- e. 15
- f. 19
- g. 17
- h. 12
- i. 14
- j. 21
- k. 8
- l. 13
- m. 10
- n. 7
- o. 11
- p. 9
- q. 3
- r. 5
- s. 2
- t. 6
- u. 4
- v. 1

2.
 - a. 14
 - b. 12
 - c. 15
 - d. 13
 - e. 9
 - f. 11
 - g. 8
 - h. 10
 - i. 6
 - j. 2
 - k. 4
 - l. 7
 - m. 1
 - n. 5
 - o. 3
3. (NOTE: The following answers may be given in any order.)
 - a. Bracket and hanger
 - b. Needle beam
 - c. Leg supports
4. (NOTE: The following answers may be given in any order.)
 - a. Reinforced concrete slab
 - b. Reinforced concrete T beam
 - c. Steel I beam
 - d. Pre-cast concrete beam
5. Performance skills will be evaluated according to the criteria listed on the progress chart.

Carpentry

PROGRESS CHART

Section G #1
Forming

764

Job	UNIT I Introductic				UNIT II Footing				UNIT III Edge Forms				UNIT IV Wall Forms						
	1				1	2	3	4	1	2	3	4	1	2	3	4	5	6	7
UNIT TEST					Construct & Set Forms For Pile Cap	Strip Pier Footing Forms	UNIT TEST	Slab On Grade Without Foundation	Edge Forms On Grade	UNIT TEST	Patented Forms	Gang Forms	Built in Place	Panel Forms	Slip Forms	Remove & Prepare For Storage			
1																			
2																			
3																			
4																			
5																			
6																			
7																			
8																			
9																			

Student's Name

Carpentry

PROGRESS CHART

Section G #3
Forming

268

Student's Name

Job	UNIT IX Fireproof Encasement		UNIT X Stair Forms				UNIT XI Bridge Deck Forms					
	1	2	1	2	3	4	1	2				
UNIT TEST												
Column & Beam Forms												
UNIT TEST												
Stairs On Earth												
UNIT TEST												
Suspended Stairs												
UNIT TEST												
Short Flights of Stairs												
UNIT TEST												
Bridge Deck Forms												
UNIT TEST												
1												
2												
3												
4												
5												
6												
7												
8												
9												
10												

Carpentry

PROGRESS CHART

26

Section G #2
Forming

Job	UNIT V Curb Forms		UNIT VI Piers & Columns			UNIT VII Beam Forms				UNIT VIII Slab Systems						
	1	2	1	2	3	1	2	3	4	1	2	3	4	5	6	
UNIT TEST																
Curb & Gutter																
UNIT TEST																
Forms For a Round Fluted Column																
UNIT TEST																
Form For a Square Column																
UNIT TEST																
Spandrel Beam Form																
Inverted Beam Form																
Beam Form Post-Tensioned																
UNIT TEST																
Two-Way Joist System																
One-Way Joist System																
Flat Slab Post-Tensioned																
Strip Two-Way Joist System																
Set Concealed Void Tubes																

Student's Name

- 1
- 2
- 3
- 4
- 5
- 6
- 7
- 8
- 9

FLOOR AND SILL FRAMING UNIT I

TERMINAL OBJECTIVE

After completion of this unit, the student should be able to define floor and sill framing terms, identify floor and sill framing members, name the styles of framing, and write the purpose of a sill sealer and termite shield. He should also be able to name the methods of fastening the sill to the foundation, construct a box sill, lay out and install the floor joist, list and apply the various types of subflooring, and use the power tools safely and correctly. This knowledge will be evidenced by demonstration and by scoring eighty five percent on the unit test.

SPECIFIC OBJECTIVES

After completion of this unit, the student should be able to:

1. Match terms associated with floor and sill framing to a list of definitions.
2. Name two styles of framing.
3. Identify eight framing members that make up the floor and sill.
4. Write the purpose of a sill sealer.
5. Write the purpose of a termite shield.
6. Name two methods of fastening sills to foundation walls.
7. Write the purpose of bridging.
8. Write the purpose of beams or girders.
9. List two types of subflooring.
10. Match the appropriate nails to their use in assembling the subfloor, sill, and joists.
11. Estimate the amount of material needed to frame a floor and sill.
12. Estimate the amount of material needed to lay a subfloor.
13. Demonstrate the ability to:
 - a. Lay the sill and install the floor joist on sixteen and twenty-four inch centers.
 - b. Install bridging.
 - c. Lay subflooring.
 - 1) Lumber
 - 2) Plywood

FLOOR AND SILL FRAMING UNIT I

SUGGESTED ACTIVITIES

I. Instructor:

- A. Provide students with objective sheet.
- B. Provide students with information, assignment, and job sheets.
- C. Make transparencies.
- D. Discuss terminal and specific objectives.
- E. Discuss information and assignment sheets.
- F. Demonstrate and discuss procedures outlined in job sheets.
- G. Give test.

II. Student:

- A. Read objective sheet.
- B. Study information sheet.
- C. Complete assignment sheet.
- D. Demonstrate the ability to accomplish the procedures outlined in the job sheets.
- E. Take test.

INSTRUCTIONAL MATERIALS

I. Included in this unit:

- A. Objective sheet
- B. Information sheet
- C. Transparency masters
 1. TM 1--Types of Framing
 2. TM 2--Floor and Sill Members
 3. TM 3--Fastening Sills to Foundation

FLOOR AND SILL FRAMING UNIT I

SUGGESTED ACTIVITIES

I. Instructor:

- A. Provide students with objective sheet.
- B. Provide students with information, assignment, and job sheets.
- C. Make transparencies.
- D. Discuss terminal and specific objectives.
- E. Discuss information and assignment sheets.
- F. Demonstrate and discuss procedures outlined in job sheets.
- G. Give test.

II. Student:

- A. Read objective sheet.
- B. Study information sheet.
- C. Complete assignment sheet.
- D. Demonstrate the ability to accomplish the procedures outlined in the job sheets.
- E. Take test.

INSTRUCTIONAL MATERIALS

I. Included in this unit:

- A. Objective sheet
- B. Information sheet
- C. Transparency masters
 1. TM 1--Types of Framing
 2. TM 2--Floor and Sill Members
 3. TM 3--Fastening Sills to Foundation

4. TM 4--Subflooring
 5. TM 5--Subflooring (Continued)
 6. TM 6--Subflooring (Continued)
 7. TM 7--Fastners
- D. Assignment Sheet #1--Material Estimating (Floor and Sill)
- E. Answers to assignment sheet
- F. Job sheets
1. Job Sheet #1--Build a Box Sill and Install a Floor Joist
 2. Job Sheet #2--Install Bridging
 3. Job Sheet #3--Lay a Subfloor
- G. Test
- H. Answers to test
- II. References:
- A. Burke, Arthur E., J. Ralph Dalzell, and Gilbert Townsend. *Architectural and Building Trades Dictionary*. Chicago, Illinois: American Technical Society, 1955.
 - B. Cooper, George H. and Stanley Badzinski Jr. *Building and Construction Estimating*. New York: McGraw-Hill, 1971.
 - C. Durbahn, Walter E. and Elmer W. Sundberg. *Fundamentals of Carpentry*. Third Edition. Chicago, Illinois: American Technical Society, 1963.
 - D. Feirer, John L. *Woodworking for Industry*. Peoria, Illinois: Charles Bennett Company, Inc., 1971.
 - E. Groneman, Chris H. and Everett R. Galzener. *Technical Woodworking*. St. Louis, Missouri: McGraw-Hill Book Company, 1966.
 - F. Wagner, Willis H. *Modern Carpentry*. Homewood, Illinois: Goodheart-Willcox, 1969.

FLOOR AND SILL FRAMING UNIT I

INFORMATION SHEET

- I. Terms and definitions
 - A. Balloon framing--A type of building construction in which the studs extend in one piece from the foundation to the roof
 - B. Beam or girder--Any large piece of timber, stone, iron, or other material used to support concentrated loads at particular points along its length
 - C. Bridging--Solid lumber or small wooden or steel pieces fitted in pairs from the bottom of one joist to the top of the adjacent joist and crossed to stiffen and help distribute the load
 - D. Crown--Relating to the high side of the crook in framing lumber
 - E. Foundation--The supporting portion of a structure below the first floor construction including the footings
 - F. Joist header--The framing member into which the common joists are fitted forming the box sill or a member used to support the free end of joists over openings such as stairs, chimneys, and other openings
 - G. Joist--One of a series of parallel framing members used to support floor and ceiling loads and supported in turn by beams or girders
 - H. Sill--The lowest member of the frame of a structure resting horizontally on the foundation and supporting the uprights of the frame
 - I. Sill sealer--A resilient waterproof material used under the sills as a seal against air, dirt, and insects
 - J. Subfloor--Boards or panels laid directly on the floor joists over which a finished floor will be laid
 - K. Termite shield--A shield, usually made of sheet metal, placed on a foundation wall or around pipes to prevent the passage of termites into the structure
 - L. Western framing--A system of framing a building where the floor joists of each story rest on the top plates of the story below, and the bearing walls and partitions rest on the subfloor of each story
- II. Framing styles (Transparency 1)
 - A. Western framing

(NOTE: Western framing is sometimes called platform framing.)
 - B. Balloon framing

INFORMATION SHEET

III. Floor and sill framing members (Transparency 2)

(NOTE: Western and balloon framing styles use basically the same members.)

- A. Sill sealer
- B. Termite shield
- C. Sill
- D. Joists
- E. Joist header
- F. Beam or girder
- G. Bridging
- H. Subfloor

IV. Sill sealer (Transparency 2)--Provides a seal against air, dirt, and insects

(NOTE: This is applied between the sill and the foundation wall.)

V. Termite shield (Transparency 2)--Prevents the passage of termites to the structure

(NOTE: This is applied between the sill sealer and the sill and around pipes.)

VI. Methods of fastening sills to foundation walls (Transparency 3)

- A. Sill anchor

(NOTE: Consists of a bolt embedded in the foundation wall that projects through the sill and provides an anchor for the sill.)

- B. Concrete nail

(NOTE: Consists of a hardened steel nail which is driven or shot through the sill into the foundation wall.)

VII. Bridging (Transparency 2)--Stiffens and helps distribute the load

- A. Solid lumber

(NOTE: The same size material is used as for the joist and is staggered during installation to facilitate nailing.)

- B. Lumber "X" bridging

(NOTE: This is usually made from one by four inch lumber and fitted in pairs from the bottom of one joist to the top of the adjacent joist and crossed.)

INFORMATION SHEET

C. Adjustable steel "X" bridging

(NOTE: Steel bridging is adjustable to fit on sixteen or twenty-four inch centers and should be installed according to the manufacturer's recommendations.)

VIII. Beams or girders (Transparency 2)--Support concentrated loads at particular points along their lengths

(NOTE: These may be any large piece of timber, stone, iron, or other material used to span an open area upon which the floor joists rest.)

IX. Subflooring (Transparencies 4, 5, and 6)

(NOTE: Before subflooring is installed all plumbing, heating, and air conditioning rough in work should be done.)

A. Lumber

(NOTE: One inch lumber is usually placed at a diagonal across the joist.)

B. Plywood

(NOTE: Usually 5/8" x 4' x 8' CD, Exterior grade, Fir plywood is recommended.)

X. Fasteners (Transparency 7)

A. Sill anchors--Used to anchor the sill to the foundation

B. Concrete nails--Used to anchor the sill to the foundation

C. Box nails

1. 16d box nails--Used to fasten joist to sill and headers to joist

2. 8d box nails--Used to fasten subfloor to joist

XI. Material estimating

(NOTE: See building specifications for kinds and dimensions of material.)

A. Sill sealer--Linear feet

(NOTE: Obtain enough to cover all foundation surfaces.)

B. Termite shield--Linear feet

(NOTE: This shield usually consists of twenty-six gauge galvanized material approximately twelve inches wide covering all foundation surfaces.)

INFORMATION SHEET

C. Sill-Board feet

(NOTE: The sill may be two by four inches, or two by six inches. Obtain enough to cover all foundation surfaces.)

D. Beams or girders--Board feet

(NOTE: Material must be of sufficient strength to carry the expected load including enough to span all areas where required. See specifications.)

E. Joists--Board feet

1. Determine length needed from foundation plan and round up to the nearest even foot

2. Determine the number of joists needed

a. For 16" on center

1) Multiply length of building by $3/4$

2) Add 1 joist for the end

(NOTE: Add one joist for each partition that runs parallel to the joists.)

b. For 24" on center

1) Multiply length of building by $1/2$

2) Add 1 joist for the end

(NOTE: Add one joist for each partition that runs parallel to the joists.)

F. Joist headers--Board feet

(NOTE: Allow enough for twice the length of the building and all openings.)

G. Bridging

(NOTE: One row of bridging is required in spans over eight feet in length and less than sixteen feet. Two rows of bridging are required in spans over sixteen feet.)

1. Wood "X" bridging--Board feet

(NOTE: Bridging usually consists of one by four inch rough lumber.)

a. Determine the number of rows of bridging needed

INFORMATION SHEET

- b. Determine the length of each row of bridging
- c. Multiply the sum of all the row lengths in lineal feet by the appropriate factor from the following table to get the total lineal feet of bridging needed for the job.

Joist Size	Spacing, In. O.C.	Lineal Feet of Material Per Foot of Bridging Row
2 x 6 to 2 x 10	16	2
2 x 12	16	2 1/4
2 x 14	16	2 1/2

(NOTE: If the joists are twenty-four inches on center, the total lineal footage of bridging rows is equal to the number of pieces of bridging material needed.)

2. Steel bridging--Number of each for joists sixteen inches on centers
 - a. Determine the number of rows of bridging needed
 - b. Determine the length of each row of bridging
 - c. Multiply the total lineal footage of bridging rows by $3/4$ to find the number of spaces between joists sixteen inches on center
 - d. Multiply the above total by two to determine the number of pieces of bridging required

(NOTE: If the joists are twenty-four inches on center, the total lineal footage of rows is equal to the number of pieces of metal bridging needed.)

3. Solid lumber bridging
 - a. Determine the number of rows of bridging needed
 - b. Determine the length of each row of bridging
 - c. Multiply the number of rows by the length of each row to determine the total lineal feet of bridging needed

INFORMATION SHEET

H. Subflooring

1. Lumber--Board feet

(NOTE: Lumber recommended is usually one by six inches or one by eight inches and may be laid diagonally or at right angles to the joist.)

- a. Calculate the area of the entire floor to be covered ignoring small openings in the floor

(NOTE: Length times width equals area.)

- b. Calculate the amount of material that must be allowed for waste by using the following table and add to the total area

Material	Allowance When Laid at Right Angles to Joists, %	Allowance When Laid Diagonally, %
1 x 6 tongued and grooved	20	25
1 x 8 tongued and grooved	15	20
1 x 6 shiplap	20	25
1 x 8 shiplap	15	20
1 x 6 square edge	12	17
1 x 8 square edge	10	15

(NOTE: A rule of thumb is that for 1" x 6" lumber add to the total area 1/6 for waste and for 1" x 8" lumber add 1/8.)

2. Plywood--Square feet or number of pieces

(NOTE: Usually 5/8" x 4' x 8' plywood is recommended.)

- a. Calculate the entire floor area

(NOTE: When laid at right angles to the joist, the waste is negligible.)

- b. Divide the square feet of area by thirty-two and round up to the next whole number to determine the number of pieces needed

778

INFORMATION SHEET

I. Nails--Pounds

1. 16d box for joists--10 pounds per 1,000 board feet
2. 8d box
 - a. For bridging--2 pound per 100 lineal feet
 - b. For lumber subfloor--32 pounds per 1,000 board feet
 - c. For plywood subfloor--10 pounds per 1,000 square feet

Types of Framing

WESTERN FRAMING

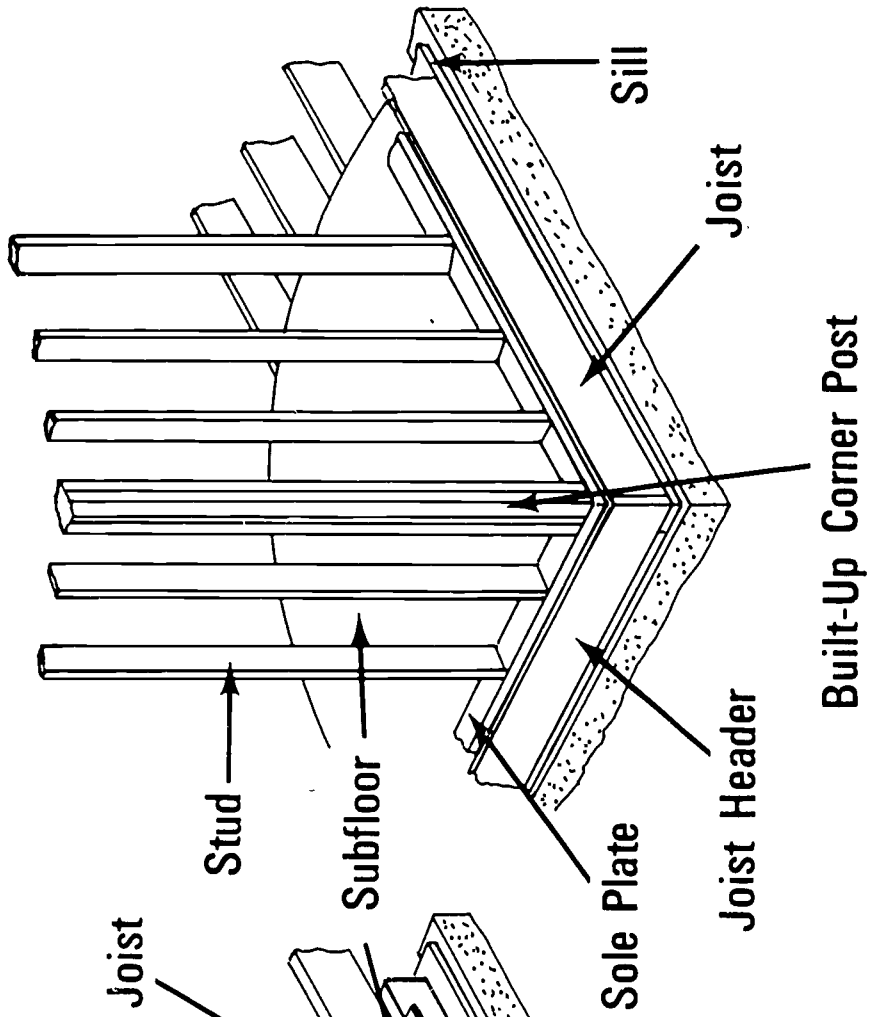

BALLOON FRAMING

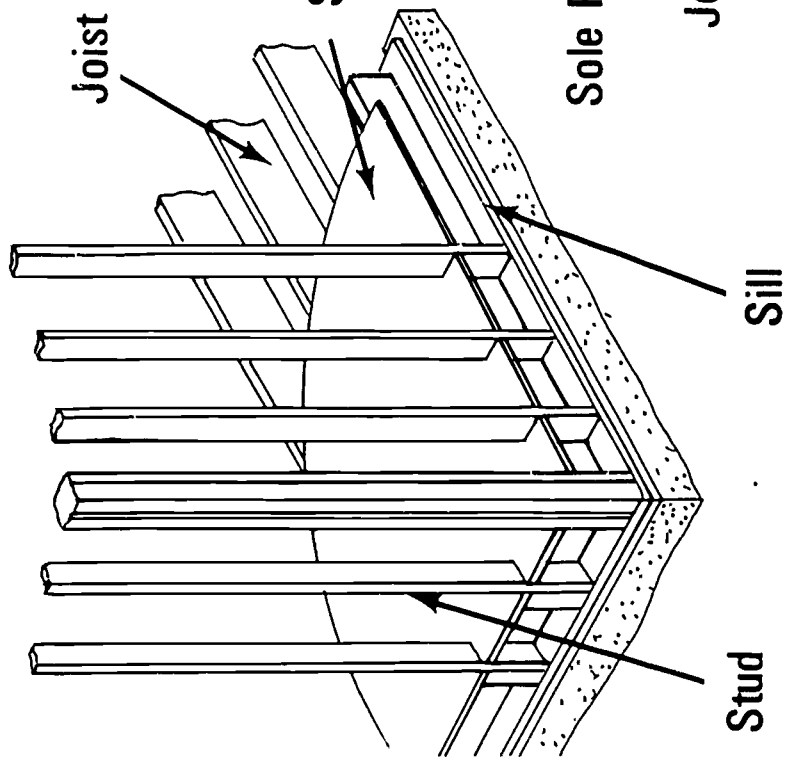

Floor and Sill Members

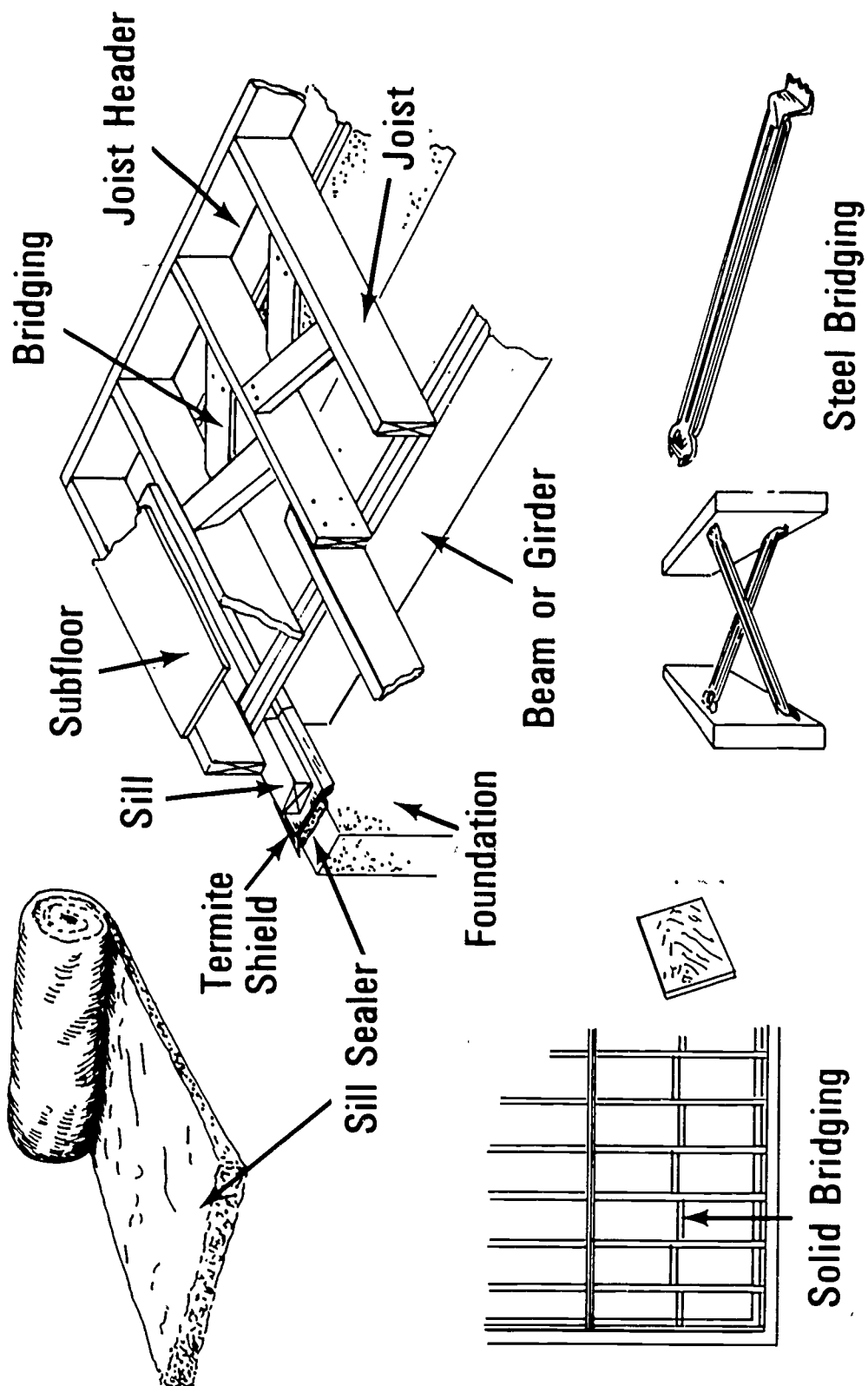

Fastening Sills to Foundation

SILL ANCHORS

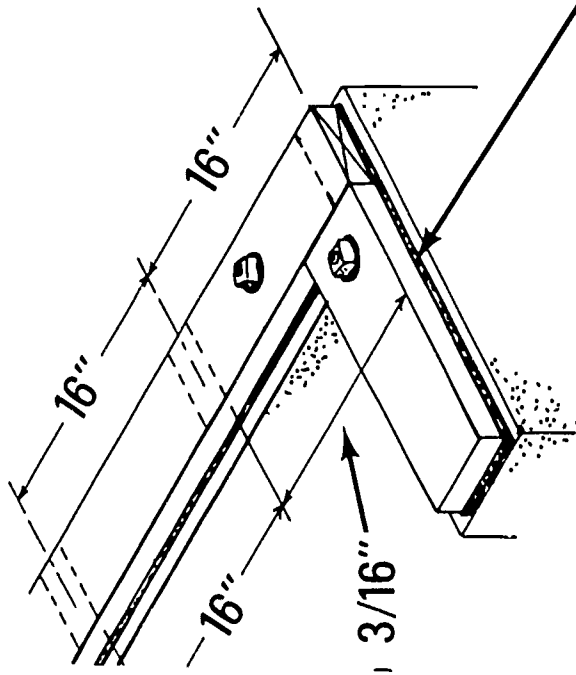

CONCRETE NAILS

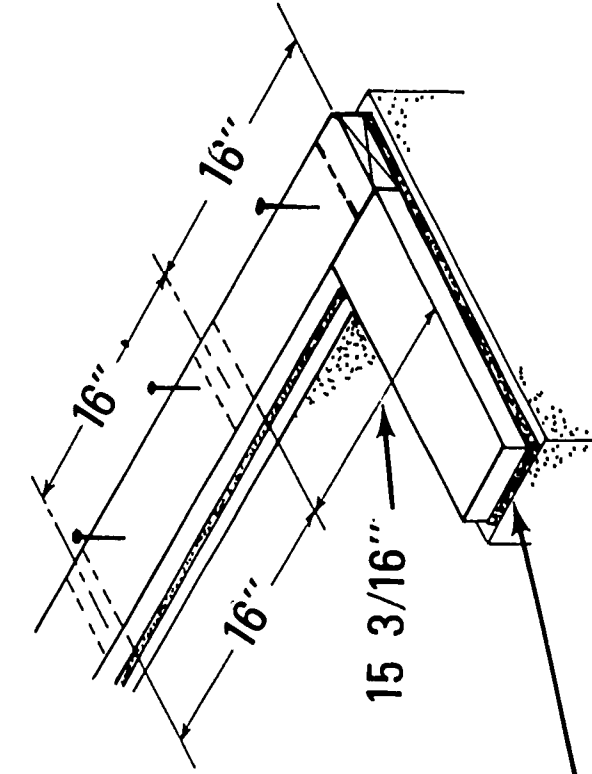

Sill Sealer

Stud or Joist Spacing
Permits Efficient Use
of Modular Materials

(NOTE: Concrete Nails Work
Well in New Concrete.)

Subflooring

Lumber Laid Diagonal to Joist

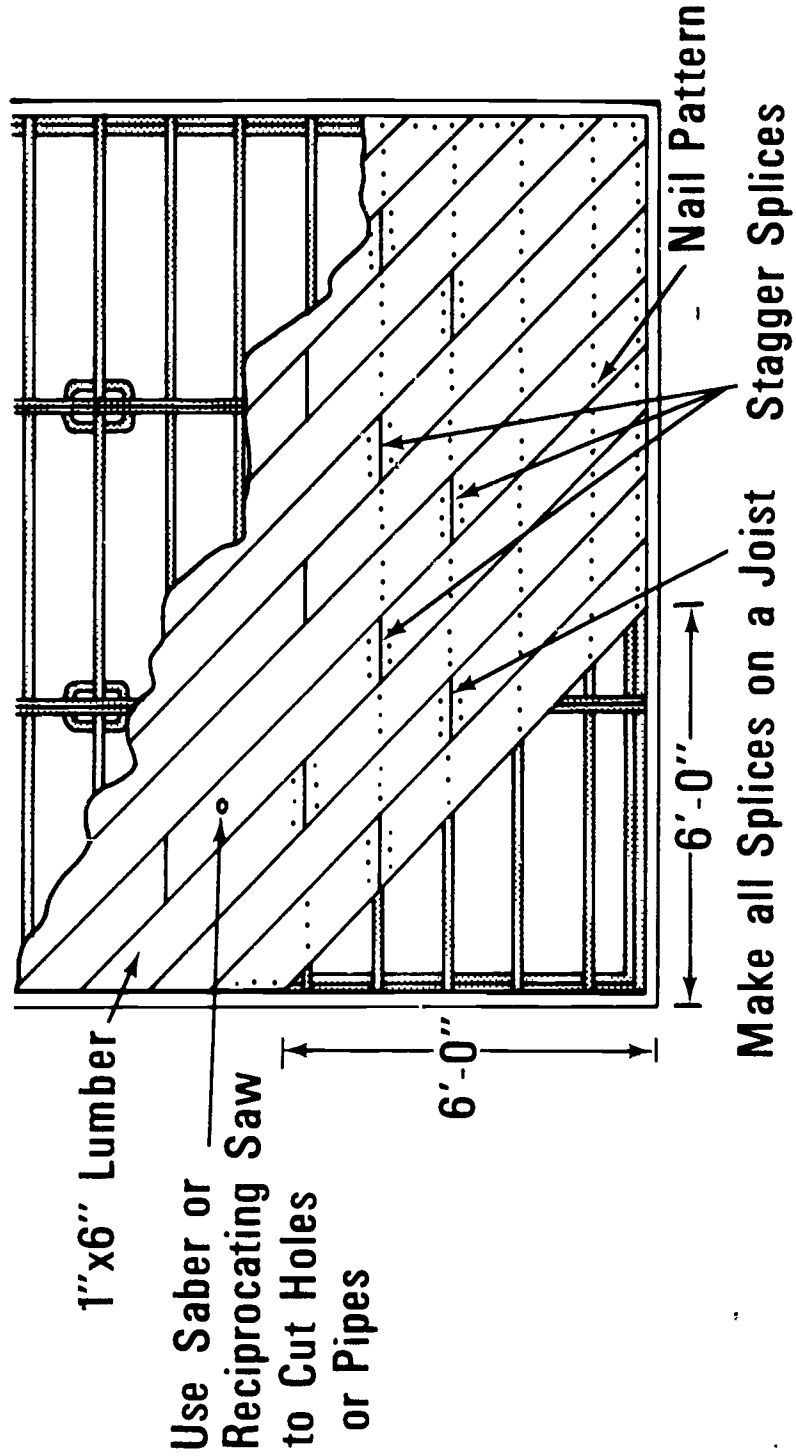

Subflooring

(Continued)

4'x8' Plywood

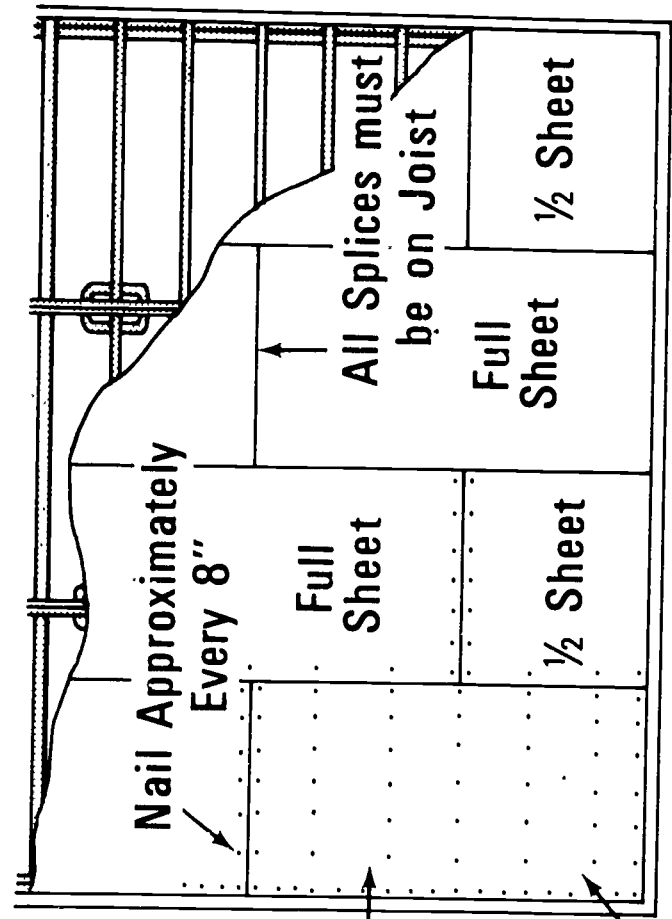

(Note: Use 8d Box Nails)

Start with a full sheet

4'x8' Plywood Sheets

Subflooring

(Continued)

Lumber Laid at Right Angles to Joist

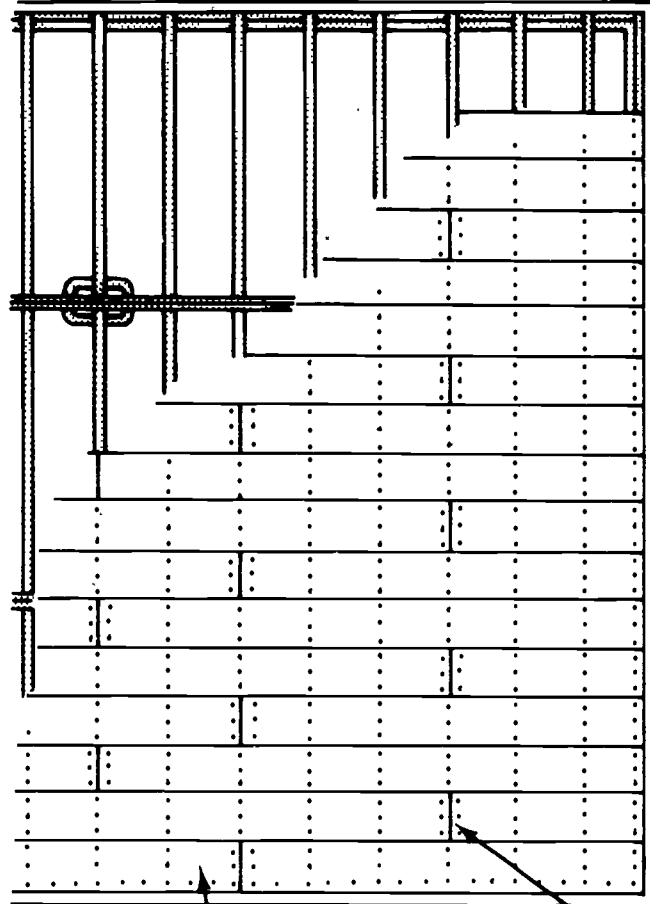

1"x6" Lumber

(Note: For 1"x8" Lumber use 3 Nails per Joist)

All Splices must Fall on a Joist

(Note: Stagger all Splices)

Fasteners

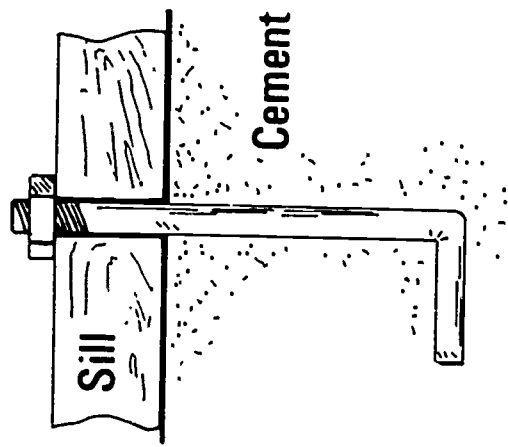
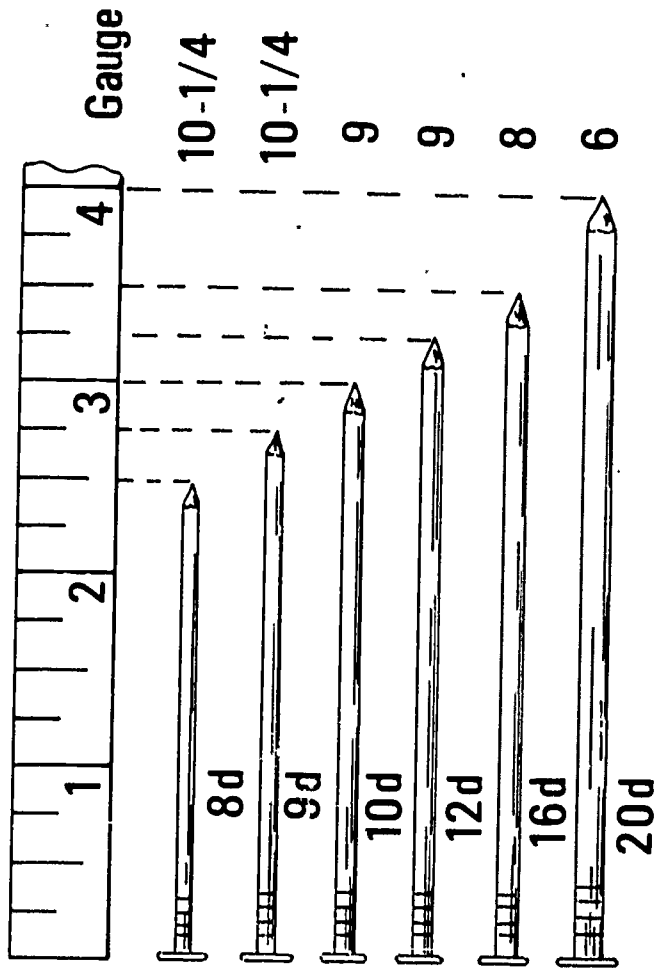

Sill Anchor



Masonry Nail

FLOOR AND SILL FRAMING
UNIT I

ASSIGNMENT SHEET #1--MATERIAL ESTIMATING
(FLOOR AND SILL)

Using the information sheet, calculate the floor and sill material needed for the house depicted below.

1. Sill sealer (Linear feet) _____
2. Termite shield (Linear feet) _____
3. Sill (Board feet 2" x 6") _____
4. Beams or girders (Board feet 2" x 12") _____
5. Joists (Board feet 2" x 8", 16" on centers) _____
6. Joist headers (Board feet 2" x 8") _____
7. Bridging
 - a. Board feet 1" x 4" _____
 - b. Metal (No. of pieces) _____
 - c. Solid lumber (Linear feet) _____
8. Subflooring
 - a. Board feet 1" x 6" square edge laid diagonally _____
 - b. Number of pieces 5/8" x 4' x 8' plywood laid at right angles _____
9. Nails
 - a. 16d _____
 - b. 8d _____
 - 1) Lumber subfloor _____
 - 2) Plywood subfloor _____
 - 3) Bridging _____

ASSIGNMENT SHEET #1

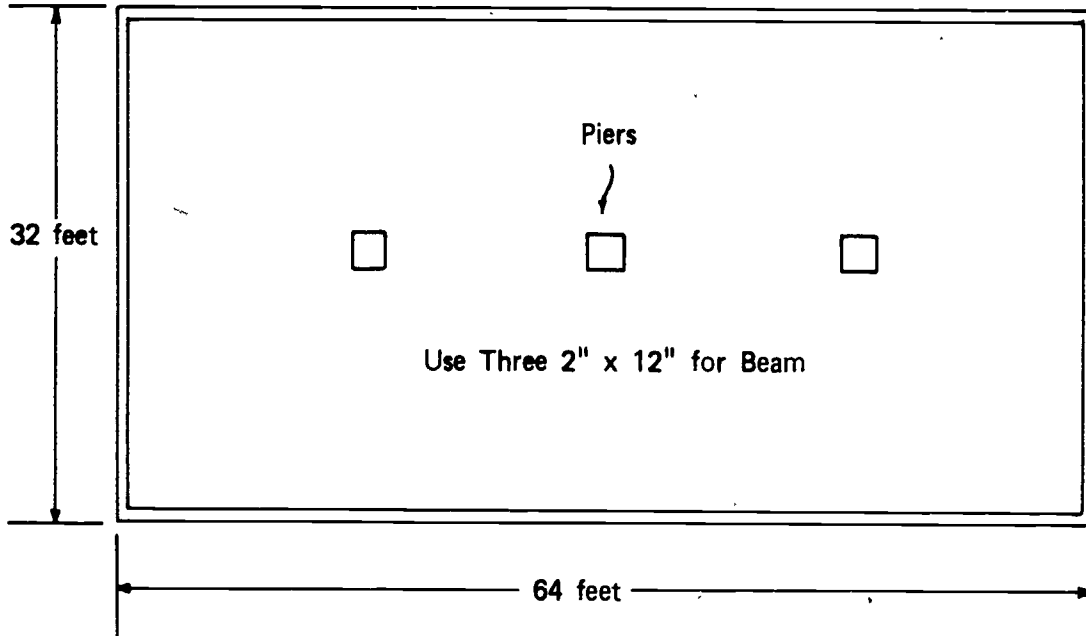

788

FLOOR AND SILL FRAMING
UNIT I

ANSWERS TO ASSIGNMENT SHEET #1

1. 192 linear feet
2. 192 linear feet
3. 192 board feet of 2" x 6" x 16'
4. 384 board feet of 2" x 12" x 16'
5. 2,091 board feet of 2" x 8" x 16'
6. 171 board feet of 2" x 8" x 16'
7.
 - a. 86 board feet of 1" x 4"
 - b. 192 metal bridging
 - c. 128 linear feet
8.
 - a. 2,397 board feet of 1" x 6"
 - b. 2,048 square feet or 64 pieces of 4' x 8' plywood
9.
 - a. 25 pounds 16d box nails
 - b. 8d box nails
 - 1) 77 pounds for solid lumber
 - 2) 21 pounds for plywood
 - 3) 2 pounds for bridging

FLOOR AND SILL FRAMING
UNIT I

JOB SHEET #1--BUILD A BOX SILL AND INSTALL A FLOOR JOIST

I. Tools and materials needed:

A. Tools

1. Electric handsaw
2. Electric hand drill
3. 5/8" flat bit
4. Tin snips
5. Claw hammer (16 ounce or larger)
6. Framing square
7. Level
8. 100 foot tape measure
9. 12 or 16 foot tape measure
10. Saber or reciprocating saw
11. 12" adjustable wrench

B. Material

1. Sill sealer
2. Flashing for termite shield
3. Beam material (See specifications.)
4. 2" x 6" for sills
5. 2" x 8" for joist and headers (See specifications.)
6. 1" x 4" or solid lumber for bridging
7. 8d box nails for bridging
8. 16d box nails for joist and headers

JOB SHEET #1

II. Procedure:

- A. Lay 2" x 6" plate material on top of foundation as per picture below and mark the location of sill anchors (Figure 1)

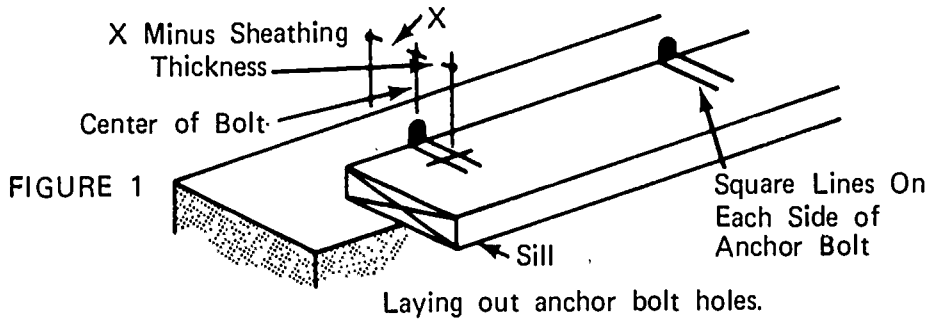

- B. Drill $5/8$ " holes through sill at anchor bolt locations
- C. Cut sill sealer to length and lay on top of foundation
- D. Cut flashing for termite shield to length, shape as in the diagram below, cut holes for anchor bolts, and place on top of sill sealer (Figure 2)

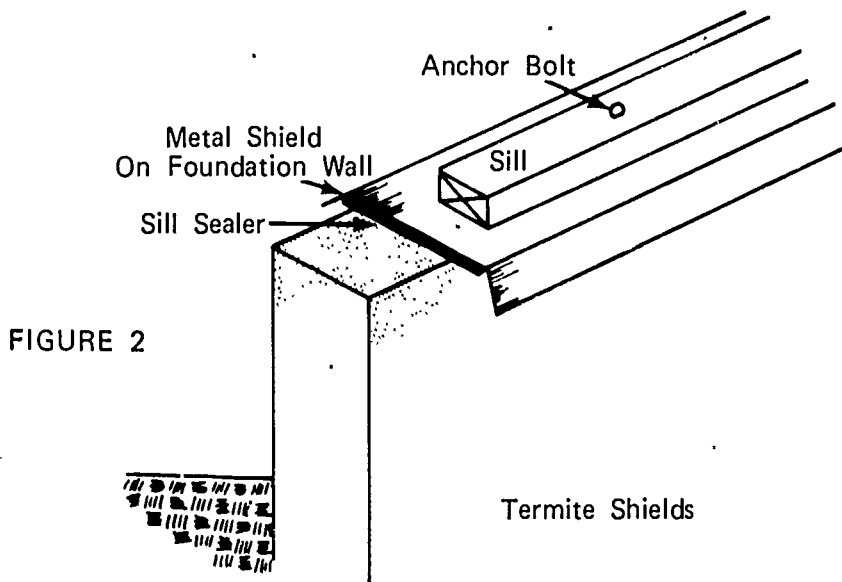

- E. Lay off sill for floor joist on 16" centers
1. Start at one end using 100' tape marked on 16" centers

JOB SHEET #1

2. Hold the end of the tape 1/2 the thickness of a 2" x 10" over the end of the sill and mark the sill every 16" for the full length repeating the operation for the other side (Figure 3)

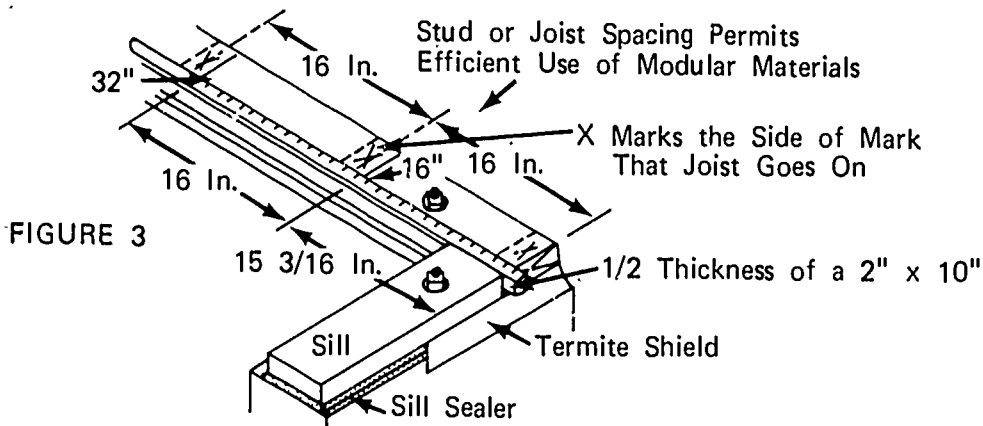

- F. Build the beam or girder, if one is necessary, and place it in position on piers (Figure 4)

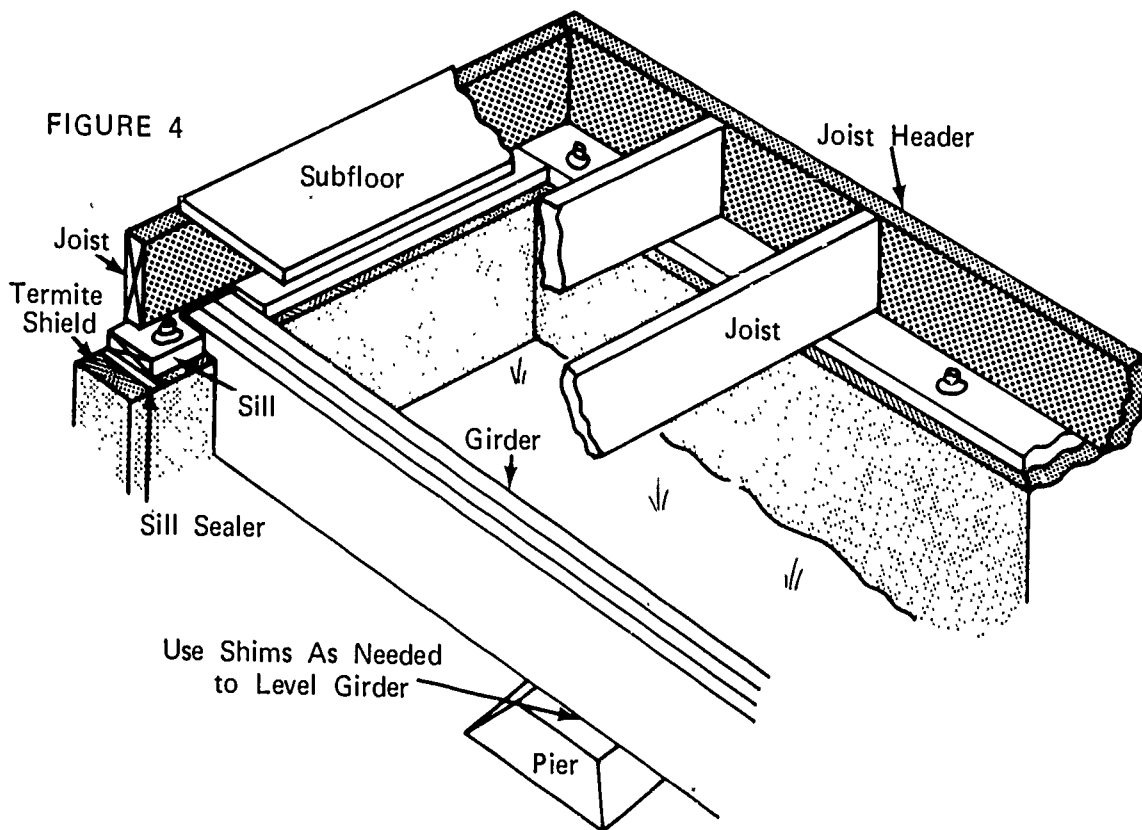

JOB SHEET #1

- G. Cut to length and nail joist headers to sill to form a box sill as illustrated below using 16d box nails (Figure 5)

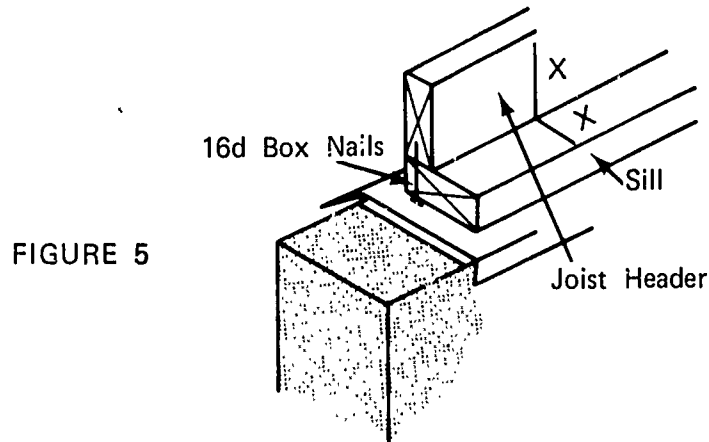

- H. Place sill and box sills on top of termite shield all around the perimeter of the house

(NOTE: Before bolting down solid, check for squareness.)

- I. Bolt sill in place

- J. Distribute floor joists at every spot marked on the sill and add an extra one under each partition wall that runs parallel to the joist as illustrated below (Figure 6)

(NOTE: Sight along the edge of each joist and lay down on sill with the crown up.)

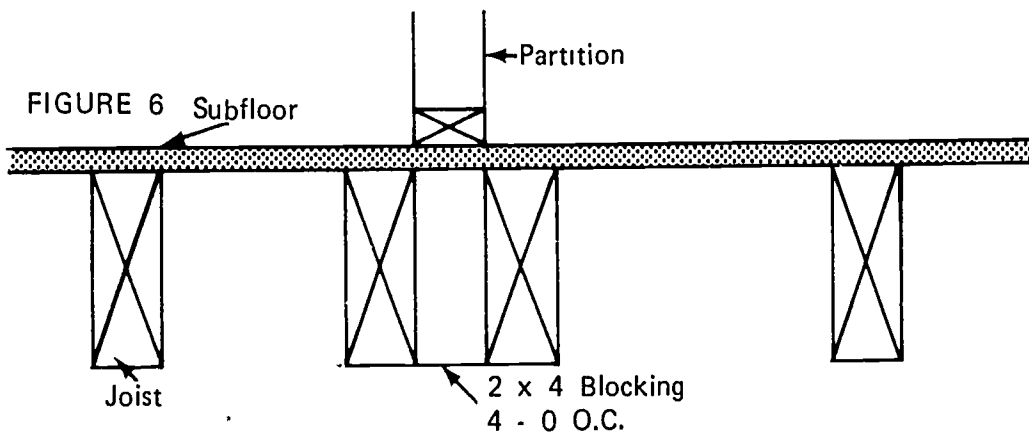

Double joists spaced apart under a partition to permit installation of heating or plumbing.

JOB SHEET #1

K. Place joist on position marked on sill and nail in place (Figure 7)

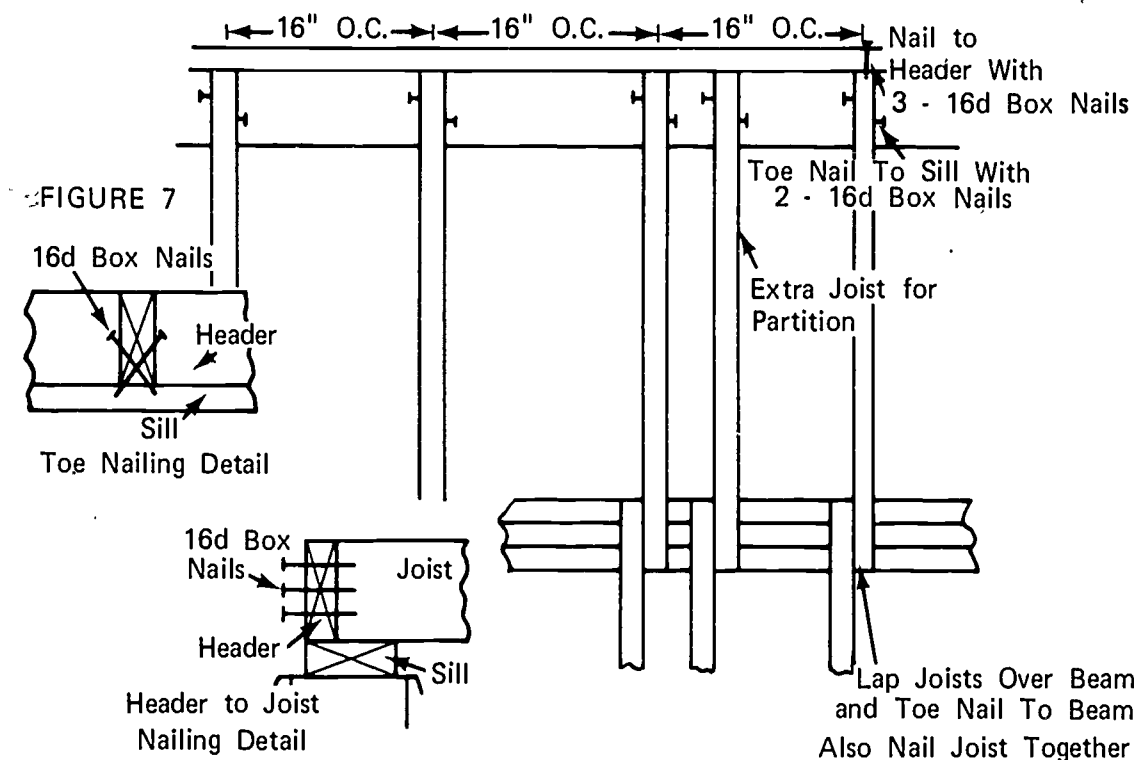

L. Frame openings in floor such as stairwells as per the illustration below

FIGURE 8

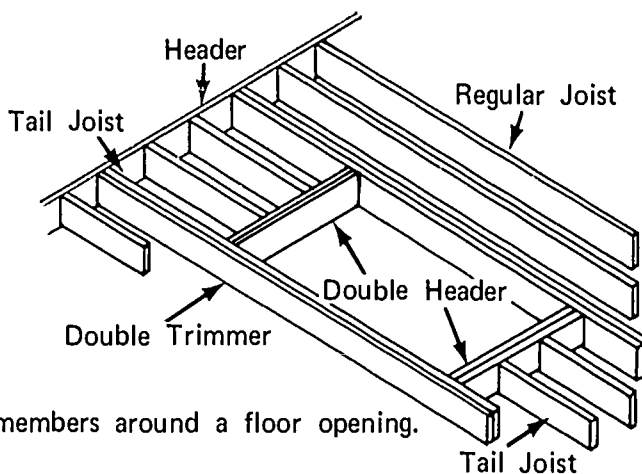

M. Allow plumbing and heating contractor to rough in gas, water, and forced air ducts

FLOOR AND SILL FRAMING
UNIT I

JOB SHEET #2--INSTALL BRIDGING

I. Tools and materials needed:

A. Tools

1. Table saw or radial arm saw
2. Framing square
3. Claw hammer (16 ounce or larger)
4. 12 or 16 foot tape

B. Material

1. 1" x 4" lumber for "X" bridging
2. Lumber the same size as the joists for solid bridging
3. Steel bridging for steel "X" bridging
4. 8d box nails

II. Procedure:

A. Wood "X" bridging

1. Figure the number of pieces of bridging needed

(NOTE: Use information sheet.)

2. Lay out and cut bridging (Figure 1)

(NOTE: Use the framing square and lay out the bridging as illustrated below.)

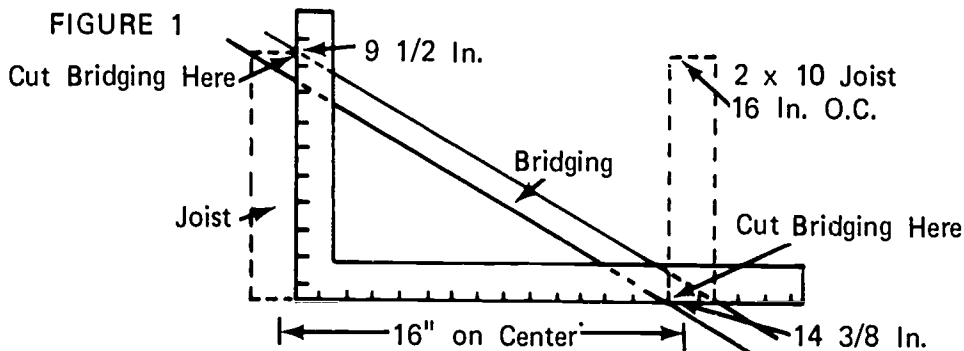

JOB SHEET #2

3. Install bridging (Figure 2)

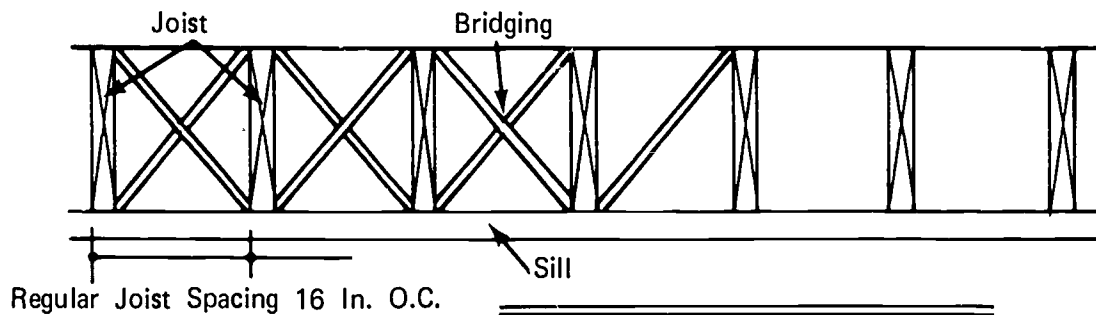
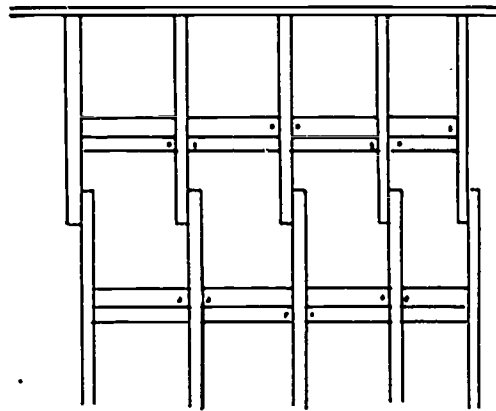

FIGURE 2



Floor frame complete and ready for subflooring.

B. Solid lumber bridging

1. Figure the number of pieces of bridging needed
2. Cut bridging
3. Install bridging in a staggered pattern to facilitate nailing

(NOTE: Use the illustration in Transparency 2.)

JOB SHEET #2

C. Steel "X" bridging (Figure 3)

1. Figure the number of pieces needed

(NOTE: Use information sheet.)

2. Install bridging as illustrated below

(NOTE: Follow manufacturer's instructions.)

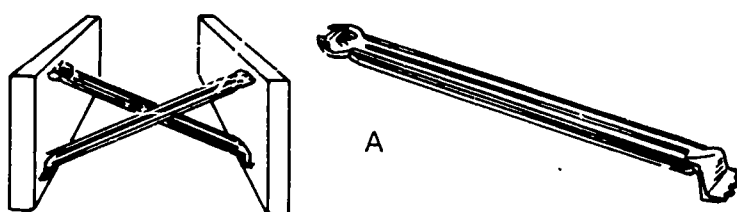

Steel bridging and completed installation.

FIGURE 3

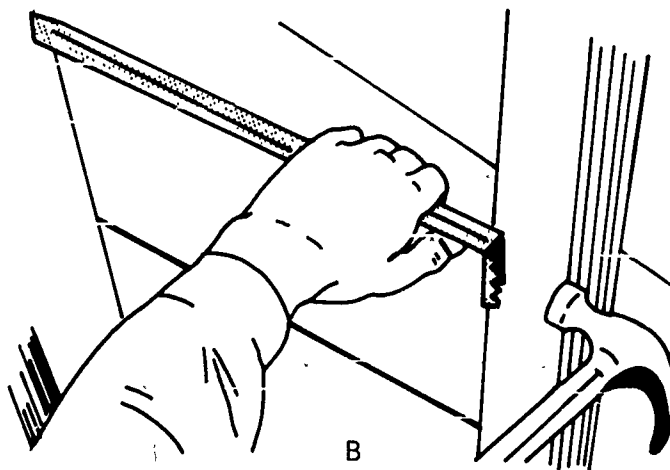

Method of installation.

FLOOR AND SILL FRAMING
UNIT I

JOB SHEET #3--LAY A SUBFLOOR

I. Tools and materials needed:

A. Tools

1. Electric handsaw
2. Electric hand drill
3. Assorted flat bits
4. Claw hammer (16 ounce or larger)
5. Framing square
6. 12 or 16 foot tape
7. Saber or reciprocating saw

8. Material

1. For lumber laid at a diagonal
 - a. Enough 1" x 6" or 1" x 8" lumber to cover floor area
 - b. 8d box nails
2. For lumber laid at right angles
 - a. Enough 1" x 6" or 1" x 8" lumber to cover floor area
 - b. 8d box nails
3. For plywood subfloor
 - a. Enough plywood to cover floor area
 - b. 8d box nails

II. Procedure--Install subfloor

A. Lumber (square end)

JOB SHEET #3

1. Diagonal to joist

- a. Measure both ways from one corner to about 6' each direction and lay the first board (Figure 1)

(NOTE: Use 3 - 8d box nails per joist for 1" x 6" lumber and 3 - 8d box nails per joist for 1" x 8" lumber. See illustration below.)

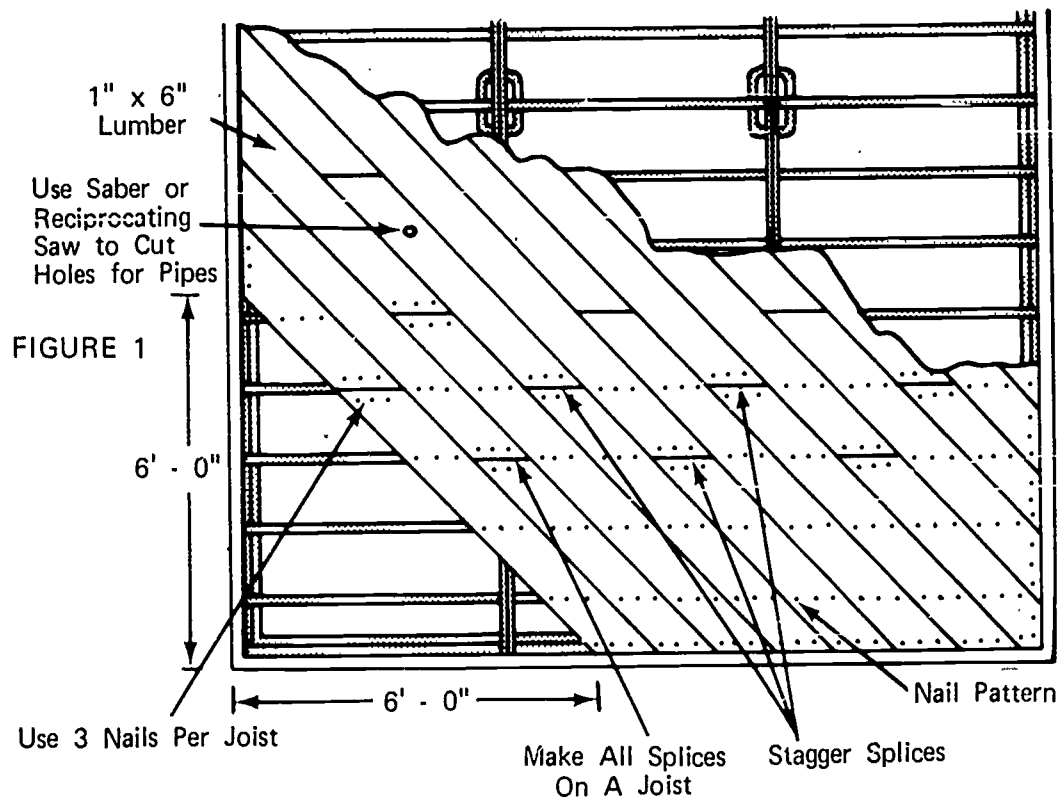

- b. Lay the remainder of the subflooring and nail in place as illustrated above

(NOTE: Ends may be allowed to run wild over the header joist and trimmed later.)

JOB SHEET #3

2. At right angles to joist
 - a. Start at corner from which the joist was laid off
 - b. Lay subfloor (Figure 2)

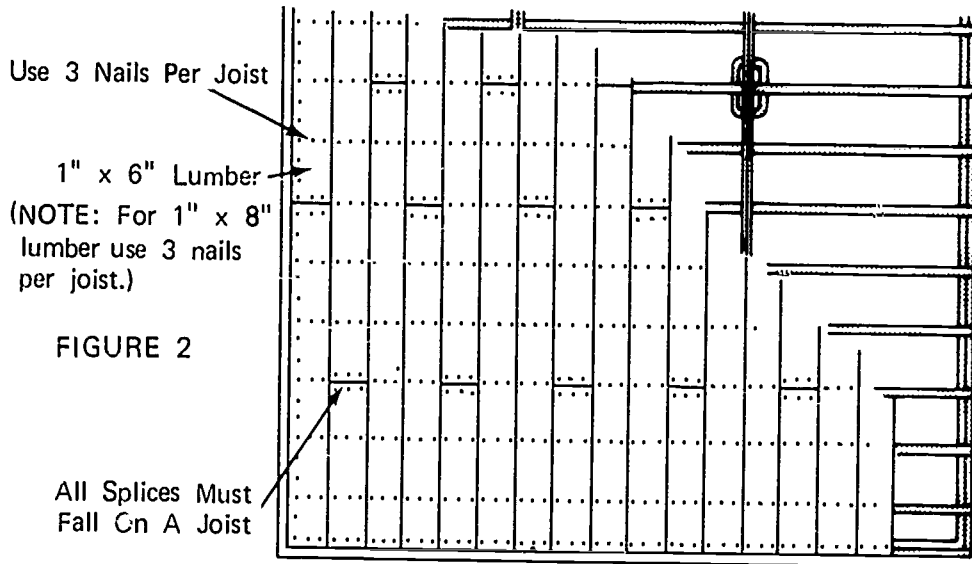
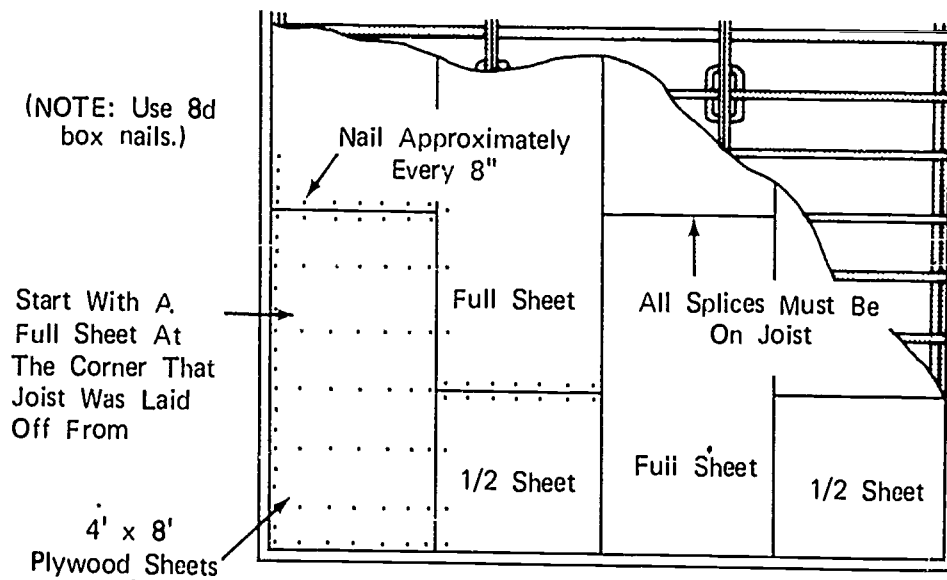

FIGURE 2

(NOTE: Stagger all splices.)

- B. Plywood (Laid at right angles)

(NOTE: See illustration below.)



FLOOR AND SILL FRAMING
UNIT I

TEST

1. Match the following list of terms to the correct definition.

- | | |
|--|---------------------|
| _____ a. A type of building construction in which the studs extend in one piece from the foundation to the roof | 1. Beam or girder |
| _____ b. Any large piece of timber, stone, iron, or other material used to support concentrated loads at particular points along its length | 2. Bridging |
| _____ c. The framing member into which the common joists are fitted forming the box sill or a member used to support the free end of joists over openings such as stairs, chimneys, and other openings | 3. Crown |
| _____ d. Solid lumber or small wooden or steel pieces fitted in pairs from the bottom of one joist to the top of the adjacent joist and crossed to stiffen and help distribute the load | 4. Foundation |
| _____ e. One of a series of parallel framing members used to support floor and ceiling loads and supported in turn by beams or girders | 5. Joist header |
| _____ f. The supporting portion of a structure below the first floor construction including the footings | 6. Joist |
| _____ g. A shield, usually made of sheet metal, placed on a foundation wall or around pipes to prevent the passage of termites into the structure | 7. Balloon framing |
| _____ h. Relating to the high side of the crook in framing lumber | 8. Termite shield |
| | 9. Sill |
| | 10. Sill sealer |
| | 11. Subfloor |
| | 12. Western framing |

- _____ i. A system of framing a building where the floor joists of each story rest on the top plates of the story below, and the bearing walls and partitions rest on the subfloor of each story

- _____ j. The lowest member of the frame of a structure resting horizontally on the foundation and supporting the uprights of the frame

- _____ k. Boards or panels laid directly on the floor joists over which a finished floor will be laid

- _____ l. A resilient waterproof material used under the sills as a seal against air, dirt, and insects

2. Name two styles of framing.

a. _____

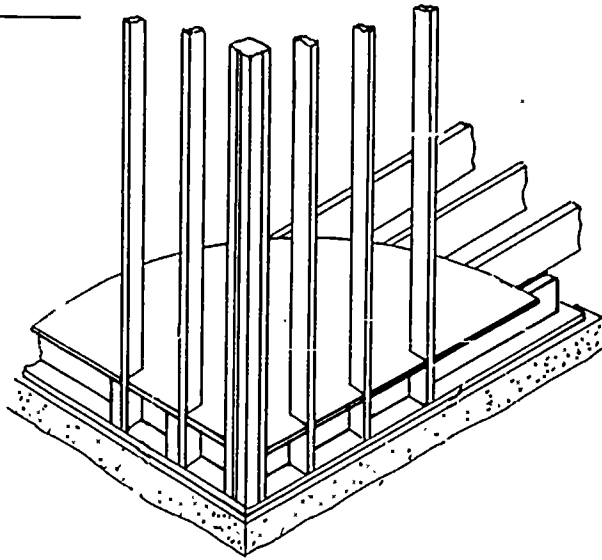

b. _____

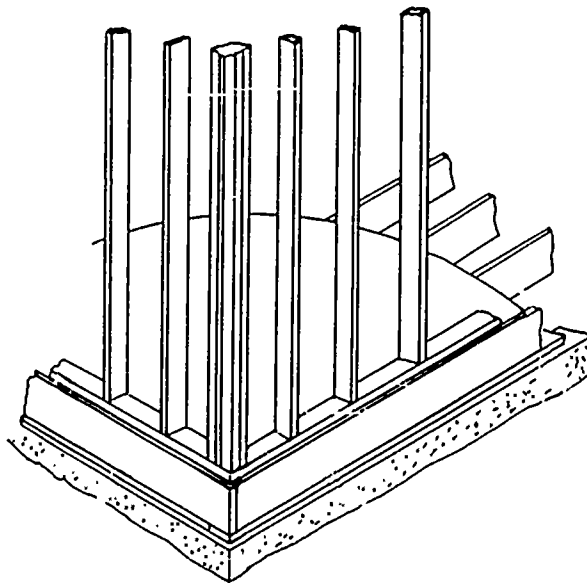

3. Identify eight framing members that make up the floor and sill.

- a.
- b.
- c.
- d.
- e.
- f.
- g.
- h.

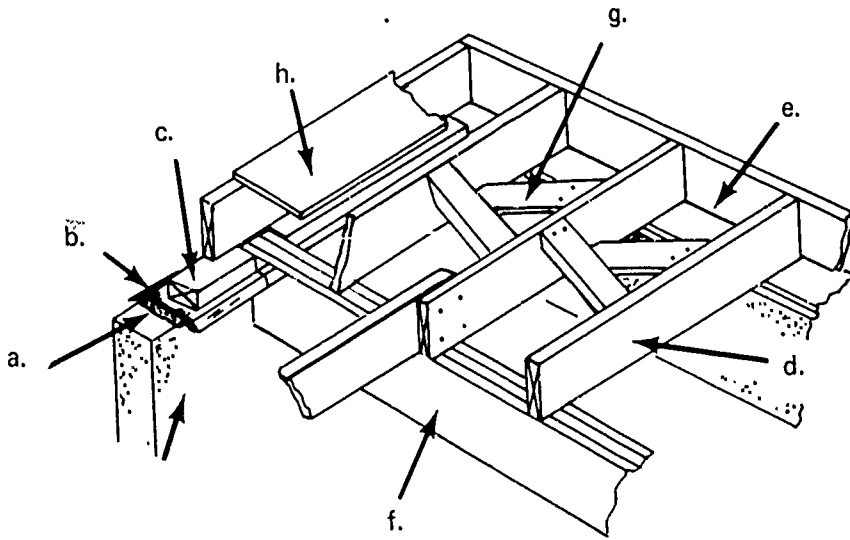

4. Write the purpose of a sill sealer.

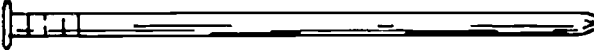
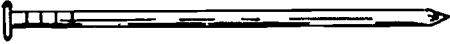
5. Write the purpose of a termite shield.
6. Name two methods of fastening sills to foundation walls.
- a.
- b.
7. Write the purpose of bridging.
8. Write the purpose of beams or girders.
9. List two types of subflooring.
- a.
- b.
10. Match the appropriate nails to use in assembling the subfloor, sill, and joist.
- _____ a. Sill and joist
- _____ b. Subfloor
1. 16d box nail
- 
2. 8d box nail
- 
11. Estimate the number of sheets of 4' x 8' plywood needed to subfloor a house of the following dimensions: 68 feet long by 36 feet wide.

12. Demonstrate the ability to:

- a. Lay the sill and install floor joist on sixteen and twenty-four inch centers.
- b. Install bridging.
- c. Lay subflooring.

- 1) Lumber
- 2) Plywood

(NOTE: If this has not been accomplished prior to the test, ask the instructor when the above activities should be completed.)

FLOOR AND SILL FRAMING
UNIT I

ANSWERS TO TEST

1.
 - a. 7
 - b. 1
 - c. 5
 - d. 2
 - e. 6
 - f. 4
 - g. 8
 - h. 3
 - i. 12
 - j. 9
 - k. 11
 - l. 10
2.
 - a. Balloon framing
 - b. Western framing
3.
 - a. Sill sealer
 - b. Termite shield
 - c. Sill
 - d. Joists
 - e. Joist header
 - f. Beam or girder
 - g. Bridging
 - h. Subfloor
4. Provides a seal against air, dirt, and insects

5. Prevents the passage of termites to the structure
6.
 - a. Sill anchor
 - b. Concrete nail
7. Stiffens and helps distribute the load
8. Support concentrated loads at particular points along their lengths
9.
 - a. Lumber
 - b. Plywood
10.
 - a. 1
 - b. 2
11. 77 sheets
12. Performance skills will be evaluated according to the criteria listed on the progress chart.

808

WALL AND PARTITION FRAMING UNIT II

TERMINAL OBJECTIVE

After completion of this unit, the student should be able to define wall and partition framing terms, identify framing members, and compute the length of common members. He should also be able to lay out, cut, and assemble a wall section, identify and apply various types of sheathing, and use the power tools safely and correctly. This knowledge will be evidenced through demonstration and by scoring eighty-five percent on the unit test.

SPECIFIC OBJECTIVES

After completion of this unit, the student should be able to:

1. Match a list of wall and partition framing terms to a list of definitions.
2. Identify the framing members used in wall and partition construction.
3. Identify the type of corner used most in western construction.
4. Identify the type of partition "T's" most used in western construction.
5. Compute the length of the regular stud.
6. Compute the length of trimmers for window and door openings.
7. Compute the length of the rough header for windows and doors.
8. Name three types of sheathing.
9. Estimate the amount of materials needed for wall and partition framing.
10. Demonstrate the ability to:
 - a. Lay out wall and partition locations on floor.
 - b. Cut studs, trimmers, cripples, and headers to length.
 - c. Build "T's", corners, and headers.
 - d. Lay out and assemble wall sections for a single story building.
 - e. Install sheathing.
 - f. Lay out and install ceiling joists.
 - g. Install windows.
 - h. Install outside door jambs and hang exterior doors.

WALL AND PARTITION FRAMING UNIT II

SUGGESTED ACTIVITIES

- I. Instructor:
 - A. Provide students with objective sheet.
 - B. Provide students with information, assignment, and job sheets.
 - C. Make transparencies.
 - D. Discuss terminal and specific objectives.
 - E. Discuss information and assignment sheets.
 - F. Demonstrate and discuss procedures outlined in job sheets.
 - G. Give test.
- II. Student:
 - A. Read objective sheet.
 - B. Study information sheet.
 - C. Complete assignment sheet.
 - D. Demonstrate the ability to accomplish the procedures outlined in the job sheets.
 - E. Take test.

INSTRUCTIONAL MATERIALS

- I. Included in this unit:
 - A. Objective sheet
 - B. Information sheet
 - C. Transparency masters
 1. TM 1--Wall and Partition Framing Members
 2. TM 2--Corners
 3. TM 3--Corners (Continued)
 4. TM 4--Corners (Continued)
 5. TM 5--Partition "T's"

6. TM 6--Partition "T's" (Continued)
7. TM 7--Partition "T's" (Continued)
8. TM 8--Stud Length
9. TM 9--Stud Length (Continued)
10. TM 10--Trimmer Studs
11. TM 11--Door and Window Headers
12. TM 12--Types of Sheathing
13. TM 13--Types of Sheathing (Continued)

D. Assignment Sheet #1--Material Estimating

E. Answers to assignment sheet

F. Job sheets

1. Job Sheet #1--Lay Out Wall and Partition Locations on Floor
2. Job Sheet #2--Cut Studs, Trimmers, Cripples, and Headers to Length
3. Job Sheet #3--Build Inside and Outside Corners and Headers
4. Job Sheet #4--Lay Out and Assemble Wall Sections for a Single Story Building
5. Job Sheet #5--Install Sheathing
6. Job Sheet #6--Lay Out and Install Ceiling Joists
7. Job Sheet #7--Install Windows
8. Job Sheet #8--Install Exterior Door Frames and Hang Exterior Doors

G. Test

H. Answers to test

II. References:

- A. Burke, Arthur E., Ralph Dalzell, and Gilbert Townsend. *Architectural and Building Trades Dictionary*. Chicago, Illinois: American Technical Society, 1955.
- B. Cooper, George H. and Stanley Badzinski, Jr. *Building Construction Estimating*. St. Louis, Missouri: McGraw-Hill, 1971.
- C. Durbahn, Walter E. and Elmer W. Sundberg. *Fundamentals of Carpentry*. Third Edition. Chicago, Illinois: American Technical Society, 1963.

- D. Oklahoma T & I Education. *Suggested Basic Course Outline in Carpentry*. State Board for Vocational Education.
- E. Smith, Ronald C. *Principles and Practices of Light Construction*. Englewood Cliffs, New Jersey: Prentice Hall Inc., 1970.
- F. Wagner, Willis H. *Modern Carpentry*. Homewood, Illinois: Goodheart-Willcox, 1969.

WALL AND PARTITION FRAMING UNIT II

INFORMATION SHEET

- I. Terms and definitions
 - A. Bearing wall--A wall which supports the floors and/or roof directly above it in addition to its own weight
 - B. Blocking--The use of wood blocks as filler pieces between framing members
 - C. Cripple stud--Any part of a framing stud that is cut less than full size as over a door or window opening and under a window opening
 - D. Double plate--The top most member of a wall section attached to the top of the studs for the purpose of stiffening the wall and for tying together splices, corners, and partitions that are at right angles to a wall
 - E. Header--Horizontal structural member that supports the load over an opening such as a window or door
 - F. Partition--A wall that subdivides space within a building
 - G. Rough opening--The opening for doors, windows, etc. formed by the framing members
 - H. Rough sill--The lower framing member which is attached to the top of the bottom cripple studs and forms the base of a rough opening for a window
 - I. Sole plate--The lowest horizontal member of a wall or partition which rests on the rough floor to which the studding is nailed
 - J. Stud--The main vertical framing members in walls and partitions
 - K. Trimmer--The vertical members that form the sides of a rough opening for a door or window upon which the header rests
 - L. Jamb--The top and two sides of a door or window frame which contact the door or sash consisting of a head jamb and two side jambs
- II. Wall and partition framing members (Transparency 1)
 - A. Sole plate
 - B. Regular studs

INFORMATION SHEET

- C. Top plate
- D. Trimmer stud
- E. Header
- F. Cripple studs
- G. Rough sill
- H. Double top plate
- I. Corner assembly
- J. Blocking

III. Types of corners (Transparencies 2, 3, and 4)

(NOTE: Illustrations and descriptions are on transparency.)

IV. Types of "T's" (Transparencies 5, 6, and 7)

(NOTE: Illustrations and descriptions are on transparency.)

V. Computing the length of the regular stud (Transparencies 8 and 9)

A. Slab floor

1. Determine the height of the finished ceiling from the finished floor including one-half inch clearance for finish material
2. Determine the thickness of the sole plate plus the double top plate
3. Determine the thickness of ceiling material and flooring material
(NOTE: For carpet or a resilient type flooring material, the thickness is negligible.)
4. Add the thickness of ceiling and flooring material to the finished ceiling height
5. Subtract the thickness of the plates from the sum achieved in step number four for the stud length

Example: When the desired finished ceiling height is 8' 1/2", the actual plate thickness is 1 5/8", and the ceiling thickness is 1/2". Proceed as follows.

(NOTE: See Transparency 8)

INFORMATION SHEET

Step #1--Finished ceiling height = $8' + 1/2" = 8' 1/2"$

	Sole Plate		Top Plate		Double Top Plate	
Step #2--	1 1/2"	+	1 1/2"	+	1 1/2"	= 4 1/2"

Finished Ceiling Height

Thickness of Ceiling

Steps #3 and #4--	8' 1/2"	+	1/2"	= 8' 1"
-------------------	---------	---	------	---------

Step #5-- $8' 1" - 4 1/2" = 7' 8 1/2"$ Stud length

B. Wood floor

1. Determine the height of the finished ceiling from the finished floor including 1/2" clearance for finish material
2. Determine the thickness of the sole plate plus the double top plate
3. Determine the thickness of ceiling material and underlayment
4. Add the thickness of ceiling and underlayment to the finished ceiling height
5. Subtract the thickness of the plates from the sum achieved in step number four for the stud length

Example: When the desired finished ceiling height is 8' 1/2", the actual plate thickness is 1 1/2", the ceiling thickness is 1/2", and the underlayment thickness is 5/8". Proceed as follows.

(NOTE: See Transparency 9.)

Step #1--Finished ceiling height - 8' 1/2"

	Sole Plate		Top Plate		Double Top Plate	
Step #2--	1 1/2"	+	1 1/2"	+	1 1/2"	= 4 1/2"
	Finished ceiling height		Thickness of ceiling material		Thickness of underlayment	
Step #3 and #4--	8' 1/2"	+	1/2"	+	5/8"	= 8' 1 5/8"
Step #5--	$8' 1 5/8" - 4 1/2" = 7' 9 1/8"$ Stud length					

INFORMATION SHEET

VI. Computing the length of trimmers for window and door rough openings (Transparency 10)

(NOTE: The tops of all windows and doors should be the same height from the floor unless otherwise specified. To compensate for variation in materials, the top of the trimmers may be scribed.)

A. Slab floor

1. Determine the height of the rough opening from the finished floor as follows:
 - a. Determine the door height and add 5/8" for clearance at the bottom of the door

(NOTE: Standard doors are 6' 8" high.)
 - b. Add 3/4" for jamb header
 - c. Add 3/4" for clearance between rough header and jamb header
 - d. Subtract the thickness of the sole plate and the result is the trimmer stud length

Example:

Step a--Door height	6' 8"
Clearance	5/8"
Step b--Jamb header	3/4"
Step c--Header clearance	+ 3/4"
	6' 10 1/8"
Step d--Sole plate	- 1 1/2"
Trimmer stud length	6' 8 5/8"

B. Wood floor

(NOTE: Compute the same as for a slab floor remembering to add the thickness of the underlayment to establish the finished floor. To compensate for variation in materials, the top of the trimmers may be scribed.)

VII. Computing header length for window and door rough openings (Transparency 11)

A. Doors rough header length

(NOTE: If pre-hung doors are used, check manufacturer's specifications for rough opening size.)

1. Determine rough opening width
 - a. Check door schedule for door sizes
 - b. Add 1/4" to door width for clearance between door edges and jamb

INFORMATION SHEET

- c. Add 1 1/2" for side jambs
 - d. Add 1" for clearance to install jambs
2. Add 3" to rough opening width for trimmer studs to get the header length

Example: For a 3' - 0" x 6' - 8" door

Step a--Door size	3' 0"
Step b--Door and jamb clearance	1/4"
Step c--Side jambs	1 1/2"
Step d--Side jamb and trimmer clearance	+ 1"
Rough opening	<u>3' 2 3/4"</u>
Thickness of trimmer studs	+ 3"
Header size	<u>3' 5 3/4"</u> or 41 3/4"

(NOTE: After computing one header size subtract the door size from it and use this figure to add to other door sizes to determine header sizes.)

(NOTE: See Transparency 11 for illustration.)

B. Window rough header length

(NOTE: Check with manufacturer to determine rough opening size and add the thickness of the two trimmer studs also taking into account whether the return on metal windows is to be sheetrock or wood.)

VIII. Types of sheathing (Transparencies 12 and 13)

- A. Gyplap
- B. Fiberboard
- C. Plywood

IX. Estimating wall framing materials for a single story building

A. Wall plates (2 x 4)

(NOTE: Plate material is usually ordered in sixteen foot lengths.)

1. Determine the lineal footage of all outside walls including openings
2. Determine the lineal footage of all inside walls and partitions including openings

INFORMATION SHEET

3. Multiply the total, inside, and outside lineal footage by three
(NOTE: There are three plates: sole plate, top plate, and double top plate.)
4. Divide the total lineal footage obtained in step number three by 16 and round up to the next full number to get the number of 16 foot 2 x 4's needed for plates

B. Studs 16 inches on center

(NOTE: Studs may be purchased precut or cut on the job from eight foot or sixteen foot 2 x 4's.)

1. Determine the lineal footage of all outside and inside walls
2. Allow one stud for each lineal foot of wall
3. If sixteen foot material is used, divide the total achieved in step number three by two for the number of sixteen foot 2 x 4's needed for studs
4. On buildings with gable roofs use one-half the plate length for determining the number of gable studs needed at each gable end
 - a. Multiply $\frac{1}{2}$ the plate length by three-fourths if the gable studs are on sixteen-inch centers to determine the number needed
 - b. Determine to the nearest whole foot the length of the longest gable stud from the double plate to the top of the roof

(NOTE: One piece of stud material will make a long and a short gable stud, this is why only $\frac{1}{2}$ of the plate length is used.)

C. Headers

(NOTE: The use of 2 x 12 headers requires more material, but the time saved more than makes up for the difference.)

1. From the door and window schedule determine the size of all doors and windows
(NOTE: List each door and window separately.)
2. Add six inches to each door and window size
3. Double the length for each window and door

INFORMATION SHEET

4. Combine lengths obtained in step number 3 into convenient lengths for ordering and to minimize waste
 5. Order a bundle of laths or a sheet of 1/2" C-D plywood to cut up for spacers
- D. Diagonal bracing (if used)
- (NOTE: Required at each end of all exterior walls. These braces run from top to bottom plate at an approximate angle of forty-five degrees. Walls eight feet zero inches high would require material twelve feet long for each brace.)
1. Determine the number of outside and inside corners in the exterior walls
 2. Multiply the number of corners by two to determine the number of twelve foot 1 x 6's needed for bracing
- E. Wall sheathing (8 foot wall)
1. Plywood
 - a. Determine the lineal footage of all outside walls
(NOTE: If there is a gable end, add one-half of the width of each gable to the total lineal footage of the outside walls.)
 - b. Multiply the total lineal footage by eight to determine the total square feet of wall area
 - c. Divide the square feet of wall area by thirty-two (the number of square feet in a sheet of plywood) and round up to the nearest whole number to determine the number of sheets of 4' x 8 plywood needed for sheathing
 2. Gyplap
 - a. Determine the lineal footage of all outside walls
(NOTE: If there is a gable end, add one-half of the width of each gable to the total lineal footage of the outside walls.)
 - b. Multiply the total lineal footage by eight to determine the total square feet of wall area
 - c. If let in bracing is used, divide the total square feet of wall area by sixteen (the square feet in a piece of gyplap) and round up to the next whole number to determine the number of pieces of gyplap needed for sheathing

INFORMATION SHEET

- d. If plywood bracing is used, determine the number of inside and outside corners to be braced and multiply by four (the equivalent to the number of pieces of gyplap it replaces) and subtract this figure from the total number of pieces in step c to get the number of pieces of gyplap needed for sheathing
 - e. Multiply the number of inside and outside corners by two to determine the number of pieces of plywood needed for bracing
3. Fiberboard
- a. Determine the lineal footage of all outside walls

(NOTE: If there is a gable end, add one-half of the width of each gable to the total lineal footage of the outside walls.)
 - b. Multiply the total lineal footage by eight to determine the total square feet of wall area
 - c. If let in bracing is used, divide the total square feet of wall area by thirty-two, (the square feet in a piece of fiberboard), and round up to the next whole number to determine the number of pieces of fiberboard needed for sheathing
 - d. If plywood bracing is used, determine the number of inside and outside corners to be braced and multiply by two (the number of pieces of fiberboard to be replaced at each corner) and subtract this figure from the total of pieces in step c. to get the number of pieces of fiberboard needed for sheathing
 - e. Multiply the number of inside and outside corners by two to determine the number of pieces of plywood needed for bracing
- F. Ceiling joist on sixteen-inch centers
1. Determine the size of joists needed from specifications
 2. Determine the length of the longest wall
 3. Number of ceiling joist needed equals wall length $\times \frac{3}{4} + 1$

(NOTE: A building greater than sixteen feet wide will require a combination of lengths of joist.)

INFORMATION SHEET

G. Nails

(NOTE: Use the table below for an estimate of the nails needed for a particular application.)

Application	Nail Size and Type	Amount
Wall Framing	8d Box	2 lb. per 1000 bd. ft.
	16d Box	8 lb. per 1000 bd. ft.
Ceiling Framing	16d Box	4 lb. per 1000 bd. ft.
Wall Sheathing		
Fiberboard 25/32"	8d Box	30 lb. per 1000 sq. ft.
Fiberboard 1/2"	2" barbed roofing	15 lb. per 1000 sq. ft.
Gyplap 1/2"	1 1/2" barbed roofing	12 lb. per 1000 sq. ft.
Plywood 1/2"	6d Box	10 lb. per 1000 sq. ft.

H. Exterior doors (Excluding overhead)

1. Determine the number of exterior jambs needed and the size
 - a. With sills
 - b. Without sills
2. Determine the number of sets of butt hinges needed and the size
3. Determine types and sizes of doors needed

(NOTE: This information usually can be obtained from the specifications and door schedule.)

4. Determine the kind and quality of lock sets needed

Wall and Partition Framing Members

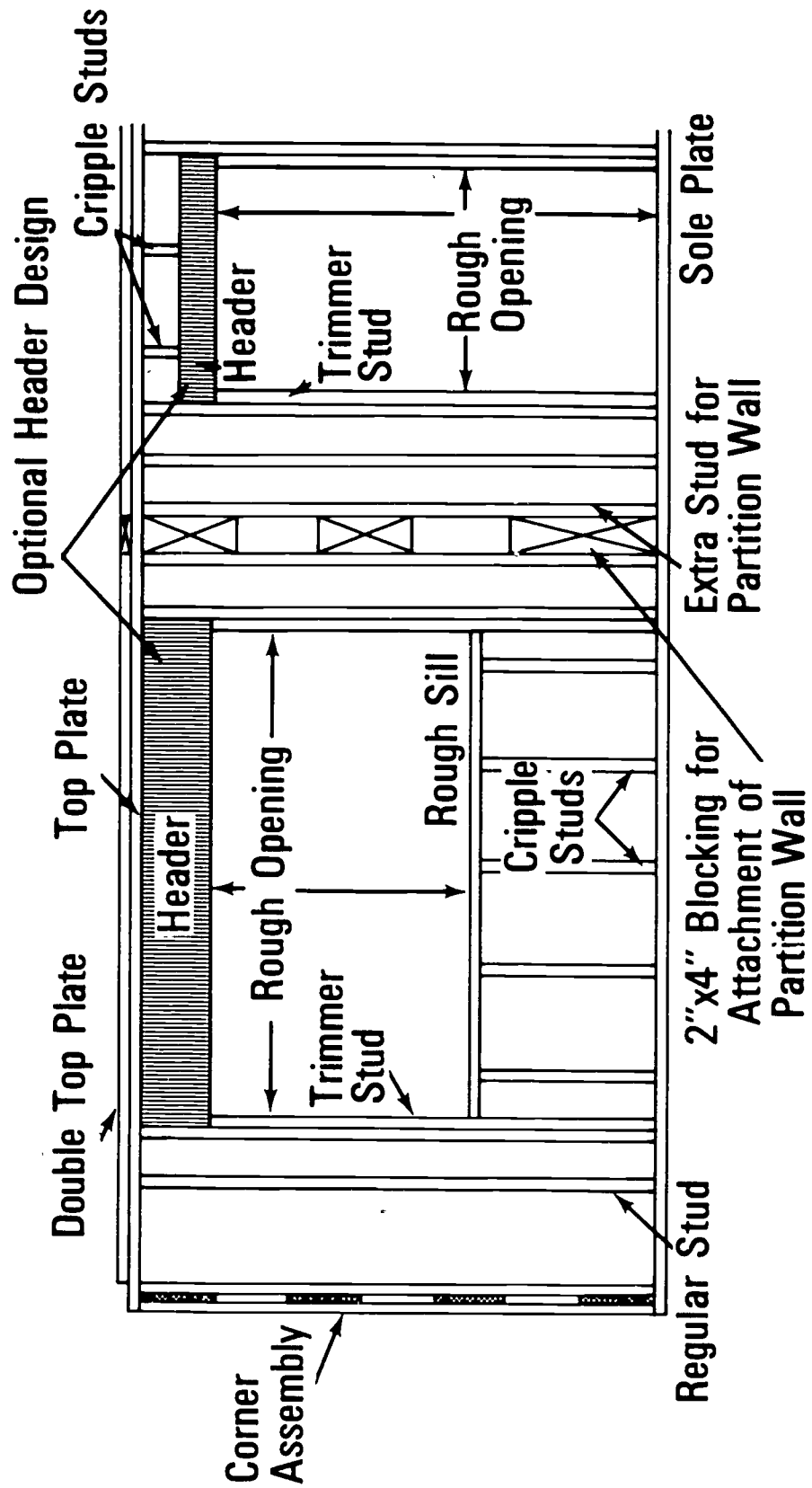

Corners

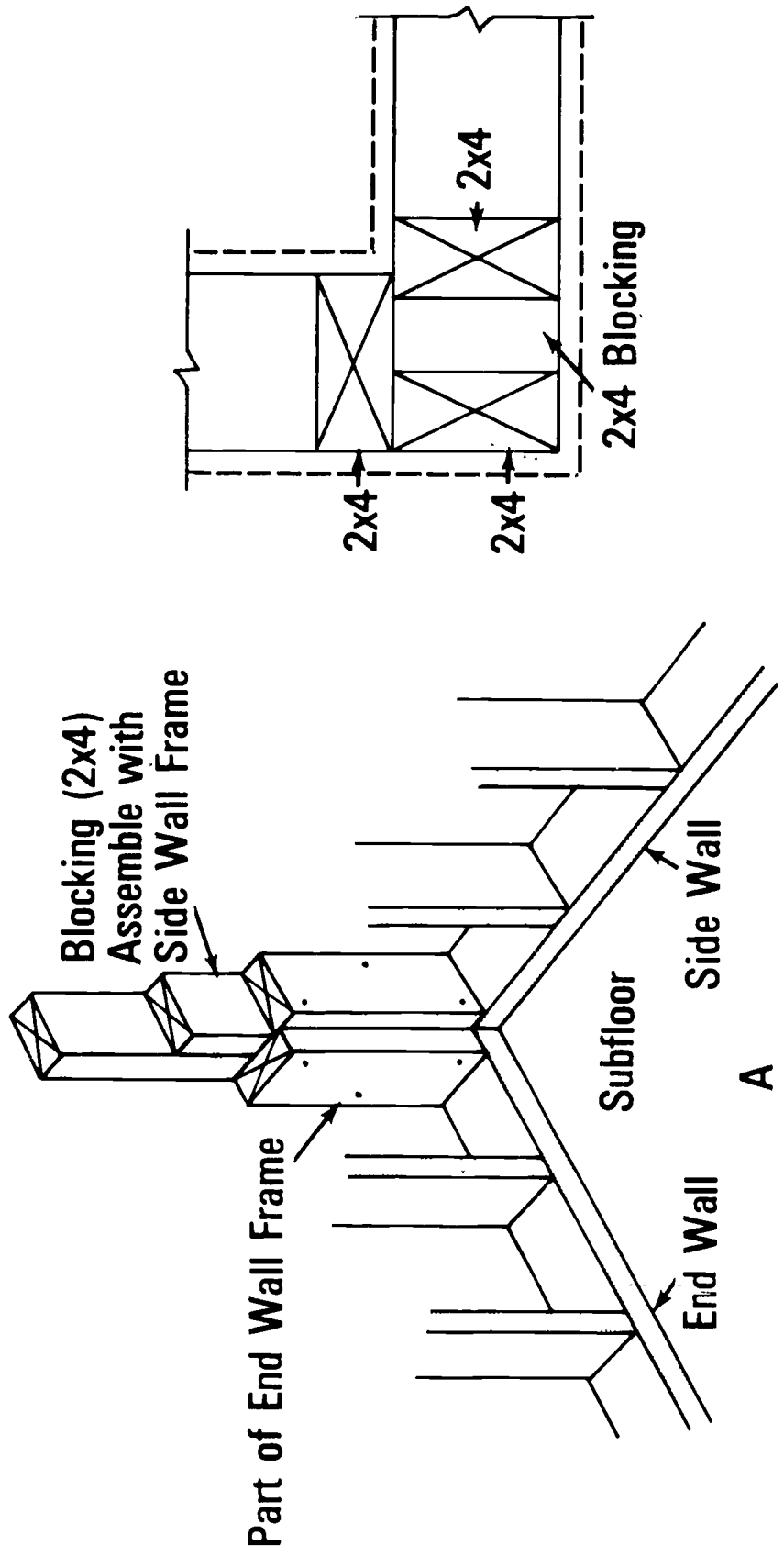

Corners

(Continued)

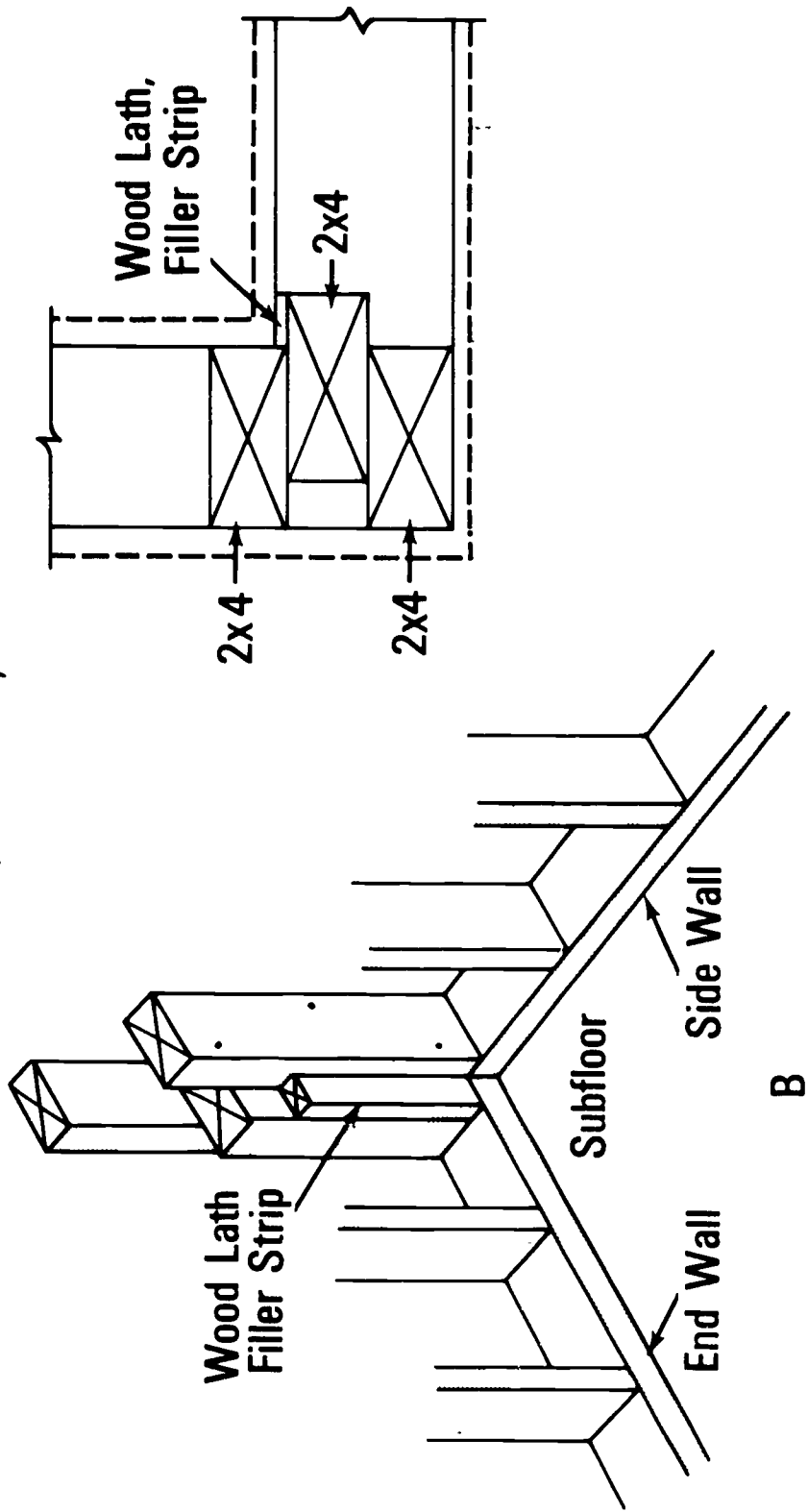

Corners (Continued)

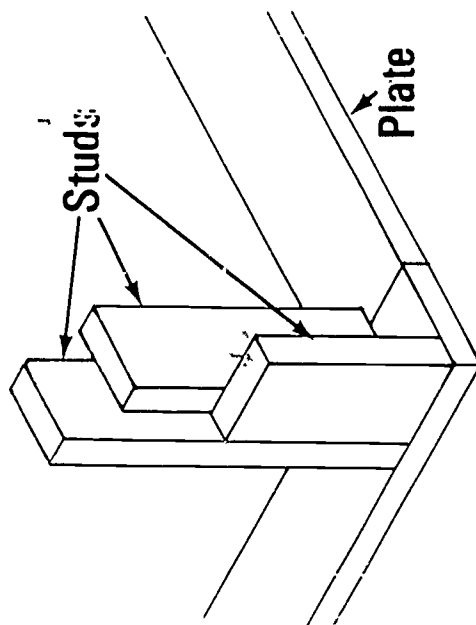
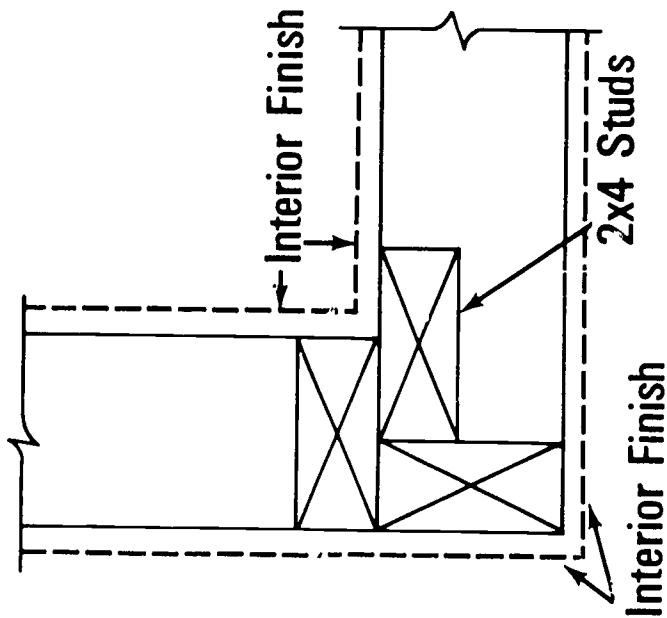

Partition "T's"

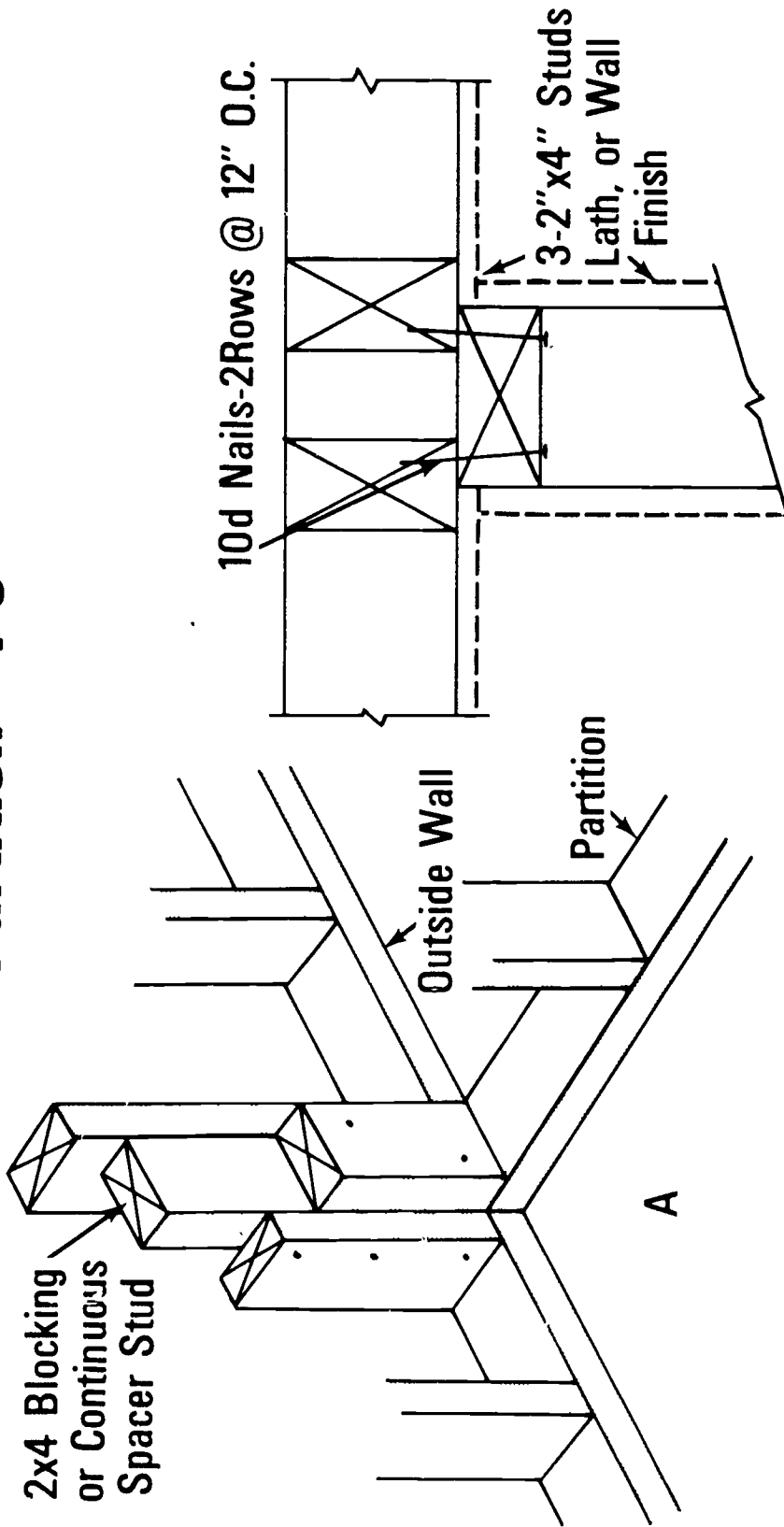

Partition "T's"

(Continued)

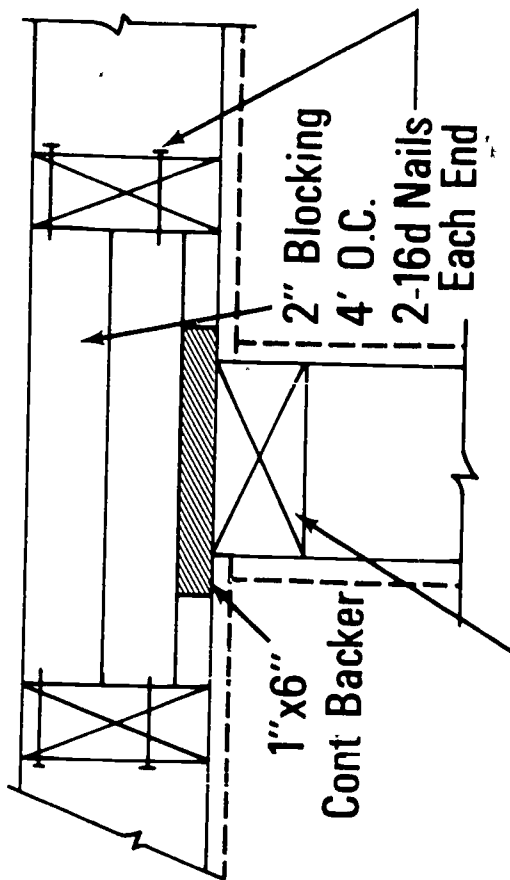
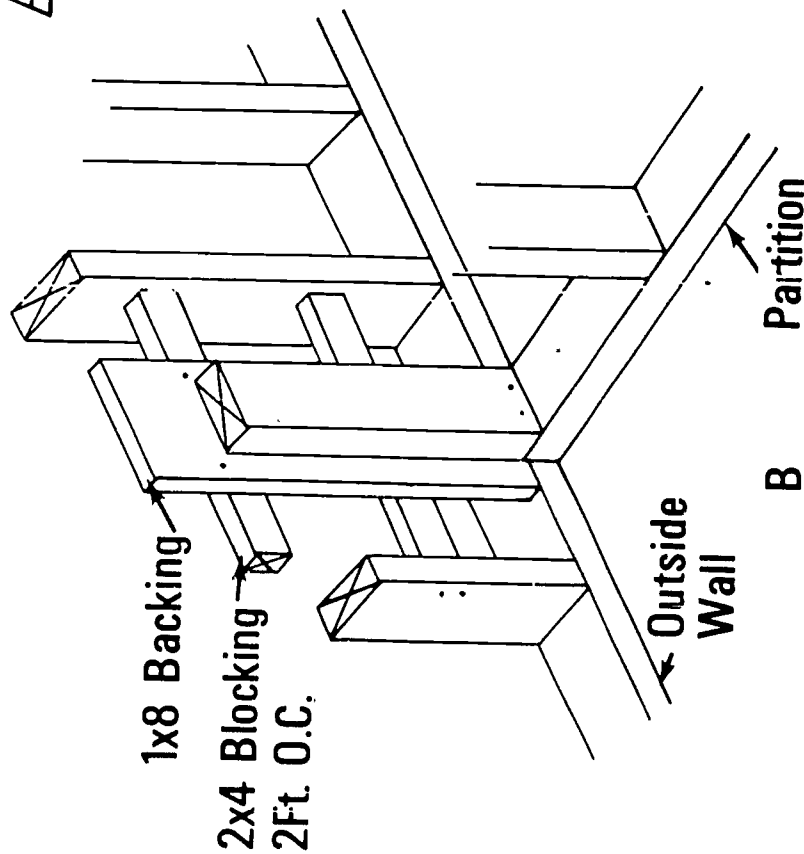

Partition "T's"

(Continued)

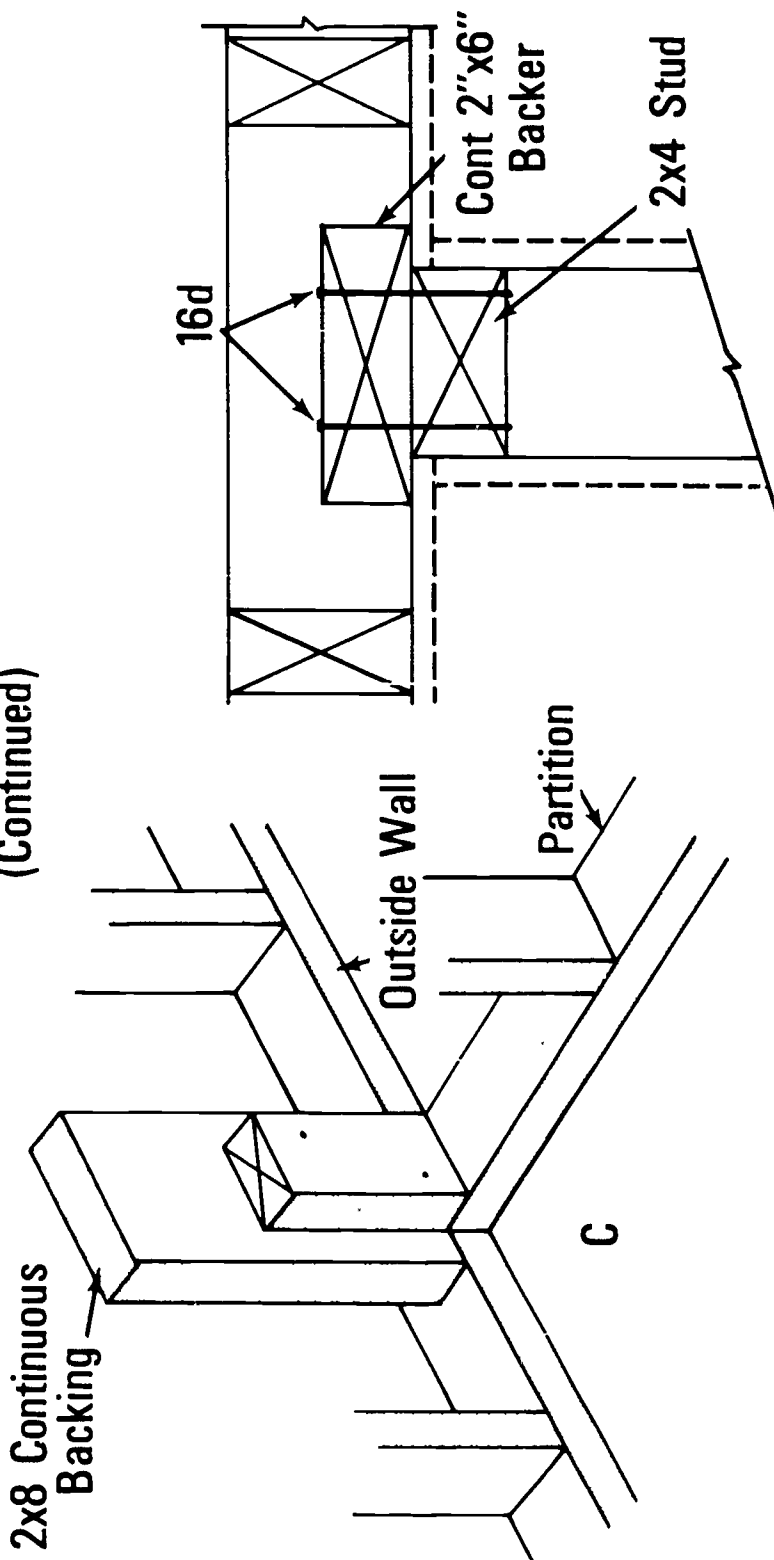

Stud Length FOR A SLAB FLOOR

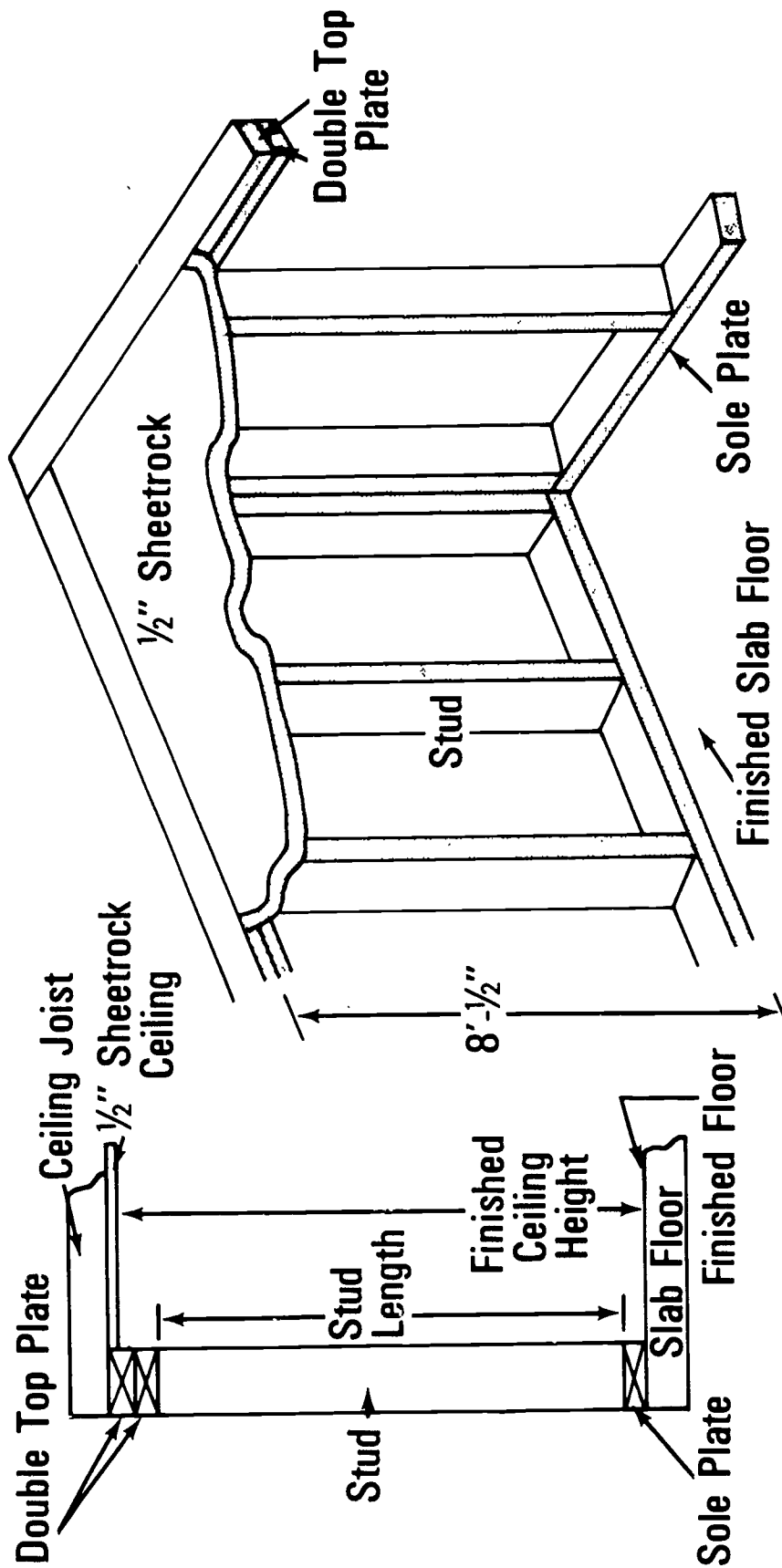

Stud Length

FOR A WOOD FLOOR (Continued)

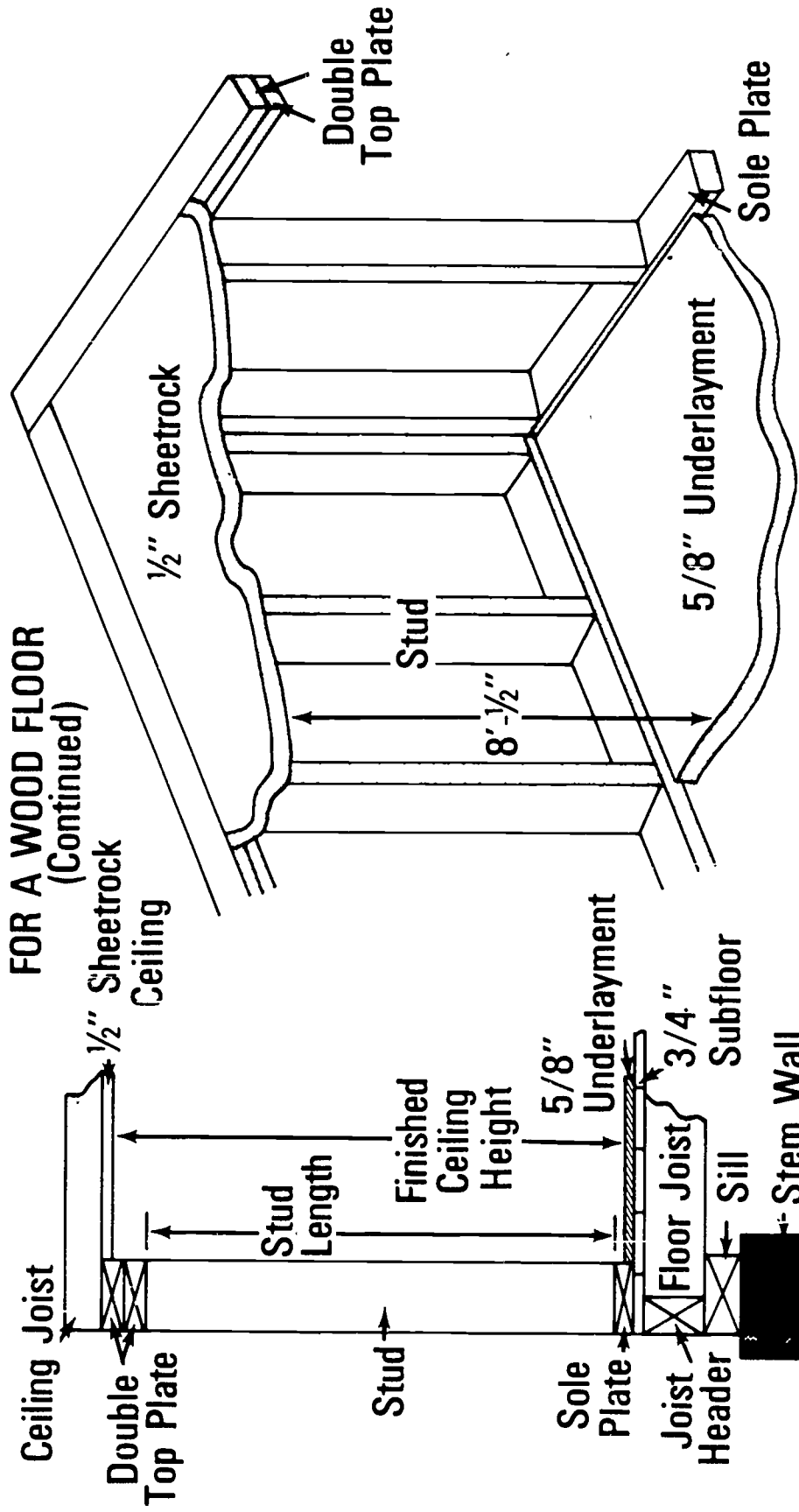

Trimmer Studs

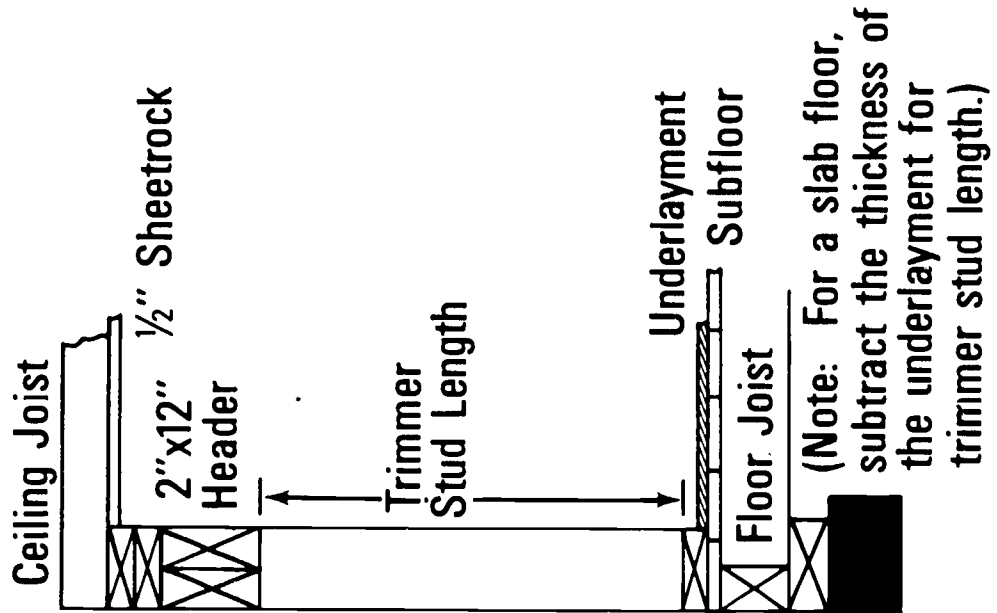

(Note: For a slab floor, subtract the thickness of the underlayment for trimmer stud length.)

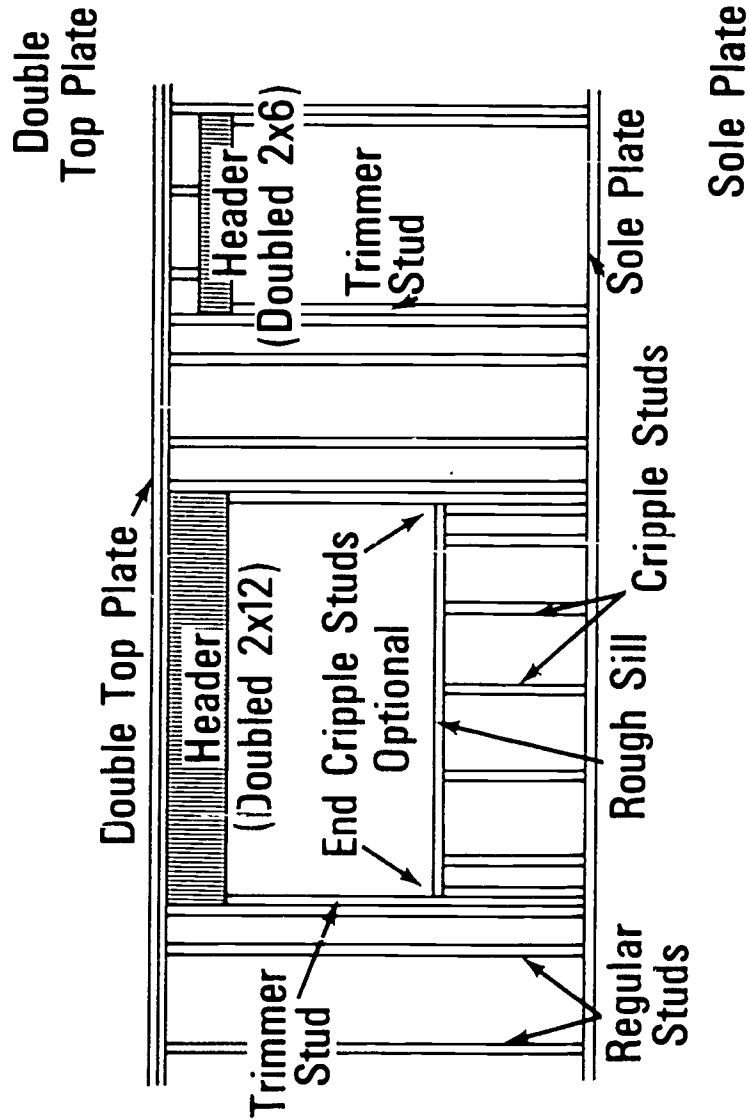

(Note: The window header is larger than required, but fills the space completely thus saving labor in cutting and assembling short cripples.)

Door and Window Headers

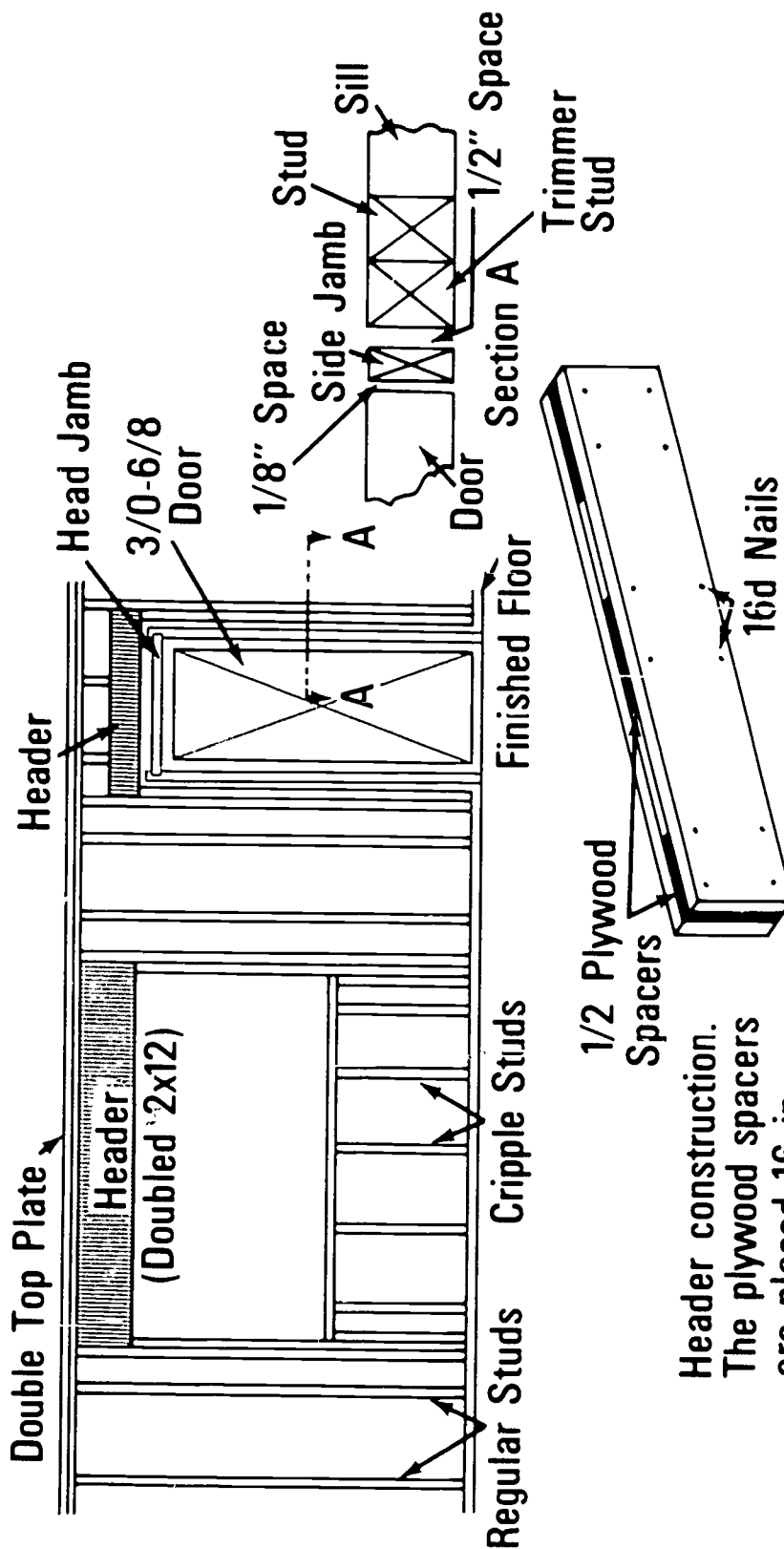

Header construction.
The plywood spacers
are placed 16 in.
to 24 in. O. C.

Types of Sheathing

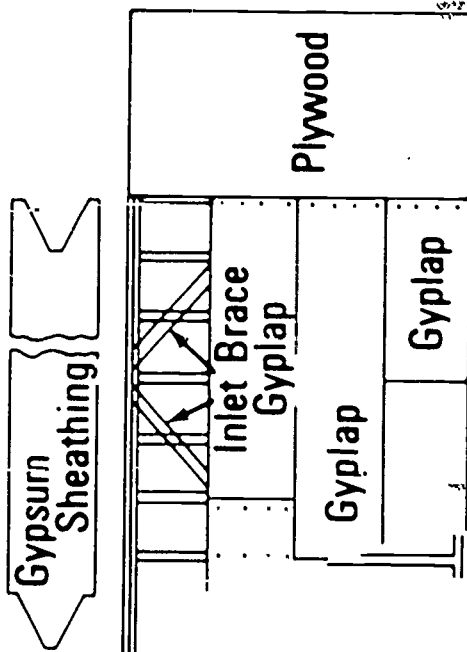

GYPLAP SHEATHING

(Note: With Gypsum Sheathing, brace wall either with 1"x4" inlet bracing or 1/2"x4"x8" verticle plywood at each corner.)

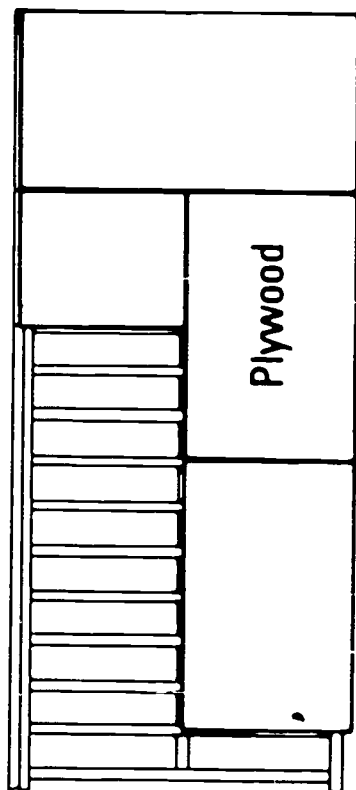

PLYWOOD SHEATHING

(Note: No additional bracing is needed with Plywood Sheathing.)

Types of Sheathing

(Continued)

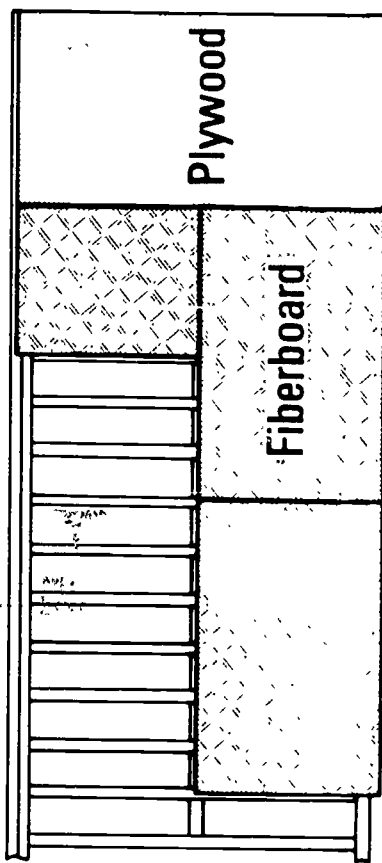
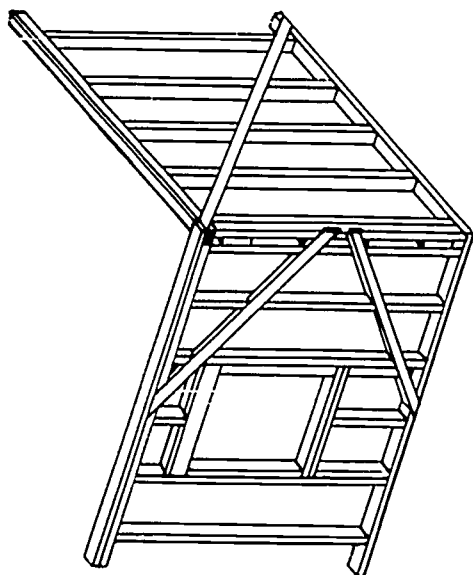

DIAGONAL SHEATHING

(Note: With Diagonal Sheathing, no additional bracing is required.)

FIBERBOARD SHEATHING

(Note: With Fiberboard Sheathing, use let in bracing or plywood at each corner.)

WALL AND PARTITION FRAMING
UNIT II

ASSIGNMENT SHEET #1--MATERIAL ESTIMATING

Using the information sheet, calculate the following framing material needed from the floor plan depicted below.

1. Wall plates (2 x 4's 16 feet long) _____
2. Studs (2 x 4's 16 feet long) _____
3. Headers (2 x 12) _____

4. Diagonal bracing (1 x 6's 12 feet long) _____
5. Wall sheathing (8 foot wall)
 - a. Plywood _____
 - b. Gyplap (using plywood bracing) _____

 - c. Fiberboard (using plywood bracing) _____

6. Nails
 - a. Wall framing _____

 - b. Sheathing (1/2" fiberboard with
 plywood bracing) _____

7. Exterior doors
 - a. Jambs _____

 - b. Hinges _____
 - c. Doors _____

ASSIGNMENT SHEET #1

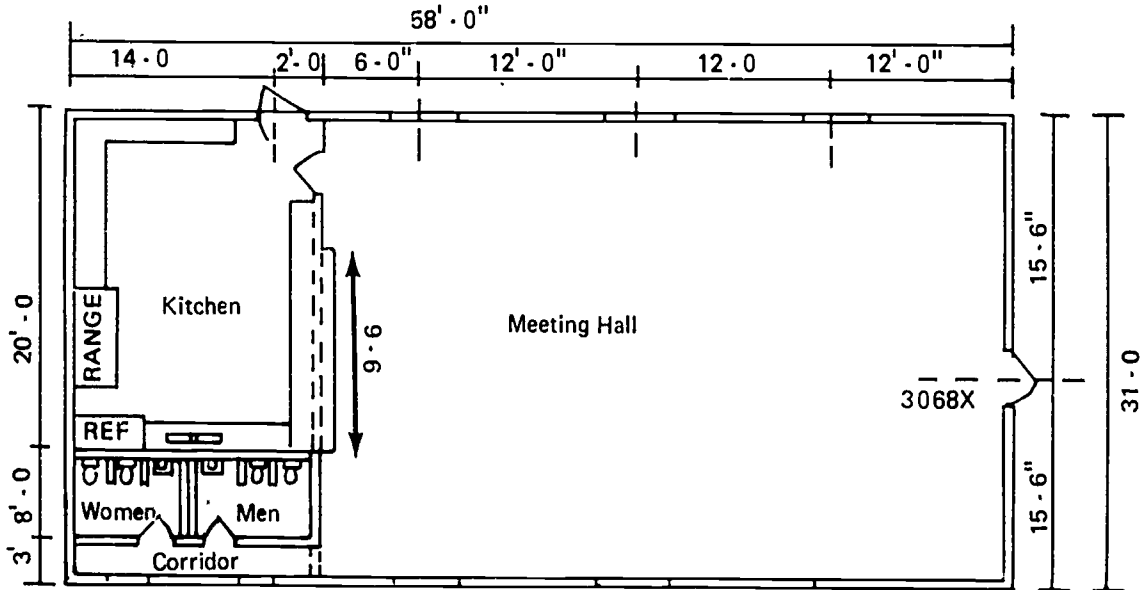

FIRST FLOOR PLAN
(HIP ROOF)

Door Sizes

Front 3068 x 1 3/4"--Ash solid core, exterior

Rear 2868 x 1 3/4"--Ash solid core, exterior,
24 x 24 lite

Toilets 2468 x 1 1/2"--Ash, hollow core

Kitchen, meeting hall--2868 x 1 1/2"
Ash, hollow core

Window Sizes

Meeting hall--5' x 4'

Corridor--3' x 4'

WALL AND PARTITION FRAMING
UNIT II

ANSWERS TO ASSIGNMENT SHEET #1

1. 47 - 2" x 4" x 16' for plates
2. 125 - 2" x 4" x 16' for studs
3. 2 - 2" x 12" x 16' for headers
2 - 2" x 12" x 10' for headers
1 - 2" x 12" x 14' for headers
12 - 2" x 12" x 12' for headers
4. 8 - 1" x 6" x 12' Diagonal bracing
5. a. 45 - 1/2" x 4' x 8' plywood
b. 74 pieces 1/2" x 2' x 8' gyplap
8 pièces 1/2" x 4' x 8' plywood
c. 37 pieces 1/2" x 4' x 8' fiberboard
8 pieces 1/2" x 4' x 8' plywood
6. a. 4 pounds 8d box nails
16 pounds 16d box nails
b. 18 pounds 2" barbed roofing nails
3 pounds 6d box nails
7. a. 1 - 3' 0"/6' 8" jamb with sill
1 - 2" 8"/6' 8" jamb with sill
b. 3 pr. 4" butt hinges
c. 1 - 3068 x 1 3/4' ash, solid core, exterior door
1 - 2068 x 1 3/4" fir, solid core, exterior door with a 24" x 24" lite

WALL AND PARTITION FRAMING
UNIT IIJOB SHEET #1--LAYOUT WALL AND PARTITION
LOCATIONS ON FLOOR

I. Tools needed:

- A. Chalk line and reel (with blue or red chalk)
- B. 100 foot tape measure
- C. 12 or 16 foot tape measure
- D. Floor plan
- E. Claw hammer
- F. 16d nails

II. Procedure

A. Lay out outside walls first

1. Measure in the width of a 2 x 4 from the outside edge of the box sill on a wood floor and from the outside of the foundation on a slab floor, and start a nail at each mark (only on wood floors)
2. Fasten the chalk line to a nail at one corner, stretch the line to another nail at an opposite corner, and work around the house

(NOTE: Make sure the line is sufficiently well chalked and have a helper hold the line in the middle to keep it from touching the floor before you are ready to snap it. If laying off a slab floor, you will need an additional helper to hold the other end of the line.)

3. Pull the line tight from one end, have the center man place his thumb on the line approximately in the center between the two nails. Holding the line firmly to the floor with his thumb he reaches out with his other hand and carefully lifts the line vertically and lets it snap to the floor, repeating the procedure for the other half

(NOTE: The operation should result in a perfectly straight line which represents the inside face of the outside wall sole plate.)

JOB SHEET #1

4. Repeat the procedure for all outside walls (Figure 1)

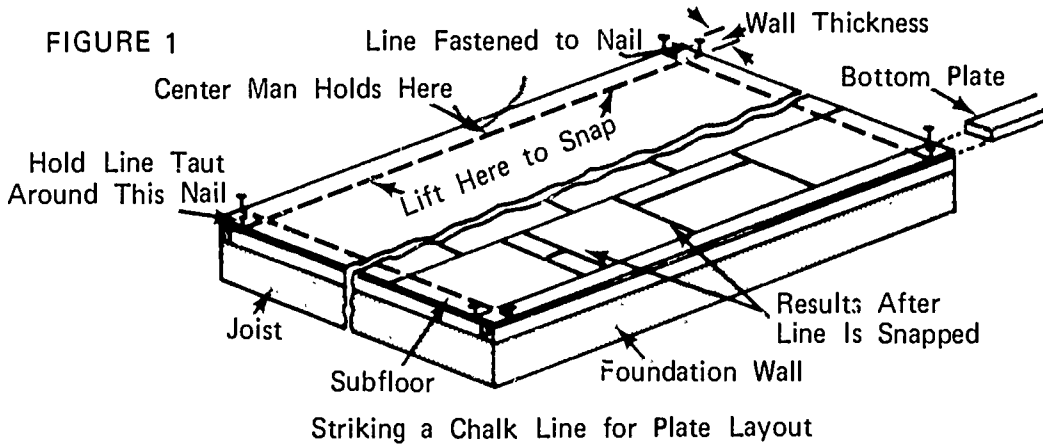

- B. Lay out inside walls--Chalk both sides of all partition walls (Figure 2)
- (NOTE: Lay out all the walls running the length of the building first and then the ones running the width of the building.)
- (NOTE: Some floor plans are dimensioned by rooms and some are dimensioned center to center on partitions.)

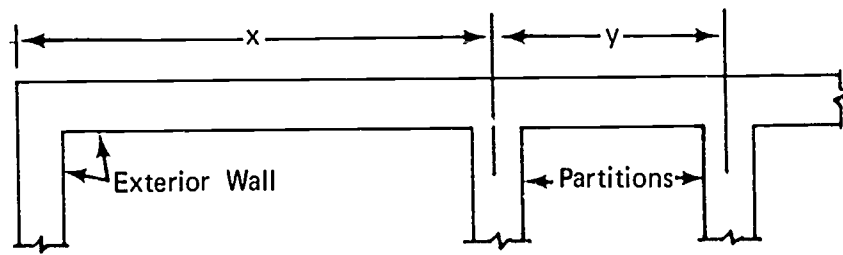

(B) Partition Center-to-Center Method

FIGURE 2

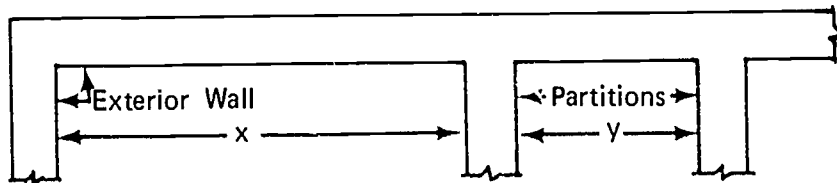

(A) Room Dimension Method

Plan View
Alternate Methods of Dimensioning a Floor Plan

WALL AND PARTITION FRAMING
UNIT II

JOB SHEET #2--CUT STUDS, TRIMMERS,
CRIPPLES, AND HEADERS TO LENGTH

I. Tools and materials needed

A. Tools

1. Radial arm saw with extensions
2. 12 or 16 foot tape measure
3. Claw hammer (16 ounce or larger)

B. Materials

1. 2 x 4's 16 feet long
2. 16d box nails
3. 2 x 12's
4. 1/2" plywood

II. Procedure

A. Studs

1. Determine the number needed
2. Determine the length of full studs
3. Set up radial arm saw to cut studs
 - a. Measure from the right side of the blade the length of the stud and make a mark on the extension table

(NOTE: See Figure 1.)

840

~~840~~

JOB SHEET #2

- b. Cut a scrap piece of 2 x 4 about sixteen inches long--Nail or clamp the scrap 2 x 4 to the right hand extension table, at the mark that was made in step "a" (Figure 1)

(NOTE: Undercut the block slightly.)

FIGURE 1

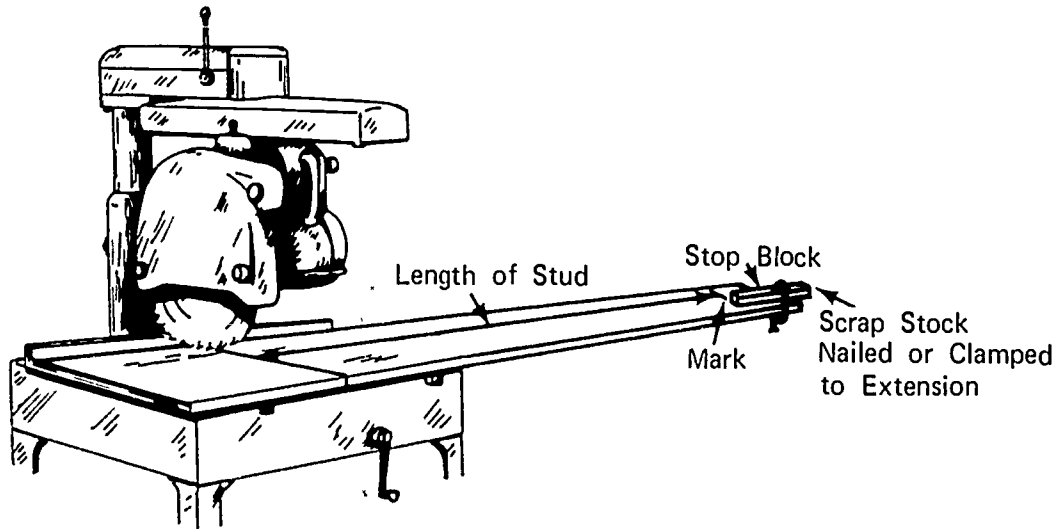

4. Cut studs from 2 x 4's sixteen foot long

(NOTE: Pre-cut studs may be purchased.)

- a. Have a helper hold long stock at left of saw
- b. Square right end of 2 x 4
- c. Slide 2 x 4 along table until it touches the stop block

(IMPORTANT: Do not bump the 2 x 4 against the stop block as this will jar the block out of position and stud length will vary.)

- d. Cut first stud

(NOTE: Check the first stud for correct length.)

- e. Repeat step "c" making two studs from each sixteen foot 2 x 4

JOB SHEET #2

(NOTE: Have an additional helper remove the cut studs from the right table and stack them.)

- f. Cut remaining studs repeating steps "b", "c", "d", and "e"

(NOTE: Check every twentieth stud to see that they are running uniform in length; if not, make the necessary adjustments.)

(CAUTION: Follow all safety rules for use of the radial arm saw.)

B. Trimmer studs

1. Determine the number needed
2. Determine the length of trimmer studs
3. Set up radial arm saw to cut trimmer studs following the procedure outlined under step number three of cutting studs
4. Cut trimmer studs from 2 x 4's sixteen feet long following the procedure outlined under step number four, "a" through "f"

C. Cripple studs

1. Determine the number needed for each length
2. Determine the lengths needed
3. Set up radial arm saw to cut cripple studs following the procedure outlined under step number three of cutting studs

(NOTE: Set up to cut the longest cripple studs first.)

4. Cut cripple studs from 2 x 4's sixteen foot long following the procedure outlined under step number four, "a" through "f"

(NOTE: Repeat the entire procedure for each length of cripple studs.)

D. Headers

1. Determine the number needed for each size opening
(NOTE: Remember that each header requires two pieces.)
2. Determine the lengths needed
3. Set up radial arm saw to cut headers following the procedure outlined under step number three of cutting studs

(NOTE: Cut the longest headers first.)

JOB SHEET #2

4. Cut headers from 2 x 12 stock following the procedure outlined in step number A four, "a" through "f"

(NOTE: Plan your cuts so that waste is held to a minimum.)

5. Cut spacers for headers out of 1/2" plywood
 - a. Three spacers are needed for short headers and more for longer headers
 - b. Spacers should be cut slightly less than the width of the header and the plywood should be cut in one and one-half inch strips

WALL AND PARTITION FRAMING
UNIT II

JOB SHEET #3--BUILD CORNERS, "T's", AND HEADERS

I. Tools and materials needed

A. Tools

1. Claw hammer (16 ounce or larger)
2. Electric handsaw

B. Material

1. 2 x 4 studs
2. 2 x 4 stock for blocking
3. 16d box nails
4. 2 x 12 header material cut to length
5. 1/2" plywood spacers for headers

II. Procedure

A. Corners

1. Determine the number of corners needed
2. Select three of the straightest studs for each corner
3. Determine which of the three types of corners to use (Figure 1)

JOB SHEET #3

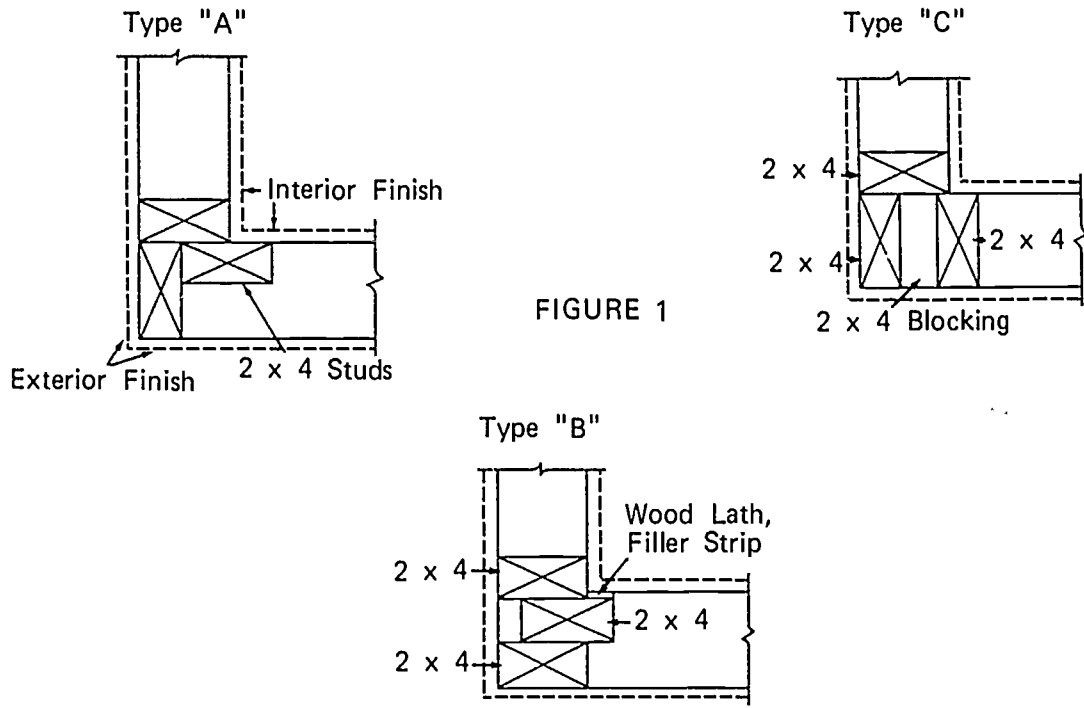

FIGURE 1

- (NOTE: Type "C" is preferred by most builders.)
4. Type "C" corners should be constructed as follows
 - a. Cut three 2" x 4" x 16" pieces of blocking for each corner
 - b. Nail two studs together with blocking between (Figure 2)

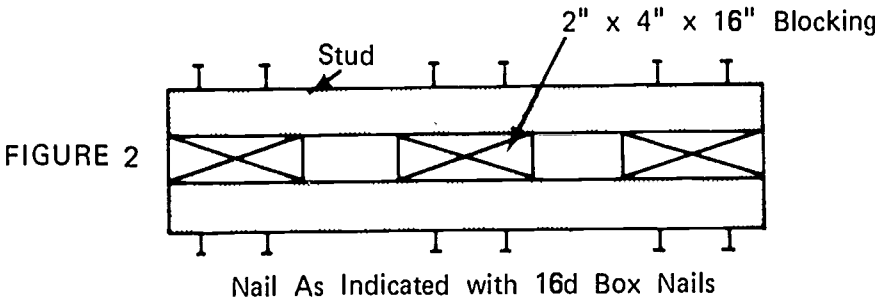
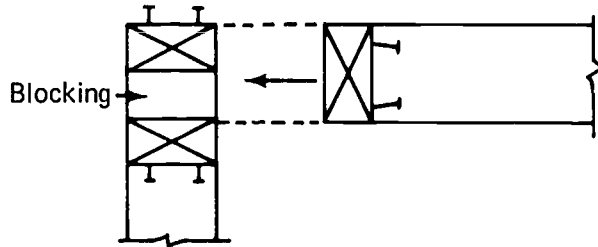

FIGURE 2

JOB SHEET #3

- c. The third stud is attached to the end of the end wall and nailed to the corner as the walls are erected (Figure 3)

FIGURE 3



B. "T's"

1. Determine the number of "T's" needed
2. Determine which of the three types of "T's" to use (Figure 4)

FIGURE 4

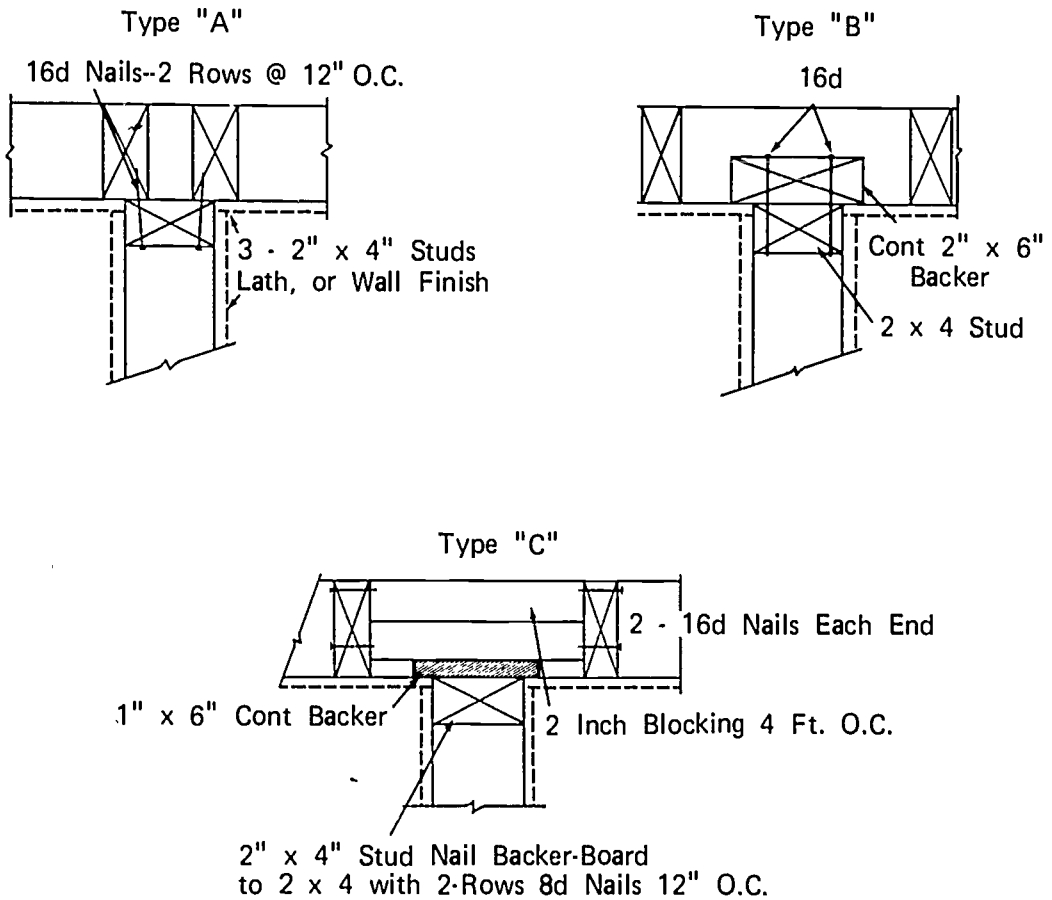

(NOTE: Type "A" is preferred by most builders.)

JOB SHEET #3

3. Type "A" corners should be constructed as follows:
- Select three of the straightest studs for each corner
 - Cut three 2" x 4" x 16" pieces of blocking for each corner
 - Nail two studs together with blocking between (Figure 5)

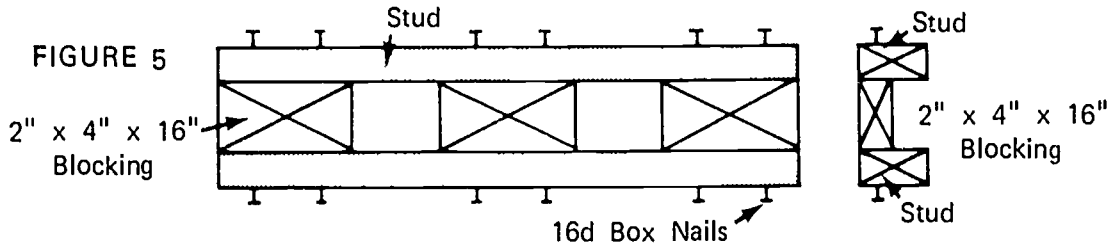

- The third stud is attached to the end of the intersecting wall and nailed to the 2 x 4" x 16" blocking as the walls are erected (Figure 6)

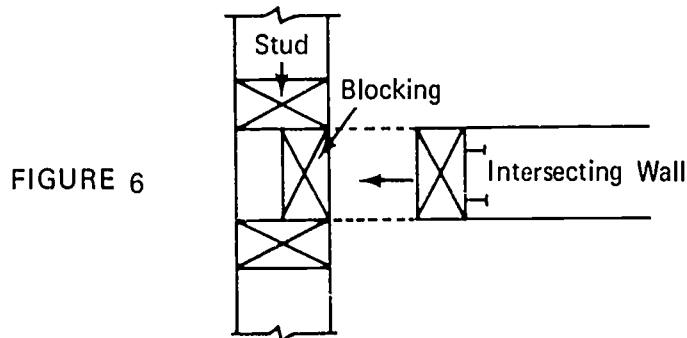

C. Headers

- Determine the number of headers needed of each size
- Nail together two 2 x 12's with spacers between, using 16d box nails (Figure 7)

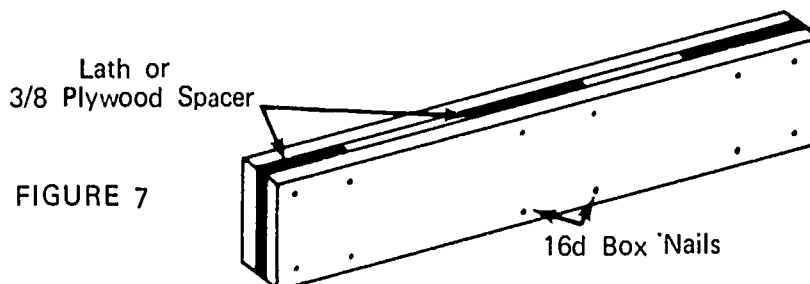

Header Construction. The Spacers Are Placed 16" to 24" O.C.

WALL AND PARTITION FRAMING
UNIT IIJOB SHEET #4--LAY OUT AND ASSEMBLE WALL SECTIONS FOR A
SINGLE STORY BUILDING

I. Tools and materials needed

A. Tools

1. Framing square
2. 100 foot tape measure (marked sixteen inches on center)
3. 12 or 16 foot tape measure (marked sixteen inches on center)
4. Electric handsaw
5. Claw hammer (16 ounce or larger)
6. Level (4 foot or longer)
7. Pencil

B. Material

1. 2 x 4's sixteen foot long for plates
2. Studs (2 x 4's cut to length for an eight foot ceiling)
3. Corners
4. "T's"
5. Trimmer studs
6. Headers
7. Cripple studs
8. 8d box nails
9. 16d box nails
10. Brace material--1 x 6's 12 foot long or 4' x 8' plywood

II. Procedure

- A. Select 2 x 4's from sixteen-foot stock for plates

(NOTE: Crooked 2 x 4's may be used for the sole plates. They can easily be straightened as they are nailed to the floor. Good straight stock must be used for the top and double plate.)

JOB SHEET #4

- B. Cut the sole plate and top plate to length and tack to floor side by side with ends flush (Figure 1)

(NOTE: Be sure to square each end of plates.)

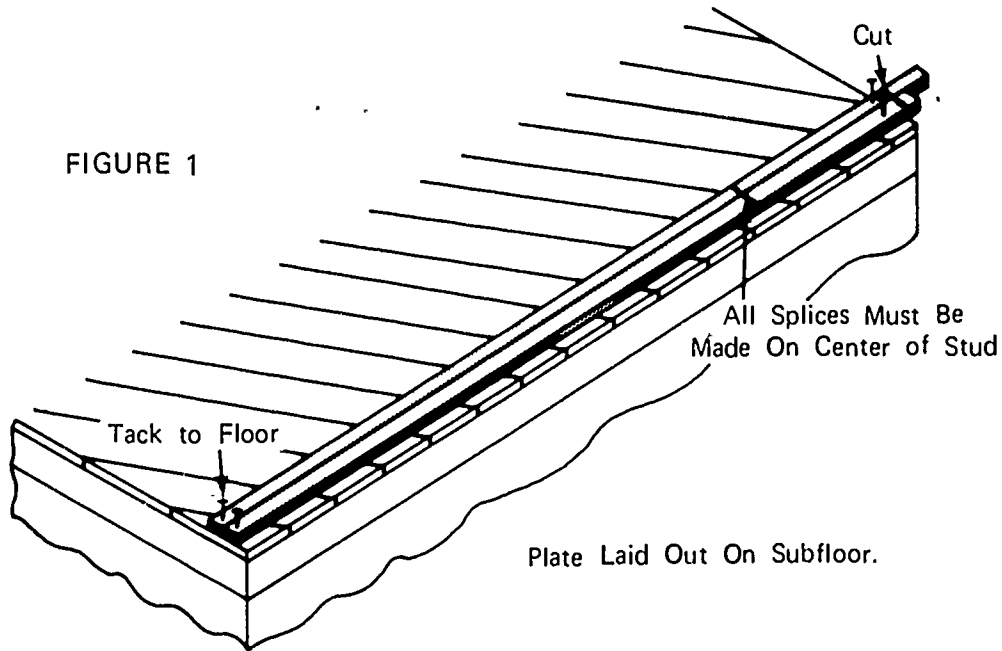

- C. Lay out stud locations on plates doing side walls first and then end walls

(NOTE: Lay out all walls from left to right.)

1. Mark plates for corner post (Figure 2)

(NOTE: Use the framing square with the blade held parallel to the edge of the plates and mark off.)

FIGURE 2

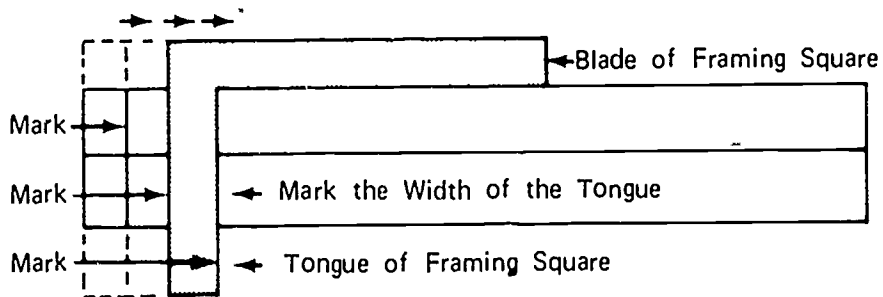

JOB SHEET #4

2. Lay out full stud locations

(NOTE: Use one-hundred foot steel tape marked sixteen inches on center to lay out side locations of all studs.)

- a. Place scrap piece of one inch material at left end of plate, hook end of tape over the one inch scrap stock, and make a mark on the plate at sixteen inch intervals, place a small "X" at the right of each mark (Figure 3)

FIGURE 3

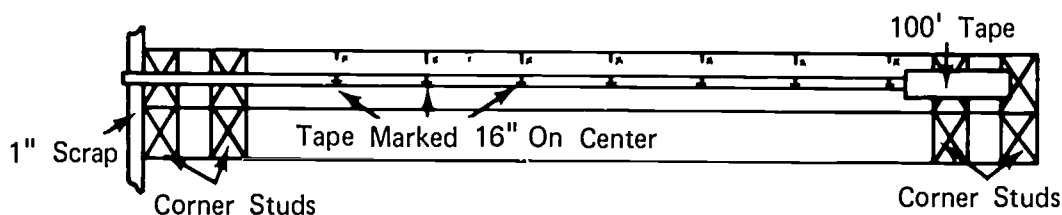

- b. Use the framing square and mark the stud locations across both plates
- c. Follow the same procedure as used for marking the corner studs (Figure 4)

FIGURE 4

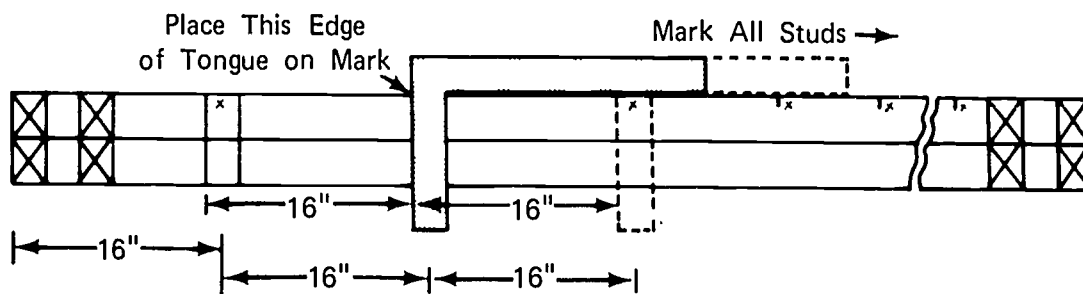

3. Locate centers of openings and lay out trimmer stud locations

- a. Divide the header size by two and mark one-half of the header length on each side of the center of the opening; this locates the outside of each trimmer stud
- b. Mark the trimmer stud locations with a "T", the full studs with an "X", and the cripple studs with a "C"

(NOTE: See the following illustration under step #4.)

JOB SHEET #4

4. Locate and mark the partitions on the plates for the style of "T" you plan to use (Figure 5)

FIGURE 5

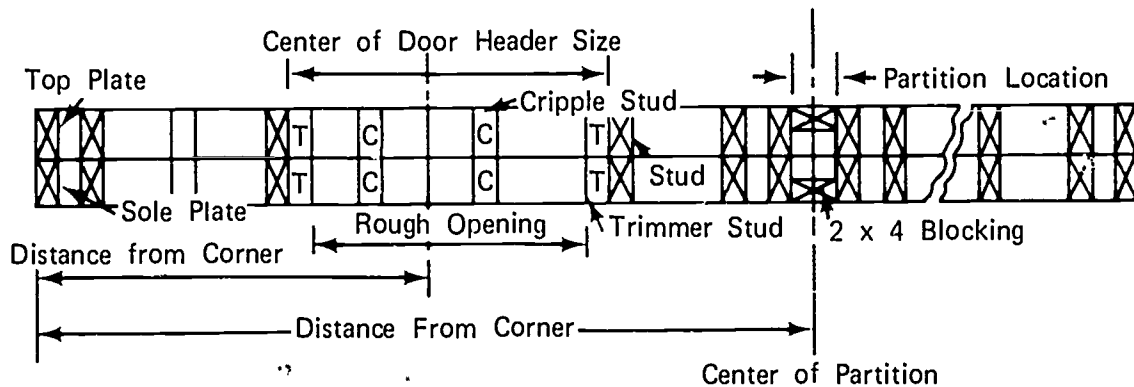

5. Lay out other side wall
6. Lay out end walls
(NOTE: Remember that the end walls will fit between the side walls, therefore, the plates must be two 2 x 4 widths shorter than the outside wall measurement.)
7. Remove nails from plates where they were tacked to the floor

D. Assemble wall sections

1. Turn plates on edge with the marks facing each other
2. Place the sole plate next to the edge of the floor and the top plate toward the center of the building approximately nine feet
3. Lay studs with crown up at each spot on plate marked with an "X"
4. Place appropriate size headers in place

JOB SHEET #4

5. Place trimmer studs at each spot marked with a "T"

(NOTE: Trimmer studs, full studs, and headers may be pre-assembled.) (Figure 6)

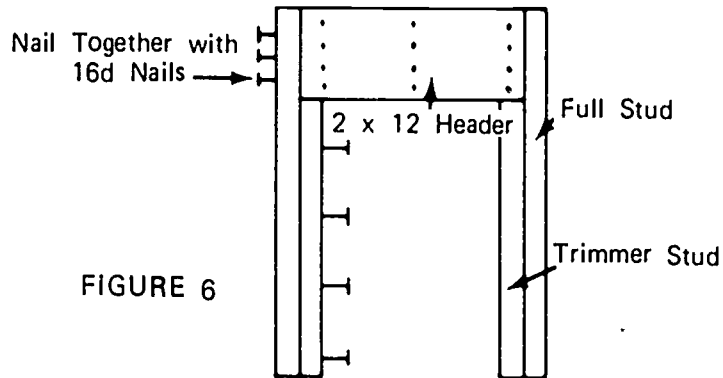

FIGURE 6

6. Place rough sills and cripple studs in place
- E. Nail the framework together as follows
 1. Use two 16d nails through the plate into the end of each stud
 2. Nail cripple studs in place and install rough sills where needed
- F. Completed wall section should appear as shown (Figure 7)

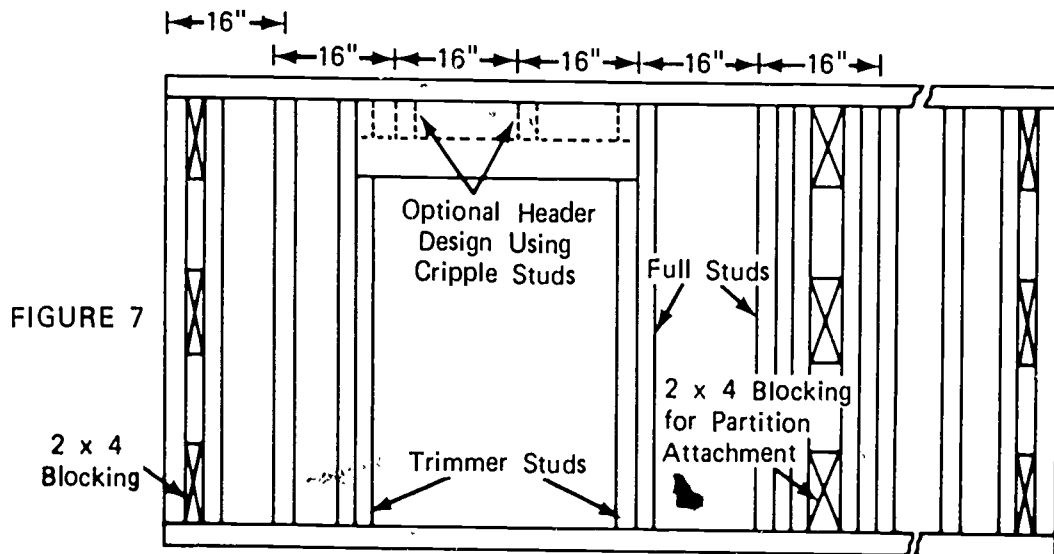

FIGURE 7

JOB SHEET #4

G. Raise wall section and nail in place

(NOTE: Some builders prefer to attach sheathing before raising wall sections.)

1. For wood floors use two 16d box nails in every other floor joist
2. For slab floors use either sill anchor bolts or drive concrete nails or steel studs every thirty-two inches through the sole plate into the floor

(NOTE: Before nailing, make sure the inside of the wall section is on the chalk line.)

3. Attach temporary bracing (Figure 8)

FIGURE 8

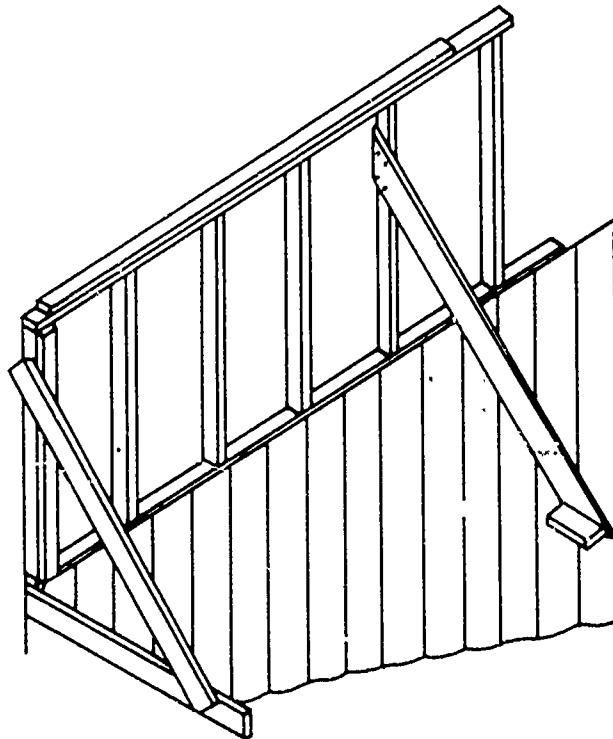

H. Construct remainder of wall sections and raise in place

(NOTE: Construct all main bearing walls first and proceed with the roof framing to get in the dry then complete the non-bearing partitions.)

- I. Nail all corners together with 16d box nails

- JOB SHEET #4

- J. Plumb the corners of the building and install permanent bracing; see illustration
1. When using diagonal lumber sheathing, no additional bracing is needed
 2. When using fiberboard or gyplap sheathing, either let in bracing or plywood corners must be used
- K. Install double plate (Figure 9)

(NOTE: Nail corners and intersections as shown in the illustration below and nail the remainder of double plate every sixteen inches alternating sides. Use 16d box nails.)

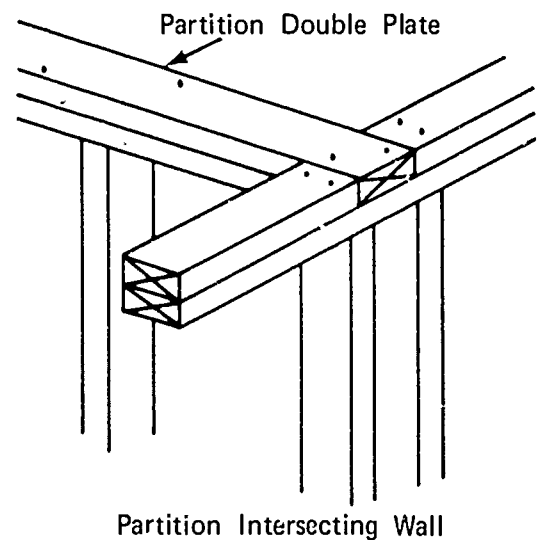
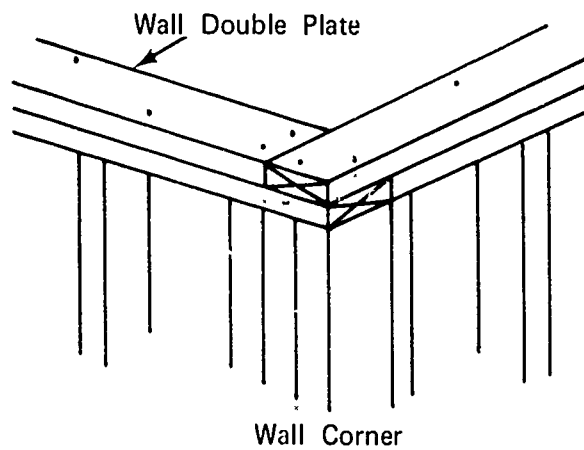

FIGURE 9

Double Plate Installation at Corners and Intersections

WALL AND PARTITION FRAMING
UNIT II

JOB SHEET #5--INSTALL SHEATHING

I. Tools and materials needed

A. Tools

1. Electric handsaw
2. 12 or 16 foot tape measure
3. Claw hammer, 16 ounce
4. Framing square
5. Chalk line and reel
6. Straight edge

B. Materials

1. Sheathing material as specified
 - a. Fiberboard
 - b. Gyplap
 - c. Plywood
2. Nails
 - a. For fiberboard--25/32" use 8d box 1/2" use 2" barbed roofing
 - b. Gyplap--1 1/2" barbed roofing
 - c. Plywood--6d box

JOB SHEET #5

II. Procedure

A. Fiberboard (4' x 9' sheets)

1. Either diagonal let in bracing or plywood corners must be installed before starting to apply fiberboard
2. Start at lower left corner of wall
3. Apply fiberboard sheathing (Figure 1)

FIGURE 1

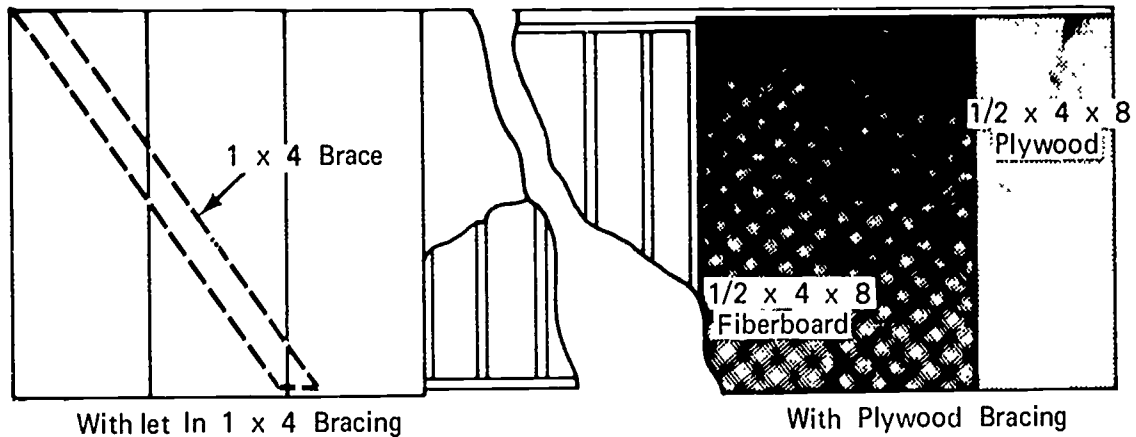

(NOTE: Tack panels in place and after wall is covered, chalk lines vertically on each stud and complete the nailing.)

JOB SHEET #5

B. Gyplap

1. Either diagonal let in bracing or plywood corners must be installed before starting to apply gyplap
2. Start at the lower left corner of the wall
3. Apply gyplap (Figure 2)

(NOTE: Tack panels in place and cover entire wall. Then chalk vertical lines on all studs and complete nailing.)

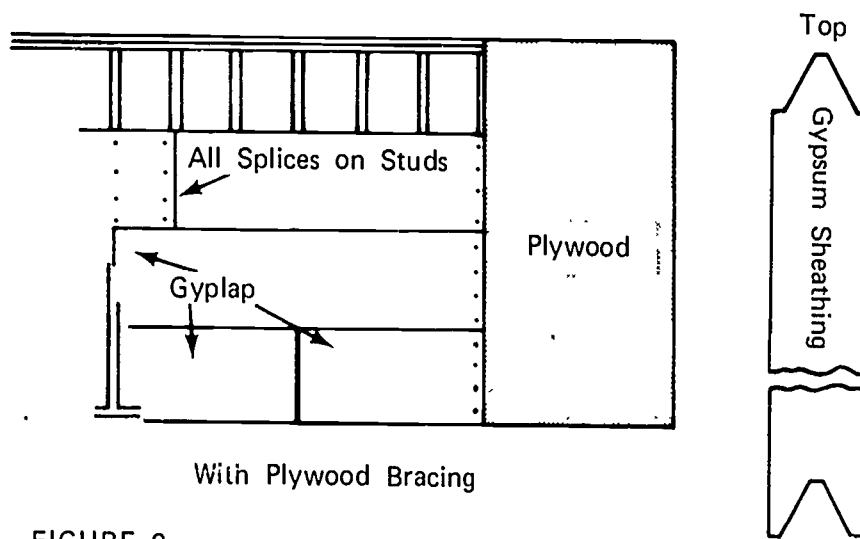
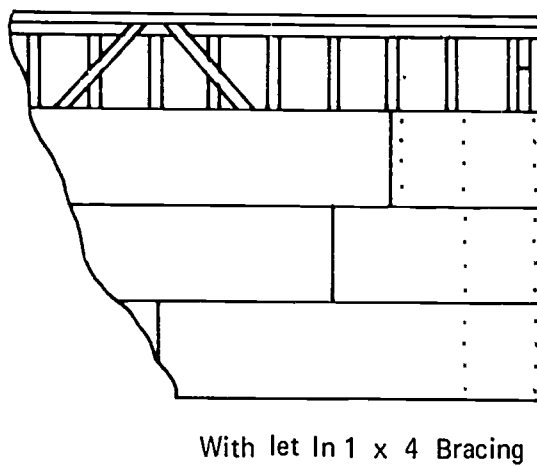

FIGURE 2



JOB SHEET #5

C. Plywood

1. Start at the lower left corner of the wall
2. Apply plywood sheathing
3. No additional bracing is required when plywood is used (Figure 3)

(NOTE: Tack panels in place and cover entire wall. Then chalk vertical lines over all studs and complete nailing. See Transparency 7.)

FIGURE 3

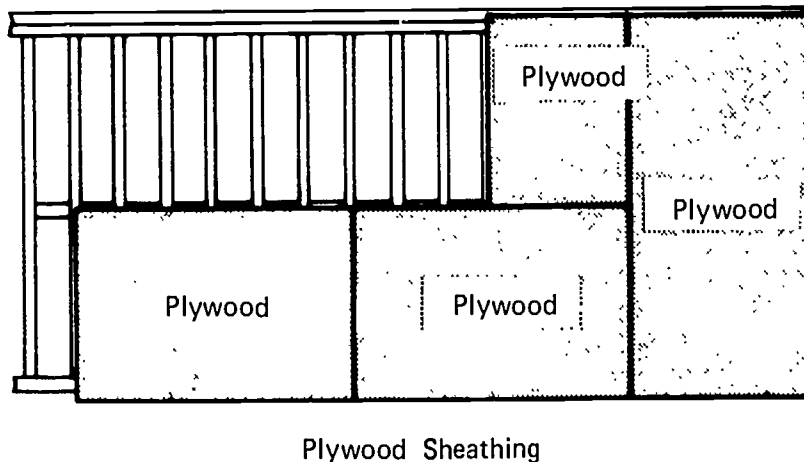

(NOTE: No additional bracing is needed with plywood sheathing.)

WALL AND PARTITION FRAMING
UNIT II

JOB SHEET #6--LAY OUT AND INSTALL CEILING JOISTS

(NOTE: When trusses are used, the bottom chord is the ceiling joist.)

I. Tools and materials needed

A. Tools

1. One-hundred foot tape measure, with markings at 16 inch centers
2. 12 or 16 foot tape measure
3. Claw hammer (16 ounce or larger)
4. Electric handsaw
5. Hatchett
6. Framing square

B. Materials

1. Joist (lengths and sizes as specified)
2. 16d box nails

II. Procedure

A. Lay out joist locations on double plate

1. For a gable roof
 - a. Determine the direction joists will run (usually the short way of the building)
 - b. Locate the outside of the first joist flush with the inside corner of the double plate

(NOTE: See Figure 1 for hip roof.)
 - c. Hold the "0" end of the one-hundred foot tape 3/4" over the inside of the end double plate and proceed to mark sixteen inch intervals on the plate moving from left to right and place an "X" to the right of each mark

(NOTE: The "X" designates the side of the mark that the joist is placed on.)

JOB SHEET #6

- d. Repeat steps "b" and "c" on the opposite wall reversing the procedure of measurement going from right to left (Figure 1)

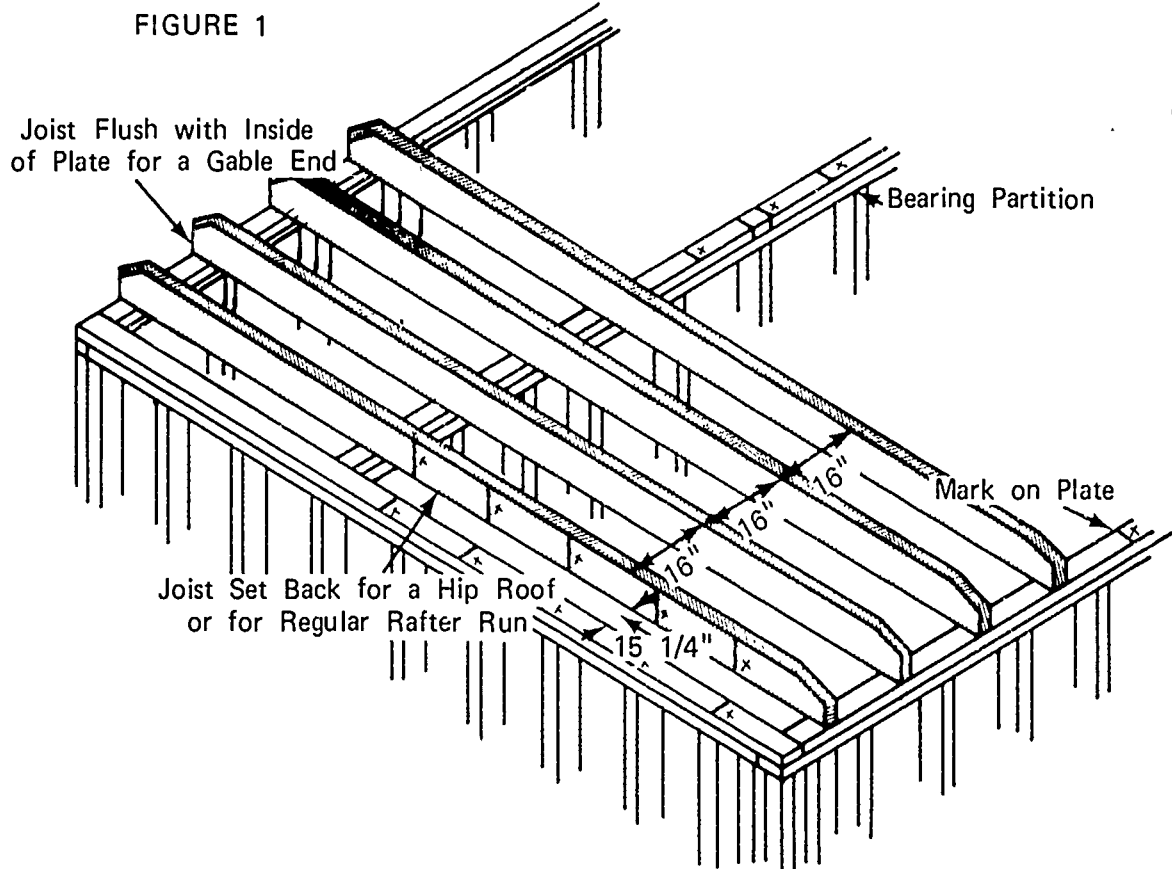

2. For a hip roof
 - a. Determine the direction joists will run (usually the short way of the building)
 - b. Locate the outside of the first joist fifteen and one-fourth inches from the inside corner of the double plate

JOB SHEET #6

- c. Hold the "0" end of the one-hundred foot tape on the mark that was just made and proceed to mark sixteen inch intervals on the plate moving from left to right and place an "X" to the right of each mark

(NOTE: The "X" designates the side of the mark on which the joist is placed.)

- d. Repeat steps "b" and "c" on the opposite wall reversing the procedure of measurement going from right to left
- e. Repeat steps "b", "c", and "d" on the end walls to receive short joist (Figure 2)

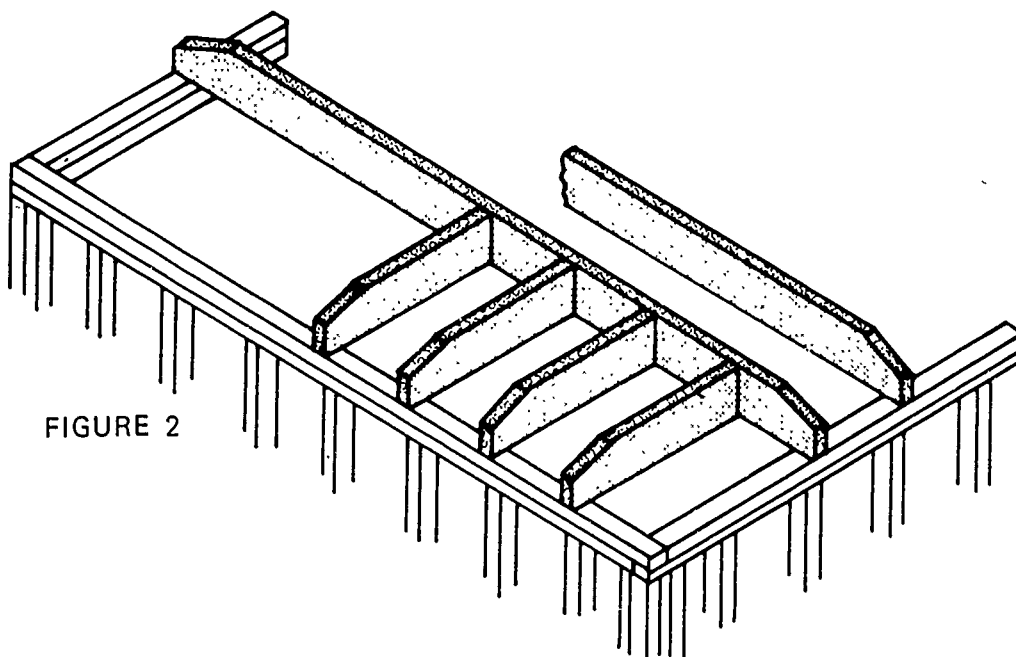

FIGURE 2

JOB SHEET #6

B. Install ceiling joist

1. Cut joist ends to the pitch of the roof (Figure 3)

FIGURE 3

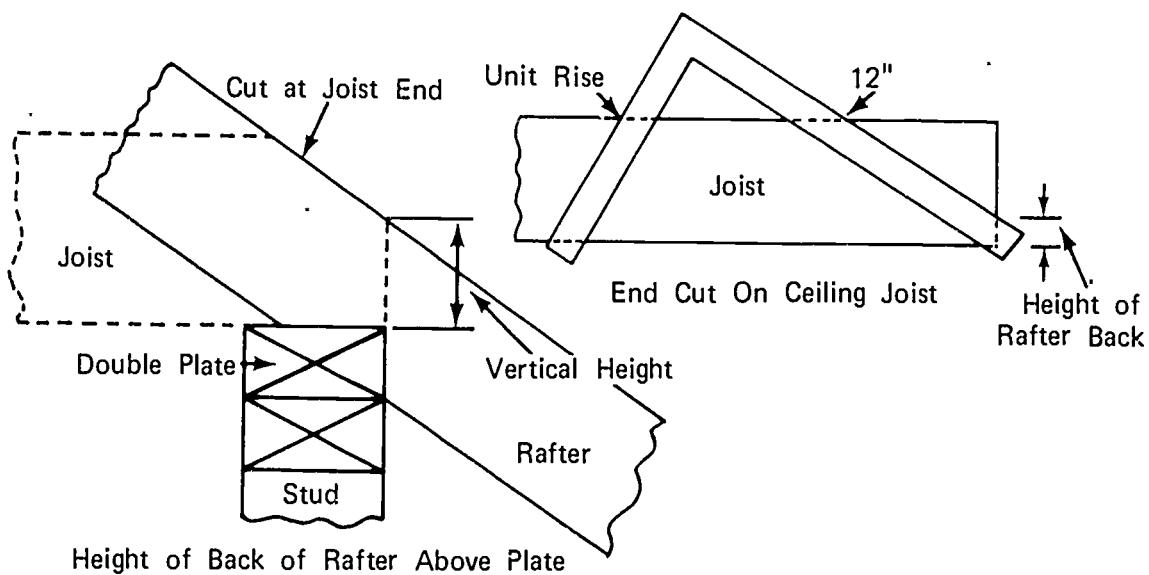

2. Place one joist, crown up, on each mark that was made on the plate

JOB SHEET #6

3. Splice joists on bearing walls (Figure 4)

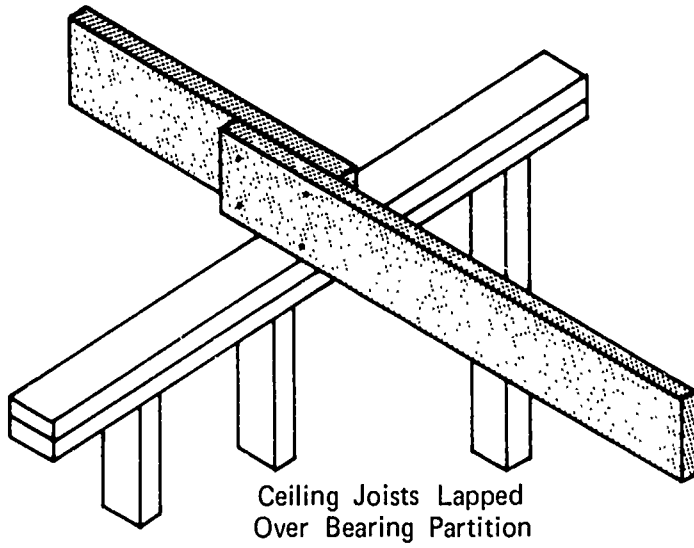
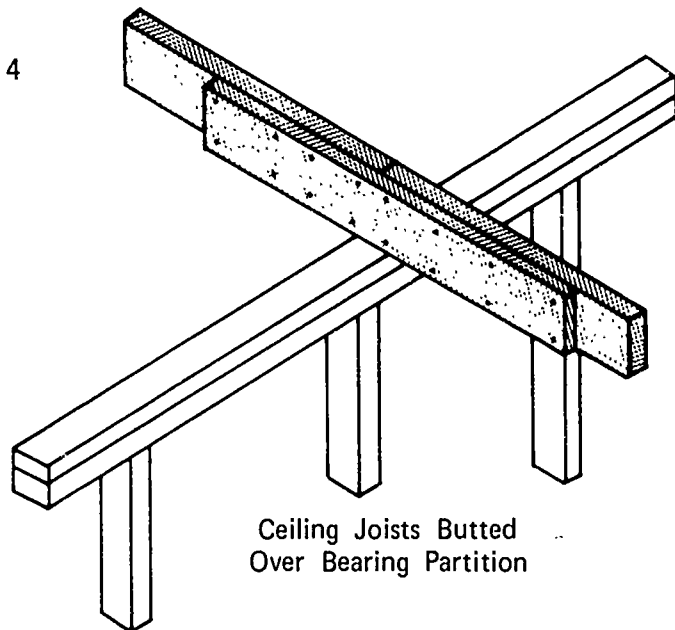
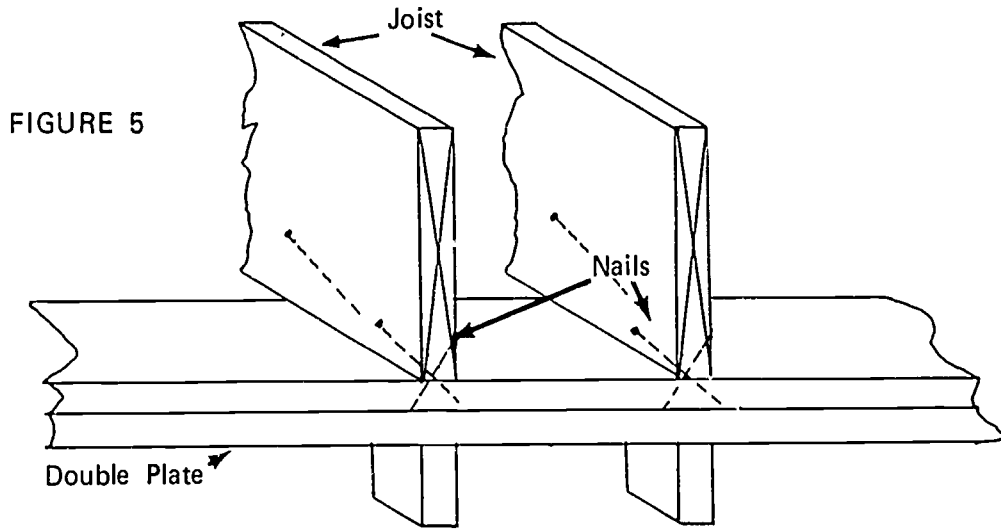

FIGURE 4



JOB SHEET #6

4. Toe nail joist to plate with three 16d box nails (Figure 5)



WALL AND PARTITION FRAMING
UNIT II

JOB SHEET #7--INSTALL WINDOWS

I. Tools and materials needed

A. Tools

1. Level (3 or 4 foot)
2. Claw hammer
3. Nail set

B. Material

1. Window units
2. Shim stock (usually wood shingles)
3. 8d or 10d casing nails (for wood window unit)
8d box nails for aluminum unit

II. Procedure

(NOTE: Check manufacturer's instructions and if they are sufficiently detailed, follow them. If not, proceed as follows.)

A. Unpack window unit

(NOTE: Leave all bracing intact for wood units.)

B. Check rough opening size

C. Set window unit in the opening from the outside

(NOTE: Have a helper hold the unit in place while checking to see that the sill is level and the sides are plumb. If the window unit is square, you should only need to level the sill.)

D. Adjust the window unit in the opening by using wood shingles as shims until the sill is level

E. Temporarily nail the unit in place through the outside casing

F. Open and close window to determine if the unit is in a bind and make adjustments

G. Nail the unit in place permanently

WALL AND PARTITION FRAMING
UNIT II

JOB SHEET #8--INSTALL EXTERIOR DOOR FRAME
AND HANG DOORS

(NOTE: Pre-hung doors are set very similarly; doors are pre-drilled for locks.)

I. Tools and materials needed

A. Tools

1. Level (6 foot)
2. Claw hammer
3. Framing square
4. Butt gauge for four inch butts
5. Wood chisle (1")
6. Boring jig
7. Mortising jig (if available)

B. Materials

1. Exterior jamb unit
2. Shim stock (wood shingles)
3. Nails 10d casing and 8d box
4. 3 - 4" Butts
5. Door
6. Lock set

II. Procedure

A. Install door frame

1. Check rough opening size
2. Cut out sill area so the top of the sill will be the correct distance above the rough floor
3. Assemble the frame

JOB SHEET #8

4. Place frame in rough opening; from the outside, center it horizontally and secure with a temporary brace
5. Use blocking and wedges to level the sill and bring it to the required height
(NOTE: Be sure the sill is well supported.)
6. With the sill level, drive a nail through the exterior casing into the wall frame on both sides of the sill at the bottom of the frame
7. Insert shims between the trimmer studs and the top of the jambs and adjust until they are plumb; use the level (Figure 1)

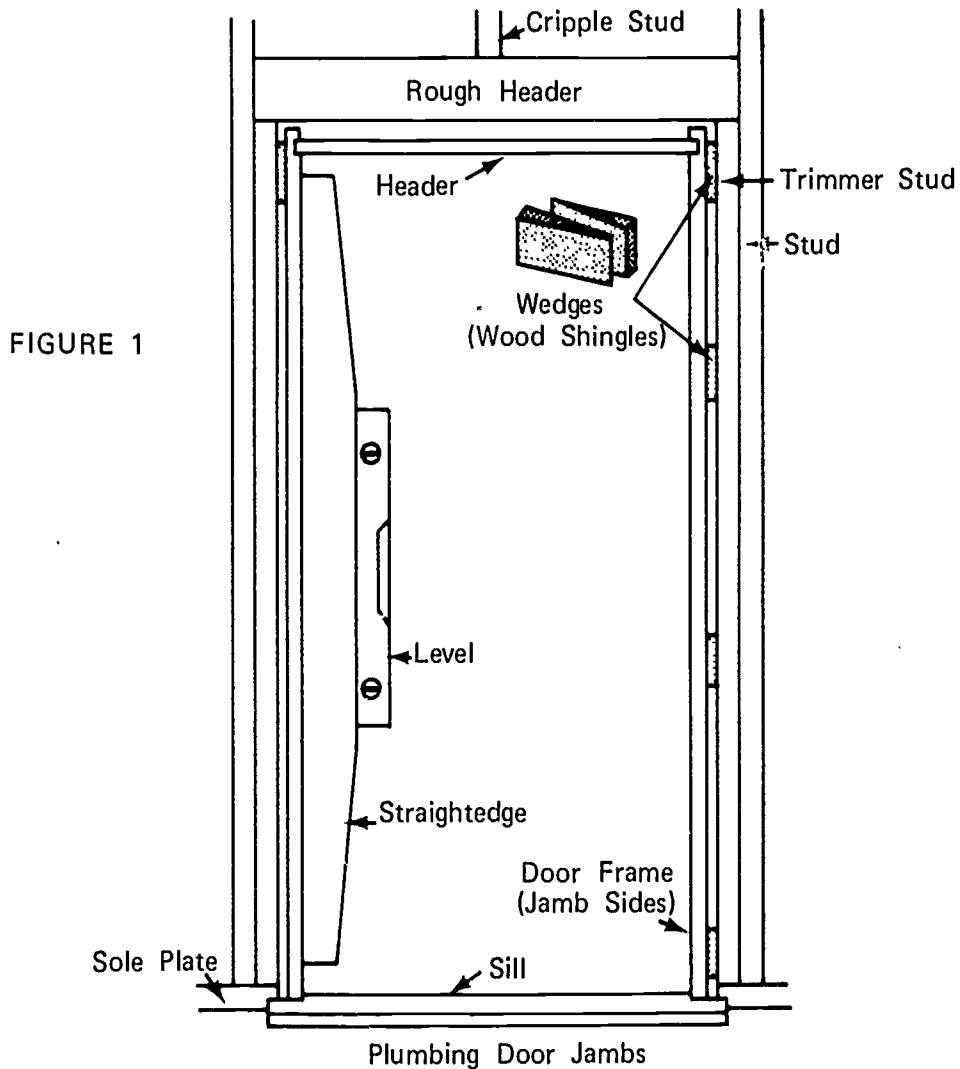

(NOTE: Casings are attached on pre-hung units; frame can be held plumb by nailing casing to stud.)

JOB SHEET #8

8. Place additional wedges between the jambs and stud frame in the area of the lock strike plate and hinges; adjust the wedges until the side jambs are well supported and straight; then nail in place through jamb, wedge, and into stud using 10d casing nails
 9. Nail exterior casing in place using 8d box nails
- B. Hang door
1. Using the butt gauge, mark the position for the 3 hinges on the jamb (usually seven inches from top, eleven inches from bottom, and centered in between)

(NOTE: Be sure the correct side of the jamb is marked.)
 2. Chisle out the gain to the correct depth for the hinges
 3. Use the butt gauge again and mark the hinge locations on edge of door

(NOTE: Check to be sure that top hinge is marked at top end of door.)
 - a. The top hinge must be marked 6 7/8" from the top of the door
 - b. Transfer the measurements for the middle and bottom hinge to the edge of the door
 - c. Cut gains with chisle
 - d. Install hinges
 - e. Hang door
 4. Install lockset (usually thirty-six inches from bottom of door)--Use boring jig

WALL AND PARTITION FRAMING UNIT II

TEST

1. Match the following list of terms to the correct definitions.

- | | |
|--|-------------------------|
| <p>_____ a. The lower framing member which is attached to the top of the bottom cripple studs and forms the base of a rough opening for a window</p> | <p>1. Bearing wall</p> |
| <p>_____ b. A wall which supports the floors and/or roof directly above it in addition to its own weight</p> | <p>2. Blocking</p> |
| <p>_____ c. The lowest horizontal member of a wall or partition which rests on the rough floor to which the studding is nailed</p> | <p>3. Cripple stud</p> |
| <p>_____ d. The use of wood blocks as filler pieces between framing members</p> | <p>4. Double plate</p> |
| <p>_____ e. The opening for doors, windows, etc. formed by the framing members</p> | <p>5. Header</p> |
| <p>_____ f. The top and two sides of a door or window frame which contact the door or sash</p> | <p>6. Partition</p> |
| <p>_____ g. Any part of a framing stud that is cut less than full size as over a door or window opening and under a window opening</p> | <p>7. Rough opening</p> |
| <p>_____ h. A wall that subdivides space within a building</p> | <p>8. Rough sill</p> |
| <p>_____ i. The main vertical framing members in walls and partitions</p> | <p>9. Sole plate</p> |
| <p>_____ j. The top most member of a wall section attached to the top of the studs for the purpose of stiffening the wall and for tying together splices, corners, and partitions that are at right angles to a wall</p> | <p>10. Stud</p> |
| | <p>11. Trimmer</p> |
| | <p>12. Jamb</p> |

- _____ k. The verticle members that form the sides of a rough opening for a door or window upon which the header rests
- _____ l. Horizontal structural member that supports the load over an opening such as a window or door

2. Identify the framing members in the illustration below.

- a.
- b.
- c.
- d.
- e.
- f.
- g.
- h.
- i.
- j.

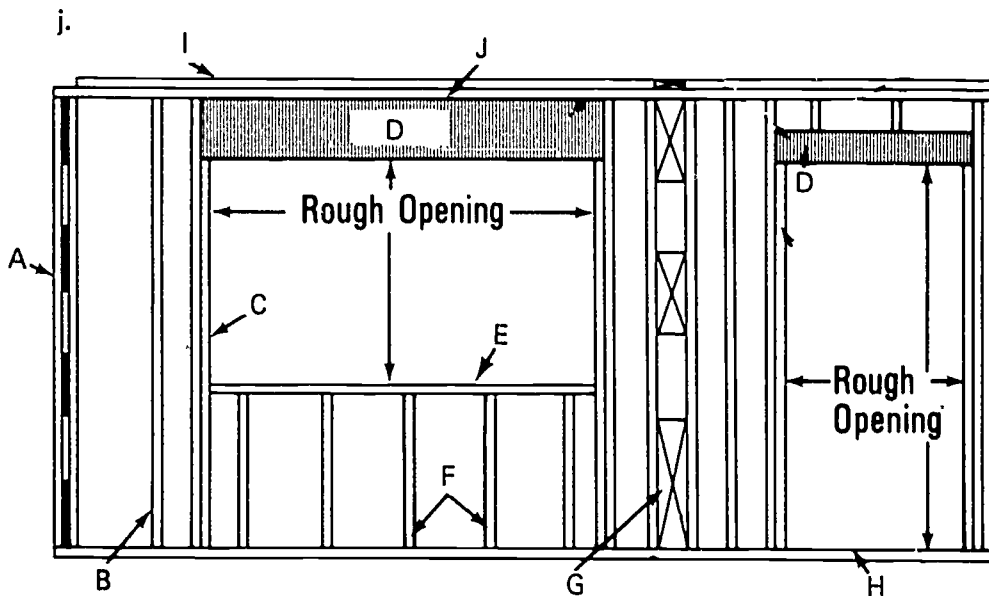

3. Identify the type of corner most commonly used in western construction.

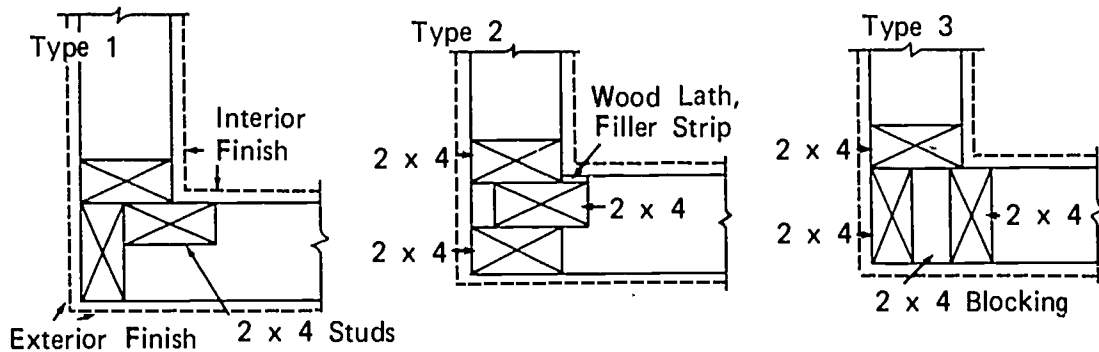

4. Identify the type of "T" most commonly used in western construction.

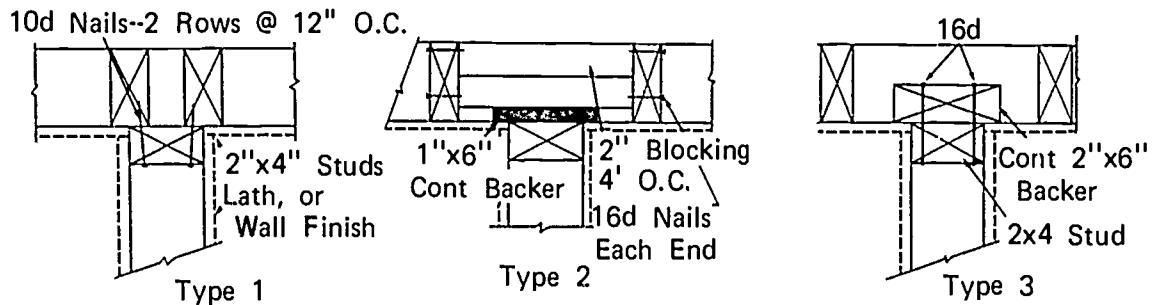

5. Compute the length of a regular stud for a finished ceiling height of 8' 1/2" on a conventional wood floor with 1/2" sheetrock ceiling.

6. Compute the length of the trimmers for a standard 6' 8" door opening on a concrete slab floor.

7. Compute the length of the rough header for a 2' 8" / 6' 8" door.

8. Name three types of sheathing.

- a.
- b.
- c.

9. Estimate the following materials for the floor plan pictured below.

- a. Studs on 16" centers
- b. Plates
- c. Sheathing--Plywood

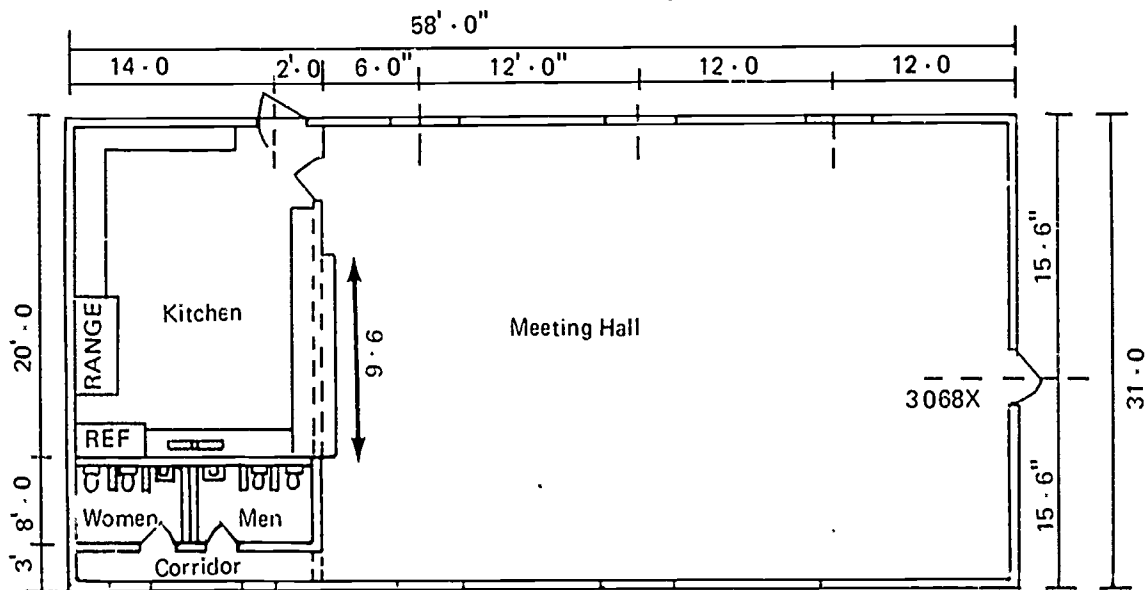

FIRST FLOOR PLAN
(HIP ROOF)

10. Demonstrate the ability to:
- a. Lay out wall and partition locations on floor.
 - b. Cut studs, trimmers, cripples, and headers to length.
 - c. Build inside and outside corners and headers.
 - d. Lay out and assemble a wall section for a single story building.
 - e. Install sheathing.
 - f. Lay out and install ceiling joist on sixteen-inch centers.
 - g. Install windows.
 - h. Install outside door jambs and hang exterior doors.

(NOTE: If this has not been accomplished prior to the test, ask the instructor when the above activities are to be completed.)

WALL AND PARTITION FRAMING
UNIT II

ANSWERS TO TEST

1.
 - a. 8
 - b. 1
 - c. 9
 - d. 2
 - e. 7
 - f. 12
 - g. 3
 - h. 6
 - i. 10
 - j. 4
 - k. 11
 - l. 5

2.
 - a. Corner assembly
 - b. Regular stud
 - c. Trimmer stud
 - d. Headers
 - e. Rough sill
 - f. Cripple studs
 - g. Blocking
 - h. Sole plate
 - i. Double top plate
 - j. Top plate

3. Type 3

4. Type 1
5. 7' 9 1/8"
6. 6' 8 5/8"
7. 37 3/4"
8. The following answers may be given in any order.
 - a. Fiberboard
 - b. Gyplap
 - c. Plywood
9.
 - a. 249 studs
 - b. 47 - 2" x 4" x 16'
 - c. 45 pieces 1/2" x 4' x 8' plywood
10. Performance skills will be evaluated according to the criteria listed on the progress chart.

ROOF FRAMING UNIT III

TERMINAL OBJECTIVE

After completion of this unit, the student should be able to identify the roofing members and roof styles, list the methods for determining rafter length, and define roof framing terms. He should also be able to cut and assemble the various roof members and use the power tools safely and correctly. This knowledge will be evidenced through demonstration and by scoring eighty-five percent on the unit test.

SPECIFIC OBJECTIVES

After completion of this unit, the student should be able to:

1. Match terms associated with roof framing to a list of definitions.
2. Identify ten roofing members.
3. Identify seven roof styles.
4. Identify the roof framing units.
5. List four methods for determining the length of a rafter.
6. Compute the length of a common rafter using the framing square length per foot of run table.
7. Compute the length of a hip rafter using the framing square length per foot of run table.
8. Compute the length of jack rafters using the difference in length tables on the framing square.
9. Estimate the material needed to frame a roof.
10. Demonstrate the ability to:
 - a. Lay out rafter locations on the plate and ridge on two-foot centers.
 - b. Lay out, cut, and erect rafters.
 - c. Apply roof sheathing.

ROOF FRAMING UNIT III

SUGGESTED ACTIVITIES

- I. Instructor:
 - A. Provide students with objective sheet.
 - B. Provide students with information, assignment, and job sheets.
 - C. Make transparencies.
 - D. Discuss terminal and specific objectives.
 - E. Discuss information and assignment sheets.
 - F. Demonstrate and discuss procedures outlined in job sheets.
 - G. Give test.
- II. Student:
 - A. Read objective sheet.
 - B. Study information sheet.
 - C. Complete assignment sheet.
 - D. Demonstrate the ability to accomplish the procedures outlined in the job sheets.
 - E. Take test.

INSTRUCTIONAL MATERIALS

- I. Included in this unit:
 - A. Objective sheet
 - B. Information sheet
 - C. Transparency masters
 1. TM 1--Roofing Members
 2. TM 2--Roof Styles
 3. TM 3--Roof Framing Units

4. TM 4--Rafter Slide Rule
 5. TM 5--Framing Square Step-Off Method
 6. TM 6--Pythagorean Theorem
 7. TM 7--Rafter Tables From a Framing Square
 8. TM 8--The Framing Square
 9. TM 9--Common Rafter Layout
 10. TM 10--Length of Ridge Board
- D. Assignment sheets
1. Assignment Sheet #1--Compute Rafter Length
 2. Assignment Sheet #2--Estimate Roof Framing Materials
- E. Answers to assignment sheets
- F. Job sheets
1. Job Sheet #1--Lay Out Rafter Locations
 2. Job Sheet #2--Lay Out, Cut, and Erect Rafters
 3. Job Sheet #3--Apply Sheathing
- G. Test
- H. Answers to test
- II. References:
- A. Burke, Arthur E., Ralph Dalzell, and Gilbert Townsend. *Architectural and Building Trades Dictionary*. Chicago, Illinois: American Technical Society, 1955.
 - B. Cooper, George H. and Stanley Badzinski, Jr. *Building Construction Estimating*. St. Louis, Missouri: McGraw-Hill, 1971.
 - C. Durbahn, Walter E. and Elmer W. Sundberg. *Fundamentals of Carpentry*. Third Edition. Chicago, Illinois: American Technical Society, 1963.
 - D. Feirer, John L. *Woodworking for Industry*. Peoria, Illinois: Charles Bennett Company, Inc., 1971.
 - E. Oklahoma T & I Education. *Suggested Basic Course Outline in Carpentry*. State Board for Vocational Education.
 - F. Smith, Ronald C. *Principles and Practices of Light Construction*. Englewood Cliffs, New Jersey: Prentice Hall Inc., 1970.

ROOF FRAMING
UNIT III

INFORMATION SHEET

I. Terms and definitions

- A. Barge rafter--An exposed rafter at the end of a gable roof, sometimes called a verge rafter
- B. Birdsmouth--A cutout near the bottom of a rafter which fits over the double plate
- C. Collar beam--A horizontal tie beam connecting two opposite rafters up near the ridge to hold them together at the ridge
- D. Common rafter--One of a series of rafters extending from the double plate to the ridge
- E. Dormer--A window, vertical in a roof
- F. Gusset--A panel or bracket of either wood or metal attached to the corners at intersections of a frame to add strength and stiffness
- G. Hip rafter--The rafter extending from the double plate at the corner of a building to the ridge forming the angle for a hip roof
- H. Jack rafter--A short rafter which fits between the plate and the hip or valley rafter or between the ridge and hip or valley rafter

(NOTE: When fitted between hip and valley rafter, it is called a cripple jack.)
- I. Pitch--The angle or degree of slope of a roof
- J. Plumb cut--The cut at right angles to the seat cut of the birdsmouth and is also the cut of the rafter at the ridge
- K. Purlin--Horizontal timbers supporting the common rafters in roofs
- L. Ridge board--The horizontal member or timber at the top of the roof to which the upper end of the rafters are nailed
- M. Rise--The incline or pitch of a roof expressed in terms of inches per one foot of run
- N. Run--The horizontal distance that underlies the slope of the roof from a wall to the ridge, usually one-half of the span
- O. Seat cut--The cut at the lower end of a rafter; the part of the birdsmouth that rests on the plate

INFORMATION SHEET

- P. Span--The horizontal distance that underlies the roof from one exterior wall to the opposite exterior wall
- Q. Valley rafter--A rafter used in an internal angle of a roof to form a valley

II. Roofing members (Transparency 1)

- A. Collar beam
- B. Common rafter
- C. Hip rafter
- D. Purlin
- E. Ridge board
- F. Valley rafter
- G. Gable studs
- H. Hip jack
- I. Valley jack

III. Roof styles (Transparency 2)

- A. Gable
- B. Hip
- C. Shed
- D. Flat
- E. Gable and dormer
- F. Mansard
- G. Gambrel

IV. Roof framing units (Transparency 3)

- A. Unit span--Always equals twenty-four inches
- B. Unit rise--Changes with slope or pitch
- C. Unit run--Always equals twelve inches
- D. Unit length--Increases with rise

INFORMATION SHEET

- V. Methods for determining rafter length (Transparencies 4, 5, 6, and 7)
- A. Rafter slide rule
(NOTE: This may be purchased from J.R. Mason Engineering Service, Kalamazoo, Michigan.)
 - B. Framing square step-off method
 - C. Pythagorean theorem,
 - D. Rafter tables from framing square
(NOTE: Rafter tables are usually in length per foot of run although some tables are in length per given run.)
- VI. Computing the length of a common rafter using the framing square (Transparency 8)
- A. Determine the common rafter layout (Transparency 9)
(NOTE: Measure from the outside of the plate on one side wall to the outside of the plate on the opposite side wall.)
 - B. Determine the run of the common rafter
(NOTE: Run equals one-half of span.)
 - 1. Divide the span by two
 - 2. Subtract one-half the thickness of the ridge board
(NOTE: This is commonly called "shortening".)
 - C. Determine the pitch of the roof or the rise per foot of run
 - D. Read the length of the rafter per foot of run from the framing square as follows:
 - 1. Locate the unit rise per foot of run on the blade of the framing square

Example: If the unit rise is four inches per one foot of run, locate the number four on the edge of the blade

INFORMATION SHEET

2. Read the figure under the unit rise for the unit length per foot of run for the common rafter; in the illustration given, this figure is 12.65 inches per foot of run
3. Multiply the unit length per foot run by the actual run

Example: If the run of the building for the illustration given is ten feet, multiply $10 \times 12.65 = 126.50$ inches or $10 \frac{54}{100}$ feet or $10' 6 \frac{1}{2}"$ is the length of the common rafter. The formula for this procedure is as follows:

$$\frac{\text{Feet of run} \times \text{Inches per foot of run}}{12}$$

(NOTE: The following table may be used to convert decimals to inches:

1 inch equals	0.083 foot
2 inches equals	0.167 foot
3 inches equals	0.250 foot
4 inches equals	0.333 foot
5 inches equals	0.417 foot
6 inches equals	0.500 foot
7 inches equals	0.583 foot
8 inches equals	0.667 foot
9 inches equals	0.750 foot
10 inches equals	0.833 foot
11 inches equals	0.917 foot

VII. Computing the length of a hip rafter using the framing square

- A. Determine the span, run, and rise the same as for the common rafter
- B. Read the length of the hip or valley rafter per foot of run from the framing square as follows:
 1. Locate the unit rise per foot of run on the blade of the framing square the same as for a common rafter

(NOTE: See the illustration for common rafters on the preceding page.)

Connecting Devices

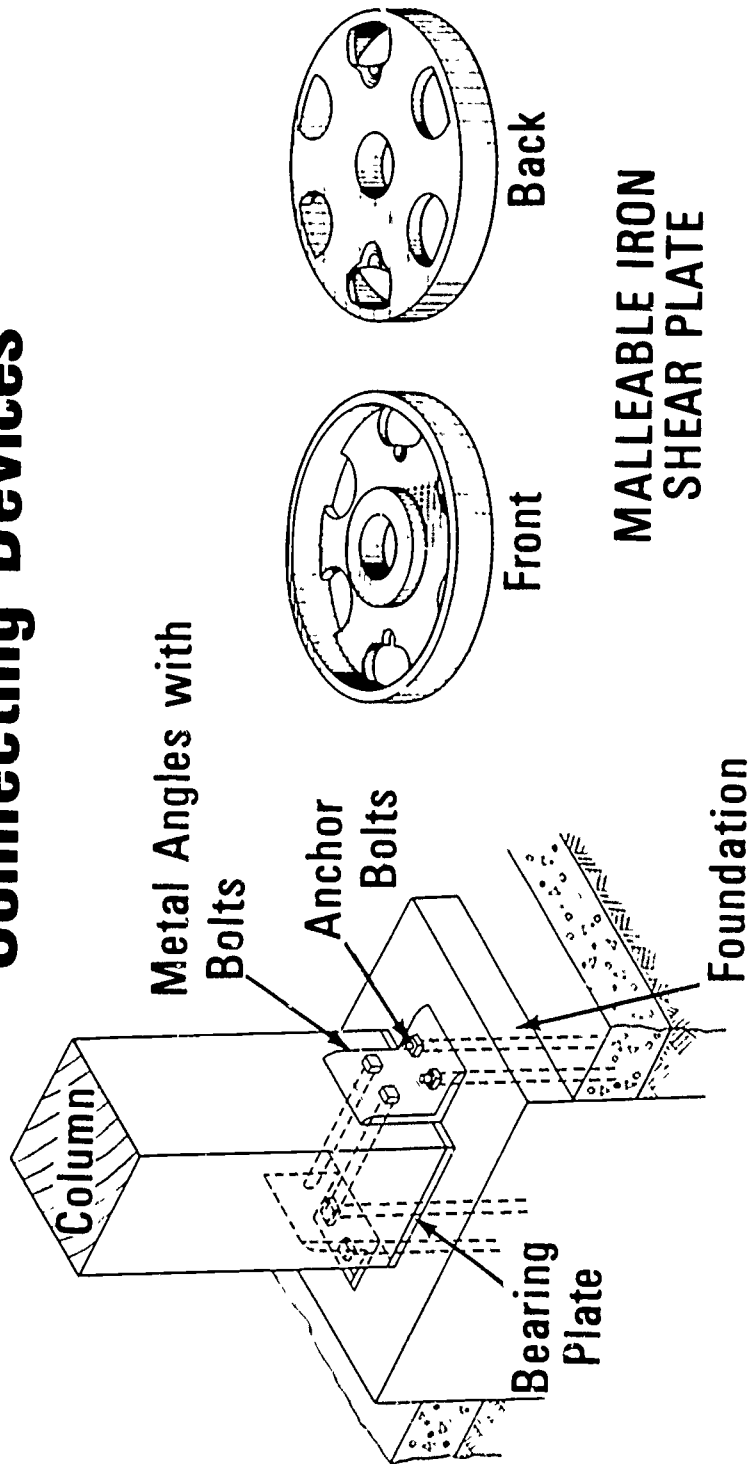

INFORMATION SHEET

- C. Read across and down to the number listed

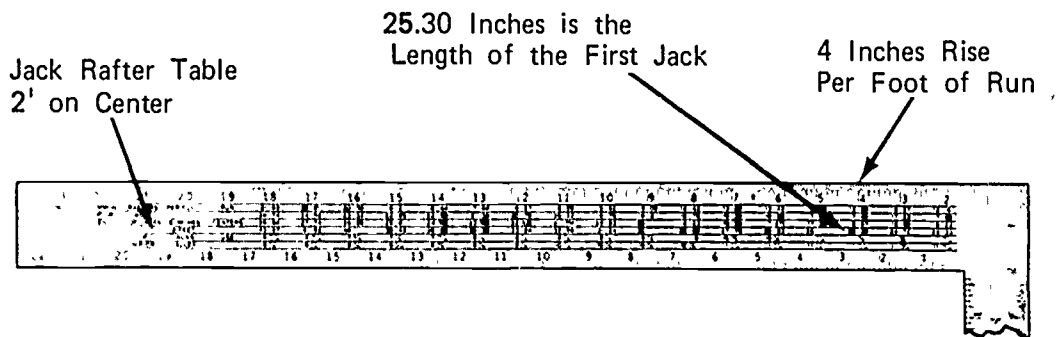

- D. For a roof of four inches rise per foot of run, the length of the first jack rafter from the table is 25.30 inches or $25 \frac{3}{8}$ " shorter than the common rafter
- E. The second jack will be two times shorter than the first jack or $50 \frac{3}{4}$ inches shorter than the common rafter
- F. The third jack will be three times shorter than the first jack or $76 \frac{1}{8}$ inches shorter than the common rafter
- G. The fourth will be four times shorter than the first and the fifth will be five times shorter and continued until the number needed is reached
- IX. Estimating roof framing materials

- A. Gable roof with rafters two feet on center

1. Rafters--For a simple rectangular building

- a. Determine the length of the rafter including overhang

(NOTE: Refer to Transparency 9.)

- b. Determine the number needed

- 1) Measure the length of one side of the building and round up to the nearest foot
- 2) Add six additional rafters, two for end rafters and four for barge rafters

INFORMATION SHEET

2. Ridge board (Transparency 10)

(NOTE: The ridge should be the next dimension wider than the rafter material.)

a. Gable roof

(NOTE: Determine the length of the plate on one side of the building and add the amount of projection over each gable end for a simple rectangular building.)

b. Hip roof

- 1) Measure the length of the building
- 2) Measure the width of the building
- 3) Subtract the width from the length and add the thickness of the ridge to the remainder for the actual ridge length

B. Hip roof with rafters two feet on center--Rafters--For a simple rectangular building

(NOTE: Refer to Transparency 9.)

1. Determine the length of the common rafters including overhang
2. Determine the length of the hip rafters including overhang

(NOTE: Jack rafters are simply common rafters that have been shortened.)

3. Determine the number of rafters needed for a simple rectangular hip roof

- a. Hip rafters--One for each corner
- b. Common and jack rafters--Measure the length of the building, round up to the nearest foot, and add two end rafters, four for barge rafters as in a gable roof

(NOTE: The same amount of material is needed for rafters for either a gable or hip roof.)

Roofing Members

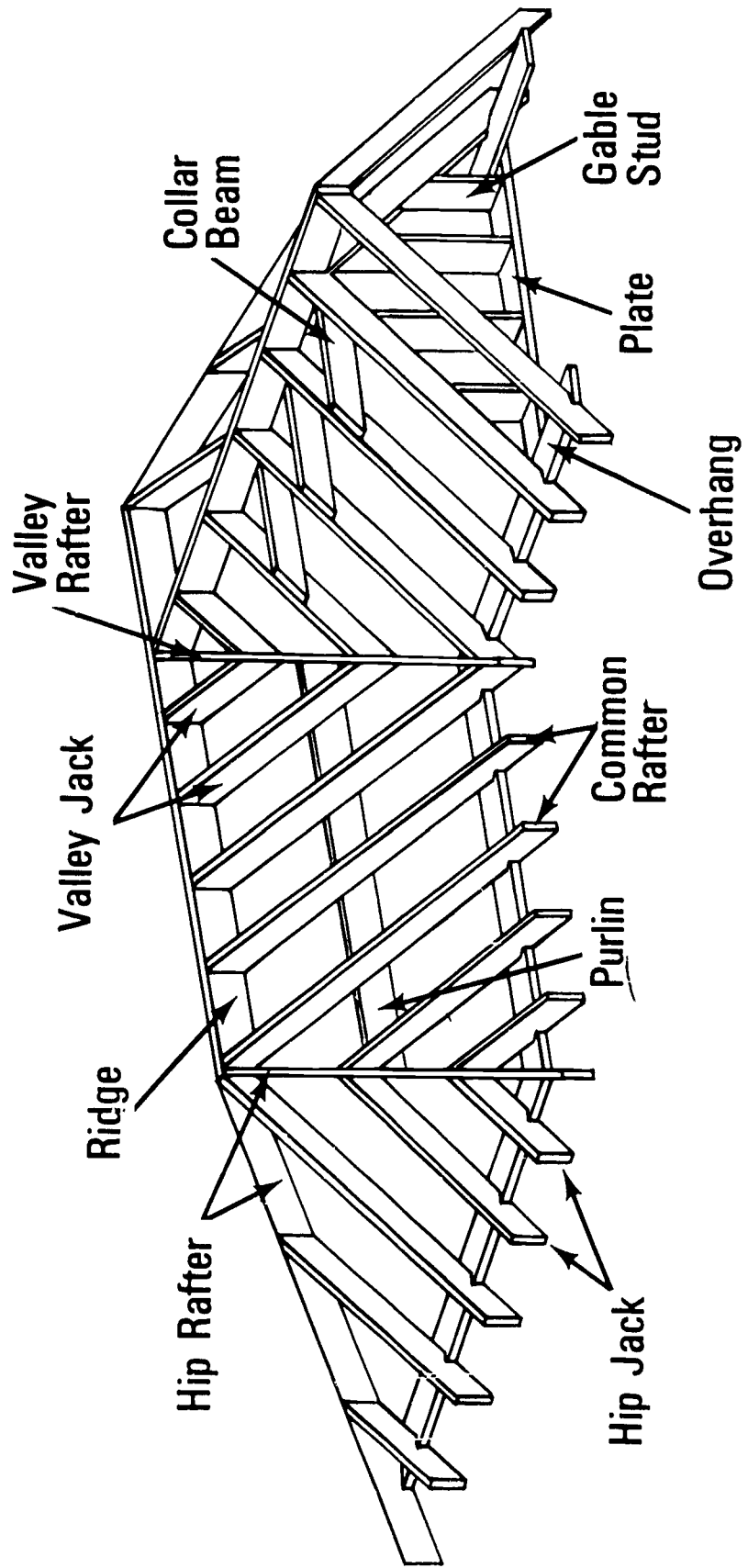

Roof Styles

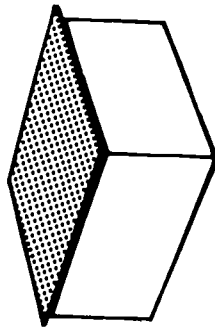

Flat Roof

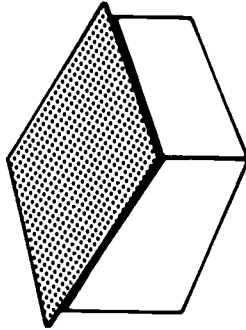

Shed or
Lean-To Roof

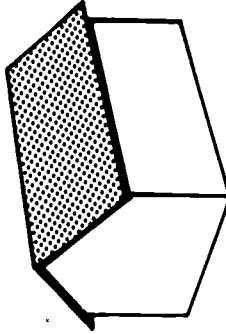

Gable Roof

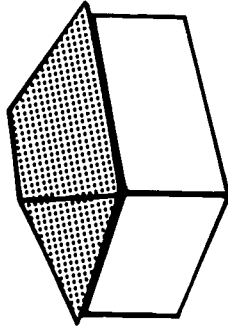

Hip Roof

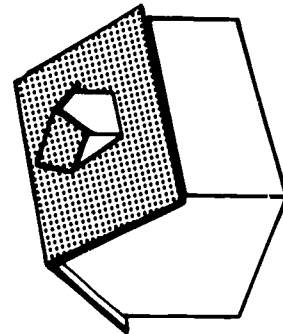

Gable Roof
and Dormer

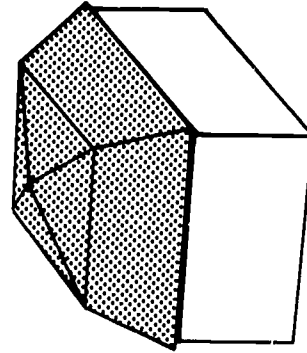

Mansard Roof

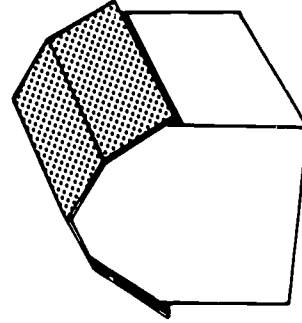

Gambrel Roof

Roof Framing Units

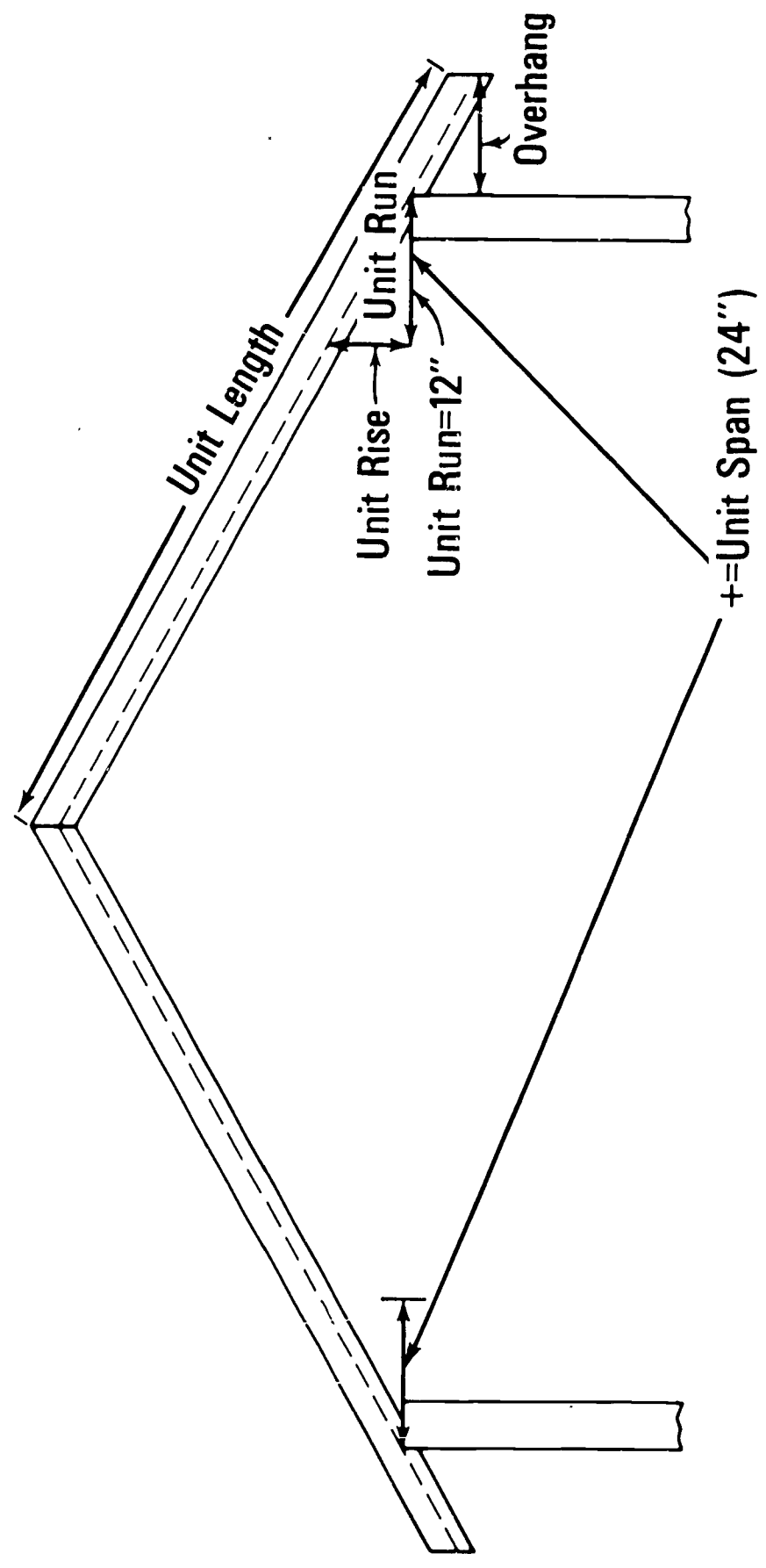

Framing Square Step-Off Method

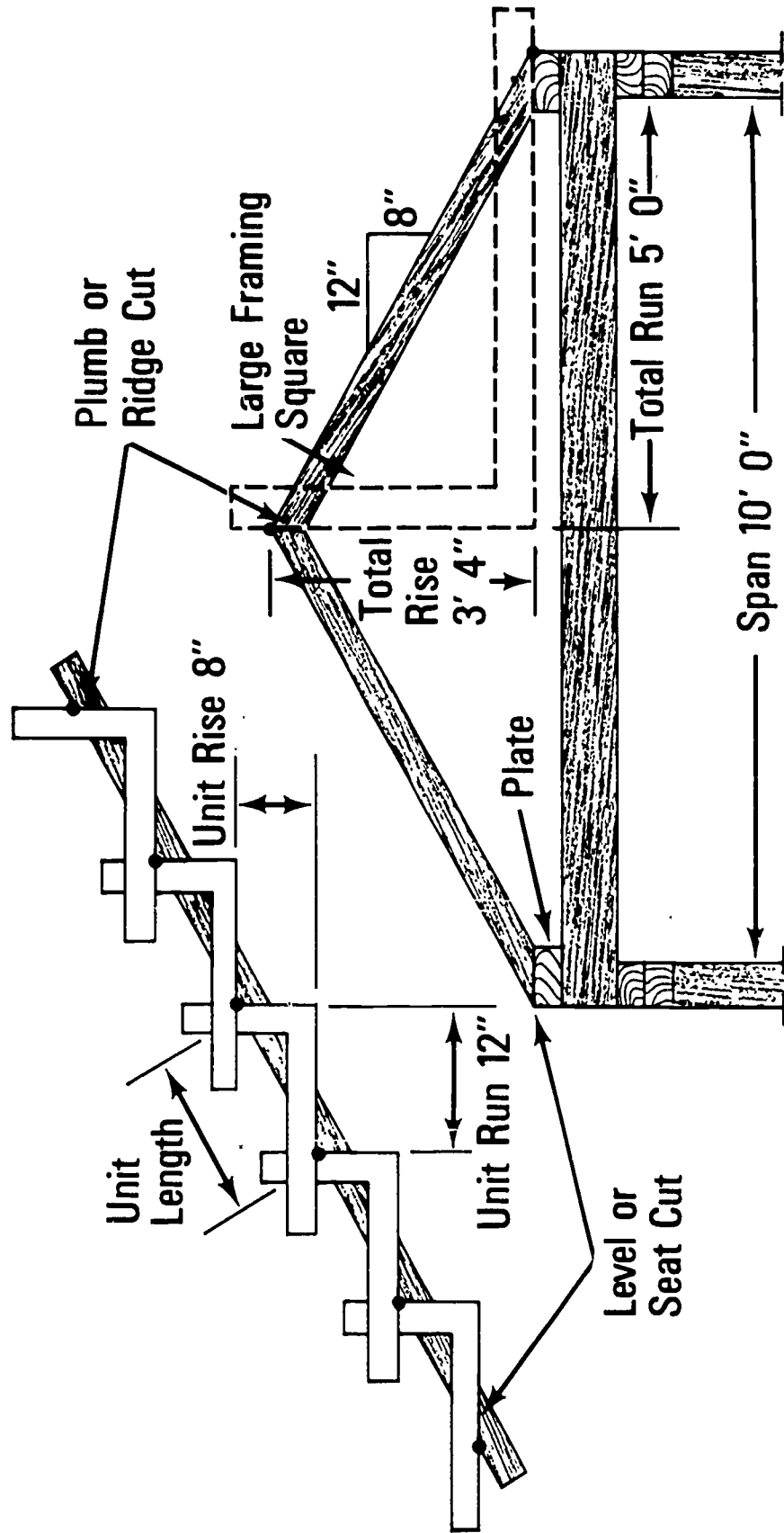

Pythagorean Theorem

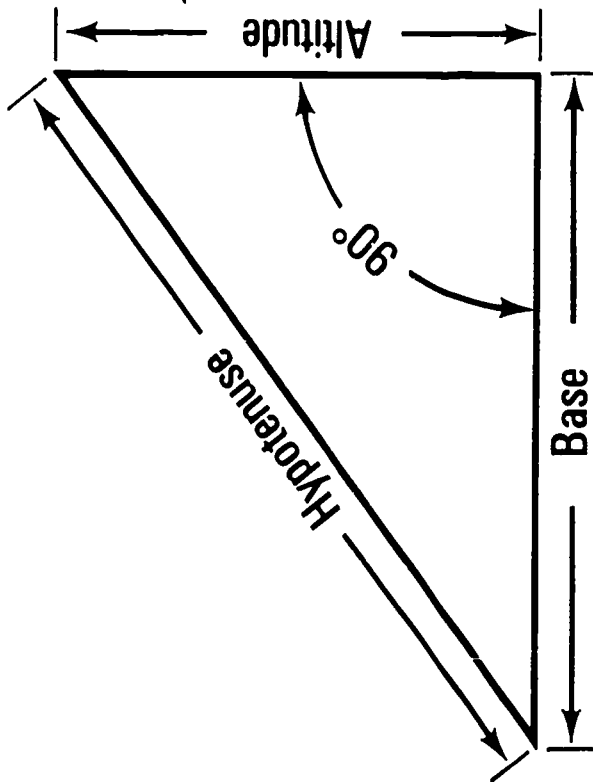
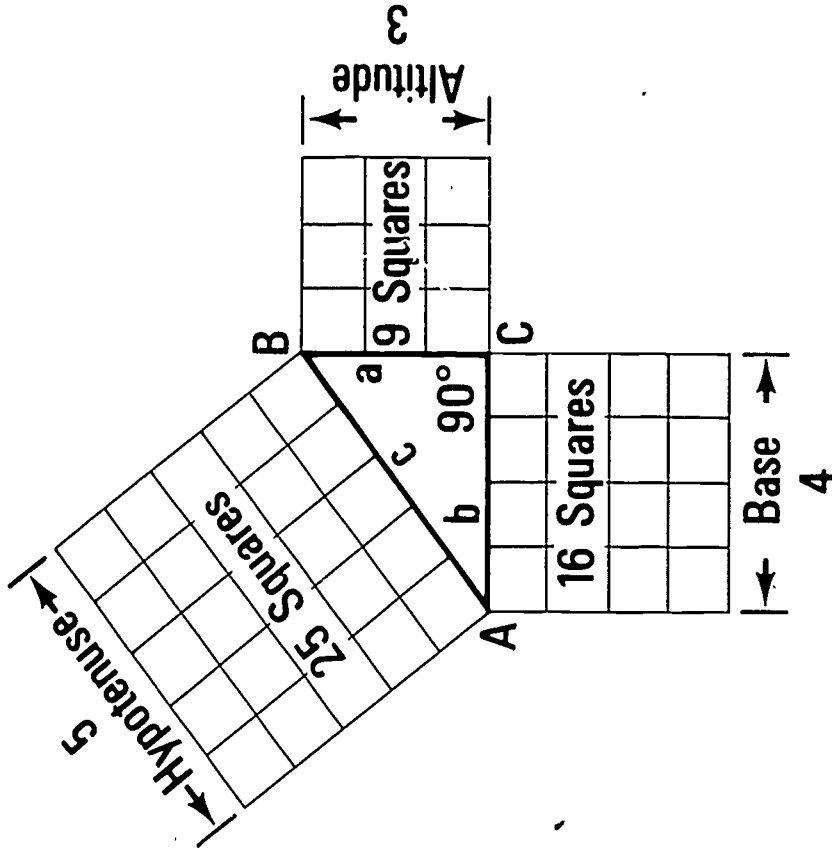

The sum of the squares of the base and altitude of a right triangle is equal to the square of the hypotenuse

Rafter layout as based on the relationship of the sides of a right triangle

Common Rafter Layout

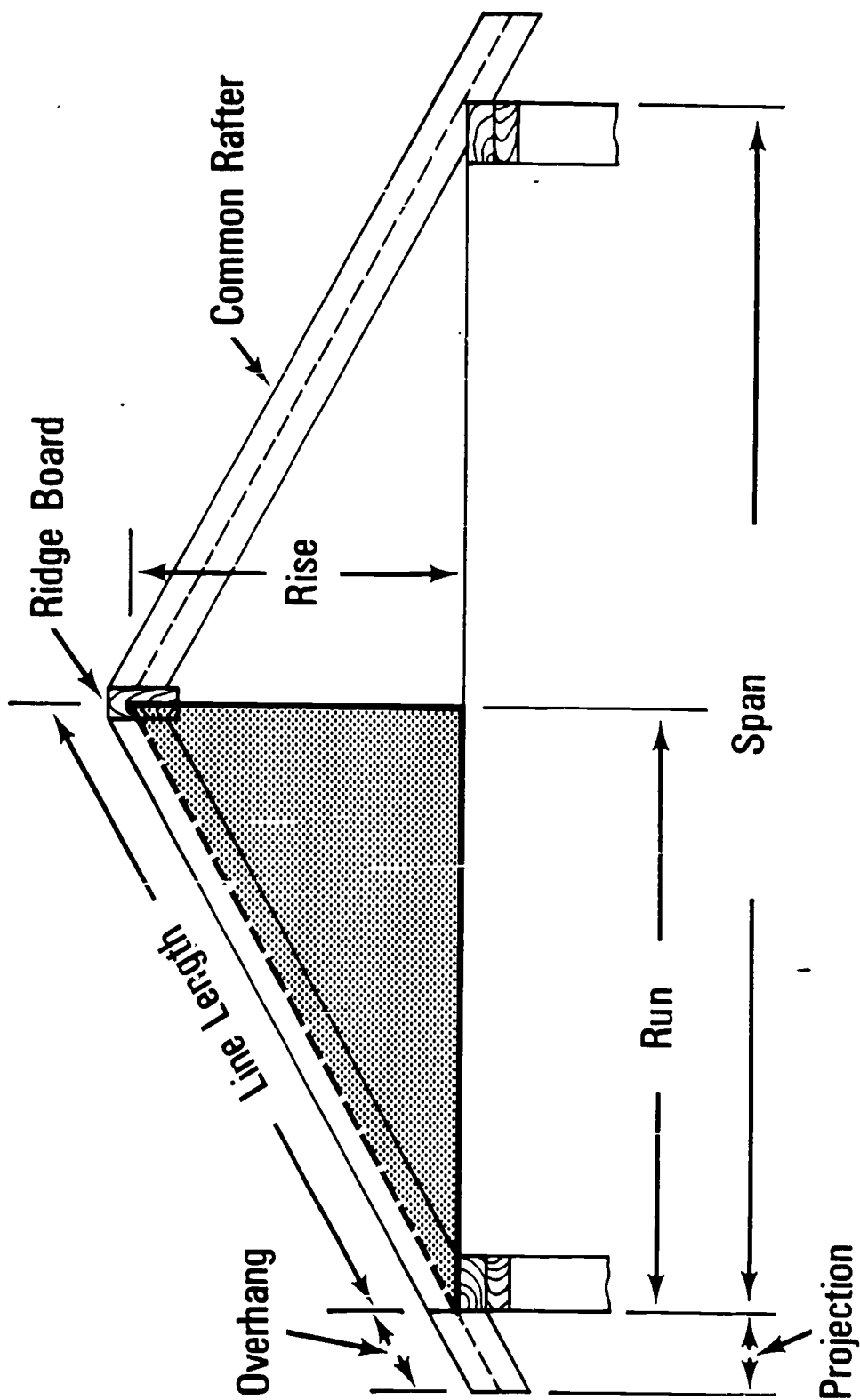

Length of Ridge Board

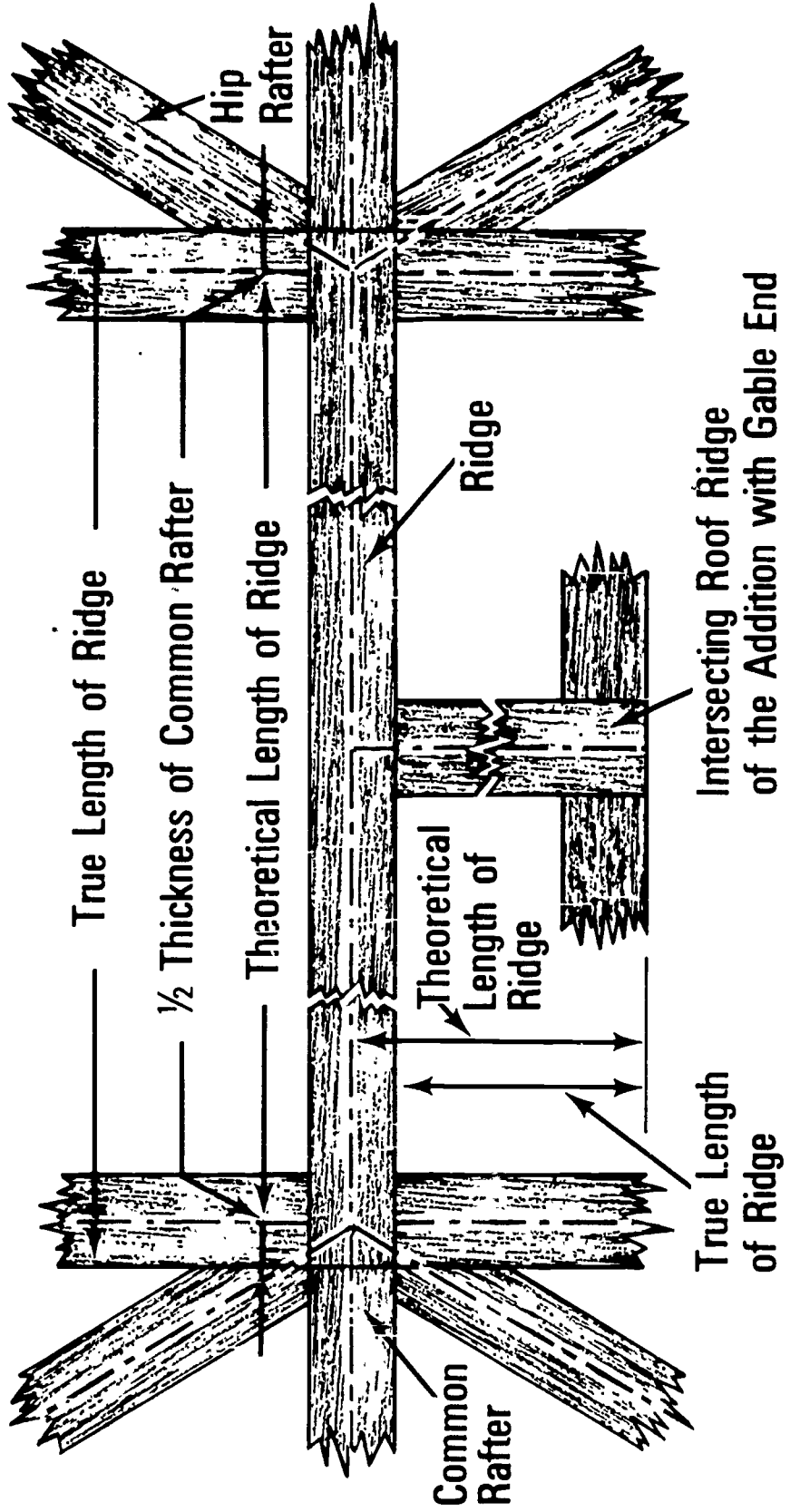

ROOF FRAMING
UNIT III

ASSIGNMENT SHEET #1--COMPUTE RAFTER LENGTH

Using your information sheet and a framing square, calculate the length of the following roof members for the building illustrated below.

(NOTE: All material 2" x 6".)

1. Common -
2. Hip -
3. The third jack -
4. Ridge board 2" x 6" x _____

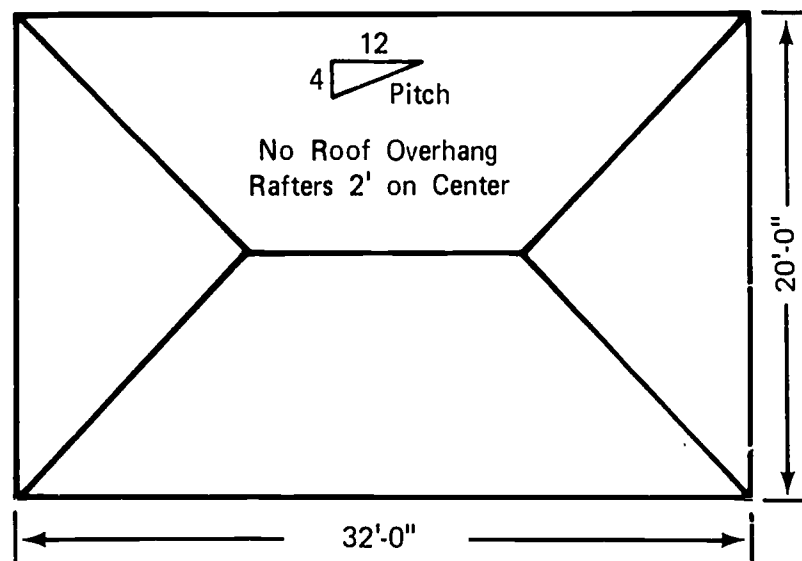

ROOF FRAMING
UNIT III

ASSIGNMENT SHEET #2--ESTIMATE ROOF FRAMING MATERIALS

Using your information sheet and a framing square, calculate the material needed to frame the roof illustrated below.

(NOTE: All material should be 2" x 6".)

1. Number and length of common rafters
2. Number and length of hip rafters
3. Number and lengths of each jack:
 - #1
 - #2
 - #3
 - #4
 - #5
4. Length of ridge board

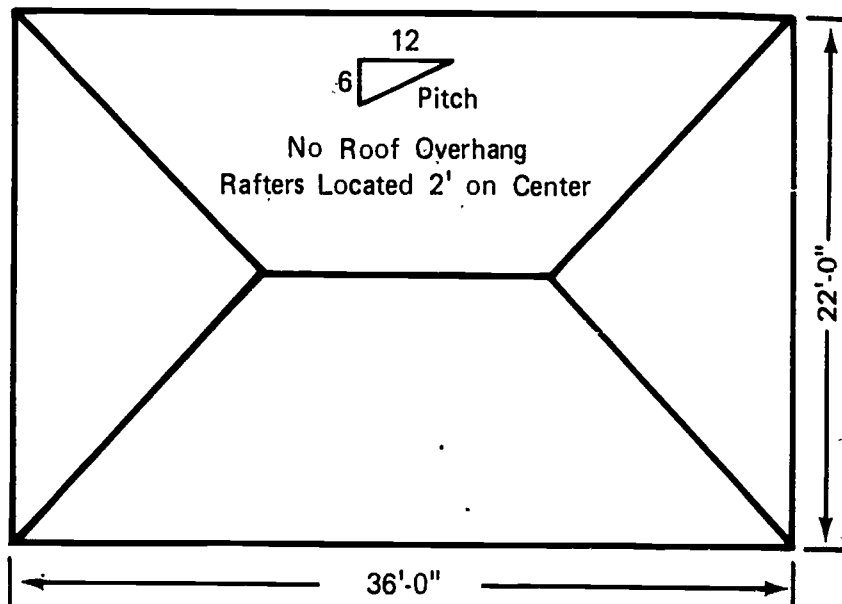

ROOF FRAMING
UNIT III

ANSWERS TO ASSIGNMENT SHEETS

Assignment Sheet #1

1. $10' 6 \frac{1}{2}"$
2. $14' 6 \frac{3}{8}"$
3. $14 \frac{5}{8}"$ or $1' 2 \frac{5}{8}"$
4. $11' 10 \frac{1}{2}"$

Assignment Sheet #2

1. $15 - 2" \times 6" \times 12' 3 \frac{5}{8}"$
2. $4 - 2" \times 6" \times 16' 6"$
3. #1 $8 - 2" \times 6" \times 10' 0 \frac{3}{4}"$
#2 $8 - 2" \times 6" \times 7' 9 \frac{7}{8}"$
#3 $8 - 2" \times 6" \times 5' 7"$
#4 $8 - 2" \times 6" \times 3' 4 \frac{1}{8}"$
#5 $8 - 2" \times 6" \times 1' 1 \frac{1}{4}"$
4. $1 - 2" \times 6" \times 14' 1 \frac{1}{2}"$

ROOF FRAMING
UNIT III

JOB SHEET #1--LAY OUT RAFTER LOCATIONS

i. Tools and materials needed

A. Tools

1. 100 foot steel tape
2. Framing square

B. Materials

1. Completed wall sections with double plate
2. Ridge board

(NOTE: This should be the next dimension wider than rafter material.)

II. Procedure

A. Gable roof (with box cornice)

1. Cut ridge board to correct length allowing for barge rafter at each end if used
2. Lay out rafter locations on double top plate
 - a. Begin at one end of plate and locate the first rafter flush with the end of plate
 - b. Using the 100 foot tape with the "0" end held against the outside end of the wall proceed to mark two-foot locations on the plate from left to right

(NOTE: Place an "X" to the right of each mark.)

- c. The last rafter must also set flush with the outside of the opposite end of the building

(NOTE: The spacing between the last two rafters may be less than but not more than two feet.)

- d. Using the framing square, square a line across the plate at each two foot mark

JOB SHEET #1

- e. Repeat the marking process on the opposite plate being sure to start from the same end of the building and work from right to left (Figure 1)

(NOTE: See the illustration below for the plate markings.)

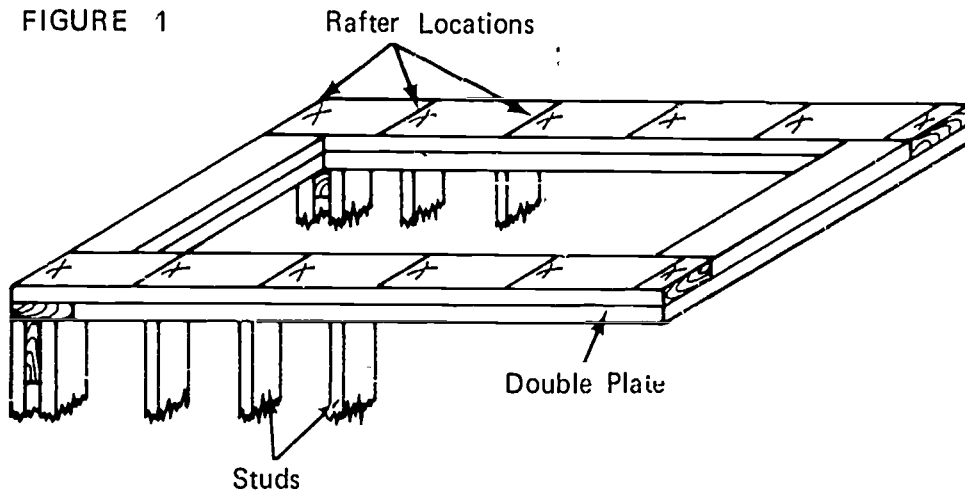

3. Lay out ridge board
 - a. Place ridge board on edge on top of the plate with equal projection over each end for the barge rafters
 - b. Mark the ridge board on both sides to correspond to the marks on the plate
 - c. Use the framing square to square lines across the face of the ridge board at each mark and place an "X" on the same side of the mark as on the plate
- B. Hip roof
1. Cut ridge board to correct length
 - a. Measure the length of the side wall from the outside of the opposite end plate
 - b. Measure the length of one end wall from the outside of the opposite side plate
 - c. Subtract b from a and add the thickness of the ridge for the true ridge length

900

JOB SHEET #1

- d. Measure and cut ridge board to this length (Figure 2)

FIGURE 2

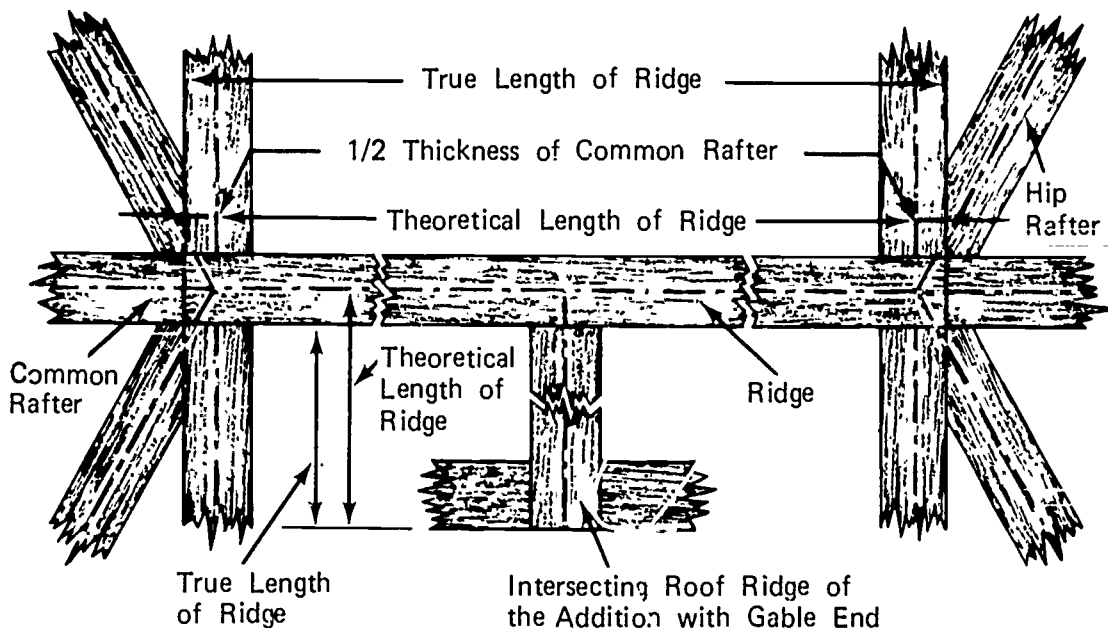

2. Lay out rafter locations on plate
 - a. Measure one-half the width of the building from the end on the top plate of one side wall; this locates the center of the first rafter; mark one-half the thickness of the rafter on either side of this line
 - b. All other rafters both common and jacks are spaced from this rafter and their location marked by squaring a line across the plate with an "X" on one side of the line to indicate the side on which the rafter is to be placed
 - c. Repeat the procedure for the opposite side
 - d. The end is laid out from the center of the end wall both ways

JOB SHEET #1

- e. Transfer the plate markings to the ridge board by holding on edge on the plate with one end flush with the outside mark for the first common rafter and marking each location on both sides of the ridge board (Figure 3)

FIGURE 3

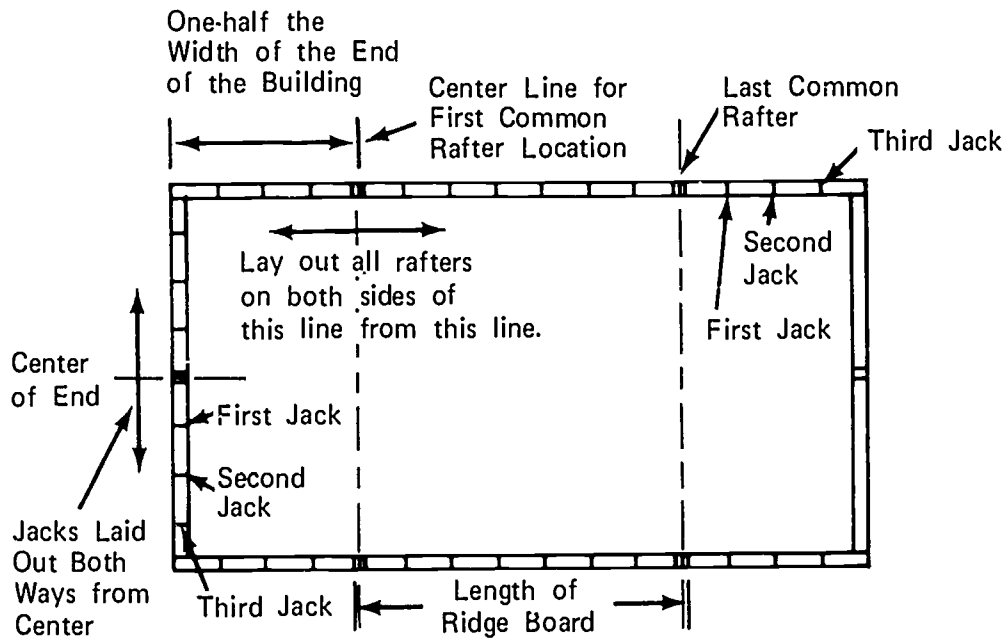

ROOF FRAMING UNIT III

JOB SHEET #2--LAY OUT, CUT, AND ERECT RAFTERS

I. Tools and materials needed

A. Tools

1. Framing square
2. Tape measure (100 foot)
3. Tape measure (12 or 16 foot)
4. Claw hammer (16 oz or larger)
5. Electric handsaw
6. Crosscut handsaw

B. Materials

1. Rafter material
2. Ridge board material
3. Nails 16d box
4. Nails 8d box

II. Procedure

A. Lay out and cut a pattern for each type of rafter needed

1. Common rafter

- a. Determine the length of the rafter (Figure 1)

(NOTE: This length is center line length of the rafter.)

FIGURE 1

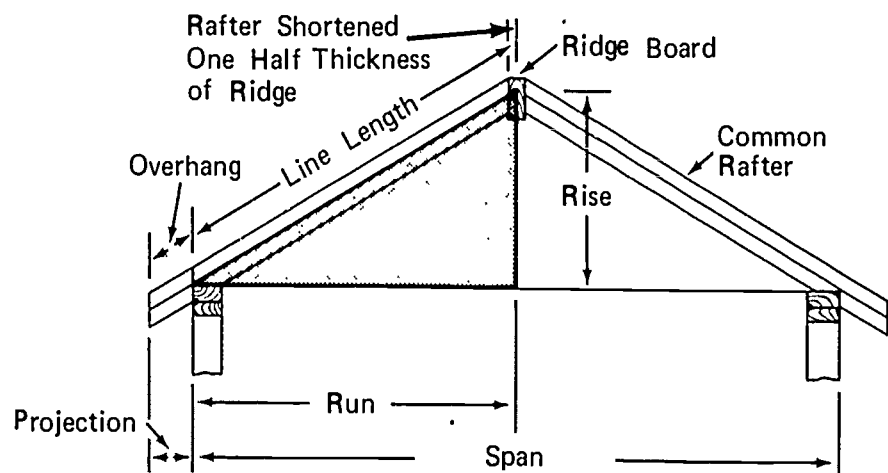

Line length + Overhang - 1/2 Thickness of Ridge Board = True Common Rafter Length

JOB SHEET #2

- b. The length of the rafter must be shortened by one-half the thickness of the ridge board (Figure 2)

FIGURE 2

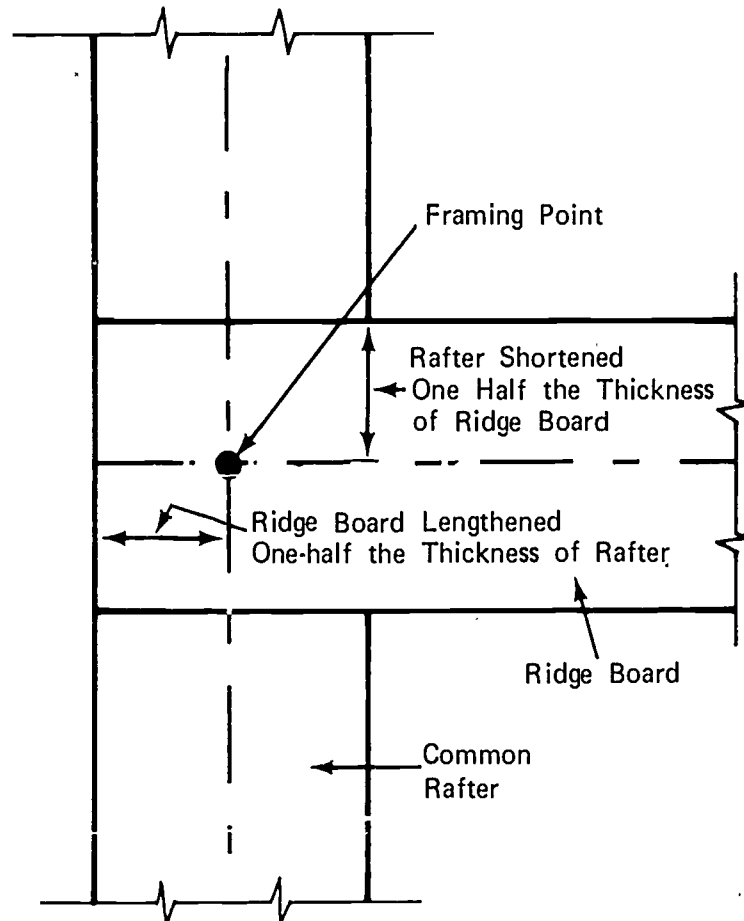

- c. Lay a 2 x 6, sufficient in length for a common rafter including overhang, across two saw horses
- d. Mark the top end or plumb cut first as follows
- 1) Determine the crown edge of the rafter
 - 2) The toe of the plumb cut should be on the crown edge
 - 3) Place the framing square across the face of the rafter near one end with the blade running lengthways of the rafter and the tongue running across the face of the rafter
 - 4) Locate the inches rise per foot of run on the tongue

JOB SHEET #2

- 5) Locate the inches of run on the blade of the square

(NOTE: The run will always be twelve inches for common rafters.)

- 6) Mark the rafter on the outside edge of the tongue (Figure 3)

FIGURE 3

Unit = 5"
 Unit Length = 13.0"
 Run = 12"

$$LCR = \frac{13.0 \times 12}{12} = 13'-0"$$

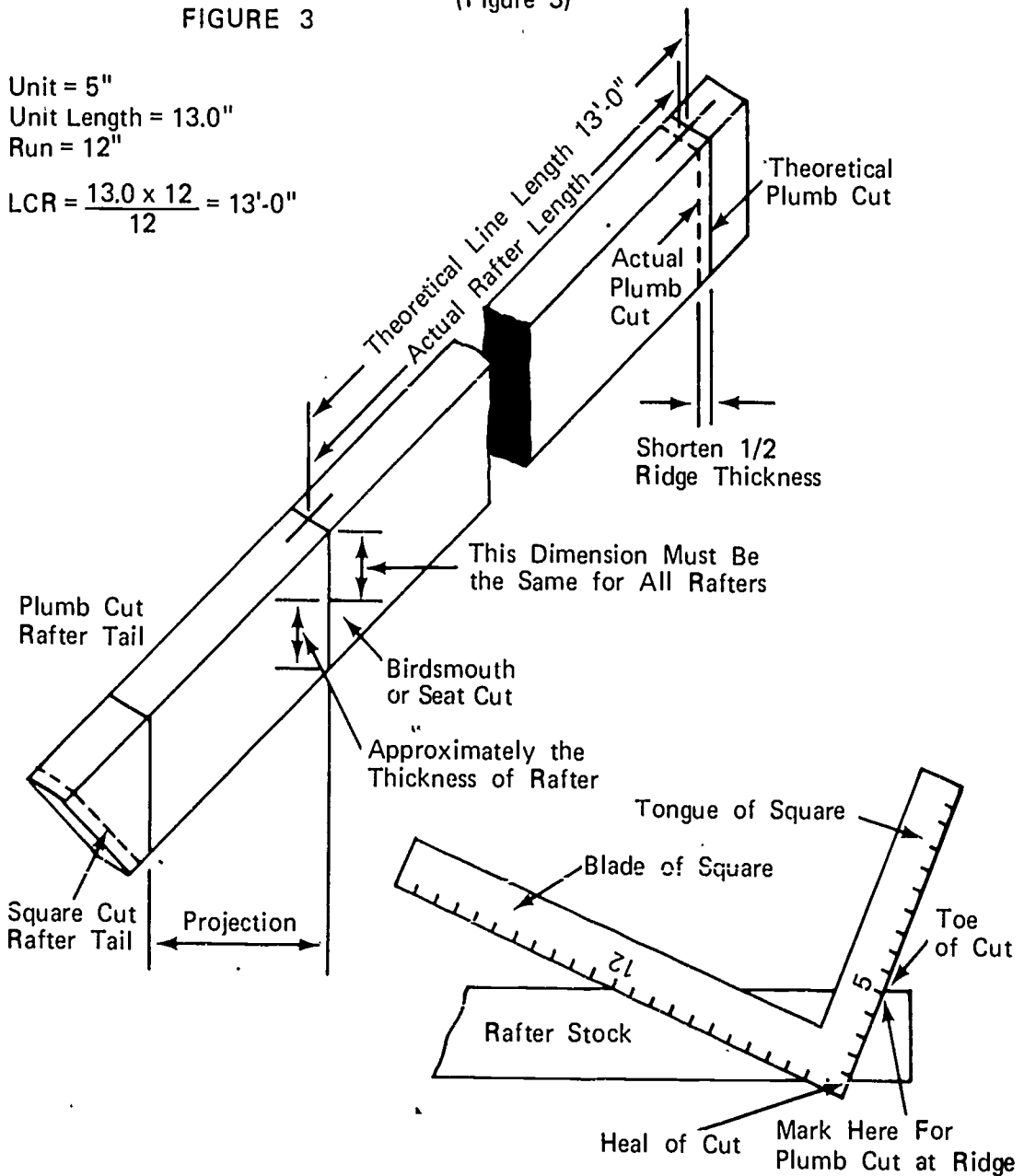

- e. Measure the length of the rafter on the top edge from the toe of the plumb cut

JOB SHEET #2

- f. Place the framing square in position to mark the plumb cut for the birdsmouth as illustrated below in step #1 and mark (Figure 4)

Step #1

FIGURE 4

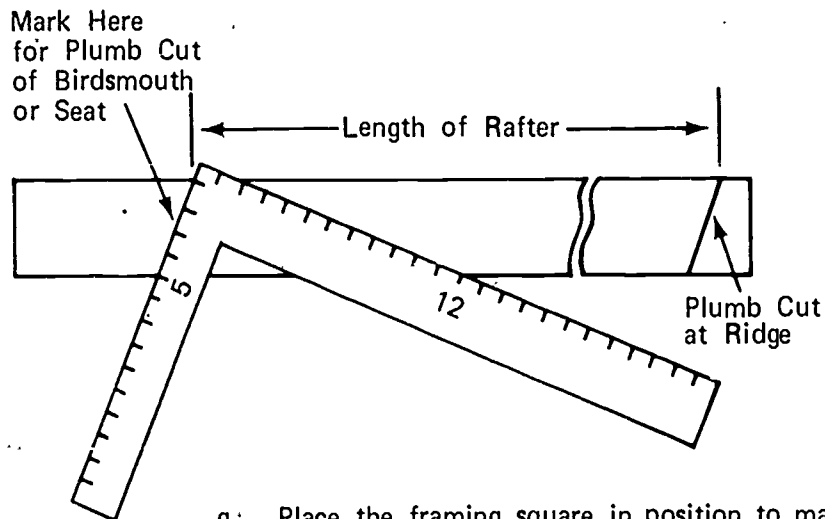

- g. Place the framing square in position to mark the seat cut for the birdsmouth as illustrated below in step #2 and mark (Figure 5)

FIGURE 5

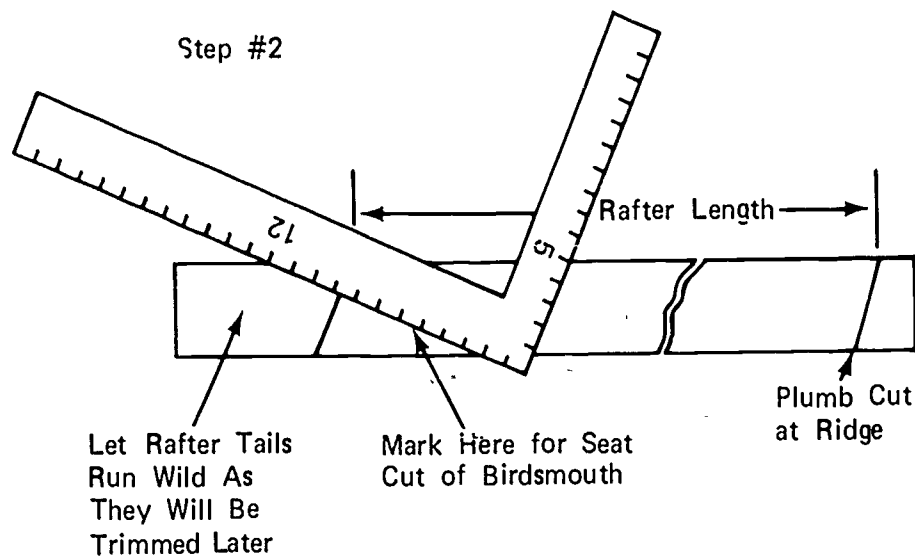

JOB SHEET #2

- h. Cut the rafter on the lines marked using the electric handsaw (Figure 6)

(IMPORTANT: Cut only part of the way on the birdsmouth with the electric saw and finish the cut with a handsaw. The finished rafter should look like the one in the illustration in step #3.)

(NOTE: Care must be taken to get a very accurate cut on the first rafter as it will be used as a pattern for the remaining common rafters. Write PATTERN on both sides.)

FIGURE 6

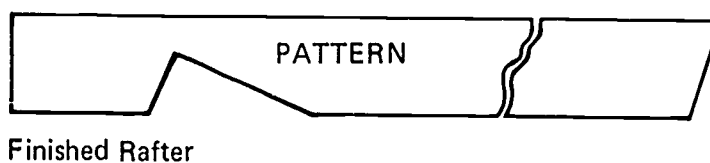

2. Hip rafter
 - a. Determine the length of the rafter

(NOTE: This length is center line length of the rafter.)

JOB SHEET #2

- b. Shorten the length of the rafter to allow for the ridge board by one-half the diagonal thickness of the rafter (Figure 7)

FIGURE 7

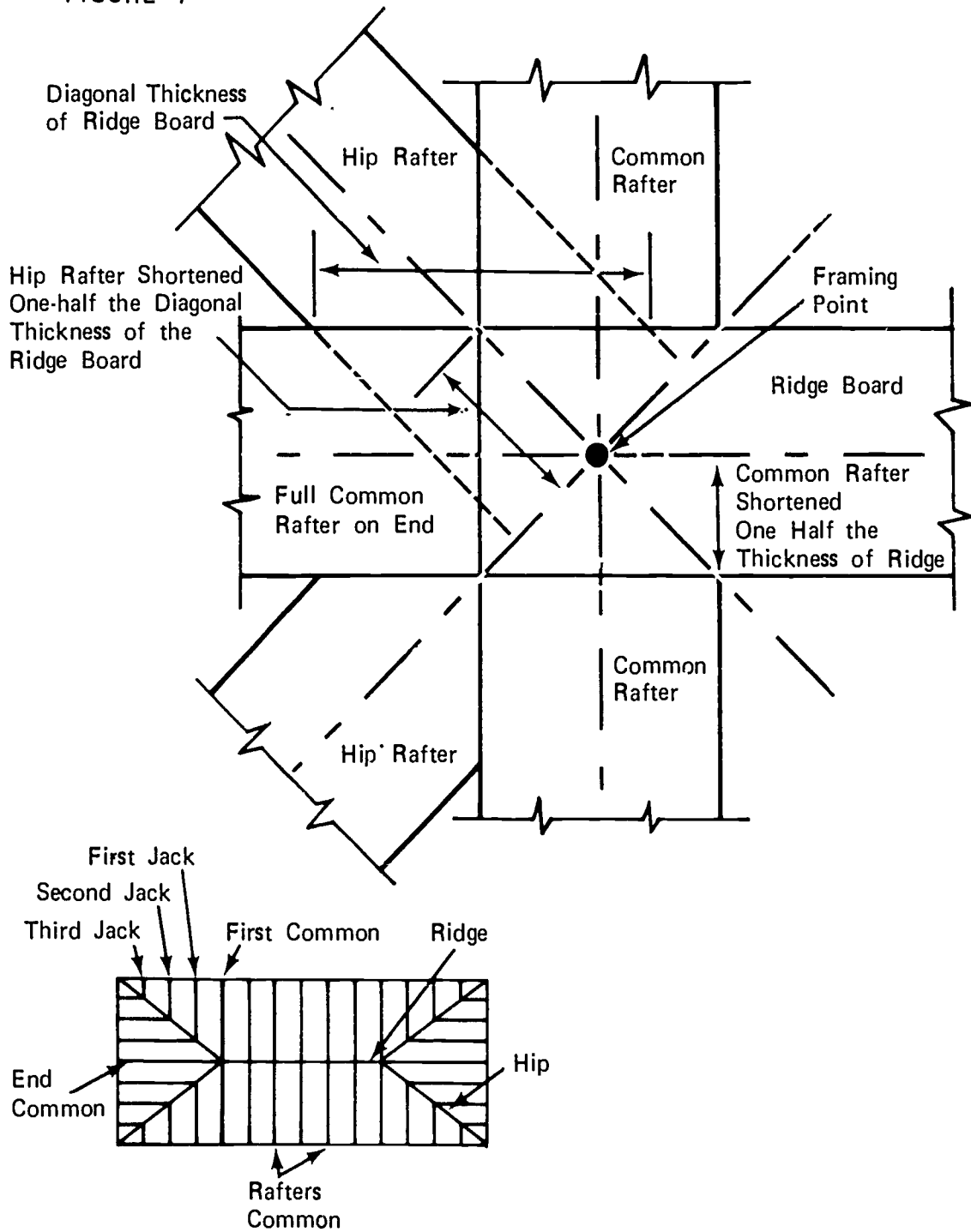

JOB SHEET #2

- c. Lay a 2 x 8, sufficient in length for a hip rafter including the overhang, across two sawhorses and lay out and cut the same as for a common rafter (Figure 8)

(NOTE: The inches run on the blade of the framing square for a hip rafter will always be seventeen.)

FIGURE 8

Unit Rise = 5"
Unit Length = 17.69"
Run = 12'

$$\text{LCR} = \frac{17.69 \times 12}{12} = 17' - 8 \frac{1}{4}"$$

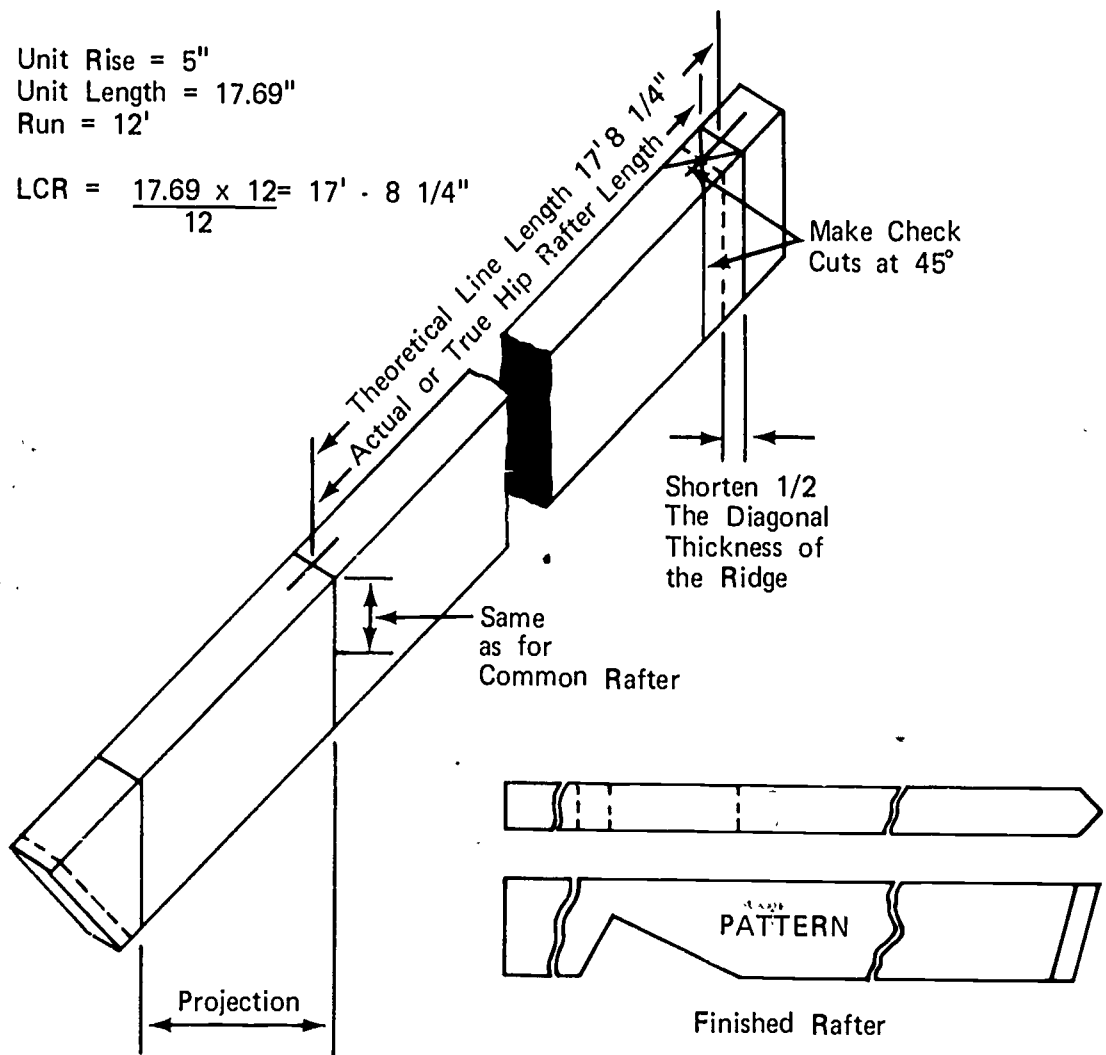

3. Hip jack rafters on two-foot centers

- a. Determine the length of the first jack

(NOTE: Remember that the figure read from the framing square is the difference in length of jack rafters from the common rafter.)

- b. Use the pattern for common rafters to mark the birdsmouth

JOB SHEET #2

- c. Measure the length of the first jack rafter from the plumb cut of the birdsmouth (Figure 9)

FIGURE 9

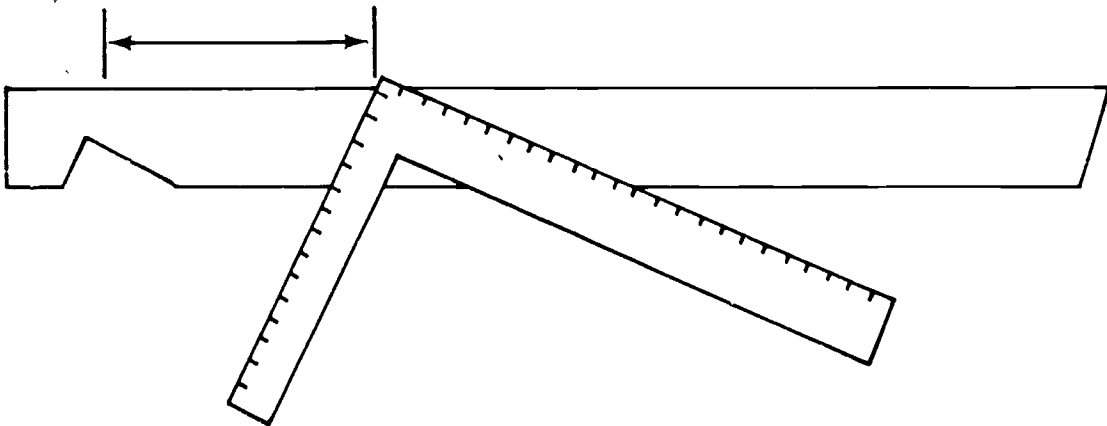
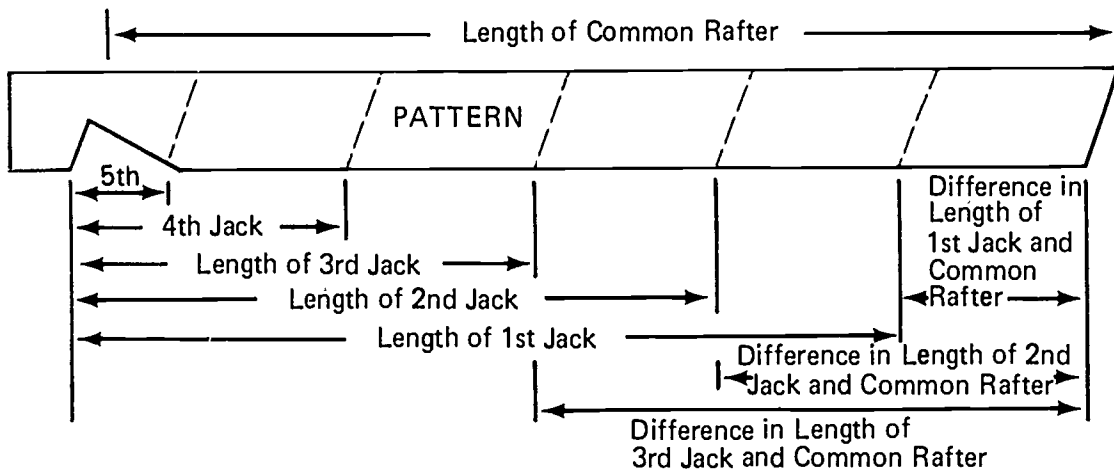

(NOTE: Remember that this is the theoretical length of the jack rafter and it must be shortened one-half the diagonal thickness of the rafter.)

2010

JOB SHEET #2

d. Shorten the rafter (Figure 10)

FIGURE 10

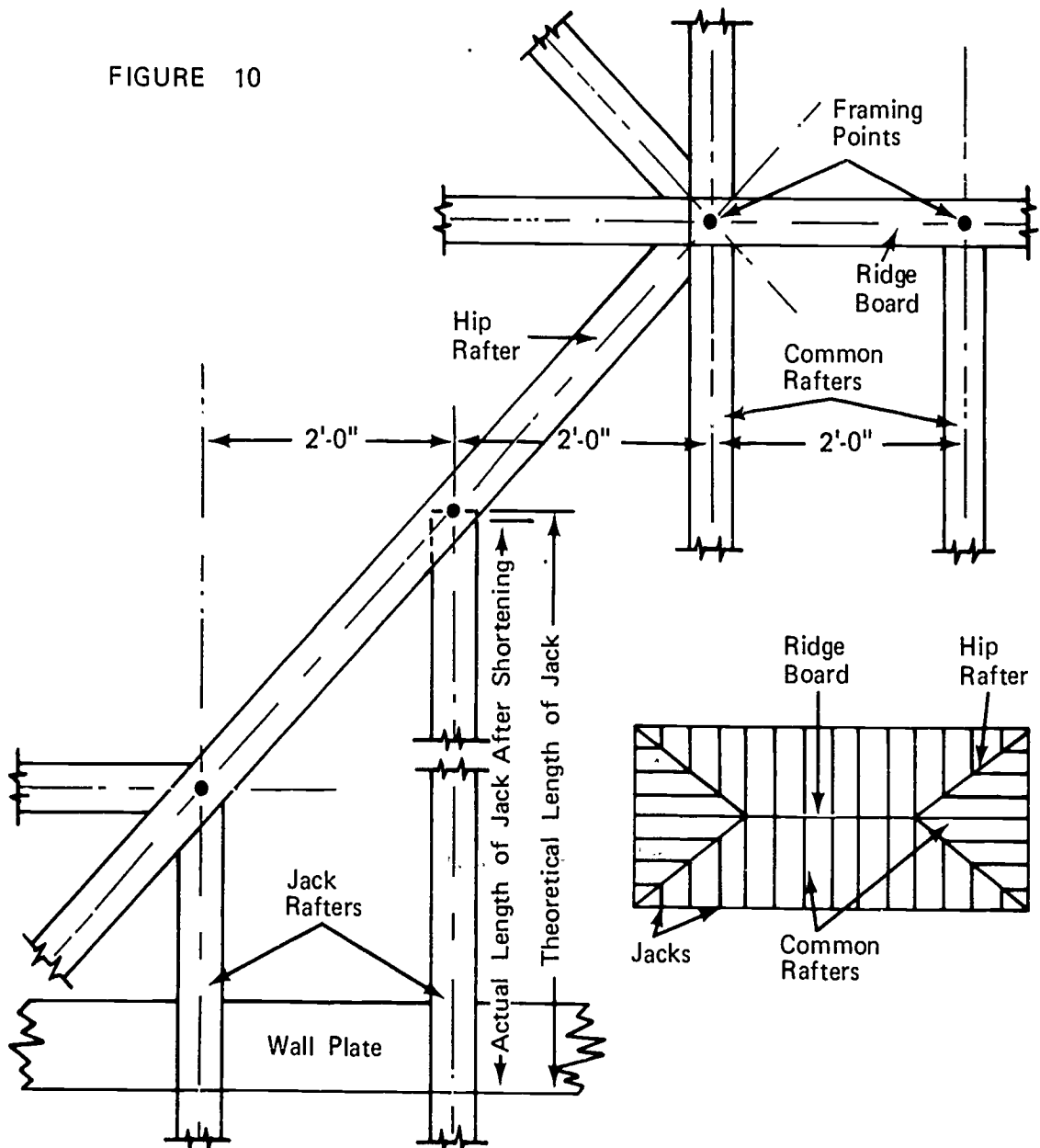

JOB SHEET #2

- e. Lay out and cut all jacks (Figure 11)

(NOTE: For every jack with a cheek cut on the left, there must be one of equal length with a cheek cut on the right.)

FIGURE 11

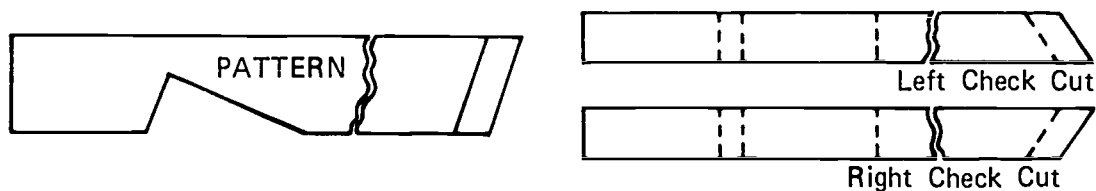

B. Erect rafters

1. Gable roof

(NOTE: This job requires a minimum of three persons to get started. One to hold each end of ridge board and one to nail rafters.)

(CAUTION: Place boards across ceiling joist to walk on to keep from falling through the joist.)

- a. Lean all of the rafters against the sides of the house at each rafter location with the plumb cut up
- b. Erect the end rafters first nailing with 16d box nails, through the ridge into the rafter (Figure 12)

(IMPORTANT: Be sure that the top of all rafters are flush with the top of the ridge board and inside the marks on the ridge.)

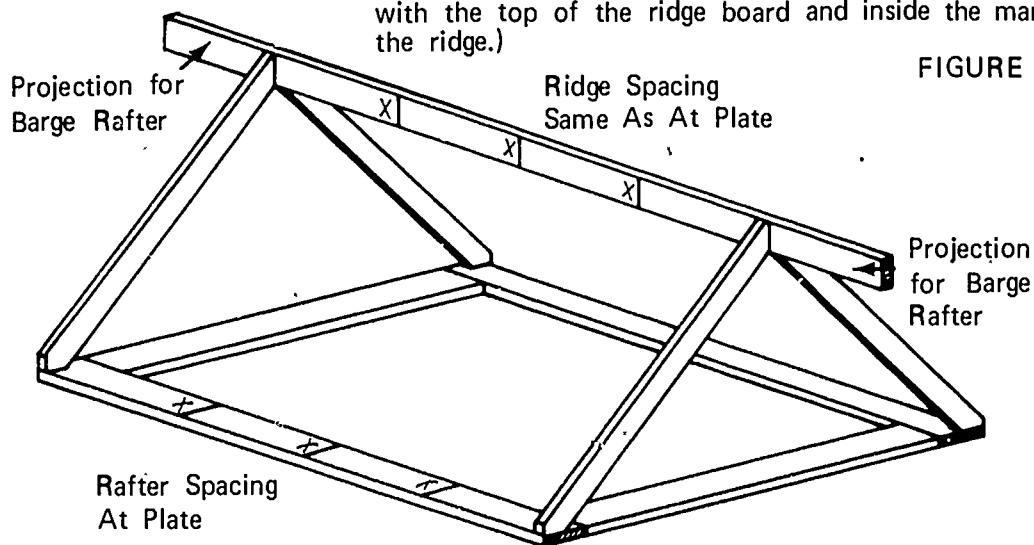

FIGURE 12

JOB SHEET #2

- c. Toe nail the seat of the birdsmouth cut to the plate using 16d box nails

(IMPORTANT: Be sure that the plumb cut of the birdsmouth is snugged up to the outside of the plate. Have a helper hold the ridge up until the nailing is accomplished.)

- d. Erect the remaining rafters following the same procedures used in erecting the end rafters

(NOTE: Keep the ridge straight. To accomplish this, erect opposing pairs and stretch a string along the top of the center of the ridge as a guide.)

2. Hip roof

(NOTE: This job requires a minimum of three persons to get started.)

(IMPORTANT: Place boards across ceiling joist to walk on.)

- a. Lean all of the rafters against the sides of the house at each rafter location with the plumb cut up
- b. Erect the last common rafters on the sides first (Figure 13)

FIGURE 13

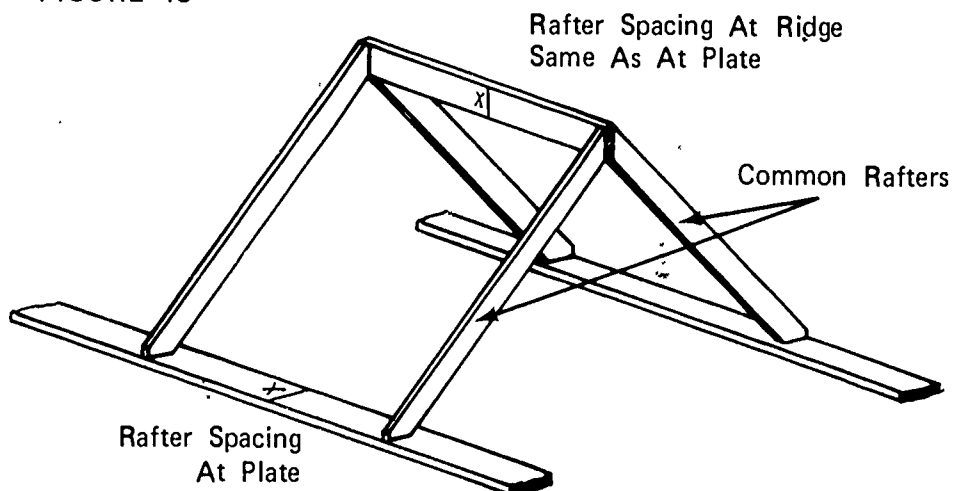

- 1) Nail through ridge into end of rafters with 16d box nails

(IMPORTANT: Be sure that the tops of all rafters are flush with the top of the ridge board.)

JOB SHEET #2

- 2) Toe nail the seat of the birdsmouth cut to the plate with 16d box nails

(IMPORTANT: Be sure that the plumb cut of the birdsmouth is snugged up to the outside of the plate.)

- c. Erect the end common rafters next, toenailing into the ridge and into the plate (Figure 14)

FIGURE 14

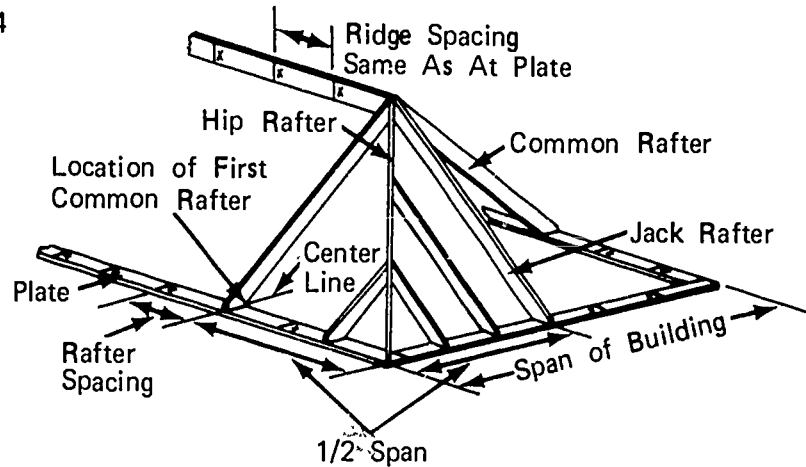

(IMPORTANT: Be sure that the top of the rafters are flush with the top of the ridge board and that the plumb cut of the birdsmouth is snugged up to the outside of the plate.)

- d. Erect the hip rafters following the same procedure given (Figure 15)

FIGURE 15

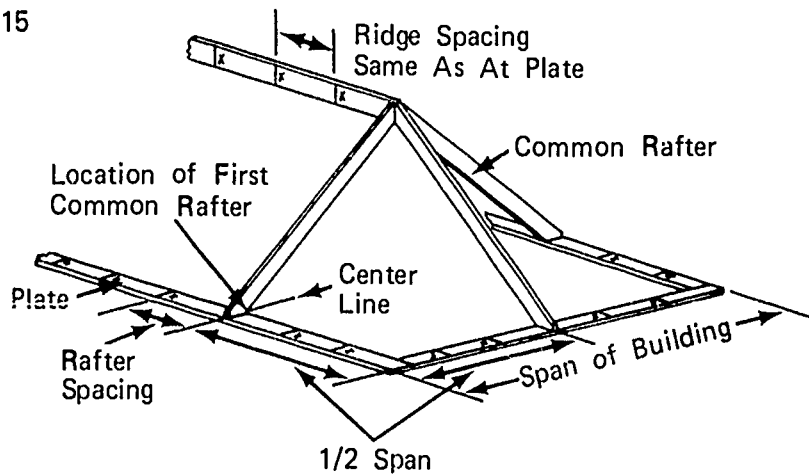

- e. Erect hip jack rafters

- 1) Proceed from the longest to the shortest

JOB SHEET #2

- 2) Do both sides of the hip at the same time (Figure 16)

(NOTE: Nail through the rafter at the cheek. Cut into the hip rafter with 8d box nails.)

(IMPORTANT: Be sure to keep the top of the hip in a straight line from top to bottom.)

FIGURE #16

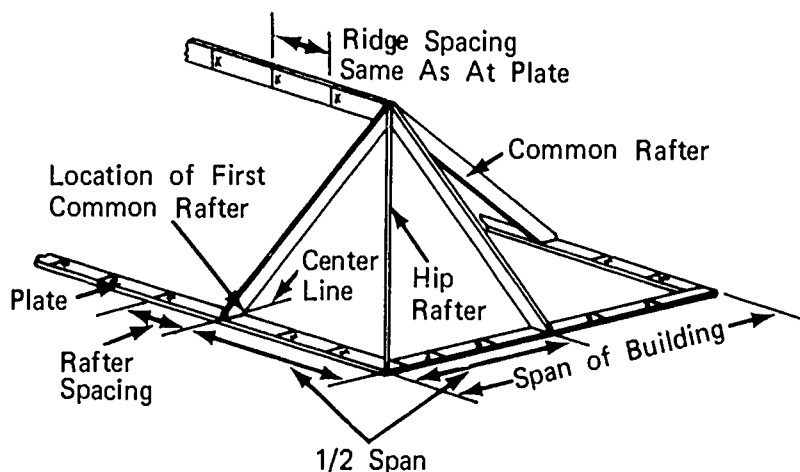

(NOTE: Stretch a string from the top of the hip to the bottom to aid in keeping the hip line straight.)

- f. Erect the remaining rafters following all of the procedures listed

C. Trim rafter tails

1. Determine the amount of overhang desired
 - a. Chalk a line on the top of all rafters to locate the cutting line
 - b. Mark the side of each rafter with the framing square for a square cut end
 - c. Cut rafter tails with the electric handsaw

(NOTE: Erect a platform using saw horses and planks to walk on while cutting.)

(CAUTION: Assume a comfortable and safe position before starting each cut.)

JOB SHEET #2

- D. Nail the false fascia to the ends of all rafters around the perimeter of the house allowing ends on gable roof to extend far enough for barge rafter (Figure 17)

FIGURE 17

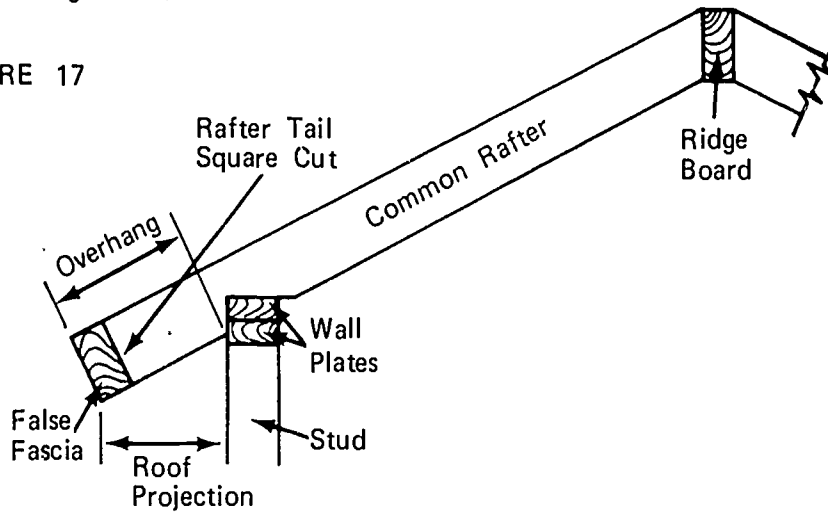

(NOTE: All splices for false fascia must be on rafter ends.)

- E. Install barge rafters on gable roof (Figure 18)

FIGURE 18

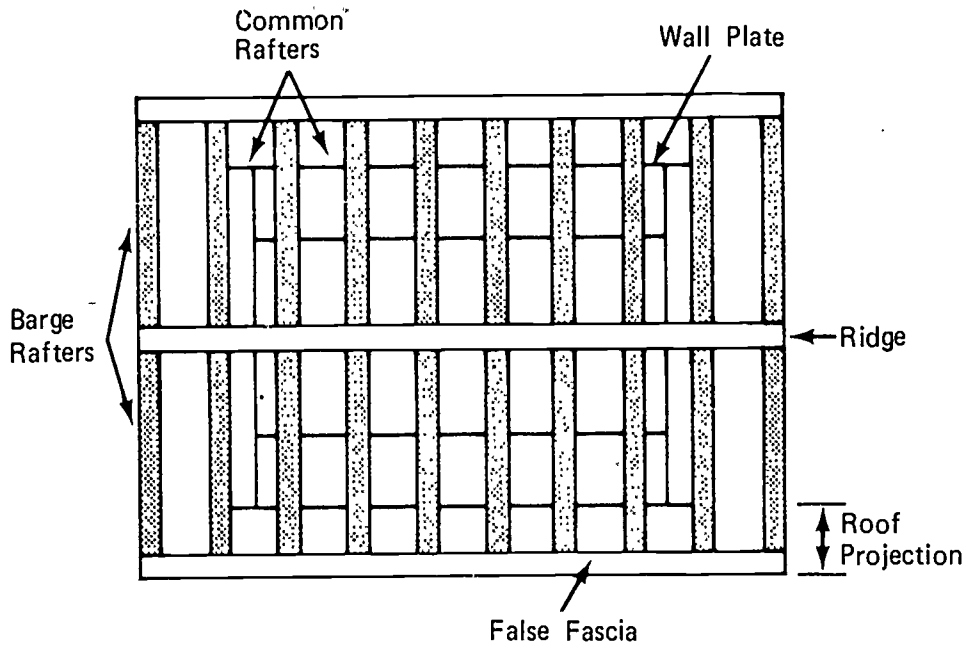

ROOF FRAMING
UNIT III

JOB SHEET #3--APPLY SHEATHING

I. Tools and materials needed

A. Tools

1. Electric handsaw
2. Claw hammer (16 oz or larger)
3. Steel tape (12 or 16 foot)
4. Chalk line and reel

B. Materials

1. See specifications for sheathing material to use
2. Nails as specified for sheathing

II. Procedure

- A. Start first sheathing board flush with the face of the false fascia and flush with the face of the barge rafter (Figure 1)

FIGURE 1

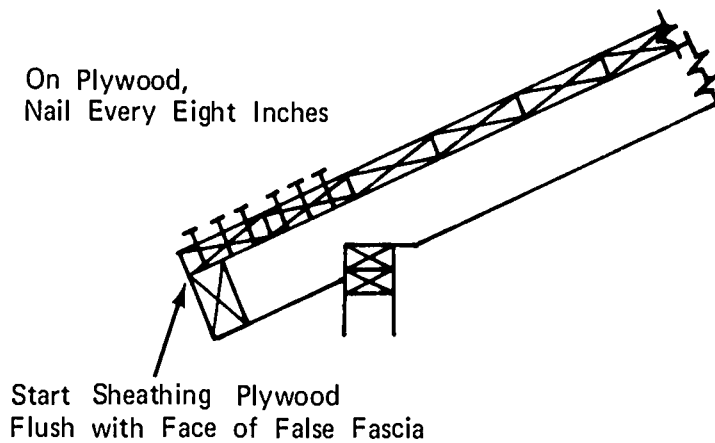

JOB SHEET #3

- B. On a hip roof allow the sheathing to run wild over the hip, chalk a line and cut with electric handsaw
- C. Tack all boards in place, chalk a line on the center of each rafter, and finish nailing

(NOTE: All splices must be made on a rafter with staggered joints.)

- D. Finishing the ridge
 - 1. Run the first side to the center of the ridge
 - 2. Run the opposite side to the center of the ridge (Figure 2)

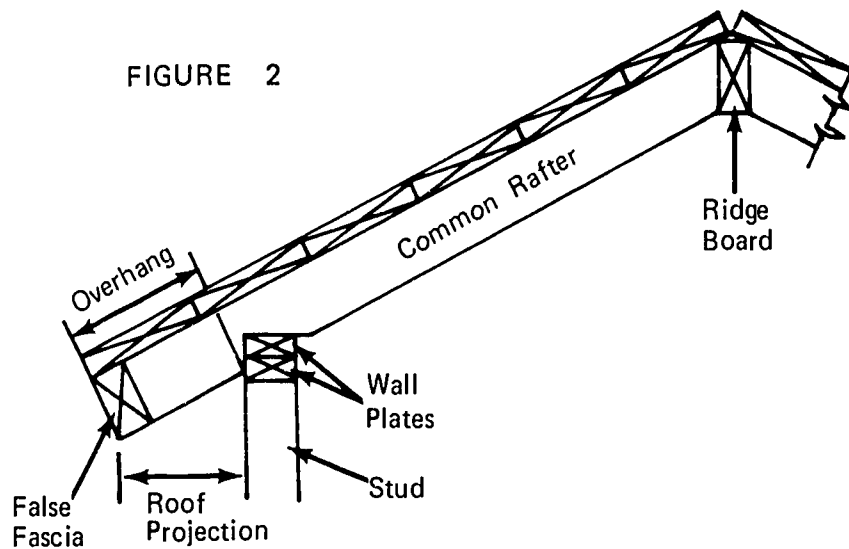

ROOF FRAMING
UNIT III

TEST

1. Match the following roof framing terms to the correct definition.
- | | |
|---|-------------------|
| _____ a. The rafter extending from the double plate at the corner of a building to the ridge forming the angle for a hip roof | 1. Birdsmouth |
| _____ b. A window, vertical in a roof | 2. Collar beam |
| _____ c. A horizontal tie beam connecting two opposite rafters up near the ridge to hold them together at the ridge | 3. Common rafter |
| _____ d. Horizontal timbers supporting the common rafters in roofs | 4. Dormer |
| _____ e. A short rafter which fits between the plate and the hip or valley rafter or between the ridge and hip or valley rafter | 5. Gusset |
| _____ f. The incline or pitch of a roof expressed in terms of inches per one foot of run | 6. Hip rafter |
| _____ g. The angle or degree of slope of a roof | 7. Jack rafter |
| _____ h. One of a series of rafters extending from the double plate to the ridge | 8. Pitch |
| _____ i. An exposed rafter at the end of a gable roof, sometimes called a verge rafter | 9. Plumb cut |
| _____ j. A panel or bracket of either wood or metal attached to the corners at intersections of a frame to add strength and stiffness | 10. Purlin |
| | 11. Ridge board |
| | 12. Rise |
| | 13. Run |
| | 14. Seat cut |
| | 15. Span |
| | 16. Valley rafter |
| | 17. Barge rafter |

- _____ k. The cut at right angles to the seat cut of the birdsmouth and is also the cut of the rafter at the ridge
- _____ l. The horizontal distance that underlies the roof from one exterior wall to the opposite exterior wall
- _____ m. The horizontal member or timber at the top of the roof to which the upper end of the rafters are nailed
- _____ n. The cut at the lower end of a rafter; the part of the birdsmouth that rests on the plate
- _____ o. The horizontal distance that underlies the slope of the roof from a wall to the ridge, usually one-half of the span
- _____ p. A rafter used in an internal angle of a roof to form a valley
- _____ q. A cutout near the bottom of a rafter which fits over the double plate

2. Identify the members in the roof pictured below.

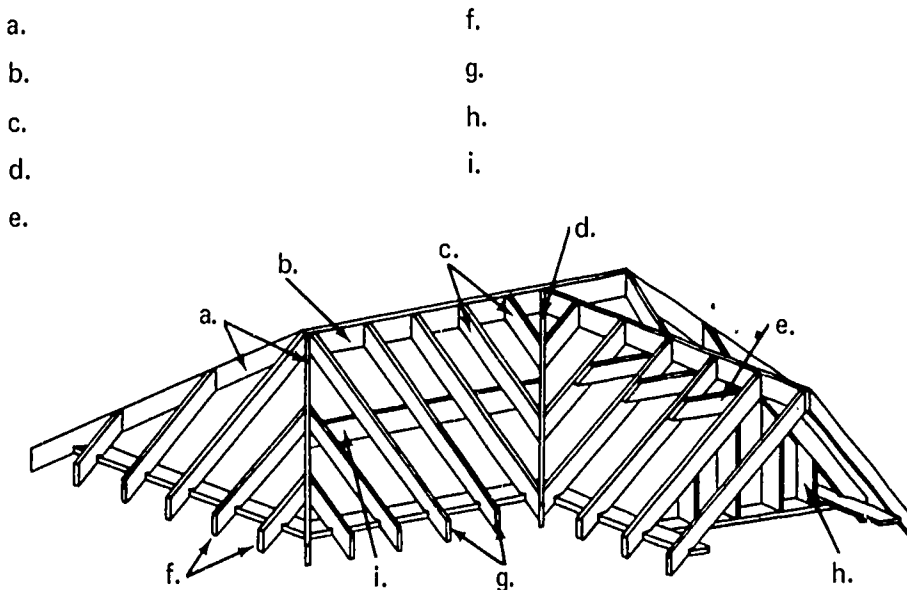

3. Identify the seven roof styles pictured below.

- a.
- b.
- c.
- d.
- e.
- f.
- g.

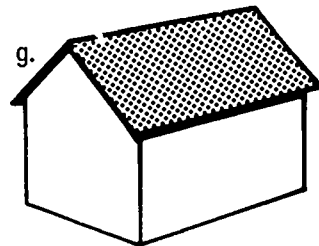
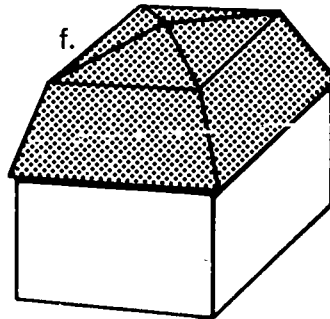
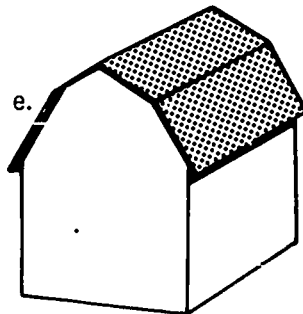
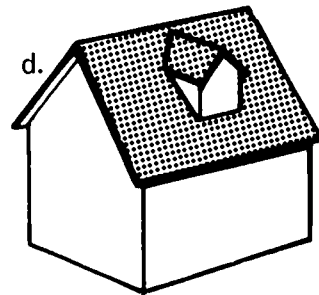
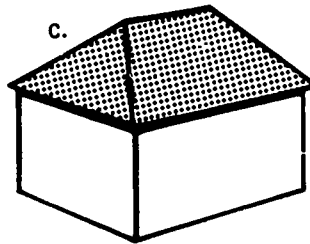
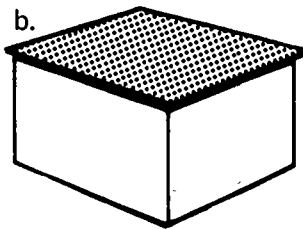
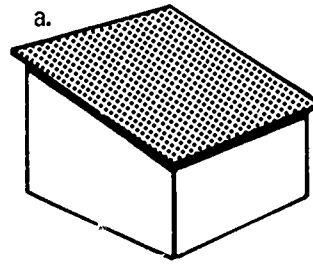

4. Identify the roof framing units pictured below.

- a. _____
- b. _____
- c. _____

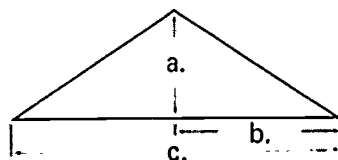

9. Estimate the number of common rafters needed for gable roof on a building twenty-four feet wide and thirty-six feet long with a twenty-four inch roof projection over the eave and gable ends. The rafters are spaced on twenty-four inch centers.
10. Demonstrate the ability to:
- a. Lay out rafter locations on the plate and ridge on two foot centers.
 - b. Lay out, cut, and erect rafters.
 - c. Apply roof sheathing.

(NOTE: If this has not been accomplished prior to the test, ask the instructor when the above activities should be completed.)

ROOF FRAMING
UNIT III

ANSWERS TO TEST

1.
 - a. 6
 - b. 4
 - c. 2
 - d. 10
 - e. 7
 - f. 12
 - g. 8
 - h. 3
 - i. 17
 - j. 5
 - k. 9
 - l. 15
 - m. 11
 - n. 14
 - o. 13
 - p. 16
 - q. 1

2.
 - a. Hip rafters
 - b. Ridge board
 - c. Valley jacks
 - d. Valley rafter
 - e. Collar beam
 - f. Hip jacks

- g. Common rafters
- h. Gable stud
- i. Purlins
- 3.
 - a. Shed or lean to
 - b. Flat
 - c. Hip
 - d. Gable with dormer
 - e. Gambrel
 - f. Mansard
 - g. Gable
- 4.
 - a. Run
 - b. Rise
 - c. Span
- 5.
 - a. Rafter slide rule
 - b. Framing square step-off method
 - c. Pythagorean theorem
 - d. Rafter tables from framing square
- 6. 15' 7 1/2"
- 7. 21' 0"
- 8. 8' 8"
- 9. 42
- 10. Performance skills will be evaluated according to the criteria listed on the progress chart.

TRUSSES UNIT IV

TERMINAL OBJECTIVE

After completion of this unit, the student should be able to identify the members of a truss and hardware used in truss construction. He should also be able to name various types of trusses and methods of fabrication. This knowledge will be evidenced by scoring eighty-five percent on the unit test.

SPECIFIC OBJECTIVES

After completion of this unit, the student should be able to:

1. Match terms associated with trusses to the correct definition.
2. Identify five main parts of a truss.
3. Identify seven pieces of hardware used in truss construction.
4. Match nine types of trusses to their correct name.
5. Name four methods of fabricating trusses.

TRUSSES
UNIT IV

SUGGESTED ACTIVITIES

- I. Instructor:
 - A. Provide students with objective sheet.
 - B. Provide students with information sheet.
 - C. Make transparencies.
 - D. Discuss terminal and specific objectives.
 - E. Discuss information sheet.
 - F. Give test.
- II. Student:
 - A. Read objective sheet.
 - B. Study information sheet.
 - C. Take test.

INSTRUCTIONAL MATERIALS

- I. Included in this unit:
 - A. Objective sheet
 - B. Information sheet
 - C. Transparency masters
 1. TM 1--Main Parts of a Truss
 2. TM 2--Hardware Used in Truss Construction
 3. TM 3--Types of Trusses
 4. TM 4--Split Ring Connectors and Bolt Fabrication
 5. TM 5--Toothed Ring Connector and Bolt Fabrication
 6. TM 6--Gusset Fabrication

D. Test

E. Answers to test

II. References:

- A. Burke, Arthur E., J. Ralph Dalzell, and Gilbert Townsend. *Architectural and Building Trades Dictionary*. Chicago, Illinois: American Technical Society, 1955.
- B. Smith, Ronald C. *Principles and Practices of Heavy Construction*. Englewood Cliffs, New Jersey: Prentice Hall, Inc., 1970.
- C. Ramsey, Charles G. and Harold R. Sleeper. *Architectural Graphic Standards*. New York: John Wiley and Sons Inc., 1970.

TRUSSES
UNIT IV

INFORMATION SHEET

I. Terms and definitions

- A. Truss--A combination of members, such as top chord, bottom chord, compression webs, and tension webs usually arranged in triangular units for a rigid framework, for supporting loads over a long span as in bridge or roof construction
- B. Top chord--Upper member of a truss
- C. Bottom chord--Bottom member of a truss
- D. Tension web--A member connecting the top and bottom chords in tension
- E. Compression web--A member connecting the top and bottom chords of a truss in compression
- F. Gang-nail connector plate--A steel plate from which a number of uniform nails have been stamped out to protrude at right angles from the plate itself

(NOTE: Gang-nail connector plates are also called gang-nails. Gang-nail connector plates are a patented product of ABC Inc.)

- G. Split ring--A steel ring with a tongue and grooved split in the band used to strengthen wood to wood connections in timber

(NOTE: A groove must be cut in the timber for installation.)

- H. Toothed ring--A thin steel ring, corrugated and toothed, which is pressed into two wood members to strengthen the connection
- I. Glue-laminated timbers--Timbers built up of thin pieces of lumber glued together and sometimes sprung to desired shaped before glueing
- J. Gusset--A brace or angular bracket used to stiffen a corner or angular intersection of two or more members
- K. Component--A subdivision of a unit
- L. Component yard--A yard or mill specializing in the fabrication of components of a building

II. Main parts of a truss (Transparency 1)

- A. Top chord
- B. Bottom chord
- C. Tension web

INFORMATION SHEET

- D. Compression web
 - E. Gang-nail connector plate
- III. Hardware used on trusses (Transparency 2)
- A. Split ring
 - B. Toothed ring
 - C. Gang-nail connector plate
 - D. Shear plate
 - E. Machine bolt
 - F. Plate washer
 - G. Malleable washer
- IV. Types of trusses (Transparency 3)
- (NOTE: Trusses can be built to fit most situations. This is a group of the most common types. All trusses may be glue-laminated.)
- A. Standard howe truss
 - B. Hip louver truss
 - C. Double W truss
 - D. Modified queenpost truss
 - E. Bowstring truss
 - F. Scissors truss
 - G. Flat truss (Howe)
 - H. Flat truss (Warren)
 - I. Hip truss
- V. Methods of fabrication (Transparencies 4, 5, and 6)
- A. Gang-nailed
- (NOTE: Trusses using this method are generally manufactured in a component yard.)
- B. Split ring connector and bolt
 - C. Toothed ring connector and bolt
 - D. Gusseted

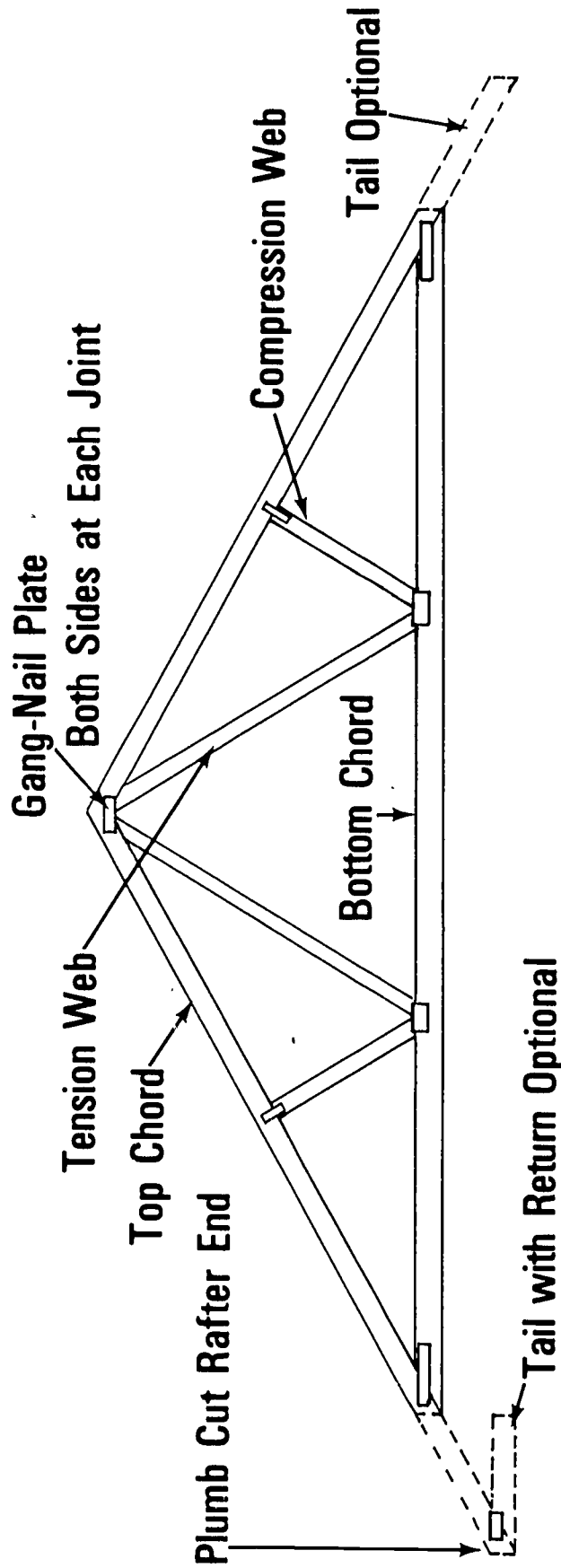

Main Parts of a Truss

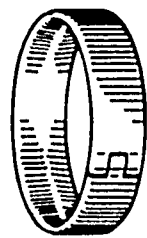

Split Ring

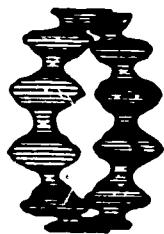

Toothed Ring Connector

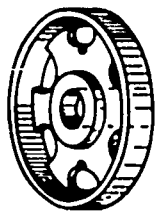

Shear Plate

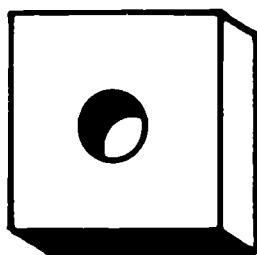
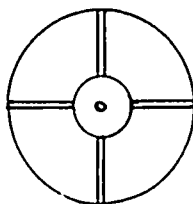

Plate Washer



Malleable Washers



Machine Bolt

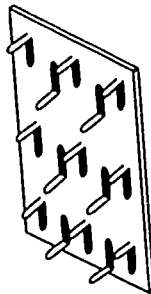

Gang Nail Plate

Hardware Used in Truss Construction

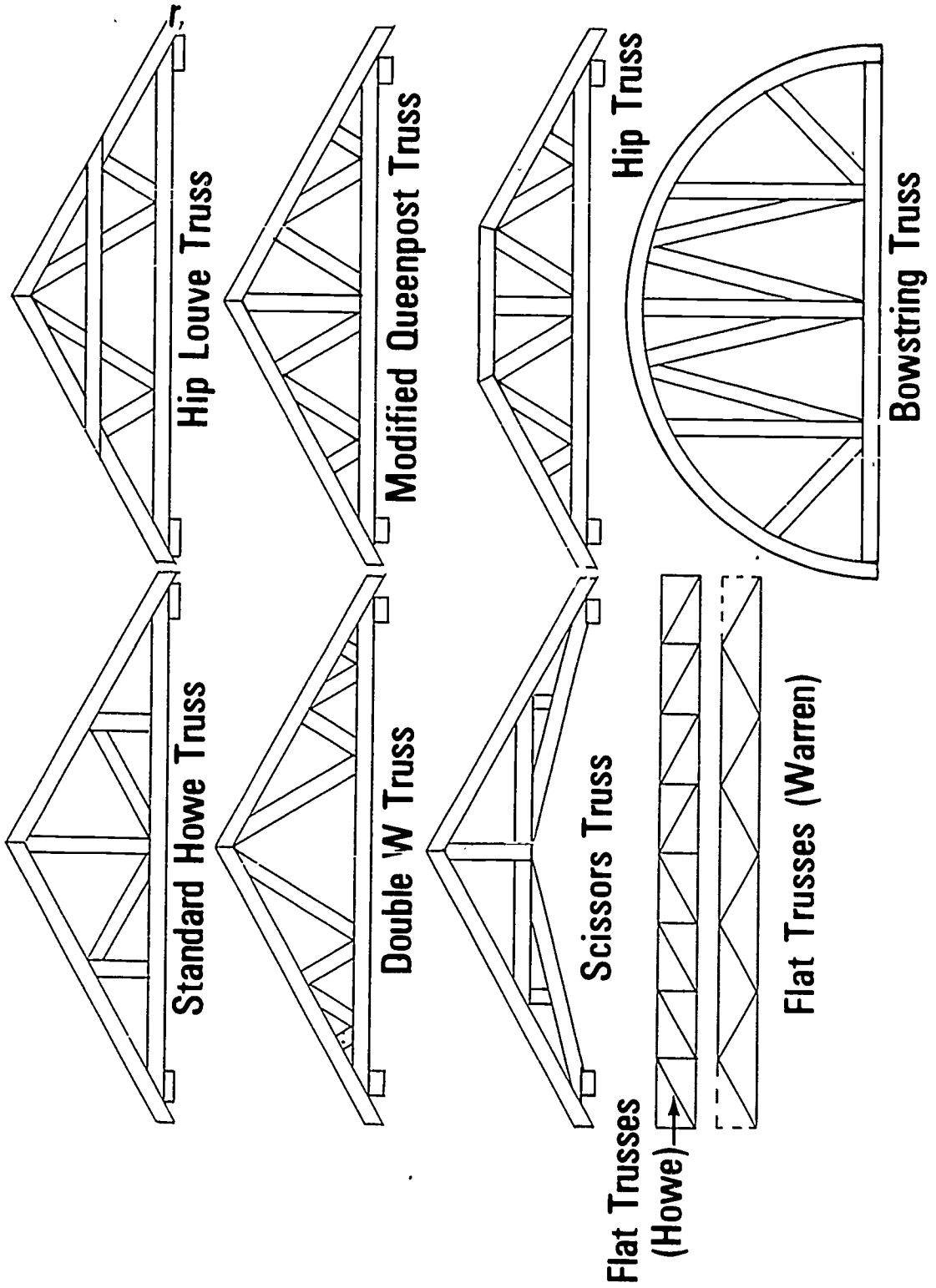

Types of Trusses

Split Ring Connectors and Bolt Fabrication

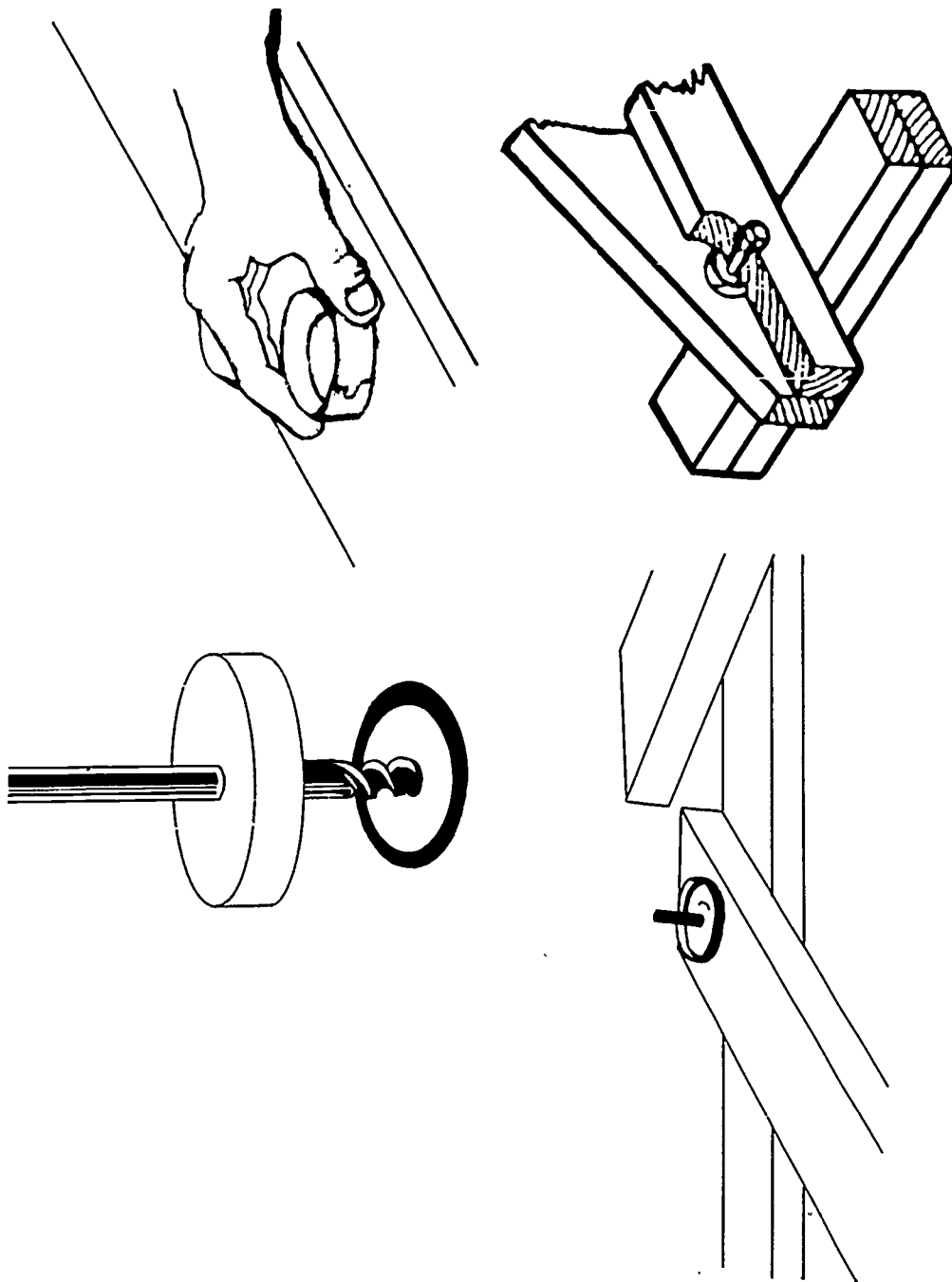

Bolt Assembly for Embedding Toothed Ring

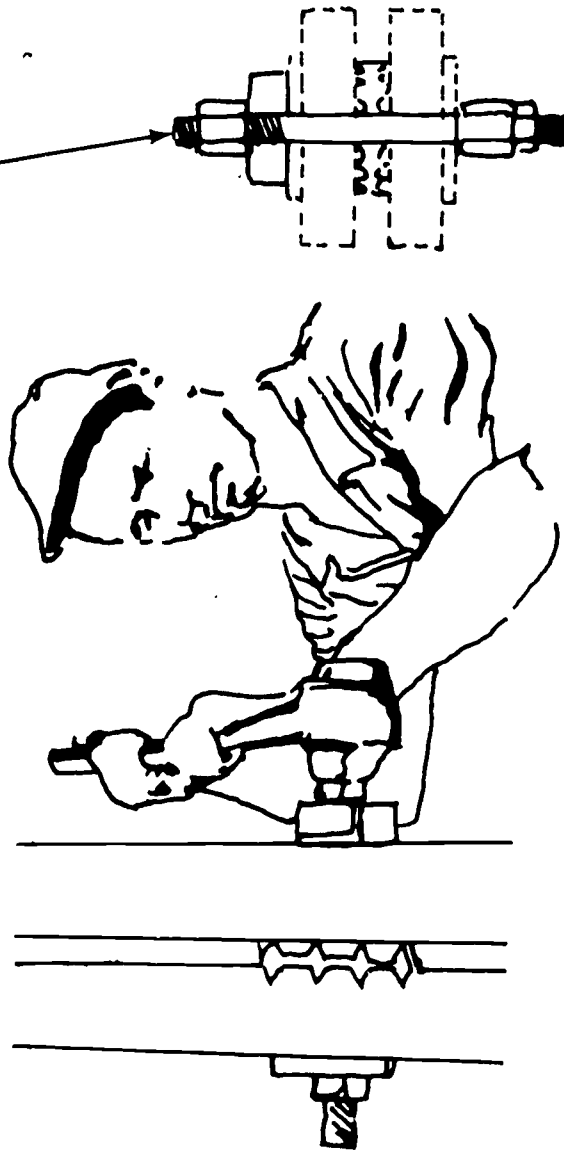

Toothed Ring Connector and Bolt Fabrication

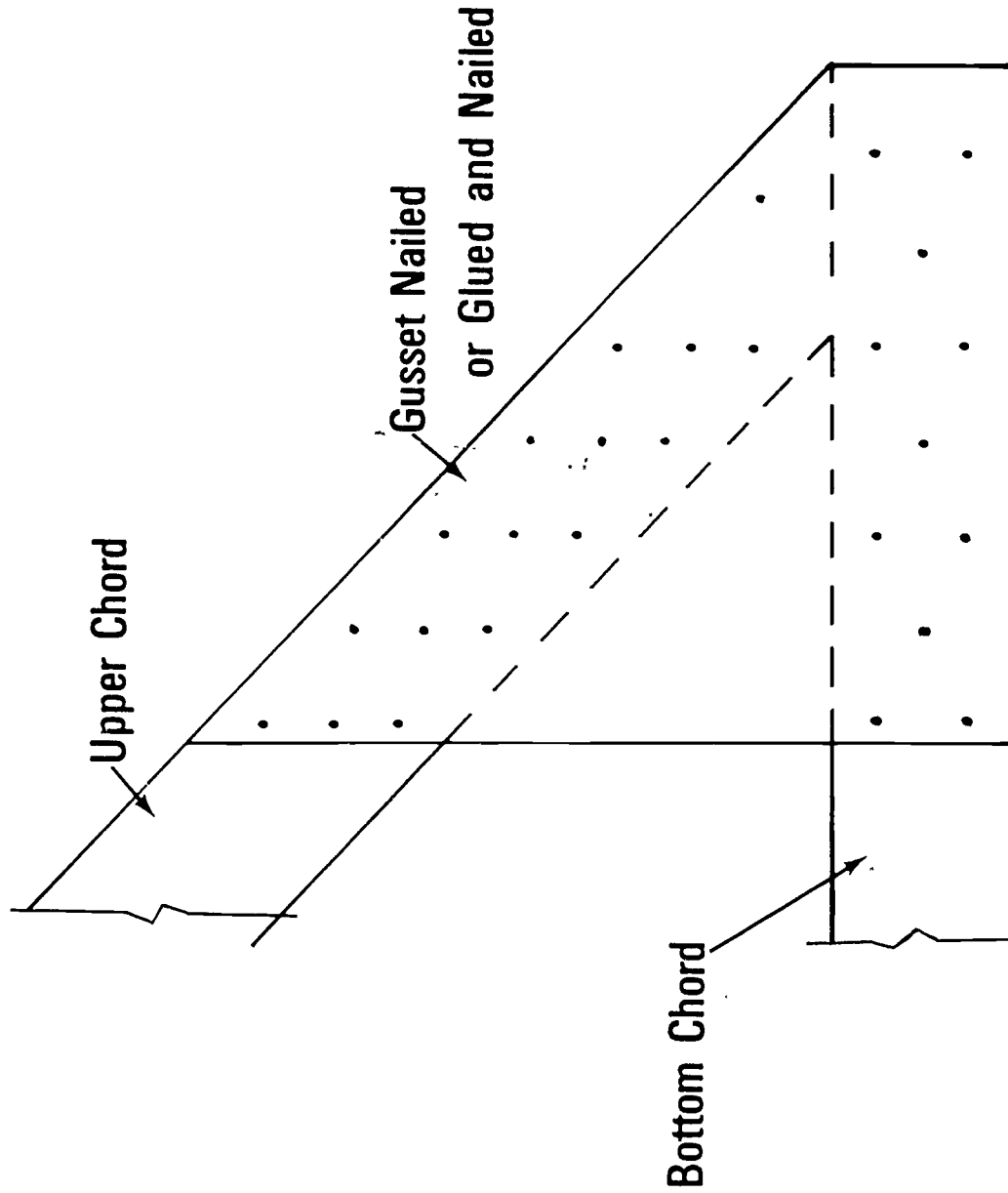

Gusset Fabrication

TRUSSES
UNIT IV

TEST

1. Match the following list of terms to the correct definitions.

- | | |
|--|--|
| <p>_____ a. A yard or mill specializing in the fabrication of components of a building</p> <p>_____ b. A member connecting the top and bottom chords in tension</p> <p>_____ c. A brace or angular bracket used to stiffen a corner or angular intersection of two or more members</p> <p>_____ d. A steel ring with a tongue and grooved split in the band used to strengthen wood to wood connections in the timber</p> <p>_____ e. A member connecting the top and bottom chords of a truss in compression</p> <p>_____ f. A subdivision of a unit</p> <p>_____ g. Timbers built up of thin pieces of lumber glued together and sometimes sprung to the desired shapes before glueing</p> <p>_____ h. A combination of members such as top chord, bottom chord, compression webs, and tension webs usually arranged in triangular units for a rigid framework for supporting loads over a long span as in bridge or roof construction</p> <p>_____ i. A steel plate from which a number of uniform nails have been stamped out to protrude at right angles from the plate itself</p> <p>_____ j. Bottom member of a truss</p> | <p>1. Truss</p> <p>2. Top chord</p> <p>3. Bottom chord</p> <p>4. Tension web</p> <p>5. Compression web</p> <p>6. Gang-nail connector plate</p> <p>7. Split ring</p> <p>8. Toothed ring</p> <p>9. Glue-laminated timbers</p> <p>10. Gusset</p> <p>11. Component</p> <p>12. Component yard</p> |
|--|--|

_____ k. A thin steel ring, corrugated and toothed, which is pressed into two wood members to strengthen the connection

_____ l. Upper member of a truss

2. Identify the five main parts of a truss.

- a.
- b.
- c.
- d.
- e.

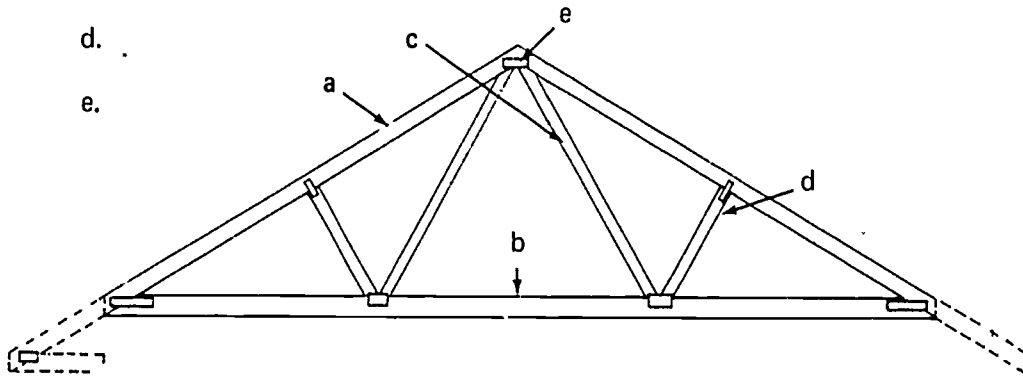

3. Identify the seven pieces of truss hardware shown below.

- a.
- b.
- c.
- d.
- e.
- f.
- g.

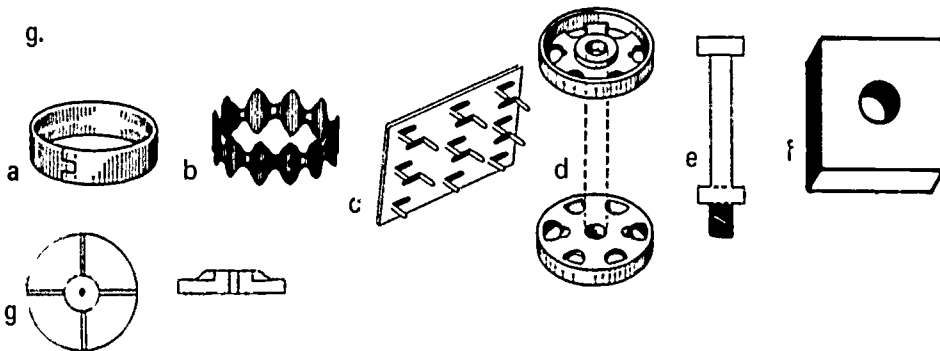

4. Match nine types of trusses to their correct name.

- _____ a. Standard howe
- _____ b. Hip louver
- _____ c. Double W
- _____ d. Modified queenpost
- _____ e. Bowstring
- _____ f. Scissors
- _____ g. Flat (Howe)
- _____ h. Flat (Warren)
- _____ i. Hip

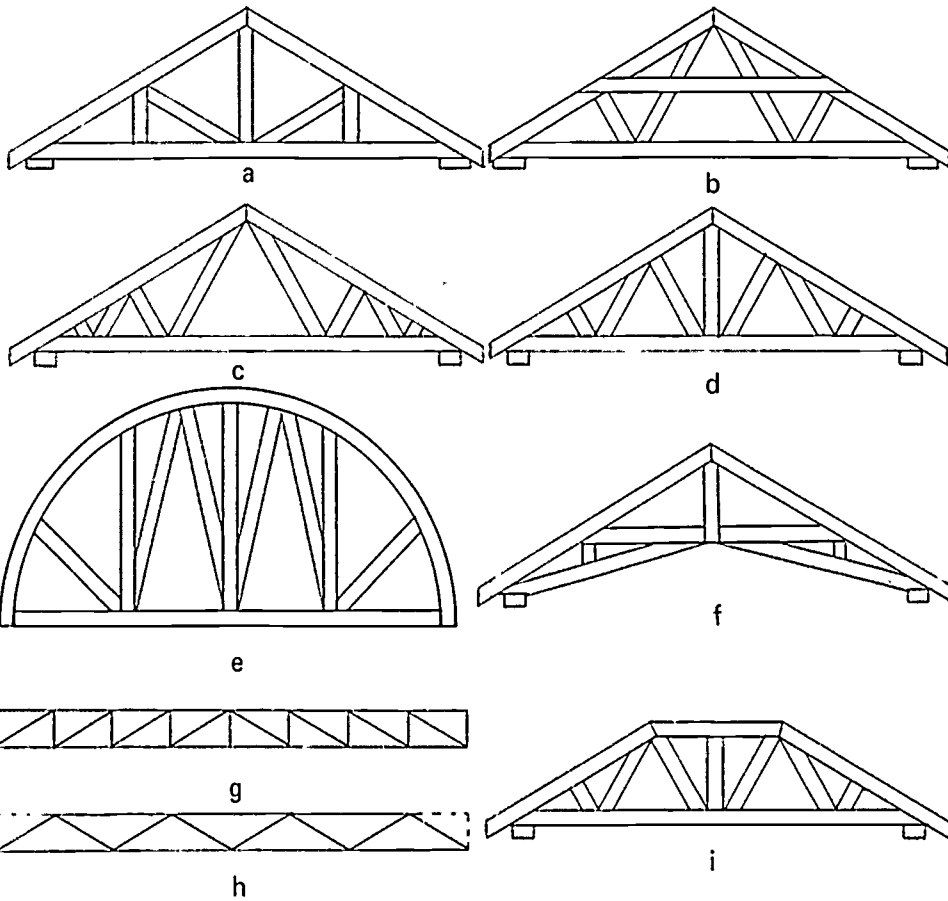

5. Name four methods of fabricating trusses.

a.

b.

c.

d.

TRUSSES
UNIT IV

ANSWERS TO TEST

1.
 - a. 12
 - b. 4
 - c. 10
 - d. 7
 - e. 5
 - f. 11
 - g. 9
 - h. 1
 - i. 6
 - j. 3
 - k. 8
 - l. 2
2.
 - a. Top chord
 - b. Bottom chord
 - c. Tension web
 - d. Compression web
 - e. Gang-nail connector plate
3.
 - a. Split ring
 - b. Toothed ring
 - c. Gang-nail connector plate
 - d. Shear plate
 - e. Machine bolt
 - f. Plate washer
 - g. Malleable washer

- 4. a. 8
- b. 6
- c. 9
- d. 3
- e. 4
- f. 2
- g. 5
- h. 1
- i. 7

- 5. The following answers may be given in any order.
 - a. Gang-nailed
 - b. Split ring connector and bolt
 - c. Toothed ring connector and bolt
 - d. Gusseted

STRUCTURAL TIMBER CONSTRUCTION UNIT V

TERMINAL OBJECTIVE

After completion of this unit, the student should be able to match terms associated with structural timber construction to the correct definitions, identify structural components, list types of buildings, list factors that determine the size of timbers, and identify connecting devices and hardware items. This knowledge will be evidenced by scoring eighty-five percent on the unit test.

SPECIFIC OBJECTIVES

After completion of this unit, the student should be able to:

1. Match terms associated with structural timber framing to the correct definitions.
2. List the types of buildings in which structural timber construction is used.
3. Identify the basic components used in structural timber construction.
4. List four factors that have contributed to the more efficient use of structural timber in modern construction.
5. List four factors that determine the size of the components in structural timber construction.
6. Identify ten connecting devices used with structural timbers.
7. Identify five hardware items used in structural timber construction.
8. Identify three types of decking or planking.

STRUCTURAL TIMBER CONSTRUCTION UNIT V

SUGGESTED ACTIVITIES

- I. Instructor:
 - A. Provide students with objective sheet.
 - B. Provide students with information sheet.
 - C. Make transparencies.
 - D. Discuss terminal and specific objectives.
 - E. Discuss information sheet.
 - F. Give test.
- II. Student:
 - A. Read objective sheet.
 - B. Study information sheet.
 - C. Take test.

INSTRUCTIONAL MATERIALS

- I. Included in this unit:
 - A. Objective sheet
 - B. Information sheet
 - C. Transparency masters
 1. TM 1--Components of Structural Timber Construction
 2. TM 2--Connecting Devices
 3. TM 3--Connecting Devices (Continued)
 4. TM 4--Connecting Devices (Continued)
 5. TM 5--Connecting Devices (Continued)
 6. TM 6--Connecting Devices (Continued)
 7. TM 7--Hardware Items
 8. TM 8--Types of Decking

- D. Test
- E. Answers to test

II. References:

- A. Burke, Arthur E., J. Ralph Dalzell, and Gilbert Townsend. *Architectural and Building Trades Dictionary*. Chicago, Illinois: American Technical Society, 1955.
- B. Smith, Ronald C. *Principles and Practices of Heavy Construction*. Englewood Cliffs, New Jersey: Prentice Hall, Inc., 1970.
- C. Ramsey, Charles G. and Harold R. Sleeper. *Architectural Graphic Standards*. New York: John Wiley and Sons Inc.

STRUCTURAL TIMBER CONSTRUCTION
UNIT V

INFORMATION SHEET

- I. Terms and definitions
 - A. Heavy timber construction--A type of construction whose structural system is composed of solid stock or glue-laminated timbers which offer a significant degree of fire resistance by limiting the minimum cross sectional dimension of members and decking
 - B. Wood beam--Timber or glue-laminated members used in a horizontal position to transfer floor or roof loads to the columns
 - C. Decking--Any lumber generally 2" or thicker laid as the roof or floor of a structure
 - D. Connection--A mechanical means of connecting timbers to each other or to a fixed object
 - E. Split ring--A steel ring with a tongue and grooved split in the band
 - F. Shear plate--A round steel plate used primarily for connecting wood to non-wood
 - G. Wood column--Timbers or glue-laminated timbers used in vertical position to support beams
- II. Types of buildings in which structural timber construction is used
 - A. Industrial
 - B. Commercial
 - C. Institutional
- III. Components used in structural timber construction (Transparency 1)
 - A. Columns
 - B. Beams
 - C. Decking or planking
 - D. Column cap or capitol
 - E. Ledgers

INFORMATION SHEET

- IV. Factors contributing to efficient use of structural timber
 - A. Development and refinement of stress graded timber, both solid and glue-laminated
 - B. Production of modern types of timber connectors
 - C. Full recognition of fire resistance of large timber sections
 - D. Use of preservatives to help timber withstand the deteriorating effects of moisture, disease, and insects
- V. Factors determining size of components in structural timber construction
 - A. Load
 - B. Span of
 - 1. Girders
 - 2. Beams
 - 3. Decking
 - C. Unsupported height of columns
 - D. Grade and species of timber
- VI. Connecting devices used with structural timber (Transparencies 2, 3, 4, 5, and 6)
 - A. Metal angle
 - B. Shear plate
 - C. Wood splice plate (with bolt)
 - D. Metal splice plate (with bolt)
 - E. Metal shoe
 - F. Metal hanger
 - G. Metal strap and shear plate
 - H. Column cap
 - I. Lateral tie
 - J. Split ring

INFORMATION SHEET

VII. Hardware items used in structural timber construction (Transparency 7)

- A. Anchor bolts
- B. Lag screws
- C. Machine bolts
- D. Washers
 - 1. Plate
 - 2. Malleable
- E. Spikes--20d 80d

VIII. Types of decking or planking (Transparency 8)

(NOTE: Three and four inch decking may be pre-drilled for horizontal nailing.)

- A. Tongue and grooved
 - 1. 2"
 - 2. 3"
 - 3. 4"
- B. Groove and spline
- C. Laminated deck (Job site spiking or glue-laminated)

Components of Structural Timber Construction

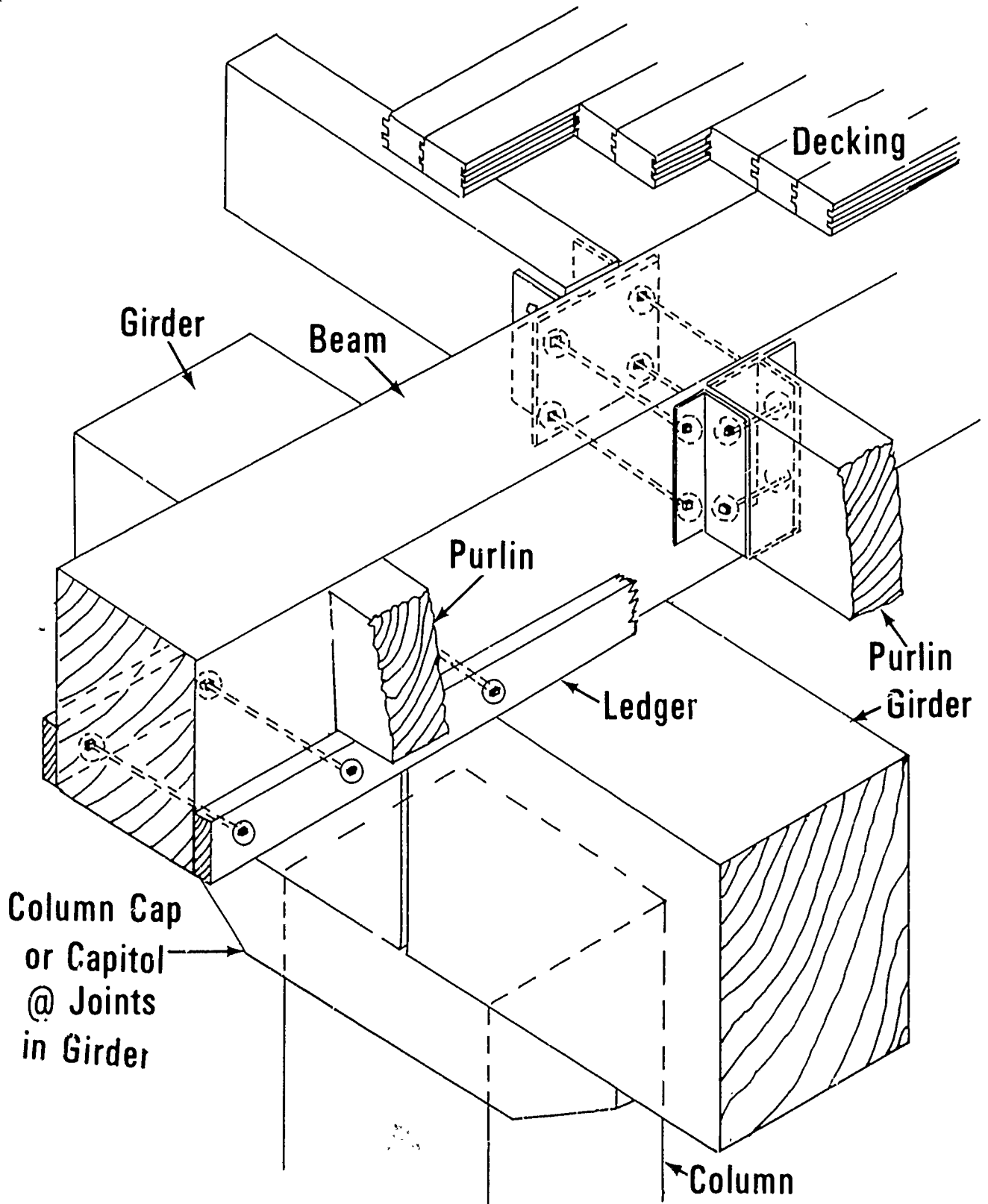

Connecting Devices

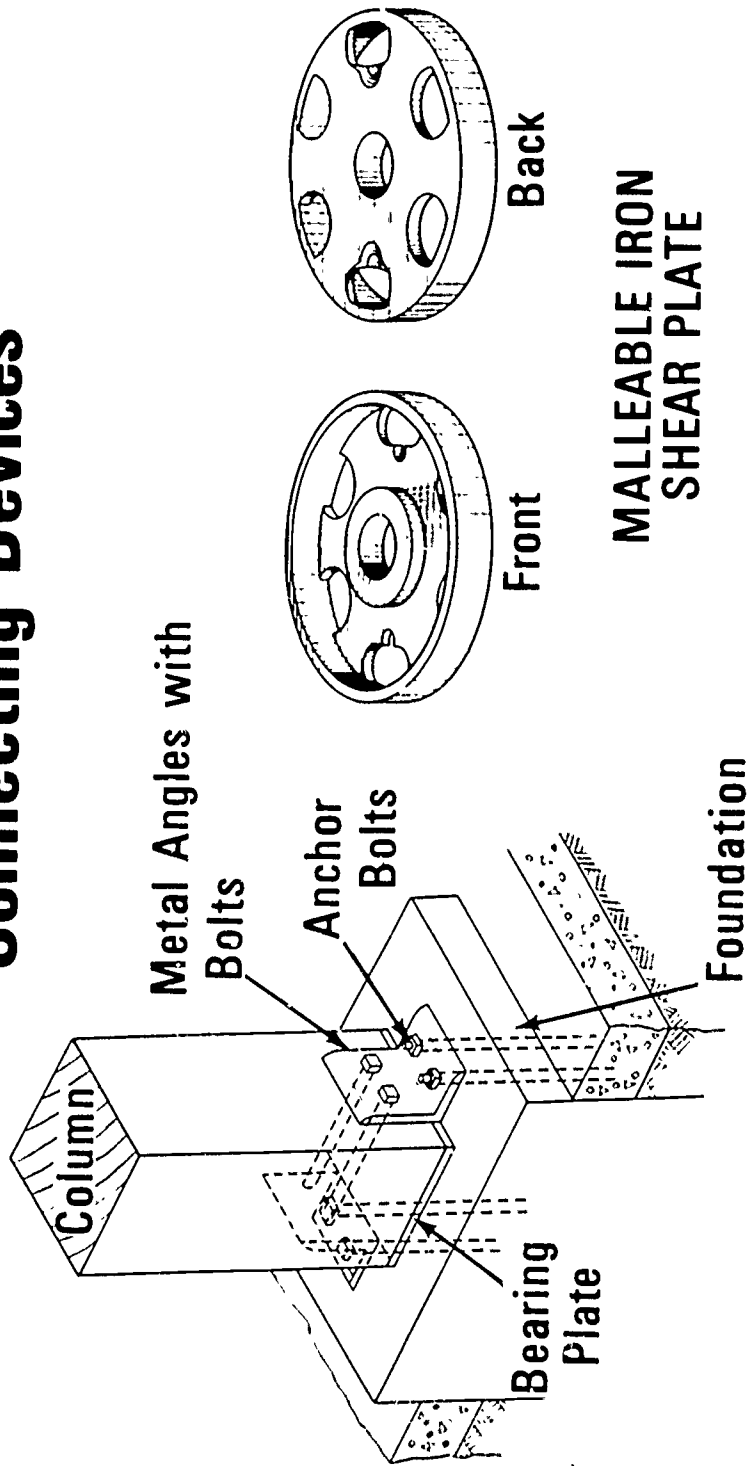

Connecting Devices

(Continued)

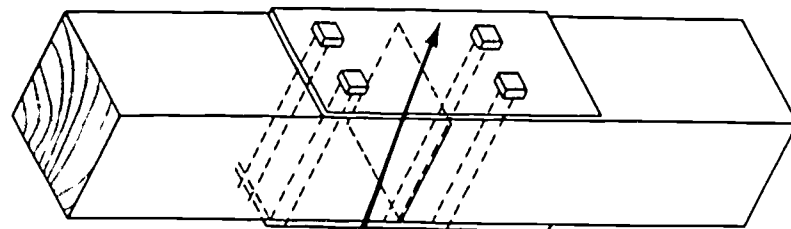

Metal Splice Plate

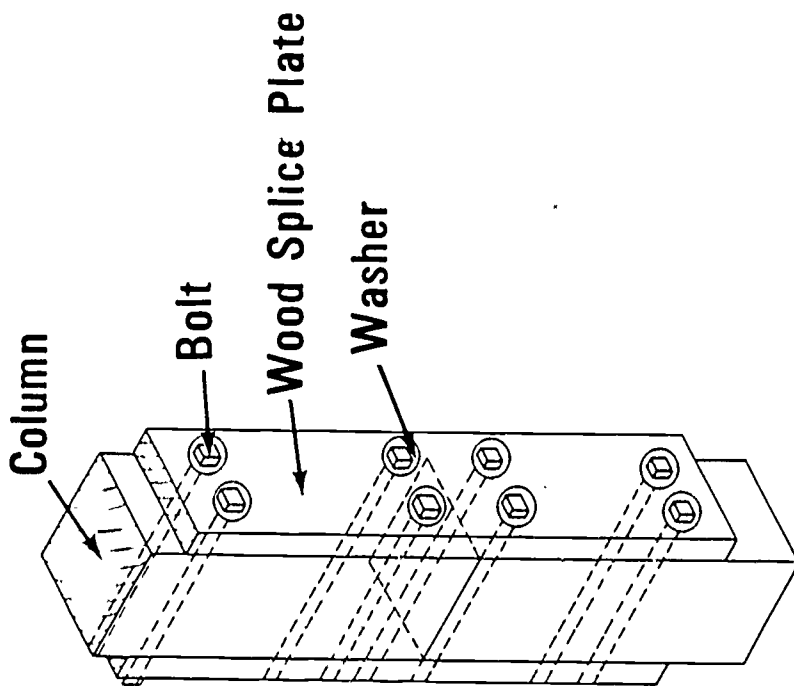

WOOD SPLICE PLATE

Connecting Devices

(Continued)

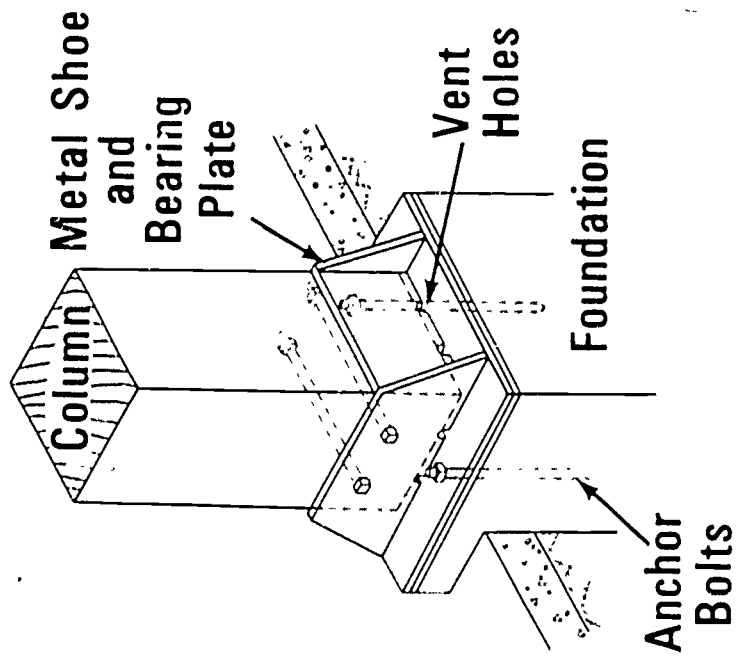

METAL SHOE CONNECTION

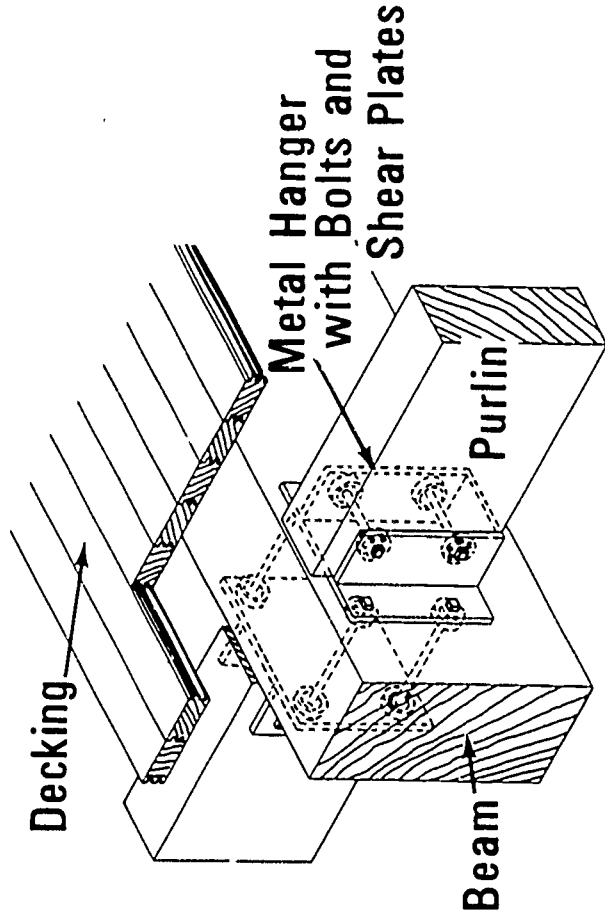

METAL HANGERS

Connecting Devices

(Continued)

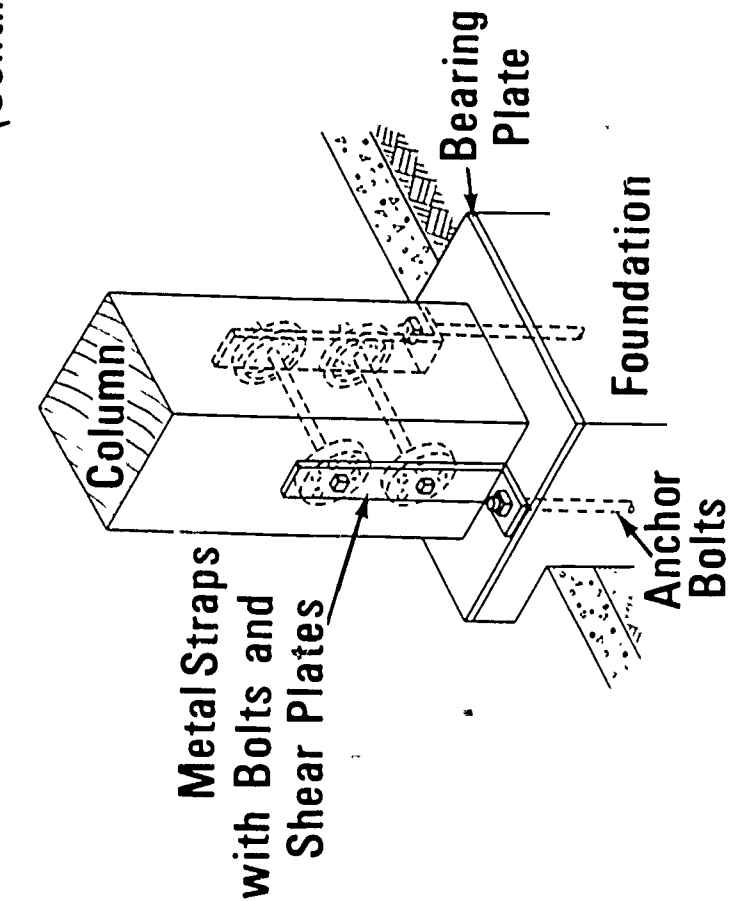

Metal Strap and Shear Plate Connection

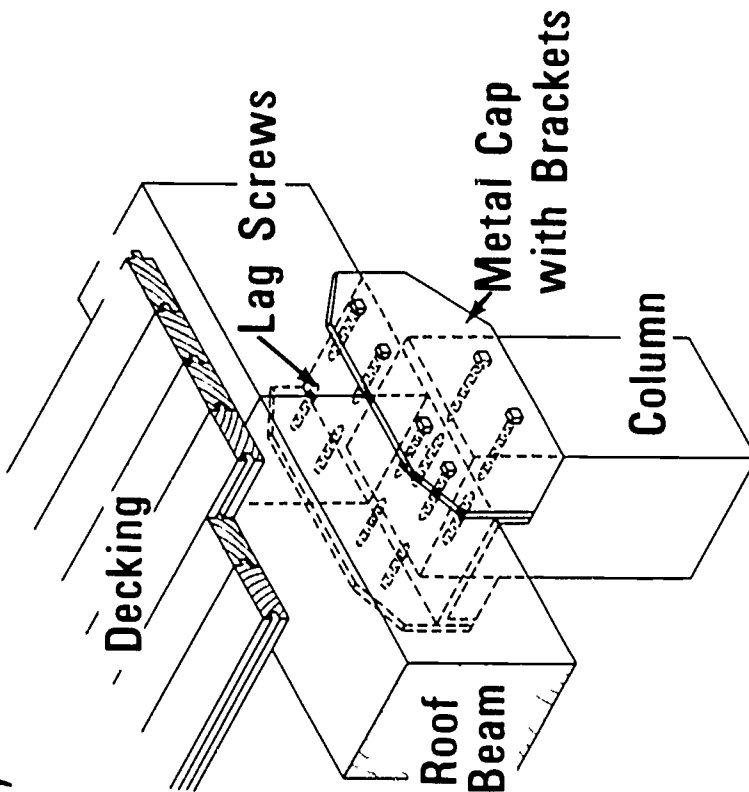

COLUMN CAP

Connecting Devices (Continued)

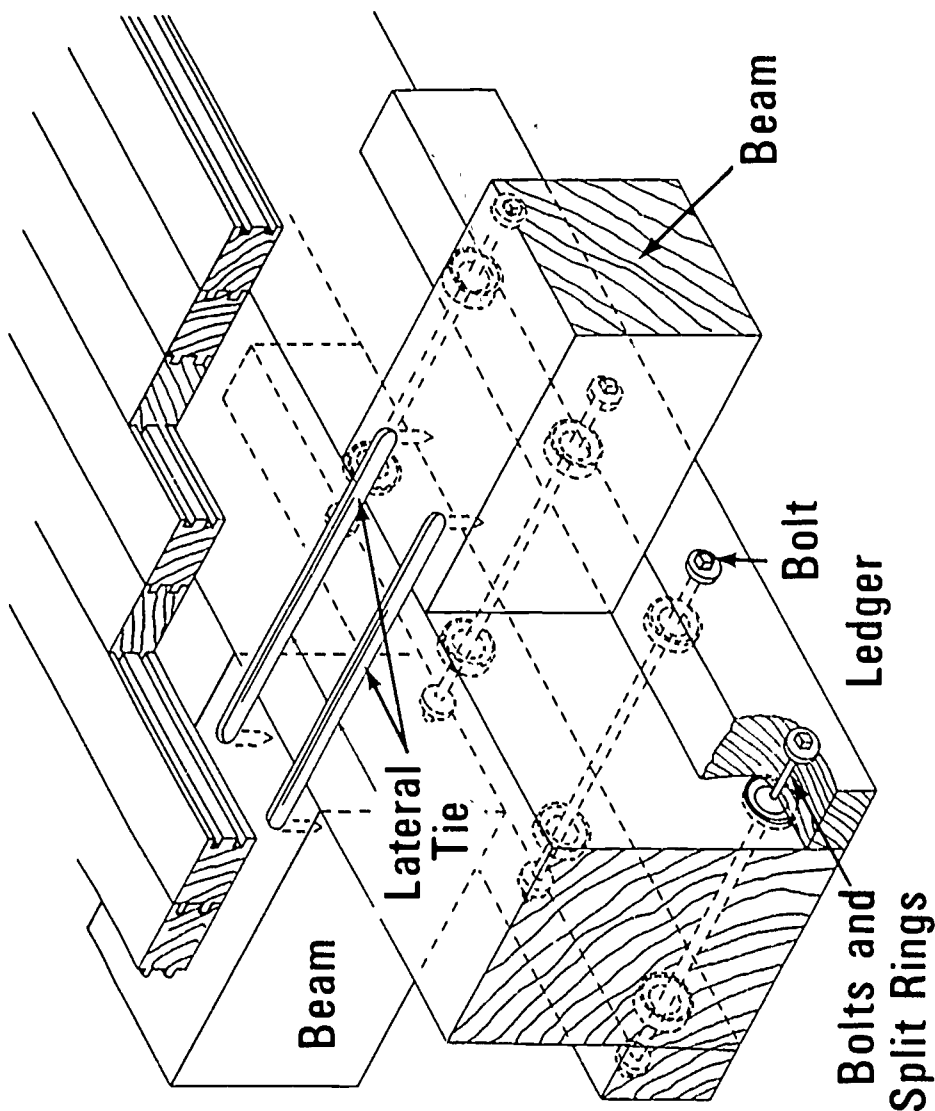

LATERAL TIES AND SPLIT RINGS

Hardware Items

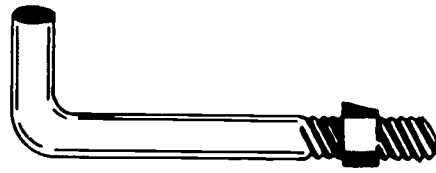

Anchor Bolt

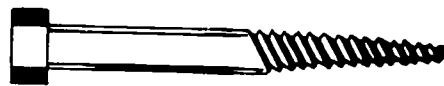

Lag Screw

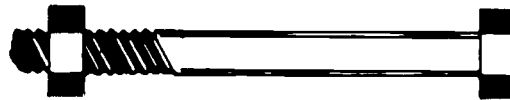

Machine Bolt

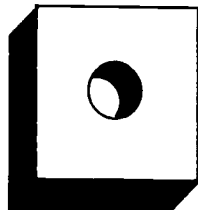
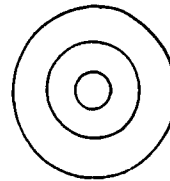
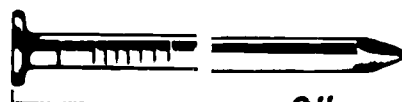

Plate Washer



Malleable Washer



20d

6"



80d

8"

Spikes

Types of Decking

TONGUE AND GROOVED



2"



3"



4"

Pre-Drilled for Horizontal Spiking



GROOVED FOR SPLINE

Types of Planking

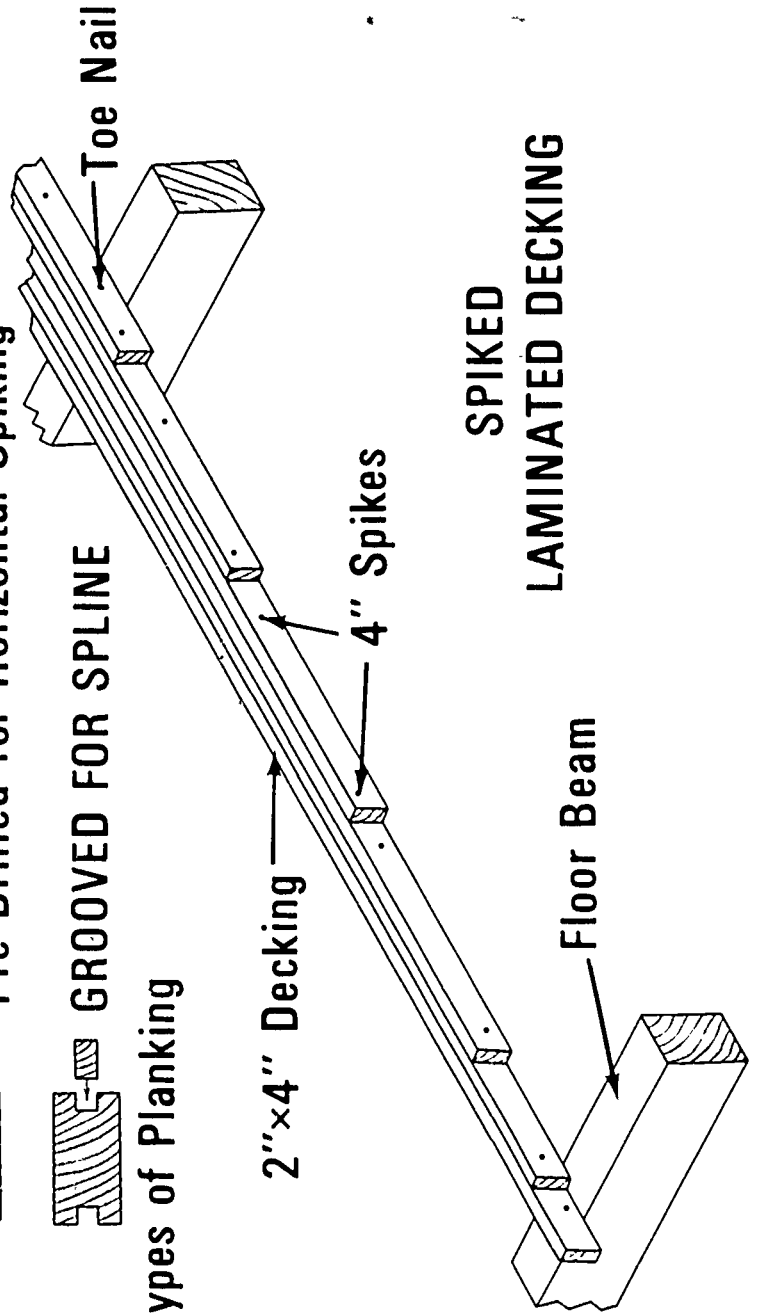

SPIKED
LAMINATED DECKING

STRUCTURAL TIMBER CONSTRUCTION
UNIT V

TEST

1. Match the following list of terms to the correct definition.

- | | |
|---|------------------------------|
| _____ a. A round steel plate used primarily for connecting wood to non-wood | 1. Wood column |
| _____ b. A type of construction whose structural system is composed of solid stock or glue-laminated timbers which offer a significant degree of fire resistance by limiting the minimum cross sectional dimension of members and decking | 2. Wood beam |
| _____ c. A mechanical means of connecting timbers to each other or to a fixed object | 3. Decking |
| _____ d. Timber or glue-laminated members used in a horizontal position to transfer floor or roof loads to columns | 4. Connection |
| _____ e. Timbers or glue-laminated timbers used in vertical position to support beams | 5. Split ring |
| _____ f. A steel ring with a tongue and grooved split in the band | 6. Shear plate |
| _____ g. Any lumber generally 2" or thicker laid as the floor or roof of a structure | 7. Heavy timber construction |

2. List the types of buildings in which structural timber construction is used.
- a.
- b.
- c.

3. Identify the basic components of structural timber construction in the illustration below by placing the correct numbers in the blanks provided.

- _____ a. Column
- _____ b. Beam
- _____ c. Decking or planking
- _____ d. Column cap or capitol
- _____ e. Ledger

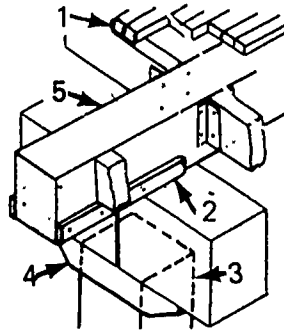

4. List four factors that have contributed to the more efficient use of structural timber in modern construction.

- a.
- b.
- c.
- d.

5. List four factors that determine the size of the components in structural timber construction.

- a.
- b.
- c.
- d.

6. Identify the ten connecting devices in the illustration below that are used with structural timbers by placing the correct numbers in the blanks provided.

- ___ a. Metal angle
- ___ b. Shear plate
- ___ c. Wood splice plate (with bolt)
- ___ d. Metal splice plate (with bolt)
- ___ e. Metal shoe
- ___ f. Metal hanger
- ___ g. Metal strap and shear plate
- ___ h. Lateral tie
- ___ i. Column cap
- ___ j. Split ring

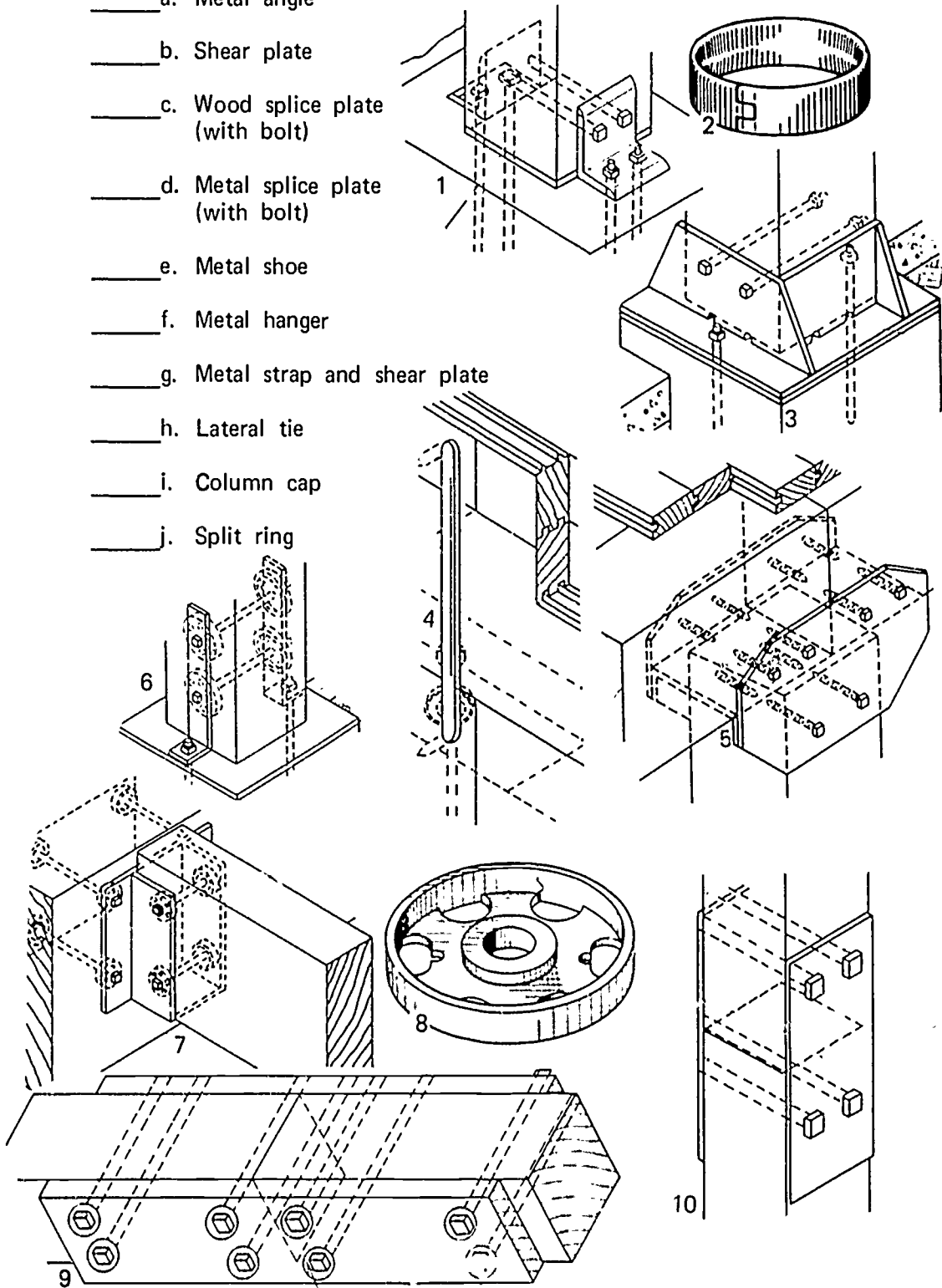

7. Identify the five hardware items in the illustration below that are used in structural timber construction by placing the correct numbers in the blanks provided.

- ___ a. Anchor bolt
- ___ b. Lag screw
- ___ c. Machine bolt
- ___ d. Washer
- ___ e. Spikes

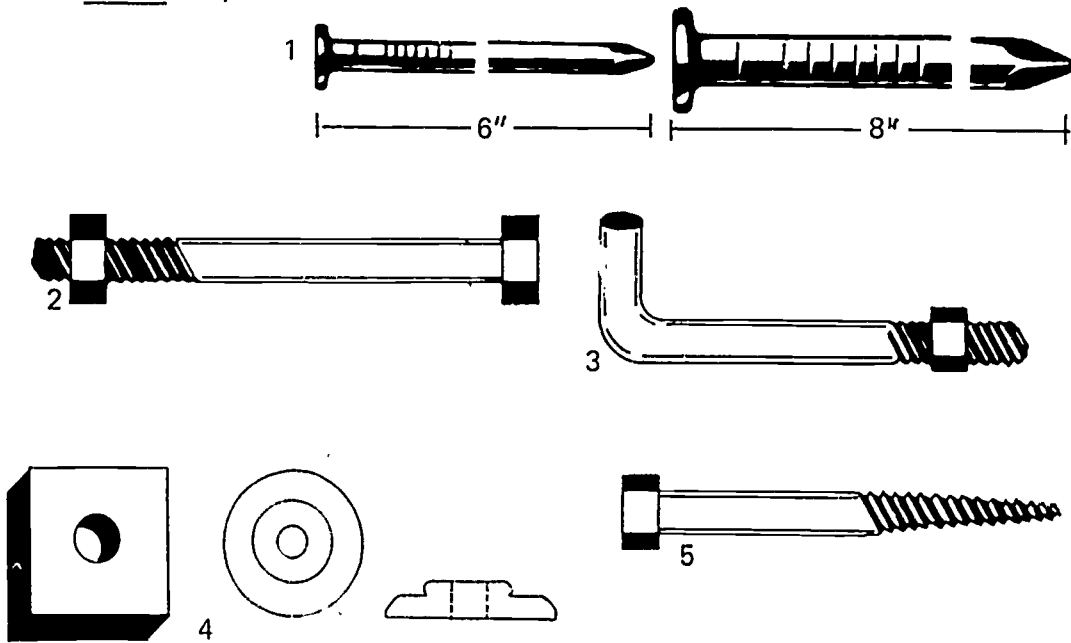

8. Identify the three types of decking or planking illustrated below by placing the correct numbers in the blanks provided.

_____ a. Tongue and grooved

_____ b. Groove and spline

_____ c. Laminated deck

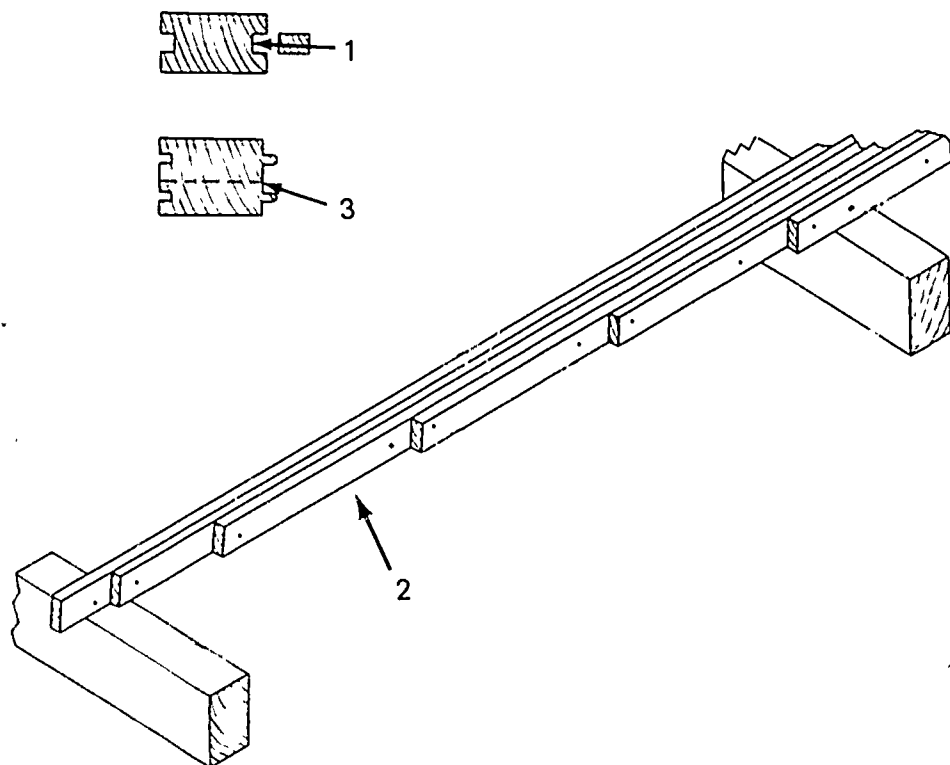

STRUCTURAL TIMBER CONSTRUCTION
UNIT V

ANSWERS TO TEST

1.
 - a. 6
 - b. 7
 - c. 4
 - d. 2
 - e. 1
 - f. 5
 - g. 3
2.
 - a. Industrial
 - b. Commercial
 - c. Institutional
3.
 - a. 3
 - b. 5
 - c. 1
 - d. 4
 - e. 2
4.
 - a. Development and refinement of stress graded timber, both solid and glue-laminated
 - b. Production of modern types of timber connectors
 - c. Full recognition of fire resistance of large timber sections
 - d. Use of preservatives to help timber withstand the deteriorating effects of moisture, disease, and insects
5.
 - a. Load
 - b. Span of girders, beams, and decking
 - c. Unsupported height of columns
 - d. Grade and species of timber

- 6. a. 1
- b. 8
- c. 9
- d. 10
- e. 3
- f. 7
- g. 6
- h. 4
- i. 5
- j. 2
- 7. a. 3
- b. 5
- c. 2
- d. 4
- e. 1
- 8. a. 3
- b. 1
- c. 2

FIREPROOF MASONRY AND METAL STUD CONSTRUCTION UNIT VI

TERMINAL OBJECTIVE

After completion of this unit, the student should be able to match terms associated with fireproof construction, define the term fireproof construction, and name four fasteners used on this type of construction. He should also be able to define the term modular units, name three components of metal stud construction, and perform those construction skills given. This knowledge will be evidenced through demonstration and by scoring eighty-five percent on the unit test.

SPECIFIC OBJECTIVES

After completion of this unit, the student should be able to:

1. Define fireproof masonry and metal stud construction.
2. Match terms associated with fireproof masonry and metal stud construction to a list of definitions.
3. Name four fasteners used for metal stud construction.
4. Define modular masonry units.
5. Name three components of a metal stud system.
6. Demonstrate the ability to:
 - a. Lay out wall lines for masonry and steel studs and install metal door bucks.
 - b. Install steel studs.

FIREPROOF MASONRY AND METAL STUD CONSTRUCTION UNIT VI

SUGGESTED ACTIVITIES

I. Instructor:

- A. Provide students with objective sheet.
- B. Provide students with information and job sheets.
- C. Make transparencies.
- D. Discuss terminal and specific objectives.
- E. Discuss information sheet.
- F. Demonstrate and discuss procedures outlined in job sheets.
- G. Give test.

II. Student:

- A. Read objective sheet.
- B. Study information sheet.
- C. Demonstrate the ability to accomplish the procedures outlined in the job sheets.
- D. Take test.

INSTRUCTIONAL MATERIALS

I. Included in this unit:

- A. Objective sheet
- B. Information sheet
- C. Transparency masters
 1. TM 1--Fasteners for Metal Stud Construction
 2. TM 2--Modular Masonry Units
 3. TM 3--Components of a Metal Stud System

D. Job sheets

1. Job Sheet #1--Lay Out Wall Lines for Masonry and Steel Studs and Set Metal Door Bucks
2. Job Sheet #2--Metal Stud Installation

E. Test

F. Answers to test

II. References:

- A. Burke, Arthur E., J. Ralph Dalzell, and Gilbert Townsend. *Architectural and Building Trades Dictionary*. Chicago, Illinois: American Technical Society, 1955.
- B. Smith, Ronald C. *Principles and Practices of Heavy Construction*. Englewood Cliffs, New Jersey: Prentice Hall, Inc., 1970.
- C. Ramsey, Charles G. and Harold R. Sleeper. *Architectural Graphic Standards*. New York: John Wiley and Sons, Inc.

FIREPROOF MASONRY AND METAL STUD CONSTRUCTION UNIT VI

INFORMATION SHEET

- I. Fireproof masonry and metal stud construction--Method of construction in which the main units are masonry and all other components are of noncombustible material
- II. Terms and definitions
 - A. Runner--A channel used to anchor the studs at floor and ceiling
 - B. Magnetic driver--A tool used to hold short concrete nails while they are being driven
 - C. Modular dimensional standards -Standards based upon a common unit of measure of four inches, known as a module, used as a base for the grid which is essential for dimensional coordination of two or more different materials

(NOTE: Dimensional standards are approved by the American Standards Association for all building materials and equipment.)
 - D. Cutter--A hand operated tool used to cut studs and runners on the job
 - E. Crimper--A hand operated tool used to attach studs to runners by crimping
 - F. Sheetrock screwdriver--An electric screwdriver with a special head
 - G. Drive pin--A type of fastener driven with powder actuated tools
 - H. Buck braces--A manufactured product with a clamp on each end that is adjustable for length; a piece of wood
- III. Fasteners for metal stud construction (Transparency 1)
 - A. Concrete nails
 - B. Drive pins
 - C. Toggle bolts
 - D. Screws
 1. Gypsum panel to standard metal framing, 1" type S Bugle Head
 2. Metal studs to door jamb anchor clips, 3/8" Type S-12 Pan Head

INFORMATION SHEET

3. Standard metal studs to runners, 3/8" Type S Pan Head
- IV. Modular masonry units--Units or a combination of units based upon common units of measure known as modular dimensional standards (Transparency 2)
- V. Metal stud system components (Transparency 3)
 - A. Studs
 - B. Runners
 - C. Metal door buck anchor clips

Fasteners for Metal Stud Construction

Concrete Nail



5/16" Diameter

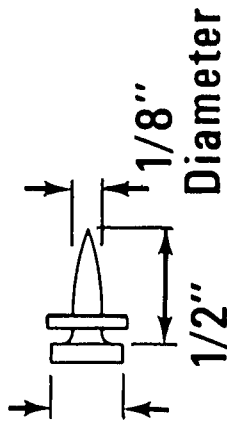

Drive Pin

Toggle Bolt



SCREWS

1" Type S Bugle Head



3/8" Type S-12 Pan Head



1/2" Type S-12 Pan Head



3/8" Type S Pan Head



Also available with
Hex Washer Head

Modular Masonry Units

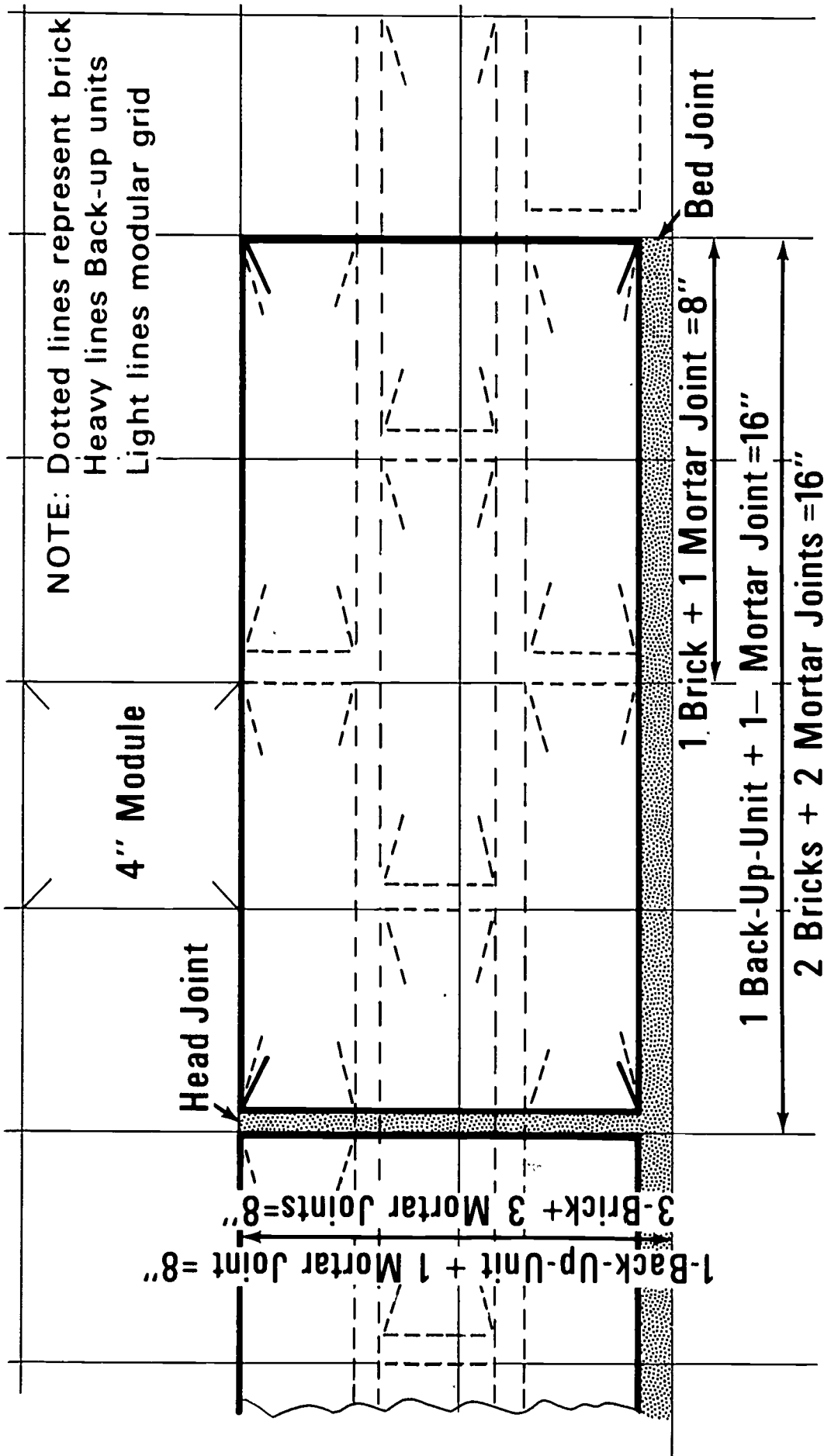

920

Components of a Metal Stud System

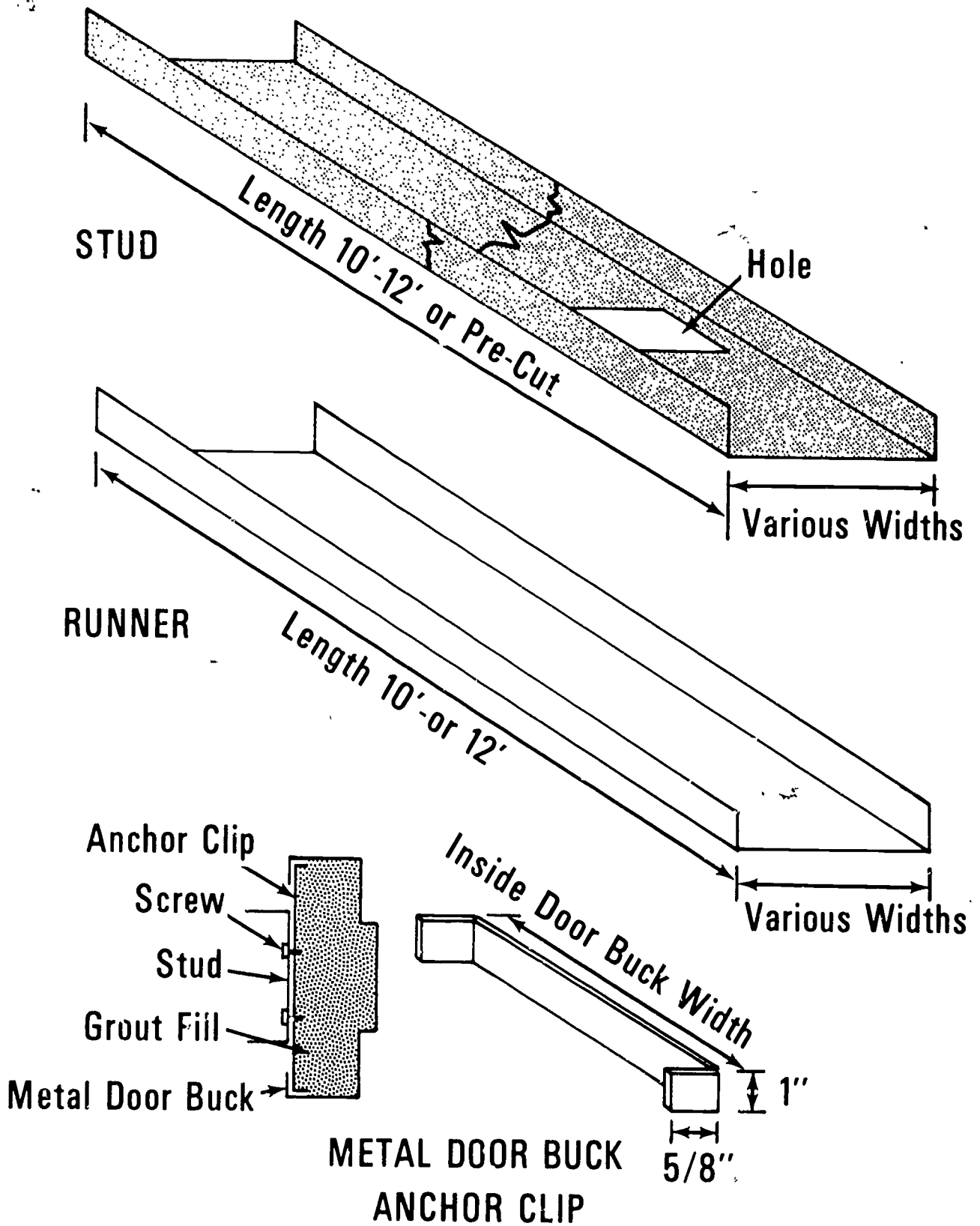

FIREPROOF MASONRY AND METAL STUD CONSTRUCTION
UNIT VI

JOB SHEET #1--LAY OUT WALL LINES FOR MASONRY AND STEEL
STUDS AND INSTALL METAL DOOR BUCKS

I. Tools and material needed

A. Tools

1. Chalk line and reel
2. 100 foot measuring tape
3. 12 or 16 foot tape measure
4. Hand level
5. Claw hammer (16 oz. or larger)
6. Powder actuated tool and drive pins

B. Material

1. Floor plan
2. Concrete nails
3. Metal door bucks
4. Can of spray paint (red or yellow)
5. Buck braces

II. Procedure

A. Lay out exterior walls (Figure 1)

1. Measure from the outside face the total wall thickness at two corners on one side of the building
2. Drive a short concrete nail on one of the marks
3. Hook looped end of chalk line on nail

JOB SHEET #1

4. Pull chalk line tight over mark on other end and snap

(NOTE: When snapping long lines, it is advisable to snap from the middle of the line by holding the line tight to the floor with one hand and snapping the two halves separately.)

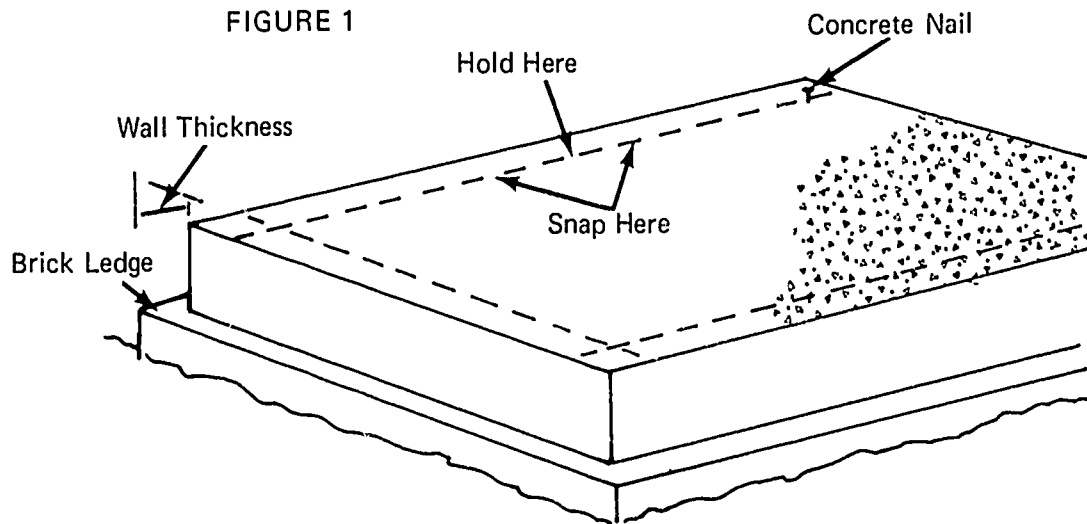

- B. Lay out inside walls and doors (Figure 2)

1. Hold loop end of measuring tape on inside wall line and mark center lines of all doors and partitions

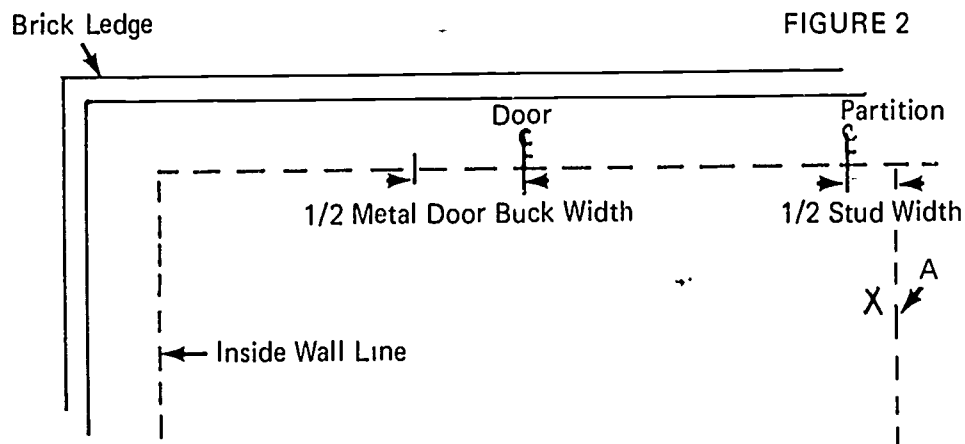

2. Repeat step 1 on opposite side of the building

JOB SHEET #1

3. Measure over one-half the thickness of the stud from the partition center line on both ends of the partition
4. Snap a chalk line between these points
5. Mark partition side of line with an X
6. Lay out all partitions following step 1 through 5
7. Lay out center lines of all openings and partitions
8. Measure one-half the width of the metal door buck each side of the door center lines

(NOTE: Check from corner to door buck and adjust for modular units.)

9. Paint partition intersections and door sides (Figure 3)

(NOTE: Lay thin boards on floor at layout lines and spray paint floor. Explain that this is basic.)

FIGURE 3

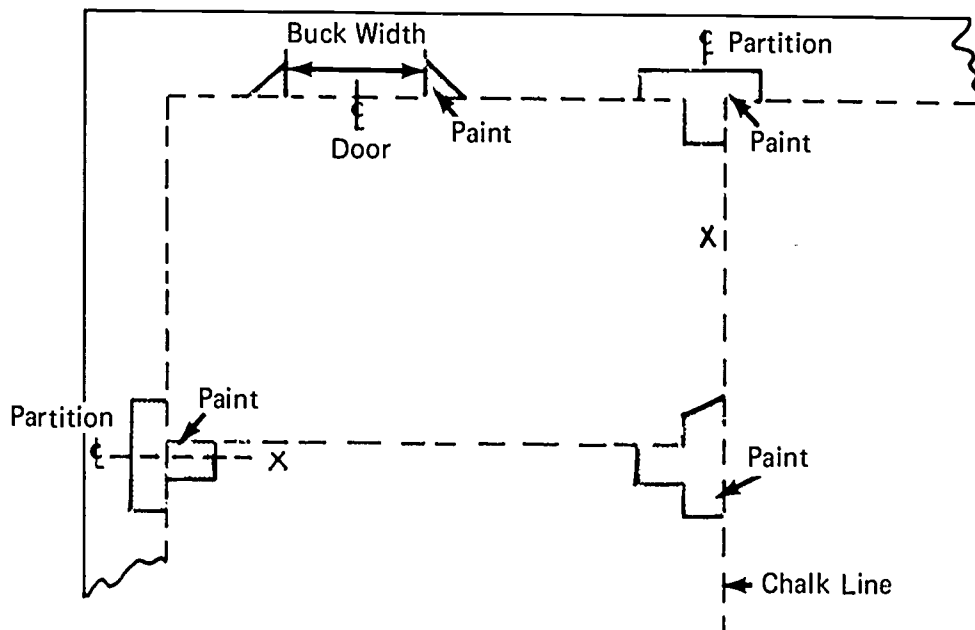

JOB SHEET #1

C. Set metal door bucks

1. Build door buck jack (Figure 4)

(NOTE: This would only be built when a large quantity of bucks are to be set. It can not be used on exterior bucks.)

FIGURE 4

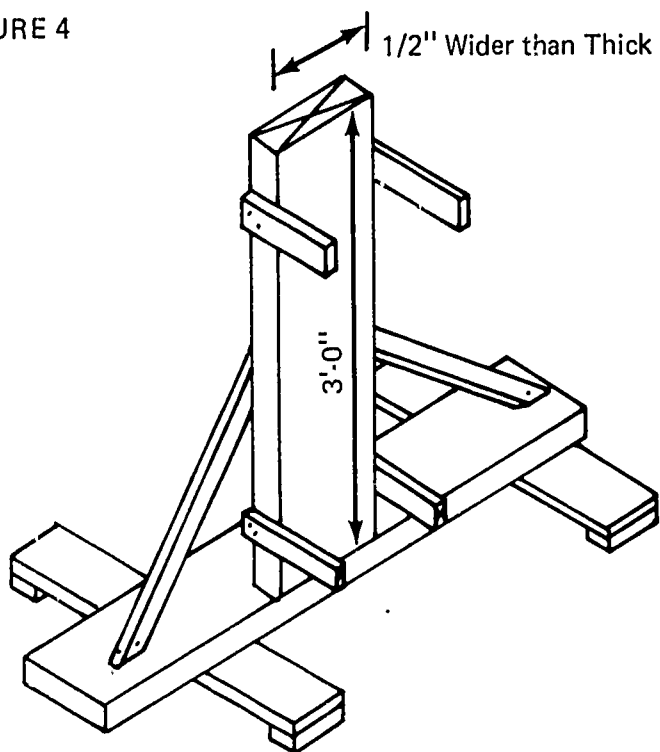

JOB SHEET #1

2. Stand buck upright at marks on floor
3. Place buck jack in position with ears on each side of buck (Figure 5)

FIGURE 5

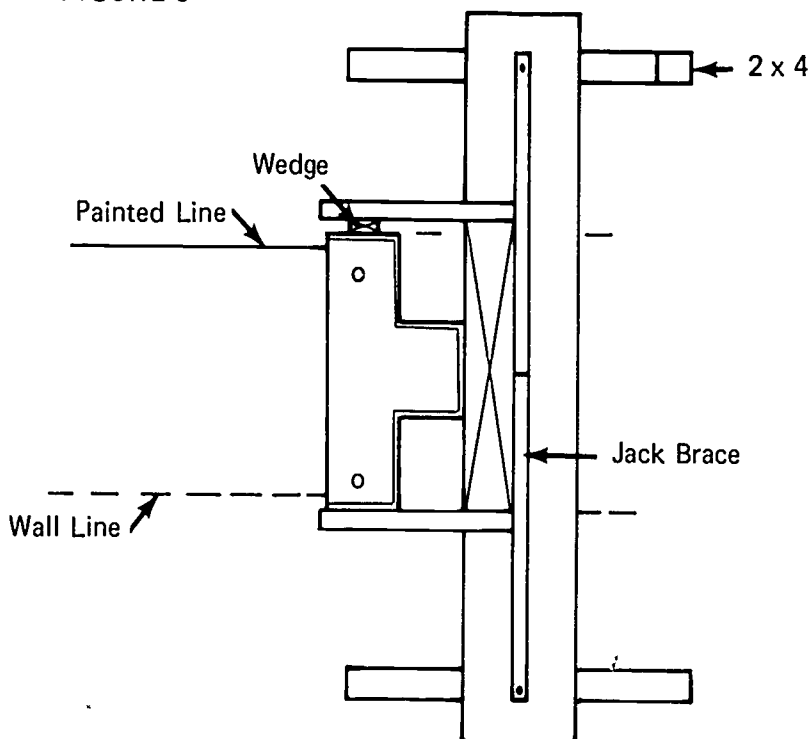

4. Anchor bottom of door buck
 - a. Line up buck in correct relationship to wall line
 - b. Shoot two drive pins in bottom anchors

(NOTE: If top of buck is not level, place shim under anchor plate before shooting drive pin.)

JOB SHEET #1

5. Insert wedges between ears on jack; bring buck to plumb position
6. Secure top brace (Figure 6)

(NOTE: There are many methods of securing the top braces. Two methods are shown in Figure 6.)

FIGURE 6

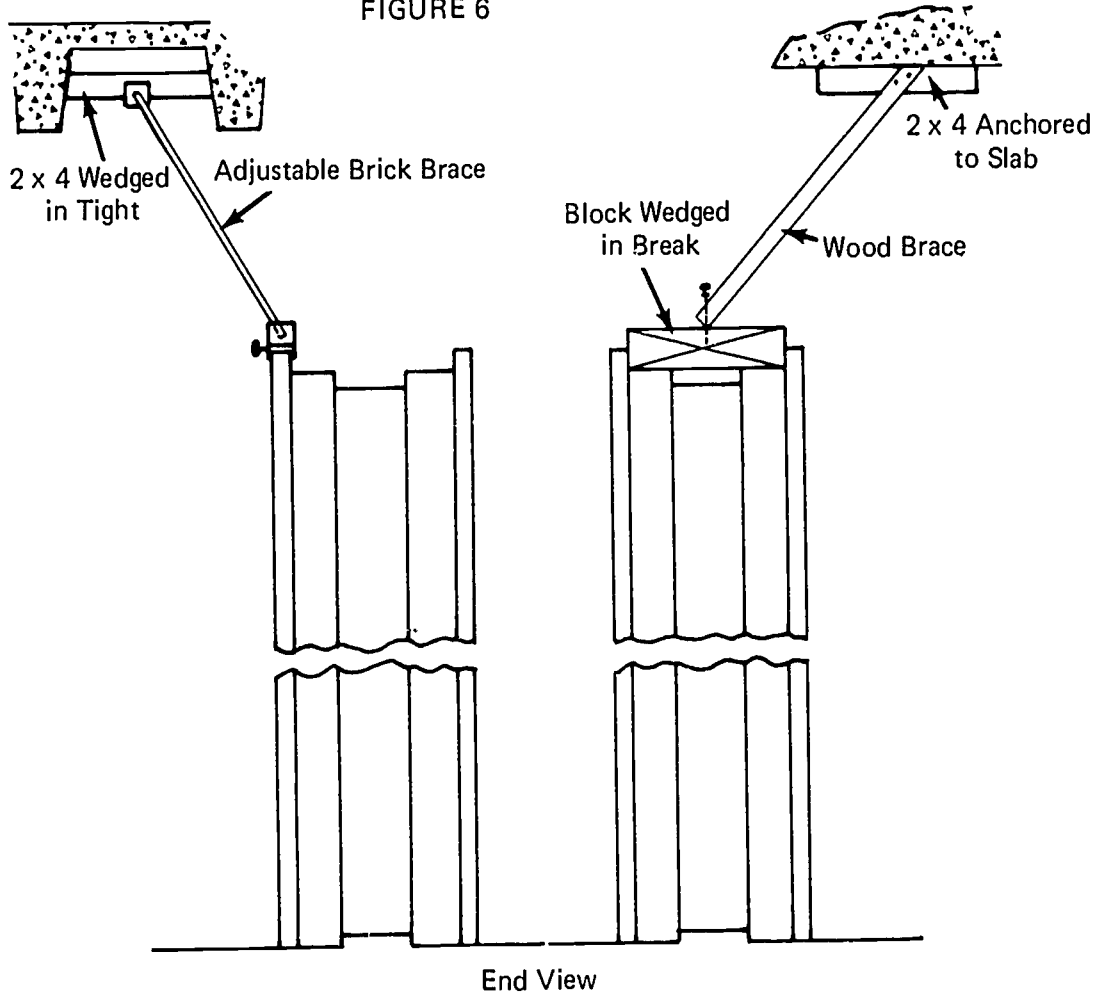

JOB SHEET #1

7. Plumb opposite side and secure brace (Figure 7)

(NOTE: Three braces are needed on the buck, two to hold the sides plumb to the wall line and one to hold it plumb to the length of the wall.)

FIGURE 7

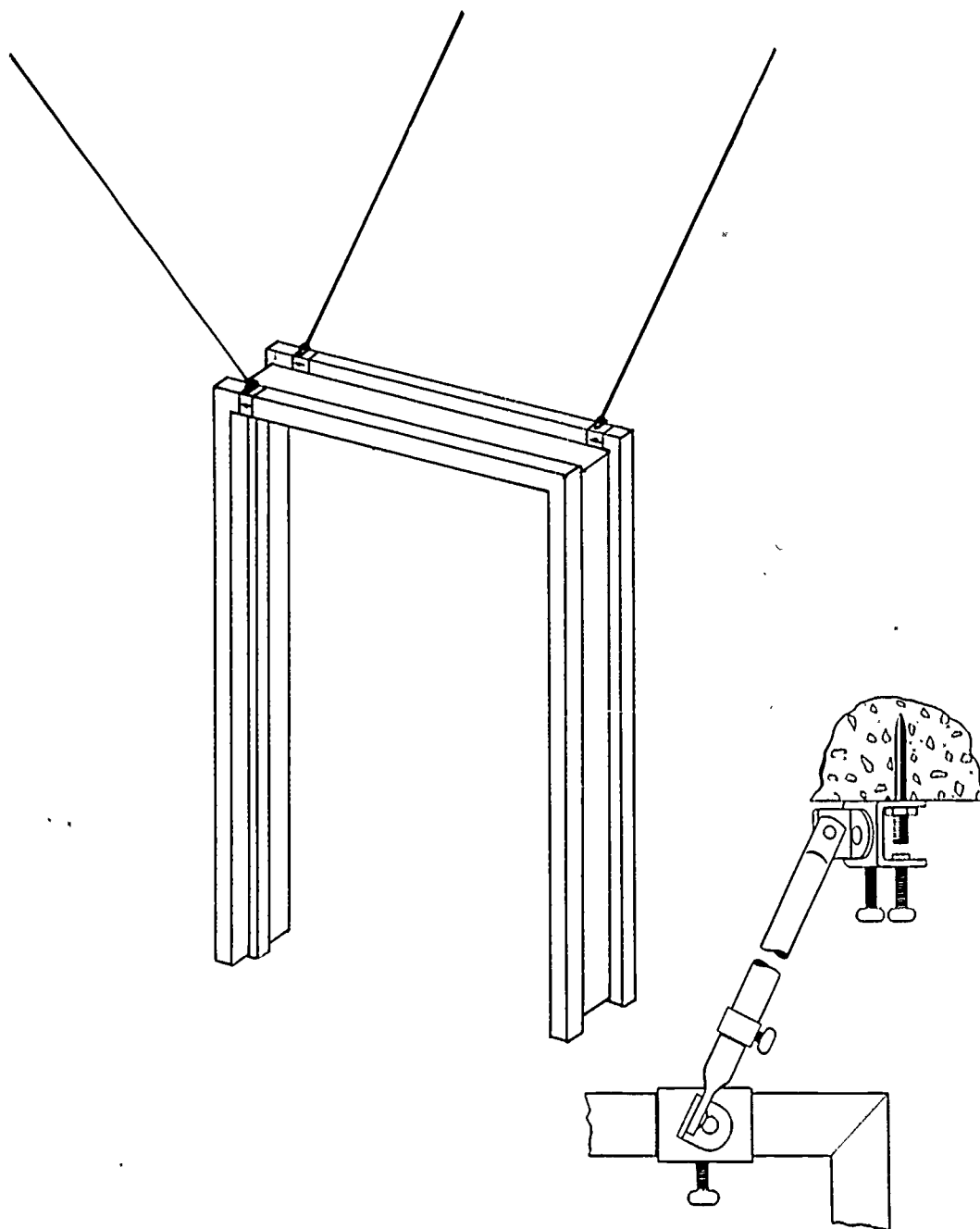

FIREPROOF MASONRY AND METAL STUD CONSTRUCTION
UNIT VI

JOB SHEET #2--METAL STUD INSTALLATION

(NOTE: Lay out and buck setting have been outlined in Job Sheet #1.)

I. Tools and materials needed

A. Tools

1. 12 or 16 foot measuring tape
2. Hand level
3. Claw hammer (16 oz. or larger)
4. Magnetic nail driver
5. Drywall screwdriver
6. Stud cutter
7. Crimper
8. Plumb bob
9. Chalk line

B. Materials

1. Studs
2. Runners
3. Metal door buck anchors
4. 1/2" concrete nails
5. Screws

II. Procedure

A. Install runners

1. Secure runners to floor

(NOTE: Use one-half inch concrete nails and magnetic driver.)

2. Plumb up from floor runner to locate ceiling runner

(NOTE: Use plumb bob at ends of wall to establish marks on ceiling.)

JOB SHEET #2

3. Snap a chalk line between points
4. Lay out stud spacing on floor and ceiling runner
5. Secure ceiling runner to ceiling

(IMPORTANT: Be sure stud layout is plumb over floor runner layout.)
6. Cut studs to length

(NOTE: Studs may be purchased pre-cut.)
7. Install full length studs
 - a. Stand stud in position at layout marks

(NOTE: Studs set inside the floor and ceiling channel.)
 - b. Secure studs to floor and ceiling runners with crimping tool
 - c. Place buck anchor in buck and secure stud to anchor

(NOTE: Buck anchors should be placed approximately two feet on center.)

JOB SHEET #2

8. Install cripple studs at doors and windows (Figure 1)

(NOTE: If wood jambs are used, screw two inch material to studs for nailers. Be sure to check rough opening size.)

FIGURE 1

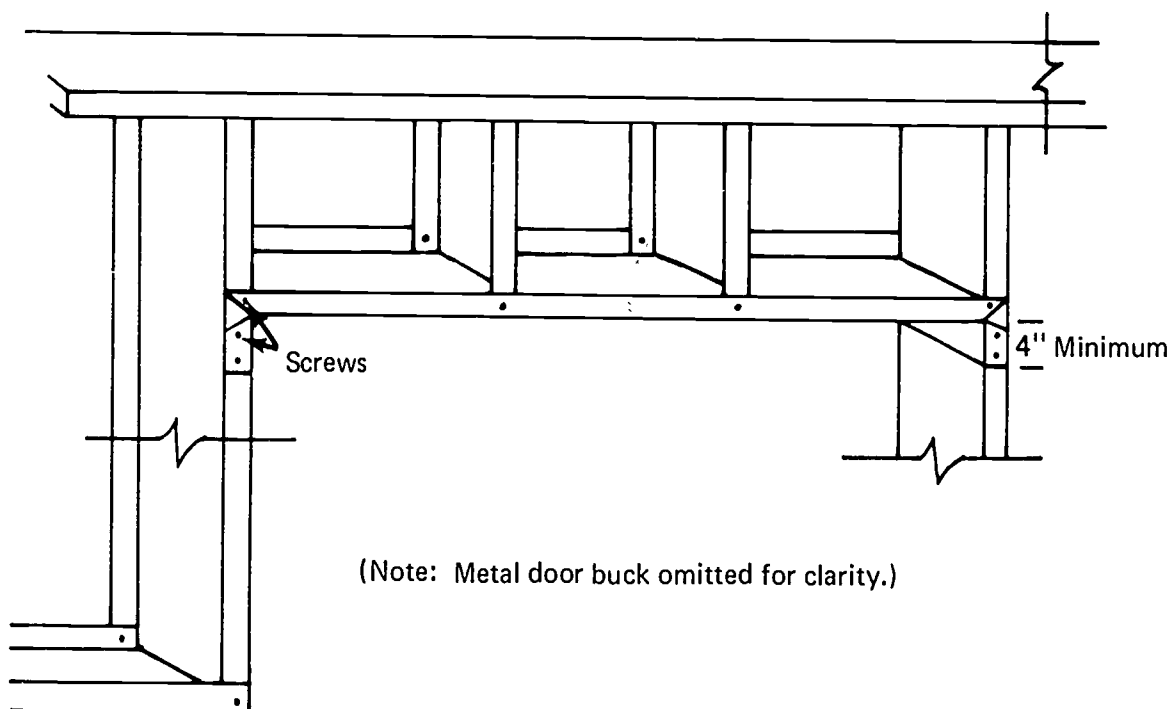

(Note: Metal door buck omitted for clarity.)

- a. Cut runner eight inches longer than opening
- b. Cut standing flanges of runners four inches from each end
- c. Bend runner down at cuts
(NOTE: See Figure 1.)
- d. Screw both ends of runner to studs
- e. Cut cripple studs to length
- f. Attach cripple studs to runners with crimping tool or screws

FIREPROOF MASONRY AND METAL STUD CONSTRUCTION
UNIT VI

TEST

1. Define fireproof masonry and metal stud construction.

2. Match the following list of terms to the correct definitions.

- | | |
|---|----------------------------------|
| _____ a. A channel used to anchor the studs at floor and ceiling | 1. Sheetrock screwdriver |
| _____ b. A tool used to hold short concrete nails while they are being driven | 2. Cutter |
| _____ c. Standards based upon a common unit of measure of four inches, known as a module, used as a base for the grid which is essential for dimensional co-ordination of two or more different materials | 3. Drive pin |
| _____ d. A hand operated tool used to cut studs and runners on the job | 4. Crimper |
| _____ e. A hand operated tool used to attach studs to runners by crimping | 5. Buck braces |
| _____ f. An electric screwdriver with a special head | 6. Runner |
| _____ g. A type of fastener driven with a powder actuated tool | 7. Modular dimensional standards |
| _____ h. A manufactured product with a clamp on each end that is adjustable for length; a piece of wood | 8. Magnetic driver |

3. Name four fasteners used for metal stud construction.

- a.
- b.
- c.
- d.

4. Define modular masonry units.

5. Name three components of a metal stud system.
 - a.
 - b.
 - c.

6. Demonstrate the ability to:
 - a. Lay out wall lines for masonry and steel studs and install metal door bucks.
 - b. Install steel studs.

(NOTE: If this has not been accomplished prior to the test, ask the instructor when the above activities should be completed.)

FIREPROOF MASONRY AND METAL STUD CONSTRUCTION
UNIT VI

ANSWERS TO TEST

1. A method of construction in which the main units are masonry and all other components are of non-combustible material
2.
 - a. 6
 - b. 8
 - c. 7
 - d. 2
 - e. 4
 - f. 1
 - g. 3
 - h. 5
3. (NOTE: The following answers may be given in any order.)
 - a. Concrete nails
 - b. Drive pins
 - c. Toggle bolts
 - d. Screws
4. Units or a combination of units based upon common units of measure known as modular dimensional standards
5. (NOTE: The following answers may be given in any order.)
 - a. Studs
 - b. Runners
 - c. Metal door buck anchor clips
6. Performance skills will be evaluated according to the criteria listed on the progress chart.

3
4
5
6
7
8
9
10
11
12
13
14
15
16
17
18
19
20

	Accuracy
	85% Correct
	1/4" of Square Diagonally
	Joist 4" OC \pm 1/8"
	No Greater Than 1/8" Deviation
	Splices on Joists, Nails in Joists
	85% Correct
	\pm 1/8" of Plan Location
	\pm 1/8" of Exact Length
	\pm 1/8" of Being Flush & Square
	All Breaks & Nails on Studs
	with Staggered Joints
	Joist 4" OC \pm 1/8"
	Square & Plumb Diagonally
	Square & Plumb
	85% Correct
	4" O.C. \pm 1/8"
	of Ridge No More than 1/4" Gap at
	Heel of Birds-mouth, Crown Up \pm 1/8"
	in Lengths of Tails 1/8" of Plumb
	Splices on Rafters, \pm 1/8" Variation
	at Gable and Nails into Rafters

Carpentry

PROGRESS CHART

Section H #2
Framing

987

Student's Name	UNIT IV Trusses			UNIT V Structural Timber Construction			UNIT VI Fireproof Masonry and Metal Stud Construction		
	1	2	3	1	2	3	1	2	3
1									
2									
3									
4									
5									
6									
7									
8									
9									

Job

UNIT TEST

UNIT TEST

Lay Out Wall Lines
Set Metal Door Bucks
UNIT TEST

Metal Stud Installation
UNIT TEST

EXTERIOR WALL COVERINGS AND TRIM UNIT I

TERMINAL OBJECTIVE

After completion of this unit, the student should be able to define terms associated with exterior wall coverings and trim. He should be able to identify the styles and parts of a cornice, identify various types of cornice molding, name the common materials used as exterior wall coverings, and identify various styles of siding. This knowledge will be evidenced through demonstration and by scoring eighty-five percent on the unit test.

SPECIFIC OBJECTIVES

After completion of this unit, the student should be able to:

1. Match terms associated with wall coverings and trim to a list of definitions.
2. Identify three styles of cornice.
3. Name the parts of a cornice.
4. Identify three types of cornice molding.
5. Name five types of exterior wall coverings.
6. Identify four styles of siding.
7. Estimate the material needed for siding and trim.
8. Demonstrate the ability to:
 - a. Build a box cornice.
 - b. Apply wood siding.

EXTERIOR WALL COVERINGS AND TRIM
UNIT I

SUGGESTED ACTIVITIES

- I. Instructor:
 - A. Provide students with objective sheet.
 - B. Provide students with information, assignment, and job sheets.
 - C. Make transparencies.
 - D. Discuss terminal and specific objectives.
 - E. Discuss information and assignment sheets.
 - F. Demonstrate and discuss procedures outlined in job sheets.
 - G. Give test.
- ii. Student:
 - A. Read objective sheet.
 - B. Study information sheet.
 - C. Complete assignment sheet.
 - D. Demonstrate the ability to accomplish the procedures outlined in the job sheets.
 - E. Take test.

INSTRUCTIONAL MATERIALS

- I. Included in this unit:
 - A. Objective sheet
 - B. Information sheet
 - C. Transparency masters
 1. TM 1--Styles of Cornice
 2. TM 2--Parts of a Cornice

3. TM 3--Types of Cornice Molding
 4. TM 4--Styles of Siding
- D. Assignment Sheet #1--Material Estimating
- E. Answers to assignment sheet
- F. Job sheets
1. Job Sheet #1--Build a Horizontal Box Cornice
 2. Job Sheet #2--Apply Wood Siding
- G. Test
- H. Answers to test

II. References:

- A. Burke, Arthur E., J. Ralph Dalzell, and Gilbert Townsend. *Architectural and Building Trades Dictionary*. Chicago, Illinois: American Technical Society, 1955.
- B. Cooper, George H. and Stanley Badzinski Jr. *Building and Construction Estimating*. New York: McGraw-Hill, 1971.
- C. Durbahn, Walter E. and Elmer W. Sundberg. *Fundamentals of Carpentry*. Third Edition. Chicago, Illinois: American Technical Society, 1963.
- D. Lair, E. A. *Carpentry for the Building Trades*. St. Louis, Missouri: McGraw-Hill, 1953.
- E. Smith, Ronald C. *Principles and Practices of Light Construction*. Englewood Cliffs, New Jersey: Prentice Hall Inc., 1970.
- F. Wagner, Willis H. *Modern Carpentry*. Homewood, Illinois: Goodheart-Willcox, 1969.

EXTERIOR WALL COVERINGS AND TRIM
UNIT 1

INFORMATION SHEET

- I. Terms and definitions
 - A. Batten--A strip of wood placed across a surface to cover joints
 - B. Barge board--The trim board or fascia at the gable end of a building and attached directly to the barge rafter
 - C. Boxed cornice--A method of closing in the eave to form a box type structure using the wall of the building, the roof, the fascia, and the plancier
 - D. Brick molding--A molding for exterior window and door frames against which the finished brick is laid
 - E. Fascia--The flat outside horizontal member of a cornice which is attached to the rafter tails
 - F. Frieze--A trim member that forms a band around the top of the wall of a building covering the joint where the wall meets the cornice
 - G. Furring strip--Flat pieces of lumber used to build up an irregular framing to an even surface for the application of flooring, ceiling, or wall covering
 - H. Lookouts--Short wooden framing members attached to a ledger board at the top of the wall and to the rafter tails for attachment of the plancier
 - i. Lookout ledger--Usually a 1 x 4 band around a building at the top of the wall to which the lookouts are attached
 - J. Overhang--The projection of the roof of a building beyond the wall
 - K. Plancier--The underside of the cornice sometimes called a soffit
- II. Styles of cornice (Transparency 1)
 - A. Horizontal box cornice
 - B. Sloping box cornice
 - C. Open cornice
- III. Parts of a cornice (Transparency 2)
 - A. Fascia
 - B. Lookouts

INFORMATION SHEET

- C. Lookout ledger
 - D. Frieze
 - E. Plancier
 - F. Rafter
 - G. False fascia
- IV. Types of cornice molding (Transparency 3)
- A. Crown
 - B. Cove
 - C. Bed
- V. Exterior wall coverings
- A. Horizontal siding
 - 1. Wood
 - 2. Composition board
 - 3. Aluminum
 - B. Shingles
 - 1. Asbestos
 - 2. Wood
 - 3. Insulated
 - C. Verticle grooved panels
 - 1. Plywood
 - 2. Composition board
 - D. Boards and battens
 - E. Masonry
 - 1. Brick veneer
 - 2. Rock veneer
 - 3. Stucco

INFORMATION SHEET

- VI. Styles of siding (Transparency 4)
- A. Bevel siding (lap siding)
 - B. Clap-boards (lap siding)
 - C. Drop siding (shiplapped)
 - D. Drop siding (tongue-and-grooved)
- VII. Material estimating
- A. Cornice
 - 1. Gable roof
 - a. Determine the type of wall covering to be used from the specifications
 - b. Determine the style of cornice to be used from the specifications
 - c. Determine the running feet of fascia needed for the eave and for the barge

(NOTE: The fascia must be wide enough to project at least one-half inch below the plancier.)
 - d. Determine the running feet of one by four lumber needed for the lookout ledger

(NOTE: The lookout ledger must extend to the outside of the barge rafter at both ends of the building for attachment of the end lookouts.)
 - e. Determine the length and number of lookouts needed for two foot centers

(NOTE: Lookouts need to extend from barge to barge on both sides of the building.)
 - f. Determine the number of sheets of plywood needed for the plancier

(NOTE: The area in square feet under the eave and rake divided by thirty-two equals the number of sheets.)
 - g. Determine the lineal feet of frieze needed

(NOTE: Cover all areas where the plancier meets the vertical wall covering of the building.)

INFORMATION SHEET

2. Hip roof
- Determine the type of wall covering to be used from the specifications
 - Determine the style of cornice to be used from the specifications
 - Determine the running feet of fascia needed around the perimeter of the roof
- (NOTE: The fascia must be wide enough to cover the false fascia and project at least one-half inch below the plancier.)
- Determine the running feet of one by four lumber needed for the lookout ledger
 - Determine the length and number of lookouts needed for two foot centers
 - Determine the number of sheets of plywood needed for the plancier

(NOTE: The area in square feet under the eave divided by thirty-two equals the number of sheets.)

B. Siding

- Determine the type of siding to be used from the specifications
 - Determine the wall area to be covered
- (NOTE: Disregard door and window openings.)
- (NOTE: Siding is generally purchased by the square foot.)
- From the table below add the necessary percentage for overlap and waste

Allowances for Overlap and Waste on Siding		
Siding	Nominal Width, In.	Percentage Added to Wall Area
Bevel	6	40
	8	25
	10	20
	12	15
Tongued and Grooved	6	20
	8	15
	10	10

INFORMATION SHEET

C. Nails required for exterior wall coverings and trim

Amounts of Nails Required	
Cornice Work Siding:	1 lb. per 100 lin. ft. of Cornice Material
6d	6 lb. per 1,000 sq. ft.
7d	6 1/2 lb. per 1,000 sq. ft.
8d	9 lb. per 1,000 sq. ft.
10d	11 lb. per 1,000 sq. ft.

Styles of Cornice

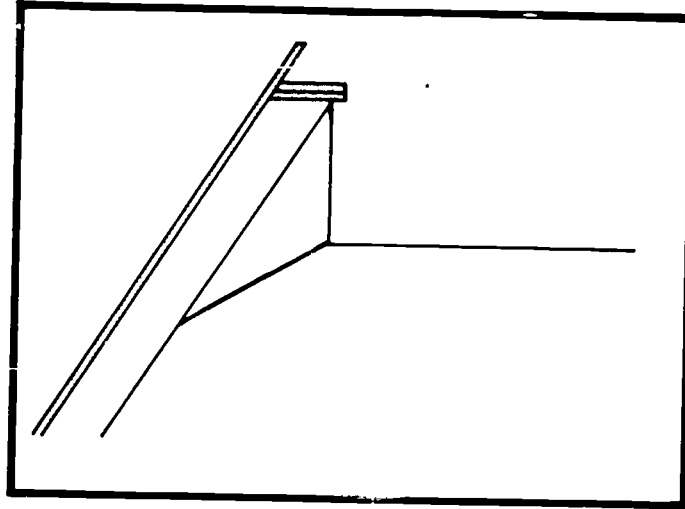

HORIZONTAL BOX
CORNICE

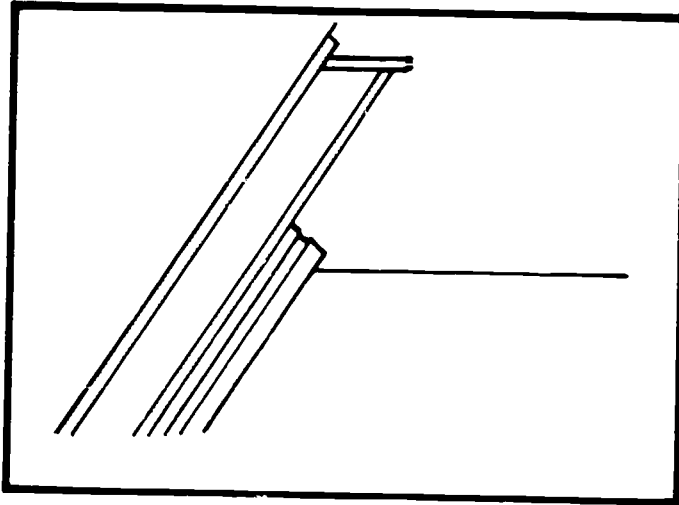

SLOPING BOX
CORNICE

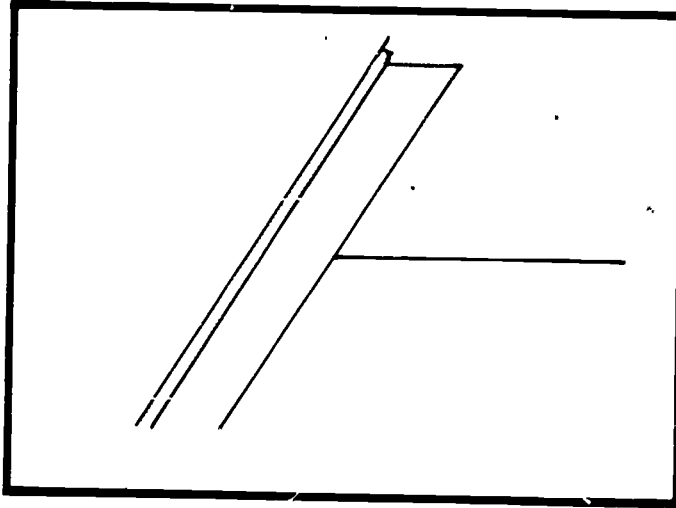

OPEN CORNICE

Parts of a Cornice

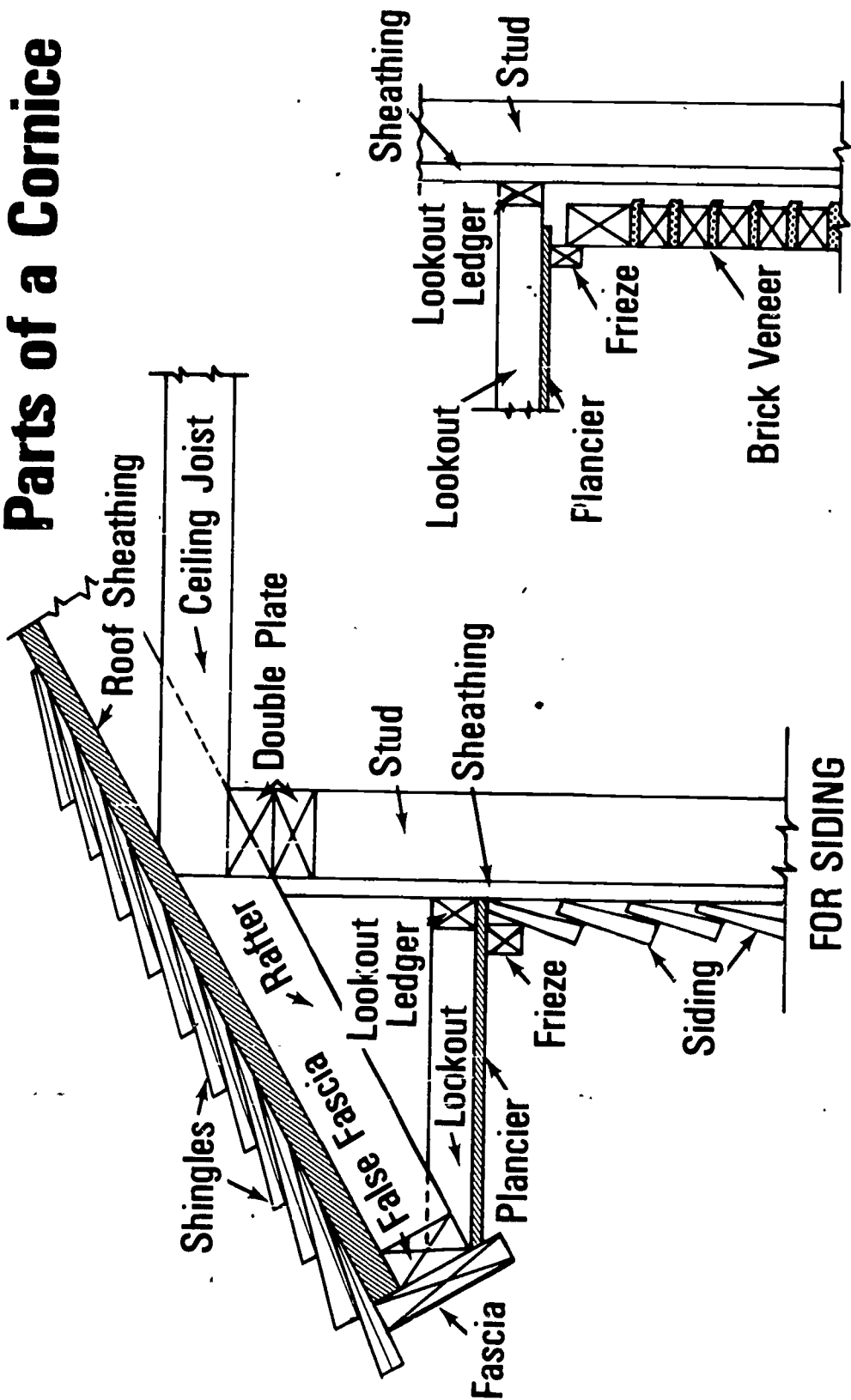

FOR SIDING

FOR BRICK VENEER

Types of Cornice Molding

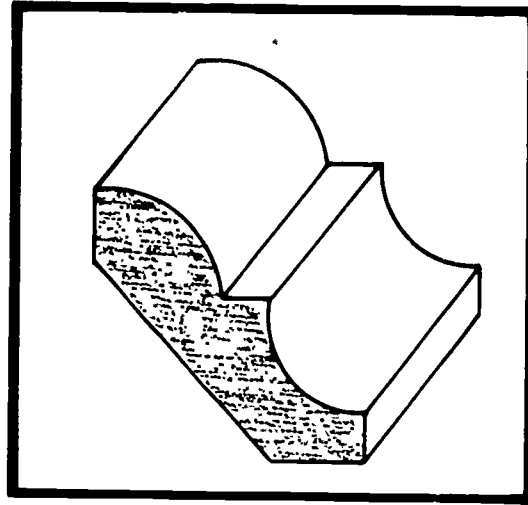

BED MOLD

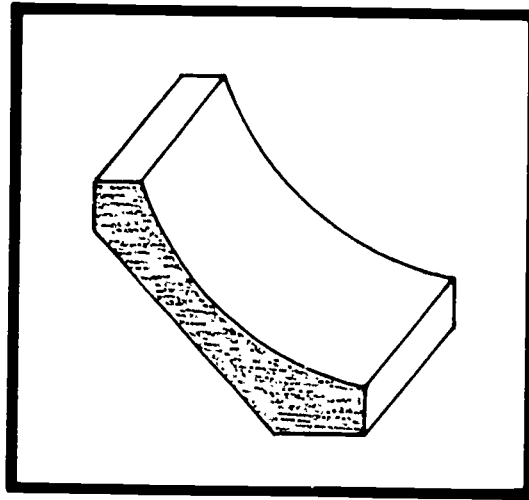

COVE MOLD

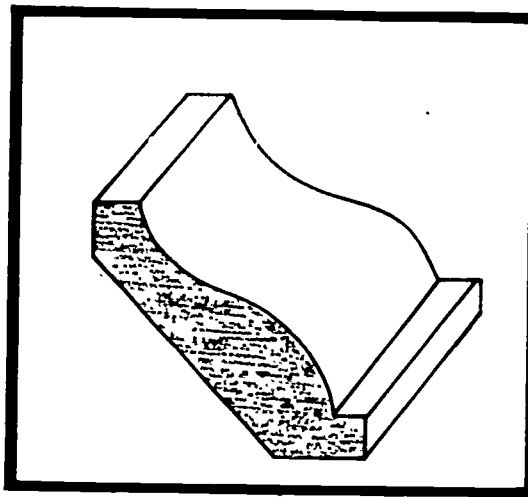

CROWN MOLD

Styles of Siding

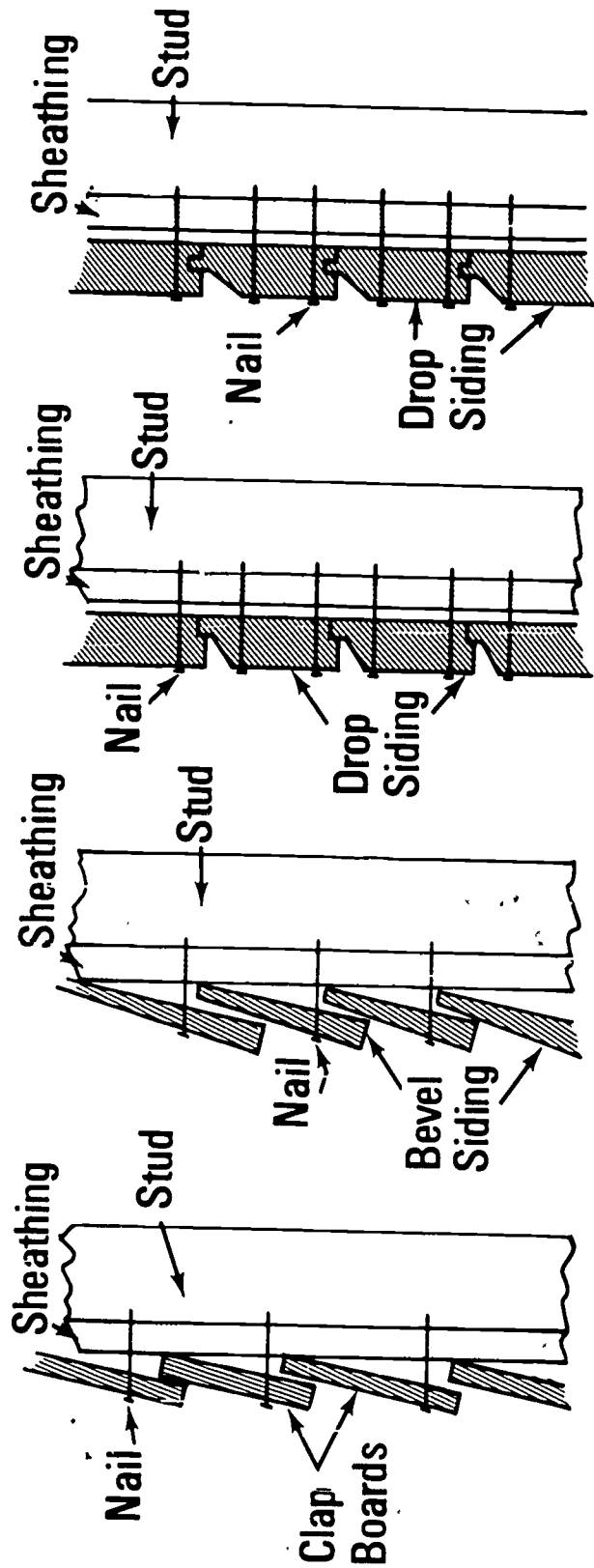

CLAP BOARDS (Lap Siding) BEVEL SIDING (Lap Siding) DROP SIDING (Shiplapped) DROP SIDING (Tongue-and-Grooved)

1000

EXTERIOR WALL COVERINGS AND TRIM
UNIT I

ASSIGNMENT SHEET #1--MATERIAL ESTIMATING

Using your information sheet, calculate the following materials for the building illustrated below.

- ___ a. 2 x 4's 15 feet long for lookouts
- ___ b. 1 x 4's 16 feet long for lookout ledger
- ___ c. Running feet of 1 x 8 fascia
- ___ d. Sheets of 1/4" x 4' x 8' exterior Fir plywood for the plancier
- ___ e. Square feet of 8" bevel siding needed
- ___ f. Pounds of 8d box nails needed for siding
- ___ g. Running feet of molding for frieze

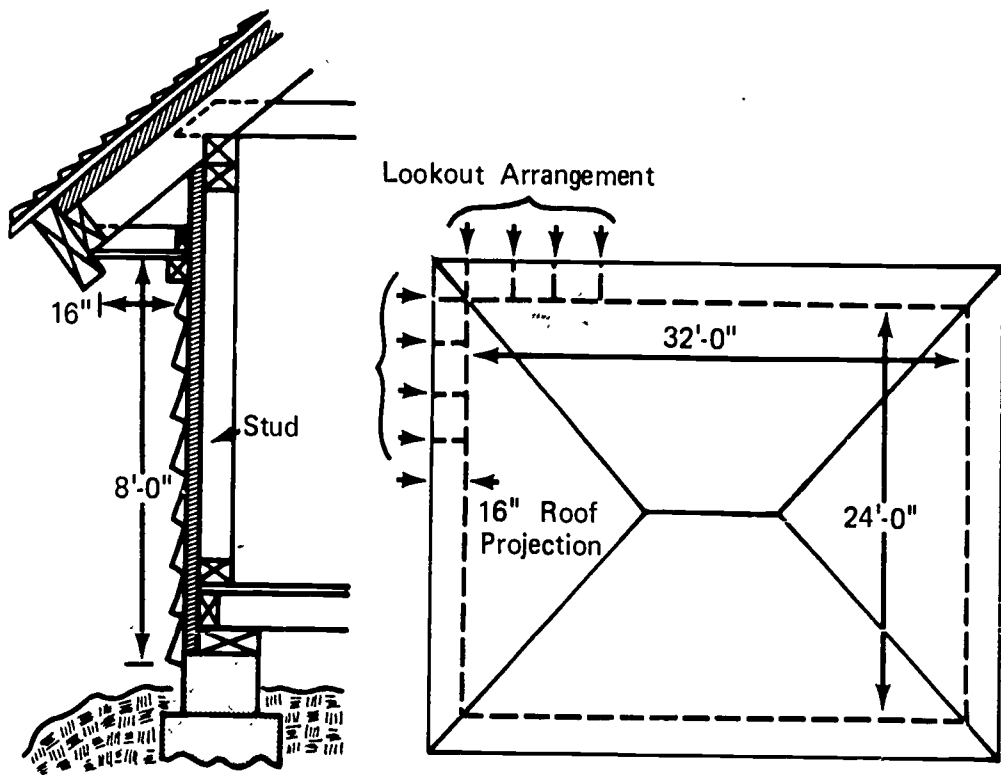

1001

EXTERIOR WALL COVERINGS AND TRIM
UNIT I

ANSWERS TO ASSIGNMENT SHEET

- a. 5
- b. 7
- c. 124
- d. 5
- e. 1120
- f. 9
- g. 112

EXTERIOR WALL COVERINGS AND TRIM
UNIT I

JOB SHEET #1--BUILD A HORIZONTAL BOX CORNICE

I. Tools and materials needed

A. Tools

1. Radial arm or table saw
2. Framing square
3. Steel tape (12 or 16 foot)
4. Claw hammer (16 ounces)
5. Level (4')
6. Crosscut handsaw
7. Chalk line and reel
8. Sawhorses
9. Planks to walk on.

B. Materials

1. 2 x 4's for lookouts
2. 1 x 4's for lookout ledger
3. Plywood for plancier
4. 1 x 8's for fascia
5. 1 x 2's for frieze
6. 4d box galvanized nails for plancier
7. 8d case galvanized nails for fascia
8. 8d box nails for lookout ledger
9. 16d box nails for lookouts

1003

JOB SHEET #1

II. Procedure (See Transparency 2.)

A. Hip roof

1. Install the lookout ledger
 - a. Locate the lower edge of the ledger level with the bottom of the false fascia (Figure 1)

FIGURE 1

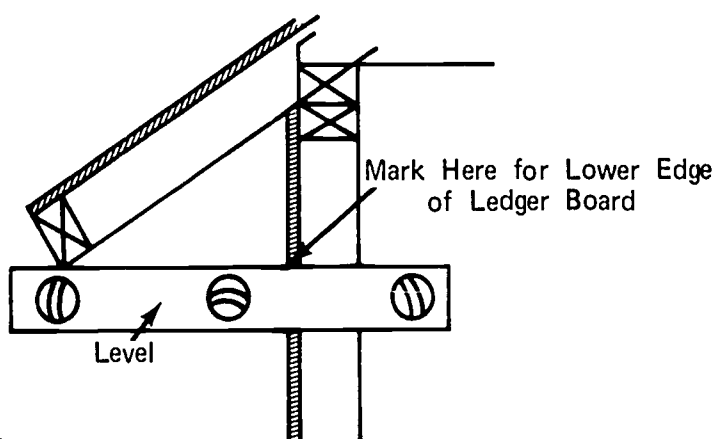

- b. Repeat step "a" at each corner
 - c. Snap a chalk line on each side of the building between the corner marks
 - d. Install one by four ledger board forming a band completely around the building
(NOTE: Nail on each stud with 2 - 8d nails.)
 - e. Mark the ledger board on twenty-four inch centers to come out on the same side of each rafter
2. Cut and install lookouts
 - a. Determine the length needed by measuring inside the lower edge of the false fascia to the outside of the ledger
 - b. Determine the number needed
 - c. Cut 2 x 4's to length using the radial arm or table saw

1004

JOB SHEET #1

d. Install lookouts

- 1) Nail the outside ends to the sides of rafters with 2 - 16d box nails
- 2) Toe nail the inside ends to the ledger board with 3 - 8d box nails

(NOTE: Be sure to keep the outside end flush with bottom of the false fascia and the inside end flush with the bottom of the ledger.)

3. Cut and install the plancier

a. Determine the width of the plancier

(NOTE: Most buildings require a sixteen or twenty-four inch plancier.)

b. Rip the plywood panels lengthwise into strips the width of the plancier

c. Mark the bottom of the false fascia at the center of each lookout

d. Mark on the sheathing in the middle of each lookout directly under the ledger

(NOTE: These marks will help to locate the lookouts for nailing the plancier.)

e. Nail the plancier in place approximately every six inches

(NOTE: All splices must be on a lookout and the outside edge of the plancier must be flush with the outside edge of the false fascia.)

4. Install the fascia

a. Start at a corner

(NOTE: Miter all corners and splices in between.)

b. Nail fascia in place using two 8d galvanized nails spaced approximately every sixteen inches

(NOTE: The top of the fascia should touch the bottom side of the shingles and the lower edge should project below the plancier at least one-half inch.)

JOB SHEET #1

5. Install the frieze

a. For wood siding

- 1) The siding must be in place before the frieze is installed
- 2) Install the frieze in the corner formed where the plancier meets the siding

(NOTE: Nail the frieze in place using 8d nails.)

b. For brick veneer (common brick)

(NOTE: The frieze may be made by ripping 1 3/4" strips of 1" lumber.)

- 1) Measure five inches out from the sheathing on the plancier and make a mark at each corner of the building

(NOTE: The spacing will vary with brick size.)

- 2) Snap a chalk line between the marks on the bottom side of the plancier

(NOTE: This line is the inside of the frieze and the outside of the brick.)

- 3) Nail the frieze to the bottom of the plancier with one 16d nail into each lookout

(NOTE: To keep from splitting the frieze, drill a hole through the frieze at each nail location.)

B. Gable roof

1. Install the lookout ledger

- a. Locate the lower edge of the ledger the same way as for the hip roof
- b. Install the 1 x 4 ledger board only on the sides of the building under the eave

(NOTE: Run the ledger board past the ends of the building as far as the outer face of the barge rafter.)

JOB SHEET #1

- c. Mark the ledger board on twenty-four inch centers to come out on the same side of each rafter
2. Cut and install lookouts
 - a. Determine the length needed the same way as for a hip roof
 - b. Determine the number needed
 (NOTE: Measure from the outside of one barge rafter to the outside of the opposite barge rafter in feet, divide by two, and add one for the end to get the number for one side. Double the number for the second side.)
 - c. Cut the four end lookouts to fit bottom of the barge rafter and install (Figure 2)

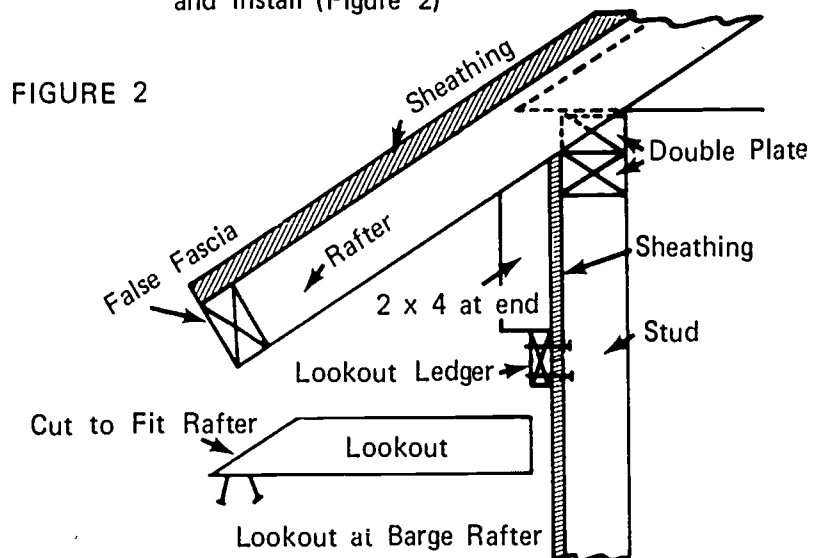

- d. Install the remainder of the lookouts the same as for the hip roof
3. Cut and install the plancier
 - a. Determine the width of the plancier
 - b. Rip the plywood panels into strips the width of the plancier
 (NOTE: The plancier for the rake of the roof may be different than for the eave.)
 - c. Mark the bottom of the false fascia at the center of each lookout

JOB SHEET #1

- d. Mark the sheathing in the middle of each lookout directly under the ledger board

(NOTE: These marks will help locate the lookouts for nailing the plancier.)

- e. Nail the plancier in place at the gable ends

(NOTE: Start at the peak of the rake and work down both sides. The lower ends need only to extend past the outside of the sheathing.)

- f. Nail the plancier in place under the eaves (Figure 3)

(NOTE: The plancier must be flush with the outside of the false fascia on the sides, flush with the outside face of the barge rafter on the ends, and flush with the outer face of the ledger where it projects past the end of the building.)

FIGURE 3

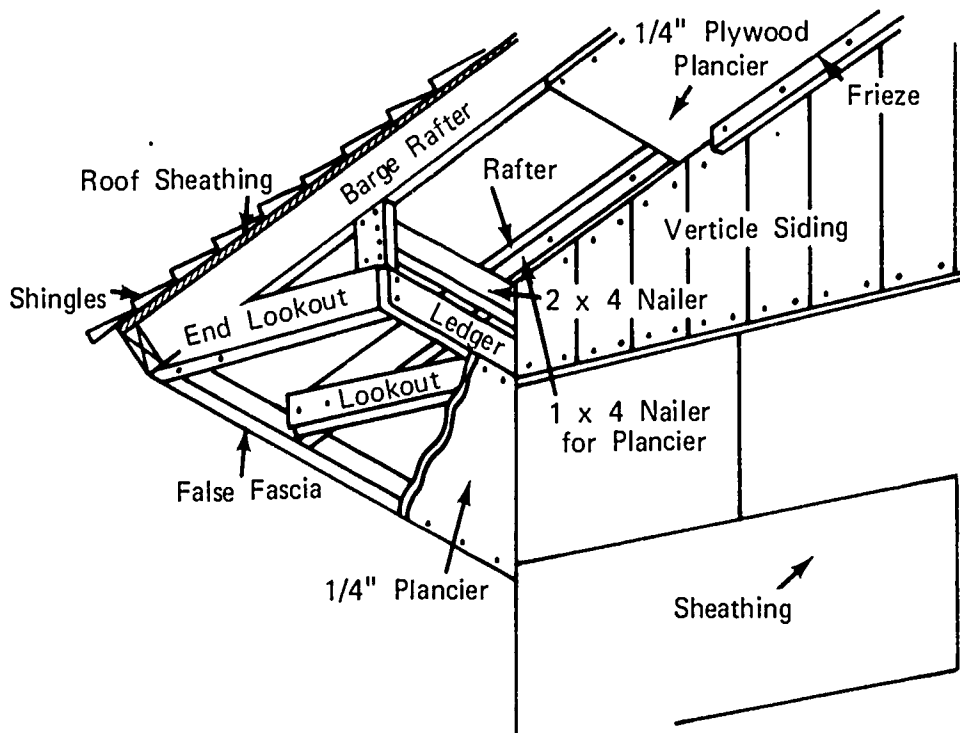

JOB SHEET #1

4. Install the fascia
 - a. Start at a corner

(NOTE: Miter all corners and splices in between.)

- b. Nail fascia in place using two 8d galvanized nails approximately every sixteen inches (Figure 4)

(NOTE: The top of the fascia should touch the bottom side of the shingles and the lower edge should project below the plancier at least one-half inch, an additional 1 x 2 trim board may be placed at the top of the fascia if desired.)

FIGURE 4

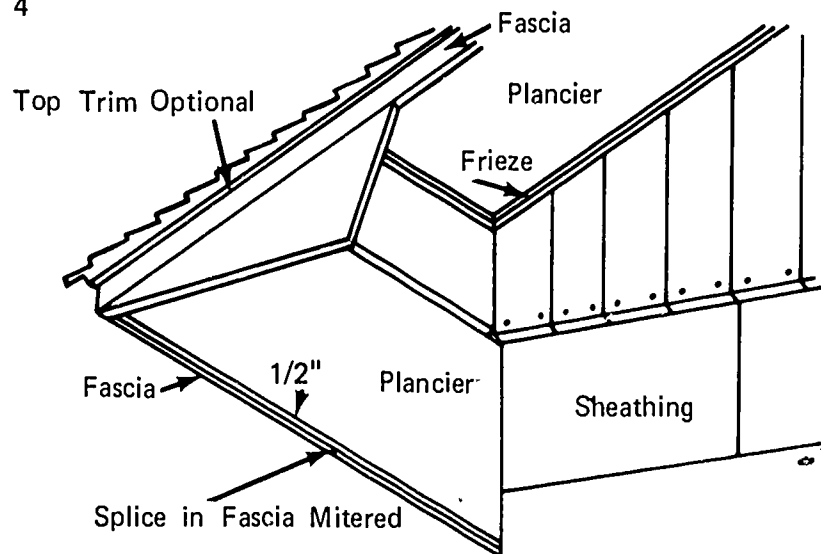

5. Install the frieze
 - a. For wood siding
 - 1) The siding must be in place before the frieze is installed
 - 2) Install the frieze in the corner formed by the plancier meeting the siding

(NOTE: Nail the frieze in place.)
 - b. For brick veneer (common brick)

(NOTE: The frieze may be made by ripping 1 3/4" strips from 1" lumber.)

 - 1) Measure five inches out from the sheathing on the plancier and make a mark at each corner of the building

(NOTE: This will vary with different brick.)

JOB SHEET #1

- 2) Snap a chalk line between the marks on the bottom side of the plancier

(NOTE: This line is the inside of the frieze and the outside of the brick.)
 - 3) Nail the frieze to the bottom of the plancier with one 16d nail into each lookout

(NOTE: To keep from splitting the frieze, drill a hole through the frieze at each nail location.)

(NOTE: All splices should be on a lookout.)
6. Finish boxing in the end of the eave (Figure 5)

FIGURE 5

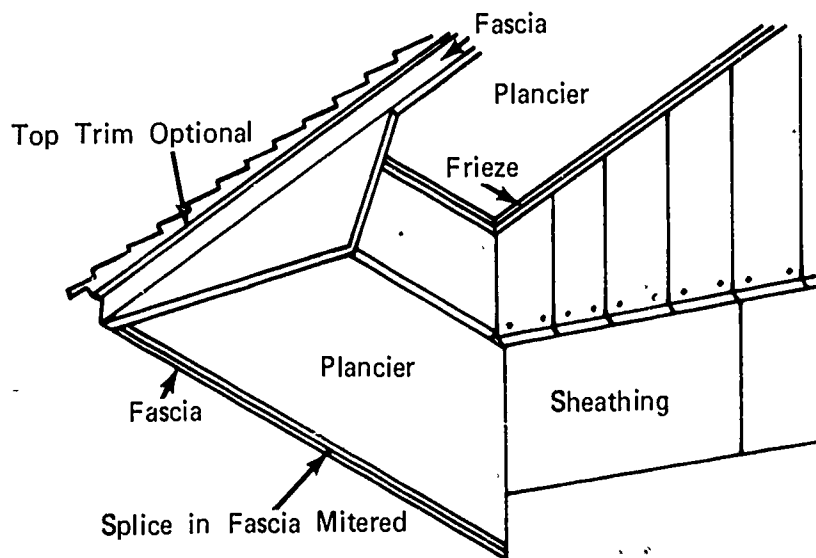

EXTERIOR WALL COVERINGS AND TRIM
UNIT I

JOB SHEET #2--APPLY WOOD SIDING

I. Tools and materials needed

A. Tools

1. Radial arm or table saw
2. Crosscut handsaw
3. Electric handsaw
4. Claw hammer (16 oz)
5. Chalk line and reel
6. Steel tape (12 or 16 foot)
7. Saw horses and planks
8. Framing square
9. Tri-square

B. Materials

1. Siding
2. Corner material
 - a. Metal (inside and outside and nails)
 - b. Lumber
3. Nails (as specified)

II. Procedure

(NOTE: All types of horizontal siding are installed basically the same except for the starter piece.)

A. Prepare building to receive siding

1. Determine the method of fitting corners. There are three basic methods (Figure 1)

JOB SHEET #2

Diagram of Corners

FIGURE 1

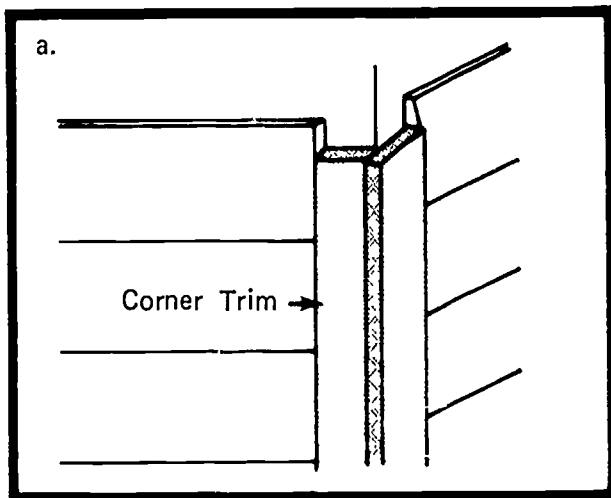

Siding cut and fitted to corner trim at the corner of the wall.

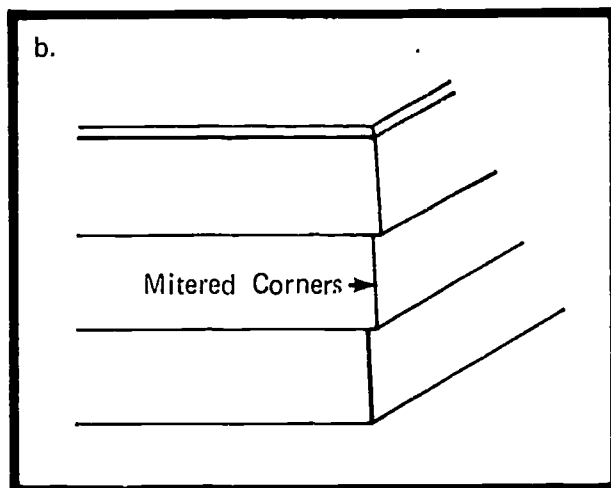

Siding boards mitered at the corners.

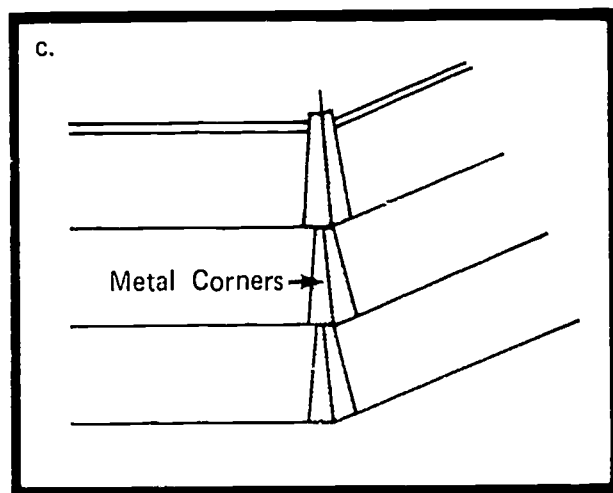

Metal corners are used to cover up the joints and to keep out moisture.

JOB SHEET #2

2. For method "A" install the inside and outside trim boards
 - a. Inside corner trim consists of a 1" x 1" strip nailed into the corner for the ends of the siding to butt against
 - b. Use 2 - 1 x 4's for the outside corners as in illustration "A"

(NOTE: The bottom of the trim boards should extend one inch below the bottom course of sheathing.)

3. Determine the amount of exposure desired for lap siding
4. Lay off the locations for the bottom of each siding board on the corner boards (Figure 2)

FIGURE 2

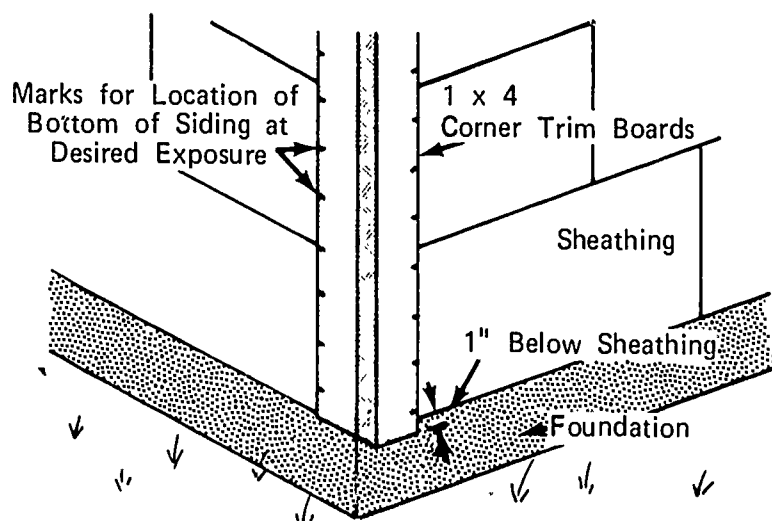

5. Cut and nail a furring strip the thickness of the top edge of the lap siding being used to the bottom of the wall (Figure 3)

(NOTE: This is done only on lap siding.)

FIGURE 3

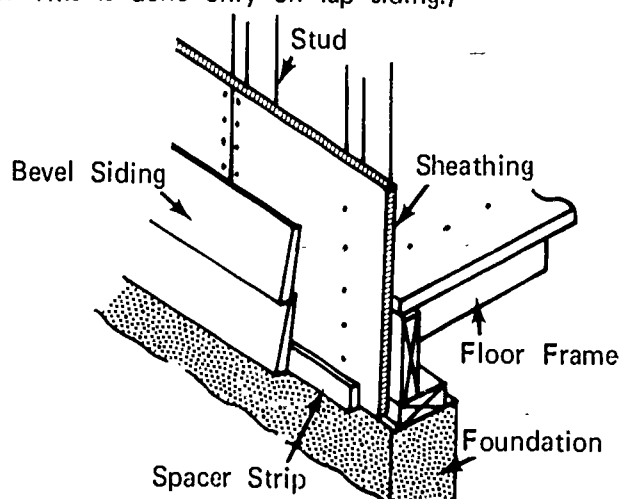

JOB SHEET #2

(NOTE: Chalk a line at the point on the sheathing where the top of the spacer strip is to be in order to insure that the first course is straight.)

6. Make a spacing jig for spacing siding in between corners (Figure 4)

(NOTE: See the illustration below for a diagram of the "spacer jig" and how it is used.)

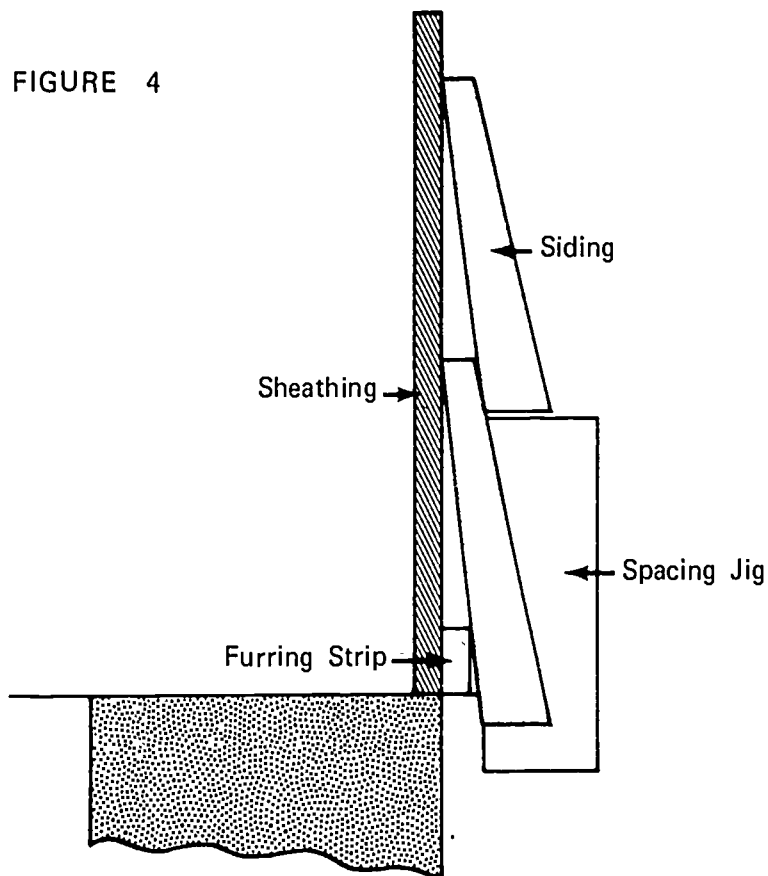

Jig for spacing siding.

7. Install the remainder of the siding working from the bottom up
(NOTE: All joints must fit tight, all splices must be on a stud.)

1014

JOB SHEET #2

- Trim around windows and doors (Figure 5)

FIGURE

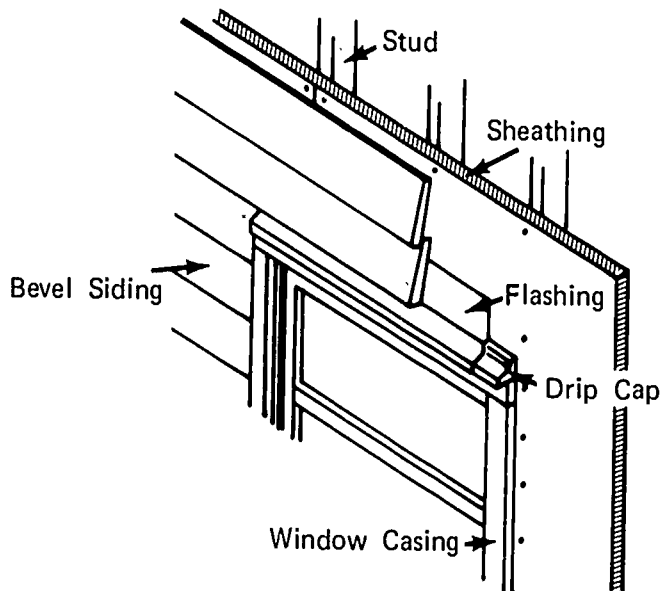

- Caulk all joints around doors, windows, and at inside and outside corners (Figure 6)
- Follow the nailing patterns for each style of siding

FIGURE 6

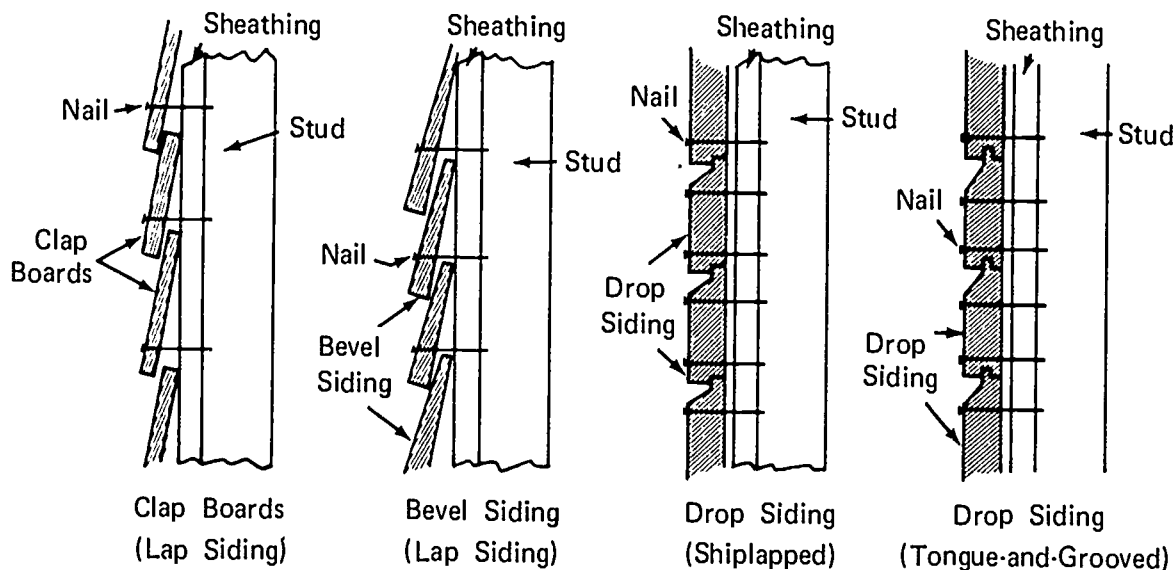

EXTERIOR WALL COVERINGS AND TRIM
UNIT I

TEST

1. Match the following definitions to the list of terms.

- | | |
|--|-------------------|
| _____ a. A strip of wood placed across a surface to cover joints | 1. Fascia |
| _____ b. A method of closing in the eave to form a box type structure using the wall of the building, the roof, the fascia, and the plancier | 2. Furring strip |
| _____ c. A molding for exterior window and door frames against which the finished brick is laid | 3. Boxed cornice |
| _____ d. The flat outside horizontal member of a cornice which is attached to the rafter tails | 4. Lookout ledger |
| _____ e. A trim member that forms a band around the top of the wall of a building covering the joint where the wall meets the cornice | 5. Plancier |
| _____ f. Flat pieces of lumber used to build up an irregular framing to an even surface for the application of flooring, ceiling, or wall covering | 6. Batten |
| _____ g. Short wooden framing members attached to a ledger board at the top of the wall and to the rafter tails for attachment of the plancier | 7. Brick molding |
| _____ h. Usually a 1 x 4 band around a building at the top of the wall to which the lookouts are attached | 8. Frieze |
| _____ i. The projection of the roof of a building beyond the wall | 9. Lookouts |
| | 10. Overhang |
| | 11. Barge board |

- _____ j. The underside of the cornice sometimes called a soffit
- _____ k. The trim board or fascia at the gable end of a building and attached directly to the barge rafter

2. Identify the three styles of cornice pictured below.

- a.
- b.
- c.

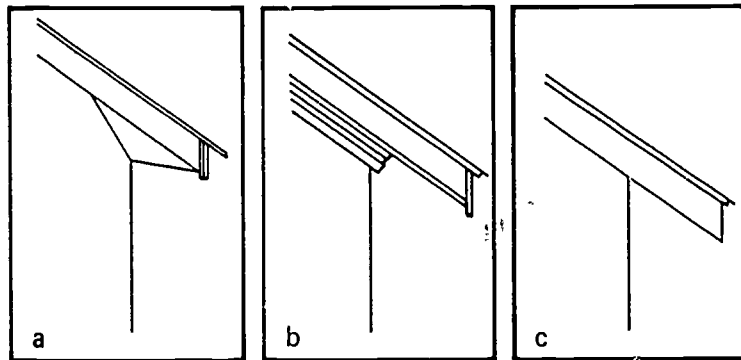

3. Name the parts of the cornice pictured below.

- a.
- b.
- c.
- d.
- e.
- f.
- g.

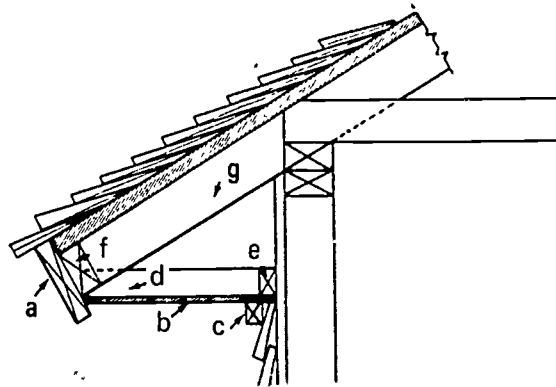

4. Identify the types of molding pictured below.

- ___ a. Bed mould
- ___ b. Crown mould
- ___ c. Cove mold

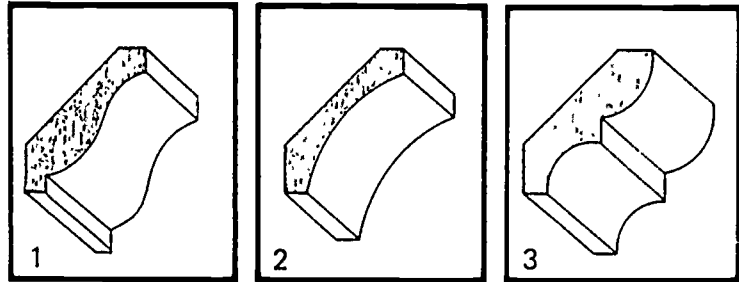

5. Name five types of exterior wall coverings.

- a.
- b.
- c.
- d.
- e.

6. Identify the four styles of siding pictured below.

- a.
- b.
- c.
- d.

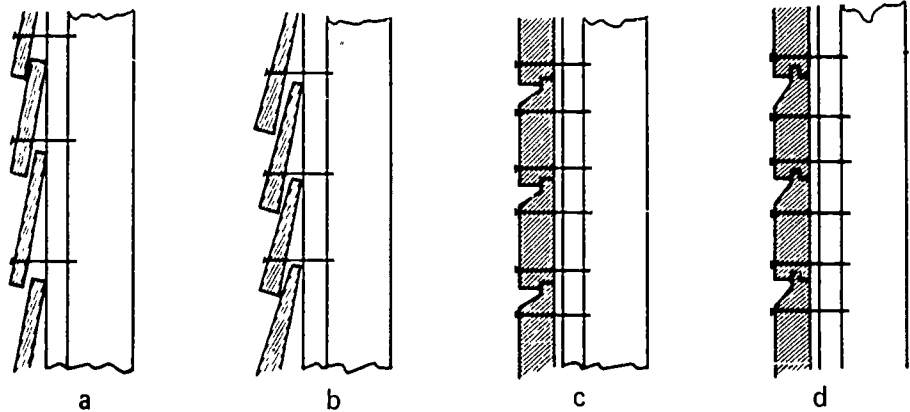

7. Estimate the number of square feet of eight-inch bevel siding needed for the building pictured below.

_____ sq. ft.

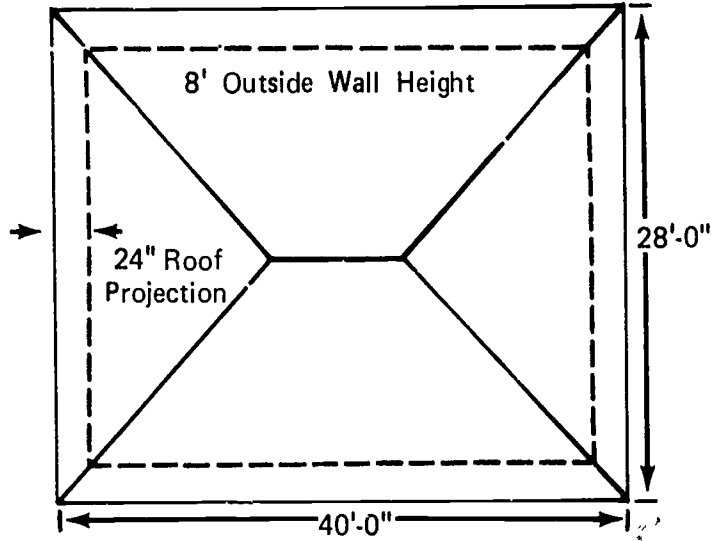

8. Demonstrate the ability to:

- a. Build a box cornice.
- b. Apply wood siding.

(NOTE: If this has not been accomplished prior to the test, ask the instructor when the above activities should be completed.)

EXTERIOR WALL COVERINGS AND TRIM
UNIT I

ANSWERS TO TEST

1.
 - a. 6
 - b. 3
 - c. 7
 - d. 1
 - e. 8
 - f. 2
 - g. 9
 - h. 4
 - i. 10
 - j. 5
 - k. 11
2.
 - a. Horizontal box cornice
 - b. Sloping box cornice
 - c. Open cornice
3.
 - a. Fascia
 - b. Plancier
 - c. Frieze
 - d. Lookout
 - e. Lookout ledger
 - f. False fascia
 - g. Rafter
4.
 - a. 3
 - b. 1
 - c. 2

5.
 - a. Horizontal siding
 - b. Shingles
 - c. Verticle grooved panels
 - d. Boards and battens
 - e. Masonry
6.
 - a. Clap boards (lap siding)
 - b. Bevel siding (lap siding)
 - c. Drop siding (shiplapped)
 - d. Drop siding (tongue-and-grooved)
7. 1,200 sq. ft.
8. Performance skills will be evaluated according to the criteria listed on the progress chart.

DRY WALL UNIT I

TERMINAL OBJECTIVE

After completion of this unit, the student should be able to define terms associated with dry wall construction and list the standard sizes and shapes of gypsum wallboard. He should be able to state the advantages of using gypsum wallboard, estimate the amount of material needed, and install gypsum wallboard and laminated gypsum wallboard. This knowledge will be evidenced through demonstration and by scoring eighty-five percent on the unit test.

SPECIFIC OBJECTIVES

After completion of this unit, the student should be able to:

1. Match terms associated with dry wall application to a list of definitions.
2. List the standard sizes of gypsum wallboard.
3. List the standard shapes of gypsum wallboard.
4. State five advantages of using gypsum wallboard.
5. Estimate the amount of material needed to finish the interior of a building with gypsum wallboard.
6. Demonstrate the ability to:
 - a. Install gypsum wallboard.
 - b. Apply laminated gypsum wallboard.

DRY WALL
UNIT I

SUGGESTED ACTIVITIES

- I. Instructor:
 - A. Provide students with objective sheet.
 - B. Provide students with information, assignment, and job sheets.
 - C. Make transparencies.
 - D. Discuss terminal and specific objectives.
 - E. Discuss information and assignment sheets.
 - F. Demonstrate and discuss procedures outlined in job sheets.
 - G. Give test.
- II. Student:
 - A. Read objective sheet.
 - B. Study information sheet.
 - C. Complete assignment sheet.
 - D. Demonstrate the ability to accomplish the procedures outlined in the job sheets.
 - E. Take test.

INSTRUCTIONAL MATERIALS

- I. Included in this unit:
 - A. Objective sheet
 - B. Information sheet
 - C. Transparency masters
 1. TM 1--Shapes of Gypsum Wallboard
 2. TM 2--Patterns for Hanging Wallboard
 3. TM 3--Fastening and Finishing Materials
 - D. Assignment Sheet #1--Material Estimating
 - E. Answers to assignment sheet

F. Job sheets

1. Job Sheet #1--Install Gypsum Wallboard
2. Job Sheet #2--Apply Laminated Gypsum Wallboard

G. Test

H. Answers to test

II. References:

- A. Burke, Arthur E., J. Ralph Dalzell, and Gilbert Townsend. *Architectural and Building Trades Dictionary*. Chicago, Illinois: American Technical Society, 1955.
- B. Cooper, George H. and Stanley Badzinski Jr. *Building and Construction Estimating*. New York: McGraw-Hill, 1971.
- C. Durbahn, Walter E. and Elmer W. Sundberg. *Fundamentals of Carpentry*. Third Edition. Chicago, Illinois: American Technical Society, 1963.
- D. Feirer, John L. *Woodworking for Industry*. Peoria, Illinois: Charles Bennett Company, Inc., 1971.
- E. Lair, E. A. *Carpentry for the Building Trades*. St. Louis, Missouri: McGraw-Hill Book Company, 1953.
- F. Smith, Ronald C. *Principles and Practices of Light Construction*. Englewood Cliffs, New Jersey: Prentice Hall, Inc., 1970.
- G. Wagner, Willis H. *Modern Carpentry*. Homewood, Illinois: Goodheart-Willcox, 1969.

DRY WALL
UNIT I

INFORMATION SHEET

I. Terms and definitions

- A. Backing--Strips of wood nailed at the inside angles of walls and partitions to provide solid corners for nailing the wallboard
- B. Dimple--The impression formed in the surface of gypsum wallboard when the nail is driven to the proper depth
- C. Dry wall--A type of construction where the interior finish material used is something other than plaster, such as gypsum wallboard
- D. Featheredge--Anything which tapers off to a thin featherlike edge
- E. Gypsum board--Modular panels from one-fourth to five-eighths inch thick, four feet wide, and six to sixteen feet in length composed of a core of gypsum sandwiched between two layers of paper
- F. Joint--The place where two pieces of wallboard meet
- G. Joint cement--A specially prepared cement used to bond the perfa-tape to the gypsum wallboard at the joints
- H. Perfa-tape--Perforated paper joint tape approximately two inches wide and in 60, 250, and 500 foot rolls
- I. Topping--A specially prepared substance in heavy paste form used to cover the perfa-tape and fill in the joint

II. Standard sizes of gypsum wallboard

A. Thickness

- 1. 1/4 inch
- 2. 3/8 inch
- 3. 1/2 inch
- 4. 5/8 inch

B. Width--4 feet

C. Length

- 1. 6 feet
- 2. 8 feet
- 3. 10 feet

INFORMATION SHEET

4. 12 feet
5. 14 feet
6. 16 feet

(NOTE: $1/2'' \times 4' \times 8'$ is the most common.)

III. Standard edge shapes of gypsum wallboard
(Transparency 1)

- A. Tapered edge
- B. Square edge

IV. Advantages of using gypsum wallboard

- A. Easy to apply
- B. Low cost
- C. Easy to maintain
- D. Saves time
- E. Non-combustible
- F. Provides a good base for applying other finish materials such as paneling, ceramic tile, accoustical tile, or wallpaper

V. Estimate the amount of gypsum wallboard needed to finish the interior walls and ceilings of a building

(NOTE: The unit of measurement for gypsum wallboard is the square foot.)

A. Determine the total ceiling and wall area to be covered

(NOTE: No allowance is made for window and door openings unless the opening is exceptionally large.)

1. Compute the area for each room separately

(NOTE: This is done to cut down on the number of joints by ordering wallboard of a size or combination of sizes to more nearly fit the room.)

2. Combine the various sizes of wallboard into groups to facilitate ordering, such as: (Transparency 2)

50 pieces $1/2'' \times 4' \times 12'$ tapered

120 pieces $1/2'' \times 4' \times 8'$ tapered

INFORMATION SHEET

20 pieces 1/2" x 4' x 10' tapered

(NOTE: Ceiling wallboard should run at right angles to the joist and horizontally on the walls whenever possible.)

- B. Determine the fastening and finishing materials required using the table below (Transparency 3)

Fastening and Finishing Materials Required for
1,000 Square Feet Gypsum Drywall

Material	Amount
1 1/4" annular ring nail	6 1/4 lb.
1 3/8" annular ring nail	6 3/4 lb.
1" drywall screw	3 lb.
1 1/4" drywall screw	4 1/4 lb.
1 5/8" drywall screw	5 1/2 lb.
Joint compound	50 lb. (25 lb. bags)
Perforated tape	360 to 400 ft. (50 foot rolls)
Texture paint	10 to 50 lb. (25 lb. bags)

(NOTE: Different drywall adhesives have different coverage capabilities. It is therefore recommended that the estimator check the coverage for the type of material to be used.)

- C. Determine the number of outside metal corners needed

(NOTE: Any outside corner that will not receive casing or any other treatment should be protected with a metal corner.)

Shapes of Gypsum Wallboard

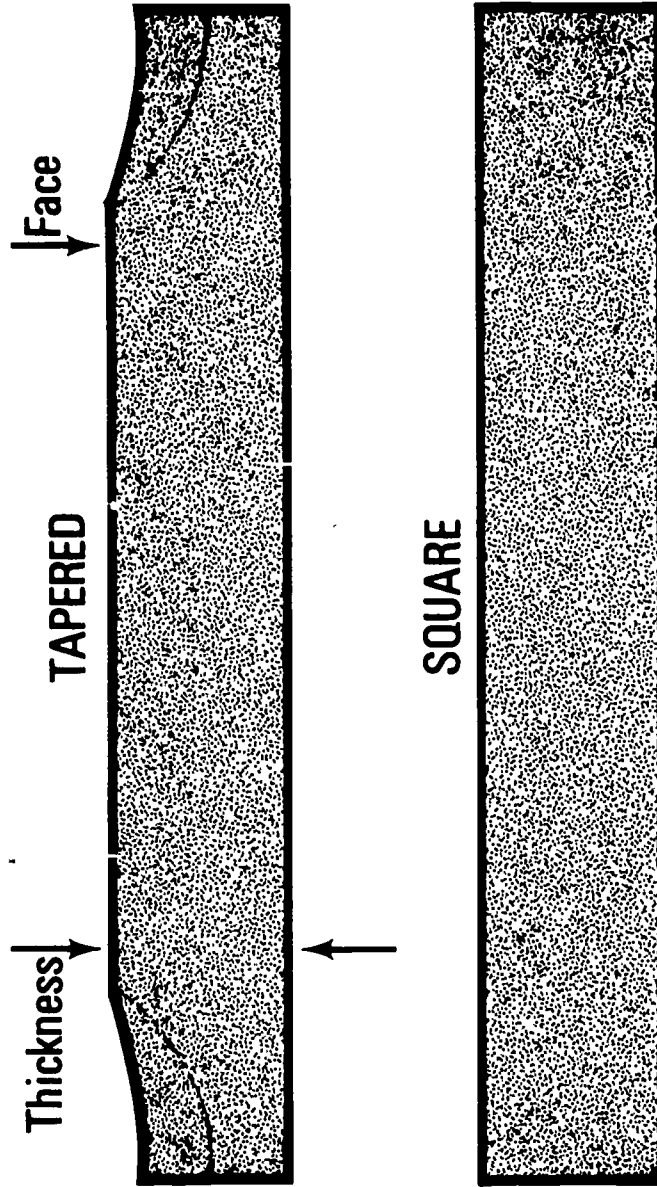

Patterns for Hanging Wallboard

CEILINGS

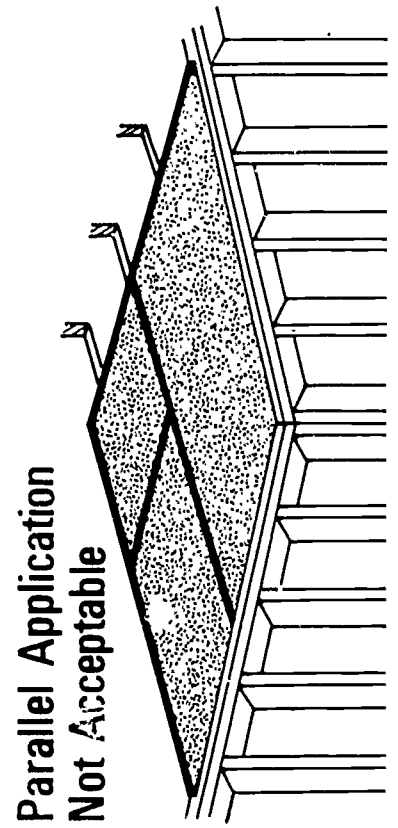
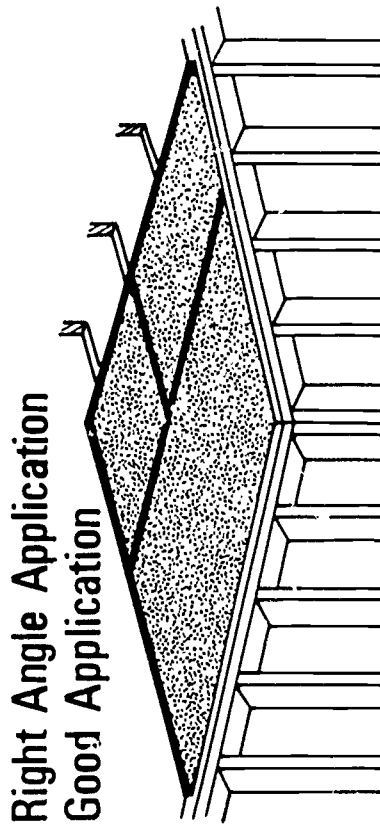

WALLS

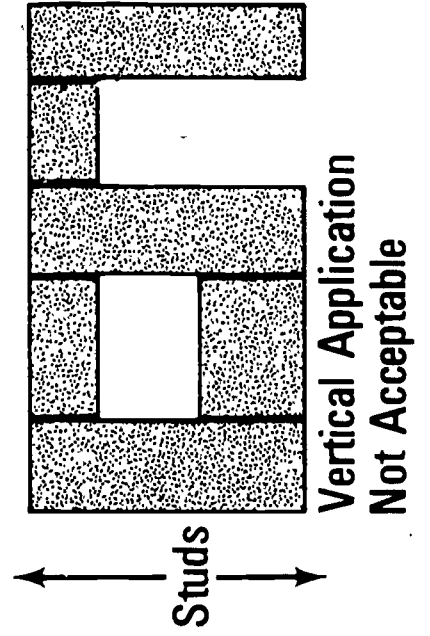
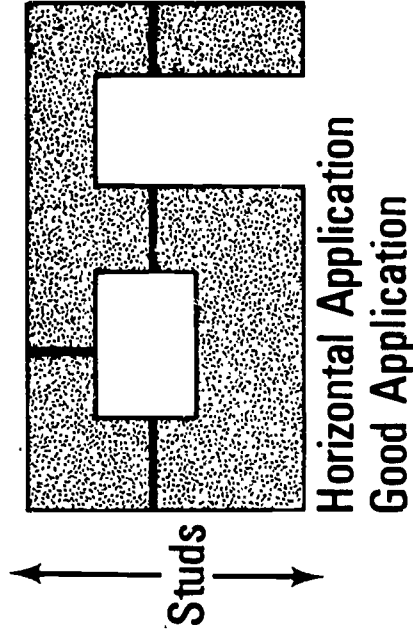

Fastening and Finishing Materials

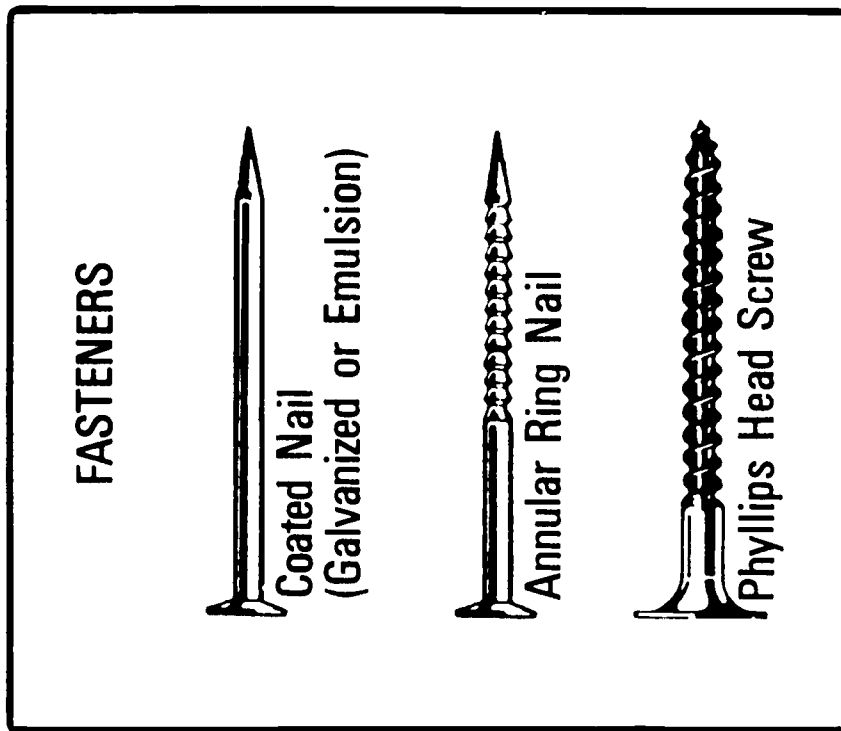
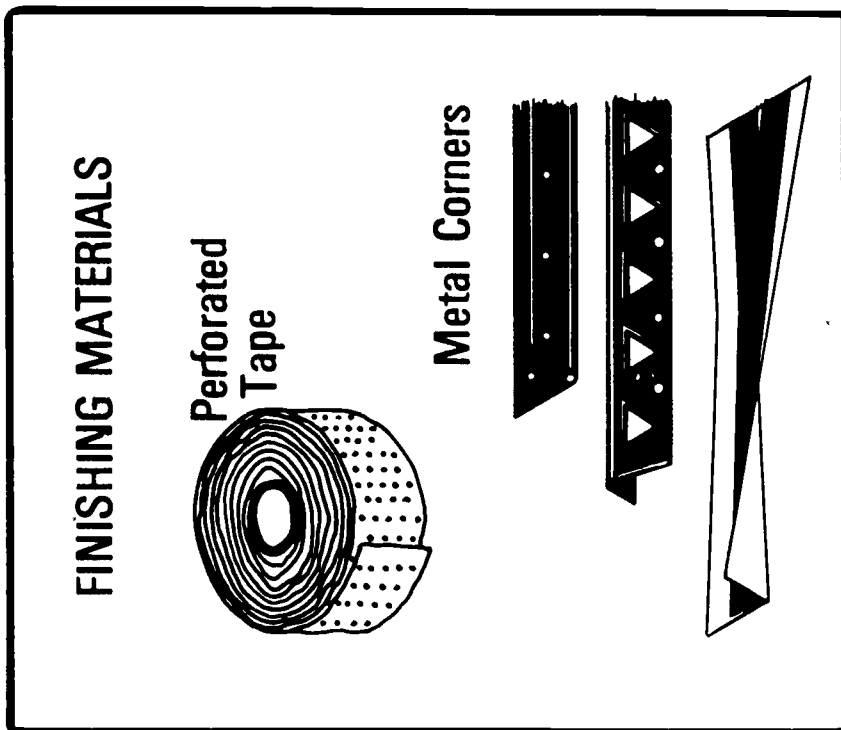

DRY WALL
UNIT I

ASSIGNMENT SHEET #1--MATERIAL ESTIMATING

Using the information sheet for this unit, calculate the amount of the following materials needed to apply and finish gypsum wallboard to the ceilings and walls of the room pictured below.

- _____ a. Sq. ft. of 1/2" gypsum wallboard
- _____ b. Pounds 1 1/4" annular ring nails
- _____ c. Feet of perforated tape (50' rolls)
- _____ d. Joint compound (25 pound bags)
- _____ e. Metal outside corners (8' lengths)

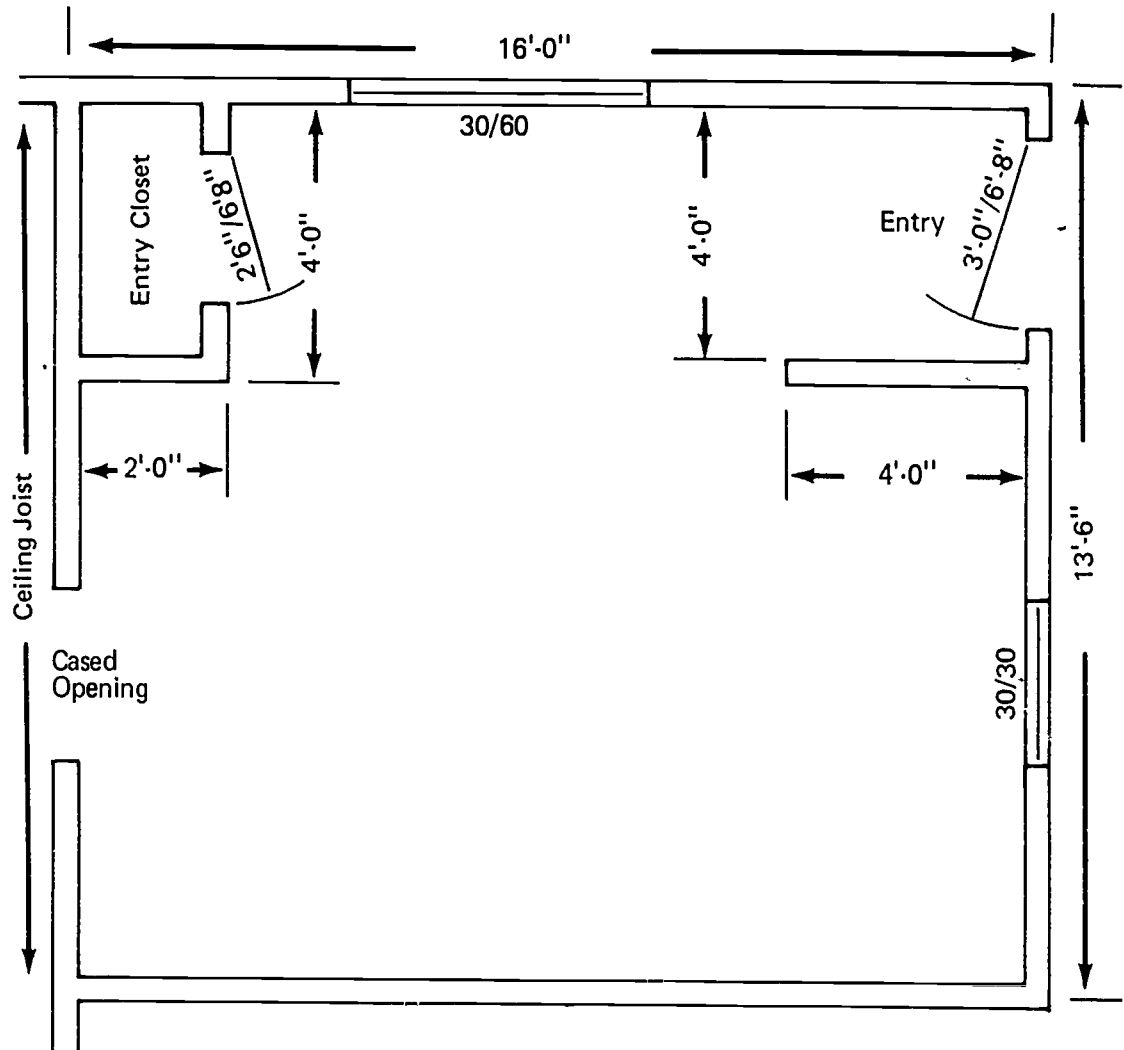

DRY WALL
UNIT I

ANSWERS TO ASSIGNMENT SHEET #1

- a. 848
- b. 5 1/2
- c. 350
- d. 100
- e. 3

DRY WALL UNIT I

JOB SHEET #1--INSTALL GYPSUM WALLBOARD

(NOTE: Metal stud installation is very similar to wood stud installation.)

I. Tools and materials needed

A. Tools

1. Drywallers hatchet (or claw hammer)
2. Steel tape measure (12 or 16 foot)
3. Nail pouch
4. Utility knife
5. Straight edge (4' or longer)
6. Compass saw
7. Wallboard jacks
8. Ceiling "T's"

B. Materials

1. Gypsum wallboard
2. Nails
3. Metal corners

II. Procedure

(NOTE: Before any gypsum wallboard is applied, be sure that all electrical, water, gas, heating, and air conditioning rough-in work is completed, and the exterior wall insulation is installed.)

A. Ceiling

(NOTE: Ceiling wallboard should always be applied first, and the length of the sheet should run at right angles to the ceiling joist.) (Figure 1)

FIGURE 1

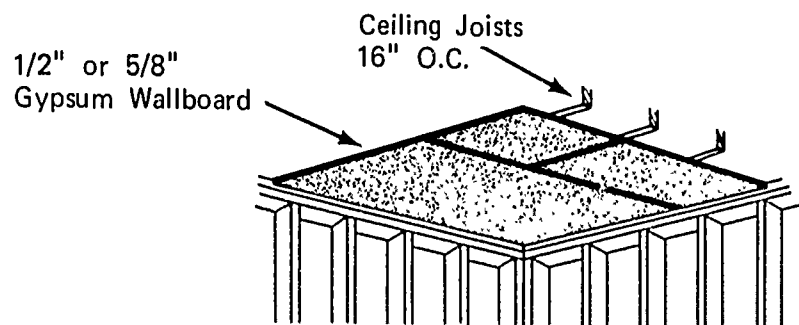

JOB SHEET #1

1. Install backing at ceiling and corners (If it has not already been done.) (Figure 2)

FIGURE 2

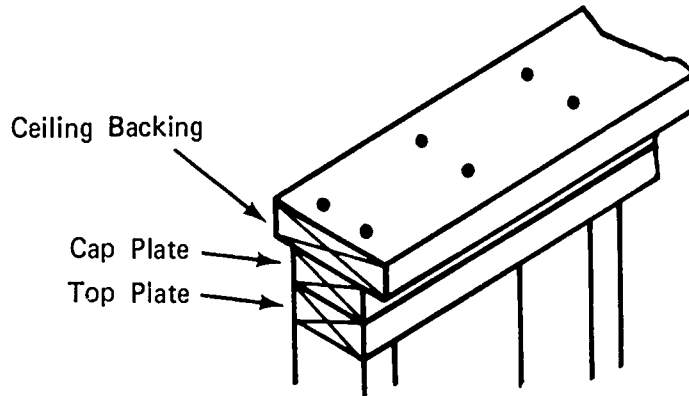

2. Construct two or more "T's" to help support the ceiling wallboard while nailing (Figure 3)

FIGURE 3

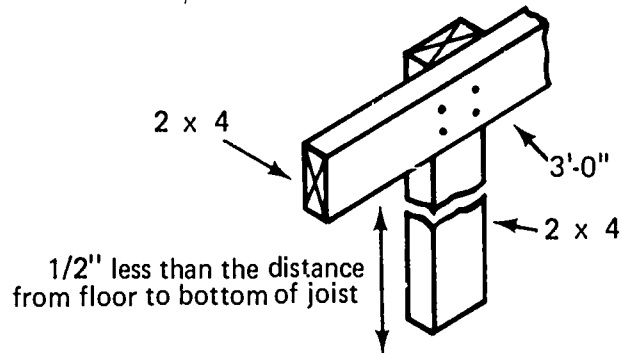

3. Make all measurements for cutting to length and width accurately

(NOTE: Gypsum wallboard will not compress if cut too long, therefore, these cuts should be made approximately one-eighth inch less than the exact measurement.)

4. Cutouts for electrical boxes should not be more than one-eighth inch greater than the outside dimensions of the box

(NOTE: All measurements should be from the top and side. Cut to length by using a sharp knife to cut along the straight edge through the outer paper, break the wallboard at the cut, and finish cutting the bottom paper with the knife. Cut out holes for electrical boxes with a compass saw.)

JOB SHEET #1

5. Ceiling wallboard should be nailed approximately every seven inches on the joists

(NOTE: Start at the center of the sheet and work out using the "T's" to support and hold the wallboard firmly against the joists.)

(CAUTION: The nails must be driven deep enough to form a slight dimple or depression in the face of the wallboard but not deep enough to break the surface paper.) (Figure 4)

FIGURE 4

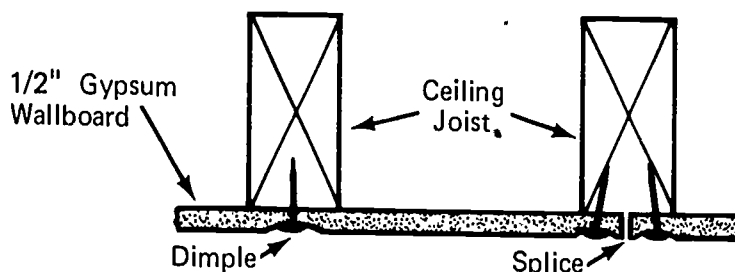

B. Walls (Figure 5)

(NOTE: Run sheets horizontally whenever possible.)

FIGURE 5

The sketch at the right shows proper cutting and fitting of the face layer, where doors and windows are in wall. Wherever practical, vertical end joints on side walls should be placed above door and window openings, to reduce the joint treatment to a minimum.

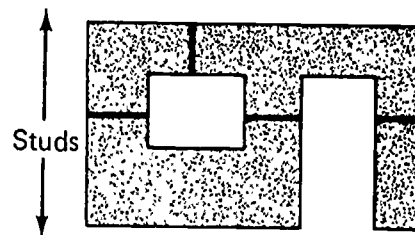

1. Hang the first sheet horizontally being sure that the top edge is snug against the ceiling

(NOTE: Nail the wallboard to the studs with a nail approximately every nine inches following the same instructions for dimpling as on the ceiling.)

JOB SHEET #1

2. Hand the bottom sheet using the wallboard jacks to lift the wallboard and hold it in place (Figure 6)

FIGURE 6

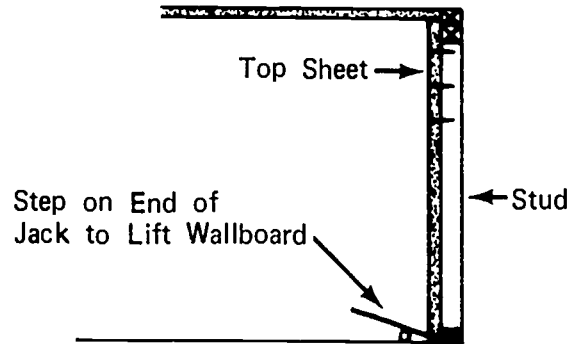

3. Follow the same procedure for cutting to length and for cutting out electrical boxes as used for the ceiling
4. Allow material to cover door and window openings and cut out later

1038

DRY WALL
UNIT I

JOB SHEET #2--APPLY LAMINATED GYPSUM WALLBOARD

I. Tools and materials needed

A. Tools

1. Drywall hammer
2. Utility knife
3. Carrier lifter
4. Foot lifter
5. Utility saw
6. Drywall T square
7. Drywall screwdriver
8. Rubber mallet

B. Materials

1. Gypsum wallboard (backer board)
2. Gypsum wallboard (recessed edge)
3. Screws
4. Adhesive

III. Procedure

A. Install base layer (backer board)

1. Stand panel with long length vertical

(NOTE: When using vinyl panels for face layer, install base layer horizontal.)

2. Center edge of panel on stud
3. Screw panel to stud

(NOTE: Stagger panels on opposite side of wall so they occur on different studs.)

4. Continue installation repeating step A-1 through A-3

(NOTE: Screw spacing for adhesive laminated face should be 8" o.c. at joints and 12" o.c. in the field.)

JOB SHEET #2

B. Install face panel

1. Cut panel for length
(NOTE: Face panel will be horizontal.)
2. Lay panel on horses back side up
3. Spread adhesive on panel (Figure 1)

(NOTE: Adhesive beads should be 3/8" wide by 1/2" high and maximum of 2" o.c.)

FIGURE 1

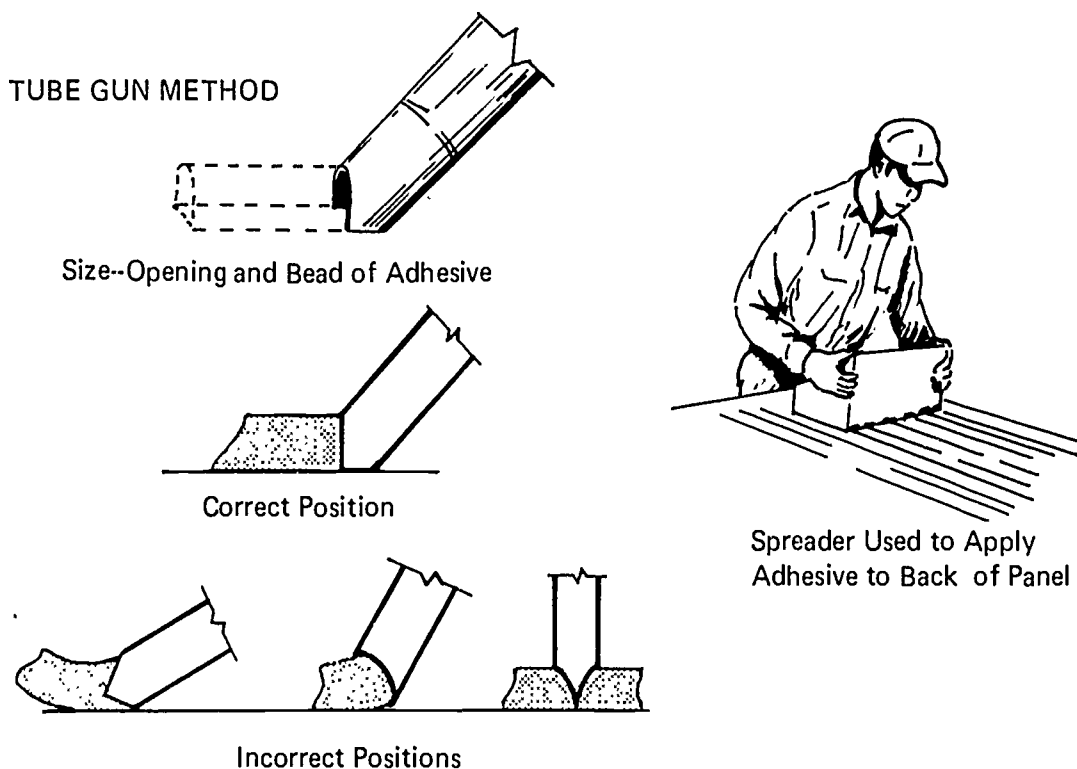

4. Position panel on base panel
(NOTE: Install top panel first on 8' - 2" ceiling.)
5. Secure panel by temporary nailing
(NOTE: Impact entire area with a rubber mallet to assure a good bond.)

DRY WALL
UNIT I

INFORMATION SHEET

I. Terms and definitions

- A. Backing--Strips of wood nailed at the inside angles of walls and partitions to provide solid corners for nailing the wallboard
- B. Dimple--The impression formed in the surface of gypsum wallboard when the nail is driven to the proper depth
- C. Dry wall--A type of construction where the interior finish material used is something other than plaster, such as gypsum wallboard
- D. Featheredge--Anything which tapers off to a thin featherlike edge
- E. Gypsum board--Modular panels from one-fourth to five-eighths inch thick, four feet wide, and six to sixteen feet in length composed of a core of gypsum sandwiched between two layers of paper
- F. Joint--The place where two pieces of wallboard meet
- G. Joint cement--A specially prepared cement used to bond the perfa-tape to the gypsum wallboard at the joints
- H. Perfa-tape--Perforated paper joint tape approximately two inches wide and in 60, 250, and 500 foot rolls
- I. Topping--A specially prepared substance in heavy paste form used to cover the perfa-tape and fill in the joint

II. Standard sizes of gypsum wallboard

A. Thickness

- 1. 1/4 inch
- 2. 3/8 inch
- 3. 1/2 inch
- 4. 5/8 inch

B. Width--4 feet

C. Length

- 1. 6 feet
- 2. 8 feet
- 3. 10 feet

DRY WALL
UNIT I

TEST

1. Match the following list of terms to the correct definition.

- | | |
|---|-----------------|
| _____ a. A type of construction where the interior finish material used is something other than plaster, such as gypsum wallboard | 1. Backing |
| _____ b. The place where two pieces of wallboard meet | 2. Dimple |
| _____ c. The impression formed in the surface of gypsum wallboard when the nail is driven to the proper depth | 3. Dry wall |
| _____ d. A specially prepared substance in heavy paste form used to cover the perfa-tape and fill in the joint | 4. Featheredge |
| _____ e. Anything which tapers off to a thin featherlike edge | 5. Gypsum board |
| _____ f. A specially prepared cement used to bond the perfa-tape to the gypsum wallboard at the joints | 6. Joint |
| _____ g. Strips of wood nailed at the inside angles of walls and partitions to provide solid corners for nailing the wallboard | 7. Joint cement |
| _____ h. Modular panels from one-fourth to five-eighths inch thick, four feet wide, and six to sixteen feet in length composed of a core of gypsum sandwiched between two layers of paper | 8. Perfa-tape |
| _____ i. Perforated paper joint tape approximately two inches wide and in 60, 250, and 500 foot rolls | 9. Topping |

2. List the standard sizes of gypsum wallboard.

- _____ a. Thickness
- _____ b. Width
- _____ c. Length

3. List the standard shapes of gypsum wallboard.

- _____ a.
- _____ b.

4. State five advantages of using gypsum wallboard.

- a.
- b.
- c.
- d.
- e.

5. Estimate the amount of one-half inch gypsum wallboard needed for the walls and ceiling of the room illustrated below.

- _____ a. Walls
- _____ b. Ceiling

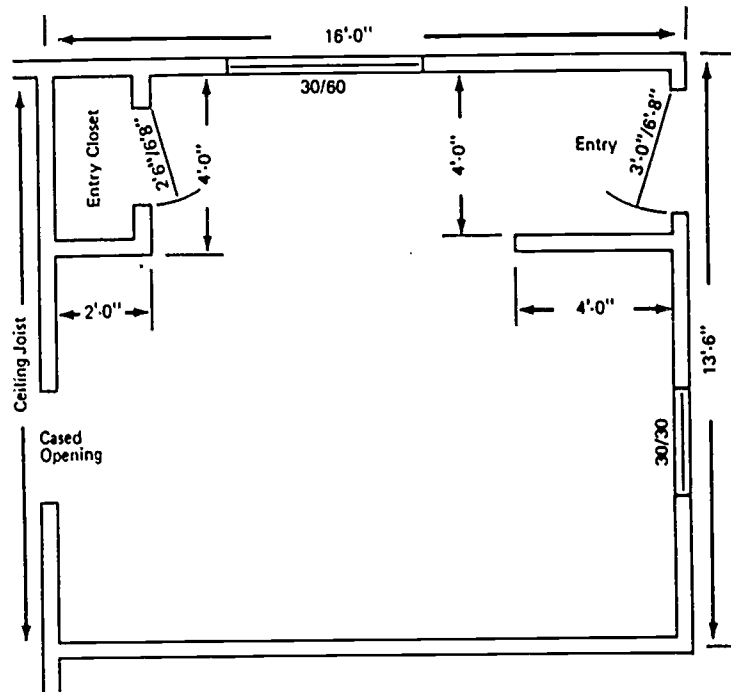

6. Demonstrate the ability to:
 - a. Install gypsum wallboard
 - b. Apply laminated gypsum wallboard.

(NOTE: If this has not been accomplished prior to the test, ask the instructor when the above activities should be completed.)

DRY WALL
UNIT I

ANSWERS TO TEST

1.
 - a. 3
 - b. 6
 - c. 2
 - d. 9
 - e. 4
 - f. 7
 - g. 1
 - h. 5
 - i. 8
2.
 - a. $1/4$, $3/8$, $1/2$, $5/8$ inches
 - b. 4 feet
 - c. 6, 8, 10, 12, 14, 16 feet
3.
 - a. Tapered edge
 - b. Square edge
4. Any five of the following:
 - a. Easy to apply
 - b. Low cost
 - c. Easy to maintain
 - d. Saves time
 - e. Non-combustible
 - f. Provides a good base for other finishing materials
5.
 - a. 656 sq. ft.
 - b. 240 sq. ft
6. Performance skills will be evaluated according to the criteria listed on the progress chart.

Carpentry

PROGRESS CHART

Student's Name	Unit I Dry Wall				Unit Test	Job
	1	2	3	4		
1						
2						
3						
4						
5						
6						
7						
8						
9						

Section J
Interior Wall Finish

1046

Student's Name

3 4 5 6 7 8 9 10 11 12 13 14 15 16 17 18 19 20

Accuracy
85% Correct
1/4" Maximum Gap

1047

STAIR CONSTRUCTION UNIT I

TERMINAL OBJECTIVE

After completion of this unit, the student should be able to identify the parts of a staircase, state the rule of thumb for unit rise and run, calculate the number of risers and treads, and list the items to consider in building a staircase. He should also be able to lay out and construct a staircase, and use the power tools safely and correctly. This knowledge will be evidenced through demonstration and by scoring eighty-five percent on the unit test.

SPECIFIC OBJECTIVES

After completion of this unit, the student should be able to:

1. Match terms associated with stair building to a list of definitions.
2. Identify the parts of a staircase.
3. Identify four basic types of stairs as to shape and how they are fitted into the building.
4. State the rule of thumb for unit rise and unit run.
5. Calculate the number of risers and treads for a stair of given dimensions.
6. List six factors that must be considered in building a staircase.
7. Estimate the materials for a housed stair.
8. Demonstrate the ability to lay out, cut, and assemble a stair.

STAIR CONSTRUCTION UNIT I

SUGGESTED ACTIVITIES

I. Instructor:

- A. Provide students with objective sheet.
- B. Provide students with information, assignment, and job sheets.
- C. Make transparencies.
- D. Discuss terminal and specific objectives.
- E. Discuss information and assignment sheets.
- F. Demonstrate and discuss procedures outlined in job sheet.
- G. Give test.

II. Student:

- A. Read objective sheet.
- B. Study information sheet.
- C. Complete assignment sheet.
- D. Demonstrate the ability to accomplish the procedures outlined in the job sheet.
- E. Take test.

INSTRUCTIONAL MATERIALS

I. Included in this unit:

- A. Objective sheet
- B. Information sheet
- C. Transparency masters
 1. TM 1--Parts of a Staircase
 2. TM 2--Types of Stairs
 3. TM 3--Rise and Run of Stairs
 4. TM 4--Unit Rise and Unit Run

- D. Assignment Sheet #1--Material Estimating
- E. Answers to assignment sheet
- F. Job Sheet #1--Layout, Cut, and Assemble a Housed Stair
- G. Test
- H. Answers to test

II. References:

- A. Burke, Arthur E., J. Ralph Dalzell, and Gilbert Townsend. *Architectural and Building Trades Dictionary*. Chicago, Illinois: American Technical Society, 1955.
- B. Cooper, George H. and Stanley Badzinski Jr. *Buiding and Construction Estimating*. New York: McGraw-Hill, 1971.
- C. Durbahn, Walter E. and Elmer W. Sundberg. *Fundamentals of Carpentry*. Third Edition. Chicago, Illinois: American Technical Society, 1963.
- D. Lair, E. A. *Carpentry for the Building Trades*. St. Louis, Missouri: McGraw-Hill, 1953.
- E. Smith, Ronald C. *Principles and Practices of Light Construction*. Englewood Cliffs, New Jersey: Prentice Hall, Inc., 1970.
- F. Wagner, Willis H. *Modern Carpentry*. Homewood, Illinois: Goodheart-Willcox, 1969.

STAIR CONSTRUCTION UNIT I

INFORMATION SHEET

I. Terms and definitions

- A. Baluster--An upright support of the handrail for a stair
- B. Head room--The clear space between the tread of a stair and the ceiling above
- C. Handrail--A rail on a stair used for support, sometimes called a baluster rail
- D. Housed stair--A staircase in which the stringers are housed between two walls
- E. Landing--A platform introduced at some point to change the direction of the stairway or to break the run
- F. Line of flight--The angle of ascent of a stair
- G. Newel post--The upper or lower post which supports the handrail of a stair
- H. Nosing--The rounded edge of a stair tread that projects over the riser
- I. Open stair--A stair which has both sides open to a room or hall
- J. Rise--The distance between two landings
- K. Riser--The vertical distance under the edge of a stair tread which may be open or closed
- L. Run--The horizontal distance from a point at the head of a stair to the outside end of the last riser
- M. Semihoused stair--A staircase which has one side open to a room or hall
- N. Staircase- A complete flight of steps leading from one floor or story to another above
- O. Stairwell A compartment extending vertically through a building in which stairs are placed
- P. Stringer--The inclined supports of a flight of stairs
- Q. Tread- That portion of a step on which the foot is placed when mounting the stairs

INFORMATION SHEET

II. Parts of a staircase (Transparency 1)

- A. Head room
- B. Landing
- C. Rise
- D. Run
- E. Tread
- F. Riser
- G. Stringer
- H. Unit rise
- I. Unit run
- J. Nosing
- K. Baluster
- L. Newel post
- M. Handrail
- N. Stairwell

III. Types of stairs (Transparency 2)

(NOTE: Stairs are classified by shape and by the way they are fitted into the building.)

- A. Straight flight
 - 1. Housed
 - 2. Semihoused
 - 3. Open
- B. Straight flight with landing
 - 1. Housed
 - 2. Semihoused
 - 3. Open

INFORMATION SHEET

C L shaped

1. Housed
2. Semihoused
3. Open

D. Winder

1. Housed
2. Semihoused
3. Open

IV. Rule of thumb for unit rise and unit run; the total of one riser and one tread should not be less than sixteen or more than eighteen inches (Transparency 3)

- A. Unit rise should be seven to eight inches
- B. Unit run should be nine to eleven inches

(NOTE: As the rise increases the run must decrease proportionally.)

(CAUTION: All treads and all risers for a stair must be of the same size.)

V. Calculating the number of risers and treads for a stair (Transparency 4)

A. Risers

1. Determine the total rise of the stair in inches

(NOTE: The total rise of a stair is from the finished floor of the lower level to the top of the finished floor of the upper level.)

2. Divide the total rise of the stair by seven to get the number of risers needed

(NOTE: The number seven is the minimum height of a riser.)

3. Round back to the nearest whole number

Example: In Transparency 4 the total rise for the stair is 7' 10 1/2" or 94 1/2"
 $94 \frac{1}{2} \div 7 = 13 \frac{2}{7}$, 2/7 will not make a full riser so we must round back to 12 full risers, $94 \frac{1}{2} \div 12 = 7.875$ or 7 7/8" unit rise.

There will be 12 risers of 7 7/8" each

INFORMATION SHEET

B. Treads

1. Determine the total run of the stair in inches

(NOTE: The total run of the stair is the horizontal distance from a point at the head of a stair to the outside edge of the last riser.)

2. Divide the total run of the stair by nine to get the number of treads needed

(NOTE: The number nine is the minimum width of a tread.)

3. Round back to the nearest whole number

Example: In Transparency 4 the total run for the stair is 9' 0" or 108.
 $108 \div 9 = 12$ full treads, $108 \div 12 = 9$ " unit run.

There will be 12 treads of 9" each.

VI. Factors to be considered in building a staircase

A. Width

(NOTE: The minimum width is three feet and preferably four feet.)

B. Head room

(NOTE: The minimum allowable headroom is 6' 8" for a main stair and 6' 4" for a basement or service stair.)

C. Line of flight

(NOTE: The preferred angle for a stair is from 30 to 35 degrees.)

D. Unit rise

(NOTE: The unit rise should be from seven to eight inches to be comfortable, but all risers for a stair must be of uniform height.)

E. Unit run

(NOTE: The unit run should be from nine to eleven inches to be comfortable, but all treads for a stair must be of uniform width.)

F. Baluster rail height

(NOTE: The distance from the top of the baluster rail to the top of a tread, at the middle, should be no less than thirty-two and no greater than thirty-six inches.)

INFORMATION SHEET

VII. Material estimating for a housed stair

(NOTE: See building specifications for kinds and dimensions of material.)

A. Stringers

1. Determine the length needed
 - a. Determine the unit rise and unit run
 - b. Determine the number of risers and the number of treads
 - c. Locate the unit rise on the tongue of a framing square and the unit run on the blade

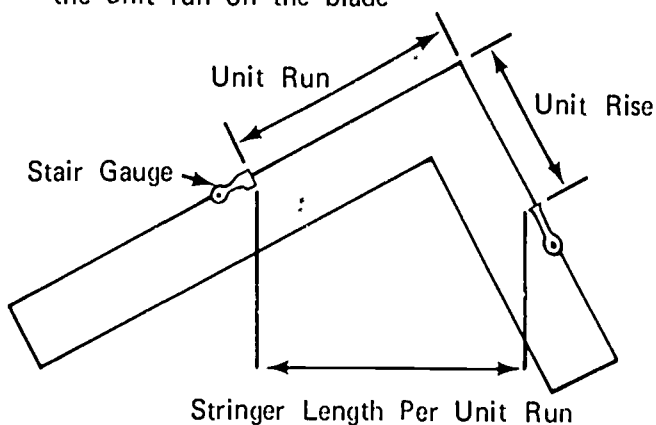

- d. The diagonal measurement from the unit run to the unit rise on the square illustrated above equals the stringer length per unit run
- e. Multiply the stringer length per unit run, in inches, by the number of treads to get the length of the stringer in inches
- f. Divide by twelve to get the length of the stringer in feet
- g. Add two feet for waste at each end

Example: Using the stair illustrated in Transparency 4 where the unit rise is $7 \frac{7}{8}$ ", the unit run is nine inches, the number of treads are twelve, and the stringer length per unit run equals twelve inches.

$$12 \times 12 = 144''$$

$$144 \div 12 = 12' + 2' = 14'$$

The stringer material needs to be 14' long

INFORMATION SHEET

2. Determine the number of stringers needed from the specifications

(NOTE: A minimum of two are needed for a stair thirty-six inches wide.)

B. Treads

1. Determine the width of a tread

(NOTE: The width of a tread is the unit run plus the amount of nosing desired.)

2. Determine the thickness of a tread

(NOTE: For a basement stair, the treads are usually made from two inch material.)

3. Determine the length of a tread

(NOTE: For a housed stair, the length of a tread will be the distance between the two walls that house the stair.)

4. The length of a tread multiplied by the number of treads equals the running feet of material needed

Example: Using the stair illustrated in Transparency 4 where the unit run is nine inches, the nosing is 1 1/4", the stairwell opening is thirty-six inches, and the number of treads are twelve. It will be necessary to use 2 x 12's for the treads.

$3' \times 12 = 36'$ of 2 x 12's

3 - 2" x 12" x 12" will make 12 - 3' treads

C. Risers

1. Determine the height of a riser

(NOTE: The unit rise will be the height of the riser.)

2. Determine the thickness of the riser

(NOTE: Risers are usually cut from one inch material.)

3. Determine the length of the risers

(NOTE: For a housed stair, the length of a riser will be the distance between the two walls that house the stair.)

INFORMATION SHEET

4. The length of a riser multiplied by the number of risers equals the running feet of material needed

Example: Using the stair illustrated in Transparency 4 where the unit rise is $7 \frac{7}{8}$ ", the width of the stairwell is thirty-six inches and the number of risers is twelve. It will be necessary to use 1 x 8's for the risers.

$$3' \times 12 = 36' \text{ of } 1 \times 8\text{'s}$$

3 - 1" x 8" x 12' will make 12 - 3' risers

D. Nails

1. 16d casing (for treads)

(NOTE: Approximately three pounds for a basement stair)

2. 16d box (for stringers)

(NOTE: Approximately two pounds)

3. 8d box (for risers)

(NOTE: Approximately two pounds)

E. Baluster rail

(NOTE: Should be the same length as the stringers and one for each side.)

Parts of a Staircase

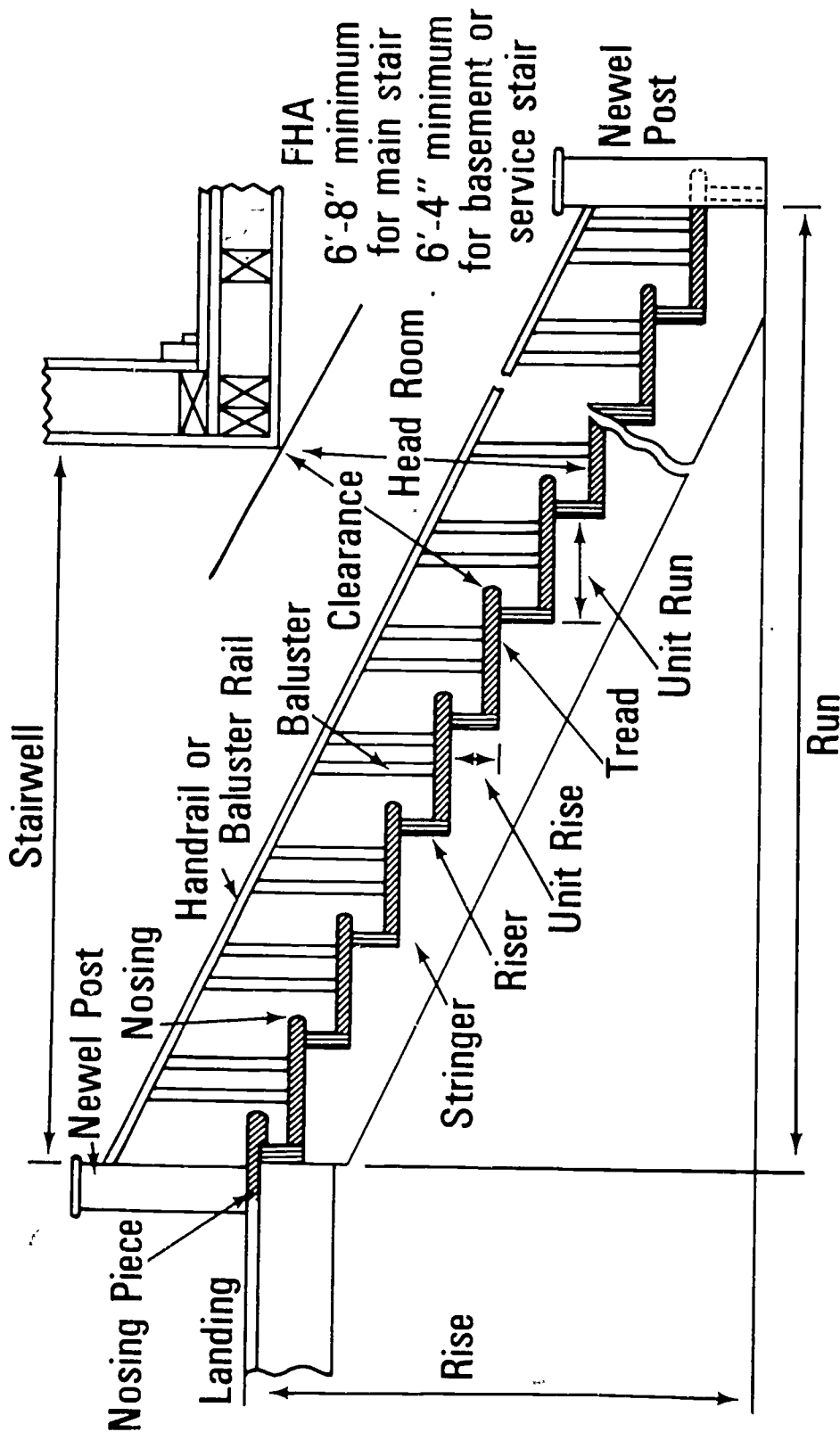

Types of Stairs

Types of stairs :

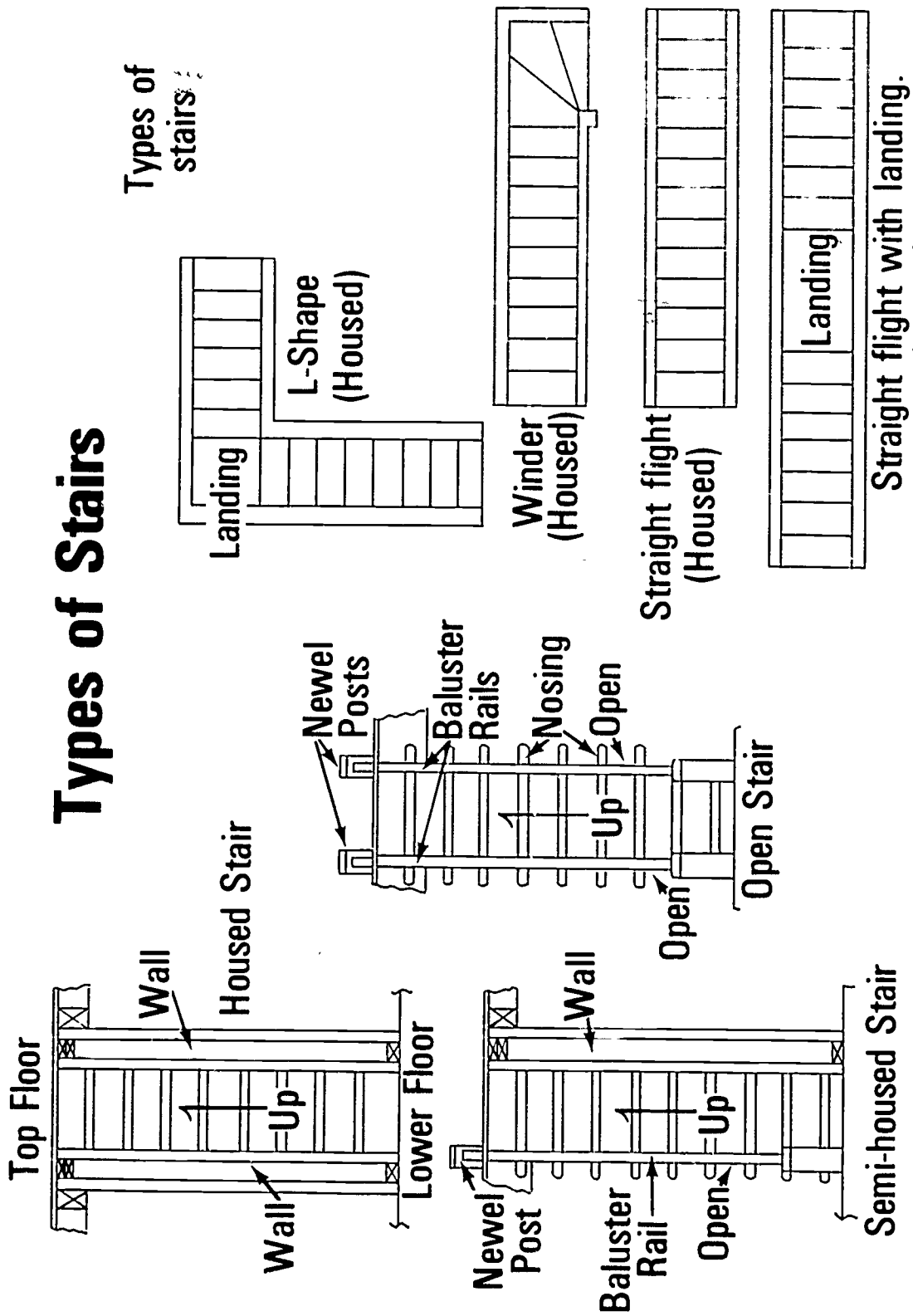

3 ways a stair is fitted into a building



Rise and Run of Stairs

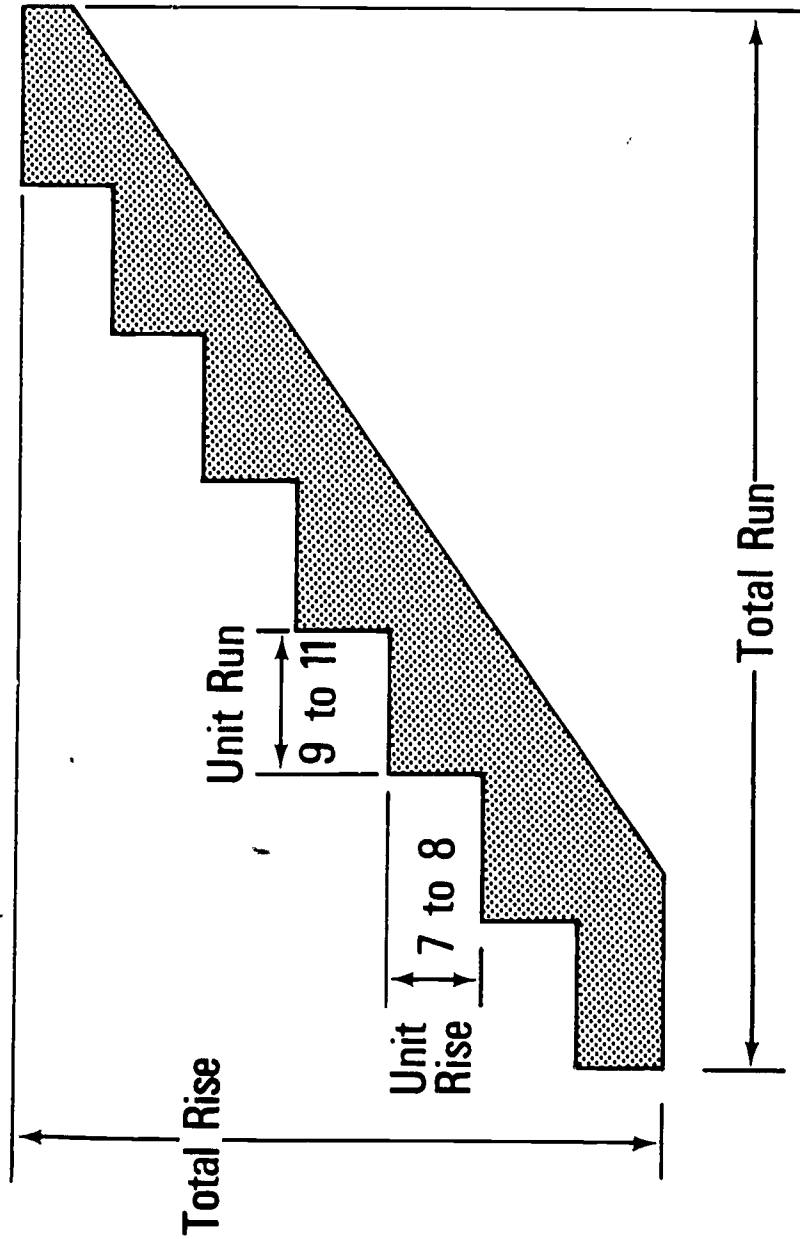

Unit Rise and Unit Run

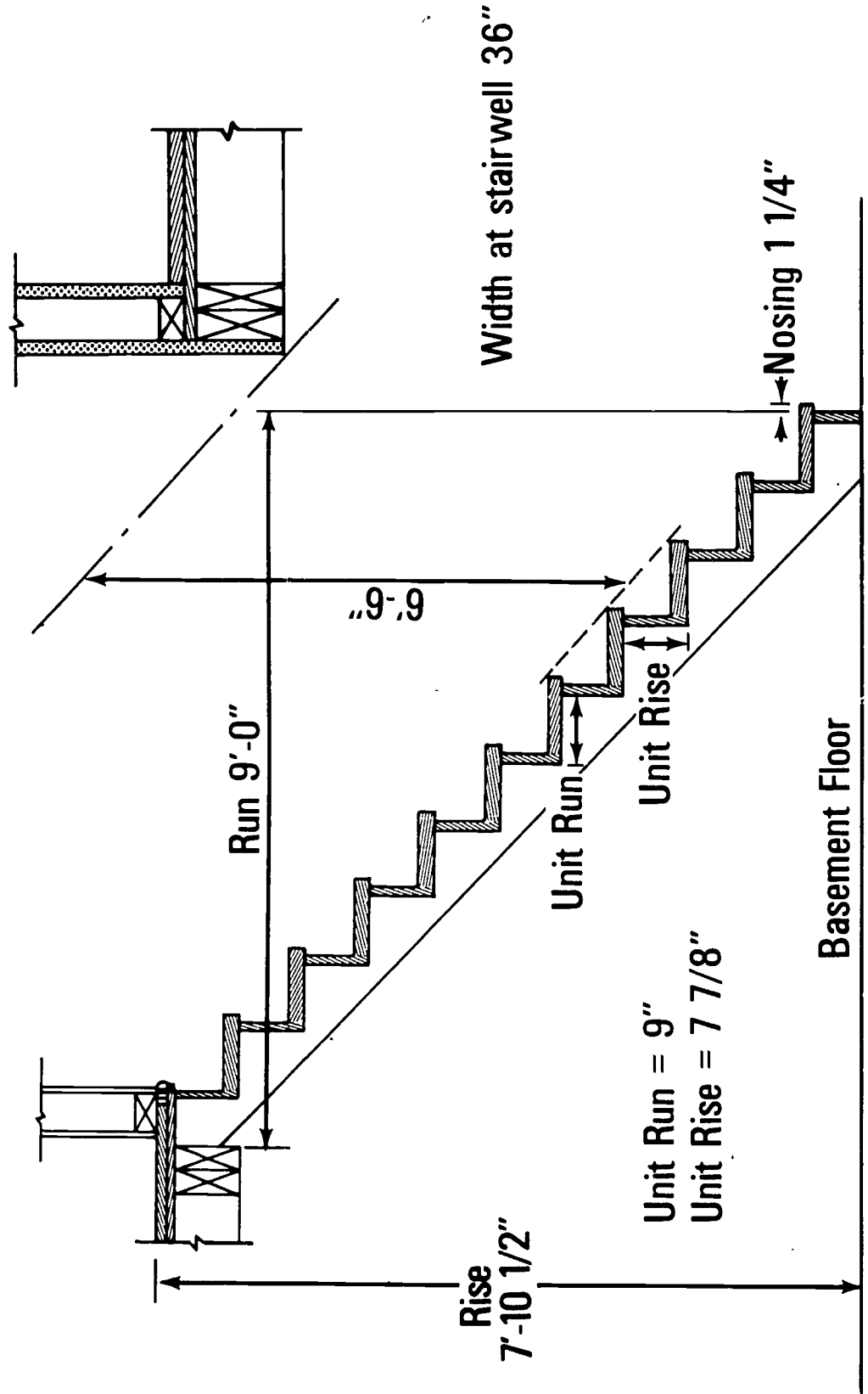

STAIR CONSTRUCTION UNIT I

ASSIGNMENT SHEET #1--MATERIAL ESTIMATING

Using the information sheet, calculate the material needed to construct a housed stair to fit the stairwell pictured below.

- a. Number of stringers _____
- b. Stringer length _____
- c. Tread length _____
- d. Number of treads _____
- e. Riser length _____
- f. Number of risers _____
- g. Unit rise _____
- h. Unit run _____
- i. Material order
 - 1) Stringers (2 x 12) _____
 - 2) Risers (1 x 8) _____
 - 3) Treads (2 x 12) _____

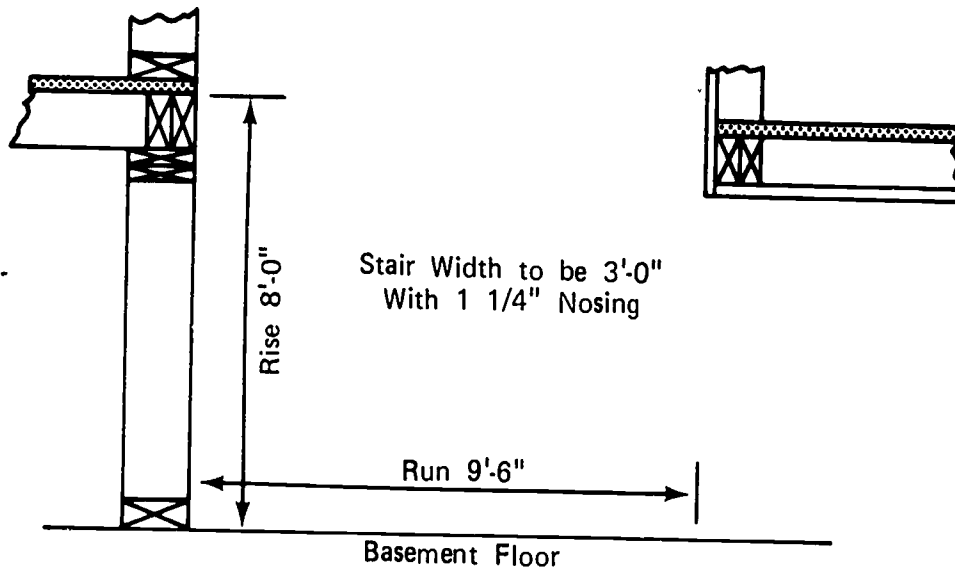

STAIR CONSTRUCTION
UNIT I

ANSWERS TO ASSIGNMENT SHEET

- a. 2
- b. 14'
- c. 3'
- d. 12 or 13
- e. 3'
- f. 12 or 13
- g. $7 \frac{3}{8}$ or 8"
- h. $8 \frac{3}{4}$ or $9 \frac{1}{2}$
- i. 1) 2 - 2" x 12" x 14'
- 2) (12 risers) 3 - 1" x 8" x 12'
- (13 risers) 2 - 1" x 8" x 12'
- 1 - 1" x 8" x 16'
- 3) (12 treads) 3 - 2" x 12" x 12'
- (13 treads) 2 - 2" x 12" x 12'
- 1 - 2" x 12" x 16'

STAIR CONSTRUCTION
UNIT I

JOB SHEET #1--LAY OUT, CUT, AND ASSEMBLE A
HOUSED STAIR

I. Tools and materials needed

A. Tools

1. 12 to 16 foot tape measure
2. Framing square
3. Electric handsaw
4. Crosscut handsaw
5. 3 or 4 foot level
6. 16 ounce claw hammer
7. Stair gauge clamps

B. Material

1. 2 x 12's for stringers
2. 2 x 12's for treads
3. 1 x 8's for risers
4. Baluster rail and brackets
5. 16d casing nails
6. 16d box nails
7. 8d box nails

II. Procedure

A. Lay out stringers

1. Determine unit rise and unit run
2. Determine the number of risers and treads

JOB SHEET #1

3. Place stair gauge clamps on the framing square at the exact unit rise and unit run (Figure 1)

FIGURE 1

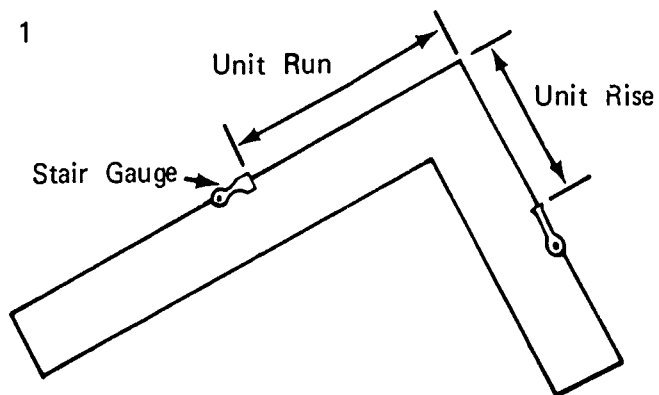

4. Lay out the tread and riser locations (Figure 2)

FIGURE 2

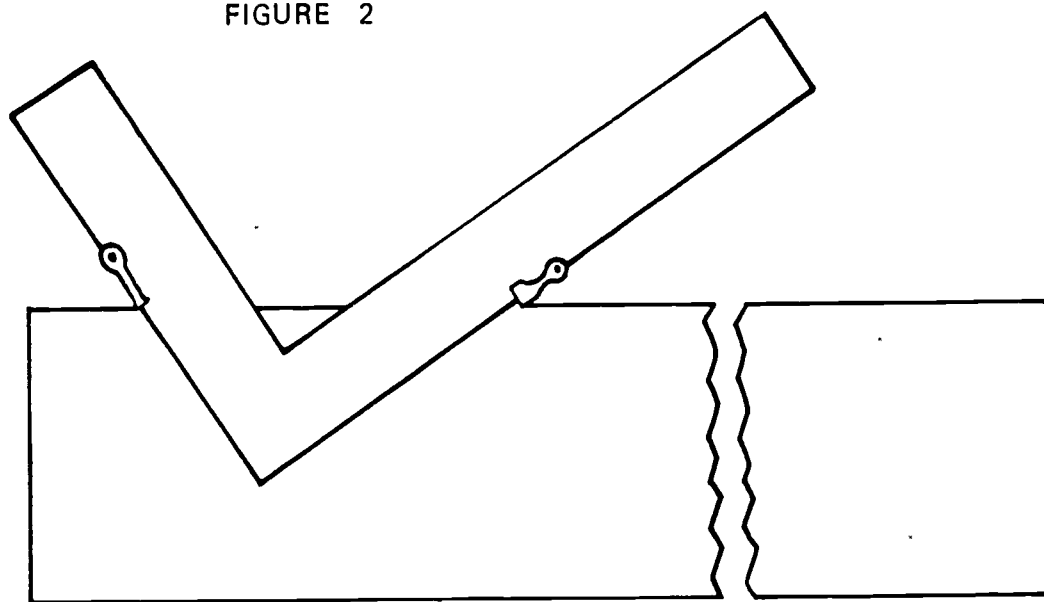

First Step in Stringer Layout

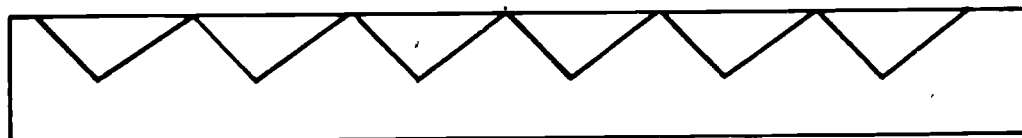

Stringer laid out.

JOB SHEET #1

5. Lay out to cut top end (Figure 3)

FIGURE 3

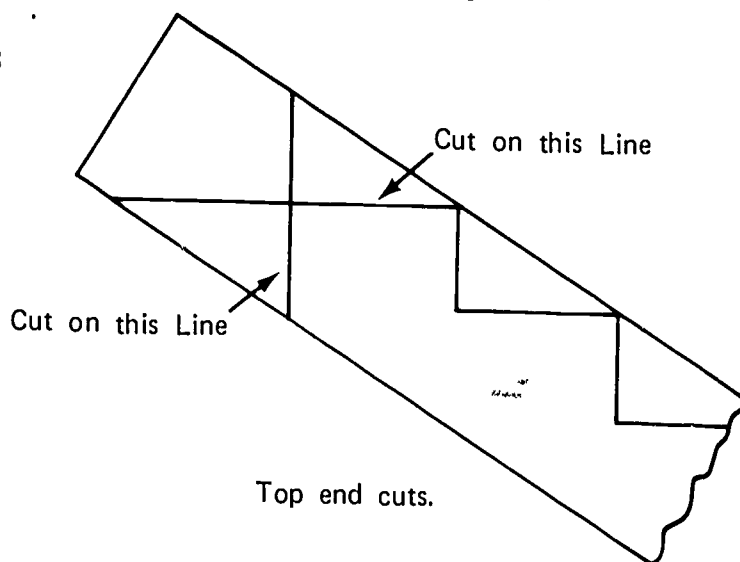

6. Lay out bottom end cuts
 - a. Lay off as you would for the last riser
 - b. Shorten the last unit rise by the thickness of the tread

(NOTE: The last riser is shortened so that the first step up from the floor will be the same unit rise as the remainder of the steps.) Figure 4)

FIGURE 4

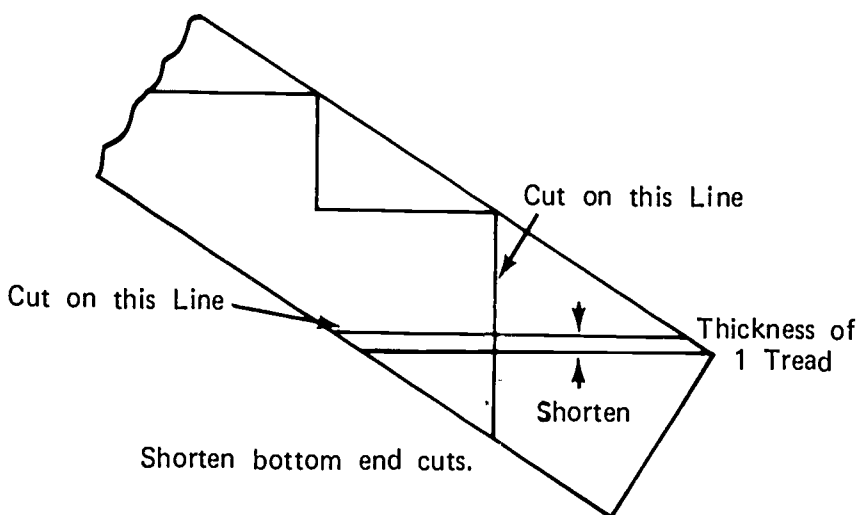

JOB SHEET #1

B. Cut out stringers (Figure 5)

1. Cut in to the point of each notch with the electric handsaw

(NOTE: Do not saw past the point of each notch as this weakens the stringer.)

2. Finish each cut with the crosscut handsaw

FIGURE 5

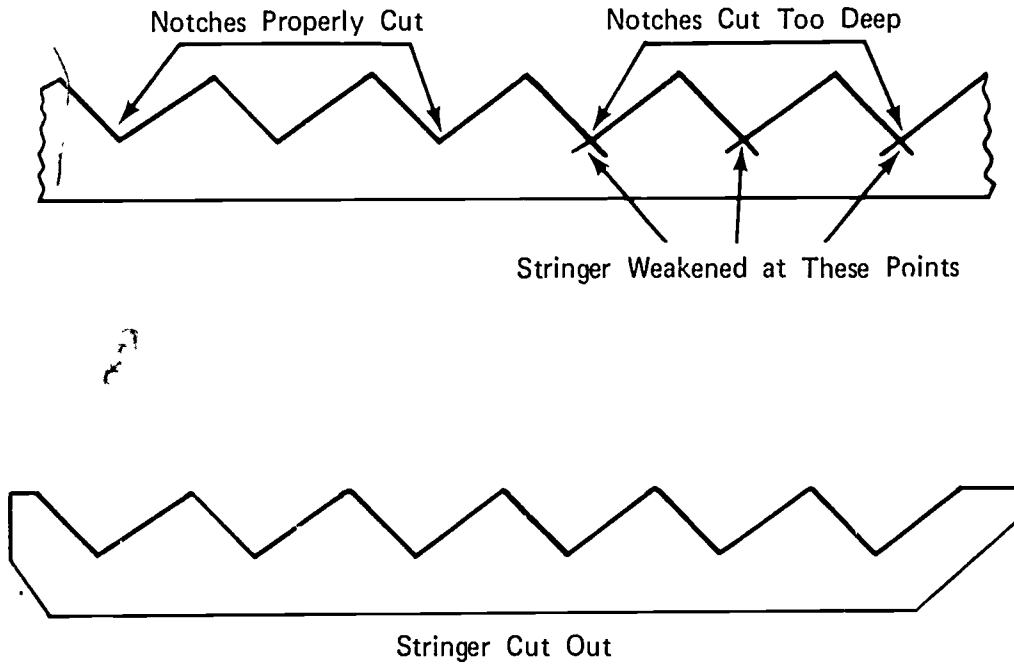

1067

JOB SHEET #1

- C. Cut risers and treads to length and width
- D. Assemble stair
1. Nail the stringers to the side walls of the stairwell (Figure 6)
- (NOTE: The stair treads must be level to prevent slipping.)

FIGURE 6

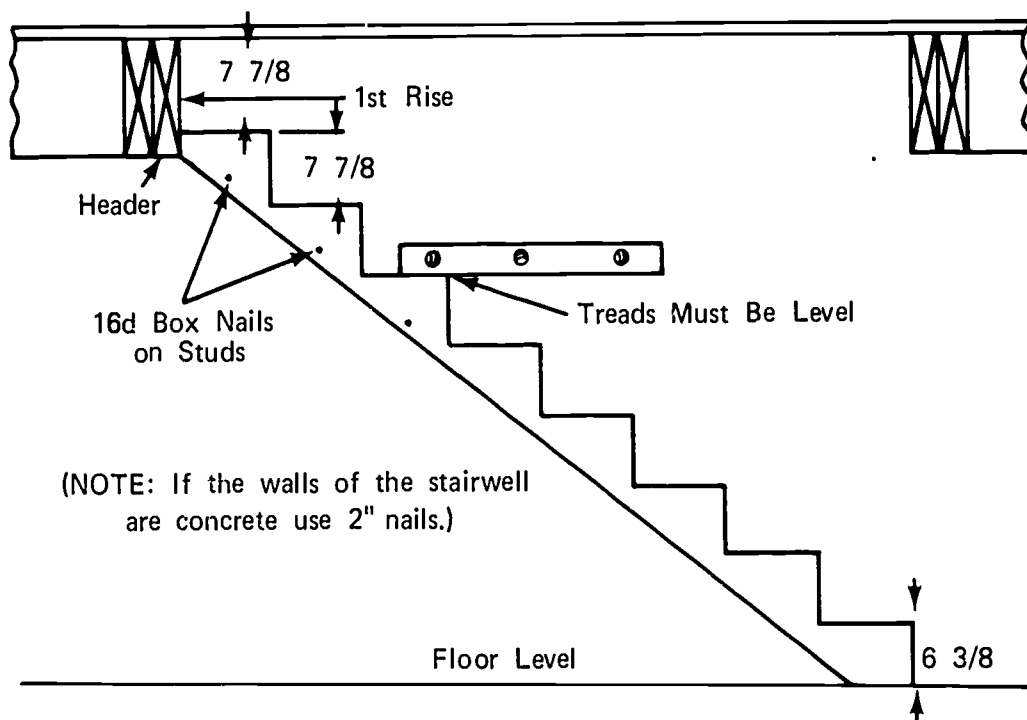

JOB SHEET #1

2. Nail treads and risers in place (Figure 7)
 (NOTE: Nail all of the risers in place first.)

FIGURE 7

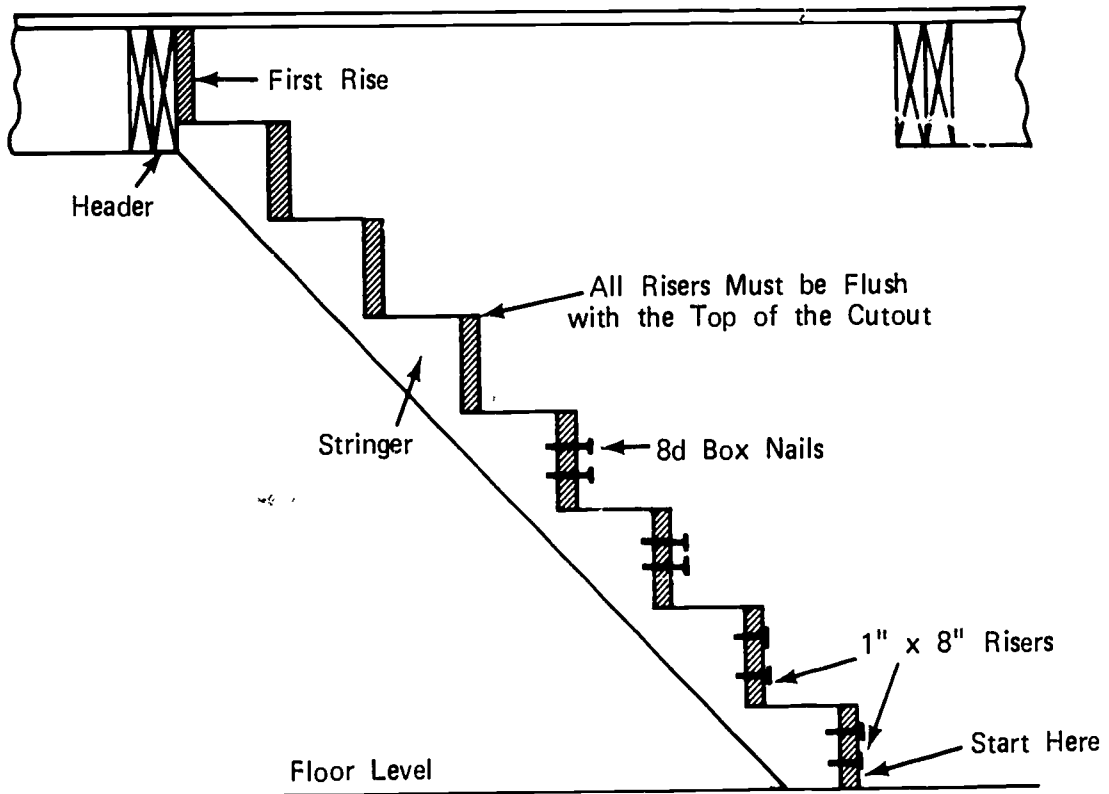

1069

JOB SHEET #1

- Nail the treads in place (Figure 8)

FIGURE 8

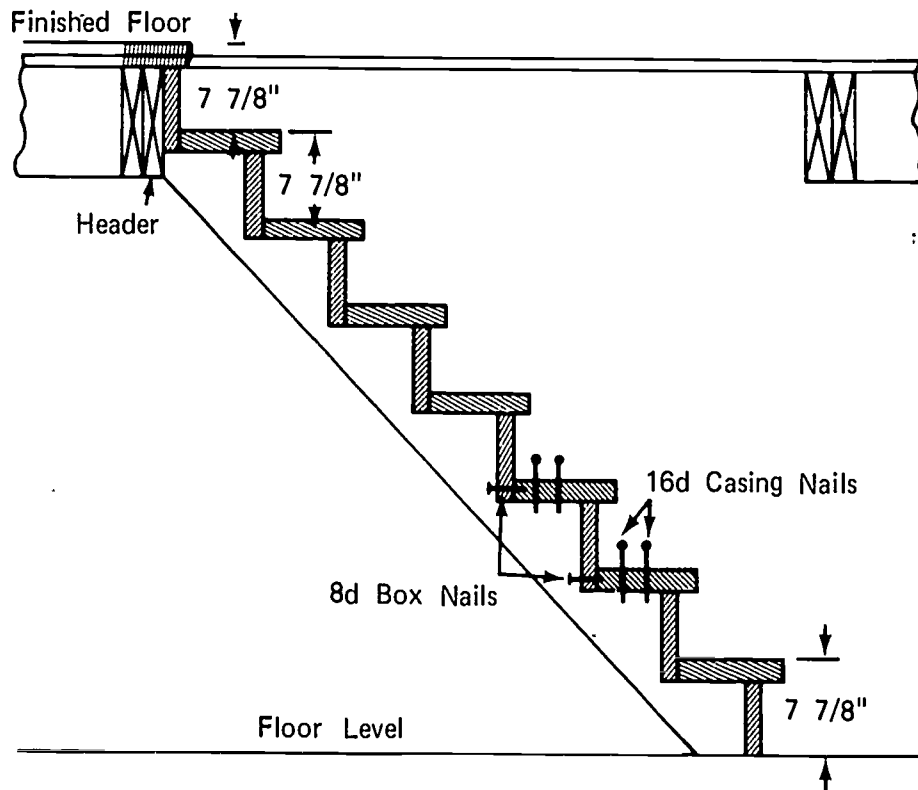

- Install the baluster rail

(NOTE: Follow the instructions that are included with the rail hardware.)

STAIR CONSTRUCTION
UNIT I

TEST

1. Match the following list of terms to the correct definition.

- | | |
|--|-----------------------------|
| <p>_____ a. A complete flight of steps leading from one floor or story to another above</p> | <p>1. Baluster</p> |
| <p>_____ b. That portion of a step on which the foot is placed when mounting the stairs</p> | <p>2. Head room</p> |
| <p>_____ c. A staircase which has one side open to a room or hall</p> | <p>3. Handrail</p> |
| <p>_____ d. An upright support of the handrail for a stair</p> | <p>4. Housed stair</p> |
| <p>_____ e. The upper or lower post which supports the handrail of a stair</p> | <p>5. Landing</p> |
| <p>_____ f. A rail on a stair used for support, sometimes called a baluster rail</p> | <p>6. Line of flight</p> |
| <p>_____ g. A compartment extending vertically through a building in which stairs are placed</p> | <p>7. Newel post</p> |
| <p>_____ h. The clear space between the tread of a stair and the ceiling above</p> | <p>8. Nosing</p> |
| <p>_____ i. The inclined supports of a flight of stairs</p> | <p>9. Open stair</p> |
| <p>_____ j. The distance between two landings</p> | <p>10. Rise</p> |
| <p>_____ k. A staircase in which the stringers are housed between two walls</p> | <p>11. Riser</p> |
| <p>_____ l. The horizontal distance from a point at the head of a stair to the outside end of the last riser</p> | <p>12. Run</p> |
| | <p>13. Semihoused stair</p> |
| | <p>14. Staircase</p> |
| | <p>15. Stairwell</p> |
| | <p>16. Stringer</p> |
| | <p>17. Tread</p> |

- _____ m. A platform introduced at some point to change the direction of the stairway or to break the run
- _____ n. A stair which has both sides open to a room or hall
- _____ o. The angle of ascent of a stair
- _____ p. The vertical distance under the edge of a stair tread which may be open or closed
- _____ q. The rounded edge of a stair tread that projects over the riser

2. Identify the fourteen parts of a stair from the illustration below.

- | | |
|--------------------|-----------------------------------|
| _____ a. Head room | _____ h. Unit rise |
| _____ b. Landing | _____ i. Unit run |
| _____ c. Rise | _____ j. Nosing |
| _____ d. Run | _____ k. Baluster |
| _____ e. Tread | _____ l. Newel post |
| _____ f. Riser | _____ m. Handrail (Baluster rail) |
| _____ g. Stringer | _____ n. Stairwell |

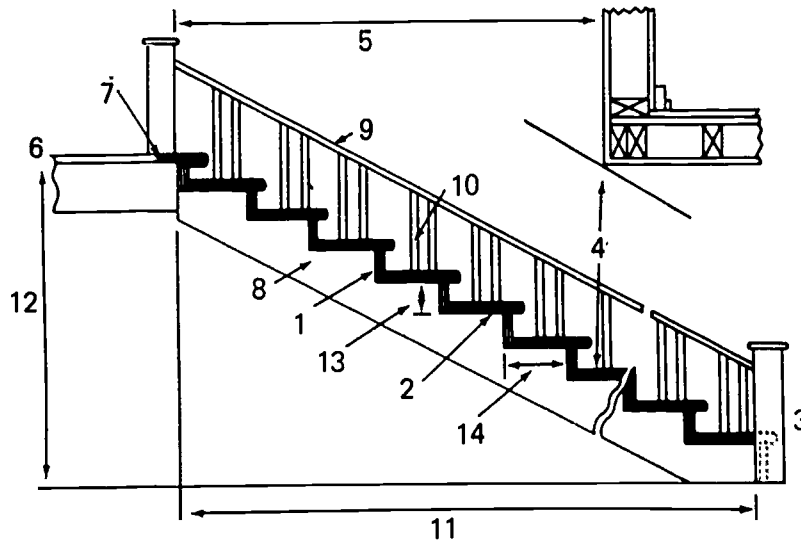

3. Identify the types of stairs pictured below.

- a. Type _____
Way fitted into building _____
- b. Type _____
Way fitted into building _____
- c. Type _____
Way fitted into building _____
- d. Type _____
Way fitted into building _____
- e. Type _____
Way fitted into building _____
- f. Type _____
Way fitted into building _____

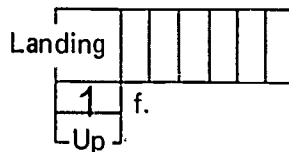
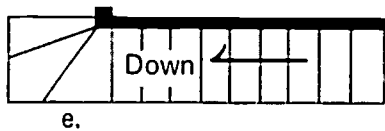
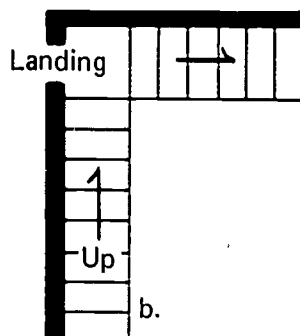
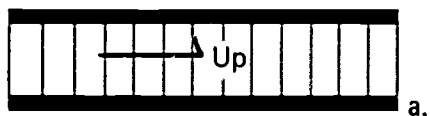

4. State the rule of thumb for unit run and unit rise.

5. Calculate the number of risers and the number of treads for the stair pictured below.

- _____ a. Risers
- _____ b. Treads

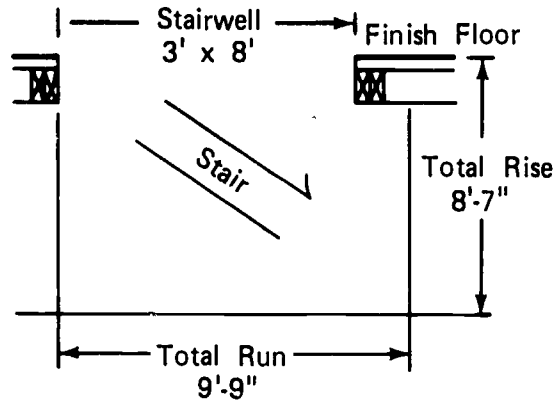

6. List six factors that must be considered in building a staircase.

- a.
- b.
- c.
- d.
- e.
- f.

7. Estimate the following materials for the housed stair in question number five.

- a. _____ - 2" x 12" x _____ for stringers
number length
- b. _____ - 2" x 12" x _____ for treads
number length
- c. _____ - 1" x 8" x _____ for risers
number length

8. Demonstrate the ability to lay out, cut, and assemble a stair.

(NOTE: If this has not been accomplished prior to the test, ask the instructor when the above activities should be completed.)

STAIR CONSTRUCTION
UNIT I

ANSWERS TO TEST

1. a. 14
b. 17
c. 13
d. 1
e. 7
f. 3
g. 15
h. 2
i. 16
j. 10
k. 4
l. 12
m. 5
n. 9
o. 6
p. 11
q. 8
2. a. 4
b. 6
c. 12
d. 11
e. 2
f. 1
g. 8
h. 13
i. 14
j. 7
- k. 10
l. 3
m. 9
n. 5

3.
 - a. Straight flight
Housed
 - b. L shaped
Semihoused
 - c. Straight flight with landing
Open
 - d. Winder
Housed
 - e. Winder
Semihoused
 - f. L shaped
Open
4. The total of one riser and one tread should not be less than sixteen or more than eighteen inches.
5.
 - a. 13
 - b. 13
6.
 - a. Width
 - b. Head room
 - c. Line of flight
 - d. Unit rise
 - e. Unit run
 - f. Baluster rail height
7.

a.	2	14'
b.	2	12'
	1	16'
c.	2	12'
	1	16'
8. Performance skills to be evaluated according to the criteria listed on the progress chart.

DOOR HANGING AND TRIM UNIT II

TERMINAL OBJECTIVE

After completion of this unit, the student should be able to identify the parts of an interior door frame, name the types of interior door construction, identify the hand of a door, and list the common door sizes. He should also be able to measure, cut, and install casing and trim, hang a door, install a pre-hung door unit, and use the power tools safely and correctly. This knowledge will be evidenced through demonstration and by scoring eighty-five percent on the unit test.

SPECIFIC OBJECTIVES

After completion of this unit, the student should be able to:

1. Match terms relating to door hanging and trim to a set of definitions.
2. Identify the parts of an interior door unit.
3. Name two general types of interior door construction.
4. Identify the hand of a door.
5. State the standard dimensions of interior doors and frames.
6. Identify the parts of a window installation.
7. Identify two types of joints commonly used to install casing and trim.
8. Identify eight types of molding.
9. Identify five types of doors according to installation.
10. Estimate the material needed to trim a house.
11. Demonstrate the ability to:
 - a. Install a door frame and hang and lock doors.
 - b. Trim a window.
 - c. Case a door frame.
 - d. Install a pre hung door unit.

DOOR HANGING AND TRIM UNIT II

SUGGESTED ACTIVITIES

I. Instructor:

- A. Provide students with objective sheet.
- B. Provide students with information, assignment, and job sheets.
- C. Make transparencies.
- D. Discuss terminal and specific objectives.
- E. Discuss information and assignment sheets.
- F. Demonstrate and discuss procedures outlined in job sheets.
- G. Give test.

II. Student:

- A. Read objective sheet.
- B. Study information sheet.
- C. Complete assignment sheet.
- D. Demonstrate the ability to accomplish the procedures outlined in the job sheets.
- E. Take test.

INSTRUCTIONAL MATERIALS

I. Included in this unit:

- A. Objective sheet
- B. Information sheet
- C. Transparency masters
 1. TM 1--Parts of an Interior Door Unit
 2. TM 2--Types of Interior Door Construction
 3. TM 3--The Hand of a Door For Locks

4. TM 4--Parts of a Window Installation
 5. TM 5--Common Trim and Molding Joints
 6. TM 6--Molding
 7. TM 7--Types of Doors According to Installation
- D. Assignment Sheet #1--Material Estimating
- E. Answers to assignment sheet
- F. Job sheets
1. Job Sheet #1--Install Interior Door Frame and Hang and Lock Doors
 2. Job Sheet #2--Trim and Case a Window
 3. Job Sheet #3--Case a Door Frame
 4. Job Sheet #4--Install a Pre-hung Door Unit
- G. Test
- H. Answers to test

II. References:

- A. Burke, Arthur E., J. Ralph Dalzell, and Gilbert Townsend. *Architectural and Building Trades Dictionary*. Chicago, Illinois: American Technical Society, 1955.
- B. Cooper, George H. and Stanley Badzinski Jr. *Building and Construction Estimating*. New York: McGraw-Hill, 1971.
- C. Durbahn, Walter E. and Elmer W. Sundberg. *Fundamentals of Carpentry*. Third Edition. Chicago, Illinois: American Technical Society, 1963.
- D. Smith, Ronald C. *Principles and Practices of Light Construction*. Englewood Cliffs, New Jersey: Prentice Hall Inc., 1970.
- E. Wagner, Willis H. *Modern Carpentry*. Homewood, Illinois: Goodheart-Willcox, 1969.

DOOR HANGING AND TRIM
UNIT II

INFORMATION SHEET

- I. Terms and definitions
 - A. Apron--A piece of trim placed horizontally under the stool
 - B. Baseboard--A finishing board covering the edge of the wallboard where the wall and floor meet
 - C. Base shoe--Small narrow molding used around a room at the base of the baseboard
 - D. Butt--A type of door hinge where one leaf is mortised into the edge of the door and the other leaf is mortised into the side jamb
 - E. Casing--The framework of trim around a window or door
 - F. Clearance--The spacing between the edge of a door and the jamb
 - G. Cope--To cut or shape the end of a piece of molding so it will cover and fit the contour of an adjoining piece of molding
 - H. Cove molding--Molding with a concave profile used primarily for trim where the wall meets the ceiling
 - I. Door frame--An assembly of wood parts that form an enclosure and support for a door
 - J. Gain--A notch or mortise cut to receive a hinge or other hardware
 - K. Head jamb--The top member of a door frame
 - L. Jig--A contrivance used for guiding tools while work is being done
 - M. Miter joint--The ends of any two pieces of board of corresponding shape cut off at an angle and fitted together in an angular shape
 - N. Quarter round--A type of molding which presents a profile of a quarter of a circle
 - O. Side jamb--The vertical side posts of a door frame
 - P. Stool--The base or support at the bottom of a window that extends into the room
 - Q. Template--A gauge which is used as a guide for forming or shaping
 - R. Threshold--A wood or metal member used to close the space at the bottom of a door at the sill
 - S. Trim--The visible finishing work in a building

1080

INFORMATION SHEET

- II. Parts of an interior door unit (Transparency 1)
 - A. Side jambs
 - B. Head jamb
 - C. Blocking
 - D. Door
 - E. Casing
 - F. Stop
 - G. Rough header
 - H. Trimmer stud
 - I. Butts
 - J. Lockset
 - K. 45° miter joint

- III. Types of interior door construction (Transparency 2)
 - A. Solid core
 - B. Hollow core

- IV. Hand of a door (Transparency 3)

(NOTE: When installing locks, the hand of a door is determined by facing the door from the outside of the building for exterior doors and from the security side for interior doors.)

- A. Right hand (RH)
 - 1. The butts are to your right
 - 2. The door swings away from you
- B. Left hand (LH)
 - 1. The butts are to your left
 - 2. The door swings away from you
- C. Right hand reverse (RHR)
 - 1. The butts are to your right
 - 2. The door swings toward you

1081

INFORMATION SHEET

D. Left hand reverse (LHR)

1. The butts are to your left
2. The door swings toward you

V. Dimensions of interior doors and frames

A. Standard interior door sizes

(NOTE: Door sizes are always given in this order: thickness, width, and height, as 1 3/8" x 2' 8" x 6' 8".)

1. Thickness 1 3/8"

(NOTE: This is standard unless otherwise specified.)

2. Width

- a. 2' 0" (special applications)
- b. 2' 4" (some closets)
- c. 2' 6" (bathrooms)
- d. 2' 8" (bedrooms)

3. Height 6' 8"

(NOTE: This is standard unless otherwise specified.)

B. Standard interior jamb sizes

(NOTE: Interior jambs are specified by the door width, length, and the thickness of the finished wall, as 2' 8" x 6' 8" x 4 1/2" interior jamb.)

1. Width

(NOTE: If the opening width is greater than 2' 8", an extra side jamb may be cut to the correct length and used as a head jamb.)

- a. 2' 0"
- b. 2' 4"
- c. 2' 6"
- d. 2' 8"

INFORMATION SHEET

2. Length 6' 8"

(NOTE: This length is standard unless otherwise specified.)

3. Thickness 4 1/2"

(NOTE: This thickness is standard for a 2 x 4 stud wall with 1/2" gypsum wallboard on both sides. If paneling is used over the wallboard the jambs will need to be special ordered or made on the job.)

C. Casing

(NOTE: Casing may be purchased precut to the jamb size or in random lengths of odd and even feet to be cut on the job.)

D. Door stop

(NOTE: Door stop may be purchased precut to the jamb size or in random lengths of odd and even feet to be cut on the job.)

VI. Parts of a window installation (Transparency 4)

A. Window unit

B. Head jamb

C. Side jamb

D. Stool

E. Casing

F. Apron

VII. Joints (Transparency 5)

A. Miter

(NOTE: A miter joint is used on outside corners and is usually forty-five degrees but may be greater or less depending on the corner.)

B. Cope

(NOTE: A cope joint is used on inside corners and may be cut to fit almost any inside angle.)

VIII. Molding (Transparency 6)

A. Casing

B. Baseboard

C. Door stop

1083

INFORMATION SHEET

- D. Quarter round
 - E. Base shoe
 - F. Cove molding
 - G. Bed molding
 - H. Corner molding
- IX. Types of doors according to installation (Transparency 7)
- A. Swinging
 - B. Bypass
 - C. Bi-fold
 - D. Pocket
 - E. Multi-fold
- X. Material estimating
- A. Doors
 - 1. Type
 - 2. Size
 - 3. Number of each
 - B. Jamb--Sets
 - 1. Size
 - 2. Number of sets of each size
 - C. Casing--Sets or lineal feet
 - 1. Sets for specific door sizes
 - 2. Lineal feet for windows, odd size openings, and aprons
 - D. Butts--Pairs
 - 1. Size
 - 2. Number or pairs
 - E. Baseboard--Lineal feet
- (NOTE: Order enough to go around the perimeter of the room and inside closets.)

INFORMATION SHEET

F. Door stop--Sets

1. Sizes
2. Number of sets for each size

G. Base shoe--Lineal feet

(NOTE: Order the same amount of base shoe as baseboard.)

H. Window jambs and sills

(NOTE: Order one board foot of the type of lumber specified for each foot or part of a foot of area around a window.)

I. Locksets

1. Type
 - a. Passageway (bedrooms)
 - b. Privacy (bathrooms)
 - c. Keyed (Entrance)
2. Style
3. Brand
4. Number of each

J. Other trim--Lineal feet as needed

1. Outside corners
2. Cove molding
3. Bed molding
4. Quarter round

K. Nails

1. Door frames, 8d casing, 1/5 lb per frame
2. Door trim, 6d finish, 1/2 lb per opening
3. Window trim, 6d finish, 1/4 lb per side
4. Baseboard, 6d finish, 1 lb per 100 lin ft
5. Base shoe, 2 lb per 1,000 lin ft

1085

Parts of an Interior Door Unit

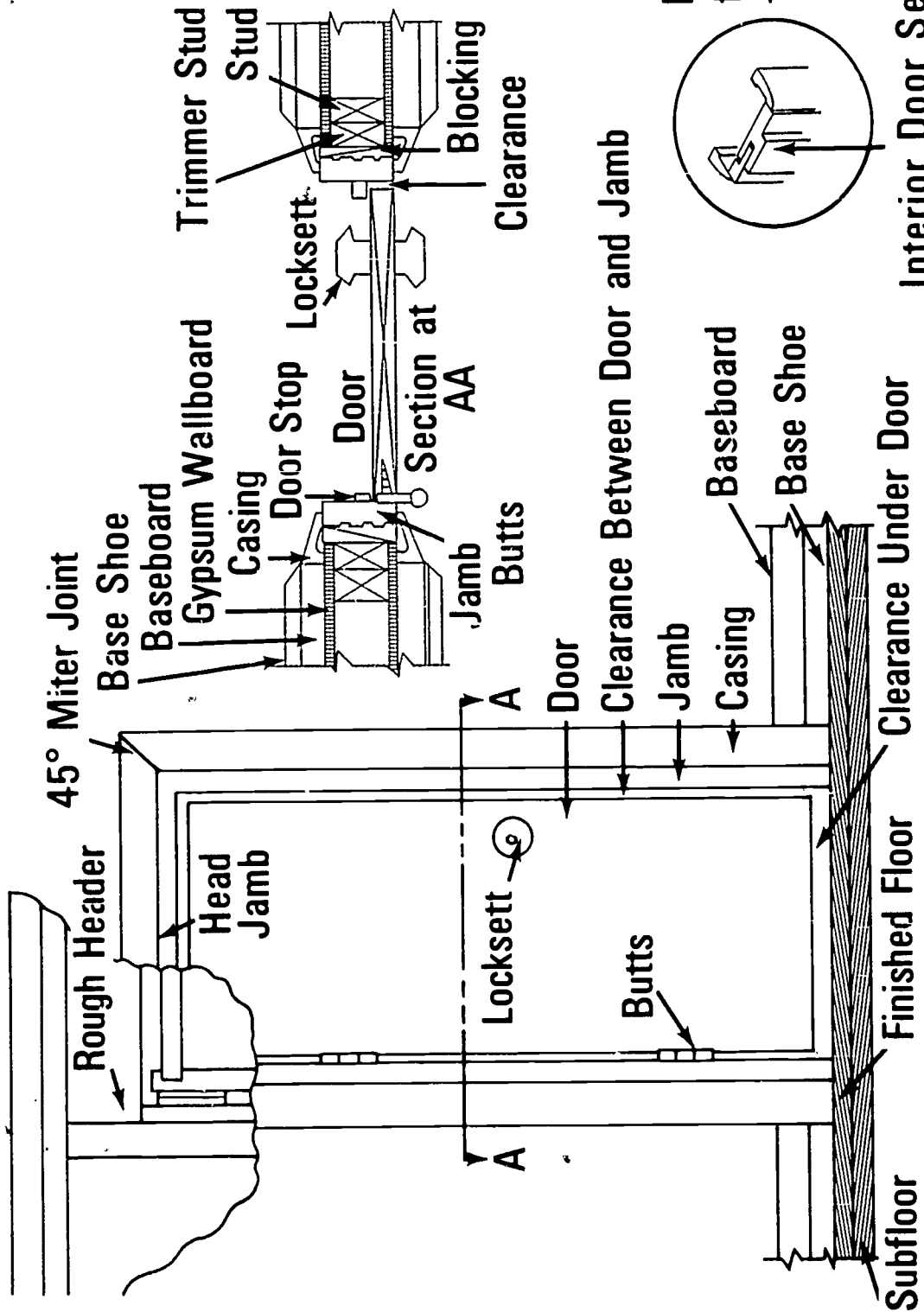

Note: Trim is factory applied to both sides of Jamb.

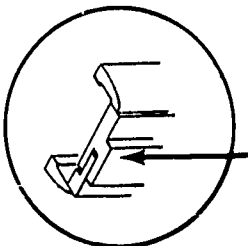

Interior Door Section



Types of Interior Door Construction

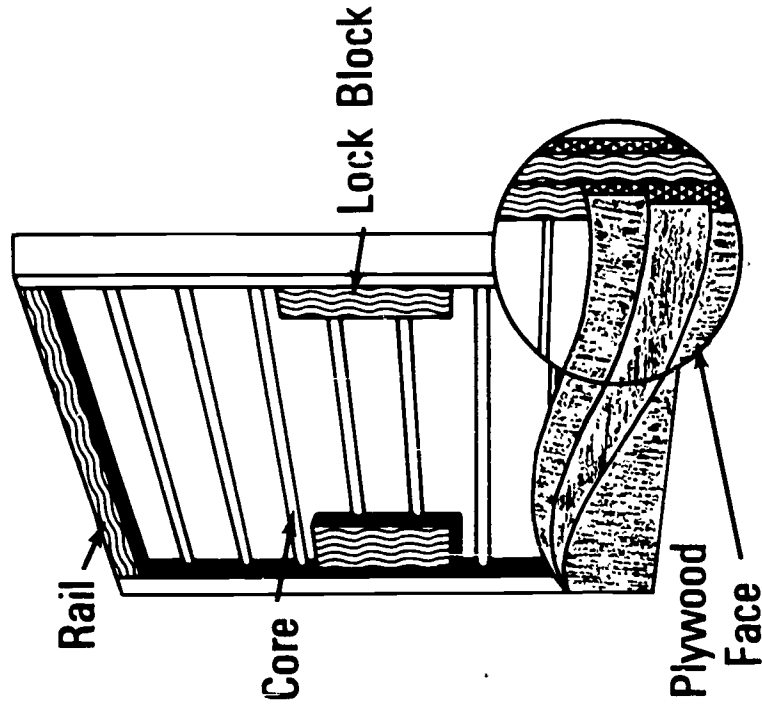

HOLLOW CORE

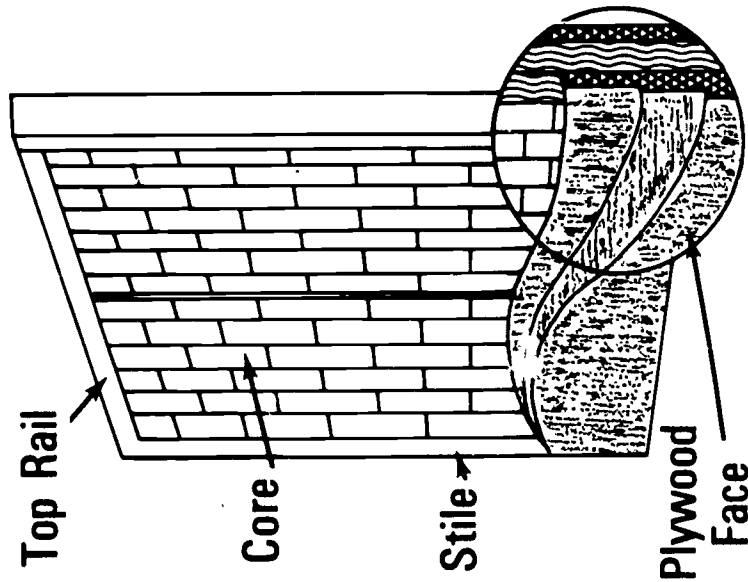

SOLID CORE

The Hand of a Door for Locks

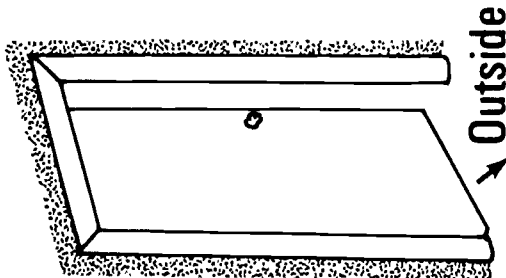

Left Hand

Hinges on Left:
Opens Inward for
Handed Locks,
Specify LH.

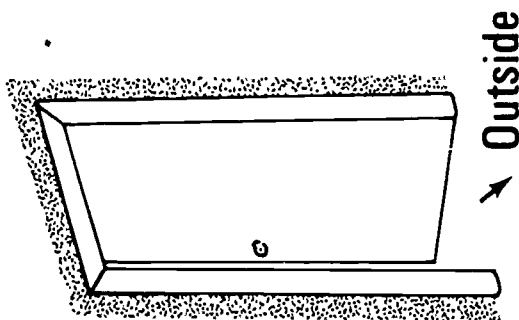

Right Hand

Hinges on Right
Opens Inward for
Handed Locks,
Specify RH.

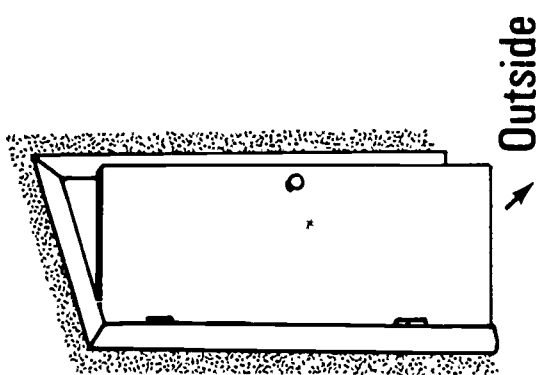

Left Hand
Reverse

Hinges on Left:
Opens Outward for
Handed Locks,
Specify LHR.

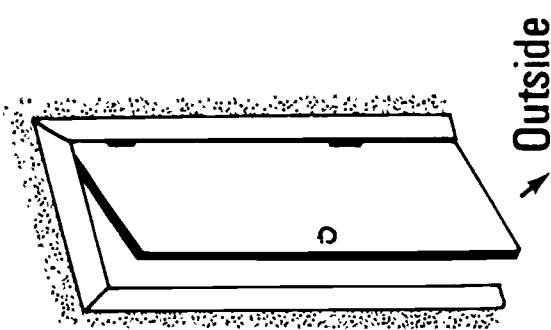

Right Hand
Reverse

Hinges on Right:
Opens Outward for
Handed Locks,
Specify RHR.

Parts of a Window Installation

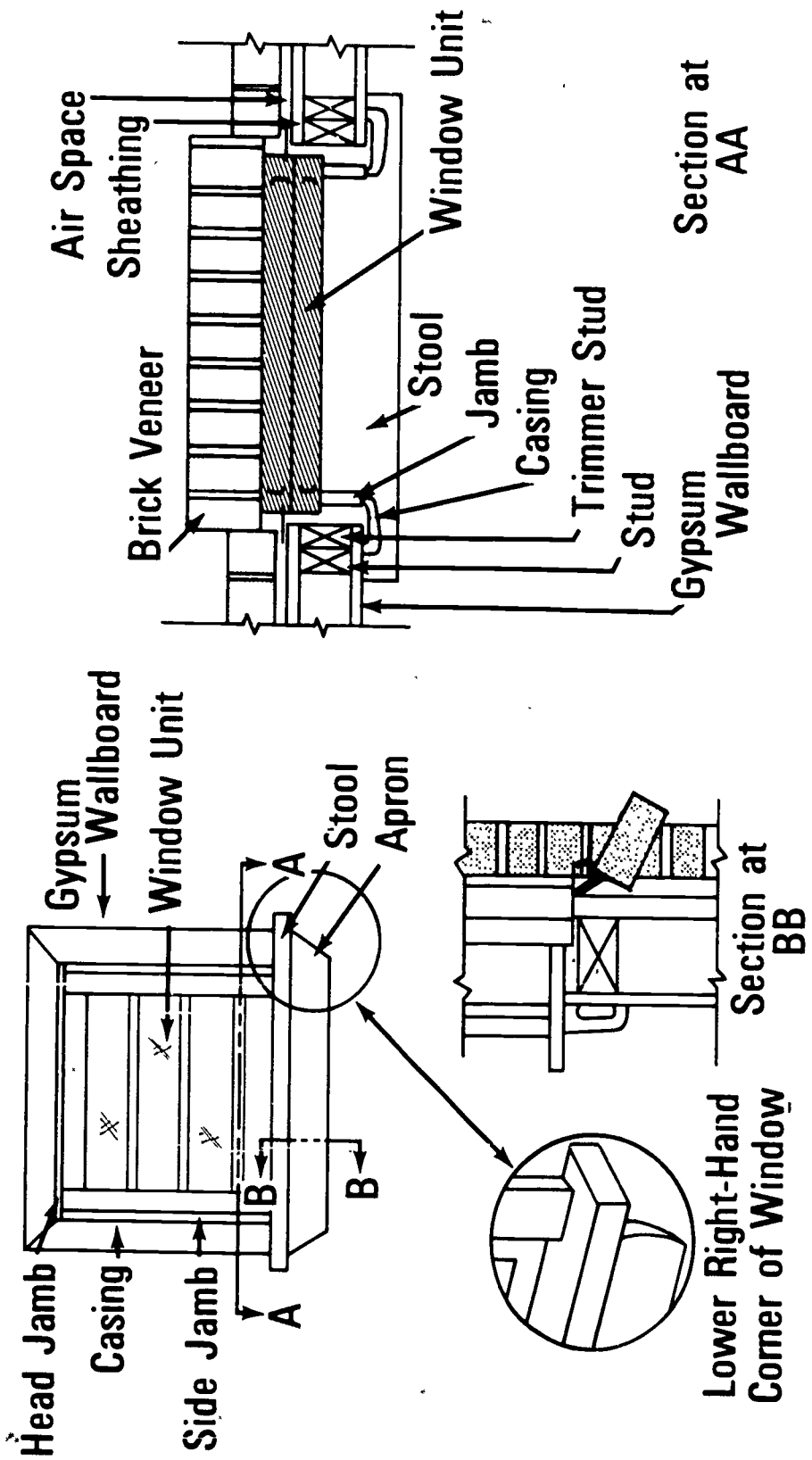

Common Trim and Molding Joints

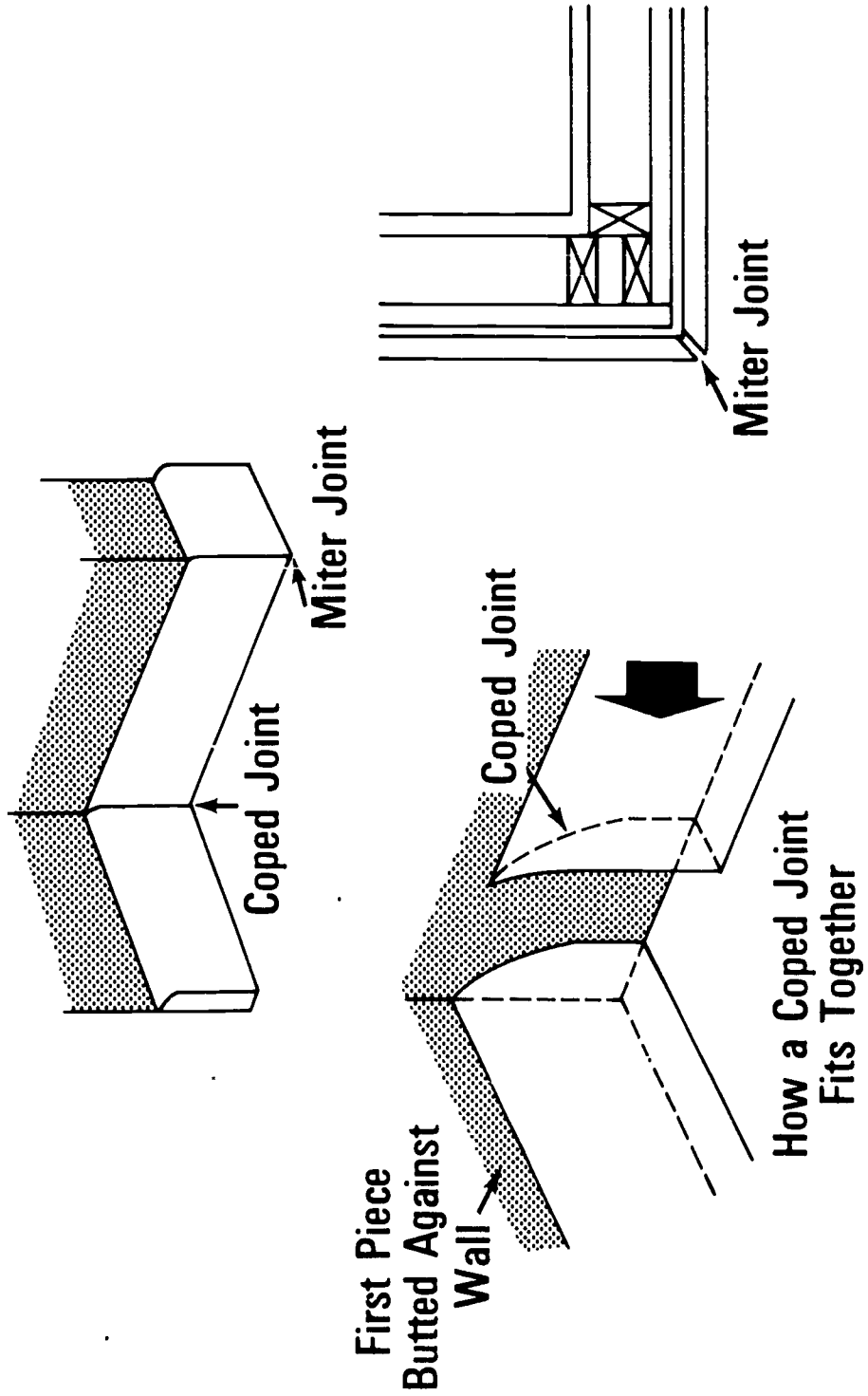

Molding

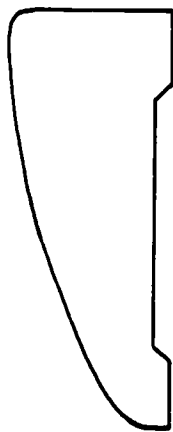

Casing

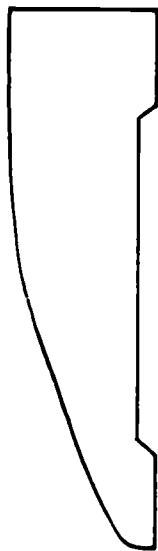

Baseboard



Door and Window Stops

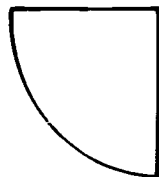

Quarter Round



Base Shoe

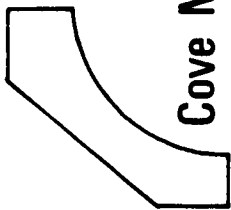

Cove Mold

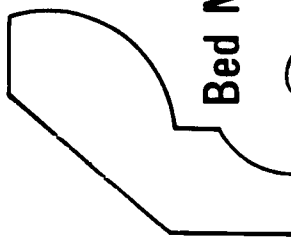

Bed Mold



Corner Mold

Types of Doors According to Installation

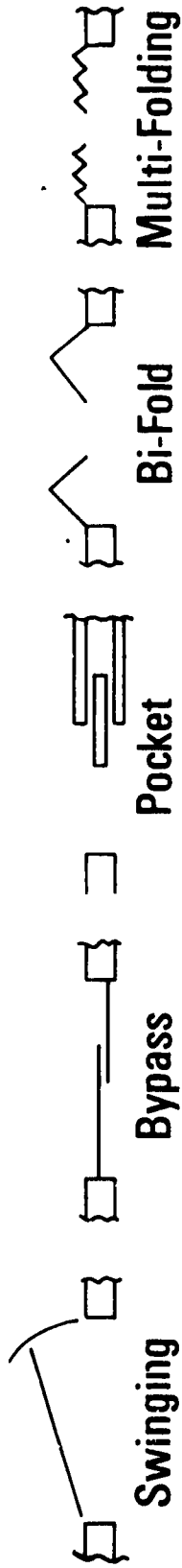
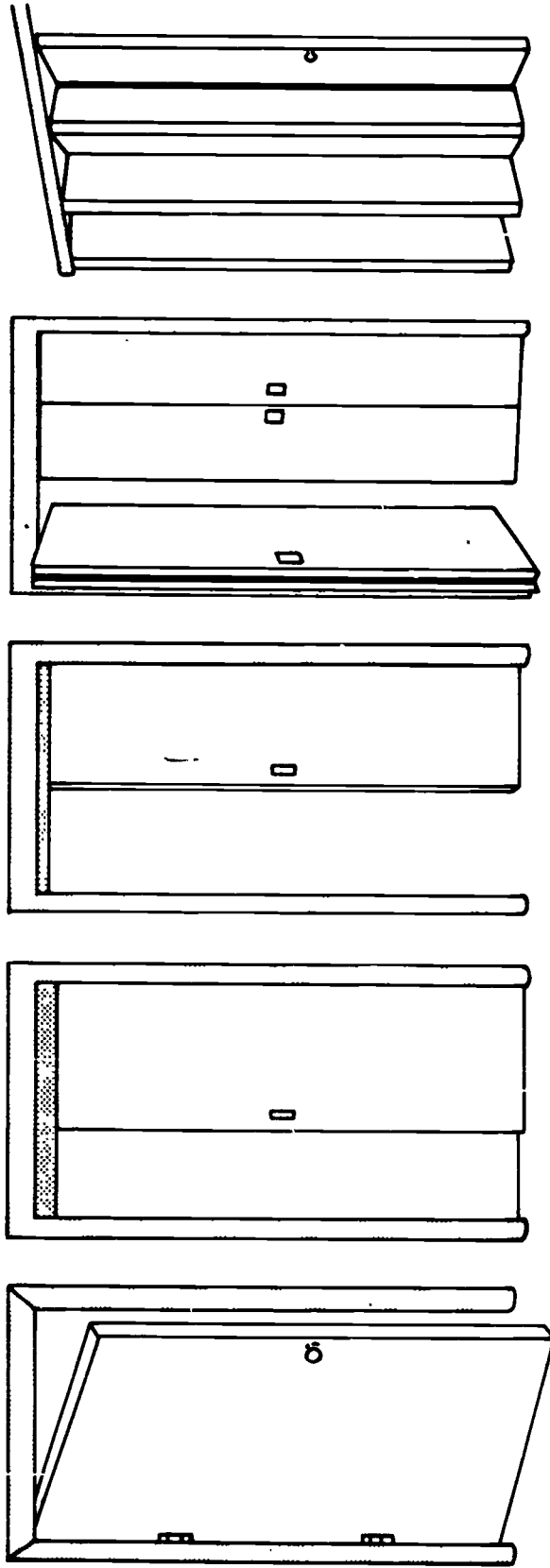

DOOR HANGING AND TRIM
UNIT II

ASSIGNMENT SHEET #1--MATERIAL ESTIMATING

Using the assignment sheet, calculate the door and trim materials listed below for the room in the illustration.

_____ a. Interior doors

_____ b. Interior door jambs

_____ c. Casing

_____ d. Door stop

_____ e. Butts

_____ f. Baseboard

_____ g. Base shoe

_____ h. Locksets

ASSIGNMENT SHEET #1

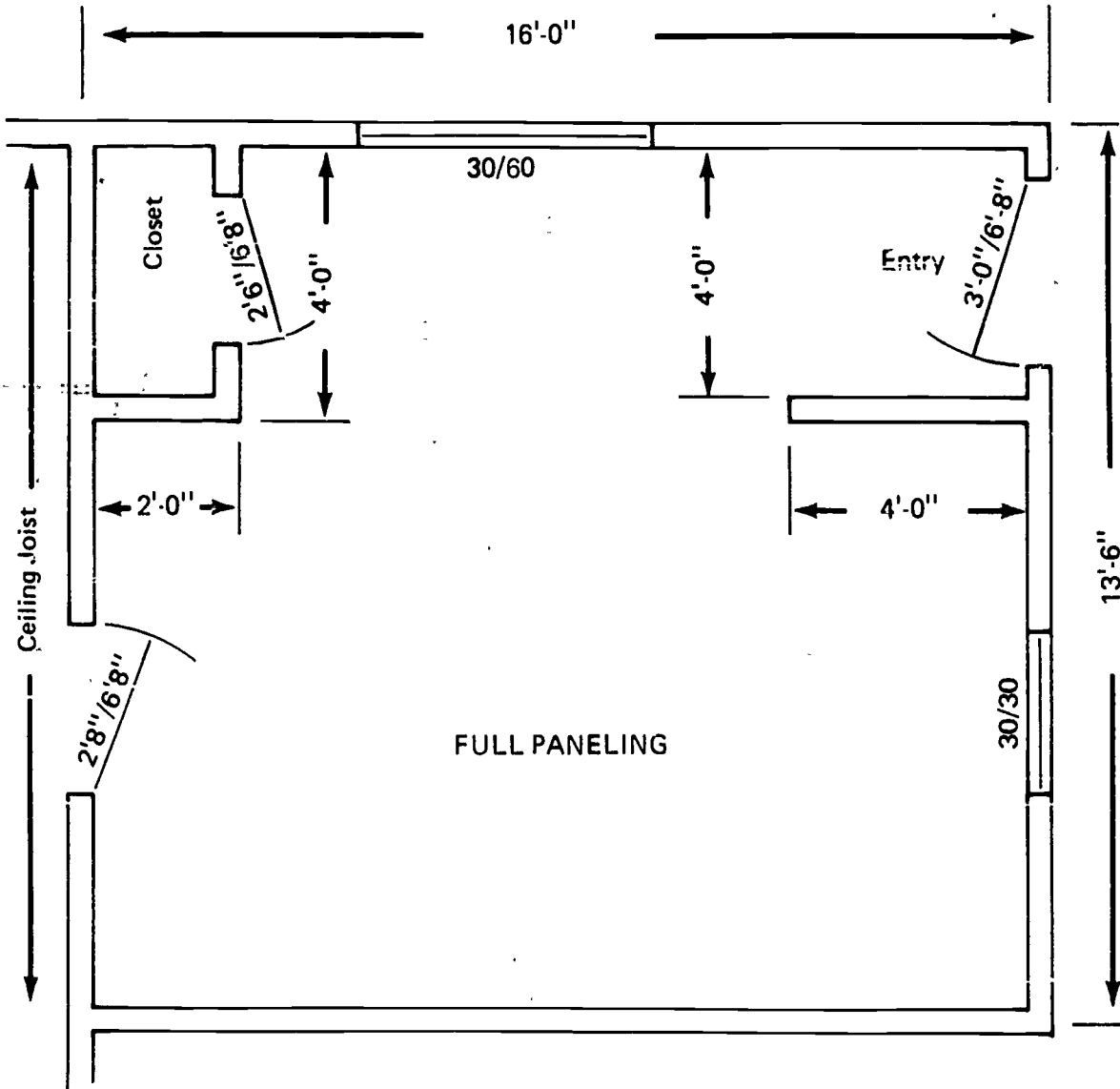

1094

DOOR HANGING AND TRIM
UNIT II

ANSWERS TO ASSIGNMENT SHEET

- a. 1 - 2' 8" x 6' 8"
1 - 2' 6" x 6' 8"
- b. 1 - 2' 6" x 6' 8"
1 - 2' 8" x 6' 8"
- c. 2 - sets of 2' 6" x 6' 8"
1 - set of 2' 8" x 6' 8"
1 - set of 3' 0" x 6' 8"
5 - pieces of casing 14' long for windows
- d. 1 - set of 2' 8" x 6' 8"
1 - set of 2' 6" x 6' 8"
- e. 2 - pair 3 1/2"
- f. 80 lineal feet of baseboard
- g. 80 lineal feet of baseshoe
- h. 2 - passage locksets

DOOR HANGING AND TRIM
UNIT IIJOB SHEET #1--INSTALL INTERIOR DOOR FRAME
AND HANG AND LOCK DOORS

I. Tools and materials needed

A. Tools

1. Levels (2 and 4 foot)
2. Framing square
3. Electric hand drill (3/8" preferably)
4. Claw hammer (13 ounce)
5. Wood chisels
6. Router with mortising bit
7. Door hanging kit (if available)
8. Boring jig (for locksets to be used)
9. Nail set (1/16")
10. Block plane
11. Screwdriver
12. Jointer or power plane
13. Butt marker

B. Materials

1. Door frames
2. Butts
3. Wood shingles for shims
4. Doors
5. Nails
 - a. 8d casing
 - b. 8d box

JOB SHEET #1

II. Procedure

A. Install a swinging door

1. Install door frames

a. Prepare the rough opening

- 1) Trim off any wallboard that projects past the trimmer stud and header
- 2) Clean off any taping mud that may be on the inside of the rough opening
- 3) Check the rough opening for size

b. Determine the hand of the door for installing butts

c. Mark the location of the butts on the edge of the door and on the side jamb (Figure 1)

(NOTE: All measurements are made on the edge of the door and transferred to the jamb.)

FIGURE 1

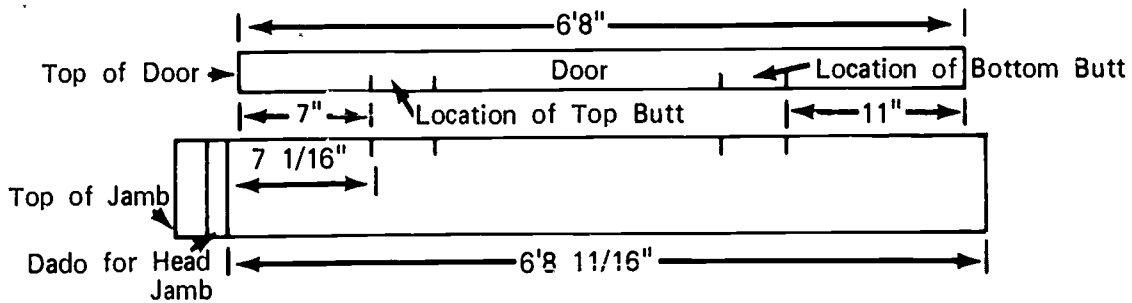

JOB SHEET #1

- d. Cut the gains in the side jamb and door edge to receive the butts
- 1) With a door hanging kit
(NOTE: Follow the instructions packaged with the kit.)
 - 2) By hand
 - a) Mark the butt location on the door edge and on the jamb with a butt marker (Figure 2)

FIGURE 2

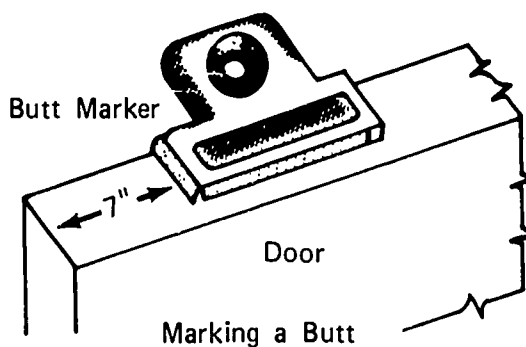

JOB SHEET #1

b) Cut out the gain with a chisel (Figure 3)

(NOTE: The butt should fit snugly in the gain with the surface of the butt slightly below the surface of the edge of the door and jamb.)

FIGURE 3

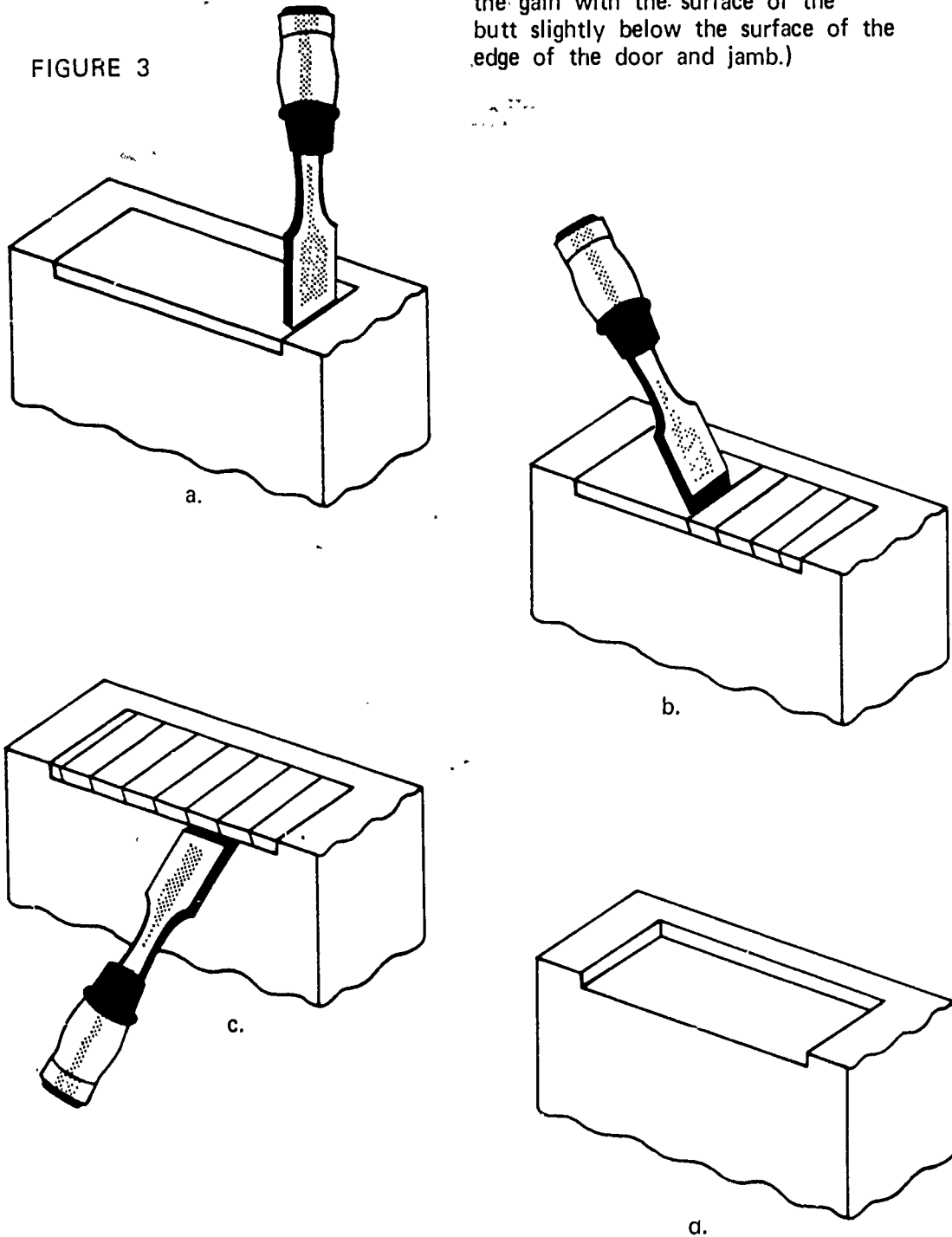

Steps in Cutting a Gain

JOB SHEET #1

- c) Place hinge leaf in the gain and mark the screw holes with a self centering punch (Figure 4)

FIGURE 4

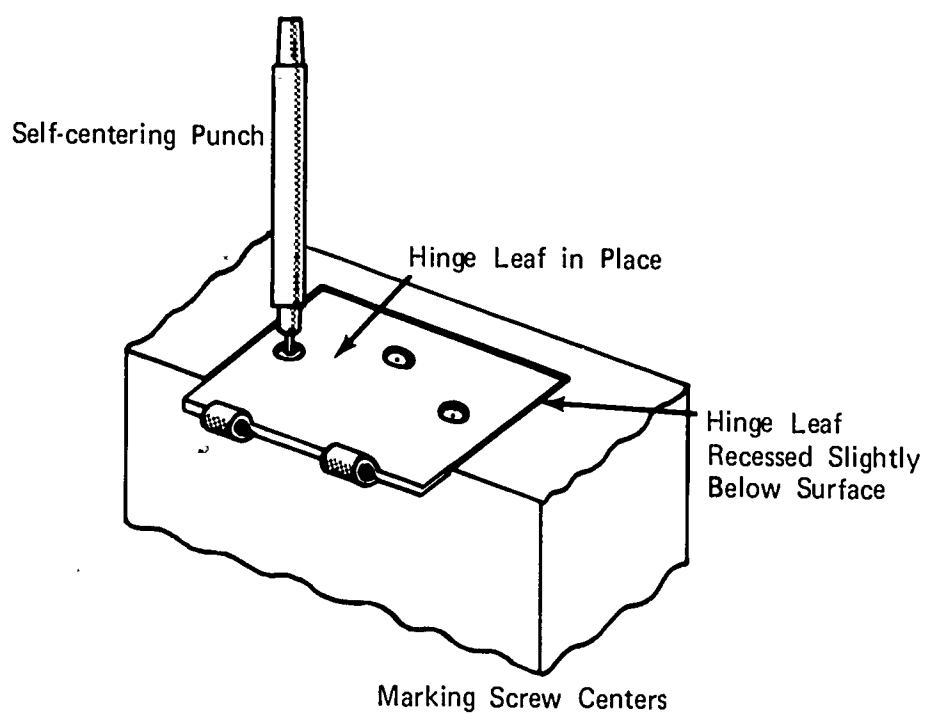

- d) Drive the screws to secure the hinge leafs to the door edge and the jamb

JOB SHEET #1

- e. Assemble the door frame--Lay the parts of the door frame on the floor (Figure 5)

FIGURE 5

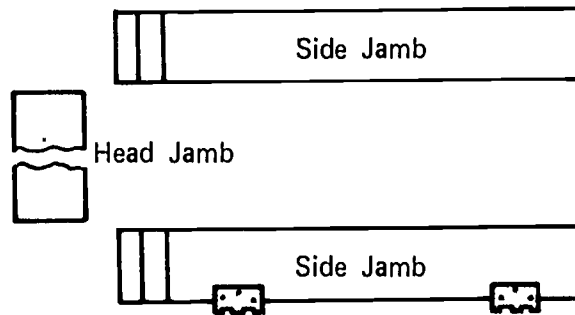

- f. Fit the door frame parts together and nail (Figure 6)

FIGURE 6

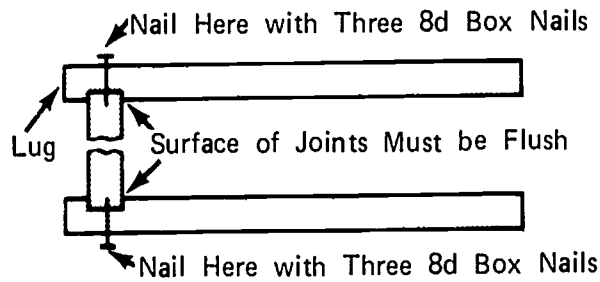

JOB SHEET #1

- g. Install blocking on the hinge side of the rough opening to plumb the side and prepare to receive the door frame (Figure 7)

FIGURE 7

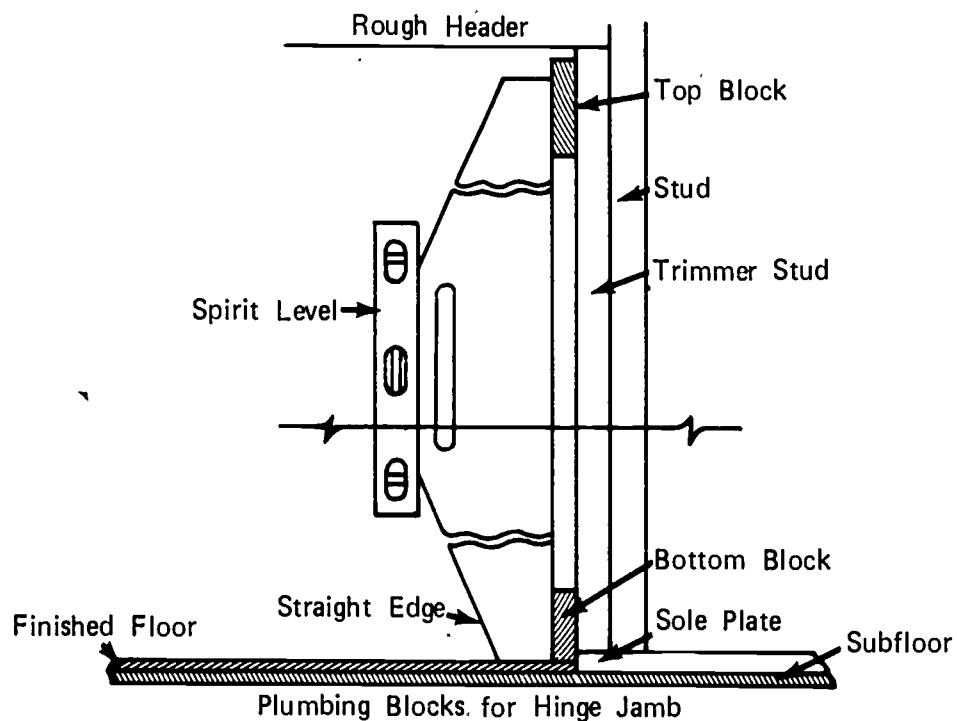

(NOTE: Be sure that the plumbing blocks are not so thick that they do not allow room for shims to plumb the opposite side.)

JOB SHEET #1

- h. Place assembled door frame into the rough opening and tack the side jamb to the plumbing blocks (Figure 8)

FIGURE 8

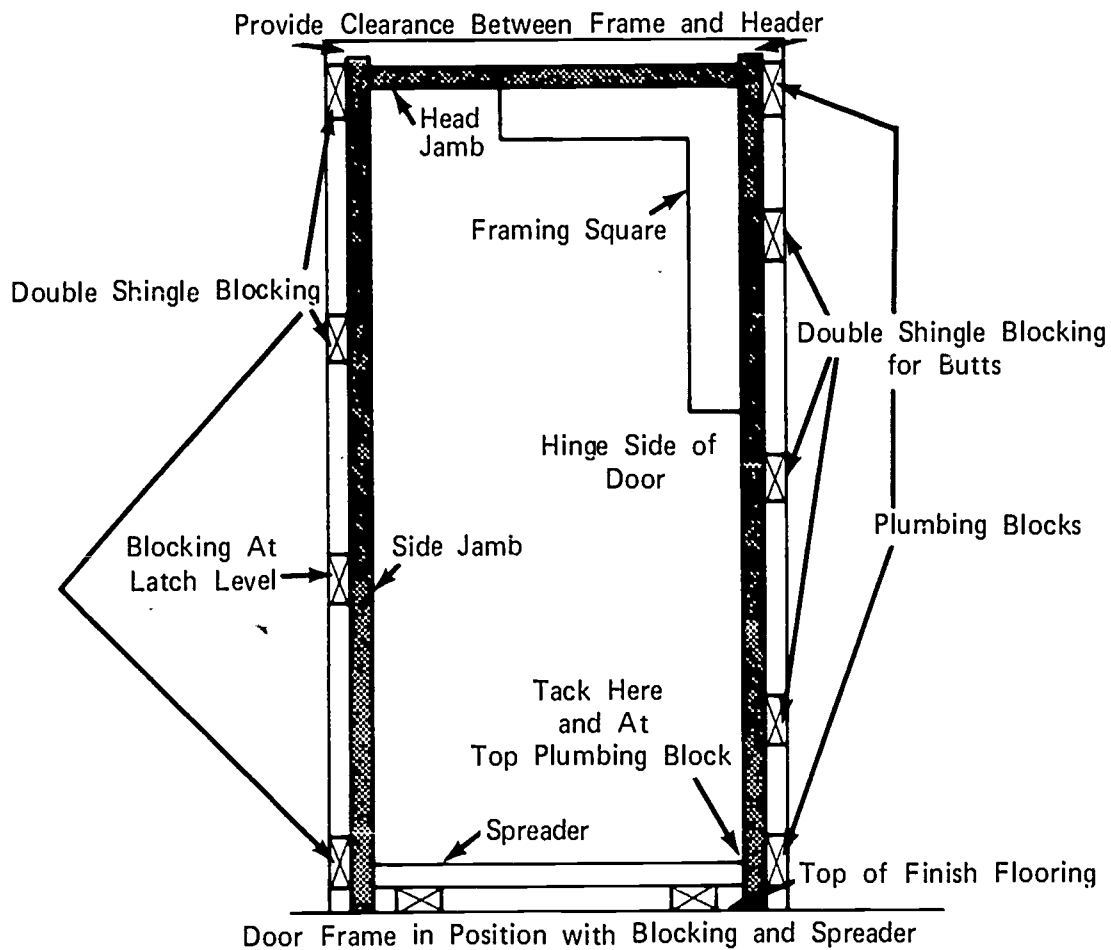

(NOTE: Check the side jamb to see that it is plumb and insert the blocking for the butts and the center of the jamb and tack in place.)

- i. Square the head jamb to the tacked side jamb as illustrated above; block the opposite side jamb and tack in place
- j. Locate the spreader at the bottom of the door frame as illustrated above and tack the bottom end of the loose side jamb in place

JOB SHEET #1

- k. Install the remaining blocking and check the frame to see that the side jambs are plumb and square to the header
 - l. Finish driving and setting the nails to permanently secure the sides
2. Hang and fit door (Figure 9)

(NOTE: The hinge side and top of door should fit with the proper clearance if the gains were properly cut.)

FIGURE 9

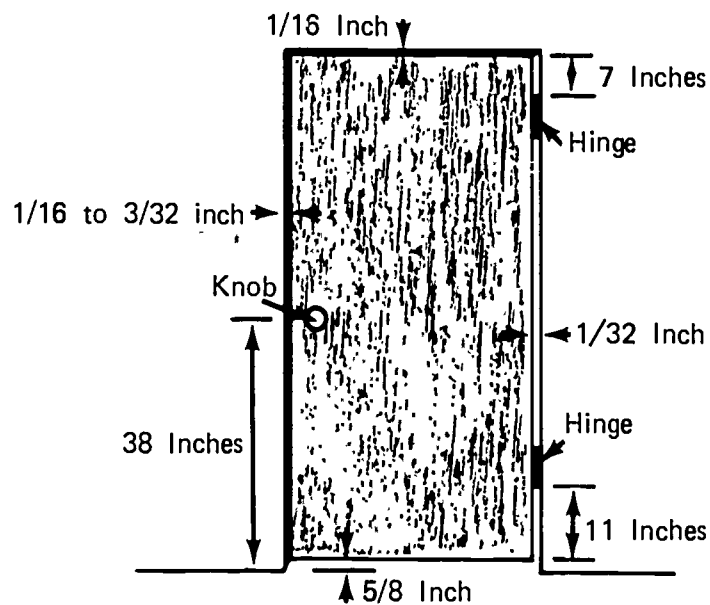

JOB SHEET #1

3. Locate and bore holes in door for the lockset

(NOTE: Use a boring jig if one is available; if not follow the instructions packaged with the lockset.)

4. Install door stop

- a. Cut stop to length

- 1) Head stop--Width of opening in door frame
- 2) Side stops--One inch shorter than distance from finished floor to the bottom of the head jamb

- b. Miter both ends of all stop pieces

- c. Install door stop

- 1) Have a helper hold the door shut with the hinge side flush with the edge of the jamb
- 2) Tack the side stops in place with approximately 1 1/6" clearance between the face of the door and the stop and with the top touching the head jamb
- 3) Open the door and fit the head stop between the sides and nail the side and head stops in place with 4d finish nails spaced approximately every twelve inches (Figure 10)

JOB SHEET #1

FIGURE 10

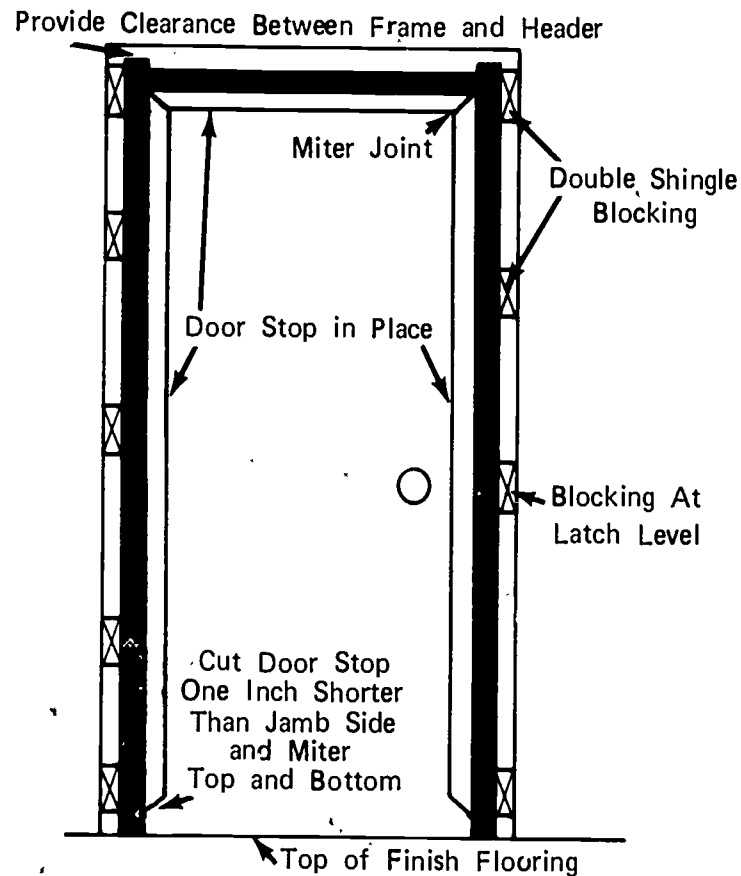

B. Install a bi-fold door

(NOTE: Follow the manufacturer's instructions for installing jambs and hardware.)

C. Install a pocket door

(NOTE: Follow the manufacturer's instructions for the installation of the pocket and hanging the door.)

D. Install by-pass sliding doors

(NOTE: Follow the manufacturer's instructions for installing the track and door hardware.)

DOOR HANGING AND TRIM
UNIT II

JOB SHEET #2-TRIM AND CASE A WINDOW

I. Tools and materials needed

A. Tools

1. Radial arm or table saw with finishing blade
2. Miter saw
3. Crosscut handsaw
4. Claw hammer
5. Tri-square
6. Tape measure (12 or 16 foot)
7. Jointer
8. Nail set (1/16")

B. Materials

1. Lumber to make the window frame
 - a. Header
 - b. Sides
 - c. Stool
2. Casing for window frame and apron
3. Nails
 - a. 8d finish (for frame)
 - b. 6d finish (for casing)
 - c. 4d finish (for casing)
4. Glue

JOB SHEET #2

II. Procedure (for trimming to an aluminum window unit)

A. Install window frame

1. Measure for the width of the side and head frame members (Figure 1)

FIGURE 1

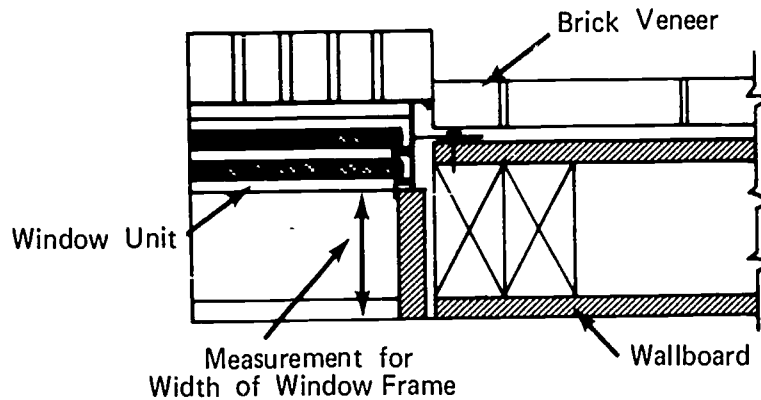

2. Measure the length of head and side frame members (Figure 2)

FIGURE 2

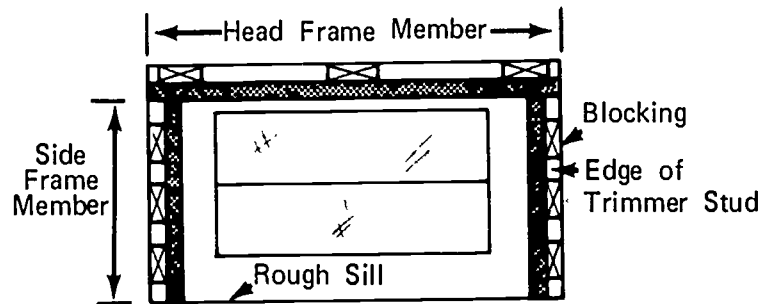

(NOTE: The head frame member is measured to fit between the trimmer studs and the side members are measured from the bottom of the head frame member to the top of the rough sill.)

3. Cut frame members to size

(NOTE: Allow enough material in the width to joint both edges.)

JOB SHEET #2

4. Install frame
 - a. Install head frame member first with the lower edge of the head frame on the trim line of the window unit; block and nail in place with 8d finish nails
 - b. Install side frames with the inside edges being on the side trim lines of the window unit, and the top butted firmly against the head frame member; block and nail in place with 8d finish nails
5. Install sill
 - a. Lay out and cut sill to size and shape
 - 1) Measure the distance between the side jambs which is dimension A in the illustration below, add dimensions B₁ and B₂ to dimension A for the rough length of the sill
 - 2) Measure the distance from the window unit to the room side edge of the side frame member for dimension C in the illustration below and add dimension D for the rough width of the stool (Figure 3)

FIGURE 3

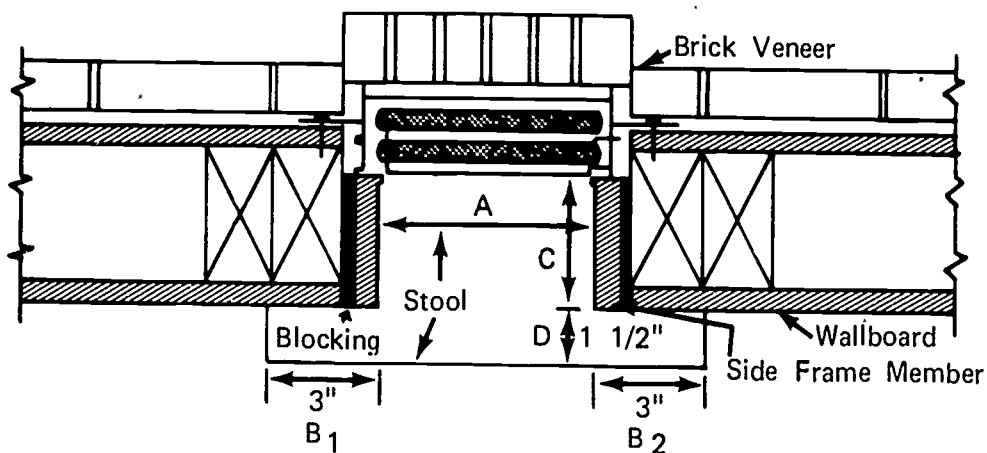

JOB SHEET #2

- 3) Lay out the stool and cut out (Figure 4)

FIGURE 4

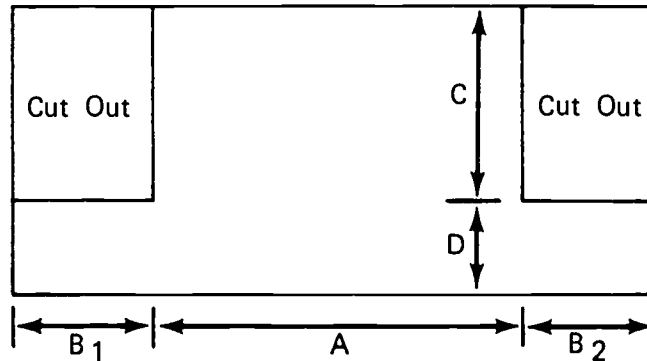

- b. Install the sill with blocking between the sill and the rough sill to bring the top face of the sill up to the trim line on the bottom of the window unit; wedge between the sides and nail in place with 8d finish nails

(NOTE: The sill must fit the window unit the frame sides and the face of the wall.)

B. Case window

1. Cut casing for sides
 - a. Measure from top of stool to bottom face of head frame
 - b. Add $\frac{3}{16}$ " for the set back on the frame

(NOTE: This is the measurement for the heel cut of the forty-five degree miter.) (Figure 5)

FIGURE 5

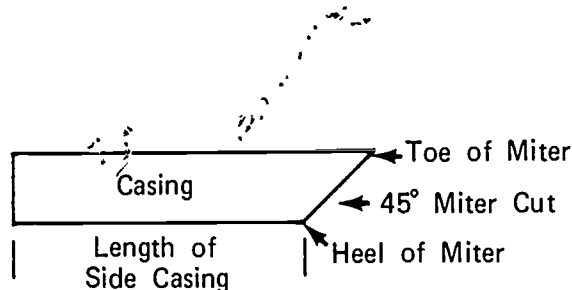

- c. Cut two sides for each window

JOB SHEET #2

2. Cut head casing
 - a. Measure the opening between the side frames
 - b. Add $\frac{3}{8}$ " for the setback on both side frames

(NOTE: This is the measurement for the heel cut of the forty-five degree miter.) (Figure 6)

FIGURE 6

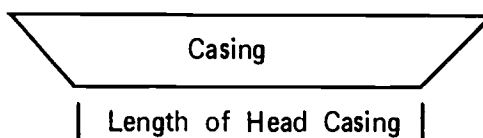

3. Install casing (Figure 7)

(NOTE: The miter joints should be glued and must fit tight all of the way across.)

FIGURE 7

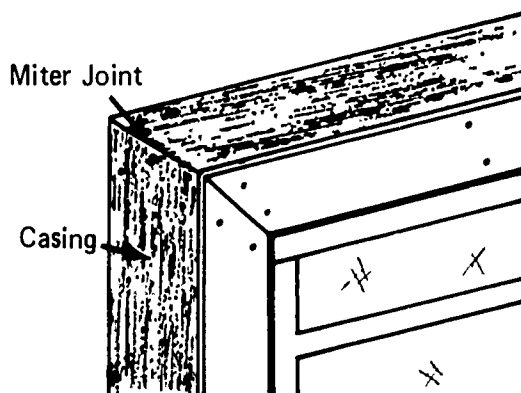

Application of casing at the upper left-hand corner of a window.

Note tight fit of miter joint.

4. Cut and install apron

JOB SHEET #2

- a. Measure the length of the apron from the outside of the casing on the left side of the window to the outside of the right casing (Figure 8)

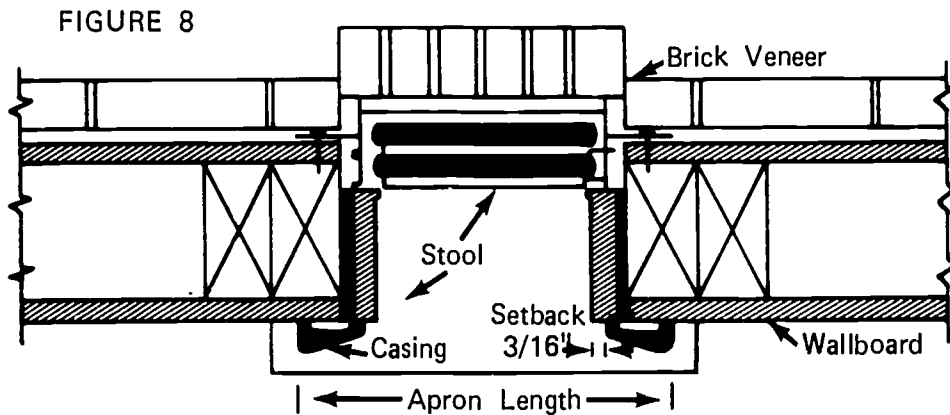

- b. Cut the apron to length, shape the ends, and nail in place directly under the stool with 6d finish nails (Figure 9)

FIGURE 9

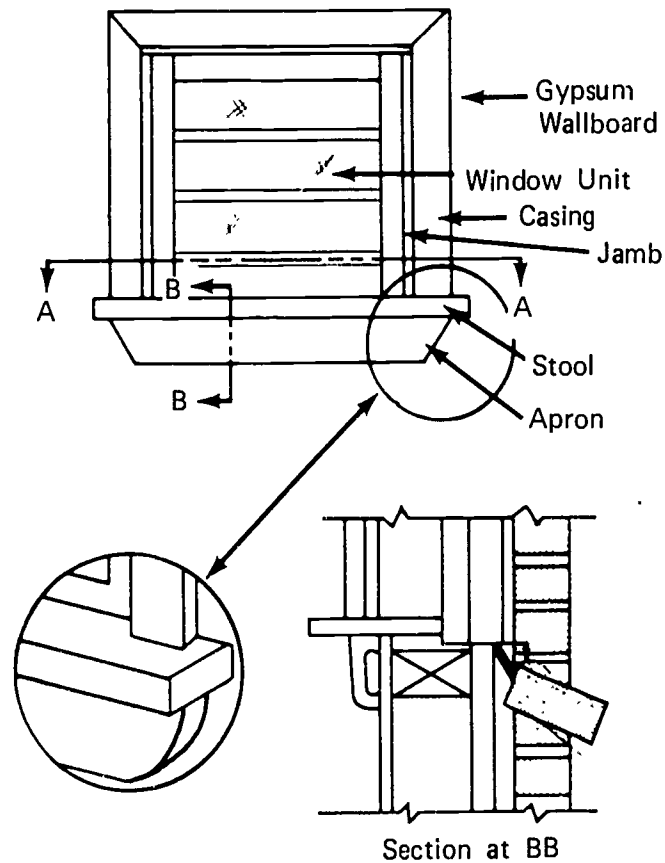

DOOR HANGING AND TRIM
UNIT II

JOB SHEET #3-CASE A DOOR FRAME

- I. Tools and materials needed
 - A. Tools
 1. Miter saw
 2. Tape measure (12 or 16 foot)
 3. Claw hammer (13 ounce)
 4. Nail set (1/16")
 - B. Materials
 1. Casing material
 2. Nails
 - a. 6d finish
 - b. 4d finish
 3. Glue
- II. Procedure
 - A. Measure and cut side casing to length
 1. Measure from the floor to the face of the head jamb
 2. Add 3/16" for set back; this is the measurement to the heel of the miter
 3. Cut a pair of sides for each side of the door
(NOTE: A pair of sides includes a left and right hand cut.)
 - B. Measure and cut head casing to length
 1. Measure between the two side jambs
 2. Add 3/8" for set back on both sides; this is the length of the header from the heel of the miter at one end to the heel of the miter at the other end
 3. Cut one for each side of the door
 - C. Install casing
 1. Nail the head casing in place with the 3/16" set back at all points

JOB SHEET #3

2. Apply glue to the miter joint and nail the side casing to the door frame (Figure 1)

(NOTE: Nail only at the corner making sure that the miter joint fits tight at all points, allow the glue to dry for several hours before nailing the rest of the side casing in place.)

FIGURE 1

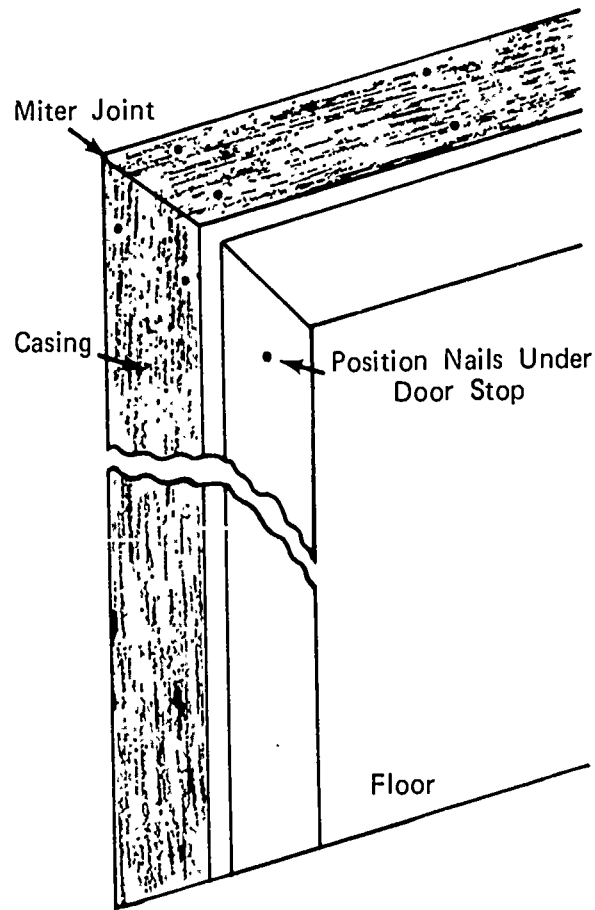

DOOR HANGING AND TRIM UNIT II

JOB SHEET #4--INSTALL A PRE-HUNG DOOR UNIT

(NOTE: All figures and procedures in this job sheet are through the courtesy of Frank Paxton Lumber Company, Des Moines, Iowa.)

I. Tools and materials needed

A. Tools

1. Hammer (13 oz)
2. Level (Hand)
3. Handsaw (12 point)
4. Nail set
5. Sawhorses (1 pair)

B. Materials

1. Pre-hung door units
2. Nails
3. Shim shingles

II. Procedure

A. Check hand and size of door (Figure 1)

(IMPORTANT: The right hand door in figure 1 would require a left hand reverse lock, the left hand door would require a right hand reverse lock if the door opens toward you when standing on the security side.)

FIGURE 1

Important: Be Sure to Specify Left Hand or Right Hand

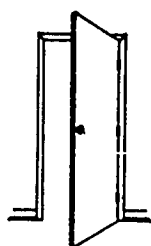

Left Hand Door

1. Face the door on the hinge side
2. Knob on the left--left hand door
3. Knob on the right--right hand door

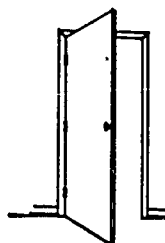

Right Hand Door

Rough Opening

Width--Door Size + 2"

Height--Door Height + 2"
from Finished Floor

JOB SHEET #4

- B. Uncrate door
- C. Lay unit on sawhorses with hinges up
- D. Remove small nails driven through the jamb into the door on the lock side (Figure 2)

FIGURE 2



- E. Separate the two halves by lifting the top half
- F. Set this portion in the rough opening (Figure 3)

(NOTE: There are three spacer blocks between the door and the side jamb and one spacer block between the door and the head jamb on the back side.)

FIGURE 3

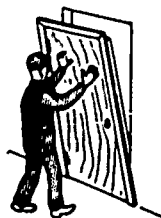

- G. Check jambs and make certain the jambs are against all spacer blocks and that both jambs are on the floor
- H. Check trim for plumb (Figure 4)

(NOTE: When trim is plumb the upper spacer block should be against the head jamb.)

FIGURE 4



1116

JOB SHEET #4

- I. Nail trim to wall

(NOTE: On lock side of door, push the jamb tight against the spacer blocks to maintain uniform clearance between the door and jamb before nailing trim.)

- J. Move through opening to opposite side of the door (Figure 5)

FIGURE 5



- K. Shim between jamb and stud

(NOTE: Close door with spacers still attached. Place shims at each hinge and at the top and bottom. Lock on the opposite jamb.)

- L. Nail through jamb and shims into stud

(IMPORTANT: Do not nail through stop.)

(NOTE: Spacer block can be removed after this step is completed.)

- M. Insert remaining half of jamb and trim into grooved section containing the door (Figure 6)

(NOTE: This half will automatically be plumb.)

FIGURE 6



- N. Nail trim to wall

JOB SHEET #4

- O. Nail jamb to studs (Figure 7)

(NOTE: Nail through stop.)

FIGURE 7



- P. Install the lock

(NOTE: The door is pre-drilled for lock.)

- Q. Check operation of the door

(NOTE: When knob is released after retracting bolt, the bolt should snap out to its fully extended position. If it does not, loosen knob screws and reposition. Also, check face of bolt for plumb.)

DOOR HANGING AND TRIM
UNIT II

TEST

1. Match the following list of terms to the correct definition.

- | | | | |
|----------|--|-----|---------------|
| _____ a. | An assembly of wood parts that form an enclosure and support for a door | 1. | Jig |
| _____ b. | A notch or mortise cut to receive a hinge or other hardware | 2. | Trim |
| _____ c. | The top member of a door frame | 3. | Template |
| _____ d. | A contrivance used for guiding tools while work is being done | 4. | Side jamb |
| _____ e. | The ends of any two pieces of board of corresponding shape cut off at an angle and fitted together in an angular shape | 5. | Door frame |
| _____ f. | A type of molding which presents a profile of a quarter of a circle | 6. | Head jamb |
| _____ g. | The vertical side posts of a door frame | 7. | Miter joint |
| _____ h. | The base or support at the bottom of a window that extends into the room | 8. | Gain |
| _____ i. | A gauge which is used as a guide for forming or shaping | 9. | Stool |
| _____ j. | A wood or metal member used to close the space at the bottom of a door at the sill | 10. | Threshold |
| _____ k. | The visible finishing work in a building | 11. | Quarter round |
| _____ l. | A piece of trim placed horizontally under the stool | 12. | Apron |
| _____ m. | A finishing board covering the edge of the wallboard where the wall and floor meet | 13. | Cove molding |
| | | 14. | Casing |
| | | 15. | Base shoe |
| | | 16. | Cope |
| | | 17. | Baseboard |
| | | 18. | Butt |
| | | 19. | Clearance |

- _____n. Small narrow molding used around a room at the base of the baseboard
- _____o. A type of door hinge where one leaf is mortised into the edge of the door and the other leaf is mortised into the side jamb
- _____p. The framework of trim around a window or door
- _____q. The spacing between the edge of a door and the jamb
- _____r. To cut or shape the end of a piece of molding so it will cover and fit the contour of an adjoining piece of molding
- _____s. Molding with a concave profile used primarily for trim where the wall meets the ceiling

2. Identify the parts that makeup an interior door unit.

- a.
- b.
- c.
- d.
- e.
- f.
- g.
- h.
- i.
- j.
- k.

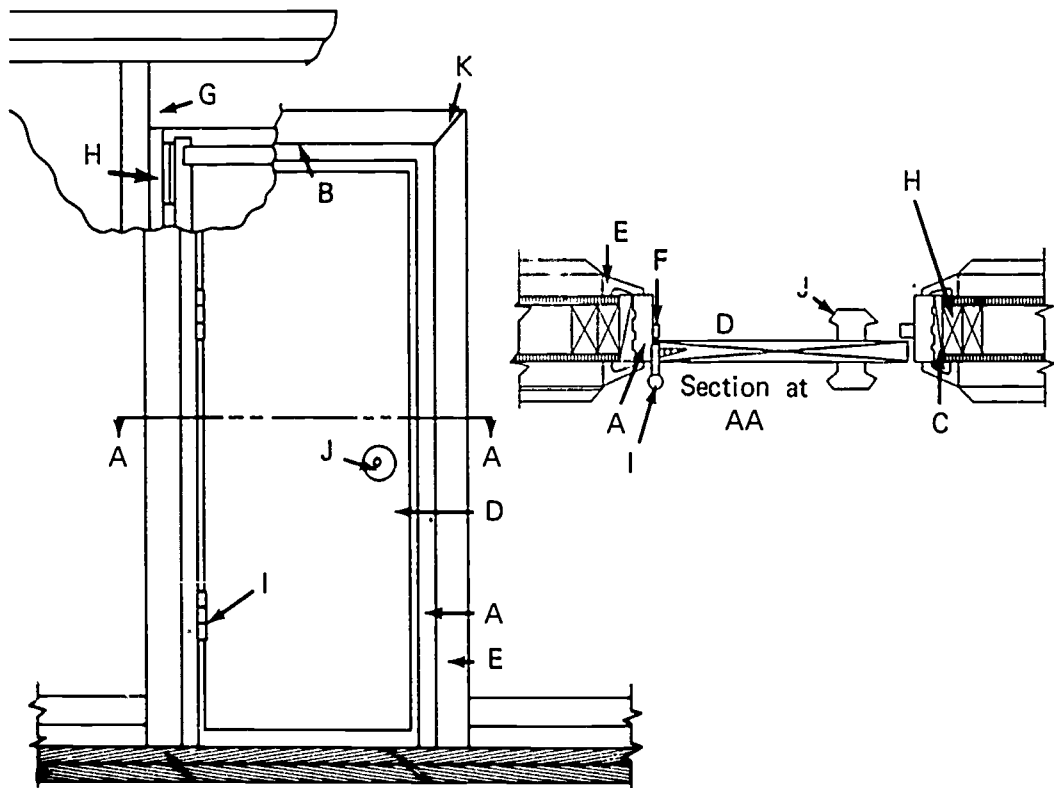

3. Name two general types of interior door construction.

- a.
- b.

4. Identify the hand of the doors illustrated below.

- a.
- b.
- c.
- d.

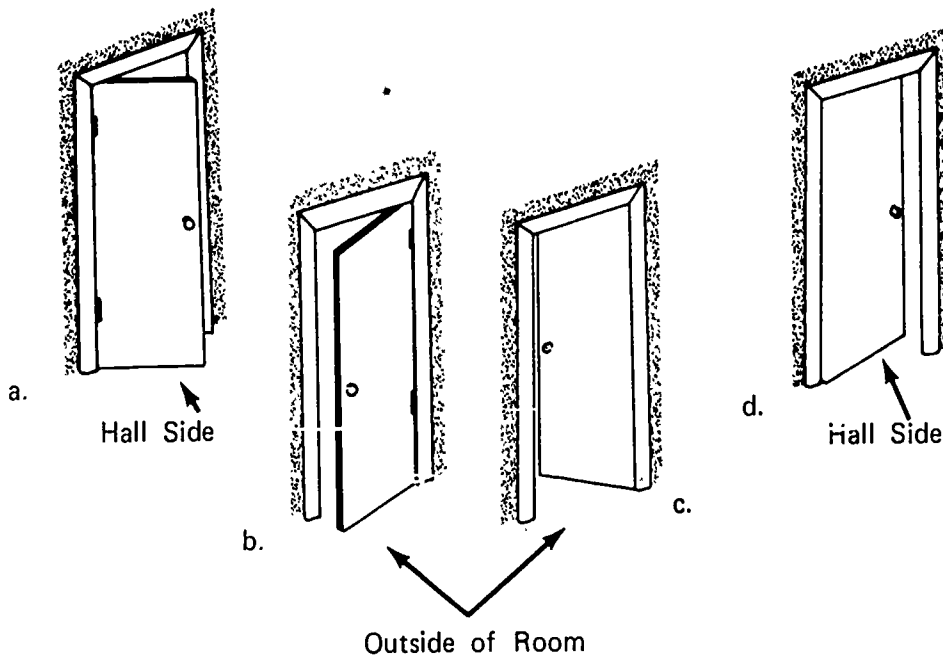

5. State the standard dimensions for the following interior door and frame components.

- _____ a. Standard interior door thickness
- _____ b. Standard widths of interior doors
- _____ c. Standard height of interior doors
- _____ d. Standard thickness of interior jamb

6. Identify the parts of a window installation from the illustration below.

- a.
- b.
- c.
- d.
- e.
- f.

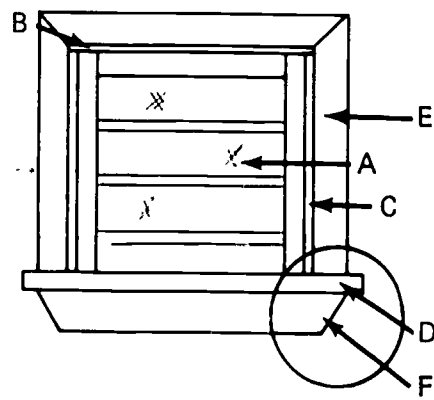

7. Identify the two types of joints commonly used to install casing and trim.

- a.
- b.

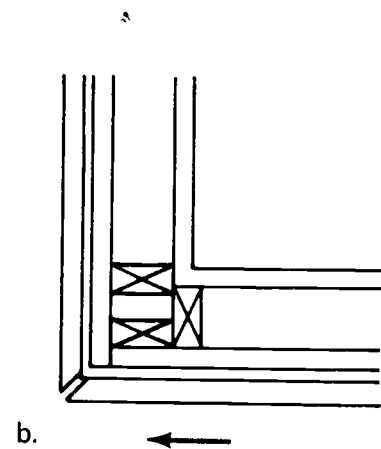
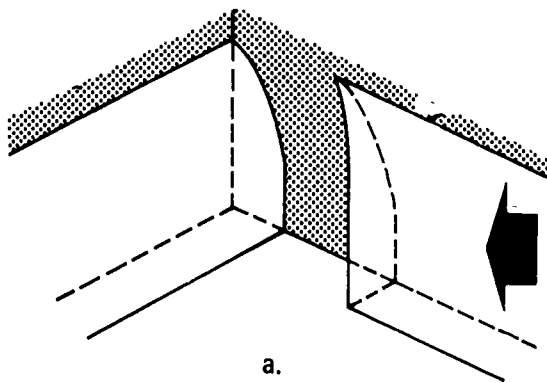

8. Identify eight types of molding.

- a.
- b.
- c.
- d.
- e.
- f.
- g.
- h.

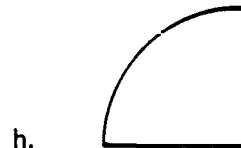
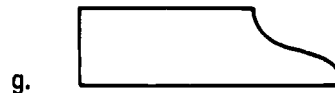
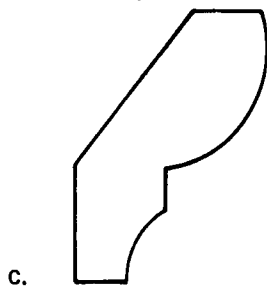
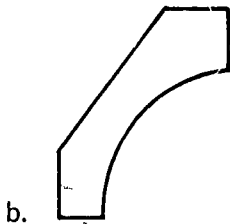
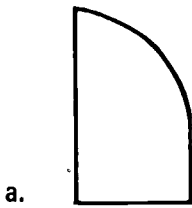

9. Identify the five types of door installations illustrated below.

- a.
- b.
- c.
- d.
- e.

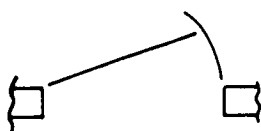

a.

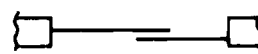

b.

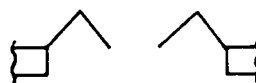

c.

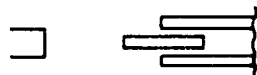

d.

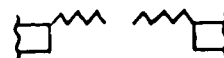

e.

10. Estimate the following material needed to trim the room pictured below.

- a. Doors--
- b. Jamb sets--
- c. Casing--
- d. Butts--
- e. Baseboard--

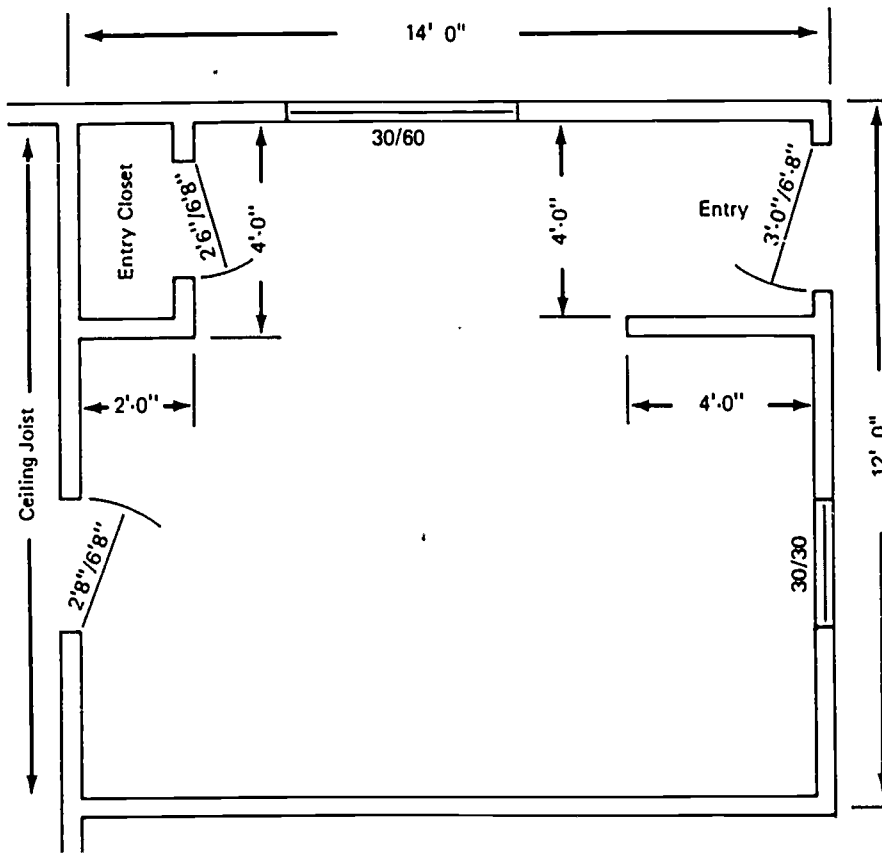

1126

11. Demonstrate the ability to:
- a. Install a door frame and hang and lock doors.
 - b. Trim a window.
 - c. Case a door frame.
 - d. Install a pre-hung door unit.

(NOTE: If this has not been accomplished prior to the test, ask the instructor when the above activities should be completed.)

DOOR HANGING AND TRIM
UNIT II

ANSWERS TO TEST

1.
 - a. 5
 - b. 8
 - c. 6
 - d. 1
 - e. 7
 - f. 11
 - g. 4
 - h. 9
 - i. 3
 - j. 10
 - k. 2
 - l. 12
 - m. 17
 - n. 15
 - o. 18
 - p. 14
 - q. 19
 - r. 16
 - s. 13
2.
 - a. Side jamb
 - b. Head jamb
 - c. Blocking
 - d. Door

- e. Casing
 - f. Stop
 - g. Rough header
 - h. Trimmer stud
 - i. Butt
 - j. Locksett *lockset*
 - k. 45° miter joint
3. a. Solid core
- b. Hollow core
4. a. Left hand reverse
- b. Right hand reverse
- c. Right hand
- d. Left hand
5. a. 1 3/8"
- b. 2' 0", 2' 4", 2' 6", 2' 8"
- c. 6' 8"
- d. 4 1/2"
6. a. Window unit
- b. Head jamb
- c. Side jamb
- d. Stool
- e. Casing
- f. Apron
7. a. Cope joint
- b. Miter joint
8. a. Base shoe
- b. Cove molding

- c. Bed molding
 - d. Corner molding
 - e. Casing
 - f. Baseboard
 - g. Door stop
 - h. Quarter round
- 9.
- a. Swinging
 - b. By-pass
 - c. Bi-fold
 - d. Picket
 - e. Multi-fold
- 10.
- a. 1 - 2' 8" x 6' 8" and 1 - 2' 6" x 6' 8" interior doors
 - b. 1 - 2' 6" x 6' 8" x 4 1/2" and 1 - 2' 8" x 6' 8" x 4 1/2" interior jamb sets
 - c. 2 - sets 2' 6" x 6' 8", 1 - set 2' 8" x 6' 8", 1 set 3' 0" x 6' 8" casing
5 pieces 14' casing for windows
 - d. 2 pair 3 1/2" butts
 - e. 72' baseboard
11. Performance skills will be evaluated according to the criteria listed on the progress chart.

CABINET AND FIXTURE INSTALLATION UNIT III

TERMINAL OBJECTIVE

After completion of this unit, the student should be able to match terms associated with cabinets and fixtures to the correct definition, identify the parts of a cabinet or fixture, types of cabinet door installation, items of cabinet hardware, and joints used in cabinet construction. He should be able to install cabinets. This knowledge will be evidenced by demonstration and by scoring eighty-five percent on the unit test.

SPECIFIC OBJECTIVES

After completion of this unit, the student should be able to:

1. Match terms associated to cabinets and fixtures to the correct definitions.
2. Identify the parts of a cabinet or fixture.
3. Identify three types of cabinet door installation.
4. Identify eight items of cabinet hardware.
5. Identify five joints used in cabinet construction.
6. Name two types of cabinets or fixtures.
7. Demonstrate the ability to install a custom built cabinet.

CABINET AND FIXTURE INSTALLATION UNIT III

SUGGESTED ACTIVITIES

- I. Instructor:
 - A. Provide students with objective sheet.
 - B. Provide students with information and job sheets.
 - C. Make transparencies.
 - D. Discuss terminal and specific objectives.
 - E. Discuss information sheet.
 - F. Demonstrate and discuss procedures outlined in job sheets.
 - G. Give test.
- II. Student:
 - A. Read objective sheet.
 - B. Study information sheet.
 - C. Demonstrate the ability to accomplish the procedures outlined in the job sheet.
 - D. Take test.

INSTRUCTIONAL MATERIALS

- I. Included in this unit:
 - A. Objective sheet
 - B. Information sheet
 - C. Transparency masters
 1. TM 1--Parts of a Cabinet
 2. TM 2--Types of Cabinet Door Installation
 3. TM 3--Cabinet Hardware
 4. TM 4--Cabinet Joints

D. Job Sheet #1--Custom Cabinet Installation

E. Test

F. Answers to test

II. References:

A. Burke, Arthur E., J. Ralph Dalzell, and Gilbert Townsend. *Architectural and Building Trades Dictionary*. Chicago, Illinois: American Technical Society, 1955.

B. Durbahn, Walter E. and Elmer W. Sundberg. *Fundamentals of Carpentry*. Third Edition. Chicago, Illinois: American Technical Society, 1963.

C. Smith, Ronald C. *Principles and Practices of Light Construction*. Englewood Cliffs, New Jersey: Prentice Hall, Inc., 1970.

D. Wagner, Willis H. *Modern Carpentry*. Homewood, Illinois: Goodheart-Wilcox, 1969.

CABINETS AND FIXTURE INSTALLATION
UNIT III

INFORMATION SHEET

I. Terms and definitions

- A. Fixture--Display and storage units
- B. Counter unit--The base unit of a cabinet having a working surface
- C. Hardware--Those items in building construction that permit movement or are decorative or both including hinges, catches, pulls, and knobs
- D. Knob--A projection, usually round, for opening doors and drawers
- E. Plastic laminate--A hard laminated plastic material used as a covering for counter tops
- F. Pull--A projecting device in the form of a handle for opening doors and drawers
- G. Rail--A horizontal bar of wood used to separate drawers and doors on the face of a cabinet
- H. Stile--One of the vertical members used to separate doors and drawers on the face of a cabinet and to support the top
- I. Toe space--A recessed space at the floorline of a base cabinet or other built-in that permits one to stand close without striking the vertical surface with his toes
- J. Wall cabinet--The upper portion of a cabinet that is wall hung above the base cabinet
- K. Soffit--The underside of any subordinate member of structure, such as the under surface of an arch, cornice, or stairway
- L. Back splash A vertical continuation of a counter top at the back and ends

II. Parts of a cabinet (Transparency 1)

- A. Toe space
- B. Soffit
- C. End panel
- D. Rails
- E. Stiles

INFORMATION SHEET

- F. Shelf supports
 - G. Shelves
 - H. Drawer guides
 - I. Drawer
 - J. Door
 - K. Hinges
 - L. Pull
 - M. Knob
 - N. Counter top
 - O. Back splash
- III. Types of cabinet door installation (Transparency 2)
- A. Lipped
 - B. Flush
 - C. Surface
- IV. Cabinet hardware (Transparency 3)
- A. Knob
 - B. Pull
 - C. Friction catch
 - D. Magnetic catch
 - E. Semi-concealed hinge--for 3/8" lipped doors
 - F. Semi-concealed hinge--for flush doors
 - G. Concealed hinge--for flush doors
 - H. Monorail drawer guide
- V. Common cabinet making joints (Transparency 4)
- A. Butt joint
 - B. Dado joint

1135

INFORMATION SHEET

- C. Rabbet joint
 - D. Miter joint
 - E. Coped joint
- VI. Types of cabinets or fixtures
- A. Custom or mill built
 - B. Modular or stock units

Parts of a Cabinet

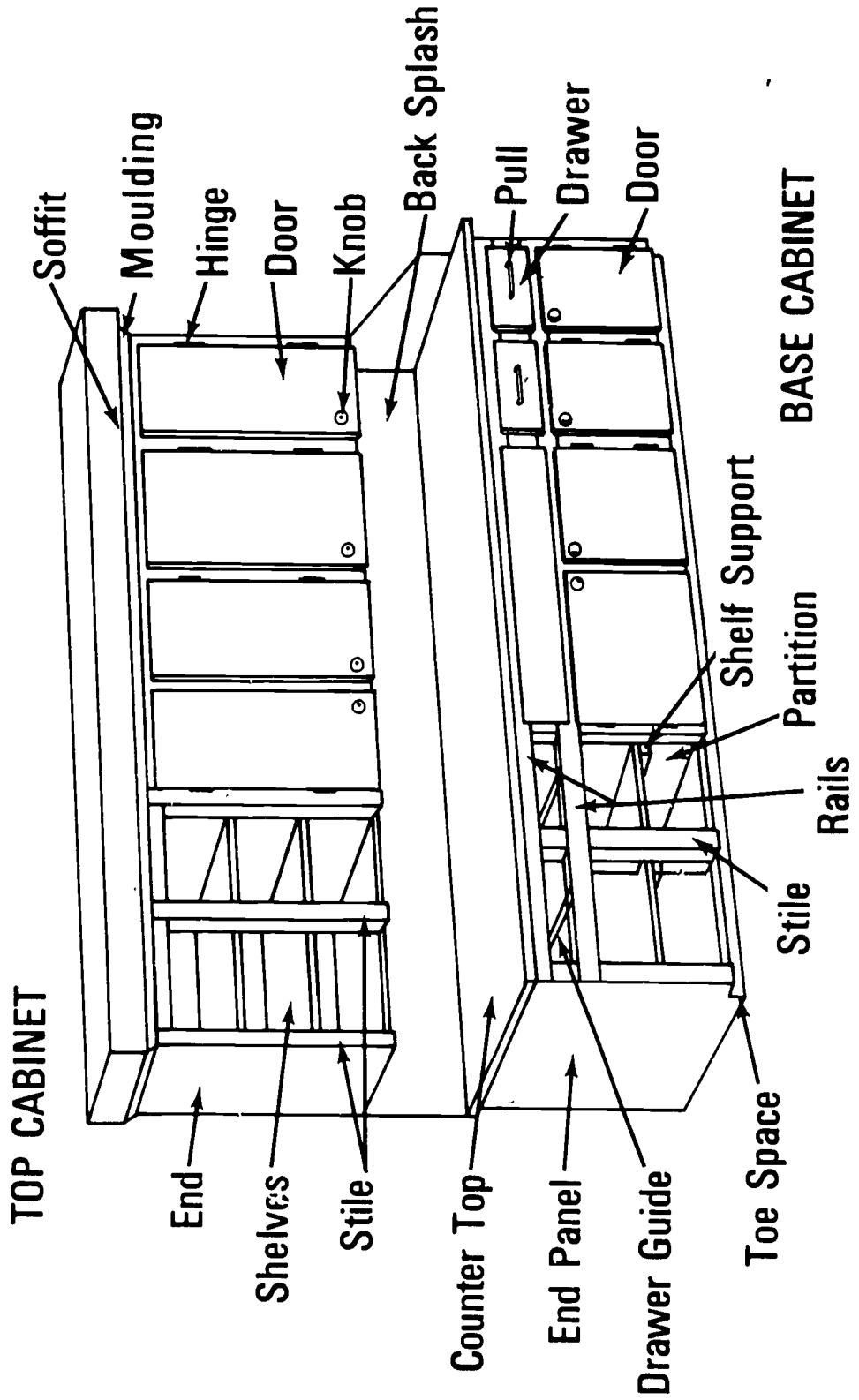

Types of Cabinet Door Installation

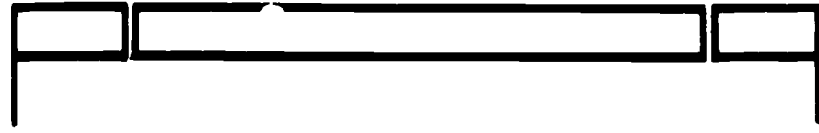

Flush Door

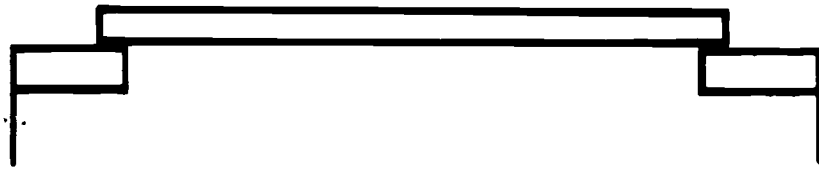

Surface Door

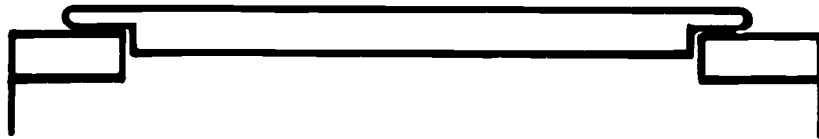

Lipped Door

1138

Cabinet Hardware

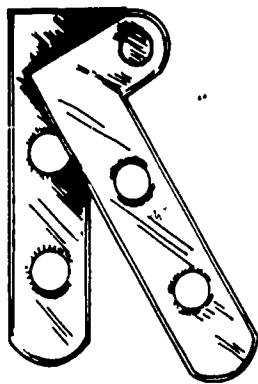

Concealed Hinge
Flush Doors



Pull

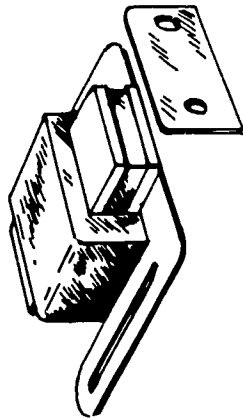

Magnetic Catch



Knob

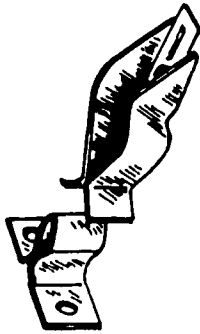

Friction Catch

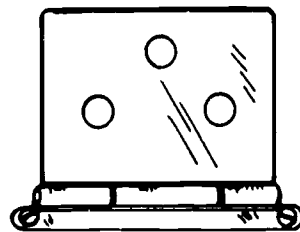

Semi-Concealed Hinge
Flush Doors

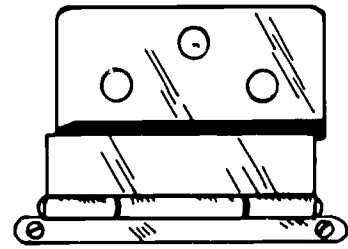

Semi-Concealed Hinge
3/8" Lipped Doors

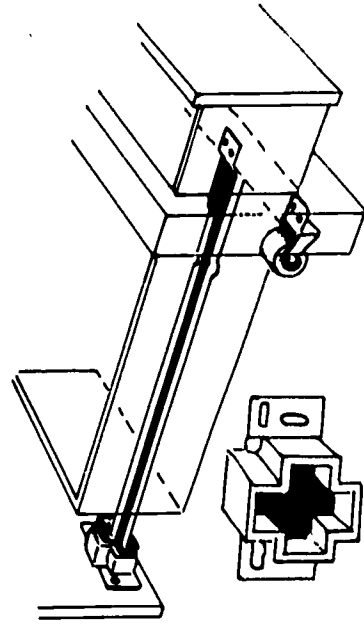

Monorail Drawer Guide

Cabinet Joints

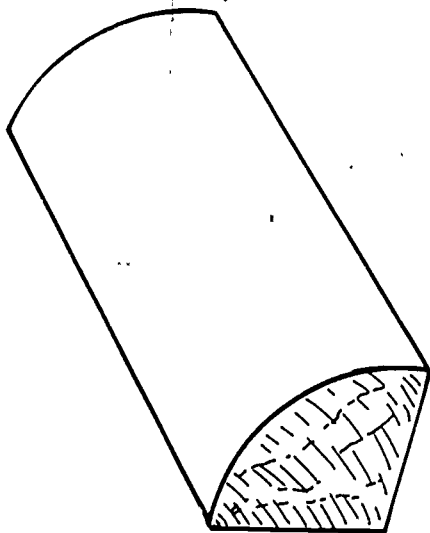

Rabbet Joint

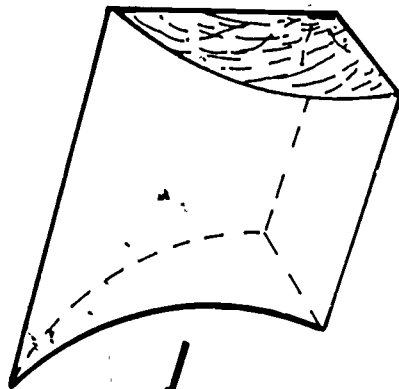

Coped Joint

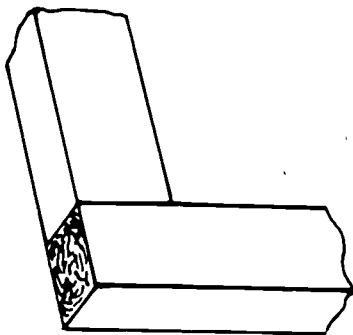

Butt Joint

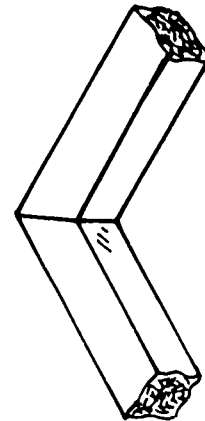
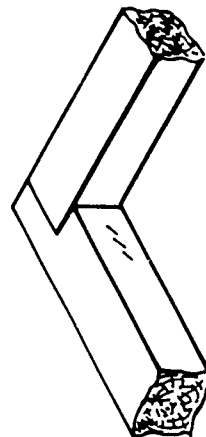

Miter Joint

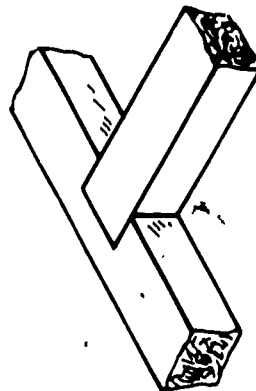

Dado Joint

CABINETS AND FIXTURE INSTALLATION
UNIT III

JOB SHEET #1--CUSTOM CABINET INSTALLATION

I. Tools and materials

A. Tools

1. Framing square
2. Level (hand)
3. Claw hammer (13 oz.)
4. Tape measure (12 or 16 ft.)
5. Nail set
6. Scriber
7. Block plane
8. Handsaw (rip)

B. Material

1. Cupboards (Mill built)
2. 1 x 2 (30' of scrap)
3. Shim shingles
4. Sandpaper

II. Procedure

A. Remove end stiles on lower cabinet

(NOTE: These are generally tacked on at the mill.)

B. Set bottom cabinet

1. Slide cupboard into location (Figure 1)

FIGURE 1

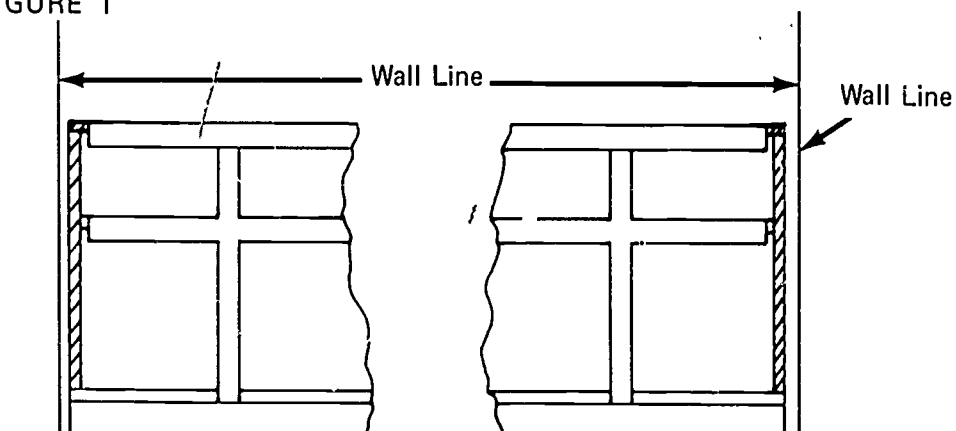

JOB SHEET #1

2. Level and plumb base cabinet

(NOTE: Use shim shingles at wall and floor line.)

3. Equalize end clearance at both ends of the unit face
4. Nail cabinet to floor and wall

(NOTE: If installation is on concrete slab, a nailing block should be secured to the slab back of the baseboard.)

5. Measure distance a and b (Figure 2)

FIGURE 2

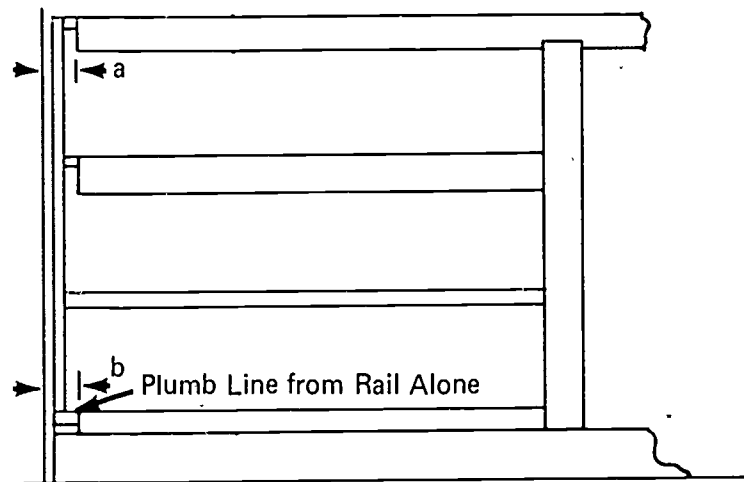

6. Transfer these distances to the loose stile (Figure 3)

FIGURE 3

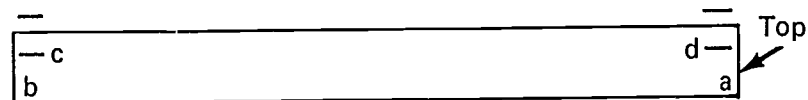

7. Tack stile to cabinet face with points c and d equal distance from the wall
8. Set scribers with the point end against the wall and adjust the pencil end to point d or c

Job SHEET #1

9. Scribe line on length of stile (Figure 4)

(NOTE: Hold scribers in the same relative position to wall and stile while scribing.)

FIGURE 4

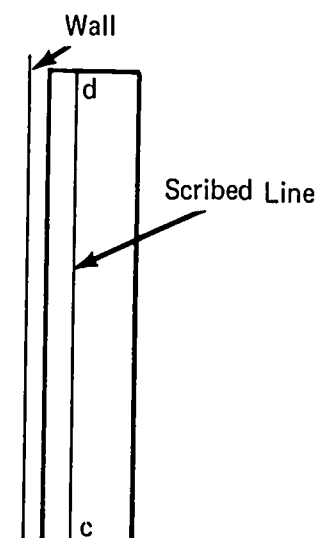

10. Rip stile on scribed line
(NOTE: Undercut the back side.)
11. Nail stile in place and set nails
(NOTE: If stile is too tight in spots, plane high spots with block plane.)
12. Install other end stile following steps B 2 through B 11
- C. Set upper cabinet
1. Remove loose end stiles
 2. Cut spacers from 1 x 2 scrap to fit between upper and lower cabinet
(NOTE: Allow for block on top of spacer so spacer will not dig into bottom of upper cabinet.)

JOB SHEET #1

3. Set upper cabinet in position and block up tight to soffit with spacers
4. Check for level
(NOTE: If cabinet is not level, shim between ceiling and rail to make it level.)
5. Scribe top rail to fit ceiling
6. Rip rail on scribed line
7. Reset cabinet tight to ceiling and secure to wall
(NOTE: Fasten cabinet to wall with appropriate fasteners.)
8. Scribe end stiles as described in steps B 2 through B 11

D. Install counter top

1. Place lines on end walls to correspond to height of splash back
(NOTE: Lines should be level.)
2. Set counter in opening (Figure 5)
(NOTE: Push counter tight to back wall.)

FIGURE 5

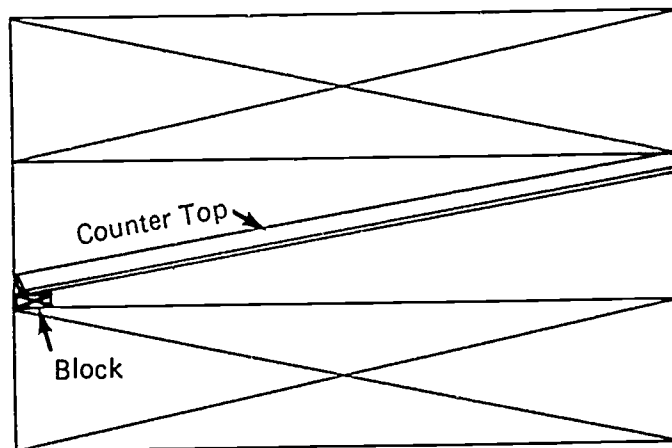

3. Block lower end of counter to line on wall

JOB SHEET #1

4. Scribe top of splash

(NOTE: It is not possible to scribe the face of splash back. Check the wall for plumb and square from the top of the cabinet to determine cut line.)

5. Remove counter top and trim to scribe line

(NOTE: If top is plastic laminate, use plane bit that has been ground and only sharpened on the rough stone to plane the laminate.)

6. Measure the exact length of the opening front and back at the top of splash lines

7. Transfer these dimensions to the counter working from the fit end

8. Set counter in opening and repeat steps D 3 to D 5 to fit

9. Replace counter in opening and check it along back wall

10. Scribe and fit back wall if needed

11. Secure counter to lower cabinet

(NOTE: Counter is generally screwed to the base cabinet from the bottom.)

CABINETS AND FIXTURE INSTALLATION
UNIT III

TEST

1. Match the following list of terms to the correct definition.

- | | |
|--|---------------------|
| _____ a. Display and storage units | 1. Knob |
| _____ b. The base unit of a cabinet having a working surface | 2. Pull |
| _____ c. Those items in building construction that permit movement or are decorative or both including hinges, catches, pulls, and knobs | 3. Stile |
| _____ d. A projection, usually round, for opening doors and drawers | 4. Wall cabinet |
| _____ e. A hard laminated plastic material used as a covering for counter tops | 5. Fixture |
| _____ f. A projecting device in the form of a handle for opening doors and drawers | 6. Soffit |
| _____ g. A horizontal bar of wood used to separate drawers and doors on the face of a cabinet | 7. Plastic laminate |
| _____ h. One of the vertical members used to separate doors and drawers on the face of a cabinet and to support the top | 8. Rail |
| _____ i. A recessed space at the floorline of a base cabinet or other built-in that permits one to stand close without striking the vertical surface with his toes | 9. Back splash |
| _____ j. The upper portion of a cabinet that is wall hung above the base cabinet | 10. Counter unit |
| | 11. Hardware |
| | 12. Toe space |

___ k. The underside of any subordinate member of structure, such as the undersurface of an arch, cornice, or stairway

___ l. A vertical continuation of a counter top at the back and ends

2. Identify the following parts of the cabinet pictured below. Place the correct number in the blanks provided.

___ a. Toe space

___ i. Drawer

___ b. Soffit

___ j. Door

___ c. End panel

___ k. Hinges

___ d. Rails

___ l. Pull

___ e. Stiles

___ m. Knob

___ f. Shelf supports

___ n. Counter top

___ g. Shelves

___ o. Back splash

___ h. Drawer guides

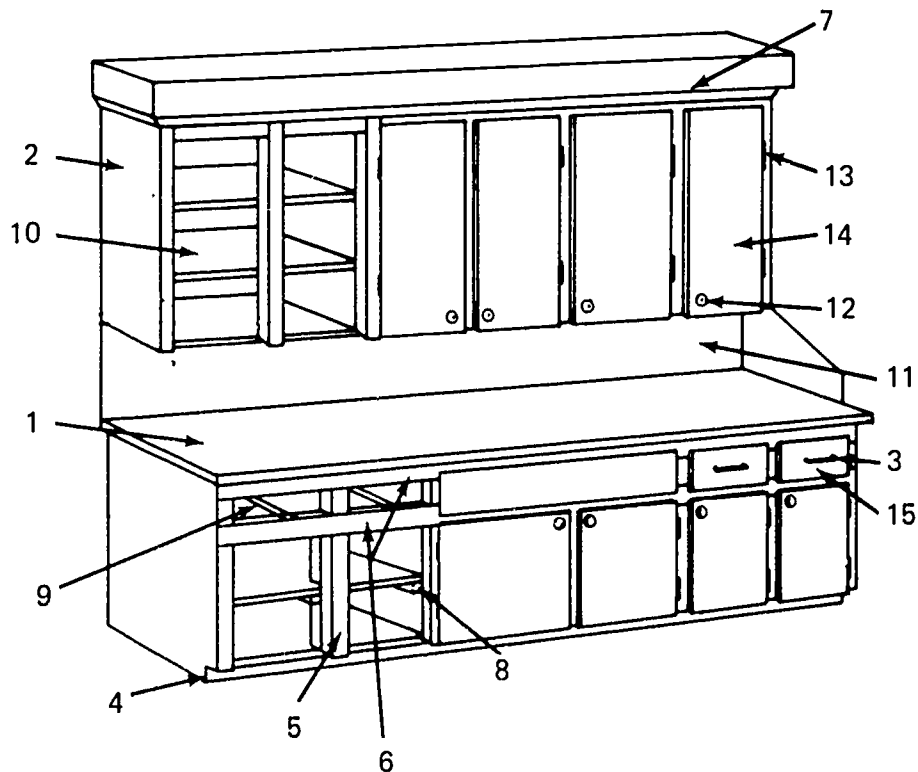

1147

3. Identify three types of cabinet door installation.

a.

b.

c.

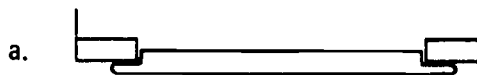

4. Identify the following eight items of cabinet hardware.

a.

b.

c.

d.

e.

f.

g.

h.

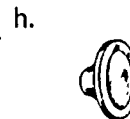
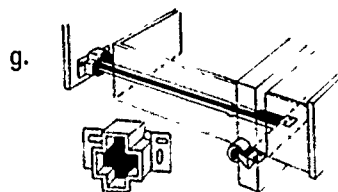
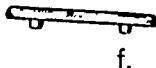
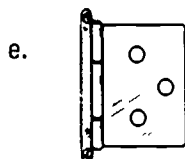
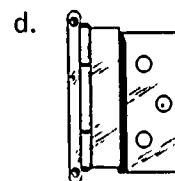
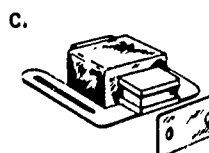
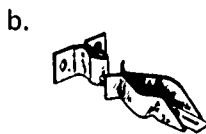
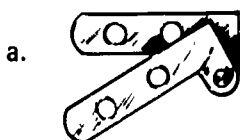

5. Identify five joints used in cabinet construction.

- a.
- b.
- c.
- d.
- e.

1.

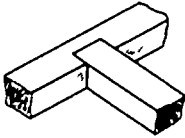

2.

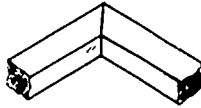

3.

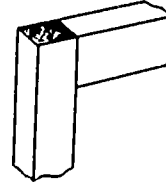

4.

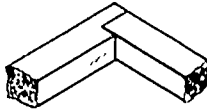

5.

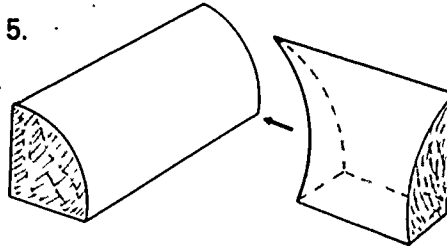

6. Name two types of cabinets.

- a.
- b.

7. Demonstrate the ability to install a custom built cabinet.

(NOTE: If this has not been accomplished prior to the test, ask the instructor when the above activity should be completed.)

CABINETS AND FIXTURE INSTALLATION
UNIT III

ANSWERS TO TEST

1.
 - a. 5
 - b. 10
 - c. 11
 - d. 1
 - e. 7
 - f. 2
 - g. 8
 - h. 3
 - i. 12
 - j. 4
 - k. 6
 - l. 9
2.
 - a. 4
 - b. 7
 - c. 2
 - d. 6
 - e. 5
 - f. 8
 - g. 10
 - h. 9
 - i. 15
 - j. 14
 - k. 13

- l. 3
 - m. 12
 - n. 1
 - o. 11
3. a. Lipped
- b. Surface
- c. Flush
4. a. Concealed hinge--for flush doors
- b. Friction catch
- c. Magnetic catch
- d. Semi-concealed hinge--for 3/8" lipped doors
- e. Semi-concealed hinge--for flush doors
- f. Pull
- g. Monorail drawer guide
- h. Knob
5. a. Dado
- b. Miter
- c. Butt
- d. Rabbet
- e. Coped
6. (NOTE: The answers do not have to be in the order given.)
- a. Custom or mill built
- b. Modular or stock units
7. Performance skills will be evaluated according to the criteria listed on the progress chart.

PANELING
UNIT IV

TERMINAL OBJECTIVE

After completion of this unit, the student should be able to define terms associated with paneling and identify various styles of paneling and methods of application. The student should also be able to apply the various styles of paneling using the different methods. This knowledge will be evidenced through demonstration and by scoring eighty-five percent on the unit test.

SPECIFIC OBJECTIVES

After completion of this unit, the student should be able to:

1. Match terms associated with paneling to a list of definitions.
2. Name three styles of paneling.
3. Identify three methods of joint treatment of paneling.
4. Name three types of wall preparation to which paneling may be applied.
5. Name two methods of fastening paneling to a wall.
6. Estimate material needed to panel a room.
7. Demonstrate the ability to install paneling.

PANELING
UNIT IV

SUGGESTED ACTIVITIES

I. Instructor:

- A. Provide students with objective sheet.
- B. Provide students with information and job sheets.
- C. Make transparencies.
- D. Discuss terminal and specific objectives.
- E. Discuss information sheet.
- F. Demonstrate and discuss procedures outlined in job sheet.
- G. Give test.

II. Student:

- A. Read objective sheet.
- B. Study information sheet.
- C. Demonstrate the ability to accomplish the procedures outlined in the job sheet.
- D. Take test.

INSTRUCTIONAL MATERIALS

I. Included in this unit:

- A. Objective sheet
- B. Information sheet
- C. Transparency masters
 1. TM 1--Joint Treatment
 2. TM 2--Wall Surface Preparation
- D. Job Sheet #1--Install "V" Grooved Paneling Directly to Studs
- E. Test
- F. Answers to test

II. References:

- A. Burke, Arthur E., J. Ralph Dalzell, and Gilbert Townsend. *Architectural and Building Trades Dictionary*. Chicago, Illinois: American Technical Society, 1955.
- B. Durbahn, Walter E. and Elmer W. Sundberg. *Fundamentals of Carpentry*. Third Edition. Chicago, Illinois: American Technical Society, 1963.
- C. Wagner, Willis H. *Modern Carpentry*. Homewood, Illinois: Goodheart-Willcox, 1969.

1154

PANELING
UNIT IV

INFORMATION SHEET

I. Terms and Definitions

- A. Batten A narrow strip of board or molding used to cover the cracks between paneling boards
- B. Butt joint--A joint made by fastening two panels together edge to edge without overlapping
- C. Chair rail--A wooden molding at chair back height placed horizontally around a room
- D. Furring Strips of lumber placed against one surface for the attachment of another surface
- E. Mastic--A substance with high adhesive qualities used to fasten paneling to a wall
- F. Open joint--A joint that does not meet but has a gap between the two sheets of paneling to accent the joint
- G. "V" grooved--A surface decoration applied to paneling consisting of cutting V shaped grooves at random spacing longitudinally on the face of paneling
- H. Wainscot--The application of paneling, only on the lower portion of an interior wall

II. Styles of paneling

- A. "V" grooved
- B. Plain
- C. Brushed

III. Methods of joint treatment (Transparency 1)

- A. Butt joint with "V" groove
- B. Batten strip
- C. Open joint

IV. Wall surface preparation for paneling (Transparency 2)

- A. Directly to studs
- B. Over sheetrock
- C. Furring strips

INFORMATION SHEET

V. Methods of fastening paneling to a wall

A. Nails

B. Mastic

VI. Material estimating

A. Paneling

1. Determine the number of feet around the perimeter of the room
2. Divide the total perimeter by four to get the number of 4 x 8 panels needed

B. Molding

1. Inside corners (count)
2. Outside corners (count)
3. Cove molding (lineal feet, allow for cutting)

C. Nails (3 or 4d finish)

(NOTE: Estimate one pound per average room.)

Joint Treatment

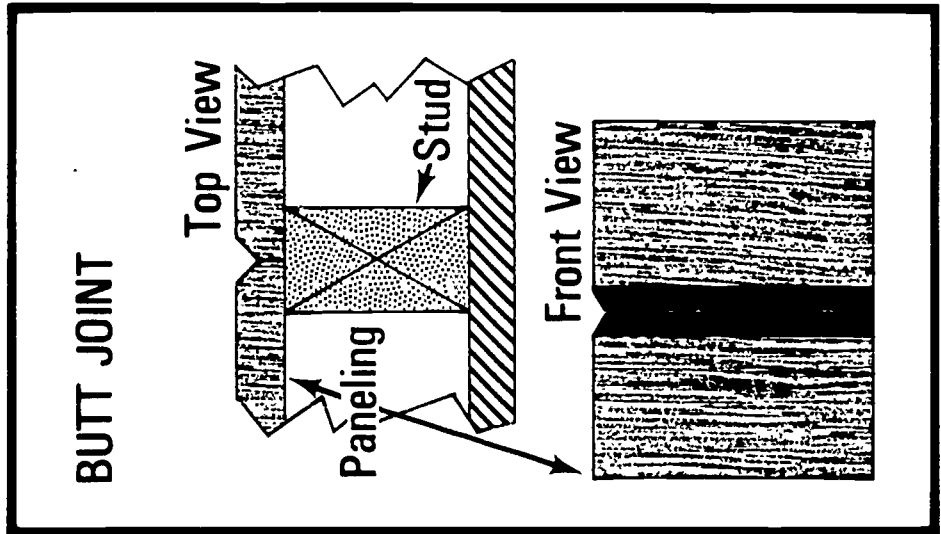
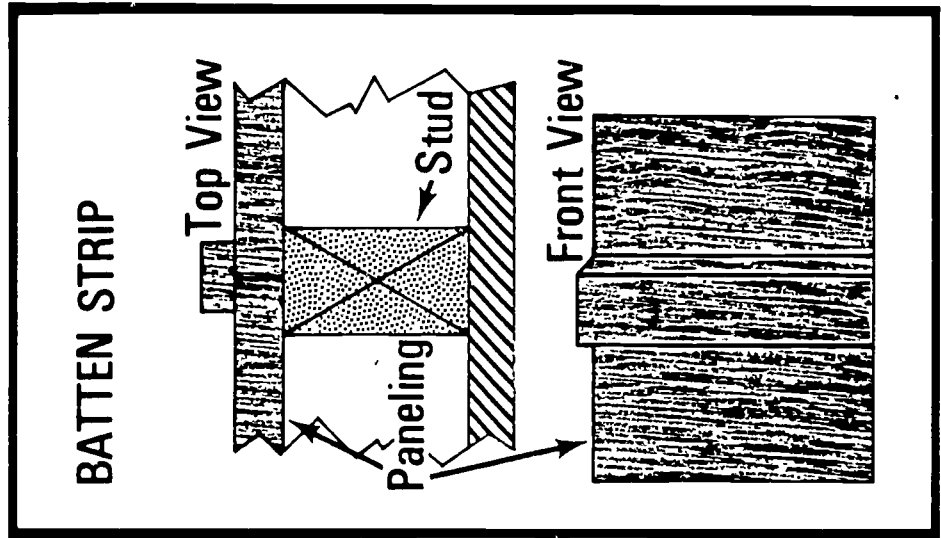
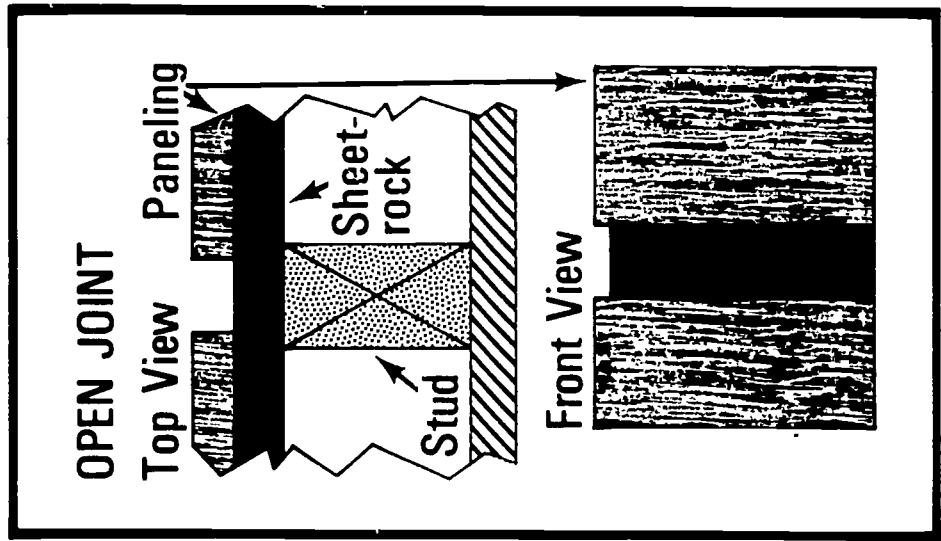

Wall Surface Preparation

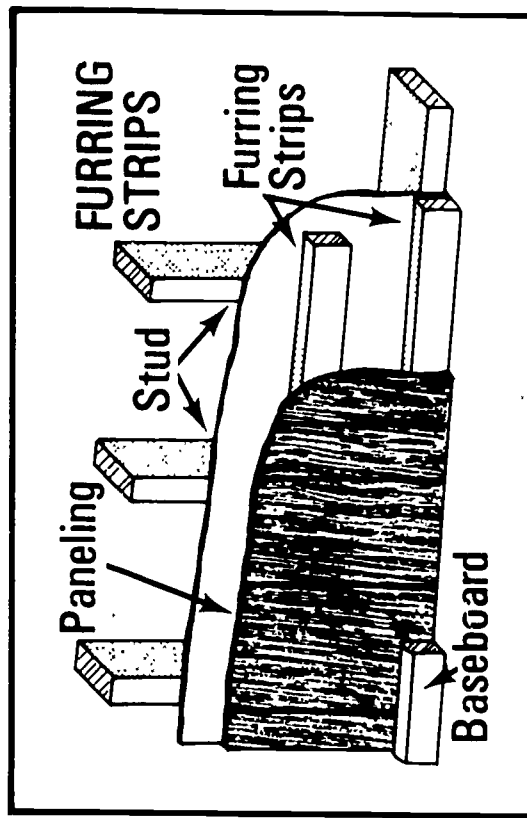
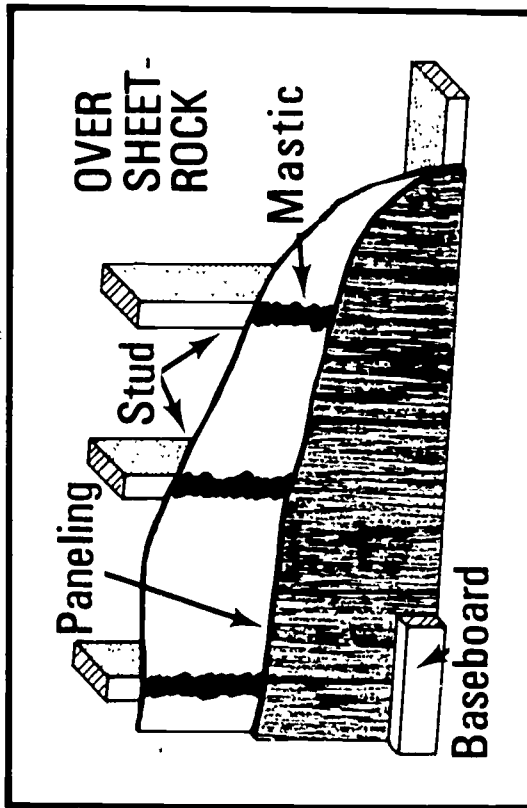
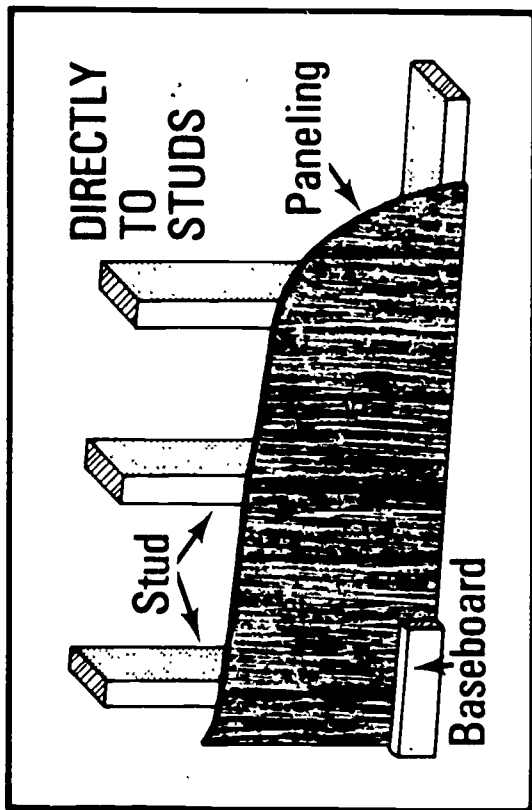

PANELING
UNIT IVJOB SHEET #1--INSTALL "V" GROOVED PANELING
DIRECTLY TO STUDS

I. Tools and materials needed

A. Tools

1. Table saw or radial arm saw
2. Saber saw
3. Block plane
4. Claw hammer (13 ounce)
5. 12 or 16 foot tape measure
6. Framing square
7. Scribe
8. Tri-square

B. Materials

1. Paneling
2. Inside corners
3. Outside corners
4. Cove molding
5. Nails (3d or 4d finish)

II. Procedure:

- A. Stand the plywood on end around the room and arrange them so that adjoining panels match as to grain patterns and color
- B. Begin at an inside corner, plumb the edge of paneling away from the corner, and scribe the opposite edge to fit the corner

(NOTE: All joints must be made on a stud.)
- C. Align the panels with the sides of door and window openings whenever possible

(NOTE: This procedure helps to cut down on waste.)

JOB SHEET #1

- D. Measure accurately and cut out holes for switches and receptacles
(NOTE: All measurements should be made from the ceiling and the side.)
- E. Install all of the paneling, working around the room
(NOTE: Nail the paneling on each stud about every sixteen inches using 3d or 4d finish nails. Set the nails, after driving almost flush.)
(NOTE: For pre-finished paneling, colored nails may be used.)
- F. Inside corners may be scribed to fit or corner molding may be installed after the cove molding and baseboard is installed
- G. Install the cove molding at the ceiling joint
- H. Install the baseboard
- I. Install outside and inside corner molding
- J. Paneling may be returned in the window openings using corner molding or they may be cased out in the conventional manner

PANELING
UNIT IV

TEST

1. Match the following list of terms to the correct definitions.

- | | |
|---|----------------|
| _____ a. A narrow strip of board or molding used to cover the cracks between paneling boards | 1. Furring |
| _____ b. A joint made by fastening two panels together edge to edge without overlapping | 2. Batten |
| _____ c. A wooden molding at chair back height placed horizontally around a room | 3. "V" grooved |
| _____ d. Strips of lumber placed against one surface for the attachment of another surface | 4. Open joint |
| _____ e. A substance with high adhesive qualities used to fasten paneling to a wall | 5. Butt joint |
| _____ f. A joint that does not meet but has a gap between the two sheets of paneling to accent the joint | 6. Wainscot |
| _____ g. A surface decoration applied to paneling consisting of cutting V shaped grooves at random spacing longitudinally on the face of paneling | 7. Mastic |
| _____ h. The application of paneling, only on the lower portion of an interior wall | 8. Chair rail |

2. Name three styles of paneling.

- a.
b.
c.

3. Identify three methods of joint treatment of paneling.

- _____ a. Batten strip
- _____ b. Butt joint with "V" groove
- _____ c. Open joint

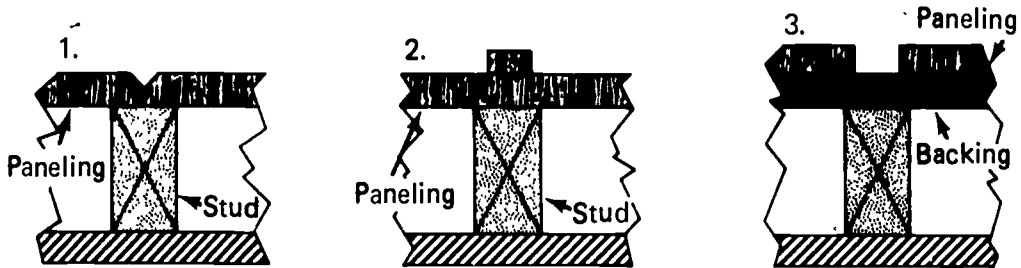

4. Name three types of wall preparation to which paneling may be applied.

- a.
- b.
- c.

5. Name two methods of fastening paneling to a wall.

- a.
- b.

6. Estimate the materials needed to panel the room illustrated below.

- _____ a. 4' x 8' sheets of paneling
- _____ b. Inside corners 8'
- _____ c. Outside corners 8'
- _____ d. Cove molding

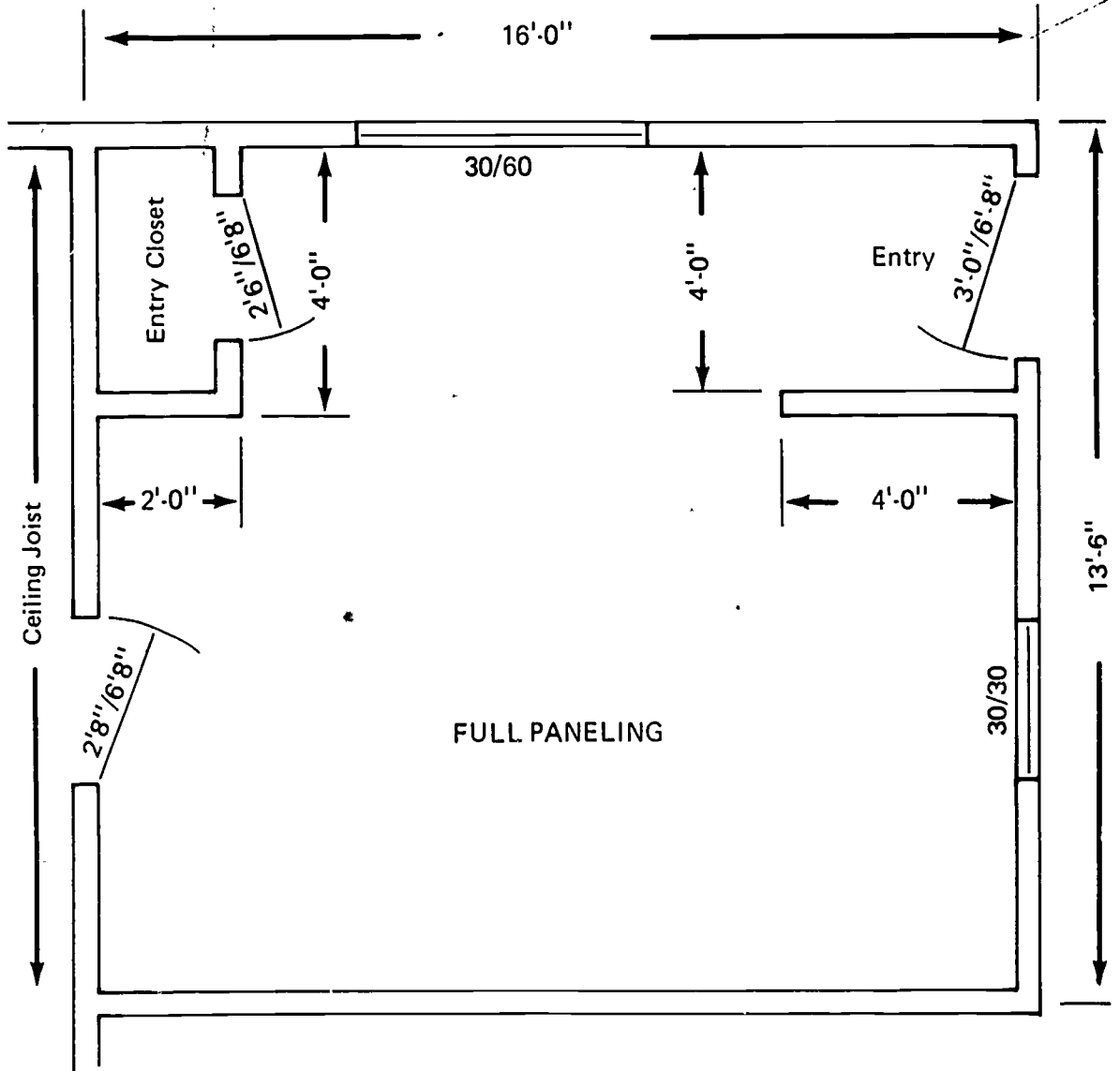

7. Demonstrate the ability to install paneling.

(NOTE: If this has not been accomplished prior to the test, ask the instructor when the above activity should be completed.)

PANELING
UNIT IV

ANSWERS TO TEST

1.
 - a. 2
 - b. 5
 - c. 8
 - d. 1
 - e. 7
 - f. 4
 - g. 3
 - h. 6
2.
 - a. "V" grooved
 - b. Plain
 - c. Brushed
3.
 - a. 2
 - b. 1
 - c. 3
4.
 - a. Directly to studs
 - b. Over sheetrock
 - c. Furring strips
5.
 - a. Nails
 - b. Mastic
6.
 - a. 17
 - b. 7
 - c. 3
 - d. 70 ft.
7. Performance skills will be evaluated according to the criteria listed on the progress chart.

