

DOCUMENT RESUME

ED 114 478

CE 005 134

AUTHOR Long, Thomas E., Ed.
 TITLE Essays on Career Education.
 INSTITUTION Pennsylvania State Univ., University Park. Dept. of Vocational Education.
 SPONS AGENCY Pennsylvania State Dept. of Education, Harrisburg. Bureau of Vocational, Technical, and Continuing Education.
 PUB DATE 73
 NOTE 92p.
 EDRS PRICE MF-\$0.76 HC-\$4.43 Plus Postage
 DESCRIPTORS *Career Education; Counselor Role; *Educational Philosophy; Elementary Secondary Education; *Essays; Guidance Counseling; *Models; Post Secondary Education; *Program Descriptions; Teacher Education; Vocational Counseling; Vocational Education Teachers

ABSTRACT

The monograph presents a series of essays written by well known educators sharing their perceptions, problems, and projects and documenting some of the practical, philosophical, situational, and theoretical aspects of career education. The essays include: The Case for Career Education, by Kenneth B. Hoyt; Basic Constructs of the School-Based Comprehensive Career Education Model, by Richard R. Olson; Pittsburgh's OVT Program "Bells the Cat" for Career Education, by Jerry C. Olson; Career Education and the School Counselor, by Edwin L. Herr; Project COED: A Career Education Program in New Hampshire, by Edward W. Donovan; The Role of Industrial Arts in Career Education, by Ralph C. Bohn; Career Education and the American Dream, by Charles Simcox; The Role of Vocational Teacher Education in Career Education, by C. Thomas Dean; The Post-Secondary Institution, New Models for Career Education, by Angelo C. Gillis, Sr.; Career Education--As Viewed by Future Educators, by Eugenio A. Basualdo, Alain E. Hunter, and Robert E. Strickler; and Career Education: Chicago Style, by Joseph L. Cain. (Author/BP)

 * Documents acquired by ERIC include many informal unpublished *
 * materials not available from other sources. ERIC makes every effort *
 * to obtain the best copy available. Nevertheless, items of marginal *
 * reproducibility are often encountered and this affects the quality *
 * of the microfiche and hardcopy reproductions ERIC makes available *
 * via the ERIC Document Reproduction Service (EDRS). EDRS is not *
 * responsible for the quality of the original document. Reproductions *
 * supplied by EDRS are the best that can be made from the original. *

SEP 16 1975

ED114478

ESSAYS ON CAREER EDUCATION

Edited by Thomas E. Long
The Department of Vocational Education
The Pennsylvania State University

U.S. DEPARTMENT OF HEALTH,
EDUCATION & WELFARE
NATIONAL INSTITUTE OF
EDUCATION

THIS DOCUMENT HAS BEEN REPRO-
DUCED EXACTLY AS RECEIVED FROM
THE PERSON OR ORGANIZATION ORIGIN-
ATING IT. POINTS OF VIEW OR OPINIONS
STATED DO NOT NECESSARILY REPRESENT
OFFICIAL NATIONAL INSTITUTE OF
EDUCATION POSITION OR POLICY.

CE005134-dg

ESSAYS ON CAREER EDUCATION

**Edited by Thomas E. Long
The Department of Vocational Education
The Pennsylvania State University**

1973

© 1973 The Pennsylvania State University

INTRODUCTION

These essays represent varied perspectives on career education and document some of the practical, philosophical, situational, and theoretical aspects of the recently popular subject of career education.

Some cite new roles for education and educators. A few describe new approaches and implications for training for both work and careers for elementary through college level students. Others ponder the effects of career education on the training and performance of present and future educators. All relate to the task and process of making all education career-relevant education. Such carelevance in education will help each student better sense the vocational and avocational implications of each of his educational experiences. Such an enterprise must face and cope with multitudinous issues. The issues are vital to the nation. Beginnings have been made. The interest of researchers and educators is high. These essays, then, describe some of the on-going efforts, related constructs, and concerns of career education.

This monograph serves as the medium which permits selected essayists to share their perceptions, problems, and projects with a wider audience. I appreciate their participation in this effort. I hope that each reader will find his reading to be a career-relevant experience in career education.

This monograph was supported by funds from the Bureau of Vocational, Technical, and Continuing Education of the Pennsylvania Department of Education and the Department of Vocational Education of the Pennsylvania State University.

Thomas E. Long
Associate Professor
Graduate Studies and
Research

TABLE OF CONTENTS

	<u>PAGE</u>
INTRODUCTION.....	i
THE CASE FOR CAREER EDUCATION.....	1
Kenneth B. Hoyt	
BASIC CONSTRUCTS OF THE SCHOOL-BASED COMPREHENSIVE CAREER EDUCATION MODEL.....	9
Richard R. Olson	
PITTSBURGH'S OVT PROGRAM "BELLS THE CAT" FOR CAREER EDUCATION.....	17
Jerry C. Olson	
CAREER EDUCATION AND THE SCHOOL COUNSELOR.....	24
Edwin L. Herr	
PROJECT COED: A CAREER EDUCATION PROGRAM IN NEW HAMPSHIRE.....	31
Edward W. Donovan	
THE ROLE OF INDUSTRIAL ARTS IN CAREER EDUCATION.....	39
Ralph C. Bohn	
CAREER EDUCATION AND THE AMERICAN DREAM.....	52
Charles Simcox	
THE ROLE OF VOCATIONAL TEACHER EDUCATION IN CAREER EDUCATION.....	57
C. Thomas Dean	
THE POST-SECONDARY INSTITUTION, NEW MODELS FOR CAREER EDUCATION.....	64
Angelo C. Gillie, Sr.	
CAREER EDUCATION - AS VIEWED BY FUTURE EDUCATORS.....	75
Eugenio A. Basualdo	
Alain E. Hunter	
Robert E. Strickler	
CAREER EDUCATION: CHICAGO STYLE.....	79
Joseph L. Cain	

THE CASE FOR CAREER EDUCATION

KENNETH B. HOYT
PROFESSOR OF EDUCATION
UNIVERSITY OF MARYLAND

Introduction

The case for career education must be made in the larger society. To attempt to speak about career education only in terms of needed changes in public education would be both myopic and ineffective. It is a societal crisis, not just a school crisis, that has created the need for career education. Both the cause and the cure must be identified in the broader society. This presentation will appear rational only to those who can accept that basic premise.

There are three goals here. First, to attempt to make the case for career education within a broad societal framework, of which the school system represents only one part. Second, to present a brief definition and discussion of career education -- its nature and mission. Finally, I would like to comment briefly on the basic components of a comprehensive career education program.

The Case for Career Education

A serious societal deficiency exists throughout our land. Those afflicted with this deficiency are individuals for whom work values fail to exist as a meaningful part of their total personal value system. For literally millions of our citizens -- both youth and adults -- the concept of work no longer is one that holds personal meaning and brings meaningfulness to their lives. Such individuals are, to some extent, unhappy persons and bring discontent to the larger society. The societal conditions resulting from this deficiency seem to me to be as intolerable as they are clear. The extent to which you can agree with me on the identification of this basic societal deficiency will be directly related to the extent to which we agree on the presence of this set of conditions. To what extent do you agree that:

1. Our welfare rolls are growing at a record rate and include many who are now making no active efforts to seek employment?
2. Growing numbers of employees are dissatisfied with their jobs and are seeking personal happiness through other means?

3. Employers are increasingly unhappy with the work attitudes of their employees and almost equally unhappy with their work skills?
4. The current high productivity of the United States is due more to technological advances than to diligence of individual workers?
5. Other nations are gaining ground on the United States in the production of both goods and services?
6. The classical Protestant work ethic, for many of our citizens, no longer represents an acceptable set of reasons for working?

To me, each of these conditions is true, and taken together, they stand as clear validation of my contention that the concept of work no longer holds personal meaning and meaningfulness for many persons in our society. Stated simply, too many of those looking for jobs are not looking for work and too many employed persons endure their jobs rather than gain meaning from their work. The need for achievement -- for accomplishment, for knowing that one has done something -- is a basic human need. Each of us is best known to himself and to others through his accomplishments. Most employed persons spend more time at their place of employment than in any other single activity. Yet, many employed persons feel that they must seek their primary sources of personal accomplishment and self worth outside of the place where they are employed. A person who is satisfied to do less than his best at any effort he undertakes deprecates and depreciates his own sense of self-worth -- and this is exactly what happens to millions of employed persons every day on their jobs.

The concept of work -- defined as effort aimed at production of goods and/or services that will be of benefit to others and/or to oneself -- obviously includes the full-time homemaker and the growing numbers of unpaid volunteers performing valuable human services in our society. Yet, far too many persons still equate the term "work" with the phrase "making a living." Worse, many seem to believe that, when they are not "making a living," they should be playing -- and, with more and more leisure time becoming available, this would truly be societal suicide.

We cannot ignore this societal deficiency, nor can we afford to allow it to continue. As we move further into a service and information oriented occupational society, the relationship between education and jobs becomes closer each year. That this increasingly close relationship has not been effectively recognized by action programs is clearly illustrated by statistics showing that the ratio of youth to adult unemployment has increased each year since 1960. In spite of recent trends indicating a general

reduction in unemployment, it is clear that the ratio of youth to adult unemployment is still on the increase.

Thus, the case for career education must be built, in part, on conditions existing within the educational system. When we examine that system and its results in a careful and objective manner, we find a set of conditions that is clearly related to the loss of work values as part of human values. The conditions I refer to here include the following:

1. With actuarial predictions indicating that less than 20 percent of the jobs existing between now and 1980 will require a college degree, it is both startling and ridiculous to find that:
 - a. Almost 80 percent of secondary school students are enrolled in either the college preparatory or general education curriculum designed to ready them for college attendance. When 80 percent are readying themselves to do what 80 percent will not be able to do, something is surely wrong.
 - b. Almost three in four community college students are enrolled in the college transfer program in spite of the fact that fewer than one in four will ever attain a baccalaureate degree.
 - c. Over 60 percent of all Vietnam veterans now using their educational benefits are enrolled in four-year college or university programs.
2. A false and dangerous myth permeates our society. According to that myth, a college degree represents the best and surest route to occupational success. As a direct result of that myth, we find today:
 - a. Thousands of students in college with no clear-cut vocational goals. Someone told them, "Go to college and you will find yourself." Many came out of college last year who have found neither themselves nor a job. Unemployment among college graduates, while still lower than for the general population, rose 100 percent between 1969 and 1971. The days when a college degree guaranteed success in finding employment are past.
 - b. Many thousands of today's college students are enrolled, not as a means of readying themselves for work, but as an alternative to work. They came out of high school asking the question,

"Should I go to college or should I go to work?" -- as though, if they went to college, they wouldn't have to go to work.

- c. The dropout-flunkout rate among college students remains among the most stable of all statistics in American education. Unless marked changes are made, 40 percent of all who entered college this fall will not make it to the junior year and 50 percent will never obtain a baccalaureate degree. This condition continues to be extremely costly to such students and their parents in terms of money, psychological damage, and inability to plan a meaningful future.
3. A general "school for schooling's sake" emphasis continues to exist in American education. The third grade teacher seems intent on readying her students for the fourth grade, the eighth grade teacher on readying her students for the ninth grade, and the high school teacher on readying her students for college. The essential message coming through to students is one that pictures the purpose of education as being simply education. Instead of preparation for something, education has become, for many students, simply preparation for more education. As a result:
- a. Far too many students, at all levels of education, do not see a personally meaningful set of reasons for being in school.
 - b. Far, far too many students can see no relationships between what they are being asked to learn in school and the world of work outside of education.
 - c. American secondary education has been trichotomized into three kinds of students with a relatively small number (those in vocational education) getting ready for work, a substantially larger number (those in college prep) getting ready to go to college, and the rest (those in general education) getting ready to receive a diploma.
 - d. Millions of elementary school children, during the very years when their basic personal value systems are being formed, are being exposed to neither the values of

a work-oriented society nor to a view of themselves as members of that society.

Conditions such as these have led to high degrees of student unrest, discontent, and disenchantment at all levels of education. Students want to "do their own thing" and "be their own selves," and, of course, we want them to do so. Yet we fail to let them really understand themselves through their accomplishments that could come from work. Students see many things wrong with our society and our world and want it to be a better place. Yet we have failed to help them realize that the world cannot become a better place if we simply wish, dream, hope, or demand that this be done. If the world is to become a better place, it must be through our productive efforts aimed at producing benefits for our fellow human beings -- and that is work.

Career Education: Its Nature and Mission

Some of us have been trying to alert people to these problems for years, but not many would listen -- and even fewer heard -- what we were trying to say. Today, these conditions have reached a sufficiently critical point so as to make clear to most people the need for some concerted program of action. The call for such action has now been centralized around the banner "career education" -- currently the number one priority of the U.S. Office of Education. There are many "definers" of career education. They vary greatly. Here, I am going to present only my own. In my opinion, "career education" can be defined as follows:

Career education represents the total effort of public education and the community to help all individuals become familiar with the values of a work-oriented society, to integrate such values into their personal value structure, and to implement some set of work values into their lives in such a way that work becomes possible, meaningful, and satisfying to each individual.

There are several implications in this definition, each of which deserves brief comment. These implications include:

1. Career education represents an effort, not merely an "attitude" as some have suggested. As such, it will require both time and some money.
2. Career education demands the active involvement of the total community. It is not something that schools can or should be expected to do by themselves.
3. The term "public education" means education

available to the public and from which the public can choose. As such, it includes, but is in no way limited to our K-12 public school system.

4. Career education is for all individuals -- for the very young child and for the older worker, for those who go to college and for those who do not, for males and for females, for the most affluent and for the most economically disadvantaged members of our society, for the intellectually gifted and the mentally handicapped.
5. Career education is only a part of education and is not intended to become synonymous with the word "education." It seeks to be added to the total educational program in ways that neither demean nor detract from any other worthy educational effort.
6. Career education recognizes the pluralistic view of work values that must exist in today's complex occupational society and seeks to impose no single, narrow set of work values on any individual.
7. The objectives of career education are to help all individuals to (a) want to work (b) acquire the skills necessary to work, and (c) perform work that is beneficial to society.
8. The goals of career education are to make work possible, meaningful, and satisfying to each individual. Each of those three words -- "possible," "meaningful," and "satisfying" -- are equally important to the career education concept.

Components of a Career Education Program

To convert the career education concept into an effective program of action requires the presence and coordination of five basic components, each of which is equally important. These five components require brief discussion.

Component 1 consists of the efforts of all classroom teachers, at all levels of education, to teach work values and to emphasize the career implications of their subject matter. Teachers can and should help their pupils learn and think about the importance of doing one's best, of completing assigned tasks, of being punctual, of the rewards that come from accomplishment, of the interdependence of workers for successful task accomplishment, of the importance of each worker in the total scheme of things.

In addition, they can and should help students learn and think about the career implications of their subject matter. In doing so, they will provide an added source of educational motivation -- one that should appeal to all of the students some of the time and to some of the students almost all of the time. Effective attainment of this goal should result in more student learning in the classroom and added motivations that will help school make sense to pupils.

Component 2 consists of vocational skill training in formal education. In part, this calls for greatly expanded programs of vocational education at both the secondary and the post-secondary school levels. (There is no point emphasizing that too many students are going to college unless viable alternatives to college preparation and college attendance are provided -- and the most viable alternative we know is vocational education). In part, this component calls for recognizing that any class may properly be considered vocational skill training for one or more of its pupils. An art class is vocational skill training for the prospective artist just as an auto mechanics class is vocational skill training for the prospective auto mechanic. For too long we have acted as though only part of the school (vocational education) was readying students for work. Far worse, we have acted as though only part of the students (those in vocational education) were preparing to work. Education as preparation for work must become a worthy goal of all who teach and all who learn.

Component 3 consists of active efforts of the business, industrial, and labor communities to provide observational work experience and work-study opportunities for students and for those who educate students -- for teachers, counselors, and school administrators. It assumes that neither students nor their teachers can learn what they need to know about the world of work outside of education through a textbook -- and that it is time we rid ourselves of the assumption that the best way to ready students for the real world is to keep them away from it. Further, this component involves the active cooperation of the schools with the business-industry-labor community in helping students make a successful transition from school to work. Finally, this component includes efforts of the business-labor-industry community to change conditions of the work place in ways that will make work more satisfying to the individual worker.

Component 4 consists of career development programs devoted to helping students understand themselves and their environmental opportunities, making reasoned decisions from among all alternatives that can be made available to them, accepting personal responsibility for the decisions they

have reached, and formulating positive plans for converting their decisions into reality in ways that will bring personal satisfaction to the individual and positive benefits to society. This component seeks to protect the God-given right of each individual to lead his own life and to help him accept the personal responsibilities that accompany that right. Career education, without this component of career development programs, becomes simply brain-washing and could be supported by no true American citizen.

Component 5, finally, involves the home and family as part of the total career education program. This component, in part, consists of efforts to emphasize the home as a work place for the entire family, not just for the mother. It is in the home where work values can first be taught to preschool children and where work values taught in the elementary school can be reinforced and emphasized through experiences in the child's home. To help all members of a family see themselves as cooperating members in accomplishing work tasks in the home holds high potential for improving the cohesiveness of family membership. Moreover, it provides an excellent demonstration of the principle that working, while essential to enjoying life, is only part of living itself, and so allows work values to be assimilated as only one portion of a larger system of personal values. In part, this component seeks to make work values meaningful to parents themselves and to help parents recognize the worth and dignity of all honest work. Without the active support and cooperation of parents, efforts of our school systems to teach work values will, in the case of many students, be unsuccessful. With parental support and cooperation, the total school program can be much more beneficial to students.

These, then, are the five basic components of a comprehensive career education program. The methodologies involved in converting these components into community action programs will vary greatly from community to community. How career education is to be accomplished is a proper matter for local decision. The concept of career education, however, will continue to be a problem of national concern.

Concluding Remarks

Our public schools belong to the public, not to those who manage our school systems. If a career education emphasis is to come to American education, it must be as a result of public demand. That demand should arise out of public awareness of the importance of restoring the personal meaningfulness of work in a form suitable for the post-industrial society in which we live. Remember, the goals of career education are to make work possible, meaningful, and satisfying to each individual. There are some four letter words that deserve to be popular. In my opinion, "work" is such a word.

BASIC CONSTRUCTS OF THE SCHOOL-BASED COMPREHENSIVE
CAREER EDUCATION MODEL

RICHARD R. OLSON¹
ASSISTANT PROFESSOR
SUNY AT BUFFALO

Introduction

Career education is basically a political reaction to national problems and public opinion. Early in 1971, leaders in the United States Office of Education decided to develop different models of career education programs. This was done to facilitate the further development of career education concepts. Four research models are presently being developed:

1. The school-based model
2. The employer-based model
3. The home/community-based model
4. The residential-based model

The Center for Vocational and Technical Education (CVTE), located at The Ohio State University, was designated by the USOE as the prime contractor for the school-based model project. This project was to develop, test, and install the school-based Comprehensive Career Education Model (CCEM).

Office of Education project guidelines directed that the CCEM project was to be managed by the CVTE and to be developed and installed in six Local Education Agencies (LEAs) throughout the country. In August 1971, the USOE selected six urban LEAs to participate in the CCEM project. They were: Atlanta, Georgia; Hackensack, New Jersey; Jefferson County, Colorado; Los Angeles, California; Mesa, Arizona; and Pontiac, Michigan. There are about 85,000 students in these six LEAs, with about 4,200 teachers and administrators.

CVTE, as the prime grantee, was to supervise individual LEA subcontracts and is accountable to the USOE for the entire program and for all funds expended. (Progress Report, CCEM, 1972, p. 7)

1

Formerly a research and development specialist at the Center for Vocational and Technical Education working on the Comprehensive Career Education Model, Dr. Olson is now assistant professor of the vocational-technical education, Faculty of Applied Science and Technology, State University College at Buffalo, Buffalo, New York.

The purpose of this paper is to describe the basic constructs of the CCEM. To do this the following will be delineated.

1. CCEM tenets and decisions
2. Project schema
3. Delivery system for career education

CCEM Tenets and Decisions

According to Taylor (1972, pp. 8-12) career development provides the major organizing construct for career education. Career education retains the essentials of education but introduces a new sense of focus and purposefulness--career development. The CCEM places career development as the central unifying element for education. One way that career development is reflected in the CCEM is through the use of awareness, exploration, and preparation stages of program emphasis. Another way is through the emphasis placed on a longitudinal guidance service.

Career development is a complex process that is still not completely understood. Likewise, career education is a complex grouping of educational concepts that has not been clearly defined. Miller (1972, pp. 6-7) noted that for operational career education models to be developed, operational definitions must be made. He listed the following tenets as having been identified by the CCEM.

1. Career education is a comprehensive educational program focused on careers. It begins with the entry of the child into a formal school program and continues into the adult years.
2. Career education involves all students, regardless of their post secondary plans.
3. Career education involves the entire school program and the resources of the community.
4. Career education infuses the total school curriculum, rather than providing discrete, high-profile "career education" blocks forced into the curriculum.
5. Career education unites the student, his parents, the schools, the community, and employers in a cooperative education venture.
6. Career education provides the student with information and experiences representing the entire world-of-work.

7. Career education supports the student from initial career awareness, to career exploration, careers direction-setting, career preparation and career placement, and provides for placement follow-through, including reeducation if desired.
8. Career education is not a synonym for vocational education; vocational preparation is an integral and important part of a total career education system.

In accepting these tenets, a number of operational choices were made. Decisions were made to accept the following as two of the CCEM goals: (1) providing every youngster exiting from the educational system with some basic employability skill that would allow him or her to enter some occupation at least an entry level in addition to preparing him for the next educational rung on his or her career ladder, and (2) to provide a placement system within the school context which would accept the responsibility for the placement of all students desiring placement. (Miller, 1972, pp. 7-8) A decision was also made to "infuse" career education concepts into present school subjects and not to develop add-on courses in career education.

It is well understood that career development is a lifelong process, and the original proposal submitted by the CVTE to the USOE called for an effort that spanned the grade levels from grade K through post-secondary. However, initial funding for the CCEM project provided for only grade levels K through 12. It was planned to add a post-secondary phase to the CCEM in the future. However, the decision to delete the post-secondary effort from the CCEM is considered by many educators to be a major error.

Project Schema

Office of Education project guidelines called for a "research and engineering" effort for the CCEM, that is, one that would develop a "systematic approach" to infusing career education into the existing K-12 curriculum. (Progress Report, CCEM p. 25)

The CCEM was envisioned as a "capstone" project. It was originally felt that most of the curriculum building blocks for career education were already a part of the mainstream of American public education. It was only necessary to seine this stream to catch career education units. Existing curriculum materials could then be identified, refined, and packaged into a transportable program. (Progress Report, CCEM, p. 18)

As the prime contractor for the CCEM project, the CVTE was obligated to have programs "up and running" in the six LEAs starting in September 1972. This was only one year after the LEAs were selected. Due to this tight time schedule, three main

tasks were carried out concurrently in the fall of 1971. These tasks were:

1. Matrix development
2. LEA career unit inventory and analysis
3. A national search for career units

Matrix Development

Early in the summer of 1971, a review of career development and related literature was conducted. In this review, a set of educational areas that seemed to adequately define career education was identified. From these educational areas the basic elements of career education for the CCEM were selected.

In order to give more meaning to the elements, the CVTE staff identified the specific outcome associated with each element. The eight basic elements and their corresponding outcomes are: (Taylor, 1972, p. 20)

- | | | |
|---|---|--|
| 1. <u>Self-Awareness</u>
(Knowledge of the components that make up self) | - | <u>Self-Identify</u>
(Know himself, consistent value system) |
| 2. <u>Educational Awareness</u>
(Perceives relationship between education and life roles) | - | <u>Educational Identify</u>
(Ability to select educational avenues to develop career plans) |
| 3. <u>Career Awareness</u>
(Knowledge of the total spectrum of careers) | - | <u>Career Identify</u>
(Role or roles within the world of work) |
| 4. <u>Economic Awareness</u>
(Perceives processes in production, distribution, and consumption) | - | <u>Economic Understanding</u>
(Solve personal & social problems in an economic environment) |
| 5. <u>Appreciations, Attitudes</u>
(Life roles feeling toward self and others in respect to society & economics) | - | <u>Self-Social Fulfillment</u>
(Active work role
Satisfying work role) |
| 6. <u>Decision-Making Skills</u>
(Applying information to rational processes to reach decisions) | - | <u>Career Decisions</u>
(Career direction has a plan for career development) |

- | | | |
|--|---|---|
| <p>7. <u>Skill Awareness & Beginning Competence</u>
(Skills ways in which man extends his behaviors)</p> | - | <p><u>Employment Skills</u>
(Competence in performance of career-related tasks)</p> |
| <p>8. <u>Employability Skills</u>
(Social and communication skills appropriate to career placement)</p> | - | <p><u>Career Placement</u>
(Employed in line with career development plan)</p> |

When placed graphically against the K-12 grade levels, the eight elements and their corresponding outcomes provide a frame of reference grid, or Matrix, was to be the main "tool" for organizing the content of the CCEM. The Matrix could be used as a seine to help net career education units for the CCEM. It could also be used as a screen to select or reject previously identified career education units. It would also be used to identify gaps in the CCEM where units should be developed.

The CVTE staff and the staff of each LEA proceeded to develop career education goals for each cell of the Matrix. Performance objectives were then written to help attain the career education goals. In this way the Matrix started to develop a finer mesh.

The goals and objectives were selected and refined through a variation of the Delphi Technique. This procedure is built on the strength of informed intuitive judgement. (Anderson, 1969) The Delphi Technique procedure included several rounds of information exchange, analysis, and revision between CVTE and each LEA. Certain pervasive goal themes that extended across all grade levels were identified during this Delphi process. These themes also helped to make the mesh of the Matrix smaller.

The output of the Matrix development process included:

1. Eight basic career education elements and their corresponding outcomes
2. 32 sub-element
3. About 1,500 career education goals
4. Over 3,000 performance objectives

LEA Inventories

The LEAs selected to participate in the CCEM project were identified by USOE as having the strongest and most comprehensive K-12 career education programs in the nation. An early operational version of the Matrix helped these LEAs to inventory their existing

career education units that delivered on the Matrix goals. By the end of 1971, about 270 of these units had survived the screening of the CVTE. (Progress Report, CCEM, p. 18)

National Search

Palo Alto Educational Systems, Inc., of Scottsdale, Arizona, was selected to locate, retrieve, screen, and classify existing noncommercial curriculum materials relevant to career education. About 730 curriculum units were identified in this national search.

A close examination of the curriculum materials identified by the national search and the LEA's (about 1,000 curriculum units) inventories found them to be far from comprehensive. Neither the quantity or quality of the curriculum units was sufficient for a visible CCEM and the "capstone" project was expanded to a major assembly and refinement program. By the end of February 1972 about 100 curriculum units had been selected for modification and installation in the LEA's during the 1972-73 school year. (Progress Report, CCEM, p. 20)

The central project strategy had become an interactive cycle of diagnosis, prescription, treatment, assessment, accepting, rejecting, and recycling. (Taylor, p. 20) Curriculum development was taboo with USOE. Nevertheless, the CCEM was becoming a major curriculum development effort.

Delivery System for Career Education

The four USOE career education models may be viewed as being four different ways of delivering on the goals of career education. A decision was made in the CCEM to "infuse" career education concepts into existing school subjects. The strategy used in the refinement or development of the CCEM units was one of infusion; i.e., attempts were made to weave career education concepts into the fabric of all school subjects.

At this time, no CCEM curriculum units are available to the public. This is as it should be since it could be dangerous to disseminate units before they have been completely validated. However, we can obtain some notion of what the CCEM curriculum units will be like from Miller (1972, pp. 22-23), who noted that to have transportable "infusion units" the curriculum units must conform to some standard format. He then outlined the components contained in the CCEM's standardized format and guidelines for curriculum unit revision. The components are:

1. A teacher guide which specifies:
The rationale for the unit

Intended use of the unit by suggested grade level, subject areas, time, grouping, and special considerations

Goals and performance objectives

2. Teaching procedures:

Learning activities

Resources

Performance evaluation

3. Teaching materials

4. Evaluation procedures

5. Specifications for in-service training of the teacher or person implementing the unit

CCEM curriculum units will vary in length up to 20 classroom hours. Present implementation plans call for existing curricula to absorb these CCEM units (e.g., a 10-hour CCEM unit in English might infuse a 100 hour English sequence.)

Concluding Remarks

Some observers of the career education scene point out the tentative and evolving nature of career education concepts. However, at the present time many educators have committed themselves to implementing "career education." This might be risky business. Most career units have not been validated, nor have the career programs been tested. Most of the career education curricula collected by the CCEM has been assessed as mediocre or poor.

The CCEM has been the most prominent of all the career education projects to date, and most educators hope it will develop successful programs. Nevertheless, it would be a mistake to think that a comprehensive career education system is just around the corner. It will take time to develop.

And it ought to be remembered that there is nothing more difficult to take in hand, more perilous to conduct, or more uncertain in its success, than to take the lead in the introduction of a new order of things. Because the innovator has for enemies all those who have done well under the old conditions, and lukewarm defenders in those who may do well under the new. (Machiavelli, 1960, p. 29)

REFERENCES

Anderson, Donald P. "The Delphi Technique." A speech presented at the 1969 Leadership Development Seminar for State Directors of Vocational Education, Columbus, Ohio, September 19, 1969.

Machiavelli, Nicolo. The Prince. J. M. Dent and Sons LTD, London, 1960.

Miller, A. J. "The Emerging School-Based Comprehensive Education Model." Paper prepared for the National Conference on Career Education for Deans of Colleges of Education at The Ohio State University, April 1972.

Progress Report. The Comprehensive Career Education Model, The Center for Vocational and Technical Education, Columbus, Ohio, July 1972.

Taylor, Robert E. "Career Education: Implications for Increased Educational Relevancy." Presented at the Central New York School Study Council Career Education Conference, Syracuse, New York, October 20, 1972.

PITTSBURGH'S OVT PROGRAM "BELLS THE CAT" FOR CAREER EDUCATION

BY

JERRY C. OLSON

ASSISTANT SUPERINTENDENT FOR SYSTEM-WIDE PROGRAMS AND SERVICES
PITTSBURGH, PENNSYLVANIA PUBLIC SCHOOLS

The major career education issues are common throughout the country but are intensified in urban centers. The magnitude of urban problems cries for a response. "Who bells the cat?" In theory, everyone wants career education, but everyone wants the other guy to do it or to come up with a specific plan. Pittsburgh's response for the past nine years has been OVT (Occupational, Vocational and Technical Education).

In education, the decade of the sixties witnessed legislative acts which were crisis-oriented. A crisis orientation is defined as curative measures or solutions for meeting situations which are maximized by the social and economic climate operating at that time. The federal legislative movement, which was aimed at encouraging state and local educational agencies to evaluate and restructure programs, was based on two general notions: compensatory programming, and the development and assessment of programming related to manpower resources (vocational education).

Although seemingly comprehensive, the national implementation of programs in the sixties was fragmented and much of education continued on in the same old way. Innovation was going on, but it was not necessarily accepted for the long range. Instead, projects were finished and filed. The concepts of continuance and assessment were not always part of the picture. Programs, ideas, and innovations frequently were not relevant to the populations served.

What happened to all the ideals invested in the crisis programming of the sixties. Perhaps part of the answer is found in the fact that investment in merely prescriptive types of programs is not the only solution for an era in which the rapidity of change demands that educational programs increasingly be made personalized and diagnostic in nature. Somehow, somewhere, the goals of education must be aligned so that student development occurs in the areas of self, attitudes, and potential contribution.

Career education, if it is indeed responsive and comprehensive, provides a very human approach to education. It is this human resource which is at the base of the thrust in Pittsburgh. Within a framework of student-centered career education activities, the Pittsburgh Public Schools seek, among other things, to develop in the learner skills and knowledge that are needed for the world of work. In our view, these skills and this knowledge must be broader than vocational education. Many components of academic education, as well, must be included. This philosophy led to the development of thirteen (13) comprehensive high schools in Pittsburgh.

Comprehensive education has been of high priority in the Pittsburgh Public School district for nine years. Pittsburgh's approach to comprehensive education has evolved through the expansion of programs for grades K through 14 and the incorporation of vocationally-related programs in academic schools with concomitant phasing out of "separate" vocational schools. This approach was initiated by Board members and the administrative staff when it became clear that nearly 60 percent of Pittsburgh's student population was not involved in relevant programs.

Facts were reviewed as to "revolutions" - social, economic, and cultural - occurring among urban populations. A local response came in 1964; the Board established the Division of Occupational, Vocational and Technical Education. The charge to this division was (a) to design a vocational education program to service the needs and demands of an urban community and (b) to develop programs which represent a comprehensive approach to education utilizing the total resources available to the school district. Programs must be responsive to existing needs and demands, not only to the demands of the industrial community, but also to demands of the social community; programs must be created to serve all, including youth, adults, the displaced, the handicapped, and the disadvantaged.

Marketable, skill-centered programming was initiated at the eleventh and twelfth grade levels, with advanced programs being established at the thirteenth and fourteenth years. In short, students, upon graduating from the Pittsburgh school system, could have both a broad academic education as well as a skill-centered education. As vocational programming expanded, counseling models were developed to establish a systems approach for guidance. At the secondary level, model programs were designed and tested for both cooperative work experience and job placement. These programs emphasized guidance and counseling.

The initial thrust completed, the Division of Occupational, Vocation and Technical Education in Pittsburgh reviewed exploratory options for students in the middle grades. As this review was undertaken, an educational movement for designing specific programs for pre-adolescents was becoming widespread nationally. The generalized term "middle school" was the concept that put forth tenets of programming for preadolescents which emphasized flexibility and counseling. These tenets became part of the rationale of the OVT Division which developed a program to orient students in grades 6 through 8 to the major factors involved in the world of work: human relations, communications, production, and economics.

There has been a dearth of programming for the school district in career education at the elementary level. However, experience with development of program modules for the middle school level has given Pittsburgh a unique benchmark for preparing programs which not necessarily add to the existing heavily programmed school day, but which seek to provide articulation among the disciplines and to identify within those disciplines objectives which are career-oriented and which provide tools for pupils to use in the decision-making process, particularly those decisions which relate

to the total development of a human being. This total development includes the choice of a vocation or a career. For an example of career education being implemented in K - 5, see Figure 1. This figure also depicts Pittsburgh's program continuum from grades K through 14.

As programs in OVT expanded to fifty four, as work experience and placement services were initiated, and as exploratory OVT education was being tested, implemented, and incorporated into a system, the vocational staff sought programming alternatives for students who were "alienated" for many reasons by regular programs, including vocational education. One of the strengths of OVT has been the ability of the staff to seek and find alternative methods for responding to students' needs. One response was to develop a project which would involve students in intensive short term training at an entry level and which would align that training with adjustive and vocational counseling. The program became known as Project S.E.T. (Select Employment Training).

The project provides pre-work preparation and work-study experience for alienated students who are demonstrating their desire and intent to leave school early. For one reason or another, many of the potential dropouts are not enrolled in skill centered programs. The intent of the program is to provide a concentrated set of experiences that will assist with "job readiness" and then offer individual attention and guidance as the student gains skills while working on a job.

Students are employed in private or public industry with 100 per cent of their salaries paid by the employer at entry-level rates. Approximately sixty students are employed in as many companies, including Bell Telephone Company, Foodland Grocery, Gimbels Department Store, the Post Office Department, Thrift Drugs, and Wheeler Paint Company. An additional sixty students who have exhibited the same characteristics in (1) no satisfactory avenue toward industrial competence; (2) non-success in a conventional school setting; (3) signs of hostility, unruliness, passivity, or apathy; or (4) having psychologically dropped out of school are participating in the VEPS (Vocational Exploration in the Private Sector) program. Operationally, the program is similar to the SET program except that in this program, 50 per cent of student wages will be paid by the employer and 50 per cent will be paid with Neighborhood Youth Corps funds. A coordinator, one counselor, six teacher-coordinators, and eight paraprofessionals are responsible for the combined operation of the SET and VEPS programs.

OVT responds in another way through Project Liaison. It is a federally funded program designed to provide services for EMR (Educable Mentally Retarded) students participating in vocational education. The goals of the program, which started in September 1971, are:

1. To increase the number of EMR students actively participating in skill-centered education programs.
2. To create a situation and atmosphere in which the EMR student can be successful in skill-centered vocational education programs, learn a salable skill, and upon graduation get a good job in the community.
3. To develop in the total school community and the outside community in general an awareness of and commitment to the EMR student.

To meet these objectives, a vocational rehabilitation counselor is assigned to each high school. These counselors serve as the liaison person between the EMR students and other school personnel. Specifically, the rehabilitation counselor is involved in:

Placement: The rehabilitation counselor recommends to the school counselor placement of the EMR student in skill-centered OVT programs.

Adjustive He counsels with EMR students assigned to his caseload. (Relatively small caseloads permit opportunities for intensive counseling.)

Coordination The rehab counselor acts as coordinator for the OVT and special education departments. Formal and informal meetings are arranged in which OVT and special education teachers can meet to discuss the needs of individual EMR students in their programs. Special education teachers will have an opportunity to learn those academic areas which should be reinforced in their classes to promote chances of success of the OVT student.

Curriculum The rehab counselor often helps to alter the OVT and special education curriculum to better meet the needs of EMR students. The rehab counselor also aids the teacher in evolving methods of teaching the EMR student within the OVT class.

Coordinates
All
Resources The rehab counselor works closely with the counselor, social worker, centrally based coordinator, and the general school faculty and administration in an effort to fully utilize a team approach to the vocational needs of EMR students.

In addition to the thirteen rehab counselors, five vocational teachers have been taken out of the classroom to serve as learning

counselors for a period of one year. They are then returned to the classroom, and five others take their place. The learning counselor meets with EMR students who are in OVT classes in small groups. The approach is used to emphasize those kinds of behavior, which lead to learning. These counselors strive for a team approach and seek to have the students support each other. The learning counselor may go into the shops with the students and reinforce proper behavior. These counselors work to encourage positive interaction between student and teacher. It's easy to see that, once these counselors return to their classrooms, they will themselves have gained a new sensitivity to the needs of EMR students.

As of November 1972, there were forty groups formed for learning counseling objectives. These groups are led by rehab counselors as well as learning counselors. When the EMR student graduates he is assisted in placement in some job.

This program is now in its second year. Before the program started, 30 EMR students were in OVT classes. Now there are 222. The objective for next year is to place 90 per cent of those who are eligible.

Still another OVT effort which responds to the career education movement is the School-to-Industry Job Development Program. This program provides practical instruction which will prepare all high school seniors to apply for a job. The main purpose is to lend employment assistance to seniors who will be seeking full-time employment following graduation. Job placement coordinators visit all senior English classes and present a lesson dealing with the completion of job applications, the employment interview, and work behavior and attitudes. Following the initial lesson, for approximately six weeks, the English teacher reinforces the presentation with lessons dealing with the employment application, letter of application, the personal data sheet, and how to go about finding a job. During April and May, a "job placement center" is set up in each school, at which time 250 to 300 employer representatives of business and industry will interview seniors who are applying for an immediate or near-future job. This program is an effort to bring together students who have developed competencies in high school and employers who are in need of personnel. Placement coordinators will periodically contact "new employees" shortly after they begin work to assist in their transition from school to work.

Continuing to seek various strategies of implementing the aspects of career education, the Pittsburgh district has expanded Neighborhood Youth Corps programs and instituted (for over five years) programs in work-study during the summer. In addition, post-secondary and adult programs have increased and include Adult Basic Education, GED preparation, Manpower Development & Training programs, entry-level adult programs, and specialized vocational counseling for adults.

The Pittsburgh School District has committed itself both

theoretically and pragmatically and strives toward the development of a total systems approach to career education K through 12 and beyond.

In urban America, size alone creates many problems and intensifies others, but programs and services that can be joined as a result of size are a plus factor if they can be coordinated. In Pittsburgh the components of (1) guidance and counseling, (2) child accounting, (3) testing, (4) psychologists, (5) psychiatrists, (6) social and mental health workers, (7) exceptional children supervision, and (8) research are pulled together through the Department of System-Wide Programs and Services.

Career education in Pittsburgh is viewed as a continuing process requiring a series of decisions. Culmination of the process is the development of salable skills and competencies which students take to the employer in business and industry or use to continue their education.

Personal decisions regarding entering the world of work are not seen as traumatic or earth-shaking, but merely as the culmination of previous experience. These decisions are not terminal and should not be considered as a final statement of the student's interest, ability potential, skills, or competencies. Initial employment may turn out to be permanent for some; for others, it may be a temporary pause or a springboard to the next stage of development.

SUMMARY

The planning, implementation and management components that are essential to "bell the cat" for career education are:

1. A broadly conceived career education program that insures inclusion of and improvement in both academic and vocational education.
2. An organizational structure that determines the direction, sets the policy, communicates the priorities, and manages the execution of the system.
3. A clear delineation of the program and curriculum changes that must be accomplished in academic and supportive fields.
4. A vision about the curriculum changes necessary for vocational education to broaden the program to serve many students with varying capabilities.

Try "belling the cat" and allow career education to be the central theme around which an education for all students can revolve!

Figure 1
Program Continuum

Career Education: Pittsburgh Public School District

Grade Levels

School District Programs

<div style="border-left: 1px solid black; border-top: 1px solid black; border-bottom: 1px solid black; padding: 2px 5px;">K</div>	<p>Articulated Career Education programs among the disciplines, e.g., social studies, grades 1-3</p>
<div style="border-left: 1px solid black; border-top: 1px solid black; border-bottom: 1px solid black; padding: 2px 5px;">1</div>	<p><u>Grade 1</u> - The Family meets its basic needs for education, food, clothing, shelter, and transportation.</p>
<div style="border-left: 1px solid black; border-top: 1px solid black; border-bottom: 1px solid black; padding: 2px 5px;">2</div>	<p><u>Grade 2</u> - Our Community; the neighborhood and communities around the world.</p>
<div style="border-left: 1px solid black; border-top: 1px solid black; border-bottom: 1px solid black; padding: 2px 5px;">3</div>	<p><u>Grade 3</u> - Pittsburgh, Pennsylvania, and some selected communities of the world.</p>
<div style="border-left: 1px solid black; border-top: 1px solid black; border-bottom: 1px solid black; padding: 2px 5px;">4</div>	
<div style="border-left: 1px solid black; border-top: 1px solid black; border-bottom: 1px solid black; padding: 2px 5px;">5</div>	
<div style="border-left: 1px solid black; border-top: 1px solid black; border-bottom: 1px solid black; padding: 2px 5px;">6</div>	<p>Phase I - OVT Exploratory Career Orientation. Introduction to Concepts of Work - Human Relations, Communication, Production, Economics.</p>
<div style="border-left: 1px solid black; border-top: 1px solid black; border-bottom: 1px solid black; padding: 2px 5px;">7</div>	<p>Phase I & II OVT Exploratory Career Orientation - 10 Areas of the World of Work: Business Communication, Information Processing; Merchandising, Foods & Nutrition, Clothing & Textiles, Health & Community Services, Construction, Manufacturing, Visual Communications, and Power & Transportation.</p>
<div style="border-left: 1px solid black; border-top: 1px solid black; border-bottom: 1px solid black; padding: 2px 5px;">8</div>	
<div style="border-left: 1px solid black; border-top: 1px solid black; border-bottom: 1px solid black; padding: 2px 5px;">9</div>	<p>Narrowed Exploratory Programs in all clusters e.g., I.A.C.P. - Construction-Manufacturing Program.</p>
<div style="border-left: 1px solid black; border-top: 1px solid black; border-bottom: 1px solid black; padding: 2px 5px;">10</div>	<p>Summer Work-Study; Neighborhood Youth Corps; Projects S.E.T.; V.E.P.S.; Project Liaison.</p>
<div style="border-left: 1px solid black; border-top: 1px solid black; border-bottom: 1px solid black; padding: 2px 5px;">11</div>	<p>54 Programs grouped into the following eight clusters; Manufacturing, Construction, Visual Communications, Electricity & Electronics, Transportation, Science Laboratory, Business Communications, Merchandising.</p>
<div style="border-left: 1px solid black; border-top: 1px solid black; border-bottom: 1px solid black; padding: 2px 5px;">12</div>	<p>Cooperative Work Experience - all programs Work Placement - all students School to Industry Job Development Program.</p>
<div style="border-left: 1px solid black; border-top: 1px solid black; border-bottom: 1px solid black; padding: 2px 5px;">13</div>	<p>Post graduate programs - Clusters; Construction, Manufacturing, Power, Visual Communication, Transportation, Information Processing, Business;</p>
<div style="border-left: 1px solid black; border-top: 1px solid black; border-bottom: 1px solid black; padding: 2px 5px;">14</div>	<p>Special Areas - Research Lab, Cashier/Checker.</p>

89

CAREER EDUCATION AND THE SCHOOL COUNSELOR

EDWIN L. HERR
HEAD, DEPARTMENT OF COUNSELOR EDUCATION
THE PENNSYLVANIA STATE UNIVERSITY

The implications radiating from career education promise to affect in significant ways the direction and the substance of American education as well as of such subsystems as guidance. Both the purposes and the processes of education and of guidance are undergoing, however subtly, a realignment as a result of the rhetoric, model building, and legislation pertinent to career education.

As the images and expectations represented by these activities are being diffused through different educational levels and settings, new models of educational structure and curricula are surfacing, possible linkage between school personnel and their counterparts in industry or the community are being forged, and classic assumptions about the purposes of both general and vocational education are being challenged (Herr, 1972). In short, there is underway a period of comprehensive redefinition of educational intent and response with regard to the needs of young people today.

As part of the educational scene, the goals and processes of guidance are undergoing the same kind of scrutiny and assessment as the broader context of which it is a part. Indeed, if guidance is an integral part of education rather than an entity simply housed in the school without any direct relation to its educational mission, its role must alter as the larger context changes.

Given the above observations, the remainder of this essay will analyze briefly some of the implications for guidance which can be expected to result from current interpretation of career education. These will be considered in terms of focus (objectives), time frame, remediation or stimulation and process (cooperative activity).

Focus

School counselors have traditionally been seen as the major facilitators of the guidance process. However, they have historically experienced difficulty in articulating what its purposes are. This difficulty has been expressed in resurgent concerns for role and function studies or some solution to role identify crises.

A partial reason for counselor role difficulties resides

in a lack of conceptual structure from which functions can be derived. In partial support of such a hypothesis is Shaw's (1968) contention that one frequently finds in descriptions of guidance services or counseling programs simple inventories of what will be done (e.g. individual counseling, testing, group work) rather than a rationale expressing why anything is to be done or the student behavior which is to result as a function of whatever is done. Thus, clear statements of objectives to guide counselor performance are frequently missing. Shaw has further maintained, as have other observers, that when guidance objectives are stated they frequently are cast in such global terms (e.g. to assist students to be happy, successful, or mature) that they cannot be operationalized nor do they represent areas which call upon skills or competencies unique to the counselor.

Tyler (1969, p. 21) seems to echo this general concern for lack of rationale when she states that: "Perhaps more than it needs answers, at this juncture counseling research needs new questions -- questions not about what counselors do but about the developmental process they are attempting to promote." She goes on to argue that the dominant personality theories which undergird counselor behavior do not deal effectively with counseling for choice or for considering the question: What might this person do? However, these are the emphases inherent in career education, and counselors, if they are to be integral aspects of it, must find conceptual structures by which to orient themselves.

It can be maintained that the approaches comprising career development theory provide a framework and the substance to tie the definition of guidance to a focus on individual decision making. However, making such a statement in no way validates its accuracy unless such a focus can be reflected in objectives which are precise enough to identify the unique contribution of school counselors to their attainment. Given the current activities of many authors and projects throughout the nation, it is possible to be optimistic about such possibilities.

If the facilitation of individual decision making is to become a major focus of school counselor behavior it is also important to consider the time frame to which guidance activities must respond.

Time-Frame

As knowledge and theory pertinent to career development have unfolded in the past decade, one of the axioms which has gained agreement is that decision making is a process which has

a longitudinal character. It finds its roots in early childhood and extends throughout one's life. Indeed, it is becoming evident that life at all levels can be analyzed in terms of the sequences of decisions which it requires the individual to make. Thus, a conception of developmental tasks which describes the sequential antecedents of increasingly complex behavior appears to have as much validity in career development as in personality or psychomotor development (Herr and Cramer, 1972). While the exploratory periods of adolescence and young adulthood are frequently emphasized in discussions of career development, affects upon this set of behavior do not begin and end at these periods. Every individual has a cumulative history which continues to express itself in present behavior and in one's orientations to the future.

In the terms that have been discussed here, decision making is a process which stands together with self-definition. Current theoretical perspectives also suggest that how man views himself and his choice possibilities are learned characteristics based upon the accuracy and scope of the information one has about the self, environmental opportunities, planning, ways of preparing oneself for what he chooses, and ways of executing what one has planned. Obviously, the information requirements and the way an individual deals with information will vary from educational level to educational level.

As suggested earlier, the nature of career development is such that its character and focus changes at different educational levels. This is true because the areas of concern which children and adolescents are working through or about which they are principally concerned changes with different chronological periods. This is, of course, a global matter which becomes more complex when one adds refinements to these areas based upon racial, sexual, socioeconomic, or other personal history variables. The point is, however, that in response to these changing emphases in career development, guidance efforts and purposes can be defined differently at the elementary, junior high and senior high school levels.

Because children's career development needs are different from those of adolescents or adults, one can relate differences in guidance efforts to this longitudinal structure with a greater sense of purpose than is obvious without such an organizing structure. For example, while there is considerable sympathy among the public for the viewpoint that counselors are required in the elementary school, there are significant questions about how they differ in function from either school psychologists, school social workers, elementary teachers or elementary principals. Other questions concern whether they should be hired on the basis of an itinerant status among buildings or teachers or if they have a role to play as a part of the staff or specific elementary

schools. Similar questions have always plagued junior high and senior high school counselors. In periods of economic turmoil, as is currently the case, such questions become a crescendo. Career education in its institutionalization of career development has provided both a framework and a stimulus to all groups of educational specialists, including counselors, to consider their specific contribution to the process. To do so, however, requires that counselors consider the implications of guidance as remediation or as stimulation.

Remediation or Stimulation

Guidance from the outset of its establishment in the schools has served principally as a remedial function. It has been implemented typically when a problem has become visible either to the person who experienced the problem or some agent of referral to the counselor. Guidance has largely been seen as synonymous with individual counseling oriented to treating some individual "maladjustment" after the fact in relation to the cause of the maladjustment. Such a position can be seen as a reactive one.

Career education reinforces another role for guidance, a more proactive one -- that of stimulating the acquisition by students of those ingredients pertinent to their individual career development. Unlike the remedial role's restriction of guidance impact to limited numbers of any student population, a stimulation role potentially permits guidance to have an impact on all students without precluding the possibility of responding to student crises when necessary.

Of obvious importance in a stimulation role is counselor identification of the attitudes, knowledge, and skills which comprise decision-making maturity. In general one can say that the individual will require information about the self, environmental alternatives, and decision making as a way of meshing the two. Each of these emphases can be further divided into vocabulary, knowledge, attitudes, and skills which need to be acquired. To illustrate the point, one might use environmental alternatives as an example. In terms of a learning sequence, it is necessary for the individual to develop a vocabulary by which to differentiate among educational, occupational, career, and social alternatives. Not all of the differences between or among these alternatives will be equally interesting or appropriate to each individual; thus it will be necessary for different persons to acquire fairly extensive knowledge about some of them. Knowing about some alternatives must then be considered in relationship to attitudes toward what one knows. In short, knowledge and attitudes toward environmental alternatives must be related to one's value system.

This latter requires skill in relating environmental information to self information and applying it through the elements of choice.

These points could be pursued at length. But the point here is that a stimulation role vis-a-vis career development accents the need for the counselor to know that he is dealing with cognitive and affective elements which are susceptible to modification and learning or relearning, that they differ at different educational levels, that individual differences in readiness and styles of acquisition require a range of techniques or experience to be available, and that many people contribute to the outcomes which result. The complexity inherent in such a view of career development indicates that counselors cannot be seen as the only group responsible for facilitating or stimulating career development. How can they contribute?

Processes

Career education by definition seems to represent a warrant for increased cooperative activity among various education professionals, the school and the home, and the school and the community. Clearly, the school counselor will have to effect new cooperative relations with others. At the least, he will have to become more involved in providing input to curriculum and experimental programs; in assisting teachers across the spectrum of general, vocational, and practical arts courses to connect their educational goals to career development concepts; in serving as an advocate for a broader and more flexible range of educational experiences tied to individual needs; and in helping representatives of business and industry to identify and muster their resources in support of career education.

In discharging the kinds of responsibilities identified above, it is possible that career education is a vehicle for implementing pragmatically the historical intent that the counselor be an applied behavioral scientist, a change agent, or a conscience of educational policy. Certainly, he is being encouraged to depart from the one-to-one mode and to move toward attention to environmental modification and other eclectic ways by which experiences can be developed to facilitate student growth.

Some people believe that the counselor's role will end with the collaborative efforts described above. However, it is equally plausible to believe that counselors will still have a role in helping individual students by providing them an opportunity to stand aside from the group and

particularize their own unique paths and the potential outcomes they represent. This will still mean individual and group counseling as well as a variety of forms of measurement activity. It is likely to include, in the latter instance, much more use of technology both computer and non-computer mediated. In addition, it seems likely that school counselors will be involved with work sampling, simulation evaluation, and other concrete assessments of student behavior relative to their developmental progress toward some set of performance criteria.

Finally, it is probably that the school counselor's role in career education will also involve him heavily in placement. Educational placement has been a large part of the counselor's task for several decades. During this period, occupational or job placement has been handled by others in the school if it has been handled at all. Now, however, many pressures are converging to support the school taking a greater responsibility for placement of all students, whether they leave before or after high school graduation, and in providing them counsel or other support as they attempt to adjust to their next level of activity. Discharging such responsibilities will require counselors to assume an outreach thrust and to work closely with rehabilitation counselors and employment services counselors. In some instances, the counselor will likely need to utilize job development opportunities either because some students will need jobs uniquely tailored to their characteristics or for educational/exploratory reasons.

Summary

This paper has attempted to extrapolate implications for the school counselor which seem apparent in current models of career education. These were identified in four areas: focus, time-frame, remediation or stimulation, and process. Together they support optimism that the guidance process is now seen as central to the educational mission and caution that counselors need to consider systematically their professional role, as well as that of others, in facilitating this process. In particular, the potential of career development theory for creating a framework for counselor action is examined.

REFERENCES

- Herr, E. L. Review and Synthesis of Foundations for Career Education. Washington, D.C.: U.S. Government Printing Office, 1972.
- Herr, E. L. and Cramer, S. H. Vocational Guidance and Career Development in the Schools: Toward a Systems Approach. Boston: Houghton Mifflin, 1972.
- Shaw, M.C. The Function of Theory in Guidance Programs. Guidance Monograph Series 1: Organization and Administration. Boston: Houghton Mifflin, 1968.
- Tyler, Leona, The Work of the Counselor (Third Edition). New York: Appleton - Century - Crafts, 1969.

PROJECT COED:

A CAREER EDUCATION PROGRAM IN NEW HAMPSHIRE

BY

EDWARD W. DONOVAN
COORDINATOR, PROJECT COED

Our children have, or should have, one thing in common; they are going to have to work for a living some day. While work is not everything, it does constitute a major part of life. We can honestly say that we live in a work oriented society. Preparing people for the world of work, then, is a legitimate concern of public schools. Schools have not given it enough attention, however. Project COED's function is to redress the balance in the schools of Supervisory Union #29. Supervisory Union #29 consists of six school districts in southwestern New Hampshire servicing 6,000 students. The districts of Chesterfield, Harrisville, Keene, Marlborough, Nelson, and Westmoreland.

COED is an acronym for Complete Occupational Education Development. It is a federally funded project with a proposed running time of three years commencing June 15, 1972. The originator and current director of the project is John J. Riesenberg.

Our primary goal is to bring students closer to career decision making and to facilitate the career decision making process wherever possible. This will be accomplished through a comprehensive program with five components: (1) elementary, (2) junior high school, (3) high school, (4) job placement, and (5) career guidance. Each will be explained in detail.

The program is intended for all students. A main target of most career education programs is the general student. Upon high school graduation, he is often prepared for neither post-secondary education nor an occupation. The general student is a primary target of our project, but we want to be able to say that each of our students is prepared for an occupation and/or is ready to take the next step in formal education upon graduation from high school.

We do not want to forget the post-secondary bound student nor the vocational education student, however. Career education can benefit these students as well. College-bound people would do well to carefully consider future possible careers. Too many seem to consider college as an end in itself. This is wrong. They too must enter the world of work at the completion of their schooling. Preparation for work should be as important to them as to anyone else. Furthermore, the fact that the attrition rate among college freshmen is around 50 per cent is a strong indication that many young people are making poor choices. A good K-12 career education program should help the student make more appropriate choices in this regard.

Students in good vocational programs are currently far ahead of other students in terms of career preparation. They graduate with job entry skills, and many will go on to post-secondary education. Still, vocational education is in need of expansion and improvement in many places. Career education will provide the impetus for change to take place.

Three Phases:

Project COED is conceived as a three-phase, recycling operation.

Phase I addresses itself to the orientation of the staff. During the 1971-72 school year, in anticipation of enactment of our programs, we held a series of five workshops for a representative group of thirty-five teachers, administrators, and counselors, grades K-12. Our purpose was to introduce the career education concept, generate interest in career education throughout the Supervisory Union, and provide a nucleus for a curriculum development group to work during the summer of 1972.

For our workshops we invited consultants from local businesses, state departments of education, and representatives from various career education programs throughout the country. The workshops were a distinct success. They achieved the goals they were meant to achieve. By the close of the school year, career education was a force to be reckoned with in the Supervisory Union. Moreover, we had a nucleus of people with which to begin phase II.

Phase II addresses itself to curriculum development. Using some of the orientation group as a core, we employed a representative group of twenty-four teachers to develop career-related curricula to be implemented during the 1972-73 school year. The group included teachers from the elementary schools, junior high schools, and high schools. After receiving one week of additional in-service training in the career education concept, and instruction in the writing of behavioral objectives and individualized learning packets, the group set to work for six weeks.

The result was eighty-eight learning packets representing all levels and disciplines. We obtained a commitment from each teacher to implement what he or she had developed and to try to get colleagues to use it also. By the opening day of school in September, career education was ready for phase III, implementation in the schools. This phase will be dealt with below as I discuss the implementation of each component.

Before moving on to this, however, I would like to explain the recycling aspect of our program. This simply means that at no point during the school year is any single phase dormant. We are constantly getting new teachers involved in this program (phase I). Teachers are developing new ideas all the time, and each summer for the duration of the project we expect to employ teachers to revise and expand curricula (phase II).

Phase III involves elementary education. The purpose of our elementary program is to create selfawareness and awareness of the world of work. In far too many cases elementary schools reinforce only children with academic skills. Those without these skills receive too little satisfaction from their school experience. I have seen students in the second or third grade actually dropping out of the educational process in spite of their physical presence. There is too little that they are able to do or are interested in doing. This is very unfair. Any educational system which undertakes the preparation of every child who has attained the age of six must develop programs which are relevant to the needs of more than a minority. Much can be accomplished in this regard by bringing career education into the elementary classroom.

We are not advocating that schools neglect teaching basic skills, but we do feel that they can be taught in a way which is accessible to more students. We also feel that the classroom situation can provide relevant training and positive reinforcement to each child regardless of what his or her talents might be.

How do we propose to do this using career education as a vehicle?

First of all, we want to bring about the student's awareness of self. With Project COED in the room, children are exposed to a number of activities involving a wide range of skills. Manual and technical skills are used as well as verbal ones. Each child is provided with a chance for genuine success. In this way he will be able to see who he is in terms of the kinds of things he likes to do and the things he does well.

The kinds of activities COED has brought into the classroom on a regular basis are such things as: woodworking, weaving, photography, animal husbandry, and others. These "hands on" activities are the springboard for our elementary program. It is through them that we develop self awareness, teach the world of work, and show the relationships between school work and the outside world.

So that we may better teach world of work and its social significance, beginning in September 1973, we are adopting a continuous program for teaching the world of work. Kindergarten children will look into occupations held by members of the family; grade 1 will focus on such services as police, fire, and public transportation. Grade 2 will focus on such community services as the hospital, bank, and public utilities. Trade occupations will be the focus for grade 3. Grade 4 will study tertiary industries such as medicine, hotel-motel, amusement, and recreation. Manufacturing is the focus for grade 5. Grade 6 will engage in occupational simulation, role playing, and developing occupational profiles. Role playing is by no means restricted to grade 6 and is encouraged in other grades; but the 6th grade will give it special attention. Our teachers will use the previously mentioned

"hands on" activities in such a way that they can be related to the various occupations within the job groups.

Of course, a teacher may not use only a "hands on" activity to deliver occupational information. She could do it in a number of ways. We have found, however, that these activities are the best motivators we have. Children like them, and in the care of a resourceful teacher, they can add significantly to the educational process. One formerly reluctant student now in a COED classroom stated, "Before I used to fake being sick so I could stay home. Now I would come even if I was dying!"

How do we relate what we are doing with basic subjects to the world of work? There are many ways, and I will cite a few examples: Candlemaking has been related to science (three states of matter) and to math (one person used it to teach volume). Cardboard Carpentry has been used to teach linear measurement. One teacher had students make two much-needed reading tables out of tri-wall and then observed, "You know, it takes fantastic math to be able to make a table out of cardboard that doesn't wobble."

The success of the elementary program to date had exceeded expectations. In September 1972 we started with a core group of eight elementary school teachers who had developed and agreed to try out their activities. We had hoped to have involved two additional teachers for every core teacher by year's end. As of March, 1973, we had five spin-off teachers for every core teacher.

Junior High School

At the junior high school students enter the exploratory part of our program.

During the first year our program at the junior high school has been fragmentary. We have had some excellent career activities, exploratory in nature, going on in English, mathematics, industrial arts, home economics, and science. We realized, however, that these activities did not add up to a comprehensive component. In December 1972, we began to develop one for grades 7, 8, and 9. Our goal is to have all students explore fifteen occupation clusters. Information and activities relative to each cluster will be infused into existing courses. We are asking each discipline to take responsibility for a certain cluster or clusters. We have recommended that the following departments accept responsibility for the following clusters:

English - Communication

Home Economics - Personal Services, Consumer-Home Making*

*

The particular department has agreed as of April 1973, to accept responsibility for this cluster.

Industrial Arts - Construction*, Manufacturing*
(Technical)

Science - Natural Resources, Marine Science, Environment*

Mathematics - Distribution and Marketing

Social Studies - Manufacturing* (general), Transportation*,
and Public Services*

Physical Education - Recreation

Health Education - Health*

Business Education - Business Office**

Some feel that a junior high school student should have been formally introduced to the occupation clusters in the elementary grades and should be ready to focus on three or four clusters of his choice in junior high school. In other words, by the time a youngster has reached the seventh grade, he or she should have a fairly specific idea of what he or she wants to do for a living as an adult. We do not accept this. We feel that the child is too young to have assimilated enough information to make such an important decision by age twelve.

We do, however, feel that the junior high school student can take a formal and comprehensive look at the occupation clusters. The cumulative effect of the elementary school awareness program and the exploratory program will prepare the youngster for the career decision-making process which must begin in senior high school.

High School

Before any school system's career education program can be called a success, its high school must be able to graduate a student with a job entry skill and/or the preparation to take the next logical step in formal education. It must be capable of providing this for virtually all students. Moreover, career preparation should be provided in all disciplines, not simply in the traditional vocational areas.

The best high school career education programs of which I am aware, while not close to this ideal, are attempting to improve existing occupational preparation and bring about something constructive which did not exist before. Unfortunately, many projects, including some highly publicized ones, do not seem to be addressing the problem in a serious way.

*

The particular department has agreed as of April 1973, to accept responsibility for this cluster.

**

This is taught through an Introduction to Business course as a part of the business education curriculum. Our project did not bring it into being. Since it addresses career education needs, however, it is included here.

We firmly believe that our project is among the first group. Our goal is to expand career preparation over the duration of the federal funding period and to have the Supervisory Union move on to achieve the ideal within a several year period after the termination of federal aid.

Specifically, what are we doing now? We are fortunate that Keene High School, which serves 90 per cent of the high school students in the Supervisory Union, is a comprehensive high school with a highly developed vocational curriculum including home economics, food services, office occupations, distributive education, machine shop, auto mechanics, electricity and electronics, and building trades. A student can go through any of these programs and graduate with a job entry skill. Although the vocational program needs additional building space to service students' needs, particularly at the pre-vocational level, it is providing a fine service.

We think that equally valuable career preparation can be given in other areas as well. This can be done through career-related material being fused into existing courses and through the creation of additional skill development courses.

During the current year we have seen career-related materials being injected into a number of classes in mathematics and science and into a few humanities classes. Teachers have attempted to show the relationship between the course material and the world of work and have exposed students to people working in various occupations. These people not only explained what they did for a living and the relationship of the subject to the job, but also informed students about such things as training required, advantages, disadvantages, and prospects for employment and advancement. These kinds of activities can and should be extended. The social studies and English programs, for example, have many courses which need career components in order to be complete. I am talking about such courses as history, sociology, psychology, creative writing, journalism, and others. We are currently working to bring this about.

One innovation of which we are particularly proud is the development of two courses in applied science for general students. The courses in general chemistry and general physics had been watered down versions of the college preparatory courses. They have been a constant source of dissatisfaction to students and teachers alike. Replacing these courses next year will be two half-year courses in laboratory technology, one in chemistry and one in physics. By taking either or both of these courses the student will be able to acquire minimum job entry skills and will be better prepared for a post-secondary program in applied science should he wish to pursue one.

Another source of pride is the development of two courses by the Business Education Department: Introduction to Small Business Management, and Data Processing. Each will be an introductory course

to a proposed program to be developed over the next few years in small business management and computer technology, respectively. Each of these programs will prepare the youngster for employment after high school and/or post-secondary education.

Job Placement

Discussion of career education at the high school leads me to our next component, job placement, which primarily serves the high school. The placement service is conducted by a coordinator and has several elements.

First, the service places students in part-time jobs, summer jobs, and permanent employment. Considerable care is taken to place a youngster in a suitable position. Currently we are attempting to establish solid working relationships between the student, the guidance department, and the placement service. In this way we hope to have more students using the service with a view in laying the foundation for a future career as well as using it to find jobs.

We have also developed a career experience element. The students are allowed to go out for a day to work with someone in an occupation or career that he or she is interested in. This is currently done on a non-paying basis. Although the practice is new, student response to date has been extremely enthusiastic. Eventually, we hope to provide longer work exposures (e.g., two weeks instead of one day). Students might also earn money in some cases.

The last of the placement coordinator's duties is to locate job slots for cooperative education students. These are students who hold paid jobs as part of their school program. Currently, the high school has cooperative education in office occupations, distributive education, machine shop, and food services. Once he locates job openings, our placement coordinator alerts the appropriate man in each interested department. The latter then assigns students to the job and carries out all follow-up activities.

Guidance

Earlier I mentioned establishing a solid working relationship with guidance with respect to placement. Such a relationship, of course, is essential to the success of the entire project. While much remains to be done with this component as with other components, some helpful starts have been made.

At the elementary level, counselors have been very supportive in our efforts with teachers and students. They have provided much valuable input, and their cooperation has done much to smooth our way. Junior High School Guidance has made contact with all students in group settings. In these contacts the counselors point out the importance of work in life, the importance of career choice, and the ways in which one can go about making that choice. Individual

career counseling is available on request. One of the counselors is in the process of developing a career information resource center.

The development of such an information center is one of our projects at the high school level as well. In addition, high school guidance and project COED are, or will be, working together on such things as follow-up studies, interest surveys, aptitude testing, and career seminars.

Evaluation

Our project contracts with a third party evaluator to assess all developments. This arrangement is one of the major reasons for our success. By maintaining close contact through full-day bi-monthly visits, the evaluator is able to keep his finger on the pulse of the program. Through him we become aware of many of our strengths and weaknesses and can act accordingly. The third party often helps us see the problems we would not otherwise see because of our closeness to the project. I strongly recommend that anyone undertaking a similar program obtain the services of a reliable evaluator who will be able to examine it often and in great detail.

This, then, is our program. We have a long way to go, but we also feel we have come a good distance in a short time.

THE ROLE OF INDUSTRIAL ARTS IN CAREER EDUCATION

RALPH C. BOHN
DEAN OF CONTINUING EDUCATION
CALIFORNIA STATE UNIVERSITY, SAN JOSE

Most industrial arts educators who have sufficient vision to see beyond the vocational aspects of career education have given an enthusiastic endorsement to the career education effort. In many ways, the goals emerging from the broad concept of career education parallel the goals of industrial arts. We should recognize that career education is far more comprehensive than industrial arts since it involves both general and special education. However, this breadth, plus the parallel nature of the concepts of career education and industrial arts, permits many of the objectives for industrial arts to be incorporated into programs of career education.

The match of industrial arts and career education exists only if a broad definition of career education is accepted. During the early days of the career education movement, some suggestions were made that vocational education should simply become career education. Had this occurred, the industrial arts role in career education would be limited to career guidance and initial career preparation. While these are critical functions, they become only a part of the total contribution of industrial arts when the broad concept of career education is accepted.

Prior to a more detailed analysis of industrial arts programs in career education, a quick review of contemporary definitions for those two concepts is in order.

What is Industrial Arts?

During 1972 and 1973, the American Industrial Arts Association (AIAA) undertook the development of a "Position Paper on Career Education." In establishing this position, the representatives of the AIAA first defined industrial arts in terms of the current concepts of career education. They identified industrial arts as

a part of the total program of education from kindergarten through collegiate and adult education. Industrial arts is the study of industry and technology. It provides unique opportunities for students to participate in representative experiences in the producing of goods or the rendering of services through the effective use of people, methods, machines, money, management, and marketing. The students also study effects of industrial technology on all elements of

society and the environment. This provides for industrial technological understanding and application.

Industrial arts provides experiences and information dealing with the world of work and occupational opportunities in industry. This develops career awareness and provides career exploration experiences.

Industrial arts assists in the discovery and development of personal aptitudes, interests, creative technical problem-solving abilities, self-reliance, sound judgment, resourcefulness, and adaptability. This provides for students' personal needs for living in a technological society.

Industrial arts is a dynamic program of student activity in a laboratory setting with three major thrusts that bring about: (a) attainment of industrial-technology literacy, (b) acquisition of knowledge of industrial-technical occupations and professions, and (c) satisfying students' personal needs, including discovery of self as related to industry and technology.¹

This is a broad definition which covers most aspects of industrial technology. Essentially, industrial arts is defined as the instructional program which brings to students all aspects of the industrial and technological world in which they live. Instruction includes information and abilities leading to career choice and development, as well as information and abilities leading to improved citizenship, and the gaining of skills and abilities leading to self-fulfillment.

What Is Career Education?

When Commissioner of Education Marland issued his call for "Career Education Now" to the National Association of Secondary School Principals in January 1971, he also established the strategy of leaving the question of definition open to as much dialogue and interaction as possible. As a result, many definitions of career education have emerged, varying from the narrow concept of career education as another name for vocational education, to a broad concept covering the individual's

¹American Industrial Arts Association, "Position Paper on Career Education," American Industrial Arts Association, Washington, D.C., 1973, p. 1.

total occupational, social, and personal life.

Two concepts are emerging from the multitude being presented. The first deals with the economic activities of people. This concept identifies career education as the full range of educational experiences designed to provide the individual with the abilities to make effective career decisions and to prepare for a chosen job or profession. Within this concept, the main purpose of career education

is to prepare all students for successful and rewarding lives by improving their basis for occupational choice, by facilitating their acquisition of occupational skills, by enhancing their educational achievements by making education more meaningful and relevant to their aspirations, and by increasing the real choices they have among the many different occupations and training avenues open to them.²

This concept is quite popular and relates career education with all activities leading to successful entry and performance in a job or profession.

The second concept probably commands less support than the one presented above. However, it is favored by this author since it expands the concept from "preparation for economic success" to "preparation for a self-fulfilling and profitable life." While both concepts can permit and assist the individual to make his "contribution to the improvement and welfare of society," the second concept is more likely to succeed.

The second concept emerged in the literature during 1972 and was developed by the directors of the two leading models for career education programs (the School-Based Model and the Employer-Based Model). Hood and Banathy, in structuring the Employer-Based Model for Career Education, defined career education as

covering the individual's total life: that is, his occupational, social, and personal concerns. The term "career" encompasses the selection of and advancement in a worthwhile vocation within the world of work. The term also encompasses one's choice and pursuit of fulfilling avocational and leisure activities and satisfying participation in the political processes of society.

Career Education is envisaged as education for one's progress through life. A [person] acquires and

²Robert M. Worthington, "An (Over) View from the Top," School Shop, Volume 32, No. 8, April 1973, p. 58.

develops knowledge, attitudes, and skills needed to engage in meaningful vocational, avocational, leisure, social, and personal pursuits. Career Education enables [one] to assess and develop realistically his own interests and potential in view of the opportunities offered and constraints imposed by society.³

A similar concept was presented by Robert Taylor, Director of the Center for Vocational and Technical Education which is developing the School-Based Model for Career Education. Goldhmer and Taylor describe career education as follows:

Specifically, career education is designed to capacitate individuals for their several life roles: economic, community, home, avocational, religious, and aesthetic. It recognizes the centrality of careers in shaping our lives by determining or limiting where we work, where we live, our associates, and other dimensions that are significant in defining our life style. Designed for all students, career education should be viewed as life-long and pervasive, permeating the entire school program and even extending beyond it.

Career education is a systematic attempt to increase the career options available to individuals and to facilitate more rational and valid career planning and preparation. Through a wide range of school- and community-based resources, young people's career horizons should be broadened. Their self-awareness should be enhanced. The framework for accomplishing these goals are the phases in the career education program: career awareness, career exploration, career preparation.⁴

Both of these definitions identify a broad responsibility, involving all activities which contribute to an individual's life style and provide him with an opportunity for self-fulfillment and recognition. Both also identify career education as a lifelong process. As a result, the effects of career education extend from elementary to adult education, and include both formal and informal education.

Industrial arts can serve both concepts but has more to offer the broad-based concept. It is hoped that this concept will prevail since it brings to education objectives which

³Paul D. Hood and Bela H. Banathy, An Employer-Based Career Education Model - A Description and an Operational Plan, Far West Laboratory for Educational Research and Development, Berkeley, California, 1972, p. 20.

⁴Keith Goldhammer and Robert Taylor, Career Education - Perspective and Promise, Charles E. Merrill Publishing Company, Columbus, Ohio, 1972, p. 6.

have been omitted or which have received minimum emphasis in the past. These include the development of life styles, abilities, and knowledges which lead to self-fulfillment.

Role of Industrial Arts In Career Education

Shortly after industrial arts was included for funding through the Vocational Education Act of 1963 (inclusion was via the Educational Amendments of 1972), USOE issued a small grant for the preparation of criteria and guidelines for funding industrial arts education. In the preparation of these guidelines, the committee identified five types of industrial arts experiences which contribute to career education. Since the committee was considering funding under the VEA of 1963, these experiences centered on the economic and employment aspects of career education rather than the broader concept listed in the previous section.

The work of this committee was very important in establishing the role of industrial arts in career education. The five contributions of industrial arts to career education have placed in motion numerous curriculum changes designed to adjust industrial arts to programs of career education. These five methods of contributing to career education are:

Self and Career Awareness. This is a program to familiarize students with the many kinds of work people do and the inter-relationship of such work in producing and using goods and services. Emphasis is placed upon attitudes and values and the relationship of manipulative activities to the total instructional program.

Career Orientation and Exploration. This program consists of laboratory instruction to give students first-hand experience with the kinds and levels of work performed in a broad range of industry and occupations for which special skills are required; to inform them of requisites for careers; to acquaint them with the significance of changing and evolving technologies; to instill in them an understanding and appreciation of the dignity of work; and to assist them in making informed and meaningful career selections.

Career Exploration and Beginning Specialization. This program is designed to provide transitional experiences to bridge the gap between the awareness/orientation focus and specialized in-depth offerings. Experiences will provide students with opportunities to select and explore individual occupational clusters and thereby assess their own performance, aptitudes, and interests.

Career Specialization. This is a program designed to prepare individuals for enrollment in advanced, highly skilled, post-secondary technical education programs. It would provide experiences which should assist students in continuing to assess their interests, abilities, limitations, and potentialities in respect to industrial-technical occupations as well as to provide them with entry-level skills and knowledge from a selected occupation cluster or segment.

Adult and Continuing Education. This program of laboratory experiences is for adults and out-of-school youth who may benefit from broad basic instruction related to industrial and technical occupations.⁵

This committee identified the responsibilities of industrial arts as including all aspects of career guidance and preparation, and spanning the educational spectrum from kindergarten to adult and continuing education. Since the committee was considering career education as it relates to the VEA of 1963, no consideration was given to the development of life styles and activities which help the individual gain meaning and purpose for life.

Career Planning and Preparation

Three distinct steps constitute the stages through which a person passes as he works toward entry into a specific occupation or profession. These are:

Career Awareness

Career Exploration

Career Preparation

Career awareness begins during preschool years and may continue on into early secondary school. The early years consist primarily of recognizing that people work and that work is an important activity and takes a large portion of a person's time. As the child matures, career awareness includes an identification of the large variety of occupations and professions and their specific characteristics and differences.

Career exploration represents an active investigation of different careers to determine characteristics and ascertain whether the career is of interest and is attainable.

Career preparation includes the development of knowledges and skills necessary to enter an occupation or profession. In some cases, prior knowledge and abilities are minimal--most skills are developed on the job. In others, such as engineering, entry requires the development of considerable knowledge and ability. On-the-job education is built on a rather substantial body of knowledge which is necessary for obtaining the position.

Built into the processes of career awareness and career exploration is the critical process of career choice. A person normally chooses a career after exploration and careful analysis. Unfortunately, many people choose careers based on job availability or simply drift into a career without making an effort to determine whether the career is really desired. There are three steps to career choice which must be integrated during career awareness and exploration. They are:

Awareness of Self

Awareness of Career Options

Matching of Self and Career Options

In order to begin the selection of an occupation or profession, a person must understand himself. This is an activity which must begin before or shortly after the student enters school. It must continue even after a career choice is made and must develop into a lifelong process. An accurate appraisal of oneself will assist in determining if or when to change positions, whether to seek advancements, and when to consider changing careers. Unfortunately, this aspect of career selection has been neglected, and the knowledge and abilities of teachers in helping students understand themselves is minimal.

In considering the question of self-awareness, Maley and a broadly representative group of industrial arts personnel identified the following questions which an individual should be able to answer:

Who am I?

What are my strengths and weaknesses?

What are my interests, ambitions and goals?

What are the kinds of activities and experiences compatible with my emotional and physiological make up?

Do I enjoy working with others?

What kind of an environment do I enjoy working in?

What do I want to do with my life?⁶

⁶Maley, Donald, et.al., Career Education Through Industrial Arts. Division of Vocational Education, Maryland State Department of Education, 1972, p. 8.

The answers to these questions are highly individualistic, but they are vital to a person who must choose a career.

The second aspect, awareness of career options, is better understood and is already a part of many school programs. This concept involves both career awareness and career exploration. A person's knowledge about careers should include knowledge of working conditions, future advancements, salaries and benefits, and any other information necessary to determine the desirability of the career.

The final aspect of career choice is matching knowledge of self with knowledge of career options. Each student must be aware of the procedure whereby one evaluates career options in terms of interests, abilities, and special talents (or shortcomings). The process of career selection can begin by eliminating incompatible careers. This will permit spending additional time learning and exploring careers that tend to match interests and abilities with entry requirements and career characteristics.

The entire process of career planning and development is the focal point of the career education effort. In the past, more effort was placed on career preparation, with career awareness and exploration ignored or given minimum attention. In order to correct this shortcoming, industrial arts should develop a strong program of career awareness and exploration in elementary and junior high school (or middle school).

Life Styles and Self-Fulfillment

The broad definition of career education recognizes that education must help students identify the life style they wish to adopt and select activities which provide for self-fulfillment. Unfortunately, surveys report that less than 50 percent of the working population gain satisfaction from their jobs. Most people work to earn the money to give them the opportunity to do the things which give them satisfaction.

The school has a responsibility to the individual student to help him identify activities which provide satisfaction and which permit him to make a contribution that will help him establish worth and a positive self appraisal. This consideration will become more important in the years ahead. If the economic forecasters are correct, the near future will begin to see the surplus of workers grow. Many people will be forced to gain their personal fulfillment from activities other than money-earning positions since these positions will not be available. While unemployment may be temporary for most people, the number of permanently unemployed due to physical ability, age, and worker surplus will probably grow in the future. Our career education programs must be available to help these people as

well as those who are fortunate enough to gain positions from which they obtain self-satisfaction.

The avocational and leisure programs of industrial arts provide the basis for fulfilling this goal. However, the problem is quite complex, and avocational and leisure activities only represent a start towards the development of programs to meet this need.

Role of Industrial Arts at Different Educational Levels

Programs of industrial arts exist at each educational level, from kindergarten through adult education. Industrial arts is able to contribute to the goals of career education at each level.

Elementary School

Industrial arts is integrated within the total elementary school curriculum. However, industrial arts teachers and supervisors should help the elementary teacher integrate career education programs related to industrial arts. The elementary school has a twofold responsibility towards career education--awareness and exploration.

Steeb has identified a set of abilities and knowledges which a student should develop in elementary school from his industrial arts experiences. These are all directed towards career education. As the result of industrial arts experiences in the elementary school -

The student describes in general terms the technical development of man and the role of business and industry in contemporary society.

The student identifies and differentiates a wide variety of occupations.

The student manipulates tools and materials to construct projects and experiments which reinforce, enrich, motivate, and increase learning related to basic elementary subjects and personal needs.

The student demonstrates a positive attitude toward work as evidenced in good work habits, including pre-planning and organizing an activity, caring for equipment and materials, respecting and cooperating with associates, cleaning up, and completing a task once it is started.

The student identifies his interests, abilities, attitudes, and skills for better understanding of himself.

The student uses correctly and safely basic hand tools as he constructs projects with a variety of appropriate materials.⁷

Middle School

The middle school must continue the program of development of career awareness and exploration started in the elementary school. It is at this level that the student must begin to understand himself enough to begin to identify careers in which he might be interested (and is capable of obtaining needed abilities and knowledge). While a definite career choice should be avoided for virtually all students at this level, the process should be understood, and the students should begin practicing its use.

As a result of the sequence of industrial arts experiences in the middle school, Steeb indicates that

The student exhibits a degree of industrial literacy--insights and knowledge--in being able to relate societal and industrial changes to technology and its development.

The student has made tentative choices or selections regarding educational and occupational goals.

The student identifies and compares industrial and technical occupations, the organization of industry, evolving technologies, and methods of production.

The student demonstrates the correct and skillful use of basic tools and materials.

The student demonstrates and exhibits industrial processes and techniques in his laboratory experiences and projects, such as mass production, personal organization, material forming processes, and the use of synthetic materials and finishes.

⁷Ralph V. Steeb, "The Role of Industrial Arts in Career Education," Man, Society and Technology, Vol. 31, No. 8, May/June 1972, p. 263

The student demonstrates or exhibits scientific, mathematic, and mechanical principles through projects or solution of practical problems.

The student solves problems by planning and constructing projects involving group and individual research, experimentation, and development.

The student exhibits safe practices in the laboratory and can relate these to situations in the school, home, and community.⁸

This level of abilities is possible since the middle school program of industrial arts should involve laboratory activities with an industrial arts specialist.

High School

The upper grades of high school continue the processes begun in the elementary and middle grades. However, the process of career preparation is introduced at this level. For many students, high school education is terminal, and entry level job skills are optional. They may provide part-time employment or provide basic knowledge about the profession being sought.

In relationship to industrial arts programs in the upper grades, Steeb, indicates that:

The student displays new insights and understandings of his material culture and its tools and technical equipment.

The student identifies and compares industrial-technical occupations, the organization of industry, technological changes, and methods of production.

The student understands and plans his economic future with consideration of the ever-changing industrial society.

The student demonstrates correct, skillful, and safe use of powered equipment and machines.

⁸Ibid., p. 264

The student applies, demonstrates, or exhibits scientific and mechanical principles through projects, experiments, or solutions of practical problems.

The student demonstrates orderly procedure for construction activities and problem solving experiences including step-by-step analysis, organization of materials, appropriate time limits, and self-education of the task when completed.

The student evaluates manufactured and constructed projects as judged by the quality of construction, appropriateness of materials, functionality of design, and utility of purpose.⁹

Post High School

Post high school industrial arts has three major contributions to career education:

Preparation of industrial arts teachers.

Providing support instruction for careers in engineering, art, and other programs requiring knowledge of industry.

Providing continuing education for adults needing industrial information to renew or advance their careers.

⁹Ibid., p. 265.

Conclusion

The contributions of industrial arts to career education are many and varied. As the primary source of industrial knowledge in elementary and secondary education, industrial arts has the responsibility of helping students (1) become aware of potential careers in industry, (2) explore careers of interest to them, and (3) begin the development of the needed skills and abilities to enter the chosen career.

CAREER EDUCATION AND THE AMERICAN DREAM

BY
CHARLES SIMCOX
ASSOCIATE PROFESSOR OF ENGLISH
WILLIAMSPORT AREA COMMUNITY COLLEGE

"Next to his God and his family, perhaps even more important than them, is a man's career!" Obviously, this observation is accurate in describing some men - business executives, doctors, lawyers, educators, the professional men of society. But it is far from accurate in describing the vast majority of any nation. For most people, work serves a single purpose: it is a means by which one earns the money that will enable him to purchase those things which make life tolerable. Careers are things that belong to the upper classes, like summer camp and dancing lessons. The lower classes don't have careers; they have jobs. And for many, the distinction between a job and unemployment or welfare is vague--both are somewhat distasteful and both bring in money.

It may be true that at a cocktail party the topic most discussed is the wonderful world of work. This is not the case at the plant picnic or the bowling banquet. At these affairs, if work is mentioned at all, it is mentioned in contrast to the fun of leisure time. For all but the professional, the world of work is entered only to acquire the resources to exchange for those things that truly give meaning to life. To focus the educational program on career preparation, then, is either lunacy or a bourgeois plot to create a more productive working class.

I take it to be derangement, the derangement of ignorance. History bulges with examples of this kind of ignorance. Each civilization has witnessed the destructive efforts of misguided zealots who work to impose their concept of the "good life" on those they perceive as less fortunate. Religious enthusiasts with the answer illustrate this point. Educators sometimes, too, believe they possess the answer. And, they perhaps do--for themselves! Career education, as it is generally described, however, is not the answer for everyone, not even for the majority of this society.

Several years ago, a popular singer, Joe South, asked us to "walk a mile in ... [his] shoes." He insisted that if we would permit ourselves to see the world through his eyes, we would be able to accept him and his ways. He admonished us to cease criticizing one another and to stop trying to reshape the world to conform to our personal tastes.

This criticism is especially appropriate to education.

Educators have for some time recognized that only after considerable experience in the ghetto can an outsider grasp the depth of its despondency. They know that only by extensive exposure to the black cause can a white realize the despair of racial inequality. Once a person understands the ghetto situation or the black problem, he generally abandons the absurd objectives of the "white man's burden" and determines to find ways to improve the life of the ghetto-dweller or the black on his own terms. He stops trying to impose his way of life on them. Educators are aware of this, and they have developed many programs which reflect this insight.

Unfortunately, these same educators have failed to apply this insight to the development of relevant educational programs. Caught up in middle-class values, they are unable to perceive another life style as either beneficial or moral. And so they use the school curriculum as their instrument to perpetuate their culture. They firmly believe, for example, that if Shakespeare were not taught to every child, editions of his plays would soon become musty piles in the cellars of libraries, touched only when moved farther out of the way. How ridiculous! If the fate of Shakespeare, or any classic or work of art, depended on the masses for its survival, it would have disappeared long ago. Regardless of what the traditional educator may preach, the objects of middle-class culture have existed and will continue to exist because of the efforts of the few who are vitally interested in them.

It would appear obvious that the historic reason for the inclusion of the study of great art (literature, music, painting, sculpture, etc.) in school curricula was simply that only the upper classes had the leisure or the inclination for formal education. Quite naturally, they shaped their program of study to suit their needs. Later, when education became the province of the many, the program went unchanged. Why? Because the educated elite were determined that all should be awakened to the pleasures of the arts. After all, they reasoned, the purpose of life is happiness, and what better way to insure happiness than through a study of man's greatest intellectual and aesthetic contributions, past and present!

Any realistic appraisal of the public school program would reveal that there are many students who either will not or cannot profit from the arts. Therefore, if they sincerely wish to help the average and below average student, educators must "walk a mile in ... [their] shoes." They must wake up to the fact that there are people who live full, happy, rewarding lives outside the realm of middle-class culture. It should be obvious that many drop out of school because they perceive nothing in the educational program that has meaning

for them. When one considers their abilities, their backgrounds, and their needs, one must conclude that, for many, dropping out of school is a rational, logical move. And what of society? Society is certainly better off with an uneducated, happy gas station attendant than a dissatisfied, rebellious student.

Our country can ill afford to keep its youth in school just because educators and politicians, among others, have agreed that school is a good thing without seriously asking the questions: good for whom? and good for what purpose? A continuation of such outrageous practice can only mean a further drain of skilled manpower which our nation cannot at this critical time endure.

Professional and lay educators must work vigorously to develop programs based on the firm belief that individuals and values representative of all walks of life are of worth. This work will be hard. It will require the commitment of all segments of the academic community. Educators must oppose the traditional educational structure when it is unrealistic. They must insist that programs be periodically re-evaluated and, when necessary, modified or replaced to meet the needs of the potential dropout. They must recognize the expertise of the counselor in the area of human behavior and involve him in curricular decisions. Only when these steps are taken will the current belief that public education serves all levels of society rise out of the muck of hypocrisy.

Career education flounders at this time in that muck. It is floundering because educators have proved vulnerable to the lure of the simple answer. Like De Soto searching for the elixir of life or Sir Epicure Mammon seeking the philosopher's stone, educators have seized each new proposal and attempted to make it the solution to the educational perplexity.

The history of education is filled with trends and counter-trends. Early in this century John Dewey told us that "the subject matter of education is what one needs to know in order to do what one is interested in doing." His followers preached this message both feverishly and, unfortunately, inaccurately. They worked with such zeal that soon the educational pendulum swung far past Dewey's beliefs until education as adjustment became the focal point of the public school system.

This doctrine of adjustment became too much for some educators, and their reaction in the heat of emotion was extreme. Robert Hutchins took the lead and forcefully waved the banner of neohumanism. He told us that "the subject matter appropriate to education is what one needs to know in order to be the kind of person one ought to be interested in becoming." Before long, the pendulum had swung too far in the direction of liberal studies.

In modern education, as in politics, it has been virtually impossible to find a balance. Each reaction has been extreme to counter a previous extreme action. Educational leaders, like political leaders, feel that the only way to gain sufficient attention is to take an extreme position and to have a gimmick! No one knows exactly when gimmickry filtered from advertising into the world of education, but educators for some time have evidenced a belief that the easiest way to communicate an idea is to use a gimmick. Is it possible that when the personnel of the United States Office of Education recognized the necessity of promoting vocational education, they developed the concept, career education, as their gimmick?

No one would argue that education in preparation for a career is not important. That would be foolish. It would be just as foolish to suggest that education for family living or social interaction or cultural appreciation or environmental awareness is not important. All are important and all will be taught. However, the emphasis will be, for a time, on career education. Then a voice of another neglected area will be heard and the educational pendulum will swing violently again.

It is sensible to make career education the focal point of the educational program when modern technological advancement forces us toward increased awareness of that old adage: "there is nothing constant except change?" Each year, each month, brings a modification of the world about us. Products, friends, the landscape, everything, is undergoing rapid transition. One returns to a former address only to discover nothing familiar. One can hardly count on working at the same job ten years hence, let alone retiring from it. And how many are currently working to produce products that did not exist when they were born? It is impossible to anticipate what the world of work will be like twenty, possibly even ten, years from now. Not long ago, it was believed that formal or informal preparation for a job ended at some identifiable point; i.e., completion of an apprenticeship or graduation from high school or college. Today, completion of a program of preparation can be taken to mean only one thing, that the graduate, at best, has acquired entry-level knowledge, and that success in any field is accompanied by continued study. The successful contemporary man goes to his grave with a book in his hand.

At this time, the United States is a major international power; it leads the world in medical, scientific, and technological advancement; it maintains the highest standard of living. Yet these accomplishments represent a mere fraction of its potential. Each accomplishment is diminished by the many threats to its survival - pollution, war, immorality, and disease. Elimination of these threats may well depend upon the maximal efforts of each citizen - one dash separated by spaces - an

unlikely possibility since most Americans have never been challenged and are not prepared to realize their potential. As the individual has sought to survive and progress using only those parts of the human brain most easily trainable, leaving underdeveloped those parts he has not discovered how to use, so the United States has sought to survive and progress educating only those students most easily taught, leaving underdeveloped those students it has not discovered how to teach. If America is to continue to grow, it must develop an educational program that will achieve a two-fold purpose: to prepare each student to cope with the complexities of contemporary living and to provide him with training useful in the productive efforts of society. An impossible goal? Perhaps not.

Within the educative reform advocated by the United States Office of Education, two concepts have considerable merit. The first is that the career education model acknowledges no educational "mainstream" of learning activity. The second is that individuals will be able to move with increasing ease in and out of educational programs and school itself.

In the past, vocational education has been unable to reach many who could have profited from occupational training. This unfortunate situation resulted from misconceptions about the role of vocational programs. Designed to prepare students for jobs, these programs have been considered undesirable, perhaps because their objectives appear to delimit the American dream of status and affluence. That this should have happened is typical of American middle-class multi-consciousness. For years, Americans have sent their children to school so that they would not have to "slave" at the mill or in the mines as did their fathers. And at the same time Americans have stressed that the purpose of education is not preparation for work but rather preparation for life, as though one were separate from the other. As a result of this contra-think, vocational education has become a "transit company" for those unable to function within an irrelevant educational system and who are as yet too young to find employment.

Career education may never become the focal point of the American school system. But the current emphasis on career education may have the effect of making vocational education a legitimate and respected aspect of the total program of study. If it does this, the career education movement will have been worthwhile.

THE ROLE OF VOCATIONAL TEACHER EDUCATION
IN CAREER EDUCATION

BY
C. THOMAS DEAN, DEAN
SCHOOL OF APPLIED ARTS AND SCIENCES
CALIFORNIA STATE UNIVERSITY, LONG BEACH

Career education has arrived on the educational scene as the most exciting concept to be proposed by educators for many decades. However, its bases are not new to education since select aspects of the concept can be found in our literature throughout recorded history. Benjamin Franklin once said, "He that hath a trade hath an estate." Career education is used in our vocabulary and in our communications to describe a vital new thrust or emphasis in education. It warrants our attention and best interests. It is complicated in its simplicity. Let's examine career education and the roles of vocational teacher education.

Currently, career education is a description of a very comprehensive program focusing on careers and designed to provide relevancy to the educational program for children, youth, and adults. An emphasis is placed on individualized instruction and articulation from grade level to grade level. Each student is guided through expanding studies of the work-a-day world and is encouraged to realistically assess his own personal abilities, interests, and aspirations, to explore occupational opportunities, to make a realistic occupational choice, and to receive instruction to develop salable skills for entry into the world of work. It is a restructuring of the basic school subjects around the theme of career development and is designed to assure that all students who leave or graduate from high school will have a salable job entry skill and, if it is required, will be prepared for further education.

Career education is a lifelong learning process which begins in early childhood and continues throughout the adult years. Programs at the lower grades are designed to increase an awareness of careers, an awareness that people do in fact work for a living, and to help the student feel that "I too, some day, will work for a living." A broad range of options is identified. At the elementary level the program is designed to develop a career awareness within the child by providing a comprehensive knowledge of all fields of employment and encouraging the development of a positive attitude toward work. The junior high school level programs are designed to provide further career studies through orientation and meaningful exploration of varied occupational clusters. The high school, community college, and adult

programs are designed to complete the homing-in process and provide job preparation and placement within an occupational cluster. A wide variety of occupational areas are included. These are supplemented through utilization of the community as a classroom for providing on-the-job work experience.

There are many educators today who are attempting to equate career education with vocational education. This attempt is placing the entire concept in jeopardy and reflects a misunderstanding of the program goals. Career education is not a synonym for vocational or occupational education. It is a blending of all the elements comprising the field of education and restructuring these into an entirely new curriculum in which vocational and occupational skill plays a new, key role.

Throughout the educational process, meaningful counseling and guidance play an important role. Developing the ability to recognize alternatives, make choices, increase an awareness of self, set goals and work toward their attainment, and build favorable attitudes concerning the personal, social, and economic significance of work are among the program parameters.

Career education, to succeed, will require educators with different orientations and attitudes. It will be essential that the teacher place the student and his comprehensive preparation for life as central to the instructional program. All educators will have to fully understand that the segment of the career education program for which they have responsibility is only a part of the whole and must be interrelated.

Career education programs must be interdisciplinary in nature and include all segments of education at all levels. It cannot succeed by utilizing only one academic program and neglecting the others. Vocational education has provided the major input for advancing this new career educational concept. A primary source for funding the development of these innovative program elements has been through utilization of Vocational Education Act funds. This is the primary vehicle currently utilized to make career education a reality. Personnel working in vocational education programs are well acquainted with the educational functions essential to a dynamic career education program. They are also familiar with the details of the fifteen occupational clusters developed by the U.S. Office of Education to be used as the base for a career education program. Without the input and support of vocational education there will be no viable career education program.

Teachers are vitally important to the emergence of career education and are the ultimate factor determining success or failure. They are the instruments through which the bulk of the educational and guidance activities are implemented and are all-important in building the career decision-making process.

Students' career decisions are influenced in varying degrees by the teacher. Because of this influence, teacher attitudes toward career education, the world-of-work, and college training are important factors in their own acceptance and implementation of the career education concept. Thus, the roles of the vocational educator continue to be identified.

The vocational educator has many roles to play in molding the career education concept into a viable program adaptable to our present system of education. It is his leadership that will provide the catalyst to move the program forward and maintain stability for its success. He is the weathervane or the "pointer of the way" in this new educational approach.

The traditional over emphasis of the secondary curriculum toward college preparation rather than career or occupational preparation must be discontinued. Former U.S. Commissioner of Education Dr. Sidney Marland has been strongly promoting career education in the last several years and has asked:

"Shall we persevere in the traditional practices that are obviously not equipping fully half or more of our young people...? Statistics show that of every ten students now in grade 5, three will not finish high school. Only two will finish four years of college. How will these people fare in the world of work. In too many cases, our system of education is not adequately preparing students for employment."

Dr. Marland has also made the following public statement:

"To make public education become relevant according to today's needs and the needs of the future, the entire school program must be restructured and it is becoming increasingly evident that public education should be focused around the theme of career education."

Vocational educators have been saying this for many years and have attempted to point out many of the fallacies that exist in an academically oriented system. They have endeavored to point out the need for change, redirection, reemphasis, overhaul, and repair of our educational system. Their success in bringing this about has been limited. They have, in too many cases, been too narrow in their own educational philosophy as it relates to skill training and have failed to see the total educational picture.

A changing concept, from the acquisition of a narrow single skill to the development of competencies in an occupational cluster has been a major redirection in the occupational education delivery system. This is one of the prime inputs for career

education and will be established through vocational education. The vocational educator is in the position to lead the way for all educators in bringing about a proper blending of philosophies to remedy many of the educational mistakes of the past. He can be the weathervane used to indicate direction for this new educational concept.

Vocational education is a prime ingredient in the emerging career education pilot programs. Over the years this area of education has provided leadership in effecting many innovative facets for education. In many cases it has challenged the system and moved into the new methodologies needed to meet today's challenges. Because of its unique make-up, it has had greater flexibility for change than that found in the more traditional, academic programs.

Career education implies a modification of curriculum content in all subject matter disciplines, for all grade levels. The mere addition of career information and career-related experiences to the current curriculum will not suffice to meet the requirements for this new educational approach. The curriculum will require major modification with a reorientation of the learning experiences around the theme of careers. Career concepts will have to be woven into all the general academic, applied arts, and vocational subjects provided within the curriculum. The vocational teacher educator is in a position to lend assistance in this regard.

In addition to modification of curriculum content, career education demands changes in the instructional process. A few of these changes have become apparent and are being utilized in many programs. Vocational educators have been a leading force in the instigation of many needed changes and have set the pace for the other academic areas. They have had vast experience in using such support techniques as advisory committees, community resources, multi-media, work experience and cooperative education. They have also been instrumental in initiating alternative instructional techniques so badly needed if career education is to continue to advance.

Vocational teacher education programs are currently undergoing reconstruction to meet many challenges on many fronts. These programs are taking into account the social impacts and qualities of today's living in order to be responsive to society's needs. They also attempt to respond to other social needs by providing more meaningful insights into the psychological principles of human behavior in an urban technological society.

The teaching of separate, distinct vocational skills can be as irrelevant and isolated as the classical curriculum. Accordingly, vocational teacher educators should lead the way in preparing vocational teachers whose primary concern is not self-perpetuation

but rather the facilitating of self-learning for career development.

Teacher preparation has not provided the leadership to bring about change at a pace to match the needs of our changing society. Vocational teacher education has been more responsive than most of the other educational programs to these conditions, but it has also found itself in a position of following rather than leading. Because of this lag, the teachers produced continue to be improperly prepared. Traditionally oriented teacher education programs produce traditionally oriented teachers. Only innovative programs alert to new concepts and practices encourage the same alertness in the future teacher. The curriculum is probably the most significant aspect of the teacher education program. The challenge of the career education concept and the role of vocational education within it will place an additional demand on vocational teacher education programs to change and become more flexible.

There are many pressures being applied today to bring about changes in the vocational education program. These have been slow in arriving but rapid in comparison to the rate of change in the vocational teacher education program. The provisions for flexibility and change in higher education are often lacking and do not permit rapid changes to meet immediate needs or emergencies. There is a need for reexamining the total field of vocational teacher preparation with particular emphasis on the curriculum and arranging for the trial and testing of promising new concepts such as personalized unitized modules of instruction, self-pacing, differentiated staffing and individualized media instruction.

The vocational teacher educator is in a position to provide real impetus to the career education movement. He can serve as the initiator or pointer of the way in assisting other educators to become acquainted with and qualified in the various essentials of career education. Through curriculum change he can be the primary ingredient for bringing about an awareness of what is necessary to train teachers in vocational, general and academic education and to reorient education toward the career education concept. It is through the teacher education input that change, redirection, reemphasis, overhaul, and repair of our total structure of education will be achieved. At the present time there are only a very few educators who are truly trained in the real career education concepts and their application. Most of these individuals have arrived on the scene through vocational education but have had no formal training other than that relating to a single skill or a specific vocational occupation. The elementary and junior high school teacher has had little or no training but is being asked to reorient his curriculum for the career concept approach. The vocational educator is being asked to provide the leadership through in-service training to orient these people to the world-of-work.

Vocational teacher educators are the individuals who can place the capstone on the educational structure and provide the

finalizing aspects of the career education program. It is through teacher training programs provided by the vocational teacher educators that career education will be properly implemented. The vocational teacher educators will have the responsibility for tuning-up the engine that makes basic education, practical arts education, guidance and counseling, vocational education, apprenticeship education, technical education, manpower training and retraining, teacher preparation, and research and development of a smooth-running, efficient machine.

At the present time the vehicle is operating on two cylinders and needs considerable adjustment to start operating smoothly. Since the teacher is the prime ingredient for the success of the program and the vocational educator has to provide the major thrust, it becomes apparent that vocational teacher education has the role of tuning the engine and getting all the components operating together as an efficient machine. He will be the catalyst to provide a tuned-up engine for career education at all levels.

Career education at the various levels requires that individuals be oriented to the world-of-work, understand its relationship to society's needs, and have an opportunity to experience satisfaction on the job. Occupational counseling and guidance is essential to the success of the program. Counseling and guidance is being done by teachers and individuals who have not been to the "market place" themselves, have not worked in business and industry, and have not witnessed personally the roles of employment other than that provided through the completion of on-campus academic classes. Thus, teachers and counselors are being asked to deliver something they themselves haven't witnessed.

Teachers at all levels from the elementary through the adult education programs need this additional training in the area of occupational counseling and guidance. The academic approach, so widely utilized in the past, will not suffice to meet the needs of the emerging career education concept. All teachers should be provided with an opportunity to actually experience what is happening in the work-a-day world and become acquainted with the changing technologies in business and industry. Without this experience they will be unable to transmit a true picture of the changing occupational needs to their students. The vocational teacher educators have the expertise to bridge this gap and should move to include this aspect of career education into their programs since occupational career guidance is one of the prime ingredients for the career education concept.

The programmatic efforts of career education are massive. The cause is great; the battle must be fought on many fronts utilizing all of the latest educational techniques. If the battle is to be won, there must be selective drafting of thousands of new teachers who will have to be trained or retrained for the exciting new roles

of delivering career education. The responsibility of assisting in this retraining and rephasing falls on the vocational educator who in turn is the responsibility of the vocational teacher educators. It is because of this enlarged task that the teacher education programs must move ahead immediately to meet the challenge for providing properly trained personnel.

The role of vocational teacher education in career education is so broad in content and so all-inclusive that it is most difficult to place it in true perspective. It is the responsibility of vocational teacher educators to point the way, place the capstone into position, tune the engine for efficiency, guide the educational forces, interpret the work-a-day world, train the troops, deliver the end product, assure that the product is good, and provide the reward for success. These are big roles, each a link in the chain that binds the philosophy of career education together and will make it into a workable unit.

To do this job there must be a re-tooling of vocational teacher education programs. Segmentation must be eliminated and a national effort brought into focus. Old traditions must be phased out and new innovative ideas inserted. Curriculum changes must be immediately implemented to bring about the reorientation and retraining of the educational personnel involved in career education. The success of the career education concept rests upon the input of the vocational educator whose success in turn is dependent upon the job performed by vocational teacher educators.

ANGELO C. GILLIE, SR.
PROFESSOR, GRADUATE STUDIES AND RESEARCH
DEPARTMENT OF VOCATIONAL EDUCATION
THE PENNSYLVANIA STATE UNIVERSITY

1. What is Career Education?

It is sufficient, for the viewpoints presented in this paper, that career education be considered a concept which encompasses the entire framework of American education. In conjunction with this position, an individual's career is meant to include all of the life experiences of a person. One critical part of career education is vocational education, which is here meant to include those aspects of a person's education which most directly relate to occupational preparation. Having established vocational education within this context, we can proceed to examine the most important role of post-secondary institutions--vocational preparation--in a new manner.

2. Definition and Description of Post-Secondary Institutions

Because of the brevity of this paper, we need to clearly indicate what schools are considered to be post-secondary in this presentation. There are several generic types, specifically:

- A. Public community colleges
- B. Private two-year colleges
- C. Proprietary schools
- D. Area Vocational Schools
- E. Less than baccalaureate degree programs in senior colleges and universities.

There are commonalities among these types of institutions. First, their students are either secondary school graduates or persons more than 17 years of age. Second, their graduates are awarded certificates, diplomas, or degrees, depending upon the "rigor" of the program and the philosophy of the school. Third, the programs are generally conducted at higher cognitive levels than customarily found in secondary school vocational curriculums. Fourth, the major orientation of the program is focused upon occupations, although considerable variations are found as to the degree of specialization. Fifth, the overwhelming majority of schools prepare individuals for occupations first, then assist them in finding jobs later.

*Adapted from "Principles of Post-Secondary Vocational Education," by Angelo C. Gillie, Sr.; Charles E. Merrill Publishing Company, 1973.

3. Shortcomings of Present-Day Post-Secondary Program Modes

This paper focuses on two major shortcomings of present day post-secondary program modes: First, there is serious deficiency in coordination among the many institutional types and, in some places, even among those of the same type. The second drawback, in the opinion of this author, is the philosophy of preparing for a job before having a job. The contention here is that this approach should be reversed, particularly in view of the great possibility that an individual may be receiving the wrong specific training. It is important to stress here that no objection is being made to high specialization. On the contrary, specialization to an even greater extent than is now the case in many instances seems to be in order. But such skill development should not be provided until the student has accepted a specific job. An alternative addressed to these two shortcomings is the basis for this paper.

4. An Alternative: A Career Education Program for Post-Secondary Institutions

The vocational aspects of individual needs can be listed as follows: 1) every person who wants to work should be provided with skills to do so; 2) it is well known that a job provides social and economic status to an individual; 3) no matter how far down the occupational ladder a person may be, he needs to believe that he has a chance to improve both his earnings and his status; 4) every person needs and deserves a maximum number of employment opportunities; 5) in order to make wise choices about occupational decisions, everyone needs a sound and up-to-date knowledge concerning the world of work. Any good post-secondary career education model would address itself to these five needs in the vocational aspects of the program.

In addition to the five stated needs, another reason for establishing a new model is the clearly observed trend toward more cognitive jobs and the increased frequency in job changing (Manpower Report of the President, 1971). The most significant change in the nation's occupational structure has been a shift toward white collar jobs (Lerner, 1970), particularly in the human service occupations. It has been stated in several places that the average 20-year-old in the work force today will change jobs four to six times during his lifetime (PL 90-576). These factors have obvious critical implications for adults in vocational education. In the proposed model, a broad type of occupational education is offered up to the point where the student no longer seems to benefit from such type of instruction. This point would be identified through careful, frequent counseling and testing. When a student reaches that point in his development, he would be placed in a job. The specific skills required would be indicated by the employer. At this time the student would return to a "skill center" environment for the acquisition of those skills needed for that job.

As can be seen, the last part of an individual's occupational program would be a topping-off process and would serve to meet the immediate skill needs of the graduate. This approach simultaneously provides the student with a solid foundation in a middle-level occupational area and training for a specific job in that occupational group. An added advantage is that workers who have a good basic preparation can be referred to the skill center for acquisition of additional skills later on. This approach meets the five personal occupationally related needs stated in the preceding paragraph.

Who should receive this kind of occupational preparation? Assuming that not more than 20 percent of the working population can become professionals (Lerner, 1970), it seems logical that a large fraction of the remaining 80 percent should obtain this kind of education. Included in this group are both younger and older elements in our population. The younger persons would consist of:

- A. High school dropouts (presently about 20 percent of students who enter high school)
- B. High school graduates who are not expected to go beyond high school immediately after graduation (50 percent of high school graduates). The high school dropouts and graduates who don't go on to college make up 60 percent of the students who enter high school (Lerner, 1970).
- C. About 70 percent of entering college freshman who are not going to become professionals. In other words, high school dropouts and about 85 percent of high school graduates should receive this variety of post-secondary career education.

In addition, other groups which would benefit from the proposed occupational education model would include persons in need of upgrading or updating their skills, and/or those needing retraining for new jobs. With a labor force of more than 80,000,000 (Manpower Report of the President, 1971), the need for these kinds of occupational services is obviously a great one. The proposed model accommodates the needs of this older group of people as well.

5. The Two-Year Model

The two-year model has a student input which consists of the two components described in the preceding paragraph (See Figure 1). It would be truly an "open door" type of school, with provisions for admission into one of the several core curriculums (three multi-level occupational cores are displayed in Figure 1). The term

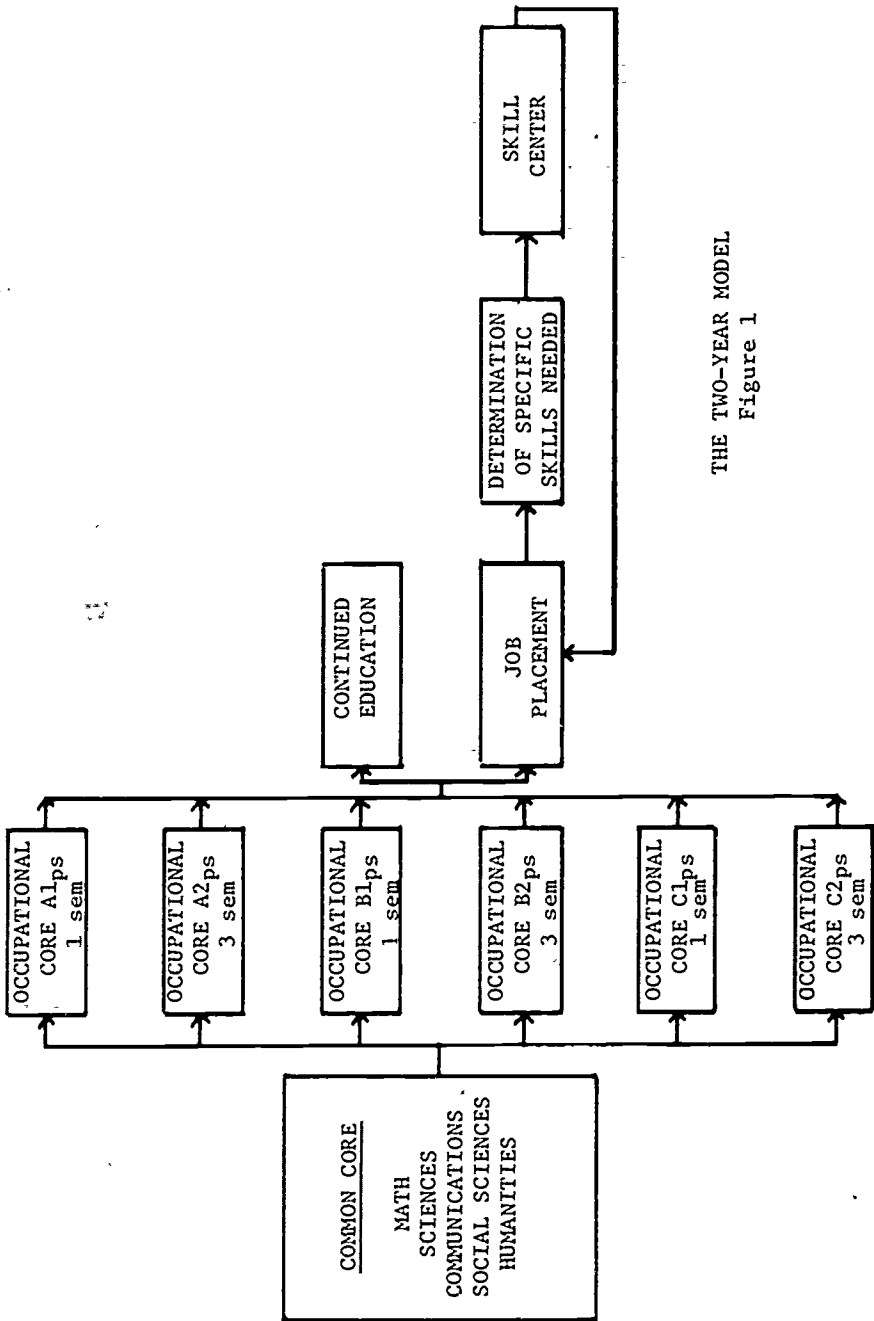

THE TWO-YEAR MODEL
Figure 1

"open door" means that all persons will be admitted, but that the program in which an individual is placed would be the one deemed best suited to his potentialities and interests. An integral part of admissions would be the counseling process, which would synthesize interviews, test results, and other records. Furthermore, a careful assessment of the individual's multiple assets would be made. All of these would be used to predict the broad occupational areas in which an individual would most likely succeed. It is important to note that a heavy reliance upon counseling and testing would require a large admissions team.

Another input for the model would be related to the skill center, where specific skill development, upgrading, and updating would take place. Job holders would be continuously entering and exiting the skill center.

How would students be placed in the model? First, a group of individuals with a determined spectrum of abilities would be counseled into each program. The differences between the upper and lower ranges of individual abilities in each occupational core would be sufficiently delimited so that the group as a whole could benefit from a considerable amount of group instruction (traditional classroom--laboratory type activities), which would be augmented and strengthened by intensive use of individualized instruction. Students with higher levels of academic abilities could utilize the individualized instruction to move beyond what is provided in the conventional instructional modes. On the other hand, the less academically inclined student would be able to proceed at his own rate in areas not dealt with in the conventional classroom laboratory approaches. Academic failure would not be a consideration in this type of a setting, as each individual progresses within the range of his own unique set of abilities and interests, and with reference to his starting point. Standards would be based on relative individual progress and not group averages.

In addition to the occupational cores, the model has one element which pervades throughout, called the common core. It would offer aspects of mathematics, sciences, communications, social sciences, and humanities to all students. These topics would be carefully extracted from traditional subject areas and taught with an eye toward their relationships to the world in which the students find themselves. As indicated, each student would be placed in a class with others who are at his level in each of these topics. This grouping would permit instruction of the traditional type for a considerable portion of the core topics. Each student would "spin-off" and proceed at his own rate later on in the common core courses by utilization of various individual instructional techniques. The time and capabilities that a student has for a given topic would largely determine where he ends his sequence. A carefully thought-out and administered combination of group and individual instruction techniques would enable each student to progress to his maximum level of performance.

How are the occupational cores determined? First, the institution should offer a sufficient variety of programs to encompass the interests and needs of most students; second, each type of program should be offered at more than one academic level, thereby permitting students to prepare for entry into an occupational area at several levels. Such comprehensive offerings cannot be offered by smaller schools. This approach might require the development of regional-type schools, particularly for rural areas, and might even have to provide residential facilities for those who came from greater distances. The suburban and urban schools would be better able to provide such a rich variety of occupational cores. Ideally, such an institution would have a population base of at least 100,000 from which to draw enrollments. The smaller schools should provide a minimum of three dual-level occupational cores, one in each of the areas of health-related, social-related, and manufacturing-related occupations. The larger institutions would likely splinter any one or more of these three into more specific cores.

It needs to be emphasized that the treatment of information and subject matter in the occupational core would be done in a cognitive and broad manner with no specialization toward particular jobs. The basic reason for avoiding specialization at this point is that each student would thereby have maximum flexibility in terms of future job selection, reserving his specific skill training for the skill center.

Because of the great amount of individual instruction demanded, a complete array of teacher aides should be integrated into the system.

Evaluation should be built into the overall program. It should be based primarily on the measurement of behavioral outcomes which were carefully established before the program began. In addition to establishing these objectives, strategies for achieving them must be developed. Finally, methods for ascertaining the extent to which the objectives were achieved and what problems were encountered in the process should be devised prior to starting the program. Long-term evaluation strategies (including follow-up studies) must also be developed so that the long-term effectiveness of the program can be assessed and used to determine where the program should be modified or discontinued.

When the student has reached his cognitive limits, he is placed in a specific job acceptable to him. Once the student has a job, the occupational guesswork is done away with since he now knows where he will work and which specific skills his employer has indicated are needed for that particular job. The new employee then goes to the skill center, where he develops the required skills.

What is the skill center? Ideally it consists of a large cluster of laboratory-shop areas where a multitude of skills at

many levels can be taught, practiced, and mastered. Learning would be an open-ended, task-oriented activity where the new worker would remain only long enough to master the skills demanded for his entering position. The skill center activities would be granted academic credits, which would be added to the learner's school record.

The skill center would also be a "diagnostic clinic" for older workers. Here they can update and/or upgrade specific skills. A truly effective center would likely have a greater number of older workers than new employees at any given time. If such a concept were completely accepted and truly integrated into the work community, the unemployment time between jobs for many persons could be reduced, if not eliminated. Once leaders in business and industry knew that the skill center was available for such tasks, perhaps they would assign a worker (who would otherwise be laid off) to the center and have him return to a prescribed new job with no period of unemployment. Such arrangements would require a relatively close liaison between the skill center and the business-industrial community.

Who will finance the skill centers? They are obviously expensive. If professionally administered, and if a large enough number of workers were serviced by it, a long-term cost per student hour of instruction could be lower than what is now spent for traditional laboratory-type courses. The key is maximum utilization, which would require some kind of original cooperative effort. The business-industrial community would have to be willing to hire new workers before they have specific skills and then to prescribe skills that they need, allow the new worker to acquire them at the skill center, and then have him report to the new job.

Who will manage the skill centers? There are several possibilities, and each might be managed differently in different locations: (1) the original institution (2) a special consortium of school districts (3) a proprietary school (4) a profit-making learning corporation.

6. The Four-Year Model

The two-year model, which is post-secondary in nature, can be expanded into a four-year model, as displayed in Figure 2. The last two years are essentially similar to the original model. The first two years would extend into grades 11 and 12. The non-academically motivated students (potential dropouts and probable non-college bound high school graduates) might be counseled into the model at the start of grade 11. The first two years would be clearly exploratory for many. This would help the nonacademically inclined youngster to come to grips with his job decision dilemma. There would also be a general education common core, with about half the entire curriculum allocated to it.

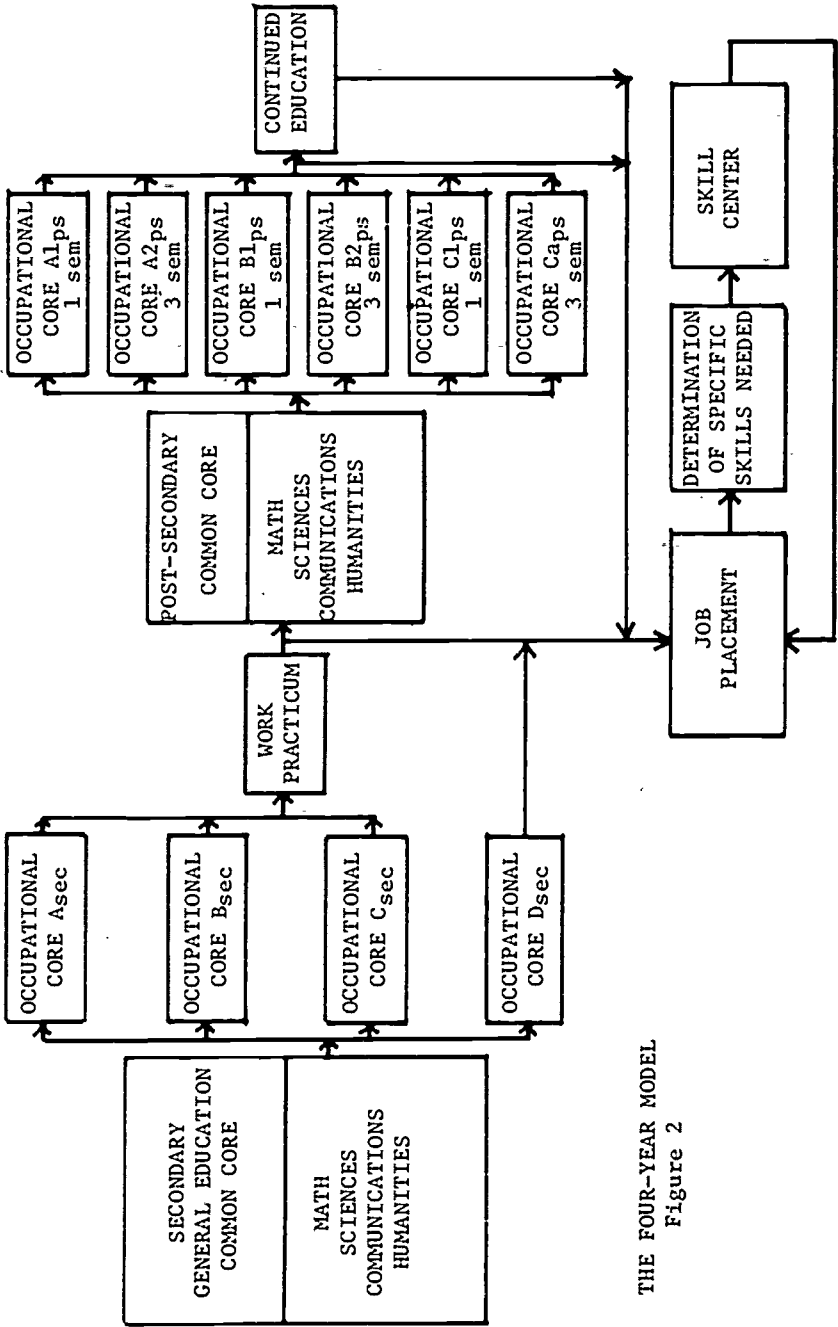

THE FOUR-YEAR MODEL
Figure 2

The secondary school portion of the model would also have occupational cores. For illustrative purposes, four are displayed in Figure 2. The number of occupational cores would vary with school size. There should be at least one occupational core which deals with clusters of low-skill type jobs. This core would provide a unique educational treatment designed for potential dropouts and would not attempt to keep them within the academic area for too long. Youngsters in this core would move rather quickly into job placement. The sequence described earlier is then followed: The employer would specify the entry skills needed which the student would obtain at the skill center; the student would then report to the first job fully qualified. This scheme removes the potential dropout from an unsuitable academic situation as early as the 11th grade. Some of them might be prepared for job acceptance and entry into the skill center in six months, and many could be functioning on their first job within seven or eight months.

Many of these individuals would likely return to school for retraining or skill updating later on. Successful implementation of this aspect of the model would result in very few youngsters leaving school without a job. This approach for potential high school dropouts has several difficulties. Foremost is the present hesitancy for business and industry to employ sixteen- and seventeen-year-olds, particularly those not holding high school diplomas. Some mechanism for encouraging business and industry to hire these students must be found--such as tax credits or the expansion of civil rights legislation to mandate employment of youngsters in proportion to their presence in the labor market. Another possibility is partial subsidization of their salaries until they are able to earn a "living wage." This aspect of the model rests upon the belief that potential high school dropouts can develop into functional and valuable workers when provided with this kind of occupational shelter.

One difference in the secondary school occupational core is the provision of the work practicum. This could be a part-time work situation in which the student would work up to about 15 hours a week for varying lengths of time. The work practicums have the following overall objectives: 1) to introduce the student to a successful work experience from which he could begin to develop positive attitudes toward work in general; 2) to enable him to acquire practical on-the-job experiences which might enable him to develop an interest in specific occupations; 3) to provide him with a limited income while he is attending school; 4) to provide him with an additional basis for making classroom-laboratory activities more relevant.

At the end of two years, a youngster completing any one of the occupational cores would have two options: he could seek job placement followed by the sequence described earlier, or he may enter an occupational core at the post-secondary level.

7. Conclusions

The major objective of the models is to provide ideal learning environments for those youngsters not likely to enter the professions. The four-year model, which encompasses the two-year version, could serve as the major "finishing" educational institution, since it would serve all but a small fraction of youngsters presently served by the traditional secondary schools and two-year colleges. This approach could reverse the present inequities in public education, where there is too much emphasis upon preparation for the professions. The reality of the situation seems to be that while the average educational attainment will increase toward 14 years, the preparation of people earning bachelor's degrees will not increase at anywhere near the same rate. Judging from the continued increase in the number of associate degrees awarded (Hooper, 1971), associate degrees are replacing the high school diploma as the point of school-leaving for many Americans. This being the case, the two-year institution should be converted into "universal colleges" which encompass grades 11 through 14, with a large majority of students steered into occupational programs (Gillie, 1973).

The two-year model is a more practical approach since it would evolve from the present community junior colleges and area vocational schools. Admittedly, the proposed two-year model has certain elements which are sufficiently deviant from the existing occupational programs to meet with almost instant opposition from some of the traditionalists. The proposed models, however, do provide alternatives to the present sources of occupational education, and they seem to more fully implement and support various career education strategies.

REFERENCES

- Gillie, A. C., Sr. Principles of Post-Secondary Vocational Education. Columbus, OH: Charles E. Merrill Publishing Company, 1973.
- Goldhammer, K. and Taylor, R. E. Career Education: Perspective and Promise. Columbus, OH: Charles E. Merrill Publishing Company, 1972.
- Hooper, M. E. Associate Degree and Other Formal Awards Below the Baccalaureate: 1969-1970. Washington, D.C.: National Center for Educational Statistics, (OE 72-48), 1971.
- Lerner, W. Statistical Abstract of the United States: 1970, 91st Annual Edition. Washington, D.C.: U.S. Bureau of the Census, 1970.
- Manpower Report of the President 1971. Washington, D.C.: U.S. Government Printing Office, 1971.
- Public Law No. 576, 90th Congress. Vocational Education Amendments of 1968.

CAREER EDUCATION - AS VIEWED BY FUTURE EDUCATORS

BY

EUGENIO A. BASUALDO, ALAIN E. HUNTER, AND
ROBERT E. STRICKLER
GRADUATE STUDENTS

DEPARTMENT OF VOCATIONAL EDUCATION
THE PENNSYLVANIA STATE UNIVERSITY

The economic and social well-being of many young Americans depends largely upon the effectiveness of the elementary and secondary educational programs and teachers who prepare them for participation in the world of work. Despite the efforts of many dedicated educators, young Americans are abandoning educational institutions at an alarming rate. Students feel that schools are not providing the information and skills necessary to cope with life in our highly industrialized and technological society. Also, many students are finding that they are unable to relate their educational experiences to the world around them, and are therefore seeking true life experiences through other means.

We need to readjust our educational priorities in order to meet the needs of youth. Perhaps the first step in this adjustment process should be a unification of goals and purposes among educators, and among the various divisions within education. As we free ourselves from this self-imposed sectarianism, we can devote more energy toward priorities which stress economic self-sufficiency, promote personal growth and satisfaction, re-establish respect for the dignity of work as well as proficiency in the academic disciplines, and provide for the needs of the individual. As a second step we need to alter our philosophy of education to link theory and practice. Students need total immersion in real world situations in which they can grow personally as well as intellectually.

Career education, as outlined by former U.S. Commissioner of Education Sidney P. Marland, Jr., advocates these concepts and provides an excellent opportunity for achievement of these goals. Support for this broad concept of education has come from many sectors of our society. The editor of School Shop Magazine sees career education not as a substitute for a good academic program, but as a means of making mathematics, English, and science relevant. Many leaders in vocational education endorse this concept because it relates education to the way children learn and develop, it recognizes the economic and social needs of youth, and it stresses the need for salable skills as preparation for future occupations.

Labor sees career education as a way to broaden the employment options which are available to young Americans and

as a means to provide the information necessary to make sound occupational decisions. Management also welcomes career education because it is not specifically skill-oriented but rather stresses flexibility and encourages decision making which is vital to many occupations in our highly technological society. Because career education positively orients the individual toward people as well as toward the world of work, he will be better equipped to work with others and solve the problems which he encounters in his daily routine. Furthermore, management perceives this type of employee as dynamic in the sense that he is better equipped to accept and adapt to changes in his work situations.

As future educators we should welcome career education because it will broaden educational experiences to encompass life in business, industry, and community. Career education draws on the best possible resources and people to prepare the student for the world of work and life regardless of where such resources may be found. The input from these various segments of society would assure the student that the education he receives will be more germane to his future well-being.

* Another contribution which career education should bring to the educational community is broader based evaluative criteria. Students will no longer be judged primarily on academic ability as displayed in classroom work. They will be evaluated on abilities such as getting along with others, creative, thinking, motor coordination, productivity, and adaptability. These are some of the criteria used in our society to evaluate success. Students who cannot compete on a high intellectual level but who have other competencies will be given a much better chance for success.

Career education will bring to the educational system a dynamic structure. In the past, change in education always lagged behind the needs of society. For example in the 1950s and early 1960s there was a great need for trained people to operate computerized equipment. The public educational system was slow in recognizing this need and slow in developing programs to meet the demand. When the public educational system finally committed itself to supply skilled people to fill this need, it prepared more data processors, computer technicians, and programmers than industry could possible use. This type of reaction occurs quite often in education. Formerly, we needed time to recognize the appropriate change and time to implement that change. Now, through the active participation of business, industry, and the community in education, changes occurring within these institutions will be more likely to take place simultaneously in the educational system.

Students who will be learning through direct association within the various segments of their society will observe the continuous process of change as it occurs. As they observe this process, they will compensate and adjust their goals to match labor market trends and demands. Through adjustive exploration, they will develop a more realistic view of their capacities. Therefore, they will realize that through the application of their talents they will be preparing to make significant contributions to society.

Presently we continue to support and maintain many educational programs because the taxpayers have poured millions of dollars into training equipment. Through implementation of career education such situations are less likely to arise. When industry perceives a need to train people for certain positions, because of the articulation between school and industry, training will start immediately. Schools will no longer need to provide the expensive equipment found in industry. As partners in providing efficient community learning situations, industry will provide the necessary equipment as well as work study opportunities.

The research in career development theories, from which career education draws heavily, points out that when people are supplied with accurate information about themselves and their environment they tend to make more realistic decisions concerning their careers. In our society these decisions are rarely of a permanent nature. According to the 7th Report of the National Advisory Counsel for Vocational Education, the average American will change occupations approximately seven times during his working career. Career education will facilitate occupational changes throughout a person's lifetime through adult education and counseling services.

Although we are optimistic about career education, we realize that this concept will not bring utopia to our educational system. Career education will alleviate many school problems. It will not abolish all sociological, economical, and psychological problems that schools are facing. Government at all levels, as well as society in general will have to work very closely with education to solve many of these problems. For example: schools may train the best labor force on earth, but they cannot guarantee jobs without the cooperation of government, business, industry, and effective placement programs. Furthermore, if government and society merely sustain their platonic support for career education instead of assuming their active responsibilities, career education will die.

The time to make education relevant to the student has arrived. If our main goal as professional educators is to help the student develop his capacities to best serve himself and his society, we must put aside our differences and begin to unify so we can achieve

this major goal. All of us should start to appreciate each other's contributions toward the development of our students and realize that all educators are important for this development.

The concept of career education may enable us to better help the student develop his abilities. Since this concept was launched, it has been gaining support from all sectors of our society. Career education recognizes business, industry, and the community as partners in our educational system. This partnership will give students a broader environment from which to draw their educational experiences, thus making education more relevant to industrial and societal needs. Since education will not be limited to the school setting, evaluation of the student will also change. It is possible that cognitive ability will no longer prevail as the main measure of a student's capabilities.

With career education, schools will no longer have to duplicate industrial settings to provide the students with meaningful experiences. Educators must recognize that this new concept will not solve all the problems that education faces today. We must, however, recognize that career education has the potential to alleviate, if not eliminate, many of these problems. It is very important for others in business, industry, community, and government to work together with educators so that career education will achieve the potential that is ascribed to it.

CAREER EDUCATION: CHICAGO STYLE

BY

JOSEPH L. CAIN

DIRECTOR OF CAREER EDUCATION, CHICAGO STATE UNIVERSITY

Hoyt and others in their book Career Education: What it is and How to Do It state:

The term 'Career Education' means the sum total of those experiences of the individual associated with the choice of, preparation for, entry into, and progress in occupation's throughout his occupational life. Career education is crucial in a society, such as ours, that has been built and continues to operate essentially in accordance with the work ethic combined with a strong protection of freedom of choice for the individual.

For some time now, the attitude of our society has been that a college education was the surest route to job employment and security. We know now that this is not always true. Many of our college graduates find themselves jobless, or find that they are untrained or unemployable in a skilled area.

This condition clearly indicates that our colleges and universities must retrain to meet the needs of today's job market.

The DHEW publication 72-39, in referring to the need for educational reform, states: "More persons are graduating from a 4-year college with a bachelor's degree than there are jobs for the degree holders. By the end of this decade, eight out of ten jobs in America will not require a baccalaureate degree."

Bulletin 72-39 further points out that career education will enable nearly all persons who complete secondary school to secure immediate employment or to go onto technical school or college. Placement services in the school system will assist every student, especially the student leaving before he completes high school, to plan the next step in his development. Job entrance will be just as important as college entrance to counselors and teachers. Skill credentials, universally recognized, will be as valid as the commonly accepted credentials for college entrance.

There will be on "dropouts," only individuals who choose to go to work or to pursue a different kind of education. Entrance and exit requirements will be flexible enough to enable all persons to acquire at any time the educational and occupational experiences that meet their needs.

Under the career education concept, proposed by the Office of Education, the student in the elementary grades K through 6 will, in

addition to his traditional educational training, at the same time explore and be exposed to the world of work. At this level he will become aware of the many job categories available and their relationship to him and the world around him.

At the middle school level, the student will examine more closely those job categories which are of specific interest to him. Finally, at the senior high school level, the student will develop some fundamental salable skills if he does plan to continue his formal schooling.

The four-year college, university, technical or specialized training institution will develop special skills in professional or technical capabilities allowing the individual to become highly specialized in one or several areas and/or to change his specialization as he deems necessary or desirable.

The State of Illinois has been one of the forerunners in the development of career education in the elementary and secondary schools. While many of the programs are still in developmental stages, others have moved toward implementation.

Our investigation has been confined to the metropolitan area of Chicago - one of the country's most highly industrialized cities. The want ad sections in the daily papers, specifically the week-end editions, reflect the possibilities existing in the job market. Yet, unemployment remains high for the college trained as well as for the unskilled.

Our educational institutions must address themselves to this problem by providing the types of programs which will change the occupational outlook for thousands of in-school and out-of-school persons.

In the Chicago area we have identified four programs which are being carried on by four different institutions: the DuSable Exemplary Project - an elementary, middle, and high school comprehensive program in career education; Posen Robbins School District 143 1/2 Career Education Model for grades 7-10; Chicago State University-Interdisciplinary Career Education programs; and the Occupational Education program of the Illinois Public Community Colleges and Technical Institutes - specifically Kennedy-King Community College.

The DuSable Exemplary Project: Bridging the Gap Between High School and the World of Work. DuSable High School and its feeder elementary schools are located in Chicago's Near South Side, which historically has been considered the least desirable residential section of Chicago. The growth of business and industry on this section of sandy wasteland relegated the area to those who were seeking low-cost housing. In the early sixties, the city,

through the Chicago Housing Authority, consolidated low income families into high-rise apartments. This provided a high density of low income families, placing a heavy burden on area schools. Unique social problems provided an additional challenge to teachers as they tried to provide not only basic education, but social and economic motivation as well.

The Bridging the Gap Between High School and the World of Work project involved career guidance at three elementary and two middle schools. The project was designed as a vertical program to prepare students for experiences available to them at DuSable High School. Occupational awareness and the development of attitudes toward work was thought to be most important in this social setting.

There are two separate but related thrusts to the program. The first is concerned with career education in the K-8 program of the schools that feed into DuSable High School. Career development materials have been developed for grades 4, 5, and 6. As a continuation of occupational awareness activities, group guidance units were developed for grades 7 and 8. The second thrust involves instruction which leads to job entry skills. The areas include:

1. Typing and general clerical procedures
2. Data processing
3. Food services
4. Offset printing
5. Automotive service occupation

Concentrated training is given in each of the areas of instruction during two periods in the morning with three additional periods at the end of the day for counseling, remedial instruction, and production. When the student has progressed to the point of placement, the afternoon is used for on-the-job training.

A part of the project has been an elementary school vocational guidance program incorporating career development and occupational information. This program was designed to (1) give elementary school pupils career information, (2) prepare them for high school by giving them a background for making more valid vocational choices, and (3) provide a continuous guidance program from school entrance to school leaving. Using the vertical plan K-12, a schedule was set up as follows:

K-4 - 20 minutes per week for
8 weeks, learning about workers
in and out of the community.

4-6 - 30 minutes per week for
10 weeks, emphasizing job
family categories and job
clusters.

7-8 - 40 minutes per week for
2 to 8 week session exposing,
exploring, and interesting
students in the various job
opportunities and helping them
to make career choices.

With the use of outside speakers, films, filmstrips, tours, group guidance techniques, and other classroom techniques, the program was designed to better enable students entering DuSable High School to make more realistic educational choices.

At the high school level, in each of the skilled areas, sufficient space and appropriate materials and equipment have been made available. The first ten weeks in the program involve orientation and basic skill development. The second ten weeks involve further skill development, introduction to grooming, job decorum development, attitude modification, and character-building traits. The first placements are made during the third ten-week period.

In addition to the above training, students are enrolled in English, social studies, physical education, and an elective to meet their academic requirements for graduation. It is assumed that these students may, if they desire, continue their education on the college level or at some other institution.

Begun January 1, 1973, and still in the developmental stage, is a project called the Development of a Career Education Model for Grades 7-10. This project is conducted by the Posen Robbins School District 143-1/2 and Chicago State University.

Posen Robbins School District 143-1/2 is a south suburban school district in Cook County, Illinois. The district serves an area that comprises the majority of the villages of Posen and Robbins. Small sections of Blue Island, Harvey and Crestwood are also part of the district. Many of the pupils attending the District's eight schools come from families that live at or below the poverty line.

The project is designed to provide career orientation through meaningful exploratory experiences for students at the junior high or middle school level, and at grade 10.

The various stages of the project will include:

1. Identification Stage

Identification of literature concerning career development for grades 7-10 for the purpose of identifying materials already prepared and tested for the middle school level.

2. The Product Bank

Review materials or existing career education curriculum guides, teaching models, and other related materials which can be adopted in a middle school career education program.

3. Decision Stage

Review and selection of existing career education materials which can be adopted to a middle school program. Acceptable material is broken down into usable modules which contain clearly defined behavioral objectives.

4. Field Testing

Modules identified and prepared at step 3 will be field tested in appropriate classrooms by teachers under the supervision of the project staff.

5. Implementation Stage

In this stage the staff, in cooperation with the school board, will develop and adopt the curriculum that is suited for the middle school grades.

6. Complete Evaluation Stage

The complete evaluation stage will review all materials under field use conditions. Progress of students, teachers, attitudes of community and school administration will be evaluated.

7. Diffusion and Installation Stage

During this last stage the completed package will be prepared for diffusion into other school districts.

The Chicago State University, mentioned previously in collaboration with a career education project at South Suburban School District 143-1/2, is highly aware of the directions higher educational institutions must take in developing career education programs. In addition to the cooperative project, Chicago State University has also initiated several other programs and/or courses in/or related to career education.

The Department of Curriculum and Instruction will begin a course during spring quarter in career education. The course title is cited Curriculum and Instruction 356 - Career Education for Grades 9 and 10, The Division of Education has also implemented a project known as "Career Education Related to Environmental Occupations." The project is based upon the premise that elementary and secondary students are being equipped with few, if any, types of marketable

skills for entry-level positions. This project is only one attempt to assist school systems in assessing their total educational programs and in designing curricula that can be successfully implemented to aid in correcting this problem.

The project is designed to train teachers and/or senior college level students in methods that can be adapted at the secondary level. The program includes two phases for the training of teachers. The first phase insures teachers have at least minimal education in their academic courses. Courses such as The Urban Child and Chemical Water Pollution are but two of the courses which would acquaint them with some of the problems encountered in working with urban children. The second phase of the project is the "Off-Campus" experience. The teachers will visit local industrial, retailing, and governmental facilities to gain first-hand information in working with personnel directors, job consultants, supervisors and employees as to what job entry competencies are necessary, what attitudes are important and what hiring practices are utilized. This intern-type experience will give the teacher training in many facilities which have positions related to environment. Thus, from the academic and intern phases, the teachers who have completed the project courses will have both information and materials with which to go into the secondary schools and work with students in relation to their career goals and choices.

The Business Laboratory Program (BLP), a part of the Business and Administration Department at Chicago State University, has been termed one of the most successful programs in the Chicagoland area. The BLP program has been specifically created for Chicago Business and industry. All projects and jobs have preestablished performance objectives. Interns receive specialized training. That training is also available to the employer and selected staff members. In addition to special training, the intern receives management training in business, finance, computer science, accounting, organizational strategy, economics, communications, and mathematics. Interns are further trained in problem analysis and decision-making. The intern receives six hours of college credit for each successfully completed internship.

Interns begin work at the entry level and progress to higher wages based on their successful accomplishment of their project or job. Intern evaluation is on-going through observation, supervisory reports, peer analysis, completion of performance objectives, completion of assignments, and reports from Chicago State University regarding academic progress. After completing his first internship with a company, the student is available after school or on alternate school days and during summer vacations. Should the employer and student agree, the student may continue his internship during his entire schooling

period. Up to 75 per cent of the students entering intern-type programs remain with their employers after graduation.

Illinois Public and Community Colleges and Technical Institutes offer career-centered programs in many occupational fields. These programs are generally occupationally oriented and confer an associate degree/certificate upon completion of the program.

Kennedy-King College, a community college located in the City of Chicago, has initiated a career oriented program in human services. The community in which the college is located is rapidly deteriorating, a trend that has been observed for over two years. The social and economic problems accompanying this deterioration are reflected in statistics on the area in terms of high unemployment, high crime rates, high school drop-out rates, and high juvenile delinquency. The career program at Kennedy-King proposes a resource-sharing program between the college and high schools in the community which would involve the technical and vocational programs of the college.

The thrust of the sharing program has two directions. One direction is to provide opportunity for advanced placement classes in vocational and technical education. The second direction is to provide greater educational motivation for minority students at all levels of high school.

The location of classes for this program would be both at the high school and college, depending on the nature of the course, and the number of students enrolled.

The Chicago Metropolitan area, with it's diverse and large labor market, is an ideal location for many and varied programs in career education. It is also an area where many schools and colleges are located. Local institutions have just begun to scratch the surface in terms of the new directions for programs in career education. In the preceding sections, we have described those programs in the Chicago area which, in the writer's opinion, are representative of what career education is all about and the directions we must go in order to achieve desirable programs.

REFERENCES

- Chicago State University, Career Education Related to Environmental Occupations, a status report. Division of Education. Chicago, Illinois, April, 1973
- Chicago State University, Career Education for Grades 9-10, a course description and status report. Department of Curriculum and Instruction, Division of Education. Chicago, Illinois, April, 1973
- Chicago State University, Business Laboratory Program, an information bulletin. Department of Business and Administration, Chicago, Illinois.
- Dumetx, Louise, The DuSable Exemplary Project: Bridging the Gap Between High School and the World of Work. An interim report - Chicago, Illinois, June 1972
- Goldhammer, Keith, Roles of Schools and Colleges of Education In Career Education. The Center for Vocational and Technical Education. Ohio State University, Columbus, Ohio, April, 1972
- Hoyt, Kenneth, et al. Career Education: What It Is and How to Do It - Olympus Publishing Company, Salt Lake City, 1972
- Kennedy-King College, Objectives For Vocational and Technical Education Programs at Kennedy King College, Applied Science Department Guidelines, Chicago, Illinois, 1973
- Pucinski, Roman, and Hirsch, Sharlene Pearlman, The Courage to Change: New Directions for Career Education, Prentice-Hall, Incorporated, Englewood Cliffs, New Jersey, 1971
- Taylor, Robert, Perspectives and Career Education, presented at the meeting of the Oregon Association of School Administrators, Oregon State University, Corvallis, Oregon, March 30, 1972
- "The Development of a Career Education Model for Grades 7-10" A narrative of the project. Posen-Robbins School District and Chicago State University, January, 1973
- U.S. Department of Health, Education and Welfare, Career Education DHEW Publication No. 72-39