

DOCUMENT RESUME

ED 114 328

95

SO 008 707

AUTHOR Perkins, David
 TITLE Cubic Corners, Oblique Views of Pictures, the Perception of Line Drawings of Simple Space Forms. Geometry and the Perception of Pictures: Three Studies. Technical Report No. 5.
 INSTITUTION Harvard Univ., Cambridge, Mass. Graduate School of Education.
 SPONS AGENCY National Science Foundation, Washington, D.C.; Office of Education (DHEW), Washington, D.C. Bureau of Research.
 BUREAU NO BR-9-0283
 PUB DATE Sep 71
 GRANT OEG-0-9-310283-3721(010)
 NOTE 52p.; For related documents, see SO 008 705-709

EDRS PRICE MF-\$0.76 HC-\$3.32 Plus Postage
 DESCRIPTORS *Art Education; Behavioral Science Research; *Developmental Psychology; *Geometry; Perception; Perceptual Development; Pictorial Stimuli; Space Orientation; Stereopsis; *Visual Arts; Visual Learning; *Visual Perception
 IDENTIFIERS *Harvard Project Zero

ABSTRACT

This is the fifth in a series of technical research reports by Harvard Project Zero which study artistic creation and comprehension as a means toward better art education. The three papers in this report all concern the bearing of projective geometry on the perceptual processes by which pictures are "read" for spatial information. The first paper describes the human inclination to interpret pictures as representing rectilinear forms when, from a geometric standpoint, they might represent nonrectilinear forms. The second paper studies how the visual system compensates for pictures seen at an oblique angle, rather than perpendicularly. The third paper examines how viewers readily and consistently interpret simple line drawings as space forms, even though conventional depth cues such as perspective, occlusion, or "familiarity" may be absent. Throughout these papers, the logical ambiguity of line drawings--their lack of distinct three-dimensional information--is stressed together with the active role of the visual system in making assumptions to resolve this ambiguity. (Author/DE)

 * Documents acquired by ERIC include many informal unpublished *
 * materials not available from other sources. ERIC makes every effort *
 * to obtain the best copy available. Nevertheless, items of marginal *
 * reproducibility are often encountered and this affects the quality *
 * of the microfiche and hardcopy reproductions ERIC makes available *
 * via the ERIC Document Reproduction Service (EDRS). EDRS is not *
 * responsible for the quality of the original document. Reproductions *
 * supplied by EDRS are the best that can be made from the original. *

ED114328

Harvard Project Zero
Operates Under U.S. Office of Education
Grant Number OEG-0-9-310283-3721 (010)
Project Number 9-0283
Basic Abilities Required
For Understanding and Creation
In the Arts

Technical Report No. 5

GEOMETRY AND THE PERCEPTION OF PICTURES:
THREE STUDIES

by

David Perkins

U.S. DEPARTMENT OF HEALTH,
EDUCATION & WELFARE
NATIONAL INSTITUTE OF
EDUCATION

THIS DOCUMENT HAS BEEN REPRODUCED EXACTLY AS RECEIVED FROM THE PERSON OR ORGANIZATION ORIGINATING IT. POINTS OF VIEW OR OPINIONS STATED DO NOT NECESSARILY REPRESENT OFFICIAL NATIONAL INSTITUTE OF EDUCATION POSITION OR POLICY.

CUBIC CORNERS, revised from Quarterly Progress Report 89, M.I.T. Research Laboratory of Electronics, 1968, 207-214.

OBLIQUE VIEWS OF PICTURES

THE PERCEPTION OF LINE DRAWINGS OF SIMPLE SPACE FORMS

Issued September, 1971

The projects presented or reported herein were performed pursuant to the above-mentioned grant from the U.S. Office of Education, Department of Health, Education, and Welfare. The opinions expressed herein, however, do not necessarily reflect the position or policy of the U.S. Office of Education, and no official endorsement by the U.S. Office of Education should be inferred.

54 008 707

2/3

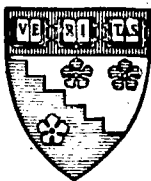

HARVARD PROJECT ZERO
BASIC RESEARCH IN ART EDUCATION

Project Zero is a basic research program at the Harvard Graduate School of Education conducting a theoretical and experimental investigation of creation and comprehension in the arts and of means toward better education for artists and audiences. A brief explanation of the Project's development and current work, along with a list of other reports, can be found at the end of this document.

00004

FOREWORD

These three papers all concern the bearing of projective geometry on the perceptual processes by which pictures are "read" for spatial information. The first of these appeared in slightly different form some years ago, and described a human inclination to interpret pictures as representing rectilinear forms when from a geometric standpoint they might represent non-rectilinear forms. The critical qualification was that such "reading in" appeared to take place only when the picture could be geometrically an image of a rectilinear object; geometric possibility served as a necessary condition. Some time passed before this natal work could be pursued further - the other two papers are recent efforts. One of these applies the conclusions of the original article to a consideration of how the visual system deals with pictures seen at an oblique angle, rather than perpendicularly. The other incorporates the early conclusions into a much broader theory of the perception of line drawings of simple geometric forms. Throughout these papers, the logical ambiguity of line drawings - their lack of distinctive three-dimensional information - is stressed, together with the active role of the visual system in making logically arbitrary but ecologically useful assumptions to resolve this ambiguity. Although the papers themselves are based on theoretical considerations and informal observation, there are many testable predictions, and currently a series of experiments based on these is underway.

David Perkins
September, 1971

David Perkins received a 1970 Ph.D. in Mathematics - specializing in artificial intelligence - from M.I.T. He is Assistant Director of Project Zero. His special interests include visual perception by human and computer; the perception of rhythm; and problem-solving and planning behavior in the arts.

Cubic Corners

Abstract

Many line drawings are interpreted as representing spatial forms, and frequently the forms are rectilinear, containing "cubic corners" - vertices with three radiating edges at right angles to one another, like the corner of a cube. Experimenting with a number of drawings determines the range of pictured vertices which viewers will accept as representing cubic corners. This range is: if the two smaller angles between the pictured edges are a and b , then either $a + b$ is greater than or equal to 90 degrees and a is less than or equal to 90 degrees and b is less than or equal to 90 degrees or all three angles are each greater than or equal to 90 degrees.

The range of angles which geometrically could be projections of cubic corners can be determined mathematically. The condition is the same as above, except that no angle can equal 90 degrees, so "greater than" replaces "greater than or equal", etc. Thus the two ranges agree except for certain borderline cases. The human perceiver is very sensitive to the geometric conditions for a three ray vertex to represent a cubic corner.

CUBIC CORNERS^{1,2}

Psychologists have studied a variety of cues which inform the observer about the spatial layout, form, and orientation of his environment. Among these are binocular disparity, interposition, texture gradients, perspective convergence, blurring with distance, and shading. In some cases, e.g., studies of texture and perspective, a central role is assigned to projective geometry and the mathematical relations between the image formed in the eye and its three dimensional origins. The subject here is another sort of cue to spatial shape and orientation in that tradition.

One structure that comes frequently before our eyes in this urban world is the cubic corner. This is simply any corner of a cube, of a desk or box, or in general 3 planes meeting at right angles. The simplest line drawing of a cubic corner consists of a point with 3 radiating straight lines of indefinite length. For easy reference, such a drawing will be called a 3-star.

The fact is that 3-stars tend to look like cubic corners. That is, the visual system tends to interpret them as the projections of cubic corners. This is not so under all conditions. Not only the 3-star itself, but any larger scene in which a 3-star is imbedded may influence its interpretation. Moreover, it is likely that our urban experience contributes to this propensity; the Watusi might not join the trend at all.

¹ I would like to thank Drs. Howard Gardner, Nelson Goodman, and Paul Kolers, for their helpful comments on the first draft of this paper.

² Essentially this same material appeared in Quarterly Progress Report No. 89, April 15, 1968, Research Laboratory of Electronics, M.I.T., Cambridge, Massachusetts. The figures are copied directly from that publication. The work was supported in part by Project MAC, an M.I.T. research program sponsored by the Advanced Research Project Agency, Department of Defense, under Office of Naval Research Contract Nonr - 4102- (01).

In Figure 1 there are some 3-stars that look like cubic corners. In Figure 2 there are some that do not.

Figure 1.

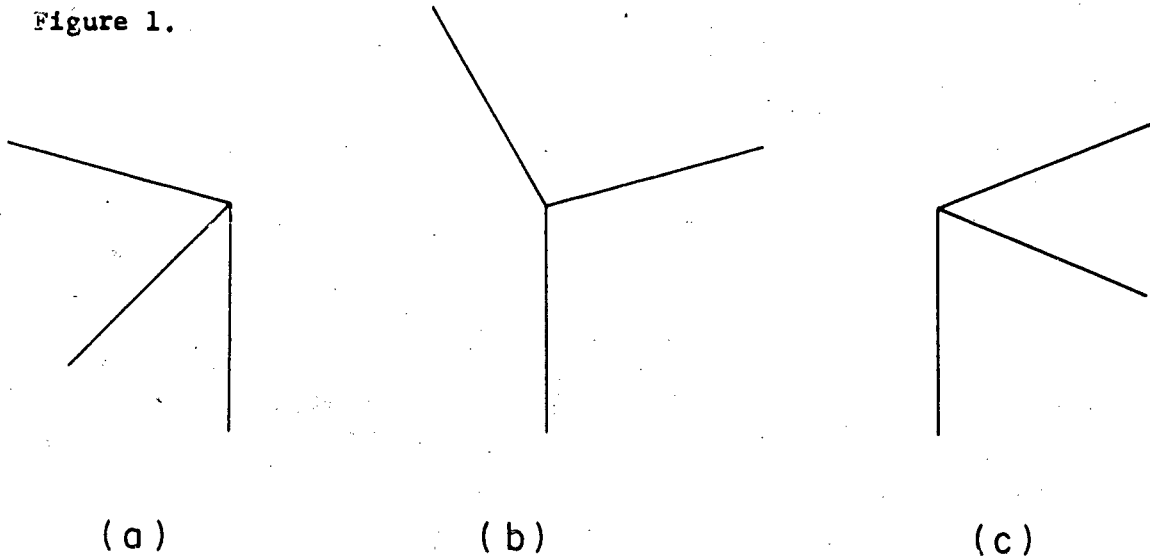

Figure 2.

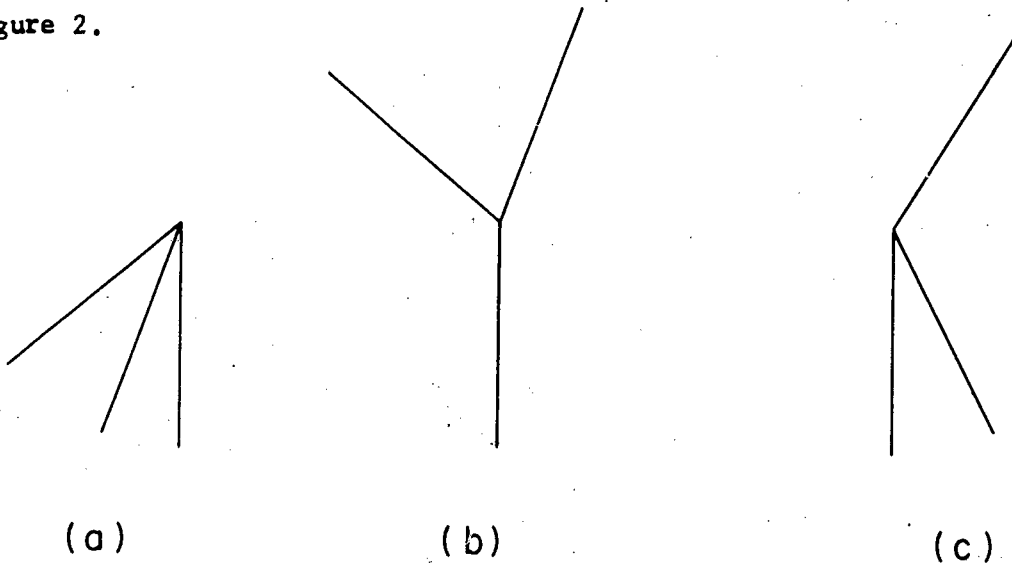
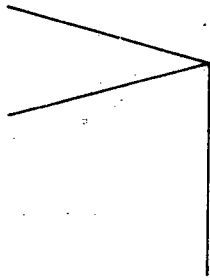
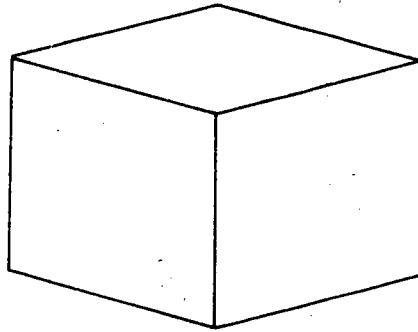

Figure 3 exemplifies how context can influence interpretation. The 3-star of Figure 3a appears in Figure 3b and 3c in places indicated by stars (*). Figure 3a may look like a cubic corner to the reader, as it does to the author. At any rate, Figure 3b contains the 3-star in a context that certainly makes it appear cubic. Figure 3c, on the other hand, contains the 3-star in such a way that it looks like a wedge of not too wide an angle. The circular arc on the left of Figure 3c suggests a wedge of cheese.

Figure 3.



(a)



(b)

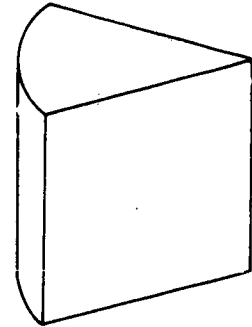

(c)

One might suspect that the interpretation of a 3-star is just a matter of context and has nothing to do with the 3-star itself. In Figure 3b, a drawing looking like a rectangular solid was constructed about the 3-star by putting the sides of the 3-star into parallelograms and completing the figure. Try this procedure with the 3-star in Figure 4a; the results are hardly analogous. Figure 4b does not look rectangular at all.

Figure 4.

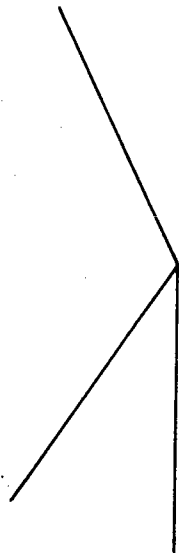

(a)

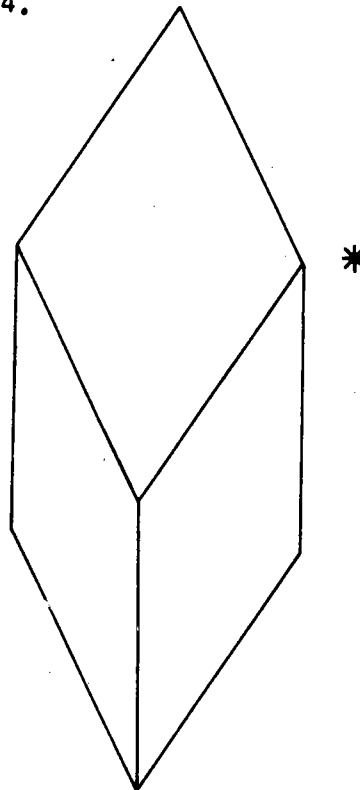

(b)

The orientation as well as the context of a 3-star can influence its interpretation. The 3-star in Figure 5a can readily be seen as a cubic corner. Yet in Figure 5b where the figure is rotated 90°, the smallest angle no longer appears to be right, but rather acute. Figure 5c speculates on one of the common scenes in our experience which might lie behind such an orientation dependency.

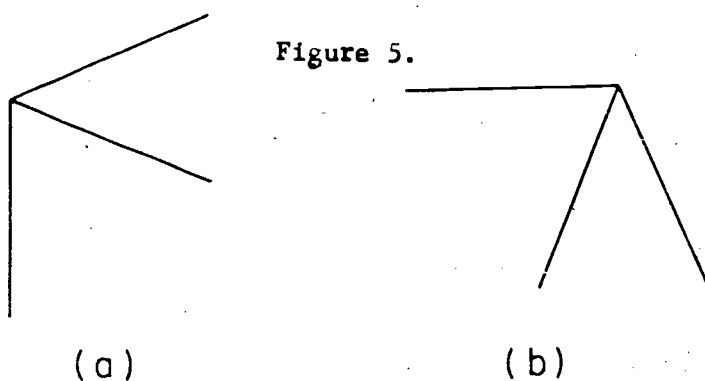

Three-stars are most likely to look like cubic corners when one of the rays points directly downward. Most cubic corners that one sees on buildings, boxes, and such things are oriented with their planes perpendicular or parallel to the ground, and consequently have one vertical edge. Probably a down-pointing ray in a 3-star invokes these experiences.

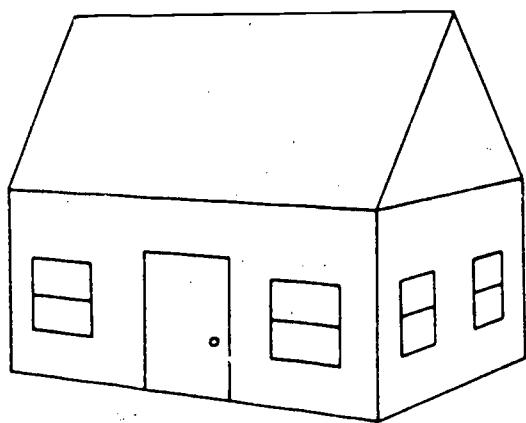

Still there is the question, how does the structure of the 3-star itself influence its interpretation? One can determine mathematically which 3-stars can be perspective projections of cubic corners. We shall illustrate this a bit later. The diagrams already presented show that the visual system will not accept that certain 3-stars look like cubic corners. The question then is, how critical is our visual system?

Does one reject 3-stars that could be cubic corners? Does one accept 3-stars as cubic corners when they could not possibly represent them geometrically? How well does the visual system align itself with the requirements of geometry and perspective?

Figures 6 and 7 contain two series of 3-stars for the judgment of the eye. All have rays pointing straight down to enhance the seeing of cubic corners. In the series of Figure 6 the 3-stars b through d and j through l are acceptable to the eye as cubic corners (if in doubt, construct parallelograms around them), and these cubic corners have two faces in view. In Figure 7 only d through g are seen as cubic corners, and these cubic corners have three faces in view.

Figure 6.

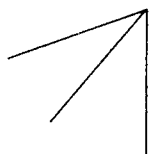

(a)

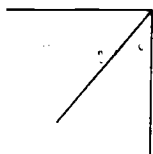

(b)

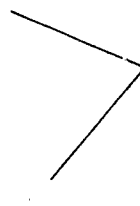

(c)

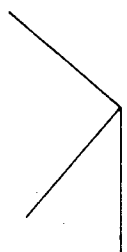

(d)



(e)



(f)

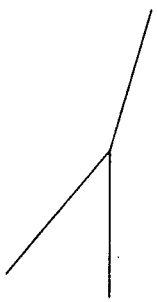

(g)

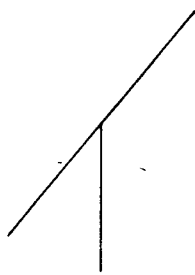

(h)

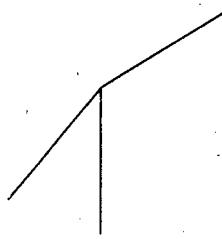

(i)

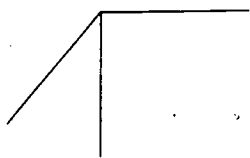

(j)

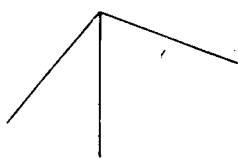

(k)

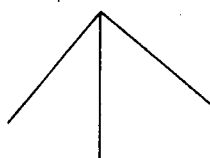

(l)



(m)



Figure 7.

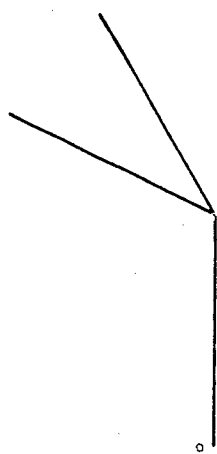

(a)

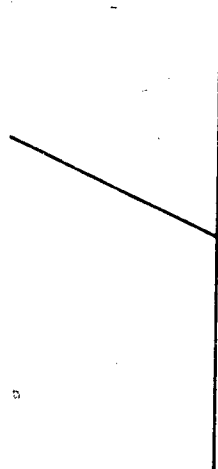

(b)

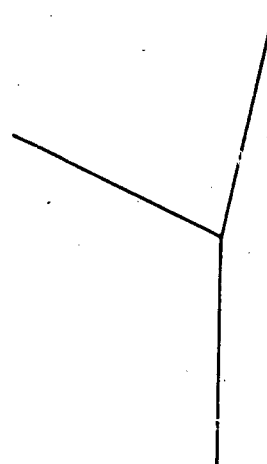

(c)

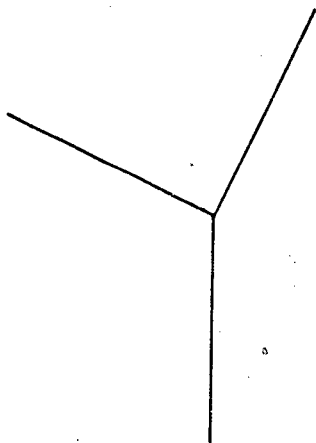

(d)

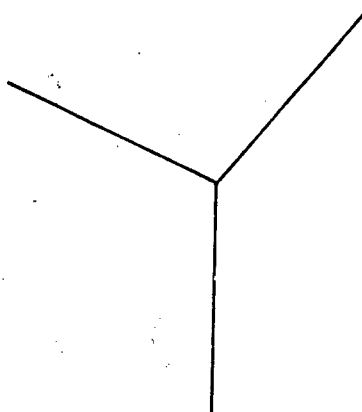

(e)

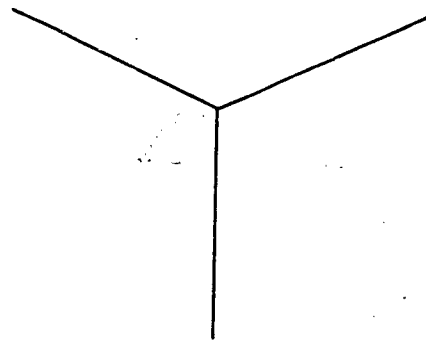

(f)

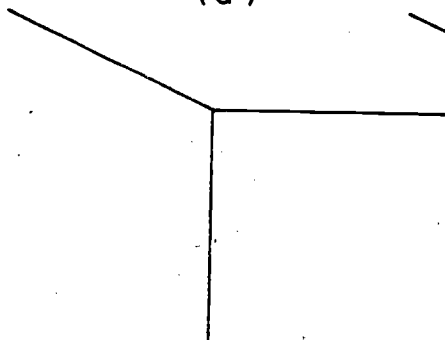

(g)

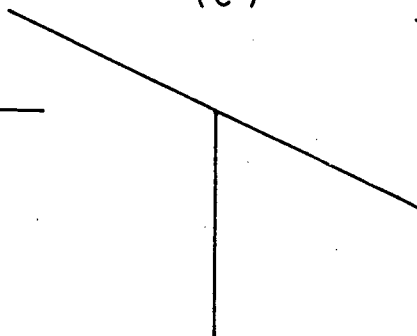

(h)

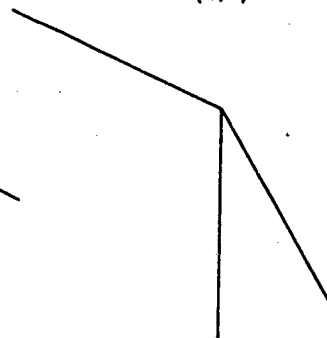

(i)

The empirical generalization suggested by Figure 6 and other sketches is:

A 3-star is acceptable to the visual system as a 2-faced cubic corner if and only if it contains 2 angles less than or equal to 90° , whose sum is greater than or equal to 90° .

The generalization suggested by Figure 7 and other sketches is:

A 3-star can appear to be a 3-faced cubic corner only if all 3 angles are greater than or equal to 90° .

Now that there is some empirically derived notion of what the visual system interprets as a cubic corner, the problem is to determine which 3-stars are perspective views of cubic corners.

At first thought, it would seem necessary to calculate an arbitrary perspective projection of an arbitrarily oriented cubic corner. This is not the case for two reasons. In the first place, the eye is assumed to be focused on the vertex of the cubic corner; in the second place, only the angles between the projected rays, and not their length in projection, are of concern. Under these conditions, perspective can be ignored and the projection of a cubic corner in X Y Z space will simply be its orthogonal projection on the X Y plane.

Suppose that some 3-star has angles between its rays a , b , c , and also that the rays are represented by unit vectors P , Q , R in the X Y plane. The question is, are there 3 vectors in X Y Z space which are mutually orthogonal and project, respectively, to P , Q , R ?

Since projection is accomplished merely by dropping the Z component, any 3 such vectors must have the form:

$$P + pZ \quad Q + qZ \quad R + rZ, \quad (1)$$

where Z is the unit vector in the Z direction, p , q , r scalars. Requiring mutual orthogonality is requiring that the dot products of these vectors in pairs be zero. Using distributivity of the dot product and remembering that P , Q , R are unit vectors yields (2), and similarly for the pairs Q , R and R , P .

$$(P+pZ) \cdot (Q+qZ) = 0 = P \cdot Q + pq = \cos a + pq = 0. \quad (2)$$

This produces three equations:

$$pq = -\cos a \quad qr = -\cos b \quad rp = -\cos c \quad (3)$$

Solving for p, q, r, we obtain

$$p = \pm \sqrt{-\frac{(\cos a)(\cos c)}{(\cos b)}} \quad q = \pm \sqrt{-\frac{(\cos a)(\cos b)}{(\cos c)}} \quad r = \pm \sqrt{-\frac{(\cos c)(\cos b)}{(\cos a)}} \quad (4)$$

Hence solutions exist and are given by these formulas, provided that $(\cos a)$, $(\cos b)$, $(\cos c) \neq 0$, and (so that the numbers under the radicals will be positive) either one or three of $\cos a$, $\cos b$, $\cos c$ are negative.

The solutions in (4) have singularities where $\cos a$, $\cos b$, or $\cos c = 0$; that is, where a , b , or $c = 90^\circ$. To what do these singularities correspond in the situation under study?

If there is only one 90° or 270° angle, this represents the situation in which one ray of a cubic corner is pointed directly away from or toward the observer, and hence only 2 edges (not a 3-star) are visible.

If there are two 90° angles, the solutions to (4) contain the indeterminate form $0/0$. This situation occurs when one plane of the cubic corner is oriented edgewise to the viewer. This is the only case when a 3-star that is a projection of a cubic corner can contain a right angle. Any other combination is impossible, since $a + b + c = 180^\circ$.

Aside from the singularities, what does the requirement that either one or three of $\cos a$, $\cos b$, $\cos c$ be negative represent? If, say, only $\cos c$ is negative, this implies that a is less than 90° , b is less than 90° , and $a + b$ is greater than 90° . If all three, $\cos a$, $\cos b$, and $\cos c$, are negative, this implies that a , b , c , are all greater than 90° .

The rules derived mathematically agree with the rules derived empirically, except for the 3-stars containing one right angle! To rephrase the conclusion:

Given a 3-star in favorable conditions of orientation and context and not containing one right angle, the visual system will accept that 3-star as a cubic corner if and only if it could in geometric fact be a projection of a cubic corner*.

Figure 8.

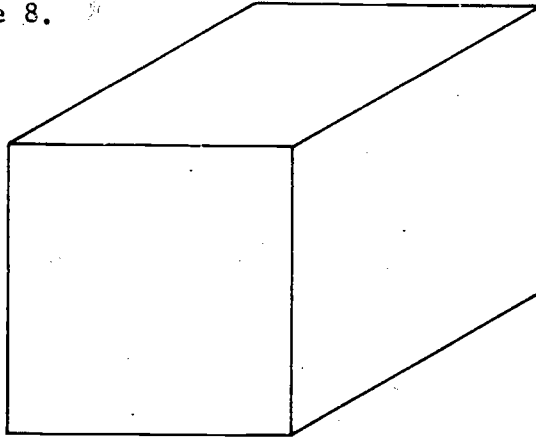

A 3-star that does have one right angle cannot be the geometric projection of a cubic corner. Yet the visual system will often accept such a 3-star as a cubic corner (Figure 8).

* Preliminary results from an experiment now in progress (July, 1971) reveal that all subjects exhibit considerable, and some high, sensitivity to the discrimination.

Oblique Views of Pictures

Abstract

Pictures, normally thought of as viewed perpendicularly, are often viewed obliquely so that a foreshortened image is projected to the eye. In what respects does the viewer adjust to, or fail to adjust to, this foreshortening distortion in interpreting the picture as representing a spatial layout? This paper concerns two particular phenomena associated with this complex issue. On the one hand, proportion of sides in a pictured box changes with viewing angle; in this respect oblique views are not compensated for, or at least not entirely. But judgments of rectilinearity provide an example of compensation. Some drawings of parallelepipeds normally appear rectilinear, whereas others appear slanted or "skew". From certain oblique viewpoints, drawings normally appearing rectilinear will present images which, according to their foreshortened shape, should seem non-rectilinear, and other drawings normally appearing non-rectilinear will present images which according to their foreshortened shape, should seem rectilinear. Does the viewer respond only to the projected image, or compensate and report its "normal" appearance? For many viewpoints, the visual system does compensate; the figure appears rectilinear or non-rectilinear not according to the projection, but as though it were perpendicularly viewed. This compensation seems a specific adaptation to the viewing of pictures, as it would be entirely non-functional in a pictureless world.

OBLIQUE VIEWS OF PICTURES¹

1. The Problem of Oblique Views

This paper deals with a certain puzzle in the viewing of pictures. Such viewing and interpreting is commonly imagined to take place with the observer directly in front of the picture, so that his line of sight is approximately perpendicular to the plane of the picture. Indeed an oblique viewpoint considerably alters the shape of the image projected to the observer's eye. In a view from one side, the image is laterally foreshortened relative to its vertical extent. The questions here approached are: 1) to what extent and 2) in what respects does the observer tolerate or compensate for oblique viewpoints. The real aim of this paper, however, is not to treat this total issue, which is complex indeed, but to draw attention to a few phenomena of compensation and noncompensation.

To what extent does the human visual apparatus cope with this foreshortening distortion? Common experience gives a rough answer. Surely taking a side seat at the cinema causes no drastic breakdown in visual function. Neither does one feel particularly uncomfortable viewing paintings or reading a book at slightly less than square on. But contrariwise, most people shun extremely oblique views (the front rows of the theater). The lesson seems to be that mildly oblique views cause little trouble but extremely oblique views cause a good deal of trouble and are avoided.

The problem of oblique views has of course been considered by others. Artists have in fact played with the phenomenon. Gombrich (1961, p. 252) offers an illustration of an "anamorphic" painting. The artist has produced a portrait which, elongated from a perpendicular view, assumes proper proportions when the line of sight is sufficiently oblique. Certainly in this case, the eye is happy to surrender any reconstruction of the perpendicular but disproportionate interpretation, and to accept the oblique, but humanly proportioned, projection. However, with normal pictures, Gombrich stresses (p. 277) that the viewer generally maintains an appropriate interpretation in spite of an oblique view.

More recently, Pirenne has elaborated much the same conclusion in Chapter 11 of Optics, Painting and Photography (1970). This work, which highlights effects of wide angle perspective projection not treated here, is throughout most relevant to the general problem of oblique views.

1. The author would like to thank Drs. Howard Gardner, Nelson Goodman, and Paul Kolers, for their helpful comments on an earlier draft of this article.

Pirenne underscores the importance of cues that inform the observer of the "pictoriality" of the display and the orientation of its surface (texture, frame, binocular disparity are relevant). Such cues may be weak or absent, as with a distant painting integrated into the architecture of a building so as to seem an extension of it. Under these conditions, the pictured spatial layout appears to distort as the observer moves from the intended viewpoint. Lacking data, he cannot adjust for the oblique view of the picture. Gregory in a related context (1963) has written of the "paradoxical" depth of pictures, which are usually quite apparently flat surfaces and yet just as apparently represent spatial organizations of forms. Polyani (1970), referring to Pirenne's work, has commented further on this, stressing the role of "subsidiary awareness" of the picture surface.

These general observations invite a close study of particular aspects of the phenomenon. A little hypothesizing is in order. How does the human visual system cope with the oblique view? Three sorts of ways come to mind (and these may not be exhaustive of course):

1. Indifference. Some visual means or heuristics may be indifferent to the oblique view in that the information they utilize (their input) is simply not affected by the foreshortening. For example, a contour interrupting another in a "T" configuration often leads the viewer to judge that one object is behind another. In pictures, this evidence of occlusion is independent of the foreshortening distortion because the "T" is just as much there when viewed obliquely as when viewed perpendicularly. Pirenne (1970 pp 160-161) offers further examples related to perspective. The prediction accordingly is: aspects of the interpretation dependent on indifferent heuristics appear the same in oblique and perpendicular views.

2. Compensation. For heuristics not indifferent to the oblique view, active compensation for the foreshortening might be involved in their operation. The prediction: again, aspects of the interpretation dependent on such heuristics would appear the same in oblique and perpendicular views. Thus "indifference" and "compensation" involve identical predictions, and must be differentiated by an assessment of the cues in the picture tapped by the heuristic under consideration.

3. Continuity. For some visual means, there might be no compensation. But certain of these might construct interpretations which depend continuously, in the mathematical sense, on the shape of the projected figure. Accordingly, a small shift in the projection to the eye would produce a small variation in the spatial interpretation. This would yield distortions unimportant in slightly oblique views, but serious for extremely oblique views. The prediction: aspects of the

interpretation dependent on continuous heuristics would always appear somewhat, and continuously, different in oblique and perpendicular views.

These hypotheses are inevitably somewhat vague, and beg for the explicitness of examples. Indeed, such was offered to accompany "indifference". Now the concern is to present examples of both the other hypotheses.

2. An Example of Continuity

Figure 1 displays a rectangular prism; the faces are seen as meeting at right angles along the edges and at the corners. To introduce a term useful later, the figure is perceived as having "cubic corners", displaying rectilinearity as does a cube.

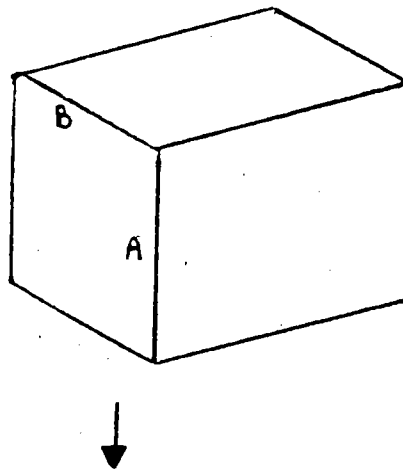

FIGURE 1

Now the reader is invited to view this figure not perpendicularly, but obliquely from the direction indicated by the arrow. A rectangular prism is still perceived, but with different lengths of sides. The effect is apparent with binocular viewing, and even more pronounced if the picture is viewed monocularly. In particular, take note of the apparent relative space lengths of the edges marked A and B. In the perpendicular view, A seems longer than B. But in a sufficiently oblique

view from the direction indicated by the arrow, A appears shorter than B. Between these states is a continuous transition, and the observer can readily see the prism deform as he shifts his viewpoint smoothly from one position to the other. This, then, is an instance of "continuity" as defined in Section 1.

What seems to be happening here, particularly with monocular viewing, is that the visual system is compensating little if any for the oblique view. Further, the figure is interpreted as rectilinear. This suffices to fix the figure's apparent orientation in space (Perkins, 1968), which taken with the projected length of lines determines their apparent length. In binocular viewing, there is competition between this and the information of stereopsis as to the edges' true lengths, and a consequence is a lessened but still definite effect.

3. Cubic Corners

The phenomenon of "cubic corners" (Perkins, 1968) proves a means to uncover an example of compensation. The cubic corners phenomenon, described briefly, is this: people often interpret a corner with three edges radiating from it, or a picture of such a corner, as a "cubic corner", that is as a space form like the corner of a cube where three edges meet at right angles. But, in the image projected to the eye, 1) only certain combinations of angles between the image edges can geometrically, really represent cubic corners and 2) the human viewer is quite sensitive to this geometric condition and usually will interpret only a vertex meeting these conditions as a cubic corner.

For perpendicularly viewed pictures of vertices, the angles between image segments are the same as the angles between the lines on the picture, and the cubic corner condition can be applied to these. The cubic corner condition is that either 1) there are two angles between the segments each less than 90 degrees, whose sum is greater than 90 degrees, or 2) all three angles are greater than 90 degrees. The borderline case where one angle is exactly 90 degrees requires special discussion (Perkins, 1968), but will not be of concern here.

For example, figure 2 seems rectilinear (i.e., having cubic corners) and indeed its vertices satisfy the cubic corner condition. On the other hand, figures 3 and 4 insist on appearing nonrectilinear, that is seem to have oblique rather than cubic corners. The vertices of these figures do not meet the cubic corner conditions.

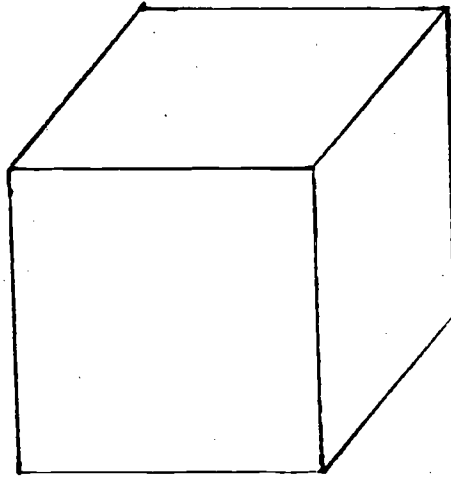

FIGURE 2

The effect is less extreme with figure 3 than with figure 4. These figures have a further role, and in general figure 3 will serve as the less dramatic example, but the example closer to the normal circumstances of viewing pictures.

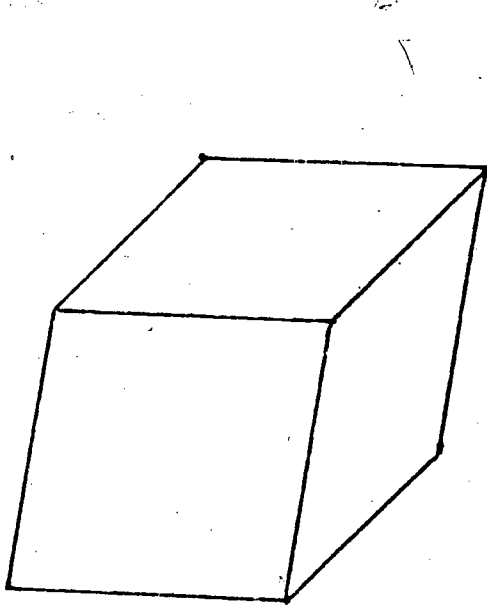

FIGURE 3

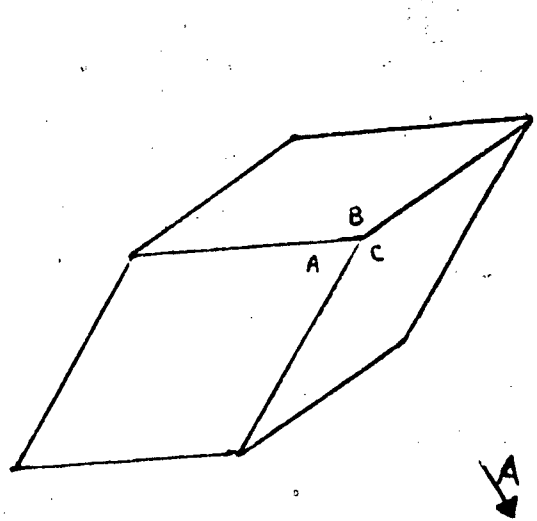

FIGURE 4

There are three common ways to interpret figures 3 and 4 as convex solids (not concave half shells): these are with angles A and B (in figure 4, and analogously in 3) perceived as right but C not, B and C right but A not, and C and A right but B not. It is possible to shift among these three states by acts of will or spontaneously as with the Necker cube. The three states are further evidence of the partiality of the human perceiver (or at least, the perceiver from an urban or "carpentered" background - Segall et al. 1966) for right angles. When unable to see a fully cubic corner he settles for any of alternative combinations of two right angles. But in the case of figure 2 the eye almost always insists on a cubic corner, and can only rarely be enticed to see such a figure as nonrectilinear. Perkins (1971) elaborates this and discusses several similar instances.

In summary, these examples suggest two general principles:

1. The visual system generally interprets as cubic only vertices meeting the geometric cubic corner conditions.
2. The visual system has a strong tendency to interpret pictured angles as right angles, subject to condition 1.

4. An Instance of Compensation

Now to the point. An oblique view of a picture may result in a set of angles between the projected segments very different from the angles between the projected segments in a perpendicular view. In particular, in an oblique view, these angles may not satisfy the cubic corner condition, when in a perpendicular view they do so. Non-compensation for oblique views would predict that in such a case the prism would not be perceived as rectilinear. Rather, an oblique prism would be perceived, as in perpendicular views of figures 3 and 4. But this prediction is not fulfilled!

Figure 2, viewed obliquely from the direction indicated and at an angle of about 30 degrees or more to the perpendicular will violate the cubic corner condition. But the prism nevertheless tends to be seen as cubic. Even at 60 degrees the prism still may look rectilinear although the violations are now large indeed.

But in both these cases the three oblique states, described above as natural to a case of violation of the cubic corner condition, can also be seen.

Figures 3 and 4 emphasize what is happening. Figure 3, viewed perpendicularly, yields a projection of the same shape as figure 2, viewed obliquely at 30 degrees as indicated. Figure 4, viewed perpendicularly, yields a projection of the same shape as figure 2 viewed at 60 degrees. Only the non-rectilinear states are perceived. Yet in obliquely viewing figure 2, a rectilinear state is seen as well as the non-rectilinear states. The projected configuration is the same. The only difference is the obliqueness of the view, known to the viewer through various other visual cues.

Both binocular viewing, and the fact that some edges of figure 2 parallel the sides of the page, appear to assist a rectilinear interpretation when the figure is seen obliquely. The visual system is in part informed about the obliqueness of the view by means of these factors. A like figure, differently oriented on the page and viewed monocularly, sometimes, but less often, seems rectilinear. Other methods of obscuring information about the page orientation have a similar effect. This is in keeping with the findings of Pirenne (1970) mentioned earlier.

This, then, is an example of compensation. In the oblique views, the condition for cubic corners is suspended (in contradiction to principle 1, section 3) and the strong impulse to see cubic corners wins out over the violation of the cubic corner condition, as it does not in perpendicular views. But this victory is somewhat ambivalent. For, counter to principle 2, section 3, nonrectilinear states of the figure can also readily be seen, whereas in perpendicular viewing, when a cubic corner can be seen, nonrectilinear states generally do not also appear.

Here a pause to remark on a possible objection: Let it be quite clear that when a figure, viewed obliquely, is "seen as a cube", this does not mean simply that the viewer, knowing of his peculiar viewpoint calls it a cube. Rather, he sees it as a rectilinear spatial configuration of edges. The point can be emphasized by adding extra lines to figure 2, to render it as a Necker cube (figure 5).

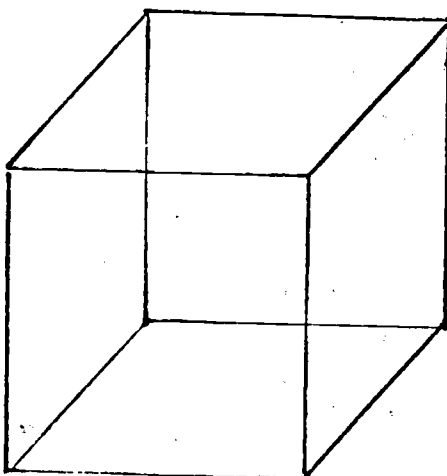

FIGURE 5

00023

Here the figure viewed either obliquely or straight on, seems especially "spatial" and the reverses typical of Necker cubes take place readily in oblique views, with a vivid sense of the prism reorienting in space, and with both alternatives distinctly rectilinear. Also shifts between rectilinear states and oblique states may be seen.

5. Ramifications

The situation as so far presented invites further exploration. It might be the case that in oblique views the visual system simply sometimes suspends application of the cubic corner condition altogether. If this were so, not only figures appearing rectilinear when viewed perpendicularly, but also figures appearing non-rectilinear would appear rectilinear when viewed obliquely. What in fact happens?

Consider a figure not obeying the cubic corner conditions from a perpendicular view. Consider oblique viewpoints from which the figure still does not obey the cubic corner condition. Examples are figure 3 and figure 4 viewed obliquely from the direction of the arrows marked "A", at any angle. The intriguing result is that they do not seem rectilinear! As with figure 2, stereo viewing and orientation of the figure on the page are important. With monocular viewing and an adjustment of orientation sometimes figure 3 will seem rectilinear, but even then not figure 4.

In another relevant case, figures as seen obliquely obey the cubic corner condition (but again not when viewed perpendicularly). Here it would seem certain that they would appear rectilinear. Not always. The entire range, from nearly perpendicular to extremely oblique views, must be considered. The directions marked "B" on figures 3 and 4 provide a case in point. If the view is sufficiently oblique, indeed the figures appear rectilinear. But throughout much of the range, the projection does satisfy the cubic corner condition, but the figure does not appear rectilinear. In particular, with a viewing angle to the perpendicular of any more than about 35° for figure 3 or 60° for figure 4, the projection satisfies the cubic corner condition. But the figures do not commence to look rectilinear until the angles are substantially greater than these. Steps to obscure information about the slant of the page and figures, steps such as monocular viewing, looking through a peephole concealing the edges of the paper, and defocusing the eye to eliminate texture information, result in the figures appearing rectilinear as soon as the cubic corner condition is satisfied.

Both these demonstrations have a common implication. In oblique views, the checking of the cubic corner condition is not simply suspended. Rather, the actual orientation of the figure and page is taken into account. Viewing at an angle, the eye in effect to some extent discriminates whether the figure would appear rectilinear if seen perpendicularly. An analogous discrimination for spherical and cylindrical objects results in a "failure" of the laws of perspective projection at wide angles (Pirenne, 1970, Chapter 9).

6. The Import

Above was presented one instance of failure to compensate (a case of "continuity"), and several of compensation for oblique views. Consider for a moment these latter phenomena. The tentative conclusion must be that these reflect a specific adaptation to the viewing of pictures. The reasoning is straightforward. In a world without pictures, there would be no occasion to interpret as a cubic corner a vertex not satisfying the cubic corner conditions. Only in pictures, viewed obliquely, does a vertex representing a cubic corner yield a projection not satisfying the cubic corner condition. The conclusion is that this remarkable adjustment of the cubic corner condition for oblique views is specifically aimed at maintaining a rectilinear interpretation of the picture, in spite of a distorted projection.

This seems justified as an at least tentative inference. But the phenomena presented raise two rather puzzling problems. First of all, if there is compensation to maintain rectilinearity, why not compensation to maintain the proportion of edges of figures? Why one and not the other? Three related considerations may underlie the difference. First of all, rectilinearity may be a central category in the perceptual coding process, a dominant aspect of the "look" of a scene. Without compensation of any kind, a slight change in viewpoint, causing an unimportant adjustment in apparent proportion of sides, might further result in violation of the cubic corners condition and thus an abrupt and drastic visual reappraisal of the nature of the scene. Such qualitative shifts would not be in keeping with the general trend toward perceptual "constancies", toward maintaining a relatively stable interpretation against perturbations in the stimulus. Second, rectilinearity often plays the role of a working hypothesis in the visual process, and indeed an hypothesis which permits proportion of sides to be inferred. The discussion of figure 1, and articles by the author (1968, 1971) explicate this point further. Thirdly, rectilinearity is a persistent feature of objects in our "carpentered" urban environment (Segall, et al. 1966), and such is certainly not true of any particular proportion of sides. Considerations one and two gain plausibility in this light; rectilinearity is appropriate to our world as a central perceptual category and as a working hypothesis from which other spatial properties are inferred. Thus the special status of rectilinearity in oblique views may perhaps be ascribed to its special status as characterized by these three factors. This is speculation of course.

In any case, another puzzle remains. It is surprising that the cubic corner condition could be suspended under any circumstances. When the cubic corner condition is violated, this means that there is no geometrically possible solution. That is, no space configuration of edges meeting at right angles could project to yield the angles in fact given in the stimulus. Then what space form is seen? Is the space configuration indeed rectilinear or is this somehow an

illusion? On what criterion is the particular configuration, rather than another, selected, since the normal determinant of a configuration both rectilinear and projecting to the stimulus image, has no solution in this case? The form seen is certainly not the same that a perpendicular view would yield; the distortion of proportion of sides, discussed earlier, ensures that.

In conclusion, it may be useful to summarize the major points of this small study. The intent was to explore some of the ways in which the eye coped with pictures seen obliquely. All three of the means outlined in section 1, "indifference", "compensation", and "continuity", are active in certain circumstances. Discussion centered on the third, compensation, and in particular as this related to the cubic corner phenomenon. When a figure is viewed perpendicularly, the visual system is very sensitive to whether the figure could, geometrically, be the projection of a rectilinear form. A figure which when viewed perpendicularly could be rectilinear will often seem rectilinear when viewed obliquely. This is so even when the angle is such that the image projected to the eye could not come from a rectilinear object.

Thus the visual system sets aside its normal geometric standard and makes allowance for the oblique view. Further, figures which could not, when viewed perpendicularly, be rectilinear, also would often not appear rectilinear when viewed obliquely. That is, the geometric criterion for rectilinearity is not simply "turned off", but is to some extent adjusted to take into account the peculiar oblique viewpoint. These phenomena appear to be specific adaptations for the viewing of pictures, as they would be entirely non-functional in a pictureless world.

The puzzle remains that proportion of sides does vary with obliqueness of viewpoint, even though perception of rectilinearity is adjusted for viewpoint. The first phenomenon is reminiscent of the anamorphic picture referred to by Gombrich and situations where the picture surface is difficult to detect emphasized by Pirenne. The second accords to the general stress in the writings of both Gombrich and Pirenne on tolerance of oblique views. Certainly failures to compensate are not confined to cases where the pictoriality of the display is concealed. Both compensation and failure to compensate are involved in the oblique viewing of ordinary pictures. Why the visual system resorts to such varied tactics on the same occasion remains obscure. The reasons may involve the special status of rectilinearity, as a prominent property of our environment, as a central perceptual category, and as a working hypothesis used in many circumstances by the visual system.

REFERENCES

Gregory, R.L. Distortion of Visual Space as Inappropriate Constancy Scaling. Nature, 199, 1963, 678-680.

Gombrich, E.H. Art and Illusion. Princeton: Princeton University Press, 1961.

Perkins, D. Cubic Corners. Quarterly Progress Report No. 89 of the M.I.T. Research Laboratory of Electronics, 1968, 207-214; and Harvard Project Zero Technical Report No. 5.

Perkins, D. The Perception of Line Drawings of Simple Space Forms. Harvard Project Zero Technical Report No. 5, 1971.

Pirenne, M.H. Optics, Painting and Photography. Cambridge University Press, 1970.

Polyani, M. What is a Painting? The American Scholar, 39 (1970), 655-669.

Seball, M.H., Campbell, D.T., and Herskovits, M.J. The Influence of Culture on Visual Perception. New York: Bobbs-Merrill, 1966.

The Perception of Line Drawings of Simple Space Forms

Abstract

The "reading" of pictures for spatial information has long been a process of special interest to psychologists. The flat picture could be the projection or image of any number of spatial configurations, but the observer somehow selects an appropriate configuration from among the infinity of logical alternatives. Viewers readily and consistently interpret simple line drawings as space forms, even though conventional depth cues such as perspective, occlusion or "familiarity", may be absent. One explanation of these troublesome cases is to model the visual system as imposing geometric constraints on the space form, constraints of rectilinearity, symmetry, parallelness and collinearity of edges, and perhaps others. Often such constraints, taken together with the requirement that the form "project" to the picture, completely determine the proportion and orientation of the apparent form. Accordingly, the theory predicts 1) what constraints a subject will report a picture as displaying, and 2) what his judgments will be of apparent proportion and slant. The theory accommodates "reversible" figures such as the Necker cube, predicting the maximum number of alternative interpretations (sometimes more than two) that they will display. The text discusses this theory as it applies to a number of pictured examples.

THE PERCEPTION OF LINE DRAWINGS OF SIMPLE SPACE FORMS¹

1. A Problem of Ambiguity

Line drawings of simple geometric forms have long posed a special puzzle for theories of visual perception. They are not intended, nor interpreted, as flat configurations of lines lying in the plane of the paper. The viewer takes them as representing spatial configurations -- cubes, prisms, tetrahedra and the like. The problem is that various conventional cues of depth are absent from these drawings, cues such as stereo, shading, texture, and often even, it must be said, familiarity of particular forms. Familiarity hardly applies generally, since it is easy to devise figures representing forms the viewer has never seen before. Perhaps Figure 1 will do. Indeed one might view figures such as this as assemblies of familiar parts or "local cues" (Hochberg, 1968), but the laws and processes of combination remain to be specified.

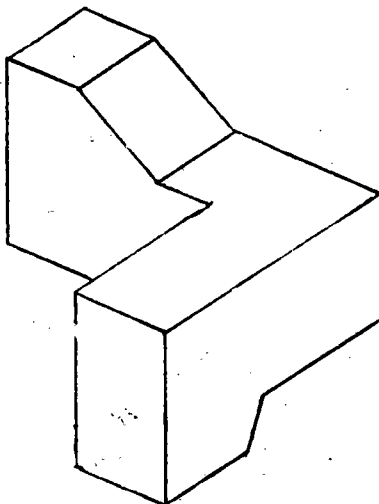

Figure 1

Thus, the real puzzle about such figures is not that the viewer interprets them spatially, but in how he selects his interpretation. From a geometrical standpoint, any such figure is extremely ambiguous. There are innumerable space forms whose edges might appear, if viewed from the proper location, coincident with the lines of the figure. Yet the experience of the viewer is by no means an experience of slippery ambiguity, the form he sees shifting through hundreds of alternatives as the seconds pass. Neither does he find his interpretation idiosyn-

¹I would like to thank Drs. Howard Gardner, Nelson Goodman, and Paul Kolers for their insightful comments on the first draft of this paper.

cratic; other viewers may make what seems, on the basis of verbal reports, to be the "same" interpretation. On the other hand, limited ambiguity is quite commonplace. Such figures will often lend themselves to alternative interpretations, 2 (as with the Necker cube), 3, 4 or even more.

In summary, a theory of the perception of such figures must account for two phenomena; (1) the extreme reduction in ambiguity; that is, the selection of a few interpretations out of the infinite set of geometrically possible interpretations, and (2) the ambiguity that remains, the shifting among a few alternative interpretations in certain cases.

2. A Theory

The proposal made here offers a rather complete account of (1) and (2) above for a wide range of figures. Certain other figures expose limitations in the theory, although even in these cases it remains quite revealing. The theory hinges on the observation that the space forms viewers see exhibit several types of geometrical regularities. For example, in both interpretations of the Necker cube the form appears rectilinear, or that is appears to be formed of edges meeting at right angles. A right angle between edges is thus one geometric constraint of interest. Another constraint which will prove relevant is symmetric equality of angles, as in an isosceles triangle.

The theory depends on a chosen set of such geometric constraints, and varying this set produces variations of the theory. For now just the above two relations, right angle, and equal symmetric angles, will suffice. Later, the further relations "collinear in space", and "parallel in space", will be added for a particular example. Treatment of earlier examples would be unaffected by the presence of these constraints; deferring their inclusion emphasizes the economy of the theory. In general the set might be adjusted or expanded as cases beyond the scope of this paper are examined. It is recognized, for instance, that the importance of rectilinearity might be a consequence of the "carpentered world" (Serall, et. al., 1966) we live in.

The theory is simply this: given a figure composed of straight lines the space interpretation made tends to be a space form which (1) has planar (not curved) faces, (2) projects to the figure, and (3) satisfies a geometrically maximal combination of constraints from the set of constraints.

This curt statement undoubtedly invites some explanation. Condition 1, concerning planar faces, seems clear enough, but not so the term "project". A space form is said to project to a figure seen from some viewpoint when that space form is so shaped and located that its edges would appear coincident with the segments in the figure, were the paper transparent. In a strict sense none of the figures in this article qualify as projections of any of the space forms discussed; none of these figures are drawn in perspective. But clearly the eye does not object, and neither does geometry very much. Perspective convergence is very slight in any form so shaped and located that its various dimensions are small compared to its distance from the eye. Also there is a certain tolerance for

lack of perspective: Gregory (1963) speaks of the "paradoxical depth" of pictures. The general scheme presented here can and will - so the author intends - be applied to perspective drawings in due course. But there are a few anomalies in the perception of pictures with strong perspective that will call for some qualifications in the theory (Pirenne, 1970). The mathematics underlying this paper is generally that of orthogonal projection (toward a plane perpendicular to the line of projection), an appropriate approximation to perspective projection (toward a point) in the cases considered. This leaves the most mysterious of the conditions, #3, to be explained in the following section.

3. An Explication by Example

Figure 2 may be seen as a convex solid, the central vertex lying closest to the eye. An alternate interpretation is that the three surface panels form a concave shell, the central vertex lying furthest from the eye. For the moment, solid interpretations are the concern. A later section will show that the account of the hollow cases parallels that of the solid.

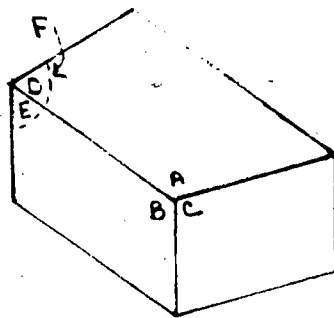

Figure 2

Even as a convex solid, the figure is ambiguous. There are three easily achieved solid interpretations of it. These are: (1) the solid is box-shaped at the near end; that is, angles A, B, and C are right angles; the far end is wedge-shaped with D not right but obtuse, although F and E are right; (2) just the reverse; the far end is box-shaped with angles D, E, and F right; the near end is wedge-shaped with A obtuse, but C and B still right; (3) in this case the solid appears to be symmetric; angles A and D are obtuse and are equal to one another; both ends are wedge-shaped, neither box-shaped; angles C, B, E and F are right angles, as also in cases 1 and 2.

This outlines the perceptual situation. How does this conform to the theory proposed above? The three alternative interpretations have already been described in terms of three different sets of geometric constraints! Not only are these sets of constraints different, they are also geometrically incompatible. For example, if the nearer end is boxlike (case 1), the further end cannot be boxlike, for if A is a right angle D cannot be. The reasoning is straightforward. Condition 1 of the theory, that all faces are planar, plus the right angularity of A and D in space, together imply that the far and near top edges of the figure are parallel in space. But these edges are not parallel in the figure. This is a contradiction, given the remarks on perspective earlier. Similar arguments show that the

constraints of 1 and 3 are incompatible, as well as those of 2 and 3.

Furthermore, each of these three sets of constraints is maximal in a certain sense. For example, take interpretation 1. The requirement that A, B and C are all right angles in fact mathematically determines the orientation of that corner in space (Perkins, 1968). This in turn, together with conditions 1 and 2 of the theory determines the orientation and shape of the entire space form. Thus no further constraints from the list, not already implied, can be required. To put it another way, if an additional constraint not already implied were required, there would be no space form meeting all the conditions. In just the same sense, the constraints for interpretation 2 and interpretation 3 are also maximal.

One further point. In fact, the three sets of maximal constraints for interpretations 1, 2 and 3 represent the only three maximal sets for this figure. This follows from a bit of geometry. The details (which the reader might well skip) are as follows. The two constraints available are symmetry and rectilinearity. The only relevant place for a symmetric angles condition is the top face of the figure; an assumption of symmetry on the other, parallelogram, faces amounts to rectilinearity. Thus either the top face is symmetric or not. If so, then all other angles not on the top face may be rectilinear; this yields one maximal set. If not, then there is no symmetry constraint at all. A rectilinearity constraint on any angle amounts to such a condition on one of the angles A, B, C, D, E, or F. But all angles cannot be right angles; in particular as mentioned above, A and D cannot both be right at once. This competition yields two alternative maximal sets, one with A right and D obtuse, one with D right and A obtuse. In both cases, all other angles not on the top face are right.

Thus the conclusions are two. First, the perceptual selection from the utter ambiguity of the figure is accounted for by the imposition of various maximal sets of constraints. Secondly, the remaining ambiguity, the three alternatives seen, corresponds to all the alternative maximal sets of constraints.

Perhaps this example has clarified the meaning of "maximal set of geometric constraints". Against this background, a general formulation will be attempted. A geometric constraint in this work is one of a list of conditions -- rectilinearity, equal symmetric angles, etc. -- associated with appropriate parts of a figure. Given a figure and a set of constraints, there may or may not be a space form which has planar faces (condition 1 of the theory), projects to the figure (condition 2) and satisfies all the constraints. If there is such a space form, there may be further constraints already implicit in those given. For instance, if one angle of a parallelogram is assumed right, it follows that the other angles are also right. That is, further constraints may be implied according to geometry. Now what is a maximal set of constraints? If a set is maximal, first there does exist a space form satisfying the constraints and the other conditions of the theory. Second, any further constraint either (1) is already implicit and not genuinely more restricting, or (2) restricts too much, so there is no space form satisfying this further constraint as well as all the others.

4. Dimensions of Ambiguity

The account of the foregoing example has ignored an issue for the sake of initial clarity. From a geometric standpoint, even these maximal sets of constraints leave this figure and others like it infinitely ambiguous in certain ways. What are these remaining geometric ambiguities, and are there corresponding perceptual ambiguities?

Not in the above example, nor in any to be presented here later, do the geometric constraints determine the apparent size or the apparent distance of the space form. The constraints suffice in the above example to fix the space form and its orientation. But the figure could equally well represent a small close form, or a large remote form. There is an infinite range of forms of different sizes and distances, each of which satisfies the same set of geometric constraints. But given any choice of size, the distance is determined, and given any choice of distance, the size is determined. This situation will be called "size-distance ambiguity".

This reciprocity of size and distance is of course derived from geometry. The question remains whether the human perceptual apparatus utilizes this principle precisely, for example, to judge the distance of objects of known size or to judge the size of objects when distance is given by other cues. Woodworth and Schlosberg (1961, pages 480-486) review evidence suggesting that the human viewer utilizes the size-distance reciprocity with considerable accuracy. Hochberg (1964, pages 76-81), while accepting these results, offers a more complex explanation, questioning the relevance of absolute size and absolute distance of the target object from the viewer. Rather, he proposes that ratios of distances and ratios of sizes are the perceptually significant variables. Such a view of course still involves the same reciprocity rule between size and distance, though the mathematics of using the rule is more complex.

However, Epstein, et al.'s review of the size-distance literature (1961) casts some doubt on whether the relation is obeyed by the human perceptual apparatus. Recent experimental work by Epstein and Landauer (1969), Stanley (1968), and various other investigators, emphasizes these uncertainties. Rump (1969) stresses the methodological problems in getting meaningful reports of size and distance, and employs a reinterpretation of the size-distance relation (Cook, 1966) which in some cases does better than the simplest formulation.

The resolution of such issues is not critical here. The geometric constraints that are a part of the theory being explained have no bearing on either size or distance. If precise reciprocity holds in some form, that would be very much in keeping with the spirit of this work. But whatever rules relate size perception to distance perception in the human visual system are not under study here.

Figures 3a and 3b will demonstrate another infinite dimension of ambiguity, a dimension involving a relation between shape and slant (Beck and Gibson, 1955). Figure 3a is an easily seen, and easily understood, example. The ambiguity of figure 3b is harder to see and harder to conceptualize. As the viewer beholds figure 3a, the pennant some-

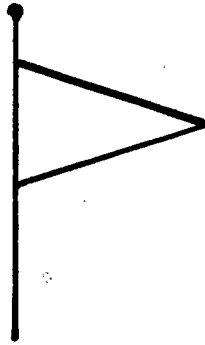

Figure 3a

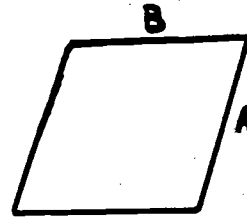

Figure 3b

times seems to come forward or to recede and at varying angles. Of course, the more the pennant slants backward or forward, the longer it must be. The same figure, that is, lends itself to interpretations with different shapes (here elongation of the triangle) and slants.

Figure 3b may be interpreted as a rectangle floating in space. This corresponds to the only maximal set of constraints for this figure: that all four angles are right. With Figure 2, the constraints sufficed to fix the orientation of the space form. Here this is not so, and the resultant ambiguity can be seen.

First of all, the rectangle may appear to be oriented face upward or face downward. The next section will further discuss this difference. But moreover, even within face-up interpretations there is an infinite range of variation. Imagine that the rectangle is as horizontal as possible, lying on the ground, so to speak, with side B furthest away. With this in mind, examine the sides A and B and note their apparent relative lengths. A seems longer than B. Now imagine that the rectangle is as vertical as possible, with the side opposite A furthest away. Again judge the relative lengths of sides. Now A will appear shorter than B. This difference in side lengths demonstrates that with two different preconceptions, one sees different rectangles in different orientations. Both of these alternatives of course satisfy the same geometric constraints, and these are in fact just two of an infinitude of rectangular interpretations exhibiting various proportions and orientations.

Such situations, where the shape and orientation of the form continuously vary together, will be called instances of "shape-slant" ambiguity. The examples used simple figures consisting of only one "panel", but the term can apply as well to each panel of a more complex figure representing a solid object. As with size-distance ambiguity, if the orientation of a panel is entirely specified the shape is determined. If the shape is entirely specified, there may be no, one, or two corresponding orientations (section 5 will expand upon this) but there is no continuous range of alternative orientations. Only when shape and slant can vary continuously will the term "shape-slant ambiguity" be used. Partially constraining the

shape, by requiring a right angle for instance, may still allow both shape and slant to vary continuously within the constraint, as with Figure 3b.

Size-distance ambiguity applies to all maximally constrained figures simply because the constraints currently part of the theory do not bear on either shape or distance. But shape-slant ambiguity applies only to some, including Figures 3a and 3b but not Figure 2. It seems strange that a form can be shape-slant ambiguous and yet at the same time maximally constrained. But "constrained" in this context means constrained by the conditions of rectilinearity, symmetry, and so forth, that are part of the theory. Sometimes as in Figures 3a and 3b, such conditions simply do not suffice to fix all the degrees of freedom involved.

Again the geometry has been described; again the question is raised: does the human visual system act according to this geometry. After brief discussion, the analogous question for size-distance ambiguity was dismissed as not germane. Here such a move is inappropriate. The constraints of rectilinearity, symmetric angles, etc., are relevant to shape and orientation, though they were not to size and distance.

The psychological literature offers a good deal on the shape-slant issue. According to Kaiser (1967), Beck and Gibson (1955) first proposed the strict geometric relation between apparent shape and apparent slant discussed here. They termed this relation the shape-slant invariance hypothesis. Unfortunately, the numerous experiments performed since the explicit formulation of Beck and Gibson have led to no firm conclusions. Some have offered evidence in favor (e.g., Kaiser, 1967) though more often the evidence has been negative (e.g., Eriksson, 1967). Both these papers refer to various other research findings pro and con. A detailed review of these studies has no place here, but some general remarks are in order. First of all, much of the confusion has derived from questions of methodology. Various means for the observer to report shape or slant or both have been tried; most have come under attack. (See for example Kaiser, 1967, Willey and Gyr, 1969). Kaiser claims to have devised an especially appropriate technique, but the uncertainties endure.

Second, it is important to point out that most experiments have dealt with isolated plane figures offering such slant cues as texture gradients, perspective and form ratios (Braunstein and Payne, 1969, Flock et. al, 1967, Flock, 1965, Freeman, 1966). But here shape and orientation are considered largely in relation to solid forms, and as affected by constraints of symmetry and rectilinearity, constraints largely unstudied experimentally. Thus the bearing of all the research, pro or con, is open to question.

Finally, the relevance of the theory here offered does not really turn on whether the geometric shape-slant relation is precisely followed by the human visual system. On the one hand, the theory remains a description of the geometric constraints such as rectilinearity, symmetry, etc., that a viewer sees, whether or not the viewer makes an accurate orientation judgment according to the shape-slant relation from those constraints. On the other, even very moderate accuracy would provide important support. Indeed, it would be surprising if the human visual system, subject as it is to a variety of illusions involving metric distortions, should perform with perfection here.

¹But see footnote on the last page of this paper.

Of course, whatever deviations there may be are not to be dismissed. They deserve detection and explanation. Perhaps the mathematics involved can be adjusted to reflect the deviations. In any case, if there are moderate differences, the theory may stand nicely as an idealized description of an aspect of form perception.

5. Continuous Families of Space Forms

The lesson of the foregoing section is that sets of constraints, even if maximal, must be viewed as specifying not a space form of particular size, shape, location and orientation, but as specifying a range of possibilities. However, further distinction is possible within this range. Typically, the range of alternatives splits in a natural way into two distinct families of forms which are disjoint from one another.



Figure 4

Figure 4 represents another parallelogram which the eye can interpret as a rectangle floating in space. This rectangle takes two general attitudes, analogous to the "face-up" and "face-down" of Figure 3b. But to stress the point, this figure is so arranged that both alternatives are readily seen ("face-up" tends to dominate in Figure 3b). First, the rectangle may float in space "face-left", with the right edge closer than the left edge. On the other hand, it may float "face-right" so that the left edge is closer than the right. The viewer will experience spontaneous shifts between these two ranges, rather like the shifts between alternate interpretations of the Necker cube.

Of course, "face-left" and "face-right" as designations are accidents of the orientation of the page and figure. But the two ranges, however referred to, correspond to a geometric reality. The space forms satisfying the geometric constraints indeed fall mathematically into two continuous and usually disjoint families.¹ That is, within each family there is a

¹Let the angle of a corner of the parallelogram be p . If the parallelogram is interpreted as rectangle in space, the sides of that rectangle corresponding to the sides of angle p will make certain angles with the plane of the paper. Let these angles be a and b . Then the trigonometric equation $\tan a \cdot \tan b = -\cos p$, must hold for the figure to indeed be a rectangle. The solutions to this equation fall into two disjoint continuous families, except for the case where p is 90° . There the two families touch.

continuous shape-slant and size-distance variation of space forms. But the two families do not touch except in the special case footnoted.

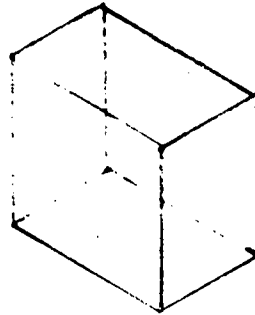

Figure 5

Another example of this two family phenomenon is Figure 5, the Necker "cube" (the edges need not be of equal length). Here again the viewer sees this figure in two distinct orientations. Again, both these interpretations satisfy one maximal set of geometric constraints, here, that all angles are right angles. The Necker cube case is less ambiguous than the prior, in that there is no shape-slant variability. The geometric constraints suffice to limit the shape and orientation to just two discrete possibilities. Thus there are two size-distance ambiguous families of "cubes". Perceptual reversal of the Necker cube is a jump between members of these two families.

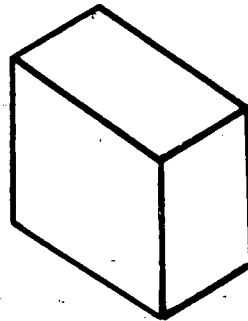

Figure 6

This same phenomenon occurs with opaque rectangular prisms as well as with transparent ones. Figure 6 may be interpreted as a convex solid or as a concave shell. These versions are analogous to the two versions of the Necker cube. Again there is only one maximal set of constraints involved, the requirement that all angles are right. But there are alternative size-distance families of solutions, the convex family and the concave family.

In section 3, only solid forms were considered for the discussion of Figure 2. There it was stated that the concave forms would be treated later. Now accounting for these is easy. The three alternative convex interpretations of the figure were found to correspond to three alternative maximal sets of constraints. But each of these sets also permits a concave form. Thus there are really six size-distance families involved, two for each of three sets of constraints.

The existence of two solution families is quite general. For any maximal set of geometric constraints there will be two families of solutions. Generally these will be non-overlapping, but in special cases they may touch one another, as in a figure which is itself a rectangle (see previous footnote). Why is this duality so persistently found? The explication lies in a sort of mirror symmetry in the geometry of the situation.

Consider a configuration of edges or wires satisfying any geometric constraint on the list -- right angle, equal symmetric angles, or parallelness or collinearity, (these two will be important to a later example). Imagine this form reflected in a mirror parallel to the plane of the page. Further, imagine that the reflected form is then picked out of the mirror and moved, without changing its orientation, to the location of the original unreflected form, to replace it. Then this reflected form has two remarkable properties. First, it satisfies exactly the same geometric constraints as the original. Second, it presents the same image to the eye of the viewer. The reflected form thus matches the original in its obedience to the conditions 1, 2 and 3 of the theory.

This symmetry always exists geometrically, but there may be no corresponding perceptual ambiguity. How is the extra geometric alternative eliminated in such cases? In general, the eye seems to favor convex over concave interpretations, but not to the exclusion of concave interpretations. Figures 7 and 8 offer some further explanation. Figure 7 readily reverses from a concave form to a convex form. But especially for an un-

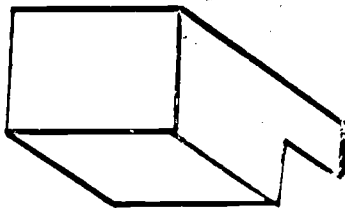

Figure 7

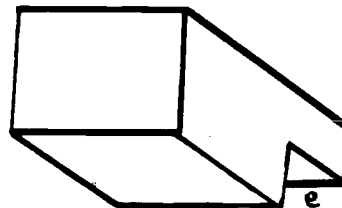

Figure 8

practised observer Figure 8 reverses much less easily, and reversals so achieved are unstable. Geometrically, of course, Figure 8 has a hollow form. But the line marked "e" is drawn to suggest that it disappears behind the edge of the figure. The convex form is compatible with this, but the concave is not. Because of this discrepancy, the eye generally rejects the concave interpretation. Figure 1 also resists concave interpretation for much the same reasons. Sometimes, though, the concave version of Figure 8 may be seen, with a wire running between a corner and an edge of the form. Figure 1 may be taken as concave with a bent wire. There is nothing inherently wrong with these interpretations, but the eye favors them less. In a complex scene, influences of convexity, occlusion, and of other sorts generally combine to completely suppress inter-family ambiguity.

6. Further Examples

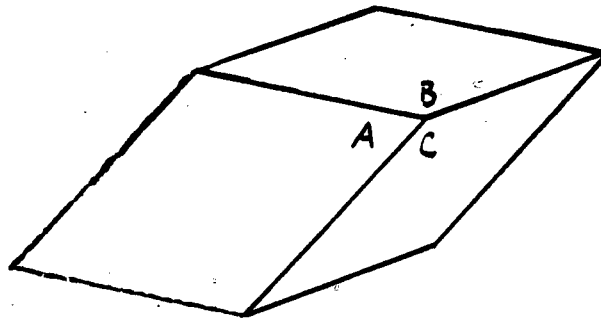

Figure 9

Now two further examples will be analyzed in terms of alternate maximal sets of constraints and alternate families for the same set of constraints.

Figure 9 is drawn much as a box would be; it is comprised of three parallelograms meeting along common edges. But something is different. The figure does not seem rectilinear at all, but rather appears slanted or oblique. Some angles are not right angles. In fact, there are three distinct ways of interpreting this figure as a convex form (and three corresponding concave interpretations). These are with angles A and B right angles, but C obtuse, with angles B and C right but A acute, or with angles A and C right and B obtuse.

What is the situation with regard to the theory? The odd thing about this figure is that a wholly rectilinear interpretation is not allowed geometrically. That is, there is no rectilinear space form that will project to this figure.¹ The requirement that all three of A, B and C be right

¹In a figure, a vertex with three radiating segments can be the projection along some line of sight perpendicular to the page of a space corner with three right angles if and only if either (1) there are two angles between segments each less than 90° , with sum greater than 90° , or (2) all three angles are greater than 90° . (Perkins, 1968). Preliminary results from an experiment now in progress (July, 1971) support the view that the human visual system is sometimes highly sensitive to these geometric requirements,

angles cannot be satisfied. But any two angles can be right, and the alternative pairs of right angles, A and B, B and C, or C and A, define maximal sets of geometric constraints that yield the three interpretations of the figure discussed above. Each interpretation has shape-slant ambiguity, though this is characteristically difficult to observe (see Section 7). When, however, a completely rectilinear interpretation is possible, as in Figure 6, no oblique states are seen. Neither are they any longer maximal, however. The requirement of three right angles, when admissible, subsumes all the pairs of right angles, and becomes the only geometrically maximal set of constraints.

All examples so far have been of single objects. Yet the concepts developed here are also applicable to at least some cases of more than one object, as Figure 10 illustrates. Only interpretations in which both objects appear convex will be considered. The status of concave forms has already been explained. Here there is the added complexity that one form may appear hollow, and the other solid; such combinations are difficult to study, being quite unstable.

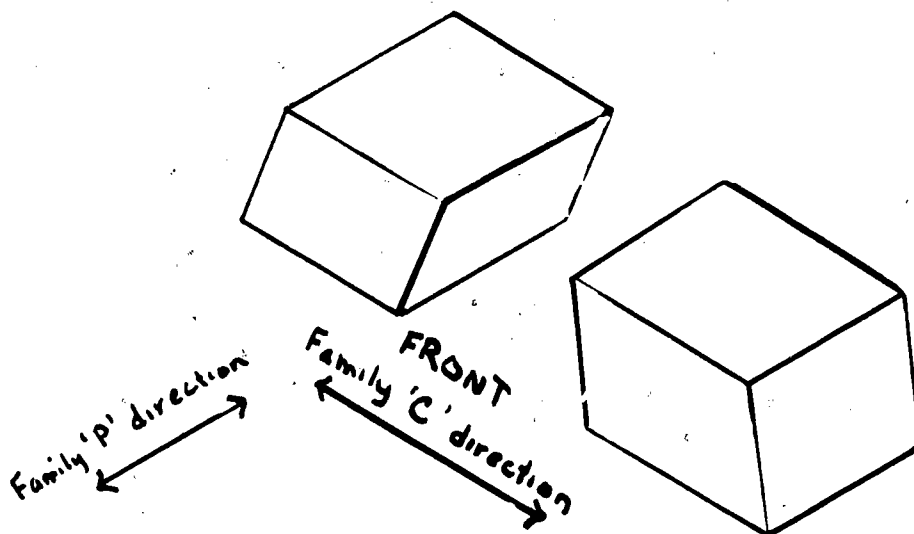

Figure 10

The key to this example is that lines already parallel or collinear in the flat figure tend to be seen as parallel or collinear in space. This links the space interpretation of the two parts together, even though they represent separate objects! Accordingly, the constraints "parallel in space" and "collinear in space" must be added to the list of allowable constraints.

The possible parallelisms and collinearities fall naturally into two families. There are parallel edges in both figures running between the lower left and upper right. They will be named family P for parallel, and may sometimes be interpreted as parallel in space. Secondly, there is a family of parallel edges, some pairs which are collinear, running from the lower right upward to the left. These will be termed family C for collinear. In some interpretations, the edges collinear in the figure all appear collinear in space. In others, all cannot be collinear at once, and there are alternative collinearities. There will be no enumer-

ation of these; rather such situations will simply be labeled as "collinear alternatives".

The following chart lists various seeings of Figure 10, describing these in terms of maximal geometric constraints. There may be other seeings and sets of constraints not listed here. Some of those given are much harder to see than others, but all are possible. One useful trick is that of rotating the figure so that edges of one object are vertical, which promotes that object appearing rectilinear.

Both objects rectilinear, no space parallels or collinearities

Left object rectilinear, right non-rectilinear

front face of right object oblique, other faces rectangles,
family C collinear, family P parallel

side face of right object oblique, rest rectangles, collinear
alternatives in C, P parallel

top face of right object oblique, rest rectangles, collinear
alternatives in C, P not parallel

Right object rectilinear, left non-rectilinear.

alternatives symmetric to those listed above for left object
rectilinear

Neither object rectilinear

front faces of both objects oblique, others rectilinear, equal
symmetric angles between the two front faces (rather than as
part of the same face as in one interpretation of Figure 2)
C collinear, P parallel

side faces of both objects oblique, others rectilinear, equal
symmetric angles between side faces, collinear alternatives
in C, P parallel

This thus lists nine different convex interpretations of the figure, not counting variability due to collinear alternatives. Such variability is only relevant to the relative distance, not to the shapes or orientations of the forms. In all nine cases shape and orientation are entirely determined; there is no shape-slant ambiguity as there was in the prior example. Even though in some of the listed cases one or both of the objects appears oblique, as with the prior example, the shape-slant ambiguity usually associated with such obliqueness is eliminated by geometric relations of collinearity, parallelness or symmetry between the two objects.

A notable feature of this example is that, in the last two cases listed, the symmetric equal angles constraint operates across space between two disconnected objects. Right angle constraints may do likewise in appropriate circumstances. For example, in Figure 11 the two parallelograms generally

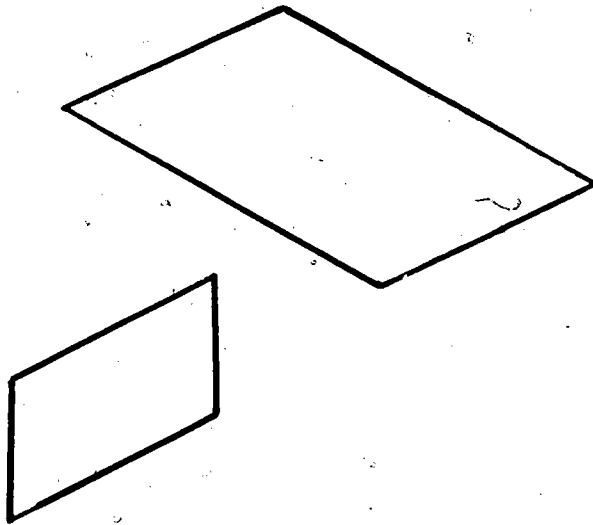

Figure 11

suggest rectangles which are perpendicular to one another. The whole domain of inter-object constraints invites extensive investigation.

7. Remnants of Ambiguity.

The prime analytical tool introduced at the beginning of this work was the concept of maximal sets of geometric constraints. The claim was that the viewer tends to interpret line drawings of simple geometric forms as maximally constrained space forms, forms which also would project to the given figure. (The qualification implicit in this "tends to" rather than a direct "does" has not been relevant so far, but will be confronted in the next section.) The eye's selection from the extreme geometric ambiguity of the given figure was characterized as a process of imposing geometric constraints.

The concept of maximal sets of constraints also served to define several sorts of remaining geometric ambiguity. There is cross-constraint ambiguity, when a pair of alternative interpretations differs in the set of geometric constraints involved. Cross-family ambiguity occurs when two alternatives are members of the two distinct and generally disjoint continuous families of forms satisfying the same maximal set of constraints. Finally, intra-family ambiguity is simply some combination of size-distance and shape-slant ambiguity, since a family is made up of a continuous variation of space forms along the size-distance and sometimes shape-slant dimensions.

Again these categories describe the geometric ambiguity. The perceptual situation is another matter. Almost all examples of perceptual ambiguity presented have been instances of cross-constraint or cross-family ambiguity. There were few examples of intra-family shifts. This

was not a consequence of the author's selection policy; clear examples of intra-family shifts seem much harder to invent. But with reference to geometry, ambiguity within a family is no less ambiguity than ambiguity across families. Indeed, if number of alternatives were any measure, the infinite variability of intra-family size-distance and shape-slant alternatives would surely be the central phenomenon. But perceptually, it is just such intra-family shifts that are uncommon, or at least uncommonly noticed.

No firm explanation can be offered here; for the time being speculation must serve. "Uncommonly noticed" may indeed be at least a partial solution to this enigma. Perhaps intra-family shifts are quite common, but the viewer does not notice that this has happened. One reason for such lapses may be the lack of categories in terms of which to identify the shift. This paper discussed examples in such words as "right angle" "equal symmetric angles", "convex" versus "concave", "face-up" versus "face-down", "closer than" versus "further than". When the viewer conceptualizes successive seeings in such terms, he can easily convince himself that a shift has indeed taken place.

These categories do not generally apply to cases of intra-family shifts. The observation that intra-family shifts are less often noticed might then be accounted for by a lack of categories with which to notice them. The discussion above of Figure 3b is a case in point. There the viewer was asked to attend to the comparative lengths of edges to observe shape-slant ambiguity. If the figure is contemplated without such deliberate attention, the figure's shifts seem far less discernible.

In proposing that certain categories may be important to discriminating shifts, the author does not mean to propose that the viewer must necessarily verbally encode in terms of these categories. Furthermore, categories aside, there are forces which work in various circumstances to restrict size-distance and shape-slant shifts. For instance, although none of the figures have been drawn in perspective, perspective nevertheless exercises an influence. A viewer will not interpret as extremely foreshortened many figures with shape-slant ambiguity precisely because the anticipated perspective convergence of lines is not there. This factor thus narrows the range of shape-slant shifting.

Further suggestions in the same vein derive from the observation that alternatives defined by different maximal sets and/or families are generally differentially easy to see. Sometimes a shift to a given alternative may occur spontaneously, sometimes only if forced by the viewer, and sometimes not at all. Lack of categories is no account of such differences, since these are cases where the categories are available, and indeed where, when shifts occur, they are most distinct. The "seeability" of such alternatives is often markedly influenced by rotating the page or fixating on a different part of the figure. Perspective, mentioned above, and page orientation suggest an analysis in terms of additional geometric constraints. Fixation effects suggest influences of the particular sequence in which the eye gathers information and of the details of the computational process by which the visual system searches for maximally constrained forms.

Both these factors probably bear on size-distance and shape-slant ambiguity as well. A more thorough analysis of such considerations may reveal something of the principles by which, in perception, selections are made along the infinite size-distance and shape-slant dimensions. At least in the examples offered here, these dimensions are the only vestiges of the indeterminacy puzzle posed by line drawings of simple geometric objects.

8. Some Reservations

This theory of maximal sets of geometric constraints, which has been so boldly presented, must now be qualified a bit. It is simply not the case that the viewer always interprets line drawings of simple geometric shapes as maximally constrained space forms. In the course of the investigation reported here, the author has discovered several instances where the viewer typically imposes a less-than-maximal set of constraints. Thus a "tends to" rather than a "does" occurs in the statement of the theory in section 2. Leeway must be allowed for these cases; but of course there is little merit in simply allowing leeway. The ultimate aim must be an account of these special cases, some explanation as to why the visual system, so persistently striving for maximality in some situations, stops short of maximality in others. But for the moment all that can be offered are some examples and speculations.

The first example is Figure 12, similar to Figures 6 and 9. But this case is peculiarly different from these prior ones. First of all, this figure geometrically can represent a rectilinear form, unlike Figure 9 but like Figure 6. Also indeed the viewer may see it as rectilinear. He may also, however, see it as an oblique non-rectilinear form, much like Figure 9. This oblique interpretation is, of course, less than maximally constrained, the maximally constrained case being the rectilinear interpretation.

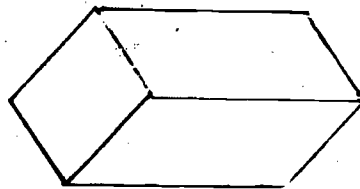

Figure 12

The orientation of the figure relative to the viewer is important; rotating the page so that the sides of the figure are vertical tends to suppress the oblique interpretation, without however eliminating it. This orientation sensitivity suggests that perhaps the visual system is imposing a horizontality requirement, or, so to speak, projecting a "floor" into the scene and requiring the form to sit flat on the floor. When the page is held upright, the rectilinear interpretation is markedly tilted but the oblique interpretation sits on the "floor" and is thus encouraged. But when the page is held tilted as suggested, the rectilinear interpretation is upright, and the oblique atilt and accordingly

discouraged.

In so far as this explanation is valid, it would restore a sort of geometric maximality to the oblique interpretation. Horizontality would appear as a new geometric constraint, usually depending on the orientation of the page relative to the viewer, a constraint which could compete with the other geometric constraints on the list. This explanation is marred, though perhaps not destroyed, by the fact that the oblique form can be seen with other orientations of the page, though not nearly as readily. The saving factor may be that the visual system, necessarily adapted to occasional peculiar positions of the head, must be able to accept any angle relative to its own axes as the real horizontal. In any case, if horizontality is a competing geometric relation, it seems a weaker one, less often dominating over rectilinearity, except for particular figures viewed with particular page orientations.

Further counterexamples are plentifully supplied by a large and familiar class of figures: triangles. A triangle on a page can readily be seen as a triangle floating in space (Figure 13).

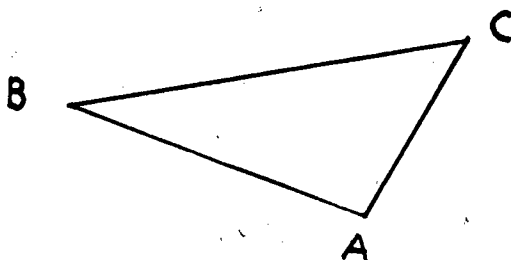

Figure 13

The interpretation is ambiguous: there are alternative shapes and orientations and shifts between them. Sets of geometric constraints account well for the ambiguity and the shifts. There are twelve continuous families of alternatives, corresponding in pairs to six different constraints. These are: angle A right, or angle B right, or C right, or angles A and B equal (an isosceles triangle), B and C equal, or C and A equal.

It is gratifying that geometric constraints account for this ambiguity. The problem is that none of these sets is maximal! Geometrically, there is room for both a right angle and an equal symmetric angles constraint at once, as, e.g., requiring A to be right, and B and C to be equal. Also a triangle with all three angles equal could be required. Yet these combinations are not generally seen. A consequence here of only one constraint being imposed is that the families display shape-slant ambiguity. This is readily observed in the figure. The viewer can persuade the triangle of Figure 13, seen say with angle A right, to appear to be quite horizontal, or much more vertical.

The truly maximal states are difficult to see even deliberately. This reluctance of the visual system is suggestive. Perhaps there are certain combinations of constraints not readily imposed, in other circumstances as well as this. Seeing a triangle as isosceles may involve establishing a perceptual axis of symmetry cutting the triangle. This may in turn interfere with discernment of, or imposition of, right angles not having sides parallel with this axis.

A final point on triangles: these are important not just as exceptions to perceiving maximally constrained forms. Also they show that the concepts of geometric constraint, shape-slant ambiguity, and so on, are useful in enumerating alternative seeings and classifying shifts between them even when the sets of constraints involved are non-maximal. These concepts thus have a relevance beyond the particular issue of maximality.

The search for less-than-maximal cases has a natural complement: the search for cases where more constraints appear to hold than is geometrically possible. So far, examples of maximal and less-than-maximal geometric constraints have been discussed. But in none of these cases did the viewer find more constraints than the geometric maximum. How is it that the viewer knows when to stop imposing? Perhaps it is permissible to speak of the eye's "concept", "model" or "theory" of Euclidean space, or that is, the principles embodied in the visual system by which the visual system evaluates the geometric possibility of a given set of constraints. Such terms in effect propose an entire area of inquiry: the investigation of the range and limits, the powers and weaknesses of visual space.

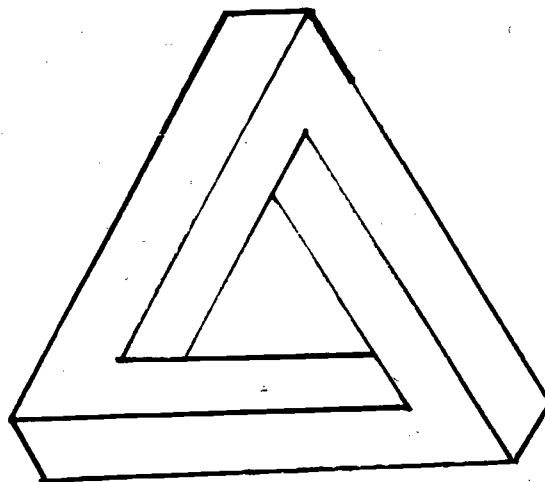

Figure 14

(Figures 14 and 15 after Penrose and Penrose (1958), who also refer to like effects in the art of Escher.)

00046

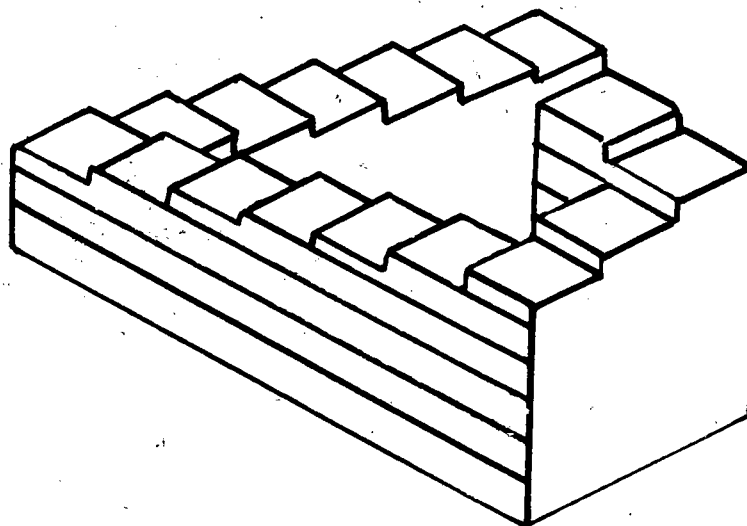

Figure 15

Sometimes the visual system is not so successful in limiting itself to the geometrically possible. As the gaze ranges from corner to corner of the "Penrose triangle", Figure 14 (Penrose and Penrose, 1958), there are dramatic reversals of its apparent orientation. These occur when the interpretation carried over from the prior fixation meets with incompatible evidence on the latest fixation. Furthermore, such geometric impossibility is sometimes not even so noticeable, much less avoided. Figure 15 (Penrose and Penrose, 1958) does not yield the striking reversals of Figure 14. Yet it is just as impossible, being an always descending stairway when traversed clockwise. Of course, neither of these figures is impossible in the sense that there is no geometric form that projects to them. Indeed, models have been constructed that when properly viewed yield such images (Gregory, 1968, Penrose and Penrose, 1958). They seem impossible only because the eye insists in taking the corners as rectilinear, the faces as flat and connected with one another even though such conditions taken together are geometrically inconsistent, and even though the eye notices this at least in the case of the Penrose triangle. Thus here is limitation to the sense of the geometrically possible built into the visual system, though generally this work has stressed its powers. What the eye's model of space is, so that both these powers and limitations follow, remains to be discovered.

9. Conclusion

This paper has offered a theory about the interpretations a viewer makes of line drawings of simple space forms. The theory addresses a particular puzzle: that such drawings might be expected to be highly ambiguous, as they offer few conventional depth cues; yet the visual experience is of one, or a few, distinct space forms. The theory proposes that the figures are interpreted as representing forms which (a) are geometrically "possible" - i.e., the figure could be a projection of that space form, and (b) which obey as many constraints of rectilinearity, symmetry, and so on, as is geometrically possible.

The theory makes testable predictions. First, space interpretations of particular figures should have certain combinations of symmetries and perpendicularities. Figures can be ambiguous, but each alternative seen should be one permitted by the theory. However, there is no prediction that all alternatives permitted by the theory can be seen, although in many cases all can. Second, the interpretations should have a specific rigid shape and orientation in space, in those cases where there is no remaining shape-slant ambiguity. Prediction one might hold without two holding: the viewer might perceive combinations of symmetries and rectilinearities as expected, without being able to draw accurately on their quantitative implications.

For a wide range of figures, this paper has presented casual evidence for prediction one. No evidence has been offered for prediction two.¹ And certainly no careful experimental evidence has been presented at all. The general success of the theory with regard to predictions one and two was tempered by a few aberrant examples. Section 8 presented two instances in which the visual system did not impose as many constraints as was geometrically possible. In two examples of "impossible figures" the visual system persisted in attempting to impose a combination of constraints that was geometrically impossible. With both sorts of counter-examples, the language of geometric constraints still proved effective for listing alternative seeings and discussing the phenomena. The general theme that the operation of the visual system in these cases could be characterized as a process of imposing geometric constraints remained valid.

It must be stressed that this paper presents a theory about the conclusions the visual system reaches, not about the processes by which it comes to those conclusions. But the text may be suggestive of certain processes. Usually, the tone of the discussion would accord with the process being one of finding local depth cues and combining them into a coherent schema (Hochberg, 1968). Another compatible view is that the visual system imposes a spatial framework or coordinate system on the figure (a framework of course appropriate to the clues in the figure) and that in the spatial interpretation the edges of the figure and/or axes of symmetry align themselves with this coordinate system's axes (Attneave, 1968). This interpretation seems especially natural in the context of section 7; the cases of less-than-maximal constraints might be described in these terms. This paper is not genuinely committed to either view, or to any other. Neither are the two views necessarily contradictory. It seems likely in fact that the two emphasize different aspects of the processes involved, and that both will play their part in any fine articulation of these processes.

This theory has been presented in a rather narrow context, that of line drawings of simple space forms. However, its relevance perhaps reaches substantially further, bearing both on the interpretation of normal photographs and paintings, and on the everyday perception of the real world. First of all, both pictures and the environment generally are replete with geometric forms, such as tables, chairs, buildings, books, roofs, stairs, arches, and so on. It seems natural to expect that processes revealed here in an austere context find their practical applications in the perception of more realistic targets such as these.

¹ But see footnote on next page.

Second, much more irregular objects, such as an automobile or the human form, nevertheless offer symmetries which might be utilized by the visual system just as in simpler cases. Thus this theory may contribute to understanding the psychological process of interpreting pictures, may offer an analytical tool with which to trace the development of Western representational art, as well as the art of other cultures, and might provide a technique for artists analogous to perspective drawing, which they could employ, deliberately flout, or ignore according to their needs. Further, the theory may clarify the perceptual processes involved in apprehending the everyday environment. Exploring the range of these possibilities, as well as seeking rigorous support for the ideas presented here are the tasks at hand.

A last minute addition: Attneave and Frost (1969) report an experiment testing subjects' judgments of apparent slant of pictured rectilinear parallelepipeds. Results corresponded closely to their prediction from projective geometry, which supports the theory presented here. Attneave and Frost framed their prediction and interpreted their results in terms of figural simplicity and redundancy, an account reasonably compatible with the present formulation.

REFERENCES

- Attneave, F. Triangles as Ambiguous Figures. American Journal of Psychology, 81, 1968, 447-453.
- Attneave, F. and Frost, R. The Determination of Perceived Tridimensional Orientation by Minimum Criteria. Perception and Psychophysics, 6, 1969, 391-396.
- Beck, J. and Gibson, J.J. The Relation of Apparent Shape to Apparent Slant in the Perception of Objects. Journal of Experimental Psychology, 50, 1955, 125-133.
- Braunstein, M. and Payne, J.W. Perspective and Form Ratio as Determinants of Relative Slant Judgments. Journal of Experimental Psychology, 81, 1969, 584-590.
- Cook, M.L. An Exact Test of the Size-Distance Invariance Hypothesis. American Journal of Psychology, 79, 1966, 568-575.
- Epstein, W. and Landauer, A.A. Size and Distance Judgments under Reduced Conditions of Viewing. Perception and Psychophysics, 6, 1969, 269-272.
- Epstein, W., Park, J., and Casey, A. The Current Status of the Size-Distance Hypothesis. Psychological Bulletin, 58, 1961, 491-514.
- Eriksson, E.S. The Shape Slant Invariance Hypothesis in Static Perception. Scandinavian Journal of Psychology, 8, 1967, 193-208.
- Flock, H.R. Optical Texture and Linear Perspective as Stimuli for Slant Perception. Psychological Review, 72, 1965, 505-514.
- Flock, H., Graves, D., Tenney, J., and Stephenson, B. Slant Judgments of Single Rectangles at a Slant. Psychonomic Science, 7, 1967, 57-58.
- Freeman, R.B. Function of Cues in the Perceptual Learning of Visual Slant: An Experimental and Theoretical Analysis. Psychological Monographs, 80, (2, Whole No. 610).
- Gregory, R.L. Distortion of Visual Space as Inappropriate Constancy Scaling. Nature, 199, 1963, 678-680.
- Gregory, R.L. Visual Illusions. Scientific American, Vol 219, No. 5 (1968), 66-76.
- Hochberg, J.E. In the Mind's Eye, in Contemporary Theory and Research in Visual Perception, (ed.) R.N. Haber. New York: Holt, Rinehart and Winston, 1968, 309-331.
- Hochberg, J.E. Perception. Englewood Cliffs, N.J.: Prentice-Hall, 1964.
- Kaiser, P.K. Perceived Shape and its Dependency on Perceived Slant. Journal of Experimental Psychology, 75, 1967, 345-353.
- Penrose, L. and Penrose, R. Impossible Objects: A Special Type of Visual Illusion. British Journal of Psychology, 49, 1958, 31-33.

Perkins, D. Cubic Corners. Quarterly Progress Report No. 89 of the M.I.T. Research Laboratory of Electronics, 1968, 207-214, and this Technical Report.

Pirenne, M.H. Optics, Painting and Photography. Cambridge University Press, 1970.

Rump, E.E. A Modified Replication of Cook's Invariance-Hypothesis Experiment. American Journal of Psychology, 82, 1969, 291-307.

Senall, M.H., Campbell, D.T., and Herskovits, M.J. The Influence of Culture on Visual Perception. New York: Bobbs-Merrill, 1966.

Stanley, G. Stimulus-Range and Magnitude Estimates of Distance Based on Object Size. Australian Journal of Psychology, 20, 1968, 67-69.

Willey, R. and Gyr, J. Motion Parallax and Projective Similarity as Factors in Slant Perception. Journal of Experimental Psychology, 79, 525-532.

Woodworth, R.S. and Schlosberg, H. The Relationship Between Size and Distance, in Experimental Psychology. New York: Holt, Rinehart and Winston, 1954, 480-487.

PROJECT ZERO

Harvard Project Zero is a basic research program at the Harvard Graduate School of Education investigating creation and comprehension in the arts and means toward better arts education. Four years ago, Project Zero commenced its search for communicable general principles that could provide some guidance in the design and evaluation of programs for artist and audience education. Such principles, we felt, should be based on a fundamental study of the nature of human abilities important to the various arts, a study investigating relationships of transfer or inhibition among those abilities and seeking means for fostering such abilities. Our effort has involved conceptual analyses, the survey of relevant experimentation and literature in Psychology and other fields, design and sometimes execution of experiments, and visits to institutions engaged in art education.

One starting point of our study was the systematic analysis of types of symbolism and symbol processing in Languages of Art, by Project Director Nelson Goodman, Professor of Philosophy and Research Associate in Education at Harvard University. We have considered such other subjects as the differential impairment of abilities under various types of brain damage, the role of problem solving in artistic endeavor, relations between the psychology of vision and the visual arts, perception of rhythm in music, and style recognition in various media. Though the development of actual curricula in arts education is not a primary concern, the Project does contribute to the field of practical education by responding when possible to requests for consultation and by suggesting needed programs. The Harvard Summer School Institute in Arts Administration was established at the recommendation and with the cooperation of the Project.

The Project sponsors a series of lecture-performances in various media, designed to give the general public and prospective public school teachers and administrators better insight into and attitude toward artists and the arts. As the series title, "Art in the Making" suggests, the purpose of the lecture-demonstrations is to reveal something of the artist's way of working, rather than to display his products. This work with artists in an educational context also brings our theoretical research into constant contact with practical and artistic realities.

PROJECT ZERO TECHNICAL REPORTS

1. V.A. Howard, Harvard Project Zero: A Fresh Look at Art Education
2. Barbara Leondar, The Arts in Alternative Schools: Some Observations
3. Howard Gardner, The Development of Sensitivity to Figural and Stylistic Aspects of Paintings
4. Howard Gardner, Three Studies of Perception of Artistic Styles
5. David Perkins, Geometry and the Perception of Pictures: Three Studies

The following reports are forthcoming:

6. V.A. Howard, On Musical Expression
On Musical Denoting
7. Frank L. Dent, The Lecture-Demonstration as a Teaching Method

PROJECT ZERO STAFF

Dr. Nelson Goodman, Director
Professor of Philosophy
Harvard University

Dr. David Perkins
Assistant Director

Frank L. Dent
Manager

Jeanne Bamberger
Lecturer and Research Associate
Education Research Center
Massachusetts Institute of Technology

Dr. Howard Gardner
Post Doctoral Fellow
Social Science Research Council

Dr. V.A. Howard
Department of Philosophy
Althouse School of Education
University of Western Ontario

Dr. John M. Kennedy
Department of Social Relations
Harvard University

Dr. Paul A. Kolers
Department of Psychology
University of Toronto

Dr. Barbara Leondar
Graduate School of Education
Harvard University

Graham Roupas
Department of Philosophy
University of Connecticut