

DOCUMENT RESUME

ED 112 087

CE 004 853

AUTHOR Troutman, Carol  
 TITLE Dishwashing--By Hand and By Machine.  
 INSTITUTION Rutgers, The State Univ., New Brunswick, N.J. Curriculum Lab.  
 SPONS AGENCY New Jersey State Dept. of Education, Trenton. Div. of Vocational Education.  
 PUB DATE Feb 74  
 NOTE 30p.

EDRS PRICE MF-\$0.76 HC-\$1.95 Plus Postage  
 DESCRIPTORS Course Content; \*Dishwashing; Laboratory Manuals; Learning Activities; \*Occupational Home Economics; Post Secondary Education; Secondary Education; \*Study Guides

ABSTRACT

The illustrated manual is designed for student use in learning home dishwashing and in preparing for a job as a dishwashing-machine operator. The six parts cover vocabulary, hand dishwashing, machine dishwashing, problems and checks, special treatment of various dishes, and safety tips. The vocabulary section presents an objective and defines 22 dishwashing terms with accompanying specific illustrative student activities. Suggestions for review and a worksheet to check comprehension complete this section. Objectives, lists of equipment, detailed outline of procedures, review suggestions, and worksheets are provided for the hand dishwashing and machine dishwashing parts. The problems and checks section also includes objectives and a worksheet with information presented in tabular form showing five problems related to dishwashing and how and why to check for each. Parts five and six briefly describe special treatment of dishes and safety tips. A 20-item true-false review concludes the manual. (MS)

\*\*\*\*\*  
 \* Documents acquired by ERIC include many informal unpublished \*  
 \* materials not available from other sources. ERIC makes every effort \*  
 \* to obtain the best copy available. Nevertheless, items of marginal \*  
 \* reproducibility are often encountered and this affects the quality \*  
 \* of the microfiche and hardcopy reproductions ERIC makes available \*  
 \* via the ERIC Document Reproduction Service (EDRS). EDRS is not \*  
 \* responsible for the quality of the original document. Reproductions \*  
 \* supplied by EDRS are the best that can be made from the original. \*  
 \*\*\*\*\*

State of New Jersey  
Department of Education  
Division of Vocational Education

## DISHWASHING - By Hand and by Machine

Carol Troutman, Instructor  
Division of Special Needs

Donald Springle, Superintendent  
Camden County Vocational and Technical Schools  
Sicklerville, New Jersey

Vocational-Technical  
Curriculum Laboratory  
Rutgers - The State University  
Building 4103 - Kilmer Campus  
New Brunswick, New Jersey

February, 1974

DIVISION OF VOCATIONAL EDUCATION  
STEPHEN POLIACIK, ASSISTANT COMMISSIONER

CURRICULUM LABORATORY  
RUTGERS - THE STATE UNIVERSITY  
BUILDING 4103 - KILMER CAMPUS  
NEW BRUNSWICK, NEW JERSEY

## TABLE OF CONTENTS

	Page
Part One –	
Vocabulary . . . . .	1
Worksheet #1 . . . . .	8
Part Two –	
Hand Dishwashing . . . . .	10
Worksheet #2 . . . . .	12
Part Three –	
Machine Dishwashing . . . . .	14
Worksheet #3 . . . . .	18
Part Four –	
Problems and Checks . . . . .	20
Worksheet #4 . . . . .	22
Part Five –	
Special Treatment of Various Dishes . . . . .	23
Part Six –	
Safety Tips To Remember. . . . .	24
Dishwashing Review . . . . .	25

## PART ONE – VOCABULARY

**Objective:** Learn what certain words mean in dishwashing.

This lesson deals with a very important skill: dishwashing. You will learn some things you need to know about washing dishes correctly. This will make you a better dishwasher at home, and may help you get a job as a dishwashing-machine operator in some business.

To do this lesson correctly, you should do the following:

1. Read and say out loud all of the vocabulary words.
2. Do the activities and learn what they have to do with dishwashing.

### Vocabulary

- \* 1. **Dirt** – Mud or dust or earth or grease or anything that is not clean.
- \* 2. **Germs, bacteria** – Very, very tiny living things, so small that we cannot see them. But they can grow into something harmful to the body.
- \* 3. **Sanitation, sanitary, sanitize, pure, clean, free from germs** – No dirt can be seen, and germs cannot be found.

### Student Activities

Get 3 plates – one washed well, one rinsed, one dirty. Get 3 petri dishes (small glass dishes with glass lids). Rub a piece of cotton on each plate; put each piece into a petri dish. Label each.



CLEAN



RINSED



DIRTY

Let them sit for several days. Each day compare what you see in the three dishes. The growth you see are the bacteria, or germs.

- a. Which dish or plate was more *sanitary*?
- b. Which had the most *bacteria*?
- c. Which would you use?
- d. What could the *germs* do to you?
- e. Do you now know the importance of *sanitation*??

\* 4. Manufacture – to make something, either by hand or by machine.

\* 5. Equipment – things needed to do a job.

Student Activities

Study the *equipment* necessary for dishwashing:

**HAND DISHWASHING**

**MACHINE DISHWASHING**

- Rubber Scraper to clear food from dishes



- Garbage can (lined with plastic)



- 3 separate tanks of water

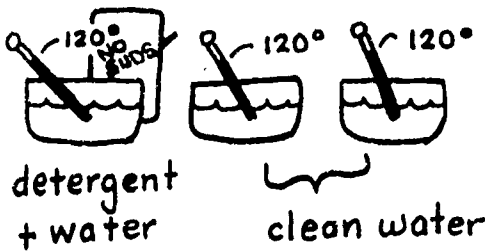

- Drying racks



- Good detergent (mild enough for hands)



- Rubber scraper to clear food from dishes

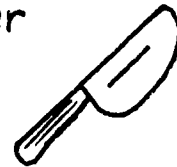

- Garbage can (lined with plastic)



- Dishwashing Machine

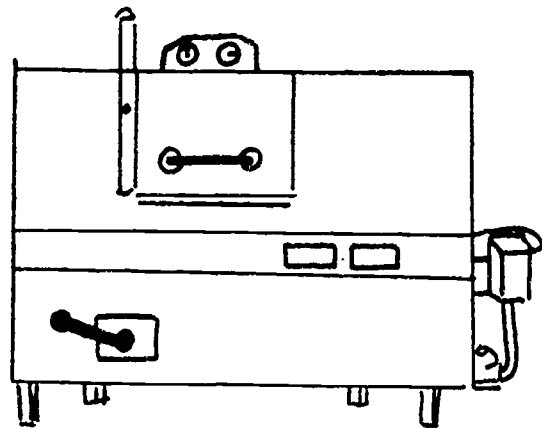

- Good detergent (strong enough to clean)



Are all of these things *manufactured*? Describe something that is *not manufactured* (example – an apple). Now something that *is manufactured* (example – applesauce). What are the differences? Why is it necessary to have *manufactured equipment* for dishwashing? Why are laws needed for the *manufacture* of this *equipment*? What could happen to your safety with equipment not manufactured properly?

\* 6. Maximum – largest, highest, greatest amount

\* 7. Minimum – smallest, lowest, least amount.

### Student Activities

Fill a glass with water. Keep adding water until it almost spills. This is the *maximum* amount of water for that glass. In another glass put as little water as possible. This is the *minimum* amount. *Maximum* and *minimum* amounts will be different for different things.



MAXIMUM



EMPTY



MINIMUM

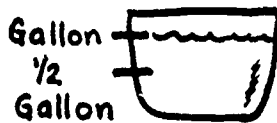

ONE GALLON OF WATER



MAXIMUM



EMPTY



MINIMUM

\* 8. Liquid – Something like water or milk that can spill over.

\* 9. Dissolve – Put something in a liquid and mix it until you can't see it (like sugar in water).

\*10. Solution – A liquid in which something has been dissolved.

\*11. Detergent – A cleaner, like soap.

## Student Activities

Fill 2 glasses with warm water. Add a powdered dishwashing detergent, a teaspoonful at a time, to one glass of water. Stir after each teaspoonful is added. Count how many teaspoonfuls you add. Is the detergent still mixed with the water? If yes, you have made a *solution*. If you see some detergent, you have put in more than the water could dissolve.

Now take the second glass of water. Add enough detergent to make a solution. Do not add so much detergent that it falls to the bottom of the glass. Now compare the two glasses:

- Which solution would be better for washing dishes?
- What would happen if there is not enough detergent in the solution?
- What would happen with too much detergent?

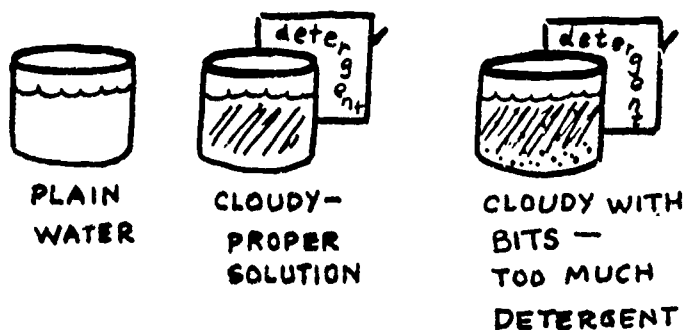

- \* 12. Glassware – Anything made from glass, like drinking glasses, juice glasses, and fruit cups.





- \* 13. Chinaware – Any dishes made from clay, like plates, cups, and saucers, soup bowls.

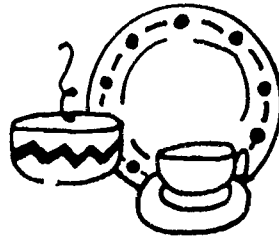

- \* 14. Stainless steel and silverware – Any metal dishes, knives, forks, spoons.



- \* 15. Temperature – heat. Temperature is measured on a thermometer.



### Student Activities

Put warm water in a sink. Measure the temperature with a thermometer. Put your hand in and keep it in for a little while. Does the water feel too hot for you? If not, add some hot water. What does the thermometer read when the water is as hot as you can take it? This is the *maximum* temperature for you – hottest your hand can take. Usually the maximum for hand dishwashing is 120° on the thermometer.

- \* 16. Water pressure – Force of the water. How hard the water comes out of the faucet.



**LITTLE WATER PRESSURE**



**A LOT OF WATER PRESSURE**

### Student Activities

Place your hand, palm up, on the bottom of the sink. Turn on the water a little. This is a *little* water pressure. Now slowly increase the water. This is a *lot* of water pressure.

- \* 17. Pre-wash, pre-flush – to rinse with water after scraping the dishes.
- \* 18. Cycle – In a dishwashing machine, a certain part of the dishwashing job.

PRE-WASH CYCLE	WASH CYCLE	RINSE CYCLE	FINAL (LAST) RINSE CYCLE
(After dishes are scraped, warm water rinses away food.)	(Detergent solution washes dishes.)	(First rinse removes soap.)	(Second rinse with hot water (180°), so dishes will dry quickly.)

- \* 19. Jets – The part of a dishwashing machine that forces water out at the proper *pressure* to clean and rinse the dishes.

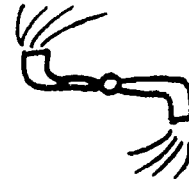

#### Student Activities

Work with a dirty plate at the sink.

- a. What happens when there is not enough pressure?
  - b. What happens when there is too much pressure?
- \* 20. Hard water – Water that has minerals from the earth, such as iron, dissolved in it. Hard water does not clean as well as soft water.
  - \* 21. Scum, film, scale – Bits of dirt, grease, or earth minerals left on dishes. A film on dishes may be because of: hard water, or not enough detergent, or not enough hot water, or a bad rinse cycle.
  - \* 22. Drain – to dry off.

#### Student Activities

Test for hard water: Put about one inch of water in a glass and let it evaporate (go off into the air). If any scum or film is found in the glass, the water is *hard*. Hard water does not run off the dishes fast, and the dishes take longer to dry. If you have hard water add a water "softener" to the final rinse. See if the dishes dry faster that way.

Review:

1. Keep an up-to-date record of your Student Activities.
2. Be able to read and explain the vocabulary words to other students and to your teacher.
3. Be sure you understand why all the things you have learned are important in dishwashing.
4. Do Worksheet #1.

WORKSHEET # 1

Vocabulary

A. Here are 10 words. Under each word you may choose (a) or (b) or (c). Choose the one that tells what the word means in *dishwashing*. (Put a circle around the letter of the answer you choose. See word # 1.)

1. *maximum*

(a) the highest (b) the lowest (c) detergent

2. *equipment*

(a) bacteria (b) overflow (c) tools to do a job

3. *sanitary*

(a) free from germs (b) dirty (c) stainless steel

4. *hard water*

(a) water frozen in pipes (b) water with minerals like iron  
(c) soft water

5. *bacteria*

(a) solution (b) back of machine (c) very tiny living things

6. *jets*

(a) airplanes (b) water with a lot of pressure (c) drying racks

7. *detergent*

(a) minimum (b) a cleaner (c) water softener

8. *manufacture*

(a) make by hand or machine (b) pre-wash cycle  
(c) break between wash and rinse

9. *scum*

(a) jet (b) film (c) high temperature

10. *cycle*

(a) wheels in machine to move racks (b) wash tank overflow  
(c) a part of the dishwashing job

B. Choose 5 words from part A and use each in a sentence about dishwashing.

---

---

---

---

---

---

---

---

---

---

---

C. List equipment used in hand dishwashing:

---

---

---

---

---

D. List equipment used in machine dishwashing:

---

---

---

---

---

## PART TWO – HAND DISHWASHING

**Objectives:** Know how the vocabulary words are really used in the actual dishwashing. Set up equipment properly. Prepare dishes for hand dishwashing – sort, pre-wash. Wash various types of dishes correctly.

Detergents used in hand dishwashing are *mild* – they do not harm the skin. Because your hands are in the water for a long time, hand dishwashing detergents have things in them to keep hands soft. They usually smell nice, too. They also make a lot of suds. Suds would clog up a machine.

The temperature of the water for hand dishwashing is much lower than for machine washing. Your hands can take water up to about 120°. A machine can use water up to 195°.

Equipment needed:

Rubber scraper

Garbage container

Detergent

Sponge or dish cloth

3 separate tanks of water at a maximum temperature of 120° with water

1 with detergent

1 with plain water for rinsing

1 for rinsing, with water softener if needed

Drying racks

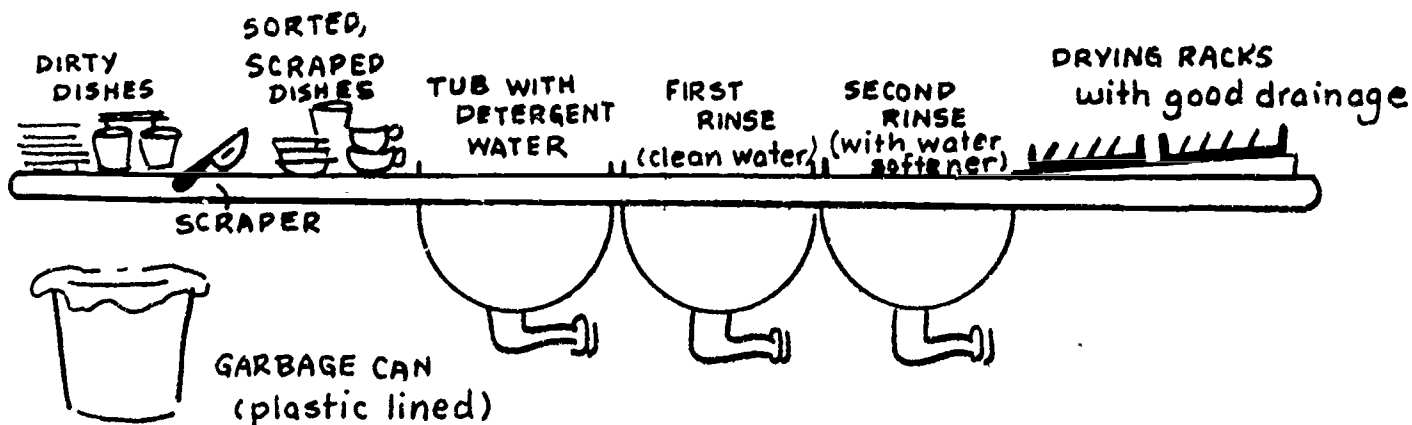

Procedure (How to do the job):

A. Set up equipment as in picture on page 10.

1. Garbage can at left
2. Place for dirty and scraped dishes
3. Three tanks of water at 120° maximum
  - 1 with detergent and water
  - 2 for rinsing
4. Draining racks so dishes will dry. The water must not drip to the floor.

B. Scrape solid bits from dishes.

C.\*Start washing.

D. If possible, begin with the glassware.

Wash dishes in first tank. Use sponge or cloth.

Rinse in second tank,

Place in third tank for 2 or 3 minutes.

Place dishes in rack to dry.

Put dishes away as soon as possible. This keeps down the number of bacteria.

CAREFUL! Watch where you are putting the dishes, or you might break them.

Review:

1. Let your teacher know when you are ready to do a dishwashing job.
  - a. Sanitation will be checked.
  - b. Dishwashing will be timed to see how long it takes you.
2. Do Worksheet # 2.

\* C. Place dishes in neat piles. This is called *sorting* dishes.

WORKSHEET # 2

Hand Dishwashing

A. Draw a picture of the setup for hand dishwashing.

B. Here is a list of things we do when we wash dishes. See if you can fill in the missing words. (See #1 – it has been filled in for you.)

1. Set up equipment.
2. Scrape the \_\_\_\_\_.
3. Sort the \_\_\_\_\_.
4. Begin the washing with the \_\_\_\_\_.
5. Wash the dishes in a solution of \_\_\_\_\_.
6. Rinse the dishes in plain \_\_\_\_\_.
7. Place the dishes in the third tank.
8. Let the dishes \_\_\_\_\_.
9. Put the dishes \_\_\_\_\_.

C. Match the following pieces of equipment to their uses (See first example.)

- |  |              |                                |
|--|--------------|--------------------------------|
| a. Used in water to clean dishes                 | <u>  b  </u> | 1. Water softener              |
| b. Used in water to help dishes dry faster       | _____        | 2. Detergent                   |
| c. Place where you wash dishes                   | _____        | 3. Tub with detergent solution |
| d. Place where the dishes dry                    | _____        | 4. Tub with plain water        |
| e. Place where you rinse off the detergent       | _____        | 5. Drainage rack               |
| f. Thing used to scrape bits of food from dishes | _____        | 6. Garbage can                 |
| g. Place to collect food you scrape from dishes  | _____        | 7. Rubber scraper              |



- D. Here is a list of words. In the sentences below, fill in each blank space with one of these words. Choose the word that makes the best sense each time. (See the first example.)

#### Word Choices

detergent	water softener
maximum	rubber scraper
bacteria	sanitary
detergent	draining racks
	floor

1. A good detergent must be used in the wash water to get dishes clean.
2. The temperature in hand dishwashing is a \_\_\_\_\_ or 120° , because hands cannot take the water any hotter.
3. Put dishes away as soon as possible to keep down the number of \_\_\_\_\_ .
4. In hand dishwashing there are 3 tubs of water. In the first there is \_\_\_\_\_ , in the second there is plain water, and in the third there can be \_\_\_\_\_ .
5. A \_\_\_\_\_ is used to clean food from the dishes.
6. Dishes that are not cleaned properly are not \_\_\_\_\_ .
7. You need good \_\_\_\_\_ so that the dishes will dry.
8. Water must not drip to the \_\_\_\_\_ when dishes are draining.

### PART THREE – MACHINE DISHWASHING

Objectives: Know how the vocabulary words are really used in machine dishwashing.

Set up equipment properly.

Understand the different operations on the machine.

Prepare dishes for machine dishwashing.

Wash various types of dishes properly by machine.

It is very, very important to wash the dishes so they are *clean* and *sanitary*. We need clean dishes because people can get sick from the bacteria on dishes that are not clean.

The government has people who come around to restaurants and check up on sanitation. They also see that the restaurant follows the rules in using dishwashing machines, water heaters, and other equipment.

Equipment needed:

rubber scraper (if machine does not contain a scraper unit)

garbage can

good detergent

water softener if you have hard water

pre-wash tub (unless machine has own pre-wash)

dishwashing machine and proper racks

stacking area at end

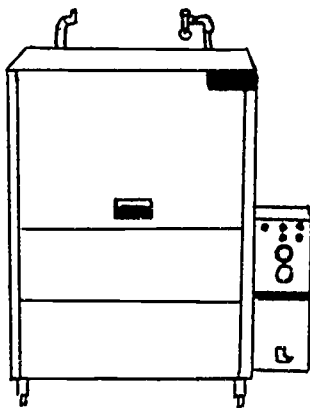

OUTSIDE OF WASHING MACHINE

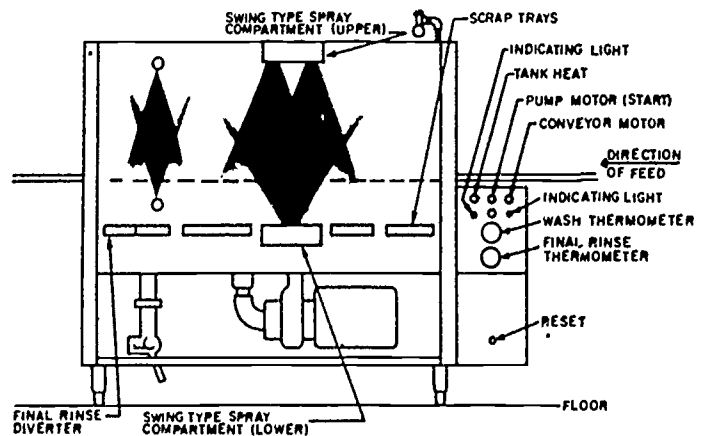

INSIDE OF WASHING MACHINE

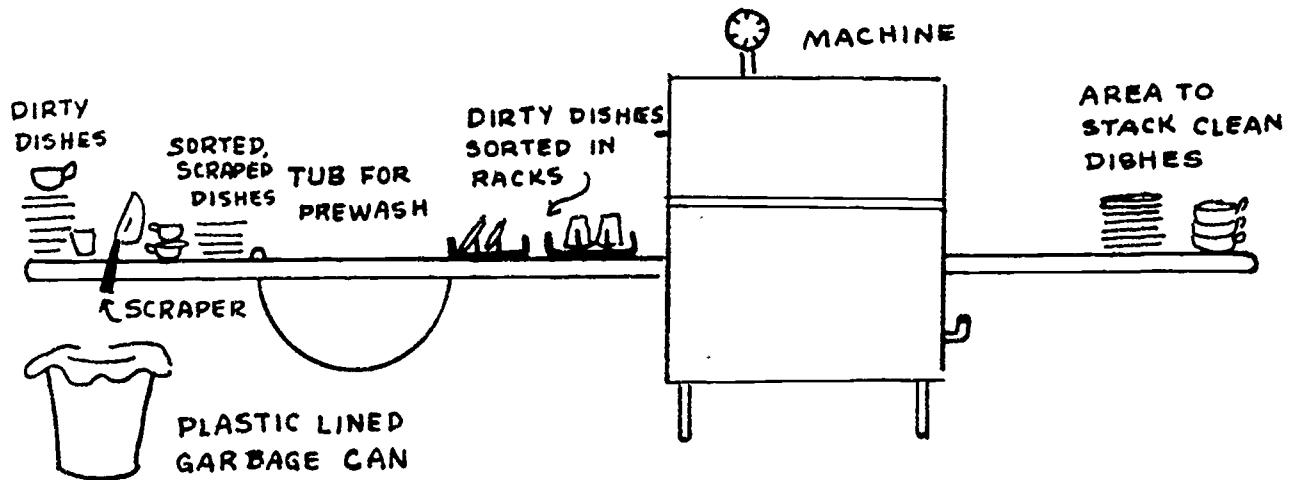

Procedure:

Set up work area as in picture above.

*Before you start:*

Soak silverware so that food will not dry on it and stick to it.

If there are not enough dishes for the machine, scrape, sort and stack the dishes. Wet them to keep food from drying if they have to wait long.

Make sure you have proper racks.

Make sure you have a place to put dry dishes.

1. Getting the machine ready:

- a. Check machine for dirt.
- b. Close drain.
- c. Fill wash tank. Tank is full when water reaches top of overflow.
- d. Put scrap trays in place.
- e. Make sure water level is up, and turn on water heater.
- f. Add detergent.
- g. Run machine through one or two cycles to get cold water out and to mix water and detergent.

## 2. Pre-washing

Scrape dishes so bits will not stop-up machine.



Pre-flush by hand or machine with hot water. This helps prevent sudsing and helps the wash cycle to clean better.



## 3. Sorting and racking

Put dishes of same size and shape in a rack that will hold them.



**NOT PROPERLY  
RACKED**



**PROPERLY RACKED**

Plates and flat dishes should be placed so that curved side will face spray.

Cups and bowl should be upside down.



Silverware should be spread apart.



**WILL NOT GET  
CLEAN**

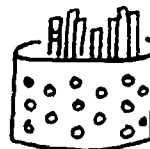

**PROPERLY  
SET UP**

If you use the proper racks and stack dishes properly, you should have no trouble!

## 4. Washing

Turn on the machine.

Be sure you know how to turn the machine OFF quickly – in case of emergency.

## 5. Drying

Quick-dry – water 180° or higher.

Rinse product (water softener) may be added for quicker drying.

Do not hand dry. Bacteria on towel may make dishes unsanitary. Also dishes are easily broken when you dry by hand.



## 6. Closing down machine

Turn off heater.

Open drain.

Empty scrap trays.

Clean inside of dishwasher.

Put a small amount of water in tank. This will keep the heater pilot light from burning the tank.

### Review:

1. Go over procedure until you know it. Let your teacher know when you are prepared to do a dishwashing job.
2. The teacher will time you when you set up the machine to see how fast you can work.
3. Keep a record each time you set up and close down the machine – whether you found the machine clean and ready; what adjustments you had to make. Your teacher will set up a form for you to follow.
4. Complete Work sheet # 3.

WORKSHEET # 3

Machine Dishwashing

A. Write in T if true, F if false (not true).

- \_\_\_ 1. Sanitation of dishes is important to health.
- \_\_\_ 2. Cups and bowls should be put in machine upside down.
- \_\_\_ 3. Silverware should be put very close together.
- \_\_\_ 4. The government has people who check up on restaurants to see that they are sanitary.
- \_\_\_ 5. Sudsing is not good in a machine.
- \_\_\_ 6. If there are not enough dishes for the machine, scrape and stack dishes.
- \_\_\_ 7. Soak silverware.
- \_\_\_ 8. Soaking dishes is bad because it makes the food stick to them.
- \_\_\_ 9. You can use any size racks.
- \_\_\_ 10. You should run the machine through 1 or 2 cycles to get rid of cold water in the pipes.
- \_\_\_ 11. Dishes do not have to be scraped, because the machine will grind up food pieces.
- \_\_\_ 12. You should always leave a small amount of water in tank. This will keep the pilot light from burning it.
- \_\_\_ 13. Hand drying is good because it speeds up the drying.
- \_\_\_ 14. Do not fill wash tank because water will overflow a full tank.
- \_\_\_ 15. The machine does not have to be cleaned.

B. Draw a picture of the setup for machine dishwashing.

C. Here is a list of things we do when we wash dishes by machine. See if you can fill in the missing words. (# 1 has been filled in for you.)

1. Set up equipment .
2. Soak the \_\_\_\_\_ .
3. Get the machine ready.
4. Scrape the \_\_\_\_\_ .
5. Pre-flush or pre- \_\_\_\_\_ the dishes.
6. Sort dishes and place them in \_\_\_\_\_ .
7. Do the \_\_\_\_\_ cycle.
8. Do the \_\_\_\_\_ cycle.
9. Close down machine.
10. Put dishes \_\_\_\_\_ .

## PART FOUR – PROBLEMS AND CHECKS

**Objectives:** Know when the machine is not working right.

Know what to check when problems come up.



Most of the time the dishwashing machine does a very good job. The dishes come out clean and sanitary.

But sometimes you may find that things go wrong. On the next page is a chart that shows some problems that might come up.

Study the chart. Learn what to check if something goes wrong, and why.

Then do Worksheet # 4.

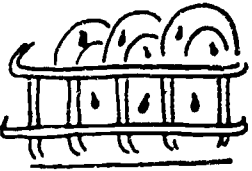
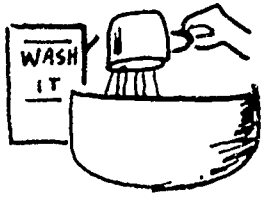
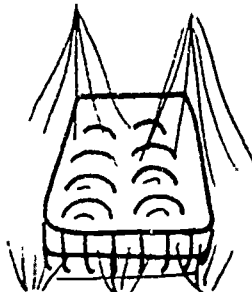
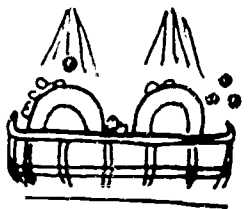

PROBLEM	CHECK	WHY
<p>1. WATER SPOTS AND FILM ON DISHES</p> 	<p>a. Final-rinse jets.  b. Hard rinse water  c. Time, Temperature, Pressure    d. Drying time    e. Not enough detergent</p>	<p>a. Final rinse removes wash water. It must cover all dishes.  b. Hard water leaves a scale.  c. Time too short leaves dirt. Temperature too hot causes flash drying; will leave spots. Pressure too low, poor rinse.  d. If too long, water left causes spots. (Rinse product can be added.)  e. Must use enough to clean properly.</p>
<p>2. GREASE IN MACHINE OR ON DISHES</p> 	<p>a. Daily cleanup  b. Spray jets  c. Not enough detergent  d. Fresh water added to wash tank.</p>	<p>a. Some places are not reached by spray and so must be cleaned daily.  b. May be stopped up.  c. Too little detergent will not clean properly.  d. Need to add fresh water so scum will overflow into drain. (But too much will make detergent weak.)</p>
<p>3. DIRTY DISHES</p> 	<p>a. Spray jets  b. Not enough detergent  c. Overflows</p>	<p>a. Stopped up sprays will not wash properly  b. Enough detergent must be used or machine will not clean properly  c. Grease should overflow from wash tank</p>
<p>4. TOO MUCH SUDSING</p> 	<p>a. Detergent  b. Rinse Product  c. Wash-water level    d. Daily cleanup</p>	<p>a. Should not be sudsing type  b. If used, should not be sudsing  c. Should be high enough to cover pump, or pump will force air in water. Also, scum should overflow.  d. Clean daily while still warm to remove any grease.</p>
<p>5. BLACK MARKS ON DISHES</p> 	<p>a. Rack and tables  b. Rubber or plastic</p>	<p>a. Marks come from touching certain things.  b. Daily cleaning will help.</p>

WORKSHEET # 4

Problems and Checks

A. What would you check if . . . . ? (Give at least 2 checks for each.)

1. There was too much sudsing.

---

---

---

2. You found grease in the machine or on the dishes.

---

---

---

3. There were black marks on the dishes.

---

---

---

4. Dishes were dirty.

---

---

---

5. You found water spots or film on dishes.

---

---

---

## PART FIVE – SPECIAL TREATMENT OF VARIOUS DISHES

Objectives: Know differences in materials used for dishes and silverware.

Know what to do for each type of material to keep it in good condition.

### Chinaware:

Made of clay.

Usually has shiny finish.

When washed and rinsed at proper temperature,  
should have no trouble.

Dries in about one minute.



### Glassware

Wash glasses first.

If possible wash in a machine with  
brushes.

Pre-wash.

Make sure wash tank is clean.



### Stainless steel and silverware

Should be washed as soon as  
possible.

Place in machine in one layer, or  
spread apart in holder.

If not fully dry, use a clean towel to dry them.

This will help prevent stains and bacteria.



## PART SIX – SAFETY TIPS TO REMEMBER

**Objectives:** Review safety procedures.

**Remember:**

Have equipment set up properly.

Use only 120° water for hand dishwashing.

Have space to put down clean, dry dishes.

Clean the place before and after washing.

In machine, be sure to have proper water temperature and detergent solution for different materials.

Check water pressure.

Leave some water in wash tank of machine after closing it down.

Dishes must be extra clean to be *sanitary*.

## DISHWASHING REVIEW

Write T if the sentence is true. Write F if it is false (not true).

- \_\_\_\_\_ 1. Bacteria can make a person sick.
- \_\_\_\_\_ 2. "Maximum" means as little as possible.
- \_\_\_\_\_ 3. If a dish is only a little bit dirty, it is sanitary.
- \_\_\_\_\_ 4. "Equipment" means the tools you work with.
- \_\_\_\_\_ 5. Glassware is washed last.
- \_\_\_\_\_ 6. Chinaware should be dried with a towel.
- \_\_\_\_\_ 7. Soak silverware so that food will not stick to it.
- \_\_\_\_\_ 8. You need good water pressure to clean dishes in a dishwasher.
- \_\_\_\_\_ 9. The temperature for machine washing is 120°.
- \_\_\_\_\_ 10. A machine has a wash cycle and rinse cycles.
- \_\_\_\_\_ 11. A pre-wash means an extra wash at the end of the wash cycle.
- \_\_\_\_\_ 12. Hard water is not as good for dishwashing as soft water.
- \_\_\_\_\_ 13. Scum and film and scale all mean the same.
- \_\_\_\_\_ 14. In a machine, the water comes out of jets.
- \_\_\_\_\_ 15. You use a rubber scraper to get the bits of food off the plates and on to the floor.
- \_\_\_\_\_ 16. It is good when the water from the drainage racks drips to the floor. This cleans the floor.
- \_\_\_\_\_ 17. A good dishwasher can make dishes sanitary without detergent.
- \_\_\_\_\_ 18. A detergent for a dishwashing machine should not make suds.
- \_\_\_\_\_ 19. Grease on the dishes may be caused by stopped up spray jets.
- \_\_\_\_\_ 20. You should wait for the machine to cool down before you clean it.