

DOCUMENT RESUME

ED 111 621

SE 017 458

AUTHOR Mackin, T. E.
 TITLE Propulsion Systems for Aircraft. Aerospace Education II.
 INSTITUTION Air Univ., Maxwell AFB, Ala. Junior Reserve Office Training Corps.
 PUB DATE 73
 NOTE 136p.; Colored drawings may not reproduce clearly. For the accompanying Instructor Handbook, see SE 017 459. This is a revised text for ED 068 292

EDRS PRICE MF-\$0.76 HC-\$6.97 Plus Postage
 DESCRIPTORS *Aerospace Education; *Aerospace Technology; Aviation Technology; Energy; *Engines; *Instructional Materials; *Physical Sciences; Science Education; Secondary Education; Textbooks
 IDENTIFIERS *Air Force Junior ROTC

ABSTRACT

This is a revised text used for the Air Force ROTC program. The main part of the book centers on the discussion of the engines in an airplane. After describing the terms and concepts of power, jets, and rockets, the author describes reciprocating engines. The description of diesel engines helps to explain why these are not used in airplanes. The discussion of the carburetor is followed by an explanation of the lubrication system. The chapter on reaction engines describes the operation of jets, with examples of different types of jet engines. (PS)

 * Documents acquired by ERIC include many informal unpublished *
 * materials not available from other sources. ERIC makes every effort *
 * to obtain the best copy available. nevertheless, items of marginal *
 * reproducibility are often encountered and this affects the quality *
 * of the microfiche and hardcopy reproductions ERIC makes available *
 * via the ERIC Document* Reproduction Service (EDRS). EDRS is not *
 * responsible for the quality of the original document. Reproductions *
 * supplied by EDRS are the best that can be made from the original. *

U S DEPARTMENT OF HEALTH,
EDUCATION & WELFARE
NATIONAL INSTITUTE OF
EDUCATION

THIS DOCUMENT HAS BEEN REPRO-
DUCED EXACTLY AS RECEIVED FROM
THE PERSON OR ORGANIZATION ORIGIN-
ATING IT. POINTS OF VIEW OR OPINIONS
STATED DO NOT NECESSARILY REPRE-
SENT OFFICIAL NATIONAL INSTITUTE OF
EDUCATION POSITION OR POLICY

FD111621

SE 017 458



Air Force Junior ROTC

Air University/Maxwell Air Force Base

ERIC

Full Text Provided by ERIC

AEROSPACE EDUCATION II

Propulsion Systems for Aircraft

T. E. MACKIN

Academic Publications Division
3825th Academic Services Group



AIR FORCE JUNIOR ROTC

**AIR UNIVERSITY
MAXWELL AIR FORCE BASE, ALABAMA**

1973

This publication has been reviewed and approved by competent personnel of the preparing command in accordance with current directives on doctrine, policy, essentiality, propriety, and quality.

This book will not be offered for sale. It is for use only in the Air Force ROTC program.

We gratefully acknowledge the contribution of Lt Col James D. Elmer, Chief, High School Curriculum Division, AFJROTC, to the development of this text.

Preface

ONE OF MAN'S most persistent dreams is to be able to fly through the air unencumbered, like a bird. This was true hundreds of years ago, probably even back beyond the dawn of history. Evidence of the dream can be found in the fact that the gods of ancient civilizations were endowed with the power of flight. Men in these early civilizations gave to their man-like gods abilities that simple, ordinary men could not have—including the ability to fly.

The dream held true in later days also, as we can see from the many preserved drawings of human beings before, during, and after the days of Leonardo da Vinci. Even this Italian genius, whose abilities in many fields amaze sophisticated modern men, thought about, experimented with, and designed machines to allow man to leave the ground. Da Vinci and most other early theorists thought in terms of bird-like wings, operated by the muscle power of the man wearing them.

The dream exists even today, as we can see by the popularity of skydiving. This is the sport of parachutists who delight in jumping from planes, then soaring through the skies alone for as long as possible before opening their parachutes.

But accompanying this ancient dream has always been a rude awakening to the fact that man is just not built for flying. His body is too heavy to be held aloft by his arms. His arms are arms, not wings. And even with wing-like devices to hold him up, man is just not strong enough to build up the force it takes to keep himself in the air. Still, man does not concede that he is never to fly by himself,

without mechanical assistance. (The skydiver is an example of this fact.) Even today, grown men fly kites and envy the paper birds they put aloft.

In his fantasies, man still dreams of overcoming his ground-bound design and soaring off by himself. After all, he reasons, the bumblebee defies all the rules of aeronautical design, and still flies. So why not man? In the meantime, however, man has accepted a compromise: if he has not yet found a way to fly under his own power, he will do the next best thing—he will use his machines for power.

Only through the use of machines has man so far been able to even partially fulfill his dream of controlled, continuing flight. After countless centuries of gazing at the sky and envying the birds, it is only within this century that man has made any real success of his ancient dream.

It is the purpose of this volume to trace the development of the power machines that man uses to propel his flying machines through the air; to study these propulsion devices as they exist today; and to look at developments that take man far beyond the range of the birds he envies.

Contents

PREFACE	iii
<i>Chapter 1—POWER IN FLIGHT</i>	1
Flight Theory	3
Internal Combustion Engines	5
Powered Flight	6
Gliders	7
More Power	8
Success	8
Jets	10
Power Terms	11
Horsepower	12
Thrust	13
Thrust Horsepower	15
<i>Chapter 2—RECIPROCATING ENGINES</i>	19
The Reciprocating Engine	20
The Mechanical System	20
Diesel Engines	25
Types of Reciprocating Engines	26
Performance of Reciprocating Engines	29
Heat and Cooling	30
Construction Materials	32
<i>Chapter 3—OTHER ENGINE SYSTEMS</i>	37
Fuels	38
Volatility	39
Octane Rating	40
The Fuel System	42
Fuel Feeding	42
Carburetion	43
Carburetor Operation	45

Carburetor Accessories	48
Other Carburetor Types	52
Fuel Injection Systems	54
Mass Air Flow System	55
Intake Metering System	56
Advantages and Problems	57
Ignition System	58
Magnetism and Electricity	58
The Magneto	62
Starting Systems	68
The Lubrication System	69
Oil Properties	70
Oil Distribution	71
Propellers	73
Nomenclature	74
Motion	75
Forces	76
Types	78
Reversing and Feathering	78
Limitations	80
<i>Chapter 4—Gas Turbines & Jet Propulsion</i>	85
Jet Engines	86
Principles of Operation	87
Ramjet	88
Pulse Jet	90
The Turbojet	92
The Turboprop Engine	102
Turbofan Engine	105
Helicopter Engines	106
Some Important Systems	109
Accessory Section	109
Starting the Engine	109
Fuel Systems	110
Lubrication Systems	111
Water Injection	111
Thrust Reversers	112
Noise Suppression	115
Pollution	117
Comparisons	118
 SUMMARY: Propulsion's Evolution	 121
INDEX	127



Chapter 1

Power in Flight

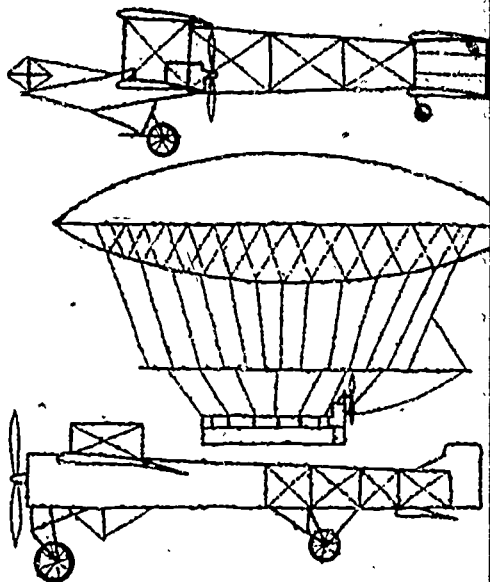

THIS CHAPTER traces the historical development of engines used to power aircraft. It gives a brief review of developments in air theory, lighter-than-air craft, and glider flight, always considering that successful powered flight incorporated advances in all of these areas. Upon completion of this chapter, you should be able to: (1) explain the main differences between internal and external combustion engines and the reasons external combustion engines proved impractical for powering aircraft; (2) tell why the internal combustion engine was so long in developing and why it was the key to powered flight; (3) explain the terms "horsepower" and "thrust" and how they are related; and (4) compare a piston engine's power to that of a jet engine.

THE SUCCESSFUL FLIGHT of powered aircraft had to await developments in several fields. The theory of flight, for instance, underwent many changes as man continued to experiment with kites and gliders, to study bird flight and the movement of sailing ships, and to think about the nature of air itself.

We have seen in such Aerospace Education books as *The Aerospace Age (AE-I)* and *Theory of Aircraft Flight (AE-II)* how man's concepts of flying developed over the years. In this book

PROPULSION SYSTEMS FOR AIRCRAFT

we look at the matter of flight from a different viewpoint: the development of the power plants that finally enabled the ancient dream to become reality.

As an adjunct to the accumulation of knowledge came physical developments. One of the most significant developments was the invention of the **steam engine** in the late eighteenth century. This new device represented man's first successful harnessing of mechanical power for useful work. It freed man from dependence on power from animals, wind, and falling water, and turned his thinking in new directions.

The steam engine was a revolutionary invention, and is still in use today. As important as the steam engine was, it had a number of basic characteristics which made it unsuitable for aircraft power. For one thing, the steam engine was too bulky. For another, it was not responsive enough to the pilot's control. It was too heavy. Moreover, it required external combustion.

External combustion meant that the fire that heated the water and turned it into steam was located outside the engine itself. This feature, with its increased danger of fire, was more than just an inconvenience for someone who intended to fly through the air under power of a steam engine. (Some steam engines were used in the early days of ballooning, but they were soon abandoned.)

Improvements in the steam engine led eventually to the development of the **internal combustion engine**, which was a very significant development in the evolution of mechanical power. One of the most important characteristics of the new engine was provision for the burning process to take place inside the engine. The internal combustion engine eventually was to provide the power for man's first successful controlled, powered flight of a heavier-than-air craft.

The development of the internal combustion engine spurred the development of new metals that were strong enough and light enough to withstand the stresses of heat and pressure in the engine, while providing sufficient power to fly an airplane. Along with the development of this new kind of engine came new thought on how power could best be produced and used.

As you have seen in previous study in the Aerospace Education course, the road to successful flight was paved with many ideas from many men over a period of many years.

Orville and Wilbur Wright collected the recorded progress in all of the fields of aviation thought, tested it, threw out what did not work, then added information on their own to the pool of knowledge. The collective knowledge produced by centuries of work by a number of people all over the world was responsible for

POWER IN FLIGHT

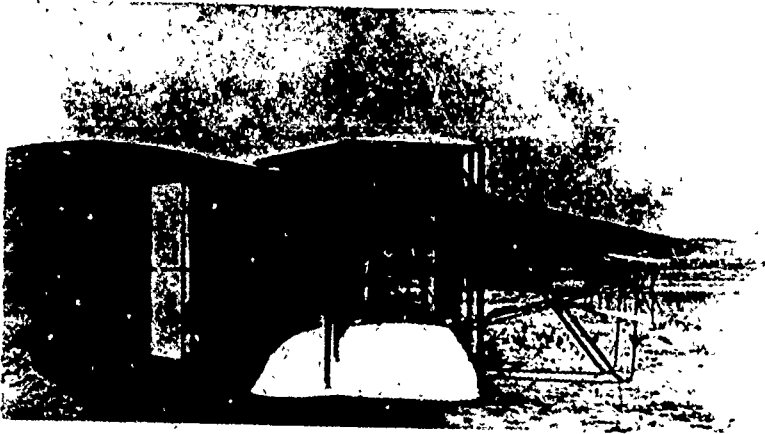

Figure 1. December 17, 1903, at Kitty Hawk, North Carolina, was the "Wright" time and place for the first successful flight of a manned, heavier-than-air machine. Here, the Wright Brothers' Flyer stands ready for its historic adventure.

the first controlled, powered, heavier-than-air flight on 17 December 1903. That historic flight lasted 12 seconds. The Wright brothers' *Flyer* (Fig. 1), with Orville at the controls, attained a forward speed of seven miles an hour, and covered a distance of about 120 feet. Those figures do not sound like much today; in fact, they were far surpassed by the Wrights themselves before the day was over. The pilots "got the hang" of flying their new machine, and they flew three more times that day. Flying into a 21-mile-an-hour wind, the last flight (with Wilbur piloting) lasted 59 seconds and covered a distance of 852 feet, at an average speed through the air of 31 miles per hour.

Orville Wright's flight represented the first successful application of the distilled knowledge of centuries of thinking, countless groping experiments, and an unknown number of unsuccessful attempts by men who would have been well satisfied to fly for 12 seconds at 7 miles an hour.

Let us briefly review that history.

FLIGHT THEORY

For centuries before the Wrights, man had used the wind for power. Wind in the sails of ships moved those ships farther and faster than humans could row. But no one knew how to use the same wind force for flight. Ancient thinkers on the matter of

flying thought that air was a sustaining force—that is, that air supported the birds, and held them up in the air. They differed on how the birds moved through the air. Some thinkers believed the birds swam through the air like a man swims through the water. Others believed the bird's forward motion was caused by the air closing around the bird's body, "squeezing" the body forward.

Leonardo da Vinci, 1452 to 1519, subscribed to the "swimming" theory, but he recognized that air hinders flight instead of helping it. Da Vinci was among the first to realize that air could be compressed, and that this compressibility acts to block flight. He made long studies of birds, and as a result, became a proponent of streamlining to cut down wind resistance as much as possible. Among da Vinci's drawings are plans for a parachute; for a kind of helicopter, which could pull itself through the air with a propeller-like screw, much as later boats would push themselves through water; and for an ornithopter, a device with bird-like wings that man could flap with his muscle power, through a system of pulleys. This wing-flapping idea seems to have been most common among early would-be aviators. (The word *aviator*, as a matter of fact, is derived from the Latin word, *avis*, which means "bird.")

In 1680, a biologist named G. A. Borelli published a work explaining, among other things, that man's muscles alone would never be able to power a heavier-than-air craft through the air. Borelli explained that man had a poor ratio of power to weight, as compared with the bird. This biological explanation did not convince everybody, though. Some "birdmen" persisted in their attempts to get off the ground with bird-like wings. There is no record that any of them succeeded.

What they could not know was that the bird's wing was far from the simple flapping arm they saw. In fact, modern high-speed photography has revealed that the outer primary feathers of a bird's wings function as propellers do to drive the bird forward (Fig. 2). Men of Borelli's time know virtually nothing about aerodynamics, however, and saw only simple flapping when they looked at a wing in operation.

Many of the air-minded thinkers after Borelli's day turned their minds to flying lighter-than-air craft, or balloons. A major problem with the balloons was how to control their direction of flight. More than a century elapsed between the publication of Borelli's work and the invention of the steam engine. The greater part of another century had gone before the steam engine was used to propel balloons.

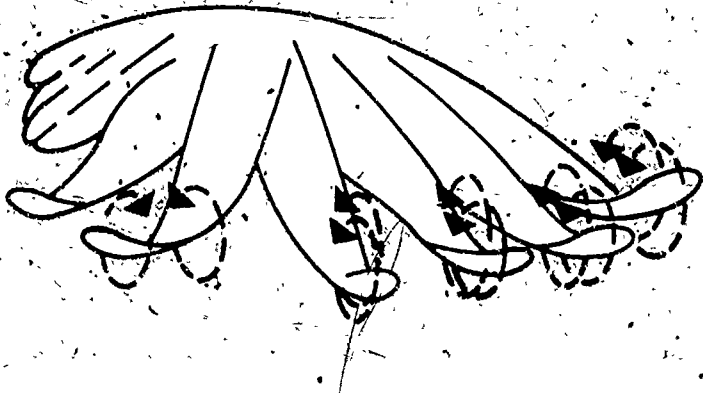

Figure 2. The early advocates of manned flight copied the wings of the birds to the best of their ability. What they did not know was that birds' wings act as propellers to drive the birds through the air. As the bird's wing beats down, the air pressure twists the outer primary feathers to the proper angle to drive the bird forward, while the remainder of the wing provides lift.

The first aircraft engine was a steam engine developed in 1851 by **Henri Giffard** of France. The engine weighed about 350 pounds and developed 3 horsepower. In September 1852, a cigar-shaped balloon flew at 6 miles an hour for 17 miles under the power of Giffard's engine, which drove directional propellers.

Internal Combustion Engines

From the time the steam engine was invented, scientists worked constantly to improve it. Their experiments led away from external combustion and toward the development of the internal combustion engine.

It is impossible to attribute to one man the invention of the internal combustion engine. Its development was made possible by an accumulation of knowledge in mechanical skills, thermodynamics (the effects of heat), experience, and the availability of materials.

The first record of the internal combustion gasoline engine was reported in 1820 by an Englishman named **W. Cecil**.

Cecil's engine operated on a vacuum-like system. The fuel burned inside the engine. As the heated air cooled, it produced an area of lower pressure. The pressure differential was used to power the engine.

Later experiments showed that better power could be obtained by using the expansion force of the burning gases, rather than the vacuum of the cooling gases. As a further refinement, in 1838, **William Barnett** of England suggested that the gasoline would produce more power if it were compressed before it was ignited.

The first really practical internal combustion engine was designed in 1860 by the Frenchman, **J.J.E. Lenoir**. Two years later, another Frenchman, **Alphonse Beau de Rochas**, came out with a theory for a four-cycle engine. His engine would have four steps: one for intake of the fuel; one for compression of the fuel; one for burning of the fuel (the power step); and one for the spent gases to be exhausted.

A German named **Nikolaus Otto** applied the de Rochas theory to real engines in 1876. He began manufacturing them in the United States in 1878. Finally, **Gottlieb Daimler** made a valuable contribution to the propulsion field when he devised a high-speed internal combustion engine in 1883.

The internal combustion engine was to be the key to powered, heavier-than-air flight.

POWERED FLIGHT

The first internal combustion engine used on an airship, as balloons were called then, used coal gas for fuel. It was devised by **Paul Hænenlein** of Germany in 1872, and had four cylinders. Eleven years later, **Albert and Gaston Tissandier** of France used an electrically-driven motor providing 1.5 horsepower on an airship.

The first use of a gasoline-burning internal combustion engine on an airship came in 1897. **David Schwartz** of Germany built the engine and installed it on a steerable balloon, or dirigible, made of aluminum sheeting stretched over a frame.

A Brazilian, **Alberto Santos-Dumont**, and a German count, **Ferdinand von Zeppelin**, both worked on dirigibles powered by internal combustion engines. Santos-Dumont started his experiments in 1898. Three years later, his dirigible flew a distance of seven miles in 29 minutes, 31 seconds. The 12-horsepower engine could move the 110-foot-long dirigible at 15 miles an hour. Count Zeppelin built a huge dirigible (420 feet long) in 1900 and powered it with two internal combustion benzine engines, developing 16 horsepower each.

Some American dirigibles were fitted with gasoline engines, as

POWER IN FLIGHT

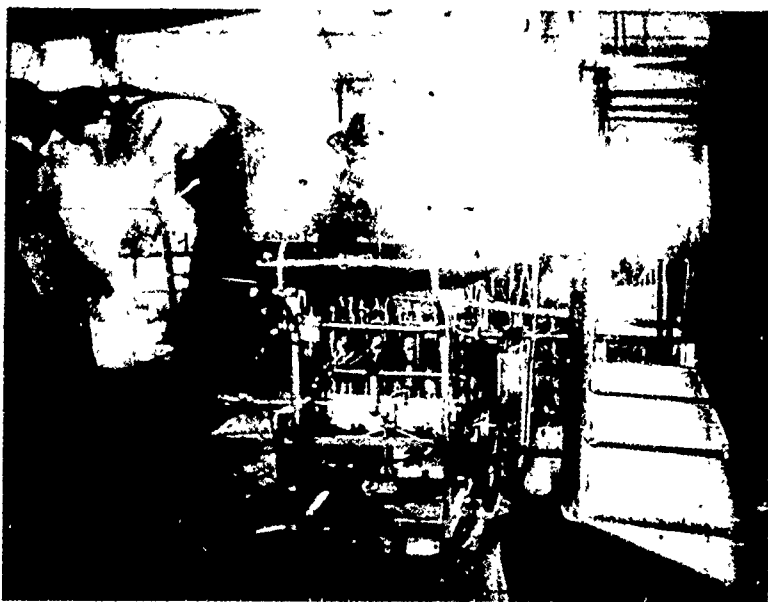

Figure 3. The age of the dirigible saw many types of propulsion applied to the steerable balloons. Here, a four-cylinder reciprocating engine is installed in the US 'Signal Corps' Dirigible Number 1, in 1908.

in figure 3. The future, however, belonged to the heavier-than-air vehicles rather than to the dirigible.

Glders

While the balloons supplied increasing information on engine design, valuable information on aircraft design was being gathered by glider builders.

Sir George Caley of England carried out pioneering experiments with gliders around 1800. Later, Germany's Otto Lillenthal became the foremost individual among glider experimenters. Lillenthal, beginning in 1871, compiled a vast amount of information on aerodynamic principles through his work with gliders. Two of Lillenthal's disciples also made important contributions to airplane design through glider work in the last decade of the nineteenth century. They were Percy Pilcher, of England, and Octave Chanute, who was born in France and moved to America at age six. Chanute was to give the Wright brothers valuable moral support and encouragement in their search for the answers to the problems of flight.

PROPULSION SYSTEMS FOR AIRCRAFT

The marriage of the internal combustion engine to an air frame that incorporated aerodynamic principles resulted eventually in a successful heavier-than-air machine.

More Power

Continuing advancement of the internal combustion engine nearly brought to **Samuel Langley**, an American, the historic honor of producing the first successful heavier-than-air craft. Langley, Director of the Smithsonian Institution in Washington, D.C., produced a series of powered model airplanes. The fifth model flew for about a minute and a half and covered nearly three-quarters of a mile. As a result of his experimentation in 1898, Congress awarded him a grant to develop a full-size aircraft.

Langley hired **Charles M. Manly**, a graduate student at Cornell University, to build an engine for the full-size aircraft. Manly responded with a five-cylinder radial engine, weighing, with accessories, 207.5 pounds and developing 52.4 horsepower. This engine, a marvel for that time, is shown in figure 4.

With Manly at the controls, Langley's *Aerodrome* was launched in October of 1903 from a catapult device mounted atop a houseboat on the Potomac River. Part of the aircraft's structure snagged on the launching gear and the *Aerodrome* plunged into the river.

The plane was repaired, and on 8 December 1903, Manly made another try. When the plane's rear wing collapsed on launch, his reward was another dunk into the river and hoots of derision from the Nation, the latter shared with Langley. Although Manly's engine was not at fault in the *Aerodrome's* failures, he shared the blame, and his chance at immortality was missed. Nine days later, Orville Wright lifted off a launching rail at Kitty Hawk, North Carolina, in the *Flyer* while brother Wilbur stood by.

Success

The Wright brothers' flight was no accident. It was the result of long, hard work, of study of everything they could find on aeronautics, of building gliders and testing them, of constructing a wind tunnel to try out their ideas. When they could not find written material on information they needed, or—as often was the case—when accepted aerodynamics theories proved to be wrong, they experimented and developed their own ideas. When they could not find parts they needed, they built their own. For example, they found no useful information on propeller design so they had to virtually invent one that would work on an airplane. The

POWER IN FLIGHT

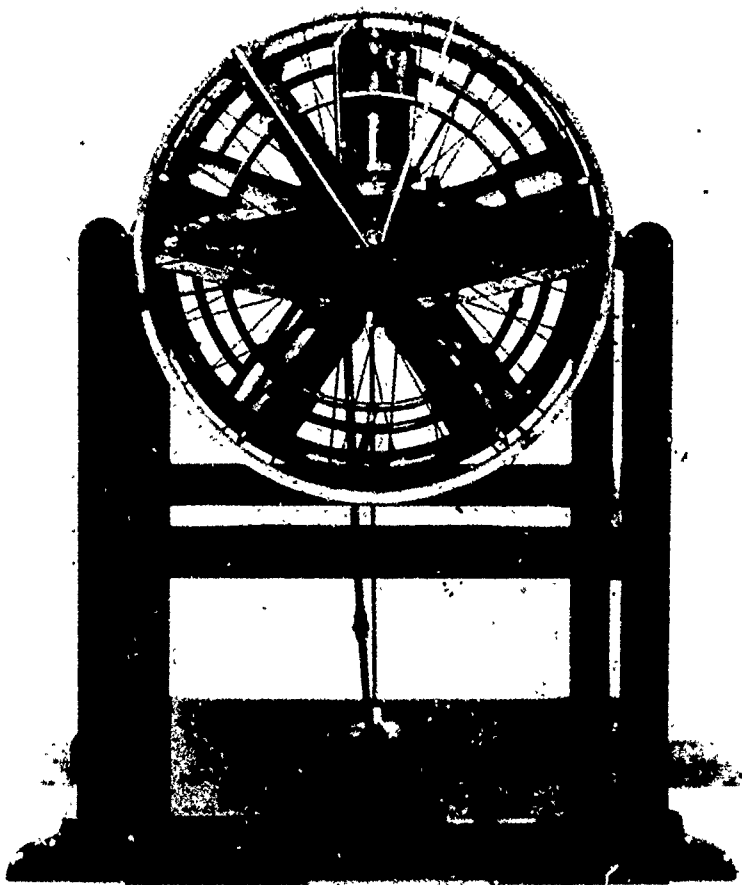

Figure 4. Charles Manly's engine was powerful and efficient enough to drive the Aerodrome, but could not overcome mistakes in the aircraft itself. A five cylinder radial engine, it used a bicycle wheel for a flywheel.

(Photo courtesy Smithsonian Institution National Air Museum)

same was true with the engine. After searching for a suitable engine to power the *Flyer*, the Wrights decided they must build their own. All known engines were rejected because they were too heavy or lacked sufficient power. (Manly was building an engine for Langley but the Wright brothers did not know this.) Finally, they powered the *Flyer* with the gasoline-burning in-

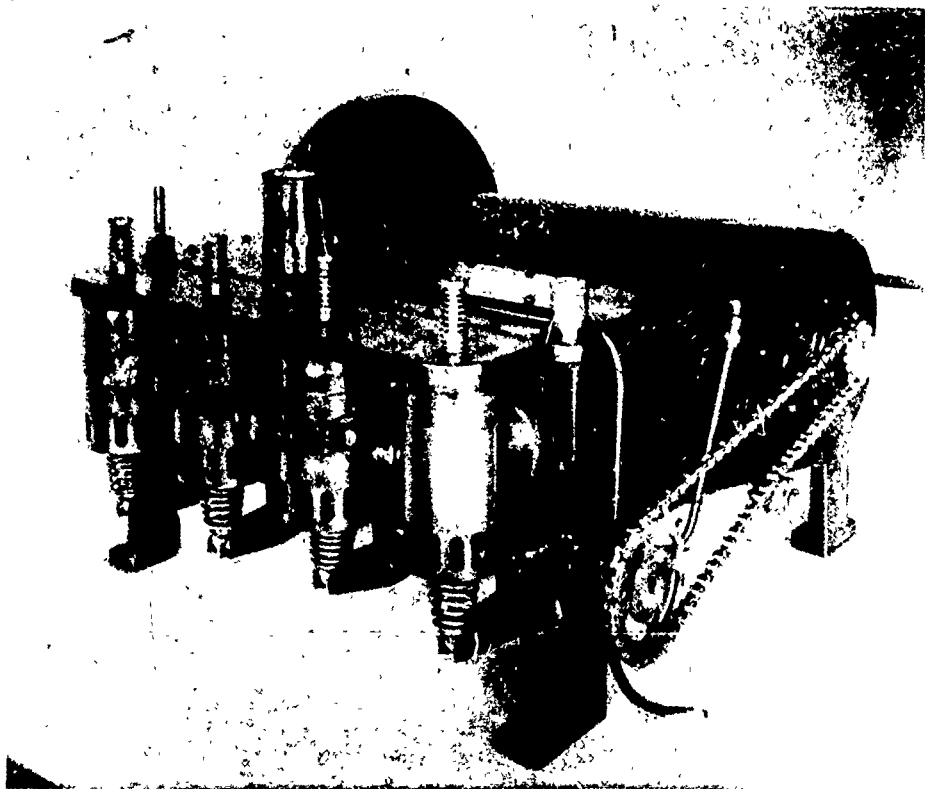

Figure 5. This engine powered the Wright brothers aeroplane at Kitty Hawk in December 1903. Although inferior to the Manley engine, it was successful because it propelled a successful aircraft.

(Photo courtesy Smithsonian Institution National Air Museum)

ternal combustion engine shown in figure 5, which was built with the assistance of their mechanic, Charles Taylor. The in-line engine had four cylinders, weighed 170 pounds, and developed 12-horsepower. It drove two wooden propellers.

The Wrights put in many hard hours of work over several years on their way to their date with history, and that work paid off in immortality.

Jets

Jet propulsion has a different history. The theory of jet power has been around for centuries, but it was not until after Isaac New-

ton published his ideas on motion in 1687 that the jet was considered feasible as a propulsion device. More than 200 years elapsed after Newton, however, before anyone considered using a jet engine on an aircraft.

Actually, despite the fact that the principle of jet propulsion was known when the aircraft was first flown, the principle was not applied to aircraft for almost forty years. There were several reasons for this delay. When aircraft first began to fly, the only known jet engines were of the external combustion type, which were too bulky and lacked power, and internal combustion jet engines could not be developed until man had come up with metals strong enough to withstand the tremendous heats and pressures produced inside such engines.

An American, **Sanford Moss**, contributed substantially to the jet engine, but more or less incidentally. Moss did research on the **gas turbine**, which was to play a big role in the jet engine's development. The turbine is a mechanical wheel-like device that spins in reaction to a fluid flow over or through it. Although the concept of a turbine was not new, Moss did much to perfect the idea. He experimented successfully with the gas turbine in 1902.

An English Air Force officer named **Frank Whittle** combined the gas turbine and an **air compressor** to make a jet engine in 1930. But progress stalled until World War II came along. The English successfully flew a jet aircraft in May of 1941, thanks to Whittle.

But he was not the first. The world's first jet aircraft flew in Germany in August, 1939. The engine was designed by **Hans von Ohain**. A year later, an Italian jet aircraft built by **Giovanni Caproni** flew 130 miles from Milan to Rome.

Whittle's ideas were imported by the United States and eventually emerged in the form of the **P-80 Shooting Star** jet aircraft in 1944. The engine in figure 6 powered the P-80, America's first operational jet aircraft. The world's first operational jet aircraft was the German Messerschmidt **ME-262**, which appeared early in 1944.

The development of the jet leaped forward after World War II.

POWER TERMS

In the discussion of propulsion systems, two terms are used to describe the power output of the engine system. These terms

PROPULSION SYSTEMS FOR AIRCRAFT

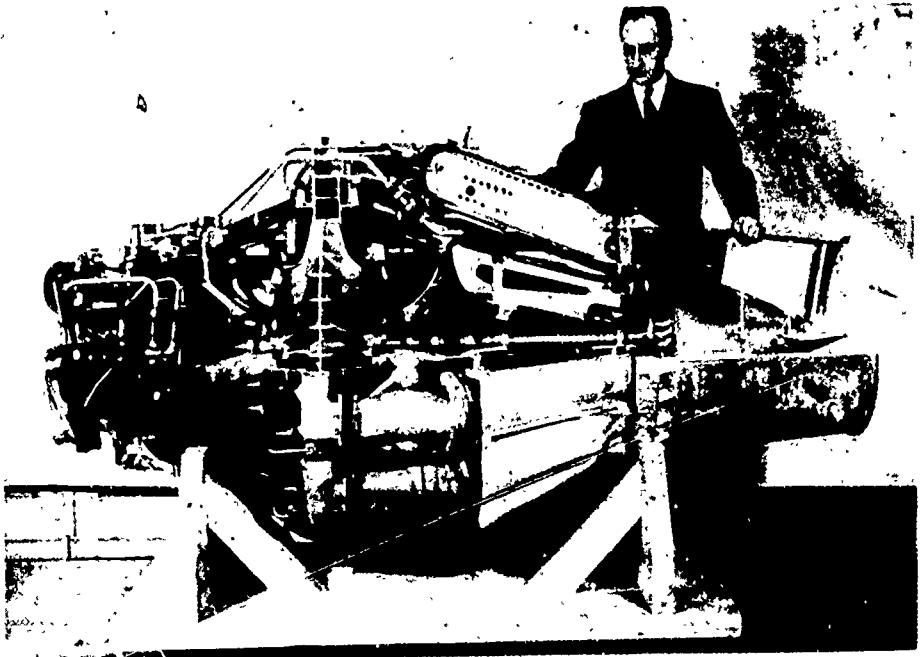

Figure 6. This jet engine powered the first operational American jet plane, the P-80. Developed by General Electric for the Army Air Force, the engine provided 4,200 pounds of thrust.

are horsepower, used to evaluate the reciprocating engine; and thrust, used to rate the jet and rocket engines.*

Horsepower

Horsepower is a more or less artificial word, invented to rate an engine's power in relation to the more familiar power source of earlier days. To understand horsepower, however, it is necessary first to understand the term work as used in a physical sense. Work is described as the exertion of a force over a given distance. It is measured in foot-pounds.

Work is the product of force, or weight, times the distance that weight is lifted. ("Force" has another definition in calculating jet engine power. See below.) Time is not a factor in finding the

*It is handy to know how horsepower and thrust are computed, but comprehending the formulas used here is not essential to understanding how the engines work. Those not mathematically inclined need not be concerned if they do not understand these formulas.

POWER IN FLIGHT

amount of work done. The formula for determining work is expressed $W = F \times D$.

When inventor **James Watt** was looking for a way to evaluate the power of his steam engine, he decided to rate the engine against a familiar power source, a horse. Watt hitched a brewery horse to a 150-pound load and prodded the animal to his best effort in lifting that load. Watt found that the best that horse could do was to lift the load three and two-thirds feet in an average second.

Using the formula for determining work, Watt found that the horse had performed about 550 foot-pounds of work per second. One horsepower, then, became equivalent to 550 ft-lb/sec. To find the horsepower rating for an engine, then, we divide the number of foot-pounds of work that an engine can perform in one second by 550—the number of foot-pounds of work the horse could perform in the same period. The formula is expressed, $hp = \frac{\text{number of ft-lb/sec}}{550}$.

With today's big engines, manufacturers have found it more convenient to figure the horsepower by the amount of work done per minute, rather than per second. This formula is stated, $hp = \frac{\text{number of ft-lb/min.}}{33,000}$. (The figure 33,000 is merely 550—horsepower in seconds—multiplied by 60 seconds.)

An engine capable of lifting 10,000 pounds of weight a distance of 50 feet in 30 seconds could lift the same weight 100 feet in one minute. Multiplying 100 feet times 10,000 pounds we find that the engine performs 1,000,000 ft-lb of work per minute. The horsepower rating, then would be: $\frac{1,000,000}{33,000} = 30.3$ hp.

Thrust

The power of jet and rocket engines is expressed in terms of thrust, instead of in horsepower.

Jet engines operate on the principles of Newton's second and third laws of motion (force is proportional to the product of mass and acceleration, and for every action there is an equal and opposite reaction).

In the jet, the *force* in Newton's second law is the power that moves the *mass* of air toward the rear of the engine. The *acceleration* is the increase in speed of the air mass from the time just before it enters the jet engine until the time it departs the jet engine.

PROPULSION SYSTEMS FOR AIRCRAFT

Acceleration rates the average speed increase for each second the air mass spends in the engine, and is expressed as feet per second per second. As a simple example, suppose the air mass entered the engine at a speed of 100 feet per second. Suppose it took three seconds to move through the engine, and that its speed at exit, or exhaust, was 1,600 feet per second. To find the acceleration of the air mass*, we subtract the initial velocity (V_1) of 100 feet per second from the exhaust velocity (V_2) of 1,600 feet per second, then divide that figure by the time required to bring about the increase (3 seconds). Expressed as a formula, it would look like this:

$$\text{Acceleration} = \frac{V_2 - V_1}{\text{times in seconds}}$$

$$A = \frac{(1,600 - 100)}{3} = \frac{1,500}{3} = 500 \text{ feet per second per second}$$

The term "feet per second per second" is too bulky for use in a formula, and is abbreviated to ft/sec/sec or, more usually, ft/sec².

The formula for determining the power, or thrust, of a jet engine is based on Newton's second law. It is, Force (in pounds) = Mass (in slugs) times Acceleration (in feet per second per second), or $F = MA$. To find the power rating of a jet engine, we substitute the word "Thrust" for the word "Force" in the formula, since the two mean the same thing in this case. Our formula now reads,

$$T (\text{Thrust}) = \frac{\text{Weight}}{32.2} \times \text{Acceleration}$$

Imagine, then, a jet engine capable of handling 150 pounds of air per second, and producing an exhaust velocity of 1,500 feet per second. Assume that the engine is stationary, making V_1 zero. The thrust could then be computed as follows:

$$T = \frac{150}{32.2} \times \frac{(1,500 - 0)}{1}$$

$$T = 4.65 \times 1,500$$

$$T = 6,975 \text{ pounds}$$

*The air mass is measured in slugs, which are computed by dividing the poundage weight of a given volume of air by the normal acceleration caused by gravity (32.2 ft/sec²). In effect, this eliminates the acceleration caused by gravity from our mathematical calculations, and gives us a truer idea of real engine power.

POWER IN FLIGHT

Thrust Horsepower

To get an idea of how thrust of a jet engine compares to horsepower of a reciprocating engine, we may use a formula for determining the unit called thrust horsepower (thp).

This formula is stated, thrust horsepower = $\frac{\text{thrust} \times \text{airspeed}}{375}$

The figure 375 in the formula is horsepower expressed in mile-pounds per hour, and is simply an expansion of the more familiar 550 ft-lb/sec, or 33,000 ft-lb/min.

Thus, if a jet engine with 10,000 pounds of thrust powers an aircraft to a speed of 800 miles per hour, the thrust horsepower would be

$$\text{thp} = \frac{10,000 \times 800}{375}$$

$$\text{thp} = 21,333.$$

WORDS AND PHRASES TO REMEMBER

acceleration
air compressor
balloon
dirigible
external combustion engine
force
ft/sec²
four cycle engine
gas turbine
horsepower
internal combustion engine

jet propulsion
mass
ME-262
ornithopter
P-80 Shooting Star
slug
steam engine
thrust
thrust horsepower
work

NAMES TO REMEMBER

Barnett, William
Borelli, G. A. (bor-EHL-lee)
Caley, Sir George
Caproni, Giovanni (kah-PROHN-nee)
Cecil, W.
Chanute, Octave (shah-NOOT)
Daimler, Gottlieb (DIME-ler)
da Vinci, Leonardo (DAH VINH chee)
de Rochas, Alphonse (duh-roh-SHAH)

PROPULSION SYSTEMS FOR AIRCRAFT

Giffard, Henri (gif-FAR)	Santos-Dumont, Alberto
Hanlein, Paul (HAHN-line)	Schwartz, David
Langley, Samuel	Taylor, Charles
Lenoir, J. J. E. (len-WAHR)	Tissandier, Albert (tee-sahn-de-AY)
Lilienthal, Otto	Tissandier, Gaston
Manly, Charles	Watt, James
Moss, Sanford	Whittle, Frank
Newton, Sir Isaac	Wright, Orville
Ohain, Hans von	Wright, Wilbur
Otto, Nikolaus	Zeppelin, Ferdinand von
Pilcher, Percy	

QUESTIONS

1. Name one basic difference between the steam engine and the engine used to power the Wright brothers' Flyer.
2. What was the contribution of balloon fliers to successful heavier-than-air flight? What was the contribution of glider fliers?
3. Why did it take engine makers so long to devise an engine capable of powering an aeroplane?
4. How did Charles Manly's engine, which he used on the Aerodrome, compare with the engine that powered the Wright brothers' Flyer?
5. The theory of jet power is very old. Why was jet propulsion not used to power aircraft in the early days of aviation?
6. What term is used to evaluate the performance of the reciprocating engine? The jet engine?
7. What formulas are used to find horsepower or thrust ratings for engines? How do "horsepower" and "thrust" compare?

THINGS TO DO

1. The development of internal combustion engines forced the development of metals and other materials capable of withstanding the stresses of heat and pressure of the new engine. Modern jet and rocket engines develop heat and pressures much greater than the first internal combustion engines. Find some good examples of new materials developed as a direct result of modern propulsion systems. List some uses for these new materials in areas other than propulsion systems.
2. Although the first men to achieve powered flight were Americans, their biggest acclaim and the most immediate follow-up to their accomplishment came from Europe. Similarly, pioneering work in rocketry was done in the United States, but Europe made far more early use of it than

America. Find out what historical and social factors led to this situation. Are any of the same or similar factors at work today, or has the situation been reversed? Explain your deductions and observations.

SUGGESTIONS FOR FURTHER READING

BRYAN, LESLIE A., and others. *Fundamentals of Aviation and Space Technology*. Urbana, Ill.: Institute of Aviation, University of Illinois, 1971.

GIBBS-SMITH, CHARLES. *The Invention of the Aeroplane, 1799-1909*. New York: Taplinger, 1966.

History of Flight. n.p.: American Heritage Publishing Co., Inc., 1962.

Jepco Briefing Booklet TB-1. *An Introduction to Turbine Aircraft*. Denver: Jeppesen & Co., 1958.

SHAMBURGER, PAGE, and JOE CHRISTY. *Command the Horizon*. Cranbury, N. J.: A. S. Barnes and Co., Inc., 1968.

VAN DEVENTER, C. N. *An Introduction to General Aeronautics*. Chicago: American Technical Society, 1965.

17/18

25

Chapter 2

Reciprocating Engines

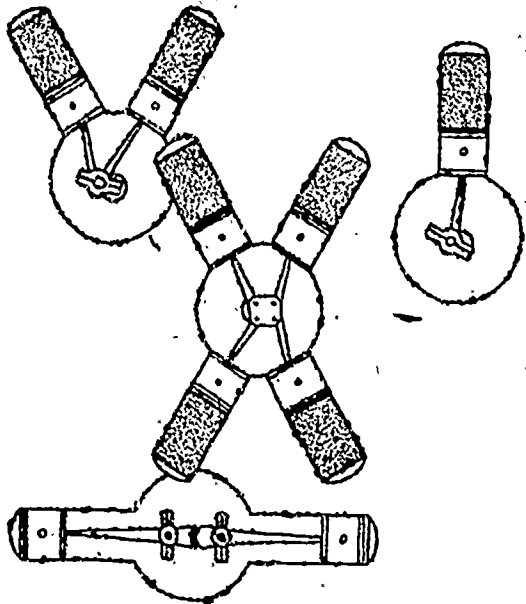

THIS CHAPTER is concerned with the performance of the reciprocating engine, the dominant engine in general aviation today. It reviews the mechanical functioning of the reciprocating engines, beginning with the power cycle and including the necessity and means of cooling the engine. When you finish this chapter, you should be able to: (1) describe the power cycle of the reciprocating engine, explaining what happens during each step; (2) explain how diesel engines differ from reciprocating engines and why diesels are not used in aircraft; (3) explain the differing characteristics of in-line and radial engines and their relative advantages and disadvantages; and (4) describe clearly the workings of air cooling and liquid cooling systems in reciprocating aircraft engines and tell which is preferred and why.

THE AGE of the jet aircraft has had a profound influence on the thinking of air-minded Americans. The jet suggests speed and glamor and, indeed, it provides both. But in the field of general aviation—that is, all aviation except commercial airlines and military aviation—more than 90 percent of all aircraft are

powered by the "old-fashioned" propulsion system of piston engine and propeller. This engine, where the power is produced by the back-and-forth motion of the pistons, is called a **reciprocating engine**.

THE RECIPROCATING ENGINE

The reciprocating engine is dominant in general aviation not only because it has been around longer than the jet, but because it is well suited for the job it is called on to perform; that is, to deliver efficient, reliable, economical service at speeds below the speed of sound and at altitudes below 40,000 feet. Because of the dominance of this engine, it is important that we know something about it. In many ways, you will find that the aircraft's reciprocating engine is similar to the engine in most automobiles, with the main differences being that the aircraft engines are more powerful, more rugged, and lighter for the horsepower they develop. We will begin our study of the reciprocating engine by examining the **mechanical system**, where the power is developed.

The Mechanical System

Reciprocating engines used in aircraft have certain mechanical parts vital to their operation. These parts may be arranged in any of several different ways, but the design of the parts themselves remains more or less standard. These vital parts include the cylinder, the piston, the connecting rod, the crankshaft, the valves, and cam shaft (Fig. 7).

Reciprocating engines used to power aircraft operate on what is called the **four-stroke cycle**. This means that the piston makes four strokes—movements from top center to bottom center of the cylinder, or from bottom center to top center—to accomplish the five stages in each complete action cycle.

The five steps in each cycle are: (1) intake, (2) compression, (3) ignition, (4) power, and (5) exhaust. The third step, ignition, occurs just before the end of the compression step and is thus considered as a part of the piston's second stroke. (Fig. 8)

The **cylinder** is the combustion chamber in which the engine's power is developed. The **piston** is designed to fit into the hollow cylinder snugly, but not so tightly as to prevent free up-and-down action by the piston. A **connecting rod** links the piston to the **crankshaft**, outside the cylinder. The crankshaft is designed to convert the piston's up-and-down motion into the circular motion

RECIPROCATING ENGINES

BASIC PARTS OF AN ENGINE

EVERY INTERNAL COMBUSTION ENGINE MUST HAVE CERTAIN BASIC PARTS IN ORDER TO CHANGE HEAT INTO MECHANICAL ENERGY



THE CYLINDER FORMS A PART OF THE CHAMBER IN WHICH THE FUEL IS COMPRESSED AND BURNED

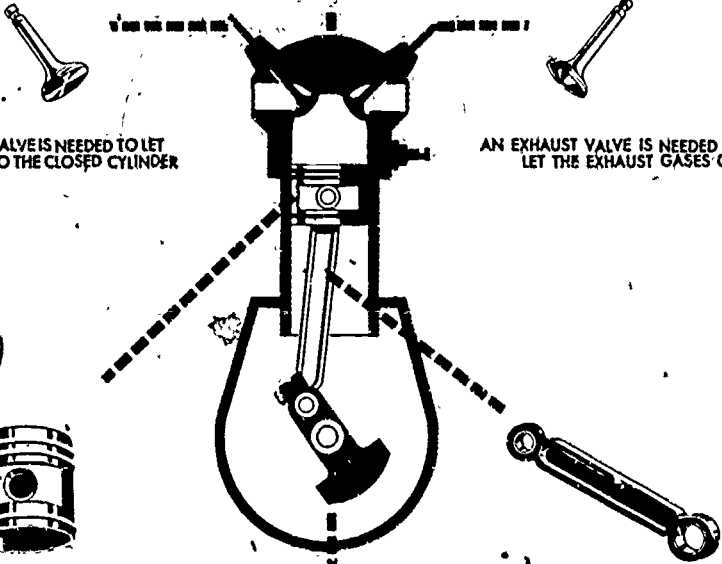

AN INTAKE VALVE IS NEEDED TO LET THE FUEL INTO THE CLOSED CYLINDER

AN EXHAUST VALVE IS NEEDED TO LET THE EXHAUST GASES OUT



THE PISTON, MOVING WITHIN THE CYLINDER, FORMS ONE OF THE WALLS OF THE COMBUSTION CHAMBER. THE PISTON HAS RINGS WHICH SEAL THE PISTON IN THE CYLINDER, PREVENTING ANY LOSS OF POWER AROUND THE SIDES OF THE PISTON.

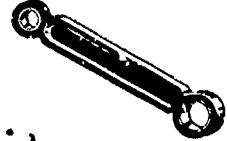

THE CONNECTING ROD FORMS A LINK BETWEEN THE PISTON AND THE CRANKSHAFT

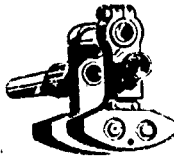

THE CRANKSHAFT AND CONNECTING ROD CHANGE THE STRAIGHT LINE MOTION OF THE PISTON TO A ROTARY, TURNING MOTION. THE CRANKSHAFT IN AN AIRPLANE ENGINE ALSO ABSORBS THE POWER OR WORK FROM ALL THE CYLINDERS AND TRANSFERS IT TO THE PROPELLER.

Figure 7. Every internal combustion engine must have certain basic parts in order to change heat into mechanical energy. This illustration shows the basic parts of the reciprocating engine and the functions they serve in the conversion process.

PROPULSION SYSTEMS FOR AIRCRAFT

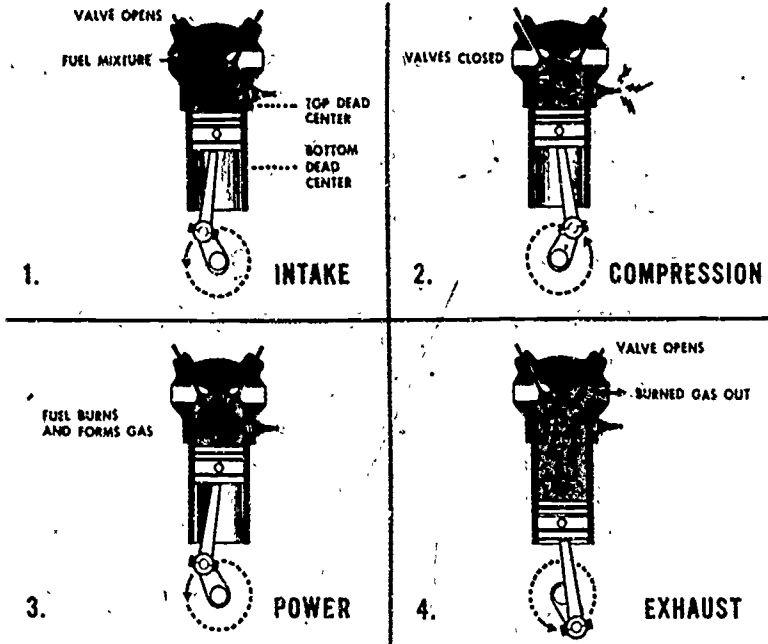

Figure 8. The movement of the piston up and down in the cylinder transmits energy to the crankshaft, which turns the propeller. The process that supplies power to the piston is the four-stroke engine cycle explained here.

required to turn the propeller, which is attached to the end of the crankshaft. As figure 9 shows, the crankshaft is not straight, but has throws or bends in it. The connecting rods are attached to these throws.

At the top of the cylinder, in the cylinder head, are located two valves, an intake valve and an exhaust valve. The opening and closing of these valves allows the fuel to enter the cylinder and the exhaust gases to leave it. As illustrated in figure 10, this opening and closing is regulated by a rocker arm, a spring-loaded finger-like device. The rocker arm is actuated by rings or lobes on a cam shaft, which is located adjacent to the crankshaft. The cam shaft is connected to the crankshaft through a series of gears.

This camshaft-crankshaft connection provides synchronization of both shafts, the valves, and the piston. The rings on the cam shaft—the cam rings—are made off-round, or eccentric. By pressing and releasing the tops of the valves in a timed sequence, the

RECIPROCATING ENGINES

cam rings act to insure that each valve opens and closes at the proper time in the cycle.

With all of this in mind, then, let us look at the action shown in figure 8 that produces the power that drives the propeller.

INTAKE STROKE.—The piston begins the cycle from the location at top center of the cylinder. Movement of the piston downward, toward the bottom of the cylinder creates a vacuum or area of reduced pressure inside the cylinder. When the intake valve at the top of the cylinder opens, the increased volume and lower pressure inside the cylinder allows the pre-mixed fuel and air charge to enter the cylinder through the intake valve opening.

COMPRESSION STROKE.—The piston reverses its direction, starting back toward the top of the cylinder. Both the intake and the exhaust valves are closed, due to the cam ring action. The piston decreases the volume inside the cylinder, compressing the fuel mixture into a small space. Just prior to the end of this stroke, about 20 or 30 degrees of crankshaft rotation from the top of the cylinder, a spark from the spark plug ignites the fuel. The momentum of the piston's upward movement carries the piston to the top of the stroke.

POWER STROKE.—The fuel mixture, ignited by the spark, is burning now as the piston again reverses its direction. The burning fuel forms a large volume of gas, which creates tremendous pres-

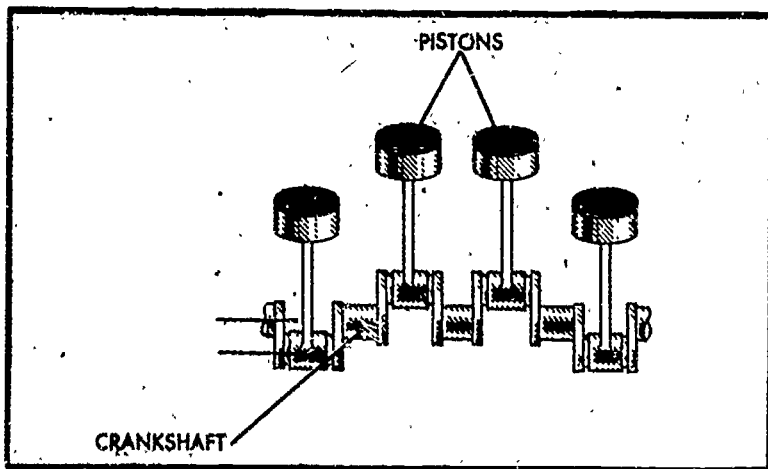

Figure 9. The piston is connected to the crankshaft by connecting rods. The throws, or bends, in the crankshaft are staggered to obtain a continuing turning motion from the piston power.

PROPULSION SYSTEMS FOR AIRCRAFT

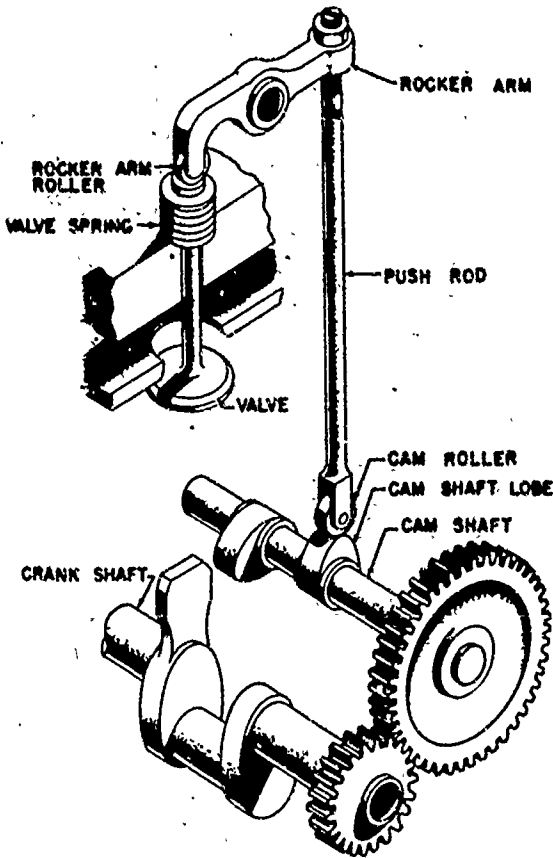

Figure 10. The camshaft, connected to the crankshaft through gears, moves a push rod in a timed sequence. The push rod operates a rocker arm. The rocker arm forces the intake and exhaust valves in the cylinder to open at the proper time in the four-stroke cycle. When the rocker arm lifts, the valves spring closed.

sure. This pressure drives the piston down forcefully. This power stroke is the whole reason for an engine.

EXHAUST STROKE.—Slightly before the piston reaches its downward limit and reverses direction once more, the exhaust valve at the top of the cylinder opens. As the piston moves upward on its final stroke of the cycle, it forces the spent gases out of the cylinder. As the piston reaches the top of its final stroke, the exhaust valve closes and the cycle begins again.

RECIPROCATING ENGINES

This four-stroke cycle occurs at the same time in the other cylinders of the engine, but no two cylinders are at the same stage of the cycle at the same time. The cylinders are timed to fire in sequence so as to turn the crankshaft smoothly, transmitting power from it to the propeller. The sequence of ignition of the cylinders in the engine is called the **firing order**.

Each cylinder goes through a complete cycle approximately 1,000 times every minute the engine is in operation. An engine with 18 cylinders, then, furnishes the propeller with about 300 power strokes per second.

Diesel Engines

The aircraft engines we are discussing use a mixture of gasoline and air for fuel. You may be familiar with another type of engine, the **diesel**. This is the powerful engine used on railroad trains and most heavy trucks today. Diesel engines are not used on modern aircraft, primarily because they are too heavy.

The diesel engine, named after Rudolf Diesel, its inventor, works on much the same principle as does the four-stroke cycle gasoline engine we have been discussing. But its fuel is an oil that is not nearly as combustible as is gasoline. In fact, there is no explosion as such in the operation of a diesel engine. The diesel has no need for spark plugs and carburetors.

A basic difference in the operation of gasoline and diesel engines is that on the compression stroke of the diesel, no fuel is yet in the cylinder. The piston compresses air only.

Compressing a gas, such as air, makes the gas hot. In the gasoline engine, the gasoline-air mixture may be compressed to about one-ninth its original volume. If compressed more than that, it will explode. The explosion would, of course, prevent the piston from reaching the top of the cylinder and the engine would not work.

In the diesel engine, however, the air in the cylinder is compressed to about one-fifteenth its original volume. The temperature of the air in the cylinder rises above the burning point of the fuel oil. At the top of the compression stroke, the fuel oil is injected under pressure into the cylinder and burns immediately. The expanding gases force the piston down and supply the power, just as in the gasoline engine.

The diesel would seem to offer advantages for use in aircraft. Since the fuel oil is not as combustible, it would be less likely to explode in case of a crash. Moreover, it is cheaper than gas-

oline. But although the diesel provides more power per cylinder than does the gasoline engine, it does not provide as much power per pound of weight. The reason for this is that the diesel engine must be built very strongly—and very heavily—to withstand the tremendous pressures of the compression inside the cylinders. For this reason, the diesel is considered too heavy for aircraft use. The diesel engine also is more sluggish than the gasoline engine and does not react as quickly to the throttle. It is better suited to use where weight is not too important and where economy is needed.

Types of Reciprocating Engines

A constant concern of engine manufacturers is the problem of how to get more horsepower from their engines. In designing reciprocating engines, there are two basic ways to accomplish this end: we may increase the number of cylinders in the engine, or we may increase the size of the cylinder.

The practical limitations on increasing the size of the individual cylinders are so restrictive that manufacturers have concentrated on the other design method, the development of multi-cylinder engines. Not the least advantage in using this method is the added smoothness of power supply, brought about because of the added number of power strokes per revolution of the crankshaft.

Manufacturers have come up with several different engine designs and configurations to accommodate the addition of cylinders. The most common designs in use today are shown in figure 11.

IN-LINE.—The in-line engine is one in which the cylinders are located in a row, one behind the other, along the crankcase (the casing through which the crankshaft runs). The cylinders, then, are "in line," hence the name of the engine.

To accommodate additional cylinders, the crankshaft must be lengthened and its number of throws must be increased.

If the cylinders are located above the crankcase, the engine type is called **upright**. Most early automobiles used upright in-line engines. If the cylinders are below the crankcase, the engine type is called **inverted**.

OPPOSED.—One type of engine has two rows, or banks, of cylinders, one row on each side of the crankcase. The rows of cylinders are directly opposite each other, and the engine type is called **horizontal opposed**.

V AND X.—Aircraft engines can come in a variety of designs, including the "V" and the "X." The "V" engine features two rows

RECIPROCATING ENGINES

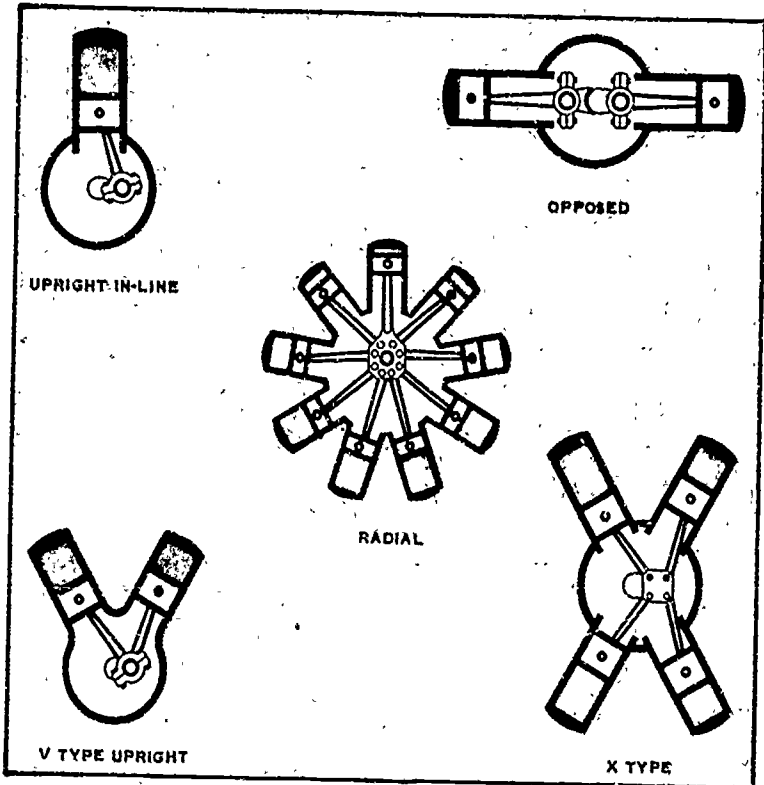

Figure 11. The most common arrangements of aircraft engine cylinders are shown here. Generally, the heavier and more powerful aircraft are fitted with radial engines, the smaller craft with the other types.

of cylinders set at an angle of about 45 degrees. The "X" engine (not a common engine) is essentially an opposed "V" engine.

In the manufacture of these engines, the cylinder heads may be cut separately or the whole bank of cylinders may be cast in one block, then machined to specification. Usually, the cooling system the engine will use determines the way in which the cylinder heads are made. If the engine is to be cooled by air, the individual cylinder heads usually are cast separately. If liquid cooling is to be used, the heads usually are cast in one long block.

Non-radial engines are used in almost all of the smaller air-

craft. The type of engine used most often for these light planes is the horizontal opposed, due to its streamlining advantages.

The engines used to power light aircraft are usually air cooled, which eliminates the need for the extra weight and machinery of the liquid cooling system. The larger, more powerful non-radial engines employ the liquid cooling system, however, because it is very difficult to cool the rear cylinders with air.

Since lightness is important in small aircraft, liquid cooling is avoided. But the use of air cooling imposes limits on the number of cylinders that can be built into a non-radial engine. The limitation on the number of cylinders restricts horsepower. The net result is that such engines rarely produce more than 250-300 horsepower. More powerful non-radial engines are available, but they must use liquid cooling. Where the demand is for more horsepower, plus the weight advantages of air cooling, the radial engine is used.

RADIAL ENGINES.—The radial engine features a crankshaft with only one throw. The cylinders are arranged around the crankshaft in a circle in such a manner that all the cylinders and connecting rods contribute their power through the single throw. One of the cylinders is designated as the **master cylinder**. The connecting rod from the piston in this cylinder is called the **master rod**, and attaches to the throw of the crankshaft.

Other connecting rods, called **articulating rods**, connect the other pistons to the large end of the master rod. The master rod, however, is the only rod that is connected directly to the crankshaft itself.

The radial engine always has an odd number of cylinders in each bank. This feature is required by the firing order of the four-stroke cycle, to assure an even delivery of power to the crankshaft. Figure 12 shows the typical firing orders for radial engines.

The maximum number of cylinders in each bank is usually nine. Where more power is needed from an engine, additional banks of cylinders may be added behind the first bank. If more banks are added, the crankshaft must be lengthened to accommodate the master cylinders in each additional bank. These extra banks operate in the same manner as does the original. In effect, a radial engine with two banks of cylinders is two engines working together, one behind the other. The design of the radial engine features fewer working parts and less weight than that of an in-line engine developing comparable power.

The radial engine is air cooled. Where more than one bank of

RECIPROCATING ENGINES

3 CYL.

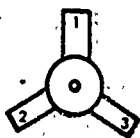

FIRING ORDER: 1-3-2

5 CYL.

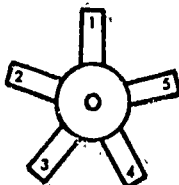

FIRING ORDER: 1-3-5-2-4

7 CYL.

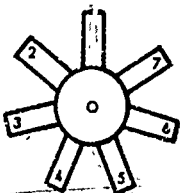

FIRING ORDER:
1-3-5-7-2-4-6

9 CYL.

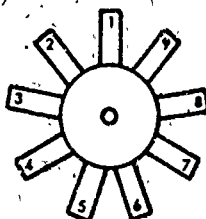

FIRING ORDER:
1-3-5-7-9-2-4-6-8

Figure 12. To keep the crankshaft turning smoothly, the engine's cylinders are designed to fire not in numerical order, but according to the best firing order for each engine. By staggering the firing, the engine makes the best use of the power from the cylinders.

cylinders is built into the engine, the air passes through the first bank and encounters a series of baffles. These baffles direct the air around and through the other banks of cylinders to cool the rear of the engine.

It is not uncommon to see radial engines with three banks of cylinders. Such engines can develop more than 3,500 horsepower each. When more power is needed, the radial engines may be used in sets of two, or even in groups of up to six engines.

Performance of Reciprocating Engines.

Manufacturers prefer the air-cooled radial engine for the heavier aircraft and the air-cooled in-line engine for planes requiring less than 300 horsepower per engine.

The propulsion system composed of a reciprocating engine and propeller is efficient at speeds up to about 400 miles per hour and at altitudes below 40,000 feet. Such a system can create a large amount of thrust at low speeds and so can get an aircraft off the ground after a relatively short takeoff run. This propulsion system

PROPULSION SYSTEMS FOR AIRCRAFT

can carry more weight farther, and on less fuel, than any other kind of propulsion system in its speed range. It is dependable, and has become, through years of development, rugged and simple to maintain.

The propeller-reciprocating engine system of propulsion can provide very fast acceleration. The engine responds immediately and can change from a low to a high power output in a very short period of time. It is versatile and efficient. That is why, in this age of powerful and very fast jet planes and rockets, the propeller-driven aircraft, powered by the reciprocating engine, is still seeing extensive use.

HEAT AND COOLING

Reduced to essentials, the purpose of an engine is to produce energy, and this energy is in the form of heat. Without heat, the engine would not drive the propeller. But that same element—heat—is the primary source of wear and tear on the engine.

When the fuel and air mixture burns in the cylinder of an engine, about one-third of the resulting heat drives the piston downward. This is the only useful energy produced by the engine. Some two-thirds of the total heat produced is wasted. Of the lost portion about one-half is pushed out into the atmosphere through the exhaust valve. The remaining heat—one-third of the total produced by the engine—does not escape and does not perform any productive work. Instead, it is trapped in the walls of the cylinder, in the piston, and in the lubricating oil of the engine. Unless this heat is disposed of, it can destroy the engine.

There are two ways to carry off the excess heat: by the air through which the engine is traveling, or by a liquid cooling agent carried along for the sole purpose of cooling the engine. Whichever is used, special features are built into the engine to assist in the cooling.

One of the most noticeable of these features is the system of fins or flanges machined onto the head and barrel of the cylinders. These fins expose a broader surface to the cooling effects of the air.

In the early days of aviation, air-cooled engines were exposed only to the direct air current through which the aircraft was flying. The air flowed over the engine, carrying off some of the excess heat, but that system proved effective only at a fairly low rate of revolutions per minute by the crankshaft.

RECIPROCATING ENGINES

With more powerful engines came advances in cooling system design. The cooling fins were added to the cylinders and the engine was enclosed in a **cowling**, or cover, with a system of **cowl flaps** and air baffles.

This system slows down the air to the speed at which it does the best job of cooling. The cowl flaps, which control the volume of cooling air entering the cowling, can be opened or closed by the pilot. This air cooling system is effective not only at cruising speeds and normal altitudes, but on the ground and at high altitudes (Fig. 13).

On the ground, the only air available to cool the engine is that produced by the propeller's action. In this situation the engine, as you can imagine, tends to run hot. In contrast, the air at high altitudes is very cold, and in addition, a greater volume of air is available due to the movement of the aircraft. In this situation, the engine tends to run colder than its most efficient operating temperature. Since the pilot can control the opening and closing of the cowl flaps, he can increase or decrease the cooling ability of the air and keep his engine near to the most efficient operating temperature.

Another development, called an **augmenter tube**, is a tube placed behind the engine. The exhaust gases flow through the tube and, by use of Bernoulli's principle, create a pressure differential between the air inlet and the outlet. The result is a suction effect which pulls the air through the engine faster, and makes air cooling more effective on the ground.

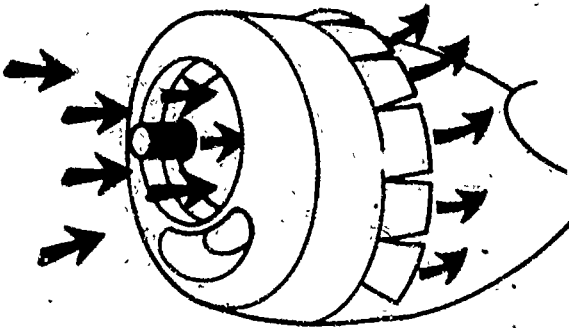

Figure 13. The cowling structure of an air-cooled engine is designed to get the cooling air to where it is needed and keep the air circulating around the cylinders. The pilot can control the air flow by opening or closing the cowl flaps.

PROPULSION SYSTEMS FOR AIRCRAFT

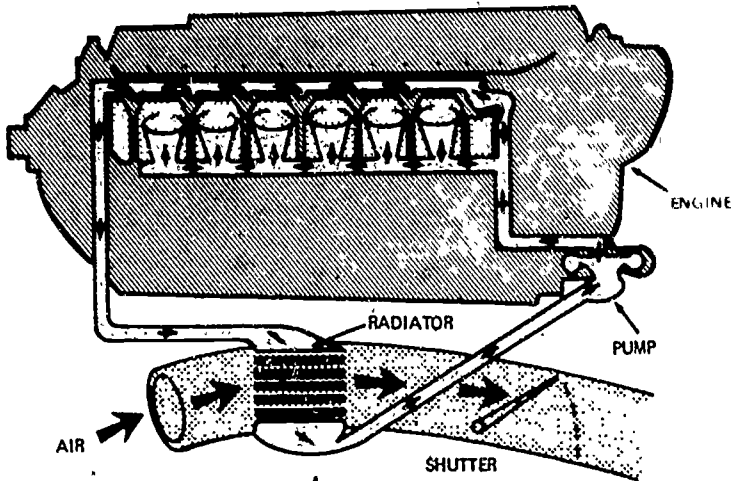

Figure 14. The liquid cooling system is more complex than the air cooling method, requiring plumbing, pumps, and radiators to keep the engine cool. Its performance is superior, however, on non-radial engines with many cylinders. This drawing traces the flow of the liquid coolant through the engine.

The liquid cooling system on an aircraft works in much the same manner as does the liquid cooling system on most automobiles. In this system, the coolant flows in a blanket through the engine block and around the cylinders. The liquid—usually ethylene glycol on an aircraft—circulates through a system of pipes to a radiator, where it is cooled by air before repeating its journey through the engine block (Fig. 14).

Proponents of the liquid cooling system claim that it cools more evenly, and therefore better, than does the air cooling system. It is more compact and usually can be built with a smaller frontal area. But since the liquid system is more costly to build and more complicated to maintain than is the air cooling system, it has been nearly abandoned by United States aircraft engine manufacturers.

CONSTRUCTION MATERIALS

Since the heat generated in an engine is so intense, manufacturers must be careful in choosing materials that can withstand the heat and keep their strength and shape.

RECIPROCATING ENGINES

The cylinder is the heart of the engine's action, and is therefore subject to very high temperatures and pressures. The cylinder barrel—the body of the cylinder—and head must be very strong. The cylinder is made of a high-grade steel alloy machined to very close specifications. The inside of the cylinder is highly polished and is very hard. The cylinder head is made of cast or forged aluminum alloy and is shrunk onto the cylinder barrel.

The shrinking process consists of heating the cylinder head, then screwing it onto the cylinder barrel. The inside of the cylinder head is slightly smaller in diameter than is the outside of the cylinder barrel. Both are threaded. Heating expands the metal of the cylinder head so that it may be screwed onto the barrel. When the metal cools, the head shrinks to its original size and is locked tightly into place.

The valves also are subjected to intense heat and high pressure. They are made of tungsten steel or chromium steel, which provide strength at high temperatures. The faces of the valves—that portion which is actually exposed to the heat inside the cylinder—are coated with a thin layer of stellite, which resists pitting and burning. The intake valve usually is solid, but the exhaust valve is hollow. The hollow center is filled with salt solution of metallic sodium, which conducts the heat away from the valve head (Fig. 15).

The pistons are made of forged or cast aluminum. Aluminum is used for the pistons because it is strong, it has compatible characteristics with the steel of the cylinder barrel, and because aluminum pistons are light enough to stop at the end of each stroke

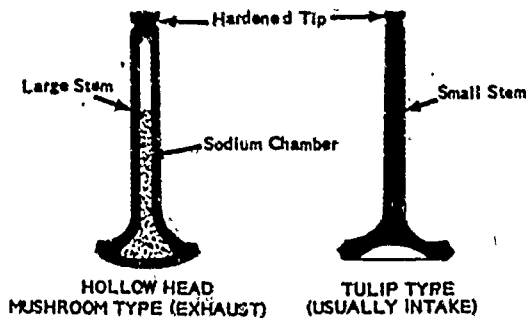

Figure 15. The cut away drawing of engine valves shows two different types of valves in use today. The sodium chamber inside the hollow head mushroom valve helps to get the high heat of the exhaust gases away from the valve head quickly.

PROPULSION SYSTEMS FOR AIRCRAFT

without causing undue stress on the other mechanical parts. Aluminum is also a good heat conductor and is therefore easy to cool.

The connecting rods are made of steel and the piston pins, which connect the connecting rods to the pistons, are made of tough-nickel steel.

The heat on the crankshaft is produced primarily by friction, and not by the action in the cylinder. But the crankshaft is subjected to the most violent twisting movement and must be made of very strong material to withstand the forces exerted on it. Therefore, the crankshaft is made of chromium steel. The crankcase is usually made of aluminum in smaller engines and of steel in the larger ones.

WORDS TO REMEMBER

articulating rod

augmenter tube

bank

cam ring

camshaft

compression stroke

connecting rod

cowling

crankshaft

cylinder

cylinder barrel

cylinder head

diesel engine

exhaust stroke

exhaust valve

firing order

four-stroke cycle

general aviation

in-line engine

intake stroke

intake valve

master cylinder

master rod

mechanical system

opposed engine

piston

power stroke

radial engine

reciprocating engine

rocker arm

shrinking

throw

QUESTIONS

1. What are the principal parts of the reciprocating engine?
2. Name the five steps in the operation of the four-stroke engine.
3. What is the function of the cylinder in the reciprocating engine? What is the purpose of the crankshaft?
4. Describe the action of a four-stroke engine.
5. Why are diesel engines not used in aircraft?

RECIPROCATING ENGINES

6. What is an "inline" engine? What is a "radial" engine? Name some advantages of each type.
7. Name some advantages of the propulsion system composed of a reciprocating engine and propeller.
8. What percentage of the heat developed in the chamber is used to drive the piston downward? What happens to the remaining heat?
9. Describe the advantages and disadvantages of air cooling as compared to liquid cooling.
10. What is meant by the description of a car engine as an "overhead cam V-8 engine"?

THINGS TO DO

1. Diesel engines were tried experimentally on aircraft in the early 1940s, but were found unsuitable. Find out if advances in the development of strong, light-weight metals and improvements in diesel design have revived the prospects of diesel aircraft engines. Report to the class and explain your findings, whether positive or negative.
2. Some modern automobiles are equipped with rotary engines, said to develop about twice the power of a piston engine of the same weight. Many early aircraft—including the Sopwith Camel of World War I fame—used rotary engines. Find out what caused this engine to fall into disuse. Are there any plans to revive the rotary engine for aircraft power?
3. Visit your school auto shop. Can you identify the various parts of the engine from the discussion in this book and in class? Can you explain how they operate?

SUGGESTIONS FOR FURTHER READING

- CARGNINO, L. T., and C. H. KARVINEN. *Aerospace Propulsion Powerplants*. Chicago: Educational Publishers, Inc., 1967.
- GUNSTON, W. T., ed. *Flight Handbook. The Theory and Practice of Powered Flight*. Los Angeles: Aero Publishers, 1962.
- MCKINLEY, JAMES L., and RALPH D. BERT. *Powerplants for Aerospace Vehicles*. New York: McGraw-Hill Book Co., 1965.
- VAN DEVENTER, C. N. *An Introduction to General Aeronautics*. Chicago: American Technical Society, 1970.
- VAN SICKLE, NEIL D., ed. *Modern Altimanship*. Princeton, N.J.: D. Van Nostrand Co., Inc., 1966.

Chapter 3

Other Engine Systems

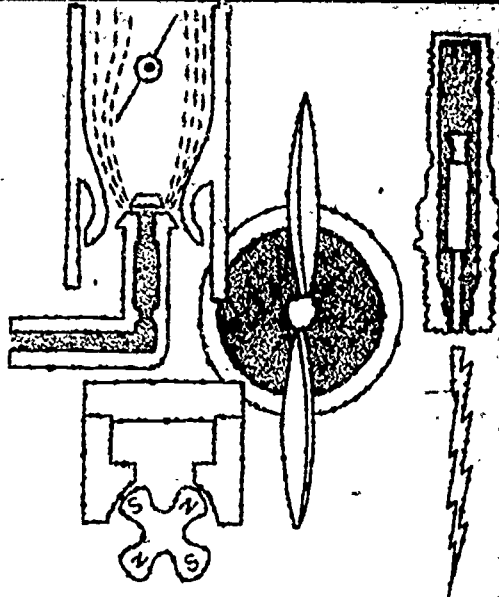

WHERE CHAPTER 2 considered the mechanical system of the reciprocating engine, this chapter considers other engine systems, namely the fuel system, with emphasis on carburetion; the ignition system; the lubrication system; and the propeller system. When you finish this chapter, you should be able to: (1) discuss the desirable qualities of gasoline and tell why it is the ideal fuel for aviation engines; (2) describe what happens in the carburetor, why this function is necessary, and how it occurs; (3) explain what happens in the operation of the ignition system; (4) explain the function of the lubricating system; and (5) describe the workings and limitations of the propeller.

THE CYLINDERS, pistons, valves, crankshaft, and related parts that we have discussed make up only one section of the engine, the section called the mechanical system. If fact, there are a number of engine sections which work together to provide power to move the aircraft. These different sections all must work properly within themselves and in cooperation with all the other sections if the total engine is to function well.

PROPULSION SYSTEMS FOR AIRCRAFT

It is only for convenience in study that we divide the engine into its different systems. With that fact in mind, in this chapter we will examine engine sections other than the mechanical system and the cooling system. These other sections include the fuel system (including the carburetor), lubrication system, ignition system, and propeller system; their related parts, and their functions as parts of the whole engine.

FUELS

The fuels in use in today's aircraft are the result of extensive experimentation in search of the best fuel for the most reasonable price. The most common forms of aircraft fuels are the hydrocarbons derived from petroleum.

Hydrocarbon is the descriptive name chemists use for materials which contain only the chemical elements hydrogen and carbon in their structure. The principle hydrocarbon fuels used in aircraft power today are gasoline and refined kerosene. These fuels, as well as diesel fuel, fuel oil, lubricating oils, and other products, all are distilled from petroleum (Fig. 16).

The gasoline and kerosene used as aviation fuels offer several advantages:

1. They are **volatile**. They evaporate quickly and can be mixed easily with air to form a combustible mixture.
2. They have relatively low **flash points**. That is, when they

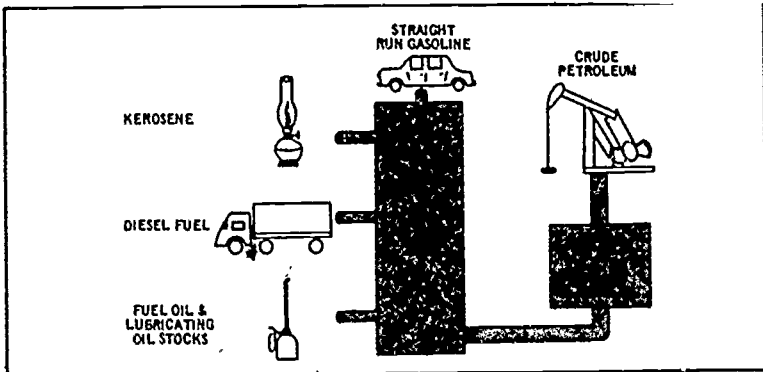

Figure 16. In the fractional distilling process, crude oil is heated to a moderate temperature under normal atmospheric pressure. The vapors from the oil are condensed to liquid compounds. The highly volatile fluids are vaporized first and the fuels with higher boiling points later.

OTHER ENGINE SYSTEMS

are mixed with air they ignite at relatively low temperatures. If the flash point of a fuel is too high, the result is difficulty in starting the engine.

3. Petroleum-based fuels have low freezing points. This is important when the aircraft is operating in the low temperatures of high-altitude flight. It also comes in handy when the fuel must be stored in the cold temperatures of the northern regions.

4. They have a relatively high heat content. This means there is much **potential energy** within the fuel which may be converted to **kinetic energy** as the fuel burns. Potential energy is that energy which is at rest. Kinetic energy is energy actually at work.

5. The fuels are relatively **stable**. They can be easily handled using fairly simple safety precautions, and they will not deteriorate when stored over long periods of time.

6. They are readily available at relatively reasonable cost.

The petroleum from which gasoline and kerosene are derived, is found deposited in most regions of the world. Petroleum also is the source of automobile gasoline and other common fuels. But the fuels used in aircraft require stricter control in production than do the "ordinary" fuels used in automobiles. These controls are important because a failure in the engine of an aircraft can be much more serious than a failure in a car engine. A pilot cannot just pull over to the side of the road and call a mechanic.

Volatility

Aircraft fuel must be highly volatile so that the engine will start easily. But it must not be too volatile, or trouble can result.

One result of too much volatility is **vapor lock**. In this condition, the gasoline "boils" in the fuel line before it reaches the carburetor. This boiling causes gas bubbles to form in the fuel line. The bubbles block or partially block the flow of the liquid fuel, so that an insufficient amount of fuel gets through to operate the engine.

Too much volatility also can lead to **carburetor icing**. We know from science that vaporization of a liquid requires heat. The heat used for vaporization of aircraft gasoline is taken from the air and from the metal surrounding the fuel. Gasoline of high volatility extracts this heat very quickly. When too much heat is taken from the metal parts for vaporization, the remaining cold will cause ice to form in the carburetor and interfere with its operation. The carburetor, which will be explained more fully later in this book, is the device which mixes the fuel and air to the proper proportions

PROPULSION SYSTEMS FOR AIRCRAFT

for engine operation. If the carburetor does not operate as it should, the engine will fail. Various tests are performed on aircraft fuels to insure that they are volatile enough for efficient engine operation but not too volatile for safe operation.

Octane Rating

The **octane rating** of aircraft fuels also is important as a measure of ability to prevent **knock**, the abnormal combustion of fuel in a cylinder. In fact, manufacturers specify the octane rating of the fuels which will function best in each engine. The octane rating is simply a number describing the antiknock performance of the particular gasoline. A fuel of low antiknock value, used in a high-performance engine, may cause dangerous consequences. These include fuel knock, detonation and pre-ignition.

Fuel knock is the result of uncontrolled burning of the fuel in the engine's cylinder. The fuel charge may burn evenly part of the way across the cylinder, then unevenly across the remainder. It may damage any of several vital engine parts.

Detonation is similar to fuel knock. It may be described as an uncontrolled explosion of the fuel in the cylinder, as shown in figure 17, due to spontaneous combustion. It is severe fuel knock which creates extreme pressures on the valves, pistons, and the cylinder head, pressures that are sometimes severe enough to completely wreck the cylinder and its parts.

Pre-ignition results when the compressed charge in the cylinder ignites before the electrical charge from the spark plug can jump the gap between the spark plug's electrodes, or points. This upsets the timing of the engine and also can cause damage, such as **backfiring** or feeding back the flame from the cylinder through the carburetor. Backfire may also be caused by an excessively "lean" mixture (which will be explained later) that is still burning when the engine cycle is completed. Pre-ignition, fuel knock, and detonation may be caused by malfunctions of the mechanical part of the engine, but they may also result from the use of low-grade fuel. That is why the gasoline to be used must have the proper octane rating.

The octane rating gets its name from one of the hydrocarbons contained in the fuel, called iso-octane. Iso-octane has high anti-knock properties, while the other common hydrocarbon in fuel, heptane, has low antiknock properties.

The octane rating applied to a particular fuel originally indicated the percentage of iso-octane contained in the fuel. Because

OTHER ENGINE SYSTEMS

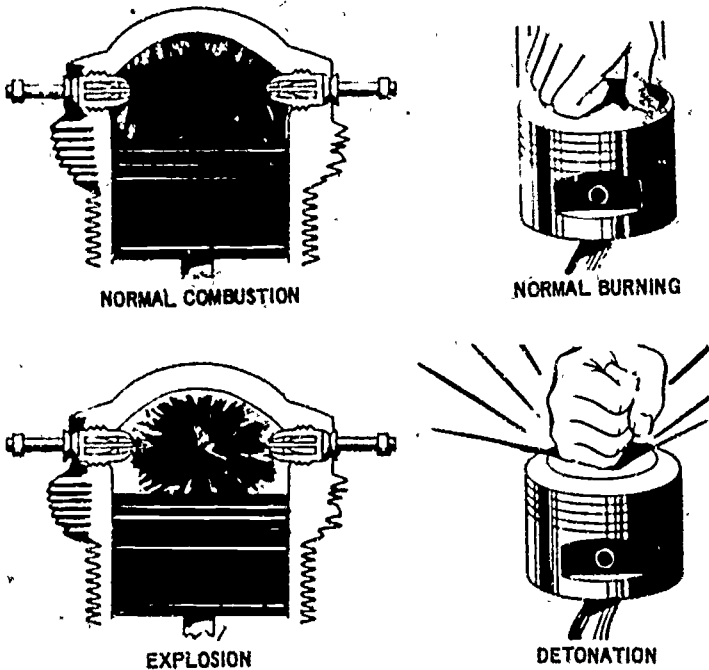

Figure 17. Under conditions of normal combustion, downward pressure on the piston is smooth and even. When detonation occurs, the pressure is sudden and violent.

of its high antiknock properties, pure iso-octane was arbitrarily given the number 100 to describe its antiknock performance. For example, a gasoline rated 65 octane would be a mixture containing 65 percent iso-octane. But you may have seen fuels with octane ratings above 100. This is possible, because chemists discovered that certain other elements blended into fuel with a high percentage of iso-octane actually could increase the antiknock performance of the fuel beyond the level of pure iso-octane. The most commonly-used of these blending agents are alkylate, naphtha, and tetra-ethyl lead.

Thus, a fuel with an octane rating of 130 would contain 70 to 80 percent of iso-octane, plus a quantity of other blending agents. The octane rating no longer describes merely the percentage of iso-octane in the fuel, but is a rating of the fuel's antiknock performance.

Fuels with high octane ratings are used primarily in large engines specifically designed for them. The high antiknock prop-

PROPULSION SYSTEMS FOR AIRCRAFT

erties of this high octane fuel allow higher compression of the fuel in the cylinder before it is ignited. The higher compression in turn yields a stronger "explosion" of the fuel charge when it is ignited, and more power from each cylinder.

Now that we know the nature of the aircraft's fuel, let us see how that fuel finds its way into the engine and through the fuel system.

THE FUEL SYSTEM

The fuel system is a network of tanks, lines, gauges, pumps, strainers, and screens. Its purpose is to deliver a steady flow of clean fuel under constant pressure. This delivery must continue at all operational altitudes of the airplane, and in all of the plane's positions, or attitudes, including diving, climbing or even flying upside down for short periods as well as level flight. To be sure these requirements are met, gravity-feed or mechanical pumping is employed.

Fuel Feeding

The gravity-feed fuel system, the simplest type used, is common in small planes whose engines have relatively low horsepower. In this system, the fuel tank is located above the level of the carburetor inlet. The pressure behind the fuel flowing through the lines is built up by the weight of the fuel behind it, flowing from the higher level of the tank to the lower level of the carburetor inlet.

The gravity-feed fuel system is light-weight, easy to maintain, and simple in design and operation. But it is not suited for high-powered aircraft, nor for extended acrobatic flight, since no fuel would flow during inverted flight.

The force-feed fuel system features an engine-driven pump which draws the fuel from the tank and forces it into the carburetor. The use of the pump means that the tanks do not have to be located above the carburetor but may be placed wherever there is ample and convenient space. Auxiliary pumps are included in the system in the event of main fuel pump failure. In small aircraft, a hand powered pump, called a wobble pump, may suffice; but most modern aircraft, large and small, are fitted with electrically-powered auxiliary pumps. The pump ar-

OTHER ENGINE SYSTEMS

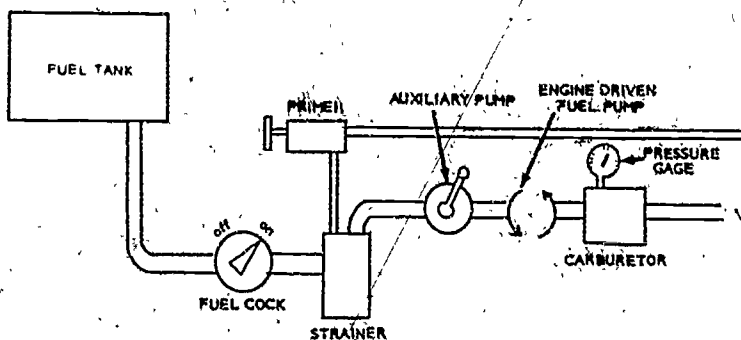

Figure 18. Fuel system with the pumps arranged in series. The auxiliary pump is used during starting of the engine, during take-off and landing, during high-altitude flight (above 10,000 ft), and in emergency operations.

Diagram of a typical fuel system in a small aircraft is shown in figure 18.

The force, or pressure, system used in larger planes delivers the high fuel pressure required by many modern aircraft carburetors. Since the constant supply of fuel is assured, the plane has more maneuverability.

A series of strainers and screens is included in the fuel system to assure that water, dirt, and other foreign matter do not get through the system. If these elements were able to go through the fuel system, dire consequences could result. For instance, water is heavier than gasoline and settles to the bottom of the tank. When the aircraft is in flight, the water may get into the fuel lines, freeze at high altitudes and block off the flow of gasoline to the engine. A tiny particle of dirt may block off the metering jet in the carburetor and wholly or partially block the gasoline's flow to the engine. In either case, the engine fails either partly or completely. To be sure that these impurities are not present in the fuel system, the ground crew usually checks the strainers, screens, and traps for accumulated water and dirt immediately after refueling the aircraft.

Carburetion

Once the gasoline has been filtered, screened, and otherwise purified, it is ready for its final preparation before it can go to work in the engine: it must be mixed with air. This step, called carburetion, is necessary because gasoline in its liquid form burns

PROPULSION SYSTEMS FOR AIRCRAFT

too slowly for good engine performance. Mixed with air, however, gasoline is the most satisfactory fuel yet discovered for use in reciprocating engines. Several times in this book we have mentioned the device that mixes the air and gasoline to the proper proportions for slow, even, complete burning. It is, of course, the carburetor.

The carburetor must be capable of measuring the gasoline and air mixture to the right proportions for the best operation of the engine. The ideal mix is considered to be about 15 parts of air to one part of gasoline. These proportions are decided by weight, not by volume, because volume varies with changes in temperature and altitude effects on the density of air (Fig. 19). Thus, the ideal fuel mixture would be about 15 pounds of air to one pound of gasoline. A mixture with a higher ratio of air is called a *lean mixture*, while a mixture with a lower ratio of air is said to be *rich*.

Gasoline will burn in a cylinder when it is mixed with air in a

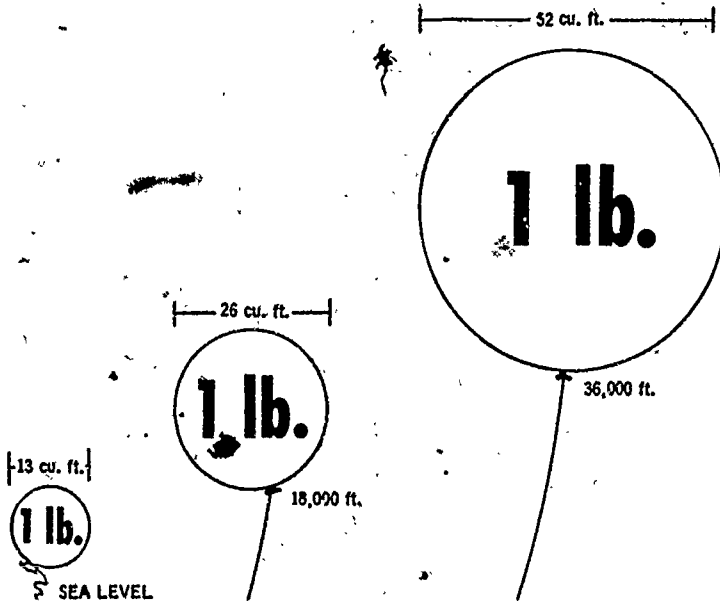

Figure 19. Air expands with altitude. At higher altitudes greater volumes of air are needed to supply the amount of air (by weight) that occupies a lesser space at lower altitudes.

OTHER ENGINE SYSTEMS

ratio of between 8:1 and 18:1, that is, when the mixture contains between 8 and 18 parts of air, by weight, to 1 part of gasoline. Generally speaking, the 15:1 ratio is nearly ideal for the best power production. One interesting difference in the aircraft engine's carburetor and the carburetor in an automobile engine is this: the pilot may change the mixture control settings of his carburetor while the aircraft is in flight, while the automobile driver has no such controls available on his dashboard. A rich fuel/air mixture is used at high and low aircraft speeds, while a slightly lean mixture is more efficient at medium, or cruising, speeds.

An overly rich mixture may result in the engine's running "rough." An overly lean mixture causes loss of power and may result in overheating in the engine. This overheating may cause detonation in the cylinder or backfiring through the carburetor.

A backfire may occur if the fuel mixture in the cylinder is still burning when the intake valve opens to begin the next power cycle. The burning fuel ignites the fuel in the intake manifold outside the cylinder and chain reaction feeds the fire back into the carburetor. Severe damage can result from this occurrence.

The carburetor must be designed and controlled so that it mixes the proper amount of gasoline with a given amount of air. Moreover, the carburetor of a modern airplane must operate well in a variety of situations. It must be capable of changing automatically to accommodate different engine speeds and altitudes.

These requirements have brought about increasing sophistication so that modern, high-performance carburetors have become quite complex. In this section, we will explore the basic workings of the carburetor and look at some of the devices developed to insure its constant, efficient operation.

The carburetor makes use of Bernoulli's principle, which states that as the velocity of a fluid at a given point increases, the atmospheric pressure at that point decreases, and of the venturi tube, which puts Bernoulli's principle to work (Fig. 20).

Carburetor Operation

There are two types of carburetor. They are the float carburetor, which is dependent on atmospheric pressure for its successful operation; and the pressure injection carburetor, which uses pressure developed by a pump instead of that supplied by the atmosphere.

The simplest kind of carburetor is the float type, used on small

PROPULSION SYSTEMS FOR AIRCRAFT

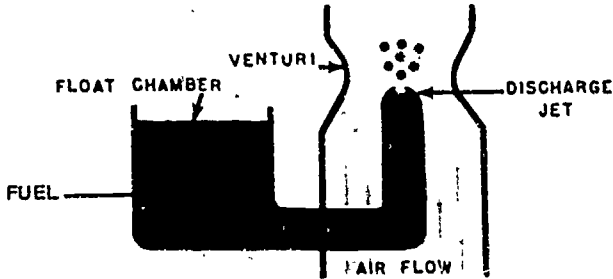

Figure 20. When the air flow speeds up to get through the carburetor's venturi (sometimes called a choke tube), pressure drops in the venturi, allowing fuel to be pushed through the discharge jet.

planes. It serves well to illustrate the basic operation of all carburetors. The float carburetor consists essentially of (1) a float chamber, (2) a main metering jet, (3) a discharge tube and nozzle, (4) a carburetor barrel, and (5) a throttle valve (Fig. 21).

The fuel is fed from the tanks into the float chamber, a reservoir used to insure a constant level of fuel within the carburetor. The float is connected to a needle valve and operates similarly

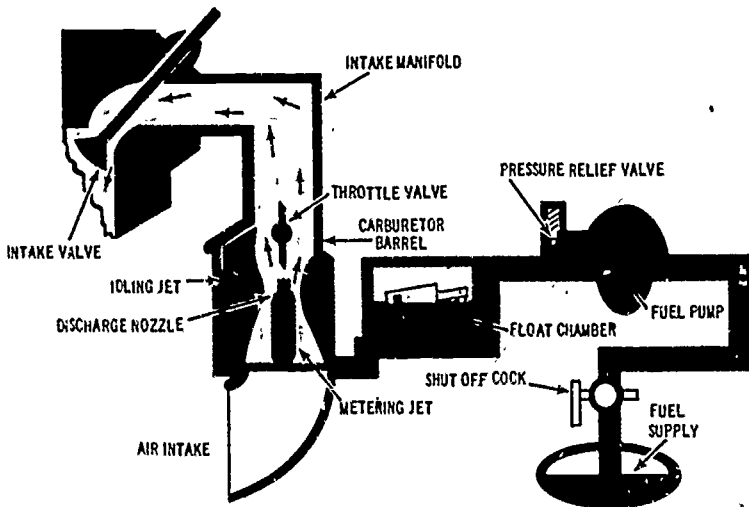

Figure 21. Outlined section shows how the carburetor works in connection with the other engine parts to feed fuel to the cylinder through the intake valve opening.

OTHER ENGINE SYSTEMS

to the float system in the tank of modern bathroom plumbing. As the fuel level in the chamber drops, the float drops with it, allowing the needle valve to open. When that valve opens, more fuel enters the chamber, the float rises again and the valve closes.

The fuel moves out of the float chamber through the metering jet, which measures it into the discharge tube. The discharge tube nozzle atomizes the gasoline—that is, breaks it up into a fine spray—as it dispenses the fuel into the carburetor barrel. The carburetor barrel, shown in figure 22, is an air chamber built in the shape of a venturi. That is, it is constricted to increase the velocity of the air flowing through it. As the velocity increases, the air pressure drops, creating an area of lower pressure and a suction effect which forces the atomized gasoline spray out of the discharge tube. The throttle

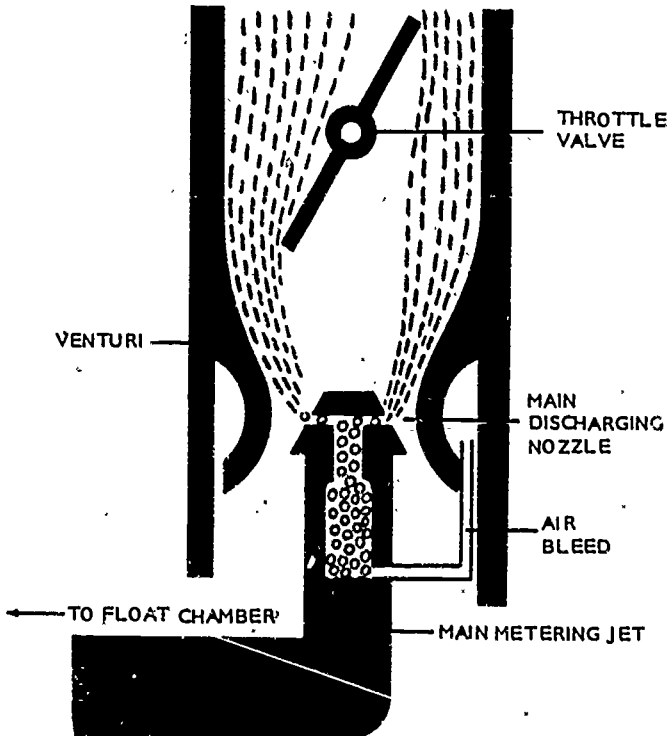

Figure 22. The throttle valve regulates the opening in the carburetor barrel in response to the pilot's movement of his throttle controls. The air bleed helps the fuel to flow freely out the discharge nozzle.

valve, set in the carburetor barrel downstream of the venturi, regulates the air flow through the carburetor. It is opened or closed by controls operated by the pilot.

Figure 21 shows what happens outside the cylinder when the pilot starts his aircraft's engine. When the engine starts, the throttle valve opens and the carburetor goes into action. The piston goes downward in the cylinder on its intake stroke, creating an area of lower pressure above it. The intake valve above the piston opens into the **intake manifold**, which is the pipe that supplies all the cylinders with the fuel mixture prepared in the carburetor. When the intake valve opens, air is pushed through the carburetor toward the cylinder. As the air rushes past the discharge nozzle and through the venturi, Bernoulli's principle goes to work and the pressure around the nozzle drops.

The pressure on the top of the discharge nozzle becomes less than the pressure on the gasoline in the float chamber. This pressure differential forces atomized gasoline into the airstream of the carburetor barrel, through the intake manifold, through the intake valve port, and into the cylinder. As the intake valve closes in the next step of the cylinder's operation (compression), the air/gasoline mixture continues to come through the intake manifold and goes into the other cylinders.

As the pilot opens his throttle control to increase engine speed, the throttle valve also opens. This allows more air to flow through the venturi; the pressure on the discharge nozzle drops more; and more gasoline is forced into the carburetor barrel. As the throttle is closed, the reverse takes place. The air stream is partially blocked by the throttle valve, the pressure rises on the discharge nozzle, reducing the gasoline flow, and the engine slows.

When the throttle is in the idle position, the throttle valve is closed as far as it will go. But the valve does not quite close off all of the air traveling through the carburetor barrel. A small amount of air is able to pass the throttle valve along the walls of the carburetor barrel. When the engine is at idle, the fuel supply does not come out through the discharge nozzle, but through a smaller opening above the nozzle, called an idling jet, shown in figure 21.

Carburetor Accessories

There are a number of devices which, while not essential to the operation of the carburetor, improve performance to such an ex-

tent that they are considered vital in modern aircraft. Some of the most important of these devices are the economizer, the accelerating system, the carburetor heater, and the supercharger.

THE ECONOMIZER.—This device, sometimes called the power enrichment system, is designed to supply additional fuel to the carburetor barrel during high-speed engine operation. It is called an economizer because it allows the use of smaller main discharge jets during normal engine speeds, but increases jet capacity (by adding its own to the total in use) during high-power periods. A typical economizer is shown in figure 23.

Not only does the economizer's extra fuel provide added power to the engine by enriching the fuel/air mix, it also helps to cool the engine by providing more vaporization at high power settings. As we have learned in our science courses, vaporization is a cooling process.

ACCELERATING SYSTEMS.—Most modern carburetors are equipped with an accelerating system designed to overcome the problem of temporary lean mixtures which occur when the throttle is suddenly thrown open. Normally, due to inertia (the tendency of bodies at rest to remain at rest; see Newton's first law), the fuel supply would require a short time to catch up with the increased amount of air flowing through the carburetor on sudden acceleration. The accelerating system, such as that shown in figure 24, overcomes that

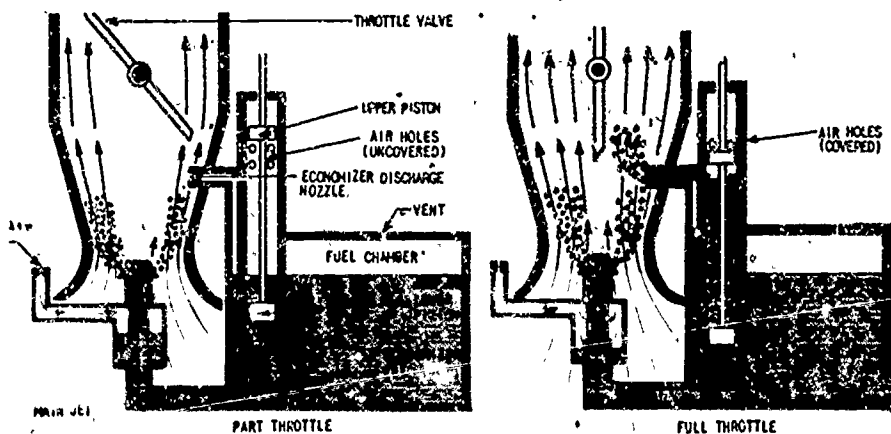

Figure 23. Operation of the piston type economizer system. Economizers come in several types, but all of them respond to the pressure differential produced when the throttle is opened.

OTHER ENGINE SYSTEMS

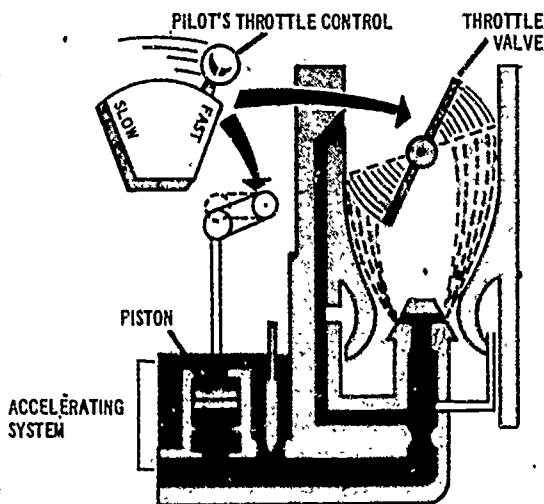

Figure 24. When the throttle is suddenly thrown open, the piston in the accelerating system pushes out extra fuel into the discharge stream to prevent "leaning" of the fuel/air mixture.

problem. It works either from a well or a pump. When the throttle valve suddenly opens, the accelerating system responds immediately by pushing more fuel through the discharge nozzle.

HEATER.—As we have seen, carburetor icing can be a serious problem. Icing can occur even on a warm day, because the temperature inside the carburetor drops dramatically during the vaporization process. To prevent icing, most carburetors are fitted with heating devices which typically transmit heat from the cylinders in the engine to the air in the carburetor. The heaters must be controlled, however, because too much heat will cause the fuel-air charge to expand and lose some of its power.

SUPERCHARGERS.—On larger aircraft, more fuel is needed to meet the greater demand for power. To increase the power output of the engine, the fuel/air charge is compressed by the supercharger, as shown in figure 25.

The function of the supercharger is to increase the amount of fuel in each charge fed into the cylinder. The superchargers are small, high-speed fans which increase the amount of air drawn into the engine; compress the charge, so that a charge of a given size, or volume, will have more air and more fuel in it; and force the compressed charge into the intake manifold.

OTHER ENGINE SYSTEMS

The supercharger forces more air through the carburetor, and the carburetor reacts by measuring in enough gasoline to keep the charge in its proper ratio. Since more air and fuel are available for burning in each combustion stroke of the piston, more power is obtained. The action of the supercharger also increases the pressure in the intake manifold, which then supplies all the cylinders with equal charges under equal pressure. High pressure in the intake manifold means smoother operation and more power from the engine as a whole.

The supercharger may be external or internal. The internal fan, or impeller, is located between the carburetor and the intake manifold. It operates through a gear connection with the crankshaft. The external fan is located between the carburetor and the free air outside, and makes use of the exhaust gases for its operation. The gases escaping the engine's cylinders on the exhaust strokes are directed through buckets of a turbine wheel, connected to the supercharger fan. Since the turbine principle is used in operating the external fan, it is called the **turbosupercharger**. Supercharger systems with the external fan usually are also equipped with the internal fan, as in figure 25.

The supercharger system is not only helpful, but actually essential for the operation of aircraft at very high altitudes. This is true because the air at high altitudes is thinner—it has less weight in the same volume—than air at sea level. And the carburetor, remem-

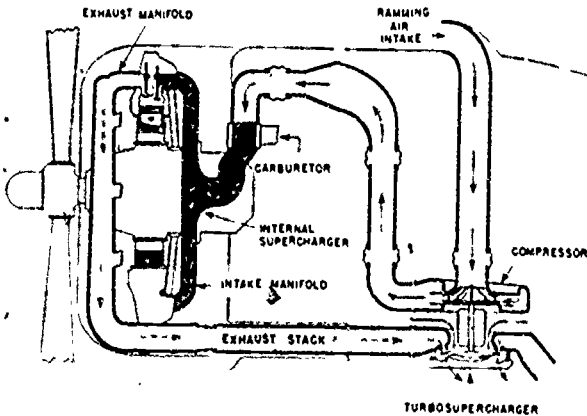

Figure 25. The supercharger's system external fan compresses intake air before it reaches the carburetor, and the fuel impeller further compresses the air mixture before it enters the intake manifold. The stronger charge means extra power in the engine.

PROPULSION SYSTEMS FOR AIRCRAFT

ber, is metered to considerations of weight, not of volume. The supercharger pulls in a greater volume of air in order to force through the carburetor enough air poundage to operate the engine.

The external fan, then—the turbosupercharger—pulls in air from outside and pushes it through the carburetor. The internal fan pulls air and gasoline out of the carburetor and pushes it into the intake manifold. Thus, the supercharger system delivers literally a “super” charge of fuel/air mixture to the cylinders.

Other Carburetor Types

The carburetor we have discussed is called the updraft float type. By updraft is meant that the air is drawn in from the outside and upwards through the carburetor venturi. There are carburetors which reverse this arrangement and pull the air downward through the venturi. They are called, appropriately, **downdraft carburetors**.

DOWNDRAFT FLOAT CARBURETOR.—The downdraft float type carburetor operates on much the same principle as does its updraft brother, but the arrangement of the parts is a little different, as we can see in figure 26. The main discharge nozzle

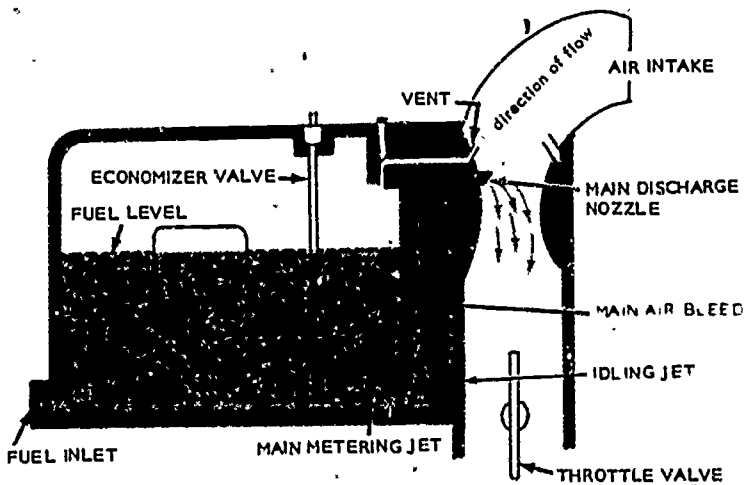

Figure 26. The downdraft carburetor is essentially the same as the updraft carburetor, except that the air intake is at the top instead of the bottom, and the air flows downward instead of upward through the carburetor barrel.

OTHER ENGINE SYSTEMS

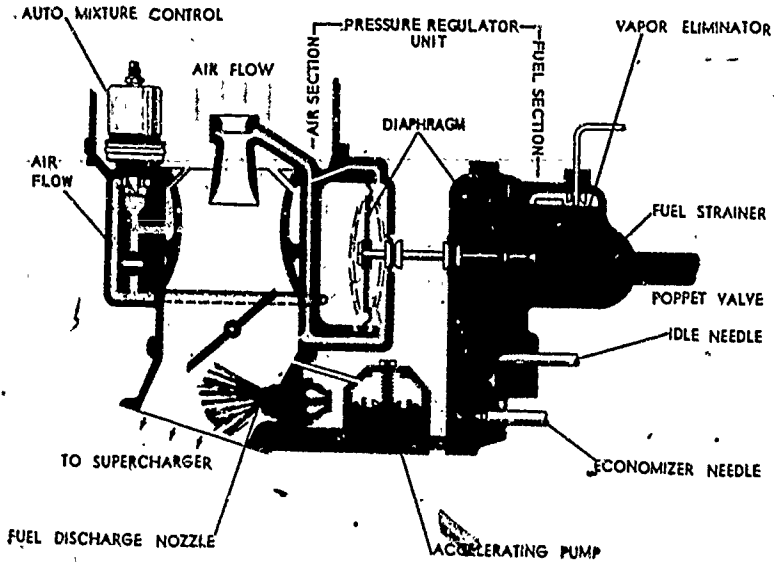

Figure 27. The pressure injection carburetor uses a system of diaphragms in the measurement of fuel. The diaphragms respond to the air flow and to the force of the fuel, which is pumped into the carburetor under pressure. The pressure regulating unit of this carburetor includes the air section and the fuel section of the metering system.

is in the venturi, but it protrudes from the side instead of being in the middle. The idling jet is below the discharge nozzle. Air is vented into the float chamber, providing enough pressure to force the fuel up through the nozzle and into the carburetor barrel.

PRESSURE INJECTION CARBURETORS.—The large piston-powered aircraft employ the pressure injection type carburetor, such as is shown in figure 27.

The pressure injection carburetor makes use of a pump to deliver fuel under pressure to nozzles in the carburetor barrel at a point just before the entrance to the internal fan (impeller). The fuel, under pressure, is atomized into the rushing air, which results in smooth, economical operation, the elimination of icing in the throttle valve, and protection against vapor lock due to the fuel's boiling in the lines.

The pressure injection carburetor is entirely closed, which means that it will operate normally during all types of aircraft maneuvers. An automatic mixture control meters the fuel at all operating alti-

PROPULSION SYSTEMS FOR AIRCRAFT

tudes and at all operating load levels. Its job is to retain the proper air-to-fuel ratio, despite changes in the density of the air. The metering is done in response to venturi air suction and changes in air pressure.

The pressure regulator unit of this carburetor consists of an air section and a fuel section, each of which is divided into two chambers with a diaphragm between.

A poppet valve, operated by the movement of the diaphragms, connects the two sections. The poppet valve opens and closes an orifice (opening) through which fuel is pumped from the aircraft's fuel system into the fuel chamber of the carburetor. Thus, all parts of the carburetor move as a unit.

The operation of the pressure injection carburetor is as follows:

Air is fed through the automatic mixture control in proportion to the air flowing through the carburetor venturi. The mixture control passes the air to the air chambers in the regulator unit. A pressure differential is formed between the two chambers of the air section. The diaphragm moves, activating the poppet valve in the fuel section. As the valve opens, fuel is pumped, under pressure, through the opening and into the fuel chamber of the regulator unit. This causes a pressure differential between the two chambers of the fuel section and activates the second diaphragm. The action of the diaphragm pushes the poppet valve back the other way, closing off the opening to the fuel supply. The fuel, still under pressure, passes from the fuel section of the regulator unit down to the fuel nozzle, through which it is sprayed into the carburetor barrel.

As you can see, the rate at which the fuel is delivered into the airflow is controlled jointly by the position of the throttle valve and by the temperature and pressure of the air, acting through the automatic mixture control.

In the pressure injection carburetor, the economizer, idling system, and accelerator system are controlled by pressure in the fuel chamber section and venturi air pressure.

FUEL INJECTION SYSTEMS

Some aircraft use a fuel injection system to perform the functions of the carburetor. Under this system, metered portions of fuel are sprayed either directly into the cylinder or into the intake manifold at a point just outside the cylinder's intake valve. The two most common types of fuel injection systems are the mass air flow type and the intake metering type.

OTHER ENGINE SYSTEMS

Mass Air Flow System

The mass air flow fuel injection system is used on large aircraft and is so named because the fuel delivery is controlled by the engine's demand for quantities of air at a given time. It consists of a master control unit, injection pump, and cylinder head discharge nozzles. The arrangement of these parts and the way they work together is shown in figure 28.

MASTER CONTROL.—The master control unit of this system operates in a similar manner to the pressure injection carburetor, except that the metered fuel is delivered to the injection pump instead of to the single discharge nozzle. The master control is located just ahead of the internal supercharger (the impeller), in the same place the carburetor would normally be. Its job is

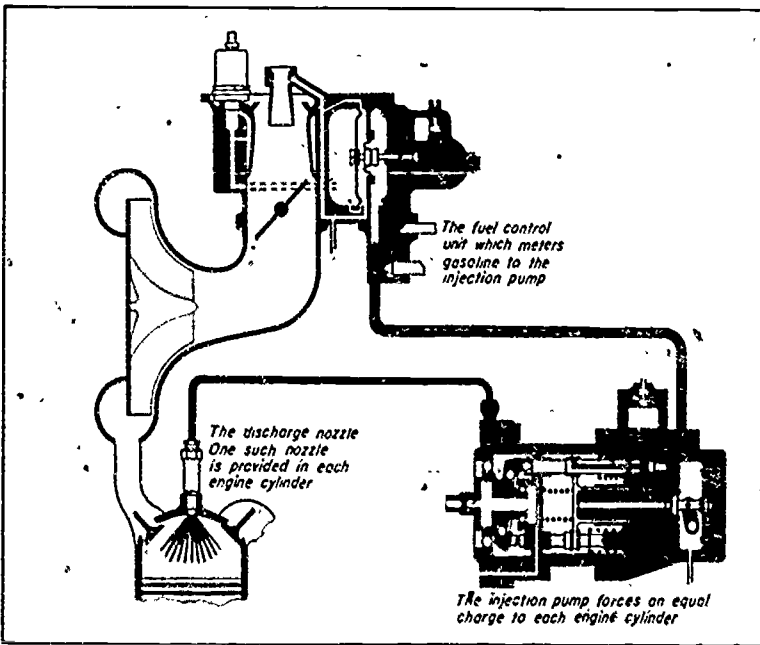

Figure 28. The mass air flow fuel injection system shown here features direct discharge of the fuel into the cylinder through the nozzle built into the cylinder head. The fuel measurement is controlled by a fuel control unit similar in operation to that of the pressure injection carburetor. Instead of delivering the fuel charge to the carburetor barrel, this system sends it to an injection pump, which divides the charge and distributes it to individual cylinders.

to measure the air flow and send the correct amounts of fuel to the injection pump.

INJECTION PUMP.—The injection pump divides the fuel it gets from the master control and sends equal parts of fuel to the individual discharge nozzles at high pressure.

DISCHARGE NOZZLE.—The fuel discharge nozzles are screwed into the heads of each individual cylinder. Each nozzle has a valve set to open at a given pressure; when that pressure point is reached, the valve opens and the nozzle sprays atomized fuel into the cylinder. This discharge is timed to occur during the early part of the intake stroke.

As can be seen in figure 28, the cylinder is much the same under this fuel injection system as with carburetion, but the intake valve furnishes air unmixed with fuel, and the fuel is added directly to the combustion chamber. The exhaust valve's function and the four-stroke cycle are no different than in engines with carburetors. In the intake metering system, the cylinders are no different than in engines fitted with carburetors.

Intake Metering System

The intake metering system, used on small aircraft engines, consists primarily of a fuel metering and pumping section, an air metering throttle valve, and discharge nozzles for each cylinder, as shown in figure 29.

Fuel in the fuel pump section is under pressure from a pump operated by a connection with the engine crankshaft. To get into the lines leading to the discharge nozzle, the fuel must pass through a metering valve and a groove in a fuel distributing plunger, as seen in figure 29. The opening groove and the valve must come into alignment before the fuel can flow, or increase, and the alignment is controlled by a mechanical connection to the throttle valve.

When the pilot moves his throttle control to get more speed, the throttle valve opens, increasing the air flow; at the same time, a mechanical connection turns the fuel valve and the plunger so that the valve opening and the plunger groove come into alignment. The fuel, under pressure, rushes through the fuel lines to

OTHER ENGINE SYSTEMS

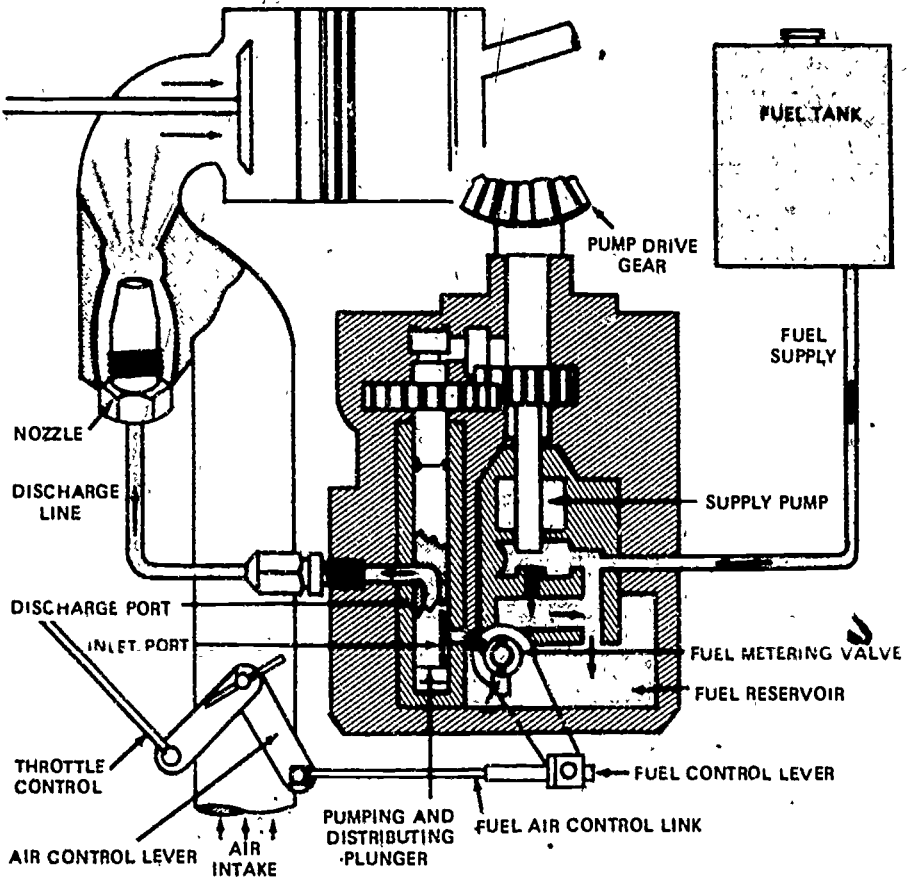

Figure 29. The intake metering system of fuel injection is used on smaller aircraft engines. It includes a mechanical linkage between the air metering throttle section and the fuel metering section and pump. Injection of the fuel charge occurs in the intake manifold just above the cylinder's intake valve, and not into the cylinder itself.

the discharge nozzle. Fuel pressure opens the discharge nozzle valve, spraying the atomized fuel into the airstream directly above and aimed into the cylinder's intake valve (not shown in figure 29).

Advantages and Problems

The fuel injection system offers several advantages over the carburetor system. It completely eliminates icing hazards and, with

fewer moving parts, is easier to maintain in good order. It also reduces fire hazards, functions well at any aircraft attitude, and improves engine efficiency.

The fuel injection system becomes quite complicated, however, when used in reciprocating engines with many cylinders. A major problem is the design and the synchronization of the spraying action with the intake cycles of all the engine's cylinders.

The fuel injection system is well fitted to jet engine operation, as we presently will see.

IGNITION SYSTEM

We have seen how the fuel travels from the tanks, through the carburetor or injection system, into the manifold, and from there to the cylinder. But before the fuel/air mixture in the cylinder—the engine's combustion chamber—can supply the aircraft with power, it must be ignited, or set fire; for as we have seen the driving force of an engine comes from the expansion of gases as the fuel mixture burns.

The ignition of the fuel in the cylinder is brought about through the use of electricity. The fuel is set off by an electrical spark from the spark plug, and the origin of that spark is the magneto.

The magneto is a type of electricity maker, or generator, that works by whirling a set of magnets around between two poles. To understand why this produces electricity, it will help us to review some facts about both magnetism and electricity.

Magnetism and Electricity

The forces of magnetism and electricity have several things in common. One of these things is that we do not know exactly what either of them is. Notwithstanding that, we do know that one can cause the other; we know that they share certain properties; and we know how to put them both to good use.

ELECTRICITY.—We know from science that all matter is composed of molecules, all molecules are made up of atoms, and all atoms are composed of protons, neutrons, and electrons. The atom (Fig. 30) is arranged like a small planetary system, with the nucleus of protons and neutrons in the center and the electrons

OTHER ENGINE SYSTEMS

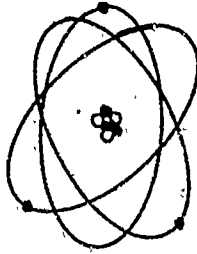

Figure 30. The atom is a miniature planetary system. Its nucleus is made up of protons and (in all elements except hydrogen) neutrons. Electrons orbit this nucleus.

whirring in high-speed orbit. The protons have a positive charge; the neutrons have neither positive nor negative charge; the electrons have a negative charge. Whatever the substance, its electrons are like the electrons of every other substance in every way: they are the same size, the same weight, and they have the negative charge.

When a substance becomes unbalanced in its proton/electron count—when there are more electrons than protons, or more protons than electrons—then the atom will show electrical properties.* This is the condition known as ionization. The substance with a deficiency of electrons (that is, with an overbalance of protons) will show a positive electrical charge. A substance with an overbalance of electrons will be negatively charged. Unlike electrical charges attract each other, while like charges repel.

An electric current results from the continuous movement of electrons along or through a conductor substance which is part of a closed circuit. Every conductor of electricity has an abundance of free electrons that can be made to flow from atom to atom along a line by the application to the circuit of an outside force, called an **electromotive force**. The strength of the electromotive force is expressed in **volts** or **voltage**. Two ways to apply an electromotive force are by chemical action, as with a storage battery; and by electromagnetic induction, the moving of conductors through a magnetic field. What causes the current to flow is the pressure of electrons trying to move from points with surplus electrons to points deficient in them.

*Because copper and soft iron can be made to assume these properties easily, they are widely used as conductors of electricity.

PROPULSION SYSTEMS FOR AIRCRAFT

An electrical current may be **direct**, in which case it will move through the circuit in the same direction all the time, usually with the same, or virtually the same, intensity. Or it may be a **pulsating direct current**, which is a direct current that varies regularly in intensity. Or it may be an **alternating current**, which changes its direction of flow at regular intervals. Alternating current is the kind found in most home electrical systems, and it is the kind of current produced by an aircraft engine's magneto.

MAGNETISM.—Magnetism is a natural form of energy closely associated with electricity but not the same. Magnets occur naturally in stone-like substances called **magnetite**, which is iron oxide. They may be produced artificially in pieces of hardened steel. Or they may be produced through the use of electricity in **electromagnets**. Whatever the case, every magnet has two points, called **poles**, where the magnetic effect is concentrated. A freely suspended magnet will attempt to align itself in a north-south direction. One of its poles will always seek to point north, the other south; and so they are known as the **north pole** of the magnet (N) and the **south pole** of the magnet (S), according to the direction they seek. Like the positive and negative electrical charges, the like poles of magnets (N and N or S and S) repel each other and the unlike poles attract.

The force of magnetic attraction or repulsion acts in definite lines, called **lines of magnetic flux**. The positions of these lines of flux may be found by sprinkling iron filings on a paper beneath which is a magnet. The filings arrange themselves along the magnetic lines of flux (Fig. 31). These lines of flux occur all through the space surrounding the magnet, and the space they occupy is called the **magnetic field**. We assume that lines of force pass out from the north pole of the magnet, make a circuit through whatever surrounds the magnet, and reenter through the south pole. Every line of flux must form a complete **magnetic circuit**, most of which occurs within the magnet itself. We can control the circuit to a degree by manipulating the space through which the lines of flux flow outside the magnet, as in figure 32, when we bend a bar magnet into the shape of a horseshoe. The smaller gap between the magnet's poles increases the strength of the magnetic force in that space.

OTHER ENGINE SYSTEMS

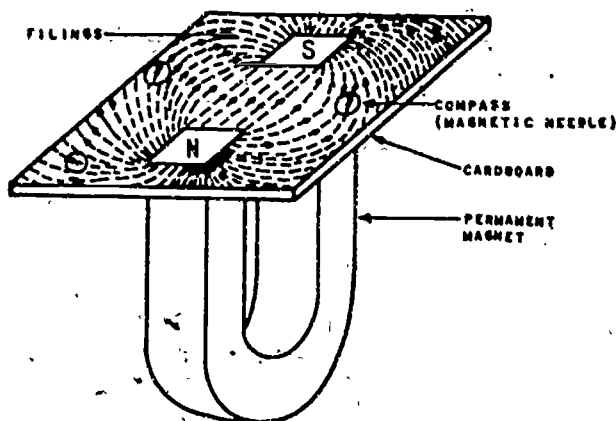

Figure 31. Iron filings sprinkled on paper held over a magnet will align themselves to the shape of the magnetic field.

ELECTROMAGNETISM.—Electricity can be used to make magnetism, and vice versa. Sending an electrical current through a conductor produces a magnetic field around the conductor. More important to this discussion, moving a conductor of electricity through a magnetic field—cutting the magnetic lines of flux with the conductor—causes an electrical current to flow through the conductor. This phenomenon is known as electromagnetic induction, and is the key to our ignition system.

Electromagnetic induction, therefore, depends on two factors: magnets, which supply the lines of flux (magnetic field) to be cut; and an electrical conductor. Current may be induced in the conductor by moving either the magnets or the conductor in such a manner that the lines of flux are intersected, or cut (see figure 33). It is important to know that the current will flow only as long as that movement continues. When the motion stops, electromagnetic induction ends.

The intensity of the induced current (its voltage) can be increased by increasing the rate at which the lines of flux are cut by the conductor. One way to do this is to increase the speed at which the magnet moves, which in effect multiplies the number of available lines of flux. Another way to increase voltage is to

PROPULSION SYSTEMS FOR AIRCRAFT

wind the conductor into a coil, which has the effect of multiplying the number of conductors; and thereby cutting the lines of flux more often in a given time. A second coil, wound concentric with the first one, can further increase the number of cuts and intensify the electrical current.

The Magneto

The magneto is an electric generator which makes use of the principles of electromagnetic induction. The most commonly-used magneto in today's aircraft is the moving-magnet type shown in figure 34.

It produces electrical current by rotating a set of magnets between two metal pole shoes. The pole shoes are joined together by a core, which is wound with two sets of wire coils to increase the voltage of the current. An important point to remember is that no electric current is induced in the coils unless the magnets are moving.

The rotating magnet part of the magneto may consist of four, six, or eight magnets, arranged in a circular pattern on one end

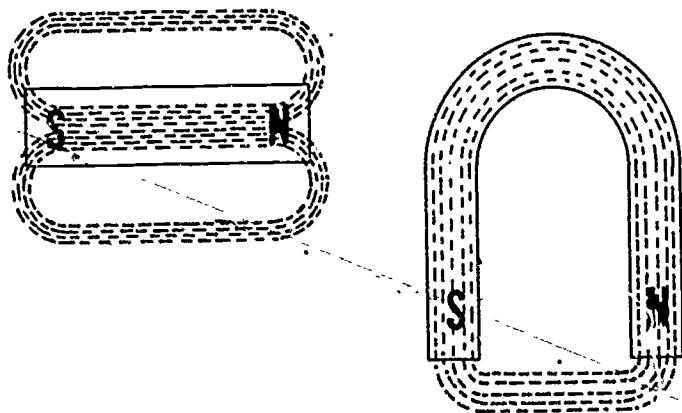

Figure 32. Bending a bar magnet into horseshoe shape makes the magnet stronger by concentrating the lines of flux.

OTHER ENGINE SYSTEMS

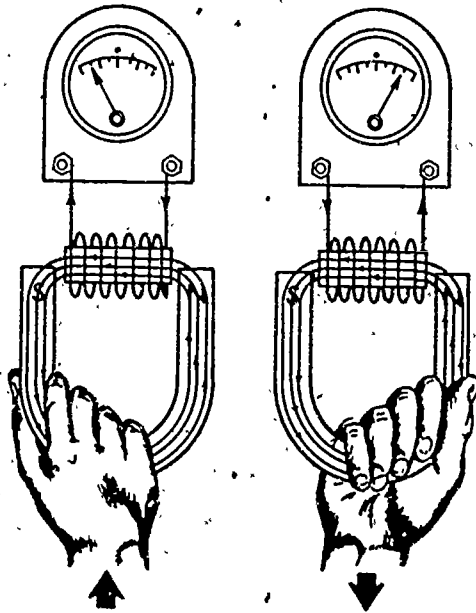

Figure 33. Current can be induced in a conductor by causing it to cut the magnet's lines of flux. Motion is required to induce the current, either by the magnet or by the conductor.

of a bar. The other end of the bar connects to the engine's crankshaft through a gear arrangement. The turning of the crankshaft turns the magnets. The purpose of the pole shoes and the core which connects them is to collect and direct the magnetic lines of flux of the whirling magnets (Fig. 34). The shoes and core are made of soft metal, which is a better magnetic conductor than is air. Since the lines of flux always flow along the path of least resistance, they flow through the shoes and core.

As the magnets turn between the shoes, the magnetic flux runs through the shoes and core. Around the core are wound two sets of coils, the primary and the secondary coils. The coils are made of a material which is an even better conductor than the metal of the core. Because of this, the current drains off the core

and through the primary coil, which is directly attached to the core.

The primary coil transfers the current to the secondary coil, which multiplies the current's voltage. The amount of voltage induced in the coils depends in great part on the number of turns of wire in the coil. For instance, a primary coil of 50 turns of wire may produce 12 volts. The secondary coil of 500 turns of wire will then produce 120 volts. (The primary coil always has comparatively few turns while the secondary coil has many.) Since the magneto produces about 22,000 volts—the voltage necessary to fire the spark plugs at the proper time—you can see that the secondary coil will consist of many thousands of turns of wire.

The current in the secondary coil cannot build up unless the current in the primary coil is either increasing or decreasing. The faster this increase or decrease takes place, the stronger the volt-

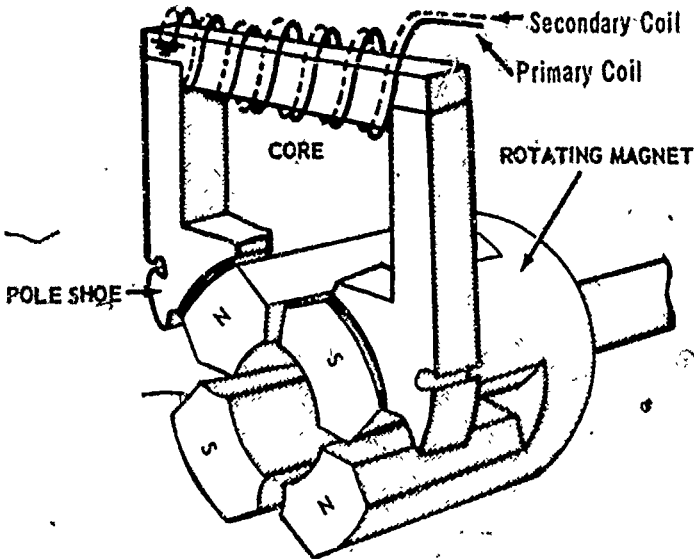

Figure 34. The movable magnets in the magneto spin between the ends of the conductor (poles and core), cutting many lines of flux and inducing an electrical current in the primary coil. The current is intensified in the secondary coil until it is strong enough to fire the spark plug and ignite the fuel, air charge in the cylinder.

OTHER ENGINE SYSTEMS

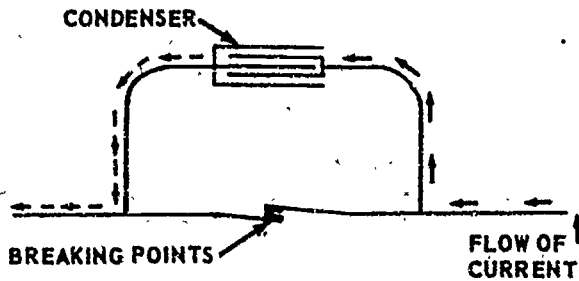

Figure 35. The condenser absorbs the self-induction ("inertia") current and prevents undesirable arcing when the breaker points open. It then discharges that current back to the primary coil, helping accomplish flow reversal.

age will be in the secondary coil. For this reason, an instantaneous collapse of the current in the primary coil is desirable. An automatic switch device, called a **breaker point**, brings this collapse about. At the moment when the current in the primary coil is greatest, the breaker point opens and the current stops immediately (Fig. 35).

But every electrical current resists any change in its intensity—whether increase or decrease. This resistance, known as **self-induction**, is similar to the inertia effect in a solid object.

Self-induction prevents the current from building up quickly and from collapsing instantly. When the breaker points open, self-induction will cause an electrical arc to jump between the points. If left unchecked, this arcing could cause burning and pitting of the points. To correct this situation, a **condenser** is used.

A condenser is an electrical device which can store electrical energy for later discharge. As we can see in figure 35, the condenser is connected in a parallel circuit with the breaker points and it intercepts the electrical arc accomplishing the instant collapse. The condenser stores the intercepted charge momentarily, then discharges it back into the primary coil. This reverses the flow of current and helps with rapid buildup of the current in the primary coil.

From the secondary coil, the current goes into the distributor; from there to a harness of cables, and from the cables to the spark plugs (Fig. 36).

PROPULSION SYSTEMS FOR AIRCRAFT

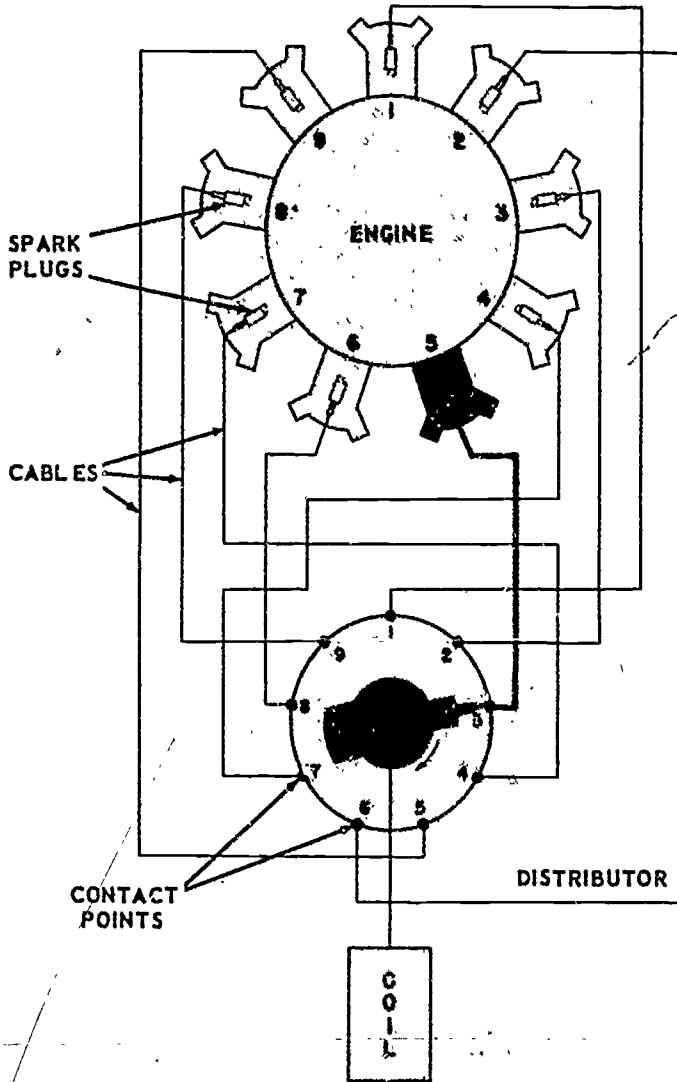

Firing Order

Magneto	Eng
1	1
2	3
3	5
4	7
5	9
6	2
7	4
8	6
9	8

Figure 36. The electrical current goes from the magneto coil to the distributor, and from the distributor through the contact points to the spark plugs in the cylinders. As noted earlier, the cylinders do not fire in straight numerical sequence. The firing order of the cylinders is calculated to provide the smoothest flow of power from the pistons to the crankshaft.

OTHER ENGINE SYSTEMS

The distributor is the device which passes out the electrical current to the spark plugs in the proper firing sequence. This is done through a revolving contact point which passes over a series of stationary contact points. There is one stationary contact point for each engine cylinder. As the revolving point passes over the stationary point, it extends the electrical circuit and feeds current into the spark plug.

The spark plug (Fig. 37) is a high tension conductor which feeds the electrical current into the cylinder. On its bottom end, the plug has two electrodes separated by a gap. The electrical impulse jumps the gap between the two points when the voltage mounts high enough to break down the resistance of the gases in the air in the gap. When the spark jumps, the fuel mixture ignites.

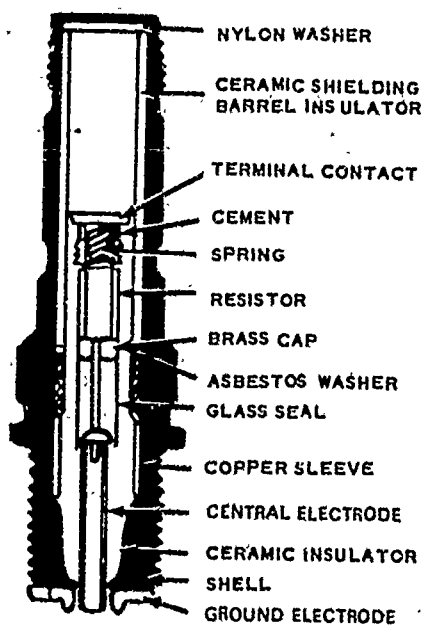

Figure 37. The spark plug must be carefully built to stand up under the stresses it is subjected to. Its job is to feed the electrical current to the cylinder. The fuel/air charge is ignited when the electrical spark jumps from the central electrode to the ground electrodes.

62/3

PROPULSION SYSTEMS FOR AIRCRAFT

All aircraft in use today that are powered by reciprocating engines have double ignition systems. Both systems connect to all the cylinders to produce faster and more efficient burning of the fuel. The double ignition system also is a safety factor.

Starting Systems

We have seen that the magneto furnishes the spark; the spark ignites the fuel; expanding gases from the burning fuel push down the piston; the piston turns the crankshaft; and the crankshaft turns the magneto (in addition to its other duties) to keep the electrical current flowing.

But we must have some way to start the whole process before the engine can take over its own operation.

Most modern aircraft are equipped with small electric motors which operate the starting mechanism. The electric motors take their power from batteries or from gasoline-powered generators called starting units. The mechanical energy of the electric motor can be applied either directly or indirectly.

In the indirect application—called inertia starting—the electric motor turns a flywheel, which builds up speed enough to activate the clutch. The clutch engages the crankshaft and starts it turning, and the crankshaft then operates the magneto. This system is used on small engines.

Direct electrical starting is most widely used, however. This system makes use of an electromagnet, called a solenoid. Electric current from the battery activates the solenoid, which directs current through a booster coil. The booster coil increases the electric voltage and provides a shower of sparks to the spark plugs until the magneto begins to operate. The solenoid-booster coil system is made of very tough material so that it can withstand, for the brief periods of time necessary, the strong current required to start the engine.

The pilot can stop the engine by means of the ignition switch. The switch is connected to the magneto across the breaker points. When the switch is turned to the "off" position, the current goes to ground rather to the breaker points. This stops the current variations in the primary and secondary coils, and thus stops the ignition process.

THE LUBRICATION SYSTEM

The engine systems we have discussed so far are all directly concerned with supplying power. The fuel system delivers fuel to the carburetor; the carburetor mixes it with air and passes it to the cylinder; there, the ignition system sparks the fuel, releasing its energy; the mechanical system converts that energy into useful work—turning the propeller.

But one essential system is not directly concerned with producing power, and that is the lubrication system. The lubrication system's job is to control heat so that the engine parts are allowed to move freely. In a way, the lubrication system and the cooling system are complementary—they are both concerned with heat control—but the emphasis of the systems is different. Whereas the cooling system is concerned with the overabundance of heat energy produced by the burning fuel in the cylinder, the lubrication system is most concerned with another kind of heat, that produced by friction.

The main purpose of the lubricating system is to prevent metal-to-metal contact between the moving parts of the engine. If this contact were permitted, the result would be excessive heat, produced by friction. The friction heat would cause the parts to expand, bringing about loss of power, rapid wear on the metal surfaces, and perhaps even temperatures high enough to melt the parts. Speaking in medical terms, if the engine were a person and the friction heat a disease, oil from the lubricating system would be preventive medicine—medicine which stops the disease before it develops.

The oil also has other functions. It provides a seal between the piston and the wall of the cylinder, which halts any gases that might otherwise escape past the piston and into the crankcase. Figure 38 shows how the piston is constructed to help accomplish this job. The oil prevents corrosion. It helps to cool the engine. And it is the fluid that operates the many hydraulic devices in the modern aircraft.

But the prevention of excessive friction heat is the most important job of the lubrication system. This is done simply by putting a thin layer of oil between the moving metal parts. When this layer is in place, the high friction that would result from metal-to-metal contact is replaced by low friction in the oil film.

PROPULSION SYSTEMS FOR AIRCRAFT

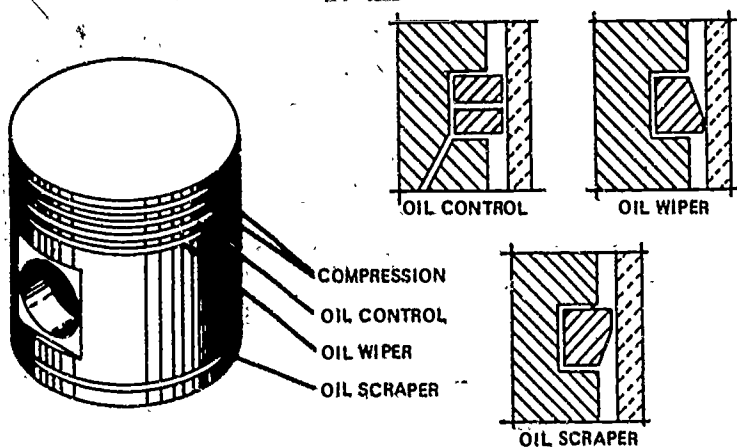

Figure 38. The piston is equipped with compression rings, which prevent gas leakage past the piston during engine operation, and oil rings, which control the amount of lubricant supplied to the cylinder walls and keep excess oil out of the combustion chamber. Oil flows to the cylinder wall through a hole in the oil control ring, and the wiper ring scrapes the excess away.

Oil Properties

The oil must be heavy enough that it will not be squeezed out from between the metal parts and light enough that it will not give too much resistance to the movement of the metal parts.

Lubricating oil, like gasoline, is composed of hydrocarbons and is refined from petroleum. In fact, the oil is taken from the part of the petroleum that is left over after the gasoline and kerosene are distilled out.

Engine manufacturers list certain specifications for the oil used to lubricate their engines. These specifications include information on viscosity, flash point, pour point, and other factors.*

Viscosity is the relative heaviness of the oil and is used as the measure of the oil's ability to be pumped through the engine at certain temperatures. A heavy-bodied oil is said to have high viscosity, while a light-weight oil is said to have low viscosity.

The **flash point** is the temperature at which the oil will give off

*It should not be assumed that automotive motor oils can be used as aviation oils. Aviation oils are subject to stricter controls during refinement and production, and differ from automotive oils in many ways, including viscosity, flash point, and pour point.

OTHER ENGINE SYSTEMS.

flammable vapors that will catch fire. The pour point is the lowest temperature at which an oil will flow. Now that we are familiar with the properties of the lubricating oil, let us see how it is put to work in the aircraft.

Some aircraft oils contain detergents, which are cleansing agents. Detergents help the oil carry off impurities such as metal particles and bits of sand and dirt, that are products of normal engine operation.

Aircraft lubrication systems use pressure pumps to force the oil through passages and into the many parts of the engine which need lubrication. Some parts of the engine, such as the cylinder walls, the piston pins, and some of the ball bearings and roller bearings, get their oil by splash or spray.

Oil Distribution

The oil system, such as is shown in figure 39, consists of an oil storage tank, a pressure oil pump, oil lines, a sump (collection place), a scavenger pump, filters, and a radiator.

The pressure pump moves the oil from the storage tank to the engine crankcase, where it is sprayed and splashed so as to do its lubricating job. The oil drains from the engine parts into the sump.

The scavenger pump forces the oil out of the sump, through a filter, through a radiator, and back into the oil reservoir for reuse. The filter screens out any dirt, sludge (a gummy residue deposited by burning oil), and metal particles the oil may have picked up on its trip through the engine; the radiator operates in the same way as does the radiator to the cooling system in liquid-cooled engines. Fast-moving air carries off excess heat collected by the oil on its trip through the engine.

In some small engines, the engine crankcase itself may carry the oil supply as it does in auto engines. This is called the wet sump system. In the wet sump engine, no scavenger pump is needed because the oil drains to the bottom of the engine crankcase by gravity after it goes through the engine. The crankcase thus acts as both storage tank and sump.

The wet sump system has some notable weaknesses that make it unsuitable for many aircraft. It will not function when a plane maneuvers so that the crankcase is not beneath the cylinders, nor in engines designed that way—such as the horizontal opposed engine. The oil capacity of the wet sump system is limited to the size of the engine casing, and it is hard to cool the oil from the heat produced in high-performance engines. The wet sump sys-

PROPULSION SYSTEMS FOR AIRCRAFT

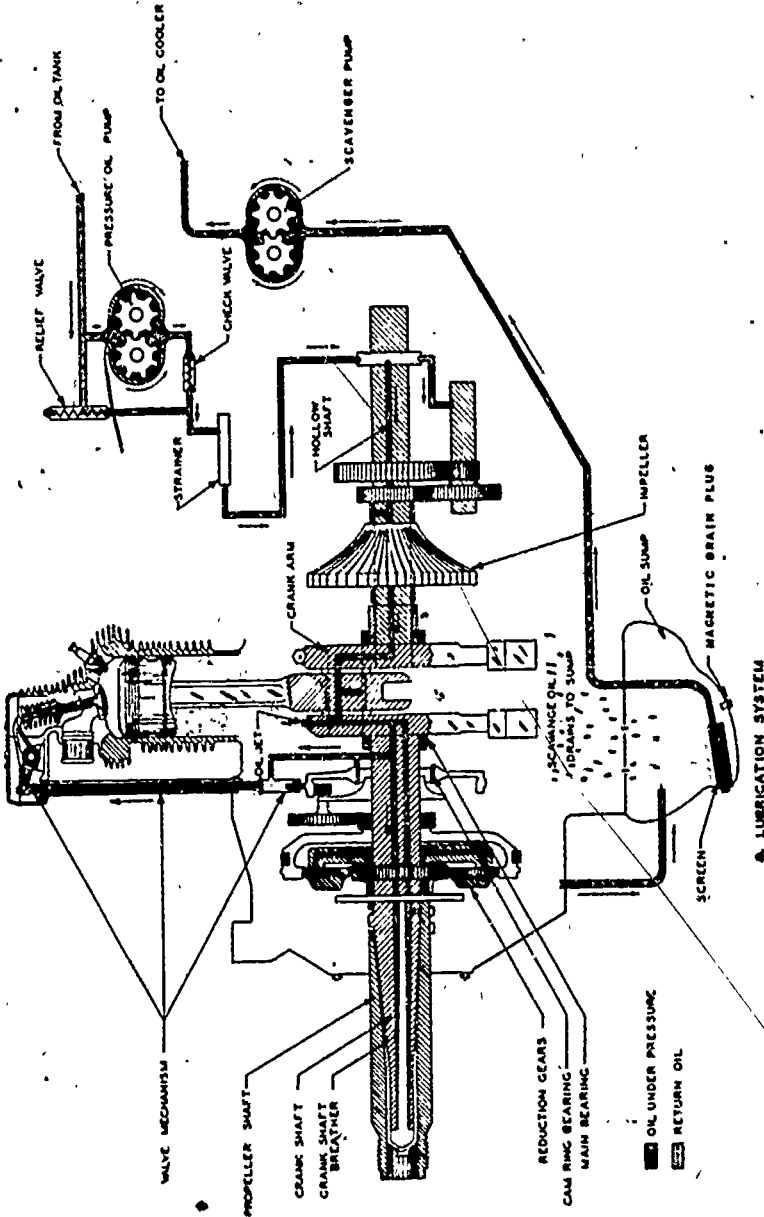

Figure 39. The lubrication system provides oil to points of friction in the engine, the crankshaft, and other associated sections. The lubricating oil in this typical radial engine lubrication system is sent under pressure to the stress points, drains into the sump, is pulled through the oil cooler, and sent back to the oil tank for reuse.

OTHER ENGINE SYSTEMS

tem is completely unsuited for such engines, as the radial air cooled, where there is no reservoir.

On the larger, more powerful non-radial engines and on all radial engines, the oil storage tank is located outside the engine. This is called the **dry sump** system. Most of the big multi-engine planes have a separate oil system for each engine.

PROPELLERS

We have now learned something about all of the different divisions of the engine, and how all of these systems work together to produce power efficiently. But remember, the whole purpose of the engine is to provide power to turn the aircraft's propeller.

Without the propeller, an aircraft with the world's greatest reciprocating engine would just sit on the runway and burn fuel. On the other hand, the world's greatest propeller could not run for very long on rubber bands. The point is that engine and propeller are parts of a power unit which is bigger than both. We have learned about engines and now we should turn our attention to propellers.

The aircraft propeller is the device which converts the energy from the engine into the thrust that drives the plane forward. It is a type of twisted airfoil, similar in shape and function to the wing of the airplane.* Propellers have a tendency to suffer nicks and dents which reduce their efficiency as airfoils. This is why pilots check the propellers carefully before every flight, and see that they are repaired or replaced, if necessary.

We can see this similarity in shape by examining the propeller in small sections of the whole blade (Fig. 40). Each section has the shape of a section of wing, but the camber and chord of each individual propeller blade section will be different from the camber and chord of every other section. Moreover, while the wing of an aircraft has only one motion—forward—the propeller blade has two motions—forward and rotary.

The propeller produces the rearward thrust to drive the aircraft forward; and this forward motion sets up the reaction between air and wing to produce lift on the wing.

The principle used in propeller operation is Newton's third law of motion, which states that for every action, there is an equal and opposite reaction. In the case of the propeller, the *action* is the forcing of large quantities of air to the rear. The *reaction* is the

*Airfoils are examined in the AE 11 book, *Theory of Aircraft Flight*.



Figure 40. Each section of this propeller, except for the shank end, can be seen to have an airfoil shape. The propeller resembles a wing in this respect.

forward motion of the plane. Additionally, when the propeller starts rotating, air flows around its blades, just as air flows around the wing of a plane in flight. But where the wing is lifted upward by the force of the air (Bernoulli's principle), the propeller is "lifted" forward, and pulls the aircraft with it.

The engine furnishes the propeller with power. In small engines, the propeller may be attached directly to the crankshaft. In the larger engines, however, the crankshaft turns too fast for good propeller efficiency, and so the propeller is attached to the crankshaft indirectly, through a set of gears. The gears reduce the propeller's rotation rate below that of the crankshaft but allow the propeller to turn fast enough to make good use of the available engine power. (Generally speaking, propellers lose efficiency very quickly if they rotate at more than 2,000 revolutions per minute. Propeller efficiency is discussed later in this chapter.)

Nomenclature

The propeller blade has a leading edge and a trailing edge, just as a wing does (Fig. 41). The leading edge is the fatter edge, the trailing edge the thinner. The blade back is the curved portion of the propeller blade. It corresponds to the top of the wing and is always located toward the front of the airplane. The face is the flat side of the propeller and corresponds to the bottom of the wing.

The hub is the metal unit by which the propeller is linked (directly or indirectly) to the crankshaft. That part of the propeller which joins the hub is called the butt, and the section between the butt and the operating portion of the propeller is the shank. The shank and butt are usually thick for strength and cylindrical in shape, and do not contribute to the propeller's thrust. The outermost end of the blade is called the tip.

OTHER ENGINE SYSTEMS

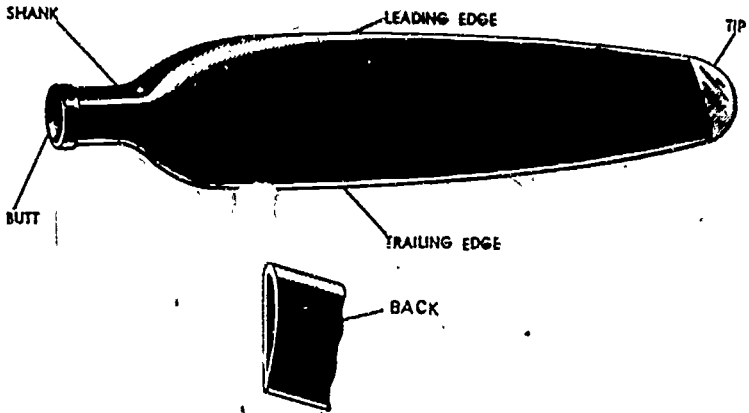

Figure 41. The propeller may seem a simple instrument, but even so it has a name for each of its surfaces and edges. The propeller's back is the curved (concave) side and is always located toward the front of the airplane. The face is the flat (chord) side and is always located toward the rear.

Motion

The propeller turns in an arc perpendicular to the crankshaft, as shown in figure 42. This arc is called the plane of rotation. The blade angle is the angle between the face of a particular section of the blade and the plane of rotation. The blade's angle of attack is the angle between the face of the blade section and the direction of the relative air stream. This corresponds to the angle of attack in the wing. The actual distance that the propeller moves forward in one revolution is called the effective pitch. This is not to be confused with the informal term pitch, which refers to the amount of twist in the blade.

The terms *pitch* and *blade angle* do not strictly mean the same thing, but they are so closely related that they are often used interchangeably. Thus, a propeller with a small blade angle would be said to have low pitch, while a propeller with a large blade angle would be called a high pitch propeller. A high pitch propeller will move an aircraft farther forward during one revolution than will a low pitch propeller; that is, it will have greater *effective pitch*.

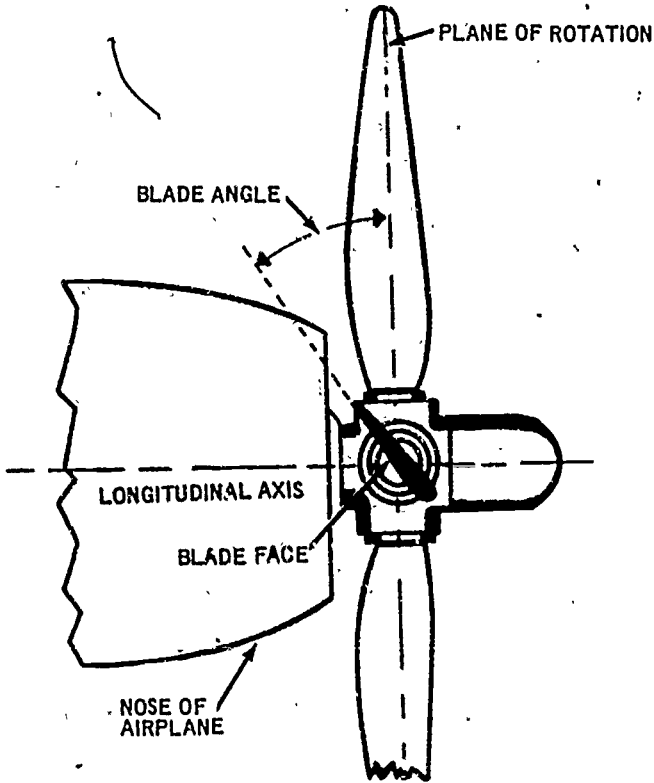

Figure 42. This drawing of a four-blade propeller demonstrates the plane of rotation and the blade angle in a simplified way. Actually, because the propeller blade is curved, the blade angle will vary along the length of the blade from butt to tip. The blade angle is important in determining the propeller's amount of thrust in relation to its drag.

Forces

Three forces act on a propeller in flight. They are thrust, centrifugal force, and torsion (Fig. 43).

The propeller produces thrust by moving volumes of air toward the back of the plane. This thrust compares with the lift force exerted on the wing by the movement of air. But in the case of the propeller, the lifting force acts forward instead of upward. As the propeller is "lifted" forward, the thrust force pulling on the blades tends to bend the blades forward. Forces tending to bend the

blades backward, caused by air drag, are small enough to be ignored.

Centrifugal force is created by the rotation of the propeller. Centrifugal force (the force which tends to throw a rotating body outward from the center of rotation) exerts a constant pull on the blades of the propeller. This force causes tensile stresses (strain on the material of which the blades are made). The hub of the propeller resists the tendency of centrifugal force by holding the blades in at the center. These conflicting forces may stretch the blades slightly during flight.

Torsion is the force tending to twist the propeller blade along its axis and straighten it out. Torsion is caused in part by the action of the air on the blades and in part by the action of centrifugal force, which tends to turn the blades to a lower angle.

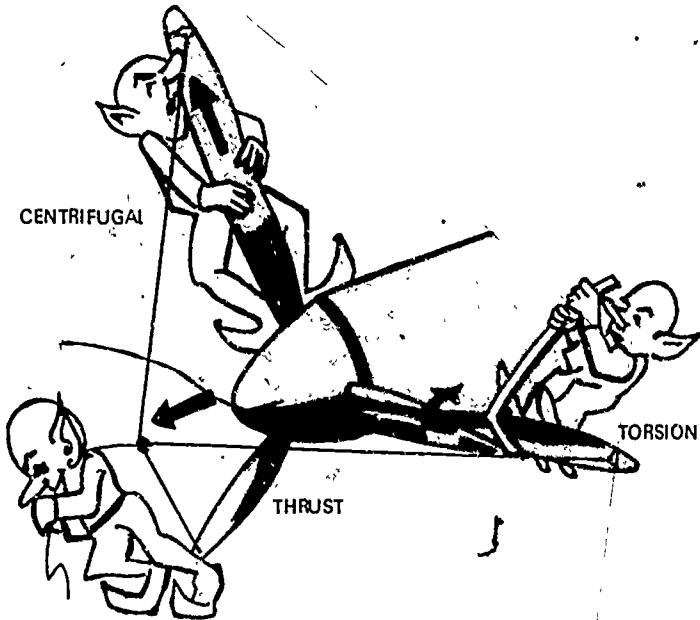

Figure 43. Three main forces act on the propeller in operation. The thrust force tends to pull the blade forward, much as the action of lift on a wing. Centrifugal force tends to pull the blades outward as a result of the turning motion. Torsion tends to twist the curve out of the blade and straighten it.

Types

There are four types of propellers, the fixed pitch, the adjustable pitch, the controllable pitch, and the constant speed propeller.

The fixed pitch propeller is the simplest of the lot. It is made in one piece, and the blade angle cannot be changed without bending or reworking the blades. This propeller is used on small, single-engine planes.

The adjustable pitch propeller usually has a split hub. This makes it possible for the ground crew to adjust the blade while the aircraft is on the ground and the engine is turned off. The propeller blades may be turned to such an angle that they will serve a particular purpose (either to provide more speed or more power). But the operation of the adjustable pitch propeller in flight is the same as that of the fixed pitch propeller.

The controllable pitch propeller is so constructed that the pilot may change the blade angle while the aircraft is in flight. This function may be compared to shifting gears in an automobile. For instance, the blades may be set at a low angle for power during take-off and climbing, then turned to a higher angle for speed at cruising altitudes. The changing mechanism may be operated mechanically, electrically, or hydraulically.

The constant speed propeller adjusts itself automatically according to the amount of power it gets from the engine. The engine controls are set to the desired rpm rate of the crankshaft, and to the desired manifold pressure rate. A flyweight arrangement (a governor) and a hydraulic control keep the propeller's blades at the angle needed to maintain the desired engine speed, whether the plane is climbing, diving, or in level flight. The governor is sensitive to changes in the crankshaft rpm rate. If the rpm rate increases (in a dive, for instance) the governor-hydraulic system changes the blade pitch to a higher angle. This acts as a brake on the crankshaft. If the rpm rate decreases (in a climb), the blade pitch is changed to a lower angle and the crankshaft rpm rate can increase. The constant speed propeller thus insures that the propeller blades are always set at their most efficient operating angle.

Reversing and Feathering

Most constant speed propellers also have a reversible pitch capability. In reversing pitch, the pilot rotates the propeller blades

OTHER ENGINE SYSTEMS

until he obtains a negative angle of pitch. This movement, coupled with increased engine power, reverses the propeller's thrust. The air is thus forced forward, away from the aircraft, instead of rearward, over the wings. The reversible thrust feature reduces the required landing run and saves considerably on brakes and tires.

The propellers on most modern planes with more than one engine also can be feathered. The term feathering refers to the operation in which the propeller's blades are turned to an angle in line with the line of flight. The propeller is feathered in case of engine failure. When the blades are turned to a position where they are streamlined with the line of flight, the pressure of the air on the face and the back of the blade is equal and the blade stops turning.

If the propeller is not being driven by the engine and is not feathered, it will windmill, or rotate from the force of the air pressure. This windmilling can damage the engine. It also can disrupt the lifting force of the wing by disturbing the smooth flow of air over the wing. The dead propeller itself creates drag, and so acts in the manner of an air brake. For this reason, the aircraft's working engine-propeller units function more smoothly and efficiently when the propeller on a faulty engine is feathered (Fig. 44).

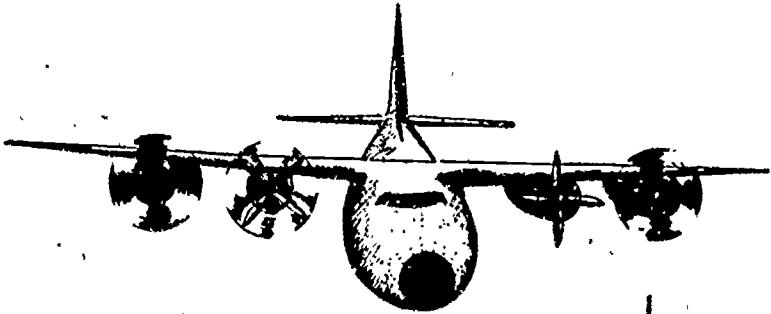

Figure 44. Disabled and unfeathered propellers create drag, acting as a brake on the aircraft. They also disturb the airflow over the wing, and the resulting turbulence can severely affect the wing's lifting power. Uncontrolled turning, or windmilling, also can damage the engine. Feathering the propeller decreases these effects by turning the blade to a streamlined position.

Limitations

Airmen have accepted the fact that no propeller will be 100 percent efficient. That is, no propeller can change to thrust all of the energy supplied by the engine through the crankshaft. This is true because some of the work done by the engine is lost to various other forces before it can be transformed into thrust by the propeller.

The maximum efficiency that can be obtained by a conventional propeller operating in ideal conditions and in connection with a conventional engine is about 92 percent. But in order to obtain an efficiency that high, the blades of the propeller at the tip must be very thin and the leading and trailing edges must be very sharp. These conditions have been found to be impractical for normal operation. The most efficient propellers in every day use provide something under 90 percent of full efficiency.

A major limitation on the use of the reciprocating engine in really high-speed flight is the fact that the speed of the tip of the propeller blade must be kept below the speed of sound.

Generally, the speed of sound is 1,120 feet per second at sea level, decreasing by about 5 feet per second for every 1,000 feet of altitude.

When the tip speed approaches the speed of sound, the propeller develops flutter, or vibration. Vibration causes strains to develop and seriously affects propeller efficiency. A propeller whose tip speed at sea level is 900 feet per second will deliver about 86 percent efficiency. But at 1,200 feet per second, the efficiency has dropped to around 72 percent.

In modern, high-powered engine-and-propeller units, it is necessary to gear down the propeller to keep its tip speed below the speed of sound. Were it not for this limitation, there is no reason why an aircraft powered by reciprocating engines could not surpass the speed of sound.

But science has not yet found a way to get around the propeller's tip speed limitation. To surpass the speed of sound, a different type of engine, loosely called the reaction engine, must be used. The term reaction engine includes both jet and rocket engines. Further, there are several different types of jet engines, and several different types of rocket engines.

Jet and rocket development lagged behind the development of reciprocating engines prior to World War II. But since that time, the reaction engine has come into its own, expanding the limits of speed and altitude at which man can move.

OTHER ENGINE SYSTEMS

Despite the numerical predominance of propeller-driven aircraft today, no modern survey of propulsion systems would be more than half complete without considering the reaction engine.

Since rocket engines are discussed at length elsewhere in the Aerospace Education program, our consideration of reaction engines in this book will be confined to jet engines.

WORDS AND PHRASES TO REMEMBER

accelerating system	electromotive force
adjustable pitch propeller	feathering
alternating current	fixed pitch propeller
atomization	flash point
automatic mixture control	float carburetor
backfiring	float chamber
Bernoulli's principle	fuel injection system
blade angle	fuel knock
blade butt	fuel system
blade shank	generator
blade tip	hub
booster coil	hydrocarbon
breaker point	ignition
carburetor	ignition system
carburetor barrel	impeller
carburetor heater	inertia
carburetor icing	injection pump
carburetion	intake manifold
centrifugal force	intake metering system
condenser	ionization
constant speed propeller	kinetic energy
contact point	knock
controllable pitch propeller	leading edge
detergent	lean mixture
detonation	lines of flux
direct current	magnetic circuit
discharge nozzle	magnetic field
discharge tube	magnetite
distributor	magneto
downdraft carburetor	mass air flow system
dry sump	master control unit
economizer	metering jet
effective pitch	octane rating
electromagnetic induction	pitch

PROPULSION SYSTEMS FOR AIRCRAFT

potential energy	supercharger
pour point	tensile stress
power enrichment system	throttle valve
pre-ignition	thrust
pressure injection carburetor	tip speed
pressure pump	torsion
primary coil	trailing edge
propeller face	turbosupercharger
reaction engine	updraft carburetor
reversible pitch	vapor lock
rich mixture	venturi
scavenger pump	viscosity
secondary coil	volatile
self-induction	voltage
solenoid	wet sump
spark plug	windmilling
stable fuel	wobble pump
starting unit	

QUESTIONS

1. Name the five systems that make up the complete reciprocating engine.
2. What are the advantages of the petroleum-based fuels used as aviation fuels?
3. What is the function of the carburetor?
4. Why does the carburetor measure fuel and air by weight instead of by volume?
5. What is the function of the supercharger?
6. Explain how magnetism is used to make electricity.
7. What is the difference between the starter system and the ignition system? When does the pilot turn off his engine's ignition system?
8. What are the various types and functions of the lubricating system?
9. How does the propeller provide thrust and lift to the aircraft?
10. Name the parts of the propeller. What is the "plane of rotation?" The "effective pitch?"
11. What three forces act on a propeller in flight? Describe these forces.
12. Why are propeller-driven aircraft incapable of supersonic flight?

THINGS TO DO

1. Political developments in the Middle East sometimes threaten America's supplies of oil from fields in that area. Find out and report on how much oil, gasoline, and other petroleum products are used in this country an-

OTHER ENGINE SYSTEMS

nually and where our sources of supply are located. Could the United States get along without Middle Eastern oil supplies?

2. Get an old generator and take it apart. See how the magnets work to produce electrical current. Estimate the number of wire turns used.
3. Light aircraft sometimes have problems with carburetor icing. Find out what system is used to combat this condition and brief the class on how that system works.
4. Visit an engine repair facility, either at your school or, with permission, at a commercial shop. See if you can identify the various parts of the engine and understand the theory of engine operation by looking at the parts you describe.

SUGGESTIONS FOR FURTHER READING

CARGNINO, L. T. and C. H. KARVINEN. *Aerospace Propulsion Powerplants*. Chicago: Educational Publishers, Inc., 1967.

MEHRENS, HAROLD E. *Power for Aircraft*. Ellington AFB, Texas: Civil Air Patrol, 1958.

McKINLEY, JAMES L. and RALPH D. BENT. *Powerplants for Aerospace Vehicles*. New York: McGraw-Hill Book Co., 1965.

VAN DEVENTER, C. N. *An Introduction to General Aeronautics*. Chicago: American Technical Society, 1965.

VAN SICKLE, NEIL D. *Modern Airmanship*. Princeton, N.J.: D. Van Nostrand Co., Inc., 1966.

83/84

89

Chapter 4

Gas Turbines and Jet Propulsion

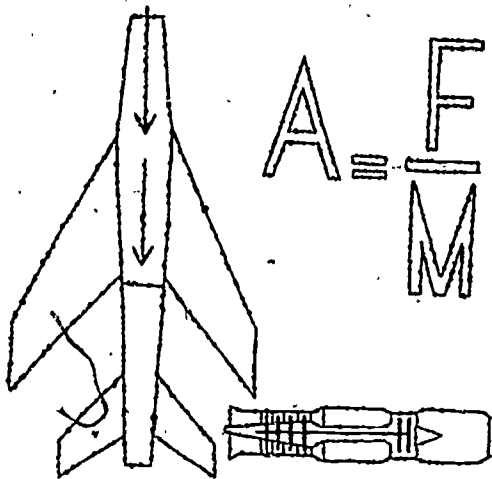

THIS CHAPTER deals primarily with turbine engines, with the emphasis on jet engines. It describes the operation of the jet in theory, gives examples of how the different types of jet engines operate, and explains the relative advantages of these engines. It also includes a section on helicopter propulsion systems. When you finish this chapter, you should be able to: (1) compare the operation and performance of the jet and the reciprocating engine; (2) describe the operational differences in the three main types of jet engines; (3) explain in some detail the operation of the turbojet engine; (4) describe such adaptations as the turboprop and the turboprop engines; and (5) explain the differences and similarities between helicopter propulsion systems and those of other aircraft.

WITH THE ADVENT of jet propulsion as a practical means of powering aircraft, a whole new experience was opened to mankind. The key to this experience was *speed*. Jet-propelled aircraft were eyed with suspicion at first by a public which distrusted airplanes without propellers. But with exposure came acceptance, and

PROPULSION SYSTEMS FOR AIRCRAFT

the world was soon electrified to learn that a manned, jet aircraft had flown beyond the speed of sound.

JET ENGINES

Compared to the reciprocating engine and propeller combination, the theoretical workings of the jet engine are simple. In broad terms, the jet engine is essentially a tube in which the four-stage combustion cycle takes place. It is composed of an air intake section, a compression section, a combustion section, and an exhaust section. Figure 45 shows how the combustion cycle of the jet engine corresponds to that of a reciprocating engine.

Although the two different propulsion systems have much in common when it comes to working principles, they are quite differ-

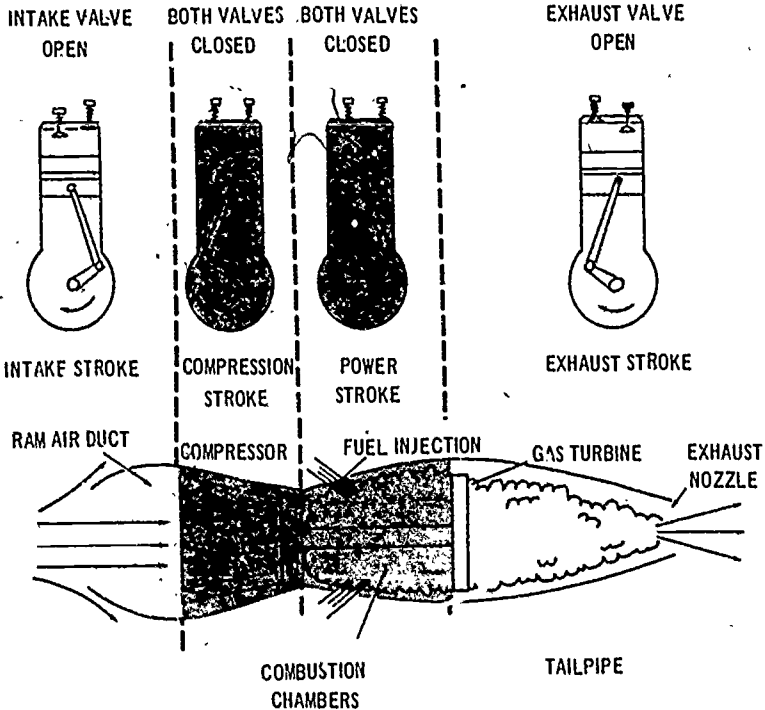

Figure 45. The power production cycle in the jet engine may be compared with the four-stroke cycle of the reciprocating engine. Like the reciprocating engine, the jet goes through intake, compression, combustion, and exhaust. But the exhaust is the force that makes the jet plane go.

ent mechanically. Both the jet and the reciprocating engine have their places in today's aviation, and they are well suited to their different uses.

The chief advantages of the jet-propelled aircraft are speed and the ability to fly at high altitudes. The chief advantage of the reciprocating engine-propeller powered craft is economy at low speeds and at low altitudes.

Both systems get their power from the gases formed by burning fuel. Both depend on the air outside the engine for the oxygen needed to burn the fuel. Both utilize the same basic laws of motion for their "push." Finally, both use the four-stage cycle of intake, compression, combustion, and exhaust.

But despite these similarities in the two engines, there are two major differences. The jet engine has no propeller; and while the exhaust in the reciprocating engine is mainly wasted, the jet engine's exhaust is the force that makes the aircraft go.

Principles of Operation

The jet engine operates on principles outlined in Newton's second and third laws of motion. force is equal to mass times acceleration; and for every action there occurs a reaction of equal force in the opposite direction.

Probably the most often-used illustration of Newton's third law is the action of a balloon released with its neck open. The balloon zips around the room as air escapes from the open neck. The flight of the balloon is not caused by escaping air pushing against the air outside the balloon, but by the force occurring *inside* the balloon in reaction to that escaping air.

The air rushing out of the balloon may be called the action. But inside the balloon, there is a reaction, just as strong, and in an opposite direction to the outrushing air. If our balloon had two necks directly opposite each other, the air would rush out of both openings and the balloon would merely drop to the floor. But since there is only one neck, the reacting air pushes against the inside surface of the balloon, in accordance with Newton's third law of motion, and moves the balloon along.

Newton's second law, applied to the jet engine, would mean that the *force* moving the aircraft (thrust) is equal to the *mass* (quantity) of air taken in through the front of the engine, multiplied by the *acceleration* (increase in speed) of that air before it leaves the exhaust nozzle at the back end of the engine. ~~that~~ what

this principle means in practical terms is explained in Chapter One of this book.*

Both the jet engine and the propeller provide thrust by throwing quantities of air backward. In the jet, the air is channeled through a tube (the engine); but the air the propeller moves is unconfined. This means that a smaller *mass* of air is being moved by the jet engine; but the jet *accelerates* that air much faster than the propeller does.

The term **jet propulsion** is understood to mean the push that occurs in reaction to the ejection of matter (air). When the jet engine ejects its exhaust gases, the reaction is the engine's thrust. And since the velocity (the *action*) of the air leaving the jet engine is very strong, so is the thrust (the *reaction*). In this book we will consider past and present jet engine types, including the ramjet, pulsejet, turbojet, turboprop, and turbofan engines.

Ramjet

The simplest type of jet engine is the ramjet. With no moving parts, the ramjet is little more than a tube fitted with fuel nozzles, and spark plugs to get it started. In fact, the ramjet has been described as a "flying smokestack" (Fig. 46).

The air is taken into the ramjet through the diffuser in the air intake section at the front of the tube. The diffuser slows down the incoming air, and the air ramming in behind that air greatly increases its pressure. The total amount of energy in the air we have taken in remains the same, but its form has been converted from the energy of velocity to pressure-type energy. The volume of the air taken in has not changed, but the weight within that volume has been increased considerably by compression. This means that the mass (weight in slugs) has been increased. Since the thrust we eventually get will depend on the mass of air we move ($F = MA$), air compression increases thrust.

This compressed air is channeled into the combustion section, where fuel is sprayed into it under pressure. An ignition plug similar to the conventional spark plug ignites the mixture. The resulting explosion hurls the air forcefully out the exhaust, and the *reaction* to that force moves the engine forward. There is equal force exerted in all directions when the explosion occurs, of course. But the high-pressure air in the diffuser blocks the expansion of the air forward, the walls of the engine and passing

*The action-reaction principle is further explained and illustrated in the AE-1 book, *Spacecraft and Their Boosters*.

GAS TURBINES & JET PROPULSION

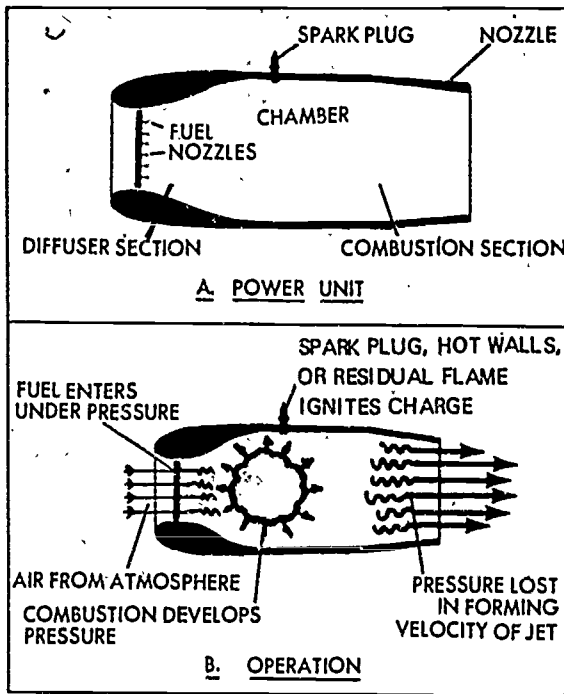

Figure 46. The ramjet, sometimes called the "flying smokstack," is the simplest jet engine in use today. Its air supply is compressed by the ramming action of the engine instead of by a mechanical compressor.

air block the expansion outward, and the hot gases are forced out the rear of the engine.

It should be pointed out that in jet engines, the ignition plugs are used to ignite the fuel charge only until the engine is started. The electric current to the plugs is then cut off. The flow of air and fuel into the combustion chamber is continuous, and so is the flame. Instead of a series of fuel/air charges, as in the reciprocating engine, the jet engine has one continuous charge which burns until the flow of air and/or fuel is discontinued.

In the ramjet the fire is held in the combustion chamber by a blocking device called a **flameholder**. Otherwise, the fire would be blown out the rear of the engine with the exhaust gases and other air.

The ramjet cannot operate until it is moving at sufficient speed to bring about compression from the ramming air in the front of



Figure 47. The Bomarc missile was fired by its rocket engine power but shifted to ramjet power when it reached sufficient speed. The ramjet is not capable of starting from a stop since it needs the ram effect to make it work.

the engine (about 250 miles per hour). Aircraft using the ramjet must have another type of propulsion to get them moving at that speed before the ramjet can be turned on. In theory, the speed attainable by the ramjet is unlimited, since the faster it goes, the more air compression it gets, the more compression it gets, the more violent the explosion in the combustion chamber, and the more violent this explosion, the more thrust is developed and the faster it goes. In practice, however, the ramjet's speed is limited to about five times the speed of sound (mach 5),* which is still a pretty fast clip. This limitation is due to friction-caused heat on the outside of the engine and the aircraft to which it is attached (called skin temperatures). Beyond mach 5, this friction heat would cause the metals now in common use to melt.

*The word "mach" is used to describe the speed of an object in relation to the speed of sound in the same medium. The number accompanying the word "mach" indicates the multiples of the speed of sound at which the object—in our case, the aircraft—is traveling. At speeds below, but approaching, the speed of sound, numerals less than 1 may be used. Thus, an aircraft moving at mach 7 would be traveling at seven-tenths the speed of sound. At mach 1, the aircraft would be moving at exactly the speed of sound. At mach 2.5, the aircraft would be moving at two-and-a-half times the speed of sound. The speed of sound at sea level, in dry air at 32 degrees F., is about 1,087 feet per second (741 miles an hour).

The ramjet engine can be used in missiles which are lifted off the ground by another engine system—usually, a rocket engine. Just before the rocket engine burns out, the ramjet “kicks in” and takes over the job of powering the missile. Although now obsolete, the Bomarc surface-to-air interceptor missile shown in figure 47 was a good example of this usage.

A recent development in ramjet engines is capable of hypersonic flight; that is, flight at speeds above mach 5. This engine is called the Scramjet, and may be used in the future on aircraft designed to cruise at hypersonic speeds, on recoverable launch vehicles, and on defense missiles.

Pulse Jet

The pulsejet is only slightly more complex than the ramjet, but it is much less useful in modern aviation. The pulsejet's chief interest is historical. It has a diffuser, a grill assembly, a combustion chamber, and a tailpipe. Air feeds through the diffuser, just as in the ramjet, and through the grill to the combustion chamber.

The grill assembly is a honeycomb of air valves which allow the air to flow through if the pressure in the diffuser chamber (intake) is greater than the pressure in the combustion chamber. These air valves are spring-loaded in the closed position and open inward, toward the combustion chamber.

When the air is allowed into the combustion chamber, a fuel charge is injected and the fuel/air mix is ignited.

As the sequence in figure 48 shows, the force of the resulting explosion closes the air valves in the grill and forces the exhaust out the tailpipe. When the pressure of that charge lessens in the combustion chamber, pressure from intake air forces the valves open again and more air moves into the combustion chamber. The cycle repeats, with the ignition of the second charge coming from the flame of the first charge.

Pulsejets powered the German V-1 missile in World War II. The characteristic noise produced by the pulse jet was responsible for the V-1's nickname of “buzz bomb.”

Although the pulsejet is simple and inexpensive to build, its speed is limited. At air speeds above mach 0.6 (slightly over half the speed of sound), the pressure in the diffuser section holds the air valves open too long for efficient operation. Because it cannot compete effectively against the reciprocating engine

PROPULSION SYSTEMS FOR AIRCRAFT

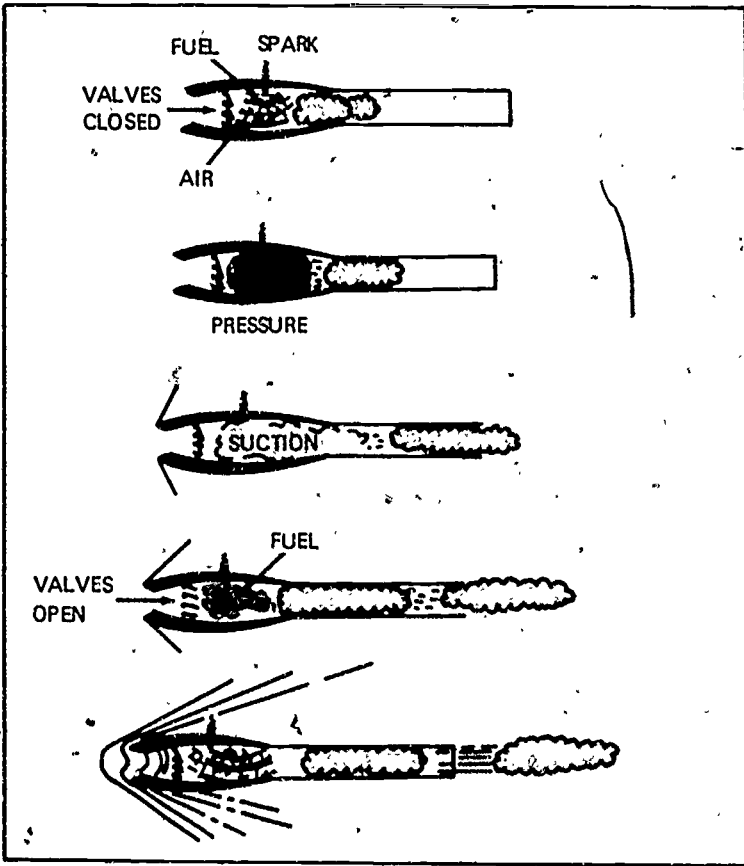

Figure 48. The pulsejet is of strictly historical interest. Cheap and simple, it was one of the earliest jet engines to be used operationally, but it was quickly abandoned when the turbojet was developed. The pulsejet's characteristic sound was responsible for the nickname "buzz bomb" being given to the V-1 missile used by the Germans in World War II.

on the one hand and more advanced jet engines on the other, the pulsejet has virtually vanished from the aviation scene.

The Turbojet

The turbojet engine, the most widely used engine in the jet world today, uses the same principles used by the ramjet and the pulsejet, but is a much more refined and practical machine.

GAS TURBINES & JET PROPULSION

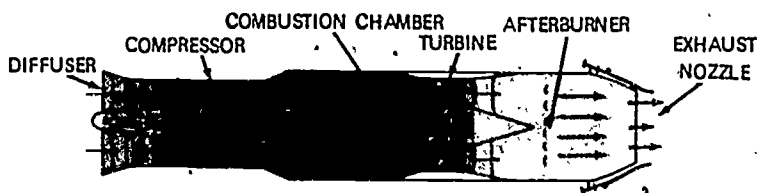

Figure 49. The turbojet engine features an air compressor which is operated by a turbine, which in turn is powered by high-velocity exhaust gases on their way to the tailpipe. The engine in this simple illustration is equipped with an afterburner for extra power.

Employing the combination of gas turbine and air compressor, the turbojet is its own master. It can start from a dead stop and can power aircraft to more than twice the speed of sound.

There are many models and several modifications of the turbojet engine, but they all share the same basic operational sequence: air enters through the air intake section (diffuser); goes through the mechanical compressor, where its pressure is greatly increased; is forced into the combustion chambers, mixed with fuel, and burned; and escapes as high-velocity gases out the exhaust nozzle, producing thrust.

The diagram in figure 49 shows that between the combustion chambers and the exhaust nozzle, there is a turbine. The exhaust gases turn the turbine wheel just as wind turns the wheel of a windmill. The turbine is connected by a direct shaft to the compressor. The rotation of the turbine operates the compressor, which sends more air through the engine to turn the turbine.

The compressor section of the turbojet is the area where the air is compacted in preparation for burning. It corresponds to the reciprocating engine's cylinder in the compression stage. Turbojet engines are generally classified as centrifugal flow or axial flow engines. These terms refer to the design of the air compressor in the engine, and the way the air flows through it. Although axial flow engines are much more widely used today, the centrifugal flow engine is of interest historically and as an example of how jet engines have progressed.

CENTRIFUGAL FLOW ENGINES.—The centrifugal flow compressor, shown in figure 50, is composed of a rotor, a stator, and a casing. The rotor is mounted within the stator, and that whole assembly is enclosed in the casing. The casing has an opening near the center for the air to enter.

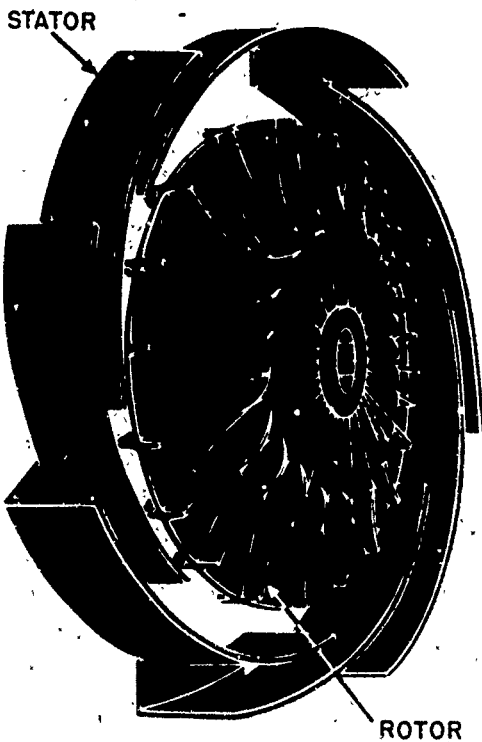

Figure 50. The centrifugal compressor used in the early models of the turbojet engine, hurled the air outward from the whirling rotors onto the stationary stators, and the stators guided the compressed air to the combustion section.

The compressor's rotor is made up of a series of flat blades. The blades revolve, take the air in, and whirl it around, increasing its velocity. Centrifugal force causes the air to move outward from the center to the rim of the rotor blades, where it is thrown out of the wheel and into the stator with considerable velocity.

The stator consists of diffuser vanes, or blades, which curl out from the central axis of the rotor. The stator does not rotate. The moving air acquires energy, in the form of velocity, in the rotor and this energy is converted to pressure energy by the stator. As the air moves through the stator's diffuser vanes, it loses velocity and acquires pressure.

From the stators, the compressed air is fed into the combustion chambers.

Each set of rotors and stators is called a stage. A single stage

COMPRESSED GASES ARE
FED INTO ENTRY OF
FOLLOWING STAGES

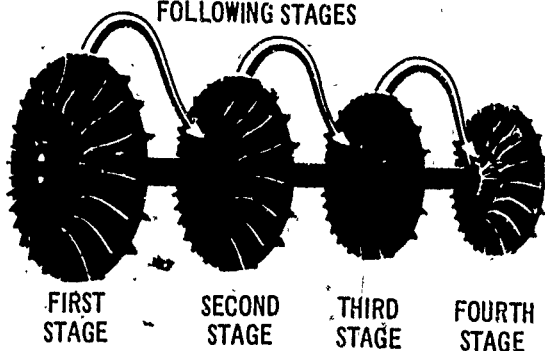

Figure 51. In the multi-stage compressor, the stators direct the compressed air onto the rotors of the next compressor stage for more air compression. The last stage, of course, sends the air into the combustion chambers.

centrifugal flow compressor will produce a compression ratio of about four to one. That is, it will reduce a given mass of air to about one-fourth the volume it had in its free state.

Additional stages, as shown in figure 51, will improve the compression ratio somewhat; but much of the potential energy of the air mass in the centrifugal flow compressor is lost through drastic changes in direction caused by centrifugal force. For this reason, most jet engines made today employ the more efficient axial flow compressor.

AXIAL FLOW ENGINES.—The axial flow compressor is also made up of rotors and stators. But the blades are shaped like airfoils instead of being flat. The rotor may be likened to a many-bladed propeller. The airfoil shape of the rotor blades guides the air mass mainly toward the rear of the engine, and only slightly outward (Fig. 52).

The stators, also of the airfoil design, are mounted behind the rotors. The stators may be likened to many small wings. They do not rotate, but receive the air from the rotors and direct it either toward the combustion chambers or onto the next set of rotors.

One row of rotors and one row of stators constitutes a stage in the axial flow compressor. The motion of the rotors compresses the air in a manner similar to the ram effect, and the stators serve to straighten out the airflow (Fig. 53).

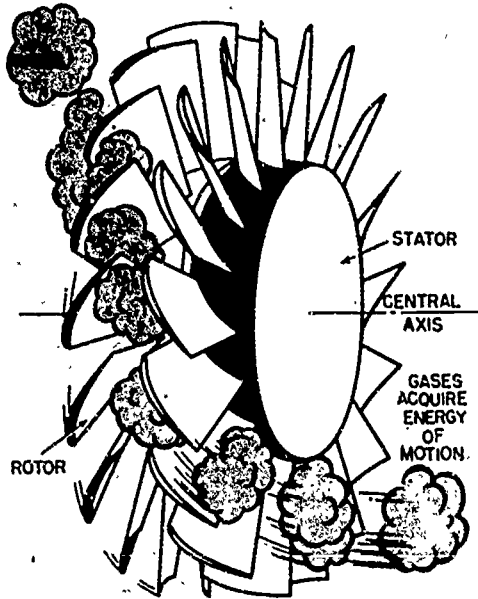

Figure 52. In the axial compressor, the airfoil-shaped rotor blades hurl the intake air rearward, and not outward as in the centrifugal compressor. The stator blades in the axial compressor are also airfoil-shaped.

The axial flow compressor may be composed of many stages. Each stage is smaller than the one before it, which increases the compression of the air. Axial flow compressors give compression ratios of more than 5 to 1.

DUAL COMPRESSORS.—Some turbojet engines have two compressor and turbine arrangements, called dual compressors. The two compressors provide greater engine flexibility and maintain high compression ratios at high altitudes, where the ram air pressure is less.

This dual arrangement consists of a high-pressure compressor driven by a turbine that is controlled by the throttle, and a low-pressure compressor driven by a free-turning turbine (Fig. 54). Dual compressors can develop compression ratios of up to 14 to 1.

At high altitudes, the air is thin and the ram pressure in the front of the engine is therefore reduced. But a free-turning com-

GAS TURBINES & JET PROPULSION

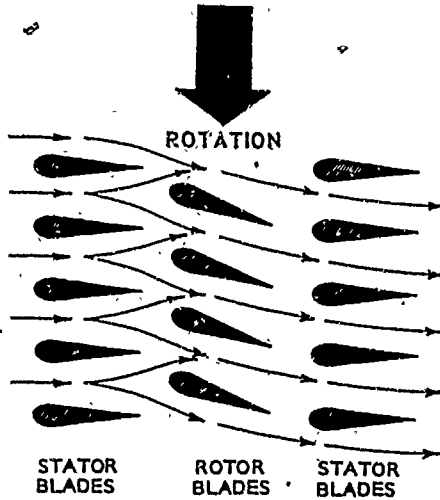
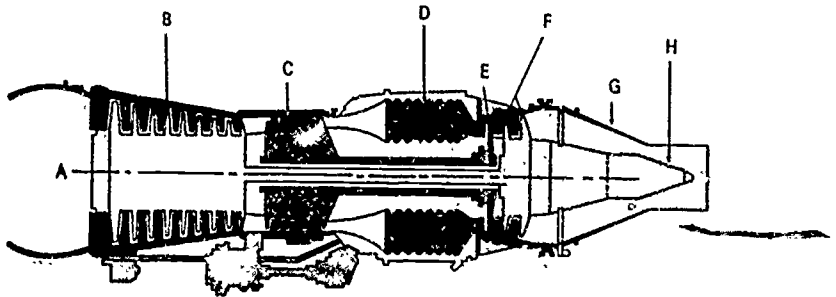

Figure 53. The stators in the axial flow compressor straighten the airflow and guide it either to the next stage of rotor blades or on to the combustion chambers. One stage of an axial flow compressor consists of a row of rotors and a row of stators.



- | | | |
|-----------------------------|------------------------------------|-----------------|
| A. INLET DUCT | D. BURNER CAN | G. TAILPIPE |
| B. LOW-PRESSURE COMPRESSOR | E. FIRST-STAGE TURBINE | H. EXHAUST CONE |
| C. HIGH-PRESSURE COMPRESSOR | F. SECOND AND THIRD-STAGE TURBINES | |

Figure 54. The turbojet engine with a dual compressor is capable of providing good air compression at high altitudes, where the air is thin. The high pressure compressor and the low pressure compressor have concentric shafts, but there is no mechanical link between them.

pressor takes advantage of the thin air's lesser resistance on its rotor blades, and turns faster, bringing in greater volumes of air. This arrangement enables the free compressor to keep the high-pressure compressor supplied with air.

The dual compressor illustrates how theory and practice do not always agree. In fact, it was devised to overcome a problem resulting from the fact/theory gap. In theory, a single axial flow compressor with many stages could develop an unlimited amount of compression. But in practice, this is true only within a limited range of engine speeds. Beyond these speeds, the smaller stages toward the rear of the compressor lose efficiency because they cannot handle the large volumes of air being forced into them by the larger stages up front. As a result, the front sections become overloaded with backed-up air and turbulence results. This turbulence interferes with the effective angle of attack of the air-foil-shaped rotors and stators, and the result is compressor stall.

With the dual compressor, the rearmost stages are large enough to handle the larger volumes of air without loss of efficiency.

COMBUSTION CHAMBERS.—On leaving the compressor, the air is forced into the combustion chambers, mixed with the fuel, and burned in the continuous combustion process. Jet engines can operate on a wide variety of fuels, but refined kerosene has been found to be the most satisfactory fuel available so far.

Only about one-fourth of the air from the compressors is used for combustion. The rest of the air is channeled around the outside of the combustion chambers, or around the fire inside the combustion chambers, for cooling purposes.

Ordinary turbojet engines may have 14 separate combustion chambers in their combustion section, divided so that the cooling air can be more effective.

The combustion chamber includes an inner chamber, where the actual burning takes place; an outer chamber; a fuel nozzle; and crossover tubes (Fig. 55).

Temperatures in the inner chamber get above 3,000 degrees Fahrenheit. But these temperatures never reach the wall of the inner chamber. The burning is centered in the chamber through careful design, and is surrounded by a blanket of air that is, of course, heated, but does not burn. All of the burning must be completed before the exhaust leaves the inner chamber, because the intense heat of the burning charge could severely damage the turbine wheel.

Air flows through the lifter between the inner and outer cham-

GAS TURBINES & JET PROPULSION

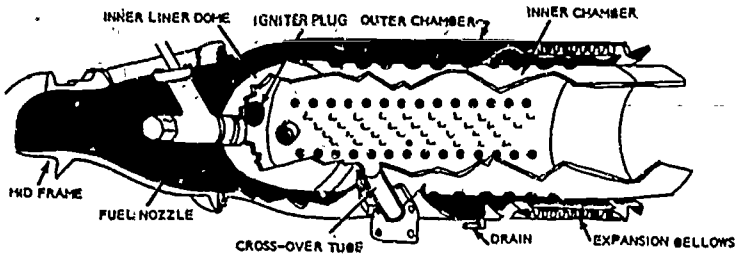

Figure 55. The combustion chamber of a jet engine includes an inner chamber, where the fuel is burned, and an outer chamber. Cooling air flow through the space between the two chambers. The igniter (spark) plug is used for initial ignition only, after which the flame is fed from chamber to chamber through the crossover tube.

bers. The outer chamber keeps a supply of high-pressure air available to the inner chamber for cooling.

The fuel nozzle sprays the proper amount of fuel into the inner chamber, using the fuel injection system. The fuel spray is under pressure and the fuel flow is regulated to achieve an air/fuel ratio of about 14 to 1.

Usually, only two igniter plugs serve the entire combustion system, and then only for the initial ignition. After the engine is started and the plugs have ignited the fuel/air mixture, electric current to the plugs is turned off.

The crossover tubes connecting the combustion chambers feed flame into those chambers without spark plugs. After the flame is introduced into all the chambers, the burning process feeds itself. The high-pressure air blanket then blocks off the openings in the crossover tubes before temperatures in them mount very high.

TURBINE SECTION.—The hot exhaust gases and unburned air leave the combustion section either through nozzles on guide vanes, which increase their velocity to about 2,000 feet per second and direct them onto the turbine wheel blades. The guide vanes constitute the stator part of the turbine, while the turbine wheel is the rotor part.

The turbine wheel is the toughest part of the jet engine. It has to be, to withstand the tremendous temperatures and other stresses on it.

The temperature of the gases striking the turbine's rotor blades may reach 1,500° F., and the wheel rotates at about 12,000 revolutions per minute. These stresses were a serious problem to

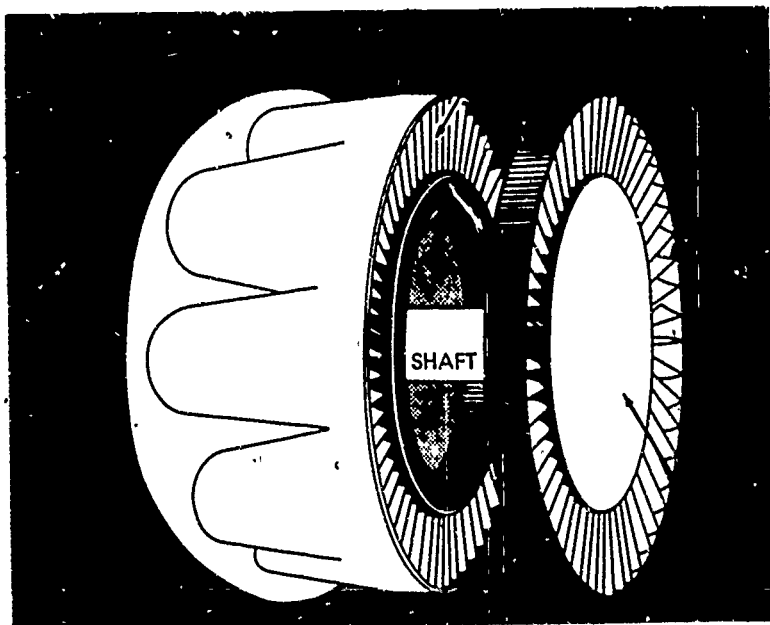

Figure 56. As with the compressor, a single stage of the turbine consists of a row of rotors and a row of stators, but in reverse order. The stators direct the exhaust gases onto the rotor blades, causing the rotor wheel to turn. The front end of the turbine shaft connects to the compressor.

early developers of the turbine. But advances in metallurgy (the science of metals) have produced metal alloys capable of withstanding the strains of heat, shock, and centrifugal force for 1,000 hours or more of operation.

Like the compressor, the turbine may consist of one or more stages. And like the compressor, the turbine is composed of alternating rows of stators and rotors.

The shaft attached to the center of the turbine is connected at the other end to the compressor, which it drives (Fig. 56).

EXHAUST SECTION.—The gases exit the turbine at temperatures of about 1,200° F. and speeds of about 1,200 feet per second and enter the exhaust nozzle. As seen in figure 57, this nozzle has an inner cone, supported by struts. Together, the nozzle, cone, and struts straighten out the flow of the gases leaving the revolving turbine wheel and send these gases through the tailpipe in a concentrated flow.

The tailpipe is designed to increase the velocity of the gases to

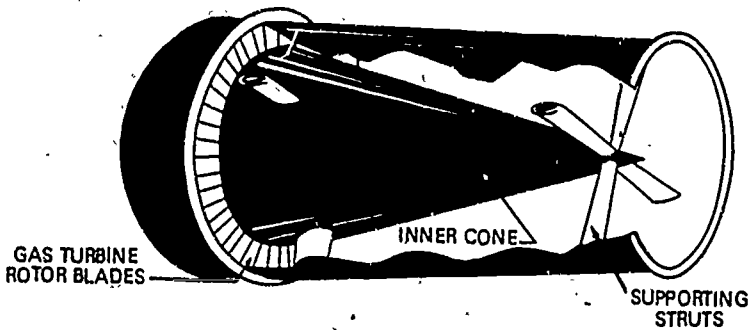

Figure 57. The exhaust section of the engine straightens the exhaust gas flow and sends it out the rear of the engine in a concentrated stream. This is the business part of jet propulsion.

a point where they furnish maximum thrust without causing the engine to overheat. As the gases leave the tailpipe, their temperature has dropped to about 1,000° F. and their velocity has increased to 1,800 feet per second or more. The velocity of the gases leaving the tailpipe is an important factor in the thrust-determining equation, $\text{Force} = \text{Mass times Acceleration}$ ($F = MA$).

THE AFTERBURNER.—Some turbojet engines, principally on military aircraft, are equipped with exhaust reheating devices called **afterburners**. These devices increase the velocity of the exhaust gases—and thereby, increase thrust—when maximum performance is required. The afterburner, shown in figure 58, acts in the manner of a small ramjet engine when it is in use and as a tailpipe extension when not in operation.

Since a large amount of the air that enters a turbojet engine is used for cooling and not for burning, there is ample oxygen in the exhaust air to operate the afterburner. As in the ramjet, fuel is injected into the afterburner under pressure. The exhaust gases from the main engine are of high enough temperature to ignite the fuel on contact, and the resulting burning greatly increases the exhaust velocity from the afterburner.

The afterburner is fitted with flameholders to keep the high-speed exhaust gases from blowing the burning gases out of the chamber.

The turbojet has become the most widely-used type of jet engine. It is found supplying the power for many different types of aircraft, from fighters to bombers and passenger planes to guided missiles. Some examples of the aircraft using the turbojet engine

PROPULSION SYSTEMS FOR AIRCRAFT

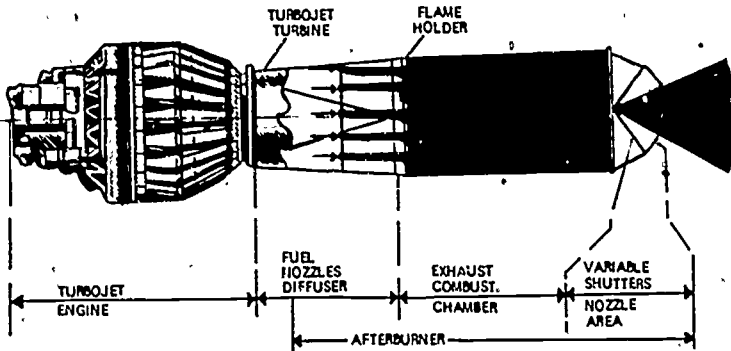

Figure 58. The afterburner, sometimes called the exhaust re-heat, provides additional thrust to an engine by injecting fuel into the high-temperature exhaust gases, mixing the fuel with the unburned oxygen in those gases, and burning the resulting mixture. When not operating, the afterburner acts as a tailpipe extension.

for power are the F-4 Phantom II, a workhorse for the United States Air Force, Navy, and Marines; the F-5 Freedom Fighter, used by a number of nations as a primary defensive aircraft; some versions of the Boeing 707 and 720 and the Douglas DC-8 passenger aircraft, used by commercial airlines; the B-52 bomber and the Hound Dog air-to-ground missile shown together in figure 59; and the mach 3-plus SR-71 strategic reconnaissance plane.

The Turboprop Engine

Experience has shown that jet-powered aircraft are superior to propeller-driven aircraft at high speeds and high altitudes, while the propeller-driven planes excel at comparatively low speeds and low altitudes. In fact, the turbojet engine does not equal the reciprocating engine-propeller system in efficiency until speeds of nearly 400 miles per hour are reached.

In an effort to combine the best features of both systems, engine designers developed the turboprop engine, which, as figure 60 indicates, uses a gas turbine-powered propeller for its drive.

The reciprocating engine probably will continue as the dominant powerplant in low speed, low power aircraft, but the turboprop is used more and more on large aircraft operating at low and intermediate speeds.

GAS TURBINES & JET PROPULSION

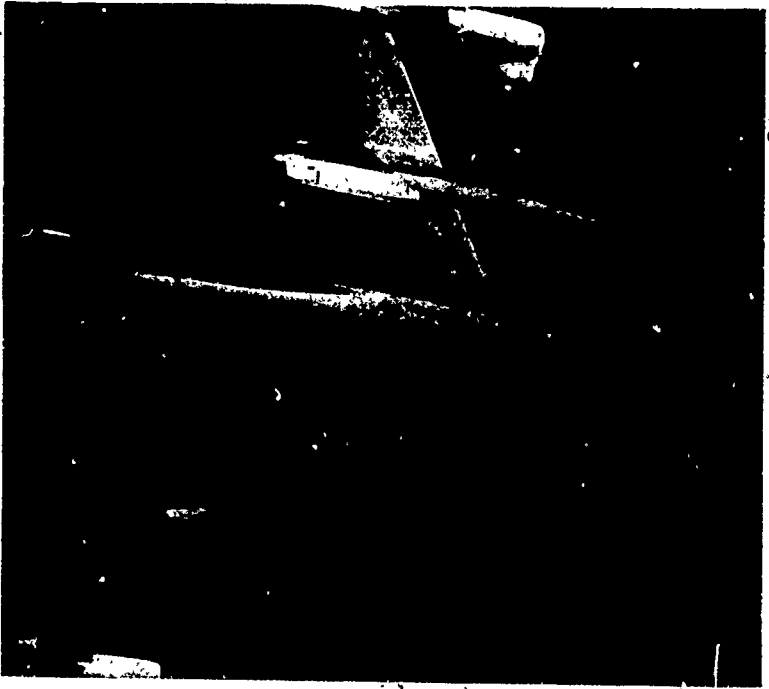

Figure 59. Turbojet engines are the powerplants for the B-52 bomber, shown here, and the Hound Dog missile, suspended from this B-52's wings.

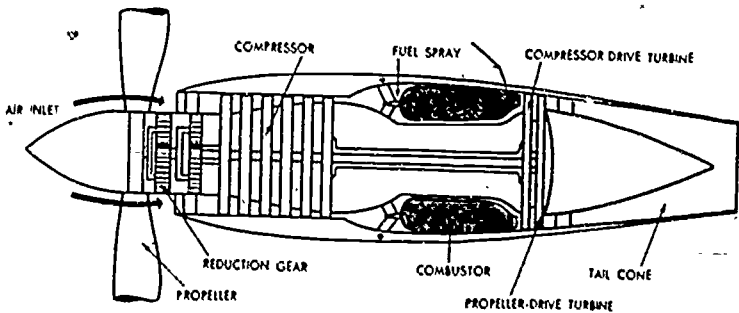

Figure 60. The turboprop engine combines the advantages of the gas turbine powerplant with the efficiency of the propeller to get a relatively quiet, cheap, and powerful propulsion system. It is not strictly a jet propulsion system.

PROPULSION SYSTEMS FOR AIRCRAFT

In the turbojet engine, most of the gases passing through the combustion chamber are forced out the tailpipe to produce thrust. Only a small amount of the energy of these gases is used to turn the turbine and compressor.

But in the turboprop engine, the reverse is true. The turboprop has a weak exhaust from its tailpipe and gets almost no "push" in reaction to it. The turbine in this engine is designed to absorb almost all the energy from the exhaust gases. Part of this energy turns the compressor, allowing the engine to function in essentially the same manner as the pure turbojet. But the bulk of the energy is passed from the turbine to the propeller, which is mounted at the front of the engine.

Turboprop-powered aircraft obtain their thrust from the propeller, which moves a larger mass of air than would the turbojet, but at a lower velocity. An aircraft using the turboprop system is not "jet propelled," since very little thrust is produced by the ejection of high-velocity exhaust gases; but its propeller is driven by a gas turbine engine, much the same as that powering jet aircraft.

The turboprop's propeller thrust can be reversed on landing, and its turbine engine can supply the propeller with double the horsepower of the conventional reciprocating engine. But reduction gearing must be used to slow the rpm rate of the propeller and keep its tip speed below the speed of sound. All the limitations of the propeller still apply despite a change of power plants.

A number of engine manufacturers and aircraft users have accepted the limitations of the turboprop engine—along with its benefits—and the engine is seeing extensive use today.

The main aircraft using the turboprop system are the Air Force's C-130 Hercules and its several commercial versions, the Convair 580; and the OV-10 Bronco, used in military observation and Forward Air Control missions.

But engine manufacturers have not stopped with that compromise between the propeller craft's superiority at low speeds and the jet engine's class at high speeds. Continuing experimentation and design changes have produced a much better "compromise" than the turboprop engine. This newest development is an improved turbojet called the turbofan engine, and it is on the way to becoming the dominant engine for high-performance aircraft.

Turbofan Engine

The turbofan engine, also called the *ducted fan*, *fanjet*, or *bypass engine*, is a more recent development than the turboprop engine. It shares the turboprop's principle of moving larger volumes of air at lower velocities, but is still strictly a jet propulsion engine.

In the turbofan engine, shown in figure 61, one or more rows of the compressor blades are extended beyond the length of the rest of the compressor blades. These elongated blades make up the *fan* of the engine. The fan pulls large volumes of air into the engine, and about 60 percent of that air passes through ducts outside the power section of the engine.

The remainder of the intake air is fed through the combustion chambers, the turbine, and the exhaust section. But the air pulled by the extended blades (the fan) is ducted outside the engine so that it bypasses the combustion chamber, is forced backward, and is discharged without burning. It is discharged with the exhaust gases. The fan resembles the propeller in the turboprop engine in that it hurls masses of air rearward. But the fan is run directly by the turbine without the necessity of reduction gearing, and it is not subject to the propeller's tip speed limitations.

The turbofan engine moves up to four times as much air as the simple turbojet. It is capable of driving an aircraft at supersonic speeds without the benefit of an afterburner.

An innovation in the turbofan engine allows burning of the air in the fan stream. This type of engine, called the fan burner, is

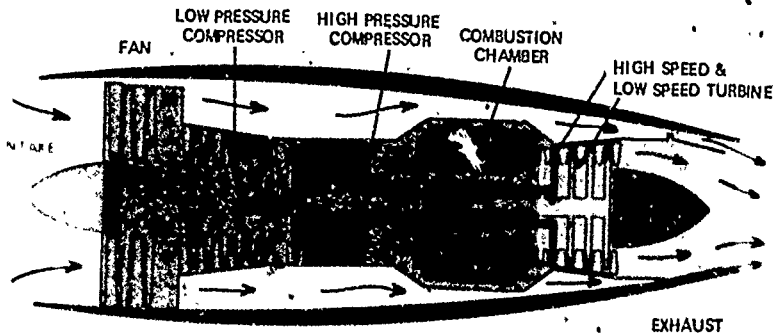

Figure 61. The turbofan engine is a true jet propulsion engine, since its principle thrust is produced by exhausting gases. The turbofan is designed to move great volumes of air, as the propeller does, but it does not have the propeller's tip speed limitations.

essentially a turbofan engine with an afterburner capability. Economical operation can be obtained from this engine at low altitudes and low speeds if the extra burner is not used. At high altitudes and high speeds, the burner may be used without too much loss of efficiency and economy. Burning fuel in the fan duct of this engine can double the normal thrust of the turbofan engine.

Compared to the more conventional turbojet, the turbofan engine furnishes greater thrust for take-off, climbing, and cruising, from the same amount of fuel, mainly due to its larger air movement. The addition of the afterburner capacity has boosted the popularity of the turbofan. Some of the outstanding aircraft now using this kind of engine are the FB-111 supersonic fighter-bomber, used by the Air Force; some versions of the B-52 bomber; the KC-135B tanker aircraft; the commercial airlines' Boeing 727 and 747 and Douglas DC-9, plus some versions of the Boeing 707; the C-141 Starlifter cargo plane; the A-7 Corsair II attack aircraft; the giant C-5 transport, the world's largest aircraft; and the new air superiority fighter, the F-15 Eagle.

HELICOPTER ENGINES

Helicopters are a different type of vehicle than the conventional aircraft we have been considering. Their wings are on top, and rotate instead of being firmly fixed to the side of the fuselage. Helicopters can go straight up and straight down, frontwards, sideways, and even backwards, or they can hang suspended, all in response to the pilot's control of the way those rotating wings are aimed. These flight characteristics require different thrust capabilities, but helicopters use essentially the same type of engines that fixed-wing aircraft use.

It is not the purpose of this volume to explore the aerodynamics of helicopters—the theory behind their flight control—but merely to look at their powerplants and some of the peculiar problems they cause.

Helicopters may be powered by reciprocating or turbine engines, located in the front of the craft, in the middle, or on top. Increasingly, gas turbine engines are being used, and on the larger helicopters with a very large rotor or more than one rotor (as the rotating wings are called), more than one engine may be used.

Helicopter engines generate power in the same way as do the reciprocating engines and the gas turbine engines we have studied in this book. The main difference is in the way the power is transmitted to the rotating wing. The situation is similar to that found

GAS TURBINES & JET PROPULSION

in the turboprop engine, where a system of gears is required to change the twisting power in the power shaft into a form that can be used by the propeller. The power shaft of the reciprocating engine, of course, is the crankshaft. The power shaft of the **turboshaft engine** (the turbine engine used in helicopters) is similar to that of the turboprop: the shaft is connected to a power turbine, which is activated by engine gases. In both the reciprocating and the turbine-powered helicopter engines, reduction gearing is necessary not only to control the tip speed of the rotating wings (rotor blades) but also to change the direction of the spinning motion to that required by the rotor blades (Fig. 62).

The pilot controls both the engine speed and the pitch of the rotor blades through his throttle control lever and grip. A twist of

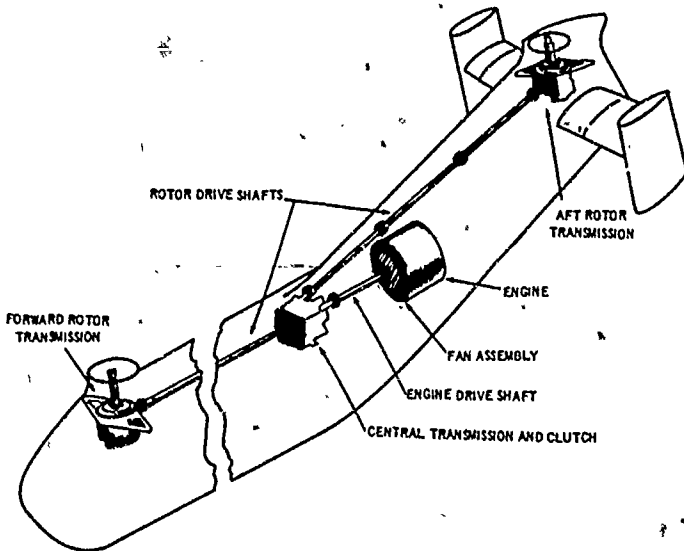

Figure 62. The propeller's engine may be located wherever it is convenient in the aircraft design. The engine's power is converted to the proper direction of spin by its system of transmission and gears.

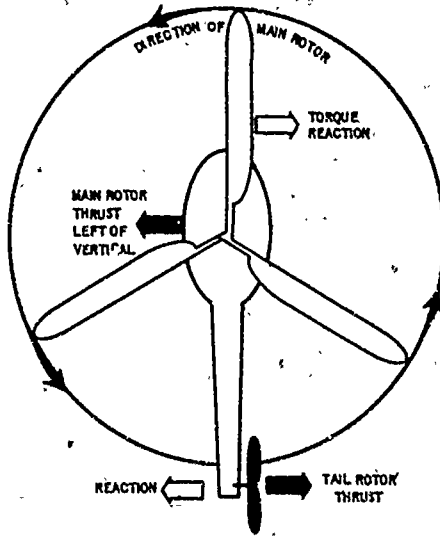

Figure 63. A tail rotor works similarly to a propeller to offset the torque from the main rotor. Reaction to the tail rotor's thrust operates in the opposite direction from the torque of the main rotor. This keeps the helicopter from spinning. Helicopters with two rotors spin the rotors in opposite directions, offsetting each other's torque.

the grip opens or closes the engine's fuel flow, and forward-backward movement of the lever controls the rotor pitch. The throttle is synchronized with the pitch control linkage to equalize the power supplied by the engine with the power required by the rotors.

The limitations on tip speed we discussed in the section on propellers also apply to helicopter rotor tip speeds, a factor in helicopter speed. Generally speaking, forward speed for helicopters in level flight is limited to about 30 percent of blade tip speed. Thus, if the tip speed were 400 miles per hour, the helicopter would have a forward speed capability of approximately 120 miles an hour.

Some of the later models of helicopter have incorporated short fixed wings on their sides and extra turbine engines that can provide forward thrust, as in pure fixed wing aircraft. These combination-type aircraft are markedly faster than the conventional

GAS TURBINES & JET PROPULSION

helicopter since tip speed limitations are lessened by the use of the fixed wings for lift in forward flight.

One force that must be reckoned with in helicopter design is rotor torque, the tendency of the helicopter's fuselage to spin in the opposite direction from its rotor. Torque is an example of Newton's third law, concerning action and reaction. Several means have been devised to overcome this force. One is the use of a small rotor on the tail of the helicopter mounted perpendicular to the main rotor and designed to produce thrust—as a propeller does—in the opposite direction from the torque action (Fig. 63). Some helicopters have dual main rotors, one mounted beneath the other, which turn in opposite directions. This system "washes out", or eliminates, most of the torque, and vertical stabilizers take care of the rest. The large helicopters with two engines and two rotors may be designed to use a counter-rotating system also, with the torque effect of one engine balancing out that of the other.

SOME IMPORTANT SYSTEMS

The jet engines that power our modern aircraft are fitted with a number of auxiliary systems that may be vital to their operation or merely added to increase their performance. This list includes starter, fuel, and lubrication systems, water injection systems, thrust reversers, and noise suppressors. Some auxiliary systems and modifications are added for reasons of environmental protection.

Accessory Section

The mechanical controls by which some of the auxiliary systems are operated may be found in the accessory section of the engine. In this section are found the engine's electric starter, generator, oil and fuel pumps, hydraulic pumps, and other devices.

The accessory section is usually housed in the front part of the engine, under the diffuser cone in the air intake section. In some engines, however, the accessory devices have been relocated to the sides and bottom of the engine for improved air intake performance.

Starting the Engine

Starting the jet engine is not as easy as starting the reciprocating engine because we must bring the engine up to substantial

PROPULSION SYSTEMS FOR AIRCRAFT

speed to get sustained ignition. About ten times as much power is required to start a jet engine as is needed for a reciprocating engine of comparable power. We need not only more power, but also more time, since it takes a while to get the engine up to ignition speed.

Usually, the aircraft's **electrical starter**, mounted in the accessory section, is a rather heavy motor which requires an outside power source for its operation—that is, an electrical connection with a power source on the ground. When the engine is started and brought up to idling speed by the starter motor, it begins to generate its own direct current for use by the other engine systems.

Sometimes **air starters** are used instead of electrical starters. In this case, a stream of air is pumped through the turbine-like starter. The starter turbine is linked to the engine's rotor shaft and it accelerates the engine to ignition speed. The air stream that activates the starter turbine is generated by a ground-based gas turbine engine. Some of the larger aircraft—the C-130 for example—have an internal air starter called a **gas turbine compressor (GTC)** which will start from the aircraft battery, eliminating the need for an external power source.

Sometimes, through a combination of factors, a jet engine may experience **flameout**—the extinguishing of the fire in the engine. This may occur if engine speed is allowed to fall below what is required to maintain proper airflow and ignition, or when fuel/air mixtures change so quickly that combustion in the burners fails. A pilot may be able to restart his engine in flight by going into a dive and relying on the resulting ram air to get the compressor up to ignition speed again; but the usual procedure is to bail out of the airplane and let it crash.

Fuel Systems

Jet engine fuel controls are complex instruments that must take into account a number of factors, such as airflow, pressures within the engine, tailpipe temperatures, and fuel/air mixture at any given moment. The controls must be designed to regulate the fuel flow into each burner at each instance in response to the pilot's change of throttle lever position.

Modern fuel supply systems meter the fuel flow according to the air flow, which may vary with any combination of engine speed, aircraft speed, and air density. Limits are set on the system to avoid

excessively rich fuel/air mixtures and to eliminate flameouts. A system of automatic controls linked to the pilot's throttle control lever assure proper fuel flow for the engine's demands.

Lubrication Systems

Jet engines are relatively simple to lubricate. This is true because they do not have a great many moving parts, and because only the turbine wheel (of all the moving parts) is subjected to the high heat of combustion.

Although wet sump lubrication systems have been used in jet engines, the modern jet typically employs the dry sump system similar to that shown in figure 64. The oil supply in this system is located in a tank outside the engine, and pressure and scavenging pumps usually are mounted in the accessory section. Another scavenging pump may be mounted towards the middle of the engine. The system sprays lubricating oil on gears, bearings, and drive mechanisms, where necessary.

Scavenged oil goes through a cooler, where it is cooled by fuel that is on its way to the engine's fuel manifold. The oil in a jet engine is not exposed to combustion heat, but must withstand high temperature in the rest of the engine. In some cases, synthetic lubricants are used instead of natural oil.

Water Injection

Many jet engines are fitted with water injection systems which can spray water into the combustion chambers as a means of increasing mass airflow through the engine. The water not only adds its own mass to the flowing matter, but cools the engine temperatures so that more fuel is burned in an attempt to bring the engine back to normal operating temperatures. The extra fuel increases the intensity of the combustion in the combustion chamber, and increases the velocity of the exhaust gases.

The tailpipe section also is affected by the cooling effects of water injection on the exhaust gases. Many tailpipes have automatically regulated orifices, or openings, through which the exhaust gases escape. As the temperatures of the gases drop, the tailpipe orifice closes somewhat as a means of bringing the temperature of the gases back to their most efficient heat. When the tailpipe opening is thus constricted, the velocity of the exhaust gases increases, and thrust increases with it.

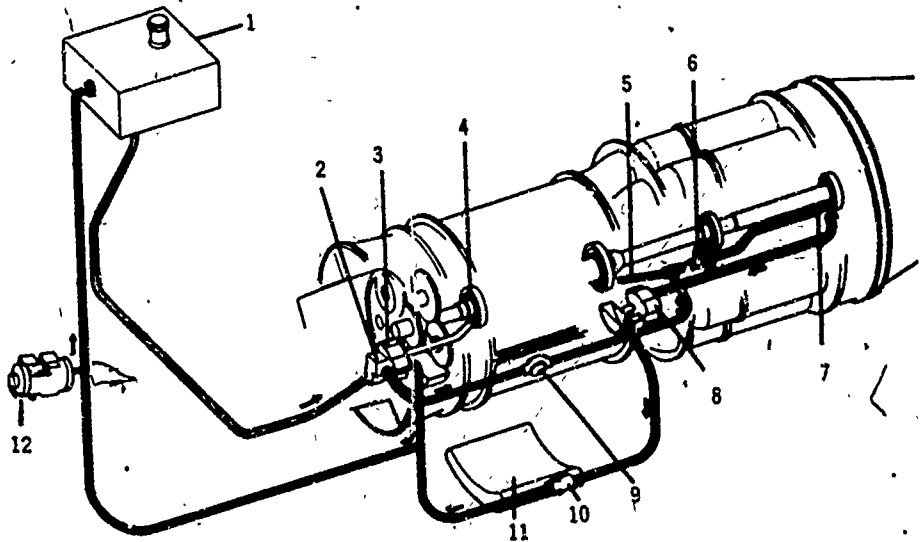

- | | | |
|------------------------|---------------------------|-------------------|
| 1. Supply Tank | 5. Mid-bearing Oil Jet | 9. Oil Filter |
| 2. Lubrication Element | 6. Damper-bearing Oil Jet | 10. By-pass Valve |
| 3. Scavenging Element | 7. Aft-bearing Oil Jet | 11. Oil Cooler |
| 4. Forward Bearing | 8. Scavenge Pump | 12. Oil Filter |

Figure 64. The lubrication system of the turbojet engine is designed to spray lubricating oil into the engine's bearings and other moving parts. Principal parts of this dry sump system are the storage tank, the oil lines, pressure pump, oil jets at each bearing point, scavenge pumps, and an oil cooler. In this illustration, the blue lines denote oil on its way to lubrication points, while the red lines represent scavenged oil returning to the storage tank.

Thrust Reversers

One big problem in the use of jet aircraft is the need for long runways for landing. The thrust force of the jet cannot be reversed in the same manner as the thrust of the propeller.

Early attempts at braking the jet aircraft made use of a parachute, which would, when released by the pilot, flare out behind the aircraft. The drag caused by the parachute slowed the plane down and reduced the required length of the landing strip.

But the drag chute was not entirely satisfactory. For one thing, its braking power could not be controlled by the pilot—it was

GAS TURBINES & JET PROPULSION

all or nothing, since the parachute would open fully when released. For another thing, it had to be repacked after each use.

Two types of mechanical thrust reversers have been devised and are in use on some jet aircraft today. These reversers are used on aircraft equipped with turbofan engines and in some turbojet-powered aircraft.

One of these reversers, called the fan and aft reverser, is shown in figure 65. It affects the airstream in the bypass duct in front of the engine and at the exhaust nozzle in the rear. The "aft" part of the fan and aft reverser is connected to the exhaust nozzle in the tailpipe section of the engine. Its three principal parts are a

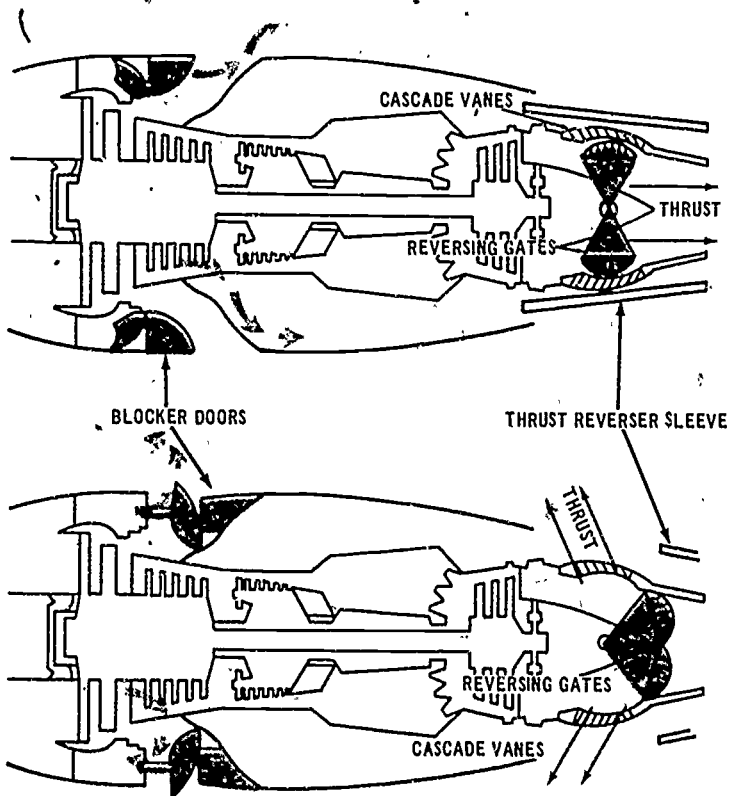

Figure 65. During normal flight, the airflow of the turbofan engine flows rearward without obstruction, as in the top drawing. When the fan and aft thrust reverser is in operation (bottom) blocker doors reverse the bypass air flow and reversing gates in the exhaust section turn the exhaust gases back through cascade vanes. With the thrust reversed, the reaction stops and the aircraft is braked.

PROPULSION SYSTEMS FOR AIRCRAFT

set of clamshell-type doors, called **reversing gates**, inside the tailpipe; a set of vaned openings, called **cascade vanes**, in the side of the engine; and a sliding **sleeve** which covers the cascade vanes until the thrust reverser is activated.

As figure 65 shows, when the fan and aft thrust reverser is activated, the sleeve slides rearward, opening the cascade vanes on the side of the engine. The reversing gates swing shut, blocking the straight rearward thrust of the exhaust gases and forcing them out the cascade vanes, at an angle slightly forward of perpendicular to the straight rearward flow.

At the same time, **blocker doors** in the engine's fan section move into the bypass duct, forcing the bypass air to reverse at about the same angle.

Another type of thrust reverser, shown in figure 66, operates only at the rear of the engine. It consists of **exhaust deflectors** mounted on the outside frame of the tailpipe section, and can be used on turbojet as well as on turbofan engines. When this reverser is activated, the doors swing shut and the exhaust gases are diverted slightly forward. On this type of reverser, the doors are mounted externally, there are no cascade vanes and there is no sliding sleeve. When this reverser is not operating, the deflectors form an extension of the tailpipe (Fig. 66). Using the mechanical

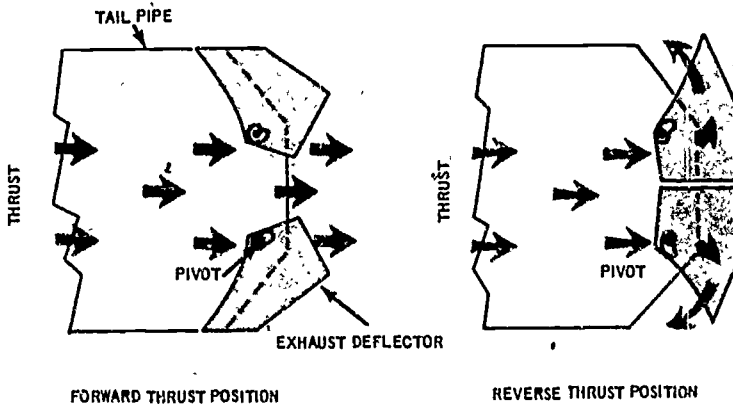

Figure 66. In the turbojet's simple tailpipe thrust reverser, the exhaust deflector acts as a part of the tailpipe when in the forward thrust position (left), but swings shut when activated and deflects the exhaust gases back toward the front of the aircraft.

thrust reverser allows the pilot to maintain full engine power while landing. In case the pilot has to pull out of his planned landing, maximum thrust can be obtained immediately by retracting the thrust reverser doors.

Noise Suppression

Since they first came into use, jet-powered aircraft have been noted for the loud, objectionable noises they make. These noises in the conventional turbojet are caused by the movement of the high-velocity jet stream (exhaust) moving through the relatively quiet, still air around it. The sound of the high-speed air is of low frequency, and travels farther than would a higher-pitched sound of the same initial intensity. These loud noises are more of a nuisance than a real threat; they annoy passengers in the aircraft and people on the ground, particularly people who live near airports. But sustained, loud exhaust noises also can have a bad effect on the efficiency of the crew.

There are important factors that work against effective noise control measures. One serious complication is that every noise suppression method devised so far has reduced the power of the engine it is used on. With reduced power available to propel the aircraft, the margin of safety is reduced correspondingly.

Human nature also has worked against efforts to keep the noise annoyance factor down. The simplest way to control the annoyance is to move the noise away from populated areas. Attempts to do this by moving the airports to areas where no one lives have failed, however, for economic reasons. When an airport is built, the area round it becomes desirable for residential and business development; but the people who build houses and shops near the new airports then complain about the noise.

And so the search for effective noise control continues in the laboratory. Researchers representing engine manufacturers and government agencies—including the Air Force and the National Aeronautics and Space Administration—have worked for years to devise methods to curb engine noises as much as possible. Research is continuing not only in the areas of engine design and materials development but into the very nature of sound: to control noise, we must first understand what it is.

Much of the sound abatement (reduction) effort of the past few years has consisted of wrapping the engine and its parts, wherever possible, in blankets of acoustical (sound-absorbing) materials or of coating certain portions of the engine's surfaces with

noise-deadening substances. The limits of effectiveness of this approach appear to have been reached, but engine noise levels still are unacceptably high.

Efforts now are being concentrated toward redesign of the engines to build more quietness into them. One type of silencer is a set of airfoil-shaped projections built into the exhaust nozzle of the engine. These **spades**, as they are called, actually change the shape of the sound waves so that they get out of the nozzle faster and react less with the metal insides of the engine's exhaust section. These spades serve to break the large exhaust stream into smaller streams, at the same raising the sound frequency (in part) outside the range of human hearing.

The coming of the turbofan has been beneficial in the quest for quieter engines. In the first place, turbofans are quieter by nature than are turbojets. In the second place, turbofans are easier to modify or redesign for extra quietness. Some success has been reached by making the fan's blades longer, so it can move a greater mass of air, and at the same time eliminating a smaller second fan stage. This is known as a **high bypass engine**.

The search for quietness is not limited to jet propulsion engines, however. Experimentation also is in the works on helicopters and reciprocating engines.

Helicopter makers have found that modifications to the rotor tips can soften the noise-making impact of the blades on the air. They have also found that by adding rotor blades, they can get comparable lift at slower rotor speeds; and slower rotor speeds mean quieter operation. Helicopter makers have also made use of acoustical blanketing to absorb some of the noise of the engines they use.

Newly designed reciprocating engines are being produced that, compared with engines of similar power output, offer noise reductions of up to 30 percent inside the aircraft and up to 50 percent outside. Among their quieting features, they employ a system of hydraulic cylinders to replace some of the noisy mechanical devices of the conventional reciprocating engine. Manufacturers of these engines hope not only to make aviation quieter, but to gain an economic benefit by slowing the trend toward the use of turboprop engines in low powered aircraft.

Many of the advances discussed here are experimental, or are just out of the experimental stages and have not yet been put into widespread use. However, government regulations on noise control may hasten both the development of quieter engines and their adoption by aircraft operators.

Pollution

Governmental regulations also have been put forth regarding air pollution, commonly cited as a nuisance of air travel—especially of jet air travel. As in the case of noise suppression, experimentation and research is under way in the field of controlling environmental pollution caused by jet engines. Here, the problem seems somewhat more complicated than in the area of noise suppression, for the cure of one problem increases another problem.

The main pollutants from jet engines are unburned hydrocarbons, carbon monoxide, and nitrogen oxides. The most visible of these is unburned hydrocarbon—the heavy black smoke that sometimes pours from the engine on takeoff and landing.

Most of the research has been aimed at eliminating the visible smoke and has centered around increasing engine temperatures, especially in the combustor. The development of new combustion chambers and of certain fuel additives has brought engine temperatures up and has virtually eliminated the smoke from the new engines.

This step, however, has not improved the situation as regards the other pollutants, carbon monoxide and nitrogen oxides. These gases are invisible, but are a much more serious threat to the environment than smoke is. Carbon monoxide is a deadly gas to inhale, but that does not seem to be the main problem. Environmentalists fear that the long range effect of discharging this gas into the atmosphere in great amounts will be the drastic alteration of the earth's climate.

Nitrogen oxides are recognized as a threat since they are an important ingredient in the production of photochemical smog. Smog is the result of the chemical action of sunshine on certain gases. In concentration, it stifles the lungs, burns the eyes, and can make the body susceptible to various illnesses. Smog and nitrogen oxides color the air a yellowish brown, and airline pilots say that every major city in the United States and the world is enveloped to some extent in this yellow-brown blanket.

In attempting to solve the smoke problem, engine manufacturers may be increasing the nitrogen oxide problem. Since the smoke is mostly unburned fuel hydrocarbons, higher temperatures will burn these hydrocarbons more thoroughly and eliminate the smoke. But increasing exhaust temperatures increases the chemical reaction by which nitrogen oxides are formed from the air outside the engine. The heat causes the nitrogen and the

PROPULSION SYSTEMS FOR AIRCRAFT

oxygen in the atmosphere to react, resulting in the poisonous gas.

Research continues into these connected problems, and involves alternative approaches such as fuel modification. Other approaches include more basic research into the real causes of pollutants, how to measure them, and how to eliminate them. But the problem of air pollution promises to be a tough one to solve.

COMPARISONS

Some of the disadvantages of the jet engine today, as compared to the reciprocating engine-propeller combination, are: high fuel consumption at low speeds, high materials costs, both in manufacture and in maintenance, exterior noise; length requirements for air strips used, and the possibility of damage to the engine from objects sucked into the air intake. Continuing research and development, however, promises to ease all or at least some of these problems.

The jet's advantages over the "conventional" engine include: freedom from vibration, since all the moving parts rotate instead of reciprocate, simplicity of design and operation, less interior noise, higher thrust-per-pound ratios, higher speeds, and reduced fire hazards, since the fuels used in jet engines are less volatile.

WORDS AND PHRASES TO REMEMBER

abatement	crossover tube
accessory section	diffuser
acoustical material	drag chute
afterburner	electrical starter
air starter	exhaust deflector
axial flow engine	exhaust nozzle
carbon monoxide	exhaust section
cascade vanes	fan
centrifugal flow engine	fan and aft reverser
combustion chamber	flameholder
compression ratio	flameout
compressor	fuel nozzle
compressor rotor	gas turbine
compressor stage	gas turbine compressor
compressor stall	grill assembly
compressor stator	helicopter rotor

GAS TURBINES & JET PROPULSION

high bypass engine
hydrocarbons
ignition plug
inner (combustion) chamber
jet propulsion
mach
nitrogen oxides
outer (combustion) chamber
photochemical smog
pulsejet
ramjet
reversing gates
rotor torque

Scramjet
sleeve
spade
split compressor
thrust reverser
turbine stage
turbine wheel
turbofan
turbojet
turboprop
turboshaft
V-1 missile
water injection system

QUESTIONS

1. What are the four main sections of the jet engine?
2. Name some similarities in and differences between reciprocating and jet engines.
3. How does the ramjet differ from the pulsejet, both in construction and performance? How do these engines differ from the turbojet?
4. What is meant by the word, "mach"?
5. What are some advantages of the turboprop engine over the conventional propeller-type engine?
6. Why is the turbofan engine the most satisfactory jet engine so far developed?
7. How does the water injection system increase thrust?
8. Why are there no supersonic helicopters?
9. What are the differences in the starter systems for jet and for reciprocating engines? How about the lubrication systems?
10. In view of the noise nuisance created by jet engines, do you think reciprocating engines will come back into prominence? Explain your answer.

THINGS TO DO

1. Turbine engines power many kinds of jet aircraft. Find out and report on some other uses for turbine systems. Include proposals and current developments in your report.
2. Some modern railroad trains are powered by turbine engines. Through research, find out how these engines resemble the turbine engines that power aircraft, and how they differ. What are the advantages of turbine engines for ground vehicles over the more traditional powerplants?

PROPULSION SYSTEMS FOR AIRCRAFT

3. Find out what the current federal regulations are concerning aircraft engine noise and pollution, and how well these standards are being met. What is the effect of these regulations on military aircraft? How does the noise problem affect plans for the development or use of supersonic commercial transport planes in the United States?
4. Find out why turbine-powered racing cars do not compete in races such as the Indianapolis 500. Have they ever competed there?

SUGGESTIONS FOR FURTHER READING

BRYAN, LESLIE A., *et al.* *Fundamentals of Aviation and Space Technology*. Urbana, Ill.: Institute of Aviation of the University of Illinois, 1966.

CARGNINO, L. T., and C. H. KARVINEN. *Aerospace Propulsion Powerplants*. Chicago: Educational Publishers, Inc., 1967.

MCKINLEY, JAMES L., and RALPH D. BERT. *Powerplants for Aerospace Vehicles*. New York: McGraw-Hill Book Co., 1965.

Northrop Institute of Technology. *Basic Science for Aerospace Vehicles*. New York: McGraw-Hill Book Co.

VAN DEVENTER, C. N. *An Introduction to General Aeronautics*. Chicago: American Technical Society, 1970.

ALSO:

Current issues of magazines such as *Aviation Week*.

SUMMARY:

PROPULSION'S EVOLUTION

Aircraft powerplants developed through the work of many men, over a period of many years. Americans were the first to achieve powered flight of heavier than air machines, but they built their success on a base laid by Europeans. While the Europeans were experimenting with approaches to usable mechanical power, America was still trying to build a solid nation, to conquer a continent, and to subdue a wilderness that was considered a threat rather than an asset. A few historical incidents can suggest, perhaps, why America trailed Europe for so long in developing a workable aircraft engine.

The origins of the first successful aircraft engine must be found in the piston-moving steam engine, invented by James Watt of Scotland. Watt invented his engine in 1769, the same year Napoleon Bonaparte was born, and four years before the Boston Tea Party. Changes in the steam engine were made gradually. In 1820, W. Cecil reported the development of an internal combustion engine in England. That same year in the United States, Congress voted to allow slavery in Missouri but nowhere else west of the Mississippi and north of the Missouri rivers. In 1860, the first Pony Express mail service crossed the American West, Abraham Lincoln was elected President of the United States, and J. J. E. Lenoir of France designed the first practical internal combustion engine. Germany's Nikolaus Otto came up with a coal gas-burning engine in 1876, the same year Gen George Custer and his troops were wiped out by Indians on the Little Big Horn and Wild Bill Hickok was shot down from behind while playing poker. Gottlieb Daimler, another German, invented a high-speed gasoline engine in 1883, three years before the Apache Indian Geronimo surrendered to the US Army. Finally, in 1903, the Wright brothers combined aerodynamics with an engine of sufficient power to get their "Flyer" off the ground. That was the year the United States agreed to dig the Panama Canal, and four years before Oklahoma became a state.

These historical parallels may demonstrate how long the search lasted for a useful aircraft engine. They also point up the speed with which the engine was developed from its first success to its present point. Of course, many factors other than American interest have contributed to this development. But the entry of this country into aviation research, after a slow start, had significant impact on progress in that field.

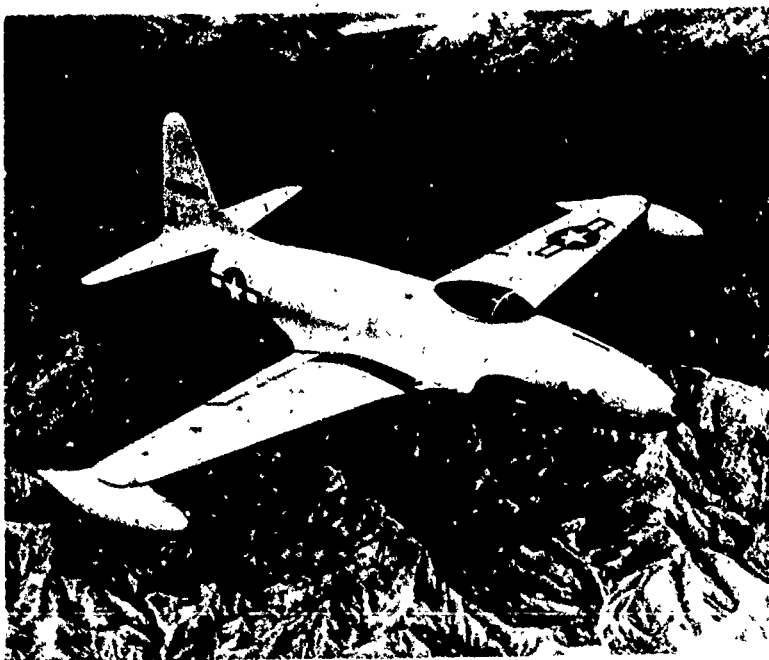

Figure 67. The P-80 Shooting Star, America's first operational jet airplane, came into service in 1944. Germany, Italy, and Great Britain had already flown jets successfully by that time.

Scientific developments in the field of aircraft propulsion have not stopped in the past few years. Even though the emphasis has been mostly on space, there has been steady progress in developing airplane propulsion systems also—but with a difference. The historical quest for ever more powerful engines and for faster and faster aircraft has shown some signs of leveling off, and the trend now seems to be toward refinements of our engines to make them quieter and more economical. Along with the new concepts and new engine types that are being tried out, the “basic” machines we have discussed here are getting better and better.

Developments in the field of jet propulsion are an example. America's first operational jet fighter was the P-80 Shooting Star shown in figure 67. When news of this aircraft was announced in 1944, the P-80 was said to be capable of speeds above 550 miles per hour, with a ceiling of 40,000 feet. By the mid-1960s jet propulsion had been developed to such a degree that two turbojet engines could power one of the United States reconnaissance aircraft (the SR-71, shown in figure 68) at more than

SUMMARY

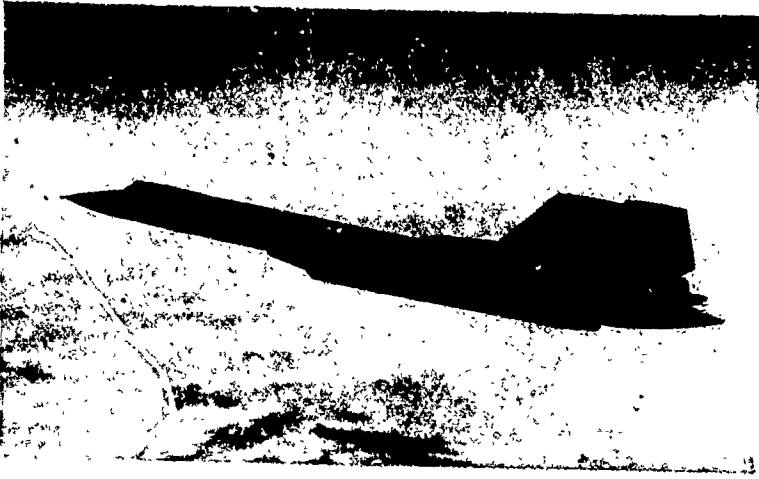

Figure 68. Two J58 turbojet engines with afterburner power the SR-71 strategic reconnaissance aircraft, the free world's highest-flying and fastest aircraft.

2,000 miles per hour and at altitudes around 80,000 feet. Each engine on this missile-shaped aircraft develops 30,000 pounds of thrust.

The F-4 Phantom fighter, in heavy use, is powered by two turbojet engines developing 17,900 pounds of thrust each, a meager amount compared to the SR-71. But the Phantom can move at mach 2.5 plus (more than two and a half times the speed of sound) and can operate above 66,000 feet. It has climbed to an altitude of 98,000 feet (18.7 miles) in six minutes, 11 seconds.

The F-111 all-weather fighter-bomber has a number of unique features, including variable wings, as shown in figure 69. Its wings can extend straight out, allowing effective operation at speeds as low as 100 miles an hour; or they can be swept back in flight to allow faster speeds. Two turbofan engines of up to 25,000 pounds of thrust power the F-111 to speeds approaching 2,000 miles an hour. Its operational ceiling is more than 60,000 feet.

Six turbojets, developing 33,000 pounds of thrust each (with afterburner), powered the now defunct XB-70 experimental bomber. This aircraft was designed to move at more than 2,000 miles an hour and to operate at altitudes of about 70,000 feet.

Turbofans mounted on the commercial 747 jumbo jetliner develop more than 42,000 pounds of thrust each, and continuing

PROPULSION SYSTEMS FOR AIRCRAFT

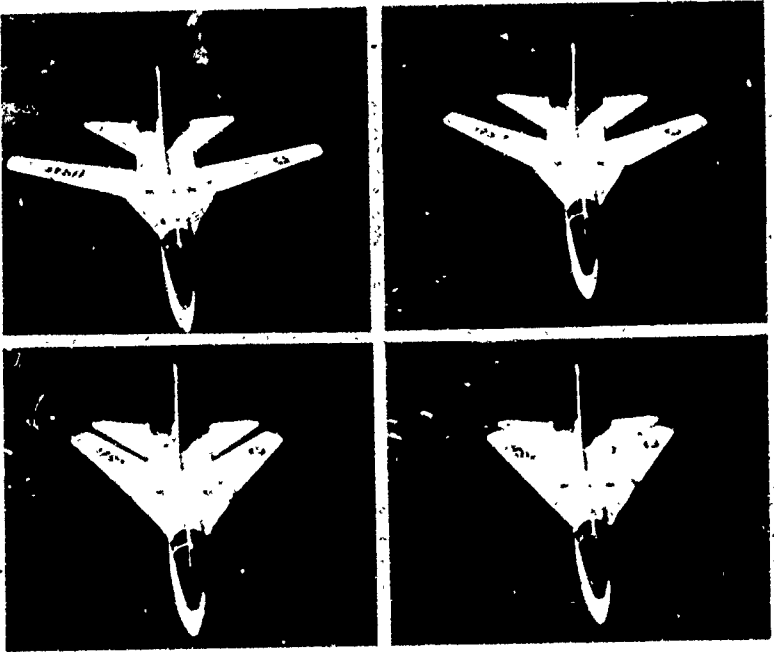

Figure 69. The F-111 has variable wings that can be extended for takeoff and landing and for slow flight, or swept back for high-speed flight. Powered by two turbofan engines, the F-111 can fly at speeds in the area of 2,000 miles per hour.

development has brought more size and power to the jet engine field. Turbojet engines designed for the American version of a supersonic transport (SST) developed more than 50,000 pounds of thrust each.

But there are signs that useful limits may have been reached, at least for the time being, in the amount of power we need from engines that power air-breathing aircraft. The limits seem both political and practical. The political issues include questions of expense and environmental considerations.

There are firm examples that the ecological limits have been reached, for instance, the public outcry over noise and air pollution, especially around airports. The American SST was abandoned (a political decision) in the wake of public alarm at its cost tag and its potential for ecological damage, particularly the sonic boom—the explosive sound caused by the shock waves resulting when an aircraft passes the speed of sound. So effective were the protests against them involving environmental harm that

SUMMARY

supersonic transports have been forbidden to operate at American airports.

The Anglo-French supersonic transport, Concorde, was expected to be the hit of an air show in England in 1972, and it did get attention when it roared past the crowd. But the show was stolen by the subsonic L-1011 TriStar, with its very quiet and smokeless turbofan engines. The question has been raised as to whether we need a supersonic transport at its financial and ecological cost. Would its advantages be overcome by the discomfort it would cause for people who do not fly?

As for military aircraft, the newest Air Force planes are not, in most cases, significantly faster than the aircraft they will replace. There are limits to the amount of useful speed, and these seem to have been reached—at least for now. But the new aircraft incorporate new and advanced technology which make them superior in other ways than speed.

The new air superiority fighter, for example, the F-15 Eagle, shown in figure 70, is designed to operate at around mach 2, which is not excessively fast, and at relatively low altitudes. However, the maneuverability of the Eagle and the fact that its engines develop more thrust than the weight of the aircraft itself make it a formidable—we hope, invincible—weapon. Similarly, the

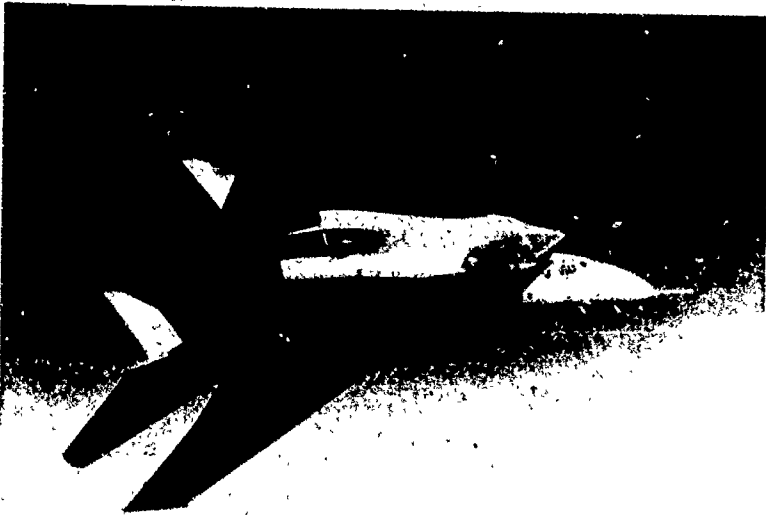

Figure 70. The F-15 Eagle is extremely maneuverable and very fast aircraft developed as an air superiority fighter. It is powered by two smokeless turbofan engines.

developing new ground support aircraft, the A-10, is subsonic, but well fitted for its particular job.

The proposed new strategic bomber, the B-1, will be supersonic, while the B-52 it replaces is not. But at the same time, there is under development a subsonic cruise armed decoy (SCAD), powered by a small turbofan engine. SCAD is a missile that can be carried by the F-52 in numbers up to 20. On the radar screen, it looks like a B-52; armed with a nuclear warhead, it can act like a B-52, which means an enemy will have to cope with SCAD just as he would with a real bomber. This missile is expected to prolong the service life of the B-52 considerably.

In the area of transport aircraft, the Air Force's newest is the C-5. Big and powerful—its turbofans develop 41,000 pounds of thrust each—the C-5 is subsonic.

Today's aircraft are being designed for specific jobs, and those jobs do not necessarily call for very high speeds or very powerful engines. We have engines now that take us to the point where anything more could be done better by ballistic missiles or other rocket-powered craft. And so the concentration has shifted to improvement of these engines, and of making engines to suit neglected types of aircraft such as the Short Takeoff and Landing (STOL) planes. We want power, but we also want efficiency, economy, quietness, and cleanliness.

From a modest beginning at the start of this century, the aircraft engine has developed to the point that it can perform any job demanded of it, from very slow flight to flight several times the speed of sound, from low power to enough strength to lift hundreds of thousands of pounds of aircraft and cargo into the air, from ground-hugging flight to performance at the edges of space. There are under development air-breathing engines capable of bridging the gap between atmospheric flight and near-space maneuvers but these engines (Scramjets) are beyond the scope of this book.

Aircraft propulsion systems have taken us to the edge of space. The rocket engines discussed in *Aerospace Education III* take over the job of propulsion at that point.

INDEX

The following is a list of subjects of interest to the study of aircraft propulsion systems, including many of the terms listed in the "Words and Phrases to Remember" sections at the end of each chapter, plus other entries. Terms in this list are adequately explained in the text, usually where first mentioned. Page references locate passages where the items are defined, discussed, or explained, as necessary.

A

Accelerating system. See Carburetor accessories
Acceleration, 13, 14, 87-88
Accessory section, 109, 110
Afterburner, 93, 101, 102, 105-106
Aircraft:
A-7, 106
A-10, 126
B-1, 126
B-52, 102, 103, 106, 126
Boeing 707, 102, 106
Boeing 720, 102
Boeing 727, 106
Boeing 747, 106, 123
C-5, 106, 126
C-130, 104
C-141, 106
Convair 580, 104
DC-8, 102
DC-9, 106
F-4, 102, 122
F-5, 102, 122
F-15, 106, 125
F-111, 106, 123, 124
Flyer, 2, 8, 9, 121
KC-135B, 106
L-1011, 125
ME-262, 11
Ornithopter, 4
Ov-10, 104
P-80, 11, 12, 122
SCAD, 126
SR-71, 102, 122, 123

SST, 124, 125

STOL, 126

XB-70, 123

Aircraft power sources: benzine, 6; electricity, 6; kerosene, 38; 39, 98; gasoline, 6, 9, 38, 39, 43-45, 48; muscle, 4; steam, 5

Air, nature of, 3, 4

Augmenter tube, 31

B

Balloon, 4, 5. See also Dirigible

Bank. See Cylinder: bank

Barnett, William, 6

Bernoulli's principle, 45, 48, 74

Borelli, G. A., 4

C

Caley, George, 7

Cam ring. See Ring, cam

Camshaft, 20, 22, 24

Caproni, Giovanni, 11

Carbon monoxide. See Pollution

Carburetion, 43-45

Carburetor, 38, 39, 44-54, 57, 69; icing, 39, 50, 53, 57; float, downdraft, 52, 53; float, updraft, 45-48; pressure injection, 45, 53, 54

Carburetor accessories, 48-54; accelerating system, 49, 50; automatic mixture control, 53, 54; economizer, 49; heater, 50. See also, Supercharger

Cecil, W., 5, 121

Chanute, Octave, 7

Combustion. See Four stroke cycle: power stroke

Combustion chamber, 89, 90, 91, 93, 94, 98-99, 104, 105

Combustion section, 88, 98-99
Compression; of air, 88-90; 93-98; of fuel, 6, 23
Compression ratio, 25, 95, 96
Compression stroke. See Four stroke cycle
Compressor, 11, 93, 100, 104; axial flow, 93, 95-97; centrifugal flow, 93-95; dual, 96-98; rotor, 93-95; stage, 94-95; stall, 98; stator, 93-95
Compressor section, 93
Condenser. See Ignition system
Cooling, 27-32, 34
Cowling, 31
Crankcase, 26
Crankshaft, 20, 22, 23, 24, 34, 56, 68, 74
Crossover tube, 98, 99
Custer, George, 121
Cylinder, 20, 23-29, 56, 69
Cylinder; bank, 33; barrel, 33; head, 22, 33; master, 28

D

Daimler, Gottlieb, 6, 121
Da Vinci, Leonardo, 4
De Rochas, Alphonse Beau, 6
Diesel engine. See Engine, diesel
Diesel, Rudolph, 25
Diffuser. See Intake section
Dirigible, 6. See also Balloon
Distributor. See Ignition system

E

Electrical system. See Ignition system
Electricity, 58-60, 67, 68; alternating current, 60; direct current, 60; electromotive force, 59; ionization, 59; self-induction, 63; voltage, 59, 61, 64. See also Electromagnetic induction
Electromagnetic induction, 61, 62
Electromotive force, 59. See also Electricity
Energy, 39
Engine, diesel, 25-26
Engine, jet; 11-13, 15, 19, 58, 85-102, 105-106, 115-118, 122-126; principles of operation, 87; pulsejet, 90-92; ramjet, 88-90, 101; Scramjet, 90, 126; turbofan, 104-106, 113, 114, 116, 123, 125, 126; turbojet, 92-104, 106, 113, 122-124. See also, Engine, turbine
Engine, reciprocating, 12, 15, 19-34, 80, 86-87, 91, 102, 104, 106, 107, 109, 116, 118; in-line, 10, 26; opposed, 26,

71; radial, 8, 28, 29, 73; "V", 26, 27; "X", 26, 27

Engine, steam, 2, 4, 5, 13
Engine, turbine, 93-111; turboprop, 102-105, 107; turboshaft, 107. See also, Engine, jet; turbofan, turbojet
Exhaust, 87, 88, 93, 99, 100, 101, 105, 111, 113-116
Exhaust section, 88, 100-101, 105
Exhaust stroke. See Four stroke cycle
Exhaust valve. See Valve, exhaust
External combustion, 2, 11

F

Firing order, 25, 66, 67
Flame holder, 89, 101. See also Afterburner; and Engine, jet; ramjet
Flameout, 110
Force. See Power terms
Four stroke cycle, 6, 20, 23-25, 56, 86, 87; compression, 20, 23; exhaust, 20; ignition, 20; intake, 20, 23; power (combustion), 20, 23-25
Ft/sec², 14
Fuel, 23, 38-42, 49; 98, 118; backfiring, 40; cleanliness, 43; detonation, 40; fuel/air charge, 23, 39-40, 43-45; flash point, 38; knock, 40-41; lean mixture, 40, 44, 45; octane rating, 40-42; pre-ignition, 40; rich mixture, 44, 45, 111; stability, 39; vapor lock, 39; volatility, 38-40. See also, Aircraft power sources
Fuel injection, 54-58; intake metering system, 56-57; mass air flow system, 55-56
Fuel system, 38, 42-58, 69, 110-111; fuel feeding, 42-43. See also Carburetor; Fuel system; and Supercharger

G

Gas turbine. See Turbine
Gears, reduction, 74, 104, 107
General aviation, 19-20
Generator. See Ignition system
Geronimo, 121
Giffard, Henri, 5
Gliders, 7-8

H

Haeffelin, Paul, 6
Helicopter, 106-109
Heat, 30, 33, 69, 71, 98-101

Hickock, Wild Bill, 121
Horsepower, 12, 26, 28-29. See also
Power terms
Hydrocarbon, 38, 40, 117. See also Pol-
lution

I
Ignition, 58
Ignition plug, 88, 89, 99
Ignition stroke. See Four stroke cycle
Ignition system, 38, 58, 61-68, 69; booster
coil, 68; breaker point, 65, 68; con-
denser, 65; contact point, 67; dis-
tributor, 65, 67; generator, 58; mag-
neto, 58, 62-65, 68; magneto coils,
63-65; solenoid, 68; spark plug, 23,
65, 67. See also Starting systems
Intake: manifold, 48, 50, 52, 54; section,
88, 90, 93, 109
Intake stroke. See Four stroke cycle
Intake valve. See Valve, intake
Internal combustion, 2, 5, 6, 8, 9, 11,
21

J
Jet propulsion, 10, 11, 85, 87, 88, 104,
105, 122. See also Engine, jet

L
Langley, Samuel, 8, 9
Laws of motion, 13, 73, 87, 109. See also
Newton, Isaac
Lenoir, J. J. E., 6, 121
Lilienthal, Otto, 7
Lincoln, Abraham, 121
Lines of flux. See Magnetic lines of flux
Lubricating oils, 69-71; detergents, 71;
flash point, 70-71; pour point, 71;
viscosity, 70
Lubrication system, 38, 69-73, 111; dry
sump, 73; pressure pump, 71; sca-
venger pump, 71; wet sump, 71-73.
See also Lubricating oils

M
Mach, 90
Magnetism, 58, 60
Magnetic circuit, 60; field, 60, 61; lines
of flux, 60-63. See also Electromag-
netic induction

Magneto. See Ignition system
Manly, Charles, 8, 9
Mass, 13, 87-88, 111
Materials, 2, 6, 11, 32-34, 100
Mechanical system, 20-25, 37, 69
Missiles:
Bomarc, 90-91
Hound Dog, 102, 103
V-1, 91, 92

N
National Aeronautics and Space Admin-
istration, 115
Nitrogen oxides. See Pollution
Moss, Sanford, 11
Newton, Isaac, 10, 11. See also Laws of
motion
Noise suppression, 115-116, 117

O
Ochain, Hans von, 11
Oil. See Lubricating oils
Otto, Nikolaus, 6, 121

P
Pilcher, Percy, 7
Piston, 20, 22-24, 33, 68, 69
Piston ring. See Ring, piston
Piston rod. See Rod, connecting
Pitch, propeller, 75. See also Propeller,
types of
Pollution, 117-118, 124-125
Power stroke. See Four stroke cycle
Power terms, 11-15, 87-88; force, 12-14,
87; horsepower, 12-13; thrust, 13-14;
thrust horsepower, 15; work, 12-13
Propeller, 8, 10, 23, 30, 38, 69, 73-80,
86, 102-105; as airfoil, 73; efficiency
of, 74, 80; feathering, 79; forces act-
ing on, 76-77; motion of, 73, 74;
nomenclature, 74; reversing, 78-79;
windmilling, 79; types of, 78
Pulsejet. See Engine, jet

R
Radial engine. See Engine, reciprocating
Ramjet. See Engine, jet

Reaction engine, 80, 81. See also Jet propulsion

Ring: cam, 22, 23; piston, 70, 71

Rocker arm, 22, 24

Rocket, 80, 81, 90, 126

Rod: articulating, 28; connecting, 20, 22, 23, 28, 34; master, 28

Rotor. See Compressor; Helicopter; and Turbine

Rotor pitch, 108

Rotor torque, 109

S

Santos-Dumont, Alberto, 6

Schwartz, David, 6

Scramjet. See Engine, jet

Shrinking, 33

Siug, 14

Smog. See Pollution

Spark plug. See Ignition system

Starting systems, 68; jet/turbine, 109-110; reciprocating, 68, 109

Supercharger, 50-52; 55; impeller, 51, 55; turbosupercharger, 51-52

T

Tailpipe. See Exhaust

Taylor, Charles, 10

Throttle, 47-48, 53-54, 56, 96, 107

Thraw, crankshaft, 22, 23

Thrust, 12, 73, 87-88, 101, 104, 106.

See also Power terms

Thrust horsepower. See Power terms

Thrust reverser, 111-115

Tip speed, 74, 80, 104, 105, 107-109

Tissandier, Albert, 6

Tissandier, Gaston, 6

Turbine, 11, 93, 96, 99-100, 102, 104; stage, 100; stator, 99; wheel, 98-99.

See also Compressor; Engine, turbine; and Engine, jet

Turbofan. See Engine, jet

Turbojet. See Engine, jet

Turboprop. See Engine, turbine

Turboshaft. See Engine, turbine

V

Valve, 20, 22-24, 33

Valve: air, 90-91; exhaust, 22-24, 33, 56; intake, 22, 23, 33, 48, 54, 57

Venturi, 45, 48, 53-54

W

Water injection, 111

Watt, James, 13, 121

Whittle, Frank, 11

Wright Brothers, 3, 7-10, 121

Wright, Orville, 2, 3, 8

Wright, Wilbur, 2, 3, 8

Z

Zeppelin, Ferdinand von, 6

