

DOCUMENT RESUME

ED 111 609

SE 017 446

AUTHOR Savler, D. S.; Smith, J. C.
 TITLE Aerospace Environment. Aerospace Education I.
 INSTITUTION Air Univ., Maxwell AFB, Ala. Junior Reserve Office
 Training Corps.
 PUB DATE 72
 NOTE 140p.; Colored drawings may not reproduce clearly.
 For the accompanying Instructor Handbook, see SE 017
 447

EDRS PRICE MF-\$0.76 HC-\$6.97 Plus Postage
 DESCRIPTORS *Aerospace Education; Aerospace Technology;
 *Astronomy; Aviation Technology; Environment;
 *Instructional Materials; *Meteorology; National
 Defense; *Physical Sciences; Textbooks
 IDENTIFIERS *Air Force Junior ROTC

ABSTRACT

This book is one in the series on Aerospace Education I. It briefly reviews current knowledge of the universe, the earth and its life-supporting atmosphere, and the arrangement of celestial bodies in outer space and their physical characteristics. Chapter 1 includes a brief survey of the aerospace environment. Chapters 2 and 3 examine the composition of the earth's atmosphere, global weather patterns, and the role played by various forces in producing weather. Chapter 4 includes recent findings on the surface characteristics and features of the Moon. The final chapter contains a brief description of the instruments used by astronomers and examines the worlds of interplanetary, interstellar, and intergalactic space. The book is designed for use in the Air Force Junior ROTC program. (PS)

 * Documents acquired by ERIC include many informal unpublished *
 * materials not available from other sources. ERIC makes every effort *
 * to obtain the best copy available. nevertheless, items of marginal *
 * reproducibility are often encountered and this affects the quality *
 * of the microfiche and hardcopy reproductions ERIC makes available *
 * via the ERIC Document Reproduction Service (EDRS). EDRS is not *
 * responsible for the quality of the original document. Reproductions *
 * supplied by EDRS are the best that can be made from the original. *

AEROSPACE EDUCATION I

U S DEPARTMENT OF HEALTH,
EDUCATION & WELFARE
NATIONAL INSTITUTE OF
EDUCATION

THIS DOCUMENT HAS BEEN REPRO-
DUCEO EXACTLY AS RECEIVED FROM
THE PERSON OR ORGANIZATION ORIGIN-
ATING IT. POINTS OF VIEW OR OPINIONS
STATED DO NOT NECESSARILY REPRE-
SENT OFFICIAL NATIONAL INSTITUTE OF
EDUCATION POSITION OR POLICY

ED111609

AEROSPACE ENVIRONMENT

AIR FORCE JUNIOR ROTC
AIR UNIVERSITY/MAXWELL AIR FORCE BASE, ALABAMA

2

5F 017 446

Aerospace Education I

Aerospace Environment

D. S. Savler and J. C. Smith
Academic Publications Division
3825th Support Group (Academic)



AIR FORCE JUNIOR ROTC

AIR UNIVERSITY

MAXWELL AIR FORCE BASE, ALABAMA

ERIC

1972

This publication has been reviewed and approved by competent personnel of the preparing command in accordance with current directives on doctrine, policy, essentiality, propriety, and quality.

This book will not be offered for sale. It is for use only in the Air Force ROTC program.

We gratefully acknowledge the contribution of Civil Air Patrol publications to the development of this volume.

This text was developed under the direction of Maj. L. E. Darrow, AE-1 Course Director, AFJROTC.

Preface

THE AEROSPACE ENVIRONMENT is an infinite realm containing millions of celestial bodies that move in an orderly arrangement across the heavens according to a regular time pattern. This environment represents incomprehensible distances of billions of miles and time scales dating back millions of years. In relation to this vast realm, the earth is only a tiny part of a solar system of nine planets, at least 31 moons, thousands of smaller bodies, and one great star, the Sun. The Sun is only one of 100 thousand million stars in the Milky Way Galaxy containing the earth's solar system. The Palomar reflector in California can photograph 1,000 million other galaxies. By multiplying 100 thousand million stars in the earth's galaxy by 1,000 million other galaxies, scientists know that the universe contains at least this number of stars.

One can get some idea of the earth's relationship to the universe by imagining the earth to be the size of a pinhead. The Sun might be approximately the size of a regulation softball some 50 feet away. This distance represents 93 million miles and shows the relationship of the earth and the Sun to the remainder of the universe. Approximately 250 feet from the Sun, Jupiter, the largest planet in the solar system, will appear to be approximately the size of a large pea. Pluto, the planet farthest away from the Sun, will be the size of a small grain of sand 1,800 feet away. The nearest star will appear as another softball approximately 2,000 miles away.

Obviously, in terms of time and distance in the universe, the earth is a mere speck containing a variety of organic matter supported by a balance of incoming and outgoing energy and protected by a blanket of atmosphere. Only 93 million miles away, a blazing nuclear furnace, the Sun, has thrown intense heat and energy at the earth since the beginning of time. In the opposite direction, approximately 4,000 miles into the center of the earth, lies an immense core of molten metal with a temperature comparable to that of the Sun. As perhaps the most advanced form of life in the solar system, man has lived and flourished on a relatively thin crust of rocky material that has evolved from this molten interior.

Organic life, such as that found on the earth, thrives only because of properly balanced forces of gravity, magnetism, solar energy, and atmosphere that permit biological development. The rapid rotation of the earth tends to equalize the earth's temperature and prevent the concentration of solar energy. Additionally, the earth's atmosphere reduces the intensity of sunlight and absorbs some solar radiation.

This text briefly reviews current knowledge of the universe—the earth and its life-supporting atmosphere, the arrangement of celestial bodies in outer space, and their physical characteristics. Beginning with a brief survey of the aerospace environment in Chapter 1, the text, in subsequent chapters, examines the composition of the earth's atmosphere, global weather patterns, and the role played by various forces in producing weather. Chapter 4 contains a somewhat detailed consideration of the region between the earth's atmosphere and the Moon, with special emphasis on the Moon. Of particular interest are the most recent findings on the

surface characteristics and features of the Moon. The final chapter contains a brief description of the instruments used by astronomers and examines the worlds of interplanetary, interstellar, and intergalactic space.

Contents

PREFACE	iii
<i>Chapter 1</i> — FROM THE GROUND UP—A SURVEY OF AEROSPACE	1
Aero-	2
Space	5
The Dimensions of Space	5
Cislunar Space	6
Interplanetary Space	6
Interstellar Space	9
Intergalactic Space	12
Life Abroad and at Home	12
<i>Chapter 2</i> — EARTH AND ATMOSPHERE	15
Atmosphere and Life	15
Composition of the Dry Atmosphere	16
Ecology and the Oxygen Cycle	18
The Roles of Water and Dust	19
Atmosphere in Motion	21
Heat Transfer	21
Levels of Atmosphere	24
Importance of the Troposphere	25
Global Weather Patterns	26
The Earth as a Weather Machine	27
The Wind	27
Air Masses	30
<i>Chapter 3</i> — MORE ABOUT THE WEATHER	35
The Weather Front	35
The Cold Front	36
Other Types of Fronts	36
Clouds and Weather	38
A Convective Thunderstorm	39

Formation of Clouds	39
Types of Clouds	40
Terrain and Weather	42
Weather Observing and Forecasting	44
Instruments for Surface Observation	45
Extending Man's Weather Eye	47
Climatology	52
Weather Hazards to Aviation	53
Turbulence	53
Icing	54
Reduced Visibility	54
Thunderstorms	55
Forecaster Capabilities and Limitations	56
What the Forecaster Can Do	56
Some Unsolved Problems	57
Man as Weather Maker	57
 <i>Chapter 4 — FROM THE EARTH TO THE MOON</i>	 61
The Fringes of Space	61
Discovery of the Upper Atmosphere	62
Characteristics of the Ionosphere	64
The Magnetosphere (Van Allen Radiation Belts)	66
The Moon	69
Astronomical Characteristics of the Moon	69
Surface Characteristics of the Moon	73
Origins and History of the Moon	81
 <i>Chapter 5 — THE WORLDS OF OUTER SPACE</i>	 87
Instruments of Astronomy	88
The Optical Telescope	88
Other Astronomical Instruments	94
The Solar System	95
The Sun	96
The Inner Planets	102
Asteroids	108
The Outer Planets	109

The World of Interstellar and Intergalactic Space	114
Interstellar Measurements	115
Galaxy Formation and Characteristics	117
Beyond the Milky Way	120
The Passing of Time in Interstellar and Intergalactic Space	124
SUGGESTIONS FOR FURTHER READING	127
INDEX	129

Chapter 1

From the Ground Up— A Survey of Aerospace



THE FIRST CHAPTER of *The Aerospace Environment* provides a broad preliminary survey of the atmosphere and space which are examined in more detail in following chapters. It describes the decrease of air density and pressure with altitude. It also considers the ability of atmosphere to sustain flight and support combustion at altitudes up to 30 miles and to burn up meteors at still higher altitudes. In the latter part of the chapter, we describe the dimensions of the universe as far as man's knowledge has conceived of it. Emphasis is given to units of measure—the astronomical unit for measuring distances within the solar system and the light year and parsec for measuring interstellar and intergalactic space. When you have studied this chapter, you should be able to do the following: (1) indicate the altitude limits of air-breathing flight; (2) explain why a satellite orbiting the earth at less than 100 miles will not stay aloft as long as one orbiting the earth at 300 miles; (3) define astronomical unit, light year, and parsec; and (4) state the principal reason why some scientists think that there is life somewhere in outer space.

aerospace— . . . of, or pertaining to, the earth's envelope of atmosphere and the space above it; two separate entities considered as a single realm for activity in launching, guidance and control of vehicles which will travel in both entities. US Air Force Glossary of Standardized Terms (AFM 11-1, 1-September, 1970).

If aerospace is a single realm, it can be thought of as extending far beyond the limits of actual or planned spaceship travel—to infinity, a word which we use

to describe the utter endlessness of the universe. Until about 400 years ago, it was generally believed that the earth was the center of the universe. As man's knowledge of space expanded, this view began to be questioned. Still, it can be useful to us. Aerospace, after all, begins at home. From our starting point on earth, then, let us move upward by stages to contemplate the universe.

AERO-

The earth is surrounded by a layer of gas, constituting the air or atmosphere. This is the "aero-" part of aerospace. Atmospheric density decreases with altitude (height above sea level).

Air may be invisible, but it is very substantial. At sea level, it exerts a tremendous pressure, 14.7 pounds per square inch. Weighing down on a table top, it would crush the table were it not for the fact that the pressure underneath the table is equal to that on top. Gas pressure at a point exerts itself equally in all directions. We would be crushed to death by the atmosphere if the internal pressure of our bodies did not equal the external pressure.

We feel the air, particularly when it moves. When the air flows against you slowly, you feel it as a gentle breeze. On the other hand, it can move with enough speed and force to knock you off your feet, uproot trees, and destroy buildings. When the wind blows, or clouds form, or rain and snow fall, or when sunshine and blue skies prevail, or when you feel warmth or cold, you are experiencing the "life" of the atmosphere. That is, you experience its movement and its changes in moisture content and temperature. These changes are called **weather**, which we discuss in Chapters 2 and 3.

As noted earlier, atmospheric density decreases with altitude. If you are a lowlander and visit the "Mile-High City," Denver, Colorado, you may initially experience slight shortness of breath, but you will become accustomed to the altitude and have no further discomfort. Less dense air also gives less lift to airplane wings. Airplanes taking off and landing at airports near Denver must use more runway than they do at lowland airports. On the

whole, however, man and his machines adapt quite easily to the atmosphere a mile above sea level.

At altitudes of two or more miles above sea level, however, life becomes a bit more difficult. Lowlanders visiting such regions must be careful not to exert themselves until they become accustomed to the thin air. Hardy natives or longtime residents of the Peruvian Andes, Nepal, or Tibet develop extra lung capacity for living in such environments. Plant and animal life consists of those species that have adapted to the thin atmosphere.

At an altitude of three and one-half miles, the pressure of the atmosphere is about half that at sea level. As you learned in *Aircraft of Today*, breathing at this altitude becomes difficult for many airplane engines as well as living creatures. Reciprocating engines need superchargers and turbosuperchargers to pump more air to them. Passengers and crew in a high-flying aircraft must carry their own atmosphere with them in the form of an oxygen-breathing apparatus or a pressurized cabin. (Figure 1.)

At a still higher level, beginning approximately seven to ten miles up (depending on location and season), air becomes so thin that it will not support or produce weather. Water molecules are so sparse that they cannot form even the most delicate clouds. At this altitude, however, the air is still sufficiently dense to give lift to wings and to fire the engines of jet aircraft. Some turbojet aircraft can fly as high as 20 miles, and some unmanned ramjets almost 30. Above these altitudes, at present, air breathing engines of any type can no longer function, nor can wings support flight.

At altitudes of 40, 50, or 60 miles, however, a great many molecules are present. The daytime sky here is black, and there is still enough air to burn up a meteor* completely through friction. An outbound space ship penetrates this layer with the help of a heat-resistant nose. A returning space ship turns its blunt nose forward and becomes white hot as it uses this extremely thin atmosphere to slow its descent. Chapters 2 and 4 provide a closer look at the different layers of the upper atmosphere.

*For a definition of meteor see Chapter 4, p. 75

AEROSPACE ENVIRONMENT

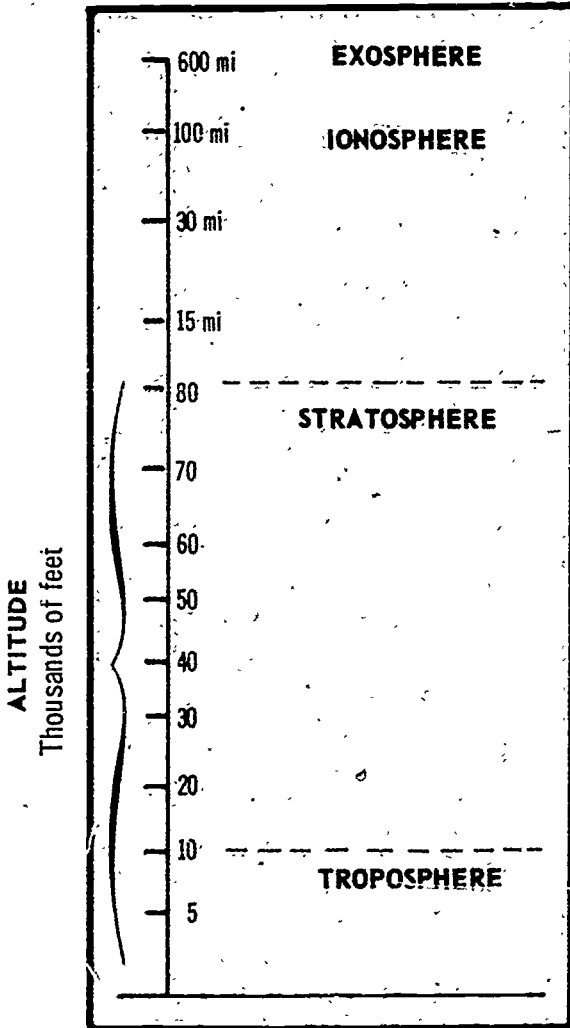

Figure 1. Our atmosphere consists roughly of four main layers—troposphere, stratosphere, ionosphere, and exosphere.

SPACE

One definition of **Space** places it somewhere about 100 miles above the surface of the earth. At least here is a level at which unpowered man-made satellites, if launched with enough velocity, can coast repeatedly round and round the earth at more than 17,000 mph, apparently unhindered by molecules.

At an altitude of 100 miles, molecules are too scattered to have any gas-like character. They do not collide and bounce against each other often enough to produce the effects of heat or pressure or to set up waves. Thus, there is no sound. Great rocket engines, which make such a deafening noise in the atmosphere, blaze away in utter silence.

Another definition of the boundary between air and space, however, sets it at 600 miles up rather than 100. Both are acceptable along with numerous other definitions of this boundary ranging from about 60 to 20,000 miles. The thinning out of the atmosphere is so gradual that no boundary can be precisely defined. Variations in the orbiting life of satellites represent one difference between altitudes of 100 miles and 600 miles. Those satellites boosted no higher than 100 miles usually come to earth within a few months. They are gradually slowed down by collisions with the thin air and other tiny particles of matter until they lack the speed to hold them at this high altitude. Each orbit is slightly lower than the previous one until the satellite eventually makes a blazing reentry into the atmosphere at a velocity that burns it up like a meteor. At 600 miles altitude, on the other hand, stray molecules are so few and far between that a satellite passing through them can stay aloft for years with undiminished velocity.

Further on in this unit, you will learn about Van Allen radiation belts (Figure 2) surrounding the earth for many hundreds of miles into space, solar winds encountered at still greater distances, and other phenomena, which indicate that, far beyond the limits considered so far, space is not a totally empty vacuum. Nor, probably, is it totally empty anywhere in the universe, as the stars themselves seem to bear witness.

THE DIMENSIONS OF SPACE

Space begins then, at most, a few hundred miles from earth. How far it extends is almost unimaginable. For the remainder of

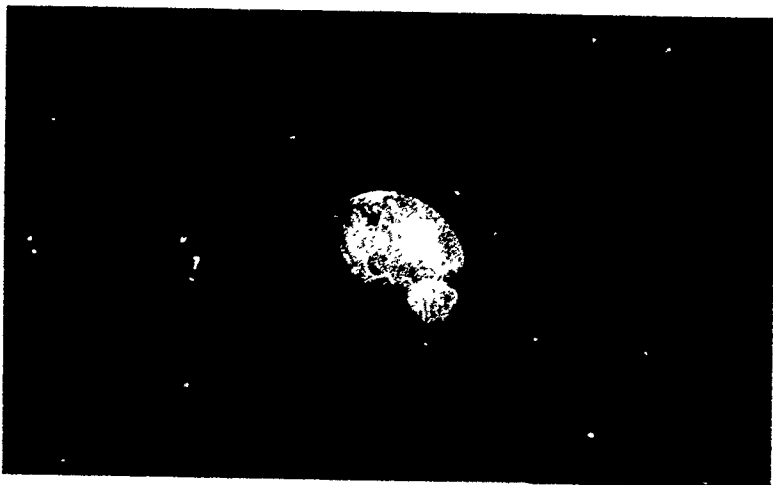

Figure 2. The Van Allen radiation belts.

this chapter, let us try only to grasp distances and dimensions as we consider cislunar space, the solar system or interplanetary space, interstellar space, and, finally, intergalactic space. In later chapters, we return to these immense realms for a closer study.

Cislunar Space

Cislunar space means "this-side-of-the-moon space." The Moon orbits the Earth at an average distance of about 238,000 miles. Therefore, for convenience, we may refer to any space within a quarter-million miles of the Earth as cislunar space. Imagine the Earth as a basketball and the Moon as a tennis ball orbiting it at a radius of about 28 feet. Man so far has moved these 28 feet into space. Moreover, not only have Americans traveled as far as the Moon, but some have landed on the Moon. But the prospect of a longer manned voyage into space is still many years away. Cislunar space, then, represents the present limit of travel for the human race.

Interplanetary Space

The Sun and all the planets and smaller bodies within the influence of the Sun's force of gravity constitute the solar system.

NEXT-DOOR NEIGHBORS. The Moon represents the limits of man's travel, but man-made unmanned space vehicles have traveled farther. Probes have been launched to Earth's next-door neighbors in the solar system, Mars and Venus.* Photographs of Mars from a distance of only a few thousand miles have been taken from US vehicles. The Soviet Union has actually landed a vehicle on Venus. At their closest approaches, Venus is 26,000,000 miles away from Earth, and Mars 34,500,000 miles. These "closest approach" figures, however, do not represent the actual distances traveled by these vehicles to reach their goals. Since they are launched into space in curved paths by the motion of the Earth as it orbits the Sun at a speed of almost 67,000 mph, they must chase their target planets in long, looping pathways around the Sun, covering hundreds of millions of miles. Such distances represent the limits of travel of man-made vehicles so far. The voyage from the Earth to either of these neighboring planets requires about seven months.

A manned voyage of such length would require a much roomier space ship than the Apollo vehicles that can barely hold three men in rather cramped quarters on eight-day round trips to the Moon. Moreover, the rocket that could launch such a large spaceship to Mars would require many times more power than the Saturn V. And a spaceship that could land on Mars and still have enough reserve fuel to thrust free of Mars and return to Earth would need a launcher many times more powerful again.

But space travel is not our subject. Another text, *Spacecraft and Their Booster*, tells you more about travels in space. Let us continue with our efforts to describe the distances of space.

THE SOLAR SYSTEM.—The solar system appears to be a rather flat, disc-shaped planet system. (Figure 3.) All but two of the planets orbit the Sun in approximately the same plane, varying only a few degrees above or below it. (The two exceptions are the innermost and outermost planets, Mercury and Pluto. The latter swings up and down from this plane 17° in its journey around the Sun.) The planets orbit the Sun at different speeds, in the same direction, which, viewed from the north, appears as "counterclockwise." The following table contains interplanetary distances and other data:

*See Chapter 5 for details of these probes.

AEROSPACE ENVIRONMENT

	<i>Mean distance from Sun (near- est 500,000 miles)</i>	<i>Mass (Earth = 1)</i>	<i>Period of orbit (Earth days or years)</i>	<i>Orbital velocity (mph)</i>
The Sun		335,500		
Mercury	36,000,000	0.05	88 days	107,100
Venus	67,000,000	0.8	225 days	78,300
Earth	93,000,000	1	365¼ days	66,600
Mars	141,500,000	0.1	1.88 years	53,900
Jupiter	484,000,000	318.0	11.86 years	29,200
Saturn	887,000,000	95.2	29.5 years	21,600
Uranus	1,784,000,000	14.5	84 years	15,100
Neptune	2,795,500,000	17.2	165 years	12,100
Pluto	3,675,500,000	0.9	284.4 years	10,600

To sum up, the planets vary in weight (or more properly, mass) from Mercury's one-twentieth of Earth to giant Jupiter's 318 times that of Earth. All, however, are dwarfed by the Sun, whose intense energy supports life upon Earth. Here, however, we are considering only its mass—335,500 times that of Earth—which is one of the factors holding the solar system in its present pattern and keeping the planets in their orbits. The periods of orbit and orbital speeds of the various planets are related to distance from the Sun, as discovered by **Johannes Kepler** almost 400 years ago. Some 300 years ago, Sir Isaac Newton discovered the principle of gravitation, which accounts for the orbital characteristics of the planets.

Consider the solar system as a giant platter, some 7.35 billion miles across, with the orbit of Pluto as its outer dimension. At the present time, there is no indication of a planet beyond Pluto, but the possibility of such a planet is not ruled out. We do know that the Sun's gravity extends far beyond the orbit of Pluto.

THE ASTRONOMICAL UNIT.—Since we now measure distances in space by the billions of miles, this unit of measurement has become a cumbersome chore—too many zeroes. Astronomers find it more convenient to use the **astronomical unit (AU)**, which is the average distance from the Sun to the orbiting Earth, or 93 million miles (more precisely, 92,959,670 miles). By this longer yardstick, Pluto orbits the Sun at an average distance of 39.5 AUs. Jupiter's mean distance from the Sun is 5.2 AUs.

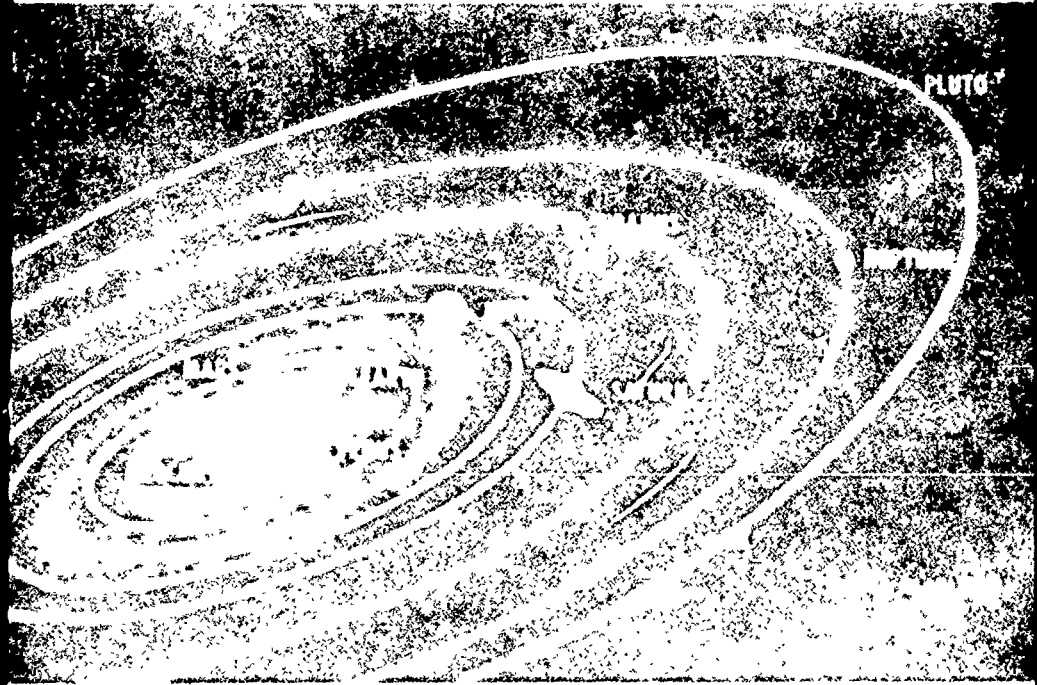

Figure 3. The Solar System.

The astronomical unit, however, is convenient for measuring distances only within the solar system. As we shall see, it is inadequate for measuring the distances of interstellar space.

Interstellar Space

Interstellar space means "peace between the stars." On a clear, moonless night, if you have good eyesight, you can distinguish some 6,000 stars with the naked eye. That is, your eye can resolve them as separate points of light. On such a night, you can also see a dense band of stars stretching across the sky from horizon to horizon. These stars appear as points of light so small, faint, and numerous that the naked eye cannot resolve them. This band of stars appears as a misty cloud. Ancients called it the "Galaxy," which is roughly translated from Latin as the Milky Way. With the use of successively more powerful telescopes, a greater number of stars became apparent. It is estimated that there are about 100 billion stars in the Milky Way.

Our Sun is a star and a member of this family. As scientists have learned, it is not the largest or brightest member. In fact, the Sun is somewhat below average in size and brilliance.

THE LIGHT YEAR AND THE PARSEC.—Since many stars much larger and brighter than the Sun are observed as points of light, the astronomical unit is not adequate for measuring interstellar distances.

The light year.—A better means of measuring interstellar distances is the **speed of light**. Light travels through space at about 186,300 miles per second. Thus, the Moon you see is the Moon as it was 1.3 seconds ago. The Sun, on the average, is eight light minutes away from earth. The rays of the Sun must travel five hours, more or less, to reach Pluto. These are some of the dimensions of the solar system measured by the speed of light. For interstellar distances, the **light year** is the most commonly used unit of measurement. One light year equals 5,878 billion miles, or about 66,000 AUs. (See Figure 4.) The nearest star, Alpha Centauri, is about 4.3 light years away from earth. The far edge of the Milky Way is about 80,000 light years away.

The parsec.—Another unit sometimes used to measure interstellar distances is the **parsec**, which is short for **parallax of one second of arc**. One parsec equals 3.26 light years. The nearest star, Alpha Centauri, is 1.3 parsecs away. Since the parsec is longer than the light year, the parsec is sometimes used to express very great interstellar or intergalactic distances. In this text, however, we shall continue to use the more familiar unit of

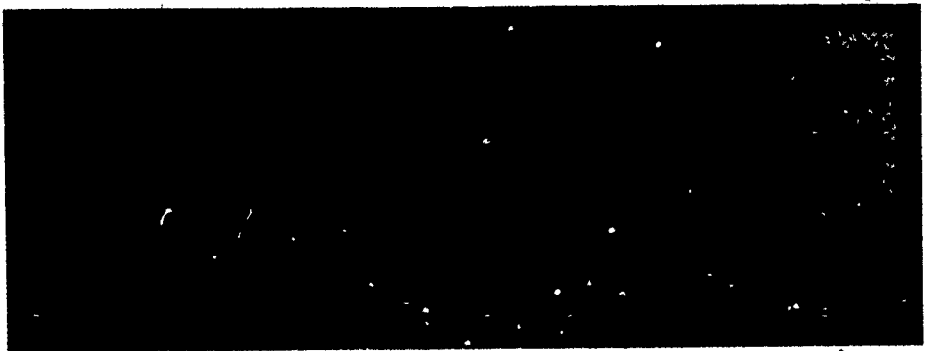

Figure 4. The light year is commonly used for measuring interstellar distances.



Figure 5. Our solar system in relation to the Milky Way Galaxy.

the light year. You should remember, however, that parsec is another unit of measurement for space.

THE MILKY WAY GALAXY.— The Sun and all the other visible stars belong to the Milky Way. The stars appear concentrated in a rather narrow belt across the sky because of the Milky Way's shape. It is a round, flat, pancake-shaped formation of stars, somewhat bulging in the middle. We are located about 30,000 light years from the center of the Milky Way, which has a diameter of about 100,000 light years. The thickness in our vicinity is about 3,000 light years and that of the bulging center, about 15,000 light years. And these are not the limits of the universe but only one small part of it. (See Figure 5.)

Intergalactic Space

In the constellation **Andromeda**, one can see what appears as a dim white region, which was originally believed to be a thin cloud of gas or **nebula**. Examination with a powerful telescope, however, reveals that the area of light in Andromeda is not a nebula but a spiral-shaped cluster of stars. In 1923, with the help of the Mount Wilson, California, 100-inch mirror telescope, the American astronomer, **Edwin Hubble**, confirmed the opinion of earlier astronomers that this cluster of stars was truly another galaxy. This galaxy is somewhat larger than the Milky Way, about 130,000 light years in diameter, and is located about 2 million light years away.

Today, we know that the galaxy in the constellation Andromeda is our next-door neighbor in **intergalactic space**—the space between the galaxies. Astronomers now estimate that the number of galaxies in the universe may exceed 100 billion. They come in groups and clusters—galaxies of galaxies!—The most remote galaxy observed is estimated to be *5 billion* light years away.

In recent years, astronomers have discovered several of what they believe to be distant stars or starlike sources of extremely intense energy called **quasars**, (short for quasi-stellar radiation sources). According to one estimate, one of these sources is as far as 9 billion light years away. Scientists are still uncertain about quasars—what they are and how distant they are. As for us, we have suggested the immensity of outer space, and we have indicated the present limits of man's observation, if not his imagination.

LIFE ABROAD AND AT HOME

Before we return to a discussion of earth, we should consider two other questions. Is there life in outer space? Are there intelligent beings in outer space?

The answer to both questions is "probably yes." With a hundred billion stars in an average sized galaxy, multiplied by the hundreds of millions of galaxies in intergalactic space, there must be vast numbers of star systems with planets in orbits around them. Every star need not have a system of planets, but the number of stars with such systems must be almost greater than we can comprehend. But even if most of the planets could not support life,

there still must be a tremendous number with favorable conditions to the evolution of life. Even without considering planets which would support only lower forms of life, mathematical probabilities still favor the existence of at least a few, possibly a great many, planets that support intelligent living beings.

By the same token, however, the probability that intelligent life exists elsewhere in our solar system are practically nil. Among only nine planets, our Earth seems to be the only one that is neither too large nor too small, neither too near nor too far from the Sun, to support life as we know it. Its gravity is strong enough to hold an atmosphere around it. Its speed of rotation is sufficient to distribute the warmth of the Sun over its whole surface. The atmosphere helps in this task of heat distribution. Sometimes the term **biosphere** (sphere of life) is used to include atmosphere, water, ourselves, and all other living things—life and the environment that supports life.

Let's, then, take a closer look at this planet of ours and its spheres of air and water.

WORDS. PHRASES AND NAMES TO REMEMBER

aerospace	Milky Way Galaxy
altitude	nebula (pl. nebulae)
Andromeda	parallax
astronomical unit (AU)	parsec
biosphere	quasar (quasi-stellar-radiation-source)
cislunar space	solar system
galaxy	space
intergalactic space	speed of light
interplanetary space	vacuum
interstellar space	weather
Kepler, Johannes	
light year	

REVIEW QUESTIONS

1. What are the altitude limits of air-breathing aircraft?
2. What evidence is there of some atmosphere at altitudes up to 60 miles?
3. What happens to sound transmission at an altitude of 100 miles? Why?
4. What are the present limits of travel of the human race? of unmanned man-made vehicles?

AEROSPACE ENVIRONMENT

5. Approximately, what is the mean distance between the Sun and the planet Pluto in miles? In astronomical units? In time at the speed of light?
6. State the approximate dimensions of the Milky Way Galaxy. How many stars, by rough estimate, does it contain?
7. What is the distance to the constellation Andromeda? To the farthest known quasar according to one estimate?
8. On what basis might we speculate that there is life in outer space?
9. What are some of the conditions which make Earth an ideal planet for supporting life?

Chapter 2

Earth and Atmosphere

THIS IS THE FIRST of two chapters on the atmosphere of the earth. In this chapter, we consider the physical aspects of the nature of the atmosphere, pressure, surface winds, and other general flow patterns. In the second chapter, we discuss the physical processes that govern the atmosphere, such as the greenhouse effect, the water cycle, and other aspects of the atmosphere. Chapter 2 is a very important chapter, and it is presented in a very interesting way. It is a chapter that you should read carefully. The chapter contains a great deal of information about the atmosphere and the weather. It is a chapter that you should read carefully. When you have finished the chapter, you should be able to do the following: (1) describe the composition of the earth's atmosphere and describe the circulation of air in the atmosphere; (2) describe the structure of the atmosphere and describe the two of them which are involved in atmospheric motion; and (3) identify and describe the characteristics of the major air masses that affect the United States.

THE ATMOSPHERE produces a wide variety of weather conditions. Weather conditions prevail at each point in our solar system, but only on the planet Earth are conditions suitable for supporting human, animal, and plant life, as we know it. The circulation of the atmosphere around the Earth plays an important part in making our planet habitable.

ATMOSPHERE AND LIFE

Before we describe the circulation of the atmosphere, we should consider other basic

ways in which the earth's blanket of atmosphere supports and protects life. In this sense we view the atmosphere without regard to its movement.

Composition of the Dry Atmosphere

Air is a mixture of nitrogen, oxygen, water vapor, and other gases. Nitrogen and oxygen are elements, meaning that the molecules in which they occur consist entirely of one kind of atom. As found in free air, both nitrogen and oxygen molecules consist of two atoms joined together, written in chemical formulas as N_2 and O_2 . Oxygen also occurs in air in a triple form called ozone (O_3), very rare near the surface but somewhat more abundant at high altitudes.

Compounds are substances whose molecules are constructed of more than one kind of atom. Pure water is a compound of one oxygen and two hydrogen atoms, the familiar H_2O . A compound in the air vital to life on earth is carbon dioxide (CO_2). Under the right conditions, different chemicals undergo reactions with each other; that is, molecules exchange atoms and form new compounds or release elements. Sometimes the reaction is slow and quiet; at other times the reaction is violent. As the molecules undergo these changes, we can compare the slow reactions to fires and violent reactions to explosions. In any event, the result is the release of energy from a number of molecules. We are aware that some chemical substances like gasoline or dynamite store a tremendous amount of energy that can be released by applying the proper stimulus.

The physical properties of air are as important as its chemical properties. Air behaves like any other gas. Its molecules constantly collide and bounce away from each other. In a container, they hit against the container walls and create pressure. Heating the air causes the molecules to move more vigorously and increase the pressure. Cooling it causes the pressure to drop. If you squeeze a quantity of air into a smaller container, the pressure increases. If you transfer the air to a larger container, it will expand to fill whatever space is available, and pressure will drop. The ocean of air surrounding the earth is not enclosed in a container, but the force of the earth's gravity keeps it bound to the earth and prevents it from disappearing into space. The physical laws governing the behavior of free air are some-

EARTH AND ATMOSPHERE

what more complex than those governing the behavior of air in containers, but some of the same principles apply. Atmospheric pressure and temperature constantly vary at any one place and from one place to another.

Despite these variations, the mixture of the component gases in the atmosphere remains remarkably constant. One ingredient, water vapor, is a variable. Without water vapor and foreign substances, the atmosphere has a dry air composed of these gases almost always in these proportions:

Nitrogen (N_2)	78 percent
Oxygen (O_2)	21 percent
Argon (Ar)	0.94 percent
Carbon Dioxide (CO_2)	0.03 percent
Rare gases	0.01 percent

Such is the air that you inhale. The air which you exhale from your lungs is a somewhat different mixture. Its oxygen content is reduced to about 16 percent, and its carbon dioxide content is increased to 4.5 percent. Your body thus consumes oxygen and produces carbon dioxide.

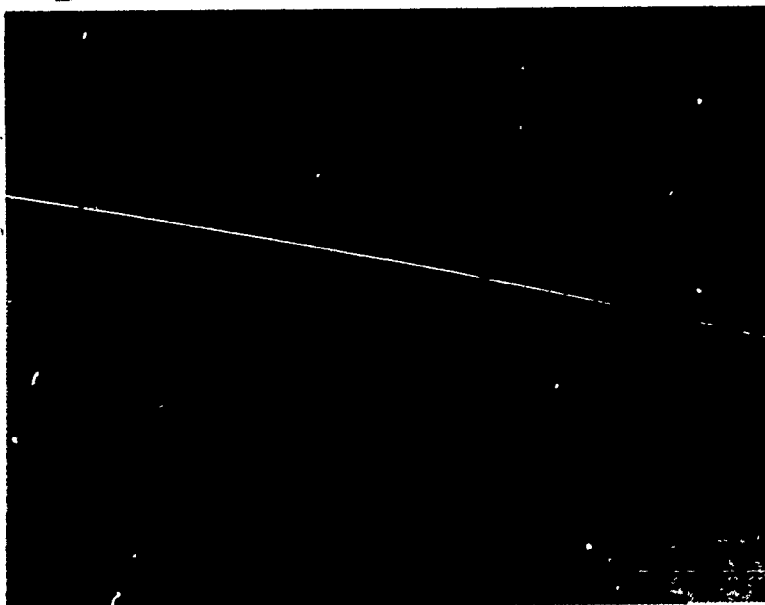

Figure 6. Mixture of gases which make up dry air and layers of atmosphere.

Nitrogen does not seem to be affected by the breathing process. It is inert as far as breathing goes. It seems to serve humans and other breathing creatures merely to dilute the active ingredient, oxygen, to the proper strength. However, in the life cycle or balance maintained by all living things, which we call **ecology**, nitrogen plays a very active role. It is drawn from the air by bacteria in the soil. Then it nourishes plants and creates proteins, which are eaten by animals and humans. In death, plants and animals decay and return nitrogen to the air. This is the nitrogen cycle essential to life on earth.

Ecology and the Oxygen Cycle

In the oxygen cycle, humans and other breathing creatures use oxygen and food to sustain life just as an air-breathing automobile or aircraft engine uses oxygen and fuel to function. The same elements—carbon and hydrogen—in different compounds provide energy for living beings or machines in the **carbohydrates** (sugars and starches) of food or the **hydrocarbons***, which are the energy-giving compounds of petroleum products and coal. Carbon dioxide gas is one of the waste products of combustion in man and machine. Even though it diffuses and becomes approximately 0.03 percent of the atmosphere, it also plays an important role in the life cycle, as we shall see.

In recent years, there has been much public concern about air pollution in many parts of the world. The average citizen frequently uses the word "ecology" to voice his concern. Not too many years ago, it was used only in the special vocabulary of scientists. Although this text emphasizes weather and not ecology, there is no denying the fact that disturbed ecology is a real problem in many localities today and is rapidly becoming a world problem. Moreover, in our discussion of the atmosphere as a part of the aerospace environment, ecology cannot be ignored. When we speak of the nitrogen and oxygen cycles of life in which the atmosphere participates, we are referring to the overall ecological pattern of the whole earth, not merely of certain regions.

As far as the basic gaseous composition of the world's atmosphere is concerned, measurements over the past few decades show no significant change despite tremendous industrial expansion

*Technically, carbohydrate is a compound including carbon, hydrogen, and oxygen. A hydrocarbon includes only carbon and hydrogen.

The oxygen content has remained the same. Air pollution, at least for the present, is a problem of what is added to the atmosphere rather than what is taken away from it.

The world's plant life constantly replenishes the world's oxygen supply through **photosynthesis**. Green plants accomplish this task of converting sunlight to food energy with the help of a substance called **chlorophyll**, which also gives them their green color. In the process, carbon dioxide is drawn from the air. The result of the synthesis is storable food energy or carbohydrates. In the same process, oxygen is released into the air. Photosynthesis, in short, is the opposite of man's and animal's breathing and eating. Instead of exhaling carbon dioxide, plants consume it. Instead of consuming oxygen, they produce it. Instead of consuming carbohydrates, plants produce and store them.

Thus, the world's biosphere depends upon energy from the Sun. All sources of food or fuel on or within the earth can be traced to plant photosynthesis and the energy of the Sun. Life also depends upon a basic chemical balance in air, water, and living things, of which carbon, hydrogen, oxygen, and nitrogen in various proportions and compounds are the prime elements.

In the previous chapter, we posed some questions about life in outer space. Nowhere else in the solar system is there the proper combination of sunlight (not too much nor too little) and atmospheric and earth chemistry to provide such a biosphere as ours. This combination, however, supports *life as we know it*. In making guesses about life in outer space, the possibility arises of a planet with an entirely different chemical and physical balance, which may consist of beings that grow, move, feel, think, and possess other aspects of "life" even under conditions impossible for earth life. But let us turn our attention to the environment of our earth atmosphere.

The Roles of Water and Dust

Two more ingredients of the earth atmosphere are also important factors in our ecology: water and dust. The water content is highly variable. In clear air, water is present as molecules of H_2O in gaseous form called **water vapor**. The amount of water vapor that a given volume can hold varies with temperature. The higher the temperature, the more water molecules it can hold, as the following table shows:

AEROSPACE ENVIRONMENT

Weight of water necessary to saturate the volume of a pound of dry air under standard conditions.

Temperature (Fahrenheit)

.005 pound	40°
.011 pound	60°
.026 pound	80°
.043 pound	100°

An unsaturated volume, then, containing a given amount of water vapor will become saturated if its temperature decreases sufficiently; as the temperature further decreases, normally some of the water vapor condenses as fog, cloud, or precipitation.

SATURATION AND EVAPORATION.—Under saturated conditions, the **relative humidity** is 100 percent. The temperature at which **saturation** occurs or will occur is called the **dew point**. When a weatherman predicts fog, he predicts that the temperature will fall to the dew point or below, or enough water vapor will be added to bring the relative humidity to 100 percent. The opposite of condensation is **evaporation**. As warming occurs, the fog or cloud disappears. In evaporation, water molecules leave water surfaces, like those of lakes, rivers, and oceans, or wet surfaces. Evaporation produces a cooling effect. Thus, we can sometimes sense differences in relative humidity at a given temperature. For example, at 80 degrees you will usually continuously perspire a certain amount, regardless of humidity. If you feel uncomfortably hot and damp at 80 degrees, it means that the body's perspiration is evaporating slowly and is therefore producing little cooling. If you feel comfortable at 80 degrees, your body perspiration is evaporating as fast as it appears on your skin and lowering your skin temperature a few degrees in the process.

FORMS OF PRECIPITATION.—There are various forms of **precipitation**. Dew forms on the ground and other surfaces when the temperature of that surface is at or below the dew point. The surrounding air may be warmer and unsaturated, but condensation occurs when the air strikes the cold surface. Frost occurs in the same manner on a surface that is below freezing temperature. When cloud or fog droplets become too heavy to float in the air and begin to settle toward the ground, they become mist or drizzle. Still heavier drops, of course, are called rain. Snow is produced by moisture freezing around a tiny ice crystal; the characteristic six-pointed or six-sided shape of the snowflake is the

result of its building on its original crystal line shape as it grows. (There is a theory that the triangular shape of the H_2O molecule is the reason.)

THE IMPORTANCE OF DUST.—Except at temperatures well below freezing, clouds and fog are composed of very small **droplets** of water which collect on microscopic water-absorbent particles of solid matter in the air, such as dust, salt from evaporating sea spray, and products of combustion. The abundance of these particles on which the droplets form, called **condensation nuclei**, permits condensation to occur generally as soon as the air becomes saturated.

ATMOSPHERE IN MOTION

We can now begin to understand some of the mysteries of weather. Added to the properties of the atmosphere that we have discussed is its motion. Motion is one of the atmosphere's ways of distributing heat:

Heat Transfer

There are basically four ways of transferring heat: radiation, conduction, convection, and advection. Only the last two of these involve atmosphere in motion, but let us briefly consider all four.

RADIATION.—**Radiation** is the transfer of heat through space or through air independent of the heat-transfer properties of the air itself. The heat energy of the Sun reaches the Earth through radiation. This method transfers heat energy without changing the temperature of anything between the source of energy and the object heated. Heat energy escapes a generating source in the form of waves. These **radiant waves** (or rays) are themselves a form of energy. When radiant energy from one object reaches another object, it is absorbed and changed again into heat energy.

Scientists classify radiant waves according to their length. Radiant waves of different lengths are assumed to form a band, or spectrum. At one end of this band are the shortest waves; at the other end, the longest waves. Waves sent out by the Sun include **ultraviolet rays**, **visible light rays**, and **infrared rays**. Ultraviolet rays are invisible rays that lie beyond the violet rays toward the short-wave end of the spectrum. Infrared rays are invisible rays that lie beyond the red rays toward the long-wave end of the spectrum. The visible light rays lie between the ultraviolet and the infrared rays.

The waves of any of these groups are not of identical length. For example, there are short infrared waves and long infrared waves, depending upon the distance of the wave from the visible red of the spectrum.

Although radiant energy is never destroyed, it may be changed in many ways. Radiant waves may be absorbed or reflected by clouds in the atmosphere; they may be scattered or reflected by dust in the atmosphere; they may be transmitted through the atmosphere; they may be absorbed by the earth and converted into heat energy.

Were there not a balance of heat between the earth, the atmosphere, and space, the earth, bombarded continually by radiant waves, would become increasingly warmer. This does not happen because the radiant energy received by the earth is, in turn, radiated from the earth into space or transferred into the atmosphere.

Meteorologists estimate that of all the solar radiation arriving at the top of the atmosphere, 42 percent is reflected into space by clouds and atmospheric dust, 15 percent is absorbed directly into the atmosphere, and 43 percent reaches the earth directly. Of the 15 percent absorbed directly into the atmosphere, 4 percent eventually reaches the earth as diffused sky radiation. Thus, a total of about 47 percent of the incident solar radiation finally reaches the earth and heats it. The heated earth's surface, in turn, radiates infrared rays upward. Part of these rays (approximately 39 percent) are absorbed by the atmosphere and are converted into heat. This process provides the principal source of heat for the troposphere. The rest of the infrared rays (about 8 percent) escape outward through the atmosphere into space with no heating effect. These radiative processes that tend to maintain the earth's heat balance are chiefly responsible for worldwide weather. (See Figure 7.)

CONDUCTION.—Conduction is the transfer of heat through matter by direct contact. It can take place in a solid or fluid (liquid or gas) but, in the fluid, there is convection, too. An example of pure conduction in a solid would be the heating of one end of a metal rod and the transfer of heat down the length of the rod. Nothing flows. One molecule of metal, as the heat reaches it, will vibrate faster and will collide with its neighboring molecules and make them vibrate faster. Thus, the energy is passed along. Air

is not a very good conductor of heat. Nevertheless, the sun-warmed earth does warm the lowest levels of air by this method. Without convection, the heat would travel very slowly upward by conduction from molecule to molecule, just as in the metal rod.

CONVECTION AND ADVECTION.—These two methods are mentioned together because they really are the same, that is, the transfer of heat by the motion of air. This is the atmosphere's principal means of heat transfer. Air is a fluid, and, like all fluids, it flows. When it is heated, it rises, and cold air takes its place. When air cools, it descends and displaces the air beneath it. The vertical motions in this cycle—updrafts and downdrafts—are called **convection**. The horizontal motions are called **advection**. We have described a kind of local circulation pattern, such as that which might occur over woodlot and cornfield on almost any summer afternoon. (See Figure 8.)

There are also larger circulation patterns, involving long-range advection—air currents flowing thousands of miles from the tropics or the poles toward middle latitudes or from the oceans toward interior plains of continents. Nevertheless, convection is a part of these grand cycles, too.



Figure 7. The heat balance.

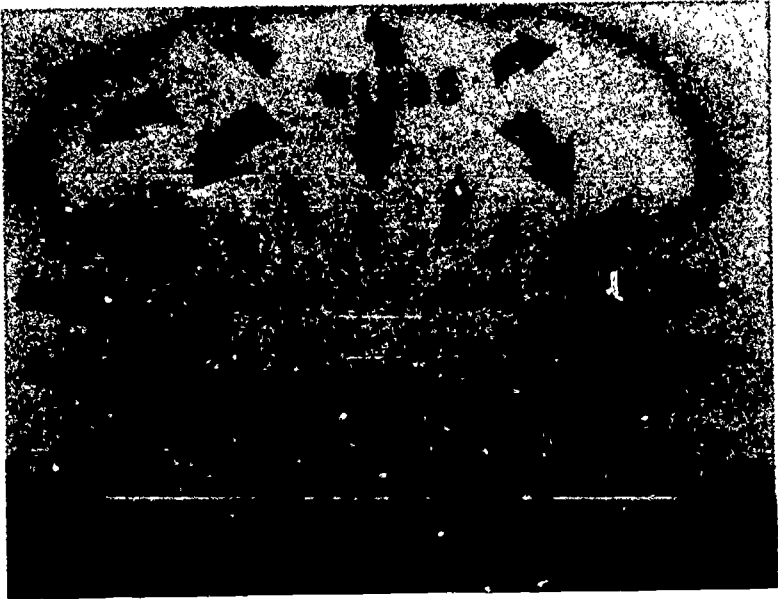

Figure 8. When a mass of air is heated and its density decreases, it will be displaced by the surrounding cooler and denser air. These vertical movements are called convection currents.

Levels of the Atmosphere

In our survey of aerospace in Chapter 1, we described the atmosphere mainly in terms of the decrease of air density and pressure with altitude. Let us take another look at the atmosphere at different levels above the earth as we consider temperature and other factors.

Even before the dawn of modern science, man could observe that temperature decreased with altitude. He had only to look up from a warm valley toward a snow-capped peak to guess this fact. Today, however, we know that a decrease of temperature with altitude occurs within the lowest few miles of the atmosphere, in the zone called the **troposphere**, and that various temperature trends occur at higher levels. An instrument-carrying rocket, as it rises, will tell us that, beyond the troposphere, the air grows warmer or remains at a constant temperature, or the rate of decrease in the temperature becomes smaller. At the same time, as we know, air density and pressure decrease with altitude until, somewhere beyond 100 miles from the earth's surface, the

atmosphere becomes so thin that it is practically a vacuum and can be called "space." Scientists divide the atmosphere into levels or "spheres" of different heights above the earth's surface. (See Figure 9.) You should become acquainted with at least the first three of the following list:

Troposphere. This is the lowest level of the atmosphere, varying in thickness from about 5 miles at the poles to about 10 miles at the equator, averaging about 7 miles over the United States. Within this level, temperature decreases with altitude at varying rates depending on weather conditions, averaging 3.6 degrees Fahrenheit per thousand feet. As we have noted, the main source of heat is not the direct rays of the sun but the sun-warmed earth, heating the air from below.

Tropopause. The tropopause is a narrow border zone between the troposphere and the next higher layer, the stratosphere.

Stratosphere. Immediately above the tropopause, the air is clear, stable*, and frigid, with temperatures near 100 degrees below zero, Fahrenheit. But temperatures in this layer, called the stratosphere, slowly increase with altitude, remain constant, or decrease less rapidly to a height of about 30 miles, where relatively mild above-zero temperatures have been reported. The presence of ozone (O_3), a radiation-absorbing form of oxygen, is believed to be the cause of this phenomenon. Ozone is also helpful in filtering out harmful radiations, such as gamma and cosmic rays, from the sun and outer space.

Upper atmosphere.—Later, we describe more fully the zones of the atmosphere, semi-atmosphere, and semi-space that lie beyond the stratosphere. Here, we note them briefly. Immediately above the stratosphere (about 35-50 miles up) is the mesosphere, where temperature again decreases with altitude. Then, in what is variously called the thermosphere or ionosphere, temperature again increases with altitude. X-15 aircraft, balloons, and unmanned rockets have probed these upper regions. Astronauts zoom through them in a minute or two on their way into orbit. But science still has much to learn about the nature and composition of these top layers of the atmosphere. Perhaps future scientific discoveries may reveal how some of the conditions on the frontiers of space affect the weather below.

Importance of the Troposphere

Whatever its remote causes may be, weather occurs in the troposphere. Packed into this lowest layer of the atmosphere are 80 percent of the air and almost 100 percent of the water molecules of the entire atmosphere. The Greek word *tropos* means "change," and the troposphere is the zone where conditions are constantly changing. It is the zone of billowing clouds, shifting winds, turbulence, rain, snow, lightning, hail—everything that we call "weather." Because the earth is the main source of heat, the troposphere and the earth's surface comprise a "weather machine." They act together to produce the changing conditions under which

*That is, "stable" means free from up-and-down currents or "turbulence." Strong winds parallel to the earth's surface do blow in the stratosphere.

HEIGHT
IN THOUSANDS
OF FEET

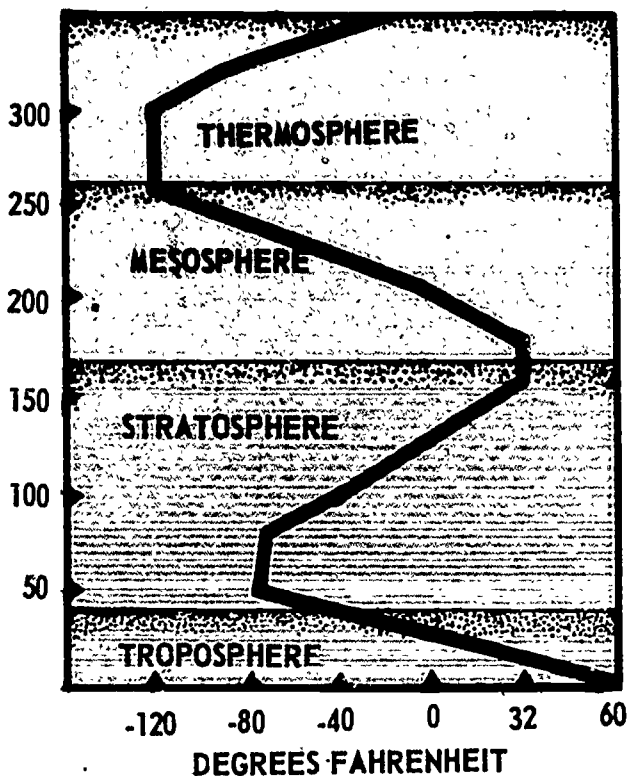

Figure 9. Layers of the atmosphere showing temperature variations.

we troposphere-dwellers live. It is on this partnership that we now concentrate our attention.

GLOBAL WEATHER PATTERNS

To understand the weather where you live, you must understand it on a worldwide scale because the entire earth and the radiation discussed earlier produce the weather. The earth contains all of the raw materials for the manufacture of weather, and the Sun furnishes the heat for blending these raw materials into the weather as we know it.

The Earth as a Weather Machine

Here, then, are the raw materials of weather. The earth swings around the Sun in a 600 million-mile orbit through space that takes slightly over 365 days. This orbital motion around the Sun, coupled with the fact that the earth tilts on its axis, is the cause of seasons. This journey and the tilt of the earth causes winter in the United States while it is summer in South America. Another feature of equal importance in causing changes in the weather is the spin of the earth on its axis, a spin of approximately 1,000 miles per hour at the equator. As a result of this spin of one revolution every 24 hours, each spot around our globe is warmed by the Sun equally as much as other spots at the same distance and direction from the equator.

The atmosphere that covers the earth is a fluid and has many characteristics of other fluids. It rises when it is heated, descends when it is cooled, and flows from place to place seeking equilibrium. This fluid effect of the atmosphere is affected by the surface features of the earth. The earth's surface heats at an uneven rate, causing a great deal of instability in the atmosphere. Besides the uneven heating of the earth's surface, the physical features of mountains, oceans, deserts, and the like, all play their separate roles in weather making.

The Wind

The rate of heating of the earth's surface is greater in the equatorial zone than it is within the temperate and polar zones. For this reason, the temperature of air in contact with the earth's surface within the equatorial zone rises more rapidly than does the temperature of air in contact with the earth's surface within the temperate and polar zones. If the earth did not rotate, these conditions would result in a gigantic convection movement of the air, with the upper air moving from the equator toward the poles and the surface air moving from the poles toward the equator. The earth does rotate, however, and, as noted above, irregularities characterize its surface. Consequently, the system of the winds is somewhat complex.

As a result of the earth's rotation, the nature of air currents generated within the equatorial zone is modified by a factor called the **Coriolis force**. This is a deflecting force, exerted by the rotation of the earth upon any object in motion, that diverts the

object to the right in the Northern Hemisphere, to the left in the Southern Hemisphere. In the Northern Hemisphere, as the heated air above the equatorial zone rises and moves northward, it tends to change its direction toward the east as a result of the Coriolis force. By the time it reaches approximately 30° N Latitude, it is blowing directly eastward and causes an accumulation of air and a high-pressure belt at this latitude.

As the air pressure builds up within this belt, some of the air is forced downward toward the earth's surface. A portion of this air flows toward the equator along the surface; another portion flows toward the poles along the surface.

Meanwhile, some of the air aloft continues to flow toward the poles, becomes cold, settles to the surface, and begins a return trip to the equator. The warmer surface air moving up from about Latitude 30° overruns this colder air and continuing northward, produces a high-pressure condition in the polar zones. At irregular intervals when the pressure becomes sufficient, massive cold air surges break out of the polar zones. These surges of

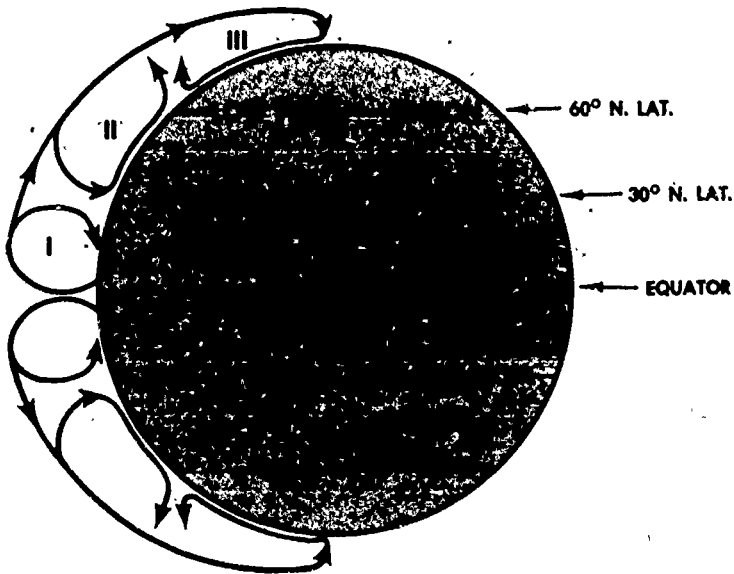

Figure 10. Global wind circulation.

air, moving toward the equator, cause the changeable weather conditions that are characteristic of the middle latitudes. (See Figure 10.)

Other factors which affect the circulation of the air are gravity, friction, and centrifugal force. Gravity tends to pull the air downward and produce a graduated air-density distribution, with the greatest air density near the earth's surface. Friction tends to retard air movement; it is effective to an altitude of about 1,000 to 6,000 feet, depending on the irregularity of the surface over which the air is moving. Over calm water, wind may be considered frictionless above 1,000 to 2,000 feet. Friction is effective to an altitude above 2,000 to 3,000 feet over level terrain. Over mountains, friction may affect air movements up to 6,000 feet or more above the peaks.

Centrifugal force acts on air moving in a curved path so as to decrease its speed within a low-pressure area and increase it within a high pressure area. In the Northern Hemisphere, the air flows clockwise around a high-pressure area and counterclockwise around a low-pressure area. In the Southern Hemisphere, the directions are reversed.

The general circulation of the air is complicated by the irregular distribution of land and water areas. Different types of surfaces differ in the rate at which they transfer heat to the atmosphere. Seasonal changes and daily variations in temperature also affect this rate of transfer. In some regions, local low-pressure areas form over hot land surfaces in summer and over the warmer water surfaces in winter. Convection currents are formed along shore lines. These currents cause the wind to blow from the water over the land during the day. During the night, they cause the wind to blow from the land over the water.

Local air circulation of limited scope is caused by the variations in the earth's surface. Some surfaces—such as sand, rocks, ploughed areas, and barren land—give off a great amount of heat. Other surfaces—such as meadows, planted fields, and water—tend to retain heat. Rising air currents occur over sand, rocks, barren land, and other surfaces that give off considerable heat; descending air currents occur over surfaces that tend to retain heat, such as water and land areas covered with vegetation.

Air Masses

The United States Air Force Dictionary defines air mass as "a large body of air within the atmosphere having approximately uniform temperature and moisture characteristics throughout in a horizontal direction." Although clouds and fog may form because of conditions and procedures within an air mass, general weather changes are usually the result of the meeting of air masses having different characteristics. Air mass characteristics parallel those of the area in which the air mass originates. A **polar air mass** is cold; a **tropical air mass** is hot; a **maritime air mass** is humid; a **continental air mass** is dry. Maritime air masses are formed over water. Continental air masses are formed over land. Meteorologists in the United States are concerned chiefly with air masses originating at two sources: those that move southward from polar regions and those that move northward from tropical regions. The cold air masses are continental polar, maritime polar, and arctic. The principal warm air mass is called maritime tropical.

As an air mass moves away from its source of origin, its original characteristics are changed because of the nature of the earth's



Figure 11. Types of air masses.

surface over which it passes. It may become warmer or colder, absorb moisture or lose moisture, be lifted by mountains, or drawn down into valleys. An air mass, however, is not likely to lose all of its original characteristics.

The temperature classification of an air mass is based upon the temperature of the air mass in relation to the temperature of the surface over which it passes. A cold air mass is colder than the earth's surface over which it is moving; a warm air mass is warmer than the surface over which it is moving. As an air mass moves from over one surface to another, it could change, for example, from a cold air mass to a warm air mass.

The characteristics of an air mass, then, depend upon the surface over which it forms, the seasons, the surface over which it travels, and the length of time it has been away from its source of origin. In general, a cold air mass is characterized by cumulus and cumulonimbus clouds and by local thunderstorms, showers, hail, sleet, or snow flurries. Pronounced turbulence exists in its lower levels; yet, except during precipitation, the ceiling and visibility are usually unlimited. On the other hand, a warm air mass is characterized by haze, fog, stratus clouds, and drizzle. Warm air masses have little or no turbulence; yet, visibility conditions are poor and ceilings are generally low. (See Figure 12.)

The general movement of the atmosphere across the continental United States is toward the east. Air masses originating in the tropical and equatorial areas move toward the northeast. Those originating in the arctic and polar regions move toward the southeast. Cold air masses move more rapidly than warm air masses. The weather at any location generally depends on the nature of a prevailing air mass or the interaction of two or more air masses.

The boundaries set up between one another by air masses of different characteristics are called frontal zones or fronts. This boundary or front moves along the earth's surface as one air mass tends to displace another. If a cold air mass tends to replace a warmer air mass, the boundary is called a cold front; if a warm air mass tends to replace a cold air mass, the boundary is called a warm front. When there is a marked temperature and humidity difference between the two air masses, weather changes along a front are pronounced. We will have more to say about weather fronts in the next chapter.

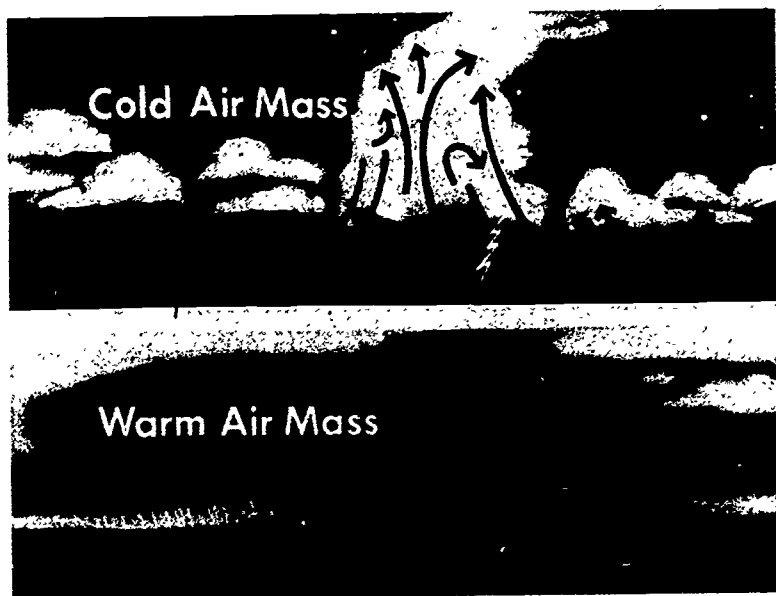

Figure 12. Characteristics of a cold and a warm air mass.

WORDS PHRASES, AND NAMES TO REMEMBER

- | | | |
|----------------------|-------------------|---------------------|
| advection | ecology | radiant waves |
| air mass | element | radiation (of heat) |
| atom | energy | relative humidity |
| carbohydrates | evaporation | saturation |
| carbon dioxide | hydrocarbons | stable air |
| chlorophyll | infrared rays | stratosphere |
| compound (chemistry) | maritime air mass | tropical air mass |
| condensation nuclei | mesosphere | tropopause |
| continental air mass | nitrogen | tropos |
| conduction | oxygen | troposphere |
| convection | ozone | ultraviolet rays |
| Coriolis force | photosynthesis | visible light rays |
| dew point | polar air mass | water vapor |
| droplets | precipitation | |

EARTH AND ATMOSPHERE

QUESTIONS

1. What are the proportions of nitrogen, oxygen, and carbon dioxide in the earth's atmosphere?
2. Trace the path of nitrogen through the life cycle.
3. Trace the path of oxygen through the life cycle.
4. What happens to moisture in the air when the air becomes saturated?
5. Why is dust an important ingredient of air?
6. What is the principal way in which the atmosphere transfers heat?
7. In which layer of the atmosphere does weather occur?
8. What is the prevailing direction of wind in tropic latitudes? In middle latitudes?
9. Which is usually colder—maritime polar or continental polar air?

THINGS TO DO

1. Make a chart showing the layers of the atmosphere and their relative depth.
2. Keep track of weather reports and maps in your local newspaper or on television and identify the type or types of air masses in your locality during the current week.

Chapter 3

More about the Weather

IN THIS CHAPTER, we continue our study of earth and atmosphere with an examination of the roles played by fronts, clouds, and terrain, such as mountains and shore lines, in producing different types of weather. Included is an introduction to the methods and instruments used by weather forecasters to observe and predict the weather. The chapter also discusses the hazards to aviation caused by weather, such as low visibility, icing, turbulence, and hail. It concludes with a survey of the art of weather forecasting, including what forecasters can do and what some of their essential problems are. When you have finished this chapter you should be able to do the following: (1) look at a contour weather map of the United States, label over the contour and identify the air masses and fronts; (2) name at least one example of a high cloud, a low cloud, and a middle cloud; and (3) describe the kinds of weather that are hazardous to flying and indicate how a forecaster might help a flyer avoid them.

THE PRECEDING CHAPTER considered the basic ingredients of weather—the earth's rotation, uneven heating by the Sun, the atmosphere, terrain, and air masses. Now let us take a closer look at weather in action.

THE WEATHER FRONT

We suggested earlier that weather is the stormiest when air masses having different temperatures meet. In general, the strongest winds and heaviest precipitation occur

along the leading and trailing edges of air masses. The boundary between two air masses is called a **front**. As we noted before, air masses and fronts generally have a component of motion toward the east across the United States—**warm fronts** from the southwest and **cold fronts** from the northwest. (There are occasional exceptions to this rule, but **retrograde** or **back-door** movements of weather systems from east to west are very infrequent.)

A weather map of the United States (Figure 13) shows this basic pattern on a typical winter night. The irregular line represents a cold front that extends southward from a low-pressure cell in Michigan and ends in Mexico. The shaded portion of the map indicates that an area of precipitation (shaded) follows this front as far south as Mississippi. Clear weather prevails in the center of a cold air mass over the western states and in a warm center (MT for "maritime tropical") over Florida.

The Cold Front

Suppose, at this moment, that you are experiencing an air mass of maritime tropical origin. It is a hot, humid day because maritime tropical air masses contain heat energy and water vapor. You are uncomfortable because there is almost no movement of air around you. The weather forecaster predicts the arrival of a cold air mass during the afternoon. The cold air mass arrives as a northwest wind, and, since it is heavier than the warm air mass, it moves under the warm moist air and shoves it upwards. This causes unstable conditions. (See Figure 14.)

Rapid condensation of moisture in a towering thunderstorm releases much energy. This produces the familiar **thunderheads** or **cumulonimbus clouds**. Intense rain, lightning, and, possibly, hail occur, and, if conditions are just right, the thunderstorm may give birth to one or more **tornadoes**, the most violent weather phenomenon known to man.

Other types of Fronts

Thus far, we have described weather that may develop in association with a **cold front**. There are several other types of weather fronts and an infinite variety of **frontal weather**. The **warm front** occurs when warm moist air displaces cooler and dryer air. Since it is lighter than the air that it displaces, the air along the warm front rises above the cooler air on the surface. Although the

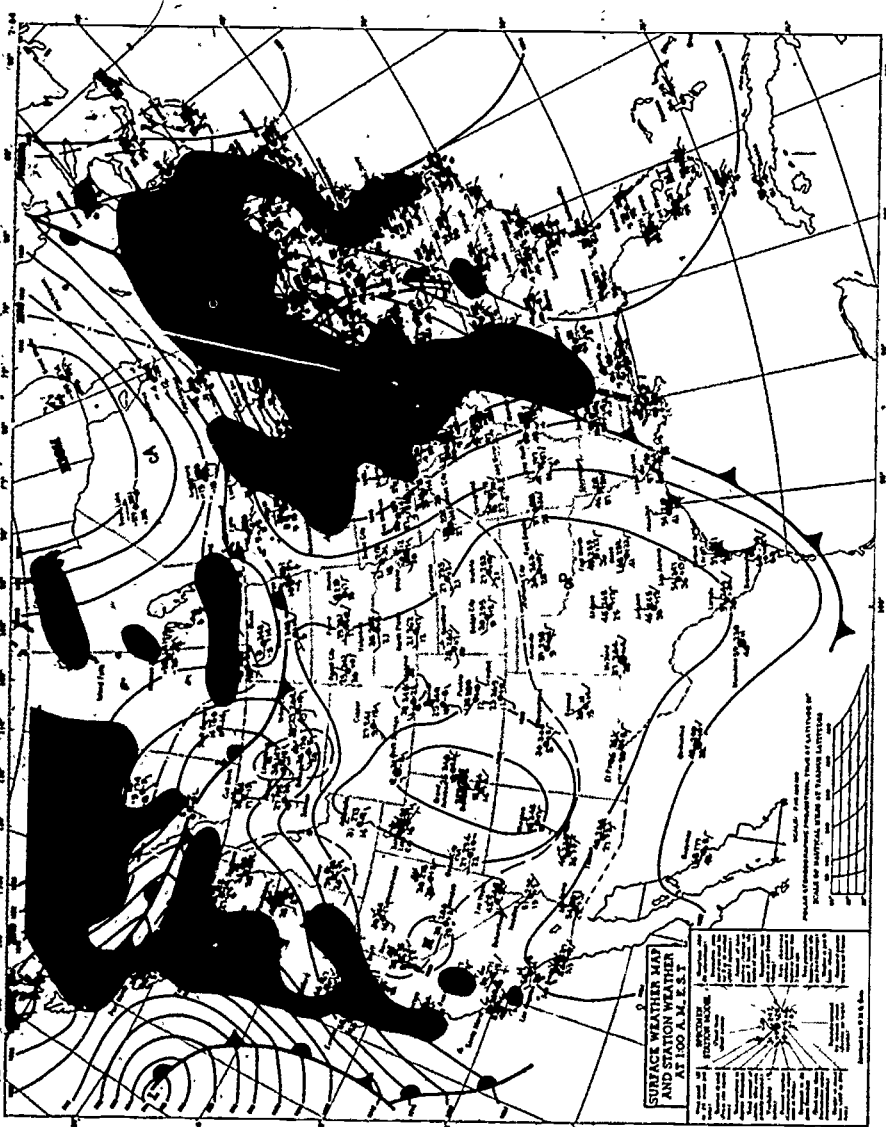

Figure 13. Regional weather map of the type prepared at a local weather station.



Figure 14. A cold front invading a warm front.

weather in a warm front may not be as spectacular as the weather in a cold front, it can be much more dismal and prolonged. Warm front weather may last for days and provide very poor flying weather in the process. In certain respects, warm front weather is even more dangerous to pilots and airmen than cold front weather. Well-organized cold-front storms are easier to see in advance and avoid, but unwary pilots can get into trouble gradually in warm-front weather, with reduced visibility and more prolonged icing conditions. One other type of weather front of particular interest to the airman and to the forecaster is the occluded front. This condition occurs when a cold front overtakes a warm front and lifts the warm air off the ground. An occluded front may contain features of both cold and warm fronts.

CLOUDS AND WEATHER

The absence of frontal zones on our weather map does not mean that all is peaceful and serene over the entire area represented by the map.

MORE ABOUT THE WEATHER

A Convective Thunderstorm

A plowed field heats at a much faster rate than the surrounding wooded areas. White **cumulus clouds** form over the field as the warm air rises and cools above it. As it rises, it leaves a partial vacuum just below it, and more air rushes in to replace the rising air. This is the process of convection described in the preceding chapter.

The puffy white cloud begins to grow. It turns gray and foreboding underneath because of the intense concentration of moisture within it. It continues to grow to 10,000, 20,000, or 30,000 feet. Rain soon begins to fall, and the cloud enlarges. Lightning flashes. A full-fledged thunderstorm with damaging winds and hail is underway.

This is what weathermen call a **convective thunderstorm**, caused by the rising of heated air. As common as clouds are, there are many things meteorologists do not know about them.

Formation of Clouds

We noted earlier that warm and moist air rises. Clouds form when water vapor condenses into water droplets. Clouds develop from the water droplets, and these water droplets merge to form raindrops or snowflakes. We have also noted the prevailing belief that raindrops form around small particles of dust. Some people say that **static electricity** forces water droplets to merge into raindrops. When this process is fully understood, it will open many more doors of discovery about the weather phenomenon known as clouds. As influencers of weather, clouds do not actually fall into any simple category as do air masses and frontal zones. Clouds are both the result and the cause of weather conditions. For example, hurricanes do not exist without the familiar wall of spiral clouds, but weathermen do not yet know the degree to which this wall of rain clouds contributes to the severity of a hurricane. They do know that all thunderstorms do not breed tornadoes, but all tornadoes are bred by thunderstorms. However, they still do not understand why, under what appears to be precisely the same conditions, one thunderstorm will produce a tornado and another thunderstorm will not. Intensive studies of clouds are presently underway to understand some of these mysteries.

Types of Clouds

As you no doubt have observed, clouds come in all sizes and shapes. To the experienced observer, these clouds have names and can be identified; to the experienced **meteorologist** (fully qualified weather forecaster), they are important weather indicators. If we draw fine distinctions, we can, perhaps, identify hundreds of different types of clouds, but, for weather reporting purposes via teletypewriter, there are 27—nine in each of three height categories. Practically any cloud in the sky, or combination of clouds, can be one of these types. We need not describe all 27 types, but you should be familiar with the three height categories and an example or two in each category. You should also look closely at Figure 15, since this picture shows the most typical clouds of all height categories.

1. **High clouds** (16,500 or more feet above the ground). These clouds most commonly consist of microscopic ice crystals.
2. **Middle clouds** (6,500 to 16,500 feet).
3. **Low clouds** (near surface to 6,500 feet). If a cloud actually touches the surface, it is reported as "fog" rather than "cloud." Sometimes, a fourth category may include clouds with extensive vertical development. Since the bases of such clouds are usually well below 6,500 feet, they are also known as low clouds, but the tops extend into higher altitudes, over 50,000 feet in extreme cases.

Each height category may contain various types of clouds.

HIGH CLOUDS:—Feathery or **mare's tail** types of clouds are called **cirrus** (Figure 16). They are often seen on days of fair weather, but they may indicate the arrival of a warm front several days later. Rainy weather may be closer at hand if the sky is completely overcast with **cirrostratus**. This is a high sheet of cloud so thin that it hardly seems like a cloud at all. It gives the sky a pale blue or slightly milky appearance and causes the Sun to cast pale but distinctly outlined shadows. At night, the Moon and the brighter stars are visible through cirrostratus. A sure indicator of cirrostratus rather than hazy skies is the "halo" that may be seen surrounding the Sun or Moon. If you hold your hand at arm's length and turn it perpendicular to your line of vision, aligning the heel of your hand with the Moon, the bright ring or halo will be located almost at your fingertips. This opti-

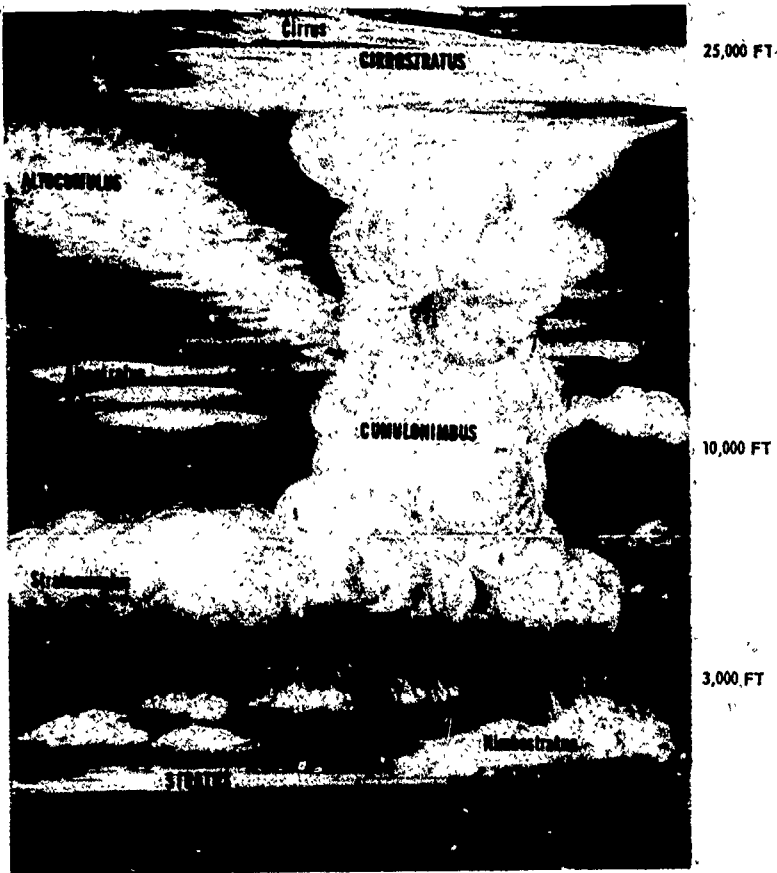

Figure 15. Cloud types at relative altitudes.

cal effect indicates ice-crystal composition of the cloud layer.

MIDDLE CLOUDS.—These clouds come in a great variety, from the smooth, gray altostratus, which may produce light to moderate but prolonged rain, to the patterned rows of small altocumulus clouds, sometimes called mackerel sky.

Low CLOUDS.—These clouds range from the small puffy white fair-weather cumulus clouds, which may bring not-so-fair weather if they appear early in the morning and acquire some vertical development by noon, to the thick, dark, even gray stratus clouds of prolonged rain or the ragged dark scud clouds of stormy weather

VERTICAL DEVELOPMENT CLOUDS.—As they grow, cumulus

clouds extend upward from rather flat bases to resemble giant cauliflowers (Figure 17). They become thunderheads or cumulonimbus when the tops reach into freezing levels and form smooth white scarfs. These formations then fan out into characteristic anvil shapes, indicating a thunderstorm or thundershower. (Figure 18)

Knowledge of these and other clouds is but one tool in the forecaster's hands. They are short-range weather indicators that sometimes indicate future weather conditions.

TERRAIN AS A WEATHER MAKER

Thus far in our study of weather, we have learned that the atmosphere is a fluid in motion, constantly moving here and there as it seeks equilibrium. In its many movements, the air rises and cools, causing clouds, rain, and other forms of visible moisture. We noted earlier that colliding weather masses or heating of the earth's surface lift warm moist air to great heights. In both instances, water vapor condenses into some visible form.



Figure 16. Cirrus at sunset. Very high "Mare's tail" clouds as seen on a clear winter evening.

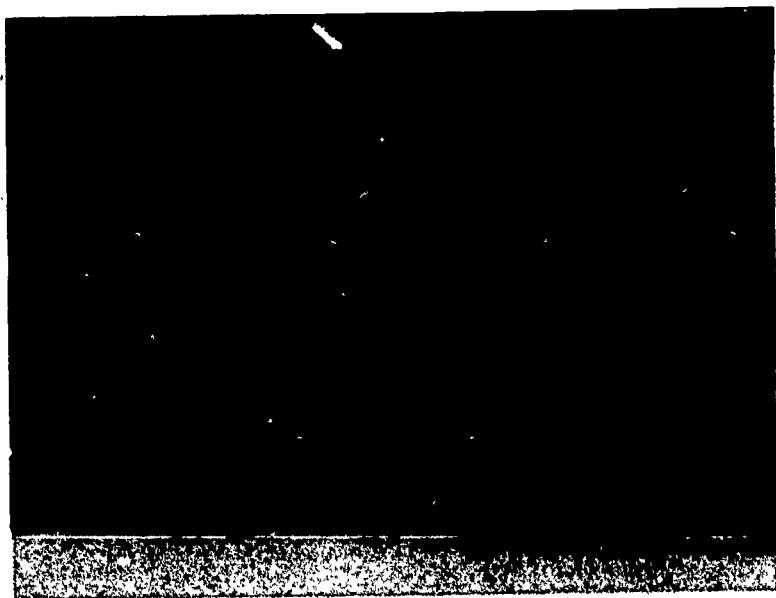

Figure 17. Cumulus clouds, forming a few miles inland from the Gulf Coast on a summer morning, already have some vertical development and may mature into thunderheads by afternoon.



Figure 18. Mature thunderheads, with characteristic anvil-shaped tops. Surface wind blows into thundershower area, as laundry on line indicates.

Irregularities in the earth's surface can also cause air to rise and cool, and the result is the same. Gentle hills and steep mountains contribute their part to the manufacture of weather. An excellent example of mountains as weather makers is the High Sierras in California. Maritime tropical air masses coming into southern California fill with moisture, heat, and energy. Lying directly in the usual path of these air masses is one of the most popular ski areas in the United States, and, just a few miles away, one of the driest spots in the world. What happens to the moisture in an air mass from the time it leaves the Pacific Ocean until it passes over Death Valley, the dry and deadly basin just east of these mountains? As the air mass enters the United States, the mountains cause it to rise. As it rises, it cools and loses practically 100 percent of its moisture on the western slopes of the mountains, accounting for the excellent ski conditions. As it descends the eastern slopes, it again expands and absorbs the small amount of moisture in the vicinity of Death Valley. This process is repeated again and again all over the world—in the Himalayas, the Alps, the Caucasus, and other ranges whose windward slopes are moistened with rain and snow and their leeward slopes are dry.

Along many seacoasts, there is a breeze from the sea by day. This moist, relatively cool air rises and heats as it passes across land. Convictional clouds form a short distance inland (Figure 17) and may bring showers by afternoon. At night, the land cools more rapidly than the sea, and the current is reversed, the breeze blowing from land to sea.

Although these types of weather are more localized than air masses or frontal weather, the weather forecaster must, nevertheless, consider them in his predictions. His task is not an easy one. He must be a combination of geographer, physicist, physical scientist, and something of a fortune teller. Although he may make some classical mistakes, he is more often right than wrong, and advancing technology makes him right more often than ever before.

WEATHER OBSERVING AND FORECASTING

Consider for a moment the weather forecaster's problem as we examine a sample of our atmosphere and the features that contribute to the manufacture of weather. The atmosphere is a fluid

that behaves according to the physical laws governing fluids. It flows; it has internal pressure and energy; it has weight and mass; and it is acted upon by inertia and centrifugal force. The spin of the earth on its axis affects it as do the pressures of surrounding samples of air. It is also filled with positive and negative electrical charges, and it contains water vapor, some of which may have condensed into invisible water droplets and ice crystals. Our sample has constant internal movement and the ability to move right or left, up or down, depending upon conditions affecting it. Now, if we add the heat of the Sun and evaporation from the earth's oceans, the complexity of the forecaster's job becomes obvious.

In the not too distant past, each man was his own weather forecaster. His technique consisted of looking at the sky and the clouds and deciding whether a given day would be suited for plowing, hunting, fishing, or staying indoors. Only in recent years, with the coming of radio, radar, and other electronic tools, has weather forecasting become more a science and less an art.

Although the weatherman's job is a formidable one, it is not impossible. As a product of heat energy and a fluid atmosphere, weather behaves according to some well defined physical laws. Air is a fluid and has the characteristics of a fluid. The heat exchange in the atmosphere can be measured and evaluated. The same is true of moisture content. The energies involved in weather behave according to the laws of energy conservation. Therefore, the weather forecaster's job is becoming easier as more sophisticated measuring devices become available to him.

Instruments for Surface Observation

About 200 years ago, men began to apply themselves to the task of understanding weather. They developed crude, homemade devices to measure the moisture content of the air, the pressure of the atmosphere, and wind speed and direction. A few individuals took to small boats and balloons and penetrated severe storms in an attempt to understand what occurred inside them. Individuals banded together into small groups and studied weather conditions. They reasoned fairly accurately that, if certain weather patterns followed certain conditions, then, when these conditions recurred, the same weather pattern would repeat itself.

Many centuries of myths and legends hampered man's original research into weather. Supposedly, bad weather was the gods' way of punishing earth. Good weather indicated that the gods were pleased with things here below. Strangely enough, many of these myths still prevail. Neptune still controls the oceans' tides and storms, and the devil still beats his wife if the Sun shines while it is raining. In many parts of the world, the thickness of a bird's nest is still a sure sign of an early and severe winter. In other areas, observers of ants and flies "foretell" the coming of a storm by the actions of these insects.

Gradually, however, scientific measuring instruments began to prove that many of these popular myths were not reliable weather indicators. The first such instrument was the **barometer** for measuring atmospheric pressure, invented in 1643 by Torricelli. To scientists of that day, the barometer was the best instrument yet devised for predicting weather several days in advance. Certain changes in the weather pattern seemed to follow rising and falling barometric pressure. However, as useful as the barometer is to the modern forecaster, it is not a positive tool for predicting the weather. There are many other factors that influence the weather besides the simple change in atmospheric pressure indicated by the barometer.

The barometer was followed by the **thermometer** for measuring the temperature of the air and the **hygrometer** for measuring the amount of moisture in the air. A later refinement of the hygrometer was the **wet and dry bulb thermometer**, or **psychrometer**, which provided a very precise measurement of the amount of water vapor dissolved in the air. As we learned in Chapter 2, the dryer the air, the greater the cooling by evaporation. Therefore, the wet-bulb thermometer, with its bulb wrapped in wet cloth, shows a lower reading than the dry-bulb thermometer. The greater the difference between the two readings, the dryer the air. When the two thermometers read the same, the air is saturated. Two other useful instruments for measuring atmospheric conditions had been used for centuries. The **weathervane** measures wind direction and the **anemometer** measures wind speed.

All these devices measure weather conditions at one location on the surface of the earth. Thus, early forecasters made surface

observations with no knowledge of weather conditions at other locations. Much of the progress in meteorology for the past century is due to the development of modern communications.

Extending Man's Weather Eye

Since the invention of the telegraph more than a century ago, man has been able to learn about the weather beyond the horizon. Development of radio communications in the twentieth century helped to fill in important gaps over ocean and wilderness areas. Other modern inventions have increased weather coverage, speeded up the collection and distribution of weather data, and extended man's ability to observe weather upward and outward into the atmosphere and space.

WEATHER ORGANIZATION.—Obviously, a huge communications network involving people and machines is necessary to provide current weather information. Since weather service must be free to all citizens, it is a Government function. Here and there, an expert meteorologist may set himself up in private business to provide specialized forecasting service for certain industries, but, like the rest of us, he must use weather reports and forecasts from the National Weather Service.* Even though we receive our weather reports via newspaper, radio, or television, these media draw their weather information from the National Weather Service.

The US military services draw upon the information and facilities of the National Weather Service, but they also have weather services of their own. These services are necessary because of the special weather needs of military aviation and other activities. Furthermore, military forces require complete weather service in regions of the world where other sources of weather information are not available. The Air Force's Air Weather Service is a division of the Military Airlift Command, but it serves all Air Force commands and most of the Army. The Navy has its own extensive weather service. The Army has a smaller weather organization to provide certain special weather services not provided by the Air Force.

In peacetime, global weather service is made possible by international cooperation, including international codes for sending most

*Formerly called the US Weather Bureau, the National Weather Service is now part of the National Oceanographic and Atmospheric Administration under the Department of Commerce.

weather messages. Global airline operations would be impossible without such cooperation. In war, knowledge of the weather can also be highly important in military intelligence. Now, let us look at the United States again and its weather at a given time, as provided by information from normal civil weather service.

THE WEATHER MAP.—The weather map shown in Figure 13 could not be constructed without numerous weather reports from stations all over the continent. The time of the reports is 1:00 am Eastern Standard time. From coast to coast—at 10:00 pm Pacific time, 11:00 pm Mountain time, and midnight Central time—all observations for this map were made and recorded at the same time. They were then rewritten in a numeral code and sent by teletypewriter (described below) into a central weather facility. The numerous tiny numbers and symbols scattered over the map are the means of transcribing local information from many stations onto a map. The forecaster analyzes this data and interprets the symbols to identify air masses and fronts. Then he indicates these air masses and fronts on the map to show the pattern of the nation's weather at the stated time.

Despite the electronic miracles described below, interconnected weather stations are to this day man's most important means of obtaining weather information beyond what he can observe at one station. A series weather map remains the most important basis for predicting tomorrow's weather, for it tells where the weather has been and how far it has moved. The weather will not necessarily continue to move in the same direction at the same speed, but, nevertheless, the map is the prime indicator of weather to come. Of all the modern weather sensing and communications machinery, let us first determine what makes the map possible.

TELETYPEWRITER.—Since the early 1930s, most military and civil weather stations have been equipped with wire-transmitting typewriters or teletypewriters. The teletypewriter can not only type out words but, by means of numerals and symbols, can also provide a thorough weather report in a single line of typing. Thus, teletype networks can speedily collect weather information from many stations and arrange it in a condensed, orderly sequence that no Morse code or voice communications can do. In modern systems much speedier than those of the 1930s and 1940s, machines in weather stations throughout a region transmit their messages in automatic sequence to other machines, which relay collections of

messages to national centers at speeds up to 800 words per minute.

FACSIMILE TRANSMISSION.—**Facsimile transmission** is another vital part of weather reporting and forecasting systems. As newspapers can send and receive photographs by wire, so can weather stations transmit and receive maps, charts, and diagrams useful in weather service. This device also speeds up weather service and eliminates duplication of effort. Formerly, each station constructed its own maps and charts from teletype data. Today, central forecasting officers prepare these graphics and transmit them by wire to numerous local weather stations and airports in much less time. (Figure 19)

RADAR.—Some weather stations are equipped with **radar**, which can scan the surrounding countryside for distances of 100 miles or more. Radar can penetrate through an area that is generally cloudy and rainy; pinpoint the location of heaviest precipitation, thunderstorm cells, and tornadoes; and track their movement.

UPPER AIR OBSERVATIONS.—Knowledge of weather conditions observed from the surface of the earth does not tell the full weather story. For forecasting purposes, it is desirable to know conditions above the ground. Winds, temperature, pressures, and humidities aloft are indicators of current flying conditions and weather to come. Some weather stations are equipped to take balloon observations by rawinsonde. **Rawinsonde** gets its name from two different systems employed separately many years ago but now combined—**radiosonde** and **rawin**. The radiosonde system included a balloon about six feet in diameter and a small package consisting of tiny weather instruments and a radio transmitter. The balloon and weather package were sent aloft to transmit temperature, humidity, and other weather data signals back to a ground receiver. The old rawin system included a similar balloon and a simple metal target, which was tracked by ground-based radar to show the direction and velocity of the winds at different altitudes. In the more modern rawinsonde system, the radiosonde package also serves as the rawin target, and the ground receiver includes both radio and radar receivers to pick up all data simultaneously. (Figure 20)

Weather soundings over remote areas where there are no rawinsonde stations can be taken from airplanes by **dropsonde**. This is the same kind of weather-instrument and transmitter package as in



Figure 19. Facsimile receiver. A weather observer removes wind aloft charts received from a central forecasting office.

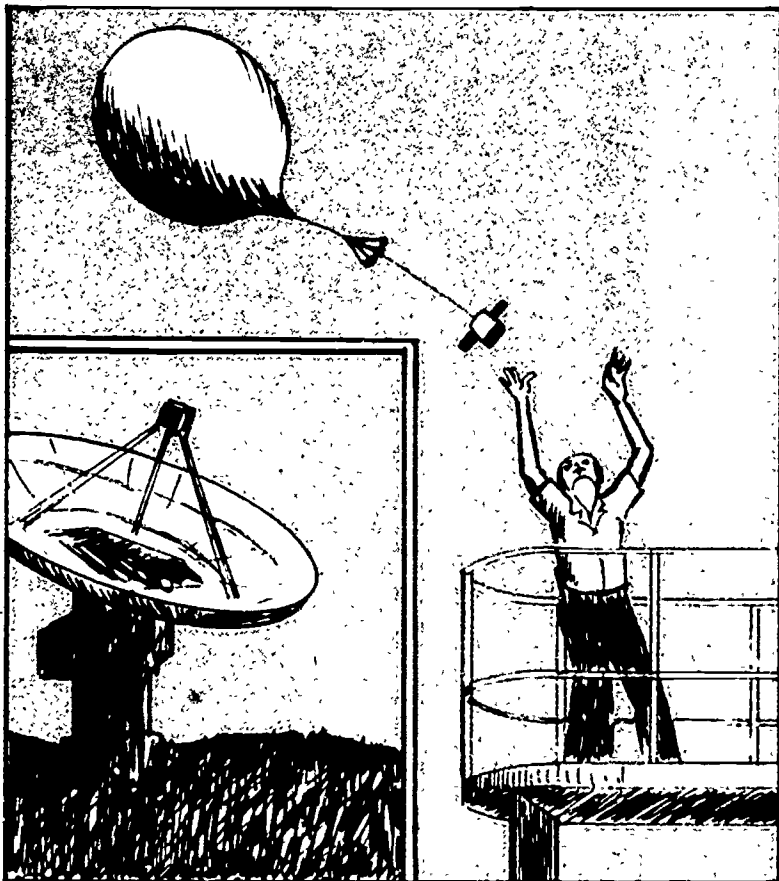

Figure 20. Weather balloon with rawinsonde equipment.

radiosonde, except that it is attached to a parachute instead of a balloon and dropped from an airplane flying at a high altitude. It sends its weather information back to the airplane on its way down. However, it cannot produce rawin data, since this requires a stationary radar for tracking. Over the years, the Air Force's Weather Service has conducted numerous weather observation flights over wilderness and ocean. At one time, weather flights over the North Pole were made routinely. Today, weather flights observe severe hurricanes and sometimes penetrate to their centers.

SATELLITES —The weather satellite is the newest and most amaz-

ing electronic device used by the forecaster. Although it does not measure weather in the sense of providing readings, the satellite is becoming more valuable than all other measuring devices combined.

From its orbit, the weather satellite aims its combination of cameras at the earth and photographs global weather and cloud patterns. Then, on command, the satellite transmits these photographs back to ground stations where they are received and evaluated. The first such weather satellite was TIROS (Television Infrared Observation Satellite), and it was highly successful or, as one scientist put it, too successful. TIROS furnished more weather data than the ground stations were equipped to evaluate. After TIROS came NIMBUS, a more highly refined satellite that made possible, through advanced photographic techniques, a 24-hour-a-day survey of global weather conditions. Cloud patterns were interpreted and analyzed from the photographs and converted into mosaics that covered entire continents and oceans. Inaccessible areas of the globe, which had never seen a weather instrument or a forecaster, were now being observed and analyzed in detail.*

Today, there are even more sophisticated weather satellites under development. Some of these satellites will utilize the newly refined laser equipment and will actually measure the latent energy and moisture content of an air mass from hundreds of miles above it. With a built-in computer, such a satellite will be highly selective in the information that it gathers and transmits to earth stations.

Climatology

The science of weather is not limited to observing today's weather and forecasting the weather for tomorrow. To advance man's knowledge of the atmosphere and to improve his forecasting ability, long-range studies are also necessary. Furthermore, people in many walks of life need statistical knowledge of the weather, as well as today's report. Knowledge of the average annual rainfall of a given locality, for instance, or the annual highs and lows of temperature may influence a farmer in deciding what crops to plant or an industrialist in deciding where to locate a factory or to market certain products. Knowledge of prevailing

*See the unit *Spacecraft and Their Boosters* for further information on TIROS and NIMBUS

wind direction influences the construction of runways and other facilities at an airport.

The term **climate** refers to atmospheric conditions of a locality or region over a long period, as opposed to **weather**, which refers to conditions at any one time. Long-range studies of atmospheric conditions are called **climatology**. One interesting type of climatology is the study of past patterns of weather as an aid to forecasting. Computers, backed by weather records on electronic tape, are used in such studies. Behind these records stand the many weather stations, where hourly weather observations are not only transmitted for immediate use but recorded and later forwarded to climatology study centers.

WEATHER HAZARDS TO AVIATION

We can gain some ideas of the weather forecaster's problems and responsibilities by considering weather hazards encountered by flyers. Farmers, shippers, and people in a variety of occupations have a vital interest in the weather, but nobody lives as intimately with the weather or needs as complete knowledge of current weather conditions as the flyer.

Aircraft must operate in the heart of the weather machine, the troposphere. Even jetliners that cruise in the weather-free stratosphere must climb and descend through the troposphere and make their landings and takeoffs there, often under conditions far from ideal. Flyers encounter many varieties of weather but, in most instances, bad weather produces three main flying hazards: **turbulence**, **icing**, and poor **visibility**. In the following sections, we discuss these three hazards and consider a weather disturbance that can combine all three in their most severe forms—the thunderstorm.

Turbulence

Air currents not only flow parallel to the earth's surface as wind but also take the form of up-and-down movements known as **turbulence**. Wind can be either a help or a hindrance to a flyer, but turbulence is always unwelcome. It can be a mere nuisance, causing airsickness in some passengers, or, at times, it can produce more serious dangers, such as a sudden loss of altitude in a downdraft or the "shear" effect caused by an encounter with both an

up and a down draft in quick succession. The most violent turbulence usually occurs in thunderstorms, where it is also a cause of hail (discussed below under thunderstorms). Moderate to severe turbulence, however, can also occur in almost any cloud with substantial vertical development and, sometimes, even in clear air. In fact, **clear-air turbulence**, known as **CAT**, has become one of the special hazards of the jet age, for it is particularly jolting to an aircraft encountering it unexpectedly at high speed.

Icing

Formerly, icing was the greatest of these three aviation hazards, but this hazard has been reduced by modern aircraft equipment designed to break or melt ice as it forms. Without such equipment, a flyer in ice-forming conditions frequently discovered that a rapid buildup of ice on the airfoil surfaces of his aircraft destroyed the craft's efficiency. Ice could form on propeller blades and force them out of balance to the point that vibrations produced other perils. It could also form in the various intake systems of an engine and shut off fuel or air. Conditions are most favorable for ice formation inside a cloud where the air is saturated and **supercooled**, that is, the temperature is below freezing, and the water droplets are still in liquid form. But the shock of an airplane passing through the cloud suddenly turns the droplets to ice. Basically, two types of ice can form on aircraft in flight—**clear ice** and a white, frosty type called **rime ice**. Of the two, rime ice is less dangerous, and ordinary deicing equipment can usually remove it. Hard, solid, clear ice is more stubborn, and a flyer encountering it may be forced to descend to a lower altitude, where warmer temperatures can melt it. A forecaster's advice on how to avoid this hazard is always welcome.

Reduced Visibility

Many things can cause reduced visibility. fog, clouds, rain, snow, dust or sand, smoke, haze, etc. Fog and low stratus clouds are statistically the most serious accident causes, since they affect landing and takeoff operations.

Both flyers and motorists understand the hazards of dense fog. But even moderate visibility restrictions imposed by fog can be an aviation hazard because of the higher speeds involved in flying. Thanks to radio, radar, and other modern navigational aids,

however, aviation is no longer as dependent upon good visibility as formerly, but even the best of pilots prefers to land on a runway that he can see! Furthermore, progress in aviation has also meant more crowding of airports and airplanes. This makes it all the more urgent to keep a close weather watch on visibility restrictions.

Thunderstorms

If turbulence, icing, and reduced visibility are the principal weather hazards, then the thunderstorm is the "triple threat" weather condition because it produces all three hazards, in addition to some rather serious side effects. If possible, pilots avoid flying into mature thunderstorms, but, sometimes, a mission may require it, and, sometimes, they enter them by accident. When this occurs, knowledge of what occurs inside a thunderstorm is very important.

Thunderstorms are attended by severe turbulence, icing, lightning, and precipitation in one form or another. The more severe thunderstorms produce hail and, in extreme cases, tornadoes.

Intense rain and snow in thunderstorms can severely limit visibility, especially when an aircraft is taking off or landing. Icing is very common in thunderstorms, but it is usually not as severe a threat as some of the other hazards. An aircraft usually passes through a thunderstorm too quickly to permit a serious buildup of ice. Lightning is the least of a thunderstorm's menaces. Although aircraft have been struck by lightning, the damage is usually slight. However, a hazard associated with lightning can be quite serious. Static induced by lightning can become so severe that radio messages cannot be read, and other electronic navigational aids may not function properly. But the most dangerous of all hazards produced by a thunderstorm is turbulence, with its by-product, hail.

The heart of a thunderhead is similar to a vast chimney, pulling air and moisture into a powerful updraft. On all sides of this chimney, downdrafts of almost equal power occur. A hapless aircraft encountering these conditions is severely buffeted. Hail occurs when an updraft carries a tiny drop of water upward into the sub-freezing temperatures of the cloud's higher levels, where it becomes a small ball of ice. Then, a downdraft sweeps it downward into the lower levels of the cloud, where it partially melts and picks up more moisture. Then it hits the updraft again.

and it is again borne aloft into the freezing zone. This process occurs repeatedly, and the small hailstone acquires layer after layer of ice, sometimes becoming as large as a golf ball, or, in some rare instances, a baseball. You can imagine the power of some thunderstorm "chimneys" if you realize that they sometimes carry a chunk of ice the size of a baseball straight up for a distance of perhaps a mile. The hailstones themselves are quite a flying hazard. A moderate number of hailstones from one-half to three-quarters of an inch in diameter can give an aircraft a severe battering in a few seconds.

To combat these hazards, the aircraft industry has built aircraft of greater structural strength to withstand the stresses of turbulence, deicing equipment to reduce the hazards of ice, and navigational aids to permit flying under conditions of reduced visibility. However, these developments have not reduced the need for swift reporting of current weather and accurate forecasting of future weather.

FORCASTER CAPABILITIES AND LIMITATIONS

Despite progress in recent years, weather forecasting is not an exact science. Since his task includes a number of unknown factors, the weather forecaster, in many instances, cannot forecast as accurately as is desirable. An airman should view the forecaster's advice as expert opinion. The experienced airman continually checks current weather against predicted weather as he proceeds with his flight. He knows that the greatest certainty of weather is its changeable nature. Consequently, the older a forecast, the more likely that some part of it will no longer be accurate.

What the Forecaster Can Do

Available evidence shows that the forecaster can predict the following weather conditions at least 75 percent of the time:

- The passage of a fast moving cold front within two hours of its arrival. The forecaster can make this prediction as much as 10 hours in advance.
- The passage of a warm front or a slow moving cold front within 5 hours of its passage. He can predict this condition up to 12 hours in advance with 75 percent accuracy.

MORE ABOUT THE WEATHER

- The rapid lowering of visibility in prewarm front conditions. The forecaster can predict such reduced visibility within 4 hours of the time that it actually occurs.
- The beginning of a thunderstorm within 1 or 2 hours of its arrival. For this prediction, the forecaster must have radar.
- The time in which rain or snow will begin falling within 5 hours time of its actual arrival.
- The rapid deepening of a low-pressure center and its associated bad weather.

Some Unsolved Problems

Forecasters cannot currently predict the following weather conditions with sufficient accuracy to satisfy the needs of a global Air Force:

- The time at which freezing rain will begin.
- The location and occurrence of severe or extreme turbulence. This is particularly true of clear air turbulence, since such turbulence is not associated with cloud formations.
- The precise location and occurrence of heavy icing conditions.
- The precise location and occurrence of a tornado.
- The beginning of a thunderstorm that has not yet formed.
- The position of a hurricane center nearer than 100 miles of its actual location more than 12 hours in advance.

The weatherman's purpose is to advise pilots and crews of the most likely weather conditions that they will encounter en route to and at their destination.

MAN AS WEATHER MAKER

Will man, someday, be able to "do something about the weather?" This is not as unbelievable as it may sound, since steps in this direction are already underway. Experimenters have, with some success, seeded clouds with dry ice and silver iodide crystals in an attempt to produce rain. Men are regularly penetrating to the heart of hurricanes to learn more about these massive storms. Eventually, they may be destroyed or turned aside before they reach populated areas. Construction of a dam across the Bering Straits between Alaska and Siberia has been proposed. This might make the

northern polar regions habitable. Another suggestion is to cover the polar ice cap with carbon black dumped from aircraft. The result would be a greater heating and melting of the ice cap, again, to make the region habitable. All of these suggestions have their drawbacks, however, and it will not be until all the consequences are evaluated that such actions are undertaken. These possibilities are not so remote as they seem when you consider that chemicals in existence today can be spread on the surface of water to reduce evaporation to practically zero. Think of what this chemical could do to the world's climate if it were spread over all the world's oceans. These and other actions are within the realm of possibility. It is not too difficult to believe that, someday, the weatherman's job will be one-half to predict the weather and one-half to change the weather.

WORDS, PHRASES, AND NAMES TO REMEMBER

altocumulus cloud	meteorologist
altostratus cloud	middle clouds
anemometer	NIMBUS satellite
backdoor	occluded front
barometer	psychrometer
cirrostratus cloud	radar
cirrus cloud	radiosonde
clear air turbulence (CAT)	rawin
clear ice	rawinsonde
climate	retrograde
climatology	rime ice
cold front	scud clouds
communications	static electricity
convective thunderstorm	stratus cloud
cumulonimbus clouds	supercooled air
cumulus clouds	thermometer
dropsonde	thunderheads
facsimile transmission	tornadoes
front	turbulence
frontal weather	visibility
hail	warm front
high clouds	weather
hygrometer	weathervane
icing	wet and dry bulb thermometer
low clouds	(psychrometer)
mare's tail	

MORE ABOUT THE WEATHER

QUESTIONS

1. Describe what happens when a cold front moves in on a warm air mass.
2. How is a convectional thunderstorm produced?
3. At what height from the earth's surface are each of the three main cloud groups found?
4. At what point do cumulus clouds become cumulonimbus? What do they then indicate?
5. How are air masses affected by mountains?
6. Define: thermometer, hygrometer, and psychrometer.
7. Explain the operation of a weather satellite.
8. Of the many weather hazards encountered in flying, which is the most dangerous? Why?
9. Name four weather conditions that cannot be predicted accurately.
10. Describe two proposed methods for warming the northern polar regions.

THINGS TO DO

1. Observe and identify clouds for a week and make a class report. Make a relief map showing the features of the earth's surface which affect weather.
2. Make a barometer, using mineral oil instead of mercury. Instructions. enclose a thermos bottle liner in a cardboard box, and attach it upside down to a wooden brace. Insert a plastic straw through the cork and cork the bottle tightly with the straw extending into the bottle one or two inches. Place the bottle cap on the floor of the brace directly under the bottle so that the other end of the straw goes into the cap. Fill the cap with oil. The oil will rise in the straw as air pressure lowers. The pressure can be measured by indicator marks on the straw.

59/60
68

Chapter 4

From the earth to the Moon

IN THIS CHAPTER, we consider the region between the earth's atmosphere and the Moon. We first reexamine the upper atmosphere to point out significant phenomena of the ionosphere. Then we describe the most significant feature of lunar space, the Van Allen radiation belts. In the latter half of this chapter, we deal with the Moon—its behavior as a body in space, its surface characteristics, and theories about its origin and history. We also consider some of the most recent findings, based on the Apollo flights. When you have studied this chapter, you should be able to do the following: (1) name and describe the characteristics of the ionosphere and the layers within it; (2) explain and compare the hazards of manned vehicles orbiting within or traversing the Van Allen radiation belts; (3) describe the surface features and other characteristics of the Moon; and (4) compare different theories on the origin of the Moon.

THE FRINGES OF SPACE

AS INDICATED EARLIER, various gradual changes occur in the region between air and space. The most basic and obvious change is the decrease in the density of the air and the resulting decrease in pressure as altitude increases. A gradual thinning of molecules causes this change, which affects life support and travel in aerospace. The different layers of atmosphere and lower space may also be classified according to temperature trends briefly noted in Chapter 2. Temperatures decrease with altitude in some zones and increase

in others. There are a number of other interesting phenomena that distinguish the upper atmosphere and the fringes of space.

Discovery of the Upper Atmosphere

Man has long wondered about the **aurora borealis** and the **aurora australis**. The aurora borealis (or northern lights) flashes brilliant colors in varying patterns across the northern skies and the aurora australis presents a similar display in the southern hemisphere. Observers have determined that these displays occur at heights ranging from 60 to 600 miles above the surface of the earth.

These and other phenomena may be associated with a zone of electrically-conductive layers in the upper atmosphere called the **ionosphere**. Discovery of the ionosphere came with the invention of the radio early in the twentieth century.

In the 1890s, **Guglielmo Marconi** conducted successful short-range experiments with radio, and, in December 1901, he sent the world's first radio message across the Atlantic Ocean from England to Newfoundland. Previously, scientists believed that **electromagnetic waves** (the carriers of radio signals) traveled only in straight lines and, therefore, could not be received beyond the curve of the earth. Hence, the limit for radio communication between any two points on the surface of the earth would be less than 100 miles, perhaps a little more if one, or the other point were located on the top of a high mountain. (This principle holds true today for certain types of transmissions, such as television, FM radio, and conventional radar.) How, then, could Marconi's radio send signals across the Atlantic?

Shortly after Marconi's feat, an American physicist, A. E. Kennelly, and a British physicist, Oliver Heaviside, independently advanced theories that a conductive layer in the upper atmosphere acted as shield and mirror to prevent electromagnetic waves from escaping into space and to reflect them back to earth. As they traveled upward at any given angle, the signals from Marconi's radio glanced off the layer at an angle, like the image from a mirror, and, thus, passed over the intervening horizon. For many years, the name **Kennelly-Heaviside layer** was applied to what is now called the ionosphere.

In the 1920s and later, a long series of ground-based observations provided a more accurate picture of the ionosphere. Radio

pulses were precisely timed as they traveled at the speed of light up to the reflecting layer and back to a receiving instrument. In this fashion, four separate reflecting layers in the upper atmosphere were discovered: the D layer, at 31 miles altitude; the E layer, at approximately 62 miles (this layer still bears the name Kennelly-Heaviside); and the **Appleton Region**, containing the F_1 and F_2 layers, at 186 and 248 miles, respectively. The lowest of these, the D layer, reflects longwave radio transmissions, such as those of the standard commercial radio broadcast bands in the United States. Higher layers reflect shorter wave transmissions. Furthermore, the higher the reflecting layer, the farther a signal can travel because it bypasses more of the earth's curvature. Thus, shortwave radio can be used for international broadcasting, and longwave radio is preferred for local commercial broadcasting although longwave stations may have ranges to approximately 1,000 miles, depending on power.

As man continued to learn more about the upper atmosphere, through ground observation, he also began to fly and send unmanned instrument packages to higher altitudes for more direct observations of the upper atmosphere.

In the middle 1930s, manned balloon ascensions by the Swiss scientist, **Auguste Piccard**, and others reached altitudes above 50,000 feet. By 1938, an Italian reciprocating-engine airplane had climbed above 50,000 feet. After World War II, jet airplanes flew to greater and greater heights. Balloons, nevertheless, continued to make useful contributions to science. The current manned balloon altitude record, set in 1961, tops 113,000 feet or 21 miles, exceeding the altitude record for manned flight in an air-breathing aircraft. Unmanned balloons, carrying scientific instruments and transmitters, have risen as high as 142,000 feet or 27 miles. Balloons have the added advantage of a stationary or slow-moving viewpoint, which is preferred for some observations.

With its propulsion system that works independently of air, the rocket, of course, has been the key to modern high-altitude and space exploration. Even before the first satellites went into orbit in the late 1950s, instrumented rockets had risen to hundreds of miles above the surface of the earth. Such **sounding rockets** (vehicles with an up-and-down rather than an orbital trajectory) are still used, and unmanned satellites orbit at altitudes from 100 to more than 20,000 miles. In the 1960s, manned

flights in the rocket-powered X-15 aircraft reached altitudes up to 67 miles. Since then, of course, Moon voyages have aroused greater interest.

Characteristics of the Ionosphere

We have already identified the upper atmosphere by various names. In Chapter 2, we noted that the mesosphere (middle sphere) and **thermosphere** (heat sphere) apply to zones of temperature trends. The ionosphere, generally including the same zones (at altitudes above 50 miles), refers to the electrical characteristics of these zones.

HOMOSPHERE AND HETEROSPHERE.—Sometimes, scientists refer to upper altitudes as the **heterosphere** (sphere of separateness) and to lower altitudes as the **homosphere** (sphere of sameness). In the homosphere, as we have noted, air is an even mixture with the proportions 78 percent nitrogen, 21 percent oxygen, etc. Above 50 miles, in the heterosphere, the different molecules tend to form separate layers because of their different atomic weights. Thus, at one altitude, oxygen will predominate, and, at another, nitrogen will be well above its normal proportion of 78 percent. The gradual weakening of the earth's force of gravity at high altitudes is one reason for the formation of the heterosphere; the thinning of the atmosphere itself is another. As they move about, molecules have fewer collisions with other molecules, and these collisions are necessary to keep the molecules in a state of mixture.

PHENOMENA OF THE IONOSPHERE.—Let us return to those electric peculiarities that give the name "ionosphere" to the upper atmosphere. Why is it at times ablaze with northern lights or other spectacles? Why does it have reflecting layers that aid man in his long-distance radio communications? And why does it sometimes black out or garble radio communications or cause magnetic compasses to spin instead of pointing steadily at the magnetic north?

To understand both normal ionospheric behavior and sudden ionospheric disturbances, or **SID**, as they are called, certain underlying facts must be considered. Let us begin with the atom.

The atom reviewed.—An atom contains almost all of its mass in a central body or **nucleus**, which is a tight cluster of smaller particles called **neutrons** and **protons**. Neutrons have no electrical charge; protons carry a positive electrical charge. Around this central body, negatively-charged **electrons** whirl in all direc-

tions. These electrons are so tiny that scientists formerly believed that they had no mass—that they were mere sparks of energy. Now, it is generally agreed that an electron has mass, approximately 1-1900 that of a proton or neutron. Electrically speaking, however, the proton and electron are equal, one charge balancing the other. A normal atom is electrically neutral because the number of electrons exactly equals the number of protons. For example, a nitrogen atom has a nucleus containing seven protons and seven neutrons, giving it an **atomic weight** of approximately 14 and an **atomic number** of 7. (The latter refers only to the number of protons.)

The ion.—With this basic review, we turn now to the **ion**, from which the ionosphere gets its name. An ion is an atom that carries a positive or negative electric charge as a result of losing or gaining one or more electrons. The name is also given to a free electron, proton, or other charged **subatomic particle** (particle smaller than an atom). Therefore, the ionosphere includes those zones of upper atmosphere and near space in which there are many charged or ionized atoms, together with numerous free electrons and other charged subatomic particles. These ions concentrate in certain layers to reflect radio waves of a given range or frequency.

Causes of ionization.—What causes **ionization** (the production of ions)? In the ionosphere, the main causes are the powerful ultraviolet radiation of the Sun, and the ultra high-frequency **cosmic rays** from the stars of outer space. Beyond the shielding effect of the thicker atmosphere at lower levels, these radiations attack the scattered atoms and molecules of nitrogen, oxygen, and other gases and ionize the electrons on the outer rims of the atoms.

Sunspots, solar flares, and other disturbances on the surface of the Sun produce fluctuations in the output of the Sun's rays. These, in turn, produce **SIDs** and other variations in the behavior of the ionosphere. The normal rhythm of nights and days also affects the behavior of the ionosphere. **SIDs**, for example, will produce excess electrons in the atmosphere, and these will absorb radio waves. The magnetic forces of the earth, which contains much iron within its solid mass, also have an affect on the behavior of the ionosphere. It is the interaction of solar radiation and the earth's magnetism that produces the aurora borealis and aurora australis. Particles stimulated by **SIDs** travel swiftly toward

the earth's two **magnetic poles** and produce these glowing displays. We discuss this effect further in the next section because the **Van Allen radiation belts** play an important part in producing it.

The ionosphere is generally regarded as a zone extending upward to more than 300 miles (some sources say 660 miles). At these altitudes, as you know, we are well beyond the zone where an atmosphere with any kind of substance exists. A name applied to space beyond the earth's atmosphere is **exosphere** (outside sphere). The ionosphere blends into the exosphere. Yet, as you have seen, the exosphere is no dead vacuum. It contains electric energy and subatomic particles. This is especially true of the next zone outward.

The Magnetosphere (Van Allen Radiation Belts)

In 1958, a University of Iowa physicist, **James A. Van Allen**, announced the discovery of a large zone of space filled with electrically charged particles, extending far beyond the limits of the ionosphere. This discovery was made with instruments of Explorer I, the first US earth satellite. Numerous other satellite and sounding rocket probes and scientific studies of the so-called Van Allen radiation belts have been made since then.

CAUSES AND BEHAVIOR.—Like the ionosphere, the Van Allen radiation belts are filled with charged particles. Also like the ionosphere, the Van Allen belts are the product of interaction between radiations from the Sun and the magnetism of the earth. Thus, some scientists regard these belts as an extension of the ionosphere. The particles are different from those prevailing at lower levels, however. They also behave differently and fall into different patterns. Another name for these outer zones of radiation is the **magnetosphere**.

The solar wind.—The charged particles come mostly from the Sun. A few may drift in from outer space. The flow from the Sun consists of a loose mixture of mainly protons and free electrons called a **plasma**, of much thinner consistency than a gas. The flow has an average speed of somewhat more than a million miles per hour, but, after a solar flare or other disturbance, both the number of particles and their velocity increases. The flow actually has a small degree of physical force that led to its name, the **solar wind**. Some years ago, the solar wind drove huge balloon-

like satellites of the Echo series off their predicted courses. Some scientists believe that a space ship could be designed with a solar sail to use the solar wind for propulsion.

Belt formation.—When these particles come under the influence of the magnetic forces of the earth, some are trapped in the Van Allen belt pattern, and others are diverted around the earth. The particles within these belts whirl around the earth in a spiral course as they travel from points above one magnetic pole to points above the other pole. As they descend into the ionosphere above the magnetic poles, they help to produce the aurora borealis and aurora australis.

STRUCTURE.—Figure 21 shows that the Van Allen radiation belts are shaped somewhat like inner and outer doughnuts surrounding the earth over the equator and middle latitudes. Inside these doughnuts, the charged particles whirl between the magnetic poles as described above. Since the magnetic poles are some distance away from the geographic poles of the earth, there are radiation-free zones above the poles, generally within the circles of 70°

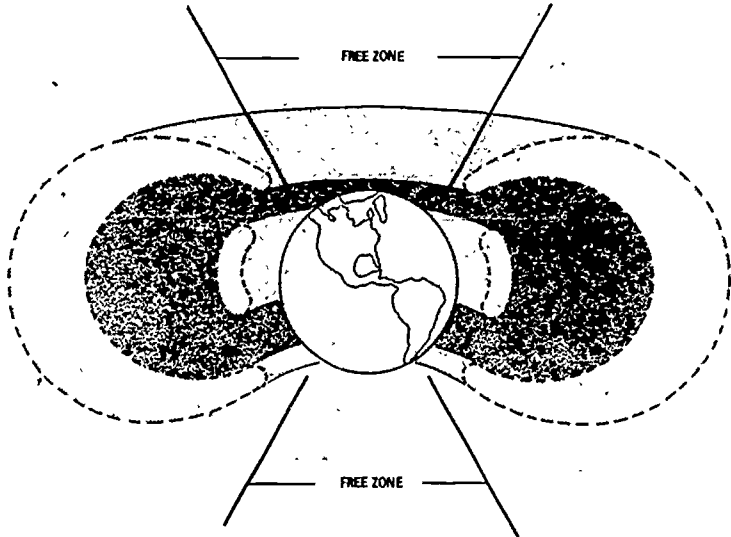

Figure 21. The Van Allen Radiation belts may be hazardous to space passengers if they are exposed to the radiations for prolonged periods.

latitude north and south, corresponding to the hole in the outer doughnut.

The inner doughnut begins at altitudes varying from 250 to 600 miles and extends outward to approximately 2,500 miles. In this zone, radiation is heavy, and it tends to be more constant, keeping at the same level for periods of several months to several years.

The outer zone begins just beyond the inner zone and extends outward to approximately 40,000 miles. It is noted for its wide fluctuations in radiation intensity, varying from day to day and even hour to hour. An extension of the outer zone in the direction away from the Sun is called the earth's **magnetic tail**. It is a flow of electrons, weak but extensive, reaching into space many thousands of miles beyond the outer Van Allen belt. Some say its influence is felt as far as the Moon.

RADIATION HAZARDS.—Radiation within the inner Van Allen belt is quite intense and can be dangerous to men aboard space ships.* The heaviest concentration of radiation and the most dangerous region for man is located over the equator at approximately 1,500 miles altitude. Astronauts on their way to the Moon pass through the Van Allen radiation belts so swiftly that their exposure to the radiations is held within the limits of safety. However, manned earth-orbiting missions must stay below 250 to 300 miles altitude to avoid dangerously prolonged exposure to the radiations. Even if the vehicles were more heavily shielded to protect their passengers against radiation, the weight of this shielding would demand much more powerful rocket propulsion than is presently required. For the present, unmanned satellite and rocket probes are still the best means of exploring the magnetosphere.

A lesser problem is that the radiations in the more intense belts adversely affect communications equipment in satellites traveling within them. The average life of such equipment aboard a satellite orbiting within the inner belts is about a year. Such equipment aboard synchronous satellites (vehicles that hover over the equator apparently motionless because they are in precise 24-hour orbit) has a life of many years, even though these satellites orbit within the outer Van Allen belts at an altitude of 22,500 miles.

*GLOSSARY NOTE. Radiation is not the same thing as radioactivity, which is the production of radiation by the expulsion of particles such as protons and neutrons from the nucleus of an unstable atom. The Van Allen belts trap radiations (in the form of loose charged particles) but make none; hence, they are not radioactive.

FROM THE EARTH TO THE MOON

Beyond the Van Allen radiation belts lies a vast area that we can simply call interplanetary space. However, it is the realm of the solar wind. It contains a sprinkling of hydrogen (H_2) molecules and numerous subatomic particles that energize the earth's radiation belts and outer atmosphere.

THE MOON

Throughout man's history, the Moon has been an object of wonder, superstition, philosophical thought, and, eventually, scientific study. Astronomers have learned much by using telescopes and other earth-based instruments, but, as they have found the answers to some questions, they have found many more questions. More recent findings from unmanned Soviet and US Moon probes, lunar orbits, and soft landings have also provided more data and more unanswered questions. Today, we live in the era of manned lunar exploration. Moon walks may also confirm data from past discoveries, add some surprises, and pose new questions. No doubt, the most important scientific results of the Moon walks will come from a study of rock and dust samples returned to earth. Some interesting findings have already been announced, but long programs of experiment and study with lunar samples are required before the full scientific value of the Moon trips can be realized. Study of the lunar samples and scientific reports indicate that significant differences of opinion about the Moon continue to exist in the scientific community.

Astronomical Characteristics of the Moon

Perhaps the most notable thing about the Moon as man has observed it through the ages is its apparent size, due, of course, to its nearness. Of all the heavenly bodies, the Moon and the Sun are the only two bodies seen by the naked eye as discs with measurable diameters. The Moon has an apparent diameter almost exactly the same as that of the Sun. Thus, during a total eclipse of the Sun, the Moon completely covers the Sun's disc but leaves visible the Sun's outer rim or **corona**.

ORBITAL BEHAVIOR.—The Moon orbits Earth in an elliptical (oval) path that places it, in round numbers, 253,000 miles away at **apogee** (furthest distance from the earth) and 222,000 miles away at **perigee** (nearest distance from the earth). The

average distance is 238,000 miles. The Moon travels around the earth at an average speed of 2,280 mph. It travels faster near perigee, and slower near its apogee. Its period of orbit is 27 earth days, 7 hours, and 43 minutes. Because the Moon rotates in exactly the same length of time as it takes to revolve around the earth, it presents the same side toward the earth.

This period of orbit/rotation does *not* coincide with the phases of the Moon (full moon, half Moon, crescent Moon, etc., as we see them from the earth, for these phases have an average cycle of $29\frac{1}{2}$ days, not $27\frac{1}{3}$. At full Moon, for example, the Sun, Earth, and Moon are almost in a straight line. (If they were *exactly* in a straight line, there would be an eclipse of the Moon.) In another $27\frac{1}{3}$ days, the Moon returns to the same position as observed from the earth against a background of stars. The earth, meanwhile, has traveled about 27° in its orbit of the Sun. Therefore, it will take two more days for the Moon to fall into line with *both* Sun and Earth and again be seen as full.*

Because of the Moon's elliptical orbit and variations in its speed of travel, observers on Earth can see at different times about 59 percent of the Moon's surface rather than just half. In 1959, a Soviet unmanned space vehicle transmitted the first photographs of the hidden side of the Moon. Since then, the far side has been repeatedly photographed by both Soviet and American spacecraft from both high and low lunar orbits. (Figures 22 and 23)

MASS AND GRAVITATION.—The diameter of the Moon is 2,162 miles, somewhat more than a fourth that of the earth. As we have noted, the two bodies compare in size as a tennis ball to a basketball. The Moon's volume is about $\frac{1}{50}$ that of the earth and its mass about $\frac{1}{81}$.** Therefore, the Moon's density is less than the density of the earth.

The pull of gravity on the Moon is about $\frac{1}{6}$ that of the earth. Therefore, a 150-pound man would weigh only 25 pounds on the Moon. If you have seen Moon walks on television, perhaps you have noted the peculiar loping gait of astronauts traveling on foot over the Moon's surface, even when they are burdened by

*The familiar term *lunar month* can mean either the $27\frac{1}{3}$ -day or the $29\frac{1}{2}$ -day period, but the $27\frac{1}{3}$ -day period is preferred usage. More technical terms are *sidereal month* for the $27\frac{1}{3}$ -day period and *synodic month* for the $29\frac{1}{2}$ -day period.

**GLOSSARY NOTE. *Mass* is a more accurate term than *weight* when speaking of bodies in space. *Weight* is a measure of a body's mass under the influence of gravity (see the next footnote, below). A body of a given mass will have different weights depending upon location and movement in space, its nearness to a planet or other body, and the mass of the other planet or body.

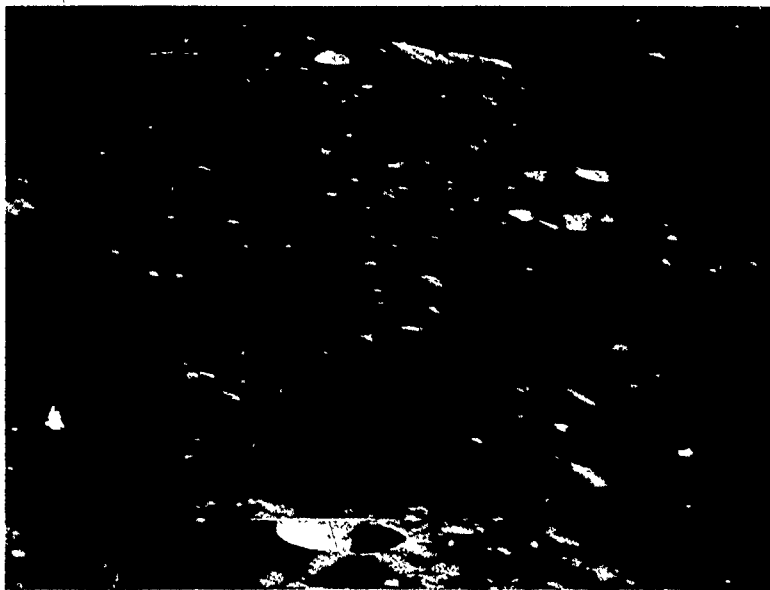

Figure 22. A view of the far side of the Moon taken from the Apollo 10 lunar module. The identity of the craters has not yet been established.

bulky space suits and oxygen tanks. This manner of walking is man's way of adapting to a low-gravity environment.

It is natural to think that the earth, as the heavier body, holds the Moon completely within its gravitational grip. This is not quite so. As Sir Isaac Newton pointed out some three centuries ago, **gravitation** is the mutually attracting force of two bodies in space. The earth attracts the Moon as the Moon attracts the earth.* The force of the Moon on the earth is seen in the behavior of the ocean tides.

CELESTIAL MECHANICS.—If the earth attracts the Moon, why does the Moon not crash into the earth? Actually, the Moon is constantly "falling" toward the earth, but it is also moving forward fast enough to keep it falling *around* the earth instead of *into* it. How or at what time in its distant past the Moon acquired this forward motion has been the subject of much scientific thought and argument, but we must consider this question still unanswered.

*GLOSSARY NOTE. Note how gravitation differs from gravity. Gravitation describes the behavior of bodies in space. Gravity describes the effect of gravitation as felt on the surface of the Earth - or the Moon or other planet.

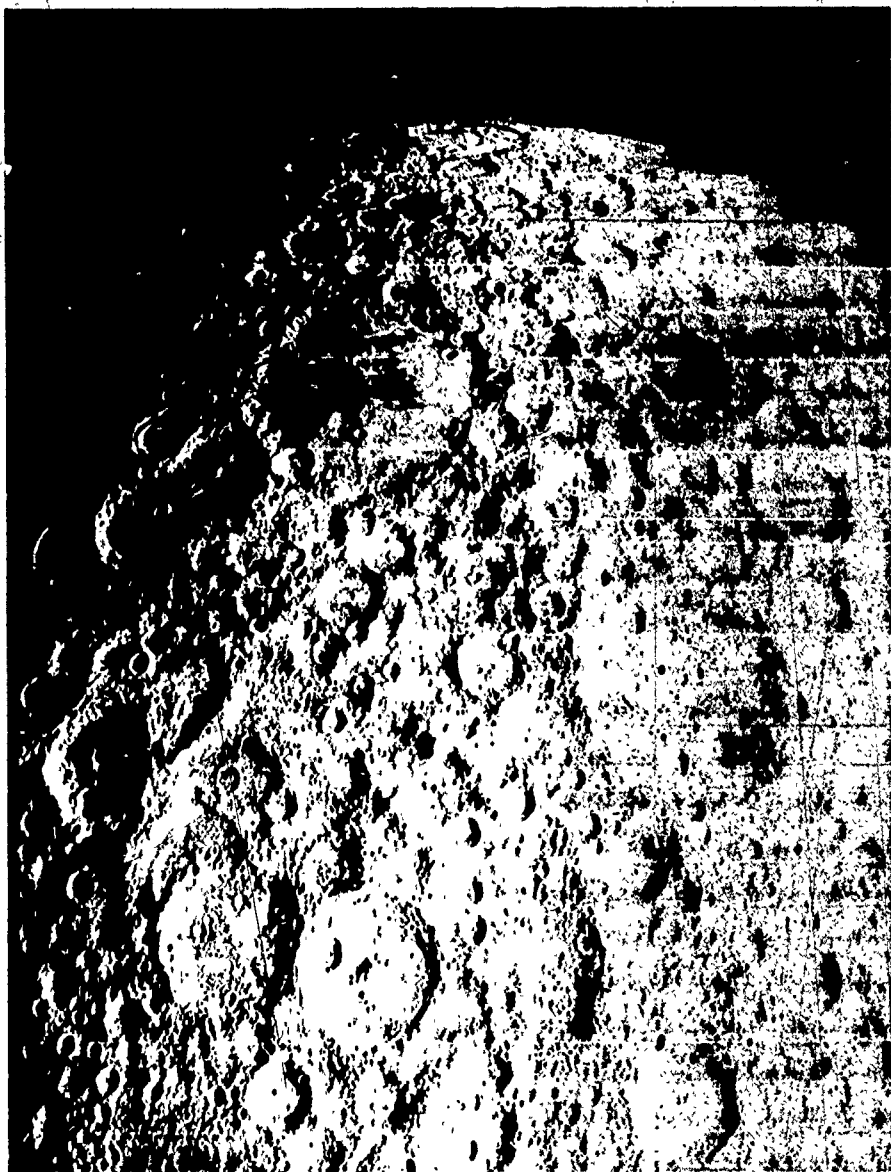

Figure 23. Luna Orbiter II was located about 900 miles above the Moon when it turned its wide angle lens on the southern half of the Moon's hidden side.

Man-made spacecraft and satellites orbit the earth with their forward velocities provided by rocket launchers. And, in the same manner, the earth and the other planets orbit the Sun. Again, the reason for the forward velocity that prevents them from falling into the Sun is an unanswered question.

Any body orbiting another body in space is called a **satellite**. The Moon is a satellite of the earth, and so is any man-made instrument package or manned vehicle hurled into orbit by rocket thrust. The earth and other planets are satellites of the Sun. The Moon, orbiting the Earth as the Earth orbits the Sun, describes a spiral in interplanetary space. The complicated gravitational laws that govern the behavior of bodies in space and determine the pathways in which they travel are called **celestial mechanics**. The basics of celestial mechanics were discovered hundreds of years ago, long before the age of space exploration. The findings of Kepler, Galileo, and Newton in the seventeenth century made the flight paths of space ships and the gait of Moon walkers predictable.

Mascons.—However, other data on Moon gravity have been acquired in recent years. Unmanned lunar orbiter flights from 1965 through 1967 detected slight irregularities in the gravity of the Moon. Apollo 10 (a manned lunar orbital flight) made a further study of these irregularities in late 1968. These irregularities were attributed to **mascons**, uneven concentrations of mass beneath the surface of the Moon. One theory about mascons is that they are large meteorites imbedded beneath the surface. Another is that they are lava flows submerged beneath the crust.

Surface Characteristics of the Moon

As observed from the Earth with the naked eye, the full Moon appears to have a smooth surface, blotchy with light and dark areas. Observers from ancient times have seen a human face in this mottled appearance, giving rise to folklore concerning a "man in the Moon" or a "girl in the Moon." When viewed with a telescope, the lighter areas of the Moon appear rugged, with numerous craters and mountains. The darker areas are smooth areas called **maria**, Latin for "seas." (The singular is **mare**.) These are not known to be barren plains, but, centuries ago, they were actually believed to be seas. Photographs taken from orbiting spacecraft show that the hidden side of the Moon is generally more

rugged than the side facing the earth, with many mountains and craters and an almost total absence of maria. (See Figure 22.)

As seen from the earth, the Moon varies in color from orange to silver, but these variations are due to the Earth's atmosphere. An astronaut's closeup view of the Moon reveals it as dull gray in color. The maria appear darker than the highlands because their surfaces of firmly packed dust absorb more light than the hard rock surfaces of the highlands.

ABSENCE OF ATMOSPHERE.—If the Moon ever had an atmosphere, it lasted for only a short period. Its mass is too small and its gravity too weak to hold an envelope of gas around it. There may be traces of heavy gases here and there, but, on the whole, the Moon's environment is a vacuum.

Effect of visibility.—Absence of atmosphere permits us to observe the surface of the Moon and study its details through a telescope. (Man in space, as we now know, gets no such view of the Earth, for, at any given time, much of our planet is shrouded with clouds. See Figure 24.) Since atmosphere diffuses light, the absence of atmosphere causes extremely sharp contrast between light and shadow. In the past, astronomers have overestimated the heights of mountains and the depths of craters on the Moon because of the black shadows cast by these features.

Effect on temperature.—Man, of course, must carry his own oxygen supply with him and wear a bulky space suit as he walks upon the Moon. He must be surrounded by an envelope of atmospheric pressure inside his space suit and insulated against the Moon's daytime heat, which can rise above 250° F. The space suit is white to reflect as much heat as possible. During the Moon's night, the temperature drops to another extreme, almost -250° F. Again, the absence of atmosphere accounts for these temperature extremes.

Effect on topography.—The absence of atmosphere also affects the Moon's topography (physical surface features). This, of course, explains why the Moon is a barren desert. The Moon's general ruggedness is due, in part, to a lack of wind and water to smooth its features by erosion (wearing away). As we learned in Chapter I, atmosphere acts as a shield to protect the earth from most



figure 24. Cloud cover obscures much of the earth's surface when viewed from space.

meteoroids,* which burn up from air friction as meteors* before they can reach the surface. The Moon has no such shield, and scientists believe that many of the Moon's craters were caused by large meteorites* slamming into its surface full force at some distant time in the past.

LUNAR TOPOGRAPHY.—The topography of the Moon is markedly different from that of the Earth. Its barrenness suggests deserts similar to those on the earth, but the profusion of craters, the maria, and certain small features are unique.

Craters.—The Moon is covered by craters of all sizes, ranging from a few feet in diameter to almost 150 miles. There are overlapping craters and craters within craters. The larger craters have

*GLOSSARY NOTE A chunk of matter in space is called a meteoroid. When it is drawn into the earth's atmosphere and is heated to a visible glow by friction, it becomes a meteor or shooting star. If a remnant of it reaches the surface of the earth, it is called a meteorite. The term meteorite will also be used in this chapter to describe masses of matter striking the moon.

surrounding walls that average 8,000 feet above the surrounding terrain but 4,000 feet above the floor of the crater. The hidden side of the Moon is more cratered than the visible side. Now that man has seen them at close range, even the "smooth" maria are pockmarked with many small craters and shallow depressions. As is true of almost any other feature of the Moon, the origin of craters is an unsettled question. Some are believed to be of volcanic origin, similar to volcanic craters on earth. Some may presently be active volcanos. One Soviet astronomer claims to have witnessed a volcanic eruption on the Moon in 1958. Another type of Moon crater, called a *caldera*, is also believed to be of volcanic origin. This type of crater probably formed when lava exploded through the crust and then fell back to form mounds or mountains within the crater.

Most experts believe that the majority of Moon craters, including some of the largest, were formed by collisions with meteorites and larger bodies called *asteroids*. According to this theory, the size of the meteorite can be but a tiny fraction of the size of the crater that it makes. Given enough velocity, a solid object will explode like a bomb upon impact. It is estimated that an iron-nickel meteorite 2,000 feet in diameter, traveling at a speed of 10 miles per second, can produce a crater 60 miles in diameter. Possibly, the maria, many hundreds of miles in diameter, may have been formed in this manner.

Certain large craters, notably Tycho, Copernicus, and Kepler, have white streaks or rays, radiating outward in all directions, seen only when the Moon is full. These white streaks may be deposits of white dust thrown out when these craters were formed, either by volcanic action or by the impact of meteors. Since these rays cross straight over other Moon features, their formation was probably more recent than that of other features.

Maria.—The "seas" of the Moon are large, flat areas several hundred miles across, and their origins are perhaps the most baffling of all the Moon's secrets. At least, they bring up the same question as that concerning the origin of craters, are they due to the impact of meteorites, or are they volcanic in origin? Some scientists say both. The Mare Imbrium (Sea of Showers) is a circular mare approximately 750 miles in diameter, situated in the northern part of the Moon. It shows evidence that it was formed from the impact of a large asteroid. Other maria, however, show

evidence of volcanic origins. The **Mare Tranquillitatis** (Sea of Tranquility), scene of the first Moon walk, and the **Oceanus Procellarum** (Ocean of Storms), scene of the second, are believed to have vast flows of hardened lava (molten volcanic rock) beneath their layers of dust.

Neither theory can settle the question of how the dust covering these and other maria came into being. Most sand, soil, and dust deposits on earth are formed by the grinding effect of wind and water erosion and transportation by wind and water. Since the Moon has no weather, how can any part of its surface be overlaid with dust? Explosive meteorite impact, pulverizing rock for many miles around, is one explanation. Slow accumulation of cosmic dust is another. The latter explanation means that space contains dust particles, which, over a period of several billions of years, could be attracted to the surface of the Moon and accumulate there.

Why are dust-covered maria concentrated on the side of the Moon facing the earth and not on the hidden side? Nobody really knows. One answer was suggested at the Houston conference of January 1971. Earlier in this chapter, we described the Earth's magnetic tail as a flow of electrons into space. Possibly, said one scientist, this could induce attraction of cosmic dust to the Moon surface facing the earth by static electricity. The theory, however, was challenged by other scientists.

Other features.—The Moon has very rugged ridges and mountains. Most of them are less than 10,000 feet high above the surrounding surface, but one isolated mountain named Leibnitz rises 30,000 feet above the surrounding area, towering higher than the highest mountain on the Earth, 29,000-foot Mount Everest.

Rilles are peculiar, long, irregular troughs. Some are narrow, like small dry stream beds, but **Hadley's Rille**, explored by the Apollo 15 astronauts is 1,200 feet deep and one mile in diameter. These are features discovered only in recent years since closeup views of the Moon from spaceships became available. Possibly, some of the smaller rilles were traced by huge rolling boulders tossed from a volcanic eruption or a meteorite impact. Larger rilles are believed to be carved out by lava flow. Figure 25 shows a valley with a rille in the middle, crossing a mountainous area and entering a mare. It looks somewhat like a river valley flowing into a sea on Earth, but it is not explainable as such.

GERMS ON THE MOON?—The Moon is *probably* completely devoid



Figure 25. Hodley Rille. This is one of the most conspicuous lunar rilles viewed with earth-based telescopes. The rille meanders through the more material of Polus Putredinius, approximately parallel to the Apennine Mountains which rise above the more surface to more than 8,000 feet.

of life in any form. However, the absence of atmosphere and visible water does not rule out completely the possibility of water beneath the Moon's surface at some locations; nor does it rule out the possibility of a very low order of life, such as bacteria or other one-celled creatures. Could these be dangerous disease germs? Astronauts of Apollo 11, 12, and 14 were quarantined for two-week periods after returning from the Moon voyages. Their quarantine was a safeguard against a possible epidemic of an unknown disease from a Moon organism, against which man had no natural or medical defenses. Even then, scientists considered the chance of such an occurrence extremely remote and, after further study of the problem, lifted the precaution in April 1971.

MOON DUST.—The dust that covers the maria and other surfaces of the Moon has interesting physical and chemical properties.

Physical properties.—Scientists knew before the Moon walks that suitable landing areas were covered with dust, which could be several feet thick. They feared that this dust would not provide a firm landing site for a space vehicle or a firm footing for a Moon-walking astronaut. However, photographic and other evidence supplied by five unmanned Surveyor vehicles that made soft landings on the Moon in a 1966-1968 program were reassuring. There would be no danger that vehicle or man would sink into lunar quicksands. Astronauts themselves later confirmed that Moon dust provided a firm base for walking and for vehicle landing and take-off, including rocket blast. With no air between them to act as "ball bearings," dust grains on the Moon cling to each other and form a firm but compressible mass, capable of supporting several pounds per square inch. Although utterly dry, the dust has a consistency somewhat similar to that of damp sand. Man leaves shallow but distinct footprints as he walks on the Moon. These are permanent mementos of his visit, for there are no winds or rains to erase them.

In November 1969, the Apollo 12 lunar module landed in the Ocean of Storms near the Surveyor 3 vehicle, which had been undisturbed for 31 months. The astronauts returned to Earth with pieces of the Surveyor vehicle for laboratory study. It was then discovered that certain surfaces of the vehicle had been sand-blasted. Careful analysis of photographs and other evidence showed that these surfaces had been facing the lunar module. There was

only one possible explanation for the sandblasting effect. The rocket engines of the Apollo 12 lunar module firing downward to provide braking for a soft landing, disturbed particles of Moon dust and propelled them across the 200 yards between the two vehicles. The velocity of the dust particles was estimated at 70 meters per second minimum, approximately 155 mph. This was much faster than such particles would have traveled on Earth through atmosphere and under stronger gravity. The Apollo vehicle came down on lunar terrain somewhat higher than the location of Surveyor 3, and the trajectory of the particles was low and direct. (Figure 26.)

Of what significance is this information? For example, how will it help us to know more about the origin of the Moon or some of its surface features, or something even more practical? Science is never hasty with such questions. It is a process of endlessly collecting bits and pieces of data and fitting them together with painstaking work. The behavior of dust particles disturbed by rocket

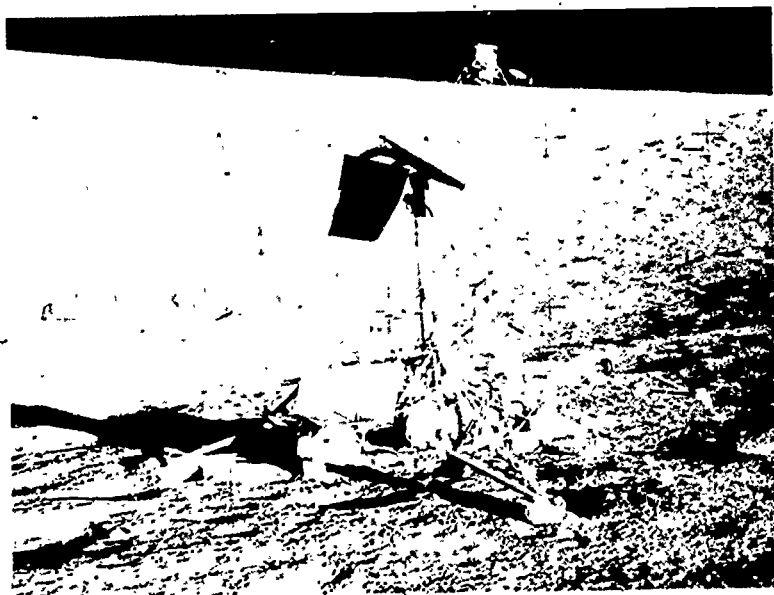

Figure 26. This unusual picture shows two US spacecraft on the Moon's surface. The Apollo 12 lunar module can be seen in the background and the Surveyor 3 spacecraft in the foreground. The Apollo 12 lunar module launched about 200 yards from Surveyor 3 in the Ocean of Storms.

blast is information that may possibly be useful some day. We cite this example only to suggest the way in which scientific knowledge slowly advances in the laboratory between the spectacular adventures of astronauts.

Chemical properties.—Experiments with Moon dust samples returned by Apollo 11 and 12 have already produced some surprises. In repeated tests, **core samples** (subsurface dust) from Apollo 11 had a sterilizing, antibacterial effect almost as strong as that of a typical mouthwash. However, the surface sample from the same mission did not produce this effect, nor did either core or surface samples from Apollo 12. Thus, we have one more of many new Moon mysteries to add to the old.

In another series of experiments, a botanist growing plants in a liquid medium in a laboratory found that widely varied plant species, ranging from **liverworts** (a primitive plant related to moss) to tobacco and corn, grew more rapidly and looked healthier when pinches of Moon dust were added to their food. The botanist suspects that this fertilizer effect is due to a lack of atmosphere on the Moon. Earth soil, exposed to atmosphere for long ages, probably has undergone certain very slow chemical changes that reduced its plant-fertilizing power. The chemistry of Moon dust has probably been unchanged for billions of years. The practical value of this discovery is a long way from reality. Either farming on the Moon or bringing back tons of lunar fertilizer is obviously impractical. (Figure 27.)

Origins and History of the Moon

How did the Moon come into being? How old is it? How did it get trapped into its apparently eternal orbit around the earth? Before the advent of the Moon walkers, there were various conflicting answers to these questions. These theories are still in conflict today.

EVIDENCE OF AGE.—Rock samples brought back from the Moon tend to support previous estimates that the Moon is approximately five billion years old. The age of a sample can be estimated by comparing its radioactivity with a known rate of radioactive decay for certain elements that it contains. Most samples from the Moon are estimated to be about 3.5 billion years old. One sample returned by the Apollo 12 expedition has an estimated age of 4.5

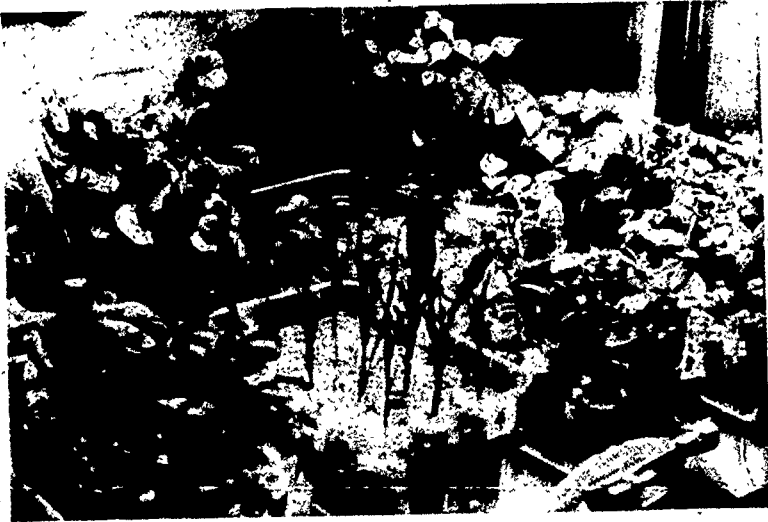

Figure 27. Several varieties of plants shown in the plant laboratory of the Manned Spacecraft Center. These plants were exposed to lunar material for 35 days before this picture was made. The back row from left to right shows radish and cabbage, lime and other citrus, and wheat and bean plants. The front row (l to r) includes radish, so ghum, canteloupe, and watermelon.

billion years. (Figure 28.) Another sample, taken from the high-land slopes at the edge of the Mare Imbrium in August 1971 (Apollo 15), is believed to be even older, but, at the time of this writing, no laboratory tests have been performed on it.

MOON-SEPARATION (DARWIN) THEORY.—Sir George Darwin, an English astronomer (son of Charles Darwin), developed a theory in the late nineteenth century that the Moon was once part of the Earth. According to this theory, the Earth, soon after its formation, was a sphere of molten rock spinning very rapidly. The gravitational pull of the Sun, combined with centrifugal force (outward force in a spinning or turning object), could have caused a huge portion of the earth to fly off and form a moon. Supporters of this theory believe that the Pacific Ocean occupies the great hole left in the side of the Earth as a result of this separation.

Criticisms of the Darwin theory, however, have been plentiful. One group of critics believes that it is impossible to set up a tide in a liquid sphere equal in mass to the earth, strong enough to cause a mass equal to the Moon to separate. If it were possible, such a force would have torn the Moon to pieces. Evidence of

rock and dust samples from the Moon has not settled this question. Chemical analysis shows that these samples are made of the same elements as those found on Earth, but some experts find the samples too rich in such elements as zirconium, strontium, barium, yttrium, and titanium, which are somewhat rare on the Earth. Nevertheless, the Darwin theory still receives the support of some qualified experts.

OTHER HOT GASEOUS THEORIES.—Other theories hold that the Earth, Moon, and the other planets formed from hot gaseous matter, which slowly liquified and condensed. One such theory is that the whole solar system was torn from the Sun by a collision or near collision with another star. The total mass of all the planets, moons, and smaller bodies in the solar system is hardly one percent of the mass of the Sun. Therefore, certain objections to this theory similar to those against the moon-separation theory are not raised. Another theory, however, holds that the gaseous matter came from elsewhere than the Sun.

ACCRETION THEORIES.—Another group of scientists discounts all

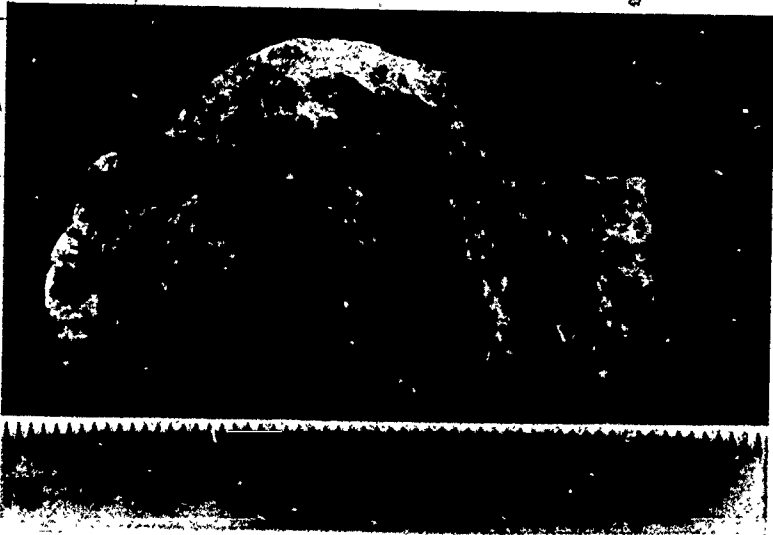

Figure 28. A sample of Moon rock believed to be 4.6 billion years old.

theories that the Earth, Moon, and other bodies began as hot gas that passed through a liquid stage before forming a hard crust. Instead, they believe that the Earth, Moon, and other planets began as small chunks of matter, like the meteoroids and asteroids that abound in some parts of the solar system, and grew by gradual accumulation of solid particles of matter, much like rolling snowballs. According to various theories, the space around the Sun was filled with a cloud of dust; others say larger pieces of matter. When particules collided with each other, they tended to stick together. Through a process of slow growth called **accretion**, the larger bodies, thus formed, would gradually sweep the solar system almost clean of smaller particles as they circled the Sun. Since volcanic activity on earth indicates that the earth has a hot molten core, and there is strong evidence that the same is true of the Moon, how would the accretion theory account for such hot interiors? Buildup of heat by pressure as the body grows by accretion seems to be the answer.

THEORIES ON ORBITAL CAPTURE.—The Darwin theory holds that the Moon orbits the Earth as a result of the centrifugal force that it acquired when it was torn free of the earth. Almost all other theories agree that the Earth and Moon were formed separately, together with the other planets of the solar system and most of their moons. The Moon was once a small planet traveling in its own orbit around the Sun until it wandered close enough to the Earth to become a satellite of the Earth.

One can be thoroughly bewildered by all these conflicting theories and unanswered questions. We have noted, also, that almost any theory about the origin of the Moon will involve a theory about the origin of the whole solar system. In the next chapter, we survey the larger worlds beyond the solar system and our Milky Way Galaxy.

WORDS, PHRASES, AND NAMES TO REMEMBER

accretion
apogee
Appleton, Region
asteroid
atomic number
atomic weight

aurora borealis
aurora australis
caldera
celestial mechanics
centrifugal force
core sample

FROM THE EARTH TO THE MOON

corona (of sun)
cosmic dust
cosmic rays
Darwin, Sir George
electromagnetic waves
electron
exosphere
gravitation
gravitational field
Hadley's Rille
heterosphere
homosphere
ion
ionization
ionosphere
Kennelly-Heaviside layer
lava
liverworts
lunar month
magnetic pole
magnetic tail
magnetosphere
Marconi, Guglielmo
mare (pl. maria)
Mare Tranquillitatis

mascon
mass
meteor
meteorite
meteoroid
neutron
Newton, Sir Isaac
nucleus (of atom)
Oceanus Procellarum
perigee
Piccard, Auguste
plasma
proton
rille
satellite
sidereal month
solar wind
sounding rockets
subatomic particle
SIDs
synodic month
thermosphere
topography
Van Allen, James A.
Van Allen radiation belts
weight (cf. mass)

QUESTIONS

1. How did Marconi's invention of long-range radio lead to discovery of the ionosphere?
2. Why is shortwave radio favored for long-distance communications today?
3. In what fashion might the earth eventually lose its atmosphere?
4. How are ions created in the upper atmosphere?
5. What are the hazards of the Van Allen radiation belts for astronauts?
6. If the Earth attracts the Moon, why does the Moon not crash into the earth?
7. Explain how the lack of atmosphere has affected the Moon's topography.
8. Describe the physical properties of Moon dust. Why is a bed of Moon dust not likely to be a dangerous quicksand?

AEROSPACE ENVIRONMENT

9. Describe some theories on the formation of the Moon craters called maria.
10. Basically, what is Sir George Darwin's theory regarding the origin of the Moon? What are some other theories of the Moon's origin?

THINGS TO DO

1. Construct a topographical three-dimensional model of the Moon. An excellent map of the Moon's surface can be found in *The Picture History of Astronomy* by Patrick Moore, Grosset and Dunlap, New York, 1961, and other similar sources in your school library.

Suggested materials: Large plastic, styrofoam, or other type of solid ball cut in half, plaster, flour, salt, and water paste, or other molding material that will adhere to the ball to form craters, maria, rilles, and so on.

2. Using your model of the Moon, design and construct a lunar observation post or Moon colony based on what you have read about future uses of the Moon for space exploration.

Suggested materials: Paste or plaster, cardboard, match boxes, balsam wood, aluminum foil, and other construction materials.

Chapter 5

The Worlds of Outer Space

THIS IS THE FINAL CHAPTER in our study of The Aerospace Environment. In Chapter 4, we examined the Moon. In this chapter, we examine interplanetary, interstellar, and intergalactic space. The chapter begins with a discussion of the instruments used by astronomers to learn more about the Milky Way, and other star systems millions of miles in deep space. Following a description of the astronomer's "tools," we consider in some detail the known characteristics of the Sun and the nine planets that comprise the solar system. Beyond the solar system is interstellar and intergalactic space, populated by billions of other galaxies and star systems. The chapter continues with an explanation of some of the techniques used by astronomers to measure interstellar and intergalactic distances. It concludes with a discussion of galaxy formation and the nature of the universe beyond the Milky Way Galaxy. When you have studied this chapter, you should be able to do the following: (1) name and describe the major instruments used by astronomers; (2) describe the significant features of the Sun and each of the nine planets; (3) explain interstellar measurements and the formation of the galaxies; and (4) describe the nature of the universe beyond the Milky Way.

IN THIS FINAL CHAPTER, we explore the worlds of interplanetary and instellar space, discussed briefly in Chapter 1.

Quite possibly, man will journey through interplanetary space within your own lifetime. Travel beyond the solar system into other solar systems has long been one of the themes of science fiction. Modern scientists have only begun to develop plans for in-

tergalactic excursions. Meanwhile, man continues his centuries-old study of astronomy, scanning the heavens and learning more about the universe from ground observatories. Whether or not these studies pave the way for manned space travel beyond our solar system, unlocking the secrets of the worlds in outer space helps us to know more about our own world.

INSTRUMENTS OF ASTRONOMY

Man has long depended on ground-based instruments for his knowledge of the heavens. With optical telescopes, together with spectroscopes and other accessories, man has been able to locate heavenly bodies, analyze their chemical content, and measure their brilliance. Radio telescopes provide additional data on the planets, stars, and space surrounding them.

The Optical Telescope

The oldest, best known, and still the most useful instrument for scanning the heavens is the **optical telescope**. Galileo is often mistakenly credited with the invention of this instrument. The actual inventor was a Dutchman named **Hans Lippershey**, who developed a simple two-lens spyglass in 1608. Galileo built similar telescopes in Italy soon afterward and used them to make important astronomical discoveries, such as the craters on the Moon, the rings around Saturn, and the spots on the Sun. (Figure 29.) Galileo's largest telescope could magnify objects about 33 times their apparent size in one dimension known as *33 diameters*, *33 power*, or *33X*. Later, in 1668, the famed English astronomer, Sir Isaac Newton, devised the first **reflecting telescope**, using a curved mirror instead of a lens as its main optical element.

REFRACTING TELESCOPES.—For another two centuries or more after Newton's invention, lens-type or **refracting telescopes** were superior to the mirror or reflecting type. Refracting telescopes operate by bending or refracting rays of light passing through the lenses. A point source of light, such as a candle or a distant star, radiates light in all directions. When light from such a source falls on an ordinary flat window pane, which has no image-forming capability, the light covers the whole area of the pane, passes through the glass, and shines dimly but evenly across several square feet on an opposite wall. If, instead of

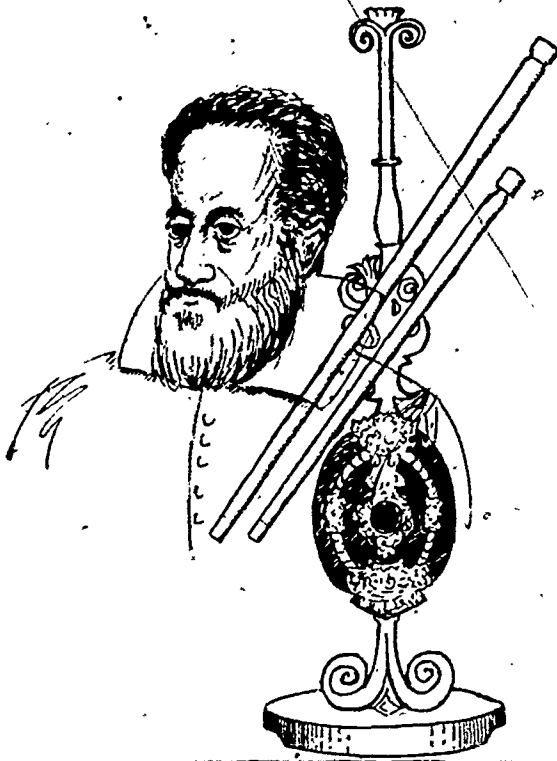

Figure 29. Artist's concept of the telescope constructed by Galileo. He was the first to use a refractor telescope.

a window pane, a large curved lens is used, it bends or refracts light rays so that they converge at a given point on the opposite wall. (The opposite wall must be precisely located a certain distance from the lens.) Thus, the rays from a candle would form a small intensified image of the candle flame on the wall. A film as in a camera or an eyepiece could be placed on the wall to magnify the image for direct viewing. In a refracting telescope, both the curve of the lens surface and the composition of the different lens elements affect the degree to which the light rays are bent. By the end of the eighteenth century, refracting telescopes with lenses over one foot in diameter were in use. (See Figure 30.)

The two largest refracting telescopes ever created were built during the last decade of the nineteenth century—the 36-inch telescope at the Lick Observatory in California and the 40-inch telescope at Yerkes Observatory in Wisconsin. Scientists then realized that refracting telescopes much larger than these would create problems because the weight of the lens would produce image-distorting or blurred stresses inside the glass itself. Nowadays, smaller refracting telescopes are still built for special purposes, but the modern high-powered heavyweight telescopes are the reflecting type.

REFLECTING TELESCOPES.—In a giant reflecting telescope, light from a star falls across most of the area of its largest or **primary**

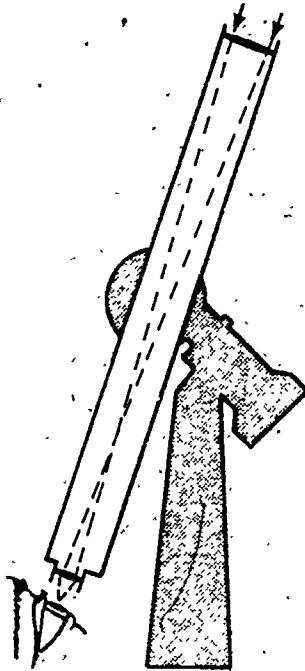

Figure 30. The refractor telescope bends or refracts rays of light that pass through the lenses. When light passes through a lens at the top of the tube, it bends the rays and directs them to an eyepiece at the lower end of the tube. The eyepiece is equipped with magnifying lenses that focus and enlarge the image.

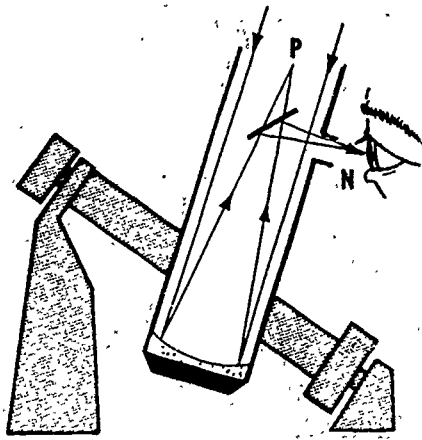

Figure 31. One type of reflecting telescope uses a large concave primary mirror at the lower end of a long instrument tube. The curve of this mirror concentrates the light and reflects it to a point of primary focus at the top of the tube. Slightly below the point of primary focus is a small, flat mirror which deflects beams through the side of the instrument tube to a final point of focus called the Newtonian focus (Point N). An observer equipped with an eyepiece views the image at Point N.

mirror. The curve of this concave mirror reflects and concentrates this large spread of light to a tiny point of **primary focus**, located at the top of the main instrument tube. Near the primary focus, a small, flat slanting mirror intercepts all the converging beams from the primary mirror and directs them through a hole in the side of the main instrument tube to a point of focus called the **Newtonian focus** (Point N). Here an observer equipped with an eyepiece or a camera can be stationed. (Figure 31.)

A much smaller concave **secondary mirror**, centrally located in the tube near its head can catch reflections from the primary mirror and beam them back, still more closely concentrated, through a hole in the primary mirror. Behind this hole at the bottom of the instrument tube is an observing or camera station located at a point called the **Cassegrainian focus** (Point C—named after N. Cassegrain, the seventeenth century French inventor of the principles. (Figure 32.) In the still more complex Coudé system (from the French word for "bent like an elbow"), the light first reaches the primary mirror and is then reflected into a concave

secondary mirror, Cassegrainian fashion. Near the primary mirror, a third flat, slanting mirror intercepts the light from the secondary mirror and reflects its Newtonian fashion to an observing or camera station at the **Coudé focus**, located to one side at the lower part of the main instrument tube. (Figure 33.)

The giant primary mirror of today's leading reflecting telescopes are made of extremely tough, rigid, heat-resistant glass. Their weight is reduced by a honeycombed or waffled structure. Only the reflecting surfaces have an optical function. These mirrors require years of slow, careful grinding and polishing to perfect the curvature. The surface is then coated with a microscopically thin reflecting layer of aluminum, which is brighter, more durable, and less subject to tarnish than the silver previously used. The entire aluminum coating of the huge 200-inch primary mirror of the **Hale telescope**, located atop Mt. Palomar in California, weighs only one ounce.

The Hale telescope (Figure 34) is currently the largest com-

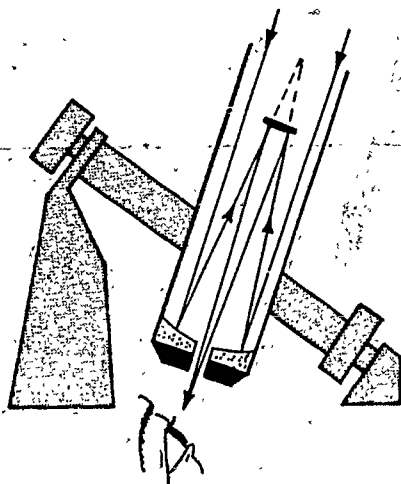

Figure 32. Another type of reflecting telescope uses a large, concave primary mirror at the bottom of the instrument tube and a smaller, concave secondary mirror near the top of the tube. The large mirror reflects concentrated light to the small mirror which further concentrates the light rays and reflects them back through a small hole in the large mirror. The observer is located behind this hole at the bottom of the instrument tube. This arrangement is known as the Cassegrainian focus.

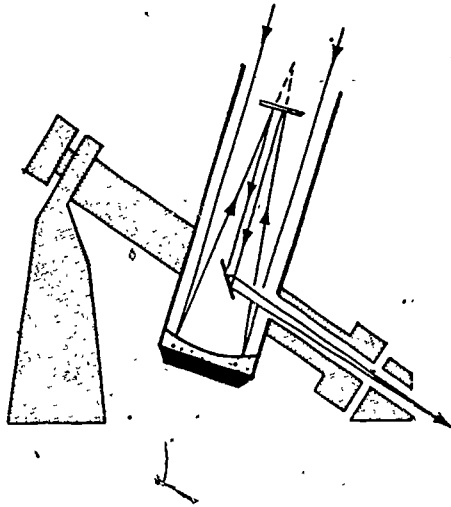

Figure 33. Still another type of telescope uses the so-called Coudé focus. This type of focus is quite similar to the Cassegrainian focus with one major exception. It uses a third slanting mirror near the bottom of the tube to deflect light rays Newtonian fashion through the side of the instrument tube.

pleted telescope in the world, but, in the Caucasus Mountains, the Soviet Union is building a larger telescope with a 236-inch primary mirror. One advantage of such giant telescopes over smaller types is not their power to magnify an image but the improved resolution which they give. A magnified but blurry image is unsatisfactory. Sharpness, or **image resolution**, is at its best when a telescope is used at somewhat less than its full power of magnification.

The third advantage of size and power in a telescope is **light intensification**, the ability to record the image of an extremely faint and distant star. To make a long exposure of a star and maintain a sharp image, the telescope must be precisely aimed to follow the star as it "swings across the sky" due to the rotation of the earth. With this time-exposure method, stars too faint to be seen or colors impossible to distinguish through the eyepiece of a telescope can be recorded on film.

In Chapter 1, we mentioned that the Andromeda Galaxy, about two million light years away, looks like a nebula the size of the Moon. The resolving power of today's giant telescopes is sufficient to show the shapes and composition of galaxies that appear through

smaller instruments as tiny, single stars. Telescopes also reveal details on bodies within the solar system—the Sun, the Moon, the planets, and their moons.

Telescopes cannot reveal the shapes and surface details of individual stars other than our own star, the Sun. Even the nearest and brightest stars seen through the largest telescopes appear as tiny pinpoints of light. They are, of course, much brighter than other pinpoints, but they have no apparent size. Furthermore, no planet belonging to any “solar system” other than our own is visible even through the most powerful optical telescopes.

Other Astronomical Instruments

Other instruments used in conjunction with optical telescopes include spectroscopes and spectrographs, the coronagraph, and various photographic attachments.

AUXILIARY INSTRUMENTS.—Just as some telescopes are equipped with various devices to intensify images of faint and distant stars, others perform an opposite function for Sun-watching purposes. These telescopes are equipped with filters to reduce the Sun’s intensity, enabling scientists to study sunspots, surface details of the

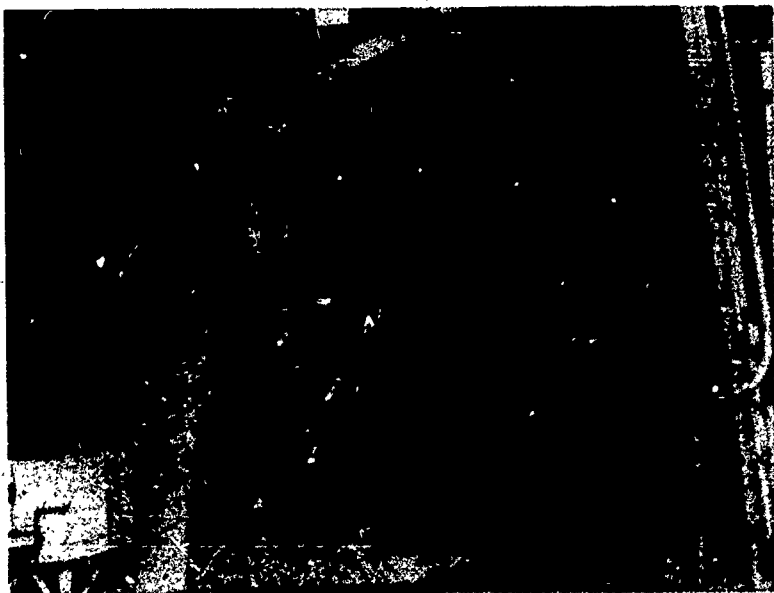

Figure 34. 200-inch Hale telescope showing observer in prime-focus cage.

Sun, and colors which indicate the Sun's chemical composition. We have previously noted that the corona of the Sun can be seen during a total eclipse. A device called a **coronagraph** creates its own artificial eclipse inside the instrument with the insertion of an opaque disc in the Sun's light path. This disc blots out the Sun's disc but leaves the Sun's corona visible. Other instruments attached to telescopes, such as **spectroscopes** and **spectrographs**, break down the light beams from individual bodies into colored bands of the visible portion of the electromagnetic spectrum. Each star, planet, or other direct or reflecting light source has its own "fingerprint," a unique arrangement of different colored bands and narrow stripes which reveal the chemical content of the body being viewed.

THE RADIO TELESCOPE.—Visible light, which is corrected, focused, viewed, and photographed by means of optical telescopes, is but a band within a broad spectrum of **electromagnetic radiations**. Any energy source, such as a star, emits radiations of both shorter and longer wave lengths than those of visible light. Within the spectrum of visible light, the largest emissions are red. Invisible wave lengths longer than red are classed as infrared; they are felt as heat rather than seen as light. Emissions of even longer wave lengths or lower frequencies of vibration are carriers of radio signals.

Giant radio telescopes with dish-shaped **parabolic** antennas the size of football fields receive radio emissions from the farthest reaches of space and bring them into focus just as optical mirror telescopes intensify star images. Radio emissions from outer space reveal the locations of stars and distant galaxies and even indicate electronic activity in interstellar space (a phenomenon similar to the Van Allen radiation belts that occupy cislunar space). Radio emissions produce images on radio telescope receivers and screens and audible sounds in other receiving instruments. A radio telescope located at Jodrell Bank, England, is 250 feet in diameter and is the world's largest "steerable dish." A 1000-foot nonsteerable dish is located in a natural amphitheater in Puerto Rico. (See Figure 35.)

THE SOLAR SYSTEM

As mentioned in chapter 1, the Sun, the planets, and smaller bodies within the influence of the Sun's force of gravity or out-



Figure 35. Radio telescope at Jodrell Bank, England.

put of energy constitute the solar system. The Sun has nine major satellites, or planets. Many of these planets have their own satellites or moons. Between the orbits of Mars and Jupiter lies a belt of numerous smaller bodies called asteroids, which travel around the Sun in independent orbits. (See Figure 36.)

The Sun

The Sun is the mother hen of the solar system. Besides being the center around which the planets rotate, the Sun is also the source of almost all light, heat, and other energy for each of the planets. Either directly or indirectly, man derives all usable forms of energy on the earth, except nuclear energy, from the Sun. Although the Sun is only a medium small star compared to other

THE WORLDS OF OUTER SPACE

stars in the universe, it generates tremendous energy. On its surface, for example, the Sun has a temperature of about 11,000° F., but, internally, it has an estimated temperature of 20,000,000° fahrenheit. During every second of elapsed time, this giant nuclear energy machine converts some four million tons of its matter into radiant energy and expels it into space. Fortunately, for inhabitants of the earth, only one-billionth of this energy reaches the earth. In other words, the Sun in one second of time produces enough energy from nuclear fusion to supply man's present power needs for over a billion years, and scientists believe that the Sun will continue this output for billions of years in the future.

Although the Sun is the only star in the universe near enough to study and is relatively insignificant in comparison with other stars, it has a diameter of about 864,000 miles. By comparison, the diameter of the earth is less than 8,000 miles, and the diameter of Jupiter, the largest planet, is less than 90,000 miles. Most of the other stars in the universe are much larger and hotter than the Sun. The Sun's mass is more than 300,000 times greater than that of the earth and represents 99.86 percent of the mass of the entire solar system. From its core to its surface, the body of the Sun consists of about 95 percent hydrogen or helium gases.

One of the most striking things about the Sun is its steadiness as

THE PLANETS

Planet	Date of Discovery	Planet's Distance from the Sun	Diameter	Period of Orbit	Orbital Velocity	Period of Rotation	Escape Velocity	Closest Approach to Earth	
Mercury	Known and observed since classical times	(Miles) 36,000,000	(Miles) 3,100	88 days	29.7	88 days	2.5	50,000,000	
Venus		67,370,000	7,575	224.7 days	21.7	Unknown	3.3	26,000,000	
Earth		93,083,000	7,900	365 days	18.5	1 day	7.5	—	
Mars		141,710,000	4,340	687 days	13.0	24 hrs 37 min	3.1	35,000,000	
Jupiter		483,900,000	89,320	11 yrs 314 days	8.1	9 hrs 55 min	37.0	347,000,000	
Saturn		887,200,000	75,921	29 yrs 108 days	6.0	10 hrs 14 min	22.0	745,000,000	
Uranus		1781	1,784,800,000	32,219	84 yrs	4.2	10 hrs 40 min	13.0	1,491,797,000*
Neptune		1846	2,793,700,000	33,000	164 yrs 26 days	3.4	15 hrs 40 min	14.0	2,700,497,000*
Pluto		1930	3,675,300,000	4,000	248 yrs	2.7	Unknown	6.5	3,582,297,000*

*Approximate figure

Figure 36. The planets.

a source of heat. The energy of many stars in the universe fluctuates quite wildly; the Sun's energy does not. Although scientists have not determined exactly what its total energy variations are, they know definitely that they are less than one-half of one percent from day to day, or from one year to the next. This steadiness is a good thing for man because even small variations in the Sun's energy would make conditions on earth variable and much more difficult for human habitation. Man in space, however, will not be so fortunate in his relationship with the Sun. In addition to the constant heat output, the area above the earth's protective atmosphere contains extremely short wave lengths in the spectrum and varying levels of penetrating, damaging radiation. According to scientists, these violently changing radiations appear to have some connection with periodic changes in some of the visible features of the Sun.

When viewed with a small telescope, the surface of the Sun appears at first glance to be a luminous disk, of smoothly varying brightness, a little more brilliant at the center than at the edges. This luminous disk, called the **photosphere**, is the layer of the Sun made up of gases and is the apparent surface of the Sun. This is the point where the Sun's atmosphere begins. Below this level, just a few miles down into the Sun, the gases change from transparent to opaque gases for all wave lengths of visible light. A closer look at the transparent surface of the Sun reveals a much more complex structure than is at first apparent. The most noticeable features are the large sunspot groups that dot the surface. Since 1750, the length of sunspot cycles has averaged about 11.4 years. In some years, sunspots have been extremely rare and, even when present, they have been small. At other times, the photosphere has frequently been covered with more than a hundred spots of all sizes and generally gathered in great clusters in the major sunspot region. On 25 December 1957, astronomers recorded the greatest number of sunspots of any date since observations were started during the time of Galileo. This peak of average solar activity in 1957 was reached during the International Geophysical Year and was the highest since 1778.

Sunspots vary from day to day and also drift from east to west as the Sun rotates on its axis. At its equator, the Sun rotates in about 26 days. Rotation appears to take longer at the poles. How much longer the rotation takes is difficult for astronomers to de-

termine because they base their observations on sunspots and these spots rarely appear above 40 degrees latitude.

Large individual sunspots are considerably cooler than the surrounding surface of the Sun. They also have enormously complex structures. For descriptive purposes, the dark center of a sunspot is called the **Umbra** and the gray area surrounding the Umbra is called **Penumbra**. Astronomers say that the principal clue to the physical nature of sunspots may be found in the magnetic fields which surround them. Students of astronomy know for example that sunspots show very complex magnetic fields which vary considerably in their magnetic properties. Some of these fields are large, some small, some positively oriented, and others negatively oriented. (See Figure 37.)

Probably the most violent and abrupt solar activity is the solar flare, which frequently appears in sunspot regions. These flares appear as intense brightenings at or near the surface of the Sun, rise to maximum brightness in periods as short as one-half minute, and then slowly decline. The decline can take up to a few

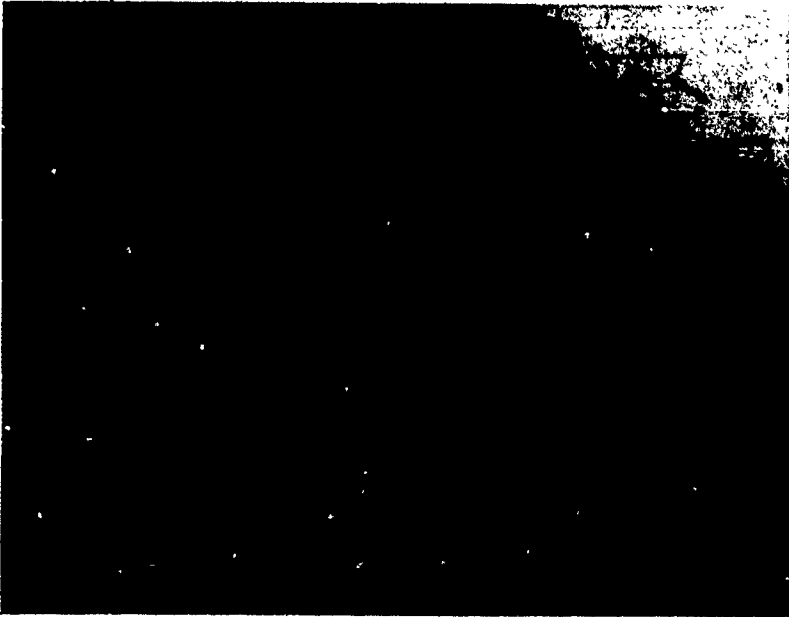

Figure 37. Sunspots with associated flares giving off energized particles that bombard the earth's atmosphere.

hours. These flares often produce violent changes in radio, ultra-violet, X-ray, and particle emission from the Sun and constitute a possible danger to the astronaut who does not have the earth's atmospheric protection. These are the **sudden ionospheric disturbances (SIDs)** mentioned in Chapter 4. Even in the earth's atmosphere, these flares often produce interference with radar and ordinary radio transmission and sudden fade-outs of long distance, short-wave radio communication during the displays of the aurora borealis and aurora australis. At the height of solar flare activity, scientists have noted obvious changes in the direction and strength of the earth's magnetic field.

Directly above the solar photosphere is the area called the chromosphere. The **chromosphere** is a layer of reddish-colored incandescent gases visible only during total eclipses. Although scientists know that the temperature of the Sun's photosphere decreases with increasing altitude, they do not readily agree on the intensity of temperatures in the chromosphere. Since the height of the Sun's chromosphere is only 9,000 miles at the most, scientists find it difficult to make reliable observations. For this reason, space scientists travel to regions of total eclipses on the earth to study the chromosphere and avoid the scattering effect which the Sun's photospheric light has on the detail. Scientists say that this layer of the Sun's atmosphere is enormously important, particularly to future space travelers, for it is here that a large part of the dangerous solar radiation begins.

Still another layer of the Sun is called the corona. Scientists formerly had to obtain pictures of the corona during a total eclipse. Now, however, they have cameras equipped with special devices which permit them to study this area of the Sun. The corona is virtually a circle of light, or halo, around the Sun. Solar experts generally agree that the corona starts just above the chromosphere and extends many miles into space. Some scientists maintain that some of the streams of gas noticed in the corona extend as far as the earth. It is also possible that temperatures as high as 4,500,000 Kelvin* exist in the coronal gases. The stream of particles which make up this coronal flow of gases is sometimes called the solar wind which contains numerous protons and electrons

The Kelvin scale is sometimes called the absolute temperature scale because 0°K is absolute zero (temperature at which there is an absence of molecular motion). On the Centigrade (Celsius) scale, absolute zero is -273.16 degrees. Thus in order to convert Kelvin degrees to Centigrade, 273.16 degrees must be subtracted from the Kelvin temperature. For example, 373.16°K is equal to 100°C.

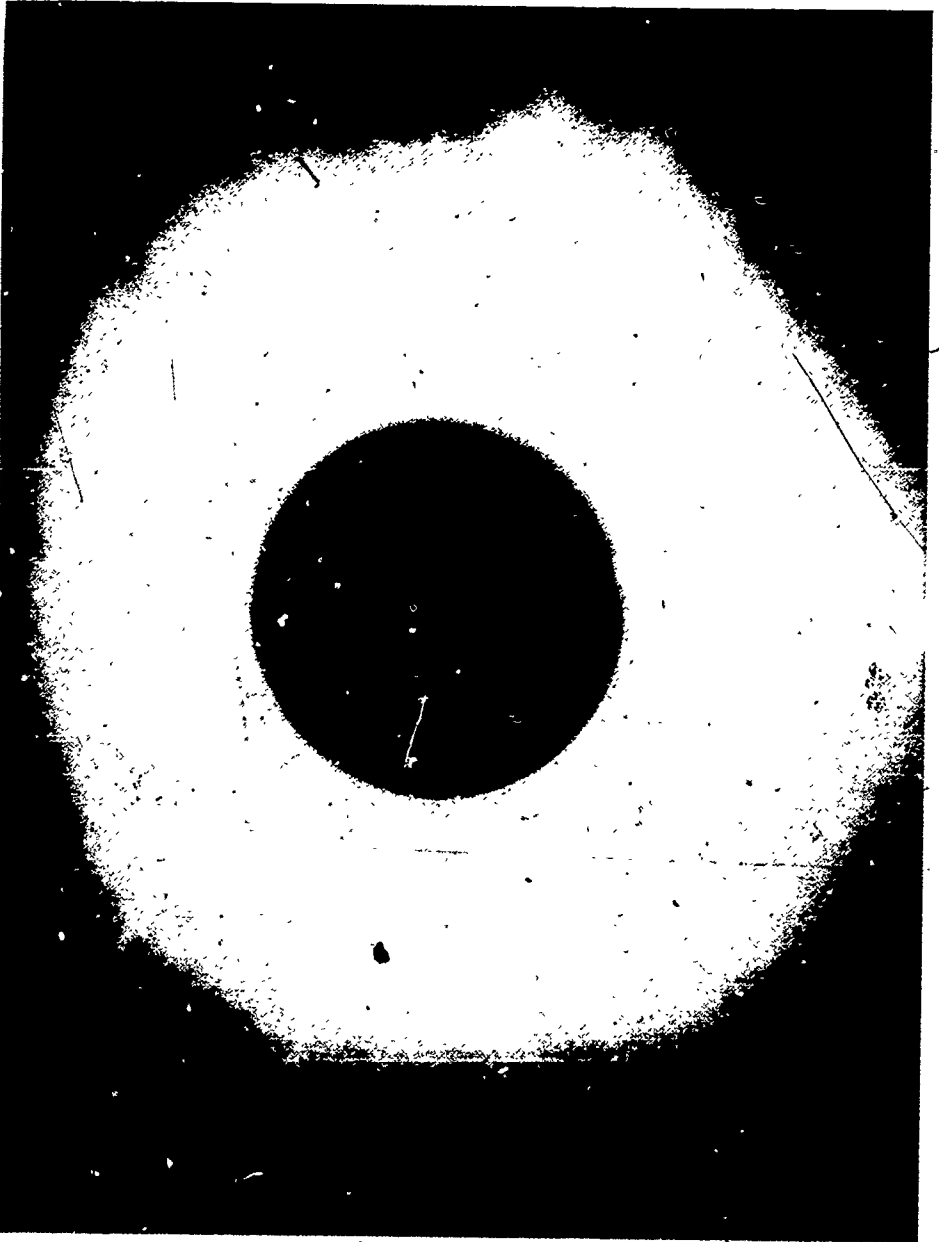

Figure 38. Solar eclipse of 7 March 1970, taken at Mishuatlan, Mexico. The Moon totally blocked out the Sun for three and one-half minutes.

speeding through space at about 800 miles per second. During increased Sun activity, the number of protons and electrons increases. Also, there is a corresponding increase in their energies. Scientists link these clouds of activity, which are observable from the earth and from satellites and space probes, with some of the Sun's outbursts and the accompanying disturbances in radio communications.

The Inner Planets

The four planets nearest the Sun are Mercury, Venus, Earth, and Mars. Mars and Venus flank the earth on either side and have the most immediate interest for planetary space research. They are also the planets likely to be targets for planetary probes for a great many years to come, and they are the ones most likely to be visited by man. A two-in-one probe of Venus and Mercury is scheduled for 1973. The Mariner will need to be heat-resistant because it will approach close to the Sun.

Mercury. At a distance of 36 million miles from the sun, Mercury is the planet closest to the Sun, and the smallest of the principal planets of the solar system. Since Mercury is relatively close to the Sun and always appears somewhere near the Sun in the sky, scientists find it very difficult to observe. Consequently, they have less accurate knowledge about it than they have of the other planets.

This planet is never visible to the naked eye except when it appears either low in the west after sunset or low in the east before sunrise. When it is seen above the eastern or western horizon, it is probably the only planet that twinkles because it is shining through a thick unsteady layer of the earth's atmosphere. Since it reaches its highest point during the daylight hours and always hovers near the Sun, it is very difficult to obtain much information about it. However, recent studies by astronomers have yielded some significant facts about this planet through the use of spectrographs, microwave, and infrared radiation* detection equipment.

With a diameter of 3,025 miles, it is more than half again as large as the Moon. It is closer to the Sun than any other planet, with an average distance of 36 million miles, and, therefore, it can complete one revolution around the Sun in less time than any of the other planets. Thus, one Mercury year is fairly short,

*Microwave and infrared radiations are part of the electromagnetic spectrum (see Figure 5)

approximately 88 days. Since Mercury rotates on its axis only once every 59 days, the length of the Mercury day is quite long as compared to the earth's day. This new information about the length of its day, gained from radar observations, contrasts with the old idea that it always had one face towards the Sun. Evidence gathered from shadow effects on Mercury, between the quarter and full phases, tends to show that its surface is about as mountainous and rocky as the Moon's surface. Also, experienced observers have seen dark blotches which resemble very closely the lunar seas (Maria).

These studies also have implied the presence of a thin atmospheric layer of hydrogen. The proposed explanation for the lack of gases other than the low molecular weight hydrogen consists of two ideas. The first and earlier idea about Mercury's atmosphere is that, since it is very close to the Sun, most of the lighter (low molecular weight) gases have "boiled off" due to the high temperature (600-700°F., of the side facing the Sun. The second is that heavier gases, such as argon, carbon dioxide, and others that are produced by radioactive decay in the planet, may still be left in the atmosphere. In 1963, Kozyrev, a Russian astronomer, made spectrographic studies during a solar eclipse. These studies indicated that hydrogen may be a major component of Mercury's atmosphere. His theory is that hydrogen lost by escape from the planet is continuously replaced by gas captured from the solar winds. Another interesting idea to emerge from recent studies is that the side of Mercury away from the Sun at any given moment has a temperature that is not as low as had been previously predicted. Radar observations made with a large dish-shaped antenna in New South Wales, Australia, indicate that this temperature is somewhere in the range of 30-60°F. This temperature reading also lends some support to the idea of a thin atmosphere around Mercury which conducts heat from one side of the planet to the other.

Venus. Like Mercury, Venus also appears as the morning and the evening "star" during the spring and fall seasons of the year. As Venus swings through its orbital path around the Sun, it approaches closer to the earth than any other planet and, at its closest point, comes within 26 million miles. Strangely enough, however, astronomers know less about this planet perhaps than any of the other planets primarily because Venus remains hidden be-

hind a very dense atmosphere and a heavy cloud cover. This cloud layer, which is a pale lemon yellow color, has for centuries perplexed astronomers who could only speculate as to its composition. Probably the most popular notion was that, because of its high reflectivity, this cloud cover must consist primarily of water, either in droplets or ice crystals. At one time, it was proposed that the entire planet was covered with water, but its high surface temperature cancels this idea. At any rate, Venus is the brightest of all the planets, 12 times as bright as Sirius, the brightest star, and receives about twice the light and heat energy from the Sun, as does the earth.

Man's first opportunity to obtain information direct from the vicinity of Venus came on 14 December 1962, when the United States spacecraft Mariner 2 passed within about 21,600 miles of the planet. Aboard the vehicle were instruments to measure surface and atmospheric temperatures, the strength of the planet's magnetic field, and the nature of its radiation belts. From this historic flight of the first man-made spacecraft in the vicinity of Venus, men learned that very little cosmic dust existed during the mission in the space which separates Venus and earth and that the density of dust in deep space was about 10,000 times less than the amount of dust encountered in near-earth orbits. As Mariner 2 drew closer to Venus, the spacecraft's magnetic measurements changed only slightly, indicating that Venus, unlike the earth, has no strong magnetic field.

The Mariner also revealed some interesting information about the surface of Venus. For example, if it were possible for an inhabitant of the earth to stand on the surface of Venus, he would probably see the Sun rise in the west and set in the east because Venus rotates in a direction opposite to that in which the earth rotates. Overhead he might see clouds about 15 miles thick hovering above the surface through which a small amount of reddish-colored sunlight would pass. The surface of the planet is most likely a searing hot desert. Since the temperature on both the dark and sunlit sides of the planet registered between 600° and 800° F., it is hardly possible that any form of life familiar to earth inhabitants can exist.

More recent probes confirmed the findings of Mariner 2 and supplied additional data concerning Venus. Mariner 5, which reached Venus about the same time as Soviet Venera 4 (Venus 4),

also recorded excessively high temperatures, this time above 900° F. Data telemetered by the American and Soviet probes were generally in agreement. Data from both probes indicated that carbon dioxide is the principal gas in the Venusian atmosphere and that some water vapor is present. Both probes also gave evidence of a corona, or circle, of hydrogen gas around the planet. Neither probe found evidence of radiation belts like the Van Allen belts surrounding the earth.

There were some differences between the American and Soviet data. The Mariner 5 indicated slight magnetic activity; the Venera 4 did not. The slight magnetic activity reported by the American probe might be evidence of an extremely weak magnetic field surrounding the planet, or it might simply be the result of the interaction of the solar wind with the Venusian atmosphere. Readings from Mariner 5 also gave evidence that the atmosphere of Venus is 75 to 100 times as dense as that of the earth, but readings from Venera 4 indicated that it is only about 20 times as dense. Later Soviet figures, based on calculations from data supplied by Venera 7, confirmed the earlier American findings about the much denser atmosphere.

The Venera 7, which parachuted through the Venusian atmosphere, ejected a capsule that made a soft landing on the planet and transmitted data about temperature. This probe recorded temperatures as high as 1,000° F. The Soviet Venera 7 was preceded by Venera 4, 5, and 6, which telemetered data only while passing through the atmosphere.

The American Venus-Mercury probe in 1973 will fly by Venus on its way to Mercury. It will carry a television camera with a special lens for penetrating the dense cloud cover of Venus. If the camera operates successfully, it may give astronomers their first view of the Venusian surface.

Mars. Next beyond earth in order of distance from the Sun, Mars moves in its orbit once in 687 days at an average distance from the Sun of about 142 million miles. It rotates on its axis once every 24 hours 37 minutes and has a diameter of 4,200 miles, about half that of the earth. It has an atmospheric pressure at its surface only one hundredth (1 percent) that of the earth and surface temperatures which range from a daytime 85° F. to a nighttime -100° F. at the equator. The average temperature, however, is -40° F. compared with -60° F. for the earth.

Strangely enough, Mars rotates on its axis at approximately the same rate as the earth and, also like the earth, it is inclined on its axis about 25° in relation to the Sun. Because of this inclination, the Martian poles turn alternately to the Sun and cause this planet to have seasons about twice as long as the earth's seasons.

At its closest point to the earth, Mars is about 35 million miles away, but, as it moves in its orbit around the Sun, it reaches a maximum distance of about 210 million miles. It makes its closest approach in late summer and, with its bright red color, becomes the most brilliant object in the sky, with the possible exception of Venus.

Astronomers have observed and mapped Mars for more than 275 years because its thin atmosphere permits viewers to study its surface features. Early observers speculated that some form of intelligent life existed on Mars and even offered evidence to support their viewpoints. In 1877, for example, the Italian astronomer Giovanni Schiaparelli reported dark-line markings on the planet that he called canali. Canali was translated as canals in English, and other astronomers interpreted these markings to be a network of canals that had been constructed by intelligent human beings. Later astronomers discarded this idea because of evidence that Mars has too little free oxygen in its atmosphere to support human life as it is known on the earth. Although human beings could not survive on Mars without some means of making extensive changes in the environment, scientists believe that a self-sustaining colony could be established there.

As astronomers continued their studies of Mars, they observed what they believe to be seasonal changes. They have noted, for example, that white ice or frost caps alternately grow and decline in size around the Martian poles as the seasons change. Since the caps melt very rapidly, they are probably only an inch to several inches in thickness. One of the questions that probes are now expected to answer is whether the ice caps are formed of water ice or frozen carbon dioxide. Scientists have also noticed that, as the seasons change and the ice cap thaws, the region around it and toward the equator darkens, giving support to the idea that these dark areas support the growth of some sort of vegetation.

Successful American probes of Mars began with Mariner 5, which reached the vicinity of the planet on 14 July 1963 and began taking television pictures. The spacecraft took 21 pictures at distances

varying from 10,000 to 7,000 miles from the planet. Astronomers were surprised when the photographs revealed a surface more like that of the Moon than the earth. The pictures, which covered only about 1 percent of the surface of the planet, showed both craters (Fig. 39) and desert areas.

To obtain coverage of a larger part of Mars, as well as additional data, Mariner 6 and 7 were launched as a pair of probes to fly by the planet in July 1969. One probe moved across the equator of Mars, and the other passed over the south polar cap. Some of the pictures were of high resolution and were made as close as 2,130 miles from the surface. The pictures probably cover all surface features to be found on Mars. They revealed two new kinds of areas: featureless deserts and chaotic areas. The featureless deserts contain no craters or any kind of surface markings. The

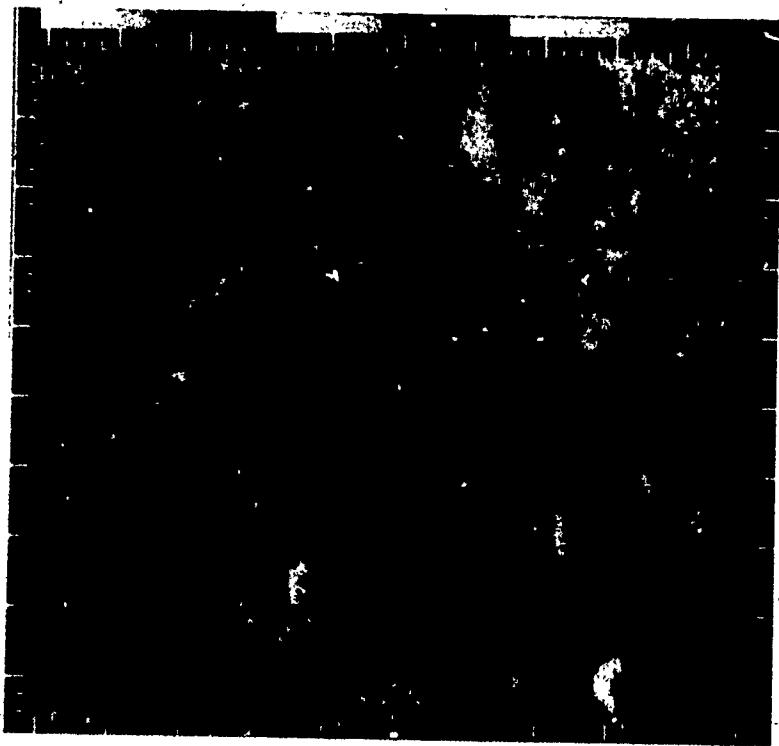

Figure 39. A computer-enhanced photograph of Mars taken by Mariner IV showing details of the Martian craters.

chaotic, or jumbled areas, consist of ridges and valleys with a few craters. They resemble areas in Alaska where the ground has caved in because of recent earthquakes. The chaotic areas shown in pictures on Mars cover an area about the size of Texas. Most of the crater walls shown in the pictures appear worn down from erosion over millions of years, but there are also some bowl-shaped craters similar to those on the Moon. The more complete coverage provided by these pictures showed that the Martian surface has its own distinct characteristics and that it resembles the surface of neither the earth nor the Moon.

The Mariner 6 and 7 probes revealed no water on Mars or evidence that oceans once existed. Samplings of the atmosphere at the south polar cap showed the presence of carbon dioxide, water ice, fog, water vapor, and some carbon monoxide. They also confirmed that the Martian atmosphere consists largely of carbon dioxide. Although the Mariner 6 and 7 probes revealed no free oxygen or nitrogen, gases that support life on the earth, small amounts of these gases may be present.

Mariner 9, the world's first planetary orbiter, reached the vicinity of Mars in November 1971 and orbited the planet to take pictures of the entire surface for mapping. About the time that Mariner 9 began orbiting the planet, two Soviet probes (Mars 2 and 3) ejected capsules onto the surface of Mars. Radio transmitters in the capsules are telemetering data about the surface of the planet. When scientists compile and interpret the data from the three most recent probes, they may find some answers to their questions about seasonal changes or life on Mars.

The United States has scheduled a new kind of planetary probe, a combined orbiter and soft-lander called the Viking, to be launched toward Mars sometime around 1975. The spacecraft is specially designed to collect and telemeter data concerning life on the planet. As probes toward Mars have continued, they have reported conditions much more hostile to life as it is known on the earth than was previously believed, but many scientists still believe that some kind of life will be found on Mars.

Asteroids

Within the vast 342,200,000-mile gap between the orbits of Jupiter and Mars, a distance of about 4 times that of the earth's average distance from the Sun, are found the minor planets, the aster-

oids. One of the traditional stories of astronomy relates to the accidental discovery of the asteroid belt. During the latter part of the eighteenth century, the German astronomer **Johann Elert Bode** set out to find what he thought should be another planet between the orbit of Jupiter and Mars. Using a series of numbers that later became known as **Bode's Law**, this scientist devised a means of determining the distance of planets from the Sun and for discovering new planets. With the support of some of his colleagues, Bode invited other astronomers to make a systematic search for the missing planet. Consequently, in 1801, while scanning the skies at the distance established by Bode's formula, an Italian astronomer, **Giuseppi Piazzi**, discovered Ceres, the largest of the minor planets and the first known asteroid.

Since 1801, astronomers have detected as many as 30,000 asteroids, most of them quite insignificant, orbiting the Sun. These bodies range in diameter from a fraction of a mile to several hundred miles, with a majority of them having diameters less than 50 miles. Only one of them, Vesta, is bright enough to be seen with the unaided eye. The total mass of all 30,000 asteroids adds up to the mass of the missing planet that should be located between Mars and Jupiter, according to Bode's Law.

Many of the asteroids have irregular forms and orbits, as shown by their variations in brightness during their rotations. This suggests that some smaller asteroids may be fragments of larger ones and the larger ones may have been chipped by collisions. One example is Eros, which is shaped like a brick and turns first a broad side and then a small end toward the earth, causing variations between brightness and faintness. Asteroids also stray occasionally. Some scientists believe that two satellites which orbit Mars and some of Jupiter's moons are errant asteroids captured by the magnetic fields of these planets. Many asteroids come within a few million miles of the earth and even collide with the earth in the form of meteorites.

The Outer Planets

The first four outer planets, Jupiter, Saturn, Uranus, and Neptune, are the giants of the solar system. These planets are massive bodies with extremely low density and large diameters and rotate very rapidly as they orbit the Sun. Evidence obtained by spectroscopes shows that these planets have a kind of "rock-in-a-

snowball" construction, consisting of small, dense, rocky cores surrounded by thick shells of ice and covered by compressed hydrogen and helium.

Beyond the four giant planets is Pluto, which is more like the earth in size and density than the giant planets.

Although it is doubtful that life in any form now exists on any of the five outer planets, scientists are interested nevertheless in sending preliminary probes to each of these planets. They believe that such probes may provide some clues to the presence of life on the earth. Furthermore, probes of all the planets should provide a better understanding of the entire solar system.

Jupiter. Although temperatures on Jupiter's cloud tops were reported as low as -230° F., measurements of infrared radiation on the planet showed that, even with its frigid temperatures, Jupiter still radiates about 2.5 times as much heat as it receives from the sun. In view of this finding and others, some scientists believe that Jupiter may be a dying star rather than a planet. Interest in this theory and in the highly charged magnetic fields surrounding the planet have led scientists to recommend probes of this planet. The United States has scheduled single Pioneer probes in 1972 and 1973 to investigate the region around Jupiter.

Jupiter has the distinction of being the largest planet. With a diameter of 88,700 miles, it is more than 10 times the size of the earth and is over five times as far from the Sun as the earth is. Its mass is 318 times as great as the earth's mass, representing 70 percent of the combined mass of all the planets. In the night sky, Jupiter regularly outshines all the planets except Venus although, on occasion, Mars appears brighter. Jupiter is an average distance of about 483 million miles from the Sun and, when it is nearest to the earth, is still 367 million miles away—four times as far as the earth is from the Sun. Jupiter's atmosphere is about 8,000 miles thick and is composed of methane (marsh) gas, ammonia, frozen crystals of ammonia, and free hydrogen. Additionally, a very thick layer of ice estimated to be 17,000 miles thick covers Jupiter's surface. Through a large telescope, Jupiter reveals a variety of color and changing detail with a standard pattern of brown bands on a yellow background paralleling its equator. The bands are broken with irregular cloud markings and spots, some of which change so rapidly that astronomers never know what the face of Jupiter might reveal from one day to the

next. One of the more permanent features, however, is a large spot, brick-red in color, known as the "Great Red Spot," which has been observed for more than 200 years. This spot is about 30,000 miles long and drifts about in the near-liquid lower atmosphere as if it were a solid (Figure 40).

It is believed that Jupiter's brown bands have some connection with the planet's extremely rapid rotation. Despite its gigantic size, Jupiter literally whirls on its axis once in every $9\frac{3}{4}$ hours. This means that it has a speed of rotation at its equator in excess of 25,000 miles per hour. Scientists say that, in a gaseous body, such as Jupiter, some sort of streaking or banding in line with the equator as a result of such speed would be expected. Oddly enough, the various regions of Jupiter rotate at different speeds, and the region around the equator appears to move more rapidly than the other regions. Various spots and markings, which appear at different points on the planet, shift and move about in rotations of their own as the planet itself rotates. This condition is attributed to the fact that Jupiter is composed primarily of gases which appear to shift about as the planet moves at terrific speeds. Although Jupiter spins on its axis like a dervish, it still requires almost 12 years to complete its orbit of the Sun.

Jupiter has 12 known satellites compared to one for the earth and, on the basis of recent findings, probably has a faint ring encircling it. Astronomers and astronauts alike are quite interested

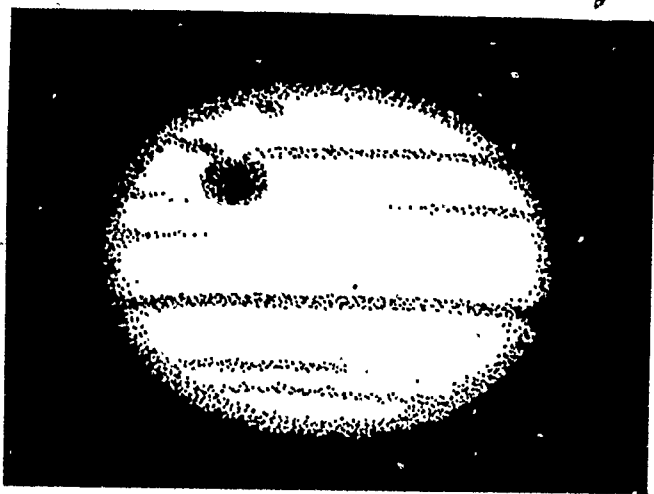

Figure 40. Diagram of Jupiter, showing the "Great Red Spot" and the bands.

in these satellites, or moons, particularly those of giant planets because they may provide initial landing points to begin observations before planetary landings are attempted. Since all the giant planets offer extremely hostile environments for human beings, these satellites should be at least as hospitable as the parent planets. Two of Jupiter's moons are about as large as the earth's moon, while two others are equal in size to Mercury and believed to be covered with snow. A fifth moon has the distinction of being the fastest of all satellites, and four others have a retrograde motion, i.e., they revolve from east to west instead of moving counterclockwise like the other eight.

Saturn. With an average distance of about 886 million miles from the Sun, Saturn's orbit lies almost twice the distance from the Sun as does that of Jupiter. Although Saturn is second in size to Jupiter, it could still contain 734 bodies the size of the earth. This planet revolves around the Sun once in $29\frac{1}{2}$ years and rotates on its axis every $10\frac{1}{2}$ hours. With a diameter of 75,000 miles. Saturn is the second largest planet and, except for its rings, resembles Jupiter in a number of ways. For one thing, it has an atmosphere composed mostly of hydrogen and helium with some methane (marsh gas) and ammonia. The surface is covered with a thick layer of ice over a rocky core. The proportion of methane to ammonia, however, is greater in Saturn's atmosphere than it is in Jupiter's atmosphere, and Saturn's maximum temperature of -243° F. is more frigid than that of Jupiter. Like Jupiter, Saturn is quite colorful, with atmospheric markings arranged in bands and greenish caps surrounding its poles.

Saturn has a total of 10 satellites or moons. Its largest satellite is called Titan, which is the only satellite in the solar system definitely known to have an atmosphere. With a diameter of 3,550 miles, Titan is also the largest satellite in the solar system. With the exception of one, the remaining satellites have diameters ranging from 300 to 1,600 miles and move in direct revolutions around the planet. The outermost satellite, called Phoebe, is a mid-get only 150 miles across, but it is over 8 million miles from its parent planet. Like four of Jupiter's moons, Phoebe follows a retrograde revolution.

Probably the most distinguishing feature of Saturn is its rings, which were never seen before the invention of the telescope, since they cannot be seen with the naked eye. This system of three rings.

unique among the planets, is located at the equator. The total width of the band is about 41,500 miles, but it is only about 10 miles thick. The outer ring is about 10,000 miles wide and is separated from the middle or bright ring, by the Cassini Division, which is about 3,000 miles wide. The middle ring is 16,000 miles wide. The inner ring, which astronomers call the crape ring, is 12,000 miles wide and runs continually with the middle ring (Figure 41). Although scientists are not at all sure what these rings are made of, the fact that stars can be seen passing behind them led to the theory that they consist of millions of tiny particles made of ice or at least covered with an icy material.

Uranus. Barely visible without a telescope, Uranus is 29,600 miles in diameter, or more than $3\frac{1}{2}$ times the size of the earth. It rotates on its axis in 10 hours 50 minutes, and, at a distance of about 1,783 million miles from the Sun, it takes 84 years to orbit the Sun. Uranus has a maximum temperature of -300° F. Although both Uranus and Neptune appear to have about the

JUPITER AND SATURN



PLANET	JUPITER	SATURN
DIAMETER	86,720 MILES	74,940 MILES
SURFACE GRAVITY RELATIVE TO EARTH	2.64	1.17
TEMPERATURE	-240° F (SURFACE)	-290° F (SURFACE)
ATMOSPHERIC PRESSURE AT SURFACE	?	?
ATMOSPHERIC COMPOSITION	AMMONIA, METHANE [HYDROGEN? NITROGEN? OXYGEN? WATER VAPOR?]	AMMONIA, METHANE HYDROGEN? NITROGEN? OXYGEN? WATER VAPOR?

Figure 41. Comparison of the planets Jupiter and Saturn.

same structure as Jupiter and Saturn, astronomers find it difficult to make out surface details because they are so far away.

Uranus is unusual because its equator is inclined almost at right angles to the plane of the ecliptic; or, in other words, the tilt of its axis lies almost in the plane of its orbit. Uranus has five known satellites, which revolve in the direction of the planet's rotation.

Neptune. Although Neptune cannot be seen with the naked eye, it always appears through the telescope as a small greenish disk upon which a few faint markings may be seen. Neptune is about 2,793 million miles from the Sun and has a diameter of about 24,600 miles. Although Neptune is often regarded as the twin of Uranus, its rotation period of 16 hours is longer and its surface temperature of -330° F. is 30° F. lower. Neptune is 30 times as far away from the Sun as is the earth, and, at this distance, the heat and light that it receives is only $\frac{1}{900}$ of that received by the earth. This planet takes almost 165 years to complete its orbit of the Sun. It has two known satellites. The larger satellite, Triton, is larger than the Moon and is closer to its planet than the Moon is to the earth. This satellite may have an atmosphere.

Pluto. Pluto is the outermost planet in the solar system. It is a very small planet with a mass less than one-tenth that of the earth. At an average distance of 3,666 million miles from the Sun, Pluto rotates once every 64 days and requires about 248 years to orbit the Sun. Since Pluto's distance from the Sun is almost a billion miles greater than that of Neptune, the fact that this planet is eternally dark and frigidly cold should not be surprising. Astronomers believe that Pluto has a gritty snow-covered surface and an atmosphere much thinner than that of the earth.

THE WORLD OF INTERSTELLAR AND INTERGALACTIC SPACE

In chapter 1, we took the measure of the Milky Way Galaxy and described it as a flat, pancake-shaped formation of stars about 100,000 light years in diameter and 3,000 light years in thickness. Actually, it might be viewed as a giant whirling cartwheel composed of something like 100 billion stars. Millions of stars spin around the hub of the wheel, and great spiral arms containing billions of other stars, clouds of dust, and gases swirl like pinwheels away from the hub. So vast is this wheel that light speeding at the rate of 670 million miles per hour requires 100,000 years to travel from rim to rim.

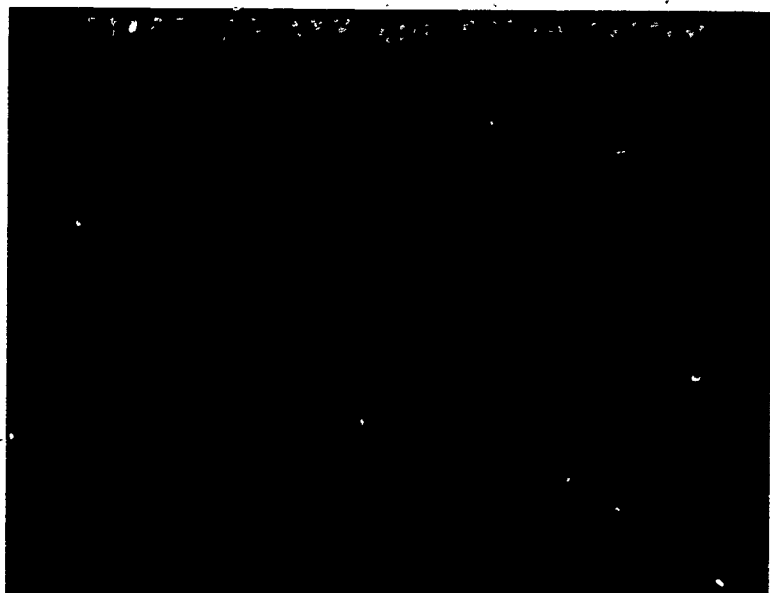

Figure 42. Stars of the universe, the Milky Way Galaxy, and our solar system. The diagonal lines point to the approximate location of our solar system in the Milky Way.

Occupying only a tiny spot in the galaxy is our solar system controlled by the Sun, which, in comparison with millions of other stars, is only an average star in size and brightness. The solar system is roughly seven billion miles in diameter. To understand the size of the solar system in comparison with the Milky Way Galaxy, we can draw an imaginary circle approximately 20 miles in diameter to represent the galaxy. Then we can imagine a small dot made with a ballpoint pen about seven miles from the center of this circle. This would be the scale necessary to compare the size of our solar system with the size of the galaxy of which it is a part. (Figure 42.)

Interstellar Measurements

Only in recent decades have scientists discovered what the stars are and how they are arranged in space. In the process, they had to find ways of computing the distances and movements of the stars. As we learned earlier, one of the most direct ways of determining a star's distance is to measure its parallax, that is, the extent of

its annual shift in position against the background of more distant stars. However, this method is effective to a limit of only 400 light years. Therefore, other means are necessary to estimate longer interstellar distances.

CEPHEID VARIABLES.—Prior to the use of parallax measurements, astronomers believed that a star's brightness (**magnitude**) determined its distance from the earth. They based their belief on the assumption that all stars burned with the same energy output or **absolute magnitude**. Thus, by measuring the visible brightness or dimness (**apparent magnitude**), they could conclude simply that the degree of a star's dimness or brightness determined its distance. More recently, however, astronomers discovered that stars vary greatly in total energy output or absolute magnitude. Therefore, their apparent magnitude is no accurate measure of their distance from the earth. For example, Sirius and Canopus are the two brightest stars in the sky. Sirius appears twice as bright as Canopus, but their parallaxes show that Canopus is 100 light years away from the earth, while Sirius is only 8.7 light years away. This means that Canopus burns at a magnitude 65 times as bright as Sirius.

Although magnitude does not determine the distance of all stars, astronomers found that certain classes of stars do reveal their distance according to the magnitude formula. One such class is the **Cepheid variable**, which ranges between 10 and 100 times the Sun's brightness. Cepheid variables are fluctuating stars that grow alternately brighter and dimmer in cycles ranging from a day to more than a month. Cepheid variables with a low absolute magnitude fluctuate in shorter cycles than Cepheid variables with a high absolute magnitude. Once they determine the fluctuation period of a given Cepheid variable, modern astronomers can calculate its absolute magnitude with 90 percent accuracy. Then, by comparing its absolute magnitude with its visible brightness or apparent magnitude, they can work out an accurate measure of its distance. This is extremely accurate whether the Cepheid is located on the farther rim of the Milky Way 650 light years away or over two million light years away in the Andromeda Galaxy.

PROPER MOTIONS.—Stellar velocities provide additional means for verifying stellar distances. Astronomers knew that stars move

about in the sky long before they learned that stars circle the center of a galaxy. Stars near the earth appear to move rapidly like low-flying aircraft, and stars in deep space, like high-flying aircraft, appear to creep through the heavens. To verify the distances of stars, astronomers measure the movements of stars in relation to the Sun and then subtract movements caused by changes in the earth's orbit through space. **Proper motions** are the simple movements of stars across space, measured by shifts in the positions of stars in relation to other heavenly bodies. Proper motions of stars near the earth can be established in a relatively short period of observation, but distant stars may require centuries.

THE DOPPLER SHIFT.—Astronomers can also measure the movement of stars in terms of their speed directly toward or away from the earth. Changes in the color of stars indicate the direction of star movement. Shifts along the color spectrum toward blue indicate the speed of star movement toward the earth, and shifts toward red indicate movement away from the earth. This shift is known as the "**Doppler effect**," which acts similarly with sound waves—increasing sound indicates movement toward a listener, and decreasing sound, movement away from a listener, such as the sound of a horn or whistle on a passing train. With measurements provided by studies of spectral hues, Cepheids and other classes of variable stars, and the calcium atoms of stars, modern scientists have a picture of a breathtaking universe in which our Sun and Earth are only two of 100 billion other orbiting bodies.

Galaxy Formation and Characteristics

If it were possible to view the Milky Way Galaxy from a star in another galaxy, we would see a flat, circular system extending over a vast area in space. The circle would appear thicker in its central region where huge red stars are densely packed and shrouded in clouds of dust. Individual stars would be barely recognizable because of their combined output of energy. Revolving around the hub or central region would be a disc of stars with a diameter about 100,000 light years, a difficult-to-understand 600 million billion miles. Radiating from the center of the disc would be vast, curved arms of dust, gas, and giant stars which spiral outward like the sparks of a whirling pinwheel. We would see the Sun, 100,000 times dimmer than its brightest neighbor, about 30,000 light years from the center. This entire vast system

rotates under the same laws that govern our relatively small solar system.

GALAXY STRUCTURE.—A side view of the Milky Way shows two principal populations of stars. A majority of the stars are confined to a flat, disc-like formation in the **galactic plane**, which forms the outer envelope of the Milky Way. In addition to multitudes of stars, this outer region contains quantities of dust and gases, which obscure our view of much of the inner star system of the Milky Way. It also provides the great spiral arms of which our solar system is a part. The Sun and all the other stars in these spiral arms follow orbits around the galactic center and form a **"Population I"** class of stars. The great mass of stars at the galactic nucleus constitute **"Population II"** stars.

This means that the world of interplanetary space is a flat **"Population I"** type of arrangement. The laws of celestial mechanics keep all planets, moons, and asteroids whirling in orbit about the Sun. For some not fully understood reason, they orbit near the **"plane of the ecliptic."** This plane is defined as the plane containing the orbit of the earth. Only comets, moving off to the north and south of the plane of the ecliptic, constitute a **"Population II"** of our solar system. In much the same manner that our **"Population I"** planets, moons, and asteroids moved outward from the Sun to form the solar system, the Milky Way Galaxy developed according to a balance of centrifugal and gravitational forces, expanding outward from its hub. The same process can be observed in other galaxies as indicated by their pinwheel or spiral appearance. Figure 43 shows in simple form the significant features of star orbits in a galaxy.

NEBULAE AND NOVAE.—As we have already noted, the Milky Way system includes countless varieties of stars and giant clouds of dust or gas. Astronomers refer to these huge clouds as nebulae. Some of these gaseous spheres glow brightly from the ultraviolet rays emitted by stars. Others, like the giant Horsehead Nebula in the constellation of Orion, appear as dark shadows because they intercept light rays traveling toward the earth from stars behind them. Astronomers believe that most nebulae are the remains of unstable stars, which, at one time, emitted huge clouds of gas and then finally disintegrated in mammoth explosions.

For example, an exploding star some 50,000 years ago probably created the Veil Nebula, a star-studded sphere of red, white,

THE WORLDS OF OUTER SPACE

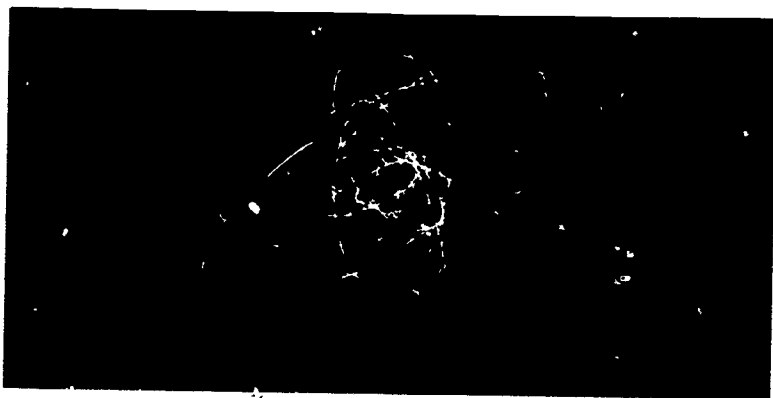

1. Orbits of stars classified as Population I stars.

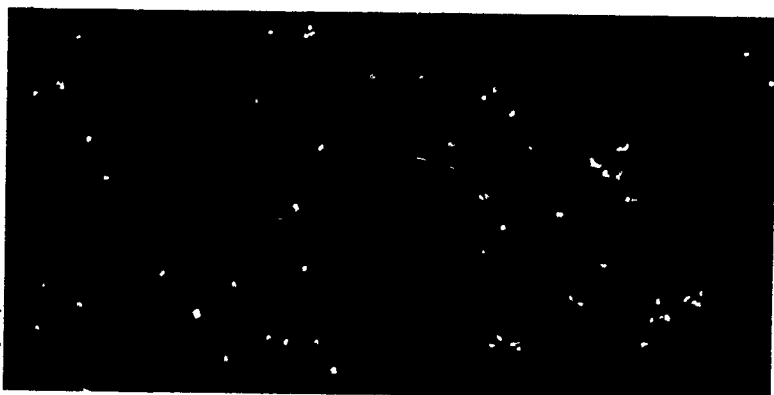

2. An oblique view of Population I star orbits in outer arms of spiral galaxies.

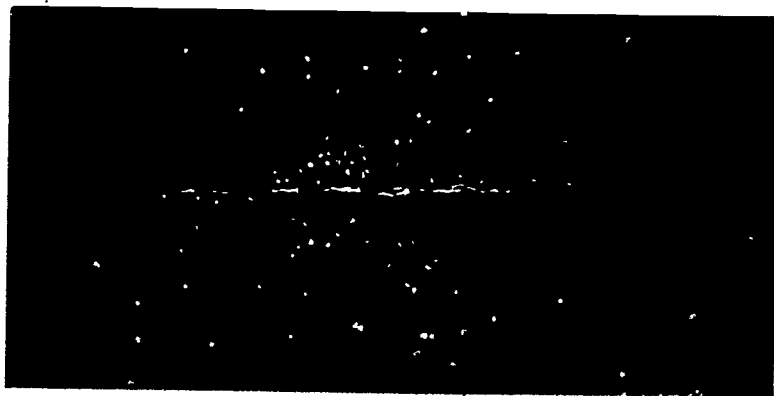

3: Side view of a Population II star system.

Figure 43.

and blue gases in Cygnus the Swan. This nebula is a huge sphere about 300 trillion miles in diameter, still traveling outward in space at the rate of 300,000 miles per hour. As it moves through space, it gives off blue light in the presence of oxygen, red in the presence of hydrogen, and white from a combination of effects.

Sometimes, when a star suddenly explodes and glows at many times its former intensity, it may appear in the sky as a "**nova stella**" (Latin for new star). A nebula sometimes consists of the gaseous residue of such an eruption. On the other hand, the loose gas and dust of a nebula may condense and form a star. In general, the gaseous consistency of interstellar nebulae is much less dense than the earth's atmosphere. In some instances, it has the same order of thinness as the plasma emitted from the Sun as solar wind.

Beyond the Milky Way

As vast as are the distances between the stars and planets of our Milky Way Galaxy, scientists have discovered that this galaxy is only one among millions of other galaxies in the universe. Beyond the Milky Way are innumerable groups and clusters of galaxies extending through the whole region of observable space. To appreciate the size and brilliance of a galaxy outside our own Milky Way, one needs only to gaze into the northern sky on a clear autumn night and find a tiny spot of brightness in the constellation Andromeda. Here is a galaxy known as **M31**, which sends light to the unaided eye from a distance of 16 quintillion miles. It is located about two million light years from the Milky Way Galaxy, billions of times farther away than the most distant planet of our solar system—Pluto. It is so far away that an observer on earth sees light which left the galaxy 2.7 million years ago. (Figure 44.)

MAGELLANIC CLOUDS.—The only two other galaxies observable with the unaided eye beyond the Milky Way are the **Magellanic Clouds**, named after the sixteenth century mariner, Ferdinand Magellan, who first observed them in the sky over the Southern Hemisphere. Although these two galaxies are satellites of our Milky Way Galaxy, they are approximately 160,000 light years away, much nearer than the Andromeda Galaxy, regarded by many astronomers as a neighbor galaxy in intergalactic space.



Figure 44. The Milky Way Galaxy is only one among millions of other galaxies that inhabit the universe.

MILLIONS OF ISLAND UNIVERSITIES.—One of the most momentous discoveries concerning the reality of galaxies beyond the Milky Way came in 1925 when a California astronomer named **Edwin Hubble** began scanning the skies with a new 100-inch telescope at Mount Wilson Observatory. Using the Cepheid measuring stick, Hubble brought into focus a sphere of about three million light years in radius, encompassing some 20 different galaxies. From this point, he charted an additional sphere containing 200 more galaxies estimated at some 30 million light years in radius. Farther out in space where single stars could not be seen, Hubble next used the brilliance of whole galaxies to estimate distances and, with this measuring system, reached the visible limits of the universe more than one billion light years away. He concluded that the universe contains almost as many galaxies as there are stars in the Milky Way. Modern astronomers with more powerful telescopes know that galaxies outnumber stars by about six to one throughout most of the sky, and each on an average contains more than a billion stars and probably even more planets.

Families of galaxies.—The studies of Hubble and other astronomers indicate that the millions of galaxies scattered throughout the universe differ in size, shape, and position. In comparison with the Milky Way Galaxy, most of them are smaller, but a few are also larger. They range in shape from formless clouds of light to star-studded circles. Despite their differences, Hubble was able to distinguish three classifications or families of galaxies according to their shape—spirals, ellipticals, and irregulars. The **spiral galaxies** contain Population I stars in their arms and Population II stars in their nuclei and the surrounding halo. They appear as great whirlpools of fire and sparks. As mentioned earlier, they contain three well-defined regions—a densely populated nucleus of stars, a spherical halo of stars and star clusters surrounding the nucleus, and a disc with spiral arms whirling outward around the halo and nucleus. **Elliptical galaxies** contain only a nucleus and surrounding halos. They appear as giant flattened beach balls with more or less densely packed nuclei, depending upon the pull of gravitational forces. **Irregular galaxies** are most often shapeless globs of blue and blue-white Population I stars with only an occasional trace of a spiral structure.

"Peculiar" galaxies and quasars.—In addition to the three standard classifications of galaxies, astronomers have observed numerous peculiar objects in deep space which do not conform to any recognizable pattern. They believe that these objects are galaxies which may have been torn apart in times past by forces beyond their present range of knowledge. Certain ones of these **peculiar galaxies** present themselves as double galaxies joined by lines of stars thousands of light years in length. Others seem to be spinning side by side, and still others send forth giant flares sufficiently long to reach across entire galaxies. One of their most puzzling characteristics is that they produce intense radio waves millions of times more powerful than those of a normal spiral galaxy. Although no one knows exactly what the so-called "peculiar" are, these mysterious objects with their powerful radio emissions have enabled scientists to study intergalactic space far beyond the normal limits of optical observation. By using radio telescopes, astronomers have located galaxies many times farther away than the thousands of faint galaxies that presently crowd together on optical telescopes.

Even more puzzling than the peculiar are the strange objects

called **quasars** (a term applied to quasi-stellar radiation sources), which appear as stars through optical telescopes. Despite their incredible distance from the earth of nine-billion or more light years, these tiny starlike objects radiate more energy at radio frequencies than the most powerful galaxies. Although astronomers do not fully understand their true nature, they believe that quasars are the most distant objects in the universe and, as such, may hold some of the secrets concerning the origin of the universe and even of life itself.

An expanding universe?—Astronomers have known for some time that distant observable galaxies are moving outward in space at extremely high speeds. Hubble quickly discovered in 1925 that the red Doppler shift is a characteristic of all galaxies beyond the Milky Way, the Magellanic Clouds, and M31. He also found that the more distant a galaxy, the greater was the Doppler shift toward the red end of the color spectrum. This indicated that the more remote a galaxy is, the faster it is speeding outward away from the Milky Way. For example, thousands of galaxies in the constellation Virgo about 50 million light years from the Milky Way are moving outward at 750 miles a second. Another densely populated group of galaxies in the constellation Hydra, about 2.7 billion light years away, is increasing its distance from us at the rate of 38,000 miles per second, roughly a fifth the speed of light.

With highly accurate measurements provided by the "Doppler effect," astronomers know beyond doubt that the universe is expanding. This knowledge raises basic questions: how long has this expansion been going on, and will the universe always continue to expand? Current measurements of distance made possible by the Doppler technique suggest that it took the galaxies something like 13 billion years to speed outward from a single dense cloud of matter to their present positions in space.

In arriving at what must be only partial answers to the second question, astronomers believe that the universe is expanding in the same manner that evenly spaced dots will move away from each other on a toy balloon when it is inflated. One view is that new galaxies form to fill gaps left by expansion, with the result that the universe will always appear in much the same state. Another view holds that expansion is causing the universe to become thinner with the passing of time. If space is partially curved, according to Einstein's theory of General Relativity, the universe

will cease to expand in some point of time and will then begin an orderly process of contraction. If, according to some astronomers, this is the partial answer to our second question, then the Milky Way and life as it is known will be extinguished. As the universe continues to contract, another universe will develop from a super-dense state, and the process of evolution will begin all over again, producing other solar systems, other earths, and other intelligent beings.

The Passing of Time in Interstellar and Intergalactic Space

In view of the spectacular achievements of the Apollo flights to the Moon, scientists and engineers now believe that man eventually will travel from planet to planet and even to other galaxies in the universe. But he must first develop more powerful propulsion systems for interplanetary, interstellar, and intergalactic space travel. One such source of power may be rocket engines driven by photons which convert light into usable energy. The high exhaust velocities of **photonic engines** make it theoretically possible to propel spaceships at speeds approaching the speed of light (186,300 miles per second). Modern scientists are conducting intensive, basic research on new and radically improved propulsion systems that may one day take man into the distant regions of the universe.

When one remembers that our Milky Way Galaxy is a monstrous 100,000 light years in diameter and that the nearest galaxy to our galaxy is almost two million light years away, it appears doubtful that man would ever travel in interstellar and intergalactic space. But, according to the Einstein theory of relativity, such travel is not impossible. Einstein concluded from his studies that the universe is not infinite but curved, and astronomers have obtained some evidence that appears to verify this conclusion. Einstein also maintained that, when the speed of an object, such as a spaceship, approaches the speed of light, time slows down for the speeding object. This circumstance (described by Einstein as the relativistic dilation of its own time) would reduce the travel time of space flights to remote galaxies to a few years—as the crews of photon-propelled space vehicles would observe the passing of time.

Scientists have already derived formulas of relativity for mass ratios, reaction mass consumption, thrust, velocity, and flight times of photon spaceships. These formulas take into account the speed of light, the energy of the expended reaction mass, acceleration.

and elapsed time as the crew of a spaceship would observe them. With the application of these relativistic formulas, some space scientists have concluded that there will be no great difference between the passing of time observed in a spaceship traveling within the solar system and that observed on the earth. The difference will be infinitely greater, however, during interstellar and intergalactic travel. For example, a trip to the center of our Milky Way Galaxy (a distance of 30,000 light years as measured by earth time) might be made in 20 years spaceship time. During such a trip, 60,000 years will have passed on the earth. A trip to Andromeda, a neighbor galaxy, would telescope some 2 million earth years into 26 spaceship years. On a round trip through the entire universe, a spaceship crew would observe the passing of 42 years, but 40 billion years would have come and gone on the earth.

These are some of the possibilities that may develop as man extends his reach beyond the Moon into deep space. As the frontiers of knowledge continue to expand, these possibilities may become realities. On the other hand, they may end as mere dreams in the long history of mankind. Of one thing we may be sure, today's events in the aerospace environment are only preludes to other momentous events in the years just ahead.

WORDS, PHRASES, AND NAMES TO REMEMBER

absolute magnitude	Hubble, Edwin
apparent magnitude	image resolution
asteroids	irregular galaxies
Bode, Johann Elert	light intensification
Bode's Law	Lippershey, Hans
canali	Magellanic Clouds
Cassegrainian focus	magnitude
Cassini Division	M 31
Cepheid variable	Newtonian focus
chromosphere	nova stella
coronagraph	optical telescope
Doppler effect	parallax
electromagnetic radiation	peculiar galaxies
elliptical galaxies	Penumbra
galactic plane	photonic engines
Hale telescope	photosphere

plane of the ecliptic
 Population I stars
 Population II stars
 primary focus
 primary mirror
 proper motions
 quasars
 reflecting telescope

refracting telescope
 secondary mirror
 spectrograph
 spectroscope
 spiral galaxies
 sunspot
 Umbra

REVIEW QUESTIONS

1. What important contribution did Galileo make to the study of the universe?
2. (a) Explain the difference between the refracting telescope and the reflecting telescope.
 (b) What is the advantage of the radio telescope over optical telescopes?
3. What is the function of spectroscopes, spectrographs, and coronagraphs?
4. Describe the various layers of the Sun and explain such phenomena as sunspots, solar flares, solar radiation, and solar wind.
5. Name and describe the major planets of our solar system. What new information did Mariners II and V reveal concerning the characteristics of Venus? What did scientists learn from Mariner IV concerning Mars?
6. What is the difference between asteroids and the major planets?
7. What are the distinguishing characteristics of the planets Jupiter, Saturn, Uranus, and Neptune?
8. Compare the size of our solar system with that of the Milky Way Galaxy.
9. Describe the techniques used by astronomers to measure interstellar and intergalactic distances.
10. Describe the structure of a typical galaxy and explain how galaxies are formed.
11. How did Edwin Hubble arrive at his conclusion that the universe contains almost as many galaxies as there are stars in the Milky Way?
12. What are the distinguishing characteristics of spiral, elliptical, and irregular galaxies?
13. What proof do astronomers have that the universe is expanding? What theories have they advanced regarding future expansion?
14. What further developments are necessary before man can venture into interstellar and intergalactic space? What do scientists have to say regarding the passing of time during intergalactic space travel?

THE WORLDS OF OUTER SPACE

THINGS TO DO

1. Find out whether the science department in your school possesses any of the astronomical instruments used by astronomers to study the universe. If so, ask your science teacher to demonstrate the use of these instruments.
2. Make a scale drawing of the solar system, indicating the relative size and distance of the planets from the Sun. Beneath the drawing, list some of the basic characteristics of each planet, including similarities and differences.
3. In a comparison of the other planets with the earth, list specific characteristics of each planet that prevent the existence of life as it is known on the earth.

SUGGESTIONS FOR FURTHER READING

- Aviation Weather*. Federal Aviation Agency, Washington, DC, 1965.
- BERNARDO, JAMES V. *Aviation in the Modern World*. E.P. Dutton & Co. Inc, New York, 1960.
- BRYAN, LESLIE A. and others. *Fundamentals of Aviation and Space Technology*. Institute of Aviation, University of Illinois, 1966.
- CLARK, ARTHUR C. *The Exploration of Space*. Harper & Row, New York, 1959.
- CONROY, CHARLES W. and MEHRENS, HAROLD E. *Navigation and the Weather*. National Headquarters, Civil Air Patrol, No date.
- HENDRICKSON, WALTER B., JR. *Satellites and What They Do*. Bobbs-Merrill Co. New York, 1963.
- HYNEK, J. ALLEN and ANDERSON, NORMAN D. *Challenge of the Universe*. National Science Teachers Association, Washington, DC, 1965.
- HYNEK, ALLEN. *Exploring the Universe*. Xerox Corporation, Middletown, Conn. 1961.
- JASTROW, ROBERT. *Red Giants and White Dwarfs*. Harper & Row, New York, 1967.
- LEY, WILLY. *Harnessing Space*. Macmillan Co. New York, 1963.
- MISENHIMER, TED G. *Aerospace*. Aero Products Research, Inc, Culver City, California, 1970.
- MURCHIE, GUY. *The World Aloft*. Houghton Mifflin Co, Boston, 1960.
- POPKIN, ROY. *The Environmental Science Services Administration*. Frederick A. Praeger, 1967.
- Realm of Flight*. Federal Aviation Agency. Superintendent of Documents, Washington, DC, rev May 1963.
- SAGAN, CARL, LEONARD, JONATHAN NORTON, and the editors of *Life*. *Planets*. Time, Inc. New York, 1966.
- SANGER, EUGEN. *Space Flight*. McGraw-Hill Book Co. New York, 1965.

AEROSPACE ENVIRONMENT

SHELTON, WILLIAM R. *Conquest of Space*. National Geographic Society, Washington, DC, 1968.

Space: the New Frontier. National Aeronautics and Space Administration, 1966.

STERN, PHILLIP D. *The Physics of Space*. Holt, Rinehart and Winston, New York, 1965.

The Universe. Scientific American, Simon & Schuster, New York, 1957.

VAETH, J. GORDON. *Weather Eyes in the Sky*. The Ronald Press Co, New York, 1957.

VAN SICKLE, NEIL D. *Modern Airmanship*. D. Van Nostrand Co, Inc, Princeton, New Jersey, 1966.

INDEX OF WORDS, PHRASES, AND NAMES

This index consists of words, phrases, and names to remember listed at the end of each chapter, with some additional items. Most of the terms in the following list are printed in boldface in the text where they first appear and elsewhere as necessary. Page numbers refer to passages where the term is defined, discussed, or explained in context.

A

absolute magnitude, 116
accretion, 83
advection, 23
aerospace, 1
air mass, 30-31
air pressure, 2-3
Air Weather Service, 47, 51
altitude, 2-3
altocumulus, 41
altostratus, 41
Andromeda, 12, 93
anemometer, 46
apparent magnitude, 116
Apennine Mountains, 78
Apollo 12, 79
apogee, 69
Appleton Region, 63
asteroids, 76, 96, 108-109
atmosphere, 2
atmospheric pressure, 17
atom, 16
atomic number, 65
atomic weight, 65
aurora australis, 62
aurora borealis, 62

B

barometer, 46
biosphere, 13, 19
Bode, Johann Elert, 109
Bode's Law, 109

C

caldera, 76
canal, 106
carbohydrates, 18
carbon dioxide, 16
Cassegrainian focus, 91
Cassini Division, 113
celestial mechanics, 73
centrifugal force, 82
Cepheid variable, 116, 121
cislunar space, 8
chemical properties of air, 16

chlorophyll, 19
chromosphere, 100
cirrostratus, 40, 41, 42
cirrus, 40
clear-air turbulence (CAT), 54
clear ice, 54
climate, 53
climatology, 53
cold fronts, 36, 38
communications, 47
compounds, 16
condensation, 20
condensation nuclei, 21
conduction, 22-23
continental air-mass, 30
convection, 23
convective thunderstorm, 39
core samples, 81
Coriolis force, 27-28
corona, 69, 100
coronagraph, 95
cosmic dust, 77
cosmic rays, 65
Coude focus, 92
cumulonimbus clouds, 36, 41, 42, 43
cumulus clouds, 39, 41, 43

D

Darwin, Sir George, 82
dew point, 20
Doppler effect, 117, 123
droplets, 20, 45
dropsonde, 49-51

E

earth as a weather machine, 27
Echo satellites, 67
ecology, 18-19
electromagnetic radiations, 95
electromagnetic waves, 62
electrons, 64
elements, 16
elliptical galaxies, 122
energy, 18, 21-23
evaporation, 20
exosphere, 66

F

facsimile transmissions, 49
 forecaster capabilities and limitations, 56-57

formation of clouds, 39-42, 43
 front, 35
 frontal weather, 36-39, 56-57

G

galactic plane, 118
 galaxy, 12
 galaxy formation, 117-120
 gravitation, 71

H

Hendley's Kille, 77
 Hale telescope, 92
 hail, 55
 heterosphere, 64
 high clouds, 40
 homosphere, 64
 Hubble, Edwin, 121
 hydrocarbons, 18
 hygrometer, 46

I

icing, 53-54
 infrared rays, 21-22
 image resolution, 93
 inner planets, 102-108
 instruments of astronomy, 88-95
 ion, 65
 ionization, 65
 ionosphere, 62, 64-66
 irregular galaxies, 122
 intergalactic space, 12
 interplanetary distances, 1
 interplanetary space, 6
 interstellar space, 9

J

Jupiter, 110-112

K

Kennelly-Heaviside layer, 62
 Kepler, Johannes, 8

L

lava, 77
 levels of atmosphere, 24-26
 Lick Observatory, 90
 light intensification, 93
 light year, 10

Lippershey, Hans, 88
 liverworts, 81
 low clouds, 40
 Luna Orbiter, 72
 lunar month, 70

M

Magellanic Clouds, 120
 magnetic pole, 66-68
 magnetic tail, 68
 magnetosphere, 66
 magnitude, 116
 Marconi, Guglielmo, 62
 mare (pl. maria)
 Mare Imbrium, 76
 mare's tail clouds, 40
 Mariner 2, 104
 Mariner 5, 104-105
 Mariner 6 and 7, 107-108
 Mariner 9, 108
 Mare Tranquillitatis, 76
 maritime air mass, 30
 Mars, 7, 105-108
 mascons, 73
 mass, 65
 Mercury, 8, 102
 mesosphere, 25
 meteor, 3, 75
 meteorites, 75
 meteoroids, 75
 meteorologist, 40
 middle clouds, 40
 Milky Way Galaxy, 9, 11, 114
 molecules, 16
 Moon, 69-84
 M 31, 110

N

National Weather Service, 47
 nebula, 12
 neutrons, 64
 nebulae and nova, 118-120
 Neptune, 114
 Newton, Sir Isaac, 71
 Newtonian focus, 91
 NIMBUS satellite, 52
 nitrogen, 16
 nitrogen cycle, 18
 nova stella, 120
 nucleus, 64

O

occluded front, 38
 Oceanus Procellarum, 77
 optical telescope, 88-94
 outer planets, 110-114
 oxygen, 16
 oxygen cycle, 18
 ozone, 25

P

parallax of one second of arc, 10
 parsec, 10
 peculiar galaxies, 122
 Penumbra, 99
 perigee, 69
 photosphere, 98
 photonic engines, 124
 photosynthesis, 19
 physical properties of air, 16
 Piccard, Augusts, 63
 plane of the ecliptic, 118
 plasma, 66
 Pluto, 7, 114
 polar air mass, 30
 Population I stars, 118, 119
 Population II stars, 118; 119
 precipitation, 20
 primary mirror, 91
 primary focus, 91
 proper motions, 117
 protans, 64
 psychrometer, 46

Q

quasar (quasi-stellar-radiation-source),
 12, 123

R

radar, 49
 radiant waves, 21
 radiation, 21, 68
 radioactivity, 68
 radiosonde, 49
 rawin, 49
 rawinsonde, 49
 reflecting telescope, 88, 90-94
 refracting telescope, 88-90
 relative humidity, 20
 retrograde or back-door movements, 36
 rille, 77
 rime ice, 54

S

satellite, 73
 saturation, 20
 Saturn, 112-113
 secondary mirror, 91
 sidereal month, 70
 SIDs, 65
 solar flare, 99-100
 solar-system, 6, 7, 93-114, 115
 solar wind, 66
 sounding rockets, 63
 space, 5

 spectrascope, 95

spectrograph, 95
 spectrum, 21-22
 spiral galaxies, 122
 speed of light, 10
 static electricity, 39
 stratosphere, 25
 stratus, 41
 subatomic particle, 65
 sudden ionospheric disturbances (See
 SIDs), 100
 supercooled air, 54 -
 Sun, 96-102
 sunspots, 98-99

T

thermometer, 46
 thunderheads, 36, 39, 42-43, 55
 thunderstorms, 39, 55-56, 57
 TIROS satellite, 52
 topography, 74
 tropical air mass, 30
 tropopause, 25
 tropics, 25
 traposphere, 24
 turbulence, 53-54

U

ultraviolet rays, 21-22
 Umbra, 99
 United States Air Force Dictionary, 30
 Uranus, 113-114
 upper atmosphere, 62-66
 vacuum, 5, 39

V

Van Allen, James A., 66
 Van Allen radiation belts, 5
 Venera 4 and 7, 104-105
 Venus, 7, 103
 visible light rays, 21
 visibility, 53-55

W

warm fronts, 36, 38
 water vapor, 20
 weather, 2, 35-39, 42-47; 52-56
 weather hazards, 53-56
 weather map, 37, 48
 weather satellite, 51-52
 weathervane, 46
 weight (cf. mass), 65
 wet and dry bulb thermometer
 (psychrometer), 46

Y

Yerkes Observatory, 90



140