

DOCUMENT RESUME

ED 109 433

004 278

TITLE . Electronics Technology Curriculum Development Project (ETCDP): Report.
 INSTITUTION Illinois Univ., Urbana.
 SPONS AGENCY National Science Foundation, Washington, D.C.
 REPORT NO NSF-GY-6182
 PUB DATE 71
 NOTE 410p.

EDRS PRICE MF-\$0.76 HC-\$20.94 PLUS POSTAGE
 DESCRIPTORS Audiovisual Aids; Computer Assisted Instruction; Computer Science; *Curriculum Development; *Curriculum Guides; *Electric Circuits; Electromechanical Technology; Electronic Equipment; *Electronics; Electronic Technicians; Engineering Technology; Individualized Instruction; Instructional Materials; Instructional Technology; Performance Criteria; Post Secondary Education; Teaching Methods; *Technical Education

ABSTRACT

The report describes in detail the Electronics Technology Curriculum Development Project, a two-year electronics technology program with six core courses (three in circuit analysis and three in fundamentals of electronics) and an introduction to electronics technology course. Two chapters present the operation, scope, and objectives of the project and include discussions of the curriculum structure and its supporting philosophy. Three chapters (140 double-column pages) comprise a curriculum guide for the seven courses. Three more chapters (100 pages) deal with instructional methods and materials, including the use of media, audio-tutorial instruction, and the use of computers and calculators. There is a chapter on facilities, instruments, and equipment providing price ranges, minimum specifications, and guidelines for selection. A chapter of suggestions and recommendations treats: adapting the curriculum to a four-semester instead of six-quarter program; expected level of student performance; and miscellaneous suggestions arising from the project. Appendixes provide information on: relevant conferences; sources of audio-visual instructional materials; and suggested texts. (PR)

 * Documents acquired by ERIC include many informal unpublished *
 * materials not available from other sources. ERIC makes every effort *
 * to obtain the best copy available. nevertheless, items of marginal *
 * reproducibility are often encountered and this affects the quality *
 * of the microfiche and hardcopy reproductions ERIC makes available *
 * via the EPIC Document Reproduction Service (EDRS). EDRS is not *
 * responsible for the quality of the original document. Reproductions *
 * supplied by EDRS are the best that can be made from the original. *

ED109433

U.S. DEPARTMENT OF HEALTH
EDUCATION & WELFARE
NATIONAL INSTITUTE OF
EDUCATION

THIS DOCUMENT HAS BEEN REPRODUCED EXACTLY AS RECEIVED FROM THE PERSON OR ORGANIZATION ORIGINATING IT. POINTS OF VIEW OR OPINIONS STATED HEREIN ARE NOT NECESSARILY endorsed by the NATIONAL INSTITUTE OF EDUCATION.

REPORT
of
ELECTRONICS TECHNOLOGY
CURRICULUM DEVELOPMENT PROJECT
(ETCDP)

Supported By The National Science Foundation
Grant Number GY-6182

ERIC
1971

MAY 23 1975

ED109433

REPORT
of
ELECTRONICS TECHNOLOGY
CURRICULUM DEVELOPMENT PROJECT
(ETCDP)

CONDUCTED BY
THE UNIVERSITY OF ILLINOIS AT URBANA - CHAMPAIGN
IN COOPERATION WITH SEVEN COMMUNITY COLLEGES

HOST INSTITUTION: PARKLAND COLLEGE, CHAMPAIGN, ILLINOIS



PROJECT STAFF

Daniel S. Babb, Project Director
Ray A. Engelland
Joel D. Galloway, Associate Director
David A. Peterson
Randall L. Thompson

STEERING COMMITTEE

Carroll W. Livesay
Roger A. Mussell
Eric S. Ruby
Neal D. Voke
Felix H. Wheeler
Robert T. Wilson

Supported by the National Science Foundation
Grant Number GY-6182

1971

PROJECT STAFF

AFFILIATION AT START OF PROJECT

Ray A. Engelland
Chairman, Electronics Department
Willmar Area VO-TECH Institute
Willmar, Minnesota

Joel D. Galloway
Associate Project Director
Lead Instructor of Electronics,
Parkland College
Champaign, Illinois

David A. Peterson
Head, Electronics Technology
Alpena Community College
Alpena, Michigan

Randall L. Thompson
NSF Fellow
University of Illinois
at Urbana-Champaign
Urbana, Illinois

PROJECT COORDINATOR

Jerry S. Dobrovolny
Professor and Head,
Department of General Engineering
University of Illinois
at Urbana-Champaign
Urbana, Illinois 61801

CURRENT AFFILIATION AND ADDRESS (*Home Address)

Ray A. Engelland
Chairman, Electronics Department
Willmar Area VO-TECH Institute
Willmar, Minnesota 56201

Joel D. Galloway
EPDA Leadership Program
University of Illinois
at Urbana-Champaign
* 203 Main Street
Mahomet, Illinois 61853

David A. Peterson
Electronics Instructor
Parkland College
Champaign, Illinois 61820

Randall L. Thompson
EPDA Leadership Program
University of Illinois
at Urbana-Champaign
* 1703 Ridgeland Drive
Champaign, Illinois 61820

PROJECT DIRECTOR

Daniel S. Babb
Professor,
Department of Electrical Engineering
University of Illinois
at Urbana-Champaign
Urbana, Illinois 61801

Copies of this report are limited in number.

Reproduction of any portion of this report for local educational purposes only, is permitted.

For further information, write to the Project Coordinator or the Project Director

STEERING COMMITTEE

AFFILIATION AT START OF PROJECT

Carrol W. Livesay
Head, Electronics Department
Lake Land College
Mattoon, Illinois

Roger A. Mussell
Coordinator of
Electronics Technology
William Rainey Harper College
Palatine, Illinois

Eric S. Ruby
Head, Electronics Department
Sauk Valley College
Dixon, Illinois

Neal D. Voke
Chairman, Department
of Technology
Triton College
River Grove, Illinois

Felix H. Wheeler
Chairman, Electronics Technology
Danville Junior College
Danville, Illinois

Robert T. Wilson
Coordinator of Electronics
Illinois Central College
East Peoria, Illinois

CURRENT AFFILIATION AND ADDRESS

Carrol W. Livesay
Head, Electronics Department
Lake Land College
Mattoon, Illinois 61938

Roger A. Mussell
Coordinator of
Electronics Technology
William Rainey Harper College
Algonquin & Roselle Roads
Palatine, Illinois 60067

Eric S. Ruby
Director of Technology
Highland Community College
511 W. Stephenson Street
Freeport, Illinois 61032

Neal D. Voke
Chairman, Department
of Technology
Triton College
2000 Fifth Avenue
River Grove, Illinois 60171

Felix H. Wheeler
Electronics Instructor
Parkland College
Champaign, Illinois 61820

Robert T. Wilson
Coordinator of Electronics
Illinois Central College
P. O. Box 2400
East Peoria, Illinois 61611

PREFACE

The Electronics Technology Curriculum Development Project (ETCDP), the activities of which are portrayed in this report, was conducted with the thought that the results would be of value to all instructors and administrators interested in programs of electronics education for the comprehensive community colleges and technical institutes. Most of the electronics instructors of two-year institutions, with their heavy teaching schedules and administrative responsibilities, do not have sufficient available time to concentrate on subject-matter and curriculum development that they know are needed to keep their programs updated. The ETCD project and this report may alleviate this situation somewhat.

The contents of this report are arranged and organized with the overriding objective to make it convenient to identify those chapters, sections and topics that are of special interest to each reader. The *Table of Contents*, which is a rather complete outline, will provide reasonable guidance.

All recipients of this report will probably have an initial interest in knowing the thinking as expressed by each of the several individuals who were directly involved in the project. Comments from each member of the Project Staff are included as an integral part of this continuing preface. Concluding remarks by each member of the Steering Committee, and other key personnel associated with the project, are near the end of the concluding Chapter 10, starting on page 339. Refer to the Table of Contents for other individualized items, reports and discussions that may be of general interest.

Chapters 3 through 8 are devoted, essentially, to subject-matter content for the core courses of an Electronics Technology Curriculum and to recommended techniques of instruction. The earlier material, through Chapter 2, is introductory in its content to describe the objectives, scope and philosophy for the project.

The material and discussions through Chapter 2, although introductory in nature, represent a significant portion of this report. It "sets the stage" for the major activities of the project. The remainder of the report will have much greater value if the reader examines this introductory material rather carefully.

Chapter 9 relates to facilities, equipment and costs. Chapter 10, the concluding chapter, is devoted to some general suggestions and recommendations pertinent to technical and vocation programs in electronics education for two-year institutions, especially for the comprehensive community colleges.

The three Appendices (A, B and C) contain detailed information relating to summer institutes, conferences, visitations, multimedia sources, suggested texts, references and a bibliography.

This report shall not be considered as a finished product similar to a textbook. The project, we believe, has opened appropriately new doors to curriculum structure and to getting started in each course such that the student may experience the educational growth in electronics to match his aptitudes and interests and, at the same time, meeting the needs of industry.

Contributions to the project have come from many individuals and sources. Refer to the Acknowledgments immediately following this preface.

It has been a personal pleasure to have had the opportunity to be professionally associated with such dedicated and outstanding electronics teachers as are the members of the Project Staff and the Steering Committee. Please "listen" to what each member of the Project Staff has to say.

Daniel S. Babb

Daniel S. Babb
Project Director

CONTINUATION OF PREFACE (BY PROJECT STAFF)

I. FROM RAY A. ENGELLAND.

Career or occupational education has many facets and levels of accomplishments for the individual who enrolls in a curriculum with occupational goals. Career programs provide a means for people to obtain gainful employment in various activities from the scientist to the semiskilled jobs of industry.

Electronics Technology Education has many facets and provides employment opportunities in many areas. The Electronics student, facing the decision of his life's work, needs an opportunity to be exposed to the many aspects of the electronics industry. The student who knows what he or she wants on arrival as a freshman student is the exception rather than the rule.

It is my opinion that Electronics Technology Education in any given school or area should be organized to provide more than one level of training in electronics. When properly programmed, this will allow all students an opportunity to begin with core courses which are common to several levels of the electronics job spectrum. The first course in importance, is a course referred to as Introduction to Electronics Technology. The course will provide the student with the opportunity to learn some fundamental concepts and to explore the magnitude of the industry. Following this course, the student should now be ready to make his own decision as to what level of the electronics job spectrum he will be interested in pursuing.

On the community college and technical institute level this will be restricted to associate degree types of Electronics Technology programs; to two-year programs which are less than associate degree level; and to one-year programs which meet the needs of local industry. The student who begins with this type of package has the opportunity to "spin off" at various times in the curriculum without undue embarrassment or loss of time.

The package must provide a strong amount of technical courses and job related training along with enough general courses to meet the basic needs of the student. This will give the student of the two-year community college or technical institute an opportunity to compete on equal ground with anyone entering the job market at the same time. It is my sincere feeling that the curriculum developed by this project will answer the needs of the industry and of the student.

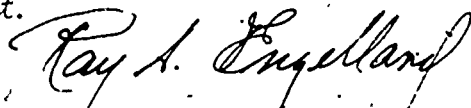

Ray A. Engelland

II: FROM JOEL D. GALLOWAY, ASSOCIATE DIRECTOR.

You will find this report committed to dividing the major subject of Electronics Technology into two core course areas: Electronics topics and circuit analysis topics. Why recommend this approach for the two year AAS programs?

The underlying theme of the educational process is to develop knowledge and skills on the part of the student that will allow him to learn on his own. Engineering technology programs, more than ever before, need to have this theme built into the curriculum. How else can we prepare today's graduate to adjust to rapid technological changes?

If this theme, or philosophy, is to be incorporated into a two year Electronics Technology program, key facets of it must be identified and structured accordingly. The student, as well as the teacher, should be able to see his way through the curriculum course maze. The student should know that as he completes each course he will be able to perform certain tasks he could not have performed prior to taking the course, and that this will assist him in learning the next topic which will allow him to perform at still another specified level, etc. At some point (presently it is two years in time and not at some level of performance) he is identified as qualified to perform in industry as an electronics engineering technologist.

The questions regarding what must be included, and unfortunately omitted, in such a short two-year curriculum must be resolved from some hierarchy of priorities. I find that sifting through this hierarchy of priorities, the answer to two basic questions improves this decision making process. These two questions are: If the student masters this, what will it allow him to do? And, can the student best learn this on his own, or after employment, or does it really require direct classroom-laboratory instruction?

It is from such a rationale that I find myself committed to developing a mathematical study of the basic scientific principles pertinent to electronic circuit analysis.

The language, the hardware, and the devices with all their applications are equally important, but it is from his quantitative study of circuit analysis that the student develops his potential to learn on his own. It is this background that provides the techniques to resolve problems and to answer the questions that he would otherwise accept on faith, or generalize in some qualitative manner.

The electronics industry is always in a constant stage of technical turmoil. New developments bring new requirements for technical personnel. Electronics Technology Curricula can make lagging adjustments in terms of hardware, instruments, devices, and techniques. The strongest attribute of these two-year programs could be the quantitative study of circuit fundamentals.

Quite capable electronics teachers have opposed this approach for various reasons, part of which relates to their own background and the evaluation of their students and related staff members.

Experience has taught me to never underestimate a dedicated teacher's ability to learn and adjust to the situation, and even more important, a motivated student's potential to master a subject.

I would like to thank Dan Babb, Jerry Dobrovolsky, Dave Peterson, Randy Thompson, Ray Engelland, the steering committee members, Parkland College staff, and all of those individuals that cooperated with us throughout the year, for the opportunity to work with them on this project.

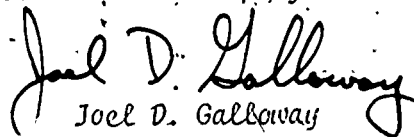
Joel D. Galloway

III. FROM D. A. PETERSON.

Upon examination of this report, it will become apparent to the reader that many changes or revisions in the sequence of topics included in the traditional Electronics Technology have been made. It must be emphasized that these changes were not made arbitrarily. The entire core material in the curriculum was scrutinized and broken into individual topics and concepts. These topics were then carefully analyzed as to the learning problems that the student might encounter. As a result of this careful examination, the topics were then grouped, sequenced and "packaged" into units or courses.

Unfortunately, it is impossible to involve the reader in the thought, discussion (sometimes heated), hair pulling and revision efforts that went into the development of the material for this report. The reader, if he could have been directly involved, could then identify more easily the rationale behind the changes recommended in this report.

Much of the material developed has been tried and tested in the classrooms and laboratories of the host institution and the Steering Committee schools. During the development stage, ideas were adopted, revised or scrapped on the basis of results of such trials.

In addition, the material has been scrutinized by many leading instructors of Electronics Technology across the country. It is hoped the sequence and the emphasis on certain topics will be carefully considered and hopefully adopted on a trial basis even though they may seem to be severe departures from a traditional approach.

At this point, it must also be noted that the materials presented in this report are not complete packages that can be used as ready-made courses. The laboratory experiments, handouts and presentations are merely examples of how the job might well be accomplished with maximum success.

Through an examination of these sample materials, perhaps the philosophy, guidelines and commitments that directed the efforts of the Project Staff through the first three phases of the project will become apparent. This philosophy is perhaps the major thing that the report attempts to sell.

In this respect, the report comprises a challenge to the electronics instructor to critically evaluate his own curriculum, the techniques and methods of instruction currently employed.

Finally, on a personal note, I wish to convey my reactions regarding the Electronics Technology Curriculum Development Project. As a staff member of the project, I had the opportunity to work with several of the most able, committed and thoughtful men in the profession. Common efforts with Dan Babb, Joel Galloway, Randy Thompson, Ray Engelland and the members of the Steering Committee, have resulted in a great personal respect for each of them as teachers and leaders, which has engendered an even deeper commitment than is probably reflected in the report.

David Peterson

D. A. Peterson

IV. FROM RANDALL THOMPSON.

The importance of effective utilization of instructional techniques and materials cannot be over-emphasized. A quality electronics technology program requires effective teaching-learning methods and materials that are integrated with a well-structured classroom and laboratory curriculum. Instructors must become aware of the benefits to be gained by the application of effective instructional techniques and materials and be stimulated to use them and to get rid of the ineffective ones currently being used.

Because of the realization that an integrated approach must be used in the electronics technology program, ETCDP has concentrated on the core curriculum and the instructional materials and techniques needed to meet the objectives of the core courses. Chapters 6, 7, 8 and sections of the Appendix contain information that is primarily concerned with instructional techniques and materials which are applicable to Electronics Technology and should be given careful consideration.

Included in these three chapters (in addition to discussions on such techniques as audio-tutorial, computer-assisted, closed circuit TV, etc.), are sample Fortran IV computer programs, audio-tutorial lessons, electronic calculator programs, and other materials that are related to the core courses. In the Appendix are instructional materials that include lists of 16 mm films with brief descriptions, Super-8 mm closed loop films, commercial slide-tape or filmstrip-tape lessons, and suggested texts and references including those for circuits, electronics, mathematics, physics, handbooks, and programmed textbooks.

The instructional techniques and materials presented in this report are by no means inclusive and are only examples of the techniques and materials that are available. Any omission of names, products, or materials is purely unintentional, if not an impossible task. The examples, materials, and ideas presented are only a beginning and additional research, development, and experimentation needs to be conducted to improve the teaching-learning process in electronics technology.

No single instructional technique can solve every problem or provide the best learning experience for every student. The instructor must not use new techniques to simply be up with the times and exclude all others, but rather to use techniques where they prove the most effective means of learning for the student. Each student is an individual and it is the responsibility of the instructor to provide the opportunity that will allow each student to achieve to his fullest capacity:

The number of people who have been so helpful throughout the project activities is overwhelming and sincere appreciation is offered to each one for the services provided. Personal appreciation is extended to Dennis DeCoste, Hewlett-Packard Company, Neil B. Graf, Wang Laboratories, for the demonstrations using electronic calculators. Additional thanks to Wang Laboratories for the loan of an electronic calculator for the summer institute. The summer institute seminar on machine language by Earl Burnett, Digiac Corporation, and Peter Collins, Aidex Corporation, was very much appreciated.

The opportunity to participate in this ETCDP project and its related activities has been a most challenging and rewarding experience. I would like to express my sincere appreciation to the other members of the project staff, steering committee, summer institute participants and to the many others who have made contributions. It has indeed been a pleasure to be associated with such a dedicated person as Dan Babb on the activities preceding and during the final preparation of this report.

Randall L. Thompson

Randall Thompson

ACKNOWLEDGMENTS

A large number of individuals and groups of individuals have contributed their talents and time to the ETCDP project. To acknowledge each and every one presents a formidable task. In a large measure, it has been the thoughtfulness and encouragement of administrators, teachers, and industry personnel that has provided the basis for the successes of the project.

With some question as to who is expressing thanks to whom, the acknowledgments which follow are expressed on behalf of the Project Staff and Steering Committee members.

THE HOST INSTITUTION:

Parkland College, Champaign, Illinois, was a most gracious and cooperative host for the project. Being in temporary facilities, some sacrifices were necessary to accommodate the project. Special thanks are extended to Mr. Gayle W. Wright, Division Chairman, Mathematics and Physical Science Division; to Dr. Donald Swank, Dean of Instruction and to Dr. William Staerkel, President.

THE PARTICIPATING COLLEGES:

Each participating college served as a host for two monthly meetings of the project. Members of the Steering Committee arranged these meetings and all of us are most grateful to their staff and non-academic personnel who provided assistance at these meetings.

SPEAKERS AT THE ETCDP CONFERENCE:

The guest speakers at the ETCDP Conference conducted at Champaign, Illinois on February 25-27, 1970 are identified in the conference program schedule starting on page 354. We wish it were feasible to reidentify each one here since their contributions were significant.

ATTENDEES AT THE ETCDP CONFERENCE:

The attendees are identified, starting on page 362. These people may not be aware of it, but their contributions through many informal and person-to-person discussions were most valuable.

PUBLISHERS:

Special thanks are extended to Lynn Baker of McGraw-Hill, to Merl Miller of Prentice-Hall and to Larry Hager of International Textbook Company for the much appreciated social hours at the conference.

Many publishers have provided valuable assistance in furnishing information on recent publications of value to electronics education.

ETCDP SUMMER INSTITUTE PARTICIPANTS:

The twenty-four participants are identified on page 350. The eight-week period of associations, academically and not-so-academically, provided plenty of opportunities for exchange of views and the development of technical materials. Many of their views and subject-matter developments are a part of this report.

INDUSTRY PERSONNEL:

Refer to page 217, a section on "Using Media to Bring Industry to the Classroom." The industries and personnel involved in that project are acknowledged there. Thanks to everyone involved in this very worthwhile project.

Many industries gave outstanding cooperation and assistance in the use of special instruments and equipment. Thanks to Dennis J. DeCoste of Hewlett-Packard; to Neil B. Graf of Wang Laboratories, Inc.; to Peter L. Collins of Aidex Corporation and to Earl E. Burnett of Digiac Corporation.

VISITATIONS:

A number of colleges were visited by one or more members of the Project Staff. These colleges and technical institutes are identified on page 353. Special thanks are extended to the many teachers and administrators of these institutions who were such gracious hosts and provided us with needed information and ideas.

THE REPORT:

Special acknowledgment must go to Mr. Randall Thompson, of the Project Staff, who assisted diligently and professionally throughout the last phase of the project--the preparation of this report into its final form. Much of his time and talents were above the call of duty as he received no compensation from the project because of an ERDA Fellowship.

Special thanks are extended to the staff of the Publications Office of the Department of Electrical Engineering at the University of Illinois at Urbana-Champaign. Several hundred copies of a 400-page report represent a lot of editing and paper handling.

Most of the art work for the report was done by Mr. Allen Lawrence, a graduate student in Electrical Engineering at the University of Illinois. The major portion of the report was typed by Mrs. Patricia Rowe, a faithful secretary throughout the project.

R. DEANE BRADLEY:

Mr. R. Deane Bradley, an Electronics Instructor at Parkland College, resigned to take another position after serving on the ETCD Project Staff during the early months of the project. Mr. Bradley provided valuable contributions, especially in the area of Instructional Technology.

LOUIS MAZE:

Mr. Louis Maze, Electronics Instructor at Triton College, River Grove Illinois, contributed his most valuable talents and time to the project. He participated in many of the monthly meetings of the Project Staff and Steering Committee and provided assistance on several special occasions.

TABLE OF CONTENTS

	Page
PREFACE	v
ACKNOWLEDGMENTS	xi
INTRODUCTION	1
OPERATION OF PROJECT.....	2
PROJECT OPERATED IN FOUR PHASES.....	2
ELECTRONICS TECHNOLOGY CONFERENCE.....	3
CONSULTANTS.....	3
SCOPE AND OBJECTIVES.....	5
ELECTRONICS TECHNOLOGY CURRICULUM.....	5
SIX CORE COURSES IDENTIFIED.....	5
A PARALLEL-INTEGRATED STRUCTURE REQUIRED.....	5
SIX COURSES PLUS ONE.....	7
THE CORE COURSES LEAD TO OPTIONS.....	7
OBJECTIVES OF PROJECT.....	7
 CHAPTER 1 DEVELOPMENTS PRECEDING THE PROJECT	 9
THE CHANGING TIMES FOR TECHNICAL EDUCATION.....	10
UPGRADING IN ENGINEERING CURRICULUM.....	10
ELECTRONICS TECHNOLOGY VS. VOCATIONAL ELECTRONICS.....	10
CIRCUIT ANALYSIS - THE KEY TO ELECTRONICS TECHNOLOGY.....	11
THE ELECTRONICS TECHNOLOGY CURRICULUM (SIX-QUARTER PROGRAMS).....	12
PROGRAM OBJECTIVES.....	12
UNIQUE FEATURES.....	12
AN ELECTRONIC-POWER TECHNOLOGY CURRICULUM.....	17
THE ELECTRONICS TECHNOLOGY CURRICULUM (FOUR-SEMESTER PROGRAM).....	21
PHILOSOPHY OF ENGINEERING TECHNOLOGY EDUCATION.....	23
GENERAL REQUIREMENTS.....	23
PROGRAM OBJECTIVES.....	23
THE CURRICULUM.....	24
FACULTY.....	24
STUDENT SELECTION.....	25
STUDENT SERVICES.....	25
UNIVERSITY INVOLVEMENT IN TECHNICAL EDUCATION.....	26
TEACHER PREPARATION.....	26
CURRICULUM RESEARCH.....	27
PROFESSIONAL ORGANIZATION, ARTICULATION.....	27
CONTRIBUTION TO THE LITERATURE OF THE FIELD.....	28
CONFERENCES.....	29
ADVISORY CONSULTANT SERVICES.....	29
PLANS FOR THE FUTURE.....	29
PROFESSIONAL, TECHNICAL, VOCATIONAL AND INDUSTRIAL ARTS EDUCATION.....	31
INDUSTRIAL ARTS EDUCATION.....	31
VOCATIONAL EDUCATION.....	31
TECHNICAL EDUCATION.....	32
PROFESSIONAL EDUCATION.....	33

CHAPTER 2 CONCEPTS FOR CURRICULUM DEVELOPMENT-	35
ELECTRONICS EDUCATION.....	36
ELECTRONICS EDUCATION IDENTIFIED.....	36
VOCATIONAL EDUCATION IN ELECTRONICS IDENTIFIED.....	36
TECHNICAL EDUCATION IN ELECTRONICS IDENTIFIED.....	37
SUMMARY STATEMENTS.....	37
RECOMMENDATIONS FOR CURRICULUM STRUCTURE (GENERALIZED).....	38
TWO KINDS OF PROGRAMS NEEDED.....	38
SPIN-OFF AND OPTION CONCEPTS OF CURRICULUM STRUCTURE.....	38
DEFINITION OF SPIN-OFF CONCEPT.....	38
SPIN-OFF CONCEPT SOLVES CRITICAL PROBLEM FOR THE COMPREHENSIVE COMMUNITY COLLEGE.....	40
SPIN-OFF CONCEPT HAS BEEN APPLIED.....	41
CHARACTERISTICS OF CURRICULUM FOR ELECTRONIC TECHNOLOGIES.....	42
THE CORE SUBJECTS IN CIRCUITS AND ELECTRONICS.....	42
ROLE OF CIRCUIT ANALYSIS FOR THE ELECTRONIC TECHNOLOGIES.....	43
ROLE OF COURSES IN FUNDAMENTALS OF ELECTRONICS.....	45
THE ROLE OF MATHEMATICS FOR THE ELECTRONIC TECHNOLOGIES.....	45
THEORY COURSES SEQUENCED TO MINIMIZE MATHEMATICAL PROBLEMS.....	47
ETCDP DEVELOPMENT FOR THE ELECTRONIC TECHNOLOGIES.....	48
THREE MAJOR STEPS OF DEVELOPMENT.....	48
PROCEDURE FOLLOWED FOR EACH COURSE.....	48
THE EDUCATIONAL ENVIRONMENT.....	49
CLASSIFICATION OF LABORATORY LEARNING EXPERIENCES.....	49
TECHNIQUES OF LABORATORY LEARNING.....	50
EMPHASIS ON SYSTEMS APPROACH.....	51
PROVIDE OPPORTUNITIES FOR INDEPENDENT LEARNING.....	51
THE INSTRUCTOR AND USE OF SOFTWARE.....	51
SEMANTICS OF ETCO PROJECT.....	53
CLOSED-LOOP CONCEPT OF EDUCATION.....	53
PATTERNS.....	53
GROUPINGS.....	53
SEQUENCING.....	54
MAJOR CONCEPTS.....	54
THE PROBLEM.....	54
KNOWLEDGE-UNDERSTANDING-APPRECIATION.....	54
CREATIVE INVESTIGATION.....	54
INTRODUCE (IN LABORATORY).....	55
GETTING STARTED.....	55
UNSTRUCTURED STRUCTURE.....	55
CHAPTER 3 INTRODUCTION TO ELECTRONIC TECHNOLOGY (INTRO COURSE)	57
PHILOSOPHY OF INTRO COURSE.....	58
TRADITIONAL APPROACH.....	58
THE NEED FOR AN INTRO COURSE.....	58
NATURE OF AN INTRODUCTION TO ELECTRONICS TECHNOLOGY COURSE.....	58
COMPONENTS AND PARAMETERS.....	59
FOUR MAJOR TOPICS FOR COURSE.....	59
TIME ALLOTTED TO INTRODUCTION TO ELECTRONICS TECHNOLOGY COURSE.....	61
SCHEMATIC DIAGRAMS PROVIDE INFORMATION.....	61
LANGUAGE OF INTRO COURSE.....	64
BASIC INSTRUMENTS.....	64
THE OSCILLOSCOPE.....	64

FUNCTION GENERATOR.....	64
BENCH POWER SUPPLY.....	64
OTHER INSTRUMENTS.....	65
SUGGESTED SYSTEMS TO STUDY.....	65
BREAKING SYSTEMS INTO SUB-SYSTEMS.....	65
SUMMARY OF BASIC SUB-SYSTEMS.....	65
COMPONENTS.....	66
HARDWARE.....	68
CONCEPTS.....	68
SPECIAL SOURCES OF INFORMATION.....	68
ILLINOIS CENTRAL COLLEGE REPORT.....	69
WILLMAR AREA VO-TECH INSTITUTE REPORT.....	73
GETTING STARTED WITH INTRO COURSE.....	78
TEACHING PROBLEMS FOR INTRO COURSE.....	91
CHAPTER 4 THE CIRCUIT ANALYSIS SEQUENCE	93
RESISTIVE CIRCUITS (CIRCUITS I).....	94
DEFINITION.....	94
MAJOR CONCEPTS.....	94
BEHAVIORAL OBJECTIVES.....	94
PREREQUISITES.....	94
OUTLINE.....	95
GENERAL GUIDELINES.....	97
GUIDELINES FOR CLASSROOM.....	100
LABORATORY GUIDELINES.....	106
SINGLE-TIME-CONSTANT CIRCUITS (CIRCUITS II).....	115
DEFINITION.....	115
MAJOR CONCEPTS.....	115
BEHAVIORAL OBJECTIVES.....	115
PREREQUISITES.....	115
OUTLINE.....	116
GENERAL GUIDELINES.....	117
CLASSROOM GUIDELINES.....	119
STC CIRCUITS LABORATORY.....	128
NETWORKS (CIRCUITS III).....	141
DEFINITION.....	141
MAJOR CONCEPTS.....	141
BEHAVIORAL OBJECTIVES.....	141
PREREQUISITES.....	141
OUTLINE.....	142
GENERAL GUIDELINES.....	143
THE PATTERN OF S-EQUATIONS.....	144
CHAPTER 5 THE FUNDAMENTALS OF ELECTRONICS SEQUENCE	151
RESISTIVE ELECTRONICS (ELECTRONICS I).....	152
DEFINITION.....	152
MAJOR CONCEPTS.....	152
BEHAVIORAL OBJECTIVES.....	152
PREREQUISITES.....	152
OUTLINE.....	153
GENERAL GUIDELINES.....	156
THE TERMINAL OR PORT APPROACH TO THE STUDY OF ELECTRONIC DEVICES...	159

LABORATORY GUIDELINES FOR RESISTIVE ELECTRONICS.....	166
A TYPICAL FINAL EXAMINATION.....	168
PULSE ELECTRONICS (ELECTRONICS II).....	170
DEFINITION.....	170
MAJOR CONCEPTS.....	170
BEHAVIORAL OBJECTIVES.....	170
PREREQUISITES.....	170
OUTLINE.....	170
GENERAL GUIDELINES.....	174
GUIDELINES FOR CLASSROOM ACTIVITIES.....	177
LABORATORY GUIDELINES.....	181
ADVANCED LINEAR ELECTRONICS (ELECTRONICS III).....	185
DEFINITION.....	185
MAJOR CONCEPTS.....	185
BEHAVIORAL OBJECTIVES.....	185
PREREQUISITES.....	185
OUTLINE.....	186
GENERAL GUIDELINES.....	187
GUIDELINES FOR CLASSROOM.....	190
LABORATORY GUIDELINES FOR ADVANCED LINEAR ELECTRONICS.....	196
CHAPTER 6 INSTRUCTIONAL TECHNOLOGY	205
GENERAL AND SPECIFIC CONSIDERATIONS.....	206
INSTRUCTIONAL TECHNOLOGY AND ELECTRONICS.....	208
WHAT IS INSTRUCTIONAL TECHNOLOGY?.....	208
DEVELOPING INSTRUCTIONAL MATERIALS.....	208
ROLE OF INSTRUCTOR.....	208
WHAT IS MEDIA?.....	209
PLANNING INSTRUCTION.....	210
THE OVERHEAD PROJECTOR.....	210
MAKING TRANSPARENCIES.....	211
PROGRAMMED INSTRUCTION.....	212
INSTRUCTIONAL FILMS.....	214
SUPER 8MM FILMS.....	215
ELECTRONICS SEMINAR.....	215
CLOSED CIRCUIT TV.....	216
AUDIO-TUTORIAL INSTRUCTION.....	216
COMPUTER-ASSISTED INSTRUCTION.....	216
COMPUTERS AND CALCULATORS.....	216
USING MEDIA TO BRING INDUSTRY TO THE CLASSROOM (AN EXPERIMENT).....	217
INDUSTRY AND THE CLASSROOM.....	217
OBJECTIVES OF THE EXPERIMENT.....	217
EQUIPMENT USED.....	217
COMPANIES SELECTED.....	217
INSTRUCTION ON EQUIPMENT.....	218
FILMING PROCEDURE.....	218
RESULTS.....	219
CONCLUSIONS.....	219
THE LANGUAGE OF ELECTRONICS.....	222
TECHNICAL VOCABULARY.....	222
SYMBOLS.....	223
DIAGRAMS.....	223
SCHEMATIC DIAGRAMS.....	223

CHAPTER 7 - INDIVIDUALIZED INSTRUCTION	229
AUDIO-TUTORIAL INSTRUCTION.....	230
WHAT AND WHY OF AUDIO-TUTORIAL.....	230
HOW TO PREPARE AN AUDIO-TUTORIAL LESSON.....	231
ADVANTAGES OF AUDIO-TUTORIAL.....	232
DISADVANTAGES OF AUDIO-TUTORIAL.....	233
APPLICATIONS OF AUDIO-TUTORIAL.....	234
WHERE IS AUDIO-TUTORIAL BEING USED?.....	234
PREPARING SLIDES FOR AUDIO-TUTORIAL.....	235
LEARNER-CONTROLLED LABORATORY.....	237
FUNCTION GENERATOR AND OSCILLOSCOPE (A-T PRESENTATION).....	240
THE CURVE TRACER (A-T PRESENTATION).....	244
LA PLACE TRANSFORMS (A-T PRESENTATION).....	247
SINGLE-TIME-CONSTANT CIRCUITS (A-T PRESENTATION).....	250
SWITCHING CIRCUITS (A-T PRESENTATION).....	255
CHAPTER 8 UTILIZATION OF COMPUTERS AND CALCULATORS	263
COMPUTER ASSISTED INSTRUCTION.....	264
WHAT IS CAI?.....	264
CAI AND ELECTRONICS.....	264
USING CAI.....	264
PLATO EXAMPLE.....	267
A CAI APPLICATION FOR ELECTRONICS.....	268
COMPUTERS AND CALCULATORS AS TOOLS.....	273
ELECTRONIC DESK TOP CALCULATORS.....	273
COMPUTER PROGRAMMING.....	273
STUDENTS, CALCULATORS AND COMPUTERS.....	274
ECAP.....	275
TIME-SHARE TERMINAL.....	276
COMPUTER APPLICATION TO ELECTRONICS.....	276
DESK TOP DIGITAL CALCULATOR MANUFACTURERS.....	277
A SUGGESTED COURSE IN COMPUTER PROGRAMMING.....	279
SAMPLE PROBLEMS USING ELECTRONIC CALCULATOR.....	284
FORTRAN IV. PROGRAM FOR PULSE ELECTRONICS.....	286
FORTRAN IV. PROGRAM TO CALCULATE BIASING RESISTANCE.....	289
FORTRAN IV. PROGRAM FOR SQUARE WAVE SYNTHESIS.....	290
FORTRAN IV. PROGRAM FOR TWO-STAGE AMPLIFIER.....	292
SOLVING A COMPLEX NETWORK WITH FORTRAN IV.....	294
FORTRAN IV. PROGRAM FOR RLC SERIES CIRCUIT.....	296
SOLUTION OF THREE-NODE RESISTIVE CIRCUIT WITH ECAP.....	301
FORTRAN IV. PROGRAM TO CALCULATE DB AND PHASE ANGLE.....	302
FORTRAN IV. LOW PASS FILTER PROBLEM.....	304
CHAPTER 9 FACILITIES, INSTRUMENTS AND EQUIPMENT	305
EQUIPMENT SELECTION.....	306
EQUIPMENT COST AND CURRICULUM OBJECTIVES.....	306
EQUIPMENT SPECIFICATIONS.....	308
EQUIPMENT OBSOLESCENCE AND MAINTENANCE.....	314
INFORMATION SOURCES FOR EQUIPMENT.....	315
TECHNICAL PERIODICALS.....	316
THE STUDENT BENCH OSCILLOSCOPE.....	320
PLUG-IN-UNITS.....	320
BANDWIDTH.....	320

SENSITIVITY.....	321
SWEEPS.....	321
VERTICAL AMPLIFIER.....	322
OTHER FACTORS.....	322
INTERPRETING SPECIFICATIONS.....	322
CHAPTER 10 SUGGESTIONS AND RECOMMENDATIONS	325
SUGGESTED ADJUSTMENTS TO THE FOUR-SEMESTER PROGRAM.....	326
GENERAL CONSIDERATIONS.....	326
FLOW CHARTS FOR BOTH QUARTER AND SEMESTER PLANS.....	326
ADJUSTMENTS FOR THE FIRST SEMESTER.....	326
ADJUSTMENTS FOR THE SECOND SEMESTER.....	327
ADJUSTMENTS FOR THE THIRD SEMESTER.....	328
ADJUSTMENTS FOR THE FOURTH TERM.....	328
LEVEL OF PERFORMANCE EXPECTED OF GRADUATES.....	329
RESPONSIBILITIES OF MANPOWER TEAM.....	329
KNOWLEDGE REQUIREMENTS OF ELECTRONICS ENGINEERING TECHNICIAN.....	330
MISCELLANEOUS TOPICS CONSIDERED BY ETCDP.....	332
WHAT ABOUT ENTRANCE REQUIREMENTS?.....	332
WHAT ABOUT AN ADDITIONAL SUMMER TERM?.....	332
WHAT ABOUT PRETECHNICAL PROGRAMS?.....	332
WHAT ABOUT TEACHER RESPONSIBILITIES?.....	333
WHAT ABOUT TEACHER QUALIFICATIONS?.....	333
WHAT ABOUT REVISION OF EXISTING PROGRAMS?.....	333
WHAT ABOUT JOB PLACEMENT OF GRADUATES?.....	334
WHAT ABOUT SOFTWARE FOR LABORATORY?.....	334
WHAT ABOUT INTERACTIONS WITH INDUSTRY?.....	334
A POSITION PAPER FOR ELECTRICAL-ELECTRONICS TECHNOLOGY.....	335
INTRODUCTION.....	335
THE ELECTRICAL-ELECTRONIC ENGINEERING TECHNICIAN.....	336
THE CURRICULUM--PHILOSOPHY, ORGANIZATION, AND CONTENT.....	336
EMPLOYMENT OF ALUMNI.....	338
EMPLOYING COMPANIES.....	338
TRANSFER OF ALUMNI TO UNIVERSITIES.....	338
CONCLUDING REMARKS BY STEERING COMMITTEE MEMBERS.....	339
CONCLUDING REMARKS BY CAROL LIVESAY.....	339
CONCLUDING REMARKS BY ROGER MUSSELL.....	339
CONCLUDING REMARKS BY ERIC RUBY.....	340
CONCLUDING REMARKS BY NEAL D. VOKE.....	342
CONCLUDING REMARKS BY FELIX WHEELER.....	344
CONCLUDING REMARKS BY ROBERT WILSON.....	344
A LETTER FROM PHILLIP CUTLER.....	346
A MESSAGE FROM THE PRESIDENT OF PARKLAND COLLEGE.....	347
A MESSAGE FROM THE PROJECT COORDINATOR.....	348
APPENDIX A SUMMER INSTITUTE, VISITATIONS AND CONFERENCES	349
ETCDP SUMMER INSTITUTE.....	350
SUMMARY OF ACTIVITIES.....	350
PARTICIPANTS.....	350
VISITATIONS AND CONFERENCES.....	353
THE ELECTRONICS TECHNOLOGY CONFERENCE.....	354
THE NEWS RELEASE.....	354
THE CONFERENCE PROGRAM.....	354

CONFERENCE SUMMARY.....	355
PARTICIPANTS AT ELECTRONICS TECHNOLOGY CONFERENCE.....	362
APPENDIX B SOURCE INFORMATION OF INSTRUCTIONAL MATERIALS	367
ERA AUDIO-VISUAL AIDS.....	368
16MM FILMS.....	372
ADDRESSES FOR FILM SOURCES.....	384
SUPER 8MM FILM LOOPS.....	386
APPENDIX C SUGGESTED TEXTS AND BIBLIOGRAPHY	388
SUGGESTED TEXTS AND REFERENCES.....	389
CIRCUIT ANALYSIS.....	389
ELECTRONICS.....	390
PROGRAMMED TEXTBOOKS.....	391
HANDBOOKS.....	392
MATHEMATICS.....	392
PHYSICS.....	393
PUBLISHERS ADDRESSES.....	394
SELECTED BIBLIOGRAPHY.....	395

INTRODUCTION

The discussions of this introduction, along with Chapter 1 (Developments Preceding the Project) are presented to provide information on what this Electronics Technology Curriculum Development Project is all about. The remaining chapters deal with the activities of the Electronics Technology Curriculum Development Project.

In this introduction, the operation of the project, its scope and objectives are stated briefly and concisely.

In Chapter 1, curriculum structures for the Electronic Technologies and supporting philosophy developed over the past several years are presented. In these previously proposed curriculum structures there exists a sequence of three courses in Circuit Analysis, a sequence of three courses in the Fundamentals of Electronics and one course (a first term course) identified as Introduction to Electronics Technology (INTRO). The project is primarily concerned with these six plus one core courses for the Electronic Technologies.

OPERATION OF PROJECT

The Electronics Technology Curriculum Development Project (ETCDP) is a cooperative endeavor involving seven Illinois two-year colleges and the University of Illinois at Urbana-Champaign. The seven colleges are identified in the frontmatter of this report.

The University of Illinois at Urbana-Champaign is the grantee of the project with Parkland College as the host institution. Each of the other six participating colleges have a representative on a Steering Committee. The personnel for the steering committee, the Project Staff and Administration are identified in the frontmatter.

The seven junior colleges and the University of Illinois are within a geographical area to permit convenience of travel for meetings as necessary. Four of the junior colleges are in central Illinois, and three of the colleges are in north central Illinois. The greatest distance separating these colleges is about 180 miles with Interstate. This geographical convenience is a stipulation for the project.

PROJECT OPERATED IN FOUR PHASES

A cooperative project of this kind is required to operate in two stages. It shall have a *planning stage* followed by an *Academic Year*, as a minimum suggested time.

In the original proposal to the National Science Foundation, the project was set up to operate in three phases. A fourth phase was added, with approval, after the project was well along in the work.

The four phases, with time intervals specified in parentheses, are stated below:

Phase I: Planning Stage (August 8 to September 7, 1969).

Phase II: Materials Development Stage (September 8, 1969 to June 20, 1970)

*NOTE: Refer to Chapter 2 for more detailed discussion relating to project activities.

Phase III: Summer Institute Stage (June 22 to August 15; 1970)

Phase IV: Dissemination of Information Stage (August 15, 1970 to February 28, 1971)

Phase I, The Planning Stage

The first two weeks of this period were used to organize the activities of the Project Staff for the total project. This involved decisions on individual responsibilities, establishment of a common philosophy, nature and extent of materials to be developed, administrative procedures and a consideration of all facets of the project.

A two-week workshop involving the Steering Committee and the Project Staff was conducted at the University of Illinois at Urbana-Champaign. Special attention was directed to the *six plus one* core courses (identified later in this chapter) and related problems of an Electronics Technology Curriculum.

During this planning stage, it was also necessary to arrange working agreements, facilities and financial, between the University of Illinois and Parkland College, the host institution, in preparation for operations in Phase II and Phase III.

Phase II, The Materials Development Stage

The Project Staff, housed in facilities provided by Parkland College, Champaign, Illinois, used this period to develop subject matter content; to develop instructional techniques, and to consider problems relevant to Electronics Technology Curriculum problems. The major effort was directed to the *six plus one* courses.

Once a month, starting in October 1969, joint meetings of the Project Staff and the

Steering Committee were conducted. On a rotating basis, a member of the Steering Committee was chairman of these sessions with his college serving as the host. These were one-and-a-half day sessions with an evening meeting followed by an all-day meeting. To avoid conflicts with individual responsibilities at their home institutions, these sessions were conducted near the end of the week and quite frequently on weekends.

During these joint meetings the Steering Committee members reacted to the materials and reports presented by the Project Staff and provided continuing guidance. Concepts and materials presented were applied to the classroom and laboratory activities of the various colleges when appropriate to the courses then in their schedules.

Phase III, Summer Institute Stage

Twenty-four experienced electronics instructors, from junior colleges and technical institutes, were selected to participate in a Summer Institute. These participants and their colleges are identified in the Appendix of this report. Information from the brochure for this Summer Institute is also reproduced in the Appendix to reveal the objectives and content of the summer session.

The participants of the Summer Institute served the dual role of student and consultant for the project. In the first few weeks, the Project Staff presented materials, concepts and instructional techniques pertaining directly to the activities of the project.

As consultants, they performed a valuable role to the project by presenting their own personal viewpoints and approaches to technical topics of considerable significance. As a group, a great amount of valuable material was submitted to the project. Much of their material will appear in this report.

Phase IV, Dissemination of Information Stage

Initially, the project was scheduled to terminate on August 31, 1970. Along about in

April, because of the amount and coverage of material prepared, it became evident that it is difficult to conduct the summer institute and prepare this final report as a worthwhile "Teachers Guide" by the scheduled date of termination.

The terminating date was therefore extended to February 28, 1971 to allow the needed time to review, assemble and prepare materials for this report.

The Project Staff and the Steering Committee were, however, officially terminated on August 15, 1970. The working staff for this Phase IV consists of the Project Director (Professor Daniel S. Babb), Randall Thompson (Formerly of the Project Staff) and a part time secretary.

ELECTRONICS TECHNOLOGY CONFERENCE

As an important element in the plans for the project, a three-day Electronics Technology Conference (on a self-supporting basis) was conducted on February 26-28, 1970 at Champaign, Illinois. Some of the details of the conference are presented in the Appendix.

The attendees at the conference (Electronics teachers, administrators and industry personnel) represented approximately 33 states and Canada. The primary purpose of the conference was to obtain some rapid feedback and reactions on the activities of the project from knowledgeable individuals on a broad geographical base. From the many positive reactions received, the conference provided tremendous encouragement to the Project Staff and the Steering Committee.

CONSULTANTS

Plans were incorporated in the project proposal to obtain guidance and reactions from experts in the discipline of Electronics Technology as consultants to the project. The most convenient and workable solution to this objective was for the Project Director and members of the Project Staff to make personal visitations at a number of colleges in several

states. In this way we could observe curricula and a number of staff people in operation at their particular college environments. About 20 colleges in 9 states, outside of Illinois, were visited during the project. The colleges and technical institutes visited are identified in the Appendix.

SCOPE AND OBJECTIVES

ELECTRONICS TECHNOLOGY CURRICULUM

A two-year Electronics Technology program can be broken down into four major divisions:

1. Fundamentals of Electronics and circuits theory (core).
2. Specialized courses in electronics (options).
3. Mathematics and Science courses.
4. Nontechnical Courses.

Each of these four areas is approximately one-fourth of the total curriculum. See Chapter 1 for sample curricula.

SIX CORE COURSES IDENTIFIED

The activities of the Electronics Technology Development Project (ETCDP) are directed, primarily, to the core courses of the curriculum.

The core courses represents a sequence of major topics in the area of *Circuit Theory* and in the area of *Fundamentals of Electronics*. Throughout this report, the theory courses in circuits are identified as:

Resistive Circuits
Single-Time-Constant Circuits
Networks

See Chapter 4 for detailed discussion of these courses.

The courses for the active circuits are identified as:

Resistive Electronics
Pulse Electronics
Linear Electronics

See Chapter 5 for detailed discussion of these courses.

The six core courses will be identified as above in either a six-quarter plan or a four-semester plan. Their contents, however, are not identical. Primarily, in comparing the two programs, there may be only a shift in the starting and terminating topics for each course.

A PARALLEL-INTEGRATED STRUCTURE REQUIRED

A parallel-integrated structure of the theory and mathematics courses became possible in an Electronics Technology curriculum through the sequence of circuits courses of *Resistive Circuits to Single-Time-Constant Circuits to Networks*, and through a sequence of courses in the fundamentals of electronics of *Resistive Electronics to Pulse Electronics to Linear Electronics*.

The details for each of these courses constitute a major time-consuming effort for the project. The nature of these detailed studies and developments will be presented in this report. Basically, the first course in each of the two sequences requires a minimum of background in mathematics. *Resistive Circuits and Resistive Electronics*, for example, require a knowledge of algebra and the elements of trigonometry. The second courses in the sequence, *STC Circuits and Pulse Electronics*, have the added requirement of only the elements of calculus.

Courses in circuit analysis and the fundamentals of electronics, when sequenced in this way, mean that the first course in circuits, *Resistive Circuits*, can be presented in the very first term of a 4-semester plan, or in the second term of a 6-quarter curriculum. *Resistive Electronics*, the first of the electronics sequence, usually follows *Resistive Circuits* but may be directly in parallel with it, if necessary.

A sample program will illustrate a curriculum structure along the lines outlined in the preceding paragraphs. The one shown is that of Parkland College, Champaign, Illinois, the host institution for the project. The six core courses are identified as ELT 111, 112, 211, 102, 201 and 202 in the Parkland College program.

PARKLAND COLLEGE
ELECTRONICS TECHNOLOGY PROGRAM
DEGREE (AAS)

TOTAL
CREDITS HRS.
WITH P.E.

QUARTER	MATH	CIRCUITS	ELECTRONICS	TECHNICAL SUPPORT	TECHNICAL SPECIALTIES	GENERAL EDUCATION	TOTAL CREDITS HRS. WITH P.E.
I	MAT 134 4-0-4 Algebra or Trig.	<i>INTRO Course</i> ELT 101 2-6-4	ELT 101 2-6-4	DRT 111 2-6-4 Drafting, Fabrication		ENG 104 4-0-4	17
II	MAT 135 4-0-4	ELT 111 3-3-4 (Resistive Ckts)		DAP 212 3-3-4		ENG 105 4-0-4	17
III	MAT 136 4-0-4	ELT 112 3-3-4 (STC Ckts)	ELT 102 3-3-4 (Resistive Elect)			SOS 101 4-0-4	17
IV	MAT 234 4-0-4	ELT 211 4-0-4 Networks	ELT 201 3-3-4 Switching	PHY 104 3-3-4 Mechanics			17
V	<i>The six CORE COURSES</i>		ELT 202 3-3-4 Linear	PHY 105 3-3-4 Mechanics II	ELT 204 3-3-4 Communication Systems	ENG 221 1-0-4 Tech Writing	17
VI			ELT 203 3-3-4 Advanced	PHY 106 3-3-4 Elect. & Magnetism	ELT 205 3-3-4 Elect. Systems		17
TOTAL	16-0-16	10-6-12	14-18-20	14-18-20	9-9-12	16-0-16	102

SIX COURSES PLUS ONE

There may be an occasional reference, in this report, to the "6 + 1" courses. The additional one has reference to an "Introduction to Electronics Technology" course which we have chosen to isolate from the six core courses. It is identified as ELT 101 in the Parkland College program. It is given separate treatment in Chapter 3 of this report.

This one course, when offered, is scheduled in the first term. It has the one important purpose of introducing the students to the field of electronic technology without getting too involved on a quantitative basis. The course is considered essential to the full success of a curriculum. There are different approaches which will be outlined in Chapter 3.

The project then, is involved with seven courses not six. This was indicated in the original proposal for the project.

THE CORE COURSES LEAD TO OPTIONS

Concentrating on the six core courses (+1) is considered important since these basic courses can lead to a number of options, either as institutional options or as student electives where enrollment is sufficient to warrant student electives.

A number of possible options are listed below: (An institution would select one or more of these rather than try to cover the whole field)

- Communications
- Computer Electronics
- Digital Electronics
- Power
- Instrumentation
- Electro-mechanical
- Medical Electronics
- Control Systems

For the most part, the six core courses can satisfy the special needs of any one of the options. Some modifications may be appropriate in the third circuits course only and in the third electronics course only. This point will

be discussed in the report.

OBJECTIVES OF THE PROJECT

The scope of the project as outlined to this point suggests the objectives for the project. These objectives are stated briefly here as general objectives and as specific objectives.

The General Objectives

The project has two general objectives.

They are:

1. To develop subject matter and instructional techniques for the six plus one core courses.
2. To consider the total educational needs for two-year associate degree programs, especially those needs that exist in the environment and philosophy of a *Comprehensive Community College*.

Specific Objectives

The specific objectives for the project are:

1. To develop those concepts and techniques for each course that are most important to the success of that course and to the total curriculum.
2. To find techniques of getting the job done in the six core courses, which require a mathematical process, without unnecessary mathematical burdens.
3. To discover some practical ways of bringing the real world of industry into the classroom.
4. To discover and recommend techniques to take better advantage of modern electronics calculators and computer facilities.
5. To discover and recommend techniques to take better advantage of available media, including individualized instruction.
6. To recommend alternative approaches and structures for the total two-year curriculum in electronics technology.

CHAPTER 1

DEVELOPMENTS PRECEDING THE PROJECT

It is doubtful that financial support would be given for a project of this kind, or that it could even be reasonably productive, without extensive development work preceding such a project.

Over the past twelve years the University of Illinois at Urbana-Champaign has provided the academic climate and facilities for interested staff members to become actively involved in technical education for the junior colleges and technical institutes.

A committee, through which significant contributions have been made, was formed in 1959 and identified as the Engineering Technology Curriculum Advisory Committee. Throughout its existence, Professor Jerry S. Dobrovolny, Head of the General Engineering Department, has served as the chairman of this committee. One of his papers entitled, "University Involvement in Technical Education" is presented in this chapter.

Other materials of the chapter are related to the philosophy and structure of Electronic Technology curriculum developed over a period of several years before the project. The Project Director has been directly involved in these specialized developments with the assistance and support of a number of Electronic Technology teachers while they were participants in summer institutes and/or academic year institutes supported by the National Science Foundation. These advanced developments, because of certain unique and innovative features, have dictated the need for this project involving several junior colleges and teachers.

THE CHANGING TIMES FOR TECHNICAL EDUCATION

To appreciate the significance of the three curriculum structures as outlined in the following section's of this chapter, it seems important to go back in time about ten or fifteen years and review the trends and developments in technical education with special attention to the Electronic Technologies.

The concepts of technical education have been around for a long time. Before the 1960's, however, these concepts were largely restricted to engineering colleges and the technical institutes, - primarily the private technical institutes. For the most part the junior colleges then in existence were largely concerned with transfer programs to senior colleges and universities. A number of states did have area vocational schools.

With the technological developments of the 1950's, it soon became apparent that a secondary school education would not be sufficient to obtain gainful employment for the remainder of one's lifetime. The vocational and technical manpower needs of industry were becoming too great in comparison to nontechnical job opportunities.

With the Federal funds made available for vocational and technical education, it was the secondary school district that provided much of the *Post-High-School* training as best they could while State Plans were being developed and legislated.

What happened, in these early stages, was that these *Post-High-School* career programs were largely vocational and terminal in their contents and objectives. Such objectives and limitations were probably appropriate for the times. During this period, however, something was happening in the senior colleges to create even wider gaps in the technical education spectrum.

UPGRADING IN ENGINEERING CURRICULUM

A trend to upgrade electrical engineering curriculum (all engineering, for that matter) began in the 1950's and is continuing to this day. An *Engineering Goals Study* came up with the strong recommendation (not implemented, as yet) that the first degree should be the M.S. degree, not the B.S. degree. This was dictated by the technological developments which required more highly educated engineers and scientists. Design and how-to-do courses were replaced with theory courses. Larger and larger numbers of engineering students were continuing their education to higher degrees. Even though they were in great demand, still industry became very concerned about the *how-to-do* gap that was being created. The new kind of engineer and scientist was creating the need for *Engineering Aids*.

In recent years, the Comprehensive Community College is recognizing its concept of comprehensiveness through programs of *Technical Education* as well as *Vocational Education* programs.

ELECTRONICS TECHNOLOGY-US-VOCATIONAL ELECTRONICS

No matter how they are now identified, or may be identified in the future, there are two kinds of programs in electronics education, (discussed in more detail in Chapter 2) both of which are needed, in two-year colleges. Essentially, one is math-science based and quantitative in nature and the other is more qualitative. One is more educationally oriented and the other is more training-skilled oriented. One is conceptually oriented and the other is more laboratory hands-on oriented.

CIRCUIT ANALYSIS--THE KEY TO ELECTRONICS TECHNOLOGY

Electronics education involves a knowledge and understanding of systems. Systems require a knowledge of circuit analysis. Circuit analysis is a mathematical process. The mathematical process involves the elements of calculus, differential equations and LaPlace transforms.

Since electronics technology involves circuit analysis, the problem that existed in curriculum structure was finding a way to get the job done in two-years while the student is still in the process of getting the needed background in mathematics.

This dictated the concept of *resistive circuits* as the first course and *STC circuits* as

the second course. This approach was suggested in the 1964 Electronics Technology curriculum guide which is reproduced (in part only) in this chapter. Until this date (1964) textbooks on circuit analysis only hinted at such a structure for a curriculum. The Project Director wrote the first book devoted to resistive circuits only and had written several chapters for a proposed text on STC circuits before the project started. Certain members of the Project Staff and the Steering Committee assisted with these developments. The project has served a valuable role in the continuation and implementation of these early developments and related concepts in an electronics technology curriculum.

THE ELECTRONICS TECHNOLOGY CURRICULUM (SIX-QUARTER PROGRAM)

The discussions and materials on this and the next few pages are taken from an Electronic Technology bulletin identified as "Engineering Technology Series No. 3, 1967" developed at the University of Illinois at Urbana-Champaign. Participants from two U of I Academic Year Institutes (1964-65 and 1966-67) for electronic teachers, supported by the National Science Foundation, were actively involved in the preparation of the total material of that bulletin. Only a small portion is reproduced here.

In the order of presentation, the following material covers: Objectives, unique features, the suggested curriculum, curriculum summary by clock hours and credit hours and a flow chart (Fig. 1) for mathematics, circuits and electronics courses.

PROGRAM OBJECTIVES

The two-year electronic technology curriculum is constructed to meet the specific objectives of an engineering technology curriculum. These objectives were presented in preceding paragraphs. The engineering technician should have a broad range of competences. He should have the abilities to design, assemble and test electronic circuits. He should have the ability to assist engineers and scientists in projects of development and research.

This two-year electronic technology curriculum is constructed as a fundamental and practical type of program to satisfy the prerequisites that will qualify the graduate to perform job functions in any one of a number of options such as communications, control systems, computer design, computer applications, industrial electronic drafting, logic systems, circuit design, system testing and measurement techniques. An additional one or two quarters for purposes of further specialization and continuing education is strongly recommended.

An electronic technology curriculum should have a proper balance between theory and practice. The theory portion of the program requires a working knowledge of mathematics through calculus along with some differential

equations and an ability to analyze a variety of circuits. For many years mathematics has determined the sequencing of topics in the circuits and electronics courses. The practical portion of the program requires a knowledge of instruments, testing and measurement techniques along with an ability to recognize and solve practical problems as actually confronted in industry.

UNIQUE FEATURES

The curriculum is designed to meet the objectives of the two-year six quarter program. The complete curriculum, as shown on page 14 has a number of unique features. The flow chart of Fig. 1 shows how the technical speciality portion of the program and the mathematics courses are interrelated.

1. The two courses, Introductory Electronics I and II, in the first and second terms respectively, are designed to acquaint the student with the content of the electronic technology curriculum through laboratory projects that are done qualitatively rather than on an analytical basis. (Since this publication, the concept of two courses as suggested here has been changed to a concept of only one course to be identified as Introduction

to Electronics Technology)

Introductory Electronics I introduces the student to measuring instruments most commonly used throughout the curriculum. Emphasis is on quantities which an instrument is capable of measuring. The details and procedures for this exploratory course are defined in the outline.

Introductory Electronics II provides an opportunity to explore the operation and response of the most common types of basic electronic circuits that serve as building blocks for practical electronic systems. The course is exploratory and qualitative analysis is emphasized. It provides the practical experience and the motivation for the detailed and quantitative studies that follow in the curriculum.

2. The seminar sessions in the last five quarters of the curriculum are designed to provide additional enrichment for the students. This should be accomplished by providing guest lecturers from industry, touring industries, viewing technical films, and through the discussion of topics pertinent to the electronic technology curriculum.

3. Circuits I (Resistive Circuits) provides the basic concepts for continued circuit analysis. The study of resistive circuits requires algebra and some trigonometry which are covered in Mathematics I in the first quarter. This course serves as a prerequisite to Electronics I (Resistive Electronics) which comes in the following quarter. Refer to the flow chart.

Circuits II (Single-Time-Constant Circuits) requires an understanding of only basic concepts of calculus. It serves as a natural introduction to Electronics II (Pulse Circuits) which comes in the following term. The circuits courses beyond Circuits II are presented in the traditional manner. Circuits III (Network Analysis), for example, is a traditional treatment of circuits, which covers general and advanced circuits and has no restrictions as in Circuits I and Circuits II.

4. There is a sequence of three electronic

courses, starting in the third quarter. They emphasize the quantitative analysis and include a detailed study of electronic circuits. They are identified as: Electronics I (Resistive Electronics), Electronics II (Pulse Circuits) and Electronics III (Advanced Electronics). These three courses in electronics follow a natural sequence that is integrated and sequenced in accordance with the background knowledge from the courses in the circuits area as well as from the mathematics area. For example: Electronics I (Resistive Electronics) follows Circuits I (Resistive Circuits), which, in turn, follows Mathematics I. The flow diagram of Fig. 1 shows the sequencing of the basic courses. Observe the heavy diagonal lines that slant downward from right to left, from the mathematics area to the circuits area to the electronics area.

5. The technical electives of the fifth and sixth quarters provide a degree of flexibility. Five areas of specialization are recommended as possibilities. A particular educational institution may wish to offer no more than one of these areas of specialization, in accordance with instructional talents and in accordance with the particular needs of industry.

The footnote at the close of the curriculum gives the recommended courses for each of the five areas of specialization. More detailed information is presented in an appropriate place later in the guide. Refer to the Table of Contents where each area is identified as an *option*.

6. This six-quarter curriculum provides at least two natural "break-off" points. After a student completes the first two quarters, he will have had the two introductory electronic courses and the two drafting courses that will provide employment opportunities especially as a draftsman or as a maintenance technician. The courses of the first quarter could also be used in a vocational program that leads to a certificate or a diploma.

7. The physics courses are outlined to reflect the present-day philosophy as to contents and sequencing of topics for a one-year comprehensive terminal course. The physics sequence serves as the basic science course in the elec-

tronic curriculum. It is introduced in the third quarter after the student has been introduced to the fundamentals of calculus. It follows an outline which is independent of the topic sequencing of electronic material.

SUGGESTED TWO-YEAR ELECTRONIC TECHNOLOGY CURRICULUM

Course	Hours			
	Class	Laboratory	Contact	Credit
1st Quarter				
Mathematics I (Algebra & Trig.)	5	0	5	5
Introductory Electronics I	1	4	5	2
Communications I	4	0	4	4
Mechanical Drafting	1	6	7	3
Psychology of Human Relations	4	0	4	4
Orientation	0	0	1	0
	<u>15</u>	<u>10</u>	<u>26</u>	<u>18</u>
2nd Quarter				
Mathematics II (Trig. & Introduction to Calculus)	5	0	5	5
Introductory Electronics II	1	4	5	2
Circuits I (Resistive Circuits)	4	2	6	5
Communications II	3	0	3	3
Electronic Drafting	1	6	7	3
Seminar	0	0	1	0
	<u>14</u>	<u>12</u>	<u>27</u>	<u>18</u>
3rd Quarter				
Mathematics III (Calculus)	5	0	5	5
Electronics I (Resistive Electronic Circuits)	3	4	7	4
Circuits II (S.T.C. Circuits)	4	4	8	5
Physics I	3	2	5	4
Seminar	0	0	1	0
	<u>15</u>	<u>10</u>	<u>26</u>	<u>18</u>
4th Quarter				
Mathematics IV (Introduction to Differential Equations)	3	0	3	3
Electronics II (Pulse Circuits)	3	4	7	4
Circuits III (Network Analysis)	3	4	7	4
Physics II	3	2	5	4
Industrial Organization and Operation	3	0	3	3
Seminar	0	0	1	0
	<u>15</u>	<u>10</u>	<u>26</u>	<u>18</u>

Course	Hours			Credit
	Class	Laboratory	Contact	
5th Quarter				
Electronics III (Advanced Electronics)	4	4	8	5
Physics III	3	2	5	4
Technical Report Writing	3	0	3	3
Technical Elective ⁽¹⁾	3	4	7	4
Economics of Industry	3	0	3	3
Seminar	0	0	1	0
	16	10	27	19
6th Quarter				
Technical Elective ⁽¹⁾	3	4	7	4
Technical Elective ⁽¹⁾	3	4	7	4
Technical Elective ⁽¹⁾	3	4	7	4
Circuits IV (System Analysis)	1	4	5	3
Nontechnical Elective	3	0	3	3
Seminar	0	0	1	0
	13	16	30	18

(1) The technical electives should be electrical courses of some one area of specialization as desired for a particular program. A few possible courses and areas are:

Power Option (See Page 68)*
 Advanced Power Circuits
 Rotating Machinery
 Power Distribution Systems
 Electrical Design

Computer Option (See Page 71)*
 Computer Logic
 Computer Programming
 Measuring Principles (Mechanical and Electrical)
 Analog Computers
 High Frequency Communication and Transmission Options (See Page 73)*
 Fields and Waves
 Transmission Lines
 Microwave Fundamentals
 UHF Communication and Reception
 Antennas

Instrumentation Option (See Page 75)*
 Measuring Principles (Mechanical and Electrical)
 Control Principles and Telemetry
 Standards and Calibration
 Computer Programming
 Industrial Control Systems Option
 (See Page 77)*
 Industrial Control Circuits and Components
 Computer Programming
 Servomechanism
 Measuring Principles

*Page numbers refer to pages in the "Engineering Technology Series No.3, 1967", published at the University of Illinois at Champaign-Urbana, Department of General Engineering.

Curriculum Summary in Clock Hours and Credit Hours

	Clock Hours	Quarter Credit Hours	Semester Credit Hours
Basic Science Courses			
Mathematics	198	18	12
Physics	165	12	8
	<hr/>	<hr/>	<hr/>
	363	30	20
Non-Technical Courses			
Communications	110	10	6.67
Humanistic-Social Studies	143	13	8.67
	<hr/>	<hr/>	<hr/>
	253	23	15.34
Technical Courses			
Technical Skills	220	6	4
Technical Specialty	946	50	33.33
	<hr/>	<hr/>	<hr/>
	1166	56	37.33
Totals	<hr/>	<hr/>	<hr/>
	1782	109	72.67

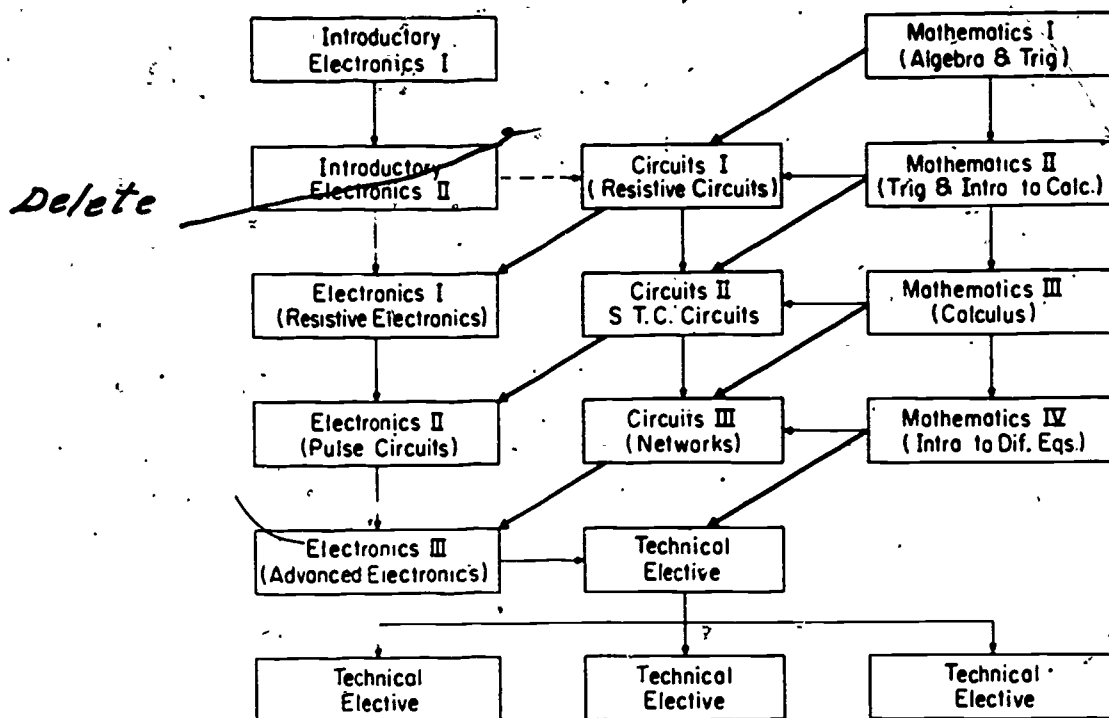

Fig. 1 Flow Chart for Mathematics, Circuits, Electronics and Technical Elective Courses

AN ELECTRONIC-POWER TECHNOLOGY CURRICULUM

The following three pages show (1) a suggested two-year curriculum for *Electronic-Power* Technology structured on a six-quarter plan, (2) the curriculum summary in clock hours and credit hours and (3) a flow chart of the significant courses in the curriculum.

Participants in a U of I Academic Year Institute (1968-69) for electronics teachers, supported by the National Science Foundation, were actively involved in the structure of this material. It is from a bulletin identified as "Engineering Technology Series No. 5, 1970" developed at the University of Illinois, Department of General Engineering, Urbana, Illinois.

The reader is encouraged to compare the structure of this *Electronic-Power* Technology Curriculum (Series No. 5) with that of the preceding section (From Series No. 3) to observe the following:

- a. The first four quarter-terms appear to be essentially the same for the two programs. Actually, however, there is some adjustment in the subject matter of Circuits III (Network Analysis) in the fourth quarter. This adjustment involves emphasis on circuits appropriate to power systems.
- b. The technical specialty courses, in the last two quarters, are directly related to the power field. This is representative of an option concept, offered or not at the discretion of a particular institution. Other options are possible, such as: Communications, Industrial Control Systems, Computers, etc.

ELECTRONIC - POWER TECHNOLOGY

(A Suggested Two-Year Curriculum)

Course	Hours			Credit
	Class	Laboratory	Contact	
1st Quarter				
Mathematics I (Algebra & Trig.)	5	0	5	5
Introduction to Electronics Technology	0	6	6	2
Communications I	4	0	4	4
Mechanical Drafting	1	6	7	3
Psychology of Human Relations	4	0	4	4
	<u>14</u>	<u>12</u>	<u>26</u>	<u>18</u>
2nd Quarter				
Mathematics II (Trig. & Introduction to Calculus)	4	0	4	4
Computer Science	3	2	5	4
Circuits I (Resistive Circuits)	4	3	7	5
Communications II	3	0	3	3
Electrical-Electronic Drafting	1	4	5	2
	<u>15</u>	<u>9</u>	<u>24</u>	<u>18</u>
3rd Quarter				
Mathematics III (Calculus)	5	0	5	5
Electronics I (Resistive Electronic Circuits)	3	3	6	4
Circuits II (STC Circuits)	4	3	7	5
Physics I	3	2	5	4
	<u>15</u>	<u>8</u>	<u>23</u>	<u>18</u>
4th Quarter				
Mathematics IV (Introduction to Differential Equations)	3	0	3	3
Electronics II (Pulse Circuits)	3	3	6	4
Circuits III (Network Analysis)	3	3	6	4
Physics II	3	2	5	4
Industrial Organization & Operation	3	0	3	3
	<u>15</u>	<u>8</u>	<u>23</u>	<u>18</u>

Course	Hours			Credit
	Class	Laboratory	Contact	
5th Quarter				
Industrial Electronics I (Devices)	2	3	5	3
Physics III	3	2	5	4
Introduction to Power Circuits	3	3	6	4
Economics of Industry	3	0	3	3
Technical Report Writing	<u>3</u>	<u>0</u>	<u>3</u>	<u>3</u>
	14	8	22	17
6th Quarter				
Industrial Electronics II (Systems)	1	3	4	2
Energy Conversion	3	3	6	4
Energy System Controls	3	3	6	4
Transmission Lines	3	3	6	4
Nontechnical Elective	<u>3</u>	<u>0</u>	<u>3</u>	<u>3</u>
	13	12	25	17

Curriculum Summary in Clock Hours and Credit Hours

	Clock Hours	Quarter Credit Hours	Semester Credit Hours
Basic Science Courses			
Mathematics	187	17	11.33
Physics	<u>165</u>	<u>12</u>	<u>8.0</u>
	352	29	19.33
Non-Technical Courses			
Communications	110	10	6.67
Humanistic-Social Studies	<u>140</u>	<u>13</u>	<u>8.67</u>
	253	23	15.34
Technical Courses			
Circuits & Electronics	418	24	16
Computer Science & Drafting	187	9	6
Power	<u>363</u>	<u>21</u>	<u>14</u>
	968	54	36
Totals	1573	106	70.67

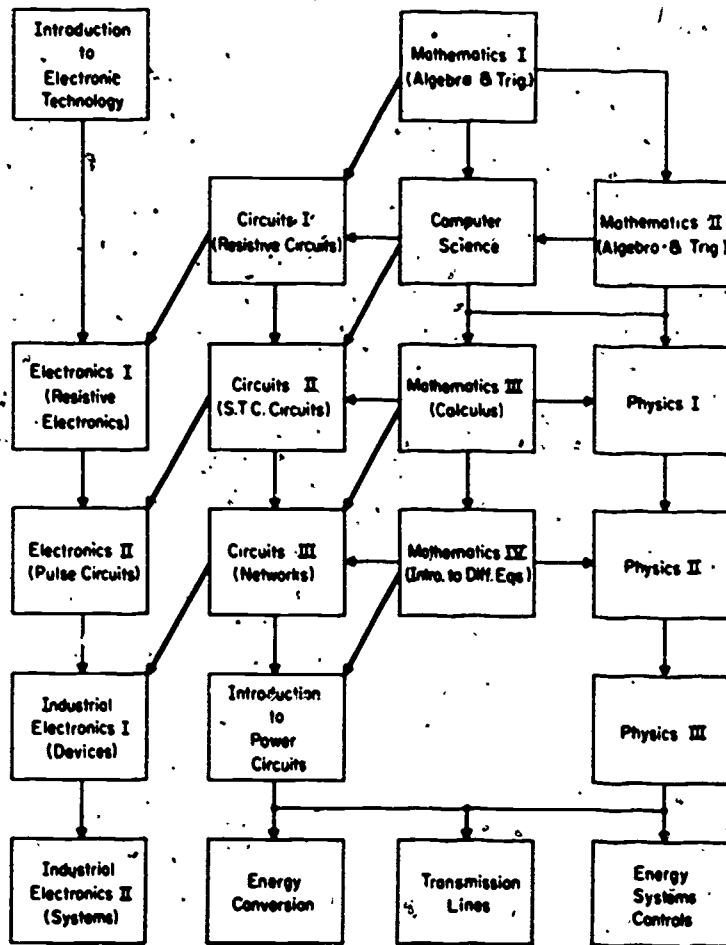

Fig. 1. Flow chart for the mathematics, circuits, electronics, power and physics courses.

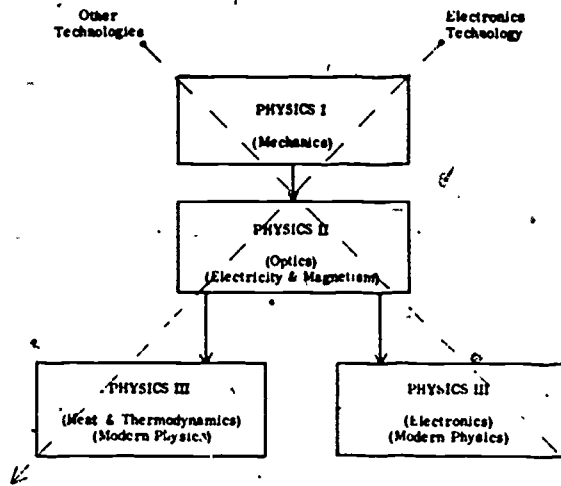

Fig. 2. Flow chart for the physics courses.

THE ELECTRONICS TECHNOLOGY CURRICULUM (FOUR-SEMESTER PROGRAM)

A suggested two-year Electronics Technology Curriculum on a four semester plan is shown on the next page. This particular program was proposed in an "Engineering Technology Series, No. 2, 1964" and developed at the University of Illinois. It was the first curriculum guide in the series of guides for electronics technology.

The reader is encouraged to compare this program with the other two (Series No. 3 and No. 5) which are presented in the preceding two sections of this report. Observe the following in these comparisons:

- a. The same sequence of circuit theory courses are found in all three programs: Resistive Circuits, STC Circuits, and Networks. This was the first time that such a sequence was proposed and published.
- b. The same sequence of courses in the *Fundamentals of Electronics* is shown in all three programs: Introduction to Electronics Technology, Resistive Electronics, Pulse Circuits and Linear Electronics. This was the first time that an INTRO course (See Chapter 3) was proposed, in a publication, as a way to get started with an electronics technology curriculum.
- c. The quarter plans probably permit more flexibility in scheduling and sequencing (particularly) of major subjects and topics.

SUGGESTED TWO-YEAR ELECTRONIC TECHNOLOGY CURRICULUM

Course	Hours			
	Class	Laboratory	Credit	Contact
1st Semester				
Mechanical Drafting	1	5	3	6
Technical Mathematics I	5	0	5	5
Communication (oral, written & Verbal)	3	0	3	3
Electronics I (Introduction to Electronics)	1	4	2	5
Circuits I (Resistive Circuits)	4	4	5	8
Orientation	1	0	0	1
	<u>15</u>	<u>13</u>	<u>18</u>	<u>28</u>
2nd Semester				
Electronic Drafting	1	4	2	5
Technical Mathematics II	5	0	5	5
Technical Physics I (Mechanics & Heat)	4	2	4	6
Circuits II (Single-Time-Constants)	3	3	4	6
Electronics II (Resistive Electronic Circuits)	2	3	3	5
	<u>15</u>	<u>12</u>	<u>18</u>	<u>27</u>
3rd Semester				
Technical Mathematics III	3	0	3	3
Technical Physics II (Light, Sound & Modern Physics)	4	2	4	6
Circuits III (Networks)	3	4	4	7
Electronics III (Pulse Circuits)	4	4	5	7
Economics of Industry	3	0	3	3
	<u>17</u>	<u>10</u>	<u>19</u>	<u>27</u>
4th Semester				
Technical Reporting	3	0	3	3
Psychology & Human Relations	3	0	3	3
Industrial Organization & Operation	3	0	3	3
Electronics IV (Linear Electronic Circuits)	3	4	4	9
*Technical Elective	3	4	4	7
	<u>15</u>	<u>8</u>	<u>17</u>	<u>25</u>

*The technical elective should be an electrical course of some one area of specialization as desired for a particular program.

A few possible courses are:

1. Servomechanisms
2. Industrial Control Systems
3. Computers and Programing
4. Electrical Machinery and Control
5. UHF and Microwaves

Curriculum Summary in Clock Hours and Credit Hours

	Clock Hours	Credit Hours
Basic Science Courses		
Mathematics	208	13
Physics	192	8
	<u>400</u>	<u>21</u>
Non-Technical Courses		
Communications	96	6
Humanistic-Social Studies	144	9
	<u>240</u>	<u>15</u>
Technical Courses		
Technical Skills	176	5
Technical Specialty	864	31
	<u>1040</u>	<u>36</u>
Totals	<u>1680</u>	<u>72</u>

PHILOSOPHY OF ENGINEERING TECHNOLOGY EDUCATION

GENERAL REQUIREMENTS

The education program described in this publication is organized to provide 2 years of full-time study in the specific field of electronic technology. The course work outlined in this publication is so arranged as to provide a competency upon completion enabling the graduate to work directly with the design, test, development, and research groups of an industrial complex.

The increasing demands of our technocracy upon our technical personnel are such that additional academic training beyond the high school is a prerequisite for successful employment placement of our youth. Job obsolescence, due to new advances in our modern technology, require employees to obtain additional training to remain employable. The abilities required by our technical personnel have been broadly defined as follows:

1. Facility with mathematics; ability to use algebra and trigonometry as tools in the development of ideas that make use of scientific and engineering principles; an understanding of, though not necessarily facility with, higher mathematics through analytical geometry, calculus, and differential equations, according to the requirements of the technology.
2. Proficiency in the applications of physical science principles, including the basic concepts and laws of physics and chemistry that are pertinent to the individual's field of technology.
3. An understanding of the materials and processes commonly used in the technology.
4. An extensive knowledge of a field of specialization, with an understanding of the engineering and scientific activities that distinguish the technology of the field.

The degree of competency and the depth of understanding should be sufficient to enable the individual to do such work as detail design procedures.

5. Communication skills that include the ability to interpret, analyze, and transmit facts and ideas graphically, orally, and in writing.

To further identify the educational criteria for programs of engineering technology, the American Society for Engineering Education has completed a study under a grant from the National Science Foundation on the evaluation of technical institute education. The results of this study have been published in a report entitled, *Characteristic of Excellence in Engineering Technology Education*.

The objectives, standards of excellence, and minimum subject area requirements as represented in the above two reports have been accepted generally by educators in the field of engineering technology. The structure and implementation of engineering technology curricula require a consideration of a number of factors, some of which are common to all engineering technology curriculum and others that are unique for the electronic technology curriculum to which this publication is directed.

PROGRAM OBJECTIVES

In general, the functions performed by the engineering technician are closely related to research, development and engineering activities. Accordingly, any engineering technology curriculum is constructed to provide the educational background necessary for the many functions of the technologist at the levels of design, development, testing, production and research.

*Taken from curriculum guides prepared at the University of Illinois

THE CURRICULUM

An engineering technology curriculum is a minimum two-year program of four semesters or six quarters leading to an Associate Degree. It is a college level program but differs significantly from a pre-engineering curriculum. The first two years of an engineering curriculum are primarily devoted to mathematics, science, and general education, with very few specialized technical courses. On the other hand, an engineering technology program must initiate specialized technical courses early in the program if the desired objectives are to be accomplished within the time available. The sequencing of courses and topics must be carefully organized to permit the student to develop to the desired levels of competence. An engineering technology curriculum must conserve the rigor of effort on the part of the student that is equivalent to the rigor of effort required in a college program.

An engineering technology curriculum must be structured so that it prepares its graduates functionally:

1. To enter into a job and be immediately productive with a minimum of on-the-job training.
2. To provide the technical and scientific background to prepare him to keep abreast of developments in technology throughout his career.
3. To enable the graduate with a reasonable amount of industrial experiences to advance into positions of increased responsibility.

In addition, it must also include sufficient work in the non-technical area to prepare the individual to participate fully in the society of which he is a part.

FACULTY

The ultimate quality of the curriculum depends largely upon the quality of the faculty. The specialized nature of the curriculum requires that the teachers have special competences. These competences are based on technical

proficiency in subject matter and industrial experience. Another important consideration is that all members of the engineering technology faculty understand the educational philosophy of such programs and be in harmony with the goals and unique organizational requirements that characterize this area of education.

To achieve the objectives of the curriculum, the subject matter cannot be taught as a series of independent courses, but must be presented as a closely integrated combination and sequence of educational experiences. The staff must work together as a unit.

It is obvious that a substantial proportion of the faculty teaching the technical specialty courses be graduate engineers. Experience has shown that engineering technology graduates who have acquired industrial experience and have continued their education often make excellent teachers in this type of program. If the curriculum is to keep pace with technology, it is not feasible to depend to any great extent upon faculty members whose technical competence is only slightly greater than that of the students. The use of an unduly large number of part-time faculty members is undesirable.

Faculty members must maintain technical competence and should be encouraged to participate in the activities of professional and technical societies. They should also be encouraged to keep up with the literature in their field, continue their education, and maintain close liaison with industry in the area of their specialties by working summers. This encouragement is most effectively provided in the form of released time and financial assistance whenever possible.

Teaching loads should be based on contact hours rather than credit hours since, in general, this type program requires the faculty member to spend a greater number of hours with the student per credit hour than do some other types of educational programs. Promotions should be based on a balanced judgment of the instructor's ability to bring a broad experience and academic

background to bear on his students, rather than solely on the acquisition of higher academic degrees.

STUDENT SELECTION

While the effectiveness of an engineering technology program depends on the quality of the faculty, its success depends even more heavily on the quality of its graduates. It is essential, therefore, that the students accepted into the program be capable of successful accomplishment of the educational objectives of the program. If the incoming students' backgrounds are inadequate, instructors will tend to adjust their courses to these inadequacies. The inevitable result will be a program of depth and scope less than that implied by the curriculum and a lack of utilization of faculty capabilities.

Any discussion of academic standards, therefore, must be preceded by a statement of admission requirements and student selection. The assumption on which this suggested curriculum is based is that the incoming students have been graduated from an accredited secondary school or have an equivalent education. In addition, the student should exhibit some evidence of sufficient ability and the necessary aptitudes for satisfactory achievement in the program.

In the opinion of the committee, a satisfactory engineering technology program requires the following minimum secondary school units:

- a. Three units of English. These should provide the student with the basic tools of effective communication.
- b. Two units of Mathematics. One unit in algebra and the other in plane geometry (or the equivalent of these in integrated mathematics).
- c. One unit in Physical Science. Whenever possible, this unit should be either in physics or chemistry.

Students entering without these minimum

secondary school units should not expect to complete the program in the allotted time. If such students are admitted, non-credit courses in these areas should be provided to bring the student to the required level of proficiency in these areas.

Transfer of credit from other institutions should be evaluated realistically on the basis of comparative course content and objectives. They may be validated, if in question, by reliable proficiency examinations. Automatic acceptance for credit without adequate evaluation should be avoided.

STUDENT SERVICES

Whenever possible, institutions offering engineering technology programs should consider the use of standardized or local tests to assist in student selection, placement, and guidance. Effective guidance and counseling are essential. The student should be aided in selecting educational and occupational objectives consistent with his interests and aptitudes. He should be advised to revise his educational objectives if it becomes apparent that he is more suited to other programs, either in engineering, or vocational training, or another technology.

The graduate should be given all possible assistance in finding suitable employment. Placement personnel should be aware of the needs of industry, familiar with the curricula offered by their institution, and should be in a position to acquaint prospective employers with the various types of positions for which their graduates are qualified. The placement function is extremely valuable to the student, the institution, and industry.

UNIVERSITY INVOLVEMENT IN TECHNICAL EDUCATION

INTRODUCTION

The title of my talk is "University Involvement in Technical Education." For the purposes of this presentation I will restrict myself to the involvement of the University of Illinois in technical education and in that way, perhaps suggest to you how other universities might undertake a similar input. The involvement began back in 1957-58 when a study was conducted and a report written to suggest how the College of Engineering might become involved in the preparation of engineering technicians. The recommendations of the report were not followed, however, this formed a basis for further activity when the implementation of the National Defense and Education Act of 1958 was passed by the National Congress charging the individual states with the responsibility of carrying out Title VIII of this act that had to do with the preparation of high-level technicians to work in the defense related industries. In 1959 a committee of the College of Engineering was organized to assist the State Board of Vocational and Technical Education in the implementation of this act in the State of Illinois. The activities that have evolved from this initial involvement consist of the following:

- Teacher Preparation
- Curriculum Research
- Professional Organizational Articulation
- Contributions to the Literature of the Field
- Conferences, and
- Advisory Consultant Services.

I would like to spend a little time to discuss each one of these topics.

TEACHER PREPARATION

When meeting with various people in the State of Illinois concerning the implementation of high-level technician training programs, it became apparent that the number one problem that faced the State of Illinois was the problem of having qualified instructors available to teach in these programs. In checking around with other states, it soon became apparent that this was a national problem. Therefore, this provided the initial impetus for the submission of a proposal to the National Science Foundation for the funding of a summer institute program to provide upgrading course work in the subject areas of machine design and electronics technology. The Summer Institute was designed to enable those people who were teaching in the field without previous academic subject matter course work to retrain themselves and, thereby, be able to prepare the high-level engineering technicians as were described by Title VIII of the National Defense and Education Act of 1958. The first such summer institute was funded in 1961 and fortunately has been funded ever since, including the one that is being funded for 1970.

In addition to this, five academic year institutes have been funded by the National Science Foundation which provided opportunities for fifteen participants each year to come and study for a year in residence on the campus over a ten month period. These were structured to provide additional opportunities for teachers to gain the necessary cognitive and pedagogical skills to present the material in the more advanced courses in high-level engineering

*Jerry S. Dobrovoly, Professor and Head Department of General Engineering,
Delivered at the Electronics Conference February 25, 1970, Champaign, Illinois.

technician preparatory programs. Approximately four hundred individuals have participated in the summer institutes and academic year institutes.

In addition to this, as a result of the experience gained in these institutes, a Bachelor of Science in the Preparation of Teachers of Engineering Technology and a Post-Baccalaureate Certificate in the Preparation of Teachers of Engineering Technology in the fields of electronics technology and machine design technology have been established as a recognized degree at the University of Illinois. These have served as models for other institutions of higher learning to follow.

A great deal more can be done in this area of teacher preparation. At the present time there is a significant number of persons with pertinent industrial experience, such as engineers with master's degrees in a subject matter specialty with five to ten years of critical experience in industry, who are entering the field of technical education. There is a great need for organizing some type of either in-service or pre-service training programs to provide them with the proper philosophic approach with respect to teaching in two-year associate degree programs in engineering technology. In addition to this, there is a need for organizing doctoral level programs to take these kinds of selected individuals with this kind of a background in their subject matter specialty and build upon that the necessary prerequisites to provide them with leadership potential as administrators and researchers in the field of technical education.

Another source of competent teacher personnel is from the ranks of the graduates of two-year associate degree programs, particularly those that have had three or four years of industrial experience. There is a great need for universities to organize new teacher preparatory programs and receive financial support for the students that will enroll in these programs. The general idea would be to build on a "plus

two" component of a four-year program that is articulated with the two-year associate degree work that had been completed by the student. In the final analysis, this type of an individual will provide the best teaching capability for the two-year associate degree programs.

CURRICULUM RESEARCH

Another very active part of the involvement on the part of the Engineering Technology Curriculum Advisory Committee at the University of Illinois has been in conducting manpower need studies, follow-up studies, and the development of various curriculum guides. All of these activities have been done in cooperation with persons from industry, as well as those that are teaching in the field. At the present time we have developed a curriculum guide in electronics technology, machine design technology, civil technology, micro-precision technology and one in electrical power technology which is being printed at the present time. In the case of the electronics and machine design, both a semester guide and a six-quarter guide have been developed. These curriculum guides have provided a foundation level for schools entering into technical education. A large number of junior colleges-- in the past primarily liberal arts oriented and now becoming comprehensive junior colleges-- have found this kind of assistance invaluable to them.

There is a need for other areas within the University to become involved in the development of resource material for the semiprofessional fields that are related to their specific subject matter specializations, such as in the health fields and the agricultural science areas. All evidence points to the expansion of this kind of an activity and a number of other colleges are becoming involved in these kinds of projects.

PROFESSIONAL ORGANIZATIONAL ARTICULATION

One of the greatest involvements by the

University of Illinois is the effort on the part of the respective members of the Engineering Technology Curriculum Advisory Committee to interact with various professional organizations, such as the American Society of Engineering Education, the Technical Education Research Center, the American Association for the Advancement of Science, the American Association of Junior Colleges, the National Science Foundation, American Technical Education Association, the National Industrial Conference Board, the U.S. Office of Education, the Commission on the Undergraduate Program in Mathematics, the College Commission on Physics and a host of others. During the past twelve years the University has been involved in a significant number of projects with these organizations. One of the most recent involvements has been with the National Industrial Conference Board, the American Technical Education Association, the U.S. Office of Education, the Engineering Manpower Commission, and the National Advertising Council. This has been a cooperative effort that has been organized primarily by the National Industrial Conference Board bringing together the above mentioned organizations for the purpose of organizing a multi-media campaign to bring to the attention of four segments of our total population the opportunities in technical education. Many of you perhaps have seen the advertising material that has been prepared for use by the television media as well as the newspapers, magazines and radio. The effectiveness of this campaign can be illustrated by virtue of the fact that within the first six months over 500,000 of the booklets that were prepared describing twenty-five technical careers have been requested by people writing in for copies of this program. Representatives from the University had a vital input in helping prepare not only the text material for the career booklet, but also some of the advertising copy. The National Advertising Council has identified this as one of its top advertising campaigns it has ever undertaken.

There continues to be a need for university

personnel to interact with the large number of professional organizations that are involved in the development of a philosophy and posture with respect to technical education. There is a need for a study to develop courses in mathematics, physics, economics, social sciences, and other related areas for technical curriculums. The off-the-shelf approach used by many today just does not meet the needs of the technical student.

CONTRIBUTION TO THE LITERATURE OF THE FIELD

I suppose, in the final analysis, a scholarly institution is measured by its peers in terms of the contributions to the literature of the field. I feel in this regard that the university involvement has been particularly effective. As a result of the work that has been done by the individual members of the University community working in this area, a number of textbooks have been developed. Professor D.S. Babb has authored, I believe, two texts in electronics and is in the process of authoring several others in his spare time. Professor R.J. Placek has written two texts in technical mathematics. I have also been involved in two texts in the graphics area. A large number of papers and reports have been generated with respect to specific topics as they are presented at various conferences throughout the United States. Many of these become resource papers for further study.

In the field of curriculum guides, I feel the contributions have been uniquely significant. It is one thing to talk in broad general philosophic terms about what the content of a two-year associate degree program in a specific technology should be and altogether a different kind of an input to actually incorporate this philosophy into a workable curriculum. The requests for these curriculum guides that have been developed by our particular effort has been in the thousands. We have had to reprint some of these guides three times.

It is fully anticipated that the contribution to the literature of the field by this electronic curriculum project again will be significant and provide a bench mark in the field of electronics technology education.

The Technical Education Supplement of Industrial Arts and Vocational Education is providing a forum for technical educators. All of you are encouraged to submit articles for publication.

CONFERENCES

One of the most effective ways of communicating the ideas developed within the university community with respect to technical education is through the vehicle of conferences. The individual members of the Engineering Technology Curriculum Advisory Committee have participated widely in conferences having to do with technical education. They include conferences sponsored by the U.S. Office of Education; the American Technical Education Association; individual subject matter conferences, such as is being held here with respect to this curriculum project; the American Society for Engineering Education; the American Society of Civil Engineers and a host of other involvements. One of the greatest problems with respect to technical education, as you all are aware of, I am sure, is the problem of semantics. It is through this vehicle of participating in these conferences that a positive posture, with respect to a unified semantic identification of the field of technical education, has been developed.

University personnel have been involved in the organization of at least two conferences a year, either at the University or at some other location. These conferences have proved to be extremely effective in terms of bringing together experts in their field for a short period of time to address themselves to the critical problems relating to technical education.

ADVISORY CONSULTANT SERVICES .

The advisory consultant services that have been offered by the Engineering Technology

Curriculum Advisory Committee over the past twelve years covers a wide range of activities. One of the most important, of course, is the volume of correspondence that continues to flow to the University from interested parties covering a wide range of subject matter.

Individual members of the Committee are called upon to meet with local advisory groups at various stages of development. Many times they are called in at the initial stages of the inauguration of associate degree programs in engineering technology. Other times they are called in after the program is started and they find they are having difficulty with some facet of program implementation. In meeting with these local groups, the individual committee member of the Engineering Technology Curriculum Advisory Committee has been able to serve as the moderator between various groups in the local community and, as a result, has been able to move programs off dead center and provide an educational opportunity for students in their respective areas.

All through the years there has been a close cooperative effort between the staff of the State Board of Vocational and Technical Education and, more recently, the junior college board staff in terms of program implementation in the State of Illinois. In addition to this, there has been an input to the State of Illinois Advisory Council on Vocational Education. This Council is a newly established body charged with the responsibility of evaluating vocational and technical education being conducted and reimbursed from the vocational education funds by the federal government. I would urge all of you to become familiar with the councils in your respective states and urge them to carry out their responsibilities as they are charged by legislation.

PLANS FOR THE FUTURE

The future for technical education is indeed bright. The greater involvement by a

larger number of universities must take place in the near future. There is a need for additional conferences involving other universities to encourage them to organize programs similar to those that have been discussed here. There is a need for undertaking new research activities in the development of curriculum material for the now and emerging technologies, such as in ocean engineering, marine biology, physical science technology, etc.

The need for the development of new graduate programs to prepare teachers and administrators for junior colleges and technical institutes, in the area of technical education, is an area where the universities can make perhaps their greatest contribution. The need for redirecting some of the resources that are now being used for outmoded programs in the preparation of industrial arts teachers and vocational educators to new kinds of programs to meet the needs of the present community college is a challenge that must be met by the universities. There is a close cooperative activity existing in this campus between representatives from the College of Engineering and the College of Education in the implementation of these kinds of activities.

The need for research in the area of student identification, motivation and program implementation at the secondary and post-secondary level is great indeed. The present testing

programs that are used in high school to identify the verbally academic talented students do not provide the vehicle for identification of those students that are motivated by other than purely academic achievement. The problem of identification of cognitive skills relating to the applicatory aspect of the new and emerging semi-professional occupations has just barely been scratched. The need for developing guidance and counseling activities in this direction, again, is an area where University involvement can make a significant contribution. Dr. Ken Hoyt, from the University of Iowa, is a pioneer in this activity.

There is a great urgency for more detailed manpower need data that accurately reflects the need of semiprofessional personnel by their respective professional groups working in our society. Here again, the universities can make a significant input. However, throughout all of these considerations, the basic thread of cooperation must exist between the university, the user of the product and those involved in the teaching and the preparation of the product. Without this cooperative spirit, the end result will be meaningless. We like to think that here at the University of Illinois we have been able to achieve a modicum of success in this interdisciplinary cooperative effort on behalf of technical education.

PROFESSIONAL, TECHNICAL, VOCATIONAL AND INDUSTRIAL ARTS EDUCATION

The changing manpower needs of our society have been extremely rapid during the last two decades. In many cases the program offerings at community colleges have been much better attuned to these needs than have the teacher preparatory programs at our teachers' colleges. One of the important areas of understanding that is required as a basis of discussion is that of the semantics relating to technical education. The four terms most relevant to the discussion are industrial arts education, vocational education, technical education, and professional education.

INDUSTRIAL ARTS EDUCATION

Industrial arts education has been considered a part of general education and is referred to as being exploratory in nature. The industrial arts programs are normally offered in junior and senior high schools and are survey courses in such subject areas as metalshop, woodshop, home economics, drafting, electricity, and autoshop. Gordon O. Wilbur in his book on Industrial Arts in General Education defines industrial arts as:

"Those phases of general education which deal with industry--its organization, materials, occupations, processes, and products--and with the problems resulting from the industrial and technological nature of society."

VOCATIONAL EDUCATION

Vocational education is normally described as preparatory in nature to prepare a person for immediate employment on a specific job on the occupational ladder. It is a level of education that concentrates on the development of manipulative skills. Some of the typical vocational curricula that are available are in such areas as trade and industrial education, distributive education, home economics education, vocational agriculture, business and secretarial

training, and various others. The occupational titles of those completing the programs are normally the following: carpenter, stone mason, plumber, auto mechanic, appliance repairman, secretary, cook, bookkeeper, salesman, etc. The U.S. Office of Education's Cooperative Project for Standardization of Terminology in Instructional Programs in Local and State School Systems defines trades and industrial occupations as follows:

"Trades and industrial occupations is the branch of vocational education which is concerned with preparing persons for initial employment, or for upgrading or retraining workers in a wide range of trades and industrial occupations. Such occupations are skilled or semiskilled and are concerned with layout designing, producing, processing, assembling, testing, maintaining, servicing, or repairing any product or commodity. Instruction is provided (1) in basic manipulative skills, safety judgment, and related occupational information in mathematics, drafting, and science required to perform successfully in the occupation, and (2) through a combination of shop or laboratory experiences simulating those found in industry and classroom learning. Included is instruction for apprentices in apprenticeable occupations or for journeymen already engaged in a trade or industrial occupation."

The significant thing to recognize when we are talking about vocational education is that there are many new fields that have developed in the last twenty years requiring a level of education at the vocational level to train persons for employment in the specific field. The health related occupational titles

have had a significant number of job classifications requiring a vocational education as a preparatory laboratory and classroom experience prior to employment.

TECHNICAL EDUCATION

Technical education is perhaps the most misunderstood term in our taxonomy. It seems to mean all things to all people. The data compatibility group of the National Center for Education Statics for the U. S. Office of Education has developed (1966) a definition of technical education to read as follows:

"Technical education is concerned with that body of knowledge organized in a planned sequence of classroom and laboratory experiences, usually at the postsecondary level, to prepare pupils for a cluster of job opportunities in a specialized field of technology. The program of instruction normally includes the study of the underlying sciences and supporting mathematics inherent in a technology, as well as methods, skills, materials, and processes commonly used and services performed in the technology. A planned sequence of study and extensive knowledge in a field of specialization is required in technical education, including competency in the basic communication skills and related general education. Technical education prepares for the occupational area between the skilled craftsman and the professional person such as the doctor, the engineer, and the scientist.

"The technical education curriculum must be so structured that it prepares the graduate to enter a job and be productive with a minimum of additional training after employment, provides a background of knowledge and skills which will enable him to advance with the developments in the technology, and enables him, with a reasonable amount of

experience and additional education, to advance into positions of increased responsibility."

"The technician frequently is employed in direct support of the professional employee. For example, the engineering technician will be capable of performing such duties as assisting in the following engineering functions: designing, developing, testing, modifying of products and processes, production planning, writing reports, and preparing estimates; analyzing and diagnosing technical problems that involve independent decisions; and solving a wide range of technical problems by applying his background in the technical specialties--science, mathematics, and communicative and citizenship skills."

The person completing a technical education program is called a technician. Most programs are two years in length and upon completion the graduate receives an associate degree in applied science or in a specific technology. In the case of the engineering related technology, the American Society for Engineering Education in its publication Characteristics of Excellence in Engineering Technology Education (1962) defines an engineering technician as follows:

"One whose education and experience qualify him to work in the field of engineering technology. He differs from a craftsman in his knowledge of scientific and engineering theory and methods, and from an engineer in his more specialized background and his use of technical skills in support of engineering activities."

The technician works very closely in support of the professional person. He assists in developing the project that the team is working on and will become involved with calculations, prototype development, liaison work with the craftsman, and a wide range of support

activities. Similar identifications of technician activities can be developed for the other professional fields, such as health, business, agriculture, architecture, etc. The content of a technical curriculum is cognitive in nature dealing with the more applicatory aspects of the particular science relevant to the technology being studied. The emphasis of using the laboratory experience as a vehicle for discovery is a significant characteristic of a technical education program. It is college level from the standpoint of the rigor and applicable from the standpoint of the method of presentation of the subject matter in respective topical areas. This includes the basic sciences, as well as the mathematics.

PROFESSIONAL EDUCATION

Professional education is designed to prepare a person to enter the occupational ladder at a level that will require the capability of decision making with respect to the solutions of the problems facing society. Some of the recognized professional identifications are the engineer, the lawyer, the doctor, the economist, the accountant, the agricultural scientist, the physicist,

the chemist, etc. The normal preparatory program requires at least four years of basic training, acquiring a bachelor's degree, followed by additional professional training and education such as law school, medical school, and advanced degrees in engineering, the biological and physical sciences. As an example, the professional engineer is identified as follows:

"A professional engineer is competent by virtue of his fundamental education and training to apply the scientific method and outlook to the analysis and solution of engineering problems. He is able to assume personal responsibility for the development and application of engineering science and knowledge, notably in research, designing, superintending, construction, manufacturing, managing, and in the education of the engineer. His work is predominantly intellectual and varied, and not of a mental or physical character. It requires the exercise of original thought and judgment and the ability to supervise the technical and administrative work of others."

CHAPTER 2

PROJECT APPROACH TO CURRICULUM DEVELOPMENT

Any teacher of electronics, or a group of electronics teachers, wishing to make adjustments in curriculum structure or in the subject matter of specified courses, must become involved with the philosophies and concepts applicable to a particular discipline (The Electronic Technologies, in this case). In other words, directing one's attention to subject matter of a course, only, is not sufficient.

Theoretically, all of the ETCO project time was devoted to the core courses of Circuit Analysis, the Fundamentals of Electronics and the Introduction to Electronics Technology Course. Development of subject matter and techniques of instruction for these courses become productive only through finding answers to questions, such as: What is electronics education? What makes it technical or vocational education? Are both of ~~these kinds~~ of education necessary in electronics programs? If so, why and what do we do? What is the role of circuit analysis? How important is mathematics? Is there a better way to teach a topic? Is there a better way to get started on major topics? Where should the emphasis be placed? Are there key words to assist in communicating ideas one to another?

(NOTE: A single word like "Objectives", or any other single word, cannot resolve all problems). What are the student needs? What are Industry needs? Are these two needs the same? We could go on-and-on. The sections of this chapter present those concepts and viewpoints that have been most beneficial to the activities of the project.

ELECTRONICS EDUCATION

ELECTRONICS EDUCATION IDENTIFIED

The "Organization Chart for Electronics Education" presented below provides a reference for the discussion of problems relating to curriculum structures, industry needs, student interests, faculty requirements and a host of other problems. Answers to such problems can be derived from this organization chart.

The organization chart defines electronics education at any level and for any educational institution. The chart is applicable to Universities, colleges, community colleges, technical institutes, secondary schools on down to elementary schools. The chart is applicable to programs leading to a certificate, a diploma, an associate degree, bachelor of technology degree, bachelor of science degree and up the line to the doctorate degree. We will use the chart, primarily, to help identify the different electronics programs designed for the education of electronic technicians in two-year colleges.

First of all, observe that electronics education consists of the two areas of theory and applied. This does not state that theory courses

are not practical or that applied courses do not involve theory. It does state, however, that the objectives and level of a program will dictate where the emphasis shall be placed.

To more fully understand what can be done, or should be done, in two-year college programs, it is helpful to subdivide the theory and the applied. The theory side of the electronics education spectrum contains the two areas of circuits and fields. The applied side of the spectrum can be regarded as containing the two areas of devices and systems. Each of these four areas can be subdivided further as indicated on the organization chart. Still further subdivisions are possible. The chart is sufficiently complete, however, for the purpose of this discussion.

The end objective for any electronics education program is to have an understanding and knowledge of systems. But, this requires a knowledge of devices, fields, and circuits. As a sequence for learning we might state: If we can understand circuits and fields, (theory) then we can understand devices and systems (applied). This must be true since much of electronics education is based on circuit models.

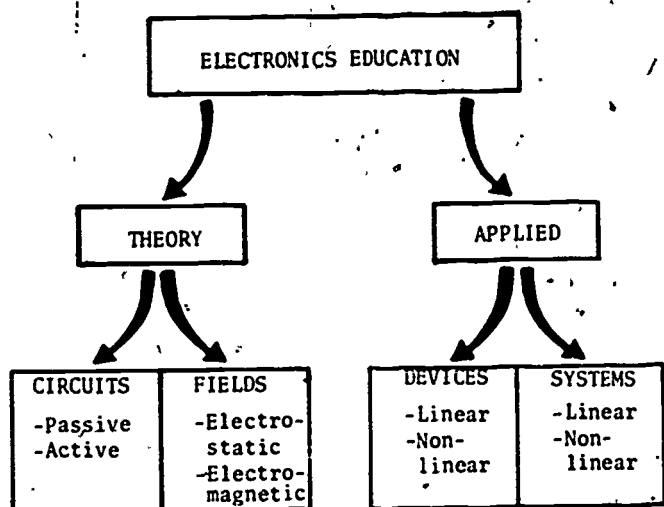

Fig. 1 Organization Chart for Electronics Education

VOCATIONAL EDUCATION IN ELECTRONICS IDENTIFIED

Educational programs in electronics are very likely vocationally oriented if the theory courses of electronics education are de-emphasized or neglected. Such programs will concentrate on particular systems, instruments and devices. Much of the course structure will depend on laboratory experiments and hands-on experiences. Good programs are structured in this way to satisfy certain industry manpower service, maintenance and operation needs.

TECHNICAL EDUCATION IN ELECTRONICS IDENTIFIED

Technical education in electronics can be identified with a brief statement by referring to the organization chart. *A technical education program in electronics will exist if the curriculum, with its objectives, are designed to place proper emphasis on the theory courses as well as on the applied courses.* We will leave this statement stand with minimum discussion here.

The ETCD project, through this report, is devoted entirely to the concept of technical education for electronics. The graduates will serve certain industry manpower needs as aids to engineers and scientists. They can provide this kind of assistance with minimum guidance in doing development work and non-routine jobs.

Study of Fields De-Emphasized

Only the elements of electrostatic fields and electromagnetic fields are necessary and desirable for the associate degree programs. Only that which is necessary to understand induced voltages, inductance, magnetic coupling and dielectrics. Nothing on such things as radiation or antenna patterns from the theory standpoint.

Fundamentals of Electronics and Circuit Analysis Emphasized

A sequence of circuit analysis courses and a sequence of electronics courses, as suggested in earlier chapters and the introduction, will satisfy the technical education requirements for electronics education.

In support of the efforts of this ETCD project it is of interest to quote one of four conclusions of a curriculum development study being conducted at Wentworth Institute. Their reports states: "Stress fundamental circuit theory and fundamentals of electronics. Depth in the study of fundamentals is preferable to surveys of many devices and systems". Their other three recommendations relate to "10% tubes to 90% solid state"; relate to "actual industry practice"; and not too much emphasis on laboratory grading of students.

Circuit Analysis is a Mathematical Process

Circuit analysis, passive or active, is purely a mathematical process. The response of circuits and circuit configurations required to give desired responses are determined by writing circuit equations and evaluating these equations.

This being true we have another way, therefore, to identify electronics education as being technical or vocational in its content and objectives. Technical programs are those that take advantage of the mathematical process.

One of the major concerns for this ETCD project, and hopefully revealed in this report, is: *How to keep the labors of mathematics at a minimum and still take advantage of the mathematical process.* All circuit analysis can be done with no more than algebra (including complex algebra) and trigonometry concepts. This is not to imply that mathematics beyond these two subjects is not required. Watch for discussions on the needs and uses of mathematics throughout the remainder of this report, especially in the detailed material for the "six plus one" courses.

SUMMARY STATEMENTS

The following statements are presented to emphasize the information that is available from the Organization Chart for Electronics Education, Fig. 1.

- a. A complete education in electronics involves *both* theory and applied.
- b. Neglect the theory (Circuits and fields) and electronics education becomes *vocational education* in electronics.
- c. Include theory subjects and electronics education becomes *technical education* in electronics (Primarily the *circuits area* for two-year colleges).
- d. Circuit analysis requires a *mathematical process*. Technical education in electronics (the Electronic Technologies) require, therefore, a sequence of mathematics courses in their curricula.

RECOMMENDATIONS FOR CURRICULUM STRUCTURE (GENERALIZED)

TWO KINDS OF PROGRAMS NEEDED

The comprehensive community college, in contrast to the technical institutes, is obligated to satisfy the objectives of both technical education and vocational education. It is strongly recommended that these two objectives be accomplished through two kinds of programs, especially in the area of electronics education. These two programs shall not be completely separate in themselves but will have a certain parallel-integrated structure to be described later in this discussion.

In general, the two recommended programs are:

1. A two-year associate degree program in *Electronics Technology* that is math-science based designed to place the graduate at the engineering support level.
2. A certificate program, less than two years in duration, that will lead to placement at a more vocational level of employment.

SPIN-OFF AND OPTION CONCEPTS OF CURRICULUM STRUCTURE

The two programs (associate degree and certificate) are designed into a parallel-integrated structure through a spin-off concept as illustrated in Fig. 1 and Fig. 2. This recommended structure is illustrated for a quarter plan. A similar structure, with modifications, would exist for the semester plan. The modifications for the semester plan require a little more careful planning in the integration of subject matter to satisfy the objectives, in the common term, for both the certificate and associate degree programs. Some institutions may wish to spin-off to the certificate before the first semester term is completed.

Now, there are a number of possible and

desirable end objectives, dependent on area of specialization, for both the certificate and the associate degree programs. In Fig. 2, a spin-off into different certificate and associate degree programs (options) is illustrated. These options may, or may not be student options. Each institution will decide on what options to offer, perhaps only one for the certificate and perhaps only one for the associate degree.

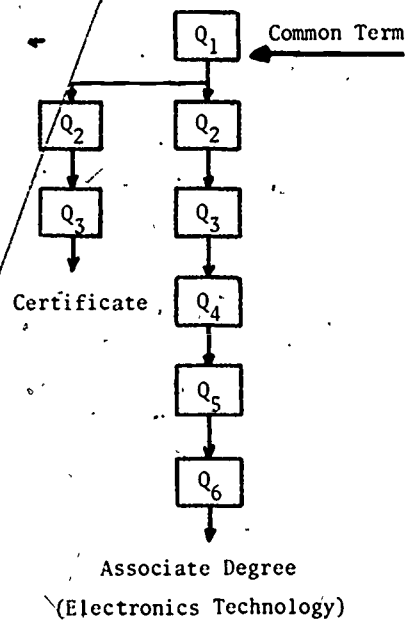

Fig. 1 Spin-off Concept of Curriculum Structure

NOTE: See Fig. 2, next page.

DEFINITION OF SPIN-OFF CONCEPT

Under the spin-off concept, all electronic students are placed into a common first quarter of courses. Students may be grouped into math and English courses based upon performance examinations, but all students take a common first quarter electronics course entitled: *Introduction to Electronics Technology*. During this quarter of study the student decides, with

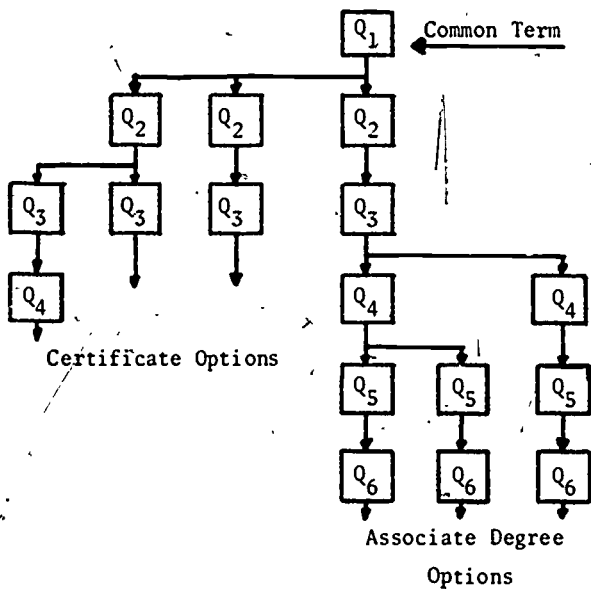

Fig. 2 Spin-off to Certificate Options or to Associate Degree Options

the help of counselors and faculty advisors, whether he has the desire, ability, and the motivation required for the various types of career training programs found within the electronics curriculum.

At the end of the first quarter the student selects a program of study that will lead to employment in the electronics industry. He may choose, with the assistance of electronics instructors and counselors, a two year associate degree program which is math and science based and designed to place the graduate at the engineering support level, or alternate programs of shorter length granting certificates that would lead to placement at a more vocational level of employment. Examples of such certificate programs are maintenance oriented programs in the home entertainment industries, electrical appliances repair and installation, or specific short term training programs for local industrial needs.

The student's spin out of the Introduction to Electronics Technology Course pursuing various avenues of occupational training based upon their ability, motivation, and interest resulting from

some self confidence and orientation gained during the first quarter. The key to success in the first quarter lies primarily in the Introduction to Electronics Course. It is a hands-on experience, or laboratory oriented course, designed to provide some real experiences and exposures to exactly where the type of instructions offered in the overall curriculum, will lead the graduate. Most of the material learned in this course is by participation in the laboratory. Basic skills requiring a very minimum of mathematical insight and scientific background are necessary. The course is more than just a means for providing exposure, exploration, and motivation. There are some basic skills taught that are applicable to all areas of electronics with very little previous experience, or training, necessary.

However, the program is a motivation course for the student interested in electronics, and he is encouraged to improve his skill in mathematics. An effort is made to show the student that mathematics will be of great assistance to him if he pursues the study of electronics technology.

This is a change in the traditional philosophy found in curriculum development. The difference is that instead of the curriculum establishing certain prerequisites that eventually leads to screening and ability grouping of applicants by teachers and counselors, the vast majority of program selection is done by the student himself. The important implication is that the student feels that he has selected the program that is best for him and that he has not been encouraged and advised into an alternate or secondary goal of achievement. Student identification is with the job opportunities available from the alternate programs and not with the rigor of the advanced curriculum or associate degree.

The question arises regarding the possibility of teaching a student, with little or no background in electronics, an adequate

amount of material necessary to qualify him for a maintenance and repair occupation within one year. Careful study has indicated that fundamental concepts in the maintenance and repair of electronics systems can be carefully sequenced to develop a core of courses that will teach the fundamentals of servicing electronics equipment. Rather than hold the student off the job market for another year to develop these skills, the student could probably learn more if placed carefully in industry with an experienced technician. He thereby gains the practical application necessary, and this in the long run may benefit the student more than an additional year of laboratory calisthenics. Therefore, the student is oriented towards the certificate program from the point-of-view that this particular program is less than two years in length because he will learn more by being placed in industry with qualified people. The engineering support program is two years in length because it takes that long to develop the math and science necessary for qualification into that classification of employment. *Job entry level is the key to program selection and qualification.*

Success with the spin-off concept is to have teachers, students, and industry convinced that one program is not lesser or greater than another program, but that all programs are needed to satisfy the diversified job opportunities available in electronics industry.

Conversations with experienced counselors and educators have indicated the following fundamental problems with student counseling: The student showing a high degree of academic achievement is more receptive to guidance and counseling, and is more readily willing to discuss his strengths and weaknesses regarding the program of instruction that he is interested in. The student who has a history of low academic achievement is by far less willing to be receptive to counseling and guidance procedures. He is even less willing to discuss his strengths and weaknesses. The spin-off concept provides the student with the opportunity to see for himself, to

evaluate himself, and to convince himself that he is either proceeding realistically or unrealistically in his career objectives. He is not forced into choosing lesser alternatives, but can be made to realize that he is pursuing different alternatives, and that he too has a contribution to his area of interest. If this is obtained in the early phases of the spin-off program, the desire and motivation to study and succeed is more realistic. The significant point is that the student has a way to choose an alternate path on his own and maintain a position of respect from his parents, friends, and particularly of himself.

SPIN-OFF CONCEPT SOLVES CRITICAL PROBLEM FOR THE COMPREHENSIVE COMMUNITY COLLEGE

The problem of the comprehensive community college is identified in some measure by the *student population distribution curves* of Fig. 3. Two curves are shown. One is the well known *normal distribution curve*. The other is a *bimodal distribution curve* applicable to vocational-technical and occupational students. The exact shape and position of the bimodal graph is not known with certainty since published data is not available at this time. We have discussed this theory with many technical teachers and administrators and all acknowledge the existence of the bimodal distribution. Many have data within their files from ACT and institutional tests to support the theory. Each of these, of course, are only small samples.

Everyone can think of a number of factors that might be responsible for the dip in the center of the bimodal curve; -- student abilities vs-interests, differences in precollege educational programs, part of the total population entering other than occupational programs within the junior college system, absence of those that enter advanced degree programs, presence of adult and continuing education students, student attitudes, the increasing need for technical and vocational programs beyond high school, etc.



Fig. 3 A Bimodal Distribution Curve suggestive of interests and aptitudes for Technical Education (T.E.) and Vocational Education (V.E.)

Now, let us recall the first heading of this section: "Two Kinds of Programs Needed" in the comprehensive community college, especially for electronics education programs for which we are prepared to discuss the problem.

If only one program in electronics education is offered, then there is the strong possibility that the one program will automatically be designed to the average which is in the dip of the bimodal curve where there is a minimum number of students. The immediate result is that the larger groups on either side become discouraged and the attrition rate becomes quite high in a very large majority of the two-year colleges.

Consequently, programs in electronics education have either been "upgraded" or "downgraded" as an effort to attract and hold more students. Traditionally, the technical institutes have initiated and retained the "upgraded" program clearly identified as technical education programs in electronics. Their attrition rate is quite high however.

The comprehensive community colleges, however, cannot contend with a high drop-out rate. As a result, their one electronics program has been adjusted to a more vocational level. This may keep more students that enter but, at the

same time, a number of potential students are not attracted to the program.

The Solution? Adopt the spin-off concept.

NOTE: The spin-off concept is recommended for more than the one reason that it will reduce the attrition rate. Enrollments will increase as a result. Also, which is most important, *two separate and distinct needs are more fully satisfied for both the students and industry.* We have discussed this problem with industry personnel in many industries, large and small, and their standard criticism of the community college programs is: "I don't know whether I am getting a graduate from a technical education program or from a vocational education program".

SPIN-OFF CONCEPT HAS BEEN APPLIED

Parkland College has used the spin-off concept in its electronics programs since 1967 when the college was first organized. Their students, at the split-off point, divide about 50-50 in the one-year certificate program and the associate degree program. Their attrition rate was zero at the last split-off time. They have been in existence long enough to have their first graduates from the associate degree program.

Willmar Area Vocational-Technical Institute, Willmar, Minnesota has used the spin-off concept since 1964. They have the certificate program and three options in the two-year technical program. The four programs average about 16 graduates evenly distributed in the four programs. They may lose only one to three students in all programs, on the average.

CHARACTERISTICS OF CURRICULUM FOR ELECTRONIC TECHNOLOGIES

The preceding section on "Recommendations for Curriculum Structure" concentrated on the following concepts:

1. Two programs in Electronics Education recommended (Vocational and technical, or certificate and associate degree).
2. The two programs are accomplished through the spin-off concept. The certificate program enhances the associate degree program and vice versa.

In this section, we will concentrate on curriculum characteristics common to a number of electronic technologies (communications, control system, digital electronics, power, and other options in the electrical-electronics field).

THE CORE SUBJECTS IN CIRCUITS AND ELECTRONICS

Any of the options of electronics technology requires a study of subjects and topics on the theory side of the electronics education spectrum. Subjects and topics relating to the *fundamentals of electronics and circuit theory* represent the core material for the various options of electronics technology. It becomes necessary, therefore, to identify and support that core material that will satisfy the needs of electronics technology programs. The discussions in the *Introduction and Chapter 1* have only identified the basic courses of circuits and electronics.

The grouping of the theory courses into a sequence of subjects of *circuit analysis* and a sequence of subjects in *electronics* comes quite naturally. If one takes the broadest possible view of electronics education, that of complete electronic *systems*, a two-part grouping becomes apparent. In analyzing any complete electronic system, one observes that they are composed of either or both passive and active circuits. In other words we encounter circuits containing only R's, L's and C's. On the other hand,

complete electronic systems may also contain active devices such as transistors, I.C.'s and other controlled sources. This natural division dictates a sequence of circuits courses (passive circuits) and a sequence of electronics courses (active circuits).

In this report, we have previously identified and proposed a circuits sequence of,

- a. Resistive Circuits
- b. Single-Time-Constant Circuits
- c. Networks

Any of the options of electronics technology are strongly dependent, with little or no adjustment of content, on the first two courses: Resistive Circuits and STC Circuits. The networks course, third in the sequence, may require considerable adjustments dependent on the option. A communications option, for example, will require emphasis on frequency response, filters, etc. A power option would require more on three-phase systems, delta and wye circuits, etc. Then, there are options in which a networks course might be omitted completely. The first two courses in circuits may be sufficient.

The sequence of proposed courses in electronics, previously identified also, consist of

- a. Introduction to Electronics Technology.
- b. Resistive Electronics.
- c. Pulse Electronics.
- d. Linear Electronics (or advanced electronics).

The first course, INTRO, is a special case and is given separate treatment in the following chapter. The remaining three courses of electronics are the true theory courses of electronics. The courses of *Resistive Circuits* and *Pulse Electronics* are recommended for many of the options of electronics technology. The last course may change as dictated by the option.

ROLE OF CIRCUIT ANALYSIS FOR THE ELECTRONIC TECHNOLOGIES

The function of a course or sequence of courses in circuit analysis is primarily to develop in the student's mind a *logical, sequential thought process* that he will be able to apply to many diversified situations. This main function is more easily identified by considering two possibilities: 1) the teaching of a course in "circuits" or 2) the teaching of a course in "circuit analysis". Consider for the moment the "circuits" approach. An instructor will present to his class the subject of the Wheatstone Bridge by introducing the typical diamond shaped circuit configuration and then making a statement which might be: "This is a balanced bridge. The bridge is balanced when the product of opposite resistances equals the product of the other resistances or $R_1 \times R_2 = R_3 \times R_4$. Under this condition the output or detector voltage is zero". The student in turn faithfully copies the circuit and resulting equation into his notebook with the intent of committing it to memory before the next quiz. This is teaching "circuits". One can readily imagine how the difficulties mushroom if this is followed by a study of other bridge configurations.

The concept of a "circuit analysis" approach is quite different. The instructor may address the same bridge circuit (unbalanced this time) by applying the nodal method to determine the output voltage, then examine the resulting equations to see what changes are necessary to make the output voltage zero. The end result is the same. But the means to this end are another matter. The emphasis here is on the application of the familiar nodal concept to achieve some end. The latter instructor is more concerned with the systematic application of fundamental concepts, and the fact that $R_1 \times R_2 = R_3 \times R_4$ is secondary. There is nothing to be memorized, but there is a logical thinking process to be learned. It is this process that should be repeatedly stressed. This logical thought process

can be further reinforced by the careful selection of the homework problems assigned to the student. Rather than assign problems that are a repetition of classroom work, i.e. given R_1, R_2, R_3 calculate R_4 , the assigned problems should be repetitions of the thought process applied to an unfamiliar circuit configuration. One might then adopt a definition for "circuit analysis" as an in-depth, systematic study of electric circuit configurations using mathematics and the fundamental circuit theories and laws as the implements of analysis.

It would seem proper at this point to discuss the "tools of circuit analysis", namely, the mathematics and circuit concepts. When these "tools" are first introduced, great care must be taken not to go overboard with a lengthy discussion of all of the ramifications of any one particular "tool". These are easily acquired as the "tool" is being used. The purpose of the circuit analysis course is to analyze circuits and not to teach mathematics. The math is acquired as a secondary goal but is not the primary function of the analysis course. A person who knows all there is to know about saws and hammers but can't build a dog house could hardly be called a carpenter. Algebra, trigonometry, the 'S' operator, KVL, KCL, and Norton's theorem are implements, means or devices employed to achieve a given end.

The primary objective of the circuit analysis sequence, the development of a logical sequential thought process, requires special attention and teaching techniques. To begin with, one must discourage memorization on the part of the student, a technique with which he is most familiar and accustomed to employing. At critical points in developing a thought process, it has been found worthwhile to require students to close their notebooks and put away their pencils to encourage them to concentrate their attention on the instructor and the chalk board. The instructor should also refrain from asking on examinations those questions which

require regurgitative answers. Examination questions, like homework problems, should require reasoning on the part of the student. The first few quizzes may be disastrous, but the student soon gets the idea.

The emphasis on a logical, sequential thought process as the primary objective cannot be overstressed. It is this thinking ability that will carry the student further and faster in other courses within the curriculum as well as in later life.

There are secondary objectives to be gained from circuit analysis as well. With repeated use the student *feels at home with the mathematics of circuitry*, and he has learned how to read information from the resulting equations.

Further courses, perhaps in the electrical-mechanical area, can build on this ability by showing the analogies that exist between circuit equations and mechanical system equations. Once the student discovers that these equations have the same form, this new course becomes a logical extension of the circuit analysis sequence.

The fundamental circuit concepts have been firmly implanted, not by memorization, but by *repetition of concepts*. With continued use of these concepts the student is well equipped to continue on into areas of active or electronic circuitry. Once the student has the capability to develop the model of the device and the conditions under which the model is applicable, the electronics problem ends, and circuit analysis enters. It should be mentioned too, that the concepts used to develop the model are concepts that are introduced and strengthened in circuit analysis courses.

It is difficult to discuss objectives of a sequence of courses without discussing the methods of achieving those objectives. Any sequence of circuit analysis courses should place emphasis on the transfer function concept, the output-input relationship. The circuits discussed should be functional, that is, they should produce a desired effect on the input. So often we are tempted to concentrate on the student's ability to repeatedly

solve various circuit configurations for *all* of the voltages, currents, and phase positions possible. Yet in essence we are concerned only with the output voltage or current and its relation to the input. The instructor of a circuit analysis course should bear in mind that ultimately the student will be involved in circuit synthesis, and that the circuit analysis is only a means of achieving circuit synthesis. There is a tendency on the part of many instructors to assume that the ability to synthesize is inherent with the ability to analyze. Perhaps a course in circuit synthesis should follow the circuit analysis course sequence.

The stress placed upon the output-input concept will do much to aid the future growth of the student. It is difficult to predict what new devices or systems will be encountered in the years to come. The ability to think logically in terms of input-output relationships or transfer functions will make the student feel comfortable when confronted with new devices.

Another secondary objective produced by circuit analysis is the ability to communicate. The engineering technician must be able to communicate with his supervising engineer, and he must be able to read the many periodicals to keep up-to-date with the field. Thus he must be knowledgeable in the language of engineering, mathematics and the 'S' operator, and block diagrams and transfer functions. Again he need not be an expert, but in their use in circuit analysis courses he has become familiar enough with the language to feel at ease with their use under entirely different circumstances.

Communications, familiarity with fundamental concepts, the ability to use mathematics and other secondary objectives are achieved thru circuit analysis. But the ability to think in a straight-forward logical manner is still the primary objective, and it is this objective that establishes the circuit

analysis sequence as the core of an electronics curriculum. The success or the failure of an electronics program can be traced to the circuit analysis sequence because of its core nature.

The measure of success or failure is not based on the number of students placed in industry or that enter directly into a four year engineering program. The success of a program is best determined three to five years after the student has graduated and is measured in terms of the students' satisfaction and growth. Has he managed to grow in responsibility? Is he doing anything to further his education? Is he doing his thing? Is he keeping abreast of new developments or is he becoming obsolete?

If the student has become successful, then so has been the program. And both are successful because the circuit analysis sequence has achieved its primary objectives, the ability to think in a logical sequential manner.

ROLE OF COURSES IN FUNDAMENTALS OF ELECTRONICS

The theory courses in electronics should present a logical and sequential grouping of the topics that are currently considered to be essential for the student to build a strong foundation. The grouping and sequencing of topics must be stressed so that the material may be properly covered and for the student to maintain a continuity of thought.

With a firm grasp of the core topics in an electronics sequence, and having completed a circuits sequence, the student can then with confidence rapidly expand his technical horizon. Applied courses such as instrumentation, control systems, communications, and computer electronics will be more easily mastered. The student has the background to learn by self-study. Subsequently, he will approach with a higher degree of confidence.

The theory courses in electronics should stimulate a desire to learn. As the student's knowledge in the fundamentals of electronics increases he finds it easier to learn. Practical and relevant applications of the theory will

create a desire for further knowledge in the area. As the laboratories progress, real world situations should be introduced as much as possible.

In the electronics sequence, many opportunities exist in the class assignments and in the laboratories for the students to improve their ability in communicating facts and ideas graphically, verbally, and in written form. If the students are to give the proper attention to this important area, active support must be given to the English Department by the technical instructors. Many graduates find that they are expected to do some technical writing and give reports of their projects shortly after employment.

The ability to work together as part of a team is of paramount importance to the engineering technician. This ability, or lack of it, is often one of the most important criteria used by personnel managers in their recruiting interviews. Frequently, a significant improvement in the attitudes of certain students can be made by interested and understanding classroom and laboratory instructors.

The theory courses should instill an awareness for the need to be flexible in a rapidly changing environment. Electronic devices that are widely used today may be obsolete in a short time. The sequence of courses in the fundamentals of electronics provides techniques and procedures of analysis that are applicable to any new devices that might be developed in the future.

THE ROLE OF MATHEMATICS FOR THE ELECTRONIC TECHNOLOGIES

The approach taken throughout the development work of this project is to introduce passive circuit elements through the defining equations for the relationships between current through and voltage across the element. Similarly, the active devices in the fundamentals of electronics sequence are introduced through volt-ampere characteristic curves as determined

at the terminals. This is stating that more emphasis is placed on the mathematics of passive and active devices than on the physics of the devices.

The mathematical approach, rather than the physics approach, solves the particular problem of "getting started" in the study of key segments of the circuits and electronics courses. Traditionally, the approach to getting started in the study of semiconductor devices, for example, has involved lengthy discussions (in beginning studies) of semiconductor physics, doping, permi-levels, diffusion, etc. Granted that all this may help the student develop an appreciation for *why* these devices display the properties they do, but it consumes time that might be better spent. The graduate only needs to know how to apply the devices and understand their function in circuits on the basis of their volt-ampere characteristics.

Although the electronics technology curriculum is math-science based, the emphasis is on the application of mathematics to electronic circuits rather than the study of pure mathematics for mathematics sake. In this light, many of the "mathematical problem solving tools" employed in the analysis of circuits can be accepted on faith and employed without previous *rigorous mathematical* derivations in every case. In some cases, the proof or derivation of the mathematical tool will come much later in the student's study of mathematics. Because the mathematics, circuits and electronics courses must be integrated within the two-year program, we must by necessity apply certain mathematical tools before they can be derived in the classical mathematical sense.

Furthermore, it is questionable as to whether mathematical tools cannot be employed without regard to derivation or proof. This point will be made in a number of instances in the detailed discussions of a later chapter that covers each of the courses. One good example will be the recommendation to use the S-operator in STC circuits and networks without going

through the derivations or having a formal mathematics background with the LaPlace transform. That can come later. This approach becomes functional by concentrating on developing the student's ability to read circuits without writing circuit equations starting from scratch every time. This is done by paying considerable attention to significant groupings of circuits that have the same kind of response.

To return more directly to the role of mathematics in an electronics technology curriculum, experiences during the project have revealed that certain communicating problems are somewhat resolved by thinking of technical mathematics as having three functions in the curriculum. The three functions of technical mathematics are:

- a. To serve the needs for the circuits and electronics courses.
- b. To serve the needs of the total curriculum.
- c. To serve the needs for continuing education.

The actual needs for the circuits and electronics courses are not great provided one is willing to use the available tools of mathematics. Perhaps algebra and trigonometry could be sufficient. On the other hand, concepts of calculus, differential equations and LaPlace transforms enhance the students appreciation of the necessary process of mathematics considerably. Still further, a more thorough study of mathematics is needed for continuing education in electronics. Much of the unhappiness that exists about technical math results from assuming only the one function of "serving the needs of the electronics courses".

- Happy conditions are likely to exist by,
- a. Acknowledging that circuit analysis is a mathematical process.
 - b. By using mathematics to advantage (not avoiding it).
 - c. Keeping the mathematical labors to a minimum (Student is not learning

circuits while in the process of cranking out the mathematics).

- d. Using computer facilities and the new programmable calculators that are available.

THEORY COURSES SEQUENCED TO MINIMIZE MATHEMATICAL PROBLEMS

The sequence of courses in circuit analysis and in the fundamentals of electronics are designed to minimize student difficulties with the mathematical process, and even to increase the students interest in the use of mathematics.

The approach that has been and is being used in many colleges is a sequence of D-C and A-C courses in circuit analysis. This approach precludes the efficient use of the mathematical process because of the fact that they are often tied to D-C sources and sinusoidal (A-C) sources. It is not the kind of source that determines the relative difficulty of a problem. The order of difficulty is determined by the presence of circuit elements (R's, C's and L's) and in what proportion, number of each, and circuit configuration.

The mathematical process develops quite

naturally with early emphasis on waveforms, or voltages and currents as a function of time.

All circuit quantities are derived from v_t and i_t .

In *Resistive* circuits, the driving functions are any kinds of waveforms and the passive elements are resistive only. No L's or C's. Concentration on v_t and i_t provides the background knowledge needed for the courses that follow. New learning situations are reduced to a minimum.

The STC circuits course has circuits where there is, effectively, either one equivalent C or one equivalent L. Such circuits have a well defined response to each driving function. Always exponential responses, for example, when steps, pulses or ramps are applied. The mathematics to derive, not to solve, is the basic element of calculus. The S-operator is used here, which reduces the math to an algebra problem. This approach becomes acceptable in the proposed sequence of circuits courses. It would not be acceptable for a D-C and A-C sequence.

Resistive circuits feeds the *Resistive Electronics* course so it can become more powerful. And STC circuits permits the existence of *Pulse Electronics* to follow *Resistive Circuits*. The entire set of theory courses become more powerful.

ETCDP DEVELOPMENT FOR THE ELECTRONIC TECHNOLOGIES

The development of curriculum and materials by the Electronics Technology Curriculum Development project is not unlike the techniques followed by a school and an individual instructor in constructing a new curriculum or in the upgrading of an existing one. Many of you have gone through this, but in order to indicate the philosophy underlying ETCDP and to clarify the specific approach taken by the project, an examination of the developmental techniques employed by the staff seems in order.

THREE MAJOR STEPS OF DEVELOPMENT

Although it may seem obvious, the primary step in the building of an electronics technology program is for the school to make a firm commitment in terms of money, faculty, and physical plant for a minimum period of four or five years. If the program doesn't get off the ground in that period of time, it is unwise to continue. Simply in terms of economics, this kind of education is far from inexpensive. Once this commitment is made and the level of programs to be offered is determined, there are three major steps to then be taken. Reference has previously been made to these procedures, but specifically, for a math-science based, college level program, they are:

1. The identification of broad topic areas composing theory content of this math-science based college level program.
2. The grouping of these topic areas into "packages", or courses.
3. The sequencing of these courses and integrating them with the mathematics courses.

The flow chart of the ETCDP curriculum presented earlier represents the result of going through these three efforts. In terms of the project, however, this foundation has been built earlier and we direct our efforts to what follows

this preparatory work. ETCDP is primarily concerned with what goes on in each of the seven theory courses included in the curriculum. The outline of developmental procedures that follows is applied to each of these theory courses.

PROCEDURE FOLLOWED FOR EACH COURSE

The process of development of each course is initiated with the identification of the *major topics* or concepts to be included in the course. Immediately following, the course is given structure by the sequencing of these major topics or concepts into a natural and logical progression, from the elementary to the complex, allowing for the best possible "flow" or transition from one topic to the next.

Upon the completion of this structuring, careful consideration is given to each individual topic. In concentrating on each topic, an attempt is made to identify *difficulties encountered* in the presentation of the topic. Among these difficulties encountered, frequently one is faced with how to get started in the topic as well as determining what *problem solving tools* are needed in handling the topic. A subsequent question that arises in considering the aforementioned "tools" is whether or not there is a need for a rigorous mathematical derivation of each or whether students can be asked to "buy" or accept the tool on faith. It may be a mistake to place too much emphasis on the derivation of tools rather than their application to circuit problems. Another consideration made regarding individual topics is the availability of prepared materials applicable in the presentation of the topic. In evaluating prepared materials, consideration is given as to whether they are of the proper level as well

as whether or not they employ a satisfactory approach that is compatible with the topic sequence used as well as the philosophy underlying the curriculum and instructor approach. More often than not, it becomes necessary for the instructor to develop his own materials.

Experience has shown that upon careful examination of an individual topic, the nature of the topic itself oftentimes suggests a more natural means of handling the topic. This is true for each of the three "modes of operation"; the introduction of the topic, the detailed analysis of the topic, and finally the application of the topic. It should be noted at this point that these "modes of operation" do not necessarily come into play in the order presented above. That is, it may be advantageous to introduce a specific topic through an application. Traditionally we have introduced topics either through a discussion of physical properties or through a mathematical approach and then developing the topic and concluding it with an application. Perhaps the introduction of many topics through an application will lead to a more thorough understanding of the topic, especially in the study of active devices, where the prime concern is with the input-vs-output parameters of the device. Selecting a means of handling a topic involves making two decisions for each mode of operation. Specifically, one must select the best educational environment, be it classroom or laboratory, and select the best method of presenting the material. These methods include the traditional lecture and laboratory experiment as well as demonstrations, auto-tutorial methods, textbook presentations, laboratory observations, and interpretation, closed circuit TV, and films, to list only a few.

THE EDUCATIONAL ENVIRONMENT

Let us now address ourselves specifically to the educational environment in which our students learn. It is felt that the ideal situation would be an electronics learning center, combining

both lecture and laboratory areas. Physically this learning center would include experimental facilities and equipment, a lecture-discussion area, auto-tutorial equipment, a computer outlet, and a demonstration area as well as a library-study space all in one large area. This learning center concept can be employed in the construction of new physical plants, but the majority of existing situations are composed of separate classroom and laboratory facilities. In these situations, we can define classroom activities as *learning circuit response through calculations*, and laboratory activities as *learning circuit response through observations, interpretations and measurements, supported by calculations as needed*. A most important consideration to keep in mind, however, is that the classroom activities and laboratory activities must be a closed-loop situation, each supporting the other. To use the laboratory simply as a means of verifying or applying what is learned in the classroom is a gross waste of both time and instrumentation available in helping the student learn.

Laboratory activities and laboratory materials are developed with the purpose of the laboratory experiment foremost in mind. These purposes are identical to the three "modes of operation" mentioned earlier. One must decide whether the laboratory experiment is being designed:

- a. To introduce a new concept.
- b. To provide for the detailed analysis of the concept.
- c. Or, to make application or a review of the topic possible.

CLASSIFICATION OF LABORATORY LEARNING EXPERIENCES

Laboratory learning experiences can be classified in terms of the amount of direction the student brings to bear in controlling the laboratory activity. On one end of this continuum is the student-controlled experiment and on the other end the instructor-controlled experiment. If one is to use the laboratory to best advantage,

use of both extremes as well as points in between them must be made. To identify these types of laboratory experiments more closely, a discussion of each is presented.

The student-controlled experiment is typified by a lack of structure allowing the student complete freedom to direct the learning process. He has the freedom to vary circuit parameters, even to their extremes and to make observations and interpretations regarding the effect on circuit response. Through this freedom, the student has the opportunity to answer any questions he may have regarding a particular circuit and therefore gain insight leading to a better understanding of the topic. Furthermore, the student is going to have to be able to work in this manner upon graduation and entering employment as a technician. If this type of experiment is to be used effectively, it is imperative that proper ground work has preceded it and that proper foundations have been developed so that the student can direct his activities in a productive manner.

The *student-instructor controlled experiment* obviously lies between the two extremes and makes up the bulk of the experiments used. These experiments should be designed so that they contain a minimum of structure and appear to the student to be *non-structured*, encouraging him to take some initiative in *investigating* the circuit under study. This objective can be achieved through the use of leading questions, sequenced activities, and grouping of circuits. A powerful laboratory of this type, called *Creative Investigation*, is particularly useful in this type of a laboratory activity. More will be said about Creative Investigation in a later discussion of laboratory techniques. An example of student-instructor controlled laboratory experiment is leading a student through an elementary design problem early in any course through the use of a *sequence of activities*.

There are many occasions when, because of the instrumentation available in the laboratory, the *instructor-controlled* laboratory experiment is a

very useful and effective teaching situation. The laboratory environment is often the ideal place to introduce new concepts, allowing the student to make some observations and then interpretations that lead to the concept to be developed. If this type of activity is to be employed, it should be followed up with strong classroom support. The instructor-controlled type of laboratory experience is needed for the learning of many important topics such as measurement techniques, test procedures, trouble shooting, and the application of concepts covered in the classroom. The latter is an example of the laboratory providing strong support of classroom activities.

TECHNIQUES OF LABORATORY LEARNING

Each of the different types of laboratory learning experiences enumerated above have in common many laboratory techniques to which we will address our attention at this point. One of the most potentially powerful is the *Creative Investigation* alluded to previously. *Creative Investigation* can be best described as a student-controlled activity that is made up of four sequential activities. These are as follows:

- a. Observation
- b. Interpretation
- c. Measurement
- d. Calculation

Specifically, the student is encouraged to *observe* the response of a circuit and make some *interpretations* regarding these observations, followed by taking *measurements* and finally to support the preceding with the calculations of circuit response. The laboratory technique of varying circuit parameters works well in conjunction with *Creative Investigation*.

A second laboratory technique that holds much promise is the introduction of new concepts in the laboratory. This calls, however, for the development and use of *laboratory textbook materials*. Due to a lack of satisfactory materials of this type, considerable effort has

been directed toward the development of this kind of materials as well as the employment of Creative Investigation, and the other techniques discussed earlier. An additional laboratory technique that has merit is that of grouping of circuits that demonstrate similar response or a duality. Not unlike grouping techniques is the sequencing of circuits as well as laboratory activities. This can be applied through the use of individual sheets making up an experiment being handed out one at a time only after the satisfactory completion of the preceding sheet. Although only a few lab techniques have been discussed here, they may be sufficient to indicate the areas of concentration of ETCDP as well as point out the potential of the laboratory as a learning environment, a potential long overlooked. In addition, the graduate of these programs must be a "hands-on", lab oriented, "can-do" person as well as one who is able to analyze and design through the use of circuit models and the mathematics.

EMPHASIS ON SYSTEMS APPROACH

There are several guidelines underlying what has been presented here that are not readily apparent but are motivating in terms of what we do and how. First, an attempt is being made to identify some of the more important and powerful techniques and to develop sample materials to demonstrate these techniques. We are not writing a complete curriculum on a day-to-day basis. Secondly, a strong emphasis is placed on the systems approach.

As a result of a rapidly changing technology where the future of even the transistor is doubtful in view of the integrated circuits and complete circuit "modules" or packaged circuits now on the market, the graduate of these programs must be ready to cope with and be comfortable using any new device encountered. Furthermore, he must be familiar with how these packages are combined to make up complete systems. This conviction is facilitated through the *Introduction of Electronics Technology* course detailed previ-

ously where the students' study of electronics begins with systems, the electronics he is familiar with and can relate to the real world. The student then breaks these systems into circuits, the building blocks of systems, and analyzes them on a function or input-output basis. This course could be appropriately called, in the vernacular, "The Big Picture". This concern with the changing technology appears in the emphasis placed in the ETCDP materials. Devices are studied from their volt-ampere characteristics and their *input and output* electrical parameters on a two terminal, three terminal or multi-terminal basis, rather than from a physical basis. This concern appears again in the approach taken in the circuits studied. They are approached from studying the circuit response, transfer function, or signal processing that applies. On this basis it is felt that we can provide the student with a theory background upon which he can specialize as well as cope with new developments.

PROVIDE OPPORTUNITIES FOR INDEPENDENT LEARNING

Similarly, an attempt to allow as many opportunities for independent learning is made. An example of this is leaving laboratory experiments open-ended and instituting an open laboratory. That is, the student isn't able to say "I'm finished". It has become apparent, too, that much of what is studied could be best treated through the use of existing "Instructional Technology", such as the employment of auto-tutorial materials, movies, slides, video tape and the various audio-visual equipment and techniques.

THE INSTRUCTOR AND USE OF SOFTWARE

In developing curriculum materials, once a decision is made regarding topics and topic sequence, a compromise may have to be made regarding textbooks. Rarely is a single text suitable, and two or more texts may have to be adopted for courses and not necessarily

used on a Chapter 1, Chapter 2, etc. basis. No commitment is made regarding semester-vs-quarter unit timing and packaging of the curriculum or materials. Nor are rigid commitments in terms of the amount of time allotted for each course or unit made. Although the project works within the quarter system framework, which Parkland utilizes, these are problems that must be solved on a local basis.

In conclusion, perhaps we have overlooked the most important link in the process, the instructor. If he isn't *interested in, excited with, and enthusiastic about* the subject matter, the student won't be either and the crucial rapport with the students will not be developed and capitalized upon, leaving the job undone, regardless of the quality of materials used.

SEMANTICS OF ETCD PROJECT

A number of significant words and phrases were generated, or recalled, during the project which proved helpful in the development of materials and techniques of instruction. Many of these key words and phrases are used in appropriate places of this report. They are listed and discussed briefly here to direct the reader's attention to them. Many of these words and phrases could be valuable guides in any institution and their electronics departments in the developments and revisions of curriculum and subject matter content.

CLOSED LOOP CONCEPT OF EDUCATION

Anyone can identify a number of closed-loop situations that can provide guidelines to teaching techniques and the structure of subject matter content that will provide more efficient teaching and learning situations. The educational process is seldom a one-way situation. Consider the following as examples.

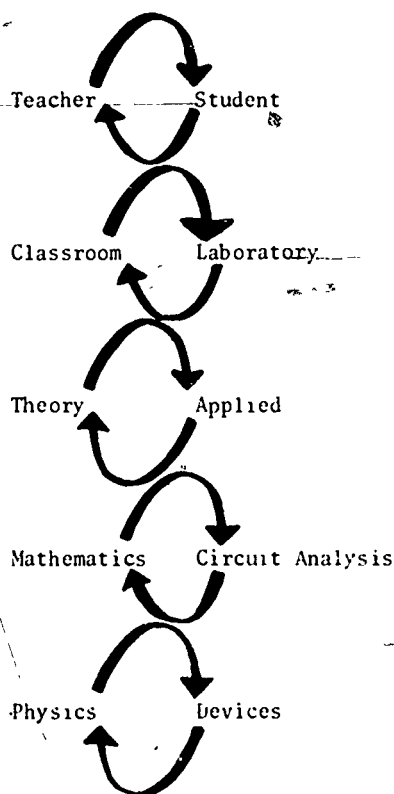

The examples shown below are sufficient to illustrate the closed-loop concept of education, as, particularly needed for electronics technology associate degree programs. No one will question the teacher-student interrelationship. On the other hand, there may be too much dedication to the belief that the classroom should feed the laboratory in every case, or that the laboratory should feed the classroom in every case, or that theory shall precede applications (or vice versa), that mathematics shall precede circuit analysis in every case, or that physics is required for devices.

Suggestion: Think of closed-loop situations and differences of opinion will more likely be resolved.

PATTERNS

Techniques of circuit analysis and a study of systems fall into definite patterns. There are circuit configurations common to many systems. There are many circuits that have the same kind of response. Mathematical techniques and procedures are repetitive.

Suggestion: Look for patterns and electronics education will become simplified, interesting and challenging.

GROUPINGS

The term "grouping" has a connotation similar to "patterns".

Suggestion: Study circuits, devices and systems in groups as much as possible. Series, parallel, series-parallel and STC circuits are examples of groups. Perhaps series, parallel and series-parallel circuits can be presented as one group. Perhaps STC circuits should be presented in two groups (exponential responses and sinusoidal responses). Perhaps too much attention should not be given to particular devices. Maybe they can be grouped for better

results. Perhaps too much attention to one, or a few systems is not desirable. Consider the possibility of grouping.

SEQUENCING

The complete teacher has the never-ending and challenging job of finding some logical order of presenting major subjects and detailed topics within each course. Anyone who can find the one complete sequence to satisfy all situations for all time could become a millionaire over night. No teacher is ever completely satisfied with a particular textbook, for example, not even the author himself. Even so, each teacher must continue to improve the sequence of topics to satisfy new and changing requirements.

Suggestion: Avoid letting nitty-gritty topics take complete control of sequencing. Keep the controlling big topics in mind.

MAJOR CONCEPTS

Major concepts are those phenomena, theorems, and techniques that are recalled and used most often in the analysis of grouped circuits, devices and systems. They are concepts such as: Kirchhoff's laws, instantaneous values, equivalent resistance, input-output characteristics, ratios (or transfer functions), defining equations, etc.

Suggestion: Identify major concepts for a course (or set of courses) and let these have a major influence on sequencing. Note: Major concepts are not the same as objectives.

THE PROBLEM

Identification of THE Problem is somewhat related to objectives. There are those who declare: "Identify the objectives first and then proceed with curriculum structure and subject-matter content". In any development work, this approach leads to serious differences of opinion and productive activity becomes difficult. Objectives are too dependent on sequencing, groupings, major concepts, and a number of other factors. The process of development of materials, in itself, dictates the need for detailed analysis

of subject matter. New subjects and new approaches must be developed before objectives can be stated. Initially, objectives are identified only in general terms and then in more specific terms as development proceeds.

Even so, identification of THE Problem (especially in laboratory activities) may be more meaningful to the students than stating the objective of an experiment. Too often, objectives are stated too loosely with too much description. By stating THE Problem, one is forced to be more specific and direct about the objective of an experiment. It's a productive way of arriving at objectives without identifying them as such in every case.

Suggestion: Think of objectives and subject matter development as a closed-loop situation.

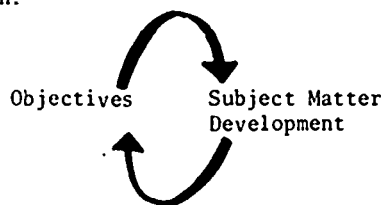

KNOWLEDGE-UNDERSTANDING-APPRECIATION

This sequence of three words, when kept in mind, may resolve certain teaching and learning problems. Knowledge is an accumulation of facts or phenomenon; Understanding is a mental process of putting related facts together to assist the educational process; and appreciation comes through applications, or knowing how facts and phenomena can be used in the real world.

Suggestion: Give students time and opportunity to develop appreciation, while he is trying to understand, while he is gaining knowledge.

CREATIVE INVESTIGATION

The thought here is to encourage theory learning in the laboratory through creative investigation, through a sequence of four activities stated in order below:

- a. Observe

- b. Interpret
- c. Measure
- d. Calculate

The reverse process, doing calculations as the first step, is design. Many of the suggested experiments for the courses of this report are designed to encourage creative investigation.

Suggestion: Perhaps in the process, our objectives should be

- a. Develop students' ability to improve as an observer.
- b. Develop students' ability to make more thorough and accurate interpretations.
- c. Develop students' ability to make better measurements.
- d. Develop students' ability to make calculations.

INTRODUCE (IN LABORATORY)

The key word here is: *Introduce*. This suggests that the laboratory, rather than the classroom, shall take control in the teaching of certain concepts. There are those who prefer this technique to be identified as *laboratory oriented*. On the other hand, some teachers think all new concept or problems should be introduced in the classroom before going to the laboratory. In the chapters on the six courses, the outline specifies those topics where it might be better to introduce in the laboratory as well as those topics that should be introduced in the classroom.

GETTING STARTED

The problems of decision making in the development of subject matter and techniques for major topics *within* a course, the course itself, or even for the total curriculum, are largely resolved through a careful *study on how, when and where* to get started.

The INTRO course (Chapter 3) proposes getting a good start on the total curriculum by taking a *systems and circuit response* approach. If one did not believe this, then perhaps the course could not serve its purpose. In any case, if

the *starting* approach is correct then the total course is more likely to be a desirable one.

The subject of STC circuits, as another example, consumed considerable project time and effort because of the problem: How to get started? Once the decision was made to use the S-Operator, without hesitation, as a workable approach, the remaining subject matter fell into place more easily.

The decision not to require a *detailed* background on the physics of devices resolved certain problems in getting started with certain topics. There are a number of other *getting started* situations that, hopefully, will be apparent to the reader in the material of the remaining chapters.

Suggestion: Careful thought to getting started with *major* topics will be time well spent.

UNSTRUCTURED STRUCTURE

A teasing phrase that can have more meaning than first glance might indicate. One is continually faced with the teaching problem of avoiding too many *cookbook* instructions. Yet, every teacher has a plan of attack, a teaching technique of his own, whereby he hopes his student will attain certain levels of achievement as he proceeds. Student's faith in a teacher is increased if he discovers that he is being satisfactorily guided. The structure is there, even though the student might not be aware of it.

Suggestion: Strive for student's respect and faith in his own ability by providing him with opportunities to say: "I thought of that!" When, as a matter of fact, that's what the teacher wanted him to think, or do, all the time. Laboratory is a good place to provide such opportunities.

CHAPTER 3

INTRODUCTION TO ELECTRONICS TECHNOLOGY (INTRO COURSE)

This chapter is devoted to the one topic, the "Introduction to Electronics Technology", a course which is frequently referred to as the INTRO course in this report.

It is important that the reader examine the information and suggestions as presented with an open mind. This is not a conventional type of course. Textbooks have not been written that satisfy the philosophy and subject-matter content as proposed here. There is some question as to whether a textbook should be used, even if one were available.

— The INTRO course is considered as extremely important by the ETCD project who believe that it should be considered in any curriculum planning for the Electronics Technologies.

An INTRO course is being adopted by a number of electronics teachers with considerable success. The course does not have the same structure and content in the various colleges. There is considerable flexibility where each instructor can use his own innovative ideas. The INTRO course is easily implemented once the philosophy of the course is understood and appreciated.

PHILOSOPHY OF INTRO COURSE

THE TRADITIONAL APPROACH

Traditionally, electronics technology curricula have begun the sequence of theory topics with a study of atomic theory and the physics of electricity. Beginning at this rather abstract point, the bedrock of the discipline, we progress into circuit parameters (voltage, current, resistance....), followed by circuits (passive then active), culminated by systems, the interconnection of circuits into complete functional units. From the physics to the consideration of systems the curriculum continually grows in scope, as indicated by the following diagram.

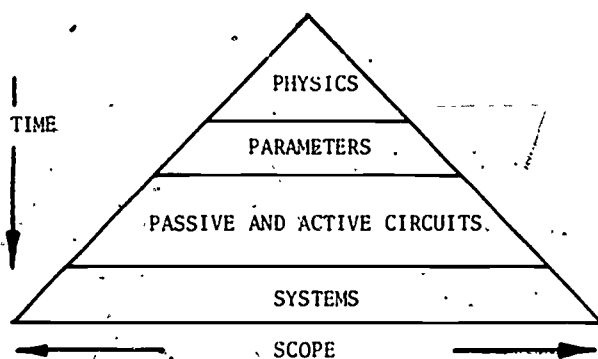

THE NEED FOR AN INTRO COURSE

Although this is the natural and logical way to develop the study, it is felt that there is a need for an introductory sequence through which the student can be better oriented into the "world of electronics." That is, it is important that the study be related to the world the student is familiar with. Through the provision of an opportunity for the student to become acquainted with "the big picture", he may

gain insight into the "whys" of what he will study later and thereby be better motivated as he progresses through the sequence of courses that follow.

When the student begins his first term in an electronics technology curriculum, his mathematics proficiency typically precludes his beginning a quantitative study of circuits (via traditional approach) and, therefore, he cannot move immediately into the material he is interested in, -- electronics. Rather than have him bide his time during that first term, it would be much better to prepare him for the material that is to come by offering him a broad insight into the discipline. In addition, there are many facets and topics in electronics that do not require the math background that can be covered in this introductory course.

In an electronics program it is necessary to have two divergent curricula if all the students are to be served, in keeping with the community college philosophy. Typically, these two programs are the two year A.A.S. degree curriculum (math-science based), and the one year certificate type of curriculum. If this introductory course is made common to both curricula, the student doesn't need to choose which one he will pursue until the completion of this course. It is felt that he will be better equipped to make this choice at this point. In addition, both curricula have a need for an introductory sequence and this course provides a common base.

NATURE OF AN INTRODUCTION TO ELECTRONICS TECHNOLOGY COURSE

The course must begin with the broadest

*Prepared by Mr. David A. Peterson and others of the Project Staff. Mr. Peterson also has had direct experience with an INTRO course which he initiated at Alpena Community College, Alpena, Michigan.

possible approach in terms of scope if the student is to get "the big picture". It is felt also that the *systems approach* satisfies this prerequisite. In other words, the sequence should begin with a consideration of the electronics the student is familiar with which at this point is complete electronic *systems*. These systems should be treated on a "building block" basis. That is, individual building block functions combining to provide a total function, -- the system function. Following next, we move to a consideration of those building blocks -- *circuits* -- on an input-vs-output or function basis. The circuits should be handled on a response basis, as "black boxes" with little regard as to how they work, but rather *what* they do. Following this, consideration is given to the individual circuit.

COMPONENTS AND PARAMETERS

The course should be a laboratory directed course, allowing the students the opportunity to get their hands on and use as much hardware and instrumentation as possible. For example, there is no reason why a beginning student can't be using an oscilloscope the first or second laboratory session of the course.

The course material or topics covered should be treated on a *qualitative* basis. This is not to say that we can't consider or measure many parameters such as amplitudes of voltage and current as well as time, frequency and gain; but it does mean that *calculations are kept to a minimum* and that no work is done with mathematical relationships between circuit parameters such as KVL, KCL, and Ohm's Law.

The course should be an overview of electronics and an introduction to hardware. Consequently, it is crucial that just the right amount of time is spent on the course. For this introductory sequence, the danger of spending too much time in the course is of more concern than spending too little. We want to *introduce* and provide an *overview*, not to go deeply into the analysis of any facet of the

sequence.

FOUR MAJOR TOPICS FOR COURSE

The content of an INTRO course had four major categories. They are:

- I. The Language of Electronics (including schematic diagrams as well as terminology).
- II. Instrumentation and Measurements.
- III. Hardware Familiarization.
- IV. Concepts.

These four categories are not to be interpreted as sequential topics. Rather, they are the four areas of concern or each major discussion or laboratory activity.

A discussion of each of the four categories is presented as follows:

The Language of Electronics

Because schematic diagrams are employed as a major means of communicating information regarding any particular system or circuit, it is important that the student become familiar with them early in his study of electronics. The conventions observed in reading and constructing the schematic diagram are oftentimes overlooked. A partial list of these conventions appears later in this discussion. The schematic diagram also provides an opportunity to make use of a systems approach in this introductory sequence. By observing, on the schematic, that the system is composed of blocks or circuits, and that the circuits are composed of individual components, the study of schematics fits perfectly with the system approach. After studying schematics in this course, the student should be able to make the transition between a wired circuit and its schematic as well as to wire any schematic given its schematic diagram.

There is an overwhelming amount of terminology that the student encounters through his study of electronics, right from the beginning, and this course affords the opportunity to familiarize him with much of it. The

instruments alone present a formidable list to be learned if they are to be used properly. A partial list of this terminology appears later in this discussion.

Instrumentation and Measurements

There are laboratory techniques, instrumentation and measurement procedures that the student needs when he encounters the laboratory portions of the circuits and electronics courses that follow. This readiness can be developed in this introductory sequence. The student should upon completion of this course be able to use the basic instrumentation at the lab station in his first circuits course with ease. It is generally agreed that these instruments must contain the following pieces: dual trace oscilloscope, function generator (with sweep capabilities), unit pulser, vom, and power supply. Additional instruments to be covered should be selected by the instructor and might include: R-C-L bridge, counter, curve tracer, DVM, etc.

Hardware Familiarization

In implementing the systems approach, the student should be afforded the opportunity to inspect the complete system that he is considering with the schematic diagram. Some examples of systems that might be used are a radio receiver, television, automatic door opener, motor speed controller, C.B. transceivers etc. When the student analyzes the system in terms of block diagrams (circuits), he should identify these sections in the actual piece of equipment.

When the student is concentrating on circuits and their function, the ideal situation is to provide him with pre-wired assembled "black box" circuits. These circuits might well include power supplies, rectifiers, filters, regulators, amplifiers, feedback units, oscillators, multivibrators, triggers, sweep circuits, detectors, discriminators, frequency doubler, gating circuits, etc. These circuits should be designed so that there are no problems with matching when they are interconnected to form

systems. There are several commercial pre-wired units that can be used to advantage in this sequence.

After studying some circuits on a function basis, the student concentrates on the circuit with its individual circuit components. He should become familiar with the common components. He should become familiar with the common components found in the laboratory: resistors, capacitors, inductors, transformers, transistors, diodes, tubes, I.C.'s, triacs, SCR's, switches, etc. This might well be followed up with the techniques of bread-boarding, soldering, and prototyping.

In terms of providing the student with additional motivation, it may well be advantageous to have the student constructing a simple project for his own use in this course. There is danger, however, of letting these projects get too involved. They should be kept simple and involve a minimum of time, but yet allow an opportunity for the student to get some experience in prototyping, layout, assembly and soldering.

Concepts

The student needs, if this introductory course is to be meaningful especially in terms of use of the instrument, to understand voltage as a force, current as a resultant of this force. These rather simple-minded definitions allow him to grasp the balance of the content of the course. No further definitions of parameters are presented at this point. The student should be introduced to common waveforms, observe them on his oscilloscope, and learn to express them both mathematically and graphically.

This point is an excellent one for the inclusion of study of the slide rule and its use as well as scientific notation and metric terminology.

Much work can be done in learning of concepts such as time-frequency relationships, gain attenuation, modulation, feedback fre-

quency spectrum, harmonics, and phase, to list only a few. These concepts can all be treated in a qualitative manner in order to better prepare the student for a rigorous analysis of them later. Included also should be the color code and a study of switches and switching.

Throughout the course, the student should be provided with exposure to the electronics industry through visits or field trips to industry, films, and speakers from industry. This enables the student to get a better feeling for what goes on.

Finally after approaching electronics from a broad viewpoint and growing narrower in scope, the physics of electricity is now covered. Our diagram of Fig. 1 can now be modified as in Fig. 2 that shows an inverted pyramid for the INTRO course on top of the traditional pyramid. The inverted pyramid for the INTRO course is expanded in Fig. 3 to reveal some of the detailed contents of the four categories.

TIME ALLOTTED TO INTRODUCTION TO ELECTRONICS TECHNOLOGY COURSE

Because the emphasis in this sequence is on getting ready for following courses, the time spent on it is of much concern. It is felt that this lab-oriented course should receive between 40 clock hours as a minimum and 60 clock hours as a maximum. This can be broken down as follows:

<u>Semester Basis (15 wks)</u>	<u>Quarter Basis (11 wks)</u>
1 hr. lecture/week	1 hr. lecture/week
2-3 hrs. lab/week	3-4 hrs. lab/week

It would serve no purpose to allow more time to the course. We only wish to "wet their appetites" not "feed 'em".

SCHEMATIC DIAGRAMS PROVIDE MUCH INFORMATION

The following are presented to reveal the tremendous amount of information that can be found on schematic diagrams of electronic systems. Schematic diagrams should be used freely in the INTRO course as an excellent source of

information.

A Schematic Diagram

1. Shows the sequence of signal operations.
2. Shows the dependence of each circuit block on neighboring blocks.
3. Provides a pattern for troubleshooting the system.
4. Provides a method for locating the parts of the chassis.
5. Shows mechanical connections, linkages, or grouping of components.
6. Shows external connections.
7. Shows relative importance of components.
8. Shows interconnection of components.
9. Tells values and limitations of the components.
10. Signal flows from left to right.
11. Signal components (coupling) are generally connected horizontally.
12. Power flows up or down.
13. Power components are generally connected vertically.
14. All lines are drawn either horizontally or vertically, unless specifically required by the symmetry of the circuit.
15. Ground is always at the bottom.
16. All test points, components, connections, pin locations, etc. are labelled.
17. Overall symmetry must be upheld through:
 - a. evenly spaced components
 - b. similar components are placed at same level on the schematic
 - c. parallel construction
 - d. progressive construction
18. Standard symbols and conventions are used.
19. Function and importance of components and circuits are indicated through component placement and orientation.

Additional discussion of schematic diagrams can be found in Chapter 7.

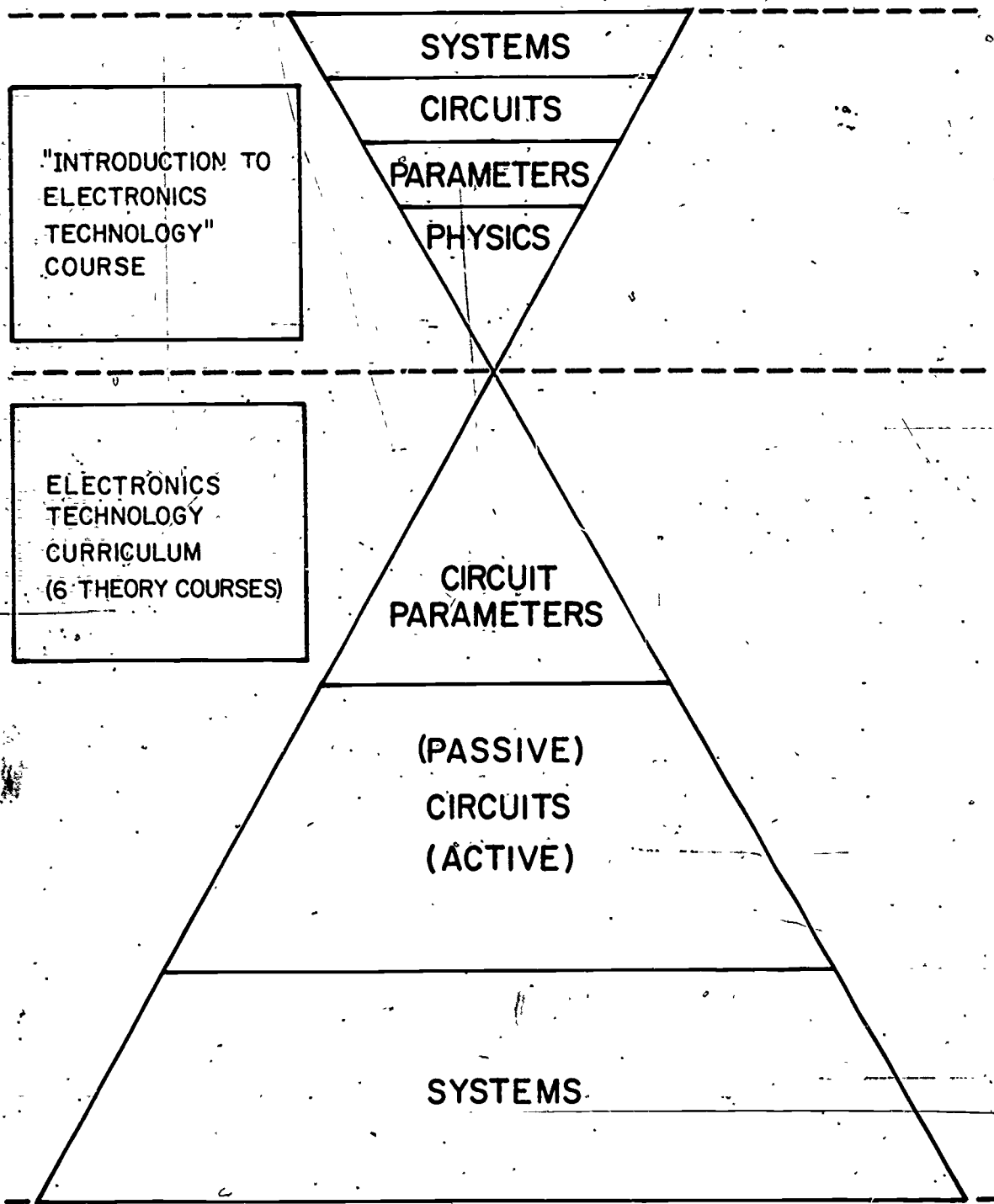

Fig. 2
Inverted Pyramid Approach

LANGUAGE OF ELECTRONICS		TERMINOLOGY (examples)	INSTRUMENTATION AND MEASUREMENTS	HARDWARE FAMILIARIZATION	CONCEPTS
SCHEMATICS					
Complete systems on block diagram basis Analysis from a function S or present stand point Y Total System S sum of "Block" T Functions E Conventions of M schematics - signal S flow, power flow, etc.	Trace, Beam, Focus, Intensity, Astigmatism, Time Base, Sweep, Axis, Trigger, Synchronizer, Chop Alterate, Deflection Display, Polarity, n.c., A.C., Calibration, Parallax, Graticule Magnifier, Multiplier Probe, Lead, Mode Compensation, Delay Ground, Range, Scale, Function, Loading, Readout, Hertz, C/S, Period Repetition Rate, Linearity, P.R.F. Frequency, Phase Amplitude, Gain Attenuation, Pulse Width, Sensitivity, Rise Time, Leading, Trailing, Ripple, Float, Regulation	Oscilloscope and Usage: Waveform Observation, Amplitude Measurement, Time Measurement. Voltmeters (VOM, VTVM, DVM): A.C. Measurements, D.C. Measurements. Counters and Usage: Time Measurements, Frequency Measurement. Function Generator: Sine Wave, Square Wave, Ramp or Triangle, Sweeping. Unit Pulser: Pulse Rate Frequency, Period, Pulse Width. Multivibrators: Astable, Monostable, Bistable. Schmitt Trigger Sweep Circuits Detectors Discriminator F Doubler Tuned Amp, etc. Resistors, capacitors, inductors, transformer, transducers, transistors, diodes, speakers, mikes, I.C. tubes, OP AMP, switch, triac, SCR Solder and breadboarding	Power Supplies Rectifiers Regulators Amplifiers (AF, RF) Feedback Oscillators table, Monostable, Bistable. Schmitt Trigger Sweep Circuits Detectors Discriminator F Doubler Tuned Amp, etc. Resistors, capacitors, inductors, transformer, transducers, transistors, diodes, speakers, mikes, I.C. tubes, OP AMP, switch, triac, SCR Solder and breadboarding	Complete Systems Such As: Radio Receiver, Television Receiver, Automatic Door Opener, Motor Speed Controlled, C.B. Transceiver, P.A. System Optional Student Project Agency, P.R.F. Slide Rule	Voltage as a Force Current as a Resultant Waveforms: Graphical Representation, Mathematical Representation (Continuous, Discontinuous--piecewise), Frequency, P.R.F. Slide Rule
"Building Blocks" treated as "Black Boxes" Function Approach: Signal Processing, Input vs Output, Terminal or Port Approach. "Support Terminals" Interconnection	Resistor, capacitor, inductor, potentiometer, rheostat, prototype, collector, emitter, base, cathode, plate, grid, watt, OHM, AMP, Henry, Farad, E, T, C.	Bridges and Usage: Resistors, Capacitors, Inductors, Transducers, Ohmmeter, Other Instruments Select-ed by In-structor such as Curve Tracer, E.T.C.	Power Supplies Rectifiers Regulators Amplifiers (AF, RF) Feedback Oscillators table, Monostable, Bistable. Schmitt Trigger Sweep Circuits Detectors Discriminator F Doubler Tuned Amp, etc. Resistors, capacitors, inductors, transformer, transducers, transistors, diodes, speakers, mikes, I.C. tubes, OP AMP, switch, triac, SCR Solder and breadboarding	Power Supplies Rectifiers Regulators Amplifiers (AF, RF) Feedback Oscillators table, Monostable, Bistable. Schmitt Trigger Sweep Circuits Detectors Discriminator F Doubler Tuned Amp, etc. Resistors, capacitors, inductors, transformer, transducers, transistors, diodes, speakers, mikes, I.C. tubes, OP AMP, switch, triac, SCR Solder and breadboarding	Gain, Attenuation Phase, Distortion, Modulation, Demodulation, Feedback, Frequency Spectrum, Harmonics, Triggering, Regulation, Ripple, Impedance, Admittance, Coupling
Circuit Diagrams with individual components and devices Symbols Diagram Mixed Circuit Tracing Signal Flow; Power Flow	Resistor, capacitor, inductor, potentiometer, rheostat, prototype, collector, emitter, base, cathode, plate, grid, watt, OHM, AMP, Henry, Farad, E, T, C.	Bridges and Usage: Resistors, Capacitors, Inductors, Transducers, Ohmmeter, Other Instruments Select-ed by In-structor such as Curve Tracer, E.T.C.	Power Supplies Rectifiers Regulators Amplifiers (AF, RF) Feedback Oscillators table, Monostable, Bistable. Schmitt Trigger Sweep Circuits Detectors Discriminator F Doubler Tuned Amp, etc. Resistors, capacitors, inductors, transformer, transducers, transistors, diodes, speakers, mikes, I.C. tubes, OP AMP, switch, triac, SCR Solder and breadboarding	Power Supplies Rectifiers Regulators Amplifiers (AF, RF) Feedback Oscillators table, Monostable, Bistable. Schmitt Trigger Sweep Circuits Detectors Discriminator F Doubler Tuned Amp, etc. Resistors, capacitors, inductors, transformer, transducers, transistors, diodes, speakers, mikes, I.C. tubes, OP AMP, switch, triac, SCR Solder and breadboarding	Gain, Attenuation Phase, Distortion, Modulation, Demodulation, Feedback, Frequency Spectrum, Harmonics, Triggering, Regulation, Ripple, Impedance, Admittance, Coupling

Fig. 3

INTRODUCTION TO ELECTRONICS-TECHNOLOGY

PHYSICS OF ELECTRONICS

LANGUAGE OF INTRO COURSE

BASIC INSTRUMENTS

In getting started in the *Introduction to Electronics Technology* sequence, there are three prerequisite studies that must be made. As one might suspect, these prerequisites are in the area of instruments. If our study of systems, sub-systems, circuits, and components in the laboratory is to be effective, the student must be able to use the *oscilloscope, function generator, and power supplies with ease*. Meters are not treated at this point for the reason that they are relatively fragile and that this study opens up the "can of worms" dealing with AC, DC, rms, avg, and average values.

Ideally, the first of these instruments to treat is the oscilloscope for measuring amplitude, frequency, and time. This is best facilitated through the use of a *central distribution system* in the lab which permits the instructor to make the waveforms to be considered (including D.C.) available at every station simultaneously. The students can then direct all their attention to observing and evaluating these waveforms in their introductory sequence in oscilloscope usage. Furthermore, the student doesn't have to learn the signal source simultaneously with the oscilloscope.

THE OSCILLOSCOPE

The goal that is kept in mind is that we want the student to be able to identify waveforms on the oscilloscope in addition to measuring their amplitude, frequency and period.

A partial list of the terminology encountered with the "scope" follows:

oscilloscope	calibration	compensation
trace	sync	parallax
chop	gratidade	beam
alternate	magnifier	focus
deflection	multiplier	intensity
display	probe	astigmatism

polarity	lead	time base
DC	mode	sweep
AC	axis	delay
trigger	BNC	ground

NOTE: For this and other lists to follow, it is suggested that the student be presented with a selected set of terms to be placed in a personal notebook for later reference with his comments as he becomes sufficiently familiar with them. This could be done with each laboratory activity.

FUNCTION GENERATOR

Once the oscilloscope is mastered, attention ought to be directed to the signal source or *function generator*. The function generator can be learned much easier now that the student can observe the effect of varying the level, waveform, and frequency of the generator output on his oscilloscope trace. The problem here is for the student to learn to set up the function generator to produce any specified output waveform of designated amplitude and frequency.

Once again, terminology is encountered that might be new to the student. A partial list follows:

square wave	sweep width	attenuation
waveshape	triangular	sine wave
trigger	period	sweep rate
Hertz	sweep	frequency
slope	manual	continuous
pulse rate	frequency	

BENCH POWER SUPPLY

Finally, the bench power supply should be treated so that sub-systems and circuits can be examined alone, out of the system. After completing this initial study of the bench power

supply the student should be able to adjust and connect it to any circuit terminals with the correct level and polarity. Terminology encountered includes:

milliamperes	capacity	positive	negative
volts	ground	ripple	AC DC
level	current	polarity	
short circuit	current		

OTHER INSTRUMENTS

The other instruments found in the laboratory are chosen by the instructor for inclusion in this study. However, the analog meters, curve tracer, and bridges are recommended. Once again, the terminology encountered must always be kept foremost in mind. For example, the analog meters involve terms such as:

milliampere	microamperes	multipliers
db	zero	lead
range	AC	scale
ohms	DC	linear
amperes	non-linear	volts
reset		

SUGGESTED SYSTEMS TO STUDY

Introduction to Electronics Technology sequence, if it is to offer the "Big Picture", should be built around approaching electronics from a systems view-point. The objective is for the student to realize that all systems are composed of sub-systems with discrete functions that, when added together, result in the total system function. Furthermore, it needs to be realized that there are only about two dozen of these sub-systems and that the way they are interconnected determines the system function.

Possible systems to study might well include:

- Public address system
- A.M. receiver
- T.V. receiver
- Motor speed control
- Receiver-transmitter
- Closed circuit monitoring system

Automated sequence control system
Light actuated control systems

BREAKING SYSTEMS INTO SUB-SYSTEMS

An example of how these systems might be broken down into sub-systems and sequenced is presented here for purposes of illustration.

1. P.A. System [First System Studied]
 - a. Transducers)
 - b. Pre-amp)
 - c. Power amp) Sub-Systems and
 - d. Power supply) Circuits
2. A.M. Radio Receiver [Second System Studied]
 - a. Transducers)
 - b. Tuner)
 - c. Oscillator)
 - d. Mixer)
 - e. I.F. amp)
 - f. Detector) Sub-Systems and
 - g. Pre-amp) Circuits
 - h. Power amp)
 - i. Power supply)

Note that in this 2-system sequence, when the student looks at the A.M. radio receiver he already is familiar with the loudspeaker as a transducer (a), and that he is familiar with the pre-amp, power amp, and power supply (g, h, i). He now can direct his attention to the 5 new sub-systems and how they fit into the system. This second system should be followed with another that incorporates both new and familiar circuits.

Terminology encountered when examining systems includes:

signal processing	block diagram	response time
input	output	transducer
schematic	power flow	feedback
cascading	symbols	

(Remainder depends on systems used)

SUMMARY OF BASIC SUB-SYSTEMS

The sub-systems that make up the bulk of



electronic systems are outlined below. The aim of this study is for the student to learn the function of each sub-system on a qualitative basis and be able to identify the signal processing function of each.

Sub-Systems

1. Power Supplies

- a. rectifiers
- b. filters
- c. bleeders
- d. regulators
- e. power supplies terminology
 - voltage regulator
 - transformer
 - filters
 - bleeder
 - half wave
 - ripple
 - metallic

- filter capacitor
- rectifiers
- choke
- center tap
- full wave
- bridge
- regulators

2. Amplifiers

- a. D.C.
- b. power
- c. small signal
- d. AF-RF-IF
- e. cascaded
- f. tuned (Do frequency doubler here)
- g. Amplifiers terminology
 - frequency responses
 - D.C.
 - RF IF
 - tuned
 - bias
 - input Z
 - distortion

- small signal AF
- power
- cascaded
- coupling
- gain
- output Z

3. Oscillators (Feedback and Switching)

- a. sinusoidal
- b. rectangular (Multivibrators)
- c. triangular
- d. oscillators terminology
 - phase shift
 - multivibrators
 - Colpitts
 - blocking
 - cut-off

- crystal
- bootstrap ramp
- frequency
- Hartley
- Miller
- switching

- saturation
- pulse rate
- falltime
- Feedback (regeneration and non-regenerative)
- risetime
- astable

4. Logic Circuits

- a. AND, OR
- b. NAND, NOR, NOT
- c. counters
- d. logic circuits terminology
 - AND; OR, NAND, NOR, NOT
 - monostable
 - octal
 - matrix

- shift register
- bistable
- decimal
- register
- binary

5. Wave Shaping Circuits

- a. differentiators
- b. integrators
- c. clampers
- d. clippers
- e. others
- f. waveshaping terminology
 - differentiation
 - integration
 - clammer
 - initial value
 - positive peak
 - area

- asymptotic value
- exponential
- clipper
- DC level
- negative peak

6. Special Purpose Sub-Systems

- a. mixers
- b. time programmable switch
- c. magnetic circuits
- d. other
- e. special purpose sub-systems terminology

Terminology depends upon those sub-systems included in the study.

COMPONENTS

In dealing with components in the Introduction to Electronics Technology sequence, the goal should be for the student to be able to identify and to demonstrate a qualitative understanding of the function of each. A listing of suggested components and associated

terminology follows:

1. Resistors

a. types

1. carbon composition
2. wire wound
3. pinch (mos technology)

b. ratings and tolerances

c. color code and std. sizes

d. pots and rheostats

e. resistor terminology

deposit film	multi turn pots
carbon	wire wound
pinch	tolerance
wattage	pots
rheostats	linear
taper	color code
leads	terminals

1. multiplier

2. Capacitors

a. types

1. ceramic
2. paper
3. electrolytic
4. others

b. ratings

1. DCWV
2. temperature

c. sizes

d. capacitor terminology

non-polarized	electrolytic
plates	dielectric
ceramic	mica
paper	mylar
tantalum	DCWV
polarized	farad
ufd	tuner
surge	padding
breakdown	leakage
trimmer	pf

3. Inductors

a. types

b. applications

1. filters
2. R.F.
3. etc.

c. inductor-associated terminology

tumblewound	bifilar wound	filter
millihenry	DC current	choke
swinging	ripple	henry
RF	DC ohms	Q

4. Transformers

a. power

b. audio

c. pulse

d. transformer terminology

voltage ratio	add currents	audio
primary	secondary	k
turns ratio	power ratio	M
power	transistor	pulse
step-up	step-down	coupling
core less	copperloss	
hysteresis		

5. Transducers

a. electrical to mechanical

b. electrical to heat

c. electrical to light

d. electrical to sound

e. electrical to chemical

f. transducer terminology

Depends on the type used, however, a partial list follows:

thermocouple	thermistor	strain gauge
speaker	microphone	photodiode
photocell	etc.	etc.

6. Devices

a. transistors

b. diodes

c. metallic rectifiers

d. vacuum tubes

e. device terminology

capacitance	saturation	barriers
collector	emitter	base
curve	input	output
junction	breakdown	cutoff
potential	V_{cc}	V_{ce}
common	NP	V_{be}
filament	stability	knee
vacuum	metallic	PN
epicap	Zener	tunnel

bias (forward, reverse)

resistance

7. Motors and Generators (easy does it)

HARDWARE

The hardware encountered in the electronic industry can be very formidable to the new electronics student. The reason for a study of basic hardware is to familiarize the student with the basic techniques and gadgets used to support and package electronic systems, sub-systems and components. A partial list of possible hardware follows:

Hardware:

board construction	component mounting
sockets and bases	fuses switching
wire and sizes	heat sinks
breadboarding	fasteners
soldering	connectors
chassis construction	
vector board and systems	

Hardware terminology:

silkscreen	connectors	fahnestock
soldering	pan brake	photoetch
twin line	heat sink	RCA phone
alligator	nibblers	phillips
nuvistor	switches	military
terminal	breakers	sockets
solder	layout	banana
vector	inline	type N
screw	round	board
resin	shear	phono
9 pin	novar	fuses
phone	7 pin	NASA
flux	lead	etch
coax	tin	pan
BNC	UGS	
cold solder	punch rivets	photo resist
inline decal	UHF connector	
circular mills	heat application	
4.40, 6-32, 8-24 nuts		
etc.		
etc.		
etc.		

CONCEPTS

In addition to familiarization, the *Introduction to Electronics Technology* sequence should also convey certain concepts. List of these concepts follows:

Concepts:

- a. voltage as a force
- b. current as a resultant
- c. instantaneous quantities
- d. waveform descriptions
- e. gain
- f. attenuation
- g. time delay
- h. distortion
- i. modulation
- j. demodulation
- k. feedback
- l. frequency spectrum
- m. frequency response
- n. harmonics
- o. $\text{freq.} = \frac{1}{T}$

This introductory sequence, in order to provide a view of the "Big Picture" of electronics, should offer the student a view of the work of the technician. This kind of material can be handled through the use of field trips, discussions, seminars, movies and visiting lecturers. Examination of this area enables the student to make a more effective choice in terms of his own career plans.

SPECIAL SOURCES OF INFORMATION

Among the assorted materials and handouts needed in order to supplement the class and laboratory materials are schematic diagrams and block diagrams of the systems studied, circuit diagrams of the sub-systems, and catalogs to be used to familiarize the student with hardware, components, and systems.

A partial list of sources may be found in the appendix.

ILLINOIS CENTRAL COLLEGE REPORT*

The Introduction to Electronics Technology course is taught during the first quarter or semester depending on the school plan. It parallels Resistive Circuits in the semester plan and precedes it in the quarter plan.

To paraphrase the movie makers of today, possibly a more appropriate name for the course would be "The Big-Picture;" or better yet since a primary objective of the course is to acquaint the student with the field of electronics technology, "The Big Picture of Electronics."

One of the age-old problems of two-year technical schools has been to package the necessary topics and materials into a two-year period. At the same time we are faced with the problem of how to organize the courses as well as the course sequence so as to be most effective. Keep in mind that we need the student to be aware of "where he is going" while progressing through this two-year sequence. Logic seems to dictate that we should begin with an overview of "what is to come."

Therefore, the objectives for the course are:

1. To provide the student with an opportunity to observe electronic circuits in operation and waveforms associated with them as well.
2. To familiarize the student with professional electronics test instruments.
3. To generate within the student an "appreciation of" and "interest in" ELECTRONICS TECHNOLOGY.

The first few sessions are devoted primarily to the measurement of current, voltage, and resistance. This segment of the course should be as brief as possible, and one should move on to the electronic circuits which are

to be investigated. Plenty of opportunities exist to measure E, I, and R while investigating electronic circuits. At this point, let me emphasize that instruments should be introduced as they are needed to analyze the function of electronic circuits and components. For instance, the oscilloscope should be introduced when it is needed to measure v_o of an electronic circuit. With this approach, students tend to regard instruments in their proper perspective; i.e., as useful and necessary tools for investigation and analyses rather than something with which to play.

Now comes the WHAT, WHY, and HOW; that is, what will we be studying, why will we be studying it, and how will we make the investigation.

The first objective, as stated earlier, is to provide the student with an opportunity to observe functional electronic circuits and waveforms associated with them; as well as, how they are used collectively to form systems. One could use either of two approaches in meeting this objective. First, a *circuit-to-system* approach. The student is introduced to circuits on an individual basis and finally studies them collectively as a system. He has little idea of what system the individual circuits will eventually make. Secondly, a *systems-to-circuits* approach. This approach seems natural since students are used to seeing systems such as radios, televisions, cartridge players, etc. Initially, the student investigates the system and gains "insight to" and "appreciation of" its overall function and purpose. Next he analyzes the individual circuits of the system by investigating input-output waveforms and/or volt-

*Prepared by Robert T. Wilson, Coordinator of Electronics, Illinois Central College, East Peoria, Illinois and presented at Electronics Technology Conference, February 26, 1970. Mr. Wilson is a member of the Steering Committee.

ampere characteristics. He then can connect the system again and observe its operation for the second time. At this point I believe that I should define a term which I have been using in this presentation. I define a "system" as being a group of electronic circuits which have inputs and outputs which are usually non-electrical. A motor speed control would be a good example as would an electric garage door opener where a button is pushed and the response is mechanical, i.e., for a door to open. Some individuals involved in the project prefer the term "sub-system" instead of "circuit." The systems to circuits approach provides the opportunity to use a closed loop educational technique as follows:

- A. Study of the functional system
- B. Study of circuits
- C. Study of the functional system

I view the systems to circuits approach as being the more valuable method for these reasons:

1. Places an operative system before the student prior to investigation of the individual circuits (or building blocks).
2. Tends to hold student interest better than circuits to systems approach.
3. Allows the student to relate the individual circuits back to the system as he is studying it.

How do we implement the study, that is, what materials will we need and so on? The method of implementation will depend upon two primary factors:

1. What type of system the school operates on, that is, the quarter system or the semester system.
2. On the individual instructor's preference.

Experience has taught us that this course can be taught effectively with fifty to sixty clock hours. If five hours per week (four lab, one lecture) are devoted to this course on the quarter system or four hours per week (three lab, one lecture) on the semester plan, we have our necessary hours. Some instructors who use

highly developed hardware systems claim they teach the course in approximately forty clock hours. The lab-lecture hours ratio clearly indicates that this is a "HANDS-ON" lab-oriented course. The majority of the learning takes place in the lab rather than outside of class through the use of written materials.

Hardware used in the course depends on instructor preference and availability of materials. Some instructors prefer to use discrete components and have the student assemble and tear down each circuit. Others prefer to use circuits already on breadboards or built in boxes where minimal amount of time is devoted to set-up and teardown. Certainly each method has its advantages.

David Peterson of the Project Staff recommends that a set of circuits be constructed in individual metal boxes whereby students can build systems by plugging boxes together. After analysis on the systems basis, this plug arrangement lends itself to individual plug investigation. That is, each plug could be studied on an input-output basis when connected to the power supply plug. While this approach might not be feasible for each system studied, it would aid the student in developing the systems to circuits approach. Plug-in or plug together hardware systems which might be used for parts of this course are becoming more readily available. Others involved in the project recommend the fabrication of breadboard circuits. These circuits, too, can be connected as systems for initial investigation and then studied on an individual basis.

Thirdly, and initially the easiest method would be to use discrete components in laboratory investigations. This method obviously is more time consuming but has other equally apparent advantages.

The instructor may desire to use more than one of these hardware systems in laboratory investigations. As time allows, however, we recommend that as many systems as

possible be built for the students. Once you have settled on one or more of the hardware systems for laboratory use you may then give attention to laboratory investigation. I believe that emphasis on laboratory investigation should be on a qualitative basis rather than quantitative. There is need for only a small amount of quantitative analysis. Let the student first look at a system and observe its overall function and he will then be eager to investigate the individual circuits of that system. Investigation of individual circuits will consist primarily of the observation of input and output waveforms. Students can also vary circuit components and observe the resulting change in time varying waveforms.

We have found a great deal of materials for use in this class. You will find industries extremely cooperative in providing schematic and block diagrams for study. Due to the nature and scope of this course, it has not been any surprise to us that we have not found what we consider an appropriate textbook. Most student materials for this course are *hand-outs* which guide the student in his investigation. Let me emphasize that I believe that each investigation or experiment should be highly structured but yet not be a step-by-step directive.

You may be wondering by now just what building blocks can be investigated in a course such as this. As an example, let me discuss with you the topics which Ray Engelland of the Willmar Area Vocational Technical Institute, Willmar, Minnesota, covers in his Introduction to Electronics Technology course. Ray requires the students to proceed through the first four of these topics in the order shown. Once they have finished the first four topics, they are free to complete the remaining lab topics in order of their choice. Most of us involved in the project are using a list of topics similar to Mr. Engelland's.

1. Electronic Voltmeter (voltage and resistance)
2. Multimeter (voltage, resistance, and

- current).
3. Oscilloscope (peak and peak-to-peak voltage)
4. Audio frequency generator (sine and square waves)
5. Half wave rectifier (no filter)
6. Full wave rectifier (no filter)
7. Full wave and half wave rectifier (with filters)
8. Lo voltage doubler
9. DC voltage amplifier
10. AC voltage amplifier
11. Paraphase amplifier
12. Push/Pull power amplifier (mike and speaker)
13. Relaxation oscillator
14. Hartley oscillator
15. Colpitts oscillator
16. Phase shift oscillator
17. Blocking oscillator
18. Unijunction oscillator
19. Astable multivibrator
20. Monostable multivibrator
21. Bistable multivibrator
22. Clocked Set/Clear flip/flop
23. Miller Run up circuit
24. Schmidt trigger
25. Triac control circuit
26. Time delay relay
27. Light operated relay
28. Limiters
29. Clampers
30. Electronic Counters

Systems studied in Introduction to Electronics Technology should be as simple as possible and relevant to student interest. For instance, I like to use the *Time Programmable Electronic Switch System* for the purpose of introducing the student to UJT and SCR devices.

Immediately the student can see the purposes for the system and, therefore, develops an interest in studying the individual circuits involved in the system. The student's interest is aroused when he sees the system operate initially, and he may want to fabricate

a simple system such as this one on his own outside the classroom. Here is an example of a system which one of my beginning students constructed on his own while enrolled in Introduction to Electronics Technology. He cut the PC board and wired the circuit of this *Time Programmable Electronic Switch System*. I did not know that he was working on the system until it was nearly completed and he showed it to me. Needless to say, this young man profited from the course and is doing well in the second semester of his freshman year.

You may have guessed by now that we feel this is the *NUMBER ONE* course in the entire curriculum. We believe it must be *NUMBER ONE* for several reasons:

1. It can provide a common background for students in all electronic programs.
2. Gives the student a preview of what is to come in later courses.
3. Keeps them coming back; that is, it will help to interest and motivate

- students who you might otherwise lose.
4. Provides opportunity for vocational guidance through the use of field trips, films, listening to technicians speak about his job in industry, etc.

And finally, the most important key to success in this course is the instructor. He must be enthusiastic so as to excite the student about electronics. The instructor must be convinced that he is teaching the most important course in the curriculum. He must choose hardware and software which provides him with the greatest teaching effectiveness. Introduction to Electronics Technology provides him with an excellent opportunity to work closely with students and to develop that ever necessary characteristic of rapport. Many things can be done to interest students - quite obviously limited only by the instructor's imagination. After teaching the course three times, I am firmly convinced of the value of Introduction to Electronics Technology in this electronics curriculum.

WILLMAR AREA VO-TECH INSTITUTE REPORT *

The INTRO course as taught at Willmar Area Vocational Technical Institute is entirely a lab oriented course. The introductory information and demonstrations are made in the laboratory area. The laboratory, the printed instructor-prepared information sheet, and the reference material make up the contents of this course. The basis of this course is to give the student an opportunity to use the "hands on" approach to learning some general concepts of electronics. The major objective of the course is to provide the students with an opportunity to observe the operation of a group of practical popular circuits which are the building blocks of all electronic systems. This particular system is used in an attempt to provide incentive, motivation, interest, and curiosity in the field of electronics. The course is taught simultaneously with a separate course in circuit analysis. The color code, soldering, use of basic hand tools is covered in the lab section of the circuits course. There is no particular reason for approaching it in this way and I am sure there are better approaches. It just happens to be the way that we do it. No attempt is made to study the complete theory of operation of any of the circuits at this stage in the student's development. The student will have an opportunity to study the individual circuits in depth in the other courses which follow.

Keeping in mind that the student that enrolls in our program is there because he feels that he is interested in electronics we attempt, through a course such as this, to nurture and develop that interest.

The experiments in this series as used at our institution are written around the material that was available in our lab. Each lab has some of the components and circuits which are around but not being used. We happened to have a complete set of demonstration equipment along with student trainers. The circuits and panels are used as the basic hardware for the course.

We feel that all circuits should be built for the student to avoid spending 3/4 of every lab session building up and tearing down circuits.

The experiments except for the first four can be taken in any order so the student can be rotated by the hardware. There are a few of the experiments or experiences, in which a sequence is desirable but not absolutely necessary for success of the program.

The experiments all follow basically the same format which we feel gives the student an opportunity to progress without a great deal of conflict. The format is a part of the teaching technique that is based on the idea of keeping the student interested. We do not feel that it is necessary to "entertain" the student with gadgets. However, we do think that the student must be given experiences that will interest him and hopefully motivate him to further study of the subject. The format that we have found successful in our situation basically starts by telling what the device or circuit is, what it does, where it is used, how it is used, the circuit diagram showing all of the strategic points in-

*Prepared by Ray A. Engelland, Electronics Department Chairman, Willmar Area Vocational-Technical Institute, Willmar, Minnesota. Mr. Engelland is a member of the Project Staff. His report represents one of the first efforts to organize and operate a complete course on the concept of an *Introduction to Electronics Technology* course.

cluding expected waveforms for voltage, how it works in very qualitative manner, which components or parameters are variable, the operating procedure (called get the circuit working), changes in conditions or parameters to allow observance of the circuit or device behavior, listing references where additional information can be obtained, and conclusions for the student to complete.

The following is the list of experiments and the general order in which these experiments are completed by the students.

1. Electronic Voltmeter (voltage and resistance)
2. Multimeter (voltage, resistance and current)
3. Oscilloscope (peak and peak to peak voltages)
4. Audio frequency generator (sine and square waves)
5. Half wave rectifier (no filter)
6. Full wave rectifier (no filter)
7. Full wave and half wave rectifier (with filters)
8. Lo voltage doubler
9. DC voltage amplifier
10. AC voltage amplifier
11. Paraphase amplifier
12. Push/Pull power amplifier (mike and speaker)
13. Relaxation oscillator
14. Hartley oscillator
15. Colpitts oscillator
16. Phase shift oscillator
17. Blocking oscillator
18. Unijunction oscillator
19. Astable multivibrator
20. Monostable multivibrator
21. Bistable multivibrator
22. Clocked Set/Clear flip/flop
23. Miller Run up circuit
24. Schmidt trigger
25. Triac control circuit
26. Time delay relay
27. Light operated relay

28. Limiters
29. Clampers
30. Electronic Counters

The electronic voltmeter (VTVM) is the first item on the list and is covered first for two reasons; the VTVM is not a difficult instrument to operate and is very forgiving of reversed polarities, over ranging and will not be damaged if a voltage is impressed across it when on the resistance scale. The basic instrument is used to measure A.C. and D.C. voltage and resistances. The source for A.C. and D.C. is a line isolated voltage divider and an assortment of batteries. The resistors used vary from a piece of nichrome wire to resistors mounted on plastic mounting boards. The size of all components and voltage are listed on the components and the source so the student learns to read the instrument only at the point.

The multimeter (VOM) is used with the same sources in the second experiment; however, the student breaks the voltage dividing chain to measure the current flow through resistances. This experiment has not been well accepted and we suspect the reason is because it is so similar to the first one that only one new concept is brought out, which is current measurements.

The oscilloscope is always interesting to the student and it can be a tremendous teaching tool. Here, we tell the student very qualitatively how the oscilloscope works. The material in the hand-out will get the trace stopped on the scope screen for the student and lead him through a sequence of steps designed to teach the operation of a simple sweep oscilloscope. The source for this experiment is a line isolation voltage through a voltage dividing network to provide the signal at different levels. The concept of peak-to-peak and peak voltage is conveyed at this point by showing a meter reading and an oscilloscope reading at the same time.

The experiment on the Sine and Square Wave generator should be combined with the one on the oscilloscope so that it could be used as a source to excite the scope. The students are given the opportunity to hear and see audio frequencies in this experiment.

The half-wave rectifier is the first real practical circuit for the student. The half-wave rectifier has an additional switch which opens one side of the transformer of a full wave supply. The student in this experiment has the opportunity to create pulsating D-C and to measure the peak value with an oscilloscope as well as measuring the D-C value with a meter. The student is given a diagram of the circuit in use and the diagram shows all of the switches, transformers, semiconductors, etc.

The full-wave rectifier uses the same hardware as the half-wave, only this time the switch is closed to complete both sides of the power supply. The procedure of this experiment is the same as for the half-wave except the student is asked to compare the results of the two and come up with some conclusions.

The full-wave rectifier circuit is now used and three different types of filter circuits (along with bleeder resistors) are attached to the basic power supply. These filters are then loaded with a resistance to show the effect of ripple. The concept of ripple content by measuring the A-C component is introduced at this point.

The doubler circuit is a very interesting experience for the student. We use a 6.3 volt filament transformer as the source of A-C because we like to keep safe levels of voltage. The student is only shown that voltage doubling is possible and the secret of its operation is the addition on stored charges. The tripler is built up as well so the student gets an opportunity to look at a tripling circuit. The diagram of the quadrupler is shown also, simply for an interest creator.

The D-C amplifier is a simple transistor on a heat sink (we use a 2Nk70) with a circuit all attached to show D-C voltage amplification. The

transistor is merely connected to a 12 volt source and the voltage is varied on the base through a voltage divider bias arrangement. This keeps the transistor operating about in the middle of the active region. A banana jack is located at the collector to monitor collector voltage. No attempt is made here to explain saturation or the active region but cutoff is defined and demonstrated. Visual cutoff is achieved by using a light bulb in series with the collector load.

The amplifier used in the D-C voltage amplifier is used in the A-C amplifier experiment; only a simple R-C circuit along with a sinusoidal and square wave source is applied. The different subjects including phase shift are shown and defined in this experiment. The input is increased in amplitude to drive the transistor into saturation and the concept of saturation is then explained qualitatively after applying both sine and square inputs to the circuit; the source is removed and a D-C level is applied and the blocking effect of the coupling capacitor is shown.

Because some circuits require output which are equal in amplitude and 180° out of phase, the paraphase amplifier is introduced next. Here the difference in phase of the two outputs is illustrated and the student is allowed to vary both emitter resistor and collector resistor within limits in order to illustrate the different amplitudes of output that can be obtained.

The push-pull amplifier follows the paraphase amplifier nicely because it requires a paraphase input. The amplifier used here is the paraphase amplifier used in Experiment 11 and a push-pull power amplifier. The output is connected to a speaker and the input to a microphone. The student is allowed to see and hear his voice or a tone, whatever is available. The student really thinks this is great.

The relaxation oscillator using a neon bulb, an RC combination and a D-C power source has a fascination for students in that they can

vary frequency of the flashing light and are able to see D-C transformed into ramp voltage via the neon tube relaxation oscillator. We use a variable resistance in the resistor leg for the purpose of giving a variable parameter. The explanation can be very qualitative and the simple circuit is very fascinating for the student. This circuit lends itself to some nice calculations when discussing single time constant circuits at a later time.

The two experiments on the Hartley and Colpitts oscillator should be combined into one experiment. The oscillators are both LC oscillators and are so much the same except for feedback technique that it is hard to justify two separate experiments for them. The variable parameters here are the L and C of the "tank circuit." The other component that may make some changes here are best left untouched as they tend to stop oscillations or create some questions that are difficult to answer with the students at this stage of the game.

The phase shift oscillator is used in the conventional way. It has a variable power supply to vary the frequency and amplitude. The student is exposed to feedback in a different manner than before and should realize the importance of the device.

A blocking oscillator of the damped single swing type is used for the next experiment. This device is readily adjustable in frequency of pulse as well as frequency of the swings. The student here has the opportunity to observe that he can change the PRF without affecting the size of his pulse or he can change the size of the pulse and not affect the PRF.

The unijunction oscillator is used to show the student another method of creating a sawtooth or a ramp type of waveform. The use of the unijunction transistor for this oscillator also provides the student with the concept of timing by the RC component. This experiment utilizes a modified panel so that different combinations can be used.

The astable multivibrator experiment can be

a success or failure depending on the approach. The first time we used the astable experiment it fell flat because we were trying to do too much with it. We then added a lamp in one leg of the astable circuit and the student was asked to adjust the frequency of flashes to the point that the circuit would just oscillate. The scope was then attached and the frequency was measured. The student is then asked to increase the frequency until the bulb just appears lighted continuously. The scope is again applied and the student is asked to measure the frequency. The concept of voltage levels and waveforms other than sinusoids and ramps can be introduced with this device.

The monostable multivibrator is not as exciting as I would like it to be and I feel the only thing that is shown is the pulse width change that can be accomplished with it. The concept of pulse stretching and reshaping is introduced here: We feed this circuit with both a single swing blocking oscillator and a spike voltage. This circuit which is of great practical value has been tough to sell to the students.

Bistable multivibrators or flip/flops are interesting if the student will use some judgment. This particular experiment utilizes a wired board with a very simple bistable circuit on it. The student has an opportunity to see the light switching on and off as the unit changes state. We run the student around the circuit using different triggering techniques to show the student that he can cause the circuit to change state by a multitude of methods.

The clocked set/clear flip/flop introduces the concept of two input-signals required to change state and also makes the student aware that these circuits can be timed or enabled by simultaneous signals. This flip/flop, as well as the bistable in the previous experiment, is monitored by lights and the oscilloscope or multimeter whichever the student prefers.

The Miller run-up sweep circuit has been a difficult circuit to work with in getting any

accuracy from it. The adjustment is very critical because we have attempted to vary the cross resistance in order to vary the linearity of the sweep. The adjustment seems very critical and I don't feel the headaches of the thing are worth the rewards.

The Schmidt trigger or voltage level discriminator experiment may not seem essential because it is really a modified bistable circuit. However, I feel the Schmidt trigger which will produce a uniform voltage level out as long as the input voltage is above a certain level is just another of the wonders of electronics. The students here use different input voltages. The use of a function generator here would be extremely helpful.

The next experiment uses a triac control circuit which is essentially a lamp dimmer or motor speed control. The student in this experiment is asked to monitor the output voltage as the variable resistance is run through the range. The concept that this circuit is controlled by an RC time circuit is introduced. One might also like to introduce effective and RMS voltages with this type of device. This device works very well for the driving source for the Schmidt trigger circuit.

The time delay relay is another circuit that utilizes the RC time idea and also brings in relay control. By using a small power supply we are able to control 110-volts A-C through a light bulb load. The student varies the time by varying the size of the resistor in the base circuit of a transistor.

The same circuit used in experiment 26 is used again in No. 27 only a photocell with an additional amplifier is used ahead of the relay current to show the techniques of the light sensitive relay. The student using a dimmer and light shield here is able to monitor the different intensities of light by monitoring the collector voltage of the first transistor. This amplifier and photocell combination is used in a later experiment with counters.

The two experiments on limiters, clippers

and clampers are so similar and self explanatory the experiment is begun by using an AF generator, one diode, and a resistor. The diode is reversed, then the parallel circuit is introduced followed by the biased clipper, the negative and positive clipper and finally the DC restorers or clamping circuit. The progression here is merely to show the different effects the circuit can produce. All voltages are made and are varied to show different clamping levels.

The last experiment in the series is the electronic counter experiment. This experiment uses 4 bistable circuits connected as a binary counter. The inputs used are the square wave generator and the light sensitive circuit mentioned and utilized in experiment 27. The frequency of fluorescent light is measured in binary numbers. If the student can visualize connecting more than four bistable circuits together, this reading can be made directly.

The development of this program was accomplished primarily through the efforts of two second-year students with guidance from the instructional staff. The experiments, as indicated previously, were constructed around what was available in our labs at the time. A few of the circuits had to be built on printed circuit cards. Some of the simpler circuits could be bread-boarded by a lab assistant in advance if necessary for the student. The circuits and work sheets of this type of course need not be fancy but they should be accurate and checked out in advance by some one who is competent. There is nothing more frustrating to a student than a circuit that does not operate when turned on.

GETTING STARTED WITH THE INTRO COURSE

PROJECT NO. 1: SHOWING AN INTEREST IN STUDENT AND HIS JOB OPPORTUNITIES

A student questionnaire as used at Parkland College, Champaign, Illinois is of sufficient value in establishing student-staff relationships to reproduce here.

The Student Questionnaire in Beginning Electronics

Listed below are some questions which would be helpful to the Electronics Technology Department at Parkland College. By answering these questions we at Parkland College will be better able to help you meet your goals. The way you answer these questions will in no way affect your grades and all answers will be confidential. This questionnaire can be of the most benefit to you if your answers are completely honest.

Write the letter of the answer that best applies to you in the space at the left, or write in your own answer if those listed do not apply. If two answers apply equally well, both may be indicated.

1. How did you learn about the electronics technology program at Parkland College?

- a. Through my high school counselor
- b. Through my high school math or science teacher
- c. Through the newspaper
- d. Through a friend

Other _____

2. Where did you live during the greater portion of the last five years?

- a. In the city limits of Champaign-Urbana
- b. In a near-by city
- c. On a farm
- d. In the country but not on a farm

Other _____

3. What do you expect to do after finishing at Parkland College?

- a. Work as an electrician wiring houses
- b. Repair radio and television sets
- c. Design electronic equipment
- d. Work with electronic equipment for a large company
- e. I do not know

Other _____

4. What experience or courses have you had in electronics?

- a. None
- b. Built some kits or other projects
- c. Worked as an electronics technician for industry
- d. Worked as an electronics technician in the military

Other _____

5. Why are you choosing the electronics technology program?

- a. I believe this program will result in a good-paying job
- b. I have an interest in electronics
- c. I have no special reason but I must do something

Other _____

6. What do you think might be your greatest hindrance to successfully completing this program at Parkland?

- a. Lack of interest in the subject material
- b. Lack of enough money
- c. No good place to study at home
- d. Not able to do the work

Other _____

7. What is the attitude of your parents toward the program you are entering at Parkland College?

- a. They are pleased with the program I am entering
- b. They are neither for nor against my taking this program
- c. They know very little about the program I am entering

Other _____

8. What is your attitude toward attending college?

- a. I expect to graduate from a four-year college or university
- b. I expect to graduate from Parkland
- c. I am not sure about what I want to do

Other _____

9. Who decided that you would enter this program at Parkland College?

- a. I did alone
- b. I did with my counselor's advice
- c. I did with my parents' advice
- d. One or both parents decided for me
- e. My counselor decided for me

Other _____

10. What is your present occupational status?

- a. I am working full-time
- b. I am working part-time
- c. I am unemployed
- d. I am a full-time student

Other _____

11. If you are employed, please answer the following two questions.

Where are you employed? _____

What type of work do you do? _____

(End of Questionnaire)

JOB OPPORTUNITIES

Discuss with the students the role of technicians, their classifications and their job opportunities. Show, or promise to show at a later time, some industry films (if available) appropriate for electronic technicians. The following outline suggests topics for these discussions.

A. Engineering Manpower Team

- 1. Scientist
- 2. Engineer
- 3. Engineering Technician
- 4. Industrial Technician
- 5. Skilled Labor
- 6. Non-skilled Labor

B. The Engineering Technician's Role and the Role of Industrial Technician

- 1. Differences in Emphasis in Training
 - a. Math
 - b. Science
 - c. Formal Analysis
 - d. Design
 - e. Trouble Shooting
 - f. Repair and Fabrication
- 2. Differences in Job Types
 - a. Cognitive-vs-Manipulative Skills
 - b. Crafts Oriented-vs-Engineering Oriented
 - c. Job Opportunities and Salaries

3. Role of Engineering Technician

- a. Engineering Support
- b. Engineering Aide
- c. Service Engineering
- d. Sales Engineering
- e. Design Support

4. Role of Industrial Technician

- a. Repair and Maintenance Technician
- b. Foreman
- c. Testing and Technician
- d. Quality Control and Inspection
- e. Prototype Technician

C. Places of Employment

- 1. Aerospace Industries (NASA)
- 2. Military Contactors

3. Computer Manufactures
4. Communications Equipment
5. Home Entertainment Industry
6. Industrial Control
7. Government Service
8. Automated Production
9. Telephone Companies
10. Railroads and Transportation

PROJECT NO. 2: DESCRIPTION OF THE COURSE
(CLASSROOM)

NOTE: These projects, by the number, are not to be interpreted as day-by-day assignments. Some projects may take less than a day while others may take more. Do not rush it, especially in the beginning. On the other hand, the instructor should not become too concerned about 100% performance in every little detail. Keep in mind, always, that this course is an *Introduction to Electronics Technology*. It is not a conventional type of a first course in electronics.

Following are some of the points that might be made concerning the content and philosophy of the course:

- a. We are concerned about electronic systems and *what* they will do.
- b. To get started, we need to learn how to use the instruments available to us in the laboratory.
- c. We need to become familiar with some of the hardware that we will use in the laboratory.
- d. We need to become familiar with the *language of electronics*. You will be given a glossary of terms from time to time as appropriate for the day. Keep these in your notebook for later references. Become familiar with these terms as quickly as possible so that you can begin to use them.
- e. We will be making measurements and some calculations but the mathematics

olved will be kept at a minimum so we can concentrate more on the purpose of electronics.

- f. Schematic circuit diagrams are employed as a major means of communication regarding any particular system or circuit. We need to learn how to read these diagrams, not in every detail in this course, but more in terms of the larger blocks.
- g. All electronic systems are made up of basic parts, or building blocks, such as amplifiers, filters, oscillators, rectifiers, sweep circuits and others. These are functional, or signal processing blocks. We will not become too involved with the internal parts (transistors, capacitors, resistors, etc.) of these functional blocks. We will become somewhat familiar with these parts. More thorough and detailed studies of discrete components are reserved for other courses of the curriculum.
- h. There are certain concepts that will be included in our studies here. Some of the more important concepts relate to knowing about voltage, current, resistance, frequency, gain, attenuation, feedback and waveforms, just to list a few. To know all about these concepts can, for some of them, lead to rather extensive and detailed studies. Again, such detailed studies as might be required are reserved for other courses. Here, we only wish to get a start in becoming familiar with certain concepts that will be of great value in our continuing education in electronics.

PROJECT NO. 3: LABORATORY ORIENTATION

Orientation to laboratory equipment and facilities starts in the first laboratory

session. The following outline is suggestive of the activities:

- I. Tour of labs
 - a. Discussion of equipment in each
 - b. General rules of housekeeping
- II. Basic Lab
 - a. Equipment at each station
 1. Oscilloscope
 2. Function generator
 3. H.V. power supply
 4. L.V. power supply
 5. VTVM
 6. VOM
 - b. Breadboarding facilities in drawers
 1. Board
 2. Mounted components
 3. Leads
 - c. Oscilloscope introduction (demonstration)
 1. Mainframe and controls
 - a. switch
 - b. scale illumination
 - c. intensity
 - d. focus
 2. Vertical and controls
 - a. position
 - b. volts/division
 - c. mode switch
 - d. calibrated position
 3. Horizontal and controls
 - a. position
 - b. time/division
 - c. mode
 - d. calibrated position
 - d. Oscilloscope orientation (Handout of glossary of terms)
 1. Students at each station locate controls
 2. Students list terminology
 3. Students turn down intensity
 4. Power on
 5. Intensity up 1/2
 6. Locate traces.
 7. Position traces

PROJECT NO. 4: VOLTAGE (CLASSROOM)

At this point, and especially for the INTRO course, it is important to concentrate on voltage and voltage waveforms. Do not talk about current. There is a definite "hang-up" to consider current before voltage simply because this would tend to require many other concepts such as Ohms law, resistance, closed circuits and sources. Stay with voltage and the terminology associated with waveforms, or voltages as a function of time. In a related laboratory activity, the student will have the opportunity to observe and study a number of waveforms on the oscilloscope.

Notes:

1. See next page for table of contents for Project No. 4.
2. On page 83 is a glossary of terms as prepared by a student in the INTRO course.
3. Pages 84 and 85 are student-prepared material on waveforms for Project No. 5.

I. Review of introductory materials

- a. Voltage as a force--E.M.F.
- b. Potential difference
- c. Resulting from imbalance in charge (q)
 1. Excess and deficiency of electrons
 2. Electro-static field
 3. Units - volt
 4. E, e, V, ϕ
 5. Double subscript notation
 6. Graphing voltage-vs-time

II. Voltage as a constant force (non-time-varying)

- a. DC
- b. Cells and batteries, power supplies
- c. Polarity
 1. Positive
 2. Negative

III. Voltage as non-constant force (time-varying)

- a. Non-repetitive
 1. Step (At $t = 0$, At $t = t_1$)
 2. ramp (slope)
- b. Repetitive (periodic) waveforms
 1. rectangular
 - a. square wave
 - b. pulses
 - c. amplitude (height, magnitude)
 - d. period - pulse-width
 - e. pulse-rate-frequency (repetition rate)
 - f. period-vs-P.R.F.
 - g. sources of rectangular waveforms
 2. triangular
 - a. triangular
 - b. sawtooth
 - c. sources of triangular waveforms
 3. Exponential wave form
 - a. original voltage
 - b. asymptotic voltage
 - c. resulting from special circuits
 4. Sinusoidal wave form (sine wave)
 - a. shape and polarity reversal
 - b. relationship to circle (generation)

- c. importance of usage and applications
- d. amplitude

(1) Peak (E_{max})

(2) Peak-to-peak

- e. period
- f. frequency
- g. period-vs-frequency ($T = \frac{1}{f}$)
- h. θ on horizontal axis
- i. ω on horizontal axis
- j. general expression for sinusoid
- k. $\omega = 2\pi f$
- l. phase
- m. effective value (.707 EM)
- n. average value (.636 EM)

5. altered sinusoidal wave forms

- a. half wave
- b. full wave
- c. A-M
- d. F-M

6. metric units

- a. mega - 10^6
- b. kilo - 10^3
- c. milli - 10^{-3}
- d. micro - 10^{-6}
- e. nano - 10^{-9}
- f. pico - 10^{-12}

IV. Voltage sources

- a. Generators
- b. Transducers (energy conversion)
 1. sound (microphones and speakers)
 2. light (photocell and bulb)
 3. heat (thermo couple and heating element)
 4. chemical (cell and plating)
 5. mechanical (piezo-electric and solenoid)
- c. Power supplies

Glossary of Terminology (Voltage)

Note to Student: The following list of terms is a list of the new words that we encounter in our study of voltage. You are to complete it, the best you can, before we leave our study of voltage and keep it in your notebook for inspection later. You will undoubtedly need to add others as we proceed.

RANDY WAHLFELD
Student

PARKLAND J.C.
College

NOV. 2, 1970
Date

Amplitude <u>Height of</u> <u>WAVE FORM</u>	Omega (ω) <u>GREEK LETTER</u> <u>FOR RESISTANCE</u>	Slope <u>RISE IN VOLTAGE</u> <u>PER UNIT TIME</u>
Amplitude Modulation (A-M) <u>VARYING AMPLITUDE (VOLTAGE) PORTION OF WAVE FORM</u>	Peak <u>HEIGHT OF POSITIVE</u> <u>PEAK-TO-PEAK HEIGHT OF</u> <u>ENTIRE WAVE FORM.</u>	Sources <u>DEVICES THAT</u> <u>PRODUCE EMF.</u>
Average Value <u>= 0.636 E_{MAX}</u>	Period <u>LENGTH OF ONE</u> <u>WAVE</u>	Square Wave <u></u>
Battery <u>PRODUCES ELECTRON</u> <u>FLOW BY CHEMICAL REACTION</u>	Photo Cell <u>CONVERTS LIGHT</u> <u>ENERGY TO ELECTRICAL ENERGY</u>	Step <u></u>
Cell <u>PRODUCES ELECTRON</u> <u>FLOW BY CHEMICAL REACTION</u>	Pi (π) <u>3.14, USED IN</u> <u>MATH CALCULATIONS</u>	Time-Varying <u>A NON-CONSTANT</u> <u>VOLTAGE</u>
Charge <u>A SURPLUS or DEFICIENCY</u> <u>of ELECTRONS</u>	Polarity <u>DIFFERENCE</u> <u>IN POTENTIAL BETWEEN PT.</u>	Thermocouple <u>CHANGES</u> <u>HEAT TO EMF.</u>
Constant <u>NON-VARYING</u>	Positive <u>A DEFICIENCY</u> <u>of ELECTRONS</u>	Theta <u>PHASE ANGLE</u>
E.M.F. <u>ELECTRO-MOTIVE</u> <u>FORCE</u>	Potential Difference <u>THE</u> <u>DIFFERENCE IN EMF IN A CIRCUIT</u>	Transducer <u>A DEVICE THAT</u> <u>CONVERTS MECH. TO ELECT.</u> <u>OR VICE VERSA</u>
Electro-Static Field <u>A</u> <u>DIFFERENCE IN POLARITY</u>	Power Supply <u>A SUPPLY</u> <u>of E.M.F.</u>	Voltage <u>UNIT of EMF.</u>
Energy Conversion <u>TRANSducer,</u> <u>CONVERTS MECH TO ELECTRICAL ENERGY</u>	Pulse <u>WAVE FORM</u> <u></u>	Waveforms <u>FORM of EMF</u> <u>ON OSCILLOSCOPE</u>
Exponential <u>WAVE FORM</u> <u></u>	Pulse Height <u>AMPLITUDE</u> <u>of PULSE</u>	E <u>UNIT of VOLTAGE</u>
Frequency <u>CYCLES PER SECOND</u> <u>PERIOD</u>	Pulse Rate Freq. <u>NUMBER</u> <u>of PULSES PER SEC.</u>	e <u>UNIT of VOLTAGE</u>
Frequency Modulation (F.M.) <u>VARYING FREQUENCY</u>	Pulse Width <u>TIME FOR</u> <u>ONE PULSE</u>	E _{ave} <u>0.636 E_{MAX}</u>
Full Wave <u>"CLIPPED UP"</u> <u></u>	Q, q <u>CHARGE</u>	E _{max} <u>PEAK VALUE</u>
Generator <u>A DEVICE USED</u> <u>TO PRODUCE A.C. EMF</u>	Ramp <u>RISE IN VOLTAGE</u> <u>PER UNIT TIME</u>	Kilo <u>1,000, 10³</u>
Half-wave <u>"CLIPPED OFF"</u> <u>RECTIFIED A.C.</u> <u></u>	Repetitive <u>A WAVE FORM</u> <u>THAT REPEATS ITSELF</u>	Mega <u>1,000,000, 10⁶</u>
Microphone <u>TRANSducer</u> <u>CHANGES SOUND WAVES TO ELECT.</u>	Sawtooth <u>WAVE FORM</u> <u></u>	Micro <u>0.00001, 10⁻⁶</u>
Negative <u>A SURPLUS of</u> <u>ELECTRONS</u>	Sine Wave <u>WAVE FORM</u> <u></u>	Milli <u>0.001, 10⁻³</u>
Non-repetitive <u>WAVE FORM</u> <u>DOESNT REPEAT</u>		Nano <u>0.0000001, 10⁻⁹</u>
		Phase <u></u>
		Sinusoidal <u></u>
		Solenoid <u>TRANSducer</u>
		Degree <u>360° PER SINE WAVE</u>
		Periodic <u>REPETITIVE</u>
		Asymptotic Value <u>THE VALUE</u> <u>A EXPONENTIAL WAVE FORM</u> <u>APPROXES BUT NEVER REACHES</u>



Project # 5

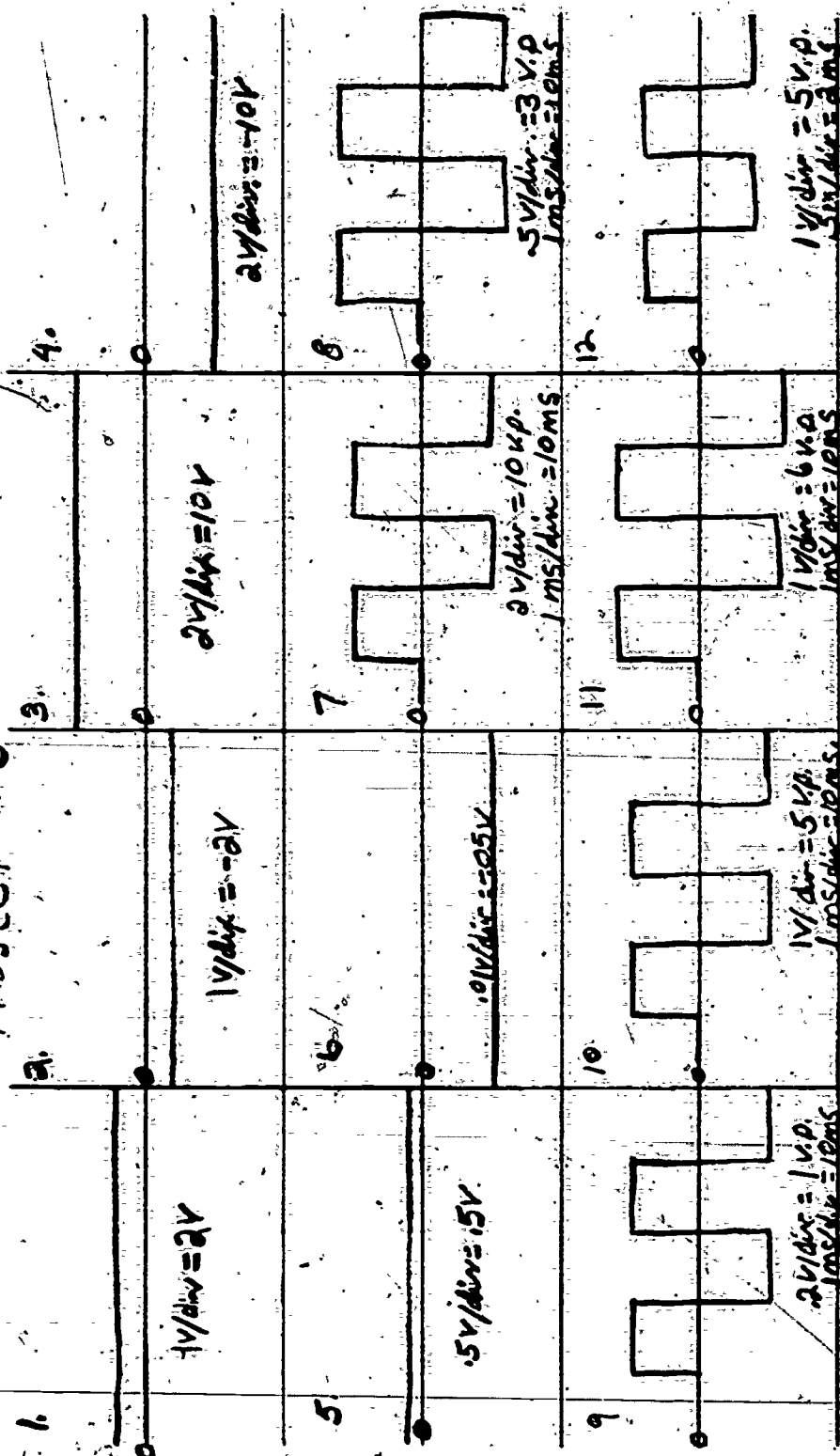

Project # 5

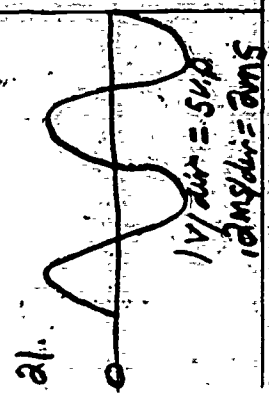
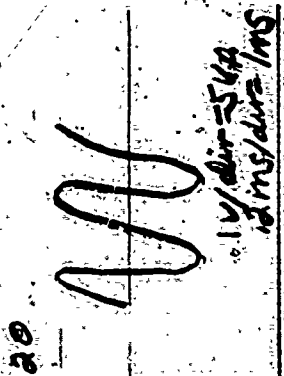
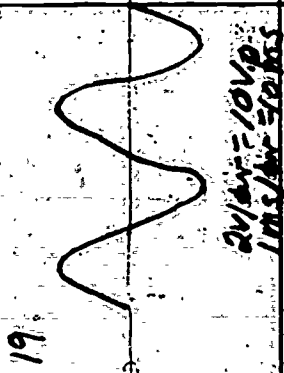
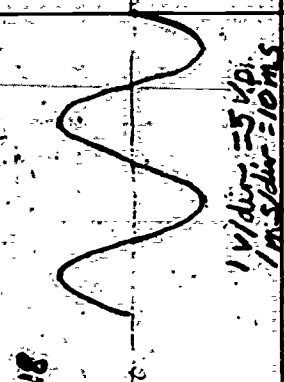
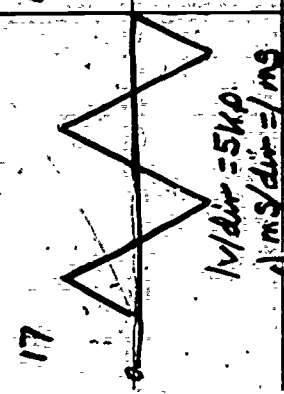
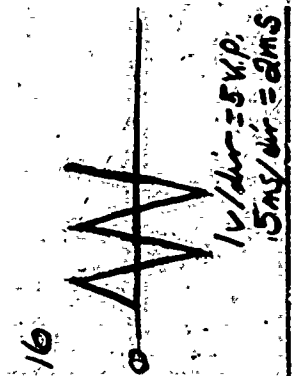
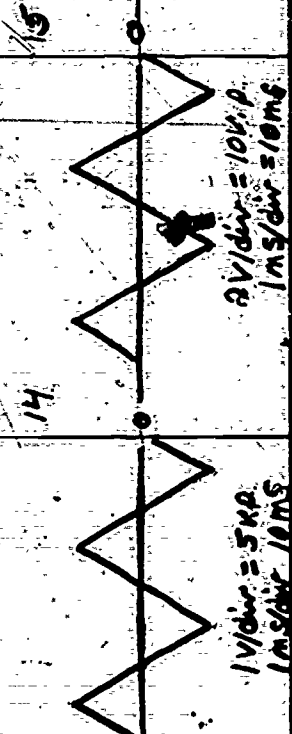
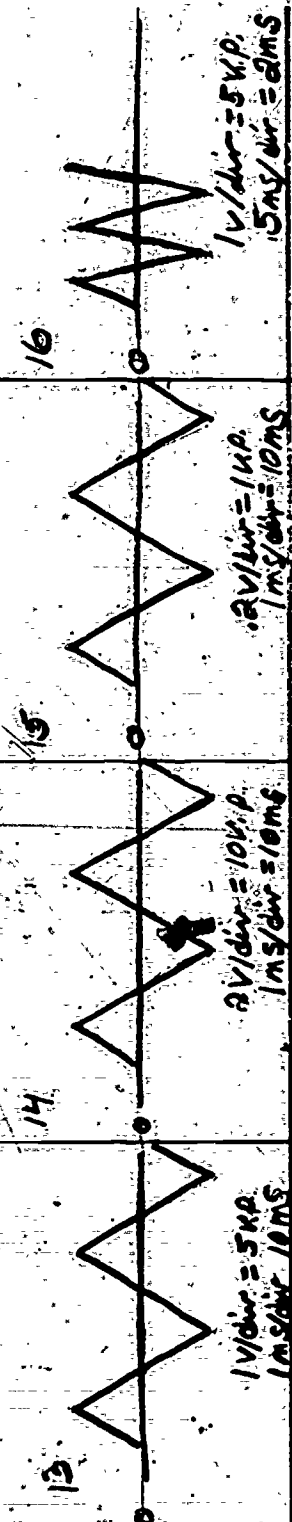

PROJECT NO. 5: VOLTAGE AND TIME MEASUREMENTS
ON THE OSCILLOSCOPE (LABORATORY)

This laboratory activity is to follow the lecture discussion of volts/time (waveforms), Project No. 4. It is assumed that the student has spent only a part of one previous laboratory period becoming familiar with the oscilloscope.

This project is structured for a laboratory that has a central distribution system whereby the instructor, from one location, can deliver any desired waveform to all stations. A central distribution system is highly recommended for electronics laboratories.

Outline of Project No. 5 (for Instructor)

- I. Review basic controls and function of each
 - a. Have students locate, trace, for both channels: 1 and 2
 - b. Adjust intensity
 - c. Position
 - d. Illuminate scale
- II. Explain distribution system and connection to oscilloscope.

III. Handout lab #2

- a. Distribution system waveforms
 1. DC + 2V
 2. DC - 2V
 3. DC + 10V
 4. DC - 10V
 5. DC + 5V
 6. DC - 5V
 7. Square wave 5V 100 HZ
 8. Square wave 10V 100 HZ
Vary amplitude
 9. Square wave 1V 100 HZ
 10. Square wave 5V 100 HZ
 11. Square wave 5V 500 HZ
Vary P.R.F.
 12. Square wave 5V 1000 HZ
 13. Triangular waveform 5V 100 HZ
 14. Triangular waveform 10V 100 HZ
Vary amplitude
 15. Triangular waveform 1V 100 HZ
 16. Triangular waveform 5V 100 HZ
 17. Triangular waveform 5V 500 HZ
Vary F

18. Triangular waveform 5V 1000 HZ
19. Sine wave 5V 100 HZ
20. Sine wave 10V 100 HZ
Vary amplitude
21. Sine wave 1V 100 HZ
22. Sine wave 5V 100 HZ
23. Sine wave 5V 500 HZ
Vary F
24. Sine wave 5V 1000 HZ

IV. Discussion of lab and results

NOTE: This project may require more than one laboratory session. The above has been done in two hours. The project is designed so that the student will need to make minimum adjustments on the scope.

In the student *handout*, information is provided for the specific settings of all controls for the particular scope used. Provide the students with graph paper and a glossary of terms.

Project No. 5 (For the Student)

In this lab sequence you will become more familiar with the oscilloscope and its usage. In addition, further familiarization with common waveforms will result from completion of this lab. Time will be provided following this lab for discussion and review of the experiment itself. Your instructor will distribute several voltage waveforms to your station which you will examine and graph from the oscilloscope observations you make.

Set the oscilloscope controls and adjustments according to information provided by the instructor.

Connect the input for oscilloscope channel #1 (top pair of banana jacks on vertical section) to the black and red jacks of the distribution system outlets at your station.

There will be a series of voltage waveforms presented (one at a time) at your station that you are to observe on your oscilloscope and sketch (including magnitude and time.

dimensions) in your notebook. There will be 24 in all and you will be allowed roughly 5 minutes for each.

As we move from one voltage waveform to another, you will need to adjust your scope in order to be able to measure the magnitude and period of the waveforms. You should *adjust only* the *vólts/div* control on the vertical section and *time/division* on the horizontal. Use graph paper to plot your oscilloscope patterns.

If you have any questions, don't hesitate to consult with your instructor.

PROJECT NO. 6: OSCILLOSCOPE AND FUNCTION GENERATOR (LABORATORY)

The student, until now, has had limited experience with the oscilloscope which have been carefully controlled and guided by the instructor to avoid confusion. He has had no more than two previous exposures. He knows how to get a display on the scope and can read voltages and time for waveforms that have been given to him under the control of the instructor. Now, he needs to be on his own, a little more. The opportunity should be provided here, using the function generator as his source of waveforms.

This is a good time and place for audio-tutorial instruction. This is not difficult to provide. Suggestions for doing this are provided in a later chapter. See *Table of Contents*.

PROJECT NO. 7: MEASUREMENTS WITH VOLTMETERS (LABORATORY)

NOTE: Information should be added to the following in accordance with instruments used.

After completion of the following laboratory exercise the student will be able to complete the following:

- a. Measure peak-to-peak volt values.
- b. Measure peak volt values
- c. Read r-m-s value from voltmeter connected in a circuit
- d. Determine r-m-s values from oscilloscope values.

In previous experiments you were given the

opportunity to work with an oscilloscope as a device for observing and measuring a waveform. In this experiment you will be exposed to using a voltmeter for measuring the same sinusoidal signal you measured with the scope.

You will be exposed to terminology, as peak-to-peak values, peak values, root-mean-square, and effective values.

Set the function generator as instructed.

Adjust the scope to observe the signal as you did before. Measure the amplitude of the signal. This amplitude of this signal is also called the peak-to-peak value. One-half of this signal is called the peak value. Record this value on your data sheet.

Set the voltmeter as instructed.

Connect output from function generator to voltmeter as instructed.

Observe and record the value obtained from the voltmeter. This value is called the root-mean-square voltage of the sinusoidal signal. Caution must be exercised when switching ranges to prevent exceeding the limits of the meter. A good practice is to always start on the largest range of the voltmeter when uncertain what the exact voltage is.

Readjust the attenuator control on the function generator. Carefully read and record the data. Observe, read, and record data for the same signal on the scope. Observe several signals on the meter and oscilloscope being careful not to exceed the range of the oscilloscope.

The question now arises why the discrepancy in the reading from the oscilloscope and the meter. In each set of data collected divide the meter reading by the peak value of the signal obtained from the scope. Record your results.

This value you obtained is the relationship that exists between the peak value of a sinusoidal signal and the voltmeter reading. The reading obtained from the meter is called the *root-mean-square* voltage. Often times it is referred to as the *effective* value.

Time permitting, make additional measurements of the signals produced by the function generator. For example, vary the frequency of the signal and complete above calculations.

PROJECT NO. 8: VOLTAGE AND CURRENT MEASUREMENTS IN CIRCUITS

Circuits of instructors choosing, primarily resistive type circuits with d-c sources, can be used for making current measurements as well as voltage measurements. One or two laboratory sessions for this.

PROJECTS 1-7 CONCLUDE FIRST PHASE OF COURSE

In this first phase of the INTRO course, concentrations has been on waveforms, voltages, and currents along with the use of certain instruments, primarily the oscilloscope. With this procedure, the student becomes familiar with much of the language of electronics.

The studies and laboratory experiences of the first phase are a prerequisite to the second phase on systems and circuits. The remaining projects are samples and suggestions of systems that might be included.

PROJECT NO. 8: INTRODUCTION TO ELECTRONIC SYSTEMS (CLASSROOM)

Show the students a color television. Look at it and ask them what it is and what it does. Ask them to look at the various parts and let them help identify and explain what they do. Point out that each part does something to make it valuable to the whole system. It has a function which is essential to the operation of the system. The functions of all of the parts add up to produce the function of the entire system.

Where is the action of the system? It is inside the circuit. We can't see it because it is inside the molecules of the circuit elements. You can't see any of the action, but you can see the results of the action. In any electrical circuit, the only things which we can observe are: Voltage, Current and their effects (heat, light, motion, etc.).

The only way we know what the function of any circuit is, is to study its effect on the voltages and currents involved (the signal).

The input vs. the output

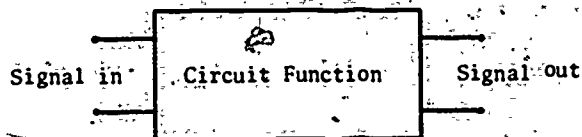

We can tell what the circuit does by looking at the input/output signals. This is a large part of the study of electronics. Half of understanding a circuit is knowing what it does. With this information we can understand, even design, entire systems using the circuits as building blocks.

The other half of understanding the circuit is to know how it performs its function. To know how the circuit works, we must understand what happens inside the circuit. It does no good to just look at the outside of the circuit itself--we must draw a functional picture of the circuit. This functional picture is known as a schematic diagram. It is a mathematical model of the circuit. Each symbol of the schematic represents the basic function of the symbol in the schematic; thus, we can understand the operation of the component. The schematic is a composite drawing of the operations of the components.

PROJECT NO. 9: THE POWER SUPPLY SYSTEM

General Description:

The electronic power supply has one purpose, to receive the alternating current from the line, process it, and distribute the various power levels to the electronic circuits which use them. Since electronic circuits generally operate on direct current and lower level AC and the power lines have alternating current, a form of processing must take place. This process may be likened to a system whose input is alternating current and whose output is direct current at various levels, as well as,

alternating current at various levels, as illustrated by Fig. 1:

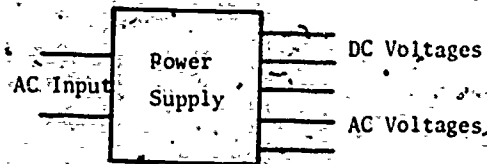

Fig. 1.

This power supply may be broken down to additional blocks as shown in Fig. 2 (see bottom of page).

Fig. 3 might well be a pictorial diagram of the entire circuit and Fig. 4 a schematic diagram of the entire circuit.

The *Transformer* (T_1) as shown in Fig. 2 has as its function of stepping down of the AC input signal. (How this is accomplished is not important at this point.)

The *Rectifier* has the responsibility of changing the alternating current from the transformer secondary to a pulsating DC (a direct current that may have a change in magnitude but does not change polarity). The rectifier may be of several different types. Advanced courses will reveal the names and details of the way these circuits operate. For purposes of familiarization only two basic types will be discussed.

The *filter* (f_1) will receive the pulsating D-C at its input terminals and lower the high spots and fill in the low spots to produce a fairly pure D-C. How well the filter does its job is a figure of merit for a power supply called *ripple factor*. In the laboratory we will observe the ripple; however, no attempt will be made to measure its *magnitude*. The load or bleeder resistor (R_L) as shown in Fig. 2 is the output of the power supply. In a practical application the load would consist of power consuming circuits. In our power supply the load is replaced by a bleeder resistor to serve as a *voltage divider* and as a safety feature.

Procedure

The procedures which should be followed in this situation will depend upon the hardware available or constructed for this particular experience. The student will observe on the oscilloscope the various levels of AC voltage available at the transformer terminals. He will observe full-wave and half-wave rectification, the purpose of filters of different types and the results of adding loads to the supply.

One way that this may be accomplished is by using a prewired circuit where the terminals are readily accessible. The desirable way of showing the difference between full-wave and half-wave is to have a switch in series with one diode so that the system can be switched from one type back to the other quite readily. In this way the student can easily go into either system without fear of injury or electrical shock.

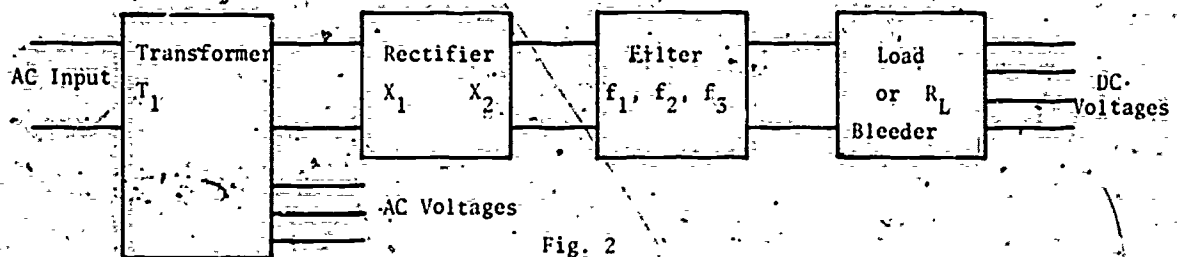

Fig. 2

Filters of several different types may be inserted into the power supply; however, the signal filter capacitor and its ripple problem makes a great place to start. It is generally desirable to have a current meter in series with the load so we may observe the current the supply is delivering to the load.

Loads can be of varying designs; however, it should be continuously variable over a fairly wide range.

Caution: a means of discharging all filters must be provided. A suggestion might be a shorting switch located so the filter cannot be removed without it being discharged. This may seem elementary to the experienced teacher but is frequently overlooked.

PROJECT NO. 10: MISCELLANEOUS CIRCUITS

Laboratory experiences with a number of basic circuits are suggested here, for most of the remaining time for the course. Refer to Report No. 2 of this chapter for suggestions and guidance.

PROJECT NO. 11: RESISTANCE, CAPACITANCE AND INDUCTANCE

Measurements of resistance, capacitance and inductance are suggested here. Do not get too involved in the concepts of these elements. One or two laboratory sessions are sufficient, supported by classroom discussion.

PROJECT NO. 12: TROUBLE-SHOOTING TECHNIQUES

The instructor and students should be conscious of trouble-shooting techniques throughout the course. This might be a good time to concentrate on this problem.

TEACHING PROBLEMS FOR INTRO COURSE

There are certain teaching problems associated with an INTRO course that need to be avoided. These problems probably exist because of the inherent difficulty of getting away from conventional techniques and conventional sequencing of topics. The concept of the *inverted pyramid* is important. Some of the more important teaching problems are now briefly summarized.

STUDY BECOMES TOO QUANTITATIVE

The instructor, in deciding that the introduction course is Mickey Mouse, tends to add quantitative material. The student should be given an exposure to the rest of the curriculum without excessive quantitative studies during the INTRO course. The early introduction of quantitative studies merely moves Resistive Circuits to the first term and completely removes the INTRO course from the curriculum. When considering circuit components, do not involve models and v/a properties of components.

INSTRUCTORS DO NOT "FEEL" THE COURSE

The staff must be "sold" on the INTRO course. The instructor who feels that this is a course used to *spin the students' wheels* until the math catches up does not really understand the philosophy of the INTRO course. Much of the foundation for future studies can be learned in these studies if the instructor is able to visualize the entire Electronic Technology field.

ILL-PREPARED MATERIALS

The staff who attempts the introduction course by utilizing existing experiments will certainly bog down. The INTRO course does not allow for experiments but *learning experiences*. We are not trying at this point to prove anything, just expose. Most existing *Lab Manuals* are written with the objectives of verifying some previously studied phenomena. This will not be the case in

Introduction to Electronics Technology.

TOO MUCH CLASSROOM EFFORT

The studies of the INTRO course should be primarily in the laboratory. This does not imply that some classroom work is not necessary. The student is given, in this course, a *Hands-On* type experience which will benefit throughout his entire life. Since one of the prime reasons for the INTRO course is the motivation of the student to further studies, the laboratory, with its fascinating instruments, is a natural learning center.

TOO MUCH TIME SPENT

The instructor who has too much time for INTRO or who takes too much time finds he has either short-changed the student by wasting his time or has confused the student by attempting to cover too much material.

THE PROJECT DOMINATES

Some INTRO proposals which have been presented in the past include a project designed to introduce the student to a variety of topics including: soldering, wiring from schematic, system analysis, etc. The use of a project is not to be discouraged. However, the emphasis of the project should be controlled to the point that it continues to meet the aims and goals of the course. Many times the project becomes the ultimate end of the course rather than a means of conveying concepts or topics of the curriculum.

THE APPROACH BECOMES TOO DETAILED

The objective of the course is to show the "Big Picture". Therefore, the emphasis is on systems and the building blocks that make up that system. At all costs, avoid the inclusion of too much detail. The student

should be prepared to use a meter, not design one.

THE INSTRUMENTS DOMINATE THE COURSE

The emphasis of the Course is to motivate, show the *Big Picture* of electronics, and to introduce concepts. The course must avoid an emphasis on one area of concentration. It is very easy to introduce the student to sophisticated instruments and give him a vague idea of what is going on, but will he really understand what a "spectrum analyzer" does at this point, for instance. The instruments that should be used for this study are the basic instruments: Oscilloscopes, signal sources, analog meters, and power sources. These instruments plus possible demonstrations on more sophisticated

instrumentation is sufficient to acquaint the student to the *Big Picture* without the student confusing himself with instrumentation he can't understand or appreciate in these early learning experiences.

TOO MUCH EMPHASIS ON HARDWARE

It is very easy at this point to over-emphasize hardware and by this over-emphasis, fail to familiarize the student with the *language* of the field. The student is able, at this point, to absorb and digest a tremendous amount of general knowledge which will help acquaint him with Electronics Technology. The knowledge the student gains now will only make his study of future circuits and electronics courses easier.

CHAPTER 4

THE CIRCUIT ANALYSIS SEQUENCE

The ~~three~~ major courses of circuit analysis (Resistive Circuits, Single-Time-Constant circuits and Networks) are presented in this chapter.

The material of the chapter will have greater significance to the reader by regarding the subject of circuit analysis as a single package rather than as three separate courses. The approaches to getting started with major topics, along with the sequencing and groupings suggested, are most important. Special attention should be directed to the first two courses in the sequence (Resistive Circuits and STC's). The third course (Networks) represents a more conventional treatment of topics in circuit analysis.

RESISTIVE CIRCUITS - (CIRCUITS I)

DEFINITION

The subject of *Resistive Circuits* is a study and analysis of circuits where all passive elements are resistances and the active elements (voltage and/or current sources) are waveforms of any kind.

MAJOR CONCEPTS

All electrical quantities and all circuit responses are derived and can be expressed as functions of instantaneous values of voltages and/or currents. This fact dictates the importance of treating all sources as functions of time, either mathematically or graphically. This also means that a first course in circuits must not be restricted to D-C sources only. The use of any of the waveforms for a source is the key that establishes the first course in circuits as a sound foundation for later studies.

Traditionally, a first course in circuits often includes L's and C's. These should be omitted for the reason that the analysis of circuits incorporating L's and/or C's requires at least some knowledge of calculus. Students will not have this mathematical background at the time when the first course in circuits must be offered in a two-year program.

Before starting a detailed study and analysis of "Resistive Circuits", it is important for the student to understand that all devices can and do have the properties of resistance. Care should be taken that the student does not restrict his concept of resistance to that of a resistor.

Obtaining the concept of resistance through volt-ampere graphs is the recommended approach. These graphs may be linear or they may be non-linear. A graph may pass through the "0-0" intercept or it may not.

With the "volt-ampere-graph" approach resistance, care should be taken that a study of de-

vices is not over-emphasized. The important point is that a resistive circuit element may represent any device exhibiting the properties of resistance.

Ohm's law becomes a part of the volt-ampere graph approach.

BEHAVIORAL OBJECTIVES

The student upon successful completion of *Resistive Circuits* will have the ability to:

- Evaluate a voltage and/or a current in any part of a resistive circuit for any kind or kinds of waveforms as driving functions whether these driving functions are voltage sources or current sources.
- Simplify the analysis of circuits, if necessary, through the use of Thevenin's theorem (or Norton's theorem), or the superposition theorem, or as a voltage-divider, or as a current-divider, or by special techniques applicable to particular circuits.
- Represent solutions graphically as well as mathematically.
- Appreciate the value of a study of resistive circuits and their uses in practical systems.

PREREQUISITE

Primarily, the student needs a working knowledge of algebra and the basic elements of trigonometry as a prerequisite to a study of *Resistive Circuits*.

In a six-quarter program, *Resistive Circuits* is scheduled for the second term. This will permit the student to attain the needed proficiency in mathematics in the first term. In addition, the "Introduction to Electronics Technology" course (strongly recommended as a

first-term course) will provide valuable practical knowledge before starting *Resistive Circuits*.

In a four-semester program, *Resistive Circuits* should be scheduled in the first term.

Those institutions that are on the semester plan will sometimes have a higher entrance requirement in the area of mathematics than those on the quarter plan. No serious problems exist, however, if the topics of the *INTRO* course and *Resistive Circuits* are integrated as needed. Some specific suggestions along this line are presented in Chapter 10 of this report.

The flow chart is presented here to illustrate the position of *Resistive Circuits* in a curriculum relative to other key subjects.

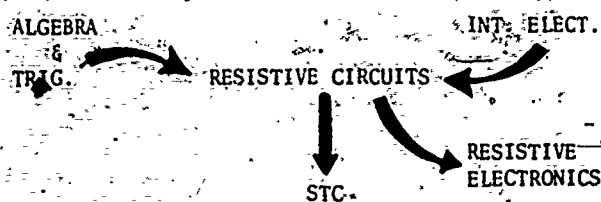

OUTLINE

I. Definition of Parameters

A. Graphing of linear functions (Classroom)

1. Cartesian coordinates
2. Time as a parameter in these graphs
3. Concept of slope

B. The volt and voltage (Lab Support)

1. Defined as energy for charge
2. Defined as a force
3. Measurement

C. Introduce volts/time concept (Classroom Introduction)

1. Adapt cartesian coordinates to volts/time
2. Emphasize writing of v_t

D. The ampere and current (Lab Support)

1. Defined as time rate of change in charge
2. Defined as a result of voltage applied.
3. Emphasize writing of i_t

E. Piecewise and Interval Notation

II. Waveforms (Classroom Introduction)

A. Expressed as function of time, v_t or i_t

1. Continuous functions
2. Interval techniques (repetitive functions, - amounts to assigning convenient references of $t = 0$)

B. The basic waveforms for forcing functions

1. Constant, ramp, sinusoid, step and exponential (Lab Support)
2. Recognize and identify each, graphically and mathematically (Lab Support)
3. Identification of significant quantities for each
4. Write equations for each as a function of time
5. Write equations for any combination of two or more of the basic functions in terms of time, t

III. Volt-Ampere Relationships

A. Volt-ampere graphs

1. Linear
2. Non-linear (Laboratory Introduction)
3. Importance of slope
4. $1/R$, interpretation from graphs
5. Circuit model for a resistor
6. Resistance as E/I
7. Ohm's Law (Rigorous classroom support)

IV. Concept of Equivalent Resistance, R_{eq}

A. V-A graph of resistive networks (Lab Support)

1. Linear
2. Non-linear
3. Combination of linear and non-linear devices

B. $e_s/i_s = R_{eq}$ (Laboratory support-use ohmmeter to verify)

C. R_{eq} for common circuit configuration

(Classroom Introduction)

1. Input resistance, R_{eq} , for series parallel and series parallel circuits
2. Introduction to circuit terminology
 - a. Nodes, junctions, branches
 - b. Sources: Independent, dependent energized, de-energized
3. Identification of common circuit configurations (Classroom)
4. Calculations of R_{eq} for common circuit configurations (Series, parallel, series parallel, etc.)
5. Subscript notations for e and i

V. Kirchhoff's Voltage and Current Laws

(Classroom Introduction-Laboratory Support)

A. Kirchhoff's voltage law

1. Defined
2. Applied to networks (Ohm's law is not used in these studies)
3. Identification of reference polarity
 - a. Double subscript notation

B. Kirchhoff's current law

1. Defined
2. Applied to networks (Ohm's law is not used in these studies)
3. Identification of positive reference current
 - a. Double subscript notation
 - b. Single subscript notation

VI. Substitution of Ohm's Law Into KVL and KCL

Equations (Classroom Introduction-Lab Support)

A. Referencing of voltages and currents

B. Problem solving

1. Replacing a voltage of KVL equation with $\pm IR$, selecting the correct sign
2. Replacing a current of KCL equation with $\pm V/R$, selecting the correct sign
3. Calculation of voltages and currents in series, parallel and series-parallel circuits (one source)
4. Analysis of single-loop circuits with two sources

C. Develop proficiency of analysis through

use of

1. Voltage divider concept (Series circuits)
2. Current divider concept (Parallel circuit)

VII. Network Equations (Classroom Emphasis)

A. Writing network equations

1. Voltage equations (Unknowns are currents)
 - a. Loop equations
 - b. Mesh equations
2. Current equations (Unknowns are voltages)
 - a. Node equations

B. Independence of equations

1. Identification of necessary and sufficient equations
 - a. The "window" technique (and its limitations)
 - b. The tree-chord technique

C. Applications and problems (Take advantage of available computers and calculators)

VIII. Analysis by Equivalent Circuits (Classroom)

A. Superposition theorem (Lab Support)

B. Millman's theorem

C. Thevenin's theorem (Lab Support)

D. Norton's theorem

E. Circuit conversions (change configuration to a familiar form)

F. Applications and problems

IX. Resistive Network Analysis

A. Single source networks (Class Introduction)

1. Bridge circuits
2. Node splitting
3. Ladder technique

B. Multiple source networks (Lab Support)

C. Networks with dependent sources

D. Applications and problems

X. Four Terminal or Two-Port Networks

A. R parameters (Class introduction and study)

1. R_{11}
2. R_{12}

3. R_{21}
4. R_{22}

GENERAL GUIDELINES

The information and suggestions of these *General Guidelines* identify the concepts, subject matter, importance of certain sequences and technique of instruction important to the subject of Resistive Circuits. More specific guidelines for the classroom and for the laboratory will follow these general guidelines.

Importance of a First Course in Circuits

A first course in circuit analysis must provide a sound background on which all other electrical-electronic courses can be structured into logical sequences or groupings.

The success of a total curriculum is largely dependent on the structure and content of this first course.

Where Resistive Circuit Analysis Actually Starts

Referring to the topical outline, resistive circuit analysis essentially starts with Topic IV on the "Concept of Equivalent Resistances". For this reason, much of the preceding material of the outline could be conveniently and appropriately presented and studied in preceding courses such as the proposed *Introduction to Electronics Technology* course. The preceding material, to which we refer, involves a knowledge of basic electrical units, waveforms and volt-ampere graphs.

Study of Waveforms is Essential

Before starting a detailed study and analysis of *Resistive Circuits*, the student should understand and have a working knowledge of:

- a. Voltage and current graphs as a function of time. The dimension of "time" in the plotting of graphs is a concept with which the student has had very little experience before entering the Electronics Technology Curriculum. The experience could be gained in the "Introduction to Electronics Technology" course when such a course is offered.
- b. Constants expressed mathematically and graphically on a time base.

- c. Sinusoidal functions expressed mathematically and graphically.
- d. Ramps expressed mathematically and graphically.
- e. These and all other functions should always be represented graphically in early studies in order to get the emphasis on instantaneous values.

Emphasis on Instantaneous Values is Important

Emphasis on instantaneous values for all voltages and currents, rather than the D-C or A-C approach, has certain definite advantages that represents a key factor to a total curriculum structure. Some of these advantages are:

- a. Permits the study of resistive circuits with any and all kinds of input waveforms.
- b. Permits a general approach to all circuit analysis from an input-output point of view.
- c. Provides a smooth transition to the analysis and study of circuits containing inductances and/or capacitances, since all electrical quantities are derived from voltages and currents expressed as functions of time.
- d. Allows the general mathematical approach since the voltages and currents are necessarily expressed as functions of time. This general mathematical approach is important since circuit analysis is a mathematical process of applying Kirchhoff's laws and Ohm's law (for resistive circuits).
- e. D-C and sinusoidal functions (A-C) are special cases.

The Driving Functions

The driving functions, voltage and/or current sources, can be constants, (D-C), sinusoidal, ramps, pulses, exponentials, singularly or in combination.

The driving functions can be repetitive or non-repetitive.

The driving functions can be mathematically defined functions or they can be so irregular that they can be expressed only by graphs as a function of time.

The Importance of Kirchhoff's Laws

The analysis of Resistive circuits really starts with the use of Kirchhoff's two laws. This means that circuit analysis should start with circuits having more than one resistive element and more than one branch. More than one resistance is needed to understand Kirchhoff's voltage law and more than one branch is needed to understand Kirchhoff's current law.

Kirchhoff's laws always hold true for *instantaneous* values, a point that will be missed if too much emphasis is placed on D-C sources in a first course on circuit analysis.

Using Ohm's law, which was actually learned first in getting the concept of resistance, is not the first step in the analysis of circuits. Kirchhoff's voltage law and/or Kirchhoff's current law represents the first step. If this first step is omitted, it is always implied.

Voltage and Current References are Essential

The quantitative analysis of any circuit requires an arbitrary assignment of positive reference polarities for voltages and an arbitrary assignment of positive reference for current direction. Kirchhoff's voltage and current equations cannot be written without these assigned reference.

The actual voltage polarities and the actual current directions are revealed from the numerical solution of the equations written for a circuit.

A serious handicap to the learner's process can exist if early studies place too much emphasis on a single D-C source using the standard symbol to represent a battery. Here the voltage polarity would be predetermined and the actual current directions are known in advance. Learning troubles will then exist when a second source is added in circuits having more than one loop. In such circuits, the actual directions of currents cannot be known in advance.

Series, Parallel and Series-Parallel Circuits

Knowing Kirchhoff's law, the one additional concept required to analyze these circuits is the concept of equivalent resistance. Consequently the student masters these circuits much more easily.

If these circuits are treated as a group especially in the laboratory, the student can grasp the full significance and importance of equivalent resistance.

Single-loop circuits with two sources are valuable studies here. Superposition theorem can be introduced.

The practical situations of voltage divider, current divider, potentiometers, attenuators, summing of two sources, etc., are presented in this area.

Node Equations and Loop Equations

Learning to write node equations before loop equations, is recommended. There are several reasons for this:

- a. Number of independent node equations required are more easily identified.
- b. The unknowns in node equations are voltages and in electronics circuits one is usually more interested in voltages than current.
- c. It permits a more natural approach to the loop equation method and the use of the valuable "Tree-Chord" technique of identifying independent loop equations.

The analysis of circuits having current sources should receive greater emphasis than has usually been true in the past.

The writing of independent loop and node equations is more important than the solution of the equations, especially in a first course in circuits.

Theorems for Circuit Simplifications

Thevenin's theorem, along with Norton's theorem, Millman's theorem and the superposition theorem are valuable tools for the simplification of circuits.

With Thevenin's theorem and Millman's theorem,

- a. The number of loops in a circuit can be reduced.
- b. Loops to eliminate can be selected to provide the needed convenience of analysis or interpretation.
- c. Attenuation factors are revealed as circuit is reduced in this way.
- d. When circuit is reduced to a single branch, an equivalent source voltage and an equivalent output resistance between two terminals is known.

Norton's theorem becomes valuable whenever it becomes advantageous to convert sources to current sources. This need will occur when one wishes to have elements in parallel rather than in series.

The superposition theorem is most valuable in a single-loop circuit having two or more sources. The equation, in its simplest form, is a sum of terms equal to the number of sources. With the superposition theorem, this simplified equation can be written directly in a single step.

Dependent Sources

The analysis of circuits having dependent sources is an important topic to include in a first circuits course. To establish these dependent sources, one simply specifies that a source is dependent on some voltage or current in the circuit. The coefficient that specifies the dependency is assigned as desired. But it is also advantageous to use β , as in transistor circuits for example, for the coefficient factor of dependency. The general procedure of analysis is compatible with that of independent sources only provided one does not disregard the factor of dependency.

When dependent sources are studied in the circuits course, the student will have much less difficulty with the analysis of electronics circuits that follow in the sequence.

Power and Energy

A detailed study of power and energy should be delayed to the end of a first course in circuit

analysis. The defining equation of instantaneous power, $p = vi$ for any circuit under any condition, dictates this. The student first, needs to know how to calculate v and i .

With emphasis on the calculations of voltages and currents in preceding studies, the student is thus prepared for a study of power and energy.

Attempts to teach power and energy early in a first course will only add to the problem to teaching voltage and current calculations.

Physics Properties of Resistors

It is important for the student to understand the parameters of resistance without confusing him with the various other characteristics of the one resistive device—the resistor.

It is desirable for the student to begin solving resistive circuits as early as possible. An early formal study of resistors would only delay this.

A thorough study of resistors requires a background knowledge of power.

Taking Advantage of Student's Background

The teaching of resistive circuits should take advantage of students' background gained in the previous *Introduction of Electronics Technology* course as well as his mathematical background in algebra and trigonometry. This background allows us to move into the study of waveforms at an early point, both in the classroom, as well as the laboratory, on a quantitative as well as qualitative basis.

Using the Laboratory Environment to Full Advantage

As the laboratory environment is used extensively in this series of topics to introduce major concepts and since the student has the background and instrumentation capability necessary for observing, interpreting, measuring, and calculating the significant waveform quantities involved, the study of resistive circuits is greatly enhanced.

Design kind of laboratory problems can be employed early as a result of student's instrumentation background.

The primary measuring instrument for this course should be the oscilloscope, again allowing the study of any waveform input.

Schematics Are a Source of Practical Problems

The problems, as found in textbooks, will be from practical kinds of circuits but the student may not be aware of this. The student would be more positively motivated toward a study of resistive circuits by knowing the possible sources of some of the problems.

Schematic diagrams of instruments and systems have all kinds of resistive circuit situations. Problems can be generated from these portions of the schematic diagrams. Perhaps only a small percentage of the circuit problems need to be from such sources, in order to satisfy the student.

GUIDELINES FOR CLASSROOM

The topical outline for *Resistive Circuits* identifies twelve major topics, I through XII. Some specific suggestions and information are now presented for these topics in the order presented in the outline. Any references to experiments will be presented in more detail in a following section of *Laboratory Guidelines*.

Definition of Parameters

The most important parameters for circuit analysis are voltage, current and time. Although voltage is defined as *energy per charge* and current is defined as *time-rate-of-change of charge*, it may be more satisfying to the student (at this early state in his studies) to think of voltage as a force and to think of current as a result of this force. An involved study of the physics of electricity is not recommended at this time. Such concepts should be reserved for the courses in physics.

No more than one, or possibly two class periods should be used for the identification and definition of electrical units and parameters. The laboratory time can concentrate primarily on voltage and current measurements and becoming familiar with the units of measurement.

WAVEFORMS

The classroom should emphasize the mathematical correlation of defined functions with the graphing, or mapping, of various functions on the cartesian coordinate system. The concept of time as one of the two parameters will need special emphasis since students will probably not be accustomed to plotting equations as a function of time. There is a learning problem that involves conversion from x and y terminology to v and t (or i and t) terminology.

A mathematical equation or current function involves the appropriate voltage polarity, or current direction, as well as magnitude. The significance of a positive or negative value must be appreciated and this comes only by assigning a reference on a diagram. The function is then defined accordingly.

Equations written for significant intervals of discontinuous functions should be employed. This means assigning a zero time reference at the start of a significant interval such as the ramp of a sawtooth waveform or each pulse of a rectangular waveform can have its own zero-time reference. This technique eliminates certain mathematical difficulties and is sometimes identified as a *piecewise* technique of analysis.

Volt-Ampere Relationships

The unique feature of this topic is the use of the laboratory to introduce Ohm's Law. It is important that the student see how this relationship is developed; therefore, the introduction is in the laboratory, not in the classroom. A recommended procedure is as follows:

The student, having been introduced to voltage/time and current/time parameters is now asked to establish current/voltage and voltage/current relationships as outlined in Experiment #3. Not only is he exposed to linear and non-linear devices, but he develops Ohm's Law by finding the slope of these volt/ampere

Relationships.

Rigorous math-based support in the classroom is important in following up what has been introduced in this laboratory experiment. This is the time for a mathematical definition of the voltage/time and current/time interrelationships. Ohm's Law is defined at this time, but its use in problem-solving will be delayed until after the development of Kirchhoff's voltage and current law.

Emphasis should be placed upon the distinction between a resistor and all its various models and the word "resistance". Resistance should be defined as voltage divided by current.

Concept of Equivalent Resistance.

A major problem for students in developing problem-solving techniques lies in the understanding and appreciation of equivalent resistance (R_{eq}), and equivalent impedance (Z_{eq}) in later courses. Therefore, before the introduction of series and parallel branches, it is desirable that the student work with an e_s/i_s ratio and identify it as R_{eq} (Equivalent Resistance). Many circuits where R_{eq} is needed, and assumed e_s with solution for e_s is the recommended technique.

This concept is introduced in the laboratory as outlined in Laboratory Experiment #4. Again, classroom support is needed for the material introduced in the laboratory.

The terminology necessary for circuit analysis is defined in the outline, along with circuit configurations and the notations necessary. This information is best studied in the classroom along with an outside assignment.

There could be strong temptation here to teach series circuits and series-parallel circuits concentrating on the solution of currents or voltages, using Ohm's law. Such temptations should be avoided. If circuit configurations that are series parallel are used, the concentration should be on the e_s/i_s ratio. This approach to equivalent resistance dictates the laboratory approach with supporting discussions in the classroom.

Kirchhoff's Voltage Law and Kirchhoff's Current Law.

The student now has enough information to determine all electrical quantities in any passive resistive circuit. A few measurements may be necessary, but, with the assistance of Ohm's Law, the student should be in a position to begin problem-solving techniques.

The advantage of delaying problem solving of resistive circuits until after the development of Kirchhoff's Voltage Law and Current Law rather than to start with Ohm's Law, is that the student can begin circuit analysis work by dealing with either a voltage equation or a current equation. Starting to problem solve with Ohm's Law involves one equation and a minimum of two unknowns. While dealing with the voltage law or current law the student may progress more readily when he is taught to solve for one unknown with one equation. Ohm's Law is used to assist the student in reducing the voltage or current equation to one equation with one unknown; therefore, he treats Ohm's Law as a basic definition that will assist him in the final solution of a current law or voltage law equation.

The classroom discussion of problem solving is important in assisting the student in developing efficient problem-solving techniques initially. An engineering technology student is expected to be efficient and organized. Therefore, good organizational procedures are important.

The assignment of outside problems can be of great assistance to the student in learning on his own if the problems are sequenced in such a manner that one problem will assist him in the solution of another problem.

Now that the classroom discussion is emphasizing problem-solving techniques, the laboratory support work begins to present design problems. Such an example of a basic design problem is presented in Laboratory Experiment #5.

In presenting Kirchhoff's laws in the classroom, it is recommended that Kirchhoff's current

law (KCL) be presented before Kirchoff's voltage law (KVL). It is further recommended that double-subscript notations be presented before single-subscript notations. In either case, KCL or KVL, the early studies should have reference to circuits having more than one loop.

A diagram such as shown in Fig. 1 is recommended for a study of KCL using double-subscript notation.

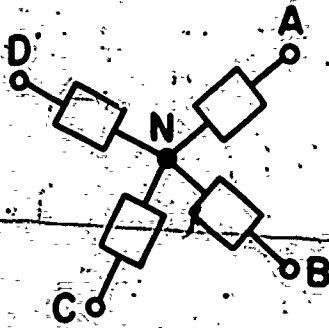

Problems are designed by specifying the currents in all but one of the branches. The student must then calculate the current in the one unknown branch from the KCL equation.

For the single-subscript notation, a similar multibranch junction is used in which reference arrows are specified for each current in each branch. The terminals are not identified in any way. This problem with single-subscript becomes a little more involved since a reference arrow can be specified in either of two directions for each branch. This generates a number of class problem situations. Again, for each problem, the student is to calculate the one unknown current. The others will be given. It may be necessary to reemphasize that KCL has reference to a summation of algebraic quantities, not just magnitudes.

The double-subscript technique for presenting a study of KVL is suggested in Fig. 2. Here the significant terminals are identified with letter (a,b,c,...) symbols. This circuit model (anything can be in the boxes) has six significant terminals. The number of given voltages properly positioned can be one less than the number of

significant terminals. Five voltages are therefore given. The objective for the student is to solve for all, or any other voltages through KVL equations. Answers for the voltages across the individual elements are represented in Fig. 3. Problems with single subscripts are not shown in this report

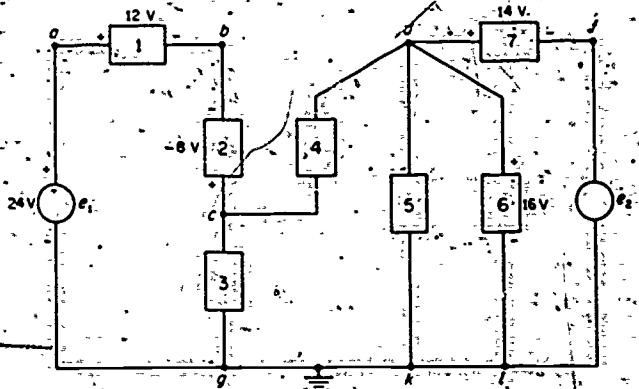

Fig. 2.

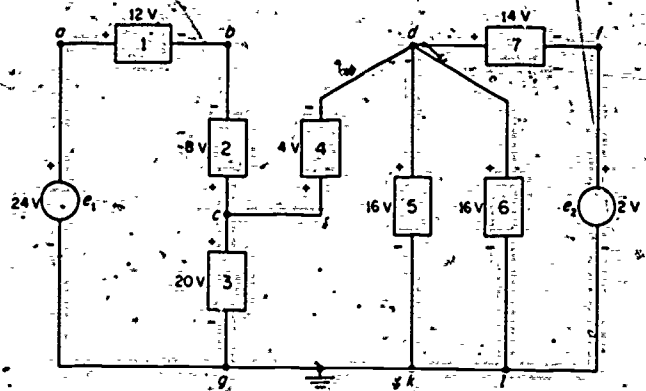

Fig. 3

Substitution of Ohm's Law Into KVL & KCL.

Until now, calculations for both currents and voltages in the same circuit have not been emphasized. The equation for Ohm's Law becomes important at this point in the course. To appreciate this fact, it is only necessary to recognize that Ohm's law equation has the two unknowns of v_r and i_r for a given resistance R . Learning problems will exist if one of these two unknowns, such as v_r , is removed by using e_s . In other words, a given source applied to a single resistance is not a sound approach.

The recommended approach is to always write

one of Kirchhoff's equations first, either KVL or KCL as convenient for a circuit, then make substitutions according to Ohm's law. Refer to Fig. 4. The problem could be to find the voltage across one of the resistances.

First, from KVL, we write

$$e_s = v_1 + v_2 + v_3$$

Then, by substituting Ohm's law for each voltage across each resistance, we have that,

$$e_s = iR_1 + iR_2 + iR_3$$

And by collecting coefficients,

$$e_s = i(R_1 + R_2 + R_3) = iR_{eq}$$

We can then evaluate the current and, consequently, any voltage. Notice that all voltages and the current must be referenced, but not necessarily the same as shown in this one case.

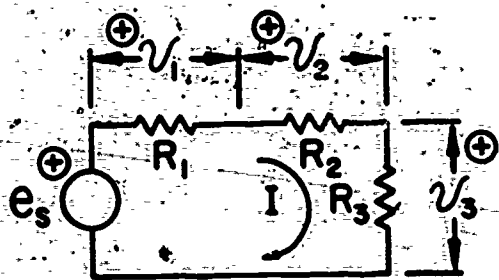

Fig. 4

Network Equations

Network equations, either loop or node equations, represent the one technique that will permit the solution of an network regardless of the number of loops, number of junctions, or number of sources and no matter whether these sources are voltages or currents, dependent or independent sources.

Node equations are presented before loop equations for reasons presented in the general guidelines. Remember that node equations are current equations written according to KCL with Ohm's law substituted. The unknowns, therefore,

are voltages that are junction-to-junction voltages with every unknown voltage measured to a common reference junction. Two significant learning problems exist. One is to write each equation correctly and the other is to identify the independence of the equations. *Writing the equations correctly* is the more time-consuming problem and the student should have sufficient opportunities to attain proficiency. Do not concentrate on the solution of the equations unless computer facilities are available and used.

The same two learning problems exist when working with loop equations. Concentrate on getting the student proficient in writing the equations correctly. Remember that loop equations are voltage equations written according to the KVL with Ohm's law substituted in the appropriate terms. This means that the unknowns are currents. Consequently, an independent loop shall not contain a current source since that current source is not an unknown. *Include circuits in these problems that have current sources.*

To handle current sources, simply show a complete current loop (any convenient loop) for each current source. Do not write an equation for this loop but do use this current in writing the voltage in each branch for which an independent loop has been correctly selected.

Writing network equations is largely a classroom problem.

Analysis by Equivalent Circuits

Combining resistances in parallel or in series to obtain an equivalent resistance is one example of analysis by equivalent circuits. Obtaining equivalent circuits not only provides a certain convenience of analysis but also adds considerable understanding to the response of a circuit.

The various theorems (Thevenin's, Norton's, superposition and others) also provide convenience and understanding to the analysis and response of circuits. With these circuit simplification techniques, it becomes possible to

interpret the response of many circuits by inspection that could not be done otherwise. The section on the use of media, later in this report, give some suggestions for obtaining proficiency in using simplification techniques for circuit analysis.

The superposition theorem, as a concept, is not difficult for the student. The major problem here, is in writing the complete equation directly from the given circuit. To overcome this, the student should be urged to sketch the equivalent circuit in a familiar form for each of the sources. After awhile this may not be necessary.

Thevenin's and Norton's theorems, as a means of circuit simplification, are not always fully appreciated by the student when he is first exposed to these theorems. They do require a certain amount of experience, and patience is encouraged. Perhaps these theorems are more readily appreciated if the student will think of a network in terms of e_{oc} (open circuit voltage) and R_{int} looking in at the output terminals. A suggested classroom procedure follows.

Classroom Presentation for Thevenin's and Norton's Theorem

I. Consideration of deactivated sources

- A) Voltage source going to zero volts (short circuit)
- B) Current source going to zero amps (open circuit)

II. Examination of two terminal network using "black box" technique

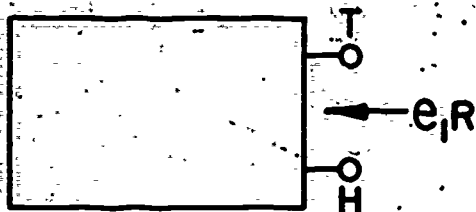

- A) Looking in at terminals T and H we see only two quantities, an e and an R , and only two.
- B) How might we draw a circuit demonstrating this e and this R ?

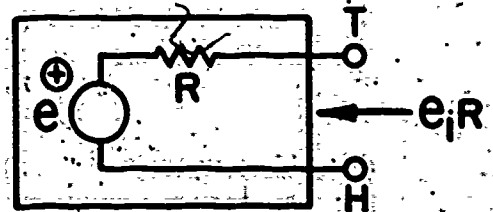

- C) Is there another circuit that will give us the same e and the same R ?

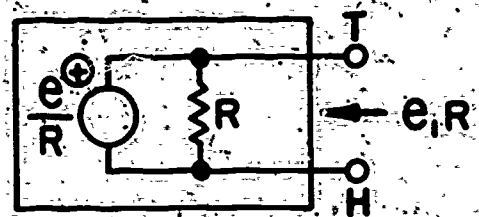

- D) If both these circuits demonstrate the same terminal quantities, they must be interchangeable at those terminals.

III. Reduction of any network to Thevenin's equivalent circuit.

- A) Referring back to black box of Part II, there could have been any network actually inside, but still demonstrate only the two quantities at terminals T and H, namely e and R .
- B) Therefore these two simple circuits must be equivalent to whatever is actually in the box.
 - 1) The series circuit we call Thevenin's equivalent circuit.

- 2) The parallel circuit we call Norton's equivalent circuit.
- C) To reduce network at any two terminals to a Thevenin's equivalent:
- 1) Find e_{th} (use methods learned to this point)
 - 2) Find R_{th} (source deactivated)
 - 3) Draw equivalent circuit.
- D) To reduce network to Norton's equivalent,

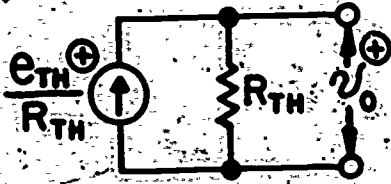

Do some problems on reducing networks to Norton's equivalent circuits.

IV. Thevenize the following kind of problem

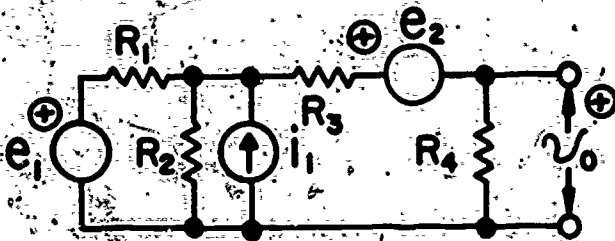

The techniques used to reduce this circuit are really applications of Thevenin's and Norton's equivalent circuits or Millman's Theorem.

Resistive Network Analysis

Some special circuits lend themselves naturally to unique methods of analysis. The node-splitting technique is extremely valuable and convenient whenever two or more parts of a circuit are returned to the same voltage source. The node-splitting method simply permits the sketching of a circuit model where the one source is "split"

and shown as many times as there are branches connected to that source. A transistor circuit that shows v_{cc} as the one supply for the collector circuit as well as for biasing is a good example. A better understanding exists if the biasing resistor is returned to a separate supply (in a circuit model) that is equal to v_{cc} . Bridge circuits are often conveniently analyzed, also, by using the node-splitting techniques.

Another technique that is useful at times is the ladder technique where a voltage is assumed at the output and we work backward toward the source and end up with a scaling ratio.

The Ladder Technique

It is often overlooked in the study of resistive circuits that the only function a resistive network can have is that of amplitude scaling. An analysis technique that emphasizes this fact is one that is commonly called the ladder technique. An example of this technique follows.

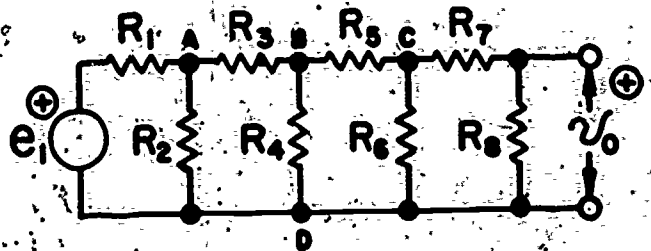

In order to solve this problem for v_o , one would be tempted to employ Thevenin's Theorem, writing 3 nodal equations, or perhaps even 4 loops. However, if one were to assume a v_o , perhaps we can arrive at a ratio that will indicate the scaling effect of the circuit above:

1. Assuming a v_o , we then have a corresponding value for v_{CD} .
2. Having this value for v_{CD} , we can then find a corresponding value for v_{BD} .

Triangular	Pulse	Pulse Width
Time-varying	Peak	Discontinuity

IV. Student Background Required:

- Linear Algebra
- Graphing & Curve Fitting
- Oscilloscope Use
- Power Supply Use
- Oscillator Use
- Function Generator Use
- Pulse Generator Use
- Experience in Connecting Circuits

V. General Notes:

The general approach taken in this experiment is structured by allowing the student more and more freedom as he progresses.

The student should be given one part at a time, allowing the instructor to examine student progress before continuing.

For The Student

The Problem: Identification and Expression (Graphical and Mathematical) of Common Waveforms

New Terminology Encountered:

Interval	Square Wave	Scaling
Triangular	Continuous	Pulse
D.C.	Pulse Width	Time-varying
Peak	Ramp	Discontinuity

Procedure: (Part I)

Connect the circuit below and examine v_o and e_s with your oscilloscope time-base adjusted so that one and only one complete cycle appears. Graph v_o vs. time, indicating all significant values for amplitude, time, etc. Write algebraic expressions for quantity graphed. When graph has points of discontinuity, write mathematical expressions in terms of significant values.

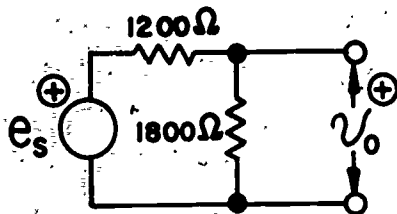

Use the values of e_s as given below:

- a₁. e_s = D.C. voltage source set at 3V
- a₂. e_s = D.C. voltage source set at -3V
- b. e_s = oscillator set at 1000 Hz
- c. e_s = function generator set for ramp (or triangle) voltage at 1500 cycles/sec.
- d. e_s = function generator set for square wave at 2000 cycles/sec.
- e. e_s = pulse generator (vary frequency and pulse width)

Procedure: (Part II)

In this sequence employ techniques, circuits, and instructions used on sheet 1, replacing e_s as indicated below. Plot e_{s1} and e_{s2} individually and then plot composite by adding points on graphs, before writing equation for resultant waveform.

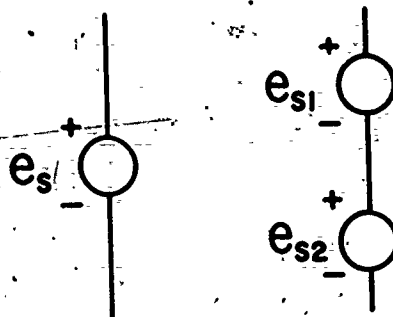

- f₁. e_{s1} = D-C source
- e_{s2} = time-varying voltages used in previous sheet
- g. Now experiment on your own in combining sources and graphing and writing equations for resultant v_o .
- h. Connect any resistive network of four resistors in any combination. Use one or two voltage sources and examine relationship between the applied voltages and the v_o you choose. What form does your v_o take with respect to applied voltages in all cases?

Experiment 3:

Notes to Instructor:

I. The Problem: Introduction of concept of resistance as ratio $\frac{e}{i}$.

A) Nonlinear R.

B) Linear R

C) Slope of v/i graph = $\frac{1}{R}$

II. Additional concepts covered: Introduction to Ohm's Law.

III. New Terminology:

Volt-Ampere Graph	Linear R
Resistance	Nonlinear R
R, ohm's, Ω	

IV. Student Background Required:

Laboratory technique in measuring v and i .

Plotting of curves.

V. This experiment employs a sequence of activities to introduce the concept of resistance, beginning with the use of both types of volt-ampere graphs for nonlinear as well as linear resistances. We then relate the slope of V/A graph with quantity measured with ohmmeter. Resistance is then defined as the ratio between voltage and current.

The sheets should be handed out individually along with the circuit element for that sheet. A #47 bulb is used for the first sheet, 100 ohm resistor for sheet #2, and a 1000 ohm resistor for the third sheet.

Finally, the student does some investigation into Ohm's Law as a lead into the classroom treatment of this topic.

The student should be warned to deactivate power source before removing element and measuring its value. This experiment necessitates the use of a scope with D.C. input.

For The Student

The Problem: $\frac{\text{Volts}}{\text{Amps}}$, $\frac{(v)}{(i)} = ???$

New Terminology Encountered:

Volt-Ampere Graph	Linear R
Resistance	Non-Linear R
R, ohm's, Ω	

Procedure: (Part I)

Connect the circuit below and plot (on both a v/i graph and a i/v graph) a sufficient number of points to produce a curve that graphically illustrates the relationship between the voltage across and current through the circuit elements. Do not exceed 250 ma current through circuit element. Use #47 bulb as circuit element. When finished, ask the instructor for Part II.

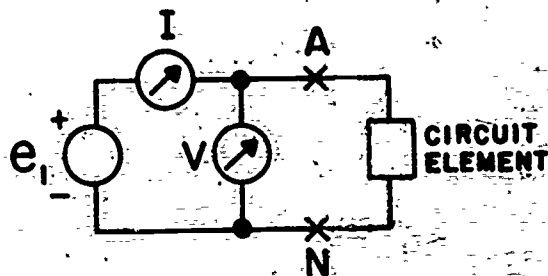

Procedure: (Part II)

Repeat Part I, replacing bulb with a second circuit element provided by the instructor.

- Calculate, from graphs, slope of each line.
- Disconnect at points A & N and measure with ohmmeter the circuit element used.
- Compare results of 1 + 2 and comment.

Procedure: (Part III)

Repeat Part I, replacing bulb with a third circuit element provided by the instructor.

- Calculate, from graphs, the slope of each line.
- Disconnect at points A + N and measure with ohmmeter the circuit element used.
- Compare results of 1 + 2 and comment.

Procedure: (Part IV)

From Parts B and C of this experiment, we have found that there is a relationship between the V/A graph of a circuit element and the quantity we measured with the ohmmeter.

Represent this relationship algebraically.

We normally express this relationship

in terms of the i/v form of volt-ampere graph.

We soon tire of expressing this as volts vs- amps or the slope of a line and call this quantity resistance (R) whose unit is the ohm.

Compare the graph you developed in Part A with those in Parts B & C. Comment.

Investigate further the interrelationship of those three quantities.

Experiment 4

Notes to Instructor

I. The Problem: Definition and approximation of R_{eq} for resistive networks.

A) R_{eq} for series, parallel and series-parallel circuits

B) Reduction of networks into series and parallel groups and combining to find R_{eq}

C) Significance of values of individual resistances on R_{eq}

II. New Terminology Encountered:

$$R_{eq} = \frac{e_s}{i_s}$$

III. Student Background, Required:

Laboratory technique

Graphing (V/A)

Ohm's Law

IV. General Notes:

This laboratory sequence introduces the concept of R_{eq} as the ratio between e_s and i_s .

It also allows the student some freedom in developing the mathematical relationship of R 's in series, parallel, etc.

Included is a sequence on relative significance of R 's in network and might well serve as a lead into a treatment of meter loading.

This lab sequence should be followed with classroom presentation of R_{eq} for series, parallel and series-parallel resistances. Included should be the treatment of network reduction, using recognition of these configurations and finding R_{eq} .

For The Student

The Problem: $\frac{e_s}{i_s} = ???$. For any Resistive Network

New Terminology Encountered:

Equivalent Resistance

$$R_{eq} = \frac{e_s}{i_s}$$

Procedure: (Part I)

Connect the two circuits, as shown by this part; and plot the volt-ampere graph for each. The circuits for this experiment are all on a separate page.

a. De-energize the source and measure with an ohmmeter the resistance that the source "sees" at the input terminals A and N.

b. Compare graphs and resistance measurements for the two circuits.

c. Compare the volt-ampere graphs obtained here with that of experiment 3 where a #47 bulb was used as the circuit element.

Comments:

Procedure: (Part II)

In Part I we discovered that a resistive network can be represented by a single resistance when we are concerned with what the source "sees". This is called the equivalent resistance (R_{eq}) for the network. We found its specific value by looking at the graphs and measuring it directly with the ohmmeter.

$$\frac{e_s}{i_s} = R_{eq} \text{ for passive any resistive network.}$$

a. Using the techniques employed in Part I, find R_{eq} for each of the given circuits found on a separate page for this experiment.

b. Without taking any measurements, could you have estimated any of these R_{eq} 's? Which ones and how?

Comments:

Procedure: (Part III)

a. Now, how would you estimate the R_{eq} for the resistive network in Part I.

b. In Part II, circuits 4, 5, and 6 demonstrate the relative significance of resistances. Comment on effect:

Procedure: (Part IV)

- a. Using any four resistors, connect them in any chosen circuit configuration to form two terminal networks and estimate Req for each. Check with ohmmeter.
- b. Try several combinations and values.

Figures for Experiment 4

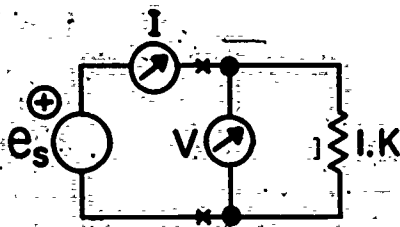
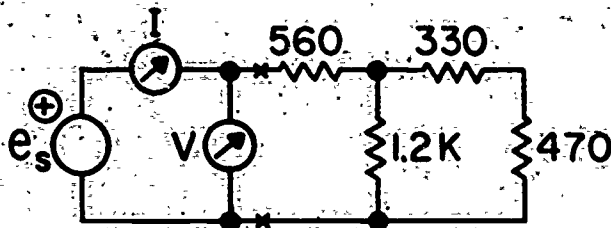

The two figures for Part I, Experiment 4

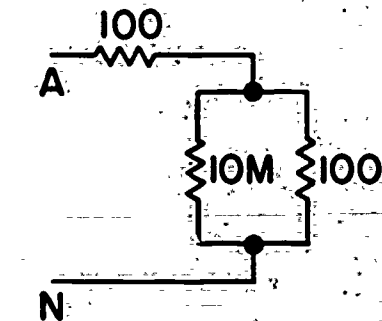
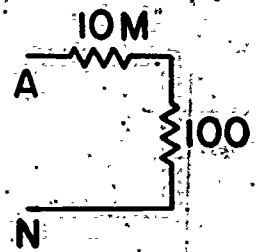
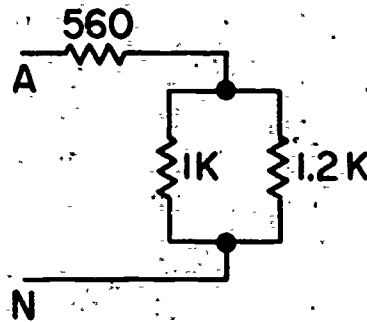
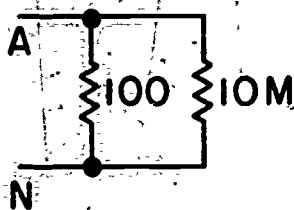
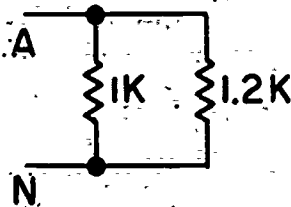
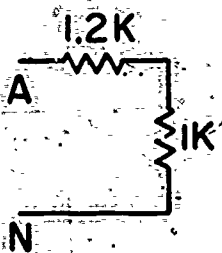

These six circuits are for Part II, of Experiment 4

Experiment 5

Notes to Instructor

- I. The Problem: Designing a divider network
 - A) Maintaining Bleeder Current at .10% of source current
 - B) Effect of adding additional loads
- II. New Terminology Encountered

i_b	Bleeder current
r_d	Dropping resistor
r_b	Bleeder resistor
- III. Student Background Required:

Ohm's Law	KCL
KVL	Familiarity with lab equipment

IV. General Notes:

This lab experiment has employed a sequence of problems leading the student to the design of a loads voltage divider. It allows the student much freedom and requires that he use a bit of initiative on his own.

The student should be informed that he will be unable to find exact resistors needed.

Procedure: (Part I)

Given your power supply, an assortment of resistors, and a #43 bulb, design and connect a circuit in which the current through the bulb is 90% of i_s . This implies a second current path. We will call the current through this path i_b .

The bulb should be operated as follows: #49 bulb 2.0V, 60 ma. What are the specifications of the second current path?

NOTE: Due to size and tolerances of resistors available, it may be necessary to measure some to find one close to value needed.

Procedure: (Part II)

In Part A of this sequence we designed a circuit in which i_b (Bleeder Current) flowing through the Bleeder Resistor (R_b) equalled 10% of i_s . We will maintain this ratio throughout the experiment.

Now, with your power supply set at 6.3V, design and connect a circuit that will allow the bulb to operate as before, according to specifications given. This will involve the use of another resistor, R_d (Dropping Resistor).

Procedure: (Part III)

Given a second bulb, a #47 with the specifications listed below, connect it to your circuit noting effect. Measure i_b and i_s . Have you upset the $i_b = 0.1 i_s$ ratio? Redesign your circuit to satisfy this requirement.

#47 bulb: 6.3V, 150 ma

Procedure: (Part IV)

Now, with your supply set at 28V, redesign your circuit to allow bulbs to function as before, maintaining i_s vs- i_b ratio.

Do you have to make any major adjustments in your previously connected circuits. If so, what changes?

Procedure: (Part V)

Design and connect a circuit that will allow for proper operation of the three bulbs provided, $i_b = 0.1 i_s$, and power supply set at 50V.

#49 bulb: 2.0V, 60 ma

#47 bulb: 6.3V, 150 ma

#313 bulb: 28V, 170 ma

Experiment 6

Notes to Instructor

- I. The Problem: Identification of all voltages and currents in a resistive network.
Measurements.
Minimum number of measurements necessary.
Identification of Nodes.
Polarities.
- II. New Terminology Encountered:
Nodes (primary and secondary).
- III. Student Background Required:
Use of instruments: voltmeter, oscilloscope, ammeter.
Double subscript notation.
Knowledge of Kirchhoff's Voltage Law.
- IV. General Notes:
Primary nodes are junctions from which there are three or more branches. A secondary node is a junction between two elements in the same branch.

There are twenty voltages to identify in the circuit of Fig. 1. Identification of four voltages will permit calculation of the remaining sixteen (16) by KVL. For any circuit the minimum number of voltages that need to be known is one less than the number of nodes.

With this kind of work done in the laboratory, the student should master Kirchhoff's voltage law and come to a better appreciation of reference polarities. The experiment should encourage the use of mathematics since the student may prefer to measure four voltages and calculate sixteen voltages rather than measure all twenty of them. The calculated values are much faster to do.

For the Student

The Problem: Identifying all voltages in the resistive circuit, Fig. 1

Background necessary: Use of instruments, voltmeter, oscilloscope.

Double subscript notation.

Knowledge of Kirchhoff's Voltage Law.

Procedure: (Part I)

Construct the circuit of Fig. 1, observing the indicated voltage polarities, and setting e_1 and e_2 to approximate the indicated voltages.

Now that the circuit has been constructed, you have the problem to identify (by measurements or by calculations) *all* of the voltages in the circuit. Before making any measurements or calculations, write down (using double-subscript notation such as v_{23} , v_{43} , etc) all of the possible voltages. Do not use numbers for these voltages as yet.

After you have done this, discuss procedures by which you might identify the numerical values of the voltages. When you are satisfied, ask the instructor for Part II of this experiment, where you will receive some specific guidance. Hopefully, you will have already decided on the guidance needed.

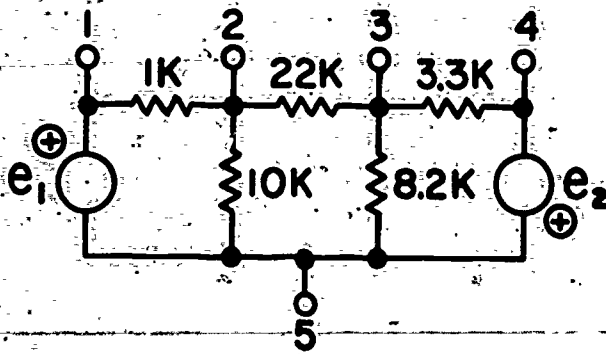

Fig. 1

Procedure: (Part II)

To assist you in finding all of the voltages in the circuit, you may wish to use the chart provided. Each square, except those on the diagonal, can be used to identify a particular voltage. The square in row 1, column 3 shall identify the voltage v_{13} . For each square, the subscripts are in the order of row-column.

Fill in all of the squares, except the diagonal. Measure if you wish, or in some cases you may prefer to calculate.

How many measurements are actually necessary if you would use KVL wherever possible? Does it make any difference where these minimum number

of measurements are made? Is there one set of minimum measurements more convenient than another?

V	1	2	3	4	5
1		v_{12}			
2					
3	v_{31}				
4					
5					

Procedure: (Part III)

Replace either, or both d-c sources of the circuit with time-varying functions, - sinusoidal, pulses, ramps as you wish.

Using the oscilloscope for making necessary measurements, arrive at a procedure for identifying all of the voltages. The technique of using the scope, with time-varying functions, is the important problem here. It is not necessary to determine all of the numerical values for the voltages. Once you decide what voltages to measure, and how to measure them, the remaining voltages are best done by calculation.

Experiment 7

Notes to Instructor

I. The Problem: Determination of Thevenin's Equivalent Circuit in the laboratory for any resistive Network.

- A) Verifying Thevenin's Theory.
- B) Application to any resistive network.

New Terminology Encountered:

Thevenin's Theorem v_{th}
 Thevenizing R_{int}

III. Student Background Required:

Problem-solving background using Thevenin's Theorem.

IV. General Notes:

Although this is a heavily structured verification-type experiment it was designed through the use of *leading questions*, to give students insight into Thevenin's Theorem and how to employ it effectively in solving laboratory problems. This technique allows students to find Thevenin's Equivalent in the lab for a network without doing any calculations.

For the Student

The Problem: Determination of Thevenin's Equivalent Circuit in the laboratory for any resistive network.

New Terminology Encountered:

v_{th} Thevenin's Theorem
 R_{int}

Procedure:

Connect the circuit of Fig. 1 with the values given.

$v_o =$

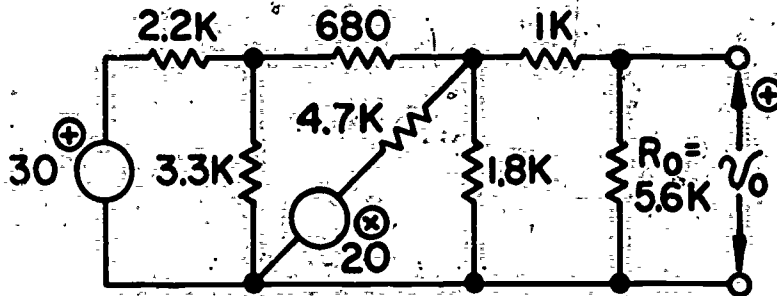
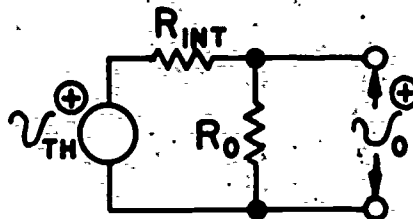

Fig. 1.



Circuits for Experiment 7

Remove R_0 from the circuit and measure a new v_o , which we will call v_{th} .

$$v_{th} = \underline{\hspace{2cm}}$$

Place a potentiometer in place of R_0 and adjust until v_o now equals $\frac{v_{th}}{2}$.

After potentiometer is set, do not change setting. We will call this value of resistance R_{int} .

Now set up the circuit of Fig. 2 using the values previously found and measure v_o .

How does this value of v_o compare with v_o measured in the first step of this sequence?

Comment or generalize:

Why was P_{ot} set so now $v_o = \frac{v_{th}}{2}$?

Construct a resistive network of your own choosing, keeping all resistors in the range of 1K to 10K and all sources under 20V. Select two terminals (T) and (H) about which to reduce the circuit. Follow the preceding procedure.

Experiment 8

Notes to Instructor

I. The Problem: Introduction of Superposition theorem in the lab.

II. Student background required:

KVL

KCL

Ohm's Law

Use of Dual-Trace Scope

Use of Dual Oscillator

Series Circuits

Parallel Circuits

Series-Parallel Circuits

Use of Dual D.C. Source

III. New Terminology Encountered

Superimposed

Superposition Theorem

Attenuated

IV. General Notes:

This experiment should be used before the student is exposed to the superposition theorem in the classroom. In getting started in the experiment, if the student is fortunate enough to adjust the d-c source *first*, then the a-c source, the superposition theorem (he doesn't know it by name) may hit him right between the eyes, since he had to adjust the two sources one at a time. He might then observe that the d-c level of v_2 is attenuated, interpret that this is true because of the voltage divider circuit, measure 4 volts, and calculate 4 volts. Then while he adjusts the a-c source he may again do the same line of reasoning (observe, interpret, measure, calculate) for the sine wave and further observe that the *attenuated* sine wave is *superimposed* on the attenuated d-c level. If he doesn't make these observations, etc, ask him to start over again with both sources set initially at zero and watch e_1 and v_2 a little more carefully while he is adjusting the sources. If he still has trouble--Tell and Show.

For those that adjust the a-c source first, and don't get the point because the attenuated d-c value is not visualized as the average of the attenuated sine wave, then suggest they start over

again adjusting the d-c source *first*.

Give them time to get the job done, provided they don't get too impatient or confused. The time required to do it themselves might be worth it. Maybe "patience" needs to be taught as something worthwhile?

For those that finish early, be prepared to suggest other circuits with the two in different places in a circuit.

For the Student

The Problem: Determining the response of a resistive circuit with more than one source.

Procedure: Connect the circuit below using your oscillator and D.C. source to stimulate e_1 . Observe both e_1 and v_2 as you adjust the two sources to satisfy e_1 . Can you find a procedure, different than any that has been presented in class, for class, for calculating and interpreting v_2 ?

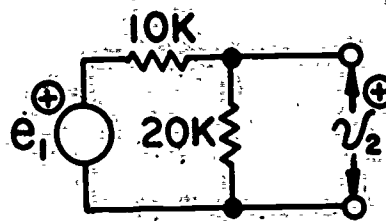

$$e_1 = 6 + 12 \sin \omega t$$

What is the contribution of the oscillator to v_2 ?

What is the contribution of the D.C. source to v_2 ?

SINGLE-TIME-CONSTANT CIRCUITS (CIRCUITS II)

DEFINITION

The subject of *Single-Time-Constant (STC) Circuits* is a study and analysis of R-C and R-L circuits that have one, and only one, equivalent capacitance in the R-C circuits and only one equivalent inductance in the R-L circuits. Mathematically, the equations for such circuits are *first-order differential equations*. From the *zero-pole* standpoint, such circuits have one, and only one, pole. They will have no more than one zero.

MAJOR CONCEPTS

Every STC circuit exhibits an exponential response to an applied voltage that is a step function or a ramp function. The solution of such circuits simply amounts to an identification of the three significant quantities of the exponentials -- the time-constant, the asymptotical value and the initial value for each possible exponential existing in the response.

With a sinusoidal source voltage, the response of every STC circuit is also sinusoidal under steady-state conditions. The output voltage, with respect to the input voltage, may exhibit a shift in phase and a lesser magnitude, -- never a larger magnitude. The current anywhere in an STC circuit may exhibit a shift in phase with respect to the applied voltage.

The STC circuits cannot "Ring", neither can they be used to produce "Nulls" or "Tuning" effects.

BEHAVIORAL OBJECTIVES

Upon satisfactory completion of the subject of *STC Circuits*, the student will have the ability to:

- a. Recognize those circuits containing resistances and capacitances (or inductances) that are single-time-constant circuits.
- b. Analyze STC circuits when the applied volt-

age is a step function, or a ramp function, or a sinusoidal function.

- c. Determine the time constant of an STC circuit with ease.
- d. Determine the R_{eq} and C_{eq} (or L_{eq}) at any set of terminals in the circuit using known techniques for circuit simplification.
- e. Know when an exponential exists; to determine its initial value, asymptotical value and time constant; and to plot all exponentials in their proper time relationships to the applied voltage.
- f. Make necessary calculations when an exponential does not have time to complete.
- g. Use complex numbers to evaluate STC circuits with sinusoidal sources.
- h. Understand the technique of analysis using S-equations.
- i. Determine and plot the frequency response of STC circuits.
- j. Correlate sinusoidal response with exponential response.
- k. Determine power and energy in STC circuits and to understand their concepts.
- l. Know the physical properties, types and structure of capacitors and inductors.

PREREQUISITES

In addition to a working knowledge of trigonometry and algebra through complex numbers and exponential functions, the student needs the basic concepts of differential and integral calculus. Complete courses in these two subjects are not a prerequisite to the subject of STC circuits.

Primarily the student needs to understand the derivative as a slope of a function and the integral as an area. These concepts of slope and area will be re-enforced in the STC circuits.

Although the use of the S-operator is recommended for a study of STC circuit, a formal academic background in the knowledge of LaPlace transforms is not, and cannot be considered as a prerequisite for STC circuits. A formal knowledge of LaPlace transforms may become a pre-

requisite for the analysis of general networks which become more involved than circuits restricted to the single-time-constant area.

The flow chart, presented here, illustrates the position of STC circuits in a curriculum relative to other key subjects.

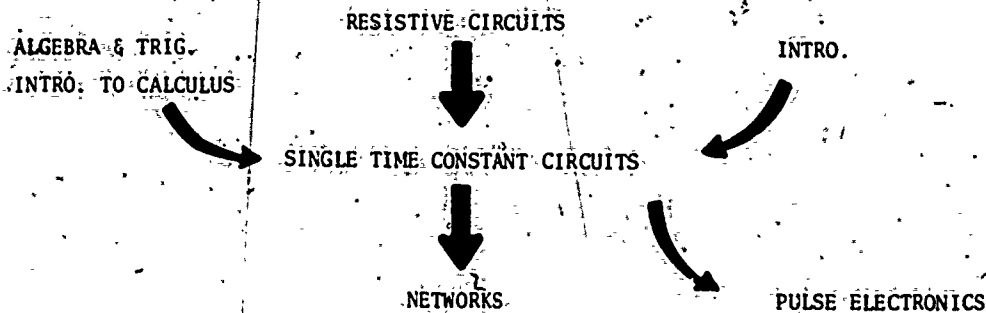

OUTLINE

I. Properties of Inductance and Capacitance

A. Storage of energy in magnetic and electrical fields.

B. Defining Equations for inductance and capacitance (Class Introduction and Study)

$$1) \ v_L = L \frac{di}{dt} \quad 2) \ i_C = C \frac{dv}{dt}$$

$$i_L = v_L / \frac{di}{dt} \quad C = i_C / \frac{dv}{dt}$$

C. Determination of C_{eq} and L_{eq}

1. Series. 2. Parallel

II. R-C and R-L circuits with step and rectangular inputs (Class Introduction and Support)

A. Input waveforms

1. General equation 3. Ave. value
2. Instantaneous values 4. Rms value

B. Output response (Lab Introduction and Study)

I. Properties of the exponential

- e^{-x}
- Initial value
- Asymptotical value
- Time factor (x)

2. Time Constants

a. R-C

Derive Units

b. R-L

c. $e^{-\frac{t}{\tau}}$

3. General equation for circuit with exponential response (Class Introduction and Study)

a. $v_t = E_{as} - (E_{as} - E_0) e^{-\frac{t}{\tau}}$

b. $i_t = I_{as} - (I_{as} - I_0) e^{-\frac{t}{\tau}}$

C. Determination of E_0 and E_{as} when exponentials do not complete (Class Introduction and Study)

D. Problem solving and application (Class Support)

1. Significance of 5 time constants and E_{as}

2. Reduction of circuits to single R_{eq} with single C_{eq} for any set of terminals.

a. Application of Thevenin's Theorem
b. Superposition Theorem

3. Finding the three significant values

a. Asymptotic

- b. Initial
- c. Time constant

III. R-C and R-L circuits with sinusoidal inputs

- A. Sinusoids
 - 1. General equation
 - 2. Instantaneous quantities
 - 3. Ave. value
 - 4. Rms value
- B. Introduction to reactances
- C. Impedance
- D. Application of complex algebra (Classroom Study, Lab Support)
 - 1. j operator
 - 2. Rectangular notation
 - 3. Polar notation
 - 4. Conversion
 - 5. Mathematical manipulations using electrical quantities
 - a. Addition
 - b. Subtraction
 - c. Multiplication
 - d. Division
 - e. Complex conjugate
 - f. Phasor diagram
- E. Solution of problem circuits for voltages and currents (Classroom Study)
 - 1. Writing equations
 - 2. Manipulation of equations
 - 3. Application of phasor diagram
- F. Bode or corner plots (Lab Support)
 - 1. Transfer function equations
 - 2. f_1 and f_2 (corner frequencies)
 - a. Half-power point
 - b. ≈ 3 db
 - c. Voltage ratio
 - d. $\theta = -45^\circ$
 - 3. Calculation of f_1 and f_2 (Classroom Study)
 - 4. Graphical representation
 - a. Semi-log scaling
 - b. Octave & decade
 - c. Asymptotes
 - d. Curve

G. Analysis by Locus Plots. (Class Introduction)

- 1. Referencing
 - 2. Series circuits
 - 3. Parallel circuits
- ### IV. Differentiator and Integrator Circuits (Classroom Introduction and Study)
- A. v_0 Not true differential or integral
 - B. Approximation
 - C. Inputs (Lab Support)
 - 1. Pulse
 - 2. Sinusoid
 - 3. Ramp
- ### V. Power dissipation in single-time-constant circuits (Class and Lab Support)
- A. Definition
 - B. Instantaneous
 - C. Average
 - D. True power vs apparent power
 - 1. Definition of Vars
 - 2. Heat dissipated energy
 - E. Decibels (db)
 - F. Duty cycle in pulse trains
 - G. Measurement
 - H. Power factor
 - I. Maximum power transfer
 - 1. Conjugate relationship between Z_L and Z_{th}
- ### VI. Inductors and Capacitors (Laboratory)
- A. Physical Construction
 - B. Types
 - C. Ratings
 - D. Models for each
 - E. Q

GENERAL GUIDELINES

The information and suggestions of these *General Guidelines* are presented to emphasize the major concepts and the importance of topic sequencing in the subject of STC Circuits. Specific suggestions applicable to classroom instruction and to laboratory instruction will follow these general guidelines.

Three Major Divisions of STC Circuits

A study of *STC Circuits* has three major divisions.

- Part I: Concepts of inductance and capacitance.
- Part II: Exponential responses of STC circuits with voltage sources that are *steps, ramps, pulses,* and rectangular waveforms.
- Part III: Steady-state sinusoidal responses to sinusoidal sources.

The three parts are stated in the recommended sequence of study.

Start With Defining Equations

The four defining equations, two for inductance and two for capacitance, are presented in the topical outline as one of the topics to be presented and studied very early in the subject of STC circuits.

The concept of inductance, or the concept of capacitance, is presented as a proportionality factor in these equations where *time* is one of the parameters. It should be emphasized in these early studies that the proportionality factor of inductance exists whenever the voltage across an element is directly proportional to the time-rate-of-change of current in that element. The quantity of capacitance exists whenever the current in an element is directly proportional to the time-rate-of-change of the voltage across the element.

Taking Advantage of Student's Background

The teaching of STC circuits should take advantage of the student's background gained in the previous subject of *Resistive circuits*. These advantages as they apply to the learning of STC circuits are as follows:

- a. The student is equation oriented and should feel comfortable with equations for defined waveforms as well as instantaneous voltages and currents.
- b. The student is aware of graphical as well as mathematical solutions.
- c. The waveforms studied in resistive circuits

allow for the omission of the traditional battery and switch approach to satisfy the students' curiosity regarding a step input. This allows for immediate use of a rectangular input waveform.

- d. The student is able to reduce resistive portions of STC circuits to equivalent models.

Sequencing of Materials in STC Circuits

The sequencing of materials in STC circuits is based on the premise that the student can better orient himself in regard to the appreciation and understanding of inductance and capacitance as well as their effect in a circuit if the R-L and R-C circuits are first approached with a rectangular input.

At first the student is encouraged to study the response of such circuits, then he is asked to calculate this response.

Since the exponential is always involved in the response of such a circuit with the rectangular input, the student can best understand what effects the inductance and capacitance have on the circuit if he varies the circuit parameters.

If the sinusoidal input were used to introduce these circuits, the student would find it difficult to appreciate the change that takes place in terms of both amplitude and time.

Using the Laboratory Environment to Full Advantage

The laboratory environment is used extensively in this series of topics to introduce major concepts because, as mentioned above, both amplitude and time are now variables, which is not the case in resistive circuits.

The student has the background and instrumentation capability necessary for observing, interpreting, measuring, and calculating the significant quantities involved, which enhances and expedites his study of single-time-constant circuits.

The laboratory sequence does not begin with

the measurement of inductors and capacitors primarily because it is more important that the student understand the response of circuits caused by inductance and capacitance.

The physical properties and the characteristics of inductors and capacitors are reserved for study near the end of the subject of *STC circuits*. This is an attempt to give the student a clear insight into the effect of inductance and capacitance in any circuit, and also to give him the practical orientation needed before delving into the physics of these devices.

The Importance of Thevenin's Theorem

Most, but not all, *STC* circuits can be reduced to a simple series circuit by applying Thevenin's theorem to the resistive circuit portion of a given circuit. This procedure removes the need for deriving the response for each and every *STC* circuit, since the necessary derivations for a series circuit will have been done previously.

In addition, the equivalent series circuit will reveal information as to attenuation factors, circuit time-constant and asymptotical values for exponential responses.

Exponential Responses Before Sinusoidal Responses

The topical outline and preceding comments of these *General Guidelines* suggest that *STC* circuits should be studied with step and ramp voltages applied before *STC* circuits are studied with sinusoidal sources.

Going directly to a study of capacitive and inductive circuits with sinusoidal sources is discouraged. Only *STC* circuits have exponential responses to steps and ramps. Any linear capacitive and/or inductive circuit, no matter how many *C*'s or *L*'s, will have a sinusoidal response to a sinusoidal source under steady-state conditions.

Once circuit analysis with sinusoidal sources is started, there is no logical place to discontinue or interrupt such studies. A study of circuits with exponential responses is essentially completed with *STC* circuits. Multiple

time-constant circuits do not have an exponential response to step and ramp functions.

Circuit analysis under sinusoidal steady-state conditions requires a working knowledge of complex numbers and the *j*-operator. The need for a knowledge of this topic in mathematics is delayed if exponential responses are studied ahead of sinusoidal responses.

An important concept of circuit analysis may become more difficult to master, if not lost completely, if exponential responses do not precede sinusoidal responses. This concept involves circuit time-constants, which are the significant quantities for any kind of driving function. It must be recognized that the concept of capacitive reactance, or inductive reactance (having the units of ohms) is applicable only for sinusoidal steady-state conditions.

Using the S-Operator

Although the *S*-operator has reference to Laplace transforms, its use is encouraged even though the student will not have a formal background in the topic of Laplace transforms at the time when the subject of *STC*'s is offered in the curriculum.

The *S*-operator is needed, primarily, for the purpose of deriving the response of an *STC* circuit. This can be done in one or two lecture periods. The table of transforms will reveal whether the circuit response is an exponential or a sinusoidal function. The problem-solving portion is the more time consuming. The technique involves going directly to the known response to identify the exponential when it exists, or the sinusoid when it exists.

CLASSROOM GUIDELINES

The information and suggestions presented in these *classroom guidelines* are directed specifically to the activities of the classroom. Any references to laboratory activities are stated for the purpose of emphasizing that certain concepts are more easily learned in the

laboratory than in the classroom.

Properties of Inductance and Capacitance

In the preceding study of resistive circuits we were faced with getting started in the study. We began by considering the physics of electricity leading into a definition of voltage as a force and current as a rate of transfer of charge resulting from the application of the force. These definitions, although rather simple minded, led us to the position where we are able to define resistance as the ratio between voltage and current, provided this ratio is not also dependent on time.

Likewise, through a study of single-time-constant circuits we can define inductance, as well as capacitance, in terms of voltages and currents with time as a third dependent factor. The defining equations, which are expressions of differential calculus and integral calculus, should not be avoided even in these early studies. This may be the student's first exposure to integral expressions but he will already understand the concept of a derivative from resistive circuits where he determined resistance as a slope on a volt-ampere graph. Now, for inductance and capacitance, derivatives with respect to time are needed.

The laboratory can be used to great advantage, in these early studies of the course, to gain an understanding of the properties of inductance and capacitance, where it can be observed that it takes time for a capacitor to charge in an R-C series circuit where a step voltage is applied and that it takes time for a current to change in an R-L series circuit when a step voltage is applied. There are a number of laboratory approaches to this problem, but in any case the early emphasis should be on the importance of time. The exact analysis and circuit calculations can come a little later.

What about the charge, Q?

Students need to know the relationship of

$$C = \frac{Q}{V}$$

which is derived from the defining equations for capacitance. Thus,

$$\begin{aligned} v_c &= \frac{1}{C} \int i dt \\ &= \frac{1}{C} \int dQ \\ &= \frac{Q}{C} \end{aligned}$$

Similarly, from the second form of the defining equation the same result is obtained. Thus,

$$\begin{aligned} i &= C \frac{dv}{dt} \\ \frac{dQ}{dt} &= C \frac{dv_c}{dt} \\ Q &= CV \end{aligned}$$

The important point being made here is that the defining equations, in the differential or integral form, represent the starting equations for all derivations involving capacitance or inductance. This approach leads more quickly with more satisfaction to the student to the important activity of the course, which is to analyze the response of STC circuits to different driving functions. Spending more than just a very little time on the physics of capacitors and inductors at this time, especially in the classroom, is strongly discouraged. The physics concepts are more appropriately done later in the course or perhaps in a physics course.

Series and Parallel Equivalence for C's and L's

The defining equation for C's and L's, provide a convenient means for derivation of C_{eq} , or L_{eq} , for series and parallel combinations. With two, or more, C's in series we write,

$$e_s = v_{c1} + v_{c2} + \dots + v_{cn}$$

then by substitution of defining equation for each capacitance we have,

$$e_s = \frac{1}{C_1} \int i dt + \frac{1}{C_2} \int i dt + \dots + \frac{1}{C_n} \int i dt = \left(\frac{1}{L_1} + \frac{1}{L_2} + \dots + \frac{1}{L_n} \right) \int v dt$$

consequently, by collecting coefficients of $\int i dt$,

$$e_s = \left(\frac{1}{C_1} + \frac{1}{C_2} + \dots + \frac{1}{C_n} \right) \int i dt = \frac{1}{C_{eq}} \int i dt$$

The following similar sequence of equations would be used for L's in series except for the need of using the differential form rather than the integral form of the defining equations. Thus, for L's in series,

$$\begin{aligned} e_s &= v_1 + v_2 + \dots + v_n \\ &= L_1 \frac{di}{dt} + L_2 \frac{di}{dt} + \dots + L_n \frac{di}{dt} \\ &= (L_1 + L_2 + \dots + L_n) \frac{di}{dt} \\ &= L_{eq} \frac{di}{dt} \end{aligned}$$

Notice, for the series combinations that the equations are written using Kirchhoff's voltage law. For parallel combination's we need to start with Kirchhoff's current law. Thus for C's in parallel, we would find C_{eq} through the following sequence of equations,

$$\begin{aligned} i_s &= i_1 + i_2 + \dots + i_n \\ &= C_1 \frac{dv}{dt} + C_2 \frac{dv}{dt} + \dots + C_n \frac{dv}{dt} \\ &= (C_1 + C_2 + \dots + C_n) \frac{dv}{dt} \\ &= C_{eq} \frac{dv}{dt} \end{aligned}$$

For inductances in parallel we have the following sequence of equations to find L_{eq} ,

$$\begin{aligned} i_s &= i_1 + i_2 + \dots + i_3 \\ &= \frac{1}{L_1} \int v dt + \frac{1}{L_2} \int v dt + \dots + \frac{1}{L_n} \int v dt \end{aligned}$$

Exponential Responses of STC Circuits

Up to this point we have been getting ready to handle STC circuits. There may be other introductory kinds of material leading up to this point that the Instructor may wish to include.

One of the major concepts to be included in this course is that an STC circuit will respond to a step, rectangular, or ramp input in the form of an exponential. Therefore, the student must be familiar with exponentials. It may be desirable in some cases to approach the exponential from a mathematical basis. However, in order to handle the problems encountered, the student must be able to analyze an exponential response, including the identification of initial values, asymptotic values, and time constants, as well as to use these values in the general equation for voltage or current in a STC circuit. Of major importance here is the realization that initial values of current or voltage when the source steps are a result of conditions in the circuit just before the source stepped.

Approaching this problem from the aspect of one time-constant yielding 63% of asymptotic value may provide qualitative insight for understanding how the circuit performs; but it is not engineering technology level of performance. The graduate from this type of program must be competent in working with the actual exponential equations involved.

Following these considerations the general technique for solving these problems is developed and the student should solve a number of these problems at this time. In order to fully understand these circuits, several cycles of operation must be plotted, emphasizing that the

original quantity is a result of what has happened before.

The sequence of classroom activities for this topic will relate closely to the laboratory activities as presented more specifically in the *Laboratory Guidelines*.

Sinusoidal Response of STC Circuits

The mathematical basis on which this topic is built is complex algebra. It is assumed at this point that the student has covered the j -operator in his study of mathematics so the treatment of this material is from an application basis. Reactances are appropriately handled as $j\omega L$ and $\frac{1}{j\omega C}$ with writing impedance as R plus these reactances. (Rectangular Form). Approaching impedance calculations as the square root of sum of squares should be avoided if the student is to develop an understanding of STC circuits with sinusoidal inputs.

This topic lends itself well to application of the "S operator", where S is defined as $S=j\omega$. If this approach is taken, S should be nothing more than an operator and reference to LaPlace should not be made.

As with our study of these circuits with rectangular inputs, many problems should be done. This may be an appropriate point to include a study of multi-phase circuits now that the mathematical basis has been developed.

It is appropriate to include at this point in the sequence a study of the use of bode or corner plots in relation to frequency response of circuits containing reactances. Among the merits of including this topic are the following:

- a. Having written a voltage or current equation for the circuit, the student can now transpose it into the transfer function form.
- b. It allows student to interpret general as well as specific circuit response by putting actual circuit values into the equation.
- c. The student is working in the frequency domain, which will prepare him for the following network course.

The student should be instructed to withhold

the insertion of circuit values into the transfer function equation until he has simplified it.

Inclusion of a consideration of locus plots may aid in understanding frequency response of STC circuits and will lead to their use in networks.

Because the student will have frequent encounters with differentiator and integrator circuits throughout his study of electronics, they should be covered and this is the natural point in the sequence to handle them.

Studies Using the S-Operator.

On the following pages there are circuits, equations and graphs presented to illustrate the use of the S -operator and its value in quickly and easily showing the relationship of an exponential response to sinusoidal response. These are identified as Table I, Table II, and Table III. (Turn three pages).

Twelve circuits, all series circuits, are shown in these tables. There are a number of other STC circuits that can be reduced to series circuits to apply the concepts presented in the three tables.

Examination of the circuits, equations, response sketches, and bode plots for those circuits treated here reveals some interesting information. Specifically, once the characteristic equation is revised, many circuit properties can be "read" directly from the equations and the others of importance appear when this characteristic equation is taken to its limits (S goes to zero and to infinity).

However, it must be pointed out that these studies are based on several pre-determined assumptions. They are as follows:

- a. No energy is stored in any circuit elements previous to time $t = 0$. In other words, there are no initial conditions.
- b. The step function input has the magnitude of unity

$$e_s = 1 u(t)$$

c. When the revised equations are taken to their limits, the dimensions of the equations must remain intact. For the equations of these studies, they must remain dimensionless.

With these considerations firmly in mind, the following outline will aid in "reading" the revised characteristic equations.

A. Initial Observations.

1. The time constant for the circuit appears as the root of the equation pole.
2. If a prefix appears in front of the equation there are several possibilities.
 - a. Dimensionless: This occurs only when the equation contains a zero $[(s + a)]$ term in the numerator. The absence of a prefix is read as a prefix of one (1). This quantity indicates the scalar for the step that occurs on the output when the input steps.
 - b. Dimension of (1/time): This occurs only when the equation contains no zero term in the numerator. If a step is applied to the input, the initial slope of the exponential on the output is equal to this prefix.

B. If no zero appears in the equation.

1. The output does not step when input steps (assuming no circuit changes).
2. There is only one bode corner (root of the equation pole).
3. Prefix indicates the initial slope of the exponential.

C. If a zero appears in equation (numerator).

1. The output will step when input steps.
2. Output step magnitude determined by equation prefix (dimensionless)
3. Root of zero $\neq 0$
 - (a) Additional bode corner appears.
 - (b) ω of additional corner = root of zero.

D. Letting S (or ω) go to infinity

1. Simplify and read
 - (a) Level of bode plot at high f
 - (b) Magnitude of step at output

E. Letting S (or ω) go to infinity

1. Simplify and read.
 - (a) Level of bode plot at low f
 - (b) Asymptotic value with step input

F. Compare exponential response with bode plots

1. When one rises, the other falls.
2. E_o = High frequency level.
3. E_{as} = Low frequency level.

Writing S-Equations for STC Circuits

Circuit equations using the S-operator are easier to write, with less confusion, than equations using the j-operator. For one thing, there is less need to watch for proper use of "+" and "-" signs. Students adjust to the use of the S-operator quite readily.

Example 1

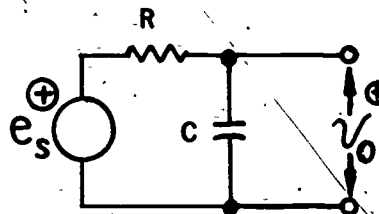

For the R-C series circuit, the S-equation for the voltage across the capacitance is,

$$V_o(s) = E(s) \cdot \frac{\frac{1}{sC}}{R + \frac{1}{sC}} \quad (\text{Eq. 1})$$

where it must be understood that $V_o(s)$ and $E(s)$ are undefined as to dimensions until the nature of the driving function is given or known. If the source is sinusoidal and steady-state conditions are desired, then let $S=j\omega$ and E can now represent peak values or effective values as desired.

If frequency response is desired, then it becomes necessary to write the equation in the following form,

$$\frac{V_o(s)}{E(s)} = \frac{1}{RC} \cdot \frac{1}{s + \frac{1}{RC}} \quad (\text{Eq. 2})$$

The corner frequency is found from the $1/RC$ term of the $(S + 1/RC)$ factor. This is the "pole" of the equation:

Returning attention to Eq. 2, if the source is a step, simply replace $E(s)$ by $1/S$ times magnitude of step, go to a transform table to find v_o as a function of time. It will be the exponential response.

Example 2:

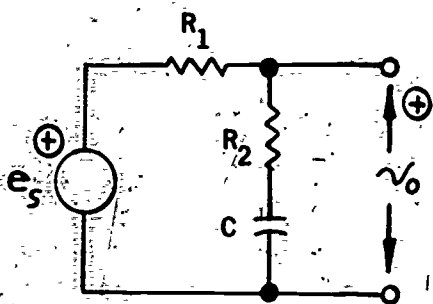

For this circuit,

$$v_o(s) = E(s) \cdot \frac{R_2 + \frac{1}{SC}}{R_1 + R_2 + \frac{1}{SC}}$$

and to get the equation in convenient form, we need to express numerator and denominator as factors of S . This is done as follows:

$$\begin{aligned} \frac{v_o(s)}{E(s)} &= \frac{R_2 SC + 1}{(R_1 + R_2)SC + 1} \\ &= \frac{R_2}{R_1 + R_2} \cdot \frac{S + \frac{1}{R_2 C}}{S + \frac{1}{(R_1 + R_2)C}} \end{aligned}$$

The steps in the above amounted to multiplying numerator and denominator by SC and then factoring out the coefficients of S in both numerator and denominator.

This equation has one pole and one zero. They are identified on a frequency plot in Table II, on a previous page.

Three Possible Forms of S-Equations for STC Circuits

An interesting fact about S-equations is that one has a natural desire to write the equation in a standard form, -- which are factors of S .

There are three, and only three, forms that S-equations can have for STC circuits. They are:

First Form: $\frac{v_o(s)}{E(s)} = \frac{1}{S + \alpha}$

Second Form: $\frac{v_o(s)}{E(s)} = K \frac{S}{S + \alpha}$

Third Form: $\frac{v_o(s)}{E(s)} = K \frac{S + \alpha_1}{S + \alpha_2}$

Observe that there is always one "pole" and perhaps one "zero" but no more. These three possibilities exist in the illustrations of Tables I, II and III.

Recommendations on Use of S-Operator

Each instructor will need to make a personal decision as to the extent he wishes to use the S-operator. Remember, however, that it does not replace the conventional use of j and $j\omega$. It is in addition to.

If the S-operator is not used, then there is no convenient procedure of analyzing the response of circuits for any kind of driving function. The association of responses to steps and sinusoids is particularly important as illustrated in three tables.

The S-equations do point out the importance of circuit time-constants, which are significant for any kind of driving function.

Without the S-operator, there can be excessive emphasis on ohms-of-reactance for L's and C's, a term which applies only for sinusoidal steady-state.

TABLE I: "S" STUDIES (SERIES STC'S WITH 1R AND 1C OR 1L)

CIRCUIT DIAGRAM	REVISED "S" RESPONSE EQUATION	RESPONSE TO UNIT STEP	FREQUENCY RESPONSE
	$\frac{V_0(s)}{E_s(s)} = \frac{1}{RC} \frac{1}{(s + \frac{1}{RC})}$ <p>WHEN $S \Rightarrow 0$: $\Rightarrow 1$ WHEN $S \Rightarrow \infty$: $\Rightarrow 0$</p>	<p>$E_0 = 0$ $E_{AS} = 1$ $TC = \text{POLE}$ $TC = \text{ROOT}$</p> <p>PREFIX: $\frac{1}{RC}$ INITIAL SLOPE OF EXPONENTIAL</p>	<p>HIGH F: $(S \Rightarrow \infty)$ $F(s) \Rightarrow 0$ LOW F: $(S \Rightarrow 0)$ $F(s) \Rightarrow 1$</p>
	$\frac{V_0(s)}{E_s(s)} = \frac{s}{(s + \frac{1}{RC})}$ <p>WHEN $S \Rightarrow 0$: $\Rightarrow 0$ WHEN $S \Rightarrow \infty$: $\Rightarrow 1$</p>	<p>$E_0 = 1$ $E_{MS} = 0$ $TC = \text{POLE}$ $TC = \text{ROOT}$</p> <p>PREFIX: 1 = SCALAR OF STEP</p>	<p>HIGH F: $(S \Rightarrow \infty)$ $F(s) \Rightarrow 1$ LOW F: $(S \Rightarrow 0)$ $F(s) \Rightarrow 0$</p>
	$\frac{V_0(s)}{E_s(s)} = \frac{s}{(s + \frac{R}{L})}$ <p>WHEN $S \Rightarrow 0$: $\Rightarrow 0$ WHEN $S \Rightarrow \infty$: $\Rightarrow 1$</p>	<p>$E_0 = 0$ $E_{AS} \neq 0$ $TC = \text{POLE}$ $TC = \text{ROOT}$</p> <p>PREFIX: 1 = SCALAR OF STEP</p>	<p>HIGH F: $(S \Rightarrow \infty)$ $F(s) \Rightarrow 0$ LOW F: $(S \Rightarrow 0)$ $F(s) \Rightarrow 1$</p>
	$\frac{V_0(s)}{E_s(s)} = \frac{R}{L} \frac{1}{(s + \frac{R}{L})}$ <p>WHEN $S \Rightarrow 0$: $\Rightarrow 1$ WHEN $S \Rightarrow \infty$: $\Rightarrow 0$</p>	<p>$E_0 = 1$ $E_{AS} = 1$ $TC = \text{POLE}$ $TC = \text{ROOT}$</p> <p>PREFIX: $\frac{R}{L}$ INITIAL SLOPE OF EXPONENTIAL</p>	<p>HIGH F: $(S \Rightarrow \infty)$ $F(s) \Rightarrow 1$ LOW F: $(S \Rightarrow 0)$ $F(s) \Rightarrow 0$</p>

TABLE II: "S" STUDIES (SERIES STC'S WITH 2R'S AND 1C OR 1L)





CIRCUIT DIAGRAM	REVISED "S" RESPONSE EQUATION	RESPONSE TO UNIT STEP	FREQUENCY RESPONSE
	$\frac{V_0(s)}{E_s(s)} = \frac{R_2}{(R_1+R_2)} \frac{S}{S + \frac{1}{(R_1+R_2)C}}$ <p>WHEN $S \rightarrow 0$: $\Rightarrow 0$ WHEN $S \rightarrow \infty$: $\Rightarrow \frac{R_2}{(R_1+R_2)}$</p>	 <p> $E_0 = \frac{R_2}{(R_1+R_2)}$ $EAS = 0$ POLE $TC = \text{ROOT}$ PREFIX: $\frac{R_2}{(R_1+R_2)}$ = SCALAR OF STEP </p>	 <p> HIGH F: $(S \Rightarrow \infty) F(s) \Rightarrow \frac{R_2}{(R_1+R_2)}$ LOW F: $(S \Rightarrow 0) F(s) \Rightarrow 0$ </p>
	$\frac{V_0(s)}{E_s(s)} = \frac{R_2}{(R_1+R_2)} \frac{(S + \frac{1}{R_2 C})}{S + \frac{1}{(R_1+R_2)C}}$ <p>WHEN $S \rightarrow 0$: $\Rightarrow 1$ WHEN $S \rightarrow \infty$: $\Rightarrow \frac{R_2}{(R_1+R_2)}$</p>	 <p> $E_0 = \frac{R_1}{(R_1+R_2)}$ $EAS = 1$ POLE $TC = \text{ROOT}$ PREFIX: $\frac{R_2}{(R_1+R_2)}$ = SCALAR OF STEP </p>	 <p> HIGH F: $(S \Rightarrow \infty) F(s) \Rightarrow \frac{R_2}{(R_1+R_2)}$ LOW F: $(S \Rightarrow 0) F(s) \Rightarrow 1$ </p>
	$\frac{V_0(s)}{E_s(s)} = \frac{R_2}{L} \frac{1}{S + \frac{R_1+R_2}{L}}$ <p>WHEN $S \rightarrow 0$: $\Rightarrow \frac{R_2}{(R_1+R_2)}$ WHEN $S \rightarrow \infty$: $\Rightarrow 0$</p>	 <p> $E_0 = \frac{R_2}{(R_1+R_2)}$ $EAS = \frac{R_2}{(R_1+R_2)}$ POLE $TC = \text{ROOT}$ PREFIX: $\frac{R_2}{L}$ = INITIAL SLOPE OF EXPONENTIAL </p>	 <p> HIGH F: $(S \Rightarrow \infty) F(s) \Rightarrow 0$ LOW F: $(S \Rightarrow 0) F(s) \Rightarrow \frac{R_2}{(R_1+R_2)}$ </p>
	$\frac{V_0(s)}{E_s(s)} = \frac{(S + \frac{R_2}{L})}{S + \frac{R_1+R_2}{L}}$ <p>WHEN $S \rightarrow 0$: $\Rightarrow \frac{R_2}{(R_1+R_2)}$ WHEN $S \rightarrow \infty$: $\Rightarrow 1$</p>	 <p> $E_0 = \frac{1}{R_2} \frac{R_2}{(R_1+R_2)}$ $EAS = \frac{R_2}{(R_1+R_2)}$ POLE $TC = \text{ROOT}$ PREFIX: 1 = SCALAR OF STEP </p>	 <p> HIGH F: $(S \Rightarrow \infty) F(s) \Rightarrow \frac{R_2}{(R_1+R_2)}$ LOW F: $(S \Rightarrow 0) F(s) \Rightarrow 0$ </p>

TABLE III: "S" STUDIES (SERIES STC'S WITH 1R AND 2C'S OR 2L'S)

CIRCUIT DIAGRAM	REVISED "S" RESPONSE EQUATION	RESPONSE TO UNIT STEP	FREQUENCY RESPONSE
	$\frac{V_o(s)}{E_s(s)} = \frac{1}{RC_2} \frac{1}{s + \frac{C_1 + C_2}{C_1 C_2 R}}$ <p>WHEN $s \rightarrow 0$: $\Rightarrow \frac{C_1}{C_1 + C_2}$</p> <p>WHEN $s \rightarrow \infty$: $\Rightarrow 0$</p>	 <p>$E_0 = 0$ $EAS = \frac{C_1}{C_1 + C_2}$ TC = POLE PREFIX: $\frac{1}{RC_2}$ INITIAL SLOPE OF EXPONENTIAL</p>	 <p>HIGH F: $(s \Rightarrow \infty) F(s) \Rightarrow 0$ LOW F: $(s \Rightarrow 0) F(s) \Rightarrow \frac{C_1}{C_1 + C_2}$</p>
	$\frac{V_o(s)}{E_s(s)} = \frac{(s \frac{1}{RC_2})}{s + \frac{C_1 + C_2}{C_1 C_2 R}}$ <p>WHEN $s \rightarrow 0$: $\Rightarrow \frac{C_1}{C_1 + C_2}$</p> <p>WHEN $s \rightarrow \infty$: $\Rightarrow 1$</p>	 <p>$E_0 = 1$ $EAS = \frac{C_1}{C_1 + C_2}$ TC = POLE PREFIX: $\frac{1}{RC_2}$ INITIAL SLOPE OF EXPONENTIAL</p>	 <p>HIGH F: $(s \Rightarrow \infty) F(s) \Rightarrow 1$ LOW F: $(s \Rightarrow 0) F(s) \Rightarrow \frac{C_1}{C_1 + C_2}$</p>
	$\frac{V_o(s)}{E_s(s)} = \frac{L_2}{(L_1 + L_2)} \frac{s}{s + \frac{R}{L_1 + L_2}}$ <p>WHEN $s \rightarrow 0$: $\Rightarrow 0$</p> <p>WHEN $s \rightarrow \infty$: $\Rightarrow \frac{L_2}{L_1 + L_2}$</p>	 <p>$E_0 = 0$ $EAS = 1$ TC = POLE PREFIX: $\frac{L_2}{L_1 + L_2} R$ INITIAL SLOPE OF EXPONENTIAL</p>	 <p>HIGH F: $(s \Rightarrow \infty) F(s) \Rightarrow \frac{L_2}{L_1 + L_2}$ LOW F: $(s \Rightarrow 0) F(s) \Rightarrow 0$</p>
	$\frac{V_o(s)}{E_s(s)} = \frac{L_2}{(L_1 + L_2)} \frac{(s + \frac{R}{L_2})}{s + \frac{R}{L_1 + L_2}}$ <p>WHEN $s \rightarrow 0$: $\Rightarrow 1$</p> <p>WHEN $s \rightarrow \infty$: $\Rightarrow \frac{L_2}{L_1 + L_2}$</p>	 <p>$E_0 = 1$ $EAS = 1$ TC = POLE PREFIX: $\frac{L_2}{L_1 + L_2} R$ INITIAL SLOPE OF EXPONENTIAL</p>	 <p>HIGH F: $(s \Rightarrow \infty) F(s) \Rightarrow \frac{L_2}{L_1 + L_2}$ LOW F: $(s \Rightarrow 0) F(s) \Rightarrow 1$</p>

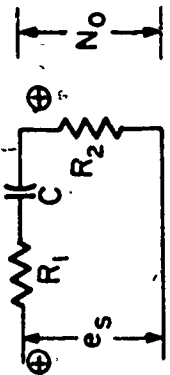
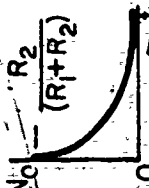
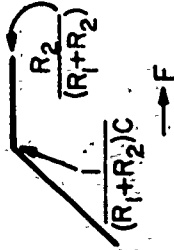
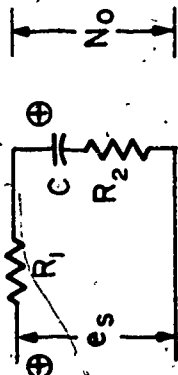
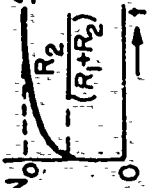
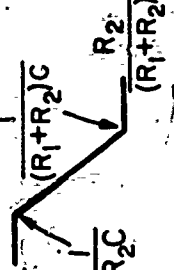
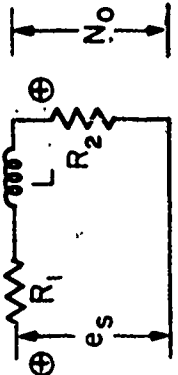
STC CIRCUITS LABORATORY

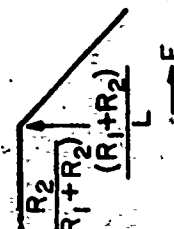
The suggested experiments which follow are in two major groupings. The first group (Experiments 1A, 1B, 2A and 2B) represents a sequencing and grouping of circuits designed to develop an understanding and appreciation for the exponential responses of simple STC circuits that exist when step voltages are applied. The second group (Experiments 3, 4, 5 and 6) are designed to develop an understanding and appreciation for the sinusoidal response of simple STC circuits when sinusoidal voltages are applied.

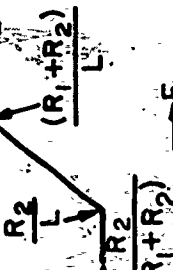
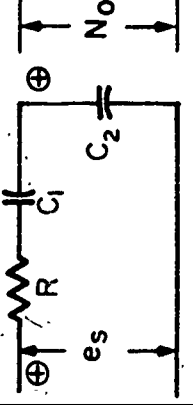
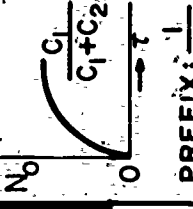
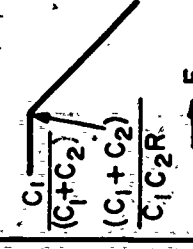
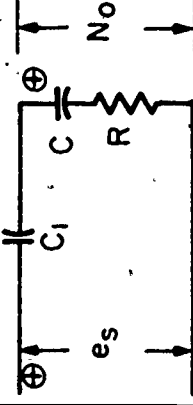
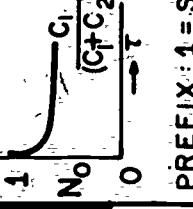
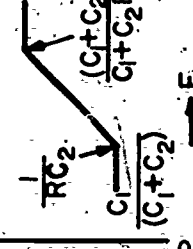
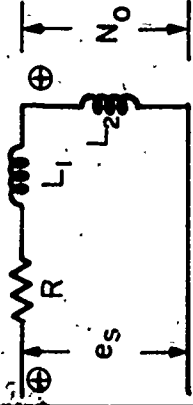
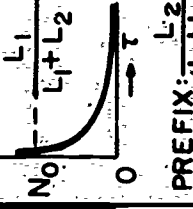
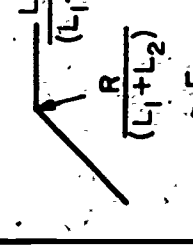
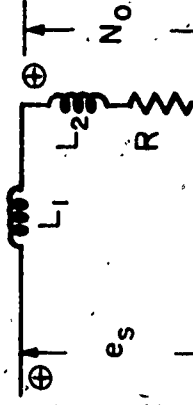
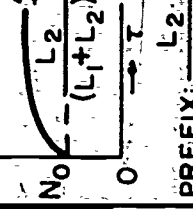
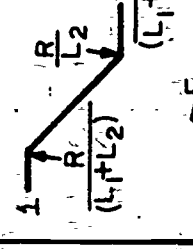
For those experiments having more than one part for the student, it is recommended that the student complete each part before receiving the next part of the experiment. The students should be so informed of this plan at the start of the laboratory session. The hope, here, is that the student will anticipate his needs for guidance to continue his studies.

EXPERIMENT 1A

Notes to Instructor:

I. The Problem:

Introduction to exponential output of STC with rectangular input.

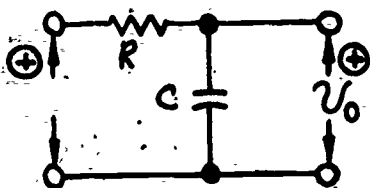

Fig. 1

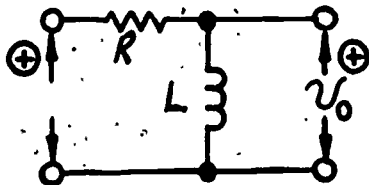

Fig. 3

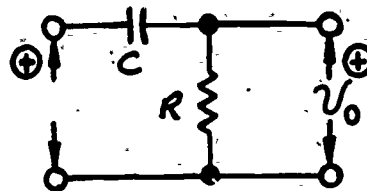

Fig. 2

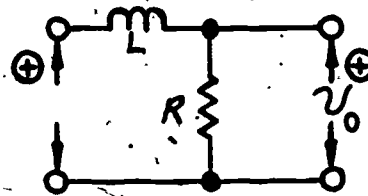

Fig. 4

Figures for Experiment 1A:

$R = 1 \text{ K}$, $C = 0.1 \text{ } \mu\text{fd}$ and $L = 100 \text{ mhy}$

II. New Terminology Encountered:

Exponential	Asymptotic Value
mhy	Original Value
Time Factor	μfd

III. Student background needed:

Resistive circuits, use of scope, use of function generator, square-wave generator, or unit pulser.

IV. General Notes:

In addition to the main "message" of this sequence (with STC: Rectangular input, - Exponential output) the student will discover that there is a duality existing between R-L and R-C circuits with same time constant. He will find too, the effects of varying R, L, C, and e_s on the three significant quantities on the exponential. He will also find that by varying parameters to extremes he will overcome the exponential response. This sequence begins in a rather restricted fashion and as it progresses, it allows the student more and more freedom to control the lab activities.

In Parts 1A-2 and 1A-3, the exponentials vary from completion in 1/5 of

an interval to completion of 1 exponential in an interval. In Part 1A-4 the student is allowed to experiment beyond these limits.

It might well be mentioned at this point that the inductors used are Torids (\$6.00-7.00 ea.) with extremely low values of R. If a sine-square generator is used by students for this experiment, a 1N34 diode should be used across the generator to produce a positive pulse referenced at zero. Furthermore, caution must be indicated in dealing with the R-L circuits so that R is not taken so low that it excessively loads the signal source.

For the Student

The Problem: Evaluation of voltages in single-time-constant circuits with step, rectangular or ramp input.

Procedure: Part 1A-1

1. Prepare for a creative laboratory study of given circuits. Note: For each of the given circuits, $e_s = 10V$ square wave with period of 0.2 ms (calibrate generator frequency with scope), $R=1K\Omega$, $L=100mH$, $C=.1\mu fd$.
2. Observe e_s and v_o for each of the following circuits. (Do not plot or record the waveforms at this time.)
3. Interpret v_o with respect to e_s .
 - a. Are there any similarities in these waveforms?
 - b. Are there any significant values on waveforms to observe?
 - c. What is each v_o interval composed of?
 - d. What happens to v_o when E_s steps?
4. Measure and plot each V_o , carefully noting all significant voltages and time quantities.

Procedure: Part 1A-2

1. Now take the two R-C circuits and values given below (Same e_s) and observe effect of varying R and C as indicated on v_o .
 - a. $C = 0.1 \mu f$
 $R = 400 \text{ ohms to } 2K$
 - b. $C = 0.01 \mu f$
 $R = 4K \text{ to } 20K$

- c. $C = 0.001 \mu f$
 $R = 40K \text{ to } 200K$

2. Interpret: What is the effect of:
 - a. Increasing R?
 - b. Decreasing R?
 - c. Increasing C?
 - d. Decreasing C?

Procedure: Part 1A-3

1. Now take the two R-L circuits used in Part A and the values given below and observe effect on v_o of varying R and L as indicated. Use same e_s .
 - a. $L = 100 mH$
 $R = 2.5K \quad 500\Omega$
 - b. $L = 500 mH$
 $R = 12.5K \quad 2.5K\Omega$
2. Interpret: What is the effect of:
 - a. Increasing R?
 - b. Decreasing R?
 - c. Increasing L?
 - d. Decreasing L?

You have observed that in each part of the experiment up to this point that the output voltage (v_o) of the STC circuits with rectangular input has been composed of exponential curves.

You also have observed the effect of varying parameters in the circuit within restricted ranges.

Procedure: Part 1A-4

1. Now vary parameters as before beyond ranges used earlier. Observe the effect on exponential segments of output waveforms (v_o).
2. Vary period and pulse width of e_s and observe effect.
3. Replace e_s with ramp input and observe output.

It is evident at this point that a STC circuit with rectangular input has an output voltage made up of exponentials. Through varying parameters we can change features of the exponential. You found that you could vary the initial value (beginning value), asymptotic value (final value approached) and the time taken to complete the exponential curve, by varying these parameters.

EXPERIMENT 18

Notes to Instructor

I. The Problem: Identification of initial, asymptotic and time-constant values for single-time-constant circuits.

II. New Terminology Encountered:

$$I_o, I_{as}, E_o, E_{as}, \tau_c$$

III. Student background needed:

Introduction to STC and exponential response.

IV. General Notes:

This introductory sequence introduces the student to the three quantities that identify an exponential and how to measure them. The student gains experience in identification of E_o and E_{as} as well as the time constant and its measurement and calculation. In addition, the time constant is developed in the laboratory, an approach that is unique. This technique leads to a better understanding of the time constant and provides a basis for the development of the general equation for an exponential. If a sine-square generator is used by students for this experiment, a IN34 diode should be used across generator to produce a positive pulse referenced at zero.

As in previous laboratory sequences, each part should be handed out individually and the student should present his work before being given successive parts of the experiment.

For the Student

In previous studies of single-time-constant circuits we discovered that when the driving function into an STC is a rectangular waveform, the output is composed of exponentials. This is also true when the input voltage is a ramp or triangular waveform. Consequently, we must be able to evaluate the exponential by identifying the significant quantities on it.

There are three significant quantities that are commonly used to define an exponential. These are as follows:

A. Initial value (E_o, I_o)

Point from which exponential begins.

B. Asymptotic value (E_{as}, I_{as})

Value exponential approaches upon completion.

C. Time Constant (τ_c)

Measure of time, exponential needs to complete.

This laboratory experience will deal with these three quantities.

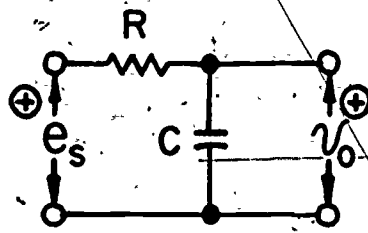

Fig. 1

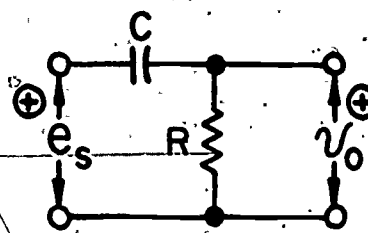

Fig. 2

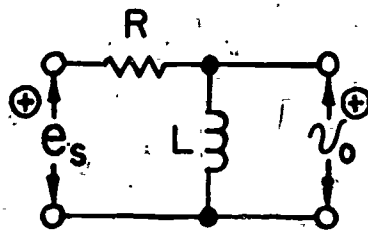

Fig. 3

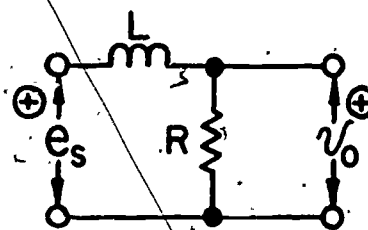

Fig. 4

The Problem: Identify initial and asymptotic values as well as the time constants for exponentials.

Procedure: Part 1B-1

- For the given circuits, graph v_o and measure the final value that exponential v_o approaches. This value is termed E_{as} . $R = 10K$, $C = .01 \mu fd$ and $L = 100 mhy$. $e_s = 10V$ square wave with period of 0.2 ms.
- Find e_{as} for exponentials in v_o .
- Vary R , L , C , and frequency of e_s as well as reducing maximum value of e_s . Measure E_{as} for each exponential on v_o .
 - What effect on E_{as} of v_o does varying these parameters have?
 - Do all exponentials measured complete? (Reach E_{as})?
- Estimate values of E_{as} for those exponentials that do not complete.

Procedure: Part 1B-2

- Using the same four circuits and values given in Part 1A-1, graph v_o and measure the original value for each exponential on v_o waveform. This value is termed E_o .
- Vary R , L , C , and frequency of e_s as well as reducing maximum value of e_s and measure E_o for each exponential in v_o .

- What effect on E_o and v_o does varying these parameters have?
- Do all exponentials in v_o begin at zero? ($E_o = 0$)

Procedure: Part 1B-3

- Connect the circuit below with the values given and examine v_o . $R = 1K$, $C = .1 \mu f$ and $e_s = 10V$ square wave with period of 2 ms. The output v_o that you have examined is made up of two exponentials.
- Let us concern ourselves with the exponential (b). From your studies of mathematics you know that this curve can be represented as $10 e^{-x}$. When x in this case is equal to unity (1) the voltage is approximately 3.7V. Another way to look at the voltage at this point is when the exponential has completed 63% of amplitude change from E_o to E_{as} . ($10V - 3.7V = 6.3V$).
- Measure the time needed for this voltage to go from 10V to 3.7V. Call this t_1 . Now examine the R and C in the circuit. Let us take the product of R and C in terms of the units involved.

$$R \times C = \text{OHMS} \times \frac{\text{Q}}{\text{E}} = \frac{\text{Volts}}{\text{Amps}} \times \frac{\text{Coulombs}}{\text{Volts}} =$$

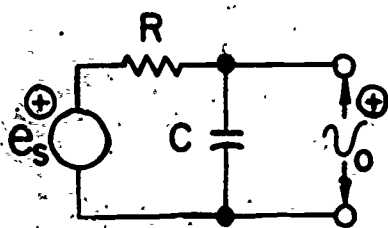

Fig. 1

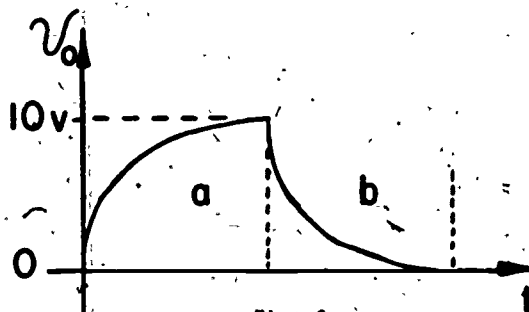

Fig. 2

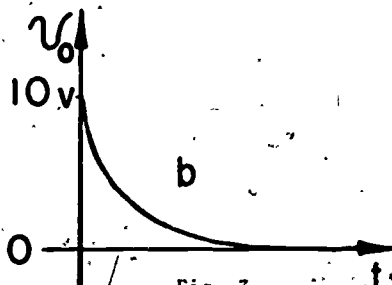

Fig. 3

$$\frac{\text{Coulombs}}{\text{Amps}} = \frac{\text{Coulombs}}{\text{Sec}} = \text{SEC}$$

The units for this product are seconds. TIME

4. Calculate τ_c for your circuit.
5. Compare this product with t_1 measured earlier.

We referred earlier to the point when the exponent (x) is equal to one (1) in the equation for the exponential being considered. x is now defined as $\frac{t}{\tau_c}$. Therefore, the equation for the curve is now expressed as

$$v_o = 10e^{-\frac{t}{\tau_c}}$$

Recall that when $\frac{t}{\tau_c} = 1$ the exponential has gone 63% of the amplitude change between E_o and E_{as} . From this then, we can measure the τ_c of an exponential.

6. Repeat Parts 1B-1 and 1B-2, measuring τ_c as well as calculating τ_c and comparing this measured value to your calculated value.

EXPERIMENT 2A

Notes to Instructor

I. The Problem:

The determination of v_o for single-time-constant circuits containing more than one R, L, or C. (Rectangular input)

II. New Terminology Encountered:

None.

III. Student background needed:

Resistive circuits; the exponential response; familiarity with E_{as} , e_s , τ_c ; use of the dual trace scope; use of the pulse generator.

IV. General Notes:

In laboratory experiment #1 in this sequence the concepts of the exponential response, the three defining quantities on the exponential, and the identification of these quantities were developed. It is assumed that in the classroom the tech-

niques of finding C_{eq} and L_{eq} for both series and parallel configuration have been developed, as well as the general equation for an exponential.

The student is now ready to handle more complex STC's and deal with resistive, capacitive, and inductive voltage division.

The values of C and R selected for this sequence of circuits are common and should be available in any laboratory situation. The inductors are the same toroids used in experiment No. 1A and No. 1B, with extremely low values of resistance. The student should be warned that when he is using more than one inductor, he should space them so that coupling between them is kept at a minimum.

The source used is a unit pulse generator. The repetition rates are

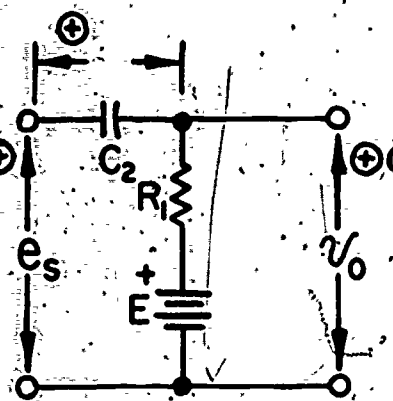

Fig. 1

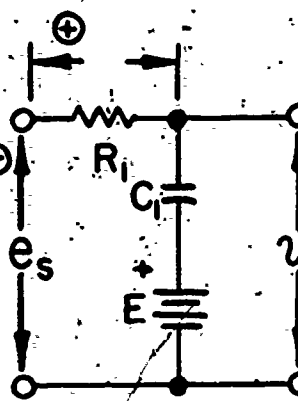

Fig. 2

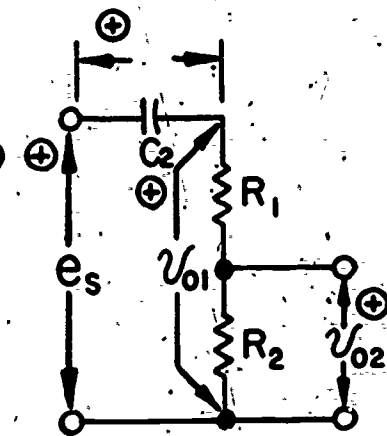

Fig. 3

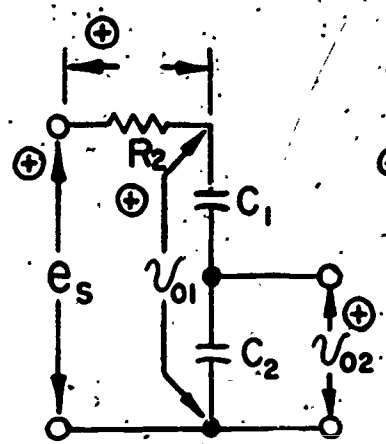

Fig. 4

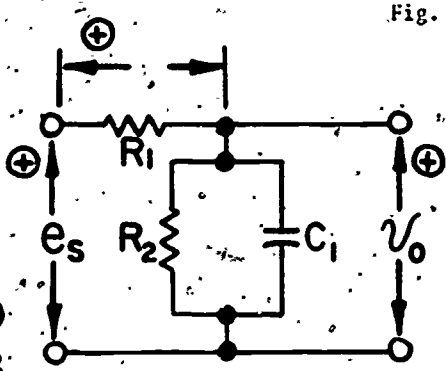

Fig. 5



kept in the audio range. A dual-trace oscilloscope is used and the student should be warned to be sure to "float" the generator and use a common circuit ground.

As in previous experiments in this sequence, each part of the experiment should be handed out individually, and the student's progress should be checked before he is provided with successive parts.

For the Student

The Problem: The determination of V_o for single-time-constant circuits containing more than one R or C. (Rectangular input)

Procedure: Part 2A-1

1. Using a dual-trace oscilloscope, observe v_o , v_{o1} , and v_{o2} (where applicable) for each circuit, comparing v_{o1} and v_{o2} in figures 3 and 4.
 $R_1 = 22 \text{ k}\Omega$, $C_1 = .005 \text{ }\mu\text{f}$, $C_2 = .002 \text{ }\mu\text{f}$,
 $E = 1.5\text{V}$ ("D" Cell), $e_s = \text{Rectangular waveform with period} = 2 \text{ ms}$.

Procedure: Part 2A-2

1. Measure the three significant quantities for each waveform interval.
2. Sketch these waveforms, indicating these significant quantities, on your sketch.
(See bottom of first page)

Procedure: Part 2A-3

1. Using Kirchoff's Voltage Law, calculate and sketch v_1 for each circuit indicating all significant quantities. Use same time base as previous sketches.

Procedure: Part 2A-4

1. What interpretations can you make regarding the effect of the inclusion of E in figures 1 and 2?
2. What interpretations can you make regarding v_{o1} and v_{o2} in figures 3 and 4?

3. What interpretations can you make regarding v_{o2} in figures 3 and v_{o2} in figure 4.

EXPERIMENT 2B

Notes to Instructor

I. The Problem:

The determination of V_o for single-time-constant circuits containing more than one R, L, or C. (Rectangular input)

II. New Terminology Encountered:

None

III. Student background needed:

(Same as Experiment 2A)

IV. General Notes:

In laboratory experiment #1 in this sequence the concepts of the exponential response, the three defining quantities on the exponential, and the identification of these quantities were developed. It is assumed that in the classroom the techniques of finding C_{eq} and L_{eq} for both series and parallel configurations have been developed, as well as the general equation for an exponential.

The student is now ready to handle more complex STC's and deal with resistive, capacitive, and inductive voltage division.

The values of C and R selected for this sequence of circuits are common and should be available in any laboratory situation. The inductors are the same toroids used in experiment No. 1A and No. 1B, with extremely low values of resistance. The student should be warned that when he is using more than one inductor; he should space them so that the coupling between them is kept at a minimum.

The source used is a unit pulse generator and the repetition rates are kept in the audio range. A dual-trace oscilloscope is used and the stu-

dent should be warned to be sure to "float" the generator and use a common circuit ground.

As in previous experiments in this sequence, each part of the experiment should be handed out individually, and the student's progress should be checked before he is provided with successive parts.

For the Student

The Problem: The determination of v_o for single-time-constant circuits containing more than one R or L. (Rectangular input)

Procedure:

1. Connect the five circuits in the sequenced order (one at a time) using the indicated values for each circuit parameter.

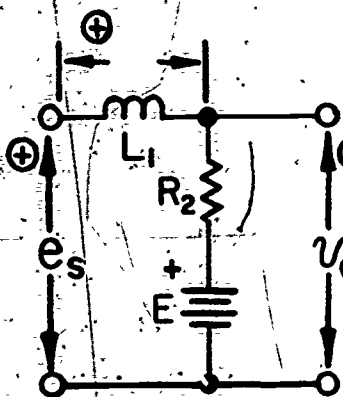

Fig. 1

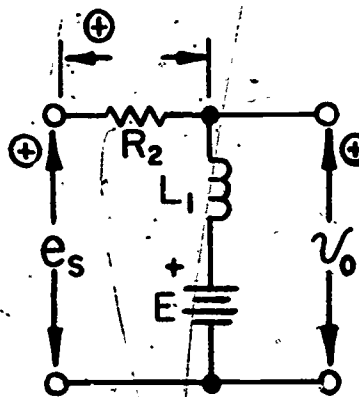

Fig. 2

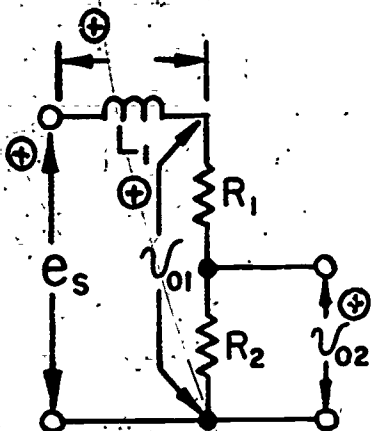

Fig. 3

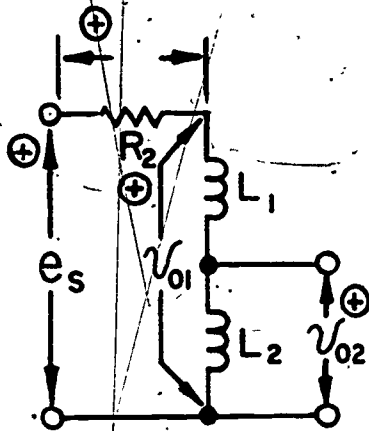

Fig. 4

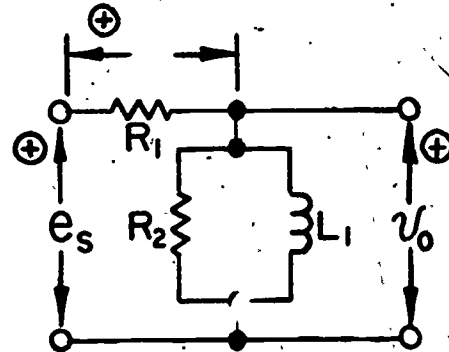

Fig. 5

Procedure: Part 2B-1

1. Using a dual-trace oscilloscope, observe v_o , v_{o1} and v_{o2} (where applicable) for each circuit, comparing v_{o1} and v_{o2} in figures 3 and 4. $R_1 = 22 \text{ k}\Omega$, $R_2 = 68 \text{ k}\Omega$, $L_1 = 500 \text{ mh}$, $L_2 = 100 \text{ mh}$, $E = 1.5\text{V}$ ("D" Cell), and $e_s = \text{Rectangular waveform}$ with period = 2 ms.

Procedure: Part 2B-2

1. Measure the three significant quantities for each waveform interval.
2. Sketch these waveforms, indicating these significant quantities on your sketch.

Procedure: Part 2B-3

1. What interpretations can you make regarding the effect of the inclusion of E in figures 1 and 2? What interpretations can you make regarding v_{o1} and v_{o2} in figures 3 and 4? What interpretations can you make regarding v_{o2} in figure 3 and v_{o2} in figure 4?

EXPERIMENT 3A

Notes to Instructor

I. The Problem:

Discovering that a STC with a sinusoidal response will have the response of amplitude-scaling and phase shift.

II. New Terminology Encountered:

Lead Lag
Frequency Response

III. Student-background needed:

STC's with rectangular input, familiarity with sinusoidal functions, phase relationships between sinusoids, use of oscilloscope, use of Dual-Trace-Scope to measure both amplitude and phase.

IV. General Notes:

This experiment, which is introductory in nature, is designed to familiarize the student to the response of an STC with sinusoidal input. In addition to the voltage response in four simple series STC circuits, the student investigates the current response in each. He is given the opportunity to vary circuit parameters and observe the effect, hopefully leading to a fuller understanding of these circuits. In Part 3A-3 the student is given complete freedom to investigate other STC's

with sinusoidal inputs on his own.

This lab should be followed by a classroom presentation of reactances and impedances.

For the Student

The Problem: Investigation of the response of a single-time-constant circuit to a sinusoidal input.

Procedure: Part 3A-1

1. Connect the four given circuits and continue. $e_s = 10 \sin 2\pi (1000) t$,
 $R = 3300 \Omega$, $L = 500\text{-mhy}$, $C = .05 \mu\text{f}$.
2. Observe, with your dual trace oscilloscope, v_o for each circuit and compare to e_s . More specifically, observe:
 - a. The amplitude relationship between v_o and e_s .
 - b. The phase relationship between v_o and e_s .
 - c. Similarities in v_o between circuits.
3. Holding the amplitude of e_s constant at 10V, vary the frequency of e_s and observe the effect on each v_o . For each circuit, what is the effect on the amplitude of v_o in each circuit of increasing ω ? What is the effect of the phase angle between e_s and v_o of

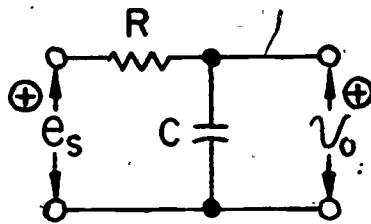

Fig. 1

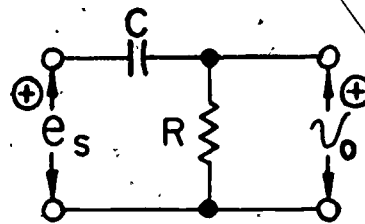

Fig. 2

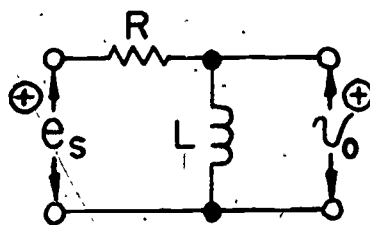

Fig. 3

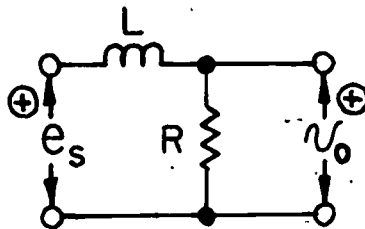

Fig. 4

increasing ω ? Decreasing ω ?

4. Vary the value of resistance in each circuit and observe the effect on v_o . What, in terms of the amplitude and phase of v_o , is the effect of increasing R? Decreasing R?
5. Vary the capacitance in figures 1 and 2 as well as the inductance in figures 3 and 4 and observe the effect on v_o . What, in terms of the amplitude and phase of v_o , is the effect of increasing L or C? Decreasing L or C?
6. Vary R and L (or C) in each circuit while holding the time constant of each circuit fixed. Observe the effect on amplitude and phase angle of v_o .

Part 3A-2

Discussion:

Referring back to the four original circuits, figures 1 and 2 are the same circuit, with the output v_o taken across opposite components; this also is true of figures 3 and 4. Recalling that the voltage across a resistance is directly proportional to the current flowing through it, it is apparent that the current response of these circuits can be analyzed by observing and interpreting the voltage across the resistance in each case. Hence to study this current response for R-L and R-C circuits we need to concern ourselves with figures 2 and 4. With this in mind, let us make some interpretations regarding the observations made in Part 3A-1.

Procedure:

1. Interpret the current response of a single-time-constant circuit to a sinusoidal input.
 - a. Does the current lead or lag the applied voltage in an R-C circuit?
 - b. Does the current lead or lag the applied voltage in an R-L circuit?
2. What is the effect on this phase angle between e_s and the current in an R-L or R-C series circuit of:
 - a. Increasing ω ?
 - b. Decreasing ω ?

- c. Increasing R?
- d. Decreasing R?
- e. Increasing C?
- f. Decreasing C?
- g. Increasing L?
- h. Decreasing L?

3. What is the effect on the amplitude of this current of:
 - a. Increasing ω ?
 - b. Decreasing ω ?
 - c. Increasing R?
 - d. Decreasing R?
 - e. Increasing C?
 - f. Decreasing C?
 - g. Increasing L?
 - h. Decreasing L?
4. Interpret the relationship between the amplitude of the current and the phase angle with e_s .
5. What is the relationship between the time constant of the circuit and the phase angle of the current?

Procedure: Part 3A-3

1. Select other complex single-time-constant circuits and investigate, in a manner similar to that employed in Parts 3A-1 and 3A-2, the behavior of these circuits with a sinusoidal input.

EXPERIMENT 4A

Notes to Instructor

I. The Problem:

Determination of half-power point and corner plot of single-time-constant circuits.

II. New Terminology Encountered:

Corner frequency -3 db
half-power: bode plot
corner plot semi-log
frequency response

III. Student background needed:

Resistive circuits, STC's with rectangular input, STC's with sinusoidal input, use of dual-trace scope--for amplitude measurement and for phase measurement, and use of oscillator or sine-square generator.

IV. General Notes:

In laboratory experiment No. 3A the student was introduced to STC's with a sinusoidal input. It is assumed that this material has been and is being covered in the classroom while this experiment is being done in the lab.

This experiment introduces student to the concepts of corner plots and corner frequencies in the lab without any previous exposure to the topic in the classroom. It should be followed up by class presentation on corner plots.

The experiment begins in a rather restricted fashion and as it progresses allows the student more and more freedom to control the activities. The experiment is intended to take two laboratory periods,

the first (lab. exp. 4A) taking one period and the second (lab. exp. 4B) taking another.

Experiment 4B provides the student full freedom to investigate STC's characteristics, which he should be ready to do after completing experiment 4A which lays a solid foundation on which the student can build.

For the Student

The Problem: Finding the frequency response of single-time-constant circuits and representing this response in a conventional manner.

Procedure: Part 4A-1

1. Connect the two given circuits with $e_s = 10 \sin \omega t$ and proceed as indicated for each circuit.
2. Vary the frequency of e_s , holding the amplitude of e_s constant and observe:
 - a. The effect of varying ω on the amplitude of v_o .
 - b. The effect of varying ω on the phase between e_s and v_o .
 - c. The effect on varying ω on v_o for figure 1 as compared to the effect on v_o for figure 2.
3. Increase or decrease the frequency of e_s until a maximum amplitude of v_o is achieved. (This V_o max should remain constant over a fairly wide range of ω .) Measure this value of V_o and record it on the attached semi-log graph paper

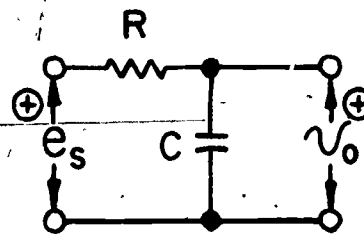
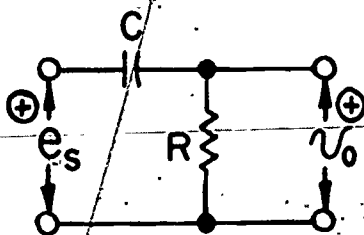

4. Now slowly change the frequency of e_s until the maximum value of v_o begins to drop. Plot values of V_o (max) versus f on the attached semi-log paper, as well as the phase shift between e_s and v_o for each circuit. Plot just enough points to sufficiently define a curve.

5. At what frequency does $\frac{V_o}{E_s} = 0.707$?

6. At what frequency does the phase angle between e_s and $v_o = 45^\circ$?

7. Compare ω_1 in procedure #5 with the ω_1 in procedure #6.

Discussion:

You found in Part 4A-1 that when the phase angle θ between v_o and e_s equals $\pm 45^\circ$ the ratio $\frac{V_o}{E_s} = 0.707$. This can be shown by the examination of a phasor diagram of those voltages.

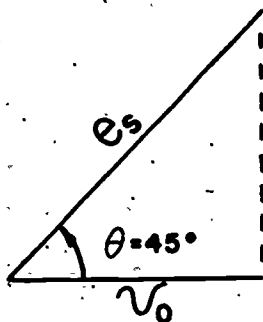

$$\cos \theta = \frac{V_o}{E_s}$$

$$\cos 45^\circ = \frac{V_o}{E_s}$$

Therefore,

$$\frac{V_o}{E_s} = 0.707$$

This point is called the corner frequency for the circuit. It is also referred to as the -3 db point. From your previous studies

recall that

$$db = 20 \log \frac{E_1}{E_2}$$

In this case

$$\frac{E_1}{E_2} = 0.707$$

Therefore, we solve for $(20 \log 0.707)$.

$$20 \log 0.707 = 20 \log \frac{1}{\sqrt{2}} = 20 \log (2)^{-1/2} =$$

$$-10 \log 2 = -10 (.301) = -3 \text{ db.}$$

In addition this frequency is also called the half-power point. Recall that

$(db = 10 \log \frac{P_1}{P_2})$ in this case we know that we are dealing with -3 db. Solving $\frac{P_1}{P_2} = \frac{-3}{10} =$

$$\log \frac{P_1}{P_2}, \frac{P_1}{P_2} = \text{antilog } -.3, \frac{P_1}{P_2} = .5; \text{ we find}$$

that the expression "half-power point" is a valid one.

Now, any reactive circuit will respond to a change in frequency in the manner previously observed. That is, the frequency response curve plotted in Part 4A-1 is typical one. This plot is called a *bode or corner plot*. We will learn later how to calculate and draw these curves without taking any measurements.

Procedure: Part 4A-2

Going back to the two original circuits in Part 4A-1, vary the R's and C's and observe the effect on ω_1 in each case.

1. For figure 1:
 - a. What is the effect of increasing R?
 - b. What is the effect of decreasing R?
 - c. What is the effect of increasing C?
 - d. What is the effect of decreasing C?
2. For figure 2:
 - a. What is the effect of increasing R?
 - b. What is the effect of decreasing R?
 - c. What is the effect of increasing C?
 - d. What is the effect of decreasing C?
3. What is the effect of varying both R and C while holding the time constant of the circuit constant?

Discussion: Part 4A-3

Referring back to circuit 1 of Part 4A-1, we can write that $V_o = E_s \frac{R}{R - j \frac{1}{\omega C}}$. Then $\frac{V_o}{E_s} =$

$$\frac{1}{1 - j \frac{1}{\omega RC}}$$

But as we discovered in Part 4A-2: at ω_1 the phase angle between E_s and V_o equals

$$45^\circ \text{ and that } \frac{V_o}{E_s} = 0.707.$$

$$\text{Therefore, at } \omega_1, .707 + 45^\circ = \frac{1}{1 - j \frac{1}{\omega RC}}$$

This means that the denominator of the right-hand fraction must equal $1.414 + 45^\circ$. In order for this to hold true, then $\frac{j}{\omega RC} = 1$.

Therefore, $\omega = \frac{1}{RC}$. It is apparent then, that the corner frequency is determined by the time constant of the circuit. More specifically, the corner frequency of a single-time-constant equals the reciprocal of the time constant.

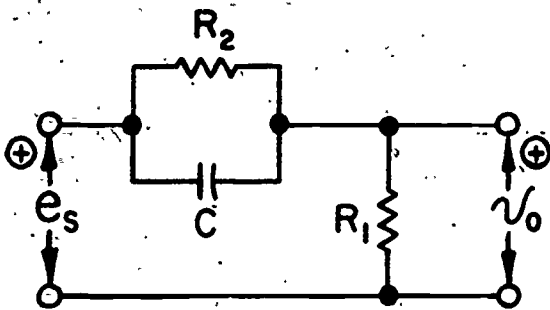

Fig. 1

Procedure: Part 4A-3

Beginning with the two circuits employed in Part 4A-1, maintaining $e_s = 10 \sin \omega t$, add an additional R to each circuit as indicated and proceed.

1. Observe the effect of the additional resistance on the circuit response.
 - a. What is the effect on $V_o \text{ max}$?
 - b. What is the effect on the corner frequency?
 - c. What is the effect on the response curve?
2. Using the techniques employed earlier, measure the new $V_o \text{ max}$ and ω_1 .
3. Interpret these new values. Why the change in $V_o \text{ max}$? Why the new corner frequency? What circuit parameters have been changed by adding the second R?
4. Using previously learned circuit analysis techniques, calculate the corner frequency, V_o at ω_1 , and the time constant for the new circuits.

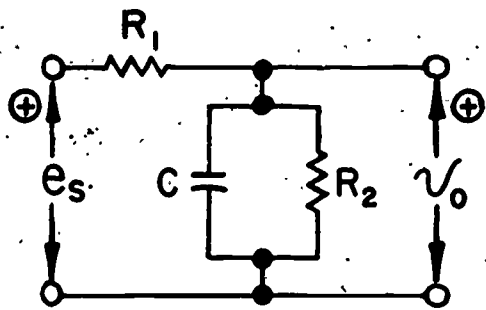

Fig. 2

NETWORKS (CIRCUITS III)

DEFINITION

A course in circuit analysis having the title of *Networks* has the implication that the student shall study any circuit of any configuration, simple or involved. Theoretically, there are no restrictions. The restrictions can be established, however, in accordance with the needs and desires of a particular curriculum.

MAJOR CONCEPTS

For a two-year associate-degree program in Electronics Technology, the following major concepts for a *Networks* course are recommended:

- a. The contents of the course shall be influenced by the technical specialty course (the option) that is selected for the remainder of the curriculum.
- b. Magnetic coupling and magnetic circuits have not been covered to this point in the preceding two courses of the sequence. These topics should be covered regardless of the remaining specialty courses.
- c. The subject of resonance needs to be covered.
- d. Emphasis shall be placed on circuit response, - not the evaluation of all currents, voltages and powers in a circuit.
- e. Emphasis shall be placed on practical circuits and responses such as: Filters, loading, frequency response, resonant circuits, coupling, three-phase systems, power distribution, the Q of a circuit, a-f and r-f transformer, etc.
- f. Take advantage of the S-operator as appropriate to the analysis of circuits.
- g. Restrict the complexity of circuits to those that have no more than two poles in the S-equation response. These are double-time-constant circuits.

BEHAVIORAL OBJECTIVES

- On satisfactory completion of the course the student shall have the abilities to:
- a. Select a method that is convenient for the analysis of given circuits.
 - b. Write the necessary equations for analysis.
 - c. Solve for both steady-state and transient responses.
 - d. Know those circuit configurations needed for their practical value.
 - e. Understand techniques of analysis that are unique for the various practical circuit configuration.
 - f. Sketch phasor diagrams as an appropriate means of representing circuit responses graphically when frequency is constant and not a variable.
 - g. Apply the S-plane technique as a graphical representation to study the response of simple circuits when frequency and time constants are of primary interest as variables.
 - h. Know how to analyze circuits having mutual coupling.
 - i. Understand the purpose of core materials to control magnetic coupling.

PREREQUISITES

The primary prerequisite for *Networks*, as proposed and outlined here, is the *Single-Time-Constant Circuits* course or its equivalent. *Networks* is the third major subject in the sequence of circuit analysis courses. It is assumed that the student already knows how to write loop and node equations, how to use Thevenin's, Norton's and superposition theorems, and how to write circuit equations as ratios (or transfer functions). The students' background in mathematics, at this

point, shall involve elements of calculus, elements of differential equations and elements of the Laplace Transform (especially the use of tables).

Note: The mathematics used, for the most part, will be no more than algebra, trigonometry and complex algebra. The advanced math will be of value for certain derivations to add understanding and appreciation.

The relative position of Networks in the curriculum is represented by the following flow chart.

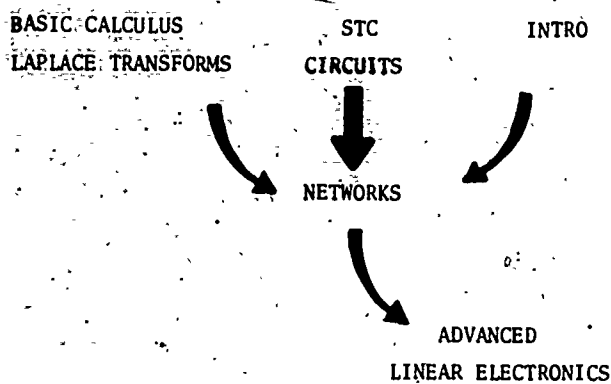

OUTLINE.

I. Review of STC's on "S" basis (Classroom).

II. RLC Series Circuits (Classroom and Laboratory).

A. Impedance (Laboratory support).

B. Phasor Analysis (Classroom oriented).

C. Resonance (Introduce in laboratory).

1. Natural, phase and amplitude resonance.
2. Q of circuit and its affect on I
3. Bandwidth.

D. Frequency response characteristics (Classroom and Laboratory).

1. Bode plots may be used to advantage.
2. "S"-plane analysis (zeros and poles).
 - a. Solution for poles and zeros (Need the quadratic equation to find roots).
 - b. Graphing circuit response.

E. Use of initial condition models.

III. RLC Parallel Circuits (Classroom and Laboratory)

A. Impedance (Laboratory support).

B. Phasor analysis (Classroom oriented).

C. Resonance (Introduce in Laboratory).

1. Natural, phase and amplitude resonance.
2. Conditions for resonance (two points, one or none) (Classroom oriented).
3. Using Q of circuit.

D. Parallel-to-series conversions (Classroom).

1. The equivalent series circuit represents equivalent impedance.

E. Frequency response characteristics (Classroom and laboratory).

1. Graphical and mathematical.
2. "S"-plane analysis.

F. Use of initial condition models.

G. Ringing circuits and damping.

IV. Series-Parallel RLC Circuits (Classroom and Laboratory).

A. A. Writing of characteristic equations (Classroom).

1. Loop equations.
2. Node equations.
3. Millman's Theorem.

B. Using theorems and conversion techniques (Classroom):

1. Superposition theorem (Laboratory support).
2. Using Thevenin's and Norton's theorem (Laboratory support).
3. π -T conversions (Classroom oriented).

C. Filters, - all types (Introduce in laboratory).

D. Impedance matching (Classroom oriented with laboratory support).

V. Multi-time-constant circuits, -not oscillatory.

A. R's and C's only.

B. R's and L's only.

C. Examples.

1. Frequency compensated attenuator (Laboratory).
2. Bridge circuits (Laboratory).

3. Lattice networks (Laboratory).

D. Techniques of analysis (Classroom).

VI. Magnetic Circuits and Coupling (Classroom and Laboratory).

A. Core materials

1. Permeability.
2. Characteristic B-H curves (Laboratory oriented).
3. Hysterisis.

B. Fundamentals of Analysis (Laboratory support).

1. Faraday's law.
2. Polarities of induced voltages.
 - a. Self-induction.
 - b. Mutual induction.
3. Induced currents.
4. Coefficient of coupling.
5. Mutual inductance (M).
6. Use of fictitious generators (Classroom).

VII. Transformers (Laboratory oriented).

A. Power transformers.

1. Equivalent circuits (Classroom).
2. Ampere-turn, Impedance relationships.
3. Reflected loads.

B. A-F and R-F transformers.

1. Single tuned.
2. Double tuned.

VIII. Three-Phase Systems (Laboratory-oriented).

A. Generation and Sequence.

B. Loading (delta and wye).

1. Balanced loading.
2. Unbalanced loading.

C. Systems.

1. Delta.
2. Wye.
3. Open delta.

D. Phasor analysis.

E. Power calculations.

GENERAL GUIDELINES

The subject of *Networks* serves two important functions in an Electronics Technology Curriculum. As the third in the sequence of circuit analysis courses, it is found that,

1. The student learns techniques of analysis for those circuits that are more involved than STC Circuits or Resistive Circuits.

2. The student concentrates on circuit configurations, that are unique to particular systems such as three-phase circuits in power systems, filters in power supplies, high-pass and low-pass filters, tuned circuits, coupling circuits, etc.

A point to keep in mind concerning the above two functions is that there is no limit to the subject matter, coverage and depth, for a Networks course. The preceding two courses (Resistive Circuits and STC Circuits) do have limits of subject matter coverage and can be terminated at some logical point.

Selection of Topics

Some freedom exists for the instructor in the selection of major topics for the Networks course. Keeping its two functions in mind, *techniques* of analysis and practical circuit configurations, the instructor should select topics that are most suitable to the total curriculum. The institutional option (communications, power, control systems, digital systems, etc) will be enhanced by the topics of Networks when selected for the particular option. For example, if three-phase circuits are not covered anywhere else in the curriculum, it may be that the only place for this subject is in Networks. On the other hand, the instructors of the electronics curriculum may wish to omit this subject entirely.

Consider the problem of resonance (series or parallel circuits) as a topic to be covered in *Networks*. There is probably agreement that this topic should be included as indicated in the *Outline* of this report. But, how much coverage and in what detail? Which parameters should be considered as variables? What about the various conditions of resonance or no resonance? What about locus diagrams, phasor

diagrams, or amplitude responses as a function of some one or more of the possible variables?

Again, as stated previously, there is much to consider with resonant circuits as with other major topics of Networks.

Suggestion: Select topics, coverage and depth, for the Networks course as carefully as possible to satisfy the needs of the end objectives of the curriculum. Do not try to cover every possible topic in every detail. Select a textbook that is most satisfactory and follow its general sequence. Add class notes as needed and delete as required

Selecting Techniques of Analysis

Much of the analysis for the circuits of the course will be done using complex numbers, phasors and the concepts of impedance, reactance (capacitive and inductive), conductance and admittance. It must be remembered that such quantities are applicable only to sinusoidal driving functions under steady-state conditions for fixed frequencies.

Some serious consideration should be given to those problems that permit a more direct analysis when it is desirable to consider frequency as a variable. Locus diagrams have been used for this purpose but are usually limited to the most simple circuits. If S-equations and the S-plane are not now being used to assist with circuit analysis, then we encourage that this be done. Just the writing of equations using "S", rather than " $j\omega$ ", is of value. If you want $j\omega$, it can replace "S" after the equation is written. If you carry the S-equations further and use the S-plane, then a graphical representation exists from which a response as a function of frequency can be interpreted.

The project did some development work with the S-equations and it is presented under the heading, "The Pattern of S-Equations" a little later in this section. There are some answers there, as to a possible technique, that may be of value.

Another circuit analysis problem that is a

little difficult for students to master involves circuits with mutual coupling. The problem is chiefly concerned with the use of the correct sign (+ or -) for induced voltages resulting from mutual inductance (M). We think the use of (dependent sources) are of value here. These are symbols for insertion into circuit models similar to voltage-source symbols, that are placed in every loop where a mutual induced voltage exists. Each one is labeled with the correct voltage-polarity reference and each one is identified by a voltage as $j\omega MI$, or $J\omega MI$, etc. as the circuit dictates. The loop equations are then easily written, inserting the proper signs as dictated by Kirghhoff's voltage law. The sign (+ or -) should no longer be a problem to the student. You see, the dependent sources of mutual inductance isolate the sign from the magnitude where they can be handled with less chance of error. This technique also helps the student to understand mutual induced voltages.

Examples are presented in Fig. 1 to illustrate the use of the dependent sources of mutual inductance. There are those who may wish to use this technique. Others may not. See next page for Fig. 1.

THE PATTERN OF S-EQUATIONS

To arrive at the S-equations for RLC circuits, the conventional procedure has involved the writing of node equations, or loop equations, or other more direct techniques and then manipulate these initially written equations into a desired form to make it easier to find the roots (poles and zeros') of the S-equation.

The project became involved in trying to find some pattern that is constant in these equations for those kinds of circuits having two poles always in these equations. If the pattern could be found, then it might be possible to read the terms for the final

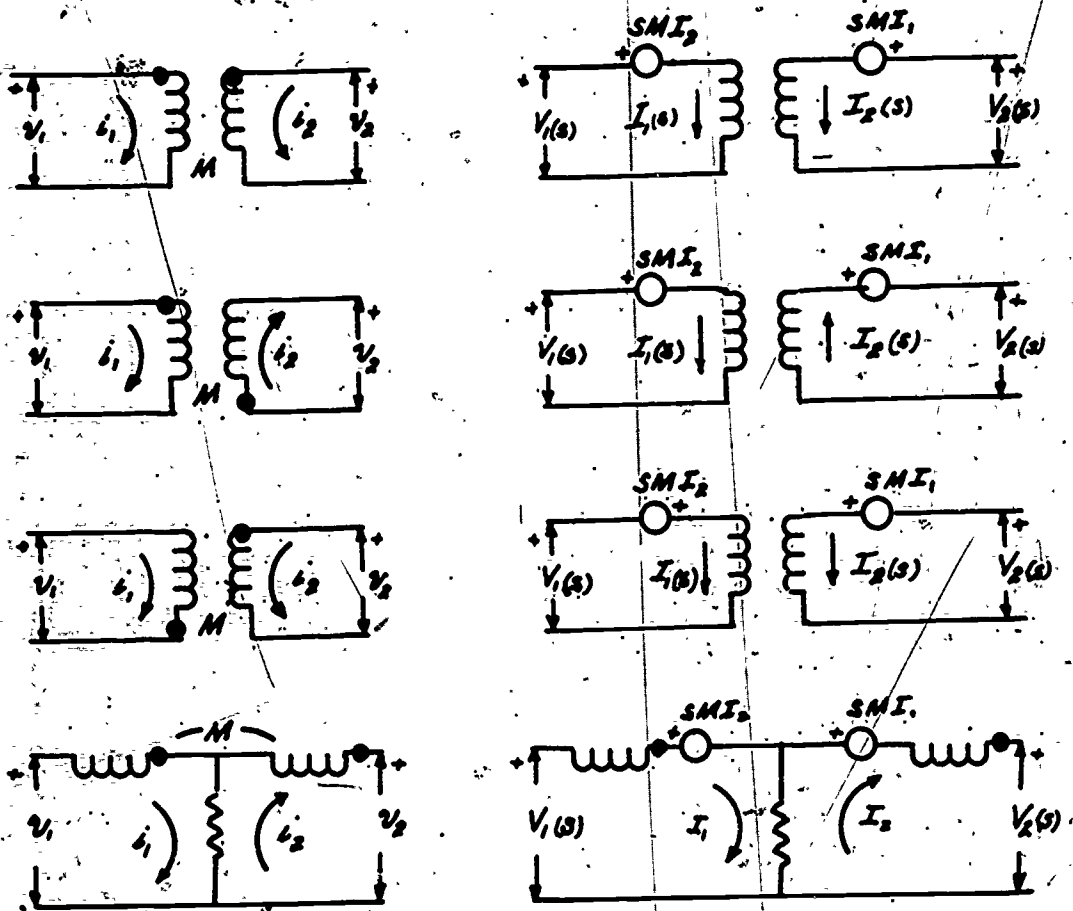

Fig. 1 Coupled circuit models showing dependent sources (right-hand column) of mutual inductance. S-operator is shown. Could use $j\omega$ as well for sinusoidal steady-state analysis.

equation without going through so much manipulation of equations. The pattern was found and is presented here for information purposes only. We are not prepared to recommend how or when this information should be used, since there has been no opportunity to try it in the classroom. The only thought here is that the analysis of RLC series circuits probably should not go beyond double-pole circuits. Some work should be done in the writing of S-equations, their roots and the use of the S-plane. The question here is: Should one concentrate on the reading of the equations?

The pattern for the S-equations is revealed

by referring to the equations for a number of circuits, as presented on pages following this discussion. Refer to those circuits and their corresponding equations and the following facts are directly observed.

- Every constant term has the dimensions of the inverse of time or of time squared.
- The coefficient of S in the denominators is always the sum of two terms where each term is a reciprocal of a time constant.
- The constant term (third term) in the denominator is always the product of the reciprocal of two different time-

constants, one of which is identical to one of the terms in the coefficient of S .

- d. The number of S -factors in the numerator may be none, one or two. Never more than two.
- e. The constant coefficient for the total equation makes the equation dimensionally correct.

Now, we are at the point of this discussion where we can reveal a procedure for reading all of the constant terms of the S -equation. First, note that all of these circuits are of the one-node-equation form represented as below.

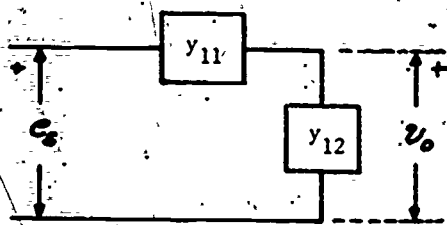

We need this model for the purpose of identifying the numerator portion of the S -equation. We will look at the denominator in a second step.

To identify the numerator factors and constant terms, refer to any one particular circuit along with the general model just presented and apply the following procedure:

- a. Open the source and place a short at v_0 .
- b. Look at the two portions of the circuit represented by y_{11} and y_{12} separately.
- c. The y_{11} circuit can contribute an S -factor to the numerator only if the stored energy has not been instantly destroyed by the open circuit.
 1. If stored energy never dissipates, only an S appears in the numerator.
 2. If stored energy dissipates with time, then an $S + d$ factor appears. The d term is the reciprocal of the time-constant of y_{11} .
- d. The y_{12} circuit, shorted, can contribute an S -factor only if the stored energy of

that circuit has not been instantaneously destroyed (or never existed in the first place) by the short.

1. If the stored energy never dissipates, only an S appears in the numerator.
2. If the stored energy dissipates with time, then an $S + d$ term appears in the numerator. The constant of this factor is the reciprocal of the time constant of y_{12} when shorted.

Now, to read the constant terms for the denominator, consider the quadratic equation of the form,

$$S^2 + bS + c$$

Use the following technique to identify b and c of the model equation.

- a. To obtain b , the coefficient of S ,
 1. Open L: The time constant of the remaining circuit (its reciprocal) is one of the two constant terms.
 2. Short C: This gets the second constant term.
- b. To obtain the third term, c of the model equation,
 1. Open L: This reveals one of the constant terms in the product. It is identical to the RC time-constant term in the coefficient of S .
 2. Open C: This gives the second time constant (reciprocal) in the third term.

NOTE: Interesting? Where do we go from here? Will this technique have a value in two-year programs? We would be interested in the results from any instructor that uses it. As a matter of fact, we are interested in experiences with the use of the S -operator in any form.

EXAMPLES WITH S-EQUATIONS

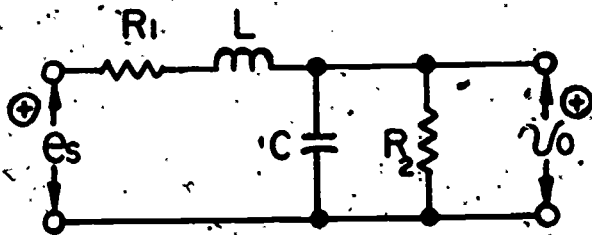

$$\frac{V_0(s)}{E(s)} = \frac{1}{LC} \frac{1}{s^2 + s\left(\frac{1}{R_2 C} + \frac{1}{L/R_1}\right) + \left(\frac{1}{R_2 C}\right)\left(\frac{1}{L/(R_3 R_2)}\right)}$$

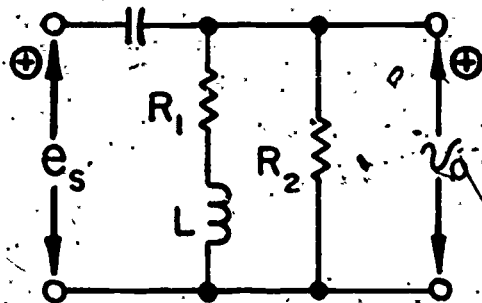

$$\frac{V_0(s)}{E(s)} = \frac{s(s + 1/LR_1)}{s^2 + s\left(\frac{1}{R_2 C} + \frac{1}{L/R_1}\right) + \left(\frac{1}{R_2 C}\right)\left(\frac{1}{L/(R_1 + R_2)}\right)}$$

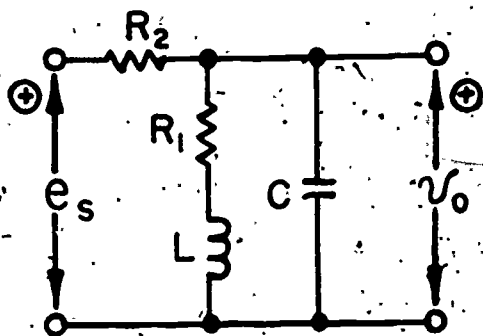

$$\frac{V_0(s)}{E(s)} = \frac{1}{R_2 C} \frac{s + 1/LR_1}{s^2 + s\left(\frac{1}{R_2 C} + \frac{1}{L/R_1}\right) + \left(\frac{1}{R_2 C}\right)\left(\frac{1}{L/(R_1 + R_2)}\right)}$$

EXAMPLES WITH S-EQUATIONS (Cont'd).

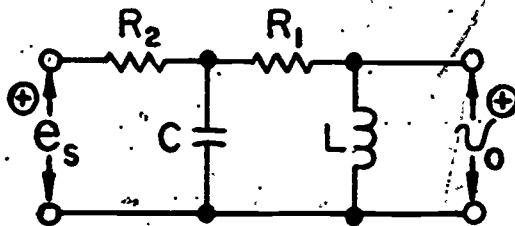

$$\frac{V_o(s)}{E(s)} = \frac{1}{R_2 C} \frac{s}{s^2 + s \left(\frac{1}{R_2 C} + \frac{L}{R_1} \right) + \left(\frac{1}{R_2 C} \right) \left(\frac{L}{R_1 + R_2} \right)}$$

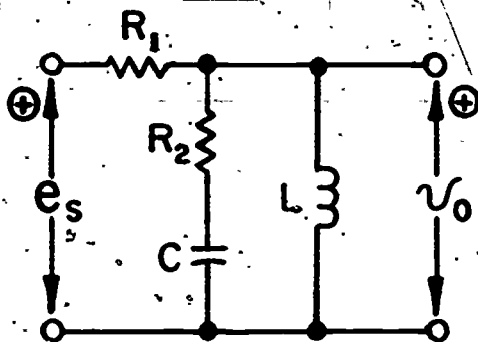

$$\frac{V_o(s)}{E(s)} = \frac{R_1 R_2}{R_1 + R_2} \frac{s \left(s + \frac{1}{R_2 C} \right)}{s^2 + s \left(\frac{1}{C(R_1 + R_2)} + \frac{R_1 R_2}{L(R_1 + R_2)} \right) + \left(\frac{1}{C(R_1 + R_2)} \right) \left(\frac{L}{R_1} \right)}$$

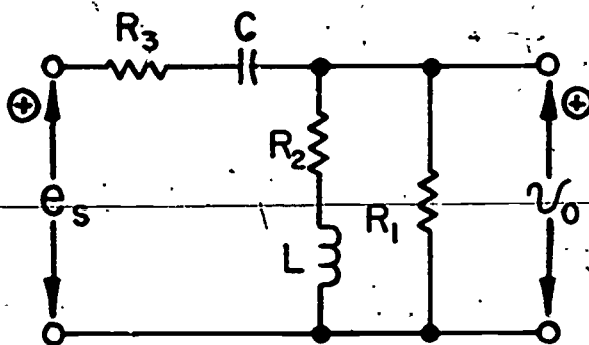

$$\frac{V_o(s)}{E(s)} = \frac{R_1}{R_1 + R_3} \frac{s \left(s + \frac{1}{L/R_2} \right)}{s^2 + s \left(\frac{1}{C(R_1 + R_3)} + \frac{R_2 + \frac{R_1 R_3}{R_1 + R_3}}{L} \right) + \left(\frac{1}{C(R_1 + R_3)} \right) \left(\frac{1}{L/(R_1 + R_2)} \right)}$$

EXAMPLES WITH S-EQUATIONS (Cont'd)

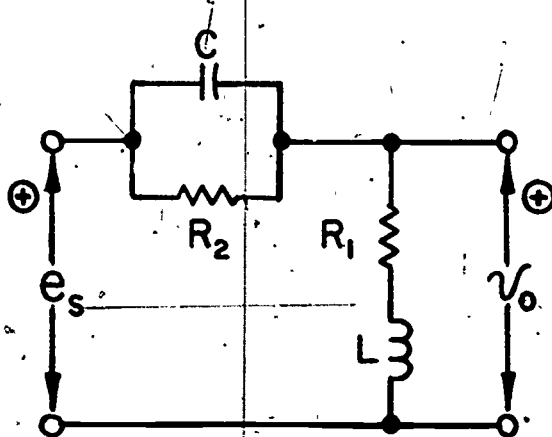

$$\frac{V_o(s)}{E(s)} = \frac{\left(s + \frac{1}{R_2 C}\right) \left(s + \frac{1}{L/R_1}\right)}{s^2 + s \left(\frac{1}{R_2 C} + \frac{1}{L/R_1}\right) + \left(\frac{1}{R_2 C}\right) \left(\frac{1}{L/(R_1 + R_2)}\right)}$$

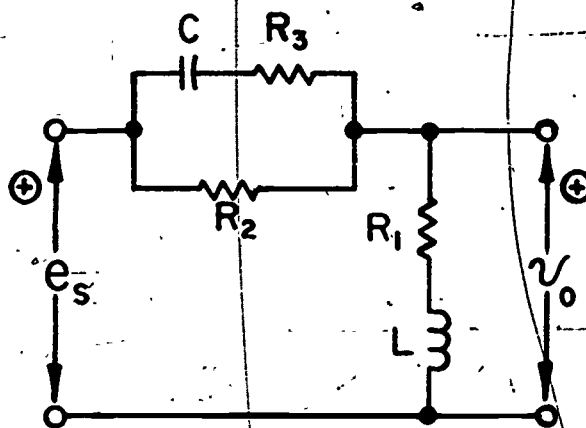

$$\frac{V_o(s)}{E(s)} = \frac{\left(s + \frac{1}{L/R_1}\right) \left(s + \frac{1}{C(R_2 + R_3)}\right)}{s^2 + s \left(\frac{1}{C(R_2 + R_3)} + \frac{1}{L/R_1}\right) + \left(\frac{1}{C(R_2 + R_3)}\right) \left(\frac{1}{L/(R_1 + R_2)}\right)}$$

Note: Many other circuits and their corresponding S-equations could be shown. Those presented here are sufficient to illustrate the pattern for the equations and the technique of identifying the constants directly from the circuit. Remember, however, that a circuit having a C in series with an L is the special case.

CHAPTER 5

THE FUNDAMENTALS OF ELECTRONICS SEQUENCE

The sequence of three courses (Resistive Electronics, Pulse Electronics and Advanced Linear Electronics), as presented in this chapter, is representative of the core material for the Fundamentals of Electronics.

As suggested for the sequence of courses in Circuit Analysis of the previous chapter, the reader is encouraged to regard the Fundamentals of Electronics as a single package rather than as three separate courses. The sequencing of the three courses is considered to be as important as the sequencing of topics within each course.

Each of the three courses contains subject-matter contents and organization of topics that are representative of conventional kinds of courses. There are two major recommendations that the ETCO Project wishes to submit. Detailed information for these two recommendations is presented in the chapter.

- a. To get started with the Fundamentals of Electronics package, or to get started with a study of any group of electronic devices, the major emphasis shall be on the electrical properties (such as volt-ampere graphs and circuit response) rather than on the internal properties. The physics of devices shall not be a prerequisite.
- b. The subject of Pulse Electronics shall be required as the second course in the sequence. Conventionally, this subject has been included in Electronics Technology curricula as an elective or as the third course in the sequence.

RESISTIVE ELECTRONICS (ELECTRONICS I)

DEFINITION

The subject of *Resistive Electronics* is, primarily, a study of the electrical characteristics, electrical parameters and the physical properties of electronic and electrical devices with limited applications of these devices as resistive elements.

MAJOR CONCEPTS

Resistive Electronics is more device oriented than circuits oriented. This approach is necessary because of the large number of devices on which the student needs information before using the devices in circuits.

Concentration on the volt-ampere characteristics of devices makes it possible to study a large number of devices. Specific information on how this is done is presented in the General Guidelines under the heading: *The Terminal or Port Approach to the Study of Electronic Devices*.

The physical properties of devices does not imply a physics and chemistry approach to how the device performs its designated function. It implies the study of a device by considering the terminals with its electrical characteristics, and interpreting this information to understand and appreciate the nomenclature such as: Current and voltage ratings, STDP, NPN, base, gate, anode, copper plated, shelf life, reliability, power rating, heat sink, etc.

BEHAVIORAL OBJECTIVES

Upon satisfactory completion of the subject of *Resistive Electronics*, the student shall have the ability to:

- a. Ascertain the electrical properties of any electronic device.
- b. Write and converse about electronic devices using acceptable terminology and nomenclature.
- c. Understand the specifications for a number of electronic devices.

- d. Select appropriate devices from catalog listings according to identification and specifications.
- e. Appreciate the need of different electronic devices, with their different electrical properties, in systems.

PREREQUISITES

Ideally, the subject of *Resistive Electronics* should have the prerequisites of *Resistive Circuits* and *Introduction to Electronics Technology*.

From *Resistive Circuits*, the student will have the needed background knowledge of the concept of resistance and how to handle resistive, or equivalent resistive elements in circuit models. The student is prepared to understand why electronic devices must be replaced with a model in order to make necessary calculations and to interpret measurements made on electronic devices.

From the subject of *Introduction to Electronics Technology*, the student has the needed systems approach and a knowledge of much of the terminology and nomenclature essential to the concentrated study of devices. Going directly to a study of electronic devices, without some information as to the purpose of these devices, would leave the student too uninspired.

The flow chart shown here, reveals the position of *Resistive Electronics* with respect to other subjects pertinent to *Resistive Electronics*.

Flow chart is presented on next page.

Resistive
Circuits

INTRO

RESISTIVE ELECTRONICS

Pulse Electronics

OUTLINE

PART 1: TRANSDUCERS

I. Identification of Switching Devices

A. Types

1. Common: Toggle, slide, knife, lever pushbutton, rotary (See a parts catalog for additional types).
2. Special types: Thermostatic, mercury, reed, microswitch (Solid state to be considered later).
3. Relays and solenoids.
 - a. Types: Stepping, time delay, thermal delay, reed (See a parts catalog for additional types).
 - b. Making and breaking voltages.
 - (1) Factors.
 - (2) Determining experimentally.
 - c. Symbols.

B. Switch Contacts

1. Types: Copper, silver plated, gold plated.
2. Physical construction.
 - a. Maximum current, i .
 - b. Maximum voltage, v .
 - c. Maximum power, i^2R .
 - d. Low resistance needed between contacts.
 - e. High frequency switches (Low R and C for frequency used).

C. Switch Action

1. SPST and symbol.
2. DPST and symbol.
3. DPDT and symbol.
4. Multiple position switch and symbol.

II. Protective Devices

A. Purpose of protective device

1. Prevent overload of source.
2. Prevent hot wires, burned insulation and fire.
3. Limit the damage to total circuit.
4. Provide little or no voltage drop (must have low resistance).
5. Provide maximum protection (Primary of transformer usually contains fuse).

B. Ratings

1. Current rating.
 - a. Low current, - small wire.
 - b. Not a voltage or power device. (Will "blow" when more than rated current goes through device).
2. Voltage rating.
 - a. Low voltage - physically short.
 - b. High voltage - physically long.
 - c. Arcing should not exist across blown fuse.

C. Replacement

1. Replace with type recommended by manufacturer.
 - a. Too high a value would not blow soon enough to protect equipment.
 - b. Too low a value could "blow" under normal usage.
2. If rating is not known, - use 150% to 200% above normal current used.

D. Types of protective devices

1. Fuses.
 - a. Fast blowing, - for instruments and meters.
 - b. Standard, - general purpose.
 - c. Delay or slow blow, - used in inductive devices.
2. Circuit breakers.
 - a. Electromechanical, - does not

destroy itself, (just needs resetting).

- b. Thermal, - Bimetal strip heats and bends to break contact.
- c. Magnetic, - Magnetic field is proportional to current.

III. Cells and Batteries

A. Primary cells

1. Chemical change not easily reversible.
2. Cannot be recharged.
3. Examples: Carbon-zinc drycell (common flashlight batteries, and mercury cells).

B. Secondary cells

1. Chemical change is reversible.
2. Can be recharged.
3. Examples: Lead acid battery (in autos and elsewhere) alkaline rechargeable, and nickel cadmium.

C. Battery

1. Definition, - two or more cells.
2. Connection of cells, - series, parallel.
3. Internal resistance.
 - a. Low when battery is charged, - high when battery is discharged.
 - b. Varies with size and type of battery.
4. Efficiency of battery is related to load.
 - a. 50% with load resistance equal to internal resistance.
 - b. Efficiency higher for higher load resistance.
 - c. Concept of maximum power transfer.
5. Testing.
 - a. No-load voltage.
 - b. Full-load voltage.

IV. Light Sensitive Devices

A. Photo voltaic cell (converts light directly to electricity)

1. Efficiency, - up to 14%.
2. Uses, - satellite power, camera light meters, light-controlled devices.
3. Most common materials, - germanium, silicon and selenium.
4. Comparison with photosensitive resistor.
 - a. Greater linearity.

- b. Faster response.
- c. More uniformity from cell to cell.
- d. Larger surface area required.

5. Photodiode.

- a. Small surface area.
- b. Fast response.
- c. Used in high speed reading, - punch cards, etc.

B. Photo conductive cell

1. Materials used, - germanium, silicon, selenium, sulfides.
2. Provides variable resistance, - decreases with increase of light.
3. Sensitivity.
 - a. Resistance a function of wave-length (usable up to 100Hz).
 - b. Rise time longer than fall time.
4. Sealed in case for protection against moisture, dust, etc.

C. Other light sensitive devices

1. Photo transistors.
2. Photo multiplier tubes, - very sensitive.

V. Temperature Sensitive Devices

A. Thermistors (a small bead of semiconductor)

1. Properties.
 - a. Negative temperature coefficient.
 - b. Detects small temperature changes.
 - c. High reliability.
 - d. Time constant, - several seconds.
2. Uses.
 - a. Temperature range (-100° to 300°C).
 - b. Detect minor temperature changes.

B. Thermocouple (Voltage produced from dissimilar metals)

1. Properties.
 - a. Thermoelectric constants, - microvolts/°C (obtain from handbook for materials such as: nickel, platinum, carbon, silver, copper, iron, nichrome, germanium, silicon).
 - b. Voltage difference at junctions is a measure of temperature difference.

c. Temperature range (to 3000°C).

VI. Electromechanical Devices

A. Mechanical to electrical

1. D-C generators.
2. A-C generators.
3. Microphones.
 - a. Carbon type (external battery source).
 - b. Dynamic (electromagnetic).
 - c. Crystal (Piezoelectric effect).
 - d. Factors to consider, - distance, noise level restrictions, frequency response desired, directional.
 - e. Phonograph cartridges.
4. Strain gauges.

B. Electrical to mechanical

1. D-C motors, - series, shunt, compound.
2. A-C motors, - synchronous, induction, shaded pole single-phase, capacitor-start motors, resistance-start motors.
3. Universal (A-C or D-C operation):

C. Sound producing transducers

1. Speakers.
 - a. Diameters and shapes.
 - b. Frequency response.
 - c. Power ratings.
 - d. Impedance matching requirements.
2. Headphones.
 - a. Magnetic.
 - (1) High impedance type (2000-10,000 ohms).
 - (2) Low impedance type (5-600 ohms).
 - (3) Frequency response.
 - b. Crystal.
 - (1) Very high impedance.
 - (2) The piezoelectric effect.
 - (3) Frequency response.
3. Reversible process possible.

4. Direction of motion for electrons and holes.

B. Electrical properties of diode

1. Volt-ampere characteristic.
2. Resistive circuit model.
3. Forward biasing.
4. Reverse biasing.
5. Forward resistance, R_f .
6. Reverse resistance, R_r .
7. Resistance ratio.
8. Power dissipation.

VIII. Diode Types

A. Zener diodes

1. Volt-ampere characteristic.
2. Specifications and ratings.
3. A voltage reference element.
4. Constant voltage property.

B. Tunnel diodes and unijunction transistor

1. Volt-ampere characteristic.
2. Specifications and ratings.
3. Properties as a fast switch.
4. Tunnel diode oscillator circuit.
5. Unijunction oscillator circuit.

C. Variable capacitance diodes

D. Metallic rectifiers

1. Volt-ampere characteristic.
2. Specifications and ratings.

E. Vacuum diodes

1. Volt-ampere characteristic.
2. Specifications and ratings.

F. Diode applications (in resistive circuits only)

1. Clipping circuits.
2. AND gate.
3. OR gate.
4. Half-wave and full-wave rectification (concept and use of load lines).

PART 2: SOLID STATE DIODES

VII. The PN junction

A. Physical structure and properties

1. P and N material.
2. Structures to form diodes.

PART 3: MULTITERMINAL DEVICES

IX. NPN and PNP transistors

A. Electrical Properties

1. Volt-ampere characteristic.
2. Ratings and specifications.

3. Leakage currents.
 - a. Collector to emitter.
 - b. Base to emitter.
 4. Saturation currents and voltages.
- B. Analysis and circuit models
1. NPN and PNP symbols.
 2. Graphical analysis.
 3. Load lines.
 4. Operating points.
 5. When used as ON-OFF switch.
 6. When used in linear operating range.
- C. Basic application (Resistive only)
1. Amplifier, - linear operation.
 2. Waveshaping when overdriven (emphasis on the effect of overdriving, - limited discussion on waveshaping.)
 3. AND and OR circuits, with transistor. Could be presented here. Limited studies, however.

X. SCR's and TRIACS

- A. Electrical properties
1. Volt-ampere characteristic.
 2. Ratings and specifications.
 3. Gate control.
- B. Applications, in simple rectifier circuits.

XI. Field Effect Transistors (FET)

A. Types

1. MOS-- FET's.
2. J - FET's.

B. Electrical properties

1. Volt-ampere characteristics.
2. Ratings and specifications.
3. Voltage controlled.
4. Input impedance.

C. Analysis and operation in circuits

1. Load lines.
2. Operating point for linear operation.
3. Saturation and cutoff values.

D. Simple applications.

XII. Vacuum Tubes

A. Triodes

1. Volt-ampere characteristics.
2. Ratings and specifications.
3. Load lines.

4. Operating point for linear operation.
 5. Saturation and cutoff values.
- B. Pentodes
1. Volt-ampere characteristics.
 2. Ratings and specifications.
 3. Load lines and operating points.
- C. Simple applications

GENERAL GUIDELINES

The information and suggestions of these *General Guidelines* for the subject of *Resistive Electronics* are presented to emphasize those major concepts, techniques of instruction and limitations of subject coverage for the course.

More specific guidelines for classroom and laboratory activities will follow these general guidelines.

Three Parts of Resistive Electronics

The subject of *Resistive Electronics* has the three major divisions as presented in the topical outline. These three groupings are: (1) Transducers, (2) Diodes and (3) Multi-terminal devices.

The course is essentially *device oriented* which is the reason for these three identified groupings.

Systems Approach Implied

The subject of transducers, in itself, implies a systems approach. Every complete electrical or electronic system requires at least one energy conversion device at the input (nonelectrical to electrical signal) and at least one energy conversion device at the

output (electrical to nonelectrical). The subject of *Resistive Electronics* is the most convenient place in the curriculum to emphasize the need for transducers and to learn as much as time will permit about these devices.

Emphasis on the volt-ampere characteristics of electronic devices also emphasizes a systems approach. Knowing the importance of the volt-ampere properties will permit the student to adjust more quickly to the use and application of new devices or of existing devices that he

did not have time to study thoroughly.

The devices are approached from a terminal or port standpoint by concentrating on the electrical characteristics which also implies a systems approach.

The systems approach must not be confused with a study of systems.

Emphasis on Electrical Parameters

As indicated previously, any active device can be approached by determining its electrical characteristics at its input and output terminals and transfer parameters. This universal approach however, is reliant upon the determination of these parameters which can be derived either through the use of specification sheets and characteristic curves provided by the manufacturer or through the use of instrumentation. The technician must be equally at ease with both methods if he is to be effective as an electronics technician.

Once these characteristics or parameters have been determined, the active circuit including the device can be analyzed through the use of either graphical methods and loadlines or the electrical model for the device. This subject, *Resistive Electronics*, employs devices in only resistive circuits and deals only with the resistive parameters of the device. This is to say that no capacitive or inductive parameters of either the circuit or device are considered. Consequently, when the operation of devices in active circuits are studied through graphical methods, only the D.C. loadline needs to be considered. Likewise, in developing models for the device, we employ the piecewise linear model with no reactive components.

In analyzing active circuits and their response, there is a good deal of associated circuitry such as biasing networks that can be reduced through the use of equivalent circuit techniques learned in the resistive circuits course. However, if these techniques are to be utilized to full benefit, the electrical parameters of the device and its electrical model

must be known. If this is the case, the circuit can be reduced to its simplest electrical equivalent, making its analysis much more convenient and its function more apparent.

The meaning and use of device parameters can be understood and facilitated only through an understanding of transfer functions. Consequently, this ground work is laid in the preceding resistive circuits course where the student is exposed to these functions. This unit or topic includes R, G, and H parameters from a port or terminal standpoint.

The Physics of Electronic Devices De-Emphasized

In introducing active electronic devices to students of electronics technology, the traditional approach has been to spend a considerable amount of time dealing with the Physics of the devices. It is felt that with the overwhelming number of new devices appearing and the limited amount of time available to study them, the emphasis placed on the physics of the devices should be minimized. The student has only 2 years in which to prepare himself to enter industry in an engineering-support capacity and extensive amounts of time spent on the physics of devices must result in less time spent on the solid foundation in theory that he must have if he is to grow and specialize in electronics in the future. In order for the student to develop the ability to approach any new device and use it properly, his attention must be directed to its electrical parameters, input-output characteristics, V/A relationships, and the curves that apply.

Furthermore, an extensive background in vacuum and semiconductor physics will be of little value in the application of devices. In the ETCDP curriculum, emphasis is placed on the use of V/A characteristics of circuit components in the courses preceding resistive electronics. With this background, the student readily accepts the introduction of each device in terms of its electrical parameters.

and equivalent model. He then can move into the use of the device in active circuits with no instruction in the physics or fabrication of the device. All that one needs to apply the device is to understand its electrical parameters. The physics are of little value in this respect. However, when each device is studied, mention may need to be made of the physics appropriate to the device in order to avoid having the student worrying about how the device works rather than concentrating on the electrical parameters of the device. Once again, this must be a brief presentation. The question might be asked, "How will an extensive background in the physics of devices help the student when he is on the job as an engineering support technician?"

If the physics of devices are to be taught, perhaps the proper place for coverage is in the sequence of physics courses that all the students take.

As mentioned earlier, this course places primary emphasis on the electrical parameters of the devices, both in the class room and laboratory. As with the physics of the devices, there has been a tendency to spend appreciable time dealing with the processes employed in the manufacture of the individual electronic devices. It seems that the physics of vacuum, gas and semiconductor devices, as well as the manufacturing and packaging processes employed, might well be treated in a unit near the end of the course. In this unit, though, the emphasis should be placed on fabrication and packaging to allow the students to feel more at ease with the "packaged" and integrated circuits.

Resistive Electronics is Laboratory-Oriented

The sequence of topics in the circuits courses are primarily problem-solving in nature with major concentration on the application of theory and mathematical techniques to passive networks. Consequently, the emphasis in these courses is on classroom work. Likewise, because of the wide range of active devices to be covered, and their inherent lack of uniformity, this first course in electronic devices and their application

is laboratory-oriented and the time allowed for the course should be allocated similarly. Furthermore, the study of electronic devices as outlined here is more of a "real-world" sequence where the models for the devices are more of an approximation than the models for passive components treated in the circuits course.

This course places major importance on the devices from an electrical parameter basis and the laboratory with its curve-tracer and other instrumentation should be used to their fullest if accurate models are to be employed in the analysis of active circuits. Semiconductor devices are not produced with uniform characteristics while many applications require specifications that are more accurate than the "average" characteristics provided with the device. The determination of these specifications is an instrumentation or laboratory problem and is given much importance in this course.

On the other hand, many other applications of electronic devices do not require such exact specifications and the technician should be able to handle these devices in active circuits with approximate characteristics. He should develop a "feel" for these active circuits and be able to quickly determine "Ball Park" values for their circuit parameters. This intuitive understanding of common active circuits can be developed only through working with a large number of them in operation.

The introduction of new devices can be facilitated in many cases, also, through the analysis of the function of an active circuit leading to the analysis of the function of the device itself, culminated by the determination of its electrical parameters. This approach lends itself well to the development of an understanding of common applications of each device as well.

The student can do design work early in the sequence in the laboratory where approximate values for parameters are used and the

student strives for maximum performance of the circuit by adjusting or refining the values of circuit components. This "cut and try" method is definitely a valid approach to much design work and is often employed in industry. This skill can be developed only through extensive laboratory experience.

Finally, time needs to be spent on the many applications of the devices studied in the classroom. This, too, is a laboratory problem or type of activity.

Getting Started with Resistive Electronics

The terminal approach utilized in this sequence of topics, along with the emphasis placed on the electrical parameters of devices, allows us to initiate our studies with a consideration of energy conversion devices or transducers.

These devices fit naturally into the sequence at this point if we restrict coverage to their electrical response to excitation, primarily on a graphical basis, without regard to the physical phenomena behind their operation.

Much of the work with transducers should be centered about the laboratory, where we can arrive at the electrical characteristics of the devices through experimentation and instrumentation. This allows freedom in the classroom in "setting the stage" or getting ready to move into the study of active devices through the kind of introductory material included in Section I of the outline.

The study of transducers might well be broken into two sections, the first being a consideration of those devices converting a non-electrical quantity or response to an electrical one. This could be followed by the opposite type of transducers, those that convert an electrical quantity or response to a non-electrical quantity or response. Several of each type have been included in the outline as *examples* only. There are many more worthy of consideration and the instructor will wish to choose those to include on the basis of availability as well as importance.

The study of transducers can easily take an

entire course if one were to be complete in their coverage. However, the intent is to make the student aware of their existence and to allow him to feel at ease in using them. It is felt that this can result through considering a few typical transducers through concentration on their *electrical response*. Extensive amounts of time *should not* be spent in this introductory sequence.

THE TERMINAL OR PORT APPROACH TO THE STUDY OF ELECTRONIC DEVICES

The study of Resistive Electronics from a "terminal" or "port" approach eventually becomes classified into two categories. One is a power flow situation and other is a signal or waveform processing problem. This is sometimes referred to by authors as d-c or a-c parameters.

These topics are well presented in many textbooks in a very rigorous and thorough matter.

The difficulty with presenting this material to the student is that he lacks a real "feel" or clear understanding of some very fundamental concepts that involve application from material learned in resistive circuits. Once again the major problem is *getting the student started* in a quantitative study of these devices and their related circuits.

The graphical analysis, or load-line approach, is still the best way to assure that the student will be able to relate principles previously learned to the particular characteristics of the device being studied. This will help the student develop a visual or mental image of how the device performs. It will also allow him to work with v/i characteristic curves with which he should be quite familiar from his studies in Resistive Circuits.

Let us consider a method for getting the student started into this type of analysis. Given the problem in Fig. 1, predict v_o and i . Starting with this problem provides a high degree of familiarity for the student since he

has had resistive circuits and is quite capable of solving the problem algebraically. However, the instructor could suggest a graphical procedure as suggested in Fig. 2 and Fig. 3, a concept which is developed as follows:

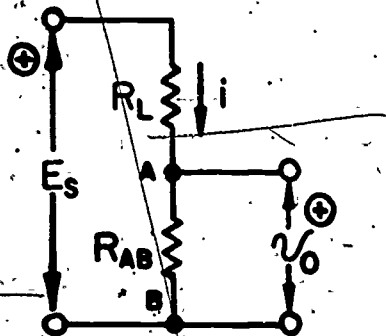

Fig. 1

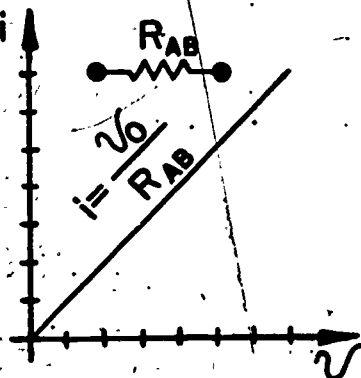

Fig. 2

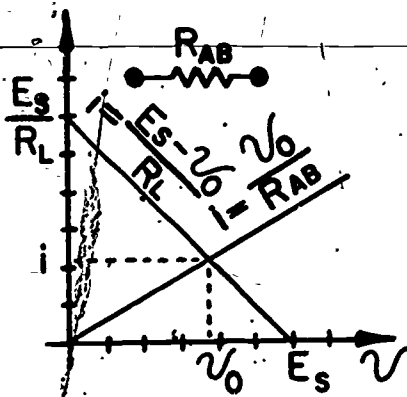

Fig. 3

Since the desired voltage v_0 is really the voltage across R_{ab} and the desired current i is also i_{ab} then the v/a characteristic curve at the terminals a and b are of particular interest to the solution of this problem. The students' background is adequate to derive the v/a characteristic curve and would be familiar with the information shown in Fig. 2. The student would also be able to look at Fig. 1 and appreciate equation 1 and equation 2.

$$(eq. 1) \quad i = \frac{v_0}{R_{ab}} \quad (eq. 2) \quad i = \frac{E_s - v_0}{R_L}$$

If the student were to graph these two equations for current i , he would get the information shown on Fig. 3.

The student can see from the graph and equation 2 that when $i = 0$, $v_0 = 0$, $i = E_s/R_L$. The student would also recognize equation 1 as the v/a characteristic curve for the R_{ab} across the terminals shown in Fig. 2.

However, this is a series circuit and there is only one i . Therefore, equations 1 and 2 can be set equal to each other. If the student were to do that, and solve for v_0 , he

$$\text{would get the equation } v_0 = \frac{(E_s)(R_{ab})}{R_{ab} + R_L}$$

Now this is the equation the student would have resolved for v_0 if left to his own endeavors and the information developed in the resistive circuits topic.

Looking at Fig. 3, v_0 can now be predicted graphically, as well as i , by projecting back to the proper axis on the v/a curve for R_{ab} .

The answer to the problem was obvious to the student before the graphical analysis approach was presented. However, it does give a firm and logical introduction to load-line analysis and it will provide a stepping stone to the next problem.

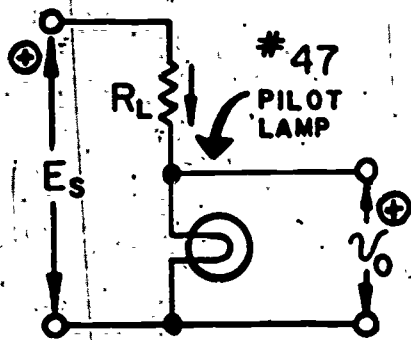

Fig. 4

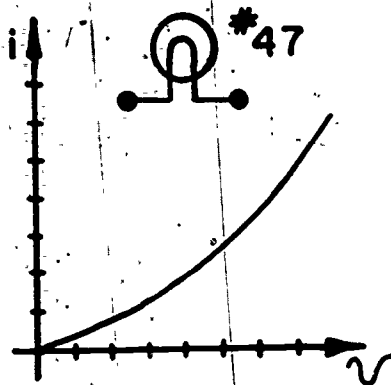

Fig. 5

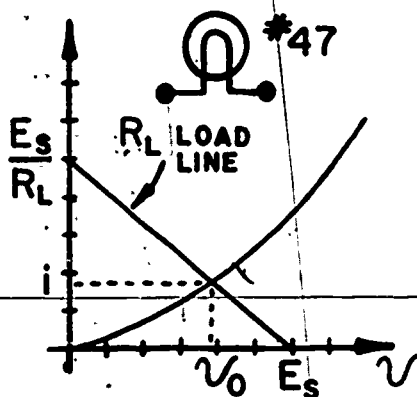

Fig. 6

The student is now asked to predict v_0 and i in the problem shown in Fig. 4. The student is no longer in a position to bypass the v/a characteristics for the device at terminals a and b as was the case in Fig. 1. Now the v/a characteristics at the terminals a and b become

essential and are presented in Fig. 5. The solution is the same as the previous problem. The big difference is that some v/a parameters are necessary to solve the problem. The student is not as apt to question *WHY* the load-line of R_L is "folded" across the v/a characteristic curve as shown in Fig. 6. The graphical solution to the previous problem should have answered that basic question, which is so crucial to understanding devices and how they relate to the overall circuit.

The instructor can now point out the quiescent point, normally called the (Q) point, and begin the introduction to nomenclature needed later in the course.

The student should now be allowed to vary the circuit parameters influencing the device at terminals a and b. He soon finds that he has two variables once he selects the device at terminals a and b; they are e_s and the value of the resistance in series with the terminals a and b. Homework and lab assignments along this line are of particular interest to the student and are very important to him in developing a feel for some very basic concepts used in the more advanced study of circuits containing active devices.

Ask the student to design a circuit so that the lamp will operate at a particular v_0 and i giving him the latitude to work backwards from the v/a characteristic curve of the device.

Next ask the student if a model could be constructed from the information on the v/a characteristic curve of the device at terminals a and b that would allow the use of techniques developed in resistive circuits. What would this model look like?

Next ask the student if this information is available in a supply catalog and for him to find out for a homework or lab problem.

The next step is an obvious one and it involves the connection of other two terminal devices at the terminals a and b and to make similar applications. Devices that students

enjoy working with in this application are Photo-sensitive diodes, Thermistors, PN diodes, forward and reversed biased, as well as Zener diodes, etc.

This graphical analysis technique developed by the student is important for his further study of electronics devices, but a very important by-product is obtained with this approach. It is a logical method for getting a visual interpretation of what is happening in the overall circuit, and this in turn gives him a feel for the terminal or port approach to the study of these devices. It will be noted that the physics and the unique properties of the device are not discussed in the analysis of the terminal characteristics nor how they affect the circuit. This can best be studied under sub topics such as: temperature coefficients, energy levels, minority current carriers, etc. at a more apropos time, and allows the student to move into a very practical study of devices, their terminal characteristics and how they operate in the circuit.

The Transition to Three Terminal Devices

A suggested starting point is with a transistor since it is current-driven and this is a problem for some students and teachers if they study voltage-driven devices first. A three terminal device could be considered as shown in Fig. 7.

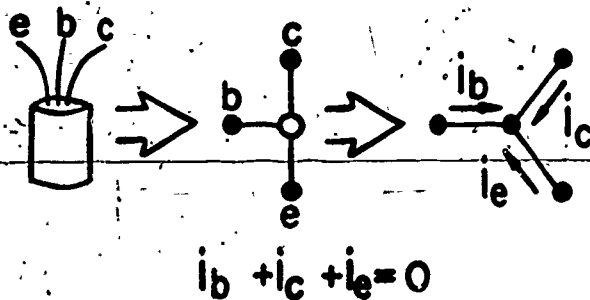

Fig. 7

The student is told to reference one of the terminals, for example, e, as was terminal b back in Fig. 1 and Fig. 4 of the two terminal devices.

Approximation values are used at this point to help the student get the feel for the device

and still allow him to do quantitative analysis work.

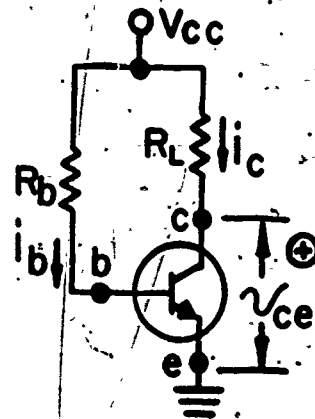

Fig. 8

Some general information can be given to the student about a transistor if the instructor so desired at this point, but he could rely upon a general interpretation of the output v/i characteristic curve for a common emitter and move very quickly into a load-line situation. The important thing to remember when presenting this material to the student is to keep the number of components to a minimum. Therefore, the circuit in Fig. 8 has many advantages for teaching this concept because it involves three components, two resistors and a NPN transistor.

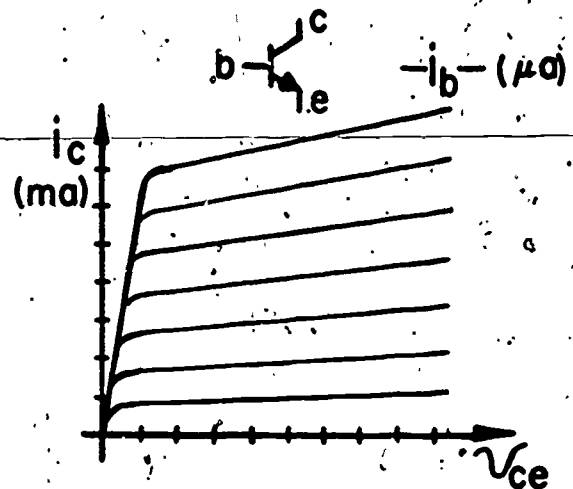

Fig. 9

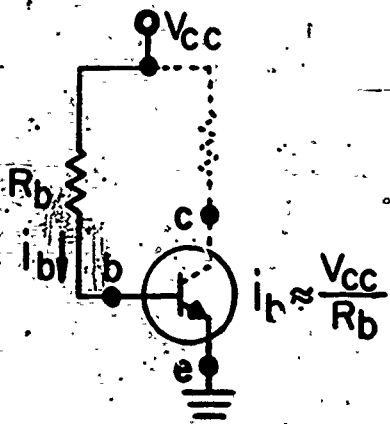

Fig. 10

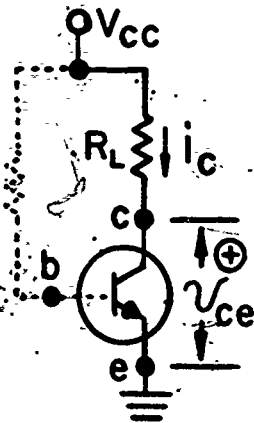

Fig. 11

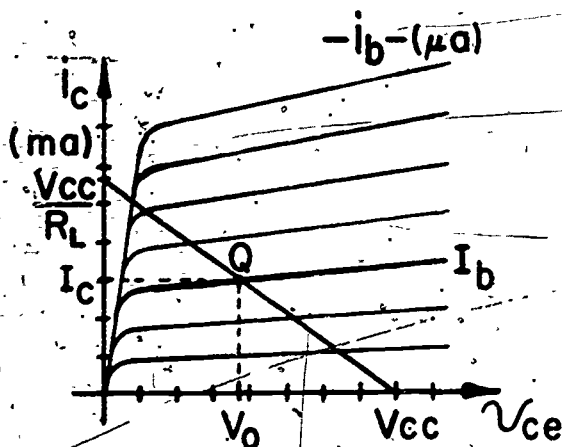

Fig. 12

The characteristic curve for the transistor shown in Fig. 9 can be shown and qualitatively explained to the student with the assistance of the information shown in Fig. 10 and Fig. 11. The formula i_b is approximately equal to

$$\frac{V_{CC}}{R_b}$$

The output v_a characteristic shown in Fig. 9 becomes easier for the student to comprehend with techniques illustrated in Figures 10 and 11. This helps the student visualize i_c and v_{ce} when i_b is equal to some predetermined value. Fig. 11 now represents a problem similar to the two terminal problems previously discussed, and of course can be handled similarly and is illustrated in Fig. 12.

The (Q) point can now be discussed as the point dependent upon i_b and the intersection of the load-line for R_L . Again this is an attempt for the student to visually interpret some basic properties involved in the study of three terminal device. This particular one is a current driven transistor.

Now is a good time to illustrate both in a class discussion period, as well as in the laboratory, the concept of saturation, cut-off, and the linear region of the device, - also an apropos time to discuss the influence of i_b , V_{CC} , and the value of R_L along with the particular characteristic curve of the three terminal current driven device selected. Exposing the student to high and low beta transistors along with the transfer function involved in beta, and its graphical explanation, becomes very helpful and meaningful to the student. The "a-c" load-line is discussed at a later time as there always seems to be a little misunderstanding in what is entailed in the selection of the a-c load-line not to mention the effect of capacitive coupling. Signal processing can be discussed using only the d-c load-line. Most authors do a very satisfactory job in developing the a-c parameters of this circuit, if the teacher feels it is necessary at this

time. (CAUTION: keep coupling capacitors LARGE).

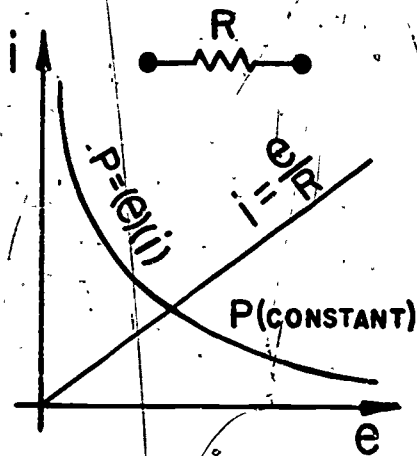

Fig. 13

The next step would be to do a similar analysis with a voltage driven device such as FET, or a triode tube. Another logical step in the development of these concepts would be to work with a power curve, in terms of the basic formula, $P = e i$ by going clear back to Fig. 2 and developing this curve as illustrated in Fig. 13.

Apply it again to two and three terminal devices and make reference to supply catalogs. The d-c load-line for R_L is a logical place to develop switching, amplification and other basic concepts involved in the study of devices and their related circuits. It is also an ideal place to get the student to develop resistive models for particular points on the d-c load-line so that he may apply network analysis techniques to solutions, and thereby set the stage for advance work.

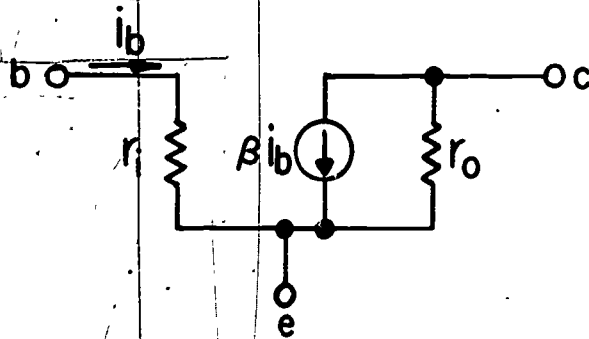

Fig. 14

Signal or Waveform Processing

Students have an orientation problem when it comes to model construction for active devices such as the one illustrated in Fig. 14. The problem results from students not having a clear understanding of the difference between the quiescent power flow conditions of the circuit and the overall signal parameters.

The helpful technique for getting the student started in model construction for analysis purposes is to begin with a circuit such as illustrated in Fig. 15. V_{cc} is explained to the student as being a power source, but a signal ground point. The students' background in circuit analysis with Thevenin's circuit reduction techniques allows Fig. 16 to be logically explained.

The student will also notice the voltage polarity references shown in Fig. 15. Laboratory clarification may be necessary and helpful.

Looking at Fig. 16 the student can be oriented to r_i from the standpoint that terminals b and e have a voltage across them as well as a current flow between them; therefore, there must be a volt/ampere ratio,

$$r_i = \frac{v_{in}}{i_b}$$

The same is true of terminals c and e called

$$r_o = \frac{v_{ce}}{i_{ce}}$$

The beta term has been developed from previous work with the d-c load-line. The model constructed in Fig. 14 is now easily explained to the student and of course will fit into

Fig. 16.

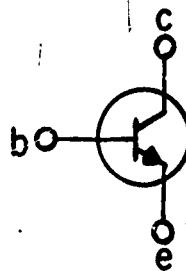

The significant point to make at this time is that signal flow is normally in a horizontal direction across a schematic diagram, whereas, power flow is in a vertical direction.

Once again authors have a very satisfactory approach to the

development of a-c parameters for these devices. Students have very little problem once they have clearly distinguished between the two basic problems for three or more terminal devices, that is the d-c or quiescent conditions versus the signal parameters.

Once the student is able to appreciate the qualitative aspects of these models; he is in a position to utilize techniques developed in his circuit analysis sequence to study and predict the signal response of active multiterminal devices.

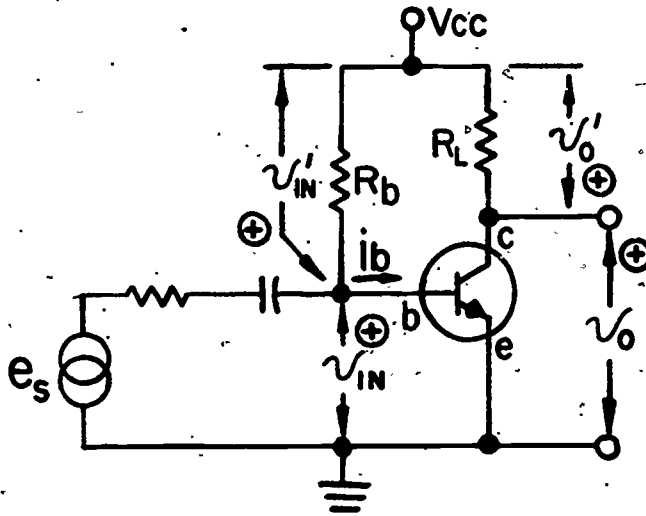

Fig. 15

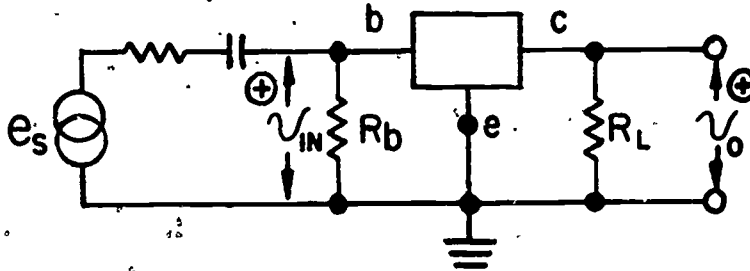

Fig. 16

LABORATORY GUIDELINES FOR RESISTIVE ELECTRONICS

The subject of *Resistive Electronics* is device oriented and as such, it is also laboratory oriented. In other words, the classroom topics for discussion are largely controlled by the content and sequence of activities in the laboratory. The projects that are presented here are, therefore, suggestive of activities for both the classroom and the laboratory. The information presented with each project is in general terms as a guideline for the instructor. More detailed information and instructions are needed for the student. The projects, it will be noted, follow the sequencing of topics as previously presented in the outline. Make good use of specifications and catalogs.

Project No. 1: Switching Devices

- I. The student will sketch schematic diagrams, using standard symbols, and set up circuits in the laboratory to do the following:
 - A. One switch for on-off control of one light bulb (#44).
 - B. One switch for simultaneous on-off control of two light bulbs (#44 and #47).
 - C. One switching device to control the two bulbs such that one is on when the other is off.
 - D. Two switches to control one bulb. Either switch can operate the light bulb.
 - E. Three switches to control one bulb. Each switch shall operate the bulb regardless of the position of the other switches.
- II. Investigation of the making and breaking voltages of selected relays.
 - A. Know the type of switching action represented by each relay.
 - B. Comparison of voltages required to open and to close a relay.
- III. Operation of reed switches in a circuit.
- IV. Investigate the various switches available as time permits. Be concerned with: Maximum frequency, rf power, type of switch contacts, life expectancy, voltage, ratings, connections, price, etc.

Project No. 2: Protective Devices

- I. Fuses: Inspect a variety of fuses as to current rating, resistance, voltage drop under full load, time to blow, and other characteristics.
- II. Circuit Breaker: Investigate and explain how a circuit breaker works. Investigate speed of operation.

Project No. 3: Cells and Batteries

- I. Identification of defective cells in multi-terminal batteries.
- II. Finding internal resistance.
- III. Circuit analysis problems using cells and batteries (could be a homework assignment).
 - A. A few problems on finding internal resistance for given circuits with necessary information to do this.
 - B. Circuit analysis problems where internal resistances are given.

Project No. 4: Light Producing Devices

- I. Inspection of a variety of bulbs as to style and base.
- II. Determination of volt-ampere graphs of a light bulb (#44) to concentrate on its non-linear properties.
- III. Operation of a bulb at different voltage ratings to observe brightness as a function of voltage (within ratings, of course).
- IV. Investigation of a relaxation oscillator using a neon bulb to observe frequency control, resistance control, capacitance control and voltage control.

Project No. 5: Light Sensitive Devices

- I. Operation of a photo cell in a circuit, using the scope for observations of waveforms, etc. Use different types of cells.
- II. Measurement of resistance characteristics of photo cells.
- III. How photo cells can be used (circuits) to control larger devices.
- IV. Sensitivity of photo cells to wavelength spectrum (classroom).

Project No. 6: Temperature Sensitive Devices

- I. Investigation of thermistors as to effects of temperature change on current. Observe thermal run-away also.
- II. Investigate the operation of heat-sensitive detectors.
- III. Investigate the simple electric thermometer for the purpose of preparing a graph of resistance as a function of temperature.

Project No. 7: Electromechanical Devices

- I. Sound producing devices:
 - A. Measurement of the D-C resistance of earphones.
 - B. How to connect several loudspeakers (4-ohms each, for example) to operate from a 4-ohm output of an amplifier.
- II. Study of the operation of motors (assuming a motor kit is available).
 - A. D-C motors:
 1. Operated with bar magnets.
 2. Operation with electromagnets.
 3. Important motor principles.
 - B. Split-phase capacitor motor:
 1. Without capacitor:
 - a. Will not start without help.
 - b. Will run in either direction.
 2. With capacitor:
 - a. Will start without help.
 - b. Direction of rotation dependent on connections to auxiliary winding.
 - c. The capacitor is bipolar electrolytic.
 3. Principles of operation.
 - C. Motor-generator system:
 1. Mechanical coupling.
 2. Generator loaded.
 3. Principles of operation.

NOTE: Now is an appropriate time for an examination--classroom type and laboratory type. The classroom examination should have been questions, each one of which is answered briefly and to the point. The laboratory part of the examination will test students

on connections and operation of specified circuits.

Project No. 8: Volt-Ampere Characteristics of Diodes

The volt-ampere characteristic of a number of different diodes are displayed on the screen of an oscilloscope. Or, a curve tracer instrument could be used. In either case, the vertical deflection will be the current and the horizontal deflection will be the voltage. If the oscilloscope is used, the student will need information on how to set up the circuitry and connections to the scope.

Compare silicon diodes with germanium diodes with Zener diodes of different ratings.

Project No. 9: Simple Diode Circuits

- I. An audio oscillator is connected to a series circuit containing a given resistor and a given solid-state diode to observe and interpret the following:
 - A. Waveform across resistor at different frequencies.
 - B. Waveform across diode.
 - C. Effect of reversing diode in A and B.
 - D. Filtering action with a capacitor across the resistance.
- II. Operation and waveforms of a full-wave rectifier circuit.
- III. Diodes operated with reverse voltage.
 - A. Silicon and germanium diodes.
 - B. Magnitudes of reverse current.
 - C. Temperature coefficients considered.

Project No. 10: Zener Diodes

Set up simple series circuits with one resistor and one or more Zener diodes in series.

- A. Use D-C source and observe or determine:
 1. Current for given values of series resistors, with and without a load resistor across diodes.
 2. Value of resistors for rated currents.
- B. Use sinusoidal source. Observe and interpret waveforms, recording all D-C levels.

Project No. 11: The SCR and Triac

Good circuits for this experiment are found in manufacturers' handbooks. Studies should be made with both a D-C source and an A-C source. For the D-C source study, simply connect the source in series with a light bulb and the SCR. To trigger, connect the gate to a low voltage bias supply. This can be connected or disconnected by hand. The student should observe that the circuit is activated in this way. But, to turn the bulb off, the main circuit must be disconnected.

With an A-C circuit, the amount of conduction each cycle is controlled by the signal to the gate. The waveforms should be studied.

NOTE: This is a good time for an examination on diodes. The questions should cover symbols, waveforms, circuit diagrams, specifications, ratings, etc.

Project No. 12: Transistors

Activities for this project involve:

A. Testing of several transistors:

1. Is it an NPN or a PNP?
2. Is it defective in either or both junctions? Check the resistances under reversed bias conditions.

B. Operation of a simple transistor circuit with D-C biasing control only.

1. Conditions necessary to place transistor in the active region. Use volt-ampere characteristic curves as a guide.
2. Check operation of transistor circuit under temperature changes.

C. Operation of transistor amplifier with a sinusoidal signal and observe and interpret:

1. Conditions for linear operation.
2. Inversion.
3. Distortion.
4. Clipping of waveforms when overdriven.

Project No. 13: Unijunction Transistor

A study of the volt-ampere characteristics

of a unijunction transistor and its operation in a relaxation oscillator circuit.

Project No. 14: FETs

A study of the volt-ampere characteristics and the control and operation of FET in a simple amplifier circuit.

Project No. 15: Vacuum Tube Circuits

The total curriculum will not devote much time to vacuum tube circuits. This project should be more of a practical circuit than the other projects of this course. As an example, the student would study a two-stage circuit to operate a loudspeaker, where a signal feeds an amplifier, then coupled to a power amplifier and then to a speaker. The student would concentrate on the voltage gain of each stage.

A TYPICAL FINAL EXAMINATION

The objectives for the subject of Resistive Electronics are illustrated by the types of questions included in a typical final examination:

- A. A set of questions in which the student gives the schematic symbols for a number of devices. The terminals are identified if necessary (fuse, thermistor, battery, diode, abbreviations for switching conditions, Zener diode, diac, SCR, triac, PNP and NPN transistors, unijunction transistor, etc.).
- B. A set of questions in which the student is required to sketch the typical volt-ampere graphs of specified devices.
- C. A set of questions that involve:
 1. Sketching a schematic diagram for specified control with switches.
 2. How the frequency of a relaxation oscillator is controlled and why.
 3. How certain types of circuit breakers work.
 4. The kind of temperature coefficient for a thermistor.
 5. How the resistance of a photo cell changes as a function of light.
 6. When to use an FET rather than a transistor.

7. Definition of β .
 8. Definition of μ .
 9. Sketching of waveforms for given diode circuits.
- D. A set of questions where student is required to sketch circuit diagrams to perform certain specified functions:
1. A workable unijunction transistor circuit with waveforms.
 2. A basic transistor amplifier circuit complete with bias, input and output waveforms.
 3. A light-dimmer circuit using a diac or a triac.
4. A tunnel diode circuit that will oscillate.
 5. A relaxation oscillator using neon bulbs.
- E. Design of a single-stage tube-type amplifier. Specifications and limits of operation are given. The student will:
1. Draw load line on the characteristic curves provided.
 2. Decide on Q-point.
 3. Identify plate current and voltage.
 4. Amplification of circuit.

PULSE ELECTRONICS (ELECTRONICS II)

DEFINITION

Pulse Electronics is a study and analysis of active circuits in which the electronic devices are operated in the switching mode.

MAJOR CONCEPTS

Since diode actions occur when electronic devices are operated in the switching mode, this means that two or more circuit models are needed for the analysis of pulse circuits. The student must come to fully appreciate the concept of circuit models and the changes that can occur in these circuit models. Then once the possible circuit models are known, it becomes a normal kind of circuit analysis problem provided the student knows the conditions and the time intervals under which a model is applicable.

The teaching and learning problems for the course are largely related to a student identification of the circuit models rather than to the analysis of these circuit models. This suggests that much of the desired learning and knowledge will not be developed if the instructor always identifies the circuit models for the student.

BEHAVIORAL OBJECTIVES

The student upon successfully completing the course should have the ability to:

- a. Analyze, with ease, the response of any electronic circuit where the electronic devices are operated in the switching mode, provided the circuit models are restricted to resistive circuits and STC circuits. A large majority of the practical circuits will fall within these restrictions.
- b. Select a circuit and design the selected circuit to give a desired response such as: An output pulse of controllable time duration, with or without a prescribed delay, and with prescribed magnitude limitations: A ramp function with a prescribed

degree of linearity and with prescribed time durations and magnitude limitations. Select and design logic circuits, clamping circuits clipping circuits, the multivibrators, the Schmitt trigger circuit, sweep circuits, and signal gating circuits.

- c. Understand triggering techniques, where applicable, and to select and design appropriate triggering systems.

PREREQUISITES

The subject of Pulse Electronics shall have the subject areas of Resistive Electronics and STC Circuits as the primary prerequisites as illustrated by the following flow chart:

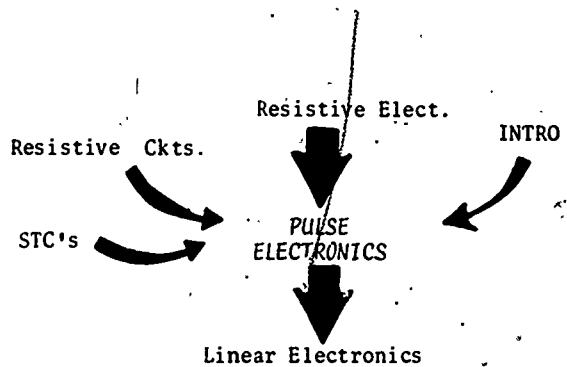

OUTLINE

This topical outline for Pulse Electronics should be regarded more as a subject-matter package rather than as a course. See Chapter 10 for specific suggestions as to content by courses on quarter and semester plans.

Note: The Outline for Pulse Electronics begins on the next page.

OUTLINE FOR PULSE ELECTRONICS

I. Resistive Diode Circuits

A. Single diode circuits

1. Single-loop (series) circuits

- a. The four basic diode clipping and limiting circuits.
- b. Control of limiting (clipping) level with biasing voltage.
- c. Influence of diode forward resistance on circuit design.
- d. Influence of diode back resistance on circuit design.
- e. Influence of diode resistance ratio on circuit design.
- f. Influence of volt-ampere non-linear characteristics on circuit design.

2. Multiple-loop single diode circuits

(Requires the use of two or more resistances and one or more biasing voltages and a diode.)

- a. Techniques of finding the critical value of e_s to place diode in transition state.

1. By assuming diode is non-conducting and setting diode voltage to zero.
2. By assuming diode is conducting and setting diode current to zero.
3. Value of Thevenin's and superposition theorems.

- b. Control and influence of attenuation factors when diode is not conducting.
- c. Circuit design to control transition level of diode and, consequently, the circuit response.

B. Multiple-diode circuits.

1. The number of different possible circuits is one more than number of diodes.
2. Response of two-diode circuits.
3. Response of three-diode circuits.

II. Review of Exponentials (voltages and currents expressed as a function of time)

1. The general equation for a voltage or current exponential.

$$v_t = E_{as} - (E_{as} - E_o) \epsilon^{-\frac{t}{\tau_c}}$$

$$i_t = I_{as} - (I_{as} - I_o) \epsilon^{-\frac{t}{\tau_c}}$$

2. $E_{as} = 0$, or $E_o = 0$, as special cases.
3. The slope at any point on the exponential, including initial slope.
4. Finding the voltage, or current, at given instants in time.
5. Finding the instants in time at given voltage, or current, values on the exponential.

$$t_1 - t_o = \tau_c \ln \frac{E_{as} - E_o}{E_{as} - E_1}$$

6. Calculations over small portions of an exponential.
7. Conditions for assuming exponential has reached asymptotical value.
8. Per cent (or per unit) slope deviation - a measure of non-linearity for a portion of exponential.

III. Resistance Switching in RC Single-time-constant Circuits. (Circuit models derived from practical electronic circuits. Switching conditions defined--no diodes nor transistors in the models).

- A. Conditions defined such that one or more of the exponentials complete.

1. Output voltage across resistive branches.
 - a. With and without biasing voltages.
 - b. Voltage across total equivalent resistive portions of circuit - excluding only the capacitance voltage.
 - c. Resistive circuit attenuations. Voltages across a portion of equivalent resistive circuit.
 2. Voltage across capacitive element.
 - a. Rise times.
 - b. Techniques of generating ramps.
 - c. Sawtooth, or repetitive sweep waveforms.
 - d. Recovery times.
 - e. Capacitive attenuation of steps (single-time-constant circuit with two capacitive elements).
- B. Conditions defined such that none of the exponentials complete. (Requires area-ratio concept).
1. Sinusoidal Source - Capacitance is arbitrarily large.
 - a. Output voltage across equivalent resistances. (Here, there will be no distortion of sine wave - only d-c displacement dependent on resistance ratio)
 - b. Output voltage across a portion of equivalent resistances. (Here, positive and negative portions are attenuated different amounts.)
 2. Rectangular Sources
 - a. Output voltage across R_{eq} of the possible circuits.
 1. Time-constants small.
 2. Time-constants intermediate.
 3. Time-constants large. (Here, output steps are equal to input steps.)
 - b. Output voltage across a portion of resistive equivalent circuit. (Here; output steps are attenuated. Positive and negative-going steps may be attenuated by different amounts.)
- IV. RC-Diode Circuits (Single-time-constant circuits having only one diode.)
- A. All time-constants are not large. (Use rectangular sources only.)
 - a. The two equivalent circuits:
 1. One with diode conducting.
 2. One with diode not conducting.
 - b. Controlling ON and OFF times of diode.
 1. With time constants.
 2. With biasing voltages.
 3. With magnitude of sources.
 - c. Possible waveforms, other than the rectangular wave, that can be generated.
 1. Positive spikes only.
 2. Negative spikes only.
 3. Positive spike overshoots.
 4. Negative spike undershoots.
 - d. Holding diode off completely with biasing, or pulsed voltage.
 - B. Clamping circuits (Requires high resistance ratio).
 1. The three basic clamping circuits dependent on location of biasing voltage.
 - a. Biasing voltage in series with diode.
 - b. Biasing voltage in series with resistance.
 - c. Biasing voltage in series with parallel combination of resistance and diode.

2. Conditions for clamping.
 - a. Positive-peak clamping.
 - b. Negative-peak clamping.
3. Conditions for no clamping.
4. Response of clamping circuits to different sources.
 - a. Rectangular sources.
 - b. Sinusoidal sources.
 - c. Others as desired, such as saw-tooth waveforms.
5. Avoiding clipping effects in clamping circuits.

V. Transistor Circuits without Feedback.

A. Review of Transistor characteristics with emphasis for overdriven applications.

1. V_{CE} (SAT) and dependence on R_L
2. $I_b = 0$ characteristic
 - a. Interpretation of Leakage current and resistance.
 - b. Conditions for collector current to be zero.
3. $h_{FE} = \frac{I_c}{I_b}$ (SAT)
4. Base-to-emitter resistance characteristic.
5. Collector junction reverse voltage characteristic.
6. Emitter junction reverse voltage characteristic.
7. Base-to-emitter properties as a diode.
8. Collector-to-emitter properties as a diode.

B. Analysis of single-transistor circuits operating under switching conditions.

1. Input Circuits (Evaluate v_{be} , i_b and v_{ce})
 - a. Variations of resistive coupling (Circuits similar to Part I - Resistive diode circuits).
 - b. Variations of R-C coupling (Circuits similar to Part IV - RC diode circuits).

2. Output circuits.
 - a. Variations of resistive circuit loading.
 - b. Variations of RC loading.
3. Waveforms generated.
 - a. Square wave output from sinusoidal sources.
 - b. Output pulses of controllable time durations from RC input circuits and rectangular waveforms as source.
 - c. Ramp outputs with C-loading.
 - d. Trapezoidal outputs with RC loading.
 - e. Positive spikes, or negative spikes, only from RC-diode loading.

4. Similar studies with FET's.

C. Analysis of two-stage transistor circuits.

1. Resistance coupling.
2. RC coupling.
3. Like transistor circuitry.
4. Complementary transistor circuitry.

VI. Regenerative Circuits.

A. Astable Multivibrators.

1. Normal operation (Transistors biased to saturation).
 - a. Evaluation of waveforms.
 - b. OFF-times-for each transistor.
 - c. Rise times.
 - d. Recovery times.
 - e. Synchronization of Astable Circuit.
 - f. Unbalance limitations.

2. Abnormal operation (Transistors biased in active region).

- a. Waveforms generated.
- b. Interpretation of waveforms.

B. Monostable Multivibrators.

- a. Triggering techniques.
- b. Two types of circuits.
 1. Fixed bias.
 2. Self bias.

- c. Principles of operation.
 - d. Evaluation of waveforms in both types of circuits.
 - e. Need for unbalanced circuit.
 - C. Bistable Multivibrators, or Binaries.
 - a. Triggering techniques.
 - b. Principles of operation.
 - D. Schmitt Trigger Circuit, or Voltage level discriminator.
 - a. Purpose of circuit.
 - b. Principle of operation.
 - c. Need for unbalanced circuit.
 - d. Hysteresis problems and methods of improvement.
 - E. Logic Circuits:
 - a. AND
 - b. OR
 - c. NOT
 - d. NAND
 - e. NOR
- VII. Special Purpose Devices and Circuits.
- A. Unijunction Transistors.
 - 1. Volt-ampere characteristics.
 - 2. Relaxation oscillator circuit.
 - B. SCR's.
 - 1. Volt-ampere characteristic.
 - 2. Applications.
 - C. Counters.
 - 1. For controlled delay.
 - a. Decade counters.
 - b. Counting to any number.
 - 2. For Storage of Count.
 - D. Phase Shift Registers.
 - E. Diode Matrix.

GENERAL GUIDELINES

These GENERAL GUIDELINES identify the concepts, subject matter and techniques of instruction that are most important for the instructor to keep in mind. More specific guidelines for classroom and laboratory activities will follow these general guidelines.

General Response Functions of Pulse Circuitry

There are a great number and variety of

automatic industrial control systems, automatic monitoring systems and automatic measuring systems that are dependent on the functions that can be performed with pulse circuitry. These kinds of systems operate in the time domain where events of operation are in a required time-sequence and/or synchronization.

The particular circuits within these systems have the three general functions of,

- a. Generating required waveforms.
- b. Holding a required voltage, or current, for a prescribed period of time.
- c. Providing accurate time references for the time-sequence events.

The Generated Waveforms and Their Significance

In general, the kinds of waveforms associated with pulse circuitry are anything other than sinusoidal. For the most part, these generated waveforms are,

- a. Pulses of controllable time duration and magnitudes.
- b. Pulses with controllable time delays including "dead" time between successive pulses.
- c. Positive and/or negative spikes and pulses of small time duration.
- d. Ramp functions of controllable slopes, magnitudes and repetition rates.

In other words, the most important waveforms in pulse circuitry are pulses, square waves, spikes, ramps or sweeps. Other specialized waveforms may be required. In any case, the output waveform of a particular circuit is different than the waveform which drives the circuit. Some of the pulse forming circuits are oscillators that require no driving function.

With these kinds of waveforms the sequence of events is timed, when scientific data is gated for measurement, and information and events are clearly and accurately identified.

The Three Major Divisions of Pulse Circuits Course

Pulse Circuits can be divided into three

major areas of study.

1. Study of fundamentals.
2. Analysis of the basic electronic circuits used in systems to generate required waveforms.
3. Special purpose circuits and sub-systems.

The Fundamentals

The fundamentals for Pulse Circuitry involves two basic types of circuits.

1. Resistive diode circuits
2. RC diode circuits

This suggests that the coupling from a source to an electronic device and between electronic devices is either *resistive coupling* or *RC coupling* for most cases. Since the electronic devices act like one or more diodes, when operated in the switching mode, then it becomes very important to understand *resistive diode circuits* and *RC diode circuits*. A reasonable understanding of these two types of circuits makes it possible to interpret and analyze the response of the remaining circuits and sub-systems of the course with minimum difficulty. The students will actually develop an ability to "read" circuit responses.

The Basic Electronic Circuits

The point should be made, first of all, that the devices of pulse circuitry are *semiconductor devices* and I.C. packages. Studies with vacuum tubes are not necessary and are discouraged.

One could list a large number of basic circuits (clippers, limiters, clampers, pulse stretchers, differentiators, integrators, relaxation oscillators, the multivibrators, sweep circuits, Schmitt trigger circuit, ...) that are common knowledge. In addition there are certain *pulse shaping techniques* where the circuitry is not always conveniently identified by a name for the circuit. These techniques may involve no more than changes in a bias voltage, or a time-constant, or a resistance ratio, and so on. In other words the circuit configuration may be the same for a large variety of different responses.

The teaching of pulse circuits requires a careful selection of *sequencing* and *grouping* of topics. Emphasis must be placed on the response of a circuit and how this response might be changed.

Special Purpose Circuits and Sub-systems

Circuits to perform the following functions are illustrative of the special purpose circuits as interpreted for this course.

- a. Diode matrix for readout of digital counters.
- b. Current devices for magnetic storage elements.
- c. Modifications of sweep circuits for linearization of ramp function.
- d. Driving circuits for SCR's. There are a number of variations.
- e. Current summing circuits for D-A conversion.
- f. Special coupling techniques.
- g. Phase-shifting techniques.
- h. Rotating electronic switches.
- i. The trinary counter.
- j. Choppers.

The sub-systems, as defined for this course, include the following:

- a. Counters.
- b. Shift-registers.
- c. Delay units.
- d. Scanning techniques.
- e. Memory techniques.
- f. Synchronization sub-systems within complete systems.

The Major Concept for Analysis of Pulse Circuits

Since diode actions occur when electronic devices are operated in the switching mode, this means that two or more circuit models are needed for the analysis of pulse circuits. The student must come to fully appreciate the concept of circuit models and the changes that can occur in these circuit models. Then once the possible circuit models are known, it becomes a normal kind of circuit analysis problem provided the student knows the conditions and time intervals under which a model is applicable.

The Significant Techniques for the Analysis of Each-Circuit Model -

Applying Thevenin's theorem and the superposition theorem are extremely valuable techniques for the analysis of the various circuit models of pulse circuitry.

Thevenin's theorem becomes especially valuable and even essential in some cases. It permits identification of resistive-attenuation factors when needed and the identification of the time-constant of an exponential as well as the asymptotical value of that same exponential. An example will illustrate.

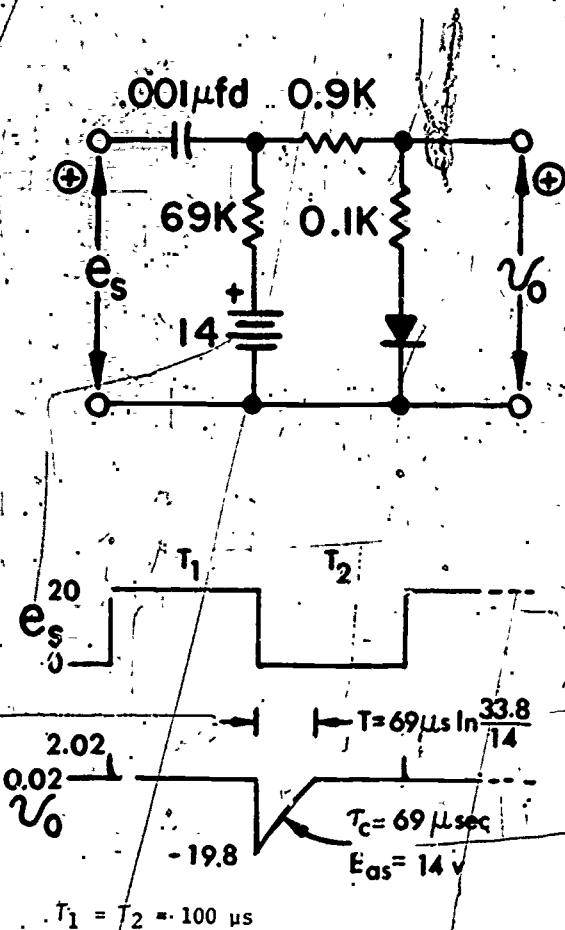

FIG 1. The given circuit model

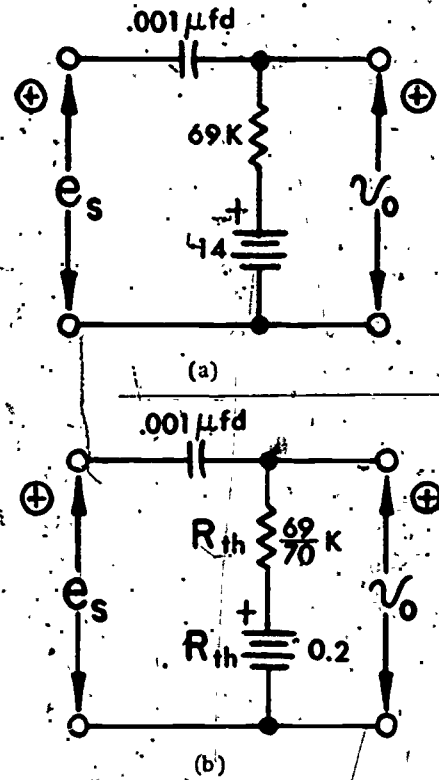

FIG 2 The two equivalent circuits, (a) The diode nonconducting and (b) The diode (ideal diode considered) conducting. Notice the application of Thevenin's theorem for circuit (b) and the advantage of the attenuation factor in find v_o from v_o . Notice, also, that the time-constant and the asymptotical values are easily determined for v_o in the first circuit and for v_o in the second circuit. Simply attenuate to get the true asymptotical value for v_o in the second circuit.

The Thevenin's theorem is, of course, applied only to resistive portions of pulse circuitry. Whether the circuit is purely resistive, or whether the circuit contains capacitance (or inductance in a few cases), this technique of using Thevenin's theorem needs to be emphasized.

The second very useful theorem to assist in the analysis of pulse circuits is the superposition theorem. Again, this theorem should be applied only to resistive portions of such circuits. An example will illustrate.

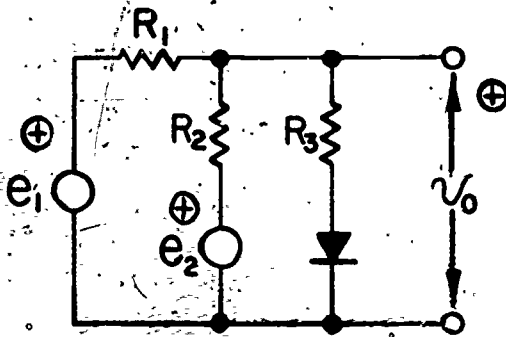

FIG 3 The given circuit model

The given circuit illustrates a circuit model that occurs in many different situations where two sources are involved as indicated. The two equivalent circuits (diode conducting, diode not conducting) could be sketched as in the earlier illustration. The voltage e_2 is often a d-c source. Sometimes it is pulses. The voltage e_1 might be any kind of waveform.

The superposition theorem comes in as a convenient tool because of a summation of two terms, in this case. One term involves an attenuation of e_1 and the other term involves an attenuation of e_2 . Thus with diode nonconducting,

$$v_0 = e_1 \frac{R_2}{R_1 + R_2} + e_2 \frac{R_1}{R_1 + R_2}$$

Knowing the superposition theorem permits the writing of this equation immediately. This is much more convenient than trying to solve for the voltage across R_2 and then adding e_2 , for example.

Taking Advantage of Knowledge of Exponentials

Whenever an exponential response is known to exist (steps or ramps applied to STC's), emphasis should be placed on identification of the three significant quantities of each exponential

(E_0 , E_{as} and τ_c). The student should be discouraged in wanting to find a voltage on a capacitance, whenever possible, in order to evaluate the exponential response. Practice in thinking directly to the exponential will pay big learning dividends. This point has been emphasized for the course on STC circuits, which is a prerequisite to Pulse Electronics.

GUIDELINES FOR CLASSROOM ACTIVITIES

Information and suggestions presented here are pertinent to classroom instruction. Guidelines for the laboratory will follow.

Resistive Diode Circuits

From *Resistive Electronics* the student will know the volt-ampere properties of diodes. Except for limited review of these V/A characteristics, a diode symbol should be regarded as an ideal diode. *Diode circuits, sketched for the purpose of analysis, become circuit models.* Modification of a circuit model to include the back resistance, forward resistance and a biasing voltage will adjust the model to more nearly represent the real conditions when desired as a part of the analysis.

Single-loop single-diode circuit models are normally quite easily mastered by the student. Consequently only a little class time (fraction of a period) should be used for a discussion of the response of such circuits.

The multiple-loop single-diode circuit, such as shown in Fig 3 of *General Guidelines*, should be presented with considerable care for the purpose of emphasizing a technique of analysis that will also apply to circuits having two or more diodes.

The recommended technique for the analysis of resistive diode circuits is one in which the student must find that particular instantaneous quantity of e_s required to place a diode in its transition state. This is done by setting the voltage across an "opened" diode to zero and solving the resulting circuit model for e_s . The same answer would result by setting the current of an assumed conducting diode to zero,

but this is more difficult than working with the assumed "opened" diode. This information on the critical value of e_s informs the student when to use each of the two circuit models relating to a diode, one circuit with the diode conducting and the other circuit with the diode nonconducting.

A majority of the class time allotted to resistive diode circuits should be used in the study of circuits having two or more diodes, mostly with two diodes and some work with three diodes. The student needs to work a number of these problems until he understands the technique of analysis reasonably well. One typical two-diode circuit is shown in Fig. 3 in the *Laboratory*

Guidelines. This circuit may be changed into a number of problems by reversing either or both diodes, by changing any of the possible resistance ratios, by changing the magnitude of the d-c voltages and by changing the location for the output voltage. In making such changes, it should be understood that anything that can be made to happen or not to happen could be a practical kind of circuit. Do not worry about "Yes" and "No" situations for these are the possible requirements of logic circuitry.

Now, if a student can work a three-diode circuit, he has it made and will have no more serious difficulties on how to analyze any resistive diode circuit.

One of the major learning difficulties with diode circuits is that the student thinks he needs to know whether a diode is conducting or nonconducting before he starts the analysis. This information cannot always be known in advance and the student must come to understand that this is a part of the analysis problem. Find the critical value of e_s for each diode and then proceed.

There is a second technique of analysis, not recommended however, where a truth table is established to represent all on and off conditions for the diode. Eight possibilities will exist, for example, with a three-diode circuit. This would indicate that there would be eight possible circuits. This is not true, for there can be

only four independent circuit models. For any number of diodes the number of independent circuits is equal to one more than the number of diodes.

Review of Exponential

It should be pointed out very clearly that the general equation for an exponential is applicable to any single exponential function where E_{as} and E_o are algebraic quantities. The student should work a sufficient number of problems where E_{as} and/or E_o are either positive or negative numbers. If either one is zero, then this becomes a special case.

If the students have worked with these exponentials in a previous course such as in *STC Circuits*, as recommended in this report, then it will not be necessary to spend much time, if any, in the review of exponentials.

Resistance Switching in RC Circuits

The shaping of waveforms is done, largely, by resistance switching in RC single-time-constant circuits. This resistance switching occurs in practical circuits as a result of the diode action of two-terminal and multi-terminal electronic devices.

These diode actions of electronic devices along with the identification of the different exponentials that can exist when step voltages are applied, represent the major learning difficulties for the students. These learning problems will be alleviated a great deal by spending some time on the response of RC circuits to step functions under defined switching conditions. Do not go directly to a study of circuits with electronic devices. A few sample problems of the kind being recommended here are shown in Fig. 1. These are the more important circuit configurations. Additional problems can be generated by changing any of the given quantities.

The representative problems of Fig. 1 are designed such that at least one of the possible exponentials will complete to its asymptotical value.

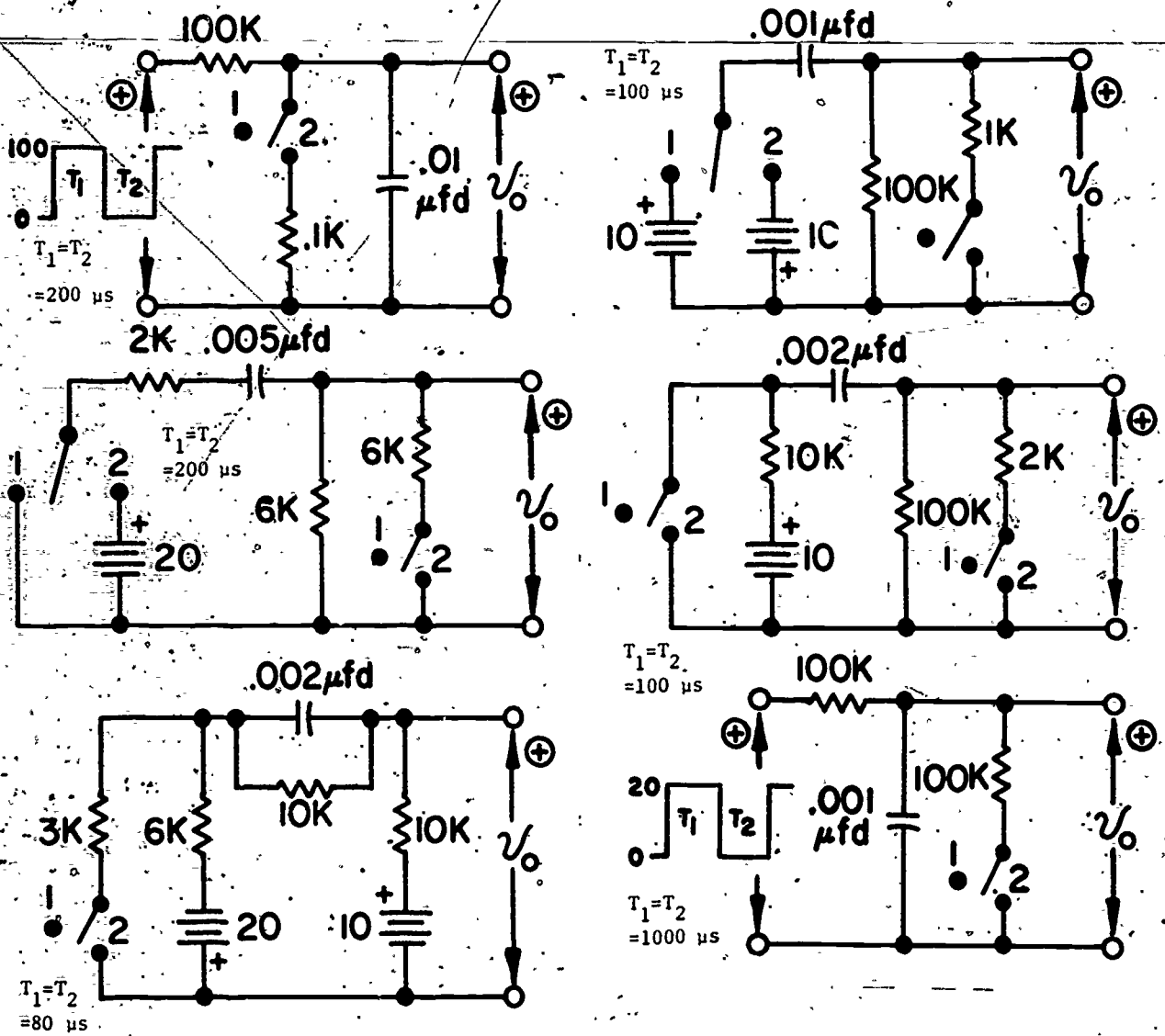

FIG. 1. Sample problems to illustrate resistance switching in RC circuits under defined switching conditions. The objective is to evaluate a steady-state cycle for the output voltage.

If none of the exponentials complete, then it may be advantageous to apply the concept of area ratios being equal to a resistance ratio. This area ratio concept is developed in most texts on Pulse Circuits. An area ratio chart or graph is needed when the source voltage is sinusoidal. Such a graph will be found as Fig. 3.7 in the text: "Pulse Circuits-Switching and Shaping", by Daniel S. Babb, Prentice-Hall, 1964.

RC-Diode Circuits

The representative type of RC-diode circuits

for study here is presented as Group 2 in the Laboratory Guidelines. Problem solving and laboratory work should be closely related for these circuits.

Transistor Circuits Without Feedback

The analysis of transistor circuitry without feedback becomes reasonably simplified with the background of resistive-diode and RC-diode circuits. The first step involves an evaluation

of the input circuit treating the base-to-emitter transistor input as a diode. The base-to-emitter voltage waveform is then known. If the transistor is current-biased heavily enough then the collector-to-emitter function can be treated as nearly ideal switch. Consequently, the output circuit can be evaluated for an indicated output voltage.

For all practical purposes, the input circuits will be either resistive diode or RC-diode kinds of circuits. Consequently, there is nothing new to be learned here. The same is true for the output circuits. The student needs to know, primarily, the biasing conditions of the transistor.

Considerable emphasis should be placed on the study of two-stage circuits using complementary transistors as well as like transistors. Emitter-follower circuits are also included.

The Multivibrators

Except for those circuits having a common-emitter resistance, multivibrators can be studied with about the same concepts as transistor circuits without feedback. There will be two equivalent circuits that operate simultaneously rather than just one circuit, effectively.

Normally, the astable and bistable circuits will not have a common-emitter resistance. There is, however, one form of the monostable circuit that does have a common-emitter resistance.

The triggering techniques, as applied to bistable circuits, become one important part of this study, more important than the "paper" design of the bistable itself.

The Schmitt Trigger circuit is appropriately included along with a study of the multivibrator.

The Sweep Circuits

The two main circuits for study here are the *Miller Sweep Circuit* and the *Bootstrap Sweep Circuit*.

The circuit configurations for these two circuits can be found in Pulse Circuits texts. The major point to emphasize in the classroom activity is the one factor which influences the

linearity of the generated "ramp" voltage. This one factor which influences the linearity is revealed from a study of the equivalent input circuit for the Miller sweep circuit. The equivalent input circuit is,

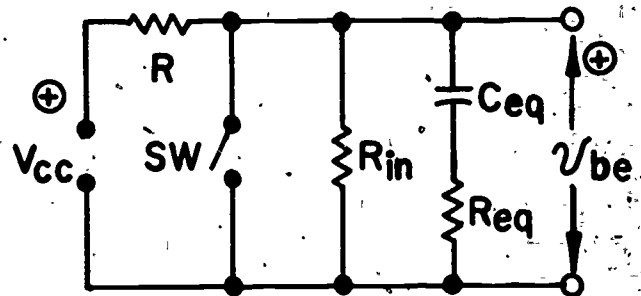

where

R_{eq} is normally very small and neglected

$$R_{in} = r_e + r_b (1 + \beta)$$

$$C_{eq} = C (1 - A_v)$$

The point concerning linearity occurs because of the presence of R_{in} which, in many circuits, is in the order of 1000 ohms magnitude. To improve linearity the E_{as} value for v_{be} must be large compared to the magnitude of voltage swing across the active region at the input. Notice that the sweep occurs when the switch Δw , representing an electronic switch, is open. During this sweep time observe that,

$$E_{as} = V_{cc} \frac{R_{in}}{R_{in} + R} = V_{cc} \frac{1}{1 + \frac{R}{R_{in}}}$$

which states that the E_{as} value is decreased as the ratio of R/R_{in} is increased. Linearity, then, is improved by decreasing the resistance, R , or by increasing the input resistance.

The input resistance can be increased by placing two or more transistors (usually three or four are used) in a Darlington circuit arrangement. Each transistor added will increase the input resistance by a factor of β , approximately.

The larger input resistance will permit a larger range of values for R without destroying the linearity appreciably. A larger range of R values, along with a permissible range of

C values, will permit a wider range of sweep times.

Logic Circuitry

In logic circuitry the output voltage (or current) is at either of two levels. One of these levels can be zero.

In these early studies of logic circuitry, emphasize the conditions necessary to make the output voltage change from one level to the other. The AND requirement and the OR requirements are thereby established. Do not place too much emphasis on the fact that the voltage is positive or perhaps negative. The fact that a voltage is positive or negative is of secondary importance. The most important fact to know first is whether there has been a change from one level to another level.

The student should quickly learn that an AND situation, with parallel arrangement of electronic devices, requires that the devices (diodes or transistors) shall be biased ON in the absence of all signals. The converse is true for OR circuits.

LABORATORY GUIDELINES

The information and suggestions presented in these *Laboratory Guidelines* outline those concepts and techniques that are most desirable and appropriate to a laboratory environment.

Philosophy Unique to Pulse Circuits Laboratory

The number of specific circuits to be studied in a laboratory course is often equated to the number of laboratory sessions available during the term. On a quarter system approximately eleven sessions would be available, assuming one meeting per week. On a semester system, about fifteen sessions are available.

In a pulse circuits laboratory, each laboratory session should involve a study of a group of circuits or a particular sequence of situations for a particular circuit, or circuits.

With suggested limitations and knowledgeable guidance from the instructor, the students should have a reasonable degree of freedom to investigate

each group of circuits in their chosen ways.

Two-man squads would be ideal to allow discussions on a one-to-one basis. Each student should keep his own notebook, but it is recommended that these notebooks shall not be graded as formal reports might be graded.

In general, the students would be given the circuits as a starting point for their investigations. Suggestions should be given as to parameters that could be changed, and the range of these parameters, to guide the students through a thorough understanding of the circuits.

Particular values of parameters for the "starting" circuits are sometimes specified. In other instances, the parameter should be specified within a desired range of values. Then there are instances when students should select their own values.

Getting Started in a Pulse Circuits Laboratory

First of all, the students should be informed as to the procedures that they should follow and what is expected of them in the laboratory. Unless specified otherwise for particular laboratory exercises, he should:

- a. Observe the possible responses for each circuit of a group before doing any calculations or making recordings of any kind. Usually these observations should require no more than 30 minutes. Hopefully less time would be required. And,
- b. while making the observations the partners should discuss with each other the reasons for a particular response or changes in responses. And,
- c. the students can then firm their understanding of the circuits by making important measurements supported by calculations. The measurements should be made before the calculations. Almost without exception, calculated and measured values should check within about 5%. Any larger error will usually suggest that the student has overlooked some significant

parameters such as: Output resistance(s) of source, input resistance and input capacitance of oscilloscope, forward and/or back resistance of a diode, stray capacitance, reverse breakdown voltage of solid state junctions, et cetera. It might not be important to include these items in calculations, but the student should at least ask himself: Would its error be decreased if they were taken into account?

Secondly, in getting started, the students should be thoroughly familiar with the instruments to be used in the course. If this familiarity does not already exist, the opportunity and time should be provided.

The two most important instruments are the unit pulser and the oscilloscope. The unit pulser is essential to permit control of pulse width as well as the repetition rate. The laboratory experiences and learning would be seriously limited if only a square-wave generator is available.

A multi-trace scope (dual-trace at least) is also essential. The student should be informed to always use external trigger and to use d-c, rather than a-c, settings for the channels being used.

The Major Groupings for Laboratory Studies

When one examines the content of a textbook or an outline for a course, there is some tendency to design the laboratory experiments to parallel each and every major topic in the textbook or the outline. For the laboratory studies in Pulse Electronics, emphasis should be placed on the following groupings in the sequence given.

- Group 1: Resistive-diode circuits
- Group 2: R-C diode circuits
- Group 3: Single-stage transistor circuits
- Group 4: Two-stage transistor circuits
- Group 5: The Multivibrators
- Group 6: The Schmitt Trigger circuit and other circuits

having a common emitter resistance

Group 7: Sweep circuits

Compare with the outline and notice that some of the major topics listed there are omitted in the above, such as: *logic circuitry*, and *special purpose circuits*. Such topics are more appropriately covered in a laboratory associated with a digital course if offered in the curriculum. If a digital course, as such, is not in the curriculum then the logic circuitry and special purpose circuits could be incorporated in such areas as a Projects Course or a Systems Course.

Group 1: Resistive Diode Circuits

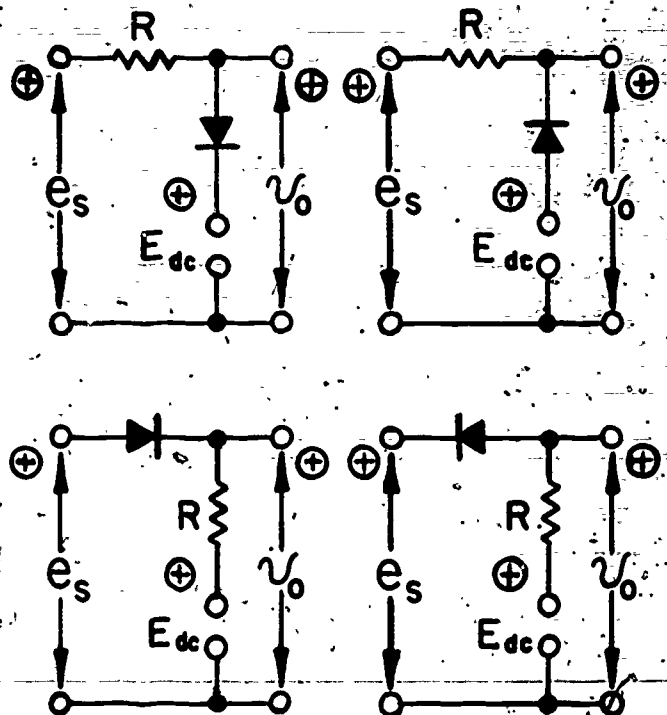

FIG. 1 The four basic diode clipping circuits

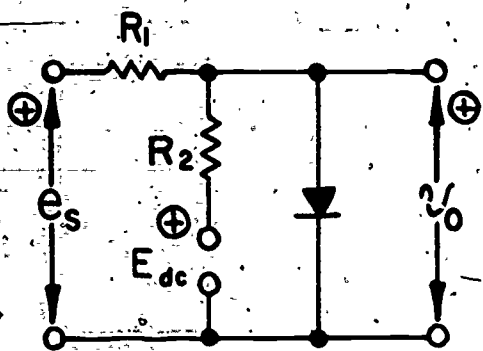

FIG. 2 A multiple-loop single diode circuit

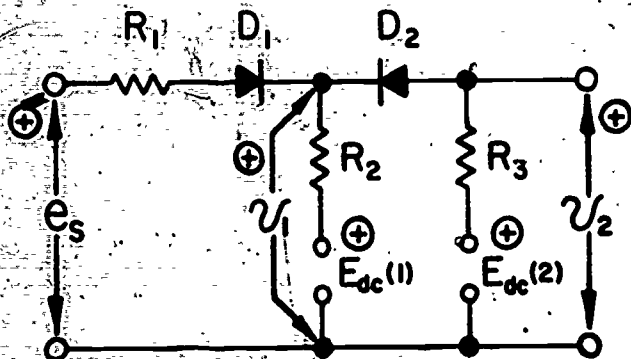

FIG. 3 A multiple-diode circuit (Orientation of diodes may also be reversed.)

Suggested Laboratory Studies for Group 1

Approximately two laboratory periods should be reserved for a study of this group.

The four basic diode clipping circuits may have been studied in the Resistive Electronics Course. If so, they can be reviewed rather quickly at this time. Any time-varying function, other than rectangular waveforms, can be used as the source to permit students to clearly observe the "break" points on the waveforms. Changing the bias voltage, negative as well as positive polarities, while observing the waveforms will provide the student with the experience necessary to permit him to "read" the response of such circuits when they appear in later subjects.

A multiple-loop single diode circuit such as that of Fig. 2 should be examined rather carefully to provide essential background information for the study of multiple-diode circuits. The resistance ratio, as well as magnitudes for the two resistances, becomes a significant factor. The student should change this ratio and support some (not all) of his studies with measurements and calculations to identify significant quantities on the waveforms.

The two-diode circuit of Fig. 3 provides considerable flexibility for a study and understanding of similar circuits. All of the possible ratios of resistances have an influence on the circuit response. Also, the relative magnitude of the two bias voltages have an influence on the response. A few of the possibilities can be suggested to the student by the instructor but the student should be encouraged to continue further studies on his own. Measurements supported by calculations should be done with one or two specific sets of values for the circuit. It is important, however, for the student to examine the circuit for other than the given sets of values. Time is not wisely used by recording measurements and calculations for each and every set of values used for the circuit.

The progressive students may wish to study three-diode circuits. Textbooks on pulse circuits will suggest some possibilities.

Group 2: R-C Diode Circuits

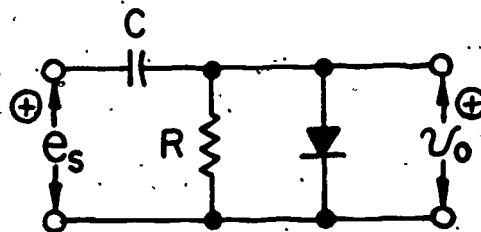

FIG. 1 The Basic R-C diode circuit (The diode may also be oriented in opposite direction.)

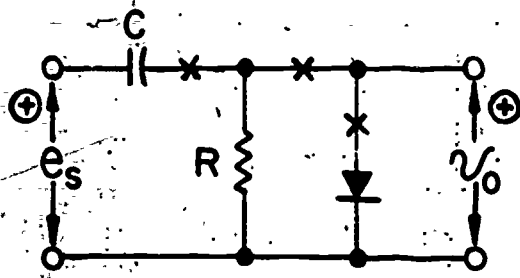

FIG. 2 An additional resistance may exist in any one or more of the \times points in the circuit (usually not all three, however, in the same circuit). The diode may be oppositely oriented.

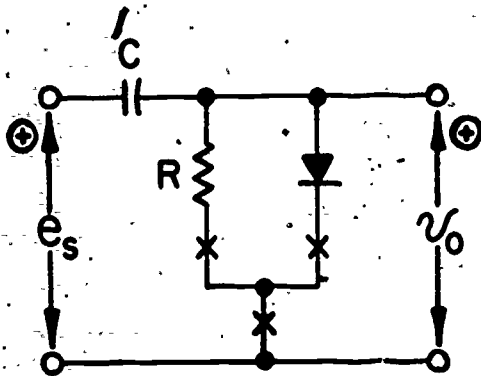

FIG. 3 A biasing voltage, or a pulsed voltage, may exist in one of the \times points in the circuit. The diode may also be oppositely oriented.

Suggestions for a Study of Group 2

R-C diode circuits, as most commonly found in practice, are identified in the three general circuit diagrams. The circuit of Fig. 1 is a most simplified representation. Fig. 2 suggests that an additional resistance may exist in one or more of three positions of the basic circuit. Fig. 3 suggests the further addition of a biasing, or a pulsed voltage in any one of three positions in the circuit.

The addition of resistance and biasing volt-

ages as suggested, along with reorientation possibilities for the diode, provide a variety of situations that need to be studied.

Two laboratory periods, hopefully no more than three laboratory periods, should be allotted for these studies. The studies in the STC circuits course, a prerequisite, should provide much of the background information needed. Primarily the three identifying quantities of an exponential will provide the basic information for understanding of most of the circuit responses.

A study of these circuits and their responses is essentially in two stages. In the first stage the circuit set is studied with a rectangular source in which the time constants of the circuit are not large. In the second stage, any repetitive source can be used (primarily rectangular and sinusoidal) where the capacitance is arbitrarily large. This is a study of clamping circuits.

Suggestions for Groups 3 through 7

The circuits of group 3, single-stage transistor circuits, require at least two laboratory periods. Use the first laboratory period to investigate the response of the circuit with RC coupling to a pulse source. When is the transistor in saturation? What are the requirements to hold it on? When is it off? Use the second period for a more specific study. May use a sinusoidal source, also, -but, not the first laboratory period. Use one or two laboratory periods for a detailed study of two-stage circuits. Concentrate on RC coupling. See *General Guidelines* for techniques. This completes the group 4 circuits. The multivibrators, group 5, are now easily mastered. Start with the astable circuit. Then concentrate on circuits that require triggering. Emphasis should be placed on the techniques of triggering. The Schmitt trigger circuit, group 6, requires an unsymmetrical circuit for full range of operation. Concentrate on the Miller-sweep circuit, -the last of the sequence.

ADVANCED LINEAR ELECTRONICS (ELECTRONICS III)

DEFINITION

Advanced Linear Electronics is a detailed study of practical electronic circuits for which linear circuit models are necessary to explain and understand their operation when the electronic devices are operating in the active region.

MAJOR CONCEPTS

Advanced Linear Electronics is circuit-response, or "Black Box" oriented. This differs from *Resistive Electronics* which was more device oriented.

A unified and simplified linear circuit model can be used to represent the major active devices (BJT, FET and VT). This simplified circuit model places emphasis on a dependent current source rather than on a dependent voltage source. If a dependent voltage source should be desired, this is done by converting a Norton's equivalent circuit to a Thevenin's equivalent circuit. This concept, or approach, reduces memory problems to a minimum.

The same kind of circuit model will always apply in feedback studies, whether the feedback be positive or negative and no matter if voltage feedback or current feedback exists.

BEHAVIORAL OBJECTIVES

The student, upon successfully completing this course, should have the ability to:

Analyze the operation of any BJT, FET, VT amplifier and to determine its basic operating characteristics: gain, bandwidth, and input-out impedances.

Attack new circuits using these devices and to be able to determine their basic characteristics.

Design small signal amplifiers using operational amplifiers with negative voltage feedback.

Analyze any type of feedback amplifier including power amplifiers and oscillators.

Understand the operation of class "C" amplifiers and oscillators.

Understand the operation of and design criteria for large signal amplifiers.

PREREQUISITES

The two courses of *STC Circuits and Resistive Electronics* are the primary prerequisites for this course on *Advanced Linear Electronics*.

Pulse Electronics is highly recommended as a prerequisite but is not absolutely essential. In some programs, it may be necessary to offer *Pulse Electronics and Advanced Linear Electronics* as parallel courses in the same term.

The third course on circuit analysis, *Networks*, could be highly desirable as a prerequisite but not absolutely essential. *Networks* could be a corequisite or offered in the same term as *Advanced Linear Electronics*, if dictated by curriculum structure problems.

The required and desired prerequisites for *Advanced Linear Electronics* are represented by the following flow chart.

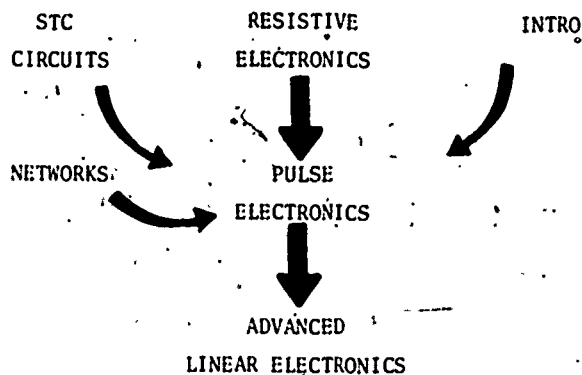

OUTLINE

I. Basic Amplifier Characteristics (Laboratory Introduction)

- A. Gain
- B. Phase shift
- C. Input/output impedance
- D. Bandwidth
- E. Signal level

II. Feedback in Amplifiers (Classroom Oriented)

- A. Feedback effects on amplifier performance
 - 1. Gain effect.
 - 2. Band width.
 - 3. Noise and distortion.
 - 4. Stability.
 - 5. input/output impedance.

III. Small Signal Amplifiers

- A. Equivalent circuit for three terminal devices (Classroom Oriented)
- B. Circuit or Sub-system configuration (Classroom Introduction)
 - 1. Common Emitter-Common Source-Common Cathode.
 - 2. Common Base-Common Gate-Common Grid.
 - 3. Common Collectors-Common Drain-Common Cathode.
(Emitter-follower)(Source Follower)
(Cathode follower)
 - 4. Single transistor split load phase inverter.

C. Three terminal devices at low frequencies (Laboratory Introduction)

- 1. Coupling capacitor effect.
- 2. Bypass capacitor effects.

D. Three terminal devices at high frequencies (Classroom Orientation)

- 1. Shunt capacity effects.
- 2. Miller effects.
- 3. Basic device limitations.
 - (a) Transit time (b) Alpha cutoff
- 4. Risetime--bandwidth relationships.

E. Multiple Stageout Amplifiers (Classroom Introduction)

- 1. Cascaded Amplifiers.
 - (a) RC coupled amplifiers.
 - (b) Direct coupled pairs.

- (1) Darlington.
- (2) FET and BJT.
- (3) Complementary.

IV. Large Signal Amplifiers

A. Single-ended amplifiers (Classroom Oriented)

- 1. Efficiency.
- 2. Transformer coupled loads.
- 3. Direct coupled loads.

B. Push-Pull Amplifiers (Laboratory Introduction)

- 1. Class of operation (conventional).
- 2. Complementary symmetry etc.
- 3. Design of class B.

C. Drivers (Classroom Introduction)

- 1. Transformer.
- 2. Paraphase amplifiers.
- 3. Drivers for complementary circuits.

V. Feedback Techniques (Classroom Oriented)

A. Voltage and current feedback

B. General feedback equations

C. Feedback analysis techniques

- 1. Single stage.
- 2. Multi-stage.
- 3. Selective amplifiers.

VI. The Operational Amplifier

A. The differential amp input

B. Inverting and Non-Inverting inputs (Classroom Introduction)

C. Mathematics Operations (Laboratory Introduction)

- (1) Addition and Subtraction.
- (2) Integration.
- (3) Differentiation.
- (4) Log operations.

D. The integrated OP AMP specifications

VII. Tuned Amplifiers (Laboratory Introduction)

A. Single tuned

B. Double tuned

C. Stagger tuning

D. Class "C" Tuned Amplifiers

- 1. Doublers.
- 2. Multipliers.

VIII. Oscillators

A. General Criteria (Classroom Oriented)

1. Nyquist diagram
2. Barkhausen criteria
3. Equivalent circuit analysis technique
4. Maximum frequency of oscillations for BJT

B. Tuned Circuit Oscillators (Laboratory Oriented)

1. Hartley
2. Colpitts
3. Crystal controlled

C. R.C. Oscillator (Laboratory Introduction)

1. Wein bridge
2. Phase shift oscillator

XIX. Power Supply Regulators

A. C & L input filter system (Laboratory Introduction)

B. Fixed voltage shunt regulators

1. Zener diode
2. VR tube

C. Series regulators

1. Fixed voltage Zener & VR tube
2. Variable voltage regulator--Emitter follower approach
3. IC Regulators

D. Current regulators

1. Current limiting
2. Constant current supplies

GENERAL GUIDELINES

Information and suggestions presented here as the *general guidelines* represent recommended approaches and behavioral objectives for the course. Specific suggestions for classroom instruction and for laboratory learning will follow these general guidelines.

The Major Electronic Devices for the Course

The electronic devices incorporated in the circuitry of the course are: The bipolar transistor (BJT), the field effect transistor (FET), integrated circuits (IC) and the vacuum tube (VT). Although vacuum tubes are considered a part of the study, any involved analysis of

vacuum tube circuitry and technology is discouraged.

Importance of the Course

This Advanced Electronics course is the last of the six core courses of the curriculum. As such this course must be the final link between the analysis courses and the practical world of system electronics. The course, therefore, must have sufficient practical problems to relate the student to the practical world of applied electronics.

This final electronics course, along with the other five core courses, should provide the student with a firm foundation. This foundation can either be used to pursue one of several institutional options or a basis in study of numerous technical electronics which the institution may wish to offer.

Advantages of the Course

Linear Model Electronics has some unique advantages which make it an essential part of the "Six Core Courses." The study of active circuits from a circuit analysis standpoint gives the two year electronics student another "tool" which can be used in future studies.

The use of "graphical analysis" of the circuits under study will lead to problems of stability and the solution of those problems.

This course, although not specifically a design course, will give the student an opportunity to design basic circuits or at least look at some basic circuits from a design standpoint to observe obvious pitfalls, etc.

The integrated circuit is introduced early in the sequence. As a Circuit or Sub-system is developed in discrete component form, an Integrated Circuit is placed in the same application to demonstrate the usefulness and problems associated with micro-electronics.

The analysis of BJT and FET Circuits in all modes of operation should make the introduction to integrated circuits and micro-electronics a natural transition without a

great deal of difficulty.

The Student's Previous Knowledge

The application of the Network Theorems previously encountered is an essential aspect of this study. The use of Thevenin's Theorem, Norton's Theorem, Superposition Theorem, Kirchhoff's Voltage Law, and Kirchhoff's current laws is stressed throughout the sequence.

Although calculus is not used extensively in this course; the fundamental concepts are most helpful in the understanding of some topics which will be studied.

The student's knowledge of STC's and his ability to read these circuits, their break points and corner frequencies will be utilized throughout the study.

The student's knowledge of devices and their use as developed in Resistive Electronics will be called upon to aid the student in understanding Linear Model Electronics as the input/output characteristics of the devices will be utilized.

The student's knowledge of the "S" operator and his previous experience with "S" studies will cause no problem in introducing different types of inputs to the circuits under study.

Driving Functions

1. The amplifier driving functions will be primarily sinusoidal; however, since amplifiers with step inputs are not covered in the course, on Pulse Electronics the step input analysis of amplifiers is included.

Limitations of the Course (What will not be covered)

1. Integrated circuits will not be analyzed in detail. Primarily the student will be looking at the device as used in some established circuits. The student who has completed this course will have attained analysis techniques that make detailed analysis of IC's a routine matter.

2. Modulation and demodulation are not covered in the sequence. These topics are more easily studied in a course which has as its primary objective the study of communication circuits and communication electronics. If a

communication course, as such, is not offered in the curriculum perhaps the subject of modulation and demodulation can be covered in a systems analysis course.

3. The fundamentals of power supplies as related to rectifiers and filters are assumed to be covered in the resistive electronics and single-time-constant circuit sequence.

4. Video and wideband amplifiers are primarily a function of communication electronics. The student who has completed this sequence of topics should have no serious problem in adapting to wideband amplifiers when that point is reached.

Depth of Study

The study of active devices must be restricted in some way to establish the degree of rigor that the course will follow. The subject of Physics and a total qualitative approach is de-emphasized as much as possible. The pure H-parameter approach as outlined in many textbooks is likewise de-emphasized. The attack that should be taken is to treat the device from its input/output characteristics. What are the conditions at its terminals?

Since we have previously studied the devices in resistive electronics in regard to gain, amplification factor, input, etc., any in-depth study of these topics would be duplication. We are primarily interested in the frequency response of the amplifiers under study at this point; therefore, we are involved more with input/output circuits and their behavior than the device itself.

A Recommended Approach

Because of the wide variety of circuits covered in Advanced Electronics, the approach which should be taken in covering them is

1. Introduce circuit in the laboratory, where appropriate, as suggested in the outline.

2. Analyze the circuit in the classroom to the extent that the student understands why it operates in the manner that he has observed in the laboratory.

3. Discuss the design criteria.

The Unified and Simplified Circuit Model

In treating the active devices in their active regions, a single equivalent circuit which will cover all of the devices, incorporated into the circuitry of this course should be stressed. Such a practical circuit, in its configuration only, is shown in Fig. 1.

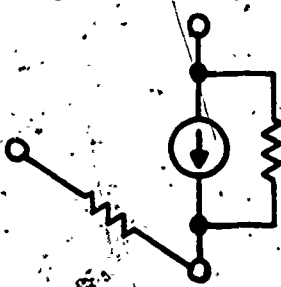

Fig. 1

When to Introduce the Unified Circuit Model

It would be better to introduce the general simplified equivalent circuit after it is used in its special forms in the bipolar transistor, field-effect transistor and vacuum tube circuits. These special forms are shown in Fig. 2

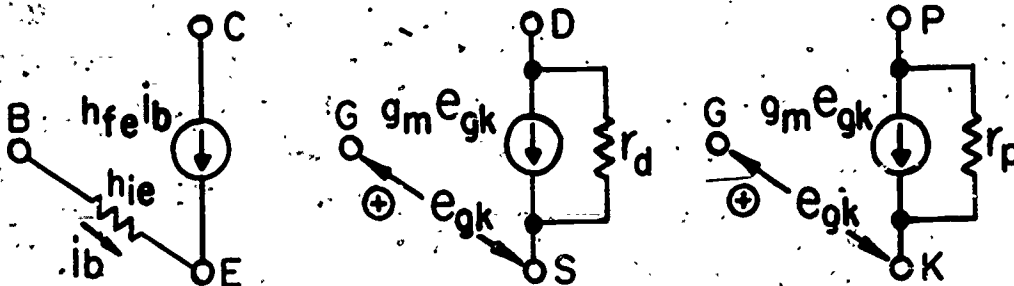

Fig. 2

By using these simplified equivalent circuits, the student can replace any active device by an equivalent circuit of the same form as any other device. In using this approach, the student may see that the form of the amplifier circuit and not the type of device used primarily determines the operating characteristics of that amplifier circuit.

In handling the FET and the VT equivalent circuits, it may be of value to mention that the $g_{m, e_{gs}}, r_d$ and the $g_m e_{gk}, r_p$ generators could be replaced by their Thevenin version, $\mu e_{gs}, r_d$ and $\mu e_{gk}, r_p$.

For High Frequency Response

In order to analyze these devices at high frequencies, it is only necessary to add one or two interelectrode capacitances to this simplified model and to replace one of these (C_{bc}, C_{gd} , or C_{gp}) with its Miller effect value at the input.

Multistage Analysis

By treating each amplifier stage as a "black box" containing its input resistance, output resistance and voltage gain, multistage analysis reduces to the determination of time constants to find the low cut-off frequency and loading effect to determine the overall voltage gain.

When to Introduce Feedback

The concept of negative voltage feedback should be introduced before detailed amplifier

analysis is attempted in order that it be placed in the proper order of importance and to "drive home" the basic properties of amplifiers.

Current feedback should be introduced in the large signal amplifiers section to show primarily how it can control the output impedance of the unit.

If design of amplifiers is to be included in this course, stress should be placed on the use of IC operational amplifiers for all small signal designs.

An Important Thought Concerning Oscillators

In treating class A oscillators, an amplifier which has decreasing voltage gain with increasing output amplitude is needed in order to successfully run these units under laboratory conditions. An "op amp" using series diodes as the feedback resistor in the inverting mode is one solution to this problem.

Power Supplies are Studied Last

The concluding study of power supplies brings in the use of small and large signal amplifiers in a closed-loop negative feedback system. Very little time should be spent here on "classical" power supply design since good regulation nowadays is accomplished through the use of electronic regulators.

Four Approaches to Subject Matter Instruction

The two-year electronics technology program has within its confines many unique aspects which require some discussion. The Electronics Engineering Technician is often identified by the concept that "he understand the theory which supports the operations he performs". This definition implies that the technician has an in-depth exposure to electronics technology. He is given "hands on" opportunities to study and observe the practical aspects of Electronics Technology.

The proportionality of laboratory-vs-classroom effort has been and will be a topic of discussion at any time we are concerned with curriculum development. The technique, most commonly used in the past, has been to introduce a subject in the classroom and to verify it in the laboratory. It is suggested that there are four different approaches to subject coverage. Their use in proper sequence can and will provide the most effective coverage of subject matter. These four approaches are: (1) Classroom Orientation (2) Laboratory Orientation (3) Classroom intro-

duction with laboratory support (4) Laboratory Introduction with classroom support.

In order to better understand the thinking behind these four approaches, the following explanation is given. The coverage of new material and concepts can not always be done exclusively in the classroom or laboratory. Each topic of the curriculum should be analyzed to determine the most effective technique used to introduce it. In some cases the exclusive laboratory or exclusive classroom approach does not seem to solve the problems at hand; however, there are some topics which do not lend themselves well to either total laboratory or classroom exposure. A combined approach is therefore recommended. The classroom introduction with lab-support approach is sometimes the answer. What is implied by this technique is that after a subject is studied in the classroom the theory is either observed or verified in the real world of the laboratory. The laboratory introduction with classroom-support approach can be the most effective way of observing a particular group of concepts and then expressing them on a quantitative basis. The student, in many cases, after observing a circuit in the laboratory requires a relatively meager amount of assistance in the classroom for an understanding of what has occurred in the laboratory.

The advantages of these four techniques are numerous. Probably the most important asset is that the theoretical world and the practical world are constantly being related and interwoven.

GUIDELINES FOR CLASSROOM

Developing an understanding and a working knowledge of the many possible circuits of the Advanced Electronics course involves three major teaching responsibilities.

1. Development and use of the simplified h-parameter model.
2. Technique of analysis for multistage circuits.

3. Technique of analysis in circuits with feedback.

Each of these are now discussed in some detail.

How to Develop and Use the Simplified h-parameter Model for the Bipolar Transistor

In order to cover a wide variety of electronic circuits in a short period of time and to give the student enough confidence to attack new circuits, it is necessary to give him as simple an equivalent circuit for the active device as possible. Not only must a simple model be developed, but also that only one model per device be stressed. For example, there exists three h-parameter equivalent circuits for the transistor operating in the common base, common emitter and common collector modes, respectively. Because most transistor circuits are of the common emitter variety and most specifications are given for the CE mode, this form and only this form should be widely used by the student in this course. In addition the simplest form should be widely used by the student in this course. In addition, the simplest form of this circuit consisting of h_{ie} and a $h_{fe} i_b$ current generator should be used no matter what configuration is under study.

To quickly make the transition from the basic h parameters to this equivalent circuit, they should be first applied to a passive circuit with two parts (a resistive "T" circuit for example). For this type of circuit, it is quite easy to obtain h_i , h_o , h_{ie} and h_{re} and to prove that this is a valid equivalent circuit for the original network.

Using this equivalent circuit to replace the transistor in its active region and typical values of all four h parameters, it is quite easy to show that h_o and h_{re} can be neglected without introducing any substantial error into the circuit calculations. It is the use of this simplified model that allows the student to attack any transistor circuit arrangement and quickly obtain its important characteristics. For example, consider the common collector amplifier (emitter-follower) of Figure 1.

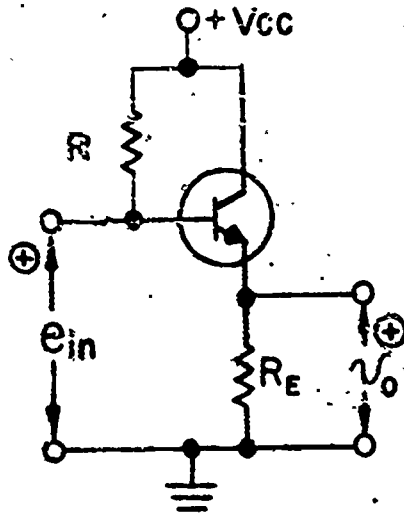

Fig. 1

If the transistor is replaced by its simplified equivalent circuit, Figure 2 results.

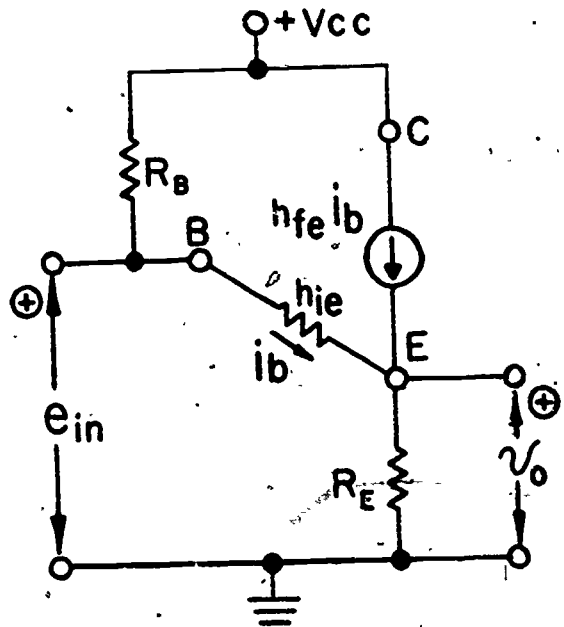

Fig. 2

Figure 2 reduces to that of Figure 3 when under dynamic conditions, the v_{cc} supply can be replaced by its internal impedance which usually is zero for all practical purposes.

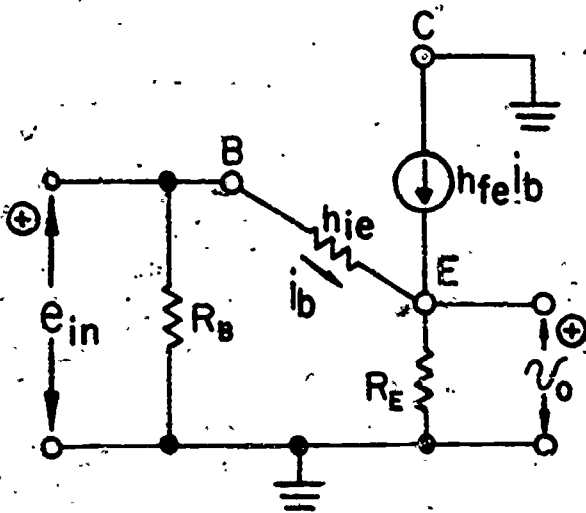

Fig. 3.

The input resistance looking into the transistor from base to ground could be found from writing the loop equation:

$$e_{in} = i_b h_{ie} + (i_b + h_{fe} i_b) R_E$$

and solving this equation for e_{in}/i_b thus yielding the input resistance of

$$R_{in} = \frac{e_{in}}{i_b} = h_{ie} + R_E (h_{fe} + 1)$$

The overall input resistance R'_{in} , which takes into account any additional effects due to the input circuit (R_B in this case), can be easily obtained by computing the parallel combination of R_B and R_{in} .

The voltage gain v_o/e_{in} can also be easily determined:

$$\frac{v_o}{e_{in}} = \frac{(i_b + h_{fe} i_b) R_E}{h_{ie} i_b + (i_b + h_{fe} i_b) R_E}$$

$$\frac{v_o}{e_{in}} = \frac{R_E (h_{fe} + 1)}{h_{ie} + R_E (h_{fe} + 1)}$$

The output impedance, while a little more difficult, still can be obtained with very little effort.

$$i_{out} + h_{fe} i_b + i_b = \frac{v_{out}}{R_E}$$

If the signal source driving the base is assumed to have a value R_s (and includes any shunting effect due to R_B) then

$$i_b = \frac{-v_o}{h_{ie} + R_s} \quad (\text{due to the defined direction for } i_b)$$

Hence,

$$i_{out} + \frac{-v_o}{h_{ie} + R_s} (h_{fe} + 1) = \frac{v_o}{R_E}$$

$$i_{out} = \frac{v_o}{R_E} + \frac{(h_{fe} + 1)}{h_{ie} + R_s} v_o =$$

$$\frac{v_o [(h_{ie} + R_s) + (h_{fe} + 1) R_E]}{R_E (h_{ie} + R_s)}$$

$$\frac{v_o}{i_{out}} = \frac{R_E (h_{ie} + R_s) / (h_{fe} + 1)}{(h_{ie} + R_s) + R_E}$$

A very important two-way concept results from this analysis; that impedances in the base circuit are "seen" at the emitter as their actual value, reduced by $(h_{fe} + 1)$ and that impedances in the emitter circuit are "seen" at the base as their actual value increased by $(h_{fe} + 1)$.

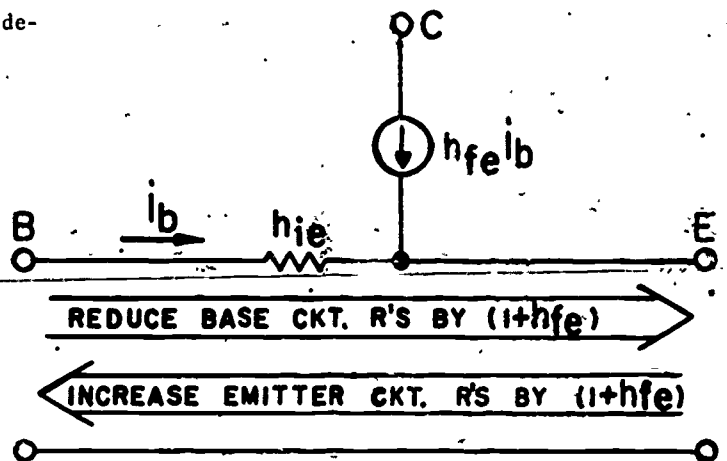

How to Handle Multistage Amplifiers

All amplifier circuits are handled in the same manner whether they are single or multiple stage circuits.

1. Determine for each stage
 - a. input resistance
 - b. output resistance
 - c. voltage gain
2. Connect the stages together with the

actual circuit element used.

3. Analyze the total performance based on this equivalent circuit.

For example, consider the direct-coupled two-stage amplifier of Fig. 1.

By noting which terminal of each transistor is not used for either input or output, it is quite simple to identify the first stage as a common-collector circuit and the second as a common-base stage.

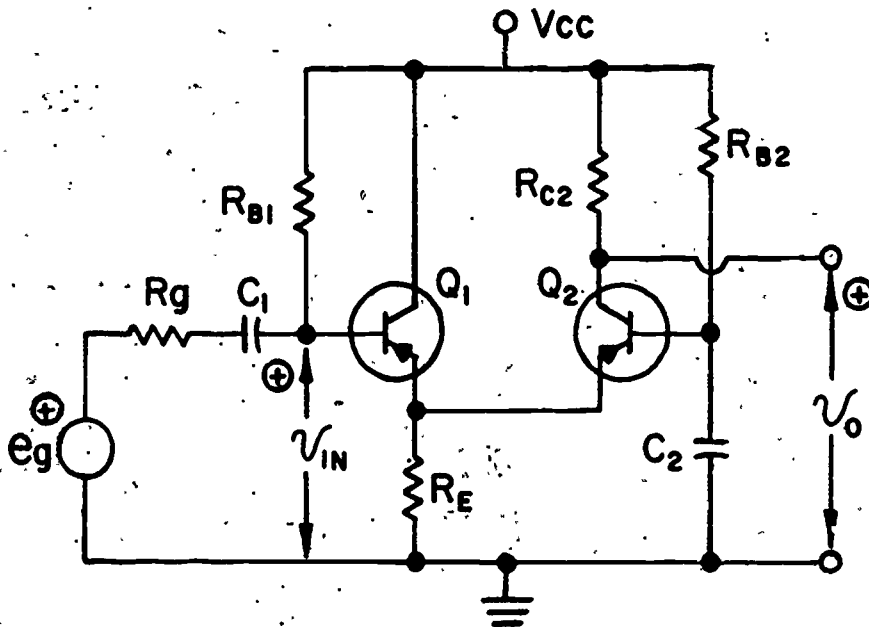

Fig. 1

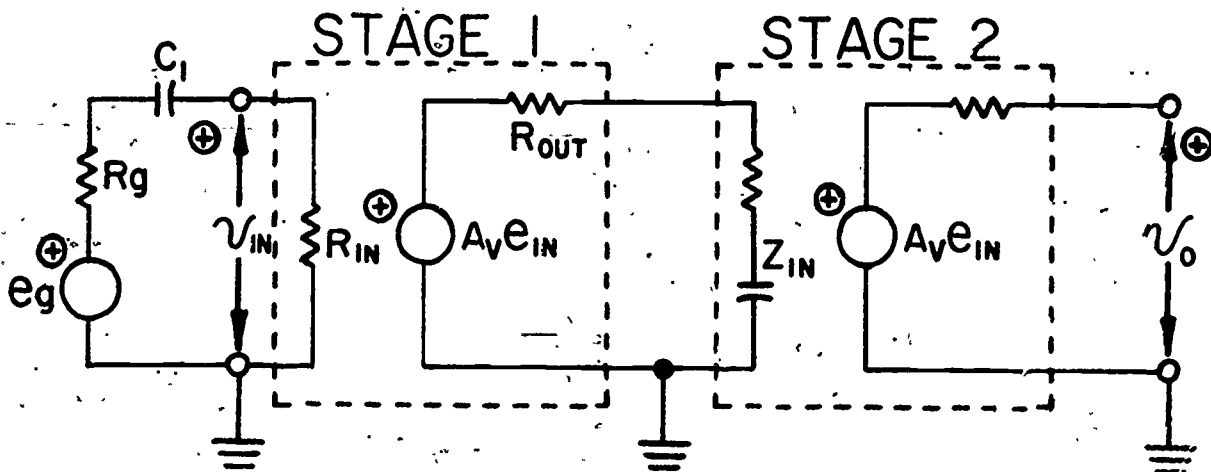

Fig. 2 The Circuit Model for Figure 1

for stage 1

$$A_v = \frac{R_E (h_{fe} + 1)}{h_{ie} + R_E (h_{fe} + 1)}$$

$$R_{out} = R_E \parallel h_{ie} + \frac{R_g R_{B1}}{R_g + R_{B1}} \frac{1}{1 + h_{fe}}$$

R_{in1} cannot be determined until we know what R_{in2} is.

In general it will be

$$R_{in1} = R_{B1} \parallel [h_{ie} + (R_E \parallel R_{in2}) (h_{fe} + 1)]$$

$$A_v = \frac{i_c R_{c2}}{i_b h_{ie}} = h_{fe} \frac{R_{c2}}{h_{ie}}$$

$$R_{in2} = \frac{h_{ie2}}{1 + h_{fe2}}$$

$$R_{out2} = R_{c2}$$

NOTE: IF X_{c2} is not $\ll h_{ie2}$, then Z_{in2} consists

$$\text{of } R_{in2} - j \frac{X_{c2}}{1 + h_{fe2}}$$

A_v is modified to:

$$A_v = \frac{R_{c2}}{h_{ie} - \frac{j}{\omega C_2}} h_{fe}$$

How To Handle Negative Voltage Feedback

Negative voltage feedback (NVFB) may be handled and introduced best by using it with an operational amplifier. The resulting equations are not only simple but, due to the large relative A_v of the OP AMPS, they can easily serve as quick approximations for the student.

Negative voltage feedback involves a feedback signal which is proportional to the output voltage but can be introduced at the input as a feedback current or voltage depending upon the circuit used to introduce it at the input.

These two approaches have quite different effects and hence *must* be covered as two cases.

Figure 1 illustrates the basic circuit used when feeding back the NVFB signal as a voltage.

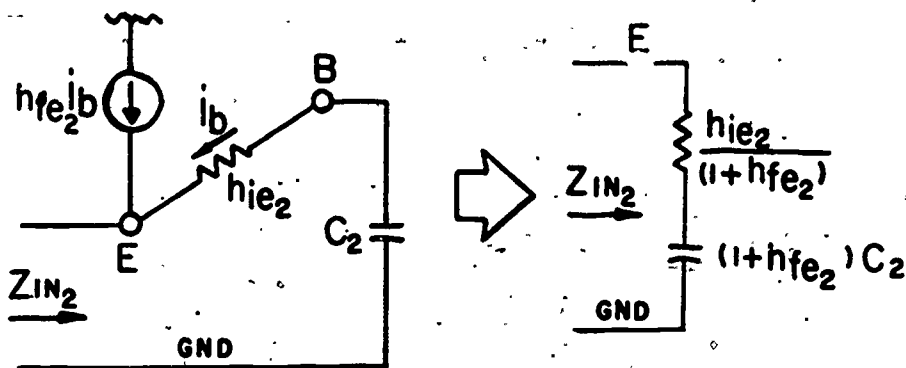

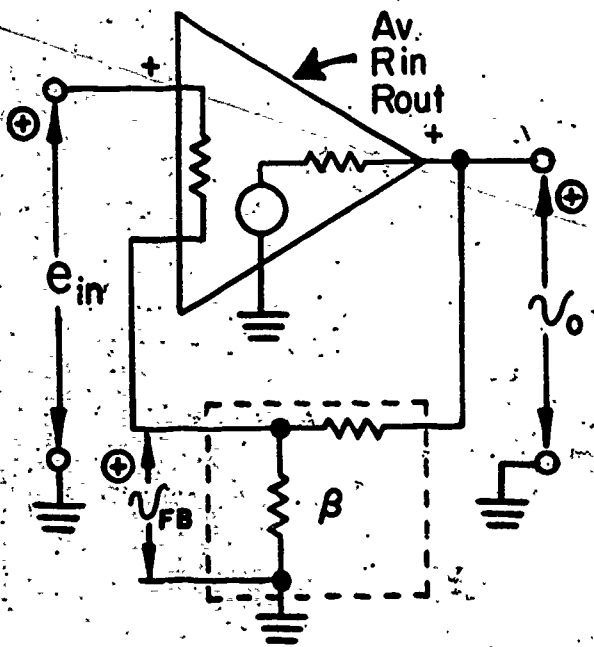

Fig. 1

Using β to represent the ratio of the feedback voltage to the output voltage, it is quite easy to show that the amplifier's properties with feedback are all altered by the "magic factor," $1 + A_V\beta$. Table I illustrates this fact.

PROPERTY	W/O NVFB	W/NVFB
Voltage Gain	A_V	$A_V / (1 + A_V\beta)$
Input Resistance	R_{in}	$R_{in} (1 + A_V\beta)$
Output Resistance	R_{out}	$R_{out} / (1 + A_V\beta)$
Lower Cutoff F	f_{cLo}	$f_{cLo} / (1 + A_V\beta)$
Upper Cutoff F	f_{cHi}	$f_{cHi} (1 + A_V\beta)$

TABLE I

If the feedback is introduced as a current at the input, the effects are not quite the same. An analysis of figure 2 yields the results listed in Table II.

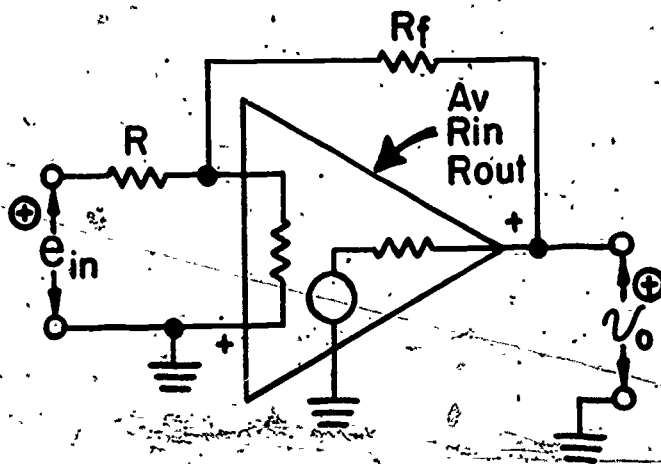

Fig. 2

PROPERTY	W/O NVFB	W/NVFB
Voltage Gain	$-A_V$	$-R_f/R$
Input Resistance	R_{in}	F
Output Resistance	R_{out}	$R_{out} R_f / (A_V R)$
Lower Cutoff F	f_{cLo}	$f_{cLo} R_f / (A_V R)$
Upper Cutoff F	f_{cHi}	$f_{cHi} A_V R / R_f$

TABLE II

These concepts should be introduced using a high gain differential input amplifier of the operational amplifier type. This can be easily "doctored" to give moderate values of A_V , R_{in} , f_{cLo} , and f_{cHi} so that the foregoing equations can be supported by a laboratory experience.

LABORATORY GUIDELINES FOR ADVANCED LINEAR ELECTRONICS

A few experiments suggested for the course are presented here. These do not represent a complete set.

Experiment No. 1: Low Frequency Response of RC Coupled Amplifiers.

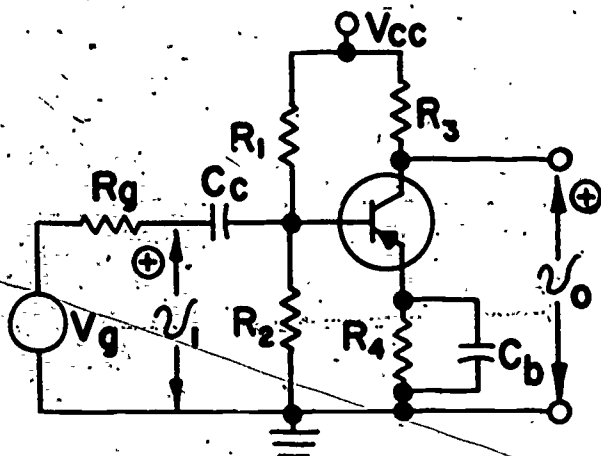

V_{cc} : -9v

R1: 56k ohms

R2: 12k ohms

R3: 1.5k ohms

R4: 690 ohms

C_b : 100 micro-farad, 25v

R_g : 600 ohms

T1: 2N404

PROCEDURE:

1. Connect the circuit shown. Before turning on the signal generator, measure all D.C. voltages.
2. Using a C_c of 0.5 micro-farad, measure V_o and V_i over a range of frequencies which will show the break frequency. Record in a table. The amplitude of the input signal should be such that no clipping is seen in the output. (Check V_i each time the frequency is changed to make sure it remains at a constant value.)
3. Repeat step #2. for a C_c of 5 micro-farad.
4. Using semilog graph paper, plot relative gain-vs-log frequency for the data taken in step #2 and step #3. (Plot both on the

same sheet using the same scale.) Determine the 3 db point from the graph for each response curve.

5. Make a general statement relating low frequency response and the size of the coupling capacitor.
6. Draw the low-frequency equivalent of the circuit used in this experiment. Calculate the f_1 point (break frequency) of the circuit for the 5 micro-farad capacitor.
7. Using semilog paper re-plot the response curve for the 5 micro-farad capacitor.
8. On the same sheet sketch the Bode plot of the response based on the calculation of step #6.
9. Compare calculated and measured response. Account for the probable cause of any discrepancies.

Experiment No. 2: High Frequency Response of a CE Amplifier

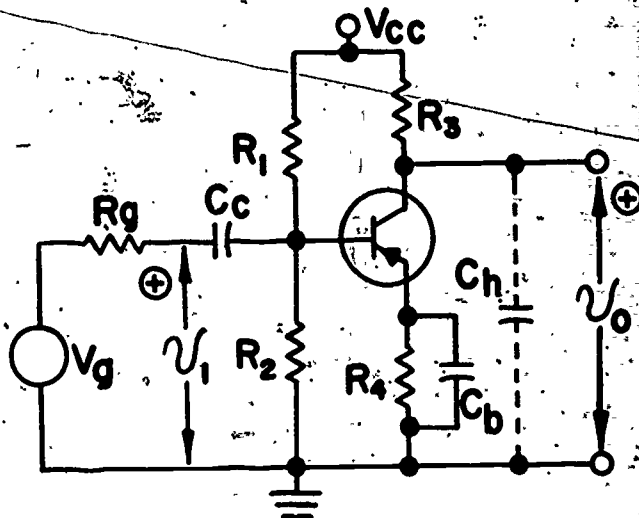

V_{cc} : -12vdc

R_g : 10 k ohm

C_c : 1 micro-farad

R_1 : 91 k ohm

R_2 : 10 k ohm

R_3 : 4.7 k ohm

R_4 : 680 ohm

C_b : 10 micro-farad

T1: 2N404

Experiment No. 3: Single Tuned RF Amplifier

1. Construct the circuit shown. Before turning on the signal generator, record all circuit D.C. voltages.
2. Set the signal generator amplitude to obtain an undistorted output waveform.
3. Measure V_o and V_i over a range of frequencies from mid-frequency beyond the upper 3 db point. (Check generator output voltage each time the generator frequency is changed to make sure it remains at a constant voltage.)
4. Place a 0.02 micro-farad capacitor across the output terminals and repeat step #3.
5. Remove the 0.02 micro-farad capacitor and add the network shown below.

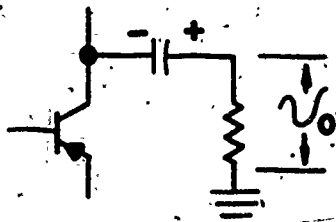
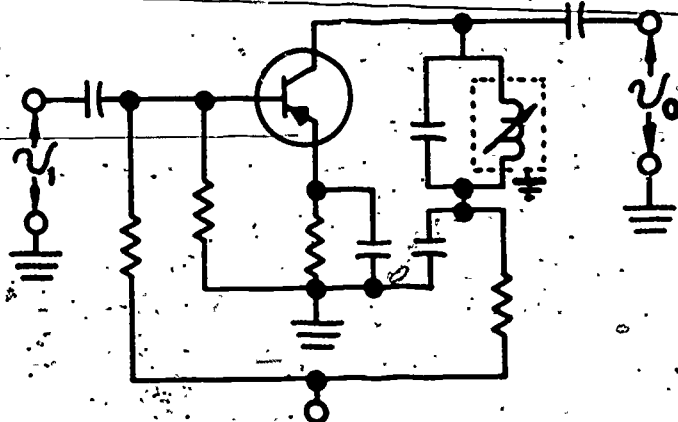

1. Construct a single-tuned, direct-coupled RF amplifier using a 2N292 transistor. (Use a mounted and shielded coil for the tank circuit. Using the "Q" meter, determine the approximate value of C needed to resonate with the tank inductance at 455kHz.) Calculate all bypass and coupling capacitors based on an f_o of 455kHz. Calculate emitter and voltage divider resistor values from the procedure outlined in the GE transistor manual. Choose an acceptable value of V_{cc} .
2. Record all DC voltage readings.
3. For the initial measurements, the tank will be shunted only by the oscilloscope.
4. Connect a signal generator to the input. Set the signal amplitude at a reasonable level. Sweep through frequencies in the vicinity of 455kHz until a signal of maximum amplitude is observed. Record the setting of the signal generator. Set the signal generator frequency at 455kHz and attempt to adjust the slug in the coil so that the output voltage is maximum. If a resonant frequency of 455kHz is not within the range of the slug-tuned coil, adjust the generator frequency slightly to obtain maximum output.

6. Repeat step #3.
7. Plot the data obtained in steps #3, #4, and #6 on semi-log graph paper. (Relative gain-vs-log frequency). Plot step #3 and step #4 on the same sheet, step #3 and step #6 on the same sheet, and step #3 and the calculated curve on the same sheet. Use the same scale for each of the three sheets.
8. Calculate the 3 db point for the original circuit and sketch the Bode plot on the same sheet as the original measured response.
9. Compare the curves of step #8 and make a general statement accounting for any discrepancies between the calculated and the measured response curves.
10. Based on the response curves plotted in step #7, make a general statement regarding the relationship between AC load resistance and high frequency response and shunt capacitance and high frequency response.

5. Measure the gain of the amplifier at resonance. Plot a response curve of relative gain vs. frequency. Determine bandwidth from the curve. Calculate circuit Q.
6. Shunt a _____ ohm resistor across the tank. Measure gain at resonance. Plot relative gain vs. frequency. Determine bandwidth from the curve. Calculate circuit Q.
7. Make a general statement relating shunting resistance and bandwidth.
8. Remove the shunting resistor. Set the generator at the resonant frequency of the tank circuit. Determine if a different probe has an effect on the resonant frequency of the tank circuit.

Experiment No. 4: Direct Coupled and Darlington Amplifiers

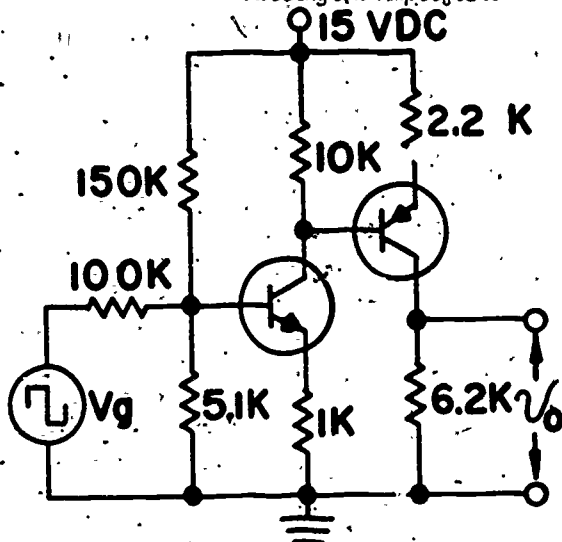

1. Connect the circuit shown in Fig. 1
2. Determine all DC voltages and currents by measurement or calculations.
3. Using a 100Hz square wave as an input determine the total voltage gain.
4. Remove the generator and reduce the supply voltage from 15V DC to 10V DC. Measure the change in V_o .
5. Determine the temperature sensitivity of the amplifier by observing the drift in V_o as the transistors are heated.
6. Connect the circuit of Fig. 2.

7. Adjust the 5k-ohm potentiometer until the DC output voltage is -5V.
8. Measure the voltage gain of the amplifier using a 100Hz square wave.
9. Determine the temperature sensitivity of the amplifier...

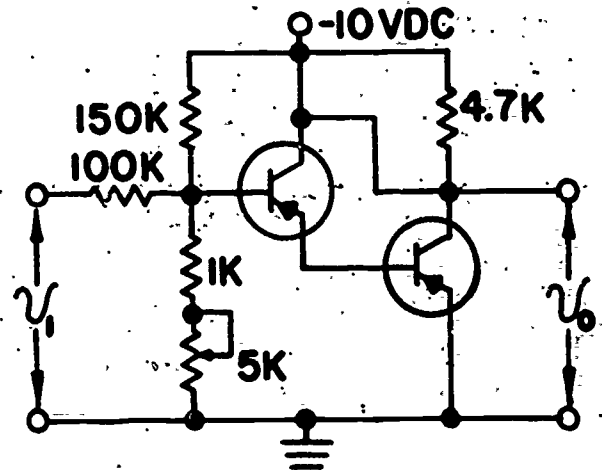

Experiment No. 5: Differential Amplifier

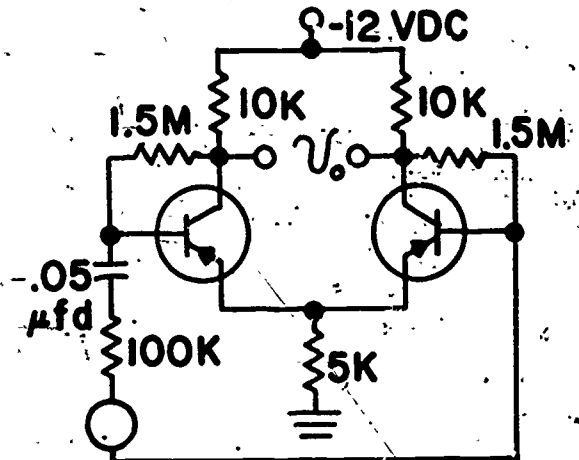

1. Connect the circuit shown in Fig. 1
2. With the signal generator output at zero, measure or calculate all DC voltages and currents in the circuit, (including the DC collector to collector voltage.)
3. Measure the voltage gain of the circuit. Set the input voltage at 100Hz, 1v. (the signal generator used must have a floating output. Also both input and output must be measured with a scope having a floating input or a differential

vertical amplifier.)

4. Draw the equivalent of the input circuit representing the floating signal source as two sources referenced to ground such that:

$$V_{in} = V_a - V_b$$

5. Connect the circuit shown in Fig. 2
6. Measure all DC voltages in the circuit.
7. Measure the voltage gain of the circuit according to the procedure of step 3.
8. Calculate the common mode rejection of the amplifier.
9. Replace the emitter resistor with a 2.7k ohm fixed resistor and a 5k ohm potentiometer. (The fixed resistor is tied from wiper arm to ground.)
10. Balance the circuit for minimum common mode gain.
11. Calculate the new value of CMR.

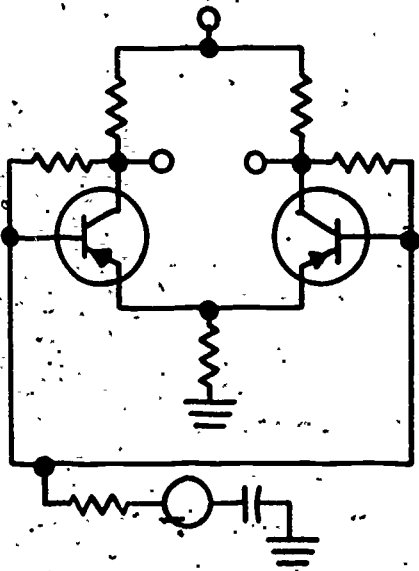

Experiment No. 6: Amplitude Modulation

OBJECTIVES: To determine the results of mixing two signals of different frequencies in linear and non-linear circuits, providing an introduction to basic concepts in amplitude modulation.

To use a transistor collector modulated amplifier to demonstrate a method of modulation commonly used in transmitters.

INTRODUCTORY REMARKS

A fundamental requirement for the production of an amplitude modulated wave is that the carrier and the modulating signal be mixed in a device in which the relation of output to input is affected by the amplitude of the modulating signal. For example, diodes, vacuum triodes, or transistors may be used as modulation by operating them in their non-linear regions. Also, class C operation of tubes or transistors, properly used, permits a rather special kind of non-linearity in which varying the plate or collector voltage varies the average transconductance of the devices over the modulating cycle. This method depends on the fact that in the class C amplifier the peak value of the output signal is approximately equal to the supply voltage when the amplifier's input signal is great enough; thus, if the supply voltage can be made to vary in accordance with the modulating signal's amplitude, the peak amplitude of the output will vary in the same way. Class C modulation is very commonly used because of its efficiency and low distortion.

MATERIAL REQUIRED

- 1-2N292 Transistor
- 1-1N64 Diode
- 1-560 ohm, 1/2 w. Resistor
- 1-1000 ohm, 1/2 w. Resistor
- 1-1500 ohm, 1/2 w. Resistor
- 1-15 k-ohms, 1/2 w. Resistor
- 1-18 k-ohm, 1/2 w. Resistor
- 1-0.05 μ f, 100v Capacitor
- Capacitor, 100 μ f, 25 volts
- Resistor, 33 kilohms, 1/2 watt (2)
- Capacitor, 0.01 μ f, 100 volts, ceramic or mica, (2)
- Capacitor, 5000 pf, 100 volts, ceramic or mica,
- Capacitor, 10 μ f, 25 volts
- Capacitor, variable, 25-280 pf.
- RF choke, 470 μ H, Miller 73F474AF or equiv.

Transformer, Miller #2031 or equivalent
 Signal generator, HP 200CD or equivalent
 Audio signal generator
 Oscilloscope
 VTVM
 Low voltage power supply

PROCEDURE:

1. Consider the circuit shown in Figure 1.
 Predict the amplitude of voltage, at each generator frequency, across the 18 kilohm resistor, assuming that each generator is developing 1 volt peak at its output terminals. Find also the resultant of the two signal voltages across the resistor, for the two extreme conditions: the two signals in phase and the two signals 180° out of phase.

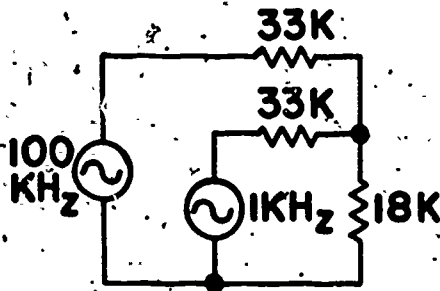

The superposition theorem is probably the most convenient way of making the above calculations. Based on the above calculations, make a sketch of the expected waveform.

2. Connect the circuit of Figure 1, adjusting the generator frequencies as indicated, and each output amplitude to 1 volt peak.
3. Observe and record the waveform and amplitudes at the generator output terminals and across the 18 kilohm resistor. Use an oscilloscope sweep speed slower than 1 millisecond per division and adjust the

triggering as necessary so that the peaks and troughs of the wave envelope are stationary. (The Sweep speed should not be set to show the individual carrier cycles, as this will give a meaningless pattern under modulation.) Show on your sketch both the predicted and measured values, indicating clearly the reference levels or portions of the waveforms concerned.

4. Consider the circuit of Figure 2. Predict the signal amplitude at each frequency, and the total or resultant, across the tuned load impedance. Use the method you employed in step 1 except that the higher frequency generator should be considered as tuned to the exact resonant frequency of the tuned circuit for convenience. (This will be in the vicinity of 100 KHz.)

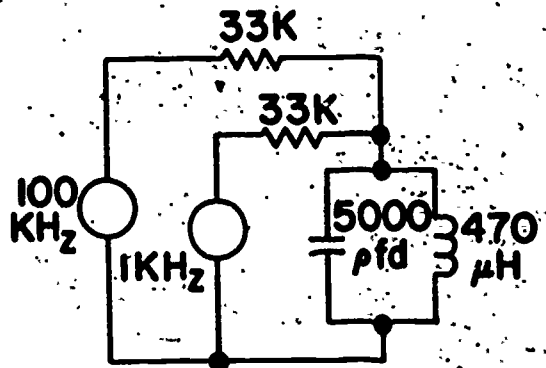

5. Connect the circuit of Figure 2, adjust the generator outputs to 1 volt peak, and adjust the higher frequency to the resonant frequency of the tuned circuit by tuning it for maximum output.
6. Observe and record the waveform and amplitude of signal across the tuned load. Indicate a comparison between predicted and measured values, as before.

7. On the basis of your experience in the investigations above, predict the waveform to be obtained across the 18 kilohm load in Figure 3. (Assume the diode to be an ideal diode: an open circuit when reverse biased; a short circuit when forward biased). Sketch the predicted waveform.

Check with the instructor before connecting the circuit.

8. Connect the circuit of Figure 3. Adjust the generators as in step 5, but, in addition, since the diode is not perfectly linear, increase or decrease the amplitude of one of the signals in order to obtain a waveform across the load in which the modulation is reasonably smooth and sinusoidal in appearance. This will probably require a waveform indicating somewhat less than 100% modulation.

Record the load waveform, using the dc mode for the oscilloscope vertical input. (The dc mode should be used on all the measurements from now on.)

Using dashed lines, indicate (roughly) the dc component and the low frequency component on this waveform. How is the frequency of the low frequency component related to the modulating frequency?

9. Consider the circuit of Figure 4. On the basis of steps 7 and 8, and remembering what impedance the tuned load offers at dc and at the modulating frequency, predict the load waveform for this circuit.

Check with the instructor before connecting the circuit.

10. Connect the circuit and adjust the generators as necessary to obtain a waveform showing a reasonably smooth, sinusoidal modulation. Again, because of non-linearity of the diode, this may have to be somewhat less than 100% modulation.

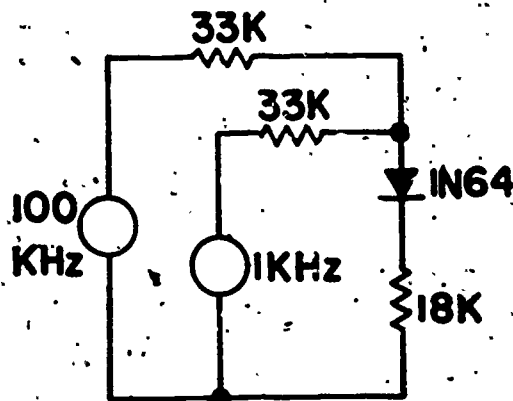

Figure 3. Modulating circuit without filtering.

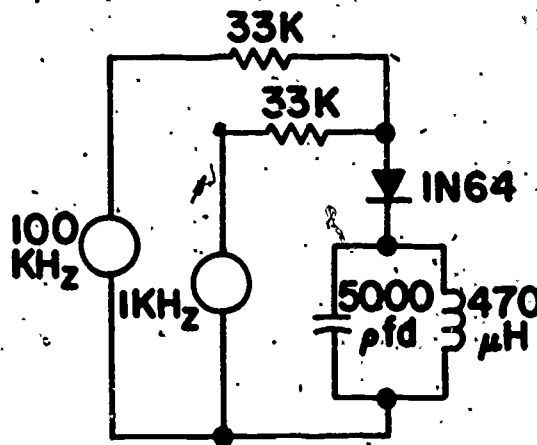

Figure 4. Non-linear mixing, or modulating circuit, with tuned load.

11. Connect the circuit of Figure 5, with the generators connected but both signal amplitudes set at zero. (See Figure 5 at bottom of next page)
12. Set V_{cc} to 5 volts, and with the RF signal input at a low level adjust the tuning capacitor for maximum output at the collector.
13. Increase the RF generator output amplitude

until the amplifier collector signal amplitude stops increasing. The amplifier is now operating into saturation.

14. Reduce V_{cc} to one-half of the value you used in steps 12 and 13. This will now permit full modulation without bringing the amplifier out of saturation. (Since full collector modulation will raise the effective collector voltage to twice the V_{cc} value, at the modulation peaks.)
15. Record the waveform and amplitude of the RF signal at the collector. Use the dc mode of the scope.
16. Adjust the oscilloscope sweep speed to the vicinity of 1 millisecond per centimeter and increase the audio signal level until a pattern of peaks and troughs appears at the collector. Adjust the oscilloscope as necessary to synchronize this pattern so that the envelope variations, at 1000 Hz, are stationary.
17. Adjust the audio signal level so that the troughs go as nearly to zero as possible without excessive distortion of the sinusoidal form of the modulation envelope.
18. Carefully record the waveform and the amplitude of the signal at the collector, using the dc mode of the scope.
19. Record the waveform and amplitude of signal at the junction of the 1-kilohm resistor and the bottom of the tank circuit. Be prepared to explain the reason for the difference between this waveform and that of step 18.
20. Record the waveform and amplitude at the "Mod. Sig. Output". Be prepared to explain why this signal differs as it does from the collector signal. Be prepared to state whether or not the low frequency component is still in this signal, and why.
21. If the modulated output signal is further amplified in a tuned amplifier, the low frequency component will be discriminated against. Make a neat sketch of the appearance of the output signal of such an amplifier assuming that the input signal is of the form of the "Mod. Sig. Output" of step 20.
22. When inductive coupling of the modulated signal output is employed (instead of

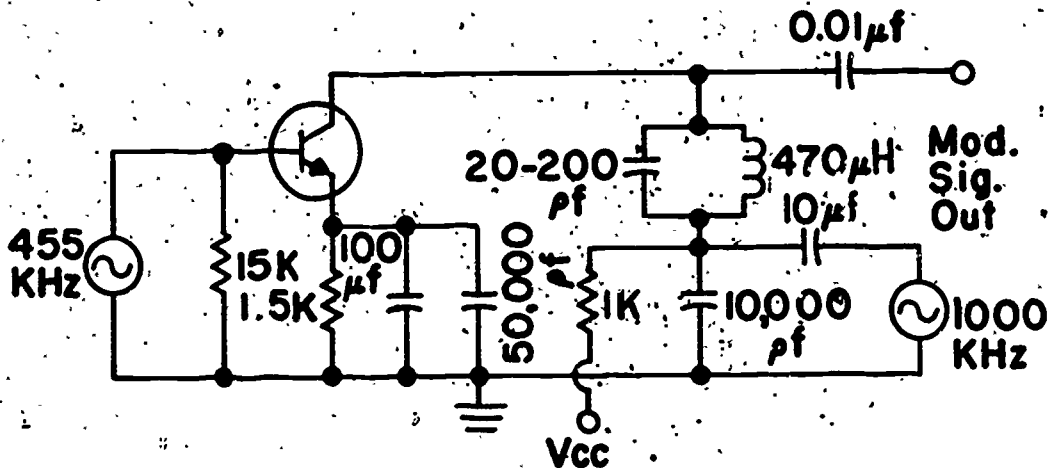

Figure 5. Circuit for simple collector modulation.

capacitive coupling as in Figure 5) the low frequency component is automatically discriminated against. Change your circuit from Figure 5 to Figure 6 (making necessary carrier frequency change) and take the necessary data to demonstrate this. Be prepared to explain why this happens.

ANALYSIS: Describe your investigation and your findings. Include in your discussion your answers to all the questions raised in the progress of the experiment.

Experiment No. 7: A.M. Detector

OBJECTIVE: To investigate some of the relationships affecting filtering, distortion, and detection efficiency in a diode amplitude demodulator.

MATERIAL REQUIRED:

Collector modulation circuit from Experiment #6, and two signal generators as used in that experiment.

- 1N64 diode
- Capacitor, 150 pf, 100 volts (4)
- Capacitor, 2000 pf, 100 volts
- Capacitor, 10,000 pf, 100 volts
- Resistor, 68 kilohms, 1/2 watt
- Resistor, 10 kilohm, 1/2 watt
- Resistor, 2.2 kilohm, 1/2 watt
- Low voltage power supply
- VTM
- Oscilloscope

PROCEDURE:

I. Filtering

1. Connect the circuit shown in Figure 1, in which the transformer shown within the dashed rectangle is the output transformer of the modulator of Experiment 9.
2. Adjust the RF and Audio signal levels in the modulator for full output and approximately 100% modulation as in Experiment 9. Use 1000 Hz for the Audio frequency.
3. Observe and record the waveform at the transformer output terminals, using a X1 probe. This is of course the type of circuit and waveform you might find at the output of the IF stages of a receiver.
4. Record the waveform across the 68 kilohm load resistor -- still using the X1 probe. Be sure to use the d-c mode of the 'scope, in order to be able to observe d-c levels:
5. Question: Since there is no filter capacitor across the 68 kilohm resistor, we should expect RF to be present as well as audio. But why is the RF amplitude as small as it is in this case?
6. Change to a X10 (low capacity) probe and observe the waveform across the load resistor. Compare the amount of RF with that noted in 4 above, and explain.

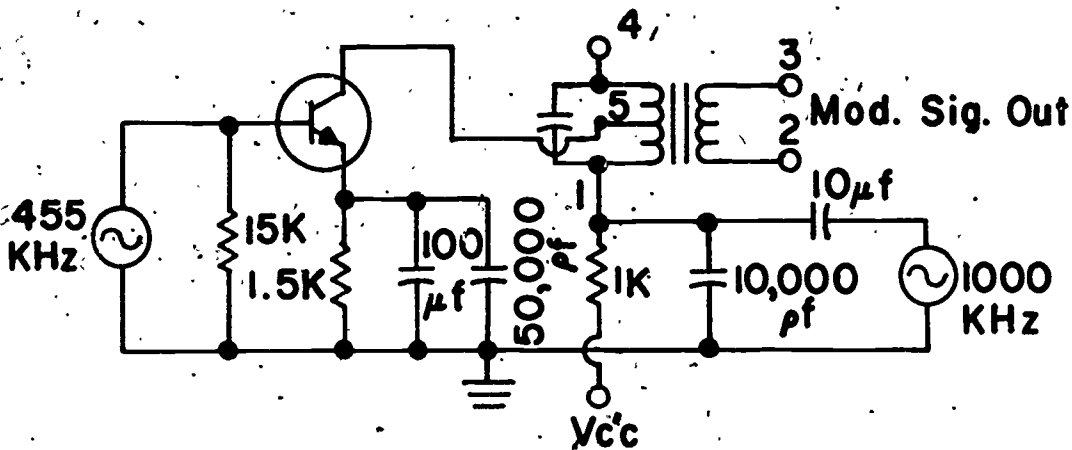

Figure 6. Collector modulation with transformer coupling to output

7. Connect 150 pf across the load resistor and note the effect on the waveform.

II. Distortion due to the diode characteristic.

1. If you are using nearly 100% modulation as instructed, there is very probably distortion (clipping) evident in the audio waveform.

By comparing with the unfiltered waveform, ascertain whether it is the peaks or the troughs of the modulated wave which are being clipped. From your text material (DeFrance: Communications Electronics Circuits) explain the probable cause of this clipping.

2. Reduce the amplitude of the audio signal input to the modulator to reduce the modulation percentage, until the clipping seems negligible.
3. Observe the waveform at the output of the modulator and make a rough measurement of the modulation percentage.

Does this seem to verify the statements in the text?

III. Diagonal clipping due to excessive filtering.

1. Still using the lower modulation percentage from step II.3., increase the RF filter capacitor to 600 pf to improve the elimination of RF from the Audio output. Record the amount of change of RF amplitude.
2. Change the Audio modulating frequency to 5KHz and by tapping off and on the additional 450 pf of step 1, note the change it causes in the audio waveform.
3. Explain diagonal clipping.

IV. Distortion vs-size of load resistance.

1. Change to 300 pf for the filter.
2. Restore the audio frequency to 1KHz but keep the low modulation percentage you have been using.
3. Carefully record the detector's audio output amplitude and waveform.
4. Change R to 2.2 kilohms, and change C to 10,000 pf. (The change in capacitance will result in roughly the same time constant as

you had with the 68 kilohms and 300 pf.)

5. Carefully record the effects of this change.

6. Reduce the modulation percentage to eliminate any clipping. Roughly measure the new modulation percentage.
7. What are your conclusions with respect to the effect of a very low load resistance on this kind of distortion? Does this seem to verify what the text had to say? In other words, is this clipping worse with low R than high R -- did you have to go to a lower percentage modulation than in step II.3?

V. Detection efficiency vs-load resistance.

1. Carefully record the amplitude of the detector's audio output in the condition obtained in step IV.6 above.
2. Without changing signal levels, restore the 68 kilohms and 300 pf in place of the 2.2 kilohms and 10,000 pf, and record the effects of this change.
3. What are your conclusions with regard to the effect of load resistance upon detection efficiency?

ANALYSIS: Briefly summarize your investigations and your findings. Explain briefly the basic cause of each effect noted.

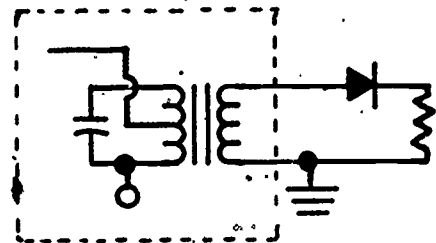

Figure 1. Simple diode detector without filtering.

CHAPTER 6

INSTRUCTIONAL TECHNOLOGY

Regardless of how well a curriculum is structured, if the instructor is not an effective teacher in the classroom and laboratory, it is useless. The instructor must be able to communicate with the student which requires an integrated systems approach that makes efficient use of both curriculum material and teaching methodology.

This chapter is the first of three in the report that is devoted to the how of teaching as compared to the preceding chapters that have concentrated on the what to teach. Included in Chapter 6, in addition to discussions of instructional methods and materials that are available, is a section that describes an experiment that the project staff conducted on using media to bring industry and the technician into the classroom. Appreciation is extended to the companies involved and to Roger Mussell for his assistance.

The last section is on the language of electronics with emphasis on schematic diagrams. The material in this section could be used very effectively in the INTRO course. Sincere appreciation is extended to R. Deane Bradley for his contributions in this area.

GENERAL AND SPECIFIC CONSIDERATIONS

There are many problems associated with the application of instructional technology that must be corrected. These include the following:

Problem: The biggest problem to overcome are people problems, not technical problems. Many electronics instructors do not incorporate media in their instruction because they simply do not know much about it, how it operates, how to use it effectively, or for a variety of other reasons. Rather than admit their inadequacies, instructors continue to teach with the same old ineffective methods.

Suggestion: There needs to be a greater expansion of in-service teacher education. This will help the instructor to know where to locate materials, how to produce simple media, how to plan instruction using media, and certainly, how to present the materials effectively. This does not mean that the electronics instructor needs to become a media specialist but rather one who knows when, where, and how to use materials effectively.

Problem: The most often used excuse given by electronics instructors is that they just don't have time for curriculum development and the design of instructional materials and techniques. They complain that it takes time to look through the many catalogs, to order properly, to improve instruction, and to develop curriculum materials.

Suggestion: Instructors must be given released time from the classroom and lab to improve the quality of instruction. The electronics instructor must learn to work with media specialists in the instructional resource center which now exists in most community colleges and technical institutes. They are experts in media and can assist the instructor to have the right method of instruction in the right place at the right time.

Problem: There is a tendency for electronics instructors to hold on to old demonstrations and aids because they have fit in with a course that was taught several years ago. They do this because it takes time to prepare new material and rationalize their actions by saying that it worked before so why make any changes.

Suggestion: The electronics instructor must keep abreast of advances in curriculum and instructional methods by reading journals and attending meetings. If he is not kept abreast of such progress, or if he is not equipped to employ new techniques,

which have proved effective, the student is going to suffer. It can be shown that the adoption of the multimedia method of instruction can give the instructor more free time to pursue the goal of becoming a better teacher.

Problem: Many instructors will not use media because they think that it will be "show and tell" and that the students will make fun of these presentations. So, they stick with the chalk and blackboard because it is the only method that they feel comfortable using, not realizing that learning requires more than just copying down information from the blackboard and taking notes from the lecture.

Suggestion: Instructors need to become aware of the value of instructional techniques and materials and stimulated to use them. He needs to be able to determine the type of instructional media best suited to the presentation. No one medium is good or bad generally. It is a matter of selecting media which possess such characteristics as to make it possible to implement the desired conditions of learning.

Problem: Another problem with using media in electronics is with the software. Very little prepared material is available that the electronics instructor can use. There are a great number of devices available with nothing to use with them in the area of electronics technology.

Suggestion: Electronics instructors must work closely with professionals to develop needed materials. If only the instructor would be more specific about his needs, commercially made materials could be developed that would be of value. To do this, the instructor must use a planned approach towards definite stated educational objectives.

Problem: Colleges and universities are not producing personnel capable to lead in-service workshops in the area of instructional technology.

Suggestion: Colleges and universities must produce qualified leaders to assume the responsibility for orienting teachers to new instructional procedures.

INSTRUCTIONAL TECHNOLOGY AND ELECTRONICS

WHAT IS INSTRUCTIONAL TECHNOLOGY?

Instructional technology in a very narrow sense is thought of by many in the field of electronics as simply the hardware that the instructor uses in the classroom. They are primarily concerned with devices such as film projectors, tape recorders, teaching machines, overhead projectors, and many other devices that are available on the market.

Instructional technology is more than just hardware and requires a more complete explanation. The following defines the way that instructional technology and applications to electronics was conducted in this project. Instructional technology can be broken down into two terms:

1. *Instruction* - Wherever, whenever, or however it should take place. It may occur in the classroom, laboratory, at home, at work; at any time by experimentation, reading, working problems, or by any other means. It may be in large groups, small groups, or individual study; in various formats such as teacher directed, co-operatively directed, or student independent inquiry.

2. *Technology* - The most general dictionary definition, *Applied Science*. A conscious and deliberate choice of combining:

a. *Technique* (techno-) - meaning the systematic procedure associated with science (electronics), a sophisticated methodology, a practical application of an idea.

b. *Study of* (-ology) - meaning the continual intellectual pursuit of ideas, the devoted search for concepts or theories upon which to base practice.

Instructional technology refers not only to hardware and software, but also to the overall process whereby the most efficient use of all resources for learning--both human and material--is made in a deliberate effort to match resources to basic educational needs.

Application of instructional technology is a systems approach to organize and condense necessary or desired experiences as concisely and systematically as possible so as to increase the probability that learning will occur and in an efficient manner. A systems concept when applied to electronics technology allows for the curriculum to be more effective and efficient in relation to the learning tasks and goals of students.

DEVELOPING INSTRUCTIONAL MATERIALS.

The techniques of curriculum development and the design of instructional materials should always have the objective to provide for learning which will best serve the learner. Two aims often neglected in the development of curriculum materials are:

1. Providing for differences in level of achievement among students.
2. Providing for differences in individual rates of learning.

In spite of the fact that not all students enter the electronics program with the same achievement background (*notice I have said achievement, not ability*), all students have an individual rate of learning, and each student has a method of learning that is best for him; the instructor tends to treat everyone the same and relies on the poorest and easiest method of instruction, the lecture. *It is past time that the electronics instructor put down his chalk and become involved with a more efficient teaching-learning process.*

ROLE OF INSTRUCTOR

Teaching electronics is a shared responsibility that is a team effort involving generalists, specialists, auxiliary personnel, resource material, and instructional media. The electronics instructor is becoming more of a diagnostician of the learning situation and knows when and where

to send the student to a particular resource for help. The tremendous expansion in electronics has caused many educators to become acutely aware that teaching and learning must have a major overhaul simply on the basis of the burgeoning quantity of knowledge, facts, and materials. Nearly any competent electronics instructor today knows that he cannot cover all the material or that a student cannot acquire all of the knowledge that is available. It is impossible for the electronics instructor to be the mediator of all learning. Attention must be given to changing some of the nature of the traditional electronics organization. To improve learning, we must get *away-from* and *more toward*:

Planned instructional sequences do not necessarily lead to rote learning. When properly designed, structured lessons can lead to highly meaningful learning of concepts which will be useful for future learning and problem solving. For example, discovery or inquiry experience should be a part of audio-tutorial lessons, but only for those objectives which require this kind of activity. A more complete discussion of audio-tutorial methods is presented in Chapter 7.

WHAT IS MEDIA?

To assist the student, the instructor must make proper use of media. A question that might be asked is: *What is meant when we speak of*

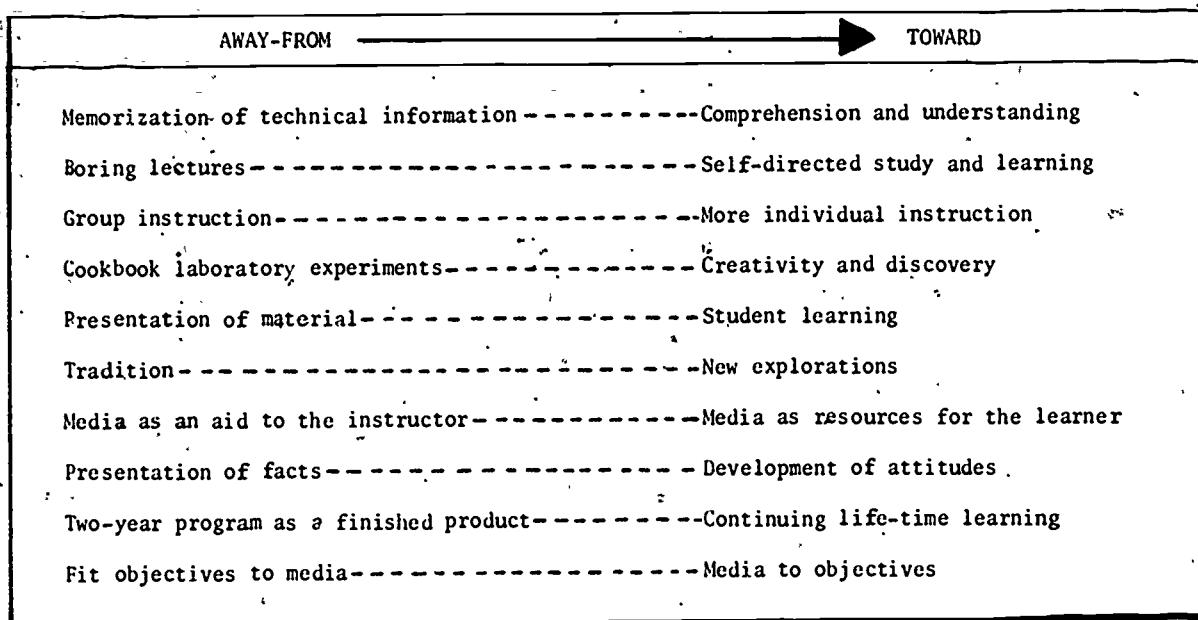

The electronics instructor needs to know where to locate materials, how to produce simple media, how to plan instruction using media, and certainly, how to present materials effectively. This does not mean that the electronics instructor needs to become a media specialist, but rather one who knows when, where, and how to use materials effectively. The advances in curriculum and instructional methods are of little value if the electronics instructor is not kept abreast of such progress or if he is not equipped to employ techniques which have proved effective.

media? Media as defined by ETCDP refers to brochures, catalogs, standards and codes, drawings, schematics, parts lists, specifications, seminars, handbooks, manuals, journals, demonstrations, measurements, films, experimentation, etc. Media allows for the body of knowledge resulting from the application of the science of teaching and learning to assist in the teaching-learning process.

Media are essentials, not just frills that are supplementary learning, not supplanting the electronics instructor. No one medium is good or bad generally, but rather it is a matter of

selecting media which possess such characteristics that will make it possible to implement the appropriate conditions of learning. *Just as an electrician has more than one tool in his tool pouch, so must there be more than one tool of instruction in electronics.*

The use of media refers to every item that might be used in the class or laboratory, extending from the overhead projector to the chalkboard; from a daily quiz to a guest speaker. Determination should be made regarding the type of instructional media best suited for student learning. Audio-visual aids, programmed instruction, audio-tutorial instruction, and team teaching are but a few of the methods which deserve consideration. This does not imply that the instructor utilizes such techniques to the exclusion of all others, or simply to be up with the times. He uses them only when and where they prove the most effective means of learning.

PLANNING INSTRUCTION

If new kinds of media have anything in common, it is the ability to look efficient, attractive, and expensive all at once. Media of any sort are absolutely useless if they do not serve a purpose. To avoid media that only look good and to develop a systems approach to learning, we should:

1. *Determine student needs*
 - a. Is what I am going to do really required?
 - b. What will the student need in the future?
2. *Determine what is required*
 - a. It is at this point that behavioral objectives are stated.
 - b. This step also determines input and output requirements.
3. *Determine how the objectives will be met*
 - a. What methods to use; audio-tutorial, on-the-job training, lecture, etc.
 - b. The critical point is that thinking must go beyond simply a course.

- c. Select materials that will be required. If commercial materials are not available, you may wish to produce simple materials yourself, or request having them made in the Instructional Resource Center.

4. *Implement the instruction*
 - a. Utilize the techniques and materials effectively to meet the required objectives.
 - b. Several different methods of instruction should be used covering essentially the same information.
5. *Monitor the feedback data*
 - a. Work out evaluation methods to determine if the objectives have been satisfied.
6. *Make necessary modifications*
 - a. Pay attention to feedback data and make necessary improvements.
 - b. At this point, the closed loop of learning is completed by inserting the necessary changes at any of the above-mentioned points. The following diagram will illustrate:

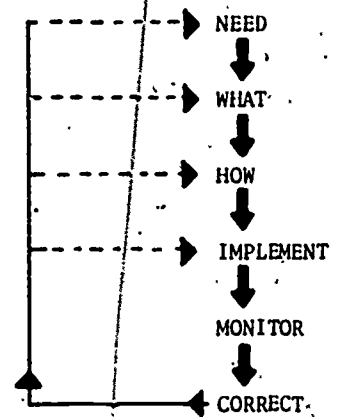

THE OVERHEAD PROJECTOR

The overhead projector is the most widely used piece of audio-visual equipment in education today. The overhead projector is a visual tool, and studies have shown that we tend to remember more and learn faster when the learning is done

with both the eyes and ears rather than with the ears alone. No matter how much research studies show the benefits to be gained by utilization of the overhead, the average teacher does not use the overhead projector in the classroom and laboratory as much as he should.

In using the overhead, the presentation can combine verbal material with personalized transparencies of four different types--dialo, thermo, heat lift, and write-on, plus commercially prepared visuals. Therefore, the instructor has a variety in the choice of materials at his disposal. The transparency is the medium that the overhead projector uses to produce a picture screen which consists of a sheet of acetate or other see-through plastic film that can be imaged chemically or by special write-on pens or pencils.

MAKING TRANSPARENCIES

The original or master from which a transparency is to be produced should be kept simple and uncluttered. Try to use less than ten lines and only about six or seven words in each line. The main point of interest should be presented in the upper two-thirds of the page. This helps to assure maximum visibility by the whole class. The cardinal rule is *keep it short and simple*.

One of the most common types of transparency makers used in schools is the infrared copying machine. Making an infrared transparency uses the principles of infrared copying--a dry, one-step operation that requires a master or original on any type of paper and compatible ink and a sheet of specially treated transparency film. The infrared transparency maker will reproduce India ink, ink used in magazines and textbooks, newsprint, Number 2 lead pencil or softer, charcoal, some lettering-kit letters and black typewriter ribbons. The original must be in a carbon base or compatible media. If the original is not of this type, a Xerox copy can be made that can be used in the infrared process.

One point overlooked by instructors when making transparencies is to assure readability of the visual. Many times the lettering is too

small. Although the room size and number of people in it determine the size of lettering needed, a good rule of thumb is: If the material is readable with the naked eye at ten feet, the transparency will project adequately. The point is, always write big. Ordinary typewriter print is too small. A speech or primer typewriter should be used to assure back-row readability. Another technique that is very effective is dry transfer lettering which can be put directly on the overlay by burnishing into place. These are available in many sizes and colors. Also, the heat-resistant dry transfer letters are available for use on originals which will be reproduced by infrared process. It is quite important that these be used because the non-heat-resistant type will melt in the machine.

It is most important that legible lettering be used. The only time type can become too large is when all of the information cannot be fitted on the overlay. When selecting already prepared material, size of type should be considered. For example, most schematics are too small to be used directly.

With the infrared process, it is possible to produce: A black image on a clear transparent background; a colored image on a clear background; a black image on a colored or tinted background. Many instructors like to use a black image with a yellow background because it is easier on their eyes.

In addition to the above techniques, an adhesive material may be used that is designed to be affixed to a bare transparency. This adhesive material is available in several colors. Also, the overlay can have color added by the use of overhead pens that are available in several colors. *You need not be an artist to create your own effective visuals.*

Only two pieces of equipment are needed for effective visual communications--an overhead projector and a copying machine for making transparencies. A transparency can be made from an original in a matter of seconds. Remember, a visual is a picture of an idea. Concentrate on one

point or one comparison for each visual. Use color for variety and emphasis.

Effective Use of Transparencies

For an effective presentation, the instructor should review the transparencies prior to their use so as to:

- a. Prepare lesson objectives.
- b. Arrange the order of presentation.
- c. Determine which ones can be used as a basis for expansion and clarification of a major point.
- d. Determine which transparencies can be used to illustrate revisions, additions, or variations.
- e. Determine which transparencies can be used to display complex figures.

Techniques of Using the Overhead Projector

There are some very important techniques that every proficient user of the overhead takes for granted that should be mentioned.

- a. Face the group at all times to maintain eye contact which allows you to talk directly to the class and monitor reactions.
- b. Look at the visual on the projector-stage rather than on the screen. *DO NOT* use a pointer and turn your back to the group. Reinforce identification by pointing with your finger or pencil on the projector-stage while discussing the illustration.
- c. Be sure everyone can see the screen. Projecting the transparency to a screen located in a corner six to eight feet high in the front of the room is most effective to assure that everyone can see. No need to turn off room lights.
- d. Control the attention of students by simply turning the projector off when you want your classes' attention, then turn it on again when you wish to direct attention back to the visual.
- e. Develop the habit of turning off the projector when changing visuals to avoid

distracting the class with unnecessary movement on the screen and position the visual before turning the switch-on. This also helps to maintain class attention.

- f. Reveal the projected material to the class a section at a time by blocking out areas of the transparency by a piece of paper, thus projecting only the material under study. This keeps the class from getting ahead of the visual lesson.
- g. Use a grease pencil or felt-tipped overhead pen to show a key concept, to underscore a point, or to indicate movement. Emphasize and supplement the transparencies by using pressure-sensitive materials.
- h. Information which lends itself to a step-by-step presentation can be broken down into its components. Each step is put on a separate transparency and then all are taped together or attached to a cardboard frame and are then folded into place as an overlay as the information is developed.
- i. Stand just a little bit left of the projector to make sure your shoulder doesn't block the screen.
- j. Encourage student participation at the overhead projector. Provide material for them in advance for them to make overlays.
- k. Use two overhead projectors, if necessary. For example, use one to show a circuit schematic and the other for problem solution. Or, use a projector and the blackboard if necessary. Do not restrict yourself to one or the other.

PROGRAMMED INSTRUCTION

Programmed instruction is another tool that the electronics instructor can use. This type of instruction may be produced in various forms such

as book, audio and video tape, computer-assisted, etc. The material is presented in a series of frames, each of which generally calls for a response from the student. The student responds, the correct answer is given, and if the answer is correct, reinforcement is provided. If the answer is not correct, the student is redirected to preceding information.

Programmed material can be an effective instructional tool for the electronics program if it is used properly. This means that there are times when this can be a very effective method for some students and should be used to supplement instruction. Programmed material is a very good place for students that are slow or having troubles. One area that works quite well is for students that are having trouble with the math. An abundance of good programmed math material is available which can help those with weak backgrounds. Also, programmed material is very good for a quick review or for the student that wants to work on his own. Programmed instruction, like any other method, has its advantages and disadvantages; and it is up to the instructor to determine when and where this method will work.

Linear and Intrinsic Programming

There are two techniques used in programmed instruction, linear and intrinsic programming. In the typical linear programs there is only one path the learner can follow. Linear frames are usually short and consist of a statement that gives a piece of information and requires the student to use this information in completing a sentence by filling in a missing word or words, and then he checks his response from the correct answer. He then goes on to the next frame, although he may be directed to skip ahead if he demonstrates command of the material at certain points or he may be directed to repeat a sequence or do a remedial sequence. He usually progresses in a step-by-step forward direction.

Intrinsic or what is commonly called branching technique provides a learning sequence that is determined by the answer he selects from the

choices that have been provided. If he selects only correct answers, his progress is direct; if he does not, he may be presented with remedial materials and proceed through a series of loops which keep returning him to points along the main path. The answer that is selected, usually from a multiple-choice group, determines the next step.

The computer undoubtedly has the greatest potential in this type of programmed instruction. The computer can accept and evaluate responses constructed by the student, can provide almost unlimited branching on a variety of criteria in microseconds of time. The computer is primarily limited by the ingeniousness of the designer of the program. A more detailed discussion of computer assisted instruction appears later in this chapter.

Problems with Programmed Instruction

The problems encountered in the use of programmed instruction in electronics include identifying those technical students who can benefit most from this method of instruction, identifying skills or concepts that can be learned best with this technique, obtaining effective prepared programmed material that is commercially available and preparing instructors to use programmed materials effectively and efficiently.

Programmed Textbooks

When I hear the word programmed instruction, I immediately think of programmed textbooks, and this is what I would like to touch on now. Very little good programmed textbooks are available for two-year electronics programs. A partial list of those available is presented in the Appendix.

Programmed textbooks should be used as a supplement to other instruction and not depended on as a primary source. It has been found that some students like and benefit from programmed texts while others do not. Therefore, programmed material should be available for those students that can benefit most. Programmed material can be a big help for the instructor, -- very good source for review and self-study for the

instructor and a good source for instructional material. A very good set of programmed instruction that is relatively inexpensive and very good are the ones from Tektronix. If you are not familiar with these, I suggest that you take a look at them. A listing of programmed textbooks can be found in the Appendix of this report.

INSTRUCTIONAL FILMS

Instructional films can be a valuable supplement to the electronics curriculum if used properly. For example, a film may be able to present phenomena that cannot be demonstrated easily by some other method. Examples might include rotating phasors, waveforms, reflected waves, fields, physics of semiconductors, etc. Almost anything that can best be presented by animation can best be done with film.

There has been considerable criticism of commercial films by electronics instructors. They complain that films require:

- a. Too much class time.
- b. Too much material is presented in too little time.
- c. Material is not up to date.
- d. Films have to be ordered so far in advance and never arrive at the appropriate time.
- e. It is hard to find good films.
- f. Rental of films costs money.

These and many more legitimate complaints are constantly being brought up by instructors. To help solve some of these problems, ETCDP has concentrated part of the year-long activities on films. Some of these activities include the following:

1. A search for, and review of, 16mm and 8mm films. The impossible task of reviewing films was kept to a minimum, although many were viewed. A comprehensive list of 16mm and 8mm films, most of which are free, appears in the Appendix.

2. A pilot experiment was conducted on making amateur films in industry. A detailed discussion of this activity is presented in a later section of this chapter.
3. Effort was made to find out why schools do not use films.
4. Investigation of the places in the curriculum that films could best be utilized. Some of these places have already been identified in a previous paragraph.

One of the reasons that schools do not use films is because instructors do not know how to properly use them. Perhaps the following suggestions might be helpful.

- a. Prepare the class and tell why the film is being shown. Ask one or more questions to stimulate student interest and list the key points to watch for. This means that the instructor must preview the film before being shown to the class (*most generally not done*).
- b. Show the film and then discuss the major concepts. Students sometimes need to see a film more than once to grasp the major points.
- c. Use films as supplements to curriculum, not in place of, where appropriate. This allows for more flexibility and relieves worrying about films arriving on time.
- d. Instead of showing films during class time, make them available during some free period or perhaps form an electronics club that might show films on occasion. Showing films during lunch time has been very effective for some schools. Also, by making films available, students can view them as often as they want.
- e. Many schools purchase films that are very effective so that they do not

have to worry about ordering them. There are several good films that fit this category which are good for recruiting students.

SUPER 8MM FILMS

In addition to 16mm films, Super 8mm films have considerable potential for electronics. Super 8 is a new kind of 8mm movie film which gives a brighter, bigger, and a much sharper picture that approaches the quality of 16mm movie film. Super 8 has the same width as 8mm, but the picture area is 52% larger because the sprocket holes are smaller and closer to the edge of the film and there is less separation between frames. Regular 8mm film is on the way out because Super 8 is so much superior. The point is, there is a difference between Regular 8 and Super 8, and therefore require different projectors or one that will play both 8mm and Super 8mm.

Film Loops

Film loops are short and are generally less than five minutes long. They may either have sound or are silent. The film loop offers all the possibilities that film can be used, such as micro-photography, animation, slow-motion, and so on. In fact, it can be used for any kind of concept where motion or time is an intrinsic part of the concept. For example, the generation of a sine wave is a concept in which time is very important.

Film loops are very easy to use. They are permanently enclosed in a plastic cartridge. To use the loop, the cartridge is simply plugged into the projector and turned on. There is no threading and the main cause of film damage is eliminated, because the fingers never touch the film.

As the name indicates, the loop is continuous and will run over and over until it is stopped. This allows the student to view the concept until he understands. The film never has to be rewound, and the film can be started or stopped or inserted or removed at any desired time, not just at the beginning or end.

As a whole, the commercial loop films that are available leave much to be desired. If there is no explanation on the film itself, it is difficult for the average learner to get much out of it. Of course, subtitles can be added to the silent unit, but this does not really satisfy. Most of the ones that I have viewed are very confusing, and very few are of the level required for this type of electronics curriculum. Most are concerned with chasing electrons.

The ideal is Super 8 with sound. This method does have great potential since a combination of good quality photography in color along with carefully written scripts will explain concepts in more detail. It is a relatively inexpensive method and one that can be done by the instructor. It is an ideal way of placing demonstration or related lessons on a permanent visual aid. A major problem, however, is that there is no standardization of hardware or cartridge for Super 8 with sound.

Super 8mm film loops are equally useful for individual study or group viewing. Each film loop comes in a ready-to-use snap-in cartridge, and covers a single concept in 3-4 minutes. The advantage is that it can be repeated over and over again. This is an advantage since in most classes the learning rate of the students is not the same. There is a difference between Regular 8mm and Super 8mm, with Super 8 being the better quality. There is very little commercial film loop material that is of any value.

ELECTRONICS SEMINAR

One of the easiest and most beneficial activities to incorporate into the curriculum is the electronics seminar. This is one of the best places to help develop interest, attitudes, knowledge, and appreciation of the electronics industry by bringing in workers in the field. This might include engineers, technicians, supervisors, past graduates, management, salesmen, etc. The electronics seminar does not necessarily have to be offered for credit, but can be an informal activity in which the students can

become familiar with activities of industry and industry can become familiar with the students and curriculum. The benefits to be gained from an electronics seminar can not be over-emphasized. If you are not presently conducting this type of seminar, I strongly recommend that you give it a try.

CLOSED-CIRCUIT TV

CCTV can be a tremendous aid to the instructor. The main advantage is that it puts every student in a front-row seat. For example, the ability of a camera to get close-up shots allows the students to literally look over the instructor's shoulders with a clear view of each element of the demonstration.

An excellent opportunity to utilize this medium is in the INTRO course. For example, a discussion of schematic diagrams allows the student to see, as well as the instructor, such things as symbols, signal flow, power flow, etc. A more detailed discussion of schematic diagrams appears later in the chapter. Instruments can be demonstrated for operation and construction techniques can be observed. With the image magnification technique, the names on every knob can be read, readings can be taken, etc. There are many applications for using this method of instruction that need to be investigated.

With the development of video-tape recording; additional applications are possible. One application is to use the VTR to record events outside the classroom to be shown in the classroom. An example that has considerable possibilities of using this method to bring industry into the classroom is presented later in this chapter. This method allows for demonstrations to be put on a semipermanent format which can be used over and over.

Another important use for video-taping techniques is instructor evaluation. This allows the instructor to view himself either in private or with someone else and to help point out places where improvements might be made. This technique

of improving teaching has been found to be very successful. A very good source for more information can be found in the March 1970 publication of *Engineering Education*. The article, "Video-taping and microteaching techniques to improve engineering education," is a report of a pilot experiment conducted at the Department of General Engineering at the University of Illinois.

AUDIO-TUTORIAL INSTRUCTION

Audio-tutorial instruction has much to offer for both the instructor and the student. It is one method of instruction that all instructors should give careful consideration. A more detailed discussion is presented in the next chapter with sample A-T lessons.

Also, in the Appendix a list of slide-tape presentations is presented with descriptions. These materials are being developed by Phil Cutler of LRA and are of the level necessary for an engineering technology program.

COMPUTER-ASSISTED INSTRUCTION

Using a computer in the teaching-learning process has much to offer for the electronics curriculum. A discussion of C-AI is presented in Chapter 8.

COMPUTERS AND CALCULATORS

The use of computers and calculators to help with problem solving allows much more flexibility, decreases time spent on repetitious calculations, and allows for more advanced work at a much earlier time in the curriculum. A more detailed discussion of computers and calculators with sample problems developed by the Summer Institute members is presented in Chapter 8.



USING MEDIA TO BRING INDUSTRY TO THE CLASSROOM

(AN EXPERIMENT)

INTRODUCTION

The following is a summary of a pilot experiment that was conducted in November of 1969 as a part of the project. It was not a true experiment with hypotheses and statistical analysis but rather an investigation of methods that might be used to bring the real world into the educational environment.

Many students enter an electronics technology program with very little knowledge of what an electronics technician does out on the job. What little knowledge he may have is probably distorted by the glorified information that he has seen on TV or commercial films. They do not represent the real world of electronics and are usually centered around a company, product, or process with the real emphasis being to advertise the company. They are very unreal and do not give a true picture of the instrumentation, techniques, and role of technicians in industry.

INDUSTRY AND THE CLASSROOM

There are several ways of bringing the industrial atmosphere into the classroom and laboratory. Some of these ways are:

1. Audio Tape
2. Co-op Programs
3. Field Trips
4. Films
5. Industry Speakers
6. Instructor Experience
7. Slides
8. Video Tape

OBJECTIVES OF THE EXPERIMENT

1. To investigate the use of selected media equipment to bring industry into the classroom.
2. To investigate the attitude of industry to this type of activity.

3. To develop a procedure for effective utilization of this media in industry and the classroom.
4. To investigate the application of this activity to the electronics curriculum.
5. To suggest guide lines whereby others may develop similar presentations.
6. To see if the average classroom teacher can complete this type of an activity with adequate results.

EQUIPMENT USED

1. A completely portable, battery-operated 1/2 inch VTR system that could be carried and operated by one person. It consisted of a hand-held video camera with zoom lens and an electronic viewfinder, with a built-in microphone connected to a shoulder-carried video tape recorder.
2. A Super 8 millimeter movie camera with automatic light control with battery operated zoom lenses.
3. A 35mm/f 1.4 camera.
4. A 16mm movie camera not battery operated.
5. A portable audio tape recorder.

COMPANIES SELECTED

Four companies in the northwest suburban area of Chicago were asked to participate. Initial contacts were made with Industry Advisory Committee members from William Rainey Harper College by Roger Mussell of Harper College and a member of the project Steering Committee. Following this, a letter was sent describing LTCDP, objective of the experiment, and a request for permission to carry out the project. All companies that we contacted offered their assistance and allowed us to

enter for the purpose previously described. The companies with their respective representatives were as follows:

Chicago Aerial Industries
550 West Northwest Highway
Barrington, Illinois, 60010

Advisors: Jerry Schasfe
Roger Wolin
Julian Saper

Motorola, Inc.
1301 East Algonquin Road
Schaumburg, Illinois 60172

Advisors: Burnham Casterline
Ed Schwellenbach
Ken Johns

Underwriters Laboratories
207 East Ohio Street
Chicago, Illinois 60611

Advisors: Harold Bond
Robert Van Brundt

Western Electric Company
Hawthorne Station
Chicago, Illinois 60623

Advisors: John Smeljanic
Don Reed
Gary Melhart

Appreciation is extended to the above companies for their co-operation and assistance. Each company went out of their way to make this project a success. It is a pleasure to work with such helpful people and to note the co-operation that exists between education and industry.

Each of these companies was selected because of the diversification of product and utilization of manpower. Each had particular points of interest for the student. For example, Chicago Aerial manufactures military aerial reconnaissance equipment, Motorola at Schamburg makes two-way FM communication systems, Underwriters Laboratories is a testing laboratory for safety of consumer products, and Western Electric is the manufacturing arm of the Bell Telephone System. These companies cover a broad spectrum of employment opportunities available to technicians.

INSTRUCTION ON EQUIPMENT

Advice on the various types of media to be used was obtained from the Instructional Resources Staff of both Harper College and Parkland College. Operation of the equipment was gone over verbally and the operation of equipment at the plant site was accomplished without prior practice. The equipment used was selected for a minimum of operator intervention, just aim and pull the trigger. Lens opening, shutter speed, and zoom capabilities that require a minimum amount of adjustment are advantageous factors for the amateur. A camera operator from Harper College was used to operate the 16mm movie camera. This was the only professional help utilized while visiting the company plant sites.

FILMING PROCEDURE

The following procedure was used at each company:

1. Generally arrive at about 10:00 a.m. and meet with company personnel.
2. A quick plant tour with points of interest noted for later return.
3. A discussion of the plant, background and history of the company, the ETCOP, what exactly we would like to shoot, etc. Settings and types of shots were discussed, proper persons notified, and permission cleared.
4. Major areas of interest were visited and filmed, video taped, and slides taken. Three persons were involved in the picture taking activities. The responsibility was as follows: One person operated the portable video tape unit; one for the 16mm camera with tripod; and the third utilizing both the Super 8mm camera and 35mm slide camera. The audio recorder was utilized primarily in the discussion sessions.
5. Usually completed by 3:00 p.m. This schedule was followed for each

of the four days spent with the experiment. Operation became smoother each day as we knew a little bit more about the operation of the equipment and the areas that we wanted to shoot.

RESULTS

1. Some industries are willing to cooperate in this type of activity.
2. Each media has various advantages and disadvantages. (See chart on next page)
3. There is definitely an application of this activity for the classroom and the electronics curriculum.
4. It is an activity that an amateur can do with little or no practice.

CONCLUSIONS

This type of activity has a lot to offer to the electronics curriculum and to the student. First-year and even second-year reactions to seeing much of the material were quite favorable and encouraging. What effect upon the students' future in the program this will have can

not be determined but is worth further investigation.

Our feeling is that the student will have a better understanding of the function of the manpower team in industry. Not just the technician but the craftsman, industrial technician, engineering technician, engineer, management, etc. Also this should help to develop a healthy attitude relating to the concepts and manipulative skills necessary for success on the job because of the actual technicians seen at work, the equipment used, and the functions performed.

Many insights can be presented through the use of media that can emphasize the real world and show the student why he must become knowledgeable in the areas of circuits, electronics, and laboratory operations. *If nothing else is of value, at least the student will see that the work bench is actually messy and cluttered with printed circuit boards, equipment, components, and not clean and neat as most commercial presentations depict.*

	35 MILLIMETER	1/2-INCH VIDEO TAPE
COST	High-Speed Ektachrome. Color Film 36-exposure \$2.50-3.00 Processing-36-exposure \$2.50-2.75 Camera \$100.00-400.00 Slide Projector \$ 60.00-200.00	Video Tape per 60-min. roll \$30.00-40.00 Processing Camera and VTR \$1200.00-1800.00 Television Monitor \$120.00-400.00 Total cost of tape with sound per min. \$.50-.70
ADVANTAGES	a. Equipment is simple to operate. b. Good quality picture. c. Available in black and white or color. d. Very inexpensive.	a. Equipment is simple to operate. b. Both sound and picture are recorded simultaneously. c. Instant feedback, no need to wait for commercial processing. d. Opportunity to erase and retake. e. Tapes can be used over as many as 500 times. f. Easy storage for tapes. g. Portable and light-weight equipment. h. Relatively inexpensive. i. Easy to edit and dub. j. Can be narrated over and over.
DISADVANTAGES	a. Still picture is not effective if movement is to be emphasized. b. Not very effective without sound (A sound-slide pre- sentation would be better).	a. Lack of compatibility between different makes and models unless universal model VTR's are used. b. Difficult for schools to exchange tapes because of compatibility. c. Can accidentally be erased. d. Initial investment in equipment is moderate, but could be a drawback. e. Usually not in color. (May or may not be a disadvantage.)
POSSIBLE APPLICATIONS	a. Very effective where movement is not a factor. For example, at Underwriters Lab, a product is tested generally at one lo- cation. b. Good for close-up stills of equipment. c. Can provide sequence of specif- ic operations with emphasis on detail.	a. Most effective for talk sessions by company personnel, technicians, engineers, etc. b. Very good method when viewing a technician at work and having him or his supervisor explain his operations and functions. c. Can show assembly line sequence of assembling, automatic soldering, etc. Can trace the process or product from raw to finished product. d. Has the greatest application when- ever sound is of prime importance.
PREFERENCE	Three	One

SUPER EIGHT MILLIMETER	SIXTEEN MILLIMETER
<p>Color film per 100 ft (8 min.) \$4.50-5.00</p> <p>Processing per 100 ft \$3.70-4.50</p> <p>Sound stripped per 100 ft \$4.50-5.00</p> <p>Camera \$200.00-800.00</p> <p>Sound Projector \$100.00-900.00</p> <p>Camera with lip sink audio equipment \$500.00-500.00</p> <p>Processing with sound per 100 ft \$12.00-13.00</p> <p>Total cost of film with sound per min. \$1.60-2.00</p>	<p>Color film per 200 ft (8 min.) \$15.00-20.00</p> <p>Processing per 200 ft \$11.00-15.00</p> <p>Sound stripped \$9.00-10.00</p> <p>Camera \$1000.00-8000.00</p> <p>Sound Projector \$500.00-1700.00</p> <p>Total cost of film with sound per min. \$4.50-5.50</p>
<p>a. Equipment is simple to operate.</p> <p>b. Good quality picture that approaches 16mm quality.</p> <p>c. Available in black and white or color.</p> <p>d. Possible to have lip sink sound.</p> <p>e. Cost is not unreasonable.</p> <p>f. A permanent record.</p> <p>g. Can be exchanged with other schools.</p> <p>h. Can be narrated over and over.</p>	<p>a. Equipment can be, but not usually simple to operate.</p> <p>b. Very good quality picture.</p> <p>c. Available in black and white or color.</p> <p>d. A permanent record.</p> <p>e. Can be exchanged with other schools.</p> <p>f. Most schools have 16mm projectors.</p> <p>g. Can be narrated over and over.</p>
<p>a. Schools may not have reel to reel magnetic sound projectors.</p> <p>b. Difficult to narrate sound to produce a good film. (Ideal is one that records sound at the same time.)</p> <p>c. Not very effective without sound.</p>	<p>a. Almost impossible to obtain lip sink sound without professional help.</p> <p>b. Can be narrated, but is not as effective as hearing other people talk.</p> <p>c. Most schools do not have a 16mm magnetic sound projector.</p> <p>d. Cost is relatively expensive.</p>
<p>a. If sound recording capability is used, the same applications can be realized as those of VTR.</p> <p>b. Without sound, very good for assembly line sequence.</p>	<p>a. If sound recording capability is used, the same application of VTR and Super 8 can be applied.</p> <p>b. Without sound, very good for assembly line sequence.</p>
Two	Four

THE LANGUAGE OF ELECTRONICS

INTRODUCTION

The study of electronics is highly dependent upon the language of electronics that is used. The language is the means by which the technician must communicate with other members of the manpower team. To be successful, the technician must be able to convey his ideas and to understand ideas that develop between craftsman, engineers, other technicians, customers, management, etc.

Although we as teachers realize the dependence on the language, we rarely acknowledge this dependence. We are limited by the language when teaching an electronic concept. Thus, the student must master the technical terms involved before he can possibly hope to understand the concept under study. If he does not master the language, he will not get the concept.

Not only is it necessary for the student to master the technical terms to learn the concept, but in many cases the technical term, itself, IS the concept. In these cases, knowledge of the technical term is the only knowledge necessary. In this respect, it must be pointed out that the technical language is more than just a tool of the technology. It is the key to the technology. A thorough knowledge of the language of the technology represents about 90% of all of the knowledge of that technology. For example, included in the understanding of the term "voltage" is an understanding of Kirchoff's voltage law.

TECHNICAL VOCABULARY

The language of electronics can be divided into three basic parts. The first of these is the most obvious, but not necessarily the most important. It is the technical vocabulary, the words that have been formulated for electronics or have been adapted to take on special meaning in electronics. This is the area in which we are most dependent upon the language when we are

lecturing to our students. They must understand the terms we use in order to understand the lecture. This is pretty much of a limitation but it is possible to turn it into an advantage. Since most topics are actually built around a few key technical terms, these terms by themselves, constitute a sort of rough outline of the topic presented. By emphasizing the technical terms in a vocabulary section we can illuminate the structure of the topic to the student at the same time we are overcoming the language barrier. In addition, the vocabulary section, by itself, can serve as a rough outline that the student can refer to any time in the future for review.

Any good understanding of a technical term includes:

- a. A definition of the term.
- b. The relation of that term to others in the technical vocabulary.
- c. The reason behind using that term for that definition instead of using some other term.

Most of these things are taken for granted by those of us who use the term every day. When you learn a technical term you unconsciously look for these points and this is an indication of a good student. The good student will see these relationships easily while the poor students will have a hard time digging out this information. If we were to stress these relationships we would help the poor students and not risk boring the better students. From the above discussion, it is apparent that stressing the vocabulary and using it to advantage will:

- a. Pinpoint the heart of concepts to be presented through the use of key words.
- b. Provide a rough outline for any lesson that the student can use as a study guide.

- c. Emphasize the key areas which a student should concentrate on when reviewing for a test.

SYMBOLS

The second basic part of the language of electronics is the use of symbols. The use of a symbol requires a precise understanding between the user and his audience about the meaning of the symbol. The symbol is used because its meaning is very precise and can be conveyed without the use of many inexact words. Without the precise understanding about the meaning of the symbol, its use causes a total void of communication. In electronics, there are two types of symbols that are commonly used: mathematical and electrical. When we use mathematical symbols it is important that we either use symbols that are quite familiar to the student or make the effort to assure that the student becomes familiar with the symbols. It has been proven that students learn a mathematical concept much more easily and quickly when they are familiar with the symbols used. If strange symbols are used the student may overlook the simplest mathematical relationships by worrying about the unknown symbols.

Most electrical symbols are a combination of a mathematical concept and the physical means of achieving the mathematical concept. For example, , the symbol for resistance, is drawn in such a way that it looks like it could slow down anything that is to travel through it. At the same time, it also indicates a way by which we can make an actual resistor. We could take a long piece of thin insulated wire and then fold it so that it will be more compact and easy to handle; then we have a resistor that looks exactly like the symbol for resistance. It should be pointed out that the symbol for resistance takes on two different meanings depending upon how it is used. If the symbol is shown by itself, it usually means the mathematical concept of resistance, not an actual physical resistor. If, however, the symbol is

part of a large schematic it usually indicates an actual resistor, or, if you will, an idealized model of an actual resistor.

When we explain the meaning of any symbol, there are several things which we must stress.

Among these are:

- a. The definition of the symbol in mathematical and physical terms.
- b. The difference between the ideal model for a device and the practical device itself.
- c. The reason that that particular symbol is used for that particular concept instead of some other symbol.

DIAGRAMS

The third part of the language of electronics technology is the illustration or the diagram. It generally is used to show relationships between two or more elements or events. In addition, it usually uses vocabulary or symbols. There are several types of diagrams used in electronics. These include:

- a. Schematic diagrams, which show the electrical relationships between elements.
- b. Charts and graphs, which are to indicate the relationships that exist between parameters of the electronic circuit.
- c. Pictorials, which indicate the special relationships between parts.

SCHEMATIC DIAGRAMS

A schematic diagram to a technician is like a square to a carpenter. A good carpenter is one that can read a square; a good technician is one that can read a schematic diagram. This ability is usually an implicit learning process that the student may or may not acquire. This is one of the most important tools that the technician uses and should be an explicit part of the curriculum. Many important concepts can be presented early if the student knows the language. The place to start with the

discussion of the schematic diagram is in the INTRO course. Schematic diagrams need not be a special topic but rather the many things that can be read from the schematic should be pointed out with emphasis at the appropriate time.

For example, the student should know that a schematic diagram shows:

- a. The sequence of signal operations.
- b. The dependence of each circuit block on neighboring blocks.
- c. A logical pattern for trouble-shooting the system.
- d. A method for locating the parts on the chassis.
- e. Mechanical connections, linkages, or grouping of components.
- f. External connections.
- g. Relative importance of components.
- h. Interconnection of components.
- i. Values and limitations of components.

NOTE: Additional discussion on these points appears later.

The student should also know the conventions that are used in drawing schematics. These include:

- a. Signal must flow from left to right.
- b. Signal components should be positioned horizontally so that the signal will flow through them from left to right.
- c. Power should be applied to the circuit at the top of the circuit.
- d. Power and bias components should be positioned vertically.

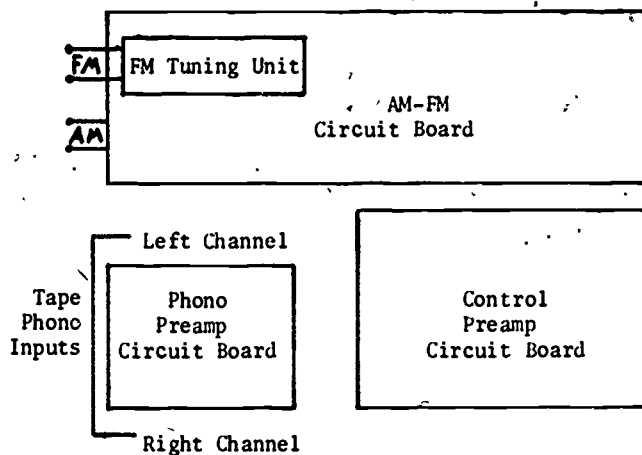

- e. All connecting lines are drawn either horizontally or vertically unless specifically required by the symmetry of the circuit.
- f. Ground is always at the bottom of the circuit.
- g. All test points, components, connections, pin locations, etc. are labeled.
- h. Overall symmetry through:
 1. Evenly spaced components.
 2. Similar components placed at the same level.
 3. Parallel construction.
 4. Progressive construction.
- i. Standard symbols and conventions are used.
- j. The function and the importance of components and circuits are emphasized by proper placement and orientation.
- k. Where possible, a picture of the waveform is provided at a test point that indicates proper operation

SCHEMATIC DIAGRAMS (A SPECIFIC EXAMPLE)

The following is a discussion of the above mentioned points concerning schematic diagrams.

Reference is made to the Heathkit AR-15 stereo solid-state receiver which is reproduced with permission from the Heath Company. Due to the size of the schematic only parts have been reproduced. To give a complete overview of the schematic lay out, refer to the following block drawing that indicates the relative position on the schematic.

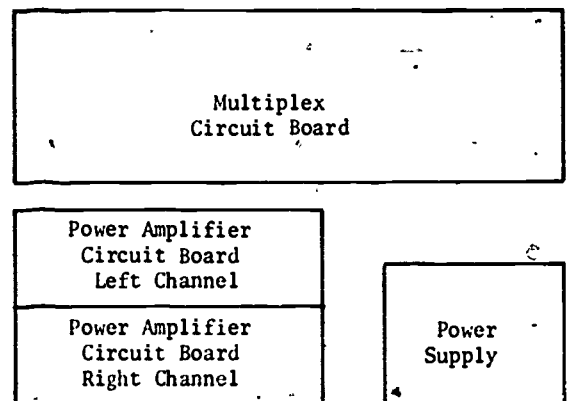

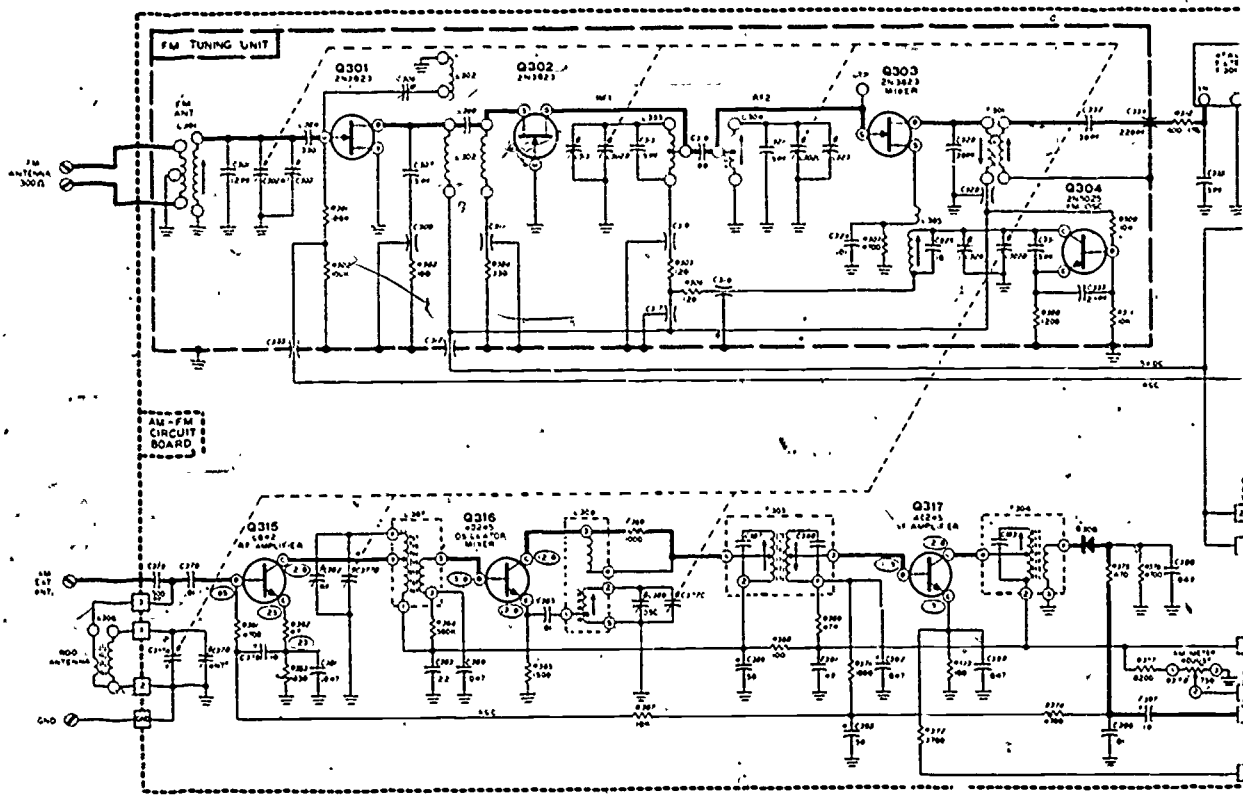

Fig. 1

Signal Flows From Left To Right

This is one of the most important points that can be emphasized about the schematic. Because one signal does flow from left to right, we can tell at a glance the sequence of operations. The true importance of the direction of signal flow is that it shows:

- The order or sequence of signal operations.
- A logical method to follow when trouble-shooting.
- The role of each circuit as a building block in making up the entire system.

Referring to Fig. 1, we see that the signal is received at the external connections on the left by the AM and FM antenna. The signal path can then be traced through the circuit by following the heavy lines. This makes it extremely easy to trace the signal through each circuit in the system. You can tell at a glance just what happens when, where and how.

This is a very simple but effective method of drawing attention to the main signal path:

Notice that the signal components are generally positioned horizontally so that the signal passes from left to right.

Ground Is Always At The Bottom

In every case, regardless of where the ground lead is in the circuit, the lead turns down before it connects to ground. Because of this, in most cases the circuit element or device symbol is usually oriented so that the ground lead will come out of the bottom of the element.

Power Is Supplied At The Top and And The Bottom Of The Circuits

The power for a circuit is usually applied at the top of that circuit and the ground return is usually at the bottom. Combining the ground at the bottom and the power at the top of the circuit, we see that the power flow

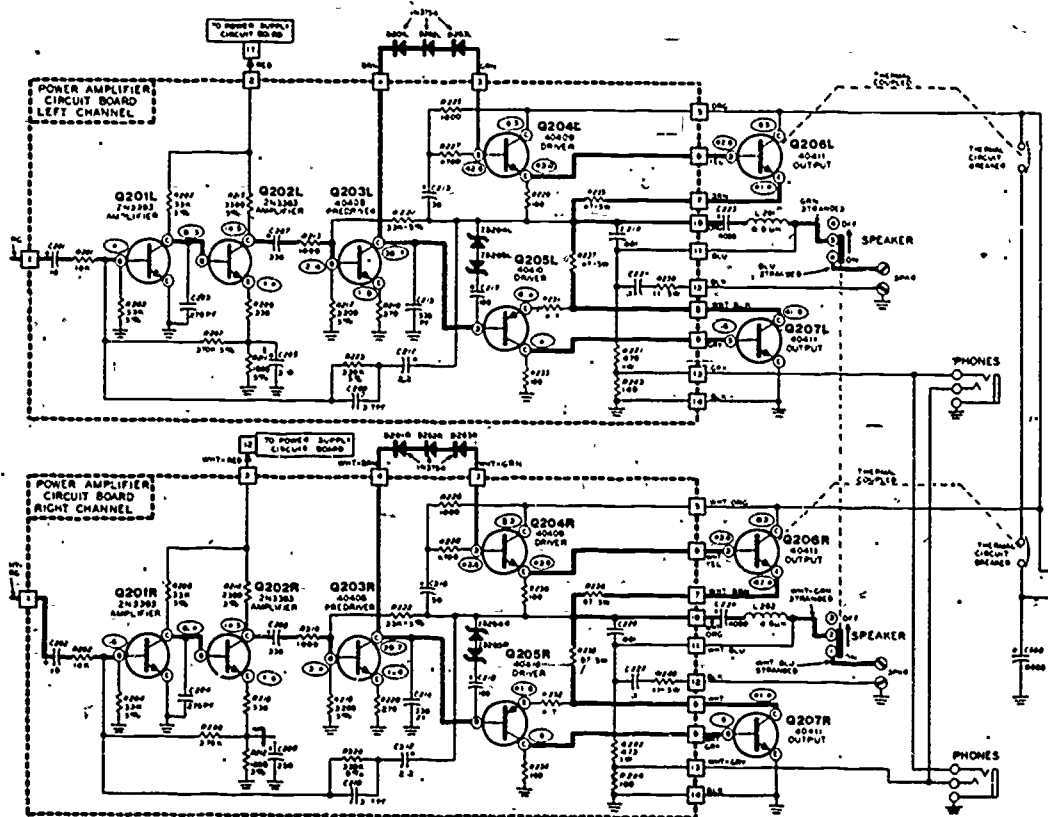

Fig. 2

through the circuit will always be vertical. Depending on the polarity of the power supply, the current will either flow from the top down or from the bottom up.

Notice that the circuit elements that carry the power to the transistors are generally in a vertical position. Not only does the power flow vertically through the transistor, but it flows vertically through all elements leading to the transistors. As a general rule, we can state that power elements are usually vertical.

The same reasoning stands for most support elements such as bias resistors. These support elements, although they don't carry signals and often don't handle power, are placed vertically to keep them from becoming confused with the signal elements.

The signal-carrying elements, as we have already indicated, are normally positioned horizontally. Generally speaking, we can say that if an element is horizontal, chances are

it is a signal element or a coupling element, and if it is vertical, chances are it is a power or a support element.

Circuits With Similar Functions Are Placed In Similar Positions

In the case of the tuner sections (Fig. 1) the parallel construction is used to show identical functions. In the case of the amplifier sections (Fig. 2) the parallel construction of the right and left channel amplifiers shows both identical circuitry as well as identical functions. Circuits of the system which have functions in common with other circuits are usually drawn parallel to those other circuits.

The similar positions of the parallel construction can be in various forms. In the AR-15, the parallel construction is essentially through vertical placement, one above the other. Another common method is to use horizontal

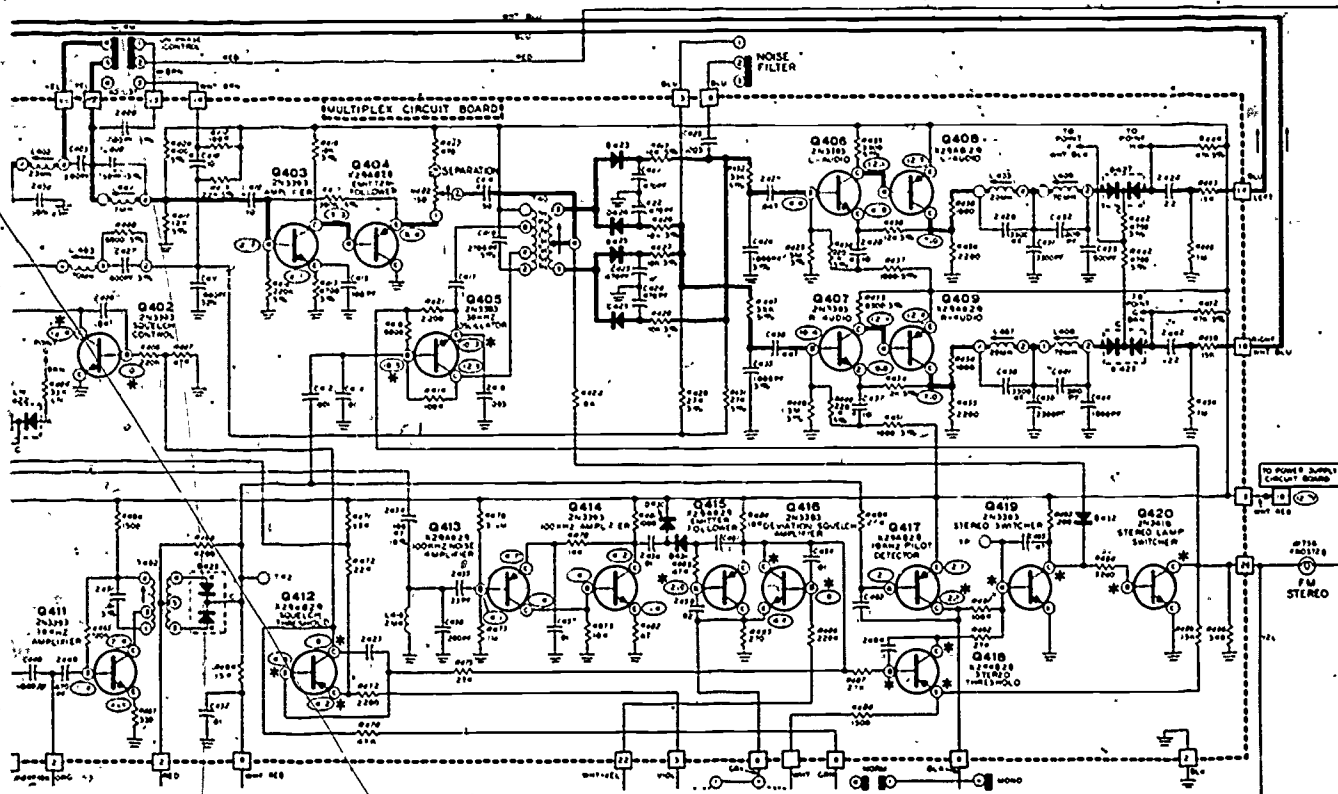

Fig. 3

placement. In this case the two circuits are placed side-by-side and the resulting signal comes out between or below them. This particular method is less preferable to the vertical placement because the signal ceases to flow from left to right and can sometimes cause confusion.

Transistor Positioning

In practically every case, the transistors are placed so that they face the right. That is, the base is on the left side. This is also in keeping with having the signal flow from left to right. Usually when a transistor is placed backwards on the schematic, it is to show a certain kind of circuit symmetry. Usually, the symmetry is used to show that the circuit is trying to find a comparison or balance between two input signals. Such is the case of the differential amplifier formed by Q415 and Q416, the deviation squelch amplifier shown in Fig. 3. Note also that the

transistors are placed on about the same level on the schematic. This tends to make the schematic pleasing to the eye and easy to read.

Supporting Circuits Are De-emphasized

The supporting circuit functions such as AGC, squelch detector, power supply, etc. are fairly well de-emphasized by their position on the schematic. For example, the power supply board is tucked away in the lower right hand corner. This seems to indicate that the power supply serves no direct function on the overall signal modification of the system. It only supports the system by supplying the power.

Utilizing Schematics

It is imperative that the student become intimately familiar with using schematic diagrams. This is a process which requires time and much experience in the reduction of

complex systems into a series of simple sub-units. The laboratory does not necessarily provide the only activity in which this experience can be gained. Circuit analysis courses provide an excellent opportunity for practicing and demonstrating the techniques of simplification and analysis.

The student, as he progresses through the electronics curriculum, should be able to analyze a problem from a schematic diagram in an efficient manner. If a system is not functioning properly, he should be able to pin point the trouble before actually trouble-shooting the system. The ability of the technician to select an efficient method for the solution problems that he faces is one that can not be over emphasized. At the end of the two years, the student should be able to identify the most logical method to use in solving a network if indeed a most logical method exists. This ability can not be instilled in the student overnight but rather must be a gradual process.

The method that will ensure that the student will possess this important attribute upon completion of his program is to make this an overt part of his curriculum.

First, what are some of the common methods that the technician can use as tools? These include:

- a. Voltage and current divides.
- b. Source conversion.
- c. Superposition.
- d. Thevenin's and Norton's.
- e. Nodal analysis.
- f. Loop analysis.

Which method to use on a particular network is not determined by a set of rigorous rules. The question of which method of analysis would be most convenient to use includes the following considerations:

- a. Network configuration.
- b. Results required.
- c. Number of equations to be solved.
- d. Ease of formulation.

In general, the Thevenin, Norton, and super-

position theorems are used under more specialized circumstances than the Loop or Nodal methods. In most cases, the problem is to find only one or perhaps two unknowns.

The Superposition Theorem is very valuable when there is a combination of A-C and D-C sources or sources that are out of phase. Thevenin's and Norton's Theorems are very useful when it is necessary to find an equivalent circuit, for example, when working with maximum power.

A network containing several parallel branches usually has more loop than nodes, thus requiring fewer node equations for its solution. In some other cases, the number of loops and nodes may be the same or there may be more nodes than loops. If a total solution is desired, the shortest or easiest method for the person solving the circuit would be best. Also, depending upon what is to be found, a current or voltage will also determine the method of attack.

In a network of any degree of complexity, the number of independent Kirchhoff Voltage Law equations generally exceeds the number of independent current law equations. For these cases, using the nodal method would be best. In general, to work with a complex network, there will be usually less nodes than loops.

It must be kept in mind that the solutions of the *loop equations* are *loop currents*. Branch currents and voltages can be found from these, but additional computation is required. Similarly, the solutions to *node equations* are *node voltages*.

There is really no cut and dried method to use for solving circuits. There are, however, techniques which can be used to simplify certain types of circuits. It is the ability to recognize these circuits that lend themselves to obvious methods of solution that will help the technician on the job.

CHAPTER 7

INDIVIDUALIZED INSTRUCTION

Audio-tutorial instruction is the subject of this chapter. The first section includes a discussion of the advantages, disadvantages, and applications of audio-tutorial instruction. Techniques of preparing A-T lessons including making the audio-tape and slides is also presented.

The second section describes the use of audio-tutorial in the electronics technology program at Purdue University. The remaining sections are sample lessons that illustrate the technique of applying the audio-tutorial method of instruction to selected topics in both the laboratory and classroom for an Electronics Technology curriculum.

A-T instruction has many possible applications for the electronics curriculum and the student. Instructors should give careful consideration to the audio-tutorial method, where applicable, as a supplementary tool in their curriculum.

AUDIO-TUTORIAL INSTRUCTION

WHAT AND WHY OF AUDIO-TUTORIAL

Audio-tutorial instruction is a technique which uses an audio-tape recording to present some part of the instructional material in a unit of study. It is more than a canned version of the traditional classroom lecture. The audio-tutorial method of learning co-ordinates a multi-media approach for independent instruction that challenges students of every background and ability. Each student can become directly involved in his own education and seek a learning rate matched to his ability and desire.

As early as 1912, the question of which mode of presentation had the greatest effect on learning was being investigated. Studies have shown that some students learn best by seeing, others by hearing, and still others by both hearing and seeing. There is no doubt that students vary in their ability to absorb and understand, yet material is presented to the entire class at the same time. Means must be available for student self-instruction, so that the student can proceed at his own pace in preparation for class and/or for reinforcement and review after the topic has been covered. The textbook alone does not seem to be very effective, because it does not provide adequate and immediate feedback to the student and appeals only to the visual sense.

The audio-tutorial method provides the opportunity for subject matter to be covered in a variety of ways by which all kinds of students can learn best. Each student can select the medium which best suits him as an individual and it is the instructor's job to provide these means.

The audio-tutorial method can be used as a basic instructional resource in the classroom and laboratory. Prepared audio-tutorial lessons can be available for students to use in the classroom, laboratory, learning resource center, or at home. Audio-tapes can be incorporated with slides, written material, equipment, textbooks, closed-

loop films, film strips, or any other medium. The audio-tutorial method of learning incorporates good learning procedures and involves sequencing and integration of subject matter.

The future success of learning in our electronics programs is dependent to a large extent on our ability to innovate successfully with what we know and are learning about the nature of learning. We should not be willing to accept present structures for teaching simply because they have existed for a long time. On the other hand, it is not worthwhile to scrap existing systems until we can replace them with workable alternatives. Applications of audio-tutorial instruction promise a means of improving educational and economical efficiency in the learning process in electronics technology. Increased attention must be given to individualization of learning to help the electronics student to become a self-activated learner, each to his ability. To accomplish this goal, the role of the electronics instructor must be redefined. The instructor must not only use the traditional media but must learn to operate in the classroom and laboratory with additional tools of learning.

The instructor has been and will continue to be the single most important factor affecting learning. Studies have shown that students can learn from the machine but it still takes a teacher to inspire, encourage, and influence a student to learn. Or as another person said, "There can be mechanical failures, but there is no such thing as a mechanical success". Audio-tutorial instruction is supplementing learning, not supplementing the electronics instructor.

In spite of all that has been written about audio-tutorial instruction, the fact remains that the techniques now available have made very

little inroad into the average technical education program. There are exceptions, but most programs are only at the edge of the full opportunities for these techniques for improving learning. This does not imply that the instructor utilizes such techniques to the exclusion of all others, or simply to be up with the times. He uses them only when and where they prove to be the most effective means of learning.

Using audio-tutorial instruction effectively requires the instructor to use a planned approach toward definite stated educational objectives. It requires the instructor to know where to locate materials, how to produce simple media, how to plan instruction using media, and certainly how to present the materials effectively. Some techniques for producing audio-tutorial lessons appear later in this chapter.

Learning is essentially an individual matter, based on maturation, ability, interest and purpose. The problem then is to recognize these individual differences and to provide the widest variety of learning experiences which will best serve the learner. Audio-tutorial instruction can help to solve these problems but does not hold all of the solutions. No one method is good or bad generally but rather it is a matter of selecting the method which possesses such characteristics as to make it possible to implement the appropriate conditions of learning.

HOW TO PREPARE AN AUDIO-TUTORIAL LESSON

Step 1.

Determine student needs and what is to be accomplished. List all of the objectives of the lesson. This is one of the most difficult and time-consuming of the several steps in preparing the instructional material. The instructor should list as carefully as possible each achievement which he expects the student to accomplish, keeping in mind the level or degree to which the students should attain. Objectives should be measurable in terms of performance but they need not always be a physical demonstration. For example,

the ability to read and interpret a schematic diagram could be an objective that could be measured in terms of specific performance. It is not enough to state an objective such as *to be familiar with*

Step 2

Material to be presented should be put in logical order and studied as to the best way the student can learn the points to be taught. It is at this point that all available media are listed which might be useful in accomplishing the established objectives. The use of media refers to every item that might be used in the class or laboratory and includes: material to be read from a textbook or periodical, problems to solve, films to be viewed, experiments to complete, a guest speaker, an audio tape, and the many other items that might be useful.

Step 3

Select the best method or methods to accomplish objectives. If the audio-tutorial method is selected, what additional tutorial materials will be necessary to supplement the audio tape. It may be necessary to refer to a piece of equipment, a diagram, a slide graph, a closed-loop film, etc.

Step 4

List the lesson material in proper sequence. For example, if it is to be a slide-tape sequence, make simple sketches on 4 x 6 index cards of what is to be included in each slide. This method allows for easy rearrangement if necessary.

Step 5

Make a rough draft tape. There are several ways that the first tape can be made and the method that is best has to be determined by each instructor. The following are some of the different methods that have been successful.

- a. One technique is to make the tape from a rough written outline. With

practice, this method works quite well but is not the one for the beginner.

- b. A second technique is to have a student helper do each item and the instructor record the tape as he directs the activities of the student through the entire lesson. This method tends to add naturalness to the material which causes each student to feel the instructor was talking directly to him. The questions that the student will ask can be very useful in determining what points need to be elaborated, that are obscure or incomplete and what items can be reduced or eliminated. This method works quite well and has the advantage of immediate feedback.
- c. A third technique is to make the tape from a complete written script. This technique may produce the smoothest tape but at the same time it can be extremely dull. One thing that you can not do is record a lecture. Also, to prepare a completely written script requires a lot of time in preparation.

Step 6

Have the audio-tape transcribed and edited critically. Ideally, the rough tape should be revised before being given to the students but this is not always possible. This step gives the instructor an opportunity to make sure the words he uses express precisely the lesson objectives. A technique which works quite well in this step is to have some students use the material early and then provide feedback and also help other students with points that were not clear or left out. If time permits, the tape could be revised before the rest of the students use the material or at least before it is used the second time.

Step 7

Make the final tape. The best way is probably to make the final tape from a manuscript which has been edited and typed. The instructor

should use a normal informal conversational voice just as if you were talking directly to the student in your office. Don't use a recording made by someone else because your voice identity is quite important. It may be helpful to have a student as an audience during the final taping of the lesson. A little background music may be used but may put the student to sleep if the material is dull.

A reel recorder is preferred for making the master tape. Cassette machines tend to coast when they are stopped and produce a disturbing sound while the reel type provides instant stop. Also, a reel can be cut, spliced, and edited much easier than a cassette cartridge. Generally the quality is better with the reel type. Many machines for duplicating tapes use a reel for the master.

On the other hand, the cassette type is better for student use than reel type. For one thing, they are smaller and easier to store and handle than reels. The cassette machines are generally easier to operate and the cassette tape can be removed at any point without having to be rewound. Many schools are buying cassette players (only play back, do not record) for students to take home. The technique of using players instead of records, reduces the cost and also helps to remove the possibility of erasing the tape.

Step 8

Implement the lesson, monitor the feedback data, and make necessary modifications. Work out an evaluation plan to determine if the objectives have been accomplished and pay attention to feedback data and make necessary improvements. Always ask for comments from your students so you can improve the effectiveness of the lesson.

ADVANTAGES OF AUDIO-TUTORIAL

- a. Requires no special training, talent, or advanced preparation on the part of the instructor. The simplicity

- of the method makes it relatively easy to get started.
- b. Provides the opportunity to learn in a variety of ways. Students can pace their learning according to their own ability and can repeat the material as often as they choose to gain better understanding.
 - c. The instructor no longer needs to be the mediator of all learning and can devote more attention to the individual needs of the student.
 - d. Forces the instructor to evaluate his procedures and to reconsider his objectives. This provides for a more uniform and integrated presentation of the instructional material.
 - e. A very inexpensive system that is easily operated. Depending upon how elaborate the system, it can easily be applied for one-tenth the cost of closed-circuit television.
 - f. More students can be accommodated without drastic expansion of facilities or faculty which will realize savings in expensive building costs, special equipment, materials and supplies, and in required staff time.
 - g. It is a convenient instructional method for the instructor who wants to make the transition from the teaching techniques of today to those of tomorrow. For example, moving toward computer-assisted instruction.
 - h. The student is an active participant. No longer does he just have to sit and listen to a lecture. He is required to become involved during the learning activity.
 - i. Above all, the students like this method. They say they learn more quickly and like the versatility that the method has to offer.

DISADVANTAGES OF AUDIO-TUTORIAL

- a. A fundamental problem with this type of instruction is the lack of adaptation which will account for the difference between fast and slow learners. Perhaps this problem can be corrected by having more than one tape and having optional advanced work for the better students and remedial tapes for the weaker students.
- b. Tapes can not be made from prior lecture notes. The reason being that lectures usually are not planned to incorporate simultaneous direct experiences with study materials by students during instruction. This is one of the main advantages of audio-tutorial.
- c. Audio-tape cannot be scanned in the same manner as written material. This is a disadvantage when a student wants to review a certain section of the tape. To overcome this problem each topic can be indexed on a outline sheet giving the approximate location on the tape where this topic is discussed. Another method would be to use a written outline which would indicate approximately the position of the tape.
- d. Units of instruction must be well programmed so that everything will be covered. This requires a sequencing and integration of learning experiences which require clearly stated objectives for student achievement. This is the most lacking element in unsuccessful audio-tutorial instruction. Requires much more planning than traditional lectures.
- e. Requires continuous monitoring of student feedback. Material must be

continuously modified and updated. This is not any more of a disadvantage than any other method of instruction. What teaching method does not require modification and updating.

- f. It is very difficult to anticipate trouble spots in the lesson. As previously discussed, using advanced student feedback can help to overcome some of the problem areas.

APPLICATIONS OF AUDIO-TUTORIAL

- a. Audio-tutorial methods of instruction can be applied to almost any area of instruction in the classroom or laboratory. The following are some ways that A-T might be used. Some examples with suggested script and supporting material appear later in this chapter.
- b. A very simple and useful technique is to use an audio-tutorial presentation for laboratory orientation at the beginning of the semester or quarter. One technique is to have audio-tapes at several locations in the laboratory with short presentations of a few minutes. Each student would then work around to all of the stations for the orientation. Another technique is to have a laboratory and even an overview of what will be covered in the course.
- c. Audio-tutorial methods can produce several basic changes in the experimental format of the traditional laboratory. It is possible to completely eliminate lab groups and concentrate on individual instruction with individual student participation in each of the experiments. Experiments are designed as audio-tutorial experiments which can be applied to almost all experiments that are normally covered in a two-year program. The student receives instructions, suggestions, information, etc. from audio-tape

and/or written material and conducts the experiment returning to the audio-tutorial material when necessary. This method works best with an open-lab in which the student is free to do the work when he is free. More students can use the same laboratory with this method. To be successful with this approach, a qualified staff member must be available at all times to assist the students. This technique allows for more personal attention for the student in the laboratory. Also, it provides for a more uniform presentation of the laboratory material.

- d. Other good places that audio-tutorial might be used would be for such things as drill, introduction of new material, review of material, problem solving, circuit analysis, familiarization with instruments, explanation of concepts, etc. These and many more applications of audio-tutorial methods can be made in the electronics program.

WHERE IS AUDIO-TUTORIAL BEING USED?

Methods of audio-tutorial instruction are being used throughout the United States but very little effort has been applied to electronics technology. The following is a list of schools that I know are working with audio-tutorial instructions in electronics:

School of Electrical Engineering,
Oklahoma State University

School of Electrical Engineering,
Purdue University

Department of Electrical Technology,
Purdue University

Washtenaw Community College,
Ypsilanti, Michigan

Oakland Community College,
Warren, Michigan

William Rainey Harper College,
Palatine, Illinois

Illinois Central College,
Peoria, Illinois

Triton College,
River Grove, Illinois

Kansas State College,
Pittsburg, Kansas

Lenore Community College,
Kingston, North Carolina

Bradley University,
Peoria, Illinois

Southern State College,
Springfield, South Dakota

tors, transistors, transformers, and standard component identification letters such as R, L, C, CR, TP, etc., used in marking electronic panels, chassis, printed circuit and terminal boards. Also available are dial patterns, lines, arrows, arcs, switch symbols, potentiometers. For more information contact:

The Datak Corporation
Guttenberg, New Jersey

Visual Art Industries
Brooklyn, New York

Visual Products Division
3 N. Center
St. Paul, Minnesota

Besides using transfer letters to produce slides, they are also very useful for meter scales, control panels, equipment labeling, etc.

PREPARING SLIDES FOR AUDIO-TUTORIAL

After the lesson material has been arranged in proper sequence and rough sketches have been made, the next step is to prepare these sketches to be photographed. A technique that I have found to be most satisfactory is to draw the necessary diagrams on 4x6 cards so that they can be easily rearranged if necessary or used at some other opportunity. These cards may be in various colors that will give a pleasant background when using color film. I would recommend that color film always be used although studies have tended to show that color does not increase learning.

In making the drawings, a pencil can be used in various colors or colored marking pens. The felt-tip pens work quite well. Also, the dry transfer lettering kits, also known as press-on, rub-on, work quite well. The letters are made up of carbon and wax and are printed on a plastic, acetate or polyethylene carrier sheet and can be transferred to virtually any dry surface such as paper, wood, metal, or glass by rubbing on the letter with a dull pencil or ball point pen. They are available in black, white and a variety of colors. Various sizes and symbols are available. Sets are available for all standard component symbols like resistors, capaci-

Technique of placing transfer symbol:

1. Draw a light line on the surface to which lettering is to be made. Or if the drawing is on a transparent material, a guide line under the surface may be used.
2. Line up and rub a finger over letter to form a contact.
3. Burnish the letter on with a burnishing tool, pen or pencil. Once in place, they cannot be relocated.
4. Pull or lift the carrier sheet away.
5. To make corrections, pressure-sensitive tape such as scotch or marking tape can be used to remove unwanted letters by lightly pressing the adhesive side of the tape to the letter and carefully peeling it off the artwork. Also, a dry transfer letter eraser, razor blade, or rubber cement eraser may be used.

Now, we are ready to take the slide. There are a wide variety of cameras, lenses, extension tubes, bellows extensions, copying stands, etc. that are available. To help you select the

necessary equipment, contact your local photographic dealer for assistance.

The most popular size for slide presentations is the standard 2x2 inch slide. For this purpose, a good 35 mm single-lens reflex camera will do the job. Most 35 mm cameras can be fitted with extension tubes or bellows, or equipped with similar means of focusing at the short distance required.

For the instructor that does not want to invest a lot of money in photography equipment, the solution might be the Kodak Ektagraphic visualmaker kit. The visualmaker is housed in a compact attache case, and contains a Kodak Instamatic 304 camera, two sizes of copy stands, film and flashcubes, plus a complete set of instructions. Each copy stand has its own built-in, prefocused supplementary lens and a reflector that provides the exact amount of light from the flashcube.

The larger of the copy stands, photographs an area up to 8x8 inches and the smaller stand an area up to 3x3 inches. A picture of the Visualmaker with the 8x8 copy stand is shown. With the Visualmaker all that you do to make a 2x2 slide or print in black and white or color, is to drop in the film cartridge, attach the camera to the appropriate stand, place the unit over your material, attach a flashcube on the camera, and shoot. *Now you can make your own top-quality visuals, and you don't have to be a photographer either!*

With the Kodak Visualmaker you can have an unlimited selection of color visual materials without fussing with focus, exposure, or framing. You can photograph directly from books, schematics, instruments, or from small three-dimensional objects such as resistors, inductors, etc. The Instamatic camera can be used on or off the copying stand which allows an additional advantage of being able to use the camera for any occasion.

The Visualmaker will give you moderate close-ups and can solve your problem of not being a professional by enabling you to produce slides

tailor-made to your requirements. *A complete visual kit that is so easy and foolproof to use that any electronics instructor can make his own slides.* The Kodak Ektagraphic Visualmaker kit costs a little over \$100. For more information, see your Kodak dealer.

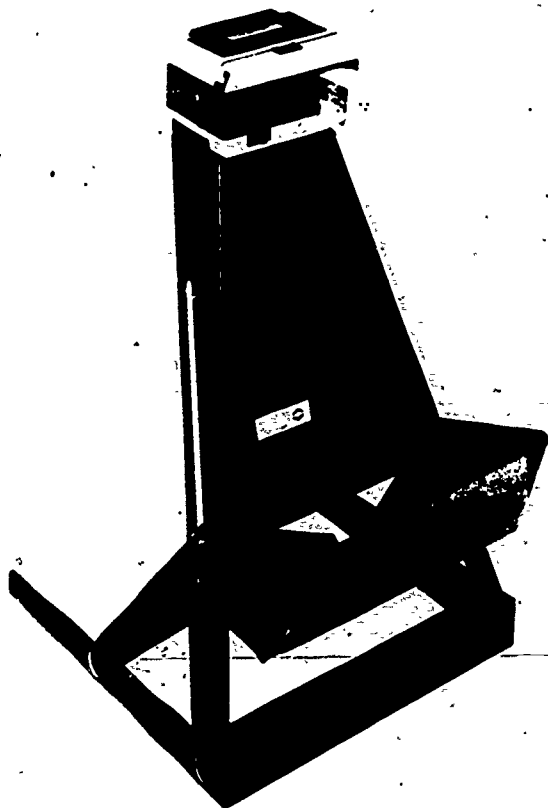

Kodak Ektagraphic Visualmaker

A WOODEN COPYING STAND

Also, for the instructor that is short on funds, considerable money can be saved by building a copy stand rather than buying one. A simple wooden copying stand that can be built for less than \$10 appears in the appendix.

LEARNER-CONTROLLED LABORATORY

The Purdue University Department of Electrical Technology is responsible for the two-year Associate Degree program for Technicians, Bachelor of Science Degree program for Technologists, continuing education courses, and technical extension courses. The Associate Degree and Bachelor of Science Degree programs are accredited by the Engineering Counsel for Professional Development (ECPD).

The Learner-Controlled Laboratory is a title used to identify Electrical and Electronic Technology Laboratories that use the AUTO-TUTORIAL teaching method. This is an adaptation of the auto-tutorial teaching method that has been used successfully at Purdue University in Biology, Botany, Veterinary Medicine and other fields. This self-teaching method, which emphasizes individual study, is made possible by the development of low-cost audio visual equipment. Schools can now afford to supply each student with audio visual instructional equipment and materials in addition to textbooks. The method has been used successfully in complete courses that include classroom and laboratory sessions. This explanation, however, is for laboratory courses that support the classroom activities.

The success of the Learner-Controlled Laboratory is based on the actual operation of the audio visual instructional equipment by the student, not the instructor. The student operates the tape player and slide projector during the performance of experiments in the laboratory. The purpose of the use of multiple instructional media is to provide the student with the opportunity for self-teaching and experimentation. The audio tapes and colored slides provide coordinated explanations and photographs of the actual circuits and equipment. This exposure to audio and visual material in addition to the

written explanations provides a greater depth of understanding and shortens the time required to attain the required performance level. The ever-increasing quantity of basic material that the student is required to master forces the instructor to obtain assistance from all sources. If the majority of students are to attain a satisfactory achievement level in the limited time that is available, the instructional materials must be available at the moment the need occurs. It is impossible for the laboratory instructor to provide this assistance for all students in the conventional laboratory.

The general procedure for the use of the auto-tutorial method in the LEARNER-CONTROLLED LABORATORY starts with the reading of the concise discussions of the theory in the laboratory textbooks. In addition to the written explanation, audio tapes are available that provide the student with a briefing on the experimental procedures. The student uses headphones that plug into a tape player and watches colored slides that are co-ordinated with the audio tape. Students are able to control the audio tapes and slides which provide them with the opportunity to repeat parts of the briefings that are causing difficulty. Although it is possible to listen to the experimental tape and watch all the slides at the beginning of the experiment, it is recommended that the student obtain the briefing on a single part, then perform that part. At the completion of a part of the experiment, the student should listen to the audio tape and observe the slides for the second part of the experiment, then complete the experimental procedure. The opportunity to read the explanations in the laboratory textbook, listen to the briefings on the audio tapes, observe the color slides

*Gilbert L. Rainey, Head, Department of Electrical Technology, Purdue University. Delivered at National Electronics Conference, February 26, 1970, Champaign, Illinois.

that support the audio tapes, and perform the actual experiments provides the students with an increased opportunity to complete the objectives of each experiment. The addition of supporting instructional materials assists the student to obtain a better understanding of the basic principles, decreases the amount of time required for the completion of each experiment, and develops attitudes that lead to self-study and experimentation.

The student has complete control of the instructional materials and may view the slides and listen to the tapes as many times as necessary to obtain the required information. Almost ALL students require repetition of the explanation of at least a few topics during the study of electricity and electronics. Students with limited background are EXPECTED to require repetition before they acquire an understanding of many of the difficult principles. The auto-tutorial method is particularly useful for the serious student with limited technical background and it is not unusual for these students to listen to the explanations of difficult material many times.

The instructor plays a different role in the Learner-Controlled Laboratory. Students obtain the basic instructions from the audio tapes and slides, which leaves the instructor free to work with the students on real problems rather than assisting with the wiring of circuits, step-by-step explanations, explanations of instrument operational procedures, and trouble-shooting. Students in today's society need personal attention and an exchange of information on a one-to-one basis. The instructor in the Learner-Controlled Laboratory has this opportunity to know the students. In fact, this is the first priority assignment of the members of the instructional team. The methods used for student contacts are actually planned by the instructional team. Placing name cards on the work bench is one method used by the team to make certain that each student is addressed on a first-name basis. A record form is used by the instruction-

al team to make certain that the planned student contacts are actually made in the laboratory.

The addition of the self-teaching instructional aids resulted in the development of the OPEN LABORATORY. Students are free to schedule work periods in the open laboratory at any time during the day. The control of the instructional materials, freedom to schedule time in the laboratory, and the removal of time deadlines for the performance of experiments change the attitudes of the students toward the laboratory course. This change in the operation of the laboratory creates a LEARNING CENTER that is an extremely important part of the technicians' and technologists' educational program which is oriented toward applications.

The student can adjust the laboratory work schedule to compensate for peak study situations in other courses and obtain additional laboratory experience beyond the requirements of the course.

The students perform a follow-up examination that is given immediately after the completion of the experiment. These examinations are usually about five or ten questions in length and are of the multiple-choice type to provide an easy method of grading. The test is graded by the laboratory instructor as soon as the experiment is completed and the results are given to the student. These tests are in the development stage at this time and may include performance exams in the future.

At scheduled time intervals, members of the instructional team meet with small groups of students. The meeting is planned by the instructional team during their weekly orientation meeting. The meeting is conducted on an informal basis and includes discussions, oral examinations, briefings on new experiments, oral reports by students and grading of the laboratory logbooks. Every attempt is made to determine the progress and to uncover the

hidden and sometimes small problems that create mental blocks or "hang-ups".

The learner-controlled laboratory that uses an open laboratory may be operated with a large number of students or a small number of students. A large number of students may be scheduled in a single laboratory throughout the week. If the student body is not large, several different laboratory classes can be scheduled in the same laboratory. Since instructional materials are available for self-instruction, the laboratory supervisor can provide the required assistance for a wide variety of experiments simultaneously. This unexpected "fall out" has made it possible to economically conduct courses with limited enrollment in the same laboratory at the same time.

Slides and tapes are already prepared for introductory courses in Electrical and Electronic Technology at Purdue University. The auto-tutorial method has great potential, but will require additional vigorous development work. The method requires carefully prepared laboratory textbooks, not brief manuals, that are co-ordinated with the slides and audio tapes. Laboratory textbooks with co-ordinated slides and tapes are already available for *D/C Electricity*, *A/C Electricity*, and *Electronic Devices*. Additional auto-tutorial instructional materials will soon be available to assist with the implementation of this dynamic teaching method.

This entire project was conducted *without* an allocation of special funds or a grant from an outside agency. The audio tapes were all made on a small portable tape recorder, and the slides were taken with the author's camera in a basement workshop. Copies of the slides for use in the Purdue Laboratories, tape players, and slide projectors were obtained from funds in the department supply and expense budget. Since that time, the amount of equipment and copies of the instructional materials has been increased in order to use the method in adult Technical Extension short courses conducted for the Electrical Power Utility Industry.

The amount of time necessary to develop the

materials to operate an entire laboratory course by the auto-tutorial method was far greater than anticipated. Fortunately the laboratory textbooks were already available either in published or temporary form for the Purdue Technology Program. We prepared materials and operated on a day-to-day basis which proved to be both discouraging and frustrating. This total commitment was an application of the "brute-force" method and it certainly is not recommended. In our situation, it was the only method since we did not have funds to hire personnel to work on the project.

Three possible procedures to start the Learner-Controlled Laboratory using the auto-tutorial teaching methods are:

1. Develop the tapes and slides for a selected experiment each semester, then gradually make the conversion.
2. Use one set of existing slides and tapes to brief the students at the beginning of the laboratory. Some students could also use the materials during the laboratory session.
3. Use the existing auto-tutorial materials and follow the procedures already developed.

The Department of Electrical Technology will provide as much assistance as possible to schools interested in the development of this teaching method. A visit with the instructional team should provide a better explanation of the procedures. The following film is recommended to explain the philosophy of the auto-tutorial teaching method:

"The Auto-tutorial System" by Dr. Samuel N. Postlethwait.

This film may be obtained through the Audio Visual Center of Purdue University, Lafayette, Indiana 47907.

FUNCTION GENERATOR AND OSCILLOSCOPE (A-T PRESENTATION)

TOPIC: First use of the oscilloscope and function generator.

ESTIMATED TIME TO COMPLETE THIS LESSON: 45 to 60 minutes.

MATERIALS NEEDED: Tektronix Type-561 oscilloscope with 3A75 vertical amplifier and 2B67 time-base, a Wavetek model-110 function generator, one BNC to banana jack converter, two banana-to-banana cords, and outline sheet.

PREREQUISITES: None.

OBJECTIVE: To introduce the student to the basic operation of the oscilloscope and function generator.

NOTES TO THE INSTRUCTOR: This lesson is set up with this equipment but can be modified to meet your needs. This audio-tutorial lesson could be done the first day in the introductory class or at least very early in the curriculum. This introduction is not inclusive and requires additional experimentation for more advanced capabilities of the oscilloscope. Slides as well as a printed outline could be used.

SAMPLE SCRIPT: This experience is an introduction to the most basic use of an oscilloscope and a function generator. Feel free at any time to stop the tape or repeat any parts as needed. The Cathode Ray Oscilloscope or as it is called in industry, Scope, is one of the most valuable tools that an electronics technician has in his possession. The field of electronics is a blind science in that we cannot see physically what is happening in the circuits that we study. The scope is the technician's eyes and when properly used will reveal what is going on within any electronic circuit.

The scope that you will be using is the Tektronix Type-561 scope. This scope uses plug-in units for both the vertical and

horizontal deflection systems. These plug-in units can be replaced with different units that can extend the capacity of the scope. For this lesson, you should be using a Type-3A75 amplifier. This is the vertical amplifier and is located below the screen. Check and see if this is the one in your scope. If not, obtain one from your instructor and remove the one that is already there by loosening the knob at the bottom and pull the unit out and replace with the correct amplifier.

For the horizontal amplifier, which is located to the right of the vertical amplifier, you should be using a Type-2B67 time-base unit.

The other piece of equipment that you will be using in this experiment is the Wavetek 110 function generator. Function generators are used throughout the electronic industry to provide external input to electronic circuits and systems. The Model 110 serves as a source of AC voltage, which may be set for sine, or triangle waveform output. The output waveform in addition to being able to produce different waveforms can also vary in frequency and amplitude. Some of these terms may be new to you, but do not be alarmed. As you progress through this laboratory study, each of these terms will be explained.

The first step in learning to use any instrument is to familiarize yourself with the function of the controls that you will use. For this introduction, some of the controls will be identified and will have a brief description. Some of the controls will not be identified but will be explained later in the course.

Each instrument has an on/off switch

which can be readily found. Locate the on/off switch on the function generator and scope. These are numbered 1 on the outline sheet. Make certain that both of these switches are in the off position.

Connect the output of the function generator to the input of the vertical amplifier. These are labeled number 2 on your outline. This will require what is called a BNC to banana jack converter to connect to the scope.

Place all other controls as follows:

Function generator; frequency set to X100 Hertz or sometimes called cycles per second (number 3 on your outline), the main dial in the center to (number 6 on the outline), Attenuation control to a vertical 12 o'clock position (number 4 on the outline), function selector to sine wave which is the middle waveform (number 5 on the outline).

Now we are ready to set up the scope. First, let's set up what is called the main frame. The main frame is the part of the scope that remains after the plug-ins are removed. Focus, number 7, to a 12 o'clock position, calibrator control, number 9, is not used for this experiment, scale illumination, number 10, completely clockwise.

Next, the vertical amplifier section. The position control, number 11, to a 12 o'clock position, the volts per division control, the outer knob, number 12 on the outline, should be set to two, the variable control clockwise to calibrated, number 13 on the outline, and the AC, DC, GRd control, number 14, to the DC position.

Now, the horizontal amplifier. The position control, number 15, to 12 o'clock, Time per division (outer knob) number 16, to .2 milliseconds, (milli meaning 1/1000), the variable control to calibrated, completely clockwise and number 17 on the outline, level control, number 18, to zero, scope

coupling source, number 19, all to the upper position, and the mode switch, number 20, to normal.

When you have all switches in the positions indicated, and the proper connection has been made between the function generator and the oscilloscope, you are ready to make your first observation.

Place both on/off switches to the on position and both pilot lights should glow. If they do not, check to see if they are plugged in and have power available to the bench. If this doesn't correct the situation, call your instructor. After allowing the instruments to warm up for 30-60 seconds, a visual display should appear on the CRT screen. What you should be seeing is one cycle of a sinusoidal signal produced by the function generator and viewed on the cathode-ray oscilloscope. The waveform is shown in figure two. If you don't have this waveform, recheck your set-up. At last resort, call on your instructor for assistance.

The position controls are the first controls that you will investigate. The waveform may not be displayed in the center of the graticule. Graticule refers to the etched illuminated lines on the CRT screen. In order to center the display, rotate the two controls one at a time to observe the effect on the display and to center the waveform trace.

In the event the trace on the screen appears very dark, advance the intensity control until the display has a pleasing brilliance. If the trace appears to have adequate brilliance, rotate the intensity control a few degrees either way and observe the effect. Too much brilliance can burn the screen, so be careful.

It is possible that the trace may not appear as a finely traced line. Rotate the focus control a few degrees. Observe the effect and see if you can

improve the focus of the trace. You should now have a trace that is in focus and has the proper brilliance.

The next step is a simple one, rotate the scale illumination control counterclockwise and note the reduction in brilliance of the etched lines. The lighted graticule is used to aid in making measurements and also for making oscilloscope photographs.

The oscilloscope is basically an instrument that plots a graph of amplitude versus time. This graph can be used to measure voltage amplitude, frequency, time shift, and many other items of interest to the electronics technician. Your oscilloscope is set up to display amplitude on the vertical axis and time on the horizontal axis. This is illustrated in Figure 2.

The oscilloscope can be used to measure amplitude. You will note that the volt/division control is set at 2. This means that for each division of the graticule we will have 2 volts of amplitude. Count the number of divisions on a vertical line from the lowest part of the waveform to the highest part. Each division is 2 volts so the amplitude should be around 12 volts, 6 small divisions in height. This is what is commonly called peak-to-peak voltage.

Change the setting of the attenuator and note the change in amplitude. Set the output voltage to 18 volts. This should be 9 small divisions or 9 centimeters. To help in counting the divisions, you may want to change the vertical or horizontal controls. Note that this only changes the position of the waveform.

Change the volts per division control to 5. How does this affect the waveform? What is the amplitude of the waveform now? You will note that the waveform has not changed in length but its height has been reduced. The voltage amplitude now will be 5 times the number of divisions. At this point, you should be able to measure

the amplitude of a waveform. Repeat this part until you are sure that you understand how to measure amplitude.

Now, let's direct our attention to the other parameter, time, that the scope measures. We are generally not so much interested in time as we are in frequency. Frequency is the number of times that a waveform repeats its self per second. The unit of frequency is the Hertz or cycle per second. There is a relationship between frequency and time. Frequency is equal to the inverse of time.

Like amplitude, time is also measured by counting the divisions and multiplying by the setting of the time per division control. How much time is required for one cycle of this waveform? The number of divisions that you should have counted is 10. The time then is 10 times 2 milliseconds or 20 milliseconds. Convert this to frequency. When converted to frequency we would divide 2-thousandths of a second into 1 which would give 500 Hertz.

Move the main dial on the function generator from 5 to 100. What is the result? What is the frequency now? There are now two cycles displayed on the screen and the frequency is now 100 Hertz. There are now two cycles, each 1 millisecond in time. What would be the frequency if there were 4 cycles instead of 1? The value of course would be 2000 Hertz.

Set the frequency back to 1000 Hertz. Two cycles should be displayed on the screen. Turn the time per division control to .1 millisecond per division. What is the result? Once again one cycle is displayed on the screen. The time of one cycle can be readily read now as .1 millisecond times 10 divisions which is 1 millisecond or 1000 Hertz.

In order to convince yourself that the horizontal amplifier actually traces with respect to real time, place the

time per division control to 5 sec per division and main dial of the function generator set to 10. Now, use your watch as a stop watch and time the trace as it races across the screen from left to right. You should discover that it takes 50 sec. for the trace to travel across the screen.

You should now be familiar with frequency and time and have the ability to measure frequency and amplitude of any waveform.

For the remainder of the laboratory session make as many observations as you can. See if you can measure frequency and amplitude of a triangle waveform or a square wave. Change the settings on the function generator, varying both amplitude and frequency. Practice measuring frequency, time, and amplitude on your scope at various settings. As the end result, you should be able to set the function generator at any position and be able to set up the scope to measure both the amplitude and time of a sine, square, or triangle wave.

If you have problems, meditate; if this doesn't help, get help from your instructor.

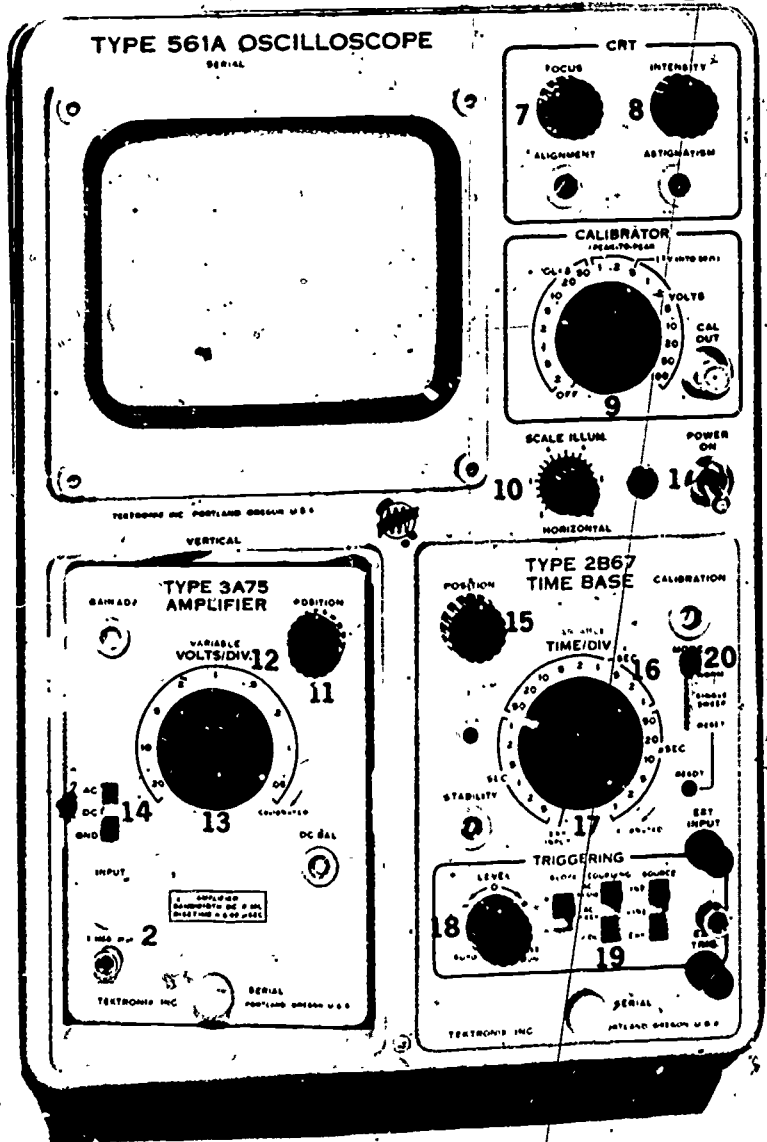
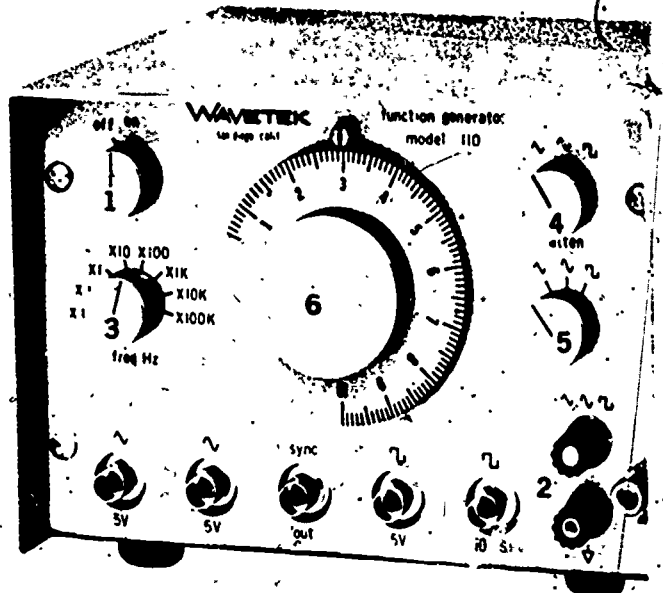

THE CURVE TRACER (A-T PRESENTATION)

TOPIC: Testing a transistor of known characteristics on the Tektronix Type-575 Transistor Curve Tracer.

ESTIMATED TIME TO COMPLETE THIS LESSON: 20 to 30 minutes.

MATERIALS NEEDED: Curve Tracer.

PREREQUISITES: None

OBJECTIVE: To set up the 575 Curve Tracer to obtain a correct display of a family of curves for a 2N404 transistor.

FLOW CHART OF THE LESSON:

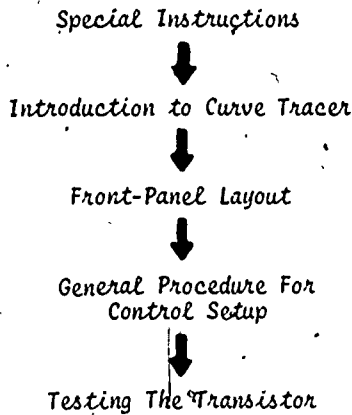

NOTES TO THE INSTRUCTOR: The first part of the audio tape should be instructions for the student. For example, the student should be informed of the objective of the lesson and the length of time expected for him to complete the setup. He should be told to stop the tape at any time and go back and review any part that he does not understand. Also, the audio signal to advance to the next slide should be indicated.

This lesson is only an introduction and should be followed by additional practice and instruction. This type of lesson would be very good to use in the INTRO course.

A piece of construction paper cut in the form of a small triangle can be used

to focus attention to a particular section of a slide. The small triangle with a piece of masking tape attached to the back so that it will stick to the curve tracer can point out the main idea being presented.

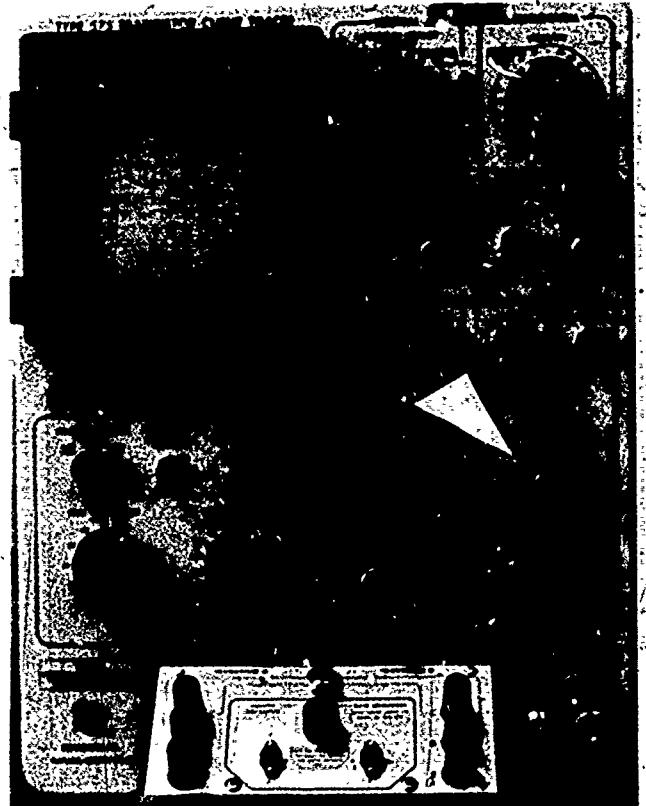

A SAMPLE SCRIPT WITH SUGGESTED SLIDES:

Slide #1 -- The Complete Curve-Tracer

The Type-575 Curve Tracer is an extremely versatile instrument that can be used to make several tests on a transistor. Its full utility can only be realized when the function of each of the front-panel controls is understood.

Slide #2 -- Vertical Amplifier

The front-panel layout can be divided into five main blocks. These blocks contain the controls for the Vertical

Amplifier which controls the vertical display.

Slide #3 -- Horizontal Amplifier

The Horizontal Amplifier which controls the horizontal display.

Slide #4 -- Collector Sweep

The Collector Sweep generator provides the sweep voltages that drive the collector of the transistor under test.

Slide #5 -- Step Amplifier

The Base (or Emitter) Step Amplifier, which develops current or voltage steps to drive the base or emitter--whichever is ungrounded.

Slide #6 -- Transistor Test Panel

And the Transistor Test Panel where the transistor is inserted for testing.

Slide #7 -- Complete Curve Tracer

Now then, see if you can identify the five main blocks of the front panel.

Slide #8 -- A Display of Correct Family of Curves (PNP)

In displaying transistor curves we are concerned with two considerations:

1. Properly displaying the curves we wish to interpret.
2. Protect the transistor under test from damage.

We will use a 2N404 PNP transistor and you should have a display like this when you have properly set the controls.

Slide #9 -- Blank Slide

The general procedure for setting up the controls for a transistor of known characteristics is as follows:

Slide #10 -- Intensity Control

Set the Intensity Control at mid-scale to prevent damage to the phosphor on the display. Turn on the power switch located in the lower right-hand corner and allow the tracer to warm up.

Slide #11 -- Comparison Switch

Now while the curve tracer is warming up, let's set up the rest of the controls. We will start with the Test Panel. Set the comparison switch to the center position to prevent any voltage or current to the transistor socket.

Slide #12 -- Configuration Switch Common-Emitter

The configuration switch can be set to either a Common-Base or Common-Emitter position. Let's use the common-emitter position.

Slide #13 -- Red and Blue Colors

When using a common-emitter configuration, those parts of the front-panel etched in blue refer to the Base voltages and currents. And those parts in red refer to the collector voltages and currents.

Slide #14 -- Collector Sweep Block

Next in the Collector Sweep Block, the peak volts range and the peak volts are set for the peak voltage with which we wish to sweep the collector. Let's sweep the collector with 10 volts and the controls are set as follows:

Slide #15 -- Peak Volts 0-20

Peak Volts Range 0-20

Slide #16 -- Peak Volts 10

Peak Volts 10

Slide #17 -- Polarity (-)

Polarity PNP (-)

Slide #18 -- Dissipation Limiting Resistor

The value of the dissipation limiting resistors depends on the maximum collector dissipation and the collector sweep voltage. The limiting resistor must be set to the proper value to limit the collector dissipation to a safe value and thereby protect the transistor from excessive power dissipation.

Slide #19 -- The Actual Reading from
the Transistor Manual

To determine this value the transistor manual will tell the maximum collector dissipation for 25°C ambient temperature, is 120 milliwatt.

Slide #20 -- Resistor Selection Graph

Looking at the Resistor Selection Graph on top of the curve tracer to obtain the correct resistance value, for a collector dissipation of 120 milliwatt and a peak collector value of 10 volts, we find the value to be 200 ohms.

Slide #21 - Dissipation Limiting Resistor

Therefore the Dissipation Limiting Resistor is set at 200 ohms.

Slide #22 -- Base Step Generator Block

The remainder of the controls are set for the conditions under which we wish to test the transistor. Let's now set up the controls in the Base Step Generator Block.

Slide #23 -- Repetitive Switch

Set the display switch to Repetitive so that we may view a continuous display.

Slide #24 -- Steps/Family Control

Next, set the Steps/Family control for the number of curves we wish to display. In this case, let's use four steps.

Slide #25 -- Polarity Switch

The Polarity Switch is set to (-) minus because the transistor under test is a PNP.

Slide #26 -- Step 1 Second Switch

We have a choice of 120 or 240 steps per second on the Steps per Second Switch. Let's use 120 steps per second.

Slide #27 -- Step Selector

The Step Selector is set for the current per step or voltage per step that we want to apply to the base. Let's use .005 ma per step.

Slide #28 -- Series Resistor Switch

Because we are applying current steps to the base by using the step selector in the current range, the Series Resistor is not needed and is not connected into the circuit. However, if voltage steps had been applied, the series resistor should be set at 22K at the beginning of the test.

Slide #29 -- Vertical Control

Now we are ready for the Vertical and Horizontal Amplifiers. The Vertical sensitivity is set by adjusting the Collector Milliamp per Division switch. Let's use .5. Note that this is in the red area.

Slide #30 -- Horizontal Control

Likewise, the Horizontal sensitivity for the collector voltage is set by adjusting the Collector volts per Division switch, also in red. Let's use 1.

Slide #31 -- Test Panel

Now we are ready to test the transistor. Place the transistor in socket A and place the Comparison Switch in the Transistor A position. This connects the transistor into the test circuit.

Slide #32 -- Screen with Display

Adjust the intensity and position controls so that a display is obtained near the upper right corner of the screen for the PNP. An NPN would be at the lower left-hand corner.

Slide #33 -- Whole Curve Tracer

It may be necessary at this time to adjust the controls until a suitable display is obtained on the screen. To do this, adjust each control, one position at a time. You should at this time have a family of curves properly displayed for the 2N404 transistor. If you do not: (1) Recheck the set-up; (2) try another 2N404, (3) call your instructor for assistance.

240

LA PLACE TRANSFORMS (A-T PRESENTATION)

TOPIC: Introduction to the LaPlace Transformation.

ESTIMATED TIME TO COMPLETE THIS LESSON: 30 to 40 minutes.

MATERIALS NEEDED: Outline sheet.

OBJECTIVE: To illustrate the use of the LaPlace Transformation method in solving circuits containing R's, L's and C's.

PREREQUISITE: Ability to use logarithms, solve algebraic equations, and an introduction to differentials and integrals.

NOTES TO THE INSTRUCTOR: This lesson could be used to introduce the topic of LaPlace Transforms and could be supplemented by addition information and problems.

FLOW CHART OF THE LESSON:

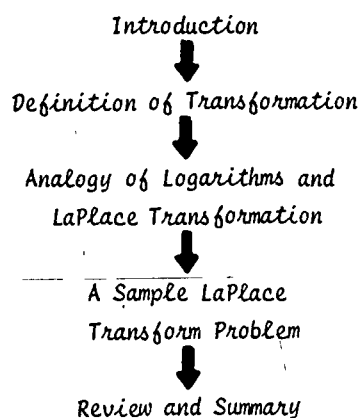

SAMPLE SCRIPT: In a network containing resistors only, the equations describing the behavior of the network are algebraic equations which are independent of the excitation waveforms. A simple extension permits the application of these same methods to single-time-constant circuits.

When a network contains both inductors and capacitors the equations describing the behavior of the network are no longer simple algebraic equations but rather differential and integral terms. These differential

equations describe the complete response of any circuit that contains L's and C's.

The classical method of solution for solving differential equations becomes increasingly difficult as the complexity of the network increases. To help with the problem of dealing with complex circuits that can have any waveform applied requires that we have a method that enables us to solve these differential equations on an algebra level.

Mathematicians have developed such a problem-solving tool which allows us to transform a differential equation to an algebraic equation that we know how to handle. This transform technique is commonly known as the LaPlace Transform and makes use of the "S" operator.

The LaPlace Transform solution is an extremely straightforward useful tool that permits the solution of complex problems by using algebraic rules and manipulations. This technique is the method by which a function is transformed from the time domain into what we call the "S" plane.

At this point you might be asking yourself, "What is a transformation?" The logarithm is an example of a transformation that we have used in the past. Rather than just multiplying numbers together, we transform these numbers by taking their logarithms. These logarithms are added or subtracted in the case of division. The resulting sum of the logarithms has little meaning unless we perform an inverse transformation. To perform the inverse transformation, we find the antilogarithm which gives us the desired numerical result. If the problem of multiplying numbers is not convincing, consider evaluating 122 to the

.1238 power without logarithms. The use of the logarithm usually saves both time and work.

Figure number one on your outline sheet shows a flow chart of the operations involved solving a product or quotient problem with or without logarithms.

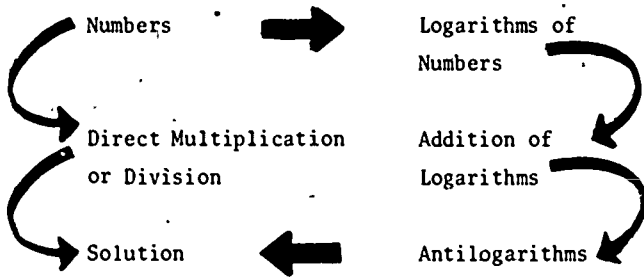

Fig. 1

The individual steps of using the logarithm transformation are first, find the logarithm of each separate number; second, add or subtract the numbers to obtain the sum of logarithms; third, take the antilogarithm to obtain the solution.

Figure number two illustrates how a problem would have been solved that could be done with or without the LaPlace Transform method.

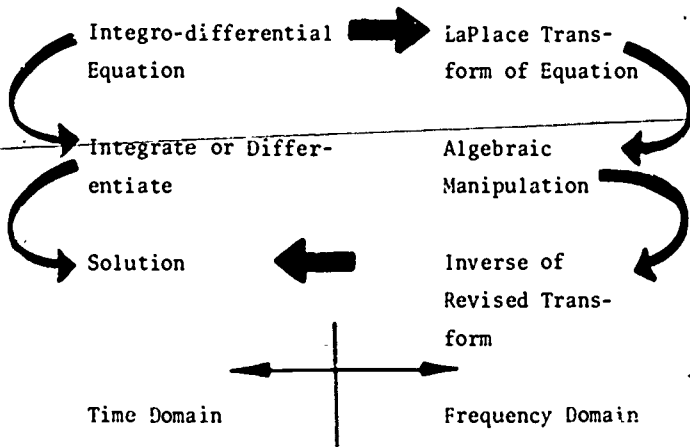

Fig. 2

The steps in solving an equation by the LaPlace Transformation method are first,

start with an integro-differential equation and find the corresponding LaPlace Transform. This is usually done by using a table of transforms; second, the transform is manipulated algebraically with initial conditions which results in a revised transform; third, we perform an inverse LaPlace transformation to give us the solution. In this step, we can also generally use a table of transforms just as we use the table of logarithms for taking the antilogarithms.

The other method of solving the equation is by the classical techniques and it looks more direct and sometimes it is for simple problems. For complicated problems, however, it is advantageous to make use of logarithms.

To illustrate the use of the LaPlace Transformation, let's take a look at a simple problem. Refer to problem number one on the outline.

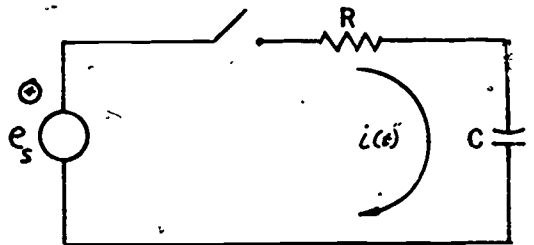

S has been open for a long time and is closed at $t=0$.

$$e_s = v \quad \text{Find } (i(t))$$

$$v_c = \frac{1}{C} \int_{-\infty}^t i dt$$

SOLUTION

$$\text{Eq. 1} \quad \frac{1}{C} \int_{-\infty}^t i dt + Ri = v \quad u(t)$$

$$\text{Eq. 2} \quad \frac{1}{C} \frac{1(S)}{S} + \frac{Q(0)}{S} + R I(S) = v \cdot \frac{1}{S}$$

Eq. 3 $I(S) \left(\frac{1}{CS} + R \right) = \frac{V}{S}$

Eq. 4 $I(S) = \frac{V/R}{S+1/RC}$

Eq. 5

$$i(t) = \frac{V}{R} e^{-t/RC}$$

Let's run through the solution and take a look at the steps involved. The circuit is a series circuit and the switch has been open for a long time. This means then that no energy is stored in the capacitor. At time t equal zero, we close the switch which applies a unit step that has a magnitude of v . We are now ready to solve for i of t so we write Kirchoff's voltage law for a series network. This gives us equation 1. The next step is to look up the LaPlace Transform of each of the terms in a table. This gives us equation 2. The term $Q(0^-)$, the charge on the capacitor before switching is equal to zero because there was no energy stored in the circuit. Equation 2 then reduces to equation 3 by factoring out $I(S)$. Clearing the left side to solve for $I(S)$ gives us equation 4. Taking the inverse LaPlace Transform of both sides by using a table of LaPlace Transforms. This then gives us the solution which is a decaying exponential that starts at a magnitude of v divided by R at t equal zero.

Let's quickly review the steps that are necessary to solve a problem by the LaPlace Transform method.

First, write the equation that describes the network.

Second, take the LaPlace Transform of the equation using a table of LaPlace Transforms.

Third, manipulate the revised transform equation to solve for the unknown.

Fourth, look up the inverse LaPlace

Transform in the table and obtain the solution.

In summary, the LaPlace Transformation method for solving differential equations offers advantages over the classical methods. First, the solution of differential equations is routine and progresses systematically and is an algebraic equation. Second, this method using the "S" operator gives the total solution in which initial conditions are automatically specified. Third, this method allows us to solve a complex network with any kind of driving function. These and many more advantages can be seen as you become more familiar with LaPlace Transforms.

BIBLIOGRAPHY

Balabanian, Norman. *Fundamentals of Circuit Theory*. Allyn and Bacon, 1964.

Spiegel, Murray. *Schaum's Outline Series: Theory and Problems of LaPlace Transforms*. Schaum Publish Company, 1965.

Strum, Robert D., and Ward, John K. *LaPlace Transform Solution of Differential Equations: A Programmed Text*. Prentice-Hall, 1968.

Valkenburg, M.E. *Network Analysis*. Prentice-Hall, 1964.

SINGLE-TIME-CONSTANT CIRCUITS (A-T PRESENTATION)

TOPIC: Single-time-constant circuits.

ESTIMATED TIME TO COMPLETE LESSON: 30 to 40 min.

MATERIAL NEEDED: Outline and slide rule.

PREREQUISITE: Resistive circuits, concept of e , and ability to calculate time constants.

OBJECTIVE: Solve single-time-constant circuits with switching conditions.

NOTES TO INSTRUCTOR: This lesson could be used in either the sequence in single-time-constant circuits or in pulse electronics. This could be used with either a written outline or slides or both slides and outline. The addition of slides could help to clarify points that are difficult to explain on tape. Also, a programmed version might be used for the outline that would simplify things considerably.

SAMPLE SCRIPT: The topic of this lesson is based on an understanding of *Single-Time-Constant Circuits*. Any circuit having only one C, or one L, and any number of R's is a single-time-constant circuit. A circuit that has both a C and a L cannot be single time constant. Circuits can have more than one C, or more than one L, and still be single-time-constant circuit. Mathematically, the basic equation for an STC circuit will always be a first order differential equation.

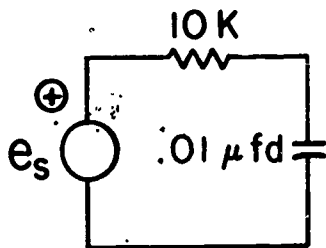

Cir. 1

A very simple single-time-constant circuit may be seen on your outline sheet as circuit number one. In this lesson we will

use RC circuits although RL circuits may be solved in a similar and dual manner.

Most capacitive STC circuits can be reduced to the form of circuit number one. That is, a single equivalent circuit that contains a series resistance and capacitance in series with a voltage source.

The response of any STC circuit will either be an exponential, a sine wave, or a combination of exponentials and sine waves. Any STC circuit that has a step, ramp, or pulse applied will have an exponential response. A sinusoidal input will produce a steady-state sinusoidal response. In this lesson we will be using a step voltage input which produces an exponential response.

As indicated previously, the basic equation for any STC circuit is a first order differential equation. At this time you have probably never heard of a differential equation and even less likely do you know how to solve one. Mathematicians have worked this problem for us and have developed a general equation for an exponential response.

The general equation for voltage is shown on your outline in equation number one.

$$v(t) = E_{as} \left(1 - e^{-\frac{t}{\tau_c}} \right)$$

Equation 1

E_{as} is the asymptotical voltage that occurs when time becomes very very large. E_{as} is referred to as E asymptotic, E_0 is the value of the voltage at the time when the exponential begins. This is usually considered to be at the time zero plus. It is the initial value and is

called E of zero. τ_c is the time constant for the circuit. In the case of a RC circuit it is the product of the resistance in ohms times the capacitance in farads. The instantaneous voltage can be found at any time by using this general equation. The general equation for the current is the same except I's replace the E's. Turn off the tape and write the general equation for current.

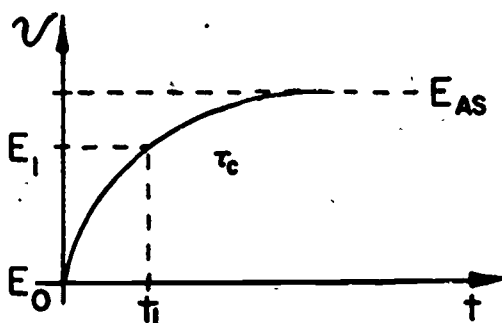
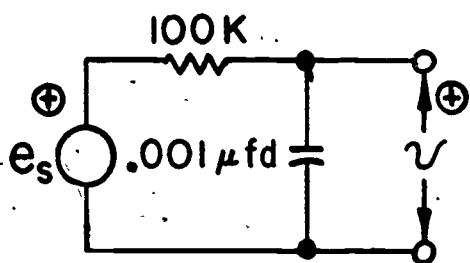

Fig. 1



Cir. 2

Take a look at circuit number two. Turn off the tape and find the time constant. The value that you should have calculated is one hundred microseconds. This value is obtained by multiplying the hundred K resistance times the point zero zero one microfarad capacitance which gives the time constant for circuit number two. Let's calculate the voltage across the capacitor when the source is a step starting at 0 with an amplitude of ten volts. Use the general voltage equation to solve for v_t . Turn off the tape and solve for v_t .

The value you should have calculated for v_t is equal to ten minus ten e to the minus t divided by 10^{-8} power.

On the graph shown in figure 1, label the values of v at one, two, three, four, five, and six τ_c constants. Also indicate v zero and v asymptotic. You should have values of 6.3, 8.7, 9.5, 9.8, and 9.9 for the time constants one through five and an asymptotic value of 10 and E zero equal to zero.

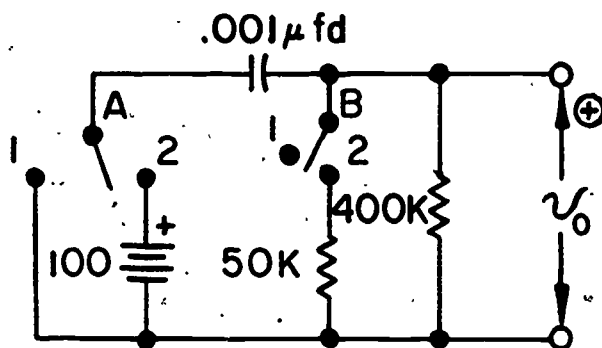

$$T_1 = T_2 = 400 \mu s$$

Cir. 3

Take a look at circuit number three. You'll notice that this is a slightly different problem than what we just completed. There are two switches in the circuit each having positions 1 and 2. The switch is in the number 1 position during time t_1 and in position number two during time t_2 . When both switches are in position number one, the time constant for the circuit is 400 microseconds. What is the time constant when both switches are in position number 2? Stop the tape and resume again when you have an answer.

The time constant you should have is 44.5 microseconds. To get the time constant the 100-volt source must be set equal to zero which can be done by replacing it with a short and then calculating the resistance that is attached directly to the capacitance. In this case, the $50K$ and $400K$ parallel combina-

tion is the resistance that the capacitance sees. These two in parallel have an equivalent resistance of 44.5 ohms. The time constant is found by multiplying point zero zero one microfarad times the resistance and should be 44.5 microseconds.

In position 2, the asymptotical value for v_o is zero. What is the asymptotical value for v_o in position 1? Stop the tape and resume when you have an answer.

After a long time, the current in the circuit would be zero and thus the voltage drop across the output would be zero.

So far we haven't considered initial values and this is where the problem usually occurs. We know that the time constant for position one is 400 microseconds and in position two, 44.5 microseconds. Remembering that an exponential will complete in approximately 5 time constants, we know that v_o will be zero volts at the end of time t_2 because the switch is left in position two for 400 microseconds and this time period is over 9 time constants long. This is a good place to start when attempting to plot the output waveform.

When switching from position 2 to position 1 we have a 100-volt decrease in the voltage on the left-hand side of the capacitor. This change is also made on the right side. That is, v_o decreases from zero volts to minus 100 volts. This unexpected event is common in single-time-constant circuits. A change on one side of a capacitor results in an equal change on the other.

We now have another portion of the output waveform. The complete waveform can be seen in figure 2 of the outline.

Notice that during time T_2 the waveform is at a value not equal to zero. Looking closer we can see that v_o is -37 volts at the end of T_1 . Let's see if we can figure out why that happened. Referring to our equation now, we remember that the asymptotical value in position 1 is 0, the ini-

tial value which we have just discovered is -100 volts, the time constant is 400 μ s.

Thus using these values in the equation, we arrive at -37 volts for v_o at the end of time T_1 . Going back to the circuit now, we observe at switch A that when switching from position 1 to position 2 an increase of 100 volts is made on the left-hand side of the capacitor. This increase is also made to the right-hand side and thus v_o increases 100 volts. The voltage at v_o when changing from position 1 to position 2 increases from -37 volts to a plus 63 volts. This total change at v_o on the right-hand side of the capacitor is 100 volts, exactly the change on the left-hand side. We're just about through with the output waveform now. Remembering during T_2 the exponential completed or went to zero we have the complete waveform.

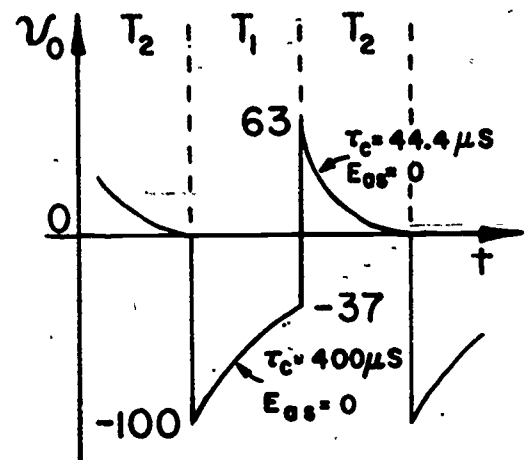
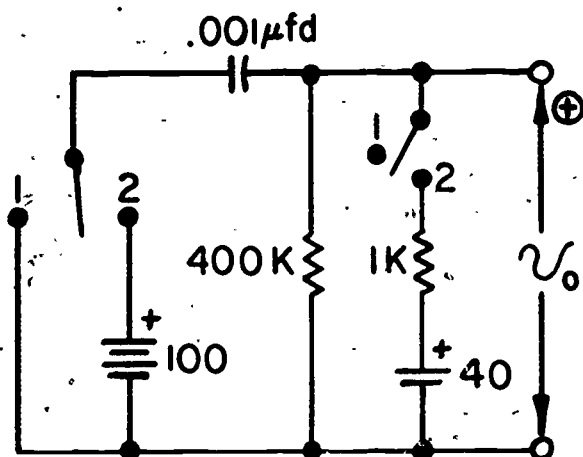

Fig. 2

Now let's try a problem which is just a little different from the last one. Look at circuit number four and see if you can determine the time constant for the circuit in position 2 and position 1. Stop the tape player and try your luck at this one.

The time constant for position 2 is

very close to 1 microsecond. The parallel combination of the 400K and 1K resistance is nearly 1K. When two resistances are in parallel and one is much larger than the other, a close approximation of the parallel resistance will be the smaller resistance. Try a few combinations of resistances and satisfy yourself that this is true if you are not for sure. The time constant in position 2 is the product of 1K times the capacitance of .001 μ fd.



Cir. 4

In position 1, the time constant is easier to figure. It is simply the 400K resistance times .001 μ fd which is 400 μ s.

Now then, let's plot the output waveform. The length of time that the switch is in position 1 is 20 μ s and this is also the length of time in position 2. Return to the tape when you have a solution.

You should have found that in position 1, the asymptotical value of v_o is zero volts. In position 2 the asymptotical value is 40 volts.

Looking at the time constant for position 2 we see that it is 1 μ s. Since the time in position 2 is 20 μ s, the output voltage will have time to reach its asymptotical value of 20 at the end of T_2 .

This gives us a starting point. Had we

chosen to find the voltage at the end of T_1 we would have had difficulty. We know the voltage does not complete at the end of T_1 because of the long time constant, thus we could not make any determination of the final voltage since we did not know the starting voltage E zero.

Going back to v out at the end of T_2 which we know is equal to 40 volts, we then switch to the start of T_1 and this produces a 100-volt change on the left of the capacitor which produces a negative change on the right hand side. Therefore, at the instant of switching, v out changes from plus 40 volts to a minus 60 volts. A negative 100-volt change.

Now that we know the initial value of v out at the beginning of time T_1 , we can use the general equation to determine the value of v out at the end of the 20 μ s period that will occur before the circuit is switched to position 2.

Plugging in our values of v asymptotical equal to zero, T_1 of 20 μ s, time constant of 400 μ s, we get a value of v out at the end of T_1 equal to minus 57 volts.

Again, when the switch is changed from position 1 to position 2, a 100-volt change occurs and will cause the voltage to jump from -57 to +43, a hundred-volt change.

We are now at 43 volts positive in position 2. We have a very short time constant and an asymptotical value of 40 volts. So the waveform will decrease very rapidly and we are back to the point where we started.

The output voltage looks sort of like a rectangular waveform and has these critical values as indicated in figure 5. At the beginning of T_1 , v_o is -60 volts and at the end of period T_1 is -57 volts. The value at the beginning of T_2 is plus 43 volts and at the end +40 volts.

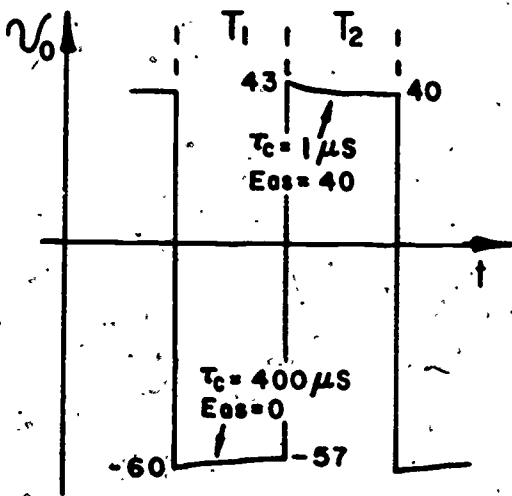

Fig. 3

This concludes the lesson. If additional help is needed, see your instructor.

SWITCHING CIRCUITS (A-T PRESENTATION)

TOPIC: Two-transistor switching circuit.

ESTIMATED TIME TO COMPLETE THIS LESSON: 45 to 60 min.

MATERIAL NEEDED: Outline and slide rule.

PREREQUISITES: Ability to solve STC circuits and knowledge of transistors.

OBJECTIVE: To calculate pulse width of output waveform of a two-transistor circuit..

NOTES TO THE INSTRUCTOR: This audio-tutorial lesson would be used in pulse electronics after the analysis of single-transistor circuits. In addition to the figures shown, you may wish to add additional figures and calculations to improve student comprehension. I would suggest that the outline material be in a programmed fashion so that the student is reinforced with the correct circuit diagram or calculation.

SAMPLE SCRIPT: The objective of this lesson is to calculate pulse width of the output waveform of a two-transistor circuit. This lesson is an introduction to switching circuits using the techniques that we have used for solving single-time-constant circuits. We will be using transistors to do the switching and they will be operated in the cutoff or in the saturated regions. Because we will be using the transistor in this type of operation, we can represent a common emitter transistor circuit with a circuit model which has a diode in the base to emitter portion and as a switch in the emitter to collector portion. This relationship can be seen on your outline sheet in figure 1 and figure 2. Turn off the tape and study the model for the common emitter circuit shown in figure 1. Return to the tape after careful examination of the two circuits.

When the diode in figure 2 which represents the base to emitter junction is conducting, the switch is in the *on* position.

When the diode is not conducting, the switch is *off*. Notice that the terminals on the switch are equivalent to the collector to emitter junction of the transistor. There are more accurate models that can be used to represent the transistor in which you consider the resistance of the transition during saturation, during operation in the active region, and when reversed, etc. A more accurate model is shown in figure 3 but for our analysis we will use the simplified equivalent circuit shown in figure 2. The model will be quite satisfactory and will allow us to attack seemingly complicated circuits.

The circuit that we are going to work with is a two-stage transistor circuit as seen in figure 4. Are these NPN or PNP transistors? *Pause.* One way I remember whether a transistor is NPN or PNP at the circuit drawing I think of the initials NPN as meaning Not Pointed In. Those of a PNP may remind you of the words Pointed In.

Because the transistors in figure 4 are NPN's, we would expect a positive voltage on the collector remembering that the collector must be reversed-bias and that base to emitter junction be forward biased.

Notice how the voltages are marked on the schematic and how they are referenced. v_{b1} is the base to emitter voltage of the first stage while v_{c1} is the collector to emitter voltage also on the first stage. How is the base to emitter voltage on the second stage labeled? *Pause.* The base to emitter voltage on the second stage is

of course labeled v_{b2} and likewise the output voltage which is the collector to emitter voltage is v_{c2} .

The input waveform for our circuit is shown in figure 5. The periods T_1 and T_2 both have a time interval of 200 microseconds. The input voltage has a 10 volt peak-to-peak value and is a rectangle wave. It will become apparent to you as we go through this circuit that only the change in the input voltage and not the level will affect our output voltage. Keep this input voltage in mind because it will become important as we progress through solving the switching problem.

What I would like you to do now is to draw the equivalent circuits for this 2-stage switching circuit. First, draw the base to emitter circuit for the first stage using the model described in figure 2. Stop the tape player and resume when you have drawn the circuit model for the base to emitter circuit.

Check your equivalent circuit against the one shown in figure 6 of the outline. Notice that I have drawn the 40K resistor to a battery source which in turn is grounded to the emitter. This is equivalent to the common representation of having the 40K resistor go to a plus-16 volt source as shown in figure 4.

Now then, try to draw the equivalent circuit that will include the collector to emitter switch of Q_1 , the coupling capacitor C_2 and the base to emitter diode of Q_2 . In other words, continue from the base to emitter circuit of Q_1 , to the base and emitter circuit of Q_2 . Stop the tape and resume when you have the circuit.

The desired circuit is shown in figure 7 enclosed in dotted lines. Also included is the base to emitter circuit of Q_1 . Notice the voltages and how they are labelled according to the original transistor circuit. The first diode in the circuit

corresponds to the base to emitter of Q_1 , and thus the voltage across the diode would be v_{b1} . Notice also on the left-hand side of capacitor C_2 , the voltage is labelled v_{c1} . The collector to emitter voltage of Q_1 is represented as a switch and finally, on the right-hand side of the circuit we find v_{b2} , the base to emitter voltage of the second stage.

Notice that the bias voltages are returned back to ground. This is done so we may be able to figure our time constants much easier.

The final circuit that we need to solve for our transistor circuit is the collector to emitter circuit of the second stage. Try to figure out this circuit for yourself and continue with the lesson when you are finished.

You will find in figure 8, if you haven't already looked, the equivalent circuit. It is probably the easiest circuit we will have to analyze.

Looking at figure 8, what will be the output voltage when Q_2 is conducting, S_2 in the on position? The voltage will be zero because the collector and emitter are at the same potential. What is the output voltage when Q_2 is not conducting? The value of course will be plus-16 volts. With the switch in the off position there is no current through the 4K resistor, therefore there is no voltage drop; v_{out} then is equal to the 16-volt source.

From this calculation, we know that the output is going to be a rectangular wave that will step from 0 to a plus-16 volts. The problem then is to determine the length of time that v_{out} will be equal to zero and the length of time it will be equal to plus-16 volts.

To solve this problem requires that

we go back to the input to the circuit and work from there. Refer to figure 7 on your outline to help with this solution. I would like for you to plot the various voltages, v_{b1} , v_{c1} , v_{b2} , v_{c2} according to time with respect to the input voltage e_s . Do this below figure 5 on your outline.

Plotting v_{b1} , first, a 10-volt positive step in e_s on the left-hand side of the input capacitor will result in a 10-volt positive step on the right-hand side of the capacitor. A 10-volt positive increase on v_{b1} will turn Q_1 on. We can assume that v_{b1} is very nearly zero when e_s goes positive. Thus during and at the end of T_1 , v_{b1} is nearly zero for all practical purposes. It is actually the voltage across a conducting diode but we will assume that we are using an ideal diode which would have 0 voltage drop. We will say it is 0-plus volts.

Next, what is going to happen to v_{b1} when e_s steps from plus-10 to zero or a negative-10 volts change? The voltage was 0-plus volts and a 10-volt decrease results in v_{b1} going from 0 to minus-10 volts instantaneously. Diode D_1 is switched off with this negative voltage across it.

Notice that when diode D_1 is off, we have a single-time-constant circuit. The time constant will be 40K times the value of the capacitance C which we have not yet determined for purposes to be revealed shortly.

We would like for the transistor Q_1 to be off for all of the time T_2 . This requires that the diode have a negative bias during this period. Knowing that a single-time-constant circuit with an initial value of minus-10 will produce an exponential that will decay to eventually in the case of 16 volts if allowed sufficient time.

We are interested in finding the minimum value of capacitance that will allow v_{b1} to be at zero at exactly at the end of

period- T_2 . To solve for this value of C_1 requires that we use the formula shown in figure 9 which has been developed from the general equation for STC circuits with step inputs. We are now ready to solve for C_1 using the following information. T_2 is equal to 200 microseconds.

E asymptotical is plus 16, E zero is minus 10 volts. E_2 we set equal to zero because this is the value we want at the end of T_2 . The time constant will be equal to 40K times the capacitance. The one unknown to solve for then is the capacitance. Turn off the tape and solve for the minimum capacitance necessary to hold Q_1 off.

The minimum value for C_1 that you should have calculated is approximately .01 microfarad. This is the minimum value necessary and any value larger than this would work in the circuit. If we always make C_1 very very large, we can be assured that Q_1 will remain off during this desired length of time.

At this point, you should be able to draw the waveform of v_{b1} . It should be 0 plus during the time T_1 and then drop to minus-10 volts at the beginning of T_2 and then exponentially rise to zero at the end of T_2 and then repeat this pattern for each cycle.

Now, let's try to solve the second part of the circuit. We are interested in solving for v_{c1} and v_{b2} . One of the difficulties in trying to solve for these is in finding a place to start.

If we look at this part of the circuit, we can assume that switch S_1 will be on for some period of time and off for some period of time. In the on position, the left-hand side of the .003 microfarad capacitor will be tied to ground. This sets v_{c1} equal to zero and after a long time the diode D_2 will be conducting because it will be forward biased. Now, switching from the on to off position of

S_1 , there will be a positive increase in v_{c1} because we have now inserted a positive 16-volt source. Let's assume diode D_2 is conducting because when S_1 is changed from on to off, a positive surge would be applied to the left side of the .003 microfarad capacitor which would also cause a positive increase on the right hand side which would turn diode D_2 on.

Ok, now with the switch off, D_2 is on, which in effect removes the 60K and 16-volt source and leaves us with a series RC circuit consisting of the 16-volt source, a 2K resistor, and a .003 microfarad capacitor. What is the time constant of this circuit? *Pause*. The time constant would be 6 microseconds, 2K times .003 microfarad. The asymptotical value of v_{c1} will be *Pause* -16 volts. About how long will it take to reach this asymptotical value? *Pause*. About 5 time constants or 30 microseconds, so it will reach this asymptotical very rapidly.

When is S_1 in the off position? S_1 is in the off position when transistor Q_1 is off. This occurs whenever v_{b1} is negative. It would be a good idea if you would mark this on your plot, that is when Q_1 is off and when it is on. It is off during time T_2 .

Now then, we can say that at the end of T_2 , when going from the off to on position, transistor Q_1 is going to turn on. When this happens, v_{c1} is going to zero. For all the time T_1 , v_{c1} will be zero. At the start of time T_2 , we go from the on position of S_1 to the off position of S_1 . This causes D_2 to turn on and makes a single-time-constant series RC circuit. v_{c1} increased from 0 to an asymptotical value of 16 with a time constant of 6 microseconds. With T_2 equal to 200 microseconds, v_{c1} changes from plus 16 volts to zero. You now have enough information to plot v_{c1} . Stop the tape and resume when you have plotted v_{c1} .

Your plot should have a value of 0 for period T_1 and an exponential with an asymptotical value of 16 volts with a time constant of 6 microseconds during time T_2 .

By looking at v_{c1} , I can also find out something about v_{b2} . First, I know that at the end of T_2 , v_{c1} went from plus-16 volts to zero. This decrease will also produce a 16-volt decrease of the right-hand side of C_2 .

When v_{c1} is positive, Q_2 is switched on. This occurs during time T_2 and since Q_2 is on, v_{b2} will be zero. Note that when Q_1 is off, Q_2 is on. So, from this, we know that during the time T_2 , v_{b2} will be zero. A good place then to start to plot v_{b2} is at the end of T_2 . Remembering that we had a negative-16 volt change when going from T_2 to T_1 , we know that v_{b2} will go from 0 to minus-16 volts. With v_{b2} at minus-16 volts, the diode D_2 will be off because it is reversed biased.

The conditions of our circuit are as follows: S_1 is in the on position, this caused a negative-16 volts to appear across D_2 , therefore, D_2 is off. What is the time constant for this part of the circuit? Turn off the tape and calculate the time constant.

With S_1 in the on position and D_2 off, we are left with the 60K resistor and the .003 microfarad capacitor in series. The time constant is then 180 microseconds. At this point, I know that v_{b2} is at -16 volts, there is a time constant of 180 microseconds, and v_{b2} is heading for an asymptotical value of plus-16 volts.

Whenever v_{b2} goes positive, the diode is going to conduct when v_{b2} is greater than 0 volts. The diode will be forward biased with the positive potential.

The problem then is to figure out how long it will take v_{b2} to decrease to zero. Stop the player and calculate this length.

of time. The value that you should have calculated is 126 microseconds; you should have used the formula shown in figure 9.

When v_{b2} reaches zero, the diode is switched on and v_{b2} is equal to zero volts. For the first 126 microseconds of T_2 , v_{b2} is some negative value starting at minus-16 and approaching zero. For the rest of the period T_2 , v_{b2} is zero.

We are now ready to plot v out. When v_{b2} is negative, S_2 is off and v out is equal to plus-16 volts. When S_2 is on, v out is zero volts. This occurs when v_{b2} is zero.

Your v out then should have a value of plus-16 when v_{b2} has a negative value and zero when v_{b2} is zero. Your completed waveforms should look like those in table 1.

What determines the output pulse width? We can change the pulse width by changing the time constant in the coupling circuit. By increasing the 60K resistor or the .003 microfarad capacitor, the pulse width of the output waveform up to a maximum of the length of T_1 . Pulse width is directly proportional to this time constant. Also, varying the bias voltage can also change the pulse width. Thus, we have a circuit in which we can vary the output pulse width by varying component values or bias voltage. What effect does varying the amplitude or length of times T_1 & T_2 ? I leave these questions unanswered and suggest that you think about them and then set up this circuit in the laboratory. Also, what effect will using PNP transistors rather than NPN's have on the output waveform? This concludes the switching circuit discussion.

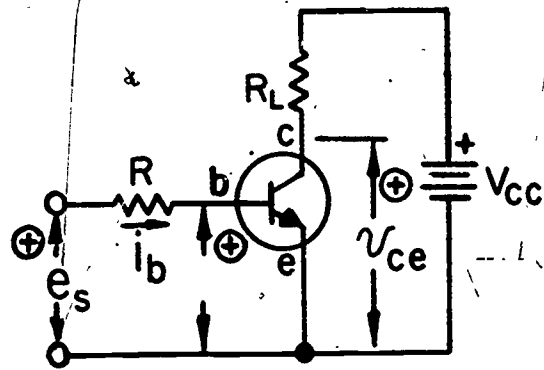

Fig. 1

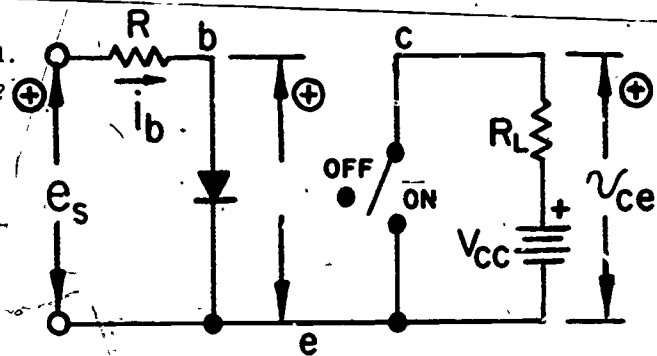

Fig. 2

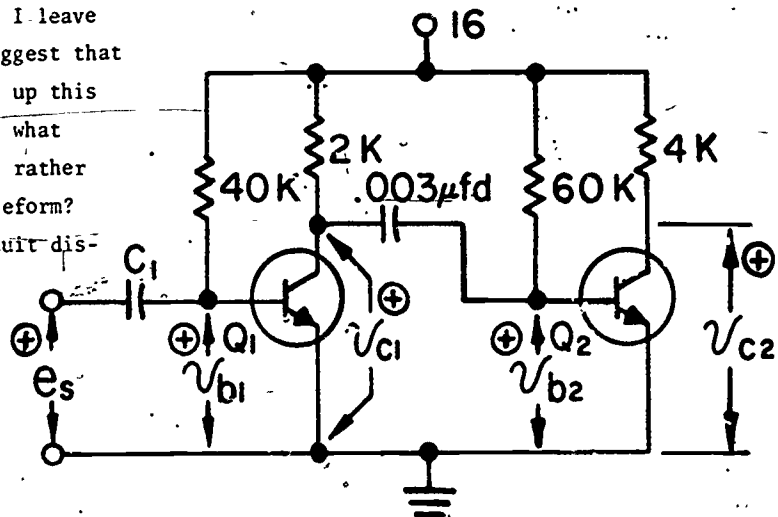

Fig. 4

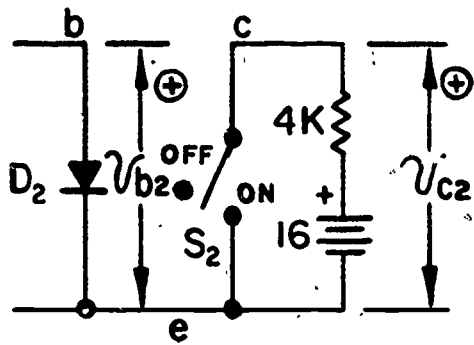

Fig. 8

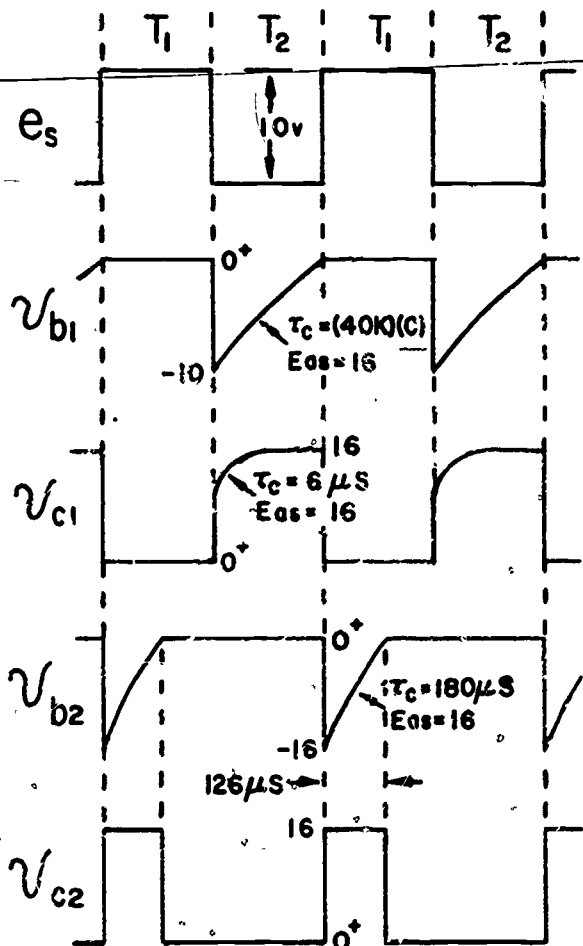

Table 1

CHAPTER 8

UTILIZATION OF COMPUTERS AND CALCULATORS

The availability of electronic calculators and computers has created new challenges for the electronics curriculum. These labor-saving tools should be utilized more fully as educational tools to supplement instruction in the two-year technology program.

This chapter includes information on both large and small-scale computers with sample Fortran, ECAP, and electronic calculator problems which were developed by members of the Summer Institute. Also included is an illustration of what is being done at the University of Illinois with computer-assisted instruction in electrical engineering. The information for this system, identified as PLATO, was provided by Mr. Roger L. Grossel.

COMPUTER-ASSISTED INSTRUCTION

WHAT IS CAI?

Of all the developments in instruction, computer-assisted instruction (CAI) has the greatest potential. The availability of computers has created new challenges for curriculum development in electronics. What is meant when we speak of CAI? In a narrow sense, CAI refers to a branching program developed for a specific course or segment of a course, programmed on a computer so that a student may interact with it through some type of remote console. In the broadest sense, it embraces the totality of computer use for assigned work in a classroom including computation associated with the solution of problems in electronics, math, or physics, or in the laboratory as a guide for simulation and design.

The use of the computer in the teaching-learning process has been represented by a number of acronyms, including CAI, CBI, CAL, CBE, and CAE. Computer-assisted or computer-aided instruction (CAI) adopted by IBM, is probably the most commonly used acronym, while Development Corporation, Stanford University, and RCA have used the term computer-based instruction (CBI). Computer-assisted learning, computer-augmented learning, computer-administered learning have been referred to as (CAL). The U.S. Naval Academy has used what they call computer-augmented education (CAE). The University of Illinois PLATO program uses computer-based education (CBE) to describe their efforts. Each manufacturer, computer system, or research and development project tend to have their own acronym. No matter what it is called, the computer is an active element in the instructional process.

CAI AND ELECTRONICS

At this point, the question might well be asked, "What has all this to do with the Electronics Educator?" The familiarity of the elect-

ronics instructor with a systems approach to a problem offers many important opportunities to contribute to the improved efficiency of the instruction process. The electronics instructor is in a unique position because of his background of technological competence and an understanding of the goals and frustrations of the teacher. The electronics educator is in a position to solve many problems with both the software and hardware. Instead of waiting for someone else to do all the work, the electronics educators should be leading the field of computer-assisted instruction. The goal to which technology should be directed is to assist the student to become an efficient, independent learner.

USING CAI

The use of high-speed digital computers as a central control element provides great flexibility in the instructional process. CAI is prepared by the instructor for presentation under computer control. The student receives instruction in a variety of methods including slides, films, video display, audio-tape messages, and typed information. Material is presented to the student and then he responds usually by typing his individualized answer on a keyset in a student terminal. The computer responds to the student's responses and determines how the instruction is to progress. Students who do not fully understand the material are branched into remedial instruction and thus avoid repetition of old material.

CAI is not synonymous with programmed instruction. It is not an automated version of the Skinner teaching machine. CAI makes possible unprogrammed instruction or student-controlled learning that differs from the basic tutorial logic of most programmed instruction.

For example, information may be stored in memory as an actual system or device such as a defective electronic circuit and through a set of instructions stored in the computer, the computer can calculate unique responses to varying student inquiries. It has the ability to provide much more opportunity for flexibility than regular programmed material.

The computer can also be used to control devices such as movie projectors, random-access slide projectors, lights, etc. Students in different terminals can interact with each other through the computer. In addition to keeping detailed records of the student's performance, the computer can provide individualized instruction, immediate feedback, and remedial instruction by the use of internal branching and the alternation of presentation or type of material based on the student's past performance. These unique features make the computer an ideal instructional tool for developing cognitive skills.

Ways in which CAI can be used in electronics technology include the following:

a. *Drill and Practice*

It is widely accepted that the computer can be a valuable tool in the presentation of drill and practice. Learning can be modified to meet the needs of each individual student both as to level of difficulty and rate of presentation. The computer can be programmed to follow each student's history of learning successes and failures and to use his past performances as a basis for selecting new problems and concepts. The computer can even be programmed to generate its own drill exercises so that a wide variety of combinations can be used without excessive teacher participation. Also, the computer can be used to pace the student so as to increase his speed of responses as well as his accuracy. Examples in electronics that fit in this area include: reading time constants, meter readings, problem

solving, writing loop and node equations, etc.

b. *Tutorial Systems*

The application of the computer to solve complex problems lies in its capabilities to easily evaluate those circuits having many loops and nodes. The pace of a student's response is controlled and he is permitted to *construct* an answer rather than select one from several given possible answers as is usually done in written programmed material. For example, the student is presented with a problem that cannot be dealt with by a simple of multiple-choice answer. A problem might be to design a transistor circuit with specified input and output conditions. This may require the student to gather information, which might be stored in memory, about the transistor he wants to use. He will have to decide what tests he wants the computer to perform or what calculations he wants it to carry out.

It is likely that no two learners will ever take the same path through a complex problem and this is where the computer has its greatest advantage over programmed instruction. It has the ability to assess the validity of an answer, judge open-ended verbal responses, and to distinguish between conceptual errors and spelling difficulties. In the tutorial mode, maximum adaptation can be made to the individual differences exhibited by the learner.

c. *Computational Mode*

The CAI system can be used as a calculator to do the mathematics required to solve a problem. Experiments can be simulated by the computer, immediately providing the student with results he uniquely requested. These

same results might require hours or even days to calculate by hand and would otherwise be too difficult or lengthy to do. In a complex system, the computer not only does the computation but also assists in the problem-solving process. It can guide the student through a problem, evaluate each step, indicating errors as they occur and can require extensive student interaction. For example, a student is to analyze a series RC circuit. His task is to determine the value of inductance and resistance necessary for a specified output across the inductance and then to vary the values and observe the result. By manipulating these values, the student gains an intuitive feeling for the effects of input waveform, inductance, and resistance, and has the ability to solve this type of problem. He could even ask the computer to plot

the output waveform or analyze various combinations of inductors and resistors.

d. *Testing, Recording, and Processing Student Performance*

The potential of CAI to make assessment of student performance is a key element in individualizing instruction. The computer can keep accurate and comprehensive records on individual student performance and can also include testing as well as collecting data on daily performance. By analysis of performance data from students on-line, quick changes can be made in the instructional sequence and even generate additional materials as needed for each individual student. This reduces the number of evaluation-revision cycles required in the development of CAI instructional materials.

PLATO EXAMPLE

The University of Illinois has been experimenting with a computer-based educational system (PLATO) since its initiation in 1959. Some of the areas in which studies have been conducted are electrical engineering, geometry, biology, nursing, library science, pharmacology, chemistry, algebra, math drill, computer programming, and foreign languages. This material has been presented by use of a variety of teaching strategies, ranging from drill and practice to student-directed inquiry.

At the present, a student terminal consists of a keyset and a television monitor as shown in Fig. 2. Information viewed on the television monitor is composed of a slide selected by the computer (random-access time less than 1 millionth of a second) and a superimposed image of graphs, diagrams, and/or alphanumeric characters drawn by the computer in a point-by-point fashion. The student uses the keyset for constructing answers, questions, and for setting up simulated or real experiments, as well as for controlling his progress through the lesson material. The computer responds to the student's requests and also controls devices such as movie projectors, lights, etc.

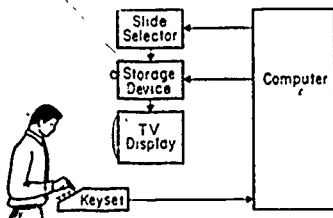

Fig. 2. Schematic representation of the Plato III system

A very promising technological innovation aimed at providing an improved low-cost student console is the plasma display panel, a recently invented graphics display device that is capable of storing on its viewing surface either computer-generated or student-generated information without the need for auxiliary storage devices. Furthermore, the panel may be addressed by way of telephone lines of conventional bandwidth. Under the trade name Digivue, this electronic device is at present in the commercial prototype development stage and offers promise of excellent performance, with significant further reductions in the cost of student terminals. Made of a thin, flat, gas-filled glass container with transparent electrodes, the plasma panel is so designed that photographic images can be conveniently projected and superimposed on the display surface. Thus, one can combine the presentation of textual material or slides with presentation of the computer-generated information, as is done in PLATO III.

Figure 3 is an artist's conception of a PLATO IV student console with keyset, plasma display panel, and a low-cost random-access image projector. The latter is another invention that resulted from the PLATO design effort. It permits random selection by the computer of any image on a microform card on which textual and photographic lesson materials are stored. Figure 4 is a photograph of a small 4- by 4-inch (10- by 10-centimeter) pilot-model Digivue panel with a superimposed photographic image. PLATO IV plans call for a panel of considerably greater size (10 by 10 inches) and a resolution better than that of television displays.

*Taken from The Design of an Economically Viable Large-Scale Computer Based Education System, CERL Report X-5, University of Illinois, Urbana, Illinois.

A new low-cost, random-access audio system will make it possible for a student to call for, or to record, vocal messages on a locally situated magnetic recording device. This unit would typically be considered an optional feature, especially useful in certain language courses.

The design of the PLATO IV student console makes possible a novel economical method for communicating with the central computer at a distance. By sending the information in digital form in carefully arranged time sequence, it is possible to transmit to as many as 1000 student stations by way of a single educational-TV channel. At a distance of 150 miles, such a communication channel would cost only a few additional cents per student-contact hour.

Each student is introduced to PLATO by the display shown in Fig. 1.

Hi-

My name is PLATO. I am the computer-based system that will assist in teaching EE 260, Networks I. I "talk" to you by writing on this display. You "talk" to me by pushing keys on the keyset in front of you.

Refer to your keyset. As you see, many keys are similar to those on a typewriter. Note that on the right side of the keyset are special keys labeled with words. Their function will become clear to you as we proceed. I will refer to these keys by putting a dash on each side of the word. For example, when you are ready to go on, push -NEXT-.

Fig. 1

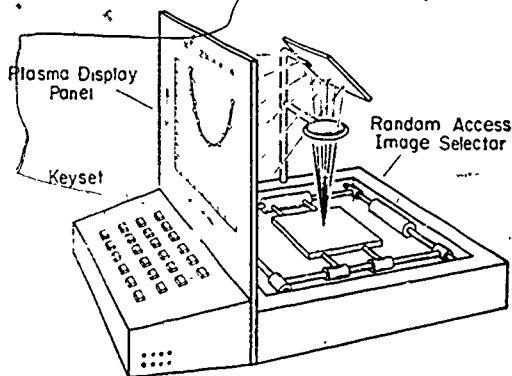
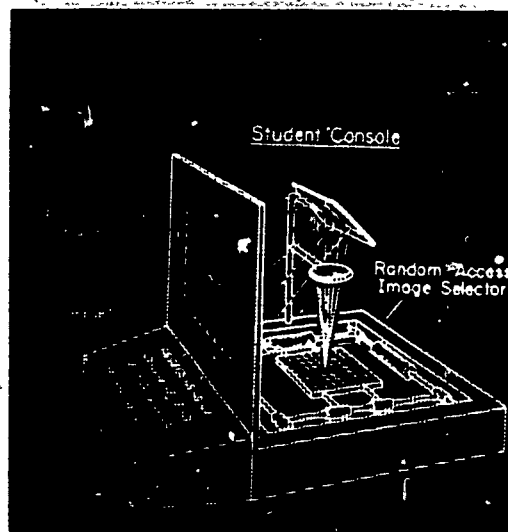

Fig. 3 (above) Schematic diagram of the Plato IV student console

Fig. 4 (right). Superimposed photographic and computer-generated images on a Digivue plasma display panel. (In normal viewing the lines which appear in the projected photograph of the student console would not be visible.)



A C-AI APPLICATION FOR ELECTRONICS

The PLATO system is currently being used to assist in teaching selected parts of EE 260, Introductory Networks, at the University of Illinois. Only those topics that are best covered by C-AI are presented on the PLATO system. These topics are integrated with lecture, laboratory, and study sessions. The following are examples of how the PLATO system is being used in the circuits course.

One of the most important concepts to get across in the first circuits course is Kirchhoff's Laws. Figures 2, 3, 4, and 5 are part of the series of displays used. For example, in Fig. 2, the student is asked to write the KCL for node 3. Note: The voltage references are given, but not the current. By using the associated reference (current enters the positive voltage terminal, which was previously introduced), the student should be able

to write the equation. If he can not write the equation, he pushes a key labeled HELP, and is given the hint as shown in Fig. 3. If he still has trouble, he pushes HELP again and is presented with the question shown in Fig. 4. Hav-

ing answered "yes," he is then shown Fig. 5, which now has the current symbols and references. The student now writes the equation and is judged "OK" by the computer. Any equivalent form of his answer would have been accepted.

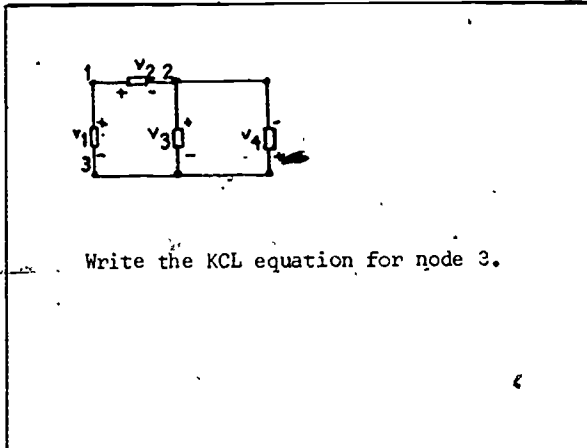

Fig. 2

You should be able to determine the current reference directions from the associated reference direction.

Please try again, but if you still have trouble, return to your lesson & use -HELP1-.

PRESS -NEXT-

Fig. 3

Do you want the current reference directions indicated instead of the voltage reference polarities?

→ y OK

PRESS -NEXT-

Fig. 4

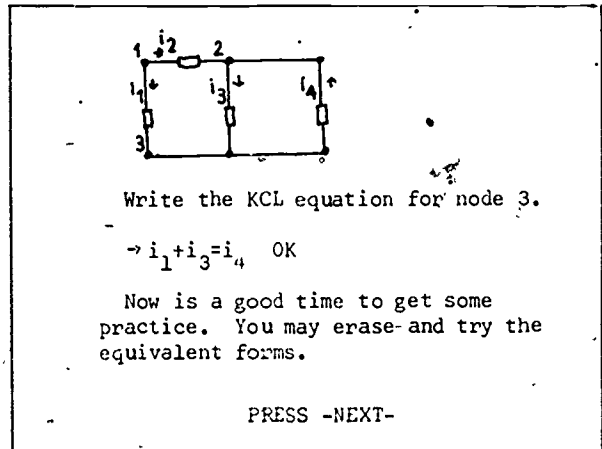

Fig. 5

A series of displays from a resistive network analysis lesson is shown in Figures 6, 7, 8, 9, and 10. Initially the student is shown a grid of 15 terminal points as indicated in Figure 6. He then enters his own network by key presses and enters each element one at a time. Each branch is drawn after all of its necessary values have been entered. When the student indicates his network is complete, he is shown Figure 7, which indicates his connections are "OK" (no shorted elements, etc.). On this display, he is asked one of five randomly selected questions about his network. For example, in

Figure 8 he is asked for the number of independent mesh currents. The student may have been asked to calculate the node voltages or the element voltage and currents solutions which are shown in Figures 8 and 9. These are computed and are available to the instructor, who has the option to withhold the solutions until he has asked questions about them. Alternatively, if he wants to allow the student to use the lesson merely in the analysis mode, he may select to show the solutions directly. In other words, the student can use the computer as a tool to calculate these voltages and currents.

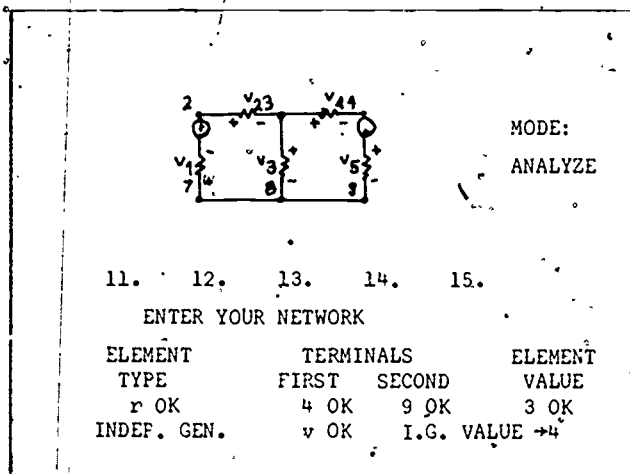

Fig. 6

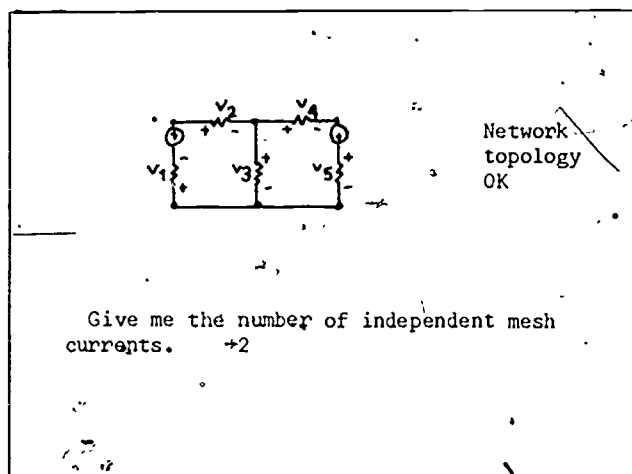

Fig. 7

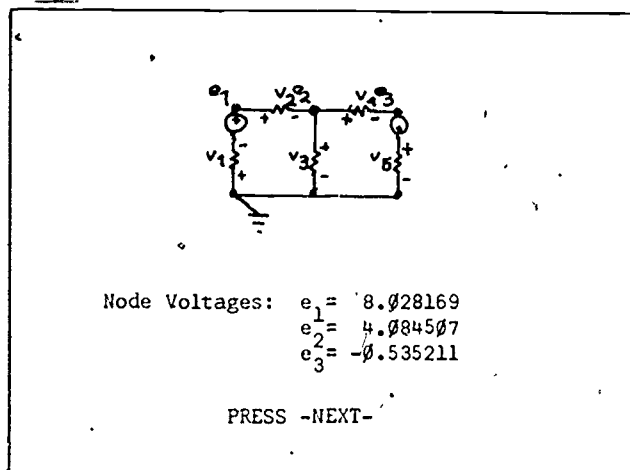

Fig. 8

Figures 10, 11, and 12 as shown on the following page present a series from a lesson on parallel RLC networks. The part shown here assumes that the theory has already been covered. The student types in the values of C, L, and R,

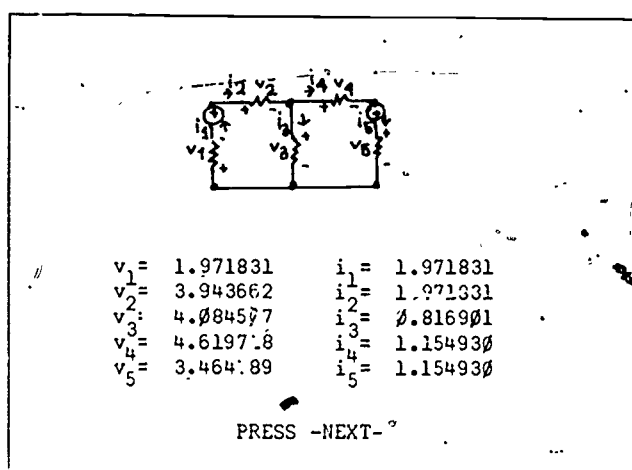
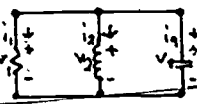

Fig. 9

and then is asked in Figure 10 if he wants to see a plot. The plot is shown in Figure 11 and shows $V_c(t)$, $i_L(t)$, and V_c vs $-i_L$ (the phase plane plot). The plots develop in simulated time as the student watches. A plot for a higher Q network is shown

2290.7 in Figure 12.

Another example from circuit analysis is as follows: The student has just analyzed a circuit containing a battery, a switch, an inductor, and a resistor, all connected in series. His task is to determine the value of the inductor and resistor that causes the current waveform to pass through the points marked on the graph after the switch is closed. He is instructed to make the resistor value small and notice the effect on the final value of the current. By manipulating these values, the student gains an intuitive feeling for the effects of the inductance and resistance, and he can proceed in an orderly way to determine their correct values as indicated on the following displays.



INITIAL CONDITIONS
 $i_L(t) = i_2$ $i_L(0) = 0$
 $v_c(t) = v_3$ $v_c(0) = 1$

CHOOSE VALUES (microfarads, microhenrys, ohms)
 $C = .1000000$ OK μF $L = 1000000$ OK μH
 $R = .1$ OK

This is the underdamped case.
 $\alpha = 0.00000050 \times 10^6$ $Q = 1.00$
 $v = 0.00000100 \times 10^6$ $f_0 = 0.00000016$ MHz
 $v_0 = 0.00000087 \times 10^6$
 $i_L(t) = 1.15 \exp(-\alpha t) \times \sin(\omega_d t)$
 $\max i_L = 0.54629$ at $t = 1204048$ μsec
 $(\Delta t = 120405 \mu\text{sec}, N = 41)$

***Do you want to see a plot? →

Fig. 10

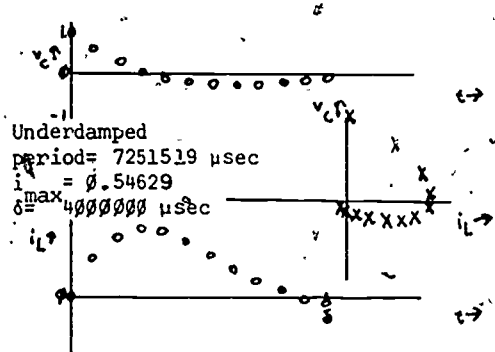

Underdamped
period = 7251519 μsec
 $i_{\max} = 0.54629$
 $\delta = 4000000 \mu\text{sec}$

PRESS -NEXT-

Fig. 11

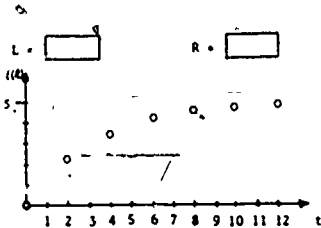

L = R =

When you are through experimenting, find values of L and R, to the nearest integer, such that the solution matches the experimental data. Judge each answer separately.

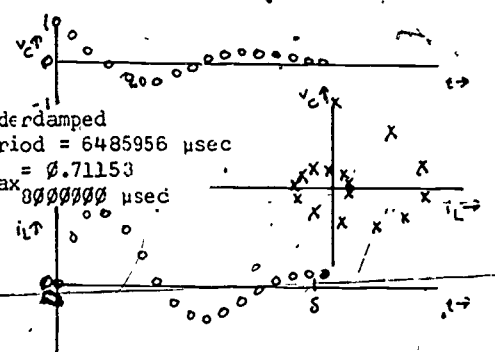

Underdamped
period = 6485956 μsec
 $i_{\max} = 0.71153$
 $\delta = 8000000 \mu\text{sec}$

PRESS -NEXT-

Fig. 12

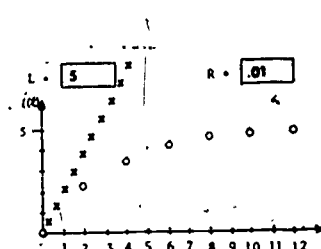

L = R =

When you are through experimenting, find values of L and R, to the nearest integer, such that the solution matches the experimental data. Judge each answer separately.

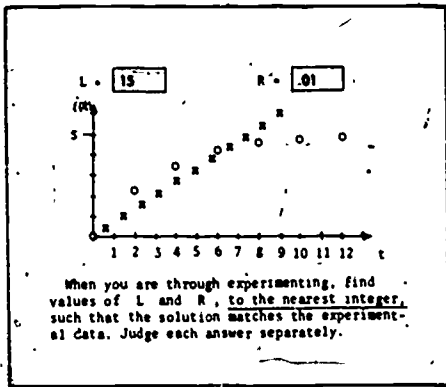

c

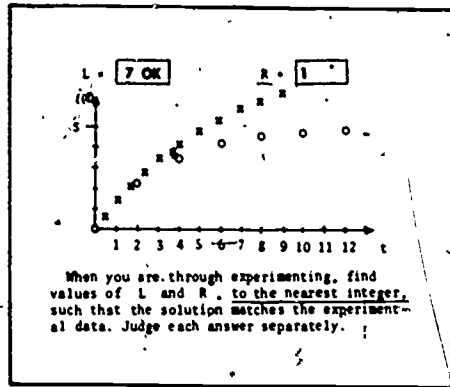

f

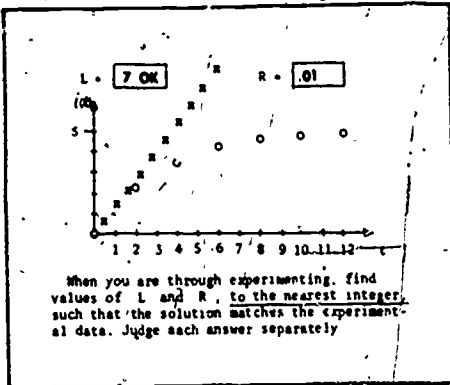

d

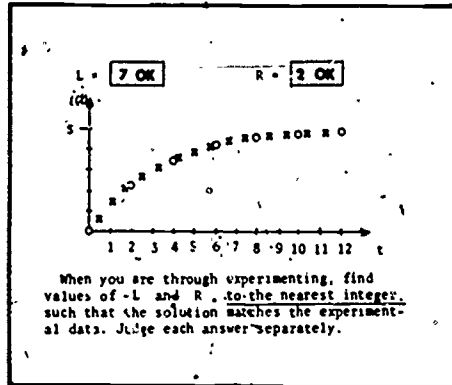

g

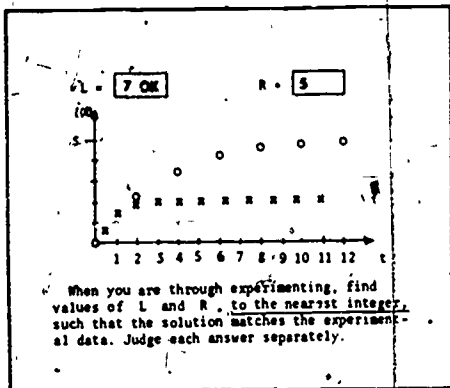

e

COMPUTERS AND CALCULATORS AS TOOLS

The availability of computers has created new challenges for curriculum development in electronics technology. The computer is a tool that increases the student's capacity to do intelligent work. It enables him to work problems more quickly, with less drudgery, and with greater accuracy. It is quite apparent that the computer should be utilized more fully as an educational tool in the two-year technology program.

ELECTRONIC DESK-TOP CALCULATORS.

The development of electronic desk-top calculators, which are really small scale computers, has particular significance in teaching electronics. The primary benefit is found in the development of concepts by the students and the exploration of these concepts by problem-solving situations utilizing the calculator to do routine operations quickly. Sample operations involving the use of calculators are: Evaluating equations, exponential functions, and trigonometry functions.

These and many other problems can be solved on the calculator. There are a variety of calculators available, many of which are programable. A partial list of electronic calculator manufacturers appears later in the chapter.

The electronic calculators which are programable can solve problems that are pretty complex. For example, the Hewlett Packard 9100B can solve a twelve by twelve determinant. A sample problem on solving a two-node circuit on the Wang 360 is illustrated in a later section of this chapter.

Peripheral equipment can be obtained for some electronic calculators such as paper printers, card readers, plotters, etc. It may be possible to have several keyboard terminals

in remote locations that operate off of one main brain. One such system is the Wang 300 series.

The main advantages of an electronic calculator are that they are relatively inexpensive as compared to a large computer and they are easy for the student to use; no special language is required.

In order for electronic calculators to be used effectively, they must be available for student use. Placement in the laboratory where students are spending much time is most effective. They must be located close to the area of study so that the student may at any time work a problem using the calculator if he so desires. *The main point of emphasis is that the student is able to explore the development of a concept without becoming hung-up with the mathematical manipulations.*

COMPUTER PROGRAMMING

Each year the engineering technician is working more and more with solving problems using the computer and will increasingly become more involved in the future. It is highly doubtful that a technician can go to work in industry and in some way not be around a computer facility. To prepare the technician for work, the electronics technology curriculum must take into account new ways for solving old problems and the host of new problems which have arisen.

At least one course in computer programming should be required in the two-year electronics curriculum. The course should be offered in the first year so that the student can use the computer as a tool in as much of the curriculum as possible. The second semester or 3rd quarter of the first year is satisfactory. The language should be a users' language which is fairly versatile for per-

forming scientific calculations but which are also easy to learn. Basic and Fortran would be good in the first year and perhaps a little bit of ECAP (Electronic Circuit Analysis Program). This is a difficult course to teach because of the student's mathematical background in the first year. It must be taught the first year to be of much value to the student.

The course in computer programming consists of a large amount of detailed instructions and should be presented precisely and thoroughly in the basic fundamentals. This course can probably be taught best by an instructor with a knowledgeable background in computer science but with the full cooperation of the electronics staff. A course outline for such a course appears later in the chapter.

Two-year electronic technology students should not be expected to become experts in programming, but rather they should be able to gain sufficient programming knowledge to make effective use of the computer in problem solving, simple design, data reduction and tabulation, model simulation, and repetitive, time-consuming calculations which students often refer to as busy work.

It is quite important that the computer facility must be readily available for use by the students. The computer should be for the student, not the administration. Also, turn-around time should be in the order of seconds or minutes, not hours. The student should have immediate results.

STUDENTS, CALCULATORS, AND COMPUTERS

Let's take a look at what computers and calculators have to offer for the student.

Classroom Instruction

1. Student comprehension and intuitive understanding can be developed.
2. Stresses the logical structure of concepts that encourages intuitive

ability rather than rote skills.

3. Develops a logical approach to problem solution.
4. Many concepts can be developed and demonstrated that would otherwise be very difficult or even impossible such as limits, frequency response, stability, exponential response, etc.
5. Students can question the process, change parameters, and observe the results of these changes.
6. Problems that are complex and require many hours of calculation can be done in microseconds.
7. No need for the student to manually perform the monotonous arithmetic over and over.
8. Difficult concepts can be introduced early.
9. Enables the student to extend their understanding of mathematics and circuits which might otherwise be beyond their reach.

Laboratory Instruction

1. Key concepts of the experiment can be reinforced as it is performed.
2. Laboratory results can be plotted providing visualization of the relationship between parameters.
3. The student can compare immediately the analysis of experimental data with the theoretical programmed model.
4. Circuits can be designed before the student gets into the laboratory.
5. The concepts of linear, non-linear, etc. can be graphically displayed.

Individual Instruction

1. Students can verify their own work, rather than an instructor correcting it.
2. Solve problems without the supervision of an instructor.
3. Students can work at their own pace.

4. A supplement to classroom instruction.
5. Increase student motivation and interest.

In solving any kind of problem, a computer is helpless until it has been given a detailed set of instructions. The computer can not figure out how to solve the problem. All it can do is slavishly follow directions step-by-step until the job is completed. The student must understand the problem completely before he can instruct the computer to solve the problem. If the student does not know how to solve the problem, the computer will be of no value to him.

ECAP

A special computer program package known as ECAP (Electronic Circuit Analysis Program) has the convenience of being easy to program but the disadvantage of requiring a large amount of computer core memory in order to utilize a full ECAP package. Some modified packages may be available. Consult your IBM representative regarding modified packages that may fit your system.

ECAP is based on nodal analysis and has capability for DC, AC and Transient analysis. Any circuit or system that can be modeled as an equivalent electrical circuit can be solved using ECAP. The outputs available are branch voltages and currents, node voltages, and branch power. These include magnitude and phase of voltages and current on AC analysis. In addition on DC analysis, sensitivities, worst case, and standard deviation are also available outputs. Sensitivity is the change in response due to a one percent change in all circuit parameters. Worst case is the response to the extreme specified variations of circuit parameters.

The AC analysis does not contain the sensitivity, worst case, or standard deviation. The AC analysis does have the capability

of producing a nodal admittance matrix in the output. Both the AC and DC analysis permit circuit parameters to be modified within the input data list.

Transient analysis utilizes the same type of input data coding except the program must include a time-stepping specification in place of the frequency specification used in AC analysis and does not permit the circuit parameters to be modified in the data input list.

The technique used for ECAP programming consists mainly of entering the circuit parameters and data. This is done by first establishing the circuit model and defining nodes and branches. The data is then entered by branch connects, and the parameter value. As an example, suppose we have a simple series RLC circuit with an AC voltage source as shown below. The nodes are indicated by the numbers enclosed in the square boxes with the arrows indicating the referenced direction. The following circuit problem illustrates the use of ECAP.

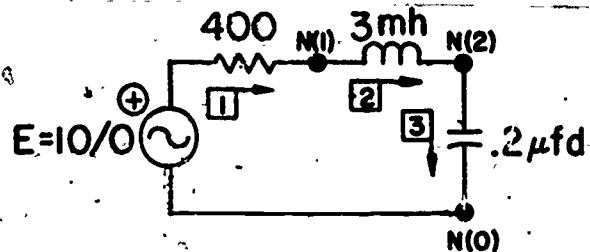

```

B1 N(0,1), R = 400, E = 10/0
B2 N(1,2), L = 3E-3
B3 N(2,0), C = .2E-6
FR = 1000
PR, NV, CA, BP
EX
END

```

The above program would calculate and print out the node voltages, branch or component currents, and the branch power for the above circuit operating at a frequency of 1,000 cps. Further examples of ECAP programs appear in later sections.

TIME-SHARE TERMINAL

Another possibility of computer usage in the electronics program besides the desktop Electronic Calculator and a large-scale computer such as a 360, is the time-share teletype terminal that is either connected through an acoustical coupler and phone line or hand-wired to a computer at some other location. The teletype terminal is a relatively inexpensive method to use depending upon your location. For a few dollars an hour, a teletype terminal can be operated in an area that has a time-share computer available.

There are many languages that are available for the teletype and most are very simple ones that require little or no previous programming knowledge. Also, such programs as ECAP or variations of ECAP may be available. Additional *Peripheral equipment* is also available such as punch tape readers and printers, plotters, etc. For the program on a tight budget this is one method that desires careful consideration.

What I have tried to do is point out various methods where computers might be used in your electronics program from the small electronics calculator to the teletype terminal to a large-scale computer. Each has its own advantages and disadvantages. I would like to recommend that a teletype terminal or a large-scale computer be used to introduce the student to computer programming and that a small electronic calculator be available in all programs for the students to use at all times.

The following are some illustrations as to how you might use the computer as a tool in your electronics program. Also, sample computer problems appear in later sections.

COMPUTER APPLICATION TO ELECTRONICS

The techniques developed in the circuit sequence lend themselves nicely to calculator and computer solution. For example during the presentation of Resistive Circuit analysis the ideas of use of the computer as a tool can be

developed by giving complete sample programs to students, letting them punch cards and run the deck through the computer center or let them work with the time-share system. The idea here is to let the problem be one they can readily see the answer to by calculation with slide rule and calculator. If this is done once every two weeks, by the end of the Resistive Circuits course they are knowledgeable in the area of Key-punch, procedures for running programs through the computer center, and interpreting the computer output.

Sample programs in Fortran and Basic can be run to show mathematical similarities where they exist. At this time do not use looping and branching just addition, subtraction, multiplication, division, exponentiation and use of built in library functions.

Running concurrently with the teaching of Single-Time-Constant circuits a course in Programming lends itself to further development of ECAP as a powerful tool to do many routine calculations. For example, the frequency response characteristics of RC or RL circuits are traditionally solved by applying the Bode plotting technique. In ECAP the circuit can be simulated and the frequency stepped through a range and the computer output evaluated. Most any forcing function can be approximated by ECAP and a piece-wise linear basis and applied to the circuit under analysis.

The techniques using ECAP find most success in the first-year program analyzing Passive circuits, examining node and branch voltage-current and element power dissipation.

As students enter the second-year program and work into the third circuits course, Networks, they have the means to work out many more complicated circuits than could possibly be done by brute force and the slide rule. However, before they approach ECAP at this level they must have a feel for the expected solution based upon solution of similar problems of lower order.

With the study of circuit models in the

second and third electronics courses ECAP techniques can be presented to observe circuit or system response in terms of expected results. At this point plotting routines can be used for circuit and response.

The purpose of ECAP is to explore the use of another tool which today's technician will find in industry. One must take great pains to make the learning of the special operating techniques as painless as possible. The steady use of this tool throughout the two-year program will supply the technician with another saleable skill. The objective here is not to make programmers but to develop the use of an additional tool. Upon completion of the two-year program the technician should be able to use these tools effectively:

1. Capable of working all scales on the slide rule.
2. Capable of working the keyboard functions displayed on an electronic calculator.
3. Capable of working with a capable Programmer or Engineer knowledgeable in the languages. He should be able to handle routine procedure, interpret results and offer constructive comments in discussion of the problem.

DESK-TOP DIGITAL CALCULATOR MANUFACTURERS

Cintra Physics Company
440 Logue Avenue
Mountain View, California 94040

Digital Equipment Corporation
146 Main Street
Maynard, Massachusetts 01754

Eldorado Electrodata Corporation
601 Chalomar Road
Concord, California 94520

Friden Corporation
2350 Washington Avenue
San Leandro, California 94577

Hewlett Packard Company
1401 Page Mill Road
Palo Alto, California 94304

IME Systems
7800 Riner Road
North Bergen, New Jersey 07047

Logic Corporation
15 East Euclid Avenue
Haddonfield, New Jersey 07033

Monroe
550 Central Avenue
Orange, New Jersey 07050

Sony Corporation
401 Carol Circle
El Segundo, California 90254

Victor Comptometer Corporation
3900 N. Rockwell Street
Chicago, Illinois 60001

Wang Laboratory
836 North Street
Tweksburg, Massachusetts 01876



Calculator — HP 9100 —

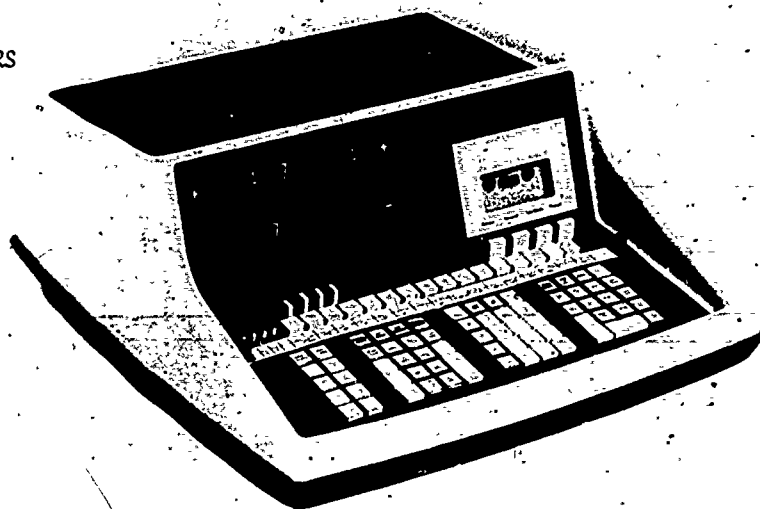

WANG MODEL 700A

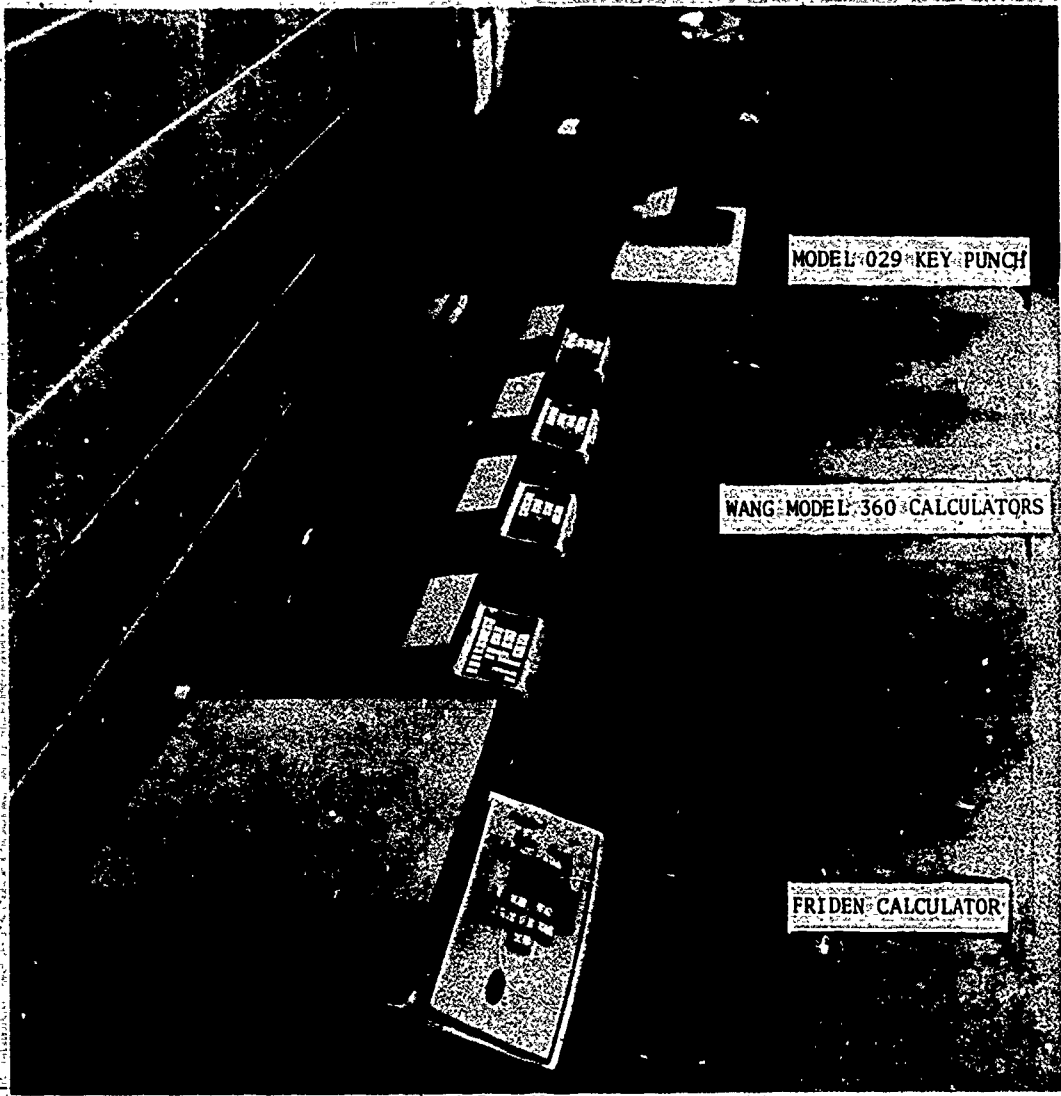

The above picture was taken at Harper College and illustrates how calculators and computers can be used in two-year electronics programs. The calculators and key punch are located in one of the electronics labs for convenient student use. Students are free at any time to use these tools for classroom and laboratory calculations.

The picture on the right illustrates the acoustical coupler needed for a time-share terminal.

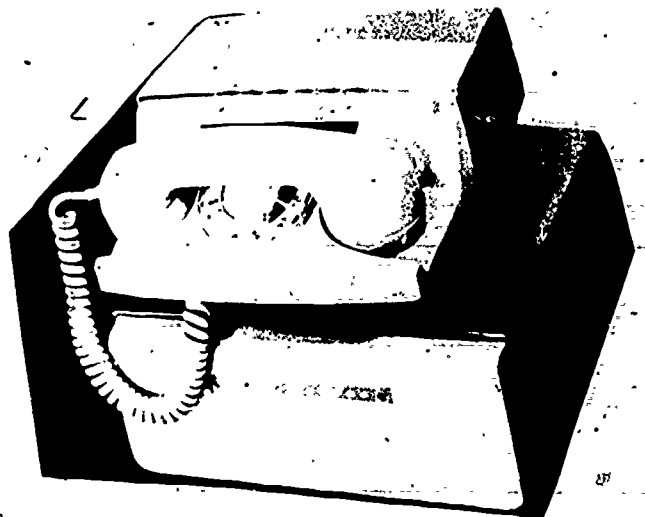

A SUGGESTED COURSE IN COMPUTER PROGRAMMING

SUGGESTIONS

This course should be 50 to 55 contact hours in length with additional time for laboratory work as required.

Although this course must remain flexible enough to be adapted to the available computer, it should start with an introduction to computers in general and some of their uses. This introduction should lead to a presentation of The Properties of The General-Purpose Computer followed by an orderly presentation of basic computer programming. Care should be taken in sequencing, so that use can be made of the computer in both this and applicable concurrent courses at the earliest date feasible.

Once the basic programming has been covered the use of in-line and auxiliary systems should be presented. The remaining time should be spent on applicable numerical techniques. Since this course is to be offered during the second quarter, or third quarter, or second semester the latest and the available time and class space may vary, several of the topics listed near the end of the course outline are indicated as being optional.

The minimum coverage for this course are Sections A and B of the course outline. Some of the topics in Section C, "Numerical Techniques" and Section D, "Optional Topics" may already be part of another course in the curriculum in which case they need not be covered in this course. Other topics in these two sections may have direct application in other courses in which case, it may be more desirable to transfer the presentation of such topics to the applicable course for presentation as needed. Such transfer is recommended. It is intended that this course be an integrated part of the total curriculum with the use of computer encouraged in as many subject areas as feasible.

A. Introduction To The Computer System

1. The Properties of a General-Purpose Computer

- a. Move information from one place to another and find information already stored
- b. Perform basic arithmetic operations
- c. Perform tests and decide which of two or more possible procedures to follow, basing such decisions on intermediate results which may not be initially known
- d. To follow a prescribed sequence of operations
- e. Change the predetermined sequence of operations to be performed, depending upon the results of intermediate operations
- f. Perform more complex operations by repetition of basic instructions and tests, possibly modifying the instructions in the course of repeating them
- g. Store in the computer the results of these operations, which may be recalled for later use

2. The Organization of a Modern Computer System

- a. Storage elements which hold information
- b. Arithmetic and control elements which operate on and control the flow of information
- c. Input/output elements which receive and display information
- d. Use of operational equipment such as the key punch

3. Programming Digital Computers

- a. Machine language
- b. Symbolic language

- c. Problem-oriented languages
- B. FORTRAN Programming
 - 1. Elements of FORTRAN-Definition of Terms
 - a. FORTRAN language
 - b. Source statement
 - c. Source program
 - d. FORTRAN compiler, FORTRAN translator, FORTRAN processor
 - e. Object program
 - 2. FORTRAN Arithmetic
 - a. Fixed-point and floating-point arithmetic
 - b. Constants
 - c. Rules governing fixed-point constants
 - d. Rules governing floating-point constants
 - (1) Floating-point constants with exponents
 - (2) Floating-point constants with exponents
 - e. Variables
 - f. Rules governing fixed-point variables
 - g. Rules governing floating-point variables
 - h. Relationships among variables, constants, and storage registers
 - 3. Arithmetic Operations
 - a. Addition
 - b. Subtraction
 - c. Multiplication
 - d. Division
 - e. Exponentiation
 - 4. Arithmetic Expressions
 - a. Priority of operations
 - b. Order of execution of operations
 - c. Use of parentheses
 - d. Nesting of parentheses
 - 5. FORTRAN Arithmetic Statements and Functions
 - a. The arithmetic statement
 - b. Mathematical functions
 - 6. Statement Numbers and FORTRAN Coding
 - a. Statement numbers
 - b. FORTRAN coding form
 - 7. FORTRAN Statements
 - a. The unconditional GO TO Statement
 - b. The IF Statement
 - c. The IF Statement and inexact numbers
 - d. The logical IF Statement
 - e. The computed GO TO Statement
 - f. The assigned GO TO and ASSIGN Statement
 - g. The CONTINUE Statement
 - 8. Program Halt Statement
 - a. The PAUSE Statement
 - b. The STOP Statement
 - c. The CALL exit Statement
 - d. The END Statement
 - 9. Input/Output Statements
 - a. The READ Statement
 - b. The WRITE Statement
 - c. The PRINT Statement
 - d. The PUNCH Statement
 - e. The FORMAT Statement
 - f. Input specifications
 - (1) F field
 - (2) E field
 - (3) I field
 - g. Output specifications
 - (1) I field
 - (2) F field
 - (3) E field
 - (4) X field
 - (5) H field
 - 10. Subscripted Variables
 - a. Arrays
 - (1) Representation of arrays in FORTRAN
 - (2) Allowable forms of subscripts
 - b. Dimension statement
 - c. The DO Statement
 - (1) General form

- (2) Rules governing the DO statement
- d. The CONTINUE Statement
- e. Input/output of arrays
 - (1) Use of the implied DO notation
 - (2) Input/output operations involving arrays
 - (3) Input/output of two-dimensional arrays
 - (4) Input/output of arrays, without subscripts
- f. Use of matrix multiplication
- g. Subroutines
 - (1) Library functions
 - (2) Built-in functions
 - (3) Arithmetic statement functions
 - (4) Function subprogram
- h. The RETURN Statement
- i. Subroutine subprograms
- j. The SUBROUTINE Statement
- k. The CALL Statement
- l. The ENTRY Statement
- 11. The Equivalence and Common Statement
 - a. The equivalence statement
 - (1) Equivalency arrays
 - b. The common statement
 - (1) The use of dimensions in a COMMON Statement
 - (2) Transmitting arguments implicitly between the calling program and the subprogram
 - (3) Dummy variable names in a common statement
 - (4) Interaction between the equivalence and the common statements
 - (5) Labeled common storage
 - (6) Use of the labeled COMMON Statement
- 12. Other Forms of Input/Output Statements
 - a. Format specifications

- (1) The A specification for input
- (2) The A specification for output
- (3) The O specification for input
- (4) The O specification for output
- (5) The scale factor for input
- (6) The scale factor for output
- (7) The use of printer carriage control
- b. Format statements read as data
- 13. Type DECLARATION Statements
 - a. Integer
 - b. Real
 - c. Double Precision
 - d. Logical
 - e. Complex
 - f. External
 - g. Type Declaration for a Function Subprogram
 - h. Type declaration in a calling program
 - i. Data statement
 - j. Block data subprogram
- 14. Complex Arithmetic
 - a. Complex numbers
 - b. FORTRAN representation of complex expressions
 - c. Input/output of complex numbers
 - (1) Library functions of complex variables
 - (2) Allowable forms of the assignment statement

C. Numerical Techniques

- 1. Computer Solution of Polynomial and Transcendental Equations
 - a. Half-interval search technique
 - (1) Bisection method
 - b. Method of iteration

- (1) Convergence of the iteration process
- (2) Methods of speeding convergence
 - c. Method of false position
 - d. The Newton-Raphson Method
2. Systems of Linear Equations
 - a. Cramer's Rule
 - (1) Evaluation of a determinant
 - b. Gauss-Jordan Elimination Method (Optional)
 - c. Gauss-Seidel Method (Optional)
 - (1) Convergence of the Gauss-Seidel Method
 - d. Matrix inversion Method
 - e. Gauss-Elimination Method
3. Quadrature
 - a. The Trapezoidal Rule
 - b. Simpson's Rule
 - c. Gaussian Quadrature (Optional)
4. Numerical Differentiation (Optional)
 - a. First central-difference
 - b. Second central-difference
 - c. First forward-difference
 - d. Second forward-difference
 - e. First backward-difference
 - f. Second backward-difference
5. Graphical Solution
 - a. Graphical display of data
 - b. Subroutine for a plot

D. *Optional Topics*

1. Logical Operations
 - a. Basic concepts of Boolean Algebra
 - b. Postulates of Boolean Algebra
 - c. Definitions
 - (1) Idempotence law
 - (2) Commutative law
 - (3) Associative law
 - (4) Distributive law
 - (5) Zero and unity law
 - (6) Law of absorption
 - (7) Law of involution
 - (8) Law of complementarity
 - (9) De Morgan's Theorems

- d. Logical constants
- e. Logical variables
- f. Logical expressions
- g. Relational operators
- h. Logical operators
- i. Precedence of operators
- j. Logical assignment statements
- k. Input/output of logical quantities
 1. The logical if statement
2. Double Precision (Optional)
 - a. Double-precision variables and expressions
 - b. Double-precision constants
 - c. Double-precision functions
 - (1) Library functions
 - d. Input/output of double-precision constants
3. Magnetic tape input/output
 - a. Magnetic tape input
 - b. Magnetic tape output
 - c. Input/output of binary information
 - d. The binary write statement
 - e. The binary read statement
 - f. Auxiliary magnetic tape instructions

SOME SUGGESTED TEXTS AND REFERENCES

Beckett, Royce and Hurt, James, Numerical Calculations and Algorithms, McGraw-Hill Book Co., Inc., New York, New York, 1967

Carnahan, Luther and Wikes, Applied Numerical Methods, John Wiley & Sons, Inc., New York, New York, 1969

Dorn, William and Greenburg, Herbert, Mathematics and Computing with FORTRAN Programming, John Wiley & Sons, Inc., New York, New York, 1967

Douthwaite, G.K., and Dunn, W.L., Introductory Engineering Problems by Computer Methods, Pacific Books, Palo Alto, California, 1964

Dunn, Walter L., Introduction to Digital Computer Problems Using FORTRAN IV, A self-instructional programmed text, McGraw-Hill Book Company, Inc., New York, New York 1969

Blatt, John M., Introduction to FORTRAN IV Programming Using the Watfor Compiler, Goodyear Publishing Company, 1968.

Cross, Dirksen, and Graham, FORTRAN IV with Watfor, Prentice-Hall, Englewood Cliffs, N. J.

Farina, Mario V., FORTRAN IV Self-Taught, Prentice-Hall, Inc., Englewood Cliffs, New Jersey, 1966.

Golden, James T., FORTRAN IV Programming and Computing, Prentice-Hall, Inc., Englewood Cliffs, New Jersey, 1965.

Hanning, Richard W., Numerical Methods for Scientists and Engineering, McGraw-Hill Book Co., Inc., New York, New York, 1962.

IBM Systems Reference Library, FORTRAN IV for IBM System/360, Forms R29-0080, through R29-0087.

IBM Systems Reference Library, IBM System/360 FORTRAN-IV Language S360-25, GC28-6515-7.

IBM Systems Reference Library, Electronic Circuit Analysis Programming (ECAP), H20-0170-1 and H20-0171-0.

Jensen, R. and Lieberman, H., IBM Electronic Circuit Analysis Program (ECAP), Prentice-Hall, Inc., Englewood Cliffs, New Jersey, 1968.

Kuo, Shan S., Numerical Methods and Computers, Addison-Wesley Publishing Co., Reading, Massachusetts, 1965.

Ledley, Robert S., FORTRAN IV Programming, McGraw-Hill Book Co., Inc.

Lee, R. M., A Short Course in FORTRAN IV Programming, McGraw-Hill Book Co., Inc., 1967.

Levin and Herman, Introduction to Computer Analysis: ECAP for Electronics Technicians and Engineers, Prentice-Hall, Inc., Englewood Cliffs, New Jersey, 1970.

McCracken, Daniel D., A Guide to FORTRAN IV Programming, John Wiley & Sons, Inc., New York, New York, 1965.

McCracken, Daniel D., and William S. Dorn, Numerical Methods and FORTRAN Programming, John Wiley & Sons, Inc., New York, New York, 1965.

SAMPLE PROBLEMS USING ELECTRONIC CALCULATOR

MAXIMUM POWER TRANSFER

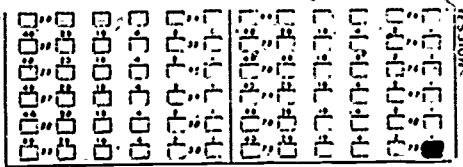
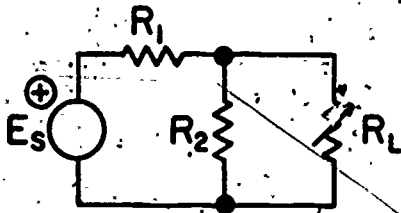
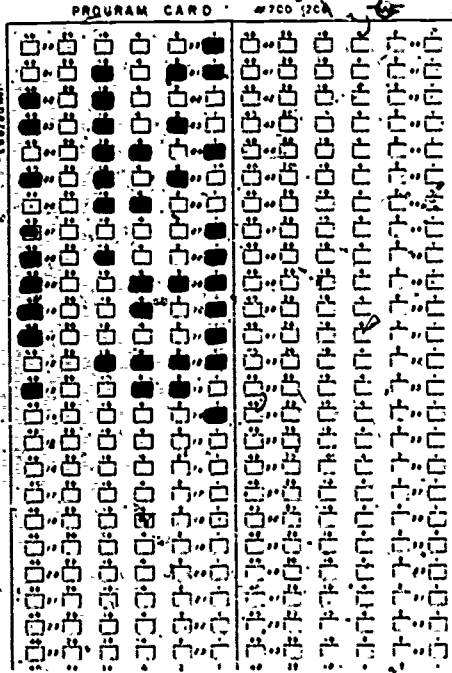

WANG LABORATORIES, INC. TEWKSBURY, MASS.

Given the above circuit, find the THEVENIN equivalent circuit to the left of R_L and then calculate the power transferred to R_L for one particular value. Establish the method that you used and then obtain the program card from your instructor for the Wang Model 360 Calculator and find the power transferred to R_L over the specified range. Plot the power transferred to R_L and determine when it is maximum.

The following is the procedure to use.

1. Enter the value of E_{th} in memory

register (0).

2. Enter the value of R_{th} in memory register (1).
3. Insert the program card into the reader.
4. Push "Start" on the card reader.
5. Type in a value of R_L on the keyboard.
6. Push "Continue" on the card reader.
7. Record R_L which appears on the digital read-out.
8. Return to Step 4 and recycle program with another value of R_L . Do this as many times as you like.

SOLVING A THREE-NODE RESISTIVE CIRCUIT

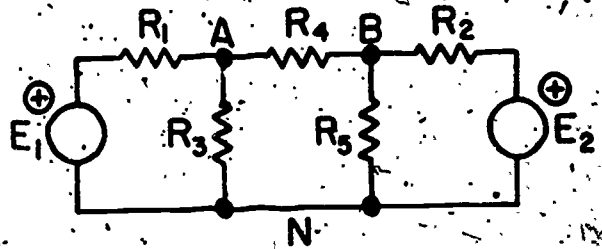

$$(1) \left(\frac{1}{R_1} + \frac{1}{R_3} + \frac{1}{R_4} \right) V_{AN} - \frac{1}{R_4} V_{BN} = \frac{E_1}{R_1}$$

$$(2) -\frac{1}{R_4} V_{AN} + \left(\frac{1}{R_4} + \frac{1}{R_5} + \frac{1}{R_2} \right) V_{BN} = \frac{E_2}{R_2}$$

The solution for the node Voltages, V_{AN} and V_{BN} , appears in coded form on the following page. This program solves the two above equations by multiplying the first equation by the coefficient of V_{BN} from the second equation and multiplying the second equation by the coefficient of V_{AN} from the first equation and then solving for V_{AN} . After solving for V_{AN} , it is then substituted back into the first equation to obtain the value of V_{BN} .

Before Starting:

Clear all, store R_5 in Right Adder, R_4 in Register 3, R_3 in Register 2, R_2 in Register 1, and R_1 in Register 0.

After the first Stop:

Store E_2 in Register 2, index and enter E_1 .

After the Second Stop:

Record VAN

After the Third Stop:

Record VBN

End of Program

Program Code	300-360 Operation	No.	Cmd	Code	Comment	No.	Cmd	Code	Comment
01	Stop	00	$\div =$	47		40	ENTER	41	
10	Store Reg 0	01	AL	56		41	RE AR	51	
11	Store Reg 1	02	RE 2	16		42	$\times =$	46	
12	Store Reg 2	03	$\div =$	47		43	CL AL	54	
13	Store Reg 3	04	AL	56		44	AL	56	
14	Recall Reg 0	05	RE 3	17		45	RE 3	17	
15	Recall Reg 1	06	$\div =$	47		46	\times^2	45	
16	Recall Reg 2	07	A	56	Coef. VAN ₁	47	ST 1	11	
17	Recall Reg 3	08	RE AR	51		48	RE AR	51	
41	Enter	09	$\div =$	47		49	ENTER	41	
42	Log _e X	10	CL AR	50		50	RE 3	17	
43	e^x	11	AR	52		51	$\times =$	46	
44	\sqrt{x}	12	RE 3	17		52	ST 3	13	
45	x^2	13	$\div =$	47		53	RE 1	15	
46	$x =$	14	AR	52		54	-AL	57	
47	$\div =$	15	RE 1	15		55	RE 0	14	
50	Clear Right Adder	16	$\div =$	47		56	CL AR	50	
51	Recall Right Adder	17	AR	52	Coef. VBN ₂	57	AR	52	
52	+ Right Adder	18	RE 3	17		58	RE 2	16	
53	- Right Adder	19	$\div =$	47		59	-AR	53	
54	Clear Left Adder	20	CH SI	77		60	ENTER	41	
55	Recall Left Adder	21	ST 3	13	Coef. VBN ₁	61	RE AL	55	
56	+ Left Adder	22	STOP	01	Store E2 Enter E1	62	$\div =$		
57	- Left Adder	23	RE 0	14		63	STOP	01	VAN
60	Numeral 0	24	$\div =$	47		64	ENTER	41	
61	Numeral 1	25	ST 0	10		65	RE :	15	
62	Numeral 2	26	RE AR	51		66	$\times =$	46	
63	Numeral 3	27	ENTER	41		67	CH SI	77	
64	Numeral 4	28	RE 0	14		68	CL AL	54	
65	Numeral 5	29	$\times =$	46		69	AL	56	
66	Numeral 6	30	ST 0	10		70	RE 2	16	
67	Numeral 7	31	RE 2	16		71	AL	56	
70	Numeral 8	32	ENTER	41		72	ENTER	41	
71	Numeral 9	33	RE 1	15		73	RE 3	17	
75	Decimal Point	34	$\div =$	47		74	$\div =$		
76	Clear Display	35	ENTER	41		75	STOP	01	VBN
77	Change Sign	36	RE 3	17		76			THE END
		37	$\times =$	46		77			
		38	ST 2	12		78			
		39	RE AL	55		79			

FORTRAN IV. PROGRAM FOR PULSE ELECTRONICS

```

1      5      WRITE(6,6)
2      6      FORMAT('1','PULSE ELECTRONICS')
3      10     WRITE(6,20)
4      20     FORMAT(T10,'THE OUTPUT ACROSS THE DIODE OF A CLIPPING CIRCUIT WITH
AA SINE WAVE (INPUT//T15,'INPUT VOLTAGE = 10SIN(WT)')//)
5      40     WRITE(6,60)
6      50     FORMAT('0',T24,'ANGLE(DEG)',T46,'SIN(WT)',T67,'E OUT')
7      60     FORMAT(' ',T10,'ASSUME IDEAL DIODE')
8      70     WRITE(6,50)
9      80     DO 160 I=1,36
10     90     DEG = 10.0*I
11     100    X=DEG*0.0174532925
12     105    A=SIN(X)
13     110    E=10*A
14     120    IF(E)130,140,140
15     130    E=0.0
16     140    WRITE(6,150)DEG,A,E
17     150    FORMAT(T26,F8.2,T45,F10.7,T65,F10.3)
18     160    CONTINUE
19     170    WRITE(6,180)
20     180    FORMAT('1',T10,'ASSUME FORWARD RESISTANCE = 1/10 OF TOTAL CIRCUIT
RESISTANCE')
21     190    WRITE(6,50)
22     200    DO 280 I=1,36
23     210    DEG = 10.0*I
24     220    X=DEG*0.0174532925
25     230    A=SIN(X)
26     240    E=10*A
27     250    IF(E) 260,270,270
28     260    E=E*0.1
29     270    WRITE(6,150)DEG,A,E
30     280    CONTINUE
31     290    WRITE(6,300)
32     300    FORMAT('1',T10,'ASSUME FORWARD RESISTANCE = 1/10 OF TOTAL CIRCUIT
RESISTANCE'/T17,'REVERSE RESISTANCE = 9/10 OF THE TOTAL CIRCUIT
RESISTANCE')
33     310    WRITE(6,50)
34     320    DO 430 I=1,36
35     330    DEG = 10.0*I
36     340    X=DEG*0.0174532925
37     350    A=SIN(X)
38     360    E=10*A
39     370    IF(E)380,420,400
40     380    E=E*0.1
41     390    GO TO 420
42     400    E=E*0.9
43     410    GO TO 420
44     420    WRITE(6,150)DEG,A,E
45     430    CONTINUE
46     440    STOP
47     END

```

PULSE ELECTRONICS

THE OUTPUT ACROSS THE DIODE OF A CLIPPING CIRCUIT WITH A SINE WAVE INPUT

INPUT VOLTAGE = 10SIN(WT)

ASSUME IDEAL DIODE

ANGLE (DEG)	SIN(WT)	E OUT
10.00	0.1736481	1.736
20.00	0.3420201	3.420
30.00	0.4999999	5.000
40.00	0.6427876	6.428
50.00	0.7660444	7.660
60.00	0.8660253	8.660
70.00	0.9396925	9.397
80.00	0.9848077	9.848
90.00	0.9999999	10.000
100.00	0.9848078	9.848
110.00	0.9396927	9.397
120.00	0.8660256	8.660
130.00	0.7660447	7.660
140.00	0.6427879	6.428
150.00	0.5000004	5.000
160.00	0.3420206	3.420
170.00	0.1736487	1.736
180.00	0.0000006	0.000
190.00	-0.1736475	0.000
200.00	-0.3420194	0.000
210.00	-0.4999993	0.000
220.00	-0.6427870	0.000
230.00	-0.7660439	0.000
240.00	-0.8660250	0.000
250.00	-0.9396923	0.000
260.00	-0.9848076	0.000
270.00	-0.9999999	0.000
280.00	-0.9848077	0.000
290.00	-0.9396926	0.000
300.00	-0.8660254	0.000
310.00	-0.7660445	0.000
320.00	-0.6427877	0.000
330.00	-0.5000001	0.000
340.00	-0.3420203	0.000
350.00	-0.1736484	0.000
360.00	-0.0000003	0.000

ASSUME FORWARD RESISTANCE = 1/10 OF TOTAL CIRCUIT RESISTANCE

ANGLE (DEG)	SIN(WT)	E OUT
10.00	0.1736481	1.736
20.00	0.3420201	3.420
30.00	0.4999999	5.000
40.00	0.6427876	6.428
50.00	0.7660444	7.660
60.00	0.8660253	8.660
70.00	0.9396925	9.397
80.00	0.9848077	9.848
90.00	0.9999999	10.000
100.00	0.9848078	9.848
110.00	0.9396927	9.397
120.00	0.8660256	8.660
130.00	0.7660447	7.660
140.00	0.6427879	6.428
150.00	0.5000004	5.000
160.00	0.3420206	3.420
170.00	0.1736487	1.736
180.00	0.0000006	0.000

190.00	-0.1736475	-0.174
200.00	-0.3420194	-0.342
210.00	-0.4999993	-0.500
220.00	-0.6427870	-0.643
230.00	-0.7660439	-0.766
240.00	-0.8660250	-0.866
250.00	-0.9396923	-0.940
260.00	-0.9848076	-0.985
270.00	-0.9999999	-1.000
280.00	-0.9848077	-0.985
290.00	-0.9396926	-0.940
300.00	-0.8660254	-0.866
310.00	-0.7660445	-0.766
320.00	-0.6427877	-0.643
330.00	-0.5000001	-0.500
340.00	-0.3420203	-0.342
350.00	-0.1736484	-0.174
360.00	-0.0000003	-0.000

ASSUME FORWARD RESISTANCE = 1/10 OF TOTAL CIRCUIT RESISTANCE
 REVERSE RESISTANCE = 9/10 OF THE TOTAL CIRCUIT RESISTANCE

ANGLE (DEG)	SIN(WT)	E OUT
10.00	0.1736481	1.563
20.00	0.3420201	3.078
30.00	0.4999999	4.500
40.00	0.6427876	5.785
50.00	0.7660444	6.894
60.00	0.8660253	7.794
70.00	0.9396925	8.457
80.00	0.9848077	8.863
90.00	0.9999999	9.000
100.00	0.9848078	8.863
110.00	0.9396927	8.457
120.00	0.8660256	7.794
130.00	0.7660447	6.894
140.00	0.6427879	5.785
150.00	0.5000004	4.500
160.00	0.3420206	3.078
170.00	0.1736487	1.563
180.00	0.0000006	0.000
190.00	-0.1736475	-0.174
200.00	-0.3420194	-0.342
210.00	-0.4999993	-0.500
220.00	-0.6427870	-0.643
230.00	-0.7660439	-0.766
240.00	-0.8660250	-0.866
250.00	-0.9396923	-0.940
260.00	-0.9848076	-0.985
270.00	-0.9999999	-1.000
280.00	-0.9848077	-0.985
290.00	-0.9396926	-0.940
300.00	-0.8660254	-0.866
310.00	-0.7660445	-0.766
320.00	-0.6427877	-0.643
330.00	-0.5000001	-0.500
340.00	-0.3420203	-0.342
350.00	-0.1736484	-0.174
360.00	-0.0000003	-0.000

FORTRAN IV. PROGRAM TO CALCULATE BIASING RESISTANCE

```

0001-      RFAL#4,IC,IB,ICQ
0002-      READ(5,10) VCC,VCF,VBE,BETA,IC,ICQ
0003-      WRITE(6,10) VCC,VCF,VBE,BETA,IC,ICQ
0004-      10 FORMAT(4F10.2,2F15.2)
0005-      WRITE(6,20)
0006-      20 FORMAT('1',T14,'%',T35,'RE',T55,'RL',T73,'R1',T100,'R2')
      C
      C      DO LOOP TO INCREMENT THE STABILITY FACTOR(S)
      C
0007-      N=4BETA/10.
0008-      DO 100 J=5,N
0009-      S=J
      C
      C      DO LOOP TO INCREMENT RE
      C
0010-      DO 100 I=500,5000,500
0011-      RE=I
      C      S=DELTA IC/DELTA ICQ = (BETA+1.)(1.+RB/RE)/(1.+BETA+RB/RE)
      C      X=RB/RE
0012-      X=(BETA+1.)*(1.-S)/(S-BETA+1.)
0013-      RB=X*RE
0014-      IB=(IC - ICQ*(BETA+1.))/BETA
0015-      VTH=IB*(RB+RE*(BETA+1.)) + VBE
      C      VTH=VCC*R2/(R1+R2)
      C      RB=RTH=R1*R2/(R1+R2)
      C
      C      SOLVING THE LAST TWO EQUATIONS SIMULTANEOUSLY YIELDS THE
      C      C FOLLOWING FOR R1 AND FOR R2
      C
0016-      R1=VCC*RB/VTH
0017-      R2=VTH*R1/(VCC-VTH)
      C
      C      FOR LARGE BETA, IC IS APPROXIMATELY = TO IF AND THE FOLLOWING
      C      C EQUATION HOLDS
      C
0018-      RL=(VCC-VCE)/IC - RE
0019-      WRITE(6,50) S,RE,RL,R1,R2
0020-      50 FORMAT('0',T10,F6.1,T30,F10.2,T50,F10.2,T70,F15.2,T95,F10.2)
0021-      100 CONTINUE
0022-      STOP
0023-      END

```

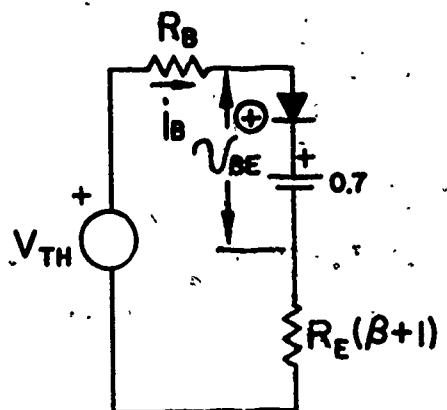
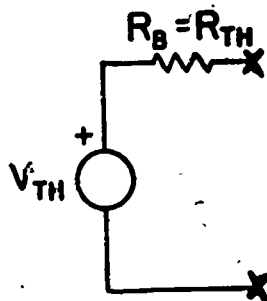
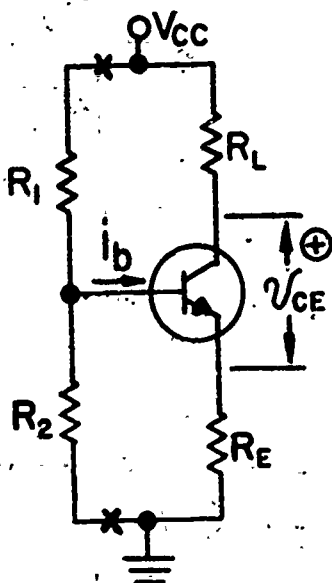

FORTRAN IV. PROGRAM FOR SQUARE WAVE SYNTHESIS

```

0001      DIMENSION Y(64,29),L(29),A(1856),TIME(1856),TX(2),TY(2),C(29)
0002      9      FORMAT('0','PERIOD =',1PE11.4)
0003      10     FORMAT(3F20.6)
0004      40     FORMAT('1',T9,I2,T22,I2,T36,I2,T50,I2,T64,I2,T78,I2,T92,I2,
CT107,I2,T121,I2)
0005      11     FORMAT(2(1PE14.4))
0006      12     FORMAT(9(1PE14.4))
0007      READ (5,10) AMPLI, DCVAL, FREQ
0008      WRITE (6,10) AMPLI, DCVAL, FREQ
0009      PERIOD = 1.0/FREQ
0010      WRITE (6,9) PERIOD
0011      T = PERIOD / 64.0
0012      13     FORMAT('0','TIME-INTERVAL IS',1PE11.4,'SECONDS')
0013      WRITE (6,13) T
0014      TINTVL=0.0
0015      K=0
0016      DO 30 N = 1,29
0017      L(N)=N
0018      C(N) = AMPLI * ABS(SIN(N*3.14159/2.0)/(N*3.14159/2.0))
0019      DO 20 I = 1,64
0020      TINTVL = I*T
0021      TIME(I)=TINTVL
0022      Y(I,N) = DCVAL + C(N) * SIN(N*3.14159*2.0*TINTVL/PERIOD)
0023      K=K+1
0024      TIME(K)=K*T
0025      NM1=N-1
0026      IF (NM1) 20,20,18
0027      18     Y(I,N) = Y(I,N) + Y(I,NM1)
0028      A(K)=Y(I,N)
0029      20     CONTINUE
0030      30     CONTINUE
0031      DO 25 J=1,64
0032      25     A(J)= Y(J,1)
0033      WRITE (6,40) (L(N),N=1,9)
0034      WRITE (6,12)((Y(I,J),J= 1, 9),I= 1,64)
0035      WRITE (6,40) (L(N),N=10,18)
0036      WRITE (6,12)((Y(I,J),J=10,18),I= 1,64)
0037      WRITE (6,40) (L(N),N=19,27)
0038      WRITE (6,12)((Y(I,J),J=19,27),I= 1,64)
0039      WRITE (6,40) (L(N),N=28,29)
0040      WRITE (6,11)((Y(I,J),J=28,29),I= 1,64)
0041      WRITE(6,12)(TIME(K),K=1,1856)
0042      WRITE (6,12) (A(K),K=1,1856)

0043      For      CALL CCP4SC (TIME,34.0,1408,1,TX)
0044      Calc      CALL CCP4SC (A,8.0,1856,1,TY)
0045      plot     CALL CCP1PL (0.5,0.5,-3)
0046      CALL CCP5AX (0.0,0.0,'TIME',-4,34.0,0.0,TX)
0047      CALL CCP5AX (0.0,0.0,'A',1,8.0,90,C,TY)
0048      CALL CCP6LN (TIME,A,1408,1,TX,TY)
0049      CALL CCP1PL (11.0,0.0,-3)
0050      STOP
0051      END

```

SQUARE WAVE SYNTHESIS

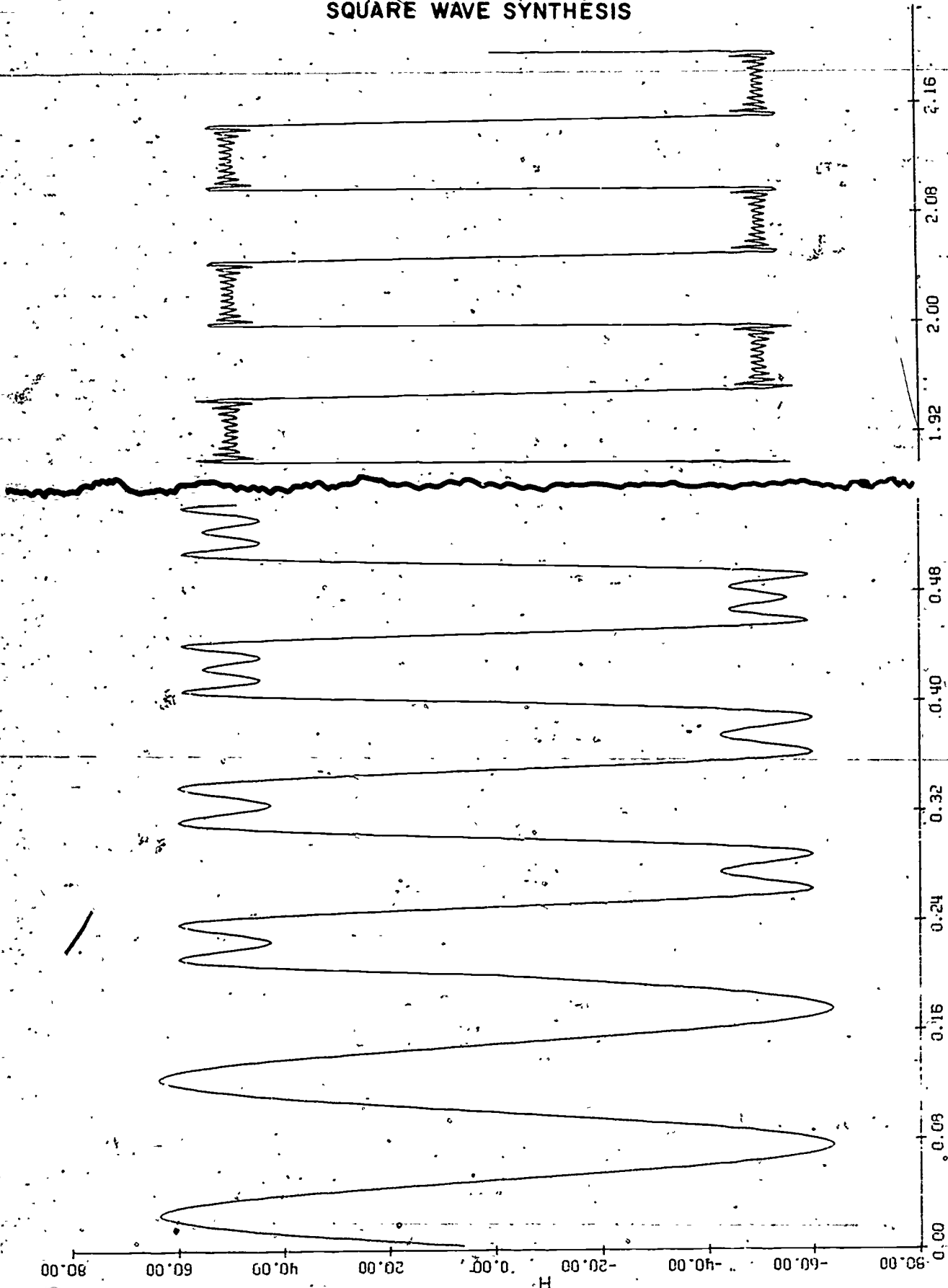

FORTRAN IV. PROGRAM FOR TWO-STAGE AMPLIFIER

```

C THE LAST NUMBER OF THE IF PARAMETERS INDICATES THE TRANSISTOR TO WHICH THE
C PARAMETER BELONGS. THE CASE ON THE LEFT OF THE CIRCUIT DIAGRAM IS NUMBER ONE.
1  PEAR(5,101) RS, RB1, P11, RB2, R12, RL, P111, H112, H121, F122,
   1F211, F212, F221, F222
2  IOT FFORMAT(8F10.2/2F10.5,2F10.2,2E10.2)
3  WRITE(6,101) RS, RB1, RL1, RB2, R12, RL, H111, H112, H121, H122,
   2F211, F212, F221, F222
4  RELF1 = H111 * F221 - F2M1 * H121
5  RELF2 = F112 * F222 - F212 * F122
6  PL2AC = RL * R12 / (RL + R12)
7  RIN2 = (RELF2 * RL2AC + H112) / (1. + F222 * RL2AC)
8  R11AC = 1. / (1./RL1 + 1./RP2 + 1./RIA2)
9  PINT = (DELF1 * R11AC + F111) / (1. + F221 * R11AC)
10  RINCKT = PFI * RIA1 / (PFI + RIA1)
11  PSI = PS * RFI / (PS + RFI)
12  RCI = (PSI + F111) / (RSI * F221 + DELF1)
13  PSP = 1. / (1./RCI + 1./RL1 + 1./RP2)
14  RQ2 = (RS2 + F112) / (RS2 * F222 + DELF2)
15  PQA = RQ2 * R12 / (RC2 + R12)
16  A15 = R12 / (RL2 + R1)
17  A14 = F212 / (1. + F222 * R12AC)
18  A13 = PL1 * RP2 / (RL1 + RP2) / ((RL1 + RP2) / (RL1 + RP2)) + RIN2)
19  A12 = F211 / (1. + F221 * R11AC)
20  A11 = PFI / (RPI + RINP)
21  AVIC1 = A11 * A12 * A13 * A14 * A15
22  AVIC2 = AVIC1 * PL / RINCKT
23  APIC1 = AVIC1 * AVIC2
24  WRITE(6,201) PS, F514 RINCKT, RIN1, RCI, RS2, RIN2, PC2, RCI
25  F501 FFORMAT(14C, 8F10.5) RESISTANCE PARAMETERS*/(5F14.5)
26  WRITE(6,211) A11, A12, A13, A14, A15, AVIC1, AVIC2, APIC1
27  F501 FFORMAT(14F, 8F10.5) GAIN PARAMETERS*/(7F10.2, F20.7)
28  AVIC3 = 20.*ALCCIC(AVIC1)
29  AVIC4 = 20.*ALCCIC(AVIC2)
30  AVIC5 = 20.*ALCCIC(AVIC3)
31  WRITE(6,221) AVIC1, AVIC2, AVIC3, AVIC4, AVIC5
32  F501 FFORMAT(16, 8F10.5) DB GAIN PARAMETERS*/(3F10.2)
33  STOP
34  END

```

```

*ENTRY
1000.00 1400.00 8000.00 12000.00 6000.00 1000.00 1400.00 1600.00
0.00000 0.00000 60.00 50.00 0.100E-04 0.200E-04
0.10000E 04 0.93327E 03 0.12660E 04 0.13929E 04 0.13462E 06
0.46347E 04 0.15966E 04 0.51657E 05 0.53756E 04
0.01 58.29 0.15 48.16 0.86 1784.51 1945.81 0.279461E 07

```

```

DB GAIN PARAMETERS
64.63 62.58 61.61

```



TWO-STAGE AMPLIFIER

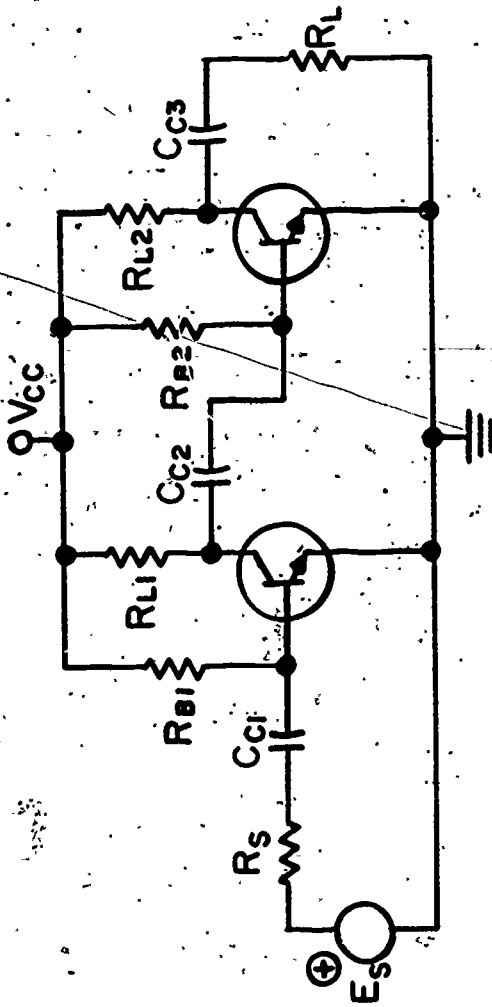

h - PARAMETER MODEL

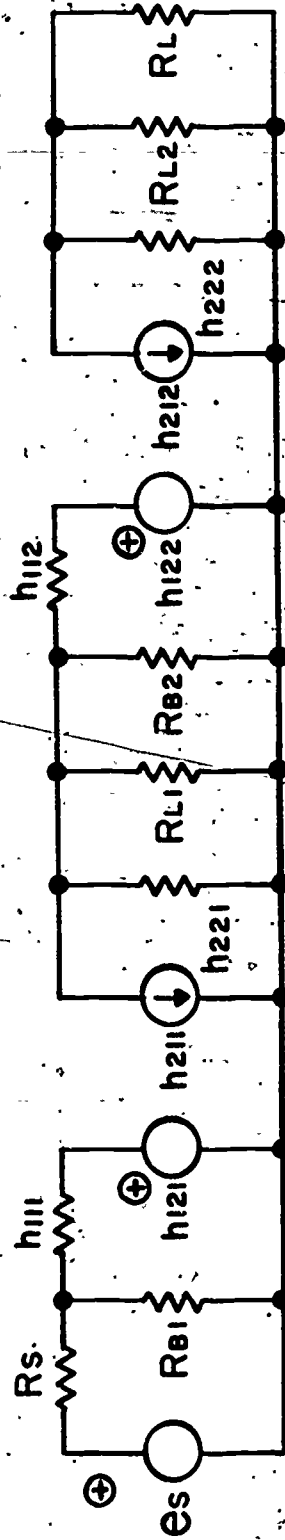

SOLVING A COMPLEX NETWORK WITH FORTRAN IV.

```

CCC1      DIMENSION A(10,10), X(10)
CCC2      COMPLEX A,X,Z1,Z2,Z3,Z4,Z5,Z6,Z7,Z8,Z9,VAN,VEN,VCA,VAR,VBC,E1,E2,E
          I3,C,P
CCC3      READ(5,101) N, AMIN
CCC4      101 FORMAT(1E,F10.5)
CCC5      NPI = N + 1
CCC6      NM1 = N - 1
CCC7      READ(5,111) E1, E2, E3, Z1, Z2, Z3, Z4, Z5, Z6, Z7, Z8, Z9
CCC8      111 FORMAT(6F10.2/6F10.2/6F10.2/6F10.2)
CCC9      WRITE(6,111) E1, E2, E3, Z1, Z2, Z3, Z4, Z5, Z6, Z7, Z8, Z9
CC10      A(1,1) = 1./Z1 + 1./Z2 + 1./Z4 + 1./Z5
CC11      A(1,2) = -(1./Z5 + 1./Z7)
CC12      A(1,3) = CMPLX(C.C,C.C)
CC13      A(1,4) = E1/Z1 - E2/Z2
CC14      A(2,1) = A(1,2)
CC15      A(2,2) = 1./Z2 + 1./Z5 + 1./Z6 + 1./Z7
CC16      A(2,3) = -1./Z7
CC17      A(2,4) = E2/Z2
CC18      A(3,1) = CMPLX(C.C,0.C)
CC19      A(3,2) = A(2,2)
CC20      A(3,3) = 1./Z3 + 1./Z7 + 1./Z8 + 1./Z9
CC21      A(3,4) = E3/Z3
CC22      K = C
CC23      121 K = K + 1
CC24      AMAX = C.C
CC25      DO 131 I = K,N
CC26      IF(AMAX - CAPS(A(I,K))) 116,131,131
CC27      116 LCC = I
CC28      AMAX = CAPS(A(I,K))
CC29      131 CONTINUE
CC30      IF(LCC.EC.K) GO TO 151
CC31      DO 141 J = K,NPI
CC32      STCFE = A(K,J)
CC33      A(K,J) = A(LCC,J)
CC34      A(LCC,J) = STCFE
CC35      141 CONTINUE
CC36      151 P = A(K,K)
CC37      IF(CAPS(A(K,K)).LT.AMIN) GO TO 191
CC38      DO 161 J = K,NPI
CC39      A(K,J) = A(K,J) / P
CC40      161 CONTINUE
CC41      KP1 = K + 1
CC42      DO 171 I = KP1,N
CC43      C = A(I,K)
CC44      DO 171 J = K,NPI
CC45      A(I,J) = A(I,J) - C * A(K,J)
CC46      171 CONTINUE
CC47      IF(K.LT.N-1) GO TO 121
CC48      IF(CAPS(A(N,N)).LT.AMIN) GO TO 191
CC49      X(N) = A(N,NPI) / A(N,N)
CC50      DO 181 L = 1,NPI
CC51      JJ = N - L
CC52      X(JJ) = A(JJ,NPI)
CC53      JK = JJ + 1
CC54      DO 181 J = JK,N
CC55      X(JJ) = X(JJ) - A(JJ,J) * X(J)
CC56      181 CONTINUE
CC57      X(4) = X(1) - X(2)
CC58      X(5) = X(2) - X(3)
CC59      WRITE(6,201) (X(I), I = 1,5)
CC60      201 FORMAT(/' VAN REAL VAN IMAG VEN REAL VEN IMAG VCN REAL VCN I
          IMAG'/6F10.3//' VAR REAL VAR IMAG VPC REAL VRC IMAG'/4F10.3)
CC61      191 STOP
CC62      END

```

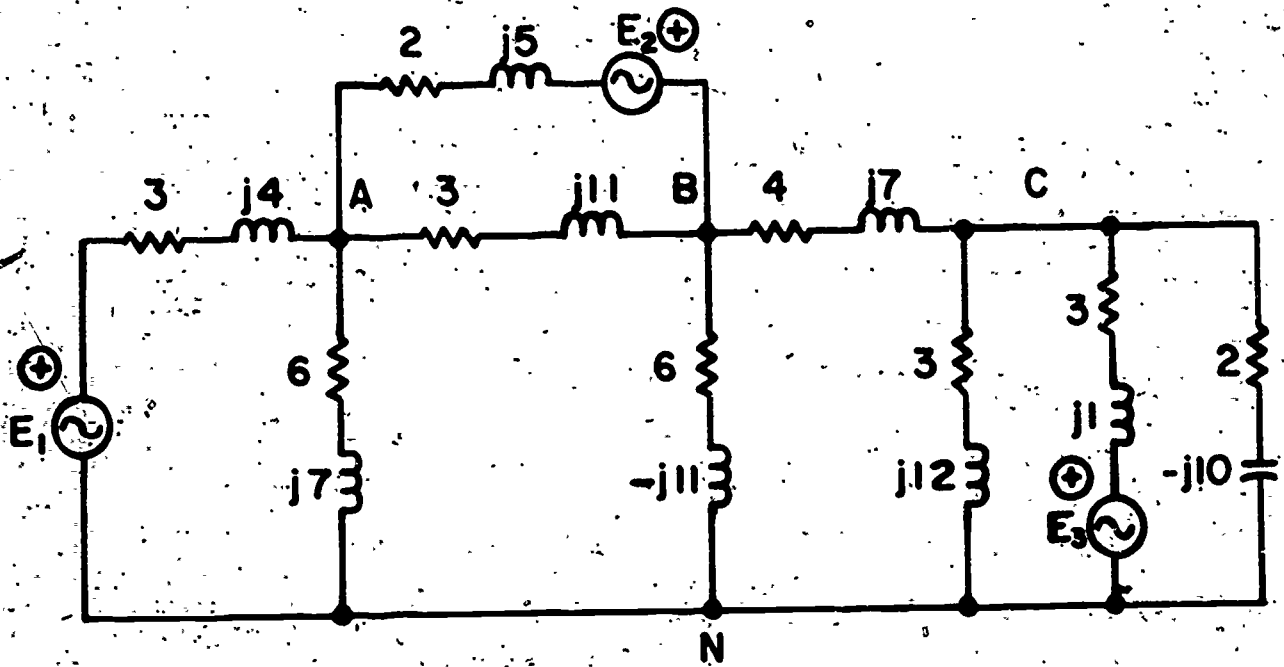

COMPLEX NETWORK

Output

120.00	0.0	120.00	0.0	120.00	0.0
3.00	4.00	2.00	5.00	3.00	1.00
6.00	7.00	3.00	11.00	6.00	-11.00
4.00	7.00	3.00	12.00	2.00	-10.00
<hr/>					
VAN REAL	VAN IMAG	VBN REAL	VBN IMAG	VCN REAL	VCN IMAG
66.606	-27.802	146.472	-56.666	109.332	-25.639
<hr/>					
VAB REAL	VAB IMAG	VBC REAL	VBC IMAG		
-78.866	28.894	36.140	-30.757		

401 WRITE (C,9901)
401 FORMAT (I3, T0,9, RECF, THE VALUES OF R, L, AND C THE CIRCUIT IS CV,
SERIAL NO. I)

C = SCAL(R**2 / (4.0 * 1**2) - 1.0 / (L * C))

K1 = -V / (2.0 * L * R)

K2 = -K1

S1 = -C1 - P

S2 = -C1 + P

CC 202 J1 = 1, LIMIT

K = J1

JJ(51) = K1 + EXP(S1 * Y(K)) + K2 * EXP(S2 * Y(K))

402 T(K+1) = T(K) + DELT

CC 10 1117

CONTINUE

CC 502 J1 = 1, LIMIT

500 IJ(J1) = ABS(IJ(J1))

NI = LIMIT - I

CC 501 J1 = 1, NI

N = J1 + 1

CC 501 K = N, LIMIT

IF (IJ(J1) .GT. IJ(K)) GO TO 501

TEMP = IJ(J1)

IJ(J1) = IJ(K)

IJ(K) = TEMP

CC 501 CONTINUE

CC 504 J1 = 1, J11

CC 502 J1 = 1, LIMIT

502 IJ(J1) = 4.0 * C * (JJ(J1) / IJ + 1.0) + 1.5

CC 503 J = 1, RI

503 IJ(IJ) = CC

WRITE (7,700) IJ(IJ)

CC 504 J = 1, RI

504 IJ(IJ) = IJ(IJ)

CC 73 J = Y(J)

LINE(J) = STAF

WRITE (6,701) LINE, Y(J), JJ(J)

LINE(J) = PLANK

LINE(21) = CC

600 CONTINUE

700 FORMAT (F, F10, F10, 15X, TIME, 10X, VARDS)

701 FORMAT (F, F10, F10, 2E13, 5)

900 CONTINUE

CALL CC(450 (Y,10,C,LIMIT,1,IX))

CALL CC(450 (Y,10,C,LIMIT,1,IX))

CALL CC(450 (C,5,C,5,-3))

CALL CC(450X (C,5,C,5,TIME,4,10,C,C,0,IV))

CALL CC(450X (C,C,C,C,AMES,5,8,C,9,C,0,IV))

CALL CC(450 (Y,10,C,LIMIT,1,IX,IV))

CALL CC(450 (Y,10,C,C,-3))

CC 11 CC

99 STOP

THE VALUES FOR VOLTAGE RESISTANCE, INDUCTANCE, AND CAPACITANCE FOLLOWS.

VOLTAGE RESISTANCE INDUCTANCE CAPACITANCE
1.0000CF CC 1.000000 C2 2.50000CF-CL 9.99990CF-F7

THE RESONANT FREQUENCY IS 29.951 HZ.

FOR THE VALUES OF Q, L, AND C THE CIRCUIT IS CRITICALLY DAMPED.

TIME AMP

C=0	O=0
C.11636F-03	C.34879F-03
C.23271E-03	O.59445E-03
C.49077F-03	C.69466F-03
C.46542E-03	C.73302F-03
C.58178F-03	O.72693F-03
C.69813E-03	C.69121E-03
C.81469F-03	C.63889E-03
C.93084E-03	C.57865E-03
C.10472F-02	C.51583F-03
C.11636F-02	O.45415F-03
C.12799F-02	C.35584F-03
C.13963F-02	C.34218E-03
C.15126F-02	C.26373E-03
C.16290F-02	O.25265E-03
C.17453F-02	C.27128E-03
C.18617E-02	O.17986E-03
C.19780F-02	C.15827E-03
O.20944F-02	O.12704E-03
C.22107F-02	C.10626F-03
C.23271F-02	C.8P630F-04
C.24435E-02	C.73740F-04
C.25598F-02	C.61213F-04
C.26762F-02	O.50769F-04
C.27925E-02	O.41928F-04
C.29089E-02	C.34607E-04
O.30252E-02	O.28519F-04
C.31418E-02	C.27467F-04
C.32579F-02	O.19284F-04
C.33743E-02	O.15826F-04
C.34907F-02	O.12927E-04
C.36070E-02	O.10622F-04
C.37234F-02	C.86880F-05
C.38397F-02	C.70546F-05
O.39561E-02	O.57559F-05
C.40728E-02	C.47777F-05
C.41888E-02	C.38532F-05
C.43051E-02	O.31300E-05
C.44215F-02	C.25537E-05
C.45378F-02	C.20768F-05
C.46542E-02	O.16878E-05
C.47705F-02	O.13708E-05
C.48869F-02	O.11127E-05
C.50032F-02	C.90771E-06
C.51196E-02	C.73193E-06
C.52359E-02	O.59316E-06
C.53523E-02	C.48045F-06
C.54688E-02	O.38888F-06
C.55852E-02	O.31478F-06
C.57016E-02	O.25653F-06
C.58177E-02	O.20588E-06
C.59341E-02	O.16640F-06
C.60504E-02	O.13444F-06

Critically Damped



THE VALUES FOR VOLTAGE, RESISTANCE, INDUCTANCE, AND CAPACITANCE FOLLOW:

VOLTAGE — RESISTANCE — INDUCTANCE — CAPACITANCE

1.000000 CC 7.250000F 2.500000E-01 5.000000E-07

THE RESONANT FREQUENCY IS 310.31 HZ.

FOR THE VALUES OF R, L, AND C THE CIRCUIT IS OVERDAMPED.

C.O	C.O	YTH	RMS
C.11234F-03	C.10020F-03		
C.23271F-03	C.60801F-03		
C.32907F-03	C.43820F-03		
C.46542F-03	C.43203F-03		
C.58171F-03	C.41200F-03		
C.69813F-03	C.38406F-03		
C.81488F-03	C.37182F-03		
C.93084F-03	C.35003E-03		
C.10477F-02	C.32916F-03		
C.11634F-02	C.30538F-03		
C.12790F-02	C.29073F-03		
C.13963F-02	C.27318F-03		
C.15128F-02	C.25670F-03		
C.16290F-02	C.24116F-03		
C.17453F-02	C.22659F-03		
C.18617F-02	C.21200F-03		
C.19780F-02	C.20021E-03		
C.20944F-02	C.18793F-03		
C.22107F-02	C.17657F-03		
C.23271F-02	C.16500F-03		
C.24435F-02	C.15387F-03		
C.25598F-02	C.14646F-03		
C.26762F-02	C.13591F-03		
C.27925F-02	C.12970F-03		
C.29089F-02	C.12126F-03		
C.30252F-02	C.11412F-03		
C.31415F-02	C.10722F-03		
C.32578F-02	C.10074F-03		
C.33741F-02	C.92658E-04		
C.34904F-02	C.89927E-04		
C.36067F-02	C.84551F-04		
C.37230F-02	C.78500F-04		
C.38393F-02	C.74755E-04		
C.39556F-02	C.69206E-04		
C.40720F-02	C.65100E-04		
C.41883E-02	C.61172E-04		
C.43046F-02	C.57474E-04		
C.44210F-02	C.54000E-04		
C.45373F-02	C.50774E-04		
C.46536E-02	C.47669E-04		
C.47700F-02	C.44787E-04		
C.48863F-02	C.42080E-04		
C.50026F-02	C.39576E-04		
C.51190E-02	C.37146E-04		
C.52353E-02	C.34901E-04		
C.53516E-02	C.32701E-04		
C.54680F-02	C.30549E-04		
C.55843E-02	C.28047E-04		
C.57006E-02	C.27197E-04		
C.58170F-02	C.25553E-04		
C.59333E-02	C.23909E-04		
C.60496E-02	C.22557E-04		

Overdamped



THE VALUES FOR VOLTAGE, RESISTANCE, INDUCTANCE, AND CAPACITANCE FOLLOWS.

VOLTAGE * RESISTANCE INDUCTANCE CAPACITANCE

1.000000 CC 1.000000 C2 2.500000 CF-C1 5.999999 CF-C7

THE RESONANT FREQUENCY IS 318.31 HZ.

FOR THE VALUES OF R, L, AND C THE CIRCUIT IS OSCILLATORY.

	YTMF	AMP
C.11636F-03	0.0	C.45066F-03
C.23271E-03	*	C.95709E-03
C.34907F-03	*	C.11599E-02
C.46542F-03	*	C.14630E-02
C.58178F-03	*	C.1638E-02
C.69813E-03	*	C.17194E-02
C.81448F-03	*	C.17058E-02
C.93084E-03	*	C.16029E-02
C.10472E-02	*	C.14203E-02
C.11636E-02	*	C.11712E-02
C.12798E-02	*	C.97171E-02
C.13063E-02	*	C.93993E-03
C.15126E-02	*	C.19479E-03
C.16290E-02	*	C.14491E-03
C.17453E-02	*	C.86153E-03
C.18617E-02	*	C.73544E-03
C.19781E-02	*	C.96576E-03
C.20944E-02	*	C.11309E-02
C.22107E-02	*	C.17290E-02
C.23271E-02	*	C.12579E-02
C.24434E-02	*	C.12182E-02
C.25598E-02	*	C.11180E-02
C.26762E-02	*	C.98258E-03
C.27926E-02	*	C.76350E-03
C.29089E-02	*	C.53376E-03
C.30252E-02	*	C.28530E-03
C.31416E-02	*	C.33769E-03
C.32579E-02	*	C.20890E-03
C.33743E-02	*	C.47818E-03
C.34907E-02	*	C.61582E-03
C.36070E-02	*	C.76210E-03
C.37234E-02	*	C.86177E-03
C.38397E-02	*	C.91152E-03
C.39561E-02	*	C.91100E-03
C.40724E-02	*	C.86251E-03
C.41888E-02	*	C.77000E-03
C.43051E-02	*	C.64264E-03
C.44214E-02	*	C.49649E-03
C.45378E-02	*	C.31181E-03
C.46542E-02	*	C.12864E-03
C.47705E-02	*	C.52573E-03
C.48869E-02	*	C.22354E-03
C.50032E-02	*	C.37457E-03
C.51196E-02	*	C.40018E-03
C.52359E-02	*	C.55150E-03
C.53523E-02	*	C.66843E-03
C.54687E-02	*	C.86500E-03
C.55850E-02	*	C.65321E-03
C.57014E-02	*	C.60373E-03
C.58178E-02	*	C.52460E-03
C.59341E-02	*	C.42191E-03
C.60504E-02	*	C.30102E-03

Oscillatory



SOLUTION OF THREE-NODE RESISTIVE CIRCUIT WITH ECAP

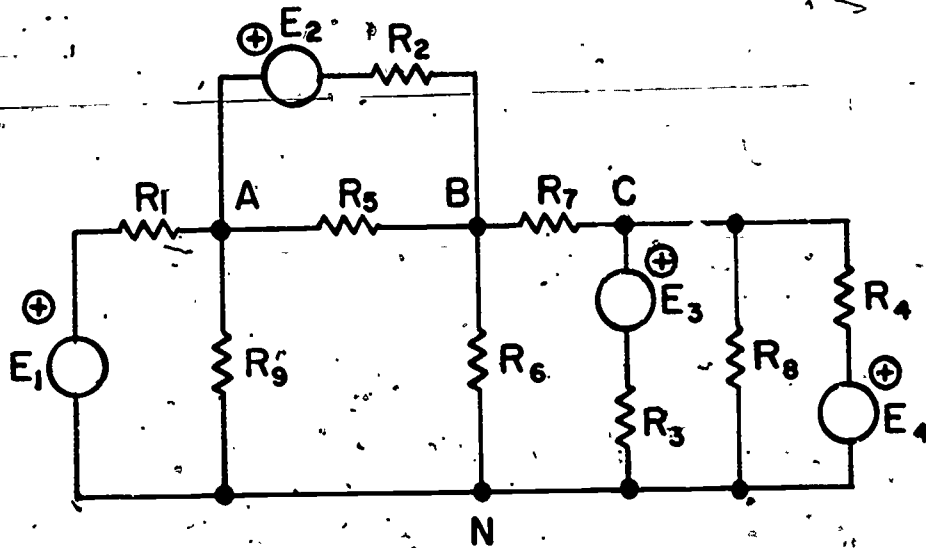

DC		
R1	N(0,1)	R = 12., F = 20.
R2	N(1,0)	R = 14.
R3	N(1,2)	R = 3.
R4	N(1,2)	R = 5., F = -24.
R5	N(2,0)	R = 11.
R6	N(2,3)	R = 13.
R7	N(3,0)	R = 9., F = -30.
R8	N(3,0)	R = 18.
R9	N(3,0)	R = 16., F = -26.

SF
PR, NV, CA, RP, SF
FX

NODE VOLTAGES

NODES	VOLTAGES
1- 3	0.15581900 02 0.44233410 01 -0.19353717 02

ELEMENT CURRENTS

BRANCHES	CURRENTS
1- 4	0.36779080 00 0.11132217 01 0.13947720 01 -0.21403030 01
5- 8	0.40257540 00 -0.11481050 01 -0.11322030 01 0.10752060 01
9- 0	-0.17403927 01

ELEMENT POWER LOSSES

BRANCHES	POWER LOSSES
1- 4	0.16232413 01 0.17352797 02 0.15543114 02 0.27495313 02
5- 8	0.17321277 01 0.17135931 02 0.12593195 02 0.20804250 02
9- 0	0.17318672 02

FORTRAN IV. PROGRAM TO CALCULATE *db* AND PHASE ANGLE

```

C      FORM NO. 1 = R1 SERIES WITH C1 OUTPUT ACROSS C1
C      FORM NO. 2 = R1 SERIES WITH C1 OUTPUT ACROSS R1
C      FORM NO. 3 BAND PASS FILTERED CIRCUIT--CAPACITOR INPUT- CAPACITOR
C      OUTPUT
1      DIMENSION F(350), DB(350), XI(12), ANGL(350)
2      10 READ(5,10),END=1)R1,R2,C1,C2,IN
3      100 FORMAT(2F10.2,2F12.5,12)
4      N=1
5      X=5.2R
6      DF = 0.0
7      FR = 1.0/(X*R2*C2)
8      FX = 1.0/FR
9      FL = FR/100.0
10     FH = FR * 100.0
11     FRC = 1.0/(X*R1*C1)
12     TXC = 1.0/FRC
13     FLC = FRC/100.0
14     FHC = FRC* 100.0
15     IF(IN-N)200,300,500
16     200 CONTINUE
17     WRITE(6,205)
18     205 FORMAT(' NO. SUCH FORM IS AVAILABLE*** GO DEVELOPE YOUR OWN
19     ZPROGRAM')
19     STOP
20     300 CONTINUE
C      THIS CIRCUIT IS IS A LOW PASS NETWORK
21     WRITE (6,201) R1,C1
22     201 FORMAT(/' THIS IS CIRCUIT FORM NO. 1',/ 'R1='F10.2, 'C1='F12.0)
23     WRITE(6,41)
24     41 FORMAT(/' FREQUNCY          DECIBELS          DEGREES (/)
25     DC 400 I = 1,200
26     F(I) = FLC+ DF
27     DB(I) = ALOG10(SQRT(1.0+(F(I)/FRC)**2))
28     DB(I) = (-20)*DB(I)
29     DF = DF + FLC* 5.0
30     ANGL(I) = (-ATAN(F(I)/FRC))*57.2R
31     IF(F(I) .EQ. FHC) GO TO 10
32     WRITE(6,301)F(I),DB(I),ANGL(I)
33     301 FORMAT(F15.2,F15.7,F15.5)
34     400 CONTINUE
35     GO TO 10
36     500 CONTINUE
37     N = N+1
38     IF(IN -N) 200,600,550
39     600 CONTINUE
C      THIS CIRCUIT IS IS A HIGH PASS NETWORK
40     WRITE (6,202) R2,C2
41     202 FORMAT(/' THIS IS CIRCUIT FORM NO. 2',/ 'R2='F10.2, 'C2='F12.0)
42     WRITE(6,42)
43     42 FORMAT(/'
44     DU 625 I = 1,200
45     F(I) = FL + DF
46     DB(I) = ALOG10(SQRT(1.0+(FR/F(I))**2))
47     DB(I) = (-20)*DB(I)
48     DF = DF + FL* 1.0
49     ANGL(I) = (+ATAN(FR/F(I)))*57.2R
50     IF(F(I) .EQ. FH) GO TO 10
51     WRITE(6,302)F(I),DB(I),ANGL(I)

```



```

51 .302 FORMAT(F15.2,F15.7,F15.5)
52 625 CONTINUE
53 GO TO 10
54 650 CONTINUE
55 N =N+1
56 IF((N-1) > 9, 630, 620)
57 630 CONTINUE
58 WRITE(6,203) F1, R2, C1, C2
59 203 FORMAT(' 1 BAND PASS FILTER CIRCUIT - FORM NO. 3', /
2 ' R1='F10.2, ' R2='F10.2, ' C1='F15.9,
/ ' C2='F15.9)
60 WRITE(6,42)
61 DO 750 I= 1,200
62 F(I) = FL + DF
63 DEN1=ALOG10(1.0+IF2/F(I)**2)
64 DEN1=ALOG10(1.0+(F(I)/FRC)**2)
65 DB(I) = (-20.0)*DEN1 + (-20.0)*DEN2
66 ANGL(I) = (-ATAN(F(I)/FRC)) + ATAN(F(I)/F) * 57.25
67 DF = DF + FL * 5.0
68 WRITE(6,303) F(I), DB(I), ANGL(I)
69 303 FORMAT(F15.2,F15.7,F15.5)
70 750 CONTINUE
71 42 FORMAT('// ' FREQUENCY DECIBELS DEGREES //')
72 620 CONTINUE
73 1 STOP
74 END

```

ENTRY

THIS IS CIRCUIT FORM NO. 2

R2= 10000.00C2= 0.000000001

FREQUENCY	DECIBELS	DEGREES
159.24	-40.0004100	29.40237
318.47	-33.9811200	88.82973
477.71	-30.4614500	98.25729
636.94	-27.9657200	87.58520
796.18	-26.0314300	37.11357
955.41	-24.4525600	86.54251
1114.65	-23.1192400	85.97211
1273.88	-21.9658900	45.40251
1433.12	-20.9501800	84.83385
1592.36	-20.0431900	84.26617
1751.59	-19.2243800	83.67958
1910.83	-18.4734500	53.13431
2070.06	-17.7939100	82.57030
2229.30	-17.1617200	82.00775
2388.53	-16.5747900	81.44673
2547.77	-16.0273700	80.88742
2707.01	-15.5147500	80.32079
2866.24	-15.0330300	79.77402
3025.48	-14.5787400	79.22017
3184.71	-14.1497300	78.66538
3343.95	-13.7430300	78.11568
3503.18	-13.3563100	77.57115
3662.42	-12.9893100	77.02599
3821.65	-12.6389300	76.48315

FORTRAN IV. LOW PASS FILTER PROBLEM

```

C          R
C *****R R R*****
C          R          *
C          *          *
C          *          *
C          CCCCC
C          CCCCC
C          *
C          *
C *****
C
C THIS PROGRAM IS FOR A LOW PASS FILTER. R & F ARE
C INCREMENTED BY DOO LOPS SO THERE ARE NG DATA CARDS INVOLVED.
C THE PRINT OUT WILL SHOW XC,Z,YAN,FOUT/FIN,RATIO,LOG CF
C THE RATIO, AND THE OUTPUT IN DB.
C
R=300.
DO 50 K=L,5
  R=R*2.0
  C=0.510F-7
  F=10.0
  WRITE(4,10)
10 FORMAT(10,/,/,T5,R,T21,XC,T36,Z,T50,TAN,T63,FRQ,
  A178,F2/E,I95,LOG F2/F,T14,OUTPUT IN DB)
  F=156.25
  DO 50 J=L,12
    F=F*2.
    XC=0.159/(C*F)
    Z=SQRT(R**2 + XC**2)
    T=ATAN(XC/Z)
    A=-180/3.14*T
    E2=XC/Z*F
    VR=E/F
    SL=ALOG10(E/E2)
    DB=-20*SL
    WRITE(6,20)P,XC,Z,A,F,VR,SL,DB
20 FORMAT(1P,F10.3,I16,F10.3,I31,E10.3,I44,2PE14.3,I60,1PE10.3,I75,
  50 CONTINUE
  STOP
  END

```

XC	Z	A	VR	SL	DB	TAN	FREQ	F2/E	LOG F2/F	OUTPUT IN DB
9.600E 03	3.619F 03	-86.467E 00	3.125F 02	0.100F 01	0.8461648F-03	-1.692E-02				
4.800F 03	4.837E 03	-92.917F 00	6.250E 02	0.101E 01	0.3366590F-02	-6.733E-02				
2.400E 03	2.474E 03	-76.002E 00	1.250E 03	0.103F 01	0.1316431F-01	-7.433E-01				
1.200E 03	1.342E 03	-63.467F 00	5.000F 03	0.117E 01	0.4845478F-01	-9.691E-01				
6.000E 02	8.485F 02	-45.023F 00	1.000E 04	0.141F 01	0.1505148F 00	-3.010E 00				
3.000E 02	6.709E 02	-26.579F 00	2.000E 04	0.224F 01	0.3494850F 00	-6.990E 00				
1.500F 02	6.185F 02	-14.043F 00	4.000E 04	0.412F 01	0.6152242F 00	-1.230E 01				
7.500E 01	6.047F 02	-71.286E-01	8.000E 04	0.806F 01	0.9064566F 00	-1.813F 01				
3.750F 01	6.017F 02	-35.781E-01	1.600F 05	0.160F 02	0.1204966F-01	-7.410E 01				
1.875E 01	6.003E 02	-17.908F-01	3.200F 05	0.320E 02	0.1505362E 01	-3.011E 01				
9.375E 00	6.001E 02	-89.563F-02	6.400E 05	0.640E 02	0.1806732E 01	-3.612E 01				
4.687E 00	6.000E 02	-44.784E-02	6.400E 05	0.124F 03	0.2107224F 01	-4.214E 01				

CHAPTER 9

FACILITIES, INSTRUMENTS AND EQUIPMENT

The importance of properly selecting equipment for the laboratory cannot be over-emphasized because the lab is one of the most important elements in the electronics curriculum. Careful consideration must be given to laboratory teaching techniques and standards, including efficient utilization of laboratory time and equipment, self-learning methods, selection, purchase, and maintenance of instruments and equipment, and laboratory facilities for a quality electronics technology program.

Included in Chapter 9 are guidelines and suggestions for the selection of laboratory instruments and equipment with suggested price ranges and minimum specifications. Because of its importance, a separate section of the chapter is devoted to the selection of the student bench oscilloscope. Additional materials of interest is a list of technical periodicals and catalogs which provide excellent sources for keeping up-to-date.

The cost of equipping a good laboratory facility is expensive. As indicated in the chapter, the cost involved in setting up a new technology program will range from approximately \$100,000 to \$175,000. Administrators and others responsible for allocating funds must be cognizant of the costs involved and the quality of instruments and equipment needed to achieve a quality electronics program. Because of constantly changing prices, new developments, and institutional requirements, the suggested prices and specifications should be used only as general guidelines.

EQUIPMENT SELECTION

The laboratory is perhaps the most vital part of the electronics curriculum. The laboratory is where the student gets *hands-on* experience with equipment and instrumentation techniques that he will be using on the job. To have good laboratories requires careful and proper consideration of curriculum objectives, specifications, cost, maintenance, obsolescence, and relevancy to industrial standards.

EQUIPMENT COST AND CURRICULUM OBJECTIVES

The level of subject material covered in the curriculum dictates to a high degree the type and quality of instrumentation and equipment needed in the laboratory. For example, in a service program a less expensive oscilloscope might be satisfactory as compared to a more expensive scope that might be required for pulse and switching circuits.

Many schools have what they call a basic lab and an advance lab with cheaper yet satisfactory equipment in the basic lab and better equipment in the advanced lab. This division generally results in first-year and second-year laboratories which may not necessarily be the best arrangement. A more logical division might be a circuits laboratory and an electronics laboratory, with additional laboratories as needed, depending upon the number of students and option areas.

The ETCD Project Staff and Steering Committee recommend that each laboratory station be equipped with a minimum of equipment as shown in Table I. Specifications for this equipment and additional equipment are presented later in this chapter. Also shown with Table I is a typical lab station at Parkland College.

The above equipment reflects a consensus of opinions and are by no means the only items that are needed. Also included in this table and in following tables is a price range. Let it be

understood that these figures are to be used only as guidelines in the selection of equipment and include the following considerations:

1. There is generally a direct relationship between the quality of equipment and the cost.
2. The quality of program is determined to a great extent by the quality of equipment.
3. Equipment necessary to meet the objectives of the curriculum can be accomplished if equipment is purchased in close approximation to the suggested price range.
4. It is highly doubtful that these objectives can be met if less money is consistently spent on equipment.
5. It is not necessary to always buy the most expensive, if objectives can be met by cheaper equipment.
6. Equipment prices are constantly changing, and therefore up-to-date prices should be checked before purchases are made.

There is no getting around the problem that equipping a good electronics laboratory is expensive. The price range is a guide that gives approximate costs involved in setting up or modifying electronics programs and is included primarily in this report to help administrators with their task of allocating funds.

When funds are unlimited, this may not be a major factor of concern, but this is rarely the case. Most institutions are on a pretty tight budget, and the cost of equipment is a determining factor in the selection of equipment for the lab. For example, a measuring instrument should be purchased that will be satisfactory, but not at such standards that there will be no funds left to purchase other vital equipment. It is at this point that the instructor must calculate

Quantity	ITEM Description.	Price Range
1	Dual-Trace Oscilloscope	\$1800 - \$2800
1	Function Generator	\$325 - \$800
1	Pulse Generator	\$380 - \$550
1	Low Voltage Power Supply	\$150 - \$300
1	Volt-Ohm-Milliameter	\$80 - \$230
	TOTAL	\$2735 - \$4680

TABLE I. Suggested Equipment for Each Laboratory Station

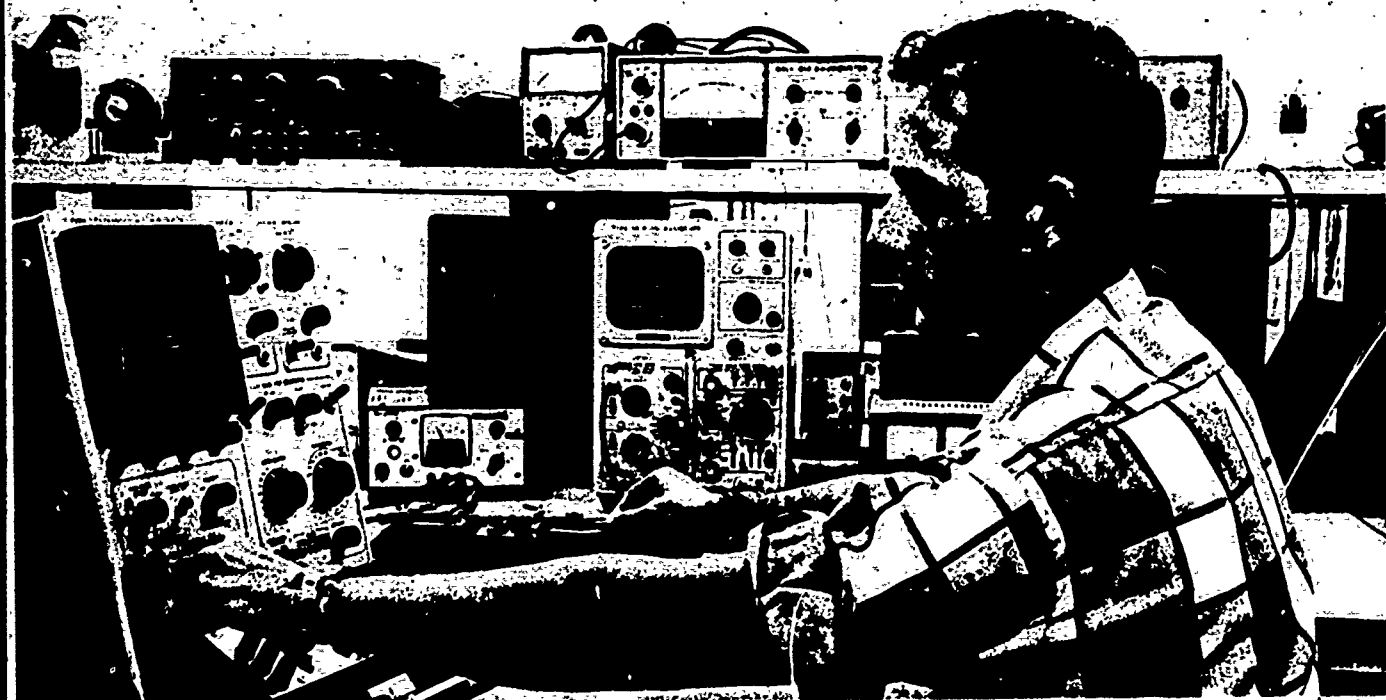

Here, an electronics student at Parkland College demonstrates some of the laboratory equipment that he uses. You are welcome to tour the electronics facilities at Parkland at any time. The electronics department is located in Science Annex I, 1615 West Springfield, Champaign, Illinois.

cost versus budget. It is the instructor's responsibility to decide whether a compromise can be reached. As a general rule, it is better to complete equipment needs in one area rather than to spread out too thin in all areas. By careful planning, necessary equipment purchases can be completed over a period of time to coincide with budget management.

An instructor must weigh the cost factors with the greatest care. He may need to release some of his own selfish desires to purchase exotic equipment that may be expensive and unique for equipment that is more practical and beneficial to the entire program. The instructor must be a wise buyer--but this does not mean to buy inadequate equipment.

The following three tables are suggested equipment for two laboratory areas, each designed for ten stations. Table II contains suggested equipment for a circuits laboratory; Table III for an electronics laboratory; and Table IV suggests additional equipment for both lab areas. The lists do not include items for specialized programs, facilities, or other supporting equipment such as hand tools, drill press, etc.

The total cost of equipping an electronics technology program, excluding facilities and supporting equipment, ranges from approximately \$96,000 to \$176,000.

There are several ways that the cost of equipping the electronics laboratories can be reduced without reducing the quality. It doesn't require much analysis to realize that the labs become expensive when a quantity of a particular piece of equipment is purchased. The best method to reduce the quantity and still retain the quality can be realized through the open-lab concept with individualized instruction. For example, by using audio-tutorial methods and keeping the lab open longer hours one could reduce the cost by at least half. This technique, besides reducing the cost, can also increase the effectiveness of the laboratory and provide the student with more individual attention. These and many more benefits might be gained by doing

away with the old traditional laboratory methods.

Other methods to consider in reducing costs are rental of equipment and the purchase of used equipment. Equipment needed for a short time during the school year may be rented for nine or ten percent per month. This allows for the use of *state-of-the-art* equipment and may be a very good method when quantity of a particular piece of equipment is needed or when a very specialized piece is needed. The other method of purchasing used or even rebuilt equipment can result in the purchase of better quality than could otherwise be afforded. Also, considerable savings can be realized by purchasing equipment from industry that is used but still in very good condition.

EQUIPMENT SPECIFICATIONS

To purchase satisfactory equipment requires that the instructor be able to understand and work with specifications effectively. To clear all of the red tape that is generally necessary and to receive the original equipment desired requires that the specifications be written with such precision that no lesser quality equipment will be purchased. Table V presents general specifications for the type of equipment desired for this level of program. A later section of this chapter is devoted especially to the oscilloscope because of its importance.

The beginning student initially enters the program with little or no background in electronics. When he enters the laboratory for the first time and begins to make measurements, his skills and ability to measure correctly are based upon his own innate or personal experiences that he brings with him to the lab. How good he will become at measuring and developing the skills necessary for the type of employment he seeks will be primarily limited by the specifications and flexibility of the instruments he will use in the laboratory. The limiting factors built into the instruments eventually become the common denominator for learning in the laboratory.

Quantity	Description	Price		Range	
		Unit	Subtotal	Unit	Subtotal
10	Oscilloscope	\$1800	\$18000	\$2800	\$28000
10	Function Generator	\$ 325	\$ 3250	\$ 800	\$ 8000
10	Pulse Generator	\$ 380	\$ 3800	\$ 550	\$ 5500
20	Low Voltage Power Supply	\$ 150	\$ 3000	\$ 300	\$ 6000
10	Volt-Ohm-Milliameter	\$ 80	\$ 800	\$ 300	\$ 3000
2	Digital Volt Meter	\$ 550	\$ 1100	\$1500	\$ 3000
2	Electronic Counter	\$ 350	\$ 700	\$2200	\$ 4400
2	RLC Bridge	\$ 450	\$ 900	\$ 800	\$ 1600
2	Wave Analyzer	\$1800	\$ 3600	\$2200	\$ 4400
2	X-Y Recorder	\$1800	\$ 3600	\$3300	\$ 6600
1	Vector Impedance Meter	\$1500	\$ 1500	\$3000	\$ 3000
2	Scope Camera	\$ 350	\$ 700	\$ 800	\$ 1600
1	Curve Tracer	\$1700	\$ 1700	\$3100	\$ 3100
	TOTAL	\$11235	\$42650	\$21650	\$78200

TABLE II. Suggested Equipment for a Ten-Station Circuits Laboratory

Quantity	Description	Price Range			
		Unit	Subtotal	Unit	Subtotal
10	Oscilloscope	\$1800	\$18000	\$2800	\$28000
10	Function Generator	\$ 325	\$ 3250	\$ 800	\$ 8000
10	Pulse Generator	\$ 380	\$ 3800	\$ 550	\$ 5500
20	Low Voltage Power Supply	\$ 150	\$ 3000	\$ 300	\$ 6000
10	Volt-Ohm-Milliameter	\$ 80	\$ 800	\$ 300	\$ 3000
2	Digital Volt Meters	\$ 550	\$ 1100	\$1500	\$ 3000
2	Electronic Counters	\$ 350	\$ 700	\$2200	\$ 4400
1	Transistor Curve Tracer	\$1700	\$ 1700	\$3100	\$ 3100
5	R-F Sweep Generators	\$1800	\$ 9000	\$2500	\$12500
5	High Voltage Power Supply	\$ 250	\$ 1250	\$ 650	\$ 3250
1	R-F Bridge	\$1200	\$ 1200	\$1800	\$ 1800
1	Distortion Analyzer	\$ 600	\$ 600	\$1500	\$ 600
2	Scope Camera	\$ 350	\$ 700	\$ 800	\$ 1600
	TOTAL	\$9535	\$45100	\$18800	\$80750

TABLE III. Suggested Equipment for a Ten-Station Electronics Laboratory

Quantity	Description	Price Range			
		Unit	Subtotal	Unit	Subtotal
1	Tube Tester	\$350-	\$350	\$600	\$600
1	Transistor Tester	\$300	\$300	\$650	\$650
2	Capacitor Tester	\$ 50	\$100	\$100	\$200
20	Microamp Meter	\$ 25	\$500	\$ 45	\$900
20	Milliamp Meter	\$.25	\$500	\$ 45	\$900
20	Galvanometer	\$ 25	\$500	\$ 50	\$1000
20	Oscilloscope Probes	\$ 15	\$300	\$ 50	\$1000
5	Watt Meters	\$100	\$500	\$200	\$1000
10	TRVM	\$250	\$2500	\$550	\$5500
60	Resistor Substitution Boxes	\$ 10	\$600	\$ 20	\$1200
60	Capacitor Substitution Boxes	\$ 10	\$600	\$ 20	\$1200
	Small Components (leads, transistors, etc.)	\$2000	\$2000	\$3000	\$3000
	TOTAL	\$3160	\$8750	\$5330	\$16550

TABLE IV. Suggested Equipment for Both Circuits and Electronics Laboratories

DESCRIPTION	RANGE	IMPEDANCE	ACCURACY	PRICE RANGE	SUGGESTIONS
Oscilloscope	50mv to 500V 0 Hz to 10 MHz	Input: 1 M ohm shunted by 50-p F.	+3%	\$1,800 to \$2,800	Dual trace, plug-in capabilities, delayed sweep
Function Generator	0 to 10 V (P-P) .005 Hz to 1 MHz	Output: 50 ohm	Dial accuracy: ±190 of maximum dial setting	\$325 to \$800	Sine, square, triangle and ramp outputs
Pulse Generator	0 to 30 M V (P-P) 0 to 300 ma	Output: 50 ohm	±10%	\$389 to \$550	Needed for pulse electronics, STC's and square wave testing
Low Voltage Power Supply	0 to 30 V DC. 0 to 300 ma	Output: Less than .25 ohms on all ranges	.05% from no load to full load: 0.1% ripple factor	\$150 to \$300	Two outputs from the same box
VOM	0 to 1000 V 0 to 10 M-ohm center scale, 20 Hz to 10 MHz	Input: 10 M ohm	+3%	\$80 to \$230	
Digital Voltmeter	0 to 1000 V .50Hz to 100KHz	Input: 2 M ohm	6 digit readout 0.1%	\$550 to \$1,500	One very good may be all that is necessary
Electronic Counter	10 Hz to 10 MHz	Input: 1 M ohm shunted by 30 p F.	7 digit readout ±1 count ± time base accuracy	\$350 to \$2,200	One very good one may be all that is necessary.
Wave Analyzer	100 M V to 300 V 30 Hz to 100 K Hz		±190 dial accuracy ±5 Voltage, full scale	\$1,800 to \$2,200	

Vector Impedance Meter	5 Hz to 500 KHz 0 to +90° phase .1 pF. to 10,000 µF.	1 ohm to 10 M ohm	±5%	\$1,500 to \$3,000	Analog output for X-Y recording
R-F Sweep Generator	0 to 1 V (P-P) 100KHz to 11 M Hz	Output: 50 ohm	±5%	\$1,800 to \$2,500	
RLC Bridge	10 pF to 1000 M Fd 1 M H to 1000 H 10 milli ohm to 10 M ohm		±2%	\$450 to \$800	
X-Y Recorder	1 M V/in to 10 V/in	Input: 20 K ohm	+0.2% of full scale	\$1,800 to \$3,300	
Scope Camera	75mm lens f 1.9 to f 16 lens 1 to Y50 sec shutter speed			\$400 to \$800	Film pack camera will not take transparency for making overlays
Distortion Analyzer	300 M V to 300 V(rms) 5 Hz to 600 KHz	Input: 1 M ohm	±.1% of full scale	\$600 to \$1200	
Curve Tracer				\$1,700 to \$3,100	Only 3 or 4 different kinds available
High Voltage Power Supply	0 to 400 V DC, 0 to 500 ma	Output: .25 ohm on all ranges	.01% from no load, to full load; less than .1% ripple factor	\$250 to \$650	

TABLE V: Suggested Minimum Specifications

There is within the specification of electronics equipment a minimum or lowest standard that will meet the objectives of the curriculum. The instructor should know the approximate price range and also the minimum specifications that the dollar will buy and purchase equipment based on this knowledge. The instructor should not be confused because of the wide price range that exists for any given instrument, nor should he listen only to company representatives. The proper selection of equipment requires careful consideration from many different angles.

The only sure way to know how a piece of gear will function is to try it out. However, this is not always possible, and the instructor must rely on his ability to work with specifications. It is a good idea to compare the specifications and prices of several different makes, and then make a logical decision on what will best suit your needs with all other things taken into consideration. In other words, *don't buy an elephant to pull a doll buggy.*

EQUIPMENT OBSOLESCENCE AND MAINTENANCE

The laboratory equipment is the keystone of the electronics curriculum, and careful thought should be given to the selection of equipment. When purchasing equipment, it should be kept in mind that it is expected that it will probably be used for several years. With this in mind, the instructor should look ahead and try to anticipate the future needs. There is no sure way of protecting against equipment becoming obsolete, but it is possible to purchase equipment that can be used for several years.

The maintenance and repair of equipment is another area that deserves careful consideration when purchasing equipment. Most equipment will eventually require repair, recalibration, or even replacement. Poor quality equipment can result in costly repairs that will eat up the budget. It is better to spend more for a piece of equipment initially than to have maintenance expenses later.

Experience is probably the best source for not buying equipment that is prone to break down. The next best source is from other instructors and people working in the field; they can soon tell you the problems that they have had to deal with on various instruments.

In the maintenance of equipment, it is quite important that you be able to obtain replacement parts. Too many times it is very difficult to obtain repairs. It may be well to stay with manufacturers that will provide this very important service.

There are a number of ways to deal with the maintenance problem. Three of the most common are listed below, along with the advantages and disadvantages that will be found with each.

Contracting or Returning to Original Manufacturer

Returning the instrument to the original manufacturer is one of the most widely used by newly developed programs. It does afford the school some advantages.

ADVANTAGES:

- a. Ensures a thorough job when a guarantee clause is possible.
- b. Does not require school to purchase expensive calibration equipment.
- c. Educational institution does not have to obtain schematics or calibration manuals.

DISADVANTAGES:

- a. Cost factor may be high (\$150.00/min. for calibration of scope).
- b. No local company available for repairs.
- c. Shipping cost may be relatively high.
- d. Time required to send and return may involve a number of weeks.
- e. Shall the equipment be sent in for only major repairs? What about minor repairs and adjustments?

Hiring a Full-Time Technician

The problem of maintenance and repair can be resolved by hiring a technician on the staff. This does offer a more appropriate solution to the problem.

ADVANTAGES:

- a. No time delay in getting the equipment worked on.
- b. Equipment can always be in constant repair and regular calibration periods maintained.
- c. Relieves instructor of responsibility of determining if instrument is in need of repair and what must be done.

DISADVANTAGES:

- a. Facilities may not be large enough to warrant a full-time technician.
- b. A technician must be trained in many different types of manufacturing electronic apparatuses.
- c. Cost of purchasing expensive calibration equipment is required.
- d. Repair parts must be kept available.
- e. Cost of sending technicians to industrial manufacturing training programs will be necessary.

Lab Instructor with Student Assistance

This method of providing for the maintenance problem can bring about the following advantages and disadvantages.

ADVANTAGES:

- a. Staff member is also used in teaching some courses.
- b. Gives employment to students in the electronics program, providing them with additional experience.
- c. The instructor becomes familiar with circuits found in the instruments.
- d. Extra pay for staff members.

DISADVANTAGES:

- a. Students may not have proper background and qualifications to be of any assistance in repairing these elaborate circuits.
- b. Instructors may not be justly compensated for repair work by reduced loads of financial remuneration.
- c. Must purchase expensive calibration equipment to maintain proper instrument standards.
- d. Instructor will need training by manufacturer in newly purchased equipment.

Each of the methods discussed must be evaluated to determine the most economical and satisfactory solution. The hiring of a technician relieves the instructor to the primary task of teaching and not concern or worry as to whether the equipment will be in functional order during the next lab session. With each of the other two solutions the instructors will be more involved. If the equipment is sent out for repairs, the instructor will be responsible for its shipment and return. With more than one instructor within the faculty their efforts must be coordinated--they can develop a conflict as to who is responsible for this task. The problem of finding students to perform repair work at very low wages can also prevent this method from getting the equipment in proper working order. The instructor who has been made responsible for this task may not be able to maintain the equipment to meet the required standards of the other instructors. This can also lead to conflict within the department.

When the factors are all considered, the most logical solution to the problem for the instructor is to hire a technician. But if the facilities are not large enough to occupy the full time of such an individual or he cannot be given some courses to teach, then other curriculums with a joint effort might be a means of resolving the justification for a full-time repair technician. If a technician cannot be found with the proper qualifications to be hired, then the alternative of the other two must be selected.

The instructor should not be required to repair equipment. His responsibility is to help the student, not to repair equipment. With a normal teaching load the instructor does not have enough time to fix equipment. Whenever equipment is purchased, the upkeep and repair and replacement of equipment should be included in the budget.

INFORMATION SOURCES FOR EQUIPMENT

The selection of equipment also requires that the instructor know where to look for up-to-

date equipment. The following is a partial list of sources for equipment, instruments, components, etc. Also included in the next section is a list of periodicals, many of which are free, that are very good sources for the electronics instructor.

Allied Catalog

100 No. Western Avenue
Chicago, Illinois 60680

Electronics Buyers' Guide

McGraw-Hill
330 W. 42nd Street
New York, N. Y. 10036

Electronic Engineers' Master

\$20.00
United Technical Publications, Inc.
645 Stewart Avenue
Garden City, N. Y. 11530

Electronic Distributing & Marketing

\$10.00 for 2 years
Electronic Periodicals, Inc.
33140 Aurora Road
Cleveland, Ohio 44139

Electronic Industry Telephone Directory

\$6.00 per copy
Electronic Periodicals, Inc.
33140 Aurora Road
Cleveland, Ohio 44139

Electronic Source Procurement

\$20.50 per copy
Electronic Periodicals, Inc.
33140 Aurora Road
Cleveland, Ohio 44139

*Fairchild Semiconductor Integrated Circuit Data Catalog **

313 Fairchild Drive
Mountain View, California

Heathkit Catalog

Benton Harbor, Michigan 49022

Industrial Catalog

Allied Electronics
2400 W. Washington Blvd.
Chicago, Illinois 60680

Industrial Electronics Catalog

Newark Electronics Corporation
500 No. Pulaski Road
Chicago, Illinois 60624

Lafayette Catalog

111 Jericho Turnpike
Syosset, L. I., New York 11791

McMaster-Carr Catalog

P. O. Box 4355
Chicago, Illinois 60680

Preferred Semiconductors and Components Catalog

Texas Instruments
P. O. Box 5012
Dallas, Texas 75222

The Radio Electronic Master

United Technical Publications, Inc.
645 Stewart Avenue
Garden City, New York 11530

TECHNICAL PERIODICALS *

Bell Laboratories Record

M.* \$2.00

Bell Laboratories
463 West Street
New York, New York 10014

Bell System Technical Journal

10/Yr.* \$15.00

American Telephone and Telegraph Company
195 Broadway
New York, New York 10007

Bell Telephone Magazine

Q.* Free to Qualified Personnel

Public Relations Department
A T & T
195 Broadway
New York, New York 10007

Communication and Electronics

Bi-M.* \$8.00

American Institute of Electrical Engineers
345 East 47 Street
New York, New York

Control Engineering

M. \$3.00

McGraw-Hill Publishing Company
330 W. 42nd Street
New York, New York

(The) Demodulator

Free

LenKart Electric Company
San Carlos, California 94070

* Bi-M. - Bi-Monthly

M. - Monthly

Q. - Quarterly

Yr. - Yearly

NOTE: Prices listed are for informational purposes only.

Digital Newsletter

Free

Digital Equipment Corporation
Maynard, Massachusetts 01754

DuPont Innovation

Circulation Department
DuPont Building
Wilmington, Delaware 19798

E. E. Digest

Bi-M.

American Institute of Electrical Engineers
345 East 47 Street
New York, New York

Educational Research and Methods

The American Society for Engineering Educ.
Oklahoma State University
Stillwater, Oklahoma 74074

Electrical Communication

Q. \$2.00

International Telephone and Telegraph
320 Park Avenue
New York, New York 10022

Electrical Construction and Maintenance

M. \$3.00

McGraw-Hill Publishing Company, Inc.
330 West 42 Street
New York, New York 10036

Electrical Design News

M. (except June, October and November when
two issues are published). Free to
Qualified Personnel. Others \$10.00

Rogers Publishing Company
3375 South Bannock
Englewood, Colorado 80110

Electrical Engineering

M \$12.00

American Institute of Electrical Engineers
345 East 47 Street
New York, New York

Electronic Age

Q. Free

Radio Corporation of America
30 Rockefeller Plaza
New York, New York 10020

Electronic Design

Hayden Publishing Company
850 Third Avenue
New York, New York 10022

Electronic Industries

Chilton Publishing Company
401 Walnut Street
Philadelphia, Pennsylvania 19106

Electronic Instrument Digest

M. \$10.00

Milton S. Kiver Publications, Inc.
222 West Adams Street
Chicago, Illinois 60606

Electronic News

M. \$3.00

Fairchild Publishing Inc.
7 E. 12th Street.
New York, New York 10003

Electronic Packaging and Productions

Milton S. Kiver Publications, Inc.
222 West Adams Street
Chicago, Illinois 60606

Electronic Products

United Technical Publication, Inc.
Division Cox Broadcasting Company
645 Stewart Avenue
Garden City, New York 11530

Electronic Technician

M. \$5.00

Ojibway Building
Duluth, Minnesota 55802

Electronic Technology

Free

Lab-Volt Educational Systems
Division of Buck Engineering
Farmingdale, New Jersey 07727

Electronic Trader

Bi-M.

Electronic Periodicals, Inc.
33140 Aurora Road
Cleveland, Ohio 44139

Electronics

M. \$6.00

McGraw-Hill Publishing Company
99 North Broadway
Albany, New York 12202

Electronics Illustrated

Bi-M. \$2.00

Fawcett Publications, Inc.
67 W. 44th Street
New York, New York 10036

Electronics New Product Preview

McGraw-Hill Publishing Company
330 W. 42nd Street
New York, New York 10036

Electronics World

M. \$5.00

Ziff-Davis Publishing Company
1 Park Avenue
New York, New York 10016

Engineer

Q. \$2.00

Engineers Joint Council
345 E. 47th Street
New York, New York 10017

Engineering Bulletin

Q. Free

Motorola, Inc.
Military Electronics Division
8201 E. McDowell Road
Scottsdale, Arizona 85252

Engineering Education

M. \$16.00

American Society for Engineering Education
Suite 400, One Dupont Circle
Washington, D. C. 20036

Engineering Opportunities

Press Tech. Inc.
2211 Fordem Avenue
Madison, Wisconsin 53701

Fairchild Semiconductors

313 Fairchild Drive
Mountainview, California

General Radio Experimenter

M. Free

General Radio Company
22 Baker Avenue
West Concord, Massachusetts 01781

Hewlett Packard Journal

Free to Qualified Personnel

Measurement News
Hewlett Packard Company
1501 Page Mill Road
Palo Alto, California 94304

IEE Student Journal

5/Yr. \$12.00

Institute of Electrical and Electronics
Engineers
345 E. 47th Street
New York, New York 10017

Industrial Research

Industrial Research, Inc.
Industrial Research Building
Beverly Shore, Indiana 46301

Instrument and Apparatus News

Bi-M. \$10.00

Rimbach Publications
845 Ridge Avenue
Pittsburg, Pennsylvania 15212

Instruments and Control Systems

M. \$4.00

Rimbach Publications
845 Ridge Avenue
Pittsburg, Pennsylvania 15212

Instrumentation

Q. Free

Honeywell Industrial Division
1100 Virginia Drive
Fort Washington, Pennsylvania 19034

Instrumentation Technology

M. \$4.00

Journal of the Instrument Society
of America
530 William Penn Place
Pittsburg, Pennsylvania 15219

Instruments and Automation

Instruments Publishing Company
845 Ridge Avenue
Pittsburg, Pennsylvania

Insulation

M. \$13.50

Lake Publishing Company
311 East Park Avenue, Box 270
Libertyville, Illinois

Junior College Journal

M. (September-June) \$4.50

American Association of Junior Colleges
One Dupont Circle, N.W.
Washington, D.C. 20036

Microelectronics and Reliability

Q. \$40.00

Pergamon Press
122 E. 55th Street
New York, New York 10022

Microwave Journal

Horizon House-Microwave Inc.
610 Washington Street
Dedham, Massachusetts 02026

Occupational Education Bulletin

Free

American Association of Junior Colleges
One Dupont Circle, N.W.,
Washington, D.C. 20036

Photofact Reporter

M. \$5.00

Howard W. Sams and Company
4300 W. 62 Street
Indianapolis, Indiana

Popular Electronics

M. \$5.00

Ziff-Davis Publishing Company
1 Park Avenue
New York, New York 10016

Power Apparatus and Systems

Bi-M. \$5.00

American Institute of Electrical Engineers
345 East 47 Street
New York, New York

RCA Review

Q. \$2.00

RCA Laboratories
Princeton, New Jersey

Radio-Electronics

M. \$4.00

Gernsback Publications, Inc.
Ferry Street
Concord, New Hampshire 03302

Semiconductor Applications

General Electric Company
Distribution Services
1 River Road
Schenectady, New York 12304

Semiconductor Products and Solid State
Technology

M. \$10.00

Cowan Publishing Corporation
14 Vanderventer Avenue
Port Washington, New York 11050

Semiconductors

Box 20912
Phoenix, Arizona 85038

Solid State Design

Free to Qualified Personnel

William Bazzy
610 Washington Street
Dedham, Massachusetts

Solid State Electronics

Pergamon Press
122 E. 55th Street
New York, New York 10022

Technical Education

\$7.25

P. O. Box 1616
Riverside, New Jersey 07075

Technical Education News

Q. Free

McGraw-Hill Publishing Company
330 W. 42nd Street
New York, New York 10036

(The) Technical Education Press

P. O. Box 342
Seal Beach, California 90740

Technology Review

M. (November-July) \$4.00

Massachusetts Institute of Technology
Cambridge, Massachusetts 02137

Tekscope

Free

Tektronix
P. O. Box 500
Beaverton, Oregon 97005

Westinghouse Engineer

Bi-M. \$2.50

3 Gateway Center
Box 2278
Pittsburg, Pennsylvania 15230

THE STUDENT BENCH OSCILLOSCOPE

INTRODUCTION

The most crucial decision to make in the selection of equipment for the laboratory is with the selection of the student bench oscilloscope. The following discussion is intended to clarify the significance of many of the technical terms that are used to describe oscilloscopes. The proper selection of a scope requires a clear understanding of the relative importance of different features that are available. (For oscilloscope specifications see page 312.)

PLUG-IN UNITS

Choice of an oscilloscope is determined largely on considerations of both performance capabilities and versatility. Versatility is greatly increased if the scope has plug-in capability that allows for different operations to be performed by simply using an appropriate plug-in. Also, performance capabilities can be updated as new plug-ins become available.

The oscilloscopes that are purchased account for a considerable part of the funds that are invested into equipment. Because oscilloscopes are a capital outlay and will be with the program for a long time, maintenance, obsolescence, and flexibility are very crucial considerations. As indicated, obsolescence can be delayed and flexibility increased by scopes that have plug-in units. Another major advantage with scopes that have plug-in units is the benefits that are gained in maintenance. When two or more plug-in units with the same function are available, the easiest way to isolate trouble is to replace the plug-in units one at a time until proper operation is restored. The faulty unit is isolated as not functioning properly and can be repaired. To aid in the trouble shooting of a plug-in, an extension plug-in may be available that will allow the unit to operate while being extended out through the front of the oscilloscope opening. If changes

in the plug-in units does not correct the problem, the main frame portion of the scope is probably faulty. The use of plug-ins greatly decrease maintenance time.

Plug-in oscilloscopes allow a very wide variety of measurements that can be made with one oscilloscope. By simply changing the vertical and horizontal plug-ins, bandwidth, sensitivity, number of channels, time-base, etc. can be changed to meet the needs. For example, one four-trace amplifier plug-in could make all compatible scopes into a four-trace scope. There is no need to invest a lot of money in oscilloscopes that have wide capabilities if those functions that increase the price are only used once in awhile for special applications.

BANDWIDTH

Bandwidth and sensitivity of the vertical amplifiers are the primary characteristics which describe how the scope will perform. Wide bandwidth is obtained at the expense of more complicated circuitry. For example, a 50 mhz scope will cost maybe twice as much as a 10 mhz scope. A decision must be made regarding what the required measurements that will be performed in the lab. For most applications, a 10 mhz scope would probably be satisfactory. If occasionally wider bandwidth is required, perhaps the necessary plug-ins could be purchased or maybe a special purpose scope.

Scopes used for measuring frequency response must be selected carefully to insure accurate readings. The bandwidth of a scope is usually specified by the upper and lower frequencies where sine wave response is down 3 db from the reference frequency. When only one number is given in the specification, it is taken as the upper frequency. Outside of this range, a scope has limited usefulness because the measurements errors increase rapidly.

The quality of a wideband scope is often specified by risetime. Risetime is the time of transition between 10 and 90 percent of the amplitude of a step signal. Accuracy of measurement decreases when a scope must indicate the risetime of signals which rise faster or nearly as fast as its amplifier. Risetime is of prime importance when making pulse measurements and is generally a good indication of relative bandwidth. In general, faster risetime means greater bandwidth in the direction of higher frequencies. For fairly accurate readings of risetime, the scope should be about 5 times faster than the signal to be measured. In this case, the risetime of the signal as displayed on the scope will only be in error about 2 percent as compared to a scope that is 2 times faster with an error of about 11 percent. Scopes which have a risetime equal to the fastest rising signal applied may be adequate depending upon the accuracy desired.

Both risetime and bandwidth are closely related. The product of risetime and frequency response should be a value between 0.33 and 0.35 when transient response is optimum. Factors larger than 0.35 probably indicate overshoot in excess of 2 percent and those larger than 0.4 indicate overshoot in excess of 5 percent. Overshoot or ringing can be a problem when fast step-signals are applied.

SENSITIVITY

As previously indicated, bandwidth, risetime and sensitivity are prime factors in determining the selection of a scope for a particular laboratory. High sensitivity requires more amplifier stages and some bandwidth must be sacrificed because of the greater background noise associated with wideband, high-gain amplifiers. High sensitivity simplifies lab set-ups if you are trying to measure transducer outputs. The transducer outputs can be connected directly to the scope.

SWEEPS

Some lab investigations will require fast

sweeps and others slow sweeps. It is obvious that an oscilloscope with the widest range of sweeps would be the most versatile. The scope however is used because of its capacity to be used as a high speed device, and very slow sweeps have only limited use. High frequency scopes seldom have sweeps which are fast enough to display one cycle of the upper passband frequency across the full horizontal scale. If a scope can meet this requirement, it is usually considered adequate.

The scope should have a continuous coverage of the total range of sweep speeds. A scope should have each stepped change in sweep-timed division a small change-ratio. This permits any time measurement to be made over a large portion of the horizontal scale.

Another desirable feature is sweep magnification and delay. This feature is quite useful when you want to display trace segments which occur too late in time after the start of the trace to be examined with faster sweeps. Such waveforms can be viewed but if the period of the waveform is short compared to the period of a full sweep, a very close examination may not be possible. The need to expand the trace for this time interval is quite obvious. The simplest way to do this is to increase the horizontal gain to spread out the waveform such that the desired portion is left on the screen. Another way is to actually generate delayed sweep triggering signals so that the sweep may be triggered just prior to the time when the signal to be examined occurs. Calibrated sweep delay can provide some advantages over ordinary sweep magnification such as:

- Greater ratios of effective magnification.
- Elimination of "time jitter" or "time drift" of displayed waveforms.
- Greater accuracy of time-interval measurements between waveforms.
- Better long-term accuracy of the displayed time-base.

Calibrated sweep delay increases the cost of a scope but is well worth it.

VERTICAL AMPLIFIER

The vertical amplifier in a scope should allow for voltage measurements to be made with at least ± 3 percent accuracy. The scope should have d-c coupling so that waveforms of slowly varying signals can be displayed and also allow for a d-c reference line to be established. For example, in vacuum tube circuits, the d-c levels the plate or screen voltages swing when signals are applied. Also a-c coupling is desirable to block d-c voltages that might drive the whole display off of the screen.

Another essential feature of the laboratory general purpose scope is the provision for two signal channels. Dual-channels provides for a comparison study of two signals, such as phase measurements or a comparison of an amplifier's output signal versus its input. Dual-channel operation can be obtained either by what is known as alternate mode and chopped mode. The alternate mode method allows for a single beam in the circuit to electronically switch between sweeps so that the waveform of one channel is displayed during one sweep, and the other waveform is displayed on the next sweep. With chopped mode operation the switching occurs rapidly and both channels are displayed during one sweep. This method is used for low-frequency waveforms which otherwise would flicker with alternate sweep presentation.

In some applications the dual-beam scope may be necessary to use rather than dual trace. This type of scope has a circuit that produces two electron beams and allows for single-shot observations of events that are too fast for chopped mode operation.

Other Factors

Nice, but not necessary, is a beam finder. The beam finder reduces the gain of both horizontal and vertical amplifiers while at the same time brightens and defocuses the trace so that regardless of the settings of the scope, the trace is brought on the screen.

To prevent the scope from loading a circuit, the impedance of the circuit impedance being

measured must be a small fraction of the input impedance of the scope. The input impedance is not the same at all frequencies and is specified by input resistance and input capacitance. To minimize loading, the input impedance should be as high as possible. Passive attenuator probes will help to reduce loading and are an essential accessory to consider when making the purchase. The absence of probes can lead to many unwanted problems.

INTERPRETING SPECIFICATIONS

Interpreting manufacturers' specifications requires the understanding of the following:

Bandwidth - Of an oscilloscope, the difference between the upper and lower frequency at which the voltage or current response is .707 (-3 db.) of the response at the reference frequency. Usually, both upper and lower limit frequencies are specified rather than the difference between them. When only one number appears, it is taken as the upper limit.

Chopping Transient Blanking - The process of blanking the indicating spot during the switching periods in chopped display operation.

Common-Mode Signal - The instantaneous algebraic average of two signals applied to a balanced circuit, both signals referred to a common reference.

Conventional Mode - That mode of operating a storage tube where the display does not store but performs with the usual phosphor luminance and decay.

Deflection Blanking - Blanking by means of a deflection structure in the cathode ray tube electron gun which traps the electron beam inside the gun to extinguish the spot, permitting blanking during retrace and between sweeps regardless of intensity setting.

Deflection Factor - The ratio of the input signal amplitude to the resultant displacement of the indicating spot (for example, volts/division).

Delay Pickoff - A means of providing an output signal when a ramp has reached an amplitude corresponding to a certain length of time (delay interval) since the start of the ramp. The output signal may be in the form of a pulse, a gate, or simply amplification of that part of the ramp following the pickoff time.

Delayed Sweep - A sweep that has been delayed either by a predetermined period or by a period determined by an additional independent variable.

Dual Trace - A multi-trace operation in which a single beam in a cathode-ray tube is shared by two signal channels. See alternate display, chopped display, and multi-trace.

Gaussian Response - A particular frequency response characteristic following the curve $y(f) = e^{-af^2}$. Typically, the frequency response approached by an amplifier having good transient response characteristics.

Input RC Characteristics - The DC resistance and parallel capacitance to ground present at the input of an oscilloscope.

Jitter - An aberration of a repetitive display indicating instability of the signal or of the oscilloscope. May be random or periodic, and is usually associated with the time axis.

Magnified Sweep - A sweep whose time per division has been decreased by amplification of the sweep waveform rather than by changing the time constants used to generate it.

Mixed Sweep - In a system having both a delaying sweep and a delayed sweep, a means of displaying the delaying sweep to the point of delay pickoff and displaying the delayed sweep beyond that point.

Multi-Trace - A mode of operation in which a single beam in a cathode-ray tube is shared by two or more signal channels. See dual trace, alternate display, and chopped display.

Resolution - A measure of the total number of trace lines discernible along the coordinate axes, bounded by the extremities of the graticule or other specific limits.

Risetime - In the display of a step function, the interval between the time at which the amplitude first reaches specified lower and upper limits. These limits shall be 10% and 90% of the nominal or final amplitude of the step, unless otherwise stated.

Signal Delay - In an oscilloscope, the time required for a signal to be transmitted through a channel or portion of a channel. The time is always finite, and may be undesired, or may be purposely introduced as in a delay line.

CHAPTER 10

SUGGESTIONS AND RECOMMENDATIONS

This concluding chapter for the ETCDP report contains suggestions and recommendations, of a miscellaneous nature, relating to the implementation of two-year Associate Degree Electronics Technology programs in Comprehensive Community Colleges and Technical Institutes.

The first section presents a brief discussion of the significant adjustments that may be necessary to implement the ETCDP material to a four-semester program. The second section discusses the level-of-performance expected of the graduates. This is followed by a section containing a brief discussion of a number of miscellaneous topics that were considered during the project. A position paper for Electronics Technology is also presented in a separate section.

The final sections of the chapter present concluding remarks from the members of the Steering Committee; from William M. Staerkel, President of Parkland College (the host institution for the project); and from Professor Jerry S. Dobrovolsky, Head of the Department of General Engineering at the University of Illinois and coordinator of the ETCO project.

SUGGESTED ADJUSTMENTS TO THE FOUR-SEMESTER PROGRAM

GENERAL CONSIDERATIONS

The development activities of the ETCD Project were directed more to the six-quarter programs for the Electronic Technologies than to the four-semester programs. The adjustments that are necessary to convert from the quarter plan to the semester plan were considered less severe than doing the development work on the semester plan and then making the necessary adjustments to the quarter plan.

The ETCD Project personnel are of the opinion that adjustments and changes are more of a philosophical nature than anything else. In other words, if one accepts the philosophy and objectives of an INTRO course; if one accepts the concept of spin-off programs; if one accepts the sequence of courses in *Circuit Analysis* as a package; and if one accepts the sequence of courses in the *Fundamentals of Electronics* as a package, then adjustments and changes within an established curriculum are quite easily implemented. Similarly, adjustments from a quarter plan to a semester plan are then easily implemented.

FLOW CHARTS FOR BOTH QUARTER AND SEMESTER PLANS

The flow chart for the *six-plus-one* courses is shown in Table I for a six-quarter plan and in Table II for a four-semester plan. For simplicity of discussion, other courses of each curriculum are omitted.

Observe, first of all, that the seven courses have the same identity (by title) in either the quarter plan or the semester plan. In the semester plan, as compared to the quarter plan, the sequence of the three courses in *Circuit Analysis* and the sequence of the three courses in the *Fundamentals of Electronics* start in the first semester and the second semester, respectively.

Now, let us direct our attention to the semester plan and examine the possible adjust-

ments that need to be made, recognizing that the more ideal sequence and integration of the *six-plus-one* courses exist for the quarter plan. These adjustments are discussed for each semester, rather than for each of the seven courses.

ADJUSTMENTS FOR THE FIRST SEMESTER

The *Introduction to Electronics Technology* (INTRO) course and the *Resistive Circuits* course are both scheduled in this first term. The adjustments that are needed to attain an appropriate sequence are itemized along with supporting philosophies.

- a. Don't be in a hurry to get started with an analysis of Resistive Circuits for about the first four to six weeks. Avoid the mathematical process - even Ohm's law - in these early weeks.
- b. For the first four to six weeks, use the time that is scheduled for both courses (INTRO and Resistive Circuits) to concentrate on the *inverted pyramid* concept of the INTRO course.
- c. Following the getting-started period, the time that is scheduled for the INTRO course is no longer used for the *inverted pyramid* approach to the first course in electronics. Two alternatives now exist for the curriculum planning. One, is for all students to continue with two-year programs. The other alternative (recommended) is to implement a one-year certificate program on the spin-off concept. (Note: Refer to the last section of this chapter for details of implementation as presented by Professor Neal Voke, Chairman of the Electronics Department, Triton College.)
- d. The analysis of Resistive Circuits starts in earnest after the first six-week period.

Table I: The Six-Plus-One Courses for a Six-Quarter Program (Refer to Chapter 1 for complete programs).

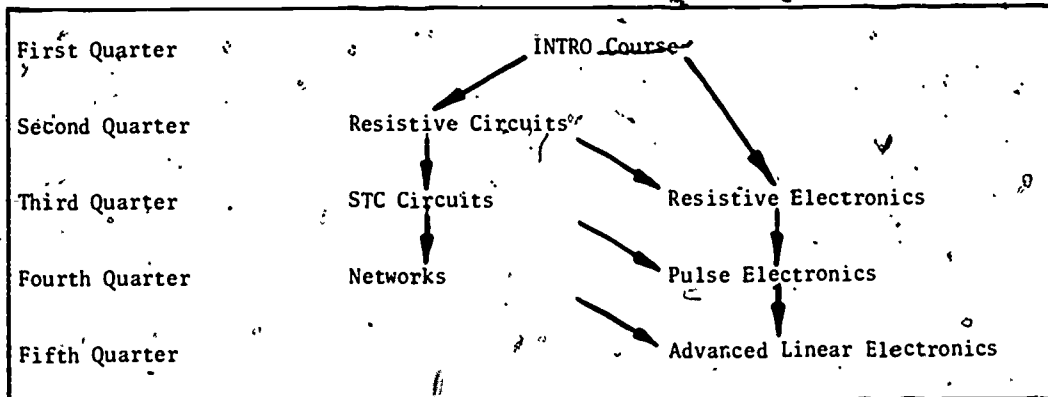
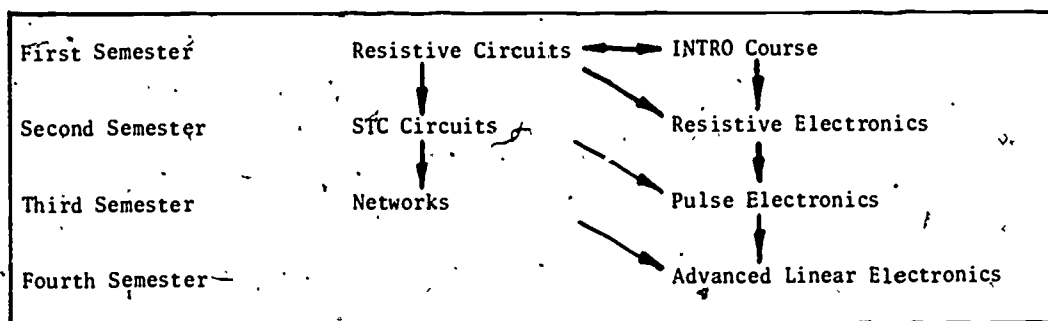

Table II: The Six-Plus-One Courses for a Four-Semester Program (Refer to Chapter 1 for complete programs).



ADJUSTMENTS FOR THE SECOND SEMESTER

The two subjects of *Single-Time-Constant (STC) Circuits* and *Resistive Electronics*, that are scheduled for the second semester, will require very little if any adjustment. Subject matter coverage will proceed a little more slowly in a second semester than in a third quarter. The few adjustments that may be necessary are now itemized.

- a. In the *STC Circuits* course, there may be time available toward the end of the term to include a few topics that would normally be in *Networks*. The topic of resonance in series circuits and perhaps parallel circuits could be initiated here. Or, perhaps some work on three-phase systems could be done.

There are a number of possibilities. Even so, no harm has been done if extra topics are not covered.

- b. The subject of *Resistive Electronics*, just as recommended, can be as large a package as an electronics department might desire. Don't overburden the students with devices, however. It's possible that they might lose interest and motivation. It is suggested that some topics, such as diode clipping circuits and perhaps some logic circuitry, should be transferred from the *Pulse Electronics* course. (Note: The most severe adjustment will exist in the first semester as previously indicated.)

ADJUSTMENTS FOR THE THIRD SEMESTER

The two subjects of *Networks and Pulse Electronics* are scheduled for this third semester. Again, there are no serious adjustments from what would exist in the quarter plan. It must be decided where each of the two courses should be divided. The sequencing of significant topics does not change. One may only wish to add some topics that might normally be included in the technical elective courses of a quarter system. In the semester plan there may be sufficient time remaining to cover some material on digital electronics (a separate course in the quarter plan) in the *Pulse Electronics* course, as one example.

ADJUSTMENTS FOR THE FOURTH TERM

Only the one course, *Advanced Linear Electronics*, is scheduled in this fourth semester. Certain topics such as *feedback, modulation and detection* might be included in technical electives of a quarter system. In the semester system, such topics (or others as desired) might be included in the *Advanced Linear Electronics* course. Considerable freedom exists as to the topics to be included in the course in both the quarter plan and the semester plan.

LEVEL OF PERFORMANCE EXPECTED OF GRADUATES

RESPONSIBILITIES OF MANPOWER TEAM

Any discussion of the level of performance expected of members of the engineering team must naturally be associated with a statement regarding the structure of this team and the division of responsibilities among the team members. To illustrate a possible structure, let's consider a hypothetical industrial site. Assume that the project involved is a missile.

The project has its inception when a governmental agency issues a bid proposal. A bid proposal consists of general nontechnical specifications based upon external criteria. It will include such things as general classification (ICBM, Guided; Manned, etc.), weight limitations, cost factors and the like.

In response to the bid proposal, the industrial group prepares a proposal. The proposal consists of:

- a. Cost estimate.
- b. Some details of the system specifications.
- c. Block diagram of the system (nature of subsystems is indicated--electrical, hydraulic gyros, etc.--but no details are proposed).

Senior level engineering personnel are utilized in the preparation of the proposal. The senior engineer at this point will not know the persons on his team, but he will need to speculate about this to make his cost estimate.

If the proposal is accepted by the government agency, the industrial group will prepare a more detailed proposal. This more detailed proposal will consist of:

- a. Cost estimate (revised).
- b. System specifications in greater detail.
- c. More detailed block diagram.

This proposal, like the first, will be constructed by senior level engineering personnel.

However, now is the time when some junior team members need to be assigned. Once the detailed proposal is completed and the initial team is formed, the concepts on the block diagram need to be expanded and reduced to schematic diagrams. Some sections may need to be depicted in a more detailed block diagram before they are reduced to schematics. Engineering technologists are usually assigned the task of developing the schematics. If these schematics are in poor condition, these people will likely not be called "engineering technologists." Nevertheless, this is one type of task for which an engineering technologist would be utilized. The engineering team now consists of several engineers and four to ten technicians, most of whom will be engineering technicians. If engineering technicians are not available, engineers will have to do this work.

Once the schematics are completed to the satisfaction of the engineering team, prototype models are constructed. The engineering technician is largely responsible for this.

The prototype must now be tested and evaluated. The engineering technician will devise these tests and evaluate the results of the tests. If the tests indicate the need to redesign the system, or any part of the system, the engineering technician will be responsible for such modifications. If the modification is minor, the engineer will probably not be aware that the change was made.

Engineering technicians will have responsibility for the production of the system. The engineering technician will be the "expert" so far as the production crew is concerned. After production, the engineering technician may find still other areas of responsibility in production testing and quality control.

KNOWLEDGE REQUIREMENTS OF ELECTRONICS ENGINEERING TECHNICIAN

What are the knowledge requirements of the Electronics Engineering Technician to reach a level of performance necessary to carry out his assignment as a part of the engineering manpower team on such a system as the one just described? Since the two-year Associate Degree program emphasizes both cognitive and manipulative skills, an occupational analysis would be difficult. There are areas, however, where examples may be used to help define the level of performance.

Instrumentation is an important aspect of the EET's job. The technician may be engaged in laboratory work to a greater extent than the engineer. He may have a greater responsibility in the selection and utilization of test equipment. In general terms, the technician should be able to perform basic tests and measurements; he must have a knowledge of the capabilities and limitations of test equipment and know how to operate the instrument. The oscilloscope will serve as an example.

The EET should be very familiar with the fundamental voltage-vs-time and voltage-vs-voltage concepts relating to the oscilloscope as well as the concepts of a triggered sweep, delayed sweep, use of the external trigger, and multiple channel vertical amplifiers. Based on the basic measurement capabilities of the scope, the EET should be able to select the right oscilloscope for the job based on such characteristics as rise time, sensitivity, band pass, and input loading and capacitance effects. The EET should also be able to apply his knowledge of special-purpose oscilloscopes, such as the transistor curve-tracer. As an example, he should be able to determine the D-C Beta of a transistor for a particular set of operating conditions, and he must have a comprehension of the curve-tracer operation so that he may apply the concepts to semiconductor device measurements in general.

Another area related to laboratory work is that of experimental techniques or procedures. The EET should have developed a technique or

procedure for the investigation of electrical phenomena so that he will have the ability to work on his own without direct supervision. This means that several basic questions must be considered by the EET when confronted with an experimental problem. Some typical questions are: What property is to be measured? What instruments are necessary to measure this property? What parameters are to be varied and which are to be held constant? What accuracy is necessary for valid results? Are the instruments capable of such accuracy? Will environmental conditions affect the results and, if so, how may they be controlled? How reliable are the results outside of the laboratory?

As a final step, conclusions must be drawn, based on experimental data, and the results communicated to others within the organizational structure.

The level of performance of the EET in the area of theory may best be established by considering the mathematics background of the technician. He has had algebra, trigonometry, and selected topics in analytic geometry, calculus, and differential equations or LaPlace Transforms. Does the technician actually use calculus in the field? Is it necessary? Does the engineer use calculus consistently enough to recall standard forms without a handbook? In many cases, he doesn't; but the concepts of calculus are important to the engineer and to the technician as well. These concepts may appear implicitly in the analysis of a problem without taking the form of an equation. One such case would be the concept of the average of a time-varying waveform. If the technician, through the concept of area under a curve, is able to visualize the average of the waveform over one period and apply the same concept to other waveforms, then he has a useful tool, regardless of whether he can remember the integral of $E_m \sin \omega t$.

In carrying out his part of an assignment, the EET must rely on his background in theory to aid in the analysis and design of circuitry. The analysis of electronic circuits requires that the

EET be able to identify and recognize common circuits and estimate response, trouble-shoot systems and circuits, and determine circuit functions. The bistable multivibrator will serve as an example. As well as being able to identify the circuit as a bistable, the EET should be able to estimate the response of the pulse-shaping network when the input to the circuit is known. Based on the circuit configuration, the RC time constant, and the pulse-repetition-rate of the input waveform, the technician should be able to determine the kind of response that will exist without writing an equation for the circuit. It should not be necessary even, to plot the graph for the output response.

The area referred to as design combines both laboratory and theory. The technician, being more hardware oriented than the engineer, should be able to convert engineering concepts or ideas to hardware; that is, if given a set of specifications, he should be able to breadboard the unit based on "ballpark" figures, optimize circuit component values, prototype the unit, work out

the hardware problems of interfacing, and perform the necessary tests and measurements on the unit.

Again, a simple example may be used to illustrate some of the questions which must be answered by the technician if he is to follow through with his part of an overall system-design problem. The specifications of a block within the system are as follows:

- a. Audio Frequency Pre-amp with a frequency response of 50 Hz to 10kHz \pm 2db.
- b. Output: 2v peak across 20kohm.
- c. Input: Dynamic microphone with an impedance of 300 ohms, and an output which is 50db below 1mw into 300 ohms.
- d. Temperature Range: 0° - 50° C.

Question: What is the overall gain required in the pre-amp? To answer this question, the equivalent circuit of the microphone must be determined. The characteristics of the driving circuit are necessary to determine the input configuration of the pre-amp. The use of logarithms and Thevenin's Theorem is required in reducing the microphone to its electrical equivalent circuit.

MISCELLANEOUS TOPICS CONSIDERED BY ETCDP

A number of miscellaneous items, questions and problems relating to the implementation of educational programs in electronics were considered by the Project Staff and members of the Steering Committee. Those which have not been previously discussed in this report are presented here with brief summarizing statements.

WHAT ABOUT ENTRANCE REQUIREMENTS?

- a. The Comprehensive Community College has an open-door admission policy.
- b. Entrance to a particular curriculum shall be determined at the Program level.
- c. The open-door policy may be applied to the Electronics Education only if there is a certificate program operated as a spin-off from a common term with an Electronics Technology curriculum, or if there is a post-high-school Pretechnical Program in operation.
- d. Those students who have the interests and aptitudes to continue with the two-year Electronics Technology Curriculum, following the common term for all students, will probably have the high-school credits essential for successful completion of the Associate Degree program. These students will probably enter with two to three units of mathematics, one unit of the physical sciences and three units of English. The personnel of the ETCDP project prefer to expect this of the entering students rather than to establish definite entrance requirements. The operation of spin-off programs, which permit an open-door policy, will resolve many of the problems. The secondary schools of each Community College District will cooperate to help solve the educational problems that are unique to the community.

WHAT ABOUT AN ADDITIONAL SUMMER TERM?

- a. A summer term, following the first academic year, is a good time to offer specialized courses not required within the framework of the curriculum.
- b. A summer term will provide an opportunity for those students who are in academic difficulties to take courses required to keep pace with the normal curriculum.
- c. A summer term is a good time to conduct a supervised CO-OP program with industry.

WHAT ABOUT PRETECHNICAL PROGRAMS?

- a. A reference: "Pretechnical Post High School Programs, Technical Education Program Series No. 12, Bulletin number OE-80049, U. S. Office of Education."
- b. The above bulletin contains some excellent information on pretechnical programs. Such programs, as stated therein, are to satisfy the unique needs of four groups of students: "those who have deficiencies in required subjects, those with underdeveloped mastery of organized studies, those who have suffered because of part-time or full-time employment while in high school, and those who left school before graduation."
- c. The following suggestions are submitted from the viewpoint of the ETCDP project:
 1. Some schools require a summer term in advance of the first academic year for those students who do not meet entrance requirements.
 2. There is a difference between pretechnical programs and remedial programs.
 3. Many students do enter with weaknesses in communication skills. One approach that has been reasonably successful for these students is to require that they

talk into a dictaphone and learn to speak better. Their writing abilities are then improved considerably.

4. There may be a tendency, through pre-technical programs, to force all students into an Associate Degree program. A vocational program leading to a certificate, requiring less than two years for completion, may be more satisfactory for a number of the students.

WHAT ABOUT TEACHER RESPONSIBILITIES?

For the Electronics Technology Curriculum, the teacher shall:

- a. Prepare some, if not all, of the experiments for the courses that he teaches, as necessary to meet his and the department's objectives. Laboratory manuals are seldom completely sufficient as the source for all experiments.
- b. Prepare lecture notes for classroom use as needed.
- c. Attend and participate in workshops, seminars and annual meetings relating to electronics education whenever possible.
- d. Enjoy the teaching of laboratory as much as in the classroom. Surveys suggest that classroom teaching is preferred by many teachers. The practical experiences that the student has in the laboratory are important.
- e. Keep in touch with the activities and needs of industry.

WHAT ABOUT TEACHER QUALIFICATIONS?

- a. An integrated approach for program staffing in electronics is recommended. This means that the teacher should have some practical industry experience; he shall have some academic work in education; and he shall have a good academic background in *Circuit Analysis*, the *Fundamentals of Electronics*, *Mathematics* and the *Physical Sciences*.
- b. The exact procedures for attaining this integrated academic knowledge, along with the practical experience, were not discussed

by the personnel of the ETCD project to any great extent. The Project Director, however, (not speaking for the project staff) would recommend a baccalaureate degree in electronics from either an engineering college or a technical institute (or equivalent) followed by a Master's degree in education. Getting the first degree in education and the second degree in electronics is not recommended. In the process of obtaining the baccalaureate degree in electronics, it might be ideal if the prospective teacher went the route of an Associate Degree in Electronics Technology. There are a number of BET programs in which such a route is self-contained. Some of these BET programs will also have the needed courses in education, in which case they may be deficient in their offerings of mathematics and the sciences.

- c. The rapid growth and the establishment of many new community colleges over the past decade has placed a special burden on the electronics teachers who received their degrees before anyone knew about the teaching needs of these institutions. Those teachers who do not have the essential academic background in their specialty need special programs to satisfy their needs. Such special programs are very limited and the needs are not being satisfied. These teachers are forced to do the best they can, through self-study, attending Summer Institutes, participation in workshops, etc.

WHAT ABOUT REVISION OF EXISTING PROGRAMS?

- a. The revision of a curriculum and/or subject matter within a curriculum is a continuous process.
- b. Revisions that might be needed are often avoided for philosophical reasons. There is an inherent fear of the making of changes. Innovative instructors will welcome change if it is needed.

WHAT ABOUT JOB PLACEMENT OF GRADUATES?

- a. It is important that the graduate be placed at the occupational level that is compatible with the curriculum objectives and subject-matter level.
- b. A major effort must be made to acquaint industry with the capabilities of the graduate and to get recruiters on campus.
- c. Need to orient and guide the graduates as to their opportunities for employment and selection of jobs.

WHAT ABOUT SOFTWARE FOR LABORATORY?

- a. There is a need for *laboratory textbooks* rather than the conventional laboratory manual. This means that there will be a discussion of the theory appropriate to each experiment.

- b. Most of the textbooks now available for Electronics Technology are written as *classroom textbooks*. There is a need for the two kinds of texts.

WHAT ABOUT INTERACTIONS WITH INDUSTRY?

- a. Make good use of the Industry Advisory Committees.
- b. Consider CO-OP programs for the students.
- c. Teachers should spend some time working in industry (summers, perhaps) at regular intervals - about every third year or so.
- d. Make use of industry personnel as part-time teachers or for the teaching of specialized courses.
- e. The teachers should get acquainted with the chief engineers of local industries.

A POSITION PAPER FOR ELECTRICAL-ELECTRONICS TECHNOLOGY

Reproduced here, and in part, is a position paper for the Electrical-Electronic Technology program at New Hampshire Technical Institute, Concord, New Hampshire. Acknowledgment for this paper is extended to Professor Stuart Cady, Department Chairman of that Technical Institute. A position paper such as this provides an excellent base for departmental and administrative operations.

INTRODUCTION

The Electrical-Electronic Engineering Technology curriculum is designed to lead an individual toward a broad background of basic knowledge and, simultaneously, a background sufficiently specialized to produce an employable graduate at the end of the two-year program.

It is recognized that the level of a program is determined by its objectives and the quality by how well it achieves those objectives. Therefore, the department strives to provide a quality technical base to the individual's education.

The department is in accord with the following definitions of engineering technology, the engineering technician, and an engineering technology curriculum as defined by the American Society for Engineering Education bulletin, "Characteristics of Excellence in Engineering Technology Education."

"Engineering Technology is identified as a part of the engineering field to indicate that it does not by any means encompass the entire field and also to differentiate it from other types of technology in areas such as medicine and biological sciences. The engineering field is viewed as a continuum extending from the craftsman to the engineer. Engineering technology falls, in the continuum, between the craftsman and the engineer, and closer to the engineer than to the craftsman.

"Engineering technology is concerned primarily with the application of established scientific and engineering knowledge and methods. Normally, engineering technology is not concerned with the development of new principles and methods.

"Technical skills such as drafting are characteristic of engineering technology. Engineers graduated from scientifically oriented curricula may be expected to have less of these skills than previously, and the engineering technician will be expected to supply them.

"Engineering technology is concerned with the support of engineering activities whether or not the engineering technician is working under the immediate supervision of an engineer. It may well be that, in a complex activity, he would work under the supervision of an engineer, a senior engineering technician, or a scientist.

"An engineering technician is one whose education and experience qualify him to work in the field of engineering technology. He differs from a craftsman in his knowledge of scientific and engineering theory and methods and from an engineer in his more specialized background and in his use of skills in support of engineering activities.

"An engineering technology curriculum is a planned sequence of college-level courses, usually leading to an associate degree, designed to

prepare the students to work in a field of engineering technology.

"The term 'college-level' in the definition of an engineering technology curriculum indicates the attitude with which the education is approached, the rigor, and the degree of achievement demanded, and not necessarily that the credits are transferable to baccalaureate programs."

THE ELECTRICAL-ELECTRONIC ENGINEERING TECHNICIAN

To excel in his work, the electrical-electronic engineering technician should have the following abilities, knowledge, skills, and responsibilities:

- A. The ability to apply mathematics through elementary integral calculus as tools in the development of ideas based on scientific and engineering principles.
- B. An in-depth knowledge of electrical and electronic circuits and devices, including the ability to design and construct basic circuitry.
- C. An extensive knowledge of laboratory test equipment and test procedures, including the necessary skills to operate, calibrate, and maintain the equipment. The ability to design basic instrumentation systems and procedures.
- D. An understanding of the methods, materials, skills, and processes commonly in use in the field.
- E. Flexibility in adapting to a changing world of work which may often involve other technical fields.
- F. The ability to analyze, interpret, and communicate facts and ideas graphically, verbally, and in written form. A significant aspect is that, since the engineering technician is frequently the liaison between the engineer and the craftsman or technical specialist, the ability to communicate with both is essential.
- G. An awareness of the broader responsibilities to society as a whole. The

engineering technician must be concerned for the welfare of those who will utilize the end results of his technical efforts as well as for any deleterious effects on the environment in which he lives.

THE CURRICULUM--PHILOSOPHY, ORGANIZATION, AND CONTENT

The objective of the Institute is to provide an educational experience that will assist the individual to function in an effective way as a citizen and a contributing member to society as well as a recognized semi-professional in his chosen field of work.

To implement this objective, the student takes a course in English or Social Science every term. Good cooperation exists between the departments as they recognize the interdependence of the areas. For example, efforts are made by the technical specialty instructors to view the students' paperwork for the qualities that members of the English department expect as well as for the technical content.

During the freshman year, the student studies the fundamentals of electric circuits, circuit analysis, and basic electronics. The mathematics and physics courses provide direct support to the technical core courses. Considering the short period of time available for the education of the engineering technician, many courses have prerequisites. It is *absolutely necessary* that the objectives of each of these prerequisite courses be met so that the student may satisfactorily master the material in the advanced courses.

Other freshman courses include engineering graphics and electrical drafting, which are taught by the Mechanical Engineering Technology Department. An orientation course provides guidance for the student to adjust to college life and to inform him about the area that he has chosen to study. A seminar course provides him with an opportunity to select and plan programs of interest.

In the senior year, the student rapidly

expands his technical horizon. Courses in electrical measurements and instrumentation develop a competency and a sense of confidence in an area that is basic to an engineering technician. A course in electrical machines and controls enables the student to gain an understanding of motors and generators. Building on the electronics course in the first year, the student studies more advanced concepts of semiconductor devices and circuits, including basic design considerations.

The first four terms are identical for both Electrical and Electronic majors. The fifth term diverges, with the Electrical majors studying advanced concepts of electrical machines and controls. This is followed in the last term by courses in servomechanisms, instrumentation, control system analysis, and a technical elective which may be chosen from computer electronics, mechanisms and design, and UHF and microwaves. This curriculum is designed to develop a control system emphasis rather than a power emphasis.

During the fifth and sixth terms, Electronic majors study communication electronics and UHF and microwaves as they develop an understanding of electronic communication fundamentals. They also have a course in industrial electronic theory and applications in addition to choosing a technical elective. The choice may be made from computer electronics, servomechanisms, control system analysis, or mechanisms and design.

The curriculum is kept current by a close relationship with industry. Faculty members visit industry individually and on field trips with students. Many also attend professional society meetings and exhibitions. In addition, a number find employment in industry during the summer.

One of the most important aspects of the student's education is that he develop the capability of working with a minimum of supervision. As he progresses through the curriculum, he assumes more responsibility for his laboratory investigations, class work becomes more challenging, and he may write technical reports in areas that are not covered in the regular class work.

As a result of the continually changing nature of technology, the student is made aware that, to remain employable at the engineering level, he will have to continue his education formally and/or informally.

The laboratory part of the courses serves to reinforce the theoretical concepts developed in the classroom and places the student in a situation where he must use his hands in producing a working result. The laboratories at the Institute are modern, well-lighted, and well-equipped with up-to-date laboratory-grade equipment. There is ample equipment so that students may work in small groups and gain skill in the operation of various instruments and in the taking of valid measurements. To add to the "hands-on time" that the student has with the equipment, laboratory sections are small enough to enable him to obtain adequate assistance from the laboratory instructor.

After observing and recording the data from his experiments, the student must analyze, interpret, and report on the data, either orally or in written form. The laboratory requirements include the writing of formal type scientific reports. After the student has demonstrated a reasonable proficiency with the formal reports, he then presents much of his future work in the form of an engineering laboratory notebook similar to one that he may be required to keep in his future work.

As the student gains experience in the laboratories, he is given more freedom to investigate the problem in question in his own way. In a sense, the student "writes his own laboratory experiment." He may determine the specific area of his investigation, design the necessary circuits, and determine the instrumentation to be used in gathering the necessary data to report on his investigation. This flexibility in the laboratories tends to more closely approximate a job situation, particularly in the more advanced courses. The student gains in self-confidence as he achieves goals in the real world, not just theoretical ones on paper.

The fabrication and project course sequence offers the student practical information on modern fabricating processes and an opportunity for development of a student-oriented project. Each student is the focal point of his project. Operating within available material, time, and cost constraints, he develops drawings, schematics, bills of materials, and cost analysis sheets, and the operational piece of hardware with final data information. The student is encouraged to use imagination and ingenuity in the development of his project.

An important aspect of the laboratory work is the skill in trouble-shooting circuits that the student acquires. The techniques that are developed in removing problems from the basic circuits may readily be extended to complex systems.

Since the engineering technician is primarily concerned with the application of scientific and engineering principles, it follows that a significant part of his time is spent in the laboratories. Approximately 48 percent of the core course time is allocated to the associated laboratory. Overall, approximately 36 percent of the total curriculum time is allotted to the supporting laboratories.

The faculty of the department recognizes that the personal and social needs of the student are equally as important to his success as is his technical proficiency when he graduates. Consequently, every effort at their command is used to make the student realize and feel that a genuine concern for his well-being is present. Basically, this concern is expressed by motivating the competent student to perform in a positive academic and social manner, by counseling and challenging the superior student capable of advancing his education through continued study at other institutes of higher learning upon graduation, and by guiding the academically weak and/or vocationally misplaced student into other levels or other programs of learning that may more satisfactorily meet his personal needs or capabilities.

EMPLOYMENT OF ALUMNI

Graduates of the Electronic Engineering Technology program have been employed in a wide spectrum of positions. More and more of the "hardware" work formerly done by engineers is being performed by the engineering technician. A number of companies have hired graduates of this program into positions formerly filled by graduate engineers. However, most of the graduates have been employed at the engineering technician level.

A representative list of initial job titles of graduates follows:

- Electronic Engineering Technician
- Engineering Aide
- Associate Engineer
- Design Engineer
- Design Draftsman
- Systems Test Technician
- Field Service Engineer
- Customer Service Engineer

EMPLOYING COMPANIES

Companies employing our graduates include:

- Advent Electronics
- Aerotronics Associates
- Browning Laboratories
- Brown Company
- Sanders Associates
- General Electric Company
- IBM Corporation
- Improved Machinery Company
- New England Telephone
- Kidder Press
- Raytheon Company
- Bell Telephone Laboratories
- Evans Radio, Inc.
- Sylvania Electric Company
- Public Service Company of N. H.
- Stone and Webster
- Digital Equipment Corporation
- New England Power Company
- Northeast Electronics Corporation
- Sprague Electric Company
- Exeter-Hampton Power Company

TRANSFER OF ALUMNI TO UNIVERSITIES

An increasing number of graduates are continuing their education and receiving significant transfer credit in engineering programs at the university level. Twenty-four graduates from the department are continuing their education full-time. Many others have matriculated in Evening Division programs leading to a baccalaureate degree.

CONCLUDING REMARKS BY STEERING COMMITTEE MEMBERS

This section contains concluding remarks by each of the six members of the Steering Committee for the ETCD project. These are presented here in the following sequence: Concluding remarks by Carrol Livesay, by Roger Mussell, by Eric Ruby, by Neal D. Voke, by Felix Wheeler and by Robert Wilson. Each of these gentlemen will be happy to discuss the problems of electronics education with any interested parties. Refer to information in the front material for their present addresses.

CONCLUDING REMARKS BY CARROL LIVESAY:

ETCDP: Can You Change?

The necessity for change is evident as the materials presented within these covers are seriously studied. The degree and the type of change in each person's situation will be different. Where you stand now must be rigorously evaluated and then compared with the efforts of others who have concentrated on this subject of electronic curriculum development.

Those who participated in this project have taken a hard look at the requirement placed upon the electronics training programs and have changed their thinking many times. For instance, it became obvious that there should be more than a rigorous math-based electronics curriculum if the community college was to match the student to the job.

You should be extremely familiar with change, if you have kept pace (to a reasonable extent) with the electronics industry over the years. You must be willing to do the same kinds of things in electronics curriculum development or guidance that you have been doing continuously as you have maintained familiarity with the electronics industry. This may mean that next year's two-thirds of a course should be completely revised or another course added just as in engineering new models of a system. A circuit of a sys-

tem might be changed from tubes, to bipolar transistors, to field effect transistors, to integrated circuits. (This may be the reason that electronics engineers usually fit into electronics technology educational positions so readily and are not adverse to changing a course or making a major curriculum change.)

The work of the ETCDP will aid in making the process of changing less painful if it is used conscientiously. This has already happened to many who attended the national conference in February, to those who participated as Steering Committee members, to those on the project staff and to many others.

CONCLUDING REMARKS BY ROGER MUSSELL:

ETCDP--The Project

The narrative of the original proposal lists six major significant objectives or activities. These objectives have been met. The contributions by the Project Staff, Steering Committee members, consultants and participants in National Science Foundation Institutes are many and are worthy of note. However, I would like to relate specifically to objectives three and five. These objectives deal with instructional media and college industry interaction:

3. To develop the uses of available media of instructional technology appropriate

to the particular needs of electronics education.

5. To determine those working relationships by which the colleges and industry can interact to their mutual advantage to satisfy the needs of industry and the student.

One of the strengths of this project is the vigor with which this area of instructional media was pursued, and the manner in which it was related specifically to the teaching of Electronics Technology. It has been proved beyond reasonable doubt that non-experts can prepare media presentations--given an adequate amount of time and support equipment.

An additional strength of this project is the fine spirit of cooperation obtained from the following companies when asked to assist in developing a technique to relate the industry to the student. The four companies are:

- Bourns/Chicago Aerial Industries
- Motorola, Inc.
- Underwriters Laboratories
- Western Electric Company

The development of media presentations using video tape, slides and movies indicates that:

- a. Industry can be brought to the classroom;
- b. Media presentations can be done at reasonable cost;
- c. Media presentations can be accomplished by amateurs;
- d. Media presentations take a reasonable amount of time and support equipment.

A further strength of this project is the investigation of Computer-Assisted Instruction, specifically, that dealing with the investigation of Circuit Analysis by Computer at the engineering technician level. In the past, this topic has primarily been an upper-division course. This topic alone has tremendous, far-reaching ramifications for future course-structuring objectives and expected student behavior. This topic should be developed further in specific relation to the curriculum as it is herein developed.

Upon completion of the project, we stand at the threshold of the entire area of media and how it can be further developed to aid the student-community college-industry interrelationship in the teaching of Electronics Technology. Enough samplings of varied techniques have been successfully completed to suggest one of the prime considerations for future work to be:

That continued and consistent effort be given to this research, based upon the findings of this project.

That the investigation be limited to the area of Electronics Technology and utilize the curriculum as developed herein to key the development of related instructional media.

CONCLUDING REMARKS BY ERIC RUBY:

Critique of ETCDP

If a community college is to live up to its challenge, it must be comprehensive. This is not an easy task. A community college does not become comprehensive simply by increasing the number of programs (or courses) which it offers. We may begin to get an idea of what it means for an institution to be comprehensive by first stating the three accepted categories usually mentioned in discussions such as this and then examining in some detail the category in which we find the curriculum of this project. The categories mentioned above are: 1) Adult (continuing or enrichment) programs; 2) Terminal (or career-oriented) programs; and 3) Transfer (or baccalaureate-oriented) programs.

The career-oriented programs are characterized by diversity. Diversity in the general fields. The range is so wide that I doubt that any one list is complete. If completeness does exist today, it is likely not to have accounted for some "emerging occupation," and consequently will become incomplete unless frequently updated. A partial list would include: electronics, electrician training, automotive careers, agriculture

related careers; business and data processing careers, optics, nursing, medical and dental technologies, petroleum technologies, etc.

The diversity does not end here. If we consider just the electronics area, we usually again see three common categories: 1) trade level; 2) industrial level; and 3) technical level.

The first two are sometimes combined into a single category called vocational. The technical level is sometimes broken into two sub-groups:

1) Industrial technology; and 2) Electronics Engineering (related) technologies.

Since this field (electronics) is so diverse, confusion is the major result of any attempts to categorize. The engineering manpower commission gave up even trying to separate the field into two groups. The semantics of the situation aren't helping. Electronics is so broad a field that it is not possible for a two-year program to completely cover the field. The curriculum developed by ETCDP has as its major objective the development of core courses to which technical electives must be added. The list of possible electives is quite long and no school could possibly offer them all. We find, therefore, that each institution offering electronics technology usually offer such programs with various emphases such as: communications options, computer options, instrumentation or control options, etc. To be comprehensive, a college would have to offer all possible such options on all possible levels.

The result of the above situation is that a college is very likely to institute trade or vocational programs (sometimes unwittingly call them technologies). The reasons for this are many, and varied. Some of the reasons are: 1) vocational instructors are easier to obtain; 2) vocational instructors do not, in general, require as large a salary; 3) it is easier (supposedly) to find students for such programs; 4) most people who serve on area-need studies have a vocational background, etc.

The paramount problem in electronics engineering technology today is the extreme shortage

of qualified instructors. The problem has many facets but one is paramount: nobody is preparing them! Vocational and technical education colleges do not give the students a sufficient background in the engineering sciences. Engineering colleges cover this, but on a math and science level which is simply not attainable in a two-year program.

There have been a number of Summer Institutes and Academic Year Institutes which have assisted. These institutes have not solved the problem. One reason is that they have been too few in number. Another is that they have all been involved in upgrading people already in electronics education. We need programs to teach people who are engineers how to teach technology. This will not be easy: engineers do not have (and are not likely to get) summers off to attend such programs.

I have digressed. My original point was that no college can be comprehensive in the strictest sense of the word. Further, no college should call itself comprehensive unless it has several levels of technical programs (including the engineering technologies).

The key to the proposed curriculum is the math content. Without the math, the objectives cannot be reached. There appear four distinct reasons for the inclusion of a given math topic:

1. If the graduate will be expected to use the topic to solve problems after graduation, the topic must be included.
2. If the field shows a trend such that the topic will probably be used by technicians of the future, it should be included.
3. If the graduate will be expected to work with (or on) equipment which performs the related math, these topics must be included.
4. If the math topic makes it easier to grasp a concept (especially a system concept), then it should be included.

It can be shown that all of the math content of the proposed curriculum meets reasons 2, 3 and 4;

and most meet reason 2. Much care must be taken that math topics go deep enough to be useful but not so deep as to unnecessarily eliminate a student who does not have a high math aptitude.

The circuits sequence is almost as important as the math, since the real world devices (transistors, tubes, FET's, SCR's, etc.) are normally studied by first determining an approximate circuit model. Such a circuit model is a grouping of resistors, capacitors, inductors, diodes and sources. If the student is to understand the device, he must first understand the circuit concepts.

The project has covered a surprisingly lot of ground. I'm very impressed with the result. The staff has exceeded my highest expectations. However, the work is not complete. Much remains to be done. Probably the most pressing of these tasks is to identify and develop alternate approaches to and sequences of the topics. This is especially true of the circuits sequence. The project did identify some alternate approaches, but did not have time to develop all of them, or to present all of the ideas that were generated as a part of this report.

CONCLUDING REMARKS BY NEAL D. VOKE:

The necessity of offering students an alternative to the math-science based Electronics Technology program has been established in the report. This "spin-off" concept provides an opportunity for those students who are less capable in math-science courses and/or who are primarily interested in servicing electronic equipment and want to remain in an electronics program. One solution to the problem, for those schools operating on the quarter plan, is to have all students enroll in the same electronics courses (i.e. Introduction to Electronics) for the first quarter. At the end of the first quarter the students, aided by the faculty and guidance staff, will decide which program is best suited to their needs, abilities, and occupational goals.

This method, however, is not satisfactory for students enrolled in schools operating on the semester plan. In view of the fact that the servicing-oriented program may be only two semesters in length, the student cannot wait until the end of the first semester to make a decision. In most cases, one semester would not be an adequate amount of time to complete the requirements of a servicing program. This means also, that the students planning to complete the math-science based program must wait one full semester before they can begin studies in circuit analysis.

The following proposal is an attempt to implement the "spin-off" concept in a semester plan. Basically, the proposal requires all students to enroll in a course called Fundamental Electronics (Section I), lasting six weeks. At the end of the six-week period, the student with the aid of the faculty and the guidance staff will decide which of the two programs (Electronic Engineering Technology or Electronics Servicing) he wishes to complete. For the remaining eleven weeks of the semester (and the balance of the program) he will study material specifically designed for a particular program. Since many servicing-oriented certificate programs are only one year in length,

Table I. First Semester Schedule

First Semester of the Electronics Engineering Technology program	
Electronic Fundamentals	3
Introduction to Electronics	3
Resistive Circuits	4
Basic Tech Math	4
Communications I (RHT)	3
	<hr/> 16
First Semester of the Electronics Servicing Program	
Electronic Fundamentals	3
Basic Electronics	5
Service Techniques	2
Elem Tech Math	3
Communications I	3
	<hr/> 16

making an early decision is highly desirable. This means also that the students in the math-science based program can start circuit analysis much earlier.

As shown by the outline of Table II, all students begin the semester in Fundamental Electronics, Communications I (Rhetoric), and Basic Technical Math. At the end of the six weeks, the students may continue in either the servicing program or the math-science based Electronics Technology program. The first semester electronics courses are listed according to semester-hour credit and the conventional lecture-laboratory ratio. However, the class schedule would list these courses as being offered during the first 6 weeks or the last 11 weeks of the semester. The conventional relationship of 2 contact hours per week per semester for 1 semester hour of credit is maintained as nearly as possible for all electronic courses. (Fundamentals of Electronics is listed as 2 lecture, 3 laboratory hours. If this were scheduled, on a semester basis, there would be

55 student-contact hours. The total student-contact hours on the 6-week schedule is 90 hours.)

All students also enroll in a Basic Technical Math course. Students desiring to complete the Electronics Servicing Program would transfer to a more elementary math course at the end of 6 weeks.

This would be an ideal situation for utilization of programmed units in elementary technical mathematics. A passing grade on a "package" of programmed units designed specifically for students in electronics servicing could be used to satisfy the requirements for the 3 semester hour course listed as Elementary Technical Mathematics.

Although each institution has unique problems relative to scheduling, registration, faculty load, etc., the need for providing students with an alternative to the math-science based program rather than forcing them out of school, should be given primary consideration.

Table II: A Portion of First Semester Schedule to Show How Spin-off is Implemented in a Four-Semester Program.

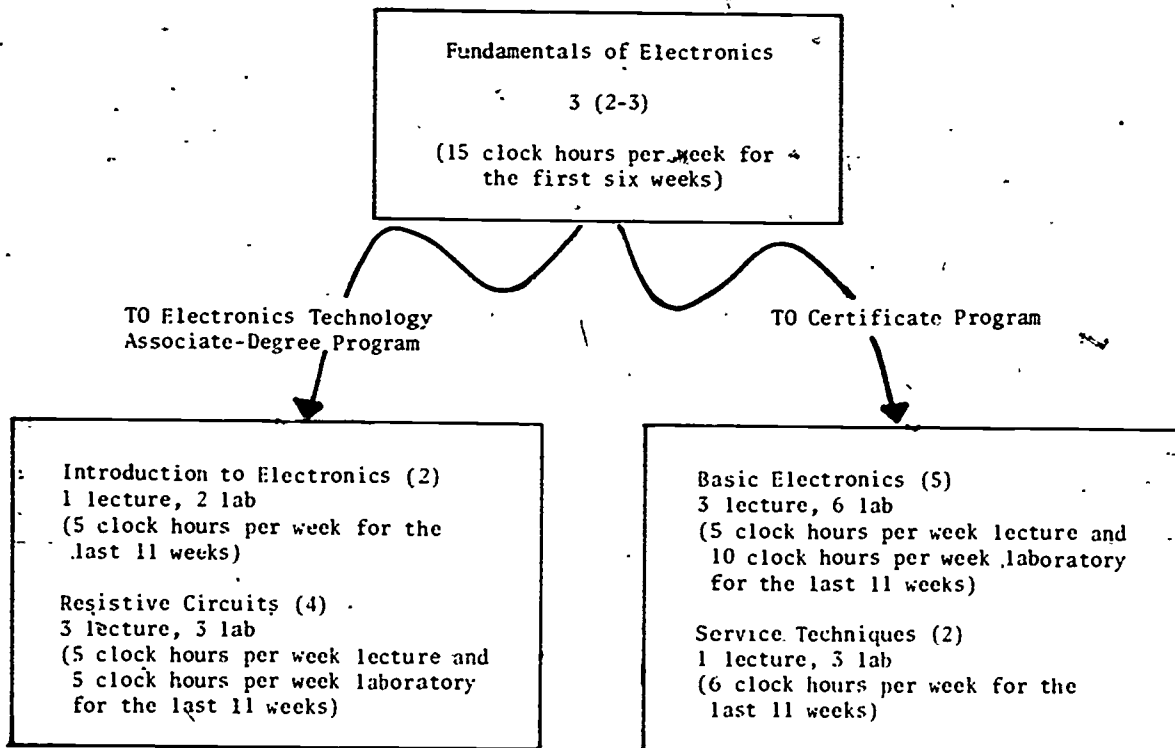

CONCLUDING REMARKS BY FELIX WHEELER:

Community colleges contemplating a college-level curriculum in electronics technology will find both a high challenge and a great assistance in the body of this report which I endorse as the final product of this NSF project. I would also like to make a few remarks, below, which may be helpful to your understanding of the nature of the challenge implied by this report.

Few colleges will admit to having programs which are of less than college level. However, many do have such programs in spite of their protestations. This is particularly true among college vocational and technical programs. The decision to have a program of less than college level often is not a conscious decision. It is simply a consistent failure to remedy the high-school deficiencies of entering students and to establish standards for program admission, particularly for vocational-technical programs. This is a decision for mediocrity and is very expensive in terms of the damage to aspirations of both the students and their teachers. It also damages the image of the institution.

Just now, it is probably true that a successful electronics technology program, that is, one having program standards and not less than sixteen graduates each year, has little chance of being developed in the absence of a strong vocational electronics program, that is, one having program standards and not less than sixty graduates each year. The reason for this connection lies in the fact that, just now, the best system for finding qualified students for the two-year program is to graduate them from the one-year program or to uncover them in the process of recruiting for the one-year program.

A better method of finding students qualified to enter the two-year programs would be to divert them from other programs. The two most appropriate fields for such diversions

are pre-engineering and liberal arts and sciences (LAS).

In the case of pre-engineering students, many will not be able to cope with the pace and rigor of the university programs. This is particularly true of students considering electrical engineering where electromagnetic fields, as applications of vector calculus and differential equations, are such that neither the student nor any counselor who is not an Electrical Engineer can see the hazards ahead. The best interests of the student would be served by providing a qualified counselor and, where appropriate, diverting the student to a career field such as electronics technology.

In the case of many LAS students, their aims are not so much for the purely cultural advantages of such a program as they are for an opportunity to search for a field of interest in which they can find rewarding careers. Here is an unlimited opportunity for good work by good counselors to help these students find a field of interest, perhaps in electronics. To do this, the counselor would need plenty of detailed information, perhaps slide/tape presentations, which authentically describe the scope, challenges and opportunities of each identifiable field of work as well as the programs and standards at that school which would help the student to succeed in each field.

If there is a place for electronics technology in your college, I hope you will take the "High Road" to electronics technology with Professor Babb. Just don't expect to find me on the "Low Road," because that's where I strayed and found by experience the things I have related briefly above.

CONCLUDING REMARKS BY ROBERT WILSON

The Electronic Technology Curriculum Development Project has been a major contribution to the "engineering technologies." Members

of the project staff did an outstanding job of surveying the existing Electronics Engineering Technology curriculum and directing attention to courses which needed revision. A great deal of attention was devoted to the math-circuits sequence. Many extremely creative ideas were brought forth by the project staff. For example, laboratory experiments were written which used the concept of introducing topics in the laboratory rather than through lecture. These experiments used a fresh and realistic approach to topics such as Thevenin's Theorem, etc.

The overall philosophy of the Electronics Engineering Technology Curriculum progressed considerably during the era of the project. A curriculum outline, which four short years ago was virtually untested, gained the support and

respect of those who have used it. Each was able to draw from his own personal experience of using this curriculum when suggesting revision or reorganization of courses. Each member of the project staff as well as the steering committee benefited greatly from the project.

Future efforts should be directed toward the Single Time Constant course and its companion math course as well as the Network Analysis course. At this point in time, there is still need for an adequate textbook for the Single Time Constant course.

I would like to take this opportunity to congratulate the project director and staff for a job well done. I would also like to thank them for the opportunity to participate as a member of the project steering committee.

Prof. Daniel S. Babb
Electrical Engineering Dept.
University of Illinois
Urbana, Illinois 61801

(Education Research Associates,
Garden Grove, California)

Dear Professor Babb:

It is very satisfying to note this project recognizes the need for providing an upgraded electronics engineering technician program, and that the success of such a program is rooted in an adequate math-science base.

I firmly believe that a two-track electronics program should be seriously considered by every community college. Those students who have the ability and inclination to pursue an upper track math-based program should have the opportunity to do so. Unfortunately, the usual practice is to lump all students together into a single track program, which desperately attempts to avoid "snowing" the vocationally oriented student without boring the engineering technician level student. The end result is a less than optimum education for both types. Very few schools are truly generating technicians trained to the best of their ability. In fact, mediocrity is so prevalent that even industry standards are often scaled down to meet the available level, and in turn the community college adjusts the quality of its output to meet these watered down requirements.

I, personally, have trained hundreds of students in advanced industrial training programs as well as community colleges, and time and time again find them capable of comprehending and analyzing material at a level far beyond that which they were originally exposed to. These students could accomplish even more if they had been offered the opportunity to pursue more challenging electronics programs in their formative years.

The effort your group is making towards identifying those broad based concepts and mathematical tools with which to implement the program is particularly worthwhile. I'm sure there are many who will say it isn't feasible, but, by the same token one can say, "nothing ventured, nothing gained". Surely, a project as significant as this is worthy of the thorough investigation your group is providing.

(Mr Cutler spent several days discussing the ETCD project with the Project Staff. His letter is appreciated.--DSB)

Sincerely yours,

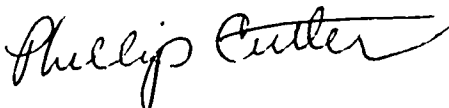

Phillip Cutler
Director

A MESSAGE FROM THE PRESIDENT OF PARKLAND COLLEGE

Parkland College was pleased to join with the University of Illinois and other institutions of higher education in the electronics technology curriculum development project. The project has now been completed, and the results have served to answer a number of questions which have significance in the important area of curriculum development.

One of these questions concerned the feasibility of several institutions working together on a major project to accomplish meaningful results. The end product of this project, which was the development of key subject matter for core courses in electronics technology, indicates conclusively that the answer is in the affirmative. From the beginning the project has gone smoothly from an administrative point of view, and the general enthusiasm and motivation for curriculum reexamination and improvement have been welcome side effects of the project. These benefits, I am sure, have been experienced by all participating institutions.

It occurs to me that what has been learned from this project in electronics technology curriculum development can be applied to other disciplines with equally good results. Desirable curriculum change, traditionally, is difficult to achieve. This project illustrates how cooperative effort can provide the foundation to accelerate this change. Projects of this type should be followed by related workshops, spanning at least a week in length, and which involve a number of institutions. In my opinion, such an approach to curriculum development shows promise of accomplishing excellent results, and would justify financial support at the federal, state or local level.

We at Parkland College were proud to serve as host institution for the electronics curriculum development project, and are confident that the results will serve to strengthen electronics technology in two-year institutions.

Sincerely yours,



William M. Staerke
President

(Parkland College, Champaign, Illinois)

WMS/rjs

A Community College Serving Twenty-Six High School Districts in East Central Illinois

A MESSAGE FROM THE PROJECT COORDINATOR

SUGGESTIONS FOR FOLLOW-UP TECHNIQUES OF ETCDP DEVELOPMENTS

The manner in which this project was conducted is unique. The involvement of university personnel with teachers of technical subjects in the two-year colleges has provided a model for future work of this nature. Now that the project is completed, the problem still exists of disseminating the information and having it used effectively in the classroom on a nationwide basis.

One of the first ways of achieving this would be to organize a series of state conferences of electronics instructors to discuss the content of this study. In some geographical areas it may be desirable to have several states go together for the conference. It is entirely feasible that the U.S. Office of Education or the National Science Foundation would be receptive to the support of a structured program of a series of conferences using the project staff, as resource personnel, to make presentations at the conferences. This could very well be organized by the Technical Education Research Center.

Another source of funding could very easily come from the Educational Professions Development Act where subject matter teachers would be brought together in summer institutes and summer conferences devoted to the study of the content of the courses and instructional techniques as presented in this report. The vehicle for the implementation of this phase will vary from state to state. The enthusiasm of those participants in the Electronics Technology Conference that was held in February 1970 in conjunction with the ETCDP project and the favorable acceptance of the results of the study by the classroom teacher convinces the project staff of the need for this kind of work.

The experiences gained in this study point to the need for the establishment of various learning resource centers that would continually develop new instructional material for the various technology programs being offered throughout the United States. There is a need for the writing of classroom textbooks, laboratory textbooks and various multimedia materials to be used in the implementation of the recommendations of this report. In addition to this, the same kind of study needs to be conducted for other engineering-related technologies.

In the organization of these centers, care must be taken to insure a continuing dynamic input to the activities of the center. The center must be so structured as to permit a constant flow of new people with new ideas. When a particular project is completed, the persons associated with the activity would go back to their respective teaching assignments.

In the immediate future it is logical for the project staff to organize a national conference for the purpose of disseminating the information generated as a result of the study. Perhaps from this conference a series of state conferences could be organized that would permit the classroom teachers to become more directly involved.



Jerry S. Dobrovolny

APPENDIX A

SUMMER INSTITUTE, VISITATIONS AND CONFERENCES

The ETCD project was conducted by seven community colleges in Illinois in cooperation with the University of Illinois at Urbana-Champaign. Procedures were incorporated into the project to provide maximum benefits on a national scale rather than to the participating colleges only.

Three major activities of the project were directed to the broad geographical objective and are described in this Appendix A. The first section describes a Summer Institute conducted for twenty-four experienced teachers of electronics from community colleges and technical institutes. The Project Staff made visitations at a number of colleges outside the State of Illinois and also attended or participated in several conferences relating to technical education. These visitations and conferences are identified in the second section. The third item of this appendix is a summary of an Electronics Technology Conference conducted on behalf of the ETCD project. The last section identifies the participants at that conference.

ETCDP SUMMER INSTITUTE

The ETCD project provided support for twenty-four experienced instructors in Electronics Technology Curricula from community colleges and technical institutes to participate in an eight-week Summer Institute conducted at the University of Illinois at Urbana-Champaign and at Parkland College. This Summer Institute constitutes the third phase (Phase III) of the project.

A portion of the brochure that was used to announce that Summer Institute is reproduced as an Exhibit on page 351. A listing of the participants along with the colleges represented is presented on this page. A group photograph of the participants and the Project Staff is presented on page 352.

SUMMARY OF ACTIVITIES

The participants registered in three different courses, the contents of which are identified in the third column of the Exhibit. The first six weeks of the Summer Institute were devoted to (1) a study of subject-matter content for the six-plus-one core courses; (2) a study of the philosophies of technical and vocational education in electronics; and (3) to a study of the techniques and procedures for computer-assisted instruction. During the last two weeks of the Summer Institute, the participants presented written and oral reports on the different aspects of the ETCD project.

This report contains many of the suggestions and much of the subject matter as developed and presented by the participants in support of the activities of the ETCD project.

PARTICIPANTS

Beers, Robert Benjamin
Broome Technical Community College
Binghamton, New York

Birong, John Denhem
Madison Area Technical College
Madison, Wisconsin

Bishop, Lyle LaVerne
Bradley University
Peoria, Illinois

Brittan, John L.
Lake Michigan College
Benton Harbor, Michigan

Broadwell, Charles McAlear
Dabney S. Lancaster Community College
Clifton Forge, Virginia

Burkett, Harry L.
DuBois Campus
Penn State University
DuBois, Pennsylvania

Cady, Stuart Wayne
New Hampshire Technical Institute
Concord, New Hampshire

Cavanaugh, Vincent E.
Florissant Valley Community College
Ferguson, Missouri

Dehn, Kenneth Elmer
Lakeshore Technical Institute
Sheboygan, Wisconsin

Dostal, Melvin Frank
Marshalltown Community College
Marshalltown, Iowa

Gross, Thomas C.
Hartford State Technical College
Hartford, Connecticut

Haywood, Jerry Louis
Illinois Valley Community College
Oglesby, Illinois

Horton, Francis Standish
Southeastern Iowa Area Community College
Burlington, Iowa

Kearney, Edward Patrick
Waterbury State Technical College
Waterbury, Connecticut

Kerr, James Goule
Western Iowa Technical
Sioux City, Iowa

Long, John Edward
Columbia State Community College
Columbia, Tennessee

Maze, Louis
Triton College
River Grove, Illinois

Paine, Robert Leland
Bristol Community College
Fall River, Maryland

Pedersen, Joe Finrow
Skagit Valley College
Mount Vernon, Washington

Phares, John V.
Kellogg Community College
Battle Creek, Michigan

Rankin, Chester L.
Kansas Technical Institute
Salina, Kansas

Russell, Dean A.
Washtenaw Community College
Ypsilanti, Michigan

Stateler, Victor Leo
Kirkwood Community College
Cedar Rapids, Iowa

Walther, Hans William
Hawkeye Institute of Technology
Waterloo, Iowa

ELECTRONICS TECHNOLOGY CURRICULUM DEVELOPMENT PROJECT

UI-NSF SUMMER INSTITUTE

UI-NSF SUMMER INSTITUTE FOR EXPERIENCED ELECTRONICS INSTRUCTORS
IN JUNIOR COLLEGES AND TECHNICAL INSTITUTES

ELECTRONICS TECHNOLOGY

CURRICULUM DEVELOPMENT

for Experienced Electronics Instructors
in Junior Colleges and Technical Institutes

OBJECTIVES

This institute is the final stage of a 13-month effort to develop concepts and instructional materials for the circuits and electronics segments of electronics technology curricula. The summer session will be directed particularly to instructing participants in methods of using the new materials. This familiarization will be accomplished through three formal courses covering both theory and laboratory practice-projects. Points of view considered will include both presentation and learning, as well as how to get classes started in stimulating ways.

ELIGIBILITY AND APPLICATIONS

Basic criterion for selection of institute participants will be at least two years experience teaching electronics technology in a junior college or technical institute. From this group, preference will then be given to applicants who have been members of previous institutes at the University of Illinois or equivalents elsewhere. Completed applications which can be requested with the attached return blank must reach the Director by February 15. The twenty-four appointments will be announced and participants notified by mail about March 5.

Supported by the
National Science Foundation

conducted by the
UNIVERSITY OF ILLINOIS
Urbana-Champaign

and
PARKLAND COLLEGE
Champaign, Illinois

June 22 through August 15, 1970

Professor Daniel S. Babb, Director
Department of Electrical Engineering
117 Transportation Building
University of Illinois
Urbana 61801



COURSE SELECTION

All participants will attend a seminar twice weekly on electronics technology education, a computer-oriented applied-mathematics course meeting six hours per week, and a lecture-laboratory course meeting ten hours per week directed to the materials developed during earlier phases of the project. The resulting instructional methods and devices will be discussed, demonstrated, and used by the participants in actual classroom and laboratory situations.

COURSE CONTENT

Electronics Technology Instructional Practice. Classroom-laboratory lecture-discussions relating directly to use of materials and methods developed during the total project. Comprehensive study in major topics of the two-year associate-degree program in electronics technology. Sample topics include: the most important points in circuit analysis, electronic devices and circuits and their applications, as in resistive circuits, single time-constant circuits, network analysis, resistive electronics, pulse circuits, and advanced electronics. Key topics of the text Introduction to Electronics will also be covered.

Applied Computer-Mathematics. Basic techniques of writing FORTRAN programs to solve technical problems, functional components of computer systems, computer-aided or based instruction for electronics, and block-diagramming techniques with applications to network analysis or synthesis.

Electronics Technology Education Seminar. Discussion on curriculum structure for electronics programs, instructional techniques in classroom and laboratory as evolved from objectives, alternate possibilities for topical sequencing, teacher qualifications, employment opportunities and job classifications, and other questions of concern to electronics technology faculty members.

ACADEMIC CREDIT

Successful completion of the institute courses will entitle the participant to as much as nine hours of credit. Participants who meet University admission requirements may count the courses toward undergraduate degrees, including that for Bachelor of Science in the Teaching of Engineering Technology, and toward the post-Baccalaureate Certificate in the Teaching of Engineering Technology. Students who meet the requirements of the Graduate College may earn credits toward the Master's degree in industrial education. All participants must take the institute courses for credit as a condition of appointment.

Exhibit: A portion of the brochure announcing the UI-NSF Summer Institute which was Phase III of the ETCD project.

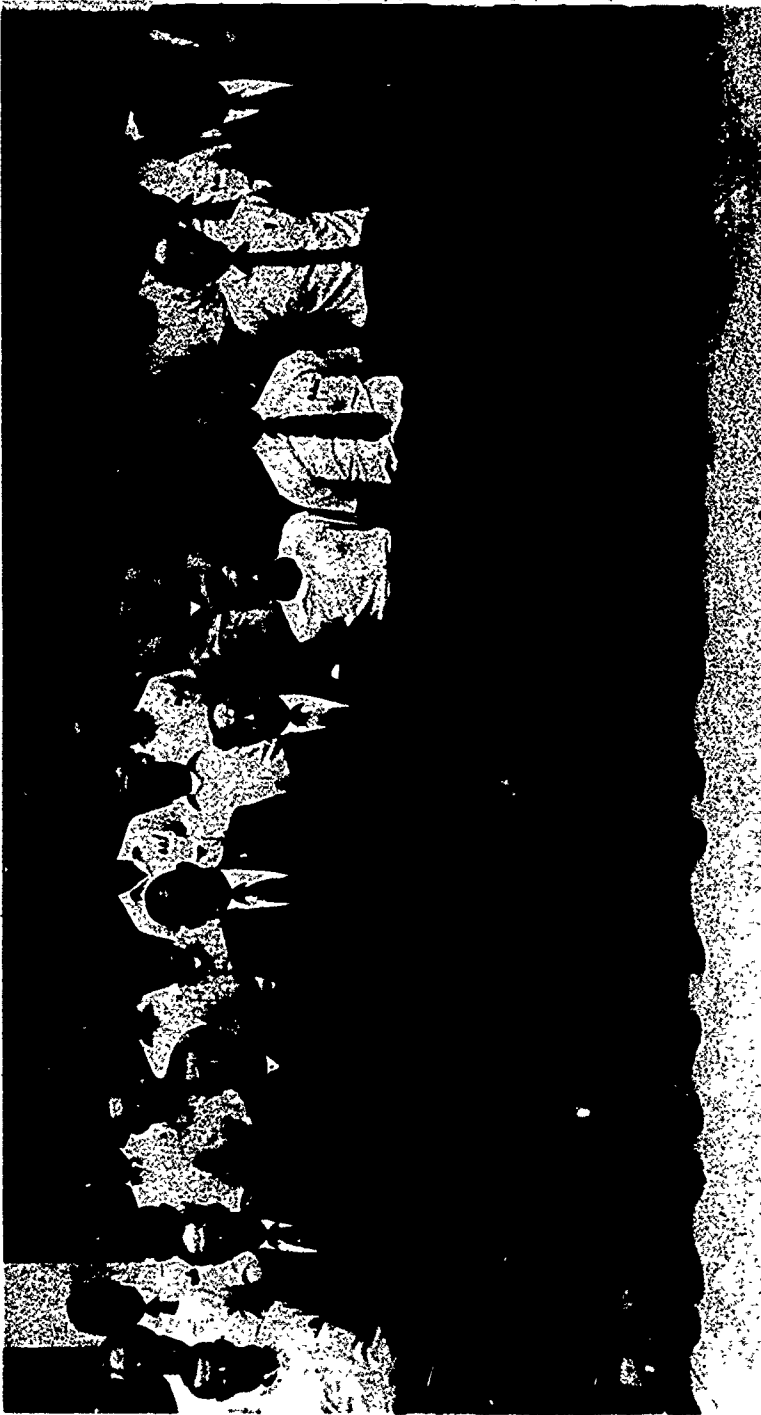

Participants of UI-NSF Summer Institute (Phase III) and ETCD Project Staff.

Front row, left to right: John E. Long, Francis S. Horton, Stuart W. Cady, Chester L. Rankin, Louis Maze, Harry L. Burkett, Randall L. Thompson, Instructor, Joe R. Pedersen, Allen R. Lawrence, Instructor.

Second Row: Professor Daniel S. Babb, Director, Dean A. Russell, Hans W. Walther, Charles M. Broadwell, Edward P. Kearney, Robert L. Paine, Victor L. Statafer, David A. Peterson, Instructor, Professor Jerry S. Dobrovolny, Project Coordinator.

Third Row: Jerry L. Haywood, Joel D. Galloway, Instructor, John V. Phares, Melvin F. Dostal, Thomas C. Gross, Kenneth E. Dehn, John L. Brittan, Lyle L. Bishop, Raymond A. England, Lecturer.

Absent: Robert B. Beers, John D. Birong, James G. Kerr and Vincent E. Cavanaugh.

VISITATIONS AND CONFERENCES

A number of community colleges, technical institutes and universities were visited by one or more members of the ETCD Project Staff within the period of the project (August, 1969 through February, 1971). Also, one or more members of the Project Staff participated, by attendance or as speakers, at a number of conferences during this period. These visitations and conferences (dates omitted) are identified on this page.

VISITATIONS

Kankakee Community College
Kankakee, Illinois

Lake Michigan College
Benton Harbor, Michigan

Miami-Dade Junior College
Miami, Florida

Johnson County Community College
Shawnee-Mission, Kansas

Washtenau Community College
Ypsilanti, Michigan

Macomb Community College
Warren, Michigan

Oakland Community College
Warren, Michigan

Hartford Technical College
Hartford, Connecticut

Waterbury Technical College
Waterbury, Connecticut

Norwalk Technical College
Norwalk, Connecticut

Thames Valley State Technical College
Norwich, Connecticut

Wentworth Institute
Boston, Massachusetts

Franklin Institute
Boston, Massachusetts

Capitol Institute of Technology
Washington, D.C.

Lenoir Community College
Kingston, North Carolina

Pitt Technical Institute
Greenville, North Carolina

Wayne Community College
Goldsborro, North Carolina

Fayetteville Technical Institute
Fayetteville, North Carolina

Sand Hills Community College
Lone Pines, North Carolina

State Technical Institute
Memphis, Tennessee

Southern Minnesota State College
Marshall, Minnesota

Purdue University
Lafayette, Indiana

Delta College
Bay City, Michigan

Oklahoma State University
Stillwater, Oklahoma

CONFERENCES

National Electronics Conference
Chicago, Illinois

American Technical Education Association
Region VI annual Conference
Arlington Heights, Illinois

American Technical Education Association National
Conference
Miami, Florida

American Power Conference
Chicago, Illinois

Illinois Vocational Association Conference
Chicago, Illinois

ASEE Effective Teaching Institute
Lafayette, Indiana

ASEE National Conference
Columbus, Ohio

ATEA-ASEE Regional Conference
Norwalk, Connecticut

North Carolina Teachers' Workshop
Lone Pines, North Carolina

Tennessee Vocational Association Conference
Memphis, Tennessee

American Vocational Conference
New Orleans, Louisiana

Electronics Technology Conference (see next
section)
Champaign, Illinois

THE ELECTRONICS TECHNOLOGY CONFERENCE

An Electronics Technology Conference, conducted at the University of Illinois at Urbana-Champaign, February 25-27, 1970, was a significant activity of the ETCO Project. One of the attendees submitted an excellent summary of the Conference to the Project staff. The information submitted here may be of interest to the reader of this report.

THE NEWS RELEASE

"A national three-day Electronics Technology Conference will be conducted February 25-27 at the University of Illinois at Urbana-Champaign. Seven Illinois junior colleges, in cooperation with the university and supported by the National Science Foundation, are working together under a thirteen-month project to develop classroom and laboratory techniques and instructional materials in the basic circuits and electronics courses of two-year associate-degree programs in Electronics Technology."

"The Project staff and representatives of the seven participating colleges will report on the status of the project. Discussions of technical and electronics education in the U. S. and of interactions of industry and community colleges to develop curriculums and identify job opportunities for graduates will be of direct interest to industry personnel, as well as to electronics teachers, school administrators, and guidance counsellors."

THE CONFERENCE PROGRAM

Session I:

Topic: Technical and Electronics Education in the United States

Presiding: Professor Daniel S. Babb
Dept. of Electrical Engineering
University of Illinois
Urbana, Illinois

- A. *Undergraduate Science Education in the U. S.*
Dr. Lyle Phillips, Division Director
Undergraduate Education in Science
National Science Foundation
- B. *University Involvement in Technical Education*
Professor Jerry S. Dobrovoly, Head
Department of General Engineering
University of Illinois
Urbana, Illinois
- C. *Electronics Technology for Two-Year Colleges*
Mr. Phillip Cutler, Author
Owner of Education Research Associates
Garden Grove, California

Session II: Dinner Meeting

Topic: The Comprehensive Community College

Speaker: Dr. William M. Staerke
President, Parkland College
Champaign, Illinois

Session III:

Topic: Electronics Technology Curriculum

Presiding: Professor Daniel S. Babb
Director, Electronics Technology
Curriculum Development Project
University of Illinois

- A. Roger A. Russell, Associate Professor
William Rainey Harper College
- B. Joel D. Galloway, Associate Director
Parkland College
Electronics Technology Curriculum Development Project
- C. Neal D. Voke, Chairman
Department of Technology
Triton College
- D. David A. Peterson, Specialist in
Engineering Technology
Electronics Technology Curriculum Development Project
University of Illinois
- E. Eric S. Ruby, Assistant Professor
Sauk Valley College
- F. Robert T. Wilson, Coordinator of Electronics
Illinois Central College
- G. Carroll Livesay, Electronics Instructor
Lake Land College

Session IV:

Topic: Instructional Technology in Electronics Programs

Presiding: Randall L. Thompson
Specialist in Engineering Technology
Electronics Technology Curriculum Development Project
University of Illinois

- A. Gilbert Rainey, Author
Head, Electrical Engineering Technology
Purdue University
Lafayette, Indiana
- B. Glenn Valentine, Director of Design and Manufacturing, Learning Sciences, Inc.
Stamford, Connecticut
- C. Nancy Risser, Assistant to Director
Computer-Based Education Research Lab
University of Illinois

Session V: Banquet

Topic: Evolution of Engineering Technology in Canada

Speaker: Herbert W. Jackson, Author
Ontario Department of Education
Toronto, Canada

Session VI:

Topic: Interactions of Industry and Community Colleges

Presiding: Ray A. Engelland
Chairman, Electronics Department
Willmar Area Vocational-Technical
Institute
Willmar, Minnesota

- A. Joseph Ammendolia, Technical Superintendent
Electronics Engineering Department
University of California
Lawrence Radiation Laboratory
Livermore, California
- B. Lewis L. Knickerbocker, Sr. Personnel Assist.
College and Professional Employment
Detroit Edison Company
Detroit, Michigan
- C. Edward F. Obrochta, Sales Engineer
Carter Electronics, Inc.
Chicago, Illinois

Session VII:

Topic: Panel Reaction on Electronics Technology

Presiding: David A. Peterson
Project Staff

(Panel members selected from conference participants)

CONFERENCE SUMMARY

The following is a summary report of the Electronics Technology Conference, submitted by Roy M. Sutcliffe, Instructor in Electronics, School of Vo-Tech Education, Idaho State University.

Preface

The Conference was part of a year-long Electronics Technology Curriculum Development Project sponsored by the National Science Foundation. The project is under the direction of Daniel S. Babb, Professor of Electrical Engineering, University of Illinois. Seven community junior colleges of Illinois are directly involved in the project, each represented on a Steering Committee. A project staff of four persons works essentially full time.

The Conference, with attendees from wide geographical areas and varied technical backgrounds, was included in the project to provide valuable guidance as well as to let the attendees know what the project was about. Twenty-four experienced electronics instructors from throughout the

the country will be selected to attend the 1970 Summer Institute at the University of Illinois to provide reactions. A final report will be published and distributed about January, 1971.

The following report is a compilation of statements made by the identified speakers and papers presented by them. I tried to take down the statements as near verbatim as possible at the time they were spoken, so as to present a fair picture of what the speaker had to say, with as little editing on my part as was possible. I have prefaced most with a brief statement about the speaker and the topic.

The Conference was conducted as indicated on the Conference Program. The opening session, Wednesday afternoon, included some general comments by Babb, Phillips, and Dobrovolsky on technical education, followed by a presentation by Cutler on what he thinks should be taught in a two-year electronics technology program, technology meaning between technical and engineering in level.

At the Wednesday night dinner session, Dr. Staerkel gave an informative talk on the roles of the community junior college:

The Thursday morning session was utilized by the staff and steering committee members of the Curriculum Development Project to present their own thoughts.

The Thursday afternoon session was essentially devoted to utilization of visual aids as a method of teaching.

Mr. Jackson of Ontario, Canada, gave a thorough and enlightening presentation on the evolution of engineering technology in Canada at the banquet on Thursday evening.

Representatives of industries employing technicians gave presentations at the Friday morning session in terms of what each wanted their technicians to know and do.

The concluding session Friday afternoon used a panel of participants selected from the attendees to respond and give reactions as each member saw fit.

Attendance

More than 200 attendees registered for the Conference the opening day. Representatives from at least 33 states and Canada attended the banquet Thursday evening, February 26.

In addition to instructors of electronics, vocations of the attendees varied from management in industry, Technical Superintendent of Lawrence Radiation Laboratory, members of State Departments of Education, local school administrators, authors, engineering faculty, etc.

The speakers were of equally varied backgrounds, representing the wide spectrum of electronics technician training and employment in this country.

The instructors present, many of whom were former participants of the NSF-sponsored Summer and Academic Year Institutes, were engaged in the training of technicians, at a variety of levels including Area Vo-Tech Schools, Community Jr. Colleges, Technical Institutes, and Universities. Programs varied in length from two to four years. Nearly all were Associate Degree programs; some were four-year degree granting programs.

The interest of the majority of participants was in the engineering technician.

The New Approach to Theory Courses

The Curriculum Development Project and this Conference are devoted to the electronics theory aspect of the total program. It is based on a two-year Associate Degree program in Electronics Engineering Technology, a level between technical and engineering, with approximate time allotments for the total program as follows: 25% each, Theory; Math and Sciences; Lab; and Non-technical.

The main concern is what, when, how, and how much to teach of electronics in terms of an ever-expanding technology, while being limited always by the traditional two-year time element imposed by state laws.

The math-theory relationship is always the greatest concern in any program. This is the problem the project is attempting to cope with and, hopefully, will arrive at some solutions and suggestions for themselves, the state of Illinois, and the nation as a whole.

There seems to be too much to do in the time allotted for the traditional serial-sequential approach to scheduled courses, the project members feel, and a more nearly parallel-integrated approach is needed. This will necessitate the student taking some mathematical and theoretical concepts for granted at first, with proofs to come later.

While many of us may not be interested in the level of this program, there are definitely implications as to what, when, and how electronics circuit analysis and synthesis courses are taught that we all should be cognizant of in our own teaching.

Impromptu Session (With Dan Babb, Dave Peterson, Stuart Cady, Phil Cutler and Mrs. Cutler)

--Discussion on what and how to teach the engineering technician. Questions mostly directed to Cutler.

--Should the engineering technician use "Ballpark" design or "Cut & Try" method?

--The technician must be able to predict output when given certain parameters and "worst cases."

--Let the student vary parameters, but he should know which way to go to get desired results and make the circuit work as desired.

--Some time in lab should be for experimenting, not all canned jobs. Some students need to look at different things. Even (especially!!) if it smokes, learning takes place.

--Babb: It boils down to--do we "analyze or synthesize?"

Welcome (by Project Director)

Daniel S. Babb, age 65, Professor of Electrical Engineering at the University of Illinois, is currently devoting 75% of his time to that position, and 25% of his time as Director of the Curriculum Development Project. His main interest in electronics is in pulse and digital circuit analysis and synthesis.

As a teacher in the Summer Institutes for teachers of electronics, sponsored by the National Science Foundation at the University of Illinois since its inception in 1961, he has been very much interested in the approach taken by teachers at junior colleges or technical institutes to circuit analysis. He is a champion of the "any waveform" approach, as opposed to the traditional sine wave analysis. He believes sine waves should be treated towards the end of the course as a special topic, rather than a foundation which becomes very wobbly when used in pulse and digital systems. Thus, his direct involvement as Director of the Curriculum Development Project.

He is most respected by those who have had the privilege of studying under him. One teacher, Harry Partin of Mississippi, one of the panel members of the concluding session, says his students always ask, "What does Professor Babb have to say about that?"

Dan Babb was given a standing ovation at the conclusion of the Conference.

--This conference is directly concerned with NSF-supported Curriculum Development Project.

--It is a short Conference--not all we get here will be from speeches. Our being here says something.

Address by Lyle Phillips

Dr. Phillips, Division Director of Undergraduate Education in Science, National Science Foundation, gave a short discussion of the National Science Foundation involvement in education.

--Some 2400 institutions are now offering training in this country. Diversity!

--Junior college is the fastest growing in numbers and importance. 500 now--500 more on drawing boards for next ten years (one/week):

--There is no average college in U. S.

--Teaching and research--more or less of each! Can one be a respectable teacher without being deeply involved in research? False.

--NSF has invested \$400 million upgrading and "patching up" poorly trained teachers in last ten years.

--Computers will become more important in science education.

--Much less rigid curricula and courses.

--More responsibility on student to learn on own.

--Some Ph.D.'s will come without "original" research, but rather in areas of his own choosing.

--The original thinking was that NSF should stay away from Vo-Tech Education. Originally, training had to be in basic science, not technical subjects--it is now breaking.

--University of Illinois was the first school to get aid for technical training (1961).

Address by Jerry Dobrovolny

(Note: The complete address is in Chapter 1 of this report.)

Jerry Dobrovolny is a Professor of General Engineering at the University of Illinois, who became very interested in technical education at a time when there was a growing need and demand for such, especially in Illinois. Through his efforts, the University of Illinois obtained the first National Science Foundation grant awarded in this country for the training of electronics teachers who were faculty members of junior colleges or technical institutes. It has been continued yearly since then, in addition to five Academic Year Institutes.

--1952: His first interest of semi-professional education.

--1958: Need for technical teachers. Everyone wants them to have a Master's Degree in Engineering and/or Education, ten years' experience, and not over 35 years old. A bit hard-to-come by!

--1961: First NSF Institute at University of Illinois, and it still continues. We have had five Academic Year Institutes, also. Approximately 400 individual participants representing every state in nation.

--University of Illinois now has a four-year course for teachers of technical education.

--There is need to train engineers with Master's Degree, 5-10 years' experience, with *philosophic* preparation to teach.

--Real need to provide support for Associate Degree people with five years' experience to teach.

--Curriculum research: (Have been working on) a calculus-based program.

--There are articulation problems.

--Contribution to literature (texts, advanced technical articles, etc.); put your thoughts in writing for critical examination by peers.

--What background to teach technical education; pedagogic techniques:

1. Capable in subject matter.
2. Individual experience.
3. How to teach.

--What do those with Associate Degrees need to go on? What do they want to do? Become engineer, or get BS Degree.

--80% of all students do not get degrees; yet 80% of all education is geared towards getting a degree!

--Four-year Technology Degree--what good? Prepares for manufacturing processes.

Address by Phillip Cutler

Mr. Cutler, though only one of the speakers at the Conference, generated much enthusiasm and interest and came close to monopolizing discussions, both formal and informal ones. He is a former teacher, as well as employee in electronics research; now almost totally engaged in his company, Education Research Associates, makers of educational audio-visual aids. He is recognized as an authority in circuit analysis because of the widely used, high-level, circuit analysis books he has authored. His wife, who accompanied him, though not so qualified in electronics is no less enthusiastic and knowledgeable of education in general. The two of them form a unique pair.

--Know what to teach: A slide and tape presentation was given regarding circuit analysis. (Note: This slide-tape presentation is available from ERA, 13181 Balboa Avenue No. 1, Garden Grove, California 92640.)

--The Electronics Engineering Technician: Understands *theory* behind function he performs at work. Meat or mashed potatoes? At either end or both ends of his training? There should be no mashed potatoes. Math and lab should support the theory. Lab should challenge him to predict outcome, then verify it.

--Happiness in electronics is understanding and using Therenin's theorem!

Address by Dr. William M. Staerkel

Dr. Staerkel, President of Parkland College, Champaign, Illinois, was a featured speaker.

--There are some 1000 Community Colleges now; there are 500 on drawing boards for the next decade (one/week)!

--A junior college means different things to different people: below college level to one person; vocational to another; technical to another; two-years instead of four-years to another.

--*Junior* is an unfortunate name; *Community* is better. The functions of a Community College:

1. Vo-Tech Education.
2. Transfer education (to four-year institution).
3. General education.
4. Continuing (adult) education.
5. Provide community services as needed.
6. Counseling and guidance.

--The Community College stresses teaching and individual student attention, as opposed to research. If you want to do research, don't come to my college!

--The Community College needs a strong counseling and guidance section.

--The Community College is financially supported by the community, so there are very close ties.

Report (Daniel Babb)

--This project did not start cold; it has developed through the efforts of ten NSF Summer Institutes.

--Algebra and some trig needed early.

--For resistive circuits: algebra and trig.

--Single time constants circuits: Engineers use first order differential equations; technicians use step functions. Therefore, there are always exponential solutions. Use LaPlace Transforms.

4-Get started early! Then off to a start that student can build on.

--Seven schools involved in this project. Instructors, not just a committee. All in Illinois, within driving distance.

--Hope this will apply to all states.

Report (Eric Ruby)

--Level of performance expected of two-year math science-based programs training Electronic Engineering Technicians.

--Cutler showed what to teach yesterday.

--What does the technician do in the industrial team?

1. The industrial proposal (government wants a missile).
2. Now industry gives estimates on cost, general system, subsystems.
3. Then a very general block diagram (no specifics). No decision here as to analog or digital computer, etc.
4. Now senior engineer with experience decides what can and cannot be done. The analog computer is decided on.
5. Now refine and revise system in terms of costs and block diagrams.
6. Then reduce blocks to schematics and finally to hardware.
7. Get team together as best you can to do job.
8. The engineering technologist begins to come into picture by coming up with schematics and values within a block, and may be in charge of building and testing it, and passes judgments as to meeting specs.

A Problem:

--Definition of Engineering Technician; McGraw's ECPD definition is more accepted now, but will be revised soon: "A person who has obtained specialized training (post-high school) to qualify him to apply for position in engineering not research-oriented."

Report (Neal Voke)--What is the Role of Electronic Engineering Technician?

--The Electronic Engineering Technician (EET) should be able to use, choose, and understand volt-time and voltage-voltage scopes.

--He should use independent thinking and judgment.

--He should study math, algebra, trig, analyt. geom., calculus, differential equations, LaPlace trans., and other selected math topics.

--Is calculus necessary on job? No, not on job, but concepts are important. Implicitly, perhaps.

--EET should be able to take specs of a block diagram and determine components. Example: Design and build a preamp which is connected to an input 300 Ω mike with input 50 DB below 1 MW, and which provides a 2-volt, 2k-ohm output.

Report (Robert T. Wilson)

(Note: See Chapter 3, page 69, for complete report.)

--Introduction to Electronics Technology--what is it? The "Big Picture of Electronics":

- circuits to systems;
- systems to circuits approach!
- Student interest; he can relate circuit back to system.

--A system where input-output functions are usually *not* electrical.

--Introductory Course--40, 50, 60 clock hours: 4 hours lab, 1 hour lecture; 3 hours lab, 1 hour lecture.

--A hands-on, lab-oriented course.

--Hardware use depends on instructor and what is available.

--Spin-off in areas of specialization.

--Instructor must consider it *most important* course, be enthusiastic, so students get and stay excited about electronics.

Report (Joel Galloway)

Mr. Galloway is Associate Director of the Project.

--Two-year math/science Associate Degree program. Curriculum must become parallel-integrated, rather than serial-sequentially oriented courses.

Math I → Introductory Electronics
Math II → Resistive Circuits → Resist. Electronics
Math III → Single Time Constants → Pulse Circuits
 → Networks → Advanced Systems

--Students often "awed" by instrumentation and math; an introductory course can overcome this.

--With Algebra and Trig move into resistive circuits.

--Move *quickly* into circuit analysis (resistive).

--Use STC (Single Time Constant) circuits to predict output from given input functions.

Report (David Peterson)

--curriculum and Materials Development. How?

--Learning Center? Ideal: Lab and theory together. Lab and theory and math complement each other.

--How to structure lab: teacher-controlled, student-teacher, and student-controlled. *Student needs some freedom to vary circuit parameters at his option.*

--Lay foundation first: Use creative investigation.

--Student-controlled environment:

1. Observation.
2. Interpretation.
3. Measurement.
4. Calculation.

--Use controlled sequencing to lead student through design problem.

Report (Roger Mussell)

--Students need five pieces of equipment in lab:
1. Dual trace time base oscilloscope.
2. Function generator.
3. VOM or DVM.
and 4. Two or more low-voltage power supplies.
5.

--Presented slide-show on schools participating in project. They are modern, have good equipment, and benches. Lab-classroom combination is prevalent.

Report (Carroll Livesay)

--What *kind* of technician should we train?

--We need multi-level programs. We must provide training to match students to jobs.

--The program should range from math-science, engineering technology based program to vocational.

Report (Randall Thompson)--Instructional Technology Aspects of Project

--Use of close-up slides for teaching:

1. Reading on VOM.
2. Operation of Equipment-VOM, Scope, Curve Tracer. With tape, talk him through it.

--Use desk calculator and/or computers to save time in student calculations.

--Pictures of Industry--What Do Technicians Do? Examples of the following were shown:

1. Super 8
2. 16mm
3. Video Tape
4. 35mm

(All were amateur. Lighting and sound was poor on most. But pictures tell stories.) (Note: See Page 217 for a report on an experiment in bringing industry into the classroom.)

--Written instruction will remain most important, but other tools should be utilized in education.

Address by Nancy Risser

--University of Illinois has twenty terminals in a room tied to computer.

--TV display; slides.

--One terminal in grade school.

--Called PLATO System.

--Computer keeps records on all students (not necessary to wait for exams).

--Students are more willing to communicate with computer (ask questions) than with a teacher!

--Learning in one-half to one-third regular time and retaining longer has been documented.

--Operation of the system doesn't require prior knowledge of computer programming.

--A roadblock: Cost! This is the first phase. Second phase: Bring cost down to comparative level of conventional educational methods. Cost today: 27¢ per student per contact hour.

--Terminals are main cost, input-output, CRT, etc.

Address by Gilbert Rainey--Talk on Learner-Controlled Laboratory

(Note: See Page 237 for complete presentation.)

--The Poor Man's Approach--Auto-tutorial Method.

--Equipment required: \$17 Cassette recorder, 75 tapes and slides sets. Received no grant, he did at home at night.

--Question not what to teach, but *how much*?

--New methods of teaching: audio visual. Auto-tutorial equipment is student operated:

1. Student picks up supplies, audio tape, slides, at store room.
2. Students were first required to work in pairs, now prefer to work alone.
3. Screen is piece of plywood nailed to bench.
4. There is much interest and motivation of students now.
5. More time for teacher-student relationship.
6. Record card on each student, make sure of contact.
7. Have informal meetings with small group (5-6 students).

--Teacher's aids can be utilized for this approach.

--This method does *not* necessarily make it *easier* for teachers. The teacher is a resource center for individual students.

Address by Glenn Valentine

Mr. Valentine is Director of Design and Manufacturing for Learning Sciences, Inc., Stamford, Connecticut.

--Putting a program together; a philosophic value judgment.

--Programmed Learning: Most teachers don't like because they don't want students to learn something while they are talking.

--The learner is the key person; the teacher is a manager.

--If responses are not correct, modify the program. Don't fail the student.

Address by Herbert W. Jackson (Featured Speaker)

--Canada is presently down on vocational education. Canada is going into upgraded vo-tech education in elementary and secondary schools.

--Students will take the subjects *they* want to.

--There is a real counseling problem in colleges and technical institutes.

--Canada is concerned with federal "megabucks" also.

--Instructors in technology are not required to take education courses. They will be accredited. They will, perhaps, be lacking in teaching methods, but students will tolerate some of this if they can be respected in their technical competence. In-service training will be provided.

--Students will not put up with traditional teaching methods in post-high school if he is to be treated as an individual in lower grades.

--There is often more teaching and educational psychology put into a 60-second TV beer commercial than some teachers put into a whole year's program. Kids watch these on the TV "boob-tube" daily and expect at least as much from us as teachers.

Report (Ray Engelland)

--An expert: A person 50 miles away from home. A specialist: A person 500 miles from home.

--We in education are turning out a product; industry sets the specifications.

--The courses must constitute a total program.

--Electronics technicians graduates going to work should know what electronics technology is.

--The school should provide the technician with a good base, regardless of whether tubes or transistors or integrated circuits are ever omitted.

Address by Joseph Amendolia

--Lawrence Radiation Laboratory is most happy with graduates from good technical programs. They have hired 50-60 graduates over the years.

--If schools don't turn out product, we don't buy.

--Advisory boards can be useful tools.

--California has much cooperation between schools and industry as to advice, equipment, etc. Schools should ask; industry will help, often donating equipment.

--He hires two junior college teachers for summer and lets work in their interest. Not interested in production, but take contributions back to school.

--In recruiting, student should be ready to sell themselves in 15-20 minutes. Applicants they don't need; talent they do.

--Technicians are not doing today what engineers did ten years ago--technicians are doing today what engineers are doing today.

--The technician is brought into designing when he can take on the responsibility himself at \$1400/month. Title: Engineering Specialist.

--Cyclotron: sometimes pulses deviate 1 pulse/hr. Physicists want to know why. Engineering technician has to come up with answer.

--P.C. design is a big need now. Paying \$1000/month.

--In atomic tests, whatever electronics are given to physicists, it is not enough. Cabling now costs \$1+ million/shot. They are now trying to come up with multiplexing system so as to reduce cabling.

--His slide show included:

1. Animals and organ testing for radiation analyzed by computers.
2. Mass spectrometer.
3. Electron activation analysis.
4. Gas chronometer.

--Two-year electronics technicians are designing interfacing for this equipment.

Address by Lewis Knickerbocker

Mr. Knickerbocker is Senior Personnel Assistant for Detroit Edison Company.

--They did train their own technicians until 1964.

--Study then made to decide what engineering technician should be and how many; establish salaries, grades. Estimate 20-24 in 1964; now looking for 60.

--Used slide-talks on recruitments.

--Invite freshmen to the show, also. Very important to provide motivation to stay in school. (Same for faculty members.)

--He suggests technical schools could use slides more in communicating with high schools.

--He is for co-op and summer programs.

--They run faculty conferences (most faculty at Detroit) and tour facilities. Have former graduates give feedback as to how doing and what is lacking. Can be brutally frank sometimes!

Address by Edward F. Obrochta

--Sell, that's what we're all here for regardless of occupation--industry, sales, schools:

S	E	L	L
Sample	Example	Logic	Live It

Closing Poem

Between 9 PM and midnight
When my stomach was beginning to sour,
Came a pause in the Conference Program
That was known as the "Happy Hour."

From Canada down to Texas
We folk in the teaching game
All brag about the job we do,
But our problems are all the same.

Like educators everywhere
We lecture, rant and preach,
But let's go back to the classroom
And try to madly teach.

Harry Partin
Hinds Junior College
Raymond, Mississippi.

PARTICIPANTS AT ELECTRONICS TECHNOLOGY CONFERENCE

Allen, Wesley O.	North Dakota State School of Science, Wahpeton, North Dakota	Del Giorno, Arthur E.	New York City Community College Brooklyn, New York
Ammendolia, Joseph	Lawrence Radiation Laboratory Livermore, Calif.	Dennler, Robert G.	John Wiley & Sons, Inc. New York, New York
Ashton, David L.	The O'Meara Company Milwaukee, Wisconsin	DeVries, David.	Parkland College Champaign, Illinois
Babb, Daniel S.	University of Illinois Champaign-Urbana, Illinois	Dobrovolny, Jerry S.	University of Illinois Urbana, Illinois
Bailey, Albert	University of Illinois Urbana, Illinois	Dragan, Richard C.	Lorain County Community College Elyria, Ohio
Baker, John B.	Jefferson College Hillsboro, Missouri	Dunn, Arthur.	Lenoir Community College Kenston, North Carolina
Baker, Lynn.	McGraw-Hill Book Co. Webster Groves, Missouri	Engelland, Raymond.	Willmar Area Vocational- Technical Institute Willmar, Minnesota
Bartz, Walter J.	State Board of Vocational Education Springfield, Illinois	Evers, Stanley R.	Kirtland Community College Roscommon, Michigan
Bastin, E. J.	Northern College of Applied Arts & Technology South Porcupine, Ontario	Everson, Scott.	North Central Technical Institute Wausau, Wisconsin
Baker, Al W.	Belleville Area College Belleville, Illinois	Fabac, John N.	Chanuce Air Force Base Rantoul, Illinois
Berry, Richard.	Penta Technical College Perrysburg, Ohio	Fitzgibbon, Edwin G.	Illinois State Board of Vocational Education Springfield, Illinois
Beers, Robert B.	Broome Technical Community College Binghamton, New York	Foster, Richard B.	Grand Rapids Junior College Grand Rapids, Michigan
Berg, Julian.	North Dakota State School of Science Wahpeton, North Dakota	Fraser, Gary T.	Agricultural and Technical College Alfred, New York
Birong, John.	Madison Area Technical College Madison, Wisconsin	Fraser, Russell E.	John Wiley & Sons New York, New York
Bishop, Lyle L.	Bradley University Peoria, Illinois	Frey, Richard J.	Kankakee Community College Kankakee, Illinois
Blasch, Larry W.	I.B.M. Corp. Springfield, Illinois	Frost, John S.	Chaffey College Ontario, California
Bohichik, George	Sinclair Community College Dayton, Ohio	Fulton, Robert B.	State Technical Institute of Memphis Memphis, Tennessee
Braze, James G.	Dutchess Community College Poughkeepsie, New York	Galloway, Joel D.	Parkland College Champaign, Illinois
Brittan, John.	Lake Michigan College St. Joseph, Michigan		

Gaonkar, Ramesh.	Onondaga Community College Syracuse, New York	Holman, Richard W.	Missouri Western College St. Joseph, Missouri
Geggis, David P.	Addison-Wesley Publishing Co. Reading, Mass.	Holmes, Richard G.	Oakland Community College Walled Lake, Michigan
Geiger, Darrell.	Cleveland Institute of Elect. Cleveland, Ohio	Howard, Maurice F.	Ferris State College Big Rapids, Michigan
Gladden, Gerald W.	Illinois Board of Vocational Education Springfield, Illinois	Inch, Eric C.	Algonquin College Ottawa, Ontario
Goldberg, Joel.	MaComb County Community College Warren, Michigan	Ingram, Fred J.	Tennessee State Department of Education Nashville, Tennessee
Graves, William.	Augusta Technical School Augusta, Georgia	Jackson, Herbert W.	Ontario Department of Education Toronto, Canada
Griggs, Joe E.	Wabash Valley College Mt. Carmel, Illinois	Jackson, Lee.	Union Carbide Knoxville, Tennessee
Gross, Thomas C.	Hartford State Technical College Hartford, Conn.	Jauch, K.E.	Harper College Arlington Heights, Illinois
Grossman, Thomas.	Niles Township High School - East Skokie, Illinois	Jamjoom, Samir.	Arizona State University Tempe, Arizona
Haas, Warren F.	Indiana Vocational Tech. College Indianapolis, Indiana	Kerr, James G.	Western Iowa Tech. Sioux City, Iowa
Hager, Larry S.	International Textbook Co. Scranton, Pennsylvania	Kidd, Jerrett W.	Wentworth Institute Boston, Mass.
Hallenbeck, Wendell.	Schenectady Community College Schenectady, New York	Klotz, Ralph W.	John Tyler Community College Chester, Virginia
Hamm, E. C.	Northern Illinois University DeKalb, Illinois	Knickerbocker, L.L.	The Detroit Edison Co. Detroit, Michigan
Haywood, Jerry.	Illinois Valley Community College Spring Valley, Illinois	Kuritz, O. M.	College of DuPage Glen Ellyn, Illinois
Hedrick, Everett W.	Parkland College Champaign, Illinois	Krumwiede, Erwin.	Melvin-Sibley High School Melvin, Illinois
Helm, M. Stanley.	University of Illinois Urbana, Illinois	Laursen, Robert A.	Sauk Valley College Rock Falls, Illinois
Herman, Edward F.	Corning Community College Corning, New York	Lehmann, Robert A.	Southwest Minnesota State College Marshall, Minnesota
Holcombe, Michael L.	Delta College University Center, Mich.	Lester, John M.	State University of New York at Farmingdale Garden City, New York
Hicken, James.	Southwest Minnesota State College Marshall, Minnesota	Littlewood, William C.	Waukesha County Technical Institute Waukesha, Wisconsin
Hoffer, Larry.	Freeport, Illinois Highland Community College	Livesay, Carroll.	Lake Land College Mattoon, Illinois
Hollitz, R. F.	Cleveland Institute of Elect. Cleveland, Ohio	Long, John E.	Columbia State Community College College Columbia, Tennessee

McNight, James E. Pennsylvania State University
DuBois, Pennsylvania

Mahdaly, Hashim. Arizona State University
Tempe, Arizona

Malmstadt, H.V. University of Illinois
Urbana, Illinois

Marotz, William H. Southwest Virginia
Community College
Richlands, Virginia

Martin, W. D. University of Illinois
Urbana, Illinois

Matthews, Andrew. Texas Southern University
Houston, Texas

Matz, Clifton. Parkland College
Champaign, Illinois

Metzger, Daniel L. Monroe County Community
College
Toledo, Ohio

Miller, Bruce. Flint Community College
Flint, Michigan

Miller, Merl. Prentice Hall Company
Park Forest, Illinois

Miller, T. R. Automatic Electric Laboratories
Northlake, Illinois

Miller, Wendell E. University of Illinois
Urbana, Illinois

Mills, Gilbert. Phoenix College
Phoenix, Arizona

Montoya, James. Parkland College
Champaign, Illinois

Murray, Robert E. Meramec Community College
St. Louis, Missouri

Mussell, Roger A. Harper College
Palatine, Illinois

Naber, Robert M. Lake Shore Technical Institute
Sheboygan, Wisconsin

Neal, James P. University of Illinois
Urbana, Illinois

Nelms, Henry Alan. Mississippi Delta Junior
College
Indianola, Mississippi

Newell, D.F. Northern Illinois University
DeKalb, Illinois

Hentoft-Nilsen, Robert M. State University of
New York
Delhi, New York

Obrochta, Edward F. Carter Electronics, Inc.
Chicago, Illinois

O'Bryant, D.C. University of Illinois
Urbana, Illinois

O'Hair, Michael T. Purdue University
Griffith, Indiana

Ortley, Don. Stout State University
Menomonie, Wisconsin

Orton, William T. Lincoln Technical College
Syracuse, Nebraska

Papp, Al. Sinclair Community College
Dayton, Ohio

Parker, Bobby D. Oklahoma City, Oklahoma
Langston University

Partin, Harry J. Hinds Junior College
Raymond, Mississippi

Pedersen, C. Robert. Hawkeye Institute of
Technology
Waterloo, Iowa

Peterson, David. Parkland College
Champaign, Illinois

Phillips, Lyle. National Science Foundation
Washington, D.C.

Place, Leonard. Fox Valley Technical Institute
Oshkosh, Wisconsin

Plotkin, Maurice. State University of
New York at Farmingdale
Garden City, New York

Pluhar, Joseph. State Technical Institute
Memphis, Tennessee

Pohmurski, Joseph C. Columbian County Branch
Kent State University
Salem, Ohio

Powell, Roy. Miami-Dade Junior College
Miami, Florida

Powers W. Ronald, Broome Technical
Community College
Binghamton, New York

Preston, Charles. University of Illinois
Urbana, Illinois

Punkay, William. Harper College
Palatine, Illinois

Rankin, Chester L. Kansas Technical Institute
Salina, Kansas

Reardon, N. L.	Automatic Electric Laboratories Northlake, Illinois	Simmons, C. Ray.	Data-Design Laboratory Cucamonga, California
Rainey, Gilbert.	Purdue University Lafayette, Indiana	Siville, Willard F.	Thornton Community College Harvey, Illinois
Reiser, Matt H.	Cleveland State Community College Cleveland, Tennessee	Sizer, Milton A.	Chicago City College- Wright Campus Chicago, Illinois
Richter, Herbert W.	Kalamazoo Community College Kalamazoo, Michigan	Smith, Winton.	Oklahoma State University Stillwater, Oklahoma
Risser, Nancy.	University of Illinois Urbana, Illinois	Soden, R. E.	Iowa State University Ames, Iowa
Robohm, Dale L.	The National Cash Register Co. Dayton, Ohio	Sorensen, Jerry.	Southern State College Springfield, South Dakota
Ruby, Eric.	Sauk Valley College Dixon, Illinois	Sperstad, Marlowe L.	Arizona State University Tempe, Arizona
Ruehl, Philip W.	Stout State University Menomonie, Wisconsin	Sprengeler, J. H.	Belleville Area College Belleville, Illinois
Rushing, Edwin Karl.	Mississippi Delta Junior College Indianala, Mississippi	Staerkel, William M.	Parkland College Champaign, Illinois
Russ, Daniel.	Southeast Junior College Chicago, Illinois	Stateler, Victor.	Kirkwood Community College Cedar Rapids, Iowa
Russell, Dean.	Washtenau Community College Ypsilanti, Michigan	Stevens, LeRoy.	Phoenix College Phoenix, Arizona
Sackett, Robert N.	Normandale State Junior College St. Louis Park, Minnesota	Sugden, Robert.	Waukesha Technical Institute Waukesha, Wisconsin
Schiefer, Edward F.	Southeastern Iowa Area Community College Burlington, Iowa	Sutcliffe, Roy M.	Idaho State University, Pocatello, Idaho
Schroeder, F. Harold.	The Detroit Edison Co. Detroit, Michigan	Swank, Donald.	Parkland College Champaign, Illinois
Schulstad, Paul G.	Commonwealth Edison Co. Park Ridge, Illinois	Swartz, Simon.	Grand Rapids Junior College Grand Rapids, Michigan
Schwarzlose, Paul F.	University of Illinois Urbana, Illinois	Symms, Jessee J.	College of the Mainland League City, Texas
Seguin, Armand M.	West Virginia State College St. Albans, West Virginia	Taylor, Vernal L.	Florida A & M University Tallahassee, Florida
Selby, Stan.	Hewlett-Packard Company Colorado Springs, Colorado	Thomas, Nick.	McGraw-Hill Hinsdale, Illinois
Sheehan, William D.	Ag. & Tech. College Alfred, New York	Thompson, Randall.	University of Illinois Urbana, Illinois
Shehane, Howard C.	Columbus Area Voc-Tech. School Columbus, Georgia	Thornberry, Merce.	Parkland College Champaign, Illinois
		Tibbets, Michael.	North Central Technical Institute Wausau, Wisconsin

Timpte, Carroll. Mesa College
 Grand Junction, Colorado

Tomlinson, Robert M. University of Illinois
 Urbana, Illinois

Unger, R. H. Iowa State University
 Ames, Iowa

Voke, Neal D. Triton College
 Glen Ellyn, Illinois

Warthen, Charles. Joliet Junior College
 Joliet, Illinois

Washburn, C.I. Belleville Area College
 Belleville, Illinois

Watt, Keith M. Southern Alberta Institute
 of Technology
 Calgary, Alberta

Webb, Earl. Victorville, California
 Victor Valley College

Weßsels, Philip L. Sauk Valley College
 Dixon, Illinois

Wheeler, Felix H. Parkland College
 Champaign, Illinois

White, Paul G. Chanute Air Force Base
 Rantoul, Illinois

Wilcox, Alvin L. Danville Junior College
 Danville, Illinois

Wilcox, Glade. Western Michigan University
 Kalamazoo, Michigan

Wilson, John Madison Area Technical College
 Madison, Wisconsin

Williams, Richard E. Onondaga Community
 College
 Syracuse, New York

Willson, Foy. Lenoir Community College
 Kinston, North Carolina

Wilson, Robert. Illinois Central College
 East Reoria, Illinois

Wittrock, Marvin A. Oklahoma State University
 Oklahoma City, Oklahoma

Wolf, J.N. Fox Valley Technical Institute
 Oshkosh, Wisconsin

Wood, Herman. Tarrant County Junior College
 Ft. Worth, Texas

Workman, William F. Atlantic Community College
 Ocean City, New Jersey

Wright, Gayle. Parkland College
 Champaign, Illinois

Zakowski, Leo F. Philco-Ford Corp.
 Chicago, Illinois

Zimmerman- Richard E. Lehigh County
 Community College
 Schnecksville, Penn.

Zumkehr, John L. Kent State University
 North Canton, Ohio

APPENDIX B

SOURCE INFORMATION ON INSTRUCTIONAL MATERIALS

Specific information on audio-visual aids and films is presented in this Appendix B. Electronics instructors who are interested in this technique of instruction may find items of particular value in the listings presented here.

There are several sources of audio-visual aids and films and it is not always easy for an instructor to identify those that satisfy his particular needs. The materials have been selected to help the instructor with this task. Even though the available materials designed particularly for Electronics Technology are not plentiful, the information provided in this appendix is not all-inclusive but rather a representative sample.

The personnel of the ETCO project believe that there is a definite need for visual aids, audio-tutorial-lessons, and films. They also believe that educational materials need to be developed to satisfy the particular needs of technical education in Associate Degree programs. Educational materials as described in the first section represent one of the few dedicated efforts and should be encouraged.

ERA AUDIO-VISUAL AIDS

Education Research Associates (ERA)
13181 Balboa Avenue #1
Garden Grove, California 92640

At present ERA audio-visual aids consist of:

1. Lectures on audiotape in semi-programmed form. The tapes are available in two forms; cassettes (1-7/8 i.p.s.) and 5 or 7 inch reels with 1/2 or 1/4 track monophonic recordings at 3-3/4 i.p.s. An audible tone signal to indicate a visual display change is superimposed upon the narration.
2. Filmstrips correlated to the taped lectures.
3. Slides correlated to the taped lectures.
4. Overhead transparencies correlated to the taped lectures.
5. Workbooks integrated with the audio-visual presentation to make a complete instructional package.
6. Instructors solutions manuals for the workbook problems.

With the above teaching aids the instructor has a most flexible choice in presenting tutorial material of meaningful depth and excellent quality with a minimum of time-consuming drudgery. For example, the instructor (or student in a self-study situation) may present a completely prepared lesson on Kirchhoff's voltage law by playing a tape and changing a slide or overhead transparency whenever he hears the audible tone signal. If a question or desire to comment should arise the recorder may be stopped and a class discussion may ensue. Following this the lesson may then be continued. Self-test questions are posed during the audio-visual presentation and reference is made to the workbook when necessary. Each tape concludes with an appropriate homework assignment in the workbook. This may be modified at the instructor's discretion.

The student may also learn or review the lesson material in a flexible manner, and at his own

pace, by withdrawing a tape and slide set (or film-strip) from the library or similar responsible agency. He then proceeds to a study carrel which contains the tape player and a suitable slide viewer. If the carrels are made part of the normal classroom situation the instructor will find considerably more time for remedial help. With suitable funds it is possible to distribute remote terminals as a part of a dial access system.

DC CIRCUITS

1. Voltage Notation (DC-190)
2. Current Notation (DC-101)
3. Ohm's Law (DC-102)
4. Resistance (DC-104)
5. Series-Circuits (DC-106)
6. Parallel Circuits (DC-108)
7. Series-Parallel Circuits (DC-110)
8. Kirchhoffs Voltage Law (DC-112)
9. Kirchhoffs Current Law (DC-114)
10. Superposition Theorem (DC-116)
11. Thevenins Theroem (DC-118)
12. Nortons Theorem (DC-120)
13. Millmans Theorem (DC-122)
14. Equivalent Circuits (DC-124)
15. Equivalent Circuits (DC-125)
16. Graphic Analysis (DC-126)
17. Determinants (DC-128)

This is a very complete package which covers most of the topics in a first circuits course. Varying waveforms are also used besides DC and fits in very well with Resistive Circuits. A workbook, "DC Circuits Analysis with Illustrative Problems: by Phillip Cutler" is available from McGraw-Hill which can be used with the DC-100 series.

BASIC ELECTRICITY

1. Practical Electricity (PE-10)

Practical electricity (PE-10) consists of 45 visuals to be used in conjunction with a taped lecture. The material may be used independently by the student or under the control of an instructor. Audible tone signals on the tape indicate when a visual change is due.

The PE-10 instructional package is intended for the beginning high school (or equivalent) student. It is specifically designed to teach the student some fundamental concepts of electric circuits, stripped to their barest essentials. Every effort is made to impart an intuitive insight into behavior of an electric circuit. Absolutely no mathematics other than simple addition or subtraction is required. An eighth grade reading level is adequate. The tape minimizes the amount of reading ability required. At the end of this lesson (PE-10) which typically runs between 3.5 and 4.5 hours, the student will be trouble shooting a rotisserie/oven/broiler.

DIFFERENTIAL AMPLIFIER

1. The Differential Amplifier (DEA-10)

This lesson introduces the general concept of the differential amplifier. It is treated solely as a black box and no attempt is made to investigate its possible contents at this time. Instead the emphasis is upon broad concepts such as: differential gain, common mode gain, common mode rejection ratio, measurement of these parameters, and the solution of instrumentation problems with the differential amplifier. This lesson works in very nicely with the operational amplifier (OA-10) lesson.

DIODES*

1. The Ideal Diode (ID-10)

This lesson introduces the concept of an ideal diode. It lays the foundations for understanding the practical solid state diode introduced

in the next lesson. Forward bias, reverse bias, and the break-point concept is introduced and applied to the analysis of some carefully chosen single diode circuits.

2. The Practical Diode (PD-12)

This lesson explains the properties of the PN junction and its behavior under forward bias, reverse bias, and reverse voltage breakdown conditions. The diode volt-ampere characteristic is developed, temperature effects are investigated, and the concepts of barrier and diffusion capacitance are introduced.

3. Diode Models (DM-14)

This lesson develops some practical piece-wise diode models that are most useful in analyzing diode circuits. It also lays the foundation for understanding the diode-like equivalent circuits or models of transistors.

4. Diode Circuit Analysis

This lesson develops techniques of single and multiple diode circuit analysis based upon ideal and practical diode circuit models. Both the assumed state and break-point method of analysis are applied.

*Available in tape/slide or tape/filmstrip.

OPERATIONAL AMPLIFIER

1. Operational Amplifiers (OA-10)*

Theory and application of operational amplifiers from a "black box" viewpoint is developed in this timely lesson. Building upon a modest background in feedback principles the student will learn powerful techniques for analyzing OP-AMP circuits.

Included among the many topics are:

- a. noninverting amplifiers
- b. inverting amplifiers
- c. buffer amplifiers
- d. voltage regulators
- e. current regulators
- f. filters

- g. integrators
- h. etc.

This lesson is presented in a semi-programmed format with considerable self-testing throughout to insure comprehension.

*Available in tape, slide or tape/filmstrip.

SIGNAL FLOW GRAPHS

1. Introduction to Signal Flow Graphs (SFG-100, SFG-102, SFG-104)

A signal flow graph (SFG) is a means of pictorially displaying the equations of a circuit or system so the physical cause and effect relationship are clearly evident. This feature makes the SFG an outstanding tool for analyzing circuits or systems and in particular those involving feedback.

This highly successful programmed course will teach:

- a. Flow-graph construction from circuit/system equations.
- b. Circuit/system equations determination from the flow graph.
- c. Manipulative techniques for reducing and modifying flow graphs.
- d. Mason's rule for determining output-vs-input relationships by inspection.

This outstanding course contains approximately 6 hours of taped instruction and 165 slides.

TRANSISTOR CIRCUITS

1. Junction Transistor (JT-10)

This lesson first introduces the concept of a controlled current source and then proceeds to synthesize such a device from the properties associated with solid state diodes. This leads to the development of the transistor in a manner which closely integrates its physical and electrical characteristics. Upon completing this lesson the student will thoroughly understand transistor action, symbols, and basic terminology.

2. Transistor Common-Base Model (JT-12)

This lesson first develops from a consideration of the transistor's physical properties an active region model in which the dependent collector current source is a function of the injected emitter current. Subsequently, a more refined piecewise model is developed from a consideration of the input and output characteristic curves. Upon completing this lesson, the student will be able to analyze some basic transistor circuits by direct or indirect application of this model.

3. Transistor Common-Emitter Model (JT-14)

This lesson develops an active region transistor model in which the dependent collector current source is a function of the injected base current. The parameters of this model are related to those of the common-base model. Completion of this lesson enables the student to analyze some basic transistor circuits by direct or indirect application of this model.

4. Transistor Biasing and Stabilization (JT-16)

This lesson discusses techniques for locating the quiescent operating point and stabilizing it. Thermal problems are considered in detail and the various stability factors are both qualitatively and quantitatively analyzed. Upon completing this lesson the student will be able to analyze a variety of biasing configurations for the location and stability of the quiescent operating point.

5. Transistor Small Signal Models (JT-18)

This lesson develops some small signal (incremental) models. In particular the emphasis is upon the "h" and "T" parameter models. The parameter interrelations between these models is developed from a circuit rather than purely mathematical approach. This reduces the math prerequisites and conveys a much better feel for these models. Upon completing this lesson the student will be able to think in terms of

either the "T" or "h" parameter model and convert from one to the other.

6. Transistor Basic Amplifiers (JT-20)

This lesson introduces the three basic amplifier configurations: common-base, common-emitter, common-collector (emitter-follower). Their various properties such as gain and impedance relationships are developed in a practical manner. Upon completing this lesson the student will be able to analyze a complete basic amplifier configuration of each type for its static and dynamic characteristics.

7. Junction-Field-Effect Transistors (JFET-10)

This lesson first introduces the student to the operating principles of the JFET and carefully interweaves its physical behavior with its electrical characteristics. Upon completing this lesson the student will thoroughly understand JFET operation, symbols, and basic terminology.

8. Field Effect Transistor Models (FET-12)

This lesson introduces means of modeling the JFET for large and small signals. The large signal model is based upon a piecewise linear approximation or an essentially parabolic transfer characteristic. The small signal incremental models are initially derived by physical reasoning and later by relating to a "y" parameter four-terminal network. Upon completing this lesson the student will have an excellent insight into the FET and its analysis.

9. FET Basic Amplifiers (FET-16)

This lesson teaches the student how to analyze and model the basic FET amplifier configurations (common-source, common-gate, and source-follower). Their various properties such as gain and impedance relationships are developed in a practical manner. Upon completing this lesson in the FET series the student will be able to analyze a complete basic amplifier

configuration for its static and dynamic characteristics.

10. Power Supply Regulators (PSR-10)

This lesson first introduces the student to the concept of a voltage regulator and some figures of merit for evaluating its performance. The Zener diode is then introduced and its application in non-feedback regulators or as a reference element is investigated. Upon completing this lesson the student will be able to thoroughly analyze a Zener diode regulator.

11. Feedback (FDK-10)

This lesson, the first in the feedback series, introduces the student to concepts and outstanding characteristics of the closed-loop negative feedback system. Upon completing this lesson the student will be able to thoroughly understand how negative feedback provides gain stabilization, output impedance is modified by voltage or current-derived feedback, and input impedance is modified by series or shunt feedback.

12. Practical Semiconductor Diodes (PSD-10)

This lesson introduces the student to semiconductors, PN junction properties, solid state diodes, and some practical applications. The presentation is conducted at an elementary level with a minimum of physics. Upon completing the lesson the student will have a practical understanding of the solid state diode and its application to some basic circuits. This course also serves as an introduction to future lessons in solid state devices and circuits at a practical level similar to the Practical Electricity (PE-10) lesson.

16mm FILMS

ACCEL REVISITED: AUTOMATED CIRCUIT CARD ETCHING LAYOUT

Contact: U.S.A.E.C.

This film, in full color, shows a computer program which designs printed circuit boards and produces the drawings for their construction with the input encoded from an engineer's schematic diagram by a clerk without knowledge of electronics.

ANALOG COMPUTER AND ITS APPLICATION TO ORDINARY DIFFERENTIAL EQUATIONS

16 mm/min./B&W/Sound/Contact: U. of M.

This film, produced in collaboration with Univ. of Mich. Professors Robert M. Howe and Wilfred Kaplan, was made especially for use in courses on ordinary differential equations. It explains the design and operation of the analog computer and illustrates its value in the study of both linear and nonlinear equations.

ANALOG COMPUTERS (INTRODUCTION TO) (S-233) (L&RC)

16mm/8 min./Contact: L&RC

ASSET (ADAPTABLE SPEECH SYSTEM USING ELECTRONIC TRAINING) (MP-1074)

16mm/11 min./color/sound/Contact: Autonetics
Demonstrates the computerized system which trains itself to recognize words spoken by a particular speaker, and to discriminate between different pronunciations and languages. Typewriter read-out provides graphic proof of the accuracy of the ASSET system.

ATOMIC ENERGY--INSIDE THE ATOM (BASIC PHYSICAL SCIENCE SERIES)

13 min./color/\$5.05/Contact: U. of I.

A cloud chamber and geiger counter are used to demonstrate the behavior of radioactive atoms. Explains the basic difference between radioactive and non-radioactive atoms and the use of nuclear reactors. Mentions several uses of the energy carried by radiation.

ATOMIC MODELS, VALENCE, AND THE PERIODIC TABLE

16mm/44 min./color/sound/Contact: U. of Iowa
Here is displayed a new type of three-dimensional atomic model showing covalent radius, valence electronic structure, and electronegativity. An elementary discussion of valence, emphasizing the teaching of directional nature and polarity by use of these models is given.

NOTE. Complete addresses are presented in the next section. The rental prices quoted are for information purposes only.

ATOMIC PHYSICS, LESSON 1: DISCOVERY OF THE ELECTRONIC

30 min./B&W/\$6.15/Contact: U. of I.

Demonstrates the general appearance of high voltage electrical discharges in partially evacuated tubes, straight line propagation, and the momentum of cathode rays.

ATOMIC PHYSICS, LESSON 2: ELECTRONIC CHARGE AND MASS

30 min./B&W/\$6.15/Contact: U. of I.

Describes and demonstrates the bending of cathode rays in an electric field and in a magnetic field. These experiments show that cathode rays are negatively charged particles. Millikan's oil drop experiment is described in some detail.

ATOMIC PHYSICS, LESSON 3: THE ELEMENTS AND THEIR ISOTOPES

30 min./B&W/\$6.15/Contact: U. of I.

Describes Thomson's mass spectrograph and his discovery of neon isotopes. Discusses isotopes and their relative abundance.

ATOMIC PHYSICS, LESSON 4: ELECTRONIC CHARGE TO MASS RATIO (LAB DEMON)

30 min./B&W/\$6.15/Contact: U. of I.

A beam of electrons from an electron gun is bent in a magnetic field, and measurements of orbit radius, accelerating voltage, magnetic field, and current are made.

ATOMIC PHYSICS, LESSON 5: LIGHT SOURCES AND THEIR SPECTRA

30 min./color/\$9.90/Contact: U. of I.

Describes and demonstrates the four general types of spectra: continuous emission, continuous absorption, line emission, and line absorption.

ATOMIC PHYSICS, LESSON 6: WAVE LENGTHS OF SPECTRUM LINES (LAB DEMON)

30 min./B&W/\$6.15/Contact: U. of I.

Uses a diffraction grating to measure the spectrum lines of mercury vapor and sodium vapor. From the results the wave lengths can be calculated.

ATOMIC PHYSICS, LESSON 7: X RAYS

30 min./color/\$9.90/Contact: U. of I.

Discusses the discovery of X rays by Röntgen, the construction and principles of X-ray tubes.

and the principles by which X-ray photographs are made.

ATOMIC PHYSICS, LESSON 8: RADIOACTIVITY

30 min./B&W/\$6.15/Contact: U. of I.
Discusses the discovery of radioactivity by Becquerel and the ionization of alpha, beta, and gamma rays. Explains and demonstrates the principles of the Wilson Cloud Chamber.

ATOMIC PHYSICS, LESSON 9: RADIOACTIVITY MEASUREMENTS (LAB DEMON)

30 min./B&W/\$6.15/Contact: U. of I.
The characteristic plateau curve for a Geiger-Mueller counter is determined experimentally, and measurements are made on a counting rate meter to verify the inverse square law.

ATOMIC PHYSICS, PART 1: THE ATOMIC THEORY

9 min./B&W/\$2.35/Contact: U. of I.
Starts with the basic theory proposed by Dalton in 1808, and outlines progress in atomic study during the nineteenth century, including Faraday's electrolysis experiments and Mendeleef's Periodic Table.

ATOMIC PHYSICS, PART 2: RAYS FROM ATOMS

11 min./B&W/\$2.65/Contact: U. of I.
Demonstrates early work with cathode rays and discovery of the electron; how positive rays were discovered and their nature established; the work of Roentgen with X rays; and the work of Sir Joseph Thomson.

ATOMIC PHYSICS, PART 3: THE NUCLEAR STRUCTURE OF THE ATOM

20 min./B&W/\$4.45/Contact: U. of I.
Reconstructs the early work of Becquerel and the Curies on radioactivity, and explains Rutherford's theory of the nuclear structure of the atom. Moseley's work in support of this theory is shown by animated diagram.

ATOMIC PHYSICS, PART 4: ATOM SMASHING THE DISCOVERY OF THE NEUTRON

22 min./B&W/\$4.55/Contact: U. of I.
Explains the work of the Curies and James Chadwick in the discovery of the neutron. Discusses the splitting of the lithium atom by Cockroft and Walton. Einstein explains his theory of mass and energy. The cyclotron and its use is also explained.

ATOMIC PHYSICS, PART 5: URANIUM FISSION

22 min./B&W/\$5.15/Contact: U. of I.
Reviews and explains events leading to the discovery of uranium fission. Outlines developments in the making of the atomic bomb. Peacetime research and a hopeful look at the future are discussed as a closing for the series.

AUTOMATIC PROCESS CONTROL

16 mm/33 min./color/sound/Contact: Instrument Society

The film discusses the four modes of control--on/off, proportional, proportional with reset, and proportional with reset and rate action--and illustrates how a typical company's product quality and economic returns can be improved with the addition of each mode.

BRATTAIN ON SEMICONDUCTOR PHYSICS

16 mm/30 min./B&W/sound/Contact: Bell
Dr. Brattain demonstrates thermal EMF, photo EMF, rectification and optical properties of semiconductors. He introduces a simple mathematical model to explain the observed properties. He also discusses the history of semiconductor development and the impact of new discoveries.

A booklet containing the film narration is available on request.

CALIBRATION OF THE PLATINUM RESISTANCE THERMOMETER

16 mm/16 min./color/sound/Contact: National Bureau Standards

Shows the National Bureau of Standards procedure for calibrating a platinum resistance thermometer at the specified defining points on the International Practical Temperature Scale. Along with the procedure, the unique and intricate equipment used at NBS for calibrating at the defining points is seen in this film.

CAPACITANCE--PART 1: PHYSICAL AND ELECTRICAL CHARACTERISTICS AND FACTORS AFFECTING CAPACITANCE

16 mm/29 min./B&W/1965 TF-11-3627/Contact: U.S.A.F.

Explains the characteristics, applications, functioning, and effects of capacitance on electronic circuits.

CATHODE RAY OSCILLOSCOPE

22 min./B&W/\$2.15/Contact: U. of I.
Shows, through animation and drawings, the parts of the cathode ray oscilloscope, and its operation and actual use for checking electrical circuits. Indicates the limitations of the ammeter and voltmeter for showing accurate instantaneous current and voltage variation.

CATHODE RAY TUBE: HOW IT WORKS

17 min./B&W/\$2.15/Contact: U.S.N. (Mn 2104)
Demonstrates the construction and function of each part of the cathode ray tube and how it produces visual images on a screen. Explains electrostatic and electromagnetic deflection

and how varied currents affect the position of the spot of light on the scope.

(THE) CATHODE-RAY TUBE - WINDOW TO ELECTRONICS

35 min./color/1961/Contact: Tektronix
The heart of the oscilloscope is its cathode-ray tube, on whose screen the measurements appear in graph form. This film shows the steps in the manufacture of this complex component. Using animated sequences, it explains briefly and simply how a cathode-ray tube works.

CERAMICS AND ELECTRONICS

22 min./color/1961/Contact: Tektronix
The importance of ceramic materials and processes in oscilloscope development and manufacture is described in this film. It shows the use of ceramic mounting strips and other parts in Tektronix' instruments. Steps in our manufacturing process are pictured.

CIRCUIT BOARDS, DESIGN AND MANUFACTURING

Contact: Tektronix
This film, in full color, shows that electronic equipment today is more complex, yet smaller and more reliable than it was a few years ago. This, in part, has been made possible through the use of solid state circuitry and Circuit Boards. The film covers the complete process in the design and lay-out of high quality boards. Problems and their solutions are discussed. The complete manufacturing process is shown to the final testing of the boards.

COMMAND AND CONTROL (SFP 1345)

18 min./color/1965/ Pp. TV. PS./Contact: U.S.A.F.
Defines the 473L data processing concept in giving speed and accuracy to Air Force command and control. Describes outdated manual method of solving high level problems and emphasizes need for an electronic approach to coping with today's world crises. Simulates a sudden brush war to demonstrate 473L capability in answering questions on weather, personnel, communications, weapon systems, medical facilities, etc.

COMPLEX WAVES I: PROPAGATION, EVANESCENCE AND INSTABILITY (1967)

16 mm/26 min./B&W/sound/Contact: Education Dev. Center

This film is one of a series concerned with electromagnetic fields and forces as they interact with moving and deformable media. This simultaneous display of the real phenomena with its associate (computer animated) omega-k dispersion relations demonstrates the effect on the phenomena as the parameters of the system are varied.

COMPLEX WAVES II: INSTABILITY, CONNECTION AND AMPLIFICATION (1968)

Same as COMPLEX WAVES I.

COMPUTER GLOSSARY

Contact: IBM--K.

This film, in full color and in animation, pictures a "fantastic voyage" into the complex microcircuitry of a computer. It also defines in basic terms the terminology of computers today such as flowchart, boolean logic, nanosecond and simulation to give the viewer an enlarged understanding of electronic data processing.

COMPUTER NETWORK ANALYSIS--AN ON-LINE INTERACTIVE APPROACH

16 mm/9 min./B&W/sound/Contact: Bell Labs
This movie demonstrates the use of an experimental software system at the Bell Telephone Laboratories for on-line circuit analysis.

CRYSTALS (0113-BLACK AND WHITE: 0114-COLOR)

16 mm/25 min./sound/Contact: McGraw-Hill
Demonstrates the nature of crystals, how they are formed and why they are shaped as they are. Shows actual growth of crystals under a microscope; discusses how they may be grown. Relates these phenomena to the concept of atoms.

CRYSTALS--AN INTRODUCTION

16 mm/25 min./color/sound/Contact: Bell
This film introduces the subject of crystals by demonstrating the orderly arrangement of atoms in the crystalline state and the relation of this arrangement to the physical properties of the substances.

Primarily designed to provide an introduction to crystallograph for students for electrical engineering, it is appropriate for courses in physics, chemistry, and metallurgy.

CRYSTALS AND THEIR STRUCTURES (4139)

16 mm/22 min./B&W/sound/Contact: Modern Learning Aids
Crystals have plane faces, sharp edges, sharp melting points, and may cleave easily to give new plane surfaces. The film raises the question of how we actually discover these arrangements.

DESIGN AUGMENTED BY COMPUTER, DAC-I

16 mm/13-1/2 min./color/sound/Contact: G.M.
One of the world's first operational man-computer design systems has been developed by and is operating at General Motors Research Laboratories. The main features of this unique facility are described in this motion picture. For college engineering classes and other technical audiences interested in the latest

Research developments in the new field of computer-aided design.

DESIGN AUTOMATION AT IBM

16 mm/18-1/2 min./color/sound/Contact: IBM--N.Y. This dynamic movie features the Design Automation System currently employed at the IBM Endicott and Poughkeepsie plants. It highlights the use of an IBM data processing system as an aid for engineering computer design and numerical control of production tools.

DIGITAL COMPUTER TECHNIQUES: INTRODUCTION (MN 8969A)

16 mm/16 min./color/sound/Contact: U.S.N. Provides a general introduction to digital computers; explains the historical origins of calculating devices; points out the differences between analog and digital computers, discussing the principal steps involved in the solution of problems subjected to the digital computing process.

DIGITAL COMPUTER TECHNIQUES: COMPUTER LOGIC (MN 8969-B)

16 mm/13 min./color/sound/Contact: U.S.N. Explains by means of animation the binary number system.

DIGITAL COMPUTER TECHNIQUES: COMPUTER LOGIC SYMBOLOGY (MN 8969-C)

16 mm/15 min./color/sound/Contact: U.S.N. Provides a general introduction to digital computers; explains the historical origins of calculating devices; points out the differences between analog and digital computers, discussing the principal steps involved in the solution of problems subjected to the digital computing process.

DIGITAL COMPUTER TECHNIQUES: COMPUTER UNITS (MN 8969-D)

16 mm/24 min./color/sound/Contact: U.S.N. Discusses in an introductory way the major units of a digital computer. Describes the input unit and how it reads the problem data and instructions, the output unit and how it delivers problem solutions in some form of output medium, the arithmetic unit and how its basic components work and the control unit and the purposes of sequencing, clocking, and timing.

DIGITAL COMPUTER TECHNIQUES: LOGIC ELEMENT CIRCUITS (MN 8969-E)-2

16 mm/16 min./color/sound/Contact: U.S.N. Illustrates how solid state electronics are used in modern computers. Shows how the circuits handle the input signals of high and/or low voltages representing binary one's and binary zero's respectively, and how the proper output signal is produced.

DIGITAL COMPUTER TECHNIQUES: PROGRAMMING (MN 8969-F)

16 mm/15 min./color/sound/Contact: U.S.N. Defines computer programming, explains what is meant by analyzing the problem, shows how a simple flow chart is prepared with symbols and gives their meaning, and shows how instructions to the computer are encoded in computer language.

DOMAINS AND HYSTERESIS IN FERROMAGNETIC MATERIALS

16 mm/27 min./color/sound/Contact: Bell Building on material presented in "The Formation of Ferromagnetic Domains," this film develops the theories that are fundamental to understanding hysteresis in magnetically soft and magnetically hard materials and shows motion pictures of domain wall motion. A full discussion of the origin of the coercive force is also included.

ELECTRIC POWER GENERATION IN SPACE (HG. NASA)

16 mm/26-1/2 min./color/sound/Contact: NASA Shows the problems of generating electric power in space and the methods used for different power levels including the battery, solar cell, and fuel cell.

ELECTRICAL POTENTIAL ENERGY AND POTENTIAL DIFFERENCE (PARTS I AND II) (0431-2)

16 mm/54 min./B&W/sound/Contact: Modern Learning Aids
In Part I of this film, the mechanism by which the battery establishes an electric field in a circuit is analyzed and the electric potential energy stored in such a system is measured experimentally and explained theoretically. In Part II, is shown how the energy transformations in a steady current-carrying circuit can be obtained from measurements of potential difference and electric current, including the energy dissipated internally in the batteries used.

ELECTRICAL QUALITY CONTROL OF RAW MICA USED IN CAPACITORS

16 mm/9 min./color/silent/Contact: Bell Labs

ELECTRICAL SAFETY IN THE HOME

14 min./color/\$4.85/Contact: U. of I. Tom and his father use an electrical safety inspection sheet as a guide in checking their home for electrical hazards. Dad's explanation of the principles of electrical safety is dramatized by flashbacks to a demonstration.

ELECTRICITY: FROM POWER PLANT TO HOME

12 min./B&W/\$2.25/Contact: U. of I.

Visits a power plant to present the basic facts regarding the generation and distribution of electric power from home use. Magnetic induction is explained through animation.

ELECTRICITY AND MAGNETISM, LESSON 1: ELECTRICITY AT REST

30 min./B&W/\$6.15/Contact: U. of I.
Demonstrates experiments with static electricity and forces between electrically charged bodies. Shows electroscopes and electrometers in use.

ELECTRICITY AND MAGNETISM, LESSON 2: COULOMB'S LAW--ELECTROSTATICS

30 min./B&W/\$6.15/Contact: U. of I.
Discusses the law of forces between electrical charges. Demonstrates charging by induction and discharging by points.

ELECTRICITY AND MAGNETISM, LESSON 5: OHM'S LAW

30 min./B&W/\$6.15/Contact: U. of I.
The relation between voltage, current, and resistance is demonstrated and treated in detail.

ELECTRICITY AND MAGNETISM, LESSON 8: THE ELECTRIC FIELD AND POTENTIAL

30 min./B&W/\$6.15/Contact: U. of I.
Defines and explains the meanings of electrical potential, potential difference, electrical field, and intensity.

ELECTRICITY AND MAGNETISM, LESSON 10: CAPACITANCE

30 min./B&W/\$6.15/Contact: U. of I.
Presents and demonstrates the principles of capacitance and the construction of fixed variable capacitors.

ELECTRICITY AND MAGNETISM, LESSON 13: ALTERNATING CURRENT THEORY

30 min./B&W/\$6.15/Contact: U. of I.
Introduces the concepts of inductance, inductive reactance, capacitive resistance, and impedance as fundamental principles relating to alternating currents. Demonstrates levitation with an operating levitator.

ELECTROCHEMICAL REACTIONS

14 min./B&W/\$3.15/Contact: U. of I.
Explains and demonstrates the principles on which voltaic and electrolytic cells operate, the actual operation of these cells, electrolysis, electroplating, and the operation of a storage battery.

ELECTROMAGNETIC COMPATIBILITY (SFP 1404)

16 mm/14 min./color/sound/Contact: U.S.A.F.

Shows how the electromagnetic compatibility program helps provide interference free communications systems. Combines a variety of known interference effects with a simulated missile launch and guidance and tracking situation to emphasize types of degradation problem.

ELECTROMAGNETS: HOW THEY WORK

11 min./B&W/\$2.35/Contact: U. of I.
Presents the principles underlying the construction and operation of electromagnets.

(THE) ELECTRON, AN INTRODUCTION

16 mm/16 min./B&W/OE 175/Contact: U.S.O.E.
Nature of electrons; electron flow in solid conductors; electromotive force; types and control of electron flow; electron flow and magnetic fields; and induced electron flow.

ELECTRONIC COMPUTERS AND APPLIED MATHEMATICS

16 mm/23 min./B&W/color/Contact: Colburn
Explains the basic principles and operation of electronic computers and the use of Binary Arithmetic so that number systems and the Place Value Concept are most meaningful. Unusual uses of the computer stimulate interest in Mathematics and Science careers.

ELECTRONIC DATA PROCESSOR (THE) NCR 390

16 mm/20 min./color/sound/Contact: NCR
This film describes the NCR 390, a digital solid state computer built with modular construction. It depicts the four methods of input and output, console keyboard, punched paper tape, punched tab cards, or external magnetic memory ledgers.

ELECTRONICS IN AUTOMATION

16 mm/22 min./B&W or color/sound/Contact: DeVry
Shows many opportunities in the coming field of automation electronics. Depicts "push-button plant" of the future and shows applications of electronic controls to production processes. Shows recently developed computers and other electronic devices, also explains the part automation is expected to play in modern offices.

ELECTRONICS, LESSON 1: ELECTROMAGNETIC WAVES

30 min./B&W/\$6.15/Contact: U. of I.
Describes and demonstrates the Leyden jar and the discovery of oscillating circuits. Describes and demonstrates electrical resonance, the propagation of electromagnetic waves, and the principles of the Tesla coil.

390

ELECTRONICS, LESSON 2: VACUUM TUBES

30 min./color/\$9.90/Contact: U. of I.
Reviews the historical development of wireless and radio from Marconi to the DeFroest Audion.

ELECTRONICS, LESSON 3: CHARACTERISTICS OF VACUUM TUBES (LAB DEMONSTRATION)

30 min./B&W/\$6.15/Contact: U. of I.
Demonstrates the measurement of grid-voltage and plate current applied to the elements of a triode vacuum tube. From these, double characteristic curves are to be plotted.

ELECTRONICS, LESSON 4: OSCILLATORS, AMPLIFIERS, AND RADIO

30 min./B&W/\$6.15/Contact: U. of I.
Describes electrical circuits using triode vacuum tubes as amplifiers and as oscillators. Discusses a simple radio transmitter and the principles of a loud-speaker.

ELECTRONICS, LESSON 5: THE PHOTOELECTRIC EFFECT

30 min./B&W/\$6.15/Contact: U. of I.
Demonstrates the phenomenon of the emission of electrons from metals, by the action of light, and explains it through the Einstein photoelectric equation. Also demonstrates the transmission of sound over a light beam.

ELECTRONICS, LESSON 6: ELECTROMAGNETIC WAVES (LABORATORY DEMONSTRATION)

30 min./B&W/\$6.15/Contact: U. of I.
VHF electromagnetic wave lengths are shown by standing waves on a conductor. Wave length of microwaves is measured by reflection of a plane surface.

ELECTRONICS, LESSON 7: RADAR AND TV

30 min./B&W/\$6.15/Contact: U. of I.
Describes the echo effect of microwaves and explains the use of wave guides. Presents the principles of scanning and of the image orthicon as used in tv.

ELECTRONICS, LESSON 8: GEIGER-MUELLER AND SCINTILLATION COUNTERS (LAB DEMON.)

30 min./B&W/\$6.15/Contact: U. of I.
Studies the counting rate capabilities of the Geiger-Mueller and scintillation counters. The resolution time of the Geiger-Mueller counter is determined from counting rate measurements.

ELECTRONS AT WORK (BASIC PHYSICAL SCIENCE SERIES)

14 min./color/\$5.05/Contact: U. of I.
Discusses the characteristics and behavior of electrons, the relation between electrons and an electric charge and the fact that electrons can be used in many ways they are controlled.

ELECTROSTATICS (SECOND EDITION)

11 min./B&W/\$2.35/Contact: U. OF I.
Shows that a knowledge of static electricity is fundamental to an understanding of modern theories of electricity.

ELEMENTS OF ELECTRICAL CIRCUITS

11 min./B&W/\$2.35/Contact: U. of I.
Shows that electric current is a flow of electrons controlled by circuits. Describes home electrical circuits, and illustrates a short circuit caused by faulty insulation.

ENGINEERING, CAREER FOR TOMORROW

23 min./color/\$6.45/Contact: U. of I.
Answers many of the questions of the high-school student who is interested in engineering as a career. Shows various fields that are open in engineering. Explains what each engineer does and the status of engineers in the world today.

ENGINEERING--THE CHALLENGE OF THE FUTURE

23 min./color/1968/Contact: Bell
Students describe their reasons for choosing a career in engineering, high school counsellors and college engineering. Professors discuss qualifications and course requirements and professional engineers tell of the challenges they face in their daily work and the job duties they perform. Potential engineering students will get a comprehensive view of what it takes to become an engineer and the variety of careers available from the kinds of people with whom they will study and work.

EXTRA HIGH VOLTAGE CONDUCTOR

Contact: Reynolds
This film, in full color, deals with new developments in conductors for extra high voltages. The film shows some of the first installations of an eight million dollar project which is to be completed in 1970. Reynolds has produced and tested an extra high voltage cable that is now in service.

(THE)FORMATION OF FERROMAGNETIC DOMAINS

16 mm/40 min./color/sound/Contact: Bell Labs
Provides a detailed elementary treatment of the origin and behavior of ferromagnetic domain structures for engineering students and technical societies.

FREQUENCY RESPONSE (PRINCIPLES OF)

16 mm/37 min./color/sound/Contact: Instrument Society

Presents in non-math terms the elements of frequency response as a tool of quantitative dynamic analysis of process control systems.

GAP ENERGY AND RECOMBINATION LIGHT IN GERMANIUM

37 min./B&W/sound/Contact: Coronet
An optical experiment is performed to measure the wavelength of the light emitted by the recombination of excess hole-electron pairs in the neighborhood of a p-n junction located near the middle of the germanium bar.

GAS-FILLED TUBES (PRINCIPLES OF) (OE 353)

16 mm/15 min./B&W/sound/Contact: DU Art
Theory of ionization applied to gas-filled tubes; control of current in circuits employing gas-filled tubes; use of the gas diode as a rectifier; action of the grid in a gas triode; and application of the gas triode as a grid-controlled rectifier.

HARMONIC PHASORS (1966)

16 mm/7 min./B&W/silent/Contact: Education Dev. Center
This film was made as a part of the program of the National Committee for Electrical Engineering Films primarily for students of electrical engineering, and was produced by Education Development Center under a grant from the NSF.

HERITAGE OF A METER

16 mm/20 min./color/sound/Contact: Westinghouse
Shows the assembly of a Westinghouse magnetic meter. Tells why, with the assets of good engineering and design, this meter will take the hardest service under the most adverse conditions.

HYBRID-INTEGRATED CIRCUIT TECHNOLOGY

16 mm/20 min./color/sound/Contact: IBM--N.Y.
This film presents two methods by which micro-electronic circuits are assembled as IBM, by means of a hybrid-integrated approach.

IBM: CLOSE UP

Contact: IBM--K.
This film, in full color, presents a look at IBM, its people and their views of the technology with which they are working. Included are glimpses into real life applications of computers in education, medicine, space, and textile design.

INSIDE TELSTAR--RELIABILITY IN THE MAKING

16 mm/20 min./color/sound/Contact: Bell Labs
Presents a pictorial history of the assembly and

testing of Telstar I, with emphasis on quality control and reliability.

INSTRUMENT ASSEMBLY AND PRODUCTION FLOW

27 min./color/1961/Contact: Tektronix
Produced as an instructional motion picture, this film describes the flow through one of our manufacturing plants of raw materials and purchased and Tektronix-made parts, from receiving, through assembly and test, to shipment of the instrument.

INTRODUCTION TO RADAR

22 min./B&W/\$2.15/Contact: U. of I.
Gives an elementary explanation of radar, covering the basic theory on which it operates, nomenclature, and the different kinds of radar (detection, search, aircraft, warning, homing and navigational aid). Includes a brief description of PPI. Ends by setting up a problem and solving it by radar. A 1944 production.

KINGSTON ENGINEERING LAB

16 mm/10 min./Contact: IBM--N.Y.
Areas of research and development in the Engineering Laboratory (IBM) are described, including thin films and cryogenics.

(THE) KLYSTRON

16 mm/17 min./sound/color/Contact: McGraw-Hill
This film explains the working of a two-cavity klystron amplifier. An electron beam travelling from a cathode to a collector passes through two cavity resonators.

MEMORY DEVICES

16 mm/27 min./color/sound/Contact: Bell
This film shows information storage devices used in modern computing machines' memories, and explains how binary information is stored in them.

Basic concepts and terms are explained and examples of mechanical, electro-mechanical, magnetic, electrostatic, and photographic memories are described. The following memory devices are shown; punched tapes, relays, magnetic tape, magnetic drums, ferrite cores, ferrite sheet, twistors, capacitor array, barrier grid storage tube, and flying spot store.

MICROELECTRONICS AND MINUTEMAN II (MP-1045)

16 mm/color/sound/Contact: Autonetics
Describes Autonetics' effort in designing and producing the world's first microminiaturized system for the Minuteman II missile.

MICROELECTRONICS, (THE) ROAD TO RELIABILITY
(MP-1033R)

16 mm/29 min./color/sound/Contact: Autonetics
Starting with the earliest attempts to reduce the size and heat generation of standard vacuum tubes, the film shows the development of semi-conductors from the first transistors to the micro-miniature components of today.

MICROWAVE OSCILLATORS

18 min./B&W/\$2.15/Contact: U. of I.
Explains the basic theory and operation of the magnetron and klystron.

MINORITY CARRIERS IN SEMI-CONDUCTORS

16 mm/26 min./B&W/sound/Contact: Education Dev. Center
This film demonstrates the existence and behavior of injected excess minority carriers in semi-conductors by repeating in modified form the Haynes-Chockley drift-mobility experiment.

MODERN MANUFACTURING-COMMAND PERFORMANCE (SFP 1153)

33 min./color/1963/PE for professional or specialized groups only/Limited prints/Contact: U.S.A.F.
Illustrates use of automation by industry to reduce costs, improve quality and speed production. Shows how manufacture of parts can be programmed so that computer tapes accurately control milling and stamping machines for precise production of precision parts.

MOS-FET (METAL OXIDE SEMI-CONDUCTOR) (MP-1084)

16 mm/14 min./color/sound/Contact: Autonetics
Graphically discusses the MOS device and explains the design, fabrication, operation, and application of the functions of the MOS device, through-live and animated footage.

MOVIES FROM COMPUTERS: AN INTERIM REPORT

16 mm/20 min./B&W/sound/Contact: Education Dev. Center
The film presents a number of extracts from existing computer generated industrial and research films. The basic purpose is to stimulate study and use of computer animation of films as a basic tool for learning.

OSCILLOSCOPE - WHAT IT IS, WHAT IT DOES

9 min./color, 1961/Contact: Tektronix
This non-technical explanation of the oscilloscope and its uses stresses the instrument's importance as a basic measuring tool for electronics in particular, and science and industry in general.

OSCILLOSCOPE DRAWS A GRAPH

20 min./color/1962/Contact: Tektronix
How an oscilloscope works is described simply in words and pictures, in this non-technical film. The importance of an oscilloscope to science and industry is emphasized. The film tells how to read information that is graphed on the oscilloscope's cathode-ray screen.

PHOTO-CONDUCTIVE EFFECT

16 mm/16 min./B&W/sound/Contact: McGraw-Hill
The film opens by showing how the photo-conductive cell is highly sensitive to heat radiation. Various methods of detecting and measuring infra-red radiation are illustrated.

PRIMARY CELL

16 mm/11 min./sound/Contact: Encyclopedia Britannica
Explains dry cell operation in terms of electron action. Through animated drawings and natural photography demonstrates ionization of an electrolyte, electron flow, action at electrodes, polarization, and function of the depolarizer.

PRINCIPLES OF GAS-FILLED TUBES

15 min./B&W/\$3.15/Contact: U. of I.
Presents the theory of ionization as applied to gas-filled tubes, the control of current in circuits employing gas-filled tubes, the use of the gas diode as a rectifier, action of the grid in a gas triode, and the application of the gas triode as a grid-controlled rectifier.

PRINCIPLES OF THE OPTICAL MASER

30 min./color/1963/Contact: Bell
Dr. C. G. B. Garrett of Bell Telephone Lab. shows how basic physical concepts are applied to make an optical maser oscillate.
The optical maser is examined as a generator of electromagnetic energy in the optical range of frequencies, having many qualities similar to standard radio and microwave oscillators. The principal types of gas and solid state optical masers are shown in the laboratory.

PRINCIPLES OF THE TRANSISTOR (ADVANCED SCIENCE SERIES)

21 min./B&W/\$4.55/Contact: U. of I.
Uses animation and demonstration to describe the development, uses and theory of semi-conductors, germanium diodes, and transistors. Shows the early uses of semi-conductors in crystal sets and explains conduction in conductors, semi-conductors, and insulators. Explains in detail how the germanium diode and the transistor function, with details

concerning the crystal lattice. P- and N-type germanium, and hole conduction. Each animated sequence of explanation is followed by a demonstration of the principle. Discusses advantages of transistors in computers, radios, and hearing aids.

PRINCIPLES OF ULTRASONICS (ADVANCED SCIENCE SERIES)

18 min./B&W/\$3.95/Contact: U. of I.
Depicts the relation and range of sonic and ultrasonic waves. Shows how these waves are detected and various types of wave generators which can be used to propagate them: loud-speaker, magneto-strictor, and crystal transducer. Explores the proper uses of ultrasonic waves and the uses to which they can be applied.

PRINTED CIRCUIT STORY

16 mm/25 min./color/sound/Contact: Bray
Shows how printed circuits are manufactured from the bare laminate through component installation on etched and plated circuit boards. Introduces recommended tools and helpful items for the servicing of printed circuits as well as repairability techniques according to accepted industry standard practices.

PRINTED CIRCUITS AND THEIR REPAIR

28 min./color/1961/PE, TV, TH, PS/Contact: U.S.A.F.

Shows how the accomplishment of many Air Force missions is dependent on reliability of printed circuits. Covers methods of manufacturing, cleaning and repair. Demonstrates types of emergency repair. Also illustrates types of tools used.

PROPER HANDLING OF CATHODE-RAY TUBES

20 min./color/1962/Contact: Tektronix
A cathode-ray tube is intricate and delicate. Abuse not only represents money lost but also presents a hazard. This film shows clearly the right and wrong ways to handle CRTs, and explains how to de-evacuate a cracked or otherwise defective tube.

RADIO WAVES -- PLANET EARTH SERIES (JPL 458)

16 mm/29 min./color/sound/Contact: Jet Propulsion Lab.
A study of the nature of the artificial radio waves; an examination of the vast electrified region above the earth and introducing the subject of natural radio waves.

RELAY (HQ. NASA)

16 mm/28 min./color/sound/Contact: NASA
A technical documentary film of the RELAY communications spacecraft. Through the use of

animation it shows the various components and how they are integrated within the spacecraft.

RESPONSE OF A RESONANT SYSTEM TO A FREQUENCY STEP (1968)

12 min./silent/Contact: Coronet
This film is a computer pantomime motion picture designed to be used as a teaching aid in demonstration fundamental concepts relevant to: (1) linear system theory; and (2) frequency modulation. Specifically, the role assumed by transients in providing a smooth transition between initial and final steady-state conditions is illustrated using rotating "phasors" to portray the envelope and phase of modulated signals.

SECOND GENERATION MICROELECTRONICS

Contact: Autonetics
This film, in full color, shows research, development and systems applications of advanced microelectronics. Evolution of integrated circuits thin films, and ceramic printed circuits to multifunctional IC's, metal oxide semi-conductors, and silicon-on-sapphire devices and their application is described. Future use of epitaxial ferrite micro-memory, silicon-on-sapphire stripline waveguides, and Gunn-effect oscillators conclude the film.

SECONDS FOR SURVIVAL (SFP 1043)

28 min./color/1960/PE, TH./Contact: U.S.A.F.
Describes NORAD-ADC-SAC alert system of which the Dew Line, RMEWS, and separate radar and aircraft control and warning systems throughout the world are important facets. Narrator is Raymond Massey.

SEMICONDUCTORS, PART 1: DIODES AND TRIODES

21 min./B&W/\$4.15/Contact: U. of I.
Presents the basic physics and theory of hole and electron flow in semiconductor materials as related to the P-N junction and fundamental principles that apply to junction rectifiers.

SEMICONDUCTORS, PART 2: LOW FREQUENCY AMPLIFICATION

22 min./B&W/\$4.15/Contact: U. of I.
Presents the fundamentals of transistor low-frequency amplification; a brief review of electron and hole flow, P-N junction characteristics, and transistor symbols; the build-up of amplifying circuits; a discussion of common emitter, base, and collector circuits; and a detailed analysis of the operation of the common emitter and common base circuits.

SIMILARITIES IN WAVE BEHAVIOR

16 mm/26 min./B&W/sound/Contact: Bell Labs
In this film, Dr. J. N. Shive, Director of the Education and Training Center at Bell Telephone Laboratories, discusses the similarities that exist in the behavior of waves in various mechanical, electrical, acoustical, and optical systems.

SOLVING THE UNBALANCED BRIDGE (WITH THEVENIN'S THEOREM)

16 mm/16-1/2 min./B&W/sound/Contact: Tektronix
This is a lecture film given by Nelson Hibbs. It is the second part in a series on Thevenin's Theorem. Presented in the same manner as previous film. With the first film on Thevenin's Theorem as a basis, this film takes a typical example, the unbalanced bridge, and shows how simply this problem is solved using Thevenin.

SOUNDS OF PROGRESS

34 min./color/1963/Contact: Tektronix
Several Tektronix manufacturing activities are shown in this film, including metal, plastics, tooling, electrochemical and front-panel production.

(THE) SQUARE WAVE

16 mm/25 min./B&W/sound/Contact: Tektronix
A square wave is one of the most useful types of test signals. In many cases it is much more useful than the sine wave in electronic testing and design. This film goes into the theory of the square wave, analyzes it and shows that a single square wave actually consists of a series of sine waves.

STANDING WAVES ON TRANSMISSION LINES

16 mm/23 min./B&W/MN 1540-K/Contact: U.S.N.
By means of animated diagrams, laboratory demonstrations, and diverse analogies explains the causes, results, and prevention of standing waves in radio high frequency transmission lines.

TECHNICIANS FOR TOMORROW

Contact: Conn. State Dept.
A 16 mm color film prepared by the Connecticut State Department of Education which presents the story of engineering technicians and the programs at Connecticut technical institutes.

TEKTRONIX: THE WORLD OF MEASUREMENT

25 min./color/1966/Contact: Tektronix
This film introduces Tektronix and describes its product, the oscilloscope, and its importance in making precision measurements in a very wide variety of scientific and technical applications. The viewer receives a "tour" of our industrial

park and its many buildings, highlighting our varied manufacturing processes: Component, cathode-ray tube, ceramics and transformer manufacture; toolmaking; metal fabrication; instrument assembly; testing, and calibration.

TEKTRONIX ON THE ISLE OF GUERNSEY

22 min./color/1962/Contact: Tektronix
An important part of Tektronix' overseas activity is our manufacturing operation on the English Channel Isle of Guernsey. This film describes the island's history and shows its scenery, people and industry - particularly Tektronix' plant, depicting how it fits into the island's economy.

THERMOELECTRICS

16 mm/18 min./sound/Contact: Industrial Ed.
The first and only film on the practical application of thermo-electricity--the new technology that is revolutionizing the approach to cooling, heating, and temperature control. The film explains concept and principles of thermoelectrics, demonstrates techniques for applying principles, portrays scores of thought-provoking applications, and gives considerations in specifying for thermoelectric devices.

THEVENIN'S THEOREM

16 mm/12 min./B&W/sound/Contact: Tektronix
This is a lecture film given by Nelson Hibbs. Using the black board and charts as props, a lecture is given on the usefulness of Thevenin's Theorem and how to use it in a practical application.

THIS IS AUTOMATION

16 mm/30 min./color/sound/Contact: G.E.
Defines automation and illustrates industrial applications of the principles of automation in the manufacture and packaging of a variety of products.

TIME AND QUANTITY

27 min./B&W/1962/Contact: Tektronix
Originally presented as part of a television program, this film relates oscilloscope measurements to other measuring techniques.

(THE) TRANSIENT BEHAVIOR OF THE DIODE

16 mm/19 min./color/sound/Contact: McGraw-Hill
The application of a square wave voltage pulse to a diode creates a current pulse of a complex form which is difficult to interpret. However, by utilizing the concentration graphs, the film gives an explanation of the transient phenomena that occur.

(THE) TRANSIENT BEHAVIOR OF THE TRANSISTOR

16 mm/17 min./color/sound/Contact: McGraw-Hill
When a stepped-voltage pulse is applied to the input of a transistor, the curve of the output current as a function of time will show deviations from the rectangular form. The rise-time t_r and the fall-time t_f are discussed with the help of the concentration graphs.

(THE) TRANSISTOR

16 mm/16 min./color/sound/Contact: McGraw-Hill
This film explains the working of a P-N-P transistor.

(MODERN) TRANSISTOR FABRICATION TECHNIQUES

16 mm/35 min./color/sound/Contact: Bell Labs
Shows how modern diffused epitaxial transistors, developed by Bell Telephone Laboratories, are manufactured by Western Electric Company. Shows how the technology used to make these transistors is also used to make many other types of transistors and integrated circuits. Included in the film are descriptions of diffusion, the photo-resist technique and other steps and controls required to manufacture these transistors.

(THE) TRANSISTOR STATES OF OPERATION

16 mm/19 min./color/sound/Contact: McGraw-Hill
The four states of operation of a transistor that occur in switching applications are examined. If both junctions are biased in the reverse direction the transistor operates in the "cut-off" state.

TRANSISTOR STRUCTURE AND TECHNOLOGY

38 min./color/Contact: Coronet
This film begins with a description of how the alloy junction transistor (PNP) is made, followed by a discussion of the limitation of its speed and voltage characteristics. The characteristics of PNP and NPN types are discussed. Fabrication of NPN transistors is shown.

TRANSISTORS. PART IV.--PULSE APPLICATIONS

16 mm/39 min./B&W/1963/TF 11-3051/Contact: U.S.A.
Features and applications of square, saw-toothed and spiked pulses; how transistors form various multivibrators.

TRANSISTORS. HIGH FREQUENCY OPERATION--AMPLIFIERS AND OSCILLATORS (MN 8479-3)

16 mm/14 min./B&W/sound/Contact: U.S.N.
Describes how transistors operate in high frequency amplifiers and in oscillator circuits; shows the influence of transit effects in the base; explains collector capacitance and base resistance on high frequency performance.

TRANSISTORS: LOW FREQUENCY AMPLIFIERS (MN 8479-d)

16 mm/15 min./B&W/sound/Contact: U.S.N.
Shows how transistors are used to amplify low frequencies in common base, common emitter, and common collector circuits. Explains transistor functions for a common base amplifier and a common emitter amplifier, and refined common emitter amplifier circuits.

TRANSISTORS: MINORITY CARRIERS (MN 8479-c)

16 mm/10 min./B&W/sound/Contact: U.S.N.
Introduces the principles of minority carriers, shows how they produce a small reverse current under normal conditions, and demonstrates the limitations imposed on transistor behavior by minority carriers when the transistor is heated or loaded.

TRANSISTORS: P-N JUNCTION FUNDAMENTALS (MN 8479-a)

11 min./B&W/sound/1957/Contact: U.S.N.
Theory and mechanisms of semi-conductor diode and transistor action. Principles that apply to all transistors and junction rectifiers.

TRANSISTORS: SERVICING TECHNIQUES (MN 8479-g)

17 min./B&W/sound/1960/Contact: U.S.N.
Common failures such as opens, shorts, high leakage current, low gain and problems in localizing them. Demonstrates special servicing techniques used with transistorized equipment.

TRANSISTORS: SWITCHING (MN 8479-f)

14 min./B&W/sound/1959/Contact: U.S.N.
Examples of switching circuits in transistorized computers. Concept of digital computation, and how transistors are used. How a simple transistor switch works. Minority carrier storage in base. How delaying effects of storage are overcome.

TRANSISTORS: TRIODE FUNDAMENTALS, (MN 8479-b)

10 min./B&W/sound/1957/Contact: U.S.N.
How junction transistors consist of three sections with two P-N junctions separating them. Fundamentals of arrangement as amplifying device.

TRANSMISSION LINES

16 mm/23 min./B&W/sound/Contact: Tektronik
This film deals with some of the basic fundamentals of transmission lines. A considerable amount of animation is used to illustrate the manner in which electrical energy is transmitted along a line.

**TRANSRESISTANCE: A SIMPLIFIED APPROACH TO
TRANSISTOR-AMPLIFIER ANALYSIS**

23 min./B&W/1966/Contact: Tektronix
Transresistance is a new concept of looking at transistors that permits rapid estimates of their operation in normal amplifier circuits. The approach is similar to understanding mutual conductance in vacuum-tube circuitry.

**TRANSRESISTANCE, AN APPROACH TO TRANSISTOR
AMPLIFIER ANALYSIS**

Contact: Tektronix
This film is a lecture type picture showing the concept of Transresistance applied to the design and analysis of transistor amplifiers. This approach makes it easy to determine the operating points, the current and the gain needed. It is assumed that the viewer has a basic understanding of electronics and transistors.

TRIODE--PLATE CHARACTERISTICS

16 mm/15-3/4 min./B&W/sound/Contact: Tektronix
A family of plate-characteristic curves tells an electronics technician many things about the behavior of a particular vacuum tube. This film discusses the plate curves for a typical triode--a 6DJ8.

**VECTORS (AN INTRODUCTION TO): COPLANAR
CONCURRENT FORCES**

16 mm/22 min./B&W/sound/Contact: W.S.U.
Explains the meaning of scalar and vector quantities; how to add scalars and vectors; methods of vector composition and vector resolution; relationship between vector composition and vector resolution; and how vectors may be used to solve engineering problems.

**WAVE VELOCITIES, DISPERSION, AND THE OMEGA-BETA
DIAGRAM (1969)**

28 min./Contact: Coronet
This film considers traveling waves and the way they propagate through transmission systems. It is designed to be used in connection with lectures on phase velocity, group velocity, backward waves, and dispersion and to show how these wave characteristics are displayed on the omega-beta diagram. Mathematical derivations are assumed to have been done prior to viewing the film, which concentrates on visualization of the concepts through animation and experiment.

WIRE FOR SOUND

10 min. or/1962/Contact:
Go behind the scenes at Western Electric and see the complex story of wire production. Starting with molten copper, this award-winning film

progresses through the mill operations, cable manufacturing, storage and installation. After a few introductory words, the whole story is told by spectacular color photography, accented by an exciting musical score.

YOUR CAREER AS AN ELECTRONICS TECHNICIAN

27 min./color/\$8.25/Contact: U. of I.
Discusses appropriate high-school courses for the person interested in becoming an electronics technician, various ways of obtaining further training, and the kinds of jobs open to well trained technicians.

ZONE MELTING

16 mm/45 min./color/1959/Contact: Bell
Describes a new method of ultra-purifying solids and controlling the distribution of impurities for solids. Prepared by William G. Pfann, the inventor of Zone Melting.

BIBLIOGRAPHY

*A Notebook of Films for Engineering
Education (Free)*

National Academy of Engineering
Commission on Education
2101 Constitution Avenue, N.W.
Washington, D.C. 20418

Air Force Film Directory

AFM 95-2
Volume II
Department of the Air Force
Washington, D.C. 20000

Catalog of Educational Films

University of Illinois
Champaign, Illinois 61820

Educators Guide to Free Films (Annual)

Educators Progress Service
Randolph, Wisconsin 53956

Learning Aids

Bell Telephone Company
Local Office

Navy Film Directory

Film Library
Department of the Navy
Great Lakes, Illinois 60088

Tektronix Film Catalog

Film Library
Tektronix, Inc.
Beaverton, Oregon 97005

ADDRESSES FOR FILM SOURCES

Autonetics
Autonetics Division
North American Rockwell Corporation Film Library
Public Relations Department
3370 Miraloma Avenue
Anaheim, California 92803

Bell
Bell System Business Office
(Consult your telephone directory for the office
nearest you)

Bell Labs
Bell Telephone Laboratories, Inc.
Film Library
Room 1F-108
Murray Hill, New Jersey 07971

Bray
Bray Studios, Inc.
729 7th Avenue
New York, New York 10036

Colburn
Colburn Associates, Inc.
1215 Washington Avenue
Wilmette, Illinois 60091

Conn. State Dept.
Connecticut State Department of Education
Room 355, Visual Aids Department
State Office Building
Hartford, Connecticut 06115

Coronet
Coronet Films
65 E. South Water Street
Chicago, Illinois 60601

DeVry
DeVry Technical Institute
4141 West Belmont
Chicago, Illinois 60641

DU Art
DU Art Film Laboratories, Inc.
U. S. Government Film Services
249 West 55th Street
New York, New York 10019

Education Dev. Center
Education Development Center
Film Librarian
39 Chapel Street
Newton Massachusetts 02160

Encyclopedia Britannica
Encyclopedia Britannica Education Corporation
425 North Michigan Avenue
Chicago, Illinois 60611

G. E.
General Electric Company
1 River Road
Schenectady, New York 12301

G.M.
General Motors Corporation
3044 W. Grand Boulevard
Detroit, Michigan 48202

Industrial Ed.
Industrial Education Films, Inc.
196 Nassau Street
Princeton, New Jersey 09540

Instrument Society
Instrument Society of America
Penn Sheraton Hotel
530 William Penn Place
Pittsburg, Pennsylvania 15219

IBM--N.Y.
International Business Machines
Film Activities
Department of Information
590 Madison Avenue
New York, New York 10022

IBM--K.
International Business Machines Corporation
Film Library
Department #957
Lexington, Kentucky 40507

Jet Propulsion Lab.
Jet Propulsion Laboratory
Photographic Services Film Library
4800 Oak Grove Drive
Pasadena, California 91103

LeRC
LeRC
NASA Lewis Research Center
Office of Educational Services
21000 Brookpart Road
Cleveland, Ohio 44135

McGraw-Hill
McGraw-Hill Book Company
Text Film Division
330 West 42nd Street.
New York, New York 10036

Modern Learning Aids
Modern Learning Aids
1212 Avenue of the Americas
New York, New York 10036

NASA
National Aeronautics and Space Administration
Headquarters
Code FAD
Washington, D. C. 20546

National Bureau Standards
National Bureau of Standards
Office of Technical Information and Publications
Washington, D. C. 20234

NCR
National Cash Register Company
Audio Visual Department
Marketing Services
Sugar Camp
Dayton, Ohio 45409

Reynolds
Reynolds Metals Company
Motion Picture Department
6603 West Broad Street
P. O. Box 2346
Richmond, Virginia 23218

Tektronix
Tektronix, Inc.
Film Library
Delivery Station 50/420
P. O. Box 500
Beaverton, Oregon 97005

U.S.A.F.
United States Air Force
AF Form 253C
USAF Central Audio-Visual Library
AF Audio-Visual Center
Norton AFB, California 92409

U.S.A.
United States Army
Signal Offices, Military
District of Washington
Washington, D. C. 20310

U.S.A.E.C.
United States Atomic Energy Commission
Sandia Laboratories, Chicago Operations Office
Office of Information
9800 South Cass Avenue
Argonne, Illinois 60439

U.S.N.
United States Navy
9th Naval District
Building 1
Great Lakes, Illinois 60088

U.S.O.E.
United States Office of Education
Washington, D. C.

U. of I.
University of Illinois
Visual Aids Service
Division of University Extension
Champaign, Illinois 61820

U. of Iowa
University of Iowa
Bureau of Audio Visual Instruction
Extension Division
Iowa City, Iowa 52240

U. of M.
University of Michigan
Audio Visual Education Center
416--4th Street
Ann Arbor, Michigan

W.S.U.
Washington State University
Visual Aids Department
Pullman, Washington 99163

Westinghouse
Westinghouse Electric Corporation
Film Division
No. 3, Gateway Center
Pittsburg, Pennsylvania 15201

SUPER 8 mm FILM LOOPS

ALTERNATING CURRENT THEORY

Animated Electronic Films
P.O. Box 2026
Eads Station
Arlington, Virginia 22202

1. The Undamped Oscillation
2. The Damped Oscillation
3. The RC Time Constant
4. The RL Time Constant
5. Series RL Circuits
6. Series RC Circuits
7. Series RLC Circuits, Part 1
8. Series RLC Circuits, Part 2
9. Parallel RL Circuits
10. Parallel RC Circuits
11. Parallel RLC Circuits
12. Parallel LC Circuits
13. Basic Transformer Action

BASIC ELECTRICITY

Animated Electronic Films
P. O. Box 2026
Eads Station
Arlington, Virginia 22202

1. Resistors in Series
2. Resistors in Parallel
3. Capacitor Construction and Actions
4. Inductance Principles
5. Inductor Construction and Actions
6. The RL Time Constant
7. The Undamped Oscillation
8. The Damped Oscillation
9. The RC Time Constant

CALCULUS

Harper & Row, Audiovisuals
2350 Virginia Avenue
Hagerstown, Maryland 21740

1. Taylor Series I
2. Taylor Series II
3. Newton's Method
4. Mean Value Theorems
5. Conic Sections

6. Conic Sections: Ellipse
7. Conic Sections: Hyperbola
8. Conic Sections: Parabolas
9. Indeterminate Forms
10. The Function of $x^n \sin(x)$

ELECTROMAGNETISM

Sales Promotion Department
Ealing Film Loops
2225 Massachusetts Avenue
Cambridge, Massachusetts 02140

and also available from

Harper & Row Audiovisuals
2350 Virginia Avenue
Hagerstown, Maryland 21740

1. The Magnetic Field
2. Monopoles and Dipoles
3. The Field from a Steady Current
4. Uniform and non-Uniform Fields
5. The Field as a Vector
6. Field-vs-Current
7. Field-vs-Distance
8. Field: The Force on a Current
9. Meters
10. Motors
11. The Concept of Changing Flux
12. Faraday's Law of Induction

ELECTROSTATICS*

Syracuse University
L. C. Smith College of Engineering
Syracuse, New York 13210
ATTENTION: W.R. LePage, Chairman

*Regular 8mm Loops

1. Electric Charge
2. Transfer and Distribution of Charge
3. Coulomb's Law - Variation of Force with Charge
4. Coulomb's Law - Variation of Force with Distance
5. Exercise Problems

Sales Promotion Department
Ealing Film Loops
2225 Massachusetts Avenue
Cambridge, Massachusetts 02140

also available from

Harper & Row Audiovisuals
2350 Virginia Avenue
Hagerstown, Maryland 21740

1. Introduction to Electrostatics
2. Insulators and Conductors
3. Electrostatic Induction
4. The Electroscopes
5. Charge Distribution:
The Faraday Ice-Pail Experiment
6. Charge Distribution:
Concentration and Point Discharge
7. The Van de Graaf Generator
8. The Photoelectric Effect
9. Capacitors and Dielectrics
10. Problems in Electrostatics

THE SLIDE RULE

University of Iowa
Bureau of Audio Visual Instruction
Extension Division
Iowa City, Iowa 52240

also available from

Sales Promotion Department
Ealing Film Loops
2225 Massachusetts Avenue
Cambridge, Massachusetts 02140

and

Harper & Row Audiovisuals
2350 Virginia Avenue
Hagerstown, Maryland 21740

1. Why It Works
2. Reading and Handling
3. Multiplication, C & D Scales
4. Division, C & D Scales
5. C I Scale
6. Squares, Cubes, and Roots
7. Two-Digit Practice
8. Three-Digit Practice

TRANSISTOR CIRCUITS

Animated Electric Films
P. O. Box 2026
Eads Station
Arlington, Virginia 22202

1. Transistor Characteristic Curves
2. Audio Voltage Amplifier
3. Direct Coupled Amplifier
4. Free Running Multivibrator
5. Tuned Collector Oscillator

TUBE CIRCUITS

Animated Electronic Films
P. O. Box 2026
Eads Station
Arlington, Virginia 22202

1. Diode-Detector
2. Full Wave Rectifier Power Supply
3. Tickler Coil Oscillator
4. Triode D.C. Load Line
5. Triode Transfer Characteristics
6. Triode Plate Characteristics
7. Triode Transconductance (Linear)
8. Triode Transconductance (Non-Linear)
9. Triode Amplification Factor (Linear)
10. Triode Amplification Factor (Non-Linear)
11. Triode Plate Resistance (Linear)
12. Triode Plate Resistance (Non-Linear)

APPENDIX C

SUGGESTED TEXTS AND BIBLIOGRAPHY

Starting on the opposite page is a listing of suggested textbooks and references for the technical courses of an Electronics Technology Curriculum. The addresses of the publishers are presented at the end of this listing. The last section of this Appendix C contains a bibliography.

SUGGESTED TEXTS AND REFERENCES

Included in this Appendix section are suggested text and references for circuit analysis area, electronics area, handbooks, mathematics, and physics. This list is by no means inclusive but rather a representation of those available for electronics technology at the time of this report.

Rather than repeating the addresses of publishers each time, a complete list is presented at the end of this section.

CIRCUIT ANALYSIS

- Babb, D.S., Resistive Circuits, International Textbook Co., 1968.
- Balabanian, Norman, Fundamentals of Circuit Theory, Allyn and Bacon, Inc., 1964.
- Balabanian, Norman & Bickart, Theodore, Electrical Network Theory, John Wiley & Sons, 1969.
- Boylestad, Robert, Introductory Circuit Analysis Charles E. Merrill, 1968.
- Carter, Robert C., Introduction to Electrical Circuit Analysis, Holt, Rinehart, & Winston, 1966.
- Close, Charles M., The Analysis of Linear Circuits, Harcourt, Brace, & World, 1966.
- Cutler, Phillip, Outline for DC Circuit Analysis, McGraw-Hill, 1968.
- Cutler, Phillip, and Hoover, Hardy, Electronic Circuit Analysis: Passive Networks, McGraw-Hill, 1960.
- Edminister, Joseph, Electric Circuits, Schaum's Outline, McGraw-Hill, 1965.
- Fishe, K.A. & Harter, J., Direct Current Circuit Analysis Through Experimentation, Technical Education Press, 1966.
- Friedland, B., Wing, O, and Ash, P., Principles of Linear Networks, McGraw-Hill, 1961.
- Jackson, H. W., Introduction to Electric Circuits, Prentice-Hall, 1970.
- Jensen, R. and Liberman, M., IBM Electronic Circuit Analysis Program, Prentice-Hall, 1968.
- Leach, Donald, Basic Electric Circuits, John Wiley & Sons, Inc., 1969.
- Mandl, Matthew, Fundamentals of Electric and Electronic Circuits, Prentice-Hall, 1969.
- Romanowitz, H. Alex, Electrical Fundamentals and Circuit Analysis, John Wiley & Sons, Inc., 1966.
- Romanowitz, H. Alex, Introduction to Electric Circuits, John Wiley & Sons, 1971.
- Speigel, Murray, LaPlace Transforms, Schaum's Outline, McGraw-Hill, 1965.
- Stanley, W., Transform Circuit Analysis for Engineering and Technology, Prentice-Hall, 1968.
- Strum, Robert and Ward, John, LaPlace Transform Solution of Differential Equations, Prentice-Hall, 1968.
- Temes, Lloyd, Electronic Circuits for Technicians, McGraw-Hill, 1970.
- Van Valkenburg, M., Network Analysis, Prentice-Hall, 1965.
- Zeines, Ben, Introduction to Network Analysis, Prentice-Hall, 1967.

ELECTRONICS

- Angelo, E.J., Electronic Circuits, McGraw-Hill, 1964.
- Angelo, James., Electronics: BJT's, FET's and Microcircuits, McGraw-Hill, 1969.
- Babb, Daniel S., Pulse Circuits: Switching and Shaping, Prentice-Hall, 1964.
- Bartee, Thomas C., Digital Computer Fundamentals, McGraw-Hill, 1966.
- Benedict, R., Electronics For Engineers and Scientists, Prentice-Hall; 1967.
- Branson, Lane, Introduction To Electronics, Prentice-Hall, 1967.
- Brazeo, James, Semiconductor and Tube Electronics, Holt, Rinehart, & Winston, 1968.
- Bryan, G.T., Control Systems for Technicians, Hart Publishing Company, 1967.
- Chow, Woo F., Principles of Tunnel Diode Circuits, John Wiley & Sons, 1964.
- Cowles, Laurence G., Transistor Circuits and Applications, Prentice-Hall, 1968.
- Cutler, Phillip, Semiconductor Circuit Analysis, McGraw-Hill, 1964.
- Cutler, Phillip, Electronic Circuit Analysis, Volume 2-Active Networks, McGraw-Hill, 1967.
- Doyle, John M., Pulse Fundamentals, Prentice-Hall, 1963.
- Doyle, John, Thin-Film and Semiconductor Integrated Circuitry, McGraw-Hill, 1966.
- Durling, Allen E., An Introduction to Electrical Engineering, The Macmillan Company, 1969.
- Evans, Walter, Introduction to Electronics, Prentice-Hall, 1962.
- Freedman, Rice, & McGinty, Basic Electronic "Autotest", Prentice-Hall, 1965.
- Gillie, Angelo C., Pulse and Logic Circuitry, McGraw-Hill, 1968.
- Gray, Paul & Searle, Campbell, Electronic Principles-Physics, Models, and Circuits, John Wiley & Sons, 1969.
- Harris, Gray, & Searle, Digital Transistor Circuits, John Wiley & Sons, 1966.
- Herrick, Clyde, Unified Concepts of Electronics, Prentice-Hall, 1970.
- Herrick, Clyde, Introduction to Electronic Communications, Charles E. Merrill, 1969.
- Hibberd, R. G. Integrated Circuits: A Basic Course for Engineers and Technicians, McGraw-Hill, 1969.
- Jensen, Randall & Liberman, Mark, IBM Electronic Circuit Analysis Program, Prentice-Hall, 1968.
- Keonjian, Edward, Microelectronics: Theory, Design, and Fabrication, McGraw-Hill, 1963.
- Khambata, A.J., Introduction to Integrated Semiconductors, John Wiley & Sons, 1963.
- Kidwell, Walter M., Electrical Instruments & Measurements, McGraw-Hill, 1969.
- Leach, Donald, Transistor Circuit Measurements, McGraw-Hill, 1968.
- Lenert, Louis, Semiconductor Physics, Devices, and Circuits, Charles E. Merrill Publ. Co. 1968.
- Levine, Sumner N., Principles of Solid State Microelectronics, Holt, Rinehart, & Winston, 1964.
- Levin, Herman, Introduction to Computer Analysis: ECAP For Scientist and Engineers, Prentice-Hall, 1970.
- Littauer, Raphael, Pulse Electronics, McGraw-Hill, 1965.
- Lowenberg, Edwin, Electronic Circuits: Schaum's Outline, McGraw-Hill, 1967.
- Lurch, E.N., Fundamentals of Electronics, John Wiley & Sons, 1966.
- Malvino, Albert, Electronic Instrumentation, Fundamentals, McGraw-Hill, 1967.
- Malvino, Albert P., Transistor Circuit Approximations, McGraw-Hill, 1968.
- Malvino, Albert & Leach, Donald, Digital Principles and Applications, McGraw-Hill, 1969.
- Manasse, Akins & Gray, Modern Transistor Electronics Analysis & Design, Prentice-Hall, 1967.
- Marcus, Abraham, Electronics For Technicians, Prentice-Hall, 1969.

Mitchell, Brinton, Semiconductor Pulse Circuits with Experiments, Holt, Rinehart & Winston, 1967.

Millman, Jacob & Taub, Herbert, Pulse, Digital and Switching Waveforms, McGraw-Hill, 1965.

Millman, Jacob & Holkias, Christos, Electronic Devices and Circuits, McGraw-Hill, 1967.

New York Institute of Technology, A Programmed Course in Basic Electronics, McGraw-Hill, 1964.

New York Institute of Technology, A Programmed Course in Basic Transistors, McGraw-Hill, 1964.

Oppenheimer, Samuel, Semiconductor Logic & Switching Circuits, Charles E. Merrill Publ. Co., 1966.

Riddle, R.L. & Ristenbatt, M., Transistor Physics and Circuits, Prentice-Hall, 1966.

Romanowitz, H. Alex, and Puckett, Russell, Introduction to Electronics, John Wiley & Sons, 1968.

Ryder, John D., Electronic Fundamentals and Applications, Prentice-Hall, 1970.

Schuster, Donald, Basic Electronic Test Equipment: Programmed Introduction, McGraw-Hill, 1968.

Stanton, William A., Pulse Technology, John Wiley & Sons, 1964.

Summer, Steven, Electronic Sensing Controls, Chilton Book Co., 1969.

Texas Instruments, Transistor Circuit Design, McGraw-Hill, 1963.

Tocci, Ronald, Fundamentals of Electronic Devices, Charles E. Merrill Publ. Co., 1970.

Turner, James, Digital Computer Analysis, Charles E. Merrill Publ. Co., 1968.

Wilcox, Glade, Electronics For Engineering Technology, Allyn & Bacon, 1969.

Zeines, Ben, Electronic Communications Systems, Prentice-Hall, 1970.

PROGRAMMED TEXTBOOKS

Dunn, Walter L., Introduction to Digital Computer Problems Using Fortran IV: A Self-Instructional Programmed Text, McGraw-Hill, 1969.

Englander, Herman & Saxon, James, The Slide Rule: A Self-Instructional Programmed Manual, Prentice-Hall, 1966.

Farina, Mario V., Fortran IV Self-Taught, Prentice-Hall, 1966.

Federal Electric Corp., Mathematics For Electronics: A Self-Instructional Programmed Manual, Prentice-Hall, 1965.

Federal Electric Corp., Special Purpose Transistors: A Self-Instructional Programmed Manual, Prentice-Hall, 1966.

Hauck, W. and Reigh, M., Brief Algebra Review Manual: A Program for Self-Instruction, McGraw-Hill, 1966.

Hoernes, G. and Heilweil, M., Introduction to Boolean Algebra and Logic Design-A Program for Self-Instruction, McGraw-Hill, 1964.

Mittelstadt, W.S., Basic Slide Rule Operation, A Program for Self-Instruction, McGraw-Hill, 1964.

New York Institute of Technology, A Programmed Course in Basic Electricity, McGraw-Hill, 1970.

New York Institute of Technology, A Programmed Course in Basic Transistors, McGraw-Hill, 1954.

New York Institute of Technology, A Programmed Course in Basic Electronics, McGraw-Hill, 1964.

New York Institute of Technology, Algebra and Trigonometry: A Programmed Course with Applications, McGraw-Hill, 1970.

Philco Technological Center, Electronic Trouble-shooting: A Self-Instructional Programmed Manual, Prentice-Hall, 1966.

RCA Institute, Basic Electronics "Autotest"-A Programmed Course in Circuits, Prentice-Hall, 1965.

RCA Service Company, Fundamentals of Transistors: A Programmed Text, Prentice-Hall, 1966.

Selby, Peter, Logarithms Self-Taught (Programmed), McGraw-Hill, 1964.

Strum, Robert & Ward, John, The Signal Flow Graph In Linear Systems Analysis: A Programmed Text, Prentice-Hall, 1968.

Strum, Robert & Ward, John, LaPlace Transform Solution of Differential Equations: A Programmed Text, Prentice-Hall, 1968.

Tektronix, Analysis of Passive Networks,
Volume 1: DC Equivalent Circuits
Volume 2: AC Theory
Volume 3: Integrators

Volume 4: Differentiators
Volume 5: Network Applications

Tektronix, Semiconductor Diodes and Transistors,
Volume 1: Basics
Volume 2: Diode Devices
Volume 3: Transistors
Volume 4: Circuits I
Volume 5: Circuits II
Volume 6: Reference for Volumes 1, 2 and 3
Volume 7: Reference for Volumes 4 and 5

HANDBOOKS

Arnold, J., The Complex Slide Rule Handbook: Principles and Applications, Prentice-Hall, 1962.

Bukstein, Edward, Industrial Electronic Circuits Handbook, Howard W. Sams, 1963.

Carröll, John, Design Manual for Transistor Circuits, McGraw-Hill, 1961.

CRC Standard Mathematical Tables, Chemical Rubber Publishing Company, 1968.

Instrument Engineers Handbook, Volume I & II, Chilton, 1970.

International Telephone and Telegraph Corp., Reference Data for Radio Engineers, American Book-Stratford Press Incorporated, 1967.

Korn, Gramino, Basic Tables in Electrical Engineering, McGraw-Hill, 1964.

Lenk, John D., Handbook of Oscilloscopes: Theory and Application, Prentice-Hall, 1968.

Lenk, John D., Practical Semiconductor Data Book for Electronic Engineers and Technicians, McGraw Hill, 1969.

Lenk, John D., Handbook of Practical Electronic Tests and Measurements, Prentice-Hall, 1969.

Lenk, John D., Handbook of Electronic Charts, Graphs, and Tables, Prentice-Hall, 1970.

Mandl, Matthew, Directory of Electronic Circuits with a Glossary of Terms, McGraw-Hill, 1966.

Norton, Harry, Handbook of Transducers for Electronic Measuring Systems, Prentice-Hall, 1969.

Pullen, Keats, Handbook of Transistor Circuit Design, Prentice-Hall, 1961.

Thomas, Harry, Handbook of Pulse Digital Devices, Prentice-Hall, 1970.

Thomas, Harry, Handbook for Electronic Technicians and Technicians, Prentice-Hall, 1965.

Thomas, Harry, Handbook of Transistors, Semiconductors, Instruments and Microelectronics, McGraw-Hill, 1968.

Thomas, Harry and Clarke, Carole, Handbook of Electronic Instruments and Measurement Techniques, Prentice-Hall, 1967.

Turner, Rufus, Diode Circuits Handbook Howard W. Sams, 1963.

MATHEMATICS

Adams, L.J., Applied Calculus, John Wiley & Sons, 1963.

Amramowitz, Milton, Handbook of Mathematical Functions, U.S. Government Printing Office, 1965.

Andrews, Allan, Practice Problems in Electronics Calculations, Howard W. Sams and Co., Inc. 1964.

Andrews, Allan, Electronics Math Simplified, Vol. I, Howard W. Sams and Company, Inc., 1964.

Andrews, Allan, Electronics Math Simplified, Vol. II, Howard W. Sams and Company, Inc., 1964.

- Andris, Paul G., Miser, Hugh J., Reingold, Haim, Basic Mathematics for Science and Engineering, John Wiley & Sons, 1965.
- Blakely, Walter, Calculus for Engineering Technology, John Wiley & Sons, 1968.
- Cairns, Edward, Mathematics for Applied Engineering, Prentice-Hall, 1967.
- Cooke, Nelson, Basic Mathematics for Electronics, McGraw-Hill, 1970.
- Crowhurst, Norman H., Mathematics for Electronics Engineers and Technicians, Howard W. Sams and Co., 1964.
- Dodes, Irving, I.B.M. 1620 Programming for Science and Mathematics, Hayden Book Co., 1963.
- Evans, Paul L., Mathematics for Electronics Technicians, John Wiley and Sons, 1966.
- Gillie, A. C., Binary Arithmetic and Boolean Algebra, McGraw-Hill, 1965.
- Herrick, Clyde, Mathematics For Electronics, Charles E. Merrill, 1967.
- I.T.T. Federal Electric Corporation, Mathematics for Electronics, Prentice-Hall, 1965.
- Juszli, Frank, Analytic Geometry and Calculus, Prentice-Hall, 1960.
- Juszli, Frank, & Roger, Charles Jr., Elementary Technical Mathematics, Prentice-Hall, 1969.
- Juszli, Mahler, & Reid, Basic Mathematics For Electronics, Prentice-Hall, 1967.
- Lytel, Allen, Calculus for Electronics Technicians, D. Van Nostrand Co., 1964.
- Maidel, George F., Basic Mathematics for Television and Radio, Prentice-Hall, 1953.
- Paul, Richard & Shaenel, Leonard, Contemporary Technical Mathematics With Calculus, Prentice-Hall, 1970.
- Paul, Stephen, Topics in Advanced Mathematics for Electronics Technology, John Wiley & Sons, 1966.
- Person, R. B., Elements of Mathematics, John Wiley & Sons, 1966.
- Placek, R. J. Technical Mathematics with Calculus, Prentice-Hall, 1967.
- Rice, Harold S., & Knight, Raymond M., Technical Mathematics with Calculus, McGraw-Hill, 1966.
- Rice, Harold A., Technical Mathematics; Exercises, Problems, Diagrams, Tables, McGraw-Hill, 1963.
- Scade, Samuel, Mathematics for Technical and Vocational Schools, John Wiley & Sons, 1965.
- Shere, Waris and Love, Gordon, Applied Mathematics for Engineering and Science, Prentice-Hall, 1969.
- Singer, Bertrand B., Basic Mathematics for Electricity and Electronics, McGraw-Hill, 1965.
- Washington, Allyn J., Basic Technical Mathematics with Calculus, Addison-Wesley Co., 1964.
- Wolf, O. and Lattner, C. G., Mathematics for Electronics, ITT Federal Electric Corp., Prentice-Hall, Inc., 1965.
- Westlake, John & Noden, Gordon, Applied Mathematics for Electronics, Prentice-Hall, 1968.

PHYSICS

- Beiser, Arthur, Concepts of Modern Physics, McGraw-Hill
- Benumof, Reuben, Concepts in Physics, Prentice-Hall
- Companion, Audrey L., Chemical Bonding, McGraw-Hill
- Division of Technical and Vocational Education, Instrumentation Technology, (OE-80033) U.S.O.E.
- Duquesne, Maurice, Matter and Antimatter, Harper and Bros.
- Feynmann, Leighton and Sands, Feynmann Lectures on Physics, Addison-Wesley.
- Ford, Kenneth W., The World of Elementary Particles, Ch. 3, Blaisdell Publishing.
- Gottlieb, Barbuny and Emmerich, Seven States of Matter, Walker Publishing.
- Gray and Coutts, Man and His Physical World, 4th Ed., D. Van Nostrand Co., Inc.
- Halliday and Resnick, Physics, Part I, Part II, 2nd Ed., John Wiley & Sons, Inc.

Harnwell and Legge, Physics: Matter, Energy and the Universe, Reinhold Publishing Co.

Holt and Roller, Foundations of Modern Physical Science, Addison-Wesley,

Hooke, Robert, Introduction to Scientific Inference, Holden-Day, Inc.

Joseph, Pomeranz, Prince and Sacher, Physics for Engineering Technology, John Wiley & Sons, Inc.

Kaempffer, The Elements of Physics, Blaisdell Publishing Co.

Melissinos, Adrian C., Experiments in Modern Physics, Academic Press, Inc.

Michels, Correll, and Patterson, Foundations of Physics, D. Van Nostrand Company.

PUBLISHERS ADDRESSES

Academic Press
115 5th Avenue
New York, New York 10003

Addison-Wesley Publishing Co., Inc.
Reading, Mass. 01867

Allyn & Bacon, Inc.
Rockleigh, New Jersey 07647

American Book-Stratford Press Incorporated
55 Fifth Avenue
New York, New York 10003

Blaisdell Publishing Co.
275 Wyman Street
Waltham, Mass. 02154

Charles E. Merrill Publishing Co.
1300 Alum Creek Drive
Columbus, Ohio 43216

Chemical Rubber Publishing Co.
221 Park Avenue South
New York, New York 10003

Chilton
401 Walnut Street
Philadelphia, Pennsylvania 19106

Doubleday and Company, Inc.
501 Franklin Avenue
Garden City, New York 11531

D. Van Nostrand Co., Inc.
120 Alexander Street
Princeton, New Jersey 08540

Harcourt, Brace and World, Inc.
757 Third Avenue
New York, New York 10017

Harper & Brothers
New York, New York 10017

Pierce, John R., Quantum Electronics, Doubleday and Co.

Rense, William A., Physical Science, Blaisdell Publishing Co.

Rosen, Siegfried and Dennison, Concepts in Physical Science, Harper and Row.

Sears and Zemansky, University Physics, Addison-Wesley Publishing Company.

Smith and Cooper, Elements of Physics, McGraw-Hill Book Co.

Stevenson and Moore, Theory of Physics, McGraw-Hill Book Co.

Towne, Dudley H., Wave Phenomena, Addison-Wesley Publishing Company.

Harper & Row.
49 E. 33rd Street
New York, New York 10016

Hayden Book Co.
116 W. 14th Street
New York, New York 10011

Holden-Day, Inc.
500 Sansome Street
San Francisco, California 94111

Holt, Rinehart, & Winston
383 Madison Avenue
New York, New York 10017

Howard W. Sams & Co., Inc.
4300 West 62nd Street
Indianapolis, Indiana 46268

International Textbook Company
Scranton, Pennsylvania 18515

John Wiley & Sons
605 Third Avenue
New York, New York 10016

McGraw-Hill Book Co.
330 West 42nd Street
New York, New York 10036

Prentice-Hall Book Co.
Englewood Cliffs, New Jersey 07632

Reinhold Publishing Corp.
430 Park Avenue
New York, New York 10022

Technical Education Press
P. O. Box 342
Seal Beach, California 90740

The Macmillan Company
866 Third Avenue
New York, New York 10022

Walker Publishing Co.
New York, New York

SELECTED BIBLIOGRAPHY

The following references have been selected from the many books, articles, and papers that have been consulted throughout the project activities. Many other references have been listed in the body of the report and in the section of suggested references and textbooks.

- Alpert, D. and Bitzer, D. L. "Advances in Computer-based Education." Science. March 29, 1970.
- Bacon, C. and Reid, K. Jr. "Audio-Tape Tutorial Methods in Introductory Engineering Systems." Presented at annual meeting of American Society for Engineering Education, Pennsylvania State University, University Park, Pa., June 23-26, 1969.
- Bitzer, D., Blomme, R., Sherwood, B., and Tenczar, P. "The Plato System and Science Education." Urbana, Illinois: Computer-based Education Research Laboratory, University of Illinois (August, 1970).
- Bitzer, D. and Skaperdas, D. The Design of an Economically Viable Large-Scale Computer Based Education System. Urbana, Illinois: Computer-based Education Research Laboratory, University of Illinois (August, 1970).
- Bowen, Charles R. "Technical Manpower-- America's Critical Resource." Presented at ATEA Regional Conference, Troy, New York, October 24, 1969.
- Commission on Education of the National Academy of Engineering. Report of the Instructional Technology Committee. Educational Technology in Higher Education: The Promises and Limitations of ITV and CAI. Washington, D.C. (September, 1969).
- Computers in Undergraduate Education: Mathematics, Physics, Statistics, and Chemistry. Proceedings of a conference sponsored by the National Science Foundation, University of Maryland, College Park, Maryland, December, 1967.
- Creative Teaching. 3 M Company, Visual Products Division. St. Paul, Minnesota: 3-M Education Press, 1966.
- Dickson, William G. "Planning Curriculum Materials: A Publisher's Viewpoint." American Vocational Journal, (March, 1967).
- Educational Media in Vocational and Technical Education. A report of a National Seminar of the Center for Research and Leadership Development in Vocational and Technical Education, 1967.
- of the Center for Research and Leadership Development in Vocational and Technical Education, 1967.
- Electronic Power Technology - A Suggested Two-Year Post-High School Program, sponsored by the Illinois Board of Vocational Education and the University of Illinois, Engineering Technology Series No. 5, 1970.
- Electronics Technology - A Suggested Two-Year Post-High School Program, sponsored by the Illinois Board of Vocational Education and the University of Illinois, Engineering Technology Series No. 2, 1964.
- Electronics Technology - A Suggested Two-Year Post-High School Six-Quarter Program, sponsored by the Illinois Board of Vocational Education and the University of Illinois, Engineering Technology Series No. 3, 1967.
- Engineering Manpower Commission. Engineers Joint Council. Salaries of Engineering Technicians. New York, N.Y., (March 1970).
- Experimentation with Computer-Assisted Instruction in Technical Education? Semi-annual Progress Report of the Computer Assisted Instruction Laboratory, The Pennsylvania State University, University Park, Pa., June 30, 1967.
- "Factors to Consider in Planning Technical Education Facilities." Industrial Arts and Vocational Education--Technical Education Supplement, Vol. 59, No. 3, March, 1970.
- A Follow-Up Study of Five Summer Institutes for Engineering Technology Teachers. J. S. Dobrovolsky and T. C. Hartley, Department of General Engineering, University of Illinois, Urbana, Illinois, August, 1968.
- A Guide for Wiley Authors in the Preparation of Auto-Instructional Programs. 3rd. ed. New York, N.Y.: John Wiley & Sons, 1967.

- "How to Prepare an Audio-Tutorial Lesson." Presented at Effective Teaching Institute for Engineering Teachers, Purdue University, Lafayette, Indiana, October 31, 1969.
- Koen, Billy V. "Self-Paced Instruction for Engineering Students." Engineering Education, (March, 1970).
- Lindenlaub, John C. "Audio-Tutorial Instruction--What, Why, and How?" Engineering Education, (March, 1970).
- McGraw, James L. "The Bachelor of Technology--A Technical Manpower Solution." Presented at American Power Conference, Chicago, Illinois, April 22, 1970.
- Mager, Robert F. Preparing Objectives for Programmed Instruction. Palo Alto, California: Fearon Publishers.
- "Mathematics for The Majority: A System of Instruction for Technical Mathematics." MATC-Mathematics Project, Milwaukee Area Technical College, Milwaukee, Wisconsin.
- Milveny, John. "Appraising Oscilloscope Specifications and Performance." Electrical Design News, (February, 1969).
- "The Need for Articulation of Two- and Four-Year Technical Training Programs." Science Education News, December, 1968.
- Novak, Joseph D. "Problems and Pitfalls in Audio-Tutorial Methods." Presented at Effective Teaching Institute for Engineering Teachers, Purdue University, Lafayette, Indiana, October 31, 1969.
- Perlberg, Arye, and O'Bryant, David. "The Use of Video-Tape Recording and Micro-Teaching Techniques to Improve Instruction on the High- α Education Level." University of Illinois, Urbana, Illinois.
- "Proceedings...National Clinic on Technical Education." Sponsored by American Technical Education Association and USOE, Miami Beach, Florida, April 22-24, 1970.
- Producing Slides and Filmstrips. 3rd. ed., 2nd printing, Eastman Kodak Company, 1969.
- Schoenhals, Neil L. "The A-V Hardware is Here...But Where's the A-V Software?" Industrial Arts and Vocational Education (June, 1969).
- "Science Based Technical Education in the American Educational System." Jerry S. Dobrovolny, Delivered at the Symposium on Science Education As It Relates to Technical Education, Dallas, Texas, December 29, 1968.
- "Science Based Technical Education in the American Educational System," Science Education as it Relates to Technical Education. AAAS Misc. Pub. 69-5, May 1969.
- "Staff Qualifications for Technical Education Programs." Industrial Arts and Vocational Education--Technical Education Supplement, Vol. 59, No. 1, January, 1970.
- "Staff Requirements for Community College Technical Education Programs." Jerry S. Dobrovolny, delivered at the Work-Study Conference on Pre-Industrial Teaching Curriculum for Community-Junior Colleges, Western Michigan University, Kalamazoo, Michigan, May 12-16, 1969.
- Technical Education for the Seventies: A Report of the National Clinic on Technical Education Programs Under the Vocational Education Act of 1963. Jerry S. Dobrovolny, St. Louis, Missouri, March 26, 27, 28, 1969.
- Technical Education Yearbook. Ann Arbor, Michigan: Prakken Publications, Inc. 1967-1968.
- "Unique Characteristics of a Curriculum in Engineering Technology." Industrial Arts and Vocational Education--Technical Education Supplement, Vol. 58, No. 9, November, 1969.
- "The Use of Video Tape Recorders and Micro-Teaching Techniques to Improve Instruction in Vocational-Technical Programs in Illinois." Final report of The Department of Vocational and Technical Education, University of Illinois, Urbana, Illinois.
- "What is Technical Education?" Industrial Arts and Vocational Education--Technical Education Supplement, Vol. 58, No. 7, September, 1969.