

DOCUMENT RESUME

ED 108 874

SE 019 041

AUTHOR Hendren, Travis E.; Bryant, C. Douglas
 TITLE Suggestions and Procedures for Developing Teaching-Learning Stations. Revised.
 INSTITUTION North Carolina State Dept. of Public Instruction, Raleigh.
 PUB DATE Jul 74
 NOTE 68p.; Listed as Appendix F of SE 019 043; For related documents see, SE 019 042 and 043

EDRS PRICE MF-\$0.76 HC-\$3.32 PLUS POSTAGE
 DESCRIPTORS Conservation Education; *Educational Programs; Elementary Secondary Education; Environment; *Environmental Education; *Field Instruction; *Instructional Materials; Natural Resources; *Outdoor Education; Program Planning; Recreation; Sciences; Teaching Guides
 IDENTIFIERS Learning Stations; Teaching Stations

ABSTRACT

This booklet is a collection of outlines for various teaching-learning stations which were developed by 21 teachers during a three-week institute held in 1972 at Barnardsville, North Carolina. The purposes for such stations, which can be developed inexpensively by students and teachers on school property, are: (1) to create outdoor and environmental awareness, (2) to create outdoor recreation and environmental sensitivity, (3) to provide occupational exploration, and (4) to provide occupational training. Twenty-nine stations are included in the booklet. Each station outline includes: (1) title of the teaching-learning station; (2) description of the station; (3) rationale; (4) requirements for land, equipment, facilities, and time for development; (5) resources; and (6) Future Farmer of America and Supervised Occupational Experience uses. Stations such as a nature trail, soil profile, weather station, fish pond, and plant and insect display are included. Completing the booklet are various lists, including lists of related books, magazines and booklets, slide sources, film sources, and resource agencies. (TK)

 * Documents acquired by ERIC include many informal unpublished *
 * materials not available from other sources. ERIC makes every effort *
 * to obtain the best copy available. nevertheless, items of marginal *
 * reproducibility are often encountered and this affects the quality *
 * of the microfiche and hardcopy reproductions ERIC makes available *
 * via the ERIC Document Reproduction Service (EDRS). EDRS is not *
 * responsible for the quality of the original document. Reproductions *
 * supplied by EDRS are the best that can be made from the original. *

ED108874

U S DEPARTMENT OF HEALTH,
EDUCATION & WELFARE
NATIONAL INSTITUTE OF
EDUCATION

THIS DOCUMENT HAS BEEN REPRO-
DUCED EXACTLY AS RECEIVED FROM
THE PERSON OR ORGANIZATION ORIGIN-
ATING IT. POINTS OF VIEW OR OPINIONS
STATED DO NOT NECESSARILY REPRESENT
OFFICIAL NATIONAL INSTITUTE OF
EDUCATION POSITION OR POLICY.

SUGGESTIONS

and PROCEDURES

for DEVELOPING

TEACHING-LEARNING STATIONS

OUTDOOR RECREATION and APPLIED ECOLOGY I - 7060

OUTDOOR RECREATION and APPLIED ECOLOGY II 7061

DIVISION OF OCCUPATIONAL EDUCATION

AGRICULTURAL EDUCATION SECTION

DEPARTMENT OF PUBLIC INSTRUCTION

RALEIGH, NORTH CAROLINA

JULY 1972

REVISED: FEBRUARY 1973

REVISED: JULY 1974

INTRODUCTION

It is the consensus of opinion of everyone that had an input into the development of the "OUTDOOR RECREATION AND APPLIED ECOLOGY" curriculum: teachers, administrators, directors, consultants, and program coordinator, that the most effective means of student learning and involvement would be through the use of TEACHING-LEARNING STATIONS. The curriculum is intentionally devised to get most of the teaching-learning activities out of the classroom and into the out-of-doors. We are convinced that the best method to do this is through the development of TEACHING-LEARNING STATIONS, either on the school campus or nearby, so that learning experiences may be live and real. We believe that the best way to learn is still "Learning To Do By Doing", which has been the means used by vocational agriculture for more than 50 years.

It is also an objective of the "Outdoor Recreation and Applied Ecology" program to involve resource people (community, state, and federal) in the teaching-learning phase, therefore, this was taken into consideration in the planning of these TEACHING-LEARNING STATIONS.

With the above guidelines in mind, the twenty-one (21) teachers (16 vocational agriculture and 5 science), representing the eight Demonstration School Centers and the alternate Centers, were involved in a special inservice education institute held at Tom Brown FFA Camp at Barnardsville, N. C. 12-29 June 1972. Working in Groups and ecology, step-by-step procedures were devised for the development of the TEACHING-LEARNING STATIONS which are found in this publication. In order to standardize the stations the following format was used:

- I. TITLE OF TEACHING-LEARNING STATION
- II. DESCRIPTION OF THE STATION
- III. RATIONALE
- IV. REQUIREMENTS
 - A. Land
 - B. Equipment
 - C. Facilities
 - D. Time for Development
- V. RESOURCES
- VI. FFA AND SOE USES

We realize that these TEACHING-LEARNING STATIONS will vary with the geographical location of the school and also that other stations in addition to these we are suggesting may be developed. It is highly recommended that students be involved in the selection of STATIONS, the setting priority in developing them, and that they be involved in the actual process of STATION development or construction. It is further suggested that other occupational program areas; ie, carpentry, construction, bricklaying, etc. be involved in STATION construction giving them live project experience.

Coordination and cooperation with other instructional programs (science, math, social studies, language arts, etc.) in the use of these STATIONS is highly recommended. Instructional media persons should also be involved and may offer teacher another excellent program resource. Student enrichment experiences

should result from team teaching efforts. The TEACHING-LEARNING STATIONS should also be available for use of Elementary Middle School and Junior High School students and the vocational agriculture teacher should help in-service these teachers so they can effectively use the STATIONS when they are not being used by the high school programs. "Outdoor Recreation and Applied Ecology" students may be effectively trained and used as Assistant Instructors and Guides when other groups of students are using the STATIONS.

Some of the broad purposes of the TEACHING-LEARNING STATIONS are:

1. To create outdoor and environmental awareness.
2. To create outdoor recreation and environmental sensitivity.
3. To provide occupational exploration.
4. To provide occupational training.

Special emphasis should also be given to the four FFA Proficiency Awards pertaining to the general area of outdoor recreation and ecology:

1. Outdoor Recreation
2. Soil, Water and Air Management
3. Wildlife Management
4. FFA Chapter Safety

It is hoped that through the development and use of these TEACHING-LEARNING STATIONS, students may be sensitized with the need for and the challenge of employment opportunities in the areas of outdoor recreation and ecology.

The first revision of this publication was made in February 1973 and the second during a Teacher Inservice Workshop held on the campus at North Carolina State University during July 1974. Teachers participating and helping with this revision were:

Bob Goodson, Carl DeBrew, James Wilburn, Alton Wilson, John Wells, Donald Vestal, Decatur Jones, Roy Eubanks, Neal Brown, J. W. Busick, Fred Bailey, and Steve Matthis.

All Teaching-Learning Stations were revised and six new stations added for a total of twenty-nine now covered in this publication.

It is hoped that these materials will be of assistance in helping teachers plan and develop these Stations.

C. V. Tart, Chief Consultant Agri. Education
 Travis E. Hendren, Consultant Occ. Programs
 M. O. Phillips, Curriculum Consultant

Division of Occupational Education
 State Department of Public Instruction
 Raleigh, N. C. 27611

TEACHING-LEARNING STATIONS
IN
OUTDOOR RECREATION AND APPLIED ECOLOGY

By: Dr. Douglas Bryant

There is nothing new in the concept that youth and adults can learn in the out-of-doors. The history of public education in America is rich with attempts to provide real and meaningful outdoor learning situations for students and teachers. One author states that the outdoor curriculum is as significant a step as Horace Mann's free public school movement.¹

Previous attempts reported in the literature to develop the outdoor theme to learning in school has unfortunately excluded mention of vocational teachers. Thus in the past, claims have been made that students learn best when their environment is a concern in the learning process. That is, students learn subject matter in biological sciences, English, Mathematics, etc. best when elements of the environment besides the four walls of the classroom are introduced into the learning process. Administrators who give leadership to such a concern and teachers who really broaden students' learning environments into the out-of-doors become concerned with more than the three-R's. They introduced other R's, such as; Responsibility, Realibility, Resourcefulness; Recreation, Reality, and Ruggedness. As one author explained, "functional outdoor undertakings call for and justify continuous emphasis in English, mathematics, science, health, safety, physical training, creative arts, recreation and social science."²

To the above, the program in outdoor recreation and applied ecology in eight demonstration schools in North Carolina adds the emphasis of occupational education. Talk today of the five day week adds greatly to the concept of leisure time and with this development enters a growth in employment opportunities. This is what is new in the North Carolina version of an outdoor curriculum - an emphasis upon career opportunities.

The development of the program where a vocational educator is a key participant will expose students to resource people who are not only keenly

¹Vinehall, William Gould, The Outdoor Schoolroom For Outdoor Living, Boston University, 1952, P. 3.

²Op. Cit.

aware of the subject matter of their field - but are also very much aware of what people do in the jobs they hold in today's society. To illustrate further it may be said that a nature trail is important because of the plant growth elements it possesses, but it is even more important to learners when they can consider that many people perform a life's work (with pay) in activities relating to what can be observed and experienced in the trail. There are scientists, writers, lecturers, engineers, technicians, teachers, and many other occupations related to what the eye can see in a nature trail or land laboratory.

Teaching-Learning Stations

The following teaching-learning stations were developed during a three week institute at Tom Brown FFA Camp in Barnardsville, N. C. The resource persons who brought various aspects of such a program to the group, each contributed to the development of the learning stations. It was recognized from the beginning that each school setting as a demonstration center would be different and would develop its program around the facilities available. The following general guidelines were developed at the institute:

1. An advisory committee consisting of membership of school and community leaders should be organized early in the development of the program.
2. A plan for utilizing the school lands most effectively should be developed in cooperation with all who are to use the facility as a learning resource.
3. Appropriate resource people should assist in the development of teaching-learning stations.
4. The vocational agriculture teacher teaching the course "Outdoor Recreation and Applied Ecology" and his students assume responsibility for coordinating and developing teaching-learning stations.
5. The course is Outdoor Recreation and Applied Ecology should encourage FFA and Supervised Occupational Experiences for the students enrolled in the course. A few examples of such involvement are:
 - a) FFA
 1. Participation in FFA Contests beyond the local chapter level including face-to-face contests.
 2. Development of local awards programs not covered by State programs-of-work.
 3. Utilizing students as guides for other students when resources are used.

4. Involve students as assistant instructors at Teaching-Learning Stations.

b) Supervised Occupational Experience

Ample opportunity is envisioned for students to gain exploratory and/or actual work experience in areas related to study either on the school project itself or in community resources available in the community.

Some examples are:

- ° a riding stable
- ° a camp ground (private, state, etc.)
- ° a sporting goods store
- ° a golf course
- ° a swimming pool
- ° a fishing resort establishment
- ° a hunting lodge
- ° with workers in agencies (ie., Game Protectors, Soil Conservation Service, Forest Ranger, etc.)
- ° boat marina

In addition to this type of involvement in Supervised Occupational Experience, we believe that some students and their parents may choose to alter their land resources to a recreational purpose. For example, a low return farm in a fast growing recreation area may well be changed into a campsite, a golf course, fishing ponds, etc. for an increased income. The high school instructional program as well as adult education efforts should encourage this development within the community.

ACKNOWLEDGEMENTS

The Director and Coordinator of the OUTDOOR RECREATION AND APPLIED ECOLOGY Institute express their appreciation to the teachers, resource persons, Tom Brown, FFA Camp personnel, and all others who contributed to the success of the institute as well as the development of TEACHING-LEARNING STATIONS materials which are found in this publication.

First the Resource People who provided consultant expertise, demonstrations, and materials for STATION planning: Luther Partin (Wildlife Commission), Mitchell Clary (Soil Conservationist), Bryan Taylor (State Parks), John Collins (Game Biologist-Wildlife Commission), M. O. Phillips (Consultant, State Department), Eugene Upchurch (State Museum), Ed. Jenkins (Water Safety-Wildlife Commission), Bill Bonner (Fish Biologist-Wildlife Commission), Jim Coffin (Haywood Technical Institute), Lyle Morgan (Hunter Safety-Wildlife Commission), Ranger McLean (Pisgah National Park), Ted Mew (Water & Air Resources), Charles Keels (Tom Brown Camp Director) and Dr. Larry Leggett (Environmental Education Center, Oteen, N.C.). Also Alan Lenk (Environmental Education Center, Oteen, N. C.) Nature Trail

Special thanks to the following teachers of vocational agriculture and science who actually developed the guidelines and procedures for the TEACHING-LEARNING STATIONS:

Felix L. Stevens (Wilkes Central) P. O. Box 744, North Wilkesboro, N. C.
 James F. Bailey (E. Montgomery) Rt. 1, Biscoe, N. C.
 J. W. Busick (W. Alamance) Rt. 1, Gibsonville, N. C.
 Brooks E. Piercy (Crest) Box 751, Boiling Springs, N. C.
 John H. Wells (Southern Nash) Box 217, Bailey, N. C.
 William S. Lucas (Northwood) Box 761, Pittsboro, N. C.
 Carlton T. Forehand (Plymouth) 306 Winesett Circle, Plymouth, N. C.
 Edison L. Towe, Jr. (Plymouth) 107 Thomas Street, Plymouth, N. C.
 Clayton S. Ragan (Deep River) Rt. 5, Sanford, N. C.
 R. B. Goodson (Charles F. Owen) Rt. 1, Box 190, Black Mountain, N. C.
 Edward S. Howard, Jr. (N. Lenoir) Rt. 1, Deep Run, N. C.
 Elwin G. Key (E. Surry) Rt. 1, Box 190, Ararat, N. C.
 James M. Wilburn (E. Surry) P. O. Box 56, Pilot Mountain, N. C.
 Mack S. Edwards (Northwest) Rt. 1, Box 191, Roanoke Rapids, N. C.
 Alton W. Wilson (Southern Alamance) Rt. 2, Graham, N. C.
 Roy A. Eubanks (N. Lenoir) Rt. 2, Box 269-A, Snow Hill, N. C.
 Ronald B. Alexander (Crest) Rt. 3, Box 922, Shelby, N. C.
 Ronald D. Atkins (E. Montgomery) Rt. 1, Jackson Springs, N. C.
 William "Bo" Cash (Cleveland Co.) Rt. 3, Box 950, Shelby, N. C.
 Edward N. Brown (Plymouth) 210 West Third Street, Plymouth, N. C.
 J. Carl DeBrew (Crest) Rt. 8, Box 366-B, Shelby, N. C.

Also helping with July 1974 Revision:

Don Vestal (Surry Central) Rt. 1, Box 336, Boonville, N. C.
 Decatur Jones (Bowman) Box 276, Mt. Gilead, N. C.
 Steve Matthis (NCSU Grad Student)

Finally to Sharon Jones our thanks for typing and editing this publication.

Dr. C. Douglas Bryant, Institute Director

Travis E. Hendren, Consultant
 Occupational Programs
 State Department of Public Instruction
 Raleigh, N. C. 27611

TABLE OF CONTENTS

| | <u>Page</u> |
|---|-------------|
| Preface | i |
| Teaching-Learning Stations in Outdoor Recreation and Applied Ecology. | iii |
| Acknowledgements. | vi |
| <u>TEACHING-LEARNING STATIONS:</u> | |
| Station No. 1: Nature Trail | 1 |
| Station No. 2: Soil Profile | 3 |
| Station No. 3: Weather Station. | 4 |
| Station No. 4: Air Pollution Detection Station. | 6 |
| Station No. 5: Noise Pollution Detection Station | 8 |
| Station No. 6: Water Pollution Detection Station | 9 |
| Station No. 7: Picnic Area. | 10 |
| Station No. 8: Wild Game Traps Display. | 13 |
| Station No. 9: Archery Range | 14 |
| Station No. 10: Horticulture Display Area | 16 |
| Station No. 11: Turfgrass Demonstration Plots | 17 |
| Station No. 12: Fish Pond | 19 |
| Station No. 13: Fishing Equipment Display | 20 |
| Station No. 14: Game Identification Display. | 21 |
| Station No. 15: Boat Ramp | 22 |
| Station No. 16: Plant and Insect Display | 23 |
| Station No. 17: Golf Green | 24 |
| Station No. 18: Erosion Test Plot | 28 |
| Station No. 19: Sewage Disposal Systems. | 30 |
| Station No. 20: Camp Grounds | 32 |
| Station No. 21: Gun Safety Training Range | 33 |
| Station No. 22: Rifle Range. | 36 |
| Station No. 23: Rock Collection. | 38 |
| Station No. 24: Tree Growth Demonstration | 39 |
| Station No. 25: Wildlife House | 40 |
| Station No. 26: Game Feeding Plots | 42 |
| Station No. 27: Horses, Riding Stables and Riding Ring | 44 |
| Station No. 28: Poisonous Plant Display. | 47 |
| Station No. 29: Chemical Control Plot | 49 |
| Books | 50 |
| Magazines and Bulletins | 52 |
| Slides | 55 |
| Films | 56 |
| List of Resource Agencies | 58 |

STATION NO 1

I. NATURE TRAIL:

II. DESCRIPTION: A trail or series of trails consisting of a network of selected teaching stations encompassing a variety of types of terrain found on the school campus or on adjoining lands.

III. RATIONALE:

- A. To provide various groups the opportunity to develop an awareness of the ecological relationships which exist between living things.
- B. To provide students the opportunity for supervised work experiences in order to develop skills and create an awareness of occupational opportunities.
- C. To provide students and other interested individuals and/or groups the opportunity to experience nature through direct contact with the environment.
- D. To develop sensitivity and appreciation.
- E. To provide training stations for various FFA contests and activities.

IV. REQUIREMENTS:

- A. Land - make the best use of available land with appropriate local advice.
- B. Equipment:
 1. Power chain saw
 2. The necessary hand tools to construct and maintain the various teaching stations.
 3. Label maker - (metal tape)
 4. Appropriate lumber for signs, bridges, and other needed facilities.
 5. Battery operated megaphone.
 6. First aid kit.
 7. Abney level.
 8. Increment borer.
 9. Biltmore sticks.
 10. 100' ft tape.
 11. Other specialty equipment for specific teaching stations if need is indicated.
 12. Lawn mower and/or "clear-away" or "weed-getter".
 13. 35 mm SLR camera and lens assortment.
 14. 7 X 35 fieldglasses.
 15. Router with templates and bits.
- C. Facilities:
 1. Pond and/or stream.
 2. Varied topography.

Station No. 1 (continued)

3. Various timber stands.
4. Outdoor classroom
5. Weather station.
6. Soil erosion plot.
7. Geology wall.
8. Poisonous plant display.
9. Wildlife habitat plots.
10. Wildlife feed stations.
11. Wildlife housing.
12. Soil profile
13. Labeling and identification of flora and fauna.
14. (Observation platform).
15. Others to be added or suggested.

D. Time for Development: Three years with continuous updating.

V. RESOURCES:

1. The Nature Program at Camp by Janet Nickelsburg, 1960, Burgess Publishing Co., 426 South 6th Street, Minneapolis 15, Minnesota.
2. Nature Recreation by William Gould Vinal, 1963, Dover Publications, Inc., New York, New York.
3. List of Various Kinds of Trails from North Carolina Museum of Natural History.
4. Career Opportunities/Ecology, Conservation, and Environmental Control, 1969, J. G. Ferguson Publishing Company, Chicago, Illinois.
5. A Handbook for Environmental Education - Nature Study for Conservation, 1971, John W. Brainerd, The MacMillan Company, New York, New York.
6. Eugene Upchurch, N. C. Museum of Natural History, Raleigh, N. C.
7. Local Soil Conservation Service Personnel.
8. Trail Planning and Layout by Bryon L. Ashbaugh, National Audubon Society, Nature Centers Division, 1130, Fifth Avenue, New York, New York 10028.
9. Developing On Site Nature Trails, Alan Lenk, Environmental Educ. Center Oteen, N. C.

*See: "Suggestions and Procedures in Developing Nature Trails"

Outdoor Recreation and Applied Ecology - 7060 and 7061

10. Nature Trails, Extension Bulletin No. 368, Agricultural Extension Ser. University of Minnesota, St. Paul, Minnesota 55101

STATION NO. 2

I. SOIL PROFILE:

II. DESCRIPTION: A protected cut away section of the earth's crust displaying the various soil layers.

III. RATIONALE:

- A. To develop an appreciation and awareness of the process of soil formation.
- B. To use as a teaching aid in the FFA Land Judging Contest and for use by science classes.
- C. To develop an appreciation and an awareness for occupations which conserve our existing soil resources.
- D. To stimulate interest in the FFA Soil, Water, and Air Management Proficiency Contest.

IV. REQUIREMENTS:

- A. Land - An accessible site where the soil profile may be excavated and maintained with a minimum of effort and soil loss.
- B. Equipment:
 1. The necessary power and hand equipment necessary to excavate and maintain the profile.
 2. The necessary tools and lumber to construct a shelter and enclosure to protect the site.
- C. Facilities: Shelter and enclosure to protect the soil profile.
- D. Time for Development: One year with continued maintenance.

V. RESOURCES:

1. Local soil conservation district supervisor and personnel.
2. Land Judging in North Carolina, North Carolina Extension Service, Raleigh, N. C.
3. Soil survey maps and aerial photographs (may acquire from local SCS).
4. Conservation for Camp and Classroom, Robert O. Bale, 1962, Burgess Publishing Company, 426 South Sixth Street, Minneapolis 15, Minnesota.
5. Nasco Catalog.

STATION NO. 3

I. WEATHER STATION:

II. DESCRIPTION:

- A. An area free for overhead obstruction which might interfere with accuracy of instruments.
- B. A series of appropriate instruments for measuring and recording weather conditions.

III. RATIONALE:

- A. To enable students to learn the use of weather instruments and to develop an appreciation of the occupations which utilize these instruments.
- B. To be able to detect changes in air conditions.
- C. To keep records of local weather conditions as they affect weather forecasting and to enable students to better understand weather reports.
- D. To create interest in the FFA soil, water, and air management proficiency contest.

IV. REQUIREMENTS:

A. Land - A suitable unobstructed area.

B. Equipment:

- 1. Rain gauge.
- 2. Wind speed and direction equipment.
- 3. Recording Barometer and charts.
- 4. Psychrometer.
- 5. Recording thermometer and charts.

C. Facilities:

- 1. Housing for instruments.
- 2. Source of power for recording devices.
- 3. Fenced or enclosed area.
- 4. Filing facilities for records.

D. Time for Development: One year with continuous updating and record keeping.

V. RESOURCES:

Station No. 3 (continued)

1. Health Department officials.
2. Local weather reporting and recording stations.
3. U. S. Weather Bureau.
4. Local Newspaper.
5. NASCO Catalog.
6. U. S. Environmental Protection Agency, Washington, D. C. 20460.
7. U.S.D.A. Catalog of weather publications # _____.
8. Book - Weather - Western Publishing Co., Racine, Wisconsin.
9. Weather, Price List 48, Stock #9000-4857
Supt. of Documents, Gov't. Printing Office
Washington, D. C. 20402

STATION NO. 4

I. AIR POLLUTION DETECTION STATION:

II. DESCRIPTION:

- A. An area free from overhead obstructions which might interfere with accuracy of instruments.
- B. A series of appropriate instruments for measuring air quality.

III. RATIONALE:

- A. To enable students to learn the use of air pollution detection instruments and to develop an appreciation for the occupations which use these instruments.
- B. To enable students to determine the source of incoming air pollutants.
- C. To create interest in the FFA soil, water, and air management proficiency contests.

IV. REQUIREMENTS:

- A. A suitable unobstructed area.
- B. Equipment.
 - 1. Directional dustfall sampler complete with slideholder and slides (APW - 1), Forestry Suppliers Inc., 205 W. Rankin St. Jackson, Mississippi 39204.
 - 2. Extra set of slides for dustfall sampler.
 - 3. Slide positioner for dustfall sampler.
 - 4. Microscope with bulb illuminator.
 - 5. Air pollution detection kit Model # AM-61, source: Educational Products Div., LaMotte Chemical Products Co., Chestertown, Md. 21620.
 - 6. Electric Vacuum Pump for above kit (AM-61).

C. FACILITIES:

- 1. Fenced or secured area.
- 2. Source of power for vacuum pump.
- 3. Pole mount for dust fall sampler.

D. Time for Development: 1 year with continuous updating.

V. RESOURCES:

- 1. Health Department Officials.
- 2. Local Air Quality Personnel.

Station No. 4 (continued)

3. U. S. Weather Bureau.
4. Local Newspaper.
5. LaMotte Chemical Products Catalog.
6. U. S. Environmental Protection Agency, Washington, D. C. 20460.
7. VEP Air of the Agricultural Environment Slidefilm.
8. Effect of Air Pollution on Plants USDA Slide Set.

STATION NO. 5

I. NOISE POLLUTION DETECTION STATION:

II. DESCRIPTION:

- A. Availability and access to various sources and levels of noise.
- B. Appropriate instruments for detecting and measuring various sources and levels of noise.

III. RATIONALE:

- A. To create an awareness of the effects of noise.
- B. To enable students to learn the use of noise pollution detection instruments and to develop an appreciation of the occupations which use these instruments.
- C. To create students an awareness of safety standards related to noise.

IV. REQUIREMENTS:

A. Equipment:

- 1. Noise and sound level tester with case, source (Broadhead Garrett)
- 2. Source of various levels of noise.

B. Time for Development: 1 year or less.

V. RESOURCES:

- 1. Noise Pollution, stock # 5500-0072, E.P.A., Office of Noise and Control, Washington, D. C. 20460.
- 2. Noise, The Environmental Problem, A guide OSHA Standards, EPA Source same as above.

STATION NO. 6

I. WATER POLLUTION DETECTION STATION:

II. DESCRIPTION: Water sources suspected of being polluted and a water pollution detection kit that can be carried to the source.

III. RATIONALE: This unit is designed to provide individuals with the opportunity to recognize water pollution and to use water pollution detection instruments so that the source of contamination might be identified.

IV. EQUIPMENT:

A. LaMott Water Pollution Detection Kit, Model AM-22.

V. RESOURCES:

1. LaMott Water Pollution Detection Kit, Model AM-22.

2. Ecology Polluted Water (Slide Set) Nasco, Fort. Atkinson, Wisconsin 53538

STATION NO. 7

I. PICNIC AREA:

II. DESCRIPTION: A land area with suitable terrain, shade, picnic tables, grills, and garbage containers to accommodate picnicking.

III. RATIONALE:

- A. To provide students opportunities to develop skills necessary in planning and constructing facilities and equipment for a picnic area.
- B. To help students become aware of occupations involving picnic area planning, developing, and maintenance.
- C. To enable students to develop skills necessary for planning group activities involving picnic facilities.
- D. To use as an FFA community service project and as a facility for FFA and other school cookouts.

IV. REQUIREMENTS:

- A. Land - a well-drained shaded area large enough to accommodate the number of tables, containers, and grills plus a parking area of approximately 5,000 sq. feet.
- B. Equipment - bricks, lumber, grill, fastening devices, concrete, mortar, paint, paint brushes, preservatives, hand tools and power tools for carpentry and masonry, chain saw, shovels, hole diggers, sling blade, and lawn mower.
- C. Facilities - picnic tables, grills, garbage cans, benches, and water and electricity if convenient.
- D. Time for development - one year with continued maintenance.

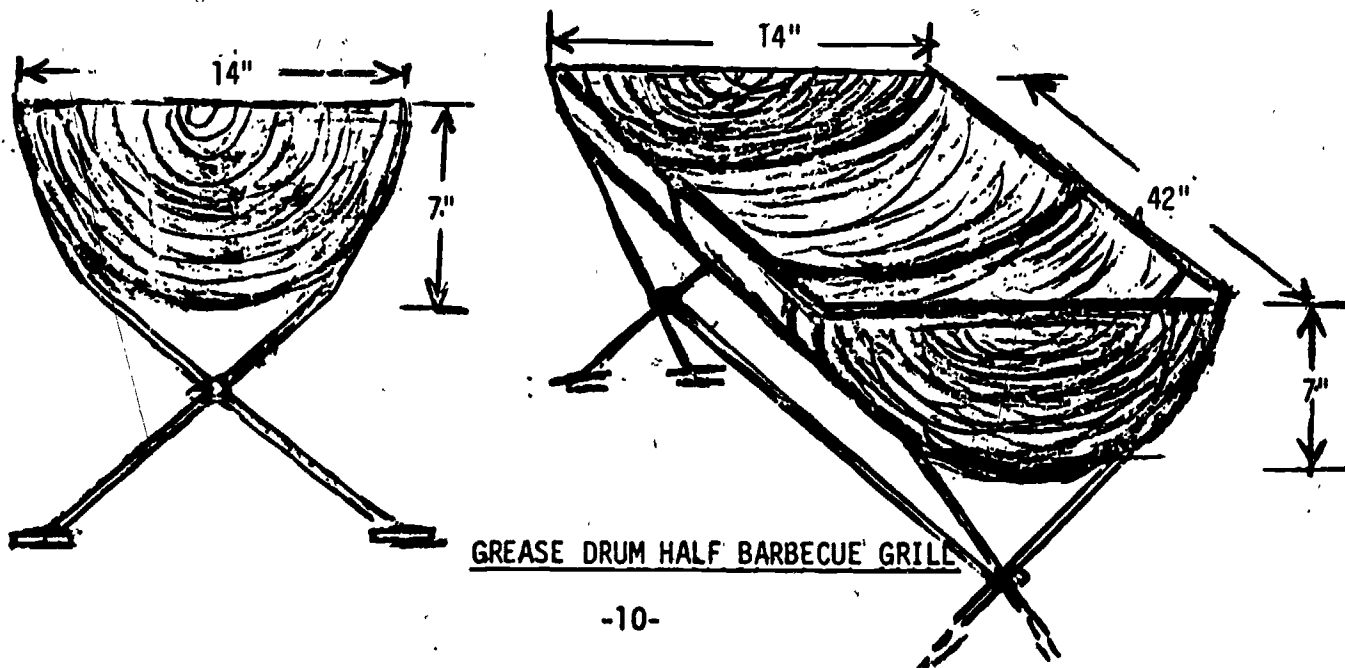

OUTDOOR FIREPLACE

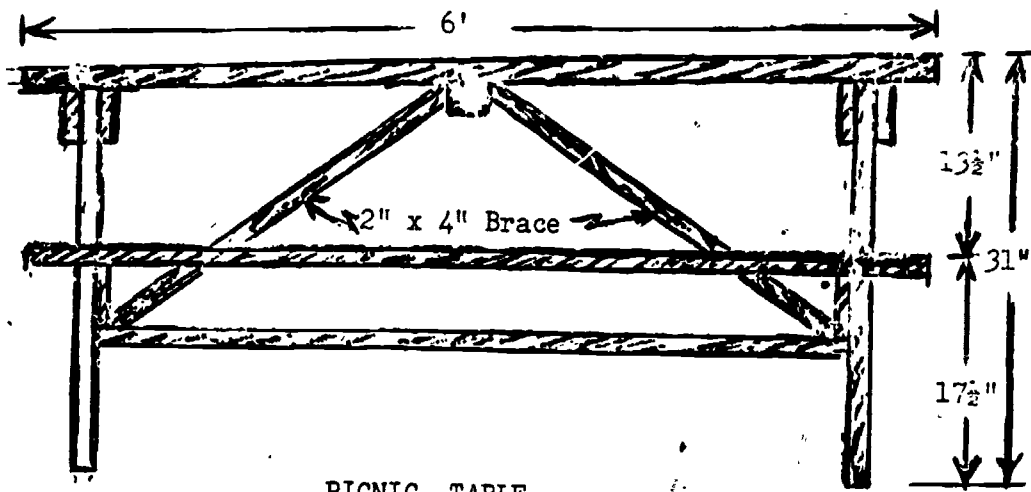
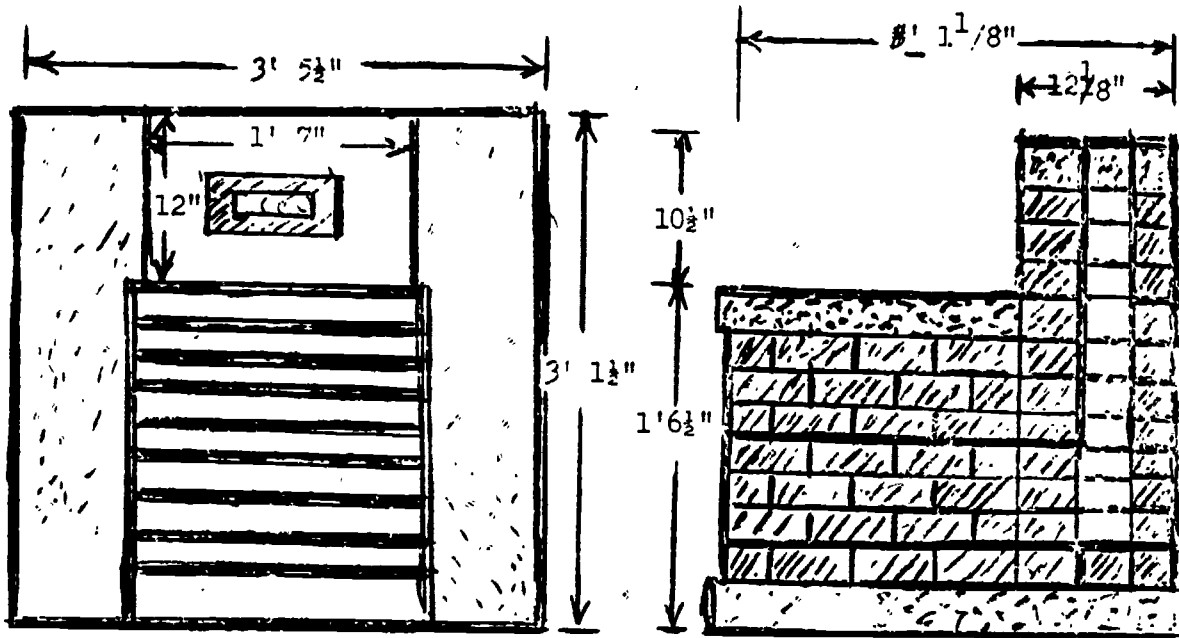

PICNIC TABLE

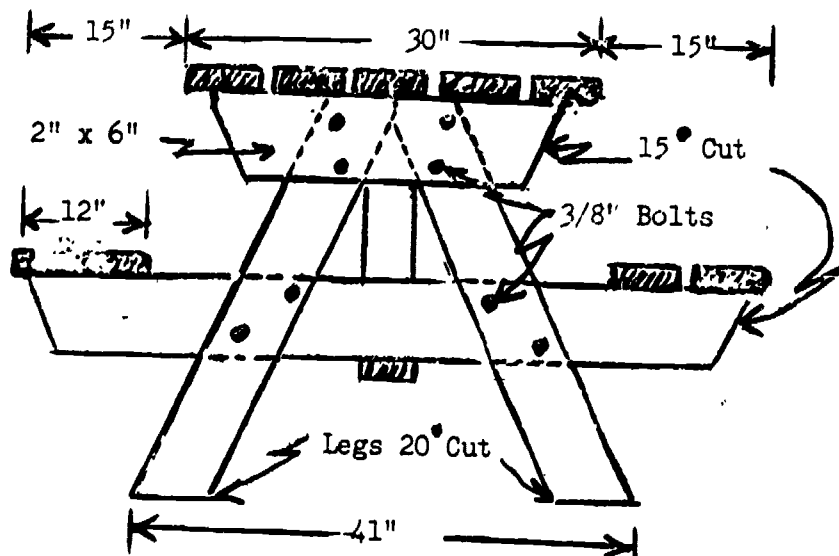

TWO TYPES OUTDOOR FIREPLACES

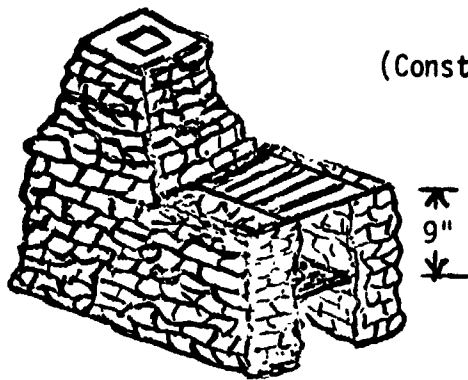

(Constructed From Native Field Stone)

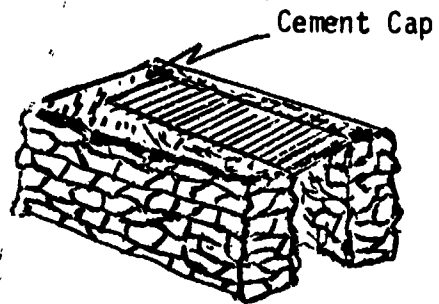

REFUSE CONTAINER & MOUNT FOR REFUSE CAN

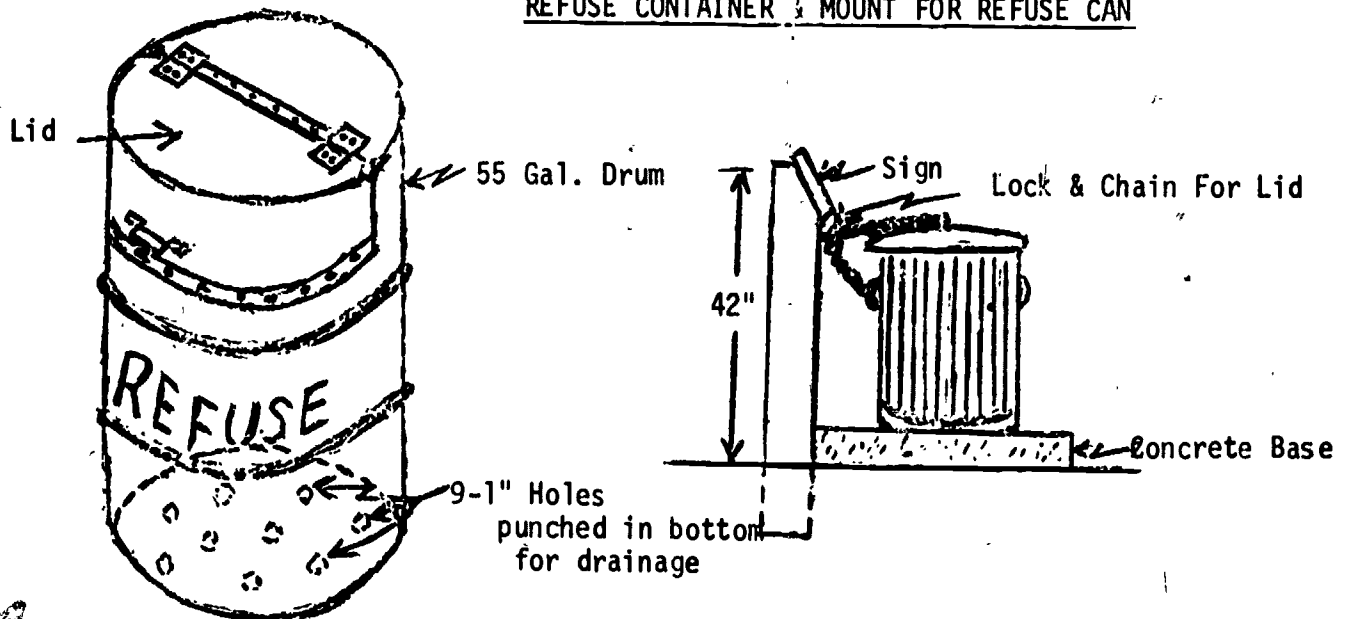

V. RESOURCES:

1. The Forestry Handbook. USDA.
2. Rural Recreation for Profit, Smith, Partain, and Champlin, 1966, The Interstate Printers and Publishers, Inc., Danville, Illinois.

STATION NO. 8

I. WILD GAME TRAPS DISPLAY:

II. DESCRIPTION: Display of four major types of traps and related information such as laws, history, and economic value.

III. RATIONALE: This learning station will be designed to acquaint student with old and new traps and their use. Students will be cautioned as to N. C. trapping regulations and should be informed as to possible economic opportunity.

IV. REQUIREMENTS:

A. Land - this could possibly be placed outdoors and sufficient land is needed.

B. Equipment:

1. Victor type traps (Jaws)
2. Conibear
3. Hav-A-Hart
4. Home Made

C. Display and storage space needed to house traps.

D. Time: one year

V. RESOURCES:

1. Fur, Fish, and Game Magazine.
2. Field and Stream Magazine.
3. N. C. Game Laws.
4. Herter's Catalog.
5. N. C. Wildlife Magazine.
6. Local Wildlife Protector.
7. Local Fur Market.

I. ARCHERY RANGE:II. DESCRIPTION:

A plot of land approximately 30 yards and 100 yards will accommodate four archers to practice at one time. Target butts should be about 8 yards apart from left to right. Shooting at the targets will begin at 5 yards and advance up to 60 yards as the individual develops his skill.

III. RATIONALE:

This unit is designed to introduce the individual to the field of archery. The individual will be given the opportunity to identify and use the pieces of equipment in a correct and safe manner. (Individuals should recognize the potential of the weapon he is learning to use.)

IV. REQUIREMENTS:

A 30 yard by 100 yard area with limited access, right and left hand bows testing 30#, 45#, target arrows with lengths of 26" and 28", arm guards, shooting tabs or gloves for right and left hand shooters; target faces, target butts and stands, combination bow rest and ground quiver, bales of tightly packed grass for backstop.

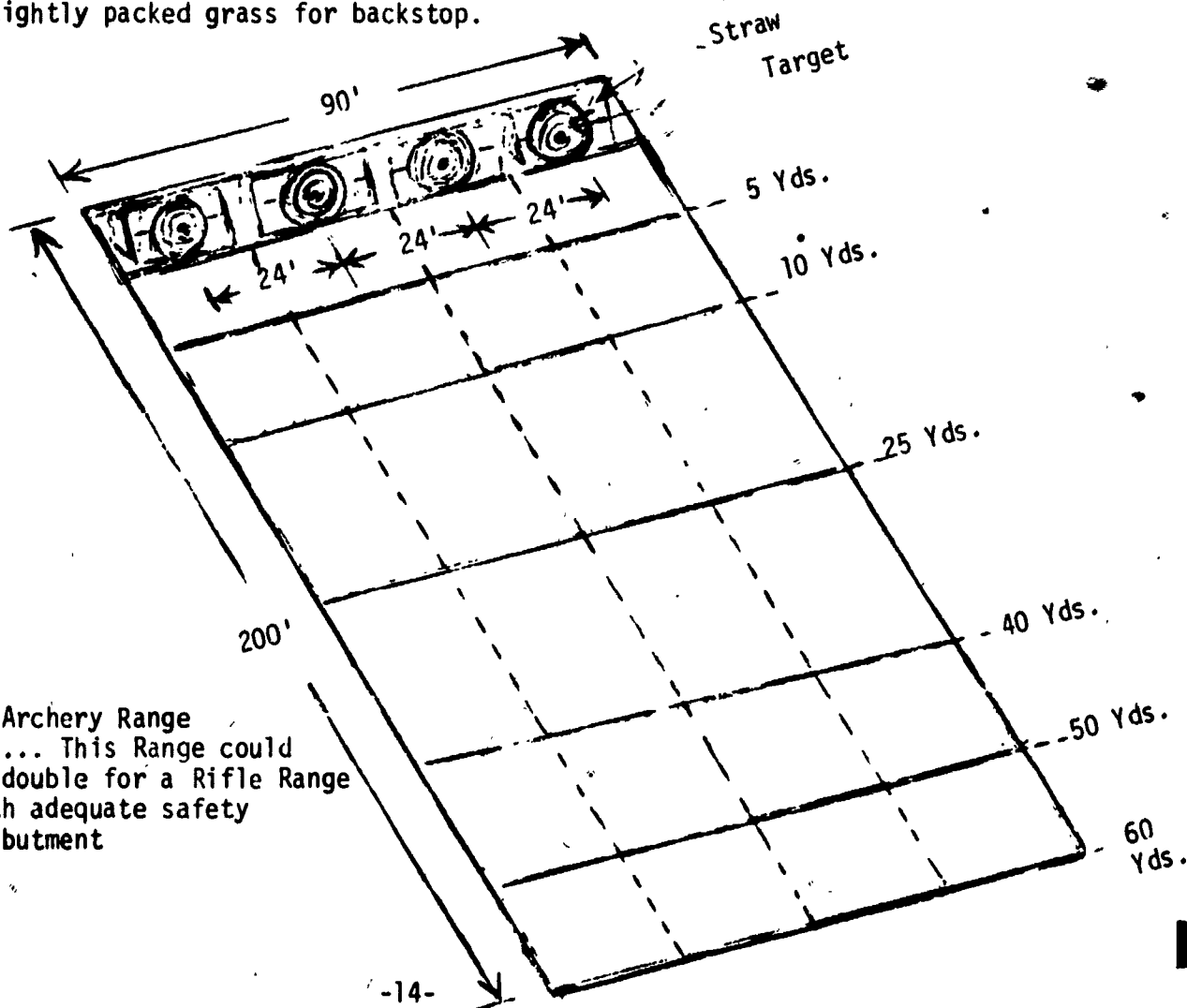

A Simple Archery Range
Layout ... This Range could
also double for a Rifle Range
with adequate safety
abutment

STATION NO. 9 (continued)

V. RESOURCES:

A. The Archer's Bible - price \$2.50 - Doubleday and Co., Inc.,
Gordon City, N.Y.

B. ABC's of Archers - 25¢ - Shakespeare Co., Kalamozoo, Mich. 49001.

Additional information may be obtained from:

C. Bear Archery Co. - Rt. 1, Grayling, Mich. 49738.

D. Browning Arms Co. - Archery Div., - 1706 Washington Avenue,
St. Louis, Missouri 63100.

E. Hoyt Archery Co., 11510 Natural Bridge, Bridgeton, Missouri 63121.

F. Ben Pearson, Inc., Pine Bluff, Arkansas 71601.

I. HORTICULTURE DISPLAY AREA:

II. RATIONALE:

- A. To show students many of the various horticulture plants used for home and commercial plantings.
- B. To teach identification for forestry, horticulture, and biology students.
- C. To teach cultural practices in growing and maintaining plants.

III. DESCRIPTION: This may be a plot of an acre or more - or it may consist of a group or series of several plots of irregular shapes and size which are not suited for other school purposes.

IV. REQUIREMENTS:

- A. Plot or plots of land.
- B. Equipment.
 - 1. Tiller (power).
 - 2. Sprayer - 2 - 3 gallons.
 - 3. Assorted hand tools - shovels, rakes, etc.
 - 4. Lawn mower.
 - 5. Garden tractor (optional).
 - 6. Irrigation - water supply.
 - 7. Supply of assorted plants.
 - 8. Lime and Fertilizer.

V. RESOURCES:

- A. Local Nurseries.
- B. Local Seed and Fertilizer Dealer.
- C. Reference books used in Horticulture Course.
- D. Bulletins from Extension Agent.
- E. Local Horticulture Teacher.

VI. FFA & SOE:

- A. Proficiency Awards.
- B. Team Horticulture Contests.
- C. Exploratory work experiences.
 - 1. Visit greenhouses - commercial.
 - 2. Visit Florist class.
 - 3. School work experience on plot.

STATION NO. 11

I. TURF GRASS PLOTS:

II. DESCRIPTION: Several plots of different kinds of turf grasses with at least 30 square feet per plot. Plots should have dividers to keep grasses from crossing into other plots.

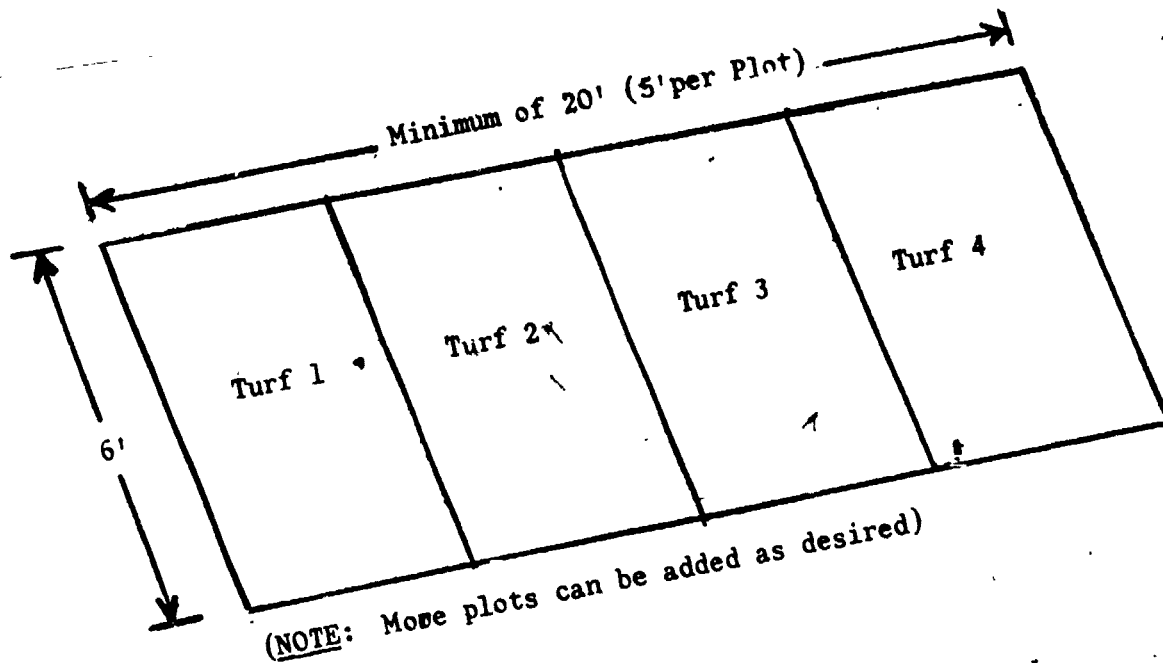

III. RATIONALE:

- A. To help students identify turf grasses used on lawns, parks and playing fields.
- B. To demonstrate maintenance of different turf grasses.
- C. To show characteristics of different turf grasses.

IV. REQUIREMENTS:

- A. At least 100 square feet of land suitable for turf grasses.
- B. Desired types of seeds or sprigs.
- C. Fertilizer.
- D. Fungicides.

Station No. 11 -(continued)

- E. Herbicides
- F. Metal, brick or wood dividers for plots.
- G. Spray equipment.
- H. Fertilization equipment.
- I. Grass cutting equipment.
- J. Soil testing equipment.

V. FFA AND SOE:

- A. Plots could be used in FFA Ornamental Horticulture Contest.
- B. Student could maintain plots after school or in summer for SOE.

VI. RESOURCES:

- A. Turf Maintenance: The Pennsylvania State University, College of Agriculture, Agricultural Experiment Station, University Park, Penn.
- B. Turfgrass, Maintenance and Establishment, A Teacher's Manual. The Pennsylvania State University, College of Agriculture, Agricultural Experiment Station, University Park, Penn.
- C. Yearly Catalog, Porter Bros., Shelby, N. C.
- D. Turf Management Handbook, Howard B. Sprague, The Penn. State University, University Park, Penn.
- E. Local Golf Courses.

STATION NO. 12

I. CONSTRUCTING A FISH POND:

II. DESCRIPTION: This will be a warm water fish pond 1/4 to 1 acre in size, 3 to 10 feet deep, 12' or more bank, trees and shrubs cleared away from immediate bank area to eliminate leaf problem. No cattle or other livestock allowed to use pond for reasons of disease and damage. Should have 3:1 slope.

III. RATIONALE: The purpose will be to offer K-14 education through the environment concerning recreational and biological aspects of warm water ponds.

IV. REQUIREMENTS:

A. Size depends upon locale and land available, recommended stocking 50 bass - 500 bluegill per acre.

B. Check with local governmental agencies on regulations.

C. Equipment:

1. Canoes, boats.
2. Mower.
3. Water test kit.
4. Plankton net.
5. Thermometers.
6. Fishing equipment.
7. "Safety cable".
8. Lifesaving devices.
9. Sample bottles.
10. Microscopes.

D. Facilities: Information and equipment storage booth, pier.

E. Time involved for fish maturity, etc. would be three years.

V. RESOURCES:

1. USDA Farmer's Bulletin #2250.
2. Our Natural Resources - Interstate Printers.
3. Pond Life, R. Ford.
4. Circular 445 - N. C. State Ag. Extension Service.
5. Techniques of Fish Pond Management, USDA Bulletin #2210.
6. Soil Conservation Service.
7. Local Health Department.

* Drain pipe, spillway.

STATION NO. 13

I. FISHING EQUIPMENT DISPLAY:

II. DESCRIPTION:

This is a teaching station designed to familiarize student with fishing equipment and use. A storage - display cabinet is desirable to store and exhibit the fishing equipment.

III. RATIONALE:

- A. This unit is designed to familiarize the student with the identification, selection and use of some of the more common kinds of fishing equipment.
- B. This knowledge plus skills in equipment use could prepare student for employment in this field.

IV. REQUIREMENTS:

- A. Equipment: (2 each)
 - 1. Cane pole
 - 2. Bait casting outfits
 - 3. Spin casting outlets
 - 4. Spinning outfits
 - 5. Fly casting outfits
 - 6. Assorted lines, lures, floats, books, and sinkers.
 - 7. Display-storage cabinet.
- B. Pond or stream access desirable:
- C. Casting practice area and targets desirable:

V. RESOURCES:

- 1. Herter's Catalog
- 2. McClanes Standard Fishing Encyclopedia

STATION NO. 14

- I. GAME IDENTIFICATION DISPLAY:
- II. DESCRIPTION: Mounts, photographs, or drawings of game animals native to local area and/or North Carolina.
- III. RATIONALE: To provide learning experiences in local game identification.
- IV. REQUIREMENTS:
 - A. Observation areas on campus or nature trail.
 - B. Taxidermy equipment, photography equipment, pictures, mounts, drawings.
 - C. Display and storage space 14 feet x 14 feet.
 - D. Secure basic mounts and add others when available.
- V. RESOURCES:
 - A. Our Wildlife Neighbors, Raleigh, N. C.
 - B. Wildlife in North Carolina, Raleigh, N. C.
 - C. Photographing Nature, D. Linton.
 - D. N. C. Museum of Natural History.
 - E. Rural Recreation for Profit, The Interstate Publishers and Printers, 1968.
 - F. Herter's Inc., Rural Route I, Waseca, Minnesota.
 - G. Herter's Professional Course in the Science of Modern Taxidermy, Herter's Inc., Waseca, Minn.

STATION NO. 15

- I. BOAT RAMP:
- II. DESCRIPTION: This ramp should be 5" thick, 10' wide, 30' long on a slope of 10-15° or adapted to local situation. Pier should be desired length.
- III. RATIONALE: To teach a student to properly locate and construct a boat ramp and pier with safety aspects in mind. Student should learn proper launching and loading of boat. Include occupational opportunities as part of the instruction.
- IV. REQUIREMENTS:
 - A. Sufficient shore for pier and ramp.
 - B. Necessary construction materials. (Creosoted posts and cypress lumber, throw rope in a cabinet, boats should be available.
 - C. Local Marina, Wildlife Access Ramps, or other boat ramps may be used as teaching-learning stations.
 - D. Check local rules and regulations or ordinances.
- V. RESOURCES:
 1. N. C. Wildlife Resources Commission, Box 2919, Raleigh, N. C.
 2. N. C. Statutes on Game, Fish, and Boat Laws.
 3. Outdoors U.S.A., 1967 Yearbook of Agriculture, U. S. Printing Office.
 4. Manual for Outboard Motors, Outboard Marina Corp., Milwaukee, Wis.

CLASSES OF MOTORBOATS

Motorboats are divided into four classes according to length. The boat's class will determine what equipment must be carried aboard. Pier and ramp requirements will also depend upon class of boat

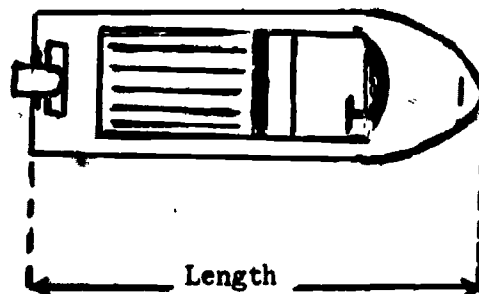
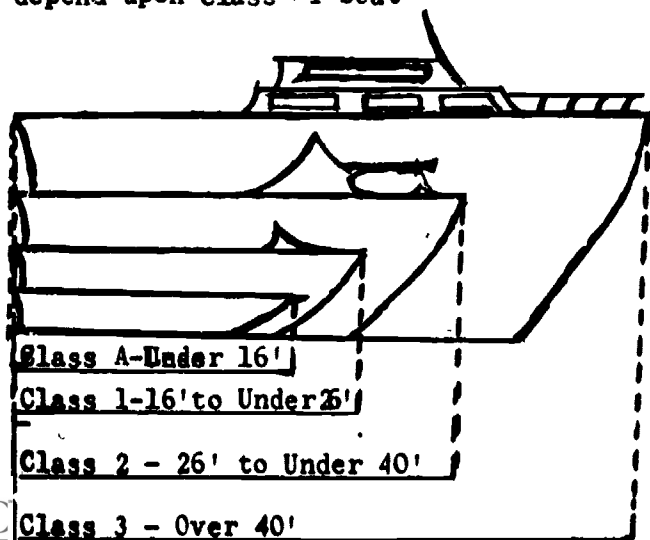

STATION NO. 16

I. PLANT AND INSECT DISPLAYS:

- A. Concentrating on plant and insect identification and relationship.
- B. Expansion to other areas important to agriculture and biology.

II. DESCRIPTION: Exhibition cases to be used in an outdoor classroom as portable materials or in an enclosed natural museum as permanent materials.

III. RATIONALE:

- A. To identify various plants and insects.
- B. To familiarize students with diseases common to the area's domestic and natural plants.
- C. To familiarize students with relative causes of these diseases.
- D. To demonstrate relationship of plants to animals - both beneficial and nonbeneficial.
- E. To introduce plant and animal life cycles.

IV. REQUIREMENTS:

- A. Student participation in collecting and mounting specimens.
- B. Plant and insect mounting kits.
- C. Portable or permanent display cases (perhaps mountings in large picture frames arranged as a book) arranged in proper groupings.
- D. Outdoor or indoor display area.

V. RESOURCES:

- A. County Extension Chairman.
- B. 4-H Publication.
- C. Field Guide to Insects.
- D. U. S. Department of Agriculture Publication on Plant Diseases.
- E. Bookstores.

VI. OCCUPATIONAL ASPECTS:

- A. Forestry.
- B. Crop Farming.

STATION NO. 17

I. GOLF GREEN:

II. DESCRIPTION:

Ground on which the turf is intensively managed to provide a suitable playing surface for the practice of golf.

A. Location - any well drained site away from automobile and pedestrian traffic.

B. Size - golf greens are subject to wide variations in size and shape. The actual putting surface is ideally surrounded by a fringe or apron which is managed as if it were part of the green except that the grass is maintained at greater length. The green is Sketch 1 is approximately 2000 square feet in size which should prove adequate in most situations.

SKETCH 1:

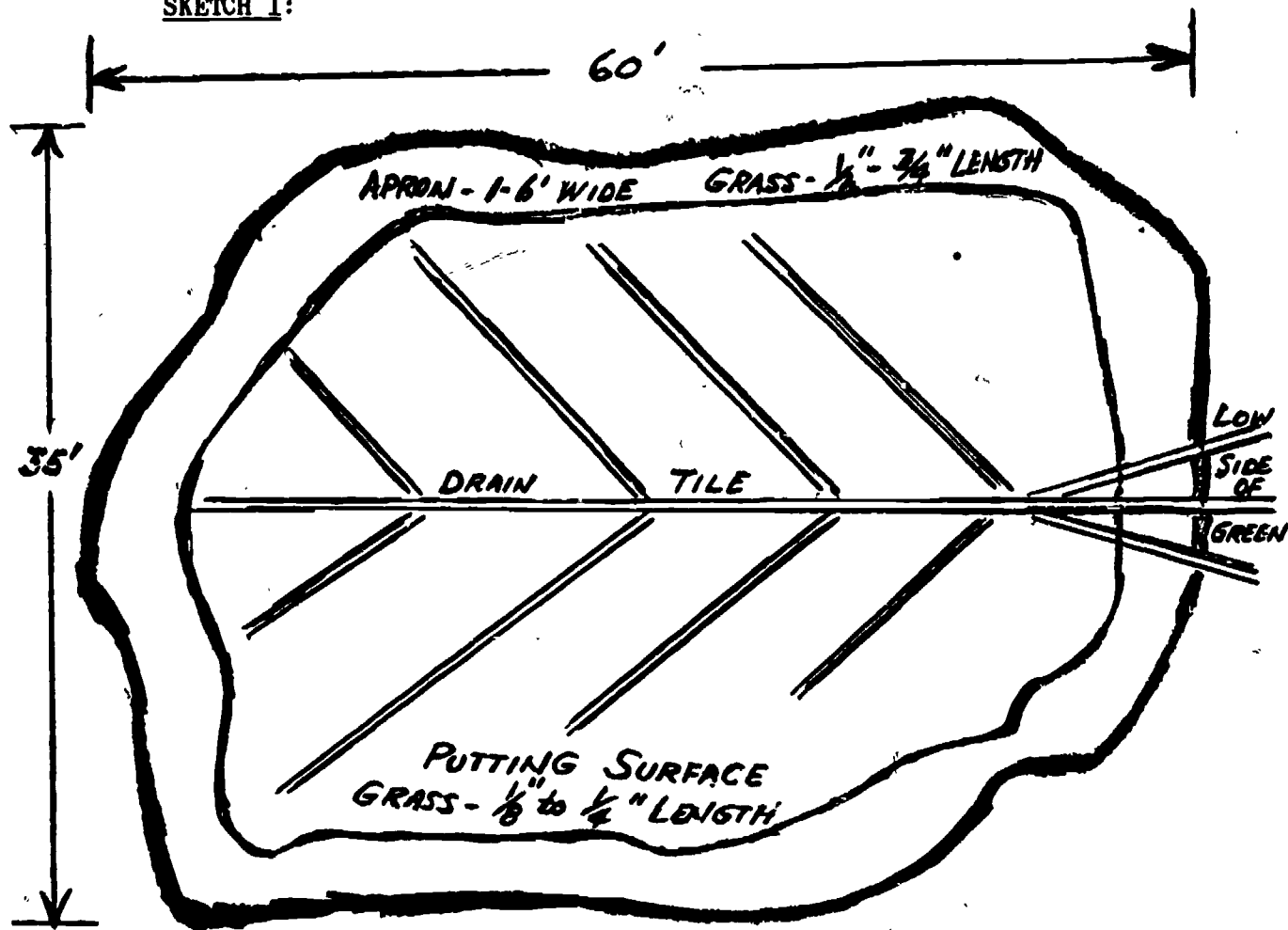

Station No. 17 (continued)

- C. Contour - gently rolling (presents golfer with a variety of shots since the ball does not always roll straight.) If space permits the golfer to practice approach shots, the green should be flanked by two or more low mounds which permit practice from a variety of lies and stances. Such mounds also give the green more perspective when approached from a distance.
- D. Profile - to insure proper drainage a green should consist of layers of gravel, sand, and a mixture of sand and organic topsoil over a tile drainage system. (See Sketch 1 and Sketch 2).

Sketch 2

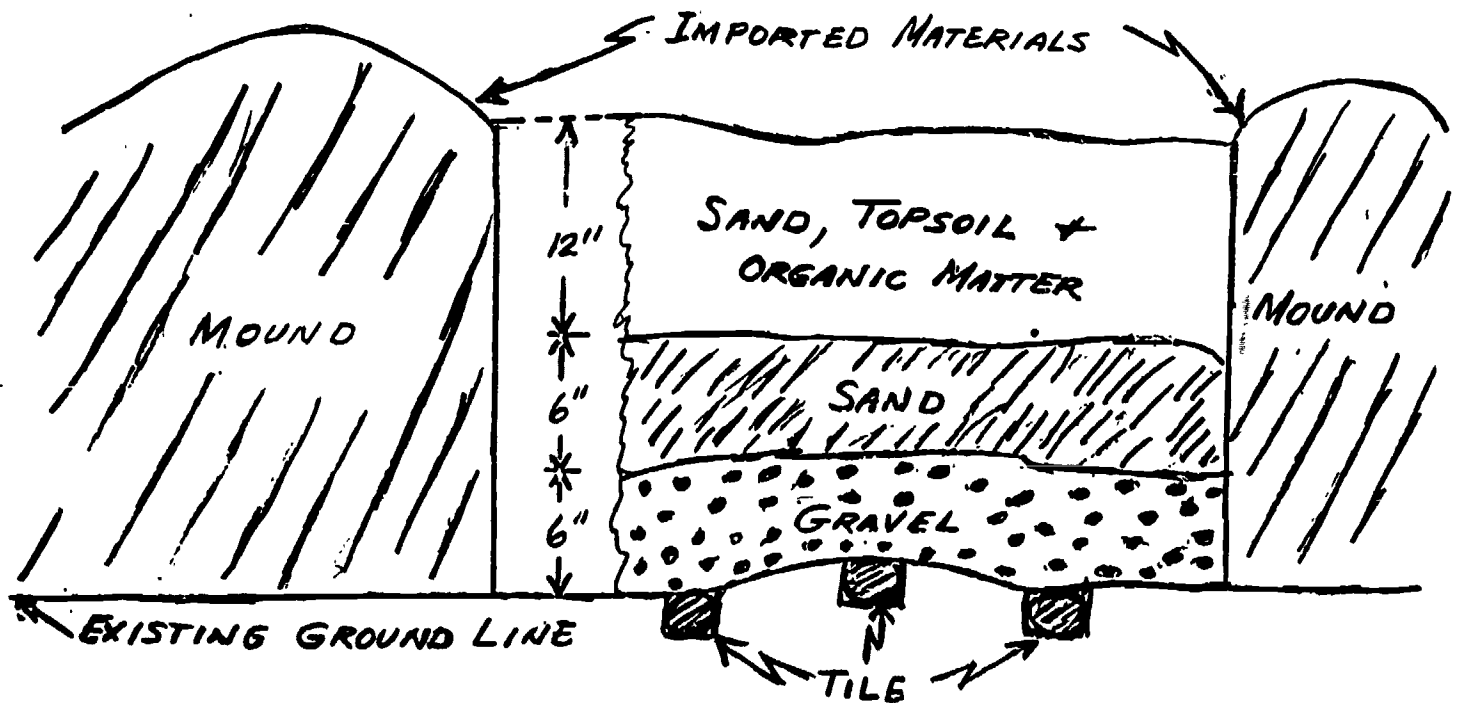

- E. Construction - 4" tile should be laid in trenches cut in the existing ground surface using a pattern such as that in Sketch 1. At no point should water be farther than 10 ft. from the nearest drain. The tile should be covered by a 6" layer of gravel. The gravel should be covered by a 6" layer of sand and the sand by an 12" layer of topsoil, sand, and organic matter mixed in varying proportions according to the drainage properties of the available materials. The Soil

Station No. 17 (continued)

Conservation Service can assist in determining the correct formula. Each layer should be packed as it is formed. The soil should be fumigated with metbyl bromide to kill weed seeds and nematodes before the green is seeded or sprigged.

F. Grasses - grasses are of two types, those which can be seeded and those which must be sprigged. Suggested varieties include Penncross bentgrass (which can be seeded) in the western part of N. C. and Tiftdwarf (must be sprigged) in the eastern part of N. C. Grasses which die back to the roots each fall may be alternated with ryegrass to keep greens green year round.

G. Maintenance - golf greens require a good deal of maintenance year round.

1. Mowing - one to six times weekly.
2. Aerifying - one to three times yearly preferably in conjunction with a turf slicing operation.
3. Watering - during dry periods.
4. Spraying - with fungicides such as Thiram, Tersan, Captan, or Iron as a treatment or preventative - with insecticides for such pests as Japanese beetles - with herbicides for weeds.
5. Fertilizing - a regular program of fertilization must be followed using varying kinds and amounts of fertilizer depending upon the soil

III. RATIONALE: by constructing and maintaining a golf green students will gain skills in the following areas:

- a. applying chemicals such as fungicides, insecticides, herbicides, and fertilizers.
- b. determining amounts of chemicals, and water needed.
- c. operating equipment used in turf management.
- d. making tests and analyzing results to determine needed treatments.

These skills can be used in greenskeeping or any other agriculture field which requires a working knowledge of turf management or the component principles.

IV. REQUIREMENTS: All the following will be needed but some items can usually be borrowed.

- a. land
- b. tile
- c. gravel
- d. sand
- e. topsoil
- f. sawdust, peat moss, or other organic matter
- g. polyethylene, cannisters of methyl bromide, the necessary applicators
- h. hoses, sprinklers
- i. hand tools such as rakes, shovels
- j. reel type mower
- k. soil aerator
- l. spraying equipment

Station No. 17 (continued)

- m. grass seed or sprigs
- n. fertilizers and other chemicals

V. RESOURCES: Green construction should not be attempted without consulting local resource personnel such as golf pros and green superintendents, agriculture extension agents, soil conservation personnel, and any others actively engaged in turf or soil management.

- a. United States Golf Association - address available from local pro-publication on golf course construction.
- b. Dr's. William Gilbert and Carl Blake, NCSU, Turf Management.
- c. Porter Bros. Inc., 1005 E. Dixon Blvd., Shelby, N. C. 28150
704-482-3424, turf care equipment and products.
- d. Any good turf or soil management text.

I. EROSION TEST PLOT:

II. DESCRIPTION: A plot of land having a 2-10% slope approximately 20' wide and 24' long divided into four 3x6 ft. sections using 2x10's for the divisions. Twenty quart containers are used to collect the run-off from each of the sections. (It is desirable to fence this plot if possible with 6' welded wire.)

Fence Surrounds 20'X24' Plot

Fence Surrounds 20' x 24' Plot

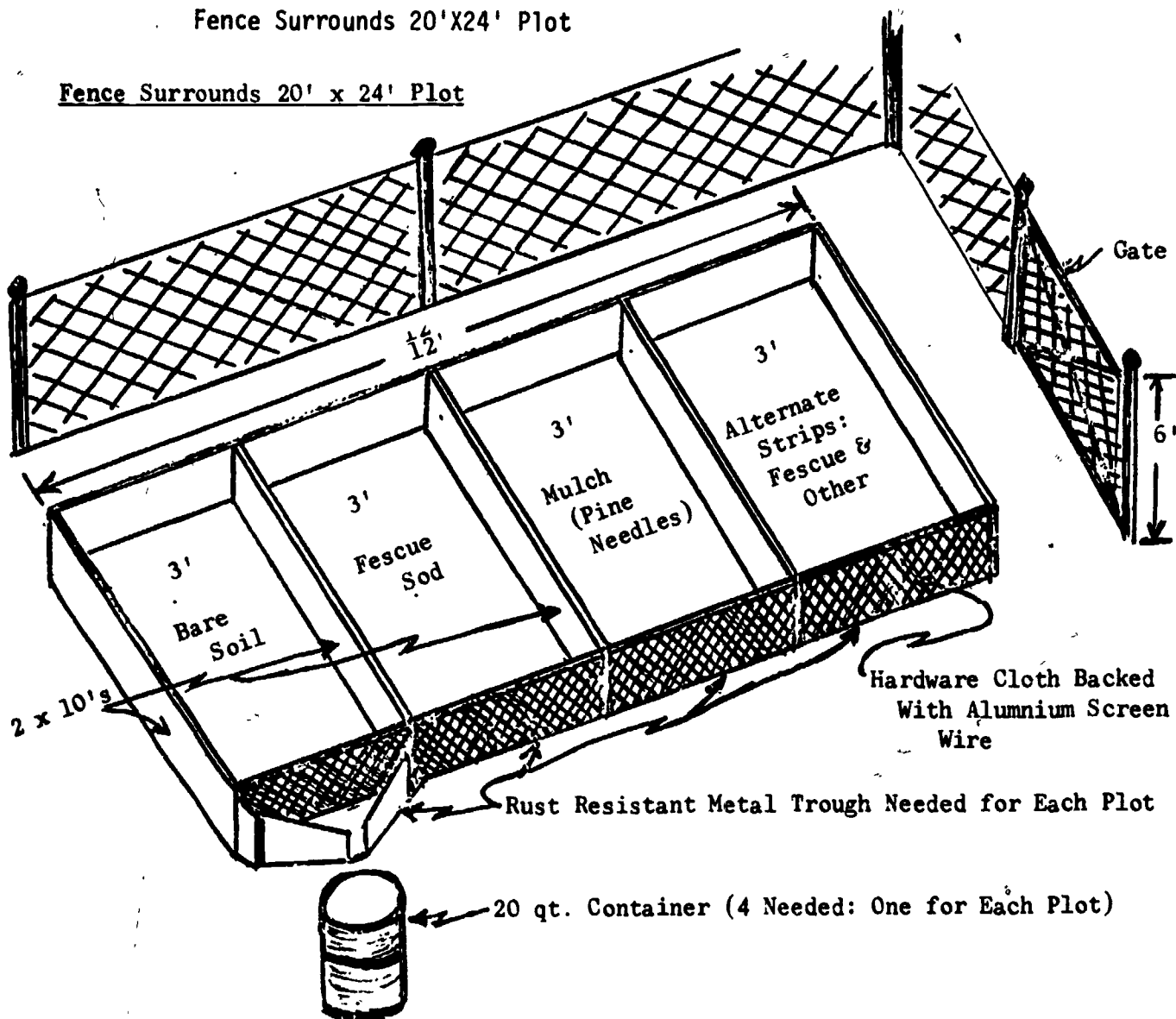

III. RATIONALE:

This unit is designed to provide individuals with the opportunity to measure observe and measure the amount of water run-off and soil loss from different types of ground covers after an established amount of precipitation has been determined.

IV. REQUIREMENTS:

Station No. 18 (continued)

A sloping plot of land consisting of approximately 480 square feet, one rain gange, four 20 quart containers, 12 square feet of screen wire, 12 square feet of 1/4 inch hardware cloth, 48 feet of treated 2X10's, 24 square feet of rust resistant sheet metal and ground covers of your choice. (Should a fence be necessary 11 eight foot posts and 88 ft of wire fencing are needed. A four foot gate should be provided.)

V. RESOURCES:

1. Soil and Water Activities for Boy Scouts, U.S.D.A., Soil Conservation Service, PA-348.
2. Conservation for Camp and Classroom, Bale, Burgess Publishing Company, 426 South 6th Street, Minneapolis 15, Minnesota.
3. Soil Science in the Southeast, Welsh, The University of North Carolina Press, Chapel Hill, N. C.
4. District Soil Conservationist.
5. Our Natural Resources, Kircher, The Interstate, Danville, Virginia.

STATION NO. 19

I. SEWAGE DISPOSAL SYSTEMS:

II. DESCRIPTION: Show cross section of drain line and septic tank and show distribution box. (See Bulletin #519 State Board Health for drawing).

III. RATIONALE:

- A. To show the importance of properly designed sewage systems with special emphasis on the following:
1. Location
 2. Grade
 3. Type of soil
- B. To make the student aware of the importance of properly treated sewage with special regard to the Ecology.
1. Prevent contamination of drinking water.
 2. Prevent the contamination of waters used for shellfish - breeding grounds or recreational purposes.
 3. Prevent a nuisance due to odors or unsightly appearance.
- C. To expose students to occupational opportunities.
1. Public health sanitarians
 2. Municipal sanitarians
 3. Installing or repairing sewage systems
 4. Septic tank manufacturing
- D. To familiarize students with the operation of the school sewage system.

IV. REQUIREMENTS:

- A. Land - minimum amount to show cross section of septic tank and drain field, should be a minimum of 50' x 50'.
- B. Equipment:
1. Septic tank
 2. Distribution box
 3. 50, 4" drain tile
 4. 10' tar paper
 5. Bag of cement
 6. 1 yard of clean stone
 7. 1 terra cotta septic tank T
 8. 1, 2' section of 4" terra cotta
 9. 200 linear feet of chain link fence
- C. FFA AND SOE

Station No. 19 (continued)

1. Students would be encouraged to include sanitary sewage disposal in their home improvement proficiency award.
 2. Students could be encouraged to work with firms directly related to sewage systems.
 3. A study of this unit would benefit the student in the FFA Land Judging.
 4. This could help the student in the Outdoor Recreation Proficiency Award.
- D. Time for Development: Could be easily developed by the students in less than one year.

V. RESOURCES:

1. Bulletin #519, State Board of Health, Raleigh, N. C.
2. Local County Health Department for local requirements and ordinances.

STATION NO. 20

I. CAMP GROUNDS:

II. DESCRIPTION: A plot of land that will provide 12 to 15 tent sites for one class for overnight camping. One or two sites for "wheel" campers.

III. RATIONALE:

- A. Provide camping facilities and experience for students.
- B. To develop an appreciation of camp development and management.
- C. Provide leadership and work opportunities for Ag students in working with youth groups.
- D. Time - one year - continuing.

IV. REQUIREMENTS:

- A. Land and site: Fairly open spot, elevated high enough to avoid early morning fogs, gently sloping land, soil of type that will absorb water, sheltered against prevailing winds, exposed to early morning sun, water suitable for drinking and bathing within a reasonable distance, available firewood, privacy, and game area.
- B. Equipment: tents (types) outdoor grill, toilet, benches, picnic table, axes, mattocks, chain saw, garbage cans, adirondike (shelter), shovels, lawn mower, tractor, and blade.
- C. Check with local authorities on regulations.

V. RESOURCES:

- 1. "Boy Scout Handbook".
- 2. "The Golden Book of Camping and Camp Crafts", Golden Press, New York, most book stores.
- 3. "Camping and Trailering Guide", The Complete Magazine of Family Outdoor Fun, Rajo Publications, Inc., 319 Miller Avenue, Mill Valley, California 94941.
- 4. "Rural Recreation for Profit", The Interstate Printers and Publishers, Inc., Danville, Illinois.

STATION NO. 21

I. GUN SAFETY TRAINING RANGE:

II. DESCRIPTION: Single trap station and an obstacle course with fence, gate, foot log, and gully or ditch. Hunter safety activity trail consisting of gate, foot log, ditch or gully and an area with a single trap for throwing skeet.

III. RATIONALE:

- A. To demonstrate safe gun handling.
- B. To show capabilities of guns.
 - 1. Shotgun gauges, rifle and handgun calibers.
 - 2. Gun actions.
 - 3. Different chokes.
 - 4. Effective ranges.
 - 5. Danger ranges.
 - 6. Types of ammunition.
- C. Proper gun fit.
- D. To demonstrate care and maintenance of guns.
- E. To practice marksmanship.
- F. To appreciate pleasures from using guns.
 - 1. Hunting.
 - 2. Target shooting.
 - 3. Gun collecting.
- G. To acquaint students with occupational opportunities involving gun use.
 - 1. Sporting goods salesman.
 - 2. Skeet and trap operator.
 - 3. Hunting guide.
 - 4. Gunsmith.
 - 5. Gun safety demonstrator.
 - 6. Representative for ammo or gun manufacturer.

IV. REQUIREMENTS:

- A. Legal aspects - clear through principal and local superintendent.
- B. Land - minimum size 150 ft. by 150 ft. with protective zone in background.
- C. Equipment:
 - 1. Portable clay target trap.
 - 2. Clay targets.

Station No. 21 (continued)

3. Shotguns, rifles and handguns representing the different gun actions.
4. Ammunition.
5. Ammunition Board.

D. Suggested Hunter Safety Activity Trail:

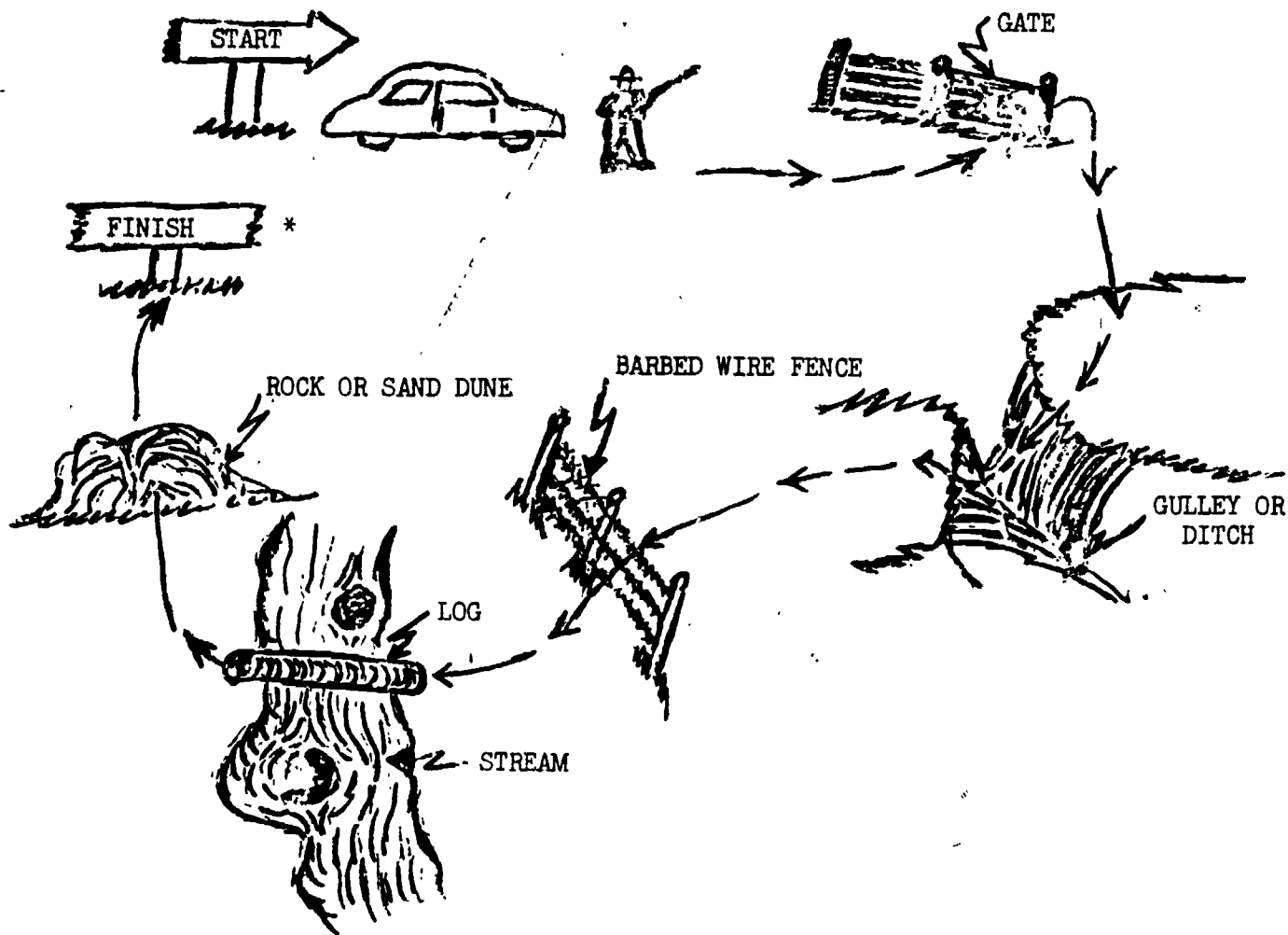

- *NOTE:
1. Other obstacles may be added.
 2. For other details: See: North Carolina Hunter Safety Manual

V. FFA and SOE:

A. Exploratory work experience suggestions.

1. Visit sporting goods department.
2. Visit skeet and trap ranges.

Station No. 21 (continued)

B. FFA Projects

1. FFA sponsored turkey sheet.
2. FFA Skeet contest.
3. Outdoor Recreation Proficiency Award

VI. RESOURCES:

- A. National Rifles Association
- B. Stoegers Gun Digest
- C. Shooters Bible
- D. Wildlife Resources Commission
- E. N. C. Hunter
- F. Gun and ammunition manufacturers

- *1. Browning Arms Co., Morgan, Utah 84050
- *2. Remington Arms Co., Inc., Bridgeport, Connecticut 06602
- *3. Winchester, Western Div., Olin Corp., 275 Winchester Ave., New Haven, Connecticut.
- *4. Ithaca Gun Company, Inc., Ithaca, New York, 14850
- *5. Harrington and Richardson, Worcester, Massachusetts
- *6. The Marlin Firearms Company, 100 Kenna Drive, North Haven, Conn. 06473
- *7. Savage Arms, Westfield, Massachusetts 01085
8. Federal
9. Mossberg
10. High Standard

*Materials known to be useful.

STATION NO. 22

I. RIFLE RANGE

II. DESCRIPTION: .22 cal. rifle range with minimum at 1000" with adequate safety areas and backstop.

III. RATIONALE:

A. Safe gun handling:

B. Capabilities of the .22 rifle.

1. Rifle actions.
2. Effective range.
3. Danger range.
4. Types of ammunition.

C. Proper gun fit.

D. Care and maintenance of rifles.

E. Marksmanship.

F. Pleasures from rifle shooting.

1. Target shooting
2. Hunting
3. Gun collecting

G. Occupational Opportunities.

1. Sporting goods salesman.
2. Rifle range operator.
3. Rifle shooting instructor.
4. Gunsmith.
5. Hunting guides (very limited in N. C.).

IV. REQUIREMENTS:

A. Legal aspects.

1. Clear through principal and local superintendent.
2. Work with Wildlife protector and gun safety officer.

B. Land

1. Minimum size - 25 feet wide and 100 feet deep.
2. Backstop - dirt mound 10 feet high.
3. Shooting stations for shootin- in the following positions:

Station No. 22 (continued)

- a. Bench rest
- b. Prone
- c. Kneeling
- d. Standing
- e. Sitting

4. Target rack.

5. .22 Rifles representing the four different actions.

V. FFA AND SOE

A. Exploratory work experience suggestions.

1. Visit sporting goods department.
2. Visit rifle range.

B. Applicable to the Outdoor Recreation Proficiency Award.

C. Chapter Safety Award.

VI. RESOURCES:

A. National Rifle Association.

B. Stoegers Gun Digest.

C. Shooters Bible.

D. Wildlife Resources Commission.

E. Gun and Ammunition manufacturers.

1. Browning Arms Co., Morgan, Utah 84050.
2. Remington Arms Co., Inc., Bridgeport, Connecticut 06602.
3. Winchester, Western Division, Olin Corp., 275 Winchester Ave., New Haven, Connecticut.
4. Ithaca Gun Company, Inc., Ithaca, New York 14850.
5. Harrington and Richardson, Worcester, Massachusetts.
6. The Marlin Firearms Co., 100 Kenna Drive, North Haven, Connecticut 06473.
7. Savage Arms, Westfield, Massachusetts 01085.
8. Federal.
9. Mossberg Arms.
10. High Standard Arms.

I. ROCK COLLECTION

II. DESCRIPTION:

- A. Concrete form with Rocks imbedded and identified.
- B. Located on Nature Trail if possible.

III. RATIONALE:

- A. This unit is designed to familiarize individuals with types of rocks common to the area and to North Carolina.
- B. Should be applicable to the different sciences and agricultural programs, especially in the study of soils and land judging.

IV. REQUIREMENTS:

- A. Rock specimens.
- B. Facility for mounting specimens permanently. (See sketch below)

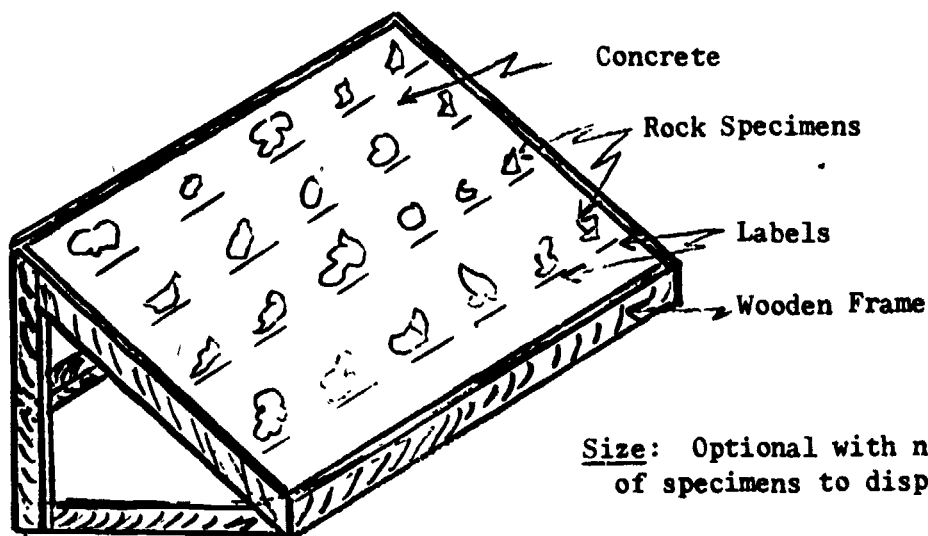

V. RESOURCES:

- A. Local Soil Conservation Service
- B. Local geologist or local college or university geology dept.
- C. Local "rock hound".
- D. Book references
 - 1. Zim's Golden Nature Guide
 - 2. Physical, Geology by Leet and Judson
 - 3. Historical Geology by Dunbar and Waage

STATION NO. 24

I. TREE GROWTH DEMONSTRATION:

II. DESCRIPTION:

- A. An existing forest area.
- B. Establish a new forest.

III. RATIONALE:

- A. Relate tree growth in different forest situations.
- B. Relate tree growth to different types of management practices.

IV. REQUIREMENTS:

- A. A forestry plot on school ground or on adjoining lands.
- B. Cross sections of different tree species illustrating growth and age.

- 1. Cross section of log.
- 2. Cross section of stump.

(See Diagram Below) You may wish to check the tree age and mark on layers the point in history when this layer was being formed: ie, The American Revolution, WWI, WWII, etc.

- C. Assortment of forestry tools.

V. FFA AND SDE:

- A. Forestry contests.
- B. Proficiency award in forest management.
- C. Soil and Water Proficiency Award.

VI. RESOURCES:

- A. County forester.
- B. Local saw mill.
- C. Pulp and paper company.
- D. Forestry textbook.

DIAGRAM:

- A ... Cambium
- B ... Inner Bark
- C ... Outer Bark
- D ... Sapwood
- E ... Heartwood
- F ... Pith
- G ... Pith Rays

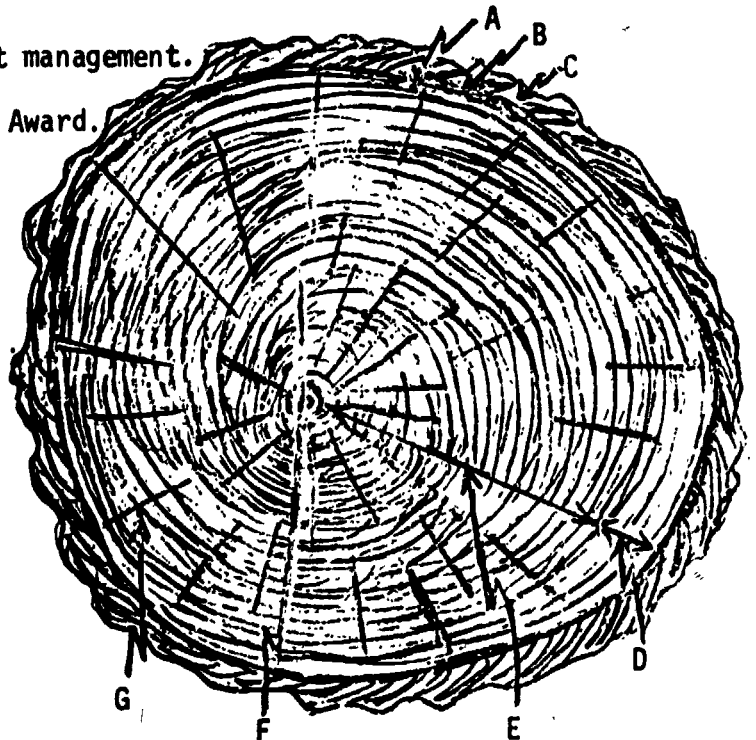

I. WILDLIFE HOUSES:

II. DESCRIPTION:

- A. Bird houses
- B. Squirrel houses
- C. Wood duck house

III. RATIONALE:

This unit is designed to familiarize individuals with types of houses for different wildlife species and acquaint them with the construction and materials used in the construction of these houses.

- A. Acquaint students and general public with types of houses for the different species.
- B. Acquaint individuals with materials useful in construction of the various houses.

IV. REQUIREMENTS:

- A. Bird houses for the different birds that will nest in houses and construction materials.
- B. Squirrel boxes and construction materials.
- C. Wood duck boxes and construction materials.
- D. Nature trail or applicable school grounds.
- E. Corner of pond.
- F. Trees on campus or nature trails.
- G. FFA and SOE Construction materials.

* Attach Bcx to tree with crimped wire to allow tree growth.

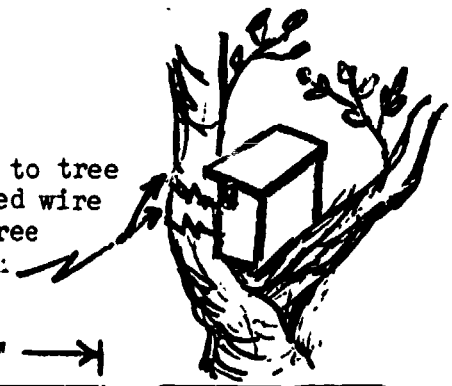

SQUIRREL BOX

| MATERIALS LIST | |
|----------------|-----------|
| Front | 8" x 20" |
| Back | 8" x 20" |
| Sides | 10" x 20" |
| Top | 12" x 14" |
| Bottom | 8" x 8" |

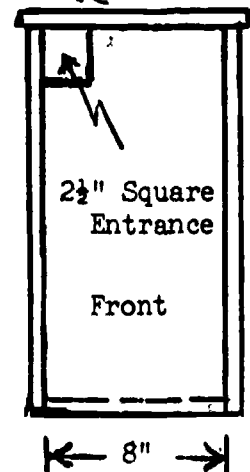
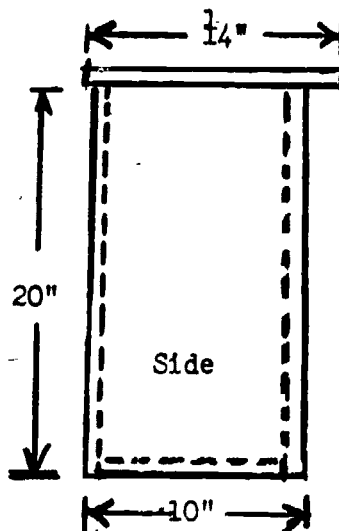

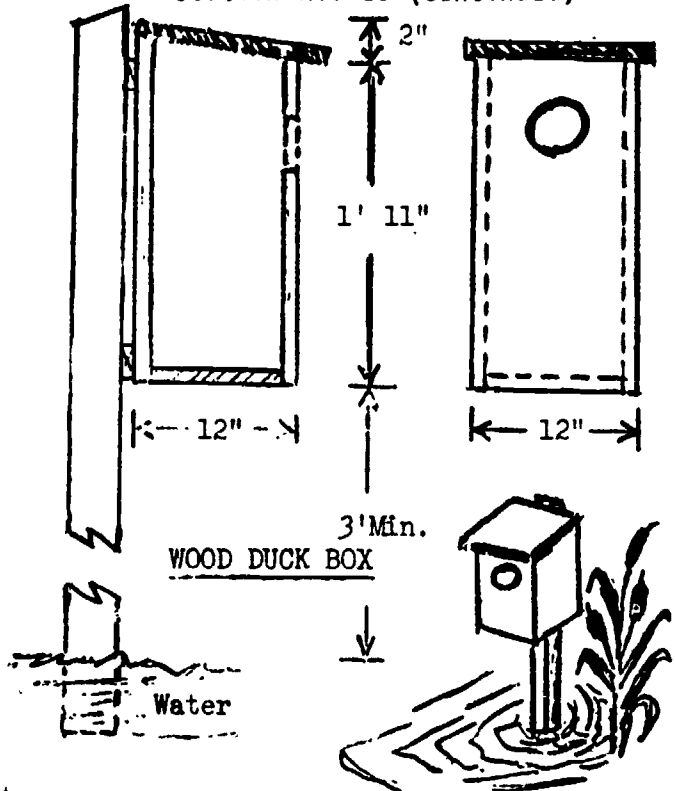

WOOD DUCK BOX

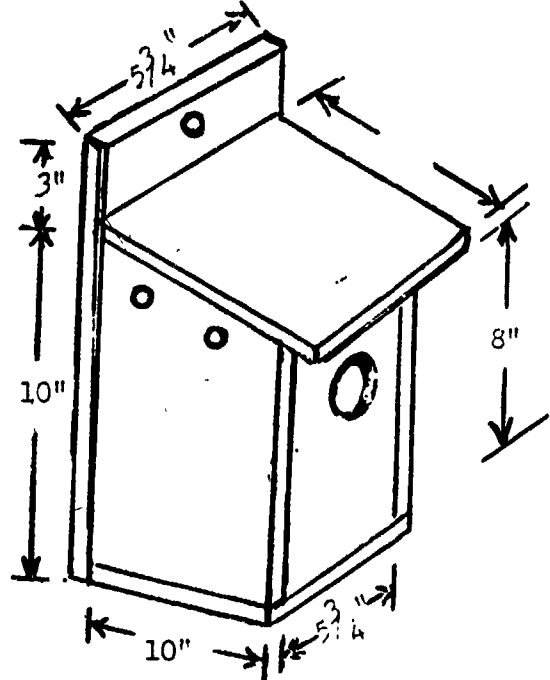

HOUSES FOR BIRDS

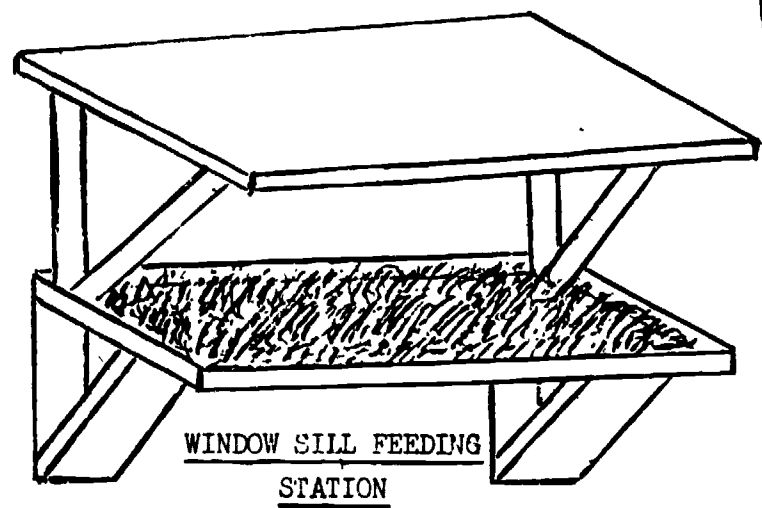

WINDOW SILL FEEDING STATION

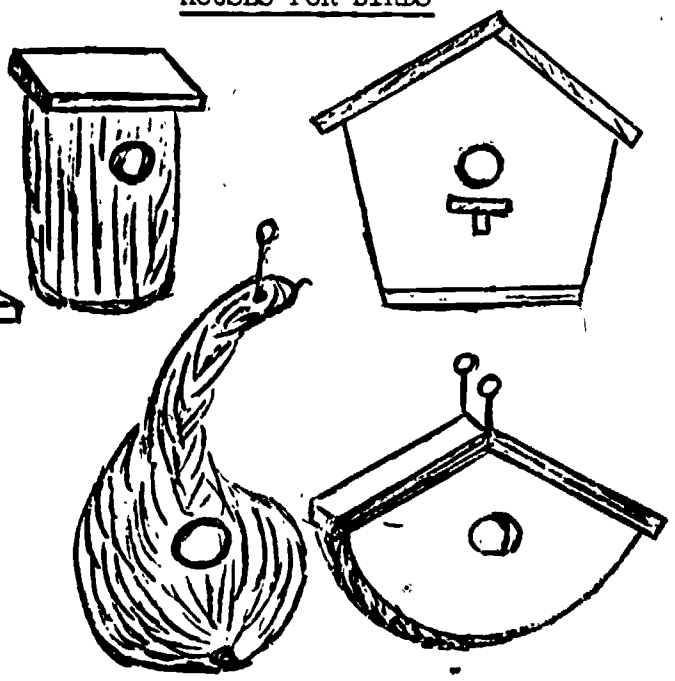

V. FFA AND SOE:

- A. Applicable to fish and wildlife management award.
- B. Project for BOAC program for the community.
- C. Possible fund raising project.
- D. An excellent hobby that can develop into a small part-time business.

VI. RESOURCES:

- A. Bird Furniture, N. C. Wildlife Resources Commission.
- B. Tarheel Wildlife on the Farm, N. C. Wildlife Resources Commission.

STATION NO. 26

I. GAME FEEDING PLOT:

II. DESCRIPTION:

Areas of land which can be seeded with appropriate wildlife food and cover crop and clearly labeled as to the type of cover used. Areas as small as 1/8 acre can serve a two-fold purpose by supplying individuals with an opportunity to study the various types of foods used by wildlife.

III. RATIONALE:

This unit is designed to familiarize the individual with different types of food and cover used to attract and hold different wildlife species in an area. Students will be provided an opportunity in establishing and maintaining the game breeding plots.

IV. REQUIREMENTS:

A. Land - Almost any wasted or unused area can be suitable for use as a game feeding plot, thus eliminating the need for securing any special lands. Roadside banks, eroded gullies power line right-of-way, or idle farmlands may be planted with the appropriate seed or seedlings to produce a game feeding plot display.

B. Equipment:

1. Tractor with bog or tiller.
2. Hand tools (shovels, rakes, etc.)
3. Fertilizer and lime.
4. Seeds (available free from the N. C. Dept. of Wildlife).
5. Signs or labels.
6. Mowers.

C. Time for Development: Complete development in 1-3 years, depending on types of seed used.

V. RESOURCES:

- A. Local Soil Conservationist.
- B. Tarheel Wildlife on the Farm, N.C. Wildlife Resources Comm., Raleigh, N.C.
- C. Farmers Bulletin #2035, "Making Land Produce Wildlife," U. S. Dept. of Agriculture, Superintendent of Documents, Washington, D. C.
- D. Our Wildlife Neighbors, N.C. Wildlife Resources Commission, Raleigh, N.C.
- E. Principles of Game Management, Madson, John and Kozichy, Olin Mathieson Chemical Corp., East Alton, Illinois 1962.

Station No. 26 (continued)

VI. COMMENTS:

The development of a game feeding plot display can be interrelated with many other areas of study such as Soil and Water Management Contests and proficiency awards, wildlife management, and land judging contest. The development of game feeding plot displays will allow students to gain the experience needed to establish their own game feeding plots on their farms or on lands unsuitable for farming.

STATION NO. 27

I. HORSES, RIDING STABLES AND RIDING RING:

II. DESCRIPTION:

A minimal facility of one typical stable plus adequate storage area. (See below). Also a show ring with judges stand. A riding trail layed out with typical stop or interest stations identified.

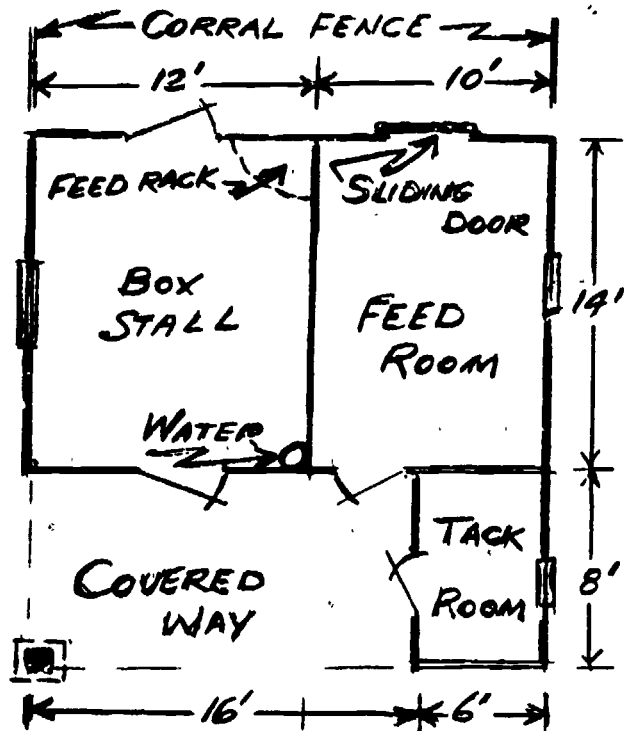
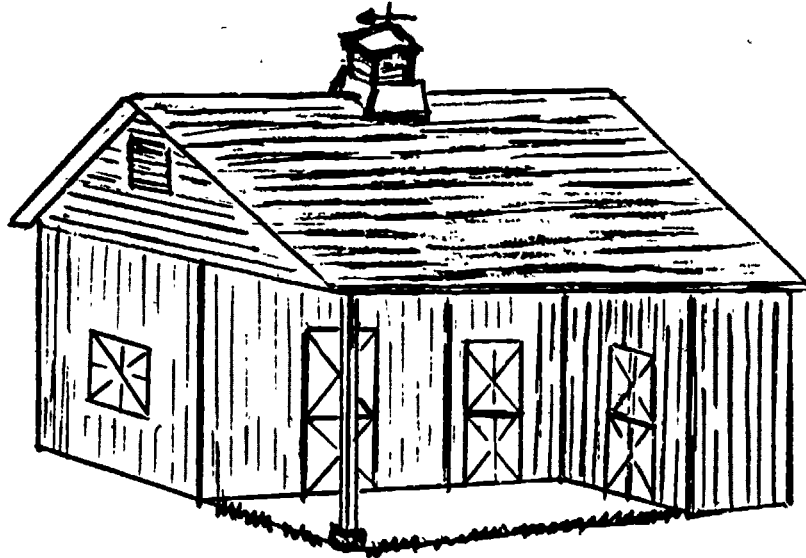

A Suggested Show Ring:

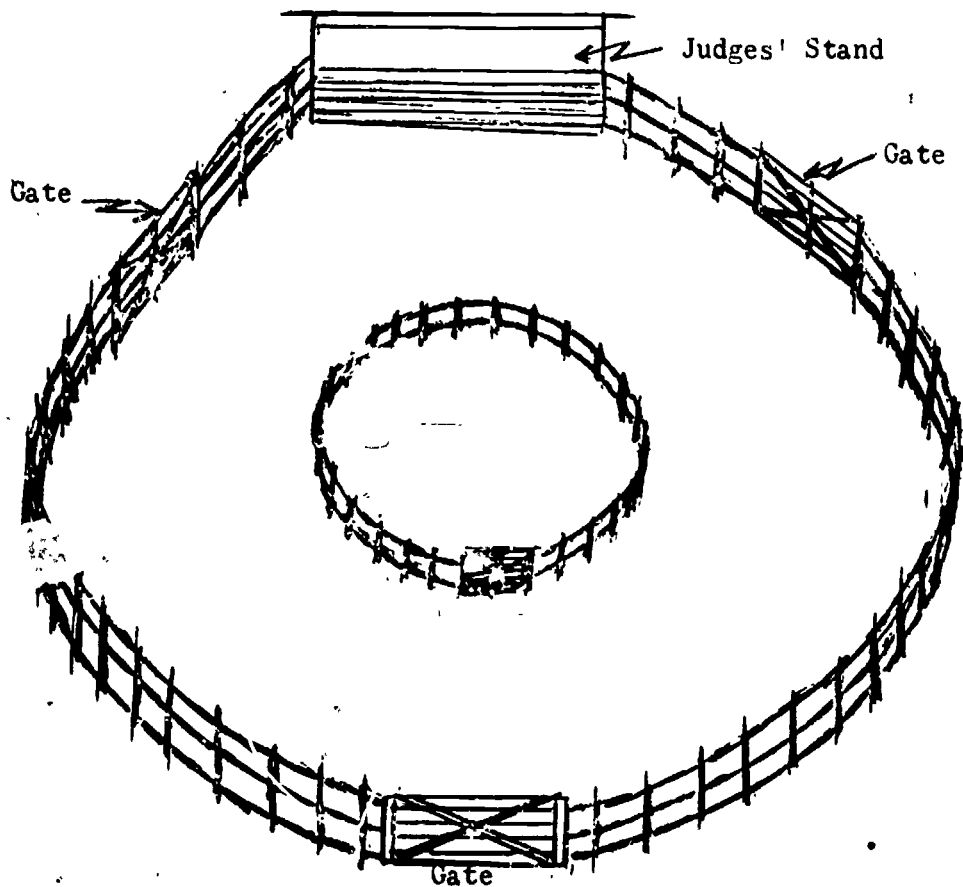

NOTE:

Size will vary with amount of ground available and amount of use that will be made of facility

Jumping Obstacles:

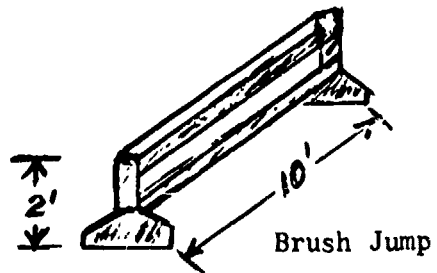
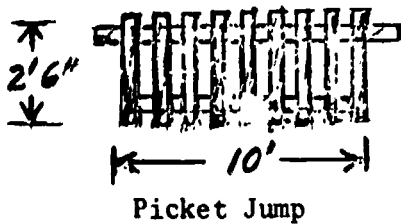
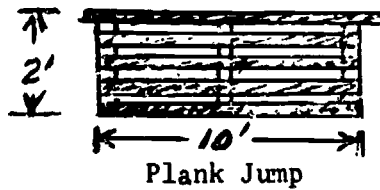
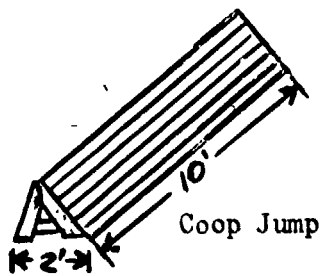

III. RATIONALE:

- A. To familiarize students with scope of riding stables enterprise.
- B. To familiarize students with kinds of horses and ponies kept in a riding stable and to help them develop skills involving horse husbandry.
- C. To familiarize students with basic facilities needed for riding stable enterprise.
- D. To familiarize students with basic equipment needed for riding stable enterprise.
- E. To enable students to acquire managerial skills necessary to work in this enterprise area.

IV. REQUIREMENTS:

- A. Construction typical stable and equipment storage area.
- B. Construction of typical show ring.
- C. Lay out of typical riding trail.
- D. Availability of one or more horses or ponies.
- E. Time for development: 3 years.

V. RESOURCES:

- A. Ensminger, M. E., Horses & Horsemanship, The Interstate Printers, Danville, Illinois, 1969.
- B. Ensminger, M. E., The Stockman Handbook, The Interstate Printers, Danville, Illinois, 1970.
- C. Ensminger, M. E., Animal Science, The Interstate Printers, Danville, Illinois, 1969.
- D. Smith-Partin-Champlin Rural Recreation for Profit, The Interstate Printers, Danville, Illinois, 1968.
- E. How To Become A Better Rider, Farman Horse Library, 1972 8701, N. 29th. Street, Omaha, Nebraska 68112.
- F. Widmer, Jack, A Practical Guide For Horse Owners, Charles Sireburs Sons, New York 1956.
- G. Ulmer Jurgenson, Approved Practices In Raising and Handling Horses, The Interstate Printers, Danville, Illinois, 1974

STATION NO. 28

I. POISONOUS PLANTS DISPLAY:

II. DESCRIPTION:

- A. Existing poisonous plants labeled on the nature trail.
- B. Color slide series for teaching purposes (locally developed).
- C. Plot of "cultivated" poisonous plants if desired.
- D. Wall posters and/or pictures for classroom display.

III. RATIONALE:

- A. For students and others to learn to identify poisonous plants in order that they may be aware of the danger and take the necessary precautions when involved in outdoor recreation or outdoor occupations.
- B. To assist in creating interest in the FFA chapter safety contest.

IV. REQUIREMENTS:

- A. Land - 100 square feet for plant plot if live plants are used.

B. Equipment:

1. Plastic gloves
2. First aid kit
3. Pruning shears
4. Sprayer for control
5. Chemical disinfectant for tools
6. Label maker (metal tape)
7. Plant drying press
8. Camera 35mm and slide film
9. Slide projector
10. Projection screen
11. Pictures or posters
12. Fence and posts

C. Facilities:

1. Existing land on the school campus and in the local community.
2. Display case for mounted plants.
3. Bulletin board.
4. Demonstration plot enclosed with fence for growing plants.

- D. Time for Development: three years with continued maintenance.

V. RESOURCES:

1. Don't Eat the Daisies by Luther Partin.
2. National Safety Council.

Station No. 28 (continued)

3. Poisonous Plants, N. C. Extension Service.
4. N. C. Museum of Natural History, Raleigh, N. C. (Eugene Upchurch).
5. USDA, Washington, D. C.
6. "To Your Health" by Paul Metzger, M. D., Carolina Cooperator, May, 1971.
7. Boy Scout Handbook.

STATION NO. 29

I. CHEMICAL CONTROL PLOT:

II. DESCRIPTION - A small area of land to demonstrate the use and benefits of agricultural chemicals.

III. RATIONALE:

- A. To demonstrate the effects of proper use of various insecticides, herbicides, fungicides, and fertilizer.
- B. To develop an appreciation for the benefits and problems of using chemicals.
- C. To provide students the necessary instruction and practice in the area of pesticide safety.
- D. To introduce students to occupations related to the manufacturing, use, and sale of chemicals.
- E. To demonstrate to students the opportunities of improving supervised practice programs through the correct use of various chemicals.
- F. To stimulate interest in the FFA Chapter Safety Contest.

IV. REQUIREMENTS:

- A. Land - 500 sq. feet of land plus greenhouse.
- B. Equipment - sprayer, methyl bromide applicator, chemicals, fertilizer applicator, rubber gloves, respirator, rotary tiller, polyethylene cover.
- C. Facilities - land and greenhouse.
- D. Time for development - one year with continuous updating.

V. REFERENCES:

- 1. N. C. Agricultural Chemicals Handbook, 1974, N. C. Extension Service, Raleigh, N. C.
- 2. Chemical Weed Control Information for North Carolina, 1972, Leaflet 174, N. C. Extension Service, Raleigh, N. C.
- 3. Insect Control for Vegetable Gardeners, N. C. Extension Service, Raleigh, N. C.
- 4. N. C. Fertilizer Handbook, N. C. Department of Agriculture, Raleigh, N.C.
- 5. N. C. Agricultural Workers Handbook, N. C. Extension Service, Raleigh, N.C.

BOOKS

1. Pond Life, Ford, Richard L.E., Morrison and Gibb Limited, London, England, (Could possibly be found in library. One copy recommended.)
2. Our Natural Resources, McNall and Kircher, The Interstate Printers and Publishers, Inc., Danville, Illinois. (This book deals with maintaining our natural resources and our total environment.)
3. Rural Recreation for Profit, Smith, Partain, and Champlin, The Interstate Printers and Publishers, Inc., Danville, Illinois. (This book will be valuable to people in planning, developing, managing and operating recreational enterprises.)
4. North Carolina Lands, Pomeroy and Yoho, The American Forestry Association, 917 17th Street, N. W., Washington, D. C. 20006. (The American Forestry Association traces the state, county, municipal, private, and federal ownership of forest lands in North Carolina with recommendations for future use.)
5. That We May Live, Whitten, D. Van Nostrand Company, Toronto, Canada. (Facts about the effects of pesticides on our national health are presented, their use, dangers, and contribution to our welfare. One copy recommended.)
6. From Sea to Shining Sea, Superintendent of Documents, U.S. Government Printing Office, Washington, D. C. 20402, \$2.50. (The President's Council on Recreation and Natural Beauty and the Citizens Advisory Board on Recreation and Natural Beauty presents information on the urban and rural environment in the U. S. and agencies sharing responsibility for action. One copy recommended.)
7. The Outdoor Schoolroom for Outdoor Living, Vinal, Cohasset, Mass. (This book is available from library at N. C. State University, Raleigh, N. C. and possibly from other large libraries.)
8. How to Plan and Plant Your Own Property, Ireys, M. Barrows and Company, Inc., New York, New York. (A well illustrated book on the design and use of plant materials in landscaping homes and cottages. One copy recommended.)
9. The Ray Harm Nature Sketch Book, Harm, The World Publishing Co., 2231 West 110th Street, Cleveland, Ohio 44102. (This book contains pictures of birds, animals, and flowers with information about each. Recommended for biology and outdoor recreation and applied ecology. One copy.)
10. Basic Gardening Illustrated, Lane Books, Menlo Park, California, \$2.95. (Self illustrated book on planning and remodeling landscape plans. One copy per student.)
11. Career Education in the Environment, U.S. Office of Education, Superintendent of Documents, U.S. Government Printing Office, Washington, D. C. 20402. (This book is designed to be used to explore environmental problems and solutions and to provide information on existing and emerging career opportunities.)
12. Guidelines to Planning, Developing, and Managing Rural Recreational Enterprises, Bulletin 30, Coop. Extension Service, V.P.I., Blacksburg, Virginia. (One copy recommended.)

Books (continued)

13. Conservation for Camp and Classroom, Bale, Burgess Publishing Co., 426 South 6th Street, Minneapolis 15, Minnesota. (This book is to serve as a guide to meaningful activities, demonstrations and activities that can be used by instructors. One copy.)
14. Techniques for Teaching Conservation Education, Brown and Jouser, Burgess Publishing Co., 426 South 6th. Street, Minneapolis 15, Minnesota. (One copy.)
15. Forests and Forestry, Anderson and Smith. The Interstate, 19-27 N. Jackson St., Danville Illinois. (Provides information on forestry management. One per student.)
16. NAPC Abstract Bulletin, U. S. Department of HEW, Public Health Service, Volume 1, No. 10, National Air Pollution Control Administration, 1033 Wade Avenue, Raleigh, N. C. 27605. (This bulletin has information pertaining to technical literature recently acquired by National Air Pollution Control Adm. One copy.)
17. Nature Study for Conservation, Brainerd, The McMillan Company, New York, New York. (This book should help biology and agriculture students in studying nature so that they may decide on appropriate conservation practices. Three or four copies.)
18. Nature Recreation, Vinal, Dover Publications, Inc., 180 Varick St., New York 14, New York. (This book deals with nature recreation, trips, activities, trails, and suggested leadership experiences.)
19. Understanding Ecology, Billington Fredrick Warne and Co., New York, New York (\$4.50)
20. Wild Flowers of N. C., Justice, Chapel Hill Press, Chapel Hill, N. C. (\$7.95)
21. Weather, Lehr, Western Publ. Co., Racine, Wisc. (\$1.50)
22. Our Soils and Their Mgt. Donahue, Interstate, Danville, Ill.
23. Turf Mgt. Handbook, Sprague, Interstate, Danville, Ill.

MAGAZINES AND BULLETINS

1. American Education Magazine, May, 1971, Article: Environmental Education Cannot Wait. HEW, Office of Education, Washington, D. C. (Librarian can subscribe for this free.)
2. Environmental Education, March, 1971, Department of Public Instruction, Raleigh, N.C. (Covers environment problems, sociocultural environmental and suggested environmental educational activities.) (Free)
3. Manual of Outdoor Interpretation, By: Joseph J. Shomon, National Audubon Society, Nature Centers Division, 1130 Fifth Avenue, New York, New York 10028, price \$3.00. (Includes nature appreciation, national park system, forest, parks, outdoor labs, camps, underwater world and caves.)
4. Career Opportunities: Ecology, Conservation, and Environmental Control, J. G. Ferguson Publishing Co., Chicago Illinois. (Contents: Careers in outdoor recreation and applied ecology.) Price \$6.95.
5. The American Rifleman Magazine, By: National Rifle Association of America, 1600 Rhode Island Ave., N.W., Washington, D. C. 20036, Cost \$7.50 per year.
6. Wildlife Magazine, By: North Carolina Wildlife Resource Commission, Raleigh, N. C. 27602. Cost \$2.00 per year.
7. It's Your World, the grassroots conservation story, U.S. Department of Interior Conservation Yearbook #5, \$2.00, Superintendent of Documents, U.S. Government Printing Office, Washington, D. C. 20402.
8. The Third Wave America's New Conservation Man ... An Endangered Species? The Population Challenge ... What it Means to America, River of Life ... Water: The Environmental Challenge, Quest for Quality. (These five and the one listed in number 7 above are six publications from the Department of Interior at a total cost of \$11 .. (Recommended 1 set per teacher).
9. Wildlife Conservation Programs of FFA, Minnesota Department of Education, Capital Square Building, St. Paul, Minnesota, 55101.
10. FFA Mallard Release Program, address same as number 9 above.
11. The Nature Program at Camp, Janet Nickelsburg, Burgess Publishing Co., 426 S. 6th. Street, Minneapolis 15, Minnesota. (Includes: nature crafts, camps, and basic camp training guide). Recommend 1 per teacher.
12. Camping and Trailering Guide Magazine, Rajo Publications Inc., 319 Miller Avenue, Mill Valley, California 94941. Cost \$5.50 per year. (Recommend one copy per school.)
13. Deer Lake Lodge - Worksheets on Ecological Subjects. Environmental Education Center, 13 Veterans Dr., Oteen, N. C.
14. Developing On - Site Nature Trails, Environmental Education Center, 13 Veterans Dr., Oteen, N. C.

Magazines and Bulletins (continued)

15. Teaching Aids for Environmental Science, January, 1971, Science and Math Teaching Center, Michigan State University, East Lansing, Michigan. (Contents: Forestry, earth science, water, air pollution suppliers, weather and water testing equipment.)
16. Publications of the National Audubon Society, National Audubon Society, Nature Center Planning Division, 1130 Fifth Avenue, New York, New York 10028. (Recommended for school library.)
17. North Carolina Wildlife Resources Commission Publications. Included Birds - 6 pub., Fish - 10 pub., Game Birds and Animals - 13 pub., Miscellaneous - 5 pub., Regulations - 9 pub., Raleigh, N. C. 27602. (See Bibliography in curriculum guide.)
18. Elementary Guide to the Mesic Hardwood Hammock Nature Trail, University of West Florida Campus, Pensacola, Florida. (Description of a nature trail established in Florida.)
19. The Edward Ball Nature Walks, A hardwood swamp By: Joe A. Edmisten, Gamma College, University of West Florida, Pensacola, Florida. (Description of a nature trail in a swampy area of Florida.)
20. Occupations in Environmental Control, ERIC Clearinghouse on Vocational and Technical Education, The Center for Vocational and Technical Education, Ohio State University, 1900 Kenny Road, Columbus, Ohio 43210. (One set per school).
21. Outdoor Classrooms on School Sites. A booklet illustrating the wide variety of outdoor learning stations. For sale by the Superintendent of Documents, U.S. Government Printing Office, Washington, D. C. 20402. Price \$.25, Stock No. 0100-1458.
22. Teaching Soil and Water Conservation - A Classroom and Field Guide. A guide depicting experiemnts in soil and water conservation with interpretations of the results of the experiments. One copy for each student is recommended. This monthly magazine provides information on land and water conservation. It is useful to teachers and to students in grades 7 and above. Order by subscription from the Superintendent of Documents, U. S. Government Printing Office, Washington, D. C. 20402. \$2.00 per year.
23. An Outline for Teaching Conservation in Elementary Schools. Recommended for use with #3 above. Available from same source, same price.
24. Cooperative Education in Vocational Agriculture - Guide for Developing Courses in North Carolina Schools Recommended for teachers of agriculture, principals, counselors, superintendents, local directors, agricultural businessmen, and others interested in adding the cooperative approach to the vocational agriculture program. Free of charge from the Division of Occupational Education, State Department of Public Instruction, Raleigh, N. C. July 1971.
25. Science Materials - Preparation and Exhibition for the Classroom. A valuable publication for use as a step-by-step guide to the preparation of materials for display. Recommended one per student. William C. Brown Company Publishers, 135 South Locust Street, Dubuque, Iowa 52003.

Magazines and Bulletins (continued)

26. Science Materials - Preparation and Exhibition for the Classroom. A valuable publication for use as a step-by-step guide to the preparation of materials for display. Recommended one per student. William C. Brown Company Publishers, 135 South Locust Street, Dubuque, Iowa 52003.
27. Tree Identification Manual for 4-H Members. Published by The N. C. Agricultural Extension Service, Raleigh, N. C.
28. Careers in Wildlife Conservation. A description of the duties, training requirements and salaries associated with the various careers. Conservation Dept., Olin Mathieson Chemical Corp., East Alton, Illinois.
29. Nature Trails, Extension Bulletin # 368, Agricultural Extension Service, University of Minnesota, St. Paul, Minn. 55101
30. Weather, A price list of publications, stock # 9000-4857, Supt. of Documents, Washington, D. C. 20402.
31. LaMotte Catalog, LaMotte Chemical Co., Chestertown, Md. 21620.
32. Land Judging In N. C., N. C. Extension Service Publication.
33. Boy Scouts of America Archery Merit Badge Manual.
34. NASCO Catalog, Ft. Atkinson, Wisc. 53538.
35. Herters Catalog, Herter's Inc. Mitchell, S. D. 57301.
36. Graves - Humphries Catalog, Roanoke, Va.
37. Ben Meadows Co. Catalog, Atlanta, Ga. 30306, 553 Amstedam Ave, N.E.
38. Forestry Suppliers Catalog, 205 W. Rankin St., Jackson, Miss. 39204.
39. Broadhead - Garrett Co. Catalog, 1213 Riverside Dr., Macon, Ga. 31201.
40. Fur, Fish and Game Magazine, Harding Pub. Co. 2878 E. Main St., Columbus, Ohio 43209 (\$4.00 per year)
41. Environmental Educ. Series, (Land Use, Noise, Plants, Water, Animals, Agri. Chemicals and Radiation, Air, Understanding the Environment) State of Washington Coordinating Council for Occupational Education 216 Old Capital Building, Olympia, Washington, 98504. (\$8.00)

SLIDES \

Slides Available From:

Technical Audiovisual Branch
Office of Technical Information and Publications
Technical Center
Research Triangle Park
North Carolina 27709

"Air Pollution Effects on Vegetation"

Produced and Distributed by:

California State Polytechnic College
Vocational Education Productions
San Luis Obispo, California 93401

Slides Available From:

Library at Visual Aids Department
N. C. State University
Box 5037
Raleigh, N. C. 27607

"Keep North Carolina Livable"

22 minutes, 30 sec. 7 1/2 IPS.

A narrated slide set designed to give a balanced picture of the major causes and effects of pollution in North Carolina. The presentation also includes practical examples of how Tar Heel citizens are working to reduce pollution and clean up their environment.

FILMS

Available From:

National Audiovisual Center
Washington, D. C. 20409

- a. "Air Pollution and Plant Life"

Available From:

Library at Visual Aids Department
N.C. State University
Box 5037
Raleigh, N. C. 27607

- a. "The Choice is Yours"
13 1/2 min. Color
- b. "Air Pollution and Plant Life"
19 min. Color

Available From:

Wildlife Resources Commission
Box 2919
Raleigh, N. C. 27602

- a. "Conservation and Balance in Nature"
- b. "Estuarine Heritage"

(See Appendix C Under Ecology in your guide Outdoor Recreation and Applied Ecology)

- c. "Cry of the Marsh"
(See guide - Pollution and Habitat Destruction)
- d. "George Washington's River"
(See guide - Pollution and Habitat Destruction)
- e. "The Persistent Seed"
(See guide - Pollution and Habitat Destruction)
- f. "Islands of Green"
(See guide - Nature Study)

Films (continued)

Request Catalog From:

Modern Talking Picture Service, 503 N. College St., Charlotte, N. C. 28202
and 2323 New Hyde Park Rd., New Hyde Park, N.Y. 11040

Department of Interior, Washington, D. C.

Miscellaneous:

1. Membership in: Outdoor Life Book Club.
2. Agencies for Resource People

List of Resource Agencies: Raleigh, N. C. 27611

Travel and Promotion Office (industrial, tourists, and community resource office)

(Administration Building)

North Carolina State Parks (Administration Building)

Forestry Resources Office (Administration Building)

Water and Air Resources Office (Old Health Building)

Wildlife Resources Commission (Albemarle Building)

State Museum (Agriculture Building)

State Department of Agriculture (Agriculture Building)

Recreation Resources Office (436 N. Harrington Street)

Archives and History Building (Jones Street)

Earth Resources Office (112 W. Lane St.)

Division of Occupational Education (5th. Floor Education Building)

State Board of Health

Also:

Local Health Department

Soil Conservation Service

Local Game Protector

Local Wildlife Club