

DOCUMENT RESUME

ED 108 055

CG 009 870

AUTHOR Mannebach, Alfred J.  
 TITLE A System for Installing Occupational Experience Programs in Local Schools.  
 PUB DATE 31 Mar 75  
 NOTE 18p.; Not available in hard copy due to marginal legibility of original document

EDRS PRICE MF-\$0.76 PLUS POSTAGE. HC Not Available from EDRS.  
 DESCRIPTORS Career Choice; \*Cooperative Education; Counseling; Decision Making; \*Educational Programs; \*School Community Relationship; Secondary Education; Speeches; \*Vocational Development; \*Work Study Programs

ABSTRACT

The purpose of this paper is to provide an awareness of the broad variety of educational programs which use the community or the work environment as a part of the curricula, to help school officials realize the benefits of using the work environment to enhance the educational program, and to suggest ways of installing occupational experience programs--either general work experience or cooperative occupational education--in local schools. Properly funded, conceptualized, planned, coordinated and implemented occupational experience programs are one of the great "untapped resources" for making education relevant for many students. Some type of occupational experience program should be an integral part of every school system in the nation. (Author/PC)

\*\*\*\*\*  
 \* Documents acquired by ERIC include many informal unpublished \*  
 \* materials not available from other sources. ERIC makes every effort \*  
 \* to obtain the best copy available. nevertheless, items of marginal \*  
 \* reproducibility are often encountered and this affects the quality \*  
 \* of the microfiche and hardcopy reproductions ERIC makes available \*  
 \* via the ERIC Document Reproduction Service (EDRS). EDRS is not \*  
 \* responsible for the quality of the original document. Reproductions \*  
 \* supplied by EDRS are the best that can be made from the original. \*  
 \*\*\*\*\*

A SYSTEM FOR INSTALLING OCCUPATIONAL  
EXPERIENCE PROGRAMS IN LOCAL SCHOOLS

DR. ALFRED J. MANNEBACH  
Associate Professor  
Department of Higher, Technical and Adult Education  
School of Education  
University of Connecticut

U S DEPARTMENT OF HEALTH,  
EDUCATION & WELFARE  
NATIONAL INSTITUTE OF  
EDUCATION

THIS DOCUMENT HAS BEEN REPRODUCED EXACTLY AS RECEIVED FROM THE PERSON OR ORGANIZATION ORIGINATING IT. POINTS OF VIEW OR OPINIONS STATED DO NOT NECESSARILY REPRESENT OFFICIAL NATIONAL INSTITUTE OF EDUCATION POSITION OR POLICY.

Paper Presented at the  
American Educational Research Association  
Special Interest Group on  
Systems Research

March 31, 1975

Annual Meeting  
American Educational Research Association  
Washington, D.C.

BEST COPY AVAILABLE

HARD COPY NOT AVAILABLE

2

ED108055

0009870

# A System For Installing Occupational Experience Programs in Local Schools

by

Dr. Alfred J. Mannebach

Occupational experience programs have been proclaimed to be one of the great "untapped resources" for helping students gain vocational maturity, make the successful transition from school to work, and prepare for adulthood.

Students, schools, employers and the community benefit from the program. In communities where occupational experience programs are in operation, a close relationship exists between the school and the business, industry and labor community.

Many schools have made use of the work environment as part of their curricula. Yet, occupational experience programs are unheard of in a large percentage of schools. Why does this situation prevail? Several reasons are proposed. Board of education members and school administrators may not be familiar with occupational experience programs. They may not recognize the need for and the purposes of such programs. They may not be aware of the benefits to be derived from cooperative arrangements, **not** understand how to initiate and install occupational experience programs in their schools.

A large part of the problem and confusion lies in the definition of occupational experience programs. For the purposes of this paper, two primary types of occupational experience programs presented in Mason and Haines (1972) will be discussed.

They are general work experience and cooperative occupational education. Both programs have several characteristics in common. Each uses the work situation as a means of enhancing learning. Both are school based and supervised. Both require school approval of the job and provide course credit

for the work experience received. However, there are significant differences between the two programs.

General work experience programs are designed to provide students with maturing experiences through employment that will help them become productive, responsible individuals. Such programs provide limited supervision and are for short periods of time. There is no correlation between the courses enrolled in at school and the tasks performed on the job. Students participating in general work experience programs may or may not be paid, and are usually not enrolled in a related class. They usually participate in the program for work experience and for general education values.

A cooperative occupational education program combines learning experiences gained through regularly scheduled supervised employment in business and industry and vocationally oriented in-school instruction. It is vocational in nature. The employer provides a laboratory where students have the opportunity to apply the principles they have learned in school. In this program, each student has a defined occupational goal. Training stations are selected by the school coordinator and experience on the job is correlated with in-school instruction. Students enrolled in a cooperative occupational education program receive pay and school credit. They are hired as learning workers. They earn while they learn. The program is more intensive, longer in duration, and more occupationally oriented than a general work experience program.

The differences between the two programs described are quite explicit. But terminology and variation of the basic programs further complicate the situation. What has been described here as a general work experience program has been referred to in some schools as cooperative work training, occupational work experience, occupational work adjustment or cooperative work experience.

What has been described here as cooperative occupational education has been referred to in some schools or states as cooperative vocational education, work experience, or concurrent work education.

Combine this terminology with variations of the basic programs described. Titles such as career orientation, career exploration, work observation, work exploration, cooperative work experience, work study, internships, diversified occupations and interrelated cooperative vocational education describe related programs. Such terminology is descriptive of specific types of programs in given states or local school systems.

The examples provided here are illustrative only. It is not the purpose of this paper to define and describe each of these programs in detail. All programs and terminology have emerged for a given purpose at a specific point in time. The purpose of this paper is to provide an awareness of the broad variety of educational programs which use the community or the work environment as a part of the curricula; to help school officials realize the benefits of using the work environment to enhance the educational program, and to suggest ways of installing occupational experience programs, either general work experience or cooperative occupational education, in local schools.

Mason and Haines (1972) state that the work environment is used by educational institutions to accomplish one or more of six major purposes or goals:

- 1: To keep over-age pupils (or under-achievers and potential dropouts) in school part time while they obtain needed general education.
2. To help pupils and college students to explore the world of work and to assist them in occupational choice-making.
3. To help maladjusted pupils with personality and behavior problems.
4. To help students earn money who otherwise would need to drop out.

5. To provide practice in what has been learned in the classroom and to assist in the transition from school to job.
6. To develop general and specific occupational skills, knowledges, and attitudes, particularly those not readily available in the school's laboratories.

A New York State Department of Education publication (1972) identifies the advantages and benefits of cooperative occupational education programs.

For the student, a cooperative occupational experience program

- provides a realistic learning setting in which he may discover his time interests and abilities;
- develops an understanding of employment opportunities and responsibilities through direct on-the-job experiences;
- provides exposure to basic information regarding agriculture, business, industry, and service occupations needed for intelligent life choices;
- develops work habits and attitudes necessary for individual maturity and job competence;
- provides a laboratory for developing marketable skills;
- gives meaning and purpose to the theoretical and practice assignments presented in the school situation;
- provides firsthand experience with other employees which leads to a better understanding of the human factors in employment;
- provides financial rewards while learning employment skills and understanding;
- provides an opportunity to participate in and profit from two types of learning environment--school life and employment;
- provides an effective test of aptitude for a chosen field of work.

For the school, a cooperative occupational experience program

- enlarges the learning facilities available for students without a major expenditure for laboratory equipment;
- brings employers and the school together in a training effort to develop a strong occupational program;

- brings to the school a wealth of social and technical information which may be used as the basis for effective instruction for the varied needs of students;
- provides the school an effective means of evaluating its overall instructional program;
- increases the holding power of the school by helping students clarify career goals and by providing a practical means of reaching them.

For the employer, a cooperative occupational experience program provides

- the opportunity to become a partner in selecting, instructing, and educating young workers in the skills and understandings needed;
- assistance of the school in instructing and counseling the cooperative student during the transition and adjustment period from the school to the job;
- access to job applicants who are likely to remain in the positions upon graduation;
- a source of new workers who are receptive to instruction;
- an opportunity to render an important public service.

For the community, a cooperative occupational experience program

- provides an effective means of developing young people for productive citizenship in the community;
- increases the economic health as companies are able to meet their needs for skilled workers;
- provides a method of introducing high school students to local employment opportunities;
- provides an opportunity to develop a unified training program;
- promotes closer cooperation and understanding between the community and its schools;
- encourages students to remain in the home community after graduation and promotes a more stable work force.

From the above list, one can readily see that benefits accrue for all who are involved in occupational experience programs.

The primary purpose of this endeavor was to develop a system for installing occupational experience programs in local schools. The terminology "occupational experience programs" in this context is being used in the generic sense. Because of the wide variety of ways in which the work environment is used for educational purposes, a generalized installation system will be presented. The system presented should be generalizable to almost any occupational experience program situation, however, it is based primarily on the successful practices of installing general work experience programs and cooperative occupational education programs.

The system for installing occupational experience programs in local schools has been conceptualized as a process model. It is intended for use by those who wish to install occupational experience programs in their local school systems. The system may also be useful to others who are responsible for initiating occupational experience programs or to those who desire an overview of the implementation process so they can identify their role in and contribution to occupational experience program development.

The system developed consists of seven major functions. They are

INVOLVE AND ORIENT KEY GROUPS (1.0), ASSESS NEEDS AND RESOURCES (2.0), DEFINE GOALS (3.0), SELECT/CREATE PROGRAM (4.0), PREPARE FOR PROGRAM INSTALLATION (5.0), IMPLEMENT OCCUPATIONAL EXPERIENCE PROGRAM (6.0), AND EVALUATE OCCUPATIONAL EXPERIENCE PROGRAM (7.0).

Subfunctions supporting the major functions are identified and discussed in further detail throughout the paper.

INVOLVE AND ORIENT KEY GROUPS (1.0) The initiation of an occupational experience program in a local school system is dependent upon the involvement and cooperation of many groups and individuals. If occupational experience programs are to be successful in a given school system; community involvement must be included. Members of the community must be involved in the planning from the start. Those responsible for, involved with and



affected by the program must be involved in the planning, implementation and evaluation of occupational education programs.

An occupational experience program may be initiated from several sources. For example, a vocational teacher or teachers may wish to provide more real life experiences for their students. Or they may want to provide students with experiences or instruction not readily available in the school setting. They may see the need to add one or more important dimensions to their instruction. Through their efforts, a cooperative occupational program may be initiated.

Another case may involve special education or guidance personnel working together to initiate some type of occupational experience program for persons with special needs. The superintendent, principal or board of education may be instrumental in getting a program started. Or the impetus may come from members of the agricultural, business or industrial community. Whatever the source, active involvement of all groups is essential to the success of the program.

Once an interest in starting an occupational experience program has been shown, the first step is to obtain administrative commitment and board of education policy (1.1). School administrators, as the chief change agents in the school system, must be familiar with the purposes and benefits of occupational experience programs and be committed to installing them in the school system. Unless the school administration realizes the potential of occupational experience programs and opens the school system to the public for its input, support and understanding, the program will have little chance for reaching its full potential as an integral part of the educational system.

In addition to administrative commitment, Board of Education policy

should be obtained. A broad policy statement specifying that the work environment within the community is a valid part of the educational program is desirable. Goals regarding the installation of occupational experience programs should be established. Policies regarding community involvement should be developed and adequate resources should be allocated to attain installation goals. Administrative commitment and Board of Education policy are important first steps in occupational experience program installation.

In organizing key groups (1.2), the involvement of parents, employers, workers, educators, students and representatives from other organized groups and agencies in the community is obtained. A steering committee composed of persons representing the above groups should be appointed by the superintendent. As a temporary committee, its main purpose is to decide whether or not an occupational experience program should be started. If so, the kind of program or programs needed should be determined. If not, reasons why it would be unwise to start an occupational experience program at that time should be given. After the work of the steering committee is completed, it should be dissolved.

The steering committee and other key groups should help develop an awareness of the purposes and benefits of an occupational experience program within the community (1.3). Many techniques of informing the public can be used. Face-to-face interaction with persons who will be most affected by the program is most effective. In addition, the mass media, including newspapers, radio and television, can be used to orient the community to the importance of occupational experience programs.

School personnel and members of the steering committee should also explore occupational experience programs currently being conducted in other schools. (1.4). Much is to be gained by observing schools having programs

in operation. Through discussion of the positive and negative aspects of existing programs, much useable information can be compiled and many pitfalls can be avoided.

**ASSESS NEEDS AND RESOURCES (2.0)** After involving and orienting the community about the purposes and benefits of occupational experience programs, an indepth evaluation of the curriculum (2.1) should be made. The evaluation of the curriculum should make evident the strengths and weaknesses of the educational system in regard to its implications for occupational experience programs.

Questions regarding how well the curriculum prepares students to attain their educational and occupational objectives should be asked. The present school-community relationships evident in the curriculum can be identified and those found lacking should be specified. Parents, employers, workers, former students and present students can be surveyed to determine how well the curriculum is meeting their needs. The curriculum should be evaluated in terms of the kinds of occupational experience programs that could be installed to enhance and enrich the current program being offered.

The next step is to survey the community (2.2). The attitude toward the program should be determined. A survey of the number of business establishments and an estimate of the number of training stations available should be made. If the students are to receive positive employment experiences in the community, an assessment of the degree of community approval and cooperation is needed.

It is then necessary to identify and inventory the resources available to install a program or programs (2.3). Contact should be made with the State Department of Education to determine whether or not the programs proposed are eligible for funding. Coordination and other aspects of many

occupational experience programs are often reimbursable. An inventory of untapped community resources should be made. Cooperative arrangements which utilize the community as the classroom should be considered. The inventory of resources can also include an evaluation of the attitudes of the community, students and faculty toward change.

**DEFINE GOALS (3.0)** Following an assessment of needs and resources, a decision should be made regarding whether or not an occupational experience program should be initiated within the school or school system. If so, the work of the steering committee is completed. The steering committee can be replaced by an advisory committee composed of persons interested and committed to the success of the program. The advisory committee members should be interested in the occupational experience program, should be representative of the community, and should have time to serve.

Once the decision has been made to initiate and install an occupational experience program, a full time coordinator should be appointed or employed. A tremendous amount of liaison work within the school and between the school and the community is essential for program success. Planning is essential for a successful program, and approximately one year of coordination effort is required to complete the many tasks necessary for program success.

The coordinator, administration, advisory committee and others should work together to define the goals of the occupational experience programs (3.0). The goals can be specified for two major categories. In (3.1) the process goals regarding the installation of occupational experience programs are specified. Goals regarding the number and type of programs to be installed, the number of students to be served, and the number and type of training stations to be utilized are examples of process goals. They are needed to provide a benchmark regarding progress made in program installation.

Goals regarding the desired outcomes of the students exiting the occupational experience program are also needed. These goals are stated as product goals (3.2). The overall product goals of the occupational experience program should be specified. In addition, sub-goals should be defined. All sub-goals and objectives later defined should contribute to the overall product goals of the occupational education program.

**SELECT/CREATE PROGRAM (4.0).** After the process and product goals are specified, the optimum occupational experience program or combination of programs for the school system can be developed. The programs selected should be designed to attain the goals specified in (3.0). In making decisions regarding the number and kinds of programs to install, several options can be considered. There is a possibility that the format of programs observed or identified can be adopted (4.1). If changes in the programs observed or identified are needed and the programs still appear to meet the needs and goals of the school system, the program can be adapted (4.2). In some cases, it may be necessary to create (4.3) a program format. A more comprehensive review of existing programs and the literature on types of occupational experience programs should be reviewed prior to creating a new program.

Ultimately, a decision regarding program design must be made. The decision made should incorporate the most desirable elements of programs observed or conceptualized, should meet the needs of the community, and should be designed to attain the goals specified.

**PREPARE FOR PROGRAM INSTALLATION (5.0).** After a decision has been made regarding the program structure, the coordinator and other persons involved must plan and prepare for program installation (5.0). Within the schools (5.1), the teachers must be oriented to the program. Guidance counselors and administrators must be informed. The curriculum must be planned, supplies and

materials ordered, and the related instruction planned. The coordinator may need to attend workshops and activate school personnel to accomplish their assigned tasks. Students must be identified and prepared for job placement.

The community program must also be prepared (5.2). School officials and the coordinator must continue to work with the advisory committee. Training stations must be identified and employers must be oriented to the purposes of the program. The program should be publicized. Training plans should be developed with employers if a cooperative occupational education program is being offered. Placement schedules and training agreements must be developed. Job interviews must be arranged.

During preparation for program installation, provision should be made for continuous involvement of key groups and advisory committee members. The community should be informed of efforts being made to prepare for occupational experience program installation.

IMPLEMENT OCCUPATIONAL EXPERIENCE PROGRAM (6.0). The implementation of the program will involve many personnel. School-community cooperation (6.1) is very essential. Both school and community personnel must carry out their specified roles. The work of the coordinator (6.2) in assuring that school, community and students are adhering to guidelines and standards is essential. The two way communication provided by the coordinator as the liaison person is vital to the success of the program. If problems or concerns arise, they should be handled promptly. Cooperation and understanding are essential in successful implementation of an occupational experience program.

EVALUATE OCCUPATIONAL EXPERIENCE PROGRAM (7.0). The evaluation of the program (7.0) completes the system for installing occupational experience programs in local schools. The program must be evaluated to determine the extent to which the needs are being fulfilled (2.0), process and product

goals are being attained (3.0) and decisions regarding program concept/ structure (4.0) are being realized.

Evaluations conducted can be continuous and periodic. The primary type of evaluation conducted should be continuous self evaluation (7.1). Persons responsible for, involved with and affected by the program should be involved in continuous self evaluation. They should make modifications in the program as needed. Periodically, an external evaluation (7.2) should be conducted. Advisory committee members, employers, former students and others knowledgeable about the program can provide valid suggestions for improvement of the program.

Analysis and reporting of findings (7.3) should be carried on continuously as well as periodically. Communication among all parties involved is essential to the success of the program. Feedback is essential regarding the degree to which the occupational experience program is meeting the needs identified and the goals specified. The evaluation findings should have implications for modifying and improving the program. Through evaluation and feedback, the system can be modified and improved until occupational experience programs are an integral part of the total educational system.

#### SUMMARY

The initiation and installation of occupational experience programs, whatever the format, is a complex detailed process. Specifics regarding installation depend upon problems encountered at the local level. Only a basic framework has been provided in this paper. A well qualified coordinator who is concerned about the welfare and education of students is the key to program success. The coordinator should be chosen with care.

Properly funded, conceptualized, planned, coordinated and implemented occupational experience programs are one of the great "untapped resources" for making education relevant for many students. Some type of occupational experience program should be an integral part of every school system in the nation.



REFERENCES

- Curriculum and Instructional Materials Center. A handbook of cooperative programs. Stillwater, Oklahoma: State Department of Vocational and Technical Education, 1972.
- Division of Curriculum. Occupational work experience. Louisville, Kentucky: Louisville Public Schools, December, 1969.
- Mannebach, Alfred J. "A system for installing career education at the local level." Paper presented at the Annual Meeting of the American Educational Research Association, Special Interest Group on Systems Research, New Orleans, March 1, 1973.
- Mannebach, Alfred J. and Stilwell, William E. "Installing Career Education: A systems approach." Vocational Guidance Quarterly 22: 180-188; March 1974.
- Mannebach, Alfred J. The effectiveness of structured occupational experience for instructors of agricultural occupations. Doctor's Thesis. Urbana: University of Illinois, 1969.
- Mason, Ralph E. and Haines, Peter G. Cooperative occupational education and work experience in the curriculum. Danville, Illinois: The Interstate Printers and Publishers, Inc., 1972.
- State of Illinois. An articulated guide for cooperative education. Springfield, Illinois: Board of Vocational Education and Rehabilitation, Division of Vocational and Technical Education, Bulletin No. 34-571.
- The University of the State of New York. Cooperative occupational education programs - administrative handbook. Albany, New York: The State Education Department, Office of Occupational Education, 1972.
- University of Minnesota. A guide for cooperative vocational education. Minneapolis, Minnesota: College of Education, Division of Vocational and Technical Education, September, 1969.

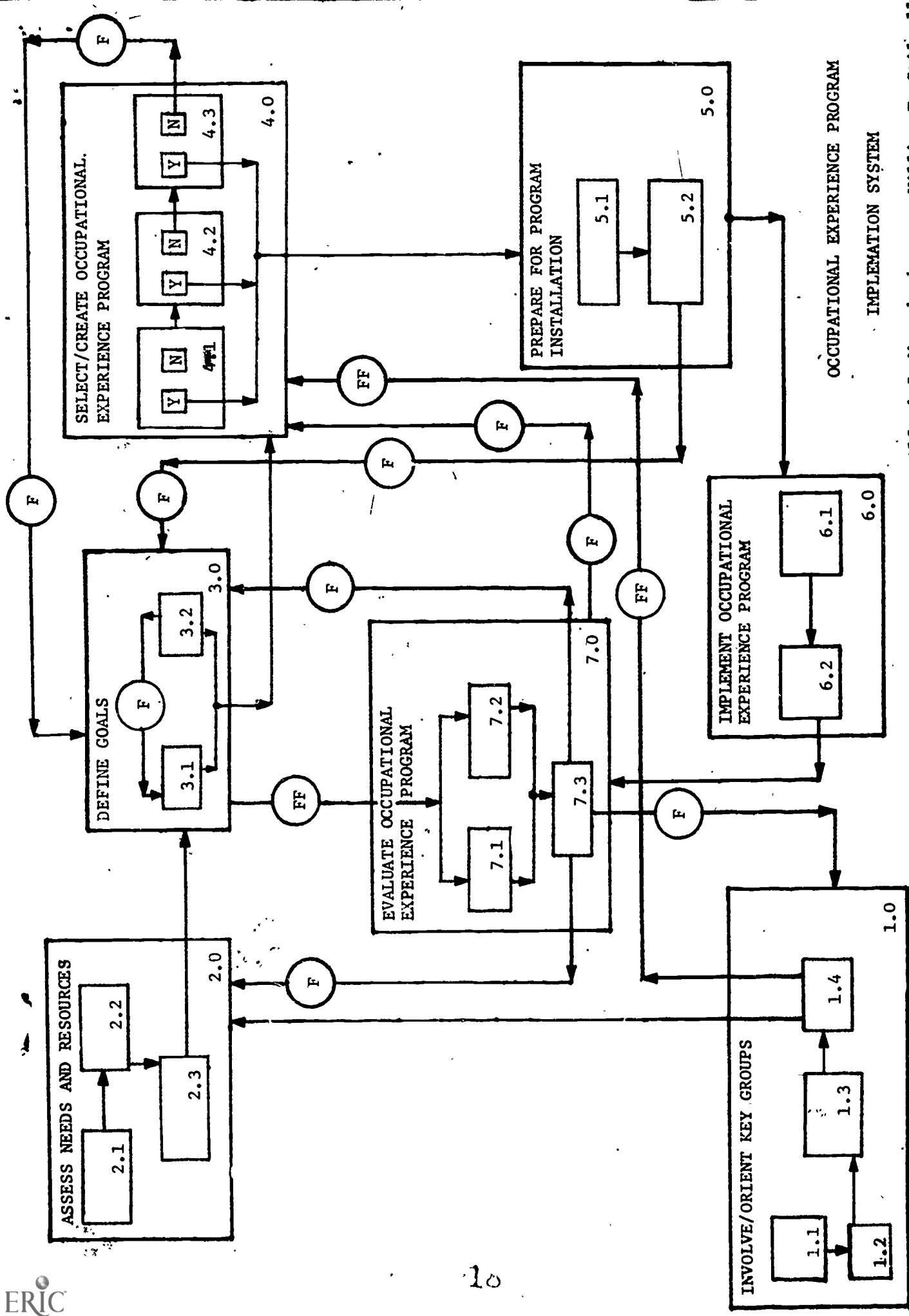

OCCUPATIONAL EXPERIENCE PROGRAM  
IMPLEMENTATION SYSTEM