

DOCUMENT RESUME

ED 107 523

SE 019 212

AUTHOR Hogerton, John F.  
TITLE Nuclear Reactors. Revised.  
INSTITUTION Atomic Energy Commission, Oak Ridge, Tenn. Div. of  
Technical Information.  
PUB DATE 70-  
NOTE 61p.  
AVAILABLE FROM USAEC Technical Information Center, P. O. Box 62, Oak  
Ridge, TN 37830  
  
EDRS PRICE MF-\$0.76 HC-\$3.32 PLUS POSTAGE  
DESCRIPTORS Electricity; \*Energy; \*Nuclear Physics; Oceanology;  
Physics; Safety; \*Scientific Research; Utilities  
IDENTIFIERS AEC; Atomic Energy Commission; Nuclear Reactors

ABSTRACT

This publication is one of a series of information booklets for the general public published by the United States Atomic Energy Commission. Among the topics discussed are: How Reactors Work; Reactor Design; Research, Teaching, and Materials Testing; Reactors (Research, Teaching and Materials); Production Reactors; Reactors for Electric Power Generation; Reactors to Supply Heat; Reactors at Sea; Reactors in Space; Reactor Safety; and Reactors of Tomorrow. The appendix contains a list of United States Central Station Nuclear Power Projects that are operable, being built, or planned as of June 1970. A list of suggested references, including books, reports, articles, and motion pictures, is included. School and public libraries may obtain a complete set of the booklets without charge.  
(BT)

# Nuclear Reactors

by John F. Hogerton

U.S. DEPARTMENT OF HEALTH,  
EDUCATION & WELFARE  
NATIONAL INSTITUTE OF  
EDUCATION

THIS DOCUMENT HAS BEEN REPRODUCED EXACTLY AS RECEIVED FROM THE PERSON OR ORGANIZATION ORIGINATING IT. POINTS OF VIEW OR OPINIONS STATED DO NOT NECESSARILY REPRESENT OFFICIAL NATIONAL INSTITUTE OF EDUCATION POSITION OR POLICY.

ED 071 23



This is made available by

**ERDA**

United States Energy Research  
and Development Administration

Technical Information Center

Oak Ridge, TN 37830

ERIC  
Full Text Provided by ERIC

9 212-

Nuclear energy is playing a vital role in the life of every man, woman, and child in the United States today. In the years ahead it will affect increasingly all the peoples of the earth. It is essential that all Americans gain an understanding of this vital force if they are to discharge thoughtfully their responsibilities as citizens and if they are to realize fully the myriad benefits that nuclear energy offers them.

The United States Atomic Energy Commission provides this booklet to help you achieve such understanding.

# Nuclear Reactors

by John F. Hogerton

## CONTENTS

INTRODUCTION . . . . .	ii
HOW REACTORS WORK . . . . .	2
The Fuel . . . . .	3
The Moderator . . . . .	7
The Control System . . . . .	7
The Heat Removal System . . . . .	9
The Radiation Shield . . . . .	10
REACTOR DESIGN . . . . .	11
RESEARCH, TEACHING, AND MATERIALS TESTING REACTORS . . . . .	12
Research Reactors . . . . .	12
Teaching Reactors . . . . .	13
Materials Testing Reactors . . . . .	14
PRODUCTION REACTORS . . . . .	16
REACTORS FOR ELECTRIC POWER GENERATION . . . . .	18
Civilian Nuclear Power Programs . . . . .	18
REACTORS TO SUPPLY HEAT . . . . .	25
REACTORS AT SEA . . . . .	26
REACTORS IN SPACE . . . . .	30
Rocket Propulsion . . . . .	30
Electrical Power . . . . .	32
REACTOR SAFETY . . . . .	36
REACTORS OF TOMORROW . . . . .	40
APPENDIX . . . . .	41
U. S. Central Station Nuclear Power Projects—January 1970 . . . . .	41
Characteristics of U. S. Civilian Power Reactor Concepts . . . . .	46
SUGGESTED REFERENCES . . . . .	50

**United States Atomic Energy Commission**

**Division of Technical Information**

Library of Congress Catalog Card Number: 73-605092

1963; 1970(rev.)

# Nuclear Reactors

## Introduction

The discovery of nuclear fission, announced by the German scientists, Otto Hahn and Fritz Strassmann, in January 1939, set the stage for the era of atomic energy development. But the real beginning came 3 years later when a group of scientists led by Enrico Fermi demonstrated that a self-sustaining fission chain reaction could be achieved and, more important, could be controlled.

Fermi's operation of the first nuclear reactor began at 3:25 p.m. on December 2, 1942, in an improvised laboratory beneath the stadium at the University of Chicago. By today's standards it was a fairly crude apparatus—essentially an assembly of uranium and graphite bricks about  $24\frac{1}{2}$  feet on a side and 19 feet high. The method of assembly, which was simply to place one brick on top of another, gave rise to the name "atomic pile"; "nuclear reactor" is now the preferred term.\*

Several hundred nuclear reactors have been placed in operation in the United States since then. Later we will discuss the various ways in which reactors are being used and examine the major development programs. Before we do this we should first discuss general reactor principles.

---

\*See *The First Reactor*, another booklet in this series.



*The first of two 60-foot-high steam generators (left) rests on its pedestal. On the right, the reactor vessel is lowered into place at the Palisades Nuclear Power Station at South Haven, Michigan. This light-water reactor will have a net capacity of 700,000 kilowatts of electricity.*

## How Reactors Work

The best place to start is with the fission reaction itself. In this reaction the center, or nucleus, of certain atoms, upon being struck by a subatomic particle called a neutron, splits into two radioactive fragments called fission products. These fly apart at great speed and generate heat as they collide with surrounding matter. The splitting of an atomic nucleus is accompanied by the emission of gamma radiation, similar to X rays, and by the release of two or three additional neutrons. The released neutrons may in turn strike other nuclei, causing further fissions, and so on. When this process continues we have what is known as a chain reaction.\*

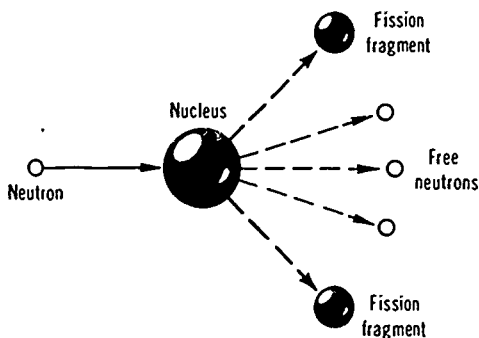

*A fission reaction.*

A nuclear reactor is simply a device for starting and controlling a self-sustaining fission chain reaction. For reasons that will become evident, it could as well be called a "neutron machine".

Nuclear reactors are used in several ways:

1. To supply intense fields or beams of neutrons for scientific experiments.
2. To produce new elements or materials by neutron irradiation.
3. To furnish heat for electric power generation, propulsion, industrial processes, or other applications.

The basic parts of a nuclear reactor are:

1. A core of fuel.
2. A neutron moderator, which is a material that aids the fission process by slowing down the neutrons.

---

\*For basic atomic science, see *Our Atomic World*, a companion booklet in this series.

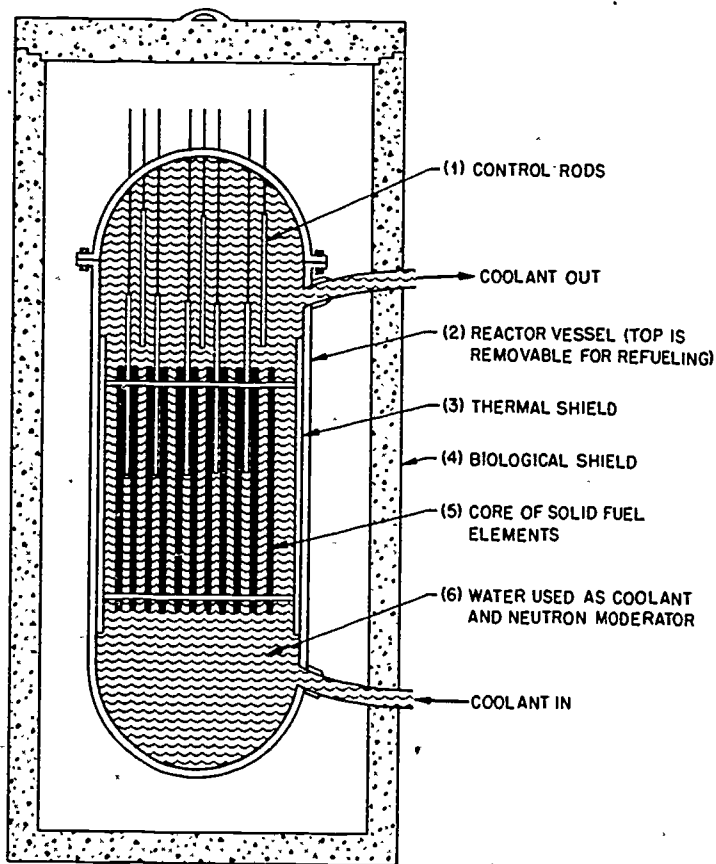

*Vertical cross section of a pressurized-water nuclear reactor.*

3. A means of regulating the number of free neutrons and thereby controlling the rate of fission.
4. A coolant, which removes the heat generated in the core.
5. Radiation shielding.

The Fuel The essential ingredient of reactor fuel is a fissionable material that is, a substance that readily breaks apart (or fissions) when struck by neutrons. The only naturally occurring substance fissionable by slow neutrons is uranium-235, an isotope of uranium constituting



less than 1% (actually 0.71%) of uranium as it is found in nature. Almost all the rest of the natural element is uranium-238, which is called a fertile material because it can be converted into a fissionable substance -namely, plutonium. This occurs when uranium-238 is irradiated by neutrons.\*

Reactor fuel usually contains a mixture of fissionable and fertile materials. As the fuel is irradiated in the course of reactor operation, atoms of the fissionable material are consumed, at the same time, *new* fissionable atoms are formed from the fertile material. The ratio of new fissionable atoms consumed to new fissionable atoms formed depends on the design of the reactor. It is possible to achieve a small net gain of fissionable materials in a breeder reactor, but almost all present-day reactors operate with a net loss of fissionable material. Incidentally, in producing more fissionable material than it consumes, a breeder reactor does not qualify as a magical machine. Breeding is simply a way, over a long period of time, of efficiently converting fertile materials to fissionable materials, thereby assuring good use of our nuclear fuel resources.



*Pellets of uranium dioxide that will be fabricated into fuel assemblies. When these assemblies are placed in the core of a nuclear reactor, each pellet can produce as much energy as more than a ton of coal.*

The percentage of fissionable atoms in the fuel mixture is an important factor because it affects the physical size of the reactor. The richer the fuel is in fissionable atoms, the more compact the reactor can be. There are practical limits to this but we are not concerned with them here. Some reactors are fueled with natural uranium in which, as was noted above, the concentration of fissionable atoms is less than 1%.

---

\*Similarly, another fissionable substance, uranium-233, can be produced by neutron irradiation of the element thorium. There are thus three basic fissionable materials (uranium-235, plutonium, and uranium-233) and two fertile materials (uranium-238 and thorium).

Some reactors use slightly enriched uranium, some, especially those designed for propulsion applications, where compactness is especially important, use highly enriched uranium.\*

Another important aspect of reactor fuel is the physical form in which it is used. Some reactors use a fluid fuel, such as an aqueous solution of enriched uranium. But in the main the fuel is a solid—either metallic uranium or a ceramic such as uranium oxide. The solid fuel material is fabricated into various small shapes—plates, pellets, pins, etc. which are usually clustered together in assemblies called fuel elements. A reactor core may contain from tens to hundreds of these fuel assemblies held in a fixed geometrical pattern by means of grid plates.



*Lowering a fuel assembly into a reactor core.*

---

\*Enriched uranium, ranging in fissionable content from 1% on up to 90% or more, is obtained by putting the natural element through an isotope-separation process.

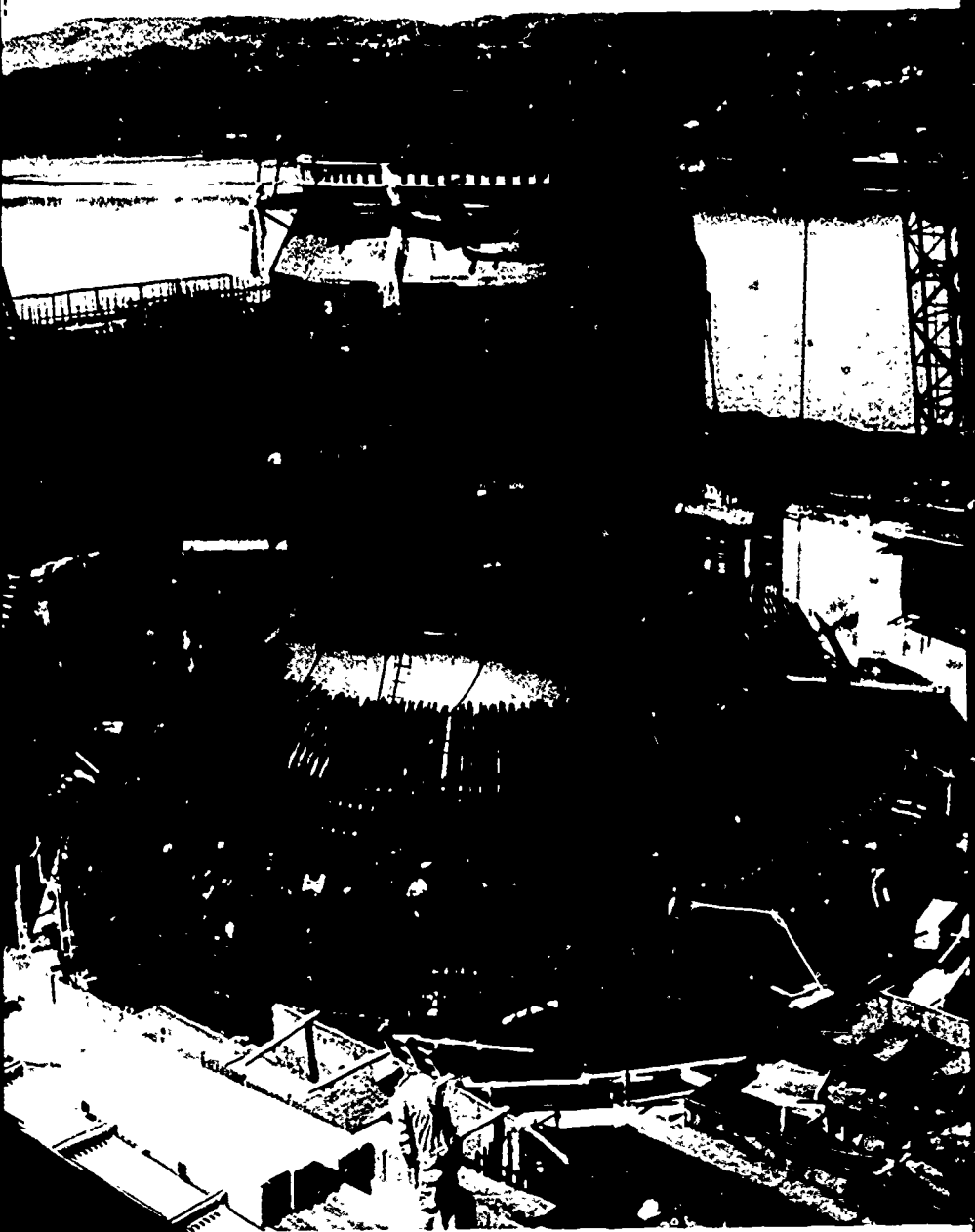

*The containment vessel of the Vermont Yankee Plant during construction at Vernon, Vermont.*

Almost all solid fuel elements incorporate what is known as fuel cladding. This takes the form of a protective coating or sheath that prevents direct contact between the fuel material and the reactor coolant and also serves as part of the structure of the fuel element. Zirconium alloys are commonly used as cladding materials in power reactors, aluminum is generally used in research reactors.\*

**The Moderator** Neutrons liberated in a chain reaction travel at first at very high speeds. They lose speed as they collide elastically with surrounding matter in the reactor core. This loss of speed is desirable because slow-moving neutrons are more effective in triggering fission than are fast neutrons. But if very many collisions are involved, an individual neutron runs considerable risk of bumping into an atom that will absorb it unproductively. (Fission products, for example, readily absorb neutrons.) What is needed, therefore, is a material that has the ability to slow down neutrons quickly and which, at the same time, has little tendency to absorb neutrons. Such a material is called a moderator.

Neutrons have a mass approximately the same as that of a hydrogen atom; therefore materials containing a concentration of hydrogen or other lightweight atoms are the most effective moderators.† Materials used for this purpose include ordinary water, heavy water,‡ graphite, beryllium, and certain organic compounds.

It is obvious that the moderator should be well distributed within the fuel zone. In some reactors this is accomplished by the spacing of the fuel elements, in others the fuel and moderator materials are intimately mixed together.

It should be added that reactors using highly enriched fuel in a concentrated array are capable of operating with fast neutrons and therefore do not require a moderator. Such systems are known as fast reactors.

**The Control System** Most nuclear reactors are controlled by regulating the "population" of neutrons in the core. This is done with

---

\*For more information about atomic fuel, see *Atomic Fuel and Sources of Nuclear Fuel*, two companion booklets in this series.

†To understand the reason for this it is only necessary to imagine trying to use a bowling ball to slow down a ping-pong ball.

‡Heavy water is water that contains significantly more than the natural proportion (one in 6500) of heavy hydrogen (*deuterium*) atoms to ordinary hydrogen atoms. Heavy water is used as a moderator in some reactors because it slows down neutrons effectively and also has a low cross section for absorption of neutrons. For definitions of other unfamiliar words see *Nuclear Terms, A Brief Glossary*, another booklet in this series.

control "poisons" substances, such as boron and cadmium, that have very high coefficients for neutron absorption. (In effect, a control poison acts as a neutron blotter.) Usually these substances are inserted into the reactor by means of adjustable rods, called control rods. A reactor may be equipped with one set of control rods (referred to as regulating rods) for routine control purposes, and a supplementary set (referred to as safety rods) to permit rapid shutdown in an emergency.

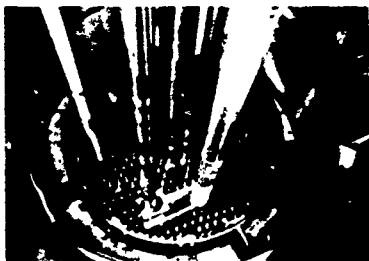

*The core of the Experimental Breeder Reactor No. 2. In the foreground are the hold-down and gripper drive shafts; in the background are the control-rod drive shafts. This is a liquid-metal-cooled fast reactor.*

It will be recalled that each fissioning atom of fuel releases two or three neutrons. The free neutrons exist for a very short time—perhaps about one ten-thousandth of a second—between the time they are released and the time they trigger another fission event or are otherwise absorbed. On this basis, if only a slight increase in the neutron population were to take place from one neutron generation to the next, the rate of fission could easily multiply many hundreds of times every second. Fortunately, some neutrons are not released instantaneously. By keeping down the neutron population of the system to the point where these *delayed* neutrons are needed to sustain the fission chain reaction, the normal rate increases are only 1 or 2% per second. They are gradual enough to be kept readily under control.

From these few facts the rudiments of reactor control can be grasped. When fuel is loaded into the device, a number of regulating and safety rods are in the "in" position. When the reactor is fully loaded it is placed in operation by withdrawing the safety rods and partially withdrawing the regulating rods. The latter step is carried out gradually and in response to signals from neutron-counting instruments used to monitor the rate of fission. Once the reactor is critical, meaning that the chain reaction has become self-sustaining, movement of the regulating rods becomes a matter of adjustment to maintain steady-state operating conditions. If the operator wants to increase the power level—that is, the steady-state reaction rate—the regulating rods are further withdrawn and then again adjusted as needed. If he wants to shut down the reactor, the regulating and safety rods are fully inserted.

A related aspect of reactor operation that should be mentioned at this juncture is loss of reactivity. We have seen that, as fuel is consumed, fission products are formed. These substances absorb neutrons wastefully and, as they accumulate, reduce the reactivity of the fuel. (It is as though a fire were gradually smothered by its own

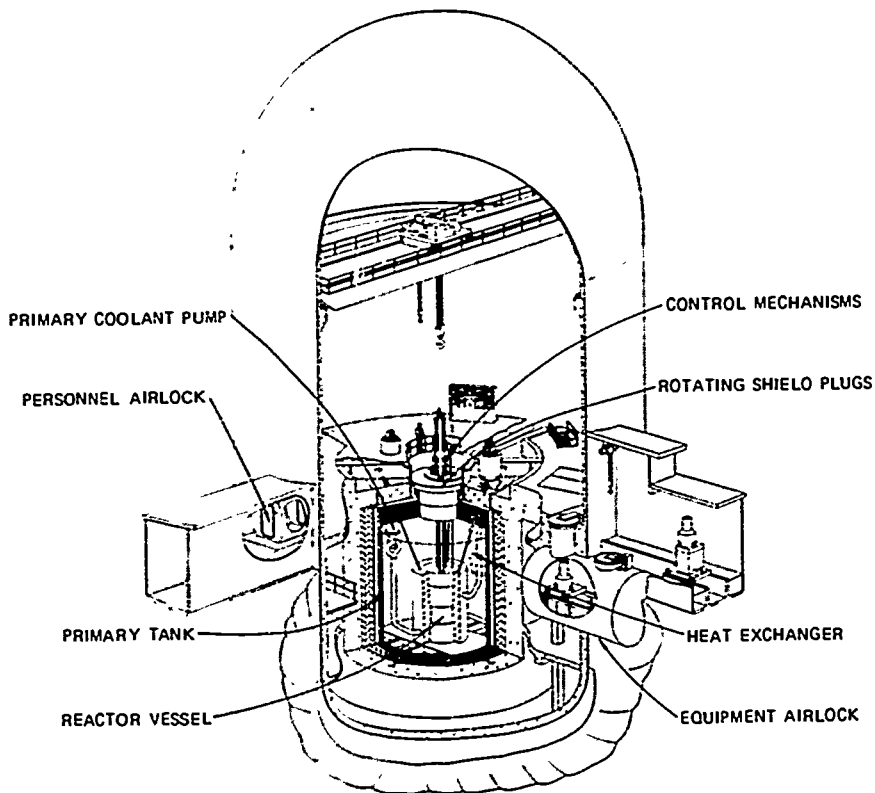

*Schematic of the Experimental Breeder Reactor No. 2.*

ashes.) To compensate for this effect (and also for the consumption of fuel) it is necessary to load the reactor with more fuel than the bare minimum needed to get a chain reaction started. This extra fuel provides excess reactivity that can be drawn upon to keep the reaction going. It is held in check by a balancing amount of control poisons, which are gradually removed as the operation proceeds. The amount of excess reactivity required has an important bearing on the design of the control system.

**The Heat Removal System** The pattern of energy release in the fission process is shown on the following page.

Kinetic energy of fission products	84.0%
Kinetic energy of neutrons	2.5
Instantaneous release of gamma rays	2.5
Gradual radioactive decay of fission products	<u>11.0</u>
	100.0%

As the fission products (and neutrons) collide with surrounding matter, their kinetic energy is more or less instantly converted to heat. Most of the heat is generated within the reactor core.

If the reactor is operated at essentially zero power (only a few watts), the small amount of heat that is generated can be allowed to dissipate itself, and no cooling system is needed. But most reactors operate at appreciable power levels (kilowatts or megawatts of heat output) and therefore must be cooled to prevent overheating and melting the core. In power, propulsion, or industrial process applications, the heat that is carried away from the core is, of course, the primary product of the reactor.

One of the most interesting things about nuclear reactors is that they are capable, in principle, of operation at virtually any power level: the limiting factor, from a practical standpoint, is the rate at which the cooling system can carry the heat away from the core. Some reactors rely upon natural convection of the coolant, most, however, are equipped with a forced circulation system. Various coolants are used, including gases such as air, helium, and carbon dioxide; liquids such as ordinary water, heavy water, and certain organic compounds, and liquid metals such as sodium and lithium. In some reactors, the coolant serves also as the neutron moderator; in others, the coolant and moderator are separate materials.

Reactors used for research are generally operated at fairly low temperatures (below 200°F). Reactors used for power generation or propulsion operate at relatively high temperatures (above 500°F) to facilitate conversion of the heat to electrical or motive power.

**The Radiation Shield** That part of the fission energy release that does not instantly appear as heat appears as penetrating atomic radiation. Nuclear reactors must therefore be heavily shielded. Here a distinction should be made between an internal or "thermal" shield, which is used in high-power reactors to protect the walls of the reactor vessel from radiation damage, and the more familiar external or "biological" shield, which serves to protect personnel from radiation exposure. The internal shield usually consists of a steel lining; the external shield typically takes the form of several feet of high-density concrete surrounding the reactor installation.

## Reactor Design

At this stage the reader may well be visualizing a nuclear reactor as a kind of three-dimensional and very high-speed pinball game played with neutrons in a box of fuel and moderator atoms, with an adjustable plunger for control and a fan for cooling. What does a reactor look like? The answer is that many basically different reactor designs have been worked out and many more are possible. (See diagrams in the Appendix on page 46.)

There are several reasons for the multiplicity of reactor designs. First, as has been brought out, the designer has a wide choice of reactor materials. Second, there is a broad spectrum of reactor uses. Third, different reactor designers often have different ideas as to the best way of designing a reactor for a given purpose.

It is time now to talk about how reactors are used and to look in on the principal areas of development and application.

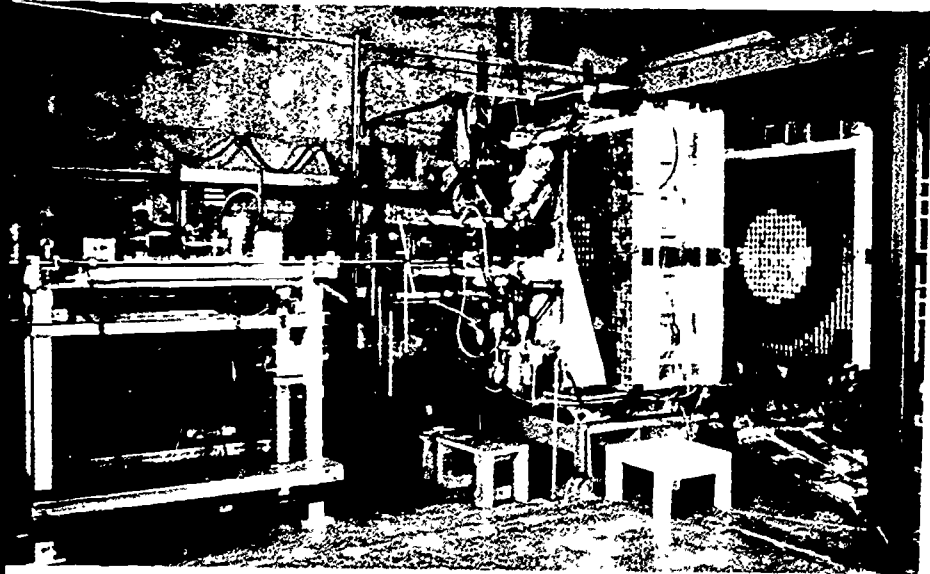

*The Zero Power Reactor No. 3 at the AEC's Argonne National Laboratory in Illinois. Its experimental data reveal problem areas in the design of large plutonium-fueled fast reactors. This mock-up reactor is operated at such low levels of radioactivity that a liquid coolant and heavy permanent shielding are not needed. For tests the two halves are slowly brought together; the ramp is raised to deflect stray radiations that are set up between the halves.*



## Research, Teaching, and Materials Testing Reactors

**Research Reactors** Research reactors are a uniquely versatile source of atomic radiation for experimental purposes. Some examples of the ways in which they can serve subject areas of science are.

*Nuclear physics.* Studying nuclear reactions by irradiating target materials.

*Solid-state physics.* Determining the crystal structure of materials by neutron diffraction techniques.

*Radiation chemistry.* Studying the effects of radiation on chemical reactions and on the properties of materials such as plastics.

*Analytical chemistry.* Identifying trace impurities in materials by activation analysis techniques.\*

*Biology.* Inducing genetic mutations in plant species by seed irradiation.

*Medicine.* Experimental treatment of certain brain cancers by a technique known as neutron capture therapy.†

*Other.* Production of radioisotopes for use in laboratory programs.

In some experiments, materials are inserted in the reactor for irradiation, in others, experimental apparatus is set up in the path of neutron beams emanating from openings (ports) in the reactor shield.

Research reactors are usually categorized by their neutron flux, meaning the intensity of the neutron fields or beams they generate. Neutron flux is related to the power level at which a reactor operates, but also depends on design factors.

There are several basically different research reactor designs. The two most commonly used are pool reactors and tank reactors. In the former, the reactor core is suspended in a deep, open pool of water, which serves as coolant, moderator, and radiation shield. This arrangement affords flexibility, since the position of the core can easily be shifted and experimental apparatus can readily be positioned; also it permits direct observation of the proceedings.

In tank reactors, the reactor core is held in a fixed position inside a closed tank. The coolant most often used is ordinary water, but some installations use heavy water. Tank reactors generally operate at higher

---

\*Every species of radioactive atom has a distinctive pattern of radioactive decay. In activation analysis, a sample is made radioactive by neutron activation. By analyzing the resulting radioactivity with sensitive detection instruments, the identity of substances present in the sample is determined. For more about this subject, see *Neutron Activation Analysis and Spectroscopy*, other booklets in this series.

†See *Radioisotopes in Medicine*, another booklet in this series.

*The glow given off by this training reactor core is called Čerenkov radiation. It occurs when electrically charged particles pass through a transparent medium at a velocity in excess of the speed of light in that medium.*



power levels than pool reactors and therefore as a rule provide a higher neutron flux.

It is difficult to generalize on the cost of research reactors since much depends on the type and extent of auxiliary facilities provided. In very round numbers, the capital cost of a pool reactor installation, including a building and supporting facilities, is generally in the range of \$1,000,000 to \$3,000,000. A corresponding range for a tank reactor installation is \$1,000,000 to \$5,000,000.\*

**Teaching Reactors** These are small, low-flux reactors designed to be used as teaching aids and to meet limited research and radioisotope production requirements. There are several types on the market. Some are self-contained units shipped as prepackaged assemblies ready for installation in available laboratory space. Their cost is in the \$100,000 to \$200,000 range, delivered and installed. Others, somewhat more elaborate but also more versatile, range in cost up to about \$500,000.

---

\*For more information, see *Research Reactors*, a companion booklet in this series.

**Materials Testing Reactors** These are high-flux reactors used to test the performance of reactor materials and equipment components under irradiation, thereby obtaining data essential for new reactor designs. They generally carry a diverse test load and are operated principally in support of power reactor development programs. The largest installation in service in the United States is the Advanced Test Reactor (ATR) at the Atomic Energy Commission's National Reactor Testing Station near Idaho Falls, Idaho. The ATR, similar in design to a tank-type research reactor but much larger, operates at power levels up to 250,000 kilowatts heat output and represents an investment of approximately \$58,000,000. It is equipped with in-pile test loops that make it possible to conduct many irradiation experiments under temperature, pressure, and flow conditions representative of actual power reactor operation.

*The core of the Advanced Test Reactor (ATR), which achieved initial criticality in July 1967, is used for testing fuels and materials in a high-neutron-intensity environment. The view below reveals the upper end of the 1-lobed serpentine core, situated 19 feet below the reactor's top head. The straight "pipes" are two of the nine in-pile tubes that will provide spaces for inserting samples of reactor fuels and structural materials to be performance-tested. The 12 curved pipes contain detector instruments used to control reactor power.*

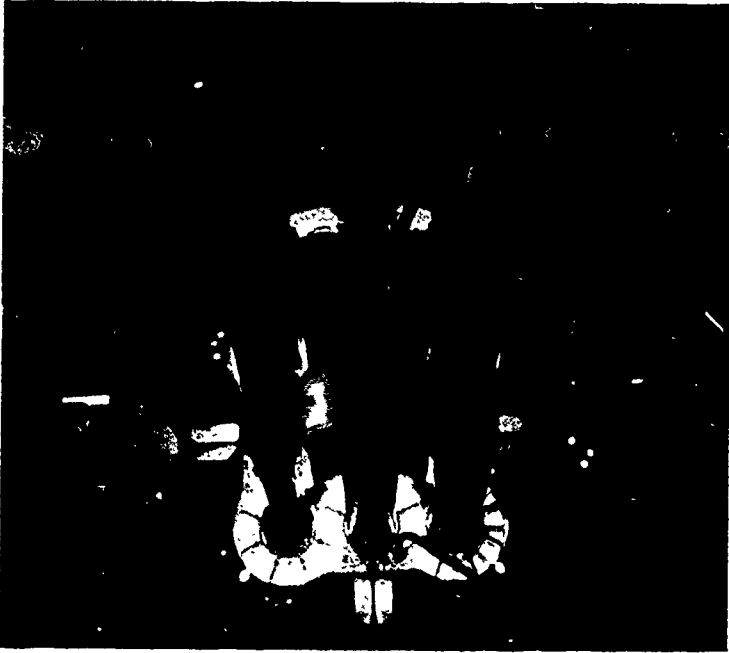

## Production Reactors

About a dozen production reactors have been built in the United States to supply plutonium for defense stockpiles. These facilities are located at two AEC production centers—the Hanford Works at Richland, Washington, and the Savannah River Plant near Aiken, South Carolina.



*The front face of a Hanford plutonium production reactor shows operators on the work platform preparing to "charge" fuel elements into one of the more than 3000 process tubes. As fresh fuel elements are inserted, the irradiated fuel elements they replace are ejected from the discharge end of the tube at the rear face.*

The reader will recall that plutonium is formed by neutron irradiation of uranium-238. The general name for the process of making one chemical element from another is transmutation. The specific reaction can be written:

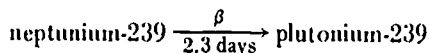
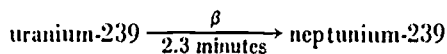

This in effect means that uranium-239 and neptunium-239, both highly unstable substances with relatively short half-lives (2.3 minutes and 2.3 days,\* respectively), are formed as intermediate products, the latter throwing off a beta particle† to form plutonium.

The production steps are: (1) fabrication of natural uranium metal into fuel elements, (2) operation of a reactor with these fuel elements,

---

\*Meaning, in the case of neptunium, for example, that half of the atoms undergo radioactive decay every 2.3 days. Thus, if there are 100 neptunium atoms in a sample at time zero, there will be 50 atoms 2.3 days later, 25 atoms 2.3 days after that, etc.

† An electron emitted from an atomic nucleus is called a beta particle, symbol,  $\beta$ .

thereby irradiating the uranium-238, (3) temporary underwater storage of the irradiated fuel elements to allow a period of time for radioactive decay—a step known as decay cooling, and (4) chemical processing of the still intensely radioactive material to remove fission products (which are then stored in underground waste tanks) and to separate the plutonium from the residual uranium.

The Hanford reactors are moderated with graphite and cooled with ordinary water. They are large (building-size) graphite structures honey-combed with tubes into which cylindrical fuel slugs are loaded and through which the cooling water flows. The Savannah River reactors are tank-type units, moderated and cooled with heavy water.

The heat generated in all but one of the existing plutonium production reactors is at too low a temperature to be useful.

*The Ball Safety System of the N reactor is an emergency shut-down capability independent of the reactor's control rods. Embedded in the biological shield on top of the reactor are hoppers, each of which holds 108 samarium oxide balls (like the ones in front of the operator in the photo). The hopper gates will open if any of a number of "out-of-limits" events occur; these neutron-absorbing balls are then poured into the reactor through vertical channels. They absorb so many neutrons that the chain reaction is stopped and the reactor shuts down.*



A rather special kind of nuclear power plant, the N Reactor (sometimes called the New Production Reactor) is at Hanford. It was the nation's first dual-purpose reactor. It is owned and operated by the AEC and produces special nuclear material for government stockpile purposes; its original design, however, provided for the recovery of the waste heat. The Washington Public Power Supply System later received approval to build a nearby steam power plant in which the hot water from the reactor is used to generate steam. The plant has a generating capacity of 790,000 kilowatts of electric power, equivalent to that of two Bonneville Dams, and it began serving the Pacific Northwest in April 1966.

## Reactors for Electric Power Generation

**Civilian Nuclear Power Programs** In conventional steam-electric power plants, a fossil fuel (coal, oil, or natural gas) is burned in a boiler and the resulting heat is used to generate steam. The steam is used, in turn, to drive a turbogenerator, thereby producing electricity. In a nuclear power plant, a nuclear reactor furnishes the heat, the reactor thus substitutes for the conventional boiler.



*This photograph, taken December 20, 1951, at the AEC's National Reactor Testing Station in Idaho, shows the first use of electric power from atomic energy. The bulbs are lighted by the generator at right that operates on heat from the Experimental Breeder Reactor.*

The dramatic, almost overnight emergence of nuclear power as a major factor in the U. S. electrical energy economy has been one of the most remarkable developments in our country's industrial history. At the start of the 1960s the U. S. roster of civilian nuclear power projects was limited to a few demonstration units with capacities in the neighborhood of 200,000 kilowatts and a number of small experimental or prototype units with capacities in the range of 3000 to 90,000 kilowatts. By the end of 1963 several large-scale (400,000–600,000 kilowatt) projects had been undertaken. The first to be licensed for construction was a 130,000-kilowatt unit at San Onofre, which received its construction permit in March 1964. In mid-1965 utility announcements of commercial nuclear power projects began to gather momentum. By the time San Onofre had been built and brought up to full power (January 1968) nearly 50,000,000 kilowatts of nuclear power capacity had been scheduled for construction. By the end of 1968 the total had risen to more than 72,000,000 kilowatts.



*On the right are the lights of downtown Pittsburgh. The Shippingport Atomic Power Station (above), the first full-scale, nuclear electric station built exclusively for civilian needs, provides electricity for the homes and factories of the greater Pittsburgh area. The pressurized water reactor, which now has a 90,000-net electrical kilowatt capacity, began commercial operation in 1957. The reactor is in the large building in the center.*

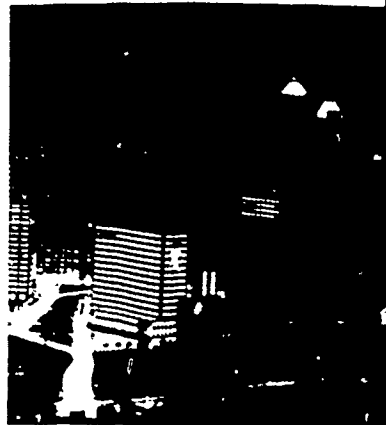

(See pages 41-44 for a complete list by state.) One way of providing perspective on this figure is to say that it represents a financial commitment, for plants alone, of somewhere in the neighborhood of \$10,000,000,000. Another and even more impressive way is to point out that the installed capacity of the U. S. electrical industry at the start of World War II totalled only 42,000,000 kilowatts.

As the dimension of the nuclear construction program grew, the unit size of the plants increased. At the end of 1968, the largest nuclear units on order were in the 1,000,000 to 1,200,000-kilowatt range, and the average unit size was above 800,000 kilowatts. These figures become all the more impressive when one realizes that up to the mid 1950s the largest conventional steam-electric unit in service in the U. S. had a capacity of only 250,000 kilowatts.

In the main, the nuclear power plants committed to date are scheduled to start operation in the 1970-1975 period. The expectation at this writing is that by 1975 some 70,000,000 kilowatts of nuclear capacity will be in commercial service, and that by 1980 the total will have increased to about 150,000,000 kilowatts. If the latter expectation is borne out, nuclear power would then account for approximately



*Big Rock Point Nuclear Plant, located near Charlevoix, Michigan, has a 70,400-net-electrical-kilowatt capacity.*

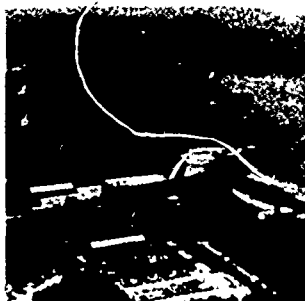

*The San Onofre Nuclear Generating Station near San Clemente, California, has a 430,000-kilowatt capacity.*



*Browns Ferry Nuclear Power Plant under construction near Decatur, Alabama. This view shows two of the three boiling-water reactors. Its total generating capacity will be over 3,000,000 kilowatts. It will be the largest atomic generating project in the world when it is completed in the 1970s.*

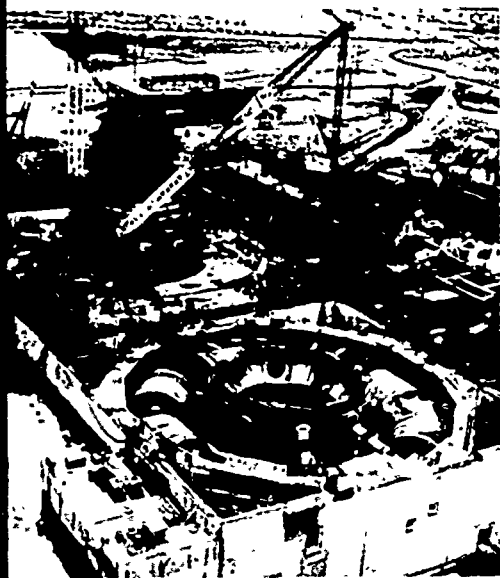

25% of the country's total electrical capacity and, because of operational economies, for an even higher percentage of the total electrical output. Looking still further into the future, many believe that by the end of this century nuclear power will account for half of the total electrical output and for essentially all power generating capacity built thereafter.\*

Having spoken of nuclear power's status and prospects, it is of interest now to trace its evolution and to say something about its technology.

Designs of power reactors for electric power generation received some attention during and immediately following the wartime atomic bomb program (Manhattan Project), but a systematic research and development effort toward this objective did not get under way until 1948. In that year the U.S. Atomic Energy Commission formed a Division of Reactor Development (now the Division of Reactor Development and Technology) to pursue this and other fields of power reactor application. For the first 5 years or so the emphasis was placed on acquiring fundamental knowledge and studying the basic characteristics of several promising reactor design concepts. During this period the work was largely carried out in AEC laboratories, some of which were operated for the AEC by universities and others by industrial contractors. Reactor technology bore a security classification in those days; moreover, laws then in effect reserved for the Government the right to own power reactors and corollary facilities. By 1954 both of these barriers to private initiative in nuclear power development had been removed and, with encouraging results being reported from the research work, the stage was set for a concentrated government-industry development effort.

Accordingly, the AEC initiated a Power Demonstration Reactor Program under which it provided financial and other assistance to electric utility companies and manufacturers prepared to undertake pioneering reactor construction projects. Most of the experimental and prototype projects referred to earlier were carried out within the framework of this program. Additionally, several pioneering projects, including two demonstration plants, were undertaken wholly with private financing. This pattern held until late 1963. By then the technology of at least two reactor systems (described on the next page) was considered sufficiently proven to permit nuclear power to enter the era of routine commercial application, and, with one exception, all large-scale projects initiated since that time have been undertaken

---

\*See *Nuclear Power Plants*, a companion booklet in this series.

without government support. The one exception involved a promising new type of reactor system.

Many different types of reactor systems were studied in the course of the research and development effort described above, however, two systems emerged as the most promising for near-term application -- the pressurized-water reactor and the boiling-water reactor. Both employ ordinary water (as distinct from heavy water) as the coolant and moderator. In the pressurized-water system, the water is kept under sufficient pressure to prevent bulk boiling in the reactor vessel and steam to run the turbine-generator is produced in a separate unit of equipment (steam generator). In the boiling-water system, the water is allowed to boil in the reactor vessel, thereby producing steam that is fed directly to the turbine-generator. The former system was first developed for submarine propulsion. Pressurized- and boiling-water reactors completely dominate the commercial U.S. nuclear power market at the present time. A prospective competitor, which at this writing is just going through the paces of large-scale demonstration, is the High-Temperature Gas-Cooled Reactor (HTGR).

The economic benefits of nuclear power are twofold. First, it is helping to reduce the cost of generating electricity in areas of the country dependent in the past on high-cost fossil fuels. Secondly, the ability to draw on atomic fuel resources greatly strengthens the country's long-range energy position.

In the first connection, a point worth mentioning is that, because of the compactness of atomic fuel and consequent elimination of fuel transportation cost differentials, nuclear power will in time act to standardize electricity costs across the nation. How compact is atomic fuel? Well, the fissioning of 1 gram of fissionable material releases 23,000 kilowatt hours of heat. This means that 1 ton of uranium has roughly the same potential fuel value as 3,000,000 tons of coal or 12,000,000 barrels of oil. In practice only a small fraction of the potential energy value of atomic fuel is extracted during a single cycle of reactor operation. Even so, a ton of reactor fuel still substitutes for many fully loaded freight trains of conventional fuel.

In the second connection, it is a remarkable fact that, with barely more than 5% of the world's population, the United States produces and consumes more than one-third of the world's electricity. An equally remarkable statistic is that, taking all forms of energy into account, the United States will probably use as much energy from fuel in the next 20 years as in all its history. And the rate of fuel consumption is expected to double in the 20 years thereafter. If this trend continues, our reserves of fossil fuels, vast as they are, will

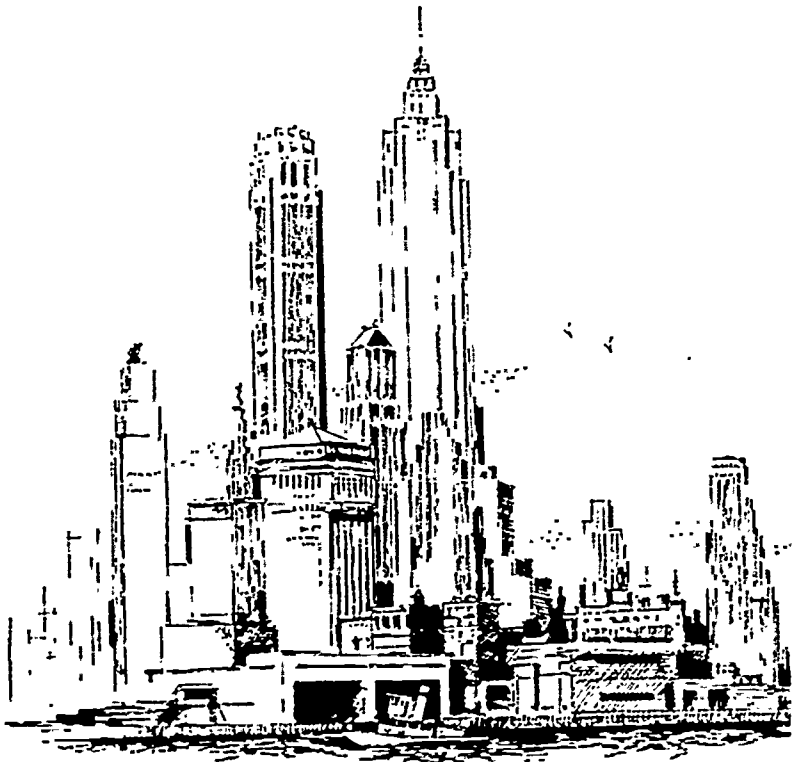

*A single truckload of enriched uranium-235 can supply the total electrical power needs of a city of 200,000 people for a year. Cities of that approximate size include Eugene, Oregon; Portland, Maine; and Raleigh, North Carolina.*

progressively be depleted. Opinion varies on this point, but even allowing for the discovery of new deposits, the chances are that if fossil fuels continue to carry as large a share of our energy burden as they do now, we will begin to experience some depletion effects as early as the turn of the century. Our resources of nuclear fuels are large and if we successfully develop technology for breeding (producing more fissionable fuel from fertile material than is consumed in the operation of a reactor), they will be almost limitless. Ultimately, though, we may have to look to still other energy sources, and that may be where *thermo*nuclear power comes in (see discussion on page 40).

Putting nuclear power on a competitive footing with conventional power has not been an easy task, for conventional power had the benefit of a long history of development. A good indicator of the progress that was made in the conventional power field is the efficiency of fuel utilization. About the time of World War II the average fuel consumption in the U. S. electric utility industry was 1.3 pounds of coal (or the equivalent) per kilowatt-hour of electricity produced; today it is less than 0.9 pounds—a gain in efficiency of 30%. An even better indicator is the unit cost of power generation, which, on a national average, is about the same today as it was 20 years ago despite steep increases in labor, equipment, and construction materials costs.

The electric utility industry gains have been accomplished in three principal ways: (1) by raising the temperature and pressure of steam boiler operation, thereby delivering higher quality steam to the turbine-generator and achieving improved efficiency in converting heat to electricity, (2) by increasing the size of power generating installations, which tends to reduce the capital investment per unit of plant capacity and thereby lower fixed charges per unit of power output, and (3) by refinements in plant and equipment design. These same avenues have been and will continue to be traveled in the development of nuclear power technology. As time goes on, however, the most important gains to be expected in nuclear power technology lie in bringing breeder reactors into commercial use. This objective is being pursued with vigor and will probably entail another cycle of government-industry partnership effort similar to that described above. Liquid-sodium-cooled fast (i.e., unmoderated) reactors are presently receiving the greatest emphasis and the outlook is for systems of this type to achieve routine commercial application sometime during the 1980s.

## Reactors to Supply Heat

In the United States, as in an increasing number of countries, engineers are turning to the sea as a reservoir from which to draw to relieve present water shortages and help meet future requirements. Nuclear reactors are a promising means of supplying the heat required for flash distillation and other processes being developed for large-scale seawater desalting operations. In many areas where there is a substantial demand for fresh water, there is also a complementary demand for electricity. In these situations, large dual-purpose water and electricity producing reactor plants offer possibilities for use in the near future. Studies to this end are being conducted by the AEC in collaboration with the Office of Saline Water of the Department of the Interior (domestic applications) and with other countries and international organizations.\*

Where large-scale requirements are to be met, reactors are also a promising means of supplying low-temperature (up to 400°F) steam for industrial processing operations such as drying, evaporation, or distillation. In 1968 plans were announced for a large dual-purpose installation in Michigan to supply electricity to the grid of a utility and process steam to a plant complex of a large chemical company.

Some day reactors may also be used to supply high-temperature heat (1500–3000°F) for industrial processes such as coal gasification. However such applications must await further development of high temperature reactor technology and hence lie in the indefinite future.

An exciting extension of multi-purpose reactors is the concept of "agro-industrial complexes"—i.e., large nuclear reactor centers that would supply low-cost electricity, process steam, and possibly also ionizing radiation for the production of a range of industrial and agricultural products. The reference here to ionizing radiation should perhaps be amplified by saying that there are two possibilities: (1) the use of radiation as a means of preserving food stuffs (radiopasteurization) or disinfecting grain (radiosterilization),† and (2) the possibility, inherently longer range, of producing basic chemicals by radiation processing. It is envisioned that the construction of such nuclear energy centers could provide a means of developing wholly new industrial and agricultural complexes in developing nations. In this field, as in straight water desalting, the AEC is conducting studies and exploring possibilities for application in collaboration with other countries.

---

\*See *Nuclear Energy for Desalting*, another booklet in this series.

†See *Radiation Preservation of Food*, another booklet in this series.

## Reactors at Sea

The first power reactor ever built began operation on March 30, 1953, in a section of a submarine hull at the National Reactor Testing Station in Idaho. This land-based installation was the forerunner of the pressurized-water system used in the submarine, *USS Nautilus*, which was launched the following year and began sea trials in 1955. Such were the first milestones of the Naval Reactors Program, a joint effort of the Navy and the Atomic Energy Commission, which has revolutionized naval strategy.

Congress has authorized 106 nuclear-powered submarines, one Deep Submergence Research Vehicle, and seven nuclear-powered surface ships. Of these 114 ships, 81 submarines and 4 surface ships have been placed in operation and have steamed over 13,000,000 miles. The principal classes of ships, all of which are powered by pressurized water reactors, are:

Class	Lead ship
Fast Attack Submarine	<i>USS Skipjack</i>
Polaris Missile Submarine	<i>USS George Washington</i>
Deep Submergence Research Vehicle	NR-1
Destroyer	<i>USS Bainbridge</i>
Cruiser	<i>USS Long Beach</i>
Aircraft Carrier	<i>USS Enterprise</i>

The revolutionary nature of this fleet is due primarily to the compactness of atomic fuel and, in the case of submarines, to the fact that oxygen is not required for engine operation. These factors translate into increased range and cruising speed and the capacity for sustained submersion by submarines.

To illustrate, conventional diesel-powered submarines have a maximum surface speed of about 18 knots which they can sustain for only half an hour or so. Their performance underwater is even more limited. World War II submarines could make only 8 knots submerged, and after an hour at this speed had to resurface to recharge their batteries. They operate submerged less than 15% of the time they are on sea duty. In contrast, nuclear-powered submarines characteristically operate submerged more than half of the time. They can steam at full power for days or even weeks and travel faster underwater than on the surface. Their maximum speed has not been disclosed but is known to be in excess of 20 knots. Their range is remarkable, for example, the long-life



*The USS Nautilus, the first atomic submarine, is escorted into New York harbor after her voyage under the arctic ice cap in 1958.*





*The USS Enterprise (foreground) and the USS Long Beach.*

cotes now being installed in nuclear submarines will propel the ship for approximately 100,000 miles.

In October 1964, the USS *Enterprise*, USS *Long Beach*, and USS *Bainbridge* completed Operation Sea Orbit, a 65 day, 30,565-mile round-the-world cruise completely free of refueling or logistic support of any kind. Operations like this have demonstrated conclusively the ability of nuclear-powered ships to operate over great distances at high speeds completely free of logistic support.

Speaking of distances at sea, the next number that comes to mind is 350,000 miles, which is the cruising range of the nuclear-powered merchant ship *Satannah*. A combination passenger cargo vessel, the NS (for Nuclear Ship) *Satannah*, was built as a joint project of the Maritime Administration and the Atomic Energy Commission to demonstrate the safety and reliability of using nuclear propulsion for commercial purposes. The *Satannah* displaces 22,000 tons and is powered by a pressurized water system that delivers 22,000 shaft horsepower. She satisfactorily completed sea trials in 1962 and is presently being operated in commercial cargo service. Through 1968

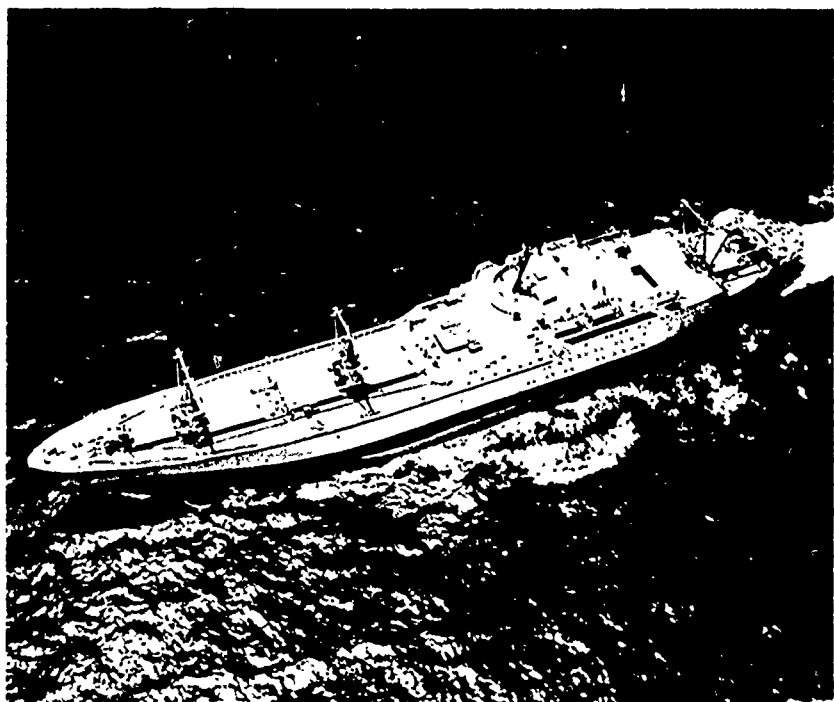

*The NS Savannah during one of her sea trials.*

she has completed about 350,000 miles of travel. The first fuel replacement took place in the fall of 1968 when four spare elements (out of 32) were installed. These will allow continued operation for about 2 years.

The potential economic advantages of nuclear propulsion for commercial vessels are. (1) elimination of fuel spaces, thus making more space and tonnage available for cargo, and (2) improved ship utilization, due to higher cruising speed and elimination of the need for frequent refueling. At present these advantages are cancelled out by the fact that the capital costs of nuclear propulsion equipment are substantially higher than those of conventional equipment. Opinion varies on when the balance will shift in favor of nuclear propulsion but it is expected that this will occur in cargo applications, such as high-speed containerized cargo ships on long trade routes.\*

---

\*For more about this topic see *Nuclear Power and Merchant Shipping*, a companion booklet in this series.

## Reactors in Space

In space, as on land and sea, atomic energy promises to pave the way into the future. As payloads grow larger and the energy required to move them around in space increases, the nuclear rocket will greatly increase the propulsion capability of our space vehicles. Electric power generated from radioisotopes or nuclear reactors will continue to become more important as we move farther from the sun, as mission lifetimes in space increase, or as power requirements become greater for more sophisticated payloads.

**Rocket Propulsion** The National Aeronautics and Space Administration and the Atomic Energy Commission jointly sponsor a program to develop nuclear rocket engines for space missions.

In a nuclear rocket, liquid hydrogen\* is pumped into a nuclear reactor where it is heated to a high temperature and ejected (as gaseous hydrogen) by expanding it through a nozzle, thereby developing thrust.

The specific impulse—that is, the pounds of thrust per pound of propellant ejected per second—that can be achieved in such a system is estimated to be two to three times that of chemical rockets.

Extremely high reactor outlet temperatures are required for efficient performance of a nuclear rocket. Very large power outputs—millions of kilowatts of heat—are required, and the reactor must be able to start and stop quickly and at the precise time needed.

In the NASA-AEC program, the mainstream development effort is the 75,000-pound-thrust flight engine called NERVA (Nuclear Engine for Rocket Vehicle Application). This engine, which is being designed by the Aerojet-General and Westinghouse Electric Corporations, will be highly reliable, and will have a specific impulse nearly twice that of the most advanced chemical rocket engines and the capability for multiple restarts in space.

NERVA is based on 14 years of analytical and experimental research by the Los Alamos Scientific Laboratory (LASL) and NERVA contractors. The goals of the nuclear rocket technology program are: (1) provide basic graphite technology and design concepts for nuclear rockets, (2) extend graphite reactor technology to improve efficiency and increase power, (3) provide technology for flight reactors based on graphite reactor technology, and (4) provide a nuclear rocket engine system technology. Aerojet-General and Westinghouse have recently

---

\*Hydrogen is liquid at temperatures less than 20°K. For a description of the extensive low-temperature technology that supports nuclear propulsion for space, see *Cryogenics, The Uncommon Cold*, another booklet in this series.

# REACTOR SPACE POWER APPLICATIONS

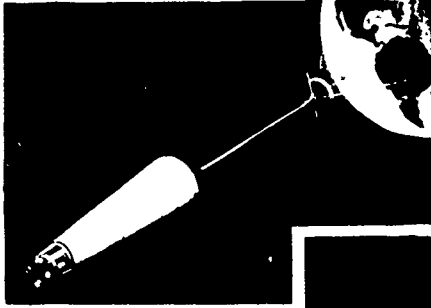

*Communications satellite.*

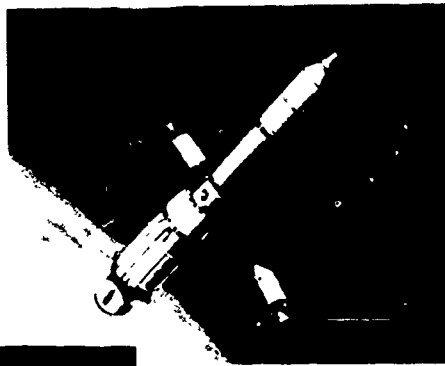

*Manned orbiting space station.*

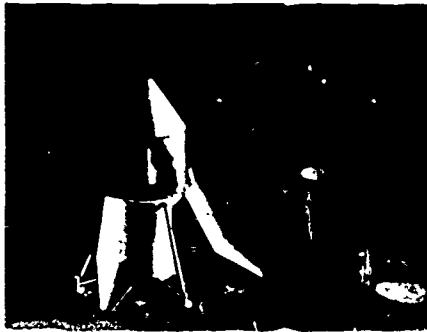

*Lunar base.*

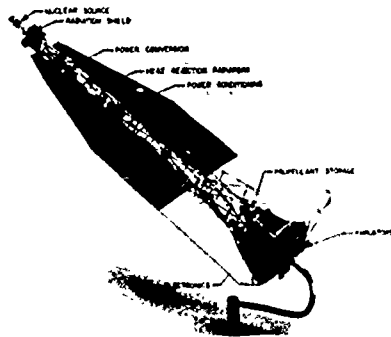

*Nuclear electrical propulsion.*

completed testing a ground-based experimental engine to obtain additional data needed for (4).

The national site for nuclear rocket reactor and engine tests (and eventually complete stages) is the Nuclear Rocket Development Station (NRDS) located in Jackass Flats, Nevada. The major installations in use at the station are Test Cell "C", a reactor test cell; Engine Test Stand

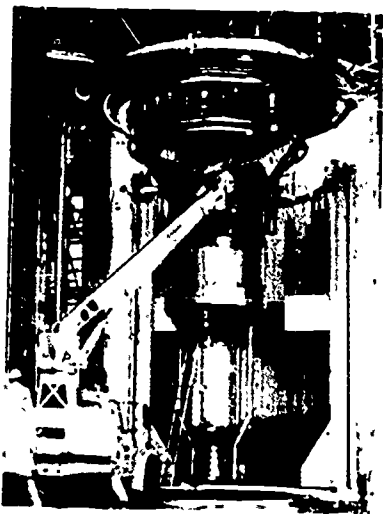

*Model of an advanced Nerva engine intended to produce 60,000 to 75,000 pounds of thrust and approximately 1500 megawatts of power.*

No. 1; R-MAD, a reactor maintenance, assembly, and disassembly building; and E-MAD, an engine maintenance, assembly, and disassembly building.\*

In addition to the NERVA work, the nuclear rocket program also supports other research for the extension of nuclear rocket technology. LASL, the Lewis Research Center, Marshall Space Flight Center, and many other government laboratories, universities, industrial organizations, and research institutes are involved in this effort. Activities of particular interest are: (1) advancements in reactor fuel technology, (2) investigation of materials properties and advanced reactor components, (3) development of nuclear vehicle technology, and (4) investigation of the feasibility of advanced nuclear rocket concepts.

**Electrical Power** The first application of atomic energy in space was a device that generates small amounts (watts) of electricity by thermoelectric conversion of the heat given off by a radioactive isotope

\*See *Nuclear Propulsion for Space*, a companion booklet in this series.

as it decays. Thermoelectric conversion is the generation of electricity (in special semiconductor devices called thermocouples) due to the conduction of heat through these devices.

On June 29, 1961, an isotope power source SNAP-3A weighing 5 pounds and generating 2.7 watts of electricity was carried into orbit aboard a Navy navigational satellite. It provides power for two of the

*The SNAP-3A generator (white ball at bottom), attached to a satellite to provide energy for the satellite's transmitters, was the first use of atomic power in space. Launched in 1961 with a design life of 5 years. SNAP-3A is still operating.*

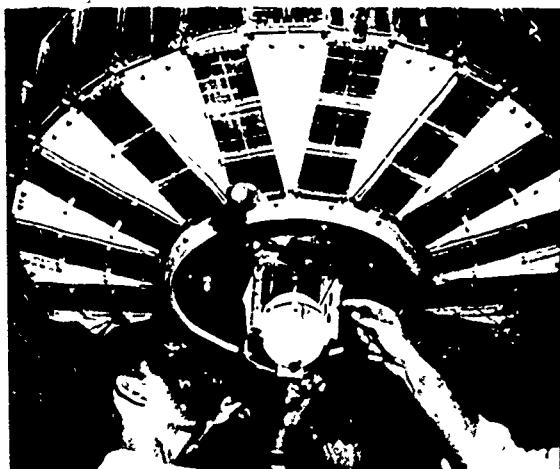

satellite's four radio transmitters, and thus gives ships and aircraft a worldwide means of determining their positions electronically. Other radioisotopic power sources, generating up to 66 watts of power for satellites, have been launched since that time including the Apollo ALSEP experiment package and the Nimbus-B weather satellite. The nuclear devices in these satellites were developed as part of the AEC space electric power program.

As part of the same program, two classes of compact nuclear reactors are being developed for the higher power space applications of the future. Their power outputs range from about 1 kilowatt to thousands of kilowatts.\*

Classes of space missions and reactor power concepts are described below.

Some unmanned satellites of the 1970s will need at least several kilowatts of electricity. If the mission requirements permit the vehicle to be long and slender, the shielding weight for unmanned spacecraft

---

\*See *SNAP—Nuclear Space Reactors*, a companion booklet in this series.

will be low enough so that reactors will be competitive with isotopes or nonnuclear power at power levels above about 1-2 kw. Probably among the earliest uses of space reactor power plants will be in manned space stations and lunar base applications, one or both of which may be launched in the 1970s. In these missions, which require heavy shielding, reactor use is advantageous above about 10-15 kw. At power levels of about 50 kw and above, which would be required in space stations and electrical propulsion missions, reactors have unique advantages over all other power concepts.

The first space reactor developed was SNAP-2, a liquid-metal-cooled zirconium hydride-moderated reactor with a thermal power output of 50 kw. This reactor together with a 500-watt thermoelectric generator was designated SNAP-10A. A flight version of SNAP-10A was launched and tested in orbit in 1965, and an identical model was tested on the ground for over a year.

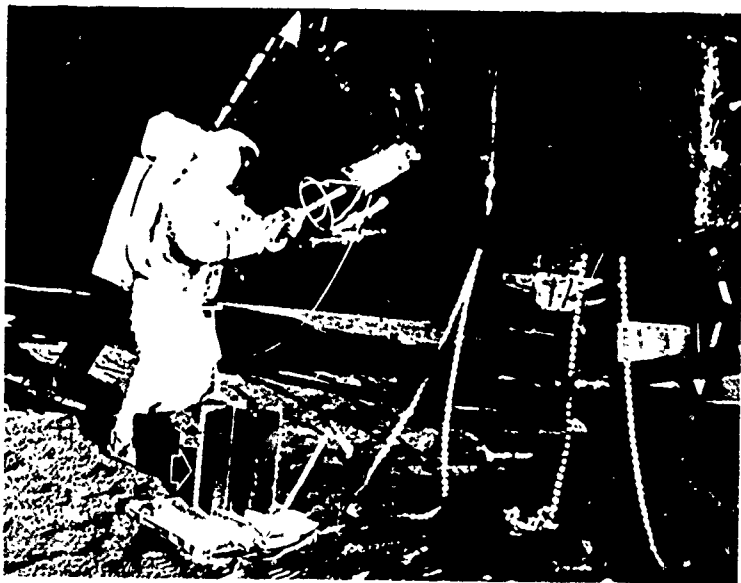

*SNAP-27 (arrow) shown on the moon, provides electrical power for the ALSEP instruments left by Apollo 12. Its minimum power output of 63 watts comes from the heat of the radioactive decay of plutonium-238. A thermoelectric system converts the heat directly into electricity.*

The present program is concentrating on two general categories of space power reactors (1) the zirconium hydride thermal reactor, which makes maximum use of currently available technology and (2) the

high temperature reactors which will be used for missions of the 1980s. The zirconium hydride reactor will be used primarily with thermoelectric conversion (which has no moving parts for power production) in the 10-35 kw range and with the mercury Rankine SNAP-8 system in the 30-70 kw range. However, the high efficiency Brayton or organic Rankine cycle technology may extend the power capability of the zirconium hydride reactor to perhaps 100 kw.

Power for electric propulsion as well as for auxiliary power uses on the spacecraft is also being developed. In electric propulsion, thrust is produced by ejecting a high-energy beam of electrically or electromagnetically accelerated vapor. This could lead to significantly improved space propulsion systems. Electric propulsion is a low-thrust concept and would be used only for propelling spacecraft once they were launched from the earth by other means.

For higher power, or for lower power plant weights, advanced space power systems using high temperature, fast reactors are required. The two power system concepts that show the most promise for this purpose are the in-core thermionic reactor and the potassium-Rankine cycle with a high-temperature, liquid-metal-cooled reactor. In a thermionic generator, electricity is produced by emission of electrons from a heated cathode (as in an electronic vacuum tube). In the in-core thermionic concept, the cathodes and collectors are integral parts of the reactor fuel elements, requiring fuel clad temperatures around 3000°F. The liquid-metal-cooled-reactor, potassium-Rankine system boils and condenses potassium in a cycle similar to that of a conventional steam power plant, but at peak temperatures around 2000°F, in order to attain the compactness required in space systems.

*SNAP-8DR is a prototype of a compact nuclear reactor that may one day supply power on the moon or aboard a spacecraft. The reactor system uses much of the technology of the SNAP-10A and at full-power operation will produce 600 kilowatts of thermal energy. Here a technician inserts one of 211 fuel elements into the core vessel during initial criticality experiments.*

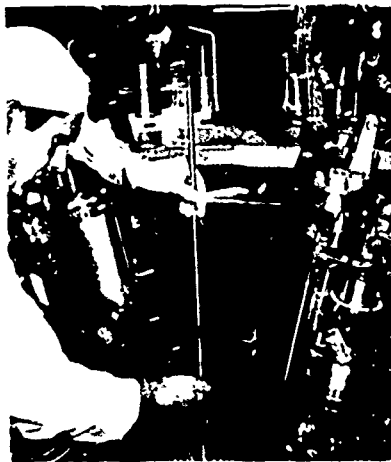



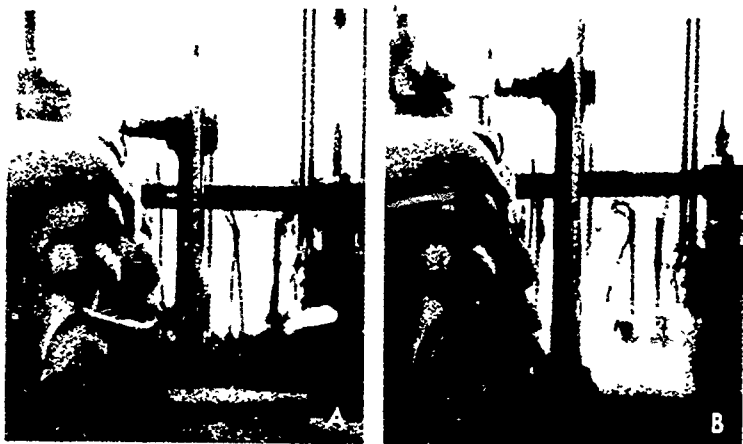

*These photographs record the sequence of events during a deliberate core destruction experiment in the SPERT-1 facility at the National Reactor Testing Station. The area on view is the top of the reactor, which was installed in an open tank below ground level. (A) A rod containing excess reactivity at upper right is*

## Reactor Safety

*Can a nuclear reactor blow up like an atomic bomb? The answer is: No.* In the first place, the fuel used in reactors could not be made to explode even in a bomb. In the second place, the design principles are entirely different. In a simple type of bomb, two or more pieces of essentially pure fissionable material are rapidly brought together to form a critical mass and are held in compression long enough for a very large explosive force to be generated. In a reactor there is nothing to hold the fuel together. If a runaway reaction occurs, the intense heat generated causes the fuel to melt or otherwise come apart. Reactors are so designed that, if this happens the fuel tends to disperse and the reaction automatically stops. Indeed, most types of reactors have an inherent self-regulating characteristic in that as the temperature begins to rise the reaction slows down.

Apart from the physical damage to the reactor, the most serious hazard in the event of fuel meltdown—or a structural failure, or any other conceivable reactor accident—is the possible escape of radioactivity. There are thus two main aspects of reactor safety, (1) prevention of reactor accidents, and (2) containment of radioactivity in the event of an accident.

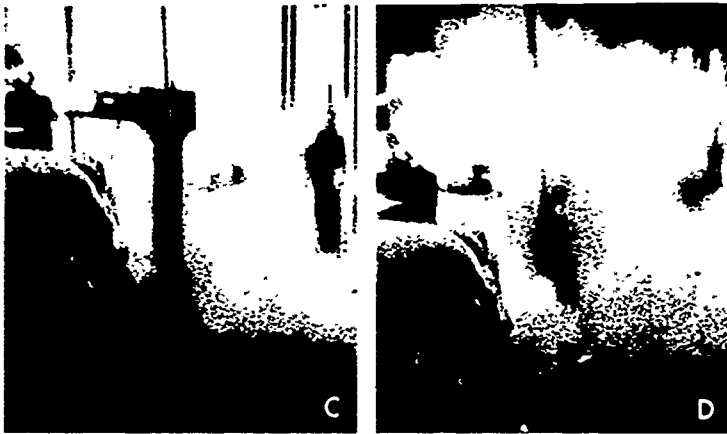

*driven down into the core. (B) Seventy-nine milliseconds after peak power was reached, steam begins escaping. (C) One hundred and five milliseconds after peak power, some of the test apparatus is knocked out of place. (D) One hundred and twenty-seven milliseconds after peak power, all details are hidden by escaping steam.*

Prevention of reactor accidents starts with conservative design of the reactor core and control system and conservative engineering of the reactor installation. Maximum advantage is taken of natural laws to build inherent safety features into the system. Starting with this base, the designer seeks to anticipate the possible sources of human error and electromechanical failure and to make provision for them in the design. For example, safety rods, which automatically insert themselves into the reactor when preset limits are reached, are designed on a "fail-safe" basis.

Accident prevention takes many other forms, such as the care that is taken to select and train operating personnel and to specify operating procedures. Before a nuclear power plant may be built in the United States, rigorous safety review procedures must be followed, including, among other steps, a specific safety review of the proposed project by the AEC and an impartial board of reactor experts (Advisory Committee on Reactor Safeguards). This review takes into account not only the features of the proposed reactor installation but also the environmental characteristics of the proposed location—distance from population centers, terrain, meteorological conditions, and the like. A similar but even more detailed review is made before a license is granted to operate the plant. Once the plant is in service, an amendment to the

license must be obtained before any significant change may be made in the plant or its operating pattern.

In the containment aspect of reactor safety, fission products account for nearly all the radioactivity in most power reactors, so they are what must be contained. In normal operation, the fission products are locked in the fuel by the fuel cladding, which is thus the plant's first line of defense against release of radioactivity.\* This material leaves the premises, so to speak, when "spent" (used) fuel elements are removed from the reactor and shipped to a fuel reprocessing plant.† Trace amounts of fission products that escape into the reactor coolant through defects in the fuel cladding are scavenged from the coolant by purification equipment, packaged and shipped to an AEC site for safe burial.‡

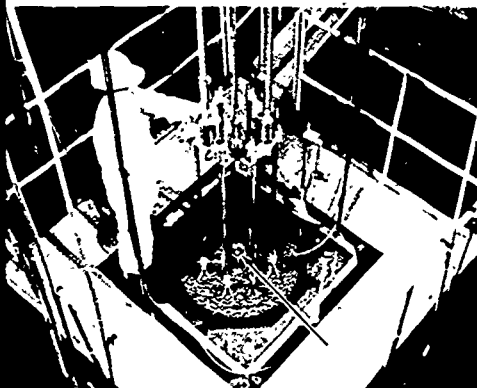

*Core of the Special Power Excursion Reactor Test No. 4 (SPERT-4). This is used for safety tests, such as determining the way in which fuel pins fail under various abnormal conditions, and the energy thresholds for fuel damage and failure under accident conditions.*

In the event a major accident such as fuel melt down, should occur, large amounts of fission products would escape their normal confinement in the fuel. Therefore civilian power reactors are provided with an additional line of defense—usually a gastight enclosure. In many plants this takes the form of a large containment shell, which encloses the reactor installation. These shells are designed to withstand the maximum vapor pressure that might be generated, and are rugged

---

\*In this connection, it is the ability of fuel and fuel cladding materials to withstand physical deformation under irradiation which often determines the allowable "fuel burnup"—that is, the length of time fuel elements can be allowed to remain in a power reactor.

†A plant at which residual fuel is recovered.

‡In some cases an airtight building suffices for containment, in other plants, major parts of the reactor system are individually contained in steel tanks. See *Radioactive Wastes*, another booklet in this series.

Miniature fuel pin (arrow), which was irradiated in the Materials Testing Reactor at the National Reactor Testing Station, is loaded into a furnace where it will be melted in pressurized steam, which simulates a loss-of-coolant accident. In this way surface coatings, decontamination procedures, sampling devices, and radiochemical analytical methods can be tested and evaluated.

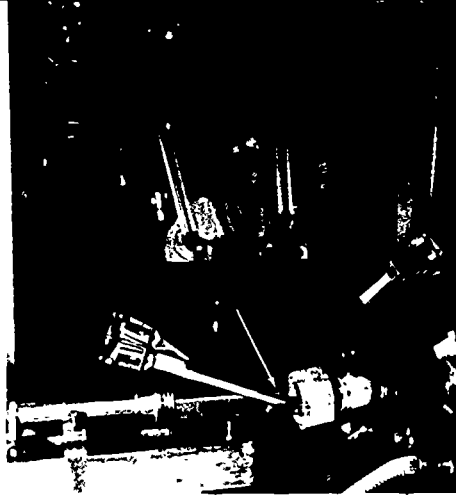

enough to resist possible shrapnel effects. They explain the familiar spherical or hemispherical shape of some nuclear power plants.

Over the more than two decades that have passed since the Fermi experiment, during which literally hundreds of reactors of various types and designs have been built for a great many purposes, an impressive safety record has been achieved. With every new reactor and each new year of operating experience, new knowledge is constantly being gained—and this is perhaps the most important safeguard of all. An equally important source of new knowledge is the Atomic Energy Commission's reactor safety program. This is a major effort and has two principal aspects. (1) study of basic accident mechanisms and (2) testing of safety features. In the latter, laboratory and prototype models of various types of reactor systems are put through rigorous tests under extreme conditions to determine the safe limits of designs, materials, and equipment components.\*

---

\*For more information on reactor safety, see *Atomic Power Safety*, a companion booklet in this series.

## Reactors of Tomorrow

A final point that should be made in this introduction to nuclear reactors is that "tomorrow"—or the day after—we may also have at our command an entirely different species of machine, namely thermonuclear reactors. In such machines power would be generated by the controlled fusion of light atoms,\* rather than by the controlled fission of heavy atoms. How this might be done is a subject unto itself; suffice it to say that scientists and engineers in at least half a dozen major laboratories in the United States, and their counterparts abroad, are busily at work on the problem.

And so it is clear that nuclear reactors, whether activated by fission or fusion, will play a significant part in the affairs of men for many years to come.

### PHOTO CREDITS:

Cover and photo on page 54 courtesy Kansas State University and General Dynamics Corporation

#### Page

1	Combustion Engineering, Inc.
4	Westinghouse Electric Corporation
5	Babcock & Wilcox Company
6	Vermont Yankee Nuclear Power Corporation
8	Argonne National Laboratory (ANL)
11	ANL
13	General Atomic Division, General Dynamics Corporation
16	General Electric Corporation
17	Battelle-Northwest
18	ANL
19	Westinghouse Electric Corporation (right)
20	Consumers Power Company (top); Southern California Edison Company (middle); Tennessee Valley Authority (bottom)
23	Union Carbide Corporation
27 & 28	U. S. Navy
29	States Marine Lines
36 & 37	National Reactor Testing Station
45	Connecticut Yankee Nuclear Power Company
50 & 51	ANL

\*Specifically, deuterium and/or tritium. These are isotopes of hydrogen, sometimes referred to as "heavy hydrogen" and "heavy heavy hydrogen." For more about this subject see *Controlled Nuclear Fusion*, a companion booklet in this series.

## Appendix

## U. S. Central Station Nuclear Power Projects—June 1970

<i>Name and/or owner</i>	<i>Location</i>	<i>Type</i>	<i>Capacity (kilowatts)</i>	<i>Startup</i>
<b>OPERABLE</b>				
Shippingport Atomic Power Station	Shippingport, Pa.	Pressurized water	90,000	1957
Dresden Nuclear Power Station, Unit 1	Morris, Ill.	Boiling water	200,000	1959
Yankee Nuclear Power Station	Rowe, Mass.	Pressurized water	175,000	1960
Big Rock Point Nuclear Plant	Big Rock Point, Mich.	Boiling water	70,400	1962
Indian Point Station, Unit 1	Indian Point, N. Y.	Pressurized water	265,000	1962
Enrico Fermi Atomic Power Plant	Lagoona Beach, Mich.	Sodium cooled, fast	60,900	1963
Itumboldt Bay Power Plant, Unit 3	Eureka, Calif.	Boiling water	68,500	1963
Peach Bottom Atomic Power Station, Unit 1	Peach Bottom, Pa.	Gas cooled, graphite moderated	40,000	1966
<b>BEING BUILT</b>				
San Onofre Nuclear Generating Station, Unit 1	San Clemente, Calif.	Pressurized water	430,000	1968
La Crosse Boiling Water Reactor	Genoa, Wis.	Boiling water	50,000	1967
Haddam Neck Plant	Haddam Neck, Conn.	Pressurized water	575,000	1967
Oyster Creek Nuclear Power Plant, Unit 1	Toms River, N. J.	Boiling water	530,000	1969
Nine Mile Point Nuclear Station	Scriba, N. Y.	Boiling water	500,000	1969
Robert Emmett Ginna Nuclear Power Plant, Unit 1	Ontario, N. Y.	Pressurized water	420,000	1969
Dresden Nuclear Power Station, Unit 2	Morris, Ill.	Boiling water	809,000	1970
<b>BEING BUILT</b>				
Millstone Nuclear Power Station, Unit 1	Waterford, Conn.	Boiling water	652,100	1970
Palisades Nuclear Power Station, Unit 1	South Haven, Mich.	Pressurized water	700,000	1970
Dresden Nuclear Power Station, Unit 3	Morris, Ill.	Boiling water	809,000	1970
H. B. Robinson S. E. Plant, Unit 2	Hartsville, S. C.	Pressurized water	700,000	1970
Quad-Cities Station, Unit 1	Cordova, Ill.	Boiling water	809,000	1971

<i>Name and/or owner</i>	<i>Location</i>	<i>Type</i>	<i>Capacity (kilowatts)</i>	<i>Startup</i>
Monticello Nuclear Generating Plant	Monticello, Minn.	Boiling water	545,000	1970
Point Beach Nuclear Plant, Unit 1	Two Creeks, Wis.	Pressurized water	497,000	1970
Surry Power Station, Unit 1	Gravel Neck, Va.	Pressurized water	780,000	1971
Oconee Nuclear Station, Unit 1	Seneca, S. C.	Pressurized water	841,120	1970
Indian Point Station, Unit 2	Indian Point, N. Y.	Pressurized water	872,890	1971
Browns Ferry Nuclear Power Plant, Unit 1	Decatur, Ala.	Boiling water	1,064,500	1971
Peach Bottom Atomic Power Station, Unit 2	Peach Bottom, Pa.	Boiling water	1,065,000	1971
Fort Calhoun Station, Unit 1	Fort Calhoun, Nebr.	Pressurized water	457,400	1972
Turkey Point Station, Unit 3	Turkey Point, Fla.	Pressurized water	651,500	1971
Vermont Yankee Generating Station	Vernon, Vt.	Boiling water	513,900	1971
Quad-Cities Station, Unit 2	Cordova, Ill.	Boiling water	809,000	1971
Surry Power Station, Unit 2	Gravel Neck, Va.	Pressurized water	780,000	1972
Pilgrim Station	Plymouth, Mass.	Boiling water	625,000	1971
Point Beach Nuclear Plant, Unit 2	Two Creeks, Wis.	Pressurized water	497,000	1971
Fort St. Vrain Nuclear Generating Station	Platteville, Colo.	Gas cooled, graphite moderated	330,000	1971
Cooper Nuclear Station	Brownville, Nebr.	Boiling water	778,000	1971
Oconee Nuclear Station, Unit 2	Seneca, S. C.	Pressurized water	886,000	1971
Zion Station, Unit 1	Zion, Ill.	Pressurized water	1,050,000	1971
Salem Nuclear Generating Station, Unit 1	Salem, N. J.	Pressurized water	1,050,000	1972
Three Mile Island Station, Unit 1	Middletown, Pa.	Pressurized water	810,000	1971
Browns Ferry Nuclear Power Plant, Unit 2	Decatur, Ala.	Boiling water	1,064,500	1972
Turkey Point Station, Unit 4	Turkey Point Fla.	Pressurized water	651,500	1972
Diablo Canyon Nuclear Power Plant, Unit 1	Diablo Canyon, Calif.	Pressurized water	1,060,000	1972
Prairie Island Nuclear Generating Plant, Unit 1	Red Wing, Minn.	Pressurized water	530,000	1972
Maine Yankee Atomic Power Plant	Wiscasset, Maine	Pressurized water	790,000	1972
Browns Ferry Nuclear Power Plant, Unit 3	Decatur, Ala.	Boiling water	1,064,500	1972

Kewaunee Nuclear Power Plant	Carlton, Wis.	Pressurized water	527,000	1972
Crystal River Plant, Unit 3	Red Level, Fla.	Pressurized water	858,000	1972
Salem Nuclear Generating Station, Unit 2	Salem, N. J.	Pressurized water	1,050,000	1973
Peach Bottom Atomic Power Station, Unit 3	Peach Bottom, Pa.	Boiling water	1,065,000	1972
Arkansas Nuclear One, Unit 1	London, Ark.	Pressurized water	850,000	1973
Donald C. Cook Plant, Unit 1	Bridgman, Mich.	Pressurized water	1,054,000	1972
Oconee Nuclear Station, Unit 3	Seneca, S. C.	Pressurized water	886,000	1972
Calvert Cliffs Nuclear Power Plant, Unit 1	Lusby, Md.	Pressurized water	800,000	1972
Edwin I. Hatch Nuclear Plant, Unit 1	Baxley, Ga.	Boiling water	786,000	1972
Rancho Seco Nuclear Generating Station, Unit 1	Clay Station, Calif.	Pressurized water	800,000	1972
Beaver Valley Power Station, Unit 1	Shippingsport, Pa.	Pressurized water	847,000	1972
Three Mile Island Nuclear Station, Unit 2	Middletown, Pa.	Pressurized water	810,000	1973
Calvert Cliffs Nuclear Power Plant, Unit 2	Lusby, Md.	Pressurized water	800,000	1973
Indian Point Station, Unit 3	Indian Point, N. Y.	Pressurized water	965,300	1973
Donald C. Cook Plant, Unit 2	Bridgman, Mich.	Pressurized water	1,060,000	1973
Brunswick Steam Electric Plant, Unit 1	Southport, N. C.	Boiling water	821,000	1975
Zion Station, Unit 2	Zion, Ill.	Pressurized water	1,050,000	1973
Prairie Island Nuclear Generating Plant, Unit 2	Red Wing, Minn.	Pressurized water	530,000	1974
Sequoyah Nuclear Power Plant, Unit 1	Daisy, Tenn.	Pressurized water	1,124,000	1973
Duane Arnold Energy Center, Unit 1	Palo, Iowa	Boiling water	545,000	1973
James A. FitzPatrick Nuclear Power Plant	Seriba, N. Y.	Boiling water	821,000	1973
Sequoyah Nuclear Power Plant, Unit 2	Daisy, Tenn.	Pressurized water	1,124,000	1974
<b>PLANNED</b>				
Hutchinson Island, Unit 1	Fort Pierce, Fla.	Pressurized water	800,000	1973
Millstone Nuclear Power Station, Unit 2	Waterford, Conn.	Pressurized water	828,000	1973
North Anna Power Station, Unit 1	Mineral, Va.	Pressurized water	845,000	1973
Diablo Canyon Nuclear Power Plant, Unit 2	Diablo Canyon, Calif.	Pressurized water	1,060,000	1973
Enrico Fermi Atomic Power Plant, Unit 2	Lagoona Beach, Mich.	Boiling water	1,123,000	1973
Trojan Nuclear Plant, Unit 1	Rainier, Oreg.	Pressurized water	1,106,000	1974
Davis-Besse Nuclear Power Station	Oak Harbor, Ohio	Pressurized water	872,000	1974



<i>Name and/or owner</i>	<i>Location</i>	<i>Type</i>	<i>Capacity (kilowatts)</i>	<i>Startup</i>
Joseph M. Farley Nuclear Plant	Dothan, Ala.	Pressurized water	829,000	1974
North Anna Power Station, Unit 2	Mineral, Va.	Pressurized water	845,000	1974
Newbold Island Nuclear Generating Station, Unit 1	Newbold Island, N. J.	Boiling water	1,088,000	1974
Limerick Generating Station, Unit 1	Pottstown, Pa.	Boiling water	1,065,000	1974
William H. Zimmer Nuclear Power Station, Unit 1	Moscow, Ohio	Boiling water	810,000	1974
Pennsylvania Power & Light Co., Unit 1	Brookhaven, N. Y.	Boiling water	1,052,000	1975
Shoreham Nuclear Power Station	Moscow, Ohio	Boiling water	819,000	1975
William H. Zimmer Nuclear Power Station, Unit 2	Moscow, Ohio	Boiling water	810,000	1975
William B. McGuire Nuclear Station, Unit 1	Cowans Ford Dam, N. C.	Pressurized water	1,150,000	1975
Forked River Nuclear Generating Station, Unit 1	Forked River, N. J.	Pressurized water	1,129,000	1975
San Onofre Nuclear Generating Station, Unit 2	San Clemente, Calif.	Pressurized water	1,140,000	1975
Malibu Nuclear Plant, Unit 1	Corral Canyon, Calif.	Pressurized water	462,000	1976
Bailly Generating Station	Dunes Acres, Ind.	Boiling water	660,000	1976
Carolina Power & Light Co.	North Carolina	Boiling water	821,000	1976
Newbold Island Nuclear Generating Station Unit 2	Newbold Island, N. J.	Boiling water	1,088,000	1976
Edwin I. Hatch Nuclear Plant, Unit 2	Baxley, Ga.	Boiling water	786,000	1976
Aguirre Nuclear Power Plant	Puerto Rico	Pressurized water	583,000	1976
Arkansas Nuclear One, Unit 2	London, Ark.	Pressurized water	950,000	1976
Limerick Generating Station, Unit 2	Pottstown, Pa.	Boiling water	1,065,000	1976
San Onofre Nuclear Generating Station, Unit 3	San Clemente, Calif.	Pressurized water	1,140,000	1976
LaSalle County Nuclear Station, Unit 1	Seneca, Ill.	Boiling water	1,100,000	1976
LaSalle County Nuclear Station, Unit 2	Seneca, Ill.	Boiling water	1,100,000	1977
Consolidated Edison Co. <sup>3</sup>	Verplanck, N. Y.	Boiling water	1,115,000	1977
Pennsylvania Power & Light Co., Unit 2	Lansing, N. Y.	Boiling water	1,052,000	1977
Bell Station	Cowans Ford Dam, N. C.	Boiling water	838,000	1977
William B. McGuire Nuclear Station, Unit 2	Cowans Ford Dam, N. C.	Pressurized water	1,150,000	1977



*Connecticut Yankee Atomic Power Plant, located at Haddam Neck on the east bank of the Connecticut River, has a 575,000-kilowatt capacity.*

## Characteristics of U. S. Civilian Power Reactor Concepts

### Pressurized-Water Reactor (PWR)

FUEL Slightly enriched uranium oxide clad with zirconium alloy  
MODERATOR Water  
COOLANT Water  
PRESSURE OF PRIMARY SYSTEM 2,250 pounds per square inch  
(psi)  
COOLANT OUTLET TEMPERATURE 605°F

NOTES Well developed technology. Coolant pressurized to prevent bulk boiling in core; hence high operating pressure.

### Boiling-Water Reactor (BWR)

FUEL Same as PWR, above  
MODERATOR Boiling water  
COOLANT Boiling water  
PRESSURE OF PRIMARY SYSTEM 1,000 psi  
COOLANT OUTLET TEMPERATURE 550°F

NOTES Well developed technology. Coolant allowed to boil in core, hence lower operating pressure than PWR. Physical size of core larger than in PWR.

### High-Temperature Gas-Cooled Reactor (HTGR)

FUEL Highly enriched uranium carbide and thorium carbide coated with pyrolytic carbon  
MODERATOR Graphite  
COOLANT Helium  
PRESSURE OF PRIMARY SYSTEM 550 700 psi  
COOLANT OUTLET TEMPERATURE approximately 1400°F

NOTES Use of helium as coolant permits achieving high temperatures (with resulting high overall plant efficiency) and minimizes corrosion problems. Core design of HTGR leads to high fuel utilization efficiency.

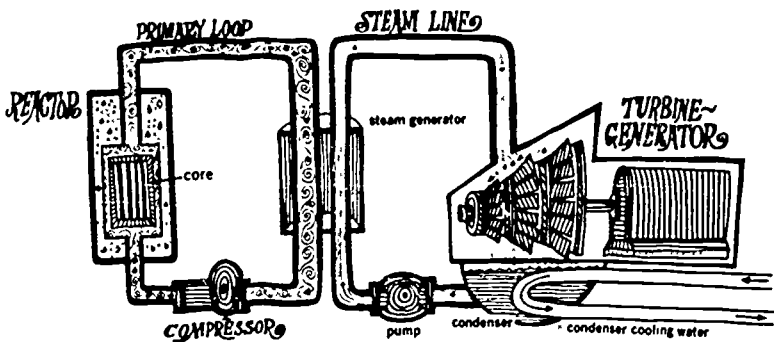
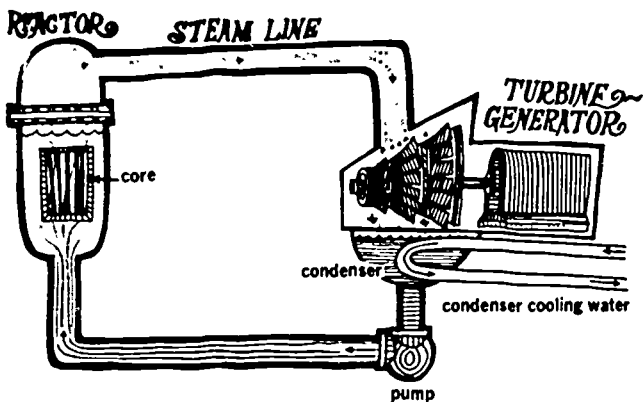
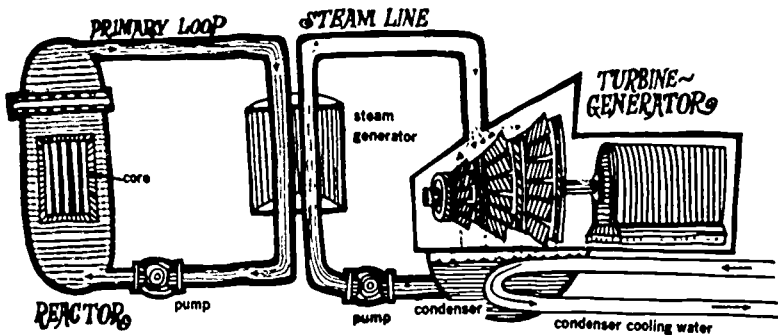

### **Molten Salt Reactor (MSR)**

**FUEL** Molten solution of highly enriched uranium and thorium in fluoride salt mixture

**MODERATOR** Graphite

**COOLANT** See notes below

**PRESSURE OF PRIMARY SYSTEM** Nominal

**COOLANT OUTLET TEMPERATURE** 1300°F

**NOTES** Circulating fuel system. Concept in experimental stage.

### **Liquid-Metal-Cooled Fast Breeder Reactors (LMFBR)**

#### **Sodium-Graphite Reactor (SGR)**

**FUEL** Highly enriched uranium-plutonium oxide clad in stainless steel

**MODERATOR** Minimal

**COOLANT** Liquid sodium

**PRESSURE OF PRIMARY SYSTEM** 100-200 psig

**COOLANT OUTLET TEMPERATURE** 800-1100°F

**NOTES** Promise of low fuel costs and efficient utilization of fuel resources through breeding. Use of sodium as coolant permits achieving high temperatures at nominal pressure, also, sodium is a very efficient heat transfer medium. The handling of sodium introduces some design and operating complications.



#### **Fast Breeder Reactor (FBR)**

**FUEL** Highly enriched uranium alloy clad with stainless steel (use of uranium-plutonium oxides projected)

**MODERATOR** None

**COOLANT** Liquid sodium

**PRESSURE OF PRIMARY SYSTEM** Nominal

**COOLANT OUTLET TEMPERATURE** 800-1150°F

**NOTES** Promise of low fuel costs and efficient utilization of fuel resources through breeding. Use of sodium as coolant permits achieving high temperatures at nominal pressure, also, sodium is a very efficient heat transfer medium. The handling of sodium introduces some design and operating complications.



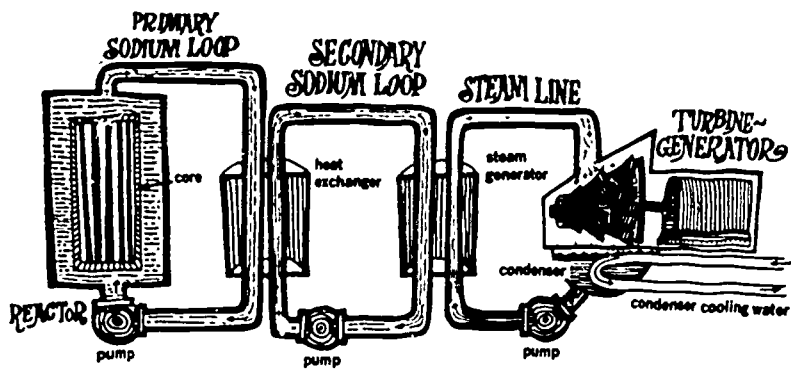

## Suggested References

### Books

- Atompower.* Joseph M. Dukert, Coward-McCann, Inc., New York 10016, 1962, 127 pp., \$3.50. (Grades 5-8)
- Atoms Afloat: The Nuclear Ship Savannah,* Edward and Ruth S. Radlauer, Abelard-Schuman, Ltd., New York 10019, 1963, 124 pp., \$3.00.
- Atomic Submarines,* William R. Anderson, James Baar, and William E. Howard, Childrens Press, Chicago, Illinois 60607, 1968, 63 pp., \$3.95. (Grades 4-8)
- Inside the Atom* (revised edition), Isaac Asimov, Abelard-Schuman, Ltd., New York 10019, 1966, 197 pp., \$4.00.
- Let's Go To An Atomic Energy Town,* Kirk Polking, G. P. Putnam's Sons, New York 10016, 1968, 46 pp., \$1.97. (Grades 3-6)
- The Atomic Energy Deskbook,* John F. Hogerton, Reinhold Publishing Corporation, New York 10022, 1963, 673 pp., \$11.00.
- Sourcebook on Atomic Energy* (third edition), Samuel Glasstone, D. Van Nostrand Company, Inc., Princeton, New Jersey 08540, 1967, 883 pp., \$9.25.
- The Useful Atom,* William R. Anderson and Vernon Pizer, The World Publishing Company, Cleveland, Ohio 44102, 1966, 185 pp., \$5.75.
- Nuclear Propulsion for Merchant Ships.* A. W. Kramer, Superintendent of Documents, U. S. Government Printing Office, Washington, D. C. 20402, 1962, 600 pp., \$2.25.
- The Atom at Work: How Nuclear Power Can Benefit Man,* C. B. Colby, Coward-McCann, Inc., New York 10016, 1968, 48 pp., \$2.97. (Grades 4-8)
- City Under the Ice: The Story of Camp Century,* Charles Michael Daugherty, The Macmillan Company, New York 10022, 1963, 156 pp., \$6.95. (Out of print but available through libraries.)



*Sketch of the first nuclear reactor built in Chicago in 1942.*

## Reports

*Nuclear Reactors Built, Being Built, or Planned in the United States* (TID-8200), revised semiannually, U. S. Atomic Energy Commission, Clearinghouse for Federal Scientific and Technical Information, 5285 Port Royal Road, Springfield, Virginia 22151, \$3.00.

The following reports are available from the Superintendent of Documents, U. S. Government Printing Office, Washington, D. C. 20402:

*Major Activities in the Atomic Energy Programs, January-December*, issued annually, U. S. Atomic Energy Commission, about 400 pp., \$1.75.

*The Nuclear Industry*, revised annually, Division of Industrial Participation, U. S. Atomic Energy Commission, price varies with each issue.

*Forecast of Growth of Nuclear Power* (WASH-1084), Division of Operations Analysis and Forecasting, U. S. Atomic Energy Commission, December 1967, 50 pp., \$0.35.

*Civilian Nuclear Power—The 1967 Supplement to the 1962 Report to the President*, U. S. Atomic Energy Commission, February 1967, 56 pp., \$0.40.

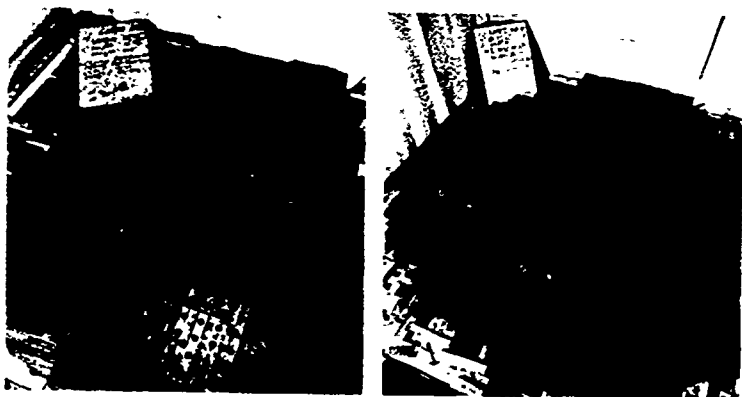

*Layers of graphite blocks were used to construct the first nuclear reactor. On the left is the tenth layer containing uranium oxide. On the right the nineteenth layer of solid blocks covers layer 18, which contains uranium oxide.*

## Articles

The Arrival of Nuclear Power, John F. Hogerton, *Scientific American*, 218: 21 (February 1968).

Next Step is the Breeder Reactor. *Fortune*, 75: 120 (March 1967).

Third Generation of Breeder Reactors, T. R. Bump, *Scientific American*, 216: 25 (1967).



## Motion Pictures

Available for loan without charge from the AEC Headquarters Film Library, Division of Public Information, U. S. Atomic Energy Commission, Washington, D. C. 20545 and from other AEC film libraries.

*Atomic Power Today: Service with Safety*, 28½ minutes, color, 1966. Produced for the Atomic Industrial Forum, Inc., and the AEC by Seneca Productions, Inc. This film tells how central station nuclear power plants serve America. Starting with basic information on how electricity is produced from water power and fossil fuels, the film introduces nuclear fuel as a new energy resource that helps keep down the cost of electricity. Components and construction of a power plant are shown, and safety features are emphasized.

*The Nuclear Ship Savannah*, 28½ minutes, color, 1964. Produced by Orleans Film Productions for the U. S. Maritime Administration and the AEC. This nontechnical film covers the historical background, design, construction, sea trials, and initial port calls of the *NS Savannah*, the world's first nuclear powered merchant ship.

*Tomorrow's Power—Today*, 5½ minutes, color, 1964. Produced for the AEC by the Argonne National Laboratory. This film explains why energy from the atom is needed to supplement that of conventional fossil fuels. It shows how heat from nuclear fission is converted to electrical power and gives a brief survey of representative atomic power plants in the U. S.

*The New Power*, 45 minutes, color, 1965. Produced for the AEC's Idaho Operations Office by the Lookout Mountain Air Force Station. This film tells how the National Reactor Testing Station in Idaho is furthering the AEC's quest for economic nuclear power. Most of the many experimental nuclear reactors located at the Testing Station are described. The film also explains the basic principles of power reactor construction and operation.

*Atomic Power Production*, 14 minutes, color or black and white, 1964. This film in the Magic of the Atom Series was produced by the Handel Film Corporation. An explanation is given of how the heat created by the controlled chain reaction of atomic fuel in a reactor is converted to electrical power. The basic differences in these power reactors are discussed: the boiling-water reactor, the pressurized-water reactor, the liquid-metal-cooled reactor, and the organic-cooled reactor. The principle of the breeder reactor is explained and its importance stressed.

*Atomic Venture*, 23½ minutes, color, 1961. Produced by the General Electric Company. This film covers the design and development of a large dual-cycle boiling-water reactor—the 180,000-kilowatt Dresden Nuclear Power Station—built by the General Electric Company for the Commonwealth Edison Company in Chicago and the Nuclear Power Group, Inc., from its beginning in 1955 to its completion in 1959.

*Power and Promise*, 29 minutes, color, 1959. Produced by the AEC. This film describes the Shippingport Atomic Power Station in Pennsylvania, which was built to advance power reactor technology and demonstrate the practicability of operating a central station nuclear power plant in a utility network.

*The Day Tomorrow Began*, 30 minutes color, 1967. Produced by Argonne National Laboratory for the AEC. This film tells the story of the building and testing of the world's first reactor. By interview, historical film footage, and paintings, the motion picture reenacts the historic events that led to the dramatic moment when the first sustained chain reaction was achieved. This milestone in man's quest for knowledge occurred under the stands of Stagg Field, Chicago, on December 2, 1942.

*SNAP 8: System for Nuclear Auxiliary Power*, 10 minutes, color, 1966. Produced by the Aerojet-General Corporation. SNAP-8 can provide a source of continuous power so that space voyagers may live in health and comfort for months at a time. In animation and live-action sequences, the fabrication and operation of this system is explained.

*Atomic Energy for Space*, 17 minutes, color, 1966. Produced by the Handel Film Corporation with the cooperation of the AEC and NASA. The film explains why only atomic energy can satisfy some of the future power needs for the exploration of deep space. Nuclear energy for space is being developed through two basic applications. The nuclear rocket for space propulsion and the isotopic or reactor power plants that produce the electricity essential for spacecraft operations. The efficiency of nuclear and chemical rockets is compared and the fission process, which produces the heat for the nuclear engine's thrust, is explained with animation. KIWI and NERVA systems are shown. SNAP systems, which can provide electricity for spacecraft and satellites, are described in detail.

*First Reactor in Space: SNAP-10A*, 14½ minutes, color, 1966. Produced for the AEC by Atomics International. Development and launch of the first reactor in space are described. SNAP-10A, consisting of a nuclear reactor and power conversion unit, operated successfully for 43 days and produced more than 500,000 watt-hours of electricity. This compact reactor is coupled to a thermoelectric converter-radiator unit that converts heat from fission in the reactor directly into electricity. The heat is then transferred to the power conversion unit by a liquid metal coolant.

*Nuclear Propulsion in Space*, 20½ minutes, color, 1969. Produced by NASA for NASA and the AEC. This film compares the heavy chemical rockets used today with the lighter nuclear rockets, which will be used in the future. These lighter rockets will cut travel time or allow an increased payload. The KIWI and NERVA tests are explained and illustrated.

*The Weather Eye*, 13 minutes, color, 1969. Produced by the AEC. The design, fabrication, and testing of SNAP-19 are described. The electrical power provided by this isotope generator will supplement the solar cell power for data-gathering instruments and transmitters aboard a Nimbus weather satellite.

## THE COVER

A large mosaic portraying the tremendous energy and limitless scope of the peaceful atom is mounted on the concrete shield of the TRIGA teaching and research reactor at Kansas State University. The mosaic was designed by students of the University's Department of Architecture after consultation with the Department of Nuclear Engineering. Six and one-half feet high and four and one-half feet wide, the mosaic contains nearly 10,000 pieces of colored glass. At the lower left are "hands of supplication" to convey mankind's hope that the gift of nuclear energy will be used wisely.

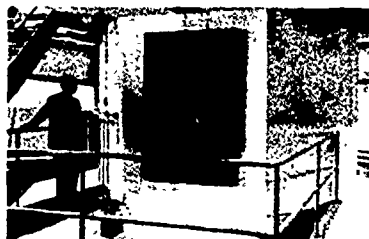

## THE AUTHOR

John F. Hogerton is a chemical and nuclear engineer (B.E., Yale, 1941) who has worked in the atomic industry from its beginning. He is now an independent consultant.

Mr. Hogerton was coauthor of the final report on the wartime gaseous diffusion project at Oak Ridge. He also served on the Manhattan Project Editorial Advisory Board which coordinated the writing of the multivolume National Nuclear Energy Series.

The first edition of the Atomic Energy Commission's four-volume *Reactor Handbook* was edited by Mr. Hogerton. For the American Society of Mechanical Engineers, he contributed to *A Glossary of Terms in Nuclear Science and Technology* and wrote the widely used booklet, *Uranium, Plutonium and Industry*. For the AEC he wrote the 1958 Geneva Conference commemorative volume, *Atoms for Peace—U.S.A., 1958*; a one-volume encyclopedia, *The Atomic Energy Deskbook*, published in 1963, *Atomic Fuel* and *Atomic Power Safety*, other booklets in this series.

The U. S. Atomic Energy Commission publishes this series of information booklets for the general public. The booklets are listed below by subject category.

If you would like to have copies of these booklets, please write to the following address for a booklet price list:

USAEC—Technical Information Center  
P. O. Box 62  
Oak Ridge, Tennessee 37830

School and public libraries may obtain a complete set of the booklets without charge. These requests must be made on school or library stationery.

- |                         |   |                         |  |
|-------------------------|---|-------------------------|--|
| <b>Chemistry</b>        |   | IB-008                  | Electricity and Man  |
| IB-303                  | The Atomic Fingerprint. Neutron Activation Analysis                 | IB-005                  | Index to AEC Information Booklets                                      |
| IB-301                  | The Chemistry of the Noble Gases                                    | IB-310                  | Lost Worlds. Nuclear Science and Archeology                            |
| IB-302                  | Cryogenics. The Uncommon Cold                                       | IB-309                  | The Mysterious Box: Nuclear Science and Art                            |
| IB-304                  | Nuclear Clocks  | IB-006                  | Nuclear Terms: A Glossary  |
| IB-306                  | Radioisotopes in Industry   | IB-013                  | Secrets of the Past: Nuclear Energy Applications in Art and Archeology |
| IB-307                  | Rare Earths: The Fraternal Fifteen                                  | IB-017                  | Teleoperators. Man's Machine Partners                                  |
| IB-308                  | Synthetic Transuranium Elements                                     | IB-014, 015, & 016      | Worlds Within Worlds: The Story of Nuclear Energy Volumes 1, 2, and 3  |
| <b>Biology</b>          |   | <b>Physics</b>          |  |
| IB-101                  | Animals in Atomic Research  | IB-401                  | Accelerators   |
| IB-102                  | Atoms in Agriculture  | IB-402                  | Atomic Particle Detection  |
| IB-105                  | The Genetic Effects of Radiation                                    | IB-403                  | Controlled Nuclear Fusion  |
| IB-110                  | Preserving Food with Atomic Energy                                  | IB-404                  | Direct Conversion of Energy  |
| IB-106                  | Radioisotopes and Life Processes                                    | IB-410                  | The Electron   |
| IB-107                  | Radioisotopes in Medicine   | IB-405                  | The Elusive Neutrino   |
| IB-109                  | Your Body and Radiation   | IB-416                  | Inner Space: The Structure of the Atom                                 |
| <b>The Environment</b>  |   | IB-406                  | Lasers   |
| IB-201                  | The Atom and the Ocean  | IB-407                  | Microstructure of Matter   |
| IB-202                  | Atoms, Nature, and Man  | IB-415                  | The Mystery of Matter  |
| IB-414                  | Nature's Invisible Rays   | IB-411                  | Power from Radioisotopes   |
| <b>General Interest</b> |   | IB-413                  | Spectroscopy   |
| IB-009                  | Atomic Energy and Your World  | IB-412                  | Space Radiation  |
| IB-010                  | Atomic Pioneers—Book 1: From Ancient Greece to the 19th Century     | <b>Nuclear Reactors</b> |  |
| IB-011                  | Atomic Pioneers—Book 2: From the Mid-19th to the Early 20th Century | IB-501                  | Atomic Fuel  |
| IB-012                  | Atomic Pioneers—Book 3: From the Late 19th to the Mid-20th Century  | IB-502                  | Atomic Power Safety  |
| IB-002                  | A Bibliography of Basic Books on Atomic Energy                      | IB-513                  | Breeder Reactors   |
| IB-004                  | Computers   | IB-503                  | The First Reactor  |
|                         |   | IB-505                  | Nuclear Power Plants   |
|                         |   | IB-507                  | Nuclear Reactors   |
|                         |   | IB-510                  | Nuclear Reactors for Space Power                                       |
|                         |   | IB-508                  | Radioactive Wastes   |
|                         |   | IB-511                  | Sources of Nuclear Fuel  |
|                         |   | IB-512                  | Thorium and the Third Fuel   |

