

DOCUMENT RESUME

ED 106 642

CE 003 816

**TITLE** Principles and Practices of Occupational Safety and Health: Student Manual: Booklet Three.

**INSTITUTION** Occupational Safety and Health Administration, Washington, D.C.

**REPORT NO** OSHA-2215

**NOTE** 56p.; For related documents, see CE 003 813-819

**AVAILABLE FROM** Superintendent of Documents, U. S. Government Printing Office, Washington, D. C. 20402 (Stock No. 2915-00039, \$1.35)

**EDRS PRICE** MF-\$0.76 HC-\$3.32 PLUS POSTAGE

**DESCRIPTORS** Accident Prevention; Autoinstructional Aids; Federal Legislation; Health Conditions; \*Health Education; \*Industrial Training; Instructional Materials; Manuals; Post Secondary Education; Programed Units; Safety; \*Safety Education; \*Study Guides; \*Supervisory Training

**IDENTIFIERS** Occupational Health; \*Occupational Safety; Occupational Safety and Health Act 1970

**ABSTRACT**

The manual is the third of six student manuals for use in a course on occupational health and safety for supervisory personnel. The manual contains lessons 6 and 7 of the 15 consecutively-numbered lessons, each of which contains study questions (and answers) interwoven with the text and review questions at the end of each section. Lesson 6 covers the recognition, evaluation, and control of hazards with specific reference to the Federal Register Occupational Safety and Health Act Standards. Lesson 7 discusses the identification and correction of safety and health hazards and covers the identification of problem areas, the types and plans of various kinds of inspections, and the use of several types of forms and reports. (JR)

ED106642

FEB 05 1975

A Programmed Instruction Course



# Principles and Practices of

SURPLUS  
DUPLICATE

4 - JAN - 9  
Copy ... 1975

# Occupational Safety and Health

U.S. DEPARTMENT OF HEALTH,  
EDUCATION & WELFARE  
NATIONAL INSTITUTE OF  
EDUCATION

THIS DOCUMENT HAS BEEN REPRODUCED EXACTLY AS RECEIVED FROM THE PERSON OR ORGANIZATION ORIGINATING IT. POINTS OF VIEW OR OPINIONS STATED DO NOT NECESSARILY REPRESENT OFFICIAL NATIONAL INSTITUTE OF EDUCATION POSITION OR POLICY.

## STUDENT MANUAL

## Booklet Three

U.S. DEPARTMENT OF LABOR  
Occupational Safety and Health Administration  
Washington, D. C. 20210

OSHA 2215

For sale by the Superintendent of Documents, U.S. Government Printing Office  
Washington, D.C., 20402 - Price \$1.35

Stock Number 2915-00039

## INDEX TO LESSONS

<i>Lesson</i>	<i>Title</i>	<i>Page</i>
No. 6	Recognize, Evaluate, and Control Hazards .	1
No. 7	Identification and Correction of Safety and Health Hazards . . . . .	27

## LESSON 6

### RECOGNIZE, EVALUATE, AND CONTROL HAZARDS

This lesson is to help you to analyze - that is, to **RECOGNIZE, EVALUATE, and CONTROL** hazards. After you have learned to recognize and evaluate some hazards, you will be given examples from the Federal Register OSHA Standards on how certain hazards are controlled in some industries.

#### RECOGNITION OF POTENTIAL HAZARDS

1. Although an action, condition, or state that exists has not harmed something, the fact that it has the *possibility* of doing so makes it a hazard. The test to apply to determine whether a hazard exists is - can it cause:
  - a. Personal injury?
  - b. Occupational illness?
  - c. Property damage?

#### IDENTIFICATION

Your responsibility to everyone with whom you work and yourself is to judge whether each situation or condition in your workplace has the possibility or capability of causing such injury, illness, or damage. This is not as difficult as it sounds. Look at the following list of conditions, actions and situations.

Any time you identify one of these potential sources of harmful contact, you have recognized a hazard:

- Is there a chance the employee, equipment, or materials can be caught in, on, or between objects?
- Is there a danger the employee, equipment, or materials can fall to a lower level?
- Can an employee slip, trip, or fall because of materials or objects in his pathway?
- Is there a chance of an employee or equipment being struck or striking against some object?
- Is the situation such that an employee may hurt himself by pushing, pulling, or lifting?
- Is the worker exposed to potentially dangerous flying objects?

If none of the above hazards can occur in your workplace, try the next group and write in your answers.

## ANSWERS TO QUESTIONS

1 a. Yes    b. Yes    c. Yes

2 Think of your workplace and indicate which of the following questions identify a potentially hazardous condition for you or the employees you supervise

	Yes	No
a. Is there the possibility of overloading the equipment's capability?	___	___
b. Are there environmental hazards such as air contaminants, radiation, noise, temperature extremes and flammable solvents?	___	___
c. Do conditions exist that are potential as fire hazards?	___	___
d. Does the work present physical and/or mental stress?	___	___

Once you have recognized the existence of a hazard, you should next ask yourself how this hazardous condition can possibly affect employees, environment, equipment or materials. Only in this manner will you be able to **EVALUATE** the hazard (the second step in reaching the objective of this lesson). Furthermore, you will probably have to recognize that there is a definite relationship between hazards and standards - existing hazards usually turn out to be violations of occupational safety and health standards.

### EVALUATION

You will evaluate each hazard that you identify to determine the degree or severity of harm that it can cause. As you will see later, there are three classifications of hazards (A, B and C), depending upon the potential loss severity. This evaluation will assist you in setting priorities for the **CONTROL** of each hazard that you have recognized.

The **CONTROL** of hazards is performed through any of three basic methods:

- Elimination of the hazard
- Segregation of the hazard
- Protection from the hazard

### OCCUPATIONAL SAFETY AND HEALTH (OSHA) STANDARDS

Let us say that you have just surveyed your workplace and you were unable to recognize any conditions you could classify as hazardous. To ensure that you haven't overlooked something, now would be the time for you to familiarize yourself with the **OSHA** Standards published in the Federal Register (a copy of the Federal Register has been included with this course for your use).

## ANSWERS TO QUESTIONS

2. If you answered "yes" to any of these, you are already identifying potential hazards in your company
- 

## YOU MUST KNOW THE OSHA STANDARDS AND APPLY THEM

In any treatment of a subject as broad and as comprehensive as the OSHA standards, it is impossible to list all standards that might affect you. However, since you represent an employer and since employers are legally responsible for following the OSHA standards, you **MUST** familiarize yourself with all the standards, particularly those that might apply to your operations. Remember, you must find, read, understand, and comply with all the OSHA standards that apply to your operations.

## WHAT THE STANDARDS COVER

The latest version of these standards (Occupational Safety and Health, 29 CFR 1910) appeared in the *FEDERAL REGISTER*\*, Volume 39, Number 125, June 27, 1974, under the headings listed below. These standards will be referred to in the rest of this lesson

- Walking - Working Surfaces - Subpart D (1910.21-1910.32)
- Means of Egress - Subpart E (1910.35-1910.40)
- Powered Platforms, Manlifts and Vehicle-mounted Work Platforms - Subpart F (1910.66-1910.70)
- Occupational Health and Environmental Control - Subpart G (1910.93-1910.100)
- Hazardous Materials - Subpart H (1910.101-1910.116)
- Personal Protective Equipment - Subpart I (1910.132-1910.140)
- General Environmental Controls - Subpart J (1910.141-1910.149)
- Medical and First Aid - Subpart K (1910.151-1910.153)
- Fire Protection - Subpart L (1910.156-1910.165b)
- Compressed Gas and Compressed Air Equipment - Subpart M (1910.166-1910.171)
- Materials Handling and Storage - Subpart N (1910.176-1910.184)
- Machinery and Machine Guarding - Subpart O (1910.211-1910.222)
- Hand and Portable Powered Tools and other Hand-Held Equipment - Subpart P (1910.241-1910.247)
- Welding, Cutting and Brazing - Subpart Q (1910.251-1910.254)
- Special Industries - Subpart R (1910.261-1910.269)
- Electrical (refer to National Elec. Code of 1971) - Subpart S (1910.308-1910.309)

## ACT SPECIFIES STANDARDS

To help recognize, evaluate, and control hazards, the Act authorizes OSHA to set up occupational safety and health standards to assure the greatest protection to men and women in the workplace. Some standards adopted by OSHA are general and apply to almost all employers. An example of this kind of standard would be

"Housekeeping" - all places of employment, passageways, storerooms and service rooms shall be kept clean and orderly and in a sanitary condition.

As you can see, this standard will apply to almost all work areas.

## SOME STANDARDS PROVIDE DETAILED GUIDANCE

Some standards are detailed and specific. The example below establishes specifications for a common item found in many workplaces:

A stair railing shall be of construction similar to a standard railing but the vertical height shall be not more than 34 inches nor less than 30 inches from upper surface of top rail to surface of tread in line with face of riser at forward edge of tread.

As you can see, this standard is quite detailed about how a stair railing is to be designed. It helps to keep employees from falling down stairs. If all stair railings were at this height, most people could reach them. If all stair railings were at this height, people would learn where the railings were always to be found and they would automatically reach for the right place if they started to fall.

3. Could a railing that is not at the right height be classified as a hazard?

- a. Yes
- b. No

## STANDARDS ARE LEGAL RULES OR REGULATIONS

Actually, many standards deal with all kinds of commonplace and practical tools and equipment like ladders, lights, and other parts of your everyday environment. As a supervisor, you should make sure your work area meets these standards. You should know the standards that apply to your jobs and your work area.

## STANDARDS CAN BE SPECIFIC

Some of the occupational safety and health standards are related to specific jobs and specific protective equipment. The following is an example of this type of standard.

In any operation such as chipping, caulking, drilling, riveting, grinding, and pouring babbit metal, in which the eye hazard of flying particles, molten metal, or liquid chemical exists, employees shall be protected by suitable face shields or goggles . . .

This standard points up the potential hazard to the employee's face or eyes and lays down a specific rule that in these specific jobs the employee must wear suitable protection (no exceptions).



## ANSWERS TO QUESTIONS

3. a. Yes. It also would be a violation subject to a citation and proposed penalty in the event of inspection by a Compliance Officer

---

## STANDARDS FOR THINGS THAT CREATE ILLNESS

Many OSHA standards deal with toxic materials, chemical agents, and other conditions under which an employee might become ill or be made sick by his job. These standards cover such things as allowable exposures, warning labels, and other controls.

## STANDARDS CHANGE

The *FEDERAL REGISTER* referred to previously originally printed the OSHA Standards on May 29, 1971. Since then, standards have been added, amended, or repealed. These changes were incorporated into another printing on June 27, 1974. Furthermore, the standards will continue to be changed from time to time in the future. This means that your employer should subscribe to the *FEDERAL REGISTER*, or better yet to the *OCCUPATIONAL SAFETY AND HEALTH SUBSCRIPTION SERVICE*, and constantly check with your nearest OSHA Area Director for new changes and additions. This will be discussed more fully in Lesson 14. Some newsletters or announcement services are published by private organizations. Some establishments choose to subscribe to these services to keep up with current changes in the Act and the standards. There are several reasons for updating the OSHA Standards in the *FEDERAL REGISTER*. They include:

- the industrial scene is always changing, progress is always accompanied by new problems;
- additional chemical, toxic, and other hazards will be recognized;
- new procedures and standards will be required

Before going into more detail concerning hazards and their control, fill in the answers to the following questions.

4. What are the three steps in analyzing hazards?

a. \_\_\_\_\_

b. \_\_\_\_\_

c. \_\_\_\_\_

5. In what publication would you find the OSHA standards?

6. Who has the *legal* responsibility for ensuring safe and healthful working places?

7. If you needed to find out the types of fire extinguishers required for your work area, under what subpart in the *FEDERAL REGISTER* would you find this information?

- a. Compressed Gas and Compressed Air Equipment
- b. Occupational Health and Environmental Control
- c. Personal Protective Equipment
- d. Fire Protection

## ANSWERS TO QUESTIONS

4 a Recognition b Evaluation c. Control

5 FEDERAL REGISTER

6 The Employer

7. d Fire Protection, Subpart L

---

8 If you needed to find out when a person should wear safety glasses, under which heading in "What The Standards Cover" (page 4) would you find this information?

Check your answer on the next page.

As discussed earlier under **EVALUATION**, there are three classifications of hazards, depending on what potential they have for causing injury, sickness or disease to people, or causing property damage. You will have to decide what this potential loss severity is.

To help you clarify differences in the degree of hazards, here are definitions or identifications of **THREE CLASSIFICATIONS OF HAZARDS** in terms of potential loss severity. The first classification.

Class "A" hazard - a condition or practice with potential for causing loss of life or body part, serious injury or illness resulting in permanent disabilities, or extensive loss of structure, equipment, or material.

Now that you have read what a class "A" hazard is, please go back and read it again. It is very important that you fully understand all of its meaning.

### **CLASS "B" HAZARD DEFINED**

The second hazard classification is called a Class "B" hazard. Because a Class "B" hazard has a lower potential loss severity, it certainly doesn't mean that it is still not important. Look at how serious the losses could be.

Class "B" hazard - a condition or practice with potential for causing serious injury or illness resulting in temporary disabilities, or property damage that is disruptive, but less severe than Class "A."

### **CLASS "C" HAZARD DEFINED**

The third type of hazard classification is called a Class "C" hazard.

Class "C" hazard - a condition or practice with probable potential for causing nondisabling injury or illness or nondisruptive property damage." (Definition: courtesy of the International Safety Academy, Macon, Georgia.)

As you can see, a Class "C" hazard has a lesser potential loss severity than a Class "A" or Class "B" hazard.

## ANSWERS TO QUESTIONS

### 8 Personal Protective Equipment

#### SETTING PRIORITIES FOR ACTION

This type of classification procedure is helpful in setting priorities for corrective action. It helps you define the potential loss severity of the various parts of the work situation so you know which problems to attack first.

9. What hazard classification do you think would be the one that needs immediate attention?

- a. Class "A"
- b. Class "B"
- c. Class "C"

#### OCCUPATIONAL ILLNESS

Whenever you classify hazards, be aware of not only those hazards with potential for causing property damage and personal injury, but also those with potential for causing occupational illness. Illness often comes on gradually and it is difficult to be sure that it is something about the job that is causing it.

#### HAZARD CLASSIFICATION ABILITY IS IMPORTANT

Since the ability to use these three hazard classifications is very important, you will be shown how to use them in making a formal safety inspection. This information will come later, in Lesson 7

#### CONTROL OF HAZARDS BY ELIMINATION, SEGREGATION OR PROTECTION

We have talked about the importance of recognition and evaluation. Now let's take a look at how you would control hazards. The first method of controlling hazards is to **ELIMINATE** them.

Another way to control a hazard is by **SEGREGATION**. This may involve isolating, enclosing, guarding, or barricading equipment or conditions. Segregation is used to make contact with a hazard less likely or, if contact does occur, less harmful. Several standards make use of this principle to control hazards.

A third type of control is called **PROTECTION**. If you can't eliminate or segregate a hazard, you should provide protection from the hazard.

Providing protective clothing and equipment is an important part of this control. Some examples of protective clothing and equipment include.

- Safety glasses
- Safety shoes
- Hard hats
- Gloves
- A "dead man's" switch

## ANSWERS TO QUESTIONS.

- 9 a "A" - since it has the potential for causing loss of life or body part, serious injury or illness resulting in permanent disabilities, or extensive loss of structure, equipment or material. This has greater potential loss severity than Class "B" or Class "C" hazards.

Lesson 9 will discuss this topic in greater detail. When you were looking through the standards earlier in this lesson, you probably noticed that several of the standards rely on the "protection" principle for their main influence on safety or health.

10. Would redesigning a piece of equipment to eliminate a hazard by making it conform to a standard be a "control" measure?
- a. Yes
  - b. No
11. If you put plastic guarding around a grinding machine, you are \_\_\_\_\_ the hazard.

## THREE CLASSIFICATIONS OF HAZARDS

12. What are the three classifications or grades of hazards that we studied earlier in this lesson?

a. \_\_\_\_\_

b. \_\_\_\_\_

c. \_\_\_\_\_

13. What have we just learned are the three ways to control a hazard?

a. \_\_\_\_\_

b. \_\_\_\_\_

c. \_\_\_\_\_

## TRAINING REDUCES INJURIES AND ILLNESSES

One way to protect employees from injuries and illnesses is to give them proper training before they start their jobs. A lack of knowledge about the job and its associated conditions is one factor that often causes injuries or illness.

When an employee begins a job, his original training can be an effective method of guaranteeing "good" work habits. A lack of knowledge and poor work habits can cause poor industrial safety or poor industrial health.

## ANSWERS TO QUESTIONS.

10 a Yes

11. Segregating

12. a. "A" b. "B" c. "C"

13 a Eliminate b. Segregate c. Protect

---

## KNOW AND TEACH THE STANDARDS

Part of your task as a supervisor is to train your employees how to perform their jobs properly. Information that you *must* learn, and that you can pass on to help your workers to assure their own safety and health as they perform their tasks, can be found in the OSHA Standards printed in the *FEDERAL REGISTER*, or in an annual (calendar year) publication: 29 CFR (Code of Federal Regulations) 1910.

We'll now take another look at some more of the Standards which have been adopted under the Act. Since this course has to be written for *all kinds* of supervisory jobs, some of the coverage will be of a *general nature*. However, remember that when you need to get more specific information that applies to your particular operation you will be able to find it in the *FEDERAL REGISTER* of June 27, 1974. The main purpose of reading about the standards in this course is to help you understand what a great variety of them are and how you can use many of them in your work.

The first type of standards we will discuss are those that deal with **WALKING AND WORKING SURFACES**. These standards will help you recognize, evaluate, and control hazards pertaining to floors, aisles, and passageways. Look at the following examples of this Standard:

1910.22(c). "Covers and/or guardrails shall be provided to protect personnel from the hazards of open pits, tanks, vats, ditches, etc."

1910.29(a)(3)(vii). "All work levels 10 feet or higher above the ground or floor shall have a guardrail of 2- by 4-inch nominal or the equivalent installed no less than 36 inches or more than 42 inches high, with a mid-rail, when required, of 1- by 4-inch nominal lumber or equivalent."

As you can see by these examples, the standards seek to control hazards with the potential for causing damage, injury, and illness

## EXIT REQUIREMENTS

Another type of standard is called **MEANS OF EGRESS** (ways to get out of somewhere). Read the examples below that help describe this type of standard.

1910.36(b)(6) "In every building or structure equipped for artificial illumination, adequate and reliable illumination shall be provided for all exit facilities."

1910.37(g)(8). "Every exit sign shall have the word 'Exit' in plainly legible letters not less than 6 inches high, with the principal strokes of letters not less than three-fourths-inch wide."

These standards seek to keep people from being hurt when they try to get out of a building. This kind of sign shows employees the way to go to get out. You have often seen illuminated sign marking the exits of

buildings. Does *your* work area have them? Does it have one on every logical exit? Are the signs wired on a standby circuit that still works if the main power fails? These are the kinds of questions that should be asked when considering the hazard potential of any particular situation

Another type of standard refers to **POWERED PLATFORMS, MAN LIFTS, AND VEHICLE-MOUNTED WORK PLATFORMS**. These standards are for the control of mechanical and electrical safety hazards in all kinds of elevators, "cherry pickers," and scaffolds. The following examples for platforms include standards for such things as ropes, cables, and pulleys:

1910.66(c)(1)(ii) "The maximum rated speed at which a power traversed roof car may be moved in a horizontal direction shall be 50 feet per minute."

Section 1910.68(b)(5)(ii) "All floor openings for a given manlift shall be uniform in size and shall be approximately circular, and each shall be located vertically above the opening below it."

### **HOW CAN IT ALL BE LEARNED?**

By this time you probably are wondering how you are ever going to learn all there is to know about all the standards, especially since there are so many standards to learn about! Well, the answer is that no one expects you to know it all! However, you **ARE** expected to know all about any standard that applies to **YOUR** job.

By now you know where to look (the *FEDERAL REGISTER*) and you have a rough idea what kinds of standards you're going to have to apply to your operations. It is a job all right, but it is well worthwhile and anyone can do it with a little practice. This course will give you a surprisingly large amount of knowledge and experience. Keep plugging!

### **CONCERNED ABOUT OCCUPATIONAL HEALTH**

Up to this point, the standards we have discussed have been concerned with death and personal harm due to injury. Since it is the Occupational Safety and Health Act, we are also concerned with occupational illness.

### **CHEMICAL HAZARDS**

The next type of standard is an **OCCUPATIONAL HEALTH AND ENVIRONMENTAL CONTROL** standard. The first standards under this heading are for air contaminants. Chemicals can enter the body in several ways. These include:

- inhalation (breathing)
- ingestion (swallowing)
- absorption through the skin (especially through unprotected cuts, sores, broken skin)

## HEALTH HAZARDS ARE OFTEN LESS OBVIOUS

- 14 How would you classify a chemical hazard that is not noticeable at all at first but causes gradually more and more severe illness after several months, or several years of exposure, with the end result being the severe disability or possible death of an employee?
- a. Class "A"
  - b. Class "B"
  - c. Class "C"

Answer the following questions:

- 15 If an employee develops a rash while working with a chemical, or shortly thereafter, could it be said that he may be contaminated by the chemical?
- a. Yes
  - b. No
- 16 If the rash is the only thing that develops because of a chemical, you would say it is a \_\_\_\_\_ hazard
- a. Class "A"
  - b. Class "B"
  - c. Class "C"
17. What are the three ways in which chemicals can enter the body?
- a. \_\_\_\_\_
  - b. \_\_\_\_\_
  - c. \_\_\_\_\_

## THRESHOLD LIMIT VALUE

Standards under this section on occupational health and environmental control often refer to a concept called the *threshold limit value (TLV)*. This specifies the greatest or highest level of exposure a person can tolerate over a whole lifetime on his job without quite becoming ill. If he is exposed to just a little more of the condition, he *would* get sick. The threshold limit values given in these standards are the concentrations of airborne contaminants under which a *majority* of employees would suffer no adverse effects. It is quite possible that someone who was more sensitive to that hazard than the average person would become very sick from an exposure far less than the TLV. The TLV is a kind of average exposure figure which has been established to protect most employees most of the time. Like all "averages," it doesn't always apply to all persons.

ANSWERS TO QUESTIONS:

14. a. Class "A" because it can cause the eventual death of a person. But many occupational diseases or sicknesses are like that - no symptoms for a long time, then gradual breakdown of health. Often, by the time the illness is fully recognized, the employee's health has been permanently damaged and cannot be restored. That is why *recognition, evaluation, and control* of health hazards is often such a difficult detective job.

Health hazards tend to be less obvious than safety hazards!

15. a Yes
16. c Class "C"
17. a Inhalation (breathing)    b. Ingestion (swallowing or entering an opening such as the eye)  
c. Absorption through the skin

---

Below is an example of a standard for *air* contamination by both carbon monoxide and turpentine. The numbers given are the TLV's:

	<i>Volume</i>	<i>Weight</i>
Carbon monoxide	50 ppm	55 mg/M <sup>3</sup>
Turpentine	100 ppm	560 mg/M <sup>3</sup>

ppm refers to parts per million by volume.  
mg/M<sup>3</sup> refers to milligrams per cubic meter (weight)

Using this information for reference, answer the following questions:

- 18 What is the acceptable standard volume for the TLV of carbon monoxide?
- 19 What is the acceptable standard weight for the TLV of turpentine?

It is important to measure conditions that exist in your own work area since an OSHA Compliance Officer may check them when he visits your establishment to look for safety and health hazards. If there is no one in your company who is qualified or equipped to help you measure and evaluate and advise controls for hazards you discover, you should get your company to bring in outside help from professionals who have a knowledge in this area. These professionals are called Industrial Hygienists, Consulting Engineers, Public Health Specialists, Sanitary Engineers, etc., depending on their area of expertise. Lesson 14 will give you several sources that you can refer to for help concerning different kinds of safety and health hazards.

### VENTILATION

Another part under the OCCUPATIONAL HEALTH AND ENVIRONMENTAL CONTROL STANDARDS deals with VENTILATION. These are controls to eliminate dust, liquid mists, vapors, or gases.

Many employees can be seriously disabled if there is poor ventilation in their work area. Among those affected greatly by this condition are painters in spray rooms, grinders in auto body shops, and construction workers spraying asbestos fireproofing material.



ANSWERS TO QUESTIONS:

18. 50 ppm

19. 560 mg/M<sup>3</sup>

---

**NOISE**

A third category of Occupational Health hazards is NOISE EXPOSURE. Trained personnel use special meters that can measure the noise level in your work area. The effects of noise include:

- disruption of concentration
- permanent loss of hearing
- ringing in the ears
- loss of sleep
- nervousness
- vision problems
- many others - it is a severe problem!

**NOISE STANDARD**

Look at the following chart. Listed are the permissible noise exposure levels given in the OSHA standard:

**PERMISSIBLE NOISE EXPOSURES**

<i>Maximum Hours of Exposure per Day</i>	<i>Sound Level Measured in dBA</i>
8	90
6	92
4	95
3	97
2	100
1-1/2	102
1	105
1/2	110
1/4 or less	115

("dB" = decibels (a loudness indication), "A" refers to the "A" scale of the sound level meter, which matches the characteristics of the human ear.)

## EXPOSURE TIME IS CRITICAL

20. Using the noise standards in the last item, look up the maximum amount of time an employee can work at 92 dBA, in any one day, without violating the standard
- Eight hours
  - Six hours
  - Four hours
  - Three hours

## HEARING LOSS

- 21 The possibility of a partial hearing loss from a certain sound level would be called a \_\_\_\_\_ hazard
- Class "A"
  - Class "B"
  - Class "C"

## IONIZING RADIATION

Another group of standards under OCCUPATIONAL HEALTH AND ENVIRONMENTAL CONTROL relates to IONIZING RADIATION. These standards deal with hazards of Alpha, Beta, and Gamma rays, X rays, and other atomic particles such as neutrons, high-speed electrons, and protons. These standards describe how to monitor radiation, evacuate people, store and ship the hazardous materials, and dispose of atomic waste materials. All of these standards are directed to the control of hazards by elimination, segregation, or protection.

The standards give specifications for warning signs for use near hazards. An example of the design of radiation signs required by the OSHA Standards can be seen below:

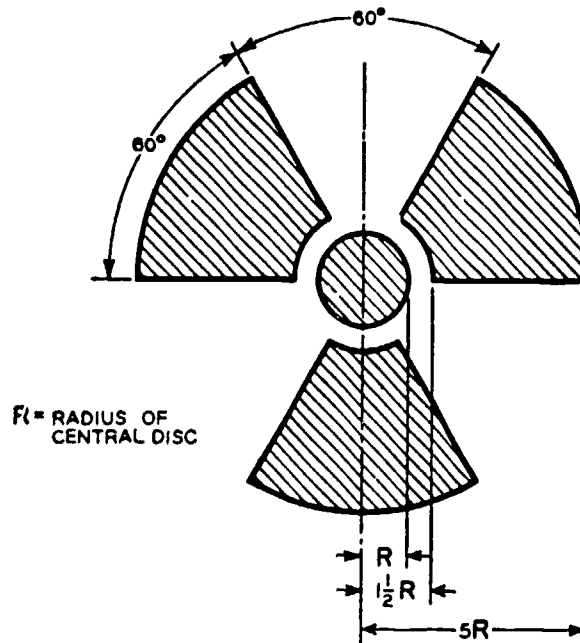

Standard Radiation Symbol

## ANSWERS TO QUESTIONS

20. b. Six hours. This means that a worker could spend up to 6 hours per day at 92 dBA sound level for his whole working life without experiencing hearing damage. Would every worker have that expectation? No! Some workers, ones with more sensitive hearing, would suffer some damage.

21. b. Class "B"

When you see one of these signs you know there is ionizing radiation material nearby. The standards often require signs or symbols to warn employees of specific hazards. There are many kinds of such signs. We will see more on this subject later.

If your employer uses radioactive materials, he must be fully aware of federal and state laws and the role of the Atomic Energy Commission. This means you need to know too!

## NONIONIZING RADIATION

Another group of standards under OCCUPATIONAL HEALTH AND ENVIRONMENTAL CONTROLS deals with NONIONIZING RADIATION. This type of radiation includes such radiations as radio waves, microwaves, infrared and ultraviolet light, and lasers. An example of a sign required for radio waves is presented below:

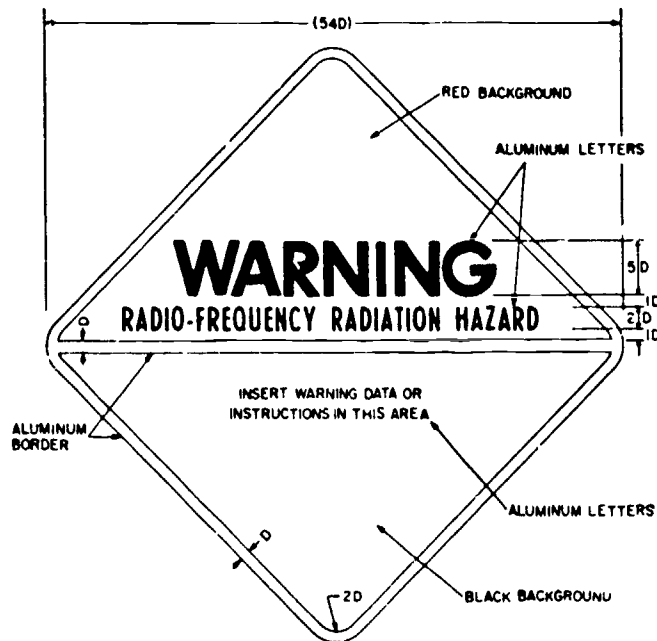

1. Place handling and mounting instructions on reverse side
2. D: Scaling unit
3. Lettering: Ratio of letter height to thickness of letter lines  
Upper triangle 5 to 1: Large  
6 to 1: Medium  
Lower triangle 4 to 1: Small  
6 to 1: Medium
4. Symbol is square, triangles are right angle isosceles

Radio Frequency Radiation Hazard Warning Symbol

## CLASSIFYING HAZARDS

Match the following (numbered) hazards with the five different (lettered) groups of Occupational Health standards

- |  |                                |
|--|--------------------------------|
| 22 Machinery noise level too high              | a. Air contamination           |
| 23 Inhalation of too many chemical fumes       | b. Ventilation                 |
| 24 Radio waves                                 | c. Occupational noise exposure |
| 25 Too many particles from a buffing operation | d. Ionizing radiation          |
| 26. X-rays                                     | e. Nonionizing radiation       |

## HAZARDOUS MATERIALS

Another major group of OSHA Standards deals with HAZARDOUS MATERIALS. These standards go into detail on the storage, handling, and necessary safety devices to use in controlling hazardous materials. Hazardous materials include things such as combustible liquids, explosives, and petroleum gases. Below you will find examples of actual standards for hazardous materials.

1910 102(a) "The in-plant transfer, handling, storage, and utilization of acetylene in cylinders shall be in accordance with Compressed Gas Association Pamphlet G-1-1966."

1910 104(b)(8)(viii) "The bulk oxygen storage location shall be permanently placarded to indicate 'OXYGEN - NO SMOKING - NO OPEN FLAMES,' or an equivalent warning."

27 What do you think the hazard classification would be if you found your employees smoking in a storeroom of exposed flammable chemicals?

- a. Class "A"
- b. Class "B"
- c. Class "C"

## PERSONAL PROTECTIVE EQUIPMENT

Another group of standards appears under the heading PERSONAL PROTECTIVE EQUIPMENT. (These standards are so important that they will be discussed in more detail in Lesson 9.)

Below is an example of a Personal Protective Equipment Standard:

1910 133(a)(1) "Protective eye and face equipment shall be required where there is a reasonable probability of injury that can be prevented by such equipment. In such cases, employers shall make conveniently available a type of protector suitable for the work to be performed, and employees shall use such protectors. . . ."

## ANSWERS TO QUESTIONS.

22. c. Occupational noise exposure
23. a. Air contamination
24. e. Nonionizing radiation
25. b. Ventilation
26. d. Ionizing radiation
27. a. Class "A"

---

1910.136 "Safety-toe footwear for employees shall meet the requirements and specifications in American National Standard for Men's Safety-Toe Footwear, Z41.1-1967."

Many other standards required by the OCCUPATIONAL SAFETY AND HEALTH ADMINISTRATION for Personal Protective Equipment are referred to in the *FEDERAL REGISTER* of June 27, 1974.

### PROTECTIVE EQUIPMENT PROTECTS - THAT'S ALL IT DOES

The use of protective equipment does not eliminate hazardous conditions, nor does it necessarily prevent injuries or illnesses. Protective equipment simply helps protect the wearer from injury, or from being as severely injured as he might be if he were not using this equipment, or from exposure to harmful substances.

### GENERAL ENVIRONMENTAL CONTROLS

Other standards are found under the heading GENERAL ENVIRONMENTAL CONTROLS. These standards apply to control of biological and mechanical hazards as waste disposal, sanitation, and water supply. These hazards are identified by the use of color coding and signs. Some of the color coding is:

- Red - identifies fire protection equipment,
- Orange - identifies dangerous parts of machines,
- Yellow - means caution,
- Purple - identifies radiation hazards.

28. If you saw a purple sign that indicated a radiation hazard was nearby, this would be \_\_\_\_\_ of a hazard?
- a. Elimination
  - b. Segregation
  - c. Protection
  - d. Identification

ANSWERS TO QUESTIONS:

28 d Identification

The presence of these hazard identification signs do not indicate that an accident has happened. It means there is a potential for an accident to occur

**WARNING SIGNS**

Here are a number of signs required by the standard 1910.145(e) to indicate various types of hazardous situations. Examine them carefully and be sure to get some made to use whenever they are appropriate in your operation. Make a check mark next to any of the caution, danger signs, or warning tags that you would need.

<i>Caution signs</i>	
Caution	Do Not Operate Men Working on Repairs
Caution	Hands Off Switch Men Working on Line
Caution	Working on Machines Do Not Start
Caution	Goggles Must Be Worn When Operating This Machine
Caution	This Door Must Be Kept Closed
Caution	Electric Trucks, Go Slow
Caution	This Space Must Be Kept Clear at All Times
Caution	Stop Machinery to Clean, Oil, or Repair
Caution	Keep Aisles Clear
Caution	Operators of This Machine Shall Wear Snug Fitting Clothing No Gloves
Caution	Close Clearance
Caution	Watch Your Step
Caution	Electric Fence

(Continued)



**Caution Sign**

**TABLE J-2—STANDARD PROPORTIONS FOR CAUTION SIGNS**

Sign size inches height width	Black rectangular panel, inches height width	Word "Caution" height of letter, inches	Maximum space available for sign wording below panel inches height width
<b>HORIZONTAL PATTERN</b>			
7 x 10	2 1/4 x 9 3/4	1 1/4	3 3/4 x 9 3/4
10 x 14	3 1/2 x 13 3/4	2 1/4	5 1/2 x 13 3/4
14 x 20	3 3/4 x 19 3/4	2 1/4	9 x 19 3/4
20 x 28	4 1/4 x 27 3/4	3 1/4	14 1/2 x 27 3/4
<b>UPRIGHT PATTERN</b>			
10 x 7	1 1/4 x 6 3/4	1 1/4	7 x 6 3/4
14 x 10	2 1/4 x 9 3/4	1 1/4	10 1/2 x 9 3/4
20 x 14	3 1/4 x 13 3/4	2 1/4	15 1/2 x 13 3/4
28 x 20	3 3/4 x 19 3/4	2 1/4	24 x 19 3/4

*Danger signs.*

- Danger Keep Off, Electric Current.
- Danger No Smoking, Matches, or Open Lights.
- Danger Men Working Above.
- Danger Not Room Enough Here to Clear Men on Cars.
- Danger Keep Away.
- Danger Men in Boiler.
- Danger Insufficient Clearance.
- Danger 2 300 Volts.
- Danger Keep Out.
- Danger Crane Overhead.
- Danger Keep Off.



**Danger Sign**

**TABLE J-1—STANDARD PROPORTIONS FOR DANGER SIGNS**

Sign size, inches Height Width	Black rectangular panel, inches Height Width	Red oval, inches Height Width	Word danger, height inches	Maximum space available for sign wording, inches
<b>HORIZONTAL PATTERN</b>				
7 x 10	3 $\frac{1}{4}$ x 9 $\frac{3}{8}$	2 $\frac{7}{8}$ x 8 $\frac{1}{2}$	1 $\frac{3}{16}$	2 $\frac{1}{4}$ x 9 $\frac{3}{8}$
10 x 14	4 $\frac{3}{8}$ x 13 $\frac{1}{8}$	4 $\frac{3}{8}$ x 11 $\frac{7}{8}$	2 $\frac{1}{16}$	4 $\frac{3}{8}$ x 13 $\frac{1}{8}$
14 x 20	6 $\frac{1}{2}$ x 19 $\frac{3}{8}$	5 $\frac{3}{4}$ x 17	2 $\frac{7}{8}$	6 $\frac{1}{2}$ x 19 $\frac{3}{8}$
20 x 28	9 $\frac{3}{4}$ x 27 $\frac{3}{8}$	8 $\frac{3}{4}$ x 23 $\frac{7}{8}$	4 $\frac{3}{8}$	9 $\frac{3}{4}$ x 27 $\frac{3}{8}$
<b>UPRIGHT PATTERN</b>				
10 x 7	3 $\frac{3}{8}$ x 6 $\frac{3}{8}$	2 $\frac{3}{8}$ x 5 $\frac{7}{8}$	1 $\frac{3}{16}$	6 $\frac{3}{8}$ x 6 $\frac{3}{8}$
14 x 10	4 $\frac{3}{8}$ x 9 $\frac{3}{8}$	2 $\frac{7}{8}$ x 8 $\frac{1}{2}$	1 $\frac{3}{16}$	9 $\frac{1}{2}$ x 9 $\frac{3}{8}$
20 x 14	6 $\frac{3}{8}$ x 13 $\frac{3}{8}$	4 $\frac{3}{8}$ x 11 $\frac{7}{8}$	2 $\frac{1}{16}$	14 x 13 $\frac{3}{8}$
28 x 20	9 $\frac{1}{2}$ x 19 $\frac{3}{8}$	5 $\frac{3}{4}$ x 17	2 $\frac{7}{8}$	20 $\frac{1}{2}$ x 19 $\frac{3}{8}$

**POISON:**



**ELECTRICITY:**

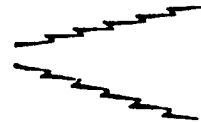

**Symbols Used on Signs**

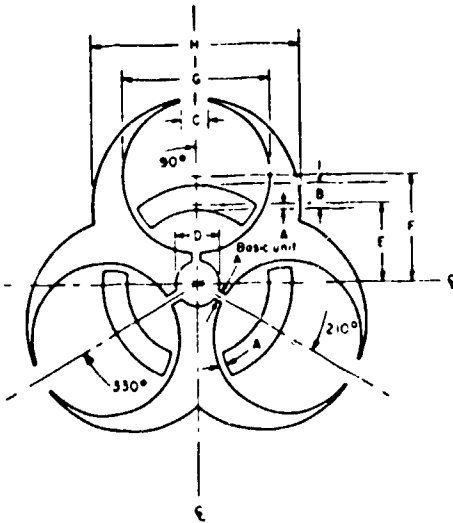

Dimension	A	B	C	D	E	F	G	H
Units	1	3 $\frac{1}{2}$	4	6	11	15	21	30

**Symbol for Biological Hazard**

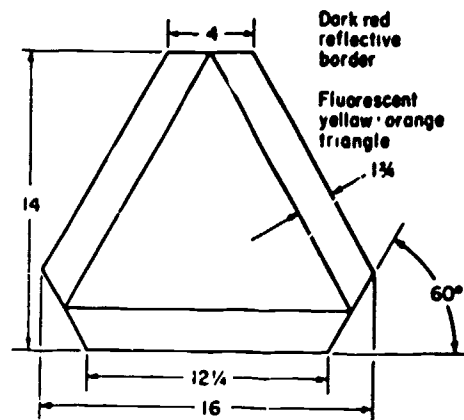

NOTE All dimensions are in inches

**Slow-Moving Vehicle Emblem**

(Continued)

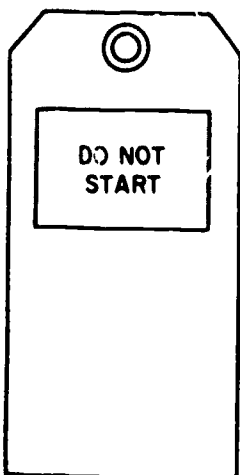

White tag  
white letters on  
red square

**Do Not Start Tag**

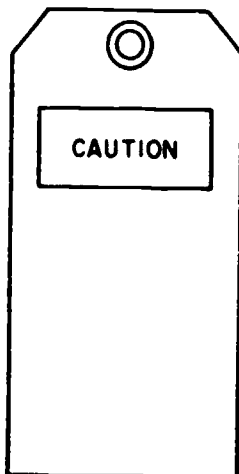

Yellow tag  
yellow letters on a  
black background

**Caution Tag**

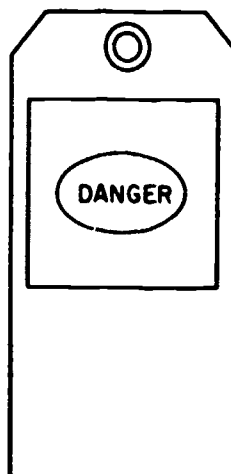

White tag  
white letters on  
red oval with a  
black square

**Danger Tag**

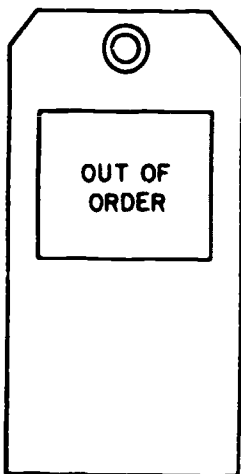

White tag  
white letters on  
black background

**Out of Order Tag**

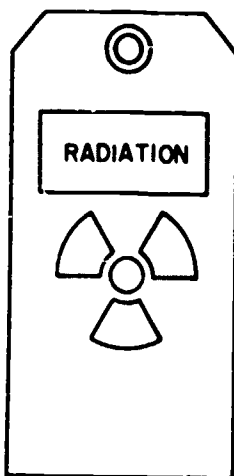

Yellow tag  
yellow letters in  
reddish-purple panel  
(Added wording in black  
on yellow background)

**Radiation Tag**

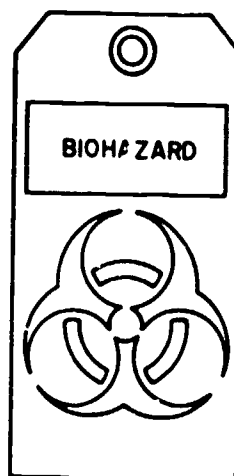

White tag  
black letters on  
fluorescent-orange  
background and  
symbol

**Biological Hazard Tag**



## MEDICAL AND FIRST AID

Another group of OSHA Standards is called MEDICAL AND FIRST AID (1910 Subpart K). Three general requirements come under this heading:

- The employer shall insure the ready availability of medical personnel for consultation on plant health.
- If an infirmary or hospital is not near the workplace, one or more employees shall be trained in first aid, and have such supplies available to them.
- If the eyes or body of an employee might be exposed to corrosive materials, facilities for quick drenching or flushing of the eyes will be made available.

The standards under this heading are in the interest of the occupational health of employees.

Providing medical facilities for employees is an important part of the Act. We will be covering this topic in more detail in Lesson 10.

## FIRE PROTECTION

A further group of OSHA standards is devoted to FIRE PROTECTION (1910 Subpart L). Look at the following examples of these standards.

1910.157(a)(1) "Portable extinguishers shall be maintained in a fully charged and operable condition, and kept in their designated places at all times when they are not being used."

1910.157(d)(2) "Extinguishers shall be inspected monthly, or at more frequent intervals when circumstances require, to insure that they are in their designated places, to insure that they have not been actuated or tampered with, and to detect any obvious physical damage, corrosion, or other impairments."

These standards are for the control of fire hazards.

## CLASSIFYING FIRE HAZARDS

29. How would you classify a potential fire hazard that would probably not cause personal injury and only minor property damage?
- a. Class "A" hazard
  - b. Class "B" hazard
  - c. Class "C" hazard

## COMPRESSED GAS AND COMPRESSED AIR EQUIPMENT

An additional group of OSHA Standards covers COMPRESSED GAS AND COMPRESSED AIR EQUIPMENT (1910 Subpart M). These standards are for controlling the hazards of gases under pressure, storage containers, and the equipment used in compression. Since these hazards are mechanical in nature,

## ANSWERS TO QUESTIONS

29 c Class "C" hazard

they deal with inspections, safety relief devices, cylinder specifications, and other related devices. Examples of this heading can be found below

1910.166(c)(3)(vii). "When denting occurs so that no part of the deformation includes a weld, the cylinder shall be rejected if the depth of the dent is greater than one-tenth of the mean diameter of the dent."

1910.168(b)(4)(ii). "Only qualified personnel shall be allowed to service safety relief devices. Any servicing or repairs which require resetting of safety relief valves shall be done only by or after consultation with the valve manufacturer."

## MATERIALS HANDLING AND STORAGE

Standards for MATERIALS HANDLING AND STORAGE (1910 Subpart N) are also controls for hazards of a mechanical nature. Examples include.

1910.178(1C). "Only trained and authorized operators shall be permitted to operate a powered industrial truck. Methods shall be devised to train operators in the safe operation of powered industrial trucks."

1910.180(d)(6). "Written, dated, and signed inspection reports and records shall be made monthly on critical items in use such as brakes, crane hooks, and ropes. Records shall be kept readily available."

When dealing with mechanical hazards, it is important to remember that the prevention of hazards to employees is of prime importance. Notice the importance given to good written reports and records.

## MACHINERY AND MACHINE GUARDING

The next group of OSHA Standards is MACHINERY AND MACHINE GUARDING. These include such machines as woodworking and abrasive wheel machinery. Some examples of them are

1910.212(a)(1). "One or more methods of machine guarding shall be provided to protect the operator and other employees in the machine area from hazards such as those created by point of operation, ingoing nip points, rotating parts, flying chips and sparks."

1910.217(c)(4). "Hand feeding tools are intended for placing and removing materials in and from the press. Hand feeding tools are not a point of operation guard or protection device and shall not be used in lieu of the 'guards' or devices required in this section."

## HAND AND PORTABLE POWERED TOOLS AND OTHER HAND-HELD EQUIPMENT

Still another OSHA Standards category is HAND AND PORTABLE POWERED TOOLS AND OTHER HAND HELD EQUIPMENT (1910 Subpart P). The following are examples of this heading:

1910.242(a). "Each employer shall be responsible for the safe condition of tools and equipment used by employees, including tools and equipment which may be furnished by employees."

1910.243(e)(2)(iv). "Walk-behind and riding rotary mowers . the total effective opening area of the grass discharge opening(s) shall not exceed 1,000 square degrees on units having a width of cut less than 27-1/2 inches, or 2,000 square degrees on units having a width of cut 27-1/2 inches or over "

Also found in these standards are such items as explosive-actuated fastening tools and abrasive wheels.

## **WELDING, CUTTING, AND BRAZING**

Another OSHA standard grouping is called WELDING, CUTTING, AND BRAZING (1910 Subpart Q). Examples of these standards can be found below:

1910.252(a)(1) "Mixtures of fuel gases and air or oxygen may be explosive and shall be guarded against. No device or attachment facilitating or permitting mixtures of air or oxygen with flammable gases prior to consumption, except at the burner or in a standard torch, shall be allowed unless approved for the purpose."

1910.252(g)(1)(vii) "The use of X-rays and radioactive isotopes for the inspection of welded pipeline joints shall be carried out in conformance with the American National Standard Safety Standard for Non-medical X-ray and Sealed Gamma ray Sources, ANSI (American National Standards Institute) Z54.1-1963 "

## **SPECIAL INDUSTRIES**

Another group of OSHA Standards is called SPECIAL INDUSTRIES (1910 Subpart R). These are industries such as logging, bakery equipment, textiles, and agricultural operations. Standards found in Subpart R apply only to these industries. Examples of SPECIAL INDUSTRIES standards can be found below:

1910.262(c)(1) "Every textile machine shall be provided with individual mechanical or electrical means for stopping such machines. On machines driven by belts and shafting, a locking-type shifter or an equivalent positive device shall be used. . ."

1910.264(c)(2)(ii) "Each drying-room fan, any part of which is within 7 feet of the floor or working platform, shall be guarded with wire mesh or screen of not less than No. 16 gage, the openings of which will reject a ball one-half-inch in diameter."

Since the use of electric power is implied in these standards, it also means that all the requirements of the articles and sections of the National Electric Code (N.E.C.) in 1910.309 must be met to achieve compliance with the federal standards.

## **ELECTRICAL STANDARDS**

The last group of OSHA Standards is called ELECTRICAL (1910 Subpart S). These standards are useful in the control of electrical hazards. It is important to note that OSHA adopted the National Electrical Code NFPA 70-1971 and incorporated it by reference in the OSHA Standards.

## **COMBINATIONS OF STANDARDS**

Some groups of standards can be combined with other groups to get the most effective total control of hazards. Suppose, for example, you supervise a welding operation. There could be sparks flying around and they could land on the welder and his clothing as well as bouncing around in the area where the welding is being done. To prevent injury to the employee, you would most likely think of the standard on personal

protective equipment. Since the sparks might start a fire, you also would want to look into the standard on fire equipment. Actually, several other standards would apply. You should use as many of the standards as may be applicable in any given situation.

## USES OF STANDARDS

Obviously, it is almost impossible to remember all of these standards. You should, however, remember what types of standards there are and where to find them. That way, they can help you when you try to control hazards. Remember, also, that new standards are being added or amendments made to those currently in effect.

## REVIEW

In this lesson you have learned the basic techniques of recognizing, evaluating, and controlling hazards

In "RECOGNITION" you learned to test a potential hazard for its ability to cause personal injury, occupational illness or property damage.

Once the hazard was identified, you classified it as to Class "A," "B" or "C." Class "A" hazards can cause loss of life or body part, serious injury or illness resulting in permanent disability or extensive loss of property.

Class "B" hazards can cause serious injury or illness resulting in temporary disability or property damage that is disruptive, but less severe than Class "A."

Class "C" hazards can cause nondisabling injury or illness or nondisruptive property damage.

After the evaluation, you learned the possible methods of controlling hazards through elimination, segregation, or protection.

To assist you in control of hazards, you are now familiar with the OSHA standards, found in the *FEDERAL REGISTER*, and how they help you in your efforts to provide a safe and healthful workplace.

## KEEP UP WITH CHANGES IN STANDARDS

The employer has a legal responsibility to protect his employees from death, injury, or sickness brought about by their work. The Federal Government has passed a comprehensive law which defines many things you are required to do or would want to do for humanitarian reasons. Standards adopted under the Law that set limits for various hazardous situations or conditions are written up as "standards." These standards are changed from time to time. They are published in the *FEDERAL REGISTER*. Since you are required by law to comply with the OSHA Standards, you should make certain that you have ready access to the *FEDERAL REGISTER* (see Lesson 14 for the address). Every year, the whole body of standards and other information about the Act are combined in a new Code of Federal Regulations.

Use the standards to help you recognize, evaluate, and control hazards in your work area. You can learn to be sensitive to hazards so they become obvious to you. You can fix many hazards yourself. You must learn to ask your employer for technical help if you can't take care of hazards yourself. Don't be afraid to ask for help. Many hazards are tricky to deal with and require professional assistance to fix, just as you require a surgeon if you need to fix a ruptured appendix. However, you can do a surprising amount on your own.

## REVIEW QUESTIONS

The following questions are designed to give you practice in finding OSHA standards in the Federal Register of June 27, 1974. Each answer should include the Subpart and Section number, such as: "Subpart R-1910.252." Answers on page 26

1. Ventilation comes under "Occupational Health and Environmental Control."  
What is the subpart and section for this standard?
2. What is the subpart and section covering "Medical and First Aid."
3. Oxygen under some conditions is a "Hazardous Material." Find the subpart and section for this OSHA standard
4. Using the alphabetical index at the back of the Federal Register, find the section number and page for the Standard on "Motor Fuels."
5. Again, use the index to find the standard for "Air Contaminants."

ANSWERS TO REVIEW QUESTIONS

1. Subpart G 1910.94.

2 Subpart K 1910.151

3. Subpart H 1910.104

4 1910 110(e)

23656

5. 1910 93

---

## INTRODUCTION TO LESSON 7

The purpose of this lesson is to provide you with information on how to identify and correct safety and health hazards before they can cause fatalities, injuries, illnesses, and or property damage

You will learn how to identify problem areas so you may apply principles of inspection, how to plan inspections, and their types, and what kinds of other personnel can assist you in determining critical factors bearing on each problem. In addition, some typical useful forms and reports will be presented and discussed.

### PERIODIC INSPECTIONS BY THE EMPLOYER

It is important to be familiar with facility inspection since some OSHA Standards require the employer to make periodic inspections to assure employees freedom from safety and health hazards.

To give you an idea of the types of things that should be inspected, Section 8(a) of the Act, with regard to inspections done by Compliance Officers, states

(1) To enter without delay and at reasonable times any factory, plant, establishment, construction site, or other area, workplace or environment where work is performed by an employee of an employer, and (2) to inspect and investigate any such place of employment and all pertinent conditions, structures, machines, apparatus, devices, equipment, and materials therein

(Section 8(a)(1 and 2) of the Act )

These seven elements that the Compliance Officer can inspect and investigate cover practically all areas where hazards to the safety and health of employees can occur. Your inspection of these elements, where applicable in your work area, will help in the hazard recognition process discussed in the previous lesson.

During your inspections, you should keep in mind the Compliance Officer's areas of interest during his inspection. Some definitions of the seven elements will be helpful to you.

- Conditions    housekeeping, lighting, temperature, noise, fire protection,
- Structures    anything built or constructed,
- Machines      any mechanical contrivance used in the performance of some kind of work,
- Apparatus    an assemblage of instruments, machinery, materials, etc., for a particular use,
- Devices       inventions or contrivances,
- Equipment    anything used or provided for any task, such as tools, protective clothing,
- Materials.    any substances found in the work area, such as chemicals, containers, raw stock, etc

Internal inspections of your work area not only identify hazards but also in effect necessitate the development and implementation of specific checklists to pinpoint the exact location(s) of hazard(s) for your employer so he can correct them. Once an inspection has been completed, your employer can use this checklist to determine which hazards need immediate attention and those which may have a lower priority.

One point to keep in mind is that YOU should fix the hazards that you have the authority to correct. Don't wait until someone is injured or becomes ill before you exercise the authority you have.

### **INSPECTIONS SHOULD BE WELL ORGANIZED**

To be effective, any inspection program must be well organized and planned in a way that assures complete and timely inspection of all facilities. This means having regular, systematic inspections, in addition to the ongoing ones you should make constantly by looking for hazards as you go about your daily routine.

Daily inspection alone - even though organized, planned, and embodying a checklist - will not do the total job of identifying all of the hazards in your work area. Periodic, planned inspections will be most beneficial to you in identifying additional hazards, as well as helping you to decide what steps must be taken to control them.

### **THREE PRINCIPLES IN A PLANNED SAFETY AND HEALTH INSPECTION**

When performing a PLANNED inspection, you need to keep in mind a number of principles, among them:

- The OSHA standards require inspections in certain situations,
- Normal wear and tear brings eventual trouble; and
- People make mistakes

These regularly scheduled inspections should come at planned times during the year, month, week, or day, depending on your particular circumstances, or upon the item(s) to be inspected. For example, you would probably want to check for cleared work areas (good housekeeping) daily, while you might want to check the fire extinguisher in your work area monthly. Therefore, you need to decide on when, or at what times, certain items need to be inspected.

### **COMPLIANCE WITH THE OSHA STANDARDS IS REQUIRED**

One of the main reasons you should be conducting facility inspection is to comply with the standards of the Occupational Safety and Health Act.

To do so, you will need to know the specific safety and health standards that can be applied to your operation. As mentioned many times previously, these standards can be found in the *FEDERAL REGISTER* of June 27, 1974, or the Code of Federal Regulations (29 CFR 1910). You will want to review the OSHA standards each time you make your inspection as part of your planning.

### **WEAR AND TEAR**

Another principle behind the need for organized, planned inspections assumes "normal wear and tear brings eventual trouble."

As the principle implies, all equipment and machinery is subject to wear and tear from use. For example, hoses may leak, pulleys may slip, and cables may fray.

Therefore, detection of equipment and machinery that needs to be fixed or replaced because of wear and tear - or for some other reason - will help to eliminate hazards before they cause injuries or illnesses. This means that adequate, systematic maintenance (as required by standards) must be performed, and maintenance must be an important part of all inspections.



## NOBODY'S PERFECT

A third principle behind the need for planned inspections is the assumption that "people make mistakes"

The "nobody's perfect" principle refers to the fact that everyone makes mistakes. One of the reasons employees make mistakes is that they may not have the required knowledge, attitude, or job skills

Employees - or anyone, for that matter - may place materials or tools (and even themselves) in unsafe positions or locations. Tools may be abused, damaged, and perhaps passed on to the next employee in an unsafe condition. Employees may use inappropriate tools or tools that are not in proper working order. Even though careful and conscientious, no one is perfect. An employee might do any of these things unknowingly, depending on his degree of safety and health awareness.

Supervisors are not infallible either. Therefore you have the added responsibility of being a constant example of safe behavior and correct practice. Whenever you are performing a planned inspection, then, you will need to recognize whether materials or tools are in an unsafe position, location, or condition, or whether proper maintenance has been performed, or whether people are performing tasks properly - or if they appear to be ill - and a host of other factors.

Whenever materials or tools are placed or used unsafely, injuries or illnesses may result. You should also ask yourself such questions as: Is the correct tool being used, is the tool in good condition, is it stored properly?

### CLASSIFY THE FOLLOWING STATEMENTS

Read the following statements and classify them in terms of:

- a. The OSHA standards require inspections under certain conditions.
  - b. Normal wear and tear brings eventual trouble
  - c. People make mistakes
1. An employee leaving a tool in the middle of an aisle
  2. The inspection of fire extinguishers
  3. A worn high pressure hose.
  4. Frayed cables
  5. Using unsafe equipment due to a lack of job skills.

If you keep these principles in mind while you are performing inspections, you will be able to identify hazardous conditions that can cause injuries or illnesses.

If systematic, planned internal or self inspections are made on a shift, daily, or other regular basis, you will be taking a giant step toward effective accident and job-related illness control.

## ANSWERS TO QUESTIONS

1. c.
  2. a.
  3. b.
  4. b.
  5. c.
- 

## TWO TYPES OF PLANNED SAFETY AND HEALTH INSPECTIONS

There are two types of planned inspections that you, as a supervisor, might use to good advantage.

- Inspection of your own work area, and
- "Audit" inspection of another supervisor's work area.

The first type of inspection, "inspection of your own work area," is vitally important because the employer is responsible for what happens in your work area, and your position makes you his representative. Also, you are probably the person most familiar with all aspects of your work area and its relationship to the seven elements previously discussed.

### OBJECTIVITY IS IMPORTANT

The importance of the second type of inspection, "audit inspection of another work area," may not be as immediately obvious as the first type.

Oddly enough, one of your greatest advantages in facility inspection - familiarity with the employees, equipment, and machines in your own area - can also be a disadvantage. Your personal involvement with your own work area can rob you of one of the most critical ingredients of a good safety and health inspection - "objectivity." The less "objective" you are, the more likely it is for you to miss dangerous hazards.

Being human, people have trouble remaining totally objective if they are personally involved in a situation. Almost all people tend to lose some degree of objectivity in repeatedly inspecting their own work area. One factor is the tendency to overlook anything not included on the checklist, so the checklist can be a disadvantage as well. Checklists are guides, and should never be considered as final or all-inclusive.

### AUDIT INSPECTIONS HELP EVERYONE

Audit inspections are planned in the same manner as inspection of your own work area (described later in this lesson). The only difference in procedure is that, in an "audit" inspection, you inspect another supervisor's work area. One important point to keep in mind when performing an audit inspection is that you are trying to HELP the other supervisor by discovering problems he may have missed in his work area.

## HAZARDS TEND TO ACCUMULATE

Many safety or health problems tend to accumulate very gradually. This gradual change is hard to recognize if the same person who does the inspection works day after day in the same area.

In an audit inspection, the cumulative effects of this gradual change will be more noticeable to a supervisor from another work area.

6. Which of the two types of safety and health inspections discussed above can a supervisor perform more objectively?
- a. Audit inspection
  - b. Inspection of own work area

## BENEFITS OF AN AUDIT INSPECTION

Audit inspections produce a two-way benefit. One benefit is that it helps two supervisors (you and your counterpart) to do each other a good turn. Secondly, the audit inspection helps each supervisor gain a new perspective. After looking over someone else's work area you may come back to your own with added or better ideas for improving your own operation. As you can see, there ARE benefits to be gained by performing audit inspections.

## FORMAL INSPECTIONS

For purposes of discussion, we shall call the audit inspection and the planned, periodic inspection **FORMAL** inspections. They occur at certain times and, as we will see later in this lesson, they give a great amount of detailed and useful information. Formal inspections are usually the most thorough and, therefore, are very important (however, keep in mind that these formal inspections cannot replace your daily inspections).

## BENEFITS OF FORMAL SAFETY AND HEALTH INSPECTIONS

7. How many of these situations in your work area would you as a supervisor like to reduce or eliminate? (Check those you would list.)
- a. Loss of personnel or time on the job due to minor, serious, or even fatal injuries and illnesses. \_\_\_\_\_
  - b. Unexpected breakdown of key equipment. \_\_\_\_\_
  - c. Work area congestion and lack of floor space. \_\_\_\_\_
  - d. "Misplaced" tools that delay production until they can be found, or replaced. \_\_\_\_\_
  - e. "Lost" material that must be replaced from supply or "dug out" when found at the bottom of the pile. \_\_\_\_\_
  - f. "Rework" or jobs that must be done over two, three, or four times because of accidents or careless work. \_\_\_\_\_

## ANSWERS TO QUESTIONS

6. a. Audit Inspection. This does not mean that you shouldn't inspect your own work area daily, or each shift. Neither should it preclude inspections by safety engineers, directors, committees, and the like. The audit inspection, though, is one of the better ways to obtain objective information about specific hazards in a work area.

g. Possible complaints from your employer about excessive costs, low productivity, and poor morale

h. Massive crash campaigns that stop all production to "get things in order" for visits by OSHA, customers, stockholders, fire inspectors, and other VIPs.

i. Total production shutdown so "we can clean this place up so we can get some work done around here"

j. Mountains of paper work connected with all of the above situations, and the hours spent in completing it.

## PLANNING A FORMAL SAFETY AND HEALTH INSPECTION

### OBJECTIVES OF PLANNING A FORMAL INSPECTION

There are two main objectives of a formal safety and health inspection:

- To recognize all undesired practices and conditions that could result in personal injury or the impaired health of your employees, or damage to equipment, and identify relevant standards, and
- To evaluate and record the general degree of hazard associated with each item as a guide to setting up remedial and preventive action priorities.

### POOR PLANNING LEADS TO POOR RESULTS

Therefore, the planning of a formal inspection is very important

If your planning is poor, your results will also be poor.

### QUESTIONS TO ANSWER BEFORE PERFORMING AN INSPECTION

To effectively plan for a formal inspection, you should always include *written* answers to these five key questions

- What problem will be inspected?
- What are the critical factors for each problem to be inspected?
- What conditions will be inspected?

## ANSWERS TO QUESTIONS

- 7 Most supervisors would consider it a blessing to reduce any one of these problems. They represent some of the greatest stumbling blocks, obstacles, and handicaps with which a supervisor must contend

Every problem in this list can be reduced, and in many cases eliminated, by formal, planned safety and health inspections. In fact, planned inspections are probably the most effective tools available to the supervisor for dealing with the basic causes of these troublesome situations

---

- How often should problems be inspected?
- Who will do the inspecting?

Each one of these is extremely important, it also is extremely important to relate the standards involved to these factors. Let's see what information you need for each of these five questions

### WHAT PROBLEMS WILL BE INSPECTED?

The first question asks, "What problems will be inspected?" The types of things you would want to inspect might include the following

- tools
- supplies
- buildings
- equipment
- materials
- procedures
- rules
- any other things that can become unsafe or cause injuries or illnesses if not inspected and/or maintained at regular intervals

In answering the first question, it would be helpful to look at past safety and health inspection reports, injury and illness investigation reports, and maintenance reports for your work area.

The injury and illness records your employer is required to keep by regulations adopted under the Act would be one of several good sources for this purpose. The required records will give you some indication of the problems that have been the cause of many of the injuries and illnesses in your work area.

## LIST THE PROBLEMS

When planning a formal inspection, it is important to list the problems that can become hazards and cause injuries and illnesses. Remember that problems can also include such things as procedures and rules. Don't look only at equipment and materials, and don't overlook people, either.

One of the best sources of information on what items should be inspected are the employees who are responsible for maintenance in your establishment.

With their technical knowledge of equipment and machinery in the work area, they are ideally qualified to identify problems that they know (or suspect) are likely to cause injury, illness, damage, or shutdowns.

Therefore, when planning an inspection, you should always consult with the maintenance people in your establishment.

Another source of information is the medical personnel - if any - in your establishment. They will be helpful in giving you a list of problems that cause job-related illnesses. Always keep in mind that the health of employees is just as important as their safety.

Other sources of information on problems are employees, manufacturers' manuals, OSHA standards and publications, and consultation with other supervisors using similar equipment or procedures.

Anything that can cause injury, health impairment, damage, delays, shutdowns, or create bottlenecks should be included in the check list of problems to be inspected. You will now have completed Step #1 in your planning for formal inspection.

## CRITICAL FACTORS

Now that you have identified the problem areas, you will be able to find the potential hazards associated with each problem. These possible hazards will be called the **CRITICAL FACTORS**.

The second question—**QUESTIONS TO ANSWER BEFORE PERFORMING AN INSPECTION**—asks, "What are the **CRITICAL FACTORS** of the problems to be inspected?" In other words, what are the factors that are most likely to cause the greatest problems when they become unsafe or unhealthy?

Critical factors, for example, may be mechanical or electronic parts that are subject to damage, deterioration, or defects. Critical factors would also include any health factors that can lead to occupational illnesses, such as contaminated air in a work area.

If, during the planning stage of an inspection, you determined that you should check a high-pressure hose on a hydraulic pump,

8 Which of these would be a problem and which would be a critical factor? (Keep in mind that critical factors are **SPECIFIC ITEMS** of a problem that you want to examine.)

a. Hydraulic pump.

b. High-pressure hose.

Using the OSHA standards on pressure hoses, you can make a comparison of what the standard calls for and how this particular critical factor should be inspected.

**ANSWERS TO QUESTIONS:**

- 8 a. The hydraulic pump is a problem to be inspected
- b. The high-pressure hose is the critical factor

**CHOOSE BETWEEN PROBLEMS AND CRITICAL FACTORS**

- 9 If you also determined that a part of your work area should be inspected for noise level, the work area would be a problem and noise level would be termed a \_\_\_\_\_ factor.

**SEEK HELP WHEN DECIDING ON CRITICAL FACTORS**

Seek help when you are trying to decide what critical factors should be inspected. Employees you supervise as well as maintenance people, medical personnel, and the OSHA standards - would be a good source for this information.

Use as many sources as necessary to determine the critical factors in your work area.

**DEFINE CRITICAL FACTORS**

10. In your own words, what are critical factors? \_\_\_\_\_  
\_\_\_\_\_

**PROBLEMS OR CRITICAL FACTORS?**

- 11 Classify the following examples as being either problems or critical factors:

- a. cables \_\_\_\_\_
- b. acid \_\_\_\_\_
- c. stress \_\_\_\_\_
- d wear \_\_\_\_\_
- e alarms \_\_\_\_\_
- f. heat \_\_\_\_\_
- g. cranes \_\_\_\_\_
- h. corrosion \_\_\_\_\_

The third of the previously stated QUESTIONS TO ANSWER BEFORE PERFORMING AN INSPECTION asks, "What conditions will be inspected?"

**WHAT CONDITIONS WILL BE INSPECTED**

How many times have you heard someone say, "Check that to be sure it's safe"? Check it for what? First you have to know what makes an item unsafe. The unsafe conditions for each item to be inspected must not only be listed, but described.

## ANSWERS TO QUESTIONS:

9. Critical. Again remember that a critical factor is a specific item of a problem that you want to examine. The OSHA Standards on occupational noise exposure should be consulted for guidance on whether or not your work area is in compliance.
10. Critical factors are those factors that are most likely to cause the greatest trouble when they become hazardous or other than normal. These critical factors are the specifics of the problem you want to inspect.
11. a. problem                      b. problem                      c. critical factor  
d. critical factor                e. problem                      f. critical factor  
g. problem                        h. critical factor
- 

This points up how important it is to put all of the things you want to inspect in writing so you won't forget something when you perform a formal inspection. In this particular discussion we are interested in the condition of problems; therefore, the list in the next item will be helpful.

## EXAMPLES OF CONDITIONS TO BE INSPECTED

In describing conditions for each item to be inspected, terms such as these should be used:

- jagged
- broken
- frayed
- leaking
- rusted
- corroded
- missing
- vibrating
- loose or slipping
- fuming
- decomposed
- gaseous
- spillage

12. If, during the planning stage, you decided you would need to check the pressure gauge of a boiler to see that the maximum pressure has not been reached, what would be the problem, the critical factor, and the condition to inspect?
- a. the boiler is the \_\_\_\_\_
- b. the maximum pressure is the \_\_\_\_\_
- c. the pressure gauge is the \_\_\_\_\_

## HOW OFTEN SHOULD PROBLEMS BE INSPECTED?

The fourth of the QUESTIONS TO ANSWER BEFORE PERFORMING AN INSPECTION asks, "How often should problems be inspected?" It is important to remember that, if certain problems are not inspected as frequently as necessary, then they are likely to cause injuries, illnesses, time-wasting breakdowns and major "cleanup campaigns."



## ANSWERS TO QUESTIONS.

12 a. problem      b. condition      c. critical factor

---

It is up to you, based on all the information available (including the requirements of the OSHA standards), to decide on how often a problem should be inspected

Again, maintenance personnel can help you decide what the intervals for inspection should be, by informing you of the experience they have had with equipment or operation breakdowns, and frequency of repair

Remember, the frequency of inspection will vary. Some items will need to be inspected daily, some weekly, some monthly, and so on.

### HOW FREQUENT SHOULD INSPECTIONS BE?

When trying to decide how frequent inspections should be, you should ask yourself the following questions:

- *What is the loss severity potential of the problem?* In other words, if the problem or critical factor should fail, how much injury, health impairment, damage or work interruption could be caused? For instance, a frayed cable on an overhead crane block has the potential to cause a much greater loss than a defective wheel on a wheelbarrow. The greater the loss severity potential, the more often the problem should be inspected.
- *What is the potential for injury or illness to employees?* This means how many, and how often, employees will be endangered if the problem or critical factor becomes unsafe. For example, a stairway used continually by many people would require more frequent inspections than one which is seldom used. The higher the probability for injury or illness to employees, the *more often* a problem should be inspected.
- *How quickly can the problem become unsafe?* This depends on the nature of the problem and the conditions to which it is subjected. Some equipment and tools get heavy use and can become damaged or defective quickly. Others may be used only rarely and seldom become damaged or worn. The location of a problem may also expose it to a greater possibility of damage than an identical problem in a different location. The shorter the time in which a problem can become unsafe, the *more frequently* it should be inspected.
- *What has been the history of failures and the results of these failures?* This can be determined from maintenance and production records as well as the injury and illness investigation reports required by the Act. These sources can provide valuable information about how frequently problems have failed and what results these failures had in terms of injury, illnesses, damage, delays and shutdowns.

When the loss severity potential is greater, your inspection of a problem should be more frequent.

### WHO WILL DO THE INSPECTING?

Another of the QUESTIONS TO ANSWER BEFORE PERFORMING AN INSPECTION asks, "Who will do the inspecting?" Some problems will have to be inspected by more than one person, such as yourself, a repairman, a maintenance man, and the operator, too. Keep in mind that while others may be involved in

certain phases of the safety and health inspection, you retain the basic responsibility for conditions in your work area.

There is one other point to keep in mind on planned inspections. Although you may find it necessary to inspect a problem daily, for example an overhead crane, the operator of the crane or any other piece of equipment should inspect the equipment before he starts to use it (at each shift). In aviation, for another example, the airplane is carefully inspected before each flight by the crew members of that flight, even though mechanics also inspect the airplane every few hours of flight time as well.

### PLANNING A SAFETY AND HEALTH INSPECTION

13 Planning for an inspection should include *written* answers to the five questions previously discussed. Fill in the following blanks with the appropriate words:

- a. What \_\_\_\_\_ will be inspected?
- b. What are the \_\_\_\_\_ factors for each problem to be inspected?
- c. What \_\_\_\_\_ will be inspected?
- d. How \_\_\_\_\_ should items be inspected?
- e. \_\_\_\_\_ will do the inspecting?

### SELF-INSPECTION GUIDE CAN SERVE MANY PURPOSES

You will probably find it useful and helpful to have a simple form on which to list your answers to the five key questions we have just discussed. This form can serve as a **PERMANENT** reference for the formal inspections you make in your work area. It can also be used as a reference or guideline for audit inspections where the inspector is not as familiar with the problems and critical factors that should be inspected.

Turn to the next page for an example of the type of form that would be useful for this purpose. Keep referring to this page while we discuss the columns of this form as the lesson progresses.

### WHAT PROBLEMS WILL BE INSPECTED?

Column 1 of the Self-Inspection Guide on page 39 asks for the specific problems in your work area that should be inspected. There are many possible problems that you might find it necessary to inspect. Then turn to the following page for examples of the possible problems you may want to look at during a formal inspection.

Remember, this is just a list of possibilities, and does not necessarily cover any or all problems that can be found in your work area.

### WHAT ARE THE CRITICAL FACTORS?

Column 2 of the Self-Inspection Guide asks for you to list the critical factors. From the previous discussion on critical factors, you know that this column is for the identification of the critical part of each problem that needs to be inspected.

Whenever you list critical factors, you should identify those critical parts and/or exposures for each problem to be inspected regularly. For example, safety devices, guards, controls, work or wearpoint components, electrical and mechanical components, and fire hazards would come under this category. Also, consider those parts and/or exposures most likely to develop unsafe or unhealthy conditions due to stress, wear, impact, vibration, heat, corrosion, chemical reaction, and misuse.

PLANNED SAFETY AND HEALTH SELF-INSPECTION GUIDE

DEPARTMENT	UNIT	SUPERVISOR RESPONSIBLE	APPROVED BY	DATE	PAGE NO.
1. PROBLEMS	2. CRITICAL FACTORS	3. CONDITIONS TO OBSERVE	4. FREQUENCY	5. RESPONSIBILITY	

ANSWERS TO QUESTIONS:

13. a. problem                      b. critical                      c. conditions  
    d. often/frequently          e. who
- 

LIST OF POSSIBLE PROBLEMS TO BE INSPECTED

- |                 |                   |
|-----------------|-------------------|
| Acids           | Hoists            |
| Aisles          | Hoses             |
| Alarms          | Hydrants          |
| Atmosphere      | Ladders           |
| Automobiles     | Lathes            |
| Barrels         | Lights            |
| Bins            | Mills             |
| Blinker lights  | Mists             |
| Boilers         | Motorized carts   |
| Borers          | Piping            |
| Buggies         | Pits              |
| Buildings       | Platforms         |
| Cabinets        | Power tools       |
| Cables          | Presses           |
| Carboys         | Racks             |
| Catwalks        | Railroad cars     |
| Caustics        | Ramps             |
| Chemicals       | Raw materials     |
| Claxons         | Respirators       |
| Closets         | Roads             |
| Connectors      | Roofs             |
| Containers      | Safety devices    |
| Controls        | Safety glasses    |
| Conveyors       | Safety shoes      |
| Cranes          | Scaffolds         |
| Crossing lights | Shafts            |
| Cutters         | Shapers           |
| Docks           | Shelves           |
| Doors           | Sirens            |
| Dusts           | Slings            |
| Electric motors | Solvents          |
| Elevators       | Sprays            |
| Explosives      | Sprinkler systems |
| Extinguishers   | Stairs            |
| Flammables      | Steam engines     |
| Floors          | Sumps             |
| Fork lifts      | Switches          |
| Fumes           | Tanks             |
| Gas cylinders   | Trucks            |
| Gas engines     | Vats              |
| Gases           | Walkways          |
| Hand tools      | Walls             |
| Hard hats       | Warning devices   |

When you have read this list, please turn to the next page and continue learning more about inspection of critical factors.

As in the problems, cited in the Inspection Guide, the preceding list of critical factors does not necessarily cover the range of critical factors that can be found in your area.

14. Which one of the following would you classify as a problem and which one would you classify as a critical factor?

- a. Stress due to noise.
- b. Motorized carts.

#### WHAT ARE THE CONDITIONS TO OBSERVE?

Column 3 of the Inspection Guide asks you to list the conditions you need to observe. *Examples* of conditions would be:

- jagged
- leaking
- sharp-edged
- flammable
- crooked
- decomposed
- frayed
- gaseous
- deteriorated
- toxic
- corroded
- contaminated

In column 3 you should list all the specific unsafe and unhealthy conditions that you need to observe during your formal inspection.

15. Could the terms "splintery," "explosive," and "loose" be classified as conditions to observe?

- a. Yes
- b. No

#### HOW OFTEN?

Column 4 of the Self-Inspection Guide likewise asks for frequency. When filling in this column, you should use descriptive terms such as: before every use, when serviced, daily, monthly, quarterly, or yearly. This, of course, depends upon the loss severity potential, history, and experience.

#### WHO WILL INSPECT THE SPECIFIC PROBLEMS?

Column 5 of the Guide concerns assignment of responsibility for conducting the inspection. In this column, you should designate the proper person by title, such as: area supervisor, user, operator, or maintenance foreman. It is important for you to decide on who will actually do the inspection of the specific problem.

Since you are the one who is held responsible for your work area, you will probably want to be the one who does the major portion of the inspection.

## ANSWERS TO QUESTIONS:

14. a. critical factor                      b. problem

15. a. yes. All of these terms indicate specific CONDITIONS that can cause injuries or illnesses.

---

## THE PLANNED SAFETY AND HEALTH INSPECTION GUIDE

Turn to the next page for a completed Self-Inspection Guide. The completed form gives you an example of the usefulness of such a form in planning a formal inspection. The Act does NOT require that you use a form such as this to plan formal inspections. You can probably see, though, that such a form is quite helpful in making sure that unsafe or unhealthy conditions, that can cause injuries or illnesses, are not overlooked. This one can be adapted to your needs, or you can develop your own.

## HOUSEKEEPING AND THE EFFECTS OF DIRT AND DISORDER

### HOUSEKEEPING AND ORDER

Before we describe how a formal inspection should be conducted, it is important to discuss another factor that can affect an employee's safety and health. This factor is called HOUSEKEEPING. Housekeeping, as you will see later, involves much more than sweeping the floor, and wiping dirt off machines and equipment. Cleanliness is part of housekeeping, but is not the only thing you should pay attention to. The most critical and most overlooked part of housekeeping is ORDER.

Many work areas may be clean, but not necessarily in order. A work area is in order when there are no unnecessary things about, and when all necessary things are in their proper places.

As long as there is one thing in an area that is unnecessary, or not in its proper place when not in use, you do not have order.

### BENEFITS OF ORDER

You may ask why order is so important. Here are a few reasons:

- Order eliminates causes of injuries, illnesses, and fires,
- Order prevents wasted energy,
- Order maintains the greatest use of precious space;
- Order keeps stores of inventory at a minimum;
- Order helps control property damage;
- Order encourages better work habits;

As you will see in the lesson on Fire Loss Control, the cause of many fires is the fact that the affected work area was not kept in order. Lack of order may eventually cause fires as well as injuries and sickness.

PLANNED SAFETY AND HEALTH SELF-INSPECTION GUIDE

DEPARTMENT	UNIT	SUPERVISOR RESPONSIBLE	APPROVED BY	DATE	PAGE NJ
Maintenance	Workshop	J. P. Smith	Ralph T. Welles	4/16/72	1
1. PROBLEMS	2. CRITICAL FACTORS	3. CONDITIONS TO OBSERVE	4. FREQUENCY	5. RESPONSIBILITY	
1. Overhead hoist	Cables, chains, hooks, pulleys	Frayed or deformed cables, worn or broken hooks and chains, damaged pulleys	Daily - before each shift	Operators	
2. Hydraulic pump	High pressure hose	Leaks; broken or loose fittings	Daily	Shift leader	
3. Power generator	High voltage lines	Frayed or broken insulation	Weekly	Foreman	
4. Fire extinguishers	Contents, location, charge	Correct type, fully charged, properly located, corrosion, leaks	Monthly	Area safety inspector	
5. General house-keeping	Passageways, aisles, floors, grounds	Free of obstructions, clearly marked, free of refuse	Daily	Shift leader foreman	

## KEEP ONLY WHAT'S NECESSARY

As was stated before, if something in your work area is not necessary, you don't have order. A good example of something not being necessary is supplies kept in your work area that you won't need for several months

16. Would housekeeping and order be considered a problem or a critical factor in a planned inspection?

- a. Problem
- b. Critical factor

## PUTTING PLANNED SAFETY AND HEALTH SELF-INSPECTION INTO ACTION

### WHAT TO DO BEFORE YOU START YOUR INSPECTION

There are several steps you must take before you begin an actual inspection tour of your work area. First, review your Planned Safety and Health Self-Inspection Guide, or any existing list of common hazards, and the relevant standards, for the work area to be inspected. Be sure to check the injury and illness investigation reports required by the Act for any injuries, illnesses, or damage that occurred in your work area since your last inspection. If something happened once before, you want to be sure to see that it doesn't happen again.

When you have completed a list, such as the Self-Inspection Guide, you will have identified which problems you need to look at during your inspection.

### USE A PREVIOUS INSPECTION REPORT

Be sure to take a copy of the last inspection report of your work area with you so that you can give particular attention to any problems that might still need corrective action.

### THE SAFETY AND HEALTH INSPECTION REPORT

To help you in recording a hazard found during your formal inspection, we are including a form called the *Safety and Health Self-Inspection Report* (page 45). Again, this form is not required by the Act, but it would be of great help to you in organizing and deciding upon the appropriate action that you should take.

On this form write down and identify the hazard immediately at the time you have observed it. Therefore, by using such a form, you will be able to immediately record the hazards that you have found while you are still looking at them. This way, your memory won't pull any tricks on you and you won't forget anything.

Turn to the next page and look at the columns of the form. As you can see, this form is quite simple to use, and also gives you the information you need to have the hazard corrected.

One point to keep in mind is that you should correct - immediately - the hazards you have the authority to correct and - equally immediately - identify to your employer or supervisor, the hazards you don't have the authority to correct.



SAFETY AND HEALTH SELF-INSPECTION REPORT

Area Inspected \_\_\_\_\_ Date \_\_\_\_\_ Inspector \_\_\_\_\_

CODE	HAZARDS	CORRECTIVE ACTIONS
ANALYSIS AND COMMENTS		

## ANSWERS TO QUESTIONS:

16. a. problem. Housekeeping and order would be a problem. Critical factors, in terms of house-keeping, would include passageways, aisles, and floors.
- 

## SOME HELPFUL POINTERS

Below are some helpful pointers to keep in mind while making an inspection:

- Be sure to look for off-the-floor problems as well as those at ground level. Be sure to look up over your head at things that may fall. Also cover those problems in out-of-the-way places that are rarely visited.
- Be methodical and thorough. Take your time. Don't ruin the whole program with a "once over lightly" approach.
- Carefully describe and locate each hazard. Give descriptions clearly and locations exactly. **WRITE DOWN** any questions or details related to a hazard. **DON'T RELY ON MEMORY!**

## CLASSIFY THE HAZARDS

As mentioned in previous lessons, it is important to differentiate between the **DEGREE OF SEVERITY** of different hazards. To help you differentiate, here are some suggestions for a classification system.

- *Class "A" Hazard* - any condition or practice with **POTENTIAL** for causing *loss* of life or body part and/or extensive loss of structure, equipment, or material.
- *Class "B" Hazard* - any condition or practice with **POTENTIAL** for causing *serious* injury, illness, or property damage but less severe than Class "A."
- *Class "C" Hazard* - any condition or practice with probable potential for causing nondisabling injury or nondisabling illness, or nondisruptive property damage.

17. What hazard classification would be the most severe?

- a. Class "A" Hazard.
- b. Class "B" Hazard.
- c. Class "C" Hazard.

18. What would be the classification of a hazard that had a potential for causing **SERIOUS** injury, illness, or property damage?

- a. Class "A" Hazard.
- b. Class "B" Hazard.
- c. Class "C" Hazard.

## ANSWERS TO QUESTIONS:

17. a. Class "A" Hazard

18. b. Class "B" Hazard This hazard is less severe than a Class "A" Hazard since it wouldn't result in a loss of life or body part.

---

## ENTER THE CLASSIFICATIONS IN THE REPORT FORM

Turn to the next page for an example of a completed *Safety and Health Self-Inspection Report*. Look closely at the first column - CODE. As you can see, Hazard 1 was given a "B" classification.

This means that the hazard had the potential for causing serious injury, illness, or property damage.

"Potential" is a shortening of the term loss severity potential that has been discussed in previous lessons.

Take time to really read the information the inspector recorded for the listed hazards. Notice how the hazards are described, how they are coded, what specific corrective action has been taken; your inspection forms should do the same.

## A CLASSIFICATION SYSTEM SAVES TIME

Another significant benefit of classifying hazards is that it saves everyone's time. It immediately describes the potential loss severity without the need for long written descriptions of potential injuries or illnesses. This is especially meaningful for your employer since it makes it possible to scan inspection reports quickly and to pick out the most important problems.

19. What hazard classification was recorded for hazard 4 in the completed form on page 48?

## LOSS SEVERITY POTENTIAL

20. Of the hazards listed in the report form, which one has the highest loss severity potential?

- a. Hazard 1
- b. Hazard 2
- c. Hazard 3
- d. Hazard 4
- e. Hazard 5
- f. Hazard 6

## ADDITIONAL SYMBOLS

Turn again to the completed form on page 48. Please note there are three different types of symbols used in the CODE column.

- ○ - intermediate measures have been taken
- ✕ - permanent measures have been taken
- \* - carried over from previous inspection reports

SAFETY AND HEALTH SELF-INSPECTION REPORT

Area Inspected Bldg. A Date 7/30/72 Inspector John Williamson

CODE	HAZARDS	CORRECTIVE ACTIONS
*1B	Guard missing on shear blade, #2 machine, S.W. corner of Bau #1 (7/16/72)	W.O. issued to Eng. for new guard (7/16/72) - wooden barrier guard in temporary use - guard still missing 7/30/72 (contacted Eng. and they will install guard by 8/3/72)
*2C	Window still cracked on S. wall, Bay #3 - W.O. was issued for replacement on 7/16/72	Maint. Dept. now plans to replace all broken windows in plant starting Aug. 3
<del>3A</del>	Oil and trash accumulated under main motor in pump room. Was to be cleaned out by 7/31/72	Cleaned out 7/31/72. Employees instructed to keep area clean, and why.
*1B	Mirror at pedestrian walk, corner of N. end of mach. shop, out of line	Jack Butler scheduled adjustment for Aug. 8 - temporary warning sign to be posted 7/31/72
<del>4</del>	Three employees at cleaning tank in electric shop not wearing eye protection	Discussed with Roberts - he held meeting with his employees on eye protection rules and benefits
*6A	Cable on jib crane, Bay #3, badly frayed	Called Don Johnson who tagged crane out of service. Cable will be replaced Sat., Aug. 1

ANALYSIS AND COMMENTS

Class "A" Hazards now getting good, high priority attention. Steady progress being made on others, too.

ANSWERS TO QUESTIONS:

19. Class "B" Hazard

20. Hazard 6. This hazard was coded A which indicated it has the highest loss severity potential.

For example, Hazard 3B is listed as ~~3B~~. This indicates that:

- Hazard 3 was rated as a Class "B" Hazard
- Intermediate action was first taken
- The hazard has now been permanently corrected
- The hazard was carried over from previous inspection report forms

21 Take example **4B** and describe its meaning:

- a. \_\_\_\_\_
- b. \_\_\_\_\_
- c. \_\_\_\_\_

**REMEDIAL ACTION FOR INJURY AND ILLNESS PREVENTION AND CONTROL**

Let's get back to the basic reason for facility inspection. the prevention and control of injuries and illnesses. Inspection by itself will do little good. Inspection must be followed by remedial action; in fact, the basic objectives of remedial action tie in directly with the basic objectives of inspection.

*Inspection Objectives*

- To inspect for all undesired practices and/or conditions that could result in personal injury or illness,
- To evaluate and record the general degree of hazard associated with each item as a guide to remedial priority.

*Remedial Action Objectives*

- To eliminate, reduce, segregate, or provide protection from the hazard associated with each item detected.
- To give special remedial attention to those items with the potential for greatest loss severity.

Therefore, it can be seen that the objectives of the inspection process are closely related to the objectives of the remedial action that must be taken to rid the work area of hazards.

**WHAT TO DO WHEN TAKING REMEDIAL ACTION**

When taking remedial action to correct hazards, there are five key points to keep in mind:

- Correct the basic or real cause whenever possible;
- Correct anything under your control immediately;

## ANSWERS TO QUESTIONS:

21. a. Hazard 4 was rated as a Class B Hazard
- b. Intermediate action has been taken.
- c. The hazard was carried over from previous report forms.

- 
- Report conditions beyond your authority and suggest solutions,
  - Take intermediate action as needed;
  - Be persistent in follow-up.

All five of these key points will help you and your employer to meet the requirements of the Act. Remember, the Act requires that the employer must provide safe and healthful workplaces for all employees.

## THE ONGOING INSPECTION

Last but not least, one more vitally important point should be made. We have talked at length about the planned formal inspection, but have not made much mention of the ongoing inspection that you should make each shift, every day, while you go about your normal duties.

Injuries and illnesses can occur at any time due to unsafe and unhealthy conditions in your work area. Some of these conditions can occur between the times allotted for the planned inspection—and usually do. Keep on the lookout, at all times, for conditions that are likely to cause injuries or illnesses, and have them corrected before serious consequences result.

You should never allow the formal inspection to supplant your daily inspections.

Remember, you cannot wait until accidents occur. You must constantly keep on the lookout, daily, for any problems that can cause injury or illness to an employee - or yourself.

## REVIEW

22. There are two types of formal inspections that can be made in your establishment. One is the inspection you perform in your own work area. The other is called an \_\_\_\_\_ inspection of another supervisor's work area.
23. When planning a safety and health inspection, you must first decide on what \_\_\_\_\_ you will inspect.
24. After you have decided on the problem to inspect, you then must determine the \_\_\_\_\_ factors of that problem.
25. "The standards require inspections" should be one principle you should keep in mind when performing a safety and health inspection. What are two other principles?
  - a. \_\_\_\_\_
  - b. \_\_\_\_\_

ANSWERS TO QUESTIONS:

- 22. Audit
- 23. Problems
- 24. Critical
- 25. (In any order)
  - a. Normal wear and tear brings eventual trouble.
  - b. People make mistakes.

---

26. A planned inspection will help identify the \_\_\_\_\_ cause of injuries and illnesses, and help you in eliminating them.

- a. Basic.
- b. Immediate.

27. How often should a planned inspection be performed?

- a. Every week.
- b. Every month.
- c. Depends on the items to be inspected and standards which may be involved.

28. Should you be the only one to decide on what problems should be inspected, or should you also seek outside help?

---

---

29. The greater the possibility for injury or illness to employees, the more \_\_\_\_\_ a problem should be inspected.

30. What are the three hazard classifications?

- a. \_\_\_\_\_
- b. \_\_\_\_\_
- c. \_\_\_\_\_

31. A Class "A" Hazard has the highest potential \_\_\_\_\_ severity.

ANSWERS TO QUESTIONS.

- 26. a. Basic.
- 27. c. Depends on the items to be inspected.
- 28. You should seek outside help. You have the best knowledge of your work area, but it wouldn't hurt to get advice from other people so that you won't leave out any problems.
- 29. Frequently/often.

- 
- 30. a. Class "A" Hazard
  - b. Class "B" Hazard
  - c. Class "C" Hazard

31 Loss

---