

DOCUMENT RESUME

ED 106 557

CE 003 729

TITLE Career Specialist Handbook for the World of Work K-10 Continuum.

INSTITUTION Warren City Schools, Ohio.

PUB DATE [73]

NOTE 86p.; For related documents, see CE 003 727 and 728. Pages 83-100, news releases and public information, were deleted because they are not reproducible

EDRS PRICE MF-\$0.76 HC-\$4.43 PLUS POSTAGE

DESCRIPTORS Administrator Guides; *Career Education; *City Wide Programs; Counselor Functions; *Educational Objectives; Elementary Secondary Education; Field Trips; Inservice Teacher Education; Occupational Guidance; Program Descriptions; Public School Systems; *Records (Forms); Resource Materials; *School Policy

IDENTIFIERS World of Work

ABSTRACT

The handbook is intended as a guide for career education specialists and includes a wide variety of materials, most of which are reproduced directly from the Warren, Ohio, city schools' World of Work project office. Following an overview of the city's program, the document emphasizes policies, procedures, and organizational functions. Three aspects of the program are discussed: career motivation for grades K-6, career orientation for grades 7-8, and career exploration for grades 9-10. These include objectives, rationale, specific teaching concepts, grade level study areas, and, for grades 9-10, career education program designs. The bulk of the handbook is devoted to sample program materials: duties and procedures for career specialists, co-teachers, and career aides; program policies, forms, guides, and memos; policies, procedures, and ideas concerning field trips; a suggested filing system; an equipment list; titles of films available locally; and sample designs and materials used for inservice teacher programs. (MDW)

ED106557

Warren City Schools

Department of Career Education

Warren, Ohio

Career Specialist Handbook

for the
World of Work
K - 10
Continuum

Dr. Richard Boyd
Superintendent of Schools

Dr. Robert Williams
Director of Career Education

Michael A. Zockle, Project Coordinator
Career Education
World of Work
K — 10 Continuum

David L. Piper
Career Specialist and Editor

U S DEPARTMENT OF HEALTH,
EDUCATION & WELFARE
NATIONAL INSTITUTE OF
EDUCATION
THIS DOCUMENT HAS BEEN REPRO-
DUCED EXACTLY AS RECEIVED FROM
THE PERSON OR ORGANIZATION ORIGIN-
ATING IT. POINTS OF VIEW OR OPINIONS
STATED DO NOT NECESSARILY REPRESENT
OFFICIAL NATIONAL INSTITUTE OF
EDUCATION POSITION OR POLICY

2/3

TABLE OF CONTENTS

5

K-6 CAREER MOTIVATION.....	1
7-8 CAREER ORIENTATION.....	8
9-10 CAREER EXPLORATION.....	11
W O W GROWTH AND EXPANSION.....	15
CAREER SPECIALIST, CO-TEACHER, CAREER AIDE.....	18
POLICIES AND MEMOS.....	28
FORMS - GUIDES - SURVEYS.....	31
FIELD TRIPS AND FIELD EXPERIENCES.....	45
REFERENCE.....	63
INSERVICE PROGRAMS.....	71
NEWS RELEASES AND PUBLIC INFORMATION.....	82

PREFACE

To All Career Specialists:

The impact of this booklet is to be a reference guide for all specialists. A guide of this sort is never in its most complete form for there are constant changes occurring. It is advised that you keep this guide in a loose leaf binder and add new ideas as they occur. This, of course, will help us up-date the next edition.

I thank all the specialists for their contribution to this booklet and to Dave Piper for his screening and editing and organization of materials.

Michael A. Zockle

K-6 CAREER MOTIVATION



STATEMENT OF INTENT

On December 23, 1969 the Warren City Schools submitted a proposal stating that, in urban centers, there is a considerable number of elementary school age disadvantaged youngsters who, because of a lack of information and motivation concerning the world of work, are unable to set realistic educational and occupational goals. It was presumed that the problem stemmed mainly from the fact that the parents of many of these students also lack this necessary understanding and are therefore not able to offer the needed guidance. The Warren schools' administration still feels that this original premise holds true. However, through further study, they feel that elementary school youth from other than the disadvantaged areas, seem to have similar problems. The administration contends that the development of an occupational motivation program which enables the child to be exposed to the full spectrum of careers will help him achieve a sense of his own potential as a future participant in society. The project is designed to show that all work is honorable and that every person should have pride no matter what his role.

The intent of the program will be to answer youths three inquiries - "Where am I going?" - "How do I fit in?" - and "Will I make it?" and "Do I have worth?"

Thus, it is the aim of this program to overcome these problems by providing the necessary occupational information for motivation, as set forth in the program objectives.

OBJECTIVES

1. As a result of participating in this program, elementary youth, their parents, and teachers will acquire a positive attitude toward all forms of education as a worthy means by which occupational goals are achieved whether it serve the needs of the college-bound, soon to-be-married, or labor market student.
2. The curriculum specialist operating in the schools will cooperatively guide teachers and parents, into a better understanding of all occupations.
3. The inclusion of Career motivation will result in a broader and more balanced elementary school educational program.
4. A closer relationship will be established between home and school as a result of the interaction activities planned in the program for career motivation.
5. A more balanced number of youth will enroll in the vocational, business and college preparation courses offered by Warren City Schools corresponding to the labor demands.
6. The new curriculum of the elementary school shall include the concept of career motivation and shall help students develop enthusiasm about the prospect of work as a way of life and see that all honest work has significance and value.
7. That all of the youth in the elementary schools' programs of Career Motivation will eventually feed into developed programs of Career Orientation 7 - 8 High school, and a Career Exploration Programs 9 - 10 in the Warren City Schools.

RATIONALE: 1970

Disadvantaged and lower class youngsters who, because of a lack of information and motivation concerning the world of work, are unable to set realistic educational and occupational goals. They find themselves unable to compete in the dominate culture and are increasingly on the outside because of being born into a minority culture. Their background becomes more of a handicap when they try to leave their group. They become caught up in a cycle of economic, educational, spiritual, experiential, and aspirational deprivation. This cycle had to be broken through educational opportunities so that new concepts could be given to them, their children, and their childrens' children. Because of the negativism which is bred in their culture, the school becomes the last hope for positive, stimulating, and encouraging experiences.

The school's program therefore provides new alternatives broading their scope of situations and demands, especially in the occupational world, for more often than not, their occupational background has been restricted to the simpler, manual forms of work.

Because the disadvantaged lower class youth has an urgent need for an improved future, and his urge is not really for achievement as much as his need for flight from discomfort, a program of Career Motivation was construed. The program is designed to show that the world's work is not only done by rich people and bright people, but it is done by responsible people, by good people, by right thinking people, by gentle people, by conscientious people, by considerate people. It is shown that all people have a part in the great adventure of work.

The program's goals for the teacher through workshops are as follows:

1. As a result of participating, the teacher shall acquire positive attitudes to all vocations as useful work in an inter-dependent democratic society.
2. They shall be guided into a better understanding of occupational information and its applications to elementary school youth.
3. They shall understand that it is important to teach that there are Occupational rewards other than pay.

Sometimes our objectives cannot be measured and we must trust in the judgment of the viewers. Some of the outcomes can be related therefore to be termed as perceptualized objectives. 1/knowledge and understanding of education, vocational, and social opportunities, requirements and expectations. 2/knowledge and understandings of abilities limitations, identities, feelings and motivation relevant to educational, vocational, and social development.

The viewer can evaluate as follows:

1. What is student enthusiasm for the world of work concept? Does it show improved attitudes and behavior and participation while world of work is taking place?
2. Do you have proper equipment, facilities and materials to conduct the program?
3. Do teachers understand what they are to do? Are they studying the field and applying their knowledge about the world of work? Can self study on the part of the teacher be as effective as a workshop?
4. Do the teachers understand the philosophy upon which the program can grow and develop? If they don't, where can they find out?
5. Is there a continuous and well planned means of communicating the program to the teachers?

6. Are the specialists and aides used as much as they should be by the teachers?
7. Are the teachers attempting not only to meet but to surpass the state minimum requirements?

The Occupational Curriculum Specialists will then provide information, "hands on" experiences, field trips, speakers, and write guides to relate to the on-going curriculum leading children to the following goals.

Early Elementary K-1-2

1. Develop wholesome attitudes toward all work.
2. Develop an awareness of the diversity of work ranging from his work as a helper, the work of his parents, relatives and community helpers.
3. Answer his myriad questions about occupations.
4. Explore the various rewards of work, since influence of his home or community may have persuaded him that money is the only reason for working.

Upper Elementary 3-4-5-6

1. There are jobs at all levels; state, national and international, and that all worthy jobs serve humanity.
2. Workers depend on one another.
3. Successful performance on most jobs requires some skills along with personal qualities as intelligence, special aptitudes, interest, personality and values.
4. Making a choice of a career is choosing a way of life.

SCHOOL OBJECTIVES

Do the schools involved have more exploratory experiences in the community directed toward the World of Work?

Do the schools involved have more visitors coming into the classroom telling about their work and their feelings toward work?

Do the teachers share ideas involving the world of work?

Are multi media materials introduced and used in the schools related to the world of work?

Here are many concepts which can be developed K – 6:

Concepts to teach¹

Grade Kindergarten

1. Work satisfies many needs.
2. Work is expected of everyone.
3. Work is admired by society.

Grade One

1. Work satisfies many needs.
2. Work is expected and admired by society.
3. An individual's major activity is his occupation.
4. People earn livings in many different ways.
5. School develops behaviors and skills needed for the world work.

Grade Two

1. The major focus of a person's activities is his occupation.
2. Individuals work for different reasons.
3. Cooperative activity meets individual needs.
4. The ability to live and work alone is essential.
5. Some jobs require specific abilities and skills.
6. Workers produce goods and services.
7. Many workers' activities are related.
8. The division of labor makes man interdependent.

Grade Three

1. People earn livings in many different ways.
2. Individuals work for different reasons.
3. Cooperative activity meets individual needs.
4. The ability to live and work alone is essential.
5. Some jobs require specific abilities and skills.
6. School develops behaviors and skills needed for life and work.
7. People need producers of services and producers of goods.

8. Occupations are classified by main activity (job families).
9. Duties within job families are related.
10. The division of labor makes man interdependent.
11. Everyone has the potential for success in a number of occupations.
12. Individuals differ in their skills, aptitudes, and interests.

Grade Four

1. Geographical location affects career opportunities.
2. Natural resources influence the world of work.
3. Supply and demand affect vocational opportunities.
4. Specialization exists in complex societies.
5. Evolving technology alters life and the world of work.
6. Facts about careers come from many sources and experiences.
7. Attitudes, values, interests and activities affect vocational choice.
8. Biological and familial factors affect career choices.
9. We learn about self from family, peers, and others.

Grade Five

1. Geographical location influences vocational opportunities.
2. Specialization exists in complex societies.
3. Advances in sciences and technology change work.
4. The selected occupation affects the life pattern.
5. Jobs and skills can be related to different school subjects.
6. Education and training can modify occupational choice.
7. Self knowledge - attitudes, values, interests, and activities as well as liabilities - is important to decision-making processes.
8. Every individual must make choices and solve problems.
9. Special abilities may qualify an individual for an unusual job.

Grade Six

1. Supply and demand affect occupational opportunities.
2. A country's economy, location, government, and laws affect career opportunities.
3. Different jobs will exist in the future.
4. Training requirements for skilled jobs have increased.
5. More job opportunities exist for females, the physically handicapped, and minority groups.
6. Information and exploration of jobs are essential to wise career decisions.
7. Occupational education and training is an on-going process.
8. Career choice is not final; it can alter in several ways.
9. Wise job choice is important to personal satisfaction.
10. Individuals are similar and, yet, dissimilar.
11. Some people are genuinely more suited to some kinds of jobs than to others.

¹ Concepts developed from statements regarding vocational information taken from Aubrey Haan, Elementary School Curriculum: Theory and Research (Boston: Allyn and Bacon, Inc. 1961), pp. 33-139, 230 - 240; and Anne Roe, The Psychology of Occupations (New York: John Wiley and Sons, Inc., 1956), pp. 3 - 80, 104 - 149, 252 - 277.

GRADE LEVEL AREAS OF STUDY

1. Kindergarten and First Grade — Learn about homes and families. Families live in houses — different kinds, sizes, made of different materials, decorated to suit family. Family members are inter-dependent. Families need time and work schedules. Adults trade work for money to buy family necessities and luxuries.

2. Second Grade — Learn about school in depth. Why attend school? How are the school facilities related to the use? Who are the adults who work at school and what are their specific duties — principal, teacher, secretary, nurse, custodian, carpenters, painters, pupil personnel services? What are the children's duties at school? Why do we need to schedule the classroom duties and to take turns performing them? Everyone works at school and observes time schedules. Face-to-face discussions and conversations with school personnel about their work.

3. Third Grade — Learn about the contributions of the community workers to home and to school. Jobs that help protect the family — police, firemen, doctors, nurses, health services. Community jobs that help provide food for the family — grocer, meat cutter, dairymen, farmer, baker, canning industry, transportation, restaurant workers, food inspectors. Community jobs that help provide clothing — store workers, tailors, cleaners, launderers, factories. Recreation jobs — playground, libraries, parks, Y.W.C.A., Y.M.C.A. The economic concepts of: needs versus wants, quality compared to price, etc.

4. Grades Four and Five — A study of the occupational opportunities in the expanded community. Study of communication and transportation occupations: diversified office workers, factory workers, distributive occupations; professions; educational and institutional workers; government occupations.

Study of basic educational and skill requirements for each occupations. How do the school curriculum offerings match these requirements? How much mathematics is needed? How about language skills? Manual dexterity?

5. Grade Six — A detailed survey of the diversified occupational needs and opportunities in the community. How do the environmental factors influence the types of jobs available? Learn about climate, soil, industry, water, location, population. Field trips to filtration plant local newspaper, telephone company, print shop, and other appropriate places.

Resource visitors to talk to and with small groups of students to explain about their occupations. Visit comprehensive high school to see course offerings leading to occupational choices. Much practical work experience at school — selling pencils, etc.

7 - 8 CAREER ORIENTATION



STATEMENT OF PROJECT INTENT

Career Orientation Grades 7 - 8

In Warren, as in other urban centers, there are a considerable number of junior high school age youngsters who, because of a lack of information and motivation concerning the world of work, are unable to set realistic educational and occupational goals. It is presumed that this problem stems mainly from the fact that the parents and teachers of many of these students also lack this necessary understanding and are therefore not able to offer the needed occupationally related information.

Because the students who participated in career orientation for the first year had only one-half year of previous career orientation experience, the program had different objectives in the first year than succeeding years. As we observe the elementary students who have had previous exposure to elementary Career Motivation Program and the junior high Career Orientation program, the scope of our program will change to reinforce what has been done in the previous years. The new approach will then be to develop a realistic program which will bridge the gap between the aims of youth and the demands of society through problem solving methods. The program also will stress student self appraisal of their personal skills and abilities which hopefully will lead to realistic occupational aspirations.

OBJECTIVES

1. To develop an increased awareness for students, parents, and teachers of the education offerings of the Warren City Schools.
2. To provide opportunities for better understanding of the interrelationships and interdependence of occupations in the neighborhood, city, county, state and nation.
3. To produce a broader and more balanced junior high school program as a result of the continuum of the elementary, junior high World of Work programs.
4. To improve the decision making and thinking process in the selection of a career.
5. To increase the students' awareness of the many occupations available.
6. To establish an active interrelationship between the home, school, and community.
7. To relate daily subject matter to the world of work.
8. To develop an attitude toward work that all fields of work are dignified and respectable.

DESCRIPTION OF PROGRAM

A. GENERAL DESCRIPTION

1. Career orientation shall be incorporated into and become a part of the total junior high curriculum.
2. In-service workshops for teacher education and curriculum development, will be provided.
3. The program shall include talks and demonstrations by students, workers, parents, and other community citizens with meaningful field trips related to occupations.
4. Meaningful work experiences shall be set up within the school for selected students.
5. Parents will meet with individual or small groups of students.
6. Occupational information shall be made available to teachers, parents, and students.

GRADE LEVEL TO BE INVOLVED

All seventh and eighth grades of the Warren City Schools shall be involved in the Career Orientation Program.

9 - 10 CAREER EXPLORATION



WARREN CITY SCHOOLS

CAREER EXPLORATION

RATIONALE:

Today, in a society orientated to higher education one out of twenty in the Warren City Schools still does not finish high school and only four in the twenty actually graduates from college. Yet a major portion of the school curriculum has been structured as though most were preparing for a four year college education.

High school life by and large has been separated from real life, from real work, and from real community service.

The Warren City Schools has seen fit to change their approach to a universal education (every student has worth) by offering a continuing program in a career oriented curriculum; K-6 Career Motivation, 7-8 Career Orientation and 9 - 10 Career Exploration.

The guidance function up to this time has mainly been the scheduling of students to the high school regimen and to guide students in proper preparation for college programs. The school's next ambition is to structure the counseling and/or curriculum to give similar help to students requiring less than a baccalaureate. An attempt shall be made to tie the curriculum to the goals of the students in such a way that they are exploring while they are in high school to be better equipped to choose from the many alternatives as they take the next step in career preparation. The next step being, on-the-job training apprenticeship, community college, or four year college.

CAREER EXPLORATION
WESTERN RESERVE HIGH SCHOOL

Career days must be every day in the modern comprehensive high school. Youth must experiment in ways in which they will some day spend their work lives and serve humanity so that their all important career decisions can be made with deeper perception.

The Western Reserve High School shall attempt to bring to the ninth and tenth grade students, a program of career exploration through the following eight designs.

Design I	Career Exploring Vocational Education
Design II	Career Exploring Units and Organizations
Design III	Achieving Your Career
Design IV	Career Media Center
Design V	Techniques and Success and Career Exploration
Design VI	Career Tours and Speakers
Design VII	Integrated Approach (Mass Media and Career Exploration)
Design VIII	Career Exploration Specialist
Design IX	Individual Explorations

EXPLANATION OF DESIGNS

Design I - Which is aimed mainly at the student who has interest in the vocational classes shall involve approximately 20% of the enrollment. This course, carrying credit, shall lead the vocational student to better understand what lies ahead in his desire for vocational training, in the high school, leading toward a life career.

Design II - Will mainly be organizations related to career clusters where by all students in their ninth and tenth grades shall be eligible to belong.

Design III - Is aimed at all ninth and tenth grade students. A required course in social studies, of which one-fifth of the time will be devoted entirely to achieving one's career. This course will carry credit.

Design IV - Career Media Center, is designed for the use of all students 9 - 12. The students shall also have a person they can depend on who will be skilled in disseminating career information to them at the center which will be located in the library.

Design V - Techniques and Success and Career Exploration will be an integrated course which will aid ninth and tenth graders who are interested in developing their own potential through self motivation.

Design IV Tours and Speakers shall cut across all areas, at all times, during the year. There shall be a major emphasis for a three day period. This shall be a highly structured and regimented approach. This is designed mainly because many of the youngsters have not had previous career motivation and career orientation experiences. All ninth and tenth graders shall have the exploration opportunity.

Design VII Is merely an example of how all courses in the high school can involve career exploration. These integrated courses will eventually be developed for all classes through the department chairman.

Design VIII - The Career Exploration Specialist shall be the person who will aide all teachers and students in the implementation of the total program. He shall be responsible to the Career Development Coordinator to facilitate a continuum K-10.

Design IX - Allows students to participate individually, or in small groups of two or three, in exploring a specific job which interests them. Students may learn more about themselves in relation to what is expected of a worker in a given job, and its various natures, education or training, and requirements. This exploration consists of observation, interview, and (if possible) work on the job. Ninth and tenth grade students are better suited for individual exploration which should last a minimum of two or three hours per session.

It is believed that if all designs are implemented, all the ninth and tenth grade students will have optimum opportunities for career exploration.

WARREN CITY SCHOOLS
WORLD OF WORK
GROWTH AND EXPANSION



**WORLD OF WORK K-10
WARREN CITY SCHOOLS**

K-6 - Motivation
7-8 - Orientation
9-10 - Exploration

PROGRAM STRUCTURE: 1972 - 73

On February 1, 1970, the Warren City Schools embarked on a K-6 Career Motivation Program involving four schools including 1,912 students. It was stated that prior to that time the schools had no direct way to convey the world of work to the elementary school youth. It was also stated that because many parents and students lacked the necessary background and knowledge they were not able to offer the needed guidance to set realistic educational goals.

The program had continued funding in 1970 - 71 year with the addition of two elementary schools and one junior high school. This gave a total of 2700 elementary school youth and a new 7-8 program totaling 700 junior high students. The total enrollment in the 1970 - 71 school year was 3400, about 20% of the school population.

In 1971 - 72 an exploration 9 - 10 program was added giving a total of 4700 students or 33% of the school population.

In 1972 - 73 the program was enlarged to eleven elementary, two junior highs and one high school, a population of 8850 or 66% of the total school population.

It is anticipated that there will be 100% implementation by the 1974 - 75 school year.

The Original plan 1/70 thru 1/71

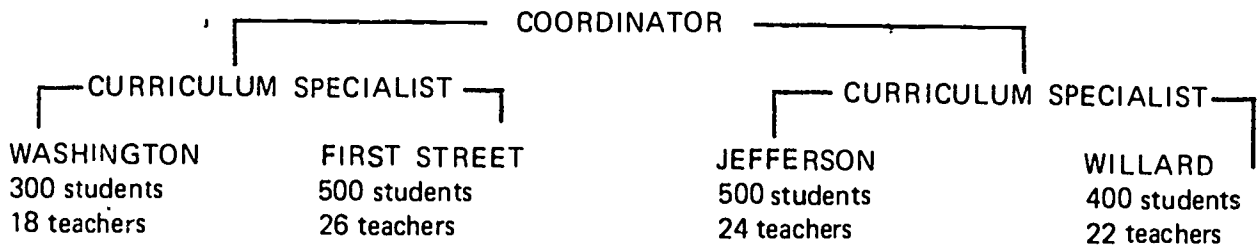

Revised Plan 1/71 thru 6/71

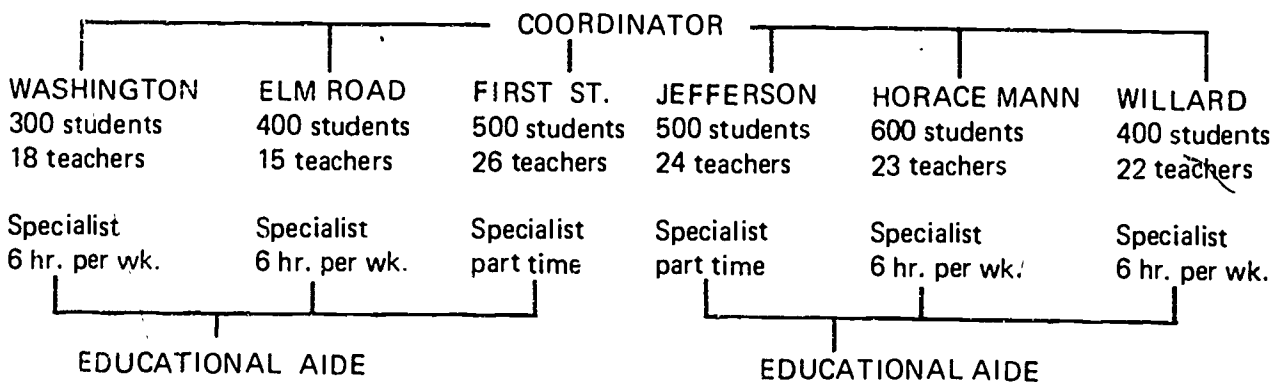

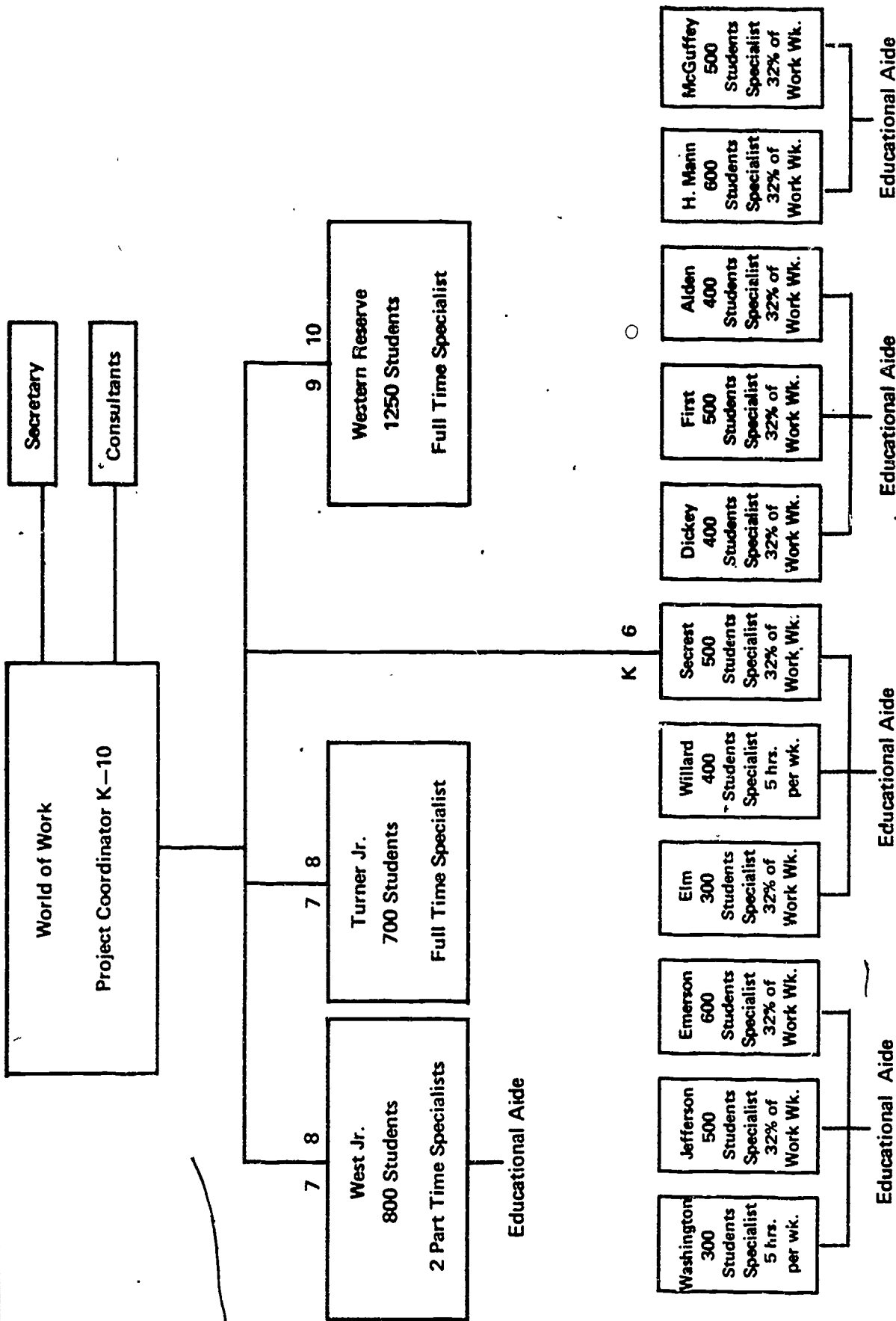

CAREER SPECIALIST

CO-TEACHER

CAREER AIDE



WORLD OF WORK PERSONNEL

Absence Procedure

Career Specialist

1. Call the secretary at World of Work office to notify her of the absence.
2. Arrange for make-up time and inform the secretary of when it will be made up.

Co-Teacher

1. Call the specialist in advance.
2. Have the specialist call the W O W office to report a change in the number of days worked in any given pay period.

Career Aide

1. Call the World of Work office
(especially to secure a substitute for a field trip)

D U T I E S O F T H E C A R E E R S P E C I A L I S T

1. Meet with teachers to discuss their curriculum plans and to help integrate Career Education concepts into the curriculum.
2. Talk to the children to get pulse of Career Education, i.e., in their school related activities.
3. Arrange for speakers and trips: new as well as old, open new possibilities and experiences.
4. Make principal aware of program development in his school and inservice him.
5. Keep the Program Coordinator informed of your plans on all matters by use of Quicki Notes.
6. Prepare forms to facilitate program.
7. Know philosophy of career education.
8. Know long range occupational market.
9. Make occasional surveys for possible field trips-survey pupils too.
10. Evaluate effectiveness of field trips and recommend grade level.
11. Enlist aide of workers and manufactures to give occupational analysis.
12. Secure suggestions relative to acceptability of field trips, speakers and curriculum materials from teacher, principal, community, etc.
13. Search for curriculum materials related to occupations - revise materials to fit grade levels and suggest for purchasing.
14. Collect information about guidance and vocational movement in Career Education.
15. Arrange with principal for adequate office space.
16. Maintain materials catalog, filing system, and professional library in your own school.
17. Check , with principal or at teacher meetings, the progress on evaluation of program. (inservice - periodic & informal)
18. Aid fellow specialists with their work. Meet periodically and combine talents for inservice workshops.
19. Keep parents informed through various means. Speak at PTO meetings, etc.

20. Meet with parents to discuss and make recommendations for improvement and evaluation of program.
21. Help set up policy for program. Be prepared to do same at workshops for specialists.
22. Attend exhibits, and conferences, workshops, and meetings that will aid the program. See coordinator for permission.
23. Keep a log of all happenings with classrooms and teachers. Write anecdotal records of any outstanding or critical occurrences.
24. Arrange through program coordinator for outstanding events to be published in the news releases. Arrange through coordinator for radio programs.
25. Make a year end progress report of the program in assigned schools; the reports could include pictures, etc.
26. Make a periodic report on progress of program. Meet personally with coordinator to revise progress.
27. Give priority to attendance for all called meetings by the program coordinator.
28. Maintain a W O W calendar for all W O W activities.
29. Prepare occupational list which apply to unit of study.
30. Prepare or acquire job descriptions and interpret on elementary level.
31. Prepare or secure occupational briefs to fit student understanding and school instruction.
32. Provide for administration of student and teacher and parent survey tests and questionnaires, with the help of the aide.
33. Prepare relationships of school studies to job requirements.
34. Arrange for parental consent for field trips.
35. Prepare student instruction sheets to show job relationships.
36. Prepare school bulletin boards.
37. Secure special instructional aids such as dummy products - models - charts - etc.
38. Write letters of thanks to all participants or contributions to the program.
39. Assist children in their special questions on occupations.

40. Prepare for certificates to be presented to all program participants with the aide's assistance.
41. Prepare school assemblies as relates to W O W.
42. Select and prepare units of study integrated with grade level subject material.
43. Appoint yearly Advisory groups - suggested turn-over one half (two year term) - teachers, parents, others in community.
44. Be present on and give personal touch on occasional trips - especially a new trip.
45. For public relation purposes, arrange so a member of our W O W staff can speak at civic clubs or other meetings.
46. Serve as a member in civic clubs to participate on educational committee.
47. Publish school newspapers to show Career Education movement.
48. Serve as a member of Curriculum committees.
49. Attend local and other professional meetings to provide Career Education spirit.
50. Join state and institutional vocational, professional organizations.
51. Enroll in, in service courses and workshops and make information on the same available to all of your staff members.
52. Do any other duties as assigned by the W O W coordinator.

CO - TEACHER ARRANGEMENTS

The specialist will receive a memorandum telling the number of designated days for the year and number of designated days per payroll period apportioned for use of a co-teacher.

It is important that the co-teacher will work on the specific days designated by you. It is also important that their days be arranged exactly as planned to fit into the pay period because our reporting to the payroll department must coincide with the plan. If any deviation is used and the co-teacher reports more often in a payroll period than what the agreement called for an error in pay may occur. It is your responsibility to inform the secretary so that such error shall not occur.

It is time consuming for the secretary to call each school each payroll period. If you do not notify us of any change we shall assume there was no change. Keep your principal informed of your use and scheduling of your co-teacher.

Scheduling of Co-teachers (Edited Memo)

Some of our scheduling practices with co-teachers may not be a fair way of doing business with them.

We asked that they be with us on x day given week. The placement office is asked that the co-teacher not be called on that x date for she will be scheduled for World of Work. Then for some reason I change a date for a workshop or you change your date for reasons of your own- then what happens-

the co-teacher loses her chance for a day of work? I know that it does become convenient to ask a co-teacher to change the date for whatever reason, but I hope to be sure that we give her the opportunity to be hired for that particular day for which she was originally scheduled. Therefore, be sure that arrangements are made with the personnel office to make it possible for them to call our co-teachers in the event of another vacancy, enabling for another day of work for them.

There may be days that you feel that you want to be in your classroom instead of the co-teacher. It may be worth it, in the long run to just have the co-teacher being there too. My reasoning may not coincide with yours at all times, I know, but I'm really concerned to keep good co-teacher attitude so that they feel that they are a part of us not apart from us.

C O - T E A C H E R D U T I E S

(Both the principal and co-teacher should have a copy of this)

1. Principal and Specialist shall select the co-teacher.
2. The co-teacher will be contracted for one day a week, the same day each week. Co-teachers shall not be contracted for Mondays or Fridays. Under extenuating circumstances this may be changed by mutual consent of principal and program coordinator.
3. The co-teacher shall share the responsibilities of the classroom. Subjects should be arranged in such a manner to enable the co-teacher's responsibility to be consistent. Procedures for the co-teacher should follow the specialist's pattern in as much as possible. The same format will be expected in the area of discipline.
4. A preferred date for the co-teacher would be on a date that other special teachers are usually in the building. This will enable the specialist to have plans for curriculum with the other teachers in the building who are having planning time.
5. The co-teacher and the specialist shall meet at the end of the assigned day to project what will be taught the following week. Thus, the co-teacher shall be able to plan ahead for that one day class. The specialist should make the arrangements for adequate planning.
6. It is recommended that in the event of absence of the specialist the regularly assigned co-teacher will be contracted for that day or days.
7. In the event of absence on the part of the co-teacher no substitute will be contracted. The co-teacher should notify the specialist and/or the school.
8. The co-teacher's day is the regular teaching day, twenty minutes before and after the in-class time or whatever time schedule followed by the assigned building.
9. If there are art, gym or music classes scheduled for the day the co-teacher will participate only at the request of that special teacher. The released time will be used for additional planning.
10. The specialist shall be held accountable for the grading of students. A conference with the co-teacher concerning student evaluation at the end of the grading period is encouraged.
11. All conferences with parents will be conducted by or through the specialist.

- C
12. Co-teacher should be responsible for any duties assigned to the specialist on the given day.
 13. Co-teachers are encouraged to take part in any school activities that they may desire. This, however, should have the consent of the school principal.
 14. Career specialist's time report to the payroll office should be recorded as ten days (as usual). The co-teacher's time should be recorded by the World of Work office. In the event of absence of the co-teacher notification should be made to the World of Work offices so that co-teachers time will be recorded appropriately.

CAREER SPECIALIST ASSIGNMENTS
TO AIDES

1. The aide must be able to point out important aspects of field trip as directed by specialist.
2. Take an evaluation form on each field trip with a preaddressed envelope.
3. Call central W O W office on bus emergencies.
4. Aides and classroom teachers work cooperatively to maintain discipline on field trips.
5. Take assignment of specific clerical duties relating to W O W as given by specialist.
6. Sign out materials to classroom teachers.
7. Greet, introduce speakers and take their pictures for certificates.
8. Send out one day teaching certificates with pictures attached if possibly with appropriate signatures.
9. Record in ledger any new tours opened, new speakers, and dates trips are taken.
10. Take Specialist supplies when needed.
Packet of materials containing:
envelopes
stationery
forms (all forms within)
11. Aide to assist with special projects in the school as needed.
12. Aide should do all errands for the specialist.
13. Specialist and aide are to meet together to discuss upcoming events.
14. Aide keeps "hold dates" for field trips to help facilitate trip arrangements.
15. Aides will bring identifying badges to put on pupils.
16. If any safety devices are needed, aide will have it at the school.

POLICIES AND MEMOS



WORLD OF WORK POLICIES

The following is a running account of memorandums that in effect establish certain policies in the career education department to make it run a little smoother. They should each be self explanatory and should be kept current by adding the new W O W office memos to them.

1. Film Processing And Purchases From Teachout's

All film processing can be delivered by you to Teachouts. However; all pickup of processed film and purchases shall be made by the designated aide, secretary, or coordinator. Mr. Teachout or the clerk shall not acknowledge any billing or pickup for film processed by any other than the three designated persons.

Remember, you may deliver but you may not pickup, for all items must be varified by the secretary for proper receiving procedure.

2. Time At Center

We do receive much materials in our office, some have been purchased and other laying around for preview. We also have many catalogues with recommended materials marked for order. Also, there may be many ideas in our brains, but they do not get out because our brains aren't picked enough. Therefore I would like for all of you to spend at least one hour per week at the office so that we can get involved with the aforementioned reasons.

3. Focus Center

Whenever possible, please service your teachers even though they may be scheduled at the Focus Center. The teacher should call on you for aide in scheduling trips and speakers. Please help us with this. We will probably run into a few snags this way, but I'm sure it will be best for all concerned being that you know some of the history of trips and speakers. The only difference should be that you are scheduling for the speaker or the trip to originate at the Focus Center rather than your school.

If you run into any problems this way, please keep me posted so that I may send aid to you in some way-shape-or-form.

4. Speakers-Visits

There must be a way that we can help prevent repeated use of certain occupations. I tend to think that the smaller the child the smaller the area of involvement.

If a child is to see a zoo, then show him a small one, so that he shall not be overwhelmed. If he is to see a store, show him one that is more to his level or, one department in a department store: could be a toy department and its workers! As the child grows so should the area of involvement, SIMPLE TO THE COMPLEX.

The same should relate to speakers - adult speakers in the elementary classroom should be those who the elementary student can identify with and those speakers who can help deal with the affective areas. Many students in vocational classes, home economics, industrial arts, high school and college, special interest high school classes; all of these can be used extensively in the elementary classroom.

The Junior High speakers should mainly attract adult speakers with occasional high school student input. (This will probably prevent overlap and encourage dove tailing the areas of interest.) The Junior highs should invite many of those un-heard-of occupations. They should be exploring the back room, back street occupations opening their spectrum of seeing who really gets things together.

The High school then can work with those most sophisticated in the area of work, dealing with the work in a non technical sense.

Does this make sense to you? If it does, try to use it as a gauge when planning for field trips or speakers.

FORMS - GUIDES - SURVEYS



CLASSROOM SPEAKERS GUIDE

Use this guide to aide any classroom speakers who are new to speaking about the world of work. Please give it to the speaker well in advance of the speech and perhaps discuss some of the questions with the speaker. The questions in this guide are prepared mostly for those students at the orientation and exploration levels. For speakers at the motivation level, these questions would have to be altered to include more self and personal types of satisfaction gained and experienced in the speakers work situation. But remember, this is only a form guide to invite inquiry about the speaker's occupation. Know your speaker well enough to decide if a good presentation can be made without a guide.

The page following the guide is a Parent Speakers Survey. It may be used in your own school to acquire new speakers. It is advisable to send some type of personal note with this form to help prompt a good response.

WARREN CITY SCHOOLS

ADMINISTRATION BUILDING
201 MONROE STREET, NORTHWEST
WARREN, OHIO 44482

PROGRAM COORDINATOR
OCCUPATIONAL MOTIVATION
and
CAREER DEVELOPMENT

The following questions are suggested as a guide for preparing your presentation in the Occupational Motivation and Career Development Program.

1. What general and specific training was needed for you to prepare for your present occupation?
 - a. How long?
 - b. What kind?
 - c. Where?
 - d. Approximate cost?
2. Was any apprenticeship program necessary?
3. What is your approximate income in very general terms?
4. Is there an opportunity for advancement?
5. Of all the subjects you studied in school, which ones do you use the most in your job?
6. Have you had to return to school, or receive additional training since you began working?
7. What is a typical day like in your present job?
8. What rules and regulations do you have to follow as an employee?
9. To whom are you responsible?
10. How does the profit motive influence you in your job?
11. Do you work regular hours, overtime, regular vacations?
12. What safety and health regulations do you have to follow?
13. Do you need any special clothing?
14. Are you represented by any labor union or association?
15. How important is your personal appearance in your job?
16. Have you made a major change in your occupation since you first entered the job market on a full-time basis? If so, why?

WARREN CITY SCHOOLS
WORLD OF WORK K-10 CONTINUUM

PARENT SPEAKERS SURVEY

PLEASE PRINT

STUDENTS NAME: _____
Last First

SCHOOL: _____

FATHER'S EMPLOYER: _____

MOTHER'S EMPLOYER: _____

TYPE OF WORK: _____

WAS ADDITIONAL TRAINING NEEDED FOR YOUR OCCUPATION? Yes _____ No _____

WHAT KIND? _____

If requested would you like to talk to the classes about the things you do at work?

Father Yes _____ No _____
Mother Yes _____ No _____

Have you discussed your employment with your children concerning skills required, training required, what education you need to improve your position etc. If not will you?

Do you think your place of employment would allow classes to visit?

Yes _____ No _____

If so, would you first contact us, so that we can work together to make the necessary arrangements?

Yes _____ No _____

Additional comments may be made on back of page.

For additional information call Career Development office – 841-2260

ONE DAY TEACHING CERTIFICATE

This is an award or piece of recognition given to any person who has spoken to a class about the World of Work. On the day the speech is given the career aide-should be notified so that a picture can be taken of the speaker. The aide will return this picture to you in a frame that also has room for this certificate. You are to give this framed certificate and picture to the speaker as soon as possible. For those speakers that come to many different schools during the year, you will not need to give the award. Ask your career aide if in doubt. Keep a list of all speakers at your school and also which ones have been given an award by you. There are many different occasions when we can use this list.

Occupational Motivation and Career Development

One-Day Teaching Certificate

This is to Certify that

*has performed commendably in teaching
children about the World of Work as*

WARREN CITY SCHOOLS

Superintendent

Program Coordinator

Supervisor, Vocational Education

Curriculum Specialist

QUICKI NOTES

Quicki Notes are a connector between the career specialist and the teacher. Quicki Notes are used to confirm any action relative to recommendations, trips, materials, suggestions, etc. They are also a record for your files of the happenings in your building. Instead of using the phone for all communications with the coordinator, these may also be used. Give the white copy to the person receiving message, send yellow copy to W O W office so coordinator has an ongoing idea of what is happening in your school. Keep pink copy for your files.

QUICKI - NOTE		CAREER EDUCATION WARREN CITY SCHOOLS
WORLD OF WORK		
CAREER SPECIALIST	Date	
TO: _____		

LONG DISTANCE TOLL CALLS

The career specialist is to complete this form after each long distance call and send it to the W O W secretary. All long distance calls should be charged to the main W O W phone: 841-2260.

**WARREN CITY SCHOOLS
LONG DISTANCE TOLL CALLS
841-2321**

CITY CALLED	NUMBER CALLED	DATE	AMOUNT
		/	

Person or Company Called

Placed By

School

Dept. To Be Charged

Remarks

Business Personal

TRAVEL EXPENSE REPORT FORMS

The following five pages are policies and forms used for reimbursement of travel expenses. The first two pages are memorandums concerning the required insurance to use your automobile for school business. The third page is a travel chart to be used when figuring the distance between school buildings. The fourth page is the Expense Report form. It is to be filled out in duplicate. The fifth page in this series is a log sheet from which total mileage is computed to be entered on the previous Expense Report form. Both these forms (two copies of Expense Report form and one of the Monthly Travel Report Log) are to be turned in at the end of each month in order to receive reimbursement of your expenses.

WARREN CITY SCHOOLS

ADMINISTRATION BUILDING
261 MONROE STREET, NORTHWEST
WARREN, OHIO, 44142

BOARD OF EDUCATION

WARREN CITY SCHOOL DISTRICT

OFFICE OF CLERK-TREASURER

January 31, 1973

MEMORANDUM

To: All Employees Completing or Signing EXPENSE REPORTS

From: Floyd E. Frederick

Re: REVISED EXPENSE REPORT FORM

The Expense Report Form that has been used when submitting a request for reimbursement of expenses and/or mileage for professional trips, etc. is now OBSOLETE. Destroy all forms that you now have on file. You will be mailed a supply of the new forms (see attached sample) by inter-office mail within the next few days. Please secure these from your school or dept. secretary.

The change in this form is the addition of the following clause, in accordance with action taken at the December 12, 1972 Board meeting:

"I hereby certify that minimum insurance coverage was in force on the vehicles used on school business, in the amount of \$12,500/25,000 Public Liability, \$7,500 Property Damage, during the time period when such auto mileage was incurred."

All employees must now comply with the above clause when submitting a request for mileage reimbursement. A copy of Mr. Mills' memorandum explaining this action is attached. PLEASE POST this information on your bulletin board and announce same at your next staff meeting.

After February 15, failure to use the new expense form will result in your form being returned to you for completion on the new form, thus delaying your reimbursement payment. NO PAYMENT WILL BE MADE ON THE OLD FORM AFTER FEBRUARY 15.

Your cooperation in this change-over will be greatly appreciated.

FEF:dmb
Attach.

(TO REPLENISH YOUR SUPPLY IN THE FUTURE, CONTACT ANTHIE TSAGARIS, EXT. 360.)

WARREN CITY SCHOOLS

ADMINISTRATION BUILDING
261 MONROE STREET, NORTHWEST
P.O. BOX 391
WARREN, OHIO 44482

MEMORANDUM

TO: Administrative Staff (PLEASE POST)

FROM: Director, Administrative Services

DATE: January 22, 1973.

RE: REQUIRED AUTOMOBILE INSURANCE FOR COLLECTION OF MILEAGE REIMBURSEMENT

Effective December 27, 1972, employees non-ownership liability coverage was incorporated into the Board of Education fleet insurance policy.

Simply stated, this means that employees who use their personal automobiles on school business will benefit from having the Board of Education policy supplement their personal motor vehicle policy in the event of a major accident.

As a condition of obtaining such coverage, personal motor vehicle insurance in the amount of the State of Ohio required minimum must be carried on the vehicle used at the time the vehicle is used on school business. This minimum coverage is as follows:

Public Liability: \$12,500.00 per Person, \$25,000.00 per Occurrence

Property Damage: \$ 7,500.00 per Occurrence

As of this date, all employees who file for mileage reimbursement will be required to certify that such coverage was in effect at the time the mileage was driven as a condition of reimbursement. The "Expense Report" form is being modified to include this statement, and revised forms will be distributed in the near future.

Please caution all employees not to reduce their personal coverage as a result of receiving the non-ownership coverage described above. The primary coverage will still be that carried by the employee.

DEI:mh

A. Travel Chart

	Board	Secrest	Alden	Fern	Willard	Washington	Tod	Roosevelt	McKinley	McGuffey	Lincoln	Laird	Jefferson	Hann	Garfield	First	Emerson	Wm	Dickey	Doven	Market	West	East	Turner	
W.H.	1.0	3.0	3.5	6.5	2.8	3.7	2.2	1.4	0.5	4.3	1.0	1.4	3.3	3.1	1.0	2.3	2.6	0.5	2.6	2.6	0.8	3.1	1.3	1.6	3.1
Service	2.2	1.6	0.0	7.7	4.4	5.3	1.3	2.0	3.3	3.7	4.5	3.5	2.0	1.0	4.6	1.7	2.3	2.6	1.2	4.7	2.3	1.0	3.5	3.5	3.5
Turner	1.1	2.2	3.5	8.1	4.2	5.1	1.3	0.2	1.2	2.9	2.5	2.7	2.6	2.5	3.1	2.5	1.7	1.6	1.6	4.0	1.9	2.4	2.6		
st	1.7	5.5	3.5	7.8	1.5	2.4	1.9	2.9	1.1	5.0	1.6	0.3	4.1	2.7	1.1	3.1	3.3	1.4	3.1	1.3	1.0	2.9			
West	2.1	2.2	1.0	9.6	3.5	4.4	1.2	2.5	3.6	3.7	4.3	2.6	1.0	0.1	4.4	0.7	2.0	2.7	0.9	3.8	1.9				
Market	0.9	2.9	2.3	7.3	2.1	3.0	1.3	1.7	1.1	4.6	2.0	0.3	3.4	1.9	1.5	2.4	2.9	0.4	1.9	2.0					
Evon	2.9	4.9	4.7	9.2	1.0	1.7	3.1	3.8	2.3	6.4	1.7	1.5	4.1	3.5	0.9	3.5	4.7	2.3	3.7						
Dickey	1.8	2.1	1.2	9.1	3.9	4.3	0.6	1.9	2.7	2.9	3.3	3.0	1.9	0.5	3.9	1.6	1.2	2.0							
Wm	0.6	3.2	2.2	7.0	2.5	3.4	1.7	1.4	0.7	4.2	1.7	1.3	2.5	2.3	1.9	1.6	2.5								
Emerson	1.9	1.1	2.5	9.1	4.4	5.3	1.6	1.5	2.7	1.7	3.3	3.4	3.0	1.5	3.9	2.5									
First	1.5	2.9	1.7	8.6	3.3	4.2	0.7	1.8	2.6	4.2	4.5	2.9	1.0	0.6	4.0										
Garf.	2.6	4.4	4.2	8.1	1.2	2.1	3.5	3.0	1.5	5.6	0.6	1.3	5.0	4.5											
Hann	2.1	2.2	1.0	9.6	3.6	4.5	1.3	2.7	3.7	3.5	4.1	2.5	1.0												
ff.	2.5	3.5	2.0	9.6	4.3	5.2	0.9	2.3	3.6	4.7	5.5	3.9													
Laird	1.8	3.7	3.5	7.9	1.3	1.3	2.0	2.3	1.2	5.1	1.8														
Lincoln	2.0	4.9	4.5	5.5	1.6	2.7	3.9	2.4	0.9	5.0															
McG.	3.6	2.0	3.7	11.2	6.1	7.0	3.3	3.6	4.4																
W.K.	1.3	4.0	5.5	5.2	2.0	3.5	2.4	1.5																	
Hops.	1.2	2.4	3.8	7.9	4.0	4.9	1.5																		
Tod	1.2	2.1	1.2	8.7	2.7	3.5																			
Wash.	3.7	6.6	5.3	10.2	1.3																				
Willard	2.8	5.0	4.4	3.3																					
Fern	7.5	10.5	7.7																						
Alden	2.2	1.7																							
Secrest	3.0																								

WARREN CITY SCHOOLS
Warren, Ohio
EXPENSE REPORT

NAME _____ Period _____, 19

SCHOOL OR DEPT. _____ To _____, 19

TRANSPORTATION FROM WARREN TO _____

PURPOSE _____

RAIL OR AIR FARE \$ _____

AUTO MILEAGE - Total Miles _____ @ \$0.10 per mile *

TAXI - BUS FARE - PARKING _____

HOTEL ROOM _____

MEALS _____

MISCELLANEOUS (Itemize) _____

The above expenses were incurred in connection with Warren City School business. Total Reimbursable Expenses \$ _____

*I hereby certify that minimum insurance coverage was in force on the vehicles used on school business, in the amount of \$12,500/25,000 Public Liability, \$7,500 Property Damage, during the time period when such auto mileage was incurred.

THIS FORM MUST BE COMPLETED IN INK OR TYPEWRITTEN AND MUST BE COMPLETE.

Employee's Signature Date Signed

FUND	ACCOUNT CODE

Approval for Payment Date Approved
Employee's Supervisor

State Department of Education
 DIVISION OF VOCATIONAL EDUCATION
 Columbus, Ohio 43215

(1) One copy to be sent to Director of Vocational Education by 5th of the following month.

MONTHLY TRAVEL REPORT
 Directors or Approved Vocational Guidance Counselor

Name _____

City _____ (2) School _____ (3) Month _____ (4) 19__

DATE (5)	PERSONS OR PLACES VISITED (6)	MILEAGE (7)	TOTAL FOR DAY (8)

DATE	PERSONS OR PLACES VISITED	MILEAGE	TOTAL FOR DAY
(5)	(6)	(7)	(8)

(9) Mileage Total for Month _____
 _____ per mile (12) Mileage Cost

(10) Signature _____ (11) Mileage _____
 (Supervisor or Counselor)

(12) Signature _____
 (Superintendent or Authorized Representative)

Approved by _____ Date _____
 (Director, Vocational Education)



F I E L D T R I P S A N D
F I E L D E X P E R I E N C E S

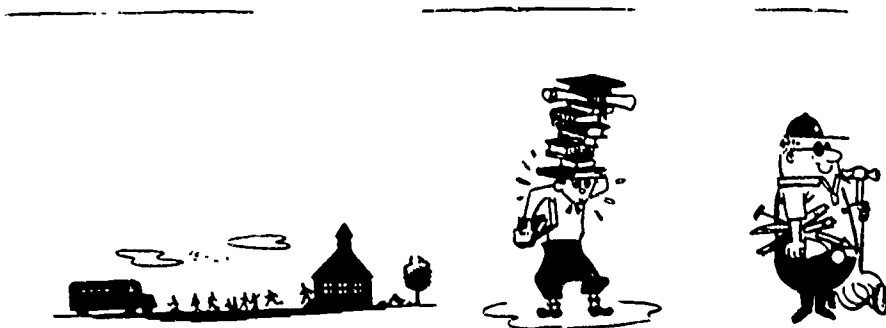

FIELD TRIP POLICIES

The following section is a composite of the policies used by the Department of Career Education that help maintain and better our relationship with those places we visit for field trips.

1. Each Career Specialist will have on file a list of those Specialists assigned certain field trip places for the purpose of making or scheduling trips to that place. Having one familiar face or voice contact them helps to maintain a good and consistent relationship with whomever we are wanting to visit.
2. When we take tours, particularly to large plants, some of the students may have parents, guardians, etc., working at the plant. Please get information on these people, like where they work, the jobs they do, the plant number, and the time shift. If the child's relative is not working during the time of the visit, it may be appropriate for that parent to visit during any speaking engagement given by the plant management. It might also be advisable to have the parent participate in the classroom studies related to the work being done at the plant. The parent may also want to attend the tour. You could provide a special recognition button or armband stating, "My parent works here." These and many other possibilities could be worked out to help the plant, parent, and student.
3. A list of tour places should be in your files and should be kept current. Update information such as new contact people at that place, or a certain specialist only should contact them, or if visitations during certain time only etc.
4. Book field trips two or more weeks in advance.
5. Write a confirming letter - short and to the point - To the speaker or place of visitation.
6. Expose classes to as many occupations possible. It is important to keep a record of the class, giving more opportunities, rather than a repeat of the same type occupations at different tour locations.
7. Factory type tours will be limited to 5th and 6th grade. Sixth grade preferred. (such as Amweld, Packard, GM) Safety devices are to be secured by students who take these trips.
8. Look-See Tours (bus type in the downtown area) should be limited to the 5th grade. Walking type in own school neighborhood can be used for lower grades.

9. All trips should be scheduled on Tuesday, Wednesday or Thursday. Trips on Monday and Friday will need the Coordinators approval.
10. Visit the office once a week to keep posted on the calendar and to confirm buses. Fill in spaces which indicate number of students.
11. Keep running account of all happenings in the world of work good and bad. This will help facilitate year end report.
12. Check with ledger to see when speaker or tour was used last. It would be best to space trips, or speakers, at least two weeks between engagements. If you think you must book sooner, discuss it with the Coordinator.
13. Please give to each speaker and each tour representative an evaluation form, accompanied with an addressed envelope to the Career Specialist.
14. Distribute trips thru-out the year, early trips are advisable - May is a bad month for scheduling. Most schools in the Trumbull area are using buses.
15. Discourage teachers from making their own contact. It is a duty of the specialist.
16. Counsel teachers for preplanning - help teachers order materials from catalog and bring other material for their use.
17. Identify student with a badge or armband showing that he represents World of Work. The aide will bring the same to the school.
18. Use parents on trips.
19. Mention appropriate dress to students and teachers.

EXPLANATION OF FORM:

Application For Field Trips

This application form offers the career specialist a vehicle to use for individually inservicing a teacher for concept building about the World of Work. Please aide the teacher in filling out the purpose and correlating part of this form by using the appropriate information given in the W O W Framework Outline. If they have listed a narrow concept you may help them broaden and expand it. The behavioral outcome can be checked when they fill out the evaluation form. A supply of these forms should be on hand to be filled out in triplicate. As each item is confirmed or approved it should be checked off. Before trip is taken one form is sent to coordinator- one to principal- one kept by specialist. All items should be checked off before trip is taken.

Use the following procedure for this form:

1. Receive the request from your teacher and have teacher fill out application information.
2. Check with coordinator for permission - check off.
3. Check with principal for permission and explain what the teacher has been doing relating to the field trip and possibly explain intentions for further pre and post activities.
4. Check with career aide and get a hold date for the trip.
5. You, the career spècialist, make the contact to the place (unless another specialist has been assigned the contact responsibility for any given place) to get date and time - check off date, times, and career specialist.

6. Check back with career aide to confirm all times and date and have the secretary secure a bus for that date and time - check off aide.
7. Have teacher get needed permission from parents by use of parental consent form. Each school is to use the standard form used by that school. The W O W office does not supply these forms. *
8. Information regarding number of students, teachers, and parents was to be filled out initially by the teacher and such information is used by the specialist when contacting the place to be visited and form bus size information.

WORLD OF WORK
APPLICATION
FOR
WORLD OF WORK FIELD TRIPS
WARREN CITY SCHOOLS

NAME _____ SCHOOL _____ GRADE _____

DESTINATION _____

PURPOSE OF TRIP; HOW DOES THIS TRIP CORRELATE WITH THE WORLD OF WORK PROGRAM?

CHECK OFF

_____ Date of Trip _____

_____ Time of Departure _____

_____ Time of Return _____

_____ Number of Students _____

_____ Number of Parents _____

_____ Number of Teachers _____

_____ Parental Consent

_____ Principal

_____ Career Aide _____

_____ Career Specialist _____

_____ Coordinator, World of Work

MAZ:cm

EXPLANATION OF FORM:

Field Trip Evaluation

After the trip has been completed, give this evaluation form to the teacher and have the teacher fill it out and return it to the career specialist. The teacher new to W O W trips could be shown this form even before the trip. You could discuss all items on it and in effect show the teacher a good trip procedure to follow. As with any good evaluation form it only questions those types of things relevant to the situation: pre and post activities, highlights, educational objective, concept relationship etc.

The career specialist can ask questions about different parts on the form to check for increasing teacher understanding:

Educational objective- does their objective change from application form, did they get new insights?

Post trip activities- does this relate to many areas or only to work activity?

Highlights- are they as teachers, getting a deeper understanding of the trips?

Post trip- if this grows, the teachers really show they have learned a lot and can do something with it!

Specifically how...- if this area on the form is not changing or improving they are status quo.

WORLD OF WORK

FIELD TRIP EVALUATION FORM

WARREN CITY SCHOOLS

School _____ Date of trip _____

Teacher _____ Grade _____

Educational Objective of trip _____

List the important pre-trip activities _____

List some highlights of the trip _____

List the important post-trip activities _____

Specifically how do you feel this trip has helped the children better understand about people and their work, and how did the World of Work concept relate to your regular teaching assignment.

Would you recommend this trip for others? _____ If not why? _____

Other comments: _____

(Use back if necessary)

MAZ:cm

EXPLANATION OF FORM:

Tour Evaluation

The aide is responsible for seeing that the following evaluation form is presented to the place of business, firm, etc., on the same date of the field trip. The aide will fill in the date, grade (with teachers name), and school before giving it to the place of business. A self addressed stamped envelope accompanies this form which is addressed to the specialist. The specialist should share the evaluation with the teacher and discuss all areas on the form particularly those that the teacher can help to further improve by classroom preparation. The specialist will forward the same to the coordinator after viewing.

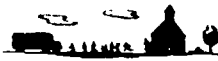

WARREN CITY SCHOOLS

Box 391
WARREN, OHIO 44482



CAREER EDUCATION
Michael A. Zuckie, Program Coordinator
WORLD OF WORK
K-10 Continuum

WORLD OF WORK Kindergarten thru Grade 10 EVALUATION OF TOURS

DATE _____

GRADE _____

SCHOOL _____

Very Good	Good	Average	Below Average	Poor	Does Not Apply
-----------	------	---------	---------------	------	----------------

1. Do you feel that the students gave you their undivided attention? _____
2. Do you feel that they were well prepared? _____
3. Do you feel that the students were properly supervised? _____
4. What were the feelings of the workers towards the visitation and the pupils? _____
5. Was the trip planned well enough to emphasize the worker rather than the machine, product or service? _____
6. Does this trip take up too much of your time?
Yes _____ No _____
7. Would you give suggestions as to how we can improve in the preplanning stages for the trip?

8. Do you have any additional comments concerning our program?

(Use reverse side for additional remarks your suggestions are our quicklines for improvements.)

Rev 12 1 72
Form 2

Signed _____

Position _____

Place of Tour _____

THE LOOK SEE TRIP

Let's Bring These Trips
Out of Extinction!

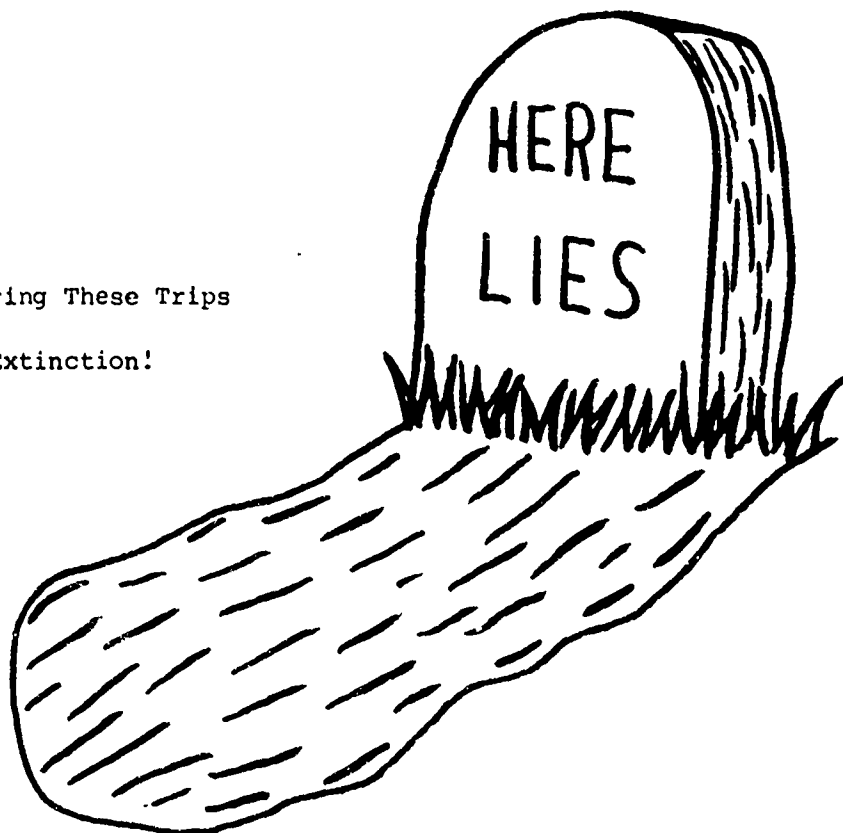

Following is a trip design that can be used as is or adapted for use to any look see tour.

WORLD OF WORK CAREER MOTIVATION K-6

A LOOK – SEE THINK – AND – TELL FIELD TRIP

This trip is designed to build an awareness of the many interdependent occupations that make up the community. The trip will take place in a ten block stretch starting at Trumbull Memorial Hospital and ending at Jim Nickel's Motors. The object is to observe the many establishments and try to presume what occupations relate to the establishments.

The trip will involve approximately ten stops, ten minutes each. An example of what will be done in the ten minute stops is as follows.

Let's say that we will park the bus at a given point just west of Laird Avenue, at Market Street. The observers will, in teams of four, one will be a recorder, try to presume the occupations, let's say, in the Hospital. They will be, secretly within the group, relating all of the presumed occupations to the recorder. The list can be as follows:

Doctors	Inhalation therapist
Nurses	Social service workers
Orderly	Lab technician
Nurse's aid	X-ray technician
Head Administrator	Medical technologist
Hospital education workers	Pathologist
Controllers	Interns
Business office workers	Medical librarian
Insurance	Personnel director
Data Processing	Pediatrician
Purchasing	Obstetrics
Store clerks	Maintenance workers
Medical record keepers	Dietitian
Pharmacists	Dietary workers
Physical therapists	Housekeeping workers
Laundry workers	Admitting clerks
Information receptionist	Mail clerks
Security guards	Volunteer workers

It can really be said that the hospital is often known as a "city within a city."

The student observers will see construction taking place on the southwest corner and will list the trades persons and laborers or deliveries to the site. On the northeast corner is a pharmacy which could list a sales clerk and pharmacist (this could have been listed as a hospital worker previously.) A church is located on the northwest corner. A minister, custodians and secretary may be working there.

This type of relating will continue on the entire trip. A more astute observer will notice the many traveling occupations on the Market Street and streets running perpendicular to it.

City workers, policemen, firemen, deputies, Brinks guards etc. also may be observe.

Upon their return the pupils, in teams, will place all the occupations in alphabetical order to help avoid duplication. The occupations will be numbered. There will be a competition to see which group had the greatest number of occupations represented.

The teacher and occupation curriculum specialists shall also develop a list which may point out the many occupations that were not observed or presumed at the observation stops. The teacher and students may want to make a "giant" list of all the occupations noticed on the Look - See - Think and - Tell Trip.

A preview to the trip may be the use of a telephone book page giving examples of all the occupations in the city. Let's take for example page 73 of the Warren United Telephone Company phone book Dairy product workers, dancing instructors and businesses, data processing workers, computer programmers, key punch operators, card punchers.

A follow up activity might be to list the occupations into the nine following categories.

1. Professional, technical and managerial
2. Clerical and Sales
3. Service
4. Farming, fishery, forestry and related
5. Processing
6. Machine trades
7. Bench work
8. Structural work
9. Miscellaneous

Another follow up activity we suggest is to depict the hospital as a city within a city and draw analysis as to why this must be so. Point out the immobility of the patients and therefore the city must come to them.

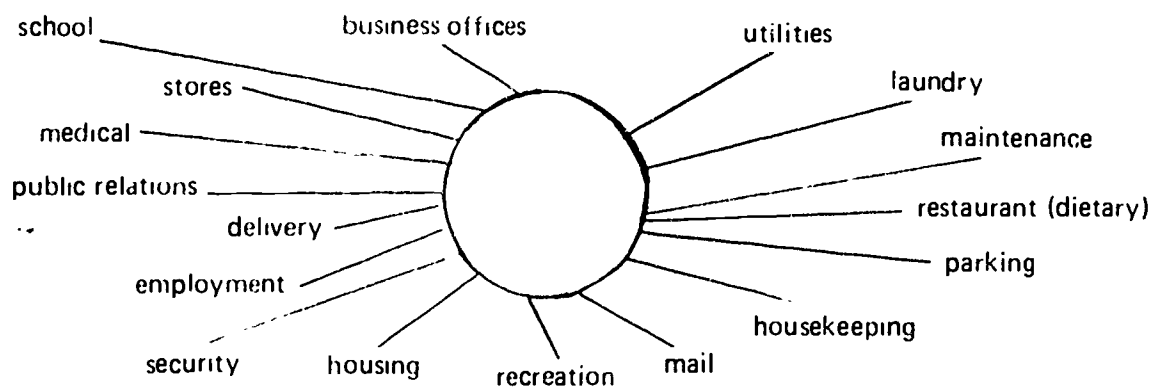

E X P L A N A T I O N O F F O R M :

Bus Orders For Field Trips

Please use this form to keep track of the dates, times, costs, etc. of all trips from your school. If you post the information for each trip when you make the arrangements, you will have an up to date record of the amount spent from your budget and a record of which teachers and students have gone where. This is the same form used at the World of Work office to keep track of the same information. When you need the exact costs of the trip please check the office copy.

WARREN CITY SCHOOLS

ADMINISTRATION BUILDING

261 MONROE STREET, NORTHWEST

391

1182

This will be the procedure by which you will know your allocation for trips. Pay special attention to bus costs. Many more trips can be taken by using school instead of private buses.

MEMORANDUM

To: Elementary Career Specialists
From: Mike Zockle
Re: BUDGET ALLOCATIONS - FIELD TRIPS

SCHOOL ALDEN AMOUNT \$450.00

During the 1973-74 school year your field trips will be budgeted as to the size of the staff in your building. You shall be allocated a budget specifically for tours. You can use your discretion as to how and when the tours will be taken. It is advised that the tours be dispersed thru-out the school year for it is difficult to book buses late in the year. I believe that greater advantage can be derived from early planned field trips. I would strongly urge that all trips be taken by April 30. I would also encourage in-town travel as much as possible. Your aim should be more field trips for your money.

Here are a few examples of costs:

Warren Suburban	Any in-town	\$45.00
"	Cleveland	\$105.00
"	Sewage Treatment	\$45.00
School Bus	Sewage Treatment	\$10.00
"	Library	\$10.00
"	Middlefield	\$25.00

You may check on specific costs from Carrie before booking a tour.

It will be your responsibility to convince your staff that the tour is supposed to bring to them W.O.W. concepts and that it would be of advantage to take less expensive trips, for the objective is the concept and not where the trips takes you.

It is urged that other school funds be used whenever convenient. We probably can interweave W.O.W. concepts within other program structures.

MAZ:cm

SUGGESTIONS FOR FIELD TRIPS

WORLD OF WORK K-10 CONTINUUM

Too often a teacher is expected to "know" and the students are expected to learn what the teacher "knows." As a result of this thinking, often teachers of teachers develop their presentations around this idea. They expect teachers, who may have a limited background in a specific area of knowledge, to learn from a lecture type presentation what the expert himself has learned from extensive experience in that field. How many times have each of us sat in a college classroom or at a conference and listened to someone who tried to teach us by using only words. The teacher must communicate with the learner - and that is a TWO WAY street.

Many of you are experts in various special areas, e.g., Elementary Education, mathematics, sports, etc. How many times have you been asked to work with a group for the purpose of teaching them something of what you know? How successful you were, depended, by a large degree, on the amount of participation by the learners.

It is our hope, then, that in the following outline we can give you some ideas of how you can make a field trip more successful.

A field trip should contribute something definite and worthwhile that could not be obtained in the classroom.

Purposes to be accomplished through visits:

1. Having youngsters develop an awareness of the many different workers in their community.
2. Helping them observe working conditions.
3. Helping them develop an awareness of the interdependence of workers.

PRINCIPLES OF GOOD LEARNING SITUATIONS:

Principle 1: Find out what the learner knows about the field trip topic.

Have the student:

Write down the purpose of a (print shop) in your own words.

(factory)

(office)

(etc.)

Write down several things that you think you will see, hear, smell, taste, or feel during the trip.

Write down several things that will be going on when you are there.

Principle 2: Find out the learner's purpose for going on the field trip. Find out what the learner wants to learn as a result of the field trip.

From the student:

What is your purpose?

What specific knowledge or skill are you seeking?

Principle 3: Include the learners in the planning.

Length of time, chance to ask questions, chance to do or participate, include the "expert" in the planning by letting him know what you want.

Principle 4: Utilize the traveling time for learning activities.

For the Teacher:

What questions could you ask, even though you have not been over the route, that can be appropriate during the particular trip?

Example: Observe different work situations to and from, during the trip.

Principle 5: Utilize the knowledge and skills gained in post trip activities.

Examples of activities to be carried out.

You may see then, that the teaching-learning process has some basic principles that must be understood by teachers. Each time you assume the teacher's role, in field trips, you must not guess, but you must know:

1. the knowledge and skills of the learner
2. the learner's purposes
3. the learner's need to participate in planning the learning activities and
4. the ways to use and evaluate the newly acquired knowledge and skills.

Follow Up:

1. What kind of workers did you see on the trip?
2. What do these workers do each day?
3. What kind of training do these workers need?

Evaluate the trip to see if the trip created more interest in Occupational Motivation and Career Development.

One final point. An educator's most important job is to produce a self-propelling learning. The learner must be an active, participating, alive member of the teaching - learning team, not a passive receiver of information.

We hope that field trips will have more meaning for you, as either a teacher or learner and that they will be just a little more interesting and adventurous.

REFERENCE



SUGGESTED FILING SYSTEM

All career specialists receive about the same types of material: memorandums, forms, guides, units of study, etc. It would be nice if we all had a consistent filing system in which all these scads of materials were filed. The career aides would also appreciate such a system when looking for such things as tour evaluation forms, class lists, etc. The following is suggested as a starter. You might then break some of the broad headings down to sub divide within the main system.

1. Career World Magazine
2. Catalogs - materials and supplies ordered & to be ordered.
3. Class lists
4. Correspondence
5. Equipment - inventory in building and available from W O W office.
6. Expense report forms
7. Field trips - lists, forms, procedures, contact people
8. Films (movie) available from W O W office
9. Forms and guidelines
10. Industrial resource material
11. Inservice - ideas for, record of the staff
12. Memorandums, bulletins, minutes from meetings
13. New releases
14. Projects - record of
15. Quicki notes (specialists pink copy) & copies of memo to staff
16. Receipts
17. Reference
18. Reports & evaluations
19. Speakers - lists, forms
20. Units of Study - behavioral science games
21. Workshops - personal trips taken for W O W or inservicing

Under Separate Drawer

1. AV catalog, current addendums
2. Letterhead, stationery, envelopes
3. Posters, bulletin board material
4. Photographs, slides, negatives, film, bulbs. camera
5. Quicki Notes
6. Career Specialist Manual
7. Curriculum Manual

EQUIPMENT AVAILABLE
FROM THE WORLD OF WORK OFFICE

The following is a list of equipment in the W O W office that may be checked out by any career specialist or teacher to aide in any projects or activities in their schools. This list will grow and should be kept current as new equipment is purchased. Please feel free to add any descriptions that will aide you in becoming familiar with the possible uses of said equipment.

1. Electronic Calculator
2. Embosograf
3. Filmosound Projector
4. Casette Player-Recorder
5. Video Camera/Player/Monitor
6. Camera for Still Pictures
7. Moustache Curler

WORLD OF WORK
MOTION PICTURE FILMS

The following is a list of motion picture films purchased by the World of Work and available to all teachers for classroom use. This list is growing one and must be periodically updated. They have not been listed categorically because of being at present time so few in number. This list is made as a quick reference by title only since each career specialist should be familiar with each film by preview, teacher usage or by a fellow specialist's recommendation. Please keep it current by adding any new films purchased. Eventually this list will be broken down and organized as needed.

CAREERS IN EDUCATION

HOPSCOTCH

GUIDANCE FOR THE SEVENTIES KIDS, PARENTS, AND PRESSURES

SCHOOL REPORT

PEOPLE WHO FIX THINGS

GUIDANCE FOR THE 70's SELF ESTEEM

ALTERNATIVE

UP IS DOWN

ESPOLIO

MORNING AIRPORT

APPLYING FOR A JOB

NIGHT PEOPLE'S DAY

COMMUNITY SERVICES

COMMUNITY TELEVISION

THE VETERINARIAN SERVES THE COMMUNITY

TRANSPORATION MAINTENANCE

WHAT WILL THE WEATHER BE

HOURS AHEAD

BALL GAME

BIRDS OF A FEATHER

MORNING ZOO

IS A CAREER IN THE HOTEL OR MOTEL BUS. FOR YOU?

IS A CAREER IN THE HEALTH SERVICES FOR YOU?

CAREERS IN HEALTH (CAREER EXPLORATION)

MAKING A DIFFERENCE

FIXING BUSINESS

NEW HORIZONS IN VOCATIONS

CAREER IN THE SERVICE INDUSTRIES

FIND YOURSELF, THEN YOUR JOB

CAST METALS

CAREERS: OPPORTUNITIES FOR TRAINING

ENG: SOMETHING MORE THAN TALK

MAKING IT IN THE WORLD OF WORK

NO REASON TO STAY

SHEET METAL TRADES

OPPORTUNITIES IN CLERICAL WORK

SALES AND MERCHANDISING

COSMOTOLOGY

GLASS FOR THE 70'S

STAY IN SCHOOL
JOBS IN AUTO TRADES
NEIGHBORHOOD YOUTH CORP
JOBS IN DRAFTING
IS A CAREER AS A TECHNICIAN FOR YOU
JOBS IN BAKING
OPPORTUNITIES IN MACHINE TRADE
JOBS IN SELLING
GET THERE
SKILLED SERVICES
WORK. W.A.A.
CAREERS TECHNICAL IND.
CHOOSING A JOB
FOOD DISTRIBUTION
WOMEN IN CAREERS
HOTELS AND MOTELS
ARE YOU READY FOR A JOB
SMALL APPLIANCES
JOBS FOR MEN: WHERE AM I GOING
BUSINESS MACHINES
JOBS IN WELDING
JOBS FOR WOMEN: WHERE ARE YOU GOING: VIRGINIA

F R A M E W O R K

This framework represents a pocket sized outline of most everything we do, plan to do, or have done in the World of Work as it relates to instruction received by students in our schools. The sooner and better our teachers and career education personnel understand and are able to use the listed Topic and Concept areas, the closer we have come to the total integration of career education with "regular classroom studies."

Five very good and very broad concept areas have been chosen. These general areas have assurance of being fully developed by use of the more specific topic areas. These more specific topic areas can of course be more fully developed in some concept areas than in others. For this reason, the instructor is directed to develop them to any of three degrees: introduction, development, or emphasis.

For a much better understanding and definition of the topic areas, the specialist is referred to the Career Development Curriculum Guide. This guide gives a definition of the topic area, basic generalizations about daily living and working which pertain to the topic, and objectives and activities for the topic at given grade levels.

Use this framework! It can serve as a guide reference for concepts needed for speakers, field trips, mini grants, material selection, lesson plans, W O W projects, inservice education, etc. Use it!

WARREN CITY
WORLD OF WORK
FRAMEWORK

CONCEPTS

WORLD OF WORK 100% -- I -- D -- E

TOPICS

SELF
&
ENVIRON.

EDUCA.
&
TRAINING

ECONOMICS

EMP. &
WORK ADJ.
SKILLS

DECISION
MAKING

1. Comparative Advantage
2. Competition and Cooperation
3. Compromise, Adjustment, & Interaction
4. Conflict
5. Culture and Institution
6. Habitat and Its Significance
7. The Industrialization-Urbanization Syndrome
8. Input and Output
9. Interdependence
10. Modified Market Economy
11. Morality and Choice
12. Power
13. Saving
14. Scarcity
15. Secularization
16. Social Change & Social Control
17. Sovereignty
18. Dignity
19. Empathy
20. Loyalty
21. Freedom & Equality

The concept areas will have assurance of being fully developed through the use of the vertical topic listings. The Topics will fit better in some subject areas than others.

CODING

- I – Introduce
- D – Develop
- E – Emphasize

(Topics and concepts will have varying levels of development at different levels of instruction and subject

SOME DESIGNS AND MATERIAL USED FOR
IN-SERVICE PROGRAMS FOR TEACHERS



PROPOSAL FOR A WORKSHOP;
TEACHING ELEMENTARY SCHOOL
TEACHERS ABOUT THE
WORLD OF WORK

RATIONALE:

Schools must awaken to a sense of identity with the cause of a community which employs many workers who serve interdependently in planning and action. Direction should be given to a specific aim in life - occupational adequacy, one of the principles of education. Unity in curriculum must grow from multiplicity of educational philosophy to one which is held together by a single purpose through a workshop in teaching the teacher about the world of work as part of the elementary curriculum.

There seems to be a conflict between actual practice and professional theory. Our present philosophy extols education through participation in community life, the winning of insight and direct taking part in the realities of living. But under existing conditions it often seems the part of humanity to protect the youth from too close contact with surrounding realities. For the defense of the young we maintain the school in isolation from life even while we proclaim that isolationism must be broken down. In a society which continuously plans its activity for the common good, we should be able to partly abandon the teaching about animals and Indians and carry out more necessary studies about humans and their work and their relationships to the interdependent society.

A workshop to teach teachers about the world of work as a part of the elementary curriculum should affect the subject matter of elementary school instruction. In spite of all educational endeavors, there are subjects in our schools which remain "aloof" and are pursued in a pedantic spirit. They too often deal with unrealistic content which has no relationship to their actual life experiences. Practical and vocational subjects are often erroneously considered to lack "depth" and "intellectual substance." They are often used for the superficial purpose of enabling individuals to "adjust" themselves externally to a profit-seeking civilization.

In a planning society, the educational method's employed in maintaining and furthering the life of the community should form the natural core of the course of study. The split between academic culture and the vocational must disappear.

PROCEDURE

The workshop proposed shall be conducted on a quarter basis with a total of sixty hours of instruction. Credit shall be given in Vocational, Elementary, or Guidance.

The workshop shall include only those teachers and administrators from the Warren City Schools who are taking part in the Occupational Motivation and Career Development program and must have approval of the Program Coordinator.

The workshop shall be conducted by the Kent State University and will involve the (1) vocational, (2) guidance, (3) elementary education, departments.

Guidance will be arranged cooperatively with the administration of the Warren City Schools.

SCOPE OF THE PROGRAM

The scope shall be as outlined in the table of contents, Occupational Information in the Elementary School by Willa Norris.

1. The importance of occupational information at the elementary school level.
2. The overall program of occupational information.
3. Early elementary school - a study of home and community.
4. Later elementary school - the industry approach.
5. Resource materials
 - A. Books and pamphlets
 - B. Films and strips
 - C. Songs and recordings

Submitted by
Michael A. Zockle, Project Coordinator
World of Work K-10 Continuum

Vocational And Elementary Education Departments To Conduct World Of Work Workshop

The Elementary Education Department and the Vocational Education Department are collaborating with the Warren City Schools for the World of Work workshop on curriculum development and in-service education.

Aims of the program are career development and social-personal development

Ultimate goal of this workshop is a complete plan for kindergarten through sixth grade which will have an impact on the aims of the total career development process in kindergarten through the twelfth grade.

Dr. Curtis Ramsey, chairman of the Elementary Education Department, is coordinating the program, and is assisted by Raymond Jacobs from Vocational Education.

Winter quarter provided twenty-three teachers and principals with a background in educational and occupational information, theories of career development, educational sociology as it relates to career development and many samples of methods and materials.

Dr. Franklin Ingraham of the School of Technology, Dr. Glen Saltzman of

Counseling and Personnel Services Education and Donna Geidel of the Kent City Schools were the main contributors to the winter quarter sessions.

Spring quarter is devoted to building on winter quarter's information, giving stage to produce a workable kindergarten through sixth grade program.

KSU EDUCATION NEWS

Vol. 8 Spring, 1971 No. 2

KSU Education News is published quarterly by the College of Education, Kent State University, Kent, Ohio 44240. Sent without charge to educators, primarily in northeast Ohio, interested in teacher education. Requests to be placed on the mailing list should be addressed to J. K. Varney. Entered as second class mail at the post office in Kent, Ohio.

J. KEITH VARNEY, *Manager*
WILLIAM A. RODGERS, *Editor*
CAROL A. MELLINGER, *Assistant Editor*

Advisory Board
L. A. H. HOUSPR (1971)
RONALD F. KINGSLY (1972)
RAYMOND JACOBS (1973)

WARREN CITY SCHOOLS

WORLD OF WORK

THINK TANK

- The purpose - To get new perspectives in the World of Work
- The method - "Think Tank" sessions will not produce an answer to each issue; rather the sessions provide opportunities for teachers (educators) to view both sides of an issue. Think Tank sessions are not necessarily meetings to extoll one's biases, but rather provide a time to encourage research and substantiate arguments either for or against the issue
- Design One "Think Tank" (two hours) every two weeks. One series shall include five sessions. Maximum participation twenty members. Time of sessions will be 7:00 p.m. at the World of Work office. Pay - \$50.00 for each participant for the series. You must attend the series. Participants may leave the session after two hours of discussion. Those wanting to continue discussion may do so. Payed participants will include no more than two educators from each building enrolled in the World of Work program. (Other interested educators may attend to satisfy their interest without remuneration)

WORLD OF WORK "THINK TANK" SESSIONS

Possible Topics

- 1 It seems quite shocking that white workers earn fifty percent more than black workers. But it is even more disturbing that the best paid fifth of all white workers earns six hundred percent more than the worst paid fifth. Thus, employers should make the wages of the best and worst paid workers equal.
- 2 The American premise of equality of opportunity means that if its people do not want to attend school or college, an egalitarian society ought to accept this as a legitimate decision and give these people subsidized job training.
- 3 In an ecologically balanced system it is necessary to have human predators, which necessitates poverty and welfare.
- 4 Until existing conditions change and new jobs are designed to replace existing ones, one work role is no more important than another, i.e., the doctor's role is no more important than the garbage collector's.
- 5 Quantity and quality of work and attendance in school have very little correlation with quantity and quality of work and attendance on the job. The motivating factor is that the quantity and quality of performance is related to the interest in the task.
- 6 In a highly mobile society of over 200,000,000 vehicles, and with the increase in projected career opportunities of persons in the transportation industry (here insert percentage of increase for next ten years) Courses in school should be designed to meet these career opportunities and replace some of the outdated courses such as Spanish, English Literature and extensive requirements in the Social Studies areas such as Ancient History and World Cultures.

7. Schools take the easy way out by assigning and structuring student organizations and assignments to those who can already perform. This is not teaching. Our task is to teach those interested to achieve performance on a near equal level in these assigned opportunities and organizations. Thus, assigned tasks from cleaning the erasers to editor of the school newspaper should be tasks that are taught rather than handed out to those who have shown competence.

SCHEDULE OF "THINK TANK" SESSIONS

TUESDAY EVENINGS

November 7, 1972 7:00 - 9:00 p.m.
November 21, 1972 - 7:00 - 9:00 p.m.
December 5, 1972 - 7:00 - 9:00 p.m.
December 19, 1972 - 7:00 - 9:00 p.m.
January 2, 1973 - 7:00 - 9:00 p.m.

Coffee will be served at 6:45 p.m.
Sessions will begin promptly.

Registration for the course will be at 6.30 to 7.00 p.m. the first evening. Sessions will be held at the Market Building.

I wish to enroll in the "Think Tank" sessions. I understand that I must attend all five sessions to receive the \$50.00 stipend. I also understand that all discussion must center around man and his work.

I agree to write a statement either for or against the topics, not to exceed twenty five words

I shall estimate my feelings using the following scale:

Strongly agree Agree Disagree in part Disagree Strongly disagree

I shall write a statement to be turned in at each following session stating my change in attitude or if no change I will also list new insights if any.

(Persons already compensated for their regular duties, by the World of Work program, are not eligible to collect a stipend for these sessions)

Signed _____

School _____ Subject area and/or Grade _____

Date _____

The Think Tank Seminar will carry a Youngstown University graduate credit option. You may enroll for one or two quarter hours. Cost will be \$15.00 per quarter hour plus a \$12.00 fee. The credits will be charged to the winter quarter. If you will be taking work during the winter quarter the \$12.00 fee will not be an additional charge.

I do want 1 hour _____ 2 hour _____ no _____ credit for the course.

Warren City Schools
DEPARTMENT OF CAREER EDUCATION
Warren, Ohio

THINK TANK
INTRODUCTION

Before undertaking an in-service project such as the "Think Tank," there are several factors which must be dealt with to help insure its success.

The first is that of the physical environment of the meeting place. The setting and atmosphere must be informal, warm and relaxed for group interaction can be inhibited by a rigid and formal setting. This activity should seldom if ever take place in a classroom.

Second, the group leader or leaders should be well versed in group interaction techniques.

Third, those leading should have a fundamental knowledge of the topic.

The fourth factor is the choice of topics themselves. The topics should be listed and presented to the participants before the first "Think Tank" session. This type of research should be encouraged, thus enhancing the quality of the session. These topics could be chosen by the initiators of the "Think Tank" or could be developed by the "Think Tank" participants in an introductory session. This session could also serve to familiarize the participants with the format and with each other.

The most important thing to remember about the "Think Tank" is that it is not meant to be an end unto itself. It is meant to stimulate curiosity and interest and create new perspectives in the contemporary issues surrounding the work concept.

WARREN CITY SCHOOLS

WORLD OF WORK

THINK TANK

PRE AND POST TEST OF ATTITUDE

DIRECTIONS. Listed below are seven major topics. Would you please indicate your present position regarding each of these topics.

- 1 Strongly Agree
- 2 Agree
- 3 Disagree in Part
- 4 Disagree
- 5 Strongly Disagree

1 It seems quite shocking that white workers earn fifty percent more than black workers. But it is even more disturbing that the best paid fifth of all white workers earns six hundred percent more than the worst paid fifth. Thus employers should make the wages of the best and worst paid workers equal

1 2 3. _ 4. _ 5. _

2 The American premise of equality of opportunity means that its people do not want to attend school or college, and equalitarian society ought to accept this as a legitimate decision and give these people subsidized job training.

1 2 3 4 5.

3 In an ecologically balanced system it is necessary to have human predators, which necessitates poverty and welfare

1 2 3 4 5.

4 Until existing conditions change and new jobs are designed to replace existing ones, one work role is no more important than another, i.e., the doctor's role is no more important than the garbage collector's

1 2 3 4. 5.

5 Quantity and quality of work and attendance in school have very little correlation with quantity and quality of work and attendance on the job. The motivating factor is that the quantity and quality of performance is related to the interest in the task.

1 2 3 4 5

6 In a highly mobile society of over 200,000,000 vehicles, and with the increase in projected career opportunities of persons in the transportation industry (here insert percentage of increase for next ten years) Courses in school should be designed to meet these career opportunities and replace some of the outdated courses such as Spanish, English Literature and extensive requirements in the Social Studies areas such as Ancient History and World Cultures.

1 2 3 4. 5.

7 Schools take the easy way out by assigning and structuring student organizations and assignments to those who can already perform. This is not teaching. Our task is to teach those interested to achieve performance on a near equal level in these assigned opportunities and organizations. Thus, assigned tasks from cleaning the erasers to editor of the school newspaper should be tasks that are taught rather than handed out to those who have shown competence.

1 2 3. 4. 5.

WARREN CITY SCHOOLS

WORLD OF WORK

THINK TANK EVALUATION

I Multiple Choice (Check the most appropriate answer)

1. How do you like this course as compared with other courses you have had, including those you are now taking?
 one of the best
 above average
 below average
 one of the poorest

2. How would you describe the attitudes of the class toward this course?
 very favorable
 fairly favorable
 average
 slightly unfavorable
 highly unfavorable

3. To what extent has this course made you think?
 very much
 a good deal
 average
 somewhat
 very little

4. How do you estimate the value of this course to you?
 the most valuable
 highly valuable
 of average value
 of little value
 of no value

5. How do you regard the class sessions?
 never want to miss them
 seldom want to miss them
 do not care whether I attend
 prefer not to attend
 dislike attending them

6. In relation to the courses I am now taking, the course is.
 very theoretical
 somewhat theoretical
 average balance between theory and practical application
 somewhat practical
 closely related to practical application

- 7 How much opportunity did you have in class sessions to express your own opinion and ideas?
- as much as I wanted or was able to use
 - more than in the average class
 - as much as in the average class
 - less than in the average class
 - practically none
8. Teacher's attitude toward questions.
- skillful in drawing out questions
 - encourages questions
 - avoids certain questions
 - ignores most questions
- 9 Class discussion:
- highly valuable
 - often unprofitable
 - largely a waste of time
10. Class atmosphere:
- too formal and uncomfortable
 - formal but not strained
 - warm, class and instructor work together
 - too relaxed - student seem to run the classroom
- 11 For my preparation and ability this course is:
- too hard
 - about right
 - too easy

II ESSAY (Please write a short answer to each of the following)

- 1 What do you consider to be one or more best features of this course?
- 2 What are the one or more least satisfactory features?
- 3 What did you get out of this course that was or will be useful to you in a practical way?
- 4 What other comments about either the discussion leader or the course that you would like to express? Do so here if you have any.

To THINK TANKERS

From Mike Zockle

Re ASSIGNMENT FOR NEXT THINK TANK SESSION

I THIS WEEKS TOPIC FOR DISCUSSION:

Strongly Agree Agree Disagree in Part Disagree Strongly Disagree

My stand on the TOPIC:

EVALUATION AFTER SESSION

Strongly Agree Agree Disagree in Part Disagree Strongly Disagree

II LAST WEEKS TOPIC FOR DISCUSSION:

My stand after the session and new insights

NEWS RELEASES AND PUBLIC INFORMATION

[Deleted from ERIC due to nonreproducibility]

