

DOCUMENT RESUME

ED 106 304

SP 009 221

AUTHOR Cowart, James F.
TITLE Instructional Aids for Adaptive Physical Education.
INSTITUTION Alameda County School Dept., Hayward, Calif.
PUB DATE 73
NOTE 24p.
AVAILABLE FROM Alameda County Schools Department, 224 West Winton Avenue, Hayward, California 94544 (\$2.50)

EDRS PRICE MF-\$0.76 HC-\$1.58 PLUS POSTAGE
DESCRIPTORS *Adapted Physical Education; *Athletic Equipment; Athletics; Exercise (Physiology); *Instructional Aids; Motivation Techniques; Muscular Strength; *Physical Fitness; *Physically Handicapped

ABSTRACT

This idea book on remedial physical education is divided into four sections. Each section contains drawings and brief explanations on ways to adapt physical education for the physically handicapped. The first section covers homemade equipment for developing muscular strength and endurance in specific muscles. Also included are resistive exercises for general body development for students with restricted use of a limb. The second section presents of adaptable ideas that make it possible for students to participate, to some degree, in a few of the more popular sports and activities (badminton, golf, bowling, archery, and ping pong). The third section contains two examples of instructional aids that can be made in order to communicate ideas related to body musculature and how it can be developed and maintained through exercise. The last section contains suggestions for encouraging students to continue participating to their limits in a conditioning program. Ideas include tests and charts to show student progress, information about the effects of exercise on the body, and information on how exercise can be used to develop and maintain physical fitness and recognition in activities generally participated in by all. (PB)

ED106304

U S DEPARTMENT OF HEALTH,
EDUCATION & WELFARE
NATIONAL INSTITUTE OF
EDUCATION

THIS DOCUMENT HAS BEEN REPRO-
DUCE EXACTLY AS RECEIVED FROM
THE PERSON OR ORGANIZATION ORIGIN-
ATING IT. POINTS OF VIEW OR OPINIONS
STATED DO NOT NECESSARILY REPRE-
SENT OFFICIAL NATIONAL INSTITUTE OF
EDUCATION POSITION OR POLICY

INSTRUCTIONAL AIDS FOR ADAPTIVE PHYSICAL EDUCATION

"PERMISSION TO REPRODUCE THIS COPY-
RIGHTED MATERIAL HAS BEEN GRANTED BY

*Alameda County
School Department*

TO ERIC AND ORGANIZATIONS OPERATING
UNDER AGREEMENTS WITH THE NATIONAL IN-
STITUTE OF EDUCATION. FURTHER REPRO-
DUCTION OUTSIDE THE ERIC SYSTEM RE-
QUIRES PERMISSION OF THE COPYRIGHT
OWNER."

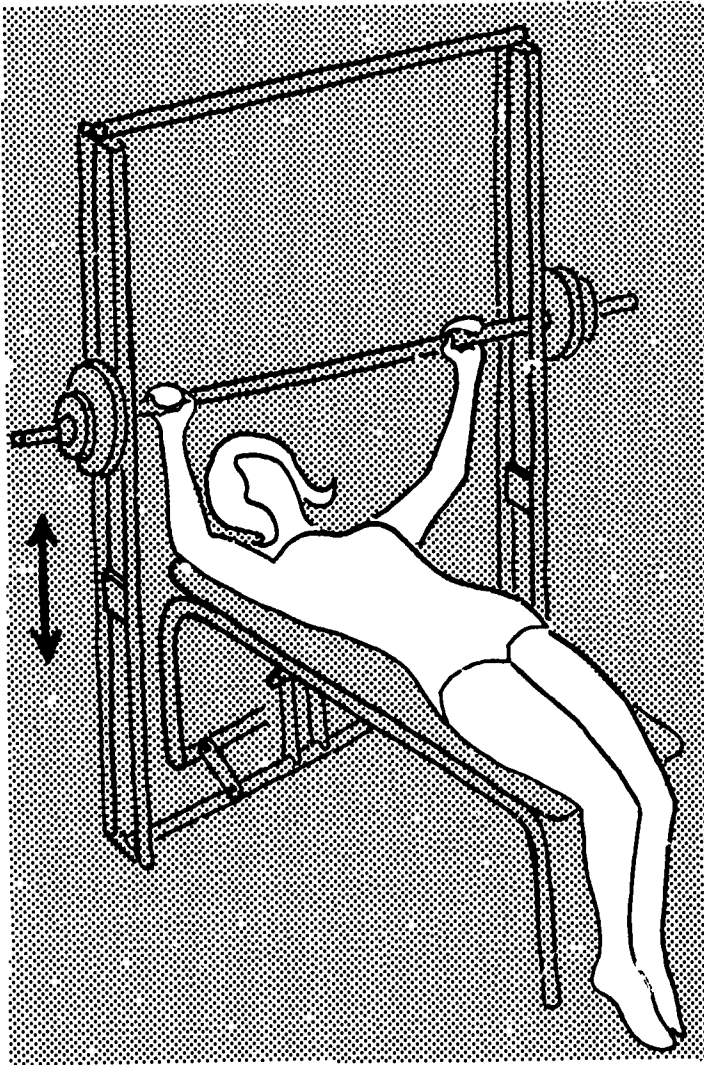

Published by the
Alameda County School Department
Rock La Fleche, Superintendent
224 West Winton Avenue
Hayward, California 94544

Alameda County Board of Education
Robert E. Clayworth, President
Ronald J. Motta, Vice President
Mrs. Virginia M. Birdsall
Charles A. Briscoe
William P. Burke
John J. Hagerty
John Penna

Copyright, Alameda County School Department, 1973

SP009 221

FOREWORD

Remedial physical education—adaptive, modified, or limited—is a State of California reimbursed program for the physically handicapped. Its highly individualized nature has required and evolved creative responses to the numerous special needs of these physically limited pupils. The teacher will find this idea book a rich source of helpful information, especially where school-provided equipment and supplies are minimal.

We are indebted to James Cowart, remedial physical education specialist of the Alameda County School Department, for developing and compiling this material.

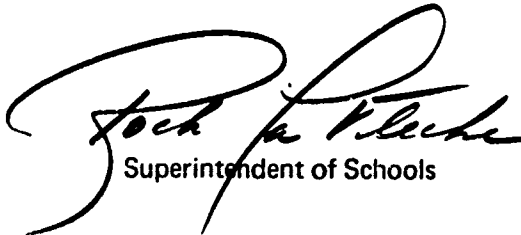
Superintendent of Schools

PREFACE

One of the admitted weak spots in special education has been the Remedial Physical Education Program ordinarily offered at the high school level. Although a detailed guide for the establishment and operation of these classes has been available*, many high schools have not made use of the classes, and some schools that have operated them have had difficulty maintaining programs which actually meet their students' needs. Some teachers assigned to the program have not been adequately prepared; and sometimes a program exists more on paper than in practice.

It is exactly those students with physical handicaps who need most to learn how to use their remaining abilities. Posture, muscle tone, regular exercise, participation in family and community activity, must be purposely taught to and developed by the person who has a handicap. The greater his handicap, the greater his need for help in these areas. Schools, however, have sometimes behaved in exactly the opposite fashion. Students with the greatest physical prowess and coordination are those who get the most individual attention, and sometimes the students with physical handicaps are left to play chess or checkers during physical education.

With this in mind, the directors of special education of the districts in the Physical Handicapped Tax Consortium, operated by the districts through the Alameda County Superintendent of Schools Office, suggested that a remedial physical education instructional supervisor be obtained and given the following assignment: To help each high school in the Consortium bring its remedial physical education program to the next higher level of efficiency. James F. Cowart was employed and in those schools where excellent programs were in operation, his duty was to help the teacher maintain, individualize, and extend those successes. In some districts, the initial step was to explore the needs and to make plans for a possible first class.

Experience during the first two years has shown that the analysis of the problem was correct: The key to the success of the remedial P.E. program is instructional supervision in a team-work relationship between the local teacher and the remedial P.E. specialist.

Cowart, who had seven years of classroom experience in such programs in Los Angeles, brought with him a great number of solutions that he had handcrafted for students with individual problems. To make some of his experience and creative ideas available to a wider audience and to help the hard-working, conscientious remedial P.E. instructor who faces novel problems in individualizing the lessons of each of his students, Cowart has agreed to write this idea book.

Injuries and malformations come in a never-ending variety and the ideas in this booklet are merely suggestions of what can, and in fact must be done to make remedial P.E. beneficial to certain students. As solutions to these unique challenges accumulate, it is proposed that a later edition of this book be printed. You are invited to correspond with Cowart by writing to him at the Alameda County School Department, 224 W. Winton Ave., Hayward, CA 94544.

On the following pages you will see instructions for creating specific tools for helping individual youngsters. This preface gives you a description of how to create a specific "tool" for the improvement of the whole program. The application of the instructional supervision model to remedial P.E. is that tool. Specialists moving between a set of teachers can help you maintain and improve the quality of your program. Without that kind of help, you very likely will experience wide fluctuations in quality and effectiveness over short periods of time.



Daniel E. Johnson
Director of Special Education
Alameda County School Department

*Dexter, Genevieve. *Instruction of Physically Handicapped Minors in Remedial Physical Education*, California State Department of Education, Sacramento, 1970, IV + 31.

In remedial physical education the teacher is confronted with a wide variety of physical problems in students. At times, equipment or supplies are not available in the schools to specifically meet the needs of some of these students; however, with a little time, initiative, and creativity many items can be made inexpensively. Existing equipment can be modified to serve the program well. If technical assistance is needed, keep in mind that your industrial arts department may be able to help.

Included in this idea book are drawings with brief explanations of items that have been developed, and/or existing equipment that has been adjusted, to meet particular needs. Some students formerly unable to participate have found new opportunities within their capabilities. When their needs are met, the students are enthusiastic and your job as a teacher becomes increasingly enjoyable and meaningful.

CONDITIONING DEVICES

This section covers homemade equipment for developing muscular strength and endurance in specific muscles. Also included are resistive exercises for general body development for students with restricted use of a limb.

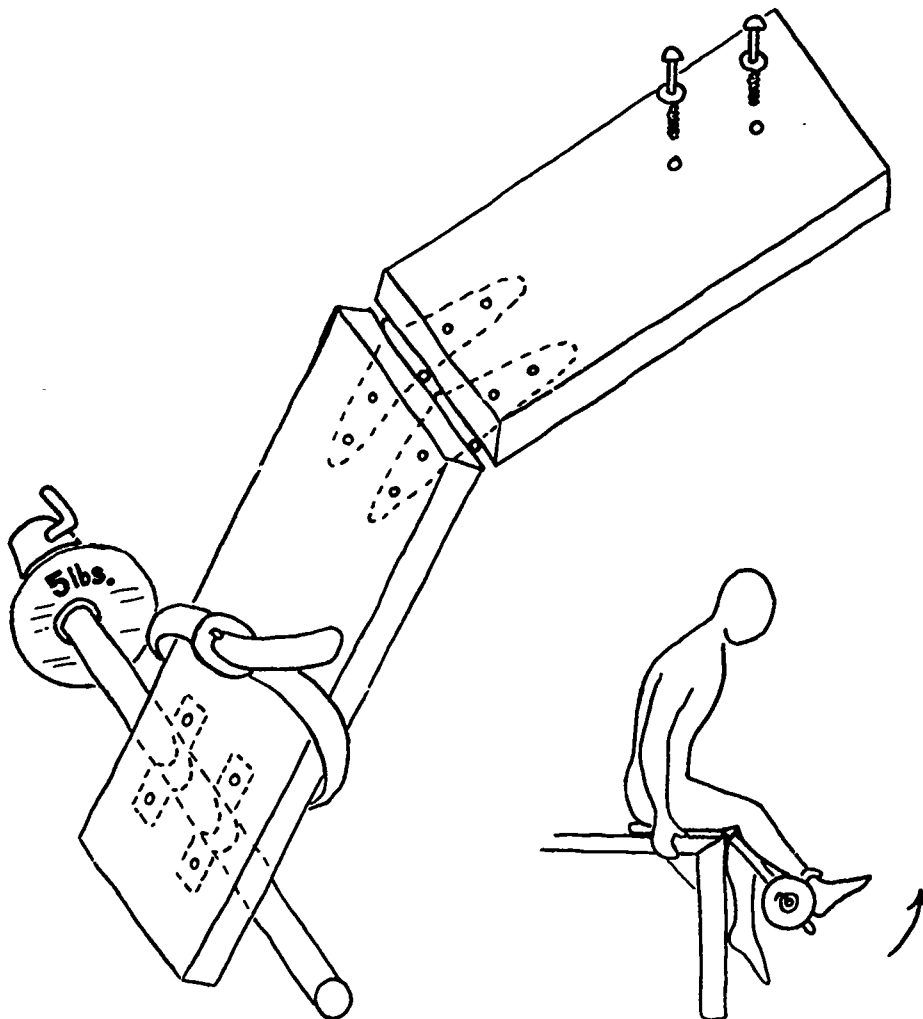

Quad Developer

This exerciser is used to increase the strength of the quadricep muscles. It has been used to help stabilize the knee joint following a leg cast removal or in conditions of knee dislocation.

Construction: Two pieces of wood are joined with hinges. The weight bar is attached at one end by means of plumber's strap bolted to the wood. A belt attached at this end serves to hold the board to the leg being exercised.

Dorsiflexor Exerciser

This device develops the dorsiflexor muscles along the front part of the lower leg. It was made for a post-polio student with atrophy of these muscles in one leg. The student's physician felt that an increase in strength of the dorsiflexors, along with continued gait training, would greatly assist the student's walking ability.

Construction: The device is made primarily from strap iron and pipe welded together and then bolted to a piece of wood. Straps hold the foot to the apparatus during exercise.

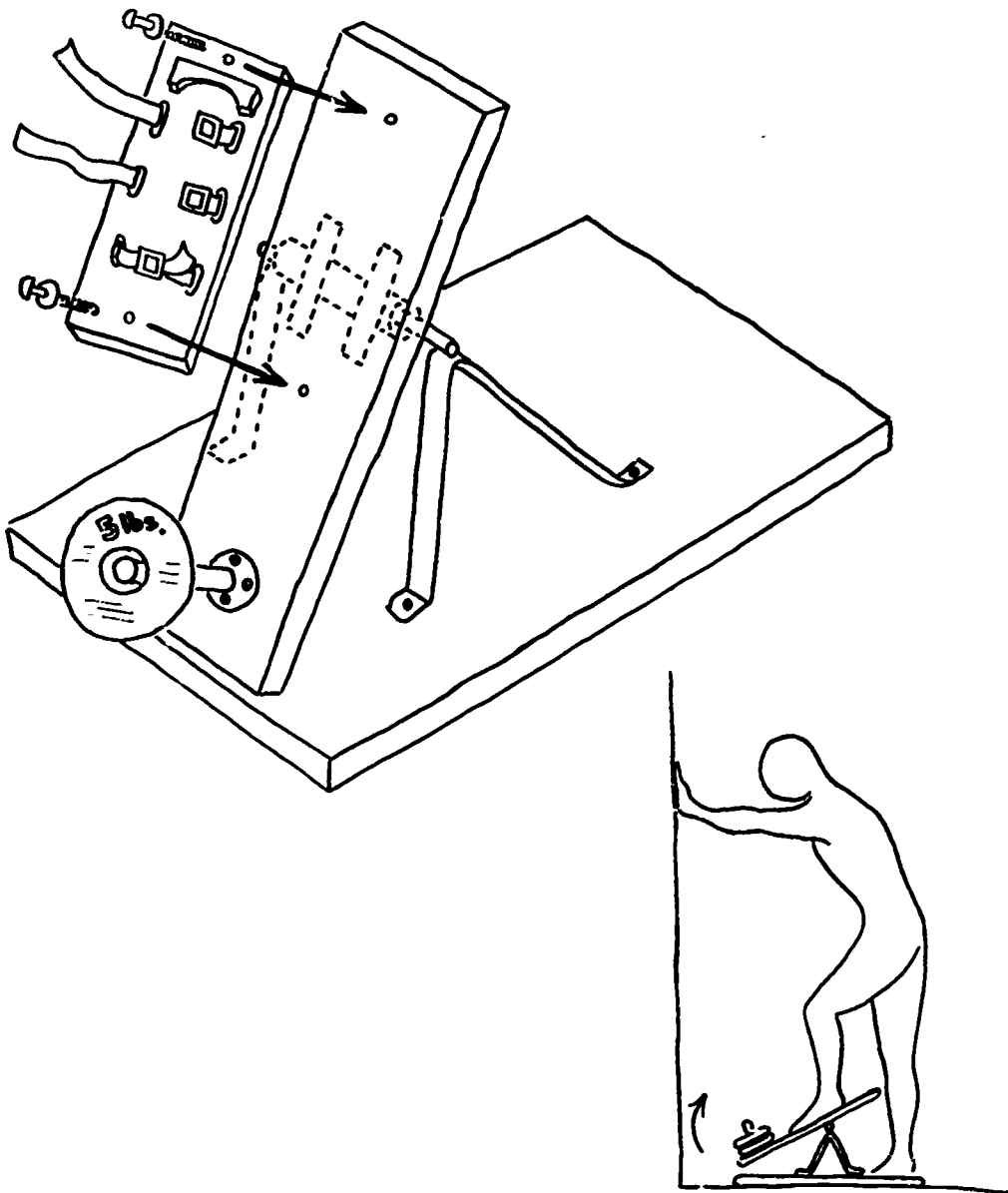

Lat Developer—Horizontal Bar

In performing pullups the latissimus dorsi muscles are one of the prime movers. Since many pupils were unable to perform this activity, and because dumbbells and barbells were the only available equipment pieces for resistive exercise, the following device was made for use with an existing horizontal bar, to develop the "lats."

Construction: Two 1" pipe clamps are attached to the horizontal bar a few feet apart. Attached to each clamp is a 5" diameter aircraft pulley wheel. Flexible cable is run over the pulleys and attached to the weight holder at one end and to the handle at the other end by means of "S" hooks. A safety screen is made of electrical pipe (lightweight for ease in weight adjustment) for keeping students away from the moving weight.

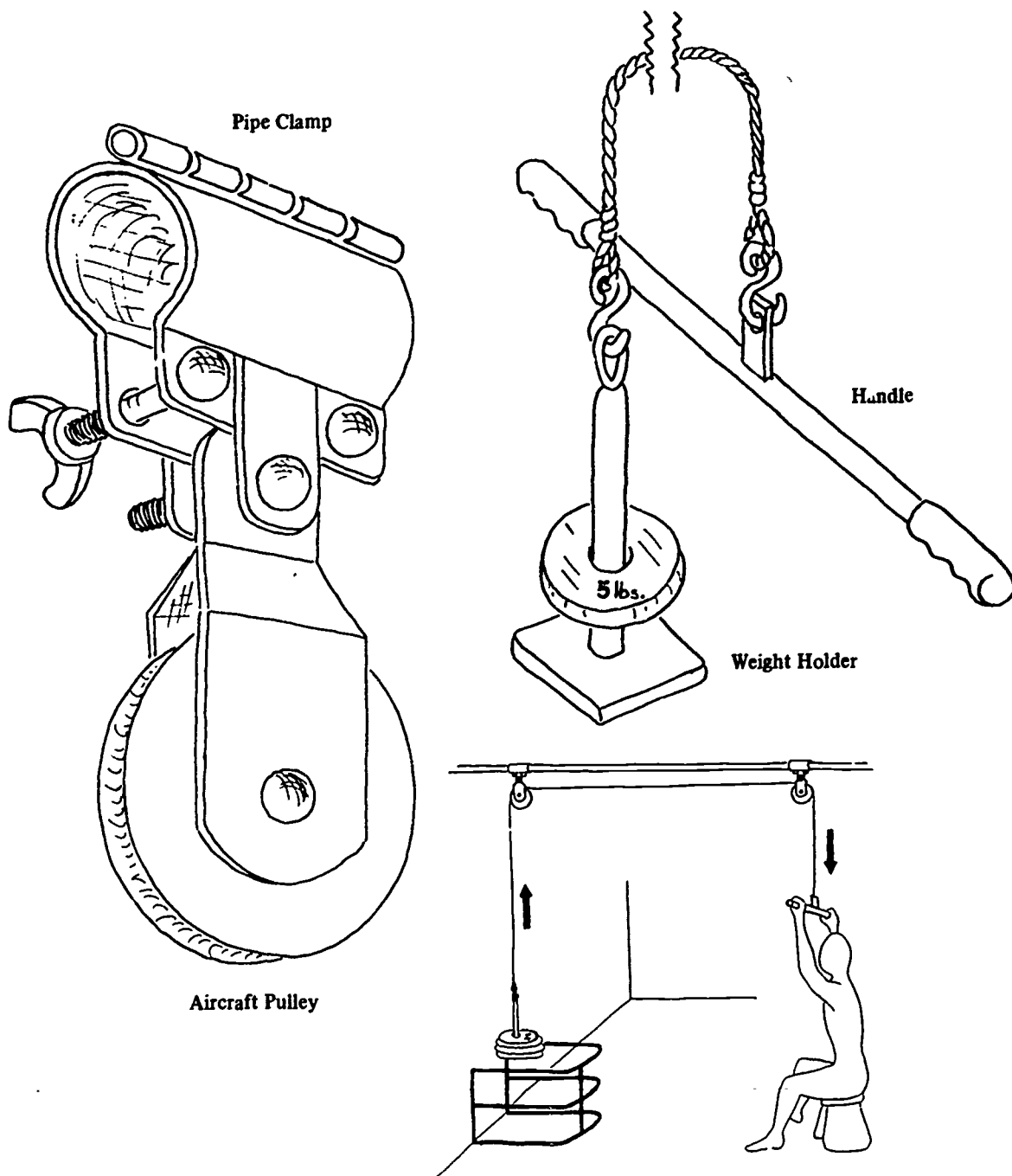

Lat Developer—Stall Bars

Another pulley apparatus used for the development of the latissimus dorsi muscles may be made to be attached to an unused portion of the stall bars.

Construction: Strips of iron are welded together, to which a pulley wheel is attached. The device can then be easily slipped over a rung of the stall bars by means of a hooked piece of metal welded to the underside. A safety screen made of electrical pipe is also used effectively with this apparatus to keep the waiting students away from the weight holder.

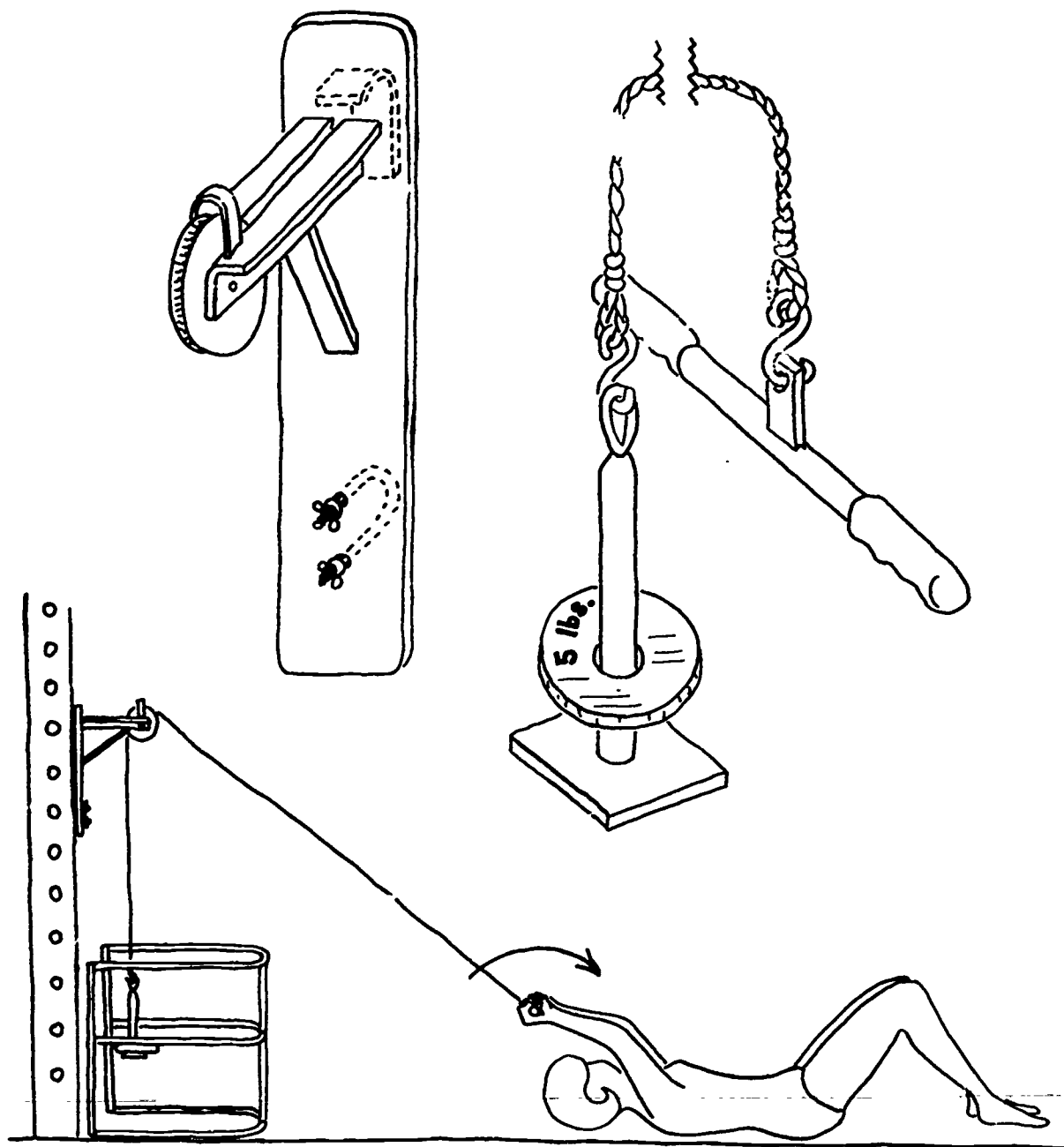

Spotting Device for Bench Press

To hand a barbell to a student who is lying on his back for the bench press exercise seemed unsafe. Thus, the following device was made to support the weight while not in actual use. In addition, it prevents the pupil from being hit if the barbell is accidentally dropped; it further acts as a guide for the weight during the lifting action.

Construction: Galvanized pipe is welded together as seen in the illustration. The apparatus is then secured to the bench by bolts.

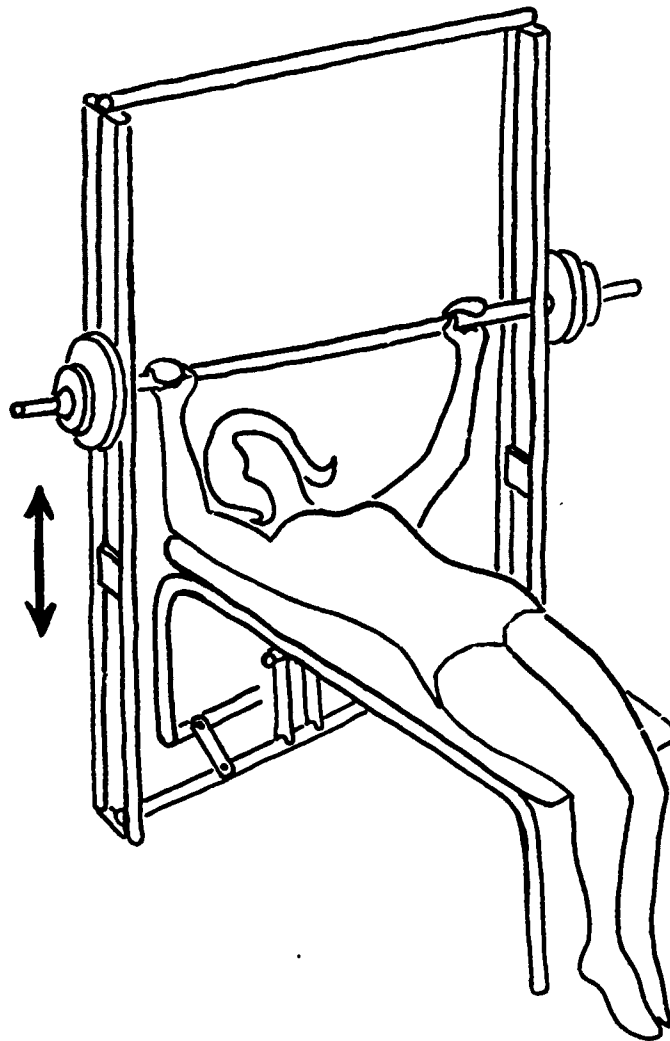

Conditioning Exercise With Hand-Arm Prosthesis

Resistive exercise by means of an Exer-Genie can be provided for a student wearing a prosthetic hook. As the pupil varies the body position and angle of pull he can develop most of the major muscles of the upper body.

In addition, a jump rope handle may be adapted (see illustration) to fit a prosthetic hook so the student can participate in coordination and cardio-respiratory exercises.

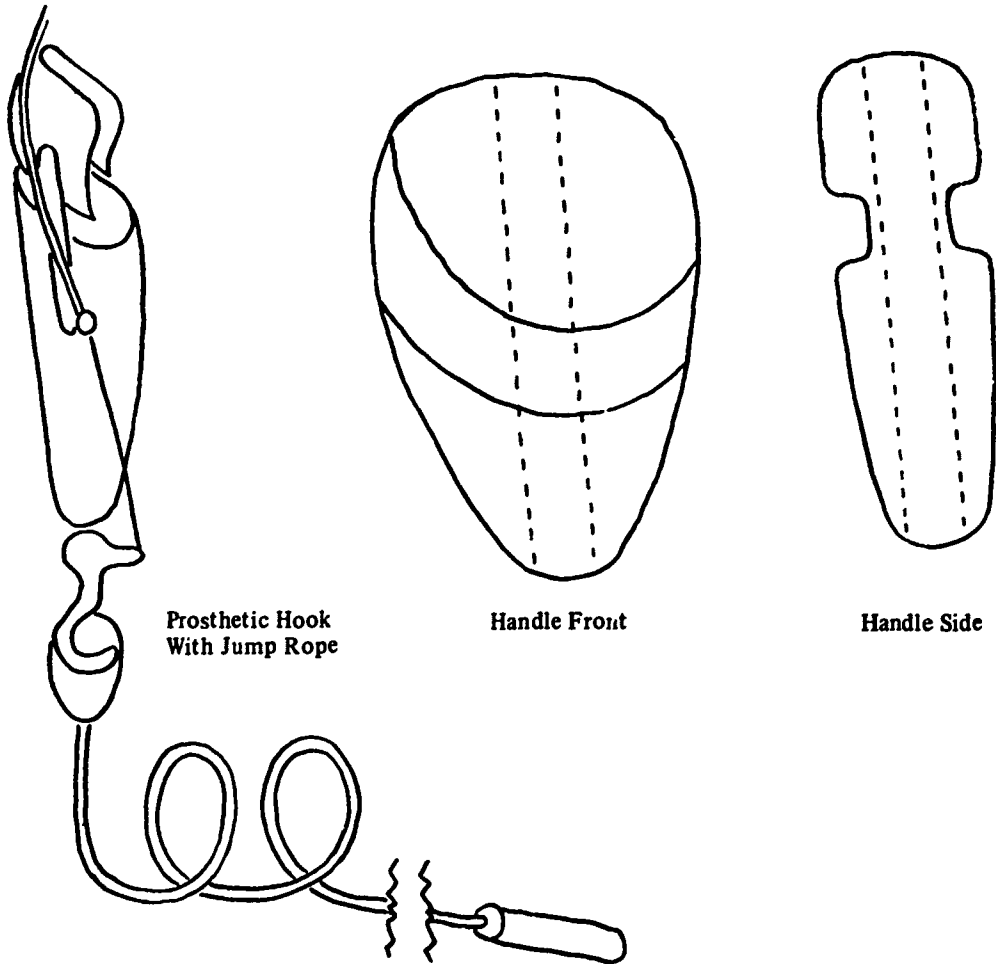

Resistive Exercises With Immobilized Limb

This section is included to emphasize that because a pupil may be partially immobilized he is not totally incapacitated. General conditioning should continue for the unaffected body parts.

Illustrated are resistive exercises for the major muscles of the upper body. These exercises make use of dumbbells and can be done while sitting and lying. For the pupil with an immobilized upper limb, two modifications are suggested (not illustrated): 1) instead of executing the supine arm lift on a bench the student performs the exercise on the floor and 2) in the prone arm lift, the pupil stands and bends at a right angle from the waist and does the lift out and upward from this position. In both cases better balance is thus provided.

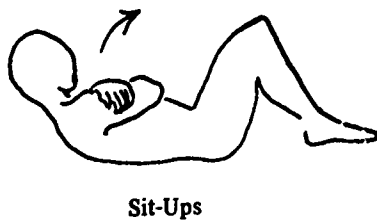
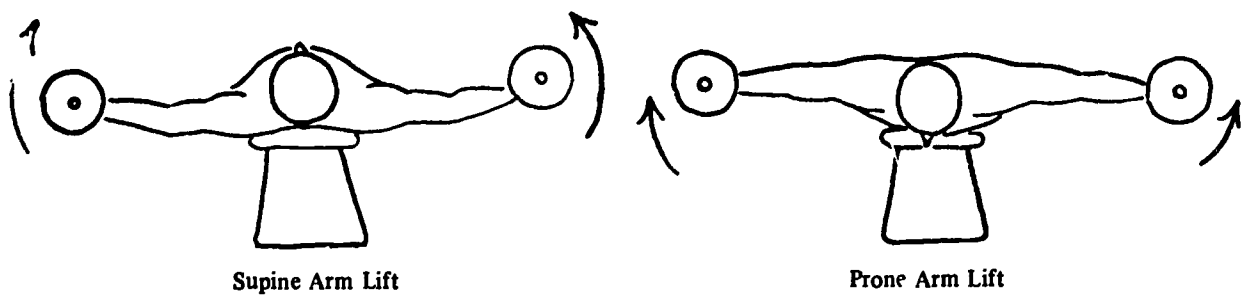
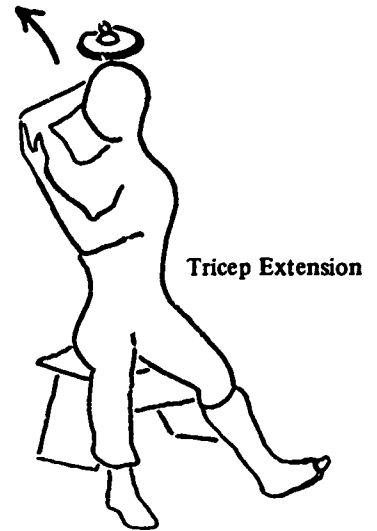
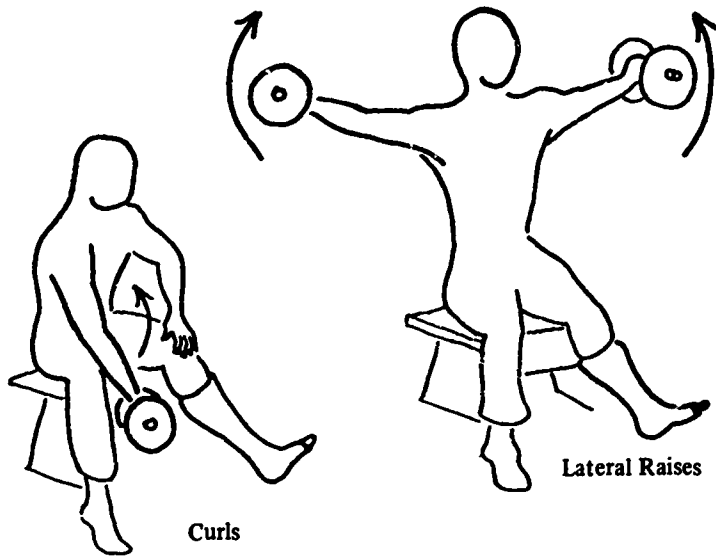

SPORTS ADAPTATIONS

Most of the sports and recreational activities offered in a regular physical education class should, when possible, be included in the remedial physical education class. Within a class some students can play the various games without any changes while others will require some adaptation. Generally, game adaptation can be accomplished without losing the game's essential elements. Reducing playing space, modifying rules, and/or adapting equipment are a few ways of providing for participation in the usual peer activities.

While a pupil may be restricted by the physician from regular game play, he may be unrestricted in performance of the sport's skills. The former presents an intense competitive situation that is seen as potentially harmful to some students. However, the sport skill itself when performed apart from the game may be seen as developmental. If the latter is the case, the pupil then should have the opportunity to develop those individual skills of which he is capable. The teacher's responsibility becomes one of presenting the skill in an interesting and challenging way to the pupil. Meeting the challenge can provide a very fruitful learning situation for both student and teacher.

If neither the particular game nor the sport's skills are possible because of a student's physical limitations, then some other activity may be necessary. Consider the following: horseshoes, shuffleboard, frisbie, croquet, bocce, mini ping-pong, etc. Each of these may be played in a relatively small outdoor area immediately adjacent to the class. This allows supervision of the few, as well as the majority, and assures a safe and convenient arrangement for continuing instruction to all in the class.

Included below are examples of some ideas for adaptation that make it possible for students to participate, to some degree, in a few of the more popular sports and activities.

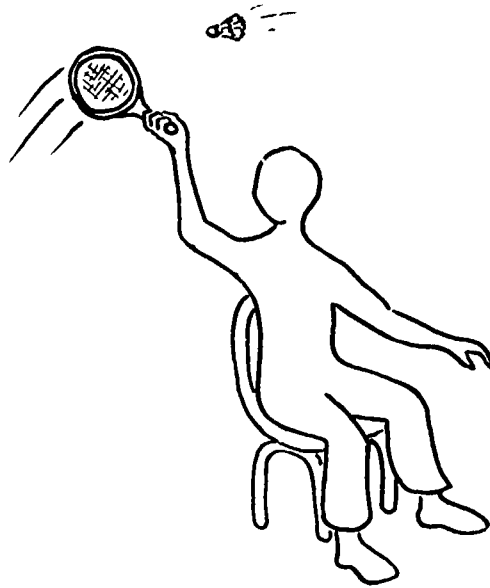

Badminton

A student severely restricted in movement and balance can sit and participate in badminton. A shortened racket allows the pupil to execute an underhand serve, overhand and underhand swings. An excellent modified badminton game for the sedentary student is called "loop badminton."* Using a hula hoop taped to a portable standard a few feet above the ground provides a target through which the bird has to be served and hit to remain in play. Because the bird is directed through a central hoop the student can sit and still be actively involved in the game.

Construction: Obtain a 5" to 6" length of doweling approximately the same diameter as an ordinary badminton handle. Lengthwise through the dowel drill a hole slightly smaller in diameter than the racquet's metal shaft to be adapted. After cutting off the metal shaft of a racquet just above the original handle, the racquet is ready for the dowel handle. Twist the doweling onto the shaft of the racquet. If the new shortened handle is somewhat loose, apply glue to secure the handle to the shaft.

*Fait, Hollis F. *Special Physical Education: Adapted, Corrective, Developmental*, 2nd edition, pp. 234-236. W. B. Saunders Co., Philadelphia, 1969.

Golf

Students confined to wheelchairs and those with some chronic conditions affecting balance find the chance to participate in this peer activity a satisfying experience. A firm stable chair for sitting and a shortened golf club are prerequisites for the student. The ball will not travel as far as those hit by a standing student, for this reason position the student to the side of the class where various challenging tasks can be moved into him. Hula hoops and/or flags are easy markers for the teacher to move about for this purpose.

Also a student using crutches can sit and swing a shortened club or he may be able to brace himself with one crutch while using the other hand to swing the club. Some students using this technique have become quite efficient in their swing.

Plastic (solid outer cover) golf balls have been used very successfully in the golf unit. They are popular not only because the ball is realistic when hit but because of the obvious safety factor of a hollow ball.

Construction: A regular golf club can be cut short and then a new grip attached. Check with your local pro golf shop for a method of putting on a new grip.

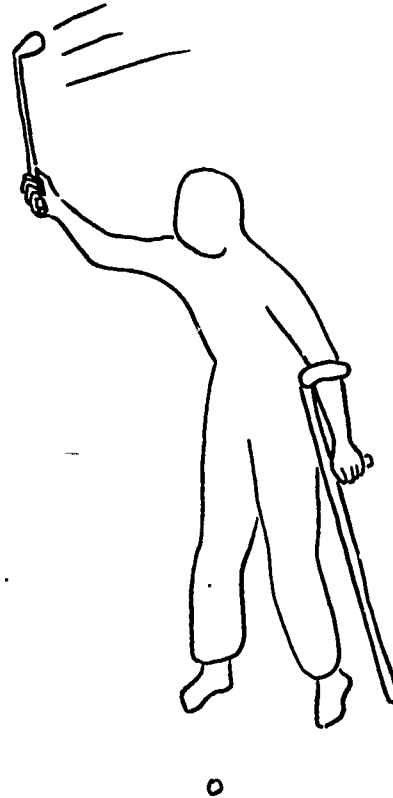
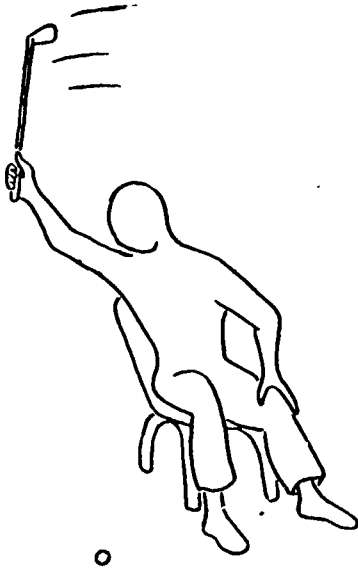

Bowling

Plastic or rubber indoor bowling sets have been used successfully with students. A student who cannot support his weight can successfully sit and bowl a 5 lb. rubber ball. (A 2½ lb. ball is available for students who have difficulty balancing in the chair while handling the 5 lb. ball.) The student in a wheel chair with permanent sides can lean over the side to allow for a free swing of the arm. Even with this handicap, the student will bowl with enough accuracy to find real pleasure in the game.

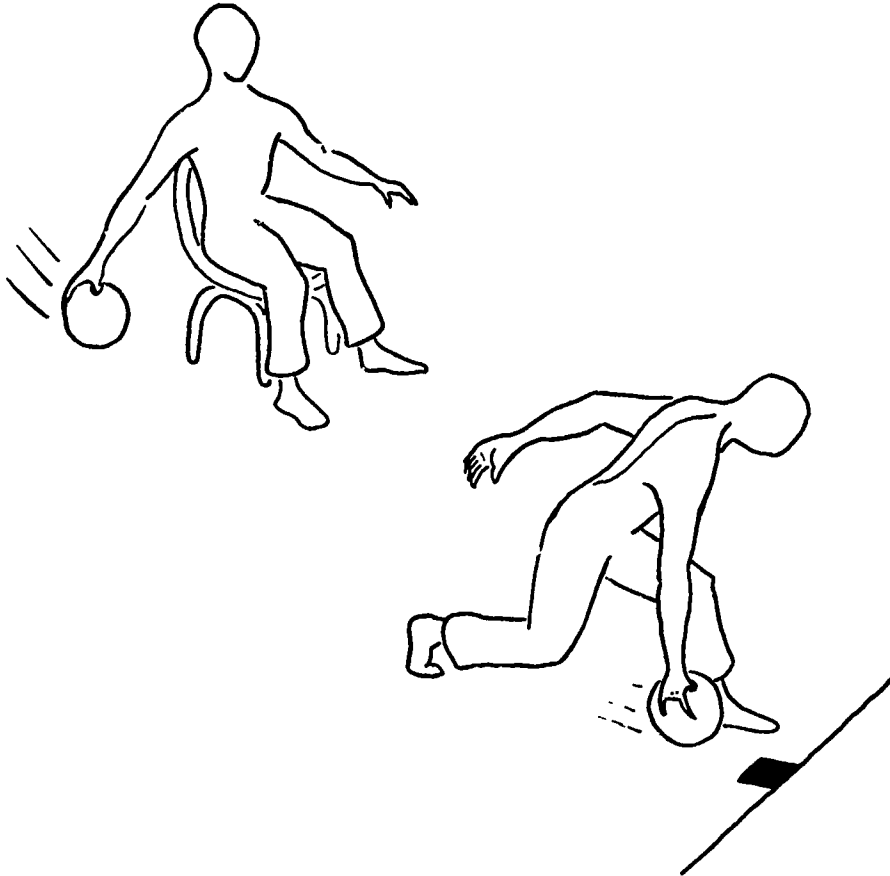

To a visually impaired student the distant bowling pins were a blurred image. To make bowling more meaningful for this student a large spot was placed on the floor just before the foul line; the spot was aligned with the headpin. Standing behind the foul line, the student then took a pendulum swing and released a straight ball on the spot. Told what pins were knocked down and what remained, the student then released the second ball, to either one side or the other of the spot.

As confidence was gained the visually impaired student could take a step and then release on the spot. The student could progress to a four-step approach and then release. An additional help might be a prominent line perpendicular to the foul line that the student could follow in making his approach before releasing the ball. Much greater success was achieved with these techniques than when the student just bowled at a "blur" at the other end of the gym.

Archery

A student restricted in leg movement can also participate in this sport by sitting. Any handicap related to his/her being sedentary is very negligible. Illustrated is an adapter* to allow a student with a prosthetic hook to participate in the game.

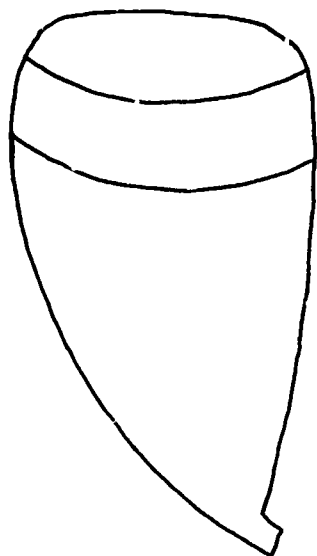
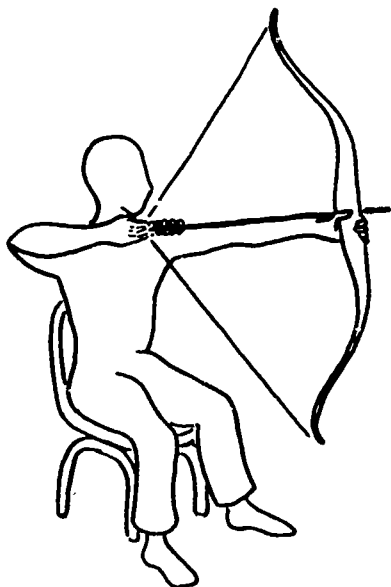

Front View



Side View

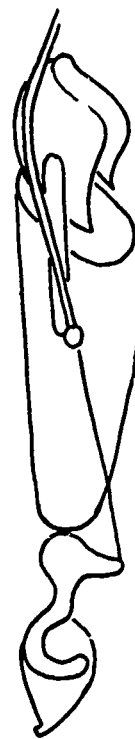

Archery adapter for student with a prosthetic hook.

*Adams, Ronald C., Alfred N. Daniel, and Lee Rullman. *Games, Sports, & Exercises for the Physically Handicapped*, pp. 234-236. Lea & Febiger, Philadelphia, 1972.

Ping-Pong

Ping-pong played on a small surface area (easily portable) is an activity adaptable to a variety of situations. The student can sit on a lawn area, the deck of a pool, or can straddle a bench; these are only some of the places where the game may be played. This activity is excellent for students who have been greatly restricted by their family physicians.

Construction: A sheet of 4'x8'x½" plywood is cut into three equal sections, as illustrated. A wooden net can be made as shown in the drawing so it slips over the board easily and quickly.* A handle is made from coat hanger wire with a piece of hose slipped over it for ease of handling.

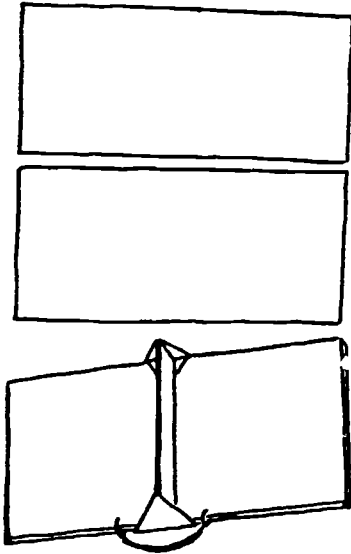

4'x8'x½" Plywood

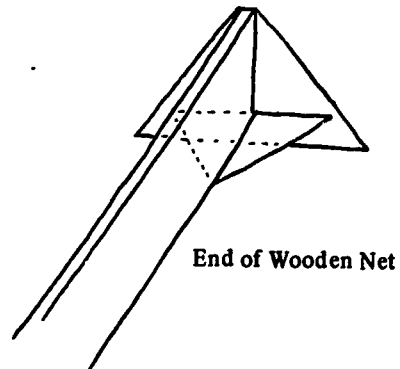

End of Wooden Net

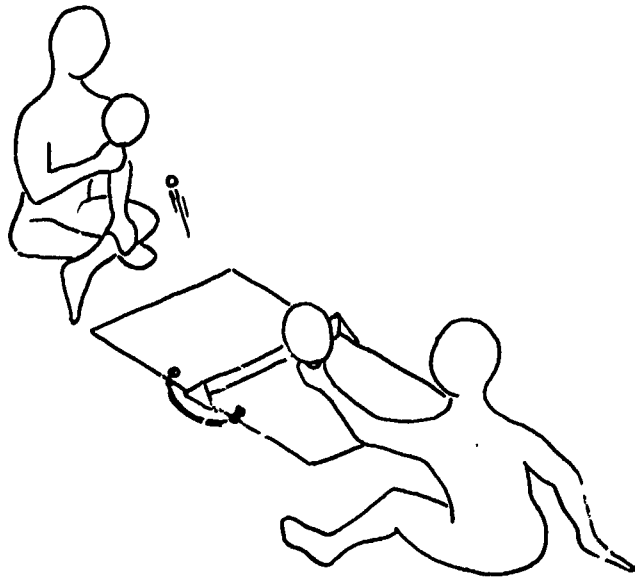

*First seen in the Los Angeles City Schools

VISUAL AIDS

To make our program more meaningful to students, factual information related to the student's own body musculature and how it can be developed and maintained through exercise should be taught. When attractive and interesting visual aids are provided, this information is well received by students.

Illustrated below are two examples of instructional aids that were made and successfully used to communicate ideas related to our bodies and to exercise.

Muscle Puzzle

Periodically I have had a student who was restricted from any physical activity for a day or two following an illness. Different sedentary tasks related to physical education were given the pupil to complete—tasks which were both educational and enjoyable.

An item along these lines that was very successful was termed a "muscle puzzle." The student was required to assemble the various pieces of a body puzzle, each puzzle piece representing a muscle or muscle group. Upon completion of the puzzle, the student had additional pieces (magnetic arrows) marked with exercises which he used to indicate the muscle(s) developed by that exercise. Further, since the muscles are listed on the puzzle-backing, the student verbally identifies the muscle by name at the teacher's request.

Construction: Using illustration board, a figure can be drawn showing the major muscles of the body. The various individual muscle(s) are cut out and a small magnet is glued on the undersides of each puzzle piece. The small arrows are also cut from illustration board and backed with magnets. A large piece of sheet metal is used for the backing, with only a general outline of the body printed on it. A handle for the backing is made from a wire coat hanger over which is slipped a piece of hose to provide a grip.

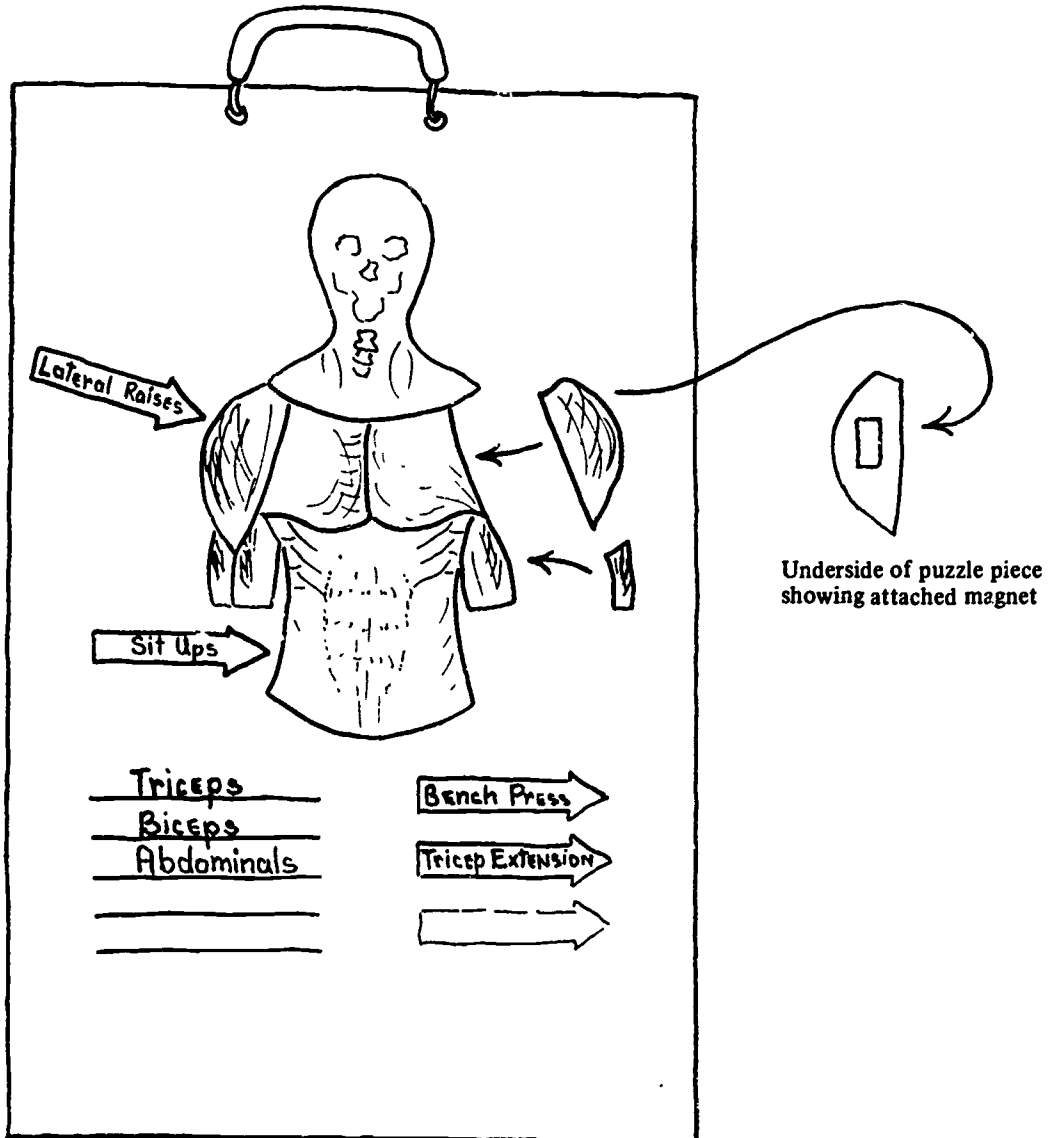

Posture Figure

This figure allows for individual movement of body segments in teaching good and poor body alignment. It is similar to the "muscle puzzle" in idea and construction, but the body segment pieces are permanently joined.

Construction: Using illustration board the body segments are cut out and magnets attached. To join these segments, ordinary stationery brads are inserted through the pieces to allow movement. While the figure is held firmly by magnets to the sheet metal backing, the various segments can be moved to indicate any intended body position.

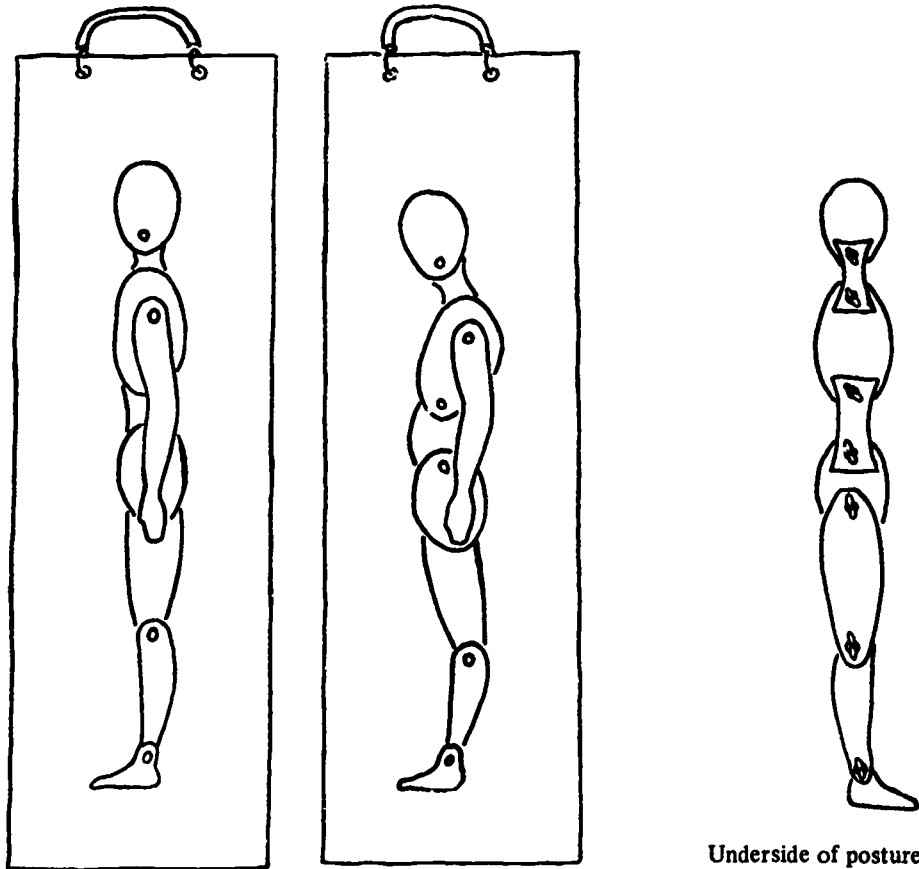

Underside of posture figure

MOTIVATIONAL AIDS

A conditioning program of resistive exercises for muscular strength and endurance and activities for cardio-respiratory endurance is basic in the curriculum. However, maintaining adequate performance on the part of the students becomes challenging as he/she continues in the conditioning program over the semester/year. The following techniques were found helpful in encouraging students to continue participating to their limits:

- Provide factual information about the effects of exercise on the body and how exercise can be used to develop and maintain fitness.

- Chart daily the weight lifted and/or repetitions completed for each exercise in the student's individualized exercise program; and/or chart the distance run in the endurance fitness program.

- Test pupils at regular intervals so improvement can be noted.

- Provide recognition within those activities generally participated in by all. Competition with a continuing chance for recognition in a variety of activities is one way to encourage students to work at maximum effort. The "exercise record board" was developed as one way to provide this recognition (see illustration). Also, an emblem to wear on gym clothes proved useful when it was provided upon achievement of a preestablished goal (see illustration).

Exercise Record Board

Prime performance in general: developmental exercises became a challenge when competition with fellow students was encouraged with this constructive aid. To allow for differences in body makeup, students were classified as either heavyweight, middleweight, or lightweight. At the end of each period pupils reported their gains, and as marks were exceeded the board was kept up-to-date. So that this competition would not encourage numerical gain at the expense of quality work, the teacher continued close observation and stressed body alignment. Eager to see their names on the board, students avidly observed one another to assess alignment. Body alignment during exercises as well as a program of lifting weights within a designed number of repetitions set by the teacher was essential to making the conditioning program valid.

Construction: To a $\frac{1}{4}$ " piece of plywood staple illustration board with an outline listing the exercise and weight divisions. (The sturdy plywood backing allows greater permanency and permits it to be easily set against walls or other objects within view of the students.) Over this is applied a firm sheet of clear plastic which may be easily written upon with a grease pencil, or erased as students' records change.

CURLS	
<u>HEAVYWEIGHT</u>	
K. Jones $\frac{70 \text{ lbs.}}{8 \text{ reps.}}$	B. Smith $\frac{60 \text{ lbs.}}{10 \text{ reps.}}$
C. Schwartz $\frac{60 \text{ lbs.}}{8 \text{ reps.}}$	
<u>MIDDLEWEIGHT</u>	
G. Takata $\frac{60 \text{ lbs.}}{9 \text{ reps.}}$	M. Cruz $\frac{50 \text{ lbs.}}{9 \text{ reps.}}$
C. Smith $\frac{50 \text{ lbs.}}{8 \text{ reps.}}$	
<u>LIGHTWEIGHT</u>	
E. Klein $\frac{40 \text{ lbs.}}{9 \text{ reps.}}$	K. Stern $\frac{40 \text{ lbs.}}{8 \text{ reps.}}$
L. Wo $\frac{35 \text{ lbs.}}{8 \text{ reps.}}$	

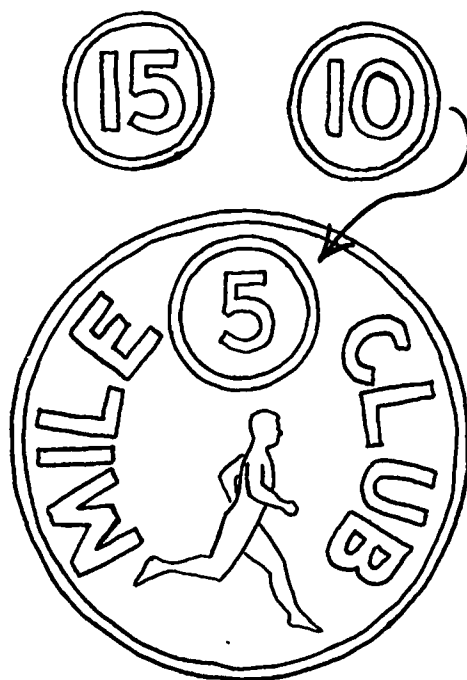

Endurance Fitness Emblem

This emblem was used to motivate the student in his cardio-respiratory work, which in this case was jogging. Upon jogging a total of five miles, the student was awarded an emblem. For each additional five miles completed, a new patch with a number indicating the miles jogged was given to replace the old one. Students unable to jog could walk or push themselves in their wheelchairs with proper adjustment made in the criteria for award achievement.

Construction: The illustrated emblem is made by silkscreening. Your print shop teacher can be of real assistance in helping you with this printing technique.